



**BROADCAST**

---

**CATALOG**

---

**SUPPLEMENT**

---

**RCA...THE MATCHED LINE**

## Broadcast Catalog Supplement

TO KEEP YOU UP TO DATE . . . with latest equipment developments, new catalog sheets will be mailed periodically. These will be numbered according to subject categories (see below).

FOR YOUR CONVENIENCE IN FILING . . . ten dividers, with index tabs, are provided in this supplement. Each corresponds to a Broadcast Equipment Catalog—Audio, Camera, Film, etc. These are the main headings below.

HOW IT WORKS . . . When you receive new catalog literature, note the "B" number in the upper right corner. Find this number series in the list below. Then file under proper divider.

IN THE FUTURE . . . occasionally a new (or revised) sheet will replace an older one in your supplement. Also when a new bound catalog becomes available (say the TV Tape), it will replace all the loose sheets in the (TV Tape) section of this supplement.

### Audio

Microphones	B.1000
Consoles	B.1100
Custom Equipment	B.1200
Amplifiers	B.1400
Rack Equipment	B.1500
Turntables	B.1600
Tape Recorders	B.1700
Speakers	B.1800
Test Equipment	B.1900

### Camera

Cameras	B.2000
Camera Accessories	B.2100
Lenses	B.2150
Lighting	B.2350
Mobile Units	B.3300

### Film

Cameras	B.3000
Projectors	B.3040
Film Accessories	B.3055

### Terminal

Custom TV	B.2250
Switching	B.2300
Monitors	B.2400
Amplifiers	B.2500
Special Effects	B.2640
Rack Equipment	B.2700
Plugs & Cables	B.2850
Sync Equipment	B.3400
Power Supplies	B.3450
Test Equipment	B.3800

### VHF Transmitting

Transmitters	B.4000
Antennas & Towers	B.4100
Consoles	B.4300
Accessories	B.4500
Common VHF/UHF Equip.	B.4700
Test Equipment	B.4900
TV Relay	B.8000

### UHF Transmitting

Transmitters	B.5000
Antennas & Towers	B.5100
Consoles	B.5300
Accessories	B.5500
Test Equipment	B.5900

### AM Transmitting

Transmitters	B.6000
Antennas & Towers	B.6250
AM/FM Transmission Line	B.6200
Transmitter Accessories	B.6300
AM Test Equipment	B.6400

### FM Transmitting

Transmitters	B.6500
Accessories	B.6600
Antennas & Towers	B.6700
Test Equipment	B.6800

### TV Tape

Tape Recorders	B.7000
Tape Accessories	B.7050
Tape Mobile Units	B.7090

### Transmission Line

TV Line	B.6900
Line Accessories	B.6950



- Lightweight broadcast microphone
- Wind and "pop" resistant
- Internal shock resistant
- Replaceable cartridge
- Uniform frequency response—50 to 15,000 Hz

## RCA Dynamic Microphone, Type BK-14A

### Description

The BK-14A is a dynamic cartridge-type microphone, ideal for indoor or outdoor broadcast use where a hand held lightweight mike with good response to voice and music is required. The microphone is omnidirectional with a frequency response essentially uniform from 50 to 15,000 Hertz.

The Type BK-14A Dynamic Microphone is contained in a non-reflecting satin nickel 8-inch long case only 3/4-inch in diameter. It is protected by a wind screen, and has internal shock and isolation construction permitting effective use in areas where loud "pop" noises are specified. The microphone has provisions for stand mounting. A swivel mount and a 30-foot, 2-conductor shielded cable with Cannon plug to fit the microphone base are supplied as standard equipment.

### Specifications

Directional Characteristics .....	Omnidirectional
Frequency Response .....	Uniform from 50 to 15,000 Hz
Output Impedance .....	Low—for use with 30 to 250 Ohm unloaded inputs
Output Level (1000 Hz):	
Effective (10 dynes/cm <sup>2</sup> ) .....	-60 dBm (150 Ohms)
EIA-G <sub>11</sub> .....	-154 dB (150 Ohms)
Hum Pickup Level (.001 gauss, 60 Hz) .....	-120 dBm (max.)
Cable (Removable) .....	30 feet, 2 conductor, shielded with Cannon XLR-3-11C to fit microphone base
Mounting .....	Hand held or stand by means of swivel mount supplied
Finish .....	Non-reflecting satin nickel
Dimensions (Overall) .....	8" long, 0.75" dia. body, screen 2" dia.
Weight .....	4 ounces less cable (113.4 gr.)

### Ordering Information

Type BK-14A Dynamic Microphone .....MI-11042

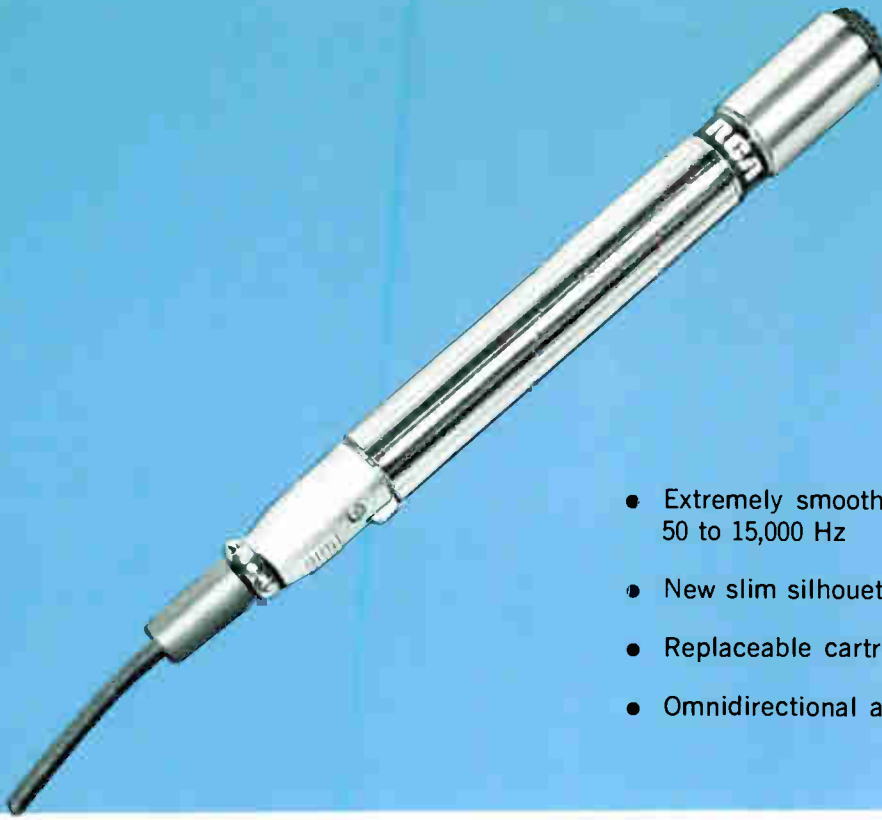

- Extremely smooth frequency response 50 to 15,000 Hz
- New slim silhouette for hand or stand use
- Replaceable cartridges
- Omnidirectional at all frequencies

## RCA Dynamic Microphone, Type BK-16A

### Description

The BK-16A Dynamic Microphone is designed for use in broadcast stations, recording studios and public address systems. Its new slim silhouette and light weight make it particularly well suited for pickups where a hand held or stand microphone is designated. The BK-16A is an omnidirectional microphone and has a smooth response over a frequency range of 50 to 15,000 Hz.

The BK-16A is encased in a non-reflecting satin nickel housing 8 inches long and 3/4-inch in diameter. It is provided with a swivel mounting and a 30-foot, 2-conductor shielded cable with Cannon connector to fit at the base. Internal shock and isolation filters assure smooth speech or music pickup, but it is not designed particularly for use with loud "pop" noises or in outdoor locations.

### Specifications

Directional Characteristics .....	Omnidirectional
Frequency Response .....	50-15,000 Hz
Output Impedance .....	Low—for use with 30 to 250 Ohm unloaded inputs
Effective Output Level at 1000 Hz:	
Sound Pressure 10 dynes/cm <sup>2</sup> .....	-60 dBm (150 Ohms)
EIA-G <sub>m</sub> .....	-154 dB (150 Ohms)
Hum Pickup Level (.001 gauss, 60 Hz) .....	-120 dBm (max.)
Cable .....	2 conductor, shielded, 30-feet with Cannon XLR-3-11C plug to fit microphone base
Mounting .....	Hand held or stand by means of swivel mount supplied (stand is supplied)
Finish .....	Non-reflecting satin' nickel
Dimensions (Overall) .....	.8" long, 0.75" diameter
Weight (less cable) .....	3 ounces (85 gr.)

### Ordering Information

Type BK-16A Dynamic Microphone .....MI-11048



- Velocity (ribbon) element
- Frequency range—30 to 20,000 Hz
- Improved unidirectional characteristic with wide pickup angle on front
- Three position voice-music switch allows selection of most desirable operating characteristic

## RCA Uniaxial Ribbon Microphone, Type BK-5B

### Description

A dependable, high quality ribbon instrument with an improved unidirectional characteristic, the RCA Type BK-5B Uniaxial Microphone is designed for broadcast, motion picture, and recording applications where quality pickup is essential. The microphone offers wide frequency response essentially flat from 30 to 20,000 Hz. Its smooth response and wide frequency range make it ideal for both speech and music.

#### “Uniaxial” Directivity

Especially engineered with the needs of radio and television in mind, the microphone's maximum sensitivity lies on a single mechanical axis, (see directivity pattern on reverse). This “uni-axial” directional characteristic simplifies microphone placement. The small size, light

weight, and attractive TV-gray finish render it especially suitable for television in that it doesn't upstage the talent. Its quality makes it admirably suited to radio broadcasting and high-fidelity sound systems.

#### Ribbon Element

The moving element of the Type BK-5B Microphone is a thin, corrugated, metallic ribbon clamped under tension. It vibrates in near perfect sympathy with almost any sound waves it intercepts. Placed between the pole pieces of a magnetic circuit, one side of the ribbon is exposed to the open air while the “rear” side “sees” an acoustical labyrinth. Phase-shift openings in the labyrinth cancel essentially all of the backwave to give the instrument its unidirectional characteristics.

#### Triple-Impedance Output

An impedance-matching transformer, housed within the microphone case, raises the extremely low impedance of the ribbon to a line impedance of 30, 150 or 250 ohms. Connected for 250 ohms at the factory, changing the connections for either 50 or 150 ohms is a simple matter done easily almost anywhere. More-than-adequate transformer shielding prevents hum pickup even in moderately strong magnetic fields (see *Specifications*).

#### Built-In Blast Filter

So faithful is the ribbon element to the sound pressures it intercepts that a sharp, loud transient—such as a gun shot—could do it harm. However, the BK-5B mike includes a double-layer blast filter that effectively shields the ribbon from

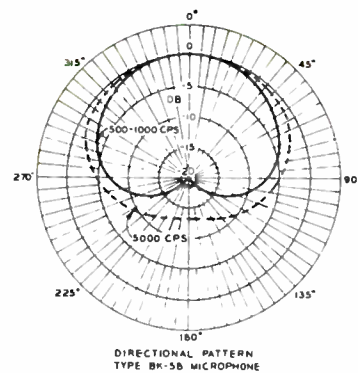
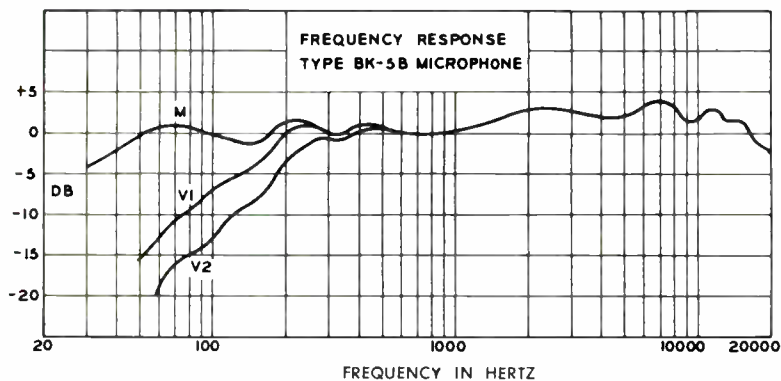

such transients without impairing its sensitivity to more pleasant sounds.

### Voice-Music Switch

The essentially-flat low-frequency response of the BK-5B (see curve above) makes it an outstanding choice for musical instrument pickup, even to 32-foot organ pipes, double string bass and the tympani.

A built-in, three-position switch allows modification of this low-frequency response for voice work. There are two levels of control (see curve): one attenuates 50-Hz response 15 dB while the other reduces response some 20 dB at 60 Hz.

### Repairable Element

Unlike many microphones available in today's marketplace, the BK-5B is built for the long haul: it is fully repairable in the event of damage and ready for recalibration at any time.

## Specifications

Directional Characteristic .....	Uniaxial (improved cardioid pattern)
Frequency Response .....	30-20,000 Hz (see curve)
Response Compensation .....	3 position, voice-music switch
Output Impedance .....	250 ohms, may be changed to 30 or 150 ohms
Effective Output Level at 1000 Hz Sound Pressure 10 dynes/cm <sup>2</sup> .....	-57 dBm
EIA Rating (G <sub>111</sub> ) (150 ohm connection) .....	-151 dB
Hum Pickup Level (.001 gauss, 60 Hz) .....	-128 dBm (max.)

BK-5B Microphone shown with Wind Screen, (MI-11011), mounted on Boom Yoke (MI-11012).



Cable Attached .....	3-conductor, shielded, 30 feet (9 m), no plug
Dimensions (overall) .....	7" long, 1 3/4" dia. (180 mm x 45 mm)
Weight .....	1 lb., 11 ozs. (less cable) (760 g.)
Finish .....	Low luster gray enamel
Mounting .....	Cushion mount, 1/2" pipe-thread (female)

### Accessories

Boom Mount (1/8-inch fitting) .....	MI-11012
Wind Screen .....	MI-11011
Desk Stand, Type 91-D .....	MI-4092-G

## Ordering Information

Type BK-5B Uniaxial Microphone .....	MI-11010-A
--------------------------------------	------------



- Exceptionally smooth frequency response
- No loss in quality with off axis pickup
- Reduced pickup of reflected sound
- Three position, voice-music switch

## RCA Velocity Microphone, Type BK-11A

### Description

The BK-11A is intended primarily for AM, FM and TV studio use where a microphone capable of highest quality reproduction is desired.

It is a dependable bi-directional microphone free of the effects of cavity resonance, diaphragm resonance and pressure doubling. The BK-11A is well shielded against stray magnetic fields and can perform satisfactorily in high hum fields. Acoustically designed sturdy stainless steel

screens protect the microphone from mechanical injury. Internal shock and vibration isolation is provided between the case and the element. The microphone is supported by a swivel mounting which permits a 45 degree forward or backward tilt.

## Specifications

Directional Characteristics .....Bi-directional  
 Frequency Response .....20 to 20,000 Hz  
 Response Compensation .....3 position voice-music switch  
 Output Impedance .....30/150/250 ohms (250 as shipped)  
 Output Level (1000 Hz):  
     Effective (10 dynes/cm<sup>2</sup>) .....-56 dBm  
     EIA—G<sub>m</sub> .....-150 dB  
 Hum Pickup Level (.001 gauss, 60 Hz) .....-130 dBm (max.)  
 Cable Attached .....30 ft. 3 conductor, shielded,  
     brown neoprene jacket  
 Mounting .....Swivel mount ½" pipe thread  
 Dimensions (overall) .....8" long, 2⅞" wide, 2⅜" deep  
     (200 x 73 x 60 mm)  
 Weight (less cable) .....2 lbs. (900 g)  
 Finish .....Low luster gray and stainless steel

### Accessories

Desk Stand, Type KS-11A .....MI-11008  
 Desk Stand, Type 91-D .....MI-4092-G  
 Collapsible Floor Stand, Type CS-1 .....MI-11021-1

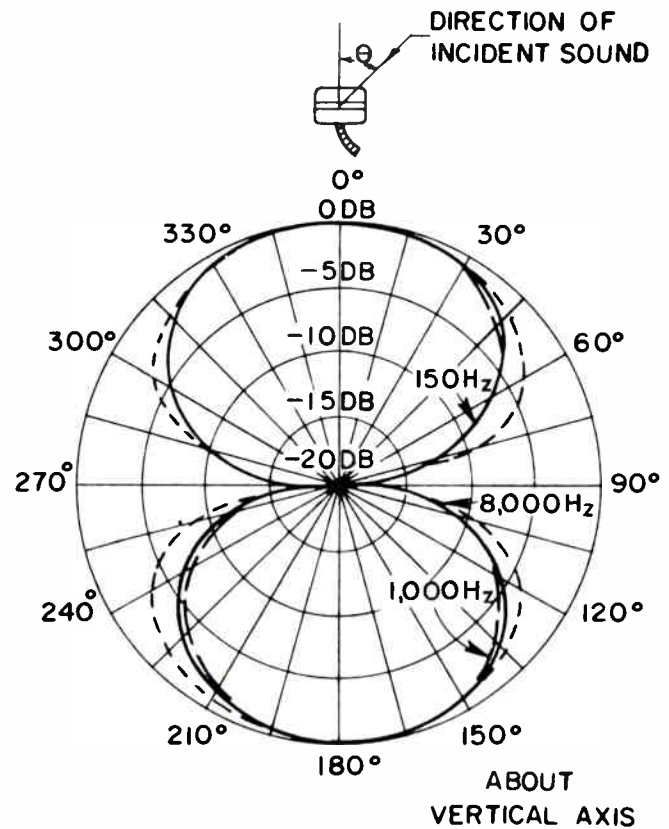
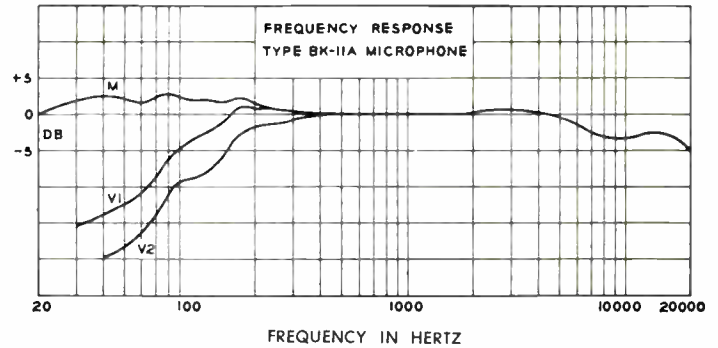

## Ordering Information

Type BK-11A Velocity Microphone (less stand) .....MI-11019



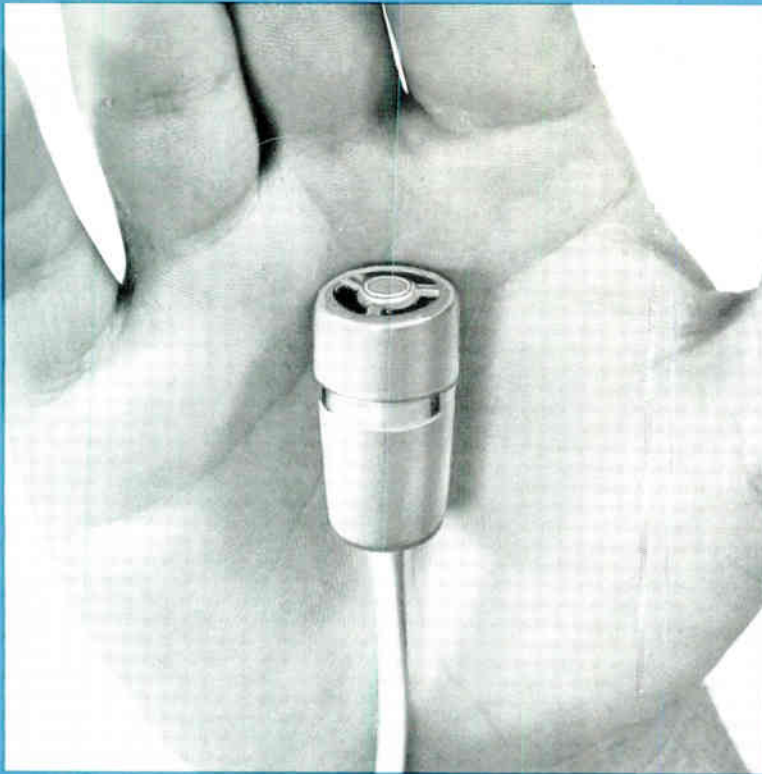

- Easily concealed—1½" long
- Non-directional pickup
- Lightweight—only 0.7 oz.
- Withstands rough usage
- Cartridge replacement eliminates factory repair

## **RCA** Subminiature Dynamic Microphone, Type BK-12A

### Description

The BK-12A Subminiature Dynamic Microphone is RCA's "New Look" in very small, extra lightweight mikes with excellent speech balance for use in television and public address applications. The BK-12's small bulk and neutral color make it inconspicuous when worn around the neck on a lanyard, clipped to the clothing, or concealed in the hand. Due to its small size, the BK-12A is essentially non-directional to 6,000 hertz, thus ordinary errors in orientation are inconsequential.

The 20-gram mike has a wide range frequency response of 60 to 18,000 Hz which has been tailored for proper speech balance. Other notable features include a line impedance voice coil that permits

use with 30 to 250 ohm unloaded inputs without changing the microphone's impedance. Through elimination of the output transformer, magnetic hum sensitivity is lower than comparable microphones that employ a voice coil to line matching transformer. The micron-mesh acoustical filter provides dirt and moisture protection as well as an excellent appearance. Through careful design and the availability of improved magnetic materials, an extremely high acoustical to electrical power efficiency has been achieved in the BK-12A despite its small diaphragm area.

Due to its small size and light weight, the BK-12A is adequately supported by the tie clip holder which fastens equally well to shirt front or lapel. A lavalier

holder is also supplied for suspending the microphone around the neck. The bracelet clasp on this accessory is extremely easy for women to use. Also supplied is a cable clip which attaches the cable to clothing to isolate noise and strain. All accessories are gold plated to present a pleasing, jewelry-like appearance.

The user need never send the BK-12A back for factory repairs. A complete replacement cartridge can be installed in a few minutes. The cable is also easily replaced. Since the microphone is designed to withstand repeated drops and the cable is made of long-flex life cadmium copper, indefinitely long service can be expected with normal use.

## Specifications

Output Impedance .....Low—for use with 30- to 250-ohm unloaded inputs  
 Frequency Response .....60 to 18,000 Hz, shaped for lavalier use (see curve)  
 Direction Characteristics .....Non-directional  
 Output Level (1000 Hz):  
     Effective (10 dynes/cm<sup>2</sup>) .....-60 dBm (150 ohms)  
     EIA—G<sub>m</sub> .....-154 dB (150 ohms)  
 Effective Output Level @ 1000 Hz .....-60 dBm (150 ohms) referred to a sound pressure of 10 dynes/cm<sup>2</sup>)  
 EIA Sensitivity Rating .....-159 dB (150 ohms)  
 Output Voltage (open circuit) .....75 mV/d/cm<sup>2</sup>  
 Hum Pickup (0.001 gauss, 60 Hz) .....-120 dBm max.  
 Cable (attached) .....30 ft. 2-conductor shielded, highly flexible, beige PVC jacket  
 Mounting .....Lavalier and tie clip holders supplied  
 Overall Dimensions .....¾" dia. (20 mm) x 1½" (38 mm) long  
 Weight .....0.71 oz. (20 grams) less cable  
 Finish .....Bronze epoxy and matte gold

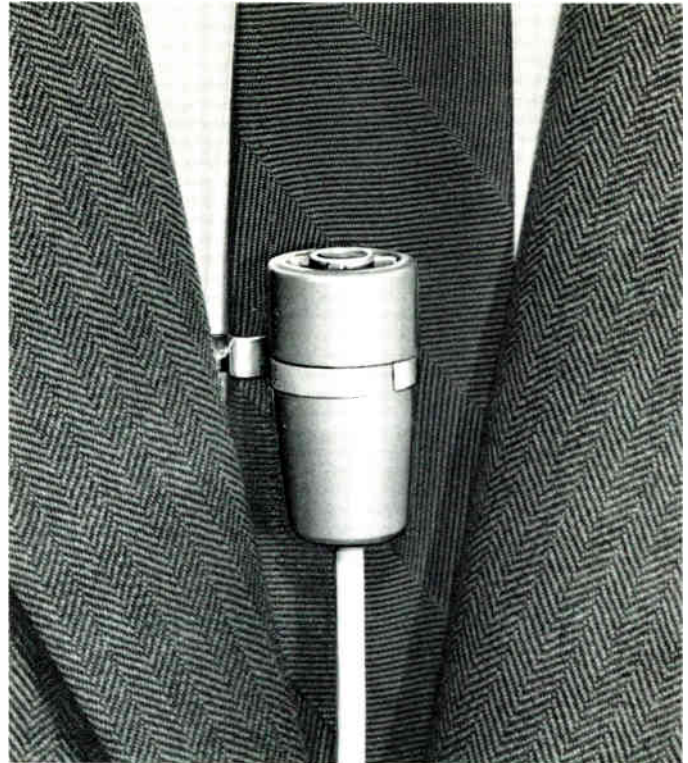

BK-12B Microphone (actual size) with clip mounting.

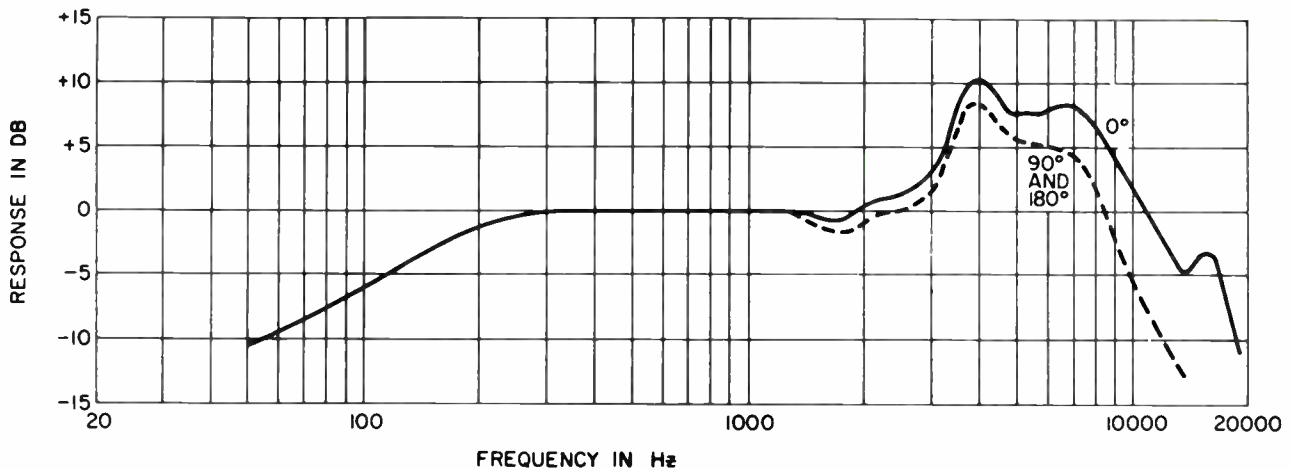

3322148

## Ordering Information

Type BK-12A Subminiature Dynamic Microphone, complete with accessory Lavalier Holder, Tie Clip Holder and Cable Clip .....MI-11024



- Frequency response — 50 to 14,000 Hz
- Lightweight — small size — attractively styled
- Designed for use as a hand-held, stand-mounted or gooseneck-mounted microphone
- Excellent for close-talking applications

## Dynamic Microphone, Type SK-30

### Description

The RCA SK-30 Dynamic Microphone is a general purpose unit with a broad range of applications. It is excellent for public address and paging use. This microphone has been designed and constructed for dependable performance and rugged service. It is relatively insensitive to mechanical shock and wind disturbances.

Frequency response of the unit is exceptionally wide, 50 to 14,000 Hz. The microphone has a non-directional pick-up pattern which tends to become uni-directional at high frequencies. Best results can be obtained by speaking directly into the mike.

Housed in an attractive, rugged zinc

alloy case, the SK-30 microphone may be hand held or mounted in a variety of ways. By removing the threaded end cap, the microphone may be gooseneck-mounted for use on lecterns. A swivel adapter, available as an accessory, permits the microphone to be mounted on any standard floor or desk stand.

### Specifications

Directional Characteristics .....	Omni-directional
Frequency Response .....	50 to 14,000 Hz
Output Impedance:	
Output Impedance:	
Low—for use with 30 to 250 ohm unloaded inputs	
Output Level (1000 Hz): (150 ohm system)	
Effective (10 dynes/cm <sup>2</sup> ) .....	—55 dBm
E.I.A.—G <sub>m</sub> .....	—149 dB

Hum Sensitivity (.001 gauss 60 Hz) .....	—115 dBm
Cable (attached) .....	2 conductor shielded cable, black plastic jacket
Mounting .....	May be hand held or mounted on a gooseneck by removing end cap. Mounts on stand with swivel adapter
Dimensions .....	1.5" diameter by 4.5" long (38 mm, 114 mm)
Weight .....	.8 ounces (140 g)
Finish .....	Midnight blue

#### Accessories

Swivel Mounting Adapter (5/8"—27 female thread) .....	MI-11032
-------------------------------------------------------	----------

### Ordering Information

Dynamic Microphone, Type SK-30:	
With 20-foot (6m) of cable .....	MI-11030-1
Less Base Cap, with 17-inch (432 mm) cable .....	MI-11030-2
With 13" (318 mm) Gooseneck and Mounting Flange .....	MI-38263

3VB



- Ribbon-type element
- Bi-directional characteristics over wide frequency range—40 to 15,000 Hz
- Rugged and reliable
- Outstandingly smooth response
- Adjustable for high or low impedance

## RCA Velocity Microphone, Type SK-46

### Description

Ideally suited to the needs of the AM-FM- or TV-announce booth, the SK-46 Velocity Microphone puts the smooth, uncolored response of the "ribbon" mike in a case size comparable to that of many dynamic mikes. The program quality and inconspicuous size make it preferred for professional audio systems of all types.

#### Unusual Low-Frequency Response

In the tradition of ribbon mikes, the SK-46 offers unattenuated low-frequency response all the way to 40 Hz and below. Because of this, the mike "hears" all of the mellowness required by the professional user. It is for this reason that many announcers prefer the ribbon—or velocity—microphone. At the normal speaking distance of one foot (305 mm), the SK-

46 is free of unnatural boominess owing to its integral acoustic damping.

#### Bi-Directional Pattern

The SK-46 Microphone's directivity pattern—the familiar "figure-8"—rejects sound energy incident to the sides of the mike. This characteristic is most useful where script noise or other distractions create unwanted background noise. It provides superior acoustic gain characteristics and is very effective for sound-reinforcement situations, particularly when the speakers are located directly above or to the side.

#### Rugged, Repairable Construction

Since the SK-46 is a professional, broadcast-quality microphone, it is built to take the hard knocks of daily use with

little loss in quality or looks. Further, its program quality is completely unaffected by temperature, humidity or barometric pressure. Being repairable, the SK-46 can always be reconditioned to perform like new. This is in sharp contrast to many mikes available today; they are "one-shot" devices which preclude reconditioning of any kind.

#### On-Camera Finish

The combination of small size and outstanding quality makes the SK-46 an excellent choice as a desk mike on TV shows. Its low-luster satin-chrome and gray finish keeps it from upstaging the talent. It fits  $\frac{5}{8}$ " x 27 threaded mike stands and weighs but 13 ounces (369 g) less the 25 feet (7.6 m) of two-conductor shielded cable.

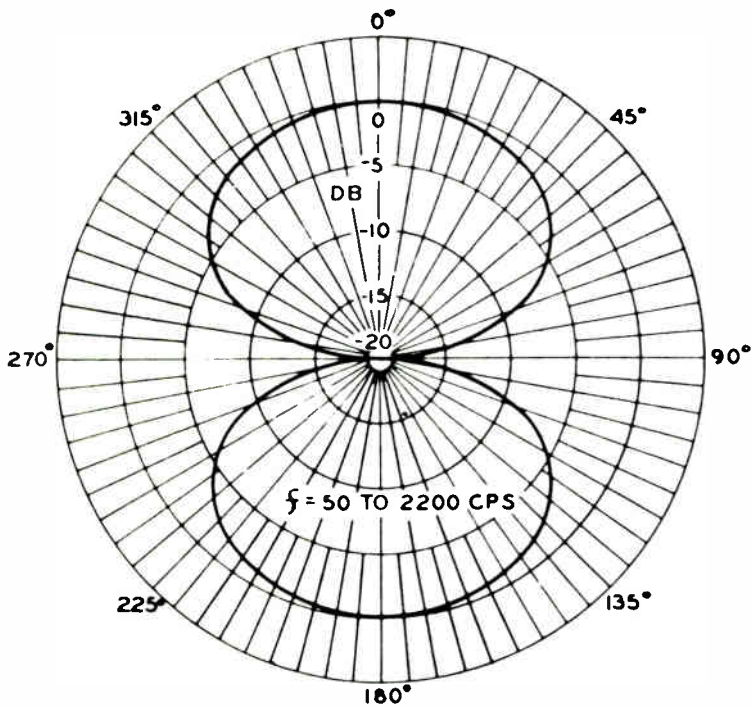
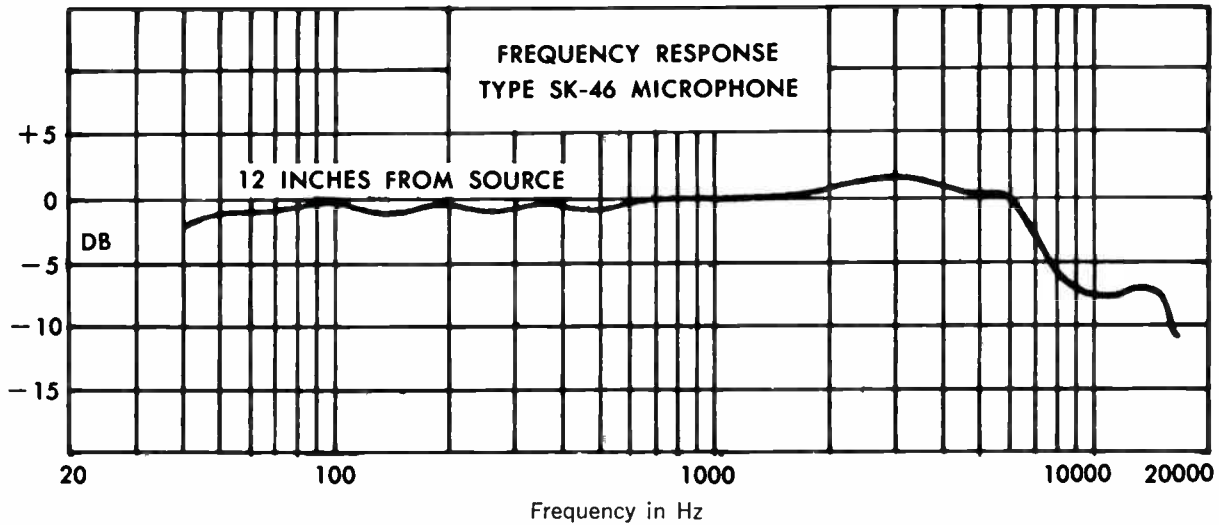

Directional Pattern, Type SK-46 Microphone

## Specifications

Directional Characteristics .....	See plot
Frequency Range .....	40 to 15,000 Hz (See Curve)
Output Impedance .....	200 ohms/15,000 ohms (200 $\Omega$ as shipped)
Effective Output Level at 1000 Hz:	
Low Impedance .....	-58 dBm, EIA G <sub>m</sub> -150 dB
High Impedance .....	-60 dB below 1 volt/dyne/cm <sup>2</sup>
Hum Pickup (.001 gauss, 60 Hz):	
Low Impedance (200 ohms) .....	-115 dBm
High Impedance (15,000 ohms) .....	-98 dB below 1 volt
Cable .....	25 feet (7.6 m), 2 conductor plus shield, no plug
Mounting .....	Swivel mount, 5/8"-27 thread
Height .....	5 1/8" (130 mm)
Width .....	1 29/32" (49 mm)
Depth .....	1 3/8" (35 mm)
Finish .....	Satin chromium and low luster gray
Weight (less cable) .....	13 ounces (369 g)

## Ordering Information

Type SK-46 Velocity Microphone and Cable .....MI-12046



- Hand-held or stand mounted
- Smooth frequency response
- Cardioid, super-cardioid and omni patterns
- Cable supplied
- Most units dual impedance

## Starmaker Dynamic Mikes, HK Series

### Description

Designed to be rugged, long-lived and unobtrusive, the *Starmaker* series of dynamic microphones consists of ten individual models which differ in frequency response, directivity pattern and finish.

#### Hand-Held or Stand Mounted

Built to take the inconsiderate handling performers sometimes give mikes, *Starmaker* microphones deliver equally good performance whether fixed in location on a stand or on-the-move.

#### Smooth Frequency Response

Bearing in mind that *Starmaker* mikes use the moving-coil principle, they offer

exceptionally smooth frequency response over the specified audio spectrum. Smooth response is particularly important in the studio equipped with a sound-reinforcing PA system because of ever-present feedback problems.

#### Cardioid, Super-Cardioid and Omni Patterns

Microphone sensitivity patterns are useful in restricting pickup of unwanted sounds: background, crowd, etc. In the *Starmaker* line there are Cardioid, Omnidirectional and Super Cardioid varieties in which the sensitivity is restricted to a small angle to the "front".

#### Cable Included

Most of the *Starmaker* mikes include a 2-conductor, 20-foot (6m) shielded cable; the cable for the IIK-105 microphone is a single conductor, shielded cable 10 feet long (3m).

#### Dual-Impedance Instruments

Each of the *Starmaker* mikes (except the low-impedance IIK-105) include a built-in impedance-changing transformer which provides for either 200 or 15,000-ohm output impedance. Changing impedance is a simple matter of plug rotation at the mike end of the cable.



### Starmaker Super-Cardioid HK-106

Frequency Response .....150-10,000 Hz  
Output Impedances:  
Low .....200 ohms  
High .....15,000 ohms  
Output Level @ 1000 Hz:  
At Low Impedance .....-62 dB  
At High Impedance .....-65 dB  
Dimensions .....5.3" (134 mm) L; 1.2" (31 mm) Dia.  
Weight (less cable) .....6.9 oz. (196g)  
Cable .....Black, 20-ft (6m), 2-cond. & shield  
Stand Holder .....Adjustable, fits 5/8"-27 thread  
Finish .....Black and Satin Chrome  
(Attaché-type carrying case & weighted desk stand supplied)



### Starmaker Unidirectional HK-110

Frequency Response .....100-12,000 Hz  
Output Impedances:  
Low .....200 ohms  
High .....15,000 ohms  
Output Level @ 1000 Hz:  
At Low Impedance .....-62 dB  
At High Impedance .....-64 dB  
Dimensions .....7.5" (193mm) L; 1.8" (46mm) Dia.  
Weight (less cable) .....8 oz. (227g)  
Cable .....Black, 20-ft (6m), 2-cond. & shield  
Stand Holder .....Fits 5/8"-27 or 3/8"-18 thread  
Finish .....Gold and black  
(Attaché-type carrying case supplied.)



### Starmaker Broadcast Omni-HK-111

Frequency Response .....50-20,000 Hz  
Output Impedances:  
Low .....200 ohms  
High .....15,000 ohms  
Output Level @ 1000 Hz:  
At Low Impedance .....-57 dB  
At High Impedance .....-60 dB  
Dimensions .....10.6" (269mm) L; 1.6" (40mm) Dia.  
Weight (less cable) .....9 oz. (255g)  
Cable .....Black, 20-ft (6m), 2-cond. & shield  
Finish .....Black and Satin Chrome  
(Attaché-type carrying case supplied.)



### Starmaker Omni-HK-112

Frequency Response .....100-13,000 Hz  
Output Impedances:  
Low .....200 ohms  
High .....15,000 ohms  
Output Level:  
At Low Impedance .....-61 dB  
At High Impedance .....-63 dB  
Dimensions .....5" (127mm) L; 1.3" (33mm) Dia.  
Weight (less cable) .....6 oz. (170g)  
Cable .....Black, 20-ft (6m), 2-cond. & shield  
Stand Holder .....Adjustable, dual-thread 5/8"-27  
and 3/8"-18  
Finish .....Black and Satin Chrome  
(Attaché-type carrying case & weighted desk stand supplied)







**Starmaker Omni-HK-115**

Frequency Response .....70-16,000 Hz  
 Output Impedances:  
   Low .....200 ohms  
   High .....15,000 ohms  
 Output Level:  
   At Low Impedance .....-62 dB  
   At High Impedance .....-64 dB  
 Dimensions .....8.3" (211mm) L; 1.8" (46mm) Dia.  
 Weight (less cable) .....7 oz. (200g)  
 Cable .....Black, 20-ft (6m), 2-cond. & shield  
 Stand Holder .....Adjustable, dual-thread, 5/8"-27/3/16"-18  
 Finish .....Black and Satin Chrome  
 (Attaché-type carrying case included)



**Starmaker Cardioid HK-97**

Frequency Response .....50-15,000 Hz  
 Output Impedances:  
   Low .....200 ohms  
   High .....15,000 ohms  
 Output Level @ 1000 Hz:  
   At Low Impedance .....-67 dB  
   At High Impedance .....-60 dB  
 Dimensions .....7 1/2" (191mm) L; 1.9" (48mm) Dia.  
 Weight (less cable) .....6 oz. (172 g)  
 Cable .....Black, 20-ft (6m), 2-cond. & shield  
 Stand Holder .....Adjustable, fits 5/8"-27 thread  
 Finish .....Black and Satin Chrome  
 (Attaché-type carrying case included)

**Microphone Accessories**

RCA markets microphone stands, booms, support arms, cables, adapters and the like as **Microphone Accessories**. The wide variety of these items precludes description here but they are described on pages devoted entirely to microphone accessories. Please request Catalog B.1030. A copy is yours for the asking at any RCA Broadcast Field Office.

**Ordering Information**

Order by type number:

**Starmaker Super Cardioid** .....Type HK-106  
**Starmaker Wideband Cardioid** .....Type HK-96  
**Starmaker Wideband Cardioid** .....Type HK-97  
**Starmaker Unidirectional** .....Type HK-103  
**Starmaker Unidirectional** .....Type HK-110  
**Starmaker Omnidirectional** .....Type HK-98  
**Starmaker Omnidirectional** .....Type HK-105  
**Starmaker Omnidirectional** .....Type HK-111  
**Starmaker Omnidirectional** .....Type HK-112  
**Starmaker Omnidirectional** .....Type HK-115

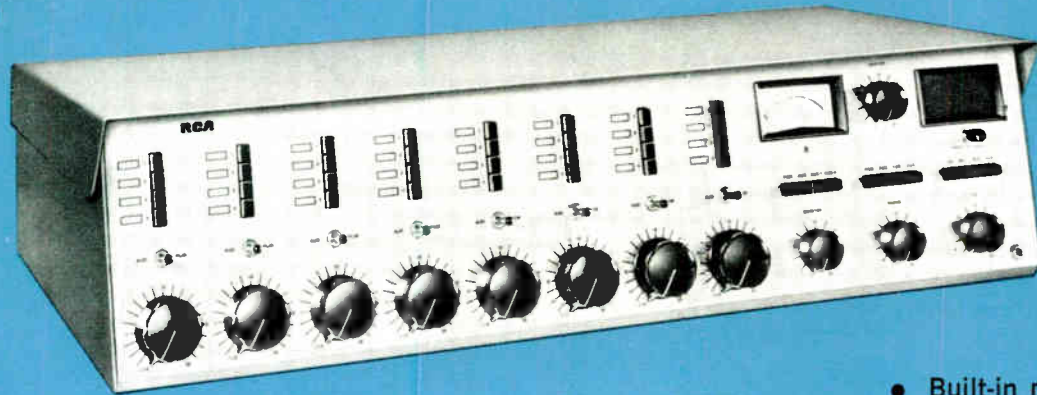

- Pushbutton input and output selection
- Ten-watt monitor amplifier
- Built-in muting relays
- Preamplifier in each mixer circuit
- Self-contained power supplies

## Basic Audio Console, Type BC-15 and BC-18

### Description

The two audio consoles described here differ only in physical size and the number of input mixers each includes. The smaller console, the BC-15, boasts five input mixers; the BC-18, eight input mixers.

These two consoles are ideally suited to the audio control needs of radio and TV program production. Too, these consoles serve in the control of sound reinforcement systems in auditoriums, amphitheatres, coliseums, stadiums and convention halls. They are high-performance units, designed for sophisticated audio production with an eye on economy and simplicity.

Each console is a self-contained audio control center featuring pushbutton input selection, high-quality step-type attenuators, telephone type lever switches, a ten-watt monitor amplifier, a cue amplifier, speaker-muting relays (with space for additional relays) a cue speaker and a self-contained power supply.

The basic consoles also feature an "Audition" channel which shares the monitor amplifier through pushbutton switching.

### Input Facilities

Each BC-15 and -18 console features step-type mixer attenuators, equipped with cue position, as mixer pots. Each attenuator handles four inputs through interlocked pushbuttons. The interlock system precludes operation of more than one pushbutton at a time.

### Preamplifier Modules

The number of preamplifiers included in each console is proportional to the number of mixers. The preamps are 40-dB, solid-state systems engineered to terminate the input line with a minimum of ten times the source impedance of 250 ohms. For high-level inputs, a bridging pad is provided between the selector pushbutton switch and its input transformer. Thus, each mixer control handles three mike inputs and one high-level input without special strapping.

### Program Channel

The program-bus boost amplifier drives the Master Gain control which, in turn, drives the program amplifier and line-driver amplifier. The driver delivers a balanced, transformer-coupled, +18 dBm

output level to the line pair. One balanced, bridging, zero-level recorder output is permanently connected to the program line. Program outputs are also provided to the Audition/Monitor Input Selector switch and the Program Headphone jack.

### Audition/Monitor Channel

The audition bus boost amplifier feeds an input of the Monitor-Input Selector. Selector pushbuttons provide Program, Audition and two Auxiliary bridging outputs. Three plug-in, speaker-mute relays are included in the BC-18 (two in the BC-15). The muting relays are energized through the mike-input selector switch.

A headphone-jack output, with volume control, delivers +10 dBm output.

### Cue Facility

The consoles include a cue amplifier and speaker. Wired through the "control-room" muting relay, the cue speaker is inoperative when the mike key is open.

### Remote Line Facilities

Each console provides facilities for remote lines; the BC-18 console, naturally, provides additional inputs selectable through pushbutton switches.

# Functional Diagrams

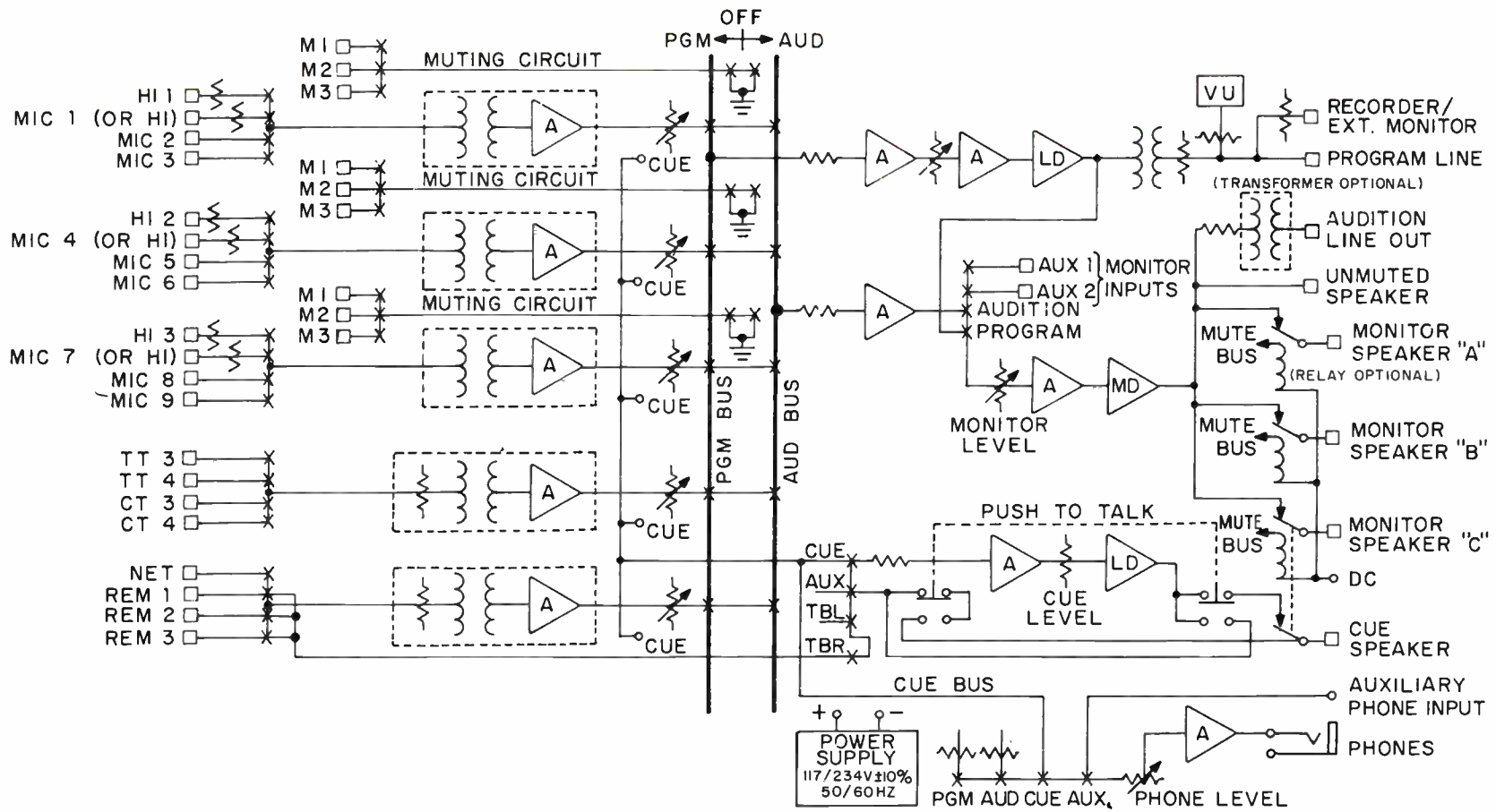

Functional Diagram  
Five-Mixer Monophonic Console, Type BC-15A

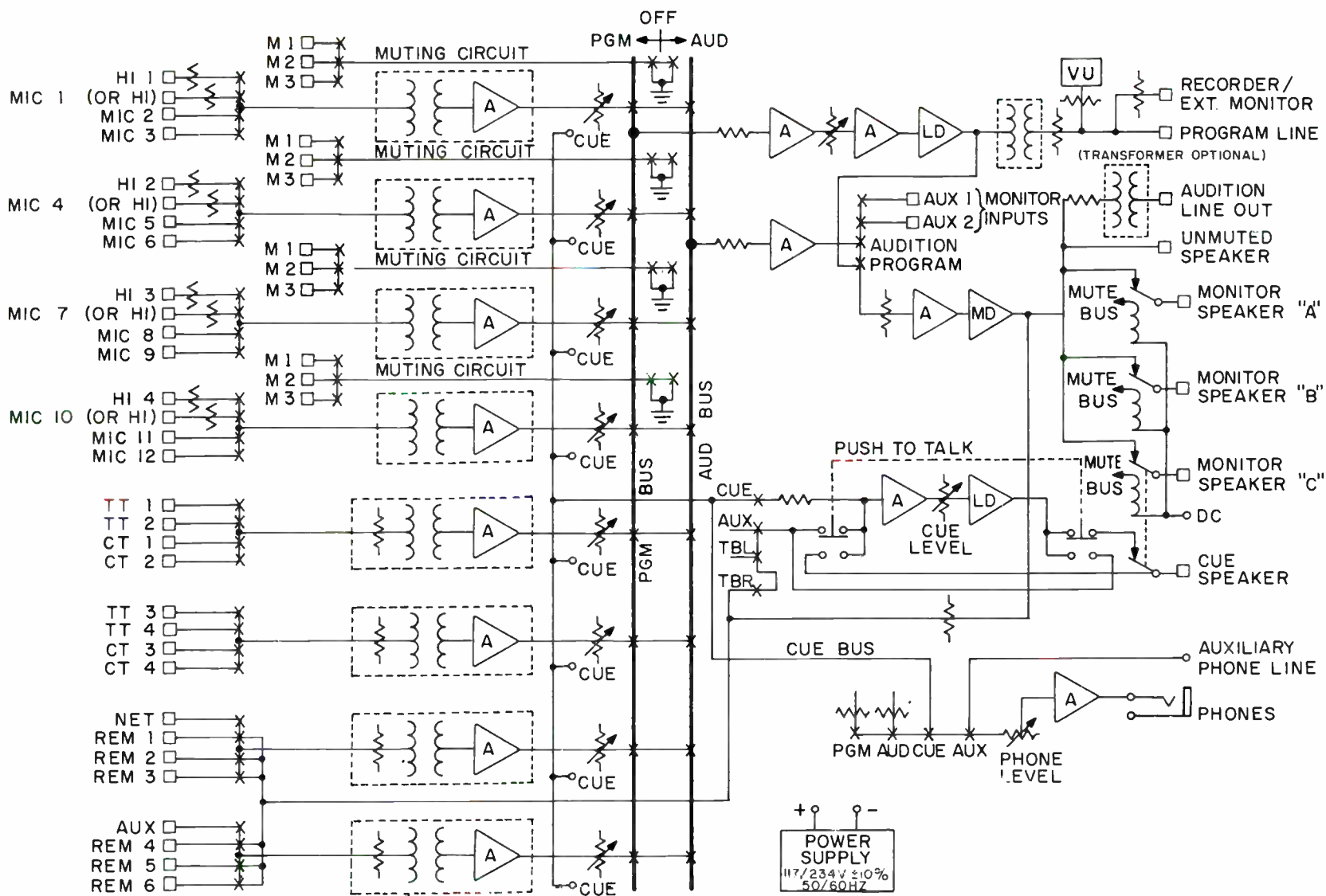

Functional Diagram  
Eight-Mixer Monophonic Console, Type BC-18A

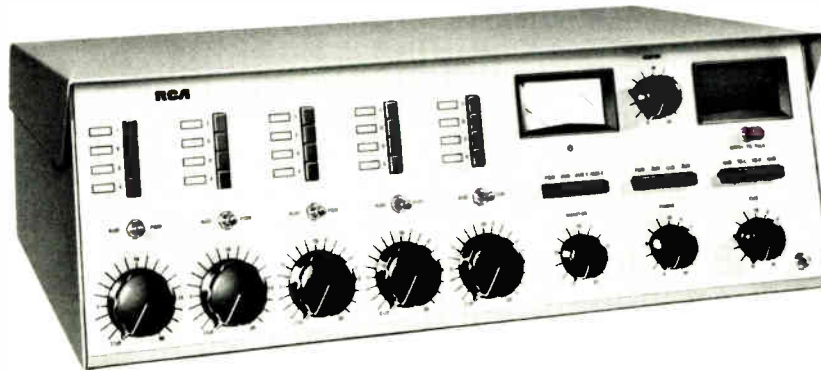

Eight-Mixer Console, Type BC-18A

## Specifications

	BC-15A	BC-18A
Mixers .....	5	8
Inputs (Total) .....	20	32
Low Level (Mike)* .....	9	12
High Level* .....	11	20
Outputs .....		
Program (at +18 dBm) .....	1	1
Audition (at +10 dBm) .....	1	1
Monitor (at +40 dBm) .....	1	1
Source Impedance .....		
Microphone Inputs .....		
(ohms) .....	150/250	150/250
High Level Inputs .....		
(ohms) .....	600	600
Input Levels (dBm) .....		
Microphones (Nominal) .....	-50	-50
Microphones (Maximum) .....	-26	-26
Net/Remote (Nominal) .....	-10	-10
Net/Remote (Maximum) .....	0	0
High Level (Nominal) .....	-10	-10
High Level (Maximum) .....	0	0
Crosstalk .....	67 dB down	67 dB down
Maximum Gain .....	104 dB	104 dB

\*Factory wired. Can be changed in field for more high-level inputs.

	BC-15A	BC-18A
Frequency Response (20 to 20 kHz) .....	±1.5 dB	±1.5 dB
Distortion (30 to 20 kHz) .....		
Program Channel .....	1%	1%
Monitor Channel (10 W @ 4 Ω) .....	2%	2%
Signal to Noise (20-20 kHz) .....	67 dB	67 dB
Power Requirements .....		
Voltage(s) .....	110/220V	110/220V
Frequencies .....	50-60Hz	50-60Hz
Power .....	110W	110W
Finish .....	Shadow Blue; Anodized Panel	
Dimensions .....		
Width .....	27 <sup>3</sup> / <sub>8</sub> " (695mm)	36 <sup>3</sup> / <sub>8</sub> " (923mm)
Height .....	9 <sup>3</sup> / <sub>8</sub> " (238mm)	9 <sup>3</sup> / <sub>8</sub> " (238mm)
Depth .....	18 <sup>3</sup> / <sub>4</sub> " (476mm)	18 <sup>3</sup> / <sub>4</sub> " (476mm)
Weight .....	40 lb. (18 kg)	47 lb. (20 kg)

### Accessories

Audition Line Transformer .....	MI-141011
Speaker-Muting Relay .....	MI-141012
Microphone Preamplifier .....	MI-141013
High-Level Preamplifier .....	MI-141014

## Ordering Information

### Ordering Information

Five Mixer Audio Console, Type BC-15 .....	MI-11676
Eight Mixer Audio Console, Type BC-18 .....	MI-11677
(Both units available for stereophonic operation.)	

### Shipping Data

	BC-15	BC-18
Package Dimensions .....	13" x 24" x 32" (330 x 610 x 813 mm)	13" x 24" x 41" (330 x 610 x 1041 mm)
Gross Weight .....	55 lbs. (26 kg)	70 lbs. (32 kg)



- BC-18: 32 inputs; BC-15: 20 inputs
- Pushbutton input and output selection
- Ten-watt monitor amplifiers
- Built-in muting relays
- Preamplifier in each mixer circuit

## Stereo & Dual-Channel Console, Types BC-15 & BC-18

### Description

The audio consoles described here differ only in physical size and the number of input mixers each includes. The smaller console, the BC-15, contains five input mixers; the BC-18, eight input mixers.

These two consoles are ideally suited to the audio control needs of radio, TV, CCTV and recording-studio production. Too, these consoles serve in the control of sound reinforcement systems in auditoriums, amphitheatres, coliseums, stadiums and convention halls. They are high-performance units, designed for high-quality audio production for cost conscious and economical operations.

Each console is a self-contained audio control center featuring pushbutton input selection, high-quality step-type attenuators, telephone-type lever switches, ten-watt monitor amplifiers, cue amplifiers, speaker-muting relays (with space for additional relays, see *Accessories*), a cue speaker and a self-contained power supply.

The basic consoles also contain an audition channel which shares the monitor amplifier through pushbutton switching.

#### Input Facilities

Each BC-15 and BC-18 console features step-type mixer attenuators, with a cue position, as mixer pots. Each attenuator

handles four inputs (8 for stereo) through interlocked pushbuttons. The interlock system precludes operation of more than one pushbutton at a time.

#### Preamplifier Modules

The number of preamplifiers included in each console is proportional to the number of mixers. The stereo consoles contain two preamplifiers for each input mixer; dual channel consoles contain a single preamplifier for each input mixer. The preamps are 40 dB, solid-state systems engineered to terminate the input line with a minimum of ten times the source impedance of 250 ohms. For high-level inputs, a bridging pad is provided between the selector pushbutton switch and its input transformer. Thus, each mixer control handles three mike inputs and one high-level input without special strapping.

#### Program Channel

A program-bus amplifier drives the Master Gain control which, in turn, drives the program amplifier and line driver amplifier. In the stereo consoles, the Master Gain controls are ganged and an adjustment is provided to balance the gain of each channel individually.

The driver amplifier delivers a balanced, transformer-coupled,  $\pm 18$  dBm output level to the line. A balanced, bridging, zero-level recorder output is permanently connected to the program line. Program outputs are also provided to the Audition/Monitor Input Selector switch and the Program Headphone jack.

#### Audition/Monitor Channel

The audition-bus boost amplifier feeds an input of the Monitor-Input Selector. Plug-in, speaker-mute relays are included: three in the BC-18 and two in the BC-15. The muting relays are energized through the mike-input selector switch.

A switchable headphone-jack output, with level control, delivers +10 dBm output.

#### Cue Facility

The consoles include cue amplifiers and speakers. Wired through the "control room" muting relay, the cue speaker is inoperative when any mike key is open.

#### Remote Line Facilities

Each console provides facilities for remote lines selectable through pushbutton switches.

Five-input, stereo-  
phonic and dual-  
channel console, Type  
BC-15D and BC-15S.



## Specifications

### Total Inputs:

BC-15	20 (9 Lo-; 11 Hi-level)
BC-18	32 (12 Lo-; 20 Hi-level)

### Mixers:

BC-15S	Five (stereo)
BC-15D	Five (mono)
BC-18S	Eight (stereo)
BC-18D	Eight (mono)

### Input Impedance (Source):

Microphone	150/250 ohms
Hi-Level	600 ohms

### Input Levels (dBm):

Microphone	-50 nom.; -25 max.
Net/Remote	0 nom.; +10 max.
High Level (Bridging)	-20 nom.; +5 max.

Overall Gain .....104 dB, max.

Frequency Response Characteristic ...20 to 20,000 Hz  $\pm$ 1.5 dB

### Distortion (20-20,000 Hz):

Program Channel	1% max.
Monitor Channel (10 W. into 4 ohms)	2% max.

Signal/Noise Ratio (20-20,000 Hz) .....67 dB min.

Power Requirements .....110/220 V., 50/60 Hz

### Weight:

BC-15S	50 lbs. (23 kg)
BC-15D	45 lbs. (20 kg)
BC-18S	57 lbs. (27 kg)
BC-18D	52 lbs. (24 kg)

### Dimensions:

BC-15S and BC-15D	27 $\frac{3}{8}$ " W; 9 $\frac{3}{8}$ " H; 18 $\frac{3}{4}$ " D (695 mm x 238 mm x 476 mm)
BC-18S and BC-18D	36 $\frac{3}{8}$ " W; 9 $\frac{3}{8}$ " H; 18 $\frac{3}{4}$ " D (923 mm x 238 mm x 476 mm)

### Accessories

Audition Line Transformer	MI-141011
Speaker Muting Relay	MI-141012
Mic Preamplifier Module	MI-141013
Hi-Level Preamplifier Module	MI-141014

## Ordering Information

Stereophonic, Five-Mixer Console, BC-15S	MI-11678
Dual-Channel, Five-Mixer Console, BC-15D	MI-11683
Stereophonic, Eight-Mixer Console, BC-18S	MI-11679
Dual-Channel, Eight-Mixer Console, BC-18D	MI-11684

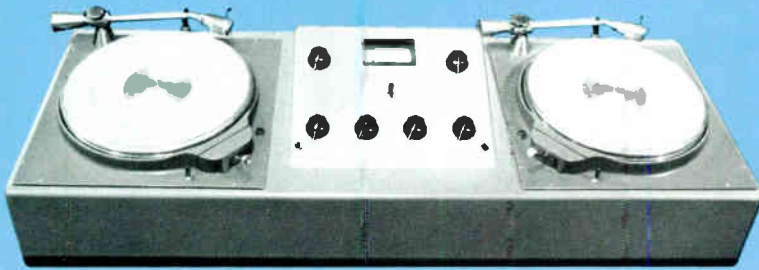

- For remote operations
- Individual mixing controls for two three-speed turntables.
- Switchable input for two microphones or remote input
- Solid state circuitry throughout
- Break-down construction

## RCA Portable Audio Console, Type BC-10B

### Description

The Type BC-10B Portable Audio Console is a completely self-contained unit that greatly simplifies the problem of on-the-spot broadcasts and setting up of remote studios. The console has two three-speed turntables with complete provisions for mixing as well as cueing recordings. A third mixer is available for use with either of two microphones or a remote line. A 50-dB pad in the remote input permits a high level program source such as a tape recorder or remote amplifier to be fed into this position and controlled on the microphone fader.

The BC-10B Console features break-down construction which permits it to be conveniently transported. The four fibreglass legs of the console, when not in use, are stored in clips affixed to the bottom of the console. The console fibreglass base is flat when the legs are in storage position. The entire unit weighs less than 68 pounds.

The BC-10B is designed to give maximum performance. Frequency response is within plus or minus 2 dB from 70 to 15,000 Hz. on the microphone channel. The turntable

channels have built-in RIAA equalization and properly equalize the GE 4G-050 cartridge. Normal output level is plus 6 VU at 3 percent or less distortion 70 to 10,000 Hz. All preamplifiers as well as the remote amplifier and power supply utilize solid state devices.

Operating controls are conveniently located on a sloping panel between the two three-speed turntables. Three faders controlling the two turntable inputs and the microphone-remote input are at the bottom of the panel. In the center is the three-way microphone-remote switch. The PA level control for feeding to external PA equipment is located above to the left and the Master Gain Control to the upper right of the panel. An illuminated VU meter is provided in the upper center of the panel.

The receptacles for two microphones, terminals for the broadcast line, PA feed and monitor jack are located in the audio panel on the bottom of the console under the left turntable. The AC receptacle and fuse are located on the AC panel under the unit on the right side. Earphones, when plugged into the phone

jack on the audio panel, can be used to monitor the program being fed to the broadcast line or to cue the records on either turntable. High impedance earphones should be used for monitoring.

### Electrical Description

The BC-10B employs etched wiring circuitry for the amplifiers. The regulated power supply is located on a separate panel and uses diodes as full wave rectifiers. The turntable preamplifiers are equalized to the standard RIAA curve. The microphone preamplifier is similar to the turntable preamplifier but has flat response. The use of thermistors keeps the distortion low and the output constant if the ambient temperature exceeds 100 degrees. The unit is capable of operating in temperatures up to 150 degrees F.

The BC-10B's output is fed through a 3 dB isolation pad to the broadcast line terminal and through isolation resistors to the monitor phone jack. A bridging transformer is used to isolate the feed to the PA system. A separate fader is used to control PA level.



# Specifications

- Frequency Response:  
 Microphone Channel ... Within  $\pm 2$  dB 70 to 15,000 Hz  
 Phono Channels ... Built in RIAA equalization;  
 equalized when used with a GE 4G-050 cartridge
- Output Level and Distortion  
 (after built-in 3 dB pad) ... +6 VU at 3% or less distortion  
 70-10,000 Hz normal; +12 VU maximum is emergency level
- Signal to Noise on Microphone Channel ... 56 dB relative noise  
 at the input is -106 dBm
- Power Line ... 117 Volts, single phase, 60 Hz
- Transistor and Diode Complement:  
 13-2N241A, 4-1N1488, 1-2N456, 1-1M12Z10
- Dimension Overall ... 44" long, 16½" wide, 10" high  
 (111.76 cm, 41.91 cm, 25.4 cm)
- Standing Height ... 31" (78.74 cm)
- Weight ... 68 lbs. approx. (30.85 kg)

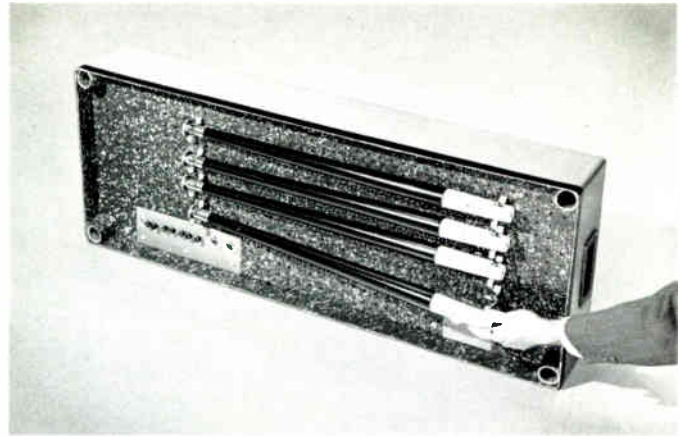

Bottom of BC-10B Console showing leg storage rack, audio panel at left, and AC receptacle at right.

Block Diagram of BC-10B Portable Audio Console.

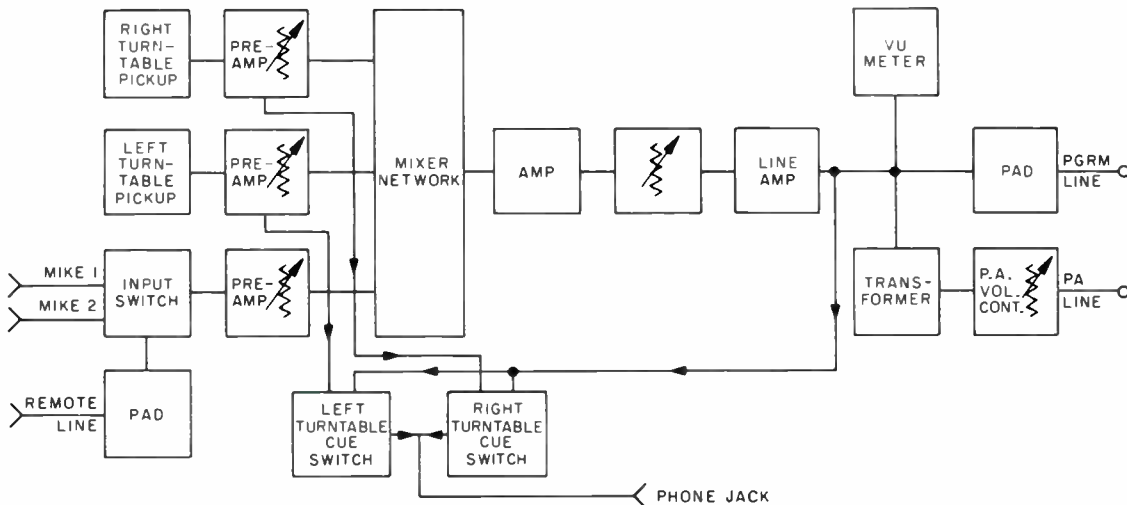

# Ordering Information

Type BC-10B Portable Audio Console complete,  
 with two turntables, tone arms and pickups  
 including power cord and plug .....MI-11655-B



- Extensive FM, AM and TV facilities
- Reliable solid state design
- Easy to operate
- Low impedance, ten-fader mixing system
- Complete cue facilities

## RCA Three Channel Audio Consolette, Type BC-17A

### Description

The BC-17A Three Channel Audio Consolette provides modern mixing and switching facilities for the AM/FM/TV broadcaster. The consolette allows an operator to quickly delegate program material to stereo or monaural FM transmitter, AM transmitter and/or external recording and monitoring equipments.

The BC-17A is a completely self-contained all solid-state console providing monophonic and stereophonic mixing facilities, together or separately. Programming to the stereo and monaural output lines is controlled entirely by built-in circuitry and panel controls. No external switching or jack assemblies are required. It features low impedance mixing circuits, self-contained power supply and built-in cue on all medium and high level faders.

The BC-17A matches other RCA audio

console equipment designed not only for operating convenience and ease of servicing, but for aesthetic value as well. The double slope front panel permits easy reading of the illuminated VU meters, and easy manipulation of all switching, mixing and operational controls. These are grouped and color coded for fast identification. The console is intended for flat top desk mounting.

### Input Facilities

The BC-17A has provisions for forty-six audio inputs; eighteen mono sources, twenty-eight stereo inputs, including two inputs for auxiliary program sources. Two extra unwired utility level keys are also provided.

Mixing is accomplished by a ten-fader low impedance system, using minimum loss ladder attenuators. Cueing positions

are provided on all medium and high level faders.

The console has 12 single, low-level channels allowing twelve single monaural microphones to be individually switched—three per channel—into four mixing channels. Three stereo pairs of microphones may be switched separately into a fifth mixing (stereo) channel.

Ten stereo inputs are provided. These medium level channels include stereo turntable, reel and cartridge tape and film projector sources, and one auxiliary input.

The high level channels include one network, one auxiliary, and three remote line inputs. They are individually switched to provide maximum flexibility for the broadcaster. These inputs are wired for one (left) channel only. However, wiring

for the right channel can be added since switch facilities are available to provide stereo when required. Two relay switching assemblies and one external auxiliary input provide fifteen stereo inputs.

### Program Channels

All input sources are routed to any one of three program channel busses which, in turn, direct monaural programs into a corresponding program amplifier. A stereo source is routed into channel #1

bus and channel #2 bus, then into program amplifiers #1 and #2 respectively. A selector switch STEREO, must be activated in order to connect the right channel of the source through the #2 program amplifier.

### Monitoring Facilities

Complete monitoring facilities permit the operator to control the mode of program fed to studio speakers. Stereo, parallel, singular, external program source, and

a spare to either the internal or external monitor amplifiers may be selected from a five-position rotary switch marked "Monitor Selector."

Other monitoring facilities include four phone jacks to program amplifier outputs, line outputs, cue information and network and remote line programs. Through a panel speaker, it is possible to select cue, networks, or remote line information and studio intercommunications at speaker signal level.

## Specifications

Mixing Channels ..... Total 10—4 Microphone-Mono, 1 Microphone-Stereo, 4 Turntable/Tape-Stereo, 1 Remote/Network-Mono/Stereo

Input Circuits ..... Total 46—12 Microphones-Mono; 6 Microphones-3 Stereo Pairs; 23 Turntables, Tape, Projector-23 Stereo Pairs; 1 Net-Mono/Stereo; 1 Auxiliary-1 Mono/Stereo; 3 Remote-Mono/Stereo

External High Level Sources ..... 1 Mono—1 Stereo Amplifier & Power Supply Complement ..... 6 Preamplifiers, 3 Program Amplifiers, 2 Monitor Amplifiers, 1 Cue/Intercom Amplifier; 1 Power Supply

Operating Modes ..... Three Channel—Stereo/Mono/Both simultaneously

#### Output Circuits:

Three Program Lines at ..... +8 VU; +18 dBm

Four Record Outputs at ..... -10 VU; -0 dBm

Five Sets of Stereo 8-Ohm Speaker

Line Outputs at maximum of ..... +30 VU; +40 dBm

Speakers in control rooms, announce booths, and other studios are muted at program source. Five sets of intercom lines which connect to 3 studios, one announce booth and one spare.

Auxiliary Input/Output Circuits ..... 1 high level auxiliary input switched through console and 1 mono external source input, 1 stereo external source input switched directly between input and line output terminals

#### Impedances:

Inputs ..... 37.5/150/600 Ohms

Net, Auxiliary and Remote Lines ..... 600/150 Ohms

Recorded Inputs (turntable, tape, film) ..... 600 Ohms unbalanced (if jumper plug is used) or 600/150\* Ohms (if plug-in isolation unit is used)

\*High level isolation unit has transformer tap for 150 Ohms; input pad resistors can be easily replaced for 150 Ohm operation.

Output Lines ..... 600 Ohms balanced

Monitor Amplifier ..... 8 Ohms, unbalanced

#### Gain:

Microphone to Program Line ..... 106 dB (pre-amp can be strapped to increase total maximum gain to 112 dB)

Recorded Inputs (turntable, tape, etc.) to Program Line ..... Maximum 66 dB

Network, Auxiliary and Remote Lines to Program Lines ..... Maximum 66 dB

Microphone Input to Speaker Line ..... Maximum 127 dB (40 dB pre-amp gain) and Maximum 133 dB (46 dB pre-amp strap)

Signal to Noise Ratio ..... Microphone to program line, normal operating position of operating controls (68 dB gain; +18 dBm output)—Minimum 68 dB

#### Response:

Program Channels ..... +0 to -1.0 dB, 30 to 20,000 Hz

Monitor Channels ..... +0 to -1.0 dB, 30 to 20,000 Hz

#### Distortion:

Program Channels ..... Less than 0.5%, 30 to 20,000 Hz

Monitor Amplifier ..... Less than 1.0%, 30 to 20,000 Hz

Dimensions (Overall) ..... 39¼" wide, 12½" high, 20" deep (99.69 cm, 31.75 cm, 50.8 cm)

#### Weight:

Console Housing ..... 110 lbs. (50 kg.)

Console with normal complement of

Stereo Programming ..... 180 lbs. (82 kg.)

#### Finish:

Main Control Panel ..... Brushed and satin anodized aluminum

Housing ..... Shadow blue textured vinyl

Power Requirements ..... 115 or 230 V AC, 60-50 Hz

Power Consumption ..... Normal, 60 to 70 Watts; Maximum, approx. 130 Watts; Standby, 60 Watts

### Accessories

Auxiliary Mixer Housing, Type BCM-2B (less all plug-in modules) ..... MI-11656-A

On-Air Light Relay ..... MI-11702-A

Warning Lights ..... MI-11706-Series

Simpson VU Meter ..... MI-53064

High Level Isolation Unit ..... MI-11665

Type BA-71C Preamplifier (less guide assembly) ..... MI-11658-B

Type BA-73C Program Amplifier (less guide assembly) ..... MI-11659-B

Type BA-74C Monitor Amplifier (less guide assembly) ..... MI-11661-C

Type BA-78B Cue/Intercom Amplifier (less guide assembly) ..... MI-11662-B

Type BX-71B Power Supply (less guide assembly) ..... MI-11663-B

VU Meter for BC-17A ..... #226033

Intercom Sub Station ..... MI-11452-A

Hook-up Wire, 2 Conductor, Shielded Pair #28 Stranded, Vinyl Jacket (for BC-17A) ..... MI-13395-1

## Ordering Information

Type BC-17A Three Channel Audio Console ..... ES-11173-A



- Compact and versatile
- Stereo or dual-channel operation
- Four stereo mixers
- Fourteen high-level inputs
- Built-in intercom

## Stereo Consolette, Type BC-19

### Description

The BC-19 is a transistorized audio mixing consolette which offers versatility and many performance features.

Multiple pushbuttons permit easy selection of high level sources (such as tape recorders, cartridge tape, turntable, etc.) to each of two stereo mixer controls. Self-contained relays switch the sources, permitting remote operation of the BC-19. Two additional stereo mixers are provided for use with microphones.

Interchangeability is another feature of the BC-19. The modular plug-in amplifiers and power supply used in this unit are identical with those incorporated in several other RCA audio consolettes, including the BC-7, BC-8, BC-9 and BC-17. Intercom facilities built into the BC-19 facilitate communications between control room and studio or remote locations.

For applications where stereo operation is not required, this versatile consolette can be used to provide two program channels and a separate intercom channel. (See functional diagram.)

### Specifications

Mixers .....	4 stereo
Inputs:	
Low Level (Microphone) .....	6 stereo (3 to each of 2 mixers)
High Level .....	14 stereo (7 to each of 2 mixers)
Outputs:	
Program .....	2 mono, 1 stereo
Monitor Speaker Relays .....	2
Source Impedances:	
Microphones .....	37.5/150/600 ohms
Turntables/Tape .....	600 ohms
Input Levels:	
Microphone .....	-22 dBm maximum
Turntables/Tape/Remote .....	-10 dBm
Maximum Gain .....	105 dB
Frequency Response .....	+0.5, -1.5 dB 30-20,000 Hz
Distortion:	
Program Channel .....	Less than 0.5% 50-20,000 Hz
.....	Less than 0.75% 30-20,000 Hz
Monitor Amplifier .....	Less than 1% 30-20,000 Hz
Signal-to-Noise Ratio .....	68 dB min.
Dimensions .....	19½" wide, 12½" high, 24" deep (495 x 318 x 610 mm)

#### Accessories

Relay Switcher Printed Circuit Board .....	MI-11795
High-Level Isolation Unit, Stereo .....	MI-11665-S
Jumper Plugs .....	MI-141015
Auxiliary Mixer Consolette (ACMB) .....	MI-11656

### Ordering Information

Type BC-19 Stereo Consolette .....	ES-11154
consisting of:	
2 Type BA-72 Preamplifiers .....	MI-11672
2 Type BA-73 Program Amplifiers .....	MI-11659
2 Type BA-74 Monitor Amplifiers .....	MI-11661
1 Type BX-71 Power Supply .....	MI-11663
1 Type BA-78 Cue Amplifier .....	MI-11662
1 High Level Isolation Unit, Stereo .....	MI-11665-S
1 Console Housing .....	MI-11671

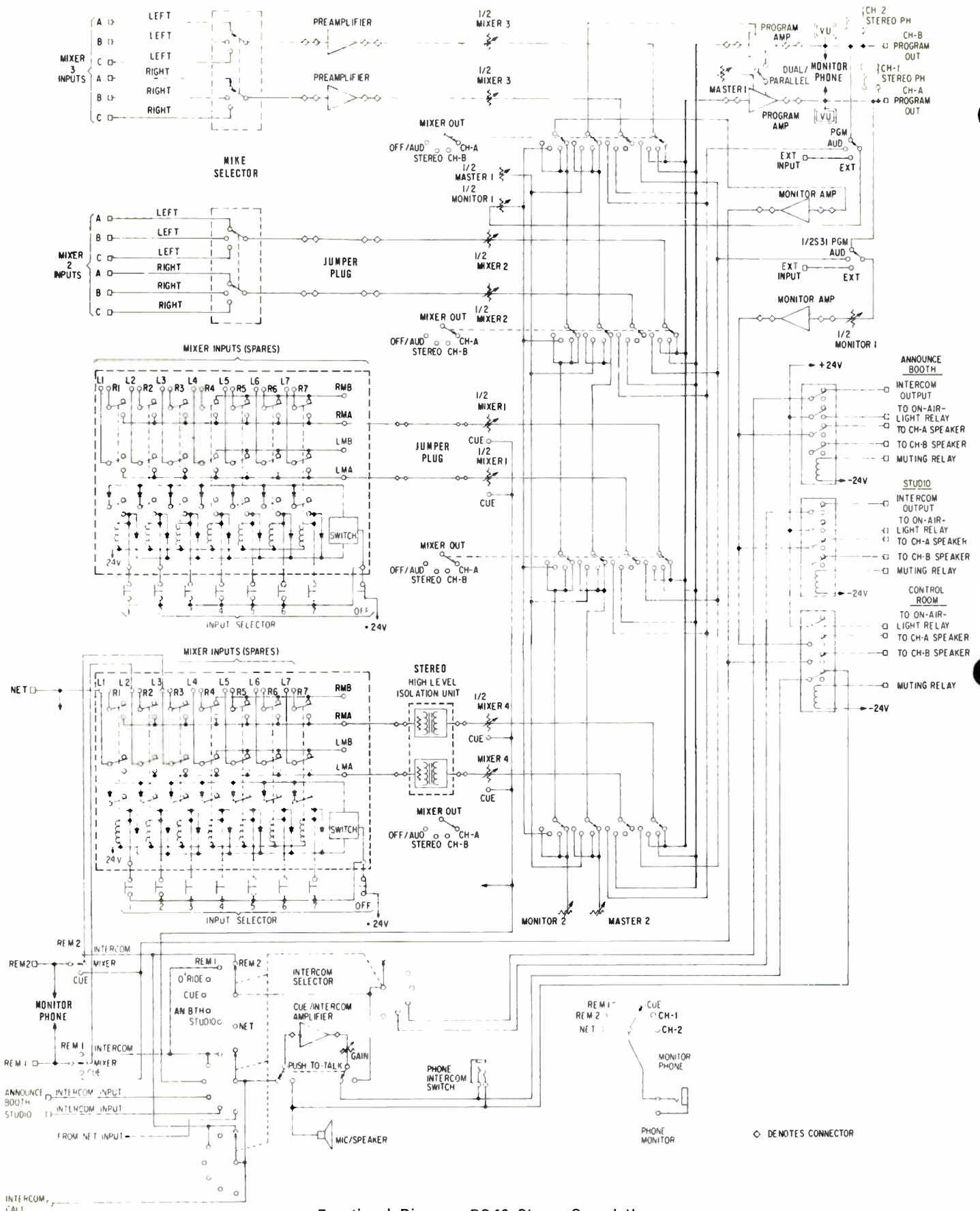

Functional Diagram, BC-19 Stereo Console

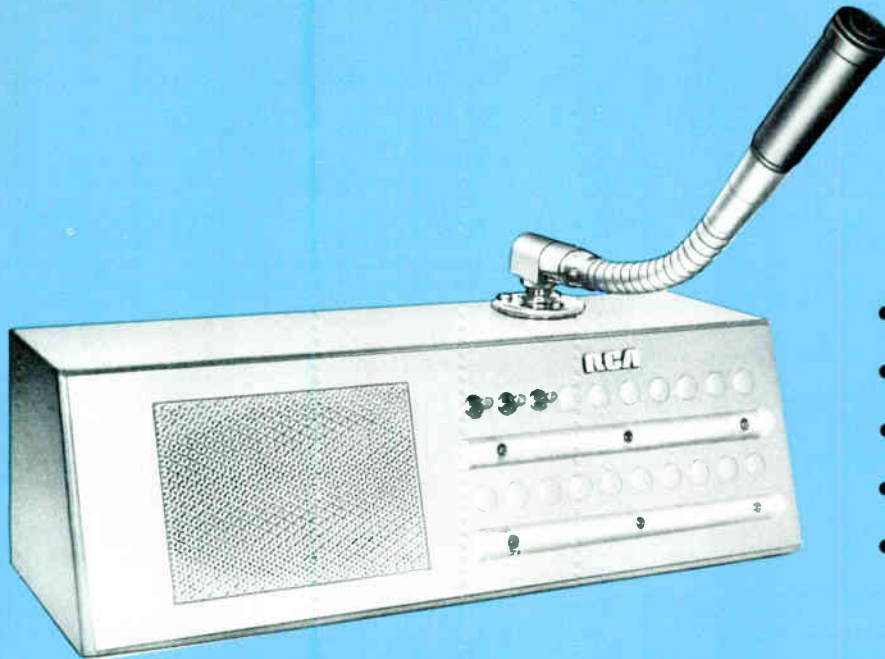

- Virtually unlimited expandability
- Custom-designed systems
- Desktop or rack-mount control stations
- Up to 5000-crosspoint capacity
- Ten basic modules

## Expandable Intercom System, Type BCS-5000

### Description

The Expandable Intercommunication System, Type BCS-5000, consists of a series of solid-state modules that may be used in various combinations to fabricate virtually any size intercom system for radio and television plant facilities.

#### Modular Construction

The modules include Microphone Preamplifiers, a solid-state Switching Matrix, Coupling Amplifiers, Monitor Amplifiers, Power Supplies and Control Panels, plus auxiliary equipment such as microphones, speakers and mounting hardware.

The "heart" of the system is a group of these modules centrally located in a standard 19-inch equipment rack plus two (or more) control panels that include microphones, speakers and/or headsets. All systems are custom designed, using the

modules described here, to meet customer's individual requirements. All of the modules are constructed on printed-circuit boards which plug into pre-wired module frames. This makes it practical to expand the system at any time in the future. As a result of the electrical and mechanical design of the system, it requires considerably less rack space than comparable systems.

#### Monitor Amplifier

The Monitor Amplifier is the basic module of the system. In addition to its function as a 3-watt output Amplifier, it provides power and plug-in mounting for a Preamplifier or Coupling Amplifier. The Monitor Amplifier module is designed to plug into a pre-wired mounting frame, that installs in a Type BR-21 shelf. All connections are made via gold-plated con-

tacts. Up to ten Monitor Amplifier modules mount in a single mounting frame.

An interstage gain control, to set the level for the preamplifier, is also incorporated on the Monitor Amplifier board. To adjust the preamplifier level control and the monitor amplifier level control, a screw driver access hole is located on the front panel. This allows setting of levels with the units plugged in.

Each amplifier module incorporates a transistorized voltage sub-regulator which furnishes  $32(\pm 1)$  volts to the amplifier. The DC sub-regulator isolation minimizes system crosstalk through the power supply.

An important feature of the unit is the solid-state circuit which mutes the output to prevent feedback from a nearby microphone.

### Carbon Microphone Preamplifier Module

This module furnishes the amplification required to feed the switching matrix from a carbon microphone. "Button" current for the microphone is supplied by the module. A unique feature is a solid-state input-switching circuit which essentially eliminates the transient generally associated with turning a carbon microphone on.

### Dynamic Microphone Preamplifier Module

This module is a preamplifier which incorporates 30 dB of automatic-gain control. The AGC feature is defeated by

turning the Threshold Control fully counter-clockwise. The preamplifier increases the output voltage of a dynamic microphone to the level required to drive the Switching Matrix. The overall gain of this module without AGC is  $50(\pm 2)$  dB with  $47(\pm 2)$  dB of AGC.

### Coupling Amplifier Module

This module provides an audio signal-interconnect with the RCA Interphone System. Mounting and connections are identical to the Carbon and Dynamic Mike Preamplifier modules.

### Solid-State Switching Matrix Module

This module consists of a plug-in board

which has provisions for mounting up to 10 plug-in solid-state crosspoints for audio switching. This module is so designed that it may be used as two 5-by-1 or one 10-by-1 switcher modules. It is similar to the Monitor Amplifier modules but requires only half the mounting space, making it possible to mount up to 20 switching modules in a single frame. Using the switching module as two 5-by-1 switchers results in reduced costs and reduced space requirements. Plug-in crosspoints of this type make future expansion or modification of a system a simple matter.

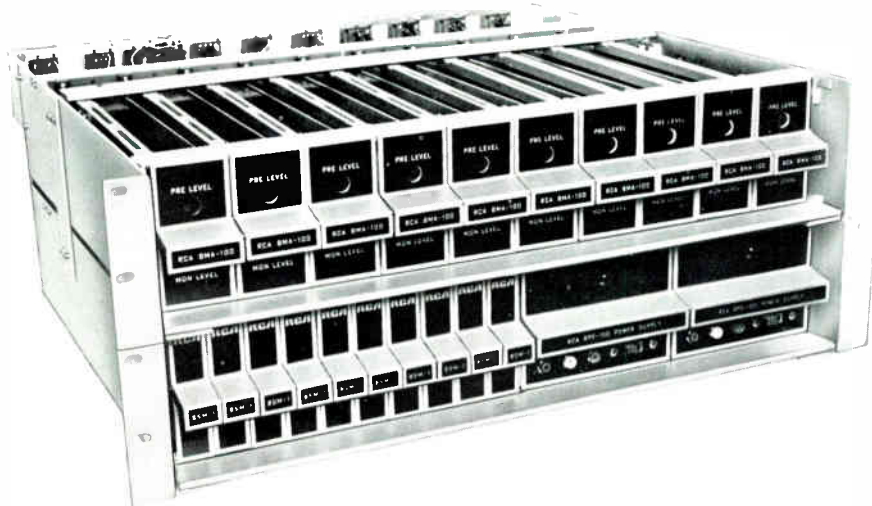

Typical module bank. All electronic functions are housed in three different modules: Preamp/Monitor Amps, Switching Matrix and Power Supply.

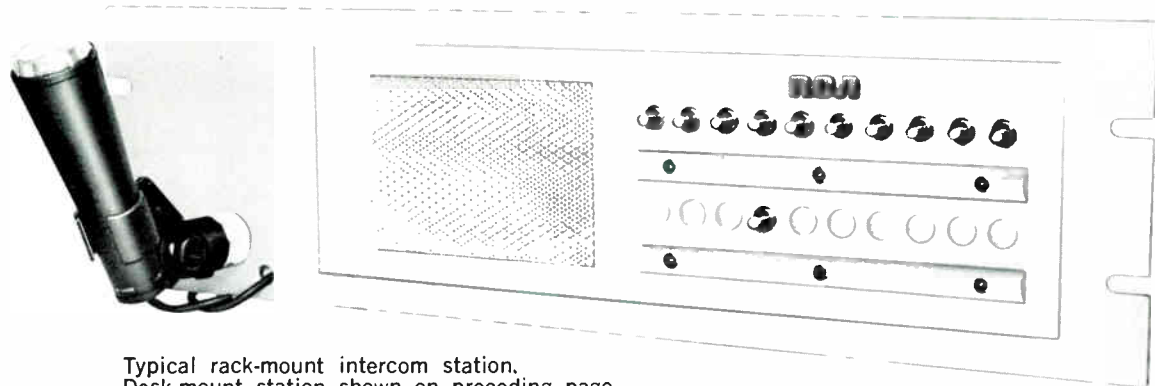

Typical rack-mount intercom station. Desk-mount station shown on preceding page.

## Solid-State Audio Crosspoints Modules

The crosspoint module is an unbalanced switching device which may be controlled remotely by means of 12-or-24-volt (DC) control energy.

The isolation between adjacent crosspoints is greater than 65 dB. The solid-state design provides a virtually transient-free switching function.

## Power Supply Module

The power supply module provides regulated DC power for operation of all the modules. Two output voltages are furnished by 40 V at 800 mA (for opera-

tion of Monitor Amplifier and Preamplifier modules) and 20 V at 200 mA (for operation of switching and associated crosspoints).

The power supply module plugs into the Mounting Frame and occupies 2/10 of the space.

## Receptacle Board—Switching Matrix

This component provides the mating receptacles for five switching matrix modules and also provides all interconnections except for the d-c control points. These must be wired to their respective locations during installation. The board

mounts at the rear of the mounting frame perpendicular to the switching matrix boards.

## Receptacle Board—Monitor Amplifier

This board provides the mating receptacle for five Monitor Amplifier modules and all the required interconnections. The board mounts at the rear of the mounting frame, perpendicular to the Monitor Amplifier modules.

## Mounting Frame

The Frame attaches the various modules of the system to the Type BR-21 Mounting Shelf.



Power Supply Module.



Preamp/Monitor Amp Module.



Crosspoint Matrix Module.

## Ordering Information

Type BCS-5000 Intercom Systems are offered on a custom-built basis. RCA people design a system to your needs using the modules, accessories and equipment listed here.

Monitor Amplifier, 3-watt, Type BMA-100 .....	MI-141080
Carbon Microphone Preamplifier, Type BMA-10 .....	MI-141060
Dynamic Microphone Preamplifier with AGC, Type BMA-11 .....	MI-141065
Coupling Amplifier (for use with RCA Interphone Equipment), Type BMA-12 .....	MI-141063
Switching Matrix, Solid-State, Type BSM-1 .....	MI-141075
Audio Crosspoint, solid-state (Normally open), Type BCP-1 .....	MI-141070
Audio Crosspoint, solid-state (Normally closed), Type BCP-2 .....	MI-141071
Power Supply, Type PPS-100 .....	MI-141085
Receptacle Board—Switching Matrix, Type BSM-1-1 .....	MI-141090
Receptacle Board—Monitor Amplifier, Type BMA-100-1 .....	MI-141095
Adaptor Kit for Type BR-21 Mounting Shelf .....	MI-141073
Dual Preamp Mounting Module, Type BPM-1 .....	MI-141076
Module Extender (for Type BMA-100), Type BMA-100-2 .....	MI-141079
Mounting Shelf, Type BR-21 (3.5-inch) .....	MI-11567
Connector Mounting Kit .....	MI-141096
Connector Kit .....	MI-141097
Lever Switch .....	MI-141069
Dual Mount Control Box (requires MI-141066) .....	MI-141068
Rack Mounting Adaptor (requires MI-141066) .....	MI-141067
Front Panel Assembly .....	MI-141066



**Accessories**

Microphone, Dynamic, Type SK-30 .....	MI-11030-1
Microphone, Dynamic, Lavalier, Type BK-6 .....	MI-11017
Cameraman Single Headset/Carbon Mic .....	MI-141006
Cameraman Double Headset/Carbon Mic .....	MI-141007
Commentator's Single Headset/ Dynamic Mic .....	MI-141009SI

Commentator's Double Headset/ Dynamic Mic .....	MI-141009DI
Single Headset/Transmitter Assembly .....	MI-11743
Double Headset/Transmitter Assembly .....	MI-11744
Flexible Gooseneck Mic Extension, 13-inch (330 mm) .....	MI-11745
Flexible Gooseneck Mic Extension, 19-inch (483 mm) .....	MI-11746
Gooseneck Adaptor Kit .....	MI-11073

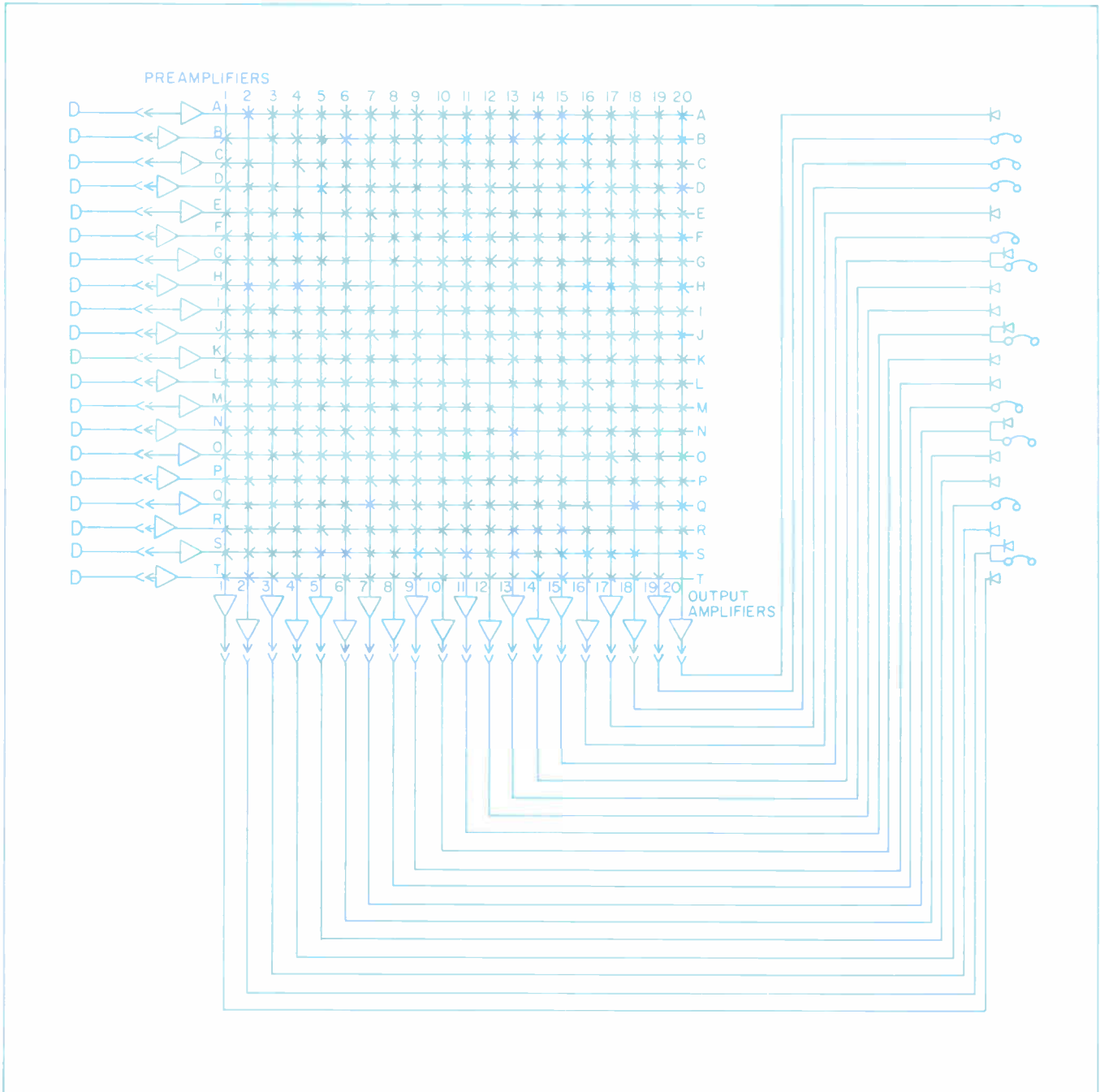

Typical 20 x 20 system diagram.

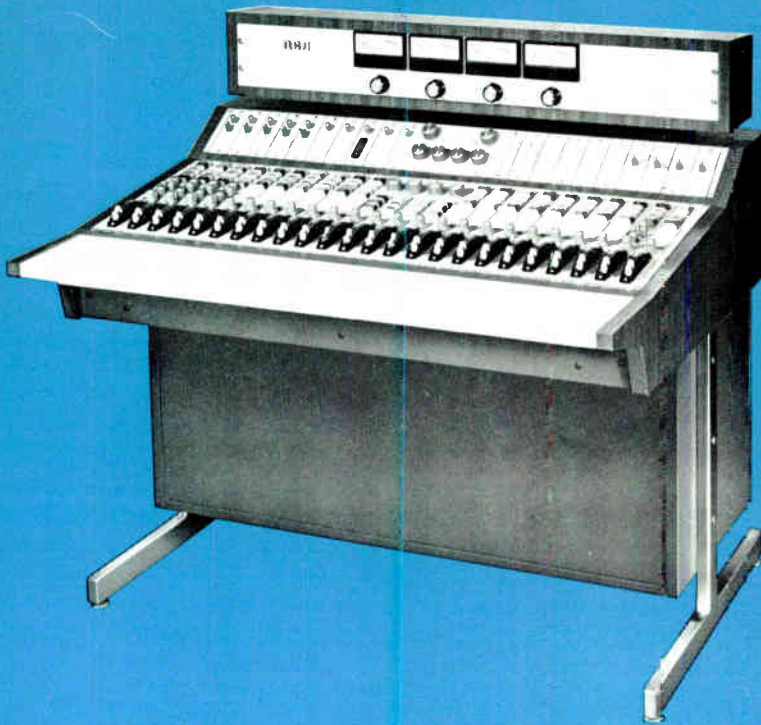

- Designed to exact customer requirements
- Modularized design
- Field expandable
- Offers programming flexibility
- Designed for operational ease
- Engineering consultation available

## RCA Custom Audio Control Equipment

### Description

In addition to the full line of "stock" consoles, consolettes and remote amplifiers, RCA designs and builds audio control equipment for specific needs in radio, TV, audio-production facilities and sound-recording studios. On the pages that follow are displayed some consoles RCA custom designed and built to customer specifications.

Pictured above is the BC-100 Audio Console, a superbly flexible facility capable of virtually any audio signal-handling assignment one might imagine.

#### Input Selection

There are five choices of input module for the BC-100 Console: two low-level and three high-level. The two low-level units are essentially identical except that one handles three inputs while the other handles but one. Each is equipped with a stepped gain control. The three high

level modules are also essentially identical except for the number of inputs; one, three or seven. The three-input module uses a rotary selector switch while the seven-input module selects input via pushbutton. High-level modules do not include gain controls.

#### Mixer Facility

Each mixer module consists of an equalizer, a vertical attenuator, a booster amplifier, an echo select-and-level control, submaster-select switches, a channel on/off switch, cue switch, and a foldback-select switch. The plug-in equalizers are optional and may be added at any time in the future. Because modules are interchangeable within the console, those with equalizers interchange quickly with those without to accommodate a change in operational needs. The vertical attenuators are bridged-*T* devices with built-in cue positions.

#### Submaster Modules

The BC-100 accommodates any number of sub-master modules depending on operational requirements. These contain an echo-mixing network, an echo-return level control with a selector switch, a sub-master attenuator, program-output selector switches and a sub-master monitor gain control. The program-output switches allow all submasters to feed output line.

#### Program Output Options

BC-100 master gain controls are rotary attenuators which can be separate or ganged (at time of purchase). The console boasts multi-channel mixing capability, however in its basic form this is expandable, on a custom basis, as are all of the console's other capabilities. For example, the console converts to eight-track recording capability simply through the addition of several modules.



Built especially for **Lewron Television** in New York City, this is one of two custom audio consoles recently installed. The console offers 20 inputs, which accept either high- or low-level signals, fed to any or all of four output channels. A fifth output channel is equipped with built-in AGC. Each output channel feeds a one-by-two splitter. Also included is a slating switch and a built-in tone oscillator.

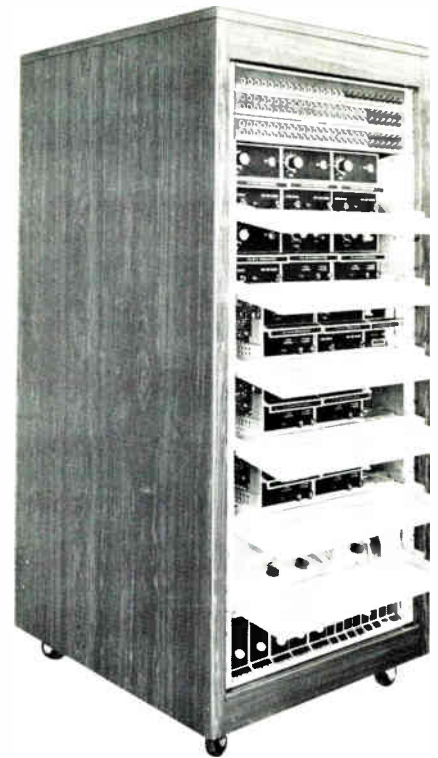

The **Lewron** consoles use auxiliary racks to house the mike-input plugs, the console power supplies and the audio jack-fields. Because the consoles and racks are designed for portability, they go most anywhere.



Now serving **WLAC's** production department, this custom-built console features 45 mike inputs via 15 three-input preamps in addition to one for the announce booth. A pushbutton matrix provides for 24 high-level inputs to the console. The facility includes each send-and-receive, equalization in eight channels, (moveable to any position). The two output channels contain AGC capability, cue, foldback, monitoring and muting.

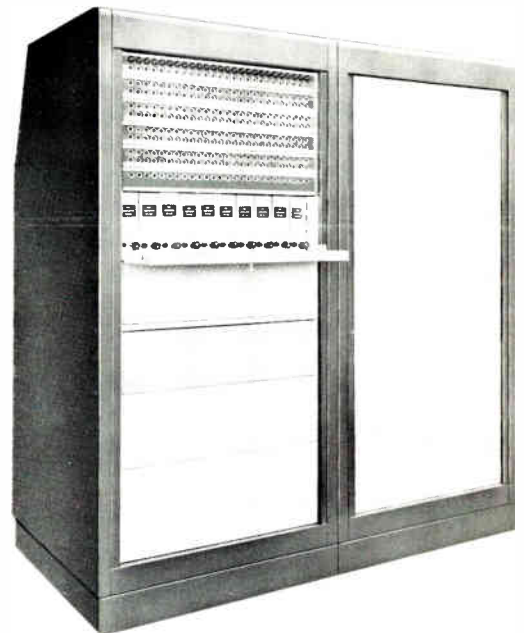

The **WLAC** facility uses a rack cabinet to house two RCA cartridge-tape (playback) machines and an audio jack-field. This photo shows the rack cabinet prior to the installation of the tape decks.

Now installed in the new **KOMO** color mobile unit, this splendid console handles ten transformer-isolated mike inputs and 14 high-level inputs. Three mixer busses and three submaster controls combine into three output channels of each equipped with a 1-by-2 splitter. Also included is a 10-by-2 switching matrix, cue, echo send-and-receive, foldback and output monitoring facilities.

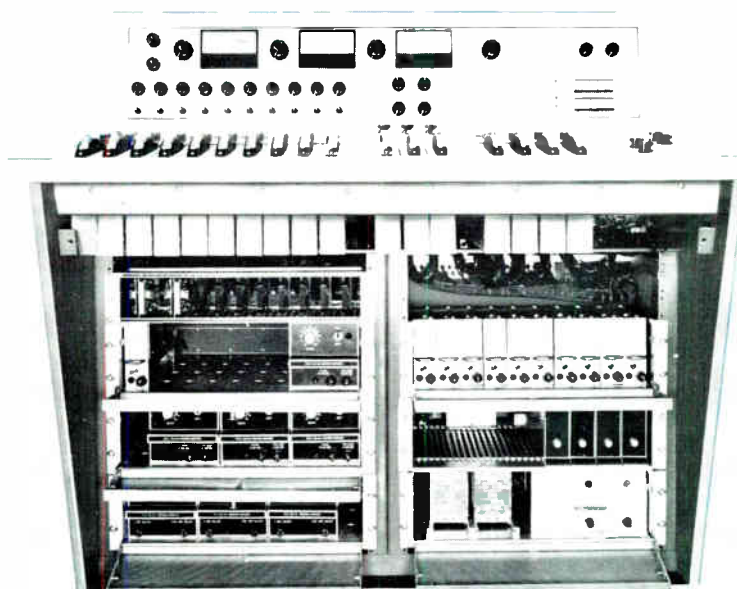
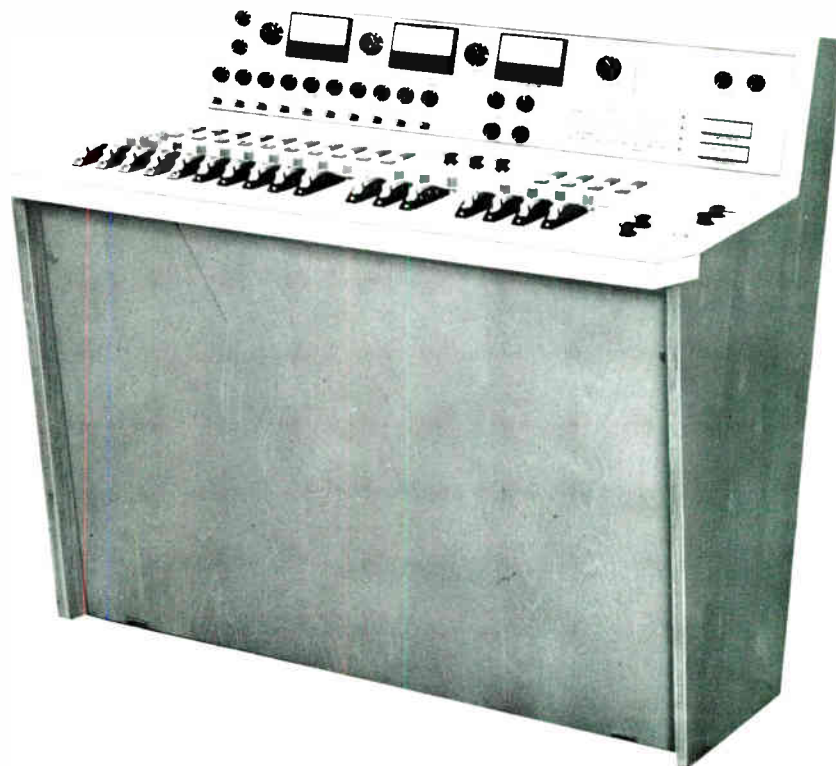

The **KOMO** Console with front cover removed. Note the orderly arrangement of the several amplifier modules on the left and the space for expansion. At lower right is the console power supply. Immediately above are 10 (BA-31) preamplifier modules.



WWL's new custom audio console now serves the station's new mobile unit and features twelve input faders of which eight are switchable to three mike inputs. The remaining four connect through switches to seven high-level inputs. All inputs can be delegated to any or all three output channels, each channel equipped with its own level control. Also included is PA bridging, an AGC amplifier, monitor amplifiers, cue amplifier, a panel-mounted cue speaker and selectable intercom facilities.

## Typical Specifications

### Microphone Inputs:

Source Impedance (Balanced) .....	150 ohms
Input Impedance .....	1500 ohms
Nominal Level (Unterminated, switch selectable) .....	-50, -40 or -30 dBm
Maximum Level .....	-5 dBm

### Auxiliary, High-Level Inputs:

Source Impedance (Balanced) .....	600 ohms
Input Impedance .....	40 kohms
Nominal Level (Terminated, switch selectable) .....	-10 or +18 dBm
Maximum Level .....	+43 dBm

### High-Level Inputs:

Source Impedance (Balanced) .....	600 ohms
Input Impedance .....	600 ohms
Nominal Level .....	-10 dBm
Maximum Level .....	+15 dBm

### Program Outputs:

Load Impedance .....	600 ohms
Output Impedance .....	Less than 60 ohms
Nominal Level .....	+18 dBm
Maximum Level .....	+30 dBm

### Monitor Outputs:

Load Impedance .....	4, 8, 16 ohms
Maximum Level .....	+40 dBm

### Echo-Send Outputs:

Load Impedance .....	600 ohms
Output Impedance .....	Less than 60 ohms
Nominal Level .....	0 dBm
Maximum Level .....	+16 dBm

### Echo-Return Inputs:

Source Impedance (Unbalanced) .....	600 ohms
Input Impedance .....	600 ohms
Nominal Level .....	0 dBm
Maximum Level .....	+13 dBm

### Frequency Response

(No Equalization, 10 dB below nominal level)	
Program .....	+0, -1 dB, 30-15000 Hz
Monitor .....	+0, -2 dB, 30-15000 Hz

### Harmonic Distortion

Program .....	Less than 0.75%, 30-15000 Hz
Monitor .....	Less than 1.0%, 30-15000 Hz

### Signal/Noise Ratio (Bandwidth

Unweighted) .....	68 dB or greater, 20-20,000 Hz
-------------------	--------------------------------

Crosstalk (At 1500 Hz) .....

More than 68 dB down between any two operating channels (console input to output)

### Headroom:

(At All Points in Program Circuits not with VU Meter)	
Above Test Level .....	+15 dB
Above Operating Level .....	+25 dB

Nominal Gain (Program) .....

+68 dB

Fader Range .....

+14 dB to -60 dB or greater

Ambient Temperature Maximum (Operating) .....

90°F. (32°C.)

### Equalization (Continuously variable)

Low Frequency .....	±18 dB @ 40 Hz
High Frequency .....	±15 dB @ 10 kHz
Presence Peaking .....	±16 dB any freq. 800-10,000 Hz

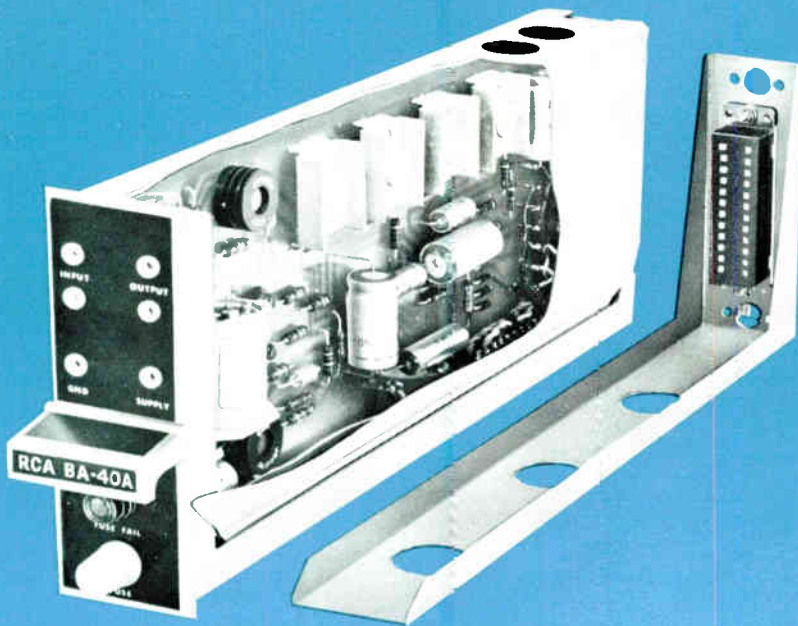

- Inputs for line-bridge or line-match
- Output level: +24 dBm
- Five isolated 600-Ohm outputs
- Negligible harmonic distortion
- Broad, flat frequency response
- Versatile input and output configurations

## RCA Distribution Amplifier, Type BA-40A

### Description

Designed for program-audio distribution, isolation and level recovery applications in AM- FM- and TV-broadcast plants, the Type BA-40A Distribution Amplifier either matches or bridges a 600-Ohm program line and splits the audio into five isolated 600-Ohm lines.

#### Long-Lived Reliability

Requiring virtually no maintenance, the amplifier uses silicon transistors throughout in a well-stabilized circuit packaged as a plug-in, modularized assembly. Circuit components are mounted on a glass-epoxy laminate substrate with etched wiring.

#### Versatile Input and Output Configuration

A high-quality transformer in the input circuit allows the amplifier to match or bridge a 600-Ohm balanced or unbalanced transmission line. All stages operate class

A, including the transformerless output. Because this stage offers extremely low output impedance, it is readily adaptable to a wide variety of load-impedance and power-splitting arrangements. The basic arrangement is a resistive network which splits the output energy among five, well-isolated 600-Ohm source-impedance outputs capable of delivering +24 dBm each.

#### Built-in Voltage Regulator

The BA-40A Amplifier operates from either a-c or d-c power. Operated from ac, it needs approximately 14 watts of 50-volt power at 50 or 60 Hz. The amplifier's internal circuitry rectifies, filters and regulates the ac to power the amplifier. Operated from an external d-c source, the amplifier needs approximately 10W of 60-volt negative-ground power. An optional power supply (see *Accessories*) offers sufficient capability to power as many as ten BA-40A Amplifiers simul-

taneously. It mounts at the rear of the mounting shelf (see *Accessories*) and connects to a 117 or 235-volt powerline.

#### Amplifiers Interchangeable

The BA-40A packaging is such that as many as ten units fit side-by-side in only 5¼ inches of rack space. Since all input and output strapping connections are made on the plug-in guide assembly, independent of the amplifier, free interchange of the amplifiers is quick and easy without restrapping.

#### Negligible Harmonic Distortion

Being of broadcast quality, the amplifier has very little harmonic distortion even at full output. This is the result of conservative design ratings in each component and careful application of inverse feedback. Harmonic distortion is less than 0.2% at +16 dBm output and 0.3% or less at maximum output, +24 dBm.

## Specifications

**Input:**  
 Impedance ..... Matching 600 Ohms  
 ..... Bridging 20k Ohms  
 Mode ..... Balanced or unbalanced  
 Max. Input Level ..... -10 dBm

**Outputs:**  
 Number of Outputs ..... Five  
 Impedance ..... 600 Ohms, load  
 Maximum Level, each output ..... +24 dBm

### Amplifier

**Gain:**  
 Using Matching Input ..... 35 ±0.5 dB  
 Using Bridging Input ..... Unity ±0.5 dB  
 Noise (20 kHz bandwidth) ..... Less than -70 dBm  
 Isolation between Outputs (signal) ..... 47 dB @ 1 kHz

**Harmonic Distortion:**  
 At +16 dBm ..... 0.2% max.  
 At +24 dBm ..... 0.3% max.

**Frequency Response:**  
 30 to 15k Hz ..... ±0.5 dB  
 20 to 20k Hz ..... ±1.0 dB

**Power Requirements:**  
 AC ..... 40-50V, 49-62 Hz, 5-12W  
 DC ..... 60-70V, Neg. gnd., 4-10W

**Physical Dimension:**  
 Height ..... 4 21/32 inches (118mm)  
 Width ..... 1 5/8 inches (42mm)  
 Depth ..... 13 inches (330mm)  
 Weight ..... 3 1/2 pounds (1.6 kg)

**Mounting** ..... Plug-in to BR-22 rack shelf  
 (10 amplifiers per shelf)

### Accessories

BR-22 Shelf ..... MI-11597  
 Spare Guide Assembly ..... MI-11593-7  
 BX-40A Power Supply (for 1 to 10 BA-40A) ..... MI-11447

## Ordering Information

BA-40A Distribution Amplifier,  
 complete ..... ES-11136  
 BA-40A Distribution Amplifier,  
 less guide assembly ..... MI-11433A

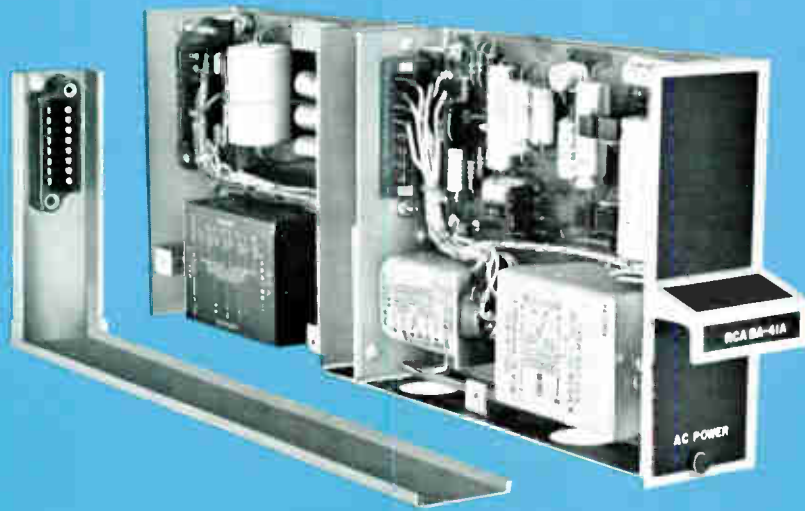

- Self contained power supply
- High gain, low noise circuitry
- 40 or 46 dB gain
- Frequency response: 20-20,000 Hz
- Accessory guide assemblies for plug-in shelf mounting
- Excellent common-mode signal rejection

## RCA Preamplifier, Type BA-41A

### Description

The RCA Type BA-41A Preamplifier comprises a BA-72A Preamplifier and a BX-72A Power Supply connected and mounted as one unit and available either with or without a guide assembly for convenient shelf mounting. The BA-41A is ideal as a microphone preamplifier, or as a booster amplifier.

The preamplifier's solid state design, coupled with the flexibility of multiple-tap input and output transformers, provide for low distortion, high gain characteristics with excellent frequency response, and low noise over a wide range of input and output impedances.

The BX-72A transistorized, low voltage, DC power supply assures trouble-free, long-life amplifier operation. When the BX-72A Preamplifier section is used separately (without the BX-72A Power Supply) power must be supplied from an external source (—30 Volts, 80 mA).



## Specifications

Source Impedance .....150 Ohms as shipped. May be changed to 600 Ohms balanced or unbalanced, 37.5 Ohms unbalanced

Input Impedance:

  Matching .....Unloaded input transformer (input impedance higher than source impedance for all frequencies from 20 to 20,000 Hz)

  Bridging .....Externally mounted bridging gain control required (approx. 20,000 Ohms input). MI-11278-E panel mounting; MI-11278-F chassis mounting

Load Impedance .....600 Ohms as shipped (may be changed to 150 Ohms)

Maximum Input Level:

  Matching .....-22 dBm with 40 dB gain strapping

  Bridging .....30 dBm

Matching Gain .....40 ±1 dB (as shipped); may also be strapped for 46 ±1 dB

Frequency Response .....±0.75 dB from 20 to 20,000 Hz (referred to 1,000 Hz)

Rated Output Level and Distortion .....Total rms harmonic distortion at +18 dBm output less than 0.5% from 25 to 20,000 Hz

Noise Level .....(20 kHz bandwidth) 127 dBm referred to input; -81 dBm referred to output; 99 dB maximum S/N ratio referred to +18 dBm

Maximum Ambient Temperature .....55°C (131°F)

### Power Requirements:

BA-41A .....Self-contained power supply operates from 105, 115, 125 or 210, 230, 250 Volts AC, 50/60 Hz

BA-72A .....Requires a 30-Volt, 80 mA power source (BX-72A or BX-71B)

### Overall Dimensions:

BA-41A .....4 21/32" high, 1 5/8" wide, 13" deep (11.75 cm, 4.13 cm, 33.02 cm)

BA-72A .....4 5/8" high, 1 3/8" wide, 7 5/8" deep (12.75 cm, 3.49 cm, 19.37 cm)

### Weight:

BA-41A .....3 1/2 lbs. (1.59 kg)

BA-72A .....2 1/4 lbs. (1.02 kg)

### Accessories

Guide Assembly for BA-41A .....MI-11593-6

Guide Assembly for BA-72A .....MI-11759-1

BR-22D Mounting Shelf (accommodates 10 BA-41A's or 10 BA-72A's) .....MI-11597-D

Bridging Gain Control (Panel Mounting with front panel knob) .....MI-11278-E

Bridging Gain Control (Chassis Mounting with screw driver type adjustment) .....MI-11278-F

## Ordering Information

Type BA-41A Preamplifier (with Power Supply and Guide Assembly) .....ES-11135-A

Type BA-41A Preamplifier (with Power Supply less Guide Assembly) .....MI-11463-A

BA-72A Preamplifier (with Guide Assembly) .....ES-11172-A

BA-72A Preamplifier (less Guide Assembly) .....MI-11672-A

BX-72A Power Supply .....MI-11320-A



- High gain—will accept microphone input level
- 10 Watt output—very low distortion
- Plug-in chassis, shelf mounting, self powered
- Ideal for recording or broadcast monitoring
- Full output protection, blown fuse indicator

## RCA Monitor Amplifier, Type BA-44B

### Description

The BA-44B Monitor Amplifier is a high fidelity amplifier, having 104 dB gain and delivering a full 10 Watts of audio power output. It is particularly designed for monitoring, audition, recording and "talk-back" applications. It may also be used as a program or a line amplifier. It is ideal for playback of transcriptions and will operate a speaker system directly from the output of an equalized pickup cartridge. The BA-44B is small in size and is designed for convenient plug-in installation in the BR-22 mounting shelf using the guide assembly MI-11593-4.

### Low Power Consumption

The use of transistors throughout the BA-44B provides a number of advantages including: small, compact design, low heat dissipation, greatly reduced power consumption, trouble-free and long-life expectancy for the amplifier. The circuit design of the Monitoring Amplifier is simple and straightforward.

### Circuit Features

The BA-44B consists of two basic amplifiers, the first a two-stage preamplifier which connects through a gain-control to the input of a multistage power amplifier. The input preamplifier, having an unloaded input transformer can be connected for 37.5, 150 or 600 Ohm sources. A bridging volume control or the self-contained bridging pad may be used for high level inputs. Negative feedback stabilizes the gain of the two-transistor preamplifier.

Following the preamplifier are two low-level stages, followed by a dual transistor phase splitter, dual transistor driver, and dual class "B" output transistors which are in series with the driver. A thermistor adjusts the idling current of the output stage to compensate for temperature changes. Secondary taps on the output transformer match 4, 8, 16, 150 and 600 Ohm balanced loads and 70-Volt line. By using three separate feedback paths, the distortion drops to a very low level. Long life silicon diodes are used in the self-contained power supply. Two fuses serve to protect the amplifier.

The amplifier is fully protected against burn out, as a result of overdriving the amplifier, and/or mismatching the output—including shorting of the output. Current limiting circuits allow the amplifier to return immediately to normal operation, without sustaining any damages whatsoever, as soon as an irregular output is restored to normal operation.

### Convenient Controls

All controls are located on the front panel including the interstage gain control knob, a power ON-OFF toggle switch, indicator lamp, blown fuse indicator and two fuses—one a  $\frac{3}{4}$  Amp. AC line fuse, the other a 1 Amp. DC fuse. The entire amplifier is mounted on a plug-in type chassis. Connections to the BA-44B are made through two 8-prong blue ribbon connectors at the back of the amplifier which plugs into a socket supplied with the mounting assembly. All input connections are made through one plug; the output and AC power through a second plug.

The BA-44B Monitor Amplifier is directly interchangeable with the BA-34C Monitor Amplifier.

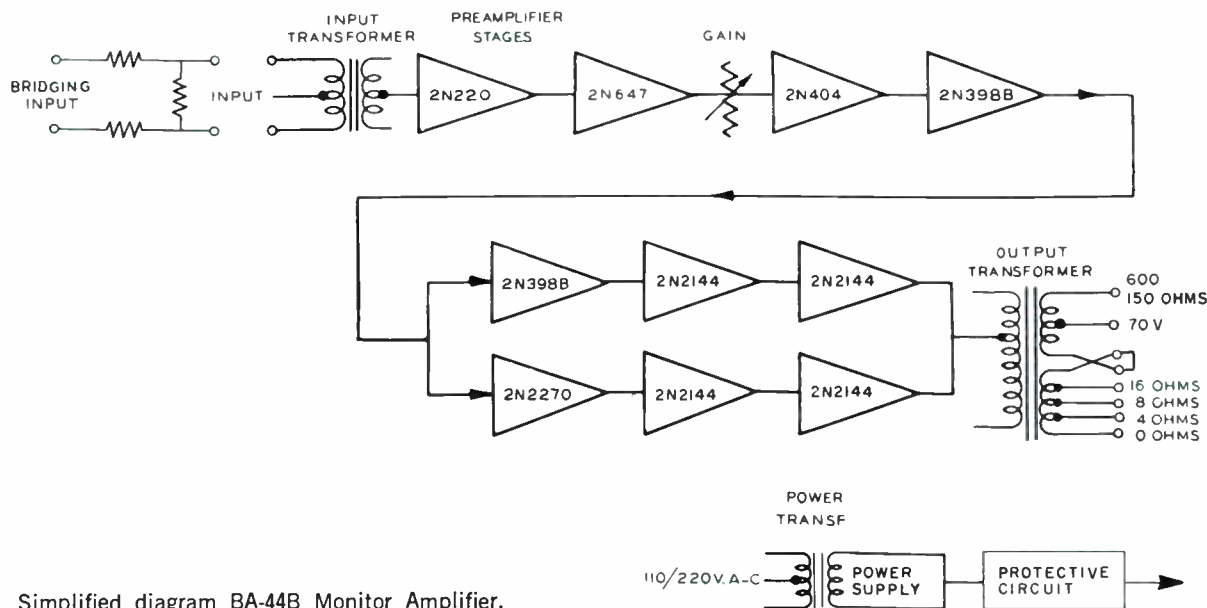

Simplified diagram BA-44B Monitor Amplifier.

## Specifications

Power Requirements	117 Volts, AC, 50/60 Hz.
	Taps at 105, 117 and 125 Volts (primary connected in parallel). 230 Volts, AC, 50/60 Hz. Taps at 210, 234 and 250 Volts (primary connected in series). 35 Watts at rated output, 10 Watts (approx.) at normal speaker volume.
Source Impedance	150-Ohm balanced source when shipped; may be reconnected to operate from a 600 Ohm balanced or unbalanced, or a 37.5 Ohm unbalanced source
Input Impedance:	
Matching	Unloaded input transformer, input impedance higher than source impedance for all frequencies from 30 to 20,000 Hz.
Bridging	50,000 Ohms
Load Impedance	4/8/16/150/600 Ohms balanced and 70 Volt line
Maximum Input Level:	
Matching	-25 dBm
Bridging	+25 dBm
Maximum Gain:	
Matching	103 dB, $\pm 1$ dB
Bridging	53 dB, $\pm 1$ dB
Average Power Output	10 Watts (40 dBm) max.
Frequency Response	+0 to -1 dB, 30-20,000 Hz
Noise Level:	
With 20 Hz to 20 kHz Bandwidth	-123 dBm referred to input; -20 dBm at output at 103 dB gain
Wideband Noise	-120 dBm referred to input (-17 dBm at output at 103 dB gain)

Harmonic Distortion	At 10 Watt output (40 dBm) and -30 dBm input less than 1%, 30 to 20,000 Hz
Ambient Temperature	55° C max. (131° F)
Fuses	0.75 Amp. 3AG (SB-AC) 1.0 Amp. 3AG (SB-DC)
Protective Circuits	The amplifier is protected against failure, as a result of external shorts (of any time duration—the output may be shorted indefinitely). The amplifier is also protected against failure due to overload (excessive input levels)
Internal DC Protection	Protects the amplifier against shorts in the DC Supply by limiting supply current to a safe level
Transistor and Diode Complement:	1—2N404, 1—2N467, 4—1N3253, 1—2N220, 4—2N2144, 2—2N398B, 1—2N2270, 1—2N4251
Dimensions, Overall	13 1/8" (33.3 cm) long, 5" (12.7 cm) wide, 4-31/32" (12 cm) high
Weight	12 lbs. (5.44 kg.)
Mounting	Plug-in mounting on BR-22 Mounting shelf, requires 3/10 of space, three amplifiers may be mounted on each shelf

### Accessories

BR-22 Mounting Shelf (mounts 3 BA-44's)	MI-11597-B
Bridging Volume Control	MI-11278-E/F
Guide Assembly	MI-11593-4

## Ordering Information

BA-44B Monitor Amplifier less Guide Assembly	MI-11442-B
BA-44B Monitor Amplifier with Guide Assembly	ES-11134-B

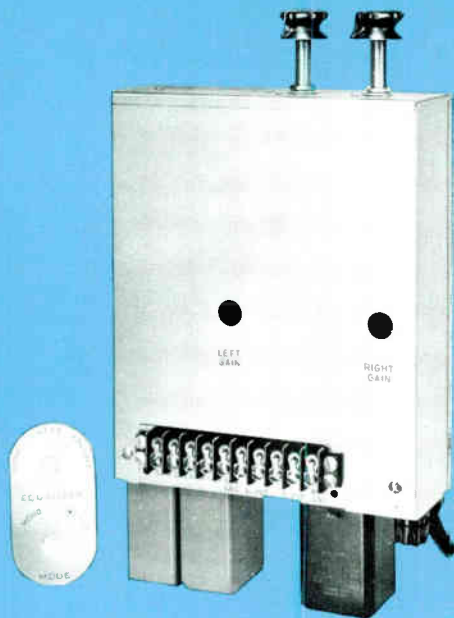

- Wide dynamic range
- Self-contained power supply
- Low distortion—high output level
- Level setting control
- NAB/RIAA response

## Pickup Equalizer-Preamplifier, Type BA-26/36

### Description

The Type BA-26 Monophonic and Type BA-36 Stereo Pickup Equalizer-Preamplifiers are designed to provide correct equalization for reproduction of records and transcriptions. Both models are designed for use with transcription turntables, such as the RCA BQ-50 and BQ-51. They are especially recommended for use with the BDR-1 Pickup Arm and the MI-11865 Pickup mounted in the RCA Lightweight Tone Arm.

#### All New Design

Both BA-26 and BA-36 equipments employ RCA low-noise type transistors in a four-stage amplifier utilizing selective feedback to achieve NAB/RIAA equaliz-

ing curve. The self-contained AC power supply utilizing silicon rectifiers provides trouble-free operation. The etched wiring assemblies are mounted inside the chassis while the output and power transformers and two control switches are mounted at the ends of the chassis. A convenient slip-off cover is provided to allow easy access to component parts and transistors. The equalizers have a terminal board for making input and output connections. A six-foot, 3-wire, AC cord with plug is attached to the equipment. This enables the unit to be grounded to the AC system ground and produces the maximum possible signal-to-noise ratio. NAB/RIAA or flat response is chosen by strapping. The

flat response, achieved by a strap change on the circuit board, is useful for test.

#### Simplified Controls

Simplified controls are features of the BA-26 and BA-36. Two control knobs and a dial plate with necessary mounting hardware are supplied with each unit. One control is a three-position filter switch which provides normal equalization, high-frequency de-emphasis and high-frequency cut-off. The second switch on the BA-26 selects either of two tone arms. The ability to select either of two tone arms is especially desirable in playing older transcriptions and 78 rpm records as well as new high-fidelity monophonic transcrip-

tions. With two tone arms mounted on a BQ-50 or BQ-51 Turntable, one with a 1-mil stylus and the other with a 2.5-mil stylus any record or transcription may be played quickly and easily by simply selecting the proper tone arm. The second control knob on BA-36 is used to switch from stereo to mono modes of play by paralleling the stereo outputs.

### Adjustable Gain Control

A built-in screwdriver-adjust, gain control allows the gain of the BA-26 to be set to exact requirements. The gain control

is accessible through a hole in the side panel of the housing. Two similar screwdriver controls are provided in the BA-36 to balance the right and left channel gains of the dual amplifiers.

### Designed For Long Life

The Pickup Equalizer-Preamplifiers are designed for long life. The RCA Type 2N220 low-noise transistor is used in the input stage followed by three Type 2N404 transistors to provide the required gain and output capabilities. Type 1N3193 silicon rectifiers are used in the power

supply. The unit is shielded for r-f energy and is free from microphonics. An output transformer provides either balanced or unbalanced output impedances of 150 and 600 ohms. Two such transformers are used in the BA-36. Etched wiring boards are utilized to provide stable trouble-free operation of the unit. Selective feedback within the amplifier eliminates the need for inductances to accomplish low-frequency equalization. This eliminates the possibility of hum pick up by the inductance.

## Specifications

### Performance\*

Power Requirements .....3 taps 105/115/125 volts, AC, 50/60 Hz

#### Power Consumption:

BA-26 .....1/2 watt  
BA-36 .....1 watt

#### Frequency Response:

NAB/RIAA .....Meets NAB Specifications  
Flat .....±0.5 dB 20 to 20,000 Hz

Hum and Noise Level .....-78 dBm max. (30 to 15,000 Hz);  
(5 microvolts equivalent 1000 Hz signal at input) (600 ohm  
input termination NAB/RIAA strapping, gain as shipped)

#### Inputs:

BA-26 ..... Either of two, selected by input switch  
BA-36 ..... Monophonic or stereo mode  
selected by input switch

#### Input Impedance:

BA-26 .....24,000 ohms shunted by approximately 100 pf.  
Up to 60,000 ohms by changing shunt resistor.  
BA-36 .....47,000 ohms shunted by approximately 100 pf.  
Up to 60,000 ohms by changing shunt resistor.

Output Impedance .....150/600 ohms (600 ohms as shipped)

Load Impedance .....150/600 ohms

#### Sensitivity at 1000 Hz:

BA-26 .....5.5 cm/sec. (lateral) for -20 dBm output level  
(with any magnetic cartridge and gain adjusted as per  
instructions)

BA-36 .....3.9 cm/sec. (45°) for -20 dBm output level  
5.5 cm/sec. (lateral) for -20 dBm output level (with any  
magnetic cartridge and Left and Right gain adjusted  
per instructions).

#### Input Voltage for -20 dBm Output

Level (1000 Hz) .....0.016 V to .013 V (approx.)  
.004 V (as shipped)

#### Output Level:

Program .....-20 VU (average record)  
Maximum .....-5 dBm

#### Distortion:

##### At -20 dBm Output Level:

Intermodulation ..... Less than 1%  
(40/4000 Hz or 400/4000 Hz 4:1)  
Harmonic ..... Less than 0.25% (30 to 15,000 Hz)

##### At -5 dBm Output Level:

Intermodulation ..... Less than 4%  
Harmonic ..... Less than 1%

High Frequency Compensation ..... 0, -3.5, or -10 dB at  
10,000 Hz with Equalizer switch

Crosstalk between Channels (BA-36) ..... Below noise level  
30 to 15,000 Hz

#### Transistor and Rectifier Complement:

BA-26: 1-2N220, 3-2N404, 1-1N3193  
BA-36: 2-2N220, 6-2N404, 2-1N3193

### Mechanical

Dimensions (overall) .....10 3/4" long, 6 5/8" wide, 2 1/2" deep  
(273 mm, 168 mm, 64 mm)

#### Weight:

BA-26 .....4 lbs. 10 ozs. (2.1 kg.)  
BA-36 .....5 lbs. 4 ozs. (2.4 kg.)

### Accessories

Stepdown Transformer 220 to 110V.

50/60 Hz, 85W. ....MI-141010-85

\* Specifications of the BA-26 and BA-36 are identical unless otherwise indicated.

## Ordering Information

BA-26 Pickup Equalizer-Preamplifier  
(mono) .....MI-11436  
BA-36 Pickup Equalizer-Preamplifier  
(stereo) .....MI-11441

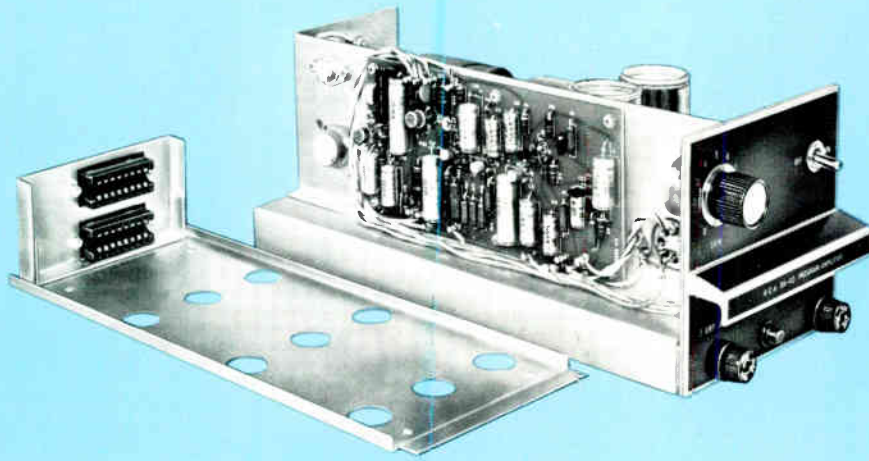

- Silicon transistor design and etched wiring provide uniform performance
- Extended frequency response and power bandwidth
- Ambient temperature range —20 to +75C
- Self-contained, regulated power supply
- Plug-in chassis for shelf mounting

## Program Amplifier, Type BA-43

### Description

The BA-43 is a wide band program amplifier designed for broadcast and professional audio service by itself or in conjunction with auxiliary Type BA-45 AGC, Type BA-46 Limiter and Type BA-47 Clipper units. New circuitry, featuring silicon transistors, provides the advantages of compact design, uniform performance, reduced power consumption and long-life expectancy. The high gain and low distortion of the unit make it an ideal choice for use as a program or line amplifier, bridging amplifier or as an isolation unit.

The BA-43 features excellent perform-

ance, especially in the areas of bandwidth, noise and temperature stability, due largely to the use of silicon transistors. The amplifier circuit consists of an unloaded input transformer and a three-stage negative feedback preamplifier followed by a continuously variable gain control that is adjustable from the front panel. This control varies the signal into a negative feedback output amplifier employing five transistors. This amplifier, in turn, drives a multi-impedance output transformer. Levels as high as +30 dBm (1 watt) can be supplied at the output.

The self-contained power supply consists of a full-wave rectifier, filter and transistor voltage regulator to assure uniform performance.

The BA-43 Program Amplifier is a plug-in type designed for mounting on the Type BR-22 Mounting Shelf. Mating sockets and a guide assembly are available for this purpose. The shelf permits convenient removal for servicing or interchanging units. Up to three BA-43 amplifiers can be accommodated on the mounting shelf.



BA-43 Amplifier shown with BA-45 AGC and BA-46 Limiter Modules, mounted on BR-22 Shelf.

## Specifications

Source Impedance	600 ohms, balanced when shipped, may be reconnected for 150 ohm balanced or unbalanced source
Input Impedance:	
Matching	600/150 ohms
Bridging	20,000 ohms
Load Impedance	600/150 ohms
Maximum Input Level:	
Matching	-17 dBm
Bridging	+13 dBm
Frequency Response Referred to	
1000 Hz	+0, -3/4 dB, 20-20,000 Hz
Maximum Output Level	+30 dBm
Harmonic Distortion	0.5% rms max. at +30 dBm output, 25-20,000 Hz
Matching Gain (Max.)	76 ± 1/2 dB (Loaded), 82 ± 1/2 dB (Unloaded)
Bridging Gain (Max.)	46 ± 1 dB (Loaded), 52 ± 1 dB (Unloaded)
Ambient Temperature Range	-20°C to +75°C (-4°F to +167°F)
Noise Level Referred to:	
Input	-126 dBm (20-20,000 Hz)
Output	-44 dBm (20-20,000 Hz)

Power Requirements	115 volts, AC, 50/60 Hz, 10 watts (transformer taps at 105, 115 and 125 V primary connected in parallel); 230 volts, AC, 50/60 Hz, 10 watts (transformer taps at 210, 230 and 250 V, primary connected in series)
Fuses	2 amps SB (Power Line); 0.4 amp SB (B+ Line)
Overall Dimensions	4 21/32" high, 5" wide, 11 1/6" deep (118, 127, 284 mm)
Weight	9 1/2 lbs. (4.3 kg.)
Mounting	Plug-in on BR-22 Shelf, (requires 3/10 of shelf)

### Accessories:

Mounting Shelf, Type BR-22	MI-11597
Signal Processor Shelf, Type BR-23 (pre-wired)	MI-11564 or MI-11565
Spare BA-43 Guide Assembly (with receptacles)	MI-11593-1
Automatic Gain Control Unit, Type BA-45	MI-11455
Limiter Amplifier, Type BA-46	MI-11456
Peak Clipper Module, Type BA-47	MI-11459

## Ordering Information

BA-43 Program Amplifier:	
Including Chassis Guide Assembly with Receptacles	ES-11128
Less Guide Assembly	MI-11454

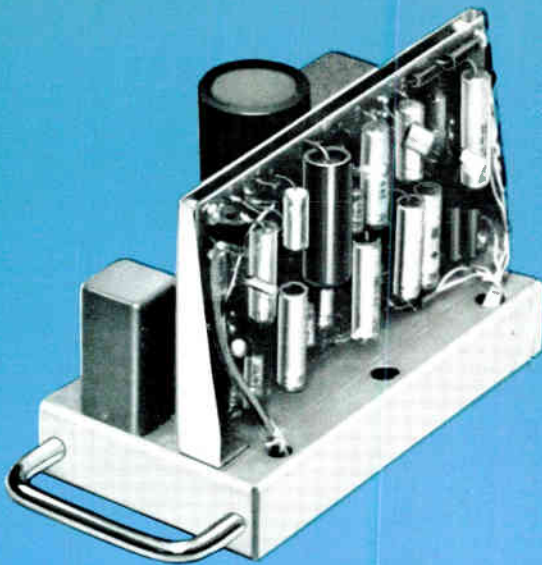

- High gain, low distortion
- Ideal for custom applications
- Very low noise level,  $-122$  dBm
- Frequency response better than  $+0$  and  $-1$  dB. 30 to 20,000 Hz

## RCA Consolette Program Amplifier, Type BA-73C

### Description

The BA-73C Program Amplifier is designed for use as a high-quality booster or program amplifier. There is provision for adding an external volume control which may be used as a master fader. Input and output transformers provide circuit isolation.

The BA-73C is one of a series of transistor amplifiers designed to plug-in di-

rectly into RCA consolettes. Accessory Guide Assembly, MI-11759-2 with mating receptacles permits the BA-73C to be mounted in a BR-22 Shelf or any enclosure used in custom construction. Up to three Program Amplifiers as well as one BA-71C Consolette Preamplifier can be accommodated on the BR-22 Shelf. Power for the amplifier is supplied by the Type BX-71B Power Supply. Up to three amplifiers may be operated by one BX-71 supply.

The BA-73C Amplifier incorporates full transistor circuitry providing the advantages of small, compact design, uniform performance, reduced power consumption and long life expectancy for the amplifier. The high gain and low distortion of the unit make it an ideal choice for any audio system. Etched wiring boards are used and all circuitry and components are readily accessible.

### Specifications

Source Impedance.....150/600 Ohms, balanced or unbalanced  
Input Impedance:

Matching .....Input transformer unloaded, with impedance higher than source impedance. Connected when shipped for 600 Ohms; may be reconnected for 150 Ohms

Load Impedance .....Connected for 600 Ohms when shipped; may be changed to 150 Ohms

Maximum Input Level:

Unloaded Input ..... $-30$  dBm

Loaded Input ..... $-24$  dBm

Frequency Response .....Better than  $+0$  and  $-1$  dB, 30 to 20,000 Hz

Rated Output Level ..... $+24$  dBm

Harmonic Distortion.....Less than 0.5% rms  $+24$  dBm output, 50 to 20,000 Hz. Less than 0.25% at 1 kHz, 24 dBm output

Gain:

Unloaded Input ..... $92 \pm 1$  dB

Matching Input ..... $86 \pm 1$  dB

Noise Level ..... $-122$  dBm referred to the unloaded input

Power Requirements .....30 Volts, 300 mA drain from BX-71C

Transistor Complement (supplied in place):

4—2N220, 2—2N270, 1—2N526, 2—2N1905

Ambient Temperature ..... $55^{\circ}\text{C}$  ( $131^{\circ}\text{F}$ )

Overall Dimensions .....9" long,  $3\frac{3}{4}$ " wide,  $4\frac{5}{8}$ " high  
(22.86 cm, 9.52 cm, 11.75 cm)

Weight .....4 lbs. (1.8 kg.)

Finish .....Cadmium plate with clear chromate dip

### Accessories

Shelf Guide Assembly for BA-73C Amplifier .....MI-11759-2

BR-22C Mounting Shelf .....MI-11597-B

Step Attenuator (external) .....MI-11751-5

BX-71B Transistor Power Supply .....MI-11663-B

Spare Transistor and Diode Kit .....MI-11786-5

### Ordering Information

Type BA-73C Consolette Program Amplifier with transistors in place and less Guide Assembly .....MI-11659-B

Type BA-73C Consolette Program Amplifier and Guide Assembly .....ES-11159-B





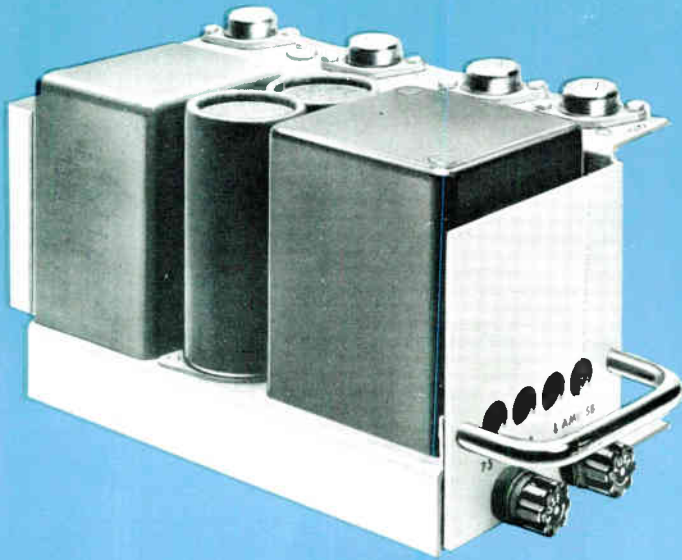

- 10 watt power output
- Very low distortion
- 64 dB gain; —50 dB noise level
- Low heat dissipation
- Self-contained power supply

## Consolette Monitor Amplifier, Type BA-74

### Description

The BA-74 Consolette Monitor Amplifier is designed for monitoring, audition and "talk back" applications. This amplifier has 64 dB gain with 10 watts of audio output. It may also be used as a Distribution, Program or a Line Amplifier.

The BA-74 is one of a series of matched plug-in amplifiers specifically designed for

console and custom applications. It can be plugged into the BC-7, BC-8, BC-9, BC-17 and BC-19 Consoles or installed on the BR-22 mounting shelf with the aid of Accessory Mounting Guide. Three BA-74 Amplifiers may be mounted on one shelf. Its small size makes it very useful in many custom-built applications.

The circuit design of the Monitor Amplifier is simple and straightforward. All circuit functions are accomplished by eight transistors and two diodes. The use of solid state components provides a number of advantages including: compact design; reduced power consumption and long trouble-free life for the amplifier.

### Specifications

Source Impedance .....	600/150 ohms
Input Impedance .....	Unloaded input transformer, high in comparison to source impedance
Load Impedance .....	4/8/16/150/600 ohms and 70 volt line
Maximum Input Level .....	-23 ±2 dBm
Maximum Gain:	
Loaded Input .....	64 ±1 dB
Unloaded Input .....	70 ±1 dB
Frequency Response .....	+0, -1 dB, 30 to 20,000 Hz
Maximum Output Level .....	10 watts (40 dBm)
Harmonic Distortion .....	Less than 1% 30 to 20,000 Hz at 40 dBm (10 watt) output level
Noise Level .....	-50 dBm maximum at 64 dB gain
Power Requirements .....	115/230 V, AC, 50/60 Hz, 30 watts, (with taps for 105, 115, 125 or 210, 230 and 250 volts)
Ambient Temperature .....	55°C (131°F) max.

Mounting .....On guide strip provided with console or using Guide Assembly for installation on BR-22 mounting shelf

Finish .....Cadmium plate with clear chromate dip

Dimensions Overall .....8" long, 5" wide, 4 5/8" high (203 mm, 127 mm, 118 mm)

Weight .....11 lbs. (4.99 kg.)

### Accessories

Shelf Guide Assembly .....MI-11759-3

Mounting Shelf, Type BR-22 (mounts 3 BA-74's) .....MI-11597

Bridging Volume Control: With Screwdriver Adjustment (externally mounted) .....MI-11278-F

With Knob Adjustment (externally mounted) .....MI-11278-E

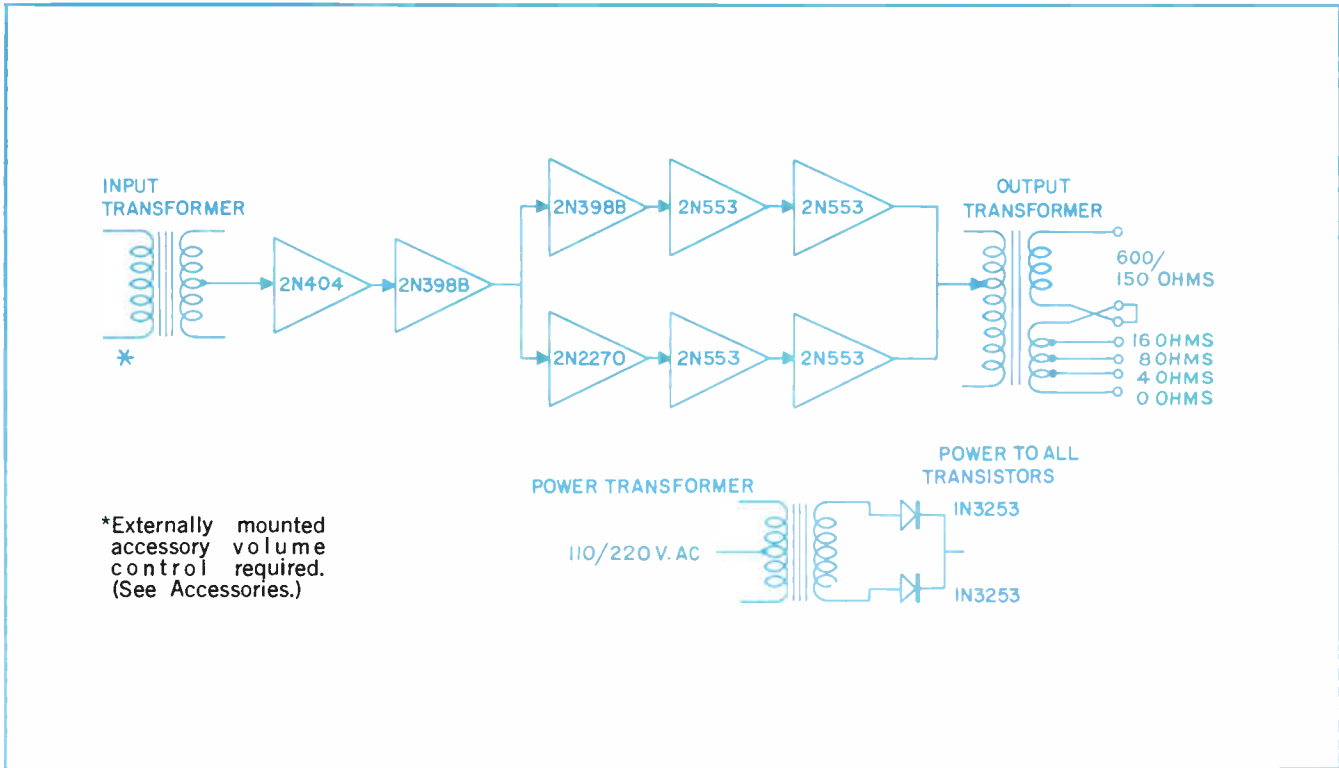

## Ordering Information

Type BA-74 Consolette Monitor Amplifier, less Guide Assembly .....	MI-11661
Type BA-74 Consolette Monitor Amplifier, with Guide Assembly .....	ES-11161

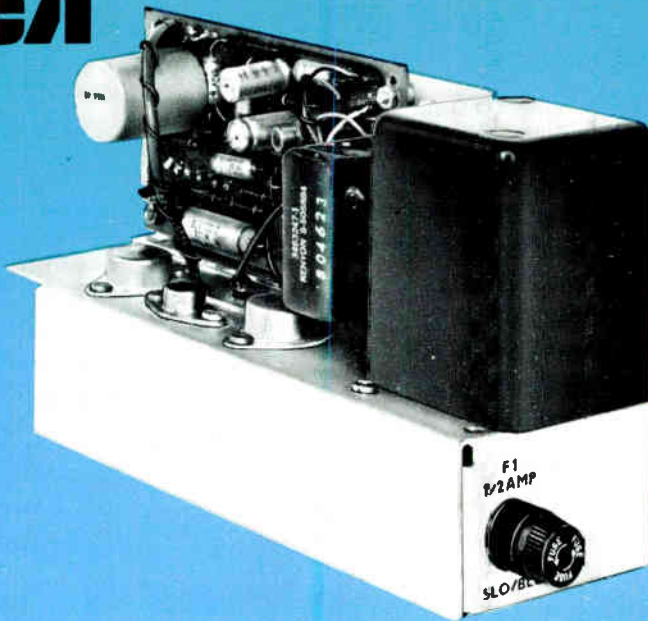

- Automatic Gain Control
- Self-contained regulated power supply
- High gain—full output with mic level input
- One watt (+30 dBm) output with AGC
- Seven watts output without AGC

## Cue/Intercom Amplifier, Type BA-78

### Description

The Type BA-78 Cue/Intercom Amplifier is a compact chassis-mounted equipment featuring solid state circuitry, automatic gain control and self contained power supply. It is designed specifically for plug-in use with the RCA Broadcast transistor consolettes, for intercom and cueing purposes. However, it may also be shelf mounted by use of accessory guide assembly (see *Accessories*).

The principal feature of the BA-78 is its ability to maintain essentially constant output for a wide variation of input level. Automatic gain control action is maintained over a 25 dB range. Output level changes are limited to approximately one dB for each five dB input change over the operating range. The BA-78 amplifier is nominally a one watt amplifier but has an output capability of seven watts with

AGC disconnected.

The BA-78 has a self-contained power supply with taps for 117 or 234 volts 50-60 Hz operation making it easily adaptable to general applications independent of the consolettes. Its relatively high power and high quality output makes it useful with loudspeakers for applications where a communication channel with AGC is specified.

### Specifications

Power Required .....117/234 volts, AC, 50/60 Hz  
 10 watts, no signal, 17.8 watts max. output  
 Source Impedance .....50-150 ohms  
 Input Impedance .....115 ohms below AGC threshold  
 Load Impedance .....50 ohms floating, 8 ohms unbalanced  
 Effective Input Level .....-69 dBm for verge of AGC action  
 -45 dBm handled by AGC action  
 Output Level .....Nominally set at 1 watt average (+30 dBm)  
 by AGC action (7 watts max. with AGC disconnected,  
 100 Hz to 20 kHz)  
 AGC Action .....Approx. 0.5 dB change in output level  
 for each 5 dB change in input level throughout operating  
 range of 25 dB  
 Gain .....100 dB with no gain reduction  
 80 dB with max. gain reduction  
 Frequency Response .....+0, -4 dB, 30 to 20,000 Hz  
 Distortion .....3% at 1 watt output with 10 dB AGC  
 action, 35 Hz to 20 kHz

Noise Level .....At least 60 dB below max. output  
 (with no gain reduction)  
 Dimensions Overall .....4 5/8" high, 2 7/8" wide, 8 1/2" deep  
 (118 x 73 x 216 mm)  
 Weight .....5 lbs. approx. (2.2 kg.)  
 Temperature Range .....-10 to +131°F (-23 to 55°C)  
 Finish .....Cadmium plate

#### Accessories

Guide Assembly for BA-78 Cue Amplifier .....MI-11759-5  
 Type BR-22 Mounting Shelf .....MI-11597

### Ordering Information

Type BA-78 Cue Amplifier, less Guide Assembly .....MI-11662  
 Type BA-78 Cue Amplifier and Guide Assembly .....ES-11162



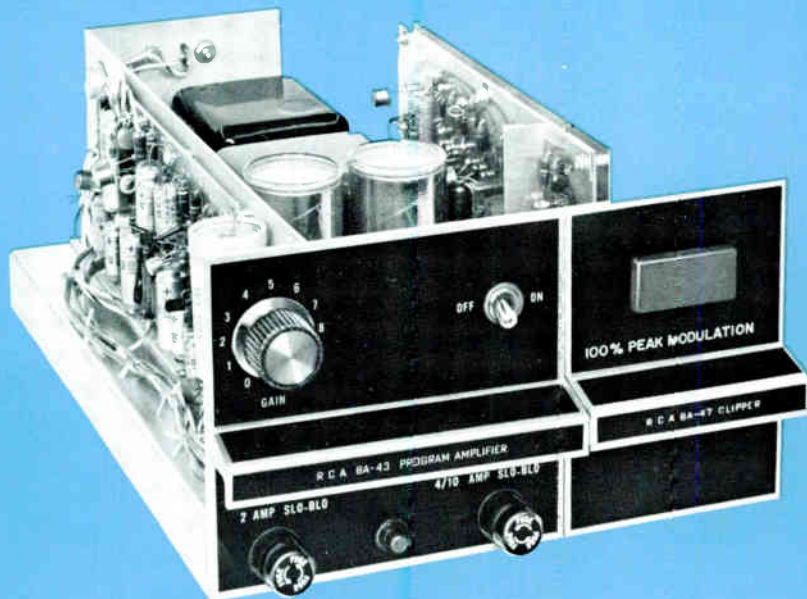

- Prevents transmitter overmodulation with no audible signal degradation
- Built-in standard 75  $\mu$ sec pre-emphasis network
- Highly sensitive monitoring circuit
- Front panel indicator light
- Reliable solid-state circuitry

## RCA Clipper, Type BA-47A

### Description

The RCA Type BA-47A Clipper, MI-11459-A, is a solid state unit that operates in conjunction with the BA-43 Program Amplifier to perform both the functions of pre-emphasis and peak clipping. When this combination is fed from a BA-43/46 Limiter Amplifier, only the signal peaks in the pre-emphasis range which are above 100 percent modulation will be clipped. The unit provides absolute protection against overmodulation with no audible signal degradation.

The BA-47A derives its operating power and the necessary audio signal from the RCA BA-43A Program Amplifier, MI-11454-A. The clipper employs shunt-connected zener diodes that clip

both the positive and negative peaks of the BA-43A audio signal output at a predetermined level (+27 dBm). An attenuator pad at the output of the Clipper is used to yield a +10 dBm output to coincide with the 100 percent modulation level of the transmitter. Other modulation levels are obtainable by changes to the attenuator pad, if desired. Any audio peaks which exceed this level are clipped and the resulting output of the Clipper never exceeds the 100 percent modulation level thus assuring absolute protection against overmodulation in FM broadcasting.

A standard 75  $\mu$ sec pre-emphasis network is incorporated in the input circuitry of the BA-47A, so that the high frequency boost can also be controlled by the clip-

ping action. Also included is a highly sensitive transistorized monitoring circuit.

It is used to monitor the clipping action and provide a visual indication by means of a front panel indicator light. When clipping occurs, this light illuminates with an intensity proportional to the amount of clipping. The visual display enables the operator to monitor the operation at a distance and immediately recognize an abnormal condition.

The Type BA-47A Clipper is designed to mount in the BR-22C or BR-23A rack shelf by means of the accessory Guide Assembly and Cable Assembly Connector MI-11593-5. One BA-47A unit takes up two-tenths of the shelf and a BA-43/47A combination requires one-half of the shelf space.

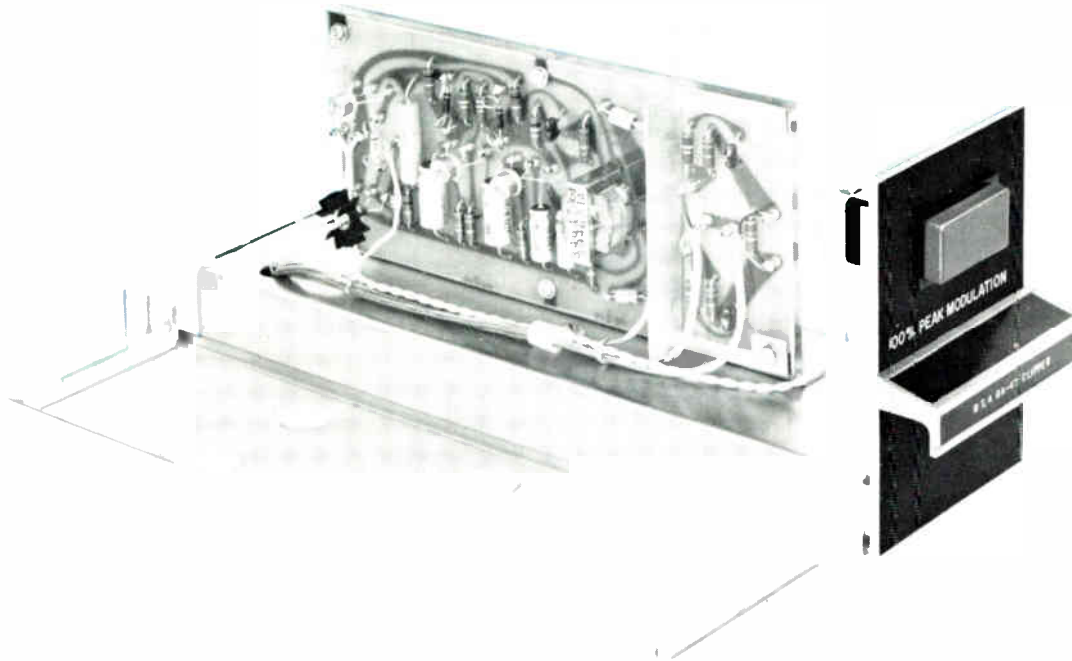

## Specifications

Source Impedance (Balanced)	600/150 Ohms
Input Impedance	Greater than 150 K Ohms (20 to 20,000 Hz)
Load Impedance	600 Ohms
Frequency Response	Standard 75 $\mu$ s preemphasis, 20 to 20,000 Hz
Harmonic Distortion (Below Clipping)	Less than 0.5% (25-20,000 Hz)
Clipping Level	+27 dBm $\pm$ 0.2 dB
Output Level	Maximum output level +27 dBm Factory set for +10 dBm $\pm$ 0.5 dB
Noise Level (20 to 20,000 Hz Bandwidth)	Referred to input -127 dBm
Gain Controls:	
Input	Continuous
Output	Fixed pad board (factory set for +10 dBm output)
Ambient Temperature Range	-20°C to +75°C (-4°F to 167°F)
Clipping Indicator Sensitivity	Less than 0.5 dB (20 to 20,000 Hz)

Power Required	115/230 V AC, 50/60 Hz, 10 Watts
Finish	Black overlay with silver lettering on panel; cadmium-plated, bronze chromate dip chassis
Dimensions (Overall):	
BA-47A Only	4 $\frac{5}{8}$ " high, 3 $\frac{3}{16}$ " wide, 11 $\frac{3}{16}$ " deep (11.75 cm, 8.41 cm, 28.42 cm)
BA-43A Only	4 $\frac{5}{8}$ " high, 5" wide, 11 $\frac{3}{16}$ " deep (11.75 cm, 12.70 cm, 28.42 cm)
Weight:	
BA-47 Only	3 lbs. (1.36 kg)
BA-43 Only	9 $\frac{1}{2}$ lbs. (4.31 kg)

## Accessories

BA-43A Program Amplifier, less Guide Assembly	MI-11434-A
Guide Assembly and Connector for BA-43A	MI-11593-1
Guide Assembly, Cable Assembly and Connector for BA-47A Clipper	MI-11593-5
BR-23 Shelf (including Guide Assembly)	MI-11565

## Ordering Information

Type BA-47A Clipper with Guide Assembly	ES-11131
Type BA-47A Clipper, less Guide Assembly	MI-11459-A



- Full 50-watt rms power output
- Very low harmonic distortion and intermodulation distortion
- Frequency response 20 Hz to 20 kHz
- Stable, solid-state design
- Provisions for remote volume control

## Broadcast Audio Amplifier, Type BA-48A

### Description

The RCA BA-48 Broadcast Audio Amplifier is ideal for program monitor facilities in professional sound studios and broadcast stations. This solid-state amplifier is capable of amplifying phono pickup, tape recorder, telephone-line sources, and the audio channels for AM, FM and video transmitters. It is capable of driving phono cutter heads, multiple speaker loads, multiple tape recording and duplicating equipments and of serving a 70-volt line for sound distribution and reinforcement systems.

The new BA-48 Broadcast Audio Amplifier produces 50 watts (rms) with or without an output transformer, with very low total harmonic and intermodulation distortion. It has a broad frequency response and is temperature

and frequency stabilized. The use of all solid-state components results in a compact design, with low heat dissipation, greatly reduced power consumption and trouble-free, long-life expectancy. The circuit design is simple and straightforward. All circuit functions are accomplished with eleven silicon transistors.

Complete output short-circuit, overload, and open-circuit protection is provided. A direct short occurring between the 8-ohm amplifier output and ground will not damage the amplifier circuitry. On the front panel are two amber "open fuse" indicator lamps.

The total harmonic distortion is less than 0.5% at 50 watts (rms) output from 20 to 20,000 hertz. (30 to 20,000 Hz with accessory output transformers.)

All transformers—power, input and output—are designed with internal shielding to minimize radiation and hum pickup. The BA-48 is stocked less the output transformer, an optional accessory that is readily mounted in the field (see *Accessories*).

Normally, the amplifier gain is controlled with a front panel potentiometer. The BA-48 gain also may be controlled remotely by means of an optional accessory kit (MI-11499) also readily installed in the field.

The BA-48 is small in size and designed for convenient plug-in installation in a BR-22 Mounting Shelf (see *Accessories*). Two amplifiers can be mounted on one shelf.



# Specifications

Power Required .....105-130/210-260 volts, 50/60Hz;  
115 W at full power output

Source Impedance .....600/150 ohms,  
balanced or unbalanced

Input Impedance:  
 Matching .....Unloaded input transformer, input  
impedance higher than source impedance for all fre-  
quencies 20 to 20,000 Hz

Bridging .....220,000 ohms

Load Impedance .....1) Directly into an unbalanced  
8-ohm load; 2) Into a 70-volt balanced line through an  
accessory transformer (MI-141003); 3) Into a balanced  
4, 8, or 16-ohm load through an accessory transformer  
(MI-141002).

Maximum Input Level:  
 Matching .....600 ohms: 0.078 V rms (-20 dBm);  
150 ohms: 0.039 V rms (-20 dBm) terminated

Bridging .....+22 dBm

Input Sensitivity (Full gain; 50 watts at 1000 Hz):  
 Into Input Transformer at 600 ohms .....14 mV (-35 dBm)  
 Into Input Transformer at 150 ohms .....7 mV (-35 dBm)

With Remote Volume Control Kit installed:  
 Into Input Transformer at 600 ohms .....24.5 mV (-30 dBm)  
 Into Input Transformer at 150 ohms .....12.25 mV (-30 dBm)  
 Maximum Volume Control Attenuation .....50 dB

Maximum Gain:  
 Matching .....82.0 ±1 dB (79 dB with remote gain control)  
 Bridging .....40 ±1 dB (36.5 dB with remote gain control)

Frequency Response .....+0, -0.5 dB, 20 to 20,000 Hz  
(+0, -1 dB with output transformer)

Noise Level (20-20,000 Hz bandwidth) .....-124 dBm re-  
ferred to input; -44 dBm referred to output; -91 dBm  
maximum signal to noise ratio

Total Harmonic Distortion .....Less than 0.5%  
(20-20,000 Hz without output transformer, 30-20,000 with  
transformer)

Rated Power Output .....50 watts rms (+47 dBm)

Ambient Temperature .....0 to 55°C max. (32 to 131°F)

Fuses .....3 A. (3AG)

Weight .....20 lbs. less output transformer (9.1 kg)  
26 lbs. with output transformer (11.8 kg)

Dimensions (Overall) .....4<sup>5</sup>/<sub>8</sub>" high, 8<sup>1</sup>/<sub>2</sub>" wide, 11<sup>3</sup>/<sub>16</sub>" deep  
(143 mm, 216 mm, 284 mm)

Mounting .....Plug-in mounting on BR-22 Mounting  
Shelf, requires 1/2 of horizontal shelf space

## Accessories

Output Transformer (4, 8, 16 ohms) .....MI-141002

Output Transformer  
(balanced, 70-volt, 100 ohms) .....MI-141003

Remote Volume Control Kit .....MI-11499

Remote Gain Control Interconnection  
Cable (specify length) .....MI-13395-1

Mounting Shelf (Type BR-22) .....MI-11597D

Guide Assembly .....MI-11593-3

# Ordering Information

Broadcast Audio Amplifier, Type BA-48:  
 Complete with Guide Assembly .....MI-11132A  
 Less Guide Assembly .....MI-11458A



- Completely transistorized
- Full +18 dBm output to line
- Built-in 400 Hz test oscillator
- High level mixing
- Self-contained power supplies
- Step-type attenuators

## RCA Four-Channel Remote Amplifier, Type BN-17A

### Description

The Type BN-17A Portable Remote Amplifier is a four-channel transistor amplifier especially designed for remote broadcast use. Its small size and low power dissipation makes it equally useful in other applications requiring additional or auxiliary mixing facilities. AC or battery operation is available at the flip of a switch. Sixteen single-type silicon transistors employed in the amplifier contribute materially to its dependability and excellent performance characteristics. Four separate balanced input channels and two high-level inputs are provided as well as cue, monitor, a test oscillator and a mixer facility.

#### Self-Contained AC and Battery Power Supplies

The BN-17A is completely self-contained for 115 or 230-volt, 50 or 60 Hz power line or battery operation. Other features include microphone input transformers for all channels, earphone monitoring, line cueing facilities and a

PA gain control. The input facilities can be expanded by interconnecting BN-17A Amplifiers through receptacles at the rear of the unit. Bridge-in and bridge-out receptacles prevent mixer-bus loading.

#### Simplified Controls— +18 dBm Output to Line

All controls are located on the front panel including an illuminated VU meter, power switch, PA gain control, cue switch, four mixer controls, the master control, and monitoring phone jack. The VU meter is used to monitor the output level and to test the battery voltage. Five long-life mercury batteries may be used as a battery power supply for the BN-17A. A separate battery provides illumination for the VU meter. The generous power output capability of the amplifier allows a full +18 dBm delivered to the line after the 6 dB line isolation pad.

#### Functional Styling

The amplifier is a functionally styled

unit in which an etched wiring board including amplifier components and transistors, controls, batteries and alternate AC power supply are all contained in a portable carrying case. The steel case, finished in midnite blue, is provided with a soft leather handle. A 6-foot power cord is located inside the carrying case. The front cover is easily removed from the hinges to serve as a tilt-rest for the amplifier. A recess in the bottom of the case protects the AC power cord, fuse holder, microphone and high-level connectors, the test oscillator switch and the line binding posts. A weather-proof canvas carrying case, MI-11377-A, is available as an accessory.

#### High Level Mixing

High level mixing on all four channels is afforded by the BN-17A Amplifier as shown in the block diagram. Each channel follows a similar path through its corresponding transformer, transistor and attenuator to the gain stage except that

the output of Amplifier 1 is fed through the CUE-Mic 1 switch. When this switch is operated in the CUE position the telephone line from the output of the amplifier is connected to the microphone 1 attenuator. Cue signals from the studio are then amplified through the BN-17A to the headphones. A pad in the cue circuit reduces the cue signal to proper preamplifier input level. The test oscillator uses the positive-feedback principle to make Amplifier 1 oscillate at approximately 400 Hz.

### PA Gain Control

The PA gain control bridges the output of the amplifier and allows the operator to conveniently control the level fed to external PA equipment. Five convenient binding posts are mounted on the rear panel of the amplifier. Two are used for feeding the PA equipment, two for line output, and one for ground.

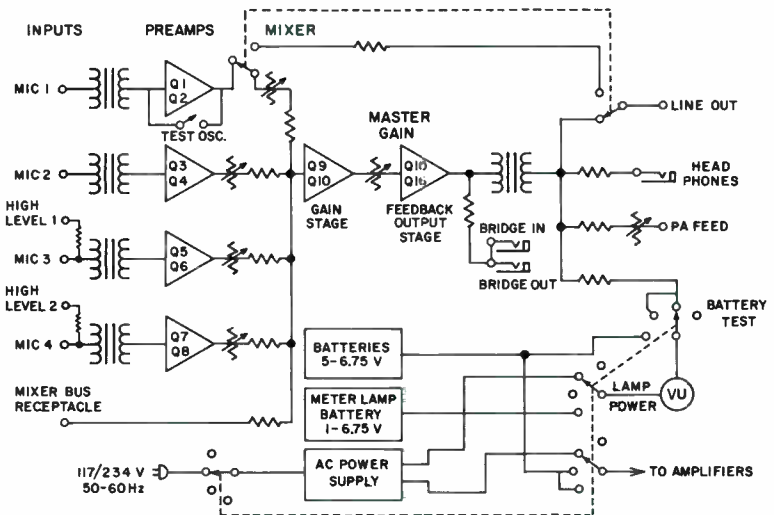

## Specifications

### Power Required:

AC Power .....117 volts/235 volts, 50-60 Hz, 5 watts  
DC Power .....6—Mallory TR-135R, 6.75 volt (not supplied)

### Inputs:

4 Microphone Inputs 37.5/150-250 ohms, balanced transformer (as shipped, strapped for 150-250 ohms)  
2 High-level Inputs, 600 ohms, balanced  
1 Mixer Bus receptacle

Output Level .....+18 dBm at 600/150 ohms, balanced (6 dB isolation provided, shipped strapped for 600 ohms)

PA Feed Output .....-7 dBm maximum, 600 ohms balanced, with adjustable attenuator

Gain .....90 dB  $\pm$ 2 dB

Frequency Response .....+0, -1.5 dB from 30 to 20,000 Hz

Harmonic Distortion .....Less than 0.75% with +18 dBm output master at step 10 and mixer control set for 68 dB gain

Test Oscillator Frequency .....400 Hz (non-sinusoidal)  
Noise Level .....-122 dBm referred to input; equivalent to 72 dB S/N with -50 dB input and +18 dBm output 30 to 20,000 Hz

Input Connections .....Type XLR (space available to mount P type or UA type connectors in place of the XLR type)

Dimensions Overall .....18½" wide, 5½" high, 10½" deep (469 mm wide, 143 mm high, 267 mm deep)

Weight .....18.5 lbs. (8.4 kg)

### Accessories

Weather-proof Canvas Carrying Case .....MI-11377-A

XLR-3-12C Input Cable Connector .....MI-11089-A

Rack-Mounting Panel (for one amplifier) .....MI-11591-1

Rack-Mounting Panel (for two amplifiers) .....MI-11591-2

## Ordering Information

BN-17A Four-Channel Portable Remote Amplifier, complete with transformers, XLR Type connectors (less batteries) .....MI-141400-A

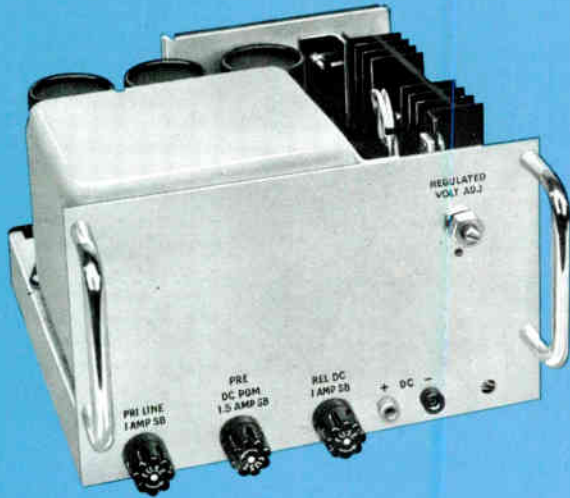

- Regulated 30-volt, 1000 mA source
- Exceptionally low hum level
- Supplies power for 22 BA-72 Preamplifiers or 3 BA-73 Program Amplifiers
- 24-volt relay supply and 6-volt a-c lamp supply provided

## Console Power Supply, Type BX-71

### Description

The Type BX-71 Console Power Supply delivers a well regulated dc voltage for operation of the BA-70 Series preamplifiers and program amplifiers. As many as 22 Type BA-72 Preamplifiers or 3 Type BA-73 Program Amplifiers or any combination of the amplifiers with total current requirement up to 1,000 mA can be operated simultaneously by one BX-71. In addition, an unregulated 24-volt supply can power various relays such as "On-Air" light relays, etc. A 6 volt a-c meter

light supply is also provided. Two outputs for the regulated —30 volts dc are provided; one for preamplifiers, the other for program amplifiers, to achieve maximum de-coupling.

The BX-71 plugs into the BC-7, BC-17, BCM-2 and other consoles or it may be used in custom audio applications with an accessory guide assembly, see *Accessories*. Guide assemblies with mating receptacles may be attached to a Type BR-22 Shelf.

The power supply operates on any

115/230 volt, 50/60 hertz a-c line. Fuses, a dc voltage control, and two pin jacks for checking the —30 volt supply are located on the front panel.

The 30-volt power supply consists of a full-wave, bridge rectifier, capacitor-input filter, and a five transistor regulator. Three zener diodes supply a reference voltage which is compared with the output voltage. The output voltage is adjustable to maintain —30 volts under varying loads up to 1,000 mA capacity.

### Specifications

Power Requirements .....100 to 130, or 200 to 260 volts, AC, 50/60 Hz, with taps at 105, 115, 125, 210, 230 and 250 volts  
 Power Output .....—30 volts at 1 amp., regulated; 24 V. at 0.56 A., unregulated, 6 V. AC at 1.5 A.  
 Regulation .....0.35% no load to full load  
 Ripple .....0.15 mV max. on 30 volt supply  
 Fuse .....1.5 and 1 ampere, slo-blow  
 Transistor & Diode Complement:  
 1—2N270, 2—2N456, 2—2N526, 1—2N1090, 6—1N3253  
 2—1N751, 1—1N752  
 Mounting .....Plug-in for consoles; as ES-11163, mounts in BR-22 and requires 2/5 of shelf space  
 Dimensions Overall .....87/8" by 7 1/2" by 4 5/8" (225 x 191 x 118 mm)

Weight .....14 lbs. (6.35 kg.)  
 Finish .....Cadmium plate with clear chromate dip

#### Accessories

Shelf Guide Assembly for BX-71 Power Supply .....MI-11759-4  
 Type BR-22 Shelf (for 2 power supplies) .....MI-11597

### Ordering Information

Type BX-71 Console Power Supply less Guide Assembly .....MI-11663  
 Type BX-71 Console Power Supply with Guide Assembly .....ES-11163

3VB





- Contemporary styling
- Especially designed for the audio studio
- Sturdy construction
- Facilitates installations
- Provides ample, orderly storage

## RCA Studio Furniture

### Description

A new line of studio furniture designed especially to meet audio requirements is now available from RCA. A series of tables, turntable cabinets, cartridge tape recording equipment cabinets and storage racks in new contemporary styling complements the present line of BR Cabinets, racks, panels and other accessories. The new line of equipment is designed

to increase station efficiency, facilitate installations, and provide ample, orderly storage space.

Each item of furniture has been semi-customized to meet specific needs in the studio. Tables with metal wire raceways for audio console equipment and their attendant wiring; one, two or three unit turntable cabinets providing new ease of operation for the disc jockey, and cabinets and storage racks providing new

ease in film handling—each creates a neat, tidy operations area for a particular task.

The equipment line is structurally sturdy and designed for years of service. Square steel framework, sheet steel and high pressure laminate are the choice of materials for the new furniture. Satin chrome finish and colors to match other RCA studio equipment provide a uniform styling for the new studio units.



Tables with movable wire raceways are ideal for mounting audio consoles and other studio equipment. Convenient levelers, left-center-right mounting provisions for the raceways, protective 1-inch aprons are construction features.

## Specifications

Construction .....	Steel and HPL Board
Finish .....	Walnut and light gray with satin chrome on metal parts
Top:	
MI-141030-1 .....	36" x 44" (91.44 cm x 111.76 cm)
MI-141030-2 .....	36" x 64" (91.44 cm x 222.56 cm)
MI-141030-3 .....	36" x 84" (91.44 cm x 273.36 cm)
Legs .....	1¼" x 1¼" x 27½" (3.18 cm x 3.18 cm x 69.35 cm)
Levelers .....	4, each 1¼"
Table Height .....	29" (73.66 cm)
Wire Raceway .....	18" wide, 12" deep, 27½" high (45.72 cm, 30.48 cm, 69.35 cm)
Weight (approximate):	
MI-141030-1 .....	35 lbs. (16 kg.)
MI-141030-2 .....	45 lbs. (20.5 kg.)
MI-141030-3 .....	65 lbs. (29.5 kg.)

## Ordering Information

44" Table .....	MI-141030-1
64" Table .....	MI-141030-2
84" Table .....	MI-141030-3

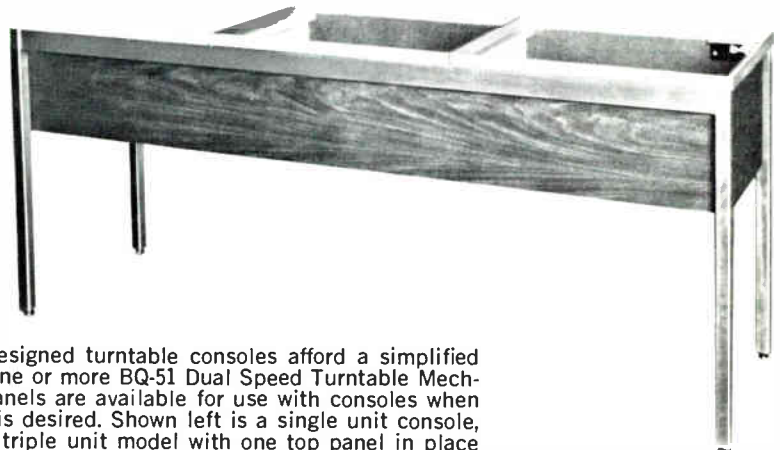

Functionally designed turntable consoles afford a simplified mounting for one or more BQ-51 Dual Speed Turntable Mechanisms. Top panels are available for use with consoles when flat work area is desired. Shown left is a single unit console, and at right a triple unit model with one top panel in place to provide work area.

### TURNTABLE CONSOLES

## Specifications

Construction .....	Steel and HPL Board
Finish .....	Walnut and light gray with satin chrome on metal parts
Top:	
MI-141026-1 .....	23 x 19½" (58.42 cm x 48.58 cm)
MI-141026-2 .....	46 x 19½" (117.16 cm x 48.58 cm)
MI-141026-3 .....	69¾" x 19½" (175.74 cm x 48.58 cm)
Legs .....	1¼" x 1¼" x 27" (3.18 cm x 3.18 cm x 69.35 cm)
Levelers .....	4, each 1¼"
Turntable Console Height .....	29" (73.66 cm)
Turntable Blank Panel .....	23" x 19½" (58.42 cm x 48.58 cm)

### Weight (Approximate):

MI-141026-1 .....	25 lbs. (11.35 kg.)
MI-141026-2 .....	40 lbs. (18 kg.)
MI-141026-3 .....	60 lbs. (27 kg.)
Turntable Blank Panel .....	6 lbs. (2.7 kg.)

## Ordering Information

Turntable Console for one BQ-51B Dual Speed Turntable Mechanism .....	MI-141026-1
Turntable Console for two BQ-51B Dual Speed Turntable Mechanisms .....	MI-141026-2
Turntable Console for three BQ-51B Dual Speed Turntable Mechanisms .....	MI-141026-3
Turntable Blank Panel .....	MI-14127



Convenient tape recorder console shown with additional stacking unit on top. Console is designed to house one Tape Cartridge Playback Unit and one Record Amplifier or two Playback Units. The stacking unit doubles the console area for additional playback/record units. Dual consoles and dual stacking units, as shown on front page of catalog are also available.

## CARTRIDGE TAPE EQUIPMENT CABINETS

### Specifications

Construction .....Steel and HPL Board  
 Finish .....Walnut and light gray with satin chrome on metal parts

#### Dimensions (Overall):

Single Floor Mount Cabinet .....21" wide, 15" deep, 29" high (53.34 cm, 38.10 cm, 73.66 cm)

Double Floor Mount Cabinet .....42" wide, 15" deep, 29" high (106.68 cm, 38.10 cm, 73.66 cm)

Single Floor Mount Cabinet with additional top cabinet .....21" wide, 15" deep, 42" high (53.34 cm, 38.10 cm, 106.68 cm)

Double Floor Mount Cabinet with additional top cabinet .....42" wide, 15" deep, 42" high (106.68 cm, 38.10 cm, 106.68 cm)

#### Weight (Approximate):

Single Floor Mount Cabinet .....25 lbs. (11.3 kg.)

Double Floor Mount Cabinet .....40 lbs. (18 kg.)

Single Floor Mount Cabinet with additional top cabinet .....40 lbs. (18 kg.)

Double Floor Mount Cabinet with additional top cabinet .....55 lbs. (25 kg.)

## Ordering Information

Cartridge Tape Equipment Cabinet, single floor model .....MI-141032

Cartridge Tape Equipment Cabinet, double floor model .....MI-141033

Single Top Cabinet .....MI-141034

Double Top Cabinet .....MI-141035

## TAPE CARTRIDGE STORAGE UNITS

### Specifications

Construction:	Revolving Case on Pedestal	Wall Mounting Storage Case
Case .....	High Pressure laminate	High Pressure laminate
Compartments .....	Hard Board	Hard Board
Pedestal .....	Steel	—
Finish .....	Walnut and light gray. Satin Chrome pedestal	Walnut and light gray

Storage Capacity .....204 tape cartridges 100 tape cartridges

#### Dimensions:

Case (On Side) .....30" wide, 18" high 44" wide, 33" high  
 (76.20 cm, (111.76 cm,  
 45.72 cm) 83.82 cm)

Case (Depth) .....12" (30.48 cm) 6" (15.24 cm)

Weight (Approx.) .....50 lbs. (22.6 kg.) 40 lbs. (18 kg.)

### Ordering Information

Tape Cartridge Storage Units:

Revolving Case on Pedestal .....MI-141037

Wall Mounting Storage Case .....MI-141038



MI-141037



MI-141038



Commercial Electronic Systems Division  
Front and Cooper Streets, Camden, New Jersey, U.S.A. 08102

**RCA** Broadcast  
Equipment

World Radio History



- Three-speed, heavy duty, ball-thrust platter
- Flutter-free quiet performance
- Simple rugged construction—dependable trouble-free operation
- Heavy-duty synchronous motor
- Easier, more positive cueing

## RCA Three-Speed Broadcast Turntable, Type BQ-50

### Description

The BQ-50 Three-Speed Turntable is designed to meet broadcast precision requirements of fine music stations, reproducing disc recordings at speeds of 33 1/3, 45, and 78 RPM. The 16-pound unit is available as a mechanism for mounting in custom-built arrangements or in RCA turntable console or cabinet.

The BQ-50 is powered by a heavy duty synchronous motor. The drive system

features a neoprene idler wheel transmitting power direct from the stepped capstan on the motor shaft to the inside platter rim. Acceleration is extremely fast, average results are 1/16 revolution of platter at 33 RPM; 1/10 revolution at 45 or 1/2 revolution at 78 RPM.

Oilite bronze bearings are employed throughout for longer maintenance free service. The solid cast aluminum platter has a black felt cover; and the base has

a midnight blue finish. Platter off-set permits more compact turntable arrangement and free movement of the tone arm when installed side-by-side. Shock mounts isolate motor vibration for flutter-free quiet performance. The turntable has a motor on-off switch light and responsive speed control lever that permits speed change while the platter is in motion. When the lever is in neutral the platter spins freely for hard to cue records.

### Specifications

Turntable Speed	33 1/3, 45, and 78 RPM
Rumble	-36 dB down (ref. level 1.4 cms at 100 Hz)
Wow or Flutter	Less than 3/10 of 1%
Motor	1/70 h.p., 1800 r/min at 50 Hz 1/70 h.p., 1500 r/min at 60 Hz
Power Supply	105-125 V, 50/60 Hz, single phase
Power Consumption	40 Watts
Turntable Diameter	12 inches (30.48 cm)
Chassis Dimensions	15 1/2 x 15 1/2 inches (39.37 cm x 39.37 cm)
Depth Requirement Below Chassis	6 1/2 inches (16.51 cm)
Weight:	
Platter only	5 1/2 lbs. (2.5 kg)
Entire Unit	16 lbs. (7.25 kg)
Finish	Midnight Blue

### Accessories

Turntable Console	MI-141026-1/2/3 (Requires 1, 2 or 3 MI-141027 Blank Top Covers)
Turntable Cabinet	MI-11809-A (Requires one adapter Plate, MI-141005)
12-inch Tone Arm (less pickup head)	MI-11894-B
16-inch Tone Arm (less pickup head to mount on MI-141005)	MI-11895
Type BDR-1 Turntable Pickup (includes pickup head)	MI-11473
BA-26B Pickup Equalizer-Preamplifier	MI-11436-C
BA-36 Stereo Pickup Equalizer-Preamplifier	MI-11441-B

### Ordering Information

Type BQ-50 Three-Speed Turntable, 60 Hertz	MI-141004
Type BQ-50A Three-Speed Turntable, 50 Hertz	MI-141004-A

7TB





- Precision, 2-speed rim-drive mechanism for 33 $\frac{1}{3}$  and 45 rpm records
- Individual rubber idler wheels for each speed
- Compact cabinet houses BA-26/36 equalizer preamplifier
- Provision for an additional tone arm for greater versatility
- Smooth and rapid starts

## RCA 12-Inch Dual Speed Turntable, Type BQ-51D/E

### Description

The RCA BQ-51D/E Dual Speed Turntable fulfills the broadcaster's need for a high-quality turntable mechanism to accommodate commercial disc recordings up to 12 inches in diameter at speeds of 33-1/3 and 45 rpm. The BQ-51D/E is available as a mechanism for mounting in custom-built arrangements. It may also be obtained as a complete assembly with a styled cabinet, MI-11809-A.

Space is provided on the top panel of the BQ-51D/E for mounting one or two standard low impedance, reluctance-type pickups that conform to EIA standards.

There are three RCA tone arms suit-

able for the BQ-51D/E Turntable: two 12-inch and one 16-inch. For highest stereo-record (12 inch) quality, the Type BDR-1 Arm is recommended (see *Accessories* on next page).

The BQ-51D/E Dual Speed 12-inch Turntable is a 2-speed rim-drive mechanism, utilizing a hysteresis synchronous motor. It is available for 60 hertz or 50 hertz operation and a 2-position speed selector switch is provided on the turntable assembly. An "Off-On" selector control operates a mercury motor switch and simultaneously engages or disengages the rubber idler wheels. This fea-

ture relieves the idlers from pressure when set to the "Off" position.

The metal cabinet assembly, MI-11809-A of functional design, affords a simplified mounting for the drive assembly mechanism. A hinged door is located on the front of the cabinet to permit ready access to the interior. A sloped bracket is provided within the cabinet to mount the BA-26 and BA-36 Series Equalizer Preamplifiers. Studio furniture is also available which provides mounting for one, two or three turntables (see *Accessories* on next page).



Fabricated of cast aluminum, the BQ-51 turntable platter turns in an almost-frictionless bearing lined with a sintered bronze bushing impregnated with oil for long-term lubrication. A hardened steel ball-bearing, at the bottom of the bearing "well", takes the thrust of the spindle and thus, the weight of the platter. A foam-rubber belt, around the outside of the plat-

ter, damps unwanted resonances while resilient motor mounts isolate motor rumble from the turntable. To prevent idler flat spots, the BQ-51 Turntable disengages the idlers from both the rim and the motor shaft during "off" periods with a simple, trouble-free linkage between the on-off switch and the drive system.

## Specifications

Turntable Speed .....	33 $\frac{1}{3}$ and 45 rpm $\pm$ 0.3%
Rumble .....	40 dB down (ref. level 1.4 cm/s at 100 Hz)
Wow or Flutter:	
At 33 $\frac{1}{3}$ rpm .....	0.1% of mean speed
At 45 rpm .....	0.1% of mean speed
Motor .....	1/100 h.p., 1800 rpm at 60 Hz or 1/125 h.p., 1500 rpm at 50 Hz
Power Supply.....	105-125 V, 50/60 Hz single phase
Power Consumption.....	40 W
Power Cord.....	8 ft. long (2.44 m)
Turntable Diameter .....	12" (305 mm)
Hub and Spindle Diameter:	
Hub for 45 rpm records .....	1.5" (43.1 mm)
Spindle for 33 $\frac{1}{3}$ records.....	0.2835" (72 mm)
Overall Dimensions:	
Turntable Drive Unit.....	22" wide, 18 $\frac{1}{8}$ " deep (559 mm x 459 mm)—height below top surface motor board, 9" (228 mm)—height above surface motor board, 1 $\frac{1}{2}$ " (38 mm)
Cabinet.....	23 $\frac{1}{8}$ " wide, 19 $\frac{1}{8}$ " deep and 29" high (586 mm x 460 mm x 736 mm)

Weight:	
Turntable Drive Unit.....	31 lbs. (14.06 kg)
Cabinet.....	47 lbs. (21.32 kg)
Motor Board Finish .....	Aluminum epoxy paint

## Accessories

Metal cabinet assembly to house turntable mechanism .....	MI-11809-A
Studio Furniture (Walnut Finish)	
Turntable Console, for one turntable .....	MI-141026-1
Turntable Console, for two turntables .....	MI-141026-2
Turntable Console, for three turntables .....	MI-141026-3
Broadcast Studio Turntable Pickup,	
Type BDR-1 (with pickup head and stylus) .....	MI-11473
12" Tone Arm (less pickup head) .....	MI-11894-B
16" Tone Arm (less pickup head).....	MI-11895-A
Universal Cartridge (less stylus).....	MI-11865
0.7 Mil Diamond Stylus (for use with Universal Cartridge).....	MI-11866-7
BA-26B Pickup Equalizer-Preamplifier .....	MI-11436-C
BA-36A Stereo Pickup Equalizer-Preamplifier .....	MI-11441-B
220 Volt Transformer Kit.....	MI-41605

## Ordering Information

BQ-51D Dual Speed Turntable Mechanism for 60 hertz operation (less Cabinet, Tone Arm and Pickup Heads) .....	MI-11810-D
BQ-51E Dual Speed Turntable Mechanism for 50 hertz operation (less Cabinet, Tone Arm and Pickup Heads) .....	MI-11810-E



- Lightweight—minimum distortion
- Accurate stylus force adjustment
- Track properly at all times
- Plug-in pickup cartridges

## RCA Lightweight Tone Arms

### Description

The RCA Lightweight 16 and 12-inch Tone Arms, MI-11895-A and MI-11894-B, and the Universal Cartridge and Stylus are designed to fulfill the need for a high quality pickup combination for playing stereo and mono fine-groove records as well as transcriptions and 78 RPM records. The tone arms are especially designed to operate with the RCA BQ-50 and BQ-51 Turntables.

The advanced tone arm design incorporates a 3-terminal pickup socket, with free floating collets, to accept the plug-in MI-11865 Universal Cartridge. This smooth-action socket provides "Instant Cartridge Change" capability. Facilities for accepting pickups which mount on standard 1/2-inch mounting centers have also been included.

#### RCA Stylus Saver

Both models of the tone arm contain the RCA "Stylus Saver" adjustment which limits the vertical downward travel of the arm so that the cartridge stylus engages only the record groove and never reaches the top of the turntable, thus preventing accidental damage to the

stylus, should the arm be knocked off the edge of the record.

#### Design Features

By careful design, tone arm resonance is well outside the operating frequency range of the system. Distortion due to tracking error in the arm and pickup has been reduced to a minimum. The anti-friction vertical and lateral pivots and low mass allow the tone arms to track properly on warped and eccentric records.

The arms are hinged at the pivot center to allow easy access to the pickup and wiring on the underside. An adjustable counterweight controlled by an accessible thumb nut at the rear of the arm provides accurate stylus force adjustment.

#### Universal Pickup Cartridge

The RCA Universal Pickup Cartridge and Replaceable Stylus, MI-11865 and MI-11866, provide a fully compatible unit for reproducing stereophonic and monophonic phonograph records in broadcast studios. It utilizes the moving magnet system which makes possible superior performance and simplified

stylus replacement. The MI-11865 cartridge is completely housed in a molded plastic case. The MI-11866 stylus may easily be removed and replaced without use of tools. This eliminates the need for ever sending the pickup out for repairs.

The cartridge proper is a three terminal device. The center pin is common and the outside pins are the left and right stereo outputs. In stereo use the head is connected in the usual manner with the left output going to the left equalizer and the right output to the right equalizer. In monophonic use, the left and right outputs are paralleled. The cartridge plugs into the MI-11894-B (12-inch) or MI-11895-A (16-inch) tone arms, or may be mounted on arms with standard 1/2-inch mounting centers. It features low distortion, and excellent frequency response and very good channel separation. The diamond stylus and low tracking force insure long life for both the stylus and recordings.

Plug-in stylus assemblies, readily identified by their color are available in three types as shown in the table under specifications.

# Specifications

## Tone Arms

Tracking Error, 16-inch Record .....Less than 4°  
 Pivot Bearings .....Anti-resonant bearings in vertical  
 and horizontal planes  
 Tone Arm Head Receptacle .....Quick-lock, plug-in type  
 Construction of Arm .....Aluminum casting  
 Length of Arm:  
 MI-11895-A .....16¾" (425 mm)  
 MI-11894-B .....12" (305 mm)  
 Height of Arm .....Adjustable  
 Weight (arm assembly, etc.):  
 MI-11895-A .....2 lbs. (906 gm)  
 MI-11894-B .....1½ lbs. (679 gm)  
 Mounting:  
 MI-11895-A .....Approx. 12" (305 mm) from spindle center  
 MI-11894-B .....Approx. 8" (203 mm) from spindle center  
 Leads .....3-conductor and shield

## Universal Pickup Cartridge

Inductance .....400 mH  
 DC Resistance .....280 Ohms  
 Output Voltage at 1000 Hz, 5 cm/sec .....5 mV  
 Channel Separation .....20 dB min. @ 1000 Hz  
 Recommended Load Impedance .....47,000 Ohms  
 Number of Terminals .....3  
 Dimensions (overall) .....1½" long, ¾" wide, ⅛" high  
 (33 mm, 19 mm, 17 mm)  
 Weight .....10.5 grams  
 Mounting .....Plug-in (standard EIA mounting centers)  
 Recommended Stylus Force .....(see table)

## Accessories

BA-36A Stereo Equalizer-Preamplifier .....MI-11441-B  
 BA-26B Equalizer-Preamplifier .....MI-11436-C



Stylus MI Number	Tip Radius	Function	Tracking Force	Color Code
11866-7	0.7 mil	Stereo records	4 gm	Black
11866-10	1.0 mil	45 RPM and LP records	4 gm	Red
11866-25	2.5 mil	Transcription and 78 RPM records	8 gm	Green

# Ordering Information

16-Inch Tone Arm (less pickup) complete with  
 arm rest and mounting hardware .....MI-11895-A  
 12-Inch Tone Arm (less pickup) complete with  
 arm rest and mounting hardware .....MI-11894-B  
 Pickup Cartridge (less stylus) .....MI-11865  
 Stereo Stylus Assembly 0.7 mil (black) .....MI-11866-7  
 Mono Stylus Assembly 1.0 mil (red) .....MI-11866-10  
 ET & 78 RPM Stylus Assembly 2.5 mil (green) .....MI-11866-25



- Integrated design for optimum performance
- Vertical and lateral balanced system
- Excellent tracking, anti-skating available
- Selection of low mass high compliance styli
- Set down limit adjustment

## Broadcast Turntable Pickup, Type BDR-1

### Description

The RCA Type BDR-1 twelve inch Pickup System with a nominal 15-degree cartridge and stylus is designed for highest quality disc reproduction. It is intended for use with broadcast type turntables such as the RCA Type BQ-51 Turntable.

The BDR-1 incorporates an extremely light weight, and therefore low inertia arm, but is sufficiently rugged for broadcast use. This has been achieved primarily by the "integrated" design in which the arm, pickup cartridge and stylus are designed together as a system.

The pickup incorporates a very low mass moving magnet cartridge with high compliance interchangeable stylus assemblies. The arm parameters have been optimized and factory adjusted to suit this cartridge. There are no balancing adjustments that the customer must make and therefore none to get out of order. An adjustment in stylus force has been intentionally made available to the customer who may have special requirements.

The integrated pickup features a low

mass vertical and laterally balanced arm. Precision low friction instrument bearings are used throughout. The low resonance frequency is approximately 10 hertz which assures tracking of warped discs. (Resonances in the audible range are highly suppressed by rigid construction.) A unique spring system (available optionally) provides correct anti-skating force without weights, threads or other similar unreliable adjustments. Tracking force is preadjusted to optimum value, but may be varied over a limited range by the user.

The moving magnet cartridge accommodates one of several stylus assemblies. Elliptical styli provide lowest distortion, wide range reproduction of stereo discs at 1.50 and 2.50 gram tracking forces. Spherical styli of .0007, .001 and .0025-inch radius are available to suit individual requirements. The cartridge has an ingenious built-in stylus guard that prevents damage to stylus tip in case the arm is accidentally dropped.

The cartridge is a four terminal de-

vice. In monophonic use, the left and right outputs are paralleled. In stereo use, the head is connected in the usual manner with left outputs going to the left channel and the right outputs to the right channel. Provision is made for the insertion of an electrical signal used for testing the system, including the cartridge, wiring, equalizer, and associated equipment. This feature eliminates use of test records except in the case where the physical condition of the stylus assembly must be checked. The pickup cartridge features low distortion and excellent frequency response with exceptional channel separation.

Quick-change stylus assemblies are readily identified by color codes and are available in several types as shown under *Ordering Information*. They may be conveniently inserted or removed without the use of tools. Styli assemblies are weighted to provide the proper tracking force for each type of stylus used; therefore, readjustment of balance is unnecessary when changing from micro groove to 78-rpm records or electrical transcriptions.



## Specifications

### Pickup Arm

Tracking Force of Pickup System .....	Factory adjusted 1.5 grams $\pm$ 0.1 gram (for 0.2 x 0.7 mil stylus)
Tracking Error .....	Less than 1½°
Bearing .....	Instrument precision anti-resonant ball bearings in vertical and horizontal planes
Heads .....	Changeable pickup heads accommodating quick change styli
Styli Assemblies .....	Quick change type
Arm Construction .....	Anodized aluminum and tooled stainless steel & brass
Length of Arm .....	12" (305 mm)
Weight (Arm Assembly, etc.) .....	13 oz. (368 g)
Mounting .....	Approx. 8" (203 mm) from spindle center
Cable Harness .....	7 conductor and shield

### Cartridge Assembly (Moving Magnet Type)

Typical Trackability (at 1½ grams) .....	400 Hz—22 cm/sec or greater 1,000 Hz—30 cm/sec or greater 5,000 Hz—30 cm/sec or greater 10,000 Hz—22 cm/sec or greater
Frequency Response .....	20 to 20,000 Hz
Vertical Tracking Angle .....	15 degrees, nominal
Output Level at 1 kHz .....	3.5 mV per channel at 1,000 Hz @ 5 cm/sec peak velocity
Channel Balance at 1 kHz .....	Output from each channel within 1½ dB
Channel Separation .....	More than 25 dB at 1,000 Hz; more than 17 dB from 500 to 10,000 Hz
Tracking Force .....	1.5 grams to 2.5 grams
Load Impedance .....	60 kohms optimum; 47 kohms minimum
Inductance .....	720 millihenries
DC Resistance .....	630 ohms (approximately)
Terminals .....	4 terminal pins
Mounting .....	Standard ½ inch (12.7mm) mounting centers
Weight .....	4.5 grams

### Accessories

BA-36 Stereo Equalizer Preampifier .....	MI-11441
BA-26 Equalizer Preampifier .....	MI-11436
BQ-51 Turntable .....	MI-11810
BQ-50 Turntable .....	MI-141004

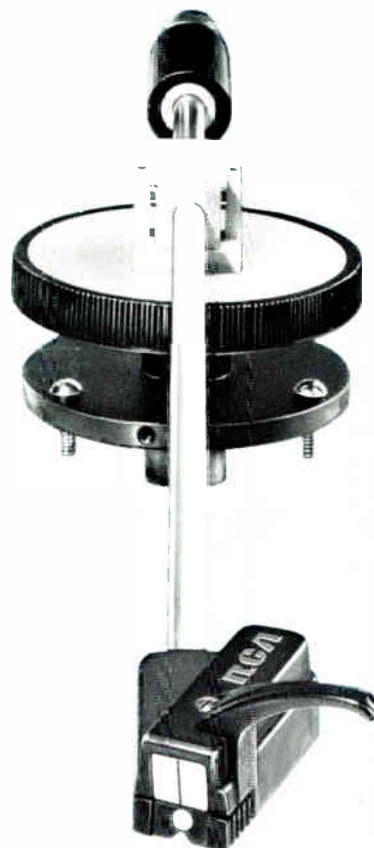

New light weight pickup arm incorporates low mass moving magnet cartridge with high compliance interchangeable stylus assemblies.

## Ordering Information

12-Inch Integrated Pickup Arm and Cartridge:	
With anti-skate feature .....	MI-11473
Without anti-skate feature .....	MI-11473-A
Pickup Cartridge (less stylus) .....	MI-11472
Stylus Assembly (Specify as follows):	
0.2 x 0.7 mil Bi-Radial Diamond Tip, 1.5 gram tracking (Color Coded Gold) .....	MI-11474-2
0.4 x 0.7 mil Bi-Radial Diamond Tip, 2.5 gram tracking (Color Coded Silver) .....	MI-11474-4
0.7 mil Diamond Tip Radius for Stereo Records, 1.5 gram tracking (Color Coded Black) .....	MI-11474-7
1.0 mil Diamond Tip Radius for 45 rpm and Mono Records, 2-gram tracking (Color Coded Red) .....	MI-11474-10
2.5 mil Diamond Tip Radius for Transcriptions and 78 rpm Records, 2.5 gram tracking (Color Coded Green) .....	MI-11474-25



- Designed for unattended, long-duration logging and monitoring
- Carefully crafted basic design provides highest reliability
- Modular, solid-state heavy duty components
- Lower tape cost
- Large reel capacity—up to 307 hours with no reel turnover

## RCA Program Logger, Type RT-19A

### Description

The Type RT-19A Program Logger a tape recorder designed for continuous long-duration recording, records and plays in both directions with equal performance. The logger is especially useful with broadcast automation systems where it can serve as a complete and accurate program log and monitor to assure compliance with FCC regulations.

Since the basic mechanism is 4-track, a broadcast station with AM, FM and TV facilities can record the AM station on Track 1, FM on Track 2, TV on Track 3 and the 4th track can be used to record external time signals. It is also possible to superimpose time signals from the external source over the respective program as it is recorded. The level of the time signals is generally reduced to at least 10 dB below the program level.

The modular solid-state electronics provides amazingly clear recording, high reliability and long, unattended operation. Even at the slowest speed of 5/16 IPS, recorded voices are clear and sharp. The

signal-to-noise ratio is better than 43 dB, flutter is low, and response is within 3 dB from 200 to 2700 Hz.

The RT-19A is simple to operate. Accessibility is rapid; no point on the tape is more than 1½ to 3 minutes away. All electronic adjustments and operation are readily accessible from the front. It boasts such features as straight-line threading, automatic tape lifters, interlocked controls which make it impossible to break or spill tape by improper control sequences, and editing and cueing versatility.

The modular, solid-state electronics provide quick plug-in replacement of any components requiring service. Extremely high reliability in the transport is inherent in the basic design. The heavy-duty components and careful construction more than meet the continuous heavy duty recording functions demanded of the equipment.

The RT-19A uses standard 10½-inch NAB reels and hubs, or EIA 7-inch plastic reels. Lowest cost tape of 1 mil plastic

base will provide nearly 154 hours of continuous recording and reproducing at a tape cost of less than 4 cents per hour. This means that six 24-hour days can be monitored for less than a dollar per day on one roll of tape. If extremely long unattended hours of recording are desired, 7200 feet of tape on an NAB hub will provide over 300 hours of continuous logging (twelve 24-hour days, or seventeen 18-hour days) at a cost well under 5 cents per hour.

The RT-19A Automated Tape Recorder is designed for rack or console mounting or can easily be incorporated in custom audio installations demanding either horizontal or vertical mountings. Several models are available to provide the utmost flexibility. The RT-19A makes four tracks available on quarter-inch tape, which may be used in a variety of ways. One channel of communication may be recorded on each of the four tracks in sequence, or four communications channels may be recorded simultaneously.

## Specifications

Head and Track Configurations .....4 track, 1 channel, 2 channel, 4 channel and multiples thereof. Erase facility included on special order.

Overall Frequency Response .....15/16 IPS:  $\pm 3$  dB, 200 Hz -8 kHz; 15/32 IPS:  $\pm 3$  dB, 200 Hz -4 kHz; 5/16 IPS:  $\pm 3$  dB, 200 Hz -2.7 kHz. Adjustable level and equalization for each head, as well as bias and calibration adjustments

Signal-to-Noise Ratio .....43 dB min.

Total Unattended Time .....204 hours 48 min. at 15/32 IPS w/triple-play tape; 307 hours 12 min. at 5/16 IPS w/triple-play tape

Inputs ("XL" connectors) .....One per channel, -15 dBm sensitivity, 100 K bridging. Provision for various plug-in units, such as 200-ohm adjustable 30-60 dB mic. preamplifier, balanced line bridging or matching transformers, etc.

Outputs ("XL" connectors) .....0, +4 or +8 dBm into 600 ohm balanced or unbalanced (per strapping). +25 dBm undistorted capability. Monitoring jacks

Distortion (circuit induced) .....Less than 0.25% THD at +8 dBm

Power Requirements .....117 volts AC, 50-60 Hz, approximately 100 Watts. Regulator stabilizes bias and signal levels against power line fluctuations

Tape Counter .....4 digit resettable, returns toward zero on reverse tape travel to reference measurements to supply reel

Size and Weight .....Transport 19" x 15 $\frac{3}{4}$ ", 47 lbs. (482 x 400 mm, 21 kg)  
Electronics 19" x 5 $\frac{1}{4}$ ", 9 lbs. (482 x 133 mm, 4 kg) (4-channel models require 2 electronics chassis)

Reel Size .....10 $\frac{1}{2}$ " NAB, or 7" EIA reels. Independent torque switches allow intermixed sizes

Tape Size and Tape Guides ..... $\frac{1}{4}$ " (6 mm) wide,  $\frac{1}{2}$  mil to 1 $\frac{1}{2}$  mil thickness, acetate or polyester base. Non-magnetic, close tolerance guides provide accurate quarter-track guidance

Tape Speeds and Playback Timing Accuracy .....Speed 15/16 IPS, 15/32 IPS, 5/16 IPS. Accuracy within 1%

Wow and Flutter (rms max.) .....1%

Fastwind Time .....3600 feet (1097 m), approx. 100 seconds

Start Time .....Less than 1/10 sec.

Remote Control .....Designed for complete adaptability to any automation system

Capstan Control .....Solenoid actuated (externally controllable)

Brakes .....Fail-safe solenoid actuated Permaband design, for smoothness and predictable action. Solid-state control eliminates relays, tape feelers, etc.

Reversing .....Low current conductive tape contacts reliably trigger reversing circuit for completely automatic action and maximum unattended playing (or recording) time

Motors .....3 motor, long-life ball bearing system

## Ordering Information

RT-19A Logger Tape Recorder, 1-channel, 4 track Automatic Triple Reverse, 5/16 IPS .....MI-141904-1

RT-19A Logger Tape Recorder, 1-channel, 4 track Automatic Triple Reverse, 15/32 IPS .....MI-141904-2

RT-19A Logger Tape Recorder, 1-channel, 4-track Automatic Triple Reverse, 15/16 IPS .....MI-141904-3

RT-19A Logger Tape Recorder, 2-channel, 4 track Automatic Reverse, 5/16 IPS .....MI-141905-1

RT-19A Logger Tape Recorder, 1-channel, 4 track Automatic Reverse, 15/32 IPS .....MI-141905-2

RT-19A Logger Tape Recorder, 2-channel, 4 track Automatic Reverse, 15/16 IPS .....MI-141905-3

RT-19A Logger Tape Recorder, 4-channel, 4 track One Direction, 5/16 IPS .....MI-141906-1

RT-19A Logger Tape Recorder, 4-channel, 4 track One Direction, 15/32 IPS .....MI-141906-2

RT-19A Logger Tape Recorder, 4-channel, 4 track One Direction, 15/16 IPS .....MI-141906-3



- Solid state design
- Monaural or stereo recording
- Tape speeds  
7½ and 15 or 3¾ and 7½ IPS
- Rack, console or portable mounting
- Pushbutton operation

## RCA Professional Audio Tape Recorder, Type RT-21D

### Description

The RCA Type RT-21D Professional Tape recorder is designed to meet rigid specifications and requirements set forth by broadcast and studio engineers for magnetic monaural or stereo tape operations. Utmost flexibility is provided in this complete transistor design, permitting programs to be recorded with greater ease.

Solid state circuitry accounts for the low power consumption, cool operation and small size of the RT-21D. Improved circuitry allows a wide range of record input levels, high playback output levels, and facilitates stereo performance. A master bias oscillator system is employed. The oscillator, located in the control module, drives power amplifiers in each amplifier module—an important feature where synchronous bias voltage is required

such as in the stereo model of the RT-21D.

The RT-21D basic recorder is supplied in two sections: a tape transport and a control panel which includes one amplifier. These components readily enable either a custom or standard installation to be made. The equipment is normally supplied for equipment-rack mounting. Console cabinet and portable carrying case are optional.

#### Ease of Operation

The panel of the RT-21D is divided into three control groups. The center contains the monaural record/playback module, the left area contains provisions for a duplicate module (used for stereo recording) and the right side of the control panel contains operating controls in

a convenient grouping. It is possible to record both tracks simultaneously in a normal manner or either of the two half-tracks by means of the A, A/B B selector switch.

#### Amplifier Controls

The record/playback amplifier modules are identical and interchangeable. Front panel controls consist of the following: a *record level* control, *playback level* control, *headset* jack, *bias* adjustment and meter-function selector to monitor *playback*, *record*, *bias* and *erase* signals. A light on each amplifier indicates *record* mode.

#### Continuously Variable Cue Speed; Interlocked RECORD Operation

The operating controls consist of the



Portable carrying case with stereophonic RT-21D system.

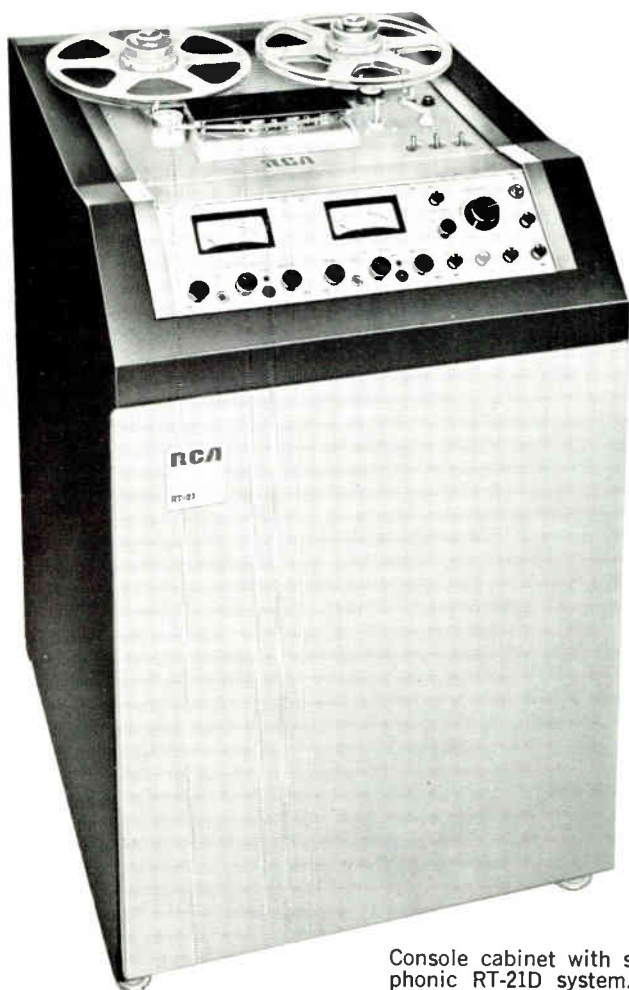

Console cabinet with stereophonic RT-21D system.

following: variable *cue speed* and related *cue delegate* button, *record*, *record delegate*, *start*, *stop*, *fast forward* and *fast reverse*. The panel features an interlocked record arrangement which requires a deliberate effort to place the machine in *record* mode and thus prevent inadvertent erasure of a valuable tape. This arrangement demands that the *record* button be depressed and then the *start* button to begin *record* operation.

The interlock feature may be defeated by simple internal strapping so that the *record* button may be depressed at any time for editing purposes, etc.

All controls are DC relay operated. The necessary 24-volt control voltages are generated within the recorder and are also available for remote control purposes.

### Tape Transport

The RT-21D Tape Transport Panel accommodates either 10½-inch or 7-inch reels. NAB 10½-inch reels and NAB hubs are available as accessory items. Proper tape tension for 10½ or 7-inch reels is provided by means of a toggle switch at the lower right of the panel. Also located in this same area are the main power *on-off* switch and a switch for selecting either *high* or *low* tape speeds. Proper tape equalization is automatically selected by the speed change switch. 7½/15 IPS and 3¾/7½ IPS models are available. An etched capstan provides a positive tape drive. Each RT-21D is supplied with the proper plug-in *record* equalizer according to the tape speed and track width.

### Velocity Brake System

The "velocity sensing brake system" provides velvet smooth braking action in the RT-21D by use of large surface area brake hubs which are integral parts of the reel motors. A microswitch, controlled by the tape-brake arm, cuts power to the capstan motor and releases the control relays when the arm is in the down position. This safety feature stops the transport mechanism in the event of tape breakage.

Threading of tape is simple and can be done without removal or movement of the head cover.

### Solenoid-Operated Tape Lifters

These lift the tape away from all magnetic heads whenever the machine is in the *fast forward* or *fast reverse* mode of operation to eliminate unnecessary head wear. When the *cue* mode is selected, tape is lifted from all heads except the playback head. This permits the operator to listen to the audio as he "jockeys" the tape for final cueing via the continuously variable *cue speed* control.

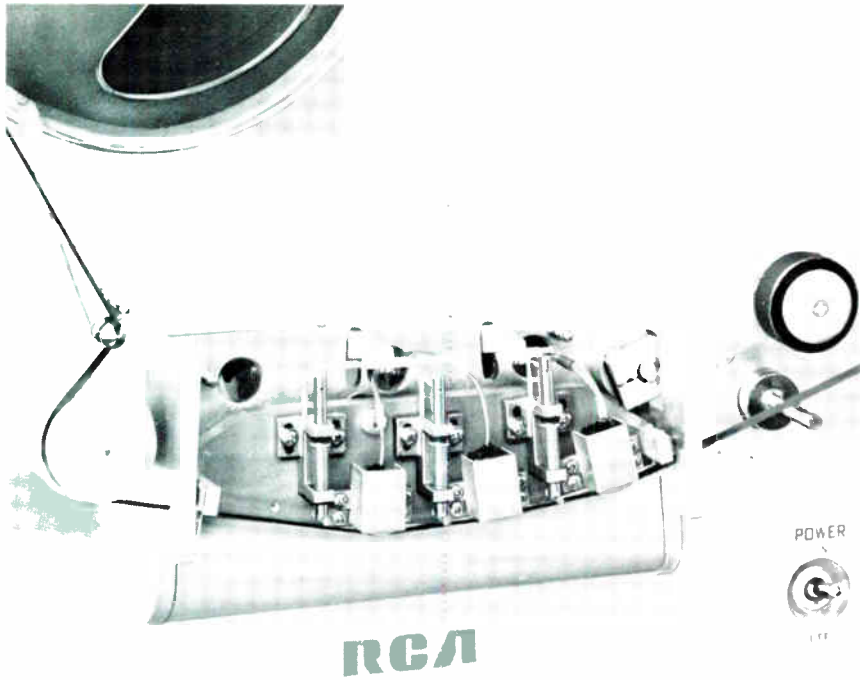

RT-21D Head Plate with cover removed reveals separate **erase**, **record** and **play** heads. Note space to left of **erase** head for fourth head. Fourth head (see **Optional and Accessory Equipment**) plays quarter-track tapes.

### Full or Dual Half-Track

A total of four magnetic head positions are available. The three heads normally supplied provide full or dual half-track recording, erase and playback (depending on model ordered, see *Ordering Information*). An optional fourth head may be used for time-delay broadcast and other special applications. A switchable four-track head kit is available for playing pre-recorded stereo tapes. All head azimuth adjustments are accessible from the front panel by simply removing the snap-on protective cover.

### Remote Control Panel

A Remote Control Panel for the RT-21D Tape Recorder is available as an optional control. The panel affords remote control of all front panel operations, including the A/B record facilities, except variable *cue speed*. The remote panel, however, has facilities for tape lifter defeat on all heads, so that tape cueing can be accomplished with the *fast forward* and *fast reverse* pushbuttons.

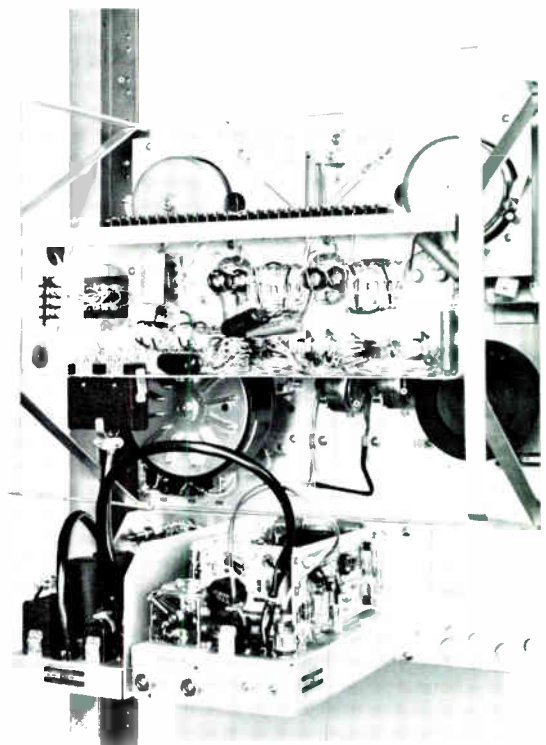
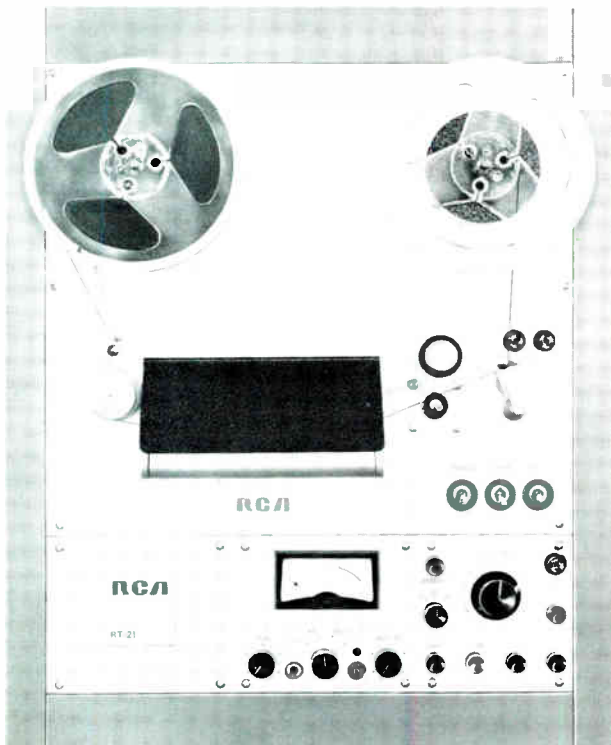

Front and rear views of RT-21D Tape Recorder showing tape transport at top, and control panel below. In rear view the modular transport-control unit is shown at left with the amplifier module in center of the panel. Space at right is reserved for a second amplifier module which serves the second channel in stereo operation.

# Specifications

Tape Speed ..... 7½ or 15 IPS, 3¾ or 7½ IPS  
 Track Width ..... Full- or dual half-track (80 mil tracks)  
 Frequency Response (Overall):  
 15 IPS ..... 50-15,000 Hz ±2 dB full- or half-track  
 (within 6 dB at 30 Hz)  
 7½ IPS ..... 50-15,000 Hz ±2 dB full- or half-track  
 (within 4 dB at 30 Hz)  
 3¾ IPS ..... 40-7,500 Hz ±2 dB full- or half-track  
 (within 4 dB at 30 Hz)  
 Signal-to-Noise Ratio: **Full Track** **Half Track**  
 15 IPS ..... 60 dB 55 dB  
 7½ IPS ..... 60 dB 55 dB  
 3¾ IPS ..... 60 dB 55 dB  
 Flutter and Wow  
 (Measured over a band of 0.5 to 250 Hz):  
 15 IPS ..... Less than 0.1% rms  
 7½ IPS ..... Less than 0.15% rms  
 3¾ IPS ..... Less than 0.2% rms  
 Starting Time ..... Less than 0.1 second full speed  
 Stopping Time ..... 2" of tape at 15 IPS  
 Playback Timing Accuracy ..... ±3 seconds in 30 minutes  
 Rewind Time ..... Approximately 90 seconds for 2400 ft.  
 on 10½" reel  
 Tape ..... ¾" wide  
 Reels ..... 7" and 10½" EIA (optional NAB hubs available)  
 Amplifiers ..... Independent **Record** and **Playback**  
 Record Input:  
 Matching ..... 150 ohms, balanced, unloaded input  
 transformer (may be strapped for 600 ohms)  
 Bridging ..... 20,000 ohms  
 Record Input Level:  
 Matching ..... -70 to -20 dBm  
 Bridging ..... -30 to +20 dBm  
 Playback Output ..... +18 dBm, maximum into 600 ohms,  
 balanced (normal program level of +8 VU)  
 Distortion ..... Less than 1% of 0 VU recording level, 400 Hz  
 (Distortion limited by tape only)  
 Metering ..... 3" illuminated VU meter reads record level,  
 playback level, bias and erase current  
 Monitoring ..... Phone jack provided to enable headphone  
 monitoring of either the record input signal before or dur-  
 ing recording, or the playback signal while recording or  
 during playback. A function switch simultaneously trans-  
 fers the VU meter and phone jack to either the record  
 amplifier or playback amplifier output so that aural, as  
 well as visual level comparisons may be made between  
 the original program and the recorded program. The same  
 switch also delegates the VU meter to read bias or erase  
 current.  
 Record Selector ..... Switch permits erasure and recording  
 on either or both tracks of stereo machines  
 Record Equalization ..... Plug-in equalizers  
 (NAB Standard, CCIR available)  
 Bias ..... Screwdriver level adjustment on front panel.  
 80 kHz frequency. Independent of line voltage variations.

Tape Lifters ..... Tape is removed from all heads,  
 automatically during fast forward and fast reverse (tape  
 lifters may be defeated from remote locations. Tape is  
 lifted from the erase and record heads when transport  
 is in the cue mode).  
 Remote Control ..... Provisions included for use of an  
 optional remote control panel. All control functions (ex-  
 cept variable cue speed) including record selector may  
 be remotely controlled. Remote panel includes control  
 for tape lifter release (all heads) so that tape may be  
 cued from a remote location.  
 Power Supply ..... Self-contained. Supplies regulated  
 30 volts for amplifiers and unregulated 24 volts for relays  
 Power Requirements ..... 105-125 volts, 50/60 Hz, single phase  
 115 watts monaural, 135 watts stereo  
 Transistor and Diode Complement:  
 Record Playback Amplifier  
 2—2N2270, 1—2N404, 3—1N3253, 5—2N526, 2—2N1183B,  
 8—2N270, 1—1N34A, 1—2N3391A  
 Control Panel Module  
 2—2N456, 2—N1183B, 1—2N270, 4—1N1763, 1—2N526,  
 4—1N3253, 1—1N1316  
 Tape Transport  
 12—1N3253, 12—1N1763  
 Dimensions (Overall):  
 Tape Transport ..... 19" wide, 15¾" high, 9" deep  
 483 mm, 400 mm, 229 mm  
 Amplifier Control Panel ..... 19" wide, 5¼" high, 9" deep  
 483 mm, 134 mm, 229 mm  
 Rack Space ..... 21" (554 mm) total—Monaural or Stereo  
 Finish ..... Anodized aluminum overlay  
 Approximate Weight ..... 75 lbs. (34 kg) monaural,  
 83 lbs. (37.65 kg) stereo

## Optional and Accessory Equipment

NAB Reel Hubs for RT-21 Recorders ..... ES-41919  
 Consisting of:  
 2 Reel Hubs ..... MI-41604  
 1 Empty 10½" Reel ..... MI-11932-2  
 Remote Control Panel for RT-21 Equipment ..... MI-141301-A  
 RT-21 Record/Playback Amplifier Module ..... MI-141351-B  
 Portable Carrying Case for RT-21 ..... MI-141302-A  
 Console Cabinet for RT-21 ..... MI-141303-A  
 Switchable 4th Head Kit (Dual ¾ track)  
 for RT-21 ..... MI-41602-A  
 Bulk Magnetic Tape Eraser ..... MI-11992  
 Auto Transformer Kit  
 (110/220 V, 50/60 Hz) ..... MI-41605

# Ordering Information

	115 V. 60 hertz	115 V. 50 hertz
Type RT-21D Professional Tape Re- corder Full Track, 3¾" and 7½" IPS, less NAB hubs.....	MI-41920-D	MI-41909-D
Type RT-21D Professional Tape Re- corder, Dual Half Track, 3¾" and 7½" IPS, less NAB hubs.....	MI-41921-D	MI-41911-D
Type RT-21D Stereo Professional Tape Recorder, Dual Half Track, 3¾" and 7½" IPS, less NAB hubs	MI-41921-DS	MI-41911-DS

	115 V. 60 hertz	115 V. 50 hertz
Type RT-21D Professional Tape Re- corder, Full Track, 7½" and 15" IPS, less NAB hubs.....	MI-41930-D	MI-41910-D
Type RT-21D Professional Tape Re- corder, Dual Half Track, 7½" and 15" IPS, less NAB hubs.....	MI-41931-D	MI-41912-D
Type RT-21D Stereo Professional Tape Recorder, Dual Half Track, 7½" and 15" IPS, less NAB hubs	MI-41931-DS	MI-41912-DS



- Automatic record/playback in stereo or monaural models
- Solid state electronics
- Wide dynamic range
- Remote control provisions
- Four-head transport

## RCA Automatic Tape Recorder, Type RT-22B

### Description

The RT-22B Automatic Tape Recorder is a reel-to-reel tape handling mechanism combined with the electronics and cueing facilities normally found only in cartridge tape equipment. The equipment is designed to meet rigid specifications and requirements set forth by broadcast and studio engineers for monaural and stereo tape operations.

The RT-22B is available as a playback only or complete record/playback system in stereo or monaural models. The record/playback systems are supplied with a standard BA-27S (stereo) or BA-27 (monaural) Record Amplifier. All units are designed for rack mounting and feature solid state and plug-in modular circuits.

The tape transport is basically the same high quality mechanism used in the RT-21 series of tape recorders, featuring a heavy duty hysteresis synchronous capstan motor, integrated reel motor and brake hub, solenoid operated tape lifters, smooth action brake system, four (4) head positions and the capability of accepting reel sizes up to 10½ inches. The RT-22B is equipped with separate erase, record, and playback heads plus a fourth cue track erase head.

The amplifier and control panel for the automatic tape recorder houses the playback amplifier; power supply; cue, end cue and trip cue amplifiers; as well as the control relays and circuitry. Front panel controls include *start*, *stop*, *fast forward*, *fast reverse*, *cue speed*, *cue* (mode

selection), *cue selection* (tone) and *cue* (tone) *erase*. Remote control panels are available as optional accessories.

### Cue Tone Automatically Recorded

At start of the recording operation a 1000 Hz *stop* cue tone is automatically recorded on the tape. During playback the *stop* cue is used to stop the transport mechanism, leaving the recorded program material in a pre-cued condition.

### Two Trip Cue Frequencies

A 150 Hz, end-of-message tone is automatically recorded at the termination of the recording operation. Upon playback, this tone activates a relay whose contacts may be used to start the next device in an automation system. The automatic re-



cord feature of the end-of-message tone may be disabled and the tone recorded manually where desired.

An 8000 Hz trip-cue tone is also provided and may be manually recorded anywhere on the tape. The trip-cue tone may be used to activate external devices during playback of the recorded program information.

### Cue Tone Search and Erase

The RT-22B contains facilities for cue tone search and erasure. The "Cue Selector" switch, located on the front panel selects one of the three cue tones as the transport stop tone. The selector switch is normally set to the "cue" position so that the 1000 Hz tone stops the tape transport, however, when it is desired to search out the "end of message" tone on "Trip" tone the "Cue Selector" switch allows the operator to positively locate the tones and erase them, if necessary, by de-

pressing the "Cue Erase" button. These tones may be re-recorded on the tape at any time by activating the appropriate control on the record amplifier. The 1000 Hz stop cue may also be erased in the same manner. Separate tally lamps indicate the presence of either the "End Cue" or "Trip Cue" tones and serve as an additional aid to the operator in locating them on the tape.

### Audio Switching Relay

An audio switching relay is provided in the output circuit of each playback channel and is activated only during play operation of the recorder. Stopping the unit removes the playback channel connections to the output. A number of RT-22B's may have their switching relays connected in cross bar fashion providing audio switching to a single program line. The program information to the line is derived only from the final unit to be placed in operation.

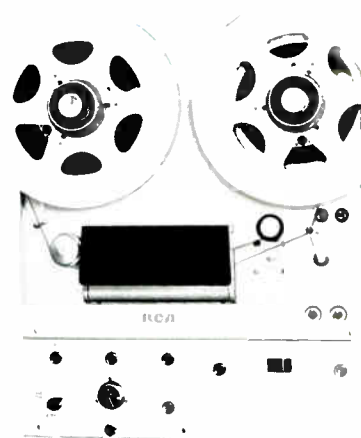

Automatic Monaural Tape Playback, ES-41924-B mounted in Cabinet Rack.

## Specifications

Tape Type.....	1/4" wide magnetic
Reels .....	10 1/2" dia. (NAB): 10 1/2", 7", 5", 4" EIA
Tape Speed.....	7.5" and 3.75" per second
Starting Time.....	0.1 sec. full speed
Stopping Time.....	2" of tape at 15 ips
Playback Timing.....	Accuracy ±3.0 sec. in 30 min.
Rewind Time.....	Approx. 90 sec. for 2400 ft. NAB reel
Frequency Response .....	7.5 ips ±2 dB 50-15,000 Hz 3.75 ips ±2 dB 40-7,500 Hz
Signal-to-Noise Ratio .....	50 dB @ 7.5 ips, 45 dB @ 3.75 ips
Distortion.....	Less than 2% at normal recording level
Cross Talk Between Channels .....	-55 dB @ 1 kHz
Flutter & Wow.....	0.25% RMS @ 3.75 ips 0.15% RMS @ 7.5 ips
Cueing Accuracy.....	Within 0.1 sec.
Cue Speed.....	Continuously variable either direction
Remote Control.....	Optional, all functions, except variable Cue Speed, Cue Selector.
Recording Input Level* .....	Microphone -70 dBm min., Matching -20 dBm max., Bridging +18 dBm max.
Input Impedance* .....	Unloaded input transformer for 37/150/250 Ohm microphones, or 20,000 bridging input
Cue Signal .....	1 kHz automatically recorded at start of recording

### Auxiliary Cue Signals:

End of Message .....	150 Hz cue tone automatic or manually selected
Trip Cue .....	8 kHz manually selected
Cue Signal Search and Erase .....	Any one of the three cue frequencies may be located and erased
Meter* .....	3" illuminated, rectangular VU
Indicator Lights.....	On, Ready, Run, Trip Cue, and End Cue
Heads.....	Three track stereo, two track monaural, separate Record and Playback Heads permit simultaneous monitoring and recording
Power Requirements .....	115 Volts AC, 60 Hz (220 Volt AC, 50 Hertz operation available)
Power Consumption .....	Record, 125 Watts; Playback, 120 Watts; Standby, 47 Watts; Fast Forward, 130 Watts; Fast Reverse, 130 Watts
Finish .....	Aluminum Epoxy Enamel
Dimensions:	
Transport.....	19" wide, 15 3/4" high, 9" deep (487 mm, 400 mm, 229 mm)
Control Panel.....	19" wide, 5 1/4" high, 16 1/4" deep (487 mm, 133 mm, 413 mm)
Record Amplifier .....	19" wide, 5 1/4" high, 11 5/8" deep (487 mm, 133 mm, 295 mm)
Weight .....	Approx. 100 lbs. (45.36 kg.)

\* Applies to complete record/playback system.

## Ordering Information

- ES-41924-B RT-22B Automatic Tape Playback, Monaural consists of:  
One MI-141124-B Transport  
One MI-141324-B Amplifier and Control Panel
- ES-41925-B RT-22B Automatic Tape Recorder, Monaural consists of:  
One MI-141124-B Transport  
One MI-141324-B Amplifier and Control Panel  
One MI-141966 BA-27 Record Amplifier  
Three MI-141800-1 Plug-In Relays

- ES-41926-B RT-22B Automatic Tape Playback, Stereo consists of:  
One MI-141123-B Transport  
One MI-141323-B Amplifier and Control Panel
- ES-41927-B RT-22B Automatic Tape Recorder, Stereo consists of:  
One MI-141123-B Transport  
One MI-141323-B Amplifier and Control Panel  
One MI-141963 BA-27S Record Amplifier  
Three MI-141800-1 Plug-In Relays

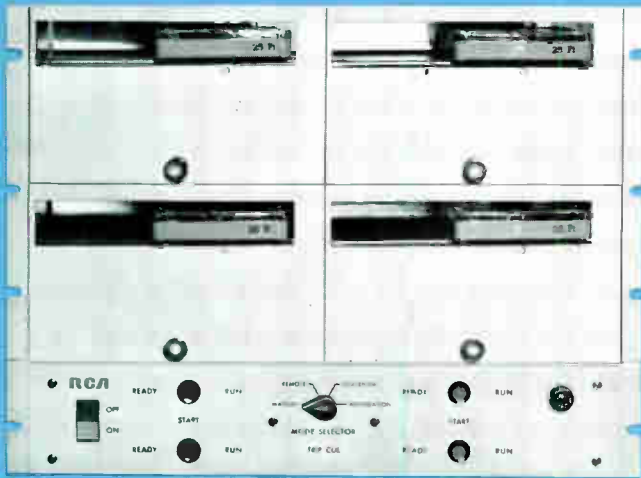

- Facilitates continuous broadcast programming
- Any one of four cartridges available for immediate playback
- Four modes of operation: manual, remote, sequential, automatic
- Independent capstan motors
- Heavy duty tape transports
- Self-contained relay power supply

## RCA Multicartridge Tape System, Type RT-18A

### Description

The RCA Type RT-18A Multiple Cartridge Tape System (either monaural or stereo) is a compact unit designed for instant playback of four pre-recorded tape cartridges in four modes of operation: manually, remotely, sequentially, or by pulses supplied from an automation system. The RT-18A meets all NAB standards and plays the three NAB cartridge sizes, with playback time from a few seconds to 31 minutes.

The RT-18A Multicartridge uses cartridges recorded on the RT-27 or equivalent cartridge tape units. There is also an RT-18A designed for stereo operation, with stereo heads and dual channel program amplifiers.

#### Tandem Operation

The RT-18A Multicartridge playback units may be connected in tandem to give systems of 4-8-12-16 or more units in an operating system. Use of multiple RT-18A units in cascade could provide enough cartridge storage capacity to give continuous programming for an entire broadcast day.

The multicartridge system consists primarily of four independent, roll-out tape transports, plug-in transistor circuit boards and control relays, a mode selector switch and separate start switches for each of the tape transports. These are housed in a rack-mounting cabinet. Preamplifiers are provided between the outputs of the tape heads and the control relays to amplify the audio signal before switching occurs. This eliminates switching noise transients from the program line.

#### Tape Transport

The drive system for the transport consists of a heavy duty, hysteresis synchronous motor, coupled via *O*-ring belts to a precision-ground capstan and flywheel assembly. The mechanism meets latest NAB standards (tape speed  $7\frac{1}{2}$  IPS with a speed accuracy of  $\pm 0.4$  percent; machine tape pulling force, minimum  $1\frac{1}{2}$  pounds; flutter less than 0.2 percent rms.)

#### Fast, Quiet Operation

Insertion of a cartridge cocks the RT-18A mechanical system by swinging the

pressure roller up to within a fraction of an inch of the capstan, assuring fast starts and quiet operation upon playback. Mechanical release of the cartridge is accomplished by merely lifting up the edge of the cartridge before removing it from the slot in the transport. All electrical connections to the transport are made through two quick disconnect cable connectors, one for power and the other for the heads.

#### Relays

A set of six plug-in relays is associated with each individual transport system. They control the *ready*, *start*, *run* and *play* control functions of the transport as well as the *cue* and *trip* (end-of-message cue) functions. A mute relay and an audio switch relay are the two relays in the system. The former prevents operational noises from entering program circuits; the audio-switch relay switches the appropriate preamp to a single program channel when two or more RT-18A's are connected in tandem. The relays are protected from dirt and dust by individual

plastic covers. Each is rigidly held in place by an overall metal cover.

### Relay Power Supply

The RT-18A is completely self-contained including a 24-Volt power supply for relay operation. Tally lamps indicate cartridge "ready" and "run". An individual cue and end-cue circuit board is associated with each tape transport. A common-to-all transport output audio amplifier is included.

### Four Position Mode Switch

A mode switch selects four play modes. These are:

- a. *Manual*—The machine automatically cues the cartridge immediately after insertion into the slot. Once

cued, tape movement stops and a *Ready* lamp lights. Then, a touch of the appropriate *Start* button initiates cartridge *Run* (or play) and the *Run* indicator lights. All cartridges hold in *Ready* until commanded to *Run*.

- b. *Remote Control*—This is basically the same as manual, except that it allows control from a remote location. Custom remote "trip cue" delegation panels may also be employed to vary cartridge sequence.
- c. *Sequential*—Any deck may be used to start a sequence. The sequence continues automatically within the RT-18A thru as many decks as there are cartridges inserted. The play se-

quence may be initiated locally or remotely.

- d. *Automation*—This mode permits external pulses to activate individual cartridge decks and "trip cue" pulses from the active deck to start the next device in the automation system. When the mode switch is in *Automation* all manual control is disabled.

### Random Trip Cue

The MI-11973-A 8000-Hertz Random Trip Cue Kit is an optional accessory. Random Trip Cue tones must be recorded in an RT-27 system during preparation of a cartridge. A "random trip cue" may be used to activate a slide projector or other device during play of a cartridge.

## Specifications

Frequency Response .....	±2 dB 50 to 12,000 Hz ±4 dB 50 to 15,000 Hz
Distortion .....	Less than 2% at normal recording level
Signal-to-noise Ratio:	
Monaural .....	45 dB at standard NAB reference level (53 dB below 3% total harmonic distortion)
Stereo .....	42 dB at standard NAB reference level (50 dB below 3% total harmonic distortion)
Crosstalk, Cue Tone to Program Channel:	
Monaural .....	Better than 55 dB
Stereo .....	Better than 50 dB
Wow and Flutter.....	Less than 0.2% RMS
Tape Speed.....	7.5 IPS
Power .....	115/230 V, AC, *50/60 Hz, single phase
Playing Time.....	1 second to 31 minutes in 3 basic cartridge sizes
Cueing Accuracy.....	Within 0.1 second
Starting Time.....	0.05 second or less

Program Output Level .....	+18 dBm, 150/600 ohms, balanced
Auxiliary Output Level .....	-38 dBV*, 3.3 kohms, unbalanced (4 for monaural, 8 for stereo)
Finish .....	Aluminum Epoxy
Dimensions .....	19" wide, 17½" high, 16¾" deep (482 mm, 444 mm, 425 mm)
Weight:	
Chassis, less decks.....	112 lbs. (50.8 kg.)
Chassis including four 10 lb. decks.....	152 lbs. (68.9 kg.)
Cartridge Transports.....	4 plug-in type
Mounting.....	Standard Relay Rack

### Accessories

Remote Control Panel (for any RT-18A Multicartridge Tape System) .....	MI-11968-1
8,000-Hz Random Trip Cue Kit .....	MI-11973-A
50-Hz Modification Kit (4 required) .....	MI-11494

\* Decibels referred to one volt

## Ordering Information

RT-18A Mono Multicartridge Tape System .....	MI-141961-A
RT-18A Stereo Multicartridge Tape System .....	MI-141961-AS

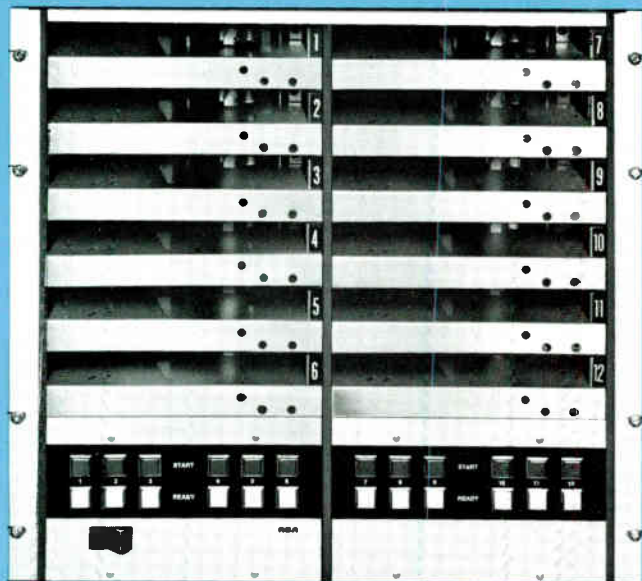

- Extended reliability—electronic switching
- Six or twelve decks per unit
- Mono or stereo playback
- Redundant, solid-state reliability
- Self-sequencing—“random” sequence
- Status-lighted pushbutton control

## Multicartridge Tape Systems, Types RT-16A, RT-26A

### Description

The Multicartridge Tape Systems described here offer improved technical quality, improved reliability and long life. The RT-16 system is a six-deck arrangement while the RT-26 offers twice as many decks with no increase in vertical rack space.

#### Extended Reliability—Solid-State Control

Improved performance capability is combined with a proportionate improvement in dependability. The RT-16 offers greater operational quality and increased reliability through the elimination of electro-mechanical relays. Solid-state logic circuitry performs the switching functions faster and more faithfully.

#### Six or Twelve Decks Per Unit

The RT-16 unit carries six cartridge-tape decks in 17½ inches (446mm) of equipment rack space. The 12-deck unit, the RT-26, carries twice the cartridge capacity at no increase in occupied rack space since each 6-deck unit is only half the width of a 19-inch rack. Each group of six decks uses a common-to-all capstan shaft. However, each deck “unplugs” without affecting the operation of the remaining five. The capstan is driven by a

synchronous motor through twin O-ring belts to a 10-lb (±5 kg) flywheel.

#### Easy Maintenance

Extra maintenance ease is the product of excellent accessibility. Each tape deck slides out to expose the tape head face and the pressure-roller mechanism. This unrestricted access speeds and simplifies maintenance procedures. Electronic maintenance is simplified by plug-in circuit boards. Since the electronics are redundant, a failure in one deck has no effect on the operation of the other decks in the system.

#### Mono or Stereo Playback

The RT-16 and RT-26 system is offered in two versions: monophonic and stereophonic. The differences between the two are merely head configurations and associated amplifiers. The stereo units require no more space and only slightly more primary power (for the additional amplifiers).

#### Redundant, Solid-State Reliability

Each RT-16 and RT-26 tape deck carries its own “set” of electronics. This redundant arrangement prevents an outage in one deck amplifier from affecting the

operation of the other decks in the system. Each deck removes easily from the system and removal in no way affects the operation of the remaining decks.

#### Self-Sequencing—“Random” Sequence

Through use of a unique “patch panel” at the rear of the system, the RT-16 (and -26) becomes a self-sequencing device. Ordinarily “patched” so that the decks sequence in numerical order, the patch system allows any conceivable arrangement one might imagine. In standard form, the RT-16 and -26 require a “command” (contact closure) for the start of each cartridge. Adding the End-Cue, Trip-Cue and Audio Switching Options (see *Accessories*) make the systems entirely self-sequencing.

#### Status-Lighted Pushbutton Control

Lighted indicators on the machine’s control panel convey the operational status of each deck. There are two indicators for each deck: a “Start” and a “Ready.” The “Ready” indicator lights when the deck is loaded and cued. Touching the “Start” button lights a lamp behind the button and extinguishes the “Ready” lamp. Thus, the operational status of each deck in the system is displayed on its front panel.

# Specifications

## Performance:

Frequency Response	
Characteristics	±2dB, 50 to 12,000 Hz ±4dB, 50 to 15,000 Hz
Distortion	Less than 2% (at normal recording level)
Signal-to-Noise Ratio	
(Ref. 3% THD, tape limited)	55dB mono—52dB stereo
Crosstalk Level (Head crosstalk)	-50dB
Wow and Flutter	Less than 0.2% rms
Tape Velocity	7.5 in/s (190.5 mm/s) ±0.4%
Equalization Curve	NAB Standard
Cartridge Capacity	All three NAB sizes
Cue Accuracy	±0.1 second
Start Time	.50 milliseconds or less

## Outputs:

Level	-20dBm
Impedance (see Accessories)	600 ohms unbalanced

## Cue Signal:

Stop Cue	1,000Hz
End Cue (see Accessories)	150Hz
Trip Cue (see Accessories)	8,000Hz

## Power Requirements:

Voltage (see Accessories)	117 volts ±10%
Frequency (see Accessories)	60Hz
Current	4 A., max.

Ambient Operating Temperature ..... 55 C. max. (130 F.)

## Physical:

Dimensions:	
Rack Model	17½" H. x 15" D. x 19" W. (446 x 381 x 483 mm)
Desk-Top Model	19" H. x 15" D. x 11" W. (483 x 381 x 279 mm)

## Weight:

Six-deck, RT-16	64 lbs. (29 kg.) Approx.
Twelve-deck, RT-26	128 lbs. (58 kg.) Approx.

## Accessories

### Output Options:

Balanced Transformer (600 ohms)	MI-141805
Monophonic 40dBm Line Amplifier (600-ohm balanced output)	MI-141806
Stereophonic 40dBm Line Amplifier (600-ohm balanced output)	MI-141806S

### Spare Cartridge Decks:

#### Monophonic

<b>For Stock Number:</b>	<b>Order:</b>
MI-141950AR & MI-141970AR	MI-141978A
MI-141951AR & MI-141971AR	MI-141979A
MI-141952AR & MI-141972AR	MI-141980A
MI-141953AR & MI-141973AR	MI-141981A

#### Stereophonic

<b>For Stock Number:</b>	<b>Order:</b>
MI-141954AR & MI-141974AR	MI-141982A
MI-141955AR & MI-141975AR	MI-141983A
MI-141956AR & MI-141976	MI-141984A
MI-141957AR & MI-141977	MI-141985A

### Primary Power Options

234V (±10%) 50Hz Transformer	MI-141010-500
Modification Kit (for 50Hz power line operation)	MI-141807

# Ordering Information

## Monophonic Systems (for rack mount)

RT-16A 6-Deck Unit with Stop Cue and Preamp	MI-141950AR
RT-26A 12-Deck Unit with Stop Cue and Preamp	MI-141970AR
RT-16A 6-Deck Unit with Stop Cue, End Cue and Preamp	MI-141951AR
RT-26A 12-Deck Unit with Stop Cue, End Cue and Preamp	MI-141971AR
RT-16A 6-Deck Unit with Stop Cue, End Cue, Audio Switcher and Preamp	MI-141952AR
RT-26A 12-Deck Unit with Stop Cue, End Cue, Audio Switcher and Preamp	MI-141972AR

## Stereophonic Systems (for rack mount)

RT-16AS 6-Deck Unit with Stop Cue and Preamp	MI-141954AR
RT-26AS 12-Deck Unit with Stop Cue and Preamp	MI-141974AR
RT-16AS 6-Deck Unit with Stop Cue, End Cue and Preamp	MI-141955AR
RT-26AS 12-Deck Unit with Stop Cue, End Cue and Preamp	MI-141975AR
RT-16AS 6-Deck Unit with Stop Cue, End Cue, Audio Switcher and Preamp	MI-141956AR
RT-26AS 12-Deck Unit with Stop Cue, End Cue, Audio Switcher and Preamp	MI-141976AR
RT-16AS 6-Deck Unit with Stop Cue, End Cue, Trip Cue, Audio Switcher and Preamp	MI-141957AR
RT-26AS 12-Deck Unit with Stop Cue, End Cue, Trip Cue, Audio Switcher and Preamp	MI-141977AR

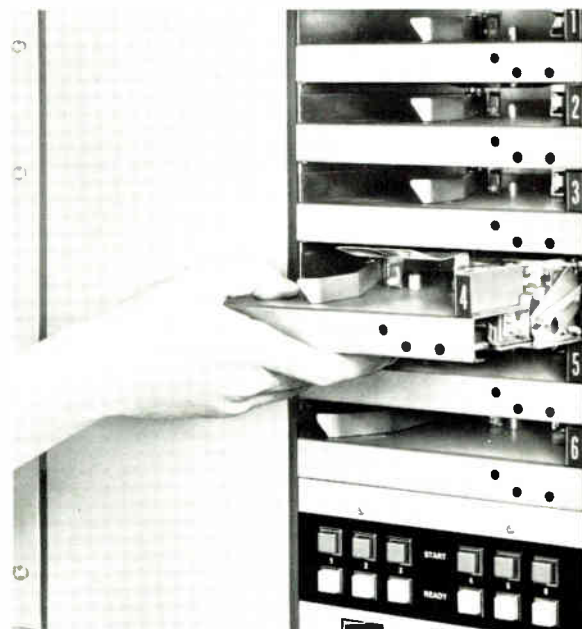

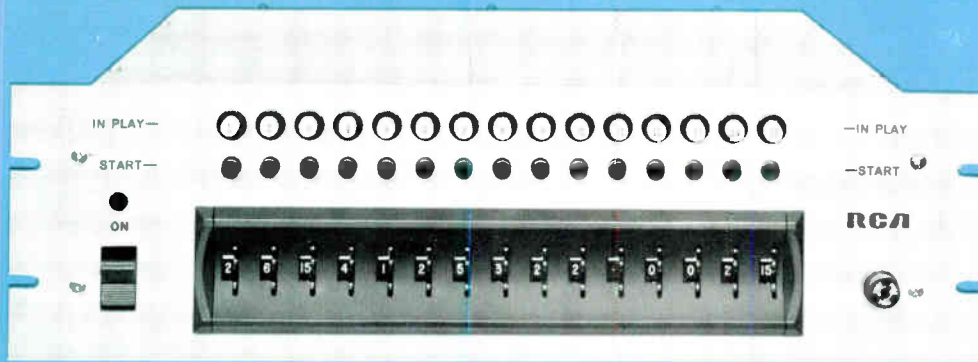

- Fifteen events, eighteen sources
- Provision for "skip" or "stop" events
- Solid state logic
- Quiet operation
- Lighted event display

## RCA Audio Tape Programmer, Type BCA-15B

### Description

The Audio Tape Programmer, RCA Type BCA-15B, programs fifteen events from any of 18 program sources. These sources can be RCA Type RT-18, RT-22, or RT-27 tape recorders or any program source if it can be started by contact closure and will provide a contact closure at the end of program material. Each of the 15 events is programmed by

means of thumbwheel switches which select any of 18 program sources. Set at "0", the switch skips an event or stops the program sequence. Upon completion of event 15, the program recycles to the first event.

The number of events may be increased easily by adding Audio Tape Program-

mer units either in series or as sub-programs to a particular event in a main program. Numbered lights indicate the event in progress and a push button permits selection of any particular event. Relays and solid-state logic circuits permit fast operation with so little audible noise that the BCA-15B may be used in close proximity with open microphones.

### Specifications

Events .....15  
 Program Sources .....18  
 Source Selector.....Thumbwheel switch  
 Source Relay Switching .....+24 Volts DC  
 Power .....115/230 Volts, AC, 50/60 Hz, 6.25 Watts  
 Panel Size.....5¼" high, 19" wide, 15⅝" deep  
 (134 mm, 482 mm, 397 mm)

Weight.....16 lbs. (7.25 kg.)  
 Terminals.....Screw type barrier terminal strips

### Ordering Information

Type BCA-15B Audio Tape Programmer .....MI-11365-B

2UB



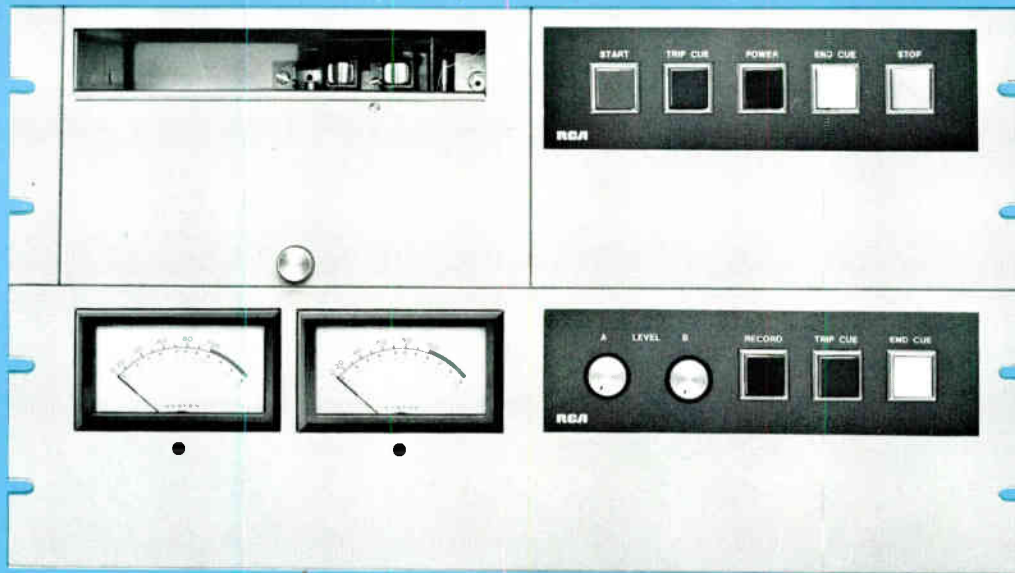

- Meets all NAB standards
- Roll-out tape deck
- Separate record and playback heads
- Full remote control capability
- Plug-in glass epoxy circuit boards
- Basic units expandable
- Silicon transistors
- Monophonic or stereo systems

## RCA Cartridge Tape Systems, Type RT-27A/BA-27A

### Description

The RT-27A/BA-27A Series Tape Cartridge Systems offer a complete line of both monophonic and stereo playback record systems. The basic components of these systems are the RT-27A Series Playback Units and the BA-27A Series Record Amplifiers which were designed on the building block concept so they are expandable to the more complex systems.

There are eight types of playback units (four monophonic and four stereo) and four types of record amplifiers (two monophonic and two stereo). The various combinations of playback units and record amplifiers provide a maximum variety of monophonic and stereo playback/record systems to meet virtually any customer requirement.

### RT-27A Series Playback Units

The basic RT-27A Monophonic Playback Unit consists of a Mono Tape Deck, a Power Supply plug-in printed circuit board, a Stop Cue Amplifier plug-in printed circuit board, a Playback Amplifier plug-in printed circuit board and two plug-in relays (Run Relay and Cue Relay). In this configuration, the tape deck contains a single playback head (two track). One track is for the monophonic audio playback through the Playback Amplifier printed circuit board (monophonic audio amplifier channel) and the other track is for the cue signals (1 kHz) which are applied to the Cue Amplifier printed circuit board (automatic start cue channel). The differences between the tape deck used in the basic

unit and the ones used in the other RT-27A Series units are the number of heads and the number of tracks on each (refer to the last page).

### Roll-Out Deck Feature

The RT-27A Series Cartridge Record Playback System features at no additional cost a unique roll-out deck assembly. This exclusive feature allows the complete mechanical deck assembly to be easily removed from the main frame assembly for periodic maintenance or adjustment.

The Power Supply printed circuit board supplies all operating power for the playback unit. In other RT-27A Units, which are used in playback/record systems, the Power Supply printed cir-



cuit board supplies operating power for both the playback unit and the record amplifier.

The basic RT-27A Playback Unit also has provisions for two additional plug-in printed circuit boards (Playback Amplifier B and End Cue/Trip Cue) and four additional plug-in relays (Trip Cue Relay, End Cue Relay, and two Audio Switching Relays). These plug-in units are the basic building blocks for expansion. The basic RT-27A unit has a single output transformer with provisions for installing an additional output transformer for stereo operation.

### Simplicity of Operation

The Cartridge playback unit is ready to go at the flick of a button. After in-

sertion of the cartridge, the *stop* light lights. Upon depressing the *start* button, the tape will run and the *start* button lights. At the end of the tape run, the equipment automatically stops, the *start* light goes out, and the *stop* light again appears. The *trip-cue* and *end-of-message cue* indicators are included.

### Three Cue Frequencies

Three cue frequencies—*start/stop cue* (1000 Hz)—*end-of-message cue* (150 Hz)—and *trip cue* (8000 Hz)—are provided in the RT-27A. The tape may be stopped at any time by pressing the *stop* button. Relays control the start and stop functions through impulses generated in a cue-tone control circuit. Cue tone bursts are inserted automatically each time the

tape starts during recording mode so that taped announcements always are properly re-cued and ready for re-use. An optional feature is the use of two additional cue circuits which are independent of the cue-tone circuit. This feature records "end of message" cue tones (150 Hz) automatically at the conclusion of the program material and/or manually at any time. It is used ordinarily to "trigger" the start of additional program devices or automation systems. The third, or trip-cue tone (8000 Hz) may be recorded at any time. This tone, when reproduced during playback, may activate associated devices such as TV-slide projectors.

Convenient terminals are provided at the rear for the addition of manual cue-defeat facilities. This provides for the manual defeat of the normally, automatically recorded, start/stop cue tone. There is also provision for automatic (or manual) recording of the end cues.

**Type RT-27A  
Monophonic Cartridge Tape Playback System**

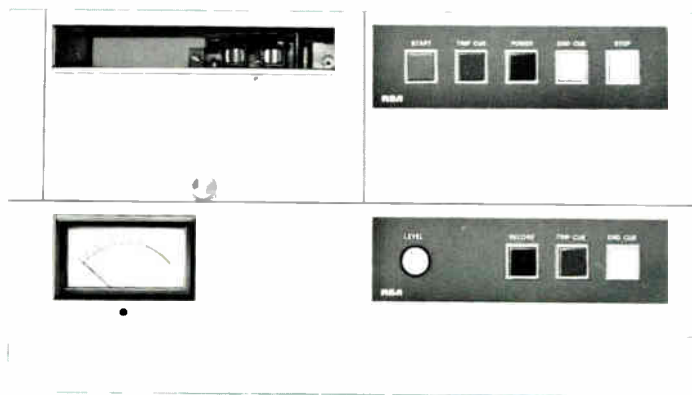

**Type BA-27A  
Monophonic Cartridge Tape Record Electronics**

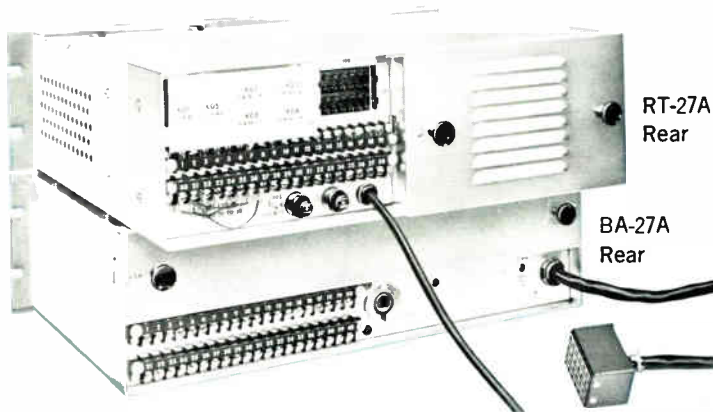

Monophonic Cartridge Tape Recorder, RCA Type RT-27A, fits neatly into 19½-inch studio rack or console and is pre-wired for conversion to stereo. The Type RT-27AS stereo counterpart is shown on the front page. Below is rear of equipment showing separate chassis construction of both RT-27A Playback Unit and the BA-27A Record Amplifiers. This building-block concept provides a variety of monophonic and stereo playback/record systems to meet virtually any requirement.

### Individual Record Level Controls

The BA-27A Record Amplifier is similar to the RT-27A Playback Unit in chassis construction and styling to provide an integrated appearance. The front panel contains the *record* button light which indicates recording mode.

### Microphone and Bridging Inputs

The BA-27A Amplifier has sufficient gain to permit microphone recording. A bridging pad may be connected for recording at line level. The *record* amplifier and the bias and cue oscillators are mounted on plug-in boards which remove easily for servicing. The unit is shielded to minimize pick-up of hum and RF fields. The recorder connects to the playback amplifier with a flexible cable and plug arrangement. Operating power for the amplifier is supplied by the Playback Unit.

### Recording

To prevent accidental recording, the recorder must be intentionally placed in the *record* mode before a recording can be made, and it automatically drops out of the mode whenever tape stops. Operation of the *record* button during playback can not place the system in the *record* mode.

### End Cue and Trip Cues

End cues and trip cues may be manually recorded at any time, without being in the *record* mode, thus permitting the operator to give full attention to the

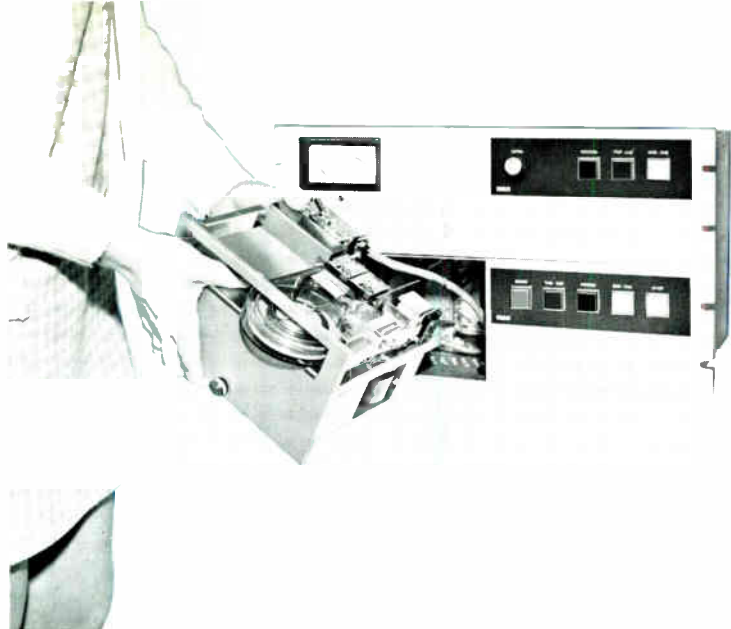

A roll-out tape deck assembly and plug-in glass epoxy circuit boards assure easy maintenance of RT-27A systems. Precision components provide quiet operation essential for on-air use. Separate record and playback heads meet all NAB cartridge record/playback standards.

recording of program material. The trip cue or end cue may be recorded during the initial recording, or recorded later, thus allowing tight synchronization of cues with program material.

### Record-Playback Heads

Separate playback and record heads permit simultaneous playback (or monitoring) while recording. The RT-27A

system employs two heads in accordance with NAB standards—one for record and one for playback.

### Remote Control

Two optional accessory panels are available for remote operation of the RT-27A/BA-27A Systems: one for remote starting of up to four playback systems and, the other, for remote control of a single *record/playback* system

including *record, start, trip cue record, end cue record, and stop* functions.

### Systems

Each RT-27A/BA-27A equipment undergoes rigid final inspection, matching, and calibration immediately before shipment to the user. Inspection and calibration tabulations are enclosed with each shipment.

### Expandability

The RT-27A Monophonic Cartridge Tape Playback System may be expanded to the RT-27AS Stereophonic Cartridge Tape Playback System at any time. Other accessory equipment such as the End Cue/Trip Cue facilities may also be added to the basic system by the user as required. Plug-in printed circuit boards and plug-in hardware are available from stock. Conversion of a Basic Monophonic Playback System to a Stereo Playback System with accessory cue facilities takes less than 15 minutes.

The RT-27A/BA-27A is available as a basic record/playback system; (with or without E/C and T/C and Audio Switching—these features may be added later by the user if required) or, as a complete system incorporating all cue features. See *Ordering Information*.

## Specifications

Frequency Response	±2 dB 50-12,000 Hz at 7½ ips ±4 dB 50-15,000 Hz at 7½ ips
Distortion	Less than 2% at normal recording level
Signal-to-Noise Ratio (Meets or exceeds NAB standard):	
Mono	55 dB, ref. 3% THD (Tape Limited)
Stereo	52 dB, ref. 3% THD (Tape Limited)
Cross Talk	Down more than 55 dB
Wow and Flutter	Less than 0.2% RMS
Bias Frequency	75 kHz
Tape Speed	7.5 ips ±0.4%
Equalization	NAB
Playback Time	2 seconds to 31 minutes, 3 basic NAB cartridge sizes
Cueing Accuracy	Within 0.1 second
Starting Time	0.05 second or less
Output Level	+18 dBm, 150/600 ohms, balanced
Recording Input Level	Microphone -70 dBm (minimum) Matching -20 dBm (maximum) Bridging -18 dBm (maximum)
Input Impedance	Unloaded input transformer for 37/150/250 ohm microphones or 20,000 ohm bridging input
Cue Signal, Start-Stop, SS/C	1 kHz automatically recorded at start of recording

### Auxiliary Cue Signals:

End Cue, End of Message Cue, E/C	150 Hz tone is recorded automatically at end of message or manually at any time
Trip Cue	8 kHz may be recorded at any time
Meters	4" illuminated, rectangular VU

### Indicator Lights:

RT-27A	"Start", "Stop", "Trip Cue", "End Cue" and "Power" indicators
BA-27A	"Trip Cue", "End Cue" and "Record"

Heads ..... 2 tracks for mono and 3 tracks for stereo. Separate record and playback heads permit simultaneous recording and monitoring

Power Requirements ..... 117/234 volts, AC, 60 Hz  
(50 Hz operation by optional conversion kit, MI-11494)

Power Consumption ..... Record, 80 watts;  
Playback, 69 watts; Ready, 54 watts; Standby, 8 watts

Ambient Temperature ..... 55°C max.

Finish ..... Aluminum epoxy with black inserts

### Dimensions (overall):

	Wide	High	Deep
RT-27A & RT-27AS	19"	5¼"	16¼"
	483 mm	133 mm	413 mm
BA-27A & BA-27AS	19"	5¼"	11½"
	483 mm	133 mm	295 mm

### Weight:

RT-27A	52 lbs. (2359 g.)
BA-27A	25 lbs. (1134 g.)

## Tape Components and Accessories

Basic Cartridge Tap Playback for RT-27A/27AS Series (Basic main frame assembly. Mono with 1 kHz SS/C cue only, select deck below) .....	MI-141965A
RT-27A Monophonic Playback Deck (with mono playback head) .....	MI-141967A-1
RT-27A Monophonic Record/Playback Deck (with mono record and mono playback heads) .....	MI-141967A-2
RT-27AS Stereophonic Playback Deck (with one stereo playback head) .....	MI-141967A-3
RT-27AS Stereophonic Record/Playback Deck (with stereo record & stereo playback heads) .....	MI-141967A-4
BA-27A Monophonic Cartridge Tape Record Electronics (without audio switching) .....	MI-141966A
BA-27AS Stereophonic Cartridge Tape Record Electronics (without audio switching) .....	MI-141963A
Plug-In PC Boards:	
Power Supply Board .....	MI-11974-1
End Cue/Trip Cue Board .....	MI-11974-2
Cue Amplifier Board .....	MI-11974-3
Bias and Cue Tone Board .....	MI-11974-5
Record Amplifier Board .....	MI-11974-6
Playback Amplifier Board .....	MI-11974-7

Plug-In Relays:	
Relay (2 Form C) .....	MI-141800-1
Relay (4 Form C) .....	MI-141800-2
Relay (6 Form C) .....	MI-141800-3
Output Transformer, Plug-In for Conversion of RT-27A (mono) to RT-27AS (stereo) .....	MI-141802
Remote Control Panel (Start pushbuttons for four RT-27A Playback Decks) .....	MI-11968-1
Remote Control Panel (Start, Record, Trip Cue, End Cue, Stop Pushbuttons for RT-27A Recorders) .....	MI-11968-2
Metal Console Cabinet (2-unit capacity) .....	MI-11984-A
Metal Console Cabinet (4-unit capacity) .....	MI-11983-A
Metal Cartridge Storage Rack .....	MI-11985-A
Cartridge Equipment	
Studio Furniture .....	See Catalog Sheet B.1505
Tape Cartridge Bulk Eraser .....	MI-11992
Tape Head Demagnetizer .....	MI-11995
Frequency Response and Azimuth Alignment	
Test Tape (mono) .....	MI-11993-3
50-Hz Conversion Kit .....	MI-11494
Tape Cartridges .....	MI-11988-Series and MI-141988-Series
See Catalog Sheet B.1704 for Complete List of Accessories	

## Ordering Information

### Cartridge Tape Systems\*

RT-27A Playback (audio, and 1 kHz start/stop cue, with playback head only). Mono RT-27A .....	ES-41940A
Stereo RT-27AS .....	ES-41944A
RT-27A Playback (audio, and 1 kHz start/stop cue, with record and playback heads). Mono RT-27A .....	ES-41940A-R
Stereo RT-27AS .....	ES-41944A-R
RT-27A Playback (audio, and 1 kHz start/stop cue, 8 kHz trip, and 150 Hz end cue, and audio switch- ing with playback head only). Mono RT-27A .....	ES-41941A
Stereo RT-27AS .....	ES-41945A
RT-27A Playback (audio, and 1 kHz start/stop cue, with 8 kHz trip cue and 150 Hz end cue, and audio switching with record and playback heads). Mono RT-27A .....	ES-41941A-R
Stereo RT-27AS .....	ES-41945A-R

Record/Playback Matched System (audio and 1 kHz start/stop cue matched system) RT-27A and BA-27A Mono System .....	ES-41942A
RT-27AS and BA-27AS Stereo System .....	ES-41946A
Record/Playback Matched System (audio and 1 kHz start/stop cue, plus 8 kHz trip cue and 150 Hz end cue with record amplifier and audio switching). RT-27A/BA-27A Mono System .....	ES-41943A
RT-27AS/BA-27AS Stereo System .....	ES-41947A
Record Electronics and Switching	
(BA-27A replacement) Mono .....	ES-41939A
(BA-27AS replacement) Stereo .....	ES-41948BA
BA-27A Monophonic Record Electronics without Audio Switching .....	MI-141966A
BA-27AS Stereo Record Electronics without Audio Switching .....	MI-141963A

\*When ordering systems for 220-volt power line, add "(220)" as suffix for "ES-" number. For example: ES-41940A(220).

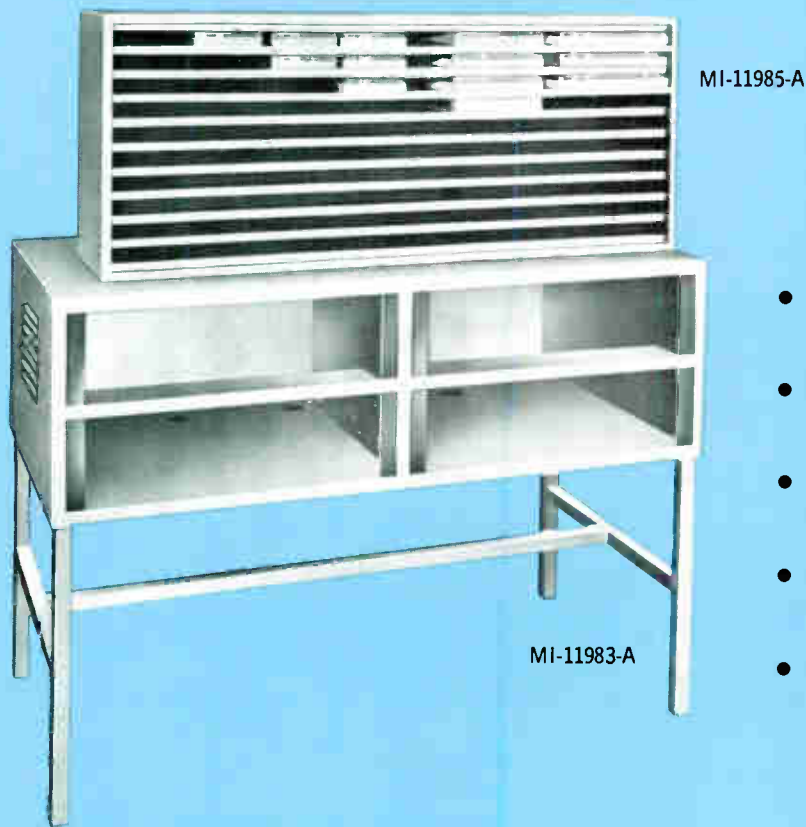

MI-11985-A

MI-11983-A

- Choice of attractively styled consoles for two or four Playback or Record amplifier units
- Matching storage cabinet with large tape cartridge capacity
- Affords ease of identification and efficient handling of cartridges
- Flexible mounting system meets varying studio space requirements
- Provisions for mounting automatic switcher, standard audio panels and other equipment

Four-unit Console (MI-11983-A) with Tape Cartridge Storage Cabinet (MI-11985-A) mounted above.

## RCA Cartridge Tape Accessories

### Description

RCA Tape Cartridge consoles provide mountings at a convenient operating level for the RT-7/17/27/37 Tape Cartridge Playback Units and the BA-7/17/27/37 Tape Cartridge Record Amplifiers. MI-11984-A is a two-unit console designed to mount two playback units, or one playback unit and one record amplifier. MI-11983-A Console is a four-unit cabinet to mount four playback or one record amplifier and three playback units.

A Tape Cartridge Storage Cabinet, MI-11985-A, provides ten shelves 1½ inches high to accommodate the tape cartridges.

The consoles are sturdily constructed of metal with a midnight blue finish. Holes in the cabinet accommodate interconnection cables and louvers afford ventilation. Protective screens, attached to the rear frames also provide ventilation.

Cabinet MI-11985-A is set up to store 80 small, 300 Series tape cartridges. The storage cabinet may be placed on top of the consoles. Two cabinets can be accommodated if placed back-to-back. Mounting feet have been provided so that the cabinet may be placed on the floor underneath the MI-11983-A Console. There is room for two storage cabinets, one on each side of the cross bar.

## Tape Cartridge Consoles



Convenient two-unit Console, MI-11984-A, for mounting one Tape Cartridge Playback Unit and one Record Amplifier or two Playback Units.

### Ordering Information

Console Cabinet for two Playback or one Playback and one Record Amplifier Units complete with legs and mounting hardware .....MI-11984-A

## SPECIFICATIONS

	2 Unit Console MI-11984-A	4 Unit Console MI-11983-A	Storage Cabinet MI-11985-A
Construction .....	Metal	Metal	Metal
Finish .....	Midnight blue	Midnight blue	Midnight blue
Legs .....	17" long, 432 mm removable	17" long, 432 mm removable	—
Dimensions (overall)			
Width .....	20 $\frac{3}{4}$ " 527 mm	40 $\frac{3}{4}$ " 1035 mm	35 $\frac{7}{8}$ " 911 mm
Depth .....	19 $\frac{5}{16}$ " 503 mm	19 $\frac{5}{16}$ " 503 mm	9" 229 mm
Height (less legs) .....	13" 330 mm	13" 330 mm	16" 406 mm
Height (with legs) .....	30" 762 mm	30" 762 mm	—
Weight (approximate) .....	25 lbs. 11 kg.	40 lbs. 18 kg.	30 lbs. 14 kg.

Console Cabinet for four Playback or three Playback and one Record Amplifier Units complete with legs, crossbar, and mounting hardware .....MI-11983-A  
Cartridge Storage Cabinet with dividers and spacer boards set up to store 80 small, 300 series tape cartridges .....MI-11985-A

## Audio Automatic Switcher

Audio Automatic Switcher, MI-11982, is an important unit in RCA's Cartridge Tape System affording a means to switch up to four outputs to one console input. The switchers may be connected in tandem to service multiple playback units when desired.

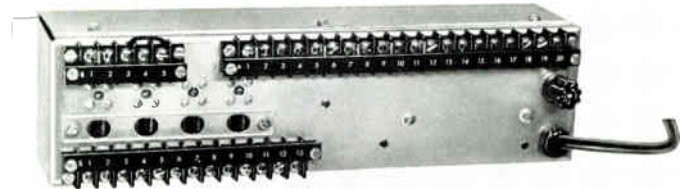

MI-11982 Audio Automatic Switcher.

### SPECIFICATIONS

Operation ..... Sequential  
Power Requirement ..110/220 volts, AC, 50/60 Hz, single phase  
Line Cord and Plug .....56" long  
Fuse .....1, slo-blo, rated 0.3 amps  
Diode .....1 Type 1N1763

Dimensions (overall) .....3 $\frac{1}{4}$ " high, 13" wide, 2 $\frac{1}{4}$ " deep  
(82 mm, 330 mm, 68 mm)  
Weight .....4 lbs. (1800 g)

### Ordering Information

Audio Automatic Switcher complete with line cord and plug .....MI-11982

## RT-27 Remote Control Panels



MI-11977



MI-11979

Remote Control Panel, MI-11977 provides a convenient means for remotely controlling from one to four Cartridge Tape Playback Units. Connections may easily be made through a rear terminal board directly to the playback units. Four red pushbuttons on an aluminum panel labelled "START," control up to four units

Remote control of the BA-27 Record Amplifier in the RT-27 Cartridge Tape System is provided by Remote Control Panel, MI-11979. Operational functions of the BA-27 can be transferred to the remote control panel with its four push-button controls—START, RECORD, STOP, AND TRIP-CUE.

### SPECIFICATIONS

Dimensions (overall) .....2 $\frac{1}{2}$ " high, 6" wide, 2 $\frac{1}{4}$ " deep  
(89 mm, 152 mm, 72 mm)  
Weight ..... $\frac{1}{2}$  lb. (250 g)  
Finish .....Dark umber gray

### Ordering Information

Remote Control Panel for RT-27 Playback Unit Complete .....MI-11977  
Remote Control Panel for BA-27 Record Amplifier ..MI-11979

## Cartridge Tape Head Degausser

The Cartridge Tape Head Degausser, MI-11995, is designed to facilitate demagnetizing of record-playback and erase heads of cartridge tape units. The unit is housed in a lightweight hand-grip case. It has a 1 $\frac{3}{8}$ -inch demagnetizing tip that can be conveniently inserted in the slot of the tape cartridge housings. A momentary-contact ON-OFF pushbutton safety switch energizes the unit.

Long Probe Degausser, MI-11995.



### SPECIFICATIONS

Power Requirements .....117 volts, AC, 50/60 Hz, single phase  
 Switch .....Momentary contact, rating 8 Amps.  
 Line Cord .....5 ft. long (1.52 m)  
 Finish .....Black

Dimensions Overall .....9 $\frac{7}{8}$ " long,  $\frac{7}{8}$ " diameter  
 (251 mm, 222 mm)  
 Weight .....9 oz. (250 g)

### Ordering Information

Cartridge Tape Head Degausser (117 V. AC) .....MI-11995  
 Cartridge Tape Head Degausser (230 V. AC) .....MI-11996

## Tape Cartridges

Cartridges, blank or tape loaded, for use with the RCA Tape Cartridge Systems are made available in varying sizes and with convenient playing times ranging from 40 seconds to more than a half hour. Cartridge cases are plastic with clear top and RCA Light Gray base. Cartridges are wound for continuous-loop operation with the RT-7, RT-17, RT-27 and RT-37 Playback Units. Special tape lengths are available on special order.

### Test Tape

Azimuth alignment and frequency response test tape (monophonic) supplied in a single 300 Series Cartridge. MI-11993-4

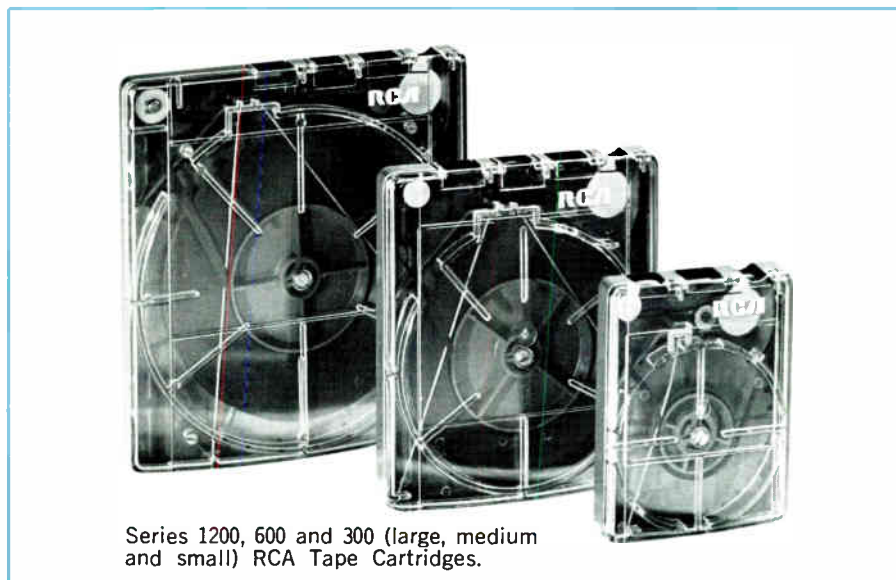

Series 1200, 600 and 300 (large, medium and small) RCA Tape Cartridges.

### Specifications and Ordering Information for Tape Cartridges

Stock Identification	Cartridge Series	Playing Time	Size Overall	Unit Weight	Packaged	MI Total Weight
MI-11988-B1	300	40 secs.	4" w x 5 $\frac{1}{8}$ " d x $\frac{7}{8}$ " h	3 oz.	6/box/MI	1 $\frac{1}{4}$ lbs.
MI-11988-B2	300	70 secs.	4" w x 5 $\frac{1}{8}$ " d x $\frac{7}{8}$ " h	3 $\frac{1}{2}$ oz.	6/box/MI	1 $\frac{1}{2}$ lbs.
MI-11988-B11	300	2 $\frac{1}{2}$ min.	4" w x 5 $\frac{1}{8}$ " d x $\frac{7}{8}$ " h	4 oz.	6/box/MI	1 $\frac{3}{4}$ lbs.
MI-11988-B3	300	3 $\frac{1}{2}$ min.	4" w x 5 $\frac{1}{8}$ " d x $\frac{7}{8}$ " h	4 oz.	6/box/MI	1 $\frac{3}{4}$ lbs.
MI-11988-B4	300	5 $\frac{1}{2}$ min.	4" w x 5 $\frac{1}{8}$ " d x $\frac{7}{8}$ " h	4 $\frac{1}{2}$ oz.	6/box/MI	2 lbs.
MI-11988-B5	300	10 $\frac{1}{2}$ min.	4" w x 5 $\frac{1}{8}$ " d x $\frac{7}{8}$ " h	5 $\frac{1}{2}$ oz.	6/box/MI	2 $\frac{1}{4}$ lbs.
MI-11988-B6	600	16 min.	6" w x 7" d x $\frac{7}{8}$ " h	10 oz.	2/box/MI	1 $\frac{1}{2}$ lbs.
MI-11988-B7	1200	31 min.	7 $\frac{5}{8}$ " w x 8 $\frac{3}{8}$ " d x $\frac{7}{8}$ " h	13 oz.	2/box/MI	2 lbs.
MI-11988-B8	300	blank	4" w x 5 $\frac{1}{8}$ " d x $\frac{7}{8}$ " h	2 $\frac{3}{4}$ oz.	6/box/MI	1 $\frac{1}{8}$ lbs.
MI-11988-B9	600	blank	6" w x 7" d x $\frac{7}{8}$ " h	3 oz.	6/box/MI	1 $\frac{1}{4}$ lbs.
MI-11988-B10	1200	blank	7 $\frac{5}{8}$ " w x 8 $\frac{3}{8}$ " d x $\frac{7}{8}$ " h	4 oz.	2/box/MI	10 oz.

## Cartridge Tape Bulk Eraser

Bulk Eraser, MI-11992, affords complete erasure of any 1/4-inch recorded reel of tape or tape cartridge. The eraser will also demagnetize record-playback and erase heads to eliminate distortion and tape background noise problems.

The bulk eraser is housed in a plastic, hand-grip case measuring only 4 7/8 (124 mm) inches in diameter and 4 3/4 (121 mm) inches high overall. A momentary-contact, ON-OFF pushbutton safety switch prevents current being applied when not in use. To operate, simply plug into any AC outlet and hold over the reel of tape, energize, then rotate the eraser around the tape for several seconds. Slowly withdraw the eraser from the tape to arms length before releasing on-off pushbutton.



MI-11992

### SPECIFICATIONS

Power Consumption .....	100-130 volts, 50/60 Hz, AC single phase, 8.5 amps
Switch .....	Momentary contact rating 15 amp AC inductive
Line Cord .....	8 ft. long (2.5 m)
Dimensions (including handle) .....	4 7/8" dia. by 4 3/4" high (124 mm dia. by 121 mm high)
Weight .....	4 lbs. approx. (1800 g)

### Ordering Information

Bulk Eraser complete in plastic, hand-grip type case, furnished with 8-foot (2.5 m) line cord, molded rubber plug .....MI-11992

## Automatic Magnetic Tape Eraser

The RCA Automatic Magnetic Tape Eraser is a self-contained unit mounted in a metal cabinet of table height requiring a floor space about 22 inches (559 mm) square. The unit is designed to erase full reels of magnetic film or tape and will accommodate up to 15-inch reels.

Audio and video signals are erased

down to the noise level of the magnetic medium in an automatic 18-second cycle. The erase cycle is fully automatic and controlled by a motor-operated mechanism. Once the reel of tape is placed on the carriage and pushed into the operating position the erase cycle is set in motion without manual operation of any

controls.

The use of an air core coil eliminates the possibility of "erasure spokes" so common in erasing with an iron core coil. Power factor correction with the air core coil provides a very high field strength from a nominal 12 ampere 220 volt input.



ES-29976

### SPECIFICATIONS

Capacity .....	6 rolls of 1/4" tape, or 3 rolls of 1/2" tape; or 2 rolls of 16mm film, 1 roll of 35mm film; or 1 roll of (2") TV tape
Roll or Reel Size .....	Up to 2" height and 15" diameter
Erase Cycle .....	18 seconds automatically controlled
Erase Coil .....	Air Core Type (approx. 600 gauss)
Degree of Erasure .....	Reduces a fully modulated signal to the noise level of the magnetic medium
Power Requirements .....	Approximately 12 amperes—220/115 volts, 3 wire, 1 phase, 60/50 Hz
Dimensions .....	22" long, 21 5/8" wide, 37 1/4" high (559 mm, 549 mm, 946 mm)
Weight .....	235 lbs. (106 kg.)

### Ordering Information

Automatic Magnetic Tape Eraser, 60 Hertz (Audio) ES-29976  
 Automatic Magnetic Tape Eraser, 50 Hertz (Audio) ES-29978  
 Automatic Magnetic Tape Eraser, (Video) 60 Hertz ES-29975  
 Automatic Magnetic Tape Eraser, (Video) 50 Hertz ES-29977



- Excellent frequency response, 25-16,000 Hz
- Improved power handling capability plus lower distortion
- Ideal for monitoring AM, FM, TV programs & recording studio playback
- Even sound radiation of all frequencies over a 120° solid angle
- Perfect for hi-level distribution sound reinforcement systems

## RCA Duo-Cone Speaker Mechanism, Type LC-1C

### Description

The LC-1C is a "Professional Quality" loudspeaker with low distortion, wide angle distribution, and extended frequency range. It is specifically designed for use in recording studios, executive offices, reception rooms, sponsor's booths, control rooms or other locations that warrant the finest sound possible. This speaker gives wide range smooth response from 25 to 16,000 Hertz with low harmonic distortion and very uniform distribution over a 120 degree angle.

The LC-1C covers four times the area that typical other high quality 60° speakers cover.

#### High-Compliance Duo-Cone

The LC-1C Loudspeaker is a high-compliance duo-cone speaker providing excellent response over a wide angle. The two coaxial cones are direct radiators and are driven by separate voice coils. An electrical filter consisting of a 4  $\mu$ F capacitor and the inductance of the low-frequency voice coil delivers the low

frequencies to the large outer cone and the high frequencies to the small inner cone. The filter (or crossover network) reduces the response of the low-frequency unit above 1600 Hertz and that of the high-frequency unit below 1600 Hz.

#### Alnico V Magnets

Other features of the construction are: a sturdy die-cast aluminum frame; separate Alnico V magnets in a non-welded structure for high and low frequencies; a high-frequency voice coil wound with copper clad aluminum wire to get full high-frequency range. Special high temperature materials plus adequate clearances provide improved power handling capability and exceptionally low distortion even in critical cross-over regions. A specially treated fabric cone suspension allows a low, 22 Hertz cone resonance and extended low frequency response. The high frequency diaphragm is mounted co-axially with the low frequency diaphragm and the two conical surfaces are in line. This minimizes out of phase com-

ponents in the cross-over range. Smooth response is also obtained by the shallow angle of the diaphragm, and flange mounting which places the face of the diaphragm practically flush with the face of the baffle.

#### New Construction Features

A feature of construction is the use of acoustical domes—largely responsible for smooth response. The series of domes placed on the speaker's large cone breaks up the unit's symmetry and eliminates the interference normally characteristic of the symmetrical shape without sacrifice of either highs or lows.

The LC-1C is designed for use either in the Olson Floor Cabinet MI-11415-A or Wall Mount Speaker Housing, MI-11406-B. The floor cabinet, functionally styled in satin walnut finish or utility finish, is especially designed to reduce variations in frequency response due to diffraction effects. It also provides maximum low frequency response. The wall housing provides excellent performance.



# Specifications

## LC-1C Duo-Cone Speaker

Impedance (nominal) .....15 Ohms  
 Frequency Response (see curve) .....25 to 16,000 Hz  
 Directional Characteristic—  
   Coverage Angle 120° .....See graph  
 Sensitivity at 1000 Hz .....94.5 dB  
   (measured with 1 Watt signal at 4 ft.)  
 Power Handling Capacity .....40 Watts of program material\*  
 Resonance .....22 Hz (in an infinite baffle)  
 Magnetic Assembly .....Two Alnico V magnets  
   (in a non-welded structure)

### Dimensions: (For Flush Mounting)

Diameter (cone) .....15 $\frac{5}{16}$ " (39.6 cm)  
 Diameter (bolt fixing circle) .....16 $\frac{1}{4}$ " (43.31 cm)  
 Diameter (overall frame) .....17" (43.2 cm)  
 Depth .....7 $\frac{1}{16}$ " (18.9 cm)  
 Weight (unpacked) .....21 lbs. (9.5 kg.)

## LS-1A Wall Housing

Mounting .....30° or 60° angle  
 Dimensions:  
   Height (max.) .....21 $\frac{3}{4}$ " (55.26 cm)  
   Width (overall) .....37 $\frac{1}{2}$ " (95.25 cm)  
   Depth (max.) .....17 $\frac{1}{8}$ " (43.5 cm)  
 Weight .....45 lbs. (20.4 kg.)

## LS-11A Floor Cabinet

Dimensions (Exterior):  
   Height (including 4-inch legs) .....44" (111.8 cm)  
   Width .....28 $\frac{1}{2}$ " (72.4 cm)  
   Depth .....16" (40.6 cm)  
 Finish .....Satin Walnut or Utility  
 Weight .....64 lbs. (27.2 kg.)

\*This mechanism is fail safe when fused with a 3AG  $\frac{3}{4}$  Ampere normal blow fuse. When so used the LC-1C may safely be driven by any high quality amplifier no matter how powerful.

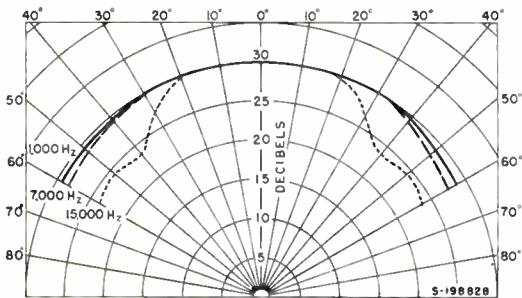
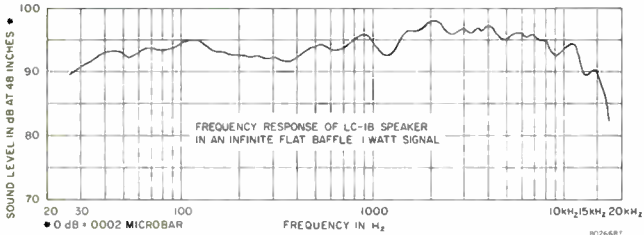

Rear view of LC-1C Duo-Cone Speaker Mechanism MI-11411-C.

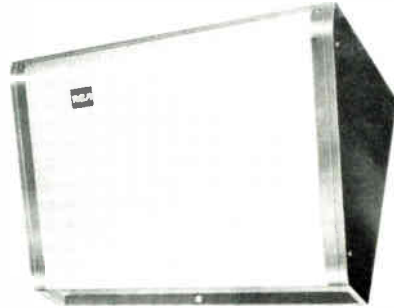

LS-1A Wall Speaker Housing MI-11406-B.

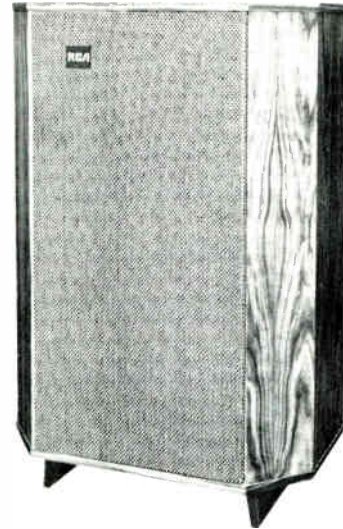

LS-11A Olson Floor Cabinet, MI-11415-A.

## Ordering Information

LC-1C 15-inch Duo-Cone Speaker Mechanism .....MI-11411-C  
 LS-1A Wall Speaker Housing  
   (Midnight Blue finish) .....MI-11406-B  
 LS-11A Olson Floor Cabinet for LC-1C  
   (Satin Walnut finish) .....MI-11415-A  
   (Utility finish) .....MI-11415-B



- Frequency response 50 to 18,000 Hz
- Balanced listening characteristic
- Indox (ceramic) permanent magnet
- Curvilinear cone plus a mechanically coupled high frequency cone

## Dioplex 8-Inch (203 mm) Speaker, Type SL-8

### Description

The SL-8 High Fidelity Dioplex 8-inch cone type loudspeaker should be specified where smooth, uniform response and natural reproduction of voice and music are desired. This 8-inch (203 mm) loudspeaker may be used with any standard 8-inch baffle, but it is recommended that for quality reproduction a minimum enclosure size of  $2\frac{1}{2}$  cubic feet (0.6 m<sup>3</sup>) be used (see *Accessories*).

### Balanced Listening Characteristic

The smooth frequency response of the SL-8 Speaker is the result of extensive research by Dr. H. F. Olson and his associates at the Acoustical Laboratories of the David Sarnoff Research Center. A special shape has been used for the curvilinear cone, and, in addition, the material for the cone has received particular attention. These two factors play important roles in giving a broad pattern to the speaker. A further refinement is the damp-

ing ring in the outer suspension of the cone which provides optimum acoustical impedance to effectively eliminate standing waves in the suspension cone. This gives improved efficiency at the bass end and relatively smooth response at the high end of the spectrum.

### Extended High Frequency Response

The mechanically coupled high frequency cone extends the smooth high frequency response well out beyond the normal listening range of the average listener.

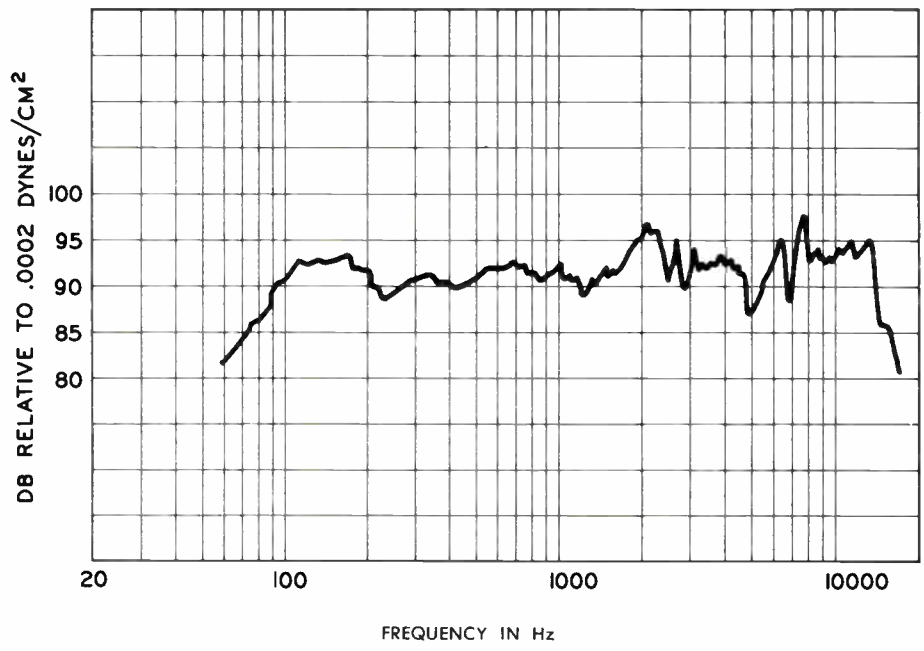

## Specifications

Frequency Response .....	50 to 18,000 Hz
Power Handling Capacity .....	10 watts
Magnet Material and Weight .....	Indox; 10 ounces (284 g)
Input Impedance .....	8 ohms
Overall Diameter .....	8 <sup>3</sup> / <sub>8</sub> inches (210 mm)
Depth .....	3 <sup>1</sup> / <sub>8</sub> inches (80 mm)
Weight .....	2 <sup>3</sup> / <sub>4</sub> pounds (1640 g)
Axial Sensitivity at 4 ft (1220 mm) 1 watt (see curve) .....	92 dB
Cone Resonance (6 <sup>1</sup> / <sub>2</sub> cubic ft. [0.18 m <sup>3</sup> ] cabinet) .....	74 Hz
Mounting Data (EIA).....	4 equally spaced slots on a 7 <sup>5</sup> / <sub>8</sub> " (194 mm) bolt circle
Flux Density.....	9000 gauss

### Accessories

Wall Housing, Type LS-3 (for 8- or 12-inch speakers) .....	MI-11407
Wall Baffle (for 8- or 12-inch speakers) .....	MI-11414-2

### Architects' and Engineers' Specifications

The speaker shall be a permanent magnet field type using 10 oz. of Indox. It shall be capable of handling up to 10 watts of audio power, and capable of producing an audible frequency response over a range of 50 to 18,000 Hz and shall have a nominal axial sensitivity of 92 dB at 4 feet (1.2 m) with 1 watt input. The voice coil impedance shall be 8 ohms at 400 Hz. It shall have a one piece, stamped-steel frame with an outside diameter of 8<sup>3</sup>/<sub>8</sub> inches (213 mm) and shall have four equally spaced slots on a 7<sup>5</sup>/<sub>8</sub>-inch (194 mm) bolt circle for mounting purposes. The overall depth shall be 4<sup>1</sup>/<sub>8</sub> inches (116 mm) or less. All ferrous metal parts shall be made rust resistant by plating. The cone shall be equipped with a mechanically coupled high frequency cone.

## Ordering Information

Type SL-8 Dioplex Eight-Inch Speaker .....MI-38311-A

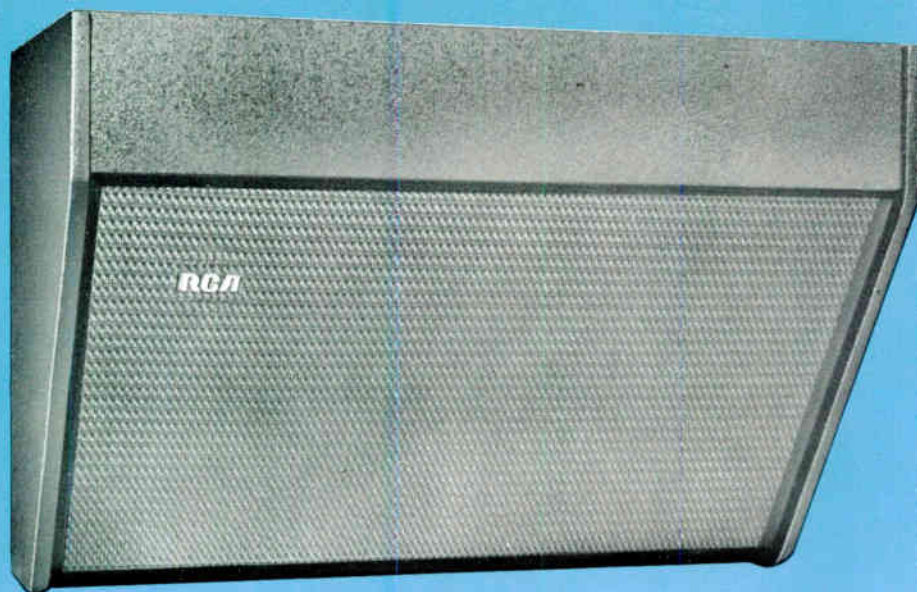

MI-11407-D

- Acoustically engineered
- For 8, 10 and 12 inch speakers
- Carefully baffled for best sound
- Fibre-acoustic padding
- Sturdy construction

## RCA Loudspeaker Cabinets

### Description

These Loudspeaker Cabinets (MI-11407-D and MI-11414-2) are designed for wall mounting standard 8-inch, 10-inch or 12-inch diameter speakers. They are especially suited for the RCA Type SL-8, SL-12 and MI-1245+-C Speakers.

Cabinets are solidly built of 1/2-inch plywood. A back panel (MI-11407-D only), glass fibre acoustic padding, two adapter plates, and two wall-mounting brackets are supplied. The adapter plate should be used when mounting 8-inch speakers in the cabinet.

### Specifications

#### MI-11407-D

##### Dimensions and Weight:

Length .....	25"
Height .....	16 <sup>3</sup> / <sub>8</sub> "
Depth .....	11 <sup>1</sup> / <sub>2</sub> "
Weight .....	12 pounds

Finish .....Midnite blue textured lacquer

#### MI-11414-2

##### Dimensions and Weight:

Width .....	13 <sup>7</sup> / <sub>8</sub> "
Height .....	15 <sup>1</sup> / <sub>4</sub> "
Depth .....	9 <sup>1</sup> / <sub>4</sub> " (top), 5 <sup>1</sup> / <sub>4</sub> " (bottom)
Weight .....	9 <sup>1</sup> / <sub>2</sub> pounds

Finish .....Midnite blue textured lacquer

### Ordering Information

Loudspeaker Cabinet, Type LS-3B, Midnite Blue .....	MI-11407-D
Loudspeaker Cabinet, Midnite Blue .....	MI-11414-2



MI-11414-2

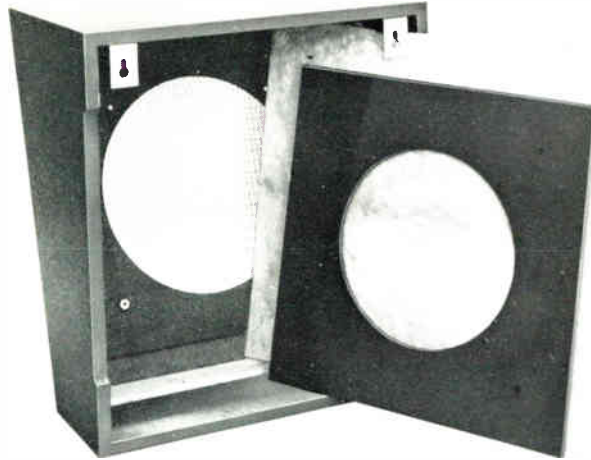

Rear view, MI-11414-2, showing padding and convenient mounting brackets.



Inside view, MI-11407, showing construction, acoustic padding, and adaptor plate.

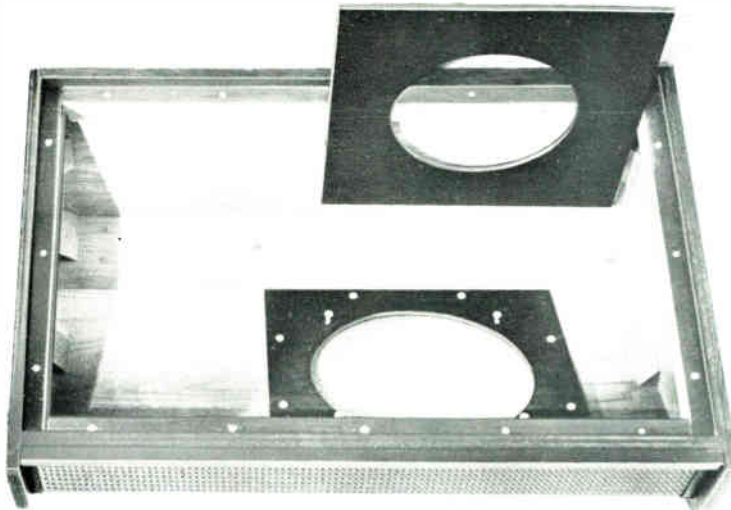

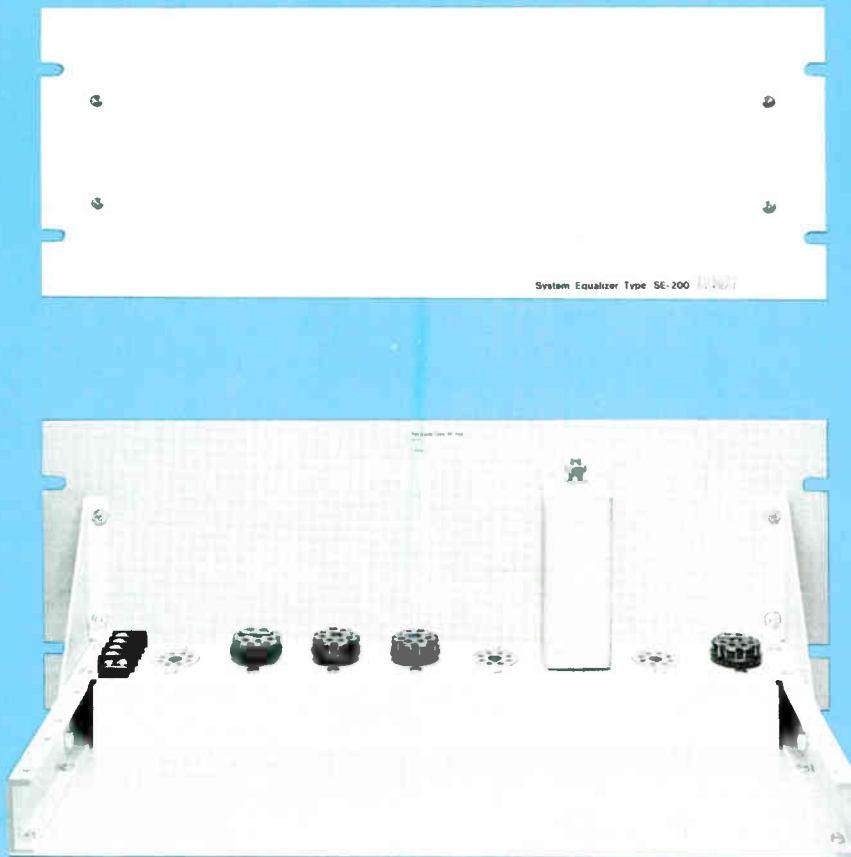

- (24) Selected one-third octave frequency channels
- Modular octal plug-in type filters
- (6) Selected special shelving range filters minimize one-third octave filter requirements
- Pre-wired socket strips/barrier type connections
- Toroidal inductors of constant-K design
- Standard 600 Ohm source impedance and 600 Ohm load impedance

## RCA Audio Equalization System, Type SE-200

### Description

The Type SE-200 Equalization system is one of the RCA Electro-Coustical systems available for perfectly matching sound reinforcement to the acoustic environment. Its application results in a balanced system which provides faithful sound reproduction throughout without annoying reverberation, feedback or "ringing."

The RCA Type SE-200 Equalization System consists of a series of modular octal base plug-in type filters which facilitates the equalization of a Professional Audio System with a minimum of on-the-

job installation time. The system consists of a (24)-channel set of MI-9672 one-third octave Band-Elimination Filters and a set of (6) MI-9673 Special Shelving Filters to correct for commonly encountered room response conditions. A standard 19" rack mounting type panel and chassis assembly MI-9671-1 provides the facilities for mounting up to four pre-wired socket strip assemblies consisting of (8) sockets per assembly.

Toroidal inductors are employed for filter stability and minimum hum pickup, and the modular enclosures are hermeti-

cally sealed. All filters are of constant-K design for use in 600 Ohm line circuitry.

Insertion loss is adjusted to the job condition by a locking potentiometer in the top of each module, and with a loss range adequate for all situations encountered. Octal socket strips are all pre-wired in the same manner and may be cascaded in any logical order to meet the various job situations. Blanking plugs are supplied as part of basic mounting panel assembly for insertion into the unused octal sockets for circuit continuity.

## Applications:

The MI-9672 filter units are plugged into the pre-wired octal socket strip as required for the correction of the room response.

A series of MI-9673 (6) Special Shelving Filters is provided to minimize the number of one-third octave filters required for final adjustment of the room response. The locking potentiometer in the top of each module provides an inser-

tion loss range of 0 to 15 dB within the reject band of the filter. There is no insertion loss with the control at zero. Two or more adjacent channels when lowered together provide a flat response minimum down to at least 15 dB. That is, a region of the spectrum may be lowered smoothly by at least 15 dB.

The MI-9672 Filters using the standard I.S.O. center frequencies from 63 Hz to 12.5 kHz with I.S.O. one-third octave band edges make up the (24) Modular

Filter set. When used with the MI-9673 Special Shelving Filters only a small portion of the set will be required to equalize a room response. It should be noted this type of equalization system requires special test equipment. The services of C. P. Boner and Associates or a licensee are recommended to make the relatively fine adjustments. (U. S. Patent 3,256,391). This service can be arranged by RCA or through one of our nationwide RCA Professional Audio Distributors.



MI-9671-5.

## Specifications

Source Impedance .....	600 Ohms
Load Impedance .....	600 Ohms
Input Level .....	Max. +18 dBm
Frequency Range:	
(One-third Octave Filters) .....	63 Hz to 12.5 kHz
(Special Shelving Filters) .....	See Ordering Information
Insertion Loss .....	0 to 15 dB with Reject Band of Filter Module
Adjustments .....	Potentiometer/Locking Nut on top each module
Filter Mounting .....	Plug-in Octal Base
Filter Size .....	Plug-in X Octal Base
Filter Finish .....	Light Gray
Filter Weight per Module .....	.10 oz.
Filter Mounting Panel Frame Assembly:	
7" x 19" Standard Rack Panel Mounting .....	Requires 7½" clearance behind panel
8 Octal Sockets per Mounting Strip (One strip supplied)	
4 Strips maximum mounting per mounting panel assembly	
Input and Output Connections .....	Cinch Jones Barrier Strips
Front Panel Finish .....	Brush Satin Anodized Aluminum
Weight .....	With 1 socket strip (less modules), 4 lbs.

## Ordering Information

MI-9671-1 Filter Mounting Panel and Frame Assembly complete with one pre-wired socket strip consisting of (8) Octal Sockets. Includes pack of (7) Blanking Plugs and all mounting hardware.

MI-9671-5 Socket Strip only accessory item for MI-9671-1 as required.

One-third Octave Filter set—(Suffix Numbers listed in Hertz and kilohertz)

MI-9672-63	MI-9672-400	MI-9672-2.5 kHz
MI-9672-80	MI-9672-500	MI-9672-3.15 kHz
MI-9672-100	MI-9672-630	MI-9672-4.0 kHz
MI-9672-125	MI-9672-800	MI-9672-5.0 kHz
MI-9672-160	MI-9672-1.0 kHz	MI-9672-6.3 kHz
MI-9672-200	MI-9672-1.25 kHz	MI-9672-8.0 kHz
MI-9672-250	MI-9672-1.6 kHz	MI-9672-10.0 kHz
MI-9672-315	MI-9672-2.0 kHz	MI-9672-12.5 kHz

Special Shelving Filter Set:

MI-9673-1 — LP 500 Hz	MI-9673-4 — HF Boost
MI-9673-2 — HP 1.0 kHz	MI-9673-5 — LP 1.0 kHz
MI-9673-3 — LP Boost	MI-9673-6 — BR 2.0 kHz



- 8 selected frequency channels
- Standard 600 Ohm source impedance to 600 Ohm load impedance
- Toroidal inductors/minimum hum pickup
- Hermetically sealed enclosures

## RCA Broadband Audio Equalization System, Type SE-100

### Description

The Type SE-100 Broadband Equalization System is one of the RCA Electro-Coustical Equalizer systems available for perfectly matching sound reinforcement systems to the acoustic environment. Its application results in a balanced system which provides faithful sound reproduction throughout, without annoying reverberation, feedback or "ringing."

The RCA Type SE-100 Broadband Equalization System is an eight-channel (2/3 octave) tuned RLC filter assembly with adjustable screwdriver type of controls for attenuating each of the eight selected frequency channels as required for the particular sound system installation.

The Type SE-100 is designed to operate in a 600 Ohm link circuit between the mixer (or line amplifier) output and the power amplifier input circuit. Each of the eight broadband filters is, in effect, a master gain control which operates only on a limited portion of the audio spectrum. This permits the Professional Audio installation engineer to reduce the amplifier gain only in the frequency bands where excessive sound system feedback occurs.

The Broadband Equalization System

is designed for use in professional type of audio systems installations such as small-to-medium size meeting rooms, churches, auditoriums, studios and other locations where a moderately priced system is required.

The RCA Type SE-100 Equalization

System requires a minimum of test equipment to equalize the system.

For the more complex, larger type of installations encountered, with highly reverberant room conditions, the RCA Type SE-200 full one-third octave modular equalization system is recommended.

### Specifications

Source Impedance .....	600 Ohms
Load Impedance .....	600 Ohms
Input Level .....	Maximum input level +18 dBm
Frequency Range .....	120 Hz to 4.0 kHz
Adjustment Channels .....	Eight in 2/3 octave steps
Insertion Loss .....	0 to 10 dB with individual adjustment of each channel
Controls .....	Screwdriver adjustments/locking nuts all located on rear of panel
Filters .....	Toroidal inductors/minimum hum pickup in hermetically sealed enclosures
Finish .....	Brushed satin anodized aluminum front panel
Dimensions .....	3½" x 19" standard rack panel mounting. Requires 4¾" clearance behind panel
Weight .....	5 lbs.

### Ordering Information

Type SE-100 Broadband Equalization System .....MI-9670





CAMERA

CAMERA

## **RCA** Three-Tube Color Camera, Type TK-44A

- Three lead oxide tubes
- Simple, high efficiency optical system
- Lightest weight—smallest size
- Solid state circuitry

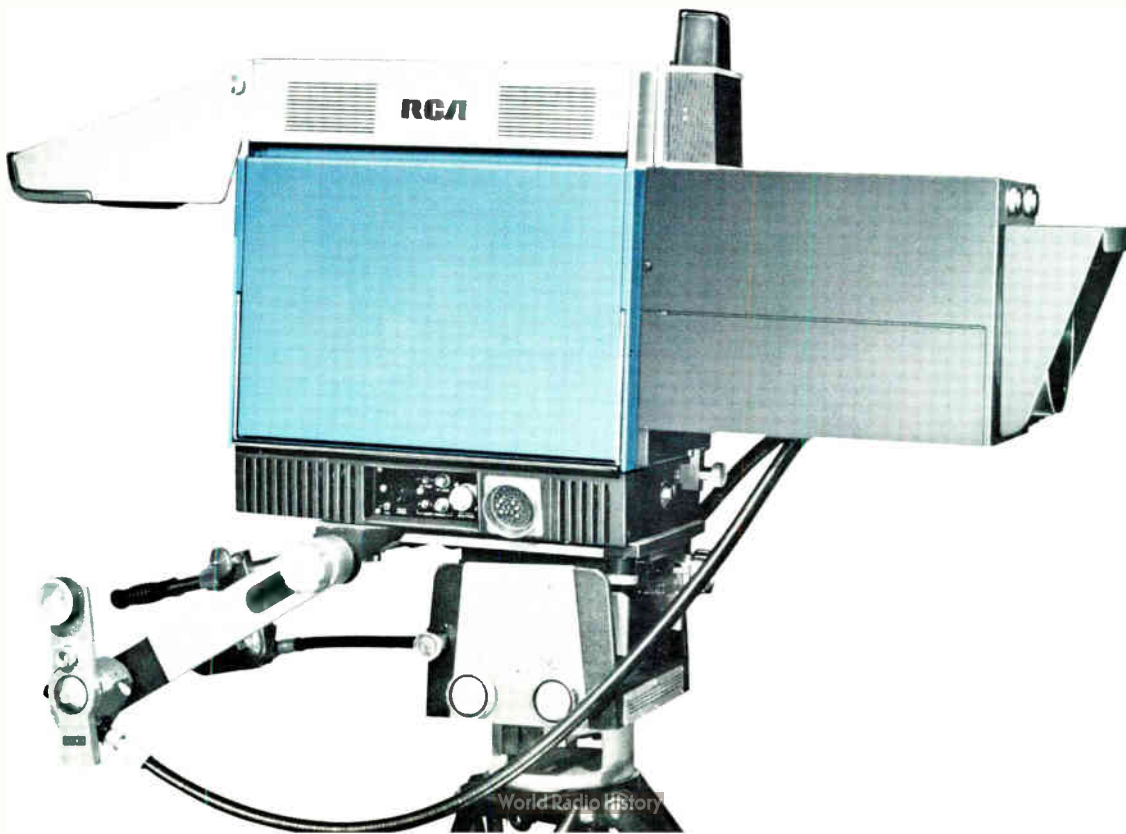

the usual increase in noise. This selective discrimination increases the effectiveness of contour enhancement—more compensation can be used before noise becomes a limiting factor.

Other advances simplify circuitry and automate camera operation. For example, the camera forms its own drive and burst flag pulses and provides automatic timing for cable delays. The net result is a substantial saving by eliminating pulse distribution amplifiers and delay lines. H and V drive pulses are derived from sync and are generated within the camera. In addition, the timing of the camera chain output signal is compared with sync timing to produce a control signal which advances the drive signals at the camera and compensates

automatically for delay in the camera cable. This eliminates the need for delay of drive pulses to monochrome cameras operating synchronously in the system.

Also built into the camera are a shading generator and a color bar generator that provides standard full raster color bar signals for colorplexer adjustment. The colorplexer has built-in instrumentation to permit setup without special test equipment.

### High Performance and Serviceability

Stability of the TK-44A is greatly enhanced by white pulse gain stabilization, an overall feedback system that provides constant output over wide temperature ranges.

Extensive integrated circuitry is employed to reduce overall circuit complexity. Camera modules are easily accessible and can be serviced in place without need for module extenders. Pin-to-pin wiring simplifies component replacement. Pick-up tube yoke assemblies are easily removed without tools for tube replacement. Interphone amplifiers are plug-in types with gain controls. Test jacks are extensively used.

### NTSC or PAL Color Standards

The TK-44A is available for operation on either NTSC or PAL color standards. The versatile power supply of the camera chain operates on source voltages and frequencies anywhere in the range of 90 to 130 (or 180 to 260) Volts and 47 to 63 Hz without changing taps.

## Specifications

### General

Scanning Standards	EIA, 525 lines, 60 fields per second or 625 lines, 50 fields per second
AC Power Input	90 to 130 Volts or 180 to 260 Volts 47 to 63Hz
Viewfinder Display Size	8-inch picture diagonal
Viewfinder Brightness	150 footlamberts
Maximum Length of Camera	Up to 2000 ft.
Cable	Up to 3000 ft. with optional Equalizer 3 Module
Video Inputs:	
Sync; Blanking; Subcarrier	2 V $\pm$ 0.5 V p-p
External Signal Input for Viewfinder	1 V p-p composite
Video Outputs:	
Line Outputs	Two independent color, composite or non-composite 0.7 Volts video into 75 Ohms or 1.0 Volts p-p video

Monitor Outputs:	
Waveform Display	1. Color Output 2. R, B and G in any combination
Picture Display	1. Color Output 2. R, B and G in any combination
Chroma Key Output	R, B and G outputs 0.7 Volts p-p
Operational:	
Gamma Correction	0.45 to 1.0 continuously variable in all channels
Contour Signal	Amplitude variable with on/off provision
Modulation Shading	$\pm$ 10% H & V saw and parabola for all channels

### Mechanical

	Height	Width	Depth	Weight
Camera Head incl.				
Viewfinder less lens	20 in.	11 $\frac{3}{4}$ in.	18 $\frac{1}{2}$ in.	98 lbs.
Auxiliary Unit	5 $\frac{1}{4}$ in.	19 in.	16 in.	45 lbs.
Colorplexer	5 $\frac{1}{4}$ in.	19 in.	15 $\frac{1}{2}$ in.	55 lbs.
Power Supply	5 $\frac{1}{4}$ in.	19 in.	18 in.	72 lbs.
Set-up Control Panel	10 $\frac{1}{2}$ in.	19 in.	8 in.	15 lbs.
Operating Control Panel	7 in.	8 $\frac{1}{4}$ in.	8 in.	5 lbs.

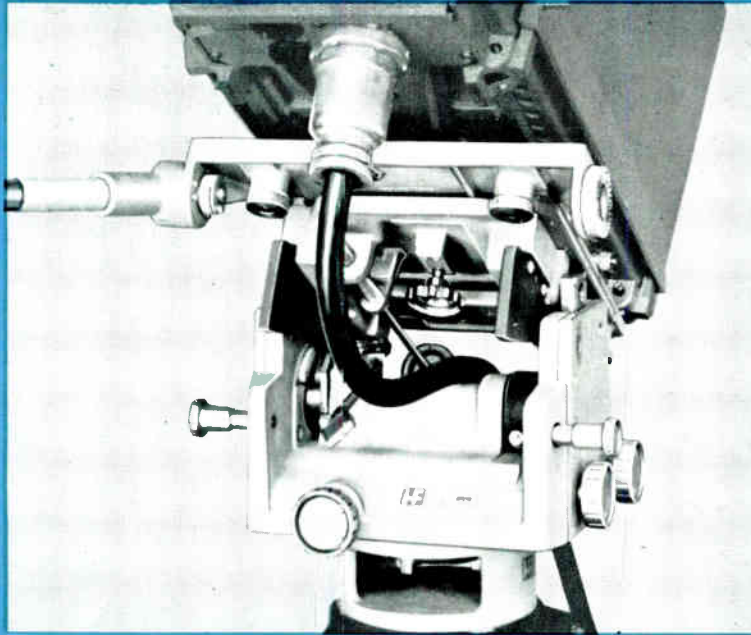

- **Consistent balance throughout tilt range**
- **Greater tilt range**
- **Simplicity of adjustments**
- **Positive horizontal safety lock**
- **Sealed bearings—trouble free operation**

## RCA Camera Cam Head

### Description

A Cam Head, designed by Houston Fearless to operate with all RCA color or monochrome TV cameras and fit on any standard pedestal or tripod, takes the work out of camera movement. Greater flexibility and adaptability as well as smooth finger-tip control of pan and tilt are made possible by the new camera positioning head. The Cam Head also features increased tilt range, simplicity of adjustments, positive horizontal safety lock, and simple trouble-free mechanical design.

The head makes use of a simple mechanical principle to provide finger-tip touch control of tilt positions. The camera is mounted so that the center of gravity of the camera is over the vertical center line of the head distributing the weight of the camera equally for balanced operation. Two identical cams, on either side of the head, are profiled so that as the camera is tilted up or down, the angular displacement of the cams counterbalances the weight of the camera in any position. The weight of the camera thus does all the

“work” of the movement—with the operator merely guiding the direction and limits of movement.

A separate cam profile has been developed for each RCA TV camera.

A color camera, for example, uses one set of cams while a lighter weight monochrome camera uses another. Cams are attached by means of four screws in the mounting yoke.

### Specifications

Angle of Tilt.....	±50° from horizontal
Angle of Rotation.....	360°
Capacity.....	500 lbs. (225 kg.) max.
Dimensions (overall).....	20" long, 18" wide, 10" high (50.8 cm x 45.7 cm x 25.4 cm)
Weight.....	46 lbs. (20.9 kg.)

### Ordering Information

#### Cam Heads Complete:

Cam Head for TK-42/43 Cameras .....	MI-557310
Cam Head for TK-44A Cameras .....	MI-557390

#### Interchangeable Cams Only:

Cams for TK-60 Camera.....	MI-557311-2
Cams for TK-40/41 Cameras.....	MI-557311-3
Cams for TK-42/43 Cameras .....	MI-557311-4
Cams for TK-44A Camera .....	MI-557311-5

## Camera Cradle Head

RCA MI-26203-C Cradle Head is specified for Monochrome Image Orthicon Cameras and the lighter weight color cameras. It fits all standard heavy duty pedestals, dollies, cranes, tripods or hi-hats, as well as the TD-7A Lightweight Camera Pedestal, and lightweight Mounting Adaptors.

The cradles provide a new balance and ease of camera operation.

When the camera is tilted up or down, the cradle rotates around a constant center of gravity, maintaining absolute balance at all times. There are no counterbalancing springs to get out of adjustment or to produce noise. Panning action is accomplished with the same ease as the tilt action due to precision ball bearing construction.

The heads have special flexibility for both studio or outdoor camera operation. The head tilts down 38 degrees and up 30 degrees. Stop blocks prevent the cradle from riding off the bearings at the extreme limits of travel. Drag adjustment is provided on the tilt. Brakes on the pan and tilt quickly lock the camera in a fixed position.



### Specifications

<b>Monochrome Cradle Head</b>	
Angle of Rotation.....	360°
Top Plate.....	6 <sup>7</sup> / <sub>8</sub> " wide x 5" long (17.5 cm x 12.7 cm)
Height.....	7 <sup>1</sup> / <sub>4</sub> " (18.4 cm)
Weight.....	26 lbs. (11.8 kg.)
Shipping Weight.....	45 lbs. (20.5 kg.)
Control Handle .....	Supplied

### Ordering Information

Monochrome Camera Cradle Head .....MI-26203-C

## Camera Friction Head

The MI-26205-C, Friction Head, may be mounted on any of the RCA type pedestals or tripods by means of a single hand-operated wing nut, which is furnished with the Friction Head. The head is of rugged all-metal construction, in which all ma-

terials have been carefully selected for both field and studio use.

Rotation through 360 degrees in azimuth and ample tilt, up and down, are provided for operation with the RCA cameras. Extremely

smooth in operation, RCA Field and Studio Cameras when mounted on this unit are well balanced in any position of tilt, by means of specially designed counterbalance springs. Thus, a minimum of effort is required by the camera operator.



### Specifications

<b>Dimensions:</b>	
Overall Height .....	8 <sup>1</sup> / <sub>4</sub> "
Overall Length .....	8 <sup>1</sup> / <sub>2</sub> "
Overall Width .....	13"
Weight (including panning handle).....	28 lbs. (approx.)
Angle of Rotation.....	360°
Finish .....	Midnight blue

#### Accessory

Hi-Hat Mounting Adaptor  
(6" high, 10<sup>1</sup>/<sub>4</sub>" mounting dia.).....MI-26190-3A

### Ordering Information

Camera Friction Head .....MI-26205-C

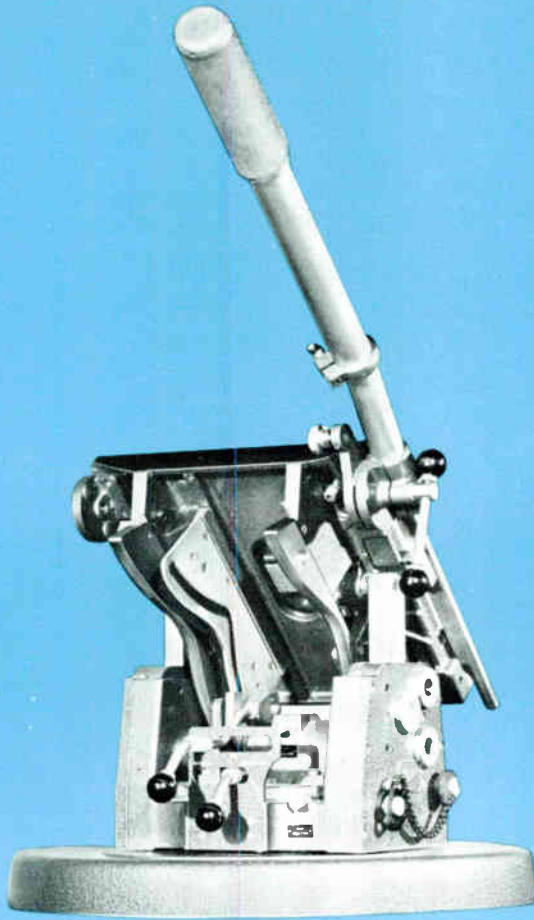

- Tilt range: 100 degrees
- Constant camera balance
- For cameras to 400 lbs. (180 kg.)
- Camera-mount plate included
- Choice of zoom-control mount
- Wedge-mount plate optional

## Vinten Camera Cam Head

### Description

Using a new and unique principle, the *Vinten* Camera Cam Head is a superior pan-and-tilt camera-mount device offering wide tilt-angle, precise camera balance and dependable operation for modern color or monochrome television cameras.

#### Constant Camera Balance

Maintaining constant camera balance at any tilt angle within its range, the *Vinten* Cam Head utilizes a cam-and-

follower system that displaces the camera's own weight for counterbalance. The cams and followers move the camera platform forward or rearward to keep the camera's center of gravity directly above the centerline of the head, regardless of tilt angle.

#### Cameras to 400 Pounds (180 kg.)

Ruggedly structured to support the camera solidly and without mechanical "play", the *Vinten* Cam Head handles

any camera-and-lens combination weighing less than 400 lbs.

#### Movable Camera Mount

An inch (25 mm) of forward and rearward camera-mount movement provides for the changes in camera center-of-gravity with lens system interchange. A simple leadscrew relocates the camera gravity center directly above the pivot. An optional platform-extension plate (*see Optional Accessories*) moves the camera



further rearward to compensate for the added weight of extra long-length lenses.

### Essentially Maintenance-Free

Because of careful attention to detail in design and fabrication, *Vinten* Cam Heads require virtually no maintenance.

### Optional Wedge-Mount

For those who mount and dismount cameras for transport, a quick connect/disconnect wedge mount is a great convenience. The mount consists of an A-

shaped plate and a rectangular adaptor plate. The adaptor plate attaches to the underside of the camera head while the A- plate attaches to the cam head. The two mate quickly and securely through a simple locking system. The device repays its purchase price several times over in the time saved. (See *Optional Accessories*)

### Choice of Zoom-Control Mount

The *Vinten* Cam Head provides a choice of lens-zoom control mount. One

choice uses a simple bracket (506/100A, *Optional Accessories*) which supports the zoom control at the cameraman's right hand, beneath the camera head. Using a short pan-handle instead of the bracket, the alternate choice allows greater freedom in zoom-control position and provides limited pan control for the cameraman's right hand. Three components make up the alternate choice as listed under *Optional Accessories* (308/11A, 426/4A and 104/537A).

## Specifications

Tilt Angle .....	50° up; 50° down
Pan Angle .....	360°
Maximum Camera Weight .....	400 lbs. (180 kg)
Dimensions .....	12" L; 14" W; 7" H (300 x 350 x 175 mm)
Weight .....	44 lb. (20 kg)

### Optional Accessories

Wedge Mount Assembly .....	MI-557545
Vinten Platform Extension Plate .....	504/1A
Vinten Zoom-Lens Control Bracket .....	506/100A
Vinten Short Pan Bar .....	308/11A
Vinten Quadrant Clamp (for Pan Bar) .....	426/4A
Vinten Universal Zoom Control Mount .....	104/537A

## Ordering Information

Vinten Cam Head for TK-44A Color Camera .....MI-557544\*

\*Zoom-Control Mount not included. Order either one 506/100A (*Optional Accessories*) or one each: 308/11A, 426/4A and 104/537A to provide mount for lens-zoom control. (See Text)

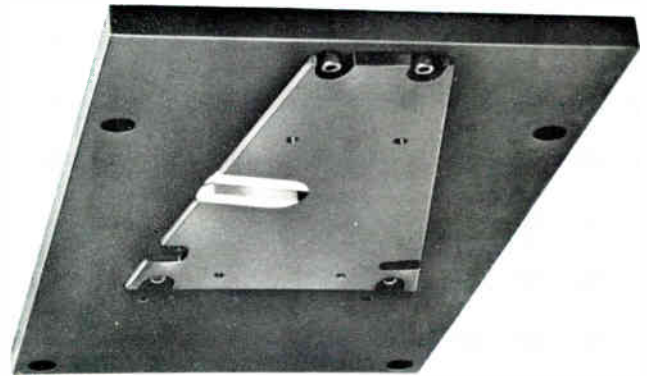

An optional wedge mount assembly allows quick mount and dismount of the camera.

EIA Television Test Charts offer a quick, convenient and reliable standard for live-camera adjustments. Using these standard checks, telecasters have an accurate and objective method of evaluating picture quality of orthicon, Plumbicon\* or vidicon cameras. Available from RCA, these test charts serve both monochrome and color operations.

# RCA Television Test Charts

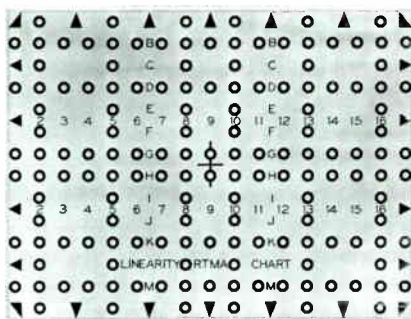

EIA Linearity Chart, MI-26822-1.

### EIA Linearity Chart

As its name implies, the Linearity Chart provides a standardized, precise method of measuring television camera scanning linearity. It is designed for use with a grating generator pattern which provides an accurate, visual reference for comparison with the charts scanned image.

The chart has an aspect ratio of 3 by 4 and is designed to be scanned to its boundaries as indicated by the arrows. The pattern consists of circles arranged in 14 horizontal and 17 vertical rows. The inside diameter of each circle is equivalent to 2 percent of picture height, and the outside diameter is equivalent to 4 percent of picture height. A grating pattern source, such as the grating generator output of the TG-3 Synchronizing Generator, is superimposed electrically upon the video signal produced by scanning the linearity chart. Observation of the relative position of each circle with respect to the grating bars permits measurement of scanning linearity within an accuracy of 1 percent of picture height.

#### Ordering Information

EIA Linearity Chart .....MI-26822-1

\*N. V. Phillips trademark.

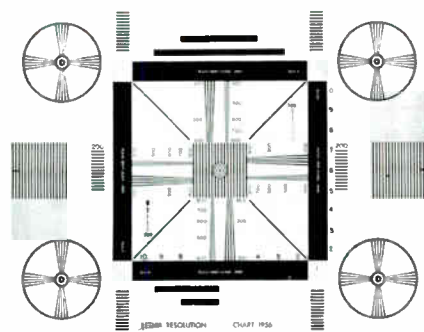

EIA Resolution Chart, MI-26822-2.

### EIA Resolution Chart

Designed as a standard reference for measuring resolution of television cameras, the EIA Resolution Chart is an aid in testing for camera streaking, ringing, interlace, shading, scan linearity, aspect ratio, and gray-scale reproduction. The horizontal and vertical resolution of many camera chains is sometimes limited by the resolving capabilities of the camera tube and not by the bandwidth of the camera's video amplifiers. Much useful information concerning the limiting resolution percentage response at various line numbers, and aging degradation of resolution of camera tubes can be obtained from a test chart containing a high number of lines. The horizontal and vertical wedges of the chart are arranged for resolution measurements from 200 to 800 lines. The reflection density of the various steps of the gray scales supplied with the chart are very accurately maintained in the manufacturing process. Arranged in ten steps, the scales cover a contrast range of approximately 30 to 1 in logarithmic decreasing values of reflectance. The difference in reflection density between adjacent steps is equal to 0.16.

#### Ordering Information

EIA Resolution Chart .....MI-26822-2

### EIA Registration Chart

The EIA Registration Chart is used to adjust and check live-color multiple cameras for optical, mechanical and electrical registration, so that the output signals are in correct time relationship. The chart uses a ruled grid pattern to aid in adjusting scan height, width, rotation, skew, centering and linearity in each channel. The ruled grid pattern also indicates any "S" distortion or bowing. The additional parallel lines about the edges allow for finer adjustments of the individual scan linearities in areas of the raster where most difficulty is likely to occur in matching the relationship of the scans.

The arrowheads at the edges are used for adjusting the amount of scan to a 3-by-4 aspect ratio. The circles indicate readily that corresponding lines are registered, and that the centering of one channel is not displaced by one complete line with respect to the others. A horizontal and vertical resolution wedge helps with fine adjustment of centering. The 45-degree radial lines indicate misregistration not easily detected with the ruled grid pattern.

#### Ordering Information

EIA Registration Chart .....MI-26822-3

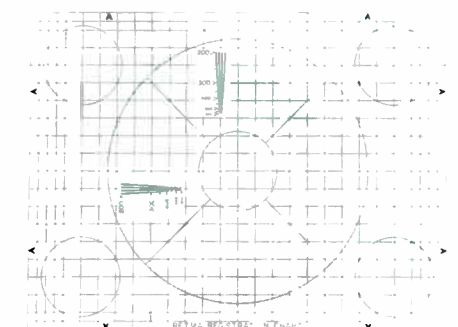

EIA Registration Chart, MI-26822-3.

### EIA Linear Reflectance Chart

The Linear Reflectance Chart is a standard reference for the measurement and adjustment of the transfer characteristics of monochrome and color TV cameras. This chart has a pair of linear gray scales running in opposite directions placed a short distance apart on a uniform gray background. Nine chips ranging from white to black provide information on reflectance, Munsell value and reflection density. The white chip offers a reflectance of 60 percent since it approximates the reflectance of the brightest object in the scene with current studio lighting practice. The contrast range of 20 to 1 covers the most useful luminance range of camera tubes used for color reproduction. The crossed gray scales differentiate between distortion due to poor transfer characteristics and those due to shading errors.

#### Ordering Information

EIA Linear Reflectance Chart ..MI-26822-4

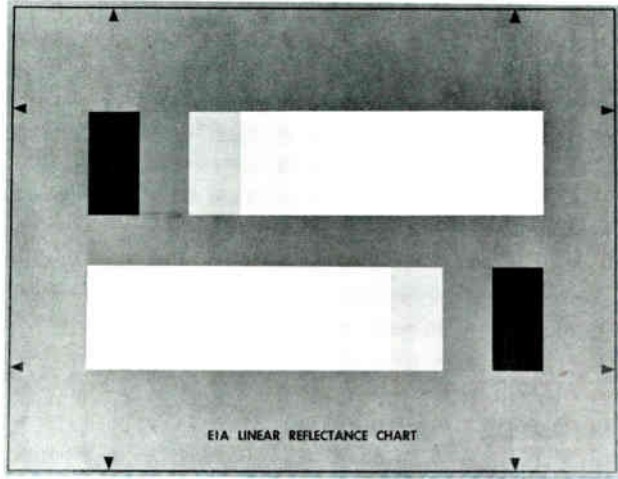

EIA Linear Reflectance Chart, MI-26822-4.

### EIA Logarithmic Reflectance Chart

The EIA Logarithmic Reflectance Chart is a standard reference for the measurement and adjustment of the transfer characteristics of monochrome and color-TV cameras. The chart carries a pair of gray scales running in opposite directions, a short distance apart, on a uniform gray background. The reflectance values of the lightest and darkest chips are similar to those of the Linear Reflectance Chart. However, the nine chips of the logarithmic chart provide equal percentage steps between reflectance values of consecutive chips. The logarithmic step pattern is of value in setting up monochrome TV cameras for optimum performance on the non-linear portion of the pickup tube transfer characteristic.

#### Ordering Information

EIA Logarithmic Reflectance Chart .....  
MI-26822-5

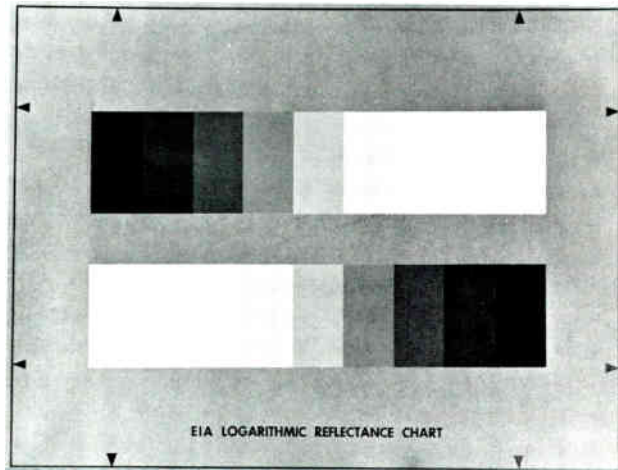

EIA Logarithmic Reflectance Chart, MI-26822-5.

### Burst Chart

The Burst Chart is an accurate means of measuring the aperture response of a live TV-camera system. There are 8 groups of alternate black and white bars; the number of black and white transitions in each group are such that when the chart is properly scanned an indication of 0.5, 1.0, 1.5, 2.0, 2.5, 3.0, 3.5 and 4.0 MHz response is obtained. The aperture response is a comparative evaluation in percentage of the response of the groups as measured on an oscilloscope.

#### Ordering Information

Burst Chart .....IB-31605

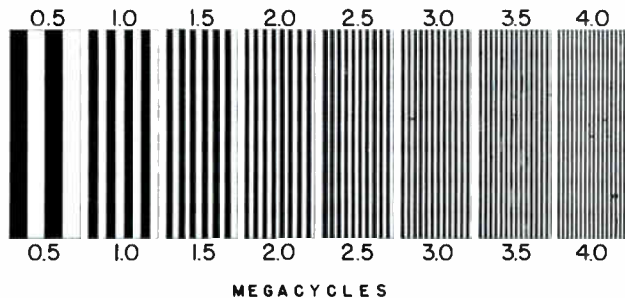

Burst Chart, IB-31605.



- Efficient, flexible
- Four lighting packages
- Easily expanded
- Built-in durability
- Almost maintenance-free

## Television Color Studio Lighting

### Description

The color studio lighting packages described here offer outstanding flexibility and control. They are designed and fabricated specifically for the needs of color TV program production. Ruggedness is combined with light weight, efficiency with economy, reliability with minimum maintenance.

#### Increased Efficiency

Tungsten-halogen is the latest in studio lighting. Its greater light level per fixture, non-blackening bulb and extra efficiency brought it quick acceptance among lighting men. Because more of the filament's light reaches the subject, less power produces satisfactory light levels. This manifests itself in a number of economies: reduced power and air-conditioning expense being the most important.

#### Constant Color Temperature

Tungsten-halogen lighting offers another very important plus: constant color temperature for the life of the lamp. As a result, T-II lighting causes no color shifts in programming, a particular annoyance in edited-tape programming.

#### Lighting Flexibility

Kliegl and Century boast an enviable reputation in stage lighting which stems from the well-refined designs in every fixture. All luminaires, patch panels and dimmers carry the UL Label.

#### Easily Expanded

Any or all of the equipment in the four lighting packages is in "open" stock. This means that the complement of any fixture, accessory, wiring device or control in the package can be increased at a future date so as to accommodate an enlargement in production or technique.

#### Built-In Durability

Another facet of the well-refined designs is unusual durability. Built to take the hard knocks of daily production, Kliegl and Century lighting fixtures look and perform like new for longer than one might expect.

#### Four Lighting Packages

Arranged around the size of the studio facility to be lighted, the four packages described here were assembled by men

with extensive experience in television studio lighting. The selection followed careful consideration of the needs—artistic, productive and economic—of the modern television studio.

The largest of the four packages, described first, consists of more than 1100 items: fixtures, lamps, accessories, wiring, etc., represents an equipment investment of about \$40,000 and provides adequate, useful, lighting for a four-thousand square-foot studio facility. The three smaller packages described on succeeding pages are arranged by decreasing size, facility and, of course, initial expense.

#### Installation Parameters

The studio-design data set out on the following pages is based upon typical installation requirements and operational conditions. Compliance with local electrical or other building codes cannot be assumed.

The data, however, is useful as a *guide* for your professional architect or engineer in the planning of a studio facility which satisfies your requirements as well as those of the local building code.

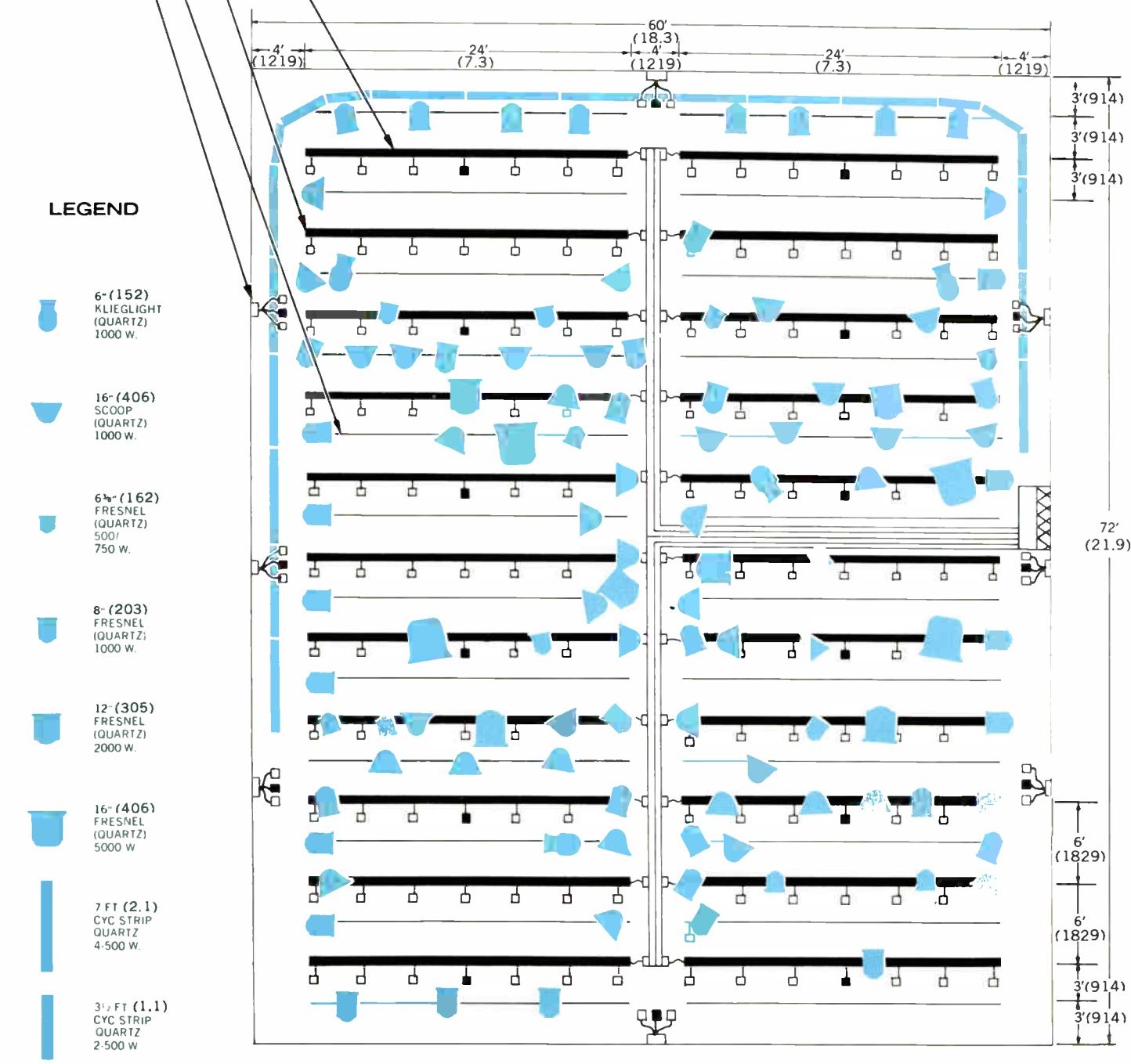
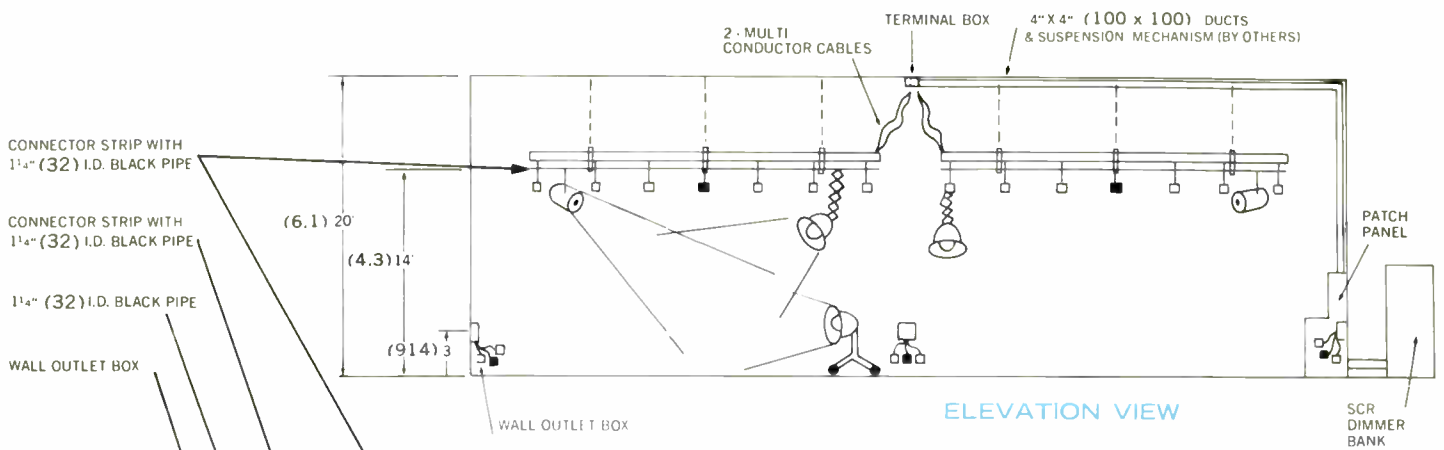

Parentetical dimensions are metric measure:  
 whole numbers, millimeters; decimals, meters.

# Lighting Package A

(for six large production areas)

## SPECIFICATIONS

Studio Area .....	4320 sq. ft. (401 m <sup>2</sup> )
Studio Dimensions .....	60 x 72 ft. (18.3 x 22 m)
Light Level .....	60 W per sq. ft. (0.107 m <sup>2</sup> )
Production Areas .....	Six (large)
Grid Load .....	(Includes lights, grid, curtains, etc.) 20 lbs./sq. ft. (10 kg/m <sup>2</sup> )
Power Requirement .....	600 A. 208 V., (3-phase 4-wire)
Heat Load .....	155 kW
Air Conditioning Load .....	45 Tons (540,000 BTU/hr)
Approximate Equipment Expense .....	\$40,000

## EQUIPMENT LIST

Qty.	Description	Kleigl Type No.	Century Type No.
44	1000 Watt Quartz Scoop 16"	3451	4271GP
4	75/150 Watt Fresnel Camera Light 3" lens	44N3TVB	3141GR
12	500/750 Watt Quartz Fresnel Spotlight 6 3/8" lens	3508	33420GP
40	1000 W Quartz Fresnel Spotlight 8" lens	3525	3413GP
6	2000 W Quartz Fresnel Spotlight 12" lens	44Q12TVG	3413GP
4	5000 W Fresnel Spotlight 16" lens	44Q16TVG	3814GP
2	1000 W Quartz Pattern Projector	1357P/6W	2327GP
2	1000 W Quartz Pattern Projector with Iris	1357/6I	2328GP
<b>Accessories</b>			
6	Four-way Barn Doors	1106A	13320
20	Four-way Barn Doors	1081A	13230
3	Four-way Barn Doors for 12" Fresnel	1082A	13230
2	Four-way Barn Doors for 16" Fresnel	1083A	13250
22	Diffuser Frames	585A	11160
2	Set of Patterns for projectors	1097	13530
11	Pantagraph Hanger Lazy Boy	111TV	3280
11	10 ft. Extension Cables for Pantagraph	10E955G	10RCCGP
2	Castered Stand	1421CR	14340
2	Extension Cable 25' for stands	25E955G	25RCCGP
<b>Wiring Devices</b>			
12	Connector Strips each 24 ft. long with six 20 A. Pigtail Outlets and one 50 A. Pigtail Outlet wired on seven circuits	619G/24/6/1X	6324/G-1SGP
10	Connector Strips each 24 ft. long with seven Pigtail Outlets wired on seven circuits	619G/24/7	6324/7-2GP
8	Wall Outlet Boxes with 2-20 A. and 1-50 A. Pigtails	2433G/2/1X	3017-3SP

Qty.	Description	Kleigl Type No.	Century Type No.
12	Ceiling Terminal Boxes	24-6G/12/2X	5430
10	Ceiling Terminal Boxes	2406G/14	5416
96 ft.	Cable	12/12	12/12
96 ft.	Cable	6/3	6/3
80 ft.	Cable	12/18	12/18

## Control Equipment

Qty.	Description
1	Main Control Panel (one-scene + two sub-scene) containing: 24 potentiometers with 3-position switches, 2 submaster switches (with blackout switch and pilot lamps), 1 main key switch with pilot lamp.
1	SCR-Dimmer Bank containing: 9 7 kW dimmer modules, 3 12 kW dimmer modules, 3 7 kW non-dim modules, 9 12 kW non-dim modules, 1 600A, 3-pole breaker, 1 Board light with switch.
1	Saf-Patch Panel containing: 158 20A counterweighted plugs, 20 50A counterweighted plugs, 132 50A automatic cold-patch jacks, 12 50A automatic cold-patch jacks, 132 20A circuit breakers, 12 50A circuit breakers, 1 Board light w/switch.

## CYC Package (OPTIONAL)

(Intended to be moved as needed) sufficient to light a "U" shaped cyc covering 1-60 ft. (18m) wall, two curves and one-half of both 72 foot (22m) walls. Two and three color strips also available.

Qty.	Description	Kleigl Type No.	Century Type No.
15	Kliegl: 7 ft. Striplights with 4 reflectors and glass color filters; Century: 8 ft. with 8 reflectors on 2 circuits.	3500FC	2-80052
6	Kliegl: 3 1/2 ft. Striplights with 2 reflectors and glass color filters; Century: 4 ft. with 2 reflectors on 2 circuits.	3500AFC	2-20052
3	Threefer Adaptors to convert 1-50 A. outlet to 3-20 A. outlets	453TVG/3	
72	Quartz Lamps (Century Quantity 216)	FDN	FHM

**Lamp Complement (3200° Kelvin) for color; representing one lamp per luminaire plus one spare each. (optional)**

88	Lamp for Scoop	Q1000T3/4	EGK
8	Lamp for Cameralight	150G16 3/4/3DC	FEV
24	500 W Lamp for 6 3/8" Fresnel	EHC	BTM
80	1000 W Lamp for 8" Fresnel	FER	BVV
12	2000 W Lamp for 12" Fresnel	CYX	BVV
8	5000 W Lamp for 16" Fresnel	DMY	DMY
8	1000 W Lamp for Kleiglites	1000T6Q/RCL/1	EGJ

# Lighting Package B

(for four medium and two large production areas)

## SPECIFICATIONS

Studio Area .....	2400 sq. ft. (232 m <sup>2</sup> )
Studio Dimensions .....	40 x 60 ft. (12 x 18 m)
Light Level .....	60 W per sq. ft. (0.107 m <sup>2</sup> )
Production Areas .....	Six (4 medium; 2 large)
Grid Load .....	(Includes lights, grid, curtains, etc. 20 lbs./sq. ft. (10 kg/m <sup>2</sup> ))
Power Requirement .....	300 A., 208 V. (3-phase, 4-wire)
Heat Load .....	96 kW
Air Conditioning Load .....	27.4 Tons (328,800 BTU/hr)
Approximate Equipment Expense .....	\$25,000

### LEGEND

-  6" (152) Klieglight (QUARTZ) 1000 W.
-  16" (406) SCOOP (QUARTZ) 1000 W.
-  6" (152) FRESNEL (QUARTZ) 500-750 W.
-  8" (203) FRESNEL (QUARTZ) 1000 W.
-  12" (305) FRESNEL (QUARTZ) 2000 W.
-  16" (406) FRESNEL (QUARTZ) 5000 W.
-  7 FT (2.1) CYC STRIP QUARTZ 4 500 W.
-  3 FT (1.1) CYC STRIP QUARTZ 2 500 W.

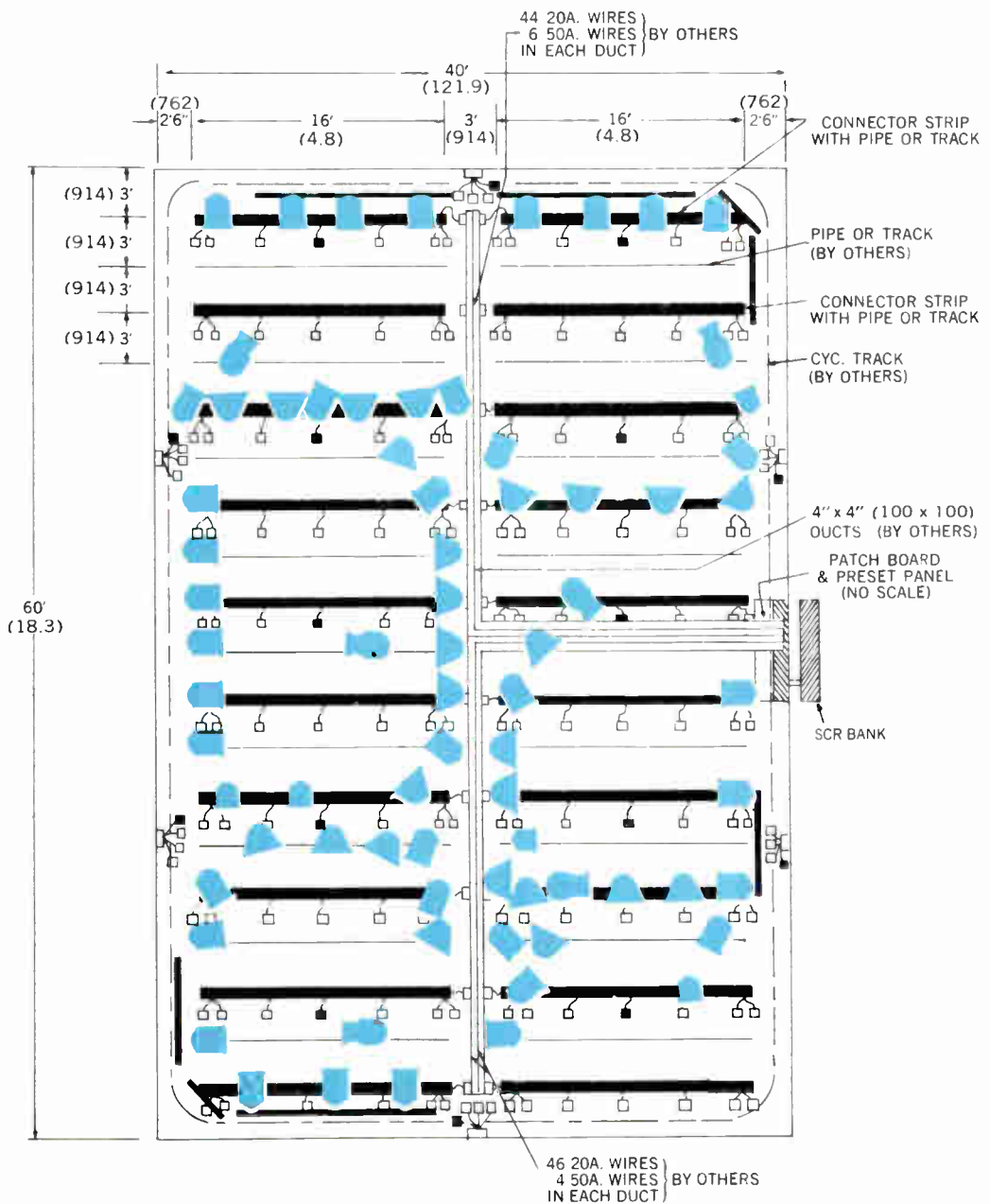

Parentetical dimensions are metric measure: whole numbers, millimeters; decimals, meters.

**EQUIPMENT LIST**

Qty.	Description	Kliegl Type No.	Century Type No.
27	1000 Watt Quartz Scoop	3451	4271GP
2	100/150 W Fresnel Cameralight	44N3 TVB	3141GR
6	500 W Quartz Fresnel	3508	33420GP
36	1000 W Quartz Fresnel	3525	3413GP
3	1000 W Quartz Pattern Projector	1357P/6W	2327GP
2	1000 W Quartz Pattern Projector with Iris	1357/6/1	2328GP
4	4-way Barn Door	1106A	13320
18	4-way Barn Door	1081A	13230
14	16" Color/Diffuser Frame	585A	11160
3	Sets of Patterns for Projector	1097TV	13530
2	Castered Floor Stands	1421	14340
9	Pantagraph Hangers	111TV	3280
9	10 ft. Extension Cables for Pantagraphs	10E955G	10RCCGP
2	25 ft. Extension Cables for floor stands	25E955G	25RCCGP
<b>Wiring Devices</b>			
10	Connector Strips each 16 ft. long and wired with two double and three single three ft. pigtail outlets on 5-20 A. circuits	619G/16/7	6316/7-2GP
10	Connector Strips each 16 ft. long and wired with two double and two single-20 A. three ft. pigtail outlets and 1-50 A. pigtail outlet	619G/16/6/1X	6316/6-2GP/1SGP
10	Ceiling Terminal Boxes	2406G/10	5416
10	Ceiling Terminal Boxes	2406G/10X	5416
100 ft.	Multi-conductor drop cable	12/8	12/8
100 ft.	Multi-conductor drop cable	6/3	6/3
100 ft.	Multi-conductor drop cable	12/12	12/12
6	Wall outlet boxes each with 3-20 A. and 1-50 A. 18" pigtail outlets	2344G/31X	3017-3SP

**Control Equipment**

Qty.	Description
1	Main Control Panel (one scene + two sub-scene) containing: 15 potentiometers with 3-position switches, 2 submaster switches (with black-out switch and pilot lamps), 1 main key switch with pilot lamp.
1	SCR-Dimmer Bank containing: 8 7 kW dimmer modules, 7 7 kW non-dim modules, 1 300A 3-pole breaker, 1 Board light with switch.
1	Saf-Patch Panel containing: 108 20A counterweighted plugs, 16 50A counterweighted plugs, 75 20A automatic cold patch jacks, 15 50A automatic cold patch jacks, 75 20A circuit breakers, 15 50A circuit breakers, 1 Board light w/switch.

**CYC Package**

(Sufficient to light an "L" shaped cyc covering one 40 ft. wall, 1 curve, and 1/2 of the 60 ft. wall)\*

Qty.	Description	Kliegl Type No.	Century Type No.
8	Kliegl: 7 ft. striplights with 4 reflectors and glass color filters; Century: 8 ft. with 8 reflectors on 2 circuits	3500FC	2-80052
3	Kliegl: 3 1/2 ft. Striplights with 2 reflectors (for curve); Century 4 ft. with 2 reflectors on 2 circuits	3500 AFC	2-20052
2	Threefer adaptors to convert a 50 A. outlet to 3-20 A. outlets	453 TVG/3	
38	Quartz lamps (Century quantity 114)	Q500T3	FHM

**Lamp Complement** (3200° Kelvin) for color; representing one lamp per luminaire plus one spare each (optional)

54	Lamp for Scoop	Q1000 T3/4	EGK
4	Lamp for Cameralight	150G	FEV
12	500 W Lamp for 6 3/8" Fresnel	16 1/4 3DC	
72	1000 W Lamp for 8" Fresnel	EHC	BTM
10	1000 W Lamp for 6" Pattern Projector	FER	BVV
		1000T	EGJ
		6Q/RCL/1	

\*2 and 3 Color Strips are also available.

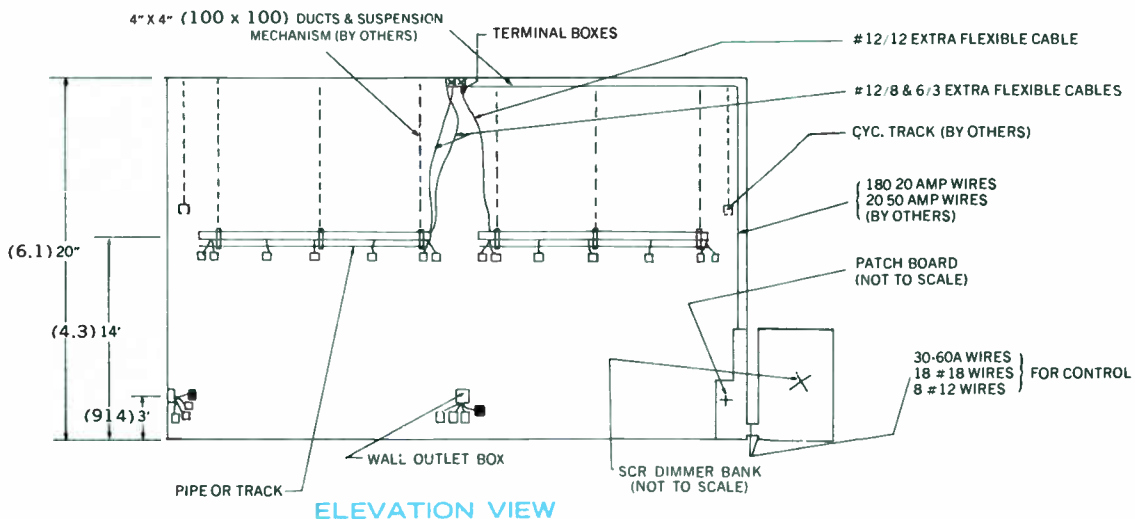







# Lighting Package C

(for two medium-size production areas)

## SPECIFICATIONS

Studio Area .....	600 sq. ft. (58 m <sup>2</sup> )
Studio Dimensions .....	20 x 30 ft. (6 x 9 m)
Light Level .....	60 W per sq. ft. (0.107 m <sup>2</sup> )
Production Areas .....	Two (medium)
Grid Load .....	20 lbs./sq. ft. (10 kg/m <sup>2</sup> )
Power Requirement .....	150 A., 208 V (3-phase, 4-wire)
Heat Load .....	26.4 kW
Air Conditioner Load .....	7.5 Tons (90,000 BTU/hr)
Approximate Equipment Expense .....	\$8,000

## LEGEND

-  6" (152) KLIELIGHT (QUARTZ) 1000 W.
-  16" (406) SCOOP (QUARTZ) 1000 W.
-  6 1/4" (162) FRESNEL (QUARTZ) 500/750 W.
-  8" (203) FRESNEL (QUARTZ) 1000 W.

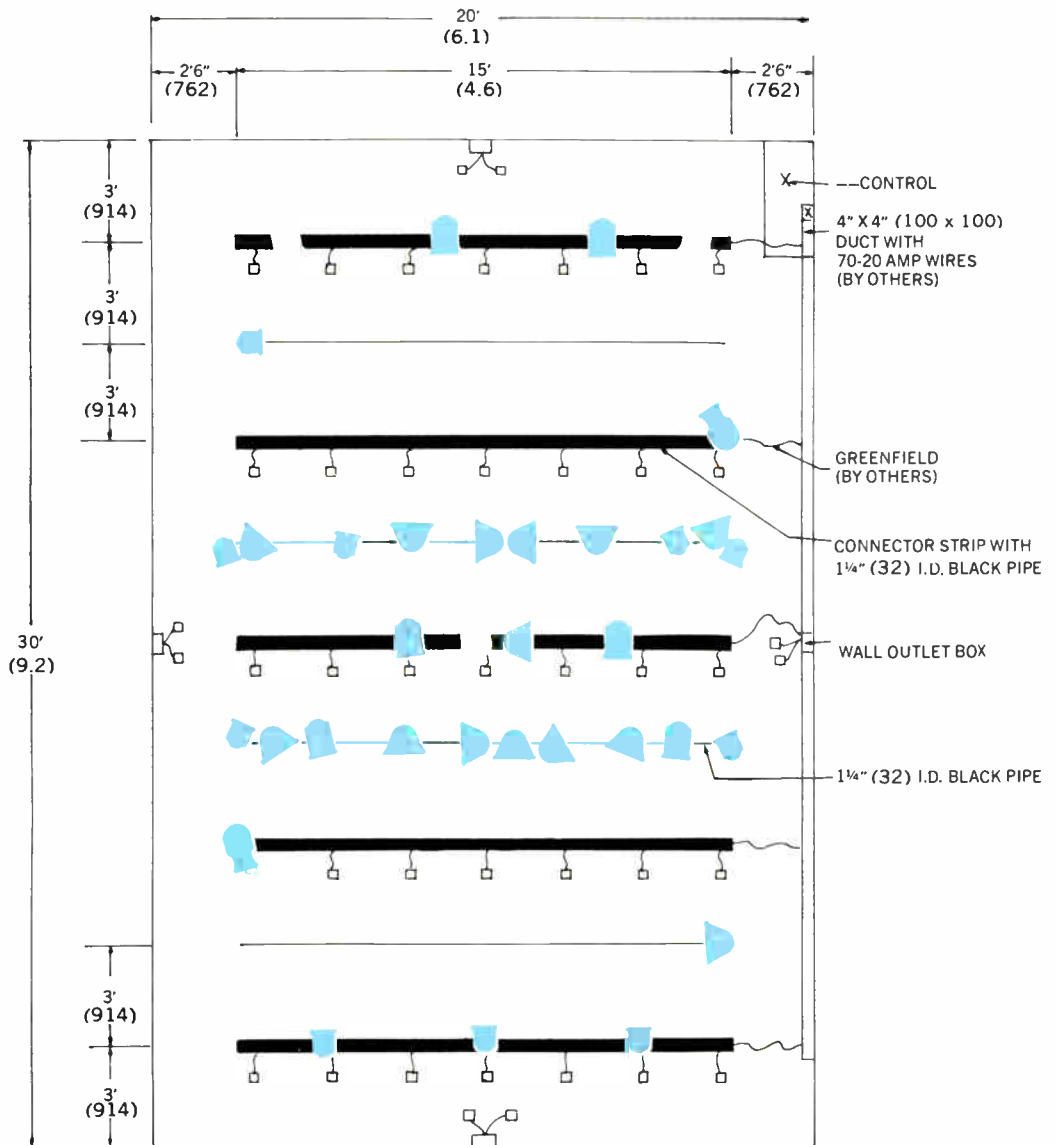

Parentetical dimensions are metric measure: whole numbers, millimeters; decimals, meters.

### EQUIPMENT LIST

Qty.	Description	Kleigl Type No.	Century Type No.
15	1000 Watt Quartz Scoops 16"	3451	4271GP
1	75/100/150 W Fresnel Camera 3" lens	44N3 TVB	3141GP
10	500/750 W Quartz Fresnel Spotlights 6 3/8" lens	3508	33420GP
8	1000W Quartz Fresnel Spotlights 8" lens	3525	3413GP
1	1000W Pattern Projector	1357P/6W	2327GP
1	1000 W Pattern Projector with Iris	1357/6/ Iris	2328GP

Qty.	Description	Kleigl Type No.	Century Type No.
1	Spun Glass—12' x 3' Roll for 3451	S-85	SGD
7	Diffuser/color frame	585A	11160
5	4-way Barn Doors	1106A	13220
4	4-way Barn Doors	1081A	13230
1	Set of Patterns for Projector	1097TV	13530
2	Caster Stand	1421	14340
6	Pantagraph Hanger	111TV	3280
6	Extension Cable 10 ft. for Pantagraphs	10E955G	10RCCGP
2	Extension Cable 25 ft. for Floor Stands	25E 955G	25RCC GP

Qty.	Description	Kleigl Type No.	Century Type No.
5	Connector Strips 15 ft. long with 7-20 amp. pigtail outlets	619G/15/7	6315/7-2GP
4	Wall Outlet Boxes	2433G/2	3018-2GP

  

Qty.	Description	Kleigl Type No.	Century Type No.
3	2500 W. Auto-Transformer Dimmer Panels		
15	2500 W. Non-Dimmer Panels		
1	150 A., 3-pole main circuit breaker		
1	Cross-Connecting system for 43-20A. patch-type circuits		

**Lamp Complement (3200° Kelvin) for Color:**  
(1 lamp plus 1 spare per luminaire)

30	Lamps for 3451 Scoops	Q1000T 3/4	EGK
2	Lamps for Cameralight	150G 16 1/2/3DC	FEV
20	500W Lamp for 6 3/8" Fresnel	EHC	BTM
16	1000W Lamp for 8" Fresnel	FER	BVV
4	1000W for 6" Klieglights	1000T6Q RCL/1	EGJ

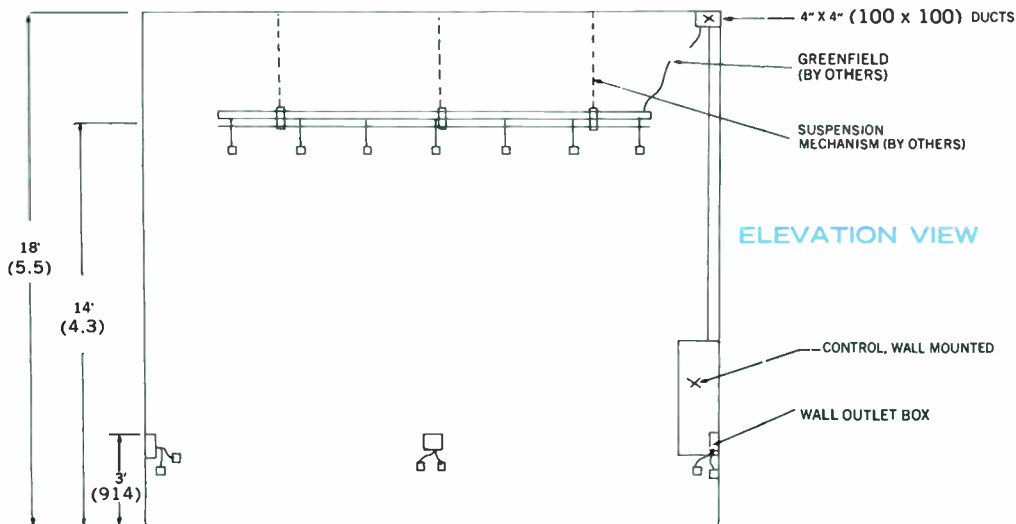

# Lighting Package D

(for two small production areas)

## SPECIFICATIONS

Studio Area .....	432 sq. ft. (40 m <sup>2</sup> )
Studio Dimensions .....	18 x 24 ft. (5.5 x 7.3 m)
Light Level .....	60 W per sq. ft. (0.107 m <sup>2</sup> )
Production Areas .....	Two (small)
Grid Load .....	20 lbs./sq. ft. (10 kg/m <sup>2</sup> )
Power Requirement .....	100 A.; 208 V (3 phase 4-wire service)
Heat Load .....	120 kW
Air Conditioner Load .....	5 Tons (60,000 BTU/hr)
Approximate Equipment Expense .....	\$6,000

## EQUIPMENT LIST





Qty.	Description	Kleigl Type No.	Century Type No.
2	500 W Baby Quartz Scoop 12"	3450	4271GP
6	1000 W Quartz Scoops 16"	3451	4271GP
4	500/750 W Quartz Fresnel Spotlights 6 $\frac{3}{8}$ " lens	3508	33420
2	1000 W Quartz Fresnel Spotlights 8" lens	3525	3413GP
1	1000 W Quartz Pattern Projector	1357P/ 6W	2327GP
4	Pantagraph Lazy Boy	111TV	3280
2	Caster Stand	1420	14340
4	Cables for 111TV	10E 955G	10RCC GP

Qty.	Description	Kleigl Type No.	Century Type No.
2	Cables for Stands	25E 955G	25RCC GP
2	Connector Strip with 30' of feed cable and load end box	2440GX/ 30	6330/3x2- 20GP/ 2-20GP
1	Connector Strip with 20' of feed cable and load end box	2440GX/ 20	6330/ 3x2-20 GP /2-20 GP
1	Non-Dim Switchboard	2409 TVG	
1	Stand for above	2418TV	
1	Location Feeder Box	2405 TVG/100	

Lamp Complement (3200° Kelvin)  
(1 lamp plus 1 spare per luminaire)

Qty.	Description	Type No. Kleigl	Century Type No.
4	Lamps for 3450 Scoop	Q500 T3/4	EGK
12	Lamps for 3451 Scoop	Q1000 T3/4	EGK
8	500W Lamps for 6 $\frac{3}{8}$ " Fresnel	EHC	BTM
4	1000W Lamps for 8" Fresnel	FER	BVV
2	1000W Lamps for Pattern Projector	1000T 6Q/ RCL/1	EGJ

## LEGEND

-  6" (152) FRESNEL SPOTLIGHT
-  8" (203) FRESNEL SPOTLIGHT
-  SCOOP WITH LAZY BOY
-  SCOOP
-  PATTERN PROJECTOR

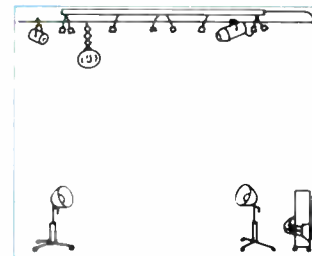
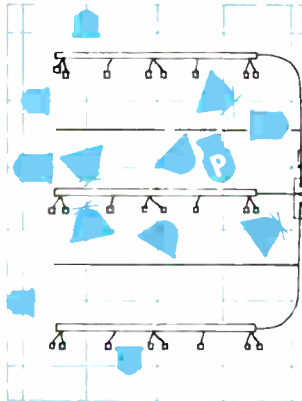

Parenthetical dimensions are metric measure:  
whole numbers, millimeters; decimals, meters.

FILM

FILM

## **RCA** All-Transistor Vidicon Film Camera, Type TK-22

- Plug-in modular circuits
- Electrostatically focused 1½-inch vidicon
- Only two operating controls
- Built-in test pulses
- Savings in power and space

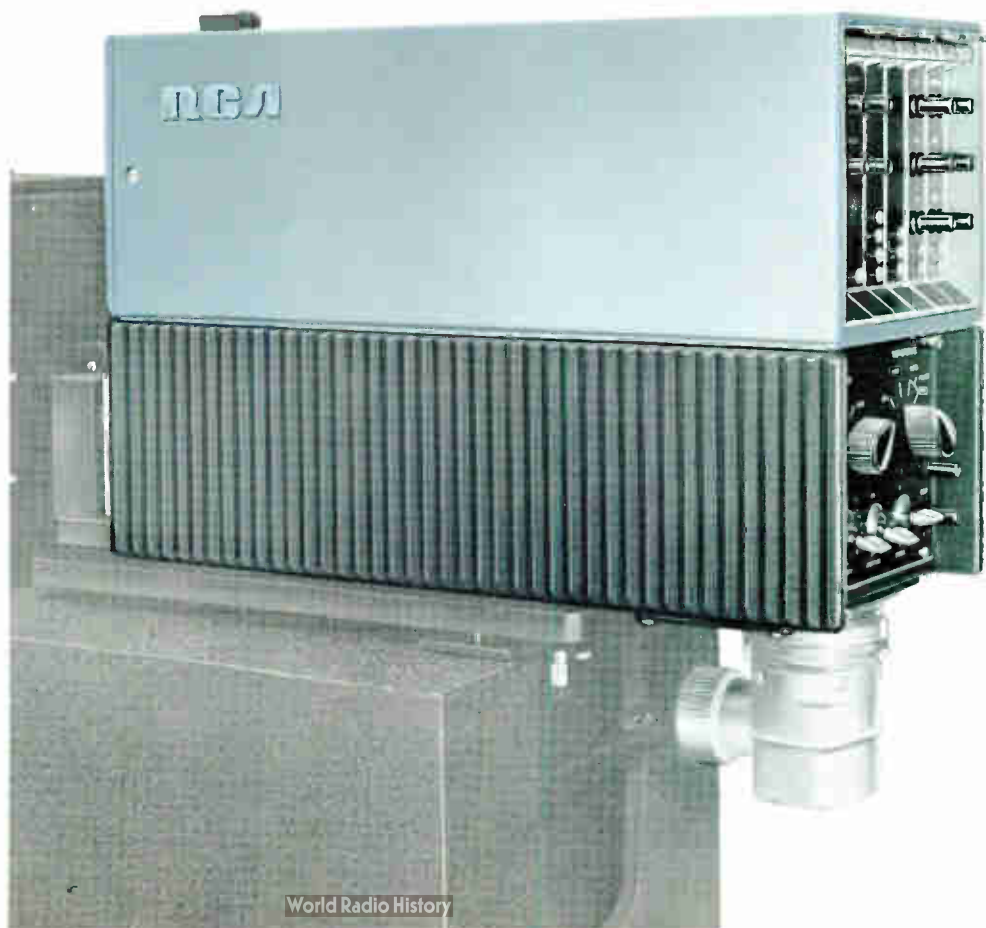

## 11 New Design

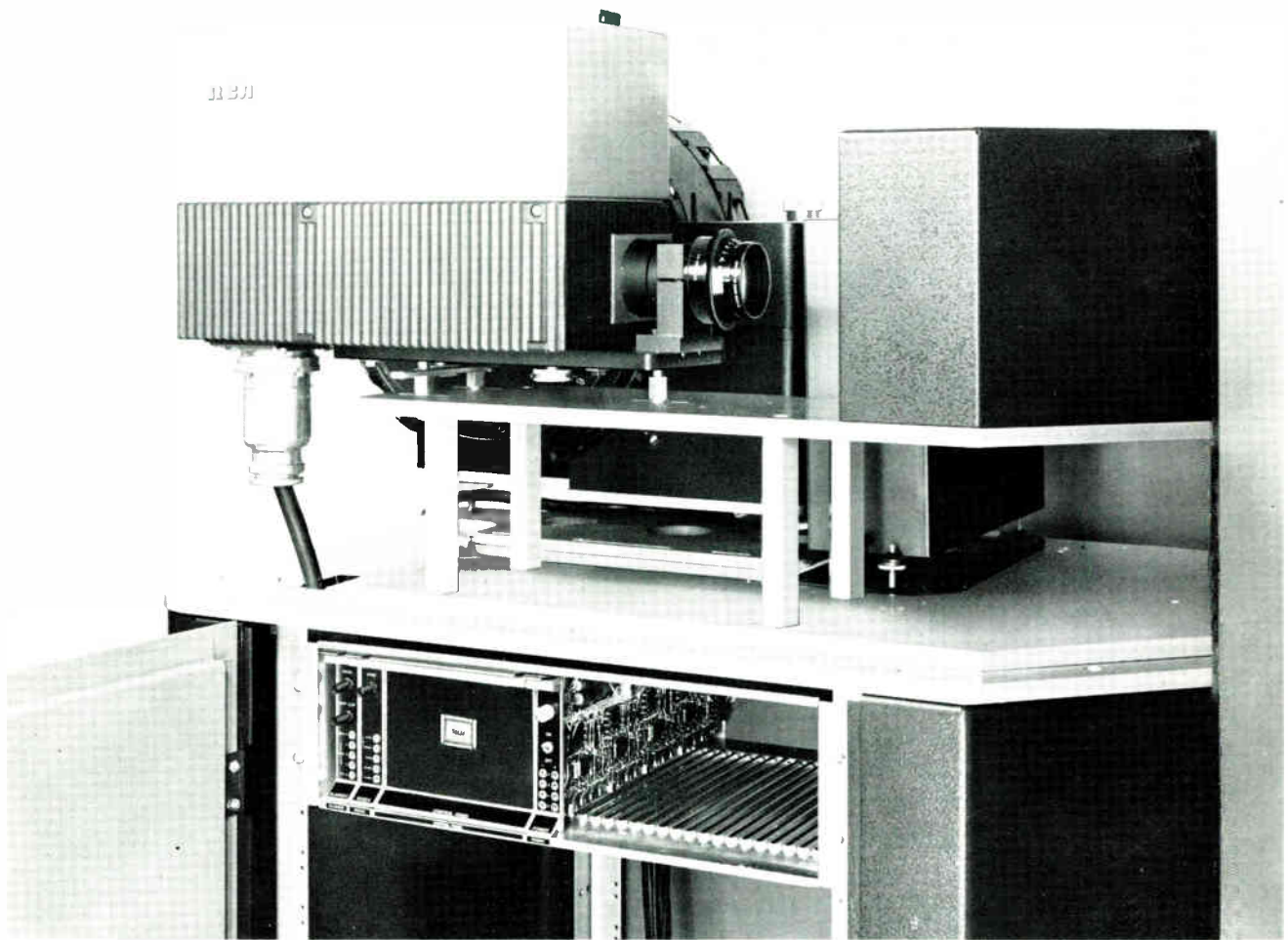

**MATCHES ALL RCA FILM SYSTEMS—COLOR AND MONOCHROME . . .** The TK-22 Vidicon Film Camera complements all RCA TV film systems, and, as shown, is easily mounted on the TP-15 Multiplexer (above) and TP-11 Multiplexer (below). Local indicator panel is shown with modules in rack below camera.

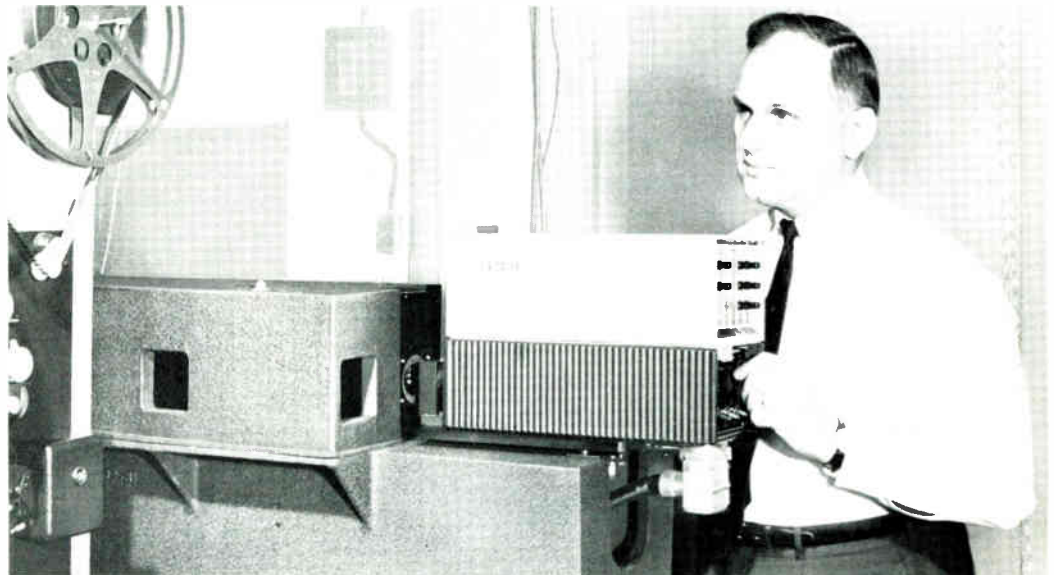

# All-Transistor Vidicon Film Camera, Type TK-22

The RCA all-transistor vidicon film camera, TK-22, introduces a new excellence in TV film picture quality and stability. It incorporates important technical advances and operational features to meet the demands of fast paced film and slide programming.

Higher resolution, increased signal-to-noise ratio and utmost picture stability result in exceptionally crisp monochrome pictures. Resolution is 800 lines without aperture correction. Low heat dissipation

and technical improvements provide a camera that requires no day-to-day adjustments nor extensive warm-up before camera is "on air."

A new camera mount permits removal and replacement of the TK-22 on multiplexers without need for any mechanical alignment adjustments. Panels for remote operation are available. Compact and compact, the TK-22 provides a degree of automatic operation heretofore unknown.

## Description

### Higher Quality Pictures

A newly designed pickup tube—a larger 1½-inch-diameter vidicon—provides a 50 percent increase in image size. Picture resolution is boosted to 800 lines—an excellent measure of picture quality . . . a figure obtained without aperture correction. Aperture response is 60 percent at 400 lines. This means pictures that are extra sharp over the entire film scene.

### Transistor Reliability

Semiconductors are used throughout, the only tube being the vidicon itself. Transistors provide a degree of reliability never before achieved. Maintenance is reduced. Circuits are stable and free from microphonics. Heat generated is virtually negligible, and power consumption is reduced to new lows.

### Ultra Stable Performance

Everything in the design of the TK-22 contributes to reduced heat. This is a big factor in the exceptional stability of the camera. Drift caused by temperature variations is virtually eliminated because there is no heat-producing focus coil for the vidicon. Cathode heater power for the tube itself is only 0.6 Watt. Extensive use of feed-back techniques provides added stability.

### Simplified Control

There are only two primary operating controls for the system—sensitivity and black level. And they are independent; adjustment of one has no effect on the other. Illuminated pushbutton switches provide selection of the following: automatic or manual control of sensitivity, video gain and black level; positive or negative film polarity; test pulse on or off.

### Automatic Operation

The TK-22 features an advanced form of automatic sensitivity control. It is achieved by varying electrode voltages on the vidicon in accordance with a video sensing signal while maintaining a fixed voltage on the target. A control is provided to limit the range of operation during fades to black and to prevent an abnormal increase in sensitivity when no image is projected on the face of the vidicon.

The blackest portion of the video signal is automatically held at a predetermined level established by the setting of the black-level control on the control panel. An automatic white-level control maintains video at a constant peak-to-peak amplitude regardless of variations in the contrast range of film or slides. This combination of ASC, ABL and AWL provides a degree of automatic operation heretofore unknown.

### World-Wide Standards

The TK-22 operates on voltages in the ranges of 90 to 130 Volts AC, or 180 to 260 Volts AC, at line frequencies of 47 to 63 Hz. The camera can be operated at 525-line/60 field, or 625-line/50 field scanning standards.

### Compatible with Other Systems

The TK-22 is compatible with existing RCA systems for both color and monochrome. For the ultimate in film performance, use it with the TP-66 film projectors and TP-11, 15 and 55 multiplexer systems.

### Ease of Installation

A new precision mounting arrangement permits removal and replacement of the camera head without need for mechanical alignment adjustments. Interconnection of units is extremely simple, requiring only a minimum of external wiring.

### Savings in Power and Space

The power required for the entire camera chain, less monitor, is only 50 Watts . . . less than 10 percent of the power requirement of previous film systems. The 5¼-inch depth of the rack-mounted modules amounts to more than a 90 percent reduction in rack space.





# Bonus Features

Sturdy, Compact, Dust-Free Camera—No Blower Required

Horizontal and Vertical Drive Generated in Camera

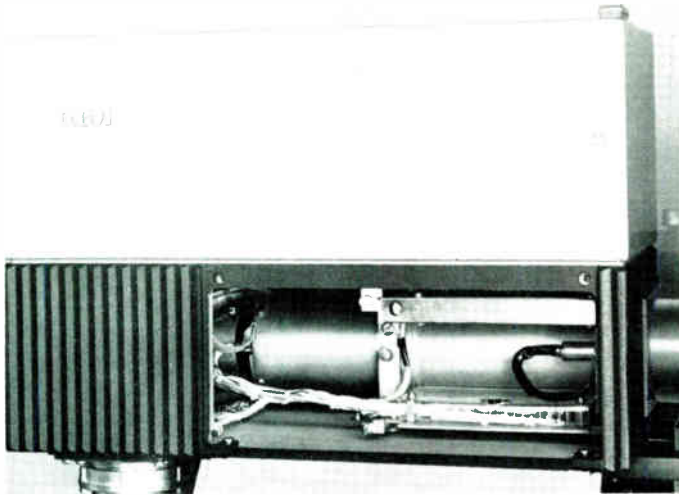

Electrostatic Focus & Magnetic Deflection Vidicon—Only Tube Used in Camera

Self-Aligning Vidicon Tube Mount

High Signal-to-Noise Vidicon Input Amplifier

Preamplifier

Test Points Throughout Equipment

Low Power Vidicon Heater

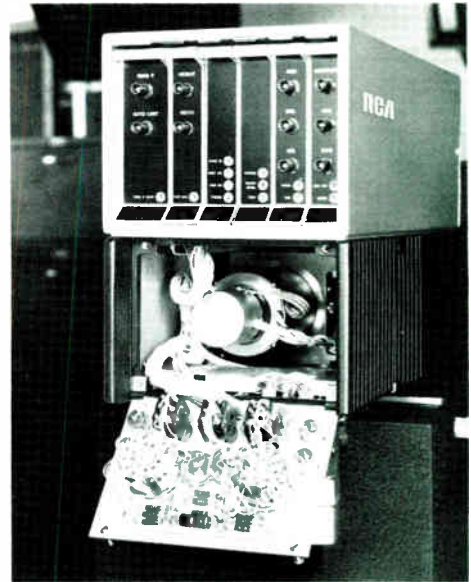

Utmost Accessibility To All Components and Circuits

Modular Plug-Ins Throughout—No Matching of Components Required

Monitor Feed and Choice of Four Signal Feeds

Variable Amplitude Aperture Correction

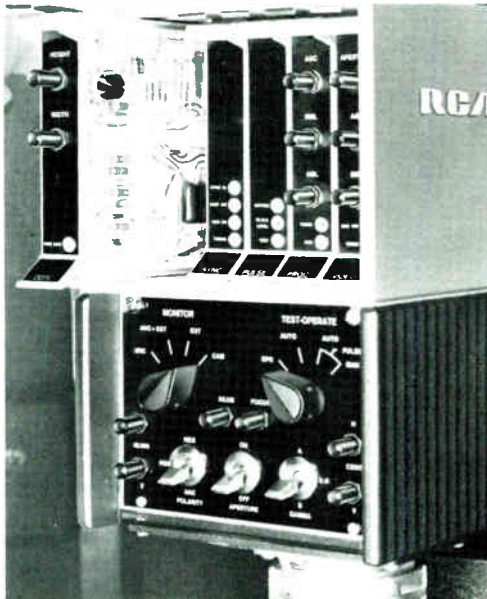

Gamma Control 0.5, 0.7 and 1.0. For Negative Film, 1.2 gamma is automatically provided.

Module Extenders Available for Test

Automatic Functions Switched On and Off Independently

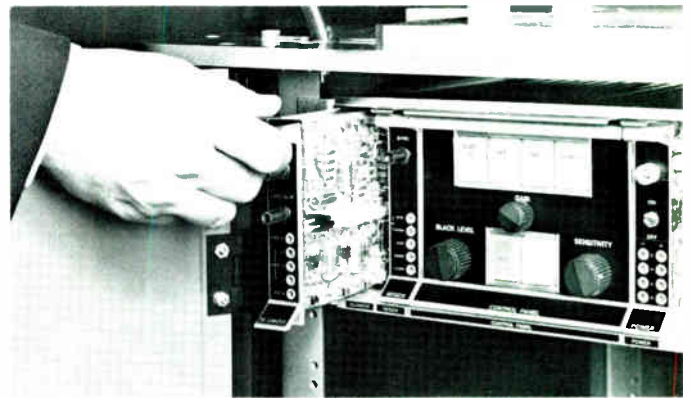

System Power Consumption Less Than 50 Watts

Only Two Operating Controls—may be located at Camera Auxiliary as shown or at Remote Position

# TK-22 Module and Panel ... Description of Functions

High Voltage    Deflection    Synchronizer    Pulse    Processor    Video

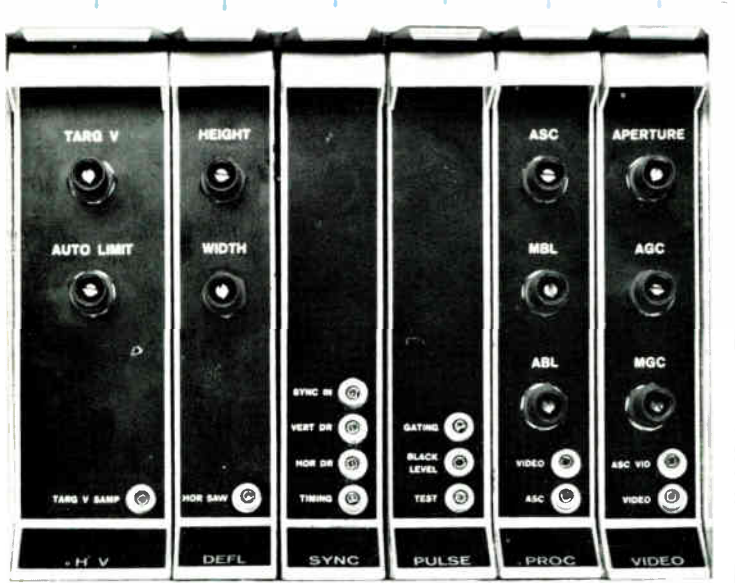

**HIGH VOLTAGE**—Contains circuitry for generation of high voltage, DC filament voltage for the vidicon and a reference voltage to operate transistor decouplers, in other modules. Vidicon blanking and target voltage ranges are set in this module.

**DEFLECTION**—Provides horizontal and vertical deflection signals. Also provides vidicon protection in case of scan failure.

**SYNCHRONIZER**—Takes sync fed to camera head and horizontal drive stop pulse from the pulse module, and generates and distributes vertical gating, vertical drive, timing pulse and horizontal drive. Contains circuitry for automatic time delay compensation and also clips and amplifies sync for use in other modules.

**PULSE**—Generates black level pulse, horizontal drive stop pulse and gating pulses. Also generates test pulses for use in set-up of the camera.

**PROCESSOR**—Clamps the video signal and inserts gamma correction. Contains circuitry for manual and automatic black and automatic sensitivity functions.

**VIDEO**—Amplifies video signal received from the preamplifier and provides aperture compensation.

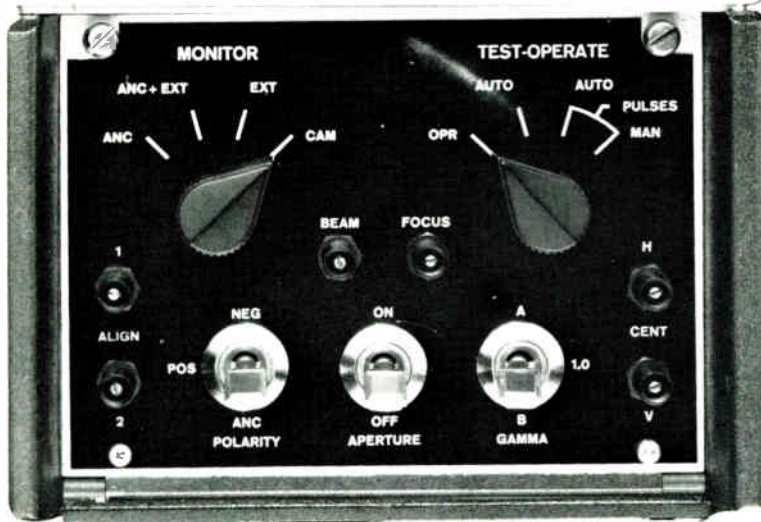

Vidicon Align.    Polarity    Aperture    Gamma    Vidicon Cent.

## Camera



**COMPACT AND ECONOMICAL . . .** The 5¼-inch depth of the rack mounted modules reduces space requirements by more than 90%. System power consumption is only 50 watts.

**BUILT-IN TEST PULSES**—provide a quick check of camera performance and simplifies set up.

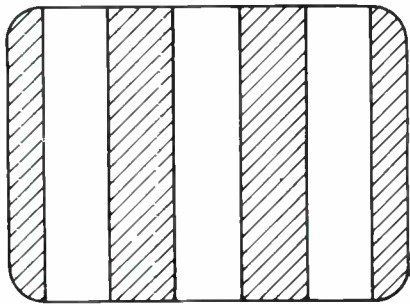

Output Level Calibration Pulse  
0.7 volt

Gated Video Pulse Showing Output of Vidicon

Pulse Representing 0.6  $\mu$ a from the Vidicon

## Auxiliary

**BLANKER**—Adds final blanking to the video signal. Contains a multiple video output line driver with sending end termination and has switchable sync addition to the output video signals. Also contains a single line driver with sending end termination which can be remotely switched to the line. An external signal coming from a loop-through input or a combination of the line and the external signal.

**REGENERATOR**—Regenerates sync, blanking and clamp pulses. Contains circuitry for horizontal drive advance to compensate for camera cable delays.

**POWER**—Supplies four separate 12.5 Volt feeds: two for auxiliary, and two for camera head. Remote sensing of voltage at camera is provided to compensate automatically for voltage drop in camera cable. Outputs short-circuit protected to prevent damage to components.

Remote Control Panels for the TK-22 Vidicon Film Camera. At left, MI-557202 panel to fit 13-inch console housing; at right, MI-557203 remote control panel to fit new 20-inch consoles.

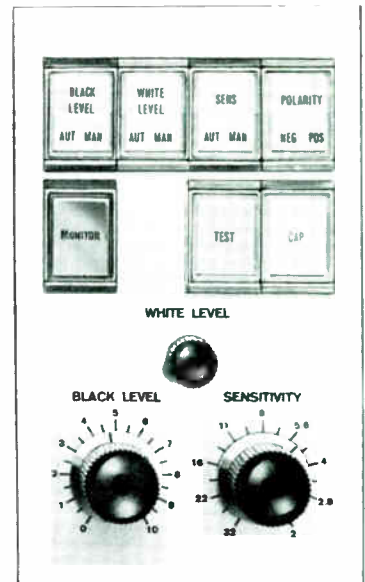

# Specifications

## General

Type of Reproduction.....Monochrome  
 Number of Scanning Lines..... 525 or 625  
 Field Repetition Rate .....60 or 50 Hz  
 Line Repetition Rate..... 15,750 or 15,625 sec.  
 Vidicon.....1¼" electrostatic focus,  
 electromagnetic deflection, type 8480

## Picture Quality

Limiting Horizontal Resolution ..... 800 TV lines minimum at  
 center, 700 lines minimum in corners  
 Signal-to-Noise Ratio .....Nominal, 46 dB peak-to-peak  
 signal/rms noise for bandwidth of 4.5 MHz  
 Overall Frequency Response .....±0.5 dB to 8 MHz,  
 down not more than 3 dB at 10 MHz  
 Gray Scale..... Reproduces 10 shades of gray from a  
 log-linear gray scale having density range of 1.3  
 Total Raster Distortion.....Within ±1% of picture height

## Operational

Gamma Correction .....Switchable to three preset values:  
 0.5, 0.7 and 1.0 also 1.2 for negative film operation  
 Aperture Correction..... Amplitude continuously adjustable  
 from 0 to 12 dB boost at 5.5 MHz, no phase distortion

## Electrical

Input Signals:  
 Sync .....2-8 Volts, p/p negative  
 Blanking .....2-8 Volts, p/p negative  
 Input Impedance..... Bridging  
 Output Signals.....3 video outputs, plus monitor  
 feed, either 1.0 Volt p/p composite, or 0.7 Volt p/p non-  
 composite, switchable in pairs  
 Output Impedance .....75 Ohms, sending end terminated  
 Power Input  
 (Camera & Auxiliary, excluding monitors):  
 Line Voltage .....90-130 Volts, or 180-260 Volts  
 Line Frequency .....47-63 Hz  
 Power Consumption .....50 Watts  
 Environmental:  
 Temperature..... -20°C to +55°C  
 Relative Humidity..... Up to 95%

## Mechanical

### Overall Dimensions

	Width	Height	Depth	Weight
Camera Head.....	6¾"	9⅞"	16"	25 lbs
	17.1 cm	24.5 cm	40 cm	11.3 kg
Camera Auxiliary .....	8½"	5¼"	18¾"	20 lbs
	21.2 cm	13.1 cm	45.7 cm	9 kg
Camera Control Panel.....	11⅞"	2⅝"		2 lbs
	27.5 cm	6.5 cm		.9 kg

# Accessories

Camera Lens for use with TP-11 Multiplexer.....MI-43202-1  
 Camera Lens for use with TP-15 Multiplexer.....MI-43202-2  
 Mounting Adaptor for TP-11 to TP-11C  
 Multiplexers (not needed for TP-11D).....MI-40128  
 Mounting Adaptor for TP-15 Multiplexer (not  
 needed for TP-15A Multiplexer using MI-40130  
 optical assembly) .....MI-40129

Field Lens for TP-11 Multiplexer.....MI-26810-2  
 Field Lens for TP-15 Multiplexer.....MI-40859-6  
 Terminal Extracting Tool.....MI-43226  
 Module Extender .....MI-557301

# Ordering Information

TK-22 Film Camera Chain, less master monitor.

TK-22 Camera Head .....MI-557201-C1  
 Type 8480 Vidicon Tube.....MI-557205  
 Camera Auxiliary Equipment .....MI-557200-B2  
 Including the following:  
 Rack Mounting Frame  
 Harness Assembly  
 Regenerator Module  
 Blanking Module  
 Power Supply Module  
 Camera Cable, 50 ft. with connectors.....MI-26725-E5  
 Pre-amplifier Module Extender .....MI-557304  
 Camera Alignment Jig .....MI-40445  
 Control Panels:  
 Remote Control Panel (for 13" console).....MI-557202-B1  
 Console Well Adaptor (for MI-557202-B1).....MI-26212  
 Remote Control Panel (for new 20" console).....MI-557203-A1  
 Mounting Frame (for MI-557203-A1).....MI-557306  
 Local Indicator Panel.....MI-557796-B1  
 Local Control Panel.....MI-557797-B1

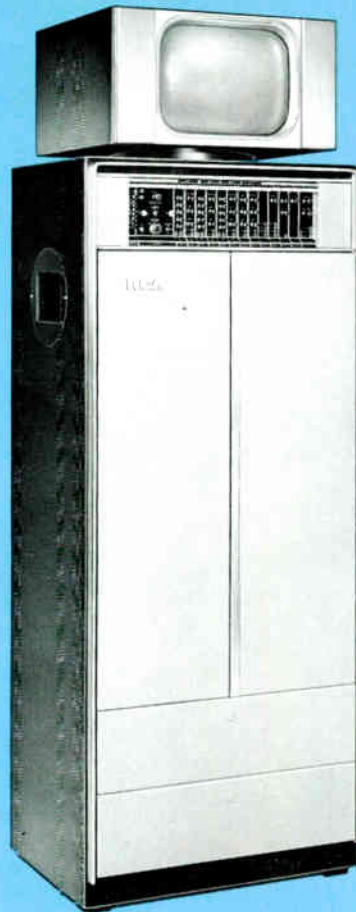

- Increased s/n—up to 50 dB
- FET-equipped preamps in all four channels
- Shorter setup time—fewer setup controls
- Automatic control of black level, white level, and sensitivity
- Contour system for picture enhancement
- New test-slide holder

## Color Film Camera, Type TK-27B

### Description

#### All Solid State

The TK-27 is completely transistorized providing greater reliability and reduced maintenance. As a result of the solid state circuits, power consumption is less than 200 watts and the floor space requirement is only three square feet. Other advantages of transistors are lower heat dissipation and freedom from microphonics.

#### Electrostatic Pickup Tubes

The four vidicon pickup tubes are electrostatically focused. This eliminates focus coils and their heat dissipation. Power consumption is negligible and performance is independent of voltage variations—*greatly improving stability*. Electrostatic focusing has reduced heat in the camera head—the main cause in all

cameras for rise in dark current—by at least 40 percent.

#### Larger Luminance Vidicon

The luminance channel employs the 50 percent larger RCA Type 8480-V1 vidicon. This tube has twice the output of other types. The result is a 6 dB gain in s/n ratio. Signal-to-noise ratio is exceptionally high due to its excellent aperture response. Stable high-peaking is assured by an FET transistor mounted on the vidicon to minimize input capacitance and present a constant impedance to the vidicon.

#### FET-Equipped Preamplifiers

Because of its high input impedance and low thermal noise, the field-effect transistor (FET) is ideally suited as the input stage of video preamplifiers.

In the TK-27 camera, each of the four preamplifiers uses an FET as its input stage. The combination of the FET amplifier and the vidicon operating at normal beam current results in a s/n ratio that is equal to that of "live" color cameras such as the RCA Type TK-41A. For "special" operation, the TK-27 can be adjusted for a s/n ratio that exceeds 50 dB.

#### Shorter Setup Time

Current TK-27 cameras set up in less time as the result of a new feature: continuously variable gamma control in each chroma channel. These virtually end compromises in color tracking between the luminance and chroma channels to improve picture quality, simplify adjustment and reduce setup time. The TK-27

now has fewer target-tracking controls so that setup is both easier and faster.

### Self-Storing Test Slide Holder

A new test-slide holder, mounted on the field lens, not only stores the slide while not in use but provides easy operation when slide use is in order. This ar-

range speeds setup because it helps in the precise adjustment of projector-lamp color temperature and camera tracking.

### "Contours" Enhancement Included

Providing combined horizontal and vertical aperture correction, the "con-

tours" facility uses the widely acclaimed "contours-with-a-comb" principle to enhance picture "edges" without a significant increase in noise.

So effective is the contours facility that 16-mm prints "look" like 35-mm on the home screen. Too, "soft" newsfilm takes on a studio-like quality when aired via a contours-equipped TK-27 camera.

### Includes "Comb" Filter

The Contours Facility generates a signal from the luminance video often referred to as the *detail, contour or correction* signal. This signal, after "combing", is matrixed with processed video. "Combing" selectively filters the *contours* signal and virtually eliminates subcarrier beatnotes between luminance and chrominance. Without "combing", these beatnotes normally produce an annoying "edge beat" and increase noise level. The comb filter allows increased contouring without significant increase in picture noise.

### NAM Monitoring

Unlike other four tube film cameras that require an experienced operator to monitor individual color levels, the TK-27 presents a single waveform that is similar to a standard monochrome signal. The method employs non-additive-mixing of receiver type color signals to produce a single waveform that at any instant represents the proper values of color and monochrome in *one presentation*. Advantages are accurate control of picture brightness and hue, and the prevention of transmitter and receiver overload. This is an important consideration in color film operation since other cameras require the operator to continuously monitor all colors in order to minimize the possibility of overmodulation.

### Plug-In Electronics

Completely transistorized plug-in circuit modules with convenient front panel test jacks provide excellent accessibility for service. Many of the circuit functions in the four vidicon channels are identical. This results in modules that are duplicates and thus interchangeable, offering greater circuit familiarity and easier maintenance. Because of a multiplicity of test points (approximately 100 test jacks) trouble can often be isolated within a module without removing the module from the frame.

### Automatic Level Control

Automatic circuits in the TK-27 provide means for controlling white level

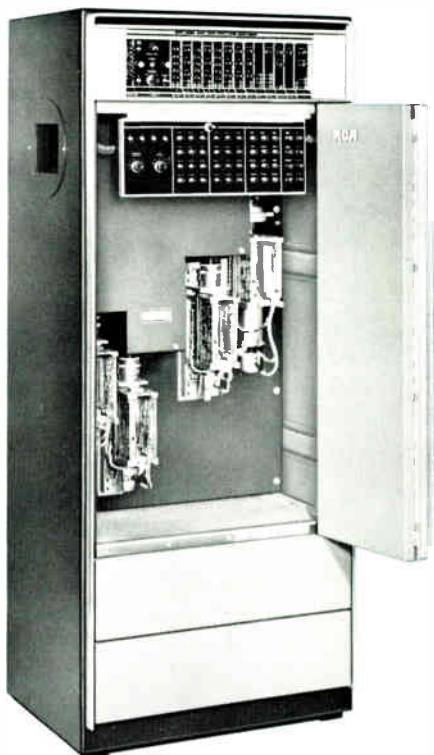

Full access to all electronics and camera optics is provided by swing-aside folding doors. The "contours" modules mount in the module space below these doors, behind a swing-down dress panel.

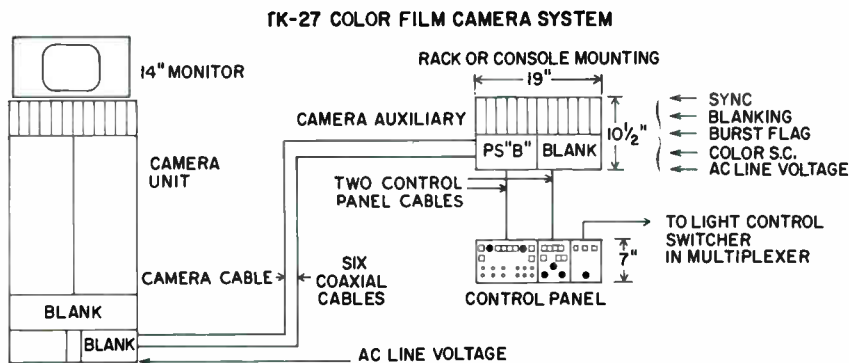

and black level proportionately in all four vidicon channels to compensate for density variations in slides and motion picture film. Automatic Preset Logic Circuitry eliminates blooming and other disturbances during transition from black to a bright scene. This is accomplished by returning the target voltage to an adjustable preset value when the picture goes to black. Video gain or white level is similarly returned to a nominal quiescent value.

### Simplified Interconnection

Horizontal and vertical drive signals for the TK-27 now originate in the film camera itself instead of in the master sync generator as with other color film cameras. This simplifies cabling and reduces the number of distribution amplifiers required by the system.

### Advanced Camera and Optics

The design of the camera and optical assemblies assure long term life and freedom from secondary reflections. Assemblies are mounted on a 1/2-inch-thick, aluminum base plate. This is rigidly fastened to the structurally reinforced cabinet which is in turn bolted to the floor. Unprecedented accuracy is achieved in superimposing optically the four images on the vidicons. Prisms are employed to separate and direct the light image to each of the four cameras. Dichroic surfaces are sealed within the optical block to eliminate any multiple reflections and to prevent contamination from dust or handling. Prisms, therefore, are maintenance-free, assuring optimum performance at all times. Plug-in design permits quick and easy removal of vidicon assemblies to facilitate tube changing or trouble shooting.

### Minimum Space Requirement

Plug-in transistorized modules associated with the camera circuits are located along the top of the camera unit above the vidicon setup control panel. The plug-in modules comprising the Auxiliary Assembly which combines pulse regeneration, blanking and colorplexing functions are housed in two module frames each only 5/4 inches high.

### Ease of Setup and Test

TK-27 camera circuits are designed so that one man can set up and adjust the camera using simple pulse techniques which speed up camera adjustments. Built in and operable by a switch, test pulses determine that pickup tubes and amplifiers are operating at proper levels.

A switch on the control panel inserts pulses for checking system stability at any time. Initial adjustment of the TK-27 is made quickly and further touch-up is rarely required. A built-in color bar generator provides full raster R, G and B signals at 75 or 100 percent level to facilitate setup of the colorplexing function using only an oscilloscope.

### Operating Features

Design of the TK-27 makes it possible to include all the remote controls for the system in three control panels that are mounted side-by-side in a console housing or in a standard rack, occupying only 7 inches of height. Operators will find it easy to maintain consistently high picture quality with minimum attention. There are several unique points about the controls. For example, white and black balance controls, used to individually control levels in each chrominance channel to compensate for deficiencies in color film, are completely non-interacting.

Chroma level may also be adjusted from the control panel.

### NTSC or PAL Color Standards

The TK-27 is available for operation on either NTSC or PAL color standards. The versatile power supply of the TK-27 operates on either 115 or 230 volts at any frequency between 47 and 63 Hz.

### Control Versatility

Three control panels mounted side-by-side contain all the controls and illuminated pushbutton indicator switches for operation of the TK-27 color film camera system from a control console or other location. The left-hand and right-hand panels are used for color operation, while the remote control panel in the center contains the main operating controls. Provision is made for "monochrome only" operation of the TK-27. With this mode, operation is similar to that of the RCA TK-22 monochrome camera. Only those circuits required for processing the signal from luminance vidicon are used.



The TK-27 Film Camera (at far left) shown with the RCA Type TP-55 Camera Multiplexer. At right is an RCA TP-77 Slide Projector and in center background, a TP-66 16-mm Film Projector.



# Specifications

## General

Type of Reproduction.....Color and Monochrome  
 Number of Scanning Lines.....525 or 625  
 Field Repetition Rate.....60 or 50 Hz  
 Line Repetition Rate.....15,750 or 15,625 Hz

## Picture Quality

Limiting Horizontal Resolution  
 Luminance Signal.....700 lines min. at center  
 600 lines min. in corners

Signal-to-Noise Ratio,  
 Luminance Signal.....48 dB @ 300 nA, 0.5 gamma;  
 50 dB @ 600 nA, 0.5 gamma

Square Wave Tilt.....Max. 2%, 60 Hz square wave  
 Video Bandwidth.....Down not more than 3 dB at 8 MHz  
 Total Raster Distortion.....Within 2% of picture height

## Operational

Gamma Correction Luminance Channel.....Switchable to three  
 preset values; 0.5, 0.7 and 1.0  
 Gamma Correction, Chroma Channels.....Continuously  
 variable, 0.5 to 1.0  
 Aperture Correction.....Switchable: no corr.; H corr. only;  
 H&V corr. (Contours); Contours level adjustable

## Electrical

Input Signals:  
 Sync.....2 to 8 volts, peak-to-peak, neg.  
 Blanking.....2 to 8 volts, peak-to-peak, neg.  
 Burst Flag.....2 to 8 volts, peak-to-peak  
 Color Sub-Carrier.....2.0 ±0.5 volts, peak-to-peak  
 3.579545 MHz, 4.4296875 MHz or 4.3361875 MHz\*  
 Input Impedance.....Bridging

Output Signals:  
 Program.....2 color and 2 monochrome  
 either 1.0 volt peak-to-peak composite or 0.7 volt peak-  
 to-peak non-composite. One color output required for  
 color monitor.  
 Monitor.....1 color and 1 monochrome  
 for internal picture and waveform monitor through system  
 monitor selector switches plus 1 composite monochrome  
 signal for optional camera position monitor.

Output Impedance.....75 ohms, sending end terminated

\* Choice of sub-carrier frequency to be specified by customer.

## Power Input

(Camera and Auxiliary, excluding monitors):  
 Line Voltage.....90-130 volts or 180-260 volts  
 Line Frequency.....47 to 63 Hz  
 Power Consumption.....200 watts

## Mechanical

Overall Dimensions:	Wide	High	Deep
Camera Unit	24" 610 mm	58" 1473 mm	18" 457 mm
Camera Auxiliary	19" 483 mm	10½" 267 mm	16½" 419 mm
Control Panel Frame (for Remote Control Panel, Color Control panel and Light Control Panel)	19" 483 mm	7" 178 mm	—
Remote Control Panel	4¼" 133 mm	7" 178 mm	7" 178 mm
Color Control Panel	8½" 266 mm	7" 178 mm	7" 178 mm
Light Control Panel	4¼" 133 mm	7" 178 mm	2" 50 mm
Monochrome Monitor and Rotatable Housing	19¼" 489 mm	12" 305 mm	18" 457 mm
Optical Centerline Height	48 inches (1220 mm) above floor level, adjustable		

## Weight (approximate)

Camera Unit.....250 lbs. (113 kg.)  
 Camera Auxiliary.....100 lbs. (45 kg.)  
 Control Panels, mounted in frame.....9 lbs. (4 kg.)  
 Monochrome Monitor and Rotatable Housing.....75 lbs. (34 kg.)

## Accessories

I/Q Module for TK-27.....MI-556554

# Ordering Information

Type TK-27B Four Tube Color Film Camera Equipment (NTSC)  
 as follows:

Qty.	Description	MI-
1	TK-27B Camera Unit	557208-E1
1	1½-inch Vidicon, Type 8480-V1	557205-A2
3	1-inch Vidicon, Type 8134-V1	557206-A2
1	Camera Auxiliary Unit	557207-A5
1	Remote Control Panel	557203-A1
1	Color Control Panel	557204-A2
1	Light Control Panel	40152
1	Mounting Frame for Control Panels	557306
1	Monitor Housing, Rotatable	557209
1	CRB-14 Picture Monitor, 14-inch	557231-A2
1	Color Film	40846
1	Test Slides	557342

The TK-27B Color Camera is also available for operation on PAL color standards. When ordering for PAL standards, specify the camera auxiliary unit as an MI-557207-B2.

Qty.	Description	MI-
Required Interconnecting Cable:		
1	Camera Cable	557345-*
1	Remote Control Panel Cable	557344-*
1	Color Control Panel Cable	557343-*
**	Coaxial Cable, RG-58/U (Four lengths used between camera and auxiliary units)	13318-A
**	Coaxial Cable, 75-ohm, double-shielded (Two lengths used between camera and auxil- iary unit)	
**	12-conductor Shielded Cable (Used to inter- connect Light Control Panel and TP-55 Multiplexer)	13380-12

\* Available in 50', 75', 100' and custom lengths. Specify lengths required.  
 \*\* Bulk Cable. Specify lengths required.

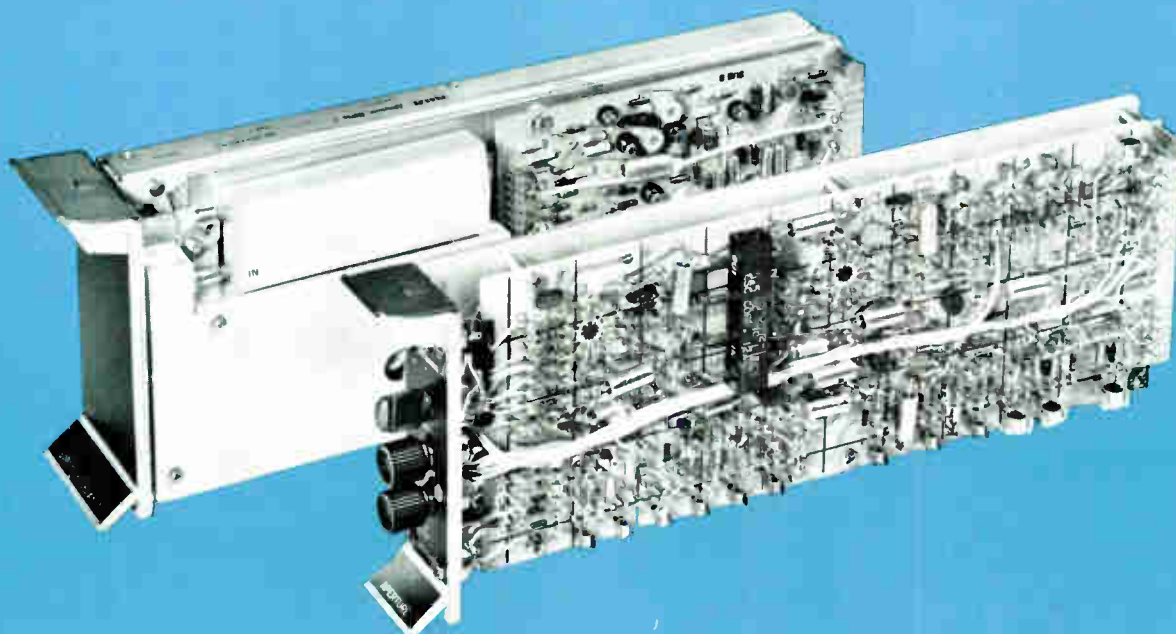

- Enhances low-resolution film
- For all RCA TK-27 film cameras
- Quick installation
- Includes "comb" filter

## RCA Contours Accessory Kit

### Description

Designed specifically for installation in the RCA TK-27 Film Camera, the Contours Accessory Kit enhances the video from the luminance channel of the camera by sharpening the contours or edges of the TV image without significant increase in picture noise.

#### Enhances Low-Resolution Film

An important tool to improve the transmission quality of film, (especially newsfilm exposed under less-than-ideal conditions), the Contours Accessory generates a signal from luminance video that, properly handled, increases the apparent resolution of the film. It is equally useful in making off-network, 16-mm rerun-prints transmit with sharpness comparable to first-generation, 35-mm prints.

#### For All TK-27 Cameras

Packaged in two plug-in modules, the Contours Accessory fits in unoccupied module space in the base of the camera. Electrically, the accessory is in the luminance signal path between the video processor and the color encoder (see block diagram).

#### Quick Installation

Normally requiring about five hours time, the Contours Accessory can be installed without disruption of camera production scheduling. Where the camera cannot be taken off duty during the broadcast day, Contours installation can be performed after sign-off and before sign-on. Contours "on-off" via remote control is provided for by a relay in-

cluded in the accessory. Utilization requires only a 12.5-volt d-c source, a single pole switch and wiring.

#### Includes "Comb" Filter

The Contours Accessory generates a signal from the luminance video often referred to as the *detail, contour or correction* signal. This signal, after "combing", is matrixed with processed video. "Combing" selectively filters the *contours* signal and virtually eliminates subcarrier beatnotes between luminance and chrominance. Without "combing" these beatnotes normally produce an annoying "edge beat" and increase noise level. The comb filter allows increased contouring without significant increase in picture noise.

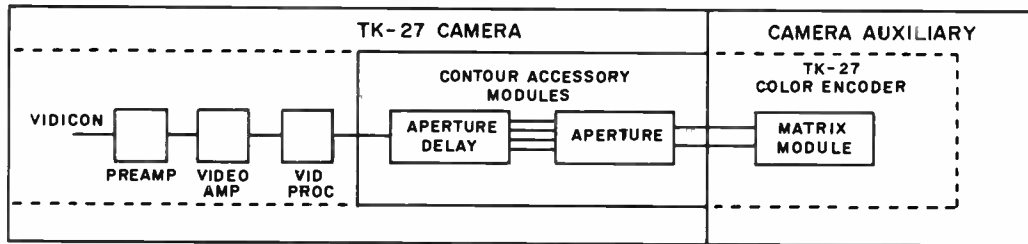

Simplified block diagram of TK-27 Film Camera showing Contour Accessory modules.

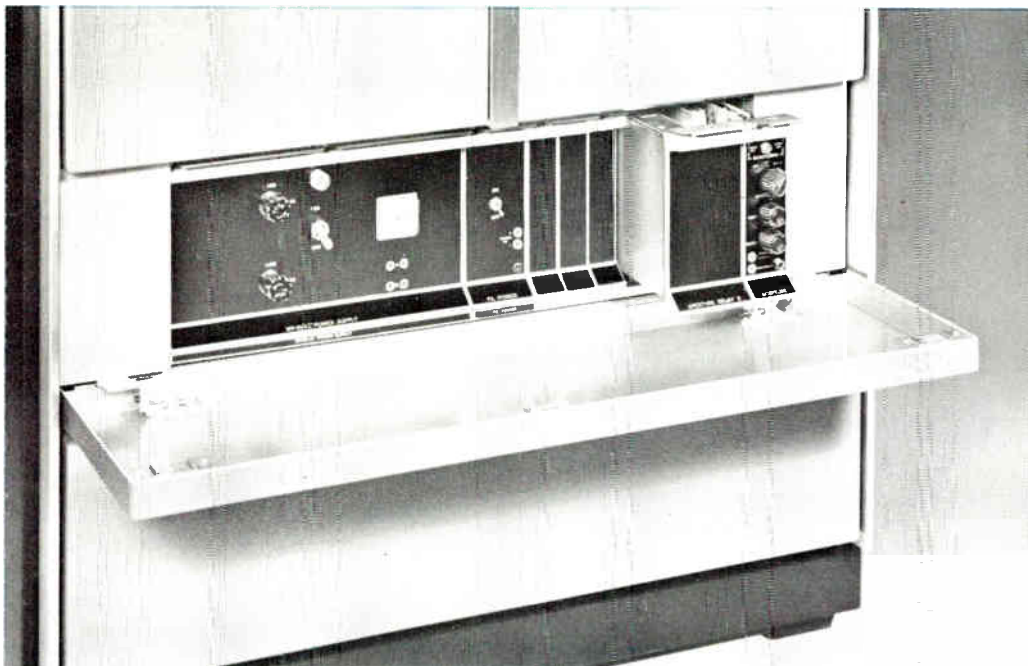

The two Contours modules fit in unoccupied space in the base of the TK-27 Camera.

## Ordering Information

Contours Accessory Kit for TK-27 Film Cameras.....MI-557806

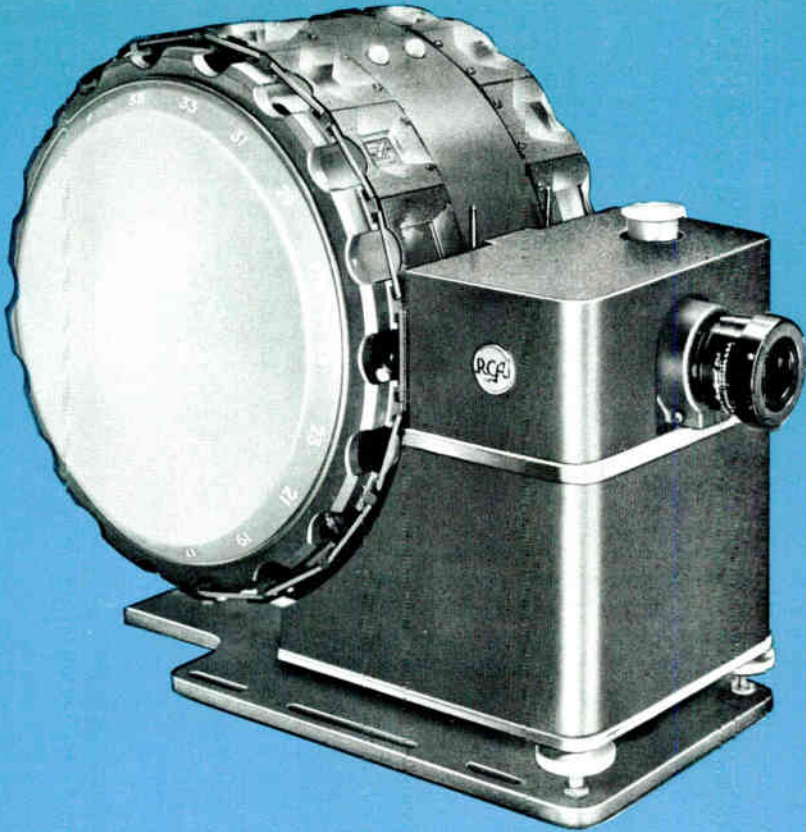

- Dual drum projector for color or monochrome TV use
- Single lamp source provides uniform image brightness
- Large slide capacity
- Instantaneous remote or local slide change

## RCA Dual Drum Slide Projector, Type TP-7B

### Application

The Dual Drum Slide Projector, Type TP-7B, provides a ready means of projecting standard 2 by 2-inch slide transparencies into monochrome or color vidicon film cameras. The optical resolution and detail contrast are excellent for any TV pickup application. The machine has adequate light output for color film pickup systems, and it provides uniform brightness over the entire field of the projected image.

The TP-7B is semi-automatic in operation, projecting the slides in a sequential manner on signal from a local or remote location. Dual drums provide a slide capacity of 36 (18 per drum), and the slide change time is practically instantaneous. The control panel on the projector permits either forward or reverse sequential projection.

Control facilities are also available on the projector control panel to hold a slide in either drum and show it alternately with a series of slides in the other channel. The emergency projection lamp may be placed in operation with a quick manual change.

The TP-7B is a quality unit for the TV film room. It may be used with any RCA vidicon multiplexer or vidicon film camera chain, using proper mounting facilities and projector lenses. The TP-7B operates on a 115 Volt, AC, 60 hertz, single phase power line. A 230 Volt, 50 hertz version of the TP-7B Slide Projector is available. It utilizes a separate step-down transformer to reduce line voltage to 115 Volts as required to operate the projector.

## Description

The Type TP-7B Dual Drum Slide Projector is intended to be used in studio color or monochrome television productions for the presentation of any standard mounted 2 by 2-inch slide. Dual condenser lens systems form two optical channels. A drum type magazine associated with each optical channel provides storage for the slides and is so arranged to bring succeeding slides into position for projection without any dark period as the projector drums are rotated. Instantaneous slide change is accomplished by a moving mirror mechanism which multiplexes the two optical channels.

### Single Lamp Source

One projection lamp is used in conjunction with the two sets of condenser optics each of which form an optical channel. Light is collected from both sides of the lamp filament by these optics and directed to each of the two slide gates (one per channel) which are offset from but symmetrically located with respect to the projection axis. Three fixed and one movable front surfaced mirrors located between the slide gates and the single projection lens multiplex the optical channel axes into the centrally located projection lens. Split second movement of this mirror in or out of the optical path switches from one slide channel to the other. A relay type condenser system with four lens elements per channel is used.

### Uniform Screen Illumination

This optical arrangement is the nucleus of the design of the TP-7B. It provides the means of meeting all objectives associated with the optics. Two channels are available to provide the desired continuity of programming. Internal multiplexing of the two channels into one projection lens permits the on-axis projection required on field lens systems. One projection lamp eliminates the possible introduction of color unbalance between the two channels with unmatched lamps. Use of a fully reflective moving mirror in the multiplex system eliminates the need for dichroic or half silvered mirrors which introduce color unbalance with their inherent spectral selectivity. A 300 Watt medium pre-focused base down

lamp provides 450 foot candles on a 3.35 by 4.46-inch screen. This is sufficient light for a television color film camera. Uniformity of screen illumination exceeds 90 percent in open gate search measurements.

### Dual Drum Operation

Separate drive motors are used for each drum. As the slide from one drum is being projected the other drum advances to a new slide position. Precision indexing of each slide position on the drum is accomplished by suitable detents.

### Forced Air Cooling

Forced air cooling is provided so that the slides remain cool, even for extended exposure. A centrifugal type blower located under the optical plate shares this space with the moving mirror mechanism. Ample air flow is provided to maintain cool operation with a 500 Watt lamp.

### Unitized Construction

Unitized construction of the TP-7B Professional Slide Projector provides easy accessibility for cleaning or servicing. The top front cover which protects the multiplexer mirrors from dust may be removed thus giving access to all optical components on the optical plate. For access to the condenser optics, the drums can be easily removed. Bottom covers and lamphouse are also removable so that access to every component is possible. Dowel pins and other devices reassure automatic alignment on reassembly.

Operating controls for the TP-7B are located at the rear of the projector. The projector also can be controlled from a remote control panel.

### Slide Change Instantaneous

A reversible shaded pole gear-head motor coupled to the mirror through a modified type of geneva movement provides the means for rapid movement of the mirror into and out of the optical paths. The mirror and its mount are pivoted on a shaft which is perpendicular to the reflective surface. This permits mirror motion only in the plane established by its surface. Although the drive motor rotor has low inertia, a friction type override clutch between

the crank and the motor reduces shock when the crank strikes its limit stops. Lever type sensing switches are operated by the crank near each end of its travel. The crank is detented in these positions to prevent spring-back when the motor is de-energized and to maintain proper pressure on the sensing switches. Actual mirror motion time is less than  $\frac{1}{5}$  second, yet the gentle accelerating and decelerating forces inherent in the geneva mechanism give smooth quiet operation.

### Ease of Operation

Soft illumination of all slides in the top and rear portions of the drums is provided in this projector. This permits visual observation of picture area when loading the slides. It also permits visual checks on orientation, loading sequence, etc. of the slides in the drum at any time without removing them from the drum. Since the drums may be readily rotated by hand, a complete check on every slide in the drum can be accomplished quickly.

A control box, furnished with the Projector may be mounted in a rack or the base of the multiplexer. This box contains all the relays used in the control circuits as well as the larger capacitors associated with the drive motor. All control circuits operate on 24 Volts DC. Interconnection between it and the projector utilizes a 24-conductor cable which is terminated in the projector on two barrier type terminal boards and at the control box by a plug. Separate jacks are supplied on the box for the two power inputs and for two types of remote control connections.

### Remote Control

Accessory remote control panels, MI-40267-A and MI-40256-A are available with ON-OFF and slide change functions. The MI-40267-A panel is  $4\frac{1}{4}$  inches wide and 7 inches high and a MI-557306 mounting frame is used for mounting this panel in either console or rack. This frame will accommodate four control panels. The MI-40256-A panel has facilities for control of the TP-7 slide projector and two TP-66 Film Projectors. It is  $2\frac{5}{8}$  inches high and  $11\frac{1}{16}$  inches long and may be rack or console mounted by use of a MI-26254-A rack mount adaptor.

## Operational Convenience and Flexibility

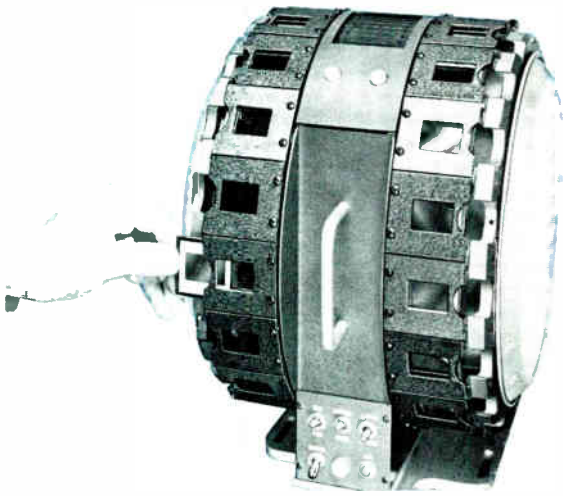

**HIGH SLIDE CAPACITY**—Up to 36 slides may be viewed sequentially in dual drum, dual channel machine.

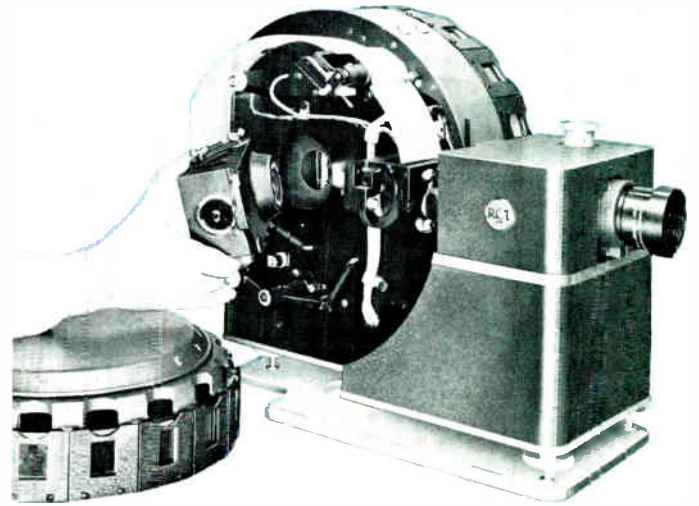

**SINGLE LAMP SOURCE** illuminates both channels, eliminating color balance problem and provides uniform image brightness.

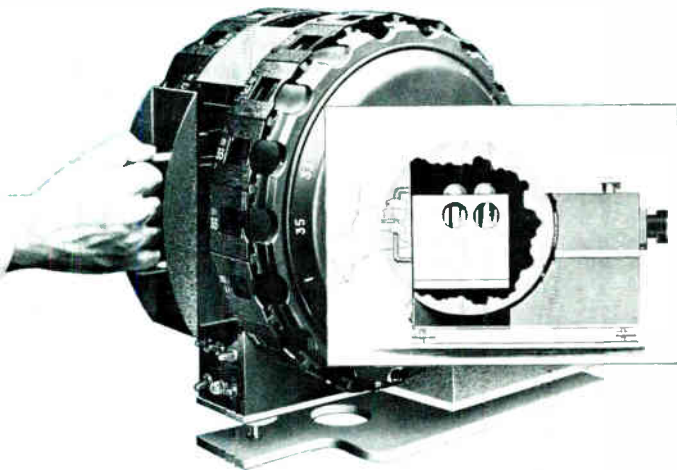

**QUICK LAMP CHANGE** mechanism which allows spare lamp to be moved quickly into place by pulling back handle.

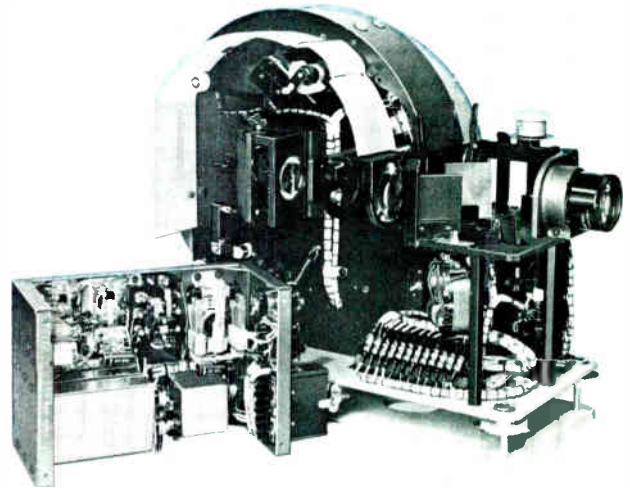

**UNITIZED CONSTRUCTION** allows complete access to control box (left) and projector assemblies.

# Specifications

Slide Size.....	2" x 2"
Lamp Size .....	300 Watts (500 Wattage available)
Usable Picture Area.....	.844" x 1.25" min. (SMPTE Standard)
Slide Changer Time.....	1/5 second
Slide Cycling Time.....	1 sec. max.
Lenses.....	Either 9"—f/6 or 7.5"—f/4
Operation.....	Dual drums operated by individual motors
Slide Capacity.....	18 per drum, total 36 slides
Control Circuit .....	24 Volts, DC
Power Requirements .....	115 Volts, 50/60 Hz, single phase, 7 A; 24 Volts, DC 1 A
Fuse .....	10 A, slo-blo, 3AG
Overall Dimensions:	
Projector.....	23" long, 11" wide, 18" high (58.42 cm, 27.94 cm, 45.72 cm)
Control Box.....	10" long, 6¾" wide, 5¼" high (25.40 cm, 17.14 cm, 13.34 cm)
Weight .....	75 lbs. (approx.) (34 kg.)
Finish.....	Midnight Blue and Silver Gray

## ACCESSORIES

Projection Lens (one required, but not supplied, select as follows):	
Lens, 7½" (for use with TP-11D or TP-15A Multiplexers, where the TP-15A is not used with a TP-16 Projector) .....	MI-26335
Lens, 9" (for use with TP-15A Multiplexer when used with a TP-16 Projector).....	MI-26336
Lens Adaptor for MI-26335 Lens when used with TP-11D Multiplexer.....	MI-26340-A
Light Control:	
Neutral Density Disc Type for use with TP-15A Multiplexer on pedestal for color or monochrome (requires Light Control Amplifier).....	MI-40150
Light Control Amplifier.....	MI-40147
Variable Transformer for all Multiplexers to decrease light output to level required for monochrome camera operation .....	MI-26097
Remote Control Panel .....	MI-40267-A
Remote Control Panel .....	MI-40256-A
Step-down Transformer—for operation from 230 Volt, 50 Hz power source .....	MI-40172

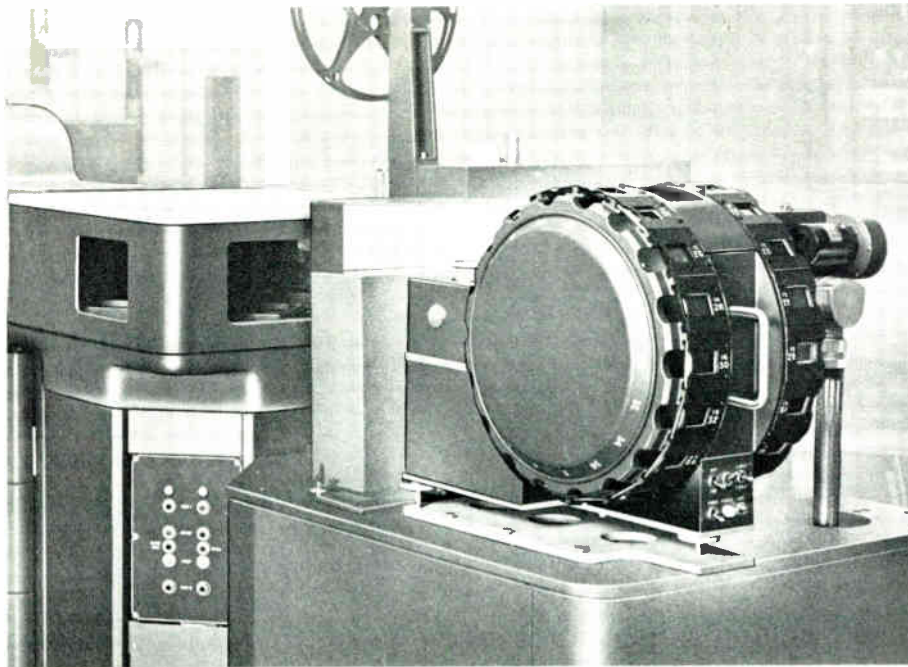

TP-7B Slide Projector offers instantaneous slide change for use with color and monochrome film camera systems.

## Ordering Information

TP-7B Slide Projector, 115 Volts, 60 Hz .....	MI-40011-B
TP-7B Slide Projector, 115 Volts, 50 Hz .....	MI-40011-BH

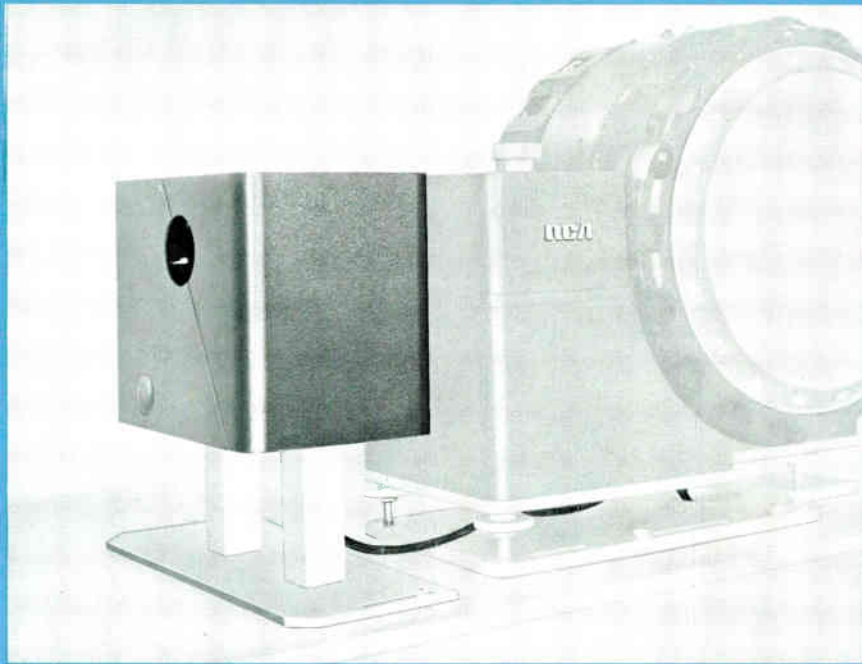

TP-7 Slide Projector Light Control

- Fully transistorized
- Maintains proper color balance
- Fast response
- Control range: 100:1
- For all RCA projectors

## RCA Projector Light Control Systems

### Description

The RCA Light Control System controls the projected image brightness of film and slide projectors. The light intensity is controlled by the angular position of a variable neutral density filter in the optical path. This control compensates for the varying density of slide and film material and permits optimum operating conditions at all times.

The RCA Light Control System is comprised of a light control unit and a servo amplifier. Three light control systems are available: The MI-40146 Assembly is designed for use with the TP-66 Film Projector, and upon installation, it becomes an integral part of that projector; the MI-40150 Assembly mounts in front of the TP-7 Slide Projector projection lens; while the MI-40187 Assembly installs inside the TP-77 Slide Projector to become an integral part of the projector.

The Light Control Servo Amplifier, MI-40147, is a transistorized unit of modular construction and includes a power

supply. Designed for mounting in any standard RCA module frame, the amplifier mounts in the module frame provided in the base of the Projector.

The light control assemblies include a servo motor and follower potentiometer that drives the variable density filter through a gear train. Because of the twin light paths in the TP-77 Slide Projector, the light control assembly for it uses twin assemblies installed at the relay-lens crossover point in each light path. In the TP-66 Film Projector, the light control assembly installs in the light path at the crossover point in the relay condenser-lens system. The mechanism in the MI-40150 Light Control Assembly and its neutral density wedge are contained in a housing which mounts on the multiplexer directly in front of the slide projector lens.

### Operational Details

In RCA Light Control Systems, a potentiometer is coupled to the drive shaft

of the filter wheel by a gear train. Another potentiometer is located at the camera control position. These two potentiometers form a bridge circuit. The difference in electrical potential between the arms of the two potentiometers feeds an AC servo amplifier and the output of the amplifier, in turn, feeds one of the two fields of a 2-phase servo motor which drives the neutral density filter wheel. The servo amplifier and two potentiometers form a null-seeking bridge circuit. When a difference between the outputs of the two potentiometers exists, the output of the servo amplifier drives the "follower" potentiometer via the servo motor gear train until the potential difference between "drive" and "follower" potentiometers reaches zero. Thus, when the output signal of the servo amplifier becomes zero, the servo motor develops no torque, and the filter wheel comes to a stop at a specific point.

The camera operator remotely controls the filter density by rotating the "drive"



potentiometer at the camera control position. This can be located anywhere in the control room. The interconnections are made by a conventional two conductor, shielded "microphone" cable. The servo amplifier is controlled locally with a control on the front panel of the amplifier. A switch is provided on the front panel of the amplifier module for selecting "local" or "remote" control.

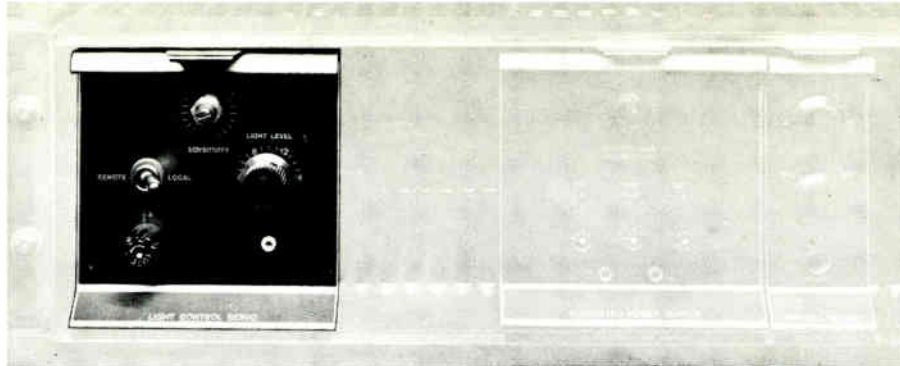

The Light Control Servo Amplifier occupies little rack space.

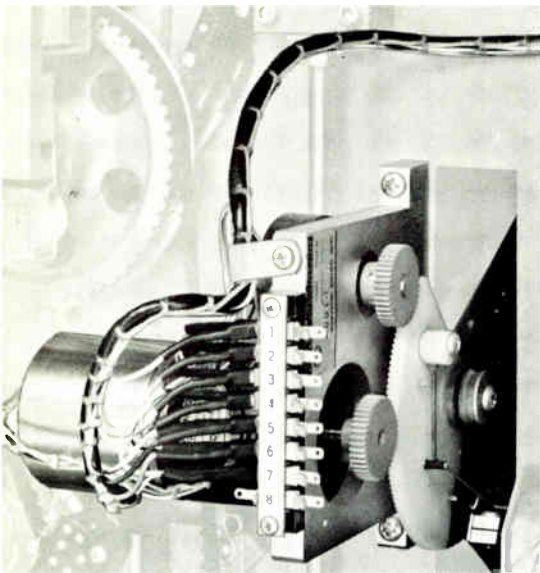

TP-66 Film Projector Light Control

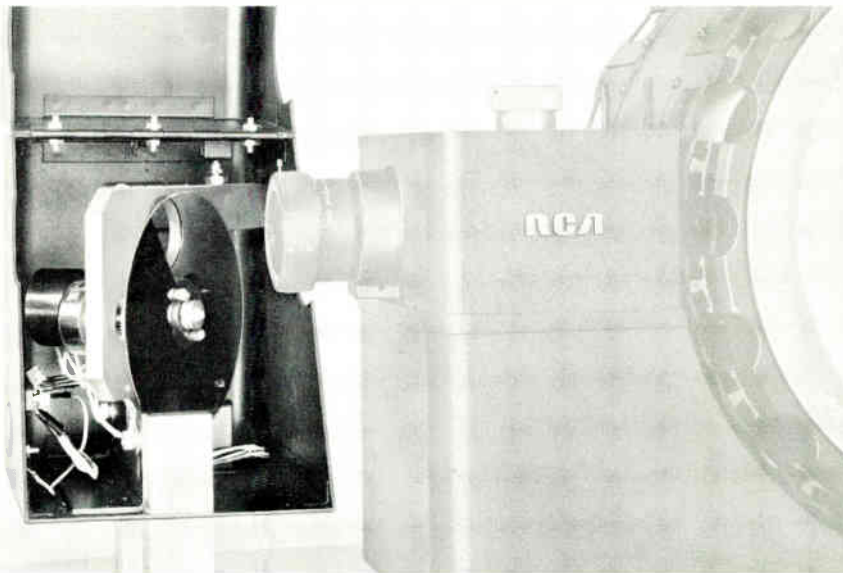

The Light Control Unit, MI-40150, for the TP-7 Projector mounts externally.

## Specifications

Power Requirements	105-130 Volts, 50/60 Hz, 16 Watts, 24 Volts, DC, 0.01 Amperes
Transistor and Diode Complement (Servo Amplifier):	2—2N2270, 2—2N1702, 5—1N3253
Light Transmission Ratio:	
MI-40146 and MI-40187	100 : 1
MI-40150	40 : 1
Operating Time (for maximum change):	
MI-40146 and MI-40187	0.3 sec.
MI-40150	0.4 sec.

Overall Dimensions:	
MI-40150	12½" high, 6¾" wide, 13¾" long (317 x 171 x 349 mm)
MI-40147 (servo amplifier unit)	5¼" high, 10 module units or 4.56" wide, 12½" long (134 x 116 x 308 mm)
Weight:	
MI-40146	2 lbs. (0.9 kg)
MI-40150	13 lbs. (5.9 kg)
MI-40147 and MI-40187	5 lbs. (2.25 kg)

## Ordering Information

For TP-7 Slide Projector, order:

- 1 Light Control Assembly (filter disc included) ..MI-40150
- 1 Light Control Servo Amplifier .....MI-40147
- 1 Adapter Plate (for TP-55 Multiplexer) .....MI-40190

For TP-77 Slide Projector, order:

- 1 Light Control Assembly .....MI-40187
- 2 Neutral Density Filter Wedges .....MI-40148
- 1 Light Control Servo Amplifier .....MI-40147

For TP-66 Film Projector, order:

- 1 Light Control Assembly .....MI-40146
- 1 Neutral Density Filter Wedge .....MI-40148
- 1 Light Control Servo Amplifier .....MI-40147

### Accessories

- Module Frame (for MI-40147 Amplifier) .....MI-557300
- Light Control Remote Panel .....MI-40152

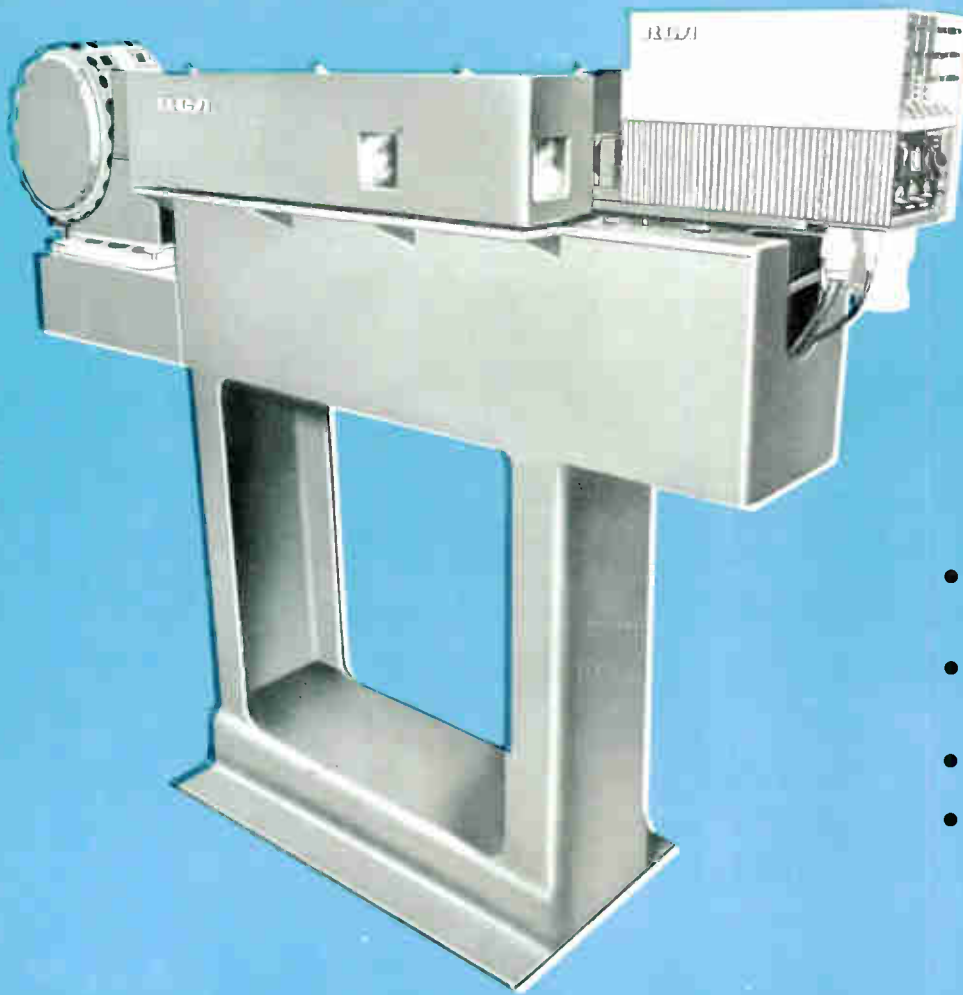

- One camera serves three projectors: two film; one slide
- Rugged construction for operational stability
- Light-tight and dust-free
- Camera and slide projector mount directly to multiplexer

## RCA Monochrome Camera Multiplexer, Type TP-11D

### Description

The TP-11D Monochrome Multiplexer provides multiple projector inputs for a single TK-22 (or a PK-310) Vidicon Film Camera. The unit can reflect images from three picture sources, ordinarily two 16mm (or 35mm) film projectors and a slide projector.

The TP-11D Monochrome Multiplexer uses two beam-splitting "cubes" for transmitting and reflecting the images from

three projector sources to the photo-conductive surface of the vidicon camera tube. The use of these prisms permits permanent arrangement of the film equipment for maximum program efficiency. Either of the two motion picture projectors or the slide projector may be switched on or off electrically while the prisms remain in a fixed position.

The equipment mounts on a rigid ped-

estal which includes an adjustable supporting shelf for the slide projector. A precision-mount arrangement permits removal and replacement of the camera head without need for optical realignment. The prisms and the field lenses mount on an adjustable optical "bench" plate for leveling the optics. The entire optical system is light-tight and dust-free. Rugged construction of the entire unit assures stability of operation.

# Specifications

Length .....	63 $\frac{3}{8}$ " (1626 mm)	Optical Center Above Floor .....	48" (1219 mm)
Height .....	56" (1422 mm)	Weight .....	150 lbs. (68 kg)
Width .....	18" (457 mm)	Finish .....	Midnight blue

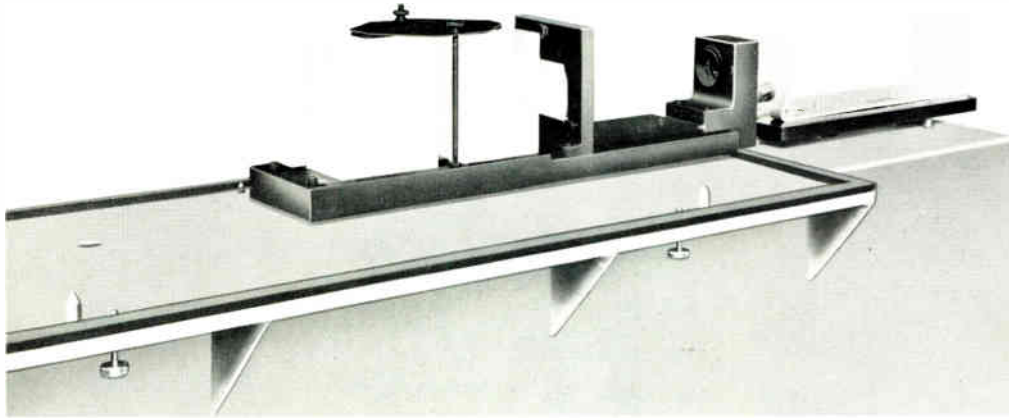

Close-up of the optical system of the TP-11D Monochrome Multiplexer. The optical system is completely covered by a housing to keep it light-tight and dust-free.

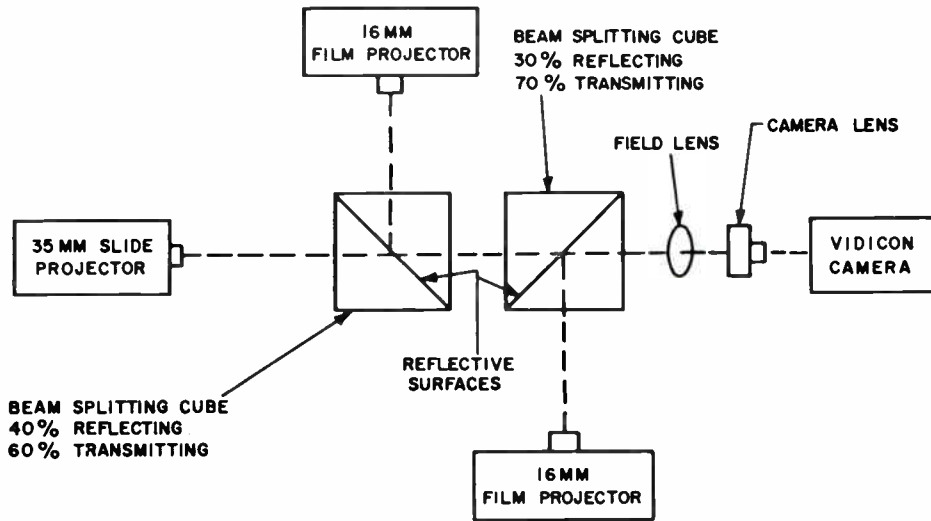

Optical Alignment Diagram, TP-11D Multiplexer.

- TP-11D Multiplexer for PK-310 or TK-22 Camera .....MI-26374-A
- Beam Splitting Prisms (req'd.) .....MI-26394
- Field Lens (req'd.) for TK-22 Camera .....MI-26810-2
- Accessory Kit (req'd.) for PK-310 Camera .....MI-47853
- TP-11 Control Accessory (required only when MI-40266 and 40267 are used to control the TP-7 and TP-66 projectors) .....MI-40168

# Ordering Information



- Improved optical switching system with vertical mirror wipe
- Sturdy integral frame construction permits easy optical alignment
- All solid state control circuitry
- Flexible mirror system for complete integration of monochrome and color film
- Light efficiency approaches 100 percent

## RCA Universal Multiplexer, Type TP-55

### Description

The RCA TP-55 is a new multiplexer designed for use in TV film camera chains with current Color/Monochrome film cameras, 16mm, 35mm and slide projectors. A flexible optical switching system using only two mirrors with a TK-27 Color Film Camera can be expanded at any time to four mirror operation with: one TK-27 and one TK-22 Monochrome Film Camera.

The multiplexer optically switches two or more projected images so that all are on the same optical path. Mirrors having a light transmission efficiency of almost

100 percent, are dropped in and out of position electrically in about 1/5 of a second when a change between picture sources is made. Centralized local or remote control panels greatly simplify switching from one projector to another.

The optional 4-mirror system not only allows complete integration of monochrome and color in the same film island, but offers ideal facilities for previewing the picture from the upcoming projector while supplying a program signal from another projector. Any two of the inputs can be fed to two outputs serving either

two monochrome film cameras, or a monochrome and color film camera.

The TP-55 has many features including an improved optical switching system with vertical mirror wipe, solid state control circuitry, and new rigid construction of the entire unit to assure stability of operation and a simple method of aligning the optical paths. Mechanical improvements offer greater accessibility, new ease in wiring and installing equipment and accessories, and fast set up and alignment.

### Precise Optical Alignment

The heart of the TP-55 Multiplexer is the mirror mechanism precisely aligned on an aluminum alloy plate above the main surface of the multiplexer. A set of two front surface mirrors designed for TK-27 Color Camera use, (or, optionally), a set of three front surface mirrors and one dual surface mirror designed for two-camera use) are operated by a switch on the control panel. Logic circuits choose the mirror arrangement that will produce the desired optical path with a minimum of mirror movement and result in a smooth continuous program pre-

sentation. The logic module employs integrated circuit components for high reliability.

The mirrors are actuated by AC motors. A vertical wipe is accomplished by means of a pin and crank arrangement. Positive braking is achieved by both mechanical and dynamic means. The movement of the mirror occurs in 1/5 second. Precision linear bearings support the vertical travel of the mirror mount.

### Integral Frame Construction

The multiplexer is fabricated of welded

square tubing which provides stiffness and stability and simplifies the mounting of other parts including doors, and access panels. Hinged doors and two end panels are easily removed for complete access to module, junction and mirror areas when required. Concealed magnetic catches hold doors and panels closed. The cover over the mirror area assembly slides back to expose the mechanism, or, if necessary, may be lifted off entirely. The unit is finished in aluminum epoxy and shadow blue textured vinyl.

Adjustable glides or feet for leveling the multiplexer during installation is a

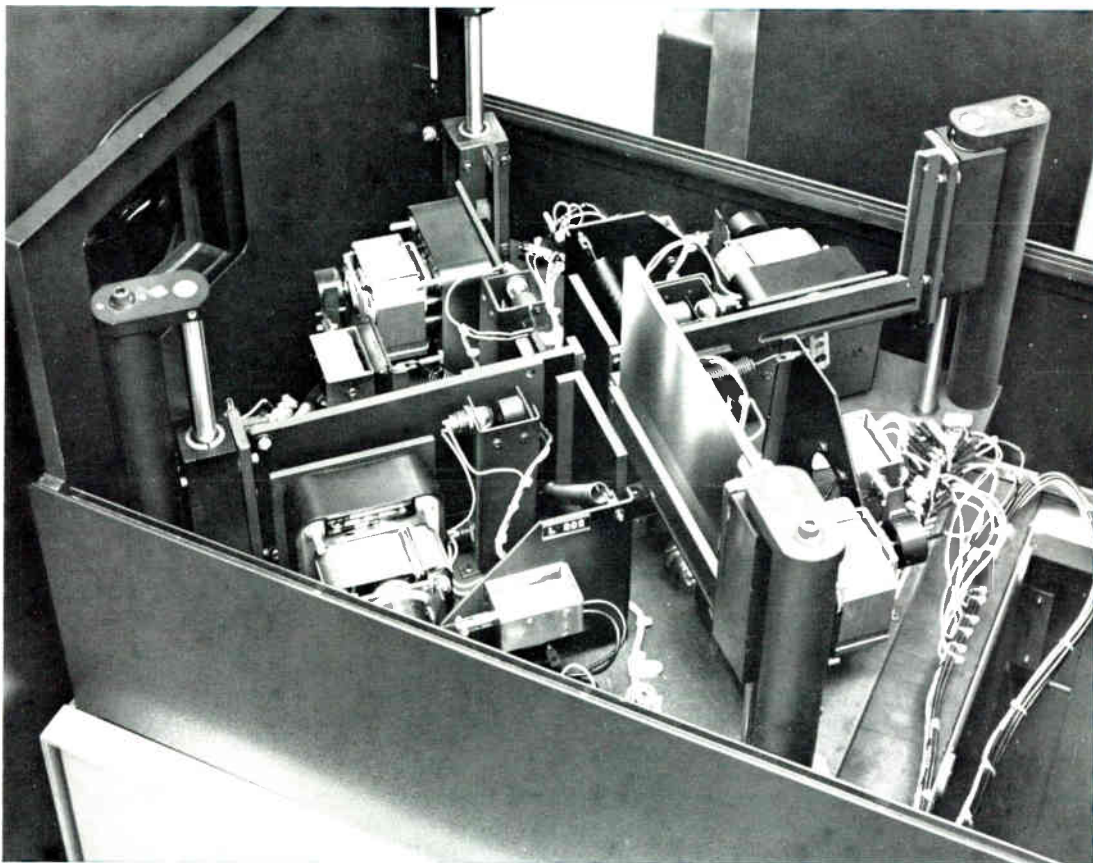

Precisely aligned mirror mechanism of the TP-55 Multiplexer showing actuating AC motors. A vertical wipe is accomplished within 1/5 second by means of pin and crank arrangement.

new feature that permits easy positive alignment. A built-in circular level provides a ready check. The leveling feet have socket heads and are easily adjusted with a socket wrench provided with the equipment.

### Solid-State Modular Controls

The module area in the new TP-55 is roomy, convenient for the operator, and completely accessible for installation and maintenance of the multiplexer and associated studio film equipment. A module frame holds the solid-state Logic, Tally, Mirror Power, and WP-24 Power Supply Modules. Space has been allotted for three additional units; the Light Control Switcher "A" and Switcher "B" Modules, and the CP Logic Module. The cables to the connectors at the rear of the module frame are long enough to allow the frame to be moved to another position in the multiplexer if this is found to be desirable. The control position of the multiplexer therefore can be transferred to either side of the unit. There is also ample space in the area for mounting other equipment if desired. A sheet metal shelf to support the control box for the TP-7 Slide Projector is supplied with the TP-55.

### Control Junction Area

The middle section of the multiplexer is a control junction area. It is ideally arranged for an orderly distribution of the many cables associated with remote control and equipment interconnections and distribution of incoming power. A group of terminal boards featuring push-on terminals, as well as direct soldering, is mounted on the inside of the door. Locating the terminal boards in this manner makes them conveniently accessible for installation, testing and trouble shooting. If necessary, the door can be removed for even greater accessibility. A clear plastic cover adds protection to the entire terminal board area. Holes are provided for cable clamps and additional interconnecting cables that may be required.

An AC input chassis is mounted at the bottom of the multiplexer frame in the control junction area. It contains an isolation and stepdown transformer (to allow for 220 Volt operation), a terminal board, a 5-Ampere circuit breaker, inductor, and diode voltage regulator. The electrical output boxes, and switch are also mounted here. They provide central power distribution to other equipments on the film island and permit compliance with local electrical codes.

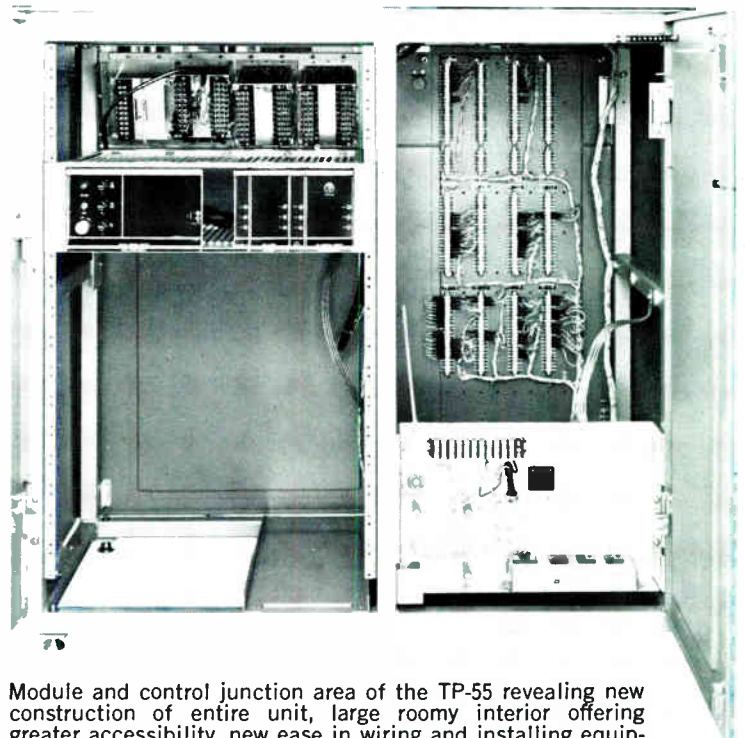

Module and control junction area of the TP-55 revealing new construction of entire unit, large roomy interior offering greater accessibility, new ease in wiring and installing equipment and accessories.

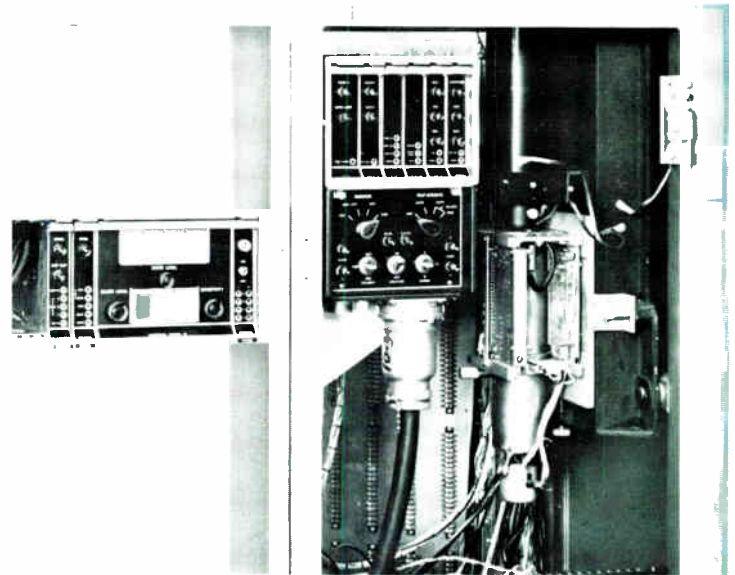

A TK-22 Monochrome Camera easily installed in the TP-55 Multiplexer, allows complete integration of monochrome and color in the same film island and also offers ideal facilities for previewing.

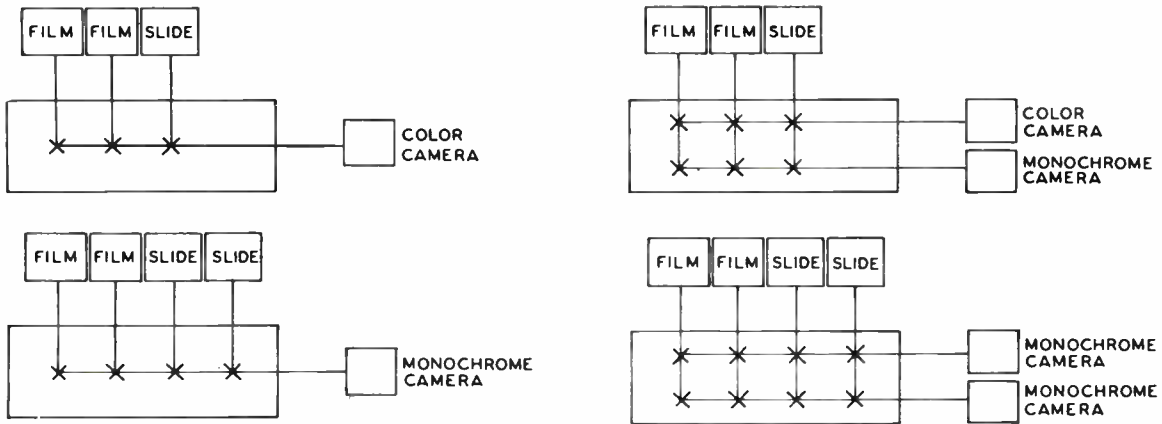

Diagram of possible arrangement of cameras, and film or slide projectors with the TP-55 Universal Multiplexer.

## Specifications

- Multiplexer Inputs .....Up to four
- Multiplexer Outputs .....One or two
- Control .....Local or remote
- Mirrors:
  - System 1 (as supplied .....2 front surface mirrors to accommodate 1 Color Camera and up to 3 Projectors
  - System 2 (with optional optics) .....4, including 3 front surface mirrors and 1 dual surface mirror to accommodate 1 Color Camera, 1 Monochrome Camera and 3 projectors
- Motors .....4—115 Volt, 50/60 Hz, gear-head shaded pole, unidirectional
- Power Requirements .....115/230 Volts, single phase, 50/60 Hz, 7 Amps.
- Dimensions .....57" long, 20" wide, 52" high (144.78 cm, 50.80 cm, 132.08 cm)
- Weight (approximate) .....450 lbs. (205 kg.)

### Accessories

- Control Panel Logic Module .....MI-40142  
(This module provides complete assignment of all projector and multiplexer control functions to a single remote control position and electrically isolates all other control positions. Specify one module for two remote positions and two modules for three or four positions.)
- Light Control Switcher "A" Module .....MI-40138  
(Required only if light controls are used in film or slide projectors.)
- Monochrome Film Camera Accessories:
  - Optical Assembly for TK-22 .....MI-40155
  - Mounting Adaptor for TK-22 Camera .....MI-40156
  - Field Lens for TK-22 .....MI-40859-6
- Auxiliary Control Chassis for TP-7 .....MI-40168  
(Converts TP-7 control circuitry from series to momentary contact control system.)
- Adaptor Plate (for TP-7 Light Control MI-40150) .....MI-40190

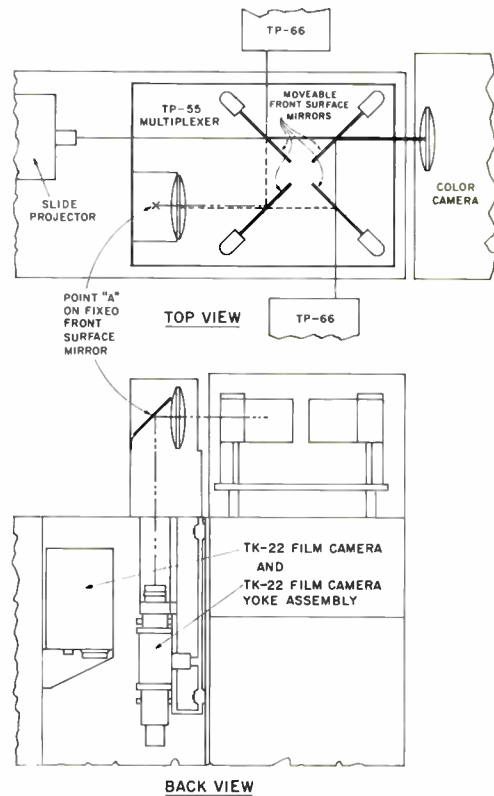

Diagram of light paths between cameras and projectors made possible by the TP-55 Multiplexer.

## Ordering Information

Type TP-55 Universal Multiplexer for 115/230 Volts, 50/60 Hz as follows:

- Type TP-55 Multiplexer  
(Complete with WP-24 Power Supply MI-556676-A1; Mul-

- tiplexer Logic Module MI-40134, Tally Module MI-40135, Mirror Power Module MI-40136, Selector Panel MI-40159, and set of two front-surface mirrors) .....MI-40055
- Control Panel for TP-66 Film Projector .....MI-40266-B  
(One required for each projector)
- Control Panel for TP-7 Slide Projector .....MI-40267-B
- Control Panel for TP-77 Slide Projector .....MI-40277

# RCA 16mm TV Film Projector, Type TP-66

- Automatic cueing, loop restoring, lamp change
- Instant start . . . still frame projector . . . film reversing
- For color and monochrome programming





# TOMORROW'S PROJECTOR...TODAY

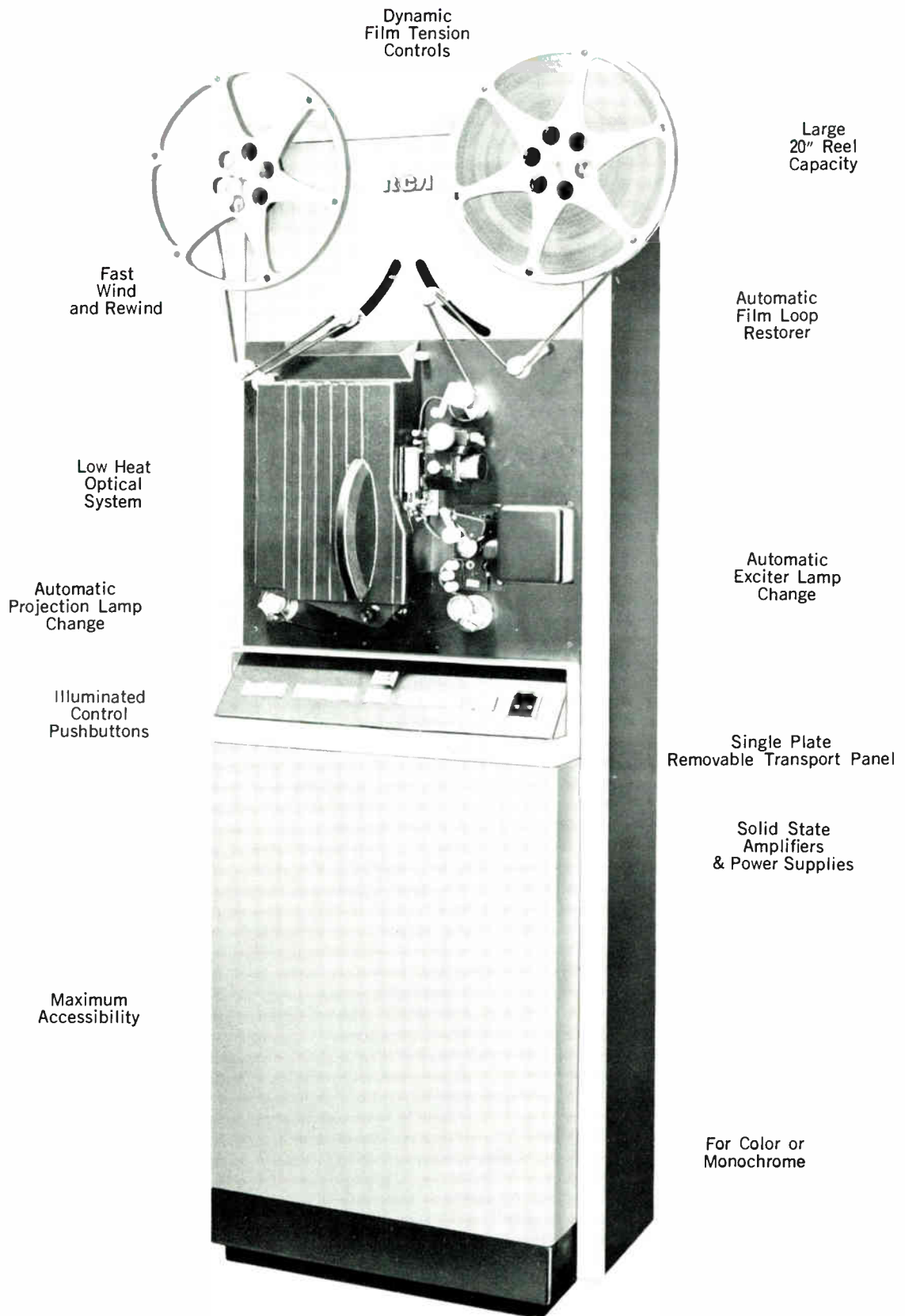

# Advanced 16 mm TV Film Projector, Type TP-66

The TP-66 is a TV Film Projector designed specifically for television. It is built to meet the modern pace of film programming. It is the final result of studying user requirements for TV film projection.

The TP-66 is an advanced projector that offers the reliability and instant reaction of transistorized circuits. It is designed with

many automatic features that reduce error. It incorporates new operating features that facilitate program creativity.

Designed for the requirements of color and of automation the TP-66 fulfills the needs of TV film programming for the present and the future.

## Description

### Rapid Start

Starting time is virtually instantaneous. Sound is sufficiently stable for program use within only 0.3 seconds from the start. No longer necessary is the usual pre-roll period prior to switching the projector "on-air." Start and show buttons—for all practical purposes—can be activated in a single operation, eliminating one more source of error during station breaks.

### Reverse Operation

The TP-66 can be operated in reverse, making possible repetition of film segments without the need for rewinding and rethreading.

This time saving feature is particularly useful during rehearsal of "live" or tape shows in which film inserts are incorporated. The TP-66 sound system is automatically disabled when the projector is being operated in the reverse direction.

### Still Frame Projection

A single film frame can be shown at full light level for extended periods of time—a feature that permits the director to preview the first frame of any upcoming film. Attenuation of light level, which is necessary during still frame projection,

is provided by a filter which is automatically placed in the light path. The shutter is indexed to assure that it is held in an open position during still frame projection.

### Large Reel Capacity

The TP-66 accommodates large, 20-inch reels, providing the capacity needed for continuous film programming. Up to one hour and 40 minutes of uninterrupted projection is possible. Film segments can be spliced together on a single large reel to save time and to avoid possible errors.

### Fast Wind and Rewind

Winding and rewinding of film is fast and easy. Film is merely threaded over the two sets of idler rollers. Winding in either direction is then controlled by manual operation of the tensioning arms. Moving either of the arms in an upward direction results in winding the associated reel. A 100-foot reel can be rewound in about 45 seconds . . . the 20-inch reel in approximately 5¼ minutes.

### Automatic Cue

Films can be stopped and cued up automatically on the TP-66, eliminating the need for manual threading and cueing

of individual films, and reducing errors that often occur with visual cue marks. Precise, clean program transitions are assured. A feature film can be programmed in advance to cue the beginning as well as any number of stopping points for station breaks or commercials. The TP-66 stops automatically at the end of each film segment, and cues up the next segment within one frame of the desired starting point. The system is activated by small patches of conductive tape attached to the film. A cue defeat switch is mounted on both the local and remote control panels so that cue patches can be overrun without stopping the projector.

### Quiet Operation

Several design features make the TP-66 particularly quiet in operation. The slow speed 1800 rpm drive motor connects sprockets, intermittent and shutter through a system of toothed belts rather than through noisy gears. The 720 rpm shutter is driven directly by the intermittent cam. Even the intermittent itself, using a cycloidal pull-down, runs smoothly and quietly. During standby, only the whisper-quiet, axial flow lamp blower is in operation.

## Easy Threading

Projectionists will appreciate the human engineering that has gone into the design of the TP-66. The entire film path has been placed at stand-up working level to eliminate the need for stooping or bending while threading the projector. The film gate and the projection lens are entirely separate assemblies, the lens remaining stationary when the gate is opened. New design makes the gate area more easily accessible for insertion of film. Film loops are easily and correctly formed by solenoid operated loop setters which act as measuring guides when the projector is being threaded.

## Automatic Loop Restorer

Loss of loop, caused by torn sprocket holes or otherwise seriously damaged film, is instantly recovered by the automatic loop restorer built into the projector. Upon sensing loop loss, the automatic restorer applies a force to cause film slippage to occur at the gate between pull-downs and thus recover enough film for correct loop size. Sufficient compliance has been provided to avoid any possible damage to the film.

## Automatic Projection Lamp Change

When projection lamp failure occurs, a spare lamp automatically moves into place and is activated immediately. Changeover mechanism consists of two projection lamps mounted on a moveable plate so that either of the two lamps can be placed in operating position. Condition of the standby lamp is indicated instantly on the control panel, and lamps can be replaced easily and quickly even while the machine is running.

## Automatic Exciter Lamp Change

A further contribution to the high degree of overall reliability is an automatic exciter lamp change device. An indicator shows when the changer is in its normal position. Removal of a single cover permits rapid replacement of the defective lamp.

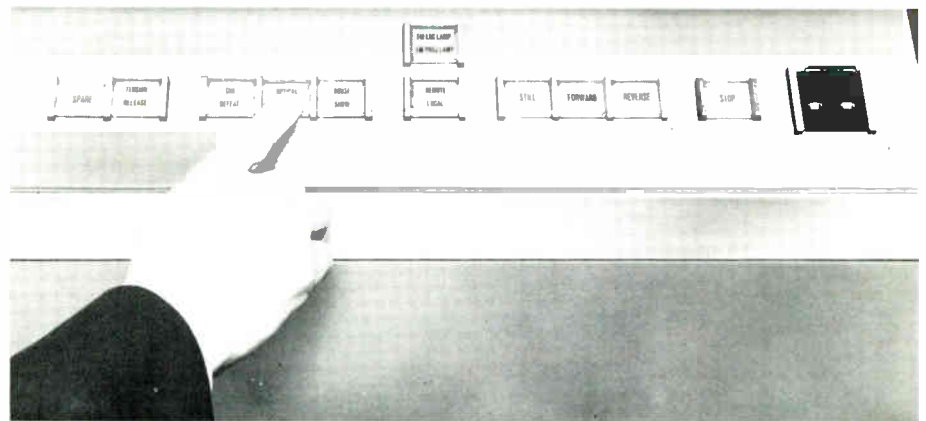

Illuminated control buttons are arranged for easy identification and operation.

## SPECIAL CONSTRUCTION FEATURES

The modules and panels that comprise the TP-66 system are housed in a rugged frame type structure designed to provide a support that is extremely rigid and one that offers utmost accessibility to all areas.

### Precision Intermittent

A high degree of picture stability is achieved through a precision claw type intermittent that uses no gears and very few moving parts. The unique mechanism combines mechanical simplicity with extreme accuracy of film indexing.

A three tooth claw assures uninterrupted passage of film—even worn film with damaged sprocket holes. The center claw is sapphire lined. Claw guides are of hardened tool steel for long trouble-free operation.

The intermittent is easily removable for servicing, and in most cases can be remounted without readjustment, although adjustments are easily made. Design permits utilization of a 50 percent application time shutter to meet color requirements.

### High Efficiency Optics

Because of the high efficiency of the optical system in the TP-66, a projection

lamp of 500 Watts provides more than adequate light output for either a monochrome or color film camera system. This also contributes to the low heat dissipation of the projector.

### Dynamic Film Tension Controls

Proper reeling tensions for any diameter from 1/4-inch to 20 inches is assured by dynamic film tension controls provided on both projector reels. Tension is decreased as the reeling diameter increases, to prevent cinching.

All film supply and take-up reeling functions for both forward and reverse operation of the projector are provided by two similar but opposed reeling modules, each a closed loop tensioning system. Actual film tension controls the position of a spring-loaded tensioning arm linked to a variable transformer. This transformer varies the voltage to a torque motor, connected to the reel spindle by means of a toothed belt drive. Proper reeling tension is assured at all times.

Since actual film tension directly controls motor torque, the function of each module can be changed from "supply" to "takeup" by control of the direction of film motion alone, as occurs when the projector is reversed.

## Features For Easy Operation

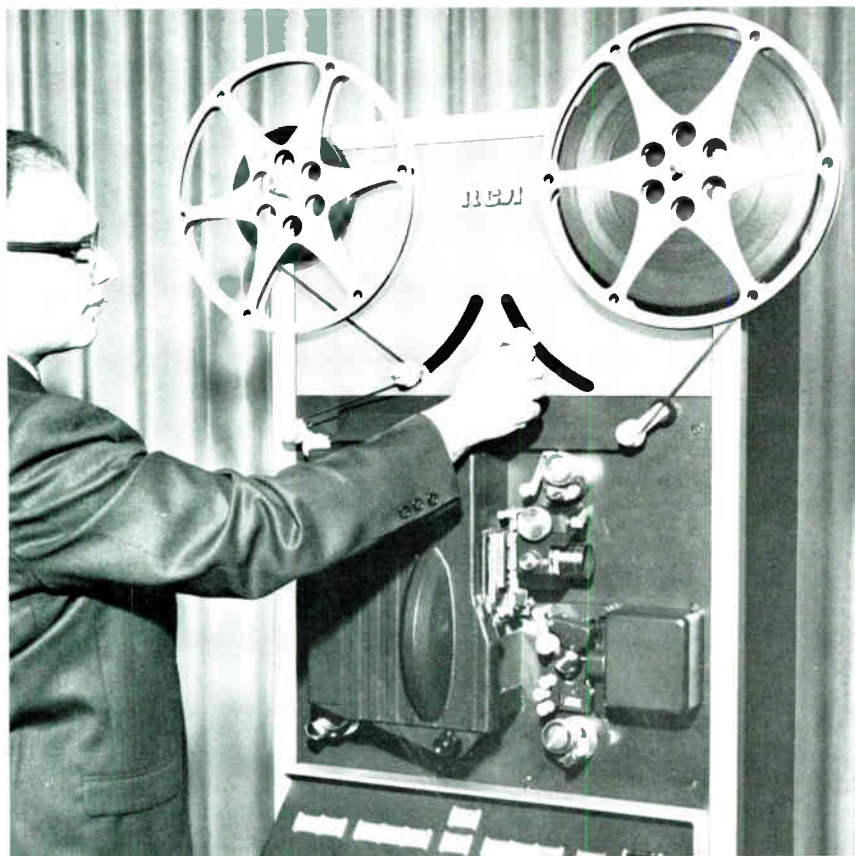

**EYE LEVEL REELS—NEW REEL LOCKS . . .** Eye level reels eliminate stooping or bending. New spring-action reel key and lock simplify placing reel on shaft.

**SIMPLE FILM PATH . . .** Wide, self-aligning film gate and simple film path make threading easy.

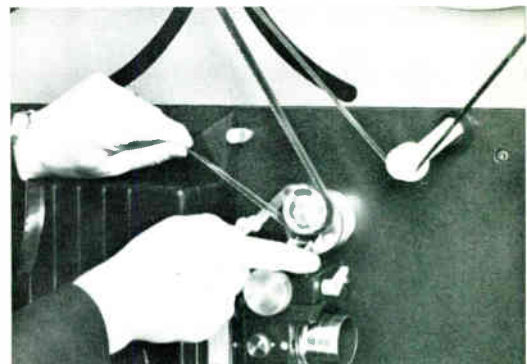

**SEPARATE GATE & LENS MOUNTS . . .** Film pressure shoe moves forward opening gate area for easy threading without disturbing lens position.

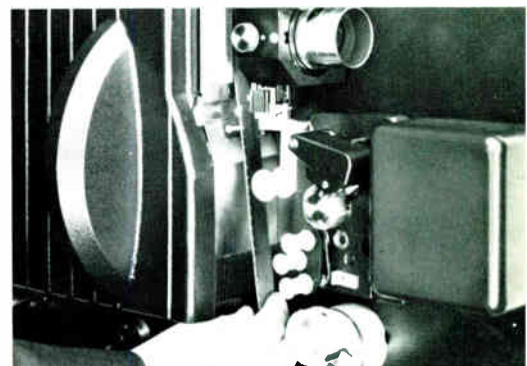

**AUTOMATIC LOOP SETTERS . . .** Loop setters (shown in position) act as measuring guides to assure correct loop size.

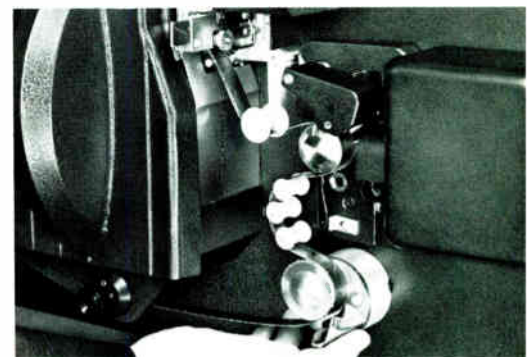

## Dependable Performance

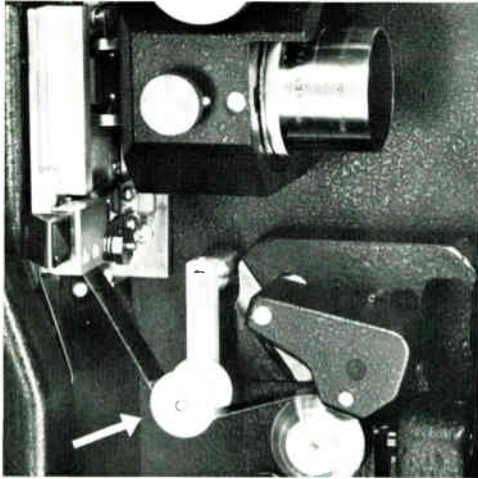

**AUTOMATIC LOOP RESTORER . . .** Loss of loop caused by defective film is instantly recovered by the automatic loop restorer shown at optimum loop position.

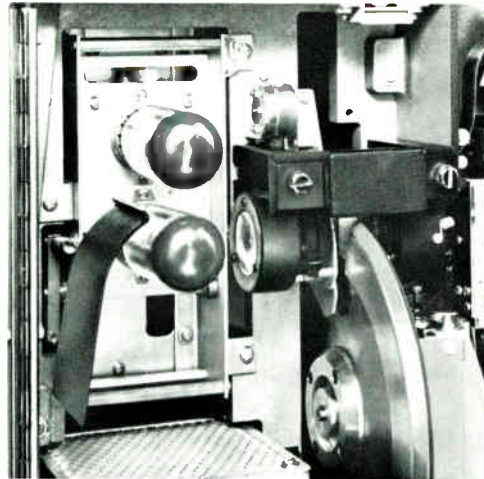

**AUTOMATIC PROJECTION LAMP CHANGE . . .** Automatic lamp change mechanism places new lamp into position within one second of lamp failure.

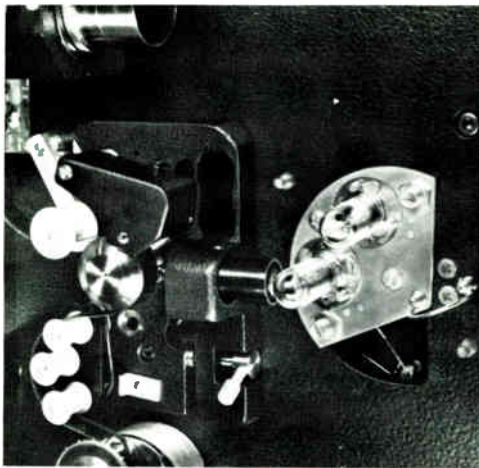

**AUTOMATIC EXCITER LAMP CHANGE . . .** With same speed as projection lamp changer, exciter lamp changer replaces defective exciter lamp automatically.

**LESS CARE AND ATTENTION . . . LONG TERM RELIABILITY . . .** (Left) Magnetically latched cover removed from TP-66 to show module frame (beneath control panel) housing plug-in amplifiers and power supplies.

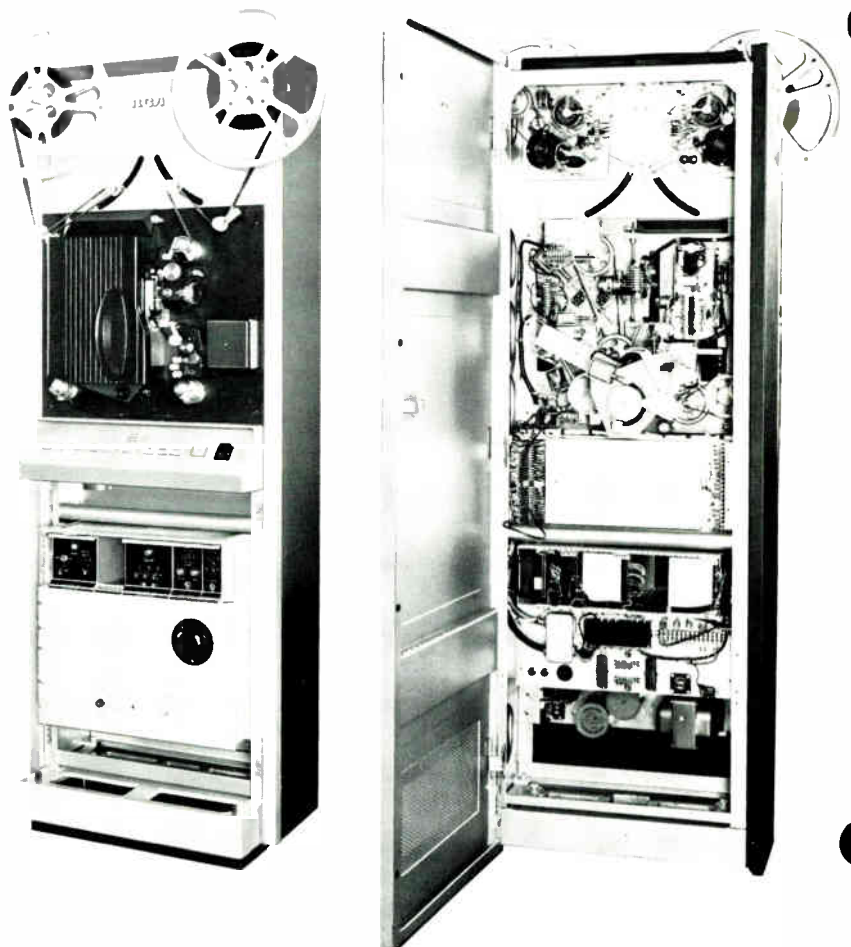

(Right) full length rear door (also removable) provides complete accessibility for inspection or service.

## Transistorized Components

Dependability is a prime feature of the TP-66 TV Film Projector. Utmost reliability in the sound system is gained through transistorization, which also provides other important benefits such as lower heat dissipation and the elimination of equipment warmup prior to operation.

The TP-66 utilizes a solid state photo transducer. This replaces the conventional photo cell used in other projectors and offers a substantial increase in operating life.

Audio amplifiers are completely transistorized and designed so that electrical shorts at either the input or output line will not cause damage. Silicon transistors are used throughout.

## Minimum Lubrication

Under normal operating conditions lubrication is required only on a semi-annual basis. The intermittent assembly runs in an oil bath. All major rotating shafts use ball bearings for utmost dependability.

## Excellent Accessibility

Quick and easy accessibility to every part of the projector drastically reduces the time required for inspection and maintenance. In keeping with this philosophy, access to the intermittent assembly for inspection, servicing or removal has been made quite simple.

Should major servicing be required, the complete main panel can be removed without affecting optical alignment.

Servicing of plug-in modules during operation is easily accomplished by use of extenders which make the module accessible for service while in operation.

The control panel is hinged and will pivot down and forward for access to the rear of the panel.

The precision optics in the TP-66 are easily cleaned to assure maximum efficiency and performance at all times. The condenser lens assembly is a plug-in unit, readily removed for cleaning.

## Ease of Installation

The projector is entirely compatible with existing RCA film systems. It can be installed with either TP-6 or TP-16 projectors and integrated with TP-11, TP-15 or TP-55 multiplexer systems.

Installation is simplified by use of a

new alignment and leveling arrangement. Adjustment screws provide ease in leveling and aligning the projector, both transverse and parallel to the optical axis.

The TP-66 is supplied as a completely assembled and system-tested unit ready to be placed in operation.

# ACCESSORIES ENHANCE OPERATION

## Variable Density Light Control

This permits smooth control of light intensity regardless of variations in film density, provides optimum conditions for color or monochrome systems, and is readily integrated into an automatic light control system.

## Magnetic Sound

Permits playback of sound recorded magnetically on pre-stripped film. Utilizes special advantages of magnetic film for local production of news films and commercials. After installation, either magnetic or optical sound can be selected.

## Remote Control Panels

Two TP-66 Remote Control Panels are available. The MI-40266-A provides for "show," "forward," "reverse" and "still" projection, "stop," "optical/magnetic sound" and "automatic cue defeat." A simplified Dual Projector Remote Control Panel, MI-40256-B, provides "start," "stop" and "show" for two TP-66 projectors and a slide projector.

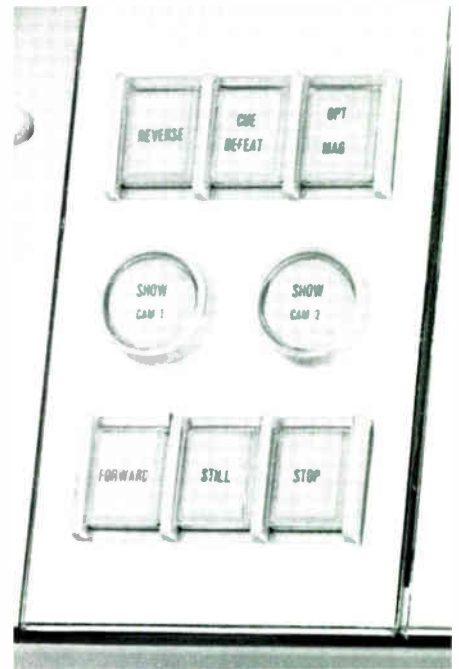

All functions of the TP-66 may be easily controlled from the convenient Basic Control Panel, MI-40266-A.



Dual Projector Remote Control Panel, MI-40256-B for use with TP-11D Multiplexer.

## Specifications

### General

Film .....	Standard 16mm
Reel Size and Capacity .....	Up to 20" (50.8 cm) diameter (100 minutes running time)
Optical Center Line .....	Adjustable, 47" (117.5 cm)- 49" (122.5 cm) above floor
Light Application .....	50%
Film Speed:	
MI-40066-A .....	24 frames/sec
MI-557066 .....	25 frames/sec
Shutter Speed:	
MI-40066-A .....	60 light pulses/sec
MI-557066 .....	50 light pulses/sec
Power Requirements:	
MI-40066-A .....	105-125 Volts, approx. 1000 W
MI-557066 .....	105-125/210-240 Volts, approx. 1000 W
Signal-to-Noise Ratio	
Optical Sound System .....	55 dB or better
Magnetic Sound System .....	52 dB or better
Harmonic Distortion (Optical Sound Pre-amplifier) .....	Not to exceed 0.5% over frequency range

Audio Output Level and Impedance .....	+18 dBm; 150/600 Ohms
Frequency Response .....	50-7000 Hz within 4 dB

### Mechanical

Dimensions .....	69" (172.5 cm) high (without reels), 24½" (63.2 cm) wide, 14¾" (36.8 cm) deep
Weight:	
MI-40066-A .....	475 lbs. (215.4 kg.)
MI-557066 .....	505 lbs. (229 kg.)
Picture Stability .....	Vertical jump and horizontal weave not more than 0.1% of picture width
Uniformity of Illumination .....	Not less than 90%
Flutter and Wow .....	Not to exceed 0.3% within 0.3 to 2 seconds after start of projector. After 2 seconds, not to exceed 0.15%

### Accessories

Light Control System .....	ES-40946
Magnetic Sound Control .....	ES-40940
Remote Control Panel for TP-66 Projector for use with either TP-11D or TP-15A Multiplexers .....	MI-40266-A
Dual Projector Remote Control Panel for use with TP-11D Multiplexer .....	MI-40256-B
Module Extender .....	MI-557301

## Ordering Information

The Type TP-66 16mm Film Projector is available for operation on 60 Hz or 50 Hz power sources.

Basic Models:	Specify as:
TP-66 16mm TV Film Projector (60 Hz) .....	MI-40066-A
TP-66 16mm TV Film Projector (50 Hz) .....	MI-557066
Projection Lenses (one required but not supplied with basic projector):	Specify as:
Lens, 3½" f/1.5 for use of projector with TP-11 Multiplexer .....	MI-26325-A
Lens, 2½" f/2.6 for use of projector with TP-15 Multiplexer .....	MI-26799-B

TERMINAL



TERMINAL

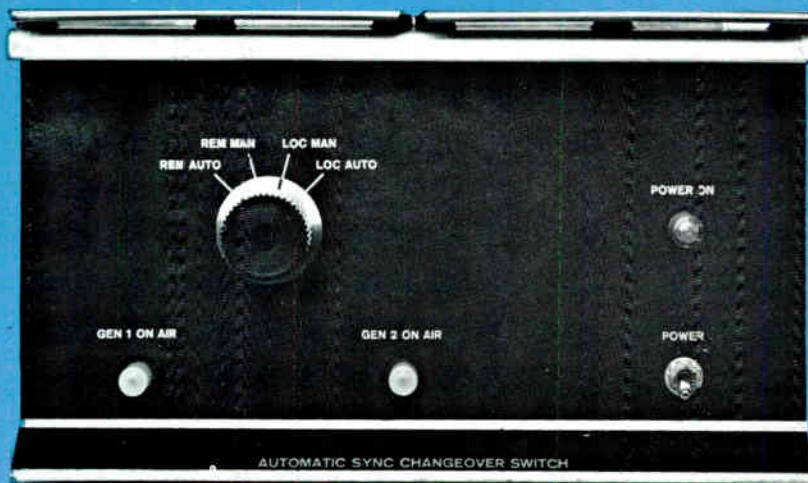

- Automatic changeover when pulse amplitude drops
- Front panel fault indicator
- Remote and manual mode switch
- Remote control panel included
- Modular construction

## RCA Automatic Sync Generator Changeover Switch, Type TS-3

### Description

The RCA Type TS-3 Automatic Sync Generator Changeover Switch provides automatic transfer of eight signals from one synchronizing generator to a second unit. The equipment consists of a sensor module, control module and a connector assembly mounted in a standard module frame.

#### Automatic Operation

The TS-3 is fully automatic. Four transfer sections containing sensing units determine when any of four sync generator signals (subcarrier, drive, blanking or sync) drop below a sensing level. The switch automatically transfers to a second sync generator if any of the pulses drop. The unit is inhibited from multiple searching should both sync generators show faults.

#### Fault Indication

A fault indicator, located both on the

front panel of the changeover switch and on the remote control panel, is illuminated when the fault is registered in a sensor. If a fault has been corrected, depressing the fault button extinguishes the lamp and presets the indicating circuit.

#### Manual Changeover

The TS-3 can be operated in the manual mode. The changeover may be accomplished manually while in the automatic mode provided the output of both sync generators is satisfactory. An auxiliary output is provided for use with the number two sync generator when number one is switched to the normal output.

#### Local and Remote Control Panels

Both local and remote control panels are supplied with the TS-3 Changeover Switch. The local panel contains tallies which indicate which generator is "On

the Air" and power is on. A mode selector button and power toggle switch are also located on the panel. The remote panel contains illuminated pushbuttons for generator changeover at a remote operating position. A nine-wire cable is required for remote operation.

#### Standard Rack Mounting

The TS-3 is supplied in a standard module frame for 19-inch rack mounting. The module frame contains a control module, sensor module and back plate assembly. The sensor module is shown at left in the picture below and is included in the module frame. Also shown is the remote indicator/control panel for the TG-3 Switcher. Duplicating the indicators on the front panels of the modules, the Remote Control Panel mounts in the control-room console to indicate switcher actions in the equipment-rack room.

Sensor Module and Remote Control Panel.

## Specifications

**Inputs (BNC Connectors):**

- #1 Generator .....Eight (four sensed, 4 non-sensed)
- #2 Generator .....Eight (four sensed, 4 non-sensed)

**Outputs:**

- #1 Generator .....Eight (UHF type connectors)
- #2 Generator .....Eight (BNC type connectors)

Modes of Operation .....Local Manual, Local Automatic,  
Remote Manual and Remote Automatic

Power Requirements .....90 to 130 V/190 to 260 V, AC,  
50/60 Hz, 15 Watts

Shipping Weight .....35 lbs. (15.8 kg.)

**Dimensions (Overall):**

- Rack Module Frame .....19" wide, 5¼" high, 18" deep  
(excluding cables) (483 mm, 134 mm, 457 mm)
- TS-3.....21 module spaces or 9¼" wide, 5¼" high, 21¼" deep  
(235 mm, 134 mm, 545 mm)

**Remote Control**

- Panel .....5 module spaces or 2½" wide, 7" high, 4" deep  
(54 mm, 178 mm, 102 mm)

**Accessory**

Interconnecting Cable for Remote Control Panel ..MI-13346-15

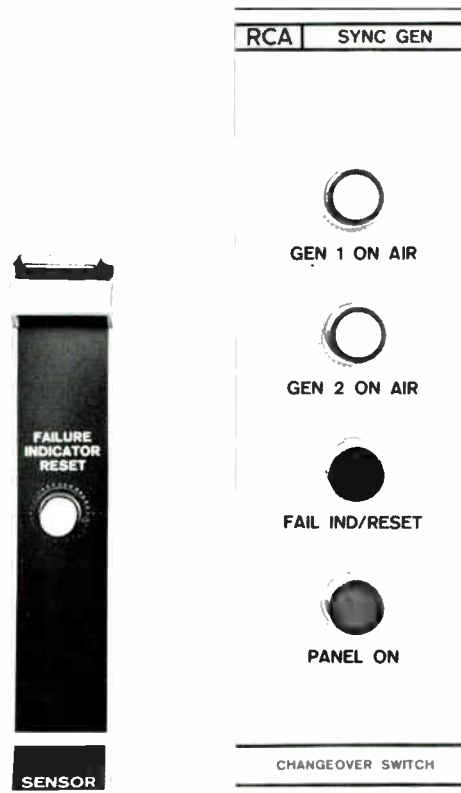

## Ordering Information

TS-3 Auto Sync Generator Changeover Switch .....MI-556594  
Includes:

- 1 Rack Module Frame
- 1 Control Module
- 1 Sensor Module
- 1 Back Plate Assembly
- 1 Remote Control Panel
- 16 4' Cables with BNC connectors
- 8 BNC 75 Ohm termination



- New hybrid microcircuit amplifier
- Five isolated outputs
- Cable equalization to 1500 feet
- Plug-in equalizers
- High performance
- Self-contained power supply

## Video Equalizing and Distribution Amplifier, Type TA-43

### Description

The Type TA-43 is intended to satisfy the critical color television industry need for a highly stable, video-distribution amplifier capable of equalizing substantial lengths of dual-shielded, coaxial cables and to maintain performance within very precise specifications over long periods of time with a minimum of attention.

The Type TA-43 may be used as a conventional video-distribution amplifier, and, where gain is required, it restores signals to the standard one-volt peak-to-

peak level. Eight amplifiers may be mounted in an RCA standard module frame along with a Power Control Module. A connector assembly is supplied with each amplifier which also accepts the plug-in equalizers, attenuators, or input loop-through card. Amplifiers may be removed without disturbing the equalizers or attenuators. BNC connectors are used for all coaxial cable inputs and outputs. A self-contained power supply in each amplifier, using IC regulators, provides

excellent reliability.

### Hybrid Video Amplifier

All of the active, solid-state elements in the video signal path are contained in a hybrid microcircuit. Semiconductor chips and thick-film resistors are integrated into a single, hermetically sealed assembly. This circuit is responsible for the very high performance and stable operation of the Type TA-43. It is replaceable and available for separate sale as MI-556806.

## Five Isolated Outputs

All five outputs are terminated internally in 75 ohms and the return loss per output is more than 45 dB below 1.0 volt to 8.0 MHz. Isolation between outputs is greater than 60 dB to 1 MHz; 46 dB to 4.43 MHz and 40 dB to 8.0 MHz. The quiescent d-c voltage on the outputs is

factory adjusted to zero ( $\pm 0.01$  V) with an internal control. This control is also used to re-adjust the d-c voltage when the gain-setting jumpers are changed.

## Fixed Gain for Precise Performance

The hybrid amplifier gain characteristics are controlled by external components

which may be strapped in three combinations to set the gain of the amplifier at 0, 6, or 15 dB.

At the zero-dB setting, the amplifier is used for normal video distribution. An input loop-through card, supplied with the amplifier, provides the connection for bridging up to eight amplifiers with a

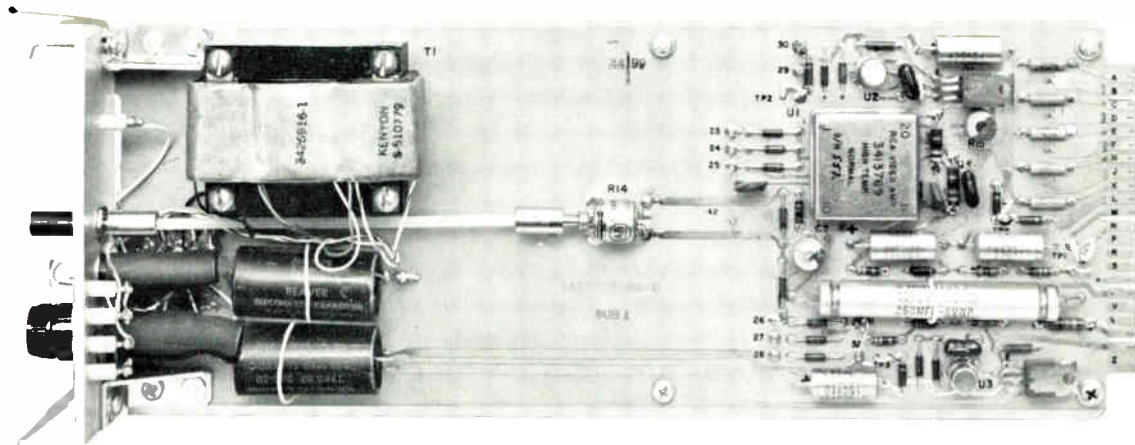

TA-43 Module from the component side of the board. The hybrid amplifier is the large, square flat-pack toward the right.

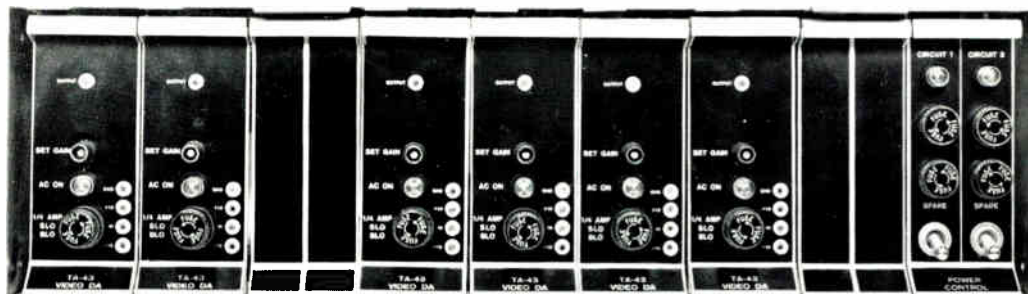

A module frame of TA-43 Amplifiers. Note the power-distribution module at far right.

return loss per amplifier of greater than 46 db to 6 MHz. An external, 75-ohm, 1% resistor is used to terminate the input line at the last bridged amplifier. Forty outputs per frame are possible from a single input. An amplifier may be removed without interrupting the input feed to the other amplifiers in the "set".

The six dB gain setting is used to restore low-level signals to the one-volt standard. Attenuators, which replace the input loop-through card are available in 1 dB steps to 6 dB. For example, a signal 2 dB below one volt requires a 4-dB attenuator to match the input signal loss to the 6 dB gain of the amplifier. A  $\pm 0.25$ -dB, front-panel gain control is used to trim the gain to an exact value. When the attenuator is used, the input line is internally terminated in 75 ohms, thus precluding input bridging. The output signal, however, can be fed to as many as eight more TA-43 inputs for distribution.

### Cable Equalization

The 6-dB gain setting is also used with the 50- to 600-foot equalizers, 12 of which are available in 50-foot steps. The cable loss, plus the equalizer loss matches the 6-dB gain of the amplifier to provide a one-volt equalized output signal. (See illustration). Input bridging is precluded when equalizers are used. The specifications for the Type TA-43 include the cable, equalizer, and amplifier, but the TA-43 performs in excellent fashion with any 75-ohm cable but the specifications apply only for Belden 8281 dual shielded coaxial cable or equivalent. If an amplifier must be replaced for any reason, the equalizer remains in place.

The 15-dB gain setting is used with the 700- to 1500-foot equalizers of which there are nine, 100-foot steps.

### High Performance

The hybrid amplifier makes possible very tight performance specifications. Every amplifier can be expected to provide the same performance as any other, so that replacing amplifiers will result in no change in system parameters such as frequency response, group delay, propagation delay, and linear distortion. There is only one capacitor in the signal path, so that cascaded amplifiers produce low frequency overshoots well within acceptable limits.

The Type TA-43 makes possible, for the first time, realizable performance in actual systems which have been calculated beforehand from a functional diagram.

## Accessories

<b>Attenuator Cards</b>	
1 dB Loss .....	MI-556802-1
2 dB Loss .....	MI-556802-2
3 dB Loss .....	MI-556802-3
4 dB Loss .....	MI-556802-4
5 dB Loss .....	MI-556802-5
6 dB Loss .....	MI-556802-6
<b>Equalizer Cards</b>	
<b>Cable Length</b>	<b>Stock Number</b>
50 ft. (15m) .....	MI-556803-1
100 ft. (31m) .....	MI-556803-2
150 ft. (46m) .....	MI-556803-3
200 ft. (61m) .....	MI-556803-4
250 ft. (76m) .....	MI-556803-5
300 ft. (96m) .....	MI-556803-6
350 ft. (107m) .....	MI-556803-7
400 ft. (122m) .....	MI-556803-8
450 ft. (137m) .....	MI-556803-9
500 ft. (153m) .....	MI-556803-10
550 ft. (168m) .....	MI-556803-11
600 ft. (183m) .....	MI-556803-12
700 ft. (214m) .....	MI-556804-1
800 ft. (244m) .....	MI-556804-2
900 ft. (275m) .....	MI-556804-3
1000 ft. (310m) .....	MI-556804-4
1100 ft. (341m) .....	MI-556804-5
1200 ft. (371m) .....	MI-556804-6
1300 ft. (402m) .....	MI-556804-7
1400 ft. (432m) .....	MI-556804-8
1500 ft. (463m) .....	MI-556804-9
Hybrid Amplifier .....	MI-556806-A1
Input Bridging Connector .....	MI-556805-A1
Module Mounting Frame .....	MI-557300-A1
Module Extender .....	MI-557301-A2
Blank Module, 4 Units Wide .....	MI-557302-4
BNC Connector, Single Crimp (Pkg. of 10) .....	MI-556673-10
BNC Termination, 75 ohms $\pm 1\%$ .....	MI-556675
BNC Crimping Tool .....	MI-556674
Connector Assembly .....	MI-556801-A1

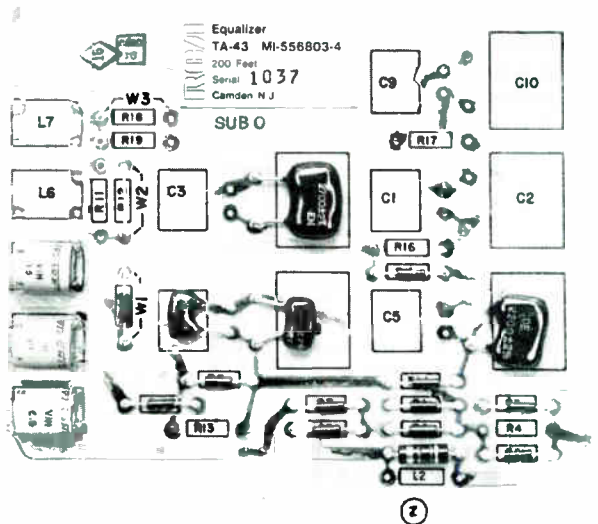

Typical Equalizer Card.

# Specifications

## General Characteristics

Input-to-Output Isolation	
To 1 MHz	80 dB min.
To 8 MHz	60 dB min.
Overload Margin	
For any input APL with 40% overshoot	3 dB
For 10 kHz to 2 MHz sinewave (all outputs loaded)	3.2V p-p
For 10 kHz to 6 MHz sinewave (one output loaded)	4.0V p-p
Amplitude Frequency Response (100 kHz ref)	
10 kHz to 6 MHz	±0.05 dB
1 Hz to 10 MHz	±0.2 dB
10 MHz to 15 MHz	±0.3 dB
Rise above 15 MHz	1 dB max.
Group Delay Frequency Response	
1 MHz to 14 MHz	1 ns max.
Propagation Delay (3.58 MHz)	16° or 12.5 ns
Square Wave Transmission	
Bar Signal Overshoot	
(15 kHz, rise time 60 ns or more)	0.25% max.
50 Hz Square Wave Sag Tilt	0.25% max.
Pulse Transmission	
K-Rating Factor (K sub 2T)	0.25% max.
K-Rating Factor (K sub T)	0.25% max.
Chrominance-Luminance Inequality	
Delay Inequality (20T pulse)	1ns max.
Gain Inequality	0.5 db max.
Non Linear Distortion at 3.58 MHz	
Differential Gain (1.0V p-p Composite Video Output all outputs loaded) for all APL's	0.1% max.
Differential Phase (1.0V p-p Composite Video Output all outputs loaded) for all APL's	0.1° max.
Signal-Noise Ratio (p-p signal vs. un-weighted ref. to 0.7V p-p pix signal over bandwidth of 10 kHz to 5.5 MHz)	
	76 dB
Low Frequency Bounce (Single time-constant performance: 63% decay time)	
	10s
50/60 Hz Hum (p-p below 0.7V p-p)	60 dB min.

## Input Characteristics

Type	High impedance, bridging
Return Loss (to 6 MHz, power on or off)	46 dB min.
Permissible Input Voltage	
Composite Video, (positive-going)	1.5V p-p max.
Color Subcarrier (3.58 to 4.43 MHz)	2.0V p-p min.
Power Requirements	100-130/200-260V., 47-63 Hz, 7.5 W

## Output Characteristics

Impedance	75 ohm source
Output Level	
(Composite Video, positive-going)	1.0V p-p
Return Loss (to 8 MHz)	45 dB min.
Isolation Between Outputs	
To 1 MHz	60 dB min.
To 4.43 MHz	46 dB min.
To 8 MHz	40 dB (min.)
Quiescent Voltage (dc) in Output	0 ±0.010 V*
Output Polarity	Positive-going

## Mechanical Characteristics

Dimensions	
Amplifier Module	119 mm H; 46 mm W; 335 mm D (4.7 x 1.8 x 13.2 inches)
Module Frame	133 mm H; 408 mm W; 379 mm D (5.2 x 16.1 x 14.9 inches)
Weights	
Amplifier	1096 g (2½ lbs.)
Attenuator Card	28 g (1 oz.)
Connector Assembly	312 g (11 oz.)
Equalizer Card	71 g (2.5 oz.)
Loop-Through Card	28 g (1 oz.)
Module Frame	6350 g (14 lbs.)

\*At 25°C into 75-ohm termination. Maintained within ±50mV over any 20° temperature change within 0 to 55°C range.

## Ordering Information

Video Equalizing and Distribution Amplifier, Type TA-43:	
Including Connector Assembly	ES-556900-A1
Less Connector Assembly	MI-556800-A1

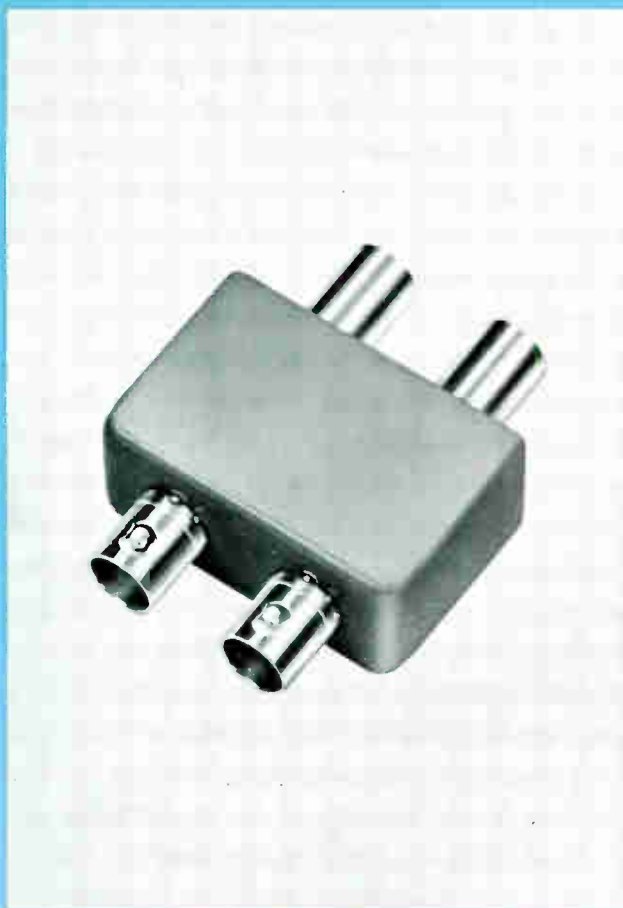

- Normal or abnormal status determined at a glance
- Fewer patching operations required
- New quick-disconnect BNC connectors
- Flexible patch facility with 22 jacks on standard 19-inch wide panels

## RCA Self-Normalling Video Jacks

### Description

These ruggedly constructed self-normalling and line-terminating video jacks are designed for the most complex and demanding video jack-field service.

The normal condition of the panel associates specific sources with specific

loads so that under normal conditions there are no patch cords or plugs inserted. Inserting a patch cord into a jack on the "source" side automatically interrupts the "normal" and terminates the line to the load. Inserting a patch cord in the load

side also interrupts the "normal" and terminates the source. The termination in either case is a 75 Ohm, 1.0 percent resistor. Thus, the number of operations is substantially reduced compared with conventional jack fields.



## Accessory Items



Patch Cord

The patch cord, MI-556582-2 is constructed to the highest standards of dependability with soldered center pin connection and crimped sleeve shield connection. It is available in lengths of 2, 4, 6 and 8 feet (610, 1220, 1830, 2440 mm). Only the two foot length is stocked.



### Convenient Test Probe

The Test Probe, MI-556582-3 and MI-556582-4 are available for sampling or testing of the normal-through circuit without interruption of the signal. The MI-556582-3 Probe has a probe tip on one end, a BNC male connector on the opposite end. MI-556582-4 has a probe tip on one end and a UHF male connector at the opposite end.

## Specifications

Crosstalk .....	118 dB rejection @ 10 MHz
VSWR .....	1.01 @ 10 MHz
Jacks .....	Beryllium
Contacts .....	Gold plated, wiping action
Jack Housing .....	Silver Plated

## Ordering Informator

Video Jack (Max of 22 per panel) .....	MI-556582-1
Patch Cord, 2 feet long (1220 mm) .....	MI-556582-2
Test Probe (with BNC male connector) .....	MI-556582-3
Test Probe (with UHF male connector) .....	MI-556582-4
Dummy Plug .....	MI-556582-5
Quick-Disconnect Connector .....	MI-556582-6
Jack Panel, less Jacks (19" x 1 3/4", 483 x 44 mm) .....	MI-556582-7
Jack Panel, less Jacks (19" x 3 1/2", 483 x 89 mm) .....	MI-556582-8



Quick Disconnect Connector

Quick - Disconnect Connectors (MI-556582-6) are designed for use with RCA MI-13325 Dual Shielded Coaxial Cable. The connector has all of the features of the standard BNC cable connector plus a knurled snap-action safety lock for improved dependability. The snap-action permits easy insertion or removal in high density patch fields.

### Choice of Jack Panels

Two jack panels are available for use with the new jacks. MI-556582-7 is a 19-inch (483 mm) wide by 1 3/4-inch (44 mm) high phenolic panel with provisions for 22 jacks with or without designation strips.

The MI-556582-8 panel is 19 inches wide by 3 1/2 inches (89 mm) high, also phenolic, with provisions for 22 jacks with or without designation strips.

#### 1 3/4-inch Jack Panel



Dummy Plug

Dummy Plug, MI-556582-5 is used with the video jack-field to provide immediate stand-by normal-through circuitry upon removal of the plug.

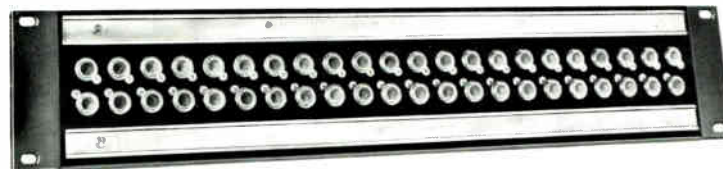

3 1/2-inch Jack Panel

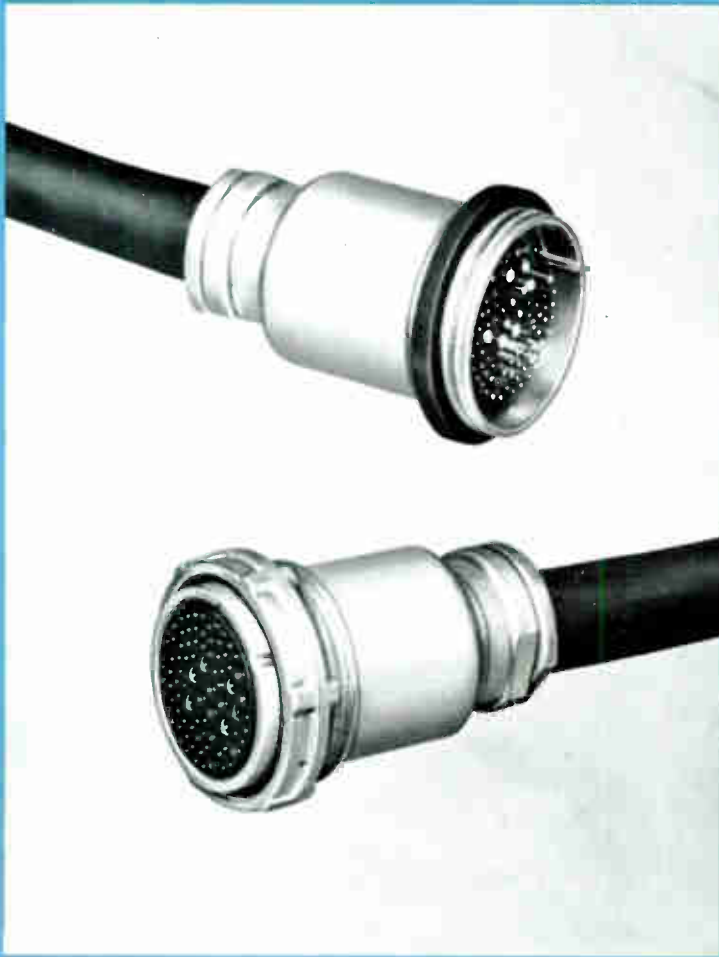

- Cable designs for every broadcast service—either studio or remote
- Exact replacements for cables and connectors supplied with RCA television equipment
- Connectors and bulk cable available separately or as wired cable assemblies
- Insulations with conservative voltage ratings and special shields employed

## RCA TV Cables, Plugs, Connectors

### Description

RCA television cables, plugs and connectors are made available for inter-connecting the various components of television equipment — studio, control room and remote. Camera, power, pulse, intercom, coax transmission line and inter-connecting cables with companion

connectors are available as individual items or in groups for use with various equipment systems.

The cables are generally designed for their particular application. The internal insulations and wire sizes are in many cases of special construction for specific

purposes. The outer jackets of the cables will provide maximum durability and flexibility for the applications to which they are subjected. Specifications and ordering information are found on the following pages.

## Cameras, Cables and Plugs

The multi-conductor, flexible camera cables listed here are supplied in convenient lengths complete with necessary male and female connectors. These cables facilitate making required inter-connections between cameras and camera controls. Conductors are stranded and covered with "color-coded" insulation. An inner shield of tinned copper braid is provided. Dust caps are provided where necessary. Outer coverings are of a durable neoprene compound.

Ordering Information	Description	Length
MI-26725-E5	25-Conductor, neoprene cover, with straight male and female connectors. With dustcaps.	50 feet
MI-26725-E6	Same as above except length.	100 feet
MI-26725-E7	Same as above except length.	200 feet
MI-26725-E9	25-conductor, neoprene cover, with 90° male and a straight female connector.	50 feet
MI-40868-2	TK-41C Color Camera Cable. 82-conductor, single cable, vinyl covered flexible, straight male and female connectors.	50 feet
MI-40868-3	Same as above except length.	100 feet
MI-40868-4	Same as above except length.	200 feet
MI-557315-1	TK-42 Color Camera Cable. 79-conductor, single cable, flexible neoprene covered, straight male and female connectors.	50 feet
MI-557315-2	Same as above except length.	100 feet
MI-557315-3	Same as above except length.	200 feet
MI-557343-1	TK-27/TK-42 Color Control Panel Cable, 52-conductor stranded, foil shielded, black vinyl jacket, straight male and female connectors.	50 feet
MI-557343-2	Same as above except length.	75 feet
MI-557343-3	Same as above except length.	100 feet
MI-557344-1	TK-22/TK-27/TK-42 Monochrome Control Panel Cable, 52-conductor stranded, foil shielded, black vinyl jacket, straight male and female connectors.	50 feet
MI-557344-2	Same as above except length.	75 feet
MI-557344-3	Same as above except length.	100 feet
MI-557345-1	TK-27 Color Film Camera Interconnection Cable, 52-conductor, stranded, foil shielded, black vinyl jacket, straight male and female connectors.	50 feet
MI-557345-2	Same as above except length.	75 feet
MI-557345-3	Same as above except length.	100 feet



## Camera Cable Connectors and Accessories

The connectors described below include both the 90 degree and straight type for use in making up camera cables in any desired length, using bulk camera cable.

Ordering Information	Type	Description
MI-11719-A	Lacing Cord.	Black #6.
MI-26759-A21	Straight Male Camera Cable Connector.	24-contact for use as a cable termination.
MI-26759-A22	Straight Female Camera Cable Connector.	24-contact for use as cable termination.
MI-26759-23	90° Female Camera Cable Connector.	24-contact for use as cable termination. Designed so cable enters connector at 90° to axis of contact pins.
MI-26759-A41	Dustcap for male cable connector.	2 1/16" dia. x 1/32" deep, internal thread, with #10 chain and fastener.
MI-26759-A42	Dustcap for female cable connector.	2 1/16" dia. 1/16" deep, internal thread, with #10 chain and fastener.
MI-26759-45	Coaxial Termination. 75 Ohm 1%.	Includes single contact coaxial connector plug, terminal assembly with a 1/2 Watt, 75-Ohm resistor.
MI-556675-1	BNC Coaxial Termination 75 Ohms, 1%.	Includes single contact coaxial connector plug, terminal assembly with a 1/2 Watt, 75-Ohm resistor.
MI-40360	BR Cable Connector for TS-40.	32-pin Ampherol.
MI-557321-1	Male cable connector for TK-42 color camera cable.	79-contact, for cable end termination.
MI-557321-2	Female cable connector for TK-42 color camera cable.	79-contact for cable end termination.

## Camera Cable Connectors and Accessories (Cont.)

Ordering Information	Type	Description
MI-557321-3	Male chassis connector, 79-contact.	For use with 79-contact cable connector MI-557321-2.
MI-557321-4	Female chassis connector, 79-contact.	For use with 79-contact cable connector MI-557321-1.
MI-557346-1	Male cable connector for TK-27/TK-42 color control cable.	48-contact for cable end termination. Used with MI-13358.
MI-557346-2	Female cable connector for TK-27/TK-42 color control cable.	48-contact for cable end termination. Used with MI-13358.
MI-557347-1	Male cable connector for TK-22/TK-27/TK-42 remote control cable.	37-contact for cable end termination. Used with MI-13358.
MI-557347-2	Female cable connector for TK-22/TK-27/TK-42 remote control cable.	37-contact for cable end termination. Used with MI-13358.
MI-557348-1	Male cable connector for TK-27 color camera cable.	48-contact for cable end termination. Used with MI-13358.
MI-557348-2	Female cable connector for TK-27 color camera cable.	48-contact for cable end termination. Used with MI-13358.

Ordering Information	Type Cable	Approx. Diam.	Characteristics
MI-13325	COAXIAL CABLE, flexible, double shielded, rubber cover.	0.305"	Impedance 74.99 Ohms at 4 MHz, normal capacitance 20 MMF/ft., max. voltage 4000 RMS.
MI-13333	POWER CABLE, 7-conductor, shielded, black rubber jacket.	0.360"	7 cond. #20 A.W.G., 600 V, RMS max.
MI-13341	POWER CABLE, 26-conductor, shielded, black vinyl jacket.	0.625"	5 cond. #16 A.W.G., twisted and shielded overall as a group, 3 pairs #22 A.W.G. each pair shielded, 15 cond. #22 A.W.G.
MI-13345-17	POWER CABLE — 34-conductor, stranded, foil shielded, black vinyl-jacket.	0.500"	34 cond. #22 A.W.G. in 17 twisted pairs, 600 V RMS maximum.
MI-13356	TK-42 COLOR CAMERA CABLE — 70-conductor, black neoprene jacket.	1.028"	60 cond. #22 A.W.G., 600 V RMS; 6 cond. #22 A.W.G., 1500 V RMS; 5 cond. #14 A.W.G., 600 V RMS; 2 cond. #10 A.W.G., 600 V RMS; 6 coaxial cables, RG-58C/U, 50 Ohms impedance. (In addition 4 drain wires and overall woven shield.
MI-13358	POWER CABLE — 52-cond., stranded, shielded, black vinyl jacket.	0.600"	52 cond. #22 A.W.G., 600 V RMS coaxially foil shielded into four groups of 4, 10, 16 and 22 conductors. (In addition 3 drain wires.)
MI-13360	POWER CABLE — 20-conductor stranded, Mylar-aluminum tape shielded with drain wire, black vinyl jacket.	0.040"	20 cond. #20 A.W.G., 600 V RMS maximum.
MI-13380-6	POWER CABLE—6-conductor, flexible, shielded, black vinyl jacket, non-contaminating.	0.450"	6 cond. #14 A.W.G., 600 V RMS maximum.
MI-13380-8	POWER CABLE — Same as above except 8-cond.	0.610"	3 cond. #14 A.W.G.; 5 cond. #18 A.W.G.; 600 V, RMS max.
MI-13380-12	POWER CABLE — Same as above except 12-conductor.	0.625"	12 cond. #18 A.W.G.; 600 V, RMS max.
MI-13394-N	TK-41C COLOR CAMERA CABLE — 82-conductor, black neoprene jacket.	1.24"	67 cond. #22 A.W.G.; 3 cond. #16 A.W.G.; 4 cond. #14 A.W.G., 8 coaxial cables, Type RG-58C/U, 50 Ohms impedance.

## Bulk Cable and Accessories

The various cables described in the accompanying table are available to the broadcaster in bulk quantities for making TV interconnections in special or nonstandard lengths as desired.

Ordering Information	Type Cable	Approx. Diam.	Characteristics
MI-75	COAXIAL CABLE—Type RG-59A/U, flexible, vinyl covered. Single inner conductor and outer shield conductor.	0.242"	Impedance, 75 Ohms. Normal capacitance 20.5 MMF/ft. max., operating voltage 2300 RMS.
MI-83A	COAXIAL CABLE—Type RG-11A/U, flexible, vinyl covered. Single inner conductor and outer shield conductor.	0.405"	Impedance, 75 Ohms. Normal capacitance 20.5 MMF/ft., max. operating voltage 4000 RMS.
MI-94N	CAMERA CABLE — 25-cond., neoprene-covered, flexible, color coded, shielded cable consisting of: 3 coaxial cond., 18 stranded, tinned copper cond., and 1 group of 4 tinned copper conductors.	0.83"	Coax cond., impedance 50 Ohms $\pm$ 2 Ohms, 18 cond. of #22 A.W.G. and 4 of #14 A.W.G. with insulation for 1000 V, RMS max.
MI-13318-A	COAXIAL CABLE—Type RG-58C/U, flexible, vinyl covered.	0.20"	Impedance 50 Ohms. Insulation for 1900 V, RMS.
MI-13319	POWER CABLE—18-conductor, rubber-covered, flexible, shielded and individually color coded.	0.590"	16 cond. #22 A.W.G., 2 cond. #16 A.W.G. with insulation for 2500 V, RMS, 60 Hz.

# Maintenance Accessories

## AMP Tools

AMP Terminal Tools are available from RCA for servicing the various "New Look" modules. These include a Ground Terminal Crimping Tool, MI-43224-1, used for installing AMP connectors in ground strip assemblies. It will accommodate No. 20 or 22 AWG sizes. Ground Terminals are available from Parts and Accessories as Stock No. 231768.

An AC Terminal Crimping Tool, MI-43224-2, is used for crimping AMP insulated AC terminals. Wire sizes AWG 18 to 22 may be used with the tool. Order the AC type terminals from Parts and Accessories as Stock No. 231761.

AMP Leaf Terminal Crimping Tool, MI-43225-1, is used for standard AMP Leaf Contacts of the module connectors. Wire sizes of 1 to 26 may be used. AMP Terminals may be ordered from stock as No. 231764.

Crimping Tool for Coaxial Adaptors, MI-40422-A, is used for crimping JAN type PL-259 UHF Connector to MI-13325 dual shielded 75-Ohm Coaxial Cable. Coaxial adaptors (a package of 25), MI-40123, is available for use with this tool.

AMP Leaf Terminal Extracting Tool, MI-43226, is useful to extract contacts from the AMP Connector Assembly as used on RCA standard modules.

AMP Crimping Tool, MI-556671, is used for crimping UHF Coaxial Cable Connectors 75-Ohm, Double Shielded Cable, MI-13325. A packet of ten UHF Connectors, MI-556670-10 is available for use with this tool.

AMP Crimping Tool, MI-556674, is designed for crimping BNC coaxial cable connectors to the 75-Ohm, Double Shielded Cable, MI-13325. Type BNC Connectors (10 to a package) may be ordered from stock as MI-556673-10.



AMP Grand Terminal Crimping Tool, MI-43224-1.



AMP AC Crimping Tool, MI-43224-2.



AMP Leaf Crimping Tool, MI-43225-1.



AMP Crimping Tool for Coax Adaptor, MI-40422-A.



AMP Leaf Extracting Tool, MI-43226.



AMP Crimping Tool MI-556671 for UHF Connectors shown right.

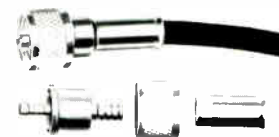

MI-556670-10



AMP Crimping Tool MI-556674 for BNC Connectors shown right.



MI-556673-10

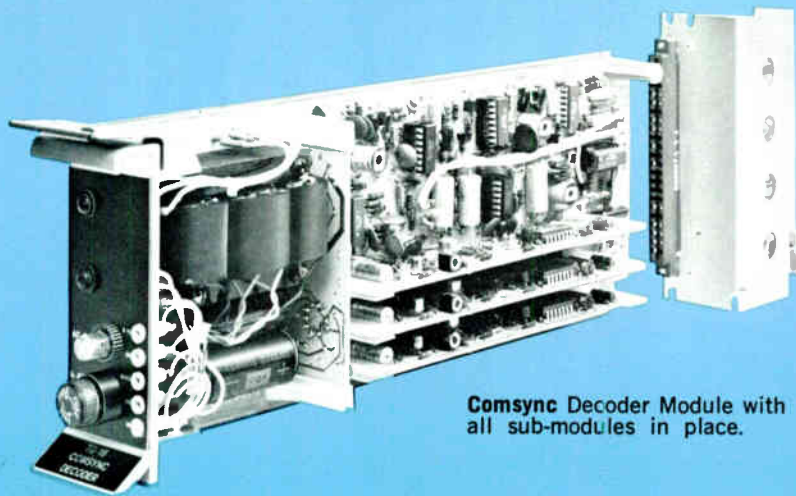

Comsync Decoder Module with all sub-modules in place.

- Reduces in-house cabling
- Simplifies pulse-assignment switching
- Rejects common-mode signals
- NTSC or PAL standards

## RCA Comsync Distribution System

### Description

A new idea in "house" sync transmission, the Comsync Distribution System reduces system complexity while improving the quality of the sync information fed to each program source. The Comsync System combines several sync generator signals into a composite waveform for transmission over a single, co-axial, un-balanced line. At the "far" end, it separates the several signals for the many sync signal applications.

#### Comsync Waveform

The Comsync waveform is a composite of the timing information contained in sync, blanking, burst flag and color sub-carrier. The Comsync Encoder accepts these signals from the sync generator and forms the Comsync signal for distribution over a single, video-quality co-ax line to almost any number of Comsync Decoders at the "far" end.

#### Reduces In-House Cabling

The Comsync Decoder separates the four signals, re-establishes the proper level of each and delivers them to eight isolated output connectors—a pair for each of the four signals. The advantage in the system is the economy involved in eliminating three out of four "sync" cables between the sync-generator location—usually in an out-of-the-way equipment room—and the studio location.

#### Simplifies Pulse-Assignment Switching

Of particular interest to larger tele-

production facilities, the Comsync System reduces sync-switching complexity in increasing proportion to the size of the system. For example, a three-studio production center might use three sync generators to supply timing signals to the three studios plus Production Control and Master Control. Assuming that the center distributes only blanking, sync, burst flag and subcarrier, the "3x5" pulse-assignment switcher needs 60 crosspoints to channel the four signals to any or all of the three studios plus production control and master control. Connecting a Comsync Encoder between each sync generator and the switcher and, a Comsync Decoder at each "load", the number of crosspoints required drops from 60 to 15 and the need for output amplifiers drops from 20 to 5. The saving in cable runs between generator and studio is three out of four.

Because each Comsync Decoder provides twin outputs for each signal, it provides twice the number of outputs at the "far" end.

#### Decoder Variations

The basic Comsync Decoder module provides dual sync, blanking and subcarrier outputs. Either of the two optional *sub-modules* provides dual burst-flag (BF) outputs; one submodule, the "extractor", delivers BF pulses timed precisely with the Comsync signal while the other delivers BF pulses with adjustable timing. The fixed-time pulses of the extractor module are used also in the generation of PAL signals.

#### Decoder Detail

The Comsync Decoder module extracts the color subcarrier through a simple R-C-L bandpass filter with negligible phase shift vs. temperature. The remainder of the Comsync composite signal is amplified, clamped and clipped to provide the output pulses. As a result, the subcarrier and pulse information is identical in time, amplitude and waveform quality to that coming out of the sync generator which may be hundreds of cable feet away (disregarding cable delays).

#### H- and V-Drive Pulses

Since some camera equipment requires separate H- and V-drive pulses, the Comsync system includes an optional module for use with the Comsync Decoder. A sub-module for the H- and V-Drive module (in conjunction with the BF extractor of the Decoder module) provides a 7.8 kHz pulse for PAL standards. The module provides dual outputs for each signal.

#### Comsync Delay Module

The Comsync Delay Module delays the Comsync signal for "timing-out" and color-phase-matching of a system. The module separates pulse information from the subcarrier, delays each signal independently and then recombines them. This improves subcarrier phase-shift stability with temperature and allows independent delay adjustment of pulse and subcarrier.

## Power Line Powered

All Comsync modules (except the H- and V-Drive module) operate from a 115/230-volt, 50/60 Hz powerline. A power-distribution module (see *Ordering Information*) is available and recommended for each module frame. The H- and V-Drive module derives its operating power from its associated Decoder module.

## Comsync Module Mounting

The several modules and connector assemblies of the Comsync system mount in the standard module frame (see *Ordering Information*). The connector assembly for each module uses BNC fittings for the signal inputs and outputs and spade-type terminals for power.

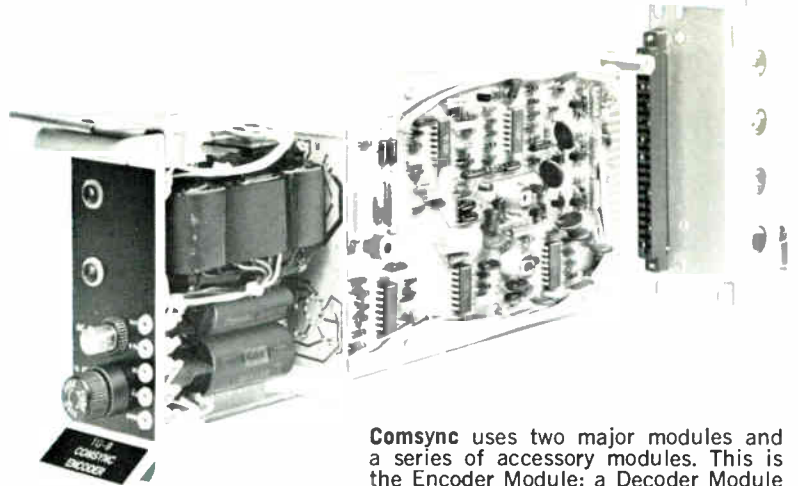

Comsync uses two major modules and a series of accessory modules. This is the Encoder Module; a Decoder Module is illustrated on preceding page.

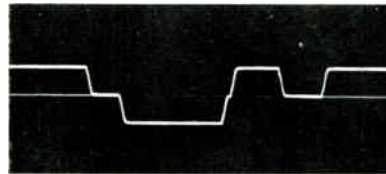
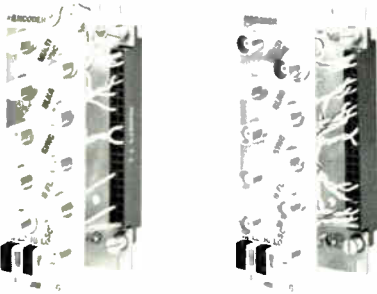

Without subcarrier, the Comsync Waveform is a simple three level waveform.

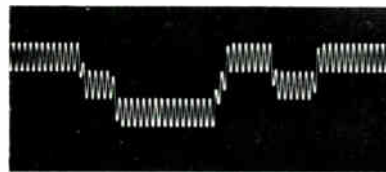
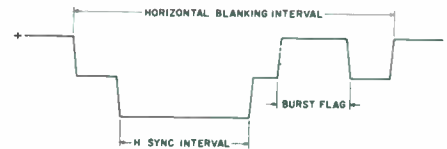

The color subcarrier joins the Comsync Waveform as shown here.

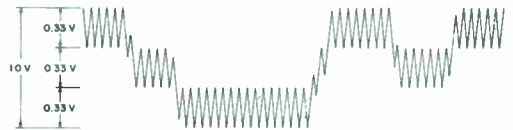

All Comsync signal inputs and outputs connect through **BNC** fittings mounted on the rear of the module plug. Power connects to the spade-type terminals at the lower edge.

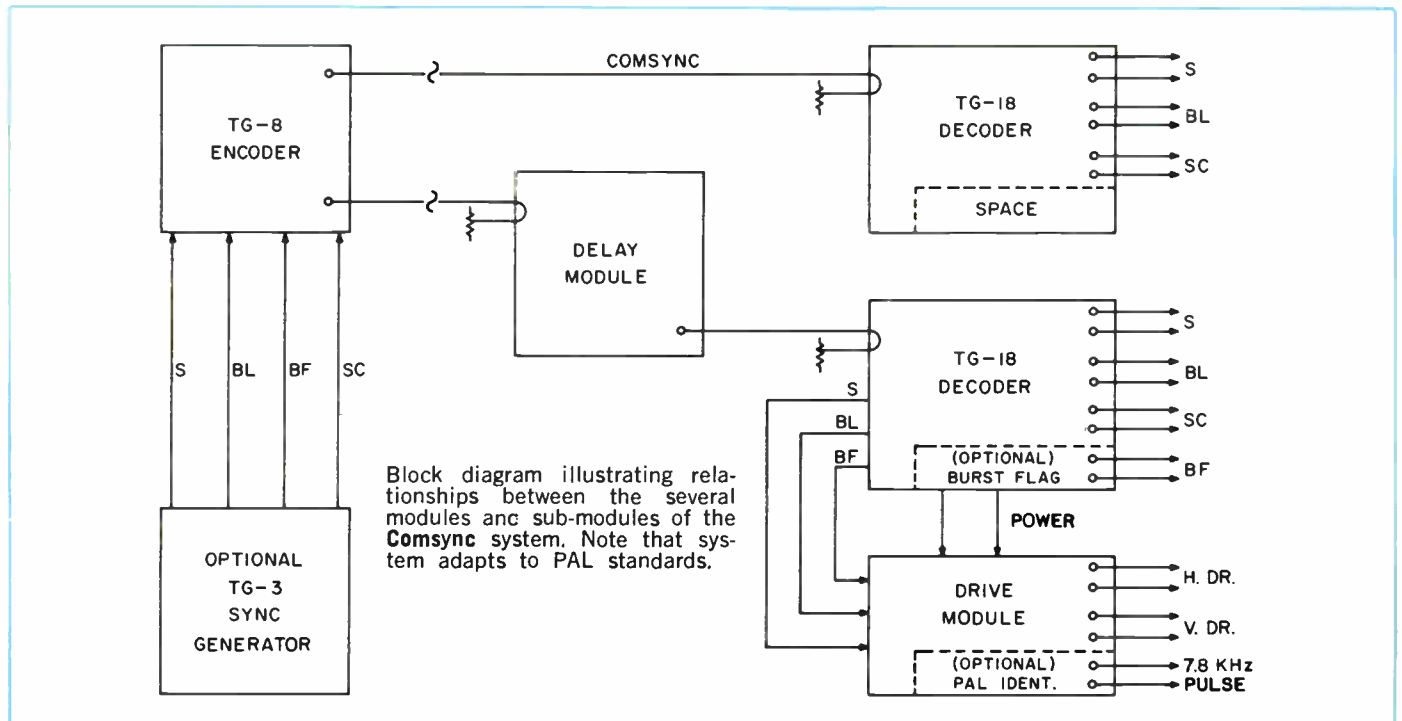

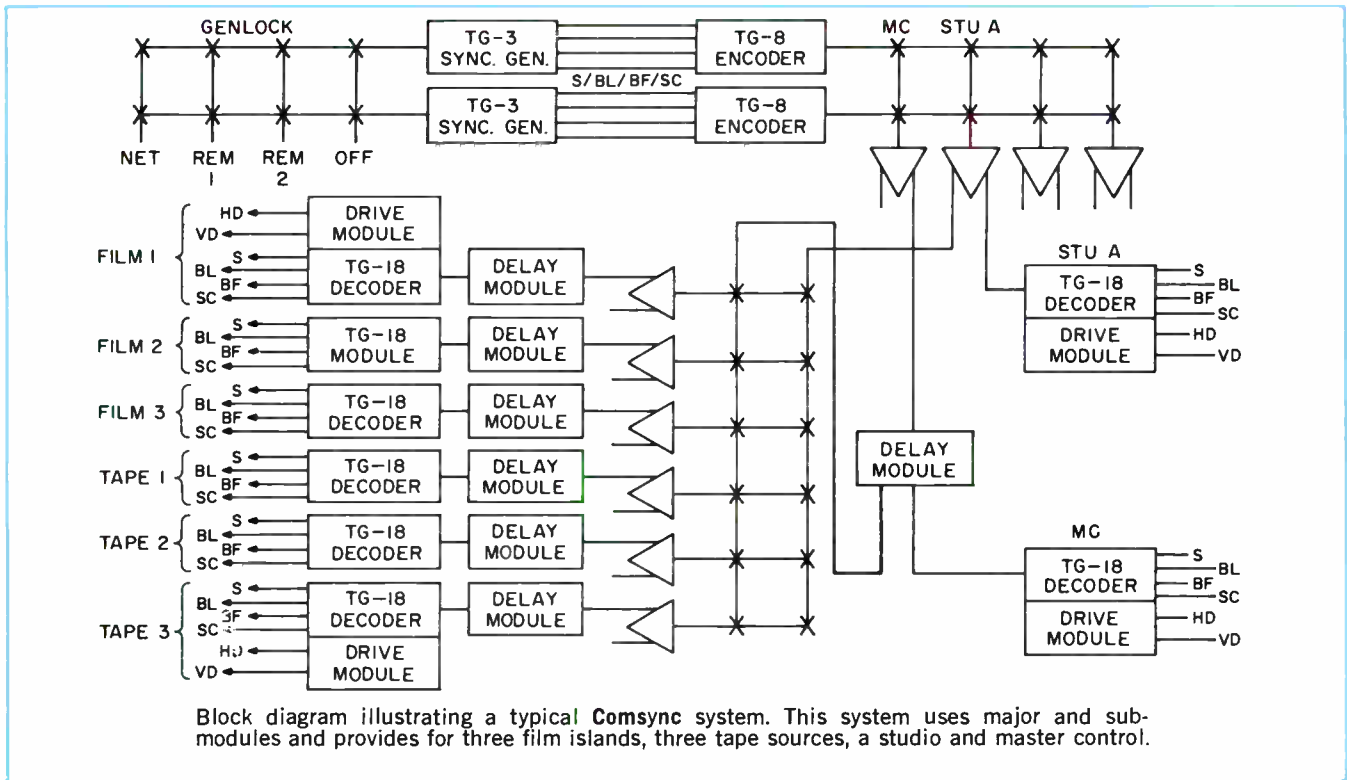

## Specifications

### Comsync Encoder Module

Input Impedance	Bridges 75-ohm line
Input Return loss, all inputs (at all frequencies to 7 MHz; bridged with 75 ohms; power on or off)	Greater than 36 dB
Input Pulse Level (nominal)	4 V, p-p nominal
Input Pulse Range	1.75 to 9 V, p-p
Input Pulse Rise Time (S, BL, BF)	190 ns, max.
Input Subcarrier Level (nominal) (3.58 or 4.43 MHz)	2 V, p-p
Input Subcarrier Range	0.9 to 4.4 V, p-p
Input Protection	±12 V, dc
Input Power	100-130 or 200-260 V, 43 to 63 Hz, 10 W
Outputs (Resistance Isolated)	2
Output Impedance (nominal)	75 ohms
Output Return Loss (all frequencies to 7 MHz)	Greater than 30 dB
Output Signal Level (adjustable)	0.95 to 1.05 V, p-p
Output Amplitude (of each signal component: S, BL, BF, SC)	33.3 ±1% of overall
Output Pulse Characteristics (SC removed):	
Rise Time (10 to 90%)	225 ±10 ns
Overshoot	Less than 1%
Low Frequency Tilt	Less than 1%
DC on Terminated Output	Less than 0.01 V
Output Protection	Grounded output causes no internal damage
Transfer Characteristics:	
Pulse Width Change (at 50% of Input and Output Pulse Edges)	Less than 10 ns
Subcarrier Temperature Effect	Phase Shift less than 0.2° (25 to 55°C)

Subcarrier Differential Phase (during any pulse relative to active line time)	Less than 0.5°
Ambient Temperature Range:	
Operating	0 to 55°C
Storage	-30 to 85°C
Dimensions	12.8" (325 mm) L; 1.8" (45 mm) W; 4.6" (122 mm) H
Weight	2.5 lbs. (1132 g)

### Comsync Decoder Module

Input Impedance	Bridges 75-ohm line
Input Return Loss (at all frequencies to 7 MHz; bridged with 75 ohms; power on or off)	Greater than 36 dB
Input Signal Level (nominal)	1.0 V, p-p
Input Range	0.6 to 2.2 V, p-p
Input Protection	±12 V, dc
Common Mode Hum Rejection	To 5 V, p-p
Input Power	100 to 130 V; 200 to 260 V, 47 to 63 Hz; 30W max.
Output Signals (Two Resistance—Isolated for Each):	
Sync (S)	
Blanking (BL)	
Sub-carrier (SC)	
Burst Flag (BF) (Requires BF Sub-Module)	
Horizontal Drive (HD) (Requires Drive Output Module)	
Vertical Drive (VD) (Requires Drive Output Module)	
PAL Identification Pulse (PI) (Requires PAL ID Sub Module)	
Pulse Output Impedance (nominal)	75 ohms
Pulse Output Return Loss (All Frequencies to 4 MHz)	Greater than 26 dB
Pulse Output Level	2 or 4 V, p-p
Pulse Low Frequency Tilt	Less than 0.5%
Pulse Rise Time	150 ±25 ns



Pulse Overshoots .....	Less than 1%
Pulse-Polarity and DC Reference .....	Neg from 0 $\pm$ 0.01 V dc
Spurious Transients and Noise Spikes on Pulse Waveforms .....	Less than 1%
Subcarrier on Pulses .....	Less than 1%
Subcarrier Harmonic Distortion .....	Less than 5%
Subcarrier Spurious Effects (from Pulse Edges) .....	Less than 2%
Subcarrier Output Impedance (nominal) .....	75 ohms
Subcarrier Return Loss (All Frequencies to 7 MHz) .....	Greater than 26 dB
DC in Terminated Output .....	Less than 0.01 V
Output Protection .....	Grounded output causes no internal damage

#### Transfer Characteristics:

Pulse Insertion Delay (at 50% of Input and Output Pulse Edges) .....	225 $\pm$ 10 ns
Pulse Width Change (at 50% of Input and Output Pulse Edges) .....	Less than 10 ns
Pulse Alternate-Line Jitter (of Output Edges Relative to Corresponding Input Edges) .....	Less than 2 ns
Subcarrier Insertion Phase Shift: At 3.58 MHz .....	52 $\pm$ 10°
At 4.43 MHz .....	64 $\pm$ 12°
Subcarrier Temperature Effect .....	Phase Shift less than 1° (25 to 55°C)

Subcarrier Differential Phase (During Any Pulse Relative to Active Line Time) .....	Less than 0.5°
Subcarrier Input Limiting Knee (Input SC Level for Output Fall of 1 dB) .....	Below 0.1 V, p-p
Ambient Temperature Range: Operating .....	0 to 55°C
Storage .....	-30 to 85°C
Dimensions .....	12.8" (325 mm) L; 1.8" (45 mm) W; 4.6" (122 mm) H
Weight .....	2.75 lbs. (1140 g)

#### Cosync Delay Module

Input Impedance .....	Bridges 75-ohm line
Input Return Loss (at all Frequencies to 7 MHz; Bridged with 75 ohms; Power On or Off) .....	Greater than 36 dB
Input Signal Level (nominal) .....	1.0 V, p-p
Input Range .....	0.6 to 1.5 V, p-p
Input Protection .....	$\pm$ 12 V dc
Input Common-Mode Hum .....	To 5.0 V, p-p
Input Power .....	100 to 130 V or 200 to 260 V; 47 to 63 Hz; 10 W
Outputs (resistance isolated) .....	2
Output Impedance (nominal) .....	75 ohms
Output Return Loss (at all Frequencies to 7 MHz; Bridged with 75 ohms; Power On or Off) .....	Greater than 30 dB
Output Signal Level (nominal) .....	1.0 V, p-p
Output Low-Frequency Tilt .....	Less than 1%

DC on Terminated Output .....	Less than 0.01 V
-------------------------------	------------------

#### Transfer Characteristics:

##### Pulse Delay (Switch-Selectable):

Minimum .....	0.65 $\pm$ 0.005 $\mu$ s (Equivalent to 42.6 $\pm$ 3.3 ft. of cable)
Maximum .....	517 $\pm$ 0.26 $\mu$ s (Equivalent to 3395 $\pm$ 171 ft. of cable)

##### Resolution Steps:

Nominal .....	0.02 $\mu$ s (13.1 ft. of cable)
Maximum .....	0.03 $\mu$ s (19.7 ft. of cable)
Pulse Gain Adjustment Range .....	-1 to +2 dB
Pulse Rise Time Degradation (At Max Delay) .....	From 225 ns at input to 300 ns at output

Pulse Overshoot or Ringing .....	Less than 2%
Subcarrier Phase Shift Adjustment Range (Continuous) .....	Greater than 360°
Subcarrier Output Level (Regulated) .....	0.33 V, p-p
Subcarrier Output Level Adjustment .....	$\pm$ 5%
Subcarrier Phase Shift with Temperature (25 to 55°C) .....	Less than 1°

##### Ambient Temperature Range:

Operating .....	0 to 55°C
Storage .....	-30 to 85°C

Dimensions .....	12.8" (325 mm) L; 1.8" (45 mm) W; 4.6" (122 mm) H
------------------	------------------------------------------------------

Weight .....	3.25 lbs. (1474 g)
--------------	--------------------

#### Cosync NTSC Burst Flag Generator Submodule

Breezeway Adjustment Range .....	0.2 to 1.0 $\mu$ s
Burst Flag Width (Nominal) .....	2.54 $\mu$ s
Burst Flag Width Adjustment .....	At least $\pm$ 0.3 $\mu$ s
Dimensions .....	6" (152 mm) L; 1.5" (38 mm) H; 0.5" (13 mm) D
Weight .....	1.5 oz. (42 g)

#### Cosync Drive Output Module

Horizontal Drive Advance Adjustment (re: Sync Leading Edge) .....	0.5 to 2.5 $\mu$ s
Horizontal Drive Width (Nominal) .....	6.35 $\mu$ s
Horizontal Drive Width Adjustment .....	$\pm$ 1 $\mu$ s
Horizontal Drive Jitter (re: Preceding Sync Leading Edge) .....	Less than 10 ns
Vertical Drive Delay (re: Leading Edge of Vertical Blanking) .....	15 $\pm$ 2 $\mu$ s
Vertical Drive Width (Nominal) .....	650 $\mu$ sec
Vertical Drive Width Adjustment .....	$\pm$ 100 $\mu$ s
Dimensions .....	12.8" (325 mm) L; 0.9" (23 mm) W; 4.6" (122 mm) H
Weight .....	1 lb. (454 g)

#### PAL Identification Sub-Module

Pulse Delay (re: H-Drive Leading Edge) .....	0.1 $\pm$ 0.05 $\mu$ s
Pulse Width .....	6.5 $\pm$ 0.3 $\mu$ s
Dimensions .....	6.5" (166 mm) L; 1.5" (38 mm) W; 0.5" (13 mm) D
Weight .....	1.5 oz. (42 g)

## Ordering Information

Encoder Module (TG-8) .....	MI-556700-A1
Encoder Connector Assembly .....	MI-556701-A1
Decoder Module (TG-18) .....	MI-556702-A1
Decoder Connector Assembly .....	MI-556703-A1
Horizontal & Vertical Drive Module .....	MI-556704-A1
Drive Connector Assembly .....	MI-556705-A1
NTSC Burst Flag Generator Sub-Module .....	MI-556706-A1

Burst Flag Extractor Sub-Module .....	MI-556707-A1
PAL Identification Sub Module .....	MI-556708-A1
Cosync Delay Module .....	MI-556709-A1
Delay Connector Assembly .....	MI-556710-A1
Module Frame .....	MI-557300
115-V Power Distribution Module .....	MI-556648-1
230-V Power Distribution Module .....	MI-556648-2

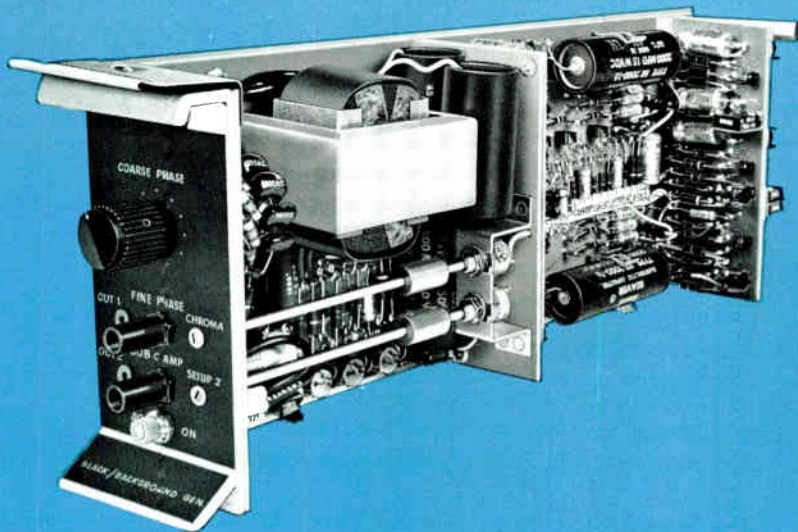

- Generates a Color-Black signal to permit proper fades to or from black, of color picture
- Creates colored title inserts from monochrome titles when used with special effects equipment
- Two outputs, composite/non-composite
- Independent remote controlled burst inhibit facility
- All pulses regenerated

## RCA Black and Background Generator, Type TG-5

### Description

The TG-5 Black and Background Generator is a self-powered unit of plug-in modular construction designed to provide a color-black signal and a background signal or two color-black signals.

The black signal permits a smooth fade from a color picture to black or conversely a smooth fade from black to a color picture.

The background signal consists of a composite feed of sync, burst, blanking and color subcarrier. The brightness and chroma content of this signal may be adjusted to any desired combination. This, in conjunction with a special effects system, such as the RCA TE-60, permits the insertion of color titles or other effects onto a color or monochrome picture from a monochrome keying signal. Thus, titles from a monochrome camera can be inserted in color onto a monochrome or color picture. This allows stations equipped with monochrome cameras to synthesize a color picture. For instance, a product can be shown in monochrome with its price or other data "supered" in color.

#### Plug-In Modularized Construction

The TG-5 may be mounted in a standard module frame along with other modularized equipment such as, TA-33 Video

Amplifiers or TA-34 Pulse Amplifiers, etc.

The TG-5 Black and Background Generator is constructed on an etched wiring board mounted on a metal plate which serves as a chassis and as a shield between adjacent units. One side of the board consists mainly of a metal surface which serves as a ground plane. Electrical components are pin mounted for convenience in troubleshooting and repair. For normal servicing it is unnecessary to remove the printed board from the chassis. Three easily accessible baby boards are mounted on the main board. The terminals of the connector assembly are easily accessible from the rear of the mounting frame.

#### Output #1

Output #1 supplies the black signal. It is used to transmit a "color black". Such a signal operates the color killer circuit in color TV sets so as to maintain the set in the color mode of reception. This permits a smooth fade into or out of a color picture. This output feed contains set-up, color burst and, if desired, sync. Thus when a cross-fade action is initiated from a color picture to the black signal, the picture set-up burst and sync levels are maintained constant, in-

sureing a smooth fade. If such a fade were to be carried out without maintaining constant burst, the effect on some sets would be a possible change in tint of the picture and on most sets a change of color saturation which would not correspond to the change in contrast called for by the fade. This condition would be due to the tendency of the automatic chroma control circuit of the TV set to compensate for any change in burst level. Furthermore, during the course of the fade, a picture disturbance would occur due to the operation of the color killer circuit which at some point switches the color set to the black and white mode of reception because of the disappearance of burst. Thus by fading to a proper color black signal, these problems are eliminated.

#### Output #2

The background signal output of the TG-5 consists of an output feed containing sync, burst, adjustable blanking level and adjustable chroma level. When used without the optional remote hue control, the hue of the background is essentially yellow which is the most popular hue for the insertion of high brightness lettering onto a scene. Provisions are made for the use of a remote hue control, if any other color is desired. For fixed tint other than yellow, the insertion of a simple 75 ohm

coaxial cable of suitable length is possible. The change of subcarrier phase will occur only on the background signal and not on the burst accompanying it.

In the event that a background signal is not desired, Output #2 may be used as a second black signal output with the same features as Output #1.

### Sync Addition and Burst Inhibit Circuitry

Both outputs may be independently arranged for composite/non-composite operation.

Each output contains its own burst inhibit circuitry which is designed to be remotely controlled.

### Self-contained Power Supply

The TG-5 Black and Background Generator contains its own solid state power

supply. The unit utilizes a transistor series regulator with "Zener" diodes for precise voltage reference. The primary power source may be 47 to 63 Hz at 100 to 130 volts AC. Power consumption is only 10 watts.

### Bridging Inputs

AC coupling is provided at the inputs. The resistance of each input is greater than 7500 ohms.

### Built-In 360 Degrees Phase Shifter

The TG-5 Black and Background Generator contains a built-in 360 degrees phase shifter. It consists of a nine position Coarse Phase switch supplemented by a potentiometer Fine Phase adjustment. The 360 degree phase shifter permits the user to adjust the TG-5 to any phase.

### Regenerated Pulses

Sync, blanking and burst flag are regenerated within the TG-5 before they are used. This makes the unit insensitive to variation of pulse input levels and eliminates distortion which may be present on the input pulses.

### Accessory Equipment

A remote hue control (MI-597635-B1) is available to permit adjustment of hue of the background signal.

A module extender (MI-557301) is available to permit servicing the TG-5 Black and Background Generator under operating conditions. The unit to be serviced is removed from the mounting frame and inserted in the extender which plugs into the mounting frame. All components are then accessible.

## Specifications

### Input Characteristics:

Subcarrier & Pulse Impedance	.....	Greater than 7500 ohms
Input Type	.....	All inputs bridging
Input Level		
Subcarrier	.....	1.5 to 4 volts peak to peak
Burst Flag	.....	2.5 to 8 volts peak to peak
Blanking	.....	2 to 8 volts peak to peak
Sync	.....	2 to 8 volts peak to peak
DC Inhibit (to kill burst)	.....	Ground circuit required for each output

NOTE: Burst Flag, Blanking & Sync Pulses are regenerated.

### Output Characteristics:

140 IEEU units correspond to a nominal level of 1 volt peak to peak.

Burst (both outputs)	.....	Adjustable nominally 40 IEEU units
Output #1 Set-up	.....	Adjustable nominally 7½ IEEU units
Output #1 Sync	.....	Adjustable nominally 0 to 40 IEEU units
Output #2 Set-up	.....	Adjustable nominally 0 to 100 IEEU units
Output #2 Sync	.....	Adjustable nominally 0 to 40 IEEU units
Output #2 Chroma Level	.....	Adjustable to more than 100 IEEU units
Output Source Impedance	.....	75 ohms ±5%
Output Load Impedance	.....	75 ohms
DC on Outputs (either output)	.....	Less than 10 mV (no adjustment required)

### Other Characteristics:

Operating Ambient Temp. Range ..... -20° to +55°C  
Burst Inhibit Control (each output) ..... Ground circuit  
required to inhibit burst addition. Open circuit enables  
burst addition.

AC power input.....100 to 130 volts at 47 to 63 hertz, 10 watts

### Dimensions Overall:

Module .....4½" high, 2-9/32" wide, 13¾" deep  
(120 mm, 60 mm, 335 mm)  
Mounting frame .....5¼" high, 19" wide, 14½" deep  
(133 mm, 482 mm, 380 mm)

### Weight:

Black & Background Generator Module .....4¼ lbs. (1.9 kg.)  
Connector Plate .....1 lb. (0.45 kg.)  
Frame .....14 lbs. (6.4 kg.)

### Semiconductor Complement

Transistors: 5-2N2102, 4-2N3638, 2-2N3640, 15-2N3646

Diodes: 4-UT112, 3-1N457, 3-1N747, 1-1N751, 1-1N752,  
1-UZ815, 4-HD1870, 1-UZ5812

### Accessories

Remote Hue Control .....MI-597635-B1  
Mounting Frame (1 required) .....MI-557300  
Power Control Module; 115 volts AC .....MI-556648-1  
Module Extender .....MI-557301  
Blank Modules .....MI-557302\*  
Termination, 75 ohms, ±1.0% .....MI-26759-45

\*Suffix indicates width in module width increments.

## Ordering Information

TG-5 Black & Background Generator .....ES-597430  
complete including:

  1 Black and Background Generator Module .....MI-597431-BL  
  1 Connector Plate Assembly .....MI-597432

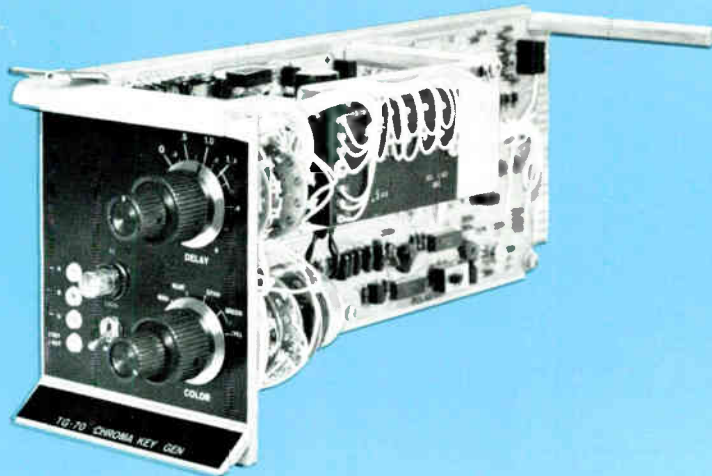

- Single-control operation of chroma keying
- Excellent selectivity—discriminate color keying
- Outstanding sensitivity prevents shadow drop-outs
- Automatic black-and-white clipping
- Clean, sharp digital keying
- Switchable keying polarity
- Simple system installation—sync only requirement
- NTSC or PAL operation

## Chroma-Key Generator, Type TG-70

### Description

The Type TG-70 Chroma Key Generator is a self-powered unit of plug-in modular construction. It is designed to provide a color-derived keying signal for use with Special Effects equipment. The Chroma-key generator accepts Red, Green, and Blue signals from a color camera, selects the desired hue signal and generates a signal which is used to "key out" that color-oriented portion of the picture. Special Effects Equipment, such as RCA Type TE-60, accepts the chroma key output as an external key signal, and provides another picture signal as a fill-in to replace the keyed-out picture portion. This enables the video director to perform many clever effects. A typical application is the keying of a performer into background scenery that has been recorded on film or tape. A news or sports announcer may be electronically placed into the news event background. Many trick effects may be provided by the use of chroma key in local weather shows.

#### One-Knob Control

The Type TG-70 may be operated locally by means of controls on the rack-mounted module or, it may be operated from the remote-control panel. The design of automatic gain, stretch, and selectivity circuits has reduced control of the chroma keyer to one-knob operation. With the TG-70, the operator need only preset the "coarse" color control to the

background color, and then adjust only the "fine" color control on the panel. The remote panel operates by d-c control only.

#### Selectivity and Sensitivity

The overall operation of chroma key has been somewhat difficult to control from the standpoint of lighting and shadows, scenery and color uniformity, background shades and performer's clothing colors, etc. It is most annoying to see color bleed-through, shadow dropouts, and subject halo.

In the design of the TG-70 Chroma Key Generator, special consideration is given to selectivity and sensitivity characteristics. The Red, Green, and Blue signals from the color camera are isolated, amplified by differential amplifiers to obtain difference signals, clamped and non-additively mixed. The Coarse and Fine color controls select the wanted color signal, which is then amplified and clipped. This provides both black-and-white clipping to provide better control of the keying signal. It also provides sufficient gain to permit keying of signals that are 20 dB down in level. A digital IC then converts the signal from video to digital to provide very sharp on-off keying signals. The system delay line and polarity reversal switch are associated with the digital circuitry. There are two 75-ohm outputs to provide separate feeds to spe-

cial effects equipment or to a key preview monitor. All circuitry is solid-state and integrated circuits are used almost exclusively.

#### Simplified Installation

The system installation of the TG-70 is simplified because only system sync is required. This reduces the station pulse-distribution and timing problems. Since blanking is generated internally keying-signal output has blanking within system blanking at the switcher.

The built-in delay line matches the delay incurred in the colorplexer and cables, so that the keying signal is positioned, in time, with the signal to be inserted at the switcher. There is a coarse system delay adjust of 1.5 microseconds in three steps and a fine-delay adjust of 0.5 microseconds in ten steps, for a total of 2 microseconds delay.

The TG-70 operates equally well on NTSC or PAL standards. It is self-powered and operates from 120 or 240 volts, 50 or 60 Hz power. The power supply regulators are self-protected against short circuits.

For those color cameras that do not provide 75-ohm outputs of RGB, a set of impedance-matching preamplifiers is available. The preamps are mounted at the colorplexer, but the power is supplied from a jack on the TG-70.

# Specifications

## Electrical

Input Signals, RGB	0.7V. p-p at 75 ohms
Input Sync	2 to 8 V. p-p at 75 ohms
Input Impedance	7500 ohms min.
Input and Output connectors	BNC
Input power	100 to 130/200 to 260 volts 47 to 63 Hz at 3 watts
Output keying signals, Two	0.7 V. p-p at 75 ohms
Output power for preamps	5 volts @ 35 mA
System delay adjust	up to 2 microseconds
Operating temperature ambient	0° to 55°C
Hue Separation	5 degrees
Shadow Capability	20 dB

## Mechanical

Chroma Key Module:	
Height	4.75 in (1200 mm)
Width (8 module units)	3.68 in (85 mm)
Depth	14.9 in (378 mm)
Weight	3 lb (1.36 kg)
Mounting	Standard Frame (MI-557300)

## Remote Control Panel:

Height	7.0 in (178 mm)
Width	2.125 in (54 mm)
Depth	4.0 in (102 mm)
Mounting	Standard Frame (MI-557306)

The Remote Control subassembly may be remounted on another panel up to 0.5 inch thick, in a 2" x 2" (51 x 51 mm) area. An extra escutcheon is supplied.

## Accessories

Standard Module Frame, (36 module units)	MI-557300
Power Control Module (4 module units)	MI-556648-3
Rack Mounting Adaptor Frame (7 x 19 in.)	MI-557306
Rack to Panel Cable, 75 feet	MI-556727-75
Rack to Panel Cable, 100 feet	MI-556727-100
Rack to Panel Bulk cable	MI-13360
Impedance Matching Preamps, set of three	MI-556762-A1
Coaxial Relay for Chroma Key Transfer	MI-40374
Pushbutton Switch for Coaxial Relay A-A	MI-556656-2
Module Extender 5.25 inch	MI-557301-A2

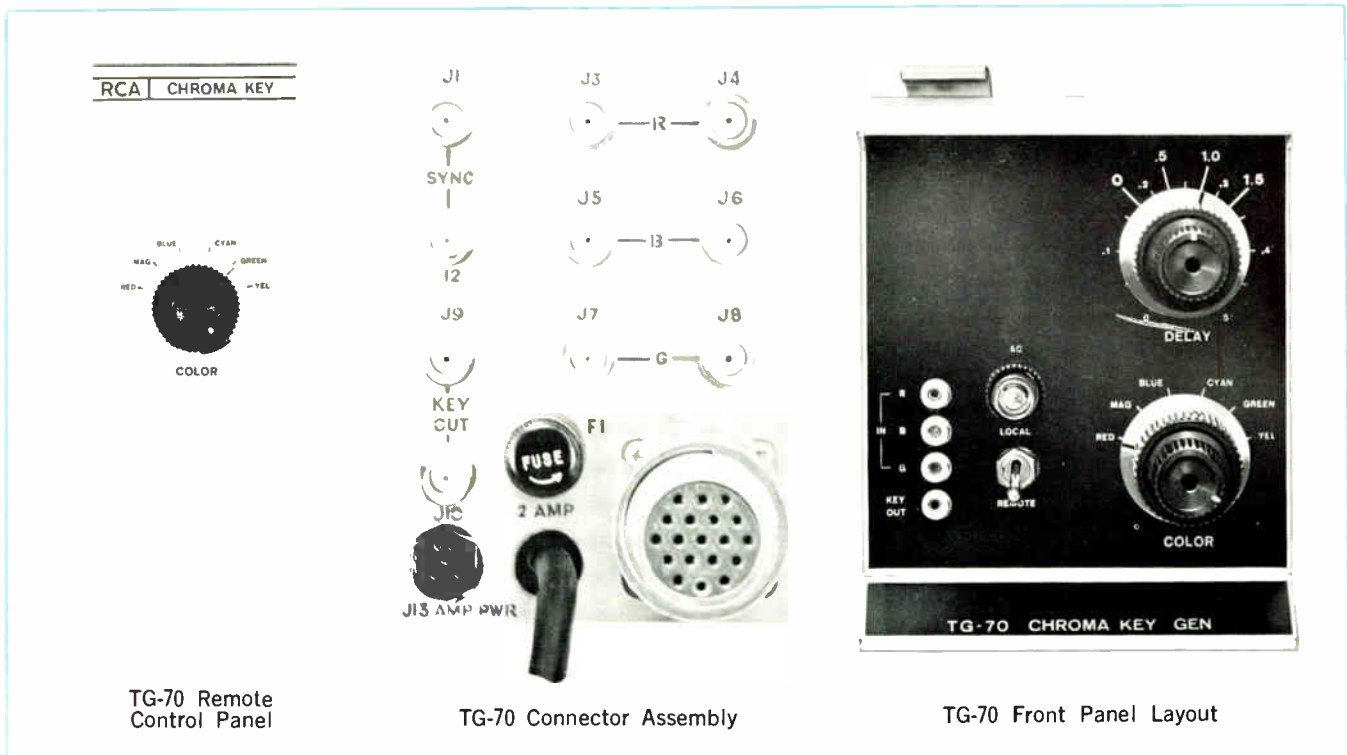

# Ordering Information

TG-70 Chroma Key Generator,  
includes module and connector assembly .....MI-556733-A1  
 TG-70 Remote Control Panel, includes  
 panel and rack to panel cable, 50' .....MI-556734-A1

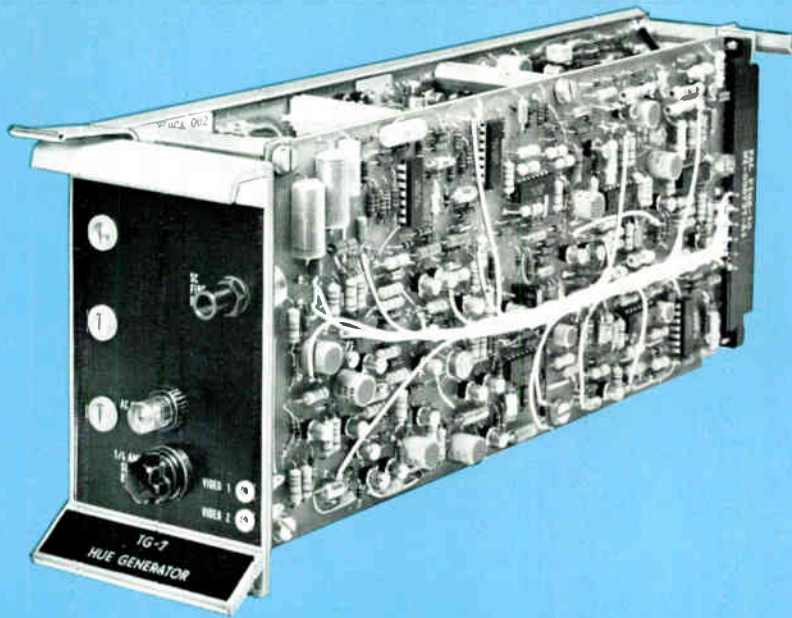

- Continuously variable hue, saturation and luminance
- Two outputs each: color background and color black
- Automatic subcarrier amplitude—colors of controlled saturation
- Capable of electronic hue modulation
- Black and white limiters
- NTSC or PAL operation

## Hue Generator, Type TG-7

### Description

The Type TG-7 Hue Generator is a self-powered unit of modular plug-in construction designed to provide color-background and black-video signals. The Type TG-7 mounts in an RCA 5.25 inch (132 mm) standard module frame. The TG-7 may be ordered for operation on NTSC or PAL color standards. Each includes the TG-7 module with proper plug-in sub-assembly, connector assembly, remote-control panel, and a 50-foot (15 m) rack-to-panel cable.

The continuously variable Hue, Saturation, and Luminance controls provide an unlimited choice of color selection to "paint" any background color. When the TG-7 is used in conjunction with a special-effects system, the operator may key color titles or effects onto a color or monochrome picture from a monochrome keying signal. Thus, titles from a monochrome camera can be inserted in color onto a monochrome or color picture.

#### Black Video Outputs

Two identical outputs are provided of color black video consisting of Sync, Burst, and Black Level, permitting smooth fades from Color pictures to Black, and vice versa. The burst can be inhibited re-

motely to provide a monochrome black signal, if desired. The Color/Mono switch is usually part of the video switcher control panel.

#### Color Background Outputs

Two identical outputs are provided of color background video consisting of sync, burst, and color subcarrier on a variable pedestal. Hue (subcarrier phase), color Saturation, and Luminance are continuously variable to produce any desired background color. The Hue control alters the phase angle of the subcarrier and simultaneously adjusts the subcarrier amplitude to produce colors of controlled saturation. The three control knobs are located on the remote control panel. A switch in the extreme counter-clockwise position of the Saturation control disables burst and color subcarrier, thereby providing a monochrome background signal. The Luminance control may be varied between black and white to provide any shade of gray. The remote panel operates by d-c control only. The incorporation of black and white limiters insure that the chroma amplitude will not go below -0.3 volt (sync tip) nor above 0.7 volt (peak white). This is very important when operators make adjustments without wave-

form monitors present to determine maximum video levels.

#### Simplified Installation

The system installation of the TG-7 consists of feeding power, sync, blanking, burst flag, and subcarrier to the unit. Sync is looped-through and then fed to the video switcher matrix through approximately 40 feet of external delay. This delay, corresponding to the insertion delay of the TG-7, usually consists of a lumped delay plus interconnecting cables. System phase is adjusted by means of a coarse phase control of 360 degrees in six steps plus a fine phase control of plus-and-minus 45 degrees.

The TG-7 is self-powered and operates on 120 or 240 volts, 50 or 60 Hz power. A separate plug-in subassembly is provided for either NTSC or PAL operation, as ordered.

Since all pulses are regenerated with controlled rise and fall times, according to CCIR specifications, the TG-7 is a precision instrument when used as a timing-reference source. The unit may be strapped to provide four isolated color-black outputs for pulse reference distribution.

# Specifications

## Electrical

Input signals, S, BL, BF .....	1.5 to 5 V p-p at 75 ohms
Input Subcarrier .....	1.5 to 2.5 V p-p at 75 ohms
Input Impedance .....	7500 ohms min.
Input and Output Connectors .....	BNC
Input Power .....	100 to 130 or 200 to 250 V., 47 to 63 Hz., 30 watts
Output signals, two black and two color background .....	1 V p-p at 75 ohms
Remote Hue control .....	Continuous 0° to 360°
Remote Saturation control .....	20% to 100%
Remote Luminance control .....	Black to 100% White
System Phase Adjust, Coarse .....	360° in 6 steps
System Phase Adjust, Fine .....	±45°
Subcarrier Output Isolation .....	50 dB
DC on Output .....	0±10mV
Insertion Delay of Sync Leading Edge .....	.60 nsec or less.
Rise and Fall Times of All Pulse Edges .....	CCIR Specifications

## Mechanical

Hue Generator Module	
Height .....	4.75 in (120 mm)
Width (6 module units) .....	2.76 in (70 mm)
Depth .....	14.9 in (378 mm)
Weight .....	Approx 3 lb. (1.5 kg)
Mounting .....	Standard frame, MI-557300
Remote Control Panel	
Height .....	7.0 in (178 mm)
Width .....	2.125 in (54 mm)
Depth .....	3.0 in (76 mm)
Mounting .....	Standard frame, MI-557306

The Remote Control subassembly may be remounted on another panel in 2 x 5" (5 x 12.7 mm) area.

## Accessories

Standard Module frame (36 module units) .....	MI-557300
Power Control Module (4 module units) .....	MI-556648-3
Rack Mounting Adaptor Frame (7 x 19 in.) .....	MI-557306
Rack to Panel Cable, 75 feet .....	MI-556845-75
Rack to Panel Cable, 100 feet .....	MI-556845-100
Rack to Panel Bulk Cable .....	MI-13346-9
Pushbutton Switch for Burst Inhibit A-A .....	MI-556656-2
Equalized Lumped Delay Line, 28 feet .....	MI-556627-8
Module Extender, 5.25 inch .....	MI-557301-A2

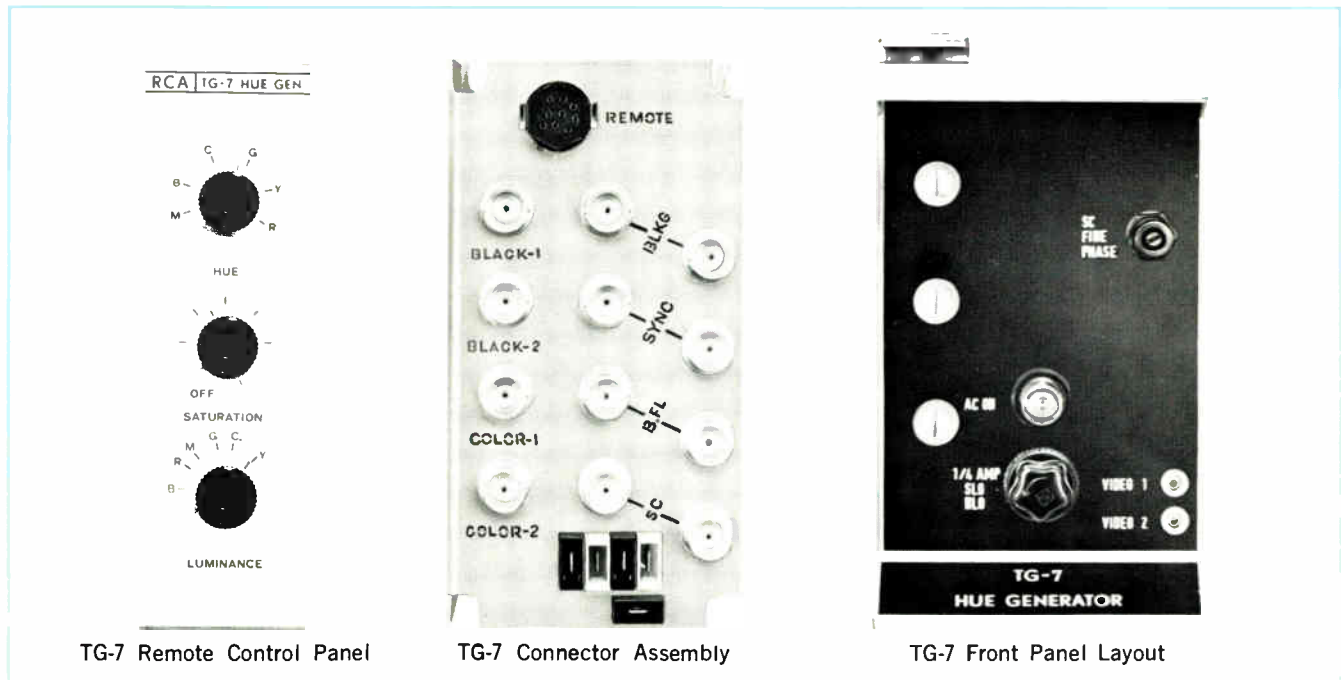

# Ordering Information

Hue Generator for NTSC, Type TG-7 complete .....	MI-556739-A1
Hue Generator for PAL, Type TG-7 complete .....	MI-556729-A1

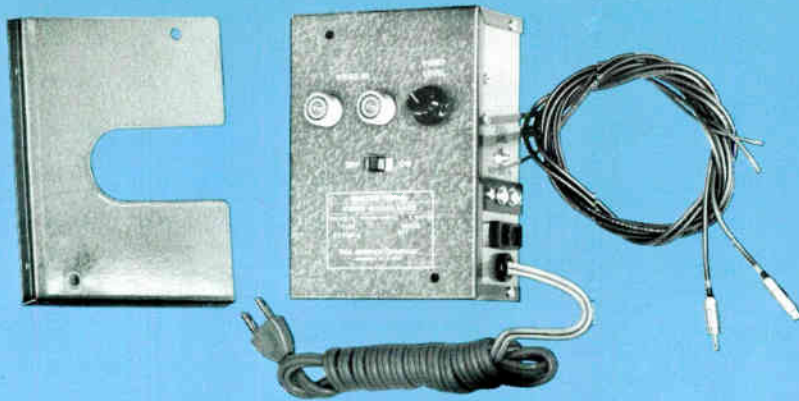

- Converts TV receiver to monitor
- Single switch operation
- Self-contained power supply
- Requires no video compensation

## RCA Video Modulator, Type ETVM-4

### Description

The RCA Type ETVM-4 Video Modulator is a self-contained solid-state unit designed to feed closed-circuit video information into the 45-MHz IF system of a black-and-white or color television receiver. The external video source may be video output from a TV camera chain, a standard 75-Ohm video line, or the output of a video tape recording system. A DC operated four-pole double-throw relay converts the TV receiver from normal operation with an antenna system receiving regularly broadcast television programs, to a closed-circuit television receiver or monitor.

#### Easy to Install

No changes are required in the television receiver circuitry and simple connections permit quick, easy installation. The ETVM-4 is thus a reliable and economical solution for providing a closed-circuit video TV receiver system for broadcast stations, schools, and other industrial applications.

#### Circuit Features

Audio input to accompany the closed circuit video information is fed to the Video Modulator from a standard 600-Ohm audio line. Switching from line audio to "off-the-air" audio is automatic. When the ETVM-4 is turned on, line

audio is fed to the TV receiver audio circuits with full control of volume by the receiver volume control. When the modulator is off, the TV receiver oper-

ates normally from its own antenna system. Re-alignment of the TV receiver is not necessary and video compensation is not required.

### Specifications

Video Signal Input	Video, sync negative, 0.5 Volt to 1.5 Volts peak-to-peak
Video Input Impedance	Bridged through
Video Signal Output	45.75 MHz RF with video modulation (negative)
Audio Input Impedance	Bridged through. Loading for one unit, approx. 10,000 Ohms. Approx. 1.5 V RMS required
Frequency Response—Video Amplifier	±1.5 dB to 7 MHz
Frequency Stability	±2.3 kHz over normal temperature range (20°C to 45°C)
Power Requirements	115 Volts, 50/60 Hz, 2 Watts max.
Solid-State Components	4 Transistors and 3 Semi-conductor Diodes
Fuse	One 0.5 A, 3AG Slo Blo
Dimensions, overall	4 1/8" wide, 5 1/8" high, 3" deep (10.48 cm, 13.02 cm, 7.62 cm)
Weight	2 lbs. (0.9 kg.)

### Ordering Information

Video Modulator  
(to convert TV Receiver to Monitor) .....RCA Type ETVM-4





VHF  
TRANSMITTING



# RCA "Maxim-Air" 30-KW VHF-TV Transmitter, Type TT-30FL

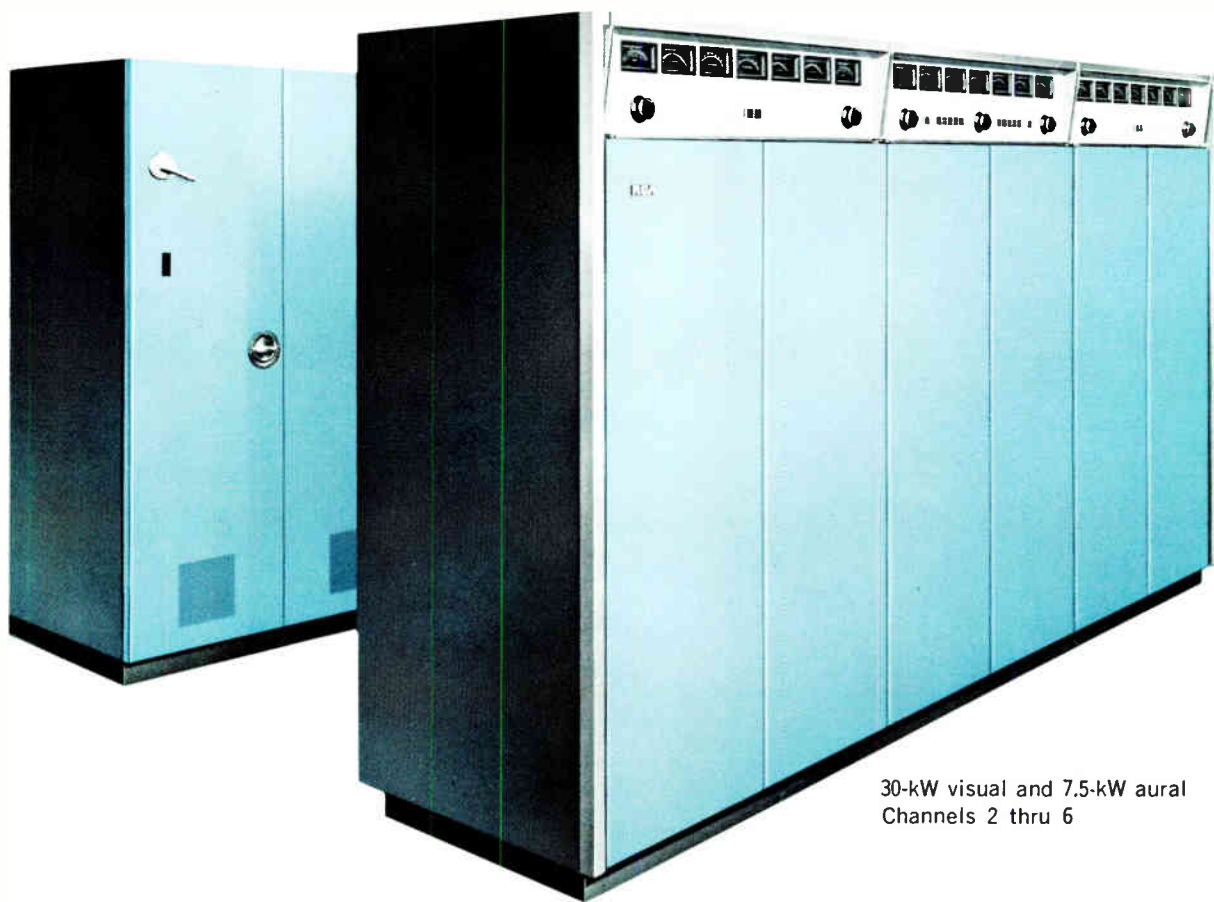

30-kW visual and 7.5-kW aural  
Channels 2 thru 6

- Designed for the future
- New standard for color broadcasting
- Eliminates off-air time
- Solid-state circuitry . . . reliable
- Parallel redundant system
- Automated exciter switching . . . more redundancy
- Full remote control

“MAXIM-AIR” TT-30FL VHF-TV TRANSMITTER  
— Channels 2 through 6 —

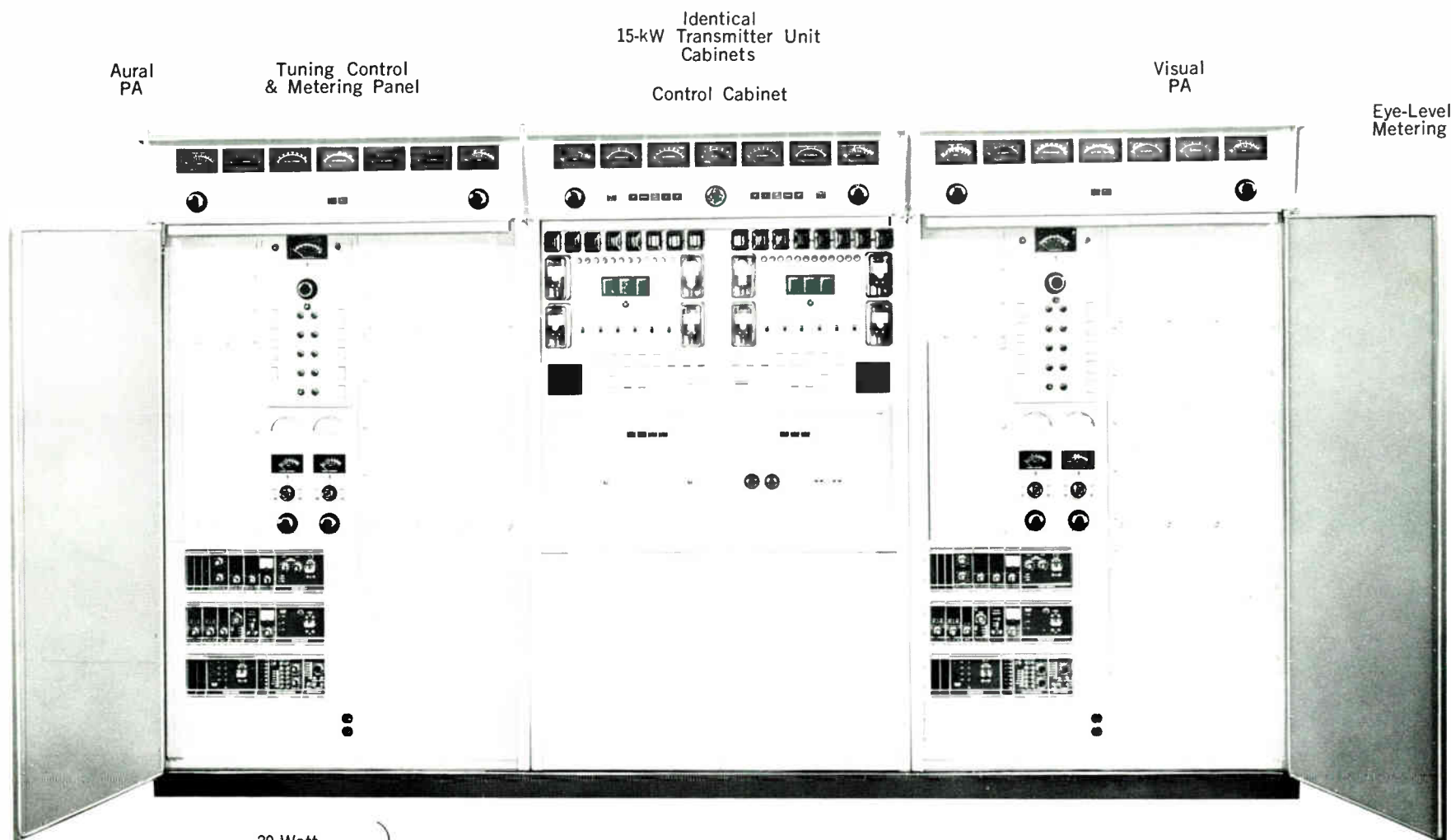

Aural PA

Tuning Control & Metering Panel

Identical  
15-kW Transmitter Unit  
Cabinets

Control Cabinet

Visual PA

Eye-Level  
Metering

20-Watt  
Visual &  
Aural Amps.

5-Watt  
Exciter

Visual  
Modulator

All  
Solid  
State

Remote  
Control

1½ Horsepower  
Blowers

Visual  
IPA

Low-Profile  
77-Inch High  
Cabinets

The TT-30FL represents a major breakthrough in VHF-TV transmitter design. Its totally new solid-state circuitry makes maximum utilization of the newest advances in broad-band techniques. Inherently, the solid-state design requires fewer components, runs cooler and provides exceptional reliability.

The "Maxim-Air" is designed for high quality color or monochrome picture transmission and for high-fidelity sound transmission on Channels 2 through 6. The peak visual power is 30 kW, and the aural power is 7.5 kW. These power levels are at-

tained by operating two 15-kW units in parallel, an arrangement that provides maximum on-air time.

The transmitter is packaged into three cabinets, making it possible to use space more efficiently. Because of the solid-state design and the use of only 10 vacuum tubes, the transmitter requires minimum floor space, consumes less operating power and requires an extremely small cooling system.

Motor-driven controls and remote metering of all major adjustments are features provided for unattended/remote control.

## Design

### Designed for the Future

The RCA "Maxim-Air" is a major breakthrough in VHF-TV transmitters . . . new high quality solid-state designs are used to achieve a sharp, clear and stable color signal . . . the best color signal transmission available to the home TV screen.

### New Standard for Color Broadcasting

A transmitter designed so far ahead of other current models that you don't have to worry about being outdated for years to come. Compare specifications . . . it's designed with specifications twice as good as previous models. Ours are so good you

only have to adjust the TT-30FL once a month to stay within specifications!!

### Eliminates Off-Air Time with Solid-State Circuitry

No corners were cut . . . RCA designed the TT-30FL to be reliable . . . it wasn't just put together with solid-state components that someone said were reliable . . . we designed new and reliable solid-state circuits for your needs . . . circuits that just cruise along in daily operation . . . they're not overstressed. What can you expect from this new solid-state circuitry? It's the first step taken to eliminate your off-air time!!

There's more . . .

### Eliminates Off-Air Time with a Parallel Redundant System

The big second step is a transmitter system comprised of two identical 15-kW units . . . this adds up to 30-kW of visual power into your antenna using only 10 tubes. If one transmitter unit fails . . . the other keeps you on the air . . . your audience in the primary coverage area doesn't even notice a change.

### Eliminates Off-Air Time with Automated Exciter Switching

The third big step is a standby exciter that will automatically switch unnoticed if the operating exciter fails—while providing an indication that the exciters have switched.

### Full Remote Control

"Maxim-Air" is designed for the future . . . with built-in transmitter operating and mode controls, metering points, status reporting devices and motorized tuning . . . it is ready for full remote control and automatic logging . . . and, eventually computer control.

## SOLID-STATE CIRCUITRY



5-Watt Exciter  
... All Solid State.



Visual Modulator  
... All Solid State.

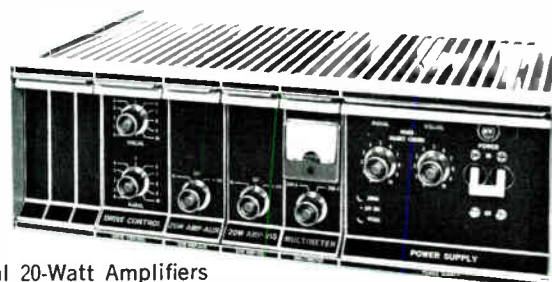

Visual and Aural 20-Watt Amplifiers  
... All Solid State.

## A Technical Description . . . For the Eyes of Engineering

The “Maxim-Air” TT-30FL is the first major breakthrough in VHF-TV transmitter design in 15 years . . . let’s take a look at some of the design concepts and the resulting avalanche of benefits . . .

### Conservative Design

“Maxim-Air” is designed using components that are capable of operating at ratings well above those used . . . the components aren’t “pushed” to their limits . . . they operate at a more “reserved” pace. When you “push” a single component, its chances of failure increase . . . when you “push” many components, failure can become a way of operation. The TT-30FL is designed for reliable operation—its components are in no way “pushed”.

In transmitters, a failure causes excessive stresses to be applied to parts in the failed circuit . . . causing additional failures to occur immediately, or later. Because the TT-30FL does not “push” components to their operating limits, the chances of excessive part stresses are greatly reduced . . . again, the TV broadcaster has greater reliability.

### Solid-State Design

“Maxim-Air” was designed from the ground up with maximum utilization of solid-state devices—it was the only way to

Maximum Solid-State Use

Long-Term Stability

Increased Reliability

Installation Flexibility

Minimum Floor Space

High Efficiency

No Neutralizing

Fewer Parts

Low Blower Noise

Only 10 Tubes

Improved Specifications

Simplified Tuning

Easy Maintenance

Economic Operation

Grounded-Grid Triode

No Bias Supplies

Improved Cooling

Standardized Modules

reach our conservative-design goals. A glance at the transmitter block diagram shows that only the IPA and PA stages use tubes . . . we couldn’t find solid-state devices that would give the required power, reliability and operating economy so we did the next best thing . . . we applied our conservative design concept and selected tubes that would just coast along while they operate. Only 10 tubes of 3 different types are used . . . superior performance with 182 less tubes than its former version.

The solid-state design requires fewer components and consumes less operating power. Fewer components mean greater reliability . . . and, a smaller parts inventory . . . high-efficiency circuits mean less power and a cooler running transmitter. Superior mechanical design enables the use of a small 1½-horsepower blower motor for adequate cooling . . . the result is a transmitter with small blowers and low blower noise . . . and less cabinet vibration . . . and a cleaner cabinet interior because of lower air circulation.

## Superior Performance – Only 3 Tube Types

Tube Complement  
for a Single 15-kW  
Transmitter Unit—  
Total Only 5.

AURAL IPA  
8791



AURAL PA  
3CX3000A7



VISUAL PA  
3CX10,000A7

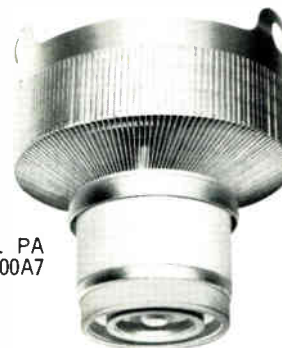

# “Maxim-Air” System Operation

## Paralleled 15-kW Transmitter Units

Two identical 15-kW transmitter units are operated in a parallel system . . . their outputs add up to 30-kW peak visual power and 7.5-kW aural power. The operation of each transmitter unit is completely independent of the other . . . should a failure occur in one unit, the other continues to provide a non-distorted signal into the antenna system.

## Redundant Solid-State Exciters

Two identical exciters feed into an automatic exciter switchover circuit . . . the circuit terminates the output of the standby exciter while the output of the operating exciter feeds the visual and aural stages. If the operating exciter output degrades or fails, it is automatically replaced by the standby exciter. The switchover circuit operates so quickly and smoothly that the video and audio are not interrupted.

## Hybrid Combiner Network

The output from each 15-kW transmitter unit is combined to provide antenna input powers of 30-kW visual and 7.5-kW aural. If a failure occurs in a transmitter unit, a 6 dB reduction in signal power occurs in the combining network . . . it is not even noticed within the primary cov-

erage area. The full power of the operating transmitter can be switched directly into the antenna to reduce the power loss to only 3 dB.

The entire switching arrangement is initiated from a single pushbutton switch, at an appropriate program time, and requires less than 3 seconds.

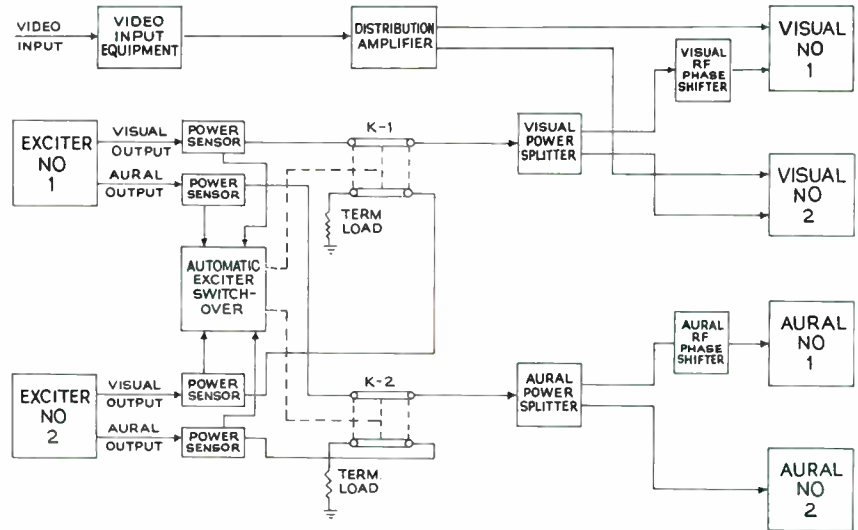

Automatic Exciter Switchover.

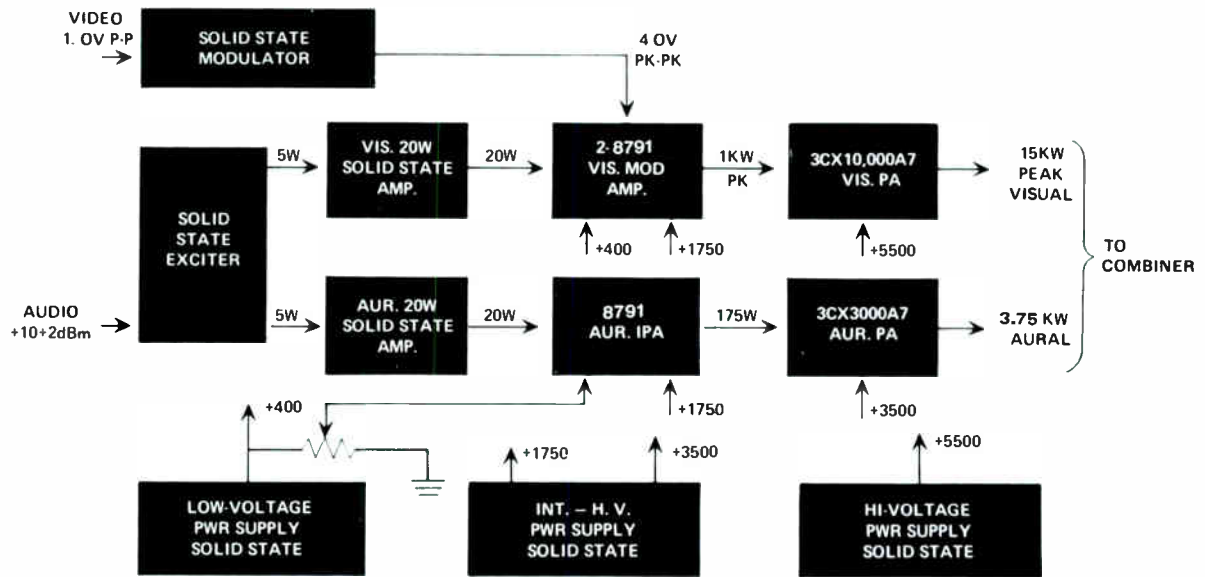

Block Diagram of one 15-kW Transmitter Unit.



### Solid-State 5-Watt Exciter

The 5-Watt aural/visual exciter, its power supply and metering circuits consist of seven plug-in modules in one standard frame.

The aural exciter circuitry uses an FM oscillator in an AFC feedback loop followed by a buffer amplifier, doubler and two amplifiers to reach the 5-Watt output level at carrier frequency. The center frequency of the oscillator is accurately main-

tained by a reference frequency that is 150 kHz above the FM oscillator. A DC error voltage that represents the difference between the center frequency and the reference corrects for any oscillator drift.

The visual exciter circuitry consists of a temperature-controlled visual oscillator followed by a doubler and two amplifiers to reach the 5-Watt output level at carrier frequency.

### Solid-State Aural and Visual 20-Watt Amplifiers

Identical 20-Watt amplifier modules are used in the aural and visual RF chains following the 5-Watt exciter. These modules, and their power supply and metering circuits consist of five plug-in modules in one standard frame.

The aural and visual amplifiers provide the drive power necessary for the visual modulated amplifier and the aural IPA. As an example of conservative design, the 20-Watt amplifiers are required to deliver only about 10 Watts.

### Solid-State Visual Modulator

The visual modulator and its power supply consist of four standard plug-in modules. A total of 38 transistors of 8 types and 25 diodes of 6 types are used. Motorized controls are furnished for VIDEO GAIN, SYNC GAIN and PED-ESTAL adjustments.

The output of the visual modulator is a 70-Volt peak-to-peak video level that is applied to the visual modulated amplifier. As another example of conservative design . . . only about 40 Volts peak-to-peak is needed for 100-percent modulation.

Differential phase and gain correction are accomplished in separate circuits with negligible interaction between the two functions. DC restoration is provided by a feedback clamp circuit that operates from the modulator output or the detected RF output of the transmitter. The clamp circuit tends to hold the transmitter output constant . . . even with power line variations.

### Visual Modulated Amplifier and PA

The design of the visual modulated amplifier circuits provides excellent modulation specifications . . . such as linearity amplitude versus frequency response, and change in response versus brightness level.

The amplifier uses two RCA Type 8791 Cermolox tubes in a push-pull grid-bias modulated circuit. The input circuit is heavily loaded to provide excellent stability and drive regulation . . . and the Type 8791 has extremely linear transfer characteristics.

The visual PA uses a zero-biased high-mu 3CX10,000A7 triode in a cathode drive circuit. The cathode circuit is a part of the double-tuned overcoupled output circuit of the visual modulated amplifier . . . providing a circuit with an

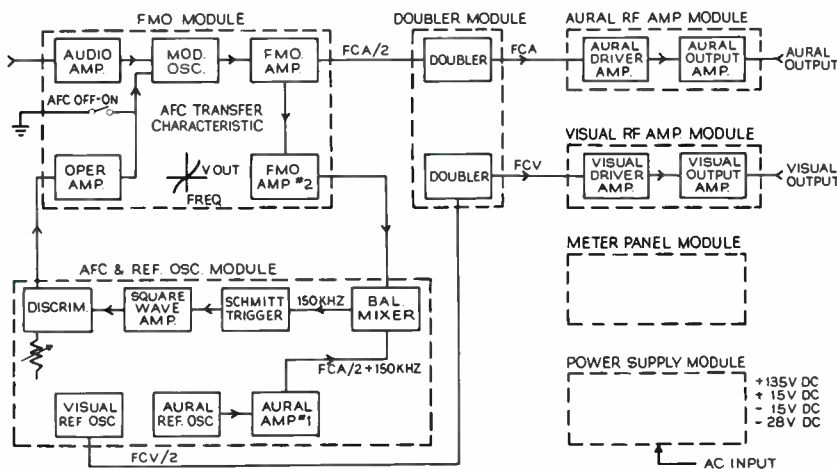

Solid-State 5-Watt Exciter Block Diagram.

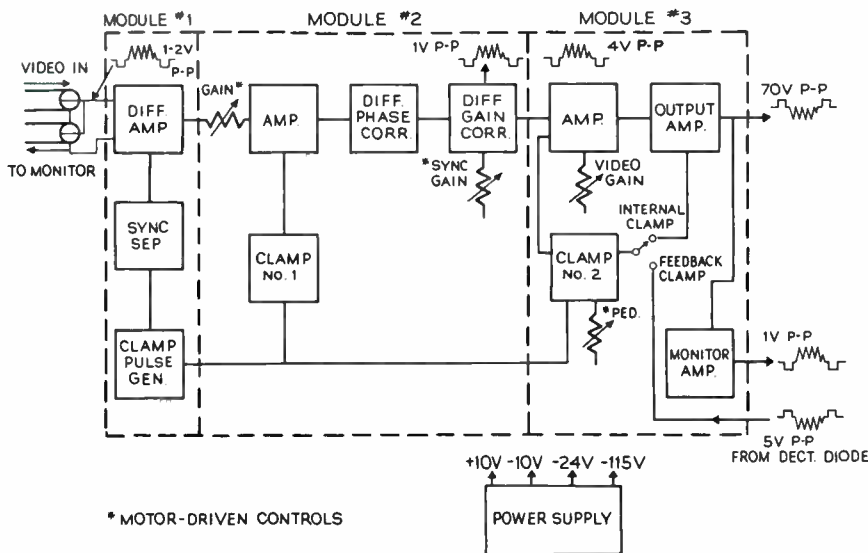

Solid-State Visual Modulator Block Diagram.

extremely wide bandwidth. Therefore, tuning of the overcoupled output circuit determines the transmitter bandwidth . . . this simplified PA tuning also reduces phase distortion.

The use of a zero-biased triode makes the PA circuitry extremely simple, dependable and easy to service. The grid is at DC ground . . . eliminating bypass capacitors and a bias supply . . . and no neutralization is required!!

### Aural IPA and PA

The aural IPA uses a single RCA Type 8791 Cermolox tube operating as a Class C amplifier. The input circuit is heavily damped to present an excellent match to the aural 20-Watt solid-state amplifier. Because of the broad bandwidth of the circuitry, it is not necessary to retune the input circuit when changing tubes. The plate circuit of the aural IPA is tuned and matched to the PA cathode by using a pi-network.

The aural PA uses a 3CX3000A7 zero-biased, high- $\mu$  triode operating as a grounded-grid Class C amplifier. It requires no fixed bias . . . and does not need neutralization.

### Motorized Transmitter Tuning

Motor-driven adjustments are provided on a tuning control panel located in each 15-kW transmitter unit. To select a function to be adjusted, you simply depress the pushbutton associated with the function. The pushbutton lights, giving an indication of your selection. Associated with each selection pushbutton is an INCREASE/DECREASE switch which, when depressed, operates a 24-Volt tuning control motor. Metering is accomplished by rotating a 20-position selector switch to the appropriate position . . . and all tuning adjustments are read on the meter provided.

The transmitter control circuits and metering can be located at a console or at a remote location . . . the circuits are ready for full remote control and automatic logging . . . and as can be seen, eventual computer control.

### Power, Distribution and Control Circuits

The power supplies for each 15-kW transmitter use silicon rectifiers which are well protected against surges, transients and overloads. The control circuits provide a choice of single button sequential starting or a step-by-step startup procedure, and automatic or manual reset following an overload.

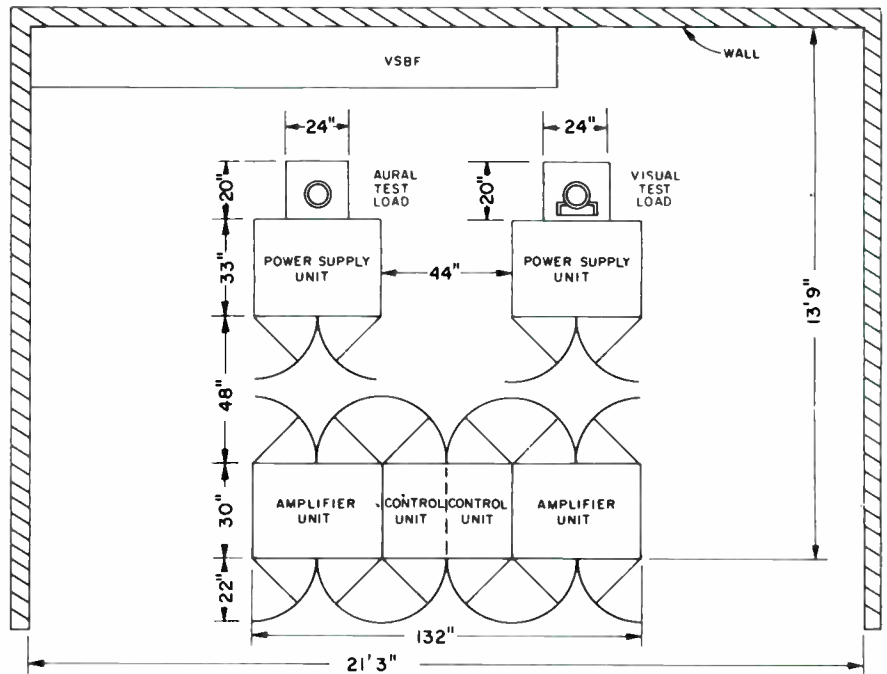

"Maxim-Air" Floor Layout.

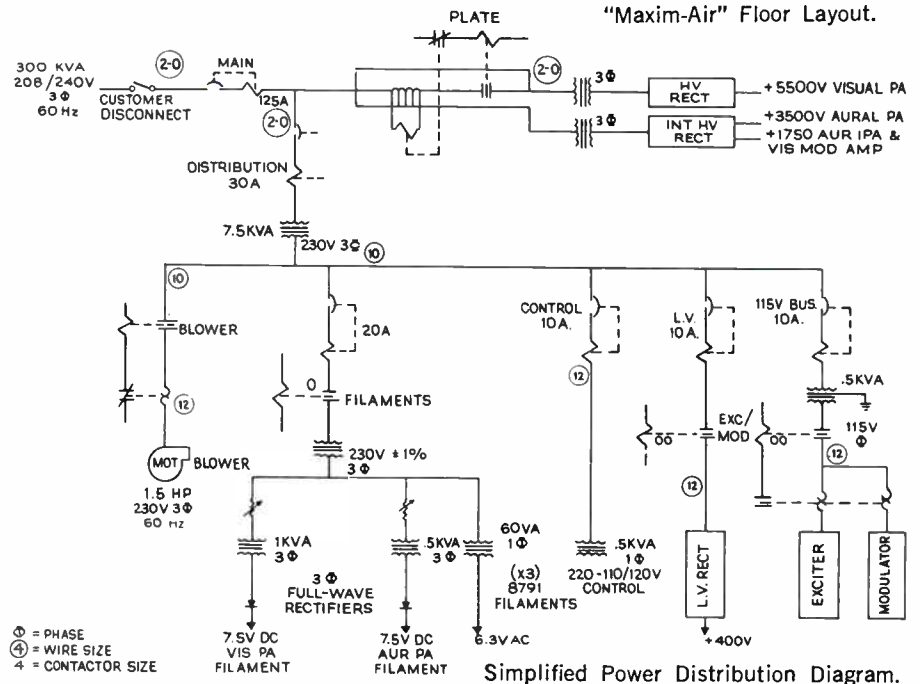

Simplified Power Distribution Diagram.

The high voltage and intermediate high voltage supplies both employ three-phase full-wave rectifier circuits and furnish plate potentials for all tubes in the transmitter. Screen potentials for the RCA Type 8791 tubes are obtained from a single-phase full-wave regulated supply. No bias supplies are required. The three-phase, 60-Hertz main power line to each 15-kW transmitter should be capable of delivering a minimum of 50 KVA and a maximum of 300 KVA at 208/240 Volts

$\pm 5\%$ . Two high-voltage transformers are provided with primary taps and are operated from the power line voltage. Power to the remaining components of the transmitter is supplied through a distribution transformer equipped with primary taps so that the output voltage is always 230 Volts. No taps are necessary on any other transformers. Constant voltage transformers are employed to maintain all filament voltages constant to within one percent.

# Specifications

## Performance

Type of Emission:	
Visual .....	A5
Aural .....	F3
Frequency Range .....	Ch 2-6
Rated Power Output:	
Visual .....	15 to 30 kW <sup>1</sup>
Aural .....	1.5 to 7.5 kW
RF Output Impedance .....	50 ohms
Input Impedance:	
Visual .....	75 ohms
Aural .....	600/150 ohms
Input Level:	
Visual .....	1.0 volts p-p min.
Aural (for $\pm 25$ kHz dev.) .....	$+10 \pm 2$ dBm
Amplitude vs. Frequency Response, Aural .....	$\pm 1$ dB, 30 Hz to 15 kHz, of 50 $\mu$ sec or 75 $\mu$ sec pre-emphasis response curve
Visual Sideband Response:	
At Carrier +0.5 MHz to 2.1 MHz .....	+0.5, -0.75 dB <sup>2</sup>
At Carrier +3.58 MHz .....	+0.5, -0.75 dB <sup>2</sup>
Between +2.1 MHz to 4.18 MHz with respect to 3.58 MHz response .....	+0.5, -0.75 dB <sup>3</sup>
At Carrier -0.5 MHz .....	+0.5, -0.75 dB <sup>2</sup>
Variation in Frequency Response with Brightness <sup>4</sup> .....	$\pm 0.75$ dB
Carrier Frequency Stability <sup>5</sup> :	
Visual .....	$\pm 250$ Hz
Aural .....	$\pm 250$ Hz
Modulation Capability:	
Visual .....	10%
Aural .....	$\pm 50$ kHz
Audio Frequency Distortion .....	0.5% max. <sup>6</sup> (30-15,000 Hz)
FM Noise (below $\pm 25$ kHz deviation) .....	-60 dB
AM Noise r.m.s.:	
Visual .....	-50 dB below sync level
Aural .....	-50 dB
Amplitude Variation over one picture frame .....	Less than 2% <sup>7</sup>
Regulation of Output .....	3%
Burst vs. Subcarrier Phase <sup>8</sup> .....	$\pm 2^\circ$
Subcarrier Amplitude <sup>8</sup> .....	0.7 dB
Subcarrier Phase vs. Brightness <sup>9</sup> (diff. phase) .....	$\pm 2^\circ$
Linearity (diff. gain) <sup>10</sup> .....	0.5 dB
Linearity (Low Frequency) .....	1.0 dB
Envelope Delay vs. Frequency <sup>11</sup> :	
0.2 to 2.0 MHz .....	$\pm 60$ ns
at 3.58 MHz .....	$\pm 30$ ns
at 4.18 MHz .....	$\pm 60$ ns
Harmonic and Spurious Radiation <sup>12</sup> .....	-80 dB

## Electrical

AC Line Input .....	208/240 volts, 3 phase, 50/60 Hz (power consumption given below), and 115 volts single phase 50/60 Hz (100 watts)
Slow Line Variations .....	$\pm 5\%$ max.
Rapid Line Variations .....	$\pm 3\%$ max.
Phase Unbalance .....	2% max.
Regulation .....	3% max.
Power Consumption (at 30 kW peak visual, & 7.5 kW aural output):	
Average Picture .....	50 kW
Black Picture .....	75 kW
Power Factor (approx.) .....	90%

## Mechanical

Overall Length (front line cabinets) .....	136" (3350 mm)
Overall Height (cabinets) .....	77" (1956 mm)
Depth .....	30" (762 mm)
Power Supply Cabinets .....	2 required
Width .....	44" (1118 mm)
Height .....	77" (1956 mm)
Depth .....	33" (838 mm)
Finish .....	Two-tone blue, brushed aluminum trim

## Environmental

Maximum Altitude .....	7,500 feet (2286 m)
Ambient Temperature .....	-20°C to 45°C

- 1 Measured at output of sideband filter or filterplexer.
- 2 With respect to response at carrier plus 200 kHz, as measured by the BW-5 sideband response analyzer at transmitter mid-characteristic.
- 3 Measured at output of VSBF. Add -0.75 dB at +4.18 MHz if filterplexer or notch diplexer is employed.
- 4 Measured at 65% and 25% of sync peak level with respect to response at transmitter mid-characteristic.
- 5 Maximum variation without circuit adjustment over a period of 30 days and over an ambient temperature range of 0°C to 45°C.
- 6 Including harmonics up to 30 kHz and measured with standard de-emphasis network.
- 7 Measured at blanking level.
- 8 Maximum departure from the theoretical when reproducing saturated primary colors and their complements at 75% amplitude.
- 9 Maximum phase difference with respect to burst, measured after the VSBF, for any brightness level between 75% and 15% of the sync peak using 10% (peak-to-peak) modulation.
- 10 Maximum variation in the amplitude of a 3.58 MHz sine wave modulating signal as the brightness level is varied between 75% and 15% of sync peak. The gain shall be adjusted for 10% (peak-to-peak) modulation of the 3.58 MHz signal when the brightness is at pedestal level. This is equivalent to 5% (peak-to-peak) modulation as indicated by a conventional diode demodulator connected after the VSBF.
- 11 Maximum departure from standard curve using TTS-1A. The tolerances vary linearly between 2.1 and 3.58 MHz and between 3.58 and 4.18 MHz.
- 12 Ratio of any single harmonic or spurious frequency to peak visual power.

## Ordering Information

The TT-30FL TV Transmitter, 30 kW visual, 7.5 kW aural with tubes, solid-state color correction filters, including low pass filter, harmonic filters, vestigial sideband filter and motorized coaxial switches complete. For 208/240-volt 3-phase, 50/60-Hz input ..... ES-560615

## Max-OnAir 35-kW VHF-TV Transmitter, Type TT-35FH



35-kW visual and 7.75-kW aural  
Channels 7 thru 13

- Designed for the future
- New standard for color broadcasting
- Eliminates off-air time
- Reliable solid-state circuitry
- Parallel redundant system
- Automated exciter switching
- Full remote control

## Max-OnAir TT-35FH VHF-TV Transmitter

Maximum air time, maximum performance and maximum return on investment. These are the main attributes of the all new TT-35FH Transmitter. Its design is an astute combination of state-of-the-art technology and years of transmitter engineering experience.

Actually two, complete, 17.5-kW transmitters combined to deliver a 35-kW visual power output plus 7.75 kW of aural power, the TT-35FH transmitter is a fully redundant facility that virtually eliminates transmitter outage.

The TT-35FH conserves occupied floor space without compromising accessibility. The solid-state circuitry enhances reliability and performance, reduces operating cost and practically eliminates obsolescence.

## Description

### Designed for the Future

As new as technology allows, the TT-35FH is a 35-kW highband-VHF transmitter offering solid-state circuitry in all stages except for the IPA and PA. There are but six electron tubes in the entire transmitter and these are of but two types. It delivers the sharpest, highest quality television signals of any present-day transmitter.

### Highest TV-Broadcast Standards

Designed so far ahead of its contemporaries that its design won't be outdated for years to come, the TT-35FH specifications are at least twice as good as those previous models with stability so solid that it holds specifications for 30 days and longer without readjustment.

### Full Transmitter Redundancy

Because the TT-35FH is actually two 17.5-kW units operating in "parallel" to deliver the 35-kW visual power output, a failure in either transmitter merely reduces output power and keeps the station on-the-air with little or no noticeable change in the primary coverage area.

### Automatically Switched Exciters

The TT-35FH includes two, complete r-f exciters with fully automatic signal sensing and switching. Should the "on-air" exciter fail, the switcher senses the failure and puts the "hot spare" on the line. This takes place so quickly that there isn't the slightest loss of program. A status light indicates switchover.

### Full Remote Control

The TT-35FH features full remote control with a generous amount of remote indicators and meter outputs. Status indication facilities, essential for complete remote control, make diagnosis, corrections and operational changes simpler than ever. Also included are provisions for automatic logging and computer-controlled operation.

### Conservatively Designed

From a technical viewpoint, the TT-35FH is about all a chief engineer might want in a television transmitter.

The TT-35FH uses every practicable design technique to increase reliability. For example, all electronic devices operate well below maximum ratings; a unique cavity design reduces cooling-air requirements. Filament-contact assemblies use space-age "heat-pipe" cooling to eliminate high-pressure air cooling. All components require a minimum of maintenance.

### Low-Pressure Air-Cooling

Because the transmitter uses only six electron tubes operating in very efficient circuitry, its demands for cooling air are considerably less than those of similar transmitters. As a result, the TT-35FH requires only low-pressure air cooling. Low-pressure air cooling reduces noise, vibration and mechanical wear which, in turn, extends system reliability.

### Solid State Circuitry

All TT-35FH circuitry below the 25-watt level on the visual side is solid state while the aural section is solid state to the 80-watt IPA stage.

### Diode Visual Modulation

Another TT-35FH engineering innovation is the diode visual modulator. Performed at the 12-watt level, the passive modulator increases modulation linearity and extends modulation capability to 5 percent.

### Paralled 17.5-kW Units

Two identical 17.5-kW transmitter units are operated in a parallel system . . . their outputs add up to 35-kW peak visual power and 7.75-kW aural power. The operation of each transmitter unit is completely independent of the other . . . should a failure occur in one unit, the other continues to provide a non-distorted signal into the antenna system.

### Redundant Solid-State Exciters

Two identical exciters feed into an automatic exciter switchover circuit . . . the circuit terminates the output of the standby exciter while the output of the

operating exciter feeds the visual and aural stages. If the operating exciter output degrades or fails, it is automatically replaced by the standby exciter.

### Hybrid Combiner Network

The output from each 17.5-kW transmitter unit is combined to provide antenna input powers of 35-kW visual and 7.75-kW aural. If a failure occurs in a transmitter unit, a 6 dB reduction in signal power occurs in the combining network . . . it is not even noticed within the primary coverage area. The full power of the operating transmitter can be switched directly into the antenna to reduce the power loss to only 3 dB. This co-axial switching system is included at no extra cost. Being motor-driven, instead of manual, switching via remote control is easily arranged. The entire switching arrangement requires less than three seconds.

### Circuit Details: 17.5-kW Transmitter Unit

#### Solid State Exciter

The aural exciter combines an extremely stable crystal oscillator with the high fidelity capabilities of direct-FM modulation, through the use of a frequency-modulated oscillator locked to a crystal through an AFC system.

The visual oscillator is a temperature-compensated, crystal-controlled oscillator also operating at one-quarter carrier frequency. Multiplied to carrier frequency and amplified to a 5-watt level in two solid-state amplifiers, the visual-carrier signal then goes to a 20-watt solid-state visual power amplifier.

#### Low-Power R-F Amplifiers

The visual- and aural-carrier signals are separately amplified in essentially identical, 20-watt solid-state amplifiers. The amplified visual carrier goes to the first of three ferrite interstage isolators while the aural carrier feeds a second power amplifier. Capable of an 80-watt power output, this amplifier raises the aural carrier to a 50-watt level for driving the aural PA.

#### Ferrite Interstage Isolators

The TT-35FH Transmitter's r-f stability is enhanced through the use of ferrite interstage isolators, a solid state device which maintains input and output impedances to close limits. Three such devices are used in the TT-35FH (see block diagram). Because the isolators hold the loads for each stage to close limits, each stage maintains a high level of performance for long terms.

## Solid State Circuitry



10-Watt Exciter . . . All Solid State

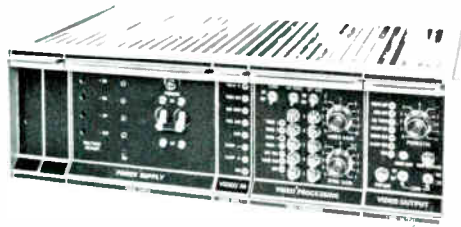

Visual Modulator . . . All Solid State

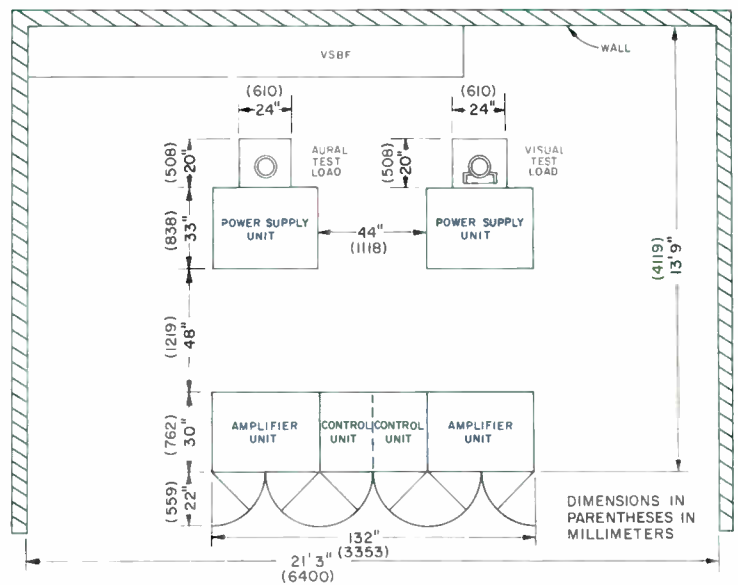

## Visual Pre-Intermediate Amplifier

Since the gain through the diode modulator is less than unity, the visual chain uses a broadband solid state amplifier following the modulator. Like all of the other solid state power amplifiers in the TT-35FH, this stage is untuned and operates at but a fraction of its power capability. The result is vastly improved gain-vs.-bandwidth stability.

## High-Power Amplifiers

The 25-watt visual carrier signal is amplified to a 1-kW power level in the linear 1PA. The cavity amplifier uses a new Type 8890 power tetrode. The aural PA uses the same tube type to develop the 4.5-kW power output. However, the aural amplifier operates class C instead of linear. The visual PA uses a Type 8891 high-power tetrode in a cavity.

## High-Level Sideband Shaping

To assure picture-output integrity, the TT-35FH uses only two tuned linear amplifiers following the visual modulator. This drastically reduces the possibility of out-of-channel radiation. In addition, the transmitter uses a sideband filter at the output to assure proper sideband attenuation.

## Self-Reset Power Supplies

All TT-35FH power supplies (except PA-plate) are automatic current limiting. In the event of overload, the power supplies limit current to a "safe" value until the overload passes.

The high-voltage, PA-plate supplies are conventional, solid-state systems consistent with the "twice-up" specification criteria of the TT-35FH Transmitter.

## Technical Features

- Solid-state amplifiers self-protected against open or short-circuited load
- Ferrite interstage isolators eliminate stage interaction
- Generous metering and status indication
- Reserve PA gain —no bandwidth vs. gain compromises
- Broadband, untuned solid-state amplifiers
- High-power sideband filter —no sideband re-establishment
- But two tubes types in entire transmitter
- Automatic current-limiters in power supply
- Solid-state "three-try" overload reset
- Nearly 100% reserve in all solid-state power amplifiers
- Solid-state overload relays —no "reset" buttons
- CW amplifier gain stability within 0.1 dB over temperature range
- Feedback clamp for black-level stability

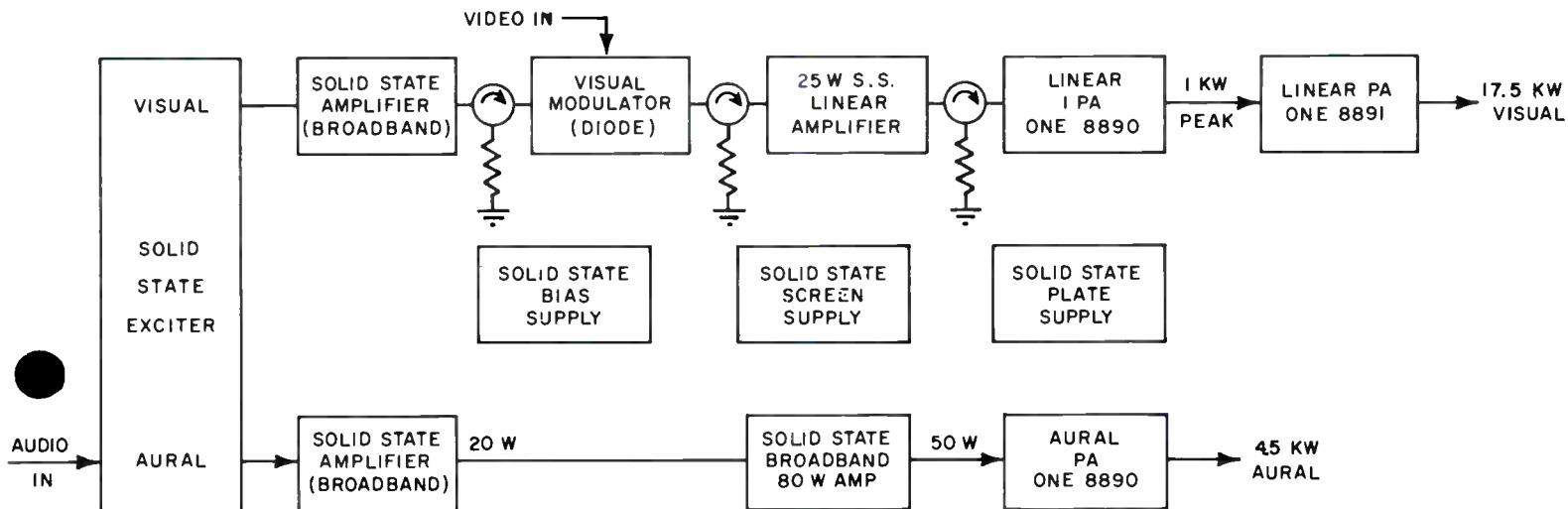

TT-35FH Block Diagram (one of two transmitter units)

# Specifications

## Performance

Type of Emission:	
Visual .....	A5
Aural .....	F3
Frequency Range .....	Channels 7-13
Rated Power Output:	
Visual .....	17.5 to 35 kW <sup>1</sup>
Aural .....	1.5 to 7.75 kW
RF Output Impedance .....	50 ohms
Input Impedance:	
Visual .....	Bridging
Aural .....	600/150 ohms
Input Level:	
Visual .....	0.5 to 2.0 volts p-p
Aural (for ±25 kHz dev.) .....	+10 ±2 dBm
Amplitude vs. Frequency	
Response, Aural .....	±1 dB, 30 Hz to 15 kHz, of 50 μsec or 75μsec pre-emphasis response curve
Visual Sideband Response:	
At Carrier -0.5 MHz to +2.1 MHz .....	±0.75 dB <sup>2</sup>
At Carrier +3.58 MHz .....	±0.75 dB <sup>2</sup>
Between +2.1 MHz to 4.18 MHz with respect to 3.58 MHz response .....	±0.75 dB <sup>3</sup>
Variation in Frequency Response with Brightness <sup>4</sup> .....	±0.75 dB
Carrier Frequency Stability <sup>5</sup> :	
Visual .....	±250 Hz
Aural .....	±250 Hz
Modulation Capability:	
Visual .....	5%
Aural .....	±50 kHz
Audio Frequency Distortion .....	0.5% max. <sup>6</sup> (30-15,000 Hz)
FM Noise (below ±25 kHz deviation) .....	-60 dB
AM Noise r.m.s.:	
Visual .....	-50 dB below sync level
Aural .....	-50 dB
Amplitude Variation over one picture frame .....	Less than 2.0% <sup>7</sup>
Regulation of Output .....	3%
Burst vs. Subcarrier Phase <sup>8</sup> .....	±3°
Subcarrier Amplitude <sup>8</sup> .....	0.7 dB
Subcarrier Phase vs. Brightness <sup>9</sup> (diff. phase) .....	±2°
Linearity (diff gain) <sup>10</sup> .....	0.5 dB
Linearity (Low Frequency) .....	1.0 dB
Envelope Delay vs. Frequency <sup>11</sup> :	
0.2 to 2.0 MHz .....	±60 ns
at 3.58 MHz .....	±30 ns
at 4.18 MHz .....	±60 ns
Harmonic and Spurious Radiation <sup>12</sup> .....	-80 dB

## Electrical

AC Line Input .....	208/240 volts, 3 phase, 50/60 Hz (power consumption given below), and 115 volts, single phase, 50/60 Hz (100 watts)
Slow Line Variations .....	±5% max.
Rapid Line Variations .....	±3% max.
Phase Unbalance .....	2% max.
Regulation .....	3% max.
Power Consumption (at 35 kW peak visual, & 7.75 kW aural output):	
Average Picture .....	55 kW
Black Picture .....	75 kW
Power Factor (approx.) .....	90%

## Mechanical

Overall Length (front line cabinets) .....	136" (3.46 m)
Overall Height (cabinets) .....	77" (1.95 m)
Depth .....	30" (762 mm)
Power Supply Cabinets .....	2 required
Width .....	44" (112 mm)
Height .....	77" (1.95 m)
Depth .....	33" (838 mm)
Finish .....	Two-tone blue, textured vinyl and brushed-aluminum trim

## Environmental

Maximum Altitude .....	7,500 feet (2287 m)
Ambient Temperature .....	0°C to 45°C

- <sup>1</sup> Measured at output of sideband filter or filterplexer.
- <sup>2</sup> With respect to response at carrier plus 200 kHz, as measured by the BW-5 sideband response analyzer at transmitter mid-characteristic.
- <sup>3</sup> Measured at output of VSBF. Add -0.75 dB at +4.18 MHz if filterplexer or notch diplexer is employed.
- <sup>4</sup> Measured at 65% and 25% of sync peak level with respect to response at transmitter mid-characteristic.
- <sup>5</sup> Maximum variation without circuit adjustment over a period of 30 days and over an ambient temperature range of 0°C to 45°C.
- <sup>6</sup> Including harmonics up to 30 kHz and measured with standard de-emphasis network.
- <sup>7</sup> Measured at blanking level.
- <sup>8</sup> Maximum departure from the theoretical when reproducing saturated primary colors and their complements at 75% amplitude.
- <sup>9</sup> Maximum phase difference with respect to burst, measured after the VSBF, for any brightness level between 75% and 15% of the sync peak using 10% (peak-to-peak) subcarrier modulation and modulation depth of 10%.
- <sup>10</sup> Maximum variation in the amplitude of a 3.58 MHz sine wave modulating signal as the brightness level is varied between 75% and 15% of sync peak. The gain shall be adjusted for 10% (peak-to-peak) modulation of the 3.58 MHz signal when the brightness is at pedestal level. This is equivalent to 5% (peak-to-peak) modulation as indicated by a conventional diode demodulator connected after the VSBF.
- <sup>11</sup> Maximum departure from standard curve using TTS-1A. The tolerances vary linearly between 2.1 and 3.58 MHz and between 3.58 and 4.18 MHz.
- <sup>12</sup> Ratio of any single harmonic or spurious frequency to peak visual power.

## Ordering Information

The TT-35FH TV Transmitter, 35-kW visual, 7.75-kW aural with tubes, solid-state color correction filters, including low pass filter, harmonic filters, vestigial sideband filter and motorized coaxial switches complete. For 208/240-volt, 3-phase, 50/60-Hz input ..... ES-560674



- Antenna systems for special coverage needs
- Common-site antenna projects
- Special structures for multiple systems
- Project coordination—prime contracting
- Backed by largest amount of experience

## RCA Custom VHF Antenna Systems

### Description

RCA Custom VHF Antenna Systems generally are of two classifications: Systems that solve unusual coverage or allocation requirements and those especially designed for installation on a multi-antenna structure capable of supporting several individual TV (and FM) antennas all serving a single market. The *Candelabra*\* tower is such a structure.

#### Four Antenna Types

The RCA antenna line includes the *Superturnstile*, *Traveling-Wave*, *Zee-Panel* and *Butterfly* antenna designs. Special versions of these four basic products

\**Candelabra* is the registered trademark of Dresser-Ideco Co.

satisfy virtually any antenna requirement. The versatility of these four types as custom antennas is contained in the material following.

#### Common-Site Antenna Projects

RCA's experience in the design, construction and installation of multiple-antenna projects dates back to 1951 when the antennas of five New York TV stations first shared the Empire State Building. Since that time, RCA has supplied antennas for eight *Candelabra*\* towers, expanded the Empire State Building antenna complex, installed the new John Hancock twin-tower facility in Chicago and erected tens of stacked-antenna tower arrays.

#### Superturnstile Antennas

The RCA Superturnstile is a highly refined antenna for all VHF channels. The Superturnstile lends itself installation on a *Candelabra*\* platform or as the top-most antenna in a "stack". Equipped with a reinforced pole, the Superturnstile antenna serves as a supporting antenna in a stacked arrangement.

Where weather conditions require, the Superturnstile's "batwings" are de-iced electrically with resistive heaters inside the batwing "spine". The heat keeps the space between the pole and spine ice-free for stable performance.

The Superturnstile design lends itself





RCA engineered, planned, tested, built and installed the antennas on the John Hancock Center (left). Above is the antenna on RCA's Gibbsboro Antenna Center. At right is the antenna on the Empire State Building tower in New York City.

to antenna diplexing where a single antenna serves two stations simultaneously. WHEC and WROC (Rochester, N. Y.) were first to use a single Superturnstile Antenna in common during 1963. There are several subsequent diplexed projects now on-the-air. The Superturnstile Antenna in its "standard" form is described in detail in Catalog Sheet B.4104 which is available from any RCA Broadcast Field Office.

### Traveling-Wave Antennas

Ideally suited to multiple-antenna applications where several antennas mount on a *Candelabra\** platform, the Traveling-Wave Antenna's relatively small cross section reflects little energy to interfere

with the radiation of adjacent antennas. TW antennas also lend themselves well to vertically stacked arrangements either as topmost or a supporting member.

For duty in icing locations, the TW antenna is fitted with a protective radome which keeps ice from altering antenna performance.

Traveling-Wave Antennas are available for the highband channels (7-13).

For general information regarding the TW antenna please consult Catalog Sheet B.4108. The basic antenna is described in detail.

### Zee-Panel Antennas

The Zee-Panel is a panel-type antenna

for highband VHF channels and is for face-mount on a tower.

Each Zee-Panel Antenna uses zig-zag radiating elements branching from a central feedpoint. Insulators maintain spacing between the radiating element and the panel which serves as a reflector.

The radiating element uses exponentially tapered illumination with continuous compensation along the element. The small amount of energy reaching the end of the element is radiated by an end-loading element.

Four Zee-Panels in a square configuration comprise a single layer. The design of the Zee-Panel Antenna is quite flex-

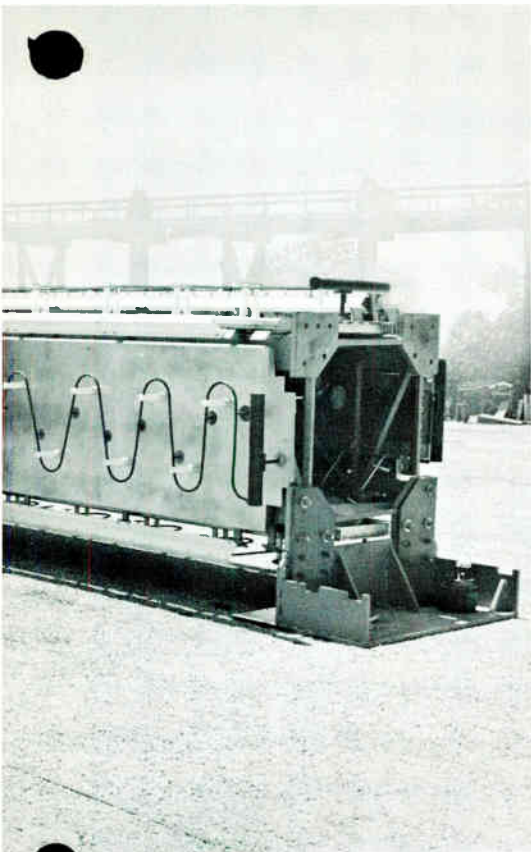

Installed the five-antenna system atop Chicago's WABC-TV Zee-Panel Antenna during construction. This is a close-up of the WABC-TV Zee-Panel Antenna in New York City.



ible and adapts to meet various requirements in horizontal pattern, power gain, null-fill values, etc. Mounted on a typical (30" on a side) tower section, the Zee-Panel Antenna delivers a horizontal circularity of better than  $\pm 2$  dB. The antenna is ordinarily totally enclosed in a cylindrical radome. However, where wind-load limitations exist, partial radomes, extending only over the feedpoints and adjacent areas, are used.

The end-loading elements on each panel are connected directly to the reflecting panel, hence the radiating element is at ground potential. This tends to make the antenna immune to lightning damage.

### Butterfly Panel Antennas

Butterfly Panel Antennas are a relatively new approach to VHF antenna design. They fill a need for a flexible panel antenna, either directional or omnidirectional, that serves singly or in stacked arrays.

The basic unit of the antenna consists of a pair of batwings mounted in "backward" butterfly-wing fashion against a reflector. The "backward" mounting improves impedance match and directivity characteristics. Fig. 5 shows a portion of the WDBO (Orlando, Fla.) Butterfly Antenna mounted on all three sides of a triangular cross-section tower. The horizontal directivity is controlled through

power distribution among the elements on each tower face. The antenna is ordinarily fed with a single transmission line. On the other hand, the antenna may be split into two separate sections fed with individual transmission lines.

For the best omnidirectional circularity, the antenna should be mounted three-around with all faces fed in-phase. When quadrature feed is desired, a four-around panel arrangement can be used. The choice of three- or four-around for directional antenna is influenced by pattern requirements.

The panel is made in three basic sizes, one each for the 54-66 MHz, 66-88 MHz and 174-216 MHz bands. The Butterfly

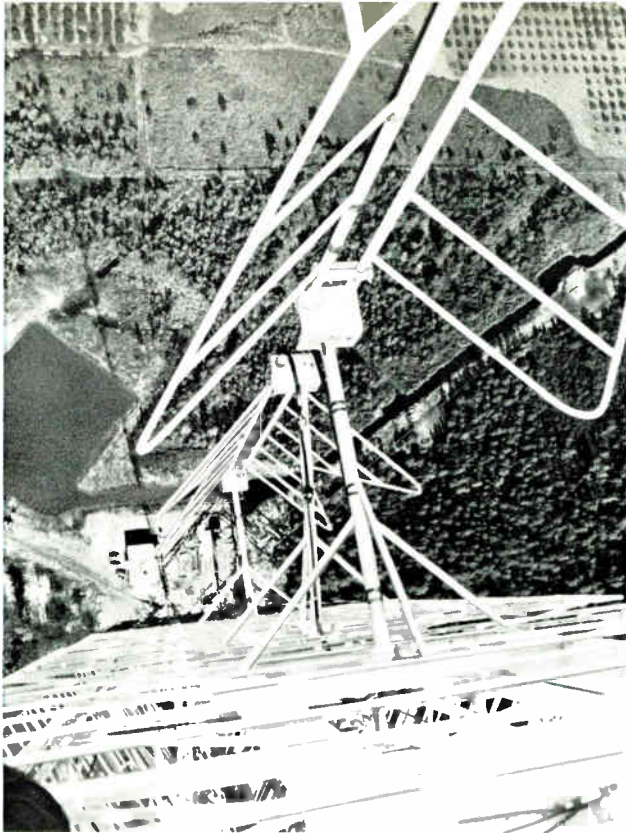
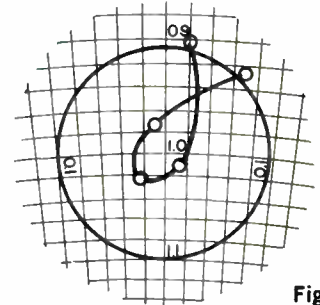
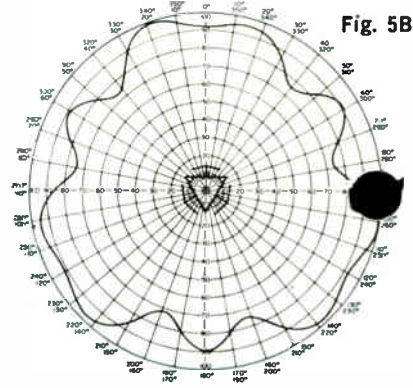
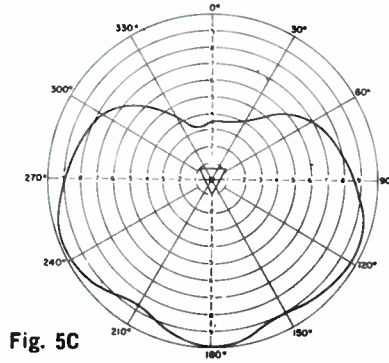
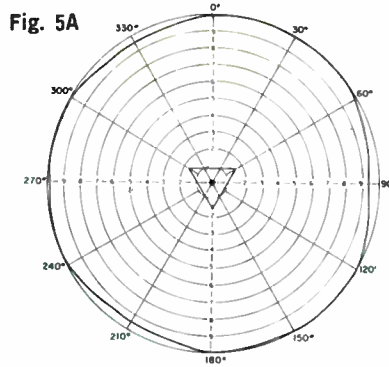

FIG. 5. Orlando's WDBO uses RCA Butterfly Antennas mounted on three sides of a triangular cross-section tower. The drawings at right illustrate various patterns possible with an RCA Butterfly Antenna. At lower right is a smith chart representation of impedance match.



Panel Antenna employs a feed system similar to the well known RCA Superturnstile Antenna. Styroflex feedlines  $\frac{3}{4}$ - or  $\frac{7}{8}$ -inch feed each panel out of a junction box feeding up to twelve individual panels or four antenna sections. Use of  $\frac{3}{4}$ -inch Styroflex results in a power handling capability of 5.25 kW per section and the  $\frac{7}{8}$ -inch size, 6.75 kW per section at channel 13.

### Excellent Pattern Circularity

Pattern and gain flexibility are outstanding features of this antenna. For example, in a stacked antenna array the basic panels mount on the faces of a triangular tower for excellent horizontal circularity at any of the VHF channels. Fig. 5A illustrates a pattern obtained by means of model measurements simulating a triangular tower 7' 6" on a side, operation on channel 4 resulting in a horizontal circularity of  $\pm 0.25$  dB. Highband

VHF performance on a 7' 6" tower face results in a horizontal circularity of better than  $\pm 2.0$  dB as illustrated by the model measurements shown by Fig. 5B. Reducing the tower-face dimension for high band VHF operation results in improved horizontal circularity.

### Pattern Shaping

Directional horizontal pattern shaping is achieved by controlling the power fed to the three faces of panels comprising the antenna. Fig. 5C shows a cardioid pattern with 10 dB of suppression achieved by this technique.

Vertical pattern shaping to introduce null-fill and beam tilting is achieved by either phasing, power division, or a combination of both, depending upon the customer's requirement.

Power gain is a function of aperture height and is closely related to the power

gain achieved by comparable Superturnstile antennas of a given number of sections, operating frequency and vertical-pattern characteristics.

### Natural Impedance Bandwidth

The impedance characteristics of the Butterfly Panel Antenna are excellent. The individual panels have a natural impedance bandwidth of 20 percent. When combined by means of the junction boxes developed for the Superturnstile antenna, this results in an antenna input VSWR more than adequate for TV requirements. See Fig. 5D for a typical smith chart plot of a single layer.

Deicing, where necessary, is accomplished by heating elements in the spine of each batwing element. Power requirements are relatively low, amounting to about three kW per layer for the mid-band panels.

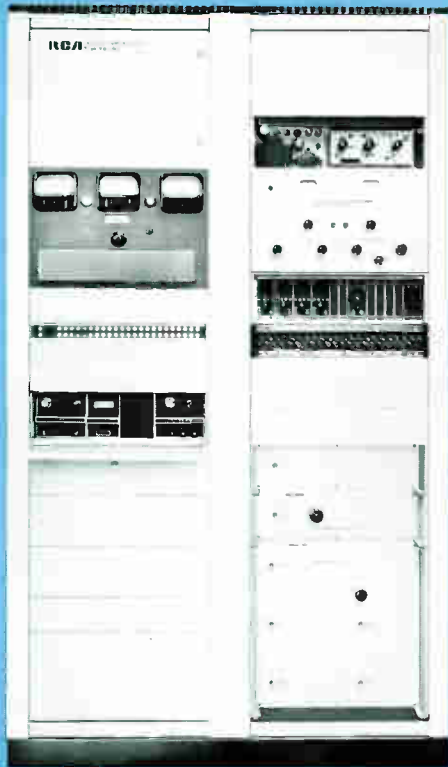

- Provides full monitoring and input control for any color or monochrome VHF or UHF transmitter
- Provides continuous check on transmitter performance
- Compact, lightweight cabinets—easily installed
- Rack components arranged with regard to operating convenience

## RCA Input and Monitoring Equipment

### Description

The RCA Type ES-19237-J/K Transmitter Input and Monitoring Equipment enables stations to meet all requirements of the FCC and good operating practice for monitoring and input control of any RCA television transmitter. The equipment items are contained in two standard mounting racks which are intended to be used in conjunction with an RCA TTC-5B Transmitter Console as a central monitoring and control center.

The units included in RCA Input and Monitoring Equipment (ES-19237-K for VHF Channels and ES-19237-J for UHF Channels) are enumerated in the accompanying specifications list. Units are arranged in the racks in the manner which makes them most effective and as compact as possible with due regard to con-

venience of operation, grouping of related units, and easy connections. The functions of each item can best be learned from a study of the block diagrams which show the interconnections of all units to a typical TV transmitter system.

### Monitoring Equipment

When RCA monitoring equipment racks are used with a TTC-5B console, they provide everything required for routine TV station monitoring. The functions monitored are:

- Visual Carrier Frequency,
- Aural Carrier Frequency,
- Aural Modulation. (This meter is on 335-ER and is repeated on the console),
- Visual Modulation (CRO on Console),

Aural Signals at all points where aural signals are available. Level of Transmitter input signal by VU meter; and sound quality by means of the monitoring amplifier and an external loudspeaker,

Visual Signals at all points where visual signals are available. Levels are measured by the CRO in the master monitor of the console and picture quality is observed on the kinescope.

### Rack Equipment

In addition to the monitoring functions listed, the racks provide:

- A. Limiting amplifier BA-43B/46A for the aural signal before application to the transmitter.

# Every Unit Chosen to Meet Most Exacting Requirements

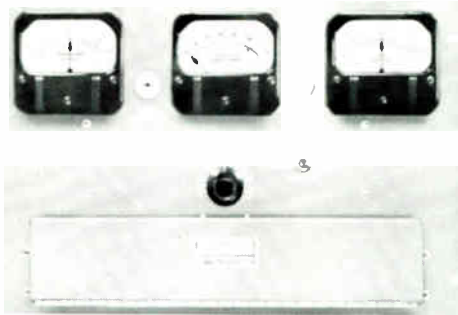

335-ER TV Frequency and Modulation Monitor



BW-5C1 Sideband Response Analyzer



TA-33 Video Distribution Amplifier



BA-44B Monitoring Amplifier

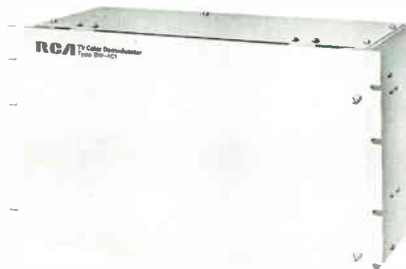

BW-4C1 Visual Sideband Demodulator

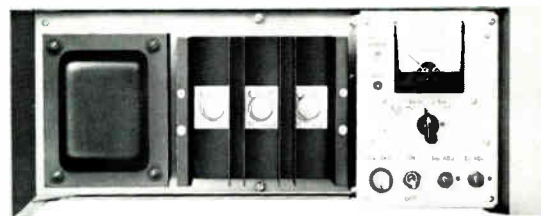

WP-16B Regulated Power Supply

- B. Stabilizing amplifier for visual signal to transmitter.
- C. Sideband response analyzer BW/BWU-5C1 which provides a special video sweep and a synchronized selective receiver for adjusting transmitter broadband response.

The output of the sideband analyzer is fed through a cable to an external oscilloscope of standard design which may be located anywhere in the transmitter room. The resultant pattern on the CRO is a plot in which the horizontal dimensions

are related to modulating frequency, and the vertical dimensions are proportional to the side-band response of the transmitter at each modulation frequency.

## Continuous Indication of Broadcast Frequency and Modulation

A compact Hewlett-Packard TV Monitor, Model 335-ER, performs every important carrier monitoring function continuously, without adjustment, and with dependability and accuracy. It is equally useful in monochrome or color broadcasting. In addition to continuous, precise indication of visual and aural

frequency deviation and percentage of aural modulation, the Model 335-ER shows inter-carrier separation directly. No calculation is required.

Carefully engineered crystal reference oscillators provide accuracy in excess of FCC requirements for all channels. Because discriminator accuracy does not depend on a tuned circuit, no time-consuming adjustments are required during operation. It is never necessary to reset carrier level or realign circuits. Proper operation of the monitor can be checked conveniently by controls located behind the hinged panel cover.

# Transmitter Input and Monitoring System

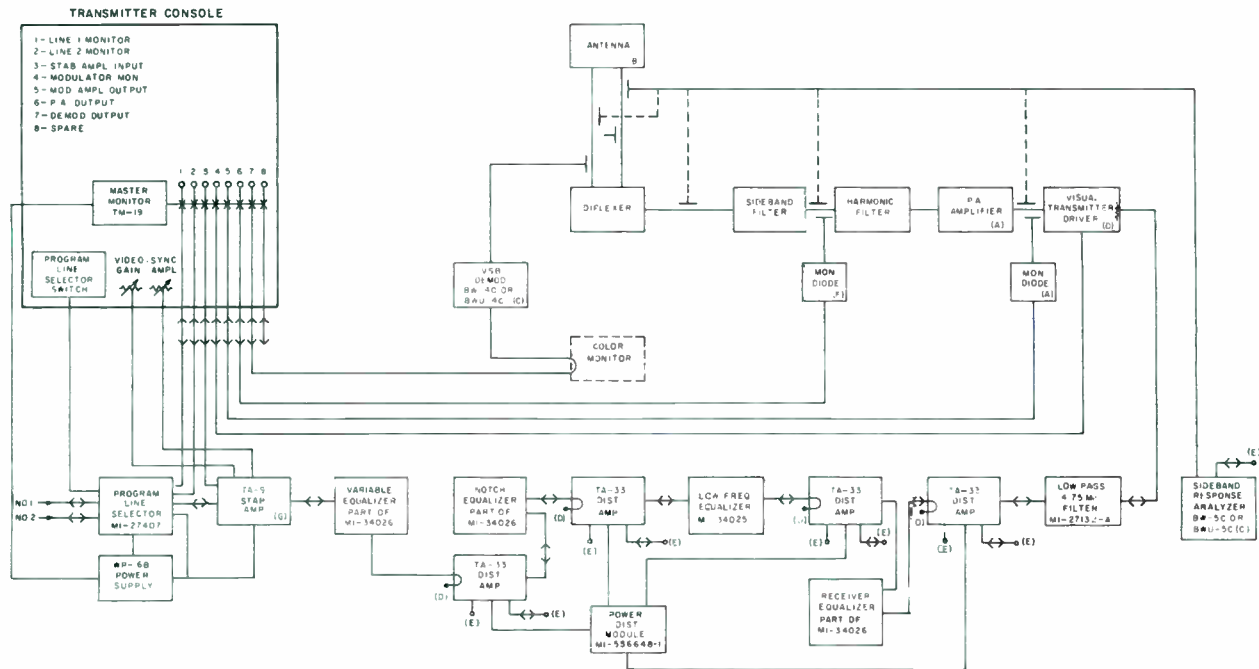

**NOTES**

- (A) ITEMS REQUIRED ONLY IF AMPLIFIER IS PRESENT
- (B) 1 BOTH ANTENNA LINES MUST BE EQUIPPED WITH MONITOR PICKUPS, ONE TO SERVE DAILY, THE OTHER AS CHECK POINT  
2 IF DEMODULATOR DOES NOT REJECT AURAL SIGNAL, ITS PICKUP POINT MUST PRECEDE THE DIPLEXER
- (C) USE DIRECTIONAL COUPLERS TO SUPPLY SIGNAL TO THE BW-4B AND BW-5A
- (D) PRECISION TERMINATIONS REQUIRED (75 Ω ± 1%)
- (E) TERMINATIONS REQUIRED (75 Ω ± 5%)
- (F) NOT USED WITH SOME TRANSMITTERS

Line drawing showing video input control and monitoring functions of ES-19237 Equipment.

## External Meters May Be Remotely Located

The three panel meters monitor visual and aural carrier frequency and percent modulation of the aural carrier with 100 percent modulation equal to 25 kHz deviation. A peak modulation indicator lamp is included as standard equipment; the instrument also has provision for remote indicating meters, remote peak modulation indicating lamp, and a demodulated signal for measuring FM and AM noise levels, frequency response and distortion of the aural transmitter and for continuous program monitoring.

## Crystal Controlled Oscillator

The master oscillator is controlled by a crystal operating in the 20-30 MHz region. The crystal is mounted in a carefully-designed oven that controls temperature to within approximately 0.10 degree C. Oven temperature is indicated by a thermometer readable at the front panel. The master oscillator is provided with a vernier tuning adjustment for correcting long time drift. A cathode-coupled type oscillator circuit has been incorporated because of the exceptionally small effect varying stray capacities have on the frequency of the crystal used in this arrange-

ment. As a further precaution, a constant-voltage transformer is provided to regulate the master-oscillator filaments.

## Easy to Operate and Maintain

The 335-ER is particularly designed for long years of trouble-free operation. Highest quality components and construction are used throughout. A new chassis design increases accessibility of components and makes possible cool operation. The chassis is mounted on slides for easy withdrawal from the rack. The instrument includes a front panel crystal temperature indicator and illuminated meter faces.

# Specifications

## Mechanical:

Unit	Overall Dimensions			
	Height	Width	Depth	Weight
BA-43A/46 Limiting Amplifier	4-21/32"	8 5/16"	11 3/8"	13 1/4 lbs.
BA-44B Monitoring Amplifier	4-31/32"	5"	13 3/8"	12 lbs.
BWU-4C1 Visual Demodulator	16"	19"	14"	43 lbs.
BW-4C1 Visual Demodulator	14"	19"	14"	41 lbs.
BW-5C1 VHF Sideband Response Analyzer	10 1/2"	19"	14 1/2"	58 lbs.
BWU-5C1 UHF Sideband Response Analyzer RF Input Unit	5 1/4"	19"	7 3/4"	14 lbs.
TA-19 Stabilizing Amplifier	5 1/4"	19"	15"	35 lbs.

Unit	Overall Dimensions			
	Height	Width	Depth	Weight
TA-33B Video Distribution Amplifier	5 1/4"	19"	14 3/4"	16 lbs.
High and Low Frequency Phase Correction Network	22 3/4"	19"	10"	33 lbs.
WP-16B Regulated Power Supply	7"	19"	13 1/2"	50 lbs.
335-ER Hewlett-Packard TV Monitoring	12 1/2"	19"	13"	67 lbs.
BR-77 Standard Cabinet Racks	77"	22"	24"	225 lbs.
Overall Equipment (Tandem Cabinets)	78"	50"	24"	550 lbs. (approx.)

## Ordering Information

Transmitter Input & Monitoring Equipment order as follows:

**For UHF Transmitter ES-19237-J**

**For VHF Transmitter ES-19237-K**

comprising the following equipment:

Qty.	MI Number	Description	Qty.
1	ES-36591-P77	BR-77P Cabinet Rack, 24", with Rear Door, Side Panels and Top Cover	1
1	ES-36591-S77	BR-77S Cabinet Rack, 24", with Rear Door, Side Panels and Top Cover	1
2	36546-A21	Electrical Shield	2
1	36546-A28	Electrical Shield	1
2	30566-A77	Single Trim Strip	2
1	30568-A77	Double Trim Strip	1
2	30526-A77	Pair of Panel Mounting Angles	2
3	4570-A2	Terminal Board Brackets	3
1	4569-A4	Audio Terminal Block	1
6	4568	Power Terminal Block	6
3	4652-D2	Audio Patch Cords, Tip, Ring and Sleeve	3
1	11666	BJ-20TRS Jack Panel, 20 Jacks	1
1	11454-B/ 11456-A	Limiting Amplifier, Type BA43B/46A	1
1	11442-A	BA-44B Monitoring Amplifier	1
1	11564	BR-23 Mounting Shelf for BA-43, 44 and 46, prewired and RF shielded	1
1	11592-2	Blank Panel for BR-23 Shelf	1
x	ES-34048-A	Visual Demodulator, Type BW-4C1	1
1	ES-34049-B	Visual Demodulator, Type BWU-4C1 Directional Coupler Required. Order Separately	x
1	335-ER	Hewlett-Packard TV Monitor, (specify frequency and offset)	1
1	ES-34034-B	High and Low Frequency Phase Equalizer	1
1	557300	Standard Video Module Frame	1
1	557301	Module Extender	1
4	ES-556933	TA-33 Video Distribution Amplifier	4

**For UHF Transmitter ES-19237-J**

**For VHF Transmitter ES-19237-K**

Qty.	MI Number	Description	Qty.
x	MI-34000-C1	BW-5C1 Sideband Response Analyzer with one set of tubes. Directional Coupler Required. Order Separately	1
1	ES-34009-C	BWU-5C1 Sideband Response Analyzer with one set of tubes. Directional Coupler Required. Order Separately	x
5	557302-4	Blank Modules for Video Frame	5
1	556582-8	Type 112 Self Normalizing Dual Video Jack Panel, less jacks	1
22	556582-1	Type 22T Dual, Normalled-through Jacks	22
6	556582-2	Type 57 Patch Cord	6
2	556582-3	Type 5B Test Probe (BNC Connector)	2
3	36547-2	3 1/2-inch Blank Panel	3
6	36547-3	5 1/4-inch Blank Panel	5
2	36547-5	8 3/4-inch Blank Panel	2
<b>Optional Equipment</b>			
1	556630	TA-19 Video Processing Amplifier including Remote Control Panel (if purchased, delete one (1) 5 1/4-inch Panel, MI-36547-3)	1
1	ES-597267-B	Sync and Blanking Adder for use with BW-/BWU-5C Sideband Response Analyzer. (Mounts in Video Frame with TA-33. If purchased, delete one (1) Blank Module for Video Frame, MI-557302-4)	1
1	27407	Program Line Selector, requires 24 Volt power source, but not included. (If purchased, delete one (1) 3 1/2-inch Blank Panel, MI-36547-2)	1
1	26084-B	Type WP-16B Power Supply (one 24-Volt Regulated Power Source required for Program Line Selector above)	1

UHF  
TRANSMITTING





# RCA 2 KW UHF TV Transmitter, Type TTU-2A

- Minimum investment
- Maximum performance
- Economical operation

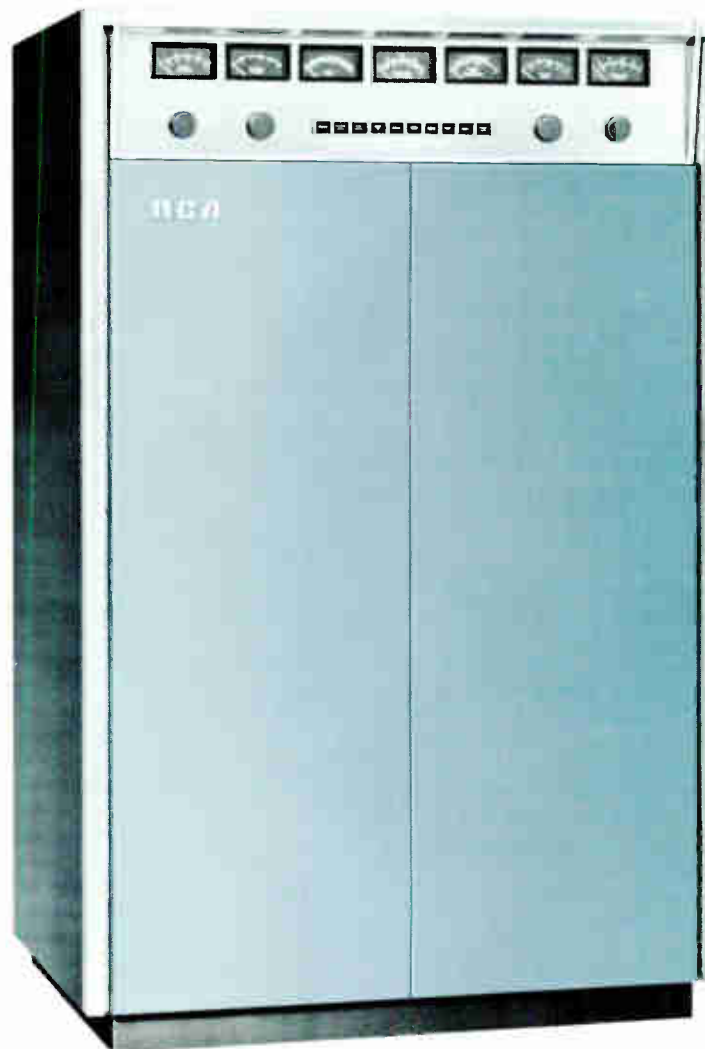

# Air Cooled 2-KW UHF Television Transmitter

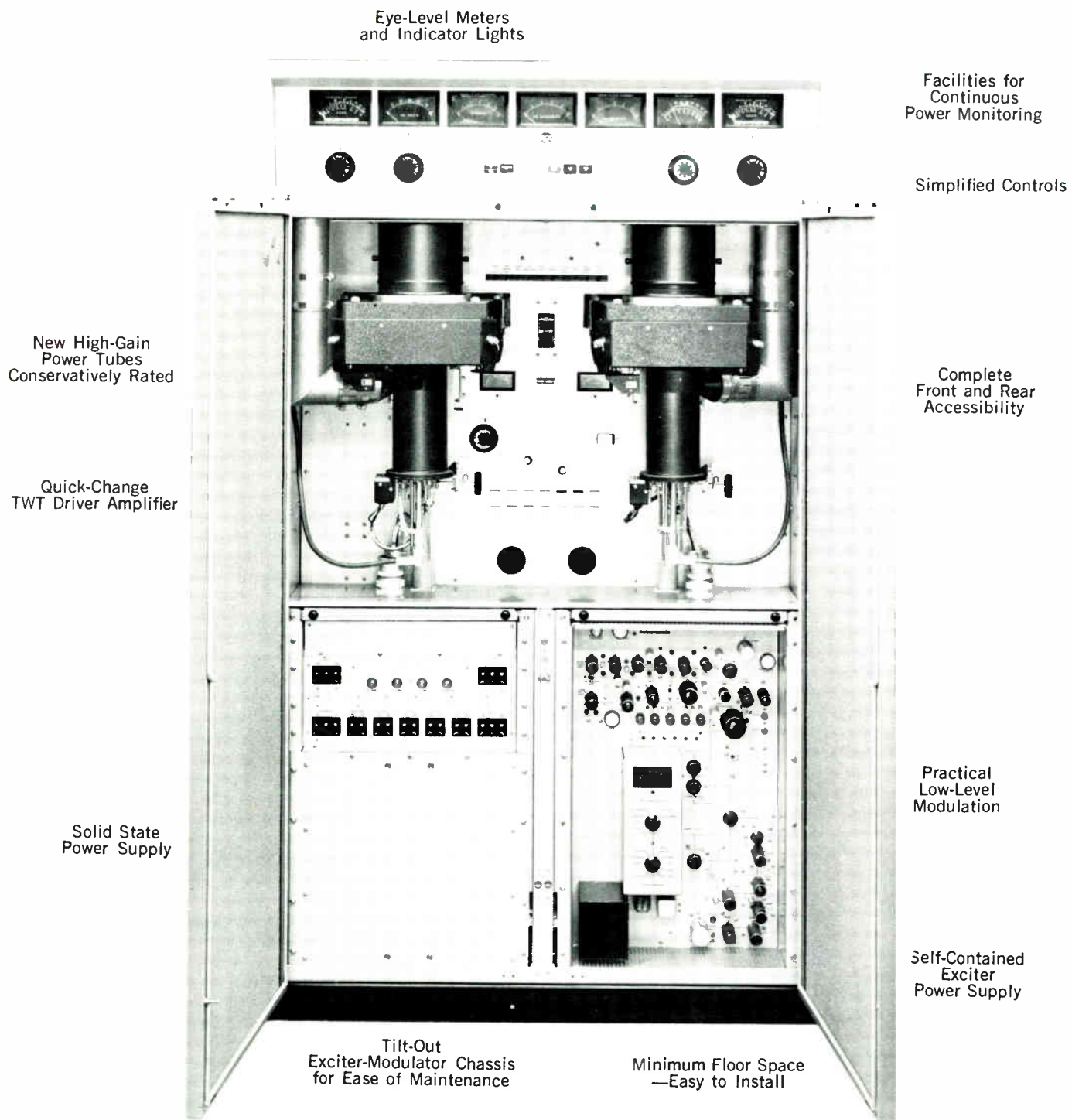

Eye-Level Meters  
and Indicator Lights

Facilities for  
Continuous  
Power Monitoring

Simplified Controls

New High-Gain  
Power Tubes  
Conservatively Rated

Complete  
Front and Rear  
Accessibility

Quick-Change  
TWT Driver Amplifier

Practical  
Low-Level  
Modulation

Solid State  
Power Supply

Self-Contained  
Exciter  
Power Supply

Tilt-Out  
Exciter-Modulator Chassis  
for Ease of Maintenance

Minimum Floor Space  
—Easy to Install

## 2-KW UHF Television Transmitter, Type TTU-2A

### Maximum Performance

The RCA TTU-2A UHF Television Transmitter is specifically designed to answer the needs of broadcasters for top performance, compact design and long-life. This all air-cooled equipment provides reliable and economical low-power operation for stations operating on any specified channel between 14 and 83. It has a rated output of 2 kW peak visual power when measured at the output of the filterplexer, and 0.225 to 2.8 kW aural power. Used with standard UHF antennas, the TTU-2A is capable of delivering up to 50-kW ERP.

### Minimum Investment

The Model TTU-2A provides a means to start broadcasting with a minimum investment in equipment and technical manpower. The transmitter serves as the basic driver section for the more powerful 10-kW UHF transmitter. Broadcasters can increase UHF power at a later date by adding a second cabinet containing additional PA stages and related power handling equipment. The transmitter can be ordered to meet any domestic or most international station's operating specifications. It is designed for remote control.

## Description

The TTU-2A is a completely new design utilizing the latest engineering design techniques to provide the best possible monochrome or color reliability for locally or remotely controlled station operation. Frequency stability of both aural and visual sections is exceptional and permits reliable offset carrier operation.

### Simplified Operation

The 2-kW UHF Transmitter is housed in the new low-profile 77-inch cabinet where the operator has complete fingertip control over operation of the transmitter. Built-in remote control circuitry, including metering points for remotely monitoring operating parameters, permits operation

at an auxiliary control console or other remote center. All normal operating controls are motor driven and may also be operated from a remote location.

### Low Operating Costs

The new TTU-2A design soon pays for itself in lower operating and maintenance

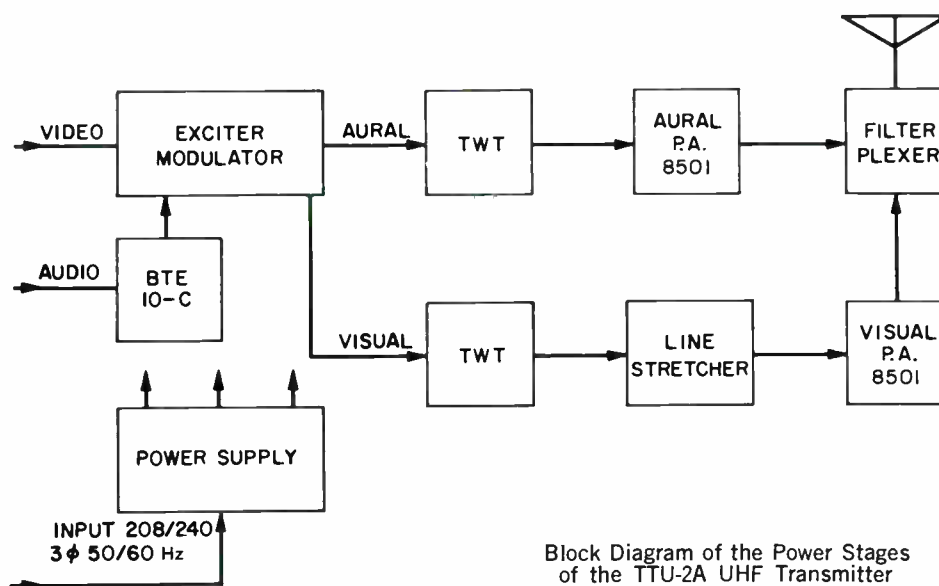

Block Diagram of the Power Stages of the TTU-2A UHF Transmitter

nance costs. In addition to its small physical size, minimum use of floor space, and ease of installation, the transmitter employs the latest proven innovations such as solid state rectifiers in the external power supply, fewer tubes, simplified controls, precision frequency control, and so on. It is the first commercial broadcast television transmitter to employ long life traveling wave tubes similar to those used in microwave transmission. This tube is in itself a complete high gain RF amplifier. It permits an amplification from 1 Watt to 250 Watts in a single stage. It requires no tuning controls.

### Complete Accessibility

The Transmitter is housed in a single cabinet which features double doors front and rear permitting maximum accessibility. An attractive powder blue and midnight blue finish provides a new look to RCA UHF studio and transmitter equipment. A separate unitized power supply houses the plate transformer and rectifier.

### Remote Unattended Operation

One-man operation of the transmitter or even remote unattended operation is possible with the TTU-2A. Simplified controls, indicator lights and necessary meters are located above the front door at convenient eye-level. Facilities are pro-

vided to permit continuous picture monitoring at various points in the system. Attractive illuminated controls include: transmitter on/air on, transmitter off, filament on, interlocks, plate ready, plate on, plate off, and overload/overload reset buttons. A matching operating console is available as optional equipment.

### Circuit Description

The TTU-2A transmitter is driven by a low power exciter containing both visual and aural chains. The separation of visual and aural carrier frequencies are accurately maintained. The RF chain is driven by a crystal controlled oscillator as a primary source of frequency control. Three doubler stages, a tripler stage and a doubler/tripler stage provide low power drive for the two 4055 mixers. The FM aural signal is derived from the new RCA BTE-10C exciter which operates with only half the number of tubes of the former exciter. There are no series or cascaded modulators to adjust for low frequency response. The 4055 mixer is a new ceramic pencil triode which has great mechanical rigidity and provides a modulated aural carrier output of one-half Watt.

A signal derived from the RF chain

after the second doubler is fed to an amplifier and its output together with the video input is fed to a mixer and modulated stage to derive a 1-Watt modulated visual carrier output. Aural and visual carrier outputs operate separately so if the aural carrier fails the transmitter still retains a picture signal. Tuning of the drive chain for the two mixers is simple and can be observed on a built-in multimeter. Long life tubes are used in the TTU-2A

### New Traveling Wave Tube

A unique feature of the transmitter is the grid modulation of the mixer which needs only low level video. Use of a traveling wave tube as the first RF amplifier makes possible the low power modulation. The TW tube provides an amplification from 1 Watt to 250 Watts in a single stage. It serves as a complete high gain RF amplifier, having a nominal power gain of 26 dB.

The use of traveling wave tubes in microwave transmission show that they have a long life history. They can operate at UHF frequencies without tuning devices. This greatly simplifies transmitter maintenance and reduces the cost of operation.

Aural/Visual Exciter/Modulator Block Diagram.

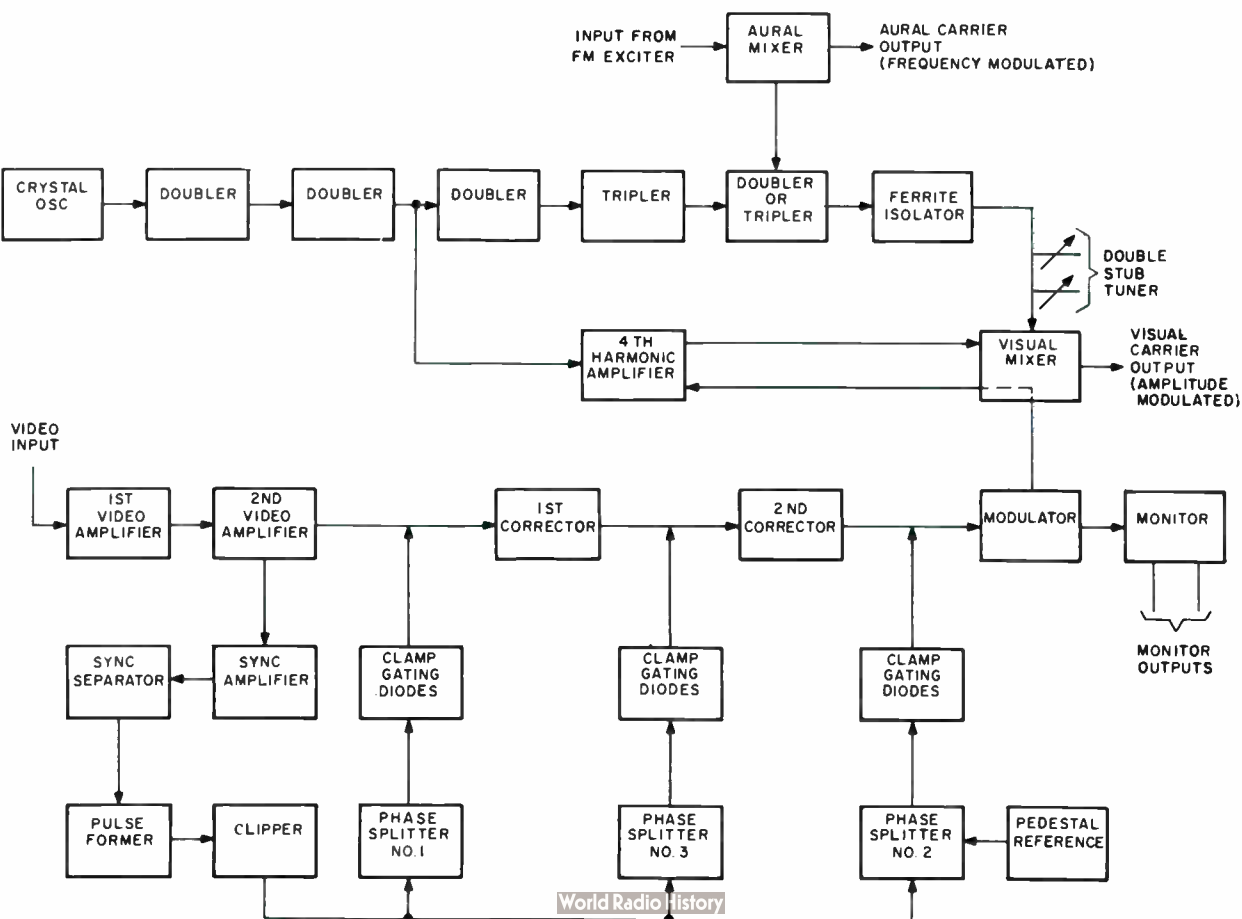

## Select Features



**EYE-LEVEL METERS AND CENTRALIZED CONTROLS**—White-on-black meter scales reduce eyestrain and improve log-keeping accuracy while illuminated control buttons quickly indicate operational status.

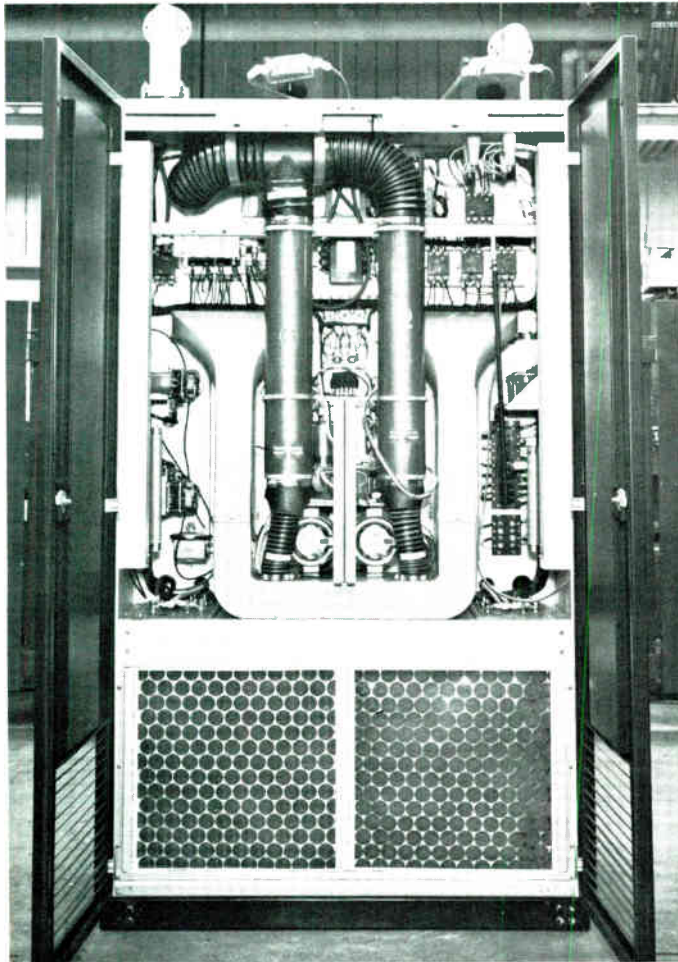

**ACCESSIBILITY UNLIMITED**—Strategic component locations add convenience and speed to maintenance.

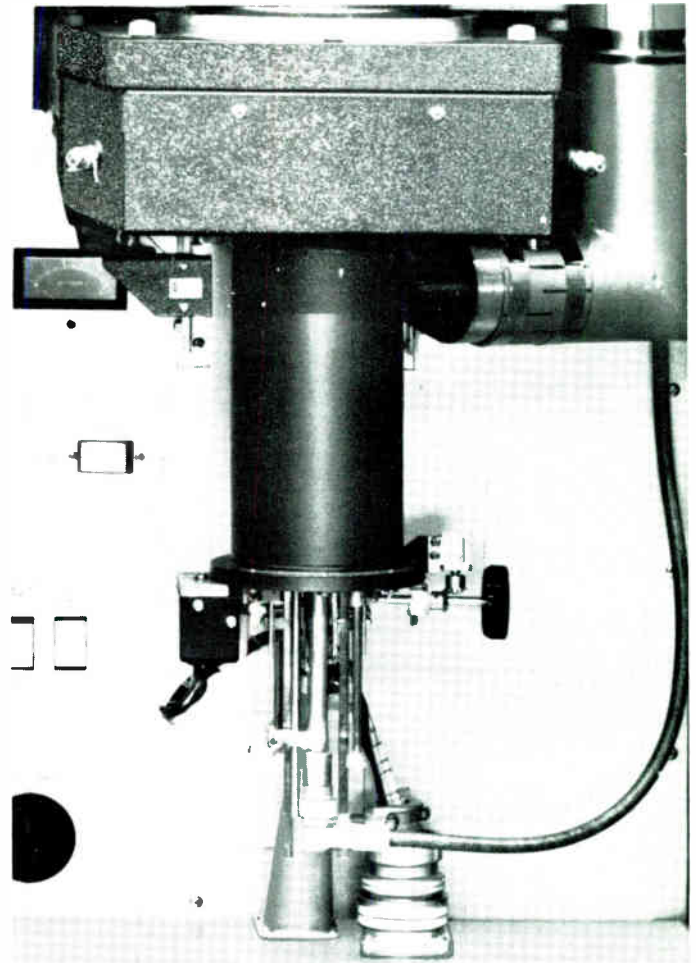

**AIR-COOLED POWER AMPLIFIER STAGES** use Type 8501 ceramic tetrodes operating well within ratings for long life.

## Direct FM Aural Exciter For Full Fidelity Sound

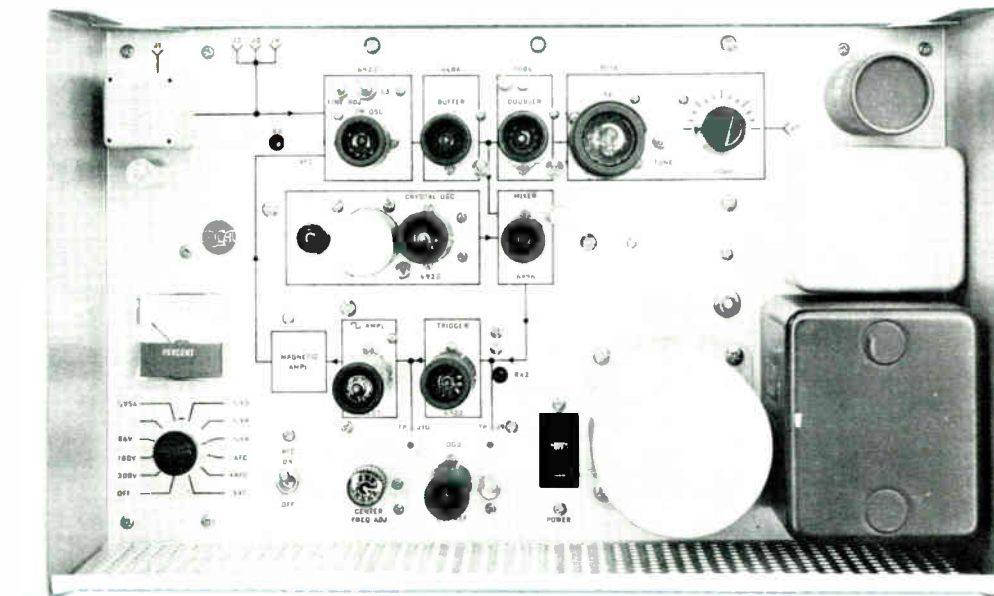

**DIRECT FM AURAL EXCITER** delivers full fidelity sound. A magnetic amplifier AFC system maintains close control of the aural carrier frequency.



**HIGH-GAIN TRAVELING WAVE TUBE** used in the driver amplifiers is a broadband device that requires no tuning at any channel frequency.

## Traveling Wave Tube Requires No Tuning

### Air-Cooled Power Amplifiers

A forced air-cooled 8501 Tube is employed as the final stage in both the aural and visual chain. This UHF power tetrode features a tungsten filament and co-axial construction. It is capable of delivering 5-kW synchronizing level power output in class "B" TV service and 5-kW in CW service up to 900 MHz. A blower is required for coolant. Prior to the visual PA a phase shifter or line stretcher serves in the video circuit as a phasing unit. Sliding contacts in a variable section of line provide a double tuned circuit effect on the input of the 8501 tube.

### Unitized Power Supply

A compact, unitized power supply furnishes power for the TTU-2A transmitter. The supply uses solid state rectifier modules. A safety disconnect switch located in the transmitter cabinet provides positive disconnect of all incoming power for personnel protection during maintenance. High current wiring is required in the power supply cabinet only. This power supply may be located either near the transmitter or in a separate and unheated area if space limitations so dictate.

### Remote Control

The TTU-2A is designed for remote control. Metering points for remotely monitoring operating parameters including aural and visual power output, aural and visual plate voltage, and aural and visual plate current are provided. Normal operating functions such as video gain, pedestal level, aural and visual excitation, and overload reset are motor driven and may be operated from a remote location. Reflectometers are provided for use in the output transmission lines of both the aural and visual amplifiers.

# Specifications

## Performance

	FCC Specs	CCIR SPECS <sup>1</sup>
Type of Emission:		
Visual .....	A5	A5
Aural .....	F3	F3
Frequency Range .....	470 to 890 MHz	470 to 890 MHz
Rated Power Output:		
Visual .....	2.0 kW <sup>2</sup>	1.8 kW <sup>2</sup>
Aural .....	0.225 kW to 2.8 kW <sup>3</sup>	0.2 kW to 2.8 kW <sup>3</sup>
RF Output		
Impedance .....	50 Ohms	50 Ohms
Input Impedance:		
Visual .....	75 Ohms	75 Ohms
Aural .....	150/600 Ohms	150/600 Ohms
Input Level:		
Visual .....	0.7 Volt	0.7 Volt
Aural .....	10 ±2 dBm for ±25 kHz deviation	16 ±2 dBm for ±50 kHz deviation
Amplitude vs. Frequency Response...	Uniform ±1 dB from 30 to 15,000 Hz	Uniform ±1 dB from 30 to 15,000 Hz
Upper Sideband Response at Carrier <sup>4</sup> :		
+0.5 MHz .....	+1, -1.5 dB	+0.5, -1.5 dB
+1.25 MHz .....	+1, -1.5 dB	—
+1.5 MHz .....	—	Reference
+2.0 MHz .....	+1, -1.5 dB	±1.0 dB
+3.0 MHz .....	+1, -1.5 dB	±1.0 dB
+3.58 MHz .....	+1, -1.5 dB	—
+4.18 MHz .....	+1, -3.0 dB	—
+4.43 MHz .....	—	+0.5, -1.5 dB
+4.75 MHz .....	-20 dB max.	—
+5.0 MHz .....	—	+1.0, -4.0 dB
+5.75 MHz .....	—	-20 dB max.
Lower Sideband Response at Carrier <sup>5</sup> :		
-0.5 MHz .....	+1, -1.5 dB	+0.5, -1.5 dB
-0.75 MHz .....	—	+0.5, -4.0 dB
-1.25 MHz .....	-20 dB max.	-20 dB max.
-3.58 MHz .....	-42 dB max.	—
Variation in Frequency Response with Brightness <sup>6</sup> ...	±1.5 dB	±1.5 dB
Carrier Frequency Stability <sup>7</sup> :		
Visual .....	±500 Hz	±500 Hz
Aural .....	±500 Hz	±500 Hz
Modulation Capability:		
Visual .....	12.5 ±2.5% (reference white)	12.5 ±2.5% (reference white)
Aural .....	±50 kHz	±50 kHz
Audio Frequency Distortion .....	1.0% max. 30 to 15,000 Hz	1.0% max. 30 to 15,000 Hz
FM Noise .....	58 dB below ±25 kHz deviation	64 dB below ±50 kHz deviation
AM Noise:		
Visual .....	48 dB r.m.s. below 100% modulation <sup>9</sup>	48 dB r.m.s. below 100% modulation <sup>9</sup>
Aural .....	50 dB below carrier	50 dB below carrier
Amplitude Variation Over One Video Frame .....	Less than 3% of the peak of sync level	Less than 3% of the peak of sync level
Regulation of Output .....	7%	7%
Burst vs. Sub-carrier Phase <sup>10</sup> .....	±6°	±6°

## FCC Specs

## CCIR SPECS<sup>1</sup>

Subcarrier Phase vs. Brightness <sup>11</sup> .....	±7° total less than 10°	±7° total less than 10°
Linearity (Differential Gain) <sup>12</sup> .....	1.5 dB max.	0.85 m/M
Subcarrier Amplitude <sup>13</sup> .....	±10% max.	±10% max.
Envelope Delay vs. Frequency <sup>14</sup> .....	±80 nsec. from 0.2 to 2.0 MHz ±40 nsec. from 0.2 to 3.58 MHz ±80 nsec. at 4.18 MHz	±80 nsec. from 0.2 to 2.0 MHz ±40 nsec. from 2.0 to 4.43 MHz ±80 nsec. from 4.43 MHz to upper sideband limit

## Electrical

### FCC Specs

### CCIR Specs

Transmitter Power		
Line Requirements	208/240 V, 3-phase 60 Hz	380/400/415 V, 3-phase 50 Hz
Slow Line Variations	±5% max.	±5% max.
Rapid Line Variations .....	±3% max.	±3% max.
Power Consumption:		
Black Picture (approx.) .....	25 kW	25 kW
Average Picture (approx.) .....	21 kW	21 kW
Power Factor (approx.) .....	90%	90%
Crystal Heaters:		
Line .....	115 V, 1-phase 50/60 Hz	115 V, 1-phase 50/60 Hz
Power Consumption	7½ Watts	7½ Watts

<sup>1</sup> Polarity of visual modulation—negative, asymmetric sideband.

<sup>2</sup> Measured at the output of the sideband filter or filterplexer.

<sup>3</sup> Aural power continuously adjustable from 0.225 kW to 2.8 kW measured at the input of filterplexer. Useable power depends on filterplexer.

<sup>4</sup> FCC Specifications—Measure with respect to the response at 200 kHz, as measured by the BWU-5B Sideband Response Analyzer at transmitter mid-characteristic. 4.75 Hz attenuation requires use of MI-27132-A LP filter in the video input circuit. CCIR Specifications—measure with respect to the response at 1.5 MHz.

<sup>5</sup> FCC Specifications—Measure with respect to the response at 200 kHz. CCIR Specifications—Measure with respect to response at 1.5 MHz.

<sup>6</sup> Maximum variation with respect to the response at mid-characteristic measured with the BWU-5B Sideband Response Analyzer at brightness levels of 22.5% and 67.5% of sync peak, using approximately 20% (peak to peak) modulation.

<sup>7</sup> Maximum variation for a period of 10 days without circuit adjustment over an ambient temperature range of +10°C to +45°C (meets FCC specifications over ambient range of -20°C to +45°C).

<sup>8</sup> With any modulating frequency 30 to 15,000 Hz with ±50 kHz deviation.

<sup>9</sup> RMS hum and noise level 50 Hz to 15 kHz. Extraneous modulation (unrelated to video modulation) above 15 kHz within the visual passband 40 dB below 100% modulation.

<sup>10</sup> Maximum departure from the theoretical when reproducing saturated primary colors and their complements at 75% amplitude.

<sup>11</sup> Maximum phase difference with respect to burst, measured after the VSBF, for any brightness level between 75% and 15% of the sync peak using 10% (peak to peak) modulation. This is equivalent to 5% (peak to peak) modulation as indicated by a conventional diode demodulator. In addition, the total differential phase between any two levels shall not exceed 10°.

<sup>12</sup> Maximum variation of amplitude of the sine wave modulation frequency when superimposed on stairstep or ramp modulation which is adjusted for excursion modulation depth of the sine wave to be 20% peak to peak of low frequency. CCIR Linearity is 0.85 at 0.2 MHz and 1.5 MHz with Brightness excursion 65 to 17%, and 0.85 at 4.43 MHz with Brightness excursion 75 to 17%.

<sup>13</sup> Maximum departure from the theoretical when reproducing saturated primary colors and their complements at 75% amplitude.

<sup>14</sup> FCC Specifications—Maximum departure from standard curve. The tolerances vary linearly between 2.1 and 3.58 MHz and between 3.58 MHz and 4.18 Hz. To meet the specification a properly terminated phase correction network, ES-34034-B is required in the video input circuit of the transmitter. CCIR Specifications—Maximum departure from standard curve. The tolerances vary linearly between 2.1 and 4.43 MHz and between 4.43 MHz and 5.0 MHz. To meet the specifications a properly terminated phase correction network is required in the video input circuit of the transmitter.



## Mechanical

	FCC Specs.	CCIR Specs. <sup>1</sup>
Dimensions Overall:		
Transmitter .....	48 1/4" wide, 33" deep, 77" high	1.22 m wide, .833 m deep, 1.96 m high
Power Supply .....	52" wide, 23" deep, 52" high (or 74" with Lid open)	1.32 m wide, .584 m deep, 1.32 m high (or 1.88 m with lid open)
Finish:		
Transmitter .....	Powder blue and midnight blue, aluminum trim	Shadow blue and midnight blue, aluminum trim
Maximum Altitude.....	7500 feet	2286 meters

	FCC Specs.	CCIR Specs. <sup>1</sup>
Ambient Temperature .....	-20° to +45°C	-20° to +45°C

## Accessories

Complete Set of Spare Tubes .....	ES-560238
Minimum Set of Spare Tubes .....	ES-560239
BWU-4C Demodulator .....	ES-34049-C
BWU-5C1 Sideband Response Analyzer .....	ES-34009-C1
BW-8A Envelope Delay Measuring Set (FCC Standards) .....	MI-34063
BW-8A Envelope Delay Measuring Set (CCIR Standards) .....	MI-34068

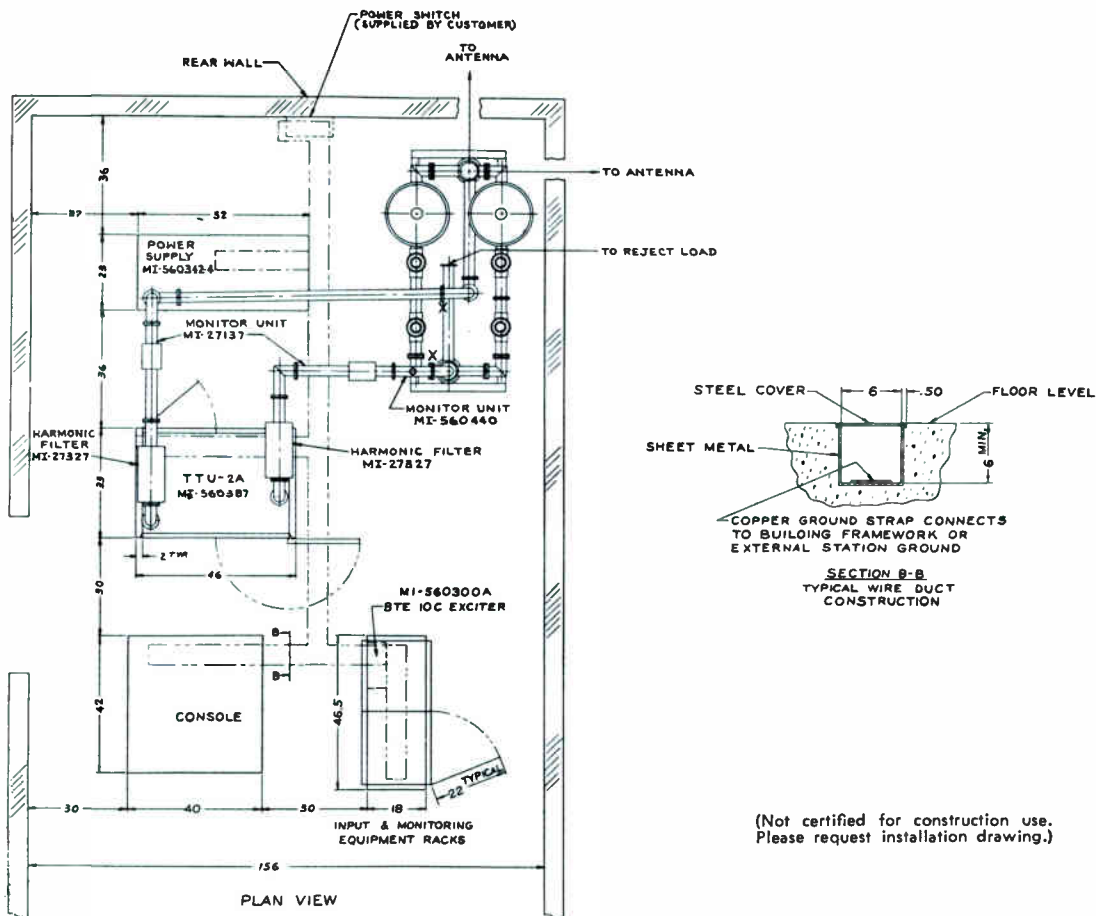

**SPACE SAVING FLOOR PLAN** makes efficient use of valuable floor area. The separate unitized power supplies may be located in the basement or other normally unused area.

## Ordering Information

TTU-2A 2 kW UHF Television Transmitter . . . Two basic models are available as follows:

For 208/240 Volt, 60 Hz input order ES-560237 which includes UHF TV Transmitter (2 kW visual, 0.225 to 2.8 kW aural) with tubes, filterplexer, low pass video filter, harmonic filters and set of crystals.

For 380/415 Volt, 50 Hz input order ES-560240 which includes UHF TV Transmitter (2 kW visual, 0.2 to 2.8 kW aural) with tubes. Output power and required filters to be determined in accordance with required operating standards.

# RCA 30 KW UHF TV Transmitter, Type TTU-30A

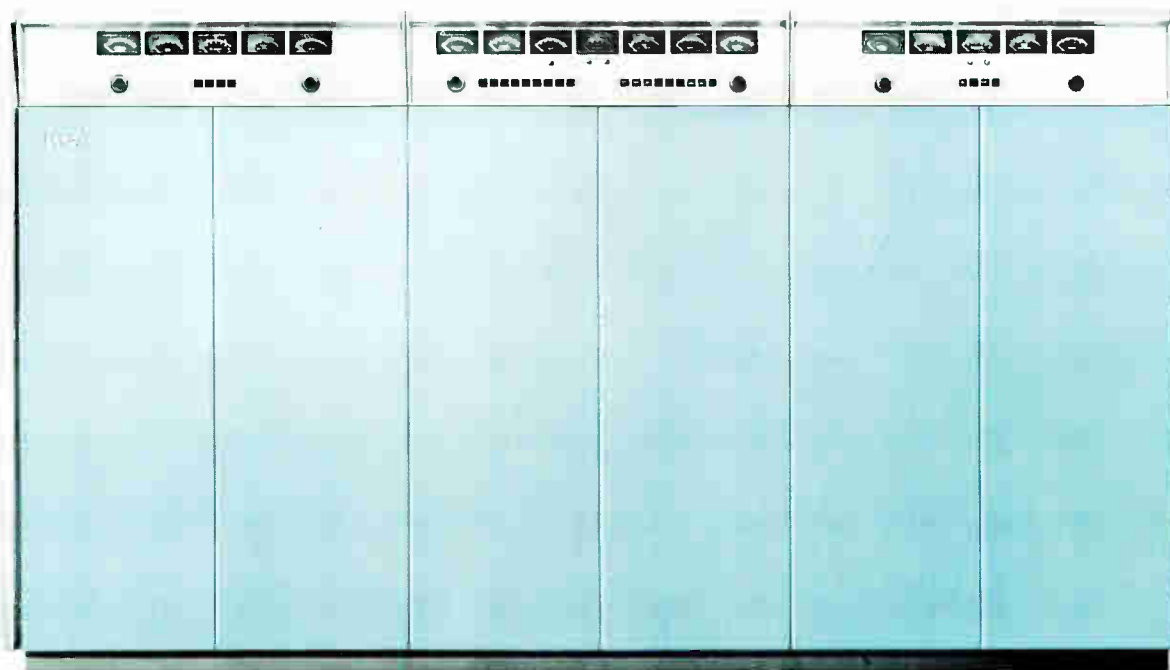

Simplified Control • Type-coded Klystrons • Quick tube-change

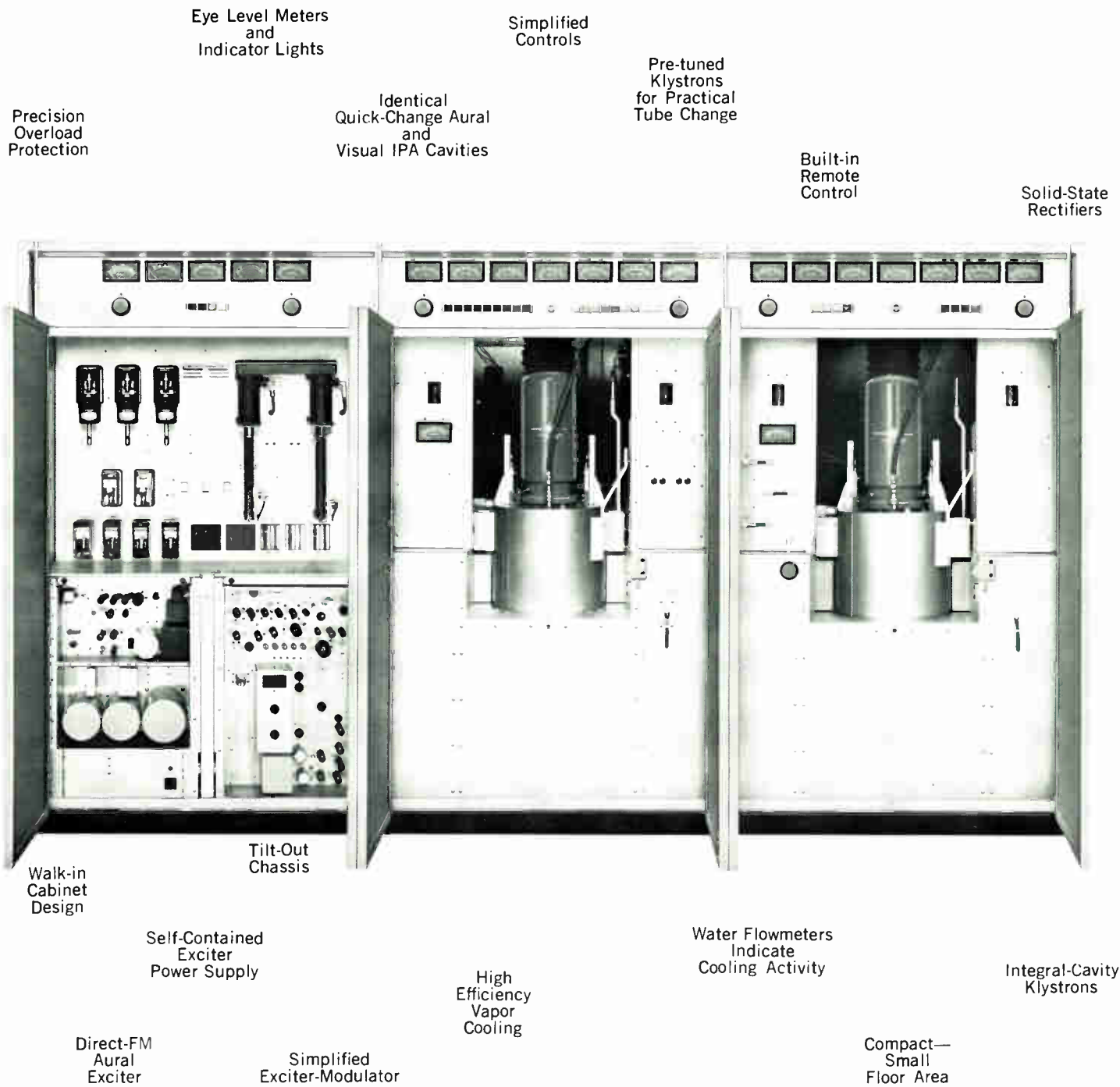

# 30 KW UHF Television Transmitter, Type TTU-30A

The RCA Type TTU-30A is a 30-kW transmitter designed for 1,000,000-Watt effective radiated power. This completely new high-power transmitter has a rated power output of 30-kW peak visual and 3.3 to 16-kW aural when used on 4.5 MHz separation standards (25 kW peak visual and 3.3 to 16-kW aural power for 5.0 and 5.5 MHz separation standards). The transmitter employs the same type of vapor-cooled klystrons used in the TTU-60A and can be modified to a TTU-60A in the field.

The TTU-30A is designed for remote control. Metering points are provided for monitoring operating parameters and many func-

tions are motor driven and therefore can be operated remotely.

The transmitter is designed to meet FCC or CCIR recommendations. For 460-Volt, 60 Hz input, the ES-560250 model should be specified. For 380/415-Volt 50 Hz input, order ES-560253.

The TTU-30A UHF Television Transmitter represents RCA's newest offering for broadcasters. Included are features such as the integral-cavity vapor-cooled klystron, low-profile styling, solid-state circuitry and built-in provisions for remote control. The increased efficiency of the new klystron offers considerable savings in operating costs.

## Description

The TTU-30A Transmitter represents a major advance in UHF technology. Incorporating all the benefits of reliable solid state devices, of new broad-band amplifier tubes with much higher gain and greater power capability, the video modulation at fractional Watt levels, the transmitter achieves simplicity and small size, yet packs more power per cubic foot than any predecessor.

### Economical Power

The transmitter is economical and easy to operate. Though the physical space re-

quired is small, effective planning of component placement for maximum accessibility makes the transmitter easy to maintain. Both small physical size and ease of maintenance result in direct savings in installation and operating costs. Every effort has been made in the TTU-30A to incorporate mechanical and electrical features to allow one-man operation of this high power transmitter, either locally or from a remote point.

The TTU-30A is housed in three new low profile 77-inch cabinets with eye-level meters and convenient finger-tip controls.

Built-in remote control circuitry, including metering points for remotely monitoring operating parameters, permits operation at an auxiliary control console or remote point. All normal operating controls are motor-driven and may also be operated from a remote location.

### Circuit Description

Ease of installation, operation and maintenance is enhanced by use of modern, reliable circuitry. Video and audio modulation takes place at a low level, thus eliminating the need for a high power

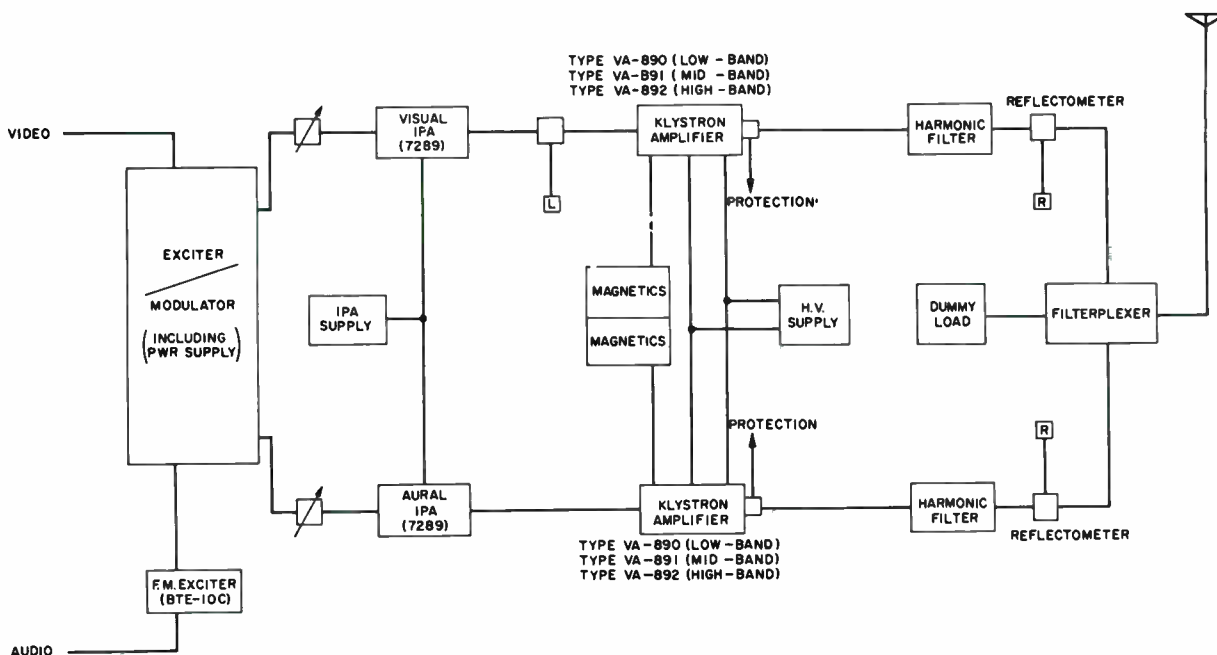

Block Diagram of TTU-30A UHF Television Transmitter.

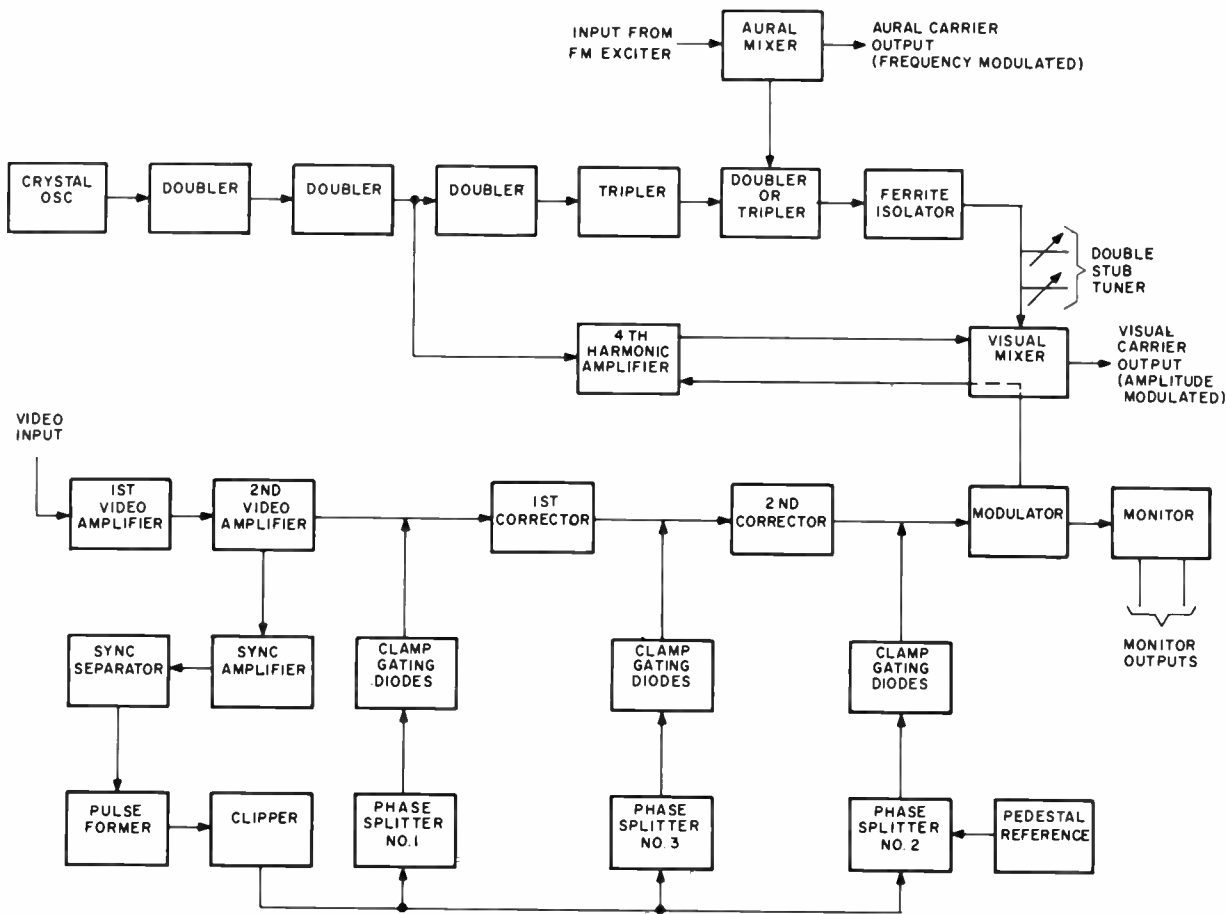

Aural/Visual Exciter/Modulator Block Diagram.

modulator. Use of high gain klystron tubes makes it possible to effect a high amplification in a single, pre-tuned RF stage.

### Direct-FM Exciter

The modern circuitry used in the TTU-30A transmitter utilizes the standard BTE-10C FM exciter to develop a stable, high quality, direct frequency modulated aural signal. The newly designed FM exciter uses a total of nine tubes—half as many as used in the previous model. Only four tubes are required to maintain an FM output signal, one indication of the reliability built into the entire TTU-30A transmitter.

The design retains RCA's "Direct-FM" modulation with particular emphasis being placed on ease of adjustment and reliable operation. All RF stages use single-tuned circuits. A built-in meter, and easily accessible test points allow metering and checking during operation. An AFC on-off toggle switch and simplified controls including the power on-off switch are all

easily accessible on the chassis of the exciter.

A self-contained silicon power supply is used. Premium tubes, carrying a 10,000 hour guarantee, have been used for reliability and long life. The BTE-10C lends itself particularly well to unattended and remote operation.

### Simplified Exciter Modulator

The exciter/modulator develops a highly stable, crystal-controlled frequency which is heterodyned with both the modulated video and aural signals, resulting in aural and visual output carriers separated by 4.5 MHz (5.0 and 5.5 MHz for CCIR recommendations). The aural signal is then fed through a variable motor-driven attenuator to an RF amplifier using a single type 7289 tube. The output of this stage drives the aural klystron.

Visual modulation takes place at the grid of a pencil triode, type 4055. All RF stages preceding this are operated Class "C" and are simply tuned by meter indi-

cations for maximum output. The output of the mixer stage is a double-tuned cavity, the correct tuning of which can be observed by monitoring the output of a built-in diode demodulator. The video modulated output of this stage, a nominal 2 Watts peak, is fed through a variable attenuator, then amplified in the following cavity tuned amplifier using a single type 7289 tube. The variable attenuator is motor-driven and, in addition to providing a good load impedance on the modulated stage, serves as the visual excitation control.

### Exciter Plus Only Two RF Stages

Following the exciter there are two identical RF stages in each channel consisting of a cavity tuned 7289 tetrode IPA and the klystron power amplifier. These tubes and cavities are identical and therefore interchangeable between the aural and visual channels.

## Select Features

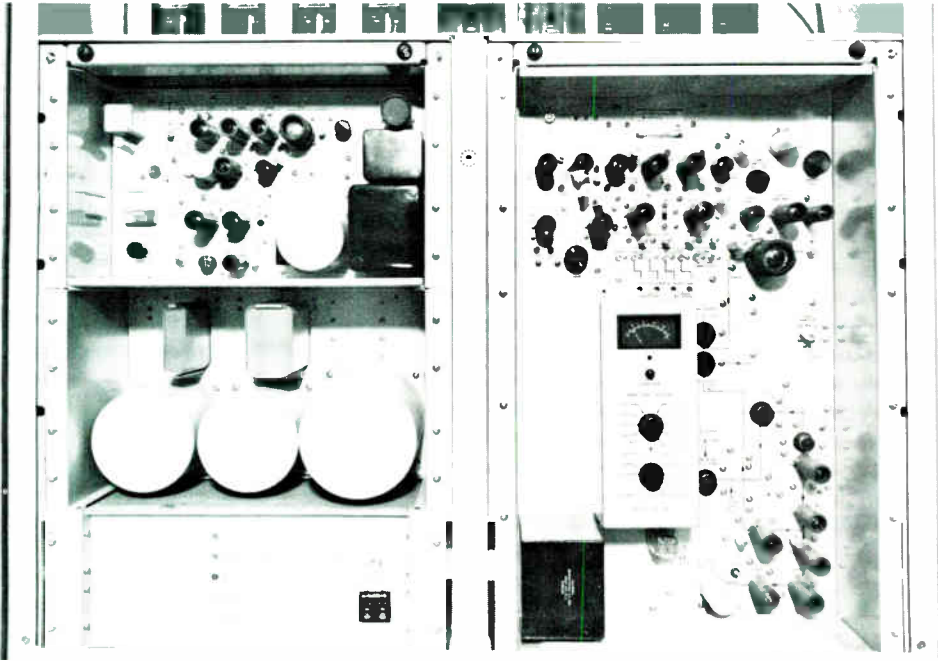

Reliable exciter/modulator employs 10,000 hour premium tubes.

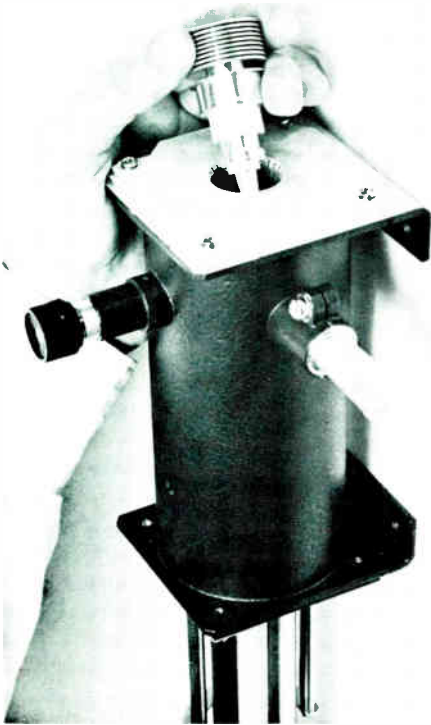

**CERAMIC-TETRODE DRIVER AMPLIFIERS** couple exciter/modulator output to the klystrons. The drivers are identical for aural and visual portions thus allowing interchangeability.

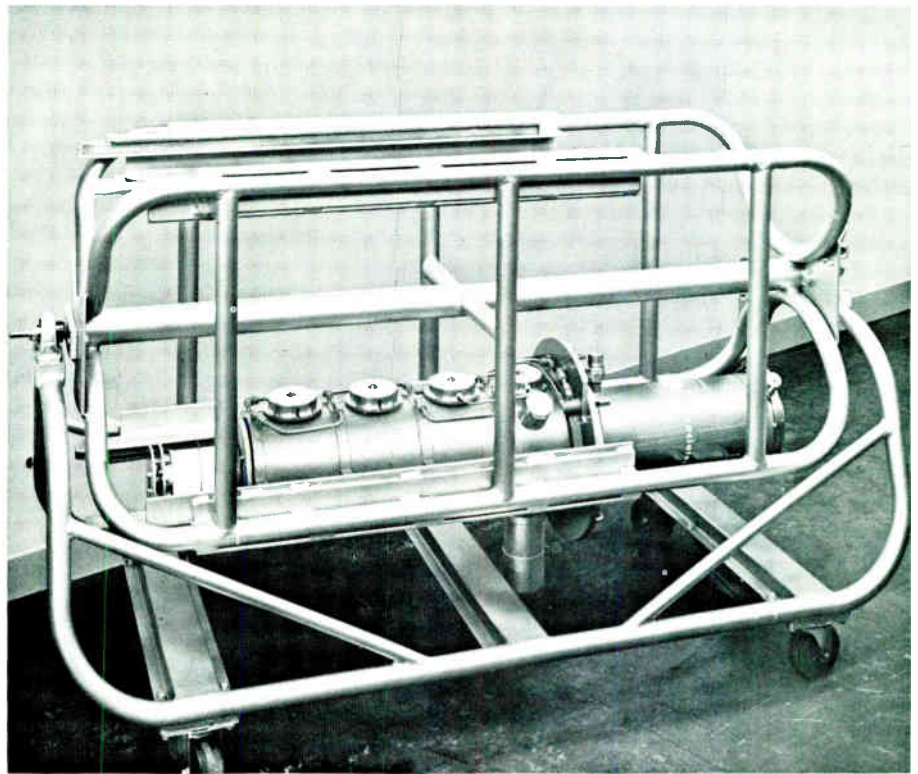

**INTEGRAL-CAVITY KLYSTRONS** are pretuned for operating frequency at factory and quick-change is provided by this "klystron carriage".

# Pretuned Klystron Amplifiers

## Easy Tube Change

The high power klystrons may be easily installed by one operator. The factory-tuned klystron is transferred in a horizontal position directly from the shipping carriage. By an ingenious built-in loading device the klystron can then be easily installed in the transmitter from the klystron carriage. No unusual ceiling height is required as the klystron remains in a horizontal position until it has been completely installed in the transmitter. It is then tilted into a vertical position by a device which is an integral part of the transmitter. Further, factory pre-tuning eliminates the station-site preparation required by external-cavity designs.

The TTU-30A Transmitter may be installed in virtually any room of appropriate width and length. The typical floor plan shows a practical set-up.

## Klystron Power Amplifier

The aural and visual amplifiers each use a vapor-cooled integral cavity klystron of the Varian type VA-890 series. The TTU-30A is the first UHF TV-broadcast transmitter to use vapor cooling. The increased efficiency of a vapor system for cooling over one of either air or water results in a considerable saving in operating costs. The vapor-cooled TTU-30A requires a power input of 10kW less than would be required for the same transmitter if it were water-cooled. Use of integral cavities means that the klystron, when received is tuned for operation on the intended channel. Tedious assembly or pre-tuning is not needed at transmitter site.

## Long-Life Power Supplies

Solid state rectifiers are used throughout. These and other power supply components are located on vertical panels which form the transmitter enclosure, as indicated in the floor plan. Experience has shown that components mounted in this manner are easily accessible for maintenance and are effectively cooled, resulting in long life.

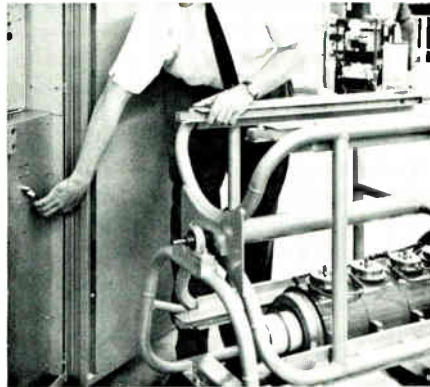

Open Water Drain

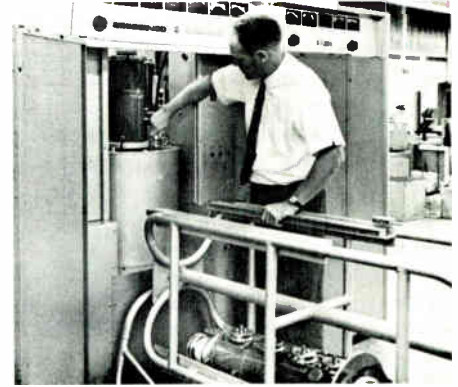

Disconnect Inlet

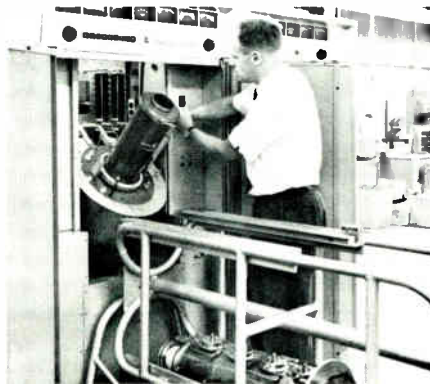

Tilt Klystron

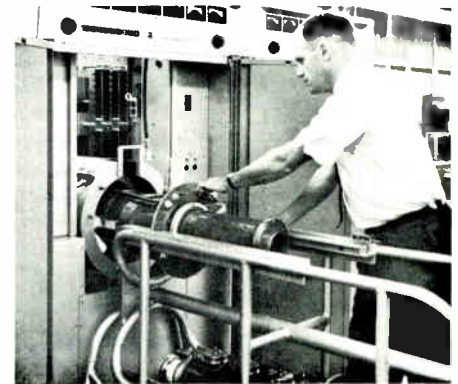

Roll Klystron Out

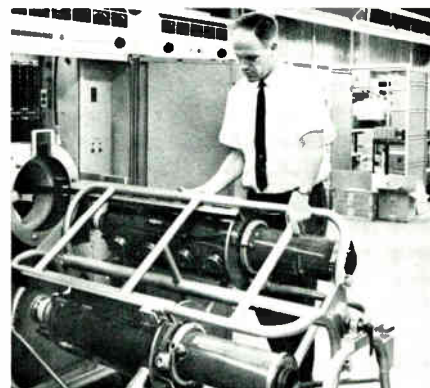

Tumble Carriage

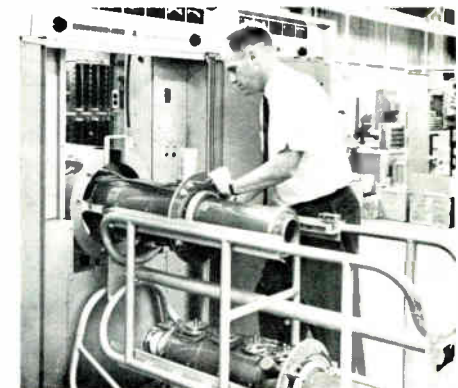

Roll Klystron In

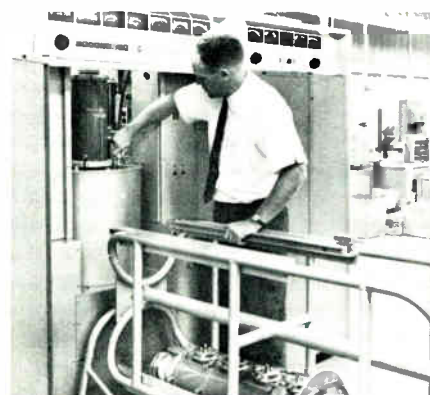

Reconnect Water

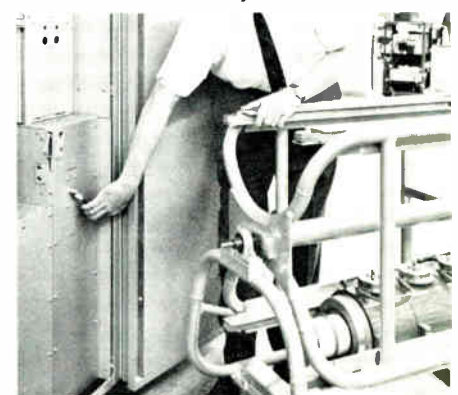

Close Water Drain

# Specifications

## Performance

	FCC Specs.	CCIR Specs. <sup>1</sup>
Type of Emission:		
Visual .....	A5	A5
Aural .....	F3	F3
Frequency Range.....	470-890 MHz (Ch. 14-83)	470-960 MHz
Rated Power Output:		
Visual <sup>2</sup> .....	30 kW	25 kW
Aural <sup>3</sup> .....	3.3 to 17 kW	3.3-16 kW
RF Output Impedance <sup>4</sup> .....	50 Ohms	50 Ohms
Input Impedance:		
Visual .....	75 Ohms	75 Ohms
Aural .....	500/150 Ohms	600/150 Ohms
Input Level:		
Visual .....	0.7 Volt peak-to-peak min.	0.7 Volt peak-to-peak min.
Aural .....	+10 ±2 dBm for ±25 kHz deviation	+16 ±2 dBm for 50 kHz deviation
Amplitude vs. Frequency Response....	Uniform ±1 dB from 50 to 15 kHz	—
Upper Sideband Response at Carrier: <sup>5</sup>		
	<b>FCC</b>	<b>CCIR</b>
		<b>5.0 MHz</b> <b>5.5 MHz</b>
+0.5 MHz	+1, -1.5 dB	+0.5, -1.5 dB
+1.25 MHz	+1, -1.5 dB	—
+1.5 MHz	+1, -1.5 dB	—
+2.0 MHz	+1, -1.5 dB	Reference
+3.0 MHz	+1, -1.5 dB	—
+3.58 MHz	+1, -1.5 dB	+1, -1.0 dB
+4.18 MHz	+1, -3.0 dB	—
+4.43 MHz	—	+0.5, -1.5 dB
+4.75 MHz	-20 dB max.	—
+5.0 MHz	—	+1.0, -4.0 dB
+5.5 MHz	—	+0.5, -1.5 dB
+5.75 MHz	—	+1.0, -4.0 dB
+6.25 MHz	—	-20 dB max.
Lower Sideband Response at Carrier: <sup>6</sup>		
-0.5 MHz	+1, -1.5 dB	+0.5, -1.5 dB
-0.75 MHz	—	+0.5, -4.0 dB
-1.0 MHz	—	—
-1.25 MHz	-20 dB max.	-20 dB max.
-2.25 MHz	—	+0.5, -4.0 dB
-3.58 MHz	-42 dB max.	-20 dB max.
Variation in Frequency Response with Brightness <sup>7</sup> ....	±1.5 dB	±1.0 dB
Carrier Frequency Stability: <sup>8</sup>		
Visual .....	±1 kHz	±500 Hz
Aural .....	±500 Hz <sup>9</sup>	±200 Hz <sup>9</sup>
Modulation Capability:		
Visual .....	12.5 ±2.5% (reference white)	12.5 ±2.5% (reference white)
Aural .....	±50 kHz	±100 kHz
Audio Frequency Distortion .....	1% max. 30 Hz-15 kHz	1% max. 30 Hz-15 kHz
FM Noise .....	58 dB below ±25 kHz deviation	64 dB below ±50 kHz deviation
AM Noise, Visual:.....	48 dB r.m.s. below 100% mod.	48 dB r.m.s. below 100% mod.
Aural .....	50 dB below carrier	50 dB below carrier

## FCC Specs.

## CCIR Specs.<sup>1</sup>

Amplitude Variation over One Picture		
Frame .....	Less than 3% of the peak of sync level	Less than 3% of the peak of sync level
Regulation of Output Burst vs. Subcarrier	7% max., 2% actual	7% max., 2% actual
Phase <sup>10</sup> .....	±6° max.	±6°
Subcarrier Phase vs. Brightness <sup>11</sup> ....	±7° max.	±7°, total less than 10°
Subcarrier Amplitude <sup>9</sup> .....	±10% max.	±10% max.
Linearity (Differential Gain) <sup>12</sup> .....	1.5 dB max.	0.85 m/M
Envelope Delay vs. Frequency <sup>13</sup> .....	±80 ns from 0.2 to 2.0 MHz ±40 ns at 3:58 MHz ±80 ns at 4:18 MHz	±80 ns 0.2 to 2.0 MHz ±40 ns 2.0 to 4.43 MHz ±80 ns 4.43 MHz to upper sideband limit
Harmonic Attenuation, ratio of any single harmonic to peak visual fundamental <sup>14</sup> .....	At least 60 dB	At least 60 dB

## Electrical

AC Line Input.....	440/460/480 V, 3-phase 60 Hz	380/400/415 V, 3-phase 50 Hz 440/460/480 V, 3-phase 60 Hz
Slow Line Variations	±3% max.	±3% max.
Rapid Line Variations .....	±3% max.	±3% max.
Regulation .....	3% max.	3% max.
Power Consumption:	128 kW for 30 kW	125 kW for 25 kW 105 kW for 20 kW

<sup>1</sup>Polarity of visual modulation—negative, asymmetric sideband.

<sup>2</sup>Measured at the output of the filterplexer.

<sup>3</sup>Measured at the input to the filterplexer. Usable output depends upon filterplexer rating.

<sup>4</sup>Output impedance of amplifier. Filterplexer output impedance 75 Ohm EIA flanged 6/8-inch line. Transformations to other standard lines available.

<sup>5</sup>With respect to the response at 200 kHz, as measured by the BWU-5C Sideband Response Analyzer at transmitter mid-characteristic. Aural carrier plus .25 MHz response requires a LP filter in the video input circuit.

<sup>6</sup>With respect to the response at 200 kHz (4.5 MHz separation standards or 1.5 MHz other standards) at transmitter mid-characteristic.

<sup>7</sup>Maximum variation with respect to the response at mid-characteristic measured with the BWU-5C Sideband Response Analyzer at brightness levels of 22.5% and 67.5% of sync peak, using approximately 20% (peak to peak) modulation.

<sup>8</sup>Maximum variation for a period of 30 days without circuit adjustment over an ambient temperature range of +10°C to +45°C. (meets FCC specifications over ambient range of +1°C. to +45°C.

<sup>9</sup>Maximum variation with respect to the standard separation between aural and visual carriers. (4.5 MHz—FCC) (5.5 MHz—CCIR)

<sup>10</sup>Maximum departure from the theoretical when reproducing saturated primary colors and their complements at 75% amplitude.

<sup>11</sup>Maximum phase difference with respect to burst, measured after the VSBF, for any brightness level between 75% and 15% of the sync peak using 10% (peak to peak) modulation. This is equivalent to 5% (peak to peak) modulation as indicated by a conventional diode demodulator. In addition, the total differential phase between any two levels shall not exceed 10°.

<sup>12</sup>Maximum variation in the amplitude of a 3.58 MHz sine wave modulating signal as the brightness level is varied between 75% and 15% of sync peak. The gain shall be adjusted for 10% (peak to peak) modulation of the 3.58 MHz signal when the brightness is at pedestal level. This is equivalent to 5% (peak to peak) modulation as indicated by a conventional diode demodulator connected after the VSBF.

<sup>13</sup>Maximum departure from standard curve. The tolerances vary linearly between 2.1 and color subcarrier frequency and between color subcarrier frequency and upper sideband limit and between 3.58 MHz and 4.18 MHz. To meet the specification a properly terminated phase correction network, ES-34034-B is required in the video input circuit of the transmitter.



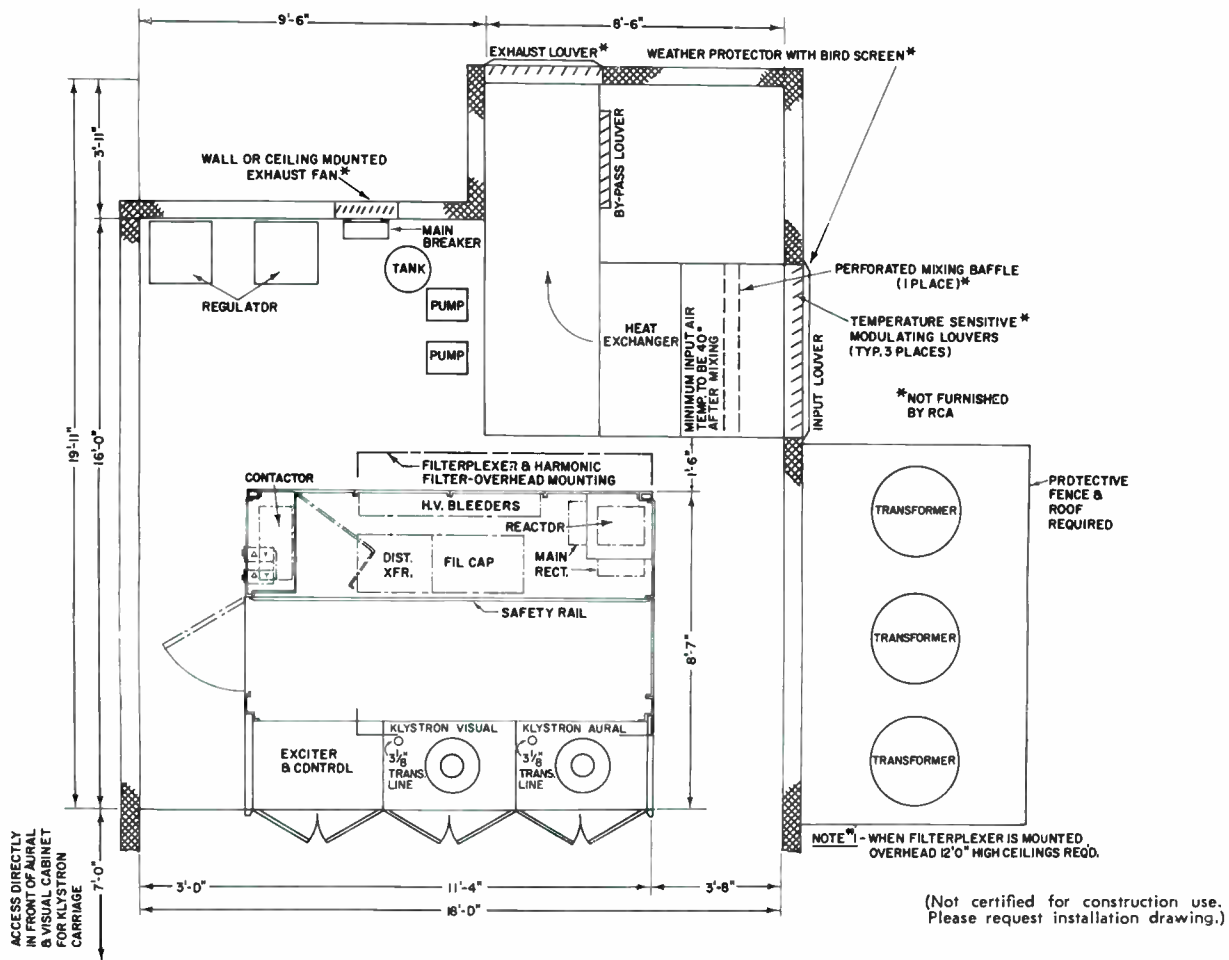

Space Saving Floor Plan of TTU-30A UHF Television Transmitter.

	FCC Specs.	CCIR Specs. <sup>1</sup>
Power Factor (approx.)	90%	90%
Crystal Heaters: Line	115 V, 1-phase 50/60 Hz	115 V, 1-phase 50/60 Hz
Power Consumption	7½ Watts	7½ Watts
<b>Mechanical</b>		
Dimensions Overall:		
Width	136"	345.5 cm
Height	77"	195.6 cm
Depth	105"	266.7 cm
Finish:		
Transmitter	Powder and Midnight blue, aluminum trim	Powder and Midnight blue, aluminum trim

	FCC Specs.	CCIR Specs. <sup>1</sup>
Maximum Altitude <sup>14</sup>	7500 feet	2285 meters
Ambient Temperature <sup>14</sup>	+1°C. to +45°C. max.	+1°C. to +45°C. max.

**Accessories**

Complete Set of Spare Tubes	ES-560251
Minimum Set of Spare Tubes	ES-560252
BWU-4C Demodulator	ES-34049-C
BWU-5C1 Sideband Response Analyzer	ES-34009-C1
BW-8A Envelope Delay Measuring Set	MI-34063
Transmitter Control Console	ES-561900

<sup>14</sup>Air Input Temperature to Heat Exchanger +10°C. to +45°C. to 7500 ft. (2286 meters). Air Temperature in transmitter area: 45°C. at Sea Level; 40°C. to 3300 ft. (1005.84 meters); 35°C. to 5000 ft. (1524 meters); 30°C. to 7500 ft. (2286 meters).

## Ordering Information

TTU-30A 30 kW UHF Television Transmitter . . .  
Two basic models are available as follows:

For 440/460/480 Volt, 60 Hz input order ES-560250 which includes UHF TV Transmitter (30 kW visual, 3.3 to 17 kW aural) with tubes, filterplexer, two sets crystals, two harmonic filters and low pass filter.

For 380/400/415 Volt, 50 Hz input order ES-560253 which includes UHF TV Transmitter (25 kW visual, 3.3 to 16 kW aural) with tubes. Output power and required filters to be determined in accordance with required operation standards.

# RCA 60 KW UHF TV Transmitter, Type TTU-60A1

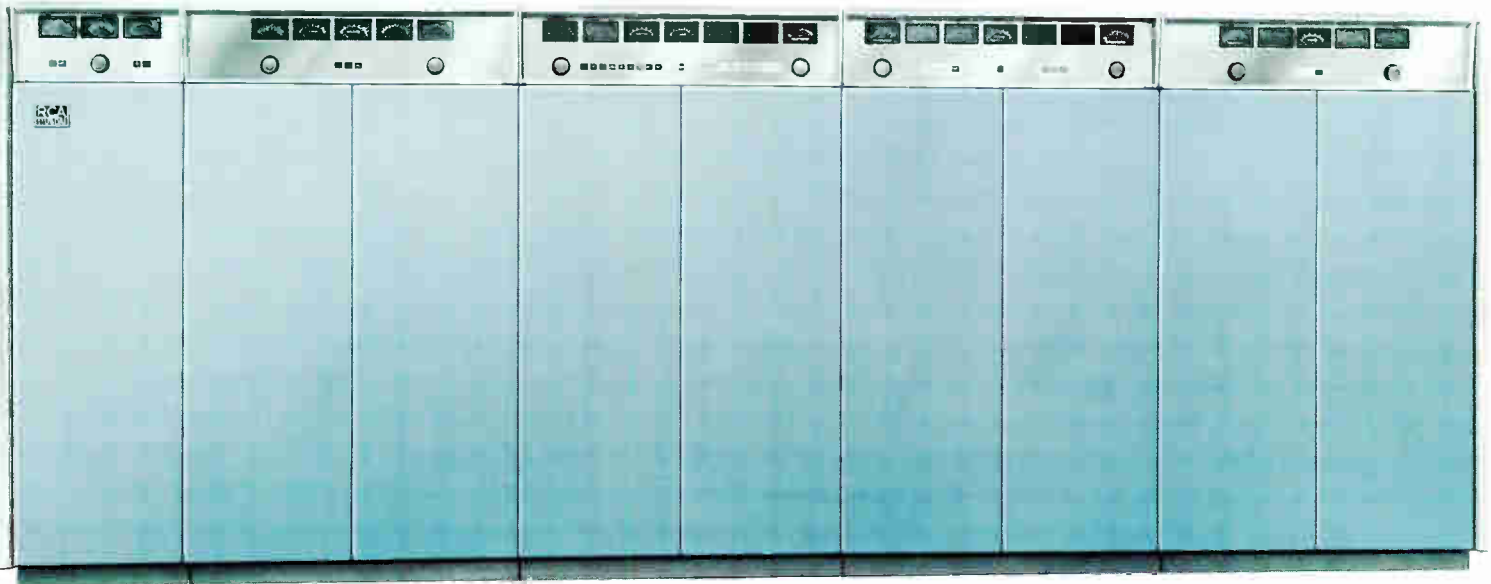

- Duplicated output
- Vapor-cooled Xyticons
- Quick tube change
- Remote control plus standby facilities

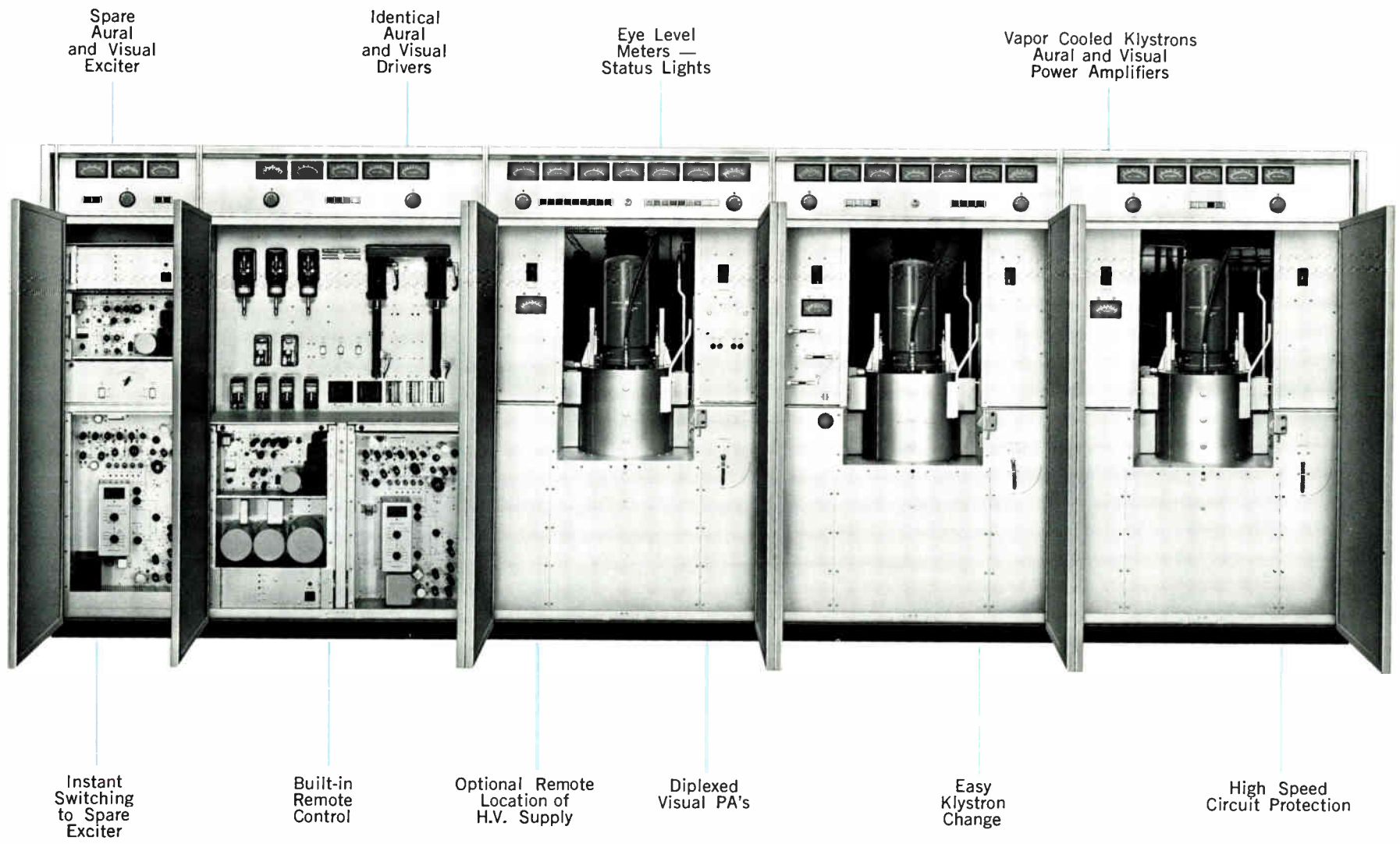

# The Most Versatile High Power UHF Transmitter

The new 60 kW UHF transmitter, Type TTU-60A1, is the finest of RCA's high power UHF offerings to broadcasters. Features such as the vapor cooled, integral cavity klystrons with their high power sensitivity, the interchangeability of aural and visual amplifier stages, and the solid state rectifier and power supply circuits, greatly enhance the transmitter's operating efficiency and performance. Reliability is increased by diplexed visual power amplifiers and a spare "hot" exciter/modulator that can be switched in for emergency standby.

The TTU-60A1 offers a measure of backup that almost equals a second transmitter. Identical IPA and PA stages for aural and visual, plus unique patch facilities, provide a redundancy which when supplemented by optional coaxial switches permit up to 50 percent normal transmitter power to be maintained should any of the three klystrons fail. If nec-

essary, the aural IPA can be substituted for a disabled visual IPA, or one of the visual PA's can replace a disabled aural PA. Each klystron cabinet includes switching facilities to remove the cabinet from the circuit for repairs without interrupting normal operation of the remainder of the transmitter.

The transmitter is economical and easy to operate. Though the space required is small, components are placed for maximum accessibility. Both small size and ease of maintenance result in direct savings in installation and operation.

The TTU-60A1 is designed to provide effective radiated power of over two megawatts for metropolitan markets. There are models to meet FCC or CCIR specifications. Model ES-560294 should be specified for FCC standards and 440/460/480 Volts, 60 Hz input. For CCIR standards and 380/400/415 Volts, 50 Hz input, order ES-560295.

## Description

The transmitter is housed in new low profile 77-inch cabinets with eye level meters and fingertip controls. Built in remote control circuitry, including metering points for remote monitoring, permit operation at an auxiliary control console

or remote point. All normal operating controls are motor driven and thus can be actuated from a remote location.

The floor plan shown for the transmitter is typical. However, several other

layouts are possible since the main rectifier cubicle and heat exchanger can be detached from the RF cabinets and located in an adjacent room or even on another level.

Block diagram of TTU-60A1 UHF Television Transmitter.

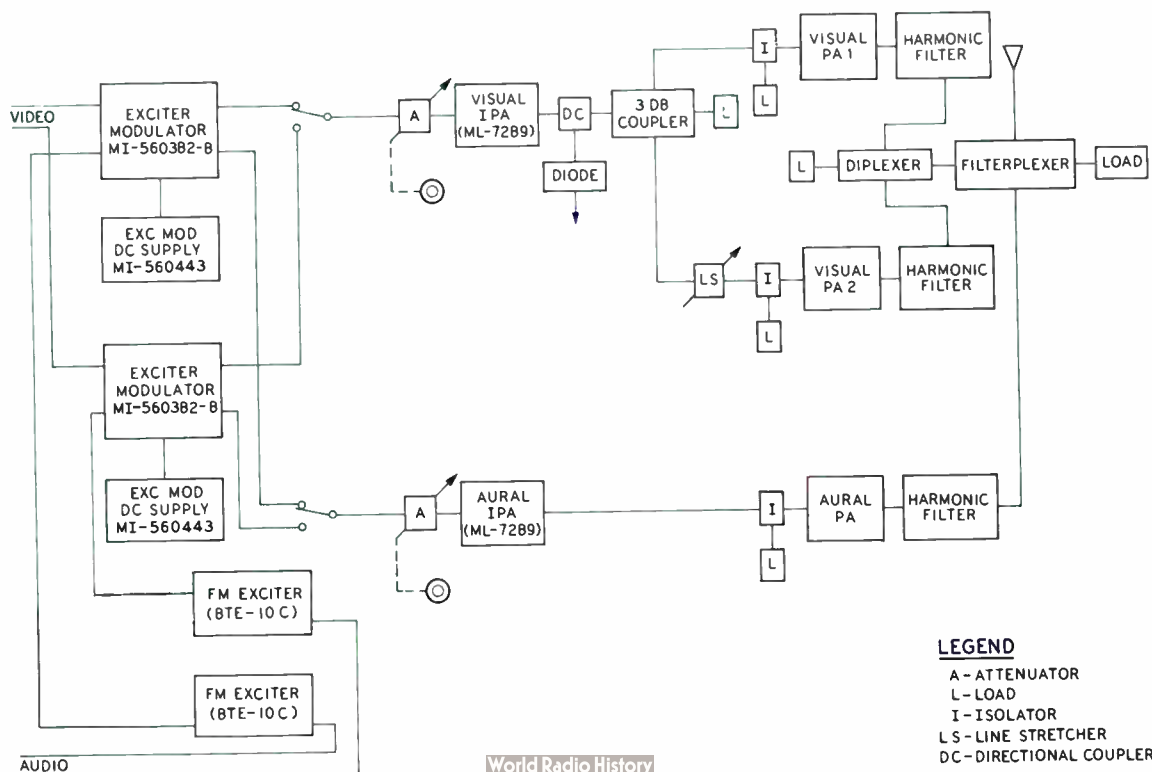

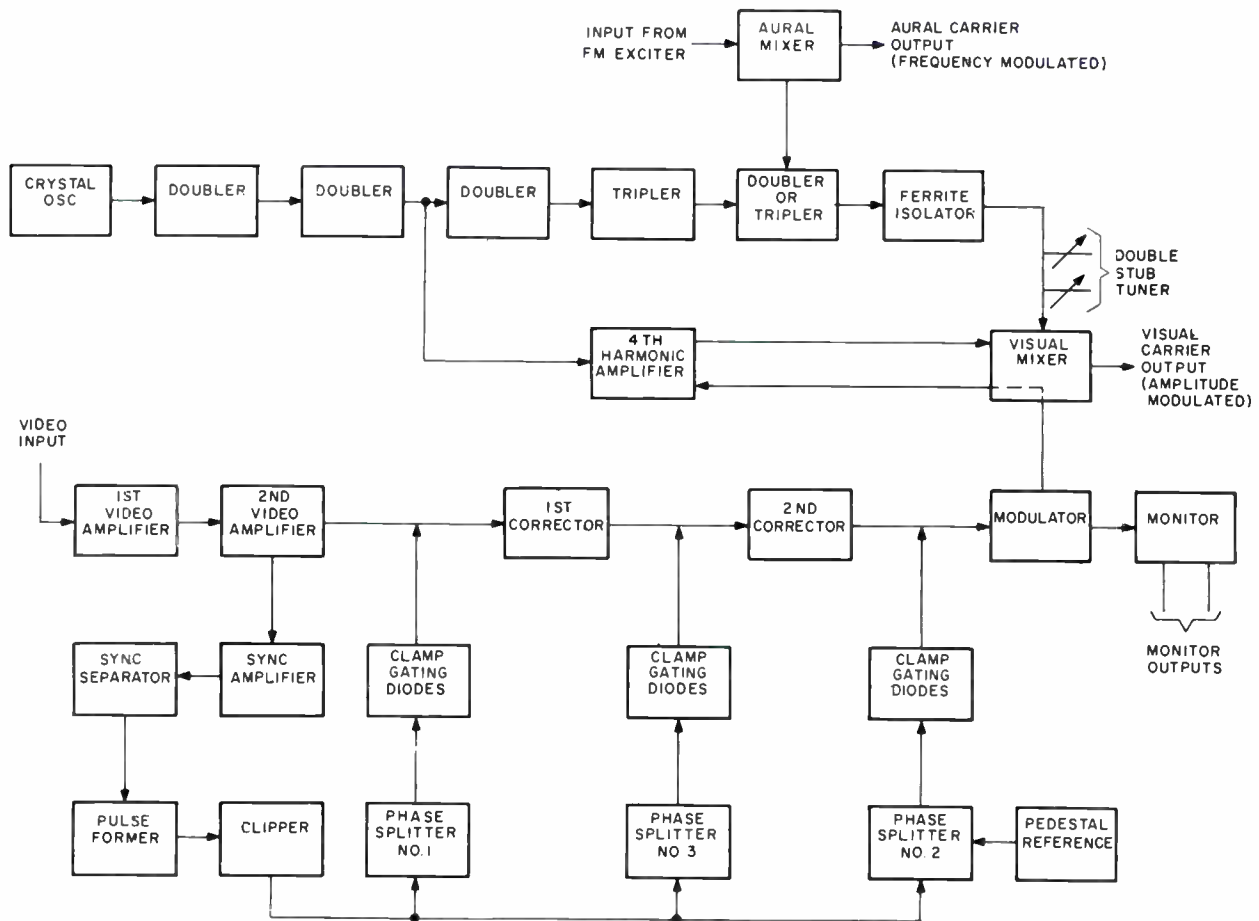

Aural/Visual Exciter/Modulator Block Diagram.

### Direct FM Exciter

Modern circuitry used in the TTU-60A1 utilizes the reliable BTE-10C FM exciter to develop a stable, high quality, direct FM aural signal. This new exciter uses only nine tubes—half the number in the previous model. Of these, only four are required to maintain an aural output signal, an indication of the reliability potential built into the transmitter.

### Pretuned Klystron Power Amplifiers

Aural and visual power amplifiers each use vapor cooled, integral cavity klystrons of the Varian Type VA-890 series. Use of integral cavities means that the klystron is tuned at the factory, eliminating the station site preparation required by external cavity designs. Three identical klystrons are used in the transmitter.

The TTU-60A1 is the first 60 kW TV broadcast transmitter to use vapor cooling. The increased efficiency of a vapor cooling system over one of either air or water results in a considerable saving in operating costs. The vapor-cooled TTU-60A1 requires a power input of approximately 10 kW less than would be required for the same transmitter if it were water cooled.

The integral cavity klystron is easily installed by one operator. It is transferred in a horizontal position directly from the shipping container into a four-wheel carriage, then by an ingenious loading device, into the transmitter. The tube remains in a horizontal position until completely installed in the transmitter. It is then tilted to a vertical position and locked. No unusual ceiling height is required as with some klystrons.

### Diplexing Increases Reliability

One of the three klystrons is employed in the aural PA. Two klystrons in a diplexed arrangement are used in the visual PA. Diplexing is more than just paralleling two tubes. If either tube fails, the other continues to operate, unaffected. Diplexing achieves an increased reliability, which according to studies, improves 150 percent in any redundant system employing identical elements. The design also offers the possibility in an emergency of patching in one of the diplexed amplifiers to take over for a disabled aural PA and thus stay on the air utilizing optional output coax switches.

These features plus the spare exciter and interchangeable drivers represent a great forward step in design to achieve the dependability required in television transmitter operation.

## Design Features

### LONG LIFE SILICON RECTIFIERS

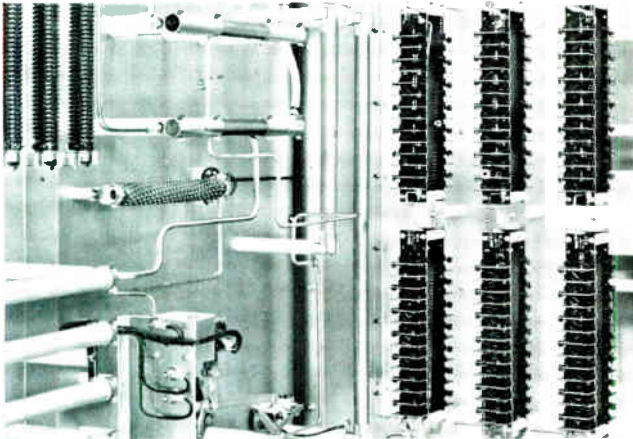

Modularized for easy maintenance.

### SIMPLE, PROVED CIRCUITRY

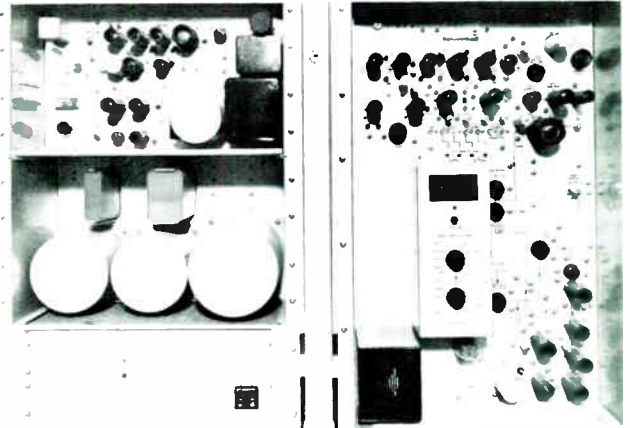

Exciter/modulator employing premium 10,000 hour tubes.

### INSTANT SELECTION OF SPARE EXCITER

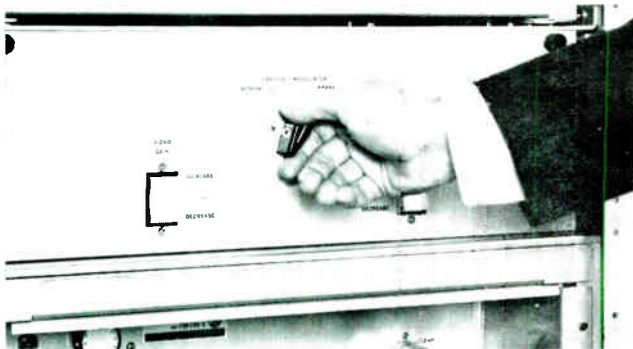

Complete standby exciter/modulator with power supply.

### QUICK ISOLATION FOR "ON-AIR" SERVICING

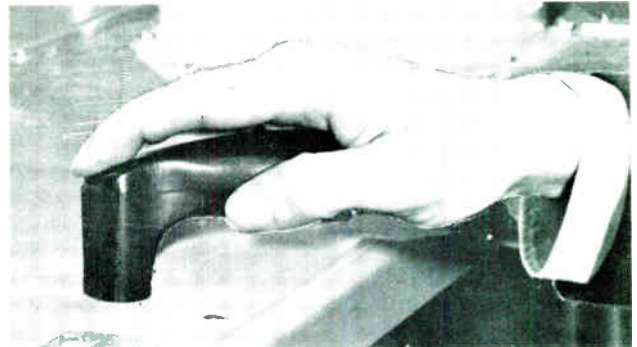

Switch for each klystron cabinet disconnects cubicle from operating transmitter.

### EASY BY-PASSING OF INOPERATIVE DRIVER

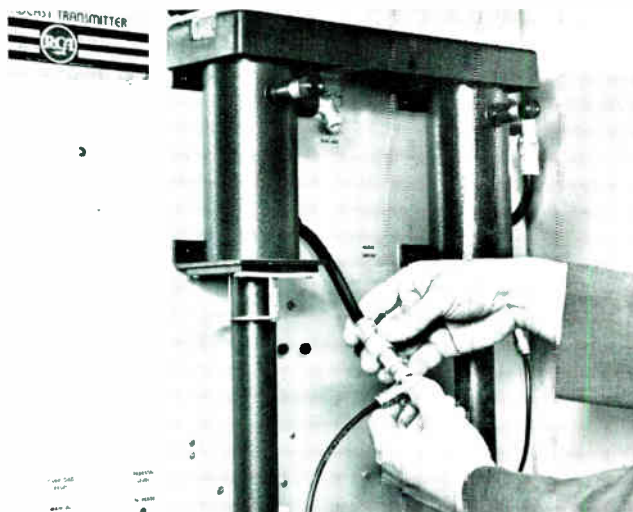

Simple cable change substitutes aural IPA for visual IPA.

### SIMPLE PATCHING OF DISABLED PA



Unique patch panel permits instant use of visual PA for aural PA.

# Pretuned Klystron Amplifiers

The design retains RCA's "Direct-FM" modulation with particular emphasis being placed on ease of adjustment and reliable operation. All RF stages use single-tuned circuits. A built-in meter, and easily accessible test points allow metering and checking during operation. An AFC on-off toggle switch and simplified controls including the power on-off switch are all easily accessible on the chassis of the exciter.

A self-contained silicon power supply is used in the exciter. Premium tubes, carrying a 10,000 hour guarantee are used in the RF circuits for reliability and long life. The BTE-10C lends itself particularly well to unattended and remote operation.

## Simplified Exciter Modulator

The exciter/modulator develops a highly stable, crystal-controlled frequency which is heterodyned with both the modulated video and aural signals, resulting in aural and visual output carriers separated by 4.5 MHz (5.5 MHz for CCIR Standards). The aural signal is then fed through a variable motor-driven attenuator to an RF amplifier using a single type 7289 tube. The output of this stage drives the aural klystron to an output of 16 kW.

Visual modulation takes place at the grid of a pencil triode, type 4055. All RF stages preceding this are operated Class "C" and are simply tuned by meter indications for maximum output. The output of the mixer stage is a double-tuned cavity. The video modulated output of this stage, a nominal 2 Watts peak, is fed through a variable attenuator, then amplified in the following cavity tuned amplifier using a single type 7289 tube. The variable attenuator is motor-driven and, in addition to providing a good load impedance on the modulated stage, serves as the visual excitation control.

## IPA Stages

Following the exciter, the aural and visual signals are amplified separately by identical cavity tuned IPA stages, each employing a Type 7289 triode. The signals are then fed to their respective klystron output stages. Both IPA stages are broadband tuned and capable of operating as a visual amplifier. Therefore, should the need arise, a simple change of small coaxial connectors at the front of the transmitter will permit the visual signal to be fed through either IPA stage while the aural signal may be fed directly to the aural klystron.

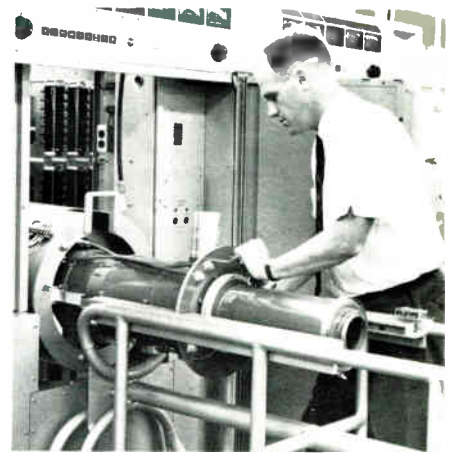

Klystrons are easily rolled into place with special carriage loading device.



Chassis units slide forward on rails for easy inspection.

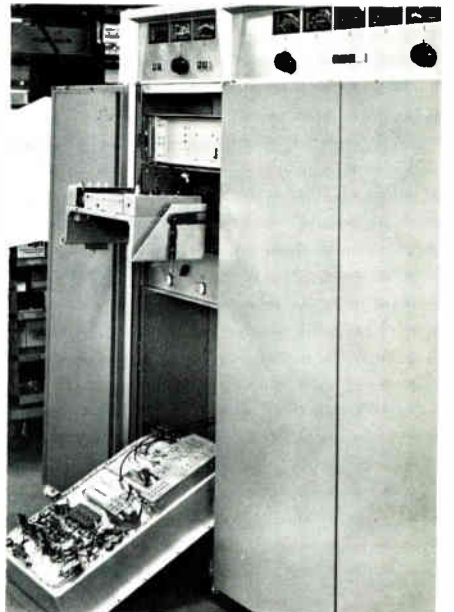

Units are hinged to tilt forward for complete accessibility.

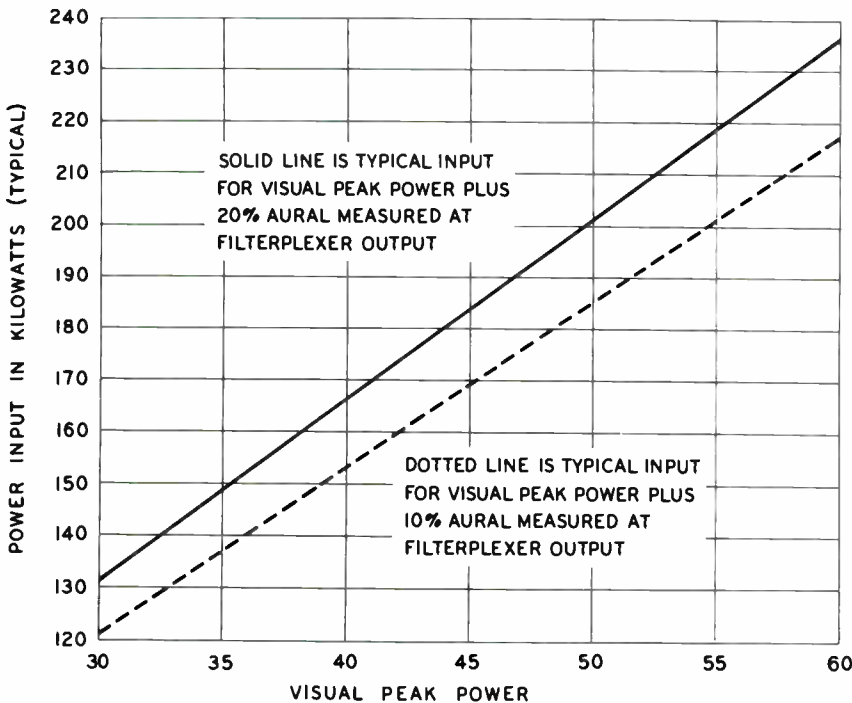

Curve showing power input vs power output values.

# Specifications

## Performance\*

	FCC Specs.	CCIR Specs.
Type of Emission:		
Visual .....	A5	A5
Aural .....	F3	F3
Frequency Range .....	470-890 MHz (Ch. 14-83)	470-890 MHz
Rated Power Output:		
Visual <sup>1</sup> .....	60 kW	40 kW
Aural <sup>2</sup> .....	6.0 to 16 kW	6.0 to 16 kW
RF Output		
Impedance <sup>3</sup> .....	50 Ohms, 3/8" flanged	50 Ohms, 3/8" flanged
Input Impedance:		
Visual .....	75 Ohms	75 Ohms
Aural .....	600/150 Ohms	600/150 Ohms
Input Level:		
Visual .....	0.7 Volt peak-to-peak min.	0.7 Volt peak-to-peak min.
Aural .....	+10 ±2 dBm for ±25 kHz deviation	+16 ±2 dBm for 50 kHz deviation
Amplitude vs. Frequency Response....	Uniform ±1 dB from 50 to 15,000 kHz	—
Upper Sideband Response at Carrier:	FCC <sup>4</sup>	CCIR <sup>5</sup> 5.0 MHz Carrier Separation
+0.5 MHz	+1, -1.5 dB	+0.5, -1.5 dB
+1.25 MHz	+1, -1.5 dB	—
+1.5 MHz	+1, -1.5 dB	Reference
+2.0 MHz	+1, -1.5 dB	—
+3.0 MHz	+1, -1.5 dB	+1.0, -1.0 dB
+3.58 MHz	+1, -1.5 dB	—
+4.18 MHz	+1, -3.0 dB	—
+4.43 MHz	—	+0.5, -1.5 dB
+4.75 MHz	-20 dB max.	—
+5.0 MHz	—	+1.0, -4.0 dB
+5.5 MHz	—	+0.5, -1.5 dB
+5.75 MHz	—	+1.0, -4.0 dB
+6.25 MHz	—	-20 dB max.
Lower Sideband Response at Carrier:		
-0.5 MHz	+1, -1.5 dB	+0.5, -1.5 dB
-0.75 MHz	—	+0.5, -4.0 dB
-1.0 MHz	—	+1.0, -1.0 dB
-1.25 MHz	—	+0.5, -1.5 dB
-1.25 MHz	-20 dB max.	-20 dB max.
-2.25 MHz	—	+0.5, -4.0 dB
-3.58 MHz	-42 dB max.	—
-4.43 MHz	—	-20 dB max.
Variation in Frequency Response with Brightness <sup>6</sup> ...	±1.5 dB	±1.0 dB
Carrier Frequency Stability: <sup>7</sup>		
Visual .....	±500 Hz	±500 Hz
Aural .....	±500 Hz <sup>8</sup>	±200 Hz <sup>8</sup>
Modulation Capability:		
Visual .....	12.5 ±2.5% (reference white)	12.5 ±2.5% (reference white)
Aural .....	±50 kHz	±100 kHz
Audio Frequency Distortion .....	1% max. 30 Hz to 15 kHz	1% max., 30 Hz to 15 kHz
FM Noise .....	-58 dB below ±25 kHz swing	-64 dB below ±50 kHz deviation
AM Noise, r.m.s.:		
Visual <sup>9</sup> .....	48 dB r.m.s. below 100% mod.	48 dB r.m.s. below 100% mod.
Aural .....	50 dB below carrier	50 dB below carrier

\* Specifications shown are measured and stated in terms of meeting United States FCC requirements. This transmitter can meet various foreign standards.

	FCC Specs.	CCIR Specs.
Amplitude Variation Over One Picture Frame .....	Less than 3% of the peak of sync level	Less than 3% of the peak of sync level
Regulation of Output Burst vs. Subcarrier Phase <sup>10</sup> .....	±6° max.	±6° max.
Subcarrier Phase vs. Brightness <sup>11</sup> .....	±7% max. total less than 10°	±7°, total less than 10°
Subcarrier Amplitude <sup>10</sup> .....	±10% max.	±10° max.
Linearity (Differential Gain) <sup>12</sup> .....	1.5 dB max.	See Note <sup>12</sup>
Envelope Delay vs. Frequency <sup>13</sup> .....	±80 ns from 0.2 to 2.0 MHz ±40 ns at 3.58 MHz ±80 ns at 4.18 MHz	±80 ns, 0.2 to 2.0 MHz ±40 ns, at 4.43 MHz ±80 ns, 4.43 MHz to upper sideband limit
Harmonic Attenuation, ratio of any single harmonic to peak visual fundamental <sup>14</sup> .....	At least -60 dB	At least -60 dB

## Electrical

AC Line Input .....	440/460/480 V, 3-phase, 60 Hz 4 wire	380/400/415 V, 3-phase, 50 Hz 4 wire
Slow Line Variations .....	±3% max.	±3% max.
Rapid Line Variations .....	±3% max.	±3% max.
Regulation .....	3% max.	3% max.
Power Consumption....	See Power Curve	240 kW
Power Factor (approx.) .....	90%	90%
Crystal Heaters:		
Line .....	115 V, 1-phase 50/60 Hz	220 V, 1-phase 50/60 Hz
Power Consumption....	7½ watts	7½ watts

<sup>1</sup>Measured at the output of the filterplexer.

<sup>2</sup>Measured at the input to the filterplexer.

<sup>3</sup>Output of RF Amplifier. Output of visual diplexer and filterplexer are 6½" 75 Ohm EIA flange.

<sup>4</sup>With respect to the response at 200 kHz, as measured by the RCA BWU-5C Sideband Response Analyzer and with the transmitter adjusted for mid-characteristics. An MI-27132-A Low Pass Video Filter is required in the input circuit.

<sup>5</sup>With respect to the response at 1.5 MHz as measured by the RCA BWU-5C Sideband Response Analyzer and with the transmitter adjusted for mid-characteristics. Use of a 5.75 MHz Video Low Pass Filter is required.

<sup>6</sup>Maximum variation with respect to the response at mid-characteristic measured with the BWU-5C Sideband Response Analyzer using approximately 20 percent (peak to peak) modulation at brightness levels of 22.5 percent and 67.5 percent of peak for FCC specifications and for brightness levels of 25 percent and 60 percent for CCIR specifications.

<sup>7</sup>Maximum variation for a period of 10 days without circuit adjustment over an ambient temperature range of +10°C to +45°C. (Meets FCC specifications over an ambient range of +1°C to +45°C.)

<sup>8</sup>Maximum variation with respect to separation between aural and visual carriers.

<sup>9</sup>RMS hum and noise level 50 Hz to 15 kHz. Extraneous modulation (unrelated to video modulation) above 15 kHz within the visual passband 40 dB below 100% modulation.

<sup>10</sup>Maximum departure from the theoretical when reproducing saturated primary colors and their complements at 75% amplitude.

<sup>11</sup>Maximum phase difference with respect to burst, measured after the sideband filter, for any brightness level between 75% and 15% of the sync peak using 10% (peak to peak) modulation. This is equivalent to 5% peak to peak as indicated by a conventional diode demodulator. In addition, the total differential phase between any two levels shall not exceed 10°.

<sup>12</sup>Maximum variation of amplitude of the sine wave modulation frequency when superimposed on stairstep or ramp modulation which is adjusted for brightness excursion stated. Modulation depth of the sine wave to be 20% peak to peak. CCIR Linearity is 0.85 at 0.2 MHz, 1.5 MHz and 4.43 MHz with Brightness excursion 65 to 17% for 0.2 and 1.5 MHz and 75 to 17% at 4.43 MHz.

<sup>13</sup>Maximum departure from standard curve. The tolerances vary linearly between 2.1 and color subcarrier frequency and between color subcarrier frequency and upper sideband limit. To meet the specification a properly terminated phase correction network is required in the video input circuit of the transmitter.

<sup>14</sup>Referenced to peak visual power.



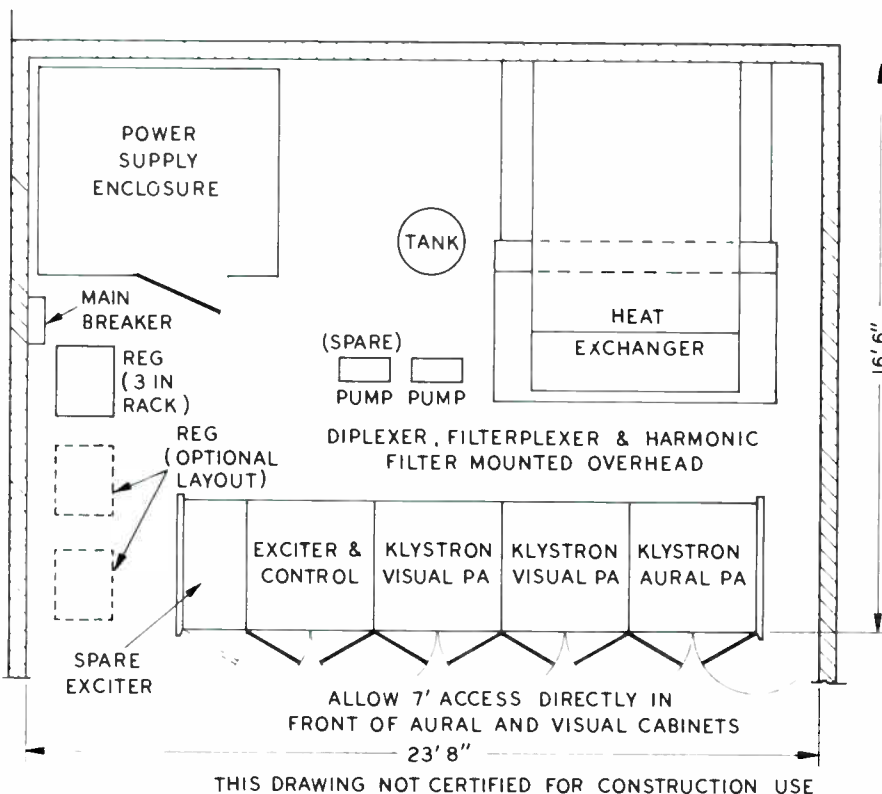

Space Saving Floor Plan of TTU-60A1 UHF Television Transmitter.

**Mechanical**

	FCC Specs.	CCIR Specs.
Dimensions Overall: Transmitter		
Front Cabinets ..	198 1/4" long, 45" deep, 77" high	503.25 cm long, 114.3 cm deep, 195.6 cm high
Power Supply Cabinet .....	84" long, 70" deep, 77" high	213.4 cm long, 177.8 cm deep, 195.6 cm high
Finish:		
Transmitter .....	Powder and Midnight blue, aluminum trim	Powder and Midnight blue, aluminum trim
Maximum Altitude ....	7500 feet	2286 meters
Ambient Temperature <sup>1,2</sup> .....	+1°C. to +45°C. max.	+1°C. to +45°C. max.

<sup>1</sup>Air Inout Temperature to Heat Exchanger +10°C. to +45°C. to 7500 ft. (2286 meters).  
<sup>2</sup>Air Temperature in transmitter area:  
 45°C. at Sea level; 40°C. to 3300 ft. (1005.84 meters); 35°C. to 5000 ft. (1524 meters); 30°C. to 7500 ft. (2286 meters).

**Accessories**

Complete Set of Spare Tubes .....	ES-560279
Minimum Set of Spare Tubes .....	ES-560252
Spare Exciter Group .....	ES-560281
BWU-4C Demodulator .....	ES-34049
BWU-5C Sideband Response Analyzer .....	ES-34009-B
BW-8A Envelope Delay Measuring Set .....	MI-34063
BW-8A1 Envelope Delay Measuring Set .....	MI-34068
Transmitter Control Console .....	ES-561900

**Ordering Information**

For 440/460/480 Volt, 60 Hz input, FCC standards, order ES-560294  
 TTU-60A1 UHF TV Transmitter 60 kW visual 6.0 to 16 kW aural with tubes, hybrid filterplexer, two sets crystals, two harmonic filters and low pass filter

For 380/400/415 Volt, 50 Hz input, and CCIR standards, order ES-560295

Output power and required filters to be determined in accordance with required operating standards

## 55-kW UHF-TV Transmitter, Type TTU55-B

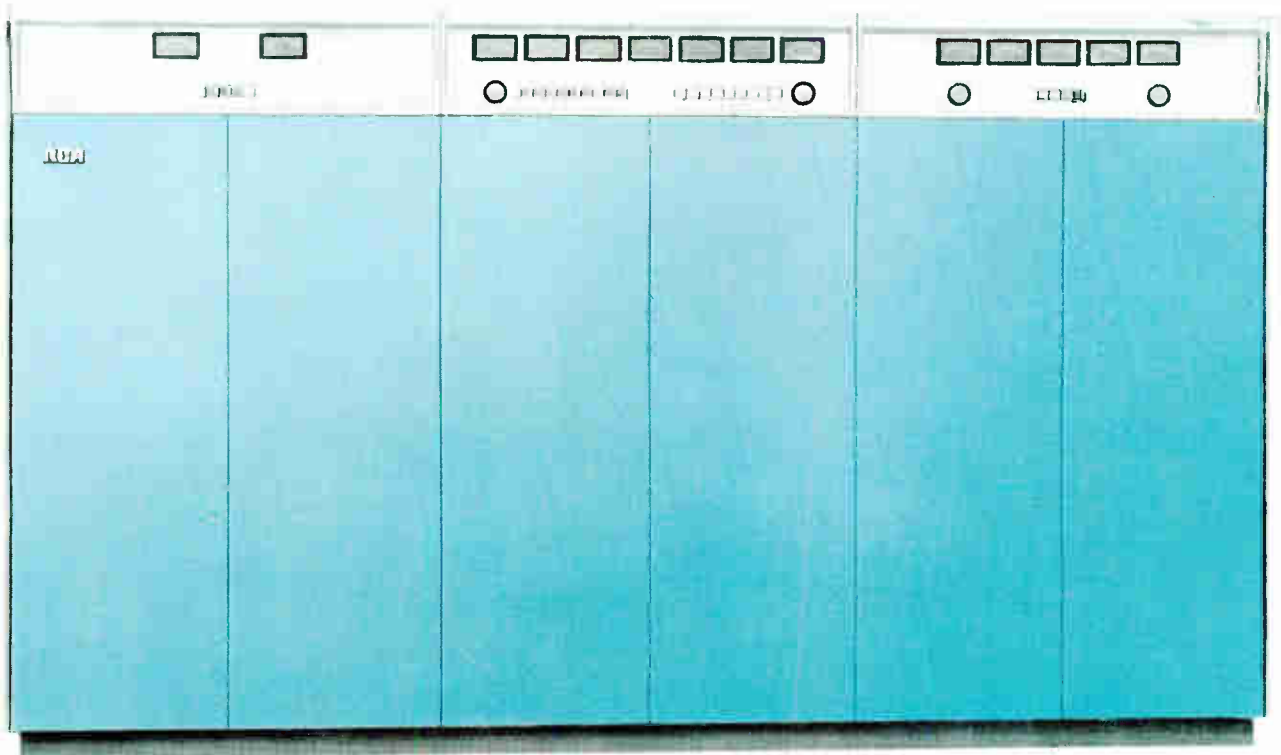

- I-F modulation with high-level sideband shaping
- Ultra-stable exciter modulator
- Economical—only two tubes

# TTU-55B Special Features

Temperature-Compensated  
Crystals

Built-In  
Remote Control

Expandable to 110-kW  
Diplexed Operation

Efficient Vapor  
Cooling

One-Step  
Power Amplifiers

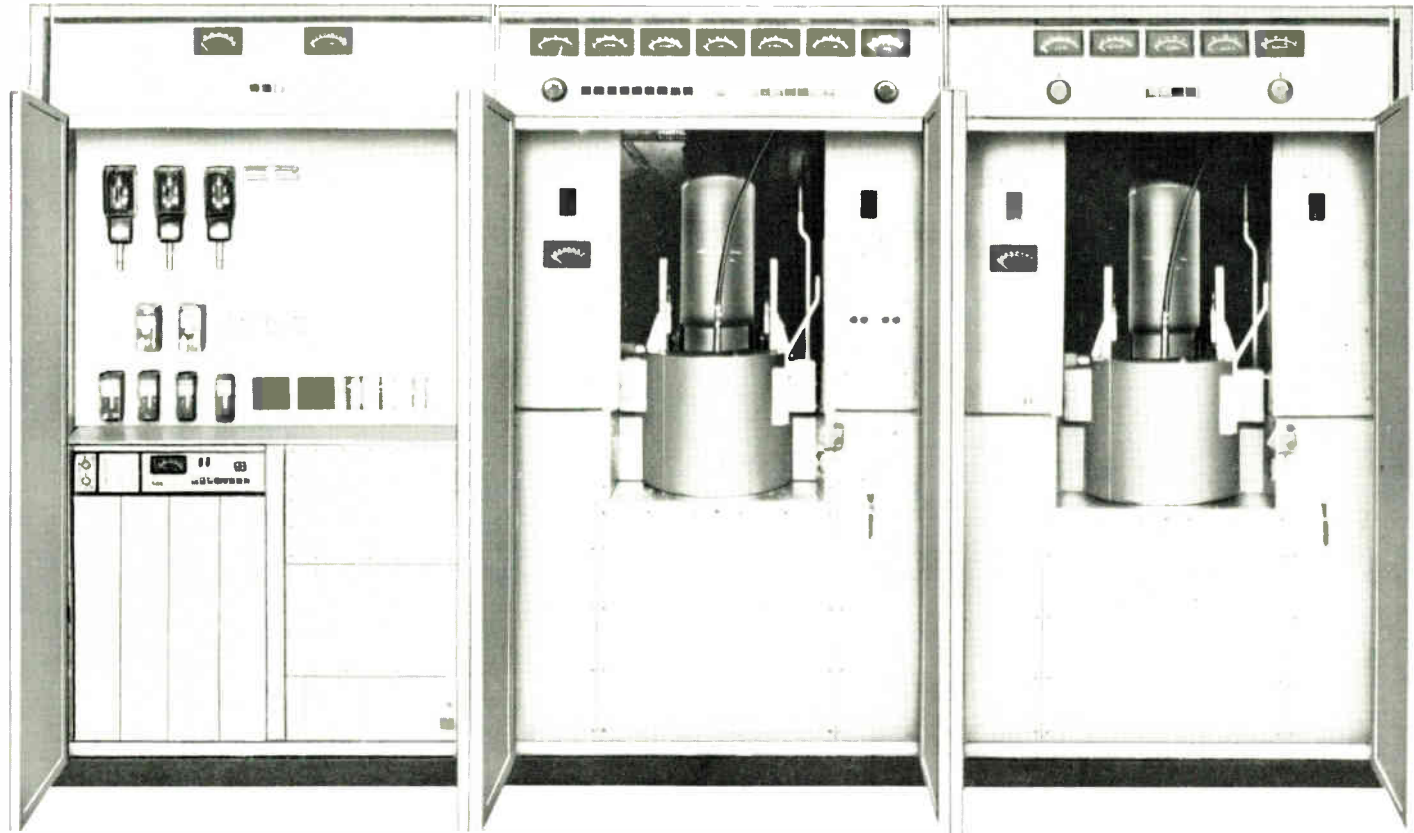

Solid-State  
Exciter/Modulator

Five-Cavity  
Klystrons

Integral-Cavity  
Klystrons

Easy, Fast  
Klystron Change—  
One Man

High-Speed  
Overload Protection

## 55-kW UHF-TV Transmitter, Type TTU-55B

The RCA Type TTU-55B is a klystron-powered transmitter designed for 2,000,000 watts effective radiated power. This completely new, high-powered transmitter has a rated output of 55-kW peak visual power and 12.2-kW aural power. The transmitter utilizes a new, advanced-design solid state exciter-modulator and integral-cavity, vapor cooled klystrons for maximum efficiency and reliability. The TTU-55B is representative of a new generation of UHF transmitters from RCA with the latest state-of-the-art components and design techniques, offering unsurpassed performance, reliability, and operating economy.

The space requirement of the TTU-55B is less than that of previous transmitters of comparable power contributing to a saving in

building costs. It is designed so that expansion to higher power may be accomplished with minimum additional investment and without loss of air time.

The TTU-55B is designed for remote control operation. Metering points are provided for monitoring operating parameters and operational adjustments may be performed remotely via motor-driven controls. The unexcelled performance specifications are based on an operating period of thirty days without the need for adjustment or correction.

This new transmitter provides the long term stability, performance, and reliability required for unattended operation while delivering the finest in signal quality.

Entirely solid-state, the exciter/modulator circuit modules are mounted on four vertical "drawers". These slide out for inspection or maintenance while the unit is operational. Comprehensive metering permits quick check of operating condition of each module.

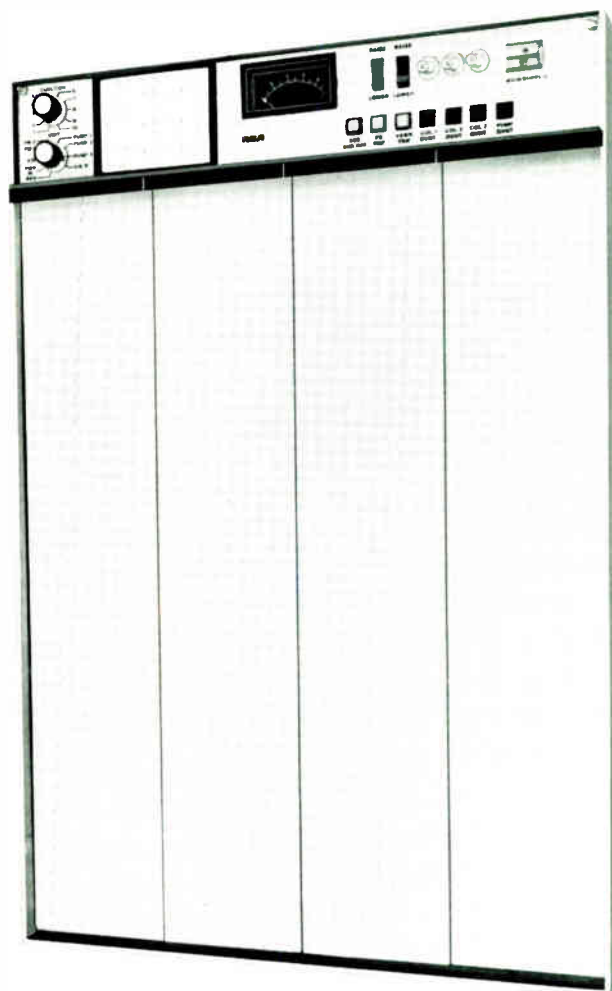

The TTU-55B transmitter is housed in three, low-profile, 77-inch high cabinets with eye-level meters and convenient finger-tip controls. Built-in, remote-control circuitry, including metering points for remote monitoring of operating parameters, permits operation at an auxiliary control console or other remote point. All normal operating controls are motor-driven and may be operated from a remote location.

### Circuit Description

The exciter-modulator, although only a small part of the transmitter, is where the television picture and sound quality and stability are established. The TTU-55B transmitter utilizes a solid-state exciter-modulator which represents an entirely new and original design approach. It is a technically advanced equipment incorporating modern components and design techniques which offers the ultimate in

performance and reliability and is virtually obsolescence-free.

### No Crystal Ovens

The exciter-modulator uses temperature-compensated crystal oscillators which eliminate the necessity for crystal heaters or ovens. Immediate, on-frequency operation results with power turn-on and specifications are maintained over a minimum of 30 days without adjustment even if the equipment is cycled over the specified ambient temperature range.

Modulation is accomplished at a low intermediate frequency (which is always the same regardless of channel frequency) permitting simple, reliable designs which are readily optimized for consistently high-grade performance. Junction field-effect transistors are used in the active i-f filter in which any component can be replaced without the need for realignment. The

use of integrated circuits in the aural chain permits an original and unique, untuned-multiplier system.

### Printed-Circuit Coaxial Lines

Constant impedance r-f microstrip printed circuit lines avoid the problems of reliability associated with coaxial cables and connectors. Each electrical function with the exception of the pump chain is incorporated on a single plug-in "card". These module cards are accessible by means of four vertical slide-out drawers. The comprehensive metering system makes it easy to observe the operating condition of each module individually. Because of the unique and functional mechanical design, no module extenders are required.

The exciter-modulator power supply is located in the exciter/control cabinet (extreme left-hand). It provides unregulated d-c to the individual regulators as-

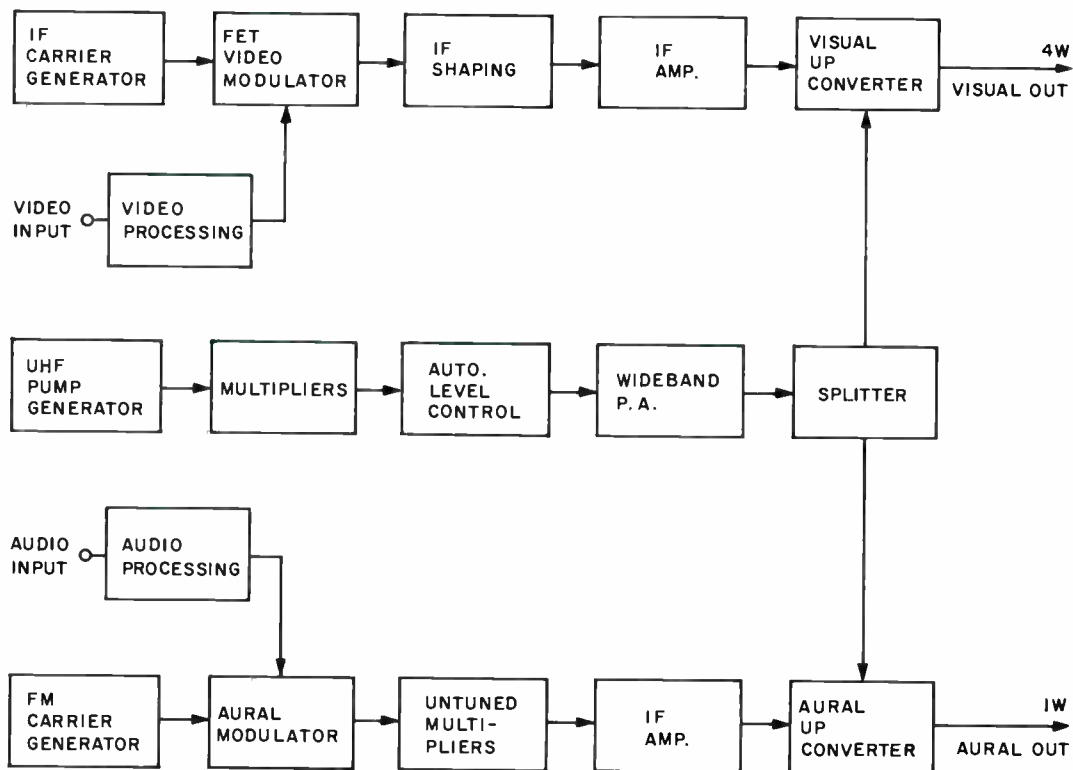

Solid-State Exciter/Modulator Block Diagram.

sociated with the modules in the exciter. These regulators are individual, plug-in units of two types. The operating voltage level of each regulator is determined through connections to the mating receptacle. This arrangement automatically provides the correct, regulated voltage for the subsystem it supplies.

### One-Step Power Amplifiers

As a result of the power output of the exciter-modulator (4 watts visual, 1 watt aural) and the high gain of the five-cavity klystrons, no active devices are employed between the exciter-modulator output and the power amplifier inputs. The result is an all-solid-state transmitter with the exception of the two klystrons in the final visual and aural power amplifiers.

### Field-Proven Klystrons

The five-cavity, integral, vapor-cooled klystrons used in the TTU-55B have been

field proven for exceptional gain stability, reliability, and long life. The klystron offers a power gain of 50 dB and a saturated efficiency of approximately 38 percent in visual and aural service.

While the use of single-tube visual and aural amplifiers lacks the redundancy of paralleled visual amplifiers, the output transmission-line complex is simplified since no visual diplexer with the associated reject load, tees, and elbows is required. Patch panel arrangements are consequently simplified.

### One-Man Klystron Change

The integral cavity klystron is easily installed by one man. It is transferred in a horizontal position directly from the shipping container into a four-wheel carriage then, with an ingenious loading device, is rolled into the transmitter. The tube remains in a horizontal position until completely installed, after which it is tilted

to a vertical position and locked. This system requires no unusual ceiling height for clearance.

### Solid-State Klystron Power Supply

The klystron power supply (common to both tubes) is a solid-state unitized supply. It contains a delta-delta power transformer, rectifier stacks, filter reactor, and a-c-snubbing networks in one oil-filled tank. The diode stacks are mounted in modular form, one for each phase, with access through a port at the top of the tank. This supply, also used in RCA higher power transmitters, has an unblemished record of reliability. The filter capacitors for the high voltage supply are located inside the transmitter rear enclosure.

### Easy Conversion To 110 kW Visual Power

The TTU-55B transmitter is designed for conversion to 110 kW with a minimum

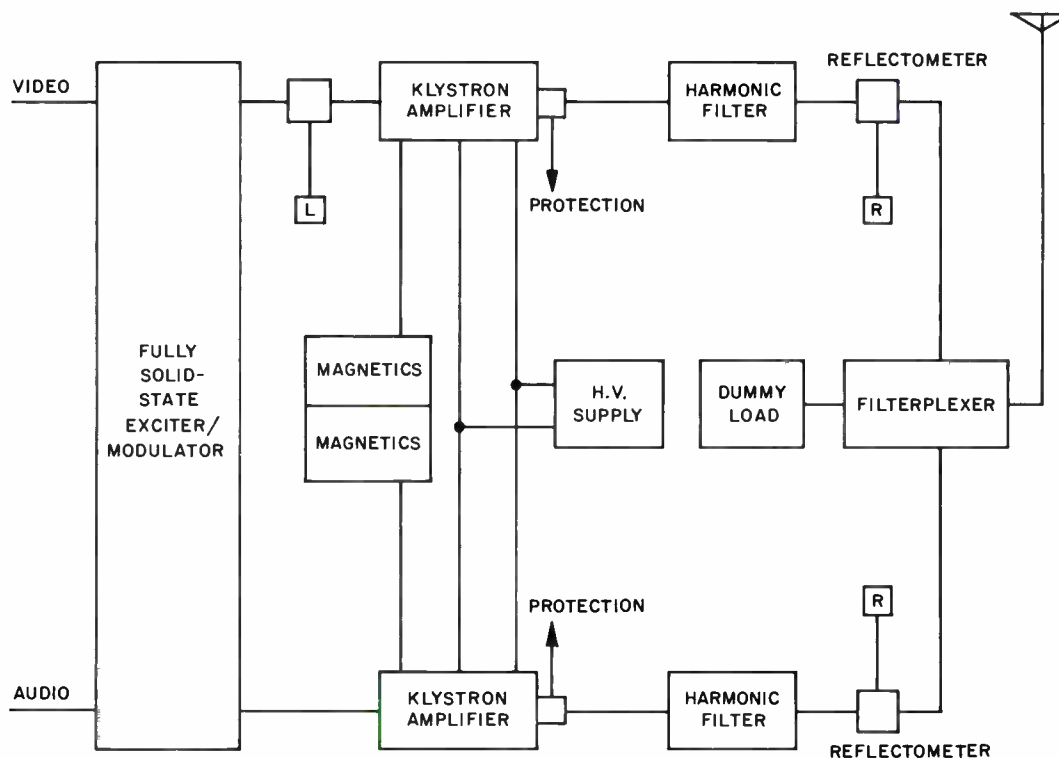

Type TTU-55B Transmitter Block Diagram.

of effort and expense. Fundamentally, the conversion requires the addition of a second visual-amplifier cabinet, a second klystron power supply, and the appropriate visual-combiner components. A higher capacity heat-exchanger is required, but this can be furnished initially if such conversion is contemplated as a possibility. The external water- and steam-plumbing, the water pumps, reservoir tank and copper tubing require no conversion. The circuit-breaker and power-input and breaker panels are replaced as complete

units enabling a higher power conversion with no loss of air time.

### Protection Circuits

The TTU-55B transmitter incorporates circuitry to provide complete protection against a-c and d-c overloads, high VSWR, and klystron arcs. The last two units feature operation whereby the r-f to the klystron is removed in 20 microseconds or less following the initiation of an arc or overload. Front panel indicators display the source of the fault.

### Spare Exciter

A spare exciter group (see *Accessories*) is available to provide exciter redundancy. The spare exciter with its associated sensing, switchover, and metering circuitry is mounted in a matching cabinet which may be installed adjacent to the transmitter exciter control cabinet. This unit provides automatic switchover to the spare exciter in event of a fault. It also may be switched manually or via a remote-control system.

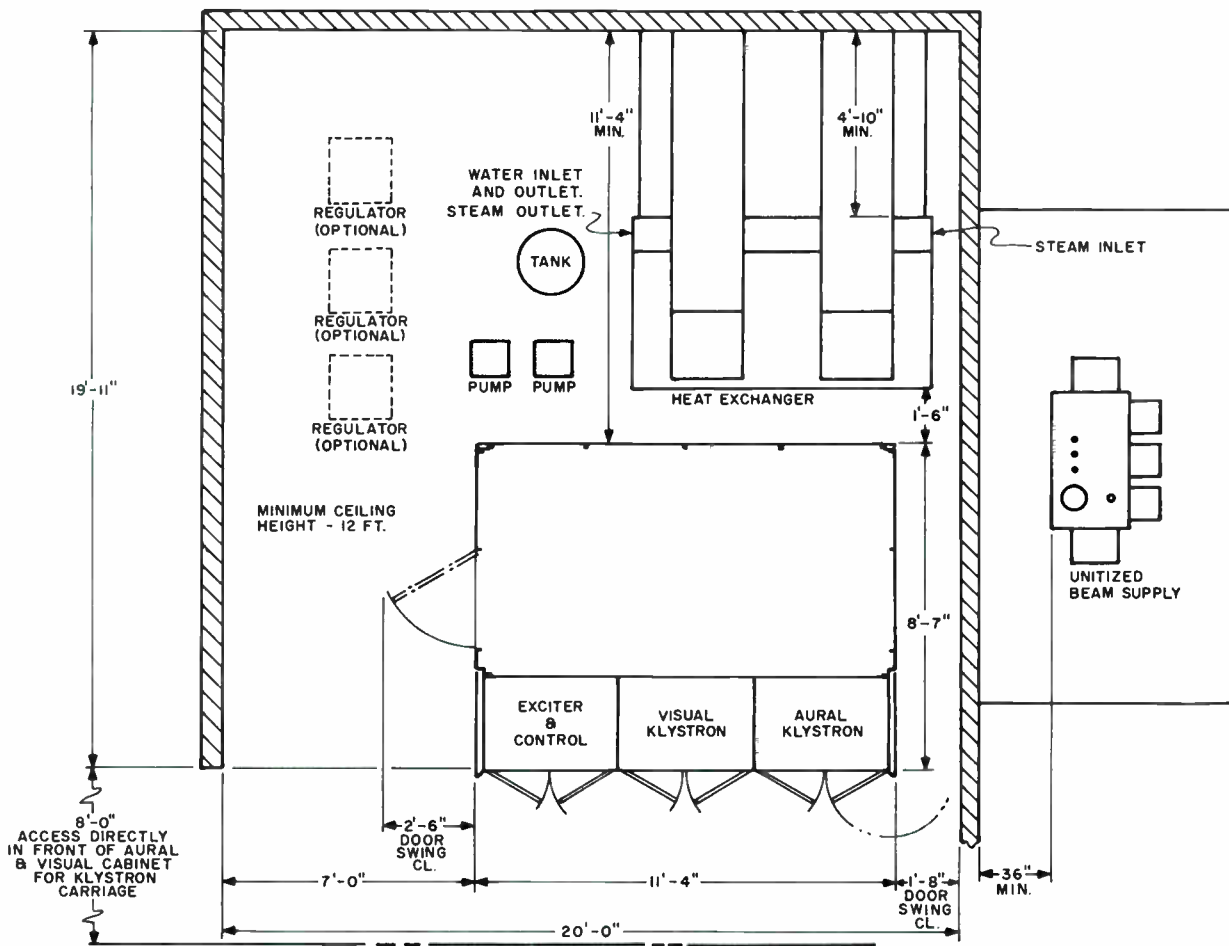

Typical Floor Layout, Type TTU-55B Transmitter.

## Quick-Change Klystrons

For quick and easy tube change, the five-cavity klystron tilts forward and slides onto a special carriage which also contains the spare klystron. This arrangement allows a one-man tube change that takes but a few minutes.

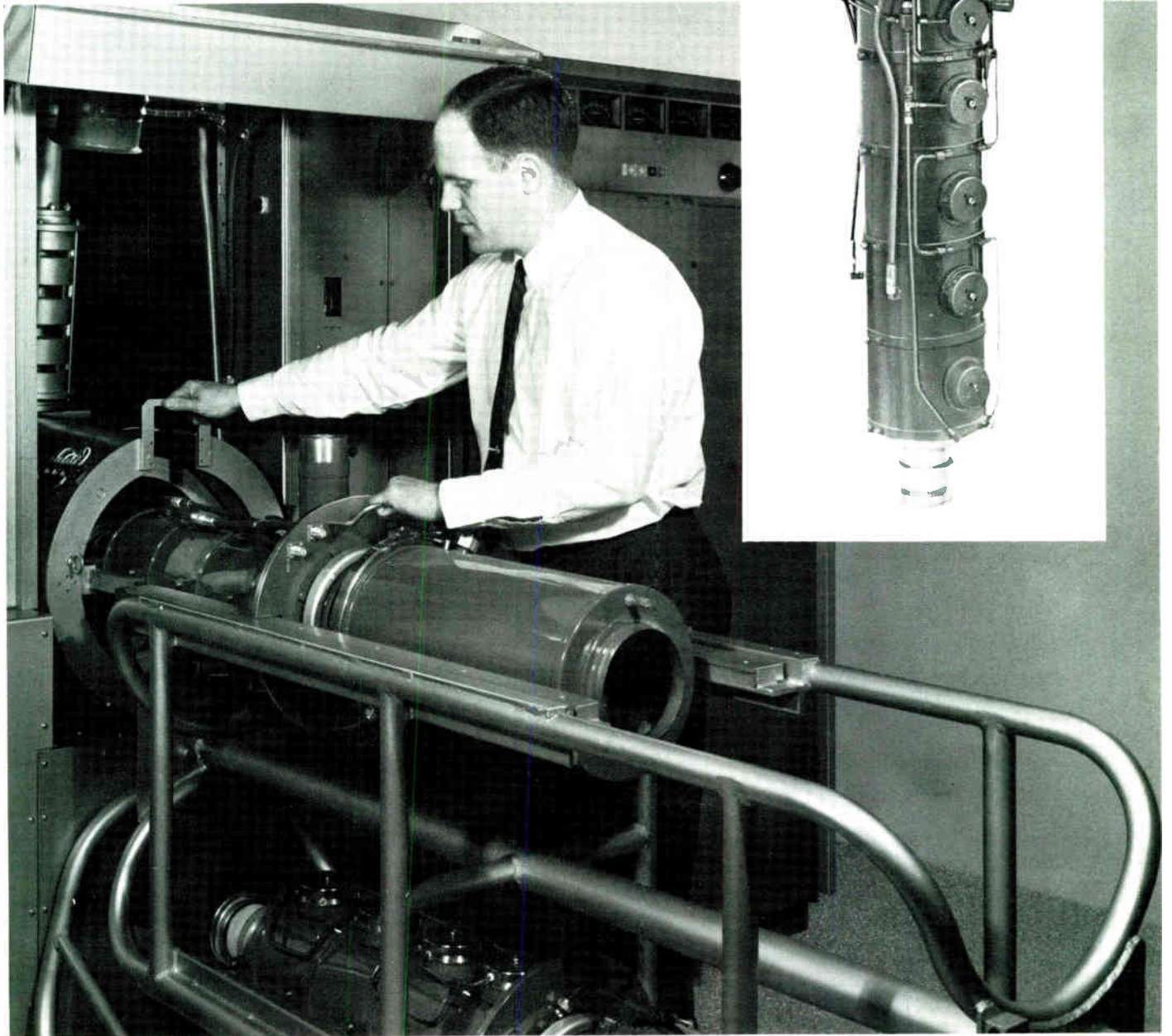



# Specifications

## Performance

Type of Emission:	
Visual .....	A5
Aural .....	F3
Frequency Range .....	470-890 MHz (Ch. 14-83)
Rated Power Output:	
Visual <sup>1</sup> .....	55 kW
Aural <sup>2</sup> .....	12.2 kW
RF Output Impedance <sup>3</sup> .....	50 ohms
Input Impedance:	
Visual .....	75 ohms <sup>13</sup>
Aural .....	600/150 ohms
Input Level:	
Visual .....	0.7 volt peak-to-peak min.
Aural .....	+10 ±2 dBm for ±25 kHz deviation
Amplitude vs. Frequency Response .....	Uniform ±0.5 dB from 50 to 15,000 Hz
Upper Sideband Response at Carrier: <sup>4</sup>	
+0.5 to 2.0 MHz .....	+1, -1.5 dB
+2.0 to 4.0 MHz <sup>15</sup> .....	+0.5, -1.5 dB
+3.58 MHz .....	+0.75 dB
+4.75 MHz .....	-20 dB max.
Lower Sideband Response: <sup>5</sup>	
-0.5 MHz .....	+0.5, -1.5 dB
-1.25 MHz .....	-20 dB max.
-3.58 MHz .....	-42 dB max.
Variation in Frequency Response with Brightness <sup>6</sup> .....	±0.75 dB
Carrier Frequency Stability: <sup>7</sup>	
Visual .....	±500 Hz
Aural .....	±500 Hz <sup>8</sup>
Modulation Capability:	
Visual .....	5%
Aural .....	±50 kHz
Audio Frequency Distortion .....	1% max.
FM Noise .....	30 Hz to 15 kHz
FM Noise .....	-60 dB below ±25 kHz swing
AM Noise r.m.s.:	
Visual .....	50 dB r.m.s. below 100% mod.
Aural .....	50 dB below carrier
K-Factor:	
2T .....	2%
20T .....	3%
Linearity (Low Freq.) .....	1.0 dB max.
Amplitude Variation Over One Picture Frame .....	Less than 2% of the peak of sync level
Regulation of Output .....	3% max.
Burst vs. Subcarrier Phase <sup>9</sup> .....	±3° max.
Subcarrier Phase vs. Brightness <sup>10</sup> .....	±3° max.
Subcarrier Amplitude <sup>9</sup> .....	0.7 dB
Linearity (Differential Gain) <sup>11</sup> .....	0.5 dB max.
Envelope Delay vs. Frequency <sup>12</sup> .....	+60 ns from 0.2 to 2.0 MHz; +40 ns at 3.58 MHz; +60 ns at 4.18 MHz
Harmonic Attenuation, ratio of any single harmonic to peak visual fundamental .....	At least 70 db

## Electrical

AC Line Input .....	440/460/480 V, 3-phase, 60 Hz
Line Voltage Variations .....	±3% max.
Regulation .....	3%
Power Consumption .....	238 kW <sup>14</sup>
Power Factor (approx.) .....	90%

## Mechanical

Dimensions Overall .....	136" long, 105" deep, 77" high (3454 x 2667 x 1956 mm)
Finish .....	Powder and Midnight blue, aluminum trim
Maximum Altitude .....	7500 ft. (2286 m)
Ambient Temperature .....	+1°C. to +45°C. max.

## Accessories

Spare Exciter Group .....	ES-560937
BWU-4C Demodulator .....	ES-34049-C
BWU-5C Sideband Response Analyzer .....	ES-34009-C
BW-8A Envelope Delay Measuring Set .....	MI-34063
Transmitter Control Console .....	ES-561900

<sup>1</sup> Measured at the output of the filterplexer.

<sup>2</sup> Measured at the input to the filterplexer. Usable output depends upon filterplexer rating.

<sup>3</sup> Output impedance of amplifier. Filterplexer output impedance 75 ohm, EIA flanged, 6/8-inch line. Transformations to other standard lines available.

<sup>4</sup> With respect to the response at carrier +200 kHz, as measured by the RCA BWU-5C Sideband Response Analyzer at transmitter mid-characteristic. Aural carrier plus 0.25 MHz response requires a lowpass filter in the video input circuit.

<sup>5</sup> With respect to the response at carrier -200 kHz (4.5 MHz separation standards or 1.5 MHz other standards) at transmitter mid-characteristic.

<sup>6</sup> Maximum variation with respect to the response at mid-characteristic measured with the BWU-5C Sideband Response Analyzer at brightness levels of 22.5% and 67.5% of sync peak, using approximately 20% (peak-to-peak) modulation.

<sup>7</sup> Maximum variation for a period of 30 days without circuit adjustment over an ambient temperature range of +10°C to +45°C. (Meets FCC specifications over ambient range of +1°C to +45°C.)

<sup>8</sup> Maximum variation with respect to the standard 4.5 MHz separation between aural and visual carriers.

<sup>9</sup> Maximum departure from the theoretical when reproducing saturated primary colors and their complements at 75% amplitude.

<sup>10</sup> Maximum phase difference with respect to burst, measured after the VSBF, for any brightness level between 75% and 15% of the sync peak using 10% (peak-to-peak) modulation. This is equivalent to 5% (peak-to-peak) modulation as indicated by a conventional diode demodulator. In addition, the total differential phase between any two levels shall not exceed 50°.

<sup>11</sup> Maximum variation in the amplitude of a 3.58 MHz sine wave modulating signal as the brightness level is varied between 75% and 15% of sync peak. The gain shall be adjusted for 10% (peak-to-peak) modulation of the 3.58 MHz signal when the brightness is at pedestal level. This is equivalent to 5% (peak-to-peak) modulation as indicated by a conventional diode demodulator connected after the VSBF.

<sup>12</sup> Maximum departure from standard curve. The tolerances vary linearly between 2.1 MHz and color subcarrier frequency and between color subcarrier frequency and upper sideband limit and between 3.58 MHz and 4.18 MHz. To meet the specification, a properly terminated phase correction network, ES-34034-B is required in the video input circuit of the transmitter.

<sup>13</sup> Loop-through differential input. Return loss -35 dB max. to 6.0 MHz.

<sup>14</sup> Depends on channel number and aural power ratio.

<sup>15</sup> Relative to carrier +3.58 MHz.

55-kW Visual, 12.2-kW Aural UHF TV Transmitter, Type TTU-55B with Klystrons, Filterplexer, Harmonic Filters, and Low Pass Filter. For 440/460/480 volt, 3 phase, 60 Hz power ES-560927

## Ordering Information

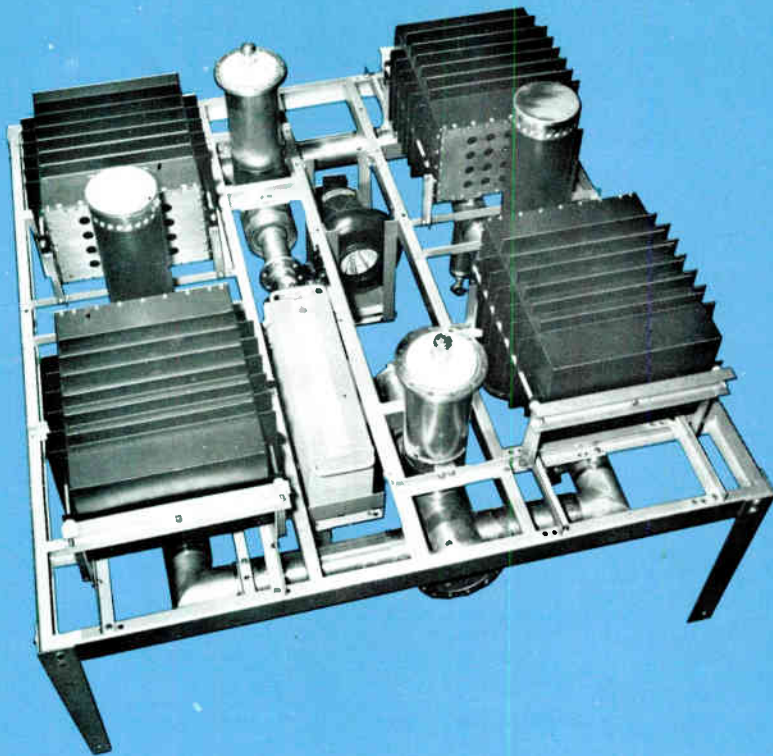

- Economical—combines functions of sideband filter and diplexer
- Non-pressurized design
- Insertion loss less than ½ dB at both the visual and aural carrier frequency
- Pretuned—no adjustments necessary
- TV power rating 60 kW
- Constant input impedance

## **RCA** 60-kW UHF Hybrid Filterplexer

### Description

The 60-kW UHF Hybrid Filterplexer, MI-561543, connects the aural and visual transmitters to a common antenna feed-line with negligible interaction or cross-talk, and shapes the transmitter frequency response to conform to vestigial sideband television transmission standards.

The Hybrid Filterplexer combines the high quality performance characteristics of both a sideband filter and a diplexer. The inputs are designed to have a constant input impedance over the band of frequencies produced.

Since resonant circuits of the lumped inductive-capacitance type are impractical at the frequencies involved, the filter sections consist of lengths of waveguide excited by probes and coaxial sections of

line; hence the term "Hybrid." The newer design techniques result in an un-gassed unpressurized filterplexer.

The filterplexer is assembled on an open frame to provide maximum ventila-

tion. It is suitable for convenient floor or ceiling mounting (horizontal position with 6½-inch connections upward only). The filterplexer is shipped completely assembled.

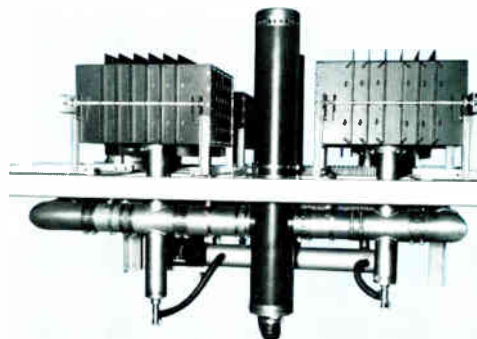

Profile view of 60 kW UHF Hybrid Filterplexer.

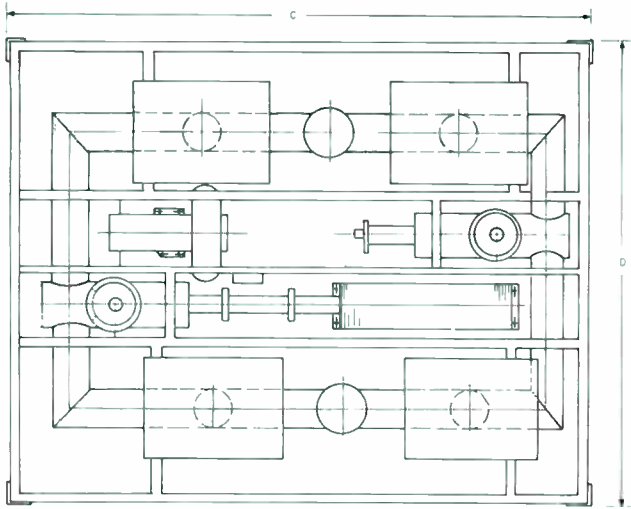

60 kW Hybrid Filterplexer showing dimensions in inches for channels 14 thru 70 in table below.

TABLE I

Channels	A	B	C	D	E
14 thru 22	26.00	49.50	70.36	66.36	6.61
23 thru 30	25.00	46.50	73.30	69.71	5.59
31 thru 41	24.00	44.50	68.74	63.95	5.59
42 thru 70	23.00	40.50	73.36	62.36	5.59

Outline Drawing 1

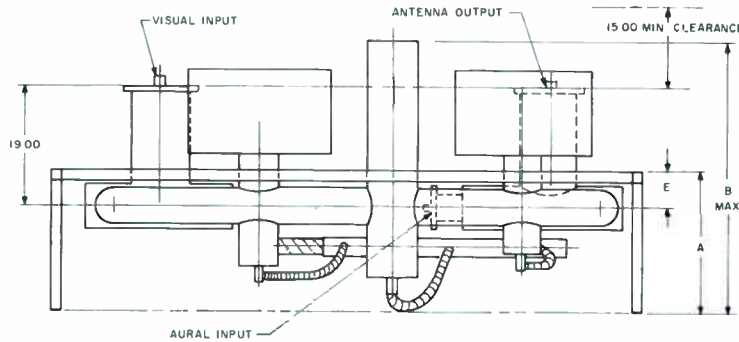

Outline Drawing 2

## Specifications

Frequency	470-812 MHz
Channels	14 to 70
Power Rating (Peak Visual)	60 kW
Visual to Aural Ratio	20% or less
Minimum Efficiency (Visual but not aural losses are included in transmitter peak power rating):	
Aural	90% (0.46 dB loss)
Visual	90% (0.46 dB loss)
Output Impedance	75 Ohms
Input Impedance (Visual)	75 Ohms
Input Impedance (Aural)	50 Ohms
Maximum Visual Input VSWR (Referred to visual carrier frequency):	
-4.5 MHz to -1.25 MHz	1.3:1
-1.25 MHz to +4.2 MHz	1.15:1
+4.2 MHz to +4.5 MHz	1.3:1

Maximum Aural Input VSWR (Referred to visual carrier frequency):	
4.5 MHz to $\pm 100$ kHz	1.3:1
Maximum Ambient Temperature	45°C
Minimum Ambient Temperature	0°C
Blower Line Requirements	230 V, 1 ph, 50/60 Hz
Interlock Circuit	5 Amp. max., 230 Volts
Dimensions	See Table I and Outline Drawings 1 and 2
Clearance	Minimum 18" additional clearance required on all sides of unit for access
Mounting	Floor or ceiling (horizontal position with 6 1/8-inch connections upward only)

Connections:	
Input (Aural)	3 1/8", 50 Ohm flanged (MI-19089)
Input (Visual)	6 1/8", 75 Ohm flanged (MI-19387)
Output	6 1/8", 75 Ohm flanged (MI-19387)
Weight (Net) Approximate	600 lbs.
	as packed are C +9.62", D +6.75" and B +4.50"

## Ordering Information

60 kW Hybrid Filterplexer ..... MI-561543\*

\* Filterplexer is shipped completely assembled.

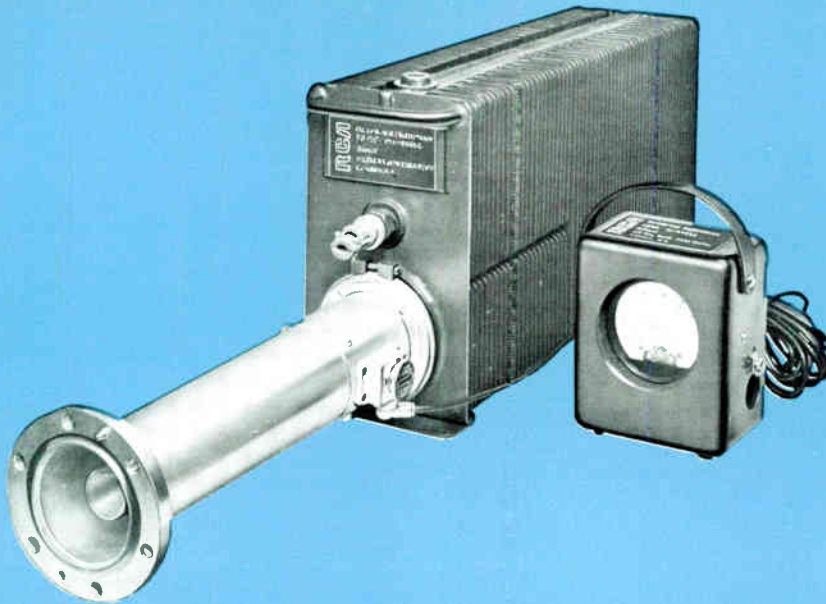

- Performs dummy TV antenna and RF power measurement functions
- Easily installed—occupies little space
- Reads directly in Watts
- Reads incident or reflected power

## RCA 1200 Watt RF Load and Wattmeter

### Description

The MI-19197 RF Load and Wattmeter is an air-cooled type 1200 Watt (2 kW peak picture power) unit designed for use in measuring the power output of the aural and visual sections of UHF television transmitters. The load properly terminates the output of either the visual or aural transmitter and reads the average RF power. It may also be used as a dummy antenna for transmitter tuning.

The RF Load is equipped with flanged fitting to mate with MI-19089 3 $\frac{1}{8}$ -inch, 50 Ohm line, and is specified for use with RCA's Type TTU-2A UHF Transmitters. The equipment's power dissipating section consists of the load resistor and a liquid coolant which are contained in a finned radiator structure. The power measuring section consists of a short length of transmission line (Thru-line), a meter, and two wattmeter elements which provide 0-150 Watt and 0-1500 Watt full-scale meter deflection. A thermostat is also supplied.

The wattmeter element is a reflectometer which consists of a coupling loop, a crystal detector, and a filter network. The wattmeter element may be rotated 180 degrees in the transmission line

housing. This permits it to indicate the incident power to the load, or the reflected power from the load.

The MI-19197 also serves as the reject load resistor on the RCA MI-19086 Fil-

terplexer series. In this application, the inner conductor of the transmission line section is specifically optimized to give a VSWR of 1.02 or better for the operating channel.

### Specifications

Frequency Range .....	470 to 960 MHz
Power Rating (Avg. at 7500 ft. max. ele.) .....	1200 Watts
RF Input Impedance .....	50 Ohms
Ambient Temperature:	
Maximum .....	45°C
Minimum .....	10°C
Mounting .....	Horizontal, vent plug up
Coolant Capacity .....	1.7 gallons
Water Required .....	None (air cooled)
Dimensions: (Overall): .....	36 $\frac{1}{8}$ " long, 6 $\frac{3}{8}$ " wide, 10 $\frac{3}{4}$ " high (93.03 cm, 16.19 cm, 27.31 cm)
Weight .....	48 lbs. (21.8 kg)

### Accessories

Reducer, 50 Ohm, 3 $\frac{1}{8}$ " to Type N .....	MI-19089-17
Adapter, Type N to Type HN .....	MI-19089-19
Connector (anchor insulator) .....	MI-19089-10A

### Ordering Information

RF Load, 1 Wattmeter, 1 Wattmeter Element (0-1500 Watts) and 1 Wattmeter Element (0-150 Watts) .....	MI-19197
------------------------------------------------------------------------------------------------------	----------



15/25-kW UHF RF Load MI-19198-A2 shown with accessory MI-27350 Thru-line RF Wattmeter and MI-19089-10A connector.

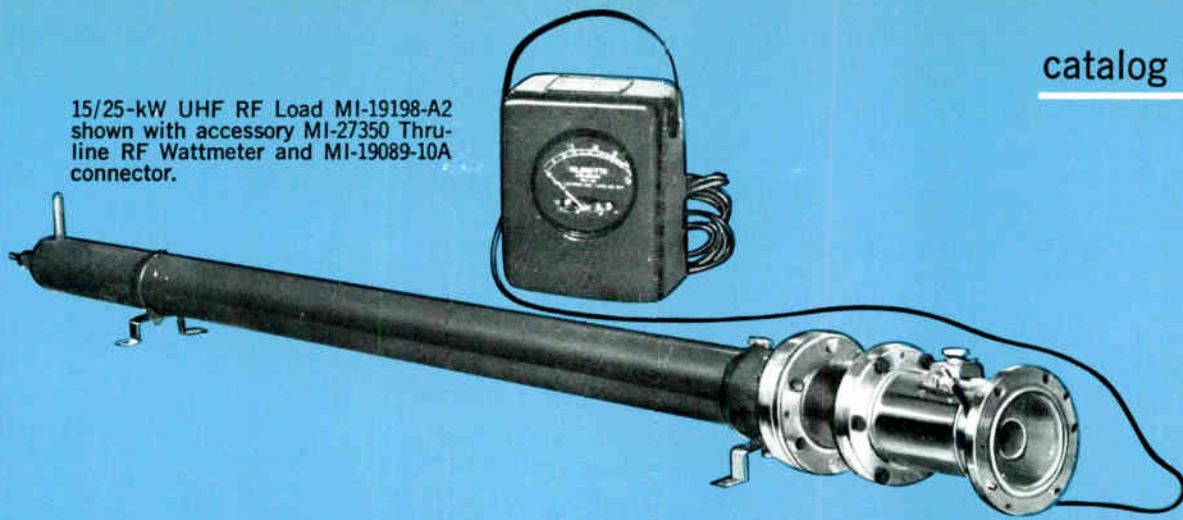

- Performs dummy TV antenna and RF power measurement functions
- Easily installed—occupies little space
- Thru-line RF wattmeter reads directly in Watts
- Reads incident or reflected power

## RCA 15/25 KW UHF RF Load

### Description

The MI-19198-A2 15/25-kW RF Load (40-kW peak visual power) is a termination type unit for operation in the UHF frequency range. It is recommended for use with the RCA Type TTU-10A and TTU-30A transmitters. This unit may be connected to either of the transmitter outputs, or the output of the filterplexer. It is equipped with a 3 $\frac{1}{8}$ -inch, 50-Ohm flanged input fitting to mate with MI-19089 line. An MI-19387-4CH reducer transformer is required for connection to a 6 $\frac{1}{8}$ -inch, 75-Ohm filterplexer output. A thermoswitch is also supplied.

The MI-19198-A2 load utilizes a column of tap water for power dissipation. The input of the load consists of a polyethylene transformer section to provide a correct impedance match to the connecting line. The opposite end of the line is short circuited and contains the input and output water connections. The water flows through the inner conductor and enters the space between the inner and outer conductor through small perforations in the inner conductor adjacent to the transformer section. The water flow continues to the output drain connection.

Broadband wattmeters, with scale ranges of 0 to 15 kW or 0 to 25 kW, can be provided as accessory equipment. The

Thru-line unit and associated wattmeter element allow direct incident power readings, or with a 180 degree turn, a reading

of the reflected power. A connector MI-19089-10A is required between the load and Thru-line unit.

### Specifications

Frequency Range .....	470 to 960 MHz
Power Rating (Avg. at 8000 ft. max. ele.) .....	25 kW
RF Input Impedance .....	50 Ohms
Ambient Temperature:	
Maximum .....	45°C
Minimum .....	5°C
Mounting .....	Horizontal, water output up
Water Required (Potable tap) .....	4.5 to 8.3 gpm (40°C max.)
Dimensions: (including	
Thru-line) .....	.89 $\frac{1}{16}$ " long, 5 $\frac{3}{4}$ " wide, 5 $\frac{3}{4}$ " high (226.85 cm, 14.61 cm, 14.61 cm)
Weight: (including Thru-line) .....	50 bs. (22.68 kg)

### Accessories

Connector (anchor insulator) .....	MI-19089-10A
Thru-line RF Wattmeter (0-15 kW for MI-19198-A2) .....	MI-27350*
Thru-line RF Wattmeter (0-25 kW for MI-19198-A2) .....	MI-27363**

\* Line section, 1 wattmeter, 1 wattmeter element (0-15 kW) and 1 wattmeter element (0-1.5 kW).

\*\* Line section, 1 wattmeter, 1 wattmeter element (0-25 kW).

### Ordering Information

RF Load Assembly (15/25 kW, 470-890 MHz).....MI-19198-A2



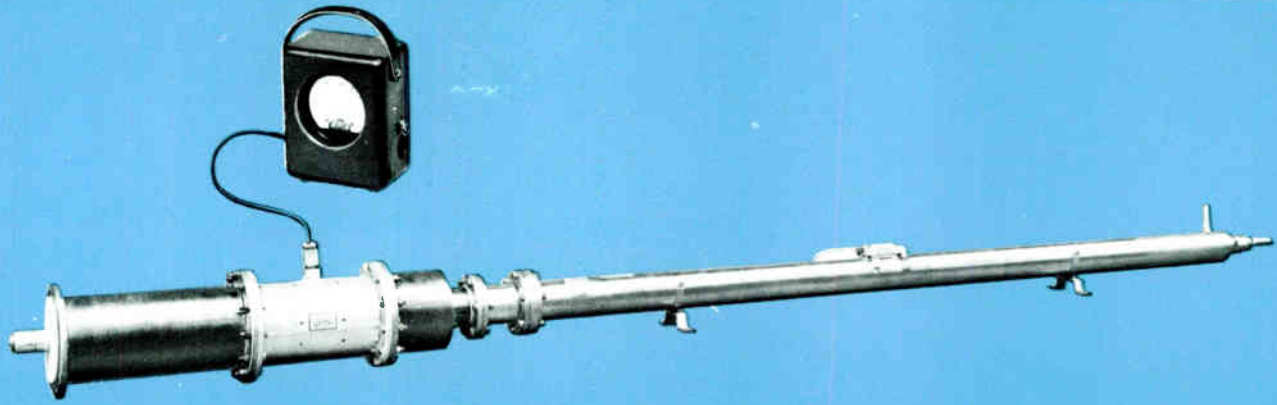

- Reads power directly in Watts
- Reads incident or reflected power
- 10/25/50 kilowatt full scale readings

## RCA 50 KW UHF RF Load and Wattmeter

### Description

The ES-561408 50-Kilowatt RF Load and Wattmeter is a water cooled termination type unit for operation with RCA Type TTU-50 UHF Transmitters. The input is 6 $\frac{1}{8}$ -inch, 75-Ohm (MI-19387) and may be directly connected to the combined visual transmitter output or the output of the filterplexer. With the aid of an MI-19387-4CH reducer transformer, the unit may be connected to either the aural or individual visual outputs which are 3 $\frac{1}{8}$ -inch, 50-Ohm (MI-19089). A thermoswitch is also provided.

ES-561408 consists of a transformer, a Thru-line unit, a reducer and an MI-19198-A2 RF load. The input transformer is designed to match the 6 $\frac{1}{8}$ -inch, 75-Ohm transmission line to the 50-Ohm Thru-line unit. The Thru-line unit is supplied with three elements and a Wattmeter to provide full scale readings of 10, 25 and 50 kilowatts. The individual elements may be turned 180 degrees to provide either incident or reflected power reading. The section reducer matches the 6 $\frac{1}{8}$ -inch Thru-line unit to the 3 $\frac{1}{8}$ -inch input of the RF load. The transformer,

Thru-line and reducer units are supplied as a complete matched and tuned assembly for a specified channel. The RF load is supplied with all hardware re-

quired to mate with the reducer unit. The water flow requirements for 50-kilowatt operation may be found in the following specifications.

### Specifications

Frequency Range .....	470 to 842 MHz
Power Rating (Avg. at 8000 ft. max. ele.) .....	50 kW
RF Input .....	6 $\frac{1}{8}$ -inch, 75 Ohm coaxial line (MI-19387)
Ambient Temperature:	
Maximum .....	45°C
Minimum .....	5°C
Mounting .....	Horizontal, water output up
Coolant .....	Potable tap water 40°C max.
Water Requirements (typical) .....	9.7 gpm @ 10°C
	to 16.4 gpm @ 40°C
VSWR .....	1.1 Maximum
Dimensions (overall) .....	114-13/32" long, 8 $\frac{1}{8}$ " (greatest diameter)
	(290.6 cm long, 20.64 cm greatest diameter)
Weight (approx.) .....	80 lbs. (36.28 kg.)

#### Accessory

Reducer Transformer .....MI-19387-4CH\*

### Ordering Information

50 kW UHF RF Load and Wattmeter .....ES-561408-CH\*

\* Specify channel in purchase order.





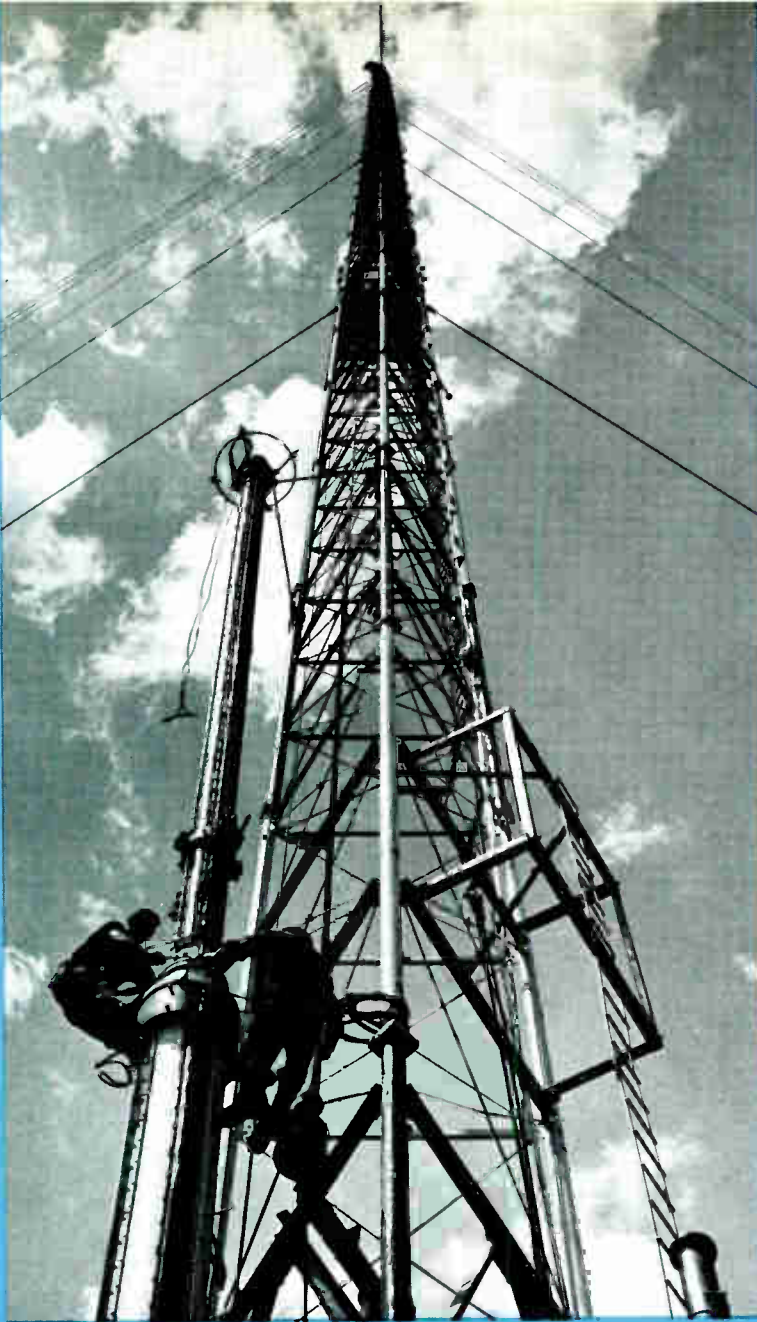

- Designs by experienced tower engineers
- Single contract service—complete tower planning, design, fabrication, installation and inspection, one responsibility
- Variety of types and heights to fit site, antenna, accessory and load requirements
- Custom designed structures to meet special or unusual requirements
- Complete tower accessories

## **RCA** Television Antenna Towers

### Description

A wide selection of towers to support the various type RCA UHF and VHF Television Antennas is available for all applications. Included are self-supporting and guyed designs. Custom towers for multiple antenna applications are also available.

RCA, as a representative of tower manufacturers, is qualified to assist the Broadcaster in the planning and selection of the proper tower and a qualified erector. A popular, one contract, one responsibility, service is available.

## Design Considerations

Relatively flat country with low surrounding hills lends itself well to the installation of tall supporting structures. Towers over 500 feet in height are usually guyed and the usual cross sectional shape is triangular so that three point guying can be used. Guyed tower costs are lower than for self-supporting structures because less steel is used and erection is less costly. The availability of land and the area involved for guy anchorage however increase costs of this type of tower. A useful method for estimating the land required for a guyed

structure is to consider the distance to the farthest guy anchorage as being approximately 70 percent the tower height. For self supporting tower the distance between tower legs is usually 10 percent of the height.

## Guyed Towers

Guyed towers normally are constant in cross-section along their entire height. They are supported by steel guy cables which span out to steel reinforced concrete anchors buried in the earth. Such towers are available with either fixed or pivoted bases. Each has certain advantages. A pivoted base tower tapers to a

point at the bottom. The tower and the foundation are connected at this single point. The tower will remain upright and plumb even if the foundation shifts unevenly. Because of this feature, pivoted base towers are normally used when the soil at the site may have unknown load-bearing qualities. Each leg of a fixed base tower is bolted to the foundation making the tower-to-foundation connection a rigid one. Fixed base towers permit direct installation of transmission lines at the ground level. They also permit installation of the elevator bottom landing closer to the ground.

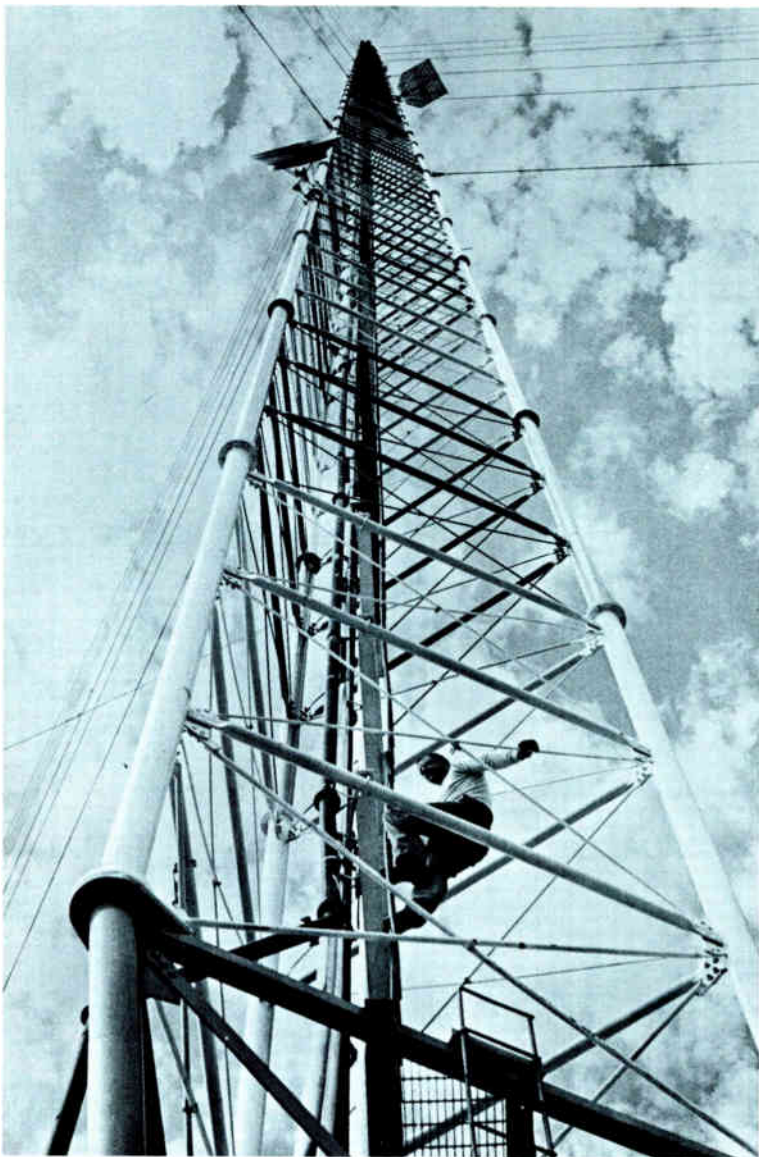

Guyed television towers can achieve great height at less cost than self-supporting structures where land value is not a determining factor. Towers are triangular and are available with either fixed or pivoted base.

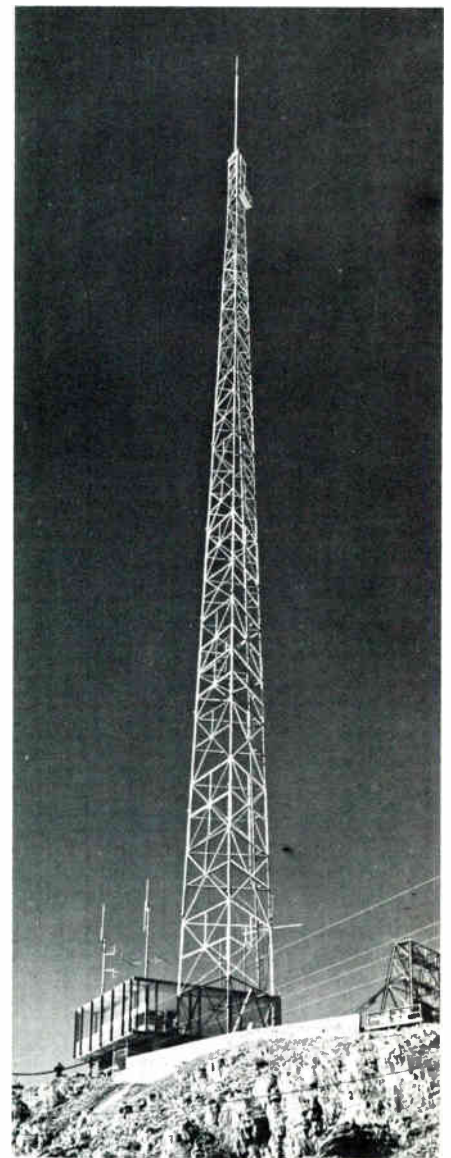

Ranger Peak, 1900 feet above average terrain, near El Paso, Texas is an ideal site for KTSM-TV's self-supporting type antenna tower.

## Self-Supporting Towers

Self-supporting towers are wide at the base and taper gradually to the top. They are not supported by guy cables but depend upon their tapered configuration for stability. Such towers are especially advantageous in city and congested districts where availability of land is limited.

The use of towers upon tall buildings is often quite practical. This normally results in smaller towers and shorter transmission lines, especially if the building is high enough to conform to the desired antenna height. Building frameworks must be reinforced and erection problems sometimes become quite complex.

Mountain-top sites in general do not lend themselves to guyed towers due to limited land area available for guy points. As a result, most of the mountain top installations are of the self-supporting type. Since coverage is proportional to height a strategically located mountain top site is desirable. On a mountain top, a short tower is acceptable to mount the antenna away from close-in reflecting objects.

## Multiple Antenna Towers

Towers carrying a number of antennas, either in a stacked arrangement or with all antennas at the same height on a top platform, or with a combination of platform and side mounted antennas can be supplied. Multiple antenna towers save each station on land cost, enable each station to utilize the area's best site, simplify air-space clearance problems, and greatly reduce receiving antenna orientation problems.

## Tower Foundations

Tower foundation design is based upon a laboratory analysis of the load bearing capacity of the soil in which the foundation will be placed, together with a determination of the uplift the foundation will be required to withstand. It is sometimes necessary to reinforce foundations with steel, wood or concrete piling. Swampy land provides a poor foundation base. Sand, gravel and clay soils are normally satisfactory. Shale or rock are good. A steel reinforced concrete foundation supports and fixes the base of most towers. Anchor bolts for the tower are cast right into the foundation with just the threaded ends protruding.

## Weather Protection

The steel superstructure may be hot dip galvanized steel where corrosive



Station WSB's triangular self-supporting tower rises skyward to support a pylon antenna. Such towers are recommended where sites are in congested areas or where a tower is designed for erection on a roof-top.

action due to fumes, salt air, etc. are known to exist. Galvanizing can be omitted if the tower sections are heavy and painting is done frequently. Climbing ladders should be located inside the tower if at all possible and preferably near the tower legs. By placing the ladder within the tower, the lattice braces form a safety cage for the serviceman. Rungs are spaced for easy climbing or descent.

### Tower Elevators

Tower elevators are recommended on towers of 1000 feet or more in height. They eliminate the danger of long periods of interrupted service through making it possible for a technician to get up the tower fast in any kind of weather. They also enable the engineer or station manager to give on-the-spot supervision to work performed on the tower, without climbing. Finally, elevators greatly simplify routine maintenance. Conventional passenger elevator safety devices should be a part of every tower elevator system.

### Service Platforms

Tower platforms are featured in most tower designs. Inside platforms are located at each light level to provide a safe rest and work area for the tower

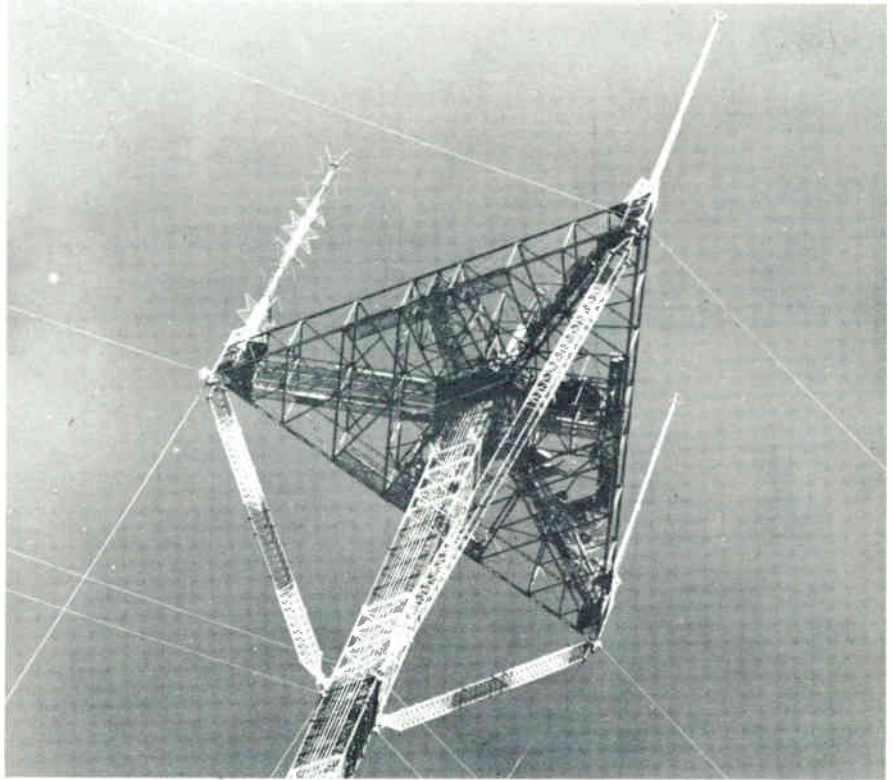

1500-foot top platform multiple antenna support tower affords substantially increased coverage for Stations KCRA, KOVR and KXTV in Stockton-Sacramento area. The economies afforded through a single tower, as opposed to three separate structures, are obvious.

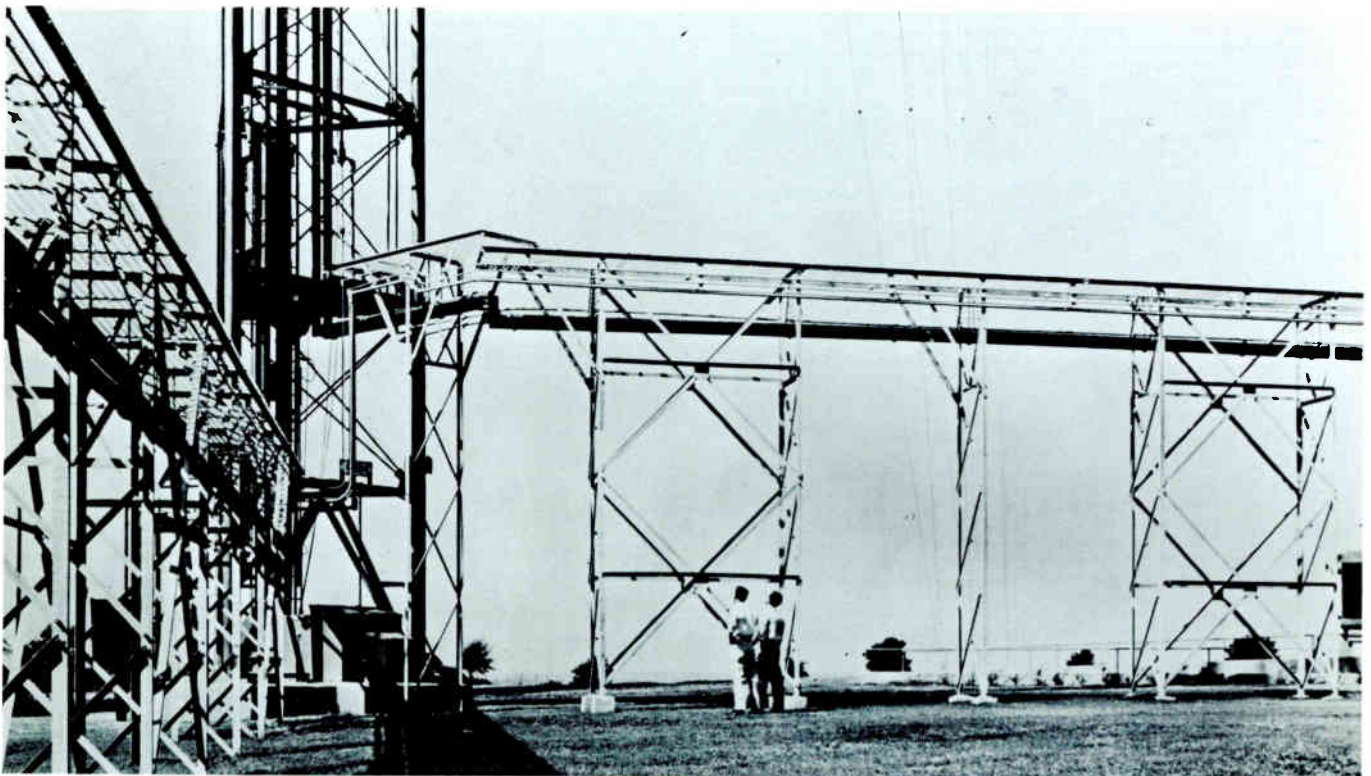

TV tower showing horizontal transmission line runs protected by ice shields.

maintenance workers. Outside platforms with railings can be installed at any level required to provide convenient access to side mounted equipment. Top platforms to carry multiple antenna installations are fitted with catwalks, railings and ladders to provide easy access to antennas and transmission lines.

Telephone lines and jack boxes can be installed on the tower to provide quick communication between maintenance workers on the tower and the ground.

### Lightning Protection

All RCA antennas mounted on the top of a tower are provided with branching type lightning protectors. These consist of four rods disposed symmetrically about the 300mm beacon and extend above it. The parts are ruggedly built and are hot dip galvanized. The branching type initiated by RCA have been used on hundreds of antennas and have been highly effective on tall towers in areas having the highest incidence of lightning in the country.

### Tower Lighting

Complete tower lighting systems, designed in accordance with FCC and FAA requirements, are supplied with each tower. Lighting systems contain a series of flashing beacons and obstruction lights at intermediate levels. The number of beacons and lights required varies with the tower height. A photo-electric lighting control, to automatically turn the tower lights on at sunset, off at sunrise, is supplied as a part of each lighting system. A lamp failure indicator panel can be installed in the transmitter building as auxiliary equipment.

A pole socket and guide flange is used to support and steady superturnstile antennas of the usual "bury" type. The guide flange is mounted at the tower top to keep the antenna perpendicular to the ground. The pole socket receives the weight of the antenna. It is mounted fifteen percent of the pole length below the tower top. RCA furnishes the pole socket and guide flange with each superturnstile antenna except the Models TF-12AM and TF-12AL. For these two types, the tower manufacturers fabricate the pole socket and guide flange.

Where necessary, arrangements may be made to provide a pedestal type mount that effectively mounts the antenna on the tower top and eliminates the "bury" section.



By placing a service ladder within the tower, the lattice braces form a safety cage for the servicemen.

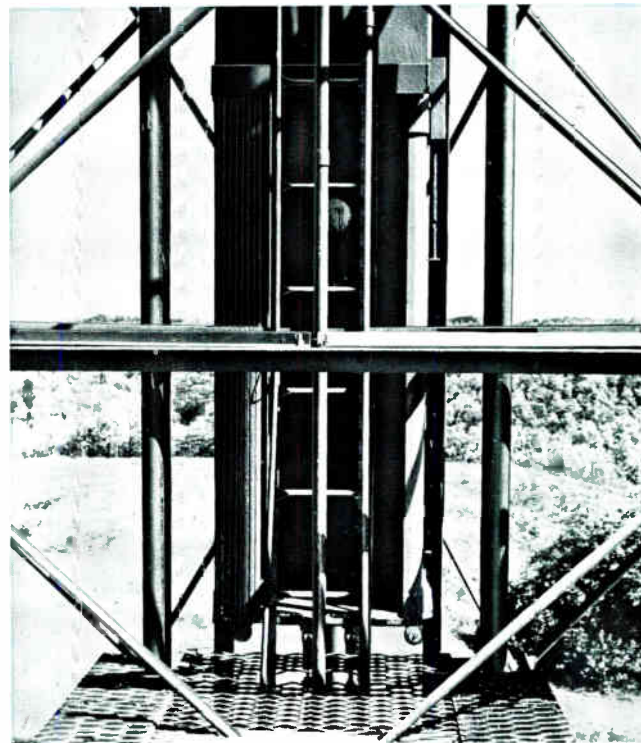

Tower elevators greatly simplify maintenance and should be considered for all towers of great height.



Typical anchorage for pivoted base type of guyed tower. Connected at a single point, the tower will remain upright and plumb even if the foundation shifts unevenly.

The twelve-section supertunestiles have an RF combining network which is accommodated below the tower top. Provisions are made so that tower cross bracing does not interfere. Mounting provisions are supplied for hangers to support this network.

Traveling wave antennas are furnished with a flange at the base for mounting on the tower top.

### UHF Antenna Mountings

The standard UHF transmitting antenna is the UHF Pylon. It is flange mounted directly to the tower top plate. Tapered wedges are supplied to obtain mechanical beam tilting of the antenna where specified.

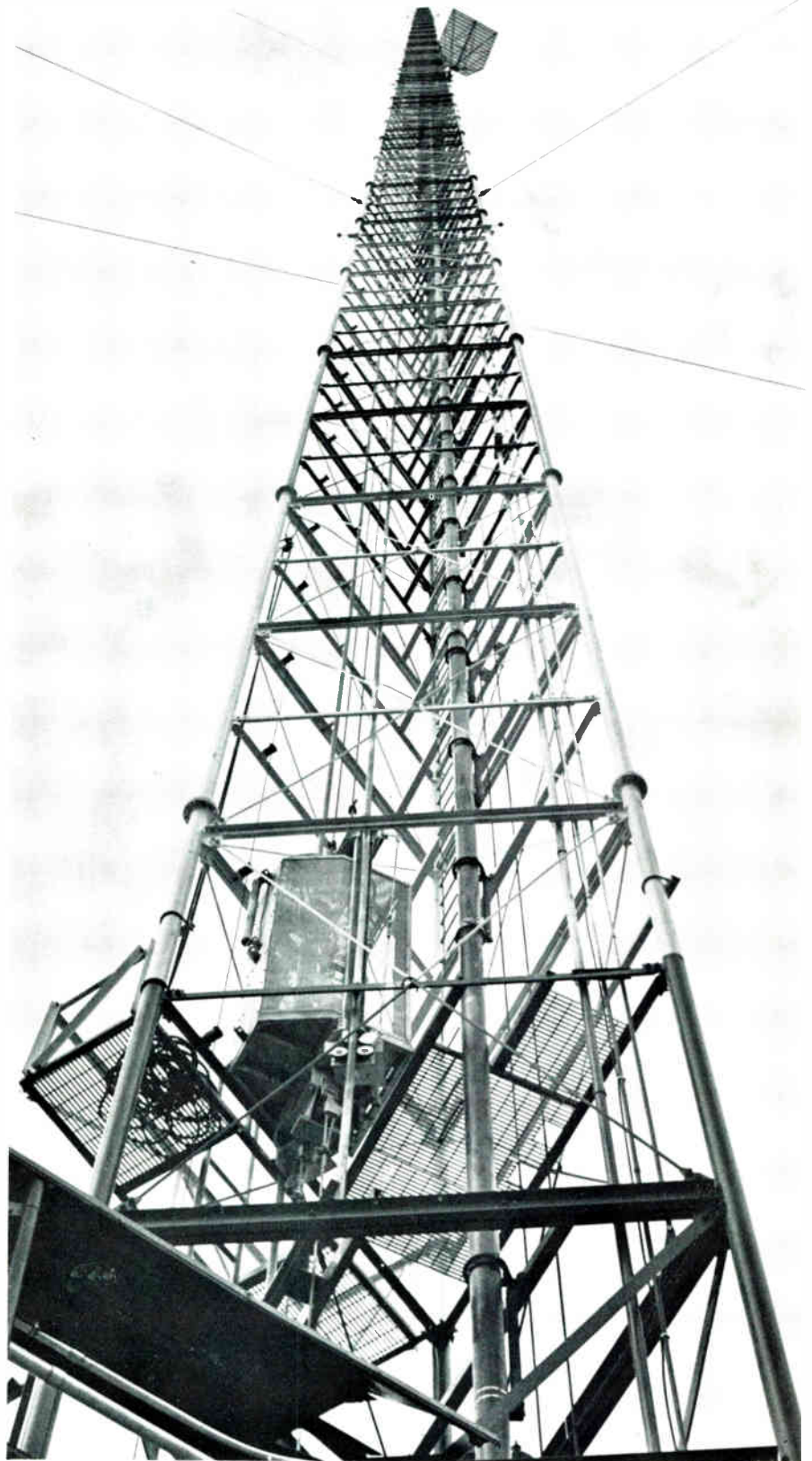

Vertical run of transmission line inside a triangular cross-section tower. Spring-tensioned hangers allow movement of the line due to thermal expansion and contraction.

## Transmission Lines

Careful consideration is given to the layout and support of transmission line on the tower to allow for expansion and contraction of line and ease of maintenance. The tower manufacturer will consult with RCA engineers to be sure there is adequate support for the line and that a minimum number of elbows are used between the antenna input and the vertical run down the tower. The tower company will supply supports for spring

hangers from the top to the base of the tower. Outline drawings with dimensions are available for all types of transmission lines and will be used in making a layout. These are shown in the RCA Transmission Line Catalog.

### Wind Load

Most towers are currently built to 50/33 pound loading. This means that tower members are designed to resist a horizontal wind pressure of 50 pounds

per square foot of projected area on all flat surfaces and 33 pounds on round surfaces.

Provision is made for all additional loadings caused by antenna, ladders, transmission and power lines, etc. and is applied to the projected area of the structure. The total load specified is applied in the direction which will cause the maximum stress in the various members. Where high winds or heavy icing is prevalent higher loading is often specified.

## Wind Velocity and Corresponding Wind Pressure on Towers

### EIA Standard Specification

Actual Wind Velocity MPH	Wind Pressure on Flat Surfaces $P = .004 V^2$	Wind Pressure on Round Surfaces	Estimated Survival Velocities F. S. 1.65
10	.4	.266	12.9
20	1.6	1.067	25.8
30	3.6	2.4	38.6
40	6.4	4.27	51.5
50	10.0	6.67	64.4
60	14.4	9.6	77.3
70.7	20.0	13.33	91.1
80	25.6	17.1	103.0
86.6	30.0	20.0	111.5
90	32.4	21.6	115.9
100	40.0	26.7	128.8
110	48.4	32.3	141.7
111.8	50.0	33.3	144.0
120	57.6	38.5	154.6
122.5	60.0	40.0	157.8
130	67.6	45.0	167.4
132.3	70.0	46.67	170.4
140	78.4	52.33	180.3
141.4	80.0	53.33	182.1
150	90.0	60.0	193.2
160	102.2	68.2	206.1
170	115.6	77.0	219.0
180	129.6	86.6	231.8
190	144.4	96.3	244.7
200	160.0	106.66	257.6

### Factor of Safety

2.5	Guy cables proof tested hardware
1.65	Tension and bending
1.70-1.94	Compression

NOTE: Cables made up with safety clip connections are derated to 85% of breaking strength.



Every tower is custom built to meet station requirements. RCA is equipped to supply a tower completely designed to meet station requirements. By specifying RCA you are assured a satisfactory installation.

Towers are designed in accordance with EIA Specifications.\* Consultation with RCA Broadcast Representatives will help to determine every requirement. Call or write your nearest representative. In order to facilitate selection of the tower most suitable, and as an aid to the station in determining specific requirements, a sample questionnaire is included here.

### Tower Considerations

The following procedure may be helpful as a check list in considering tower requirements.

1. Determine station location with respect to service area. This study which will involve among other things joint operation with other stations, FAA approval, cost of land, zoning restrictions, local regulations, etc., will result in a decision to use:
  - a. A self-supporting tower when land is unavailable as in city limits or on top of a building.
  - b. Or a guyed tower where land is available and a greater height is desired.
  - c. Or a multiple antenna tower.
2. Determine design parameters:
  - a. Wind load for area in which tower is located.
  - b. Deflection at tower top for type of service required.
  - c. Type of antenna which is to be supported.
3. Determine tower accessories such as:
  - a. Ladders.
  - b. Platforms.
  - c. Railings.
  - d. Lighting.
  - e. Microwave dishes.
4. Determine method of routing transmission line taking into account:
  - a. Accessibility.
  - b. Location of structural members.
  - c. Location of special networks below tower top.

### Accessories

RCA can furnish in addition to the antenna supporting tower, tower lighting equipment and installation and erection assistance.

\* EIA Standard "Structure Standards for Steel Transmitting Antennas, Supporting Steel Towers" RS-222.



Self-supporting 135-foot microwave tower at Station WAVE-TV showing two receiving dishes on platform—one fixed and one rotatable. The reflector handles a 7000 MHz STL microwave and also a 2000 MHz STL, both with roof-mounted antennas.

<b>Antenna Tower Questionnaire</b>		
LOCATION		
City .....	State .....	
QUOTATIONS TO BE FURNISHED		
(Check those required)		
Tower	Guyed .....	( )
	Self-supporting .....	( )
	Multiple .....	( )
Tower Lighting Equipment.....	( )	
Tower Erection:		
Antenna and Assembly Installation.....	( )	
Transmission Line Installation.....	( )	
SPECIFICATIONS		
Tower Height: Ground to top of tower.....	.....	
	Ground to top of base insulator.....	
Tower Use: Antenna support.....	.....	
Channel or Frequency.....	.....	
TV Antenna: Type.....	.....	
	Description.....	
Transmission Lines:	Size	No.
Design Load: .....	.....	
Remarks:	(Special requirements, site accessibility, etc.)	

AM  
TRANSMITTING



## **RCA** 1 KW AM Broadcast Transmitter, Type BTA-1R3

- Excellent frequency response
- Low distortion
- Circuit breaker overload protection
- Low operating costs

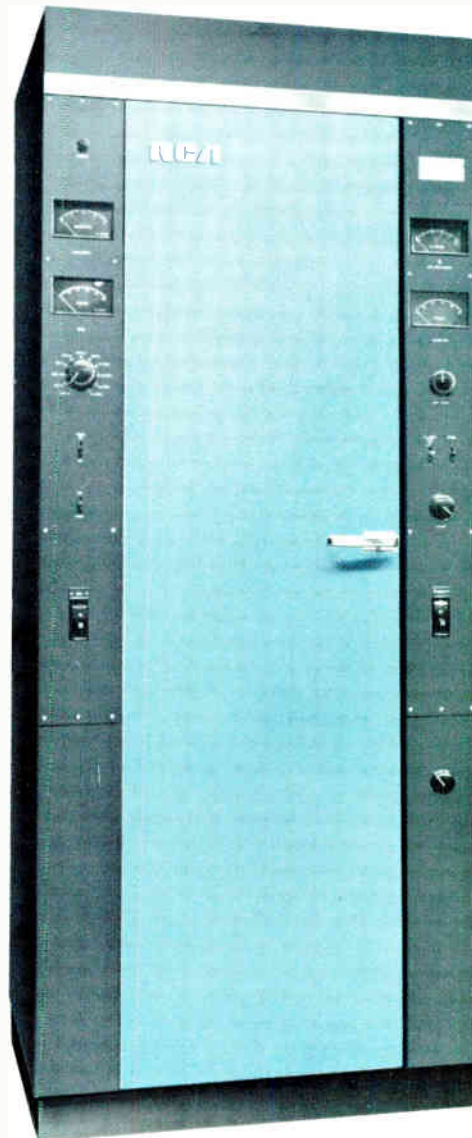

3TB

BTA-1R3 Transmitter with front door removed showing accessibility of tubes and components. Power amplifier and Modulator tubes are shown on top chassis; below is exciter chassis. All normal operating controls are on two side panels.

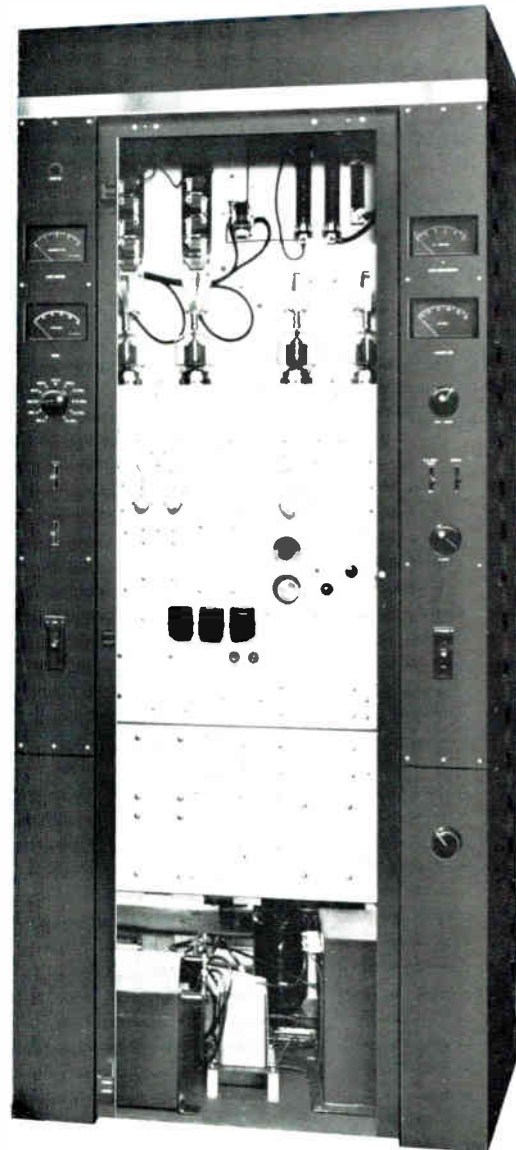
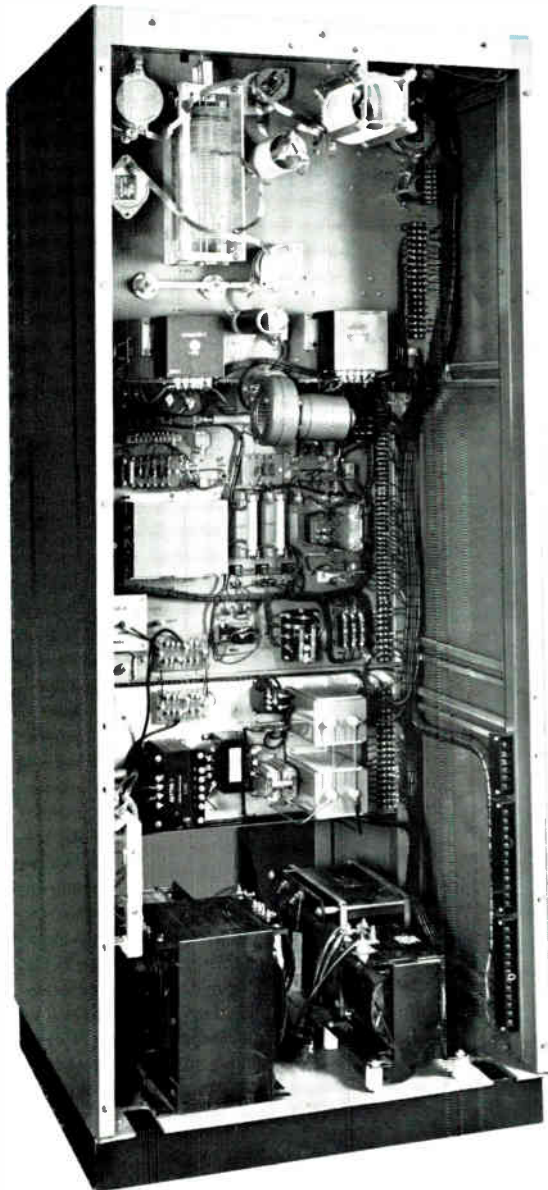

Rear view of BTA-1R3, with rear panels removed, showing vertical construction and accessibility of component parts.

## Description

The RCA Type BTA-1R3, 1-kilowatt AM Broadcast Transmitter is designed for reliability, outstanding fidelity, and economical operation. It provides a high quality amplitude modulated signal at any frequency in the 535 to 1620 kilohertz band and is capable of producing a maximum of 1100 Watts.

Highly perfected audio circuits together with a large, high-quality transformer and reactor provide tremendous modulation capability and unusually High Fidelity sound. Stable, long-life tubes and avalanche diode rectifiers have been used throughout the transmitter. Circuit breakers—not fuses—provide complete overload protection.

Provision for remote control and simplified power cutback are reflected in the BTA-1R3 design. Front panel or remote control selection of any two power levels of 1000, 500 or 250 Watts is available. No unnecessarily complicated circuitry or superfluous parts have been included and all components are easily accessible for maintenance and inspection. The transmitter is designed for 208 or 240 Volt operation.

### Functional Design

Improved functional design includes RCA's new color combination. Square construction permits locating the transmitter against the wall, or it can be installed against other equipment. The vertical construction makes it accessible from both front and rear for ease of maintenance. A single front panel tuning control provides simplified operation. Remote control provisions permit unattended operation of the transmitter.

### Simplified Power Cutback

The BTA-1R3 easily fits into operations where power reduction at night is required. For "day-night" operation an optional Power Cutback Kit may be incorporated in the transmitter. By pressing a switch on the front or at a remote panel, the transmitter can be cut back in power to either 500 or 250 Watts. Efficient operation at the low power levels is achieved by reducing the high voltage by primary taps on the plate transformer.

### Complete Accessibility

The entire transmitter is housed in a single steel cabinet that is mounted on a sturdy welded steel base. Control components are conveniently located on the

control panels on both sides of the front door and all meters are at eye level. Easy access is provided by a hinged front door and two interlocked removable panels. Most BTA-1R3 components are mounted on a vertical center chassis. Tubes and overload relays are mounted on the front and the other components are mounted on the rear. Larger power components are mounted on the base.

### Solid State Power Supplies

Three power supplies are used: a low voltage supply for plate and screen voltages of all low voltage tubes, a bias supply for the modulator tubes, and a high voltage supply for the modulator and power amplifier tubes. All power supplies use avalanche diodes which results in lower power drain, cooler operation and more reliable performance.

### Power Requirements

The transmitter operates from a 208-240 Volt, 60 Hz single phase power source for the main power. In addition, the crystal heaters require an additional 115 Volt power input. The transmitter can be modified for operation on 50 Hz AC current if desired.

### Switchable Crystals

The BTA-1R3 offers the customer a choice of tube type or solid-state exciter-buffer. Both employ two switchable TVM-130B temperature controlled crystal units. These units maintain the frequency constant to within plus or minus five Hz. Selection of the desired crystal is by means of front panel switches and latching relays. The oscillator employs a broadband circuit with no adjustments.

### Simple, Straightforward Circuitry

The buffer feeds a single 6I46A driver tube which in turn feeds the power amplifier which consists of two 4-400A tubes connected in parallel. Tetrodes have been utilized throughout the RF section of the transmitter reducing the required stages and the power consumption. Tetrodes also eliminate the need of neutralization.

The modulator comprises two 2E26 tubes in push-pull resistance coupled to two 4-400A modulator tubes. The modulator tubes operate as a class AB<sub>1</sub> amplifier without grid current which results in an overall distortion of less than 2 percent up to 10,000 Hz.

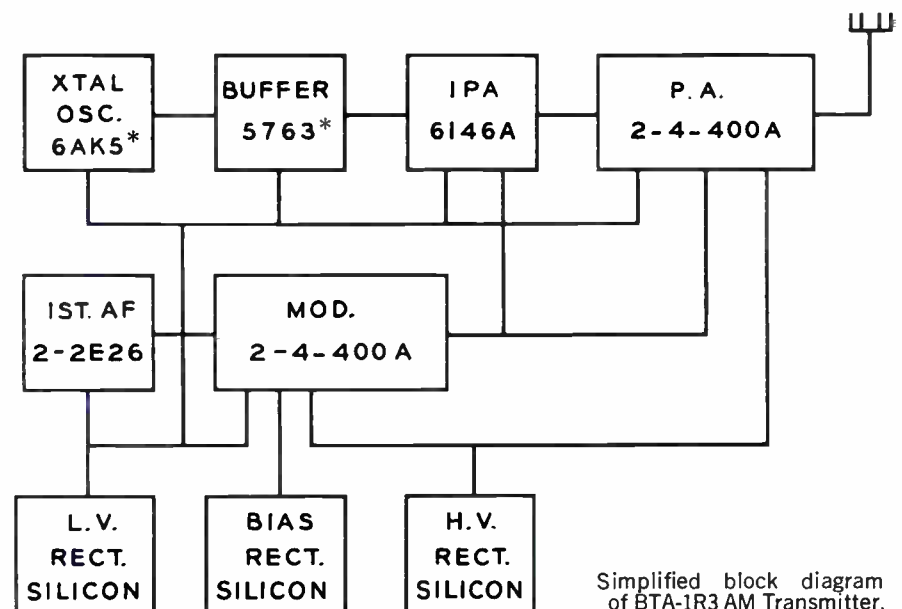

Simplified block diagram of BTA-1R3 AM Transmitter.

\*Tube or solid-state Oscillator-Buffer can be specified.

# Specifications

## Performance

AF Input Impedance .....	150/600 Ohms
AF Input Level (100% modulation) .....	+10 ±2 dBm
AF Response:	
50-7500 Hz .....	±1 dB
30-10,000 Hz .....	±1.5 dB
30-15,000 Hz .....	±3 dB
AF Distortion (95% modulation):	
50-10,000 Hz .....	2%
50-12,000 Hz .....	3%
Noise (below 100% modulation) .....	60 dB
Frequency Range .....	535-1620 kHz
Frequency Stability .....	±5 Hz
Type of Output .....	Single ended
Carrier Shift (0-100% modulation) .....	3%
Output Impedance .....	40-250 Ohms

## Electrical

RF Voltage (for frequency monitoring) .....	10 V RMS 75 Ohms
RF Voltage (for modulation monitoring) .....	10 V RMS 75 Ohms
Power Output (nominal) .....	1000 Watts
Power Output Capability .....	1100 Watts
Power Supply .....	208/240 Volts
Line Frequency .....	60 Hz
Phase .....	1
Power Consumption:	
(0% modulation) .....	2900 Watts (approx.)
(100% modulation) .....	3900 Watts (approx.)
(average program modulation) .....	3200 Watts (approx.)
Power Factor .....	90%
Permissible combined line voltage variation and regulation .....	±5%
Crystal Heater Power Supply .....	115 Volts 50/60 Hz

## Tube Complement

1	6AK5*	Crystal Oscillator
1	5763*	Buffer
1	6146A	Intermediate Power Amplifier
2	2E26	Audio Frequency Amplifier
2	4-400A	Modulator
2	4-400A	Power Amplifier

## Mechanical

Height .....	84" (213.4 cm)
Width .....	34" (86.4 cm)
Depth .....	32½" (82.6 cm) (less door handle)
Weight (net) .....	1700 pounds (772 kg) (approx.)
Altitude Range .....	0-5000 ft. (0-1524 m)
Ambient Operating Temperature:	
(min.) .....	-20°C (-4°F)
(max.) .....	+45°C (113°F)

## Accessories

Operating Spare Tube Kit .....	MI-27696-A
Recommended Minimum Spare Tube Kit .....	MI-27695-A
Type BTR-11B Remote Control System .....	ES-34280
Type BW-11A Frequency Monitor (Specify frequency) .....	ES-34042
Type BW-66F Frequency Monitor .....	MI-30066-B
Power Max (Negative Peak Limiter) .....	MI-34654
RF Ammeters .....	MI-7157-F Series
Ammeter Mounting Panel .....	MI-34656
Remote RF Pickup Unit (less meter) .....	MI-27966-B
Remote Antenna Meter .....	MI-27644 Series
Automatic Logging Equipment .....	On Application
Power Cutback Kit .....	MI-34079
Remote Power Adapt Kit .....	MI-34080
Oscillator-Buffer (Tube Type) .....	MI-27632-A
Oscillator-Buffer (Solid-State) .....	MI-27592

# Ordering Information

Type BTA-1R3 1000-Watt AM Broadcast Transmitter  
complete .....

.....ES-27238-D\*  
(\*Ordering information should specify tube or solid-state type Oscillator Buffer.)

# **RCA** 5-10 KW AM Broadcast Transmitter, Type BTA-5U2/10U2



- Outstanding sound
- High efficiency circuits
- High reliability
- Great overall economy
- Solid state oscillator and buffer



# High Efficiency 5/10 Kilowatt Transmitter

Only Two  
Tuning Controls

Dependable  
Semi-Conductor  
Power Supply

High  
Efficiency  
Cathode  
and Plate  
Resonators

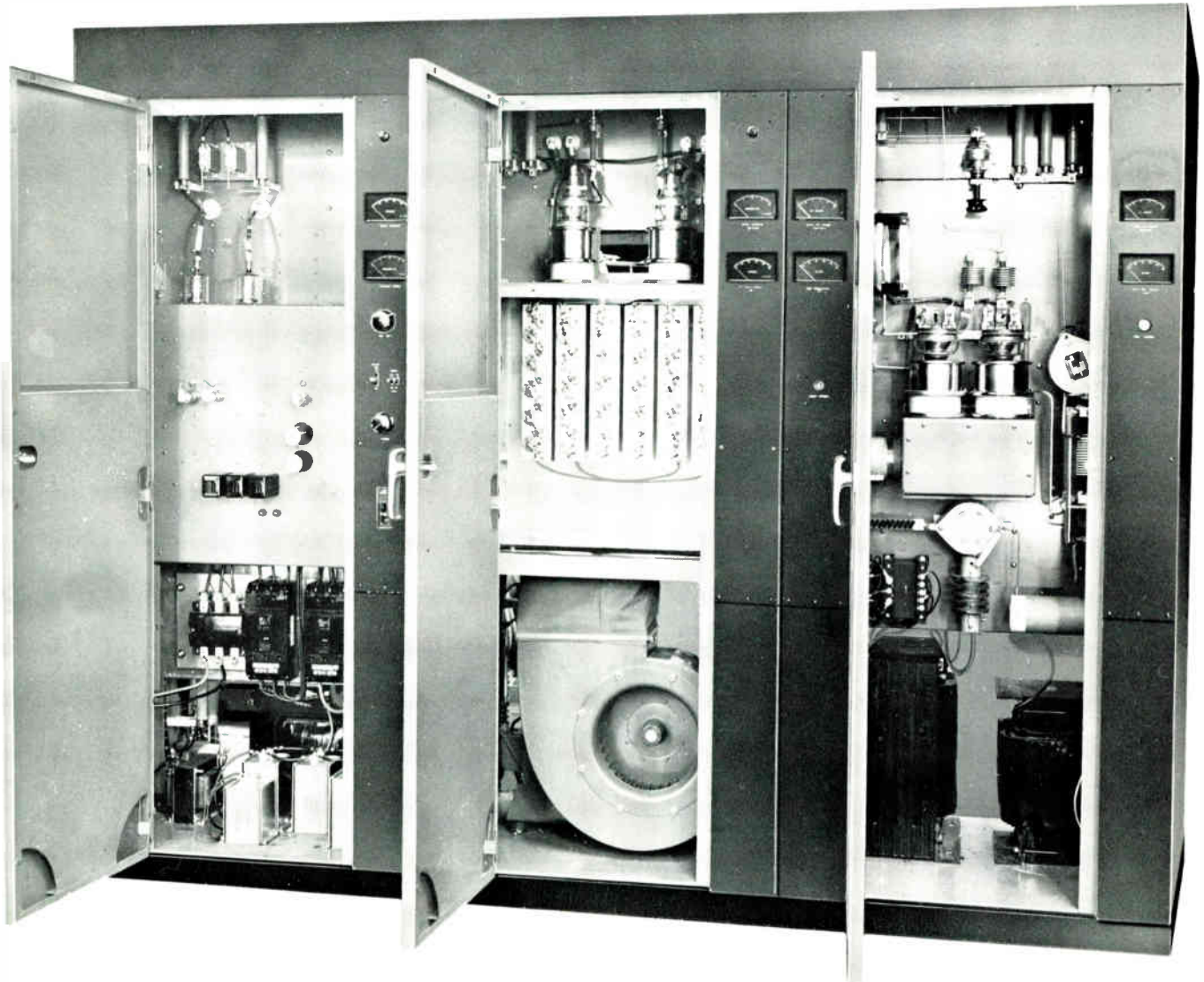

Built-in Remote  
Control Provisions

Completely  
Air Cooled

Self-contained 5-kW  
Plate Transformer

## 5/10 KW AM Broadcast Transmitter, Type BTA-5U2/10U2

The BTA-10U2 is a 10 kW amplitude modulated, high fidelity, broadcast transmitter for operation in the standard band between 535 and 1620 kHz. The new model incorporates RCA's plug-in solid state Oscillator-Buffer, MI-27592 with two switchable, temperature-controlled crystal positions.

The RCA BTA-5U2 AM Broadcast Transmitter is the fully converted deluxe BTA-10U2 with a second 5762 Amplifier tube removed to provide 5 kW output. Both transmitters are outstanding in appearance and reliability, and meet requirements of the FCC and EIA.

The BTA-5U2/10U2 operates from a 208/240 Volt, 50/60 Hz, three-phase power source for the main power. The crystal heaters re-

quire an additional 115-Volt 50/60 Hz single phase AC power input. Both transmitters exceed nominal power output rating to compensate for losses in the antenna tuning equipment.

The spacious cabinet of the BTA-5U2 Transmitter permits internal mounting of the 5 kW plate transformer. There are provisions for easy conversion to higher power at a later date. The transmitter allows simplified power change to 1 kW or 500 Watts, if desired, by installing an optional Power Cutback Kit, MI-34646-A. Similarly, the BTA-10U2 can be operated at 5 kW, or at 1 kW. The BTA-5U2/10U2 is provided with an oil-filled modulation transformer for increased reliability.

### Description

The BTA-5U2/10U2 is an air-cooled transmitter with numerous design improvements, including an important development in Class C amplifier design. The new high efficiency, plate modulated power amplifier permits one or two long-life 5762 tubes to deliver the nominal 5 or 10 kW with 5.5 or 10.6 kW power output capability. The plate efficiency appreciably exceeds that of a conventional Class C amplifier. As a result, considerable power savings can be realized. Referring to the simplified schematic, the circuit arrangement is very similar to a conventional Class C amplifier, except for the presence of two high efficiency resonators. The amplifier is stable and easy to adjust. The high-voltage, low-voltage and bias supplies employ silicon rectifiers throughout.

Other new design techniques of the transmitter provide simplified tuning, increased safety, longer tube life and improved performance. After initial adjustments, the transmitter can be tuned from the front panel. This is accomplished by only two controls. Provisions for manual or remote control operation are incorporated in the transmitter. For safety, all doors and panels are interlocked and grounding switches protect operating personnel. The transmitter is air-cooled by a single blower housed in the center cabinet.

### Improved Mechanical Design

The transmitter is housed in three attractively styled cabinets made of anodized aluminized steel to provide improved magnetic and electrostatic shielding. The left cabinet, or cubicle, contains the Transmitter Driver. The center cabinet houses the Modulator and High Voltage Rectifier, and the Blower. In the right hand cabinet is located the Power Amplifier, and the 5-kW Plate Transformer. The plate transformer of the BTA-10U2 is an external unit which can be mounted near the cabinets.

### Accessible Vertical Panel Construction

Each cabinet consists of end panels with wrap-around front edges formed to provide control panels, mounted on a sturdy, welded steel base. Vertical center chassis are fastened between the end panels to form a basic "H" cross section. Reach-in accessibility to transmitter components is afforded by hinged front doors located between the control panels. Rear access to each cabinet is provided by a hinged, interlocked door. Control components are conveniently located on the panels on both sides of the front doors where all meters are situated at eye level.

The matched cabinets are designed to combine an attractive appearance with the utmost in utility. Vertical construc-

tion permits easier maintenance and service. It also permits installation of the transmitter against a side wall, or allows other equipment to be placed on either side of the cabinet. The front doors of the transmitter give immediate access to the front of the vertical panels on which circuit components such as tubes and overload relays are mounted. Remaining small components are mounted on the rear of these chassis, while the larger power components are situated in the base of the cabinet.

### Efficient Circuit Design

The BTA-5U2/10U2 Transmitter incorporates RCA MI-27592 solid state Oscillator with two, switchable, temperature-controlled crystal positions. Crystal stability is plus or minus 5 Hertz. The desired crystal can be selected by means of a front panel switch or by means of a remote-control switch since relays are built into the exciter. The oscillator employs broadband circuits that require no adjustments. This unit is built on an etched circuit panel easily accessible for service by removing the cover. The entire oscillator unit can be removed by disconnecting a cable-plug and retaining screws. Also a part of the basic exciter is the 6146 IPA stage which is operated very conservatively. A pair of 2E26 tubes is used as the first AF stage of the modulator circuit.

## Select Features

### REACH-IN ACCESSIBILITY

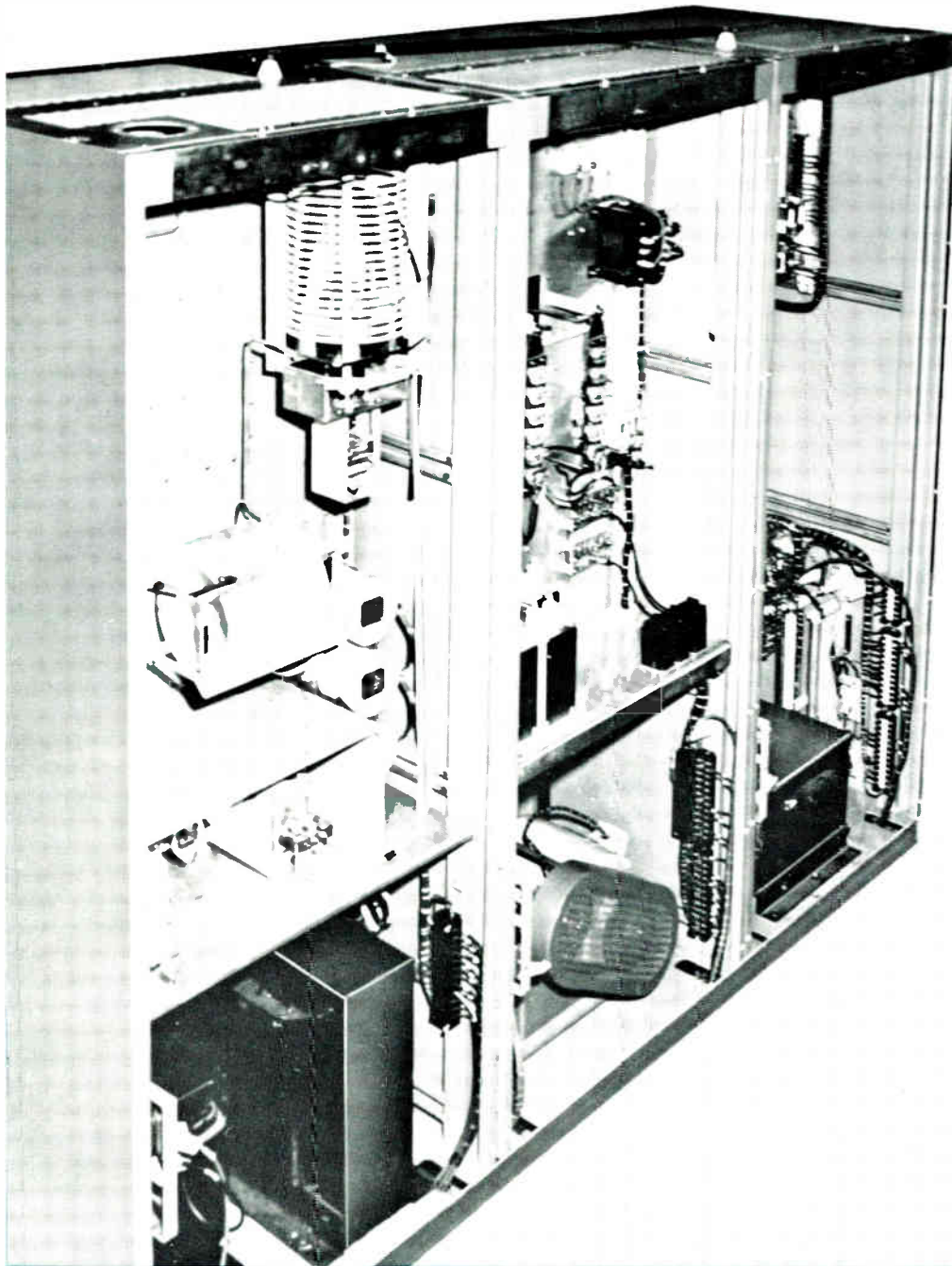

Rear view of transmitter with doors removed showing vertical construction permitting complete accessibility to all transmitter facilities. The modulation transformer and final PA tank circuitry are seen in foreground, rear of modulator and blower in center cabinet, while heavier components of driver are shown mounted on floor of third cabinet.

**BUILT-IN REMOTE CONTROL**

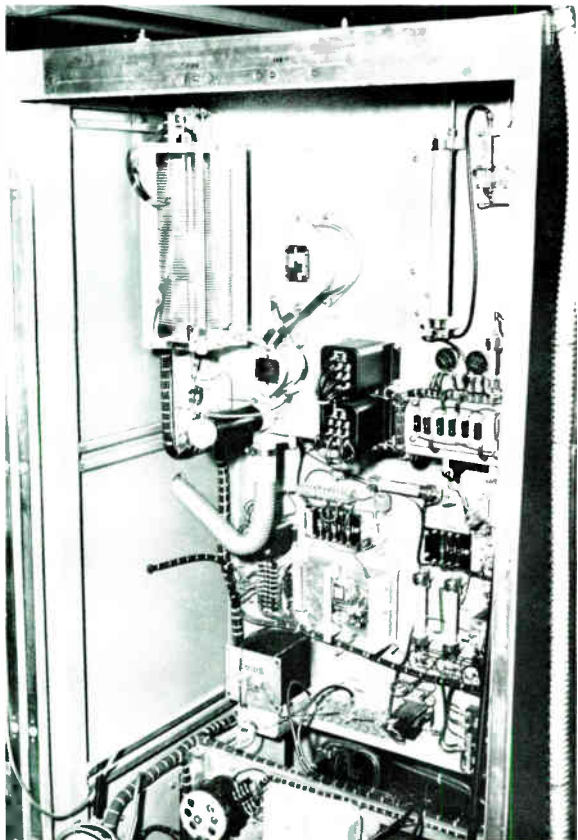

Rear view of BTA-10U2 exciter and control cabinet.

**POWER ECONOMY**

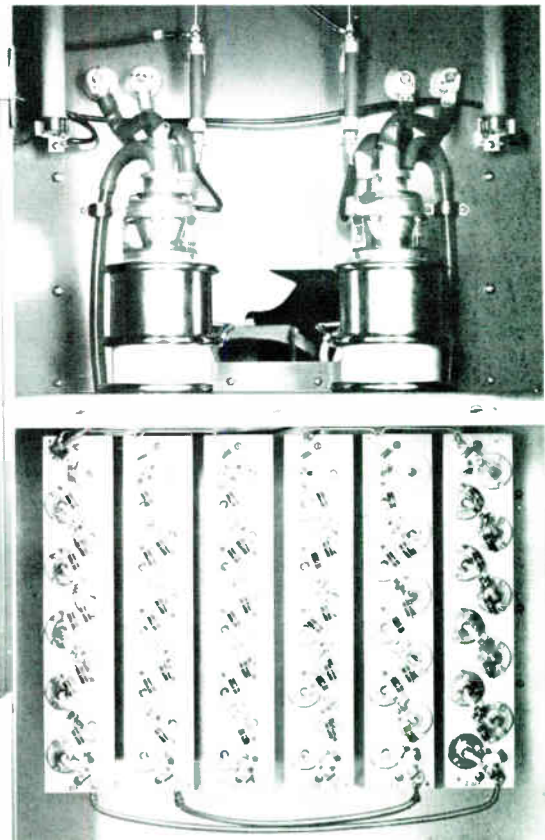

Modulator tubes and silicon high voltage rectifiers with cover removed.

**STABLE CIRCUIT DESIGN**

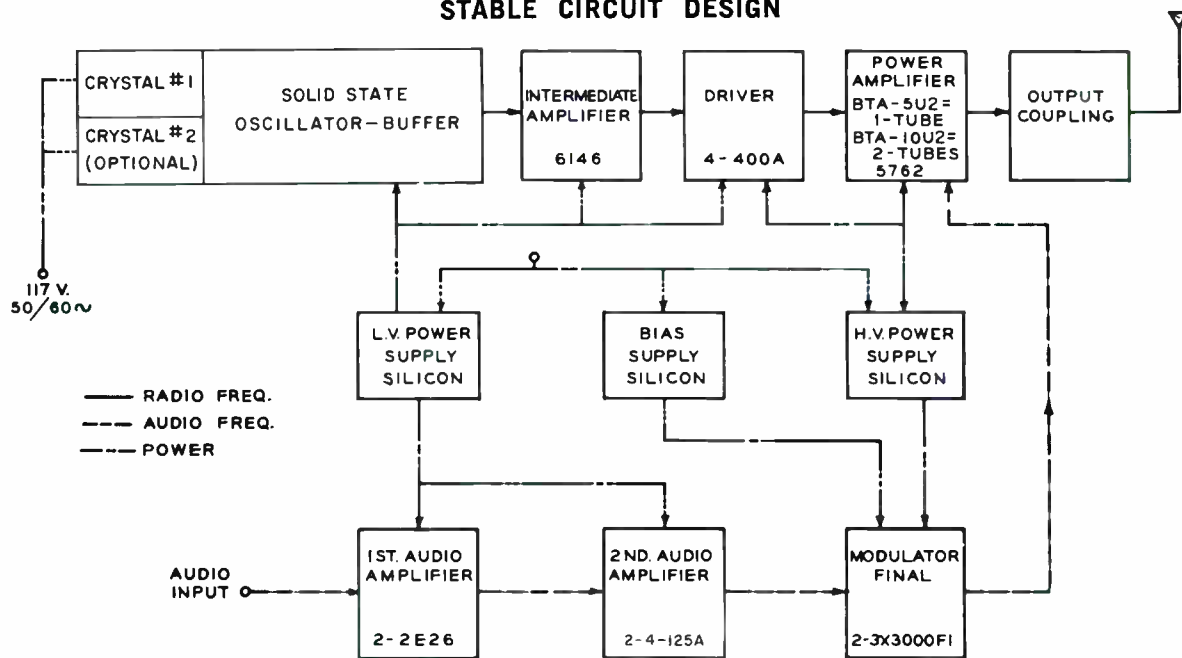

Block diagram of Type BTA-5U2 and BTA-10U2 Transmitters.

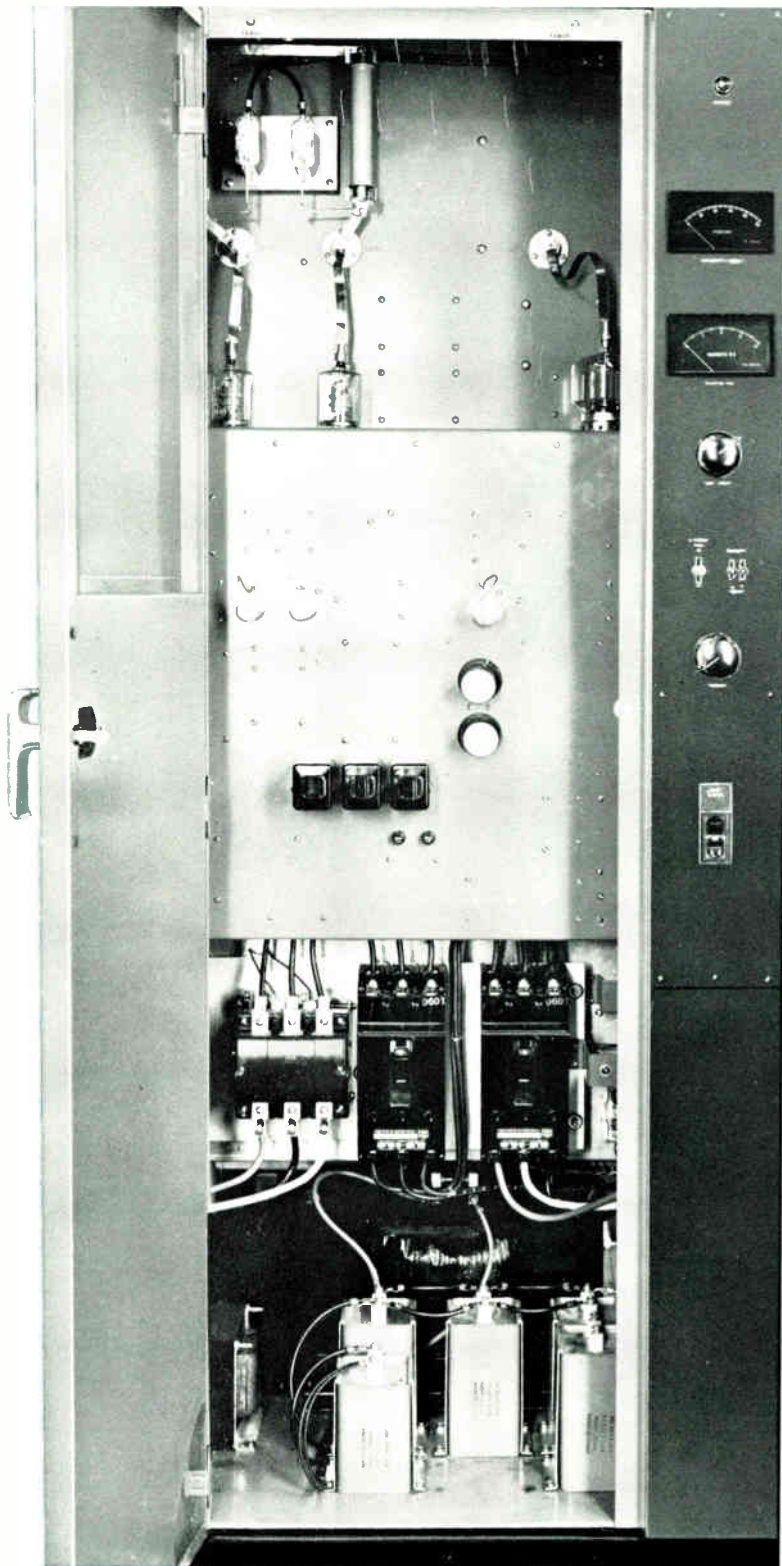

Driver cabinet including exciter and control panel.

The output of the 6146 IPA stage is broadband and requires no tuning. It drives a single 4-400A tube where tuning is accomplished by using a slug-tuned coil controlled from the front panel. This tube, in turn, drives one or two high-efficiency, long life 5762 output triodes. A front panel control of a vacuum variable capacitor tunes the plate circuit.

### Broadband Neutralization

A new slug-tuned coil was developed for the power output adjustment and it is driven by a reversible motor. The motor is actuated at the front panel or by remote control. The second harmonic trap uses a slug-tuned coil, thus eliminating the possibility of contact pitting from high RF currents. Neutralization of the PA is achieved by a broadband transformer and a variable vacuum capacitor.

The modulator of the transmitter consists of a pair of 2E26 tubes located in the exciter portion, resistance coupled to drive two 4-125A second audio frequency amplifiers which, in turn, are resistance coupled to drive a pair of 3X3000F1 modulators. These modulator tubes are low mu triodes, drawing no grid current. They are capable of excellent response and fidelity. Due to the low plate dissipation of the new PA system, the power input of the modulator is also reduced affording appreciable power economies.

### Dependable Semiconductor Power Supply

The BTA-5U2/10U2 incorporates RCA silicon rectifiers in the high-voltage circuits. This rectifier is ideal not only in a combined operation, but even more so in a remote-control application.

The rectifiers are hermetically sealed so they will not be adversely affected by weather conditions. They can operate at ambient temperatures ranging from  $-20$  degrees to  $+45$  degrees C and at altitudes up to 7500 feet above sea level. There is no significant aging of the forward drop characteristics. Across each of the individual silicon cells a resistor has been shunted so that they will all share equally the peak inverse voltage. RCA specifications have been set higher than EIA standards by adding an additional 30 percent peak inverse voltage safety factor.

### Cooling System

The transmitter is completely air-cooled. Added refinements such as a delay relay have been built-in to keep the

blower system in operation for one minute after the transmitter has been shut down. The continued supply of air extends tube life. The exciter cabinet employs convection cooling. A louvered lower back panel and top grill panel provide good ventilation. In the second cabinet a blower air system distributes air to the modulator as well as to the Power Amplifier tubes in cabinet three.

### Overload Protection

To provide additional reliability, improvements were made in the control and protective circuitry of the transmitter. All primary lines are protected by means of circuit breakers with instantaneous overload trip protection. Line and high-

voltage plate circuit breakers have additional built-in thermal protection. The 3-phase blower is protected by a contactor with a thermal cutoff in each phase. Relay switching is sequential so that filaments will not come on unless the blower is operating. Low voltage is delayed to allow proper filament heating. The high voltage is interlocked with the low-voltage and the bias supply so that it will come on only after the low-voltage and bias potentials are present. Overload protection is also provided in the low-voltage supply, the second AF stage, the IPA stage, the modulator, the PA stage and the high-voltage rectifier. They are instantaneous in action and each overload relay carries a spare set of contacts wired

to terminals that may be connected to an external indicator. A two cycle plate overload relay also permits the transmitter to return to the air automatically after one interruption has occurred.

Starting surges in the plate transformer, high voltage rectifier, and the filter capacitor are eliminated by the use of a step-start and damping circuit. This at one time was only available in the higher-power transmitters, but now longer life and added reliability are provided in the BTA-5U2/10U2 with the incorporation of these circuits for the suppression of starting transients. The damping circuits and the primary line reactors afford continuous protection against possible operational transients.

Typical floor plan for BTA-5U2 and BTA-10U2 transmitters. External plate transformers are required only for the BTA-10U2 transmitter since the transformer for the BTA-5U2 can be mounted in the PA cabinet.

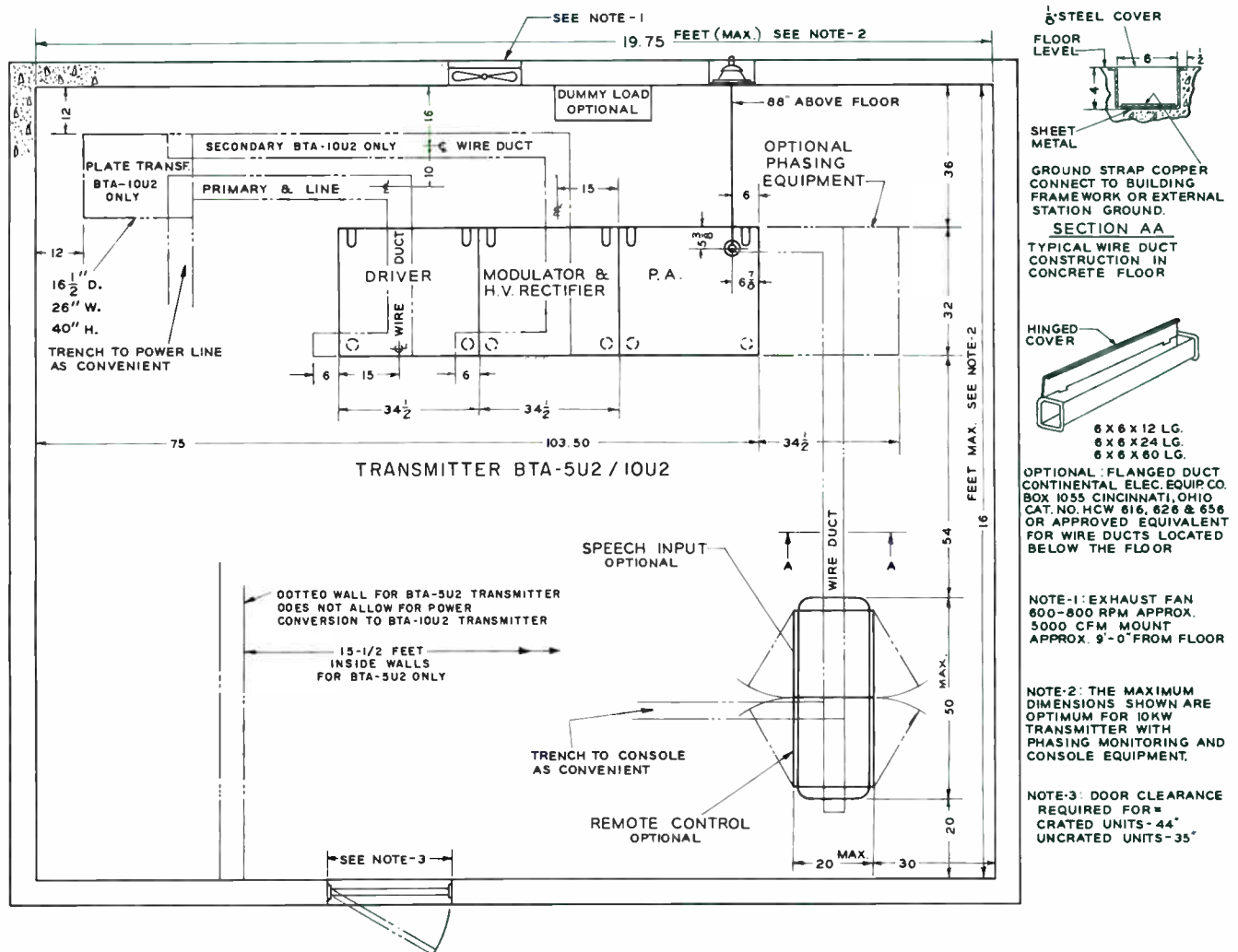

# Specifications

## Performance

AF Input Impedance	150/600 Ohms
AF Input Level (100% modulation)	+10 ±2 dBm
AF Response:	
50—7500 Hz	±1 dB
30—10,000 Hz	±1.5 dB
AF Distortion (95% modulation):	
50—10,000 Hz	2.5%
Noise (below 100% modulation)	60 dB
Frequency Range	535—1620 kHz
Frequency Stability	±5 Hz
Type of Output	Single Ended
Carrier Shift (0—100% modulation,	
400 Hz)	3% at constant line voltage
	5% at normal line voltage regulation
Output Impedance	40—250 Ohms

## Electrical

RF Voltage (for Frequency Monitoring)	10 Volts RMS 75 Ohms	
RF Voltage (for Modulation Monitoring)	10 Volts 75 Ohms	
Power Output (nominal):		
BTA-5U2	5000 Watts	
BTA-10U2	10,000 Watts	
Power Output Capability:		
BTA-5U2	5500 Watts	
BTA-10U2	10,600 Watts	
Power Source Required	208/240 Volts ±11 Volts	
Line Frequency	50/60 Hz	
Phase	3	
Power Consumption:		
	<b>BTA-5U2</b>	<b>BTA-10U2</b>
(0% modulation)	10.0 kW	17.5 kW
(100% modulation)	14.5 kW	26.0 kW
(Average program modulation)	11.0 kW	21.0 kW
Power Factor	90%	90%
Permissible Combined Line Voltage		
Variation and Regulation	±5%	±5%
Crystal Heater Power	117 Volts 50/60 Hz	
Tube Complement:		
1 6146 Intermediate Power Amplifier		
1 4-400A Driver		
2 2E26 1st Audio Frequency Amplifier		
2 6155/4-125A 2nd Audio Frequency Amplifier		
2 3X3000F1 Modulator		
1 5762 Power Amplifier for BTA-5U2		
2 5762 Power Amplifier for BTA-10U2		

## Mechanical

Overall Height	88" or 223.5 cm
	(84" or 213.4 cm less floor channels)
Cabinet Height	84" or 213.4 cm
	(80" or 203.2 cm less floor channels)
Width	103½" or 262.9 cm
Depth	32" or 81.3 cm (less door handle)
Overall Depth	55" or 139.7 cm (with door open)
Net Weight:	
BTA-10U2 Transmitter	4700 lbs. or 2132 kg. (approx.)
Plate Transformer	600 lbs. or 272 kg. (approx.)
BTA-5U2 Transmitter	
including Plate Transformer	4850 lbs. or 2200 kg. (approx.)
Altitude Range	0—7500 ft. (0—2286 m)
Ambient Operating Temperature	-20°C (-4°F) min., +45°C (113°F) max.

## Accessories

Complete Set of Operating Tubes (for BTA-5U2)	ES-34233
Complete Set of Operating Tubes (for BTA-10U2)	ES-27290
Filament Hours, Elapsed Time Indicator*	MI-34684*
Type BTR-11B Remote Control System	ES-34280
Type BTA-20D Remote Control System	ES-561415
Antenna Tuning Equipment	ES-27256
Recommended Spare Tubes for BTA-5U2	
and BTA-10U2	ES-27291
Type BW-11A AM Frequency Monitor	ES-34042
Type BW-66F AM Modulation Monitor	MI-30066-B
Alarm Indicator	MI-27567
Power Conversion Kit (BTA-5U2 to BTA-10U2)	ES-34279-A
Power Cutback Kit 5 kW to 500/1000 W	MI-34646-A
Power Cutback Kit 10 kW to 500/1000 W	ES-34287
Power Cutback Kit 10 kW to 5 kW	ES-34286
Remote RF Pick-up Unit	
for powers up to 5-kW (less meter)	MI-27966-B
Remote RF Pick-up Unit for higher powers	
(less meter)	MI-28027-C
Remote Antenna Meter	MI-27644-A Series
RF Ammeter Mounting Hardware	MI-27713

\*The 5U2/10U2 Transmitter has a blank meter bezel which may be replaced with an elapsed time indicator, MI-34684. Specify 50 or 60 Hertz.

# Ordering Information

Type BTA-5U2 Transmitter (including 1 set of tubes and 1 crystal)	ES-27285-B
Type BTA-10U2 Transmitter (including 1 set of tubes and 1 crystal)	ES-27286-B
(specify operating frequency and output impedance)	

## **RCA** 50 KW "Ampliphase" AM Transmitter, Type BTA-50J



- Excellent audio quality
- Wide range frequency response
- Only six tubes in transmitting circuits
- Proven stability
- Designed for remote control
- Over 110 percent positive modulation capability



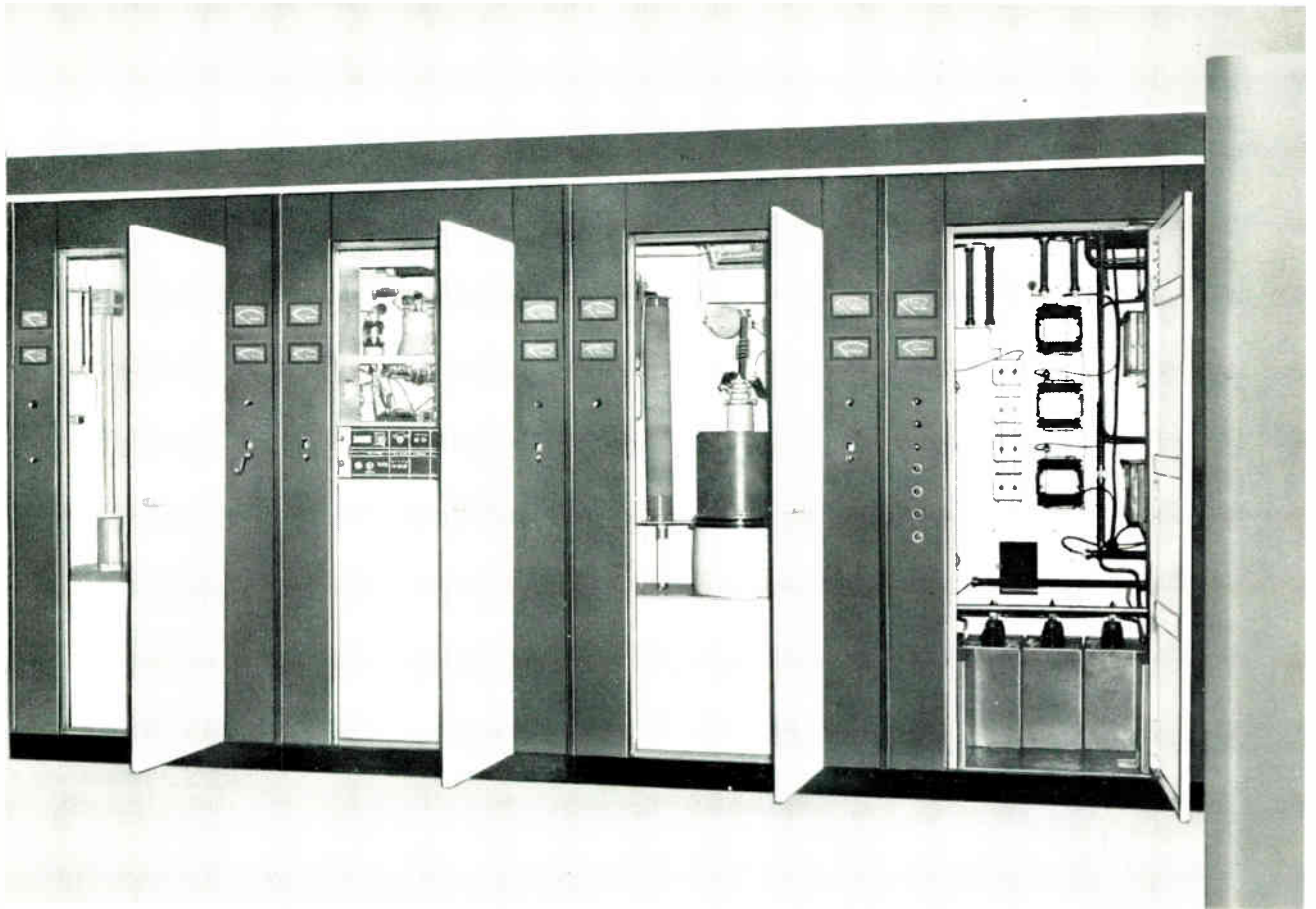

Compact in-line construction of BTA-50J showing left to right, left hand power amplifier, exciter, right hand power amplifier, and rectifier-control cubicle.

## Description

The RCA Type BTA-50J AM Broadcast Transmitter is a completely air-cooled, 50-kW phase-to-amplitude modulated transmitter designed for high fidelity transmission in the standard broadcast band (535 kHz to 1620 kHz). It provides a signal containing exceptionally low distortion and extended frequency response. Measured response is flat within  $\pm 3$  dB from 35 Hz to 25,000 Hz. The equipment is capable of being modulated over the frequency range of 10 Hz to 30,000 Hz. Frequency response has been extended largely through the elimination of unnecessary transformers in the audio system as well as improved circuitry.

Low harmonic distortion with negligible carrier shift at maximum signal output has been achieved in the BTA-50J by selection of adequate power tube types and advanced solid state circuits in

the exciter-modulator-drive regulator design throughout the entire equipment. The design features an inherently linear system capable of continuous high modulation levels impervious to inadvertent overmodulation. For example, the transmitter may be modulated 100 percent at any frequency between 30 and 15,000 Hz continuously for many hours without detrimental effects to any of the component parts. A small amount of overall feedback is incorporated to provide the exceptional performance. With the feedback circuit removed, the BTA-50J will still meet the FCC specifications for audio frequency response, harmonic distortion and noise.

### Lowest Operating Cost in 50-KW Transmitters

A number of new refinements as well as time tested features which have proven their worth are incorporated in RCA's

latest 50-kW transmitter. Power requirements are moderate for the equipment. Power amplifier plate efficiency of the order of 76 to 80 percent is obtained. Total power consumption for 50-kW carrier power will run approximately 94 kW, approximately 100 kW will be required for average levels of modulation, and approximately 130 kW will be required for 100 percent modulation.

Fewer major components, as compared to those required by many 50-kW transmitters, are used in the BTA-50J. In addition to the low cost of operation of the transmitter a Power Cutback Kit, MI-27688-B can be added which will permit operation at 10 kW.

### Dual RF Chains

Two identical RF chains, each developing a power of 25 kW, are incorporated in this equipment. Since they are identi-

cal, servicing is made easy by comparison of the two chains. Components are directly interchangeable, which allows substitution for comparison purposes. All components are easily accessible which results in a minimum schedule for maintenance. In addition, fewer replacement parts are required for adequate protection against lost air time should a failure occur. Low power consumption, fewer major components and a reduced maintenance schedule make the BTA-50J operation cost the lowest in the 50-kW field.

### Remote Control Operation

The transmitter has been designed with remote control operation in mind. Ready for use with standard RCA remote control equipment, all transmitter components and wiring are standard in the equipment for FCC required metering and control facilities. In addition, other optional metering and control facilities may be incorporated by utilizing components and wiring that is supplied with the equipment. Details relative to incorporating remote switching to an auxiliary transmitter, dummy load and auxiliary power supplies can be supplied according to the needs of the individual customer.

### Lightweight Type 6697 Tubes in Final PA

One Type 6697 power amplifier tube is used in each of the two RF chains. Each amplifier tube is capable of delivering in excess of the normal 25 kW of modulated power to the common load. The Type 6697 is rated at 35 kW dissipation and under average modulation conditions it is only required to dissipate approximately 14 kW. Operation of the PA tubes so far below their maximum ratings assures the user of long tube life. In addition to providing long life, the 6697 is physically small in size and weighs only 29 pounds. One person, without the aid of mechanical assistance can quickly and easily replace any tube in the transmitter.

One Type 4CX5000A tube is used in each of the driver stages in the two RF chains. The 4CX5000A is also operated well below its maximum ratings and will give long trouble free service. The only other tubes used in the transmitter are the two 4-250A Intermediate Power Amplifier tubes. There are also four tubes in the monitor circuits. These are of the small, low cost variety. Tube complement is such that inventory cost for required spares is kept at a minimum while ade-

quate protection to the broadcaster is maintained.

### Solid State Rectifiers Used Throughout

All power supplies utilize solid state rectifiers. The plate supplies, bias supply and low voltage supply use silicon units which are very conservatively rated to assure long life. The current rating of the units is such that any conceivable load fault is cleared without jeopardizing the diode units. The use of solid state rectifiers permit the transmitter to operate in ambient temperatures as low as -20 degrees centigrade.

### Meets FCC Harmonic Suppression

A completely shielded two section low pass filter is incorporated in the BTA-50J. It consists of one pi ( $\pi$ ) section and one T section and each inductive series element is completely shielded. Two series-tuned, shunt-connected traps are used to provide added attenuation of the second harmonic.

### Transmitter Equipment

Type BTA-50J AM Broadcast Transmitter consists of four equipment cabinets, two of which house the power amplifiers, one the exciter unit and the fourth cabinet the rectifier and control unit. The high-voltage reactor is housed in the lower rear compartment of the exciter cabinet, and the H/V plate transformer in the lower rear compartment of the rectifier and control cabinet.

Each of the four transmitter cabinets measure 44 inches wide by 60 inches deep by 84 inches high, and consists of an all aluminum cubicle erected on a welded steel base. This cubicle consists of a series of panels fabricated and assembled to form a rigid structure. The use of aluminum eliminates unnecessary weight and provides excellent shielding to assure effective confinement of spurious energy. Maximum accessibility to all transmitter components are afforded by 28-inch wide, full-length front doors, while rear access is through two covers attached with quick-disconnect fasteners for easy removal.

A center vertical panel separates the cabinet into a front compartment and rear compartment which is further divided by a rear horizontal shelf into upper and lower compartments, giving each cabinet three basic totally shielded compartments in which to mount the electrical components. The eye-level meters, pilot lights and interlocks, mounted on

eight-inch wide panels flanking each of the front doors, are also shielded.

In the rear at the top of each cabinet there is a built-in wire duct which joins similar ducts of the adjacent cabinets to form a continuous duct on the four cabinets. This duct has a divider down the center on which the interconnection terminal boards are mounted. The rear half of the duct is used for interconnection wiring while the front half is used for internal cabinet wiring from the terminal boards. The internal wiring is carried through conduits to its destination in the cabinet thus shielding all power and control wiring from RF fields. Provision is also made at the top of the cabinets for the addition of an exhaust air duct.

### Power Amplifiers

The left end cabinet and the third cabinet from the left end are identical and contain the final power amplifier stages. The 6697 tube and its grid circuits and part of the plate circuits are contained in the front portion of the cabinet. The upper rear section contains the plate tank coil, filament transformer and grid leak resistors. The lower rear section contains a low noise blower which cools the 6697 tube and its cabinet and the adjacent half of the exciter cabinet. The two 6697 power amplifiers are designed to supply equal amounts of power to the output network. Because of the balanced dissipation in the two 6697 PA tubes, less air pressure with resultant lower air flow is required for adequate cooling of the power amplifier cubicles. The lower rear panel contains an impingement type air filter for the blower. The PA cabinets are constructed so that the blowers and filters can be mounted externally to the cabinets, if so desired.

### Solid State Exciter-Modulator

Located directly between the two power amplifier units is a cabinet that houses in its front section all the solid state components from the oscillator through the driver stages. The separate branches are assembled as mirror images for symmetrical feed to the PA units at left and right. The rear cabinet section contains the 50 kW common output circuit, harmonic filter, and reflectometer protective circuits.

Above are two vertical sub-compartments behind interlocked doors which contain the 4-250 and 4CX5000A stages. A meter panel for these stages is located at the bottom of these sub-compartments.

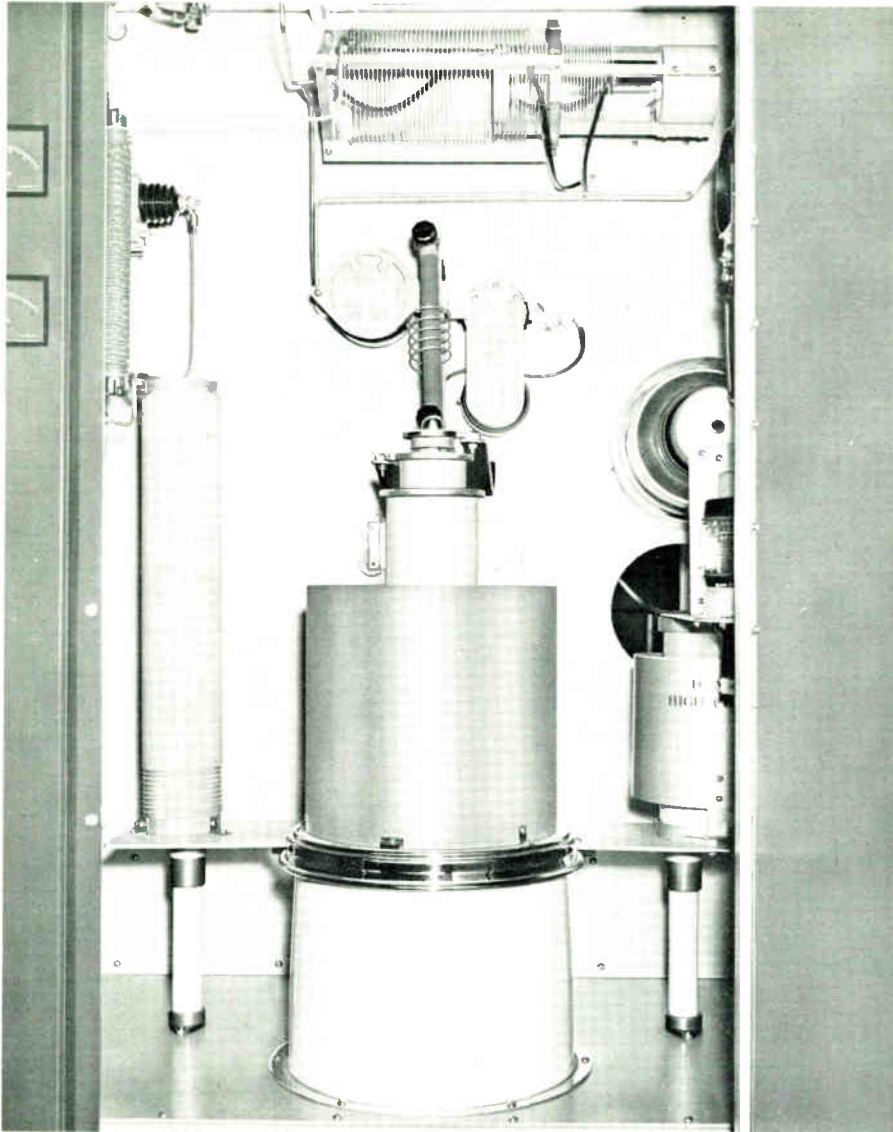

Close-up view of one of the dual final power amplifier stages. The new type 6697 tube together with grid circuits and part of the plate circuits are readily accessible from the front of the transmitter.

The common output capacitors of the two PA tanks and the harmonic filter are located in the upper rear of the cabinet. Sub-partitions are so arranged in this section that complete isolation and shielding is effected between the various sections of the filter and the output capacitor. The lower rear section of this cabinet contains high voltage filter reactor and driver DC filament supplies.

### Provisions for Standby Operation

Space is provided in the exciter-modulator cabinet for the mounting of a second exciter-modulator unit. Each of the modulator-exciter units are complete

and arranged so that either may be selected instantly by means of cutover switches. Thus while modulator #1 is in operation, modulator #2 is in standby condition. These provisions with the extreme reliability designed into the high power stages essentially provides a second 50-kW transmitter for standby service.

### Rectifier and Control Unit

The right hand cabinet contains the high power rectifiers, low power distribution components, and the majority of the control components. The front of the cabinet contains the solid state 15-kV, 5-kV, and low-voltage bias supplies. Also in-

cluded here are the high voltage grounding switches and the 15-kV filter capacitors. The top rear section of the cabinet contains the control relays, overload relays, distribution contactors, and the low power distribution circuit breakers. The distribution breakers and overload relays are readily accessible, even though recessed so that they will not be damaged or improperly operated. The bottom rear of the cabinet contains the 5-kV rectifier components including plate transformer.

The PA output circuit is a conventional pi-network type of tank circuit. Each tube has its own tank circuit, with a common output shunt element. Each network is adjusted to provide the proper load to the power amplifiers.

### Drive Regulator

The drive regulator samples the audio signal, amplifies it, and applies a desired value to the grids of the second IPA, providing adequate drive to the final amplifiers as required by the level of audio input applied to the equipment. This technique contributes considerably to the overall linearity during modulation.

During periods of 100 percent modulation, the 6697 power amplifier tubes require 15-kV DC at 7.5 Amperes, which is obtained by using RCA silicon power rectifiers in a three phase full wave rectifier circuit. Two other plate voltages, 5-kV and 1-kV, are provided by separate silicon supplies. Bias voltages for all tubes are supplied by an additional supply. The high power distribution equipment for the transmitter consists of an electrically operated air circuit breaker, and a manually operated delta-wye switch for the 15-kV rectifier. The remaining transmitter power is distributed through a manually operated distribution circuit breaker to a 460 to 230-Volt distribution transformer to voltage regulators and thence to the various low power distribution circuit breakers.

### Transmitter Control

Control circuits in the BTA-50J contain a number of features which are designed to provide maximum flexibility in control, protection and operation. Among these are choice of single-button or step-by-step starting, automatic timing and sequencing of starting operations, and location of transmitter faults by a system of indicators. Protection of the operator is achieved by a system of interlocking grounding devices; protection of the equipment by conventional relays and circuit breakers.

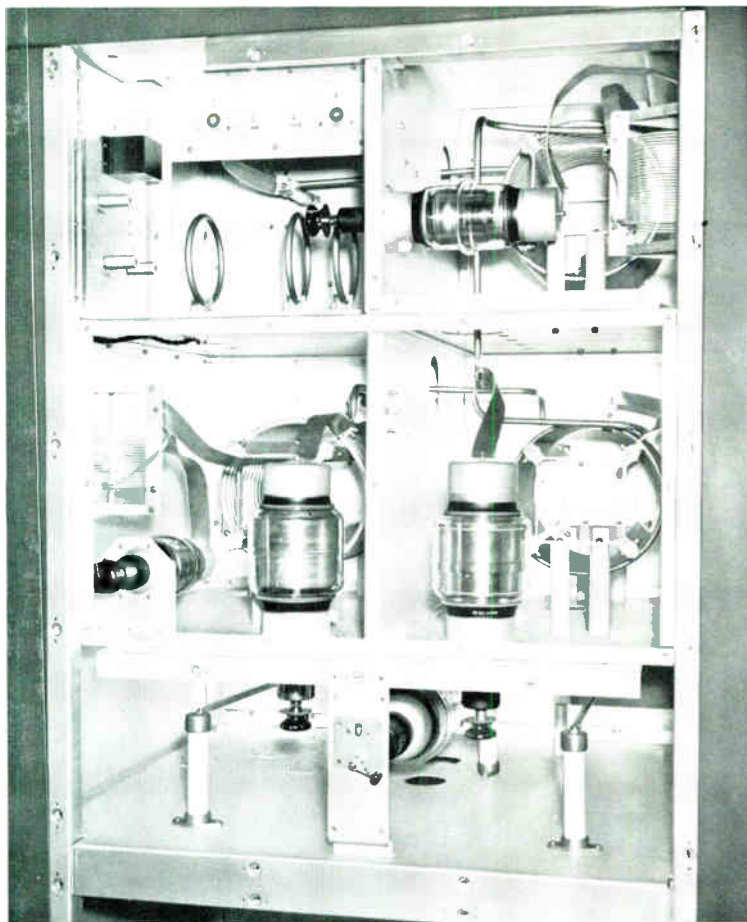

There are provisions for the protection of the equipment against transmission line irregularities and air failure. A reflectometer is incorporated in the BTA-50J that is sensitive to the changes in voltage to current ratio on the output transmission line to the antenna. A great change in transmitter load acts to remove the carrier by removing drive momentarily to allow any RF fault to clear. If, however, the fault persists after removing carrier several times, the plate power is automatically removed.

Control of the transmitter is accomplished from the front of the rectifier and control cabinet. All necessary wiring to allow control from a remote location or console has been provided. Lamps which show the status of the transmitter control circuits are also mounted on the front of this cabinet. The control ladder is arranged and interlocked so that the BTA-50J can either be turned on by operating the control switches in sequence or by leaving all control switches in the ON position with the exception of the start switch, which when operated to the ON position allows the transmitter to automatically come on.

Upper rear of exciter portion of the BTA-50J showing the combining and output networks.

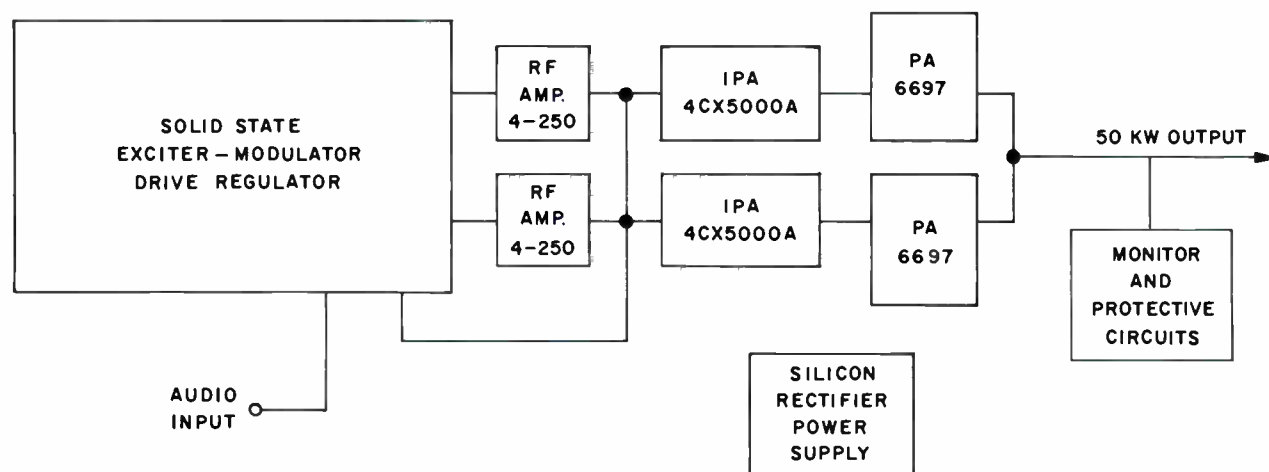

Simplified block diagram of the BTA-50J.

The two types of overload circuits used in this transmitter are the current type, instantaneous or time delay, that are connected directly in the tube circuit and rectifier ground leads, and the thermal magnetic circuit breakers connected in the AC power leads used as back up protection and disconnect switches. The transmitter circuitry is arranged so that an overload will either lock out the plate circuit or allow a single reclosure that will reset if there are no further overloads. In either case, when a lockout position has been reached, the transmitter can be reset by means of an overload reset control. The principal overload relays have indicating flags so that even after the overload has been cleared there is a record of which overload has operated. Another feature of the control circuit is provision of indication lamps on each cabinet that indicate the status of the interlock in that particular cabinet.

### Installation and Layout

Outstanding features of the BTA-50J are the small floor space requirements and ease of installation of the transmitter. In general, the transmitter layout consists of three basic parts: the four in-line cabinets which contain the major part of the transmitter; the wall mounted switchgear components; and the main plate transformers. The floor plan illustrates a typical layout of the complete equipment. Elimination of the need for under-floor cable trenches and considerable reduction in external air ducts, simplifies installation and reduces costs.

As shown in the layout, it is desirable to leave a passageway at the right end of the frontline cabinets since the circuit breakers and overload relays are most accessible from this end of the transmitter. The layout of the front line cabinets is such that a common exhaust duct can be used to carry off heated air from the transmitter.

Wall mounting as shown on the overall floor plan is suggested to make the BTA-50J most adaptable to existing transmitter buildings. The mounting of these components, however, is not critical as to location. They can be mounted in existing power distribution areas if desired. These components include the main plate circuit breaker, a delta-wye switch, a distribution circuit breaker, a 460 to 230-Volt bank of distribution transformers, and two single phase open delta connected regulators with their control panels. These components are wired through conduit and overhead ductwork to the main plate transformers and the transmitter cabinets.



Front section of the exciter-modulator containing all components from oscillator through the driver stages.

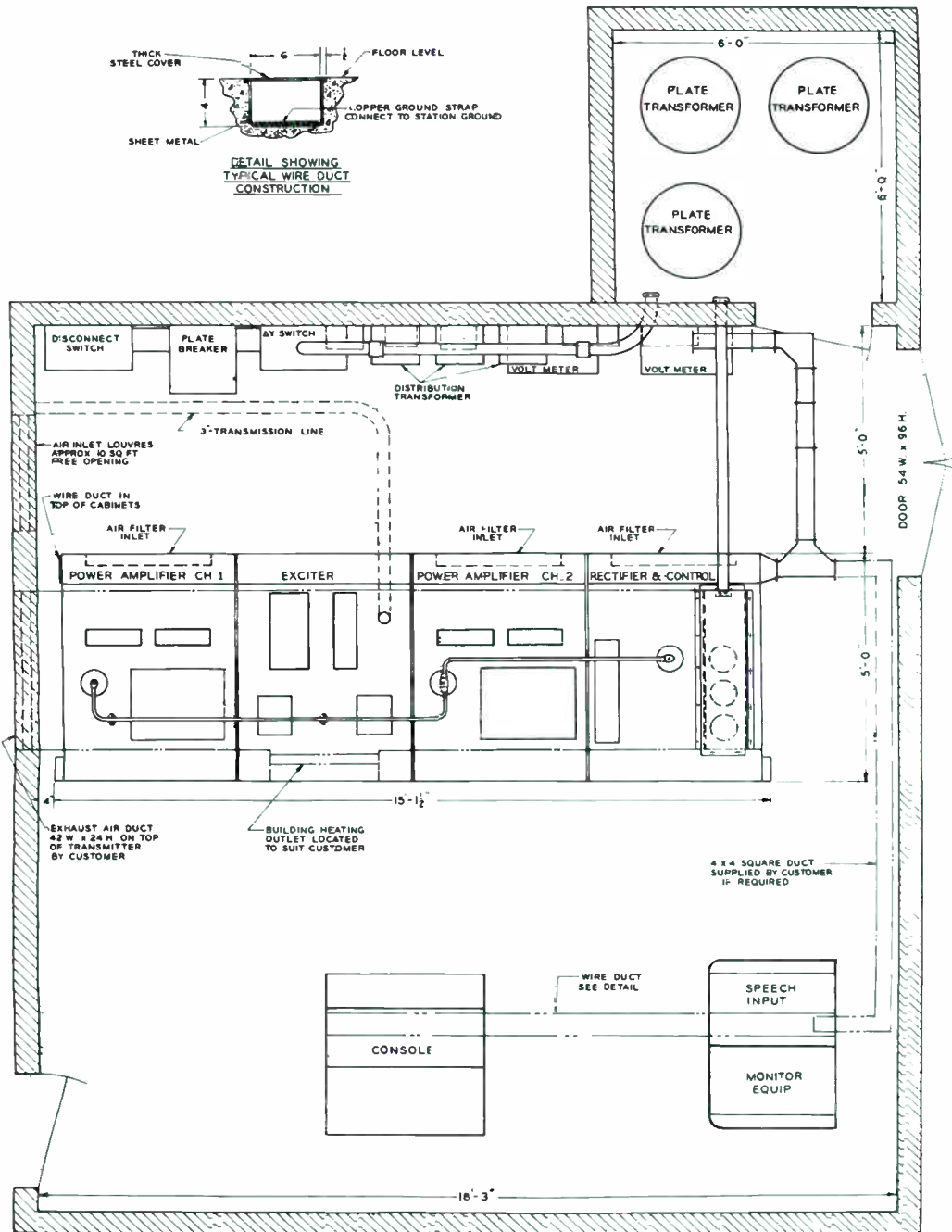

Typical floor plan for the BTA-50J Transmitter.

## Specifications

### General

Power Line Requirements:

Line	460 Volts, 50/60 Hertz, 3 phase
Combined Regulation and Variation	Not more than $\pm 5\%$
Power Consumption	94 kW (approx.) at zero modulation
Power Consumption	100 kW (approx.) at average modulation
Power Factor	Better than 90%
Crystal Heaters	110 Volts
Type of Emission	A3
Power Output (at transmitter terminals)	56 kW (max.)
Frequency	Any specified between 535 and 1620 kHz
Frequency Stability	Assigned frequency $\pm 5$ Hertz
Type Modulation	Phase to amplitude
AF Input Impedance	150/600 Ohms
Audio Input Level	+10 $\pm 2$ dBm
Audio Response	$\pm 1.5$ dB 30–10,000 Hz
AF Distortion	Less than 3% RMS 50–7500 Hz
Noise Level	60 dB below 100% modulation
Carrier Shift	Less than 5% neg. 100% modulation
Type Output	Unbalanced
Output Impedance	51.5 Ohms or others specified
Spurious Emission (2nd Harmonic and above)	83 dB down

### Mechanical

Cabinet Size	44" wide, 84" high, 63" deep (111.8 cm wide, 213.4 cm high, 160 cm deep)
Overall Weight	12,000 lbs. approx. (545 kg)
Maximum Altitude	7500 ft. (2286 m)
Ambient Temperature	-20°C +45°C
Maximum Cabinet Weight	3,093 lbs., approx. (1403 kg)
PA Cabinet Weights (each)	953 lbs., approx. (432 kg)
Plate Transformer Weight (total)	820 lbs., approx. (372 kg)

Rectifier Weight	3,093 lbs., approx. (1403 kg)
Exciter Weight	1,241 lbs., approx. (563 kg)
Filter Reactor	570 lbs., approx. (259 kg)

### Tube Complement

RF Amplifier Section:

2	4-250A	Intermediate Power Amplifier
2	4CX5000A	Driver Amplifier
2	6697	Power Amplifier

Monitor Circuits:

1	1614	Frequency Monitor Amplifier
2	6AL5	Reflectometer
1	2D21	Thyratron Control

### Accessories

Complete Set of Operating Tubes	ES-27222-D
Recommended Spare Set of Tubes	ES-27223-D
Type BTR-11B Remote Control Equipment (10 Functions)	ES-34280
Type BTR-20D Remote Control Equipment (20 Functions)	ES-561415
BTRX-40A—20 Position Extension for BTR-20C	MI-27556
50/10-kW Cutback Kit for BTA-50J Transmitter	MI-27688-B
Dummy Load Schedule of Parts and Instructions	ES-34234
BPA-50 Antenna Tuning Unit	MI-28903-A/B
BPA-50 Antenna Tuner (230 Ohms)	ES-28903-A
BPA-50 Antenna Tuner (70/51.5 Ohms)	ES-28903-B
RF Ammeter (for BPA-50)	MI-7147-Series
Remote RF Pickup Unit (less Meter)	MI-28027-C
Remote Antenna Meter	MI-7157-Series
Type BW-11A Frequency Monitor	ES-34042
Type BW-66F Modulation Monitor	MI-30066-B
Automatic Logging Equipment	On Application

## Ordering Information

Type BTA-50J 50-kW AM Broadcast Transmitter with two crystals, remote meter, one set of operating tubes, silicon rectifiers, and one exciter. Does not include antenna tuning unit. (Specify operating frequency and output impedance) ES-27221-D

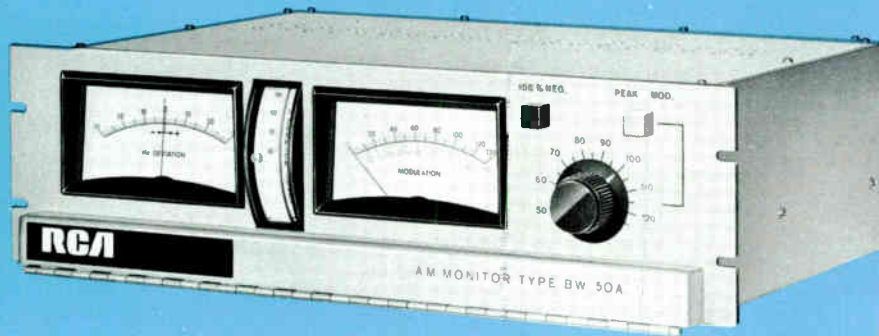

- Two monitors in one unit
- Monitors negative peaks
- Built-in modulation calibrators
- Carrier-off alarm built-in
- Easy-read, three-meter display
- Remote-meter provisions included

## AM Frequency & Modulation Monitor, Type BW-50A

### Description

A unique new approach to accurate AM transmitter monitoring, the Type BW-50 is the first all solid-state combination frequency and modulation monitor featuring a separate, 100 percent *negative* peak indicator which is independent of any calibration procedures.

#### Indicates Positive and Negative Peaks

State-of-the-art monitoring circuitry allows indication of positive peaks on the "normal" lamp and modulation meter. When negative peaks exceed 99.5% modulation, they light the "100% Neg."

indicator lamp on the front panel.

The true peak-reading modulation meter responds accurately to the shortest duration program peaks encountered in modern programming. The BW-50 Monitor is available from stock for immediate shipment to any destination.

### Specifications

Input Sensitivity .....	5 to 10 rms volts
Input Impedance .....	50 ohms
Input Frequency Range .....	535 to 1605 kHz
Frequency Deviation Meter Range .....	±30 Hz
Frequency Reference Accuracy .....	Better than 4 ppm 10 to 40 C.
Modulation Level Meter Range .....	0-133%
Carrier Level Meter Range .....	80-110%
Modulation Meter Accuracy .....	Within 4% at any level
Modulation Peak Indicator	
Threshold Adjustment .....	50 to 120%
Negative Modulation Peak	
Indicator Threshold .....	99.5%
Audio Frequency Response .....	30-15,000 Hz ± 5 dB
Audio Frequency Distortion .....	Less than 0.25%, 30-15,000 Hz
Signal/Noise Ratio .....	75 dB
Remote Meter Loop Resistance .....	5,000 ohms
Power Requirements .....	117/234*V. ±10%, 50-60 Hz, 10 W.

Dimensions .....	5¼" (133 mm) H.; 19" (483 mm) W.; 10½" (267 mm) D.
Weight .....	14 lbs. (6.4 kg)
Shipping Data	
Weight .....	18 lbs. (8.2 kg)
Package Dimensions .....	21½" x 16½" x 10" (546 x 419 x 254 mm)

\*Operation at 234 volts requires simple primary reconnection.

#### Accessories

Type BW-60 R-f Amplifier (for off-air monitoring) .....	MI-560770-1
------------------------------------------------------------	-------------

### Ordering Information

Type BW-50A AM Frequency & Modulation Monitor:	
Factory wired for 117-volt power line .....	MI-560767-1
Factory wired for 234-volt power line .....	MI-560767-2

11UB





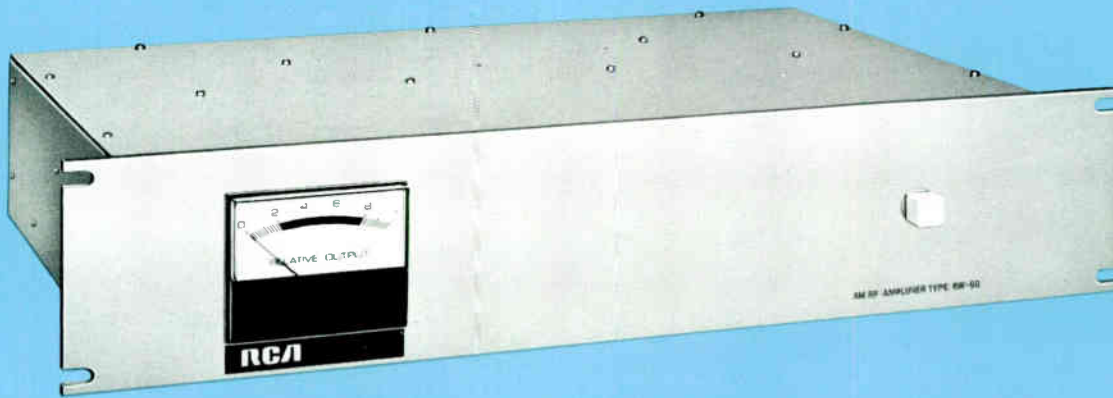

- Fully solid-state circuitry
- Wide dynamic range
- Symmetrical (zero-axis) limiting
- Excellent selectivity
- Linear phase bandwidth
- 100  $\mu$ V sensitivity

## Monitor RF Amplifier, Type BW-60

### Description

The BW-60 Monitor RF Amplifier, an adjunct to the RCA BW-50 Frequency and Modulation Monitor is designed to allow use of the BW-50 at a point, usually the studio, remote from the transmitter site. The BW-60 amplifies an off-air signal (100  $\mu$ V or greater) without modification of the air-signal's characteristics other than amplitude.

#### Fully Solid-State Circuitry

Only solid-state circuitry offers the stability and dependability required of a device such as the BW-60. However, the design is enhanced through the use of integrated circuits to reject interfering signals and provide large dynamic range.

#### Excellent Selectivity

The combination of a high level of

selectivity and zero-axis limiters in the amplifier results in the rejection of unwanted signals (those of other stations in the area), thereby increasing the usefulness and accuracy of the monitored parameters. The BW-60 Amplifier's excellent selectivity (see *Specifications*) is the result of a linear, balanced mixer system that down-converts the off-air signal to an intermediate frequency (260 kHz) amplifier, where it is amplified, filtered and then up-converted back to its precise, *original* frequency for coupling to the indicating monitor. This complete independence of frequency comes about because the *same* oscillator—operating at 260 kHz above (or below) air frequency—feeds both mixers simultaneously (see block diagram). Thus, the "input" signal is identical to the "output" signal in

every respect except in amplitude and is stripped of interfering signals. All I-F amplifier tuned circuits are specially designed and fabricated for maximum phase linearity and selectivity. The linear, balanced mixers are free of spurious responses.

#### Wide Dynamic Range

At the threshold of limiting, the BW-60 requires only 100  $\mu$ V to deliver 5-volt (260 kHz) and 300 mV(f) signals to the 1000 ohm monitor inputs. As the result of a highly linear pre-selector and a zero-axis limiter, the BW-60 handles input signals as large as 0.50 volt without overload. This represents a dynamic range of 70 dB. Symmetrical, "zero-axis" limiters maintain constant output level adjustable over an input variation of 70 dB.

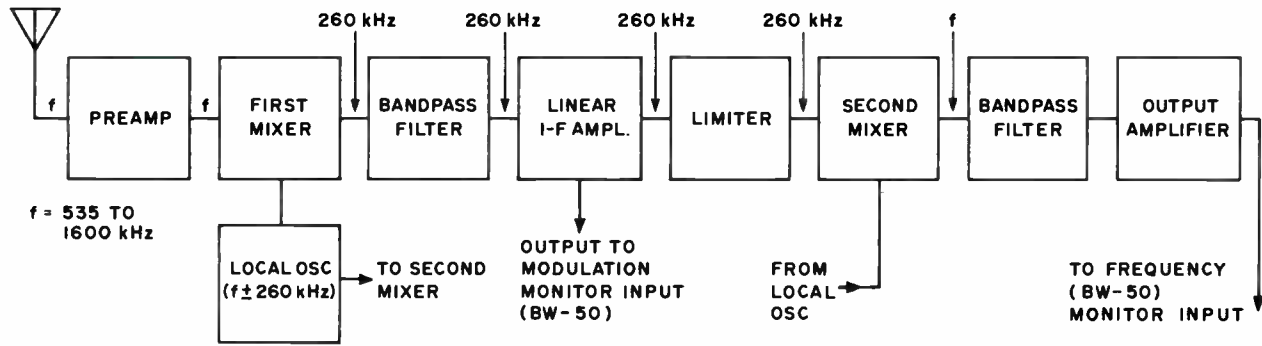

BW-60 Monitor RF Amplifier Block Diagram.

## Specifications

Input Frequency Range .....535 to 1600 kHz  
 Minimum Input Level (for threshold of limiting) .....100  $\mu$ V  
 Maximum Input Level .....0.5 V  
 Input Impedance .....50 ohms  
 Output Impedance .....1000 ohms  
 Output Level .....Adjustable to 1 watt  
 Bandwidth (3 dB points) ..... $\pm$ 16 kHz  
 I-F Frequency Rejection .....Greater than 50 dB  
 I-F Frequency .....260 kHz

Image Rejection .....Greater than 50 dB  
 Response at  $\pm$  40 kHz .....40 dB below that of center frequency  
 Response at  $\pm$ 10 kHz .....0.2 dB below that of center frequency  
 AGC Characteristics:  
   Carrier Shift (@ 12 dB change) .....less than 2%  
   Usable Range .....30 dB  
 Power Requirements .....117/234 V  $\pm$ 10%, 50/60 Hz, 5 W.  
 Dimensions .....3 $\frac{1}{2}$ " (89mm) H, 19" (438mm) W, 11 $\frac{1}{2}$ " (292mm) D

## Ordering Information

BW-60 Monitor RF Amplifier (Specify operating frequency)  
 For operation on 117V power .....MI-560762-1  
 For operation on 234V power .....MI-560762-2

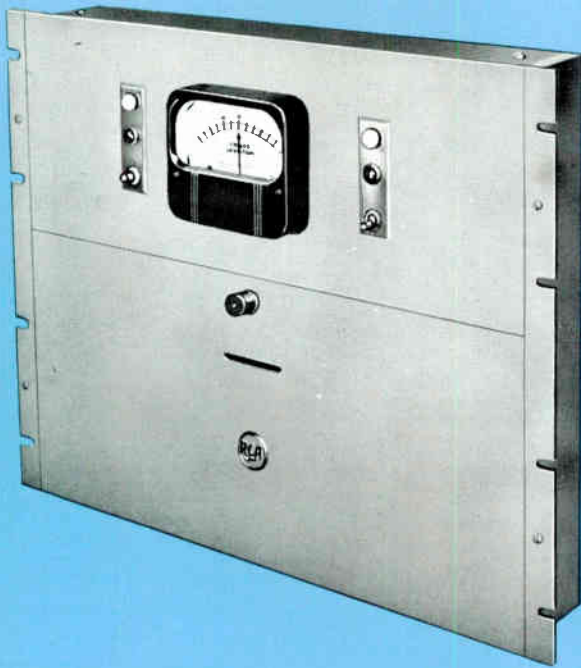

- Continuous reading deviation meter
- Wide input range
- Minimum accuracy at subcarrier frequency  $\pm 5$  Hertz for 1 year
- Protected trimmer adjustments for frequency calibration
- Warning lamp indicates failure of transmitter carrier or monitor crystal oscillator
- Provision for simultaneous operation of remote indicating or recording meter

## RCA Frequency Monitors, Types BW-11A/11AT

### Description

The RCA Frequency Deviation Monitors BW-11A and BW-11AT indicate continuously, and directly in Hertz-per-second the magnitude and direction of any departure of the carrier signal from its proper frequency. The two models are used as follows:

1. Type BW-11A for AM broadcast stations to measure departure of the carrier from its assigned channel frequency.
2. Type BW-11AT for TV broadcast stations to measure departure of the color subcarrier from 3.579545 MHz standard frequency.

The BW-11A monitor bears FCC approval for use in standard broadcast stations. The BW-11AT more than meets FCC requirement for subcarrier accuracy of  $\pm 10$  Hertz maximum and will pro-

vide an accurate and convenient method of calibrating and monitoring the color frequency standard now used by stations originating color programs.

### Monitoring Provisions

The monitor is AC operated and is mounted on a single relay rack panel. Coupling of the BW-11A Monitor to the transmitter is obtained from a short length of wire attached to the input terminals to act as an antenna. The BW-11AT Monitor's input voltage is obtained by "looping through" a coaxial cable circuit carrying a subcarrier signal.

### One Tuning Adjustment

The oscillator crystal is maintained at a constant temperature by means of a mercury thermostat-controlled oven. Additional isolation against external influ-

ences is effected by the use of low heat conductivity wire to the crystal circuits and thermal cutout. No tuning adjustments are required other than the setting of a single capacitor. A wideband amplifier increases the crystal signal uniformly over the frequency range.

### Heavy Duty Features

Since the equipment is designed to operate continuously without adjustment, only two switches are provided on the front panel, the monitor toggle switch, and the check pushbutton switch. The monitor switch controls power for all circuits except the oven heater which is thermostatically controlled and functions whenever the power cable is connected to the AC power source. The check pushbutton switch permits a quick check on all circuits. When the monitor is work-

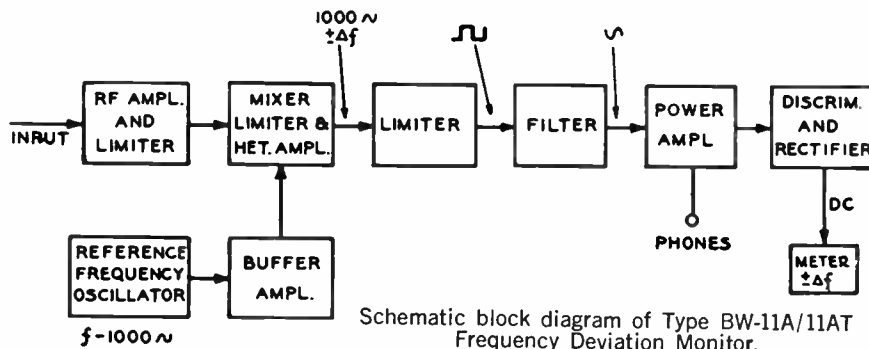

ing normally and this button is pressed, the meter deflection increases by approximately 5 Hz. A change appreciably different from 5 Hz indicates a defective circuit.

### Circuit Description

The circuit arrangement of the BW-11A/11AT is shown in the accompanying block diagram. Voltage from a temperature-controlled piezo-electric oscillator (frequency  $f - 1000$  Hz) and the carrier to be monitored (frequency  $f \pm \Delta f$ ) are amplified and fed to a converter tube from which their difference frequency ( $1000 \pm \Delta f$ ) is obtained. This audio-

frequency is converted to a constant amplitude square wave by means of a limiter amplifier and then restored to a constant amplitude sine wave of frequency ( $1000 \text{ Hz} \pm \Delta f$ ) by a filter stage. After power amplification the audio frequency is applied to a discriminator and rectifier circuit, from which DC is obtained. The amplitude and polarity of the DC is determined by the deviation from 1000 Hz. Deviation is indicated on a linearly calibrated zero-center meter with a scale calibration of  $\pm 30$  Hz. A jack is provided for a remote indicating or recording meter, which can be operated simultaneously with the panel meter.

Circuits are designed so that wide variations in tube characteristics and line voltage cause negligible error in deviation indications. Negative feedback is used on the power amplifier, and in other circuits, limiting and voltage regulation are employed to minimize these effects.

### Operational Convenience

The oven thermometer is visible through a slot in the lower section of the front panel and it is illuminated for easy reading. Tubes and crystal oven, located on the back of the chassis, are easily accessible for servicing. The monitor is contained in a single unit which occupies a 15 $\frac{3}{4}$ -inch vertical space in a standard 19-inch cabinet rack. To facilitate maintenance, the bottom section of the front panel may be lowered to expose the monitor circuits for continuity checks, and all the routine maintenance controls. An MI-7982-B Crystal Unit specially ground to 1000 Hertz below the transmitter frequency is provided for the BW-11A, and MI-7962-C Crystal Unit especially ground for the subcarrier frequency is specified for the BW-11AT Monitor.

## Specifications

### Performance Specifications

	Model BW-11A	Model BW-11AT
Frequency Range	500 to 2000 kHz	3.579545 MHz
Frequency Deviation Range readable to 1 Hz)	$\pm 30$ Hz	$\pm 30$ Hz
Accuracy	$\pm 10$ parts per million	$\pm 1$ Hz for 30 days $\pm 5$ Hz for 1 year
R-F Input Voltage	Approx. 10 mV to 25 Volts	Approx. 0.15 to 25 Volts
Power Supply	105-130 Volts, 50/60 Hz, single phase	
Power Input	120 Watts	
Dimensions	19" wide, 15 $\frac{3}{4}$ " high, 9 $\frac{5}{8}$ " deep (48.26 cm, 40 cm, 24.45 cm)	

Weight	60 lbs. (27.2 kg)
Finish	Silver gray
FCC Approval Number for BW-11A	1471
Tube Complement:	
	5—6AU6, 1—6BE6, 1—6V6-GT, 3—6AL5, 2—2D21, 1—5Y3-GT, 2—OC3/VR105

### Accessories

Remote Meter (order from Replacement Parts)	SN-93688
Tube Kit for BW-11A/AT	MI-8295
Crystal Unit for BW-11A (specify frequency)	MI-34070
Crystal Unit for BW-11AT (frequency 1192.848 kHz)	MI-7962-C

## Ordering Information

BW-11A AM Broadcast Frequency Monitor complete including Crystal Unit MI-34070.  
(Specify operating frequency).....ES-34042

BW-11AT Color TV Sub-Carrier Frequency Monitor complete including Crystal Unit, MI-34075.  
(Specify operating frequency).....ES-34040-A

FM  
TRANSMITTING



## **RCA** 1-KW FM Broadcast Transmitter, Type BTF-1E2

- New solid-state exciter
- Available for mono or stereo  
—with or without SCA
- Designed for remote control
- Direct FM exciter



3TB



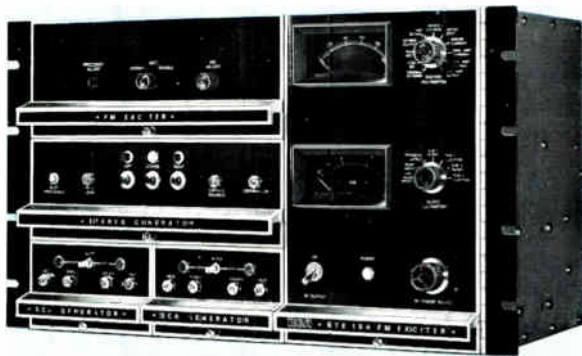

New solid-state FM Exciter system, Type BTE-15A, showing "Direct FM" exciter housed with optional stereo generator and SCA generator units.

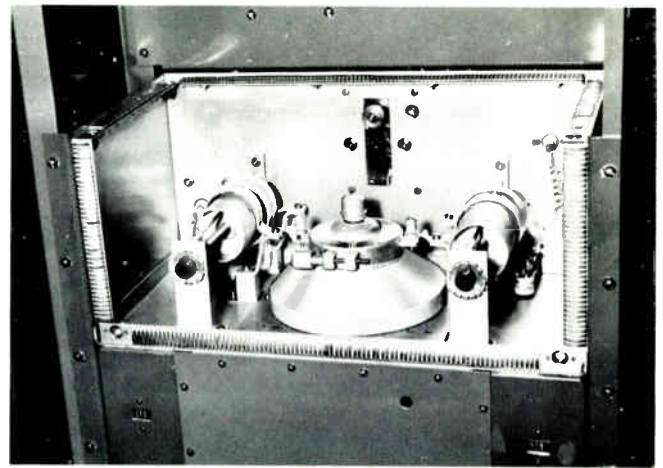

RF cavity with shielded cover removed.

## Description

RCA's Type BTF-1E2 FM Transmitter provides 1,000 Watts output for stations operating in the 88 to 108 MHz band. It is designed to provide the finest possible performance and reliability, and is specifically built to meet the stringent requirements of multiplex and stereo service transmission. It is a simple and compact unit easy to install.

The BTF-1E2 Transmitter supplies the latest in FM broadcast techniques. Only one tube beyond the exciter is required to supply 1000 Watts output. No IPA stage is required. The transmitter is extremely stable because it incorporates RCA's time-proven "Direct FM" Exciter. This exciter requires no special tuning or setting up for standard or for multiplex operations. It has all solid-state components. Cross-talk and noise are kept to an absolute minimum.

### Easy to Install and Operate

Other features incorporated in the BTF-1E2 include silicon rectifiers which provide long life with a minimum of maintenance. Accessibility is assured both front and rear by vertical chassis construction, surface mounting of components, and hinged mounting of the exciter. Mechanical and electrical overload protection is provided. To assure performance in accordance with FCC requirements, the transmitter is supplied with harmonic filter. Provisions for remote control have been provided in the transmitter.

High quality FM stereo transmission can be obtained by the addition of an RCA BTS-1B Stereo Generator. SCA programming may be transmitted simultaneously with stereo by the use of the optional BTX-1B subcarrier generator. The BTF-1E2 is type accepted for such simultaneous program transmission.

### Single Cabinet

The Type BTF-1E2 FM Transmitter is completely housed in one cabinet with total floor dimensions of only 26 by 21 inches. The cabinet is functionally styled to present a pleasing appearance. All meters and operating controls are conveniently located. Front and rear hinged doors give easy access to all portions of the transmitter.

Located at the front are the overload relays, the 1 kW amplifier and RF box containing tuning dials for the amplifier. A control panel and screen supply are located next, followed by the hinged mounted exciter. Concealed in the bottom of the transmitter are the high voltage rectifier and power transformer. The rear of the transmitter gives access to the bias resistors, metering circuitry and blower, followed by the rear of the control panel and screen supply. A voltage regulating filament transformer is mounted on the control panel.

### Solid-State FM Exciter

Excellent monaural, stereo and SCA

performance that more than meets industry and FCC standards are achieved by the new RCA modular, solid-state "Direct FM" exciter.

### Simplified Circuits

Modulation of the temperature compensated basic on-frequency oscillator is achieved by applying the composite stereo or SCA signals from the BTS-1B and BTX-1B Generators, respectively, to a pair of push-pull varicap diodes which are coupled to the basic oscillator frequency determining resonant circuit. The output of the basic oscillator is isolated from the following buffer amplifier by a 10 dB resistive attenuator. Thus, the stability and modulation characteristics of the basic direct FM oscillator are not disturbed by following RF power amplifiers.

The output of the buffer amplifier, approximately 500 mW, is used to drive the 15-Watt, three-stage RF amplifier as well as the binary divider chain in the AFC circuit. The basic oscillator, buffer amplifier, and AFC circuit are mounted inside a shielded enclosure. The RF power amplifier is also completely shielded.

Automatic frequency control (AFC) for the on-frequency basic oscillator is achieved by taking a sample of the buffer output frequency and dividing it by two, 14 times. A low-frequency reference crystal operating at 1/1024th of the de-

sired output frequency is divided by two, 4 times. Integrated circuits operating in the saturated mode are used in both binary dividing chains. The outputs from the reference and basic oscillator binary dividers are phase compared in a time-sharing IC comparator. The output of the circuit, which represents the AFC error voltage, is filtered and applied to another pair of varicap diodes coupled to the basic oscillator tuned circuit. Thus, the basic oscillator is phase locked to the 1024th harmonic of the oven controlled reference crystal.

An off-frequency detector is incorporated in the design of the BTE-15A FM Exciter. When the basic oscillator frequency is not phase locked to the reference crystal, an AC component appears at the AFC output. This voltage is rectified to operate a relay whose contacts can be used to turn off the FM transmitter.

Two multimeters are located on the hinged door of the exciter in front of the regulated power supply section. One of these meters is used to indicate power supply and operating voltages within the exciter and 15-Watt RF Amplifier. The second meter is a peak-reading voltmeter that is used to indicate all modulating signal levels.

The RF power output of the BTE-15A can be continuously adjusted from the front panel control from 7 to 15 Watts. The primary power is turned on with a circuit breaker. RF output is turned on

with a front panel switch or by jumping contacts available on the rear of the unit. The exciter will tolerate load mismatches from short circuit to open circuit for a reasonable time without damaging the output transistor. Another safety feature prevents turning on the 41 kHz SCA subcarrier when the BTS-1B Stereo Generator is in the stereo mode.

### Power Amplifier

The output of the exciter is fed to the input of the ceramic 4CX1000A amplifier tube. The amplifier input circuit is a simple parallel resonant circuit, tuned by a variable inductance with resistance swamping for stability of operation. This stage is neutralized by varying inductance in series with the screen. The output circuit is a modified pi network, having a variable inductance across the tube capacity—which is used to adjust the loading. All capacitors in the final stage are of the fixed ceramic type. A blower mounted on the back of the RF compartment provides sufficient filtered air for cooling at stations operating below 7500 feet. The filament transformer is of the automatic regulator type and keeps filament voltage constant within one percent.

The power amplifier is new in many respects. The variable inductors use no sliding contacts. There are no variable capacitors in the power amplifier. A single tube, the 4CX1000A, is used in the BTF-1E2 power amplifier and it is driven directly by the output of the exciter in an exclusive RCA circuit.

### Neutralizing Probe

A neutralizing probe is furnished with the transmitter. It utilizes the multimeter to indicate correct neutralization of the power amplifier.

The high voltage and screen power supplies make use of silicon rectifiers in a bridge circuit. This combined with choke input and adequate filtering results in an excellent well-regulated power source. A variable transformer is used in the primary of the screen power supply to control power output of the transmitter. Filament voltage regulation is provided for the 4CX1000A power amplifier tube.

### Harmonic Filter

The harmonic filter supplied with all RCA FM transmitters is not a simple harmonic trap. The filter consists of an M-derived half-T section, several low-pass filter sections, and a constant-K, half-T section. The M-derived section provides rapid cut-off in the second harmonic region, and a termination impedance at one end of the filter of 50 Ohms. Attenuation of the harmonics is accomplished by the low-pass filter sections, while the constant-K, half-T section serves to give a termination impedance of 50 Ohms at the other end of the unit. The use of such a filter assures compliance with FCC requirements regarding spurious radiation, as all harmonics through the seventh are effectively attenuated.

Simplified Block Diagram of BTF-1E2 Transmitter, showing optional stereo and SCA.

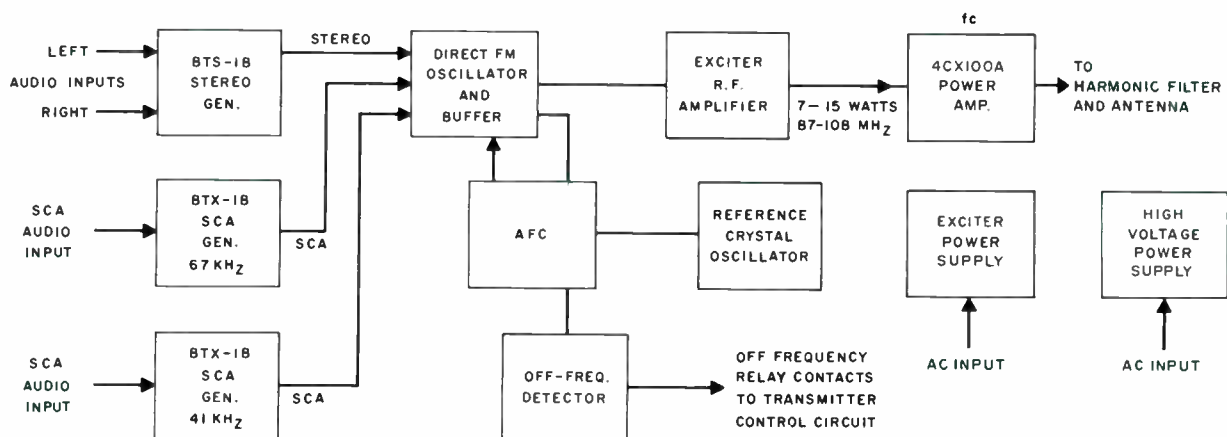

## Protective Circuits

Power circuits are protected by magnetically tripped circuit breakers as well as overload relays. An interlock relay prevents application of plate power until the 4CX1000A filament has heated and the exciter has reached a stable operating condition. Overload relays are used in the high voltage and screen power supplies. There is also an interlock in the air blower circuit. If the blower should fail or air-flow be reduced below the proper level, the transmitter is taken off the air thus avoiding possible damage.

The overload relays are reset remotely or by means of an instantaneous key switch on the front panel. An overload indicator lamp signals when an overload

has taken place. All relays are easily accessible. Access to high voltage areas is protected by built-in high voltage shorting devices.

## Control Features

The BTE-15A exciter has a self-contained multimeter. In the amplifier of the transmitter, provision is made for metering PA plate current, plate voltage, output power and VSWR; a probe is furnished for neutralizing the transmitter and is used in connection with the multimeter. All tuning controls are located on the front panel for easy accessibility. They include key switches for filament on-off, plate on-off, and overload reset. The variable power control is also

mounted on the front as are the overload indicator and plate power-on lights. The use of latching relays make it possible to control the transmitter with one button.

## Remote Control Provisions

The BTF-1E2 transmitter incorporates connections for remote control and remote meter reading when combined with a remote control system such as the BTR-11B or BTR-20E. Terminals for transmitter on-off, plate on-off, overload reset, plate voltage, cathode current, and power output are provided. To control transmitter power output remotely, an accessory motor drive may be connected to the screen supply control.

# Specifications

## Performance

Type of Emission.....	F3 and F9
Frequency Range.....	.88 to 108 MHz
Power Output.....	250-1000 Watts
Output Impedance (1½" O.D. Line).....	50/51.5 Ohms
Frequency Deviation, 100% modulation.....	±75 kHz
Modulation Capability.....	±100 kHz
Carrier Frequency Stability.....	±1000 Hz max.
Audio Input Impedance.....	600/150 Ohms
Audio Input Level— <sup>1</sup> (100% mod.).....	+10±2 dBm
Audio Frequency Response— <sup>2</sup> (50 Hz-15 kHz).....	±1 dB max.
Pre-emphasis Network Time Constant.....	75 or 50 µs or flat as desired
Harmonic Distortion— <sup>3</sup> (50 Hz-15 kHz).....	0.5% or less
FM Noise Level (referred to 100% FM mod.).....	-65 dB max.
AM Noise Level (referred to 100% AM mod.).....	-50 dB max.
Subcarrier Input Level (100% mod.).....	-15 to +10 dBm adjustable
Subcarrier Input Impedance.....	600/150 Ohms bal.
Subcarrier Frequency.....	20-67 kHz
Main-to-Subchannel Crosstalk.....	-50 dB referred to ±7.5 kHz deviation of the subcarrier by a 400 Hz tone. Main channel modulation 70% by 50-15,000 Hz tones.
Sub-to-Main-Channel Crosstalk.....	-60 dB referred to ±7.5 kHz deviation of the main carrier by a 400 Hz tone. Subchannel modulated 100% (±7.5 kHz/s) by 50-6000 Hz tones. Subcarrier modulated 30% on main carrier.

## Electrical

Power Line Requirements:	
Line.....	240/208 Volts, single phase, 60 Hz <sup>4</sup>
Slow Voltage Variation.....	±5%
Power Consumption.....	2800 Watts (approx.)
Power Factor (approx.).....	80%

## Tube Complement

Power Amplifier:  
1—4CX1000A

## Mechanical

Dimensions (overall).....	26" wide, 77" high, 20½" deep (66.04 cm, 195.58 cm, 52.23 cm)
Weight.....	790 lbs. (3.58 kg.)
Finish.....	Textured vinyl in midnight blue and shadow blue, satin aluminum trim
Altitude.....	7500 ft. max. (2290 m)
Ambient Temperature Range.....	-20° to +45°C

## Accessories

Recommended Spare RF Transistors for Exciter.....	MI-560718
Spare Crystal and Oven (Specify operating frequency).....	MI-560717
Spare Transmitter Tube.....	MI-34709
1-kW RF Load and Wattmeter.....	MI-19196L/H
Type BTR-11B Remote Control System (10-function).....	ES-34280
Type BW-75A FM Frequency and Modulation Monitor.....	MI-560735
Type BW-85A FM Stereo Frequency and Modulation Monitor.....	MI-560740
Type BW-95A SCA Frequency and Modulation Monitor.....	MI-560745

<sup>1</sup> Level measured at input to pre-emphasis network.

<sup>2</sup> Audio Frequency response referred to 75 or 50 micro-second pre-emphasis curve.

<sup>3</sup> Distortion includes all harmonics up to 30 kHz and is measured following a standard 75 or 50 micro-second de-emphasis network.

<sup>4</sup> 50-Hz operation requires MI-34316-20 regulator.

# Ordering Information

Type BTF-1E2 1-kW FM Broadcast Transmitter ...ES-27279-C\*

\*Please specify assigned frequency, power-line frequency and altitude of installation and select a BTE-15A Exciter System from the following:

Mono.....	ES-560631
Mono and one SCA Channel.....	ES-560632
Mono and two SCA Channels.....	ES-560633
Stereo.....	ES-560634
Stereo and one SCA Channel.....	ES-560635
Stereo and two SCA Channels.....	ES-560636

## 3-kW FM Broadcast Transmitter, Type BTF-3E1

- New solid-state exciter
- Available for mono or stereo  
—with or without SCA
- Designed for remote control
- Direct FM exciter
- Grounded-grid PA

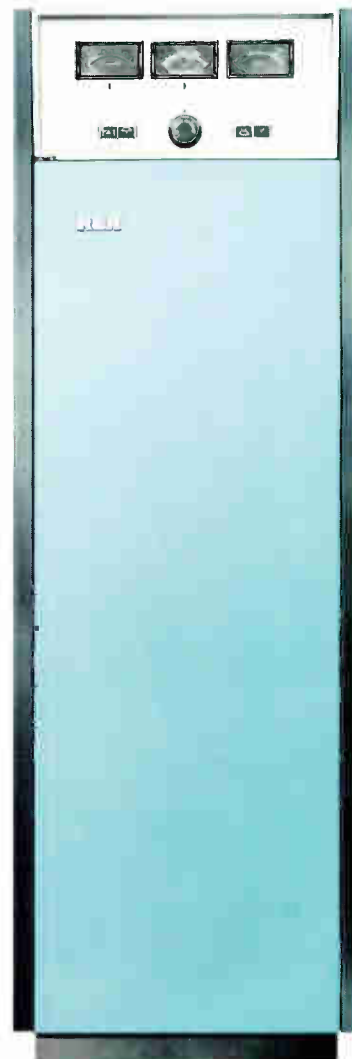

## Description

RCA's Type BTF-3E1 FM Transmitter provides 3,000 watts output for stations operating in the 88 to 108 MHz band. It is designed to provide the finest possible performance and reliability, and is specifically built to meet the stringent requirements of multiplex and stereo service transmission. It is a simple and compact unit easy to install.

### Two Stages Follow Exciter

From the 15-watt output of the BTE-15A exciter, only two power stages are required to generate the three-kilowatt power level (see block diagram). The power output stage operates in a grounded-grid circuit.

### Easy to Install and Operate

Other features incorporated in the BTF-3E1 include silicon rectifiers which provide long life with a minimum of maintenance. Accessibility is assured both front and rear by vertical chassis construction, surface mounting of components, and hinged control panel. Mechanical and electrical overload protection is provided. To assure performance in accordance with FCC requirements, the transmitter is supplied with harmonic filter. Provisions for remote control have been provided in the transmitter.

High quality FM stereo transmission can be obtained by the addition of an RCA BTS-1B Stereo Generator. SCA programming may be transmitted simultaneously with stereo by the use of the optional BTX-1B subcarrier generator. Space for two SCA generators is provided.

### Single Cabinet

The Type BTF-3E1 FM Transmitter is completely housed in one cabinet with total floor dimensions of only 26 by 33 inches (660 x 838 mm). The cabinet is functionally styled to present a pleasing appearance. All meters and operating controls are located conveniently. Front and rear hinged doors give easy access to all portions of the transmitter.

Located at the front are the overload relays and tuning controls for the amplifier. A control panel and screen voltage control are located next, followed by the Type BTE-15A exciter system. Concealed in the bottom of the transmitter are the high voltage rectifier and power transformer. The rear of the transmitter gives

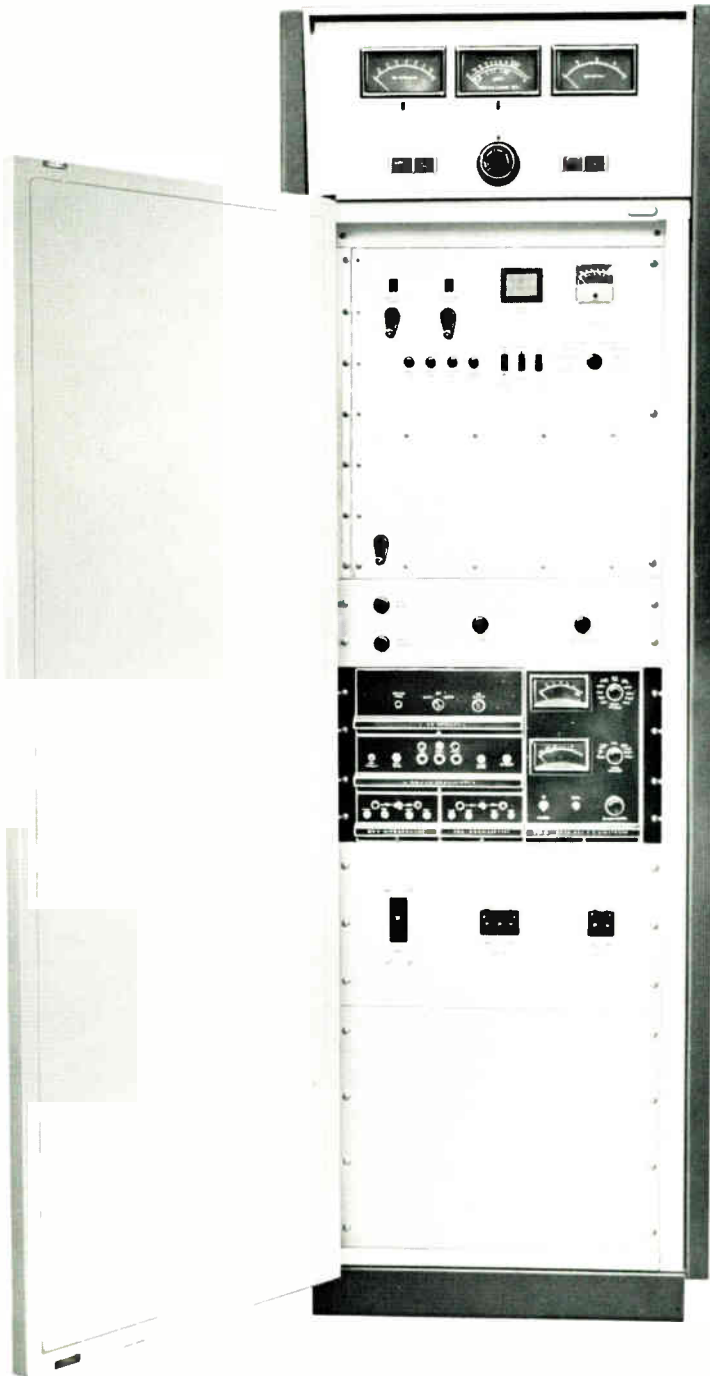

Heart of the BTF-3E1 Transmitter is the solid-state exciter, shown here with stereo and two SCA modules in place.

access to the RF box, metering circuitry and blower, followed by the rear of the control panel.

### BTE-15A Solid-State FM Exciter

Excellent monophonic, stereophonic and SCA subcarrier performance that more than meets industry and FCC standards are achieved by the new RCA modular, solid-state "Direct FM" exciter, operating at carrier frequency.

### Simplified Circuits

Modulation of the temperature compensated basic on-frequency oscillator is achieved by applying the composite stereo or SCA signals from the BTS-1B and BTX-1B Generators, respectively, to a pair of push-pull Varicap diodes which are coupled to the basic oscillator frequency determining resonant circuit. The output of the basic oscillator is isolated from the following buffer amplifier by a 10 dB resistive attenuator. Thus, the stability and modulation characteristics of the basic, direct-FM oscillator are not disturbed by following power amplifiers.

The output power of the buffer amplifier, approximately 500 mW, is used to drive the 15-watt, three-stage amplifier as well as the binary divider chain in the AFC circuit. The basic oscillator, buffer amplifier, and AFC circuit are mounted inside a shielded enclosure. The power amplifier is also completely shielded.

Automatic frequency control (AFC) for the on-frequency basic oscillator is achieved by taking a sample of the buffer output and dividing it by two, 14 times. A low-frequency reference crystal operating at 1/1024th of the desired output frequency is divided by two, 4 times. Integrated circuits operating in the saturated mode are used in both binary dividing chains. The outputs from the reference and basic oscillator binary dividers are phase compared in a time-sharing IC comparator. The output of the circuit, which represents the AFC error voltage, is filtered and applied to another pair of Varicap diodes coupled to the basic oscillator tuned circuit. Thus, the basic oscillator is phase locked to the 1024th harmonic of the oven controlled reference crystal.

An off-frequency detector is incorporated in the design of the BTE-15A Exciter. When the basic oscillator frequency is not phase locked to the reference crystal, an AC component appears at the AFC output. This voltage is rectified to operate a relay whose contacts can be used to turn off the FM transmitter.

Two multimeters are located on the hinged door of the exciter in front of the

regulated power supply section. One of these meters is used to indicate power supply and operating voltages within the exciter and 15-watt RF Amplifier. The second meter is a peak-reading voltmeter that is used to indicate all modulating signal levels.

The RF power output of the BTE-15A can be continuously adjusted from the front panel control from 7 to 15 watts. The primary power is turned on with a circuit breaker. RF output is turned on with a front panel switch or by jumping contacts available on the rear of the unit. The exciter will tolerate load mismatches from short circuit to open circuit for a reasonable time without damaging the output transistor. Another safety feature prevents turning on the 41 kHz SCA subcarrier when the BTS-1B Stereo Generator is in the stereo mode.

### Grounded-Grid Power Amplifier

Two simplified, single-ended amplifiers follow the exciter. The 250-watt driver stage uses a Type 8122 tube, and the final power amplifier, operating grounded-grid, uses a triode.

### 3-kW Final Amplifier

The output tube, a ceramic triode, offers high power-gain. Using this tube, only two stages of amplification are required between the exciter and the antenna for the 3,000-watt output. Fewer components results in improved reliability.

### Adjustable Power-Output Control

Power output is controlled by means of a variable resistor which controls the screen-voltage supply. The use of semiconductor (silicon) rectifiers reduces operating and maintenance costs.

### Harmonic Filter

The harmonic filter supplied with all RCA FM transmitters is not a simple harmonic trap. The filter consists of an *M*-derived half-*T* section, several low-pass filter sections, and a constant-*K*, half-*T* section. The *M*-derived section provides rapid cut-off in the second harmonic region, and a termination impedance at one end of the filter of 50 ohms. Attenuation of the harmonics is accomplished by the low-pass filter sections, while the constant-*K*, half-*T* section serves to give a termination impedance of 50 ohms at the other end of the unit. The use of such a filter assures compliance with FCC requirements regarding spurious radiation, as all harmonics through the seventh are effectively attenuated.

### Self-Protected Against Overload

Power circuits are protected by magnetically-tripped circuit breakers in addition to overload relays. An automatic sequencing system prevents turn-on of plate power before all filaments have heated. In addition, a latching relay automatical-

Simplified Block Diagram of BTF-3E1 Transmitter, showing optional stereo and SCA.

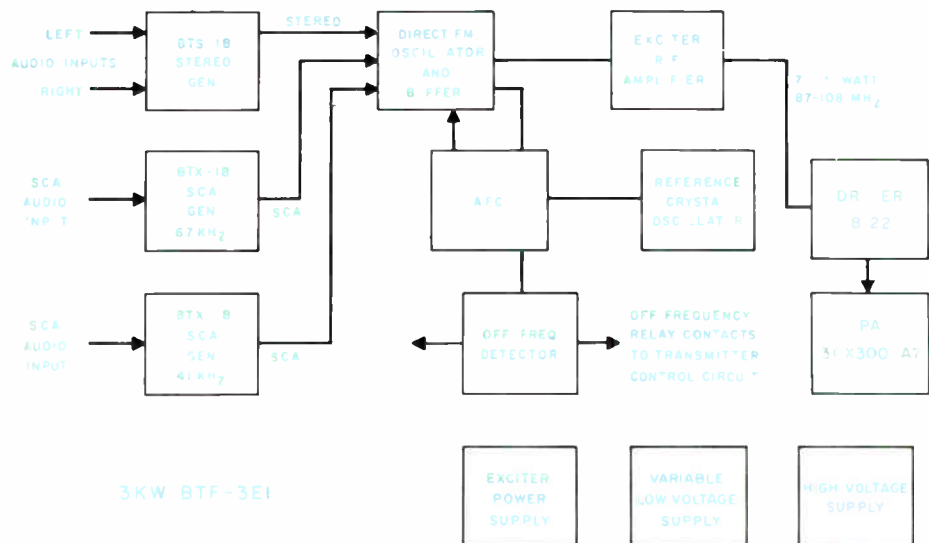

ly re-applies power to the transmitter three times before locking-out in the event of brief overloads or power interruptions. The overload relays are reset by pushbutton switches on the front panel. Separate tally-light indicators are provided for overloads in the driver, power amplifier and high voltage rectifier circuits.

### Control Features

The BTE-15A exciter has a self-contained multimeter. In the amplifier of

the transmitter, provision is made for metering PA plate current, plate voltage, output power and VSWR. All tuning controls are located on the front panel for easy accessibility. They include switches for filament on-off, plate on-off, and overload reset. The variable power control is also mounted on the front as are the overload indicator and plate power-on lights. The use of latching relays make it possible to control the transmitter with one button.

### Remote Control Provisions

The BTF-3E1 transmitter incorporates connections for remote control and remote meter reading when combined with a remote control system such as the BTR-15 or BTR-30. Terminals for transmitter on-off, plate on-off, overload reset, plate voltage, cathode current, and power output are provided. To control transmitter power output remotely, an accessory motor drive may be connected to the screen voltage control.

## Specifications

### Performance

Type of Emission .....	F3 and F9
Frequency Range .....	.88 to 108 MHz
Power Output .....	1000-3000 watts
Output Impedance (% O.D. Line) .....	50/51.5 ohms
Frequency Deviation, 100% modulation .....	±75 kHz
Modulation Capability .....	±100 kHz
Carrier Frequency Stability .....	±1000 Hz max.
Audio Input Impedance .....	600/150 ohms
Audio Input Level— <sup>1</sup> (100% mod.) .....	+10±2 dBm
Audio Frequency Response— <sup>2</sup> (50 Hz-15 kHz) .....	±1 dB max.
Pre-emphasis Network Time Constant .....	.75 or 50 μs
Harmonic Distortion— <sup>3</sup> (50 Hz-15 kHz) .....	0.5% or less
FM Noise Level (referred to 100% FM mod.) .....	-65 dB max.
AM Noise Level (referred to 100% AM mod.) .....	-50 dB max.
Subcarrier Input Level (100% mod.) .....	-15 to +10 dBm adjustable
Subcarrier Input Impedance .....	600/150 ohms bal.
Subcarrier Frequency .....	20-67 kHz
Main-to-Subchannel Crosstalk .....	-50 dB referred to ±6.0 kHz deviation of the subcarrier by a 400 Hz tone. Main channel modulation 70% by 50-15,000 Hz tones.
Sub-to-Main-Channel Crosstalk .....	-60 dB referred to ±75 kHz deviation of the main carrier by a 400 Hz tone. Subchannel modulated 100% (6.0 kHz/s) by 50-6000 Hz tones. Subcarrier modulated 30% on main carrier.

### Electrical

Power Line Requirements:	
Line .....	240/208 volts, three phase, 50/60 Hz
Combined Voltage Variation and Regulation .....	±5%
Power Consumption .....	6000 watts (approx.)
Power Factor (approx.) .....	90%

### Tube Complement

Power Amplifier:	1—3CX3000A7
Driver:	1—8122

### Mechanical

Dimensions (overall) .....	25" wide, 77" high, 33" deep (635 mm, 1956 mm, 840 mm)
Weight .....	850 lbs. (385 kg.)
Finish .....	Textured vinyl in charcoal gray and shadow blue, satin aluminum trim
Altitude .....	7500 ft. max. (2290 m) <sup>4</sup>
Ambient Temperature Range .....	-20° to +45°C

### Accessories

Remote Power Control .....	MI-561023
Recommended Spare RF Transistors for Exciter .....	MI-560718
Spare Crystal and Oven (Specify operating frequency) .....	MI-560717
Spare Transmitter Tubes .....	ES-560920
RF Load and Wattmeter .....	MI-561422
Type BW-75 FM Frequency and Modulation Monitor .....	MI-560735
Type BW-100 RF Amplifier .....	MI-560738
Type BW-85 FM Stereo Frequency and Modulation Monitor .....	MI-560740
Type BW-95 SCA Frequency and Modulation Monitor .....	MI-560745

<sup>1</sup> Level measured at input to pre-emphasis network.  
<sup>2</sup> Audio Frequency response referred to 75 or 50 micro-second pre-emphasis curve.  
<sup>3</sup> Distortion includes all harmonics up to 30 kHz and is measured following a standard 75 or 50 micro-second de-emphasis network.  
<sup>4</sup> Blowers available for higher altitudes.

## Ordering Information

Type BTF-3E1 3-kW FM Broadcast Transmitter ...ES-560915\*  
 \*Please specify assigned frequency, power-line frequency (if other than 60 Hz) altitude of installation and select a BTE-15A Exciter System from the following:

Monophonic .....	ES-560631
Mono and one SCA Channel .....	ES-560632
Mono and two SCA Channels .....	ES-560633
Stereophonic .....	ES-560634
Stereo and one SCA Channel .....	ES-560635
Stereo and two SCA Channels .....	ES-560636

## **RCA** 5-KW FM Transmitter, Type BTF-5E1

- New solid-state exciter
- Ultra stable—easy to tune
- Available for mono or stereo—  
—with or without SCA
- Field-expandable  
to 10 or 20 kW
- Ready for remote control

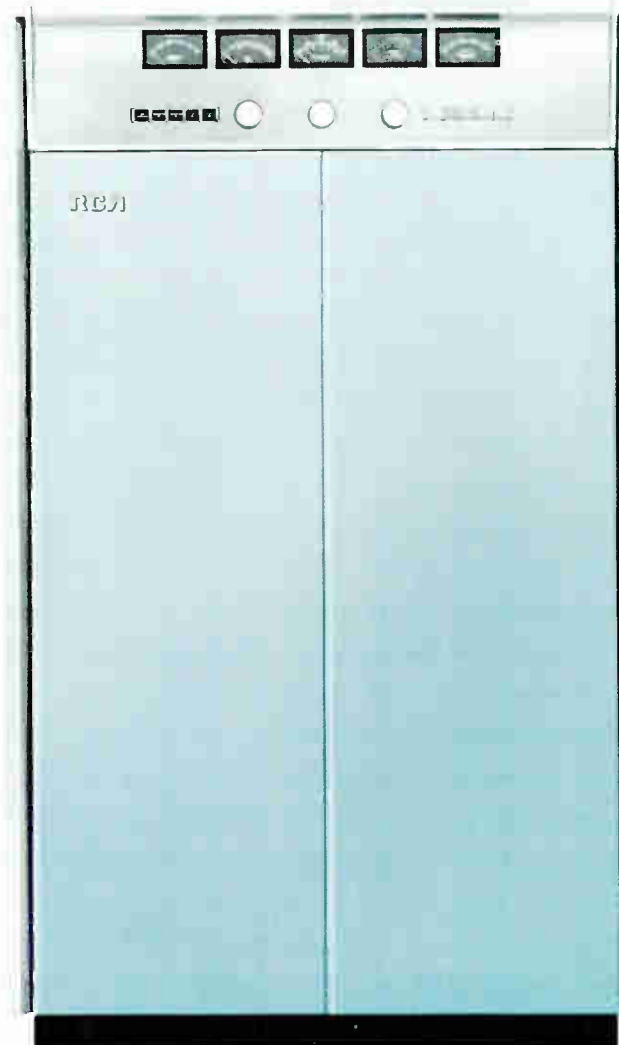



# 5 KW FM Broadcast Transmitter

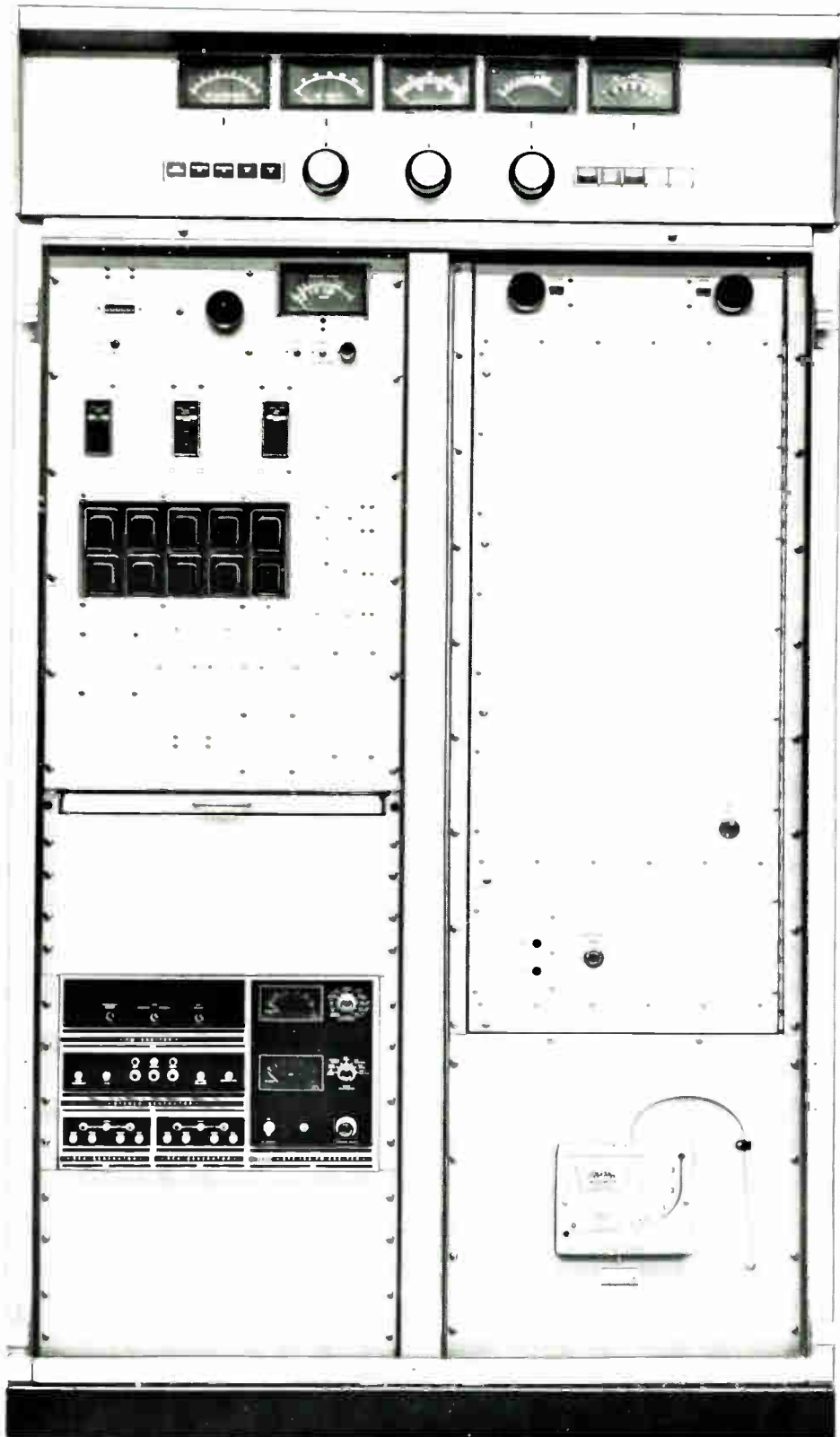

Centralized Controls

Ready for remote control

Self-protected against overload

Tilt down chassis for easy maintenance

Direct-FM Exciter

Eye-level metering

Complete Accessibility

Two Stages Follow Exciter—IPA and PA

"Filter-Minder" Manometer

Fully Air Cooled

## Full-Fidelity FM Transmitter, Type BTF-5E1

RCA's Type BTF-5E1 FM Broadcast Transmitter provides 5,000 Watts output for stations operating in the 88 to 108 MHz band. It is designed to provide the finest possible performance and reliability, and is specifically built to meet or exceed the stringent requirements of multiplex service transmission. The equipment is FCC type accepted and meets all requirements for harmonic and spurious emission.

The BTF-5E1 employs a new exciter that uses the time-tested and field-proven *direct-FM* system. The circuit uses capacitive diodes as modulators of an oscillator to produce *direct FM*. Automatic frequency-control maintains oscillator frequency to close tolerances under virtually all operating conditions.

Because of its wide frequency response and extreme stability, the exciter (and the trans-

mitter) is ideally suited for multiplex and stereo programming.

The Type BTA-15A Exciter in the BTF-5E1 uses all solid-state components for long life and great dependability. For ease of tuning, the exciter has a built-in multimeter and highly-accessible test points permitting convenient metering and checking while operating.

Frequency response of the transmitter's main channel is 30 to 15,000 Hz ( $\pm 1$  dB maximum) and the distortion over the same bandwidth is less than one-half of one percent.

The BTF-5E1 is designed specifically to be field-expandable to a 10- or 20-kW transmitter. It is noteworthy that this expansion is substantially electrical and there is virtually no increase in floor-space requirements.

## Description

### Mono or Stereo

The transmitter features a new exciter designed for stereo and multiplex. The exciter, including its self-contained power supply, is mounted on a single vertical chassis.

### Two Stages Follow Exciter

From the 15-Watt output of the exciter, only two tubes generate the full 5-kW signal. A harmonic filter is included to reduce spurious radiation. Vacuum capacitors are used to tune the IPA plate and the PA grid.

### Ready for Remote Control

The transmitter is designed and built for remotely-controlled operation. Internal wiring and terminals are provided for remote control of these transmitter functions: transmitter on/off; raise/lower output power and overload reset. Remote metering facilities for the PA include: cathode current; plate voltage and power output.

### New Styling

Functional styling combined with fewer tubes permits the BTF-5E1 to be housed

in a single, double-door cabinet in a new midnight blue and shadow blue vinyl finish. For contrast, the meter panel is in bright aluminum and the cabinet is trimmed in satin-finished aluminum. The swing-out doors in the front and rear afford the excellent accessibility for which RCA transmitters are famous.

All operating controls and meters are mounted on a panel above the front doors.

### BTE-15A FM Exciter

Excellent monaural, stereo and SCA performance that more than meets industry and FCC standards are achieved by the new RCA modular, solid-state "Direct FM" exciter.

### Simplified Circuits

Modulation of the temperature compensated basic on-frequency oscillator is achieved by applying the composite stereo or SCA signals from the BTS-1B and BTX-1B Generators, respectively, to a pair of push-pull varicap diodes which are coupled to the basic oscillator frequency determining resonant circuit. The output of the basic oscillator is isolated from the following buffer amplifier by a

10 dB resistive attenuator. Thus, the stability and modulation characteristics of the basic direct FM oscillator are not disturbed by following RF power amplifiers.

The output of the buffer amplifier, approximately 500 mW, is used to drive the 15-Watt, three-stage RF amplifier as well as the binary divider chain in the AFC circuit. The basic oscillator, buffer amplifier, and AFC circuit are mounted inside a shielded enclosure. The RF power amplifier is also completely shielded.

### "On Carrier" Frequency Operation

Automatic frequency control (AFC) for the on-frequency basic oscillator is achieved by taking a sample of the buffer output frequency and dividing it by two, 14 times. A low-frequency reference crystal operating at  $1/1024$ th of the desired output frequency is also frequency divided by 16 in a binary chain. Integrated circuits operating in the saturated mode are used in both binary dividing chains. The outputs from the reference and basic oscillator binary dividers are phase compared in a time-sharing IC comparator. The output of the circuit, which represents the AFC error voltage, is filtered

## Select Features

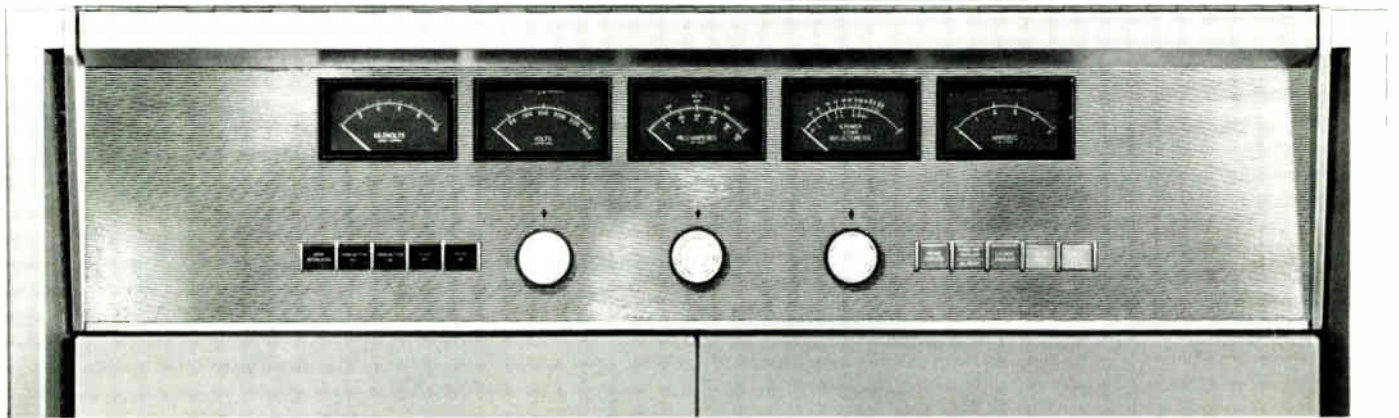

BTF-5E1 Control Panel. Tally lights and push-button controls simplify operation.

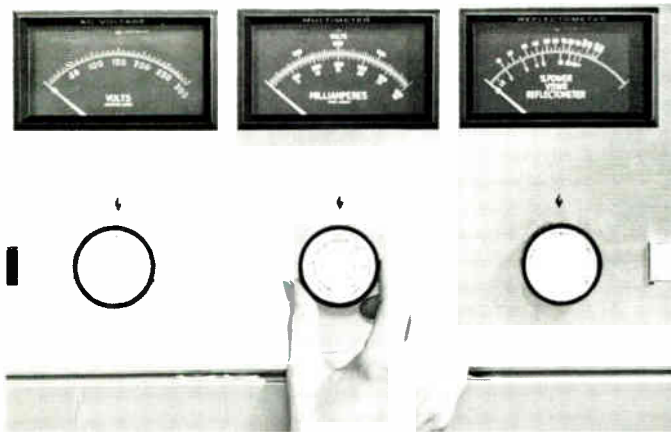

The large-diameter multimeter knobs speed log-keeping and minimize error.



New solid-state FM Exciter system, Type BTE-15A, showing "Direct FM" exciter housed with optional stereo generator and SCA generator units.

and applied to another pair of varicap diodes coupled to the basic oscillator tuned circuit. Thus, the basic oscillator is phase locked to the 1024th harmonic of the oven controlled reference crystal.

An off-frequency detector is incorporated in the design of the BTE-15A FM Exciter. When the basic oscillator frequency is not phase locked to the reference crystal, an AC component appears at the AFC output. This voltage is rectified to operate a relay whose contacts can be used to turn off the FM transmitter.

Two multimeters are located on the hinged door in front of the regulated power supply section. One of these meters is used to indicate power supply and operating voltages within the exciter and 15-Watt RF Amplifier. The second meter

is a peak-reading voltmeter that is used to indicate all modulating signal levels.

The RF power output of the BTE-15A can be continuously adjusted from the front panel control from 7 to 15 Watts. The primary power is turned on with a circuit breaker. RF output is turned on with a front panel switch or by jumping contacts available on the rear of the unit. The exciter will tolerate load mismatches from short circuit to open circuit for a reasonable time without damaging the output transistor. Another safety feature prevents turning on the 41 kHz SCA sub-carrier when the BTS-1B Stereo Generator is in the stereo mode.

### Class "C" Power Amplifiers

Two simplified, single-ended ampli-

fiers operating class "C" follow the exciter. The 250-Watt driver stage uses a Type 7203/4CX250B tube, and the final power amplifier uses a Type 4CX5000A (ceramic tetrode). Vacuum variable capacitors tune the pi network between driver and PA. The power amplifier, too, uses pi-network circuitry and tuning is accomplished by variable inductors operating at ground potential.

### 5-kW Class "C" Final Amplifier

The output tube, a ceramic tetrode, 4CX5000A, offers very high power-gain with little drive. Using this tube, only two stages of amplification are required between the exciter and the antenna for the 5,000-Watt output. Fewer components result in improved reliability.

## Motor-Driven Power-Output Control

Power output is controlled by means of a motor-driven variable transformer which controls the low-voltage power supply. This supply controls the driver-plate and the screen voltages of both stages simultaneously. A separate grid bias supply increases transmitter stability and reliability. The use of semi-conductor (silicon) rectifiers reduces operating and maintenance costs.

## Harmonic Filter Standard Equipment

To keep spurious emission to a minimum, a harmonic filter is standard equipment with the BTF-5E1. The filter consists of an "M"-derived "half-T" section, several low-pass filter sections, and a constant-"K", "half-T" section. Attenuation of the harmonics through the seventh is accomplished by the passband of the low-pass filter sections, while the constant-

"K", "half-T" section serves as a 50-Ohm termination impedance.

## Self-Protected Against Overload

Power circuits are protected by magnetically-tripped circuit breakers in addition to overload relays. An interlock system prevents turn-on of plate power until all filaments have heated and the exciter has reached a proper operating condition. In addition, a latching relay automatically re-applies power to the transmitter once before locking-out in the event of brief overloads or power interruptions. The overload relays are reset by illuminated push button switches on the front panel. Separate tally-light indicators are provided for overloads in the driver, power amplifier and low-voltage rectifier circuits.

## Fully Air-Cooled

Cooling air for the BTF-5E1 is supplied by a blower mounted below the

amplifier stages. Heavy sound insulation reduces blower noise to a minimum. The blower supplies forced air to both the IPA and PA stages.

## Simplified Control

The transmitter has all operating controls and meters located on a panel just above the front doors. The push-button controls include: transmitter on/off, plate on/off, overload reset and power raise/lower. A cabinet disconnect switch, low-voltage circuit breaker, and filament control circuit breakers are located behind the left-hand door. The main- and low-power circuit breakers are located in the unitized rectifier cabinet. When servicing the BTF-5E1, operation of the disconnect switch removes all voltages from the transmitter cabinet. Personnel are also protected by fully interlocked rear doors in addition to interlocked doors on the PA cubicle.

Simplified Block Diagram of the BTF-5E1 Transmitter, showing optional stereo and SCA.

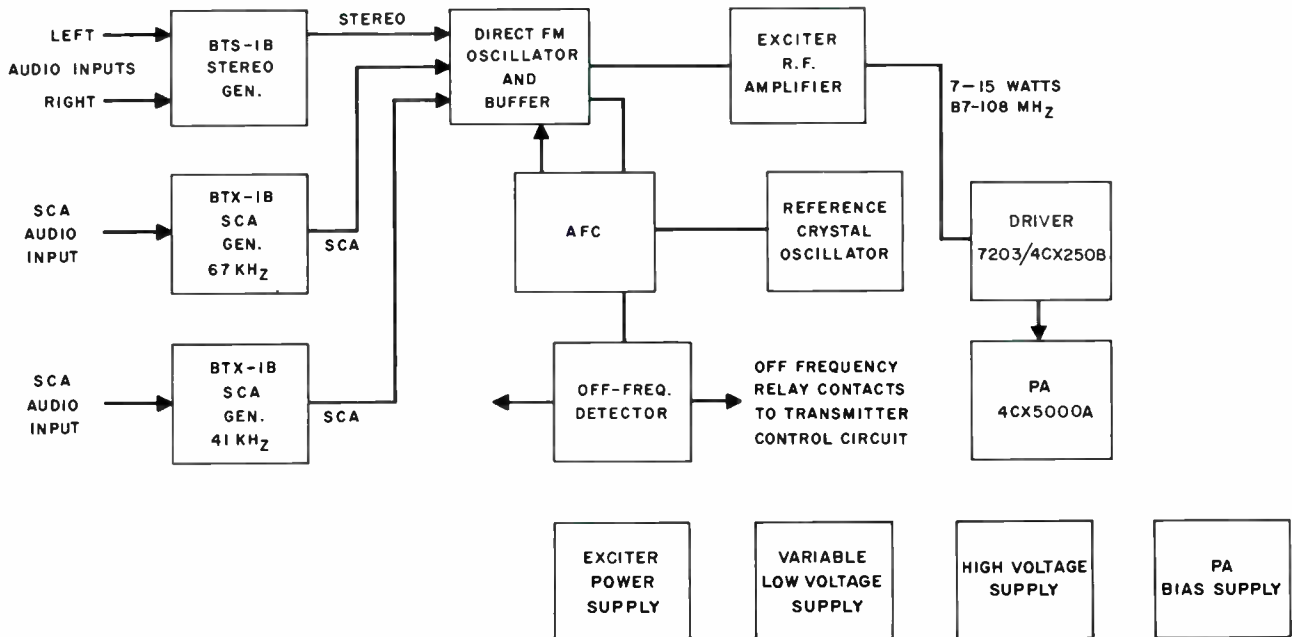

### Full Metering

Six easy-to-read front-panel meters are provided for each amplifier. One for PA-plate voltage, another for PA-plate current, and a third for AC line and filament voltage. The remaining three are a reflectometer indicating output, a multimeter, and VSWR meter. Separate meters are used to measure the forward power and VSWR. The multimeter reads grid current, screen current and screen voltage of both power tubes. In addition the exciter has its own self-contained multimeter. This one provides complete information on operating conditions in the exciter.

### Ready for Remote Control

Remote control provisions are included in the transmitter, and terminals are provided for use with remote control units such as the Type BTR-11B or BTR-20D and Automatic Logging Equipment. Additional terminals are provided for remote control of transmitter on/off, plate on/off, raise/lower power, and overload reset. Remote metering connections in the final amplifier for plate current, plate voltage, and power output are also provided.

### High-Voltage Power Supply

The high-voltage power supply is housed in a unitized cabinet measuring

27 inches wide, 23 inches deep and 43 inches high. It can be installed at any convenient site in the station. The cabinet houses the high-voltage-plate transformer, a bank of plug-in semiconductor rectifiers, a line-circuit breaker, a high-voltage circuit breaker, and the plate contactor. Personnel are fully protected from shock through interlock and grounding switches.

The rectifier section comprises silicon-junction diodes (with equalizing resistors and capacitors) in a three-phase, full-wave-bridge circuit. Circuit breakers are used instead of fuses in the transmitter adding to the dependability, particularly when operating remote control.

**ONLY TWO TUBES BETWEEN EXCITER AND OUTPUT**—View showing interior of PA and IPA cabinet with the 4CX5000A ceramic tetrode and one 7203/4CX250B IPA tube below shelf.

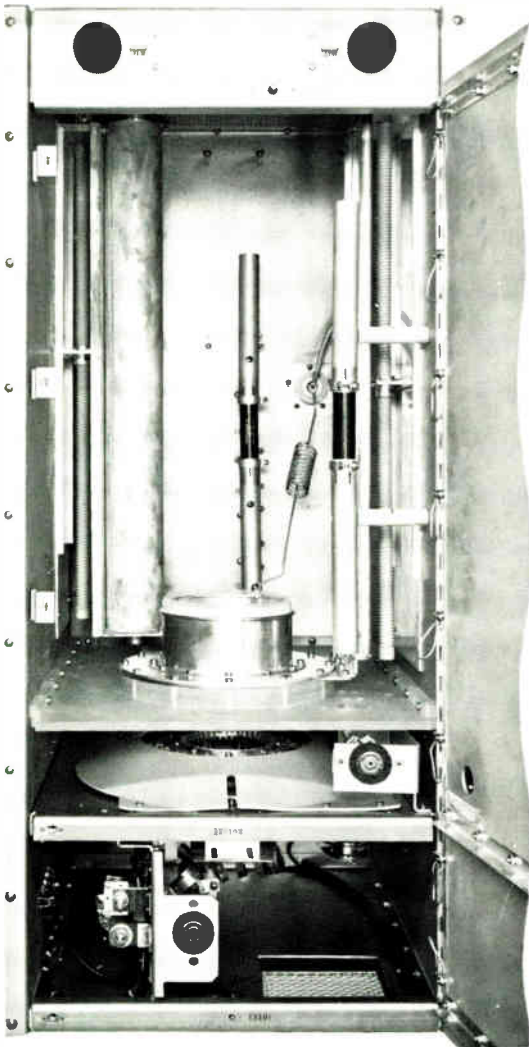

**COMPLETE ACCESSIBILITY**—Rear view of the BTF-5E1 revealing the clean, vertical construction of PA cavity to left and control panel to right.

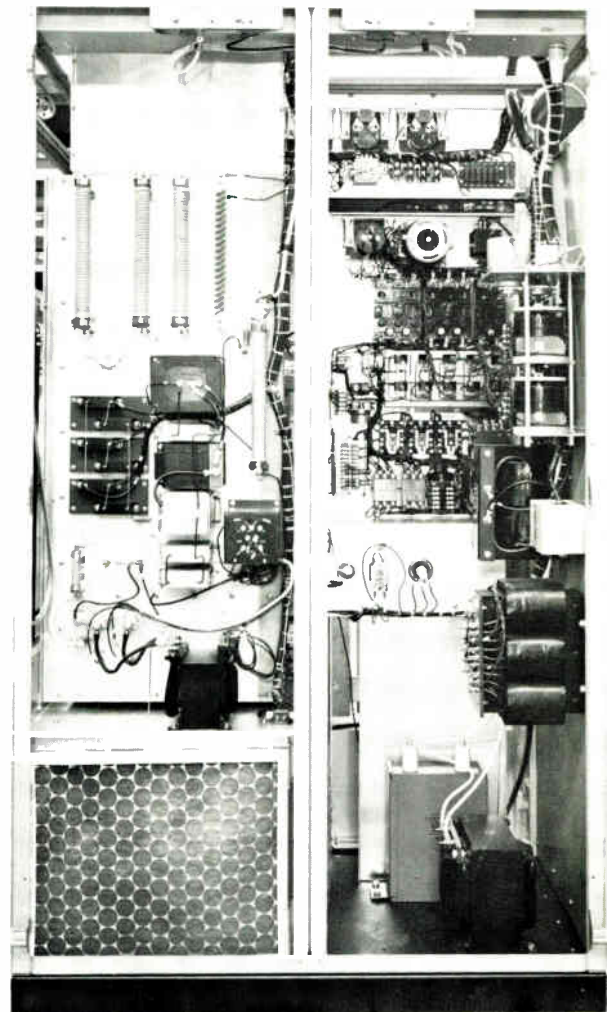

## Specifications

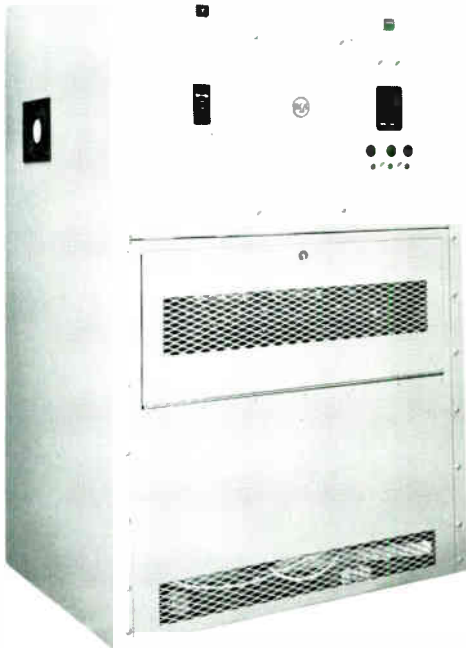

**UNITIZED HIGH VOLTAGE POWER SUPPLY**—With location not tied to the transmitter, the unitized power supply affords many installation and operating economies.

**MODULAR SILICON RECTIFIERS**—Quality components such as this plug-in silicon high-voltage rectifier are important elements in the BTF-5E1's superior performance.

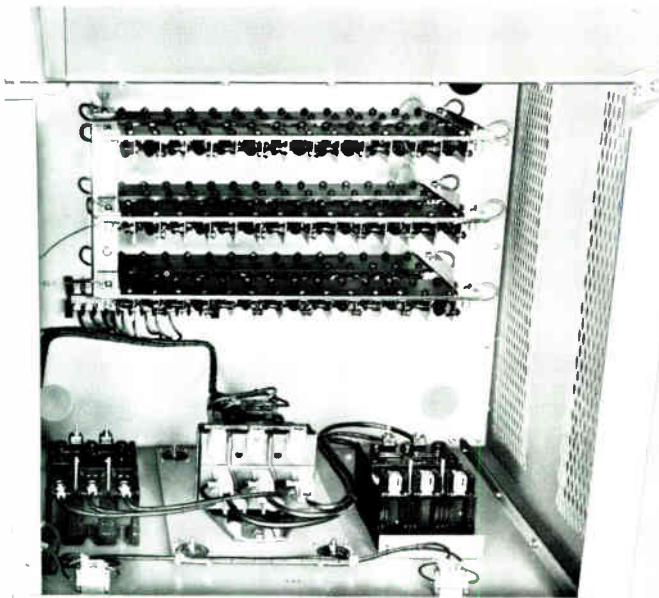

### Performance

Type of Emission.....	F3 and F9
Frequency Range.....	88 to 108 MHz
Power Output .....	5 kW
Output Impedance (3/8" O.D. Line) .....	50 Ohms
Frequency Deviation 100% modulation .....	±75 kHz
Modulation Capability .....	±100 kHz
Carrier Frequency Stability .....	±1000 Hz max.
Audio Input Impedance .....	600/150 Ohms
Audio Input Level—*(100% mod.).....	+10 ±2 dBm
Audio Frequency Response—**(50-15,000 Hz) .....	±1 dB max.
Pre-emphasis Network Time Constant.....	75 or 50 μs, as desired
Harmonic Distortion—***(50-15,000 Hz) .....	0.5% or less
FM Noise Level (referred to 100% FM mod.).....	-65 dB max.
AM Noise Level (referred to 100% AM mod.).....	-50 dB max.
Subcarrier Input Level (100% mod.) .....	-15 to +10 dBm adjustable
Subcarrier Input Impedance .....	600/150 Ohms bal.
Subcarrier Frequency .....	20-67 kHz
Main-to-Subchannel Crosstalk...-50 dB referred to ±7.5 kHz deviation of the subcarrier by a 400 Hz tone. Main chan- nel modulation 70% by 50-15,000 Hz tones.	
Sub-to-Main-Channel Crosstalk...-60 dB referred to ±7.5 kHz deviation of the main carrier by a 400 Hz tone. Subchan- nel modulation 100% (±7.5 kHz) by 50-6000 Hz tones. Subcarrier modulated 30% on main carrier.	

### Electrical

Power Line Requirements:	
Line.....	240/208 Volts, 3 phase, 50/60 Hz
Combined Line Voltage Variation and Regulation.....	±5%
Power Consumption.....	10,000 Watts (approx.)
Power Factor (approx.).....	90%
Crystal Heater:	
Line .....	117 Volts, single phase, 50/60 Hz
Power Consumption.....	7½ Watts

### Tube Complement

Driver:	
1—	7203/4CX250B
Power Amplifier:	
1—	4CX5000A

### Mechanical

Dimensions (overall):	Transmitter	High-Voltage. Power Supply
Width .....	48½" (123 cm)	27" (68.6 cm)
Height .....	77" (195.6 cm)	43" (109.2 cm)
Depth .....	32½" (82.5 cm)	23" (58.5 cm)
Weight (approx.) .....	1250 lbs. (567 kg.)	590 lbs. (267.6 kg.)
Finish .....	Textured Vinyl in midnight blue and shadow blue, satin-aluminum trim.	
Altitude .....	7500 ft.† (2290 M)	
Ambient Temperature Range.....	-20° to +45°C	

\* Level measured at input terminal J1.

\*\* Audio Frequency response referred to 50- or 75-microsecond pre-emphasis curve.

\*\*\* Distortion includes all harmonics up to 30 kHz and is measured following a standard 50- or 75-microsecond de-emphasis network.

† Blowers can be provided for operation at higher altitudes.

Specifications subject to change without notice.

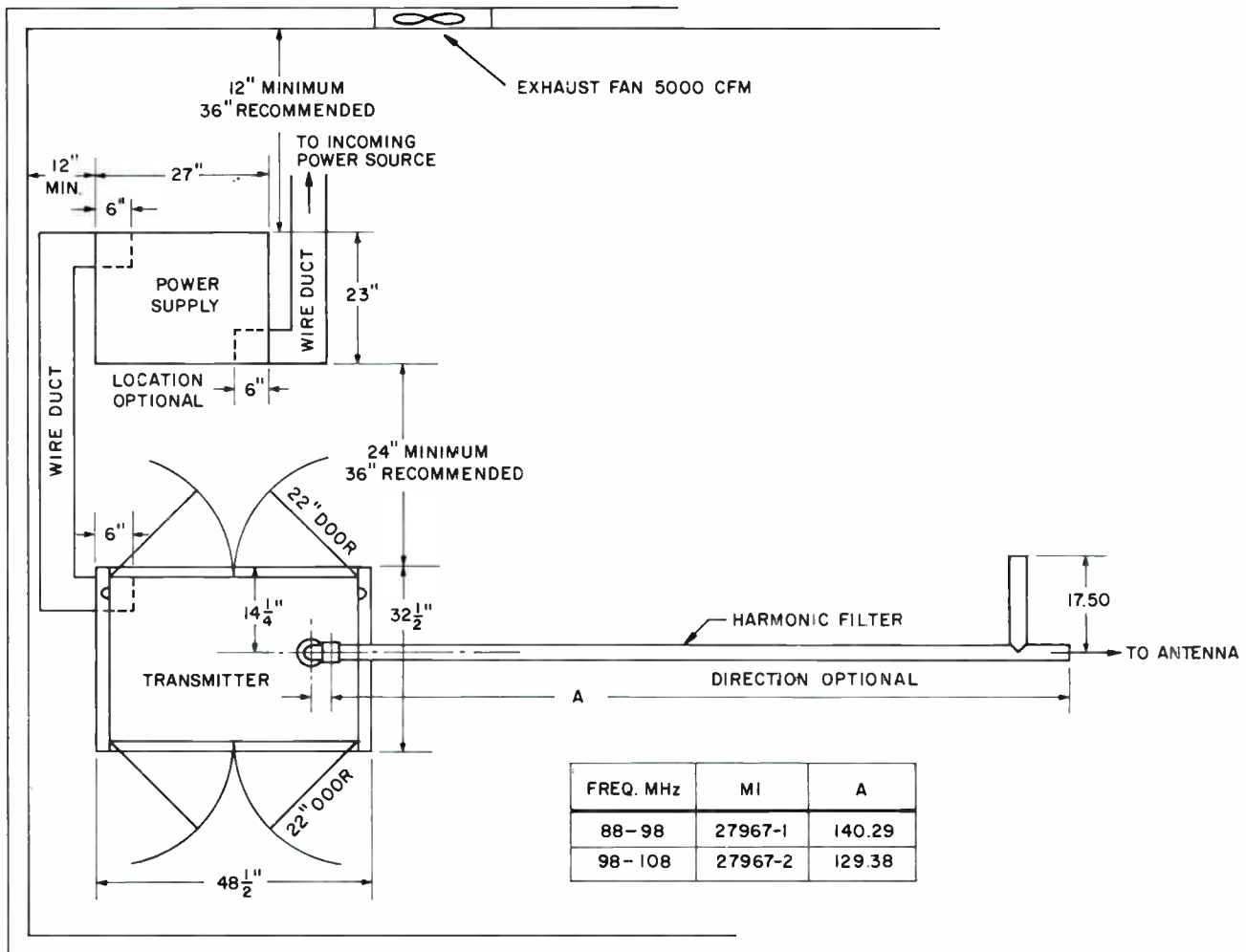

Space-saving floor plan of the BTF-5E1. The separate, unitized power supply may be installed in the basement, attic, closet, or other convenient place. (Wire duct and fan shown are not furnished.)

### Accessories

- Recommended Spare RF Transistors for Exciter ....MI-560718
- Spare Crystal and Oven  
(Specify operating frequency) .....MI-560717
- 5-kW RF Load and Wattmeter .....MI-561422
- Type BTR-11B Remote Control System  
(10-function) .....ES-34280

- Type BTR-20D Remote Control System  
(20-function) .....ES-34274-C
- Type BW-75A FM Frequency and  
Modulation Monitor .....MI-560735
- Type BW-85A Stereo Frequency and  
Modulation Monitor .....MI-560740
- Type BW-95A SCA Frequency and  
Modulation Monitor .....MI-560745

## Ordering Information

- Type BTF-5E1 5-kW FM Transmitter .....ES-560600\*
- \*Please specify assigned frequency, power-line frequency, and altitude of installation and select BTE-15A Exciter System from the following:

- Mono .....ES-560631
- Mono and one SCA Channel .....ES-560632
- Mono and two SCA Channels .....ES-560633
- Stereo .....ES-560634
- Stereo and one SCA Channel .....ES-560635
- Stereo and two SCA Channels .....ES-560636

## **RCA** 10-KW FM Transmitter, Type BTF-10E1

- New solid-state exciter
- Ultra stable—easy to tune
- Available for mono or stereo—  
—with or without SCA
- Power increase to 20-KW
- Ready for remote control

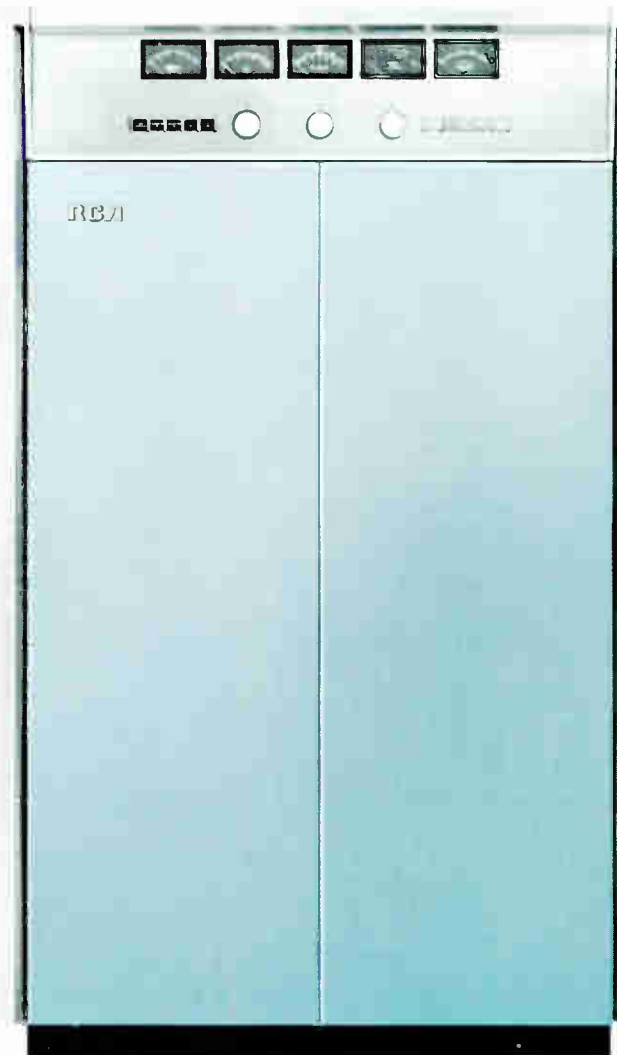

315



# 10-KW FM Broadcast Transmitter

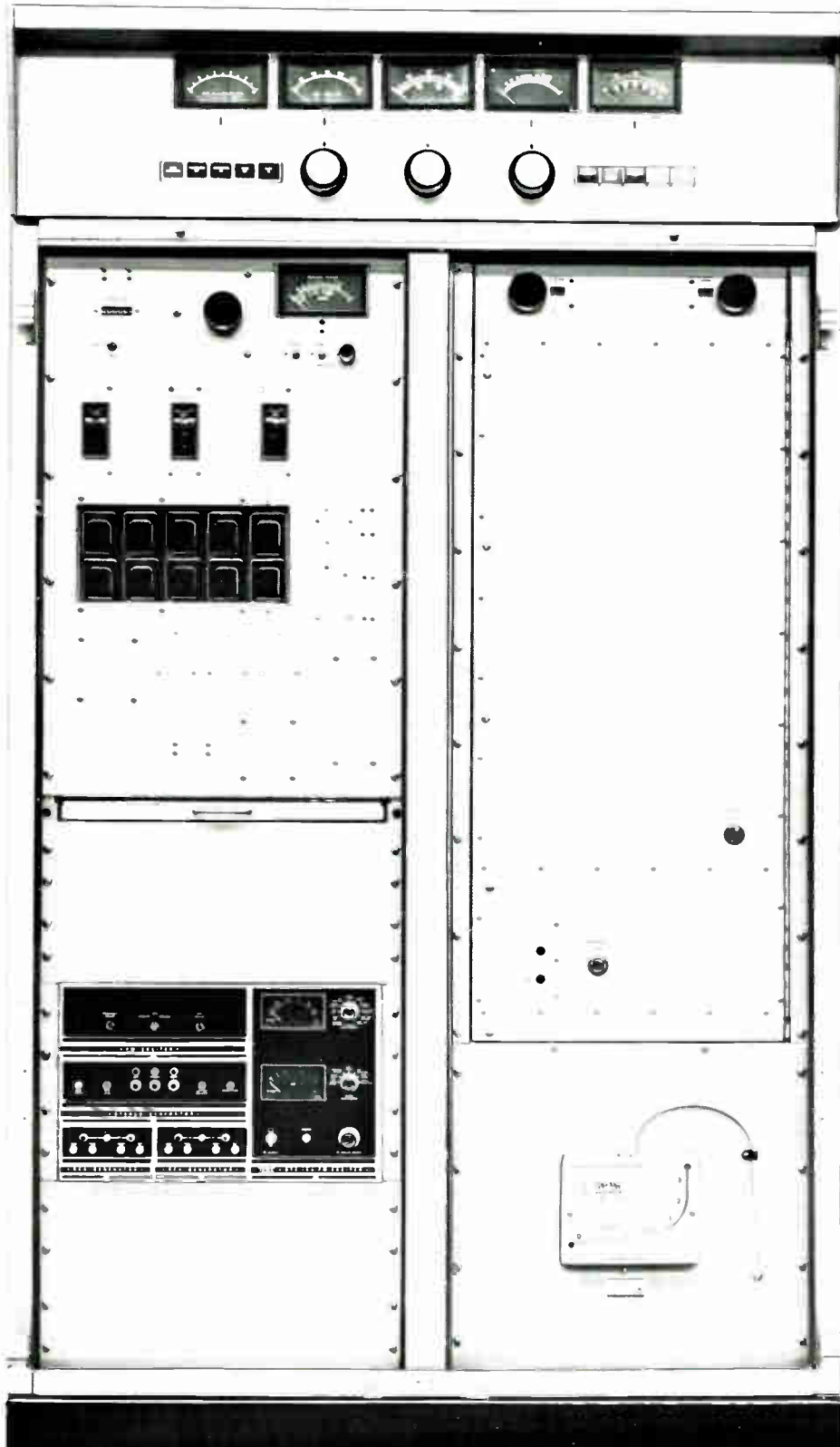

Eye-level  
metering

Centralized  
Controls

Ready for  
remote control

Self-protected  
against overload

Tilt down chassis  
for easy maintenance

Direct-FM  
Exciter

Complete  
Accessibility

Two Stages Follow  
Exciter—IPA and PA

"Filter-Minder"  
Manometer

Optional Stereo  
Sub-Carrier Generator

Fully  
Air Cooled

## Full-Fidelity FM Transmitter, Type BTF-10E1

RCA's Type BTF-10E1 FM Broadcast Transmitter provides 10,000 Watts output for stations operating in the 88-to-108 MHz band. It is designed to provide the finest possible performance and reliability, and is specifically built to meet or exceed the stringent requirements of multiplex service transmission. The equipment is FCC type accepted and meets all requirements for harmonic and spurious emission.

The BTF-10E1 employs a new type BTE-15A Exciter that uses the time-tested and field-proven RCA *Direct FM* System. The circuits employ all solid-state components. Their inherent long-life and cool operation assure extended reliability and lend themselves particularly to unattended, remote operation.

Frequency response of the transmitter's main channel is 30 to 15,000 Hz ( $\pm 1$  dB maximum) and the distortion over the same bandwidth is less than one-half of one percent.

A new feature of the transmitter is the built-in manometer. This device indicates air-filter efficiency and warns of reduced cooling-air supply over the power tubes. Properly used, the manometer can add hundreds of hours to power-tube life.

The BTF-10E1 is designed specifically to be field-expandable to a 20-kW transmitter. It is noteworthy that this expansion is substantially electrical and there is no increase in floor-space requirement.

## Description

### Mono or Stereo

The transmitter features a new exciter designed for stereo and multiplex. The exciter, including its self-contained power supply, is mounted on a single vertical chassis.

### Two Stages Follow Exciter

From the 15-Watt output of the exciter, only two tubes are required for full 10-kW output. A harmonic filter is included to reduce spurious radiation. Vacuum capacitors are used to tune the IPA plate and the PA grid. In the power amplifiers, all adjustments are at ground potential.

### Ready for Remote Control

The transmitter is designed and built for remotely-controlled operation. Internal wiring and terminals are provided for remote control of these transmitter functions: transmitter on/off; output power raise/lower and overload reset. Remote metering facilities for the PA include: cathode current; plate voltage and power output.

### New Styling

Functional styling combined with fewer tubes permits the BTF-10E1 to be housed in a single, double-door cabinet in a new midnight blue and shadow blue textured vinyl finish. For contrast, the meter panel is in bright aluminum and the cabinet is trimmed in satin-finished aluminum. The swing-out doors in the front and rear afford the excellent accessibility for which RCA transmitters are famous.

Operating controls and meters are mounted on a panel above the front doors.

### Field Expandable to 20-kW

Since the BTF-10E1 is, basically, a 20-kW transmitter operating at 10-kW, it is readily modified, after installation, to a 20-kW output. It is noteworthy that this expansion in power capability requires no additional floor space.

Expansion of the power output is particularly valuable if the station using a BTF-10E1 decides to combine horizontally- and vertically-polarized signals. This feature avoids any change in floor plan as a result of the power increase.

### BTE-15A FM Exciter

Excellent monaural, stereo and SCA

performance that more than meets industry and FCC standards are achieved by the new RCA modular, solid-state "Direct FM" exciter.

### Simplified Circuits

Modulation of the temperature compensated basic on-frequency oscillator is achieved by applying the composite stereo or SCA signals from the BTS-1B and BTX-1B Generators, respectively, to a pair of push-pull varicap diodes which are coupled to the basic oscillator frequency determining resonant circuit. The output of the basic oscillator is isolated from the following buffer amplifier by a 10 dB resistive attenuator. Thus, the stability and modulation characteristics of the basic direct FM oscillator are not disturbed by following RF power amplifiers.

The output of the buffer amplifier, approximately 500 mW, is used to drive the 15-Watt, three-stage RF amplifier as well as the binary divider chain in the AFC circuit. The basic oscillator, buffer amplifier, and AFC circuit are mounted inside a shielded enclosure. The RF power amplifier is also completely shielded.

## Select Features

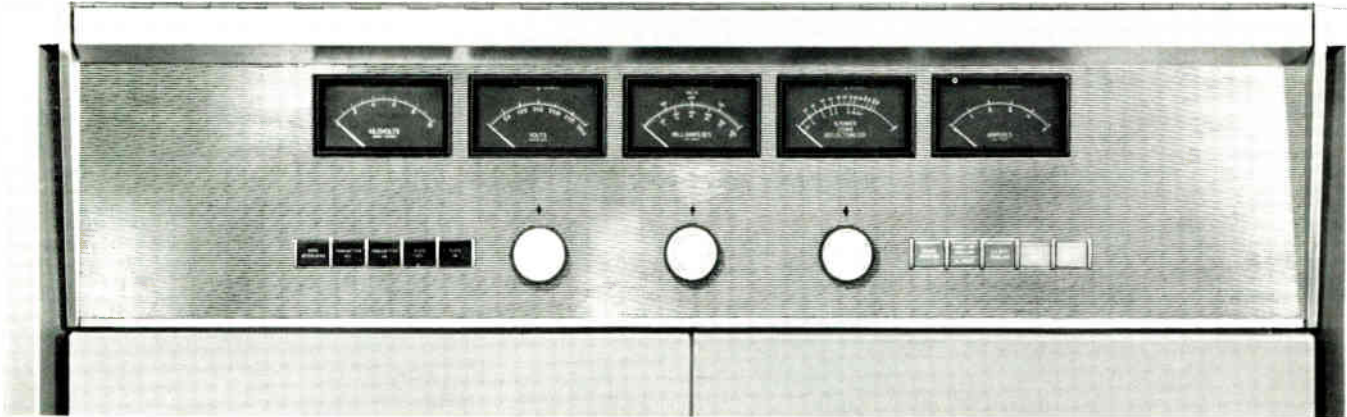

BTF-10E1 Control Panel. Tally lights and push-button controls simplify operation.

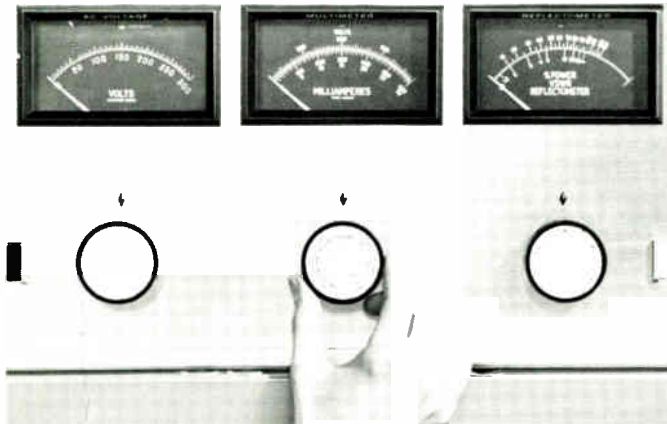

The large-diameter multimeter knobs speed log-keeping and minimize error.



New solid-state FM Exciter system, Type BTE-15A, showing "Direct FM" exciter housed with optional stereo generator and SCA generator units.

### "On Carrier" Frequency Operation

Automatic frequency control (AFC) for the on-frequency basic oscillator is achieved by taking a sample of the buffer output frequency and dividing it by two, 14 times. A low-frequency reference crystal operating at 1/1024th of the desired output frequency is divided by two, 4 times. Integrated circuits operating in the saturated mode are used in both binary dividing chains. The outputs from the reference and basic oscillator binary dividers are phase compared in a time-sharing IC comparator. The output of the circuit, which represents the AFC error voltage, is filtered and applied to another pair of varicap diodes coupled to the basic oscil-

lator tuned circuit. Thus, the basic oscillator is phase locked to the 1024th harmonic of the oven controlled reference crystal.

An off-frequency detector is incorporated in the design of the BTE-15A FM Exciter. When the basic oscillator frequency is not phase locked to the reference crystal, an AC component appears at the AFC output. This voltage is rectified to operate a relay whose contacts can be used to turn off the FM transmitter.

Two multimeters are located on the hinged door in front of the regulated power supply section. One of these meters is used to indicate power supply and operating voltages within the exciter and

15-Watt RF Amplifier. The second meter is a peak-reading voltmeter that is used to indicate all modulating signal levels.

The RF power output of the BTE-15A can be continuously adjusted from the front panel control from 7 to 15 Watts. The primary power is turned on with a circuit breaker. RF output is turned on with a front panel switch or by jumping contacts available on the rear of the unit. The exciter will tolerate load mismatches from short circuit to open circuit for a reasonable time without damaging the output transistor. Another safety feature prevents turning on the 41 kHz SCA sub-carrier when the BTS-1B Stereo Generator is in the stereo mode.

## Class "C" Power Amplifiers

Two simplified, single-ended amplifiers, operating in class "C", follow the exciter. The 250-Watt IPA stage uses a Type 7203/4CX250B tube, and the final power amplifier uses a Type 4CX10000A (ceramic) tetrode. Vacuum variable capacitors tune the pi network between driver and PA. The power amplifier, too, uses pi-network circuitry and tuning is accomplished by variable inductors operating at ground potential.

### 10-kW Class "C" Final Amplifier

The output tube, a ceramic tetrode, 4CX10000D, offers very high power-gain with little drive. Using this tube, only two stages of amplification are required between the exciter output and the antenna for the 10,000-Watt output. Fewer components result in improved reliability.

### Motor-Driven Power-Output Control

Power output is controlled by means of a motor-driven variable transformer

which controls the low-voltage power supply. This supply controls the driver-plate and the screen voltages of both stages simultaneously. A separate grid bias supply increases transmitter stability and reliability. The use of semiconductor (silicon) rectifiers reduces operating and maintenance costs.

### Harmonic Filter Standard Equipment

To keep spurious emission to a minimum, a harmonic filter is standard equipment with the BTF-10E1. The filter consists of an "M"-derived "half-T" sections, several low-pass filter sections, and a constant-"K", "half-T" section. Attenuation of all harmonics through the seventh is accomplished by the passband of the low-pass filter sections, while the constant-"K", "half-T" section serves as a 50-Ohm termination impedance.

### Self-Protected Against Overload

Power circuits are protected by mag-

netically-tripped circuit breakers in addition to overload relays. An interlock system prevents turn-on of plate power until all filaments have heated and the exciter has reached a proper operating condition. In addition, a latching relay automatically re-applies power to the transmitter once before locking-out in the event of transient overloads or power interruptions. The overload relays are reset by illuminated push button switches on the front panel. Separate tally-light indicators are provided for overloads in the driver, power amplifier and low voltage rectifier circuits.

### Fully Air-Cooled

Cooling air for the BTF-10E1 is supplied by a squirrel-cage blower mounted below the amplifier stages. Heavy sound insulation reduces blower noise to a minimum. The blower supplies forced air to both the IPA and PA stages.

Since the "drag" of a clogged air filter can reduce power-tube life, the transmit-

Simplified block diagram of BTF-10E1, showing optional stereo and SCA.

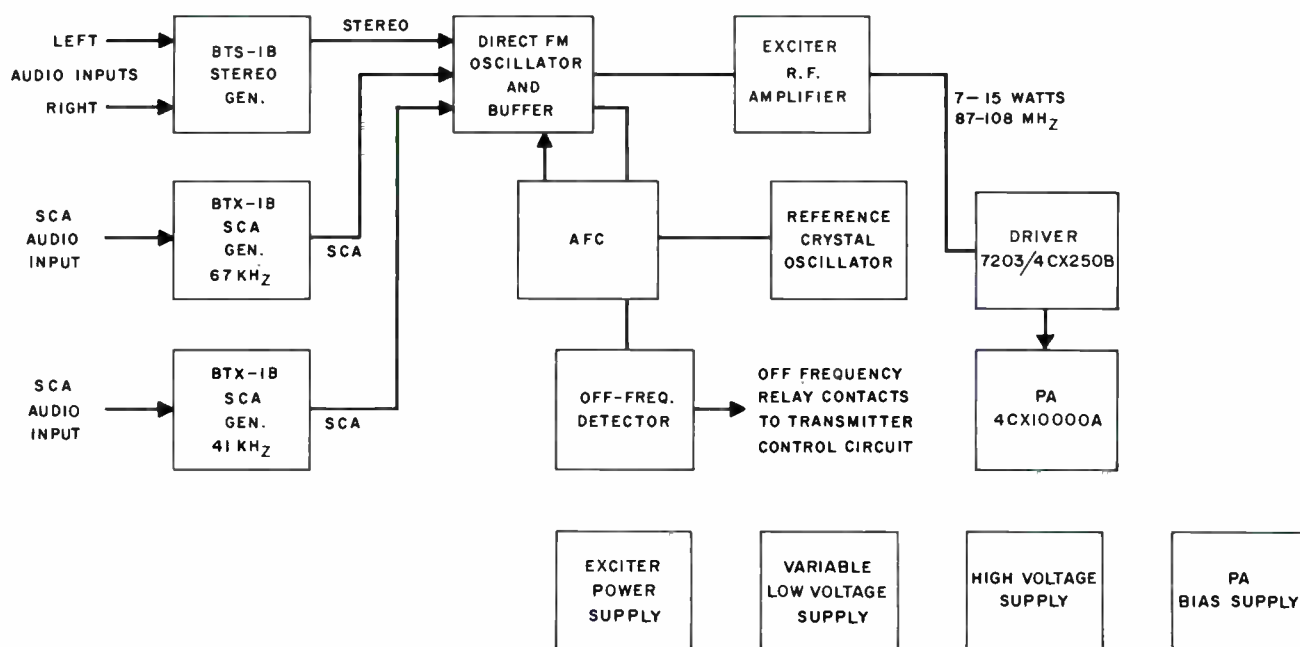

ter monitors this drag with a high-resolution manometer. This device senses the relative air pressure at the fan "side" of the fiber-glass filter in inches of water. Properly monitored, the manometer indicates when filter clog has reduced the volume of cooling air supplied to the power tubes. Maintenance of filter efficiency is very important in realization of the potential life of the power tubes.

### Simplified Control

The transmitter has all operating controls and meters located on a panel just above the front doors. The push-button controls include: transmitter on/off, plate

on/off, overload reset and power raise/lower. A cabinet disconnect switch, low-voltage circuit breaker, and filament control circuit breakers are located behind the left-hand door. The main- and low-power circuit breakers are located in the unitized rectifier cabinet. When servicing the BTF-10E1, operation of the disconnect switch removes all voltages from the transmitter cabinet. Personnel are also protected by fully interlocked rear doors in addition to interlocked doors on the PA cubicle.

### Full Metering

Six easy-to-read front-panel meters are

provided for each amplifier. One for PA-plate voltage, another for PA-plate current, and a third for AC line and filament voltage. The remaining three are a reflectometer indicating output, a multimeter and VSWR meter. Separate meters are used to measure the forward power and VSWR. The multimeter reads grid current, screen current and screen voltage of both power tubes. In addition to this metering, the exciter has its own self-contained multimeter. This one provides complete information on operating conditions in the exciter.

**ONLY TWO TUBES BETWEEN EXCITER AND OUTPUT**—View showing interior of PA and IPA cabinet with the 4CX10000A ceramic tetrode and one 7203/4CX250B IPA tube below shelf. These supply the necessary power for the full fidelity BTF-10E1.

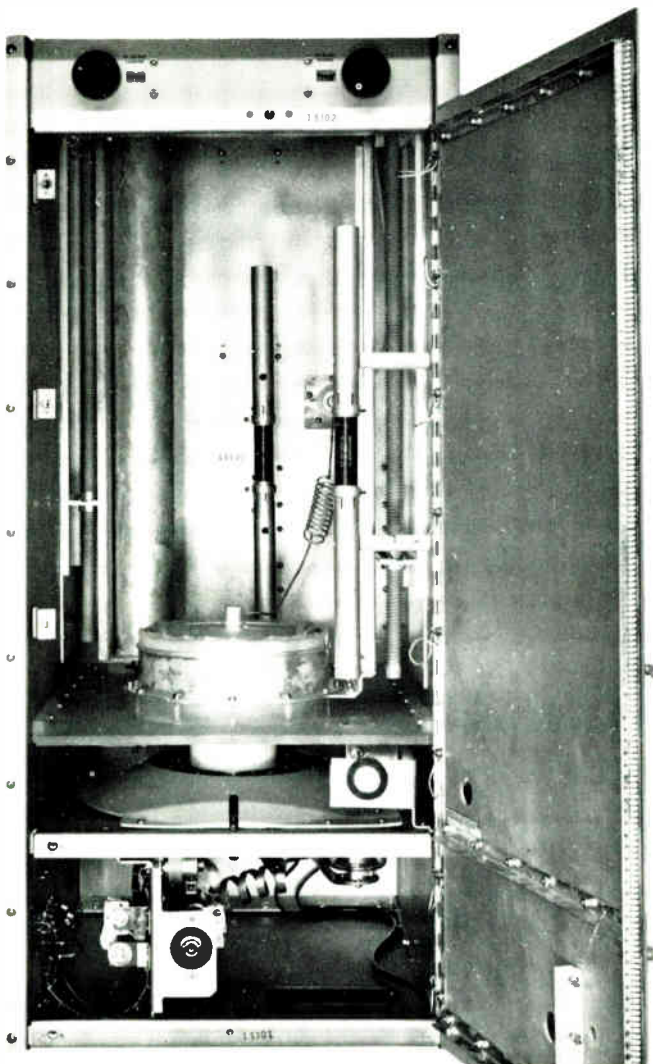

**COMPLETE ACCESSIBILITY**—Rear view of the BTF-10E1 revealing the clean, vertical construction of PA cavity to left and control panel to right.

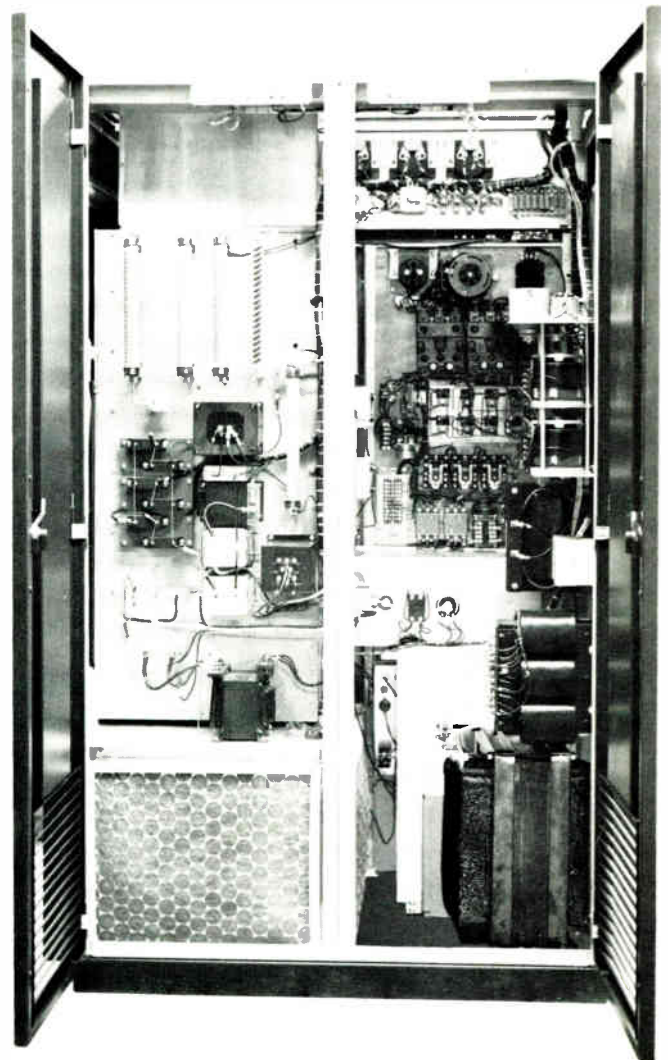

# Specifications

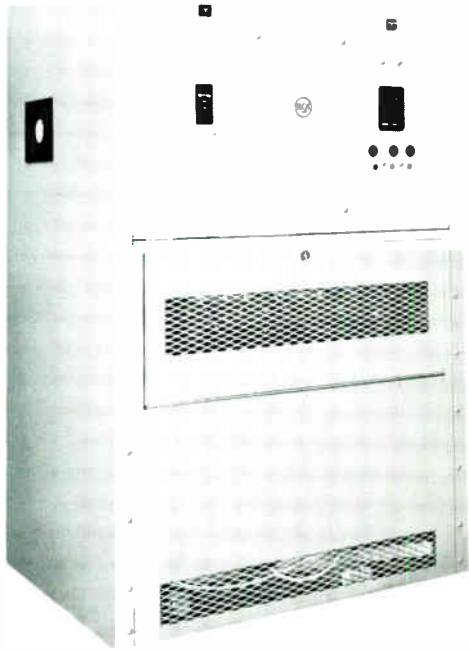

**UNITIZED HIGH VOLTAGE POWER SUPPLY**—With location not tied to the transmitter, the unitized power supply affords many installation and operating economies.

**MODULAR SILICON RECTIFIERS**—Quality components such as this plug-in silicon high voltage rectifier are important elements in the BTF-10E1's superior performance.

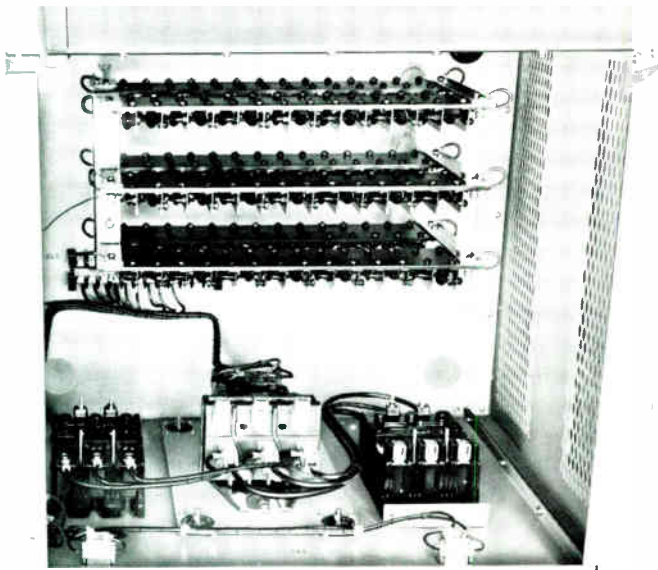

## Performance

Type of Emission.....F3 and F9  
 Frequency Range.....88 to 108 MHz  
 Power Output .....10 kW  
 Output Impedance (3/8" O.D. Line) .....50 Ohms  
 Frequency Deviation 100% modulation.....±75 kHz  
 Modulation Capability .....±100 kHz  
 Carrier Frequency Stability.....±1000 Hz max.  
 Audio Input Impedance.....600/150 Ohms  
 Audio Input Level—\*(100% mod.).....+10 ±2 dBm  
 Audio Frequency Response—\*\*(50-15,000 Hz) .....±1 dB max.  
 Pre-emphasis Network Time Constant.....75 or 50 μs, as desired  
 Harmonic Distortion—\*\*\*(50-15,000 Hz) .....0.5% or less  
 FM Noise Level (referred to 100% FM mod.).....-65 dB max.  
 AM Noise Level (referred to 100% AM mod.).....-50 dB max.  
 Subcarrier Input Level (100% mod.) .....-15 to +10 dBm adjustable  
 Subcarrier Input Impedance .....600/150 Ohms bal.  
 Subcarrier Frequency .....20-67 kHz  
 Main-to-Subchannel Crosstalk...-50 dB referred to ±7.5 kHz deviation of the subcarrier by a 400 Hz tone. Main channel modulation 70% by 50-15,000 Hz tones.  
 Sub-to-Main Channel Crosstalk...-60 dB referred to ±75 kHz deviation of the main carrier by a 400 Hz tone. Subchannel modulation 100% (±7.5 kHz) by 50-6000 Hz tones. Subcarrier modulated 30% on main carrier.

## Electrical

### Power Line Requirements:

Line.....240/208 Volt, 3 phase, 50/60 Hz  
 Combined Line Voltage Variation and Regulation.....±5%  
 Power Consumption.....19,000 Watts (approx.)  
 Power Factor (approx.).....90%

## Tube Complement

### Driver:

1—7203/4CX250B

### Power Amplifier:

1—4CX10000A

## Mechanical

Dimensions (overall):	Transmitter	High-Voltage Power Supply
Width .....	48½" (123 cm)	27" (68.6 cm)
Height .....	77" (195.6 cm)	43" (109.2 cm)
Depth .....	32½" (82.5 cm)	23" (58.5 cm)
Weight (approx.) .....	1300 lbs. (589.7 kg.)	840 lbs. (381 kg.)
Finish .....	Textured Vinyl in midnight blue and shadow blue, satin-aluminum trim.	
Altitude .....	7500 ft.† (2290 M)	
Ambient Temperature Range.....	-20° to +45°C	

\* Level measured at input terminal J1.

\*\* Audio Frequency response referred to 50- or 75-microsecond pre-emphasis curve.

\*\*\* Distortion includes all harmonics up to 30 kHz and is measured following a standard 50- or 75-microsecond de-emphasis network.

† Blowers can be provided for operation at higher altitudes.

Specifications subject to change without notice.

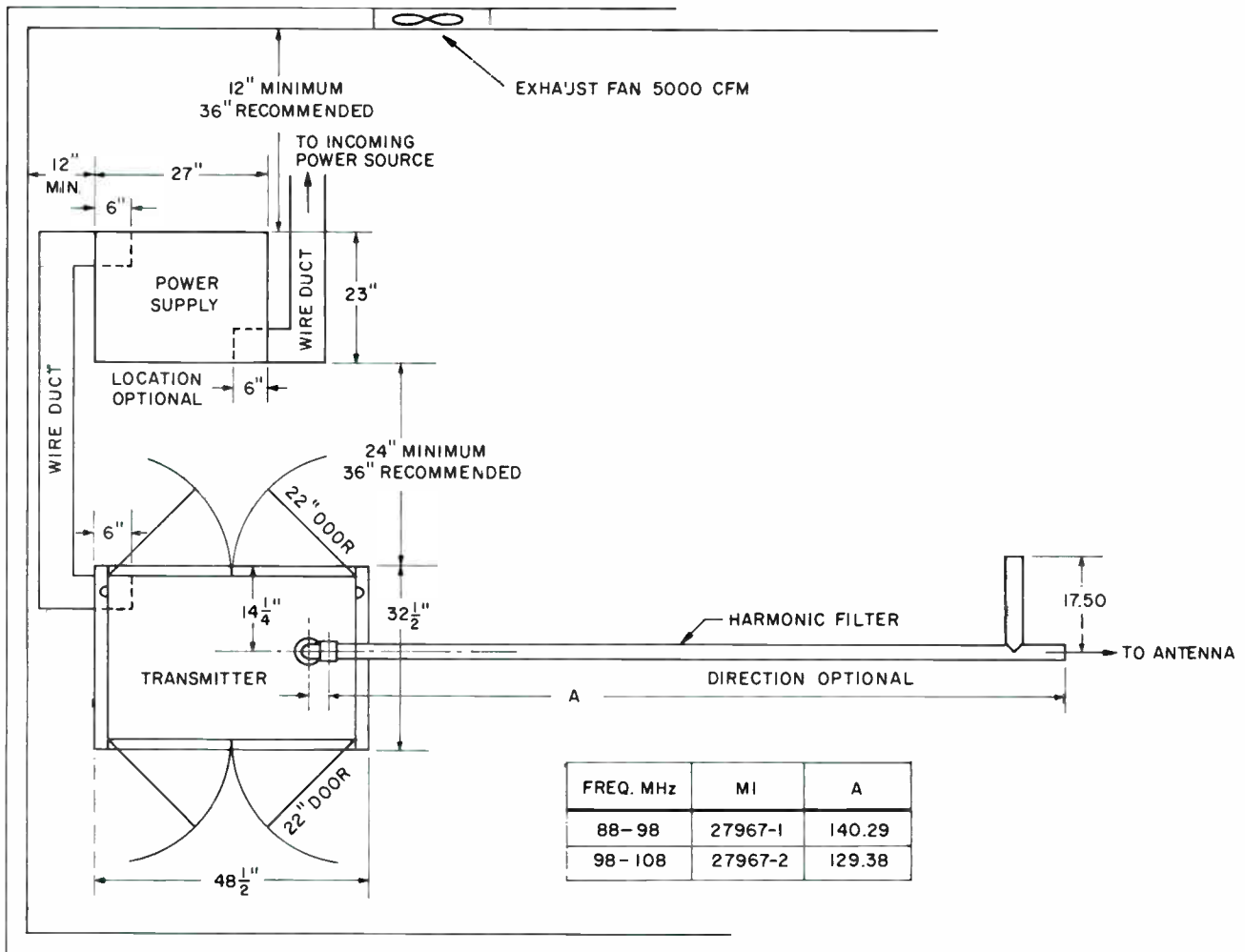

Space-saving floor plan of the BTF-10E1. The separate, unitized power supply may be installed in a basement, attic, closet or other convenient place. (Wire duct and fan shown are not furnished.)

### Accessories

- Recommended Spare RF Transistors for Exciter .....MI-560718
- Spare Crystal and Oven  
(Specify operating frequency) .....MI-560717
- Complete Set of Spare Tubes .....ES-560608
- 10-kW RF Load and Wattmeter .....MI-19267
- Type BTR-11B Remote Control System  
(10-function) .....ES-34280

- Type BTR-20D Remote Control System  
(20-function) .....ES-34274-C
- Type BW-75A FM Frequency and  
Modulation Monitor .....MI-560735
- Type BW-85A Stereo Frequency and  
Modulation Monitor .....MI-560740
- Type BW-95A SCA Frequency and  
Modulation Monitor .....MI-560745

## Ordering Information

Type BTF-10E1 10-kW FM Transmitter .....ES-560601  
Please specify assigned frequency, power-line frequency and altitude of installation and select BTE-15A Exciter System from the following:

- Mono .....ES-560631
- Mono and one SCA Channel .....ES-560632
- Mono and two SCA Channels .....ES-560633
- Stereo .....ES-560634
- Stereo and one SCA Channel .....ES-560635
- Stereo and two SCA Channels .....ES-560636

## RCA 20-KW FM Transmitter, Type BTF-20E1

- New solid-state exciter
- Ultra stable—easy to tune
- Available for mono or stereo—  
—with or without SCA
- 100 KW ERP with 6-section  
antenna
- Ready for remote control

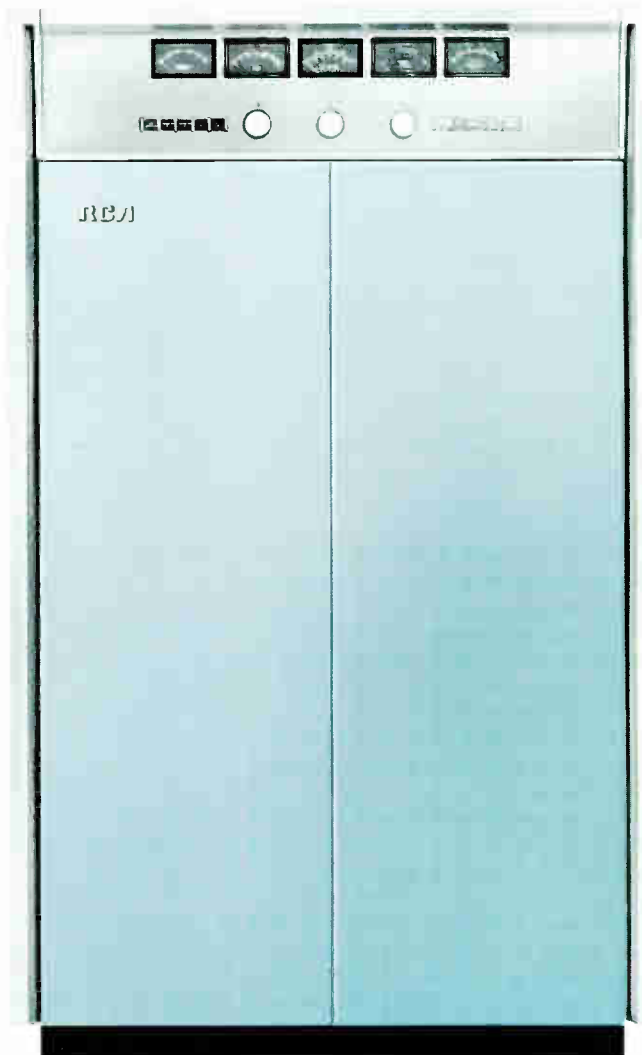

378



# 20-KW FM Broadcast Transmitter

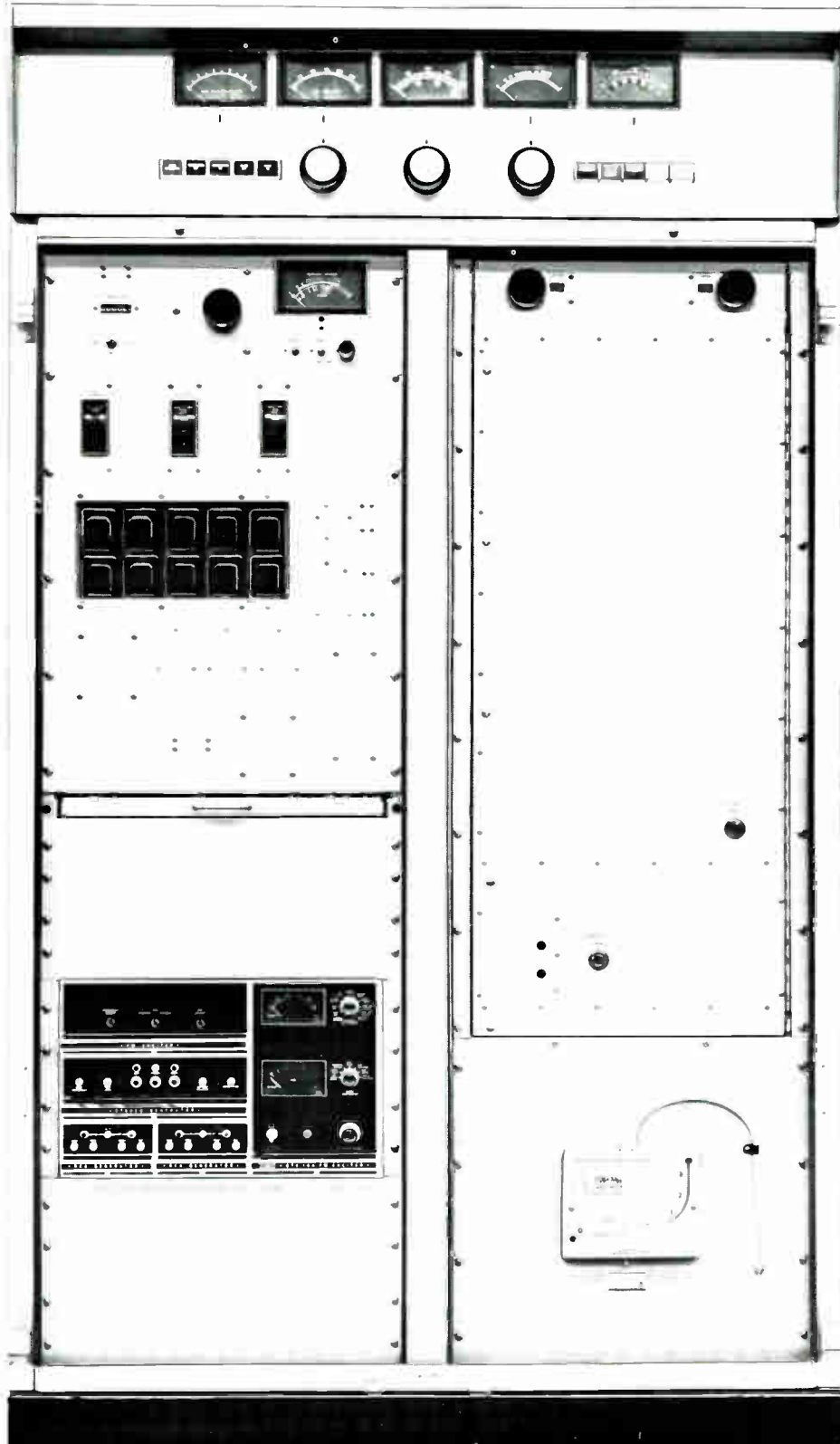

Centralized Controls

Ready for remote control

Self-protected against overload

Tilt down chassis for easy maintenance

Direct-FM Exciter

Rack Space for Optional Stereo Sub-Carrier Generator

Fully Air Cooled

Eye-level metering

Complete Accessibility

Two Stages Follow Exciter—IPA and PA

'Filter-Minder' Manometer

# Full-Fidelity FM Transmitter, Type BTF-20E1

The RCA Type BTF-20E1 20-kW FM Broadcast Transmitter is designed for high-power operation in the standard FM band, 88-108 MHz, and is specifically engineered to meet and exceed the stringent requirements of multiplex service transmission and stereo programming as specified by the FCC.

The BTF-20E1 employs a new Type BTE-15A Exciter that uses the time-tested and field-proven *direct FM* system. The circuits employ all solid-state components. Their inherent long-life and cool operation assure extended reliability and lend themselves particularly to unattended, remote operation.

The transmitter features a Type 4CX-15000A Power Amplifier driven by two 7203/4CX250B tubes in the IPA stage.

Silicon-rectifier power supplies also provide long life and dependability. All RF circuits are single tuned for utmost tuning simplicity. Except for the high voltage power supply, the transmitter is housed in a single, modern-styled, two-door cabinet.

Frequency response of the transmitter's main channel is 30 to 15,000 Hz ( $\pm 1$  dB maximum) and distortion over the same range is 0.5 percent or less.

A useful feature of the transmitter is the built-in manometer. This device indicates air filter efficiency and warns of reduced cooling-air supply over the power tubes. Properly used, this device can add hundreds of hours to tube life.

## Description

### Mono or Stereo

The transmitter features a new exciter designed for stereo and multiplex. The exciter, including its self-contained power supply, is mounted on a single vertical chassis.

### Two Stages Follow Exciter

From the output of the exciter, only three tubes, two in the IPA and a ceramic-tetrode 4CX-15000A PA generate the full 20-kW signal. A harmonic filter is furnished to reduce spurious radiation.

Vacuum capacitors are used to tune the IPA plate and PA grid. In the power amplifier, all adjustments are at ground potential.

### Ready for Remote Control

The transmitter has been designed and built for remote controlled operation. Terminals are provided for remote control of transmitter on/off, raise/lower power and overload reset, while remote metering connections for the PA include cathode current, plate voltage and power output.

### New Styling

Functional styling together with fewer tubes and components has permitted the new BTF-20E1 transmitter to be housed in a single, double-door cabinet, in a new midnight blue and shadow blue finish, set off with aluminum meter panel and trim. Maximum accessibility is afforded by swing-out doors on the front and rear of the cabinet. All operating controls and meters used for rapid check of transmitter functions are located on a panel above the front doors. A separate unitized high-voltage power supply may be located anywhere in the FM station.

### BTE-15A FM Exciter

Excellent monaural, stereo and SCA performance that more than meets industry and FCC standards are achieved by the new RCA modular, solid-state "Direct FM" exciter.

### Simplified Circuits

Modulation of the temperature compensated basic on-frequency oscillator is

achieved by applying the composite stereo or SCA signals from the BTS-1B and BTX-1B Generators, respectively, to a pair of push-pull varicap diodes which are coupled to the basic oscillator frequency determining resonant circuit. The output of the basic oscillator is isolated from the following buffer amplifier by a 10 dB resistive attenuator. Thus, the stability and modulation characteristics of the basic direct FM oscillator are not disturbed by following RF power amplifiers.

The output of the buffer amplifier, approximately 500 mW, is used to drive the 15-Watt, three-stage RF amplifier as well as the binary divider chain in the AFC circuit. The basic oscillator, buffer amplifier, and AFC circuit are mounted inside a shielded enclosure. The RF power amplifier is also completely shielded.

Automatic frequency control (AFC) for the on-frequency basic oscillator is achieved by taking a sample of the buffer output frequency and dividing it by two, 14 times. A low-frequency reference crystal operating at 1/1024th of the desired

## Select Features

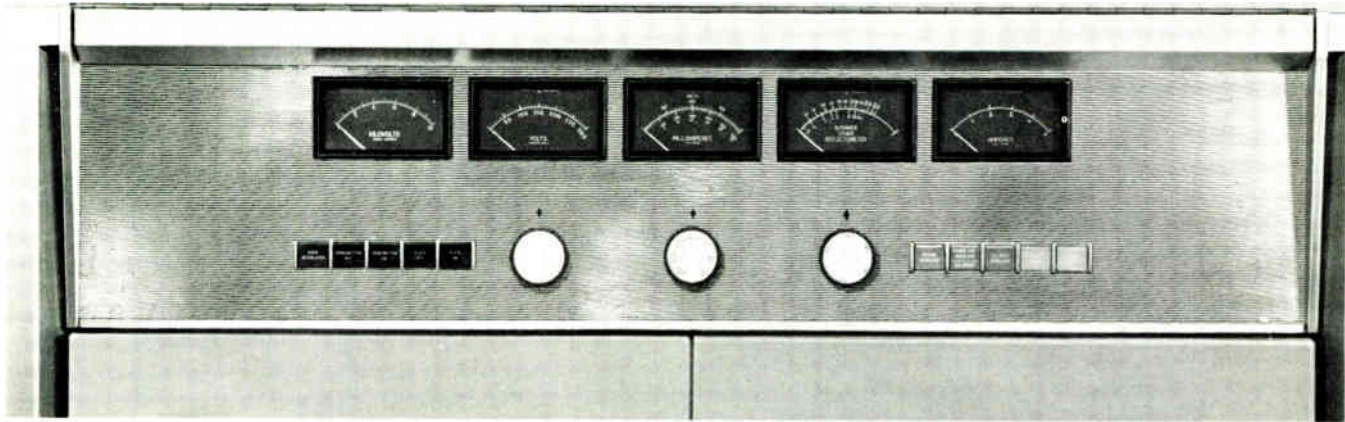

BTF-20E1 Control Panel. Tally lights and push-button controls simplify operation.

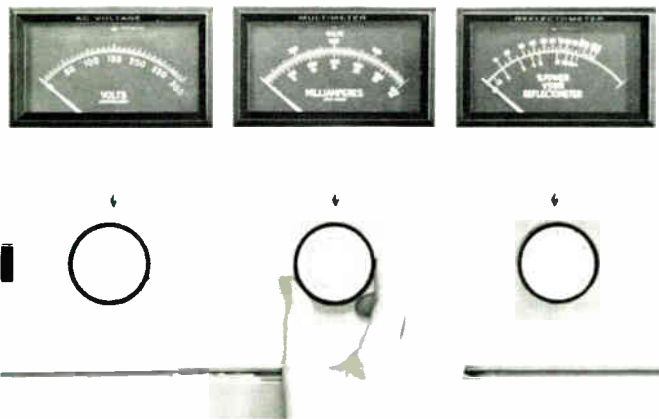

The large-diameter multimeter knobs speed log-keeping and minimize error.

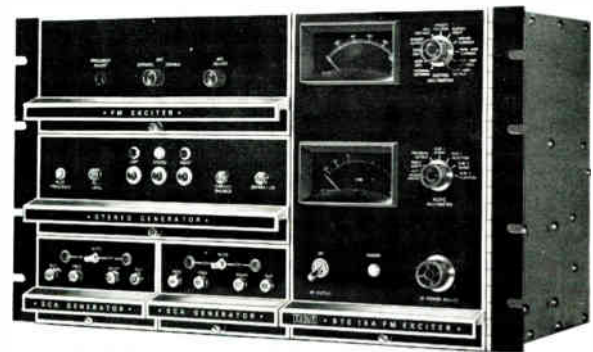

New solid-state FM Exciter system, Type BTE-15A, showing "Direct FM" exciter housed with optional stereo generator and SCA generator units.

output frequency is divided by two, 4 times. Integrated circuits operating in the saturated mode are used in both binary dividing chains. The outputs from the reference and basic oscillator binary dividers are phase compared in a time-sharing IC comparator. The output of the circuit, which represents the AFC error voltage, is filtered and applied to another pair of varicap diodes coupled to the basic oscillator tuned circuit. Thus, the basic oscillator is phase locked to the 1024th harmonic of the oven controlled reference crystal.

An off-frequency detector is incorporated in the design of the BTE-15A FM Exciter. When the basic oscillator frequency is not phase locked to the reference crystal, an AC component appears at the AFC output. This voltage is rectified to operate a relay whose contacts can be used to turn off the FM transmitter.

Two multimeters are located on the hinged door in front of the regulated power supply section. One of these meters is used to indicate power supply and operating voltages within the exciter and 15-Watt RF Amplifier. The second meter is

a peak-reading voltmeter that is used to indicate all modulating signal levels.

The RF power output of the BTE-15A can be continuously adjusted from the front panel control from 7 to 15 Watts. The primary power is turned on with a circuit breaker. RF output is turned on with a front panel switch or by jumping contacts available on the rear of the unit. The exciter will tolerate load mismatches from short circuit to open circuit for a reasonable time without damaging the output transistor. Another safety feature prevents turning on the 41 kHz SCA sub-

carrier when the BTS-1B Stereo Generator is in the stereo mode.

### Single-Ended Driver Amplifier

Two simplified, single-ended amplifiers (operating Class "C") follow the exciter. The IPA stage consists of two ceramic 7203/4CX250B tetrodes operating in parallel, and the final power amplifier is Type 4CX15000A tube. Variable vacuum capacitors are used to tune the interstage network between driver and PA.

### 20-kW Class "C" Final Amplifier

The power amplifier also uses pi-network circuitry, however, the tuning of this stage is accomplished by variable inductors operating at ground potential. The output tube is designed for very high power gain with little drive. Power output is controlled by means of a motor-driven variable transformer connected in the primary

of the low voltage power supply for the driver amplifier. This controls the IPA-plate and the PA-screen voltages simultaneously.

For increased transmitter stability and reliability, a separate grid bias supply is incorporated in the BTF-20E1. This supply, too, uses semi-conductor rectifiers.

### Harmonic Filter Standard Equipment

To keep spurious emission at a minimum, the transmitter is furnished with a 6 $\frac{1}{8}$ -inch harmonic filter as standard equipment. The filter consists of a series of transmission line elements with a uniform outer diameter conductor, a stepped inner conductor, and a shunt stub. The conductors are fabricated of a high-grade copper alloy. Attenuation of all harmonic radiation above channel limits is accomplished in an "M-derived" section, and a

series of "constant-K" T-sections. This design provides a broad passband with a sharp high-frequency cut-off and excellent attenuation of frequencies above the passband.

### Self-Protected Against Overload

Power circuits are protected by magnetically-tripped circuit breakers in addition to overload relays. An interlocked system prevents turn-on of plate power until all filaments have heated and the exciter has reached a proper operating condition. In addition, a latching relay automatically re-applies power to the transmitter once before locking-out in the event of brief overloads or power interruptions. The overload relays are reset by illuminated push-button switches on the front panel. Separate tally-light indicators are provided for overloads in the driver, power amplifier and low voltage rectifier circuits.

Simplified Block Diagram of BTF-20E1 FM Transmitter, showing optional stereo and SCA.

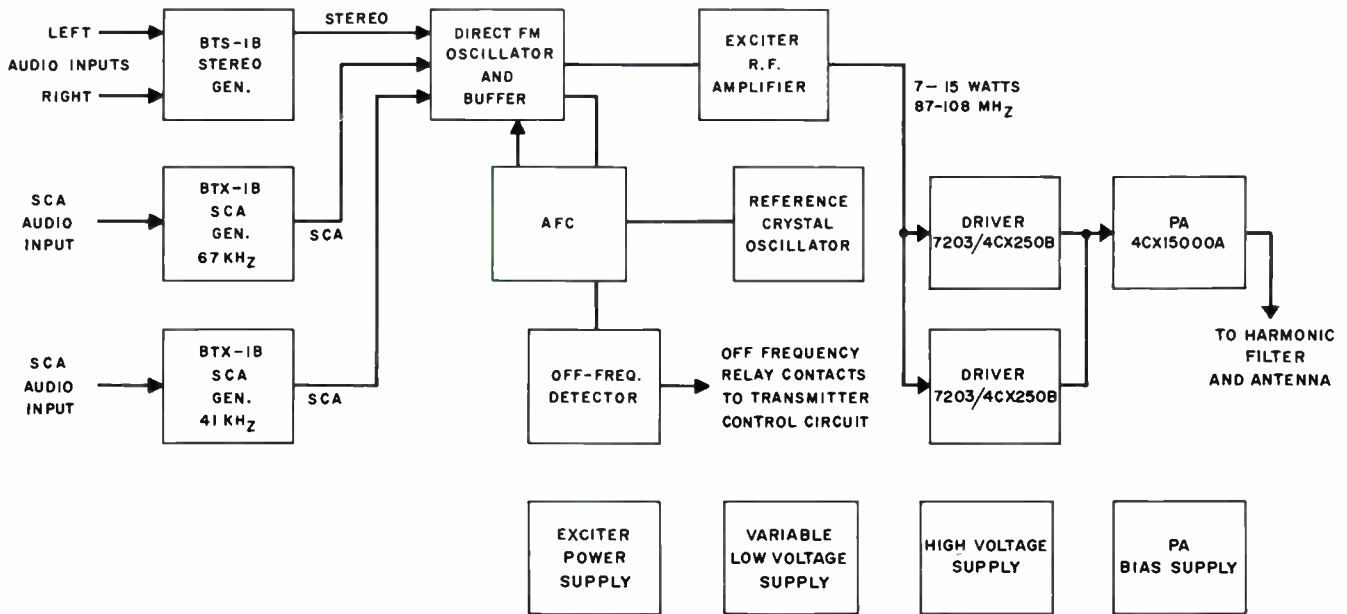

### Fully Air-Cooled

Cooling air for the BTF-20E1 is supplied by means of a blower mounted below the amplifier stages. A manometer indicates the efficiency of the fiber-glass filter at the inlet and heavy sound insulation reduces blower noise to a minimum. The blower supplies forced air to both the IPA and PA stages.

### Simplified Control

The transmitter has all operating controls and meters located on a panel just above the front doors. The push-button controls include: transmitter on/off, plate on/off, overload reset and power raise/lower. A cabinet disconnect switch, low-voltage circuit-breaker, and filament- and control-circuit breakers are located behind

the left-hand door. The main- and low-power circuit breakers are located in the rectifier unitized cabinet. When servicing the BTF-20E1, operation of the "disconnect" switch removes all voltages from the transmitter cabinet. Personnel are protected by fully interlocked rear doors, in addition to interlocked doors on the RF PA cubicle.

### Full Metering

Six easy-to-read front-panel meters are provided for each amplifier. One for PA-plate voltage, another for PA-plate current, and a third for AC-line and filament voltage. The remaining three are a reflectometer indicating output, a multimeter and VSWR meter. Separate meters are used to measure the forward power and VSWR. The multimeter reads the grid current, the screen current and the screen voltage of both power tubes. In addition, the exciter has its own self-contained multimeter. This one provides complete information on operating conditions in the exciter.

### Ready for Remote Control

Remote control provisions are included in the transmitter and terminals are provided for use with remote control units such as the Type BTR-11B (or BTR-20E) and Automatic Logging Equipment. Additional terminals are provided for remote control of transmitter on/off, plate on/off, raise/lower power, and overload reset. Remote metering connections in the final amplifier for plate current, plate voltage, and power output are also provided.

### High-Voltage Power Supply

The high-voltage power supply is housed in a unitized cabinet measuring 32 inches wide, 23 inches deep and 49 inches high. It can be installed at any convenient place in the station. The cabinet houses the high-voltage-plate transformer, a bank of plug-in semiconductor rectifiers, a line-circuit breaker, a low-power circuit breaker, and the plate contactor. Personnel are fully protected from shock through interlock and grounding switches.

The rectifier section comprises silicon-junction diodes (with equalizing resistors and capacitors) in a three-phase, full-wave-bridge circuit. Circuit breakers are used instead of fuses in the transmitter adding to the dependability particularly when operating by remote control.

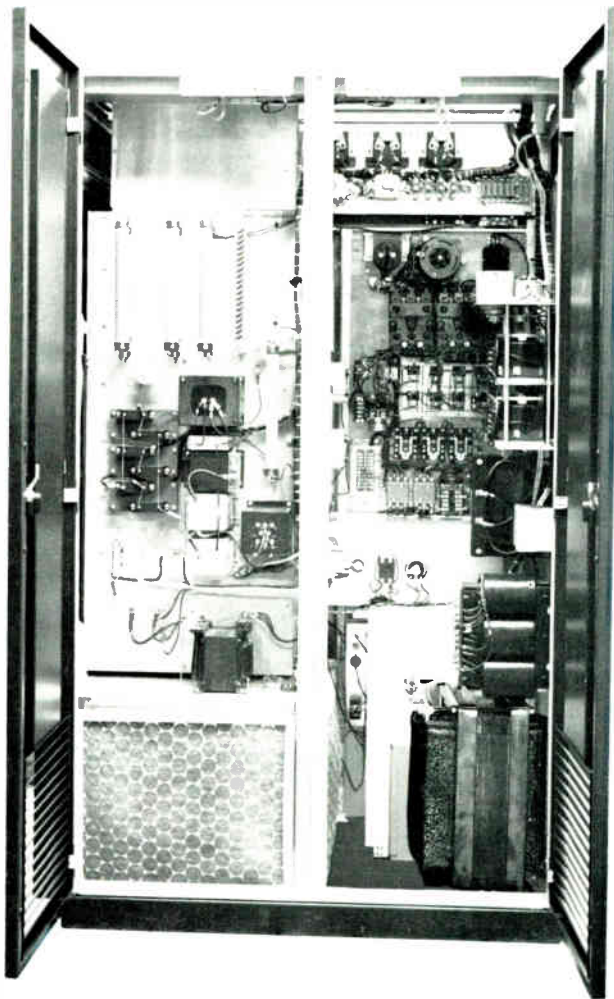

**COMPLETE ACCESSIBILITY**—Rear view of the BTF-20E1 revealing the clean, vertical construction of PA cavity to left and control panel to right.

## Specifications

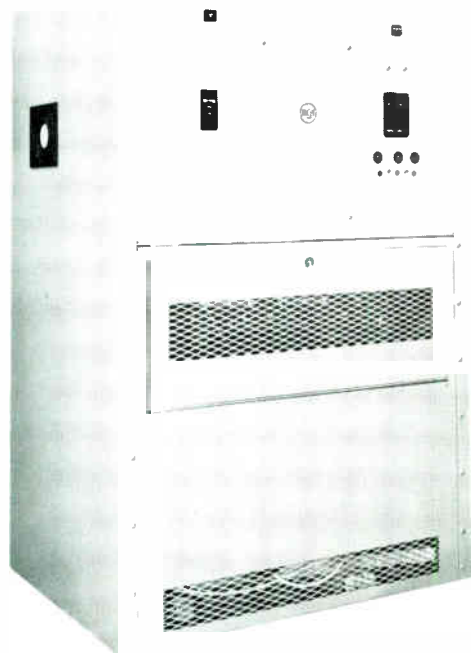

**UNITIZED HIGH VOLTAGE POWER SUPPLY**—With location not tied to the transmitter, the unitized power supply affords many installation and operating economies.

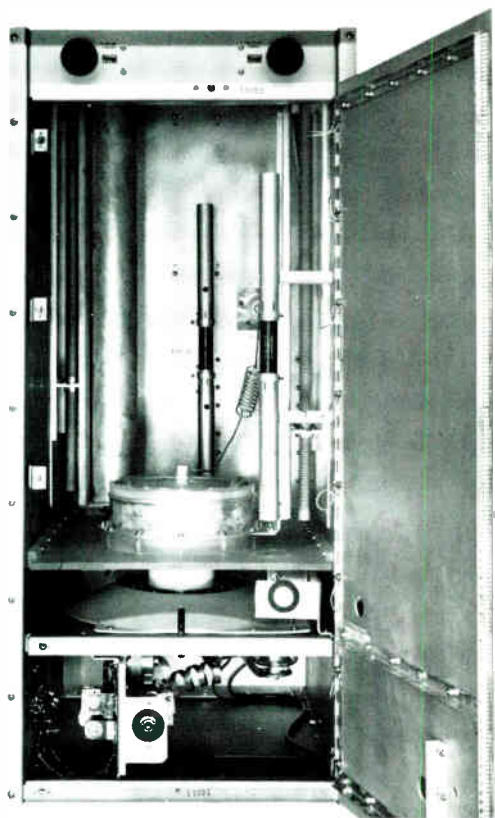

**ONLY THREE TUBES BETWEEN EXCITER AND OUTPUT**--View showing interior of PA and IPA cabinet with the 4CX15000A ceramic tetrode and two IPA tubes below shelf.

### Performance

Type of Emission.....	F3 and F9
Frequency Range.....	88 to 108 MHz
Power Output .....	20 kW
Output Impedance (3/8" O.D. Line) .....	50 Ohms
Frequency Deviation 100% modulation.....	±75 kHz
Modulation Capability .....	±100 kHz
Carrier Frequency Stability.....	±1000 Hz max.
Audio Input Impedance .....	Resistive, 600/150 Ohms
Audio Input Level—*(100% mod.).....	+10 ±2 dBm
Audio Frequency Response—**(50-15,000 Hz) .....	±1 dB max.
Pre-emphasis Network Time Constant.....	75 or 50 μs, as desired
Harmonic Distortion—**(50-15,000 Hz) .....	0.5% or less
FM Noise Level (referred to 100% FM mod.).....	-65 dB max.
AM Noise Level (referred to 100% AM mod.).....	-50 dB max.
Subcarrier Input Level (100% mod.) .....	-15 to +10 dBm adjustable
Subcarrier Input Impedance .....	600/150 Ohms bal.
Subcarrier Frequency .....	20-67 kHz
Main-to-Subchannel Crosstalk....	-55 dB referred to ±7.5 kHz deviation of the subcarrier by a 400 Hz tone. Main channel modulation 70% by 50-15,000 Hz tones.
Sub-to-Main-Channel Crosstalk....	-60 dB referred to ±75 kHz deviation of the main carrier by a 400 Hz tone. Subchannel modulation 100% (±7.5 kHz) by 50-6000 Hz tones. Subcarrier modulated 30% on main carrier.

### Electrical

Power Line Requirements:

Line.....	240/208 Volt, 3 phase, 50/60 Hz
Combined Line Voltage Variation and Regulation.....	±5%
Power Consumption .....	36,000 Watts (approx.)
Power Factor (approx.).....	90%

### Tube Complement

Driver:

2—7203/4CX250B

Power Amplifier:

1—4CX15000A

### Mechanical

	Transmitter	High-Voltage Power Supply
Dimensions (overall):		
Width .....	48½" (123 cm)	32" (81.3 cm)
Height .....	77" (195.6 cm)	49" (124.5 cm)
Depth .....	32½" (82.5 cm)	23" (58.5 cm)
Weight (approx.) .....	1425 lbs. (646.4 kg.)	1025 lbs. (164.9 kg.)
Finish .....	Textured Vinyl in midnight blue and shadow blue, satin-aluminum trim.	
Altitude .....	7500 ft.† (2290 M)	
Ambient Temperature Range.....	-20° to +45°C	

\* Level measured at input terminal J1.

\*\* Audio Frequency response referred to 50- or 75-microsecond pre-emphasis curve.

\*\*\* Distortion includes all harmonics up to 30 kHz and is measured following a standard 50- or 75-microsecond de-emphasis network.

† Blowers can be provided for operation at higher altitudes.

Specifications subject to change without notice.

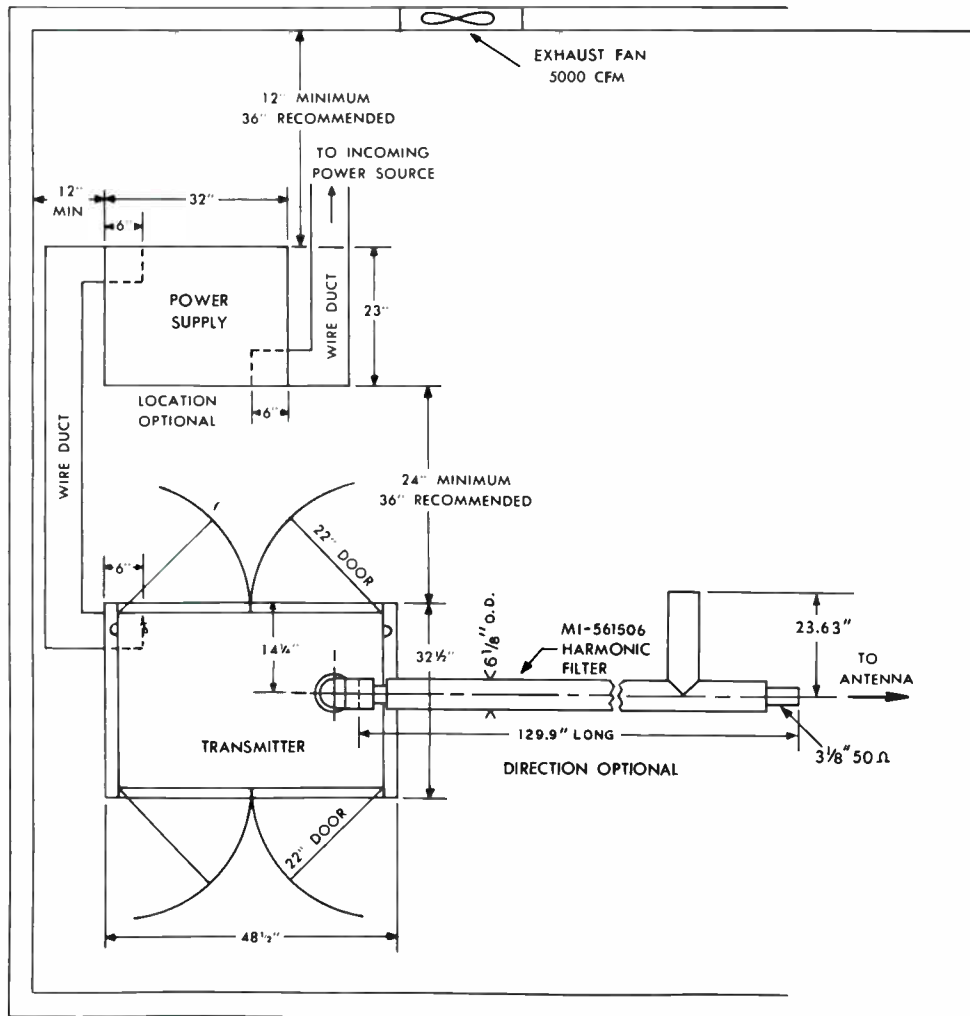

Space-saving floor plan of the BTF-20E1. The separate, unitized power supply may be installed in a basement, attic, closet or other convenient place. (Wire duct and fan shown are not furnished.)

### Accessories

- Recommended Spare RF Transistors for Exciter .....MI-560718
- Spare Crystal and Oven  
(Specify operating frequency) .....MI-560717
- Complete Set of Spare Tubes .....ES-560609
- 20-kW RF Load and Wattmeter (water-cooled) .....MI-19267-L/H
- Type BTR-11B Remote Control System  
(10-function) .....ES-34280

- Type BTR-20D Remote Control System  
(20-function) .....ES-34274-C
- Type BW-75A FM Frequency and  
Modulation Monitor .....MI-560735
- Type BW-85A FM Stereo Frequency and  
Modulation Monitor .....MI-560740
- Type BW-95A SCA Frequency and  
Modulation Monitor .....MI-560745

## Ordering Information

- Type BTF-20E1 20-kW FM Transmitter .....ES-560602
- Please specify assigned frequency, power-line frequency and altitude of installation and select BTE-15A Exciter System from the following:

- Mono .....ES-560631
- Mono and one SCA Channel .....ES-560632
- Mono and two SCA Channels .....ES-560633
- Stereo .....ES-560634
- Stereo and one SCA Channel .....ES-560635
- Stereo and two SCA Channels .....ES-560636

# RCA 40-KW FM Transmitter, Type BTF-40E1

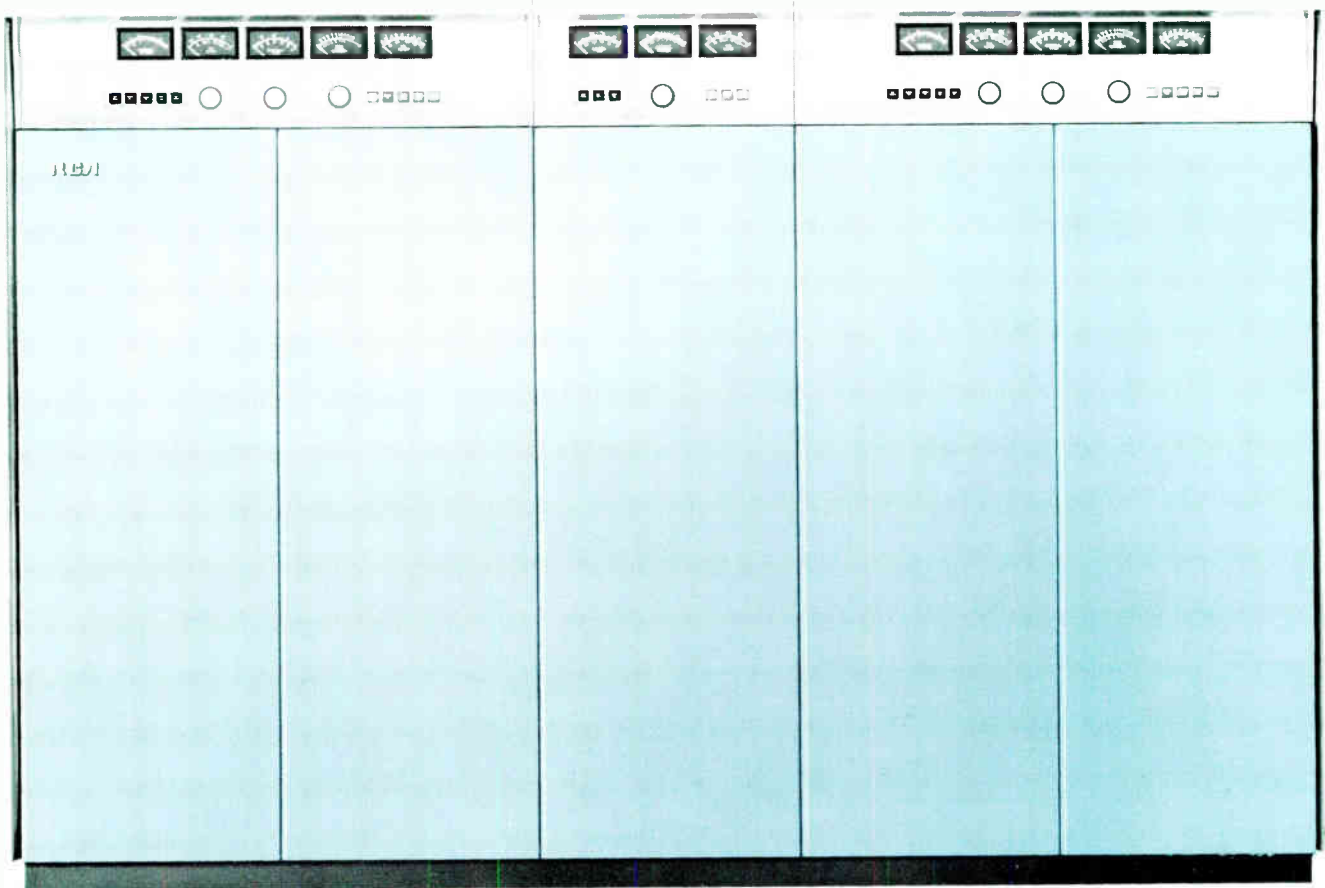

- Ultra stable—easy to tune
- New solid-state exciter
- Available for mono or stereo—with or without SCA
- Reliable dual RF amplifiers
- Ready for remote control



40-KW FM Broadcast Transmitter

Eye level Meters and Status Lights

Diplexed Outputs

Complete Circuit Protection

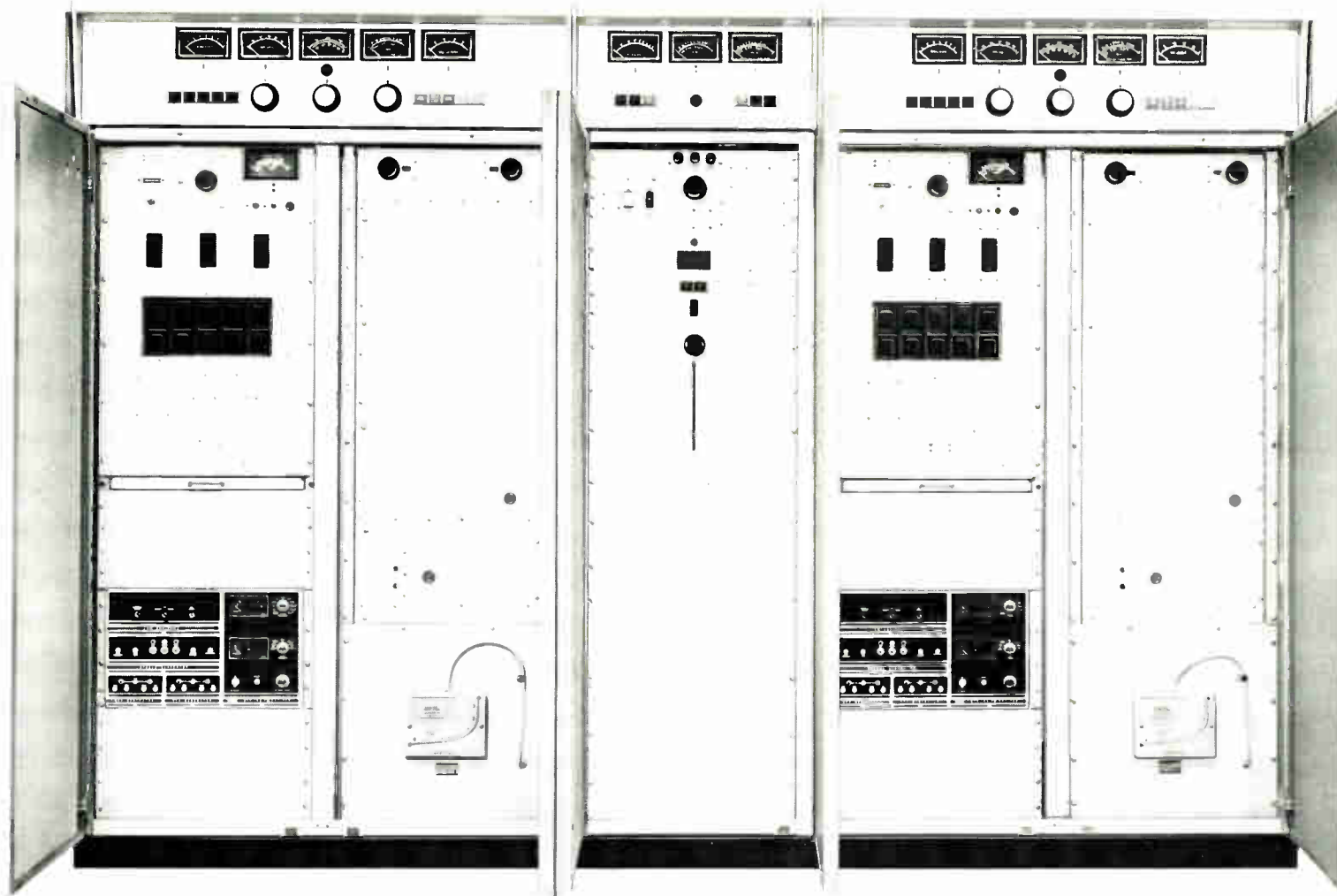

Spare Exciter

Built-in Remote Control

Instant Switching to Spare Exciter

New Solid-State FM Exciter

Air Flow Indication

## 40-KW Full-Fidelity FM Transmitter, Type BTF-40E1

The RCA Type BTF-40E1, 40 kW FM Broadcast Transmitter is designed for high-power operation in the standard FM band, 88-108 MHz and is specifically engineered to meet and exceed the requirements of multiplex service transmission.

The transmitter consists of two twenty kW units driven from a single exciter. The use of exciter switching and an output diplexing system assures continuous operation even when one power amplifier or exciter is removed from service for maintenance or repair. The transmitter is housed in two cabinets separated by a control panel and the diplex assembly.

The BTF-40E1 employs a new Type BTE-15A Exciter that uses the time-tested and field-proven RCA *direct FM* system. The circuits employ all solid-state components. Their inherent long-life and cool operation assure

extended reliability and lend themselves particularly to unattended, remote operation.

Because of its wide frequency response and extreme stability, the exciter is ideally suited for multiplex and stereo programming, as specified by the FCC.

The BTF-40E1 uses silicon-rectifier power supplies for long life and dependability. For ease of tuning, the exciter has a built-in multimeter and accessible test points permitting metering and checking during operation. Built-in manometers can add hundreds of hours to tube life by indicating air filter efficiency and warning of reduced cooling-air supply over the power tubes.

Frequency response of the transmitter's main channel is 30 to 15,000 Hz ( $\pm 1$  dB maximum) and distortion over the same range is 0.5 percent or less.

### Description

The BTF-40E1 is a diplexed transmitter consisting of two 20E transmitters united by a mid-combining panel. The diplexed output combiner, a 3 dB Hybrid Coupler, and one 6 $\frac{1}{8}$ -inch Harmonic Filter, are external to the cabinets of the 40E1.

The combining panel consists of five sections, the first of which contains the following control and metering functions: six illuminated pushbuttons for operating the combined unit on, off, plate on, plate off, and to indicate transmitter overload, and output line VSWR overload. Also located here are three meters essential for operation of the 40E1. A "Reject Power" meter is used to indicate power into the air cooled reject load. The second, a "Reflected Output Power Meter," serves to indicate reflected power and to protect the transmitter from an unusually high VSWR in case of a line or antenna fault. The control can be adjusted to any value of VSWR. The third meter indicates "Power Output."

The second section in the combining panel is used to mount the set point module of the meter-control and to mount the reflectometer adjustments and controls. Below this, a third section contains illuminated switches for Exciter 1 or 2, control circuit line breaker, and a meter indicating reject power in the input balun. The fourth section has a control for adjustment of the line stretcher used for phasing the input circuits of the combined 20E units. The last section is a blank panel.

In the top of the combiner unit is a blower, thermostatically controlled, so that in case of failure of either of the 20-kW transmitters, the heat from the 10-kW reject loads will be removed from the cabinet. Each air cooled 5-kW load is also equipped with a thermo controlled fan for cooling.

The transmitter can be controlled as a 40-kW unit from the combining cabinet panel, or as individual 20-kW transmitters from their own control positions. The

BTF-40E1 transmitter, or the individual 20-kW sections can be operated by a remote control system.

Relays automatically switch all inputs, that is, stereo and two SCA channels from one exciter to the other. The primary power to each exciter is always fed from the transmitter that is not shut down.

#### Mono or Stereo

The transmitter features a new exciter designed for stereo and multiplex. The exciter, including its self-contained power supply, is mounted on a single vertical chassis.

#### Two Stages Follow Exciter

From the 15-Watt output of the exciter, only three tubes, two in the IPA and a ceramic-tetrode 4CX-15000A PA, generate the full 20-kW signal from each amplifier. A harmonic filter reduces spurious radiation. Vacuum capacitors tune the IPA plate and PA grid. All PA adjustments are at ground potential.

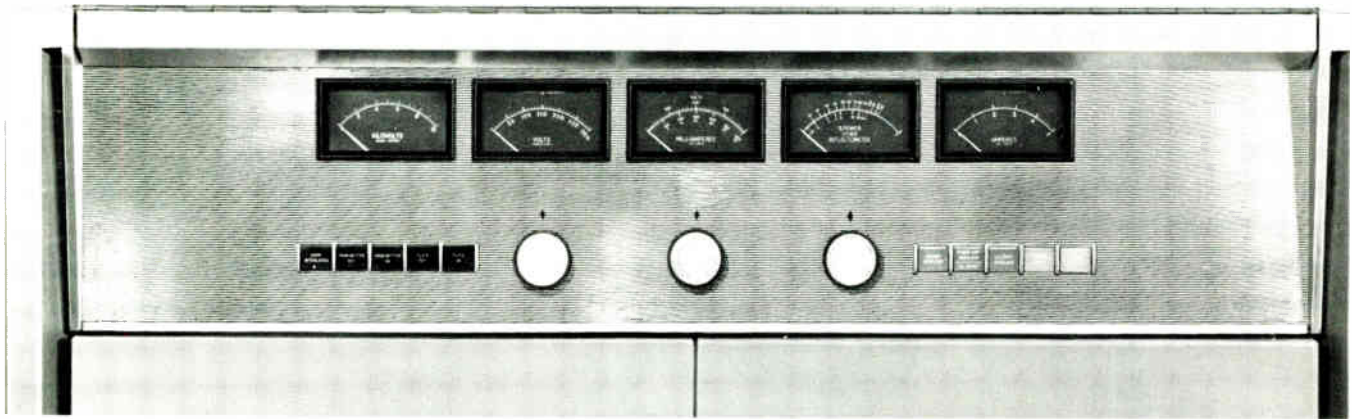

Control Panel of one of the diplexed 20-kW transmitter units. Tally lights and pushbutton controls permit operation of BTF-40E1 even when one power amplifier or exciter is removed from service. The large diameter multimeter knobs speed log keeping and minimize error.

### New Styling

Functional styling together with fewer tubes and components has permitted the new BTF-40E1 transmitter and a control panel to be housed in two double-door cabinets. They employ the new midnight blue and shadow blue finish, set off with aluminum meter panel and trim. Swing-out doors on the front and rear of the cabinet give maximum accessibility. Two separate unitized high-voltage supplies may be located anywhere in the FM station.

### New Solid-State FM Exciter

Excellent monaural, stereo and SCA performance that more than meets industry and FCC standards are achieved by the new RCA modular, solid-state "Direct FM" exciter.

### Simplified Circuits

Modulation of the temperature compensated basic on-frequency oscillator is achieved by applying the composite stereo or SCA signals from the BTS-1B and BTS-1B Generators, respectively, to a

pair of push-pull varicap diodes which are coupled to the basic oscillator frequency determining resonant circuit. The output of the basic oscillator is isolated from the following buffer amplifier by a 10 dB resistive attenuator. Thus, the stability and modulation characteristics of the basic direct FM oscillator are not disturbed by following RF power amplifiers.

The output of the buffer amplifier, approximately 500 mW, is used to drive the 15-Watt, three-stage RF amplifier as well as the binary divider chain in the

Block diagram of the BTF-40E1 FM Transmitter.

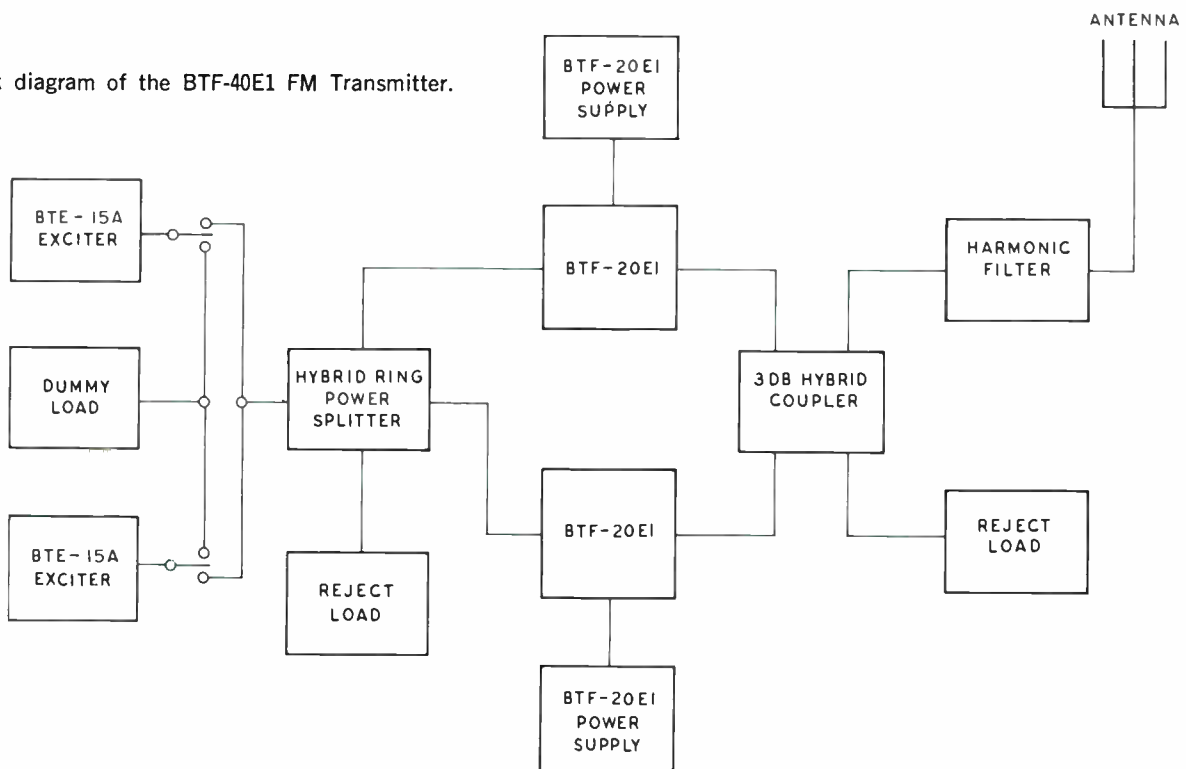

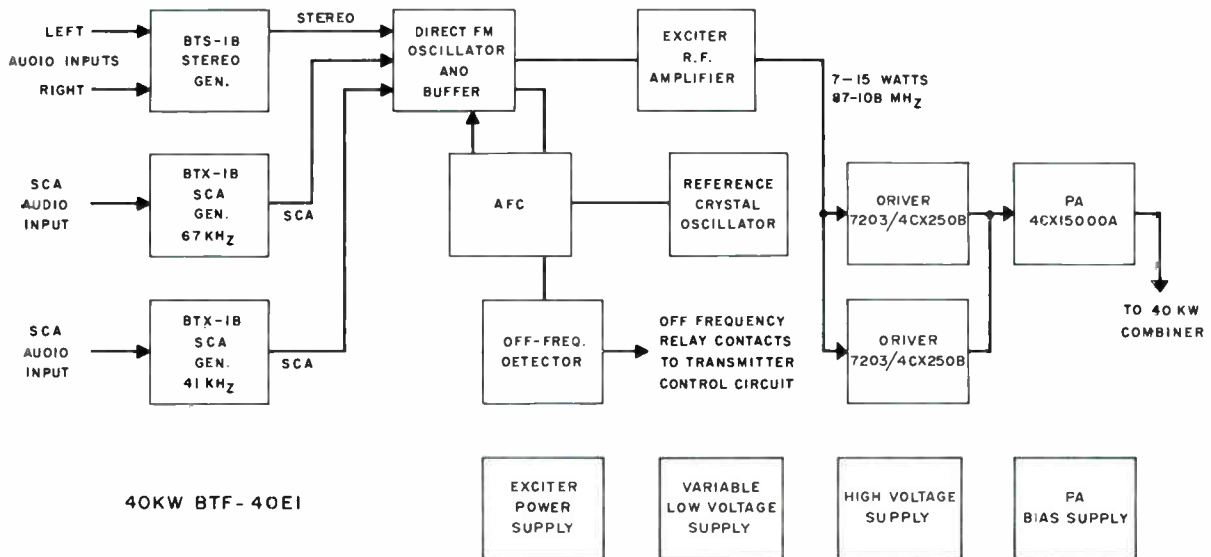

Block diagram of one of the diplexed 20-kW units of the BTF-40E1 Transmitter, showing optional Stereo and SCA.



New solid-state FM Exciter system, Type BTE-15A, showing "Direct FM" exciter housed with optional stereo generator and SCA generator units.

AFC circuit. The basic oscillator, buffer amplifier, and AFC circuit are mounted inside a shielded enclosure. The RF power amplifier is also completely shielded.

### "On Carrier" Frequency Operation

Automatic frequency control (AFC) for the on-frequency basic oscillator is achieved by taking a sample of the buffer output frequency and dividing it by two, 14 times. A low-frequency reference crys-

tal operating at 1/1024th of the desired output frequency is divided by two, 4 times. Integrated circuits operating in the saturated mode are used in both binary dividing chains. The outputs from the reference and basic oscillator binary dividers are phase compared in a time-sharing IC comparator. The output of the circuit, which represents the AFC error voltage, is filtered and applied to another pair of varicap diodes coupled to the basic

oscillator tuned circuit. Thus, the basic oscillator is phase locked to the 1024th harmonic of the oven controlled reference crystal.

An off-frequency detector is incorporated in the design of the BTE-15A FM Exciter. When the basic oscillator frequency is not phase locked to the reference crystal, an AC component appears at the AFC output. This voltage is rectified to operate a relay whose contacts can be used to turn off the FM transmitter.

Two multimeters are located on the hinged door in front of the regulated power supply section. One of these meters is used to indicate power supply and operating voltages within the exciter and 15-Watt RF Amplifier. The second meter is a peak-reading voltmeter that is used to indicate all modulating signal levels.

The RF power output of the BTE-15A can be continuously adjusted from the front panel control from 7 to 15 Watts. The primary power is turned on with a circuit breaker. RF output is turned on with a front panel switch or by jumping contacts available on the rear of the unit. The exciter will tolerate load mismatches from short circuit to open circuit for a reasonable time without damaging the

output transistor. Another safety feature prevents turning on the 41 kHz SCA sub-carrier when the BTS-1B Stereo Generator is in the stereo mode.

### Single-Ended Driver Amplifier

Two simplified, single-ended amplifiers (operating Class "C") follow the exciter in each 20-kW unit. The IPA stages consist of two ceramic 7203/CX250B tetrodes operating in parallel, and both final power amplifiers are Type 4CX15000A tubes. Variable vacuum capacitors are used to tune the interstage network between driver and PA.

### 20-kW Class "C" Final Amplifier

The power amplifiers also use pi-network circuitry, however, the tuning of

these stages is accomplished by variable inductors operating at ground potential. The output tubes are designed for very high power gain with little drive. Power output is controlled by means of motor-driven variable transformers connected in the primary of the low voltage power supply for the driver amplifiers. This controls the IPA-plate and the PA-screen voltages simultaneously.

For increased transmitter stability and reliability, separate grid bias supplies are incorporated in the BTF-40E1. These supplies also use semi-conductor rectifiers.

### Harmonic Filter Standard Equipment

To keep spurious emission at a minimum, the transmitter is furnished with

a 6 $\frac{1}{8}$ -inch harmonic filter. The filter consists of a series of transmission line elements with a uniform outer diameter conductor, a stepped inner conductor and a shunt stub. The conductors are fabricated of a high-grade copper alloy. Attenuation of all harmonic radiation above channel limits is accomplished in an "M-derived" section, and a series of "constant-K" T-sections. This design provides a broad passband with a sharp high-frequency cut-off and excellent attenuation of frequencies above the passband.

### Self-Protected Against Overload

Power circuits are protected by magnetically-tripped circuit breakers in addition to overload relays. An interlocked

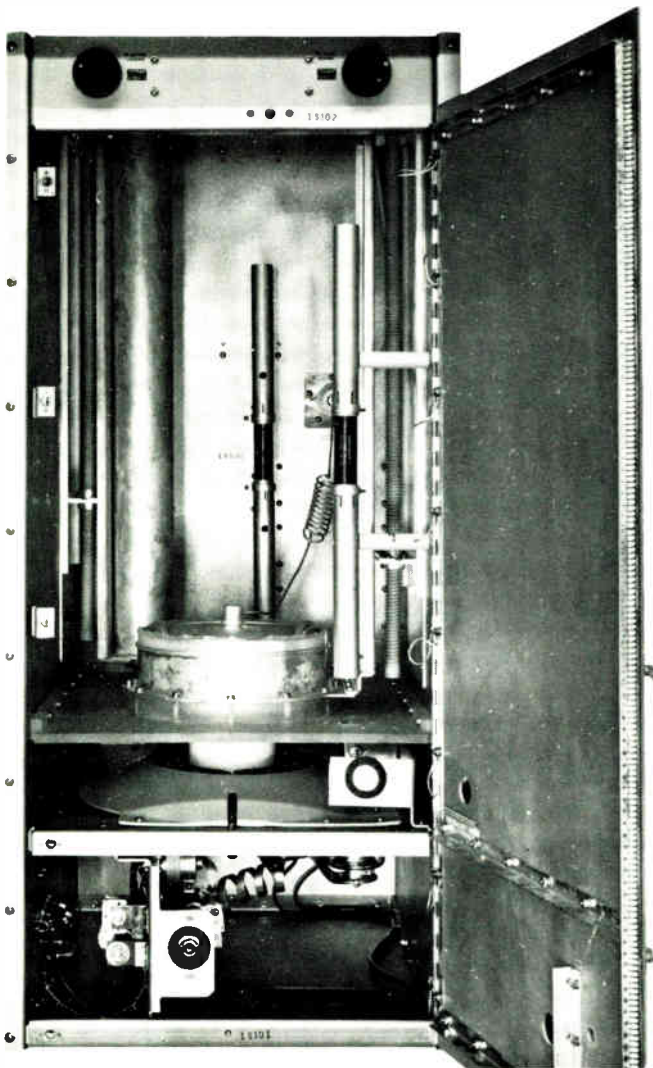

View showing interior of one of the two identical PA and IPA cabinets with the 4CX15000A ceramic tetrode and two IPA tubes below shelf.

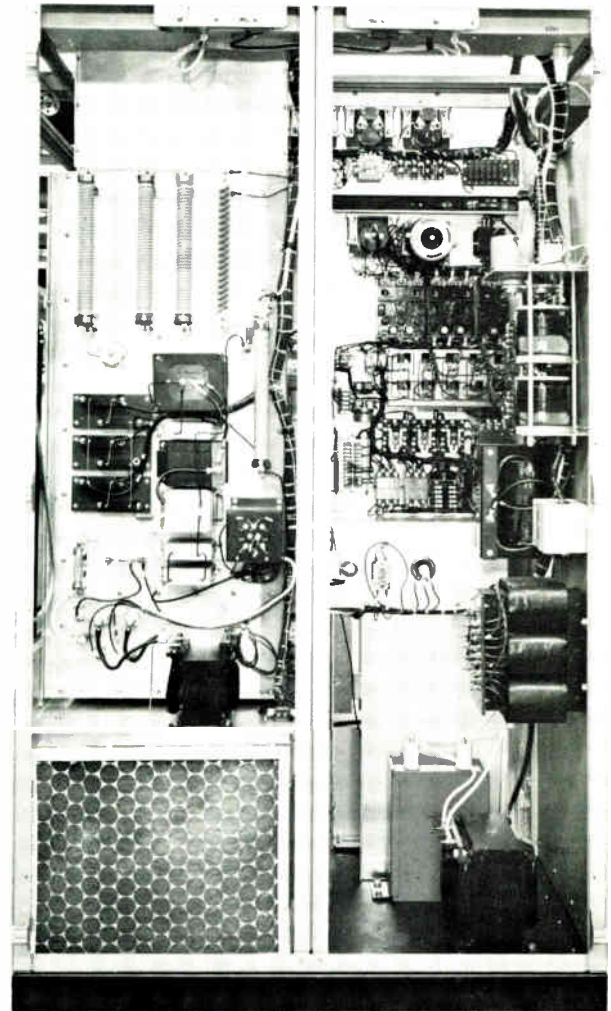

Complete accessibility. Rear view showing one of the amplifiers of the BTF-40E1 revealing the clean, vertical construction of PA cavity to left and control panel to right.

system prevents turn-on of plate power until all filaments have heated and the exciter has reached a proper operating condition. In addition, a latching relay automatically re-applies power to the transmitter once before locking-out in the event of brief overloads or power interruptions. The overload relays are reset by illuminated push-button switches on the front panel. Separate tally-light indicators are provided for overloads in the driver, power amplifier and low voltage rectifier circuits.

### Fully Air-Cooled

Cooling air for the BTF-40E1 is supplied by the use of two blowers mounted below the amplifier stages. Manometers indicate the efficiency of the fiber-glass filter at the inlet and heavy sound insulation reduces blower noise to a minimum. The blowers supply forced air to all IPA and PA stages.

### Simplified Control

In addition to the combining control panel already described, each 20-kW unit has operating controls and meters located on a panel just above the front doors. The push-button controls include: transmitter on/off, plate on/off, overload reset and power raise/lower. A cabinet

disconnect switch, low-voltage circuit-breaker, and filament- and control-circuit breakers are located behind the left-hand door. The main- and low-power circuit breakers are located in the rectifier unitized cabinet. When servicing the BTF-40E1, operation of the "disconnect" switch removes all voltages from the transmitter cabinet. Personnel are protected by fully interlocked rear doors, in addition to interlocked doors on the RF PA cubicles.

### Full Metering

Six easy-to-read front-panel meters are provided for each amplifier. One for PA-plate voltage, another for PA-plate current, and a third for AC line and filament voltage. The remaining three are a reflectometer indicating output, a multimeter and VSWR meter. Separate meters are used to measure the forward power and VSWR. The multimeter reads the grid current, the screen current and the screen voltage of both power tubes. In addition, the exciter has its own self-contained multimeter, that provides complete information on operating conditions in the exciter.

### Ready for Remote Control

Remote control provisions are included

in the transmitter. The Terminals are provided for use with remote control units such as the BTR-20 Series and BTG Series Automatic Logging Equipment. Additional terminals are supplied for remote control of transmitter on/off, plate on/off, raise/lower power, and overload reset. Remote metering connections in the final amplifier for plate current, plate voltage, and power output are also provided.

### High-Voltage Power Supply

The high-voltage power supplies are housed in unitized cabinets each measuring 32 inches wide, 23 inches deep and 49 inches high. They can be installed at any convenient place in the station. The cabinets house the high-voltage-plate transformers, a bank of plug-in semiconductor rectifiers, a line-circuit breaker, a low-power circuit breaker, and the plate contactor. Personnel are fully protected from shock through interlock and grounding switches.

The rectifier section comprises silicon-junction diodes (with equalizing resistors and capacitors) in a three-phase, full-wave-bridge circuit. Circuit breakers are used instead of fuses in the transmitter adding to the dependability, particularly when operating by remote control.

## Specifications

### Performance

Type of Emission .....	F3 and F9
Frequency Range .....	.88 to 108 MHz
Power Output .....	40 kW
Output Impedance (6½" O.D. Line) .....	50 Ohms
Frequency Deviation 100% modulation .....	±75 kHz
Modulation Capability .....	±100 kHz
Carrier Frequency Stability .....	±1000 Hz max.
Audio Input Impedance .....	600/150 Ohms
Audio Input Level—*(100% mod.) .....	+10 ±2 dBm
Audio Frequency Response—**(50-15,000 Hz) .....	±1 dB max.
Pre-emphasis Network Time Constant.....	.75 or 50 µs, as desired
Harmonic Distortion—***(50-15,000 Hz) .....	0.5% or less
FM Noise Level (referred to 100% FM mod.) .....	-65 dB max.
AM Noise Level (referred to 100% AM mod.) .....	-50 dB max.
Subcarrier Input Level (100% mod.) .....	-15 to +10 dBm adjustable
Subcarrier Input Impedance .....	600/150 Ohms bal.
Subcarrier Frequency .....	20-67 kHz
Main-to-Subchannel Crosstalk.....	-50 dB referred to ±7.5 kHz deviation of the subcarrier by a 400 Hz tone. Main channel modulation 70% by 50-15,000 Hz tones.
Sub-to-Main-Channel Crosstalk.....	-60 dB referred to ±7.5 kHz deviation of the main carrier by a 400 Hz tone. Subchannel modulation 100% (±7.5 kHz) by 50-6000 Hz tones. Subcarrier modulated 30% on main carrier.

### Tube Complement

Driver:	4—7203/4CX250B
Power Amplifier:	2—4CX15000A

### Electrical

Power Line Requirements:	
Line .....	240/208 Volt, 3 phase, 50/60 Hz
Combined Line Voltage Variation and Regulation .....	±5%
Power Consumption .....	72,000 Watts (approx.)
Power Factor (approx.) .....	90%

### Mechanical

Dimensions (overall):	Transmitter	High-Voltage Power Supply
Width .....	114¼" (288.2 cm)	64" (162.6 cm)
Height .....	77" (195.6 cm)	49" (124.5 cm)
Depth .....	32½" (82.5 cm)	23" (58.5 cm)
Weight (approx.) .....	2950 lbs. (1336.4 kg)	2050 lbs. (329.8 kg.)
Finish .....	Textured Vinyl in midnight blue and shadow blue, satin-aluminum trim.	
Altitude .....	7500 ft. (2290 m)†	
Ambient Temperature Range .....	-20° to +45°C	

\* Level measured at input to pre-emphasis network.

\*\* Audio Frequency response referred to 50- or 75-microsecond pre-emphasis curve.

\*\*\* Distortion includes all harmonics up to 30 kHz and is measured following a standard 50- or 75-microsecond de-emphasis network.

† Blowers can be provided for operation at higher altitudes.

Specifications subject to change without notice.

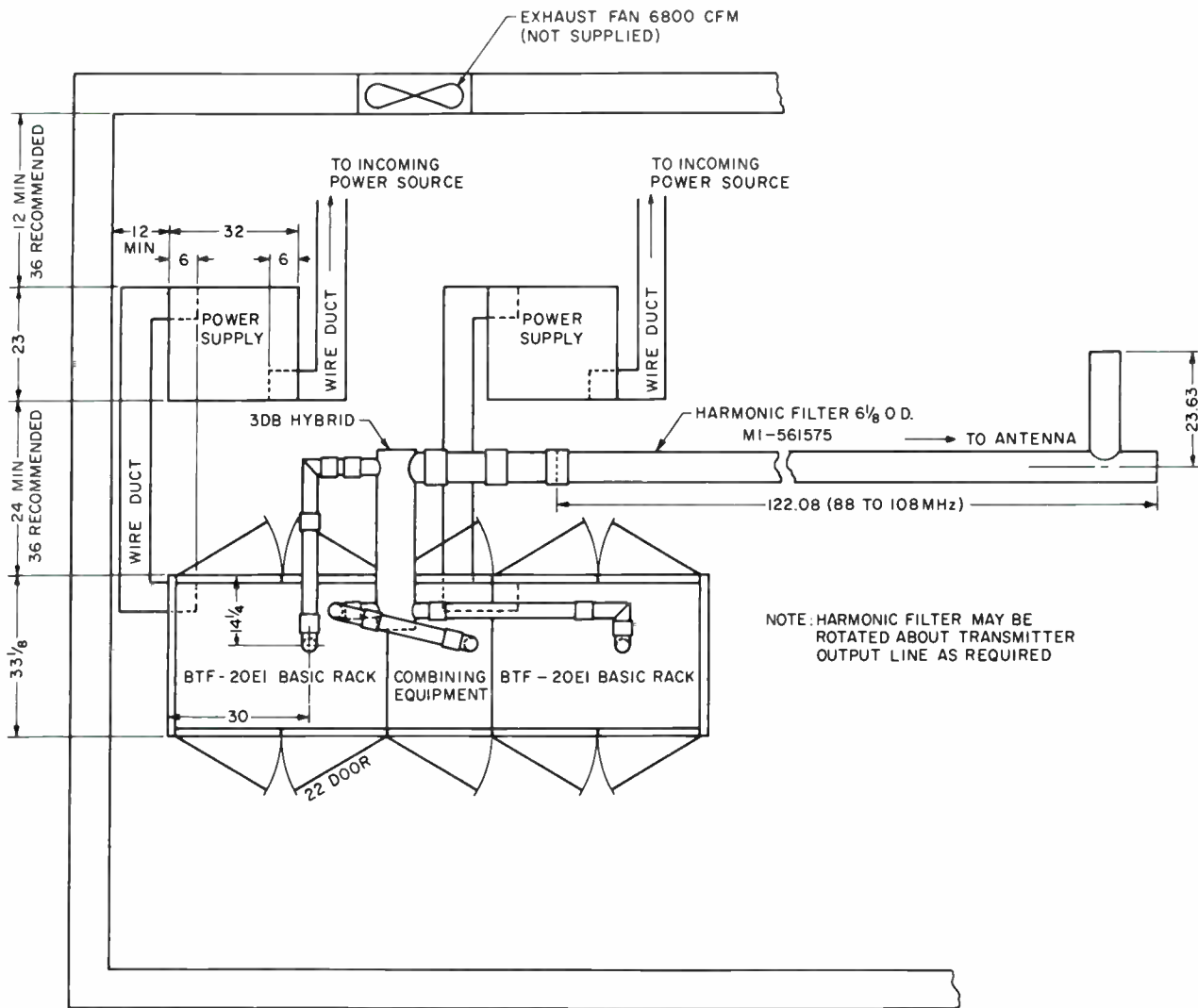

Space-saving floor plan of the BTF-40E1. The separate, unitized power supply may be installed in a basement, attic, closet or other convenient place. (Wire duct and fan shown are not furnished.)

**Accessories**

- Recommended Spare RF Transistors for Exciter ....MI-560718
- Spare Crystal and Oven  
(Specify operating frequency) .....MI-560717
- Complete Set of Spare Tubes .....ES-560613
- 20-kW RF Load and Wattmeter .....On application
- Type BTR-11B Remote Control System  
(10-function) .....ES-34280

- Type BTR-20D Remote Control System  
(20-function) .....ES-34274-C
- Type BW-75A Frequency and  
Modulation Monitor .....MI-560735
- Type BW-85A Stereo Frequency and  
Modulation Monitor .....MI-560740
- Type BW-95A SCA Frequency and  
Modulation Monitor .....MI-560745

**Ordering Information**

Type BTF-40E1 40-kW FM Transmitter .....ES-560606  
Please specify assigned frequency, power-line frequency, and altitude of installation and also select a Type BTE-15A Exciter System from the following:

- Mono .....ES-560631
- Mono and one SCA Channel .....ES-560632
- Mono and two SCA Channels .....ES-560633
- Stereo .....ES-560634
- Stereo and one SCA Channel .....ES-560635
- Stereo and two SCA Channels .....ES-560636



- Latest modular design employing solid-state integrated circuits
- "Direct FM" modulation
- Excellent frequency response—low distortion and noise
- Simplified operation—easy to service
- Automatic muting of subcarrier
- Fully metered
- Off-frequency detector

## RCA FM Exciter System, Type BTE-15A

### Description

RCA's new FM Exciter Stereo System Type BTE-15A, with optional Stereo and SCA generator units provides on-air FM stations with an inexpensive means of broadcasting two or more services simultaneously over their regularly assigned broadcast channel. Stations can offer background music or other services while retaining presently scheduled FM mono or stereo broadcast programming. The use of the equipment for SCA and stereo is type accepted by the FCC.

The heart of the system is the new Type BTE-15A Exciter, an all solid-state unit utilizing integrated circuits, and employing RCA's "Direct FM" principle of operation. An important feature of the new exciter system is that it is fully metered using two meters to measure not only operating parameters but also modulating signals.

Stereophonic programming requires the use of an optional plug-in Stereo Generator, Type BTS-1B. One or two Type BTX-1B Subcarrier Generators

permit one or two additional program channels to be transmitted along with the regular FM mono program channel. This is accomplished by transferring the sub-channel programs into the supersonic frequency range and frequency modulating the subchannel program on 41-67 kHz subcarriers. The FM supersonic carriers are then used to modulate the RF carrier. When a BTS-1B Stereo Generator is switched into the system only one BTX-1B SCA Generator on 67 kHz can be used.



## BTE-15A FM Exciter

Excellent monaural, stereo and SCA performance that more than meets industry and FCC standards are achieved by the new RCA modular, solid-state, "Direct FM" exciter. This exciter can be substituted directly for the BTE-10C Exciter in present BTF-1E1 or BTF-5/10/20E FM Transmitters and can be operated into either short circuit or open circuit without damage to the output transistor.

New design features include a modular design that plugs into a frame accommodating the Exciter, Power Supply and Switching, BTS-1B Stereo and one or two BTS-1B SCA Generator modules. When operating monaural only, the BTS-1B Stereo Generator is replaced with another module. The exciter frame is 19 inches wide and designed for standard rack mounting. A module extender is provided to permit easy servicing of modules outside the main frame.

### Circuits

Modulation of the temperature compensated basic on-frequency oscillator is achieved by applying the composite stereo or SCA signals from the BTS-1B and BTX-1B Generators, respectively, to a pair of push-pull varicap diodes which are coupled to the basic oscillator frequency determining resonant circuit. The output of the basic oscillator is isolated from the following buffer amplifier by a 10 dB resistive attenuator. Thus, the stability and modulation characteristics of the basic direct FM oscillator are not disturbed by the following RF power amplifiers.

The output of the buffer amplifier, approximately 500 mW, is used to drive the 15-Watt, three-stage RF amplifier as well as the binary divider chain in the AFC circuit. The basic oscillator, buffer amplifier, and AFC circuit are mounted inside a shielded enclosure. The RF power amplifier is also completely shielded.

Automatic frequency control (AFC) for the on-frequency basic oscillator is achieved by taking a sample of the buffer output frequency and dividing it by two, 14 times. A low-frequency reference crystal operating at 1/1024th of the desired output frequency is also frequency divided by 16 in a binary chain. Integrated circuits operating in the saturated mode are used in both binary dividing chains. The outputs from the reference and basic oscillator binary dividers are phase compared in a time-sharing IC comparator. The output of the circuit, which represents the AFC error voltage,

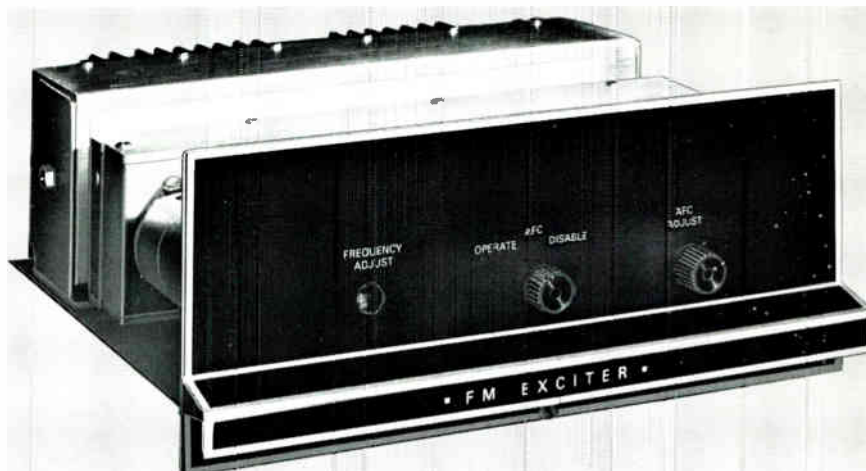

BTE-15A FM Exciter.

is filtered and applied to another pair of varicap diodes coupled to the basic oscillator tuned circuit. Thus, the basic oscillator is phase locked to the 1024th harmonic of the oven controlled reference crystal.

An off-frequency detector is incorporated in the design of the BTE-15A FM Exciter. When the basic oscillator frequency is not phase locked to the reference crystal, an AC component appears at the AFC output. This voltage is rectified to operate a relay whose contacts can be used to turn off the FM transmitter.

Two multimeters are located on the hinged door in front of the regulated power supply section. One of these meters is used to indicate power supply and operating voltages within the exciter and 15-Watt RF Amplifier. The second meter is a peak-reading voltmeter that is used to indicate key modulating signals.

The RF power output of the BTE-15A can be continuously adjusted from the front panel control from 7 to 15 Watts. The primary power is turned on with a circuit breaker. RF output is turned on with a front panel switch or by jumping contacts available on the rear of the unit. The exciter will tolerate load mismatches from short circuit to open circuit without damaging the output transistor. Another safety feature prevents turning on the 41 kHz SCA subcarrier when the BTS-1B Stereo Generator is in the stereo mode.

### BTS-1B Stereo Generator

In the Model BTS-1B Stereo Generator, latest techniques have been employed to obtain the finest possible stereo operation. The LEFT and RIGHT input channels are identical, each having resistive input terminations, isolating transform-

ers, 15-kHz low-pass filters, and an operational amplifier for obtaining pre-emphasis. The pre-emphasis is convertible from 75 to 50 microseconds in the field, or can be removed entirely. The LEFT and RIGHT channels can be matched to within ½ percent gain difference and ½ degree phase difference from 30 to 15,000 Hz, including the 15-kHz low-pass filters. These filters are less than 0.5 dB down at 15-kHz, and greater than 50 dB down at 19 kHz and above. This insures an absolute minimum of disturbance to the pilot carrier and subcarrier regions by the program material.

The pre-emphasized and filtered LEFT and RIGHT audio signals are applied to a switching modulator which alternately switches between the two audio channels. The balanced and symmetrical 38-kHz switching signal is derived from a buffered 38-kHz output of a bi-stable multivibrator. The negligible amount of second harmonic (76 kHz) in the 38 kHz switching signal assures a minimum of interference to a 67 kHz SCA channel. The 76 kHz crystal-controlled signal driving the binary divider assures a frequency stable 38-kHz stereo subcarrier.

The output of the switching modulator, along with the sinusoidal pilot (less than 1 percent distortion) is applied to a phase linear filter to remove the third and all higher order harmonic components of the switching signal. The complete composite stereo signal, or a LEFT or RIGHT monaural signal, is selected by relays and applied to the input of an operational amplifier. The output of this amplifier is then applied to the wide-band input of the BTE-15A FM Exciter.

Switching between monaural right, monaural left, or stereo may be accomplished by front panel pushbuttons on

the BTS-1B or by momentary remote control contact closures. The selected mode is indicated by front panel lamps. Left, Right and Composite program outputs are also applied to a peak reading meter on the main frame of the BTE-15A FM Exciter.

### BTX-1B SCA Generator

The Model BTX-1B SCA Generator, using all hermetically sealed metal cased integrated circuits and transistors, is a high performance unit designed to operate on either the 41-kHz or 67-kHz SCA channels. The audio input is applied to a resistive terminating pad and then to an isolating transformer before being amplified. An accessory 5-kHz low-pass filter must be inserted in the input to prevent higher order lower sidebands of the 67-kHz subcarrier from penetrating the upper regions of the stereophonic spectrum.

The audio amplifier includes an active pre-emphasis network outdating earlier passive schemes, and may be easily changed from 75 microsecond to 50 or 150 microsecond or adjusted for a flat response. The audio sensitivity of the BTX-1B is sufficiently high that line amplifiers are not required.

The processed audio input signal is then applied as modulation to a direct FM SCA generator, that includes a temperature compensating circuit for extreme frequency stability. A vernier center frequency control is available on the front panel.

Following this generator is a series diode muting gate, a buffer amplifier, and a wide-band low-pass filter to re-

move subcarrier harmonics. The total harmonic content of the subcarrier output is less than 1 percent and the incidental AM is less than 5 percent peak with 10 percent subcarrier modulation. The output of the low-pass filter is applied to another buffer amplifier and output level control for application to the multiplex input of the BTE-15A FM Exciter.

A sample of the pre-emphasized audio is used to drive a peak reading multimeter on the main frame of the BTE-15A. Automatic muting of the subcarrier is accomplished in the following manner. A portion of the pre-emphasized audio is applied to a variable gain amplifier and using an adjustable time constant, peak detected to operate a Schmitt trigger circuit. The output of the Schmitt trigger is shaped with a low-pass filter and used to turn on or off the series diode

muting gate. When audio is applied to the input of the BTX-1B, the muting diode gate is turned on to allow the subcarrier output to appear. In the absence of audio, the Schmitt trigger pauses for a selected time interval before turning off the diode muting gate. The subcarrier envelope rise and fall times are constant and so chosen to minimize "clicks and pops" in a SCA multiplex receiver. The amount of Schmitt trigger delay is adjustable with a front panel control. With this control, subcarrier muting can be adjusted to occur from 0.5 to 5 seconds after the audio input is removed. Two transistors are used to operate front panel lamps to indicate the on-off status of the subcarrier. Also, a front panel switch provides manual control of the subcarrier output, or the use of the automatic muting feature. The subcarrier also can be turned on or off remotely.

BTS-1B Stereo Generator.

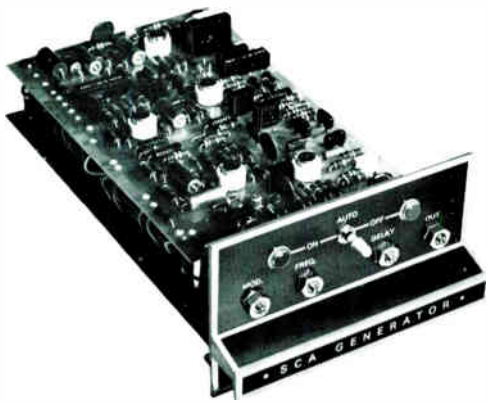

BTX-1B SCA Generator.

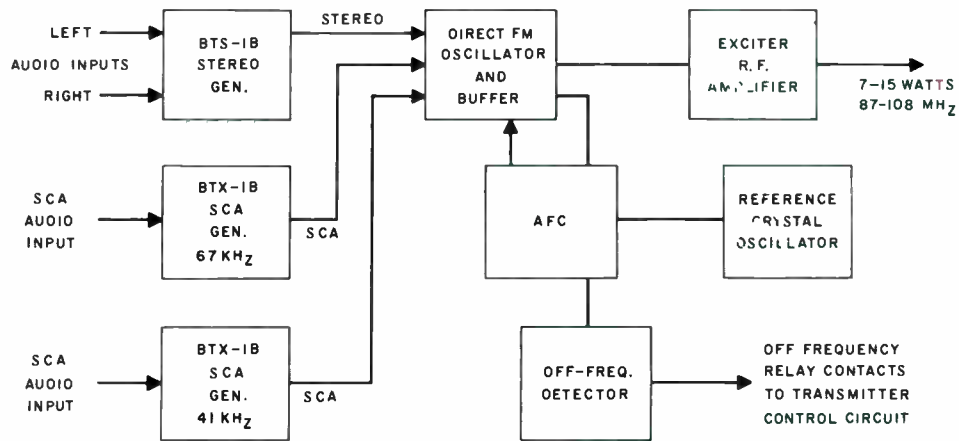

BTE-15A System.

Rear view of BTS-1B Stereo Generator with board raised to show easy access to printed circuit board.

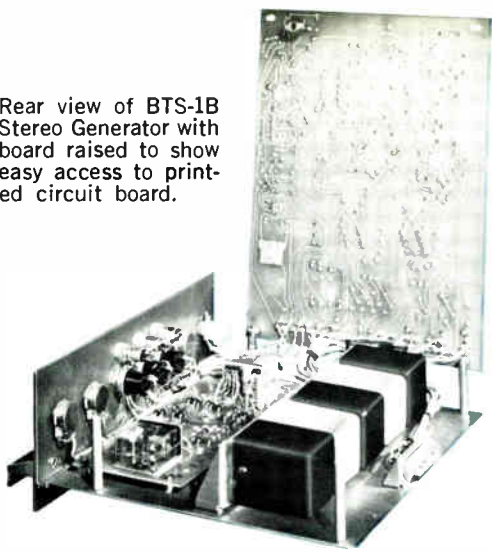

## Specifications

### TYPE BTE-15A EXCITER

#### Performance

Type of Emission .....	F3-F9
Frequency Range .....	87-108 MHz
Power Output .....	15 Watts
Output Impedance (BNC Connector) .....	50 Ohms
Frequency Deviation for 100% Modulation .....	±75 kHz
Modulation Capability .....	±125 kHz
Carrier Frequency Stability .....	±1000 Hz
Audio Input Impedance .....	600/150 Ohm resistive
Audio Input Level (100% Modulation) .....	+10 ±2 dBm at 400 Hz
Audio Frequency Response:	
50 Hz-10 kHz—pre-emphasis 75 μs .....	±0.5 dB max.
10 kHz-15 kHz—pre-emphasis 75 μs .....	±1.0 dB max.
Pre-emphasis Network Time Constant .....	75 or 50 μsec. as desired
Harmonic Distortion (50 Hz-15 kHz) .....	0.5% max.
FM Noise Level (referred to 100% FM mod. at 400 Hz) .....	-68 dB max.
AM Noise Level (referred to carrier voltage) .....	-60 dB max.

#### Electrical

Power Line Requirements:

Exciter:

Line .....	240/208 or 117 V, AC, 50/60 Hz, single phase
Slow Voltage Variations .....	±5%
Power Consumption .....	80 Watts max. (Including Stereo & SCA)

All specifications subject to change without notice.

## Ordering Information

Main Frame for FM Exciter/Stereo/SCA (Includes integral Power Supply and Metering) .....	MI-560710
Main Frame for Stereo (Includes integral Power Supply) .....	MI-560711
Main Frame for SCA (Includes integral Power Supply) .....	MI-560720
BTE-15A FM Exciter .....	MI-560712
BTS-1B Stereo Generator .....	MI-560713
BTX-1B SCA Generator (Specify SCA Frequency) .....	MI-560714

### Mechanical

Overall Dimensions .....	19" wide, 10½" high, 9" deep
Weight .....	40 lbs.
Maximum Altitude .....	7500 ft.
Ambient Temperature Range .....	-20°C to +60°C
Finish .....	Black Background with Aluminum Epoxy Trim

### STEREO SUBCARRIER GENERATOR, TYPE BTS-1B

#### Performance

Pilot Carrier Stability .....	19 kHz ±1 Hz
Subcarrier Suppression .....	-45 dB or better
Frequency Response, 30-10 kHz .....	±0.5 dB max.
Frequency Response, 10 kHz-15 kHz .....	±1.0 dB max.
Pre-emphasis .....	75 or 50 μsec.
Left-Right Channel Separation .....	35 dB or better
Crosstalk-Stereophonic (main channel to subchannel) .....	45 dB
Crosstalk (subchannel to main channel) .....	45 dB
Harmonic Distortion (100% modulation by composite stereo) .....	1% or less

### Mechanical

Obtains power from BTE-15A

Plugs into BTE-15A Exciter

41 kHz SCA Lockout when using Stereo

Stereo-Mono Remote Switching—Either Left or Right Channel can be Remotely Switched to give Mono Operation

### TYPE BTX-1B SUBCARRIER GENERATOR

#### Performance

Type of Modulation .....	FM
Center Frequency Range of Subcarrier .....	30 kHz to 75 kHz
Output Voltage .....	4.0 Volts RMS into 10K Ohms
Frequency Deviation (100% subcarrier modulation) .....	±10% of center frequency
Modulation Capability .....	±15% of center frequency
Carrier Frequency Stability .....	±0.2%
Audio Input Impedance .....	600 Ohms bal.
Audio Input Level (100% modulation) .....	-15 to +10 dBm adjustable
Audio Frequency Response (30 Hz-10 kHz)* .....	±1 dB†
Harmonic Distortion (50 Hz-10 kHz) .....	Less than 1%†
FM Noise Level (referred to 100% modulation) .....	-65 dB max.
AM Noise Level (referred to carrier) .....	-50 dB max.

\*50 or 150 μs pre-emphasis optional

†Without low pass filter, measured on a wideband detector.

### Mechanical

Plugs into BTE-15A Exciter

Obtains Power from BTE-15A Exciter

Blank Panel (To replace BTX-1B SCA) .....	MI-560715
Monaural Input Adapter (Replaces BTS-1B Stereo Generator) .....	MI-560716
Oven with Crystal for BTE-15A Exciter (Specify operating Frequency) .....	MI-560717
Recommended Spare RF Transistors .....	MI-560718
Module Extender .....	MI-560719
5 kHz Low Pass Filter (for SCA) .....	MI-560721

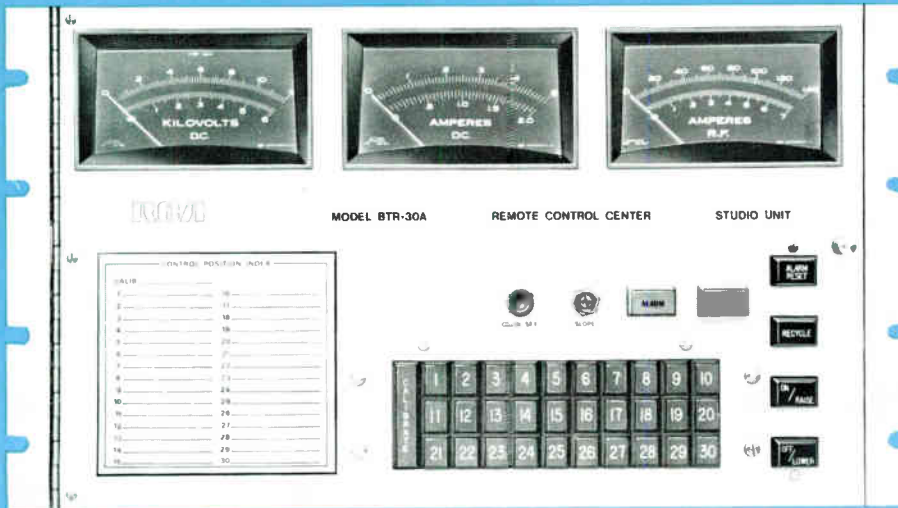

- For AM, FM or TV transmitters
- Fail-safe design
- Thirty metering channels
- Sixty control functions
- Computer-type logic circuitry

## RCA Remote Control System, Type BTR-30A

### Description

With 30 metering channels and 60 individual control functions, the all solid-state Type BTR-30A Remote Control System handles most of today's remote control requirements. Designed explicitly for the broadcaster, it incorporates many new features. Flexibility and adaptability are easily obtained with the BTR-30A. Wire or radio (STL) service is selected simply by plugging in the appropriate printed-circuit modules. Audible or sub-audible telemetry return is chosen in the same manner. No rewiring is necessary.

#### All Solid State

The circuitry of the BTR-30A is of modular construction, using carefully chosen combinations of integrated circuits and discrete components. Only one stepper relay is used in the transmitter unit. Solid-state, computer-type logic circuitry is used in the studio unit in place of a stepper relay or mechanical logic devices thus increasing reliability. The studio unit is essentially noiseless.

#### Quick Access to Circuitry

Some features of the Model BTR-30A are of special interest. An indication of the stepper relay position is provided on the front panel of the transmitter unit. This is especially useful during weekly calibrations. Color-coded, push-button switches on the transmitter unit are used for local control. The LOCAL/REMOTE buttons are illuminated red and green for quick indication of system status. Swing-away front panels on both units provide access to all printed circuit modules, and all initial and routine adjustments are made from the front of the equipment. An extension board is provided for testing each module.

#### Five-Input Alarm System

Included with the BTR-30A is a five input alarm system. A contact closure is used to activate any one of the five inputs. This can be utilized for continuous surveillance, sensing such things as illegal

entry, temperature, flooding and the like. The alarm signals are returned to the studio unit as part of the telemetry information. When an alarm condition exists, a visual indication is given at the control point by the amber *ALARM* lamp.

#### Fail-Safe Design

The Model BTR-30A requires one two-way, communications-grade signal circuit between the control point and the transmitter site. Fail-safe provisions meet all existing FCC requirements and will function with the loss of primary power or control information reception to the transmitter unit or malfunction of the equipment itself. The fail-safe tone generated in the studio unit also actuates the stepper relay at the transmitter unit. The tone is momentarily interrupted, creating, in effect, short-duration pulses which control the stepper. An interruption of approximately 15 seconds trips the fail-safe circuitry. Two functions,

designated *ON/RAISE* and *OFF/LOWER*, can be performed on each channel selected. A metered indication of the parameter being controlled can be observed simultaneously. The frequencies used are *FAIL/SAFE* 920 Hz, *ON/RAISE* 790 Hz, and *OFF/LOWER* 670 Hz. High-Q temperature-stabilized toroidal inductors and capacitors are used in all oscillator and tone detector circuits to assure drift-free operation. Two types of control outputs are available from the BTR-30A: (1) A pre-selected external control voltage or, (2) contact closures.

Contacts in the BTR-30A are rated for 50-watt non-inductive loads.

### Linear, Voltage-Controlled Oscillator

Telemetry is accomplished by converting the DC sample voltages from the transmitter to a frequency in the 22 Hz to 36 Hz spectrum by means of a linear voltage-controlled oscillator. This signal is relayed to the studio unit and converted back to a DC voltage proportional to the input sample for display on any of the 4" taut-band, panel-mounted meters.

Multiturn calibration controls are provided on the transmitter unit.

### For Wire or Radio Link

Two basic versions of the Type BTR-30A are available; one for wire interconnection and one for radio (STL) service.

### Wire Service

For wire service, only a single voice-grade telephone line (full duplex) is required for interconnection. DC continuity is *not* required. The 22 Hz to 36 Hz

Transmitter-control unit, Type BTR-30A. Note window at upper left which displays position of stepper relay. (See preceding page for Studio Unit.)

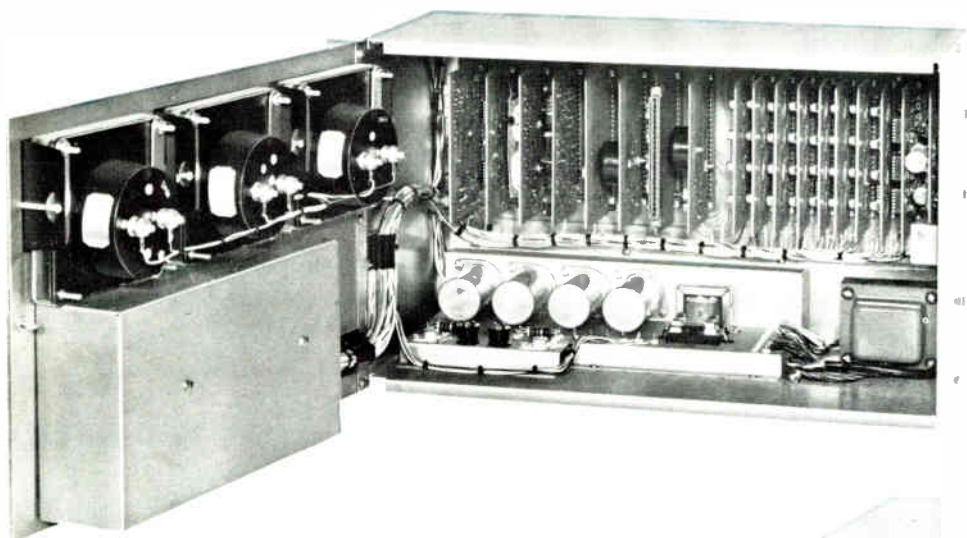
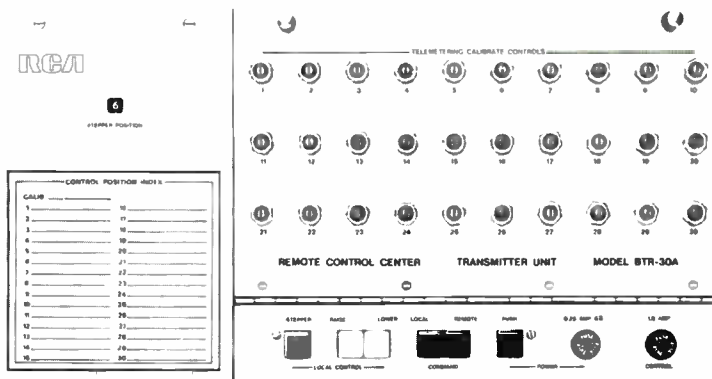

Swing-aside front panel exposes the largely integrated circuitry of the Studio Unit. Note modularized construction and neat layout.

Fold-down front panel in transmitter-control unit provides quick access to all modules. Note 10-turn potentiometers on panel.

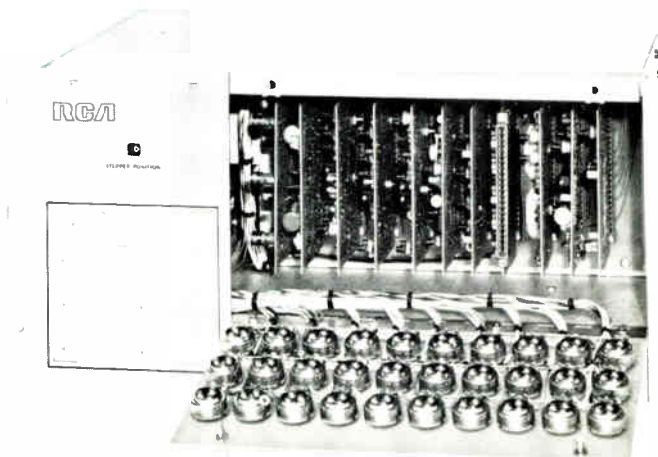

telemetry information is returned to the studio unit by means of an amplitude-modulated 1280 Hz signal. Thus, all audio signals appearing on the telephone line are confined to the 670 Hz to 1280 Hz spectrum.

### Radio (STL) Service

For radio service, the BTR-30A is designed to mate with RCA aural STL equipment. Control information is transmitted to the transmitter unit on sub-carriers multiplexed on the STL. Included in the BTR-30A are a control subcarrier

generator and detector. These are printed circuit modules. A 26-kHz control sub-carrier frequency is used for monaural or dual-stereo aural STL systems and 135-kHz for composite-stereo aural STL. Telemetry information is sinusoidal and subaudible, 22 Hz to 36 Hz. The return path of the telemetry information can be on an SCA channel of an FM transmitter, the main channel of an AM transmitter or other radio circuit capable of handling 22 Hz to 36 Hz. Audible telemetry information is available on special order for voice radio circuits.

Rear view of transmitter-control unit showing barrier-strip connections for the 60 control and 30 metering function.

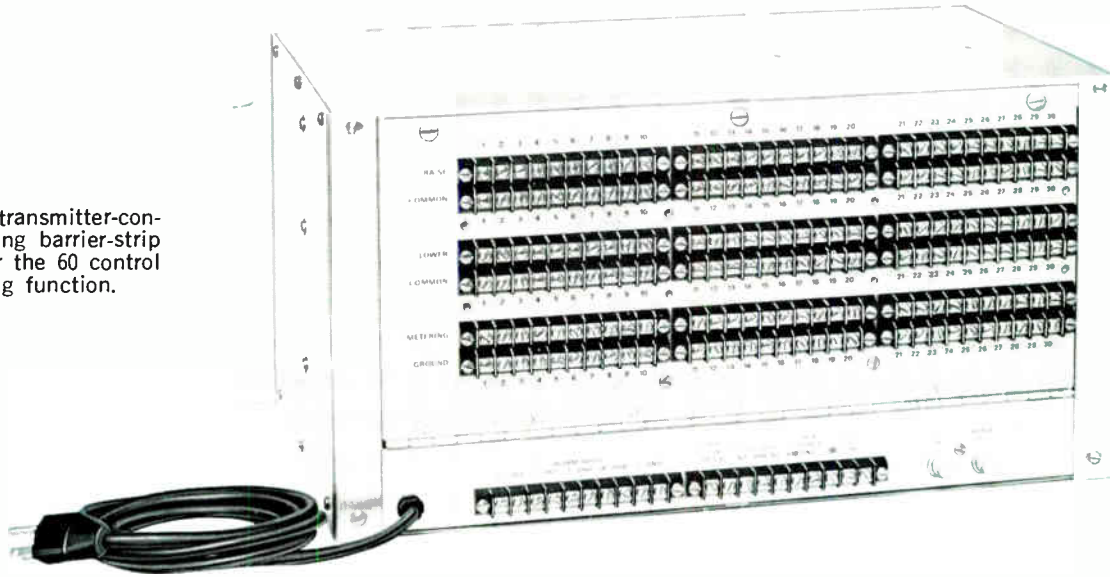

Typical BTR-30A printed-circuit modules. Note integrated circuit devices and uncrowded layout.

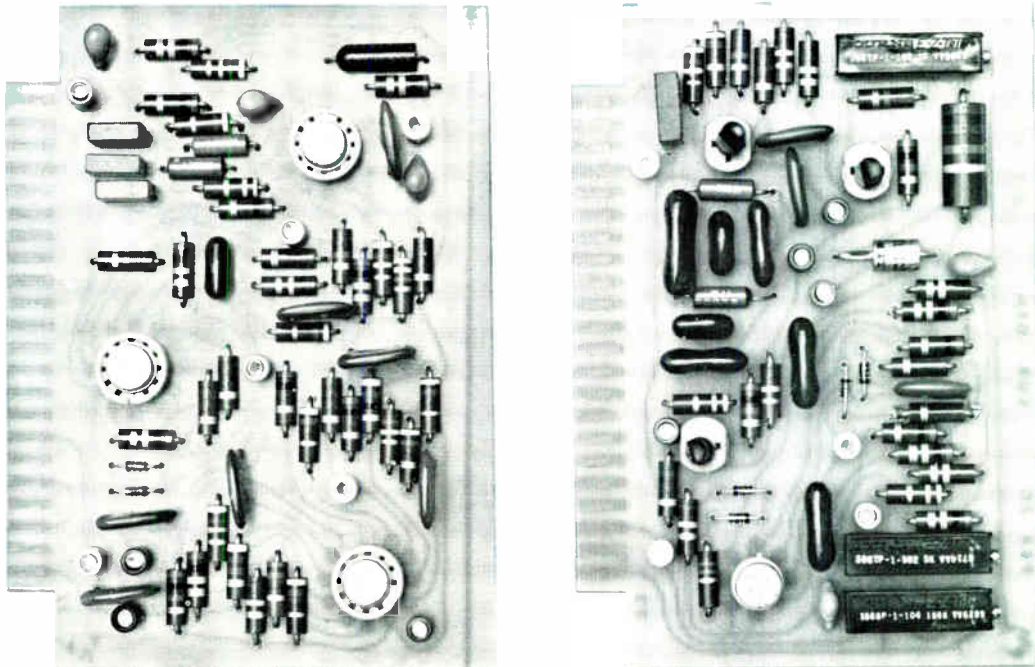

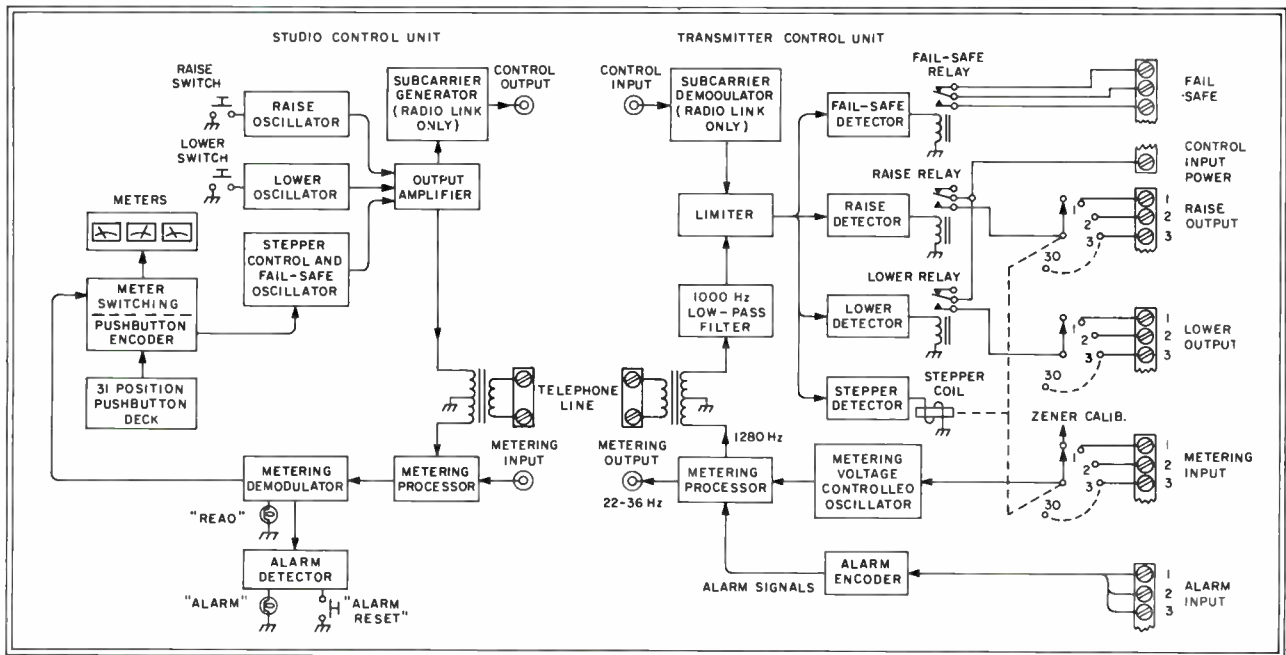

BTR-30A Block Diagram. The Subcarrier Generator and Demodulator units are required only when an air link between studio and transmitter replaces the land-line link.

## Specifications

Metering .....30 telemetry channels, plus calibration  
 Control Functions .....60; 30 ON/RAISE, 30 OFF/LOWER  
 Meters .....3, taut-band with carefully controlled ballistics. Provisions for 7 external meters  
 Metering Stability .....Better than 1% with weekly checks  
 Telemetry Input Requirements .....1V-10V DC, negative ground, for full-scale deflection. Input impedance 20,000 ohms

Telemetry Frequencies:  
 Audible .....1280 Hz  
 Subaudible .....22 Hz-36 Hz  
 Control Frequencies .....FAIL-SAFE—920 Hz; ON/RAISE—790 Hz; OFF/LOWER—670 Hz  
 Control Subcarrier Frequencies .....26 kHz or 135 kHz, nominal

Interconnection Requirements:  
 Wire .....Ordinary voice-grade two-way telephone line, 600 ohms, 20 dB allowable loss from 650 Hz-1350 Hz. (DC continuity not required)

Radio:  
 Control Circuit .....Control subcarrier generator and detector provided. Input and output 0.5V rms, 2,000 ohms nominal  
 Telemetry Circuit .....Telemetry return path capable of handling 22 Hz-36 Hz, sinusoidal  
 Transmitter Control Unit Output .....0 dBm, 500 ohms  
 Studio Unit Input .....0 dBm, 8,000 ohms nominal  
 Calibration Reference .....Zener diode  
 Semiconductor Devices .....All silicon diodes, integrated circuits and JEDEC registered transistors  
 Operating Temperature Range .....-10°F to +140°F (-12°C to 60°C)  
 Power Requirements .....120/240 V, 50/60 Hz, Studio Control Unit—15W, Transmitter Control Unit—25W

Dimensions:  
 Studio Unit .....10½" (267mm) H, 19" (483mm) W, 8½" (216mm) D  
 Transmitter Unit .....8¾" H, 19" W, 10½" D (222 x 483 x 267 mm)  
 Weight (shipping, approx.) .....60 lbs. (27 kg)  
 Shipping Volume (approx.) .....2.2 cu. ft. (0.67m<sup>3</sup>)

## Accessories

One-Meter Panel .....MI-561445-1  
 Two-Meter Panel .....MI-561445-2  
 Three-Meter Panel .....MI-561445-3  
 Meters (for above) .....MI-561444 Series  
 Relay Panel .....ES-561447  
 FM Monitor Amplifier, Type BW-100B .....MI-560738  
 AC Voltage Pickup (115/230 volt) .....MI-27516  
 Tower Lighting Monitor and Control .....MI-27519  
 Tower Lighting Monitor .....MI-27544  
 Weatherproof Enclosure (for MI-27544) .....MI-27543  
 Latching Relay Panel (includes two relays) .....MI-27509-A  
 Latching Relay, DPST 6A .....MI-27524-1  
 Latching Relay, DPST 30A .....MI-27524-2  
 Latching Relay, 4PST 0.5A .....MI-27524-3  
 RF Relay, 12.5A .....MI-27545-1  
 Momentary Relay, DPDT, 15-20A .....MI-27545-2  
 RF Contactor, SPDT, 25A (Latching) .....MI-27755-1  
 RF Contactor, DPDT, 25A .....MI-27755-2  
 Remote RF Pickup (to 50 kW) .....MI-28027-B  
 Remote RF Pickup (to 5 kW) .....MI-27966-B  
 Indoor Temperature Indicator, (-30 to 150°F) .....MI-27550-1  
 Outdoor Temperature Indicator, (-30 to 150°F) .....MI-27550-2

## Ordering Information

BTR-30A Remote Control System .....ES-561440

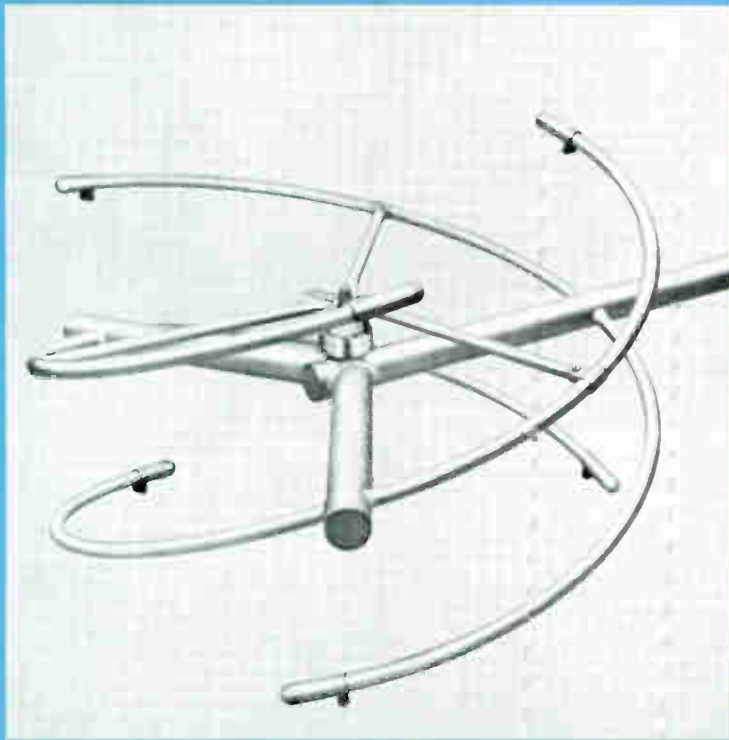

- Excellent bandwidth
- High power handling capability
- Adjustable input transformer included
- Efficient, factory replaceable deicers

## FM Tri-Pole Antenna, BFG Series

### Description

The RCA BFG Series of FM Antennas is designed for use in monaural, stereo and multiplex FM broadcast service. These antennas provide a low standing wave ratio over a 200 kHz channel providing optimum conditions for stereo or multiplex operation.

The BFG Antenna radiates a circularly or elliptically polarized wave intended to provide improved reception in FM automobile radios employing vertical whip antennas and in home receivers employing built-in or "line cord" antennas. The BFG Antenna can be used to advantage in any application which previously required the

use of separate vertically and horizontally polarized antennas. Use of the BFG Antenna provides the advantages of lower windload and weight plus reduced complexity and simplified installation requirements.

### Power Gain

The new antenna features time proven sectionalized construction and materials and can be supplied with as many sections as are required for a given application. The BFG Antenna has factory rotatable dipoles designed so that the ratio of vertical-to-horizontal polarization

may be adjusted to suit the user's requirements. Thus, if insufficient transmitter power is available to obtain the required horizontally and vertically polarized ERP, the horizontally polarized gain may be increased at the expense of the vertically polarized gain. In this manner, the horizontally polarized ERP may be maintained at the maximum allowable level while the vertically polarized ERP is reduced.

Due to the adjustment ease of the ratio of horizontal-to-vertical polarization, the BFG antenna is the basic element of RCA directional FM antennas.



## Rugged Construction

Mechanically, the antenna is designed for rugged service in all types of weather conditions, and will withstand wind velocities up to 110 miles per hour. Radiating elements are made of durable stainless steel that eliminates electrolysis and corrosion when bolted to the copper feed system. The design is flexible and permits ease of installation on the side of an existing tower, or pole mounting on top of towers or buildings. Mounting brackets are supplied with antennas for standard or conventional installations at no extra cost. Custom brackets can be supplied at extra cost for special or unusual types of installations. The antenna can be supplied with standard poles using either pedestal or socket mounts.

## De-icing Provisions

De-icing equipment is an accessory item which must be ordered with the antenna. The de-icing equipment is recommended for most areas and especially where icing and sleet conditions are common. The de-icing equipment is designed to provide long life and trouble free operation and is factory replaceable.

Each bay of a BFG Antenna with de-icers has a current transformer which is mounted either on the pole or on a leg of the tower. This transformer, fed with 208/240 volt single phase, delivers three volts at about 375 amperes. The output

of this transformer is fed via a heavy Teflon-insulated wire through each of the arms of the antenna and is grounded internally at the ends of the arms. The current passing back through the stainless steel arms heats the arms directly.

## Sectionalized Construction

The RCA Type BFG FM Antenna is of sectionalized construction; each section consisting essentially of three crossed semi-circular radiators attached to a Y-shaped supporting frame and a section of  $3\frac{1}{8}$ -inch transmission line. The antenna input is provided with a 50 ohm EIA flange for connection to other  $3\frac{1}{8}$ -inch transmission lines. Adaptors are available for other transmission line types and sizes. Standard antennas have power gains from approximately 0.5 to 16 depending on the number of sections and the ratio of vertically to horizontally polarized gain. An adjustable transformer section is located near the input fitting. A voltage standing wave ratio of 1.1:1 or better can be achieved with a minimum of field trimming.

## Radiation Pattern

The horizontally polarized azimuthal radiation pattern of the BFG antenna is essentially omnidirectional for top mounting. The extent of deviation from a circular pattern for a side mounted array is dependent on type and size of the tower. It is recommended that the array be

mounted, if possible, above the top set of guys on a guyed tower. Where this is not possible the guys in the immediate area of the antenna should be broken by insulators every  $3\frac{1}{2}$  feet for a distance of at least 14 feet. In addition, each guy in the vicinity of the antenna should be insulated at the point where it connects to the tower.

## Mechanical Features

Each section consisting of three interleaved semi-circular radiators is mounted on a short Y-shaped horizontal section of  $1\frac{5}{8}$ -inch transmission line fitted with an insulated central feed point and supported from the  $3\frac{1}{8}$ -inch feed system. Only one coaxial transmission line is used to feed all sections of the antenna, and the individual radiating sections are identical mechanically and electrically. The radiators are both shunt fed and mechanically supported by the interconnecting feed system which consists of modified lengths of RCA  $3\frac{1}{8}$ -inch rigid coaxial transmission line. The BFG-1A through BFG-7A Antennas terminate mechanically in a pressurized top cap with bleed valve and a bottom input flange for connection to the desired type of transmission line.

The type BFG-8A through BFG-16A Antennas are center fed through a matching tee and the lower and top radiators terminate mechanically in pressurized caps.

Mounting Dimensions and Feed Line Locations, BFG Series FM Antennas.

(See Table on opposite page)

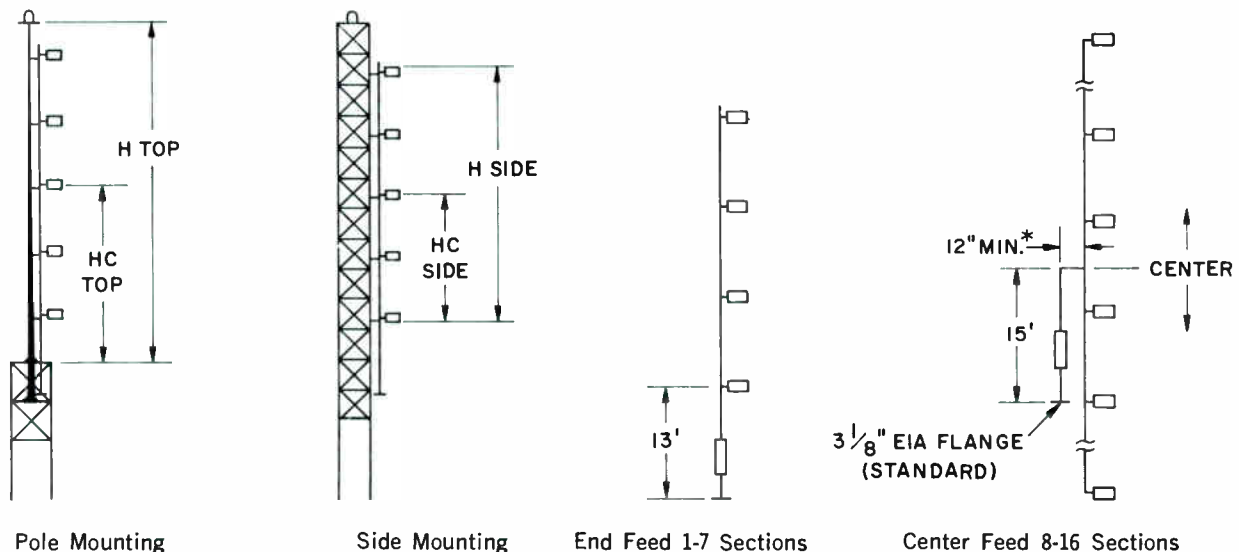

\* Can be made to dimension desired to bring input line to correct support position.

# Specifications

ELECTRICAL DATA						MECHANICAL DATA						
Total Gain (Horizontal plus Vertical) <sup>1</sup>				Power Rating <sup>2</sup>		Dimension in Feet					Windload at 50/33 PSF	
RCA Type	Power	dB	Field	kW	dBk	Freq. <sup>3</sup> MHz	Hc Top	Hc Side	H Top	H Side	Less De-icers	With De-icers
BFG-1A	0.9	-0.45	0.95	6.0	7.78	88	5.0	.80	8.0	1.7	178	198
						98	5.0	.80	8.0	1.7	178	198
						108	5.0	.80	8.0	1.7	178	198
BFG-2A	2.0	3.01	1.41	12.0	10.79	88	10.6	6.4	19.2	12.8	337	377
						98	10.0	5.8	19.2	11.7	327	367
						108	9.5	5.4	18.0	10.8	319	359
BFG-3A	3.0	4.77	1.73	18.0	12.55	88	16.2	11.9	30.4	23.9	495	555
						98	15.0	10.9	28.9	21.8	475	535
						108	14.1	9.9	27.5	19.9	459	519
BFG-4A	4.2	6.23	2.05	24.0	13.80	88	21.7	17.6	41.5	35.2	653	723
						98	20.0	15.9	38.4	31.8	623	703
						108	18.6	14.5	36.8	29.0	599	679
BFG-5A	5.4	7.32	2.32	30.0	14.77	88	27.3	23.2	52.7	46.4	810	911
						98	25.0	20.9	49.4	41.8	791	871
						108	23.2	19.0	46.1	38.1	763	839
BFG-6A	6.4	5.06	2.53	36.0	15.56	88	32.9	28.8	63.9	57.6	970	1090
						98	30.0	25.4	59.3	50.9	920	1040
						108	27.7	23.6	54.9	47.2	882	1000
BFG-7A	7.6	8.80	2.76	40.0	16.02	88	38.5	34.3	75.0	68.7	1128	1268
						98	35.1	30.9	68.7	61.9	1068	1208
						108	32.3	28.1	64.2	56.3	1020	1160
BFG-8A	8.6	9.34	2.93	40.0	16.02	88	44.0	40.0	86.2	80.0	1308	1468
						98	40.1	35.9	78.9	71.9	1238	1398
						108	36.8	32.7	73.2	69.4	1182	1342
BFG-10A	11.0	10.41	3.32	40.0	16.02	88	55.2	51.1	108.6	102.2	1625	1875
						98	50.1	46.0	98.6	92.0	1535	1735
						108	45.9	41.8	91.2	83.7	1483	1663
BFG-12A	13.2	11.20	3.63	40.0	16.02	88	66.4	62.3	131.0	124.7	1942	2182
						98	60.1	56.0	119.8	112.1	1832	2072
						108	55.0	51.0	109.6	101.9	1744	1984
BFG-14A	15.6	11.93	3.95	40.0	16.02	88	Note 4	73.5	Note 4	147.0	2258	2538
						98		66.1		132.2	2128	2408
						108		60.0		120.1	2088	2304
BFG-16A	17.8	12.50	4.22	40.0	16.02	88	Note 4	84.7	Note 4	169.4	2575	2895
						98		76.1		152.3	2425	2745
						108		69.1		138.3	2205	2625

<sup>1</sup> Horizontally polarized gain may be specified between 50 and 90% of total gain shown in table. Vertical gain is then  $G_{\text{vert}} = G_{\text{total}} - G_{\text{horiz}}$ . For each polarization the field gain is equal to the square root of the power gain. The effective field intensity at one mile for one kilowatt input is equal to 137.5 times the field gain.

<sup>2</sup> Based on a 40° C. ambient. Multiply values by 0.8 for 50° C. ambient. BFG-6A and larger antennas with higher power input ratings can be made available on application.

<sup>3</sup> Interpolate for in-between frequencies.

<sup>4</sup> Pole mounting not recommended for BFG-14A and BFG-16A antennas.

# Specifications

## Electrical

- Frequency Range ..... Factory tuned to any channel in the 88 to 108 MHz band
- Polarization ..... Elliptical to circular, clockwise
- Power Gain (over dipole)  
 Horizontal Polarization ..... See table, preceding page  
 Vertical Polarization ..... See table, preceding page
- Azimuthal Pattern  
 Horizontal Polarization: Circularity  $\pm 1.0$  dB in free space  
 Vertical Polarization: Circularity  $\pm 1.0$  dB in free space
- VSWR at input (without field trimming)  
 Top Mounting ..... 1.2:1 or better  
 Side Mounting ..... 1.5:1 or better
- VSWR at input (with field trimming)  
 Top or Side Mounting 1.1:1 or better can be achieved over entire 200 kHz channel
- Input Connection .....  $3\frac{1}{8}$ ", 50 ohm EIA flange
- Power Input Rating ..... See table

## Mechanical

- Windload ..... 50 psf for flat surfaces:  
 33 psf for cylindrical surfaces based on true extreme velocity of 110 mph. (see table of specific antenna windloads)
- Section Dimensions:  
 Height ..... 20" max. (508 mm)  
 Diameter ..... 25" (635 mm)
- Feed Point:  
 BFG-1A through BFG-7A ..... Approx. 13' below #1 radiator  
 BFG-8A through BFG-16A ..... Center fed  
 Feed point approx. 15' below center

Approximate Weight in Pounds:*		Less Deicers	With Deicers
Type			
BFG-1A	.....	76	136
BFG-2A	.....	137	257
BFG-3A	.....	198	378
BFG-4A	.....	259	499
BFG-5A	.....	320	620
BFG-6A	.....	381	741
BFG-7A	.....	442	862
BFG-8A	.....	513	993
BFG-10A	.....	635	1235
BFG-12A	.....	757	1477
BFG-14A	.....	879	1719
BFG-16A	.....	1001	1961

\*Weight includes BFG Elements, Feed System to Input & Mounting Brackets (13" to 18" extension).

## Ordering Information

Type BFG FM Antenna with standard support brackets for mounting on conventional towers (specify type or furnish tower drawings). Order by stock number as follows:

	Less Deicers	With Deicers
BFG-1A Single sec. FM antenna	ES-561951-A	ES-561951-B
BFG-2A Two sec. FM antenna	ES-561952-A	ES-561952-B
BFG-3A Three sec. FM antenna	ES-561953-A	ES-561953-B
BFG-4A Four sec. FM antenna	ES-561954-A	ES-561954-B
BFG-5A Five sec. FM antenna	ES-561955-A	ES-561955-B
BFG-6A Six sec. FM antenna	ES-561956-A	ES-561956-B
BFG-7A Seven sec. FM antenna	ES-561957-A	ES-561957-B
BFG-8A Eight sec. FM antenna	ES-561958-A	ES-561958-B
BFG-10A Ten sec. FM antenna	ES-561959-A	ES-561959-B
BFG-12A Twelve sec. FM antenna	ES-561960-A	ES-561960-B
BFG-14A Fourteen sec. FM antenna	ES-561961-A	ES-561961-B
BFG-16A Sixteen sec. FM antenna	ES-561962-A	ES-561962-B

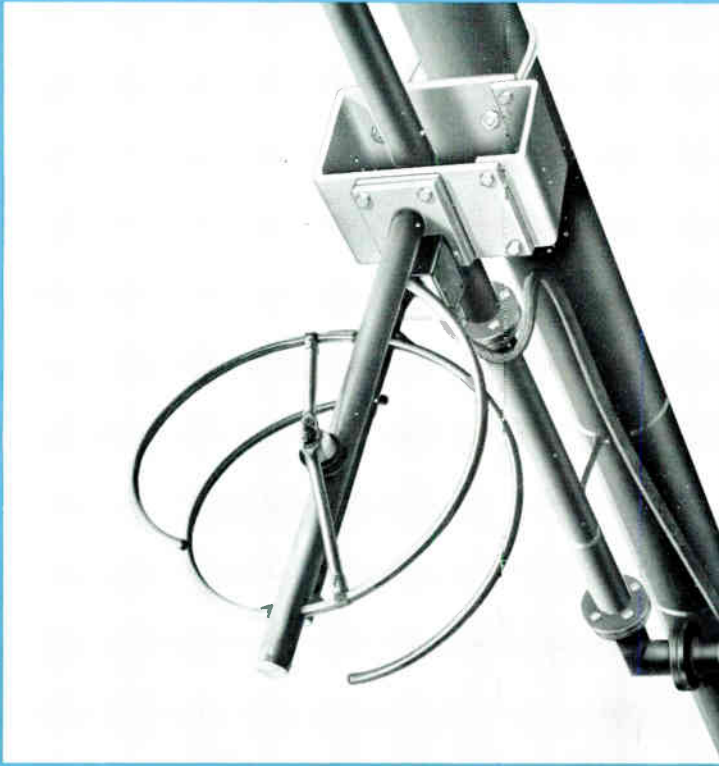

- Ideal for class A stations
- Efficient, factory replaceable deicers
- Low windload

## Circularly Polarized FM Antenna, BFH Series

### Description

The RCA BFH Series of Circularly Polarized FM Antennas is designed for Class A FM station use in monaural, stereo and multiplex broadcast service. These antennas provide a low standing wave ratio over a 200 kHz channel providing optimum conditions for stereo or multiplex operation.

The BFH Antenna radiates a circularly polarized wave intended to provide improved reception in FM automobile radios employing vertical whip antennas and in home receivers employing built-in or "line cord" antennas. The BFH Antenna

can be used to advantage in any application which previously required the use of separate vertically and horizontally polarized antennas of equal power gain and equal power input requirements. Use of the BFH Antenna provides the advantages of low windload and weight plus reduced complexity and simplified installation requirements.

#### Power Gain

The new antenna features time proven sectionalized construction and materials and can be supplied with up to 8 sections.

The BFH Antenna radiates a circularly polarized wave, thus the power gain in the horizontally polarized plane or in the vertically polarized plane is approximately equal to the number of sections divided by two (the number of equivalent planes of polarization). When using circular polarization in place of simple horizontal polarization, the transmitter power can be doubled without exceeding the licensed horizontal effective radiated power since the additional power radiated is in other planes of polarization; or conversely, for a given transmitter power, the antenna

gain can be doubled for the same reason. An external power splitter is not required. The antennas are designated BFH-1A, BFH-2A, BFH-3A, etc., depending on the number of stacked sections required.

### Rugged Construction

Mechanically, the antenna is designed for rugged service in all types of weather conditions, and will withstand wind velocities up to 110 miles per hour. Radiating elements are made of durable stainless steel that eliminates electrolysis and corrosion when bolted to the copper feed system. The design is flexible and permits ease of installation on the side of an existing tower, or pole mounting on top of towers or buildings. Mounting brackets are supplied with antennas for standard or conventional installations at no extra cost. Custom brackets can be supplied at extra cost for special or unusual types of installations. The antenna can be supplied with standard poles using either pedestal or socket mounts.

### De-icing Provisions

De-icing equipment is an accessory item which must be ordered with the antenna. The de-icing equipment is recommended for most areas and especially where icing and sleet conditions are common. The de-icing equipment is designed to provide long life and trouble free operation and is factory replaceable.

Each bay of a BFH Antenna with de-icers has a current transformer which is mounted either on the pole or on a leg of the tower. This transformer, fed with 208/240 volt single phase, delivers three volts at about 250 amperes. The output of this transformer is fed via a heavy teflon insulated wire which has high heat handling capability through each of the arms of the antenna and is grounded internally at the ends of the arms. The current passing back through the stainless steel arms heats the arms directly.

### Sectionalized Construction

The RCA Type BFH Circularly Polarized FM Antenna is of sectionalized construction; each section consisting essentially of two crossed semi-circular radiators attached to a supporting frame and a section of 1 5/8-inch transmission line. The antenna input is provided with a 50 ohm EIA flange for connection to other 1 5/8-inch transmission lines. Adaptors are available for other transmission line types and sizes. Antennas have power gains from approximately 0.5 to 4.0.

### Radiation Pattern

The horizontally polarized azimuthal radiation pattern of the BFH antenna is essentially omnidirectional for top mounting. The extent of deviation from a cir-

cular pattern for a side mounted array is dependent on type and size of the tower. It is recommended that the array be mounted, if possible, above the top set of guys on a guyed tower. Where this is not possible the guys in the immediate area of the antenna should be broken by insulators every 3 1/2 feet for a distance of at least 14 feet. In addition, each guy in the vicinity of the antenna should be insulated at the point where it connects to the tower.

### Mechanical Features

Each section consisting of two crossed semi-circular radiators is mounted on a short horizontal section of 1 5/8-inch transmission line fitted with an insulated central feed point and supported from the 1 5/8-inch feed system. Only one coaxial transmission line is used to feed all sections of the antenna, and the individual radiating sections are identical mechanically and electrically. The radiators are both shunt fed and mechanically supported by the interconnecting feed system which consists of modified lengths of RCA 1 5/8-inch rigid coaxial transmission line. The BFH-1A through BFH-8A Antennas terminate mechanically in a pressurized top cap with bleed valve and a bottom input flange for connection to the desired type of transmission line.

Mounting Dimensions and Feed Line Locations, BFH Series FM Antennas.  
(See Table on opposite page)

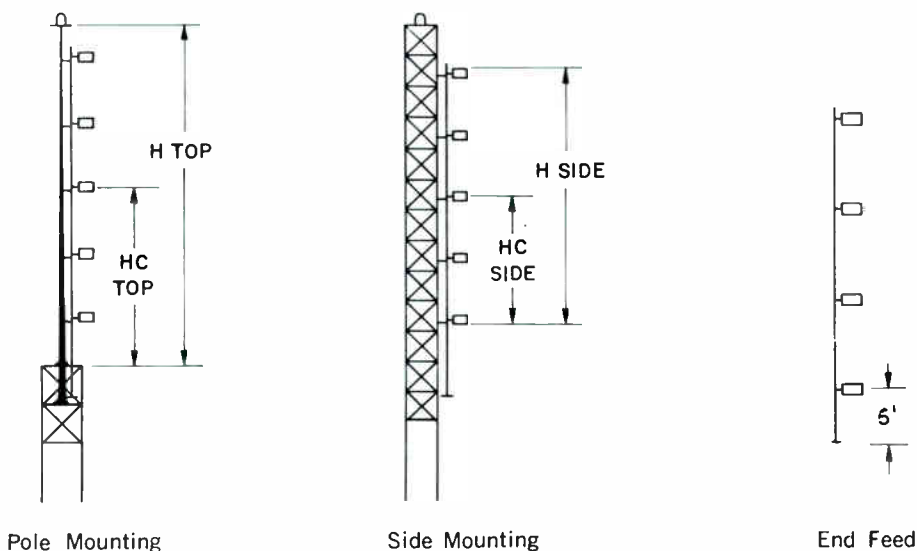

# Specifications

ELECTRICAL DATA										MECHANICAL DATA						
RCA Type	Gain						Power Rating			Freq. <sup>2</sup> MHz	Dimension in Feet				Windload at 50/33 PSF	
	Horizontal			Vertical			Field Intensity <sup>1</sup>	kW	dBk		Hc Top	Hc Side	H Top	H Side	Less De-icers	With De-icers
	Power	dB	Field	Power	dB	Field										
BFH-1A	0.46	-3.37	0.678	0.46	-3.37	0.678	93.2	2.0	3.01	88	5.0	0.8	8.0	1.7	178	198
										98	5.0	0.8	8.0	1.7	178	198
										108	5.0	0.8	8.0	1.7	178	198
BFH-2A	1.0	0	1.0	1.0	0	1.0	137.5	4.0	6.02	88	10.6	6.4	19.2	12.8	337	377
										98	10.0	5.8	19.2	11.7	327	367
										108	9.5	5.4	18.0	10.8	319	359
BFH-3A	1.5	1.76	1.23	1.5	1.76	1.23	168.4	6.0	7.78	88	16.2	11.9	30.4	23.9	495	555
										98	15.0	10.9	28.9	21.8	475	535
										108	14.1	9.9	27.5	19.9	459	519
BFH-4A	2.1	3.22	1.45	2.1	3.22	1.45	199.2	8.0	9.03	88	21.7	17.6	41.5	35.2	653	723
										98	20.0	15.9	38.4	31.8	623	703
										108	18.6	14.5	36.8	29.0	599	679
BFH-5A	2.7	4.31	1.64	2.7	4.31	1.64	225.2	8.0	9.03	88	27.3	23.2	52.7	46.4	810	911
										98	25.0	20.9	49.4	41.8	791	871
										108	23.2	19.0	46.1	37.1	763	839
BFH-6A	3.2	5.05	1.79	3.2	5.05	1.79	246.0	8.0	9.03	88	32.9	28.8	63.9	57.6	970	1090
										98	30.0	25.4	59.3	50.9	920	1040
										108	27.7	23.6	54.9	47.2	882	1000
BFH-7A	3.8	5.80	1.95	3.8	5.80	1.95	268.0	8.0	9.03	88	38.5	34.3	75.0	68.7	1128	1268
										98	35.1	30.9	68.7	61.9	1068	1208
										108	32.3	28.1	64.2	56.3	1020	1160
BFH-8A	4.3	6.34	2.07	4.3	6.34	2.07	285.2	8.0	9.03	88	44.0	40.0	86.2	80.0	1308	1468
										98	40.1	35.9	78.9	71.9	1238	1398
										108	36.8	32.7	73.2	65.4	1182	1342

<sup>1</sup> Effective free space field intensity at one mile in mV/m for one kilowatt antenna input power for either equivalent horizontally polarized component or equivalent vertically polarized component.

<sup>2</sup> Interpolate for in-between frequencies.

<sup>3</sup> To obtain corrected windload data, multiply these figures by 0.65 for antennas less de-icers and 0.7 for antennas with de-icers.

# Specifications

## Electrical

Frequency Range ..... Factory tuned to any channel  
in the 88 to 108 MHz band

Polarization ..... Circular, clockwise

Power Gain (over dipole)  
Horizontal Polarization: Approximately equal to half the  
number of sections stacked (see table)  
Vertical Polarization: Approximately equal to half the  
number of sections stacked (see table)

Azimuthal Pattern  
Horizontal Polarization: Circularity  $\pm 1.0$  dB in free space  
Vertical Polarization: Circularity  $\pm 1.0$  dB in free space

VSWR at input ..... Adjusted to 1.1:1 at factory\*

Input Connection ..... 1 5/8", 50 ohm EIA flange

Power Input Rating ..... See table

\*When mounted on tower, the VSWR may be higher than 1.1:1  
due to coupling effects.

## Mechanical

Windload ..... 50 psf for flat surfaces:  
33 psf for cylindrical surfaces based on true extreme  
velocity of 110 mph. (see table of specific antenna  
windloads)

### Section Dimensions:

Height ..... 20" (50.80 cm)  
Diameter ..... 20.7" (52.58 cm)

### Feed Point:

BFH-1A through BFH-8A ..... Approx. 6' below #1 radiator

### Approximate Weight in Pounds:†

Type	Less Deicers	With Deicers
BFH-1A	30	82
BFH-2A	51	154
BFH-3A	79	226
BFH-4A	104	300
BFH-5A	128	372
BFH-6A	153	446
BFH-7A	177	520
BFH-8A	205	595

†Weight includes BFH Elements, Feed System to Input &  
Mounting Brackets (13" to 18" extension).

# Ordering Information

*Type BFH Circularly Polarized  
FM Antenna with standard sup-  
port brackets for mounting on  
conventional towers (specify type  
or furnish tower drawings).  
Order by stock number as  
follows:*

	Less Deicers	With Deicers
BFH-1A Single sec. FM antenna	ES-561941-A	ES-561941-B
BFH-2A Two sec. FM antenna	ES-561942-A	ES-561942-B
BFH-3A Three sec. FM antenna	ES-561943-A	ES-561943-B
BFH-4A Four sec. FM antenna	ES-561944-A	ES-561944-B
BFH-5A Five sec. FM antenna	ES-561945-A	ES-561945-B
BFH-6A Six sec. FM antenna	ES-561946-A	ES-561946-B
BFH-7A Seven sec. FM antenna	ES-561947-A	ES-561947-B
BFH-8A Eight sec. FM antenna	ES-561948-A	ES-561948-B

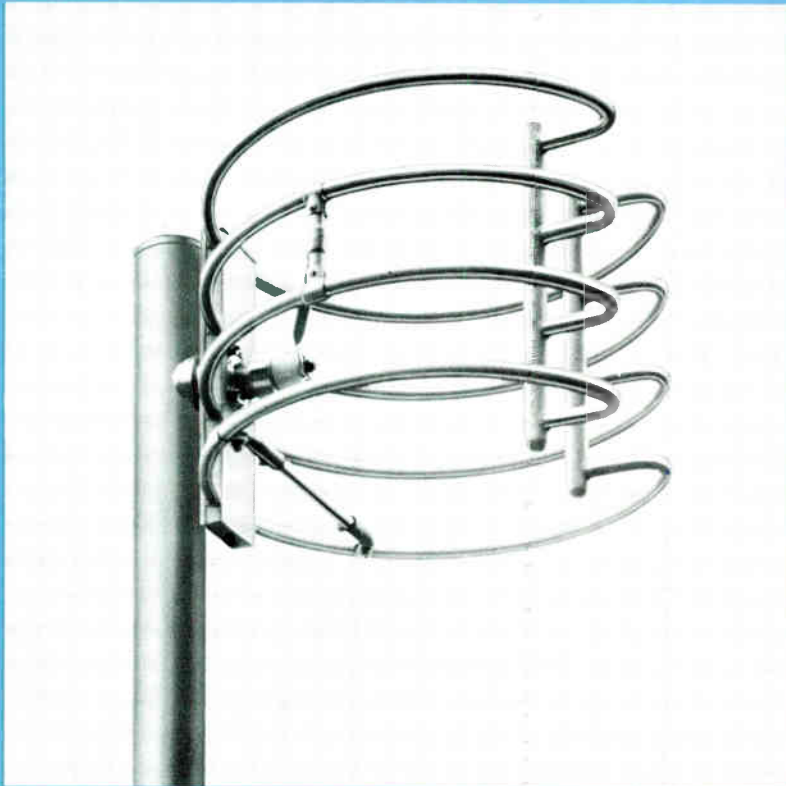

- Horizontal or circular polarization
- Excellent bandwidth
- Low windload
- Simple installation
- Low cost feed line

## Educational FM Antenna, BFI-Series

### Description

The BFI-Series of FM antennas is designed for educational FM broadcast stations operating with a transmitter power of ten watts. They are suitable for monophonic, stereophonic or multiplexed sub-channel operation and they provide a low standing wave ratio over a 200 kHz channel.

The BFI-Series antennas are available in horizontally or circularly polarized versions and in either one or two sections. The horizontally polarized units are designated Types BFI-1H and BFI-2H for the one- and two-section antennas with

gains of 0.9x and 1.9x respectively. The circularly polarized units are designated Types BFI-1C and BFI-2C and have gains of 0.45x and 1.0x respectively.

A Type "N" connector terminates the antennas so that they may be fed from a flexible, solid-dielectric, 50-ohm cable such as Type RG-213/U.

A simple mounting arrangement permits fastening the antenna to many different types of supports such as a tower leg, pipe or flagpole. The antennas are designed for rugged service and withstand

wind velocities up to 110 miles per hour. Windload has been reduced so that the cost of the support structure can be held to a minimum. Radiating elements are made of durable stainless steel which resists corrosion under all weather conditions.

Horizontally polarized azimuthal radiation patterns of the BFI-Series antennas are essentially omnidirectional for top mounting. The extent of deviation from a circular pattern for a side mounted antenna is dependent on the type and size of the tower.



# Specifications

Frequency Range ..... Factory tuned to any channel, 88-92 MHz  
 Polarization:

BFI-1C, BFI-2C ..... Circular, clockwise  
 BFI-1H, BFI-2H ..... Horizontal

Azimuthal Pattern .....  $\pm 1.0$  dB in free space

VSWR ..... Adjusted at factory to 1.1:1\*\*

Input Connection ..... Type "N" connector

Input Impedance ..... 50 ohms

Section Dimensions:	<b>BFI-1C, BFI-2C</b>	<b>BFI-1H, BFI-2H</b>
Height	20" (508 mm)	12" (305 mm)
Diameter	20.7" (526 mm)	18" (457 mm)
Weight per Section	18 lbs. (8 kg)	22 lbs. (10 kg)

Type No.	Gain						Field Intensity*	Wind-load at 50/33 psf
	Horiz. Polar.		Vert. Polar.					
	Pwr.	dB	Field	Pwr.	dB	Field		
BFI-1C	0.46	-3.37	0.68	0.46	-3.37	0.68	93.2	50
BFI-2C	1.00	0	1.00	1.00	0	1.00	137.5	109
BFI-1H	0.9	-0.45	0.95	—	—	—	130.0	46
BFI-2H	2.0	3.01	1.41	—	—	—	194.0	105

\*Effective free space field intensity at one mile in mV/m for one-kilowatt antenna input power for either equivalent horizontally polarized component or equivalent vertically polarized component.

\*\*When mounted on tower, the VSWR may be higher than 1.1:1 due to coupling effects.



Circularly Polarized Antenna, Type BFI-1C.

# Ordering Information

- Single Section, Circularly Polarized FM Antenna, BFI-1C ..... ES-561933
- Two Section, Circularly Polarized FM Antenna, BFI-2C ..... ES-561934
- Single Section Horizontally Polarized FM Antenna, BFI-1H ..... ES-561935
- Two Section Horizontally Polarized FM Antenna, BFI-2H ..... ES-561936



- Circularly polarized
- Directional or omnidirectional patterns
- High power capability
- Radomed elements

## Multi-Station FM Panel Antennas, Types BFD, BFE, BFF

### Description

FM Panel Antennas, Types BFD, BFE, and BFF are broadband, custom-tailored antenna systems that permit a number of high-powered FM stations to share a common antenna. They are circularly polarized for optimum coverage and perform excellently in either omnidirectional or directional applications. Bandwidths range from 6 to 20 MHz in the FM broadcast band, and power ratings extend up to 80 kilowatts (CW) per panel.

In omnidirectional use, three (or four) panels are mounted around a tower to make up an antenna layer, and as many layers as necessary are used to obtain the

desired power gain. Power gain is equal to approximately one-half the number of antenna layers. Directional radiation is the result of asymmetrical location of panels and power distribution to the panels.

Each panel consists of a pair of crossed dipoles with a reflecting screen. The two dipoles are fed in phase quadrature with separate transmission lines from a hybrid coupler. Each panel carries one-half the power of all the stations sharing the system.

A multi-station FM panel antenna system serving five stations is shown in the

block diagram. Four or fewer stations are accommodated by use of *T* combiners to feed the *A* and *B* ports of the hybrid coupler. Ports *C* and *D* each contain half the total power of each station in phase quadrature. More than four stations are combined with notch diplexers as illustrated. In this case, the broadband input port of the last notch diplexer may be used in an emergency to take the output of either station #1 or #2 should the *T* combiner fail.

Depending upon transmission line limitations, the power rating of a complete FM panel antenna is equal to the power

rating per panel times the number of panels. For example, assume a 12-layer antenna (gain = approximately 6) with three panels per layer and a rating of 80 kW per panel. The rating of this antenna is:

$$80 \times 12 \times 3 = 2880 \text{ kW}$$

Since the vector sum of the output voltages is greater for several transmitters as compared to those of a single transmitter of equivalent power, the antenna then becomes voltage rather than power limited. The equivalent power of a number of stations feeding the common is expressed as:

$$P = (\sqrt{P_1} + \sqrt{P_2} + \sqrt{P_3} \dots)^2$$

or, when all stations have equal power:

$$P = n^2 P$$

where  $n$  is the number of stations and  $P$  is the power per station.

The equivalent power of twelve 20-kW stations would be:

$$12^2 \times 20 = 2880 \text{ kW.}$$

Therefore, a 12-layer antenna can handle twelve 20-kW stations, and, with a gain of 6, provides an ERP of 100 kW per station.

Typical five-station shared-antenna scheme for FM-broadcast stations using Type BFD-, BFE- or BFF- Panel Antennas.

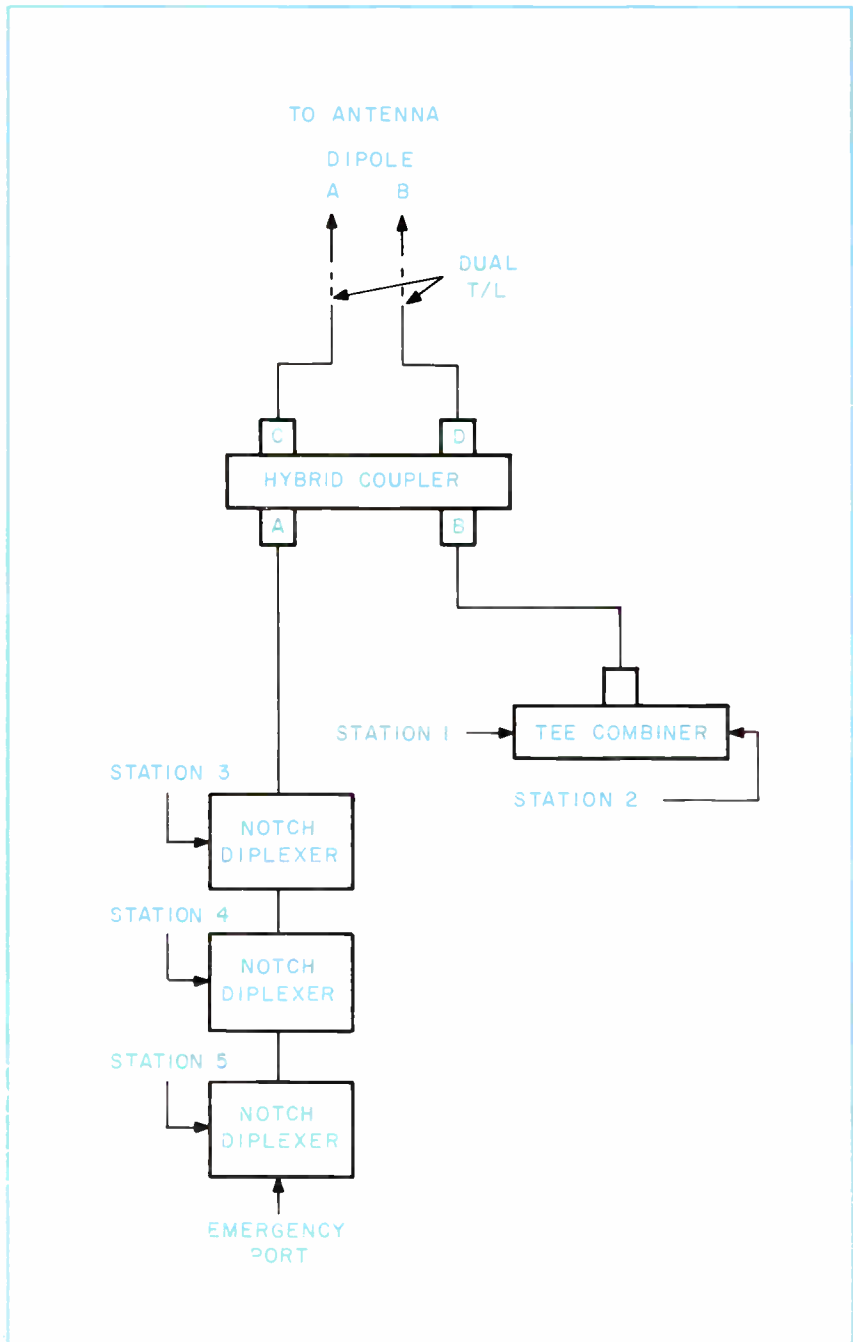

## Ordering Information

Types BFD, BFE and BFF FM Panel Antennas are sold only as part of a custom-built array because of the individuality of each multi-channel arrangement. Your RCA Regional Representative stands ready to help plan and execute a multi-station FM antenna.

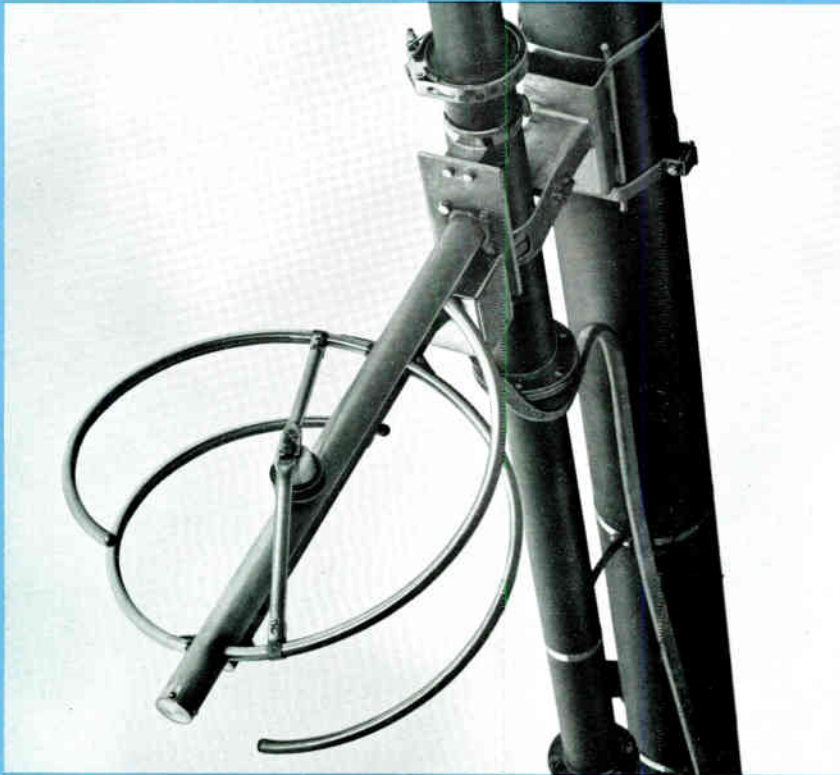

- Excellent bandwidth
- Low installation and maintenance costs
- Efficient, factory replaceable deicers
- Radome optional

## Circularly Polarized FM Antenna, BFC Series

### Description

The RCA BFC Series of Circularly Polarized FM Antennas is designed for use in monaural, stereo and multiplex FM broadcast service. These antennas provide a low standing wave ratio over a 200 kHz channel providing optimum conditions for stereo or multiplex operation.

The BFC Antenna radiates a circularly polarized wave intended to provide improved reception in FM automobile radios employing vertical whip antennas and in home receivers employing built-in or "line cord" antennas. The BFC Antenna can be used to advantage in any appli-

cation which previously required the use of separate vertically and horizontally polarized antennas of equal power gain and equal power input requirements. Use of the BFC Antenna provides the advantages of lower windload and weight plus reduced complexity and simplified installation requirements.

### Power Gain

The new antenna features time proven sectionalized construction and materials and can be supplied with as many sections as are required for a given applica-

tion. The BFC Antenna radiates a circularly polarized wave, thus the power gain in the horizontally polarized plane or in the vertically polarized plane is approximately equal to the number of sections divided by two (the number of equivalent planes of polarization). When using circular polarization in place of simple horizontal polarization, the transmitter power can be doubled without exceeding the licensed horizontal effective radiated power since the additional power radiated is in other planes of polarization; or conversely, for a given

transmitter power, the antenna gain can be doubled for the same reason. An external power splitter is not required. The antennas are designated BFC-1B, BFC-2B, BFC-3B, etc., depending on the number of stacked sections required.

### Rugged Construction

Mechanically, the antenna is designed for rugged service in all types of weather conditions, and will withstand wind velocities up to 110 miles per hour. Radiator assemblies are made of durable stainless steel that eliminates electrolysis and corrosion when bolted to the copper feed system. The design is flexible and permits ease of installation on the side of an existing tower, or pole mounting on top of towers or buildings. Mounting brackets are supplied with antennas for standard or conventional installations at no extra cost. Custom brackets can be supplied at extra cost for special or unusual types of installations. The antenna can be supplied with standard poles using either pedestal or socket mounts.

### De-icing Provisions

De-icing equipment is an accessory item which must be ordered with the antenna. The de-icing equipment is recommended for most areas and especially where icing and sleet conditions are common. Radomes are available for use in areas where severe conditions exist. The de-icing equipment is designed to provide long life and trouble free operation and is factory replaceable.

Each bay of a BFC Antenna with de-icers has a current transformer which is mounted either on the pole or on a leg of the tower. This transformer, fed with 208/240 volt single phase, delivers 3.0 volts at about 250 amperes. The output of this transformer is fed via a heavy *Teflon*-insulated wire which has high heat handling capability through each of the arms of the antenna and is grounded internally at the ends of the arms. The current passing back through the stainless steel arms heats the arms directly.

### Sectionalized Construction

The RCA Type BFC Circularly Polarized FM Antenna is of sectionalized construction; each section consists essentially of two crossed, single-turn helical radiators attached to a supporting frame and a section of 3/8-inch transmission line. The antenna input is provided with a 50 ohm EIA flange for connection to 3/8-inch transmission lines. Adaptors are available for other transmission line types and sizes. Standard antennas have power gains from approximately 0.5 to 8.0. Special designs are available on application. An adjustable transformer section is located near the input fitting. A voltage standing wave ratio of 1.1:1 or better can be achieved with simple field trimming.

### Radiation Pattern

The horizontally polarized azimuthal radiation pattern of the BFC antenna is essentially omnidirectional for top mounting. The extent of deviation from a cir-

cular pattern for a side mounted array is dependent on type and size of the tower. It is recommended that the array be mounted, if possible, above the top set of guys on a guyed tower. Where this is not possible the guys in the immediate area of the antenna should be broken by insulators every 3/2 feet for a distance of at least 14 feet. In addition, each guy in the vicinity of the antenna should be insulated at the point where it connects to the tower.

### Mechanical Features

Each section consisting of two crossed helical radiators is mounted on a short horizontal section of 1 5/8-inch transmission line fitted with an insulated central feed point and supported from the 3/8-inch feed system. Only one coaxial transmission line is used to feed all sections of the antenna, and the individual radiating sections are identical mechanically and electrically. The radiators are both shunt fed and mechanically supported by the interconnecting feed system which consists of modified lengths of RCA 3/8-inch rigid coaxial transmission line. The BFC-1B through BFC-7B Antennas terminate mechanically in a pressurized top cap with bleed valve and a bottom input flange for connection to the desired type of transmission line.

The type BFC-8B through BFC-16B Antennas are center fed through a matching tee and the lower and top radiators terminate mechanically in pressurized caps.

Mounting Dimensions and Feed Line Locations, BFC Series FM Antennas.

(See Table on opposite page)

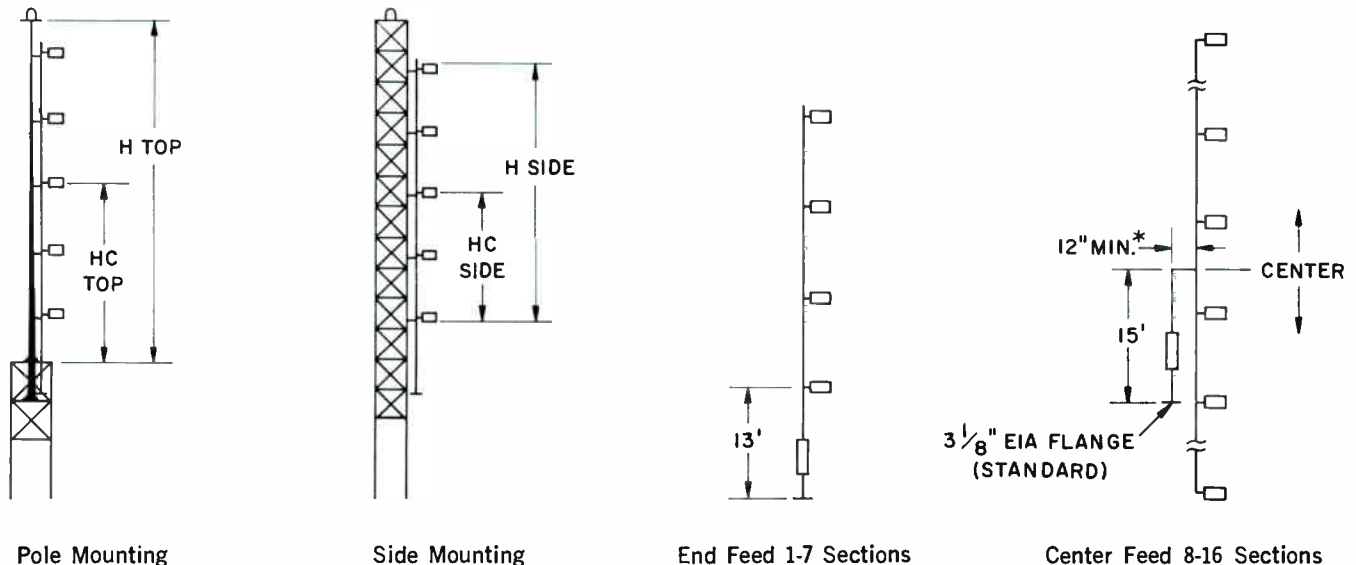

\*Can be made to dimension desired to bring input line in line with main vertical run.

# Specifications

ELECTRICAL DATA												MECHANICAL DATA							
RCA Type	Gain						Power Rating <sup>2</sup>					Dimension in Feet					Windload at 50/33 PSF		
	Horizontal			Vertical			Field Intensity <sup>1</sup>	With Radomes		Without Radomes		Freq. <sup>3</sup> MHz	Hc Top	Hc Side	H Top	H Side	Less De-Icers	With De-Icers	With Radomes
	Power	dB	Field	Power	dB	Field		kW	dBk	kW	dBk								
BFC-1B	0.46	-3.37	0.678	0.46	-3.37	0.678	93.2	10.0	10.0	4.0	6.02	88 98 108	5.0 5.0 5.0	0.8 0.8 0.8	8.0 8.0 8.0	1.7 1.7 1.7	178 178 178	198 198 198	332 332 332
BFC-2B	1.0	0	1.0	1.0	0	1.0	137.5	20.0	13.01	8.0	9.03	88 98 108	10.6 10.0 9.5	6.4 5.8 5.4	19.2 19.0 18.0	12.8 11.7 10.8	337 327 319	377 367 359	645 635 627
BFC-3B	1.5	1.76	1.23	1.5	1.76	1.23	168.4	30.0	14.77	12.0	10.79	88 98 108	16.2 15.0 14.1	11.9 10.9 9.9	30.4 28.9 27.5	23.9 21.8 19.9	495 475 459	555 535 519	957 937 921
BFC-4B	2.1	3.22	1.45	2.1	3.22	1.45	199.2	40.0	16.02	16.0	12.04	88 98 108	21.7 20.0 18.6	17.6 15.9 14.5	41.5 38.4 36.8	35.2 31.8 29.0	653 623 599	723 703 679	1269 1239 1215
BFC-5B	2.7	4.31	1.64	2.7	4.31	1.64	225.2	40.0	16.02	20.0	13.01	88 98 108	27.3 25.0 23.2	23.2 20.9 19.0	52.7 49.4 46.1	46.4 41.8 38.1	810 791 763	911 871 839	1581 1541 1510
BFC-6B	3.2	5.05	1.79	3.2	5.05	1.79	246.0	40.0	16.02	24.0	13.80	88 98 108	32.9 30.0 27.7	28.8 25.4 23.6	63.9 59.3 54.9	57.6 50.9 47.2	970 920 882	1090 1040 1000	1874 1824 1784
BFC-7B	3.8	5.80	1.95	3.8	5.80	1.95	268.0	40.0	16.02	28.0	14.47	88 98 108	38.5 35.1 32.3	34.3 30.9 28.1	75.0 68.7 64.2	68.7 61.9 56.3	1128 1068 1020	1268 1208 1160	2183 2123 2075
BFC-8B	4.3	6.34	2.07	4.3	6.34	2.07	285.2	40.0	16.02	32.0	15.05	88 98 108	44.0 40.1 36.8	40.0 35.9 32.7	86.2 78.9 73.2	80.0 71.9 65.4	1308 1238 1182	1468 1398 1342	2514 2454 2390
BFC-10B	5.5	7.40	2.35	5.5	7.40	2.35	322.4	40.0	16.02	40.0	16.02	88 98 108	55.2 50.1 45.9	51.1 46.0 41.8	108.6 98.6 91.2	102.2 92.0 83.7	1625 1535 1483	1875 1735 1663	3165 3075 3003
BFC-12B	6.6	8.20	2.57	6.6	8.20	2.57	353.2	40.0	16.02	40.0	16.02	88 98 108	66.4 60.1 55.0	62.3 56.0 51.0	131.0 119.8 109.6	124.7 112.1 101.9	1942 1832 1744	2182 2072 1984	3790 3680 3592
BFC-14B	7.8	8.92	2.79	7.8	8.92	2.79	383.9	40.0	16.02	40.0	16.02	88 98 108	See Note 4	73.5 66.1 60.0	See Note 4	147.0 132.2 120.1	2258 2128 2088	2538 2408 2304	4414 4284 4244
BFC-16B	8.9	9.49	2.98	8.9	9.49	2.98	410.2	40.0	16.02	40.0	16.02	88 98 108	See Note 4	84.7 76.1 69.1	See Note 4	169.4 152.3 138.3	2575 2425 2205	2895 2745 2625	5039 4889 4669

<sup>1</sup> Effective free space field intensity at one mile in mV/m for one kilowatt antenna input power for either equivalent horizontally polarized component or equivalent vertically polarized component.  
<sup>2</sup> Based on a 40° C. ambient. Multiply values by 0.8 for 50° C. ambient. BFC-5 and larger antennas with higher power input ratings can be made available on application.

<sup>3</sup> Interpolate for in-between frequencies.

<sup>4</sup> Pole mounting not recommended for these antennas.

# Specifications

## Electrical:

Frequency range .....Factory tuned to any channel  
in the 88 to 108 MHz band

Polarization .....Circular, clockwise

Power Gain (over dipole)  
Horizontal Polarization: Approximately equal to half the  
number of sections stacked (see table, preceding page)  
Vertical Polarization: Approximately equal to half the  
number of sections stacked (see table, preceding page)

Azimuthal Pattern  
Horizontal Polarization: Circularity  $\pm 1.0$  dB in free space  
Vertical Polarization: Circularity  $\pm 1.0$  dB in free space

VSWR at input (without field trimming)  
Top Mounting .....1.2:1 or better  
Side Mounting .....1.5:1 or better

VSWR at input (with field trimming)  
Top or Side Mounting 1.1:1 or better can be achieved  
over entire 200 kHz channel

Input Connection .....3/8", 50 ohm EIA flange

Power Input Rating .....See table

## Mechanical:

Windload .....50 psf for flat surfaces:  
33 psf for cylindrical surfaces (based on true extreme  
velocity of 110 mph. (see table of specific antenna  
windloads)

### Section Dimensions:

Height .....20" (508 mm)  
Diameter .....20.7" (526 mm)

### Feed Point:

BFC-1B through BFC-7B .....Approx. 13' below #1 radiator  
BFC-8B through BFC-16B .....Center fed  
Feed point approx. 15' below center

### Approximate Weight in Pounds:\* (2.2 lbs. per kilogram)

Type	Less Deicers	With Deicers	With Radome
BFC-1B	76	136	118
BFC-2B	137	257	221
BFC-3B	198	378	334
BFC-4B	259	499	427
BFC-5B	320	620	530
BFC-6B	381	741	633
BFC-7B	442	862	736
BFC-8B	513	993	849
BFC-10B	635	1235	1055
BFC-12B	757	1477	1261
BFC-14B	879	1719	1467
BFC-16B	1001	1961	1673

\* Weight includes BFC Elements, Feed System to Input & Mounting Brackets (13" to 18" extension).

## Ordering Information

Type BFC Circularly Polarized FM Antenna with standard support brackets for mounting on conventional towers (specify type or furnish tower drawings). Order by stock number as follows:

	Less Deicers	With Deicers	With Radomes
BFC-1B Single sec. FM antenna	ES-561921-A	ES-561921-B	ES-561921-C
BFC-2B Two sec. FM antenna	ES-561922-A	ES-561922-B	ES-561922-C
BFC-3B Three sec. FM antenna	ES-561923-A	ES-561923-B	ES-561923-C
BFC-4B Four sec. FM antenna	ES-561924-A	ES-561924-B	ES-561924-C
BFC-5B Five sec. FM antenna	ES-561925-A	ES-561925-B	ES-561925-C
BFC-6B Six sec. FM antenna	ES-561926-A	ES-561926-B	ES-561926-C
BFC-7B Seven sec. FM antenna	ES-561927-A	ES-561927-B	ES-561927-C
BFC-8B Eight sec. FM antenna	ES-561928-A	ES-561928-B	ES-561928-C
BFC-10B Ten sec. FM antenna	ES-561929-A	ES-561929-B	ES-561929-C
BFC-12B Twelve sec. FM antenna	ES-561930-A	ES-561930-B	ES-561930-C
BFC-14B Fourteen sec. FM antenna	ES-561931-A	ES-561931-B	ES-561931-C
BFC-16B Sixteen sec. FM antenna	ES-561932-A	ES-561932-B	ES-561932-C



- Conducts FM power across AM tower base insulator with minimum effect on AM tower operating impedance
- Standard EIA connections—easy to install
- Rugged design includes weather and lightning protection
- Inserts directly in pressurized FM coaxial transmission line

## RCA AM-FM Antenna Isolation Units, Type BAF-15A/16A

### Description

The RCA Type BAF-15A and BAF-16A FM-AM Isolation Units are designed to transfer FM power across the base insulator of an AM antenna tower to feed an FM antenna mounted atop the tower. The units provide isolation of FM and AM signals and efficient operation over the entire FM frequency range.

The BAF-15A Isolation unit is a rugged

pressurized copper section designed to mount directly in 1½-inch FM transmission line between transmitter and antenna by means of standard EIA\* fittings. It serves as a 10-kW isolation unit and second harmonic filter providing high harmonic attenuation. The BAF-16A Isolation unit provides the same functions and is designed to fit in 3/8" EIA co-

axial lines fed by transmitters with up to 40 kW FM power. Both units can be mounted to the tower leg by means of standard hangers. They are pressurized from the regular FM coaxial line and permit gas to pass through to thus pressurize the vertical run of line feeding the antenna. Protection against weather and lightning are design features.



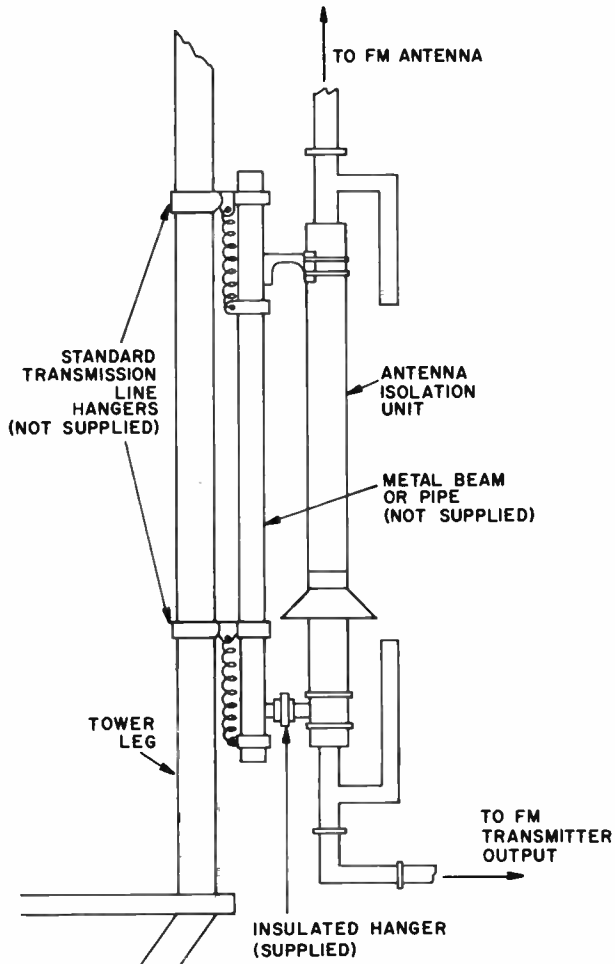

## Specifications

### TYPE BAF-15A

Frequency Range	88-108 MHz
Nominal Impedance	50 ohms
Maximum VSWR with 50 ohm Load	1.08
Maximum Operating Power FM	10 kW
Maximum Tower Base Voltage AM	10 kV peak
Insertion Loss	Less than 0.1 dB
Internal Capacitance to AM	130 pF
Maximum Gas Pressure for Pressurizing	30 psig
Weight	Approximately 55 lbs. (25 kg)
Dimensions	Diameter 3 1/8 inches (80mm) Length 130 inches (3300mm)
Connectors	Coaxial line (1 5/8-inch) EIA* (41mm)
2nd Harmonic Rejection	70 dB
4th Harmonic Rejection	50 dB
6th Harmonic Rejection	30 dB

### TYPE BAF-16A

Frequency Range	88-108 MHz
Nominal Impedance	50 ohms
Maximum VSWR with 50 ohm Load	1.08
Maximum Operating Power FM	40 kW
Maximum Tower Base Voltage AM	14 kV
Insertion Loss	Less than 0.1 dB
Internal Capacitance to AM	130 pF
Maximum Gas Pressure for Pressurizing	12 psig
Weight	Approximately 100 lbs (45 kg)
Dimensions	Diameter 6 1/8 inches (156mm) Length 161 inches (4189mm)
Connectors	Coaxial line (3 1/8-inch) EIA (80mm)
2nd Harmonic Rejection	80 dB
4th Harmonic Rejection	60 dB
6th Harmonic Rejection	40 dB

\*Use adapter (MI-19112-62) to connect with RCA 1 5/8" line.

## Ordering Information

### Type BAF-15A (10 kW) Isolation Unit

For assigned channels between:

88-93 MHz	MI-561573-1
93-98 MHz	MI-561573-2
98-103 MHz	MI-561573-3
103-108 MHz	MI-561573-4

### Type BAF-16A (40 kW) Isolation Unit

For assigned channels between:

88-93 MHz	MI-561574-1
93-98 MHz	MI-561574-2
98-103 MHz	MI-561574-3
103-108 MHz	MI-561574-4

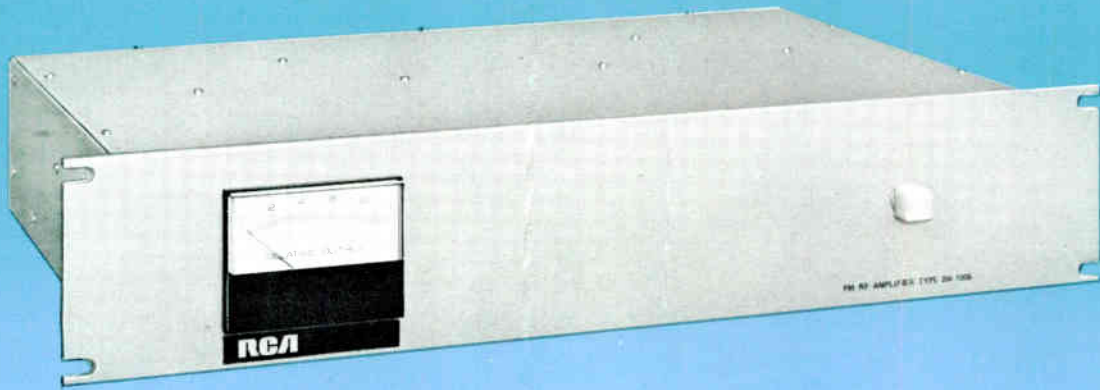

- Fully solid-state circuitry
- Wide dynamic range
- Symmetrical (zero-axis) limiting
- Outstanding selectivity
- Linear phase bandwidth
- 100  $\mu$ V sensitivity

## Monitor RF Amplifier, Type BW-100B

### Description

The BW-100B Monitor RF Amplifier, an adjunct to the RCA BW-75A Frequency and Modulation Monitor is designed to allow use of the BW-75A at a point, usually the studio, remote from the transmitter site. The BW-100B amplifies an off-air signal (100  $\mu$ V or greater) to a 1-watt level without modification of the air-signal's characteristics other than amplitude.

#### Fully Solid-State Circuitry

Only solid-state circuitry offers the stability and dependability required of a device such as the BW-100B. However, the design is enhanced through the use of integrated circuits to reject interfering signals and provide large dynamic range.

#### Outstanding Selectivity

The combination of a high level of

selectivity and zero-axis limiters in the amplifier results in the rejection of unwanted signals (those of other stations in the area), thereby increasing the usefulness and accuracy of the monitored parameters. The BW-100B Amplifier's outstanding selectivity (see *Specifications*) is the result of a linear, balanced mixer system that down-converts the off-air signal to an intermediate frequency (10.7 MHz) amplifier, where it is amplified, filtered and then up-converted back to its precise, *original* frequency for coupling to the indicating monitor. This complete independence of frequency comes about because the *same* oscillator—operating at 10.7 MHz above air frequency—feeds both mixers simultaneously (see block diagram). Thus, the "input" signal is identical to the "output" signal in every respect except in amplitude and

is stripped of interfering signals. All I-F amplifier tuned circuits are specially designed and fabricated for maximum phase linearity and selectivity. The linear, balanced mixers are free of spurious responses.

#### Wide Dynamic Range

At the threshold of limiting, the BW-100B requires only 100  $\mu$ V to deliver a 1-watt signal to the monitor input. As the result of a highly linear pre-selector and a zero-axis limiter, the BW-100B handles input signals as large as 0.50 *volt* without overload. This represents a dynamic range of 70 dB. Symmetrical, "zero-axis" limiters maintain constant output level adjustable over an input variation of 70 dB. The output level is adjustable from zero to 1.0 watt across 50 ohms.

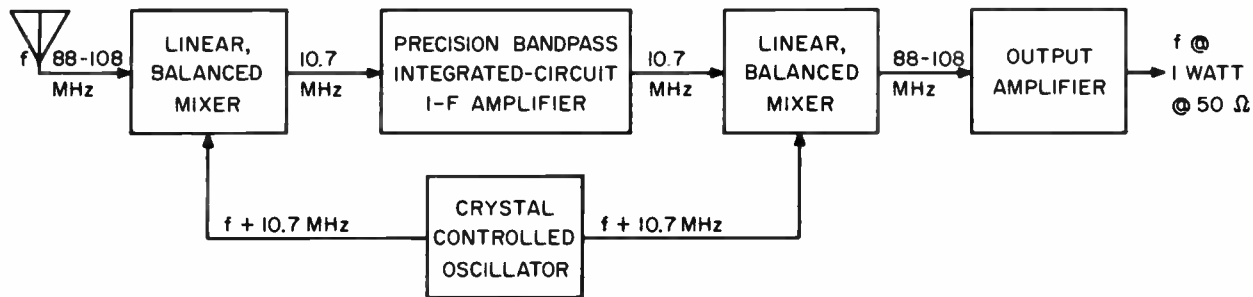

BW-100B Monitor RF Amplifier Block Diagram.

## Specifications

Input Frequency Range .....88 to 108 MHz  
 Minimum Input Level (for threshold of limiting) .....100  $\mu$ V  
 Maximum Input Level .....0.5 V  
 Input Impedances .....50 to 75 ohms  
 Output Impedance .....50 ohms  
 Output Level .....Adjustable to 1 watt  
 Bandwidth (3 dB points) ..... $\pm$ 225 kHz

Phase Linear Bandwidth ..... $\pm$ 300 kHz  
 Image Rejection .....Greater than 80 dB  
 Response at  $\pm$ 800 kHz .....50 dB below that of center frequency  
 Response at  $\pm$ 400 kHz .....25 dB below that of center frequency  
 Power Requirements .....117 V  $\pm$ 10%, 50/60 Hz, 5 W.  
 Dimensions .....3½" (89mm) H, 19" (483mm) W, 10½" (267mm) D

## Ordering Information

BW-100B Monitor RF Amplifier  
 (Specify operating frequency) .....MI-560738

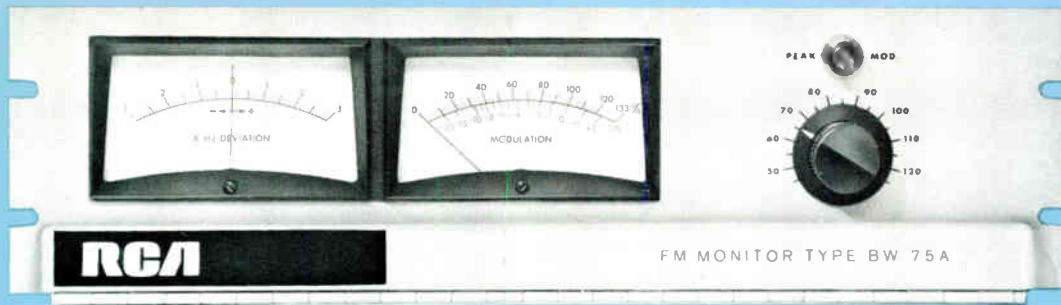

- Latest solid state design
- Front panel modulation calibrator
- Type approved for remote metering
- Total modulation meter responds accurately to peak amplitudes
- Provides pure signal for companion Stereo and SCA monitors

## RCA FM Frequency & Mod. Monitor, Type BW-75A

### Description

The Type BW-75A FM Frequency and Modulation Monitor is a wide-band, all solid state instrument designed to meet all the latest requirements for monaural monitoring. In addition, it provides a virtually pure, distortionless demodulated signal to drive the companion BW-85A Stereo Monitor and the Type BW-95A SCA Monitor for multiplex monitoring. It is type approved for remote metering.

All frequency and modulation measurements are combined in the compact BW-75A that weighs only 14 pounds and is designed for mounting in standard mounting racks or cabinets. It is designed to accurately monitor FM transmitters over long periods of time and operate without adjustment week after week.

The BW-75A features a total modulation meter that responds accurately to the peak amplitude of the complex waveforms encountered in today's programming. The peak flasher is completely independent of modulation polarity in that it samples both positive and negative peaks simultaneously and automatically selects and registers the greater amplitude if the present level is exceeded. Calibration accuracy can be easily checked at any time by means of a front panel modulation calibrator.

### Specifications

RF Input Sensitivity .....	0.2 to 10 Volts RMS
RF Input Impedance .....	50 Ohms
RF Frequency Range .....	88-108 MHz
Deviation Meter Range .....	$\pm 3$ kHz
Modulation Meter Range .....	133% (100% at 75 kHz)
Modulation Meter Accuracy .....	Better than 5% over entire scale
Peak Modulation Indicator .....	50 to 120%
Frequency Response .....	$\pm 0.1$ dB, 50-75,000 Hz, 3 dB down at 180 kHz
Distortion .....	0.1% max. 50-75,000 Hz
Stereo Separation .....	50 dB (at composite output jack)
Signal-to-Noise Ratio .....	75 dB with 75 $\mu$ sec de-emphasis
Outputs .....	4 wide band isolated outputs to drive the BW-85A and one or more Type BW-95A distortion meter output, and monitoring output
Remote Metering .....	Both carrier deviation and modulation meters may be remotely metered, 5,000 Ohms external loop resistance
Size .....	5 $\frac{1}{4}$ " high, 19" wide, 10 $\frac{1}{2}$ " deep
Weight .....	14 lbs.
Finish .....	Silver Panel

### Ordering Information

Type BW-75A FM Frequency and Modulation Monitor .....	MI-560735
Type BW-85A Stereo Frequency and Modulation Monitor (Optional Unit) .....	MI-560740
Type BW-95A SCA Frequency and Modulation Monitor (Optional Unit) .....	MI-560745



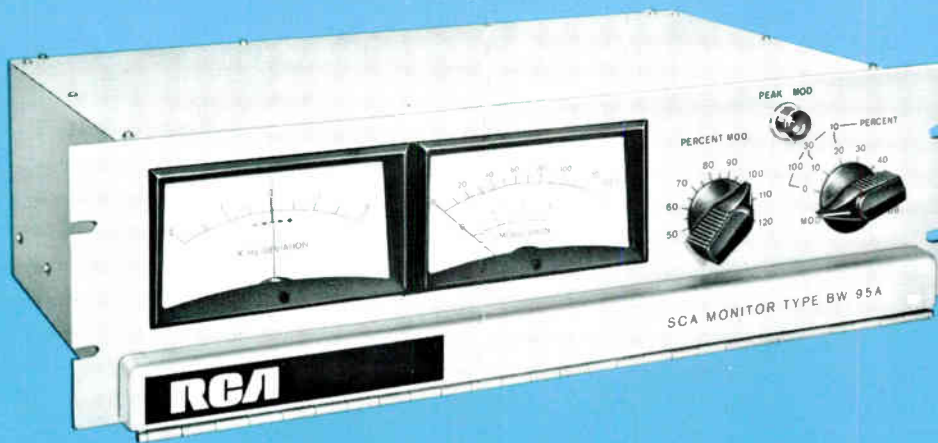

- Complete SCA monitoring to four channels
- SCA modulation calibrator
- Three deviation ranges (6, 4 and 2 kHz)
- Remote metering facilities
- Wideband discriminator—minimum distortion and crosstalk
- Rack or cabinet mounting
- Separate peak flasher for SCA modulation independent of polarity
- AM and incidental AM-noise test functions

## RCA SCA Frequency and Modulation Monitor, Type BW-95A

### Description

The Type BW-95A SCA Frequency and Modulation Monitor, used in conjunction with the BW-75A FM Frequency and Modulation Monitor, allows complete monitoring and test functions for subcarrier programming or remote telemetry applications. Four crystal-switch positions enable up to four channels to be operated and tested.

Totally integrated, the solid-state electronics of the BW-95A allow unlimited SCA frequency selection through a series of interchangeable crystals. With the appropriate crystals, it is possible to moni-

tor four subcarrier channels through push-button selection. A frequency change is simply a matter of a crystal change.

The BW-95A is a companion equipment to the RCA BW-75A and BW-85A monitors (see *Accessories*) and incorporates all the latest electronic-design techniques. Lightweight and occupying but 5¼ inches of rack space, it derives its signal, a virtually pure, distortionless demodulated signal from the BW-75A Monitor.

Features of the new BW-95A include three deviation ranges: Six, four and two

kHz for optimum operation. The six-kHz range is designed for normal mono operation. The four-kHz range is functional during simultaneous stereo and SCA, while the two-kHz range serves telemetry applications. The 30-kHz discriminator bandwidth assures minimum distortion and crosstalk. A separate SCA modulation-peak flasher operates independently of modulation polarity. A front-panel modulation calibrator, push-button actuated, allows quick check of calibration accuracy at any time.

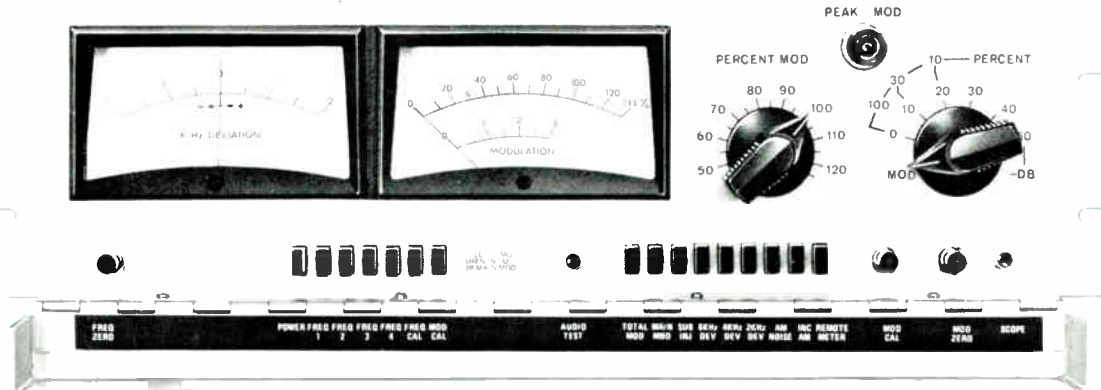

Note the several pushbutton controls to increase monitor flexibility. Ordinarily these controls are hidden behind the flip-down cover.

## Specifications

Frequency Range .....	Any four SCA frequencies (switchable) up to 74 kHz
Deviation Meter Range .....	$\pm 2$ kHz
Modulation Meter Range .....	133% (100% at $\pm 6$ kHz, $\pm 4$ kHz, or $\pm 2$ kHz, switched)
Modulation Meter Accuracy .....	Within 5% over entire scale
Maximum Modulation Frequency .....	5 kHz at 6 kHz deviation
SCA Modulation Calibrator .....	2 kHz
SCA Subcarrier .....	24 kHz to 74 kHz, four switched crystal positions. SCA subcarrier and deviation maintained in the FCC allowable total frequency deviation
SCA Injection Level .....	133% to 5%
Peak Modulation Indicator .....	Follows deviation scale 50 to 120%
Frequency Response .....	$\pm 1$ dB, 50-5,000 Hz

Crosstalk Rejection .....	65 dB or greater
Crosstalk Meter Range .....	70 dB (10 dB steps)
Outputs .....	Distortion meter, aural monitor and oscilloscope
Remote Metering Facility .....	Both meters, separate circuits, 5000 Ohms external loop resistance
Size .....	5¼" (133 mm) H, 19" (583 mm) W, 10½" (267 mm) D
Weight .....	14 lbs. (5.5 kg)
Finish .....	Silver Enamel

### Accessories

Type BW-75A FM Frequency and Modulation Monitor (Required Unit) .....	MI-560735
Type BW-85A Stereo Frequency and Modulation Monitor (Optional Unit) .....	MI-560740
Remote Control Panel (for BW-95A) .....	MI-560746

## Ordering Information

Type BW-95A SCA Frequency and Modulation Monitor (Specify SCA subcarrier frequencies) .....MI-560745

TRANSMISSION  
LINE





## Coaxial Transmission Line Switches

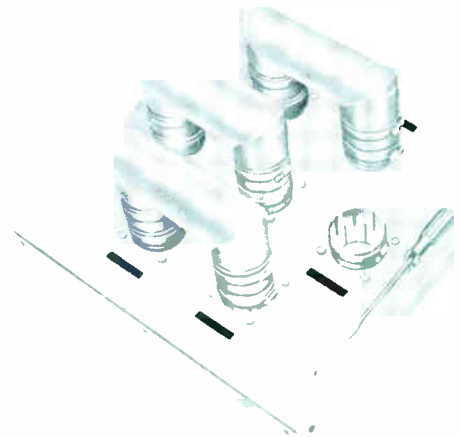
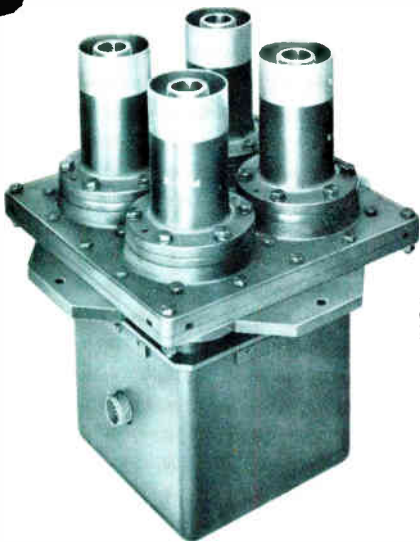

- Low VSWR
- Maximum isolation
- High reliability
- Wide frequency range
- Manual and motor-driven types

# Coaxial Transmission Line Switches

Coaxial transmission line switches provide convenient, rapid and reliable switching of r-f power circuits. Standby transmitter changeover, emergency antenna selection, dummy load connections, temporary by-passing of components, and many other functions are readily accomplished.

Switches for either manual or powered switching accommodate different sizes and types of rigid lines, and single- or multiple-line power transfer. They maintain high reliability, maximum isolation and low VSWR in all VHF and UHF circuits in which they are used.

## VHF/UHF Motor Driven Coaxial Switches

The motor driven 3/8-inch coaxial switch, MI-561562, is a simple but extremely versatile component that provides reliable and fast switching of r-f energy between coaxial lines with control from a remote point.

Completely compatible with standard coaxial line components, the switch may be used as a four-port transfer switch or a three-port single-pole, double-throw switch. This versatility lets the switch serve a variety of switching situations.

Reliability is an outstanding feature of this switch. The mechanical drive is simple and the number of moving r-f conductors is at a minimum so that operations in excess of 100,000 cycles are possible without failure.

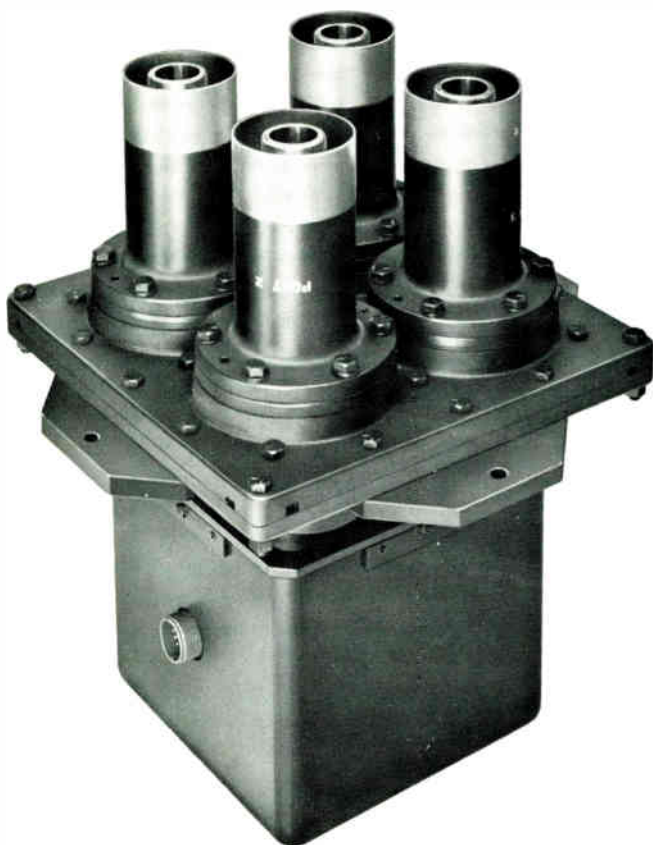

- Mounts in any position
- Includes auxiliary contacts for tally lights and transmitter-interlock circuitry
- DPDT or SPDT switching
- Emergency manual operation

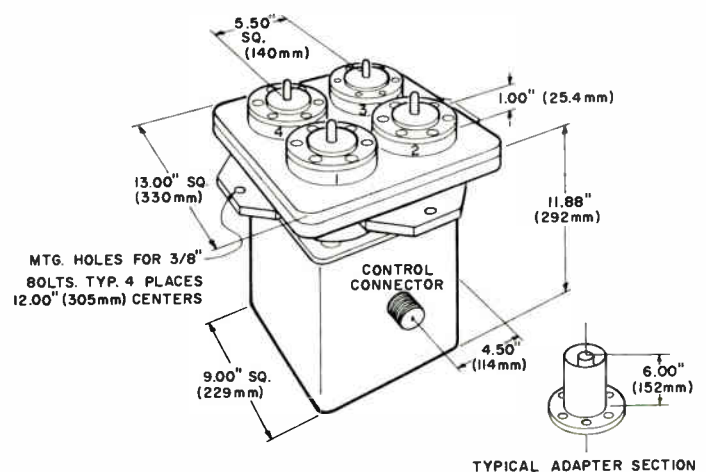

# Suggested Switching Plans

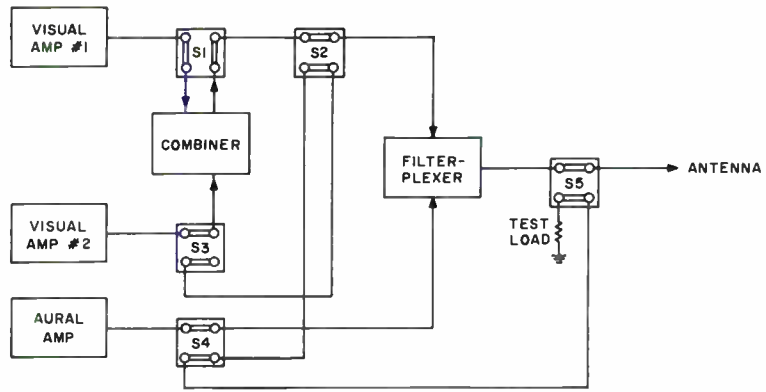

Typical UHF transmitter switching arrangement.

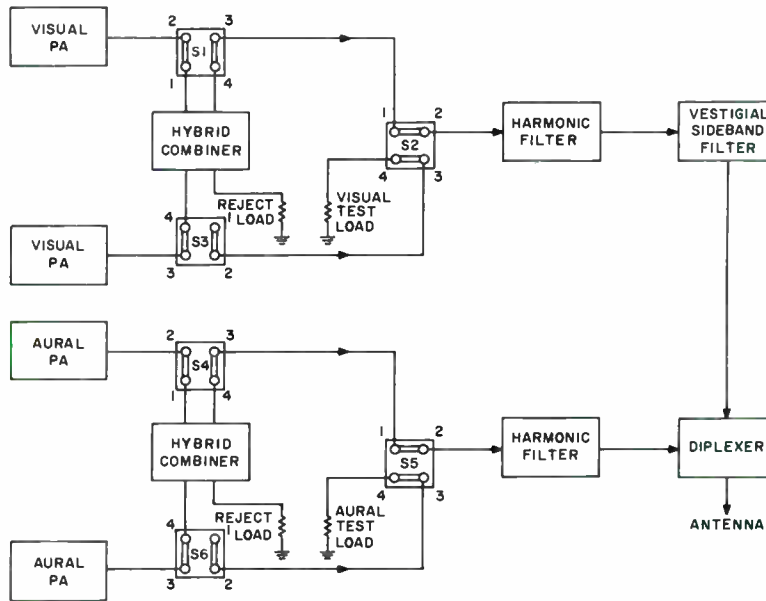

Typical redundant VHF transmitter/antenna switching arrangement.

## Specifications

### Electrical

Operating Frequency .....	Any to 900 MHz
Characteristic Impedance .....	50 or 51.5 ohms
Power Rating .....	Identical to T/L used
VSWR	
50-220 MHz .....	1.05:1 or less
450-900 MHz .....	1.03:1 or less
Insertion Loss .....	0.05 dB or less
Isolation (50-880 MHz) .....	60 dB or more
Switchover Time (nominal) .....	2 seconds
Drive Motor:	
Voltage .....	115V ±10%
Frequency .....	50/60 Hz
Current:	
Start .....	2.0A
Run .....	0.48A
Current Rating of Auxiliary Relay Contacts .....	15A, 250V AC

### Mechanical

Dimensions .....	see drawing
Weight .....	65 lbs. (28 kg)

## Ordering Information

Motor driven Coaxial Switch .....MI-561562(\*)

\*Designate suffix letter from Table below:

MI Designation	Transmission Line Type
MI-561562-A .....	MI-19089, 50 ohms, flanged
MI-561562-B .....	MI-27791-K, 50 ohms, unflanged
MI-561562-C .....	MI-19313-NF, 51.5 ohms, unflanged
MI-561562-D .....	MI-19313, 51.5 ohms, flanged
MI-561562-E .....	MI-27791-D, 50 ohms, male flange
MI-561562-F .....	MI-27791-D, 50 ohms, female flange

### Accessory

An optional control panel for use with the MI-561562 Switch is available. It mounts in a standard 19-inch relay rack and includes an On-Off switch, operating switch and position-indicator lights. Order as MI-561596.

Note: Contact RCA representative for information on similar switches for other line sizes.

# VHF Manual Coaxial Switches

RCA manual coaxial switches for VHF provide a convenient and rapid means of switching r-f-power circuits. They utilize standard coaxial transmission line fittings mounted on a panel in a way that switching functions are readily accomplished by the "patch cord" method. Switches differ in construction to meet the

various sizes and types of transmission lines. The accompanying table should be consulted for ordering purposes.

Fittings come in 3/8- or 6/8-inch sizes and the switch plugs are constructed of double 3/8- or 6/8-inch elbows which form a U section, maintaining line impedance throughout the switch. Panels are

reinforced with angle bends on all four sides. Holes in the side angles provide for mounting. The 3-pole switch has one U-type connector, and the 7-pole, three. The U-connectors clamp to the fittings. Various connections and impedances are available. See *Ordering Information*, below.

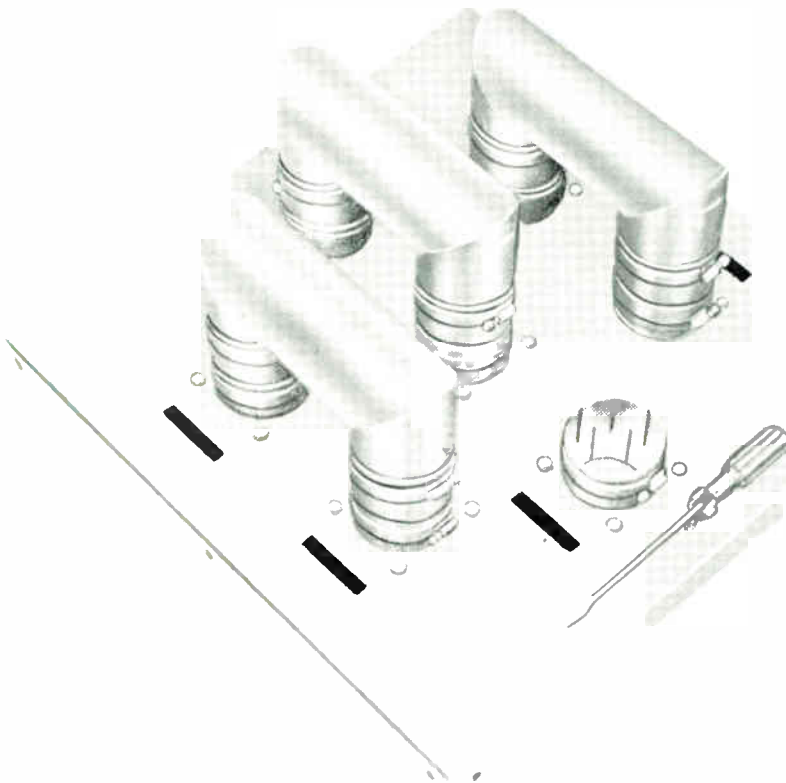

- Sturdy, reinforced steel bases
- 3-pole and 7-pole types
- Low VSWR
- Maximum isolation

## Specifications

### Electrical

Power Rating..... Same as various Transmission Line to which they apply  
 Ambient Temperature..... To 50° C  
 Elevation .....5000 ft. (1500 m) max. for full power rating  
 VSWR.....1.02 to 1 or better  
 Impedance .....See Ordering Information

### Mechanical

Dimensions.....See Outline Drawings  
 Weight:

3 Pole, 3/8" (79 mm) Models .....32 lbs. (14.5 kg)  
 7 Pole, 3/8" (79 mm) Models .....67 lbs. (30.4 kg)  
 3 Pole, 6/8" (156 mm) Models .....75 lbs. (34 kg)  
 7 Pole, 6/8" (156 mm) Models .....220 lbs. (100 kg)

## Accessories

3/8" 50 ohm adaptor used to connect straight sections of line to MI-27912-50 and 51 .....MI-27912-52  
 3/8" 51.5 ohm adaptor used to connect straight sections of line to MI-27717 and MI-27718 .....MI-27337  
 6/8" 51.5 ohm adaptor used to connect straight sections of line to MI-27719 and MI-27720 .....MI-27709  
 Spare "U" bend 3/8", 7" (178 mm) centers for use with MI-27717 and MI-27718 .....MI-27999

**INSTALLATION NOTE:**  
 Because of inner conductor considerations, either an elbow or an adaptor component must connect to the several switch ports.

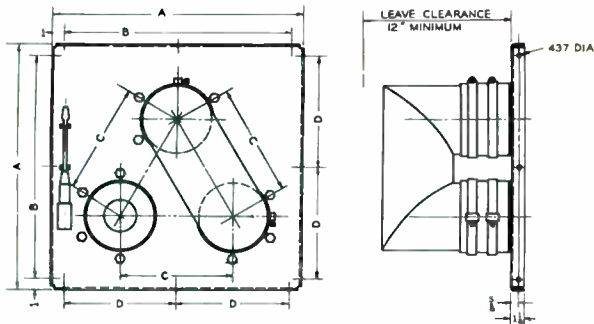

SIZE	A	B	C	O
3 1/8"	15 1/2"	13 1/2"	7"	—
80 mm	393	343	178	—
6 1/8"	25"	23"	13"	11 1/2"
156 mm	635	584	330	292

Outline Dimensions, 3-Pole Panels

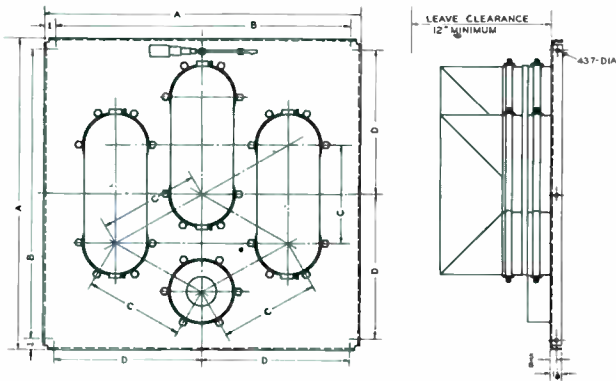

SIZE	A	B	C	O
3 1/8"	23"	21"	7"	—
80 mm	584	533	178	—
6 1/8"	38"	36"	13"	18"
156 mm	965	914	330	457

Outline Dimensions, 7-Pole Switches

### Suggested Uses for Manual Coaxial Switches

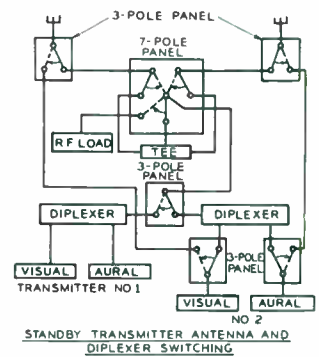
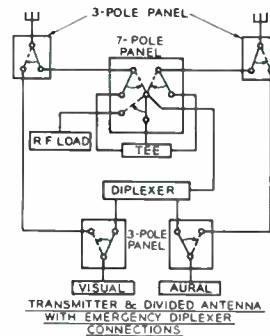
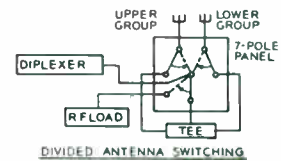
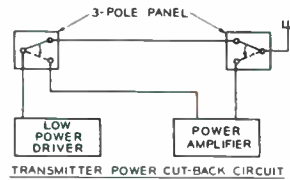
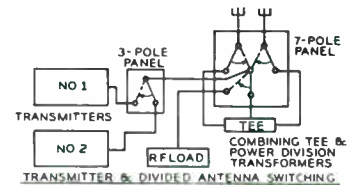
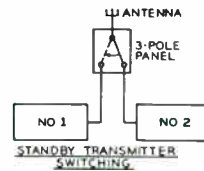

## Ordering Information

Stock Identification	Diameter	Impedance	Poles	Type Connector	For Use with RCA Line
MI-27717	3 1/8" (79 mm)	51.5 ohms	3	Sleeve	MI-19113-C or MI-19313
MI-27718	3 1/8" (79 mm)	51.5 ohms	7	Sleeve	MI-19113-C or MI-19313
MI-27719	6 1/8" (156 mm)	51.5 ohms	3	Sleeve	MI-19314-C
MI-27720	6 1/8" (156 mm)	51.5 ohms	7	Sleeve	MI-19314-C
MI-27912-50	3 1/8" (79 mm)	50 ohms	3	Inside, Universal	MI-27791-K
MI-27912-51	3 1/8" (79 mm)	50 ohms	7	Inside, Universal	MI-27791-K

The above are standard designs fitting most requirements. Other configurations to fit special switching requirements are available on special order.

# UHF Manual Coaxial Switches

Convenient and efficient switching of coaxial r-f power lines is achieved by this advanced UHF manual coaxial switch. Power cutback, dummy-load switching, emergency-antenna connection and standby-transmitter switching are accomplished easily and quickly. Two switch types are available: a 3-pole switch with

a single U-connector, and 7-pole switch with three U-connectors. Typical switching arrangements are shown in the diagrams.

Quick disconnect Marman clamps on universal flanges hold U-connectors securely in place. Each port includes an inner conductor, anchored in place with an

insulator and locking flange ring on the "rear" side of the port. Flange connections on this side of the switch accommodate 3/8-inch (MI-19089), 50-ohm line, 6 1/8-inch, 75-ohm line (MI-19387), 8-3/16-inch line (MI-561566D), or 9-/316-inch, 75-ohm line (MI-27793D).



- Fast disconnect Marman clamps
- Anchored inner conductor
- 3-pole and 7-pole types
- Low VSWR

## Specifications

Power Rating.....	Same as various transmission lines to which they apply
Ambient Temperature.....	45°C max.
VSWR.....	1.02 to 1 or better
Impedance .....	See Ordering Information
Dimensions .....	See Outline Drawings (on page B.6950-8)
Weight (Approx.):	
3-pole, 3 1/8" (79 mm) .....	65 lbs. (30 kg)
3-pole, 6 1/8" (156 mm) .....	175 lbs. (80 kg)
3-pole, 8 3/8" (208 mm) .....	355 lbs. (160 kg)
3-pole, 9 3/8" (233 mm) .....	370 lbs. (167 kg)
7-pole, 3 1/8" (79 mm) .....	165 lbs. (75 kg)
7-pole, 6 1/8" (156 mm) .....	400 lbs. (182 kg)

## Accessories

Spare "U" bend, 3 1/8", 7" (178 mm) centers for use with MI-27333-A and MI-27334-A .....	MI-27098*
Spare "U" bend, 6 1/8", 13" (330 mm) centers for use with MI-27710-A and MI-27711-A .....	MI-27099*
Spare "U" bend, 8 3/8", 22" (559 mm) centers for use with MI-561570 .....	MI-561571*
Spare "U" bend, 9 3/8", 23" (584 mm) centers for use with MI-561568 .....	MI-561567*

# Typical Coaxial-Switch Schematics

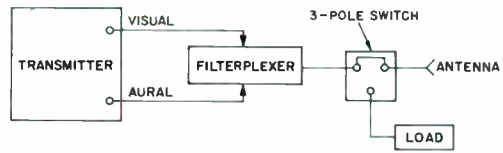

Basic Antenna/Test Load Switch Circuit

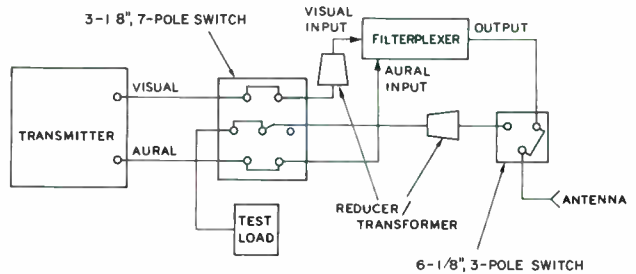

Adding a 7-Pole Switch to Basic Circuit Increases Switching Flexibility

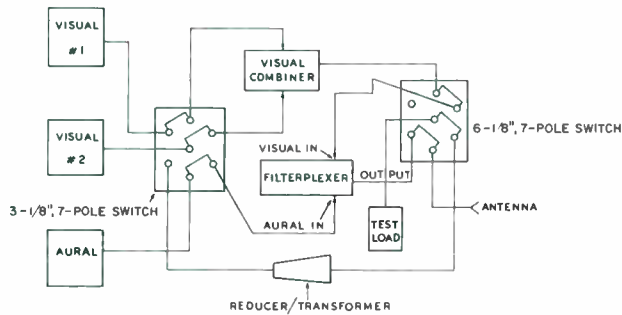

Typical Dual 7-Pole Switch Arrangement

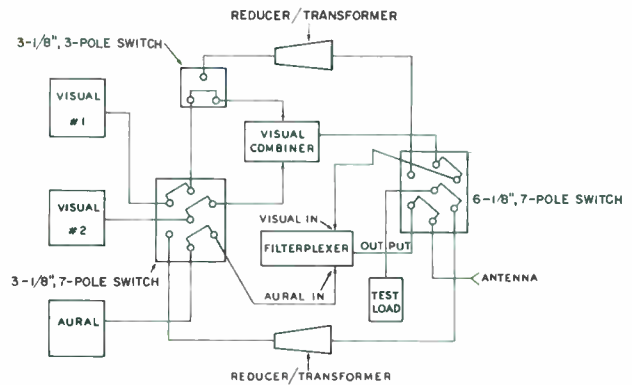

Two 7-Pole and One 3-Pole, Maximum Flexibility

## Ordering Information

Stock Identification	Diameter	Impedance	Pole	Type Connector	For use with RCA Line
MI-27333-A*	3 1/8" (79 mm)	50	3	EIA Flange	MI-19089
MI-27334-A*	3 1/8" (79 mm)	50	7	EIA Flange	MI-19089
MI-27710-A*	6 1/8" (156 mm)	75	3	EIA Flange	MI-19387
MI-27711-A*	6 1/8" (156 mm)	75	7	EIA Flange	MI-19387
MI-561570*	8 3/16" (208 mm)	75	3	Marman Flange	MI-561566-D
MI-561568*	9 3/16" (233 mm)	75	3	Marman Flange	MI-27793-D

\* Sales order must specify customers channel.



# Outline Drawings-UHF Manual Switches

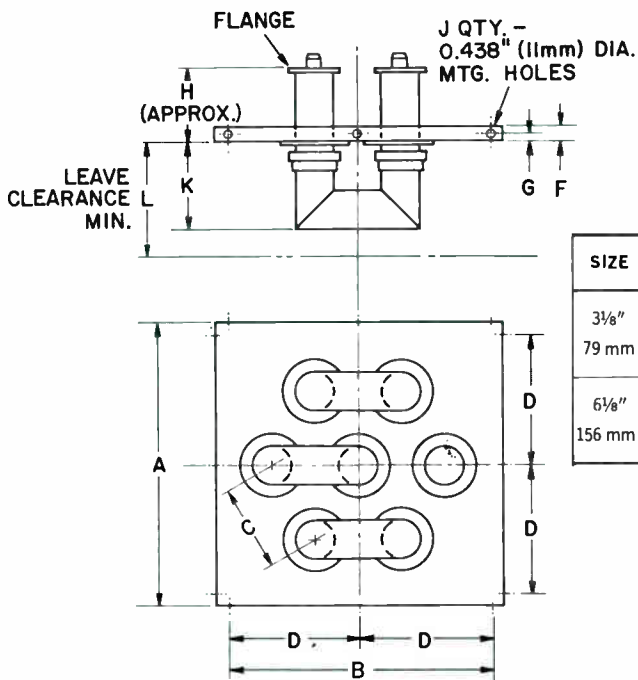

SIZE	A	B	C	D	F	G	H	J	K	L	Flange For Use With
3 1/8" 79 mm	23 584	21 533	7 178	10 1/2 267	1 1/8 29	5/8 16	4 102	12 305	7 178	9 229	EIA MI-19089
6 1/8" 156 mm	38 965	36 914	13 330	18 457	1 1/4 32	3/4 19	3 1/4 83	12 305	11 3/4 298	13 3/4 349	EIA MI-19387

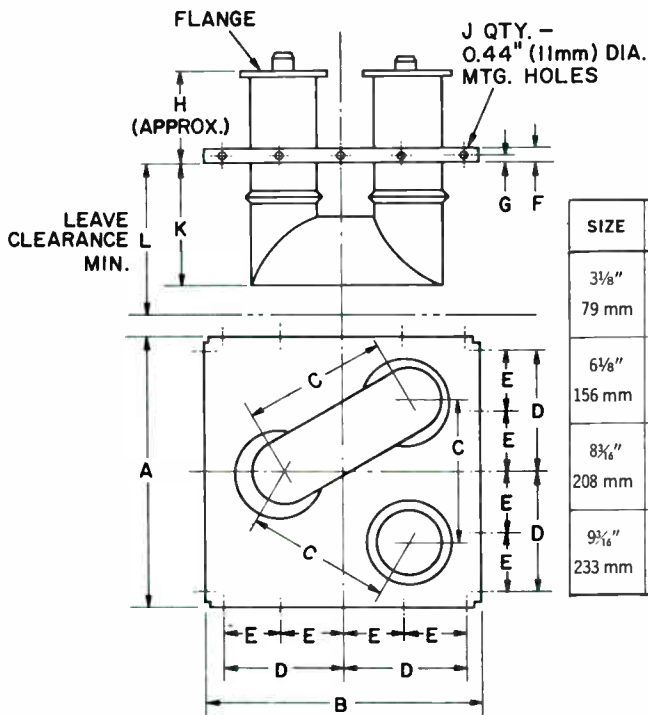

SIZE	A	B	C	D	E	F	G	H	J	K	L	Flange For Use With
3 1/8" 79 mm	15 1/2 394	15 1/2 394	7 178	6 3/4 171	—	1 1/8 29	5/8 16	4 102	12 305	7 178	9 229	EIA MI-19089
6 1/8" 156 mm	25 635	25 635	13 330	11 1/2 292	—	1 1/2 38	31/32 25	3 1/4 83	12 305	11 3/4 298	13 3/4 349	EIA MI-19387
8 1/8" 208 mm	41 1041	38 965	22 559	16 406	8 203	2 1/4 57	1 3/8 35	10 3/4 273	20 508	14 1/2 368	18 1/2 470	Universal MI-561566-D
9 1/8" 233 mm	43 1092	40 1016	23 584	16 406	8 203	2 1/4 57	1 3/8 35	10 3/4 273	20 508	15 381	19 483	Universal MI-27793-D

B.6950-8

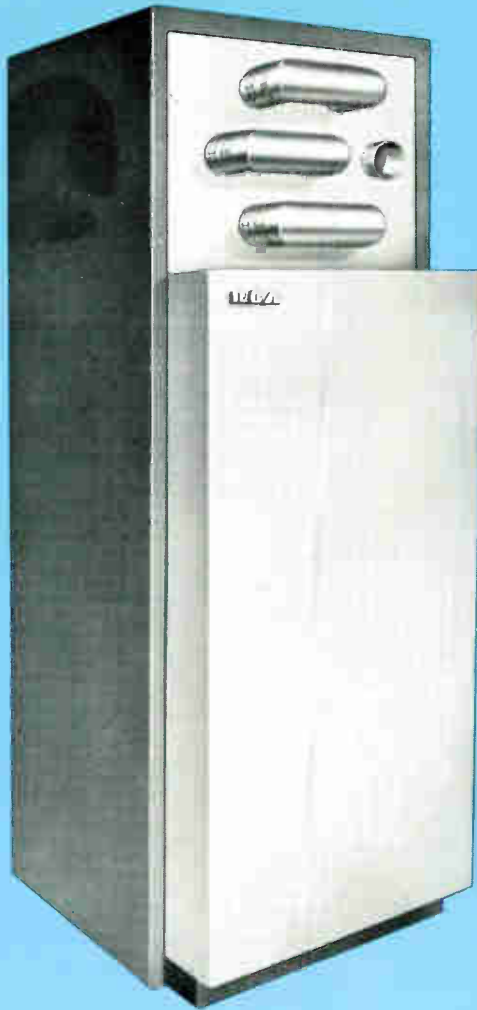

- Lowers VSWR, improves picture quality
- Switches parallel transmitter outputs with minimum load change
- Factory assembled, optimized and tested
- Reduces transmitter system installation cost
- Styled to match RCA transmitters

## OPTO Switcher for Paralleled VHF Transmitters

### Description

The RCA OPTO Switcher (Optimized Parallel Transmitter Output switching system) is an attractively packaged assembly of output combiners, motorized coaxial switches and a manual patch panel designed especially for use with RCA parallel highband and lowband "F"-Line VHF television transmitters. OPTO Switcher components are optimized for best VSWR across the channel and shipped to the installation site as a simple, integrated unit with no further adjustment required.

### Versatility

As can be seen in the block diagram, the OPTO Switcher provides extreme versatility for switching outputs in a typical two-transmitter system. The visual and aural outputs of each individual transmitter are switched as a unit. Basic switching modes are as follows:

1. Normal paralleled mode (combined visual and combined aural into antenna).
2. Transmitter #1 aural and visual on the air, Transmitter #2 aural and visual into separate test loads.
3. Transmitter #2 aural and visual on the air, Transmitter #1 aural and visual into separate test loads.
4. Manual patching.  
Variety of options depending upon antenna combinations, i.e., split-fed antennas, spare antennas, quadrature-fed antennas, etc.

### Superior VSWR Performance

Since the OPTO Switcher components are assembled and optimized at the factory and not in the field, statistical addition of component VSWR's, normal with on-site installations, no longer exists. As a result, the VSWR through any switching mode is reduced to 1.02:1 or less.\* This low VSWR minimizes the effect of transmitter loading changes with mode switching. Also, it minimizes the need for

transmitter retuning with mode switching, a feature of particular value with remote control operation. Field installation of switching facilities and cutting of connecting line sections is minimized.

### Reliability

Motorized coaxial switches in the OPTO Switcher provide simple, fast and reliable switching of r-f energy, with operations in excess of 100,000 cycles possible before failure.

### Powered Through Transmitter

Power for the OPTO Switcher motors is provided through RCA "F"-Line Transmitters which are also equipped with controls for operation of the unit. When the OPTO Switcher is used with other transmitters, some custom work is necessary to interface the unit with transmitter power and control circuits.

\*Reflections of components, shown in dotted lines, which are external to the OPTO Switcher are not included in this figure.

Typical motor-driven coaxial switch used in the OPTO Switcher. This is 3 1/8-inch size; the OPTO Switcher uses three 1 3/8-inch and three 3 1/8-inch switches arranged as shown in drawing at right.

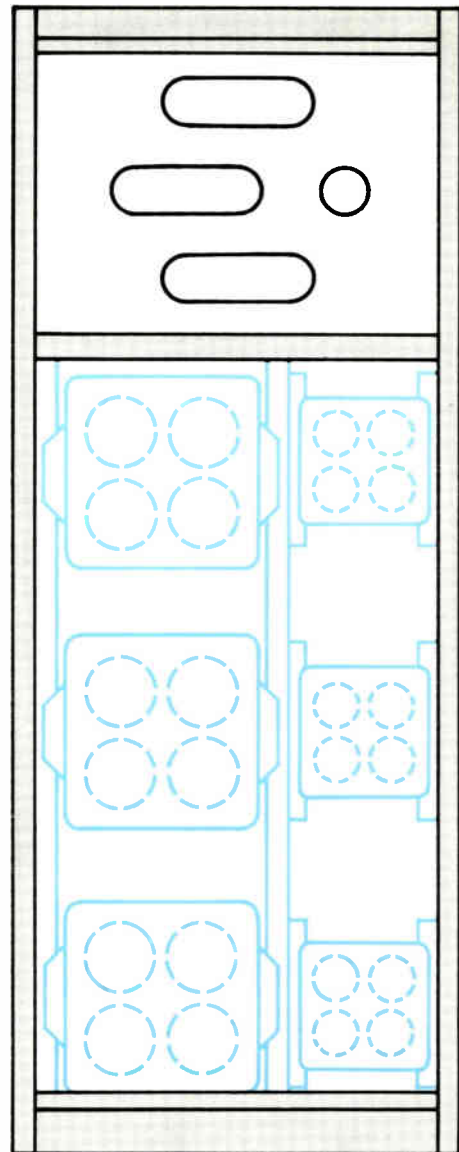
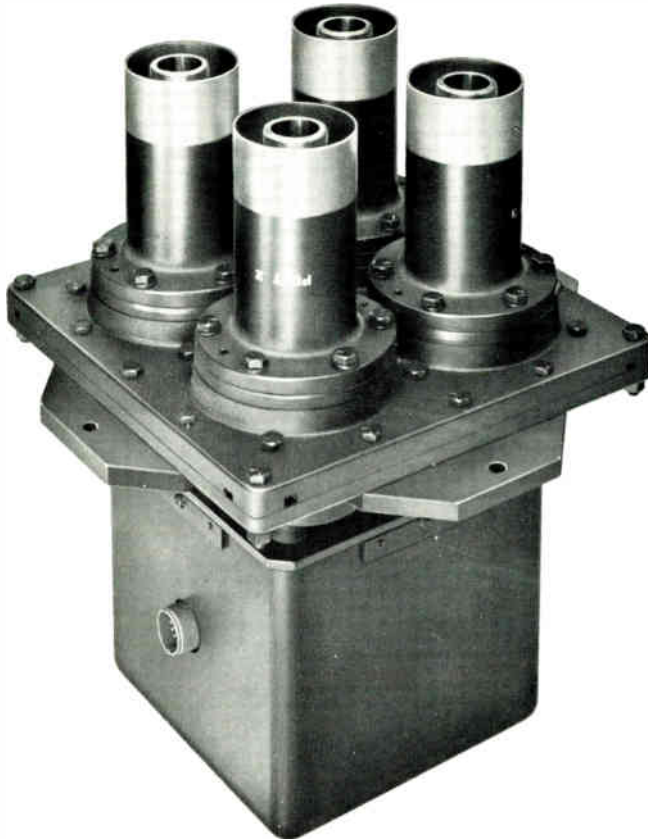

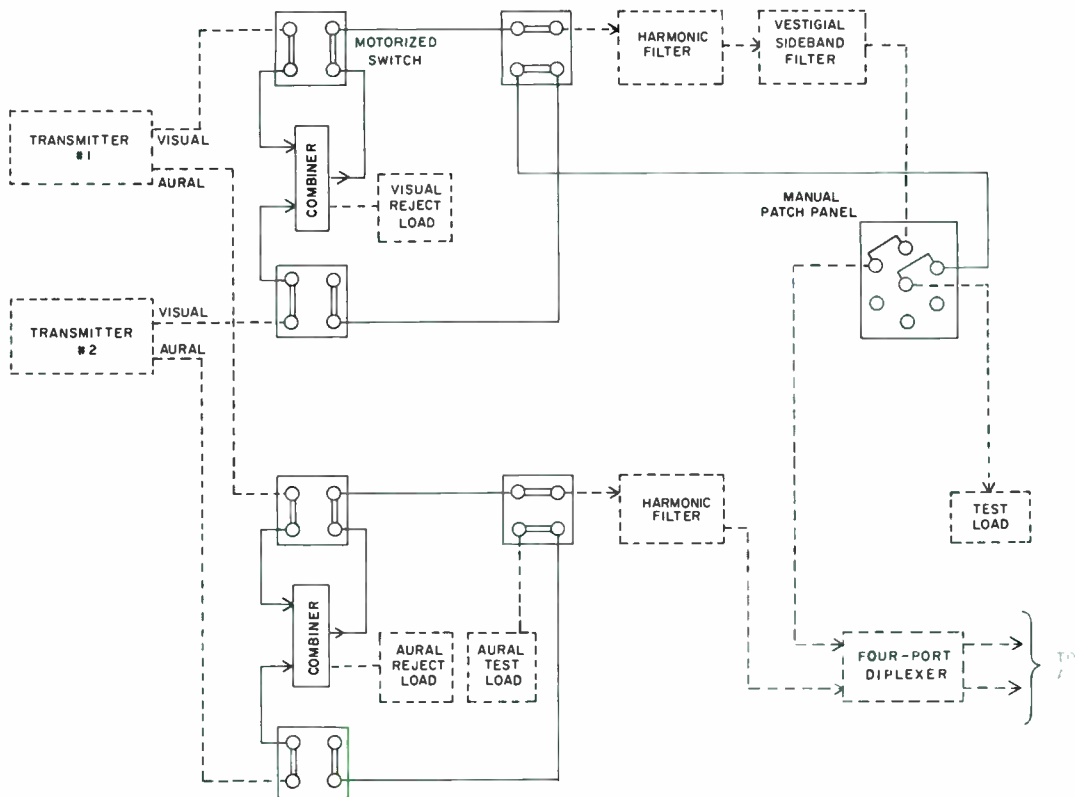

Typical OPTO Switcher scheme for quadrature-fed antenna systems using sideband filters. Components shown in solid lines are within OPTO Switcher cabinet.

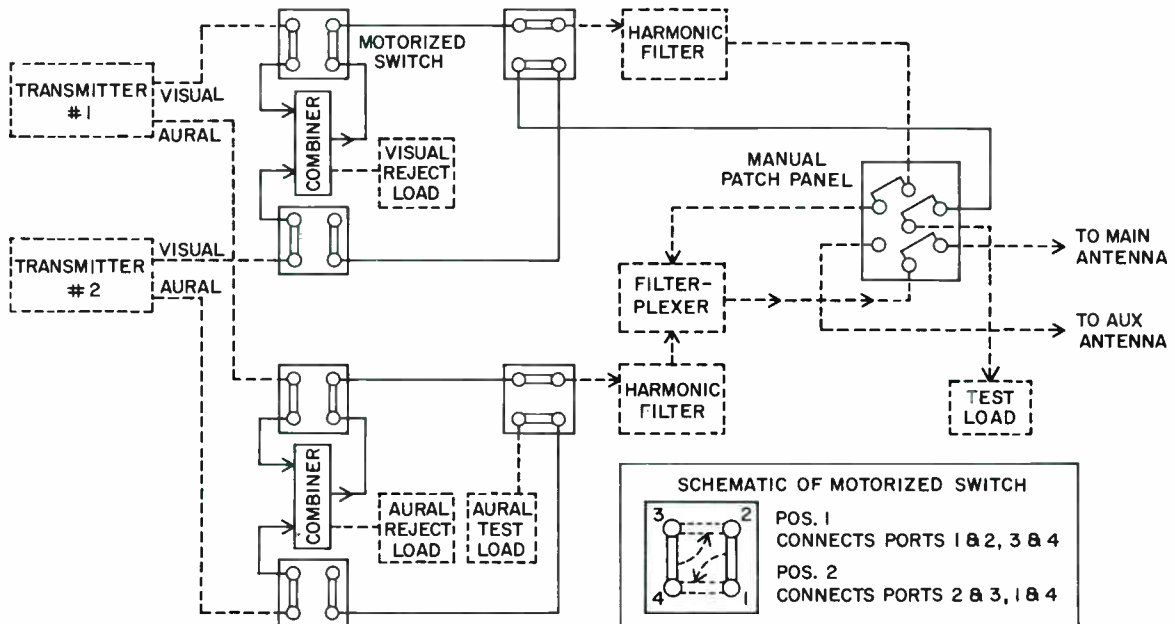

Typical OPTO Switcher scheme for single-line antenna system. Scheme shown uses a filterplexer for combining aural and visual signals.

# Specifications

R-f Connections:  
Visual input and output connections .....50-ohm, 3 $\frac{1}{8}$ " Line (MI-27791K)  
Aural input and output connections .....50-ohm, 1 $\frac{5}{8}$ " Line (MI-561565)  
Power Requirements .....115V 50/60 Hz from RCA "F"-Line transmitter; other transmitters require custom consideration.  
Interlocking .....Interfaces with "F"-Line transmitters; other transmitters require custom interfacing

VSWR .....1.02:1 or less, any input to any output, when terminated in a perfect match  
Dimensions .....30" W x 44" D x 77" H  
(762 mm x 1118 mm x 1956 mm)  
Weight .....1200 lbs. (approx.)  
(543 kg)  
Shipping Dimensions .....34" W x 48" D x 85" H  
(864 mm x 1219 mm x 2159 mm)  
Shipping Weight .....1300 lbs. (approx.)  
(590 kg)

# Ordering Information

OPTO Switcher:  
For low-band "F"-Line Transmitters only\* .....ES-561802  
For high-band "F"-Line Transmitters only\* .....ES-561803

\*OPTO Switcher uses certain coaxial components ordinarily supplied as part of the transmitter. When an OPTO Switcher is part of the transmitter order, these components are deleted from the transmitter equipment, incorporated into the OPTO Switcher unit, optimized and tested as a unit before shipment.





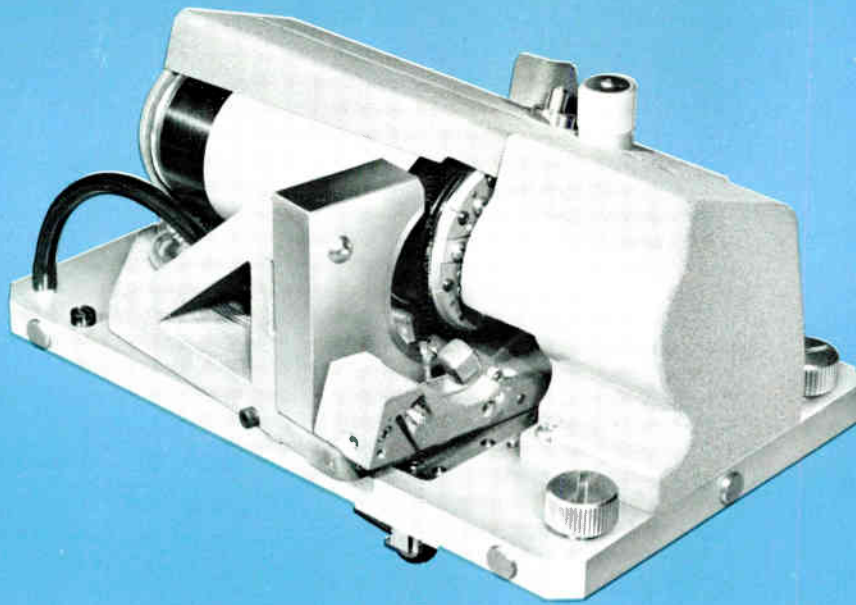

- New Alfecon alloy increases life
- Built-in elapsed-time indicator
- Automatic precision record-guide positioning
- Built-in FM-sweep probe (for TR-70)

## RCA Highband VTR Headwheel Panels

### Description

Directly interchangeable with earlier RCA highband VTR headwheels, the *Alfecon II* headwheel panel increases headwheel life while maintaining both record and play performance.

#### A New Head Material

*Alfecon II* is a newly developed alloy for VTR headwheels which simultaneously improves machine performance, uniformity and headwheel durability. The increase in VTR headwheel life reduces operating costs in addition to minimizing the down-time usually set aside for routine VTR system adjustment.

#### Automatic, Precision Record-Guide Positioning

RCA Highband Headwheel Panels afford a very high degree of record-guide position accuracy as the result of precision mechanical components, automati-

cally activated as the machine goes into *record* mode. (Highband recorders earlier than the RCA TR-70C require a simple modification to utilize the automatic guide positioning system.)

#### Built-In FM-Sweep Probe

Incorporated within the housing of the Highband Headwheel Panel is an integral FM-test probe which is accurately positioned for maximum response and minimal operational error. Coupling the probe to the system is accomplished through the standard headwheel panel connections.

#### Built-In Elapsed-Time Indicator

Actuated by vacuum-guide engagement, the built-in elapsed-time indicator accurately logs panel operating hours. Particularly valuable to facilities where 10-mil headwheels are interchanged for 5-mil

and vice versa, the indicator simplifies log-keeping.

#### New Headwheel Protection

A cover protects all rotating headwheel components from accidental impact damage while the panel is on or off of the machine. A "hand hold", molded into the rear portion of the headwheel cover, provides extra convenience and comfort during headwheel panel installation or removal.

#### Fitted for Tip-Protrusion Indicator

Highband Headwheel Panels include a "tool post" for the mounting of a tip-protrusion indicator (see *Accessories*). So equipped, the panel affords accurate measurement of progressive head wear. The design controls axial positioning of the indicator which, in turn, assures its accuracy.



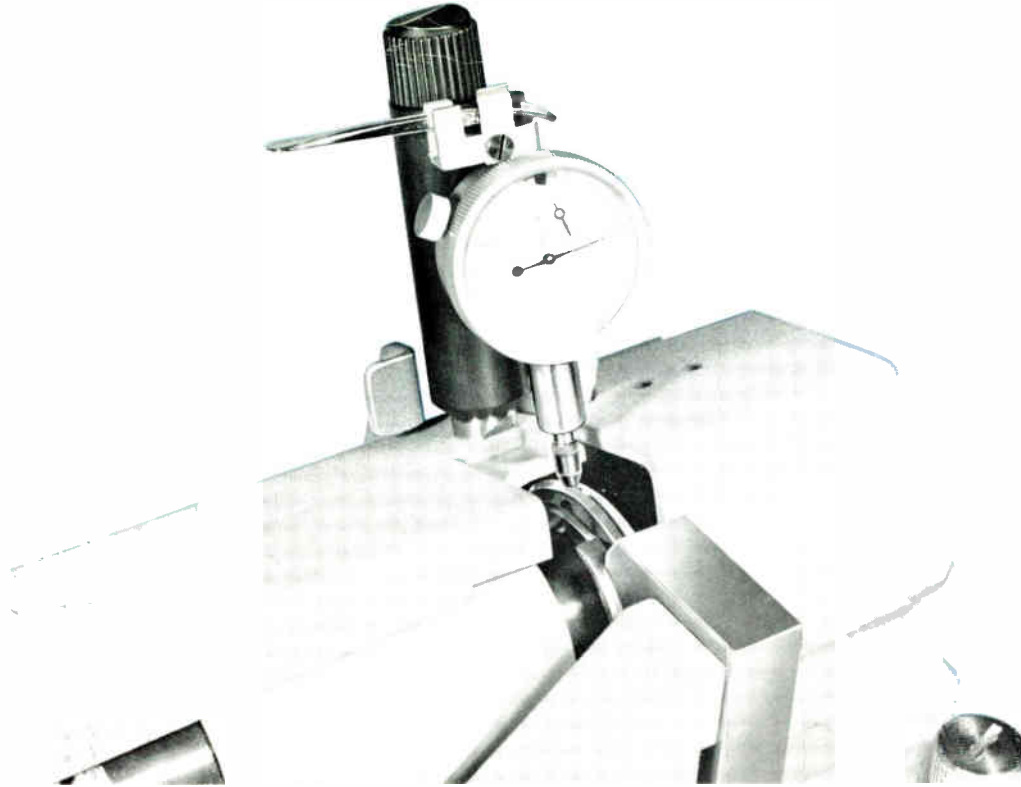

Offered as an optional accessory, the Tip Protrusion Indicator mounts atop a "tool post" on the headwheel assembly.

## Guide Position Adjustor for Headwheel Panel

The Vacuum Guide Adjusting Mechanism, MI-43351-A, is a mechanical accessory that enables video tape operators to accurately adjust the vacuum guide position on TR-3/4/5/50 Tape Recorders. It is designed to be used with Quadruplex Video Alignment Tapes.

If penetrations other than the standard are desired, rapid manual adjustments can be affected during playback of a tape, by means of a knurled adjusting screw. The unit is provided with a direct read-

ing dial indicating the actual position of the vacuum guide. Dial readings of up to +1 mil and as low as -3 mils may be read directly. The dial may be returned to the zero reading even during operation to secure a standard recording.

In order to actuate this adjustment without opening the headwheel cover, a special rim drive disc is provided for use on the TR-3/4/5/5 headwheel panel cover.

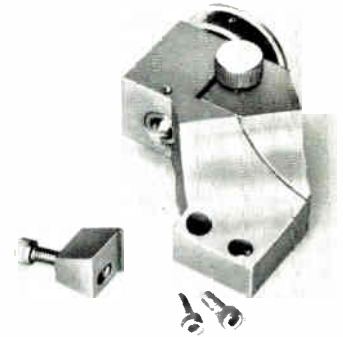

## Ordering Information

10-Mil Highband Headwheel Panel .....MI-591410A  
 5-Mil Highband Headwheel Panel .....MI-591420A

### Accessories

Tip Protrusion Indicator .....MI-43219  
 Guide Position Adjustor .....MI-43351-A

# RCA Color TV Tape Recorder, Type TR-70B

- Superb color tapes
- Finest multiple generation copies
- Automatic FM standards selector
- FM test facility
- Record current optimizer
- Auto stop cue

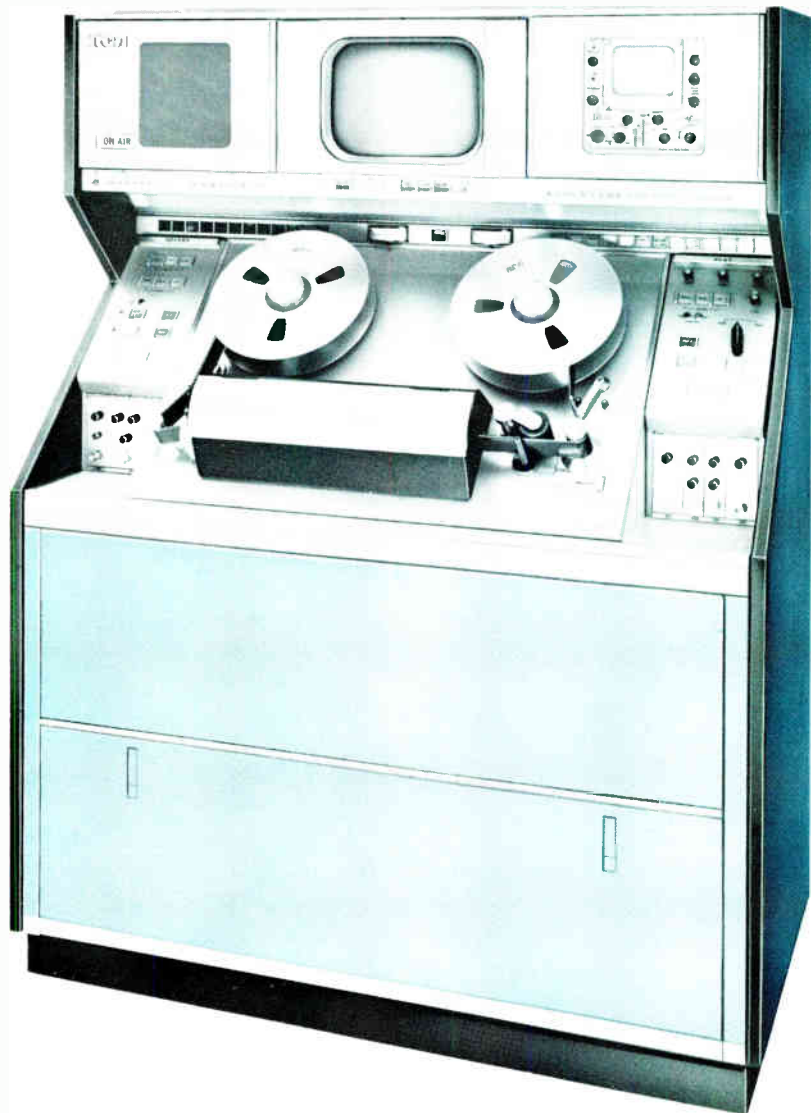

3TB

# TR-70B, For Finest Color Performance

EAR-LEVEL AUDIO MONITORING  
Hi Fi Audio

EYE-LEVEL VIDEO MONITORING  
Picture      Waveform

SOLID STATE MONITORS

SLIDE OUT MONITORS

CENTRAL DC METERING

PUSHBUTTON  
STANDARDS SELECTOR  
FM Standards  
Line Standards  
Machine Speed

AUTOMATIC INSTRUMENTATION  
Automatic FM Standard Selection  
Automatic Stop Cue  
Central Alarm System

RECORD CURRENT  
OPTIMIZER

INPUT/RECORD CONTROLS  
Automatic Guide Positioner  
2-Channel Input Selector  
H-F Compensation Control  
Channel Identification

SPOT ERASE

STANDARD MODULES  
All Plug-In  
Pre-Wired for Accessories  
Single Service Extender

REAR SIDE MASTER ERASE

HETERODYNE MODULATOR

OUTPUT/PLAY CONTROLS  
Choice of 3 Servo Modes  
Variable Speed Wind Control  
CT Phase Control  
Simultaneous Play

HIGH PERFORMANCE  
HEADWHEEL

4-MODE FM TEST FACILITY

BUILT-IN AIR SUPPLY

FM DEVIATION  
CALIBRATION PULSE

FOOT BRAKE RELEASE

UP-FRONT  
ACCESS SERVICING  
Pushbutton Monitoring Points  
160 Test Points  
Hinged Control Panels

AUTOMATIC WATER DRAIN

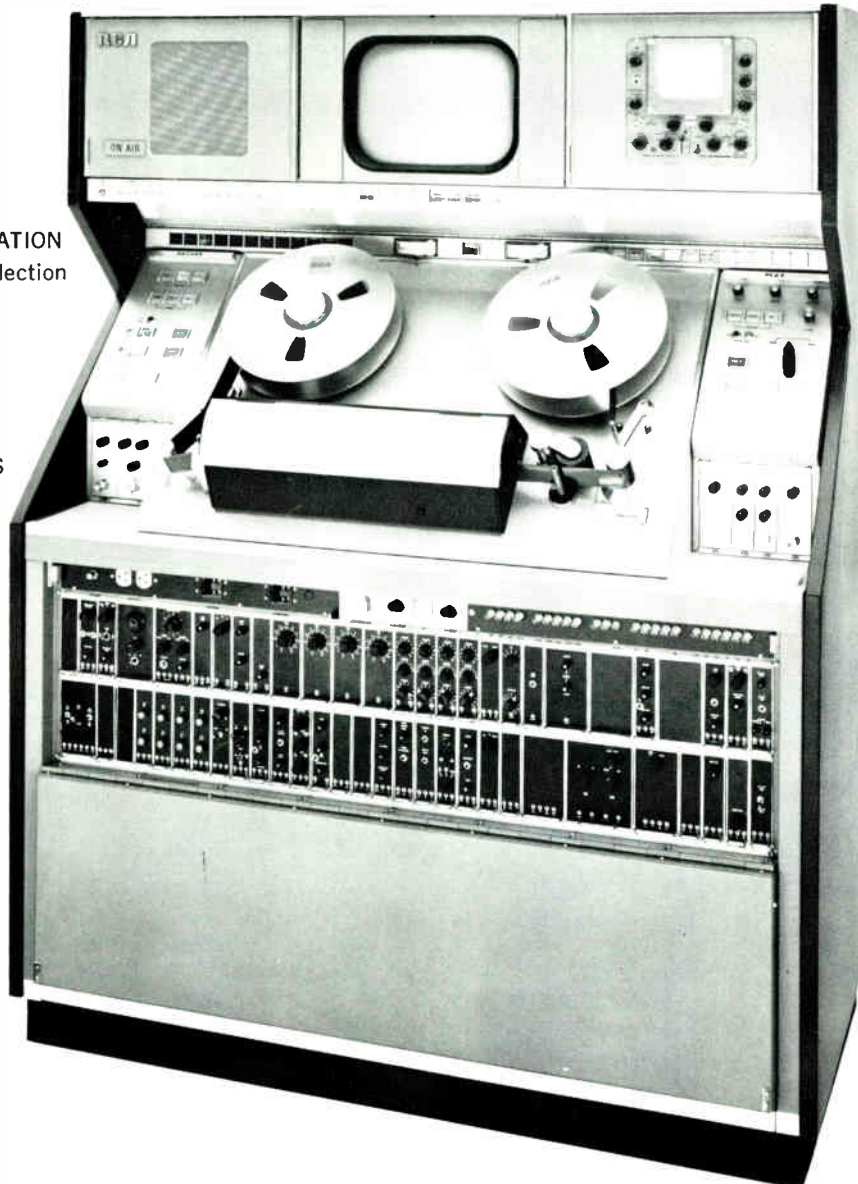

## Color TV Tape Recorder, Type TR-70B

The RCA TR-70B Color TV Tape Recorder is designed to produce the finest tapes available with the greatest dependability and least operator attention. New technical refinements assure tapes of astonishing color fidelity. Multiple generation tapes challenge comparison with originals. Automation of routine functions and long life-dependability save valuable man-hours of operation and maintenance.

Technical specifications are unsurpassed especially in important areas such as differential gain and phase, moire, 20T pulse response.

Continuous research and engineering programs constantly develop new refinements in video tape recorders, improving their efficiency and versatility. Among the firsts in the beautifully styled TR-70B are: an automatic FM standards selector which prevents improper replays because of operator choosing the incorrect standard; a record current optimizer that proves an important time-saving device; a high gain servo for color-frame-editing capability; and an automatic stop cue.

Other important features include a new selective rearside erase to reduce tape

scratches and tape dropouts and to prolong tape and head life; new positive-lock reel hubs to eliminate chatter and distortion; and an expanded visual warning system. From the viewpoint of the user, these features make it the finest tape recorder available.

### Description

The TR-70B design provides many important advantages for the busy video tape operator—ease of operation, automation of routine functions, generous monitoring and metering facilities, and a full complement of indicator lights to signal assurance of proper performance. Plug-in electronics make the recorder the easiest to maintain and service.

#### Automatic FM Standards Selector

Among the new exclusive features of the TR-70B, the automatic FM standards selector eliminates guesswork for the operator and prevents replays on an incorrect standard. All the operator has to do is press the AUTO/MANUAL switch and start the tape. The standards selector will secure the blanking frequency of the

tape being played and switch the machine's circuits to the appropriate standard; i.e., highband, lowband mono, or lowband color.

The automatic mode is limited to playback only. In the manual position, of the AUTO/MANUAL switch, however, the three standards are instantly selectable by pushbuttons for use in either record or playback modes. There is no need to change modules, since the circuitry is built in.

#### Record Current Optimizer

Another very important time-saving device for the operator that is standard equipment in the TR-70B is the Record Current Optimizer (RCO). With this device, the record currents can be adjusted to their optimum condition in less than thirty seconds. This means that the trial and error method previously used which could take up to fifteen minutes to accomplish has been eliminated, saving precious time for the operator. The RCO is not only fast, but accurate.

The necessary switching logic and monitoring facilities to enable simultaneous record current readout are provided. The

## Major New Features

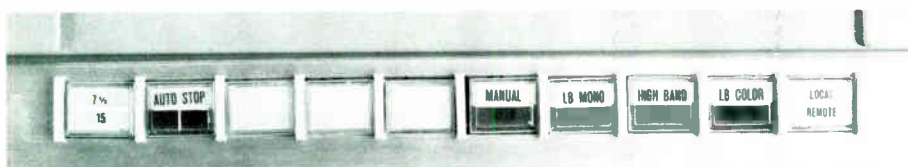

TR-70B pushbutton panel, below the picture monitor, provides instant selection of Automatic Stop Cue, tape speed, line standards, manual selection of three FM standards, and automatic selection of FM standards in playback mode.

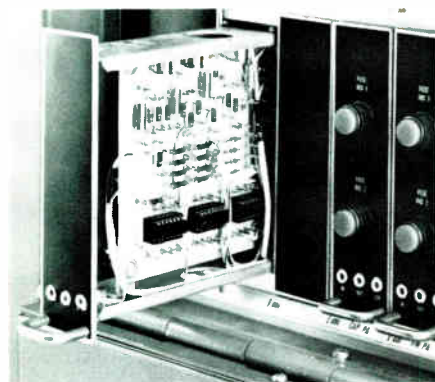

The record current optimizer permits complete adjustment of all four heads in less than 30 seconds. The device is actuated by pressing the "test" pushbutton and the "master" record pushbutton (on the record panel) at the same time.

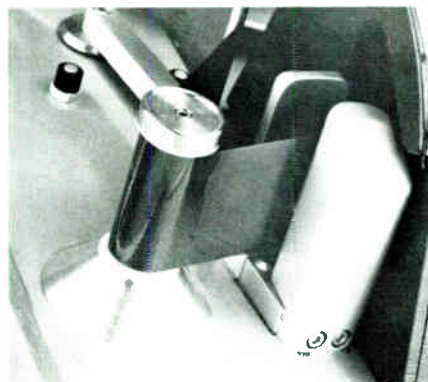

Erase head on non-magnetic side of tape erases through the tape, minimizing wear and chance of scratching. Head also functions as a selective erase head in electronic editing.



TR-70B reel knobs feature a rubber O-ring compressed against the sidewalls of the reels for a firm, accurately-centered lock, preventing chattering and reel distortion.

## Fully Instrumented for Peak Performance



Multi-position switchers monitor important pictures and waveforms.

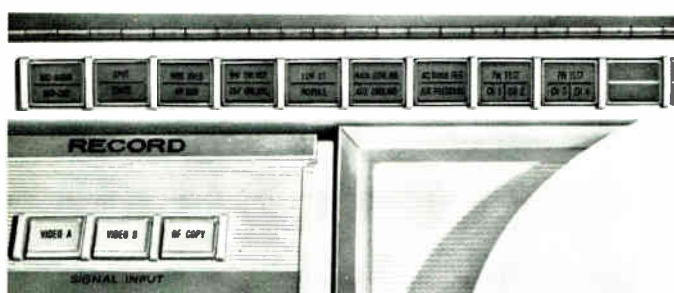
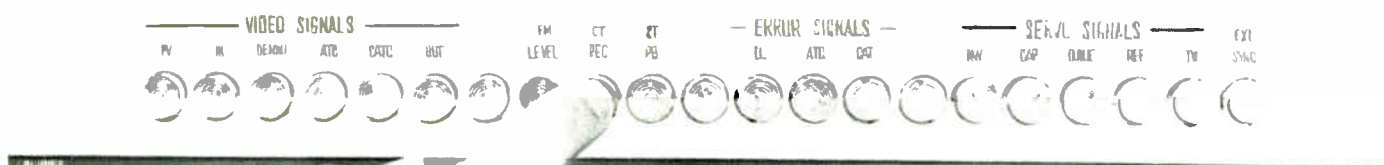

Expanded warning indicating system.



Non-standard mode indicator panel.

RCO is activated by the FM test panel which is also used to sweep the video heads for resonance adjustment as well as other special test modes.

### High Gain Servo

Long term stability of the headwheel servo system is required if electronic splicing is to be done with any degree of accuracy of repeatability which is especially important in color editing. A new High Gain Servo inherently produces the long term stability required to accurately maintain the proper position of vertical sync as recorded on the tape, which is essential in electronic as well as mechanical editing.

Correct color editing also demands that the proper color fields be spliced in the correct sequence to avoid discontinuities. The color frame consists of four color fields; therefore, to make proper edit requires that field one be followed by field two, field two be followed by field three, et cetera. The servo in the TR-70B provides an option to produce a 15 Hz edit pulse to accommodate correct color field editing on domestic machines.

Pixlock, linelock, and non-phased color modes can be selected from the play control panel. Pixlock assures horizontal and vertical coincidence to permit fades,

supers, lap-dissolves and other special effects with other studio sources. The linelock mode promotes fast recovery from disturbances such as poor mechanical or electrical splices, non-synchronous switches, or similar disturbances. Color dubs made through the heterodyne process require the non-phased color mode (NPC) for proper replay. Also available are tone wheel and switchlock servo modes.

### Auto Stop Cue

The TR-70B incorporates an Auto Stop Cue device. This permits cueing tapes by recording on the audio cue track a tone burst which can be properly sensed to stop the machine on cue.

The Auto Stop Cue (ASC) adds a timesaving feature which will be most welcome to the tape operator. Of particular interest is the application to "spot" commercials. During a station break when time is usually very limited, the stations' tapes can be electronically "pre-cued" to stop automatically when the cue is read out. Cueing the tape electronically is accomplished by placing the tape in playback mode and, at the desired point in time (first audio or first video), the machine is manually stopped and rolled back for the normal tape-roll cue.

This point being determined, the tape is then replayed and at the predetermined point, the audio cue record head is activated, marking the tape electronically. This completes the procedure for the start cue. Another cue can be placed on the tape at the end of the commercial which will also stop the machine when in the Auto Stop mode.

With the pre-recorded cues now on tape, the operator can select Auto Stop Cue mode, thread the tape, push the play button, and walk away from the machine. The cue will be read out and the machine will stop, cued and ready to be replayed either at the machine location or remotely. When the machine is started from either location, the tape will play to the end cue, and stop.

The function switch and indicating system to activate the Auto Stop mode are located directly below the picture monitor.

### Selective Rearside Erase

In order to minimize tape wear and tape scratch, a rearside master erase head was designed. This new head still maintains its function as a selective erase head (required for electronic editing). Tape erasure actually is made through the tape; i.e., from the mylar side through

the tape to the oxide side. Since the erase head does not contact the oxide portion of the tape, greater tape life, greater erase head life, and minimum scratches result.

### New Reel Hubs

The reel hubs have been redesigned to add a nearly absolute method of locking the tape reels in place, which promotes uniform tape wind. The reel hub has a rubber "O" ring around its circumference which is compressed equally to lock the reels in place. It can be viewed as a three section cylinder with the middle section being the rubber "O" ring. When the top portion or locking knob is turned, the "O" ring is compressed against the side walls of the reel. The action pro-

vides a firm accurate lock to the reel thus preventing chattering and distortion.

### Expanded Warning System

An audible buzzer and a flashing warning light are new additions to the TR-70B. The present warning system (red lights) serves to alert the operator of possible malfunction, providing he is looking at the machine in the general area of the warning indicators. Now a central warning light is tied to the existing lights which results in a dual indication of trouble. For example, if the headwheel warning light were to light up, the central light would also light. To attract attention the light is driven at approximately ninety pulses per minute thus flashing a warning. Further, to attract at-

tention a buzzer is set in action when the warning light is activated.

### FM Test Facility

The FM Test Facility, which is completely self-contained, can be programmed to perform several special tests in optimizing the TR-70B. These include noise, moire, frequency, and headwheel record and playback optimization. The TR-70B now can be programmed by the flick of a switch. Trial and error methods of matching the headwheel panel to the electronic system are eliminated.

### Operation-Tested Features

Time tested features of RCA TV tape recorders are standard in the TR-70B. These include continuously variable winding speed, separate guide position control for record and play, brake release switch, magnetic tone wheel, selective erase head, simultaneous monitoring of servo control track, spot audio erase, simultaneous audio playback and complete cue facilities.

### Human Engineered Design

The TR-70B has been human engineered to provide a well-lighted control center designed to assist the operator in trouble-free, error-proof recording and playback. Audio monitor, picture and waveform monitors are conveniently located at eye level. The tape transport panel separates operational functions with the RECORD control panel on the left and the PLAYBACK control panel on the right. For every operational step there is a full complement of indicator lights to signal assurance of good performance or to signal warning of potential trouble or faulty operation. They help to pinpoint and quickly correct malfunctions should they occur.

The tape deck of the TR-70B is set waist high at an angle of 45 degrees for ease in loading reels and threading tape. Tape reels as large as 12 or 14-inch diameters are quickly loaded and removed with ease. Threading is facilitated by cone-shaped guide posts.

The banks of plug-in transistor modules containing the circuitry for video and FM processing and for all the servos required by the machine are located below the tape deck. Long life, cool operation, and the ultimate in stability are attained by the centralized plug-in electronic modules and careful layout. The console base contains the power supplies, vacuum and air bearing pumps, and main cooling blower. Front protective panels are easily opened to assure complete accessibility for all normal operation and maintenance.

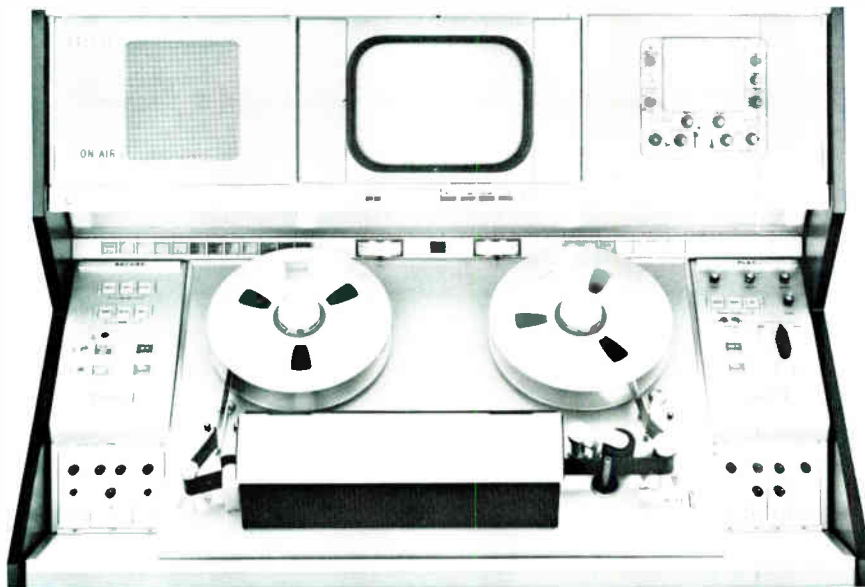

The TR-70B tape deck separates the record controls at the left from the play control on the right, saving the operator steps, and reducing chance of error. Above the tape deck are the instrumentation panels mounting the pushbuttons and color coded status and warning lights. Speaker, picture monitor and waveform monitor are at ear and eye levels.

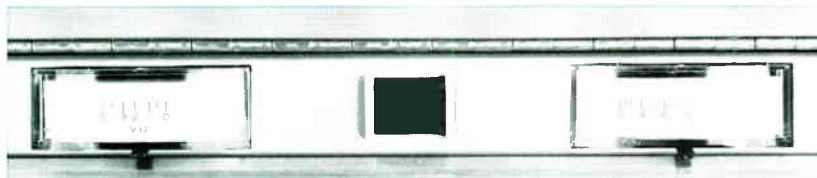

New central warning system shown above features a flashing light and sound alarm to further attract operator's attention. Feature is centrally located between the VU meter and the multimeter.

## Teleproduction Accessories

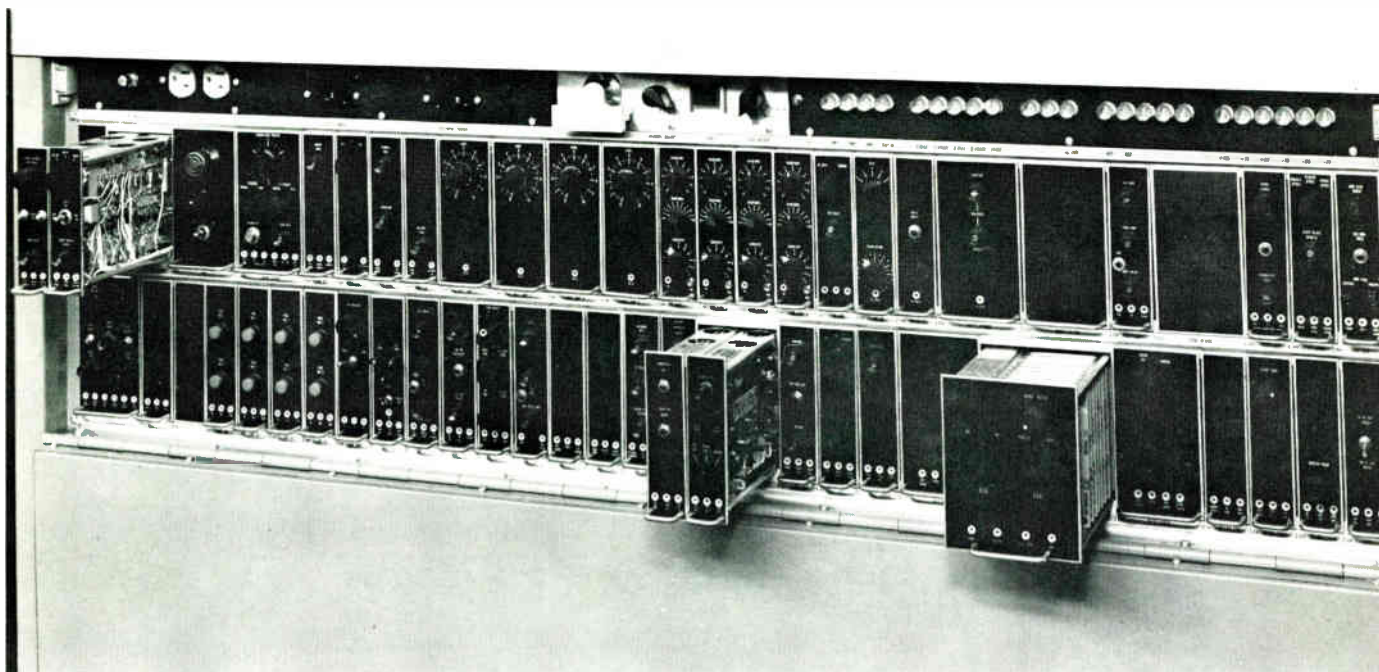

Electronics bank of the TR-70B. Plug-in modules withdrawn from left to right are the accessory equipments—Electronic Splicer, Dropout Compensator, and Chroma Amplitude and Velocity Error Corrector.

### Pre-Wired for Accessories

The TR-70B is pre-wired to accommodate the Electronic Splicer, Tape Editing Programmer, and Color Dropout Compensator Accessories. The CAVEC requires about one to two hours to install. However, accessories can be ordered and factory installed if the customer so desires.

### Preferred Dropout Compensation

The TR-70B utilizes the video method of compensation, which is preferred by users over FM insertion for its effectiveness. The Dropout Compensator, which is available as an accessory, divides the video signal into its two active video components: luminance and chrominance. As a result of this division and processing within the dropout compensator, the re-inserted material substituted during a dropout contains wideband luminance information and correctly-phased chrominance. The similarity between the inserted material and missing elements minimizes the visible effects of picture dropouts.

### Electronic Splicing

Featured as an accessory to the TR-70B is a pushbutton electronic splicer which offers a fast, accurate means of

electronically adding or replacing sequences in recorded color or monochrome tape without need for cutting and re-joining the tape. There are three modes of operation, "add-on", "insert" and "normal" (non-splicing mode).

### Automatic Tape Editing

A new Tape Editing Programmer can be combined with the Electronic Splicer to further automate program tape preparation on the TR-70B. TEP, which times the splice function of the Electronic Splicer, permits the tape editor to preview the splice before actually splicing into the master tape. The Tape Editing Programmer may be installed in any standard 19-inch rack or in the New Look console. This may be located remote from the tape recorder, in which case a mode control panel is available for remote control of the tape recorder from the TEP location. The Tape Editing Programmer also has capability to start other equipment such as film chains or recorders when they are used for signal sources in editing.

### CAVEC Corrected Replays

The TR-70B accepts the Chroma Amplitude and Velocity Error Corrector ac-

cessory known as "CAVEC" which is designed to eliminate the familiar saturation and hue errors often seen when replaying color tapes. Saturation banding is the result of differences in head-to-head frequency response, tape surface variations and tape-to-head contact differences. The effect is a change of chroma amplitude between bands, or even within a band. The CAVEC has the capability, unique to any device in its class, of correcting not only chroma errors between bands, but also correcting each line of a band, so that chroma errors within a band are also eliminated. Hue banding, or velocity error, results from differences in head scanning velocity between the record machine and the playback machine.

CAVEC is beneficial in producing multiple copies of tapes and in maintaining a consistent quality of replay of outside tapes. It also permits high quality replays of inter-spliced tapes recorded on different headwheels without the need for changing channel equalizer settings. The accessory is also desirable on PAL color standards. Choice of 3.58 MHz or 4.43 MHz subcarrier operation is accomplished through the normal machine standards switching.

**RCA**

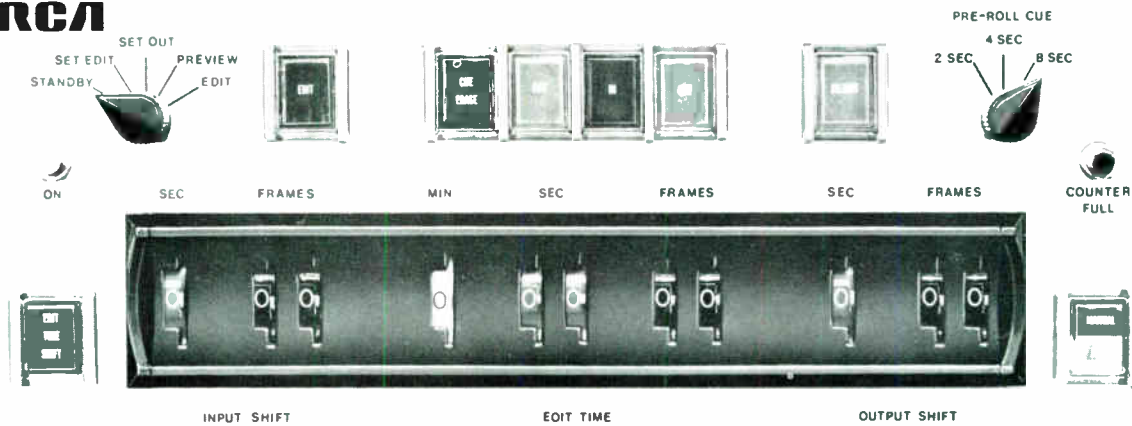

Tape Editing Programmer is used with Electronic Splicer to automate splicing function. This unit may be located remotely from the tape machine performing the editing.

**List of Accessories**

CAVEC .....	ES-43537	Spare Headwheel Panel .....	MI-40899-A
Color Dropout Compensator .....	ES-43538	Dolly Assembly .....	MI-40668
Electronic Splicer .....	MI-35961	Mechanical Splicer Table .....	MI-40592
Tape Editing Programmer .....	ES-591903	Mechanical Tape Splicer .....	MI-40772
Remote Control Panel (Mode) .....	MI-40691-B	(15 IPS) including developer	
Remote Control Panel (Signal) .....	MI-40692-B	Mechanical Tape Splicer .....	MI-40748
		(7½ IPS) including developer	

**Specifications**

**General**

Recording Medium .....	Magnetic tape 2" wide RCA type 7200 or equivalent	
	<b>50 Field</b>	<b>60 Field</b>
Tape Speed .....	15.6 in. (39.7 cm) 7.8 in. (19.8 cm)	15 in. (38.2 cm) 7½ in. (19.1 cm)
Picture-Sound Separation .....	14.8 frames sound leading, 29.6 @ 7½ in.	18.5 frames sound leading, 37 @ 7½ in.
Recording Time .....	92 min. on a 14 in. reel (7200 ft.) 184 @ 7½ in.	96 min. on a 14 in. reel (7200 ft.) 192 @ 7½ in.
Rewind Time .....	Approx. 5 min. for 7200 ft. reel	Approx. 4 min. for 7200 ft. reel
Recording Time Reference .....	To incoming video signal or an external reference	
Playback Time Reference .....	To an external reference or an internal precision oscillator	
Stopping Time .....	Less than .2 seconds from Record or Play mode	
Tape Interchangeability .....	Tapes made on any machine may be played back on any other machine providing they are made in accordance with all applicable SMPTE recommended practices and USASI standards.	

Tape Timer .....	Accumulated time measured in minutes and seconds. Accuracy within 3 seconds per hour.
Color Stability .....	±3 ns
Temperature .....	0°C to 45°C
Relative Humidity .....	20%-90%
Lock Up Time from Stop Mode for Stable Audio and Video; Color Mode .....	Less than 6 seconds, normal or half speed

**Input Signal Requirements:**

Video:	
Channel A .....	0.5 Volts to 1.4 Volts P/P composite signal terminated in 75 Ohms
Channel B .....	Same as Channel A
Audio:	
Channel A .....	Line input level between +4 and +36 dBm when bridging a 600 Ohm line. 600 Ohm termination available. May be reconnected for 600 or 150 Ohm matching input, balanced or unbalanced
Channel B .....	Same as Channel A
Cue .....	Same as AUDIO Channel A



Sync:  
 Channel A .....Negative polarity 3 to 5 Volts bridging or terminated in 75 Ohms  
 Channel B .....Same as Channel A  
 Burst Flag (PAL Systems) .....3.5-4.5 Volts p-to-p negative polarity, bridging or terminating impedance  
 Color Subcarrier .....1.5 to 2.5 Volts P/P bridging or terminated in 75 Ohms  
 RF Copy .....1 Volt P/P nominal terminated in 75 Ohms

**Output Signal Availability**

Video (Monochrome or Color)  
 Three line outputs .....Composite or non-composite 75 Ohms unbalanced  
 One monitor output .....Composite  
 Video level .....0.5 to 1 Volt P/P  
 Sync level .....0.2 to 0.4 Volt P/P  
 Pedestal level .....±20% of video level  
 Burst level .....0.2 to 0.4 Volt (color only)  
 Chroma level .....±20% of nominal (color only)

**Audio:**

One line output .....+18 dBm maximum into 150/600 Ohms balanced or unbalanced  
 One monitor output .....+37 dBm (5 Watts) maximum level into 8 Ohm speaker  
 Cue .....Same as AUDIO  
 Sync .....3 to 5 Volts P/P standard EIA signal  
 RF Copy .....1 Volt P/P, 75 Ohms terminated

**Electrical**

Power Requirements:  
 60 Hz .....117 Volts AC ±10% single phase 3.2 kW  
 50 Hz .....234 Volts AC ±10% single phase 3.2 kW

**Audio**

50/60 Hertz	Program	Cue
Frequency Response:		
15 IPS	±2 dB 50 Hz, 15 kHz	±2 dB, 50 Hz, 12 kHz except 36 dB notch at 240/250 Hz
7½ IPS	±2 dB 60 Hz, 10 kHz	±3 dB, 60 Hz to 10 kHz except 36 dB notch at 240/250 Hz

Flutter and WOW (RMS) 0.1% @ 15 ips 0.15% @ 7½ ips  
 (For components from 0.5 to 250 Hz)

**Signal-to-Noise:**

Audio .....Better than 55 dB, measured overall between a recorded level corresponding to 3% total rms distortion at 1000 cycles per second and noise present when playing back an erased unmodulated tape  
 Cue .....Better than 40 dB, measured overall between a reference 5% record level and the noise present when playing back an erased, unmodulated tape

**Mechanical**

Transport .....Centrally located at 45 deg. angle and at a reel height of 48" (122 cm)  
 Cooling .....Filtered, forced air  
 Dimensions: Width (overall) 55" (140 cm), Width (Less End Panels) 53" (134 cm), Height 71¼" (181 cm), Depth 26½" (67 cm)  
 Shipping Information: Width 61¼" (155.5 cm), Depth 35" (88.8 cm), Height 84" (213 cm), Volume 125 ft.<sup>3</sup> (3.75 M<sup>3</sup>), Gross Weight 1800 lbs. (816 kg)

**Video (Color System Characteristics)**

	Lowband		Highband	
	525/60	625/50	525/60	625/50
Frequency Response (100 kHz ref.)	±1 dB 30 Hz—3.8 MHz -3 dB max. at 4.2 MHz	±1 dB 25 Hz—4.5 MHz -3 dB max. at 5.0 MHz	±0.5 dB 30 Hz—4.1 MHz -3 dB max. at 4.5 MHz	±0.5 dB 25 Hz—5.5 MHz -3 dB max. at 6.0 MHz
Signal-to-Noise—(Normal Speed) (Peak-to-peak Video/RMS Noise on an interchange basis)	43 dB (Mono) 40 dB (Color)	42 dB (Mono) (Color) not applicable	46 dB	43 dB
Transient Response K-Factor				
2 T sine <sup>2</sup> test signal	2%	2%	1%	1%
20 T sine <sup>2</sup> test signal	1.5%	not applicable	1%	1%
Rise Time or Fall Time (20 ns or less on input)	120 ns max.	100 ns max.	110 ns max.	80 ns max.
Low Frequency Linearity	2% max.	2% max.	1% max.	1% max.
Differential Gain	3%	not applicable	3%	3%
Differential Phase	3° at 3.58 MHz	not applicable	3° at 3.58 MHz	3° at 4.43 MHz
Moire (Color bars, 75% modulation)	30 dB	not applicable	43 dB	34 dB

**Ordering Information**

Two basic models are available:  
 (1) a 525 line machine  
 (2) a switchable machine for 525/625/405 line operation

They may be ordered as follows:  
 For 525 line operation, specify ES-35977-D  
 For 525/625/405 line operation, 50 Hertz, specify ES-35979-D

## **RCA** Compact Color TV Tape Recording System, Type TR-60

- High gain servo
- Head resonance compensation
- Requires less floor space than any other color high band recorder
- Rear side master erase

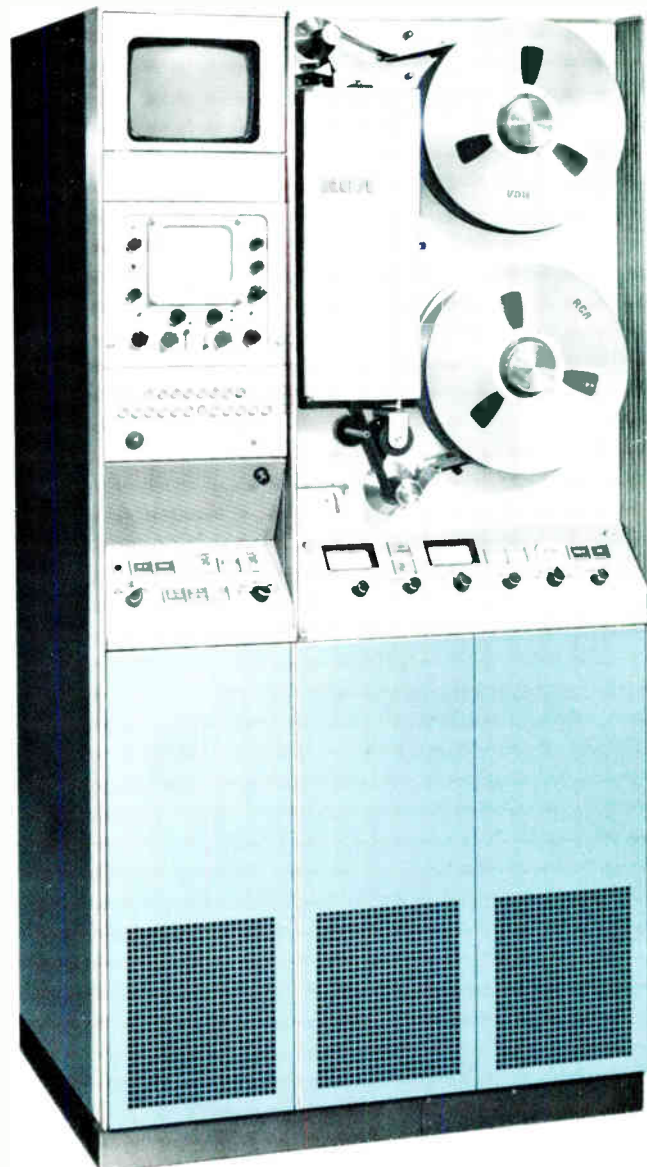

1158

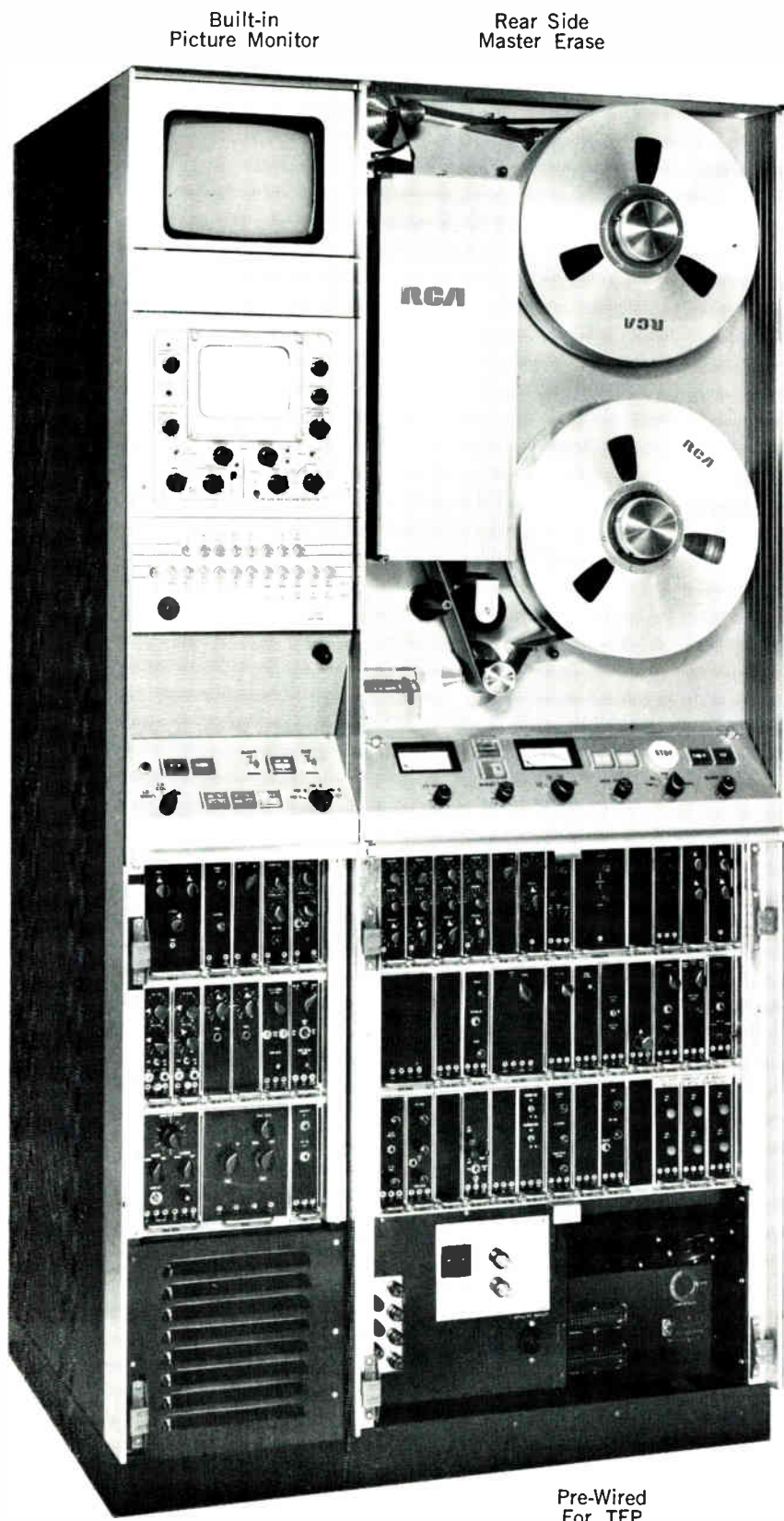

Built-in  
Picture Monitor

Rear Side  
Master Erase

Tape Motion  
Sensor

Built-in  
Waveform Monitor

Pushbutton  
Monitor  
Selection

External  
Scope Probe

Record Control Panel  
Highband Lowband Operation  
Non-Standard FM Indication

Servo Mode  
Selector

Anti-Resonance  
Adjustments

Crystal Deviation  
Settings for all Standards

Pre-Wired  
For DOC

Pre-Wired  
Splicer

Hi Gain  
HW Servo

Guide Servo

Available Accessories:

- Electronic Splicing
- Drop-out Compensator
- TEP
- CAVEC
- Record Current Optimizer

Pre-Wired  
For TEP

# Compact Color TV Tape Recording System, Type TR-60

## Description

The TR-60 is the most compact and inexpensive color highband/lowband machine available. It features many of the latest developments of larger, more expensive tape recorders such as rear side erase head, complete monitoring of all critical machine waveforms and video signals, accessible controls and prominent functional indication signals, high gain servo, and head resonance compensation. The machine has many new conveniences such as a tape motion sensor, utility power outlet for servicing, provision for accurately setting the position of the vertical interval, and three switchable composite or non-composite video outlets. It is prewired for rapid installation of four available accessories including electronic splicer, tape editing programmer, dropout compensator, and chroma amplitude and velocity error corrector.

### Switchable Standards

The new TR-60 is available in two models. The domestic NTSC model and the international NTSC/PAL model. Both machines incorporate circuitry to permit operation on 525 or 625 line standards. Automatically, the machine logic insures selection of correct deviation standards, correct video low pass filter, and other internal machine time changes required by the switch in standards.

### FM System Record

Operation on highband or lowband standards is selectable by an FM standards selector switch on the record panel. The combined video input circuitry and FM record and playback FM provide the highest degree of system linearity.

Input circuitry of the TR-60 provides for adjustment of video level and chroma level. Before the FM modulation process, a video low pass filter removes any spurious high frequency noise in the video signal.

FM modulation is achieved through a heterodyne modulator, insuring the lowest order of intermodulation distortion. Control of the modulator's oscillator frequency is accomplished through a crystal controlled AFC circuit with blanking level reference. A crystal controlled white reference pulse provides an accurate means for setting of the FM deviation. The FM signal with the necessary record process equalization is fed to the video heads through solid state record amplifiers.

To aid in the setting of individual record currents, a noise test position is provided that records a set carrier on the tape. When used with the Record Current Optimizer option, the adjustment takes approximately 30 seconds.

### FM System Playback

A low noise, high impedance preamplifier is the first in a series of FM amplifiers in the playback signal path. It contributes to the excellent signal-to-noise ratio and differential gain of the TR-60. To compensate for the resonance effects that would otherwise be introduced by the heads that are feeding this high impedance circuit, two anti-resonance (resistance and reactance) controls are provided. The two controls permit the operator to match the response of the heads individually and very accurately eliminate the differential banding from the machine. The individual frequency equalization of the four heads plus the overall FM equalization is accomplished through uniform phase equalizers. Automatic adjustment of the FM frequency response can be accomplished through the use of the CAVEC option.

Demodulation of the FM signal is accomplished through a pulse count demodulator. The low pass video filter following the demodulation process is of the Golay type with cut-off frequencies selected to give low K factor ratings, minimum chrominance/luminance delay, and excellent moire performance.

### Servo System

Selection of the servo replay mode is made by a convenient selector switch on the play control panel. Selection can be made of Tonewheel, Switchlock, Pixlock, Linelock, or NPC. The TW/SL positions are used in monochrome operation where the "off tape" horizontal sync phase is not controlled. Where production effects are required, or in color operation, Pixlock is the normal mode of operation. Linelock is a mode of operation that insures quick recovery of the servo lock during a non-synchronous switch. This mode is also used for color. The NPC mode is provided so that color dubs made by the heterodyne process can be replayed.

### Hi Gain Headwheel Servo

In the record mode, the TR-60 servo operates with a higher gain than in earlier machine models. This higher gain insures that the position of the vertical interval as it is recorded on tape is controlled to a tighter degree, and thus provides better electronic and mechanical splices.

As an option that is left to the customer's discretion, is the ability to record 15 Hz edit pulses. This permits the editing together of the correct color fields. The international machine edit pulse frequency when recording color is 12.5 Hz.

### Vertical Interval Positioning

As a further aid to operators, the small tonewheel markers that can be displayed on the monitor have a definite phase relationship to the recorded vertical position on tape. Thus, by correctly setting up the markers, all tapes are recorded uniformly with respect to the positioning of the vertical interval.

Day-to-day operational stability of the RCA servo is maintained through a few controls that seldom need to be adjusted.

### Time Base Correction

Correction of residual servo jitter and minute headwheel geometry differences is accomplished with ATC and CATC units that are electrically identical to those in use in the RCA TR-70 machines.

Control over horizontal phase, burst phase, and system phase is provided so that the tape signal can be considered completely synchronous with other signal sources. On international tape recorder systems, control is also provided over the burst quadrature.

The CATC unit supplied with the International TR-60 can operate on either NTSC or PAL coded color signals. It should be noted that in order to record PAL color signals correctly, it is necessary to have installed the CATC.

### Signal Processor

The TR-60 signal processor unit completely regenerates the horizontal sync, vertical sync pulses, and blanking. When used with a color signal, regenerated local subcarrier is "gated in" to form the color burst. The new burst is correctly positioned and contains the correct number of cycles of burst even if the original signal that was recorded was incorrect.

There are controls to regulate video level, setup, sync level, and burst level. Thus, the signal output of the tape machine is completely standard.

### Remote Control

Certain machine functions can be controlled from a remote position through the use of the RCA Remote Control Panels, or through the use of customer built panels. Functions that can be remotely are: Stop, Record, Play, Fast Forward, Rewind, Video Level, Setup, Sync Level, Burst Phase, and System Phase.

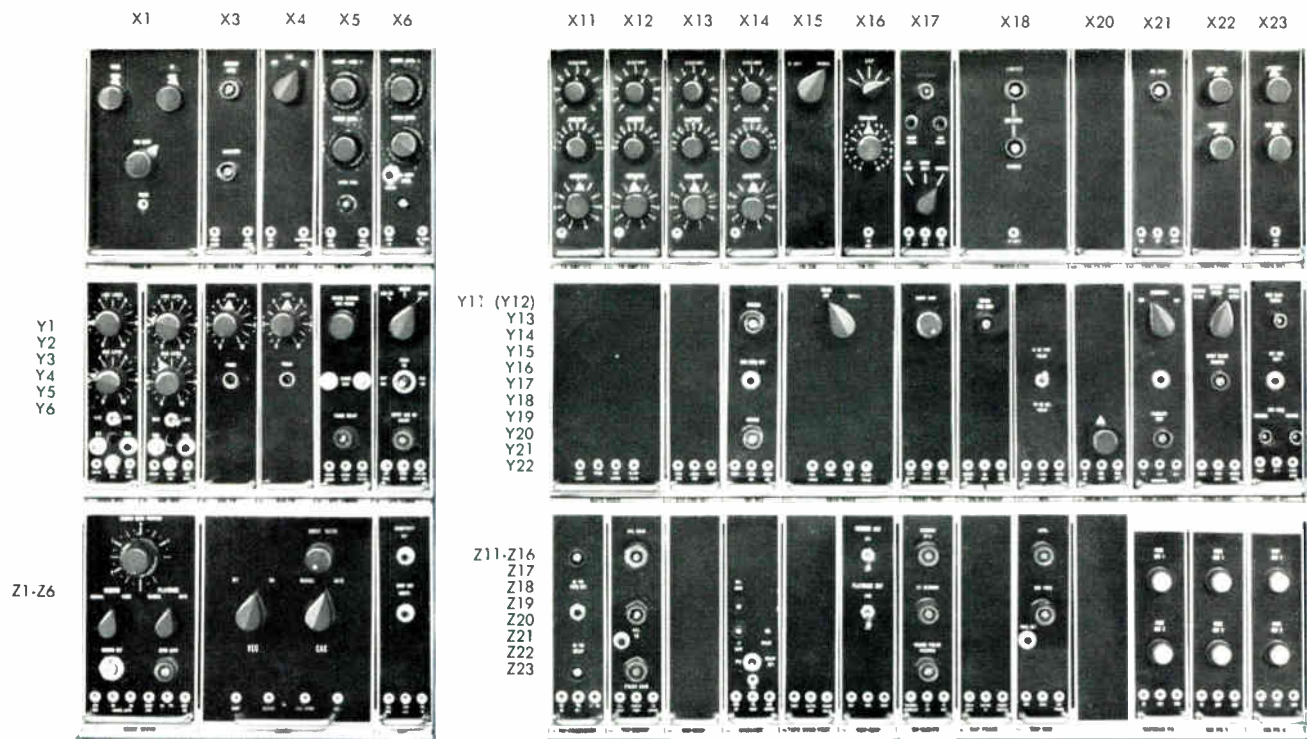

## Module Description

### X1—Video Input

Basically a video distribution amplifier with control over video level and high frequency response. A video low pass filter is also included to prevent high frequency noise from passing onto the modulator.

### X3—Modulator

Provides the heterodyne modulation system to change the video signal to an FM signal.

### X4—Modulator AFC

Provides the necessary clamp signals and DC voltages to control the blanking frequency of the modulator. The reference level being crystal controlled.

### X5—FM Reference

Provides the video pre-emphasis characteristics. Houses the channel 1 and 3 record amplitude controls. The crystals for the white reference markers are also contained in this module.

### X6—Record Switch

Houses the channel 2 and 4 record amplitude controls plus the individual 4 lead record amplifier drivers.

### X11/12/13/14—Playback Amplifier

Contains the playback amplifier for one each of the video heads. Variable compensation is provided for setting the head resonance and frequency response characteristics of each of the heads. An AGC system controls the level of the FM.

### X15—FM Switcher

Combines the output of the 4 individual heads into one continuous signal.

### X16—FM Equalizer

Provides for the overall equalization of the FM through the use of a cosine equalizer with variable frequency cutoff.

### X17—Dropout Compensator

This space is allotted to the dropout compensator option. Machine is prewired.

### X18—Demodulator

Provides limiting to the FM signal and employs a pulse count demodulation system to derive the AM video component.

### X20—Video Filter

Provides 2 video low pass filters to remove residual FM carrier and to pulse form the demodulated video.  $F_c = 4.2$  MHz and 4.5 MHz in domestic unit or  $F_c = 4.2$  MHz, 4.5 MHz, 5.0 MHz, 6.0 MHz in international model.

### X21—Post Emphasis

Supplies the necessary de-emphasis characteristics to the video signal prior to processing by the ATC, CATC, and video processor.

### X22—Video Processor

The regenerated blanking, burst chroma, and luminance signals are combined to form a non-composite signal.

### X23—Video Output

Sync is added to the non-composite signal from X22. Five video outputs are available at the output of the module, two are used internally and three are available for external use. The three external signals are selectable either composite or non-composite.

### Y1—Audio Record

Provides audio amplification and level control, bias and erase current. Audio only record is activated by a pushbutton on the module front.

### Y2—Cue Record

Same as for Y1.

Y11 (Y12)  
Y13  
Y14  
Y15  
Y16  
Y17  
Y18  
Y19  
Y20  
Y21  
Y22

Z11-Z16  
Z17  
Z18  
Z19  
Z20  
Z21  
Z22  
Z23

### Y3—Audio Output

Provides the audio line out with standard program levels.

### Y4—Cue Output

Same as for Y3.

### Y5 & 6—Splicer Modules

Space is provided for the Electronic Splicer option. Machine is prewired.

### Y11—ATC Video

Contains the variable delay line and video circuits associated with the ATC.

### Y13—ATC Error

Supplies and generates the ATC error signal that is used to modulate the ATC variable delay line.

### Y14—Internal Reference

Tape sync is processed to form reference pulses for the machine use. Pulses are timed through the use of a tapped delay line.

### Y15—CATC Video

Contains the variable delay line and driver circuits for the CATC.

### Y17—Burst Processor

Provides for the processing of both the local subcarrier and the off tape burst. This off tape processed burst is used in the CATC error detector and the CAVEC. The locally processed subcarrier is used in the CATC for the regenerated burst for the processor.

### Y18—Color Error

Generates the CATC error signal through comparison of off tape burst to the local subcarrier. The error signal modulates the variable delay line in the CATC video module.

### Y19—Non-Phased Color

Provides the necessary delay generators to permit the replay of a heterodyne dub.

## Monitoring

The TR-60 is equipped with an extensive system monitoring facility. The picture monitor can show the video signal at the input, demodulator output, ATC output, CATC output, and processor output as a normal picture or in the pulse cross position.

The waveform monitor is capable of monitoring 16 separate waveforms plus the expansion capability that is afforded by the use of an external probe facility.

## Standard Features

The TR-60 now has as standard features, the guide servo, 7½/15-inch operation, cue channel, indication of modulator AFC failure, rear side erase head, tape motion sensor, and indication of non-standard PAL operation. The operator-oriented, sloping control panels of the TR-60 follow in the footsteps of the big machines. Record and Playback controls are grouped and separated to elimi-

nate any possibility of error. Generous use of meters and status lights permits the operator to duplicate quality to many generations.

## Record Current Optimizer, ES-43563

The Record Current Optimizer (RCO) is a new accessory that can be added to the TR-60 to reduce the time required to optimize headwheel. By reducing the tape speed yet maintaining the normal headwheel rotation speed, a simultaneous record, replay system may be achieved. The RCO provides the necessary switching and gating signals so that when channel 1 is recording channel 2 is replaying the signal just recorded by channel 1, and so on. Thus during the optimizing process the peak RF level being recorded can be detected quickly and accurately set through the simultaneous replay facility. Installation of this accessory into the TR-60 requires both wiring harness and some module modifications.

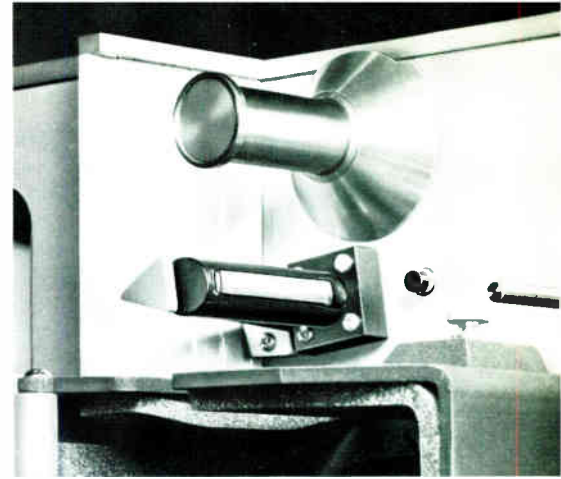

The use of a rear side erase head minimizes the possibility of scratching the oxide surface of the record tape.

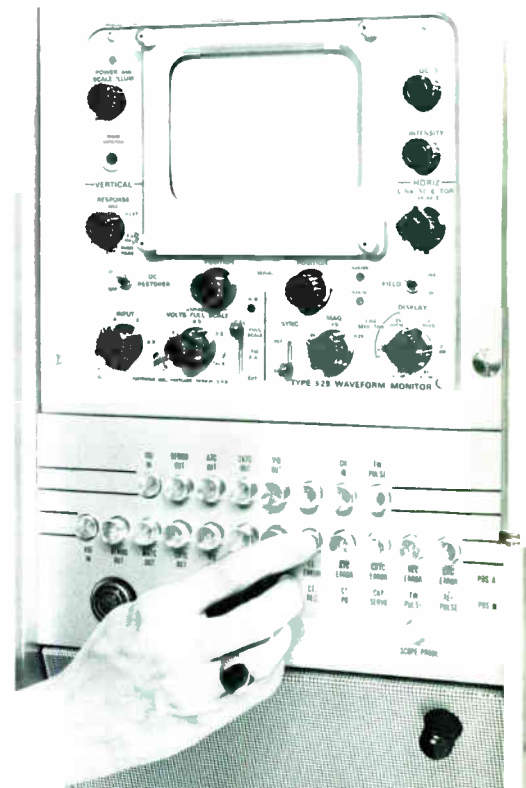

The wide range of built-in monitoring is further expanded through the use of an external scope probe. The probe can be used to view the waveforms at the module test points.

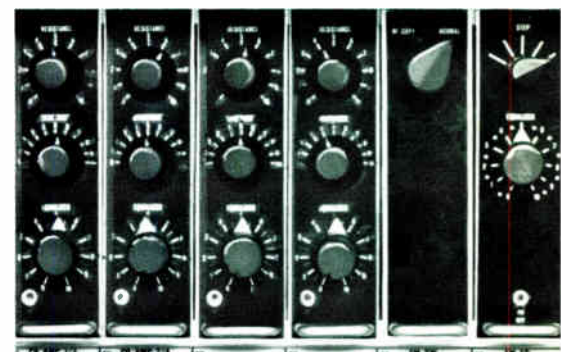

Ability to match the individual head responses is provided by the RESISTANCE, REACTANCE, and EQUALIZATION controls.

## Y20—Color Phase

Provides for the adjustment of burst phase and system phase.

## Y21—Vertical Advance

Provides the means to switch between 525 and 625 TV standards. Also provides the necessary counters to regenerate the vertical interval.

## Y22—Sync Logic

Generates horizontal and vertical blanking and combines them into composite blanking. Provides selection of house sync, gated sync or re-generated sync to be used in the video output module. Generates a start pulse to trigger the vertical advance circuitry.

## Y23—Horizontal AFC

Time base corrected tape sync is used to generate new horizontal sync, front porch, and horizontal blanking.

## Z1—Guide Servo

A servo unit to automatically position the vacuum guide in both the record and playback modes.

## Z3—CAVEC

Space is provided for the CAVEC option. Machine is basically prewired with some modification required to the FM equalizer and burst processor.

## Z7—Dropout Processor

Space is provided for this module which forms part of the Dropout Compensator option.

## Z11—TW Processor

Processes the tonewheel pulses and provides the 960 Hz for the FM switcher.

## Z12—TW Servo

Produces an error signal that controls the headwheel in playback and record.

## Z13—HW Modulator

Provides the amplitude modulated drive to control the headwheel. The O/P of this module feeds the H/W power amplifiers. Control is also provided over the recorded headwheel phase.

## Z14—Linelock

Provides the necessary headwheel phase control in the Pixlock and Linelock modes of playback operation.

## Z15—Tape Sync Processor

Provides noise immunity processing to the off tape sync.

## Z16—Reference Generator

Produces reference horizontal and vertical pulses from the incoming external composite sync.

## Z17—Control Track Record/Playback

Circuitry is provided to record and replay the control track signal.

## Z18—Capstan Phase

The control track pulses feed a chain of counters which eventually determine the capstan motor phase.

## Z19—Capstan Oscillator

This module contains the oscillator to drive the capstan motor. A DC error voltage controls the actual frequency of the oscillator.

## Z20/21/22—Power Amplifier

This module contains a power amplifier to drive the capstan or headwheel motors.

## Z29—PAL

The module is only used on international machines. When operating on PAL, certain machine operating parameters must change. These changes are accomplished with the PAL module circuitry.

## Modular Accessories for every taping need

### Cavec Accessory, ES-43537

When the ultimate in color quality is required, CAVEC through its line-by-line corrective action of both phase and gain variations of the color subcarrier, eliminates all but the most extreme errors. The velocity error corrector portion of the CAVEC unit insures that head-wheel velocity scanning errors due to differences in mechanical parameters between record and replay machines are reduced below the level of perceptibility,

even through multiple generations. Likewise, the line-by-line corrective action of the chroma amplitude corrector insures that both the band-by-band and the line-by-line chroma amplitude errors are corrected.

CAVEC is required on either the NTSC or PAL systems of color transmission. Installation of the CAVEC unit into the TR-60 can be accomplished in less than one hour.

### Electronic Splicer, MI-35961

Disturbance free splicing is assured through the use of the RCA Electronic Splicer. Set up and adjustment of the splicer can be accomplished with internally generated test signals. The overlap splicing technique utilized in the RCA Electronic Splicer insures that small mechanical differences between tape machines do not affect the quality of the splice. Any combination of Audio, Video,

and Cue recording can be accomplished with the Electronic Splicer.

When editing must be done, preserve tape life and reduce splicing time through the use of an Electronic Splicer. The Electronic Splicer can be fitted to a TR-60 in a matter of minutes with no modifications. The splicer works equally well on 525 or 625 line TV standards, monochrome or color.

### Dropout Compensator, ES-43538

The function of the Dropout Compensator (DOC) is to remove the visible disturbances caused by small head-to-tape contact discontinuities. Dropouts are characterized by a white or black flash that occurs instead of the original picture information. A memory system consisting of a glass delay line with an equivalent delay of one TV line is used to store video information for use when a dropout occurs. In effect, when a dropout in the RF exceeds a predetermined level, the

DOC inserts stored information from the previous line.

To set up the DOC to insure the levels are correct and the sensitivity of the unit is adjusted correctly, a dropout processor module is furnished along with the Dropout Compensator module.

When operating on NTSC standards, the DOC inserts color of the correct phase. On PAL standards, it is recommended that wide bandwidth monochrome only information be reinserted.

### Tape Editing Programmer, ES-591903

TEP extends the production capability of the TR-60 so as to provide accurate editing and production effects.

The TEP works in conjunction with the electronic splicer in determining the actual position of the splice position. By programming the TEP, splices to an accuracy of one TV frame can be accomplished. In addition to obtaining a high degree of splicing accuracy, the TEP permits the tape editor to preview the edits without destroying the original material. External cues are also available

automatically from the TEP electronics at 8, 4, and 2 seconds before the edit is made.

During the preview cycle, if the selected edit points are incorrect, a correction factor of  $\pm 3$  seconds in one frame increments is available. All of the timings required for the pre-programming of the TEP are provided by a single cue tone placed on the cue track approximately 14 seconds ahead of the ingoing splice point.

# Specifications

## General

Recording Medium	Magnetic tape 2" (50.80mm) wide RCA 7200 or equivalent	
	<b>60 Hz Field Rate</b>	<b>50 Hz Field Rate</b>
Nominal Tape Speed	15 in/sec (38.1 CM/sec)	15.6 in/sec (39.6 CM/sec)
	7.5 in/sec (19.05 CM/sec)	7.8 in/sec (19.8 CM/sec)
Picture Sound Separation	18.5 Frames Sound Leading at 15 IPS	14.8 Frames (235mm) Sound Leading at 39.6 CM/sec
	37 Frames Sound Leading at 7½ IPS	29.6 Frames (235mm) Sound Leading at 19.8 CM/sec
Recording Time	96 min. on a 14" reel (7200 ft.) at 15 IPS	92 min. on a 35.56 CM reel (2.194 KM) at 39.6 CM/sec
	192 min. on a 14" reel (7200 ft.) at 7.5 IPS	184 min. on a 35.56 CM reel (2.194 KM) at 19.8 CM/sec
Edit Pulse Frequency	30 Hz mono signals 30 Hz color signals	25 Hz lowband standard 12.5 Hz highband standard Phase of pulse in accordance with EBU standards 3084-E
Rewind Time	Approx. 4 min. for 7200' Approx. 5 min. for 2.194 KM	
Record Reference	To incoming video or external composite sync	
Playback Reference	To external reference or power line (color playback must be referenced to external)	
Stopping Time	Less than .2 secs. from record or play mode	
Tape Interchangeability:		
60 Hz Field Rate	Tapes that are recorded on the TR-60 are made in accordance with SMPTE recommended practices and USAS1 standards and may be replayed on any quadruplex machine meeting these standards	
50 Hz Field Rate	Tapes that are recorded on the TR-60 are made in accordance with EBU standards for Tape Recording 3084E and may be replayed on any quad- ruplex machine meeting these standards	
Tape Timer	Accumulated time measured in minutes and seconds to an accuracy of 3 secs. per hour at 15 IPS/ 15.6 IPS	

## System Performances Video

### 60 Hz Field Rate:

	<b>525 Low Band Mono</b>	<b>525 Low Band Color</b>	<b>525 Highband Mono/Color</b>
Deviation Standards	4.28 MHz-6.8 MHz	5.5 MHz-6.5 MHz	7.06 MHz-10.0 MHz
Bandwidth (100 kHz Reference)	±1 dB 60 Hz- 3.8 MHz -3 dB max. at 4.2 MHz	±1 dB 60 Hz- 3.8 MHz -3 dB max. at 4.2 MHz	±0.75 dB 60 Hz- 4.1 MHz -3 dB max. at 4.5 MHz
Rise and Decay Times	120 nsecs.	120 nsecs.	110 nsecs
Signal-to-Noise at 15 IPS (P-P video to RMS Noise on an interchange basis)	43 dB	40 dB	46 dB

## Playback Stability:

Monochrome Systems	Total jitter and geometric distortion over a 30 sec. period, 50 nsecs. peak-to-peak
Color Systems	Total phase jitter of the color subcarrier, 6 nsecs. peak-to-peak
Temperature Range	0°C-45°C
Relative Humidity	20%-90%
Lock Up Time for Synchronous Color Operation	Less than 6 secs. from stop
Burst Switching Angle for PAL Systems	±45°
Burst Flag for PAL Systems	4 V peak-to-peak

## Input Signal Requirements

### Video/Sync:

Video Signal Input	0.5 V to 1.4 V P-P composite signal unbalanced. Terminated in 75 Ohms ±1%
External Sync Input	Negative going 3-5 V P-P. Hi impedance bridge or terminate
Color Subcarrier Input	1.5-2.5 V P-P sine wave. Hi impedance bridge or terminate
Burst Flag (PAL Systems Only)	3.5-4.5 V P-P negative going. Hi impedance bridge or terminate

### Audio:

Line input level between +4 and +36 dBm when bridging a 600 Ohm line	600 Ohm termina- tion available. May be reconnected for 600 or 150 Ohm matching input balanced or unbalanced
Cue Signal Input Level	Same as for Audio Channel

### Power:

60 Hz	117 V ±10% single phase 3.2 KW Line Frequency 60 Hz ±2 Hz
50 Hz	230 V ±10% single phase 3.2 KW Line Frequency 50 Hz ±2 Hz

(one utility outlet is provided rated at 1 KW)

## Output Signals

### Video:

Outputs	Three individually selectable composite or non-composite, 75 Ohms unbalanced. 1 additional out- put used for internal monitoring
Video Level	0.5-1.0 V P-P
Sync Level	0.2-0.4 V P-P
Pedestal	±20% of video level
Burst Level	0.2-0.4 V P-P
Chroma Level	±20% of nominal

### Audio:

Outputs	One line, +18 dBm in 150 or 600 balanced or unbalanced, and one monitor, +37 dBm into internal 8 Ohm load. (Connections are available for external speaker). Audio Monitor output switchable to cue channel
---------	-------------------------------------------------------------------------------------------------------------------------------------------------------------------------------------------------------------------------

Cue ..... Same as for Audio



## System Performances Video

60 Hz Field Rate:  
(Continued)

	525 Low Band Mono	525 Low Band Color	525 Highband Mono/Color
K Rating 2T/20T (2T HAD 0.25 μsec)	2%/NA	2%/1.5%	1.5%/1.5%
Amplitude Linearity (Blanking to white)	1%	1%	1%
LF Tilt	1%	1%	1%
Moire (75% saturated color bars)	NA	30 dB	40 dB
Differential Gain (Blanking to white)	NA	Less than 5%	Less than 5%
Differential Phase (Blanking to white)	NA	Less than 5°	Less than 5°

50 Hz Field Rate:

	625 Line Low Band	625 Line Highband
Deviation	4.95 MHz-6.8 MHz	7.16 MHz-9.30 MHz
Bandwidth	±1 dB 50 Hz-4.5 MHz -3 dB max. at 5.0 MHz	±0.75 dB 50 Hz-5.5 MHz -3 dB max. at 6.0 MHz
Rise and Decay Time	100 nsecs.	80 nsecs.
Signal-to-Noise at 39.6 CMS (P-P video to RMS Noise on an interchange basis—unweighted)	42 dB	43 dB
K Rating 2T/20T (2T HAD = 0.2 μsec.)	2%/NA	1.5%/1.5%
Amplitude Linearity (Blanking to White)	2%	2%
LF Tilt	1%	1%
Moire (75% saturated color bars)	NA	32 dB
Differential Gain (Blanking to White)	NA	5%
Differential Phase (Blanking to White)	NA	5°

## Audio

	15 IPS/39.7 CMS	7½ IPS/19.8 CMS
Bandwidth	±2 dB 50 Hz-15 kHz	±2 dB 60 Hz-10 kHz
Wow and Flutter (for components 0.5 Hz to 250 Hz)	0.15%	0.2%
Signal-to-Noise (measured with reference to a level corresponding to 3% THD)	50 dB	

## Cue

	15 IPS/39.7 CMS	7½ IPS/19.8 CMS
Bandwidth	±2 dB 50 Hz-12 kHz with 36 dB notch at 240/250 Hz	±3 dB 60 Hz-10 kHz with 36 dB notch at 240/250 Hz
Wow and Flutter (for components 0.5 Hz to 250 Hz)	0.15%	0.2%
Signal-to-Noise (measured with reference to 5% THD at 1 kHz)	40 dB	

## Mechanical

Dimensions:	
Width	33" (84 cm)
Height with built-in casters	66" (168 cm)
Depth	24" (61 cm)
Shipping Information:	
Width	38¾" (98.2 cm)
Depth	29" (73.5 cm)
Height	77" (195 cm)
Volume	60.1 <sup>3</sup> (1.80 M <sup>3</sup> ) Gross
Weight	1200 lbs. (524.3 kg)

## Accessories

CAVEC	ES-43537
Color Dropout Compensator	ES-43538
Electronic Splicer	MI-35961
Remote Control Panel (Mode)	MI-40691-B
Remote Control Panel (Signal)	MI-40692-B
Spare Headwheel Panel, 10 mil	MI-40899-A
Spare Headwheel Panel, 5 mil	MI-40913-A
Mechanical Tape Splicer (15 IPS) including developer	MI-40772
Record Current Optimizer	ES-43563
Alignment Tape (525 line)	MI-41699
Alignment Tape (625 line)	MI-41698
Test Module Extender	MI-40649
Test Module Extender (Control Section)	MI-557301
CATC — NTSC Only	ES-591208
CATC — NTSC/PAL	ES-591209
Tape Editing Programmer	ES-591903

## Ordering Information

The Type TR-60 TV Tape Recorder is available for operation on 525/625 line tv standards. Normally color. Monochrome on request.

Two basic models are available:

- 525 60 Hz machine  
NTSC Color ..... ES-591910
- 525/625 50 Hz machine  
NTSC/PAL Color ..... ES-591912

All 405 and 819 Line Requirements on Request  
SECAM Requirements on Request

All models include the following equipment:

- 1 TV Tape Recorder (Cabinet Mounted) complete
- 1 Headwheel Panel Assembly
- 1 Kit of Maintenance Materials
- 1 High-Band Video Alignment Tape



## Low-Cost High Band Recorder, Type TR-50

- Switchable highband/lowband operation
- Color operation, choice of NTSC or PAL
- Requires less floor space than any other color high band recorder



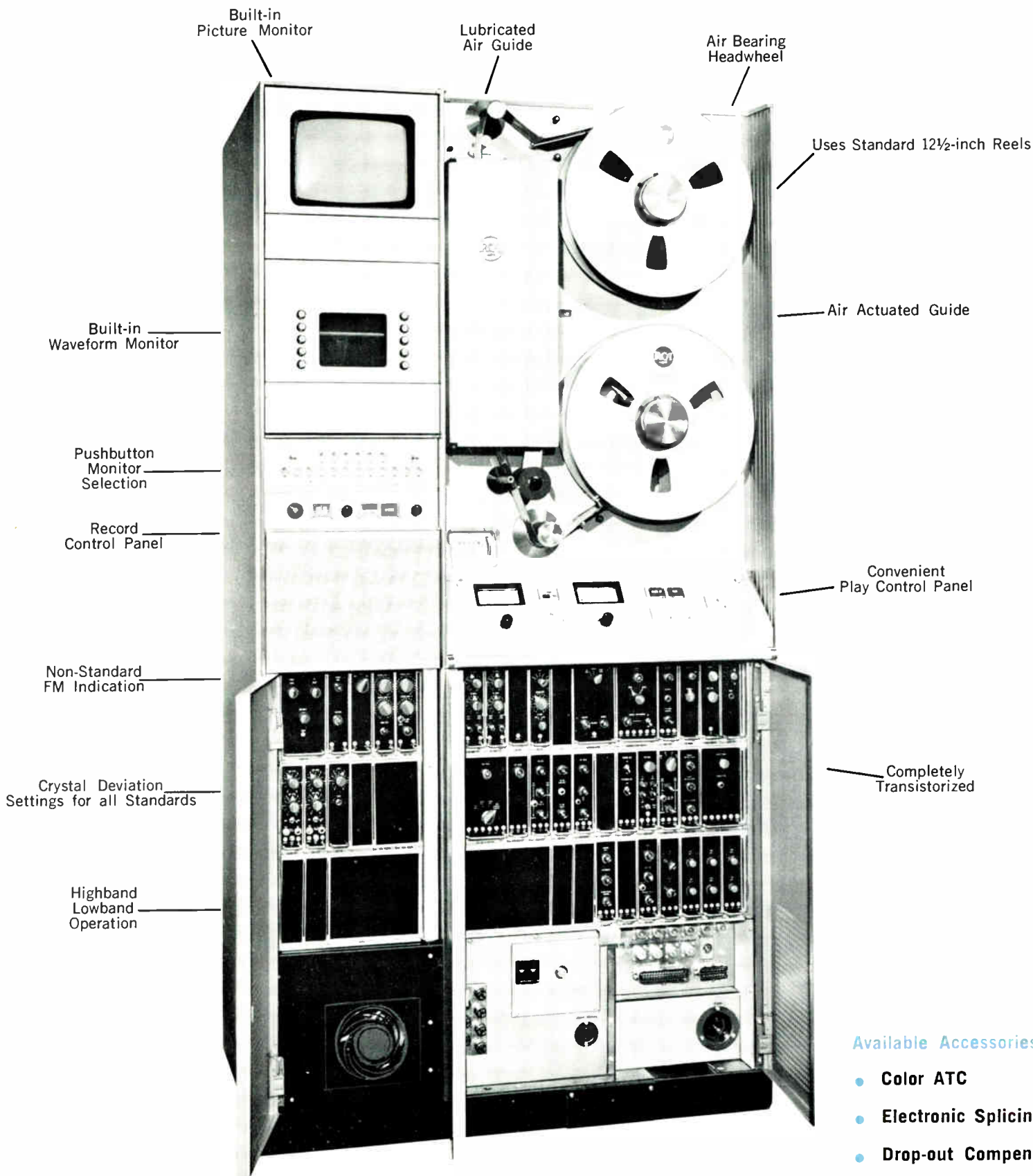

Built-in Picture Monitor

Lubricated Air Guide

Air Bearing Headwheel

Uses Standard 12½-inch Reels

Built-in Waveform Monitor

Air Actuated Guide

Pushbutton Monitor Selection

Record Control Panel

Convenient Play Control Panel

Non-Standard FM Indication

Crystal Deviation Settings for all Standards

Completely Transistorized

Highband Lowband Operation

Available Accessories:

- Color ATC
- Electronic Splicing
- Drop-out Compensator
- Guide Servo
- CAVEC

# Low-Cost High Band Recorder, Type TR-50

The RCA TR-50 is a compact, completely transistorized Television Tape Recorder. It is designed for High Band and Low Band applications and produces excellent tapes of uniform quality.

## Description

The TR-50 is the most compact and inexpensive color high band/low band machine available. Requiring only 5.5 square feet of floor space, this machine contains all the circuitry necessary for switchable high band/low band operation.

### High Band Standards

High Band standards have been incorporated in this model, to make the machine as new as tomorrow. The result is a new standard of excellence in a compact, completely self-contained Television Tape Recorder.

### Built-in Two Speed Operation

Circuits are provided in the TR-50 which allow for a choice of either the standard 15 inches per second operating speed, or a half speed operation of 7½ inches per second. The use of a narrow track headwheel in place of the headwheel normally supplied permits twice as much information to be recorded on the same length of tape. Thus substantial savings in tape stock can be realized.

### Switchable Standards

High Band, a new recording standard that utilizes higher FM deviation frequencies for both color and monochrome, is basic to the TR-50. The new standards are incorporated with the previously available standards for Low Band operation. The selection of the various recording and playback standards is accomplished by a single switch. All necessary circuitry changes are automatically selected to place both the record and playback electronics in the proper mode.

### High Band Headwheel

In order to make full use of the new deviation standards, the TR-50 uses the RCA High Band Headwheel Panel. This panel operates on both the high band and low band standards. The RCA High Band Headwheel is available for 7.5 IPS or 15 IPS operation. A feature of the RCA High Band Headwheel is the "Quadrature Free" factory setting of the four individual heads, eliminating the need for any field adjustments.

### Pixlock/LLO Servo

Four modes of operation are selectable on the TR-50. Tone Wheel and Switchlock are modes used when replaying monochrome tapes that do not require precise control of horizontal time base errors. Pixlock and Linelock are modes of operation that must be used when color operation is required. The Pixlock mode provides phasing of the off-tape horizontal and vertical sync with that of an external reference. Linelock provides only horizontal phasing of the off-tape sync; this mode is the suggested replay mode when replaying tapes that contain non-synchronous switching.

The RCA Servo System is one that requires a minimum of setup adjustments, combined with excellent day-to-day reliability.

### Built-in Audio Cue Channel

Every detail of the TR-50 is complete. The second audio channel is included as standard equipment. The Audio Cue Record/Playback unit permits the recording of cueing information along the edge of the tape. This information can be in the form of voice, tone or digital cues.

A special feature of the Audio Cue unit, as well as the standard program channel, permits independent recording of the audio signals without disturbing the prerecorded video.

### Built-in MATC

The RCA Monochrome Automatic Timing Corrector performs the function of electronically correcting time base errors. The correction signal is derived by comparing the time base errors off the tape to that of a fixed reference. The resultant picture, after correction, contains virtually no geometric errors. For color operation, it is necessary to further reduce the residual timing errors.

### CATC

The RCA CATC (Color Automatic Timing Corrector) further reduces the residual time base errors of the system to a figure required for playing back color recordings. Stabilization is achieved by measuring the residual jitter, after pre-stabilization by the MATC unit and then applying a further correction through an electronically variable delay line.

### Prewired for DOC/Splicing

The TR-50 has incorporated within the basic unit the wiring necessary for field installation of the Color Dropout Compensator and Electronic Splicer.

The Dropout Compensator detects a lack of signal from the tape and reinserts the missing information. The result is the extension of tape life and, of course, the highest quality color playbacks.

The Electronic Splicing accessory allows corrections, changes and/or additions to previously recorded material without physically cutting the recording medium. Although sup-

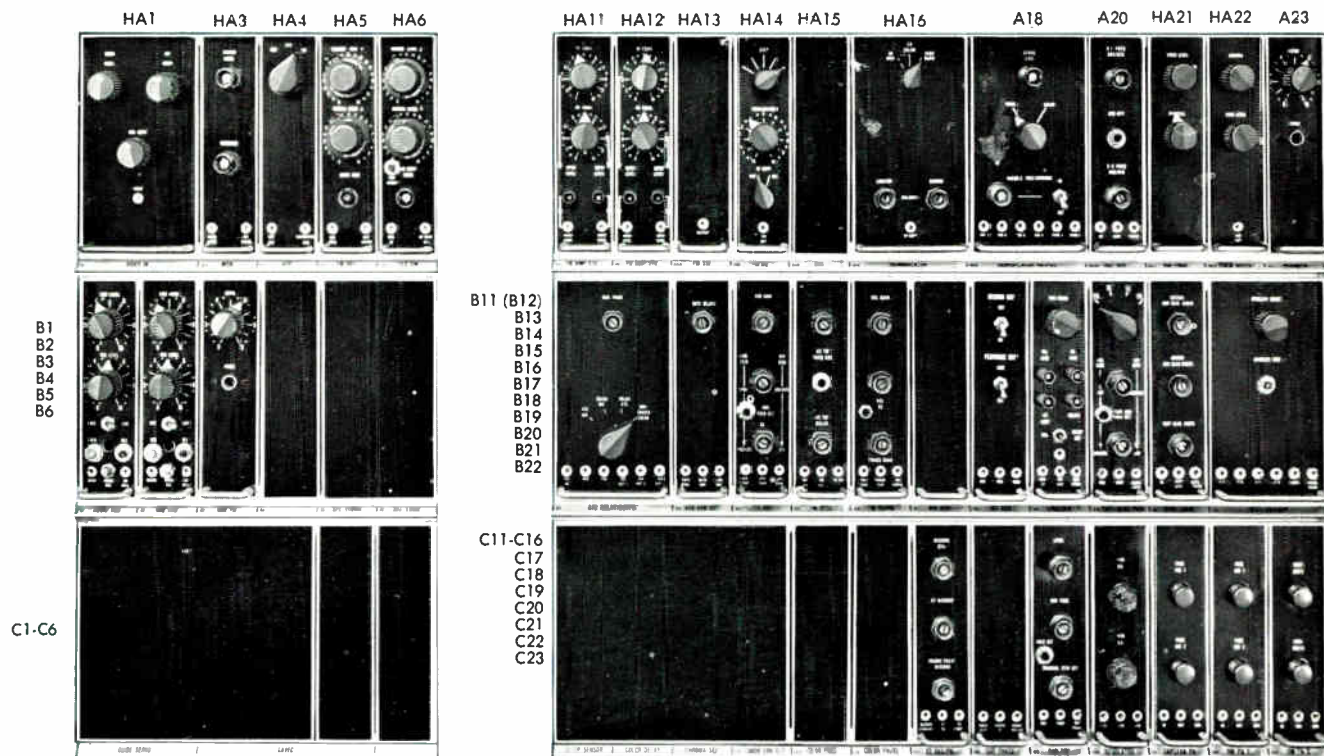

#### HA1—Video Input

A video distribution amplifier with controls for selecting unity gain or variable gain. Sets input level to the modulator.

#### HA3—Modulator

Clamps pre-emphasized video and modulates a dual heterodyne type modulator.

#### HA4—AFC

Maintains blanking level carrier frequency of the modulator to assure correct deviation regardless of sync amplitude variations.

#### HA5—FM Reference

Contains the necessary pre-emphasis networks for the various line and deviation standards. Contains crystals for correct setting of deviation standards. Provides the rose test facility for headwheel adjustment.

#### HA6—Record Switch

Provides white insert pulse for setting deviation. Also contains the four head drivers plus channels 2 and 4 level controls.

#### HA11—Playback Amplifier

Contains the playback amplifiers for Channels 1 and 3 with their associated controls for level and equalization.

#### HA12—Playback Amplifier

Same as HA11 but for Channels 2 and 4.

#### HA13—FM Switch

Combines the output of the 4 x 2 switcher in the head amplifier through an additional 2 x 1 switcher to reconstruct the FM signal.

#### HA14—FM Equalizer

Provides for the overall equalization of the playback FM signal.

#### HA15—Blank

Spare module space for optional DOC.

#### HA16—Demodulator

Demodulates and filters the playback FM signal. Provides for approximately 55 dB or limiting of the FM signal.

#### A18—Demodulator Output

Separates tape sync from tape signal and provides line drivers to feed unprocessed video to monitoring circuits and to processing amplifier. It also contains post-emphasis circuit.

#### A20—Horizontal AFC

Tape Sync from the demodulator output is used to control frequency and phase of a multivibrator. This, in combination with other circuits, generates a new horizontal sync, front porch, and blanking.

### HA21—Video Processor

### HA22—Video Output

### A23—Audio Playback

Provides audio output to the program line and provides a jack for the headphone monitor.

### B1—Audio Record

Provides the audio amplification, bias and erase current. A selector switch on the front permits selection of the microphone or the audio line input.

### B2—Cue Record

Provides the audio amplification, bias and erase current. A selector switch on the front permits selection of the microphone on the cue line input.

### B3—Cue Playback

Provides audio output to the cue line and provides a jack for the headphone monitor.

### B11-(B12)—ATC Delay and Output

Delay video is time modulated line-by-line in the variable delay line. Output line drives provide time corrected video signals for monitoring and processing.

### B13—ATC Error Detector

Generates error signal which is amplified (non-linearly) and fed to two phase splitters. Four error outputs drive the variable delay line.

### B14—ATC Reference

Contains AFC which may be locked to local sync signal or tape sync signal, ATC trapezoid is generated from ATC pulse. A clamp sync separator provides a time corrector sync output to the processing amplifier.

### B15—Tone Wheel Processor

Shapes the tone wheel pulse and provides 960 Hz switcher drive.

### B16—Tone Wheel Servo

Derives error signal controlling the headwheel motor in the tone wheel mode of operation.

### B17—Headwheel Modulator

Amplitude-modulates the headwheel motor drive sine waves. Gives wide-band, two-phase output for Scott-T transformer.

### B18—Reference Generator

Processes local sync to produce horizontal-rate reference, field-rate reference, and frame-rate reference. The module also processes the 60 Hz power line reference.

### B19—Linelock

Locks the machine to local horizontal and vertical sync signals to permit the use of special effects, fades, etc. Module includes automatic sensing to permit automatic drop-back to switch-lock whenever the signal is interrupted.

### B20—Tape Sync Processor

Processes tape sync to produce horizontal-rate reference, field-rate reference and frame-rate reference.

### B21—Sync Logic

Generates horizontal and vertical blanking; combines them into composite blanking. Combines tape sync and regenerated horizontal sync into composite regenerated sync. Generates a start pulse which phases the counting of the vertical advance circuitry.

### B22—Vertical Advance

Special circuitry counts out number of pulses in a field to accurately determine position for regenerated vertical blanking. It includes 3-position standards switch in switchable standards model.

### C1 thru C6—Spare Modules

### C11 thru C16—Color ATC

(Delete on Mono Systems)

### C17—Control Track Record/Playback Amplifier

The 240 Hz control track signal is amplified, filtered to produce clean 240 Hz sine wave, clipped, and shaped into a pulse.

### C18—Capstan Phase

The preceding pulse feeds a chain of binary counters which divide the pulse frequency by eight to produce a 30 Hz output pulse.

### C19—Capstan Oscillator

A phase detector which compares incoming pulse to local frame pulse and produces a DC voltage proportional to magnitude of the phase error. DC error voltage controls frequency of the oscillator which supplies the drive frequency for the capstan motor. Tape speed is thereby synchronized to local reference.

### C20—Regulator

Provides regulated voltages to operate the transistor circuitry of the machine.

### C21—Capstan Power Amplifier

PA for the capstan motor.

### C22—Headwheel Motor PA #1

Provides power to drive one phase of the Scott-T transformer which in turn drives the three phase headwheel motor.

### C23—Headwheel Motor PA #2

Provides power to drive one phase of the Scott-T transformer which in turn drives the three phase headwheel motor.

## FUNCTIONAL DIAGRAM

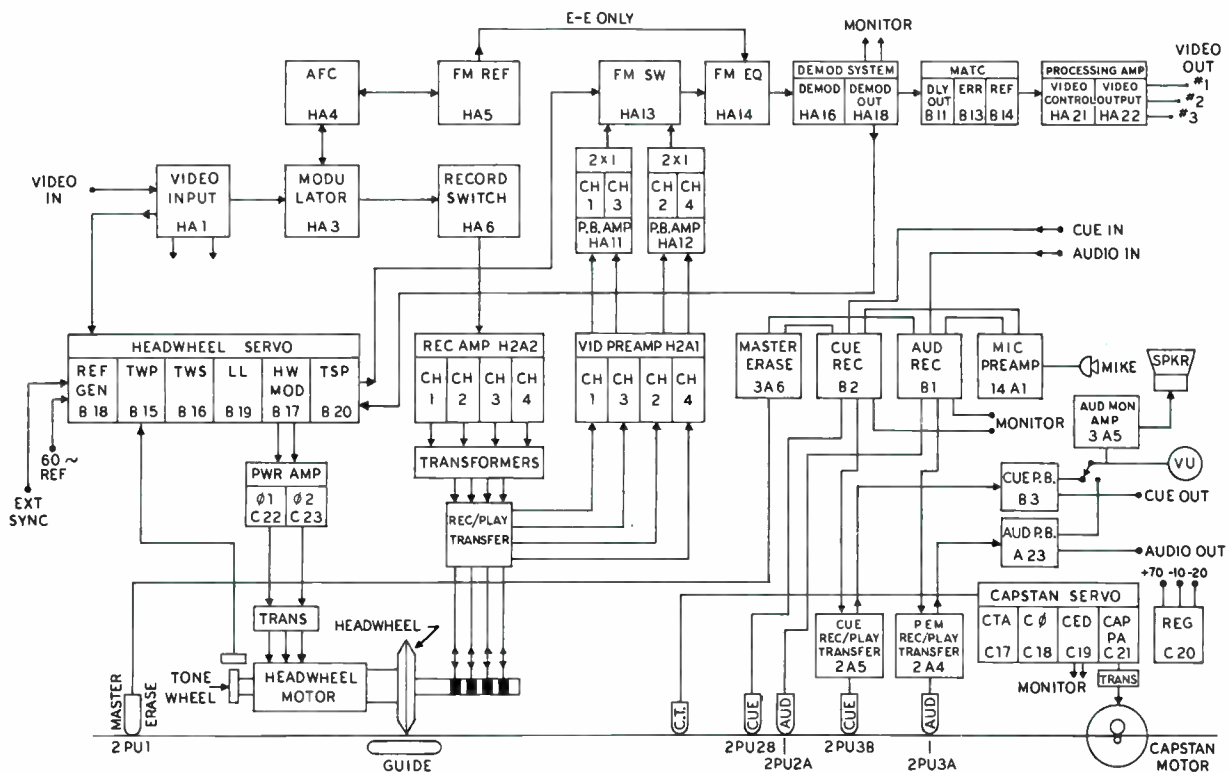

# Modular Accessories

for every tapping need

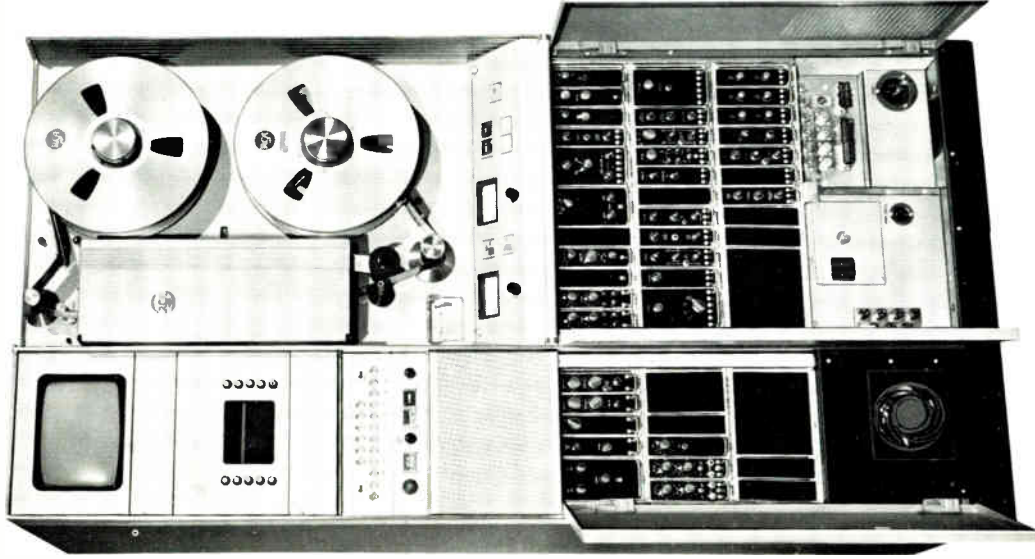

Guide Servo



CAVEC

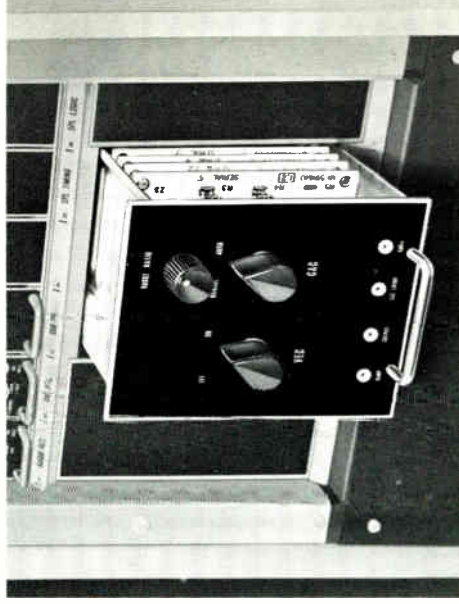

Color ATC

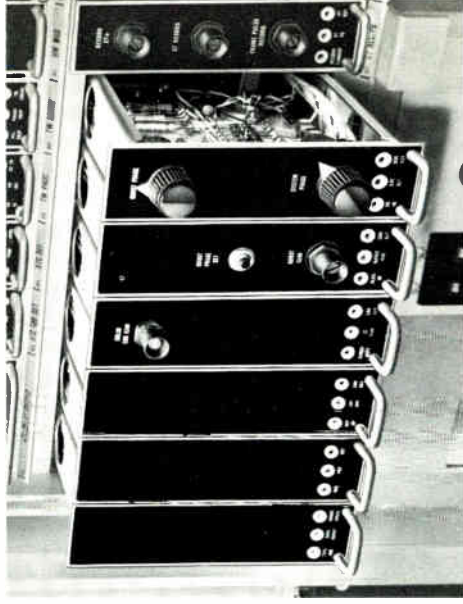

Drop Out Compensator



Electronic Splicing

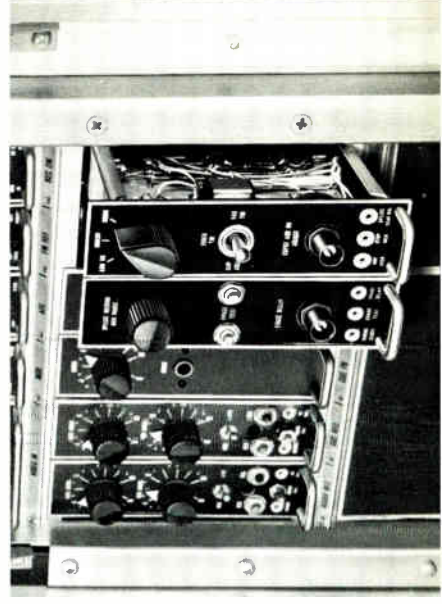

plied as an accessory, the wiring has been incorporated in the TR-50 to permit easy field installation.

### CAVEC

A unique accessory item, which may be incorporated in the TR-50, is the Chroma Amplitude and Velocity Error Corrector. The action of this accessory is twofold in that two types of errors are measured and corrected. The slight changes in tape to head contact, during record and playback, results in a variation in the chroma content of the signal. The Chroma Amplitude correction section of CAVEC accessory measures and equalizes these variations. The Velocity Error section of CAVEC measures and corrects for changes in head velocity that occur during record and playback which

result in banding within the picture. The CAVEC accessory is available for use with the TR-50 and space within the cabinet is available for mounting the modular unit.

### Guide Servo

The guide servo accessory, when incorporated in the TR-50, accurately positions the vacuum guide to eliminate picture skewing.

The guide servo can operate in any of four modes. The first mode, called AUTOMATIC, is the servo mode which automatically measures and corrects for skewing in the picture. The second mode, MANUAL, bypasses the servo and permits the operator to manually position the guide. The third mode, RECORD, is identical to manual, except the

guide control is preset to a fixed position. The fourth mode, RECORD SET, is included to allow the operator to set penetration for recording by activating the record control during tape playback.

### Additional Accessories

Other accessory units are available for use with the TR-50. These include remote control panels for control of the tape recorder from remote locations. Two panels are available, one to control the operating mode of the machine and a second to control the signal levels from the machine. In addition, narrow track headwheel panels are available for utilizing the slower tape speed of 7½ IPS. Video alignment tapes are available for determining standard penetration.

## Specifications

### General

Recording Medium .....	Magnetic tape 2" wide RCA 7200 or equivalent	
	<b>60 Field</b>	<b>50 Field</b>
Tape Speed .....	15 in. (38.2 cm) 7½ in. (19.1 cm)	15.6 in. (39.7 cm) 7.8 in. (19.8 cm)
Picture-Sound Separation .....	18.5 frames sound leading, 37 @ 7½ in.	14.8 frames sound leading, 29.6 @ 7½ in.
Recording Time .....	96 min. on a 14 in. reel (7200 ft.) 192 @ 7½ in.	92 min. on a 14 in. reel (7200 ft.) 184 @ 7½ in.
Rewind Time .....	Approx. 4 min. for 7200 ft. reel	Approx. 5 min. for 7200 ft. reel
Recording Time Reference .....	To incoming video signal or an external reference	
Playback Time Reference .....	To an external reference or AC line	
Stopping Time .....	Less than .2 seconds from Record or Play mode	
Tape Interchangeability.....	Tapes made on any machine may be played back on any other machine providing they are made in accordance with all applicable proposed SMPTE recommended practices and proposed ASA standards.	
Tape Timer .....	Accumulated time measured in minutes and seconds. Accuracy within 3 seconds per hour.	
Stability (with CATC)		
Total jitter and geometric distortion .....	±3 ns peak-to-peak	
Temperature .....	0 C to 45 C	
Relative Humidity .....	20%-90%	
Lock Up Time from Stop Mode for Stable Audio and Video; Color Mode .....	Less than 6 seconds, normal or half speed	

Lock Up Time from Stand-by or Set-up for Stable Operation .....	Less than 5 seconds normal or half speed
--------------------------------------------------------------------	---------------------------------------------

### Signal Levels

Input Signal Requirements:	
VIDEO .....	Input signal level may be between .5 Volt p/p and 1.4 Volts p/p composite signal. Signal terminated in 75 Ohms
AUDIO .....	Line input level between -20 dBm and +18 dBm into a 10,000 Ohms balanced bridging impedance
Subcarrier .....	For color operation, 2 V peak-to-peak
Burst Flag (PAL only) .....	4 V peak-to-peak
Sync .....	Negative polarity 3 to 5 Volts p/p, loop through or terminated in 75 Ohms
RF Copy .....	.8 to 1.2 Volts, 75 Ohm terminated
Output Signal Availability:	
VIDEO-MONOCROME or COLOR (Processed):	
Three Line Outputs .....	Individually selectable— composite or non-composite
One additional composite line used internally for monitoring	
Video level .....	.05 to 1 Volt P/P
Sync level .....	.02 to 0.4 Volt P/P
Pedestal level .....	±20% of video level
Burst level .....	.02 to 0.4 Volt (color only)
Chroma level .....	±20% of nominal (color only)
AUDIO:	
One line output: +18 dBm max. into 150/600 Ohms bal- anced or unbalanced line	
One phone jack output for high impedance phones	
Cue .....	Same as AUDIO
Sync .....	.3 to 5 Volts P/P standard EIA signal
RF Copy .....	.1 Volt P/P, 75 Ohms terminated

## ACCESSORIES

CAVEC .....	ES-43532	Alignment Tape (525 line) .....	MI-40793
Color Dropout Compensator .....	ES-43549	Alignment Tape (625 line) .....	MI-40797
Electronic Splicer .....	MI-43568	Test Module Extender .....	MI-40649
Remote Control Panel (Mode) .....	MI-40691-A	Test Module Extender .....	MI-557301
Remote Control Panel (Signal) .....	MI-40692-A	(Control Section)	
Spare Headwheel Panel, 10 mil .....	MI-40899	CATC — NTSC .....	ES-43599
Spare Headwheel Panel, 5 mil .....	MI-40913	CATC — PAL .....	ES-43543
Mechanical Tape Splicer .....	MI-40772	Guide Servo .....	MI-35891
(15 IPS) including developer			



### Video (Color System Characteristics)

	525/60	Lowband 625/50	Highband 525/60	Highband 625/50
Frequency Response (100 kHz ref.)	±1.5 dB to 3.8 MHz -3 dB max. at 4.2 MHz	±1.5 dB to 4.5 MHz -3 dB max. at 5.0 MHz	±1.5 dB to 3.8 MHz -3 dB max. at 4.2 MHz	±1.5 dB to 4.5 MHz -3 dB max. at 5.0 MHz
Signal-to-Noise—(Normal Speed) Peak-to-Peak Video/RMS Noise on an interchange basis	Better than 42 dB (Mono) Better than 39 dB (Color)	Better than 37 dB (Mono)	Better than 43 dB	Better than 40 dB
Transient Response (2 T sine <sup>2</sup> input)	Less than 3%	Less than 3%	Less than 3%	Less than 3%
Rise Time or Fall Time (20 ns or less on input)	120 ns max.	120 ns max.	120 ns max.	120 ns max.
Low Frequency Linearity (Blanking to White)	2% max.	2% max.	2% max.	2% max.
Differential Gain (Blanking to White)	Less than 10%		Less than 10%	Less than 10%
Differential Phase	Less than 10°		Less than 10° at 3.58 MHz	Less than 10° at 4.43 MHz
Moire (Color bars, 75% modulation)	30 dB or better		40 dB or better	28 dB or better

### Audio

50/60 Hertz	Program	Cue
Frequency Response:		
15 IPS	±2 dB 50 Hz, 15 kHz	±2 dB, 50 Hz, 12 kHz except 36 dB notch at 240/250 Hz
7½ IPS	±2 dB 60 Hz, 10 kHz	±3 dB, 60 Hz to 10 kHz except 36 dB notch at 240/250 Hz
Flutter and WOW (For components from 0.5 to 250 Hz)	0.2% RMS	0.2% RMS
Signal-to-Noise: Audio	Better than 50 dB, measured overall between a recorded level corresponding to 3% total rms distortion at 1000 Hz and noise present when playing back an erased unmodulated tape	

Cue .....Better than 40 dB, measured overall  
between a reference 5% record level and the noise  
present when playing back an erased, unmodulated tape

### Electrical

Power Requirements:  
60 Hz .....117 Volts AC ±10% single phase 2.5 kW  
50 Hz .....234 Volts AC ±10% single phase 2.5 kW

### Mechanical

Dimensions: Width 33" (84 cm), Height (with built-in casters)  
66" (168 cm), Depth 24" (61 cm)

Shipping Information: Width 38¾" (98.2 cm), Depth 29" (73.5  
cm), Height 77" (195 cm), Volume 60.1 ft.<sup>3</sup> (1.80 M<sup>3</sup>), Gross  
Weight 1085 lbs. (491.9 kg)

## Ordering Information

The Type TR-50 TV Tape Recorder is available for  
operation on 525, 625, 405 and 819 line tv standards.  
Can be supplied as color or monochrome equipment.

Two basic models are available:  
(1) a 525 line machine  
(2) a switchable machine for 525/625/  
405 or (optional 819) line operation  
They may be ordered as follows:  
For 525 line operation, specify  
ES-43571-HB  
For 525/625/405 line operation, 50 Hz,  
specify ES-43573-HB-405  
For 525/625/819 line operation, 50 Hz,  
specify ES-43573-HB-819

All models include the  
following equipment:

- 1 TV Tape Recorder  
(Cabinet Mounted) complete
- 1 Headwheel Panel Assembly
- 1 Kit of Maintenance Materials
- 1 Monochrome Video Alignment Tape



**RADIO CORPORATION OF AMERICA**  
BROADCAST AND COMMUNICATIONS PRODUCTS DIVISION, CAMDEN, N. J. 08102

PRINTED  
IN  
U.S.A.

## **RCA** Mobile TV Tape Recorder, Type TR-5

- Compact, quadruplex recorder on wheels
- Makes tapes for broadcast and closed circuit
- Records both monochrome and color pictures

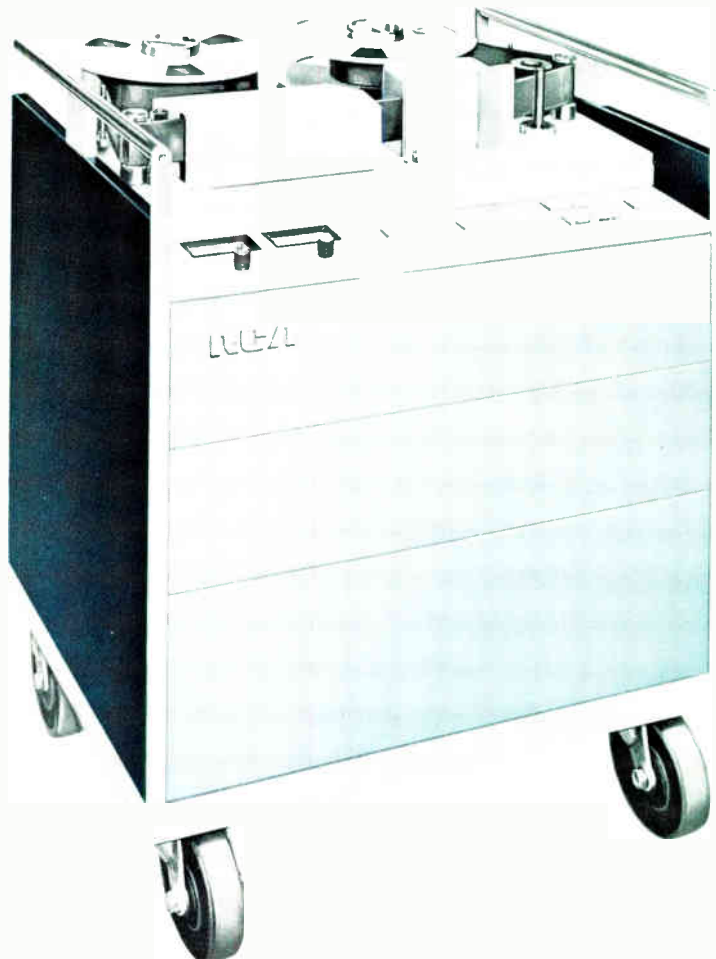

# Mobile TV Tape Recorder

for making quadruplex tapes in studio or field

Standard  
12½-inch Reels

Master  
Erase Indicator

Built-in  
Switchlock

Switchable  
Standards

Fully  
Transistorized

Two-speed  
Operation

Built-in Playback  
Reference

Interchangeable  
Plug-in Modules

Compact ...  
Easily Transportable

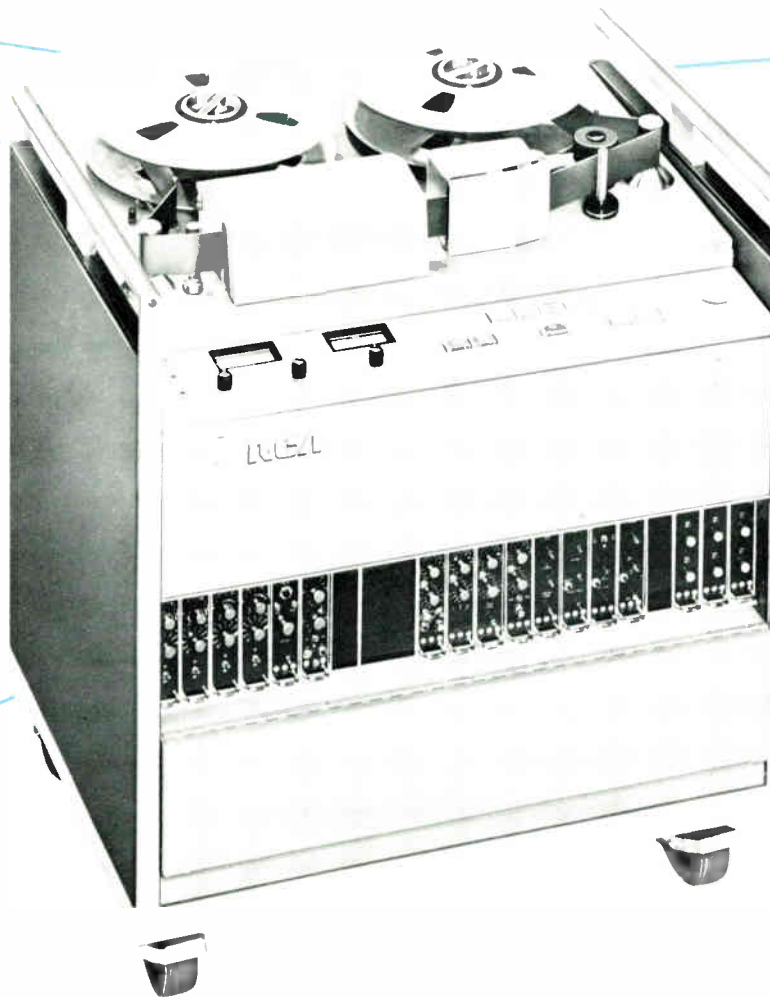

## Available Accessories:

- Electronic Splicer
- Audio Cue Record/Playback Channel
- Remote Control
- Tape Counter

## COMPACT QUADRUPLEX RECORDER FOR A VARIETY OF APPLICATIONS

### Mobile Recording



### Educational TV Programming

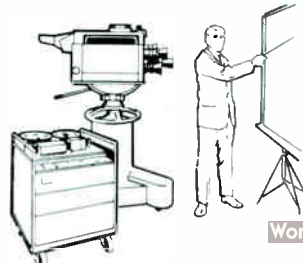

### Tape Duplication



### Client Presentations

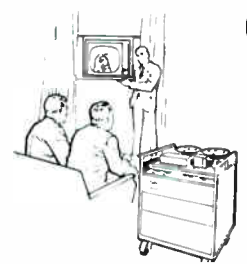

## Mobile Tape Recorder, TR-5

The TR-5 TV Tape Recorder "on wheels" is an RCA "New Look" equipment especially designed for recording of video tapes, color and monochrome, at various locations in the plant or in the field. It is small in size and mounted on casters for easy movement from one location to another. The recorder conforms to highest

broadcast standards. Tapes recorded on it are fully compatible with all standard broadcast quadruplex recorders. For closed circuit applications it comprises a complete recording and playback facility. It may also be used for on-air playback by adding a signal processing amplifier.

### Description

The RCA Type TR-5 TV Tape Recorder is engineered to produce TV Tapes that faithfully reproduce the high quality monochrome and color pictures now provided by new, improved TV Cameras. It employs standard RCA transistorized, interchangeable modules. It accommodates cue record/playback and electronic splicer accessories.

#### Switchable Standards

The TR-5 is equipped for operation on international (switchable) or domestic standards. To change from one standard to another, an operator merely moves the standards selector switch to the desired position. This master circuitry provides instantaneous switchover from 525 to 625 to 405 TV line standard.

#### Built-In Two Speed Operation

Circuits to permit choice of operating speeds, 15 or 7½ inches per second, are built into the TR-5. Recording time of up to 60 minutes at 15 IPS and 120 minutes at 7½ IPS is possible with the 12½-inch tape reels.

#### Transistorized for Reliability

Advanced transistorized modular circuits are used through the TR-5. These solid state circuits operate on lower voltages and require much less power and generate less heat. As a result power supplies are small, efficient units, and air conditioning requirements are reduced. Transistors have proved extremely reliable and stable. All TR-5 circuits are conservatively rated, and permit semi-automatic "pre-set" type of operation. Warm-up

time is greatly reduced, practically eliminated, since no warm-up cycle is required.

#### Record/Playback Circuitry

The record circuitry of the TR-5 includes a standard modulator and four standard record amplifiers. Each of the amplifiers provide quadrature delay as well as FM level control. Color or monochrome video signals are recorded with amazing realism.

The playback circuitry involved includes playback quadrature delay, four-channel equalization and head switching. Switchlock is also featured as part of the basic machine. For direct on-air broadcasts it is recommended that a signal processing amplifier be utilized. The equipment is designed with built-in audio playback for line drive as well as earphone level monitoring. Stable video playback of any properly recorded quadruplex tape is achieved.

#### Compact-Transportable

The Tape Recorder is contained in a small cabinet on casters measuring only 31 inches high (37 inches with casters), 33 inches wide and 24 inches deep. It weighs approximately 475 pounds. It may readily be moved from one studio to another or transported to remote locations.

#### Ease of Servicing

TR-5 modules can be easily removed for repair or replacement. They may also be checked without removing through use of module extenders supplied with the equipment. Spares can be inserted as

fast as one can pull out the module and plug in another. This standardization of modular circuits permits interchange of many modules between various RCA models in multiple equipment installations. Furthermore, complete modular spares can be stocked for emergency use.

#### Horizontal Tape Transport

The low contour of the TR-5, so essential for ease of transportation to remote locations has been achieved not only by the compact transistorized circuitry, but also by a horizontally mounted tape transport. This transport has all the conveniences and fine performance qualities of the TR-3 and TR-4 Tape Recorders. Air lubricated guide posts provide long tape life, while tapered guide post flanges aid tape threading. The transport panel is hinged for complete access to components.

#### Finger Tip Controls

Push-button operating controls are conveniently located. They afford complete mode control of play, record, fast forward, fast reverse and stop. In addition there is a two-speed indicator, local and remote switch, audio/mike switch and (tone wheel/switchlock) indicator. A switchable audio-video VU meter and metering facilities for control track phasing can also be used for measuring sync tip frequency. Three front panels provide complete access to mode control modules, the module bank, and the base of the equipment where power supply and air system are located.

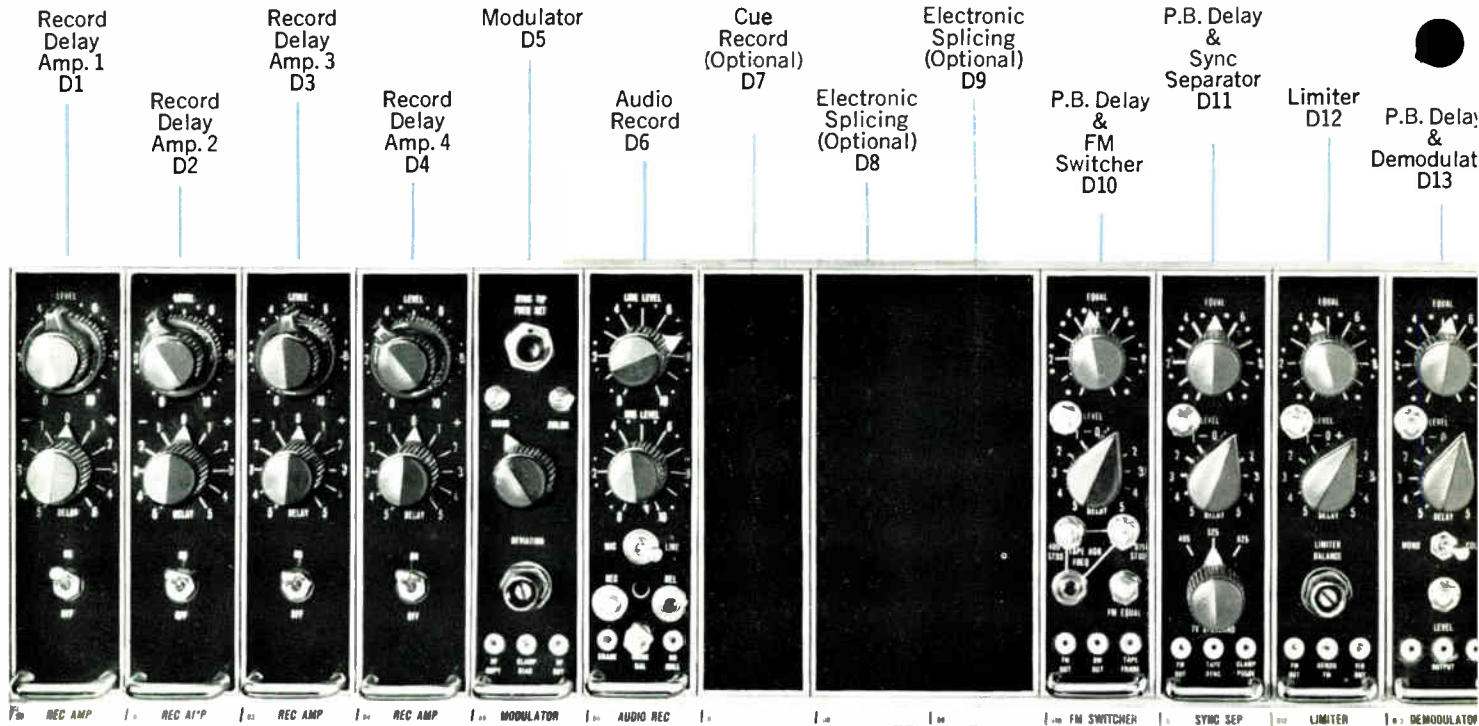

## TR-5 Module Bank... Description of Functions

### D1—Record Delay Amplifier #1

The Record FM signal is increased in level to a value sufficient for recording on tape and adjustable delays are introduced to compensate for head quadrature errors.

### D2—Record Delay Amplifier #2

Same functions as D1.

### D3—Record Delay Amplifier #3

Same functions as D1.

### D4—Record Delay Amplifier #4

Same functions as D1.

### D5—Modulator

Input video is pre-emphasized, clamped at the sync-tip level and used to modulate a capacity-diode-controlled heterodyne modulator. Circuitry is included for RF copy facility.

### D6—Audio Record

Provides audio record bias and erase currents. The microphone input control is included in the module.

### D7—Cue Record (Optional)

Space is provided in the TR-5 for the accessory Cue Record Module.

### D8—Electronic Splicing (Optional)

Space is provided for the accessory Splice Timing Module.

### D9—Electronic Splicing (Optional)

Space is provided for the accessory Splice Logic Module.

### D10—FM Switcher

This module includes a 2x1 switching circuit which alternately connects heads 1 and 3 and heads 2 and 4 to the output. Also included are tape sync processing circuits that produce horizontal-rate reference, field-rate reference and frame-rate reference. The playback delay amplifier, FM equalizer and FM level control for Head #1 are located in this module.

### D11—Sync Separator

This module includes a sync separator and circuitry to provide the switching pushout pulse. The playback delay amplifier, FM equalizer and FM level control for Head #2 is included.

### D12—Limiter

Module includes limiting circuits where the FM signal is converted to push-pull, passed through several stages until overall limiting character-

istic of at least 55 dB is achieved. The playback delay amplifier, FM equalizer and FM level control for Head #3 is included.

### D13—Demodulator

The Playback delay amplifier, FM equalizer and FM level control for Head #4 is included in this module which accepts signal from limiter and contains demodulator and output filter circuits. Provides output line driver.

### D14—Control Track & Record/Playback

The 240 Hz control track signal is amplified, filtered to produce a clean 240 Hz sine wave, clipped, and shaped into a pulse. The pulse is then fed to a chain of binary counters that divide the pulse frequency by eight to produce a 30-Hz output pulse. Switchlock circuitry is also provided in this module.

### D15—Capstan Oscillator

Acts as a phase detector which compares incoming pulse to the local frame pulse and produces a DC voltage proportional to the magnitude of the phase error. The DC error voltage controls the frequency of the oscillator which supplies the drive frequency for the capstan motor. Tape speed is thereby synchronized to local reference.

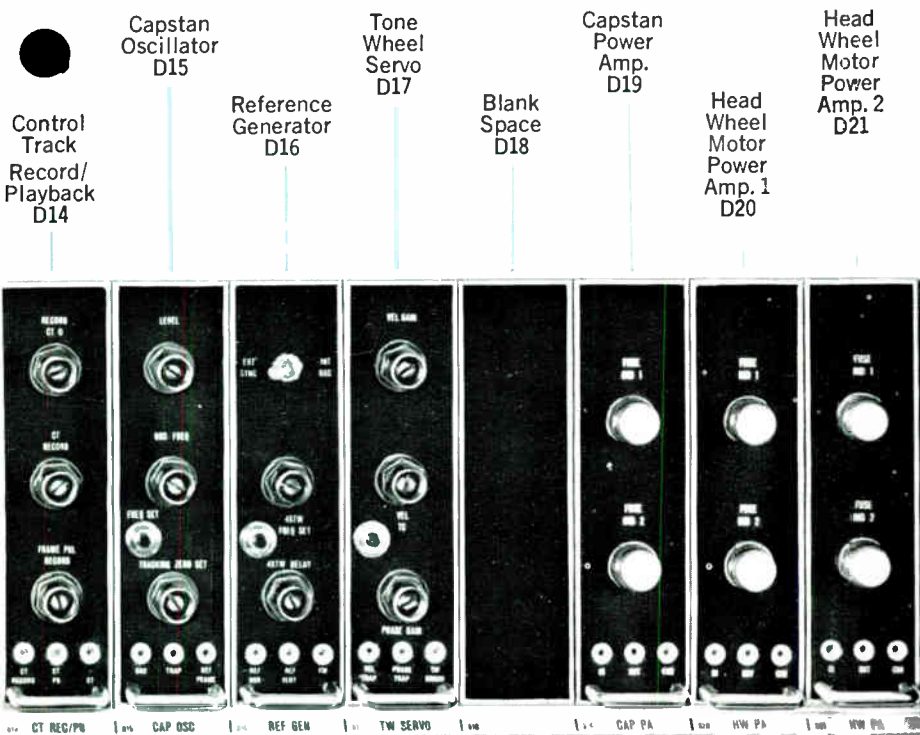

**D16—Reference Generator**

Processes local sync to produce horizontal-rate reference and field-rate reference. Provides playback reference from internal oscillator when local sync is not available. Module also includes the tone wheel processor which shapes the tone-wheel pulse and provides 960 Hz switcher drive.

**D17—Tone Wheel Servo**

Derives error signal controlling the headwheel motor. Module includes circuits which amplitude-modulate the headwheel motor-drive sine waves. Gives wide band two-phase output.

**D18—Blank Space**

**D19—Capstan Power Amplifier**

Provides power amplification required by the capstan motor.

**D20—Head Wheel Motor Power Amplifier #1**

Power amplifier for one phase of the headwheel motor drive.

**D21—Head Wheel Motor Power Amplifier #2**

Power amplifier for one phase of the headwheel motor drive.

**FUNCTIONAL DIAGRAM**

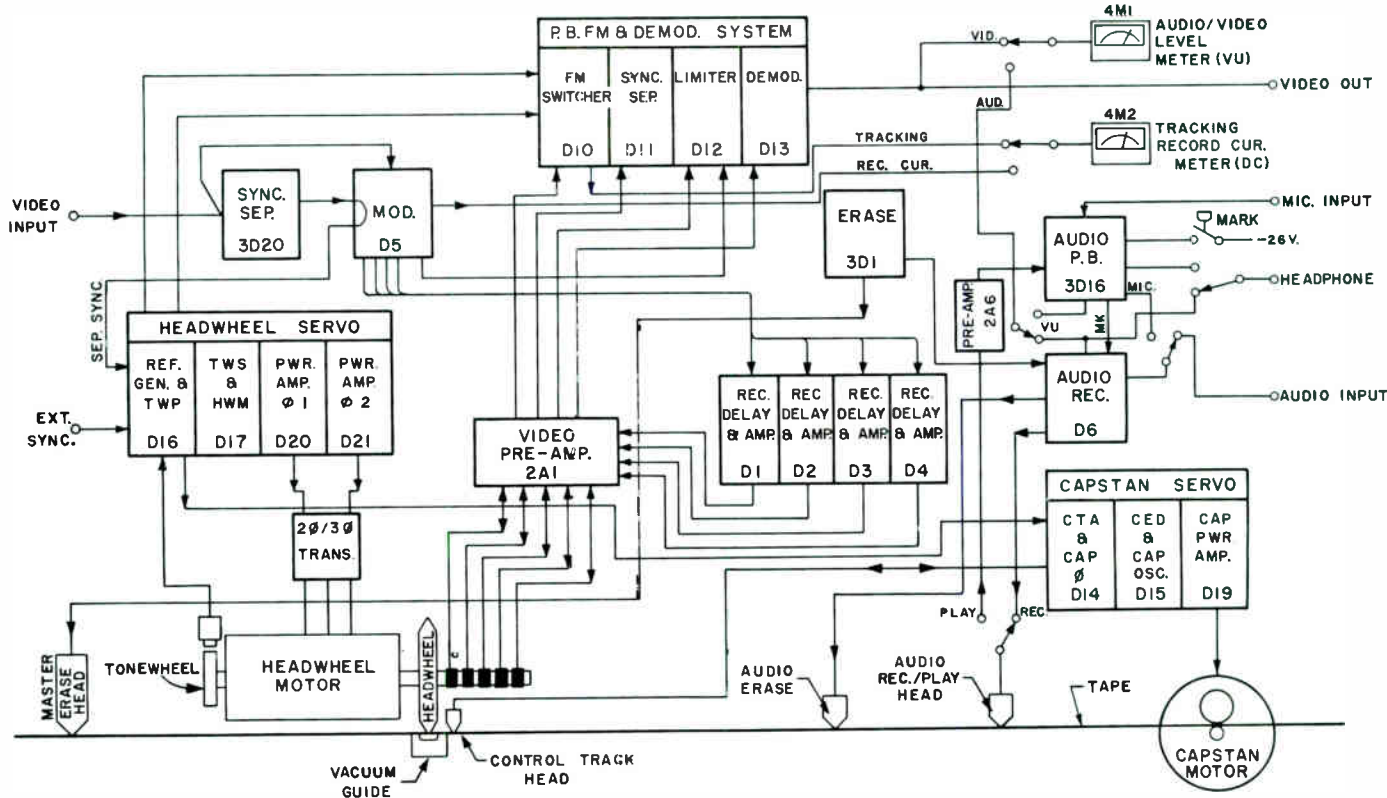

# Modular Accessories

increase recording capability

Audio Cue Record/Playback

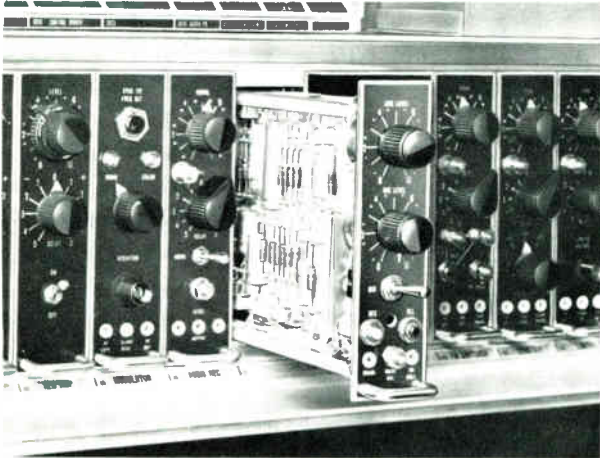

Tape Counter

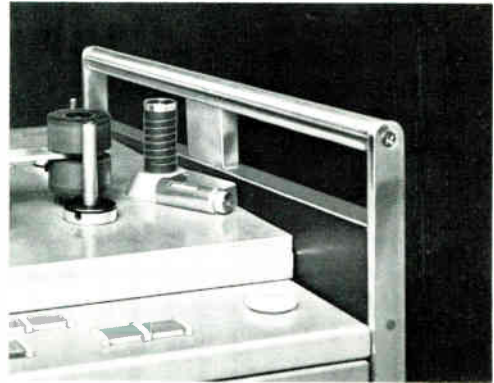

Electronic Splicer

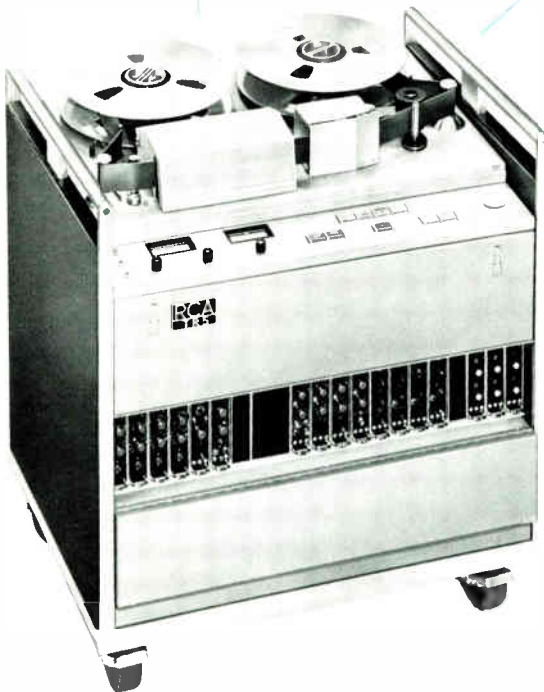

Remote Mode Control



## Major Accessories

Space is provided in the TR-5 for the addition of two convenient accessory equipments—an audio cue channel and the electronic splicer.

### Cue Record/Playback

The cue record/playback accessory head provides a means for recording cue information along one edge of the video tape. This can be in the form of voice, tone or digital information. A special feature of the program and cue channel is that recording can be done independent of video recording; in other words, sound may be dubbed in while playing back or previewing the video signal.

### Tape Counter

The Tape Counter accessory provides

an accurate elapsed time indication on record and playback. Ideal for the cueing and editing of tapes.

### Electronic Splicing

Splicing and editing of TV tape by electronic means can be accomplished with the TR-5 by addition of an electronic splicer. It will permit program segments to be added to a recorded segment or inserted within it. It operates at either 7½ or 15 IPS tape speeds.

The equipment comprises three transistorized modular units (splice timing, splice control and splice logic modules), selective erase head, wiring harness and auxiliary modification material.

The modular construction affords easy accessibility to all components. Furthermore, removal of any module automatically returns the tape recorder to normal operation. This by-pass feature is only one of several improvements in electronic splicing. Other features are two-speed operation, switchable standards, and push-button set-up procedure.

### Remote Control

A Remote Mode Control Panel, MI-40691-A, enables the following functions to be performed: stop, fast forward wind, reverse wind, record and play. The control panel can be operated from either an internal or external power source.

## COMPLETE LIST OF ACCESSORIES

Electronic Splicing .....	ES-43566	Tape Counter .....	MI-43359
Cue Record/Playback .....	MI-43348	Guide Position Adjuster for Headwheel Panel .....	MI-43351-A
Remote Control Panel (Mode).....	MI-40691-A	Video Preampfier Module (spare).....	MI-40603-BS
Air Bearing Conversion Kit with Compressor, 117/60, external mount.....	MI-43344	Mechanical Tape Splicer (15 IPS).....	MI-40772
Air Bearing Conversion Kit with Compressor, 230/50, external mount.....	MI-43345	Mechanical Tape Splicer (7½ IPS).....	MI-40748
Air Bearing Conversion Kit, Less Compressor, for systems using house air.....	MI-43342	Test Module Extender.....	MI-40649
Headwheel Panel Assembly (Standard Track Air Bearing).....	MI-40790-A	Special Module Extender (44 terminals).....	MI-557301
Headwheel Panel Assembly (Standard Track Ball Bearing).....	MI-40760-B	Ceramic Headset .....	MI-38028-2
Headwheel Panel Assembly (Narrow Track Air Bearing).....	MI-40799	Monochrome Video Alignment Tapes (525 line, 60 Hz) .....	MI-40793
Headwheel Panel Assembly (Narrow Track Ball Bearing).....	MI-40791	Monochrome Video Alignment Tapes (625 line, 50 Hz) .....	MI-40797
		Magnetic Tape Head Degausser, 117/50 or 60.....	MI-11995
		Magnetic Tape Head Degausser, 220/50 or 60.....	MI-11996



# Specifications

## Record

Recording Medium.....Magnetic tape 2" wide

Tape Speed:	<b>50 Hz</b>	<b>60 Hz</b>
Normal Speed	15.6" (39.7 cm)	15" (38.2 cm)
Half Speed	7.8" (19.8 cm)	7.5" (19.1 cm)

Picture-Sound Separation:

Normal Speed	14.8 frames sound leading	18.5 frames sound leading
Half Speed	29.6 frames sound leading	37 frames sound leading

Recording Time:

Normal Speed	61 min. on 12½" reel (4800 ft.)	64 min. on 12½" reel (4800 ft.)
Half Speed	122 min. on 12½" reel (4800 ft.)	128 min. on 12½" reel (4800 ft.)

Rewind Time .....Approx. 5 min. for 12½" reel      Approx. 4 min. for 12½" reel

Stopping Time.....Less than 0.2 sec. from record or play mode

Recording Time Reference.....Composite video signal

Starting Time for Stabilized Picture and Sound.....5 secs. from stop; 3 secs. from set-up

### Tape Interchangeability:

Record.....Tapes recorded on the TR-5 are made in accordance with all applicable proposed SMPTE recommended practices and proposed ASA standards and may be played back on any quadruplex machine.

### Horizontal Displacement of Vertical Aligned

Picture Elements.....Not to exceed 0.02 microseconds when recordings from the TR-5 are played back on machines adjusted for correct playback of MI-40793 or 40797 alignment tape.

### Input Signal Requirements:

VIDEO.....Input signal level may be between 0.8 and 1.2 Volts p/p composite signal; signal may be looped through or terminated in 75 Ohms.

AUDIO .....Line input level between -20 dBm and +18 dBm into a 10,000 Ohms balanced bridging impedance

SYNC .....Negative polarity 3 to 5 Volts p/p loop through or terminated in 75 Ohms

## Playback

Playback Time Reference.....To external sync or internal reference

### Output Signal Availability:

Video (Unprocessed).....One composite line; video level 1.0 Volt p/p into 75 Ohms

Audio .....(1) One line output +18 dBm max. into 150/600 Ohms balanced or unbalanced line. (2) One monitoring output for high impedance phones

Audio Mark.....A built-in audio mark oscillator is provided for insertion of a 400 Hz tone on the Audio Talk

Power Requirements .....115/230 Volts AC, ±10%, 48-62 Hz, single phase, 1.2 kw

### Frequency Response:

Video Channel Monochrome .....405/525 ±1.5 dB 25 Hz to 4 MHz; 625/819 ±1.5 dB 25 Hz to 4.5 MHz; -3 dB at 5 MHz

### Audio Channel:

Normal Speed .....±2 dB 50 to 15,000 Hz  
Half Speed .....±2 dB 0 to 10,000 Hz

### Signal-to-Noise Ratio:

Video at 15 ips  
405/525 Line Monochrome .....Better than 40 dB (37 dB at 7½ ips)  
625 Line Monochrome .....Better than 37 dB (34 dB at 7½ ips)

Audio.....Better than 50 db measured overall between a recorded level corresponding to 3% total rms distortion at 1000 Hz and noise present when playing back an erased unmodulated tape

### Wow and Flutter:

Total RMS Wow and Flutter 0.5 to 250 Hz range:

Normal Speed.....0.2% rms  
Half Speed.....0.25% rms

Picture Jitter.....Recordings from the TR-5 may be played back on a TR-22 or equivalent machine in Pixlock mode with picture jitter less than ±0.1 microsecond

Ambient Temperature and Humidity.....Between 35° and 110°F (0° and 45°C) at 20 to 90% relative humidity

## Mechanical

### Dimensions:

Width.....32¾" (83 cm)

### Height:

Overall with casters.....37" (94 cm)  
Overall less casters.....31" (79 cm)

Depth.....24" (61 cm)

Shipping Information: Width 36½" (93 cm), Depth 28¼" (71.6 cm), Height 48" (122 cm), Volume 34.5 ft.<sup>3</sup> (1.035 M<sup>3</sup>), Gross Weight 525 lbs. (238.16 kg)

# Ordering Information

The Type TR-5 Mobile TV Tape Recorder operates on 525, 625, and 405 line tv standards.

Type TR-5 TV Tape Recorder, for 525/625/405 line, 50/60 Hz, switchable .....ES-43565-405

Type TR-5 TV Tape Recorder, for 525/625/405 (or optional 819) line, 50/60 Hz, switchable .....ES-43565-819

All models include the following equipment:

- 1 TV Tape Recorder (Transportable Cabinet) complete
- 1 Headwheel Panel Assembly (Ball Bearing)
- 1 Kit of Maintenance Materials .....MI-43350
- 1 Monochrome Video Alignment Tape: 525 Line .....MI-40793  
625 Line .....MI-40797

# RCA TV Tape Electronic Accessories

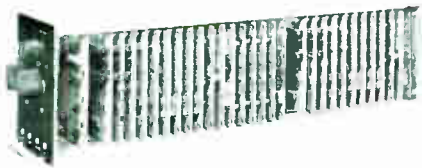

CAVEC

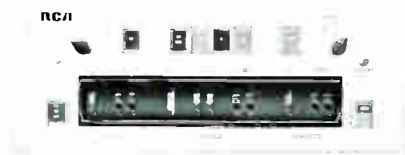

Tape Editing Programmer

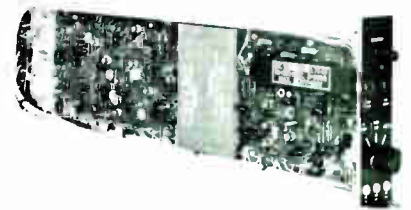

Dropout Compensator



Color ATC

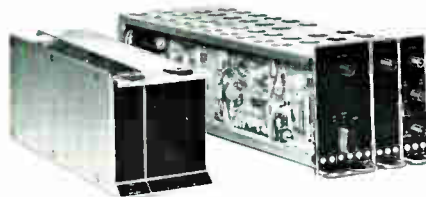

Monochrome ATC

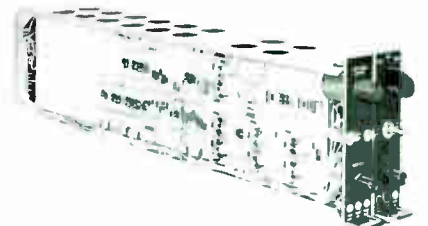

Electronic Splicer



Guide Servo



Cue Record Playback

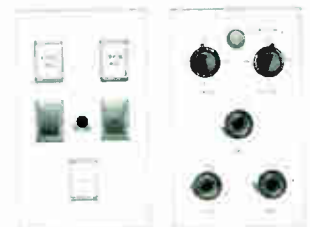

Remote Control Panels

# Chroma Amplitude and Velocity Error Corrector (CAVEC)

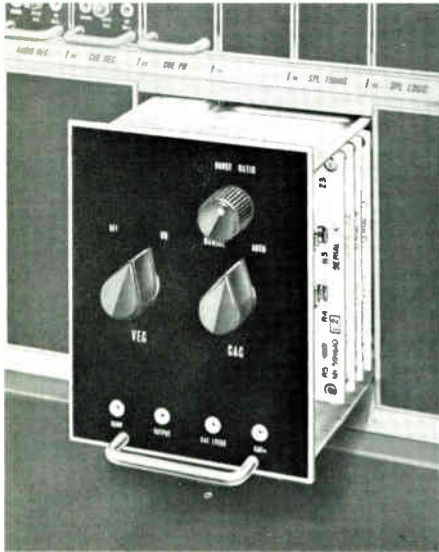

## Description

A line-by-line chroma amplitude and velocity error corrector (CAVEC) has been developed by RCA for use with its line of high band television tape recorders and reproducers. CAVEC functions only in playback to correct for mechanical and operational deficiencies in quadruplex recorders that cannot be compensated for by normal operator adjustment.

### Easy to Operate

Operationally, the unit provides a minimum of adjustments to achieve consistently the highest quality color replay. Multiple generation copies can be made with a minimum of hue and saturation errors. The CAVEC unit is most beneficial to stations receiving a large number of interchange recordings.

Once set up, the CAVEC unit has only one operational adjustment — "Burst Ratio." The adjustment is to compensate for tapes where the burst to chroma ratio is incorrect.

### PAL Operation

The CAVEC unit can also be used on PAL Standards without any modification. On the PAL Standard, CAVEC eliminates any side effects such as desaturation or hanover bars caused by the velocity error. Correction of the chroma saturation is required to the same extent as in the NTSC system.

### Circuit Description

The diagrams below will serve to

illustrate the principal functions of the CAVEC accessory. The action of both the velocity and chroma amplitude correctors is to provide accurate line by line compensation of both types of errors. Use is made in the CAVEC unit of one set of digital electronics to provide the necessary gating signals for the two sets of analog electronics.

Using the ATC and CATC error signals, a third signal is derived that will correct for the hue errors. These errors occur when the guide height is incorrectly set or when head scanning differences occur between the record and the playback machines.

The saturation or chroma amplitude errors are corrected by comparing the demodulated color burst level with that of a fixed reference. Correction of chroma amplitude errors is necessary due to minute head to head differences, compensation for incorrect guide height setting, and non-uniform coating of the actual tape.

### Installation

RCA's CAVEC unit can be installed in any RCA High Band or High Band converted machine. Some machine modification is necessary to install the CAVEC unit. Modification time varies between different types of machines. Four to 8 hours is the average installation time.

- Insures consistent quality replays
- Line by line correction of hue and saturation errors
- Only one operational control
- Integrated circuits provide maximum reliability

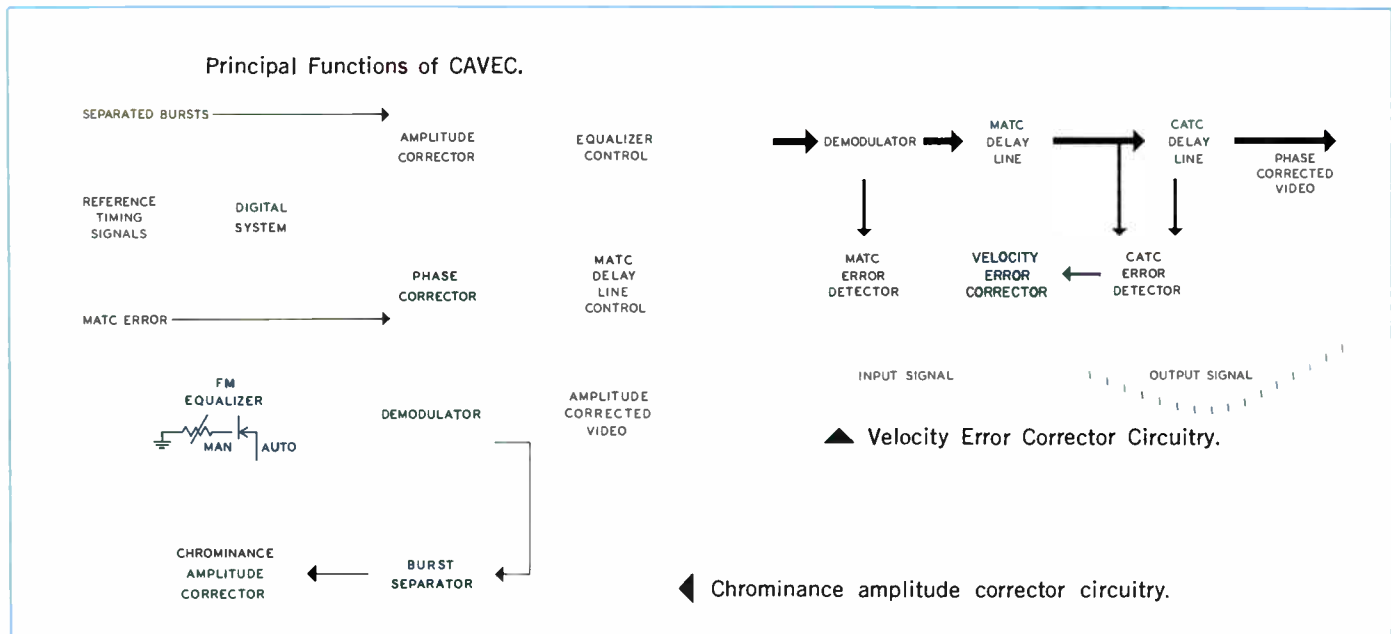

## Specifications

### Controls:

1. VEC ON/OFF .....Allows operator to bypass operation of VEC without affecting CAC
2. CAC ON/OFF .....Allows operator to bypass operation of CAC without affecting VEC
3. Burst Ratio .....Allows operator to adjust for normal chroma level with variations in recorded burst of  $\pm 6$  dB

### Correction Range:

Chroma Amplitude .....The unit will correct chroma amplitude variations on a line by line basis by as much as  $\pm 2$  dB High Band, and  $\pm 3.5$  dB Low Band (Not applicable to EBU/CCIR standards)

Chroma Phase .....The unit will correct for phase errors corresponding to 200 Nanoseconds timing error on a line by line basis

### Correction Time: (As long as the unit is operating within the correction range)

Chroma Amplitude .....Average chroma amplitude variations of 3 dB shall be corrected to within 0.5 dB of their final value not more than 0.1 second after these changes occur

Chroma Phase .....Average changes of chroma phase shall be corrected to within 10% of their final value no more than 0.1 second after these changes occur

### Correction Factor (As long as the unit is operating within correction range):

Chroma Amplitude .....Average chroma amplitude variations of 3 dB at blanking level shall be reduced by a factor of 24 dB for each line

Chroma Phase .....The average phase variations for each line shall be reduced by a factor of 26 dB for line to line variations of 45° or more. Variations of 45° or less shall be reduced to a maximum error of 3°

## Ordering Information

### Chroma Amplitude and Velocity Error Corrector:

For TR-70 (S/N 7001-7100) .....	ES-43534-A
For TR-70 (S/N 7100 and upwards) .....	ES-43535-A
For TR-22HB .....	ES-43533-A
For TR-4HB/TR-50 .....	ES-43532-A
For TR-3HB* .....	ES-43531-A
For TR-60/70B .....	ES-43537

\* Requires 1 Penthouse Module Frame, MI-591604.

## Remote Control Panels

### Description

Two panels—Mode Control and Signal Control—combine to provide full remote control of TV Tape Machine functions. The mode and signal control panels are designed for use with any RCA TR-3/4/22/50/70 Tape Recorder. The mode remote control panel may also be used on a TR-5.

#### Mode Control

The Mode Remote Control Panel, MI-40691-B, provides for the control of the Play, Reverse Wind, Forward Wind, Stop, and the record function. All modes but the record mode can be initiated by the depressing of the appropriate button. To initiate the record mode, two buttons must be pushed simultaneously. This feature is provided as a precaution against accidentally initiating the record mode.

#### Signal Control

The Signal Remote Control Panel, MI-40692-B, provides control of the processing amplifier sync level, video level, and pedestal level. Control is also provided over the system and burst phase of the color burst. Both the system and burst phase controls are fitted with locks so that a preset position may be selected for a particular studio.

The control panels are designed for use with an adaptor frame, MI-557306, which is a standard 19 inches in width and 7 inches in height. Up to four control panels can be mounted in one frame. The new style panels may be mounted in standard racks or the well or sloping area of "New Look" and 22-inch console housings.

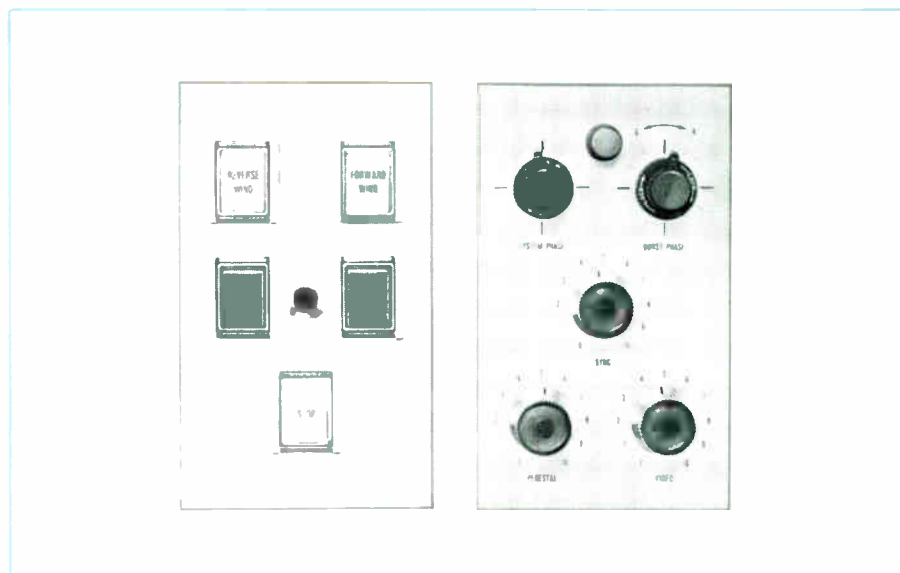

## Specifications

Width .....	4¼" (10.6 cm)
Height .....	7" (17.6 cm)
Weight .....	1 lb.
Finish .....	Silver Gray

## Ordering Information

Mode Remote Control Panel .....	MI-40691-B
Signal Remote Control Panel .....	MI-40692-B
Adaptor Panel (Mounts up to four panels in Standard Racks or 20" Console) .....	MI-557306

# Tape Editing Programmer

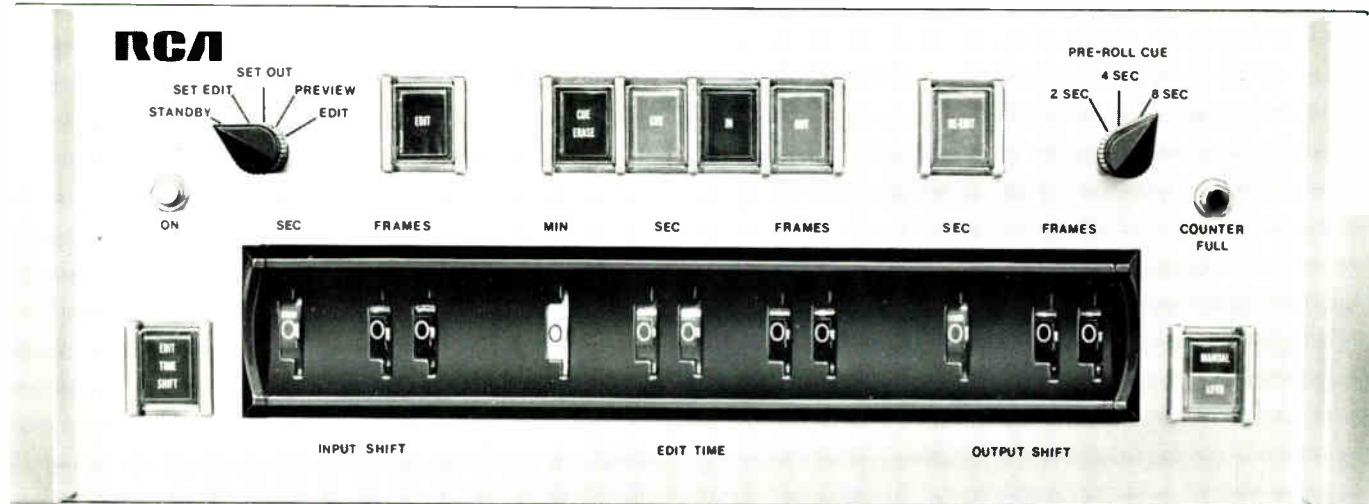

- Preview splice points
- Precise splice location
- Multi-machine use
- External advance cue

## Description

The RCA Tape Editing Programmer is designed to electronically initiate the splice function of the Electronic Splicer. In addition, it provides the production department with the facility to preview the splice before actually splicing into the master tape. Should the selected splice points be incorrect, they may be repositioned by up to two seconds and twenty-nine frames during the preview cycle, by simply readjusting the ingoing and/or outgoing splice timing points.

### Splicing Operation

Operation of the RCA Tape Editing Programmer is controlled by a cue tone placed on the cue track approximately 14 seconds prior to the point where the initial ingoing splice is contemplated. When the splice points are initially established, a preview of the splice sequence may be performed, splice points shifted if necessary, and finally, the splice executed.

### Control Functions

The main operational control is the Mode Selector. This control selects the mode of operation, either "set edit," "set out," "preview," or "edit." "Set edit" activates the circuitry that will permit the operator to select the ingoing and outgoing splice points. "Set out" permits the operator to fix the outgoing splice points. "Preview" activates the circuitry necessary to preview the splice. "Edit," in combination with the edit pushbutton, prepares the machine and programmer to perform the edit.

### Design Features

The input and output shift controls vary the amount of time the splice point may be shifted relative to the initially selected splice point. The permissible change is  $\pm 2$  seconds, 29 frames.

External cues are available at 2, 4 and 8 second intervals prior to the ingoing splice. The external cue time is selected by the switch on the control panel.

### "Edit Time" Provisions

The "edit time" setting is used when an insert of a known length is to be inserted into a program. For example, if a 30 second commercial is to be inserted in a program, all that is necessary is for the operator to select 30 seconds on the edit time thumbwheels and determine the ingoing splice point.

When animation is required, the length of the recorded sequence is selected on the "edit time" thumbwheel and the manual shift pushbutton is activated each time an edit is made in order to shift the splice point by the amount indicated on the "edit time" thumbwheel.

### Re-Edit Mode

Re-edit mode is used when a segment that was previously inserted using the programmer is now required to be substituted by a new segment. As the cues necessary are already on the cue track, no splice location process is required.

Regardless of the operating mode, the RCA Tape Editing Programmer incorporates an automatic rewind. The rewind occurs 4 seconds after the outgoing splice

point enabling the tape editor to be sure he has placed the splice point in the correct position. The machine will rewind to the master cue point and stop.

### Remote Control Provisions

With the aid of a mode remote control panel, the programmer may be operated completely remote from the tape machine location.

Electronic packaging of the equipment utilizes the latest "plug-in" integrated circuits and the computer controlled wrapped wire technique. This type of packaging insures reliability and in the event of failure, ease of servicing.

### Installation

The programmer can be installed in any RCA High Band Recorder operating on 525 or 625 line standards, 7½ or 15 IPS. Machine logic compensates for changes between line and speed changes. With suitable harness, the programmer electronics can be plugged into any number of machines, similar to the RCA electronic splicer.

Mounting can be remote from the machine location or in the tape area. It mounts in any standard 19-inch rack or in the "New Look" RCA console. Supplied with the equipment is 25 feet of control cable. Additional control cable may be purchased.

Three prerequisites for use of the unit are indicated. The machine must have cue track facilities, it must be equipped to accept the RCA electronic splicer, and must be capable of recording and replaying high band recordings.

## Specifications

Minimum Insert Time .....	18 frames
Minimum Add On Time .....	4 frames
Splicing Accuracy .....	1 frame
External Cue At .....	2, 4 and 8 seconds selectable
	±2 seconds, 24 frames, 625 lines
Splice Point Shift .....	±2 seconds, 29 frames, 525 lines
Dimensions .....	19" x 7" x 17.5"
	(48.2 cm x 17.8 cm x 44.5 cm)

## Guide Servo

- Provides fixed record reference
- Virtually eliminates tip projection errors on replays
- Manual or automatic guide positioning of tape playback

## Description

The Guide Servo accessory can be fitted to any RCA TR-3/4/50 type recorder. It functions equally well on all TV line standards. Installation of Guide Servo provides the operator with a fixed record reference and automatic guide setting in the replay mode, as well as manual overrides in both conditions.

The position of the guide is one of the factors determining the compatibility of playback between tapes which have

been recorded by video heads whose degree of wear may vary from one machine to another. Thus, the operation of guide servo in maintaining the proper guide position during recording and playback is of great importance.

### Simple Operating Controls

The Guide Servo module contains the electronic circuitry which controls the guide servo system. Operating controls located on the module include the guide positioning control which may be utilized prior to recording, the record control switch which allows selection of a fixed or a manually preset guide position ref-

erence during record, and the playback control switch which allows selection of manual or automatic guide positioning during tape playback.

### Guide Servo Installation

Installation of the Guide Servo accessory may be made in any RCA TR-3/4/50 type machine. Prior to installation into a TR-3 Player, a penthouse accessory mount is required. The operation involves modification to various modules, installation of the servo mechanism, and the installation of the guide servo module. Approximately six hours are required for installation.

## Ordering Information

Tape Editing Programmer for Type TR-60/70B .....	ES-591903
Tape Editing Programmer for Type TR-70 .....	ES-591900
Tape Editing Programmer for Type TR-22HB .....	ES-591901
Tape Editing Programmer for Type TR-4HB/50 .....	ES-591902
TEP Harness required for Type TR-70/70A .....	MI-591730
TEP Harness required for Type TR-22HB .....	MI-591731
TEP Harness required for Type TR-4HB/50 .....	MI-591732

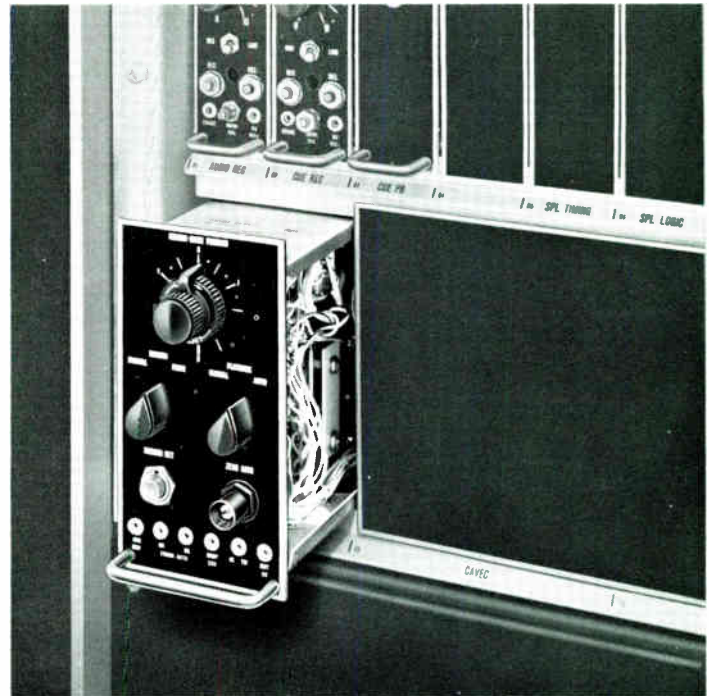

## Ordering Information

Guide Servo for Type TR-3/4/50 Series .....	MI-35891
Penthouse Accessory Mount (For TR-3 Player) .....	MI-591604

# Dropout Compensator

- Correct phase color reinsertion
- Prolongs tape life
- Ease of set-up

## Description

Irregularities in video tape surface or lack of head to tape contact produce brief interruptions to the RF signal being picked up by the head. These interruptions are termed dropouts and result in objectionable "flashes" in the reproduced picture. To compensate for these dropouts, RCA offers a dropout compensator that can be fitted to any RCA High Band or High Band converted machine.

### Information Retrieval

The dropout compensator functions by detecting a loss of RF from the heads during which time information from the previous line is inserted.

Correcting for dropouts in a monochrome signal is relatively simple, as the difference in information from one line to the next is very small. Dropouts in color present a different set of circumstances. The luminance information change between any two consecutive lines is very small, however, the chrominance information changes greatly between lines.

Due to the phase change of the subcarrier between lines, additional processing of the signal is required in order for the reinserted video information to be as indistinguishable from the original information as is possible. The composite color signal is thus divided into its two major components, luminance and chrominance.

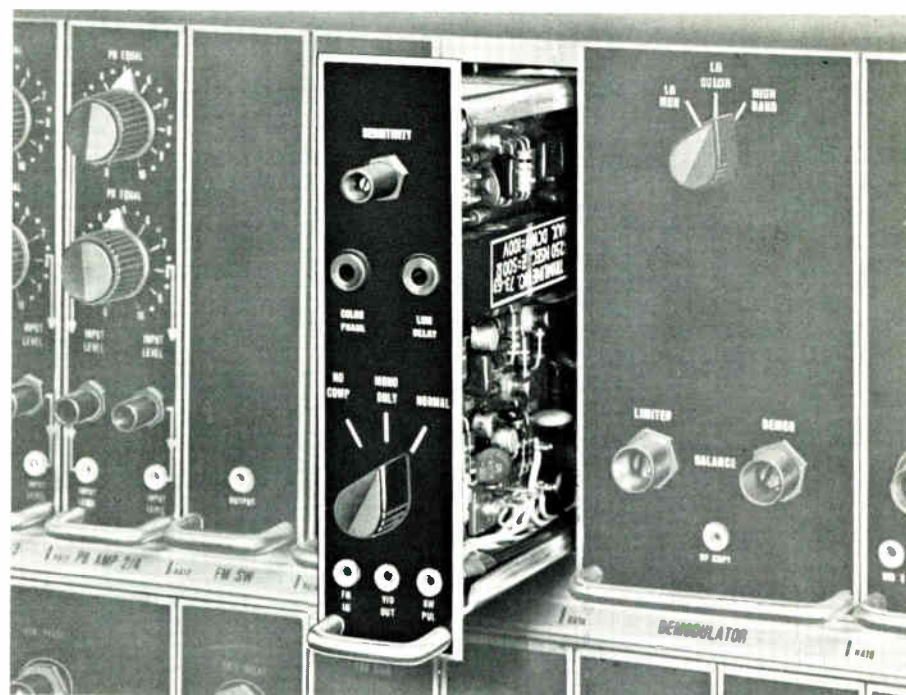

The luminance signal is delayed by one line. Use is made of a glass delay line modulated with a 10 MHz carrier in order to achieve the one line delay and still maintain a wideband width signal. The chrominance portion of the signal is delayed by one line plus 180 degrees of the subcarrier frequency, insuring the reinserted signal has the correct color phase. The two delayed signal components are mixed together prior to their use.

### Color DOC Equipments

When used in a TR-70, the color dropout compensator circuitry provides built-in test signals for setting the sensitivity of the dropout detector and the amplitude and phase of reinserted video information. It is therefore possible to set up

the dropout compensator using an accurately generated set of electronic signals.

The color dropout compensator for the Type TR-22HB/4HB/3HB/50 series of machines consists of a color dropout compensator module and a dropout test tape. The purpose of the test tape is to permit the set up of the dropout compensator using a prerecorded color bar signal with known characteristics.

### Switchable Standards

The DOC is switchable between 525/625 line standards without any modifications. When used on the PAL color standard, it is recommended that the monochrome only mode of compensation be used. This is due to the difficulty in handling of the PAL color subcarrier.

## Specifications

Reinserted Information	Linearity $\pm 1\%$
	Differential Gain—Less than 3%
	Differential Phase—Less than 3°
	2T Bar risetime 0.35 $\mu$ sec. maximum
Switching Transients	70 Nsecs. $\pm 0.2$ Volts max. amplitude
Dropout Threshold	Adjustable -10 dB to -20 dB

## Ordering Information

Color Dropout Compensator for TR-60/70B	ES-43538
Color Dropout Compensator for TR-70, Serial Numbers 7001-7100	ES-43558
Color Dropout Compensator for TR-70, Serial Numbers 7101 and upwards	ES-43536
Color Dropout Compensator for TR-3/4/22 and 50	ES-43549

## Electronic Splicing Accessory

- Pushbutton setup
- Modules interchangeable between machines
- 7½ or 15 inch operation
- "Insert" or "add on" mode

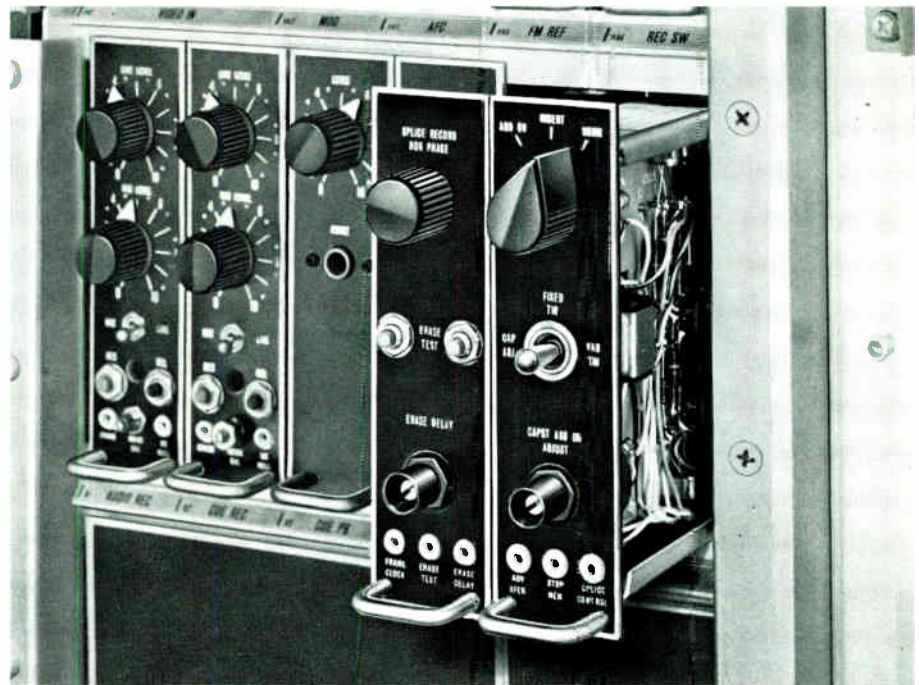

## Description

The RCA electronic splicer provides a fast, accurate means of adding or replacing segments of program material without physically damaging the tape. The electronic splicer can be fitted to any RCA TR-4, TR-5, TR-22, TR-50 or TR-70 type tape recorder.

### Switchable Standards

Either monochrome or color splicing can be accomplished with the RCA Electronic Splicer. The splicing accuracy is within the range of ATC and CATC of the replay system, insuring disturbance free switching. The circuitry of the splicer is capable of switching between 525 and 625 line operation as well as 7½ inch and 15 inch operation. This

switching operation is performed automatically by the machine logic.

### Operational Modes

The electronic splicer provides facilities for two modes of operation, "Add-On" and "Insert." In the Add-On mode, additional program sequences may be added consecutively in order to build up a program. In the "Insert" mode, program sequences such as commercials may be inserted into previously recorded program material. In using the insert or add-on mode, the operator has the choice of retaining or rerecording the audio and cue tracks.

### Functional Operation

The electronic splicer modules contain a system of counters that turn on or off

various machine functions at particular times. The turn off and turn on sequence is particularly important as it is this switching sequence that insures that there is no disturbance at the splice point.

Set up of the electronic splicer is easy to accomplish without the need for external equipments. Using the inbuilt test signals, normal operational adjustments may be performed in a matter of seconds.

Once set up, the electronic splicer requires no further adjustment unless the headwheel panel is changed or the modules are placed in another machine. Initial installation is easily performed. The degree of modification required varies between machine types, the later model the machine, the less modification required.

## Specifications

<b>Delay:</b>	
Into Splice.....	0.5 sec at 15 IPS; 1.0 sec at 7½ IPS
Out of Insert Splice.....	0.5 sec at 15 IPS; 1.0 sec at 7½ IPS
Out of Add-On Splice.....	Zero sec
Minimum Splice Time.....	0.5 sec at 15 IPS; 1.0 sec at 7½ IPS
Weight.....	15 lbs. approx. (6.8 kg.)

## Ordering Information

Electronic Splicing Accessory for TR-60/70/A/B .....	MI-35961
Electronic Splicing Accessory for TR-22D .....	MI-40695-A
Electronic Splicing Accessory for TR-22-A/B/C.....	ES-40922-A
Electronic Splicing Accessory for TR-4.....	ES-43578-A
Electronic Splicing Accessory for TR-4A .....	ES-43569
Electronic Splicing Accessory for TR-4B/C/50 .....	ES-43568
Electronic Splicing Accessory for TR-5.....	ES-43566



# Color ATC Equipment

- Operation on NTSC or PAL signals
- Direct recovery of color information
- Provides for insertion of regenerated burst

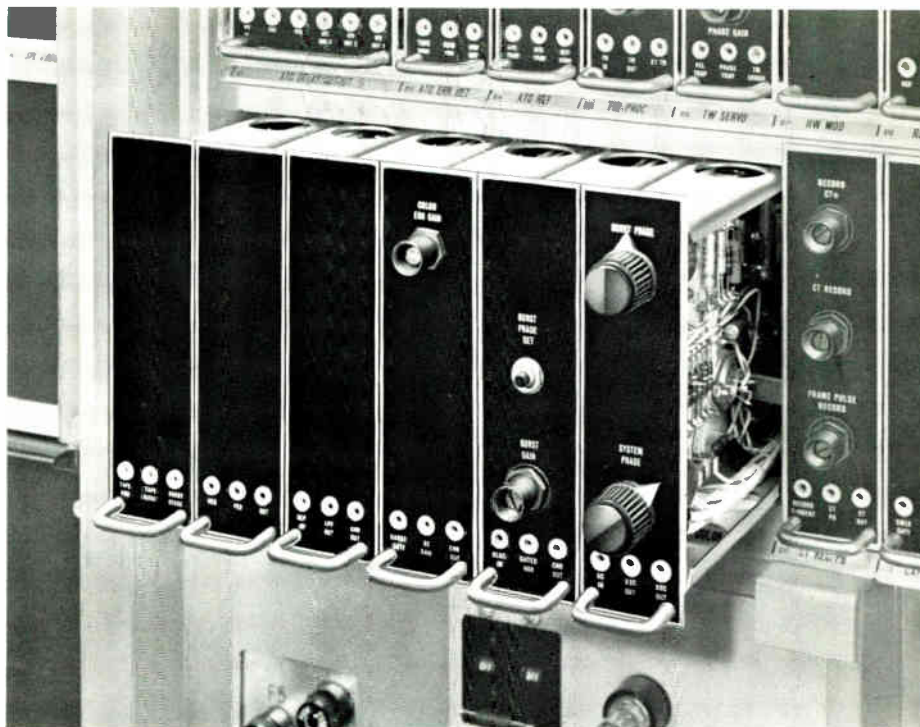

## Description

The RCA Color Automatic Timing Corrector (CATC) is designed to provide accurate correction of time base errors permitting the direct recovery of the color signal in accordance with FCC and EBU requirements. CATC can be added to any machine which is equipped with monochrome ATC. International customers also require High Band deviation standards (7.16-9.3 MHz).

Monochrome ATC performs the primary function of reducing the servo timing errors to be within the corrective capabilities of CATC. It is then the function of CATC to further reduce these errors to  $\pm 3$  nanoseconds.

### Automatic Operation

Corrective action of the CATC is achieved by comparing the stable studio color subcarrier to the off tape burst. The resulting error signal is then applied to an electronically variable delay line through which the video is passed prior to the output of the CATC system.

### Simplified Controls

Operational controls on the CATC permit the adjustment of burst phase and system phase. The burst phase controls the phase of the regenerated burst relative to the chroma content of the picture. The system phase controls the

phase of the composite signal relative to the phase of other signals within the studio. A burst gain control is also provided that permits setting of the burst amplitude independent of other signal components.

The PAL International version of CATC provides for adjustment of the burst switching angle. When installed in TR-50/22/4/3 Series machines, the CATC can be used on either color standard, NTSC or PAL.

## Specifications

Differential Phase .....	3°
Differential Gain .....	2%
Switching Angle (PAL systems only) .....	$\pm 1^\circ$
Correction Range .....	360° of subcarrier
Video Input .....	Receives signal from monochrome ATC
External Signals .....	2 V p to p subcarrier
	4 V p to p composite sync
	4 V p to p burst flag
	(PAL systems only)
Power Requirements .....	Obtained from TR-3/4/22/50 tape systems

## Ordering Information

Color ATC Equipment:	NTSC	PAL
(For TR-22A/22B/22C) .....	ES-43581-A	ES-43540
(For TR-22-D) .....	ES-43598	ES-43541
(For TR-3/3A/4/4A) .....	ES-43582-A	ES-43542
(For TR-3B/3C/4B/4C) .....	ES-43599	ES-43543
(For TR-60/70B) .....	ES-591208	ES-591209

# Monochrome ATC Equipment

- Maintains near perfect picture geometry by automatically compensating for skewing, quadrature errors, and jitter
- Fully automatic—no operating controls
- Automatic error correction factor of 35 to 1 over total delay range of one microsecond

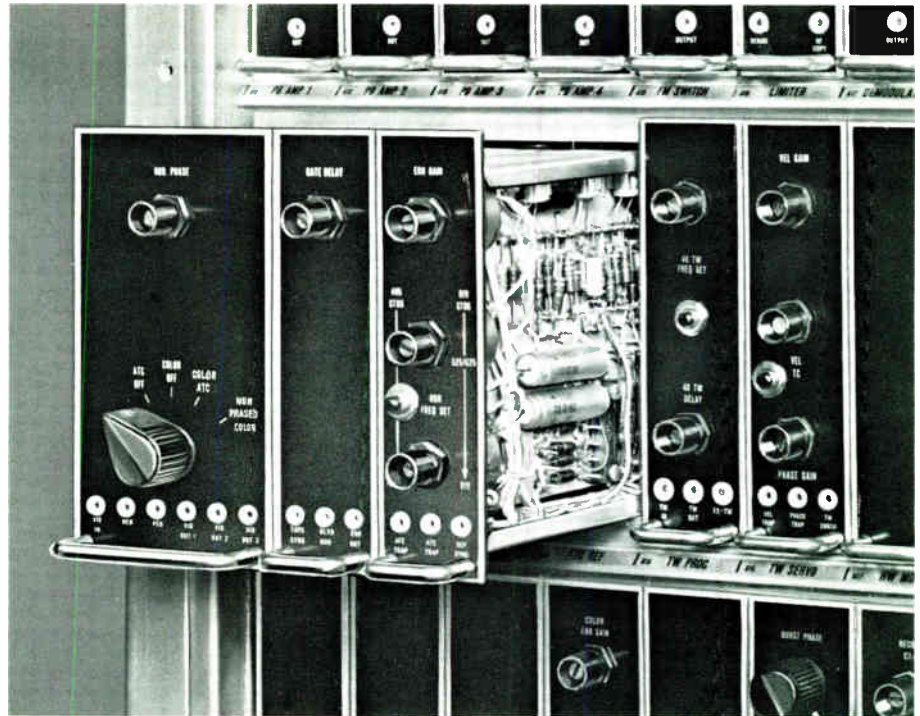

## Description

The RCA Automatic Timing Corrector (ATC) is a transistorized video device providing electronic compensation for geometric distortion in the reproduced TV monochrome or color tape signal. Distortion, whether due to quadrature, skewing, or jitter is virtually eliminated when time delay errors are passed through ATC. It thus serves as a continuous mon-

itoring and correction device which automatically reduces the time delay errors occurring in the playback signal, thereby assuring the highest possible quality at all times. It is a pre-requisite for color ATC.

### Modular Design—Easy to Install

The equipment is supplied in kit form, ready for installation in the RCA TR-3,

TR-4 and TR-22 Series TV Tape Recorders. The kit consists of a connector and cable assembly, three ATC plug-in circuit modules, a fixed delay line, and the required hardware and electrical parts required for installation. Installation of monochrome ATC includes the harness assembly required for Color ATC.

## Specifications

### ELECTRICAL

Video Input.....From demod. output module  
1 Volt peak-to-peak

Video Output .....4 outputs (1 to oscilloscope,  
1 to picture monitor, 1 Proc. Amp., 1 color ATC) 1 Volt  
peak-to-peak

Delay Control Range .....Minimum error reduction factor  
35 to 1 for input errors up to 1 microsecond peak-to-peak

Frequency Response .....30 Hz to 6 MHz  $\pm 1$  dB over total  
delay range ( $\frac{1}{2}$  dB variation at 3.58 MHz and 4.43 MHz)

Low Frequency Tilt .....5% on 60 Hz square wave

Differential Gain.....3% (50% APL delay at mid-range,  
standard level)

Differential Phase.....3° (50% APL, delay at mid-range,  
standard level)

Total Residual Jitter.....80 nanoseconds peak-to-peak

Power Requirements.....Obtained from TR-3/4/22 tape systems

### MECHANICAL

Dimensions (overall).....3 modules which fit into spaces  
provided in basic TR-3, TR-4, and TR-22-A/B/C

Weight.....15 lbs. (6.8 kg)

## Ordering Information

### Automatic Timing Corrector:

For TR-3/3A/4/4A ..... ES-43580-C

For TR-3B/4B ..... ES-43597-A

For TR-22-A/B ..... ES-43579-C

For TR-22C ..... MI-43391-C

## Cue Record/ Playback

- Adds voice, tone or pulse information
- Provisions for preview
- Plug-in modular construction
- Microphone and line inputs
- Improved frequency response

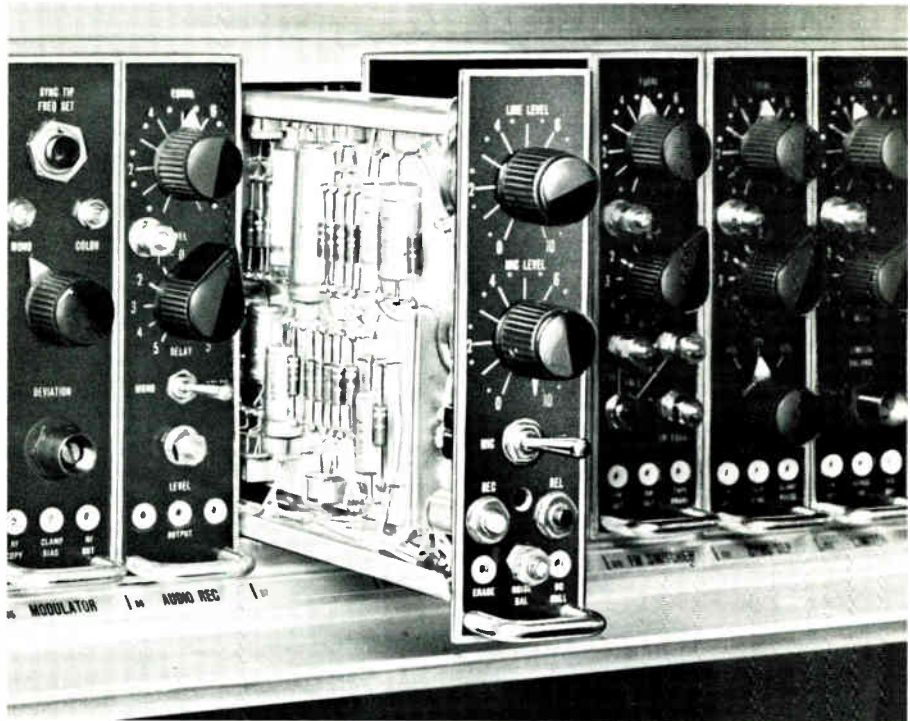

## Description

### Cue Record/Playback

Cue Record/Playback, a standard feature of RCA TR-22/4C Tape Recorders, can be provided for the TR-4 and TR-5 machines as accessory equipments. Space is provided in the module bank to accommodate this accessory. An audio/cue playback accessory kit for external mounting is available for use with the TR-3 Player.

### Voice, Tone, or Pulse Cue

The Cue Record/Playback accessory head provides a means for recording cue information along one edge of the video tape. This can be in the form of voice, tone or pulse information. Recording can be done independent of video recording; in other words, sound may be dubbed in while playing back or previewing the video signal.

### Accessory Kit

The TR-3 Cue Playback Accessory enables the cue track to be monitored for any special instructions or for program start information. The kit consists of a preamplifier, audio/cue playback head, audio amplifier and speaker, for external mounting. A harness is included to connect the cue preamplifier to the mounting system.

## Specifications

Line Input Level ..... 0 dBm to 18 dBm into a 10,000 Ohm balanced bridging impedance; may be reconnected for -20 dBm to 0 dBm matching input, 600 or 150 Ohm, balanced or unbalanced.

Microphone Input..... Recordings may be made from built-in microphone and pre-amplifier simultaneously with or separately from audio channel.

Line Output Level ..... 18 dBm max. into 600 Ohm balanced or unbalanced line; may be reconnected for a 150 Ohm line

Phone Jack Output ..... 600 Ohm or high impedance microphone

### Frequency Response:

At 15 IPS (39.8 cm) .....  $\pm 2$  dB, 50 to 190 Hz and 310 to 10,000 Hz

At 7½ IPS (19.8 cm) .....  $\pm 3$  dB, 60 to 190 Hz and 310 to 10,000 Hz (A 240/250 Hz notch filter removes crosstalk from the control track. Effect of this filter on tonal balance of speech and music is imperceptible.)

Signal-to-Noise Ratio ..... Better than 34 dB measured between a reference signal recorded at 1000 Hz and 5% third harmonic distortion and none present when playing back on erased, unmodulated tape.

## Ordering Information

Cue Record/Playback (for TR-4/4A/4B) ..... MI-43355  
 Cue Record/Playback (for TR-5)..... MI-43348  
 Audio/Cue Playback (for TR-3/3A/3B) ..... MI-43369

## Record Current Optimizer

- Fast and accurate head current optimization
- Operates with both 5 or 10 mil heads (7½ and 15 IPS tape speeds)
- Switching logic IC design
- Easy to operate
- Practical to optimize for each recording

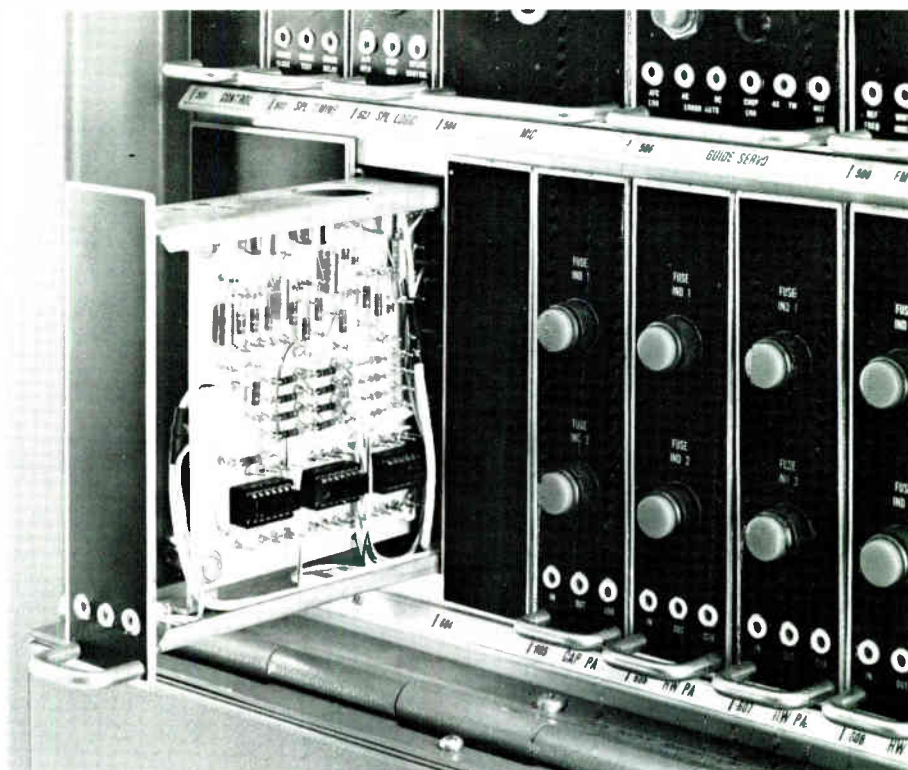

## Description

The Record Current Optimizer (RCO) provides a fast and accurate means of maintaining record currents in the video headwheel at peak performance. With RCO record currents can be set to their optimum values within a few seconds because of the simultaneous readout display facility. Furthermore, because head current optimization with RCO is so fast, it is now practical to optimize before each recording. This assures the highest level of quality and consistency for each video tape recording.

The accessory consists of a module designed for easy incorporation in RCA Video Tape Recorders (TR-70/70A/60/50/411B/2211B). Logic to provide the necessary switching functions and to activate the slow speed capstan is accom-

plished by integrated circuits. The solid state IC design provides maximum reliability and low maintenance. RCO operates with both 5 or 10 mil headwheel panels for tape speeds of 7½ and 15 IPS.

The former conventional method of optimization of record currents was tedious, slow and required a fairly high degree of technical knowledge to produce the desired results. The old method required that a test recording be made with an audio track announcing incremental current settings for each of the four heads. It was then necessary to rewind and replay the tape observing the effects of each current level change for each head. If this did not produce a "flat" field (proper optimization), the process would

be repeated (maybe three or four times) until a match of the four heads was accomplished.

RCO eliminates this "trial and error" method. The operator selects and activates RCO mode by simultaneously initiating a special test switch and master record. This automatically drives the capstan to the required speed to produce the condition of simultaneous record/replay, i.e. head #2 replays head #1 recording and at the appropriate time, head #3 replays head #2 recording, etc. Then, the operator adjusts the record current level for maximum on each of the four head channels. This completes the operation. No repeats or evaluations are necessary.

## Ordering Information

RCO Accessory (for TR-70/70A Recorders) .....	ES-43562
RCO Accessory (for TR-60 Recorders) .....	ES-43563
RCO Accessory (for TR-22HB* Recorders) .....	ES-43557
RCO Accessory (for TR-4HB*/50 Recorders) .....	ES-43564

TR-22's and TR-4's equipped with single-speed puck drive or direct drive capstans require a replacement two-speed belt drive capstan assembly. Machines with single speed capstans order MI-40651-A, all others order MI-43266.

# Monitor/Record Assemblies

## Description

The TR-3 TV Tape Player upon addition of a Monitor Rack Assembly (MI-43361) and Record Accessory (MI-43360-A) provides the same record-playback versatility as the RCA TR-4 TV Tape Recorder. In addition, space is provided for the addition of Electronic Splice, Cue Record/Playback, Drop-out Compensator and future accessories. The Monitor/Record Assemblies thus allow stations presently requiring only playback facilities, to expand the TR-3 at any time more recording facilities are needed.

### Monitor Rack Assembly, MI-43361

The monitor rack lends the TR-3 greater ease of maintenance as well as reduced setup time for refined servo adjustments. The picture monitor switcher is capable of selecting any one of the following: demodulator out, video out, mono ATC out, color out, and one position for an external video signal. In addition, tone wheel dots, representative of headwheel servo stability, may be superimposed on any of the previous displays.

### CRO Monitor

The CRO Monitor can be switched to observe any of the following waveforms: demodulator out, video out, FM switcher out, control track playback, capstan servo, reference pulse, and monochrome ATC error.

The monitors are assembled in a compact rack cabinet, that also contains the monitor switchers and an audio monitoring system. It has a prewired harness that connects with the various servo and video signals in the TR-3. The cabinet has space for addition of the record

electronics and internal mounted air-bearing compressor kit.

### Record Accessory, MI-43360-A

The Record Accessory requires the MI-43361 Monitor Assembly as a prerequisite. The Record Accessory is provided with the prewired harness and a module frame, designed to bolt into the monitor assembly cabinet, and a record

control panel, erase head, erase transformer, and an audio record head post.

The addition of the MI-43361 Monitor Assembly and the MI-43360-A Record Accessory increase the versatility of the TR-3 in a two step process that is easy on the budget, while allowing the continuous playback of video tape at a low initial cost.

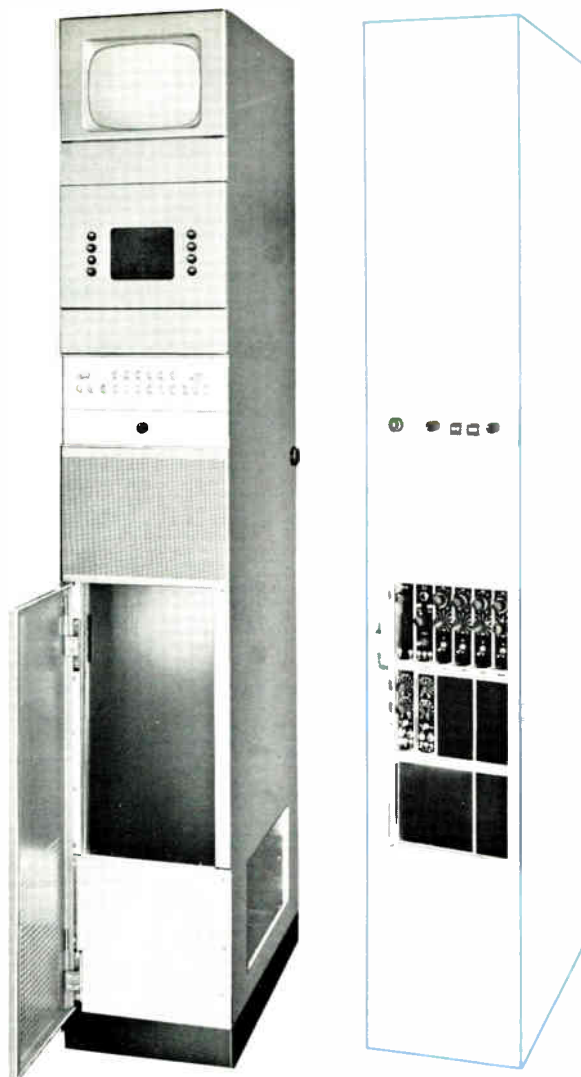

Monitor Rack.

Record Accessory.

## Specifications

### TR-3 Monitor Rack, MI-43361

Power Requirements .....115 Volt, AC, 60 Hz  
50 Hz single phase, 300 Watts max.; 230 Volts, AC, single phase, 300 Watts max.

Overall Dimensions.....66" high, 11" wide, 23½" deep  
(167.64 cm, 27.94 cm, 59.69 cm)

Weight.....165 lbs. (75 kg) approx.

### Record Accessory, MI-43360-A

Overall Dimensions.....TR-3 Monitor rack assembly is pre-requisite. This accessory fits into above equipment physically and remains same size overall.

Weight.....50 lbs. (23 kg) approx.  
Addition of this accessory and the MI-43361 will convert the TR-3 to a complete TR-4 Tape Recorder and all specifications of the TR-4 apply (see TR-4 Catalog).

## Ordering Information

Monitor Rack Assembly .....MI-43361  
Record Accessory .....MI-43360-A



# TV Tape Electronic Accessories



CAVEC

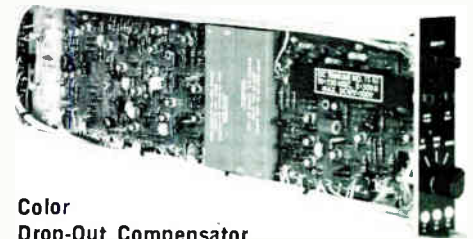

Color  
Drop-Out Compensator



Color ATC



Automatic Timing Corrector (ATC)

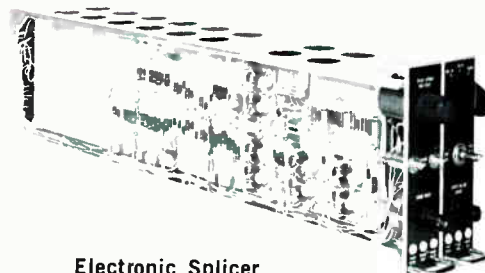

Electronic Splicer

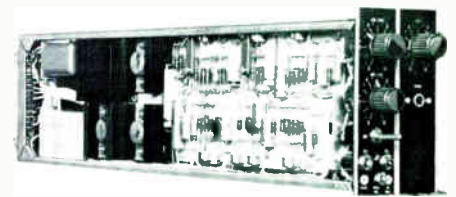

Cue Record

# Chroma Amplitude and Velocity Error Corrector (CAVEC)

- Insures consistent quality replays
- Line by line correction of hue and saturation errors
- Only one operational control
- Module package—simple to install

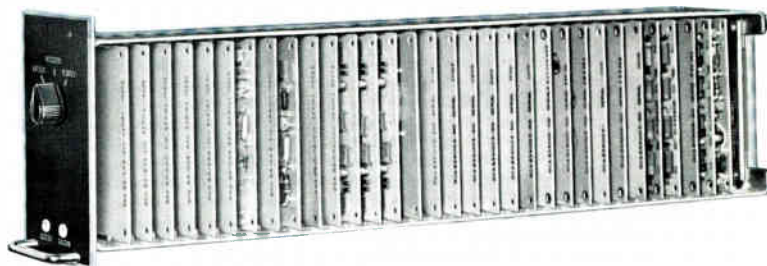

## Description

A line-by-line chroma amplitude and velocity error corrector (CAVEC) has been developed by RCA for use with its line of high band television tape recorders and reproducers. CAVEC functions only in playback to correct for mechanical and operational deficiencies in quadruplex recorders that cannot be compensated for by normal operator adjustment.

CAVEC will prove invaluable to stations receiving tapes from outside sources, to production houses and to those handling a large number of edits. The equipment provides a consistent quality replay. When producing tape dubs, it eliminates most operator errors as well as tape hue and saturation errors.

### NTSC or PAL Color Standards

CAVEC operates on 525 NTSC coded color signals as well as PAL CCIR 625 line signals. In the case of the TR-70, the change of standards is on a switchable basis; for TR-22/3/4 high band converted machines, retuning of the CATC is required.

Specifically, CAVEC is designed to eliminate color banding resulting

from two factors: First, the line-to-line chroma variations which occur due to oxide differences on tape, and small tape-to-head contact fluctuations. Secondly, the velocity errors which occur due to differences in head scanning velocities during record and playback, which result if tape tensions and mechanical tolerances are not maintained within very tight limits.

### Employs Computer Techniques

CAVEC heralds an entry into the television tape recorder of integrated circuits and the use of computer techniques. Correctional circuitry has been condensed into one module where great use is made of integrated circuits. Within CAVEC are small circuit boards that can be placed on an extender for servicing and setup.

To correct the hue and saturation errors, two different processes are carried on simultaneously within the module. The first is to correct for saturation banding. Corrective action is achieved when the off tape burst amplitude is compared to a predetermined reference, and an error signal is developed, stored and fed to the master FM equalizer

where the FM signal is appropriately compensated.

The corrective action that is used to compensate for hue banding is one whereby the ATC and CATC error signals are added together, stored and reused in a different form one head scan later.

### Single Operational Control

There are no day to day adjustments, only one operational control with CAVEC. As the correct burst to chroma ratio may not be recorded on every tape, a control is given whereby the burst to chroma ratio may be varied. On a monochrome tape the chroma correcting circuitry is automatically switched out and the equalization of a monochrome tape reverts to the manual equalizers on the playback amplifiers.

### Penthouse Module Frame

The installation of CAVEC is not complicated; a matter of two or three hours and the equipment is performing its corrective action. When adding CAVEC to a TR-3HB TV tape Player, it is necessary to purchase a "penthouse" module frame.

## Ordering Information

Chroma Amplitude and Velocity Error Corrector:	
For TR-70 .....	ES-43534
For TR-22HB .....	ES-43533
For TR-4HB .....	ES-43532
For TR-3HB .....	ES-43531*

\* Requires 1 Penthouse Module Frame, MI-591604.

## Color Drop-Out Compensator

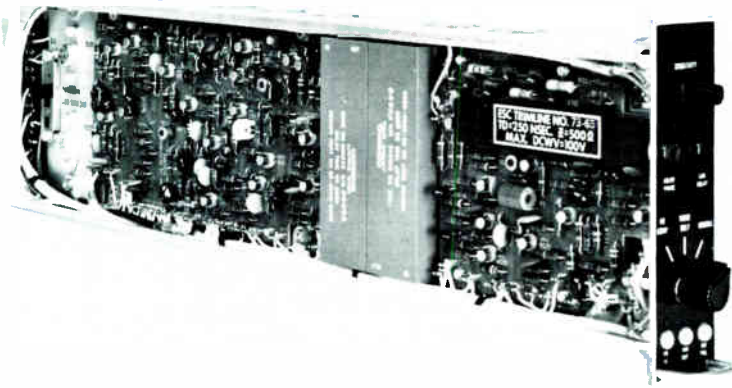

## Description

Irregularities in video tape surface or lack of intimate head to tape contact produces a brief reduction in RF carrier amplitude and results in distracting streaks in the reproduced picture. The RCA Color Drop-Out Compensator is designed to reinsert material of the correct phase and level during the periods of these disturbances. The viewer will not be aware of the substituted signal.

The unit is especially useful when multiple generation copies are made. The Color Drop-Out Compensator assures high quality, dropout free playbacks and copies. The Color Drop-Out Compensator operates on either 525 or 625 NTSC standards.

## Ordering Information

Color Drop-Out Compensator (for TR-70) .....	ES-43558
Color Drop-Out Compensator (for TR-22/3/4 High Band) .....	ES-43549

## High Band Conversion Accessory

The RCA High Band Conversion Accessory assures maximum utilization of existing TV Tape Recorders by expansion of the machine capability to include high band standards. It imparts to the user the major advantages of the high band standards; namely, improved signal to noise and virtual elimination of moire patterns. In addition, the user

will achieve compatibility with present day recorders.

Installation of the High Band Conversion Accessory will provide the recorder with a new "high" in signal handling capabilities. Improvements will be realized in differential phase, differential gain and transient response essentially pro-

viding ideal color recordings and reproductions.

The conversion kit consists of video and FM system modules, ancillary power supplies, wiring harness and auxiliary modification material. Installation is accomplished by replacement and/or modification to existing system electronics.

## Specifications

	525/60	625/50
Frequency Response..	3.8 MHz -3 dB @ 4.2 MHz	4.5 MHz -3 dB @ 5.0 MHz
Transient Response (2T sine <sup>2</sup> input) ....	Less than 3%	Less than 3%
Differential Phase ....	Less than 10° @ 3.58 MHz	Less than 10° @ 4.43 MHz
Differential Gain (Blanking to White)	Less than 10%	Less than 10%
Signal to Noise (Normal speed — P-P Video/RMS noise) .....	43 dB	40 dB
Moire .....	37 dB	28 dB
Low Frequency Linearity (Blanking to White) 2%		2%

## Ordering Information

High Band Conversion Accessory (For TR-22 Series) .....	ES-35988*
High Band Conversion Accessory (For TR-4 Series) .....	ES-35987*
High Band Conversion Accessory (For TR-3 Series) .....	ES-35986*
* Requires High Capacity Air Bearing Conversion, plus High Band Head-wheel Panel (see below).	
Replacement High Capacity Compressor (Internal Mount); 117/60 Hz TR-22/4 Series .....	MI-43238
234/50 Hz TR-22/4 Series .....	MI-43237
Replacement High Capacity Compressor (External Mount); 117/60 Hz TR-3/4 Series .....	MI-43236**
234/50 Hz TR-3/4 Series .....	MI-43235**

\*\* Replacement compressor not required if any of the following air conversion kits have previously been installed: MI-43340/MI-43341, MI-43364, MI-43276/MI-43277.



## Color ATC Equipment

- Operation on NTSC or PAL signals
- Direct recovery of color information
- Provision for playback of color "dubs"

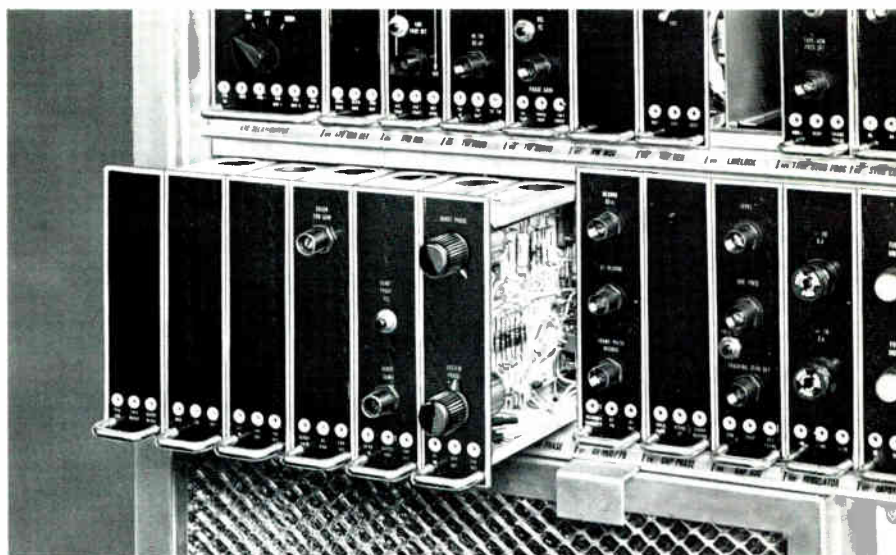

## Description

The RCA Color Automatic Timing Corrector is designed to provide time base correction to the tape playback signal. It operates in conjunction with the monochrome ATC and pixlock line lock servo systems, both of which are required.

The color ATC system comprises six transistorized modular units which plug into the module bank of the RCA TR-3, TR-4 and TR-22 TV Tape Recorders, and a fixed delay line which mounts in the console. Circuitwise, it is inserted into the video path between the monochrome ATC and the signal processing amplifier during tape playback. The resultant color signal is of the highest quality and requires no further processing.

### Functional Operation

Stabilization is accomplished by measuring the residual timing errors in a signal that has been pre-stabilized by the pixlock and monochrome ATC systems and eliminates these errors or reduces them to a negligible value, utilizing a time-error correcting circuit whose major component is an electronically variable delay line.

The Color ATC output signal is directed to the signal processing amplifier. As an adjunct to this stabilization process, the Color ATC also cleans the blanking interval and inserts regenerated burst.

The NTSC Color ATC has two modes of operation. In the first mode, the device is used to stabilize a normal color recording. In the second mode, the color ATC is capable of stabilizing the chroma content of a second-generation color "dub" made by a heterodyne process. For PAL operations only direct recovery color is possible.

### Automatic Operation

Operation of the color ATC system is completely automatic; i.e., it is inserted into the video path by the selection of color deviation FM standards, and its correcting action commences immediately after the machine has achieved "lock-up" in the pixlock or line lock servo mode. The relatively few set-up adjustments need not be touched for long periods of time once they have been properly set. The Color ATC modules are interlocked so that when any color

module is disconnected from its receptacle the color ATC system is automatically bypassed.

### Only Two Operational Controls

The Color ATC system contains only two operational controls. These are the "burst phase" and "system phase" controls located on the color phase module. The burst phase control is utilized in adjusting the system to obtain a proper color picture containing natural flesh tones, etc., as observed on the color monitor, while the system phase control is utilized as a cable length compensating device to insure that when mixing various color signal sources the phase of each is identical with respect to a reference.

### Easy to Install

The equipment is supplied in kit form, ready for immediate installation in the tape machine. The kit consists of six color ATC plug-in circuit modules, a fixed delay line and the required hardware and electrical parts required for installation. All of the necessary connectors and cable assemblies are supplied as part of the monochrome ATC kit.

## Specifications

Differential Phase .....	3°
Differential Gain .....	2%
Correction Range .....	360° of subcarrier
Video Input .....	Receives signal from monochrome ATC
Power Requirements .....	Obtained from TR-3/4/22 tape systems

## Ordering Information

Color ATC Equipment:	NTSC*	PAL*
(For TR-22A/22B/22C) .....	ES-43581-A	ES-43540
(For TR-22-D) .....	ES-43598	ES-43541
(For TR-3/3A/4/4A) .....	ES-43582-A	ES-43542
(For TR-3B, 3C/4B/4C) .....	ES-43599	ES-43543

\* Applies to domestic and international equipment. Color ATC is dependent upon TR-3/4/22 machines having available monochrome ATC and pixlock modules.

## Color Drop-Out Compensator

## Description

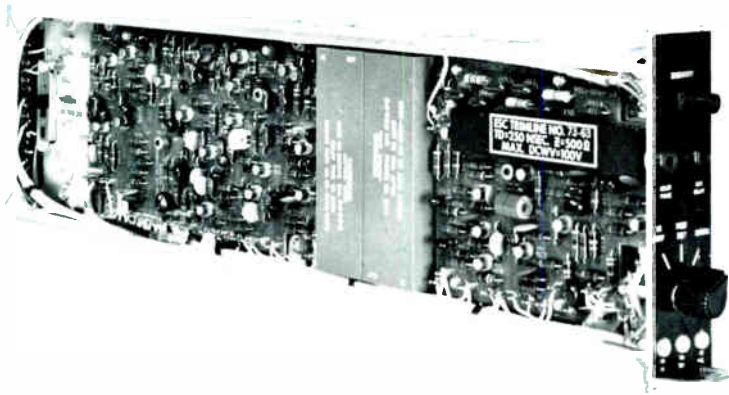

Irregularities in video tape surface or lack of intimate head to tape contact produces a brief reduction in RF carrier amplitude and results in distracting streaks in the reproduced picture. The RCA Color Drop-Out Compensator is designed to reinsert material of the correct phase and level during the periods of these disturbances. The viewer will not be aware of the substituted signal.

The unit is especially useful when multiple generation copies are made. The Color Drop-Out Compensator assures high quality, dropout free playbacks and copies. The Color Drop-Out Compensator operates on either 525 or 625 NTSC standards.

## Ordering Information

Color Drop-Out Compensator (for TR-70) .....	ES-43558
Color Drop-Out Compensator (for TR-22 3/4 High Band) .....	ES-43549

## High Band Conversion Accessory

The RCA High Band Conversion Accessory assures maximum utilization of existing TV Tape Recorders by expansion of the machine capability to include high band standards. It imparts to the user the major advantages of the high band standards; namely, improved signal to noise and virtual elimination of moire patterns. In addition, the user

will achieve compatibility with present day recorders.

Installation of the High Band Conversion Accessory will provide the recorder with a new "high" in signal handling capabilities. Improvements will be realized in differential phase, differential gain and transient response essentially pro-

viding ideal color recordings and reproductions.

The conversion kit consists of video and FM system modules, ancillary power supplies, wiring harness and auxiliary modification material. Installation is accomplished by replacement and/or modification to existing system electronics.

## Specifications

	525/60	625/50
Frequency Response..	3.8 MHz -3 dB @ 4.2 MHz	4.5 MHz -3 dB @ 5.0 MHz
Transient Response (2T sine <sup>2</sup> input) ....	Less than 3%	Less than 3%
Differential Phase ....	Less than 10° @ 3.58 MHz	Less than 10° @ 4.43 MHz
Differential Gain (Blanking to White)	Less than 10%	Less than 10%
Signal to Noise (Normal speed — P-P Video/RMS noise) .....	43 dB	40 dB
Moire .....	37 dB	28 dB
Low Frequency Linearity (Blanking to White) 2%		2%

## Ordering Information

High Band Conversion Accessory (For TR-22 Series) .....	ES-35988*
High Band Conversion Accessory (For TR-4 Series) .....	ES-35987*
High Band Conversion Accessory (For TR-3 Series) .....	ES-35986*
* Requires High Capacity Air Bearing Conversion, plus High Band Head-wheel Panel (see below).	
Replacement High Capacity Compressor (Internal Mount); 117/60 Hz TR-22/4 Series .....	MI-43238
234/50 Hz TR-22/4 Series .....	MI-43237
Replacement High Capacity Compressor (External Mount); 117/60 Hz TR-3/4 Series .....	MI-43236**
234/50 Hz TR-3/4 Series .....	MI-43235**

\*\* Replacement compressor not required if any of the following air conversion kits have previously been installed: MI-43340/MI-43341, MI-43364, MI-43276/MI-43277.

## Color ATC Equipment

- Operation on NTSC or PAL signals
- Direct recovery of color information
- Provision for playback of color "dubs"

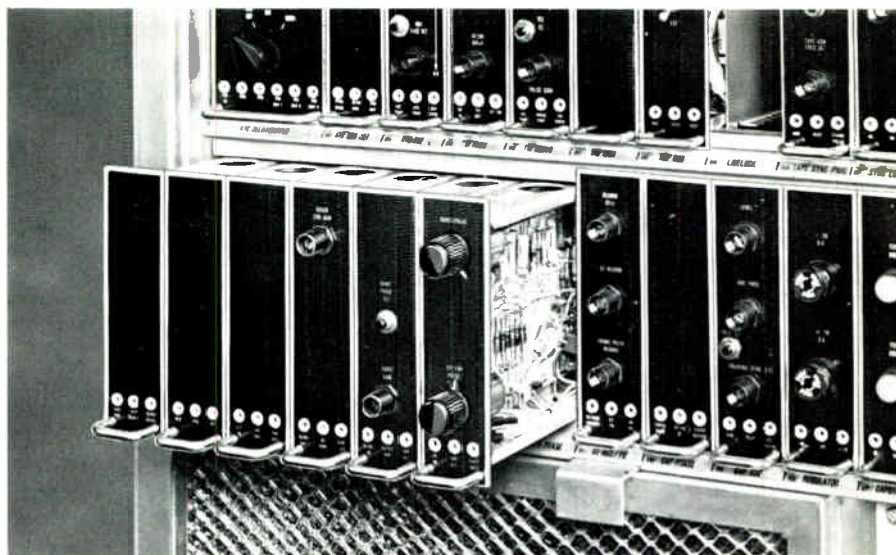

## Description

The RCA Color Automatic Timing Corrector is designed to provide time base correction to the tape playback signal. It operates in conjunction with the monochrome ATC and pixlock/line lock servo systems, both of which are required.

The color ATC system comprises six transistorized modular units which plug into the module bank of the RCA TR-3, TR-1 and TR-22 TV Tape Recorders, and a fixed delay line which mounts in the console. Circuitwise, it is inserted into the video path between the monochrome ATC and the signal processing amplifier during tape playback. The resultant color signal is of the highest quality and requires no further processing.

### Functional Operation

Stabilization is accomplished by measuring the residual timing errors in a signal that has been pre-stabilized by the pixlock and monochrome ATC systems and eliminates these errors or reduces them to a negligible value, utilizing a time-error correcting circuit whose major component is an electronically variable delay line.

The Color ATC output signal is directed to the signal processing amplifier. As an adjunct to this stabilization process, the Color ATC also cleans the blanking interval and inserts regenerated burst.

The NTSC Color ATC has two modes of operation. In the first mode, the device is used to stabilize a normal color recording. In the second mode, the color ATC is capable of stabilizing the chroma content of a second-generation color "dub" made by a heterodyne process. For PAL operations only direct recovery color is possible.

### Automatic Operation

Operation of the color ATC system is completely automatic; i.e., it is inserted into the video path by the selection of color deviation FM standards, and its correcting action commences immediately after the machine has achieved "lock-up" in the pixlock or line lock servo mode. The relatively few set-up adjustments need not be touched for long periods of time once they have been properly set. The Color ATC modules are interlocked so that when any color

module is disconnected from its receptacle the color ATC system is automatically bypassed.

### Only Two Operational Controls

The Color ATC system contains only two operational controls. These are the "burst phase" and "system phase" controls located on the color phase module. The burst phase control is utilized in adjusting the system to obtain a proper color picture containing natural flesh tones, etc., as observed on the color monitor, while the system phase control is utilized as a cable length compensating device to insure that when mixing various color signal sources the phase of each is identical with respect to a reference.

### Easy to Install

The equipment is supplied in kit form, ready for immediate installation in the tape machine. The kit consists of six color ATC plug-in circuit modules, a fixed delay line and the required hardware and electrical parts required for installation. All of the necessary connectors and cable assemblies are supplied as part of the monochrome ATC kit.

## Specifications

Differential Phase .....	3°
Differential Gain .....	2%
Correction Range .....	360° of subcarrier
Video Input .....	Receives signal from monochrome ATC
Power Requirements .....	Obtained from TR-3/4/22 tape systems

## Ordering Information

Color ATC Equipment:	NTSC*	PAL*
(For TR-22A/22B/22C) .....	ES-43581-A	ES-43540
(For TR-22-D) .....	ES-43598	ES-43541
(For TR-3/3A/4/4A) .....	ES-43582-A	ES-43542
(For TR-3B/3C/4B/4C) .....	ES-43599	ES-43543

\* Applies to domestic and international equipment. Color ATC is dependent upon TR-3/4/22 machines having available monochrome ATC and pixlock modules.

# Monochrome ATC Equipment

- Maintains near perfect picture geometry by automatically compensating for skewing, quadrature errors, and jitter
- Fully automatic—no operating controls
- Automatic error correction factor of 35 to 1 over total delay range of one microsecond

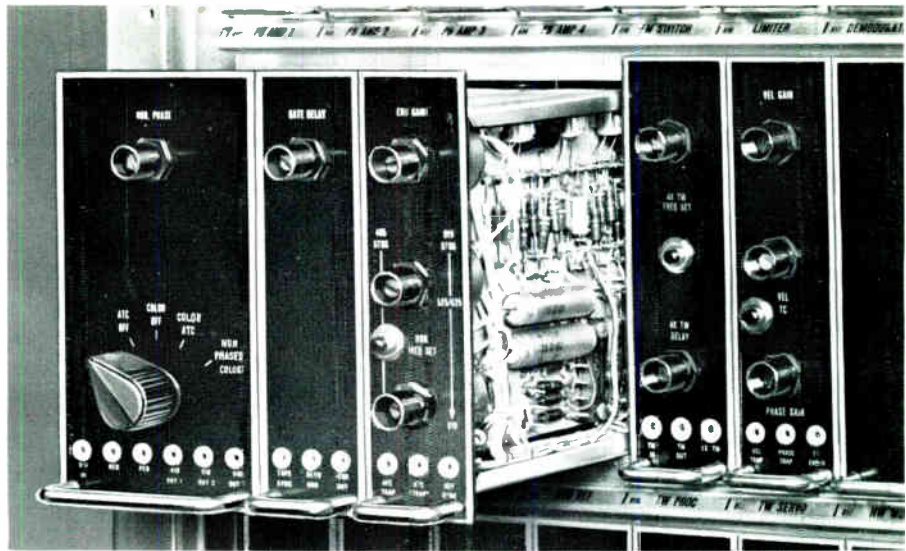

## Description

The RCA Automatic Timing Corrector (ATC) is a transistorized video device providing electronic compensation for geometric distortion in the reproduced TV monochrome or color tape signal. Distortion, whether due to quadrature, skewing, or jitter is virtually eliminated when time delay errors are passed through ATC. It thus serves as a continuous monitoring and correction device which automatically reduces the time delay errors occurring in the playback signal, thereby assuring the highest possible quality at all times. It is a pre-requisite for color ATC.

### Operational Modes

The ATC circuit operates in either of two modes . . . "internal" or "external". The internal mode is used when the machine is in the tonewheel or switchlock modes. While in the internal mode, ATC

corrects geometric distortion but does not synchronize horizontal sync pulses from the tape recorder with the corresponding sync pulses from the local sync generator.

The external mode is used when the headwheel servo is in Pixlock or LLO. In the external mode, ATC in addition to correcting geometric distortion, greatly reduces residual horizontal jitter and results in an extremely stable output. The ATC circuits sense the mode of Servo operation and automatically switch to the internal or external modes.

### Bypass Provisions

If ATC is not desired, a switch on the ATC delay/output module permits manual bypassing of ATC circuits. In the bypass condition, the ATC modules can be tested or removed while normal playback con-

tinues, since the ATC circuits are completely removed from the signal path. Input signals are still provided to the ATC so that it can be checked while out of the signal path. All modules are interlocked so that removal of any module during ATC operation will cause automatic bypassing.

### Modular Design—Easy to Install

The equipment is supplied in kit form, ready for installation in the RCA TR-3, TR-1 and TR-22 Series TV Tape Recorders. The kit consists of a connector and cable assembly, three ATC plug-in circuit modules, a fixed delay line, and the required hardware and electrical parts required for installation. Installation of monochrome ATC includes the harness assembly required for Color ATC.

## Specifications

### ELECTRICAL

Video Input.....From demod. output module  
1 Volt peak-to-peak

### Video Output:

TR-22/TR-3/TR-4.....4 outputs (1 to oscilloscope, 1 to picture monitor, 1 Proc. Amp., 1 color ATC) 1 Volt peak-to-peak

### Delay Control Range:

TR-22/TR-3/TR-4.....Minimum error reduction factor 35 to 1 for input errors up to 1 microsecond peak-to-peak

### Frequency Response:

TR-22/TR-3/TR-4 .....30 Hz to 6 MHz  $\pm 1$  dB over total delay range ( $\frac{1}{2}$  dB variation at 3.58 MHz and 1.43 MHz)

### Low Frequency Tilt

.....5% on 60 Hz square wave

Differential Gain.....3% (50% APL, delay at mid-range, standard level)

Differential Phase.....3° (50% APL, delay at mid-range, standard level)

Total Residual Jitter.....80 nanoseconds peak-to-peak

Power Requirements.....Obtained from TR-3/4/22 tape systems

### MECHANICAL

Dimensions (overall).....3 modules which fit into spaces provided in basic TR-3, TR-4, and TR-22-A/B/C

Weight.....15 lbs. (5.8 kg)

## Ordering Information

### Automatic Timing Corrector:

- For TR-3/3A/4/4A .....ES-43580-C
- For TR-3B/4B .....ES-43597-A
- For TR-22-A/B .....ES-43579-C
- For TR-22C .....MI-43391-C

# Electronic Splicing Accessory

- Color or mono splicing
- Pushbutton setup
- Switchable standards
- Audio/cue retain
- Splice at 7½ or 15 IPS

## Description

The RCA Electronic Splicing Accessory, provides a fast, accurate means of adding or replacing a sequence electronically in recorded color or mono video tape program material without mechanically cutting and rejoining tape. The electronic splice is achieved by the addition of three transistorized modular units included in the Splicing Kits for the TR-4, 5, 22 and 70 Recorders.

### Electronic Splicing

The Electronic Splicer provides facilities in TV tape recorders for two new modes of operation—"ADD-ON" and "INSERT" that can often prove a more effective substitute for the former mechanical splicer. With electronic splicing, video tape is not cut or damaged, hence, the tape is not weakened at the splice nor is tape life shortened. The operation is fast, accurate, requires little or no skill on the part of the operator, yet every splice is consistently good. Mechanical splicing was slow, tedious, and required considerable skill to obtain consistently good splices.

### Installation

The equipment comprises three transistorized modular units (splice timing, splice control and splice logic modules), new selective erase

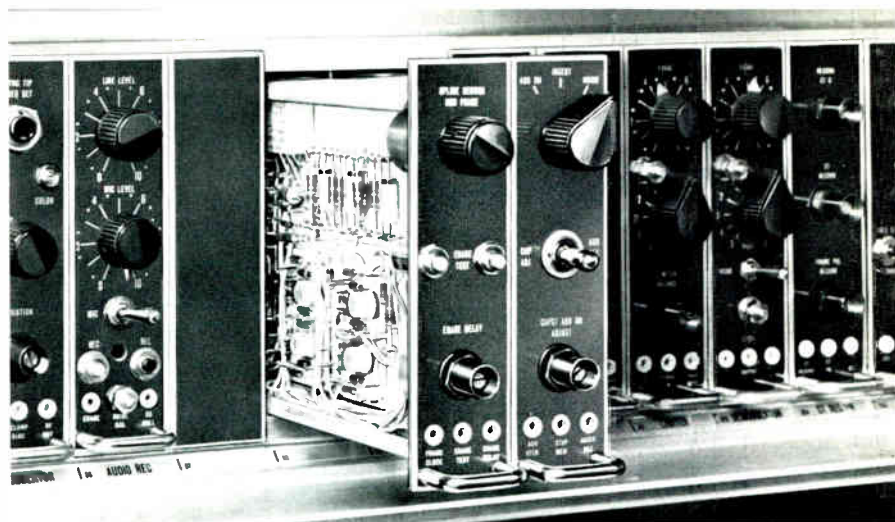

head, wiring harness and auxiliary modification material. The addition of Electronic Splicer in the TR-4/5 and 22 is accomplished by installing the new selective erase head, module sockets, wiring harness, and minor modification to other modules in the recorder. The TR-4B, 22D and TR-70 Tape Recorders are pre-wired for the splicing accessory.

### Audio Cue Retain

An audio/cue retain feature permits recording video information while not disturbing previously recorded audio or cue information. The audio retain feature is activated only in the splice mode, allowing normal operation of audio record in the non-splice mode.

### Operational Features

The plug-in modular construction affords easy accessibility to all components. Furthermore, removal of any module automatically returns the tape recorder to normal operation. This by-pass feature is only one of several improvements in electronic splicing. Other features are two-speed operation, switchable standards, and pushbutton setup procedure. When used on TV tape recorders equipped with the two-speed accessory, the splicer auto-

matically switches to provide correct operation at either tape speed. When used on switchable TV standards recorders, the splicer automatically provides correct operation on all TV standards. Momentary pushbuttons are provided for quick check of splicer adjustment using normal machine monitoring facilities.

### Operation Controls

There is one operating control which permits a choice of "ADD-ON", "INSERT" or "NORMAL" (non-splicing mode) operation. There are two set up controls. In the ADD ON mode, the recorder is capable of adding a new recording on to a previous recording with erasing and recording functions controlled so that the new material is spliced on to the old material with a transition similar to a clean video switch transfer. The INSERT mode provides a similar facility, except that the new recording may be inserted in the center of an old recording. Both ingoing and outgoing splices are accurately timed to ensure complete continuity. All splicing is done in the SWITCHLOCK servo mode. The splicer operates in color or monochrome, and provision is made for remote control of the splicer mode selector switch.

## Specifications

### Delay:

Into Splice.....0.5 sec at 15 IPS; 1.0 sec at 7½ IPS  
 Out of Insert Splice.....0.5 sec at 15 IPS; 1.0 sec at 7½ IPS  
 Out of Add-On Splice.....Zero sec

Minimum Splice Time.....0.5 sec at 15 IPS; 1.0 sec at 7½ IPS

Weight.....15 lbs. approx. (6.8 kg.)

## Ordering Information

Electronic Splicing Accessory for TR-70 .....	MI-35961
Electronic Splicing Accessory for TR-22D .....	MI-40695-A
Electronic Splicing Accessory for TR-22-A/B/C.....	ES-40922-A
Electronic Splicing Accessory for TR-4.....	ES-43578-A
Electronic Splicing Accessory for TR-4A.....	ES-43569
Electronic Splicing Accessory for TR-4B/C .....	ES-43568
Electronic Splicing Accessory for TR-5.....	ES-43566

## Monitor/Record Assemblies

The TR-3 TV Tape Player upon addition of a Monitor Rack Assembly (MI-43361) and Record Accessory (MI-43360-A) provides the same record-playback versatility as the RCA TR-4 TV Tape Recorder. In addition, space is provided for the addition of Electronic Splice, Cue Record/Playback, Drop-out Compensator and future accessories. The Monitor/Record Assemblies thus allow stations presently requiring only playback facilities, to expand the TR-3 at any time more recording facilities are needed.

### Monitor Rack Assembly, MI-43361

The monitor rack lends the TR-3 greater ease of maintenance as well as reduced setup time for refined servo adjustments. The picture monitor switcher is capable of selecting any one of the following: demodulator out, video out, mono ATC out, color out, and one position for an external video signal. In addition, tone wheel dots, representative of headwheel servo stability, may be superimposed on any of the previous displays.

### CRO Monitor

The CRO Monitor can be switched to observe any of the following waveforms: demodulator out, video out, FM switcher out, control track playback, capstan servo, reference pulse, and monochrome ATC error.

The monitors are assembled in a compact rack cabinet, that also contains the monitor switchers and an audio monitoring system. It has a prewired harness that connects with the various servo and video signals in the TR-3. The cabinet has space for addition of the record electronics

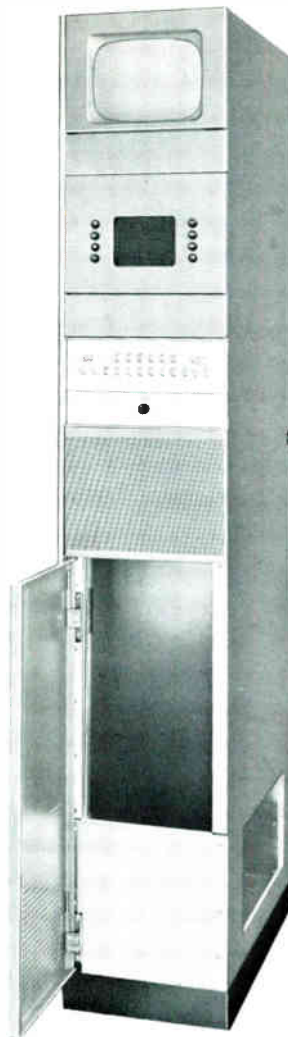

Monitor Rack

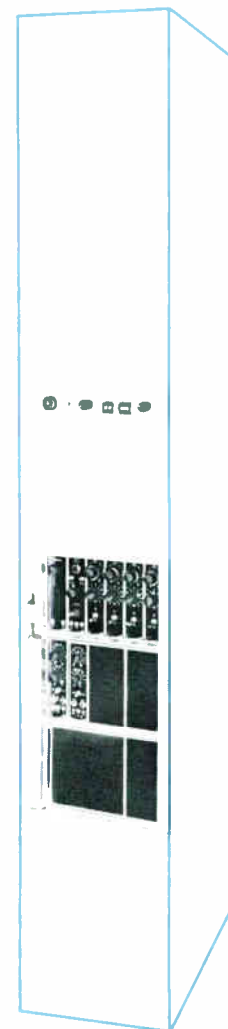

Record Accessory

and internal mounted air-bearing compressor kit.

### Record Accessory, MI-43360-A

The Record Accessory requires the MI-43361 Monitor Assembly as a prerequisite. The Record Accessory is provided with the prewired harness and a module frame, designed to bolt into the monitor assembly cabinet, and a record control panel,

erase head, erase transformer, and an audio record head post.

The addition of the MI-43361 Monitor Assembly and the MI-43360-A Record Accessory increase the versatility of the TR-3 in a two step process that is easy on the budget, while allowing the continuous playback of video tape at a low initial cost.

## Specifications

### TR-3 Monitor Rack, MI-43361

Power Requirements .....115 Volt, AC, 60 Hz  
50 Hz single phase, 300 Watts max.; 230 Volts, AC, single  
phase, 300 Watts max.

Overall Dimensions.....66" high, 11" wide, 23½" deep  
(167.64 cm, 27.94 cm, 59.69 cm)

Weight.....165 lbs. (75 kg) approx.

### Record Accessory, MI-43360-A

Overall Dimensions.....TR-3 Monitor rack assembly is  
pre-requisite. This accessory fits into above equipment  
physically and remains same size overall.

Weight.....50 lbs. (23 kg) approx.

Addition of this accessory and the MI-43361 will convert the TR-3 to a complete TR-4 Tape Recorder and all specifications of the TR-4 apply (see TR-4 Catalog).

## Ordering Information

Monitor Rack Assembly ..... MI-43361

Record Accessory ..... MI-43360-A

## Cue Record/ Playback

- Adds voice, tone or pulse information
- Provisions for preview
- Plug-in modular construction
- Microphone and line inputs
- Improved frequency response

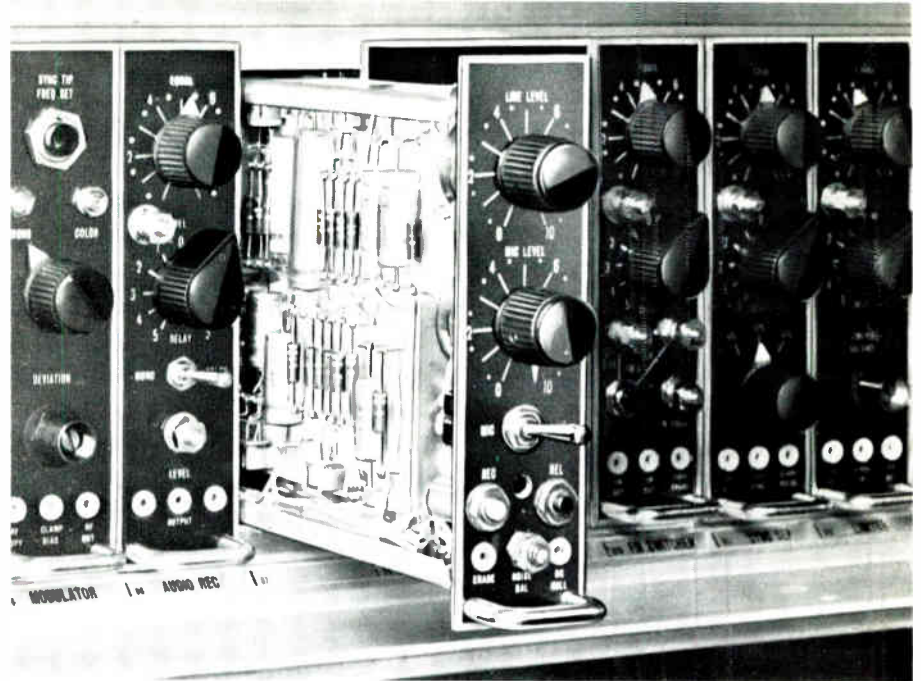

## Description

### Cue Record/Playback

Cue Record/Playback, a standard feature of RCA TR-22 Tape Recorders, can be provided for the TR-4 and TR-5 machines as accessory equipments. Space is provided in the module bank to accommodate this accessory. An audio/cue playback accessory kit for external mounting is available for use with the TR-3 Player.

### Voice, Tone, or Pulse Cue

The Cue Record/Playback accessory head provides a means for recording cue information along one edge of the video tape. This can be in the form of voice, tone or pulse information. Recording can be done independent of video recording; in other words, sound may be dubbed in while playing back or previewing the video signal.

### Accessory Kit

The TR-3 Cue Playback Accessory enables the cue track to be monitored for any special instructions or for program start information. The kit consists of a preamplifier, audio/cue playback head, audio amplifier and speaker, for external mounting. A harness is included to connect the cue preamplifier to the mounting system.

## Specifications

Line Input Level ..... 0 dBm to 18 dBm into a 10,000 Ohm balanced bridging impedance; may be reconnected for -20 dBm to 0 dBm matching input, 600 or 150 Ohm, balanced or unbalanced.

Microphone Input.....Recordings may be made from built-in microphone and pre-amplifier simultaneously with or separately from audio channel.

Line Output Level ..... 18 dBm max. into 600 Ohm balanced or unbalanced line; may be reconnected for a 150 Ohm line

Phone Jack Output ..... 600 Ohm or high impedance microphone

### Frequency Response:

At 15 IPS .....  $\pm 2$  dB, 50 to 190 Hz and 310 to 10,000 Hz

At 7½ IPS .....  $\pm 3$  dB, 60 to 190 Hz and 310 to 10,000 Hz (A 240/250 Hz notch filter removes crosstalk from the control track. Effect of this filter on tonal balance of speech and music is imperceptible.)

Signal-to-Noise Ratio ..... Better than 34 dB measured between a reference signal recorded at 1000 Hz and 5% third harmonic distortion and none present when playing back on erased, unmodulated tape.

## Ordering Information

Cue Record/Playback (for TR-4/4A/4B) .....	MI-43355
Cue Record/Playback (for TR-5).....	MI-43348
Audio/Cue Playback (for TR-3/3A/3B) .....	MI-43369



**RADIO CORPORATION OF AMERICA**

# RCA High Band Conversion Accessories



- Improved signal to noise ratio
- High Band compatibility

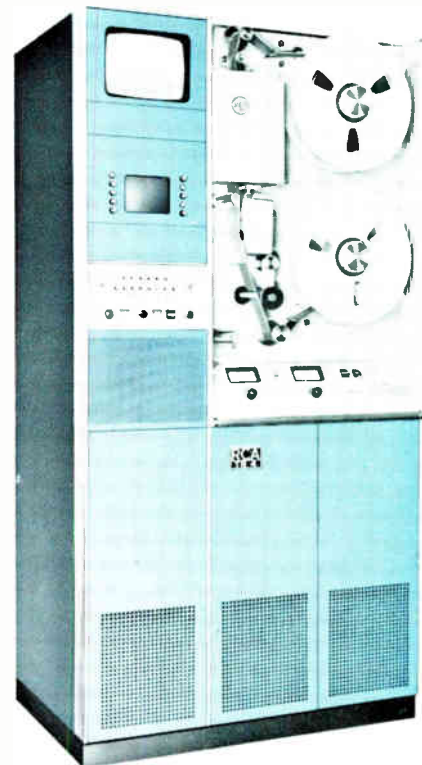

- Reduced moire effects
- Switchable standards



# High Band Conversion Accessories

High Band Conversion Accessories to update low-band RCA TR-22/4 Series Tape Recorders to the new deviation standards are now available. High-banding existing recorders provides such major advantages as improved signal-to-noise and virtual elimination of moire patterns. Additionally, the machines will achieve compatibility with present day recorders utilizing the latest highband standards.

Although other parameters, such as differential phase, differential gain and transient response are "state of the art", it is common to achieve improvements in these parameters utilizing the High Band Conversion Accessory. This conversion accessory ensures maximum life of present recorders with minimal outlay of funds.

## Description

The High Band Conversion Accessories consist of video and FM system modules, ancillary power supplies, wiring harness and auxiliary modifications material necessary to update present TR-22/4 Series Recorders for the high band deviation standards. Installation is accomplished by replacement and/or modification to existing system electronics.

### High Band Conversion TR-22 Series

Conversion of a machine, in the TR-22 Series, to high band standards involves both mechanical and electronic changes. Mechanically, it is necessary to relocate fixed delay lines and the air blower. Electronically, the FM system and a greater portion of the video circuitry is changed or modified. In carrying out the modification to the electronic circuitry it is necessary to add modifications

to existing modules only where the modification to the circuitry is limited. In the areas of extensive modification completely new modules are employed. This permits a relatively fast conversion and has the added advantage of utilizing "completely checked" modules.

### High Band Conversion TR-4 Series

The conversion of a machine in the TR-4 Series encompasses similar changes as those in the TR-22 Series. However, the mechanical changes associated with the modification are minimal in number. The electronic changes will again consist of changes to the FM system and video circuitry. In this conversion accessory, as in the conversion accessory for the TR-22 Series, modification to existing modules is limited to minor changes,

with replacement of the total module being made where the modifications are extensive.

### VIDEO SYSTEM MODIFICATION

#### Input Module

The changes to the video system are quite extensive. The video input module is replaced with a new module containing a low pass filter to eliminate spurious or undesirable intermodulation components, created by high frequency noise. Incorporated in this new module is a "unity/variable" gain switch and a "unity/variable" frequency response characteristic. The unity gain and unity response features are incorporated to facilitate recordings which adhere to the standards of video levels and frequency response parameters.

#### Video Processor

Two new modules are supplied for the processing amplifiers. The

new modules provide an improved chroma mixing process, a variable chroma level adjustment and improved differential gain characteristics.

### **FM System Modifications**

A major portion of the High Band Conversion is accomplished in the FM section of the recorder. In addition to the expansion of the FM system to employ additional standards, extreme care is exercised to assure optimum operation within any given standard. The result is an improvement in all parameters heretofore limited by the standard FM system.

### **Modulator**

A new "double heterodyne" modulation system is employed. The oscillators utilized are in the 100 to 108 MHz region. Employing these frequencies results in a marked improvement in modulation linearity. In terms of picture quality, the results are seen in a reduction of moire and an improved signal-to-noise ratio.

### **Modulator AFC**

A new modulator AFC module is used in the High Band Conversion Accessory, which assures that the carrier frequency is clamped at blanking level. Elimination of a carrier frequency control is possible utilizing this type of AFC system.

### **FM Standards**

Incorporated within this new standards module are the white

reference crystal markers to facilitate setting of carrier deviation. Controls for setting the record currents for two of the four channels are also contained in this module.

### **Record Amplifiers**

The new record amplifiers for each head channel are contained in this module. The additional two controls, identical to the controls contained in the FM standards module, for setting record current are in this module.

### **Playback Amplifiers**

These two modules house the four playback amplifiers. Controls for two channels are contained on a single module. Elimination of anti-resonance compensation is made possible through the use of very low impedance pre-amplifiers during playback. The 4 x 2 switching functions are also accomplished in these two modules.

### **FM Switcher**

The existing switcher module is modified to carry out the remaining switching function. Since the combining of two playback channels is previously accomplished in the two playback amplifier modules, only a 2 x 1 switching function need be accomplished within this module.

### **FM Equalizer**

Having changed the frequencies employed in the modulation process, it is necessary to utilize a new standards module.

### **Demodulator**

A new limiter demodulation combination is part of the High Band Accessory. This unit plays an important part in the reduction of intermodulation interference and an improvement in the transient-response characteristics of the machine.

### **Minor Modifications**

It is necessary to perform minor modifications to existing modules to enable integration of the new system modules and components with existing equipment. The areas that are affected are the demodulator output module, horizontal AFC module, reference generator, sync logic module, capstan oscillator and power regulator.

### **Headwheel Panel**

The headwheel panel which is to be used which has been converted to high band operation is the same headwheel panel which is used on the TR-70 Recorder. This new headwheel is available in either a 10 mil or 5 mil configuration. The panel is only available with air bearings which will dictate the addition of an air bearing conversion kit on machines presently not equipped for this type of headwheel panel. In addition it will be necessary to supply an air pressure of 55 lb/in<sup>2</sup> at .5 cu. ft./min., which in some instances will necessitate a change in air compressors. The ordering information contained on the last page of this folder will furnish the proper information.

# TR-22 High Band Conversion



NEW ITEM



MODIFIED ITEM

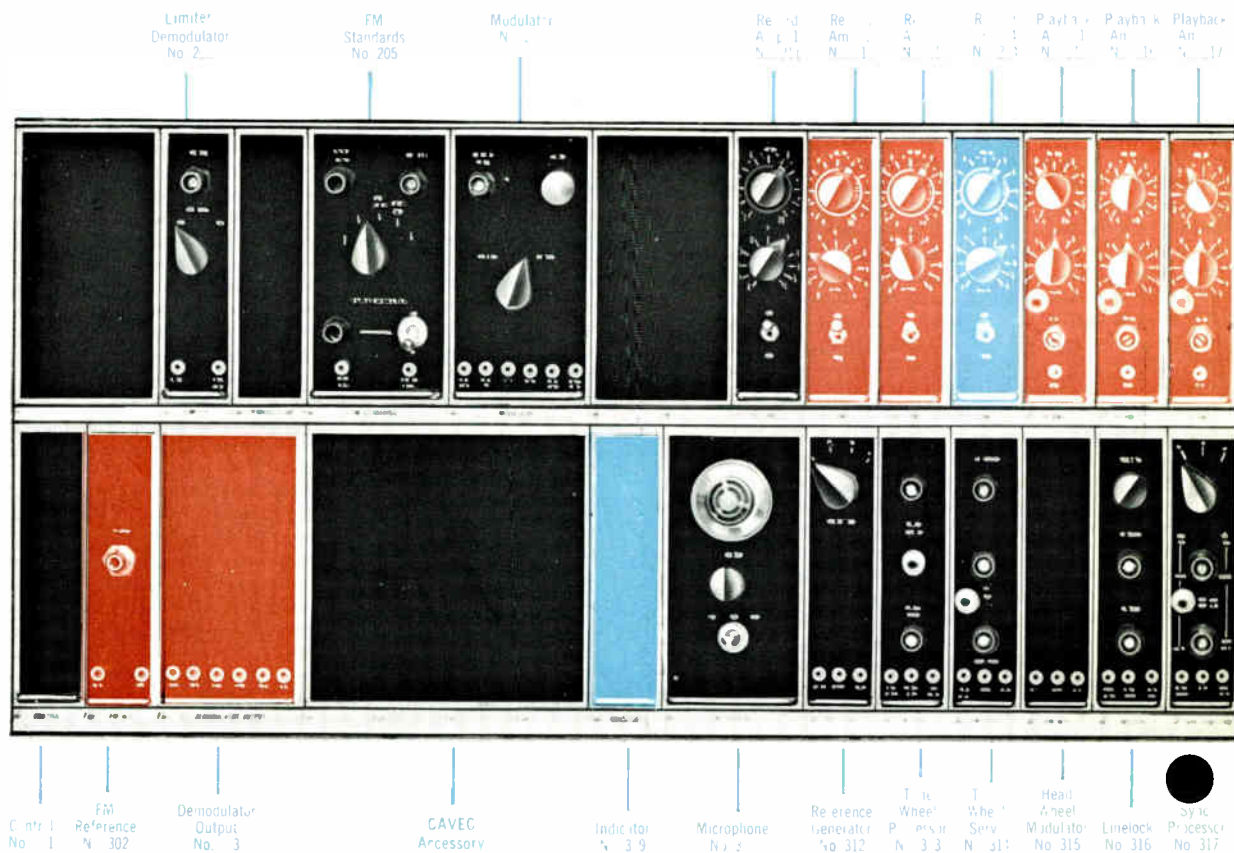

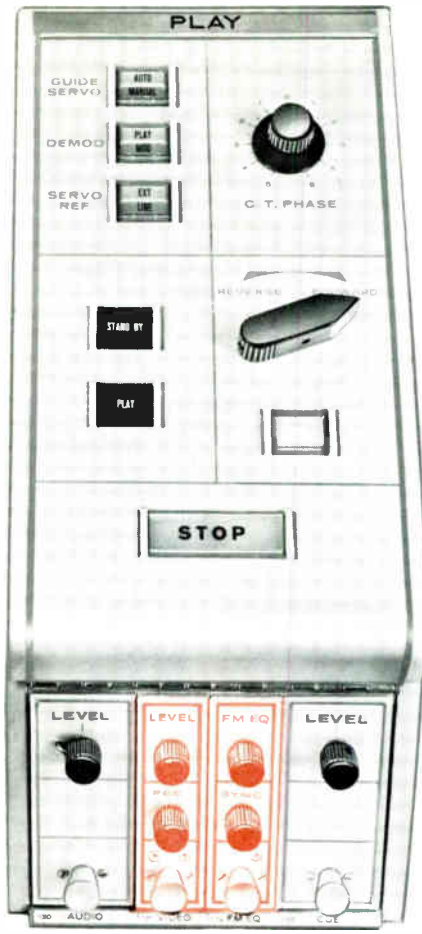
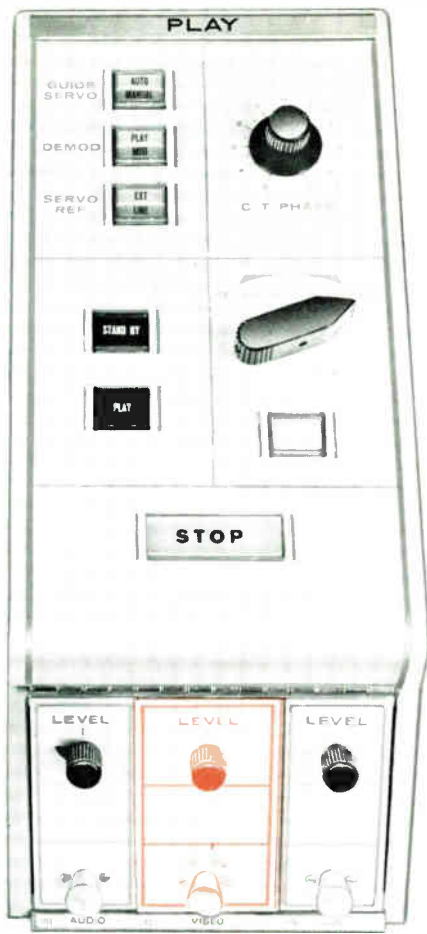

Playback  
Anti-  
N 1

Auto  
Servo  
N 2

ATC Output  
N 3

AT Filter  
N 25

AT Filter  
N 26

Head  
AF  
N 27

Vertical  
Advance  
No 2

Sync  
Logic  
No 230

Video  
Output  
N 23

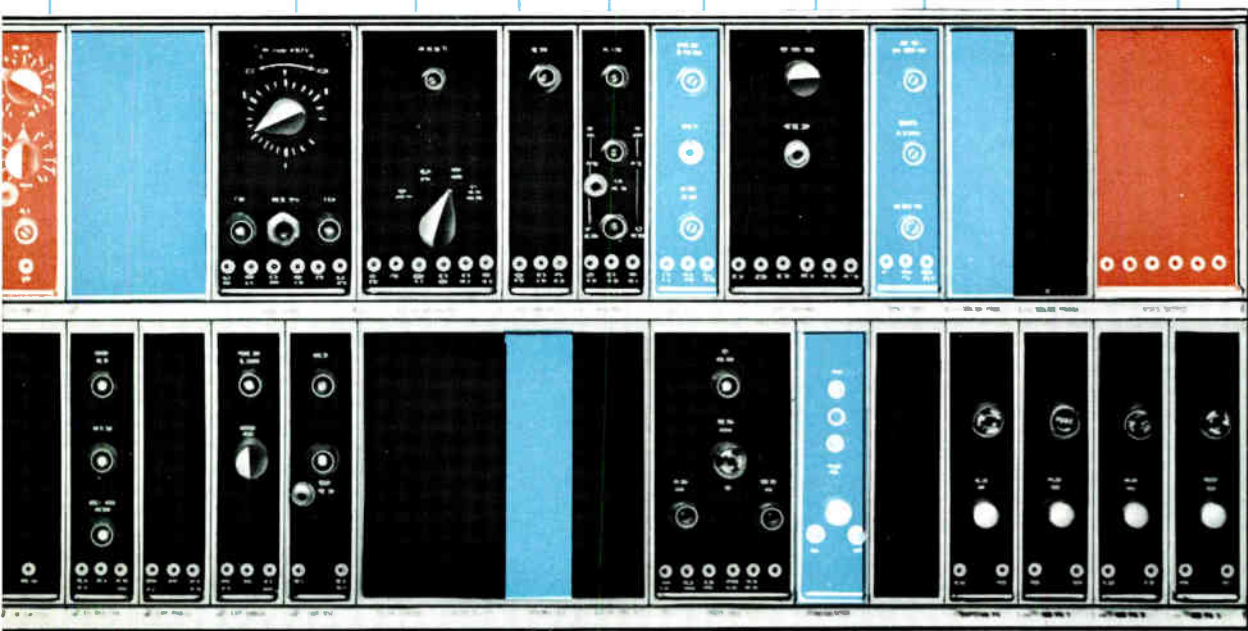

FM  
Switch  
No 318

Control  
Track  
Replay  
N 3

Capacitor  
Phase  
No 3

Filter  
Delete  
No 3

Capacitor  
Oscillator  
N 322

Expander  
N 3

Regulator  
N 3

Capstan  
Motor  
PA  
N 331

Head Wheel  
Motor  
PA  
No 332

Head Wheel  
Motor  
PA 2  
N 333

Head Wheel  
Motor  
PA 3  
No 334

# TR-4 High Band Conversion

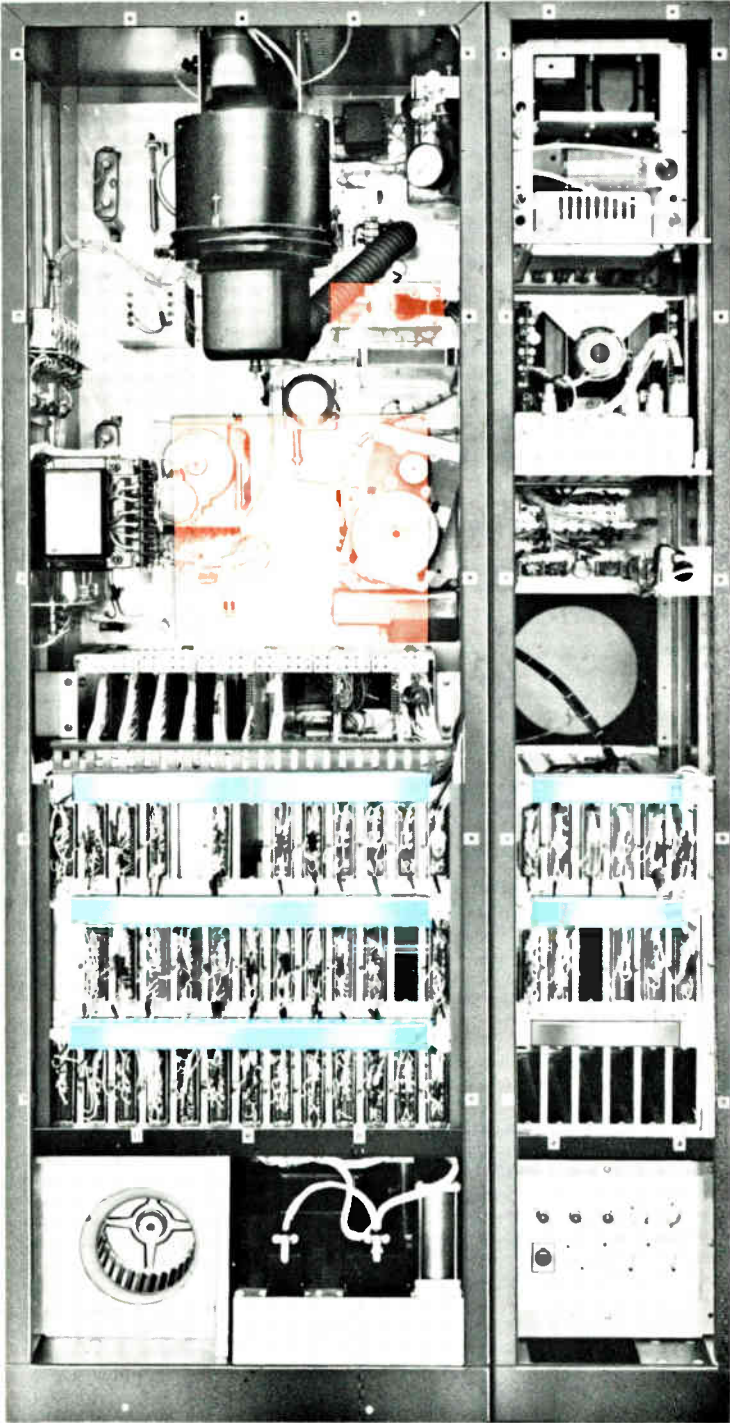

NEW ITEM  
 MODIFIED ITEM

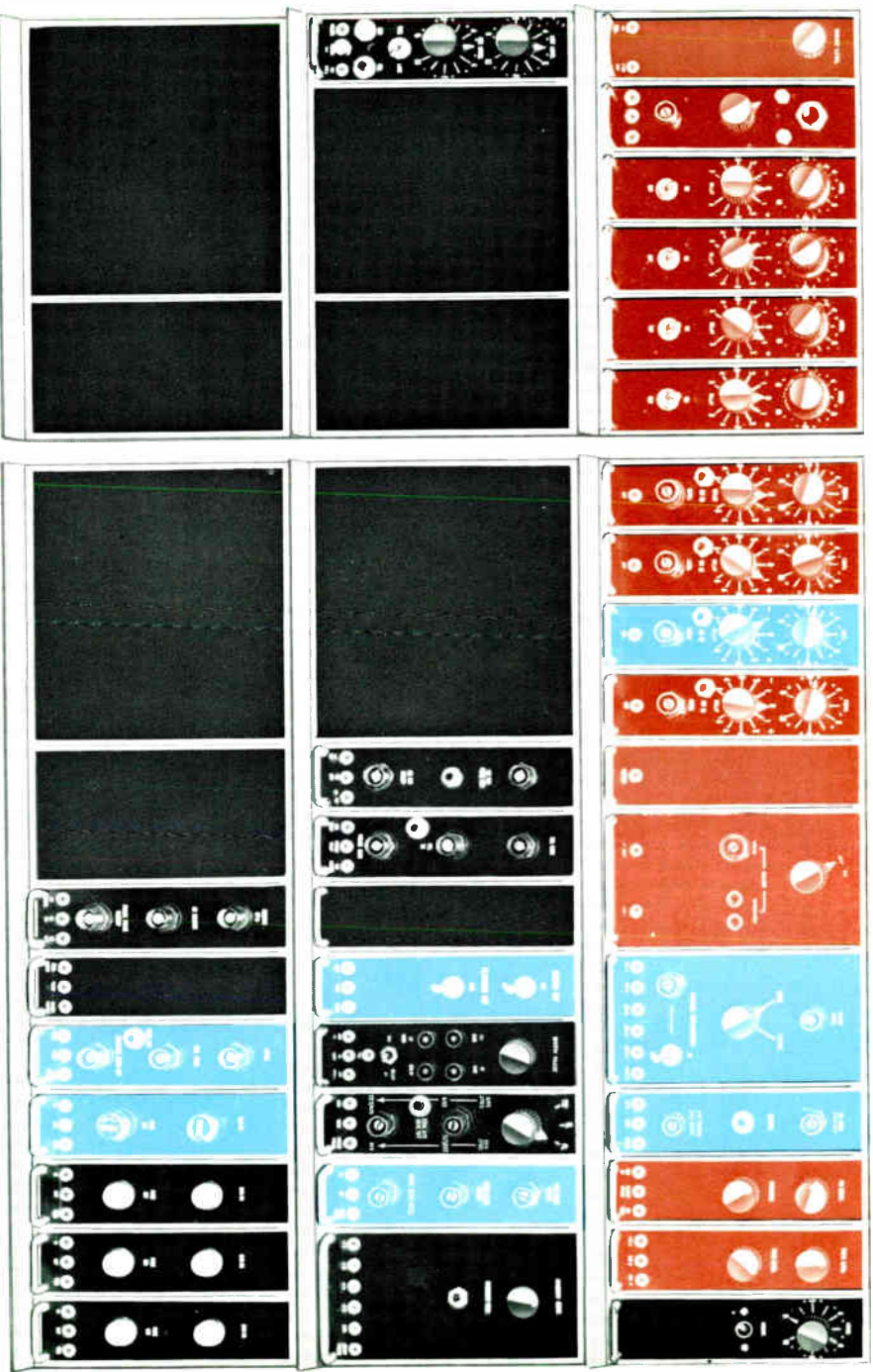

RECORD SECTION

PLAY BACK SECTION

## Specifications

	525/60	625/50
Frequency Response..	$\pm 1.5$ dB to 3.8 MHz -3 dB @ 4.2 MHz	$\pm 1.5$ dB to 4.5 MHz -3 dB @ 5.0 MHz
Transient Response (2T Sine <sup>2</sup> Input) ...	Less than 3%	Less than 3%
Differential Phase ...	Less than 10° at 3.58 MHz	Less than 10° @ 4.43 MHz
Differential Gain (Blanking to White)	Less than 10%	Less than 10%
Signal to Noise (normal speed — P-P Video/RMS noise) .....	43 dB	40 dB
Moire .....	37 dB	28 dB
Low Frequency Linearity (Blanking to White) .....	2%	2%

### Accessories

Chroma Amplitude and Velocity Error Corrector:

For TR-22HB .....	ES-43533-A
For TR-4HB .....	ES-43532-A

Color Drop-Out Compensator:

For TR-22/4 High Band .....	ES-43549
-----------------------------	----------

## Ordering Information

High Band Conversion Accessory (For TR-22 Series) .....	ES-35988*
High Band Conversion Accessory (For TR-4 Series) .....	ES-35987*
High Capacity Compressor (Internal Mount):	
117/60 Hz TR-22/4 Series .....	MI-43238**
234/50 Hz TR-22/4 Series .....	MI-43237**
High Capacity Compressor (External Mount):	
117/60 Hz TR-4 Series .....	MI-43236**
234/50 Hz TR-4 Series .....	MI-43235**
Headwheel:	
10 mil .....	MI-90899-A
5 mil .....	MI-40913-A

\* Requires High Capacity Air Bearing Conversion, plus High Band Headwheel Panel. (See Below)

\*\* Replacement compressor not required if any of the following air conversion kits have previously been installed: MI-43340/MI-43341, MI-43364, MI-43276/MI-43277.



## High Band Conversion Accessories



- Improved signal to noise ratio
- High Band compatibility

- Reduced moire effects
- Switchable standards



# High Band Conversion Accessories

High Band Conversion Accessories to update low-band RCA TR-22/3/4 Series Tape Recorders to the new deviation standards are now available. High-banding existing recorders provides such major advantages as improved signal-to-noise and virtual elimination of moire patterns. Additionally, the machines will achieve compatibility with present day recorders utilizing the latest highband standards.

Although other parameters, such as differential phase, differential gain and transient response are "state of the art", it is common to achieve improvements in these parameters utilizing the High Band Conversion Accessory. This conversion accessory ensures maximum life of present recorders with minimal outlay of funds.

## Description

The High Band Conversion Accessories consist of video and FM system modules, ancillary power supplies, wiring harness and auxiliary modifications material necessary to update present TR-22/3/4 Series Recorders for the high band deviation standards. Installation is accomplished by replacement and/or modification to existing system electronics.

### High Band Conversion TR-22 Series

Conversion of a machine, in the TR-22 Series, to high band standards involves both mechanical and electronic changes. Mechanically, it is necessary to relocate fixed delay lines and the air blower. Electronically, the FM system and a greater portion of the video circuitry is changed or modified. In carrying out the modification to the electronic circuitry it is necessary to add modifications

to existing modules only where the modification to the circuitry is limited. In the areas of extensive modification completely new modules are employed. This permits a relatively fast conversion and has the added advantage of utilizing "completely checked" modules.

### High Band Conversion TR-3/4 Series

The conversion of a machine in the TR-3/4 Series encompasses similar changes as those in the TR-22 Series. However, the mechanical changes associated with the modification are minimal in number. The electronic changes will again consist of changes to the FM system and video circuitry. In this conversion accessory, as in the conversion accessory for the TR-22 Series, modification to existing modules is limited to minor changes,

with replacement of the total module being made where the modifications are extensive.

## VIDEO SYSTEM MODIFICATION

### Input Module

The changes to the video system are quite extensive. The video input module is replaced with a new module containing a low pass filter to eliminate spurious or undesirable intermodulation components, created by high frequency noise. Incorporated in this new module is a "unity/variable" gain switch and a "unity/variable" frequency response characteristic. The unity gain and unity response features are incorporated to facilitate recordings which adhere to the standards of video levels and frequency response parameters.

### Video Processor

Two new modules are supplied for the processing amplifiers. The

new modules provide an improved chroma mixing process, a variable chroma level adjustment and improved differential gain characteristics.

### **FM System Modifications**

A major portion of the High Band Conversion is accomplished in the FM section of the recorder. In addition to the expansion of the FM system to employ additional standards, extreme care is exercised to assure optimum operation within any given standard. The result is an improvement in all parameters heretofore limited by the standard FM system.

### **Modulator**

A new "double heterodyne" modulation system is employed. The oscillators utilized are in the 100 to 108 MHz region. Employing these frequencies results in a marked improvement in modulation linearity. In terms of picture quality, the results are seen in a reduction of moire and an improved signal-to-noise ratio.

### **Modulator AFC**

A new modulator AFC module is used in the High Band Conversion Accessory, which assures that the carrier frequency is clamped at blanking level. Elimination of a carrier frequency control is possible utilizing this type of AFC system.

### **FM Standards**

Incorporated within this new standards module are the white

reference crystal markers to facilitate setting of carrier deviation. Controls for setting the record currents for two of the four channels are also contained in this module.

### **Record Amplifiers**

The new record amplifiers for each head channel are contained in this module. The additional two controls, identical to the controls contained in the FM standards module, for setting record current are in this module.

### **Playback Amplifiers**

These two modules house the four playback amplifiers. Controls for two channels are contained on a single module. Elimination of anti-resonance compensation is made possible through the use of very low impedance pre-amplifiers during playback. The 4 x 2 switching functions are also accomplished in these two modules.

### **FM Switcher**

The existing switcher module is modified to carry out the remaining switching function. Since the combining of two playback channels is previously accomplished in the two playback amplifier modules, only a 2 x 1 switching function need be accomplished within this module.

### **FM Equalizer**

Having changed the frequencies employed in the modulation process, it is necessary to utilize a new standards module.

### **Demodulator**

A new limiter demodulation combination is part of the High Band Accessory. This unit plays an important part in the reduction of intermodulation interference and an improvement in the transient-response characteristics of the machine.

### **Minor Modifications**

It is necessary to perform minor modifications to existing modules to enable integration of the new system modules and components with existing equipment. The areas that are affected are the demodulator output module, horizontal AFC module, reference generator, sync logic module, capstan oscillator and power regulator.

### **Headwheel Panel**

The headwheel panel which is to be used which has been converted to high band operation is the same headwheel panel which is used on the TR-70 Recorder. This new headwheel is available in either a 10 mil or 5 mil configuration. The panel is only available with air bearings which will dictate the addition of an air bearing conversion kit on machines presently not equipped for this type of headwheel panel. In addition it will be necessary to supply an air pressure of 55 lb/in<sup>2</sup> at .5 cu. ft./min., which in some instances will necessitate a change in air compressors. The ordering information contained on the last page of this folder will furnish the proper information.

# TR-22 High Band Conversion



NEW ITEM



MODIFIED ITEM

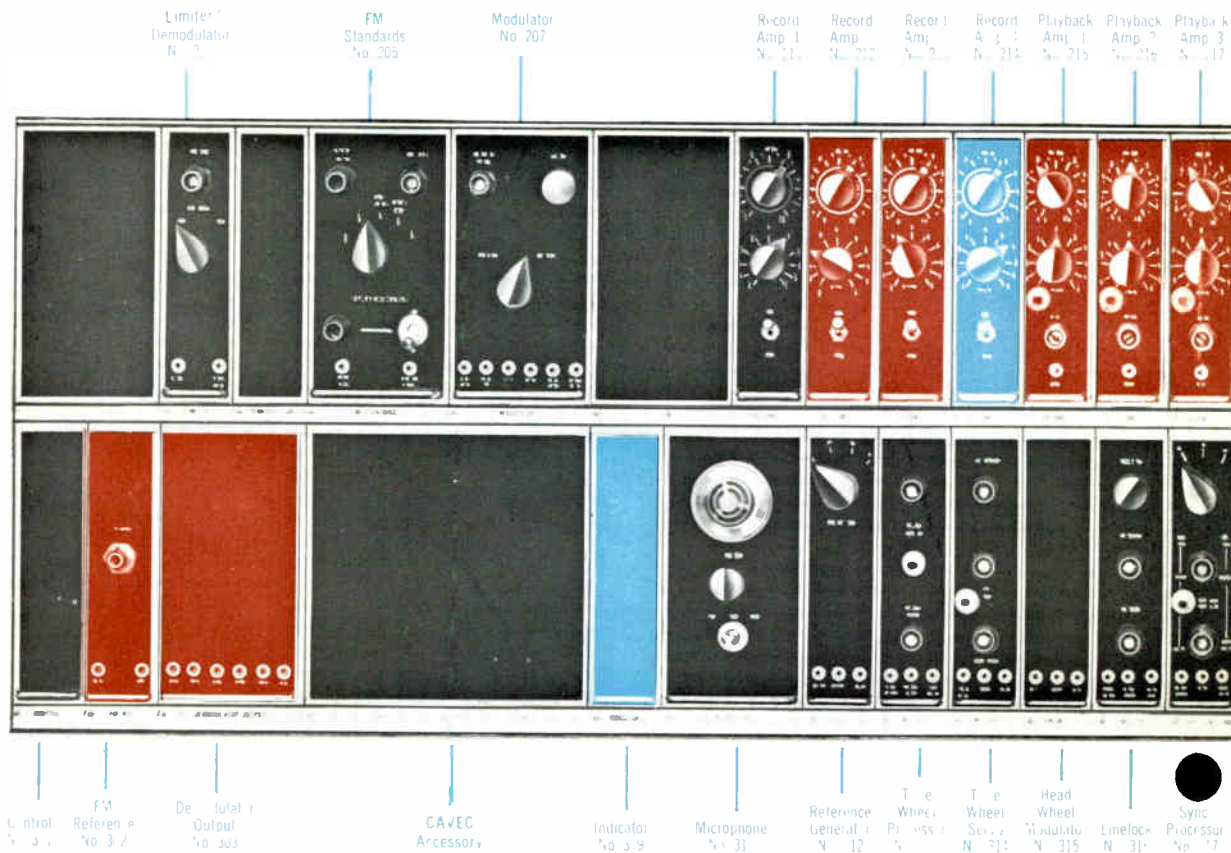
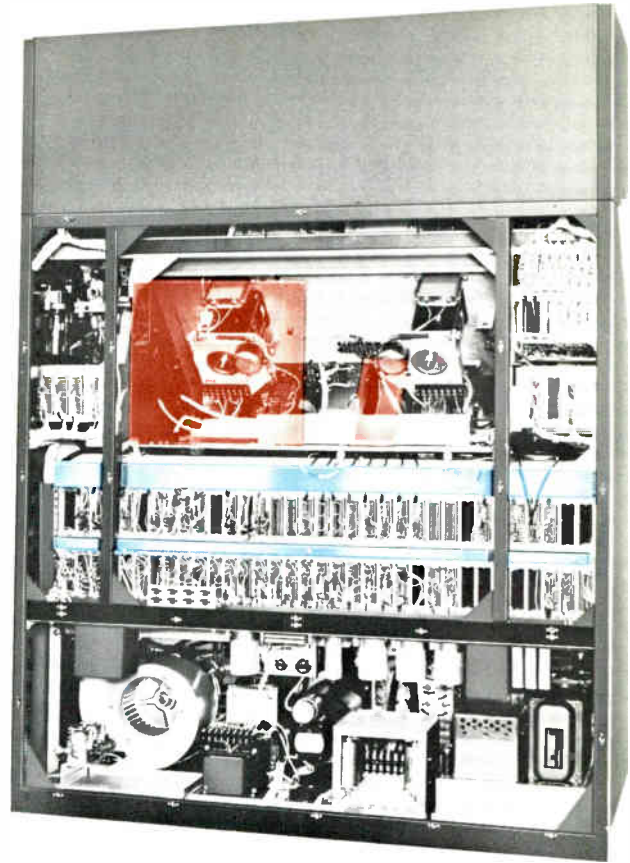

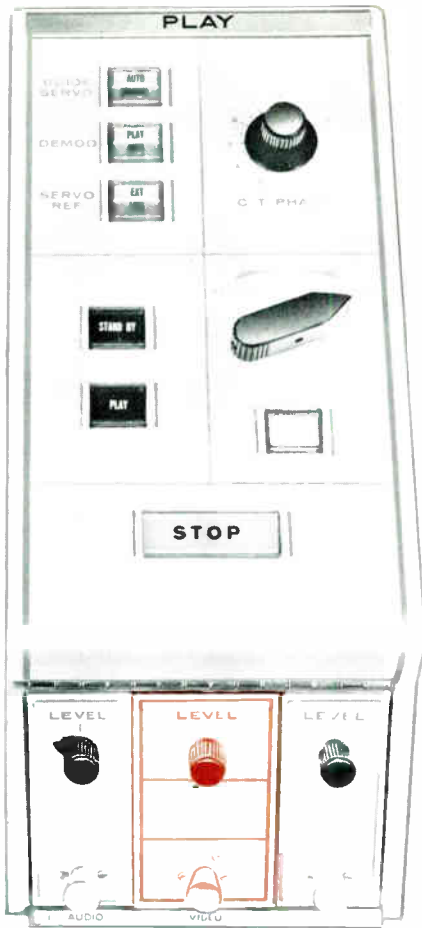

Play  
 Guide  
 Demod  
 Servo Ref  
 C.T. Phase  
 Stop  
 Level  
 Video  
 Level  
 FM EQ  
 Level  
 Audio  
 Video  
 Video

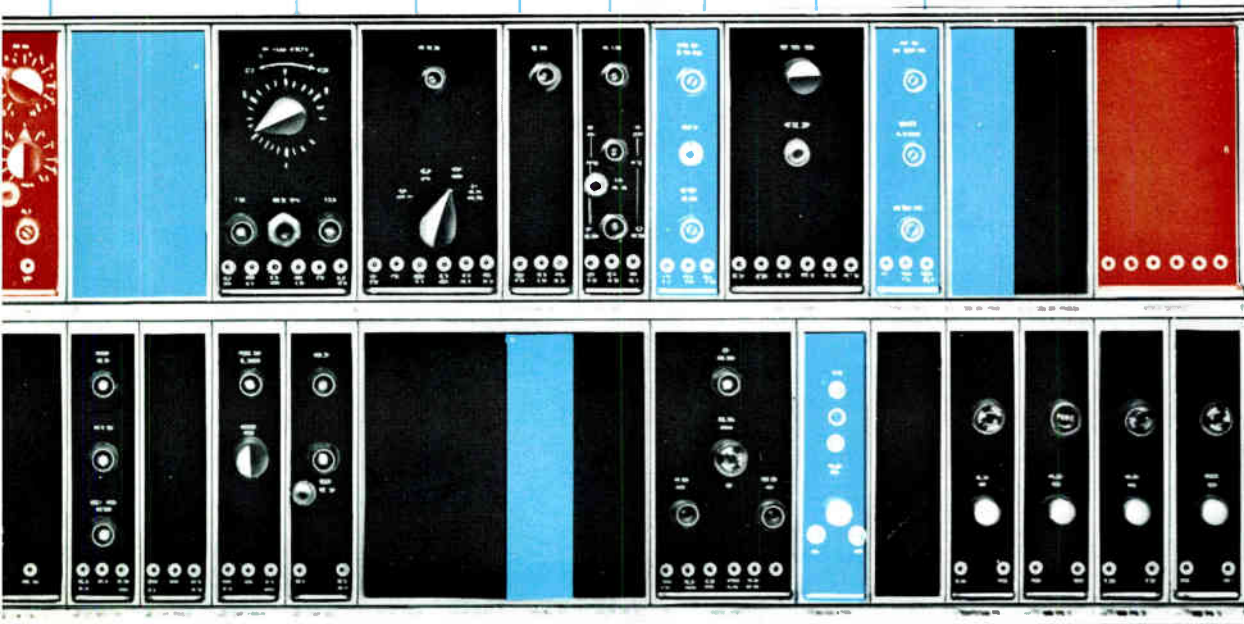

FM Switch No. 318  
 Control Truck  
 Head Wheel Motor PA 1  
 Head Wheel Motor PA 2  
 Head Wheel Motor PA 3  
 Head Wheel Motor PA 3

# TR-3/4 High Band Conversion

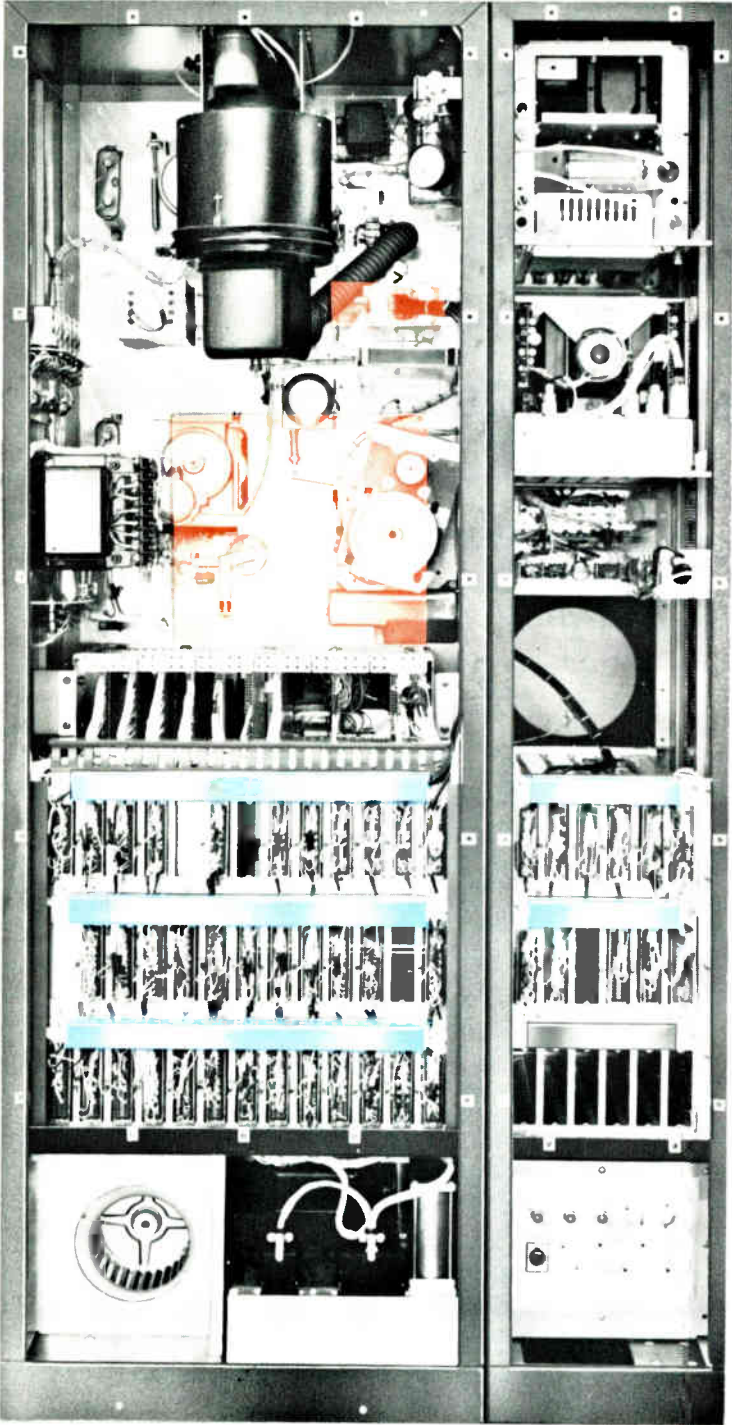



NEW ITEM



MODIFIED ITEM

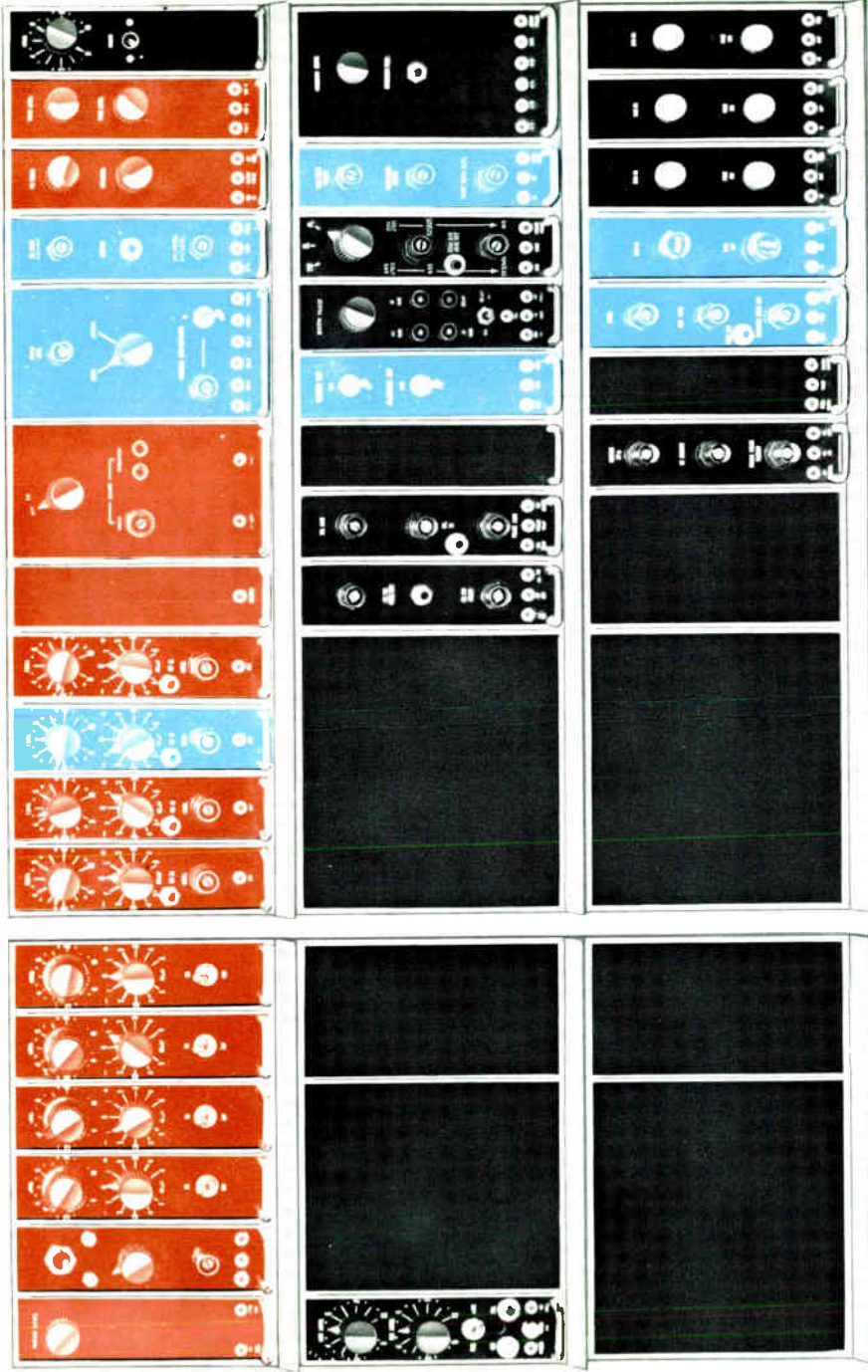

PLAY BACK SECTION

RECORD SECTION

## Specifications

	525/60	625/50
Frequency Response..	$\pm 1.5$ dB to 3.8 MHz -3 dB @ 4.2 MHz	$\pm 1.5$ dB to 4.5 MHz -3 dB @ 5.0 MHz
Transient Response (2T Sine <sup>2</sup> Input) ...	Less than 3%	Less than 3%
Differential Phase ...	Less than 10° at 3.58 MHz	Less than 10° @ 4.43 MHz
Differential Gain (Blanking to White)	Less than 10%	Less than 10%
Signal to Noise (normal speed — P-P Video/RMS noise) .....	43 dB	40 dB
Moire .....	37 dB	28 dB
Low Frequency Linearity (Blanking to White) .....	2%	2%

### Accessories

#### Chroma Amplitude and Velocity Error Corrector:

For TR-70 .....	ES-43534
For TR-22HB .....	ES-43533
For TR-4HB .....	ES-43532
For TR-3HB .....	ES-43531*

#### Color Drop-Out Compensator:

For TR-70 .....	ES-43558
For TR-22/3/4 High Band .....	ES-43549

\* Requires 1 Penthouse Module Frame, MI-591604.

## Ordering Information

High Band Conversion Accessory (For TR-22 Series) .....	ES-35988*
High Band Conversion Accessory (For TR-4 Series) .....	ES-35987*
High Band Conversion Accessory (For TR-3 Series) .....	ES-35986*
High Capacity Compressor (Internal Mount):	
117/60 Hz TR-22/4 Series .....	MI-43238**
234/50 Hz TR-22/4 Series .....	MI-43237**
High Capacity Compressor (External Mount):	
117/60 Hz TR-3/4 Series .....	MI-43236**
234/50 Hz TR-3/4 Series .....	MI-43235**
Headwheel:	
10 mil .....	MI-90899
5 mil .....	MI-40913

\* Requires High Capacity Air Bearing Conversion, plus High Band Headwheel Panel. (See Below)

\*\* Replacement compressor not required if any of the following air conversion kits have previously been installed: MI-43340/MI-43341, MI-43364, MI-43276/MI-43277.



**RADIO CORPORATION OF AMERICA**