

**TECHNICAL MANUAL**  
**770 SERIES**  
**REEL-TO-REEL**  
**RECORDING AMPLIFIER**

**INTERNATIONAL TAPETRONICS CORPORATION**

2425 South Main Street

Bloomington, Illinois 61701

**TECHNICAL MANUAL  
(890-0025-000)**

**770 SERIES  
REEL-TO-REEL  
RECORDING AMPLIFIER**

This Technical Manual is intended to be used as a supplement to, and in conjunction with ITC Technical Manual 890-0024-000, for the 770 Series Reel-to-Reel Reproducer.



**INTERNATIONAL TAPETRONICS CORPORATION**

2425 SOUTH MAIN STREET • BLOOMINGTON, ILLINOIS 61701

© Copyright 1981 International Tapetronics Corporation.

Made under one or more of the following patents:  
3,800, 323 3, 801, 043 3, 801, 329 3, 833, 925 3, 865, 719  
other patents pending

# PREFACE

## THE ITC INSTRUCTION MANUAL

International Tapetronics Corporation Manuals are written with the intent of assisting the reader-user toward a better understanding of ITC equipment. Most instruction manuals are seldom read except at the time of crisis when equipment malfunction is suspected. When this happens, the manual is usually missing, or at best, difficult to locate. PLEASE FIND A CONVENIENT SPOT TO KEEP THIS MANUAL.

We at ITC have tried to produce a useable manual. But, being human, we are subject to the frailties of behavior. Therefore, should you discover any errors or omissions, or should you wish to contribute any recommendations, please send us your comments. We will be most appreciative.

# TABLE OF CONTENTS

<b>PREFACE</b> .....	i
<b>TABLE OF CONTENTS</b> .....	iii
<b>ILLUSTRATIONS</b> .....	v
<b>SECTION I. INTRODUCTION</b>	
A. General .....	1-1
B. Recorder Electronics .....	1-1
C. Head Assembly .....	1-1
D. Specifications .....	1-1
E. Warranty .....	1-2
<b>SECTION II. INSTALLATION</b>	
A. Unpacking and Handling .....	2-1
B. Installation in Rack or Console .....	2-1
C. Connecting Audio Lines .....	2-1
D. Remote Control Connections .....	2-1
E. Preliminary Tests .....	2-2
<b>SECTION III. UNIT OPERATION INSTRUCTIONS</b>	
A. Controls and Indicators .....	3-1
1. Record Set Switch	
2. Channel Select and P.R.S. (Play-Record Synchronization)	
3. Meter Select Switches	
4. LED Indicators	
B. Recording .....	3-2
<b>SECTION IV. SETUP, ALIGNMENT, AND CALIBRATION</b>	
A. General .....	4-1
B. Playback Meter Calibration .....	4-1
C. Record Head Alignment .....	4-1
D. Bias Trap Adjustment .....	4-2
E. Bias Adjustment .....	4-2
F. Recording Amplifier Equalization .....	4-3
G. Record Line Meter Calibration (Rec) .....	4-3
H. Two Speed Recording Amplifier Level Calibration .....	4-4
I. P.R.S. Amplifier Bias Trap .....	4-4
J. Bias Meter Calibration .....	4-4
K. P.R.S. Amplifier Meter Calibration .....	4-4
<b>SECTION V. ROUTINE MAINTENANCE</b>	
A. General .....	5-1
B. Maintenance Tools and Aids .....	5-2
C. Spare Parts .....	5-2
<b>SECTION VI. THEORY OF OPERATION AND DESIGN</b>	
A. General .....	6-1
B. Recorder Control Logic .....	6-1
C. Bias Oscillator .....	6-1
D. Meter Amplifiers .....	6-1
E. Program Recording Amplifier .....	6-2
F. Play-Record Synchronizing (P.R.S.) Amplifier .....	6-2

**SECTION VII. ELECTRICAL DRAWINGS AND PARTS LIST**

A. Record and Meter Amplifier Component Loading and Overlay . . . . . 7-1  
B. Record and Meter Amplifier Parts List . . . . . 7-2  
C. Bias Oscillator and Recorder Control Component Loading and Overlay . . . . 7-5  
D. Bias Oscillator and Recorder Control Parts List . . . . . 7-6  
E. L.E.D. Indicator Card Component Loading and Overlay . . . . . 7-8  
F. Mother Board Component Loading and Overlay . . . . . 7-9  
G. Mother Board Parts List . . . . . 7-10  
H. Record Amplifier Schematic . . . . . 7-11

## ILLUSTRATIONS

		<b>Page</b>
Figure 2-1	Record Amplifier Input Connections .....	2-1
Figure 2-2	Remote Control Connections .....	2-2
Figure 2-3	Cable Interconnect Diagram .....	2-2
Figure 2-4	Rear Panel Connectors .....	2-3
Figure 3-1	Front Panel Controls .....	3-1
Figure 4-1	Meter Calibration Adjustment Points .....	4-1
Figure 4-2	Head Adjustment Points .....	4-2
Figure 4-3 thru 4-6	Oscilloscope Phase Patterns .....	4-2
Figure 4-7	Bias Adjustment Points .....	4-3
Figure 4-8	Equalization and Level Adjustment Points .....	4-3
Figure 5-1	Maintenance Schedule .....	5-1
Figure 7-1	Record and Meter Amplifier Component Loading and Overlay .....	7-1
Figure 7-5	Bias Oscillator and Recorder Control Component Loading and Overlay .....	7-5
Figure 7-8	L.E.D. Indicator Card Component Loading and Overlay .....	7-8
Figure 7-9	Mother Board Component Loading and Overlay .....	7-9
Figure 7-11	Record Amplifier Schematic .....	7-11

# SECTION I – INTRODUCTION

## A. GENERAL

The 770 Series Recorder is designed for the broadcaster. It is ideally suited for use as a utility recorder automation system. The 770 Series is:

- designed to meet or exceed the NAB (National Association of Broadcasters) standards for reel-to-reel tape recorders;
- available in a variety of configurations including, . . . . one or two track, mono or stereo capabilities and . . . . tape speeds of 3-3/4 to 7-1/2 and 7-1/2 to 15 IPS;
- designed with a heavy 1/2 inch (12.700 mm) thick aluminum tool plate deck for stability;
- designed with a unique, high quality, professional head assembly;
- utilizes individual torque motors for supply and take up reel handling, and a D.C. servo capstan motor for tape drive; and
- designed for simplicity and serviceability of electronic components.

The 770 Series Record Amplifier and Transport features:

- low maintenance, positive action differential disc brakes;
- strong, cast stainless steel turntables;
- long life control switches and an ingenious switch support;
- multispeed D.C. servo capstan motor;
- improved playback head.

All 770's are factory wired to accept the ITC sub-audible 25 Hz detector module assembly, which is available as an option. This plug-in module is designed to provide a variety of operating modes.

## B. RECORDER ELECTRONICS

The electronics of the 770 Series Recording Amplifier provides simplicity and serviceability. The mother/daughter board and ribbon cable connectors eliminate bulky wiring. All maintenance adjustments are either accessible at the front panel or directly above the printed circuit cards.

Front panel meter switching allows the operator to monitor the playback outputs, the recorder inputs, Play-Record Synchronizing, and program recording bias. The meter monitoring mode may be automatically switched to program play when in the play mode even though the recorder input monitor switch may be selected.

An input from the meter amplifier is brought out to the front panel of the recorder. Headphones may be plugged in at this point for monitoring purposes. An additional output is brought out to the rear panel of the recorder which may be used for the same purpose.

The stereo model is equipped with the Play-Record Synchronizing feature. P.R.S. allows the recording of information on one track in synchronization with material previously recorded on the other track.

The recorder electronics may be mounted directly below the reproduce transport or in a remote location up to 42 inches (1066.80 mm) away. A roll-around console is available as a special option.

## C. HEAD ASSEMBLY

The ITC 770 Series recorder is equipped with a unique, high quality professional head assembly. The head is mounted in a bracket designed to allow total azimuth, height and zenith adjustments. Three plug-in heads are used in conjunction with independently mounted tape guides. The head assembly is equipped with a solenoid actuated tape lifter. Electrical connections to the head assembly, located on the transport deck, are made through special interconnect cables.

## D. SPECIFICATIONS

### Power:

(includes reproduce deck and recorder electronics)  
105-125 volts, AC, 60 Hz, 165 watts max.

### Recorder Source Impedance:

600 ohms

### Recorder Input Impedance:

5000 ohms balanced (15 K ohm bridging strap-pable)

### Input Level:

-22 dBm (.061 volts) minimum to record at "0" reference level (185 nWb/m flux level) +8 dBm (1.96 volts) maximum

### Distortion (Record to Play):

Using 400 Hz tone recorded at NAB standard reference level (\*) with reproduce amplifier adjusted for 0 dBm output, and measuring on a distortion analyzer with a 700Hz to 20 kHz bandwidth

15 IPS 1.2%

7.5 IPS 1.5%

3.75 IPS 2.0%

NOTE: All distortion readings are tape-limited.

### Amplifier Headroom:

Maximum amplifier headroom above reference level (185 nWb/m) using frequencies of 1 kHz and 10 kHz.

Tape Speed	1 kHz	10 kHz
15 IPS	+ 23 dB	+ 23 dB
7.5 IPS	+ 23 dB	+ 19 dB
3.75 IPS	+ 23 dB	+ 12 dB



**Crosstalk:**

Better than 50 dB at 1 kHz

**Frequency Response:**

3-3/4 ips (+2dB-3.5dB) 25 to 35 Hz; ±2dB 35 to 8,000 Hz.

7-1/2 ips (+2dB-3dB) 25 to 35 Hz; ±2dB 35 to 15,000 Hz.

15 ips (+2dB-3.5dB) 25 to 35 Hz; ±2dB 35 to 18,000 Hz.

**Equalization:**

NAB with adjustments for high frequency control

**Headphone Output:**

8 ohms or greater

**Meter Amplifier Monitor:**

600 ohms (available at rear chassis)

**Remote Control:**

Record set switch and record indicator lamp

**External Connectors:**

Latching and phono types. Mating plugs and sockets furnished.

**Head and Track Configuration:**

Full Track monophonic

Half Track monophonic

Half Track stereophonic (2 channel)

Quarter Track stereophonic (2 channel)

**Metering:**

Taut-band movement with "A" scale. Meter switch selection for metering the following:

Normal line recording level, P.R.S. bias and program play, (Meter sensitivity may be calibrated for 0 to + 18 dBm output level.)

**Erase Depth:**

Below Noise Level

**Ambient Operation Temperature:**

55°C - 131°F maximum

**Mounting:**

Rack mounting. (Console cabinet optional.)

**Dimensions:**

19 inches wide (482.60 mm)

9 inches deep (228.60 mm)

3-1/2 inches high (88.90 mm)

**Weight:**

15 pounds (6.805 kg) unpacked

(\*) Measurements made using 3M type 206 or equivalent tape

**E. WARRANTY**

Seller warrants to purchaser that the equipment sold is free of defects of workmanship or material and conforms to the specifications referred to set out herein. This warranty extending only to the original user is for a period of two years from date of shipment and no claim shall be maintained hereunder unless written notice is received by Seller within thirty days after discovery of the facts giving rise to the claim. The sole or exclusive liability of Seller for breach of warranty shall be to refund the purchase price of the item sold, or at its option, to replace or repair the item or part concerned FOB its factory, or such other place as it may designate. Seller's liability shall arise only if purchaser causes the defective part or item to be delivered to Seller for inspection upon Seller's request at purchaser's expense. Items manufactured by persons other than Seller shall bear the warranty given by such other persons and no other warranty. This warranty shall not be effective if the alleged defect is due to maltreatment, exposure, excessive moisture, or any other use of equipment other than the use for which the manufacturer prescribed.



## SECTION II – INSTALLATION

### A. UNPACKING AND HANDLING

Carefully remove the 770 Series Recording Amplifier from the shipping carton and inspect the unit for damage. All packing material must be retained if a claim for shipping damages is to be filed, and therefore, should be kept on hand until installation has been completed in case concealed damage is discovered. If shipping damage is found, contact ITC for assistance in claims. It is suggested that packing material be retained for any future use.

### B. INSTALLATION IN RACK OR CONSOLE

All 770 Series Recording Amplifier modules are supplied in a 19" (482.60 mm) rack mounting configuration. If an excessive amount of heat is present in the rack in which the machine is to be mounted, be certain to supply adequate ventilation for proper operation of this unit. Ideally, the recording amplifier module should be mounted directly under the 770 Series Playback Deck, so that heat rising from the torque motors and other heat producing components will not contribute any heat to the recording electronics.

All consoles for ITC reel to reel recorders and reproducers are shipped separately and, therefore, will require mounting following shipments.

After removing the console from the packing material, install the four casters in the bottom of the console legs. Set the console upright and rotate the transport deck table to its vertical position by pressing the release button located on the front upper right hand side of the console cabinet. This will allow the table to rotate and lock in various planes. With the aid of another person, carefully slide the transport mechanism into the mounting area.

NOTE: When handling the transport, be careful not to damage items such as motors and brakes.

After the transport is properly located, carefully rotate the table back to its horizontal position. Secure the assembly with the enclosed rack mounting screws and washers.

Included with the console is a 1-3/4" (44.45 mm) filler panel. This panel must be mounted toward the top end of the transport deck assembly in order to fill the vacant space.

The recorder chassis is mounted by sliding it into position from the front of the console and then securing it with the enclosed hardware.

### C. CONNECTING AUDIO LINES

A 6-pin socket is provided with each 770 Series Recording Amplifier for the audio input connections. Refer to Figure 2-1 for the connection of this socket. Observe the proper phase relationship on two channel units.

A 600 ohm unbalanced output of the meter amplifier(s) is provided on the rear of the recording amplifier chassis. J703 and J704 are standard phono type connector sockets.

It is recommended that two conductor shielded cables be used for recorder input connections. Single conductor shielded cable may be used for the meter amplifier output connections.

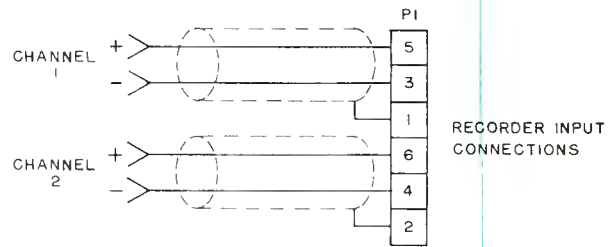

FIGURE 2-1

In order to provide proper monitoring and control facilities, several interconnect cables are used to connect the recording amplifier chassis and the reproducer deck. The first cable contains two 6-pin plugs, one at each end. One end connects to J102 located on the reproducer deck, the other end plugs into connector J4 located on the rear panel of the recording amplifier chassis. The playback audio output connections must now be connected to output connector J3 which is also located on the back of the recording amplifier.

The second interconnect cable has 15-pin plugs located at each end. One end plugs into connector J101, which is located on the reproducer deck, the other end plugs into connector J2, which is located on the recording amplifier.

In addition to the two previously described interconnect cables, there are two head cables (4 cables in stereo units) which must be connected between the appropriate head connectors on the recording amplifier and the reproducer deck. These cables are individually identified and must be connected to their matching sockets and plugs. If not connected properly, bias will need to be recalibrated.

### D. REMOTE CONTROL CONNECTIONS

Remote control functions are provided through connector J101 for START, STOP, FAST REWIND, FAST FORWARD, and associated lamp circuits (24 volt, 40 ma.). All functions are direct, pin for pin connections.

The control functions, record set, and record lamp are shown in Figure 2-2. If desired, the RECORD SET switch may be wired from pin 17 to pin 1 rather than pin 17 to

pin 11 as shown on the remote schematic. When wired in this manner, RECORD SET is active both prior to and during the START - RUN mode of operation. The remote switch must be a momentary contact, normally open single pole type. Remote indication of the RECORD SET function is obtained by connecting the RECORD SET LAMP between pin 16 and pin 1. The circuit is designed to operate a 24V, 40 ma. incandescent bulb.

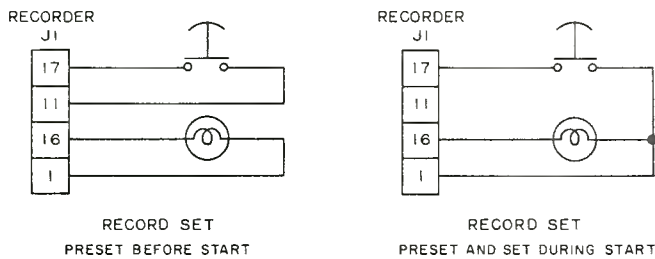

FIGURE 2-2

### E. PRELIMINARY TESTS

Check all motors and rotating parts before operating the 770 Series machine. They should rotate freely. Be certain the P.C. cards, relays, and ribbon cable connectors are properly seated. Before plugging in the power cord insure that the line frequency and voltage are correct, 117 volts  $\pm$  10%, 60 Hz.

The ready indicator LED should illuminate if the tape has been properly loaded onto the deck. After loading the tape press either or both channel select switches. (Only one switch if the machine is mono.) When pressed, the record set LED(s) indicator should illuminate.

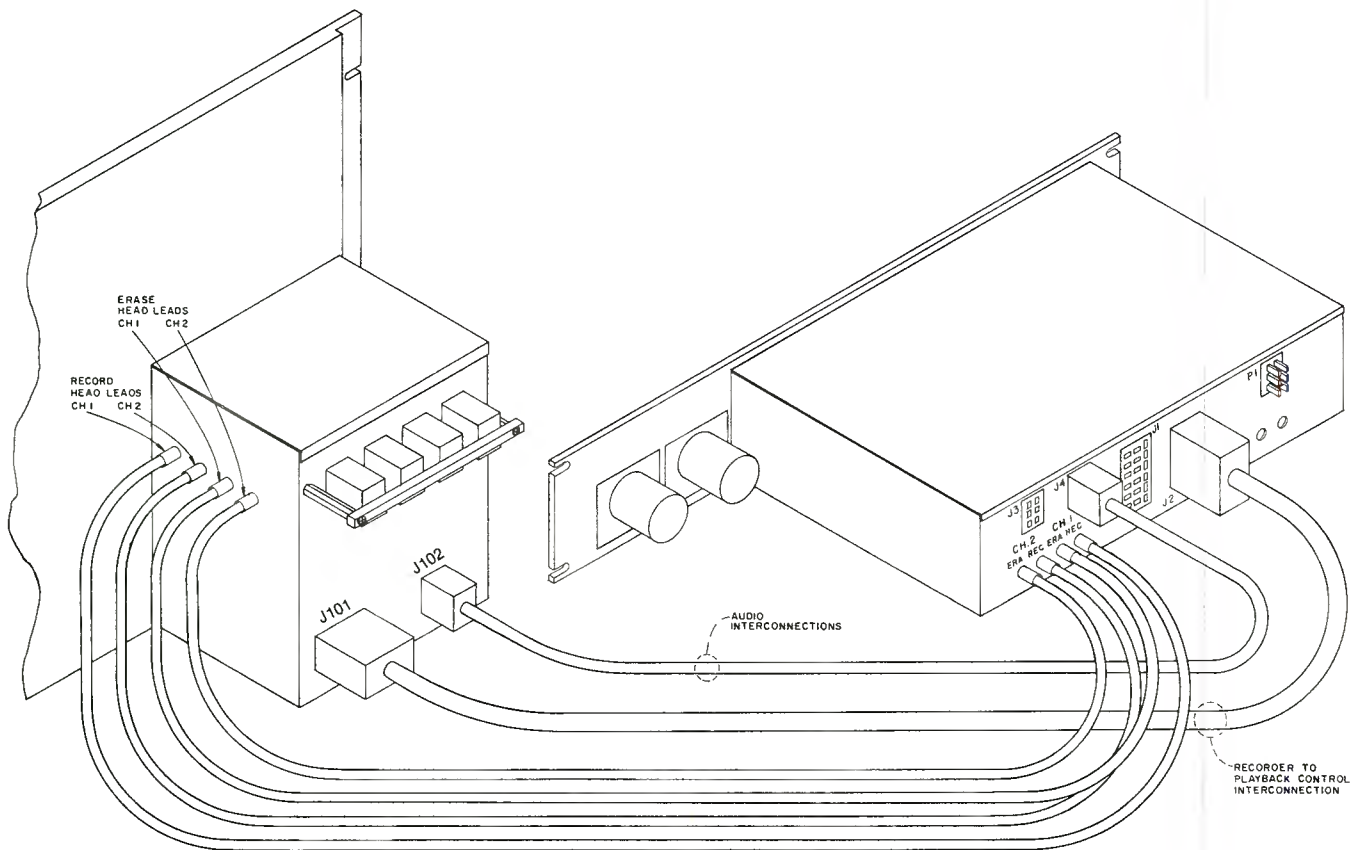

FIGURE 2-3

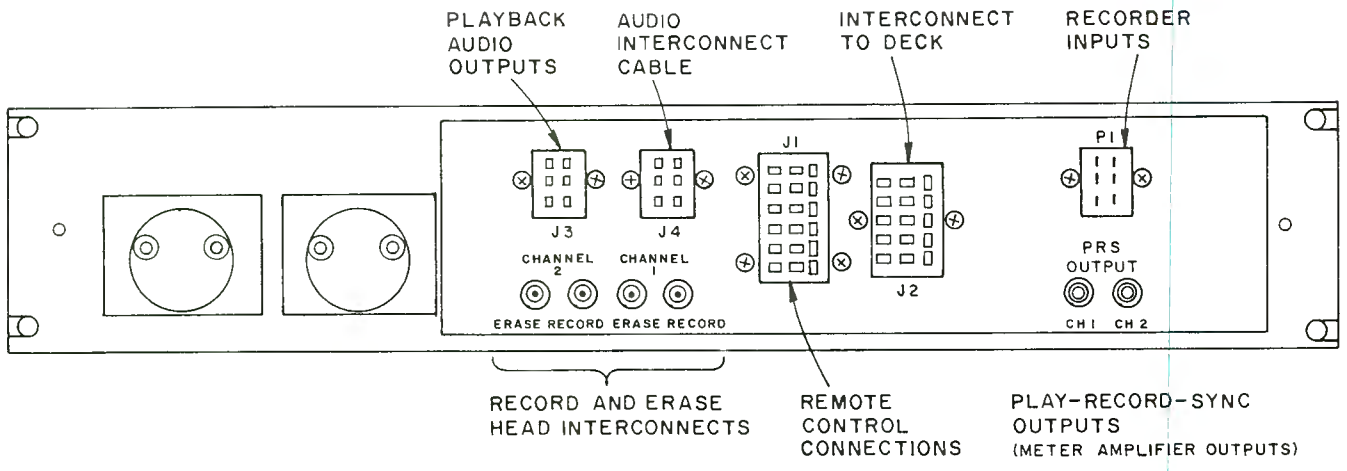

FIGURE 2-4

# SECTION III – OPERATING INSTRUCTIONS

## A. CONTROLS AND INDICATORS

Six switches are present on the stereo system and five on the mono.

### 1. Record Set Switch

The record switch may be operated in two different configurations. The configuration depends upon the strappable option selected.

- If points A and B on the bias oscillator and recorder control PC board are strapped together, the record set switch will be active only during the START - RUN mode.
- If points C and D are strapped together, the RECORD SET switch will be active in either the READY mode or during the START - RUN mode of operation.

The RECORD SET switch is active only when the correct CHANNEL SELECT switch(es) is depressed. This provides a "SAFE" condition whereby pre-recorded material may not be erased. On a two channel unit the individual CHANNEL SELECT switches provide the Play-Record Synchronizing as another built-in feature.

### 2. Channel Select and P.R.S. (Play-Record-Synchronization)

The P.R.S. feature is standard on all two channel 770 reel to reel recording amplifiers. The P.R.S. circuitry allows the recording of information on one track while monitoring material previously recorded on the other track. The following conditions must exist for proper operation of P.R.S.:

- The METER SELECT switch must be in record (REC) position;
- Either Channel 1 or Channel 2 SELECT switch must be depressed; and (If both CHANNEL

SELECT switches are depressed simultaneously P.R.S. is nonfunctional.)

c) The recorder must be set to the RECORD mode and moving tape.

If the operator is recording on Channel 1, the Channel 2 meter circuit will monitor program material which has been previously recorded on Channel 2. The monitoring is through the recording head, and therefore is in perfect synchronization with the material being recorded on Channel 1. The output of the P.R.S. amplifier may be monitored through the front panel headphone output and/or the rear chassis meter mode output connector. At all other times, the meter switching will function normally.

### 3. Meter Select Switches

a) Play

With this switch depressed, the meter circuitry will monitor the output of the reproduce amplifier at all times.

b) Bias

With this switch depressed, program bias will be continuously monitored during the recording mode. There will be no meter indication during the play mode.

c) Record (REC)

This switch performs three basic functions

- 1) Monitors the input of the recorder if in the RECORD SET mode;
- 2) Monitors the P.R.S. output as previously described; and
- 3) Automatically switches to and monitors the reproducer output if not in the RECORD SET mode.

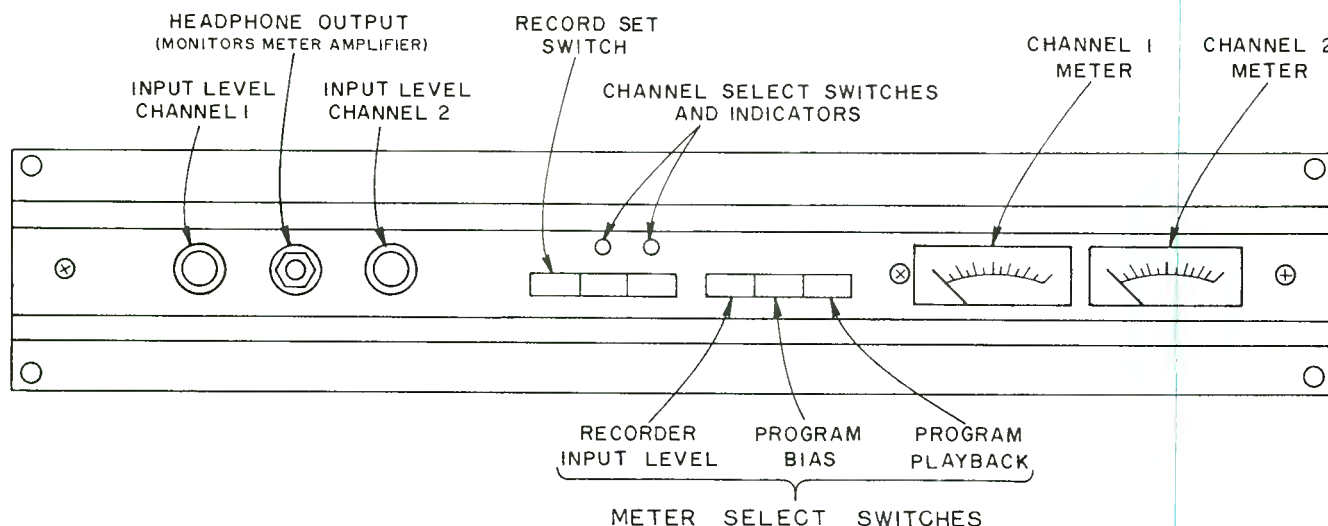

FIGURE 3-1

#### **4. LED Indicators**

The red LED indicators will be illuminated only when a channel has been selected and the RECORD SET switch depressed as previously described.

#### **B. RECORDING**

To record a reel of tape:

1. Load and thread a reel of tape;
2. Depress the appropriate channel select switches;
3. Press the RECORD SET switch and observe that the record LED illuminates, indicating the machine is in the RECORD mode.
4. Press the START switch. The RECORD switch can be pressed after the START switch, if so wired.
5. Adjust recording level on the VU meters so that major peaks do not exceed the 0 VU point, but should remain as close to the ZERO indication as possible.



# SECTION IV. – SETUP, ALIGNMENT, AND CALIBRATION

## A. GENERAL

All ITC recording amplifiers and record/reproducers are fully tested and adjusted at the factory for optimum performance and normally require no further adjustments prior to installation. However, due to normal variations in tape types and oxide formations, the factory adjustment of the Record Amplifier may be “tweaked” for optimum performance with the tape brand you are using. As with any tape recorder, optimum performance is achieved only when the Record Amplifier is carefully adjusted to a specific tape type and brand. Customers using several types and brands of tape should expect variations in performance due to different oxides, and should be aware that performance characteristics of the 770 System can and may vary depending on the tape used. Best consistent performance is achieved when a single tape type is used, and the Record Amplifier is adjusted for that particular tape.

Adjustments of the recording amplifier should not be undertaken unless a defined lack of performance exists and the reproducer has been carefully tested and found not to be a contributing factor. The adjustments described in this section of the Technical Manual should be followed in the sequence presented to achieve a fully and accurately aligned recorder. Access to adjustments points is by removal of the front switch panel dress plate and top stainless steel chassis plate. Note that many adjustments are dependent upon and interact directly with each other. Therefore, when one specific adjustment is changed, it may be necessary to perform through the entire adjustment procedures for the recorder.

**Do not make any recorder adjustment until the reproducer has been totally and accurately calibrated.**

## B. PLAYBACK METER CALIBRATION

1. Depress the play meter switch S605.
2. Connect a 600 ohm load(s) across pins 3 and 5 (Channel 1 for Mono) and pins 4 and 6 (Channel 2 for stereo) of connector J3. Connect an accurate high impedance voltmeter across the load on pins 3 and 5.
3. Thread and play an NAB standard reference tape or its equivalent and observe that the voltmeter reads 0 dBm. If necessary, adjust the front panel level control on the reproducer deck to obtain this reading.
4. While playing the reference tone, (700 Hz at 185 nW/m), adjust R408 for a “0” VU reading on the front panel meter.
5. Follow the same procedures outlined in Step 4 to calibrate the Channel 2 VU meter. The calibration potentiometer is R472. See Figure 4-1 for location of these trimmers.

## C. RECORD HEAD ALIGNMENT

Be certain that prior to making any record head azimuth adjustments that the reproduce head is accurately aligned, as outlined in Section IV, B-1 of the 770 Reproducer Technical Manual.

1. Connect an audio signal generator to the input plug P1, pins 3 and 5. Set the frequency of the oscillator to 15 kHz and level to -10dbm.
2. Connect a high impedance voltmeter to the load on pins 3 and 5 of the reproducer output J3 and set the range to 0 dBm.
3. Thread a reel of blank tape typical of that normally used.
4. Press the START and RECORD button.

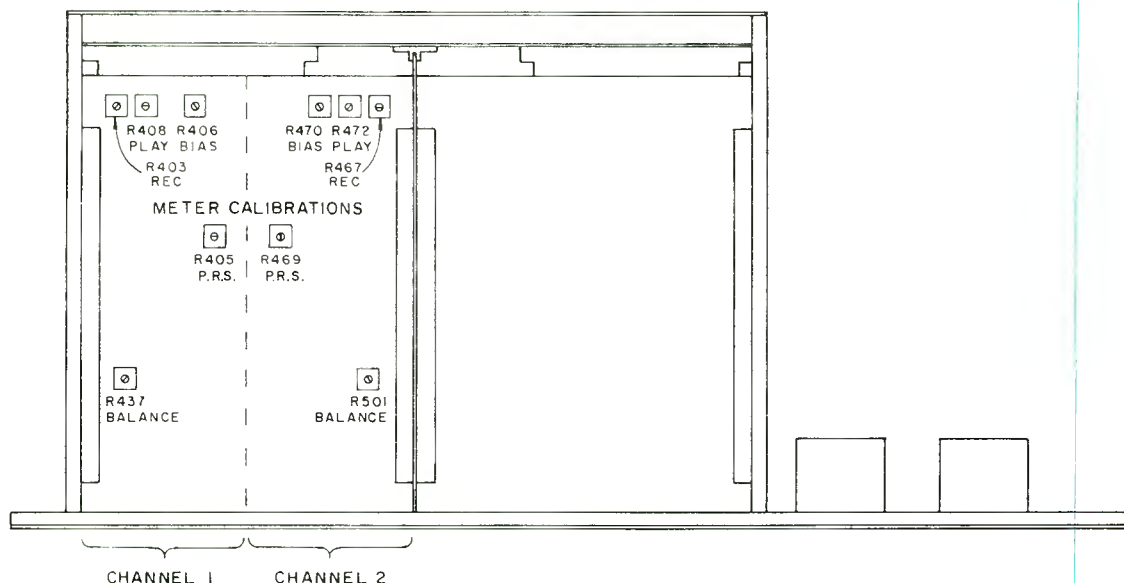

FIGURE 4-1

5. Turn the Channel 1 record level control to provide a mid-scale reading on the voltmeter.

6. Carefully adjust the record head azimuth for maximum reading on the voltmeter (reduce the record level as necessary to keep the voltmeter on scale). Refer to Figure 4-2 for location of the record head azimuth control.

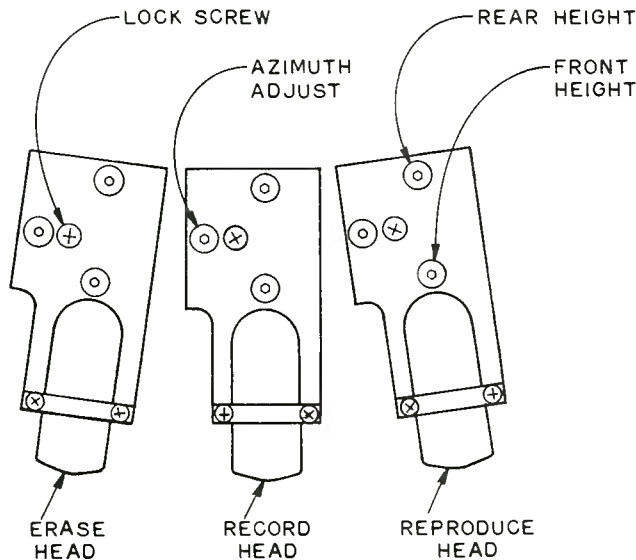

FIGURE 4-2

7. The following procedure should be used on stereo recorder/reproducer units:

a) Connect the audio signal generator both Channel 1 and Channel 2 input, adjust the oscillator frequency to 15 kHz, and amplifier level to approximately -10 VU. Be certain that the Record Amplifier inputs are being fed in-phase.

b) Connect the "X" or vertical input of an oscilloscope to pins 3 and 5 of the reproducer output, and connect the "Y" or horizontal inputs of the scope to pins 4 and 6. Verify that both scope inputs are properly phased. With tape loaded, press both channel select switches, the record set switch, and the start switch. Adjust the oscilloscope horizontal gain to provide a deflection equal to that of the vertical.

c) While recording the 15 kHz tone, adjust the record head azimuth screw until a pattern similar to that shown in Figure 4-3 is achieved. This pattern represents "0" or near "0" phase shift in the system.

d) Sweep the signal generator from 15 kHz to 1,000 Hz and watch the phase shift pattern on the oscilloscope. If the pattern turns over (Figure 4-4 or Figure 4-5) the record head azimuth screw must be readjusted until no phase reversals occur. An in-phase scope pattern must be observed for all frequencies between 15 kHz and 50 Hz. Adjust the record head azimuth until this condition exists. NOTE: At very high audio frequencies, a small amount of scope pattern "jitter" is normal.

e) Once proper azimuth and phasing has been obtained, carefully tighten down the head locking screw while watching the oscilloscope to be certain that alignment has not changed.

f) Recheck alignment by starting and stopping tape motion several times and also by sweeping the generator the full audio range while in the record mode.

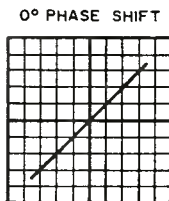

FIGURE 4-3

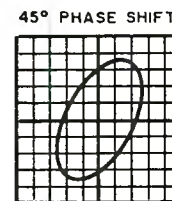

FIGURE 4-4

90° or 270° PHASE SHIFT

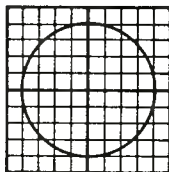

FIGURE 4-5

180° PHASE SHIFT

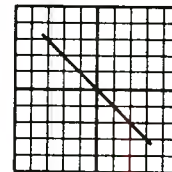

FIGURE 4-6

#### D. BIAS TRAP ADJUSTMENT

1. Remove the top cover of the recording amplifier.
2. Connect a low capacity probe and oscilloscope to the junction of resistors R450 and R451. See Figure 4-6.
3. Depress both channel select switches, the record set switch and the start switch.
4. Using a fiber screwdriver, adjust bias coil L601 until a minimum reading is seen on the scope.
5. Repeat the same procedure on stereo units except monitor the signal at the junction of resistor R514 and R515 while adjusting bias trap coil L602.

#### E. BIAS ADJUSTMENT

1. Connect a 600 ohm load to P1, pins 3 and 5, (Channel 1 or mono input) and pins 4 and 6 (Channel 2 on stereo units) of the recorder.
2. Connect an audio signal generator across the load on pins 3 and 5. Set the output to approximately -10 dBm and the frequency to 1 kHz.
3. Connect a high impedance voltmeter to the 600 ohm load on pins 3 and 5 of the reproducer output J3. Set the range of the voltmeter to 0 dBm.
4. Thread a reel of tape, typical of that regularly used. It is important that the type of tape used when setting bias is the type that is to be regularly used, as various types of magnetic recording tape have differing bias requirements. (See comments regarding tape type in SECTION IV. A.)
5. Press START and RECORD buttons.



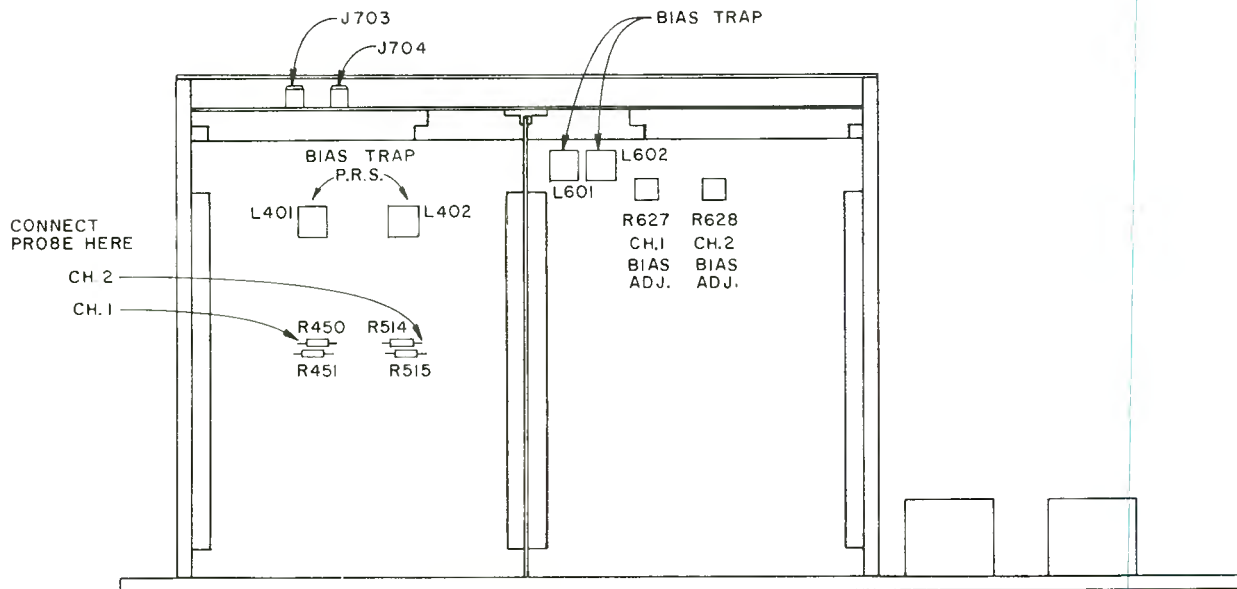

FIGURE 4-7

6. Advance the Channel 1 level control to provide a mid-scale reading on the voltmeter.

7. Adjust trimmer potentiometer R627 (see Figure 4-6) for a maximum reading on the voltmeter.

**NOTE: A delay will be presented between the recording and play process. Make these adjustments slowly.**

8. On stereo units, use the same procedure as outlined above to adjust Channel 2 bias, using trimmer potentiometer R628.

#### F. RECORDING AMPLIFIER EQUALIZATION

1. Thread a reel of blank tape of the type regularly used in the machine. **It should be noted that a single tape type be used from day-to-day as frequency response characteristics and bias requirements vary considerably between the various tape formulations.**

2. Connect the audio signal generator across the load on P1 pins 3 and 5. Set the frequency to 700 Hz and level to approximately -10 dBm.

3. Connect the high impedance voltmeter to the load on pins 3 and 5 of the reproducer outputs J3. Set the range to 0 dBm.

4. Set the speed switch to the "high" position.

5. Press the record and start button.

6. Advance the Channel 1 record level control until a -10 dBm reading is observed on the voltmeter.

7. Change the frequency of the audio signal generator to 15 kHz (on 15 IPS and 7-1/2 IPS machines only), and observe the output level on the voltmeter.

8. While recording the high frequency tone, adjust the high speed equalization pot until the high frequency is equal in level to the -10 dBm reference tone established in step 6. Refer to Figure 4-8 for location.

9. Slowly sweep the signal generator from 15 kHz to 700 Hz while observing output level.

10. Set the speed switch to the low speed position.

11. Record a 700 Hz tone and adjust the Channel 1 input level control for a -10 dBm reading on the voltmeter.

12. Change the frequency of the signal generator to 15 kHz (7.5 kHz if this is a 3-3/4 IPS machine) and adjust the low equalization control for a -10 dBm reading on the voltmeter. See Figure 4-8.

#### G. RECORD LINE METER CALIBRATION (REC)

1. Set the speed switch to the high speed position.

2. Connect the signal generator to the inputs of the recorder, and the voltmeter across the output of the reproducer unit. Make certain that all 600 ohm loads are in place.

3. Record a 700 Hz tone and adjust the input level controls for a 0 dBm reading on the voltmeter.

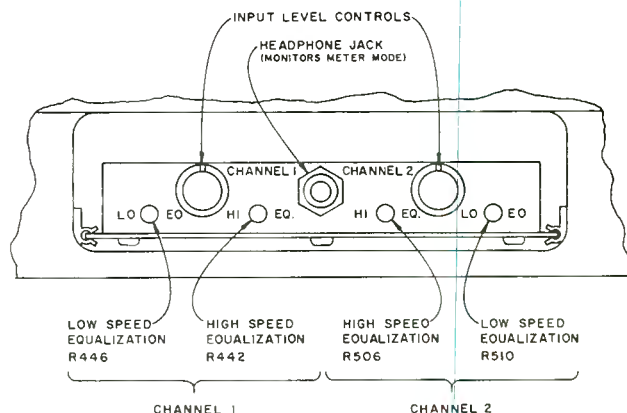

FIGURE 4-8

4. Depress the REC meter switch, S603.
5. Adjust the record meter calibration control R403 for a "0" reading on the VU meter. See Figure 4-1.
6. On two channel units, repeat the above procedure, using R467 to calibrate the Channel 2 record line meter.

#### H. TWO SPEED RECORDING AMPLIFIER LEVEL CALIBRATION

**Make this calibration only after the steps in Section G have been performed.**

1. Set the signal generator input so that a "0" VU reading is obtained on the front panel VU meter at 700 Hz. (The REC meter select switch and the Record Set switch must be depressed.)
2. Put the speed select switch in the low speed position.
3. Adjust R437, balance for a 0 dBm reading on the high impedance voltmeter connected across the output terminals. Figure 4-1.
4. On stereo units, use the same procedure as outlined above but use R501 for the Channel 2, recording amplifier level calibration control. Figure 4-1.

#### I. P.R.S. AMPLIFIER BIAS TRAP

1. Refer to Figure 4-7 for the location of the components used in the following adjustments.
2. Connect an audio voltmeter to the meter amplifier output jack J703 located on the rear panel of the record chassis.
3. Set the Channel 1 record select switch to the off position (out) and set the Channel 2 record select switch S602 to its on position (in).
4. Load a blank reel of tape onto the playback deck transport.
5. Press the record and the start switches.

6. While in the record mode with the tape in motion, adjust bias trap L401 for a minimum reading on the voltmeter.

7. Repeat the same procedure for Channel 2. Channel 1 record select switch should be in, Channel 2 record select switch should be out, and the bias trap for Channel 2, L402, should be adjusted.

#### J. BIAS METER CALIBRATION

1. Press the bias meter select switch S604.
2. Load a reel of tape and set the machine to record and start. (Both channel select switches should be depressed.)
3. Adjust potentiometer R406 until a "0" VU indication is read on Channel 1 meter. See Figure 4-1.
4. Adjust potentiometer R470 for a "0" VU reading on the Channel 2 meter.

#### K. P.R.S. AMPLIFIER METER CALIBRATION

1. Record a 2-minute length of 700 Hz tone on Channel 1. **Be certain that this tone is recorded at a 0 VU level.**
2. Depress the Channel 2 record select switch and be certain that the Channel 1 record select switch is out (OFF).
3. Rewind the tape to the beginning of the 700 Hz tone.
4. Set the machine for the record mode and press the start switch. While playing the tape, adjust R405 for "0" VU on the Channel 1 meter.
5. Repeat the above procedure for calibrating the Channel 2 P.R.S. meter. The channel select switch for Channel 2 should be in the off position and the channel select switch for Channel 1 would be in the on position. Use calibration potentiometer R469.

## SECTION V. – ROUTINE MAINTENANCE

### A. GENERAL

International Tapetronics Corporation has designed the 770 Series Reel-to-Reel for high reliability, and maximum length of service before routine scheduled service.

The DC Servo capstan motor utilizes both a permanently lubricated ball bearing and an oilite bearing. Under continuous use the oilite bearing should be periodically oiled, and will be detailed later.

The solenoid plunger is TEFLON coated, and operates within a brass tube. This combination eliminates the need for any lubrication and wear is negligible.

Brake discs and pads are a high strength metal alloy, and will endure 250,000 operations or more before maintenance is required.

Torque motor bearings are permanently sealed and should never require maintenance.

Daily inspection of the heads is recommended, and more frequent inspection is desirable if the unit is in heavy or continuous use. Head cleaning should be

performed on a frequent and regular basis to insure optimum performance. Use a clean cotton swab dipped in Isopropyl alcohol for this procedure. All metal components in the tape path-capstan, tape guides, idler arm, and guide posts-should also be frequently cleaned. The 770 pressure roller should also be kept clean in order to maintain the best tape pulling characteristics. During the cleaning, insure that all traces of oxide and lubricant are removed from mechanical components in the tape path. Allow all cleaning fluid to dry before re-threading tape onto the machine, to reduce the possibility of damage to the tape.

**CAUTION: Do not allow cleaning fluid to enter the bearings in the pressure roller and the guide posts. Cleaning fluids may deteriorate the lubricant in these bearings and cause premature failure.**

Front panel overlays and dress plate may be brushed periodically with a soft camel's hair or synthetic bristle

### MAINTENANCE SCHEDULE

This maintenance schedule is intended as a guide for maintaining your unit in optimum condition, and is for units in routine daily use. The schedule may be varied depending on your particular machine duty cycle. The intent is to develop a schedule to allow maximum use with minimum maintenance time. In most cases, this maintenance schedule will enable you to pinpoint potential trouble areas before they become problems that may potentially remove the machine from service.

	DAILY	WEEKLY	MONTHLY	6 MONTHS
CLEAN HEADS, PRESSURE ROLLER, TAPE GUIDES, TAPE GUIDE POSTS, AND IDLER ARM	●			
CLEAN FRONT PANEL OVERLAY, HEAD COVER, AND ESCUTCHEON		●		
DEGAUSS ALL HEADS AND TAPE GUIDES			●	
CHECK HEAD AZIMUTH, ZENITH, HEIGHT			●	
CHECK FREQUENCY RESPONSE - EQUALIZATION			●	
CHECK BRAKE SLIP TORQUE				●
CHECK TORQUE MOTOR TORQUE				●
CHECK CAPSTAN MOTOR SPEED (HIGH AND LOW SPEED)				●
CHECK PRESSURE ROLLER PRESSURE				●
LUBRICATE CAPSTAN MOTOR				●
CHECK RECORDER BIAS AND EQUALIZATION			●	
CHECK RECORDER METER CALIBRATION				●
CHECK 25 Hz TONE DETECTOR SENSITIVITY*				●
CHECK INPUT, OUTPUT LEVEL CALIBRATION				●

\*IF APPLICABLE

paint brush to remove dust and oxide buildups. Should thorough cleaning be required, use a soft rag and a mild household cleaner such as "409"® or "FANTASTIK"®. Be sure to use cleaners sparingly, and wipe dry with a soft cloth to eliminate residue and smudges.

The Servo Capstan motor requires periodic oiling. Please refer to the 770 Series Reproducer Technical Manual for specifics regarding capstan motor lubrication procedures.

## **B. MAINTENANCE TOOLS AND AIDS**

NEEDLE-NOSED PLIERS

STANDARD SLOT SCREWDRIVER, 6" SHAFT, 1/4" BLADE

1/8" HEX WRENCH

3/64" HEX WRENCH

MINIATURE SLOT SCREWDRIVER, 3" SHAFT, 1/8" BLADE

MINIATURE PHILLIPS SCREWDRIVER, 3" SHAFT, #0 BIT

SPRING SCALE, 2 POUND

10-1/2" NAB HUB EMPTY TAPE REEL

3 FT LACING CORD, OR HEAVY TWINE

ITC TAPE HEIGHT GAUGE, PART NO. 830-0022-021

ITC BRAKE GAP GAUGE, PART NO. 830-0036-001

TAPE HEAD DEGAUSSER

NAB ALIGNMENT TAPE\*

FREQUENCY COUNTER

V.O.M., V.T.V.M., OR F.E.T.V.O.M.

OSCILLOSCOPE

INSULATED OR NON-METALLIC SLOT SCREWDRIVER, 6" SHAFT, 1/4" BLADE

AUDIO OSCILLATOR

FLUTTER TAPE\*

\*ONE TAPE NEEDED FOR EACH SPEED OF OPERATION

## **C. SPARE PARTS**

Your new 770 Series Record Amplifier unit was shipped with a Maintenance Parts Price List enclosed in the front of this Technical Manual. We sincerely hope you never have to replace parts on your unit. But being a mechanical device, we recognize that components wear out after a time and must be replaced. Should parts replacement become necessary, ITC will supply those parts to you, and at no charge if within the warranty period. (See Warranty, in the front of the Technical Manual.)

If you desire a quantity of spare parts in case of breakdowns, please review the Maintenance Parts Price List. This list does not contain every part in the 770, but is a list of the most frequently requested parts, and are readily available from inventory. If you have questions regarding spares, or items not listed, call ITC Technical Service for assistance.



# SECTION VI – THEORY OF OPERATION AND DESIGN PRINCIPLE

## A. GENERAL

The ITC 770 Series Reel to Reel Recording Amplifier electronics are contained on two plug-in printed circuit cards and one mother board assembly. The plug-in PC cards contain the program recording amplifiers, the bias oscillators, the meter amplifiers, and control electronics. On some models it also contains a play record sync amplifier. The recorder derives its power and related control information from the associated reproducer unit through the interconnect cables.

## B. RECORDER CONTROL LOGIC

The major portion of the recorder's control logic is located on the bias oscillator and control PC board. Please refer to the 770 Series Recording Amplifier schematic Figure 7-11 for location of the following component references.

Transistor Q607 serves both as a "ready" switch and as a "safe" switch. Forward bias to Q607 is supplied through R630 and/or R634 through the channel select switches S601 and S602 to "ready" ground, if both channel switches are depressed and the machine is in a true ready condition. The "ready" ground control is obtained through pin 15 of J702, through the interconnect cable of the playback portion of the 770 Series. This point is at ground potential only when the machine is in a "ready" condition and tape is loaded properly. If this "ready" condition does not exist, no forward bias current is possible for transistor Q607 and therefore, the record set circuitry, Q609 and Q608, cannot be activated.

If the "ready" condition exists, Q608 and Q609 are turned on by depressing the record set switch S606. This action causes a ground potential at the collector of Q608 which in turn forward biases Q609, and latches the two transistor on.

A 24 volt DC potential will now exist at the collector of transistor Q609 which supplies current to the front panel LED indicators CR604 and CR606. This 24 volts also sets up a potential forward bias current loop for transistor Q611. Q611 functions as an AND gate which, if a record set and a run condition exist, causes transistor Q610 to turn on and in turn supply voltage to the bias oscillator circuitry.

The channel select switches S601 and S602 may be operated independently and still cause the previously described circuit functions to exist. During this condition one LED instead of both LED indicators will be illuminated and one power oscillator section as opposed to both power oscillator sections will be active.

The secondaries of T602 and T603 provide recording and erase bias currents to the appropriate heads.

Potentiometers R627 and R628 are used to adjust recording head bias current.

## C. BIAS OSCILLATOR

The bias and erase oscillator circuitry in the 770 Series Recording Amplifier is composed of a master oscillator with two slave power oscillators. The master oscillator is turned on whenever either channel select switch is activated. The recording mode is entered by way of diode matrix CR601 and CR602. The power oscillators are independently activated depending on the channel select switch selection.

Transistors Q601 and Q602 are connected as a push-pull oscillator circuit, with power supplied to the center tap of the primary winding of the transformer T601. Bias frequency is approximately 120 kHz. The turn-on time of the oscillator is controlled by resistor R607 and capacitor C604. The secondary of T601 is coupled to the two slave power oscillators, which are essentially the same circuitry as the master oscillator with the exception that the feedback loops are connected to the secondary of T601 so that both oscillators operate at the same frequency.

## D. METER AMPLIFIERS

The meter amplifier circuitry consists of IC U403, Section A and B. This is a low impedance output amplifier which is used to drive three separate sources: (1) the headphone monitor output J401, (2) the full wave bridge rectifier and meter, and (3) the rear chassis mode monitor outputs J703 and J704.

The switching of the meter amplifier circuitry required for the various monitoring modes is controlled through the use of an analog switch U402, and its associated control logic. U402 consists of four inputs which may independently be switched to a common output bus. P.R.S., normal record, bias, and playback are fed into these four individual inputs on pins 2, 6, 9, and 13. Inputs are switched at the appropriate times to the output terminal pin 11. Output signals are then fed to the input of the meter amplifier U403A. To "switch" any of the four monitoring points to the output terminal of the analog switch, a low or ground potential is required at the appropriate control pin. To prevent an input from being switched through to the output, its appropriate control point must be at approximately 15 volts DC potential.

Transistors Q401, Q402, and Q403 perform the appropriate switching function at the required time. Switching voltages to control these transistors are obtained through the contacts of the pushbutton switches

located on the recorder control PC board. With transistor Q403 forward biased, as it would be if the bias monitor switch had been depressed, a ground potential exists on the collector which is connected to pin 7 on U402.

Transistor Q402 controls the normal record switching input terminal. This transistor is turned on only if the Channel 1 select switch is depressed, the normal record meter switch has been selected and the machine is set to record. If the Channel 2 select switch is depressed, the Channel 1 select switch is out, and the machine is not recording, transistor Q401 is forward biased through the contacts of the Channel 1 select switch. Transistor Q402 is not forward biased, so a 24 volt DC potential is present at the junction of CR403 and R417. The voltage however, is not present at the junction of R417 and R418 because CR402 and Q401 reroute it to ground.

Pin 14 on U402 is normally tied to ground through resistor R423. Diode matrix CR401, CR403 and CR404 however, will cause a 24 volt DC potential to occur at the top of resistor R422 during the proper circumstances (i.e. neither play meter switch depressed, or record meter switch selected but machine not in the recording mode). This in turn, switches the playback input off by virtue of the voltage present at divider R422 and R423. The playback meter monitoring mode is active unless any one of the other three meter select conditions exists.

Voltage divider network R410 and R411 in combination with "pull-up" networks R412, R413, and R414 normally prevent the P.R.S., normal record, and bias control points from being biased on unless switched to ground through one of the appropriate switching transistors.

## **E. PROGRAM RECORDING AMPLIFIER**

Since both Channel 1 and Channel 2, recording amplifier circuits are identical, only the Channel 1 circuit will be described. The recording amplifier circuit consists of input transformer T701, level control R428, IC U404A and B, and the output switching network consisting of Q407, Q408 and Q409.

Two-speed recording amplifier circuits require two separate equalization networks for ideal performance characteristics. ITC therefore has chosen to use an IC with a low output impedance and high input impedance so the two individual equalization networks may be easily switched in and out at the appropriate times, creating the proper recording contours. The network consisting of resistors R433, R434, R435, R436, R440, R442, R443, R444, and R445 and the associated capacitors make up the high speed equalization network. The low speed equalization network is very similar in design. These two individual equalization networks may be switched in or out by switching transistors Q404 and Q406 on and off at the appropriate times. When the machine is in the high speed mode, the voltage at pin 10 of J701 is 0.0 and

therefore, does not provide forward bias current for transistors Q405 and Q406. However, Q404 is biased on through resistors R453, and R452 to 24 volts DC. With transistor Q404 turned on, the low speed equalization network is bypassed to ground so that the high speed network will be active. When the machine is in the slow speed mode of operation, transistors Q406 and Q405 are forward biased because of the 24 volts DC at pin 10 of J701. The high speed network is bypassed to ground through the collector of transistor Q406. The low speed network is active because transistor Q404 is no longer turned on due to the base current being bypassed to ground through transistor Q405. An ideal, totally independent equalization network control is achieved.

R444, C427, R445, and R442 make up the high pass network in the negative feedback loop of the IC circuit. The high frequency equalization adjustment control is achieved by varying the amount of negative feedback through the use of R442 and C426 in series with R443 to ground. R433, R435, and R436 and the components associated with those resistors are minor corrective components to compensate for inaccuracies and deficiencies in the recording head. Capacitors C420, C421 and resistor R434 are also used to make minor corrections from the contouring effect of the amplifier circuit. The low speed equalizer circuit is similar, and therefore will not be described.

The recording head must be switched from the output of the recording amplifier to the input of the P.R.S. amplifier on two track units and therefore, a special switching network is provided to control this function. Q408 and Q409 are FET's used as analog switches. The recording head is normally switched to the input of the P.R.S. amplifier through Q409. When Channel 1 Select Switch and the Record Set Switch have been depressed, Q407 is forward biased through R459, back through the contacts of the channel select switch. This turns on Q408 through R462 and Q407 to ground and simultaneously "pinches off" Q409 through voltage divider R463 and R464. The two FET's perform as a single pole double throw switch.

## **F. PLAY-RECORD SYNCHRONIZING (P.R.S.) AMPLIFIER**

All two channel 770 Reel-to-Reel Recording Amplifiers incorporate as standard equipment the PLAY/RECORD synchronization amplifier circuitry. This amplifier is similar in contour effects to the reproduce amplifier circuit, except for differences in equalization to compensate for gap losses in the recording head.

Located on the input of the P.R.S. amplifier, U401A is a bias trap and roll-off network consisting of C401, L401, and C403. These components are tuned to roll off any remnant bias cross talk from the opposite channel on the recording head. U401 is internally compensated so that only a minimum of external components are required to

achieve the necessary response contours. The output of the P.R.S. amplifier is connected to a calibration network R404 and R405 which feed the P.R.S. input of analog switch U402. The input to the P.R.S. amplifier is

normally switched to the recording head through FET Q409 except during the conditions described earlier under the recording amplifier circuit description.



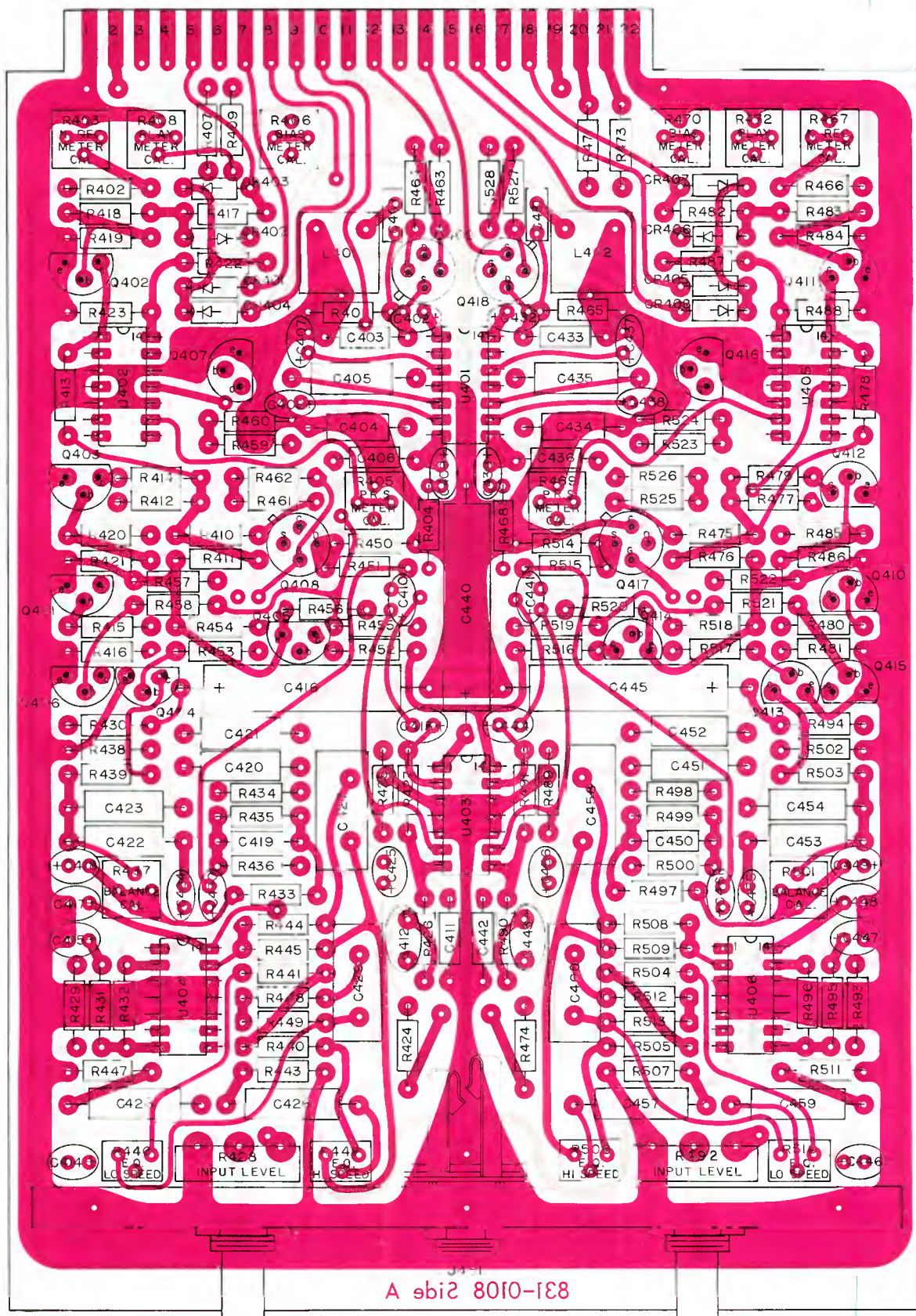

RECORD & METER P.C. BOARD  
 831-0108-003 MONO 7 1/2 IPS - 3 3/4 IPS  
 831-0108-013 STEREO 7 1/2 IPS - 3 3/4 IPS  
 831-0108-023 MONO 15 IPS - 7 1/2 IPS  
 831-0108-033 STEREO 15 IPS - 7 1/2 IPS

### RECORD AND METER AMPLIFIER PCB





SYMBOL	PART NUMBER	DESCRIPTION	SYMBOL	PART NUMBER	DESCRIPTION
R412	630-0087-000	10 K ohm	R472	636-0019-000	20 K ohm potentiometer
R413	630-0087-000	10 K ohm	R473	630-0111-000	100 K ohm
R414	630-0087-000	10 K ohm	R474	630-0055-000	470 ohm
R415	630-0095-000	22 K ohm	R475	630-0058-000	620 ohm
R416	630-0087-000	10 K ohm	R476	630-0063-000	1 K ohm
R417	630-0089-000	12 K ohm	R477	630-0087-000	10 K ohm
R418	630-0087-000	10 K ohm	R478	630-0087-000	10 K ohm
R419	630-0087-000	10 K ohm	R479	630-0087-000	10 K ohm
R420	630-0095-000	22 K ohm	R480	630-0095-000	22 K ohm
R421	630-0087-000	10 K ohm	R481	630-0087-000	10 K ohm
R422	630-0059-000	680 ohm	R482	630-0089-000	12 K ohm
R423	630-0063-000	1 K ohm	R483	630-0087-000	10 K ohm
R424	630-0055-000	470 ohm	R484	630-0087-000	10 K ohm
R425	630-0103-000	47 K ohm	R485	630-0095-000	22 K ohm
R426	630-0047-000	220 ohm	R486	630-0087-000	10 K ohm
R427	630-0107-000	68 K ohm	R487	630-0059-000	680 ohm
R428	636-0014-000	2500 ohm potentiometer	R488	630-0063-000	1 K ohm
R429	630-0079-000	4700 ohm	R489	630-0103-000	47 K ohm
R430	630-0087-000	10 K ohm	R490	630-0047-000	220 ohm
R431	630-0083-000	6800 ohm	R491	630-0107-000	68 K ohm
R432	630-0111-000	100 K ohm	R492	636-0014-000	2500 ohm potentiometer
R433	630-0073-000	2700 ohm	R493	630-0079-000	4700 ohm
	630-0083-000	6800 ohm	R494	630-0087-000	10 K ohm
R434	630-0081-000	5600 ohm	R495	630-0083-000	6800 ohm
	630-0075-000	3300 ohm	R496	630-0111-000	100 K ohm
R435	630-0079-000	4700 ohm	R497	630-0073-000	2700 ohm
R436	630-0073-000	2700 ohm		630-0083-000	6800 ohm
	630-0081-000	5600 ohm	R498	630-0081-000	5600 ohm
R437	636-0018-000	10 K ohm potentiometer		630-0075-000	3300 ohm
R438	630-0075-000	3300 ohm	R499	630-0079-000	4700 ohm
	630-0083-000	6800 ohm	R500	630-0073-000	2700 ohm
R439	630-0081-000	5600 ohm		630-0081-000	5600 ohm
	630-0083-000	6800 ohm	R501	636-0018-000	10 K ohm potentiometer
R440	630-0079-000	4700 ohm	R502	630-0073-000	3300 ohm
R441	630-0079-000	4700 ohm		630-0083-000	6800 ohm
R442	636-0010-000	10 K ohm potentiometer	R503	630-0081-000	5600 ohm
R443	630-0035-000	68 ohm		630-0083-000	6800 ohm
R444	630-0086-000	9100 ohm	R504	630-0079-000	4700 ohm
R445	630-0111-000	100 K ohm	R505	630-0079-000	4700 ohm
R446	636-0010-000	10 K ohm potentiometer	R506	636-0010-000	10 K ohm potentiometer
R447	630-0035-000	68 ohm	R507	630-0035-000	68 ohm
R448	630-0086-000	9100 ohm	R508	630-0086-000	9100 ohm
R449	630-0111-000	100 K ohm	R509	630-0111-000	100 K ohm
R450	630-0107-000	68 K ohm	R510	636-0010-000	10 K ohm potentiometer
R451	630-0083-000	6800 ohm	R511	630-0035-000	68 ohm
R452	630-0087-000	10 K ohm	R512	630-0086-000	9100 ohm
R453	630-0079-000	4700 ohm	R513	630-0111-000	100 K ohm
R454	630-0079-000	4700 ohm	R514	630-0107-000	68 K ohm
R455	630-0091-000	15 K ohm	R515	630-0083-000	6800 ohm
R456	630-0079-000	4700 ohm	R516	630-0087-000	10 K ohm
R457	630-0079-000	4700 ohm	R517	630-0079-000	4700 ohm
R458	630-0091-000	15 K ohm	R518	630-0079-000	4700 ohm
R459	630-0099-000	33 K ohm	R519	630-0091-000	15 K ohm
R460	630-0095-000	22 K ohm	R520	630-0079-000	4700 ohm
R461	630-0135-000	1 meg ohm	R521	630-0091-000	15 K ohm
R462	630-0111-000	100 K ohm	R522	630-0079-000	4700 ohm
R463	630-0111-000	100 K ohm	R523	630-0099-000	33 K ohm
R464	630-0127-000	470 K ohm	R524	630-0095-000	22 K ohm
R465	630-0107-000	68 K ohm	R525	630-0135-000	1 Meg ohm
R466	630-0069-000	1800 ohm	R526	630-0111-000	100 K ohm
R467	636-0019-000	20 K ohm potentiometer	R527	630-0127-000	470 K ohm
R468	630-0107-000	68 K ohm	R528	630-0111-000	100 K ohm
R469	636-0020-000	1000 ohm potentiometer			
R470	636-0019-000	20 K ohm potentiometer			
R471	630-0127-000	470 K ohm			

**SYMBOL    PART NUMBER    DESCRIPTION**

**INTEGRATED CIRCUITS**

U401	606-0009-000	LM382
U402	608-0003-000	AH5009
U403	606-0008-000	LM378
U404	606-0008-000	LM378
U405	608-0003-000	AH5009
U406	606-0008-000	LM378

**PART NUMBER    DESCRIPTION**

**MISCELLANEOUS**

415-0013-000	Knob, level control
380-0035-000	Jack, 1/4 inch phone
613-0001-000	Socket, transistor
613-0008-000	Socket, IC, 14 pin DIP

LED CARD  
831-0115  
LOCATED  
WITH SHADED  
AREA.

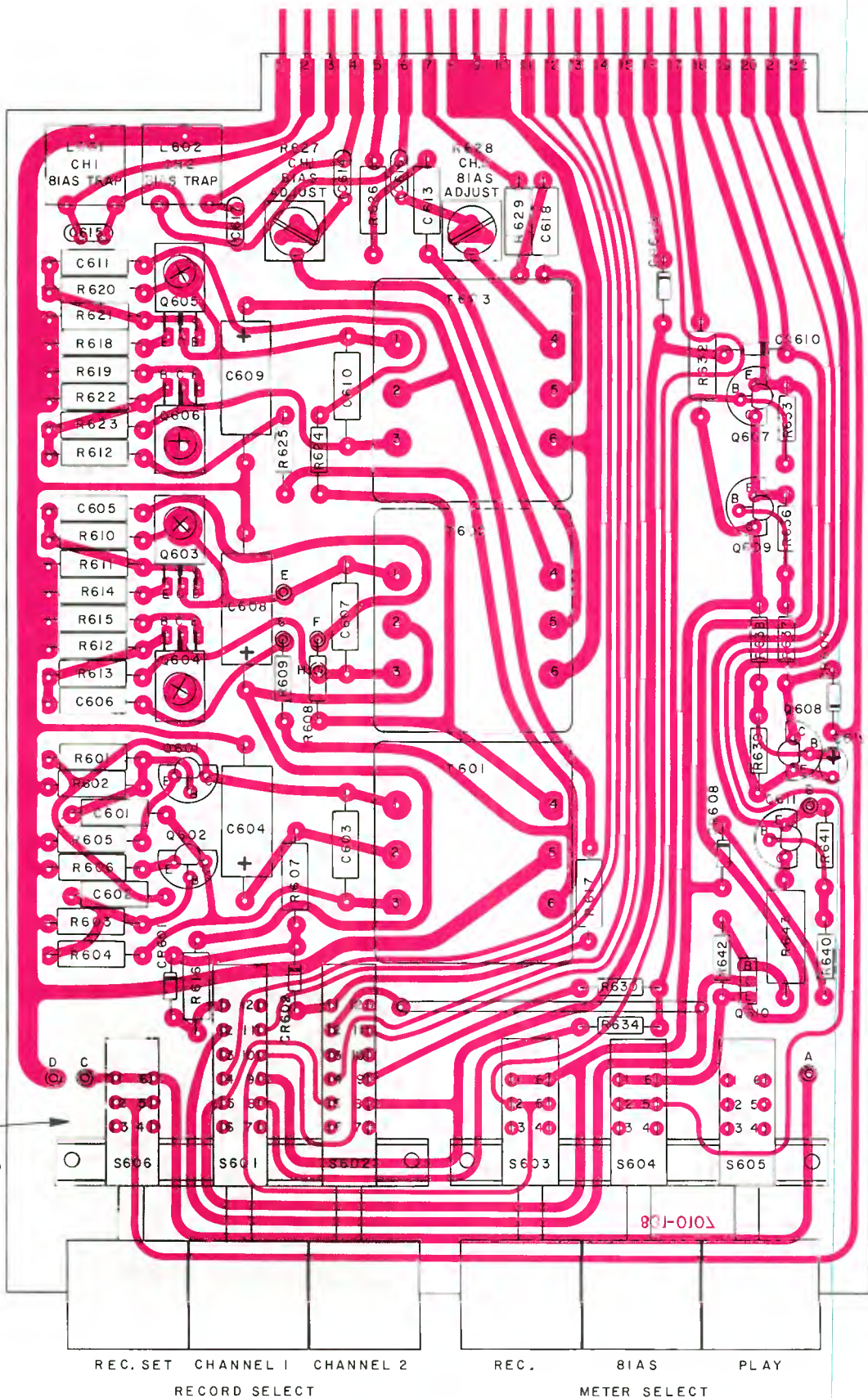

BIAS OSCILLATOR & RECORDER CONTROL  
831-0107-003 MONO HALF TRACK  
831-0107-013 STEREO HALF TRACK  
831-0107-023 MONO HALF TRACK

### BIAS OSCILLATOR AND CONTROL PCB



2. Bias Oscillator and Recorder Control  
(831-0107-003 Mono  
831-0107-013 2 Channel)

SYMBOL	PART NUMBER	DESCRIPTION	SYMBOL	PART NUMBER	DESCRIPTION
<b>RESISTORS</b>					
R601	630-0303-000	47 K ohm			
R602	630-0279-000	4700 ohm			
R603	630-0279-000	4700 ohm			
R604	630-0303-000	47 K ohm			
R605	630-0239-000	100 ohm			
R606	630-0239-000	100 ohm			
R607	630-0223-000	22 ohm			
R608	630-0091-000	15 K ohm			
R609	630-0099-000	33 K ohm			
R610	630-0303-000	47 K ohm			
R611	630-0279-000	4700 ohm			
R612	630-0279-000	4700 ohm			
R613	630-0303-000	47 K ohm			
R614	630-0223-000	22 ohm			
R615	630-0223-000	22 ohm			
R616	630-0223-000	22 ohm			
R617	630-0223-000	22 ohm,			
R618	630-0223-000	22 ohm,			
R619	630-0223-000	22 ohm,			
R620	630-0303-000	47K ohm,			
R621	630-0279-000	4700 ohm,			
R622	630-0279-000	4700 ohm,			
R623	630-0303-000	47 K ohm,			
R624	630-0091-000	15 K ohm,			
R625	630-0099-000	33 K ohm,			
R626	630-0263-000	1 K ohm,			
R627	630-0111-000	100 K ohm,			
R628	630-0111-000	100 K ohm,			
R629	630-0263-000	1 K ohm,			
R630	630-0075-000	3300 ohm,			
R631	626-0463-000	1 K ohm,			
R632	630-0239-000	100 ohm,			
R633	630-0079-000	4700 ohm,			
R634	630-0075-000	3300 ohm,			
R635	626-0463-000	1 K ohm,			
R636	630-0079-000	4700 ohm,			
R637	630-0069-000	1800 ohm,			
R638	630-0099-000	33 K ohm,			
R639	630-0071-000	2200 ohm,			
R640	630-0087-000	10 K ohm,			
R641	630-0079-000	4700 ohm,			
R642	630-0063-0000	1 K ohm,			
R643	626-0463-000	1 K ohm,			
<b>TRANSFORMERS</b>					
T601 thru T603	540-0001-000	T70-T2			
<b>CAPACITORS</b>					
C601	681-0038-000	.0022 mfd,	200v, Pacer		
C602	681-0038-000	.0022 mfd,	200v, Pacer		
C603	681-0046-000	.01 mfd,	200v, Pacer		
C604	696-0119-000	25 mfd,	25v, Electrolytic		
C605	681-0038-000	.0022 mfd,	200v, Pacer		
C606	681-0038-000	.0022 mfd,	200v, Pacer		
C607	681-0046-000	.01 mfd,	200v, Pacer		
C608	696-0119-000	25 mfd,	25v, Electrolytic		
C609	696-0119-000	25 mfd,	25v, Electrolytic		
C610	681-0046-000	.01 mfd,	200v, Pacer		
C611	681-0038-000	.0022 mfd,	200v, Pacer		
C612	681-0038-000	.0022 mfd,	200v, Pacer		
C613	681-0040-000	.0033 mfd,	200v, Pacer		
C614	677-0003-000	300 pfd,	300v, Silver Mica		
C615	677-0001-000	100 pfd,	300v, Silver Mica		
C616	677-0003-000	300 pfd,	300v, Silver Mica		
C617	677-0001-000	100 pfd,	300v, Silver Mica		
C618	681-0040-000	.0033 mfd,	200v, Pacer		
C619	694-0002-000	10 mfd,	20v, Tantalum		
<b>DIODES</b>					
CR601	575-0007-000	1N4005			
CR602	575-0007-000	1N4005			
CR603	575-0007-000	1N4005			
CR604	575-0012-000	LED (red)			
CR605	575-0007-000	1N4005			
CR606	575-0012-000	LED (red)			
CR607	575-0007-000	1N4005			
CR608	575-0007-000	1N4005			
CR609	575-0007-000	1N4005			
CR610	575-0007-000	1N4005			
<b>INDUCTORS</b>					
L601	513-0004-000	8-20 mh.			
L602	513-0004-000	8-20 mh.			
<b>TRANSISTORS</b>					
Q601	590-0017-000	2N5816			
Q602	590-0017-000	2N5816			
Q603	590-0016-000	2N4922			
Q604	590-0016-000	2N4922			
Q605	590-0016-000	2N4922			
Q606	590-0016-000	2N4922			
Q607	590-0018-000	2N5817			
Q608	590-0017-000	2N5816			
Q609	590-0018-000	2N5817			
Q610	590-0020-000	2N4918			
Q611	690-0017-000	2N5816			
<b>SWITCHES</b>					
S601, S602, S606	391-0014-000	3 Station Assembly (2 Channel)			
S601, S606	391-0016-000	2 Station Assembly (1 Channel)			
S603, S604, S605	591-0015-000	3 Station Assembly			
<b>MISCELLANEOUS</b>					
	831-0115-000	PC Board, LED mounting			
	613-0001-000	Socket, Transistor			

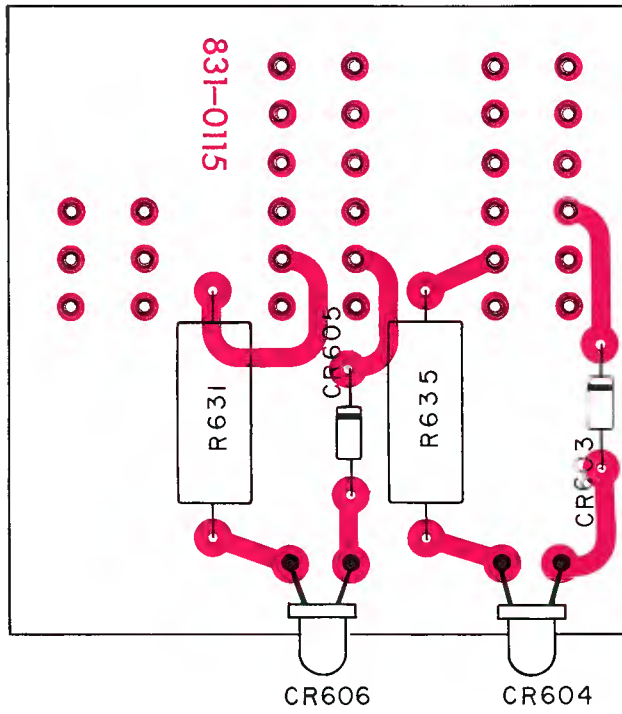

LED INDICATOR P.C. BOARD  
 831-0115-003 MONO  
 831-0115-013 STEREO

**LED INDICATOR  
 PC BOARD**



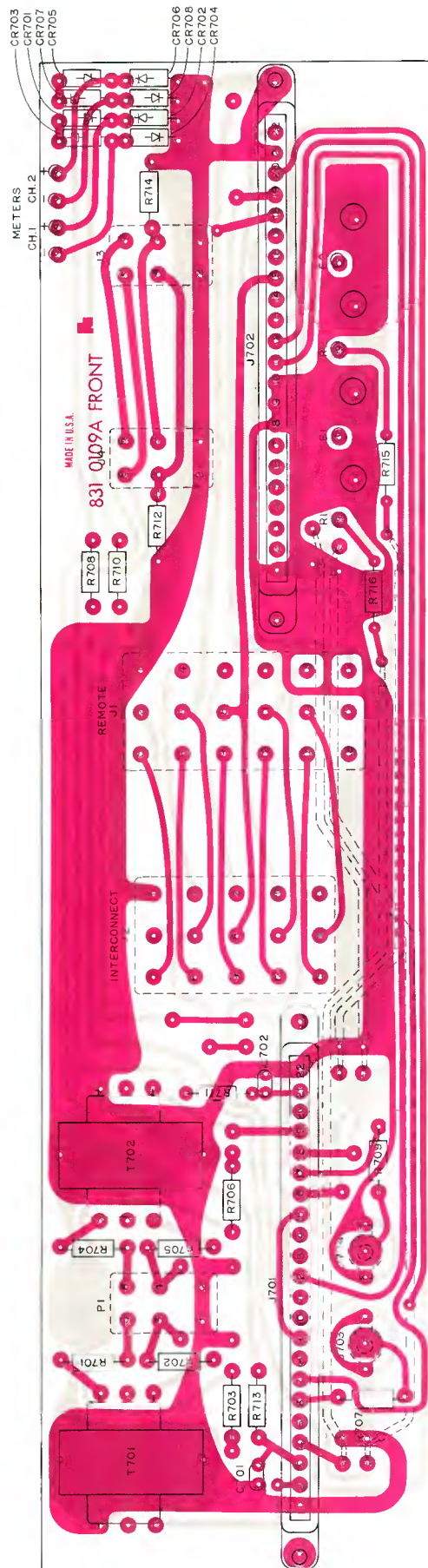

MOTHER BOARD  
 831-0109-013 MONO  
 831-0109-013 STEREO

**RECORD AMPLIFIER  
 MOTHER BOARD**

- 3. Mother Board
  - 831-0109-003 Mono
  - 831-0109-013 2 Channel

**SYMBOL    PART NUMBER    DESCRIPTION**

**DIODES**

CR701 thru CR708	575-0001-000	1N295
------------------------	--------------	-------

**RESISTORS**

**(All 1/4 watt, 5% unless otherwise stated)**

R701	630-0067-000	1500 ohm
	630-0084-000	7500 ohm
R702	630-0067-000	1500 ohm
	630-0084-000	7500 ohm
R703	630-0075-000	3300 ohm
R704	630-0067-000	1500 ohm
	630-0084-000	7400 ohm
R705	630-0067-000	1500 ohm
	630-0084-000	7500 ohm
R706	630-0075-000	3300 ohm
R707	630-0055-000	470 ohm
R708	630-0077-000	3900 ohm
R709	630-0055-000	470 ohm
R710	630-0077-000	3900 ohm
R711	630-0111-000	100K ohm
R712	630-0087-000	10K ohm
R713	630-0111-000	100K ohm
R714	630-0087-000	10K ohm
R715	630-0127-000	470K ohm
R716	630-0127-000	470K ohm

**TRANSFORMERS**

T701 and T702	532-0005-000	NT2823
------------------	--------------	--------

**MISCELLANEOUS**

PU2	504-0013-000	Head, Erase 2 Channel (1/2 track)
	504-0014-000	Head, Erase, full track, Mono
PU3	504-0003-000	Head, Record, 2 Channel (1/2 track)
	504-0018-000	Head, Record, full track, Mono
M701, M702	554-0002-000	Meter, VU Scale

**CAPACITORS**

C701	677-0005-000	47 pfd,	300v Silver Mica
C702	677-0005-000	47 pfd,	300v Silver Mica

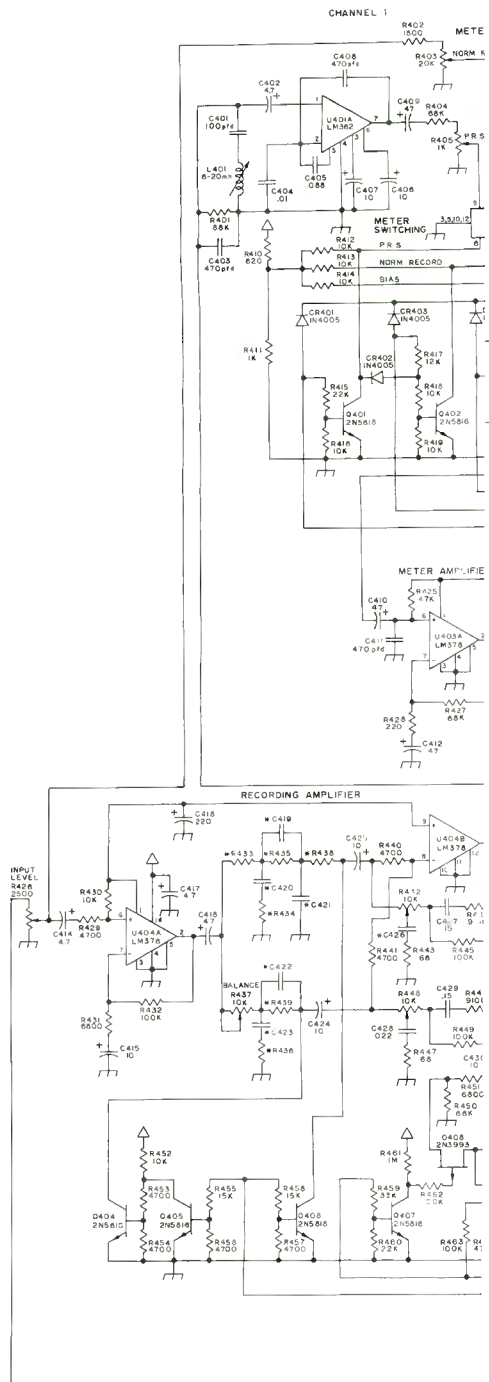

**TABLE OF COMPONENT VALUES**

COMPONENT NUMBER	COMPONENT VALUE	3W-701125	702-15	IPS
C418	NOT USED			.0015
C420	.001			.01
C421	NOT USED			.0055
C422	.0047			NOT USED
C423	.0047			.01
C428	.022			.01
C433	.0000			2700
R434	3300			5600
R435	JUMPED			4700
R436	1500			2700
R438	.8000			3300
R439	.8000			5600
C480	NOT USED			.0005
C451	.001			.01
C452	NOT USED			.0055
C453	.0047			NOT USED
C454	.0047			.01
C457	.022			.01
R457	.8000			2700
R458	3300			5600
R459	JUMPED			4700
R500	.8000			2700
R501	.8000			3300
R503	.8000			5600

- NOTES**
- ALL POINTS MARKED -D- ARE AT +24V DC
  - SEE TABLE OF COMPONENT VALUES
  - ALL RESISTORS ARE 1/4 WATT 5% UNLESS OTHERWISE SPECIFIED
  - ALL CAPACITOR VALUES SHOWN IN MICROFARADS UNLESS OTHERWISE SPECIFIED
  - CONNECT A TO B FOR RECORD SET DURING START-UP  
CONNECT C TO D FOR RECORD SET PRIOR TO AND DURING START-UP
  - ON MONOPHONIC UNITS  
"E" CONNECTS TO "D"  
"F" CONNECTS TO "H"  
"G", "H", "I", "J", "K", "L", "M", "N", "O", "P", "Q", "R", "S", "T", "U", "V", "W", "X", "Y", "Z" IS OMITTED
  - ALL OTHER COMPONENTS UNIQUE TO CHANNEL 2 ARE OMITTED
  - VALUES OF COMPONENTS ARE TYPICAL. SCHEMATICS ARE INTENDED TO BE AS ACCURATE AS POSSIBLE. HOWEVER, AS NECESSARY, COMPONENTS ARE SUBSTITUTED WITH COMMON STANDARD VALUES TO INSURE PROPER OPERATION AND CALIBRATION

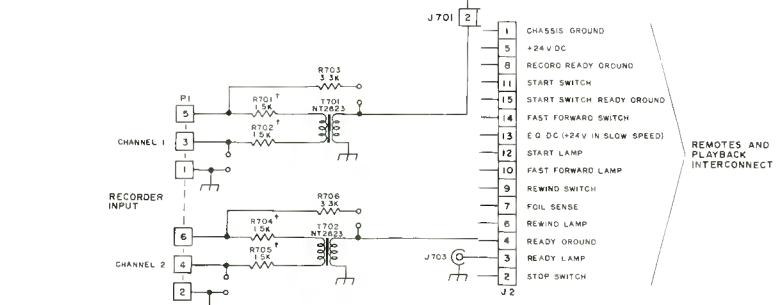

F INPUT SHOWN FOR 5K OHM BALANCE. MET CH  
 F FOR 15K OHM BRIDGING (REPLACE 1.5K OHM RESISTORS WITH 7.5K OHM RESISTORS.)

# RECORD AMPLIFIER SCHEMATIC

INTERNATIONAL TAPETRONICS CORPORATION  
 2425 South Main Street  
 Bloomington, Illinois 61701

Telephone (309) 828-1381

TWX 510-352-2500 ITC BLMG

770 SERIES RECORDING AMPLIFIER  
 MAINTENANCE PARTS PRICE LIST

April  
 1981

PART NUMBER	DESCRIPTION	PRICE
<u>CAPACITORS</u>		
677-0001-000	100 pfd 300V Silver Mica	.45
677-0003-000	300 pfd 300V Silver Mica	.75
677-0005-000	47 pfd 300V Silver Mica	.75
681-0030-000	470 pfd 200V	.75
681-0034-000	.001 mfd 200V	.50
681-0036-000	.0015 mfd 200V	.50
681-0038-000	.0022 mfd 200V	.50
681-0040-000	.0033 mfd 200V	.50
681-0042-000	.0047 mfd 200V	.50
681-0044-000	.0068 mfd 200V	.45
681-0046-000	.01 mfd 200V	.60
681-0050-000	.022 mfd 200V	.75
681-0056-000	.068 mfd 200V	.75
681-0001-000	.15 mfd 100V Mylar	.50
687-0006-000	220 mfd 25V Electrolytic	.40
694-0002-000	10 mfd 20V Tantalum	1.75
694-0003-000	4.7 mfd 35V Tantalum	1.75
694-0007-000	47 mfd 20V Tantalum	3.50
696-0119-000	25 mfd 25V Electrolytic	3.50
<u>DIODES</u>		
575-0001-000	1N295 Diode	.50
575-0007-000	1N4005 Diode	.25
575-0012-010	L.E.D. (Red)	.75
<u>INDUCTORS</u>		
513-0004-000	8-20mh Weecoil 387-20M	4.50
532-0005-000	Audio Input Transformer NT2823	11.75
540-0001-000	Bias Transformer T70-T2	15.75
<u>INTEGRATED CIRCUITS</u>		
606-0008-000	LM378 I.C. Op Amp	4.00
606-0009-000	LM382 I.C. Op Amp	2.50
608-0003-000	AH5009 I.C. Analog Switch	10.00

0381 DM

(1)

770RA MPPL

PART NUMBER	DESCRIPTION	PRICE
-------------	-------------	-------

HEADS

504-0003-000	Head, Record, 2 Channel (Half-track)	50.00
504-0013-000	Head, Erase, 2 Channel (Half-track)	75.00
504-0014-000	Head, Erase, Full Track	75.00
504-0018-000	Head, Record, Full Track	72.50

RESISTORS

636-0010-000	10k Ohm Potentiometer	1.50
636-0014-000	2500 Ohm Potentiometer	4.00
636-0018-000	10k Ohm Potentiometer (Laydown)	1.75
636-0019-000	20k Ohm Potentiometer (Laydown)	1.75
636-0020-000	1000 Ohm Potentiometer (Laydown)	2.50

SWITCHES

391-0014-000	3-Station Switch Assembly(2 Channel Rec. Set)	10.00
391-0015-000	3-Station Switch Assembly (Meter Switch)	9.50
391-0016-000	2-Station Switch Assembly (Mono Rec. Set Switch)	7.00

TRANSISTORS

590-0016-010	2N4922 Transistor	1.75
590-0017-010	GES5816 Transistor	.60
590-0018-010	GES5817 Transistor	.60
590-0020-010	2N4918 Transistor	1.25
596-0003-010	2N3994 -P Channel F.E.T. (Replaces 596-0001-010, 2N3993 F.E.T.)	3.00

MISCELLANEOUS

284-0007-010	Level Knob Hole Plug	.75
380-0035-000	Jack, 1/4" Phone	1.75
315-0013-000	Knob, Level Control	1.50
432-0005-000	Cable, Control Interconnect	27.00
432-0006-000	Cable, Audio Interconnect	18.00
432-0007-000	Cable, Head Interconnect (Record, Erase) BNC	22.50
554-0002-000	Meter, V. U.	30.00
613-0001-000	Socket, Transistor	.75
613-0008-000	Socket, I.C., 14-Pin DIP	1.00
890-0025-000	Instruction Manual, 770 Record Amp	7.50

PRINTED CIRCUIT CARDS

831-0107-003	Bias Oscillator and Recorder Control DCB, Mono-Half Track	115.00
831-0107-013	Bias Oscillator and Recorder Control PCB, Stereo	180.00

0381 DM

(2)

770RA MPPL

PART NUMBER	DESCRIPTION	PRICE
831-0107-023	Bias Oscillator and Recorder Control PCB, Mono-Full Track	125.00
831-0108-003	Record and Meter Amp, Mono 3.75-7.5 PCB	150.00
831-0108-013	Record and Meter Amp, Stereo 3.75-7.5 PCB	245.00
831-0108-023	Record and Meter Amp, Mono 7.5-15 PCB	145.00
831-0108-033	Record and Meter Amp, Stereo 7.5-15 PCB	250.00
831-0109-003	Motherboard, Record Amp Mono PCB	80.00
831-0109-013	Motherboard, Record Amp Stereo PCB	120.00
831-0115-000	L.E.D. Mounting PCB	15.00

OPTIONS, ACCESSORIES, and SERVICE AIDS

830-0022-021	Head Height Gauge	19.00
830-0036-001	Disc Brake and Turntable Gauge	6.00
831-0075-003	Reproduce Amp Test Extender PCB	24.00
831-0119-003	Record Amp Test Extender PCB	27.50
833-0018-200	25 Hz Detector Module	150.00
864-0014-010	Console Cabinet	625.00
864-0015-000	Stacking Kit (for Consoles)	70.00
833-0013-370	Remote Control - Reproducers	225.00
833-0013-380	Remote Control - Record/Reproducers	230.00
281-0014-012	Filler Panel - 19"W x 1 3/4"H	10.00

This price list is provided for your convenience. These parts are readily available from our stock, as maintenance or repair items. Because our selling price is based on our actual costs, you may find that some items may be purchased locally at comparable or lower cost than from ITC.

All prices are subject to review and change without notice.  
Please retain this list for reference.

All prices listed above are U.S. Domestic. Prices will vary outside territorial U.S.

Minimum order \$15.00.



INTERNATIONAL TAPETRONICS CORPORATION  
 2425 SOUTH MAIN STREET  
 POST OFFICE BOX 241  
 BLOOMINGTON, ILLINOIS 61701  
 TELEPHONE (309) 828-1381  
 TWX 510-352-2500 ITC BLMG

MAINTENANCE PARTS PRICE LIST FOR:  
 770 SERIES REEL TO REEL REPRODUCERS AND RECORDER/REPRODUCERS

PART NUMBER	DESCRIPTION	PRICE
CAPACITORS		
677-0001-000	CAPACITOR, 100PFD 300V SILVER MICA	.45 EA
677-0003-000	CAPACITOR, 300 PFD,300V SILVER MICA	.75 EA
677-0005-000	CAPACITOR, 47 PFD 300 V SILVER MICA	.75 EA
681-0030-000	CAPACITOR, 470 PFD, 200V	.75 EA
681-0034-000	CAPACITOR, .001MFD 200V	.50 EA
681-0036-000	CAPACITOR, .0015 MFD 200V	.50 EA
681-0038-000	CAPACITOR, .0022 MFD 200V	.50 EA
681-0040-000	CAPACITOR, .0033 MFD 200V	.50 EA
681-0042-000	CAPACITOR, .0047 MFD 200V	.50 EA
681-0044-000	CAPACITOR, .0068 MFD 200V	.50 EA
681-0046-000	CAPACITOR, .01 MFD 200V	.60 EA
681-0050-000	CAPACITOR, .022 MFD 200V	.75 EA
681-0056-000	CAPACITOR, .068 MFD 200V	.75 EA
683-0012-000	CAPACITOR, 7.5MFD,236 VAC OIL FILLED (FOR HOWARD TORQUE MOTORS)	9.00 EA
683-0016-000	CAPACITOR, 6MFD, 236 VAC OIL FILLED (FOR WSM TORQUE MOTORS)	9.00 EA
687-0006-000	CAPACITOR, 220 MFD, 25V ELECTROLYTIC	.40 EA
687-0007-000	CAPACITOR, 470 MFD, 25V ELECTROLYTIC	.55 EA
687-0009-000	CAPACITOR, 2200MFD, 35V ELECTROLYTIC	2.00 EA
687-0010-000	CAPACITOR, 3300MFD, 50V ELECTROLYTIC	6.25 EA
694-0002-000	CAPACITOR, 10MFD, 20V TANTALUM	1.65 EA
694-0003-000	CAPACITOR, 4.7MFD, 35V TANTALUM	1.70 EA
694-0005-000	CAPACITOR, 1MFD, 35V TANTALUM	.75 EA
694-0007-000	CAPACITOR, 47MFD, 20V TANTALUM	4.90 EA
696-0078-000	CAPACITOR, 100MFD, 12V ELECTROLYTIC	.90 EA
696-0117-000	CAPACITOR, 10MFD, 25V ELECTROLYTIC	.75 EA
696-0119-000	CAPACITOR, 25 MFD 25V ELECTROLYTIC	.90 EA
696-0122-000	CAPACITOR, 50MFD, 25V ELECTROLYTIC	1.00 EA
696-0207-000	CAPACITOR, 200MFD,250V ELECTROLYTIC	5.50 EA
CONNECTORS / CABLES		
375-0005-000	QUICK SLIDE FEMALE TERMINAL	.15 EA
376-0049-000	3-PIN POST HEADER,LOCKING	.50 EA
376-0050-000	10-PIN POST HEADER,POLARIZED	1.00 EA
376-0051-000	18-PIN POST HEADER,POLARIZED	1.60 EA
378-0001-000	PLUG, 3-PIN MOTOR	.75 EA
378-0002-000	PLUG, 6 PIN MALE (AUDIO OUTPUT)	2.20 EA
378-0005-000	PLUG, 6-PIN MOTOR	1.10 EA
380-0001-000	SOCKET, 3-PIN MOTOR	.90 EA
380-0007-000	SOCKET, 6-PIN MOTOR	2.00 EA



## 770 SERIES REEL TO REEL REPRODUCERS AND RECORDER/REPRODUCERS

PART NUMBER	DESCRIPTION	PRICE
CONNECTORS / CABLES		
380-0035-000	PHONE JACK, 1/4" STEREO	1.75 EA
380-0044-000	6-PIN SOCKET, PC MOUNT	1.25 EA
380-0045-000	15-PIN SOCKET, PC MOUNT	2.75 EA
380-0048-000	BNC SOCKET, CHASSIS MOUNT	5.00 EA
380-0066-000	CONNECTOR HEADER, 26-PIN	4.75 EA
380-0127-000	CONNECTOR HOUSING, 3-PIN AMP #640440-3	.40 EA
380-0130-000	22-PIN PC CARD EDGE CONNECTOR	5.50 EA
432-0005-000	CABLE, 770/750 CONTROL INTERCONNECT	35.00 EA
432-0006-000	CABLE, 770/750 AUDIO INTERCONNECT	23.50 EA
432-0007-000	CABLE, 770/750 HEAD INTERCONNECT, BNC (RECORD, ERASE HEADS)	24.75 EA
432-0031-002	CABLE, 770 MOTION SENSE INTERCONNECT	4.50 EA
487-0003-000	RELAY SOCKET, PC MOUNT	1.10 EA
832-0760-021	HEAD CABLE, CHANNEL 1 (MONO) REP.	4.50 EA
832-0760-022	HEAD CABLE, CHANNEL 2 REP.	4.50 EA
832-0765-022	CABLE, HEAD 750/770 CH2 P OF R/P	3.50 EA
837-0016-002	SWITCHCARD TO MOTHERBOARD CONNECTOR CABLE	13.50 EA
DIODES / RECTIFIERS		
575-0001-000	DIODE, 1N295	.50 EA
575-0007-000	DIODE, 1N4005	.25 EA
575-0012-010	DIODE, LIGHT EMITTING-RED	.75 EA
575-0022-000	MDA 206 BRIDGE RECTIFIER	3.75 EA
577-0005-000	DIODE, 1N4372A ZENER	.50 EA
HEADS		
504-0003-000	HEAD, RECORD 2 CHANNEL (HALF TRACK) NORTRONICS LPB2H4R	54.00 EA
504-0013-000	HEAD, ERASE 2 CHANNEL (HALF TRACK) PRB2EH4	80.00 EA
504-0014-000	HEAD, ERASE FULL TRACK FR-131EF4N0	90.00 EA
504-0015-000	HEAD, PLAY FULL TRACK 7NHIFX-0	45.00 EA
504-0018-000	HEAD, RECORD FULL TRACK FR-R1F4R-N0	60.00 EA
504-0027-000	HEAD, PLAY QUARTER TRACK	125.00 EA
504-0038-000	HEAD, PLAY HALF TRACK (VIKRON)	59.00 EA
INDUCTORS		
513-0004-000	INDUCTOR 8-20MH VARIABLE	4.50 EA
540-0001-000	BIAS TRANSFORMER T70-T2	15.75 EA

## 770 SERIES REEL TO REEL REPRODUCERS AND RECORDER/REPRODUCERS

PART NUMBER	DESCRIPTION	PRICE
-----		
INTEGRATED CIRCUITS		
605-0007-000	IC 24V VOLTAGE REGULATOR 7824KC TO-3	4.00 EA
605-0015-000	IC 5V VOLTAGE REGULATOR 78L05 ACP	1.50 EA
606-0006-000	IC LM 324	1.50 EA
606-0007-000	IC LM358	1.50 EA
606-0008-000	IC LM378	5.00 EA
606-0009-000	IC LM382	3.50 EA
608-0003-000	IC AH5009 ANALOG SWITCH	7.25 EA
609-0001-000	IC LM3905 TIMER	2.00 EA
MAJOR ASSEMBLIES		
338-0001-000	BRAKE DISC ASSEMBLY 770 (SUPPLY)	67.25 EA
338-0002-000	BRAKE DISC ASSEMBLY 770 (TAKEUP)	67.25 EA
477-0006-002	SOLENOID ASSY WITH PLUNGER-FRONT MOUNT	40.00 EA
832-0705-010	770 POWER TRANSFORMER ASSEMBLY	55.00 EA
832-0710-010	770 SOLENOID ASSEMBLY W/LINKAGE & PLUG	58.50 EA
832-0710-020	770 SOLENOID ASSEMBLY W/PLUG,W/O LINKAGE	49.00 EA
832-0710-021	SOLENOID LINKAGE ASSEMBLY	9.50 EA
832-0720-010	TENSION ARM W/FOIL SENSE POST	11.75 EA
832-0720-020	FOIL SENSE POST	8.75 EA
832-0725-000	TAPE GUIDE BEARING ASSEMBLY	22.50 EA
832-0735-000	OPTO-SENSOR, TAPE BREAK	15.00 EA
832-0770-000	770 SUPPLY MOTOR AND BRAKE ASSEMBLY	159.50 EA
832-0775-000	770 TAKE UP MOTOR AND BRAKE ASSEMBLY	159.50 EA
832-0780-000	770 PRESSURE ROLLER ASSEMBLY	55.00 EA
	(FORMERLY 837-0008-002)	
832-0785-000	770 HEAD COVER ASSEMBLY	20.50 EA
837-0017-000	770 DISC BRAKE SHELL & BRACKET ASSEMBLY	41.00 EA
837-0018-000	DISC BRAKE INNER PAD/SOLENOID ARMATURE	41.00 EA
837-0019-000	DISC BRAKE ROLLER CLUTCH/OUTER PAD	27.00 EA
	(SUPPLY--RED CODE)	
837-0020-000	DISC BRAKE ROLLER CLUTCH/OUTER PAD	27.00 EA
	(TAKE-UP--GREEN CODE)	
864-0012-000	REEL RETAINER-V.I.F.	22.50 EA
MISCELLANEOUS PARTS		
251-0019-000	BEARING (SKF 626-2), TAPE GUIDE	7.00 EA
255-0002-000	BUMPER, RUBBER	.20 EA
264-0002-001	CLEVIS SCREW	2.50 EA
272-0022-001	GUIDE, TAPE, NON ROTATING	5.00 EA
284-0007-010	LEVEL KNOB HOLE PLUG	.75 EA
297-0022-012	SHIELD, PROGRAM AMPLIFIER	5.25 EA
297-0024-002	SHIELD HEAD PLAY 770	2.50 EA
300-0036-001	BEARING, STANDOFF	.50 EA
315-0013-000	KNOB, LEVEL CONTROL	1.65 EA
417-0007-000	FUSE, 2 AMP SLO-BLO	.75 EA
418-0001-000	FUSE HOLDER AND CAP	2.00 EA
433-0001-000	LINE CORD	3.50 EA

5-11

770 SERIES REEL TO REEL REPRODUCERS AND RECORDER/REPRODUCERS

PART NUMBER	DESCRIPTION	PRICE
-------------	-------------	-------

---

MISCELLANEOUS PARTS

478-0002-001	AIRPOT R-R	22.50 EA
554-0002-000	METER, VU	30.00 EA
613-0001-000	SOCKET, TRANSISTOR	.75 EA
613-0008-000	SOCKET, I.C. 14 PIN DIP	1.00 EA
613-0009-000	SOCKET, I.C. 16 PIN DIP	1.25 EA
832-0765-021	750/770 HEAD CABLE CH1 P OF R/P	3.50 EA
864-0010-011	REEL RETAINER, RUBBER	1.50 EA
890-0024-000	770 REPRODUCER TECHNICAL MANUAL	10.00 EA
890-0025-000	770 RECORD AMP TECHNICAL MANUAL	7.50 EA

MOTORS

451-0066-003	MOTOR, REEL TORQUE WSM (REPLACES 451-0057;451-0065)	75.00 EA
455-0003-013	MOTOR, CAPSTAN NIDEC DCB, W/ CONTROLLER	210.00 EA

OPTIONS, ACCESSORIES, SERVICE AIDS

281-0014-012	FILLER PANEL-19"W X 1.75" H	12.50 EA
830-0022-021	GAUGE HEAD HEIGHT	21.00 EA
830-0036-001	770 DISC BRAKE/TURNTABLE GAUGE	6.00 EA
831-0075-003	PCB REPRODUCE AMP TEST EXTENDER	26.50 EA
831-0119-003	PCB RECORD AMP TEST EXTENDER	28.75 EA
833-0013-370	REMOTE CONTROL-770 REPRODUCE ONLY	260.00 EA
833-0013-380	REMOTE CONTROL-770 RECORD/REPRODUCE	275.00 EA
833-0018-200	25 HZ DETECTOR MODULE-750/770	165.00 EA
864-0014-010	R-R CONSOLE CABINET-750/770	650.00 EA
864-0015-000	STACKING KIT (FOR CONSOLES)	75.00 EA
878-0069-000	AT-0002 AUDIO TRANSFORMER KIT STEREO	40.00 EA

PRINTED CIRCUIT BOARDS

831-0107-003	PCB BIAS OSCILLATOR AND RECORDER CONTROL, MONO HALF TRACK	142.25 EA
831-0107-013	PCB BIAS OSCILLATOR AND RECORDER CONTROL, STEREO	180.00 EA
831-0107-023	PCB BIAS OSCILLATOR AND RECORDER CONTROL, MONO FULL TRACK	150.00 EA
831-0108-003	PCB RECORD AND METER AMP MONO 3.75-7.5 IPS	193.75 EA
831-0108-013	PCB RECORD AND METER AMP STEREO 3.75-7.5 IPS	341.75 EA
831-0108-023	PCB RECORD AND METER AMP MONO 7.5-15 IPS	193.75 EA
831-0108-033	PCB RECORD AND METER AMP STEREO 7.5-15 IPS	345.00 EA
831-0109-003	PCB MOTHERBOARD RECORD AMP MONO	97.25 EA
831-0109-013	PCB MOTHERBOARD RECORD AMP STEREO	135.25 EA

## 770 SERIES REEL TO REEL REPRODUCERS AND RECORDER/REPRODUCERS

PART NUMBER	DESCRIPTION	PRICE
-----		
PRINTED CIRCUIT BOARDS		
831-0115-003	PCB LED MOUNTING MONO	15.00 EA
831-0115-013	PCB L.E.D. MOUNTING STEREO	17.50 EA
831-0116-003	PCB 25 HZ DETECTOR	157.00 EA
831-0209-003	PCB MOTHERBOARD, TRANSPORT, W/O MOTION SENSE (PLAY STEREO)	310.00 EA
831-0209-013	PCB MOTHERBOARD, TRANSPORT, WITH MOTION SENSE (P OF RP STEREO)	362.50 EA
831-0209-023	PCB MOTHERBOARD, TRANSPORT, W/O MOTION SENSE (PLAY MONO)	280.00 EA
831-0209-033	PCB MOTHERBOARD, TRANSPORT, W/MOTION SENSE (P OF RP MONO)	325.00 EA
831-0210-003	PCB SWITCHCARD, WITH RIBBON CABLE	95.00 EA
831-0229-002	PCB MOTION SENSE (W/O INTERCONNECT)	42.75 EA
831-0230-003	PCB REPRODUCE AMP, 7.5-15 IPS MONO	106.00 EA
831-0230-013	PCB REPRODUCE AMP, 7.5-15 IPS STEREO	176.50 EA
831-0230-023	PCB REPRODUCE AMP, 3.75-7.5 IPS MONO	106.00 EA
831-0230-033	PCB REPRODUCE AMP, 3.75-7.5 IPS STEREO	176.50 EA

## RELAYS

480-0005-000	RELAY, SIGMA 24VDC, SPDT	8.75 EA
480-0007-000	RELAY, 24VDC SPDT	3.50 EA
480-0009-000	RELAY, 24VDC 4PDT HOODED CONTACT (REPLACES 480-0006-000)	10.00 EA

## RESISTORS

628-0179-000	RESISTOR, 50 OHM 20 WATT WIREWOUND	1.50 EA
628-0189-000	RESISTOR, 75 OHM 8 WATT WIREWOUND	1.70 EA
636-0004-000	POTENTIOMETER, 10K OHM, P.C. LAYDOWN	1.25 EA
636-0010-000	POTENTIOMETER, 10K OHM	1.50 EA
636-0011-000	POTENTIOMETER, 25K OHM	4.50 EA
636-0013-000	POTENTIOMETER, 100K OHM	1.20 EA
636-0014-000	POTENTIOMETER, 2500 OHM	4.00 EA
636-0017-000	POTENTIOMETER, 500K OHM, P.C. LAYDOWN	1.50 EA
636-0018-000	POTENTIOMETER, 10K OHM (LAYDOWN)	1.75 EA
636-0019-000	POTENTIOMETER, 20K OHM (LAYDOWN)	1.75 EA
636-0020-000	POTENTIOMETER, 1000 OHM (LAYDOWN)	2.50 EA
636-0042-000	POTENTIOMETER, 200K OHM	1.75 EA
638-0002-000	RESISTOR, 250 OHM, 25W ADJUSTABLE W.W.	3.25 EA
638-0005-000	RESISTOR, 150 OHM, 12W ADJUSTABLE WW	3.75 EA
638-0007-000	RESISTOR, 1000 OHM, 12W ADJUSTABLE WW	3.75 EA
648-0001-000	VARIATOR, V150LA20A	4.75 EA

## SWITCHES, LAMPS, LENSES

390-0015-000	SWITCH, TOGGLE, C&K	6.00 EA
391-0014-000	3-STATION SWITCH ASSEMBLY (2 CHANNEL RECORD SET)	10.00 EA



## 770 SERIES REEL TO REEL REPRODUCERS AND RECORDER/REPRODUCERS

PART NUMBER	DESCRIPTION	PRICE
SWITCHES, LAMPS, LENSES		
391-0015-000	3-STATION SWITCH ASSEMBLY (METER SWITCH)	9.50 EA
391-0016-000	2-STATION SWITCH ASSEMBLY (MONO RECORD SET SWITCH)	9.00 EA
391-0021-000	SWITCH, PUSHBUTTON LICON #05-266	2.40 EA
404-0049-000	LENS, WHITE	1.10 EA
404-0050-000	LENS, GREEN	1.10 EA
404-0051-000	LENS, BLUE	1.10 EA
404-0052-000	LENS, YELLOW	1.10 EA
TRANSFORMERS		
526-0015-000	TRANSFORMER, POWER, AM8845	47.00 EA
532-0005-000	AUDIO INPUT TRANSFORMER NT2823	11.75 EA
532-0009-000	TRANSFORMER, AUDIO OUTPUT AM9064	23.50 EA
TRANSISTORS		
590-0013-010	TRANSISTOR 2N5089	.50 EA
590-0016-000	TRANSISTOR 2N4922	1.80 EA
590-0017-010	TRANSISTOR GES 5816	.75 EA
590-0018-010	TRANSISTOR GES 5817	.75 EA
590-0020-000	TRANSISTOR 2N4918	1.25 EA
590-0022-000	TRANSISTOR 2N6038 NPN DARLINGTON	1.75 EA
596-0003-000	TRANSISTOR 2N3994 (REPLACES 596-0001-000 ; 2N3993)	3.00 EA

THIS PRICE LIST IS PROVIDED FOR YOUR CONVENIENCE. THESE PARTS ARE READILY AVAILABLE FROM OUR STOCK, AS MAINTENANCE OR REPAIR ITEMS. BECAUSE OUR SELLING PRICE IS BASED ON OUR ACTUAL COSTS, YOU MAY FIND THAT SOME ITEMS MAY BE PURCHASED LOCALLY AT COMPARABLE OR LOWER COST THAN FROM ITC.

ALL PRICES ARE SUBJECT TO REVIEW AND CHANGE WITHOUT NOTICE. PLEASE RETAIN THIS LIST FOR PART NUMBER REFERENCE. PRICES LISTED ARE U.S. DOMESTIC. PRICES WILL VARY OUTSIDE TERRITORIAL U.S.

MINIMUM ORDER \$15.00.