

**INSTRUCTION  
BOOK**

**CRITERION SERIES  
PLAYBACK AND  
AMPLIFIER**

**HARRIS  
INTERTYPE  
CORPORATION**

**GATES**  
AUTOMATIC TAPE CONTROL DIVISION

## WARRANTY

Seller warrants new equipment manufactured by Gotes Radio Company against defects in material or workmanship at the time of delivery thereof, that develop under normal use within a period of one year (6 months on moving parts) from the date of shipment, of which Purchaser gives Seller prompt written notice. Other manufacturers' equipment, if any, including electron tubes, and towers, shall carry only such manufacturers' standard warranty.

n  
Seller's sole responsibility for any breach of the foregoing provision of this contract, with respect to any equipment or parts not conforming to the warranty or the description herein contained, is at its option, (a) to repair or replace such equipment or parts upon the return thereof f.o.b. Seller's factory within the period aforesaid, or (b) to accept the return thereof f.o.b. Purchaser's point of installation, whereupon Seller shall either (1) issue a credit to Purchaser's account hereunder in an amount equal to an equitable portion of the total contract price, without interest, or (2) if the total contract price has been paid, refund to Purchaser an equitable portion thereof, without interest.

If the Equipment is described as used, it is sold as is and where is. If the contract covers equipment not owned by Seller at this date it is sold subject to Seller's acquisition of possession and title.

Seller assumes no responsibility for design characteristics of special equipment manufactured to specifications supplied by or on behalf of Purchaser.

Seller shall not be liable for any expense whether for repairs, replacements, material, service or otherwise, incurred by Purchaser or modifications made by Purchaser to the Equipment without prior written consent of Seller.

EXCEPT AS SET FORTH HEREIN, AND EXCEPT AS TO TITLE, THERE ARE NO WARRANTIES, OR ANY AFFIRMATIONS OF FACT OR PROMISES BY SELLER, WITH REFERENCE TO THE EQUIPMENT, OR TO MERCHANTABILITY, INFRINGEMENT, OR OTHERWISE, WHICH EXTEND BEYOND THE DESCRIPTION OF THE EQUIPMENT ON THE FACE HEREOF.

## RETURNS AND EXCHANGES

Do not return any merchandise without our written approval and Return Authorization. We will provide special shipping instructions and a code number that will assure proper handling and prompt issuance of credit. Please furnish complete details as to circumstances and reasons when requesting return of merchandise. Custom built equipment or merchandise specially ordered for you is not returnable. Where return is at the request of, or for the convenience of the customer, a restocking fee of 15% will be charged. All returned merchandise must be sent freight prepaid and properly insured by the customer. When writing to Gotes Radio Company about your order, it will be helpful if you specify the Gotes Factory Order Number or Invoice Number.

## WARRANTY ADJUSTMENTS

In the event of equipment failure during the warranty period, replacement or repair parts may be provided in accordance with the provisions of the Gotes Warranty. In most cases you will be required to return the defective merchandise or part to Gotes f.o.b. Quincy, Illinois, for replacement or repair. Cost of repair parts or replacement merchandise will be billed to your account at the time of shipment and compensating credit will be issued to offset the charge when the defective items are returned.

## MODIFICATIONS

Gotes reserves the right to modify the design and specifications of the equipment shown in this catalog without notice or to withdraw any item from sale provided, however, that any modifications shall not adversely affect the performance of the equipment so modified.

## CONTENTS

---

Introduction		I
Section 1	General Description	1-1
1.1	Playback Unit	1-1
1.2	Record Amplifier	1-1
1.3	Specifications	1-2
1.3.1	Playback Unit	1-2
1.3.2	Record Amplifier	1-3
Section 2	Installation	2-1
2.1	Unpacking and Inspection	2-1
2.2	Installation Procedure	2-1
2.2.1	General	2-1
2.2.2	Playback, Monophonic	2-1
2.2.3	Playback, Stereophonic	2-1
2.2.4	Playback/Record, Mono or Stereo	2-1
2.2.5	Remote Control Connections	2-1
Section 3	Operation	3-1
3.1	Recording	3-1
3.1.1	Record Amplifier Control Functions	3-1
3.1.2	Recording Procedure	3-1
3.2	Playback	3-2
3.2.1	Control Functions	3-2
3.2.2	Playback Procedure	3-2
Section 4	Adjustments	4-1
4.1	Recording Amplifier	4-1
4.1.1	Bias Level	4-1
4.1.2	Cue Record Levels	4-2
4.1.3	Cue Frequency	4-2
4.2	Playback	4-2
4.2.1	Cue Sensitivity	4-2
4.2.2	Program Gain	4-2
4.2.3	Head Alignment	4-2
Section 5	Maintenance	5-1
5.1	Record Amplifier	5-1
5.2	Playback Unit	5-1
5.2.1	Heads	5-1
5.2.2	Pressure Roller	5-4
5.2.3	Cue Sensitivity Levels	5-4
5.2.4	Deck Adjustments	5-4
5.2.5	Maintenance Checklist	5-6
Section 6	Parts List - Drawings	6-1
6.1	Playback Unit	6-1
6.1.1	Parts List	6-1
6.1.2	Drawings	6-5
6.2	Record Amplifier	6-6
6.2.1	Parts List	6-6
6.2.2	Drawings	6-9

## INTRODUCTION

In 1962 the major manufacturers of cartridge equipment began a co-operative effort to establish standards for cartridge tape equipment. A series of meetings, under the direction of the NAB, extended into 1964 and during this time, certain terms came into general use. Many of these terms are used in this manual, and are defined below.

**CUE TRACK:** The lower track of a two track cartridge monophonic system, and the lowest track of a three track cartridge stereophonic system.

**PROGRAM TRACK:** The upper track of a two track cartridge monophonic system, the upper track (left channel) and middle track (right channel) of a three track cartridge stereophonic system.

**HEAD A:** The magnetic (reproducing) head nearest the capstan.

**HEAD B:** The magnetic (recording) head adjacent to head A.

**PRIMARY CUE TONE:** A 1000 cycle tone recorded on the CUE TRACK and used for positioning the tape in the cued position; the stop tone.

**SECONDARY CUE TONE:** A 150 cycle tone recorded on the CUE TRACK and used as the "end of message" signal. This tone is generally used for starting other equipment in an automation system.

**TERTIARY CUE TONE:** An 8000 cycle tone recorded on the CUE TRACK and used as desired. This tone has been known in the past as an auxiliary or trip cue tone.

**CARTRIDGE SIZE A:** The size A cartridge was previously known as Series 300 or the smallest size.

**CARTRIDGE SIZE B:** The size B cartridge was previously known as Series 600.

**CARTRIDGE SIZE C:** The size C cartridge was previously known as Series 1200.

## GENERAL DESCRIPTION

### SECTION 1

---

#### 1.1 PLAYBACK UNIT

The basic Criterion Series Playback Unit is a solid state SINGLE-TONE cue machine available in slide-out rack panel mounting or trimline desk console in either monophonic or stereophonic versions. Second and third tone operation is optional. All versions of the Criterion series equipment meet NAB specifications and offer features such as 24 volt DC external switching for safety in remote starting applications, and adaptability to automated systems. Electronics are of plug-in design; including relays, circuit modules, front panel switch assemblies and external connections. The improved, laminated heads are high quality all-metal face heads providing for long wear and low oxide accumulation. Improved solenoid action and shock mounted relays contribute to the quiet operation of the unit, and the proven full-swing pressure wheel linkage makes actual studio operation easy and fool-proof.

The heart of the Criterion Series playback unit is the heavy-duty ATC tape transport with its hysteresis synchronous positive speed direct capstan drive motor. The Criterion Series tape transport offers speed accuracy comparable to the finest reel-to-reel machines. Sealed precision instrument type ball bearings are used making transport flutter less than .2% rms.

Plug-in circuit modules offer the finest in advanced solid state engineering. The new modular construction provides for modifications as may be required to make the Criterion Series compatible with other makes of existing cartridge equipment including all ATC equipment now in service. Quality pin terminal board construction is used throughout for easy component access should maintenance be required. A regulated power supply is used to power all circuit modules assuring correct operating parameters and reliable operation at all times.

#### 1.2 RECORD AMPLIFIER

The basic Criterion Series Recording Amplifier is a solid state, SINGLE-TONE cue device for use in association with any monophonic model Criterion Playback. As is the Criterion Playback, the Recording Amplifier is available in slide-out rack panel mounting or trimline desk console in either monophonic or stereophonic versions. Second and third tone operation is optional. Operation on regulated DC power from the associated Playback, assures correct operating parameters at all times. The top-surface mounting of all components in the Criterion Recording Amplifier provides for easy and efficient maintenance. Unique terminal board construction permits easy field modification of any single-tone amplifier to three-tone operation.

## 1.3 SPECIFICATIONS

### 1.3.1 PLAYBACK UNIT:

POWER SOURCE: 117 volts, 60 cps, 50 cps on special order.

POWER REQUIREMENTS: 65 watts maximum

FREQUENCY RESPONSE: The overall record-playback response of the Criterion Series System is plus or minus 2 db from 50 to 12,000 cps and plus or minus 4 db from 50 to 15,000 cps.

NOISE: 55 db, or better, below the maximum signal of 400 cps at 3% THD.

DISTORTION: Record to Playback, 2% or less, at 0 VU record level, 400 cps.

EQUALIZATION: In accordance with NAB cartridge recording and reproducing standards. The recording amplifiers are equalized to maintain the required playback characteristics.

AMBIENT TEMPERATURE: 55 degrees C., maximum

OUTPUT, PLAYBACK: Plus 4 dbm, normally -6VU, 600 ohms, balanced.

CUE SIGNALS: The Criterion equipment is furnished with the standard 1000 cycle Primary Cue. 150 cycle Secondary and 8000 cycle Tertiary Cue facilities are available as optional equipment.

REMOTE CONTROL: All control functions.

TAPE SPEED:  $7\frac{1}{2}$  inches per second.

TAPE DRIVE SYSTEM: Direct capstan drive, sealed ball bearings.

WOW AND FLUTTER: .2% or less.

TIMING ACCURACY: .4% or better.

DIMENSIONS: Rack Mount, 7" high, 19" panel width,  $13\frac{1}{2}$ " deep.  
Desk-Top Cabinet, 5" high,  $13\frac{1}{2}$ " wide, 14" deep.

WEIGHT: 25 pounds

HEADS: In accordance with NAB Standards. Permits monitoring while recording.

### 1.3.2 RECORDING AMPLIFIER

**POWER SOURCE:** From regulated supply of Playback Unit.

**AUDIO INPUT:** Minus 20 dbm minimum, plus 18 dbm maximum, 600 ohms balanced.

**BIAS OSCILLATORS:** Separate push-pull bias oscillators for Program and Cue circuits.

**TOE GENERATORS:** Individual tone oscillators for each frequency. Frequency and output adjustable.

**AMBIENT TEMPERATURE:** 55 degrees C. maximum.

**REMOTE CONTROL:** All control functions.

**DIMENSIONS:** Rack Mount, 5 $\frac{1}{2}$ " high, 19" panel, 11 $\frac{1}{2}$ " deep.  
Desk-Top Cabinet, 4" high, 13  $\frac{3}{8}$ " wide, 12 $\frac{1}{2}$ " deep.

**WEIGHT:** 17 pounds

## INSTALLATION

### SECTION 2

---

#### 2.1 UNPACKING AND INSPECTION

Remove all packing material and carefully lift the units from the boxes. Check the equipment against the packing slips. Visually inspect the units for any apparent damage and for missing or loose components. Check for proper operation of the front panel controls. Any claims for damage should be filed promptly with the transportation agency. If such claims are to be filed, all packing material must be retained.

#### 2.2 INSTALLATION PROCEDURE

##### 2.2.1 GENERAL:

The location in an individual station will be determined by the arrangement of the main control room facilities. The placement of equipment and wiring should be planned carefully before any installation work is started. Care should be taken to provide for adequate ventilation.

##### 2.2.2 PLAYBACK, MONOPHONIC:

Connect a two-conductor shielded cable between the desired audio console input terminals and the 600 ohm program output terminals 3 and 5 of Playback Connector J2. The shield of the cable should be connected to terminal 1. See Figure 2.2.

##### 2.2.3 PLAYBACK, STEREO:

Connections for the Stereo left channel are the same as for the monophonic audio channel. The right stereo channel is connected to terminals 4 and 6 with pin 2 for connection to the shield. Phasing should be carefully observed. Terminals 1-3-5 are identical to terminals 2-4-6 respectively. See Figure 2.2.

##### 2.2.4 PLAYBACK-RECORD MONOPHONIC OR STEREO:

Install the Playback-Amplifier interconnecting cable between connectors J3 of the Playback and P602 of the Recording Amplifier. Connect the audio input (monophonic or stereo left channel) to terminals 3 and 5 of J601 with the shield connected to terminal 1. For stereophonic installations, connect the right channel audio to terminals 4 and 6 of J601 and the shield to terminal 2. See Figure 2.4.

##### 2.2.5 REMOTE CONTROL CONNECTIONS:

All control functions of both the Playback and Record Amplifier units may be remote controlled. See charts 2.2 and 2.4 for proper connections.



## CRITERION PLAYBACK UNIT

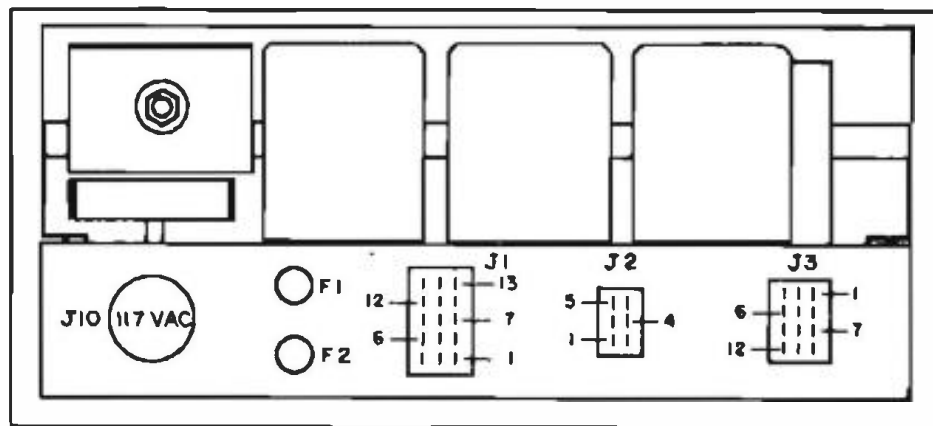

REAR VIEW

### EXTERNAL CONNECTIONS

Terminal	Function
<b>CONNECTOR J1</b>	
1	Ground
2 - 3	Remote Start
4 - 5	Remote Stop (see note 1)
6 - 7	Auxiliary Start (momentarily closed as unit starts)
8 - 9	Cue Start (momentarily closed as unit cues) (see note 2)
10- 11	Auxiliary Switching (Closed momentarily by Secondary Tone)
12- 13	Auxiliary Switching (Closed momentarily by Tertiary Tone)
14	Remote STOP light circuit
15	No connection
<b>CONNECTOR J2</b>	
1	Audio Ground
3 - 5	Monophonic (or left stereo) audio output
2	Audio Ground
4 - 6	Right Stereo audio output (if used) (see note 3)
<b>CONNECTOR J3</b>	
Connector J3 is for use with the Playback/Recording Amplifier connecting cable.	

**Notes:**

1. These terminals are strapped together (on the back of the connector) at the factory. Remove this strap if the REMOTE STOP facility is used.
2. Relay contacts may be changed to provide a momentary open circuit.
3. Phasing must be observed in Stereo systems. Terminals 1-3-5 are identical to terminals 2-4-6 respectively.

FIGURE 2.2

RECORDING AMPLIFIER-

REAR VIEW

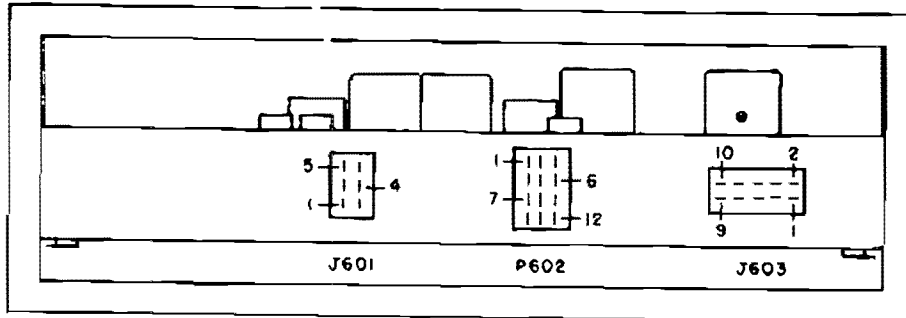

FIGURE 2.3

EXTERNAL CONNECTIONS	
TERMINAL	FUNCTION
CONNECTOR 601	
1	Audio Ground
3-5	Monophonic (or left stereo) audio input
2	Audio Ground
4-6	Right Stereo audio input (if used)
CONNECTOR 602	
Connector 602 is for use with the Playback/Recording Amplifier connecting cable.	
CONNECTOR 603	
1-2	Remote Record Set
3	Remote Lights Common
4	No Connection
5-6	Remote Secondary Tone Keying
7-8	Remote Tertiary (Auxiliary) Tone Keying
9-10	No Connection

FIG. 2.4

## OPERATION

### SECTION 3

---

#### 3.1 RECORDING

##### 3.3.1 RECORDING AMPLIFIER CONTROL FUNCTIONS:

**GAIN CONTROL:** The Recording Amplifier gain control R608 is used for regulating the recording level as indicated by the VU meter M601.

**RECORD SET:** The Record Set switch S601 is used for placing the production system in the recording mode.

**SECONDARY CUE:** The Secondary Cue switch S603 is used for keying the 150 cycle tone generator.

**TERTIARY (AUXILIARY) CUE:** The Tertiary, or Auxiliary, Cue switch S602 is used for keying the 8000 cycle tone generator.

##### 3.1.2 RECORDING PROCEDURE:

The procedure for recording one or more productions is as follows:

- a. Insert an ERASED tape cartridge into the right side of the cartridge slot in the Playback Unit. Note that the STOP indicator is illuminated indicating the cartridge is properly placed.
- b. Momentarily press the RECORD SET switch S601. The switch will be illuminated by the internal pilot lamp.
- c. Adjust the INPUT CONTROL R608 so the program level reads 0 (zero) on the VU meter on the most intense program peaks.
- d. Press the START switch on the Playback Unit and start recording immediately.
- e. Upon completion of the recorded production, momentarily press the STOP switch ONLY if more than one production is desired on the same cartridge. If only one production is to be used on the cartridge, allow the tape to continue running until it is stopped by the automatic cue tone.
- f. When recording more than one production on a single tape cartridge, follow the procedure listed in steps c through e for each recording. Upon completion of the final recorded production, allow the tape to continue running until it is stopped by the automatic cue tone.

The 1000 cycle Primary cue tone is recorded automatically at the beginning of the recording. If the Tertiary tone is to be used, it may be applied at any time during the recording. If the Secondary (end of message) tone is used, it should be applied immediately after the end of the program material. If desired, the Secondary and Tertiary tones may be inserted after the message has been completely recorded. This permits monitoring and accurate placement of the tones.

## 3.2 PLAYBACK

### 3.2.1 CONTROL FUNCTIONS:

**START-RUN:** The START switch S1 causes the control circuits and the solenoid to be energized; and the tape to be set in motion. This switch is illuminated by an internal lamp when the tape is running in either the Playback or Record mode.

**STOP-READY:** The STOP switch S2 is used to manually stop tape motion. This switch is illuminated by an internal lamp when the cartridge is properly inserted and the Playback is in the "ready" mode.

**ON-OFF:** The ON-OFF switch S3 applies power to the entire unit. An internal neon lamp illuminates this switch when the unit is ON.

**PROGRAM GAIN:** The Program Gain Controls R1 and R3 are mounted on the main chassis, and are used for adjustment of program output level. R3 is not used in monophonic units.

**CUE SENSITIVITY:** The Cue Sensitivity control R2 is mounted on the main chassis.

### 3.2.2 PLAYBACK PROCEDURE:

The procedure for routine on-the-air playback of program material is as follows:

- a. Insert a recorded tape cartridge into the right side of the cartridge slot.
- b. Observe that the STOP-READY control is illuminated, indicating the cartridge has been properly inserted, and that the unit is ready for on-the-air playback.
- c. Momentarily press the START switch S1. Tape motion will be started and will continue until the automatic cue tone is picked up by the cue head.

## ADJUSTMENTS

### SECTION 4

---

#### 4.1 RECORDING AMPLIFIER

4.1.1 BIAS LEVEL: When purchasing a new record amplifier or replacing record heads, it will be necessary to check the bias adjustment on the record amplifier. Since the inductance of the record heads may vary from head to head, bias voltage should be readjusted each time the record amplifier is used with a new head or a different playback unit in order to maintain proper recorded frequency response and output. The bias adjustment should be made using the type of tape which will normally be used. The following procedure should be used when bias adjustments are required:

SET-UP--The output of the playback should be connected to a console or any convenient VU meter. Connect an audio oscillator to the record amplifier input. For location of adjustment controls see Record Amplifier Chassis Layout.

Steps to follow in adjustment--

1. Set the oscillator frequency at 1000 cycles.
2. Insert an erased  $3\frac{1}{2}$  or  $5\frac{1}{2}$  minute cartridge in the Playback Unit.
3. On the Recording Amplifier--Press the Record Set Button and adjust the Record Level to -5 VU.
4. While recording, monitor the Playback output and adjust trimmer C806 with a non-magnetic screwdriver for maximum playback reading. Readjust C806 in both a clockwise and counterclockwise direction, until a  $\frac{1}{2}$  db drop in output is noted. Then adjust to the exact peak.

NOTE: Re-erase cartridge if unit cues.

5. On the Playback Unit Head Assembly--unplug the green (cue play) head lead and insert the red (program play) head lead in its place. This permits monitoring of the cue track from the playback output while cue bias adjustments are being made.
6. Remove the cover from K603 in the Record Amplifier and manually operate the relay. This will cause 1000 cycles to be recorded on the cue track.
7. While manually operating K603, adjust trimmer C805 with a non-magnetic screwdriver for maximum playback reading. After the peak adjustment has been reached, turn C805 counterclockwise until the output reading has dropped  $1\frac{1}{2}$  db. Leave C805 adjusted to this setting.

8. Return the head leads to their proper plugs (see Head Bracket Assembly) and place unit in service.

4.1.2 CUE RECORD LEVELS: The Cue Record Levels are adjustable by R917 (Primary), R905 (Secondary) and R906 (Tertiary). So long as replacement heads are of the same type as the original, no change in Cue Recording Levels should be necessary. Proper adjustment of the level controls (after Cue Bias adjustment has been performed in accordance with 4.1.1) should provide recovery levels from the Cue Play head as follows:

Primary (1KC).....	1.5 MV
Secondary (150 cycles)....	0.5 MV
Tertiary (8 KC).....	1.5 MV

4.1.3 CUE FREQUENCY: The Cue Frequencies are adjustable by means of the slug tuned coils L903 (Primary), L901 (Secondary) and L902 (Tertiary). Adjustments of these coils are performed at the ATC factory and should be attempted in the field only provided proper equipment is available for accurately checking the oscillator frequencies.

#### 4.2 PLAYBACK

See Playback Chassis Layout for location of adjustment controls.

4.2.1 CUE SENSITIVITY: The Cue Sensitivity is adjustable by R2 which is mounted on top of the main chassis of the playback unit. This control is preset at the ATC factory and should require no further adjustment.

CAUTION: Increasing the Cue Sensitivity beyond 0.75 MV at 1KC may cause false cueing of the Playback Unit. See 5.2.

4.2.2 PROGRAM GAIN: The Program Gain controls R1 and R3 are mounted adjacent to R2 on the main chassis of the playback. R3 is not used in monophonic units. The Program Gain control is preset at the ATC factory and should require no further adjustment.

4.2.3 HEAD ALIGNMENT: As head alignment should be a matter of routine preventative maintenance, this topic is covered in Section 5 of this Manual.

## Broad-Tuning the Criterion Primary Cue Amplifier

The NAB standards specify, "That the primary standard cue tone frequency shall be 1000 cps  $\pm$  75 cps." The Criterion primary cue oscillator, amplifier, and detector are designed in accordance with this standard. Cue tone generators, amplifiers and detectors built prior to the adoption of the NAB standards for cartridge tape recording and reproducing varied greatly from 1000 cps.

When the Criterion playback is used to reproduce cartridges recorded on older equipment, the primary cue amplifier must, therefore, be broad-tuned.

A broad-tuned primary cue amplifier will respond to all cue frequencies lying between 150 cps and 8000 cps. This precludes the use of secondary and tertiary cue tones on a modified Criterion playback.

### Modification Instructions

Cut the leads on a 25 mfd., 25 vdc, electrolytic capacitor  $1\frac{1}{2}$  inches long, cover the leads with  $1\frac{1}{2}$  inch lengths of spaghetti, and install the capacitor as shown in Figure 1.

The 25 mfd. capacitor bypasses the tuned circuit and results in a non-tuned tone detector which will respond to a wide range of frequencies.

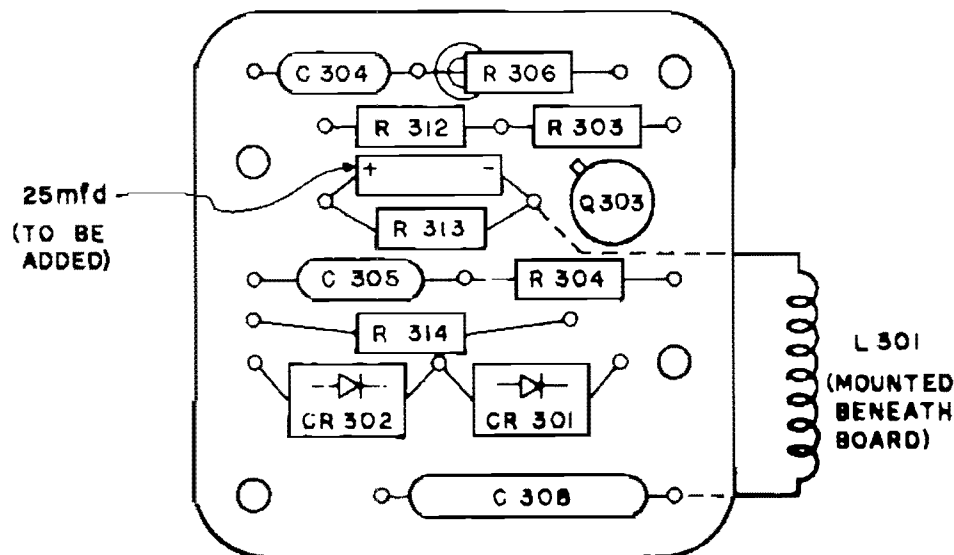

**BOTTOM BOARD**  
PRIMARY CUE AMPLIFIER  
CRITERION PLAYBACK UNIT

FIGURE 1

## MAINTENANCE

### SECTION 5

---

#### 5.1 RECORDING AMPLIFIER

Under normal operating conditions the Recording Amplifier requires no routine maintenance.

#### 5.2 PLAYBACK UNIT

The ATC Criterion Playback Unit is factory adjusted to provide peak performance and under normal operating conditions should require no routine electrical maintenance.

**5.2.1 HEADS:** As with any quality tape equipment frequent checks of head alignment, condition and cleanliness are imperative for maximum performance and trouble-free operation. Proper head care is especially important on the production equipment.

Dirty, misaligned or worn heads are frequently at fault when problems are encountered in the areas of low program output, poor frequency response and false or missing cues. Cueing problems are easily detectable, therefore, serve as good indicators for the need of head maintenance. (CAUTION: In the majority of cases cueing problems are only compounded by readjustment of either Cue Record Level or Cue Sensitivity to settings other than those outlined in Section 4).

To facilitate easy head alignment checks standard tapes should be recorded immediately upon receipt of the equipment.

Tapes should be recorded as follows:

- a. Record one cartridge with 12KC at a Record Level of -10 VU. Playback the cartridge and note the output level.
- b. Record one cartridge while manually operating K603 in the Record Amplifier (no program input on this tape). This action records a continuous 1KC tone on the Cue Track. Reverse the Cue Play and Program Play head leads. Play back the tape and note the output level.
- c. While manually depressing the Secondary Cue (150 cycles) button on the Record Amplifier (do not manually operate K603) repeat step b for one cartridge.
- d. While manually depressing the Auxiliary Cue (8KC) button on the Record Amplifier (do not manually operate K603) repeat step b for one cartridge.



- e. Using a clean  $3\frac{1}{2}$  minute cartridge record a single 1000 cycle cue tone (do not record program material on this tape). The tone is recorded automatically at the beginning of the recording process. Allow the machine to run until the tape cues. Rerun the tape and note the exact time required for playback. This tape should be kept on hand as a timing standard.

Of the various causes of cueing difficulties, that of head misalignment is most frequently encountered. The following discussion describes mounting and alignment of heads on the Criterion equipment.

#### Installation of Heads:

- a. Install the thin lock nut on the head mounting stud.
- b. Carefully thread the head leads through the head mounting hole. Use tubing over leads as protection against cutting insulation while threading the head. Screw the head into the mounting hole until the apex of the head face is  $27/32$ " plus or minus  $1/32$ " from the front edge of the support member.

#### NOTES:

1. Do not twist or apply tension to the head leads.
2. When tightening the head, apply pressure only to the boss located on the back of the head cup--not directly to the head.
3. Solder the head leads only after completion of the installation.

#### Height Adjustment:

Figure I illustrates the location of adjustment points, mounting screws and output connectors. The following steps outline proper adjustment procedures:

- a. Turn the lock screw counterclockwise until the screw is well above the lock (maximum down) position.
- b. Adjust screw A for  $9/16$ " height of the top of the upper track above the deck surface.
- c. Adjust screw B for exact perpendicularity between the deck surface and pole faces. This may be done using a metal gauge (e.g. metal rule) which is known to be square. Resting one edge of the gauge on the deck surface, move the gauge against the face of the head. At the point of perpendicularity, no space should be visible between the head and gauge as the gauge is resting flat on the deck.

FIGURE II

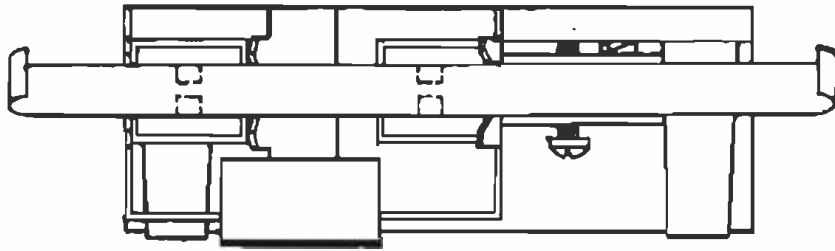
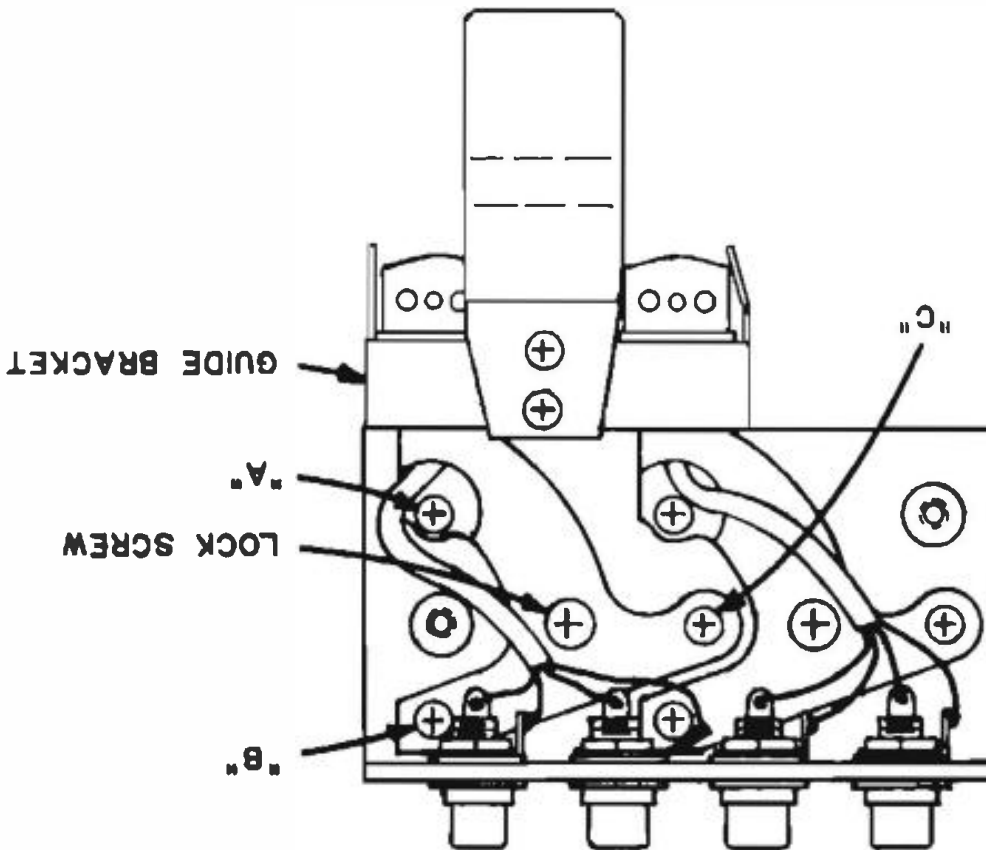
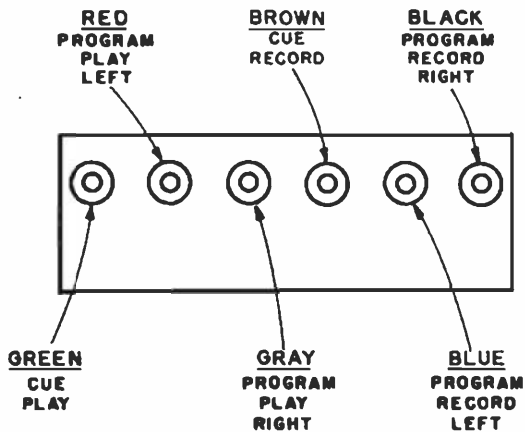
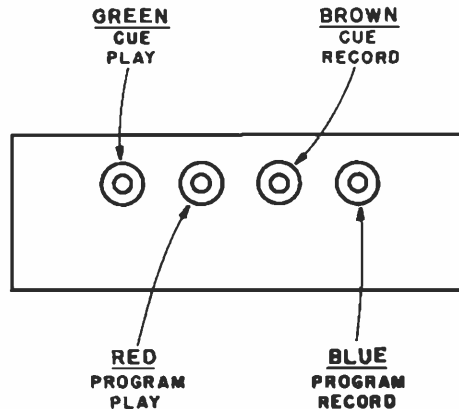

FIGURE I





**STEREOPHONIC**



**MONOPHONIC**

**HEAD LEAD COLOR CODE  
MICROSET ASSEMBLY**

**(REAR VIEW)**

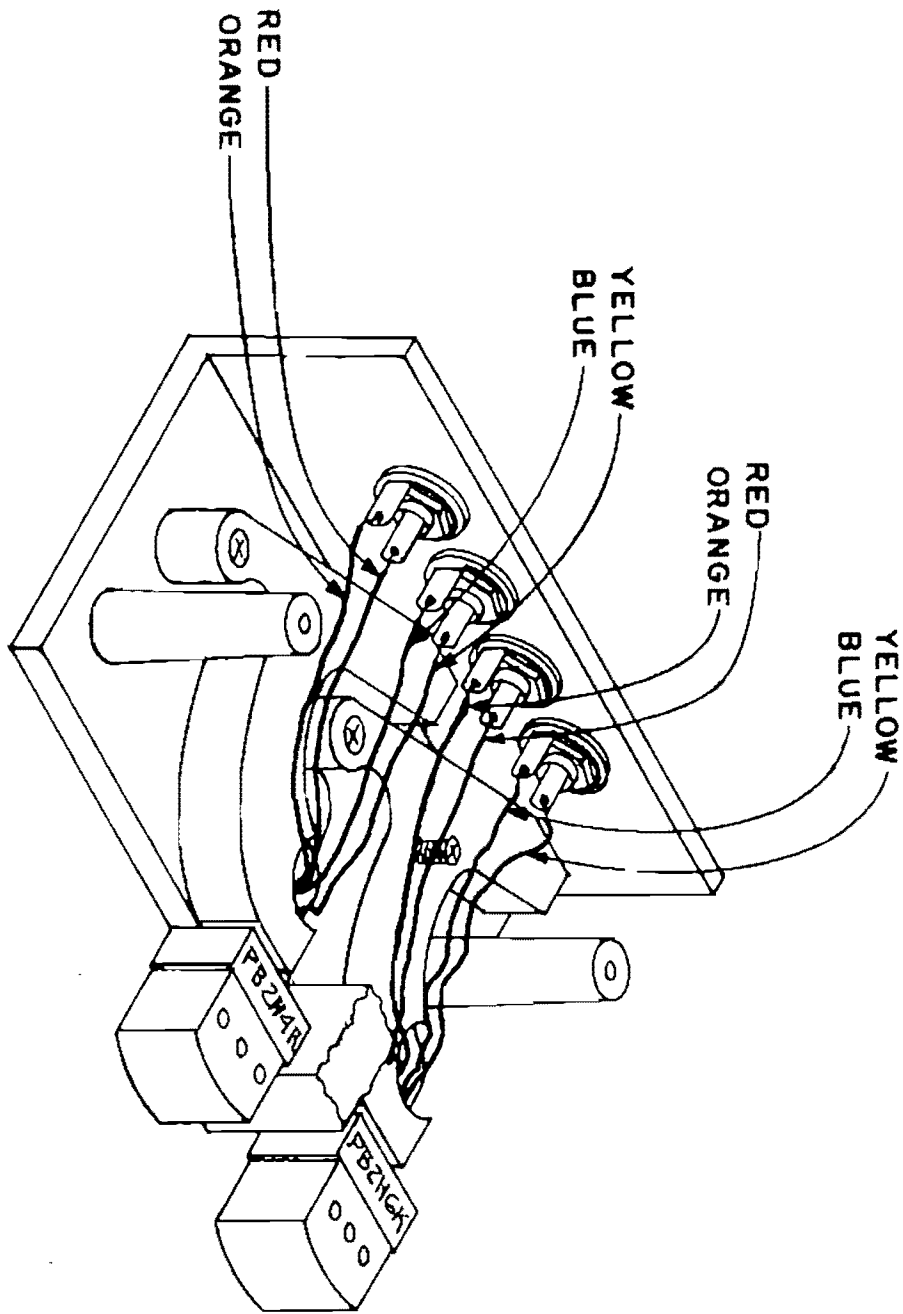

MONOPHONIC

HEAD WIRE COLOR CODE  
MICROSET ASSEMBLY

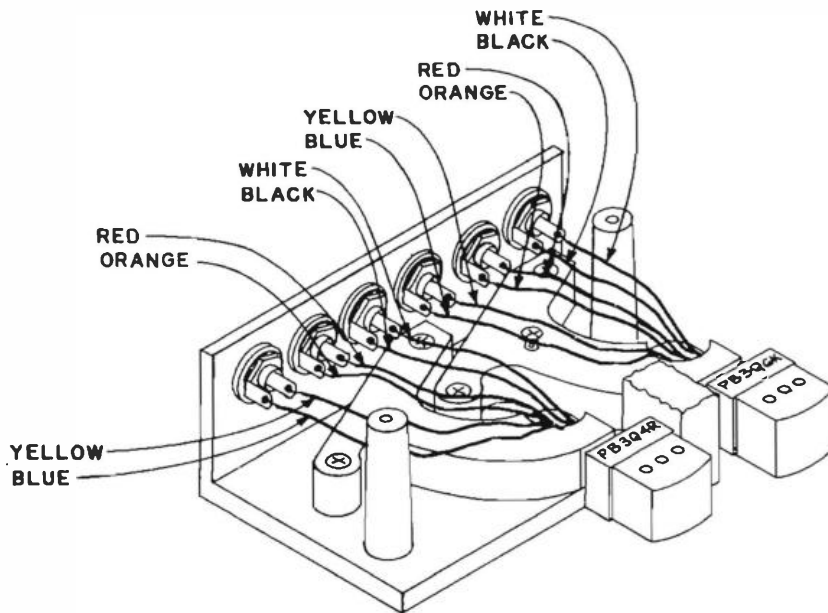

STEREOPHONIC

HEAD WIRE COLOR CODE  
MICROSET ASSEMBLY

- d. To facilitate fine adjustment of height, a strip of clear mylar should be prepared by removing the lubricant and oxide from a short length of  $\frac{1}{4}$ " tape. Flux remover or shellac thinner will suffice to loosen the oxide so it may be wiped off the transparent mylar base.
- e. Refer to Figure II and position the mylar across the head faces and properly engaged in the tape guides. This is the position of the tape when a cartridge is being played on the machine. To free one hand for adjustments, fasten the mylar to the right side of the guide bracket. Proper tape position in the tape guide is at the point where minimum distortion of the tape is observed. This distortion is due to the tape contacting the guide and is visible as a slight crinkle at either the top or bottom of the tape. With the left hand hold the mylar in a position contacting the heads as shown in Figure II.
- f. While holding the mylar in this position, alternately adjust screws A and B to position the tracks with respect to the tape. Screw A should be adjusted a small amount then B should be adjusted an equal amount in the same direction. This procedure is repeated until the correct height is obtained. Proper height is that height at which the top of the upper pole piece is at the same level as the top of the tape and the bottom of the lower pole piece is at the same level as the bottom of the tape.

This completes the height and perpendicularity adjustments. The procedure should be repeated for the record head (if used).

#### Azimuth Adjustment

- a. Remove the mylar and insert the tape which was recorded with 12KC tone.
- b. While monitoring the output of the playback unit, adjust screw C of the Playback head for maximum output level.
- c. Tighten the lock screw for this head.
- d. To facilitate monitoring playback from the Record head, the Program play (red) head lead and the Program record (blue) head lead should be reversed.
- e. Align the Record head in the same manner as described in paragraphs b and c above. Output from the Record head will be slightly less than from the Playback head.

- f. Return the head leads to their proper jacks and install the head cover.

NOTE: As a check of azimuth on the Production playback, the following should be performed:

- a. While recording a constant level 12KC tone, monitor the output from the playback head.
- b. Carefully adjust the azimuth screw of the RECORD head for maximum output.

Heads may be cleaned with a cotton swab and isopropyl alcohol. Care should be exercised to prevent misalignment of the heads by excessive pressure from the swabs.

5.2.2 PRESSURE ROLLER: Cotton swabs and isopropyl alcohol may also be used to remove deposits which accumulate on the pressure roller.

5.2.3 CUE SENSITIVITY LEVELS: When cue problems develop, a step-by-step analysis is helpful to rapidly ascertain the cause of the difficulty. When such problems arise, the following procedure is recommended as a sample analysis schedule:

As an example consider a Playback Unit which is missing the 150 cycle Cue Tone.

1. Insert the 150 cycle Standard Cue Tape recorded in 5.2 into the machine. Determine if the machine is cueing with the Standard Tape. If the Unit does not cue, return to 5.2 and realign the heads with the Standard 12KC Tape.
2. Again insert the 150 cycle Standard Cue Tape, and determine if the machine cues properly. Unless the heads are worn or the Cue Sensitivity Level is low, the Playback should now cue properly.
3. If in step 2, the Unit did not cue properly, advance the Cue Sensitivity slightly and again determine if the Playback Unit Cues properly. NOTE: The Cue Sensitivity should be advanced ONLY following the performance of steps 1 and 2 of this discussion.

#### 5.2.4 DECK ADJUSTMENTS

This article is intended as a guide for maintenance of those portions of the deck assembly which affect tape drive. If wow and flutter or other tape drive problems are encountered, it should be determined that cartridges are not at fault before adjustments are made.

1. LINKAGE ASSEMBLY. The purpose of the linkage assembly is to convert the reciprocating movement of the solenoid to the revolving movement necessary for the cross shaft.

2. CROSS SHAFT ASSEMBLY. The pinch-roller mounting shaft is pressed into the rotating cross shaft and, therefore, occupies a fixed position with respect to the cross shaft. Because of this the capstan must be adjusted relative to this assembly.

3. MOTOR ASSEMBLY. The position of the drive motor is adjustable by means of two mounting screws which are accessible from above the main deck structure. To provide access to the mounting screws the head bracket should be removed, and to facilitate replacement of the bracket its position should be marked on the main deck prior to removal. This assembly should be positioned to locate the capstan shaft as far toward the head bracket as possible and  $3 \frac{9}{16}$  inches from the front edge of the deck (not the front casting). This dimension is critical and should be closely observed.

4. NYLON SLIDE BLOCKS. Refer to figure 5.5. Loosen the four mounting screws. Separate the blocks at the solenoid end as far as possible. Snug the two screws on this end to hold the blocks in place. With the linkage in the rest (off) position squeeze the opposite ends of the slides tight against the aluminum slide without actually binding. Work the slide several times by hand to make certain no binding exists. Tighten the four mounting screws.

5. SOLENOID ADJUSTMENT SCREW. The adjustment screw on the back of the solenoid should be adjusted to a point where five threads are visible. This adjustment is broad and should require no further attention in most instances.

6. SLIDE COVER SCREW ADJUSTMENT. Figure 5.1 shows the position of roller bearing A and nylon bearing B with the solenoid de-energized (machine off). In figure 5.2 the solenoid has been energized and the machine is running. It can be seen that nylon bearing B has rolled over bearing A, causing the cross shaft to rotate and bring the pressure roller in contact with the tape and capstan. Note that bearing B is held captive between roller A and track C. At this time the aluminum slide should be floating free between the V grooves of the nylon blocks as in figure 5.3.

Proper adjustment of the slide cover screw should be made as follows:

- a. Loosen the lock nut.
- b. Adjust the screw to a point where 2 threads are visible above the lock nut.
- c. While manually actuating the deck microswitch, engage the solenoid by depressing the start switch.
- d. With the solenoid engaged note the position of the plunger in the solenoid.
- e. Press the stop button.



- f. With the solenoid disengaged turn the cover adjustment screw 1/8 turn (no more) clockwise.
- g. Again engage the solenoid and note the position of the plunger in the solenoid.
- h. Repeat steps e, f, and g as many times as necessary to center the plunger in the solenoid hole. This adjustment is important and care should be exercised to center the plunger exactly in the solenoid as nearly as possible.
- i. While the solenoid is engaged, measure the amount of pressure roller compression. This measurement should be 1/64 inch. If an ATC compression tool #101 is not available for this measurement, a scale may be used.
- j. If too much compression exists, release the solenoid and turn the cover screw no more than 1/8 turn clockwise. If too little compression exists turn the screw no more than 1/8 turn counterclockwise.
- k. Repeat steps i and j until the proper compression is obtained.

7. CROSS SHAFT RETURN SPRING. The cross shaft return spring is located on the end of the shaft and is visible when viewing the machine from above the deck. This spring should be adjusted for a positive return of the pressure roller.

8. RETURN LIMIT BUMPER. The return bumper is visible at the panel end of the slide assembly and may be adjusted by its support screw which is tapped into the main deck. The bumper limits the return travel of the pressure roller and should be adjusted along the solenoid axis to a point at which the roller is not above nor more than 1/16 inch below the deck surface.

9. BRONZE CUSHION SPRING. The Bronze cushion spring is held in place between the limit bumper support bracket and the deck. The bronze leaf extends below the aluminum slide and is free to travel vertically in the deck slot. Adjustment of the leaf should be made from the under side of the deck. Proper adjustment is obtained by bending the spring toward the pressure roller as the slide hits the return limit bumper.

#### 5.2.5 SUGGESTED CRITERION SERIES MAINTENANCE CHECKLIST

DAILY (1) Clean heads as necessary. Dirty heads may usually be detected by visual inspection. Dirty heads will cause loss of audio level, poor response and missed cues.

- (2) Clean pressure roller and capstan. Dirty pressure rollers usually appear somewhat glazed and shiny. Poor tape drive and slippage will occur if this condition exists.
- (3) Check alignment of tape cartridge pressure pads. Check for forward and lateral adjustment. Check for loose or missing polyurethane. This should be done each time the cartridge is handled.
- (4) Run cartridge an instant before starting a recording. Through normal handling the tape may sag slightly in the cartridge. This will sometimes result in overlapping of program and cue tracks, audible in playback.
- (5) If a poor recording is noted, check: a. cartridge pressure pads, b. left-hand white guide post for proper seating and, c. cartridge warpage. Make certain the record and/or playback heads are clean.

- 
- WEEKLY
- (1) Check heads for signs of excessive wear. This will cause poor frequency response in recording or reproducing and low cue sensitivity resulting in missed cues.
  - (2) Play the 12KC test cartridge and check the playback level. Any deterioration of the 12KC level would indicate a need for head alignment or replacement.
  - (3) With ATC tools 101 and 102 check alignment of the deck. Carefully check the pinch roller adjustment with Tool #101.
  - (4) Using the timing standard cartridge, carefully measure the playback time with a stop watch. If the playback time is extended by two seconds or more, check the pinch roller and adjustment.
  - (5) Lightly oil the pinch roller bearing. Be sure all lubricant is removed from the capstan shaft.

---

SIX MONTHES

- (1) Replace heads and pinch roller.
- (2) Rewind cartridges which are found to have worn or scored tape.

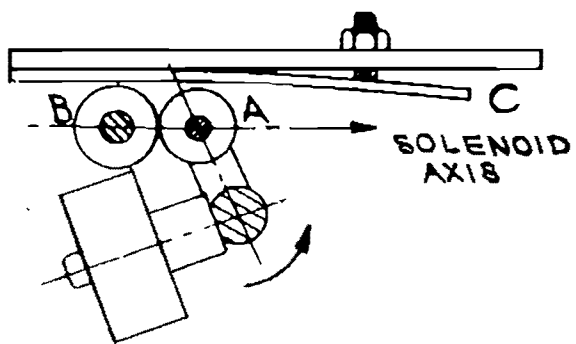

FIG. 5.1

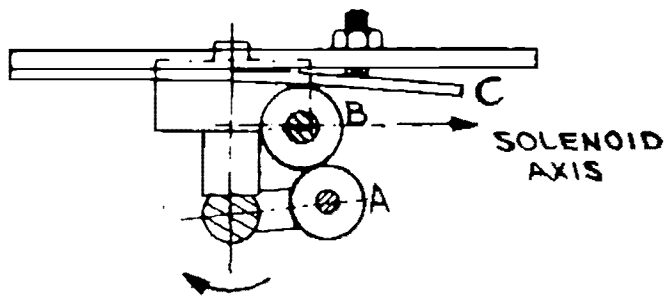

FIG. 5.2

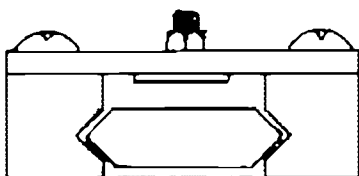

FIG. 5.3

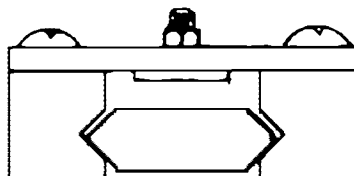

FIG. 5.4

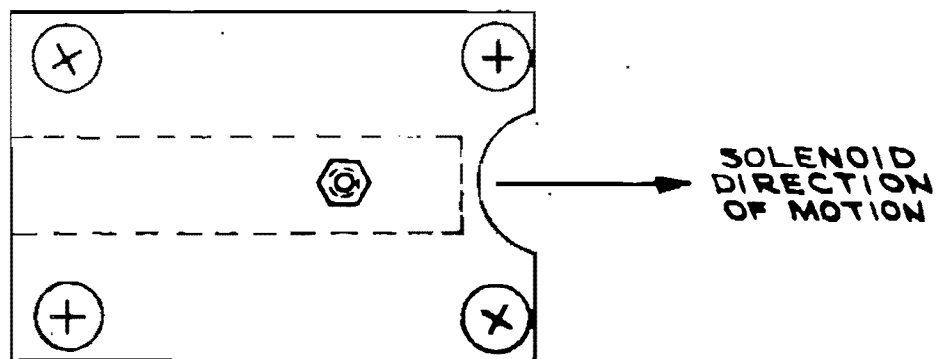

FIG. 5.5

## PARTS LIST - DRAWING

## SECTION 6

## 6.1 PLAYBACK UNIT

6.1.1	PARTS LIST	PLAYBACK UNIT	MAIN CHASSIS
Symbol	Stock No.	Description	
B1	J-2023-C	Motor, synchronous, 115 VAC, 60 CPS	
C1	12-7310	Capacitor, electrolytic, 1000 mfd, 50V	
(Jew) C2	12-7310	Same as C1	
C3	12-7216	Capacitor, electrolytic, 150 mfd, 250V	
C4	12-5105	Capacitor, electrolytic, 5 mfd, 25V	
C5	12-5175	Capacitor, electrolytic, 75 mfd, 25V	
C6	12-5103	Capacitor, electrolytic, 2 mfd, 25V	
C7	12-2210	Capacitor, .1 mfd, 400V	
C8	12-7101	Capacitor, non-polarized, 1.5 mfd, 300 VAC	
CR1	14-1015	Diode, silicon, 1N3255	
CR2	14-1015	Same as CR1	
CR3	14-1015	Same as CR1	
CR4	14-1015	Same as CR1	
CR5	14-1015	Same as CR1	
CR6	14-1015	Same as CR1	
CR7	14-1015	Same as CR1	
CR8	14-1015	Same as CR1	
F1	19-2001	Fuse, .8 ampere, slow-blow	
F2	19-2001	Same as F1	
J1	16-2062	Socket, CJ, S-315-AB	
J2	16-2016	Socket, CJ, S-306-AB	
J3	16-2050	Socket, CJ, S-312-AB	
J4	16-2030-7	Socket, CJ, S-310-AB, Power Supply	
J5	16-2030-6	Same as J4, Primary Cue Amplifier	
J6	16-2030-4	Same as J4, Program Amplifier	
J7	16-2030-2	Same as J4, 8KHz Cue Amplifier	
J8	16-2030-8	Same as J4, 150 Hz Cue Amplifier	
J9	16-2030-4	Same as J4, Program Amplifier (Stereo only)	
J10	16-3106	Plug, AC, flush mounting	
-	16-2059	Socket, relay, PB, 9KM-1, Relays K1-K5	
J11	16-2014	Socket, motor, 78-S3S	
J12	16-2014	Same as J11 (for switch S1)	
J13	16-2014	Same as J11 (for switch S3)	
J14	16-2014	Same as J11 (for switch S2)	
K1	21-1031	Relay, PB, KHP17D11, 24 VDC 4	
K2	21-1031	Same as K1	
K3	21-1032	Relay, PB, 11 VDC (See Note #1)	
K4	21-1032	Same as K3 (See Note #1)	
K5	21-1032	Same as K3 (See Note #1)	
-	20-1011	Head, magnetic, PB2H6K-R-4U, Mono Play	
-	20-1014	Head, magnetic, PB2H4R-R-4U, Mono Record	
-	20-1015	Head, magnetic, PB306K-R-4U, Stereo Play	
-	20-1016	Head, magnetic, PB394R-R-4U, Stereo Record	
L7	21-5005	Solenoid Assembly	

WL FM

AT BILL GENCK

Symbol	Stock No.	Description
P1	16-3016	Plug, 15 pin, C-J, P-315-CCT
P2	16-3036	Plug, 6 pin, C-J, P-306-CCT
P3	16-3013	Plug, 12 pin, C-J, P-312-CCT
-	16-3035	Plug, 71-3S, for on-off switch
-	16-3035	Plug, motor, 71-3S
-	16-3035	Plug, 71-3S, for stop switch
-	16-3035	Plug, 71-3S, for start switch
R1	11-6111	Resistor, variable 50K ohms, audio taper
R2	11-6110	Resistor, variable 50K ohms, linear
R3	11-6111	Same as R1
R4	11-2070	Resistor, 470 ohms, 1W, 10%
R5	11-1055	Resistor, 220 ohms, 1/2W, 10%
R6	11-2070	Same as R4
R7	11-1105	Resistor, 4.7K ohms, 1/2W, 10%
R8	11-5110	Resistor, 100 ohms, 10W, 10%
R9	11-3135	Resistor, 10K ohms, 2W, 10%
R10	11-1151	Resistor, 22K ohms, 1/2W, 1%
R11	11-1151	Same as R10, (Stereo Only)
S1	18-1015	Switch, panel, NO-1175-2, w/28V lamp, Start
S2	18-1016	Switch, panel, NC-A-1175-2, w/28V lamp, Stop
S3	18-1014	Switch, panel, R-1175-2, w/115V neon lamp, On-Off
S4	18-5004	Switch, Micro, SPDT, N.O.
T1	25-3008	Transformer, power, AM-2706, 115V Pri, 48V Sec. C. T.
T2	25-3008	Same as T1
T3	25-2006	Transformer, audio, 600/600 ohms (150 ohm tap not used)
T4	25-2006	Same as T3 (Stereo Only)

Misc. Chassis Parts

23-4009	Cord, AC, w/2-18 wire, 10'
19-9001	Holder, fuse
W-1038	Retainer, C ring for pinch roller
W-1037	Roller, pinch
W-1093-1	Screw, Allen for motor mounting
W-1086-1	Washer, nylon, for pinch roller

Note #1: Relays with red covers are for use as K3, K4 or K5 only.

PARTS LIST		PLAYBACK UNIT	PROGRAM AMPLIFIER
Symbol	Stock No.	Description	
C101	12-5105	Capacitor, electrolytic, 5 mfd, 25V	
C102	12-4231	Capacitor, .003 mf, 500V, 2%	
C103	12-5105	Same as C101	
C104	12-5105	Same as C101	
C105	12-5211	Capacitor, electrolytic, 100 mfd, 15V	
C106	12-5221	Capacitor, electrolytic, 200 mfd, 12V	
C107	12-5221	Same as C106	
C108	12-5221	Same as C106	
C109	12-5211	Same as C105	
P101	16-3019-4	Plug, 10 pin, CJ-P-310-AB	

170

Symbol	Stock No.	Description
Q101	14-2001	Transistor, 2N508
Q102	14-2001	Same as Q101
Q103	14-2001	Same as Q101
Q104	14-2001	Same as Q101
R101	11-1147	Resistor, 15K, $\frac{1}{2}W$ , 1%
R102	11-1135	Resistor, 10K, $\frac{1}{2}W$ , 10%
R103	11-1165	Resistor, 47K, $\frac{1}{2}W$ , 10%
R104	11-1100	Resistor, 1.8K, $\frac{1}{2}W$ , 10%
R105	11-1165	Same as R103
R106	11-1036	Resistor, 100 ohms, $\frac{1}{2}W$ , 1%
R107	11-1166	Resistor, 47K, $\frac{1}{2}W$ , 1%
R108	11-1070	Resistor, 470 ohms, $\frac{1}{2}W$ , 10%
R109	11-1166	Same as R107
R110	11-1090	Resistor, 1000 ohms, $\frac{1}{2}W$ , 10%
R111	11-1120	Resistor, 4.7K, $\frac{1}{2}W$ , 10%
R112	11-1145	Resistor, 15K, $\frac{1}{2}W$ , 10%
R113	11-1082	Resistor, 680 ohms, $\frac{1}{2}W$ , 10%
R114	11-1165	Same as R103
R115	11-1105	Resistor, 2.2K, $\frac{1}{2}W$ , 10%

PARTS LIST		PLAYBACK UNIT	REGULATED POWER SUPPLY
Symbol	Stock No.	Description	
C201	12-5128	Capacitor, electrolytic, 25 mfd, 25V	
C202	12-5175	Capacitor, electrolytic, 75 mfd, 25V	
C203	12-5175	Same as C202	
CR201	14-1015	Diode, silicon, 1N3255	
CR202	14-1015	Same as CR201	
CR203	14-1085	Diode, Zener, 1N759	
P201	16-3019-7	Plug, 10 pin, CJ-P-310-AB	
Q201	14-2001	Transistor, 2N508	
Q202	14-2001	Same as Q201	
Q203	14-2003A	Transistor, 2N1183	
R201	11-1010	Resistor, 10 ohms, $\frac{1}{2}W$ , 10%	
R202	11-1120	Resistor, 4.7K, $\frac{1}{2}W$ , 10%	
R203	11-1035	Resistor, 100 ohms, $\frac{1}{2}W$ , 10%	
R204	11-1082	Resistor, 680 ohms, $\frac{1}{2}W$ , 10%	
R205	11-1120	Same as R202	
R206	11-1160	Resistor, 33K, $\frac{1}{2}W$ , 10%	
R207	11-1126	Resistor, 5.6K, $\frac{1}{2}W$ , 5%	
R208	11-1128	Resistor, 6.8K, $\frac{1}{2}W$ , 5%	

PARTS LIST		PLAYBACK UNIT	PRI. CUE AMPLIFIER (1000 CPS)
Symbol	Stock No.	Description	
C301	12-5105	Capacitor, electrolytic, 5 mfd, 25V	
C303	12-5105	Same as C301	
C304	12-1412	Capacitor, disc, ceramic, .1 mfd, 50V	
C305	12-1412	Capacitor, disc, ceramic, .1 mfd, 50V (two required)	
C306	12-5221	Capacitor, electrolytic, 200 mfd, 12V	
C307	12-5221	Same as C306	
C308	12-2148	Capacitor, Mylar, .047 mfd, 200V, 10%	
CR301	14-1015	Diode, silicon, 1N3255	
CR302	14-1015	Same as CR301	
L301	20-2003	Inductor, toroid, 500mh	

Symbol	Stock No.	Description
P301	16-3019-6	Plug, 10 pin, CJ-P-310-AB
Q301	14-2001	Transistor, 2N508
Q302	14-2001	Same as Q301
Q303	14-2001	Same as Q301
Q304	14-2003C	Transistor, 2N1183
R301	11-1145	Resistor, 15K, $\frac{1}{2}w$ , 10%
R302	11-1135	Resistor, 10K, $\frac{1}{2}w$ , 10%
R303	11-1145	Same as R301
R304	11-1115	Resistor, 3.3K, $\frac{1}{2}w$ , 10%
R306	11-1120	Resistor, 4.7K, $\frac{1}{2}w$ , 10%
R307	11-1165	Resistor, 47K, $\frac{1}{2}w$ , 10%
R308	11-1035	Resistor, 100 ohms, $\frac{1}{2}w$ , 10%
R309	11-1165	Same as R307
R310	11-1105	Resistor, 1K, $\frac{1}{2}w$ , 10%
R311	11-1120	Same as R306
R312	11-1145	Same as R301
R313	11-1120	Same as R306
R314	11-1120	Same as R306

PARTS LIST		PLAYBACK UNIT	SEC. CUE AMPLIFIER (150 CPS)
Symbol	Stock No.	Description	
C401	12-5105	Capacitor, electrolytic, 5 mfd, 25V	
C402	12-5105	Same as C401	
C403	12-2320	Capacitor, Mylar, 2 mfd, 100V, 10%	
CR401	14-1015	Diode, 1N3255	
L401	20-2003	Inductor, toroid, 500mh	
P401	16-3019-8	Plug, 10 pin, CJ-P-310-AB	
Q401	14-2001	Transistor, 2N508	
Q402	14-2003B	Transistor, 2N1183	
R401	11-1145	Resistor, 15K, $\frac{1}{2}w$ , 10%	
R402	11-1115	Resistor, 3.3K, $\frac{1}{2}w$ , 10%	
R403	11-1145	Same as R401	
R404	11-1120	Resistor, 4.7K, $\frac{1}{2}w$ , 10%	
R405	11-1120	Same as R404	

PARTS LIST		PLAYBACK UNIT	AUX. CUE AMPLIFIER (8000 CPS)
Symbol	Stock No.	Description	
C501	12-1412	Capacitor, disc ceramic, .1 mfd, 50V	
C502	12-1412	Same as C501	
C503	12-2168	Capacitor, Mylar, .068 mfd, 100V, 10% (see note #1)	
CR501	14-1015	Diode, 1N3255	
CR502	14-1015	Same as CR501	
L501	20-2004	Inductor, Toroid, 5mh (see note #2)	
P501	16-3019-2	Plug, 10 pin, CJ-P-310-AB	
Q501	14-2001	Transistor, 2N508	
Q502	14-2003C	Transistor, 2N1183	
R501	11-1120	Resistor, 4.7K, $\frac{1}{2}w$ , 10%	
R502	11-1145	Resistor, 15K, $\frac{1}{2}w$ , 10%	
R503	11-1115	Resistor, 3.3K, $\frac{1}{2}w$ , 10%	
R504	11-1145	Same as R502	
R505	11-1120	Same as R501	
R506	11-1120	Same as R501	

Note #1: C503 Stock #12-2050 is .005 mfd in 3200 CPS Cue Amplifier.

Note #2: L501 Stock #20-2003 is 500mh in 3200 CPS Cue Amplifier.

#### 6.1.2 DRAWINGS--PLAYBACK UNIT

The drawings contained in the following section are designed to promote rapid and thorough maintenance and/or service.

Included in this section are complete schematic diagrams and layout details for the Criterion Playback Unit.

As a matter of convenience, a schematic diagram of the Playback/Record Amplifier interconnecting cable is also provided.



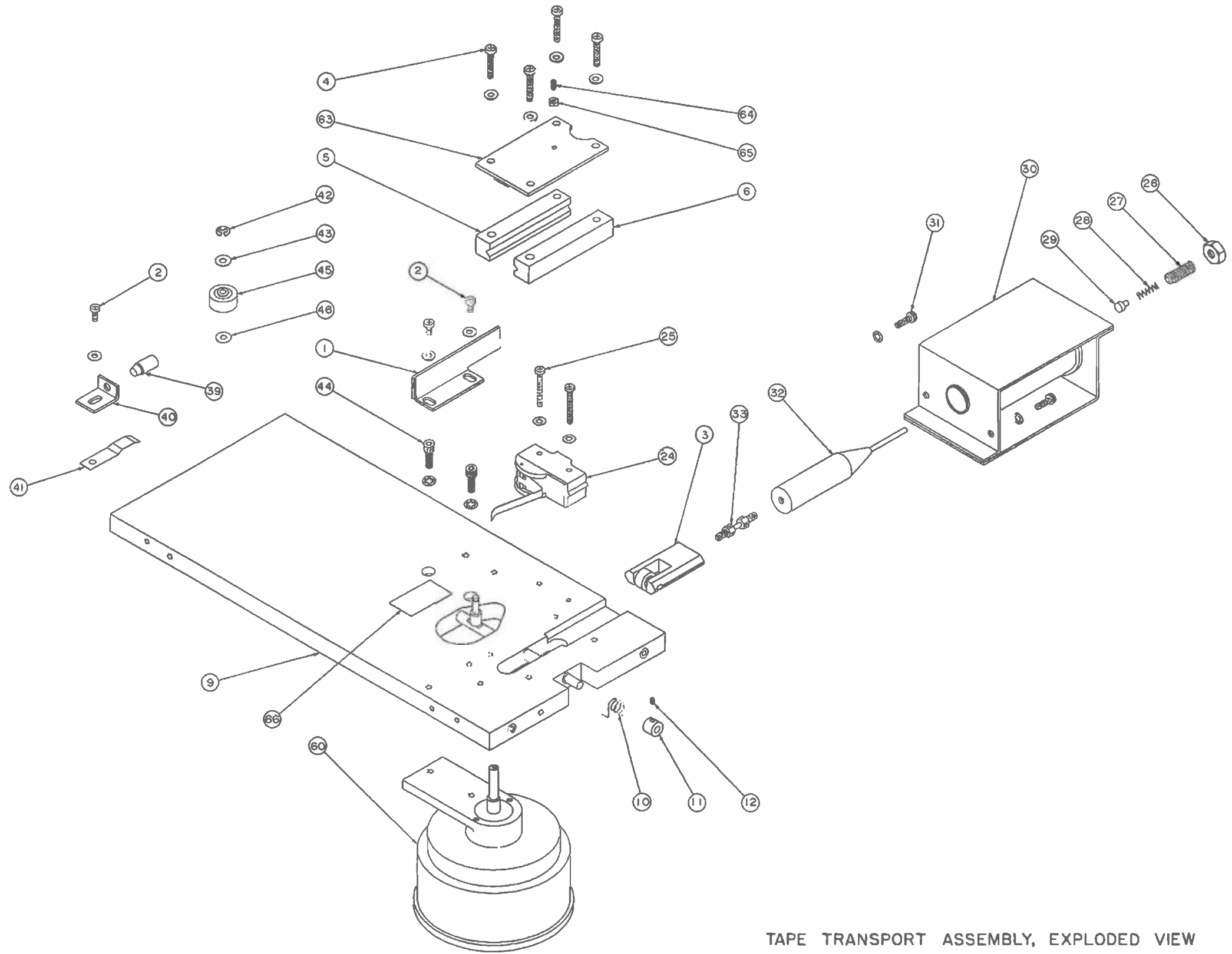

TAPE TRANSPORT ASSEMBLY, EXPLODED VIEW

## PARTS LIST

## TAPE TRANSPORT ASSEMBLY

<u>ITEM</u>	<u>STOCK NO.</u>	<u>DESCRIPTION</u>
1	W-1042	GUIDE, Cartridge
2	W-1092-5	SCREW, Mounting
3	W-1041	SLIDE ASSEMBLY
4	W-1092-6	SCREW, Mounting
5	W-1117	GUIDE, Slide, Left
6	W-1000	GUIDE, Slide, Right
9	J-2006	DECK, Sub-assembly
10	W-1016	SPRING, Slide Return
11	W-1049	HOLDER, Return Spring
12	W-1090-3	SET SCREW
24	18-5004	SWITCH, Micro
25	W-1092-7	SCREW, Mounting
26	W-1091-1	NUT, Lock
27	W-1090-1	SET SCREW
28	W-1023	SPRING, Solenoid Cushion
29	W-1019	CUSHION, Solenoid Plunger
30	21-5005	SOLENOID, Sub-assembly
31	W-1092-8	SCREW, Mounting Solenoid
32	W-1033	PLUNGER ASSEMBLY, Solenoid
33	W-1074	LINK, Drag Assembly
39	W-1009	BUMPER, Rubber
40	W-1025	BRACKET, Bumper
41	W-1076	SPRING, Bumper
42	W-1038	RING, Retainer

PARTS LIST  
TAPE TRANSPORT ASSEMBLY

<u>ITEM</u>	<u>STOCK NO.</u>	<u>DESCRIPTION</u>
43	W-1086-1	WASHER, Nylon
44	W-1093-1	SCREW, Mounting
45	W-1037	PINCH ROLLER
46	W-1084	WASHER, Pinch Roller
60	J-2023C	MOTOR
63	W-1124	COVER, Slide Assembly
64		SCREW, Set
65		NUT, Locking
66	Q-1034	PLATE, Cartridge Support

MICRO-SET HEAD ASSEMBLY, EXPLODED VIEW

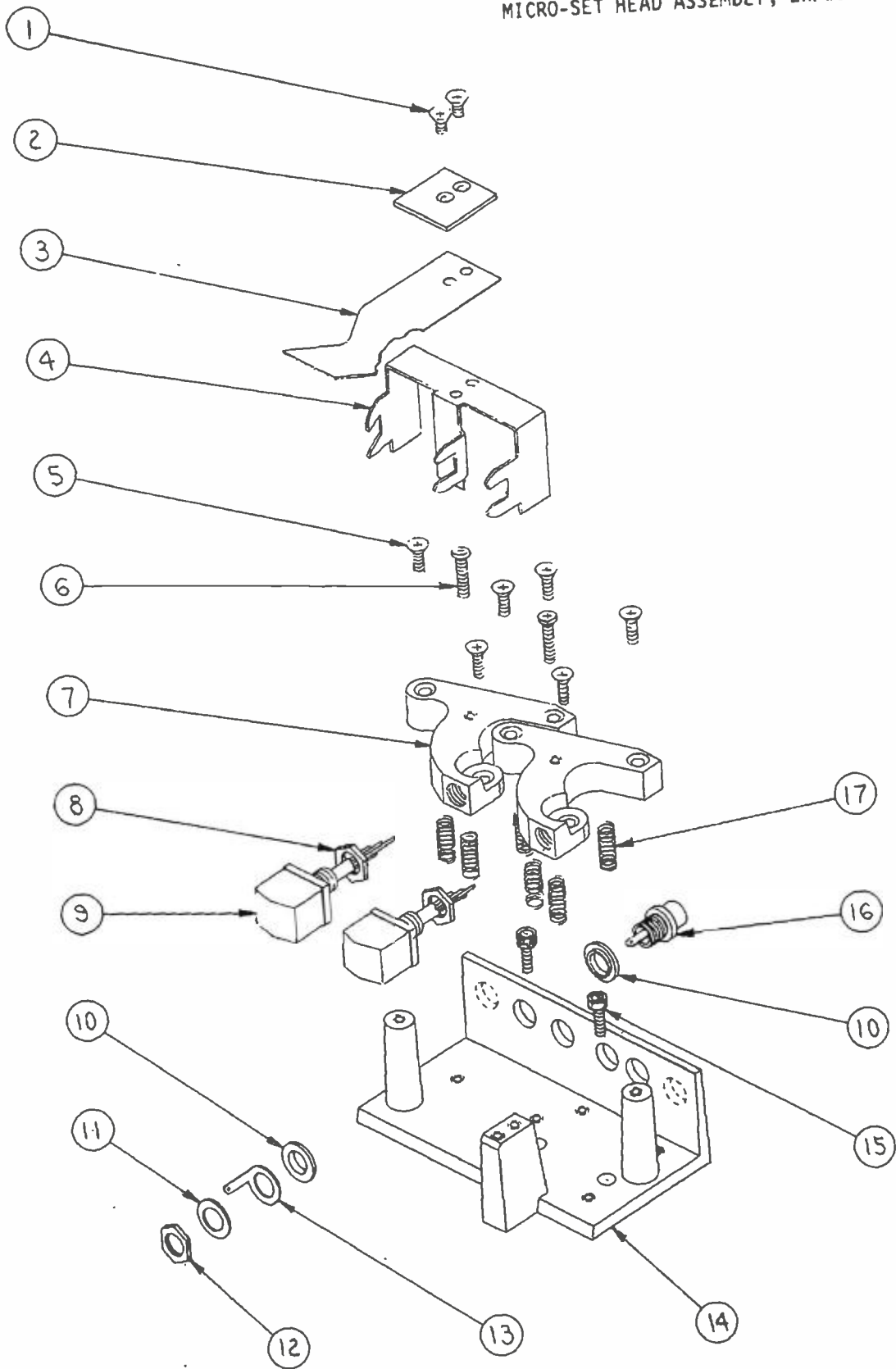

## PARTS LIST

## MICRO-SET HEAD ASSEMBLY

<u>ITEM</u>	<u>STOCK NO.</u>	<u>DESCRIPTION</u>
	26-1021	MICRO-SET HEAD ASSEMBLY; Mono (Includes base, head bkts., spring, cover, jacks, hardware and mounting screws.) Assem- bled. (Does not include heads.)
	26-1022	MICRO-SET HEAD ASSEMBLY; Stereo (Includes base, head bkts., spring, cover, jacks, hardware and mounting screws.) Assem- bled. (Does not include heads.)
1		SCREW, 4-40x $\frac{1}{2}$ , phillips 100° flat head
2	Q-1036	PLATE, spring mounting
3	Q-1035	SPRING, Cartridge Hold-down
4	<del>Q-2024</del>	<del>TAPE GUIDE</del>
5		SCREW, 4-40x11/32, phillips 100° flat head (six used)
6		SCREW, 4-40x5/8, phillips pan head (two used)
7	Q-2025	HEAD SUPPORT (apostrophe)
8	23-3022	NUT, 1/4-28x3/8x1/16
9		HEAD -- Shown for reference only -- See Playback Unit Parts List
10		WASHER, fiber, extruded, 1/4x5/16x1/2
11		WASHER, 1/4x7/16x1/64 (Furnished only as part of jack -- See Item 16)
12		NUT, 1/4-32x3/8x1/16 (Furnished only as part of jack -- See Item 16)
13		SOLDER LUG (Furnished only as part of jack -- See Item 16)

PARTS LIST

MICRO-SET HEAD ASSEMBLY

<u>ITEM</u>	<u>STOCK NO.</u>	<u>DESCRIPTION</u>
14	Q-3018-1 Q-3018-2	BASE, mounting, <u>Mono</u> BASE, mounting, <u>Stereo</u>
15		SCREW, 8-32x3/8, allen head (9/64)
16	16-1010	JACK, Switchcraft 3501 FP
17	W-1023	SPRING (six used)

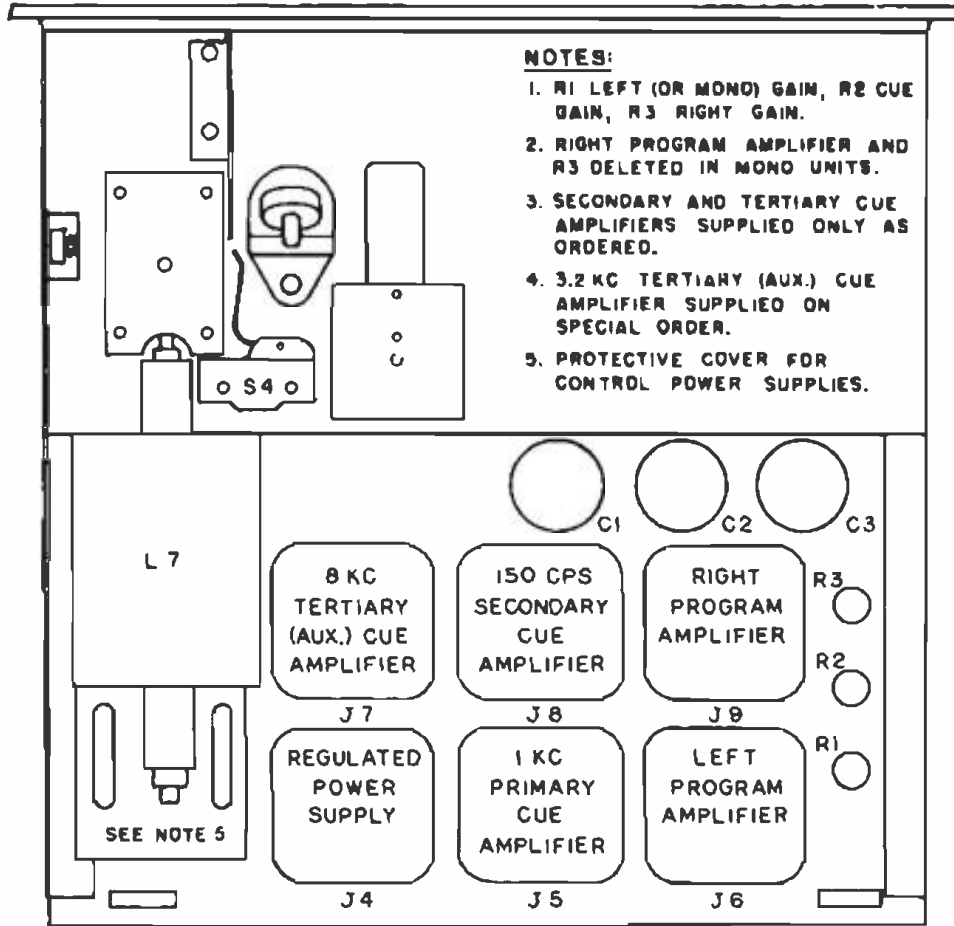

CHASSIS LAYOUT - TOP VIEW

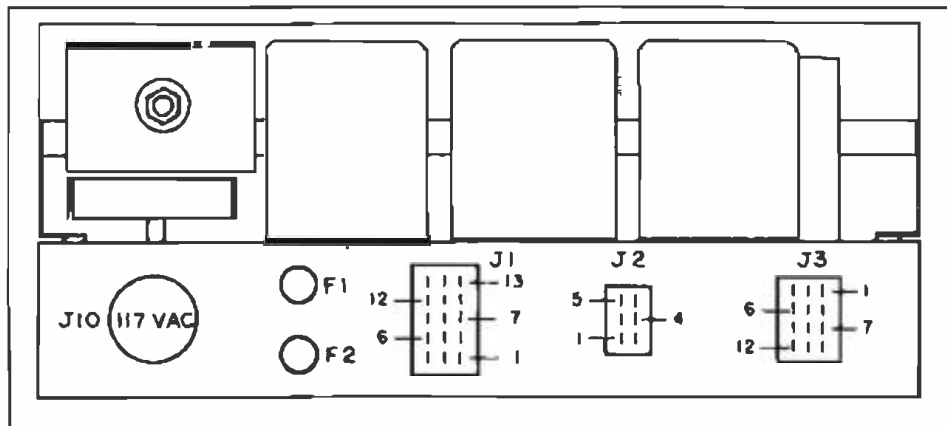

REAR VIEW

CRITERION PLAYBACK UNIT

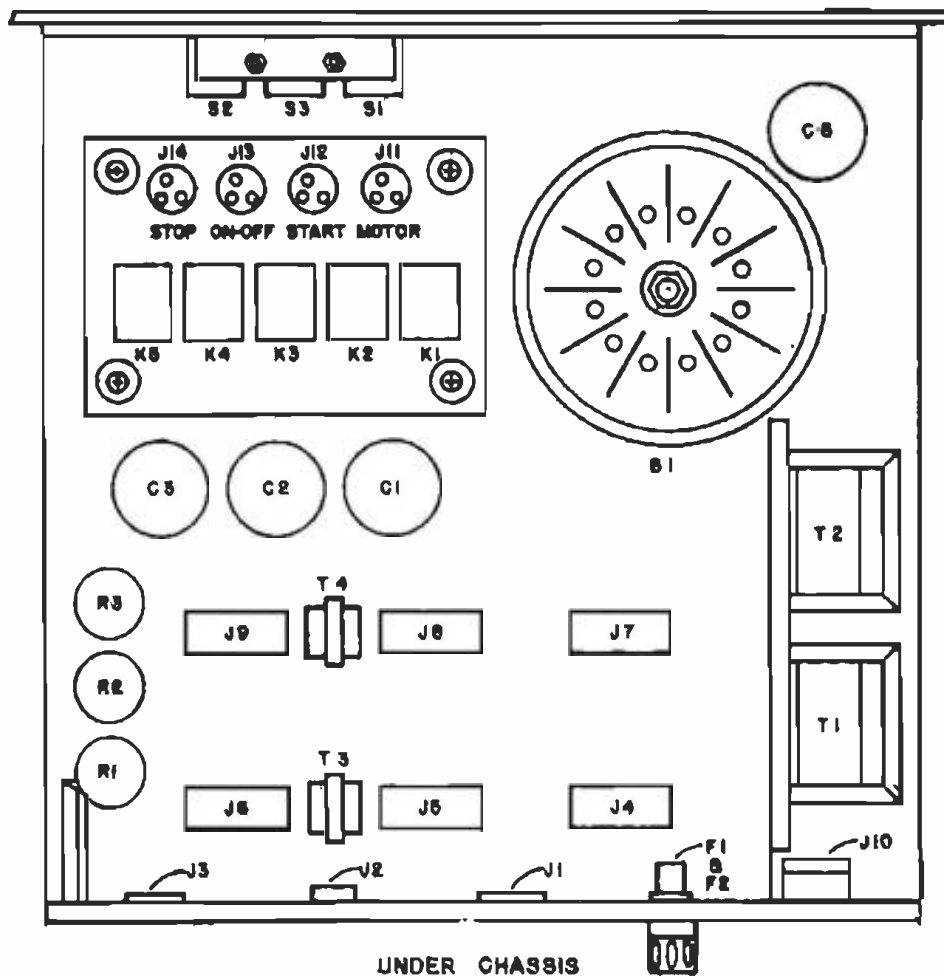

**NOTES:**

1. R3, T4 AND J9 USED IN STEREO UNITS ONLY.
2. K1, K2 AND K3 USED IN ALL UNITS, K4 IN DUAL CUE UNITS, K4 AND K5 IN TRIPLE CUE UNITS.

**CRITERION PLAYBACK UNIT**



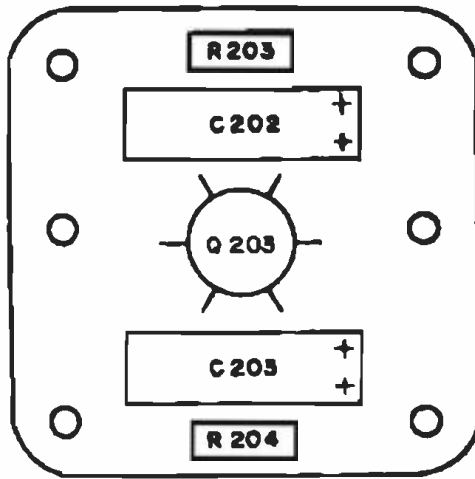

TOP BOARD

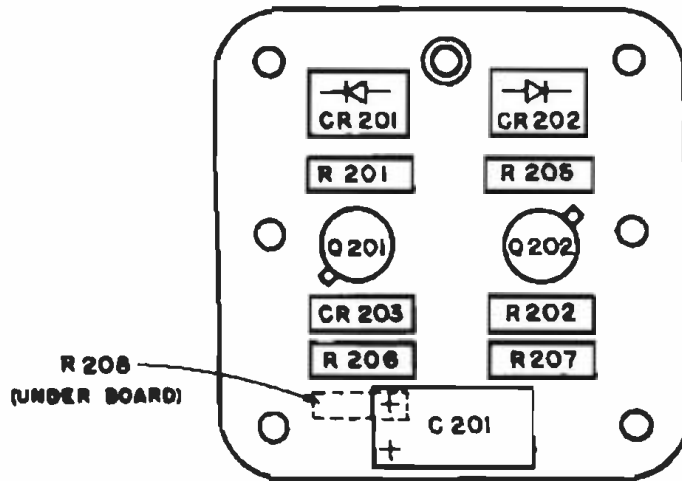

BOTTOM BOARD

REGULATED POWER SUPPLY

CRITERION PLAYBACK UNIT

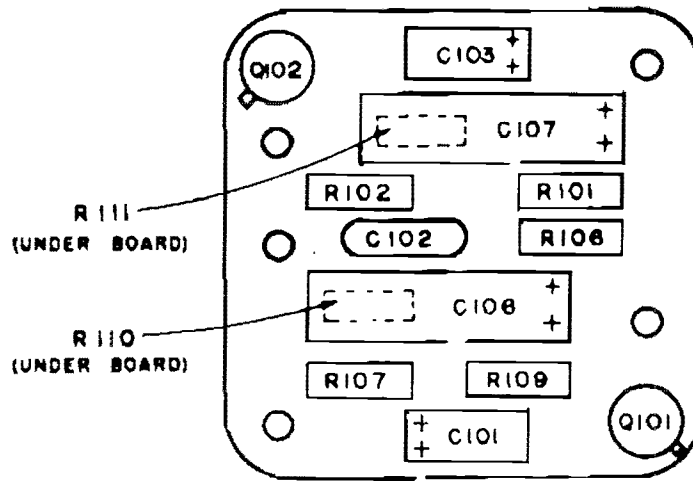

TOP BOARD

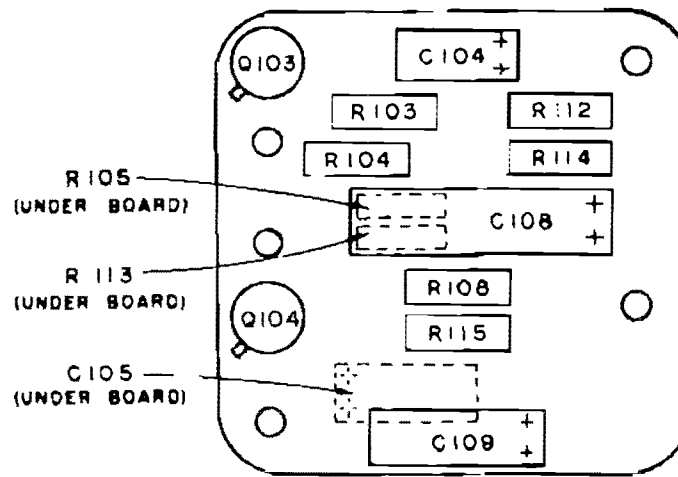

BOTTOM BOARD

PROGRAM AMPLIFIER

CRITERION PLAYBACK UNIT

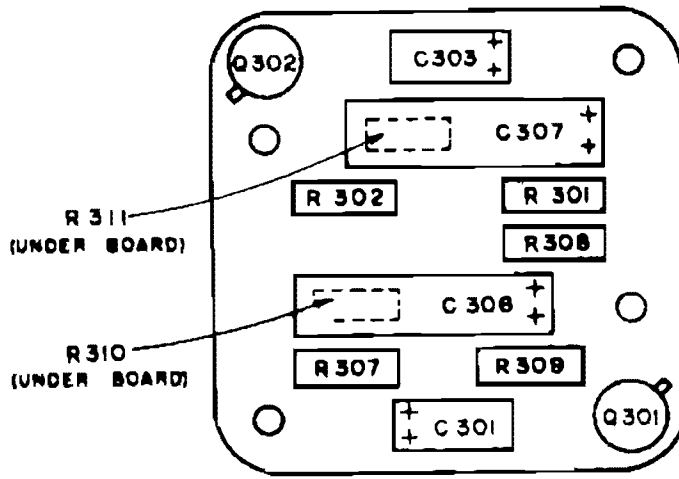

TOP BOARD

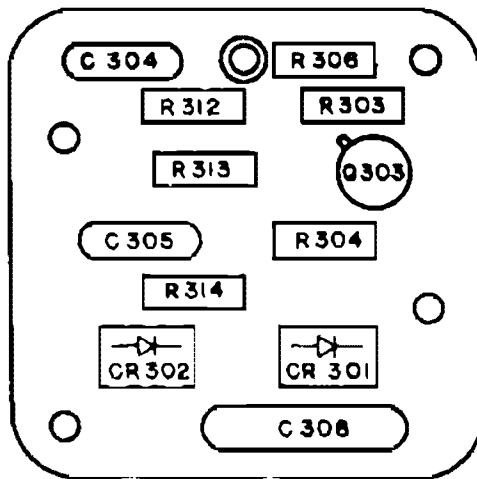

BOTTOM BOARD

PRIMARY CUE AMPLIFIER

CRITERION PLAYBACK UNIT

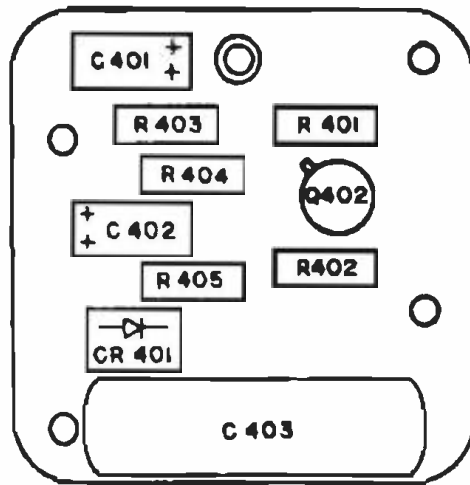

SECONDARY CUE AMPLIFIER

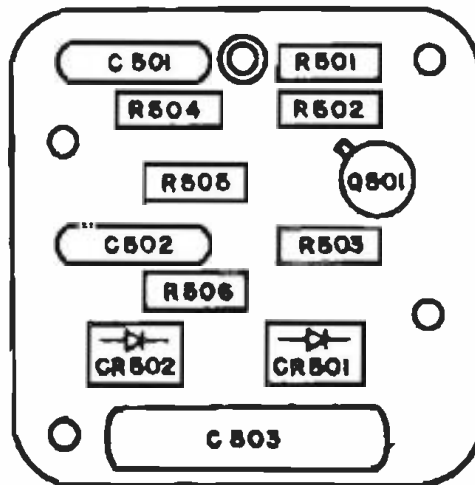

TERTIARY CUE AMPLIFIER

CRITERION PLAYBACK UNIT

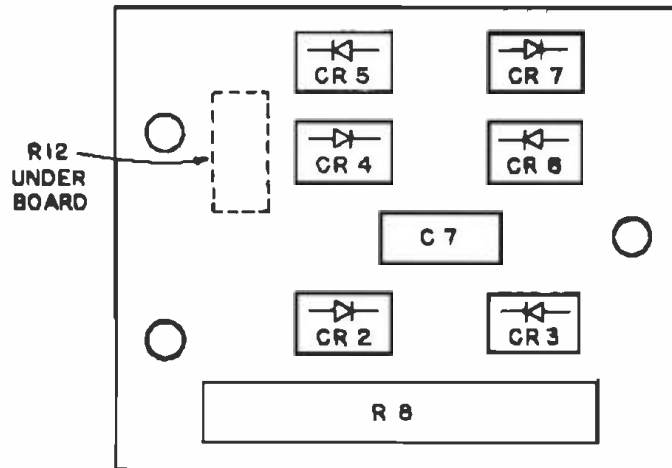

RELAY AND SOLENOID POWER SUPPLY

CRITERION PLAYBACK UNIT

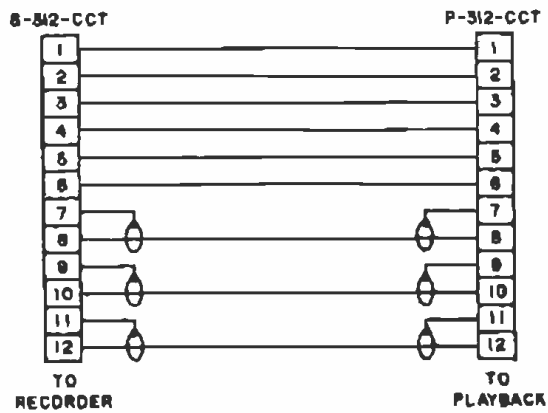

PLAYBACK/RECORDING AMPLIFIER

INTERCONNECTING CABLE

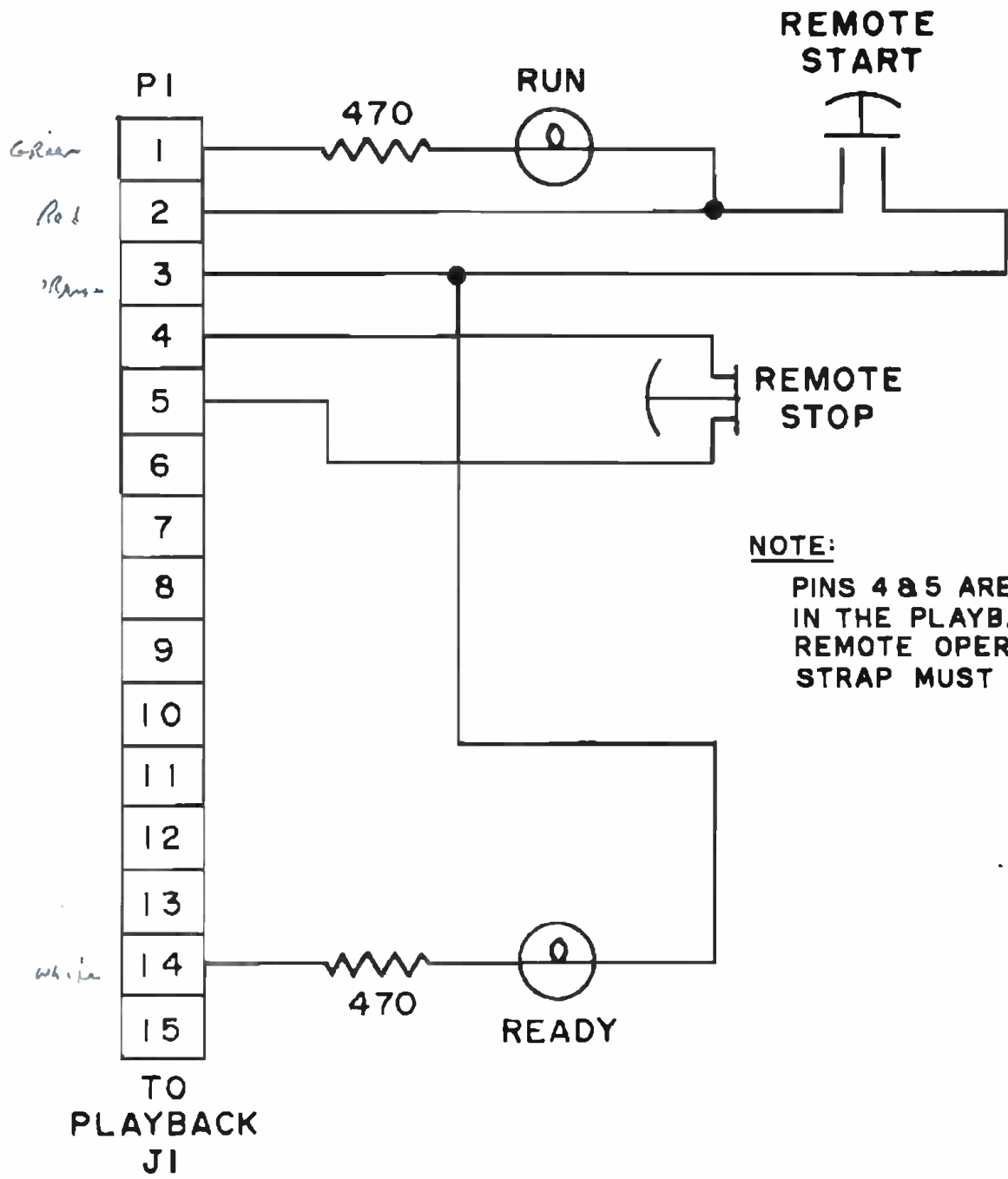

**NOTE:**  
 PINS 4 & 5 ARE STRAPPED  
 IN THE PLAYBACK UNIT. FOR  
 REMOTE OPERATION, THIS  
 STRAP MUST BE REMOVED.

**CRITERION PLAYBACK REMOTE CONTROL**

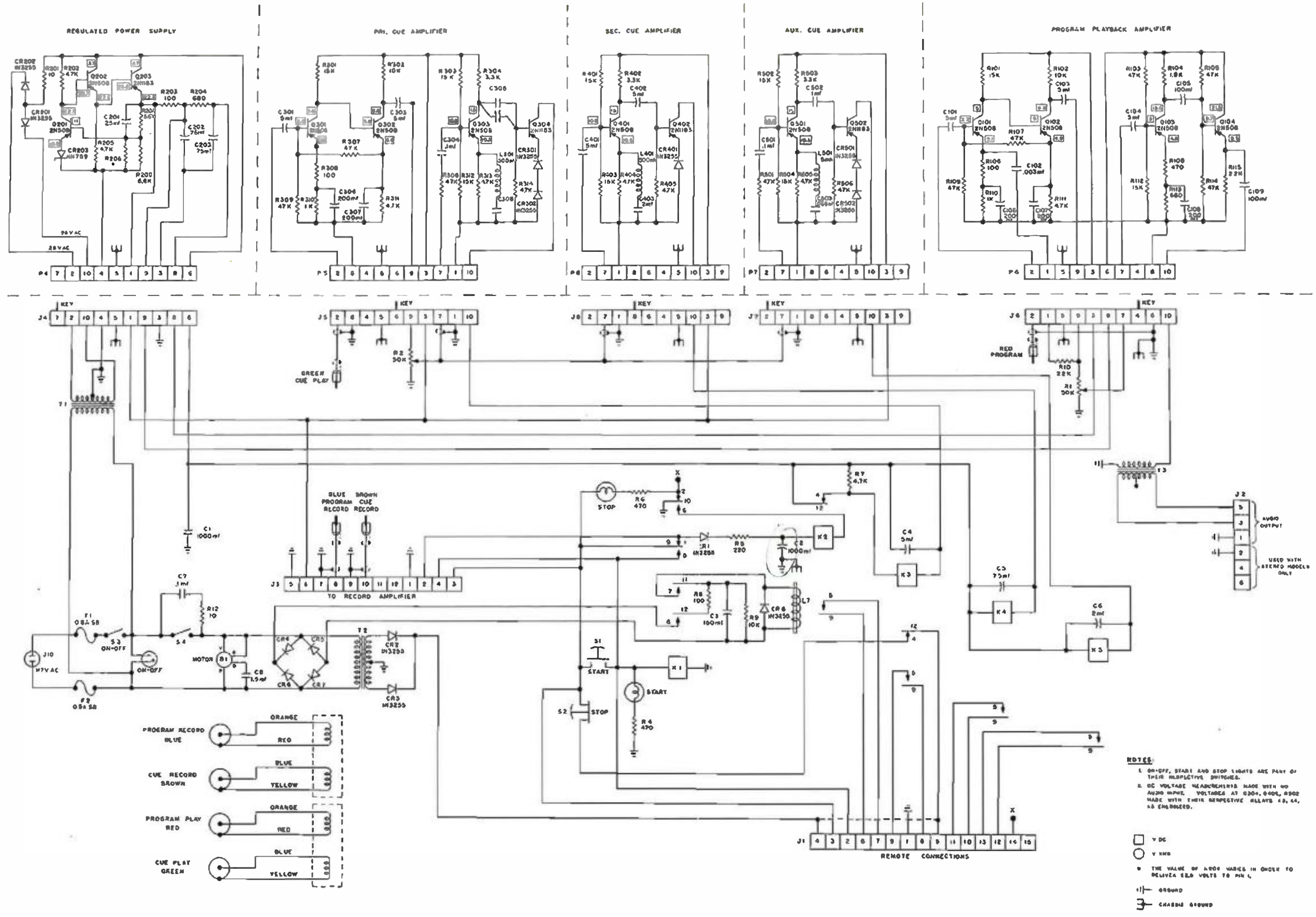

CRITERION PLAYBACK UNIT

## 6.2 RECORDING AMPLIFIER

6.2.1 PARTS LIST	RECORDING AMPLIFIER	MAIN CHASSIS
C601	12-5215	Capacitor, 150 mfd, 50V.
C602	12-5175	Capacitor, 75 mfd, 25V, CRE-620A
C603	12-5175	Same as C602
C604	12-5175	Same as C602
CR601	14-1015	Diode, 1N3255
J601	16-2016	Socket, C-J, S-306-AB
J603	16-2030	Socket, C-J, S-310-AB
K601	21-1031	Relay, P & B, KHP17D11, 24 VDC
K602	21-1031	Same as K601
K603	21-1031	Same as K601
K604	21-1031	Same as K601
K605	21-1031	Same as K601
M601	24-1001	Meter, 200 microamperes, movement, VU scale
M602	24-1001	Same as M601 (Stereo only)
	16-3035	Plug, for Rec. Set Switch, Amphenol 71-3S
	16-3035	Plug, for Sec. Cue Switch, Amphenol 71-3S
	16-3035	Plug, for Ter. Cue Switch, Amphenol 71-3S
	16-3036	Plug, C-J, P-306-CCT
	16-3010	Plug, C-J, P-310-CCT
	12-2051	Socket, C-J, S-312-CCT
P602	16-3012	Plug, C-J, P-312-AB
R601	11-1055	Resistor, 220 ohms, $\frac{1}{2}W$ , 10%
R602	11-2070	Resistor, 470 ohms, 1W, 10%
R603	11-2070	Same as R602
R604	11-2070	Same as R602
R605	11-1010	Resistor, 10 ohms, $\frac{1}{2}W$ , 10%
R606	11-1050	Resistor, 180 ohms, $\frac{1}{2}W$ , 10%
R607	11-1035	Resistor, 100 ohms, $\frac{1}{2}W$ , 10%
R608	11-6112	Resistor, variable, 50K, CTS-BC48377, type 320
R609	11-1035	Same as R607
R610	11-1035	Same as R607
R611	11-1035	Same as R607
R612	11-1035	Same as R607
R613	11-1085	Resistor, 820 ohms, $\frac{1}{2}W$ , 10%
R614	11-6112	Same as R608 (Stereo only)
	16-2014	Socket, for Rec. Set Switch, Amphenol 78-S3S
	16-2014	Socket, for Sec. Cue Switch, Amphenol 78-S3S
	16-2014	Socket, for Ter. Cue Switch, Amphenol 78-S3S
	16-2059	Socket, for K601, P & B 9KH1 w/retaining clip
	16-2059	Socket, for K602
	16-2059	Socket, for K603
	16-2059	Socket, for K604
	16-2059	Socket, for K605
S601	18-1019	Switch, Panel, Molex NO-A-1175-2
S602	18-1018	Switch, Panel, Molex NO-B-1175-2
S603	18-1017	Switch, Panel, Molex NO-W-1175-2
T601	25-2006	Transformer, Audio 600:600 ohms (150 ohm tap not used)



PARTS LIST		RECORDING AMPLIFIER	PROGRAM AMPLIFIER
Symbol	Stock No.	Description	
C701	12-5105	Capacitor, 5 mfd, 25V, CRE-604A	
C702	12-5105	Same as C701	
C703	12-2022	Capacitor, .0022 mfd, Mylar, 10%, PVC4222	
C704	12-5105	Same as C701	
C705	12-5105	Same as C701	
C706	12-4133	Capacitor, 330 mmf, 5%, CD15, F331J	
C707	12-5221	Capacitor, 200 mfd, 12V, CRE-431A	
C708	12-5105	Same as C701	
C709	12-2233	Capacitor, .33 mfd, Mylar, 10%, PVC1033	
C710	12-4243	Capacitor, .0043 mfd, 5%, CD19, F432J	
C711	12-5105	Same as C701	
C712	12-5221	Same as C707	
C713	12-5128	Capacitor, 25 mfd, 25V, CRE-612A	
C714	12-5105	Same as C701 (Stereo only)	
C715	12-5105	Same as C701 (Stereo only)	
C716	12-2022	Same as C703 (Stereo only)	
C717	12-5105	Same as C701 (Stereo only)	
C718	12-5105	Same as C701 (Stereo only)	
C719	12-4133	Same as C706 (Stereo only)	
C720	12-5221	Same as C707 (Stereo only)	
C721	12-5105	Same as C701 (Stereo only)	
C722	12-2223	Same as C709 (Stereo only)	
C723	12-4243	Same as C710 (Stereo only)	
C724	12-5105	Same as C701 (Stereo only)	
C725	12-5221	Same as C707 (Stereo only)	
C726	12-5128	Same as C713 (Stereo only)	
CR701	14-1025	Diode, 1N462	
CR702	14-1025	Same as CR701 (Stereo only)	
L701	20-4003	Inductor, variable, 8-20 mh, 387-20M	
L702	20-4003	Same as L701	
L703	20-4003	Same as L701 (Stereo only)	
L704	20-4003	Same as L701 (Stereo only)	
Q701	14-2001	Transistor, 2N508	
Q702	14-2001	Same as Q701	
Q703	14-2001	Same as Q701	
Q704	14-2001	Same as Q701 (Stereo only)	
Q705	14-2001	Same as Q701 (Stereo only)	
Q706	14-2001	Same as Q701 (Stereo only)	
R701	11-1185	Resistor, 100K, $\frac{1}{2}$ W, 10%	
R702	11-1110	Resistor, 2.7K, $\frac{1}{2}$ W, 10%	
R703	11-1200	Resistor, 180K, $\frac{1}{2}$ W, 10%	
R704	11-1135	Resistor, 10K, $\frac{1}{2}$ W, 10%	
R705	11-1153	Resistor, 22K, $\frac{1}{2}$ W, 5%	
R706	11-6110	Resistor, variable, 50K, CTS-RV4LAYS A503-B	
R707	11-1151	Resistor, 22K, $\frac{1}{4}$ W, 1%	

PARTS LIST		RECORDING AMPLIFIER	PROGRAM AMPLIFIER
Symbol	Stock No.	Description	
R708	11-1110	Same as R702	
R709	11-1135	Same as R704	
R710	11-1020	Resistor, 47 ohms, $\frac{1}{2}W$ , 10%	
R711	11-1065	Resistor, 330 ohms, $\frac{1}{2}W$ , 10%	
R712	11-1127	Resistor, 5.6K, PW, 1%	
R713	11-1150	Resistor, 22K, $\frac{1}{2}W$ , 10%	
R714	11-1105	Resistor, 2.2K, $\frac{1}{2}W$ , 10%	
R715	11-1160	Resistor, 33K, $\frac{1}{2}W$ , 10%	
R716	11-1117	Resistor, 3.9K, $\frac{1}{2}W$ , 10%	
R717	11-1120	Resistor, 4.7K, $\frac{1}{2}W$ , 10%	
R718	11-1055	Resistor, 220 ohms, $\frac{1}{2}W$ , 10%	
R719	11-1100	Resistor, 1.8K, $\frac{1}{2}W$ , 10%	
R720	11-1155	Resistor, 27K, $\frac{1}{2}W$ , 10%	
R721	11-1035	Resistor, 100 ohms, $\frac{1}{2}W$ , 10%	
R722	11-1185	Same as R701 (Stereo only)	
R723	11-1110	Same as R702 (Stereo only)	
R724	11-1200	Same as R703 (Stereo only)	
R725	11-1135	Same as R704 (Stereo only)	
R726	11-1153	Same as R705 (Stereo only)	
R727	11-6110	Same as R706 (Stereo only)	
R728	11-1151	Same as R707 (Stereo only)	
R729	11-1110	Same as R702 (Stereo only)	
R730	11-1135	Same as R704 (Stereo only)	
R731	11-1020	Same as R710 (Stereo only)	
R732	11-1065	Same as R711 (Stereo only)	
R733	11-1127	Same as R712 (Stereo only)	
R734	11-1150	Same as R713 (Stereo only)	
R735	11-1105	Same as R714 (Stereo only)	
R736	11-1160	Same as R715 (Stereo only)	
R737	11-1117	Same as R716 (Stereo only)	
R738	11-1120	Same as R717 (Stereo only)	
R739	11-1055	Same as R718 (Stereo only)	
R740	11-1100	Same as R719 (Stereo only)	
R741	11-1155	Same as R720 (Stereo only)	
R742	11-1035	Same as R721 (Stereo only)	

PARTS LIST		RECORDING AMPLIFIER	BIAS OSCILLATORS
Symbol	Stock No.	Description	
C801	12-1310	Capacitor, .01 mfd, disc, ceramic, 20%	
C802	12-1310	Same as C301	
C803	12-5128	Capacitor, 25 mfd, 25V, CRE-612A	
C804	12-2158	Capacitor, .056 mfd, 100V, PVC1156	
C805	12-3002	Capacitor, variable, 9-180 mmf, 60-342	
C806	12-3002	Same as C805	
C807	12-2133	Capacitor, Mylar, .033 mfd, 100V, 10%	
C808	12-5128	Same as C803	
C809	12-1310	Same as C801	
C810	12-1310	Same as C801	

PARTS LIST		RECORDING AMPLIFIER	BIAS OSCILLATORS
Symbol	Stock No.	Description	

C811	12-3002	Same as C805 (Stereo only)	
Q801	14-2002	Transistor, 2N1414	
Q802	14-2002	Same as Q801	
Q803	14-2002	Same as Q801	
Q804	14-2002	Same as Q801	
R801	11-1010	Resistor, 10 ohms, $\frac{1}{2}W$ , 10%	
R802	11-1010	Same as R801	
R803	11-1150	Resistor, 22K, $\frac{1}{2}W$ , 10%	
R804	11-1150	Same as R803	
R805	11-1035	Resistor, 100 ohms, $\frac{1}{2}W$ , 10%	
R806	11-1035	Same as R805	
R807	11-1150	Same as R803	
R808	11-1150	Same as R803	
R809	11-1010	Same as R801	
T801	25-1003	Transformer, Nortronics T60-T2	
T802	25-1003	Same as T801	

PARTS LIST		RECORDING AMPLIFIER	CUE TONE OSCILLATORS & AMP
Symbol	Stock No.	Description	

C901	12-5110	Capacitor, 10 mfd, 25V, CRE-607A	
C902	12-2310	Capacitor, 1 mfd, 100V, PVC11	
C903	12-5103	Capacitor, 2 mfd, 25V, CRE-601A	
C904	12-5103	Same as C903	
C905	12-2233	Capacitor, .33 mfd, 100V, PVC1033	
C906	12-4230	Capacitor, 3000 mmf, 2%, mica	
C907	12-5103	Same as C903	
C908	12-2212	Capacitor, .1 mfd, 100V, PVC101	
C909	12-5103	Same as C903	
C910	12-5105	Capacitor, 5 mfd, 25V, CRE-604A	
C911	12-5105	Same as C910	
C912	12-4143	Capacitor, 430 mmf, 5%, mica	
C913	12-5128	Capacitor, 25 mfd, 25V, CRE-612A	
L901	20-4002	Inductor, variable, VIC-12	
L902	20-4004	Inductor, variable, VIC-8	
L903	20-4004	Same as L902	
L904	20-4003	Inductor, variable, 8-20 mh, 387-20M	
Q901	14-2001	Transistor, 2N508	
Q902	14-2001	Same as Q901	
Q903	14-2001	Same as Q901	
Q904	14-2001	Same as Q901	
R901	11-1170	Resistor, 56K, $\frac{1}{2}W$ , 10%	
R902	11-1145	Resistor, 15K, $\frac{1}{2}W$ , 10%	
R903	11-1135	Resistor, 10K, $\frac{1}{2}W$ , 10%	
R904		Not Used	
R905	11-6009	Resistor, variable, 500 ohms, linear	
R906	11-6009	Same as R905	
R907	11-1165	Resistor, 4.7K, $\frac{1}{2}W$ , 10%	
R908	11-1135	Same as R903	
R909	11-1145	Same as R902	

Symbol	Stock No.	Description
R910	11-1170	Same as R901
R911	11-1125	Resistor, 5.6K, $\frac{1}{2}W$ , 10%
R912	11-1125	Same as R911
R913	11-1170	Same as R901
R914	11-1145	Same as R902
R915	11-1135	Same as R903
R916	11-1130	Resistor, 7.5K, $\frac{1}{2}W$ , 5%
R917	11-6009	Same as R905
R918	11-1125	Same as R911
R919	11-1185	Resistor, 100K, $\frac{1}{2}W$ , 10%
R920	11-1135	Same as R903
R921	11-1140	Resistor, 12K, $\frac{1}{2}W$ , 10%
R922	11-1105	Resistor, 2.2K, $\frac{1}{2}W$ , 10%

### 6.2.2 DRAWINGS--RECORDING AMPLIFIER

To facilitate ease of maintenance the following section contains complete schematics and layout details for the Criterion Series Recording Amplifier.

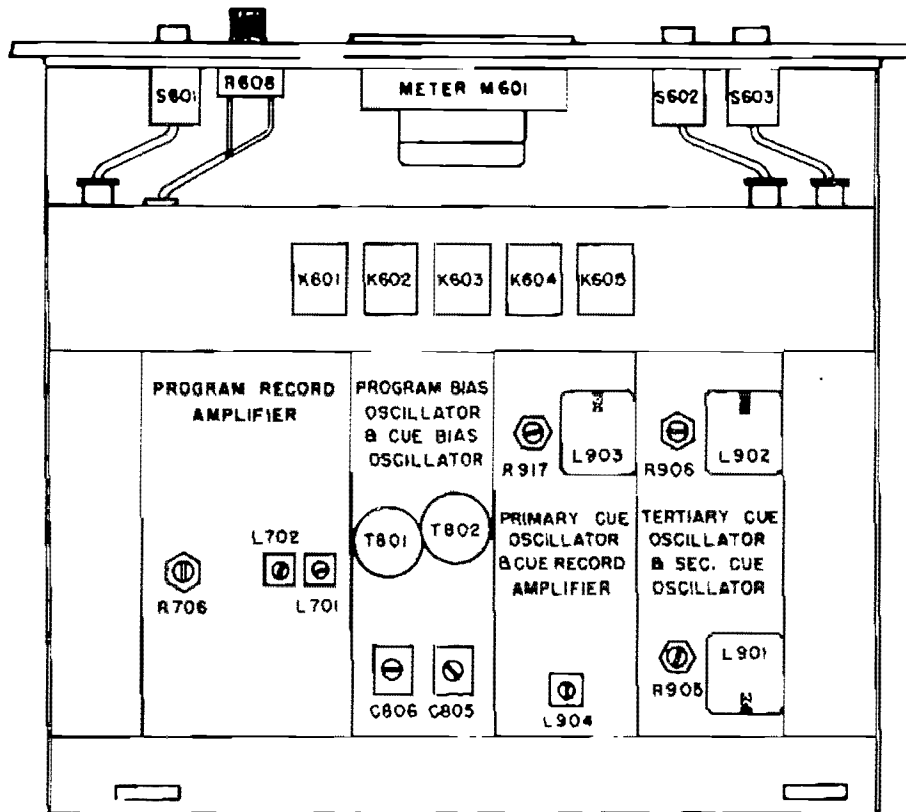

CHASSIS LAYOUT

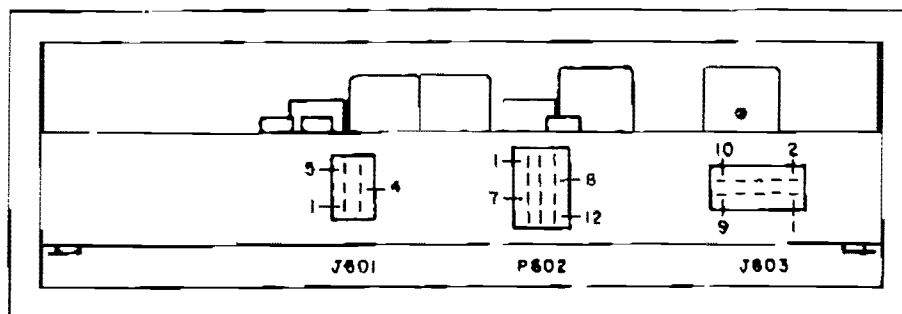

EXTERNAL CONNECTIONS

CRITERION RECORDING AMPLIFIER

MONOPHONIC

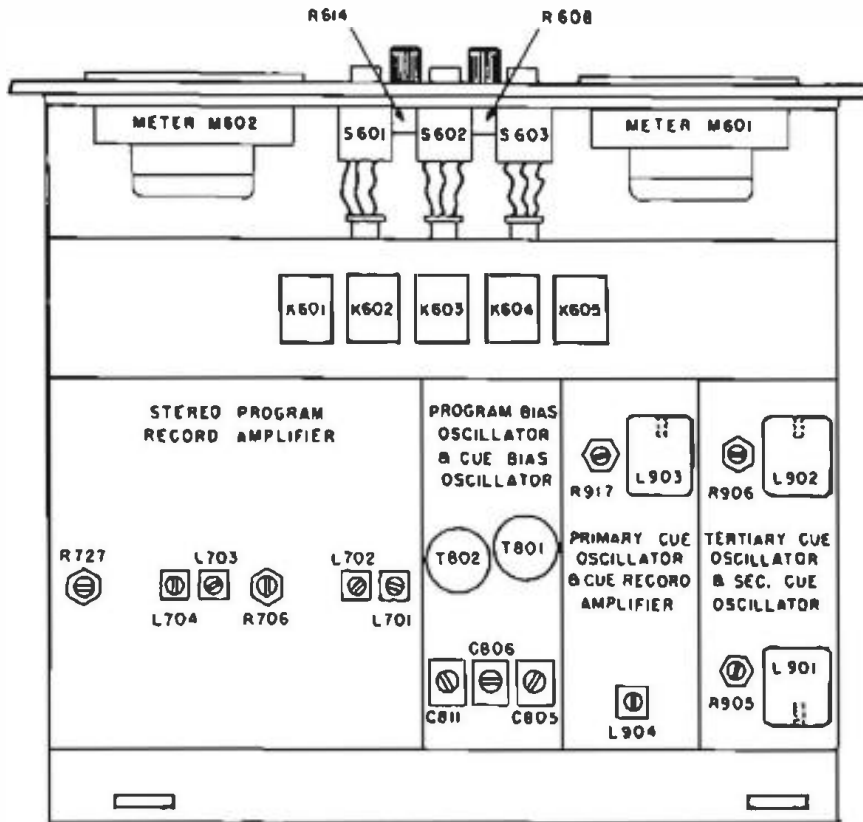

CHASSIS LAYOUT

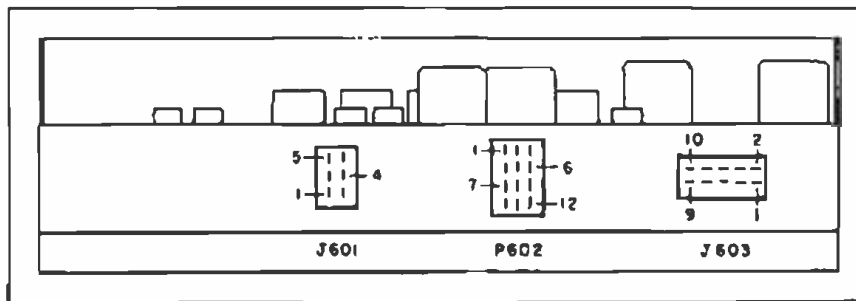

EXTERNAL CONNECTIONS  
CRITERION RECORDING AMPLIFIER

STEREO

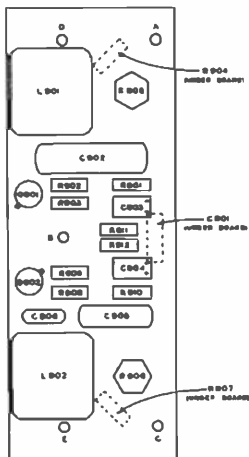

SECUNDARY AND TERTIARY CUE OSCILLATORS

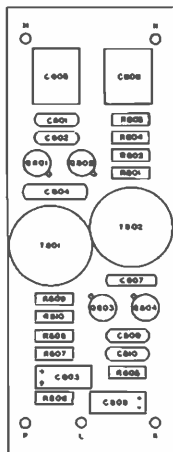

CUE B PROGRAM BIAS OSCILLATORS

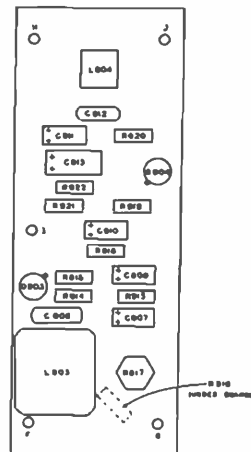

PRIMARY CUE OSCILLATOR  
B CUE RECORD AMPLIFIER

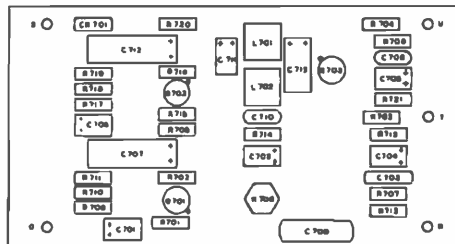

PROGRAM RECORD AMPLIFIER

MONOPHONIC  
CRITERION RECORDING AMPLIFIER  
BOARD LAYOUTS

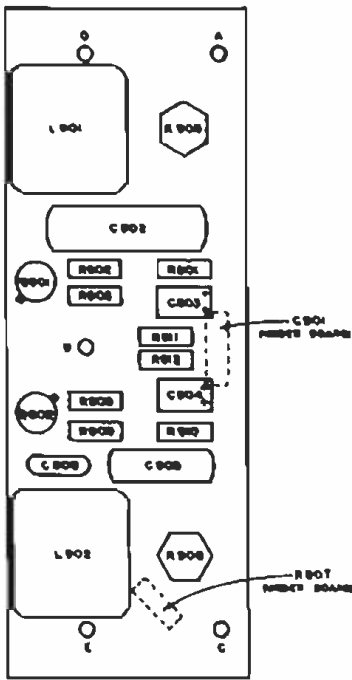

SECONDARY AND TERTIARY  
CUE OSCILLATORS

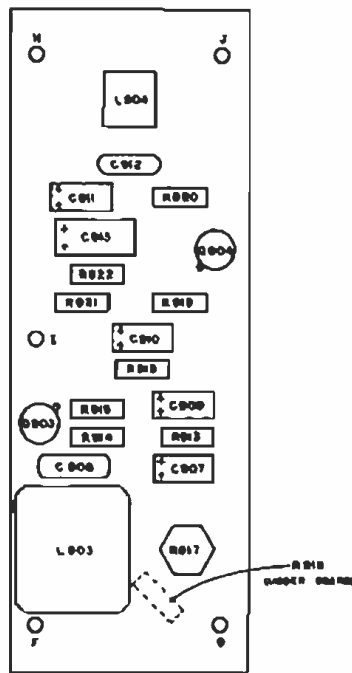

PRIMARY CUE OSCILLATOR  
& CUE RECORD AMPLIFIER

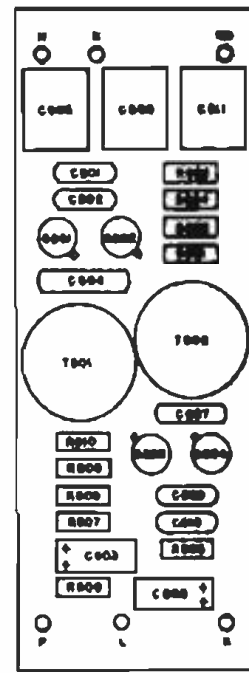

STEREO  
CUE & PROGRAM BIAS OSCILLATORS

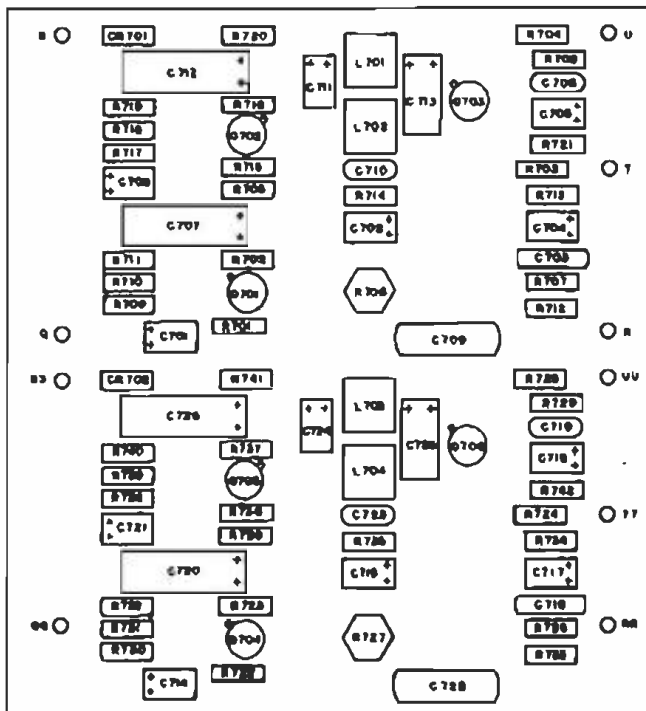

STEREO  
PROGRAM RECORD AMPLIFIER

STEREOPHONIC  
CRITERION RECORDING AMPLIFIER  
BOARD LAYOUTS



P 603

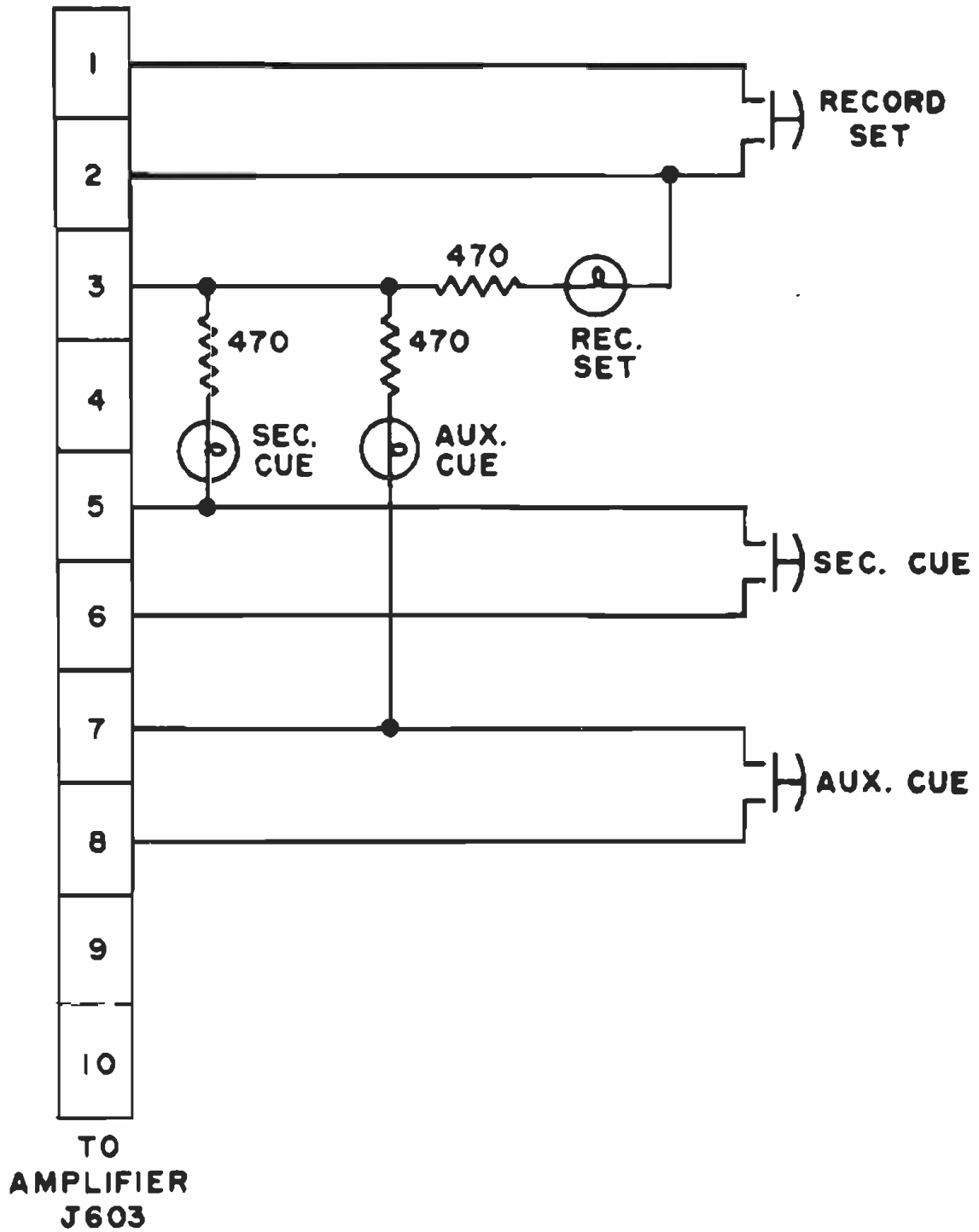

CRITERION RECORDING AMPLIFIER  
REMOTE CONTROL