

**BROADCAST AND
COMMUNICATIONS
EQUIPMENT**

HARRIS
INTERTYPE
CORPORATION

GATES[®]
A DIVISION OF HARRIS-INTERTYPE

INTRODUCTION

Gates proudly presents one of the most comprehensive selections of broadcast equipment ever assembled in one catalog. Here you will find a complete range of AM, FM, Color Television, and Short Wave Broadcast Transmitters, together with the world's most extensive line of audio control consoles and studio equipment.

Gates broadcast products are noted for their quality of craftsmanship and excellence of engineering design. Our goal has always been to set the standards for others to meet—and in recent years this determination has led to the pioneering of such outstanding products as: UHF and VHF color television transmitters with IF Modulation, the first FCC type accepted 100% solid-state FM exciter, Criterion tape cartridge equipment and broadcast automation systems, and the first 50 kW AM transmitter with Vapor Phase Cooling manufactured in the United States. The Pulse Duration Modulator is also a patented Gates development. You will find these and many more Gates "firsts" on the following pages.

Field sales and service is extensive. Branch offices are located in New York, Houston, Washington and Los Angeles. Direct Gates employee Sales Engineers cover all of the continental United States. The New York and Houston Service Centers carry a large inventory of equipment and service parts, serving the Eastern Seaboard from the New York Service Center and the entire South and Southwest from the Houston Service Center. In Canada, sales are handled by Gates Radio Company, (Canada), a division of Harris-Intertype Limited (Canada). Gates International Sales Department, located in New York, coordinates the international market activities with local agents located in most countries of the world.

Gates is a division of Harris-Intertype Corporation, a world leader in graphic arts and electronics, and one of the nation's 500 largest corporations. The corporation's electronics divisions, in addition to Gates, include Radiation Systems, Harris Semiconductor, Radiation Control, PRD Electronics, RF Communications and Intertype. A new dimension has been added to Gates' research and development efforts by the establishment of a corporate product development center at Melbourne, Florida. This facility enables Gates to draw from a large staff of scientists and engineers, as well as from the engineering group at Quincy, to assure our customers that Gates' broadcasting and communications equipment is synonymous with product leadership.

If your need is in radio broadcasting, television broadcasting or HF communications, we wholeheartedly invite your patronage. Each member of the Gates organization will do his very best to justify your confidence.

GATES RADIO COMPANY

A division of Harris-Intertype Corporation
QUINCY, ILLINOIS 62301

Our Modern Manufacturing Facilities



Situated on an attractive 40-acre plot in Quincy, Illinois, the new Gates factory has a total floor space of 108,000 square feet—and is one of the nation's most modern facilities devoted to the manufacturing of broadcast and electronics equipment.

Sales and Service Facilities

NEW YORK—Centralized Eastern Facilities of Gates Radio and Television Field Sales Offices, International Sales Department, and Gates New York Service Center are located at:

130 East 34th Street
New York, New York 10016

Telephone:
New York Service Center—Area (212) 889-0790
International Sales Dept.—Area (212) 725-9800

Gates New York and Houston Service Centers carry thousands of sundry items just for the broadcaster. Fast and efficient service from the New York Service Center to broadcasting stations on the East Coast and from the Houston Service Center to broadcasting stations in the South/Southwest, is available through today's air transportation system.



HOUSTON—Gates stock carrying branch.
4019 Richmond Avenue,
Houston, Texas 77027
Telephone: Area (713) 623-6655

WASHINGTON, D. C.—Gates Radio Company.
730 Federal Building, 1522 K Street, N.W.
Washington, D.C. 20005
Telephone: Area (202) 223-5508

LOS ANGELES—Attractive Western field sales office.
1945 South Figueroa,
Los Angeles, California 90007
Telephone: Area (213) 747-7129

CANADIAN SALES

MONTREAL OFFICE—Gates Radio Company
(Canada) Ltd.
212 Brunswick Boulevard,
Pointe-Claire, Quebec, Canada
Telephone: Area (514) 695-3751

TORONTO OFFICE—Gates Radio Company
(Canada) Ltd.
19 Lesmill Road,
Don Mills, Ontario, Canada
Telephone: Area (416) 447-7234



Table Of Contents

	PAGE
AM BROADCAST TRANSMITTERS	
100 kW to 250 watt transmitters • Phasing and coupling equipment • Monitors • Dummy antennas.....	5
FM BROADCAST TRANSMITTERS	
40 kW to 10 watt transmitters • Stereo and SCA generators • FM relay packages • Antennas • Monitors.....	35
BROADCAST TRANSMITTER ACCESSORIES	
Remote control • Transmission line • Antenna towers • Tower lights • Inductors and mica capacitors.....	69
VHF AND UHF TELEVISION TRANSMITTERS	
220 kW to 100 watt color transmitters • Television accessories • Monitors	81
AUDIO CONTROL CONSOLES.....	119
PROGRAM AUTOMATION.....	149
AUDIO EQUIPMENT	
Solid state limiter • Automatic gain control amplifiers • System-type audio amplifiers • Accessories • Speakers and baffles • Microphones • Remote amplifiers • Turntables • Equipment cabinets • Proof of performance • Tape recorders.....	165
HIGH FREQUENCY BROADCAST TRANSMITTERS.....	209
SINGLE SIDEBAND AND COMMUNICATIONS TRANSMITTERS	
ISB Exciters • HF linear amplifiers • ISB HF transmitters • Transmitter consoles.....	217
ACCESSORY EQUIPMENT	
Remote pick-up equipment • STL equipment • Transmitting tubes • Transistors.....	229
INDEX.....	237

The mechanical and electrical design of the equipment described herein is subject to change without notice as deemed necessary by Gates Radio Company or its suppliers in the interest of advancing industry requirements or the state of the art.

AM BROADCAST TRANSMITTERS



100,000 Watt Medium Wave Broadcast Transmitter

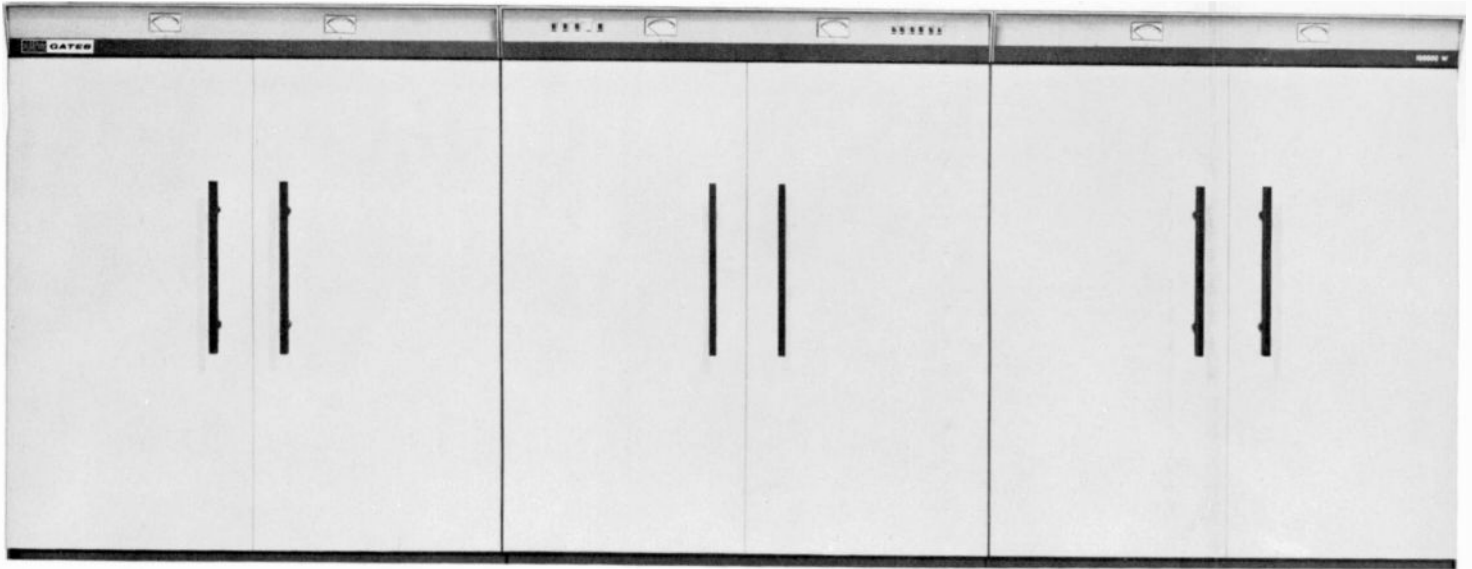

MODEL VP-100

Gates VP-100 is the most advanced 100 kW medium wave transmitter in the world. It provides an over-all performance superior to that of any other AM broadcast transmitter in the same power range—at lower operating costs. With its amazingly high efficiency, and advanced cooling system design, this transmitter represents the latest state-of-the-art in high power broadcast equipment.

HIGH EFFICIENCY—EXCEEDS 65%: The modulation system employed in the VP-100 transmitter is almost 90% efficient (instead of the usual 50% or 60%), enabling the transmitter to achieve an unusually high over-all efficiency of greater than 65%. This means about one-third less power consumption than that of other high-level plate modulated 100 kW transmitters.

ONLY FIVE TUBES: The entire transmitter employs just five tubes—with modern ceramic 4CV100,000C tetrode power tubes operating well below manufacturer's dissipation ratings. All power supplies utilize long-life solid state silicon rectifiers. Highest quality components, conservatively rated, are used throughout the VP-100 to assure a maximum degree of reliability.

CONTINUOUS 100% MODULATION RATING: This continuous sine wave modulation capability permits a higher average modulation (such as trapezoidal) to boost signal strength, without increasing transmitted carrier power. Another feature of this high efficiency modulation system is convenient front panel carrier power adjustment over a wide range.

QUIET OPERATION: Cooling by the Vapor Phase method reduces noise by eliminating the need for large blowers. The heat exchanger is cooled by a single two horsepower blower, resulting in whisper-quiet operation. Vapor Phase Cooling also extends tube life by helping to eliminate "hot spots" and maintains tube anode temperatures far below those attained by other methods.

GREATLY REDUCED FLOOR SPACE: Due to the high efficiency of the transmitter, and the elimination of large iron core components such as the modulation transformer and modulation reactor, the VP-100 requires only 8.8 square meters (95 square feet) of floor space. The advanced cabinet design provides easy accessibility to all components.

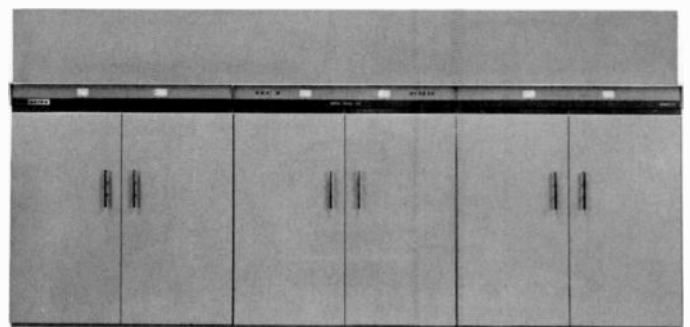

VP-100 with heat exchanger.

100,000 Watt Medium Wave Broadcast Transmitter—VP-100

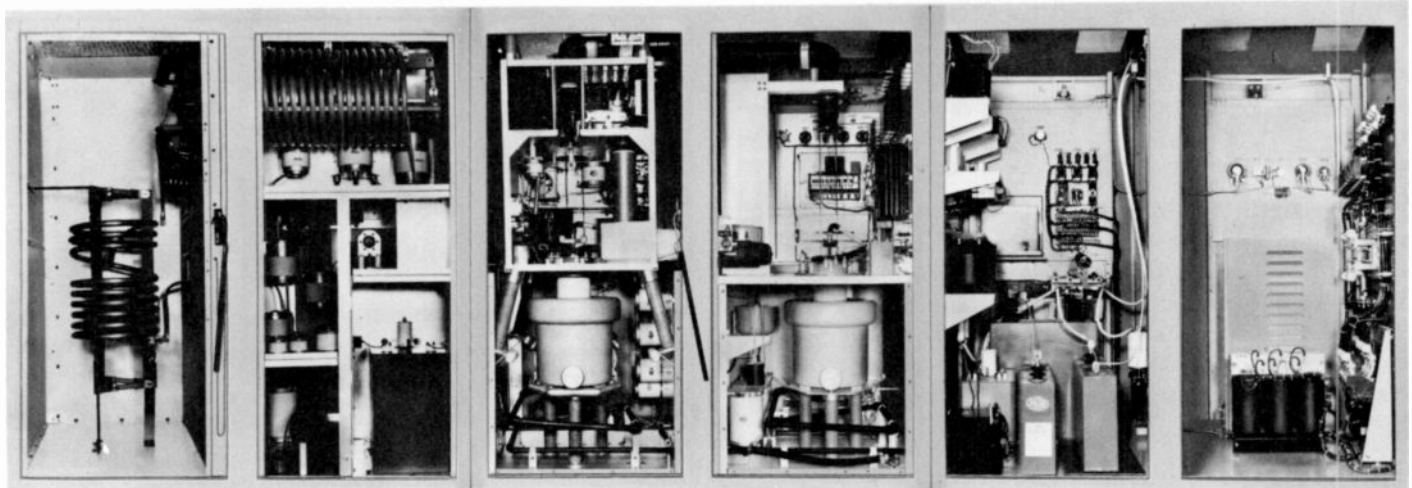

RF Output Cabinet.

Power Amplifier and Modulator Cabinet.

AC Control Cabinet.

Rear View of VP-100 with doors removed.

RF SECTION: The RF chain is conventional, using a transistorized oscillator, buffer, emitter follower, and a 4CX1500B tetrode tube amplifier to drive a single 4CV100,000C tetrode Class C power output stage. An automatic drive control limits the PA screen current to 2.2 amps, eliminating the usual problem of over dissipating the screen of a tetrode during tune-up. A convenient efficiency meter peaks as the efficiency of the transmitter increases, to allow rapid tuning. No "trial-and-error" tune-up methods are necessary.

THE MODULATION SYSTEM: This advanced system is characterized by low plate dissipation and low tube peak currents; peak cathode currents are about one-half that of other 100 kW transmitters. Average plate dissipation runs substantially below rated levels, and all peak voltages are main-

tained well below component ratings. Wide frequency response is possible as large reactive components are not used in the system. Control of the transmitter power output over a wide range is by means of a front panel vernier control. No adjustment is necessary in any high power RF circuits, including the loading coil.

PROTECTIVE CIRCUITS: All major components of the VP-100 are protected by circuit breakers. Tubes and transistors are protected by overload relays or current-limiting devices. A quick-acting series "crowbar" circuit protects against damage from high voltage arcs by limiting the energy in such arcs to less than 10 watt seconds. Protection against voltage standing wave ratios of greater than 1.2 to 1.0 is provided . . . both forward and reflected power is metered at the front panel. In case of momentary RF overloads the VP-100 will recycle twice automatically. Should a third overload occur within a thirty second period, the transmitter will remain off until manually reset. However, if the time between overloads is greater than thirty seconds, continuous recycling will occur.

TRAPEZOIDAL RESPONSE: Trapezoidal modulation may be used to gain additional power on the air without increasing transmitted carrier power. To do this the audio input wave (A), at left, is flattened at the top, by clipping, then reamplified to form a trapezoidal wave (B). The shaded areas in the diagram indicate the power gain. All the additional power gained by clipping the audio input is delivered at the output of the transmitter, thus increasing volume at the receiver.

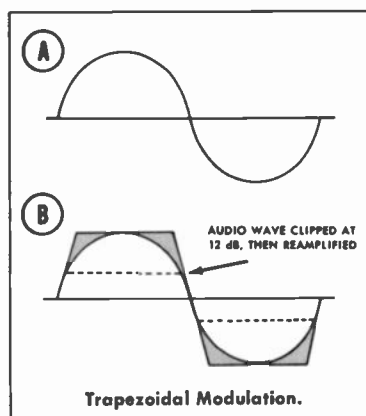

100,000 Watt Medium Wave Broadcast Transmitter—VP-100

DUAL OSCILLATOR AND MODULATOR: Gates has provided redundancy in all transistor sections to relieve any concern over solid state circuitry in high-power transmitters. Although the reliability of transistor circuitry has been proven in transmitters now operating under extreme conditions, this duplication is your double assurance of dependability.

DESIGNED FOR A WIDE RANGE OF CLIMATES: The VP-100 will give top performance in a wide range of climates—from hot and humid, to dry and dusty. With Vapor Phase Cooling, ducting outside air into the transmitter is not necessary. All transformers and similar components are hermetically sealed, encased, or vacuum impregnated. All high power radio frequency networks contain silver-plated inductors and vacuum capacitors.

TRANSMITTER LAYOUT: The standard VP-100 consists of three cabinets, a heat exchanger designed for mounting on top of the cabinets, and an external high voltage power transformer. Front and rear doors, and meter panel are magnetically latched. External connections to the transmitter are made through the top of the units so that floor ducts are not necessary.

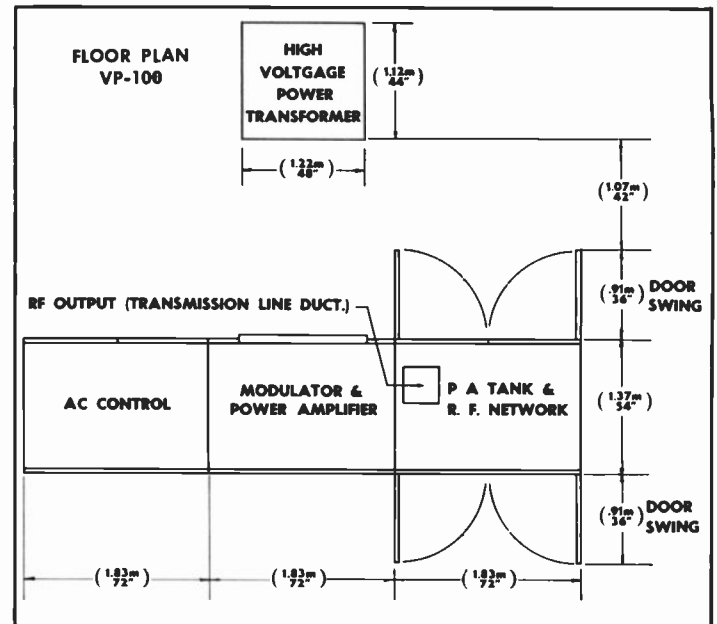

SPECIFICATIONS

POWER OUTPUT: 100,000 watts nominal unmodulated; capable 110,000 watts.

RF FREQUENCY RANGE: 535 kHz to 1620 kHz.

RF OUTPUT IMPEDANCE: 230 ohms, unbalanced. Other output impedances available as specified.

FREQUENCY STABILITY: ± 10 Hz of assigned frequency.

CARRIER SHIFT: Less than 4% at 100% modulation.

MODULATION: High level.

TRAPEZOIDAL MODULATION: Less than 5% tilt or overshoot 100 Hz to 2,000 Hz.

MODULATION LEVEL: 100% sinusoidal, continuously, over an audio frequency range of 50-5000 Hz.

RF HARMONICS: -80 dB below fundamental (well within CCIR requirements).

AUDIO FREQUENCY RESPONSE: ± 1.5 dB from 50 to 10,000 Hz, referenced to 1000 Hz at 95% modulation.

AUDIO FREQUENCY DISTORTION: Less than 3% from 100 to 7500 Hz; 4% from 50 to 10,000 Hz at 95% modulation.

NOISE: -55 dB below 1000 Hz, 100% modulated level.

AUDIO INPUT IMPEDANCE: 600/150 ohms, balanced or unbalanced.

AUDIO INPUT LEVEL: +10 dBm ± 2 dB at 1000 Hz for 100% modulation.

POWER CONSUMPTION: 155 kW—No Modulation.
160 kW—30% Modulation.
215 kW—100% Modulation.

POWER INPUT: Any specified voltage 380 V to 480 V, $\pm 5\%$, 3 phase, 50 or 60 Hz as ordered.

POWER FACTOR: 95%.

VOLTAGE REGULATOR: Built-in electronic voltage regulator for all power supplies other than high voltage.

CROWBAR RESPONSE: Less than 5 microsecond operate time.

OVER-ALL EFFICIENCY: 65% @ average modulation.

ALTITUDE: Up to 1829 meters (6000 feet) above sea level (higher on special order).

TEMPERATURE RANGE: Ambient air temperature from -20°C to $+50^{\circ}\text{C}$ (with Dowanol* in water system).

STORAGE TEMPERATURE: -35°C to $+60^{\circ}\text{C}$.

HUMIDITY: Up to 95% maximum within the above temperature range.

SIZE: Each of the three cabinets measures 1.83 meters (6 feet) wide, 1.37 meters (4.5 feet) deep, and 1.98 meters (6.5 feet) high. The heat exchanger adds another 1.21 meters (4 feet) in height. The HV transformer measures 1.21 x 1.12 x 1.52 meters (48" x 44" x 60").

WEIGHT: Export packed 8165 kilograms (18,000 lbs.). Main transmitter assembly 5443 kg (12,000 lbs.). Power transformers 2268 kg (5000 lbs.). Heat exchanger 454 kg (1000 lbs.).

CUBAGE: Export packed 39.6 cubic meters (1400 cubic feet). Main transmitter assembly 31.6 cu. meters (1115 cu. ft.). Power transformer 3.8 cu. meters (135 cu. ft.). Heat exchanger 4.1 cu. meters (150 cu. ft.).

FINISH: Two-tone beige-gray.

TUBES: Two, 4CV100,000C; two, 4CX1500B; one, F-1099 (damper diode).

ORDERING INFORMATION

Model VP-100 with one set of tubes and two crystals.....994-6561

100% set spare tubes for VP-100 transmitter.....990-0566

Recommended minimum spare tubes for VP-100 transmitter.....990-0567

* Trademark of Dow Chemical Company.

50,000 Watt Medium Wave Broadcast Transmitter

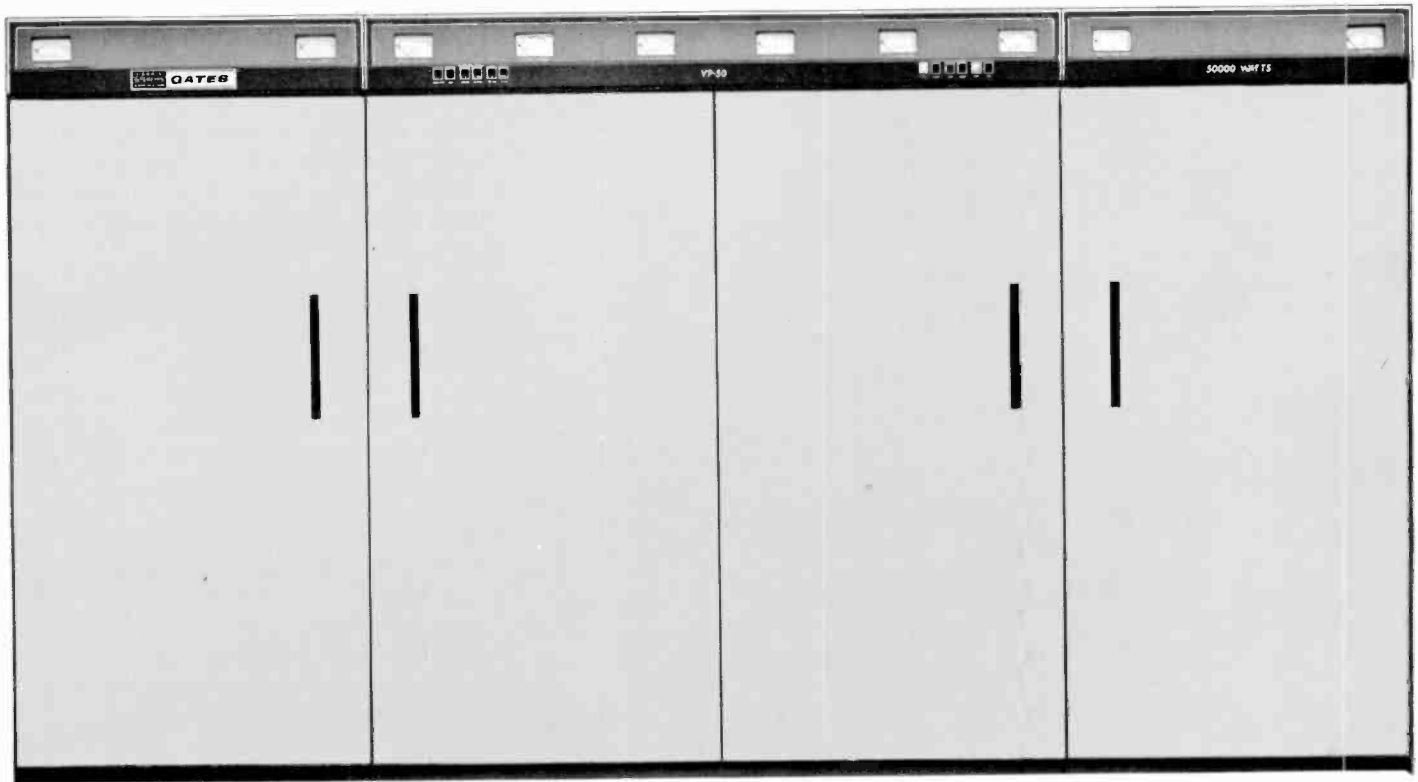

MODEL VP-50

Inside and out, the VP-50 is the first really new 50,000 watt AM transmitter produced in the last decade. Advanced engineering in the cooling system design has produced the coolest, quietest, and most efficient 50 kW broadcast transmitter ever manufactured.

OPERATING ECONOMY: Vapor cooling of the single triode PA tube and the two triode modulator tubes produces a high level plate modulated transmitter with a power consumption of only 85 kW at 0% modulation. Tube costs are the lowest of any 50 kW transmitter, yet the constant temperature maintained by the cooling system helps to extend tube life. All transmitter components are operated well below manufacturers' ratings for longer, more dependable operation.

WHISPER QUIET OPERATION: With the vapor cooling method employed in the VP-50, large blowers, and associated noise, are eliminated. As a result, the VP-50 is the quietest 50 kW transmitter on the market today.

INSTALLATION FLEXIBILITY: The VP-50 is compact in size—designed to fit most existing buildings or to permit construction of low-cost new buildings. It can be installed without complex under-floor wiring ducts, as all high voltage lines are run into the top of the cabinets.

SOLID STATE POWER SUPPLIES: Silicon rectifiers are used throughout the VP-50. The result is greatly improved performance, as silicon cells are particularly resistant to aging, moisture, and extreme temperature variations.

DUAL SOLID STATE EXCITER: Both the oscillator and intermediate RF amplifier are all transistor. In addition, the exciter has a duplicate oscillator and intermediate amplifier for highest reliability. If one unit should fail to operate, the back-up exciter can be switched into service immediately.

POWER AMPLIFIER: A single 4CX3000A IPA tube drives the conservatively rated 7480 triode PA tube to produce a full 50 kW power output.

HIGH LEVEL PLATE MODULATION: The VP-50 uses two 3CV30,000H3 triodes operating Class B to modulate the single 7480 triode final RF amplifier. A conventional three stage audio amplifier is used to drive the modulator tubes. High level plate modulation has the advantage of simplicity, since final amplifier tuning is simplified. Unlike other techniques, high level modulation is not affected by changes in the final RF amplifier loading.

50,000 Watt Medium Wave Broadcast Transmitter—VP-50

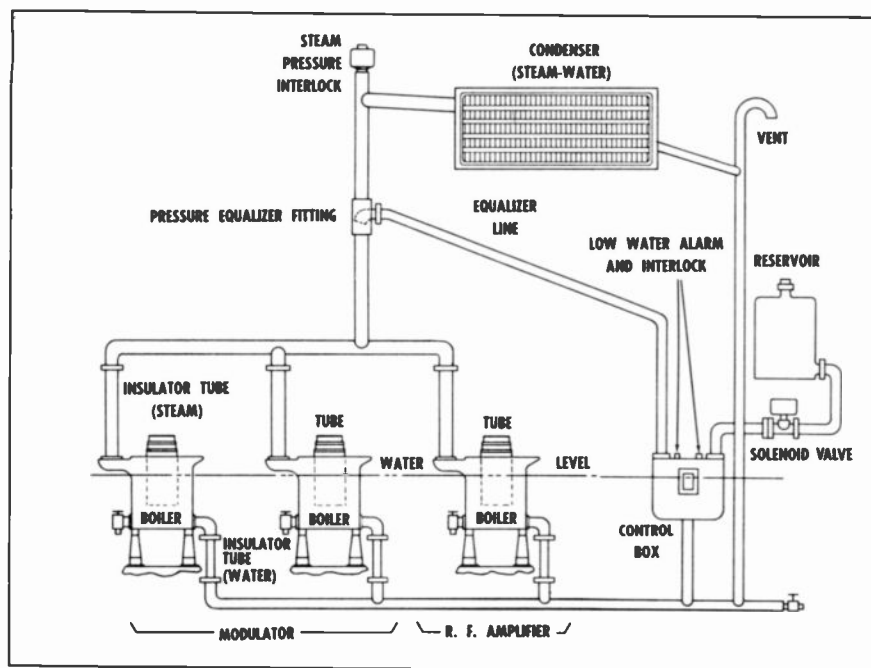

Vapor Phase Cooling.

VAPOR PHASE COOLING:

Cooling by vapor takes advantage of the latent heat of vaporization of water. Raising the temperature of one pound of water 1°F requires one BTU; however, changing a single pound of water at 212°F to steam vapor takes 970 BTU's. Thus, vapor cooling will remove nearly twenty times as much energy as a circulating water system.

As power is applied to the tube anode, dissipation heats the water to 212°F. Further heating causes the water to boil and change to steam. This vapor is passed through a heat exchanger, where it is converted to liquid. Water is returned to the boiler reservoir for re-use.

Water losses are compensated for by the reserve tank, which will replenish the boiler if the water level drops one-quarter inch. Tube anodes have a constant supply of water with fail-safe protection. The vapor system operates near atmospheric pressure and is fully vented.

In the Gates VP-50 transmitter water pumps are not required, as normal vapor pressure will move the steam from the boiler to the heat exchanger, and return water is gravity fed back to the boilers.



Easy to handle PA tube.

PROTECTIVE DEVICES: DC overload relays are provided, as well as AC overload relays, which are used in conjunction with the start contactors in the HV power supply. Magnetic breakers protect the bias, screen and intermediate high voltage supplies. In case of RF overload, the output VSWR circuit will automatically turn off the transmitter and recycle up to three times, giving momentary troubles a chance to clear.

OPERATING SIMPLICITY: Automatic sequence control circuits are provided. This assures simple and fool-proof operation, and helps avoid costly errors. With a total of 14 meters, including 10 located on the front of the main transmitter assembly, all vital transmitter circuits can be monitored constantly. The few tuning controls that require adjustment are readily accessible through the front doors.

EASY MAINTENANCE: Full front and rear access to all components makes the VP-50 one of the easiest to maintain high power transmitters ever designed. Ideal for use in all climates, this transmitter greatly reduces the problems of cleaning and filtering of outside air required in forced air systems. The cooling system requires little attention other than maintaining the proper purity and water level in the reservoir tank.

50,000 Watt Medium Wave Broadcast Transmitter—VP-50

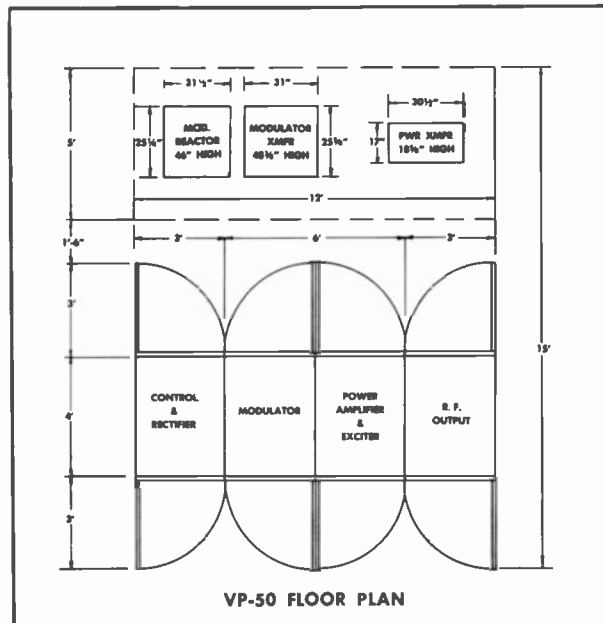
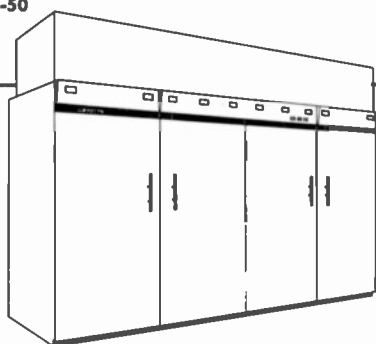
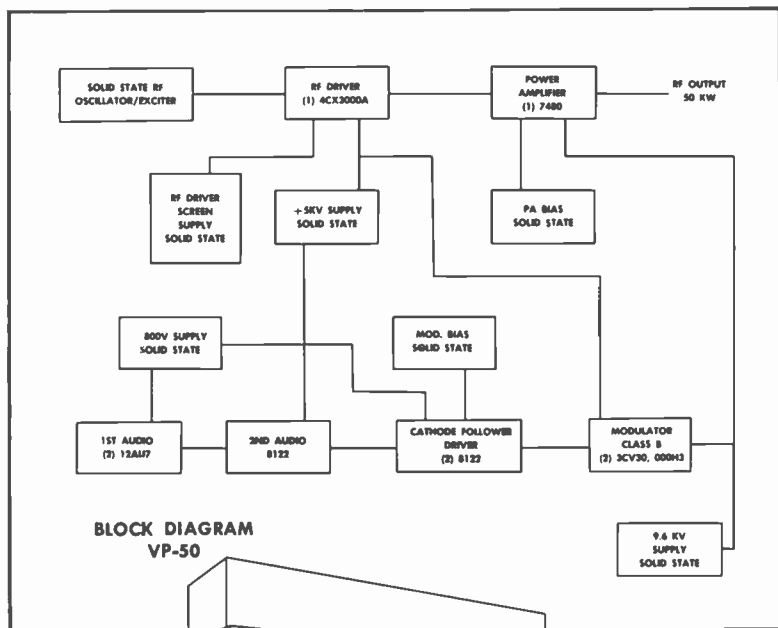

SPECIFICATIONS

POWER OUTPUTS: 50,000 watts (rated), 55,000 watts (capable). Convenient power reduction to 25,000 or 10,000 watts.

RF FREQUENCY RANGE: 535 kHz to 1620 kHz, supplied to frequency as ordered.

RF OUTPUT IMPEDANCE: Any impedances from 50 to 300 ohms.

FREQUENCY STABILITY: ± 2 Hz.

CARRIER SHIFT: Less than 3% at 100% modulation.

RF HARMONICS: Exceeds FCC and CCIR specifications.

AUDIO FREQUENCY RESPONSE: ± 1 dB, 50 to 7500 Hz $\pm 1\frac{1}{2}$ dB, 30 to 12,000 Hz.

AUDIO FREQUENCY DISTORTION: Less than 3%, 50 to 7500 Hz at 95% modulation.

NOISE: (Unweighted) -60 dB or better below 100% modulation.

AUDIO INPUT: 600/150 ohms at +10 dBm ± 2 dB for 100% modulation.

POWER CONSUMPTION:

	50 kW Output	25 kW Output
0% modulation	85 kW	48 kW
30% modulation	95 kW	53 kW
100% modulation	125 kW	69 kW

POWER INPUT: 380 V, or 460 V, 3 phase, 50 or 60 Hz as ordered.

POWER FACTOR: 90% or better.

ALTITUDE: To 6,000 feet standard (higher on special order).

TEMPERATURE RANGE: -20°C to $+50^{\circ}\text{C}$ (with Dowanol* in water system).
* Trademark Dow Chemical Co. (Used only where temperatures go below 0°C .)

HUMIDITY: 95%.

SIZE: 78" high, 144" wide, 48" deep (transmitter cabinet). External components include: Modulation transformer, modulation reactor, and power transformer. Heat exchanger mounted on top of VP-50 adds 24" to overall height.

WEIGHT: 12,000 lbs. unpacked (approximate).
14,250 lbs. domestic packed (approximate).
15,500 lbs. export packed (approximate).

CUBAGE: 1003.5 cu. ft.

FINISH: Beige-gray.

TUBES USED: (1) 7480; (2) 3CV3000H3; 4CX3000A; (4) 8122; (3) 12AU7.

ORDERING INFORMATION

Model VP-50 with one set of tubes and two crystals.....994-6523
100% set of spare tubes for VP-50 transmitter.....990-0537
Recommended minimum spare tubes for VP-50 transmitter.....990-0538

20,000 Watt Medium Wave Transmitter



MODEL BC-20H

The BC-20H, 20 kW transmitter consists of two standard BC-10H 10 kW transmitters, a 20 kW combiner, and a common drive unit. All components are housed within the transmitter cabinet, eliminating the need for external ducting and enclosures. Askarel (oil) filled modulation transformers are provided as standard equipment for added reliability.

SOLID STATE CIRCUITRY: The BC-20H employs transistors in all circuitry except the RF driver, power amplifier and modulator for superior performance. Only ten tubes are used in the entire transmitter.

RF SECTION: In addition to the oscillator/exciter incorporated in each 10 kW transmitter, a third oscillator is provided in the BC-20H to permit maximum operating flexibility. This independent exciter is used as a common drive to each transmitter and is enclosed in the center cabinet. Output of this unit is split and drives independent buffer amplifiers for isolation and phase adjustment. The RF signal then feeds individual oscillators in each 10 kW transmitter, which in turn excites the 4-400 driver and the high level plate modulated 3CX2500F3 power amplifiers. Overall efficiency of the power amplifiers is typically 85% or better, a direct benefit of the

high efficiency RF circuits that are utilized.

RF output of each transmitter is fed into a bridged-tee combiner network, housed in the middle cabinet. A 10 kW dummy load is provided with an in-line RF ammeter for visual indication of current to the reject branch of the combiner network. Under optimum conditions, no current will exist in this branch. No critical adjustments are required and simplified overall operation is stable.

In the event that maintenance or adjustment, such as initial tune-up of the transmitters is required, the 10 kW dummy load may be switched manually so that the output of one power amplifier feeds the load directly while the other amplifier can drive the antenna system. While in the combined mode, monitoring is accomplished by a pickup loop at the combiner output for indication of modulation level of the entire transmitter system.

AUDIO SECTION: Audio is processed by a transistorized audio amplifier which drives the Class B 3CX2500F3 modulators. High level plate modulation techniques are used with enhanced performance obtained by applying audio to the RF driver stage.

20,000 Watt Medium Wave Transmitter-BC-20H

RELIABILITY: The design philosophy employed in the BC-20H assures long term operation with no lost air time. 100% redundancy of equipment means that a signal can remain on the air with no down time for maintenance. One transmitter can be turned off while the other continues to operate.

ADDITIONAL FEATURES: Important features include reliable silicon diodes in all power supplies; built-in circuitry for remote control; ample cooling for all climatic conditions with quiet, low-speed blowers; and low operating cost, with only two tube types used in the BC-20H.

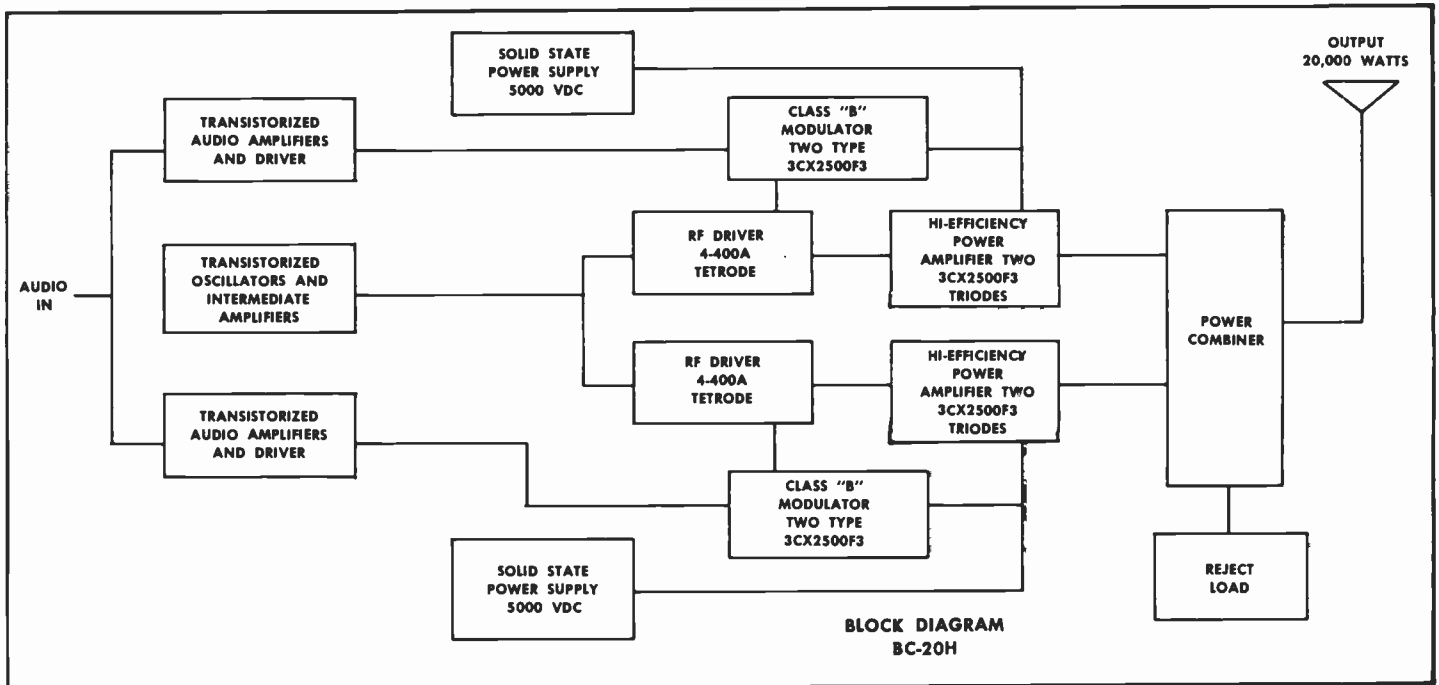

SPECIFICATIONS

POWER OUTPUT: (Rated) 20,000 watts. (Capable) 21,600 watts.

RF FREQUENCY RANGE: 535 kHz to 1620 kHz, supplied to one frequency as ordered.

RF OUTPUT IMPEDANCE: Supplied for 50 ohms, or other as specified.

RF FREQUENCY STABILITY: ± 2 Hz.

CARRIER SHIFT: Less than 3% at 100% modulation.

RF HARMONICS: Meets or exceeds FCC specifications.

AUDIO FREQUENCY RESPONSE: ± 1 dB, 50 to 10,000 Hz. $\pm 1\frac{1}{2}$ dB, 30-12,000 Hz.

AUDIO FREQUENCY DISTORTION: 2.5% or less 50 Hz to 10,000 Hz at 95% modulation.

NOISE: (Unweighted) 60 dB or better below 100% modulation.

AUDIO INPUT: 600/150 ohms at +10 dBm, ± 2 dB.

POWER INPUT: 208/230 volts, 3 phase, 50 or 60 Hz. 37 kW no modulation. 42 kW average modulation. 55 kW 100% modulation.

AMBIENT TEMPERATURE RANGE: -20° to $+50^{\circ}$ C.

ALTITUDE: To 7,500 feet standard (higher altitudes on special order).

SIZE: 78" high, 177" wide, 32" deep (completely self-contained).

WEIGHT: 5200 lbs. unpacked (approximate). 6800 lbs. export packed (approximate).

CUBAGE: 390 cubic feet packed.

FINISH: Beige-gray.

TUBES USED: (8) 3CX2500F3; (2) 4-400A. Total: 10.

GENERAL INFORMATION: Monitors: 10 RF volts output at 50/70 ohms for frequency and modulation monitors.

ORDERING INFORMATION

Model BC-20H transmitter, consisting of two standard BC-10H 10 kW transmitters, a 20 kW combiner and a common drive unit -----

994-6669

10,000 Watt Medium Wave Broadcast Transmitter



MODEL BC-10H

The most outstanding 10,000 watt AM transmitter on the market today, the BC-10H has gained wide acceptance and approval from broadcasters throughout the country in the two years since its introduction. Excellent on-the-air quality, high reliability, and low operating costs are proven features that have helped to make the BC-10H so popular.

SOLID STATE CIRCUITRY: The BC-10H uses transistors in all circuits except the RF driver, power amplifier and modulator to provide a richer, fuller sound for the listener, and increased reliability for the broadcaster.

LOW TUBE COST: Ceramic type 3CX2500F3 triode tubes are used in the power amplifier and modulators, and a type 4-400A tetrode is used as the RF driver. All tubes are operated well below their maximum ratings for long tube life. This combination provides the lowest cost tube complement of any 10 kW AM broadcast transmitter on the market today.

RF SECTION: Two transistor oscillators are instantly switchable, and oscillator output is amplified to provide the proper signal level for the driver, a 4-400A tetrode, which is modulated to improve the over-all transmitter performance. The 4-400A drives two 3CX2500F3 power amplifiers which are high level plate modulated. These air-cooled power amplifiers have an efficiency as high as 90%, and feed a full Tee network. The RF output capability of the BC-10H, 10,800 watts, easily accommodates complicated multi-tower phasors.

AUDIO SECTION: Four push-pull solid state audio amplifier stages amplify the audio signal from input level to full drive power for the modulator stage. The modulator consists of two 3CX2500F3 triodes, operated Class AB₁. Inverse feedback, and an advanced design low leakage reactance modulation transformer/reactor group, results in signal quality of the highest fidelity. The modulation transformer is oil (Askarel) filled.

10,000 Watt Medium Wave Broadcast Transmitter—BC-10H

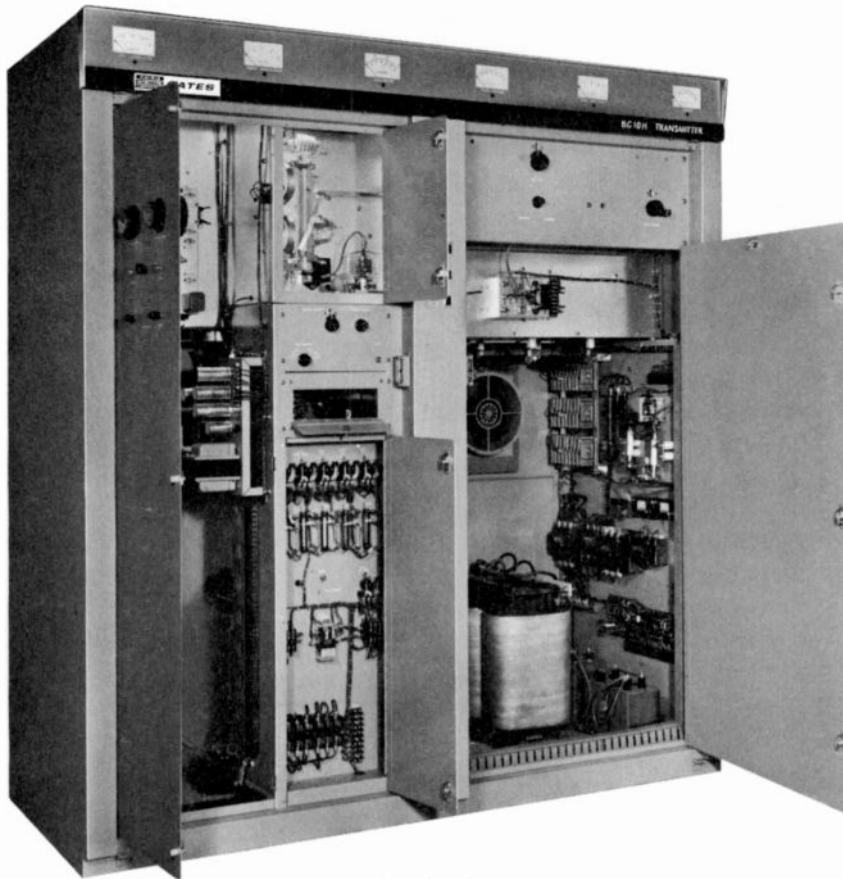

Front view, interior.

INTERCHANGEABILITY: Added tube life may be achieved from the 3CX2500F3 triodes by interchanging the modulators and the power amplifiers, as the same tube type is used in both stages.

SOLID STATE POWER SUPPLIES: Lifetime silicon rectifiers in all power supplies provide a 2 to 1 voltage and a 5 to 1 current safety factor. This high margin of safety assures trouble-free performance.

CONTROL CIRCUITRY: Careful attention has been given to the design of the control circuitry in the BC-10H. Complete AC and DC overload protection is standard equipment. A recycling feature, which will automatically turn the transmitter off when an overload occurs, is built-in.

HARMONIC RADIATION: A full Tee network and second harmonic trap are assurance that the BC-10H can exceed harmonic reduction regulations within the transmitter itself without relying on the harmonic attenuation of a phasor or

antenna coupler. Either of these then becomes a bonus factor in harmonic suppression.

EFFICIENT COOLING: Individual low-speed Rotron blowers in the RF and modulator stages, and a specially designed air exhaust, allow only a limited amount of direct heat to be dissipated into the interior of the BC-10H—for extra-cool operation.

OPERATING ECONOMY: Long tube life, low tube cost, and the highly efficient tank circuit combine to make economy of operation an important feature of the BC-10H.

ACCESSIBILITY: Designed for easy servicing, the transmitter front features 2 full length doors, with operational controls located between the two. Meters which indicate transmitter operating parameters are located across the front of the cabinet, above the doors. All necessary tuning controls are adjustable in full view of these meters. Further access to the transmitter from the front may be gained by releasing the catches on various front access panels. In addition, 4 panels may be removed from the rear of the transmitter for 100% accessibility.

The BC-10H is completely self-contained within one cabinet.

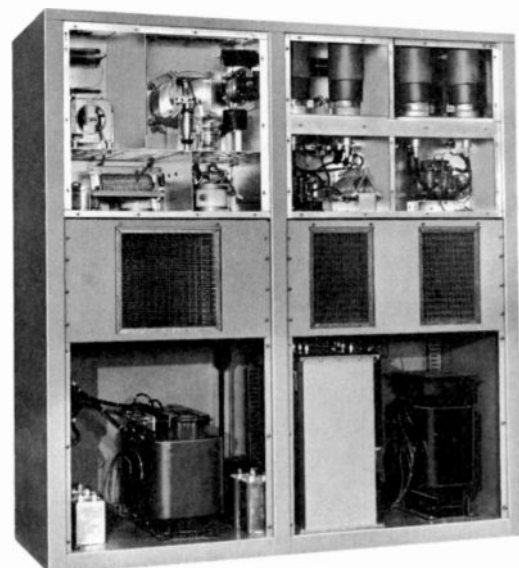

Rear view, interior.

10,000 Watt Medium Wave Broadcast Transmitter—BC-10H

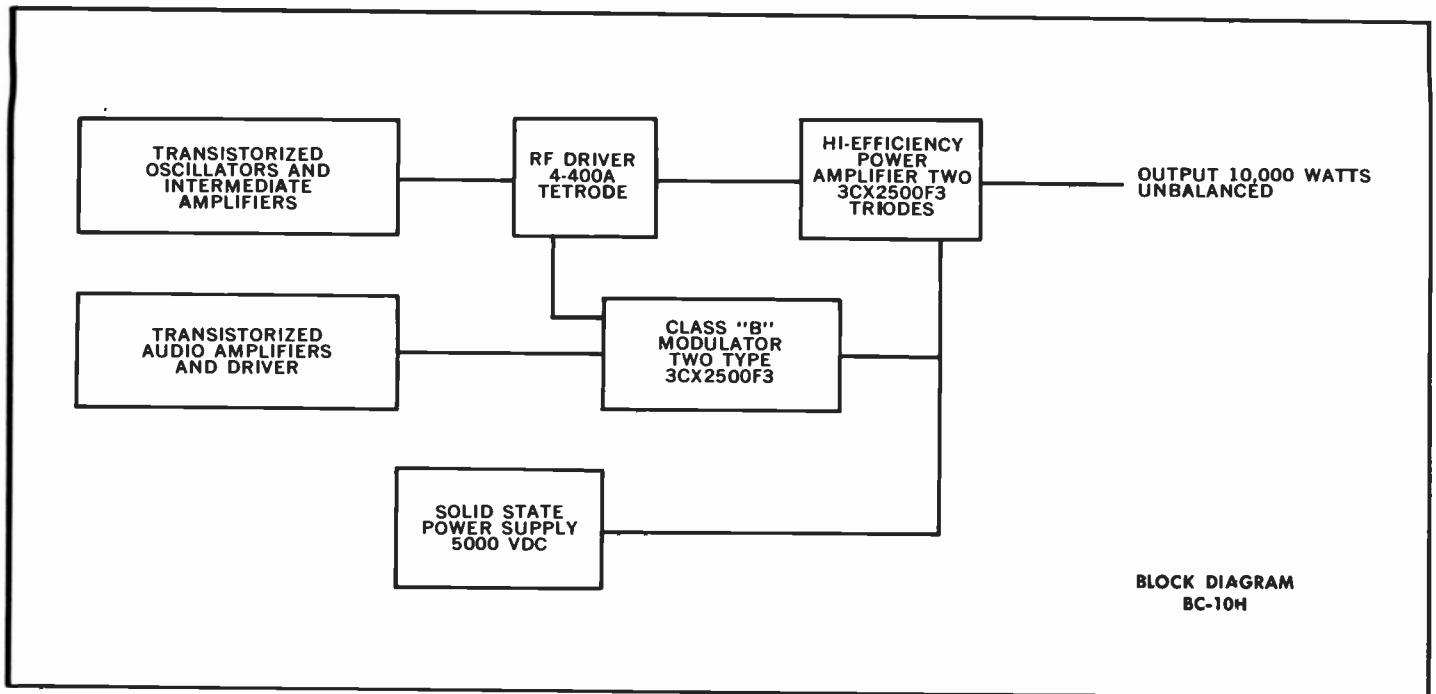

SPECIFICATIONS

POWER OUTPUT: (Rated) 10,000 watts. (Capable) 10,800 watts. Power reduction to approximately 2,500 watts included.

RF FREQUENCY RANGE: 535 kHz to 1620 kHz supplied to one frequency as ordered.

RF OUTPUT IMPEDANCE: Supplied for 50 ohms, or other as specified.

RF FREQUENCY STABILITY: ± 2 Hz.

CARRIER SHIFT: Less than 3% at 100% modulation.

RF HARMONICS: Meets or exceeds FCC specifications.

AUDIO FREQUENCY RESPONSE: ± 1 dB, 50 to 10,000 Hz. $\pm 1\frac{1}{2}$ dB, 30-12,000 Hz.

AUDIO FREQUENCY DISTORTION: 2.5% or less 50 Hz to 10,000 Hz at 95% modulation.

NOISE: (Unweighted) 60 dB or better below 100% modulation.

AUDIO INPUT: 600/150 ohms at +10 dBm, ± 2 dB

POWER INPUT: 208/230 volts, 3 phase, 50 or 60 Hz. 18.5 kW zero modulation. 21.0 kW average modulation. 27.5 kW 100% modulation.

AMBIENT TEMPERATURE RANGE: -20°C to $+50^{\circ}\text{C}$.

ALTITUDE: To 7,500 ft. standard (higher altitudes on special order).

SIZE: 78" high, 72" wide, 32" deep (completely self-contained).

WEIGHT: 2,500 lbs. unpacked (approximate). 3,050 lbs. domestic packed (approximate). 3,250 lbs. export packed (approximate).

CUBAGE: 184 cubic feet packed.

FINISH: Beige-gray.

TUBES USED: (4) 3CX2500F3, (1) 4-400A. Total—5.

GENERAL INFORMATION: Monitors: 10 RF volts output at 50/70 ohms for frequency and modulation monitors.

ORDERING INFORMATION

Model BC-10H transmitter with one set of tubes and two crystals.....	994-6522
100% set spare tubes for BC-10H transmitter.....	990-0539
Set of spare transistors for BC-10H (diodes not included).....	990-0540
Kit for remote control of power output.....	994-6548

5000 Watt Medium Wave Broadcast Transmitter

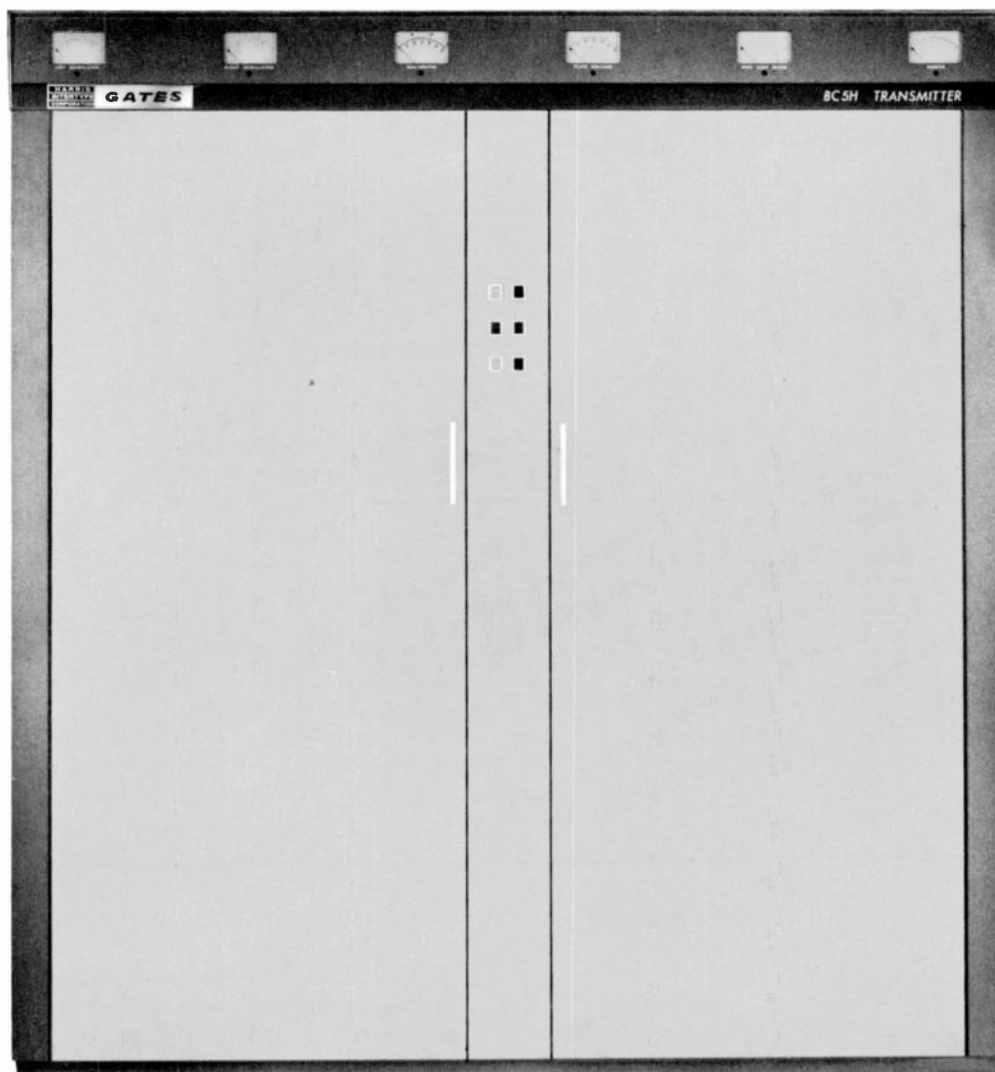

MODEL BC-5H

Representing the finest in engineering design, the BC-5H provides superb over-all performance, with top quality audio, high reliability, and extra low power consumption through the use of high efficiency power amplifier circuits.

The transmitter is completely self-contained, and requires a floor space of only 72 inches (wide) and 32 inches (deep). The over-all height is 78 inches.

Other features that have helped to make the BC-5H the most popular broadcast transmitter in its power range are: large edgewound silver plated tank and Tee network coils; a low leakage reactance modulation transformer for excellent sound quality; a design that permits easy attachment of remote control; unusually high efficiency; and lowest tube cost of any 5000 watt AM transmitter.

TRANSMISSION FIDELITY: Wide frequency response and low carrier shift are important considerations in the design of an AM transmitter. The extremely wide audio response and superior reproduction of audio dynamic range in the BC-5H testify to its advanced engineering development—evident to all who hear this transmitter's excellent broadcast signal.

RF SECTION: In the RF circuit, a transistor oscillator (instantly switchable to a back-up oscillator), drives a transistorized amplifier, which provides drive for the type 4-400A tetrode RF driver. This driver stage is modulated to improve the over-all performance of the transmitter. The 4-400A drives a single 3CX2500F3 power amplifier tube, which is high level plate modulated, and uses high efficiency RF circuits to improve the power amplifier efficiency to 90%. The power amplifier feeds a full Tee network.

5000 Watt Medium Wave Broadcast Transmitter—BC-5H

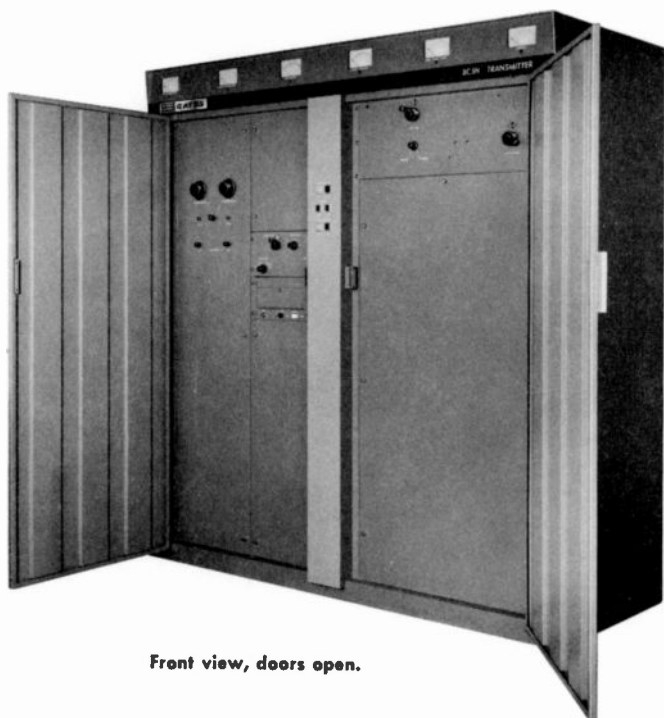
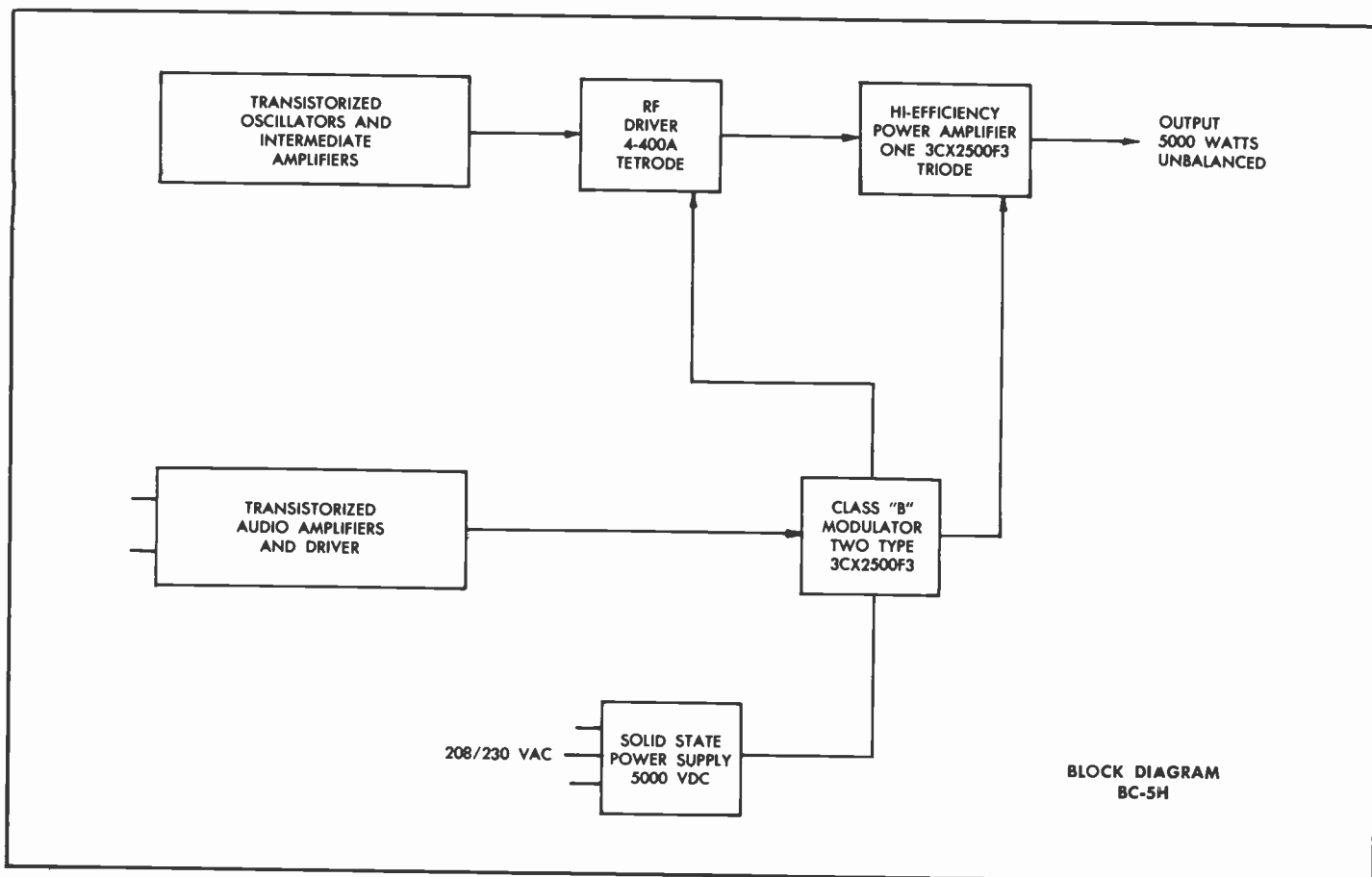

Front view, doors open.

AUDIO SECTION: Four push-pull solid state audio amplifier stages amplify the audio signal from input level to full drive power for the modulator stage. The modulator stage, consisting of two Class B type 3CX2500F3 triodes, provides more than ample power to high level modulate the power amplifier, and modulate the RF driver. Inverse feedback, and an advanced design low leakage reactance modulation transformer/reactor group, results in signal quality of the highest fidelity. The rugged modulation transformer is oil (Askarel) filled for additional protection.

TUBE INTERCHANGE: Both the RF power amplifier and modulator stages use 3CX2500F3 long-life triodes. By periodic rotation many added tube life hours may be gained. Only four tubes of two different types are used in the entire transmitter.

SOLID STATE POWER SUPPLIES: Five separate power supplies assure fine regulation, and add to reliability. Lifetime silicon rectifiers in all power supplies provide a 2 to 1 voltage and a 5 to 1 current safety factor.

HARMONIC ATTENUATION: Harmonic reduction meets rigid FCC regulations, and is achieved through the use of a Tee network in the output circuit, and a second harmonic filter. The harmonic attenuation from the phasor or antenna coupler thus becomes a bonus for still greater harmonic reduction.

5000 Watt Medium Wave Broadcast Transmitter—BC-5H

REMOTE CONTROL: Use of relays in the transmitter control circuits makes installation of remote control simple. Terminals are factory installed in the transmitter, so that circuits to be remote controlled may be easily connected.

PROTECTIVE CIRCUITS: Relays are provided for overload, start/stop and interlock circuits, along with pressure type switches. An output power/VSWR meter is standard equipment, and is interlocked in the transmitter control circuitry as a protective device against antenna system malfunction.

RECYCLING: In the event of a direct short in the high voltage supply, the transmitter will recycle three times and then shut down. In the event of flashover, due to an electrical storm, the transmitter will momentarily shut down and then return to the air with no mechanical limit on the number of times recycling may occur.

EFFICIENT COOLING: One low speed Rotron blower cools all tubes, and a special air exhaust vents heat directly to the transmitter exterior to prevent heat circulation within the transmitter cabinet.

ACCESSIBILITY: The BC-5H is 100% accessible, with full length front doors, drop down front panels and removable rear panels. The transmitter control panel is located between the two front doors, and necessary tuning controls are adjustable from the front, in full view of meters which indicate operating parameters.

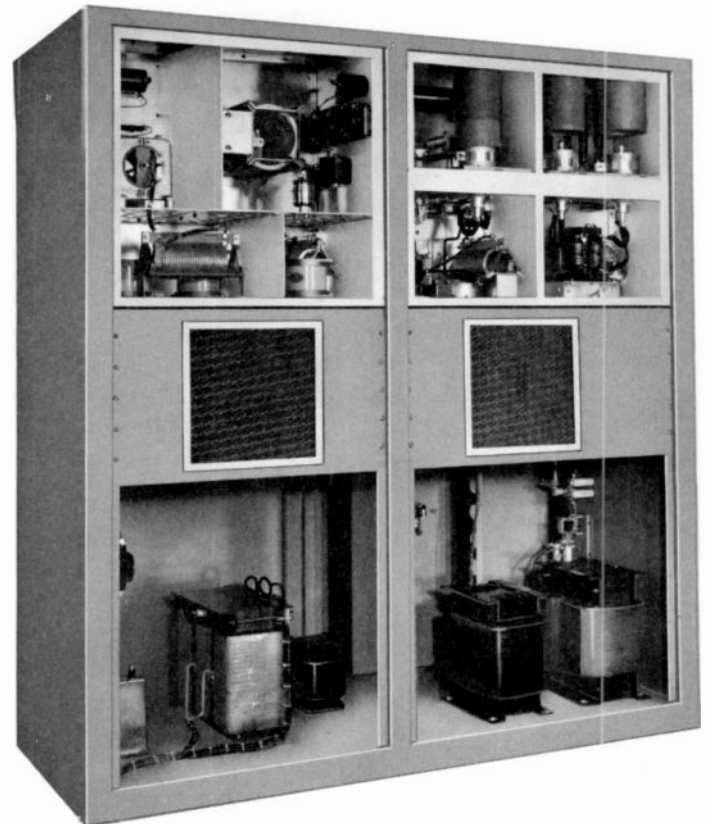

Rear view, dust covers removed.

SPECIFICATIONS

POWER OUTPUT: (Rated) 5000 watts. (Capable) 5600 watts. Power reduction to approximately 1000 or 500 watts available.

RF FREQUENCY RANGE: 535 kHz to 1620 kHz—supplied to one frequency as ordered.

RF OUTPUT IMPEDANCE: Supplied for 50 ohms, or other as specified.

RF FREQUENCY STABILITY: ± 2 Hz.

CARRIER SHIFT: Less than 3% at 100% modulation.

RF HARMONICS: Meets or exceeds FCC specifications.

AUDIO FREQUENCY RESPONSE: ± 1 dB 50 to 10,000 Hz. $\pm 1\frac{1}{2}$ dB 30 to 12,000 Hz.

AUDIO FREQUENCY DISTORTION: 2.5% or less 50 Hz to 10,000 Hz at 95% modulation.

NOISE: (Unweighted) 60 dB or better below 100% modulation.

AUDIO INPUT: 600/150 ohms at +10 dBm, ± 2 dB.

POWER INPUT: 208/230 volts, 3 phase, 50 or 60 Hz. 10.7 kW zero modulation. 11.9 kW average modulation. 15.6 kW 100% modulation.

AMBIENT TEMPERATURE RANGE: -20°C to $+50^{\circ}\text{C}$.

ALTITUDE: To 7500 feet standard (higher altitudes on special order).

SIZE: 78" high, 72" wide, 32" deep. Completely self-contained.

WEIGHT: 1850 lbs. unpacked (approximate); 2200 lbs. domestic packed (approximate); 2450 lbs. export packed (approximate).

CUBAGE: 120 cubic feet packed.

FINISH: Beige-gray.

TUBES USED: (3)3CX2500F3, (1)4-400A.

GENERAL INFORMATION: Monitors: 10 RF volts output at 50/70 ohms for frequency and modulation monitors.

ORDERING INFORMATION

Model BC-5H transmitter with one set of tubes and two crystals.....	994-6521
100% set spare tubes for BC-5H transmitter.....	990-0535
100% set spare transistors for BC-5H (diodes not included).....	990-0540
Kit for remote control of power output.....	994-6548

1000/250 Watt AM Broadcast Transmitter

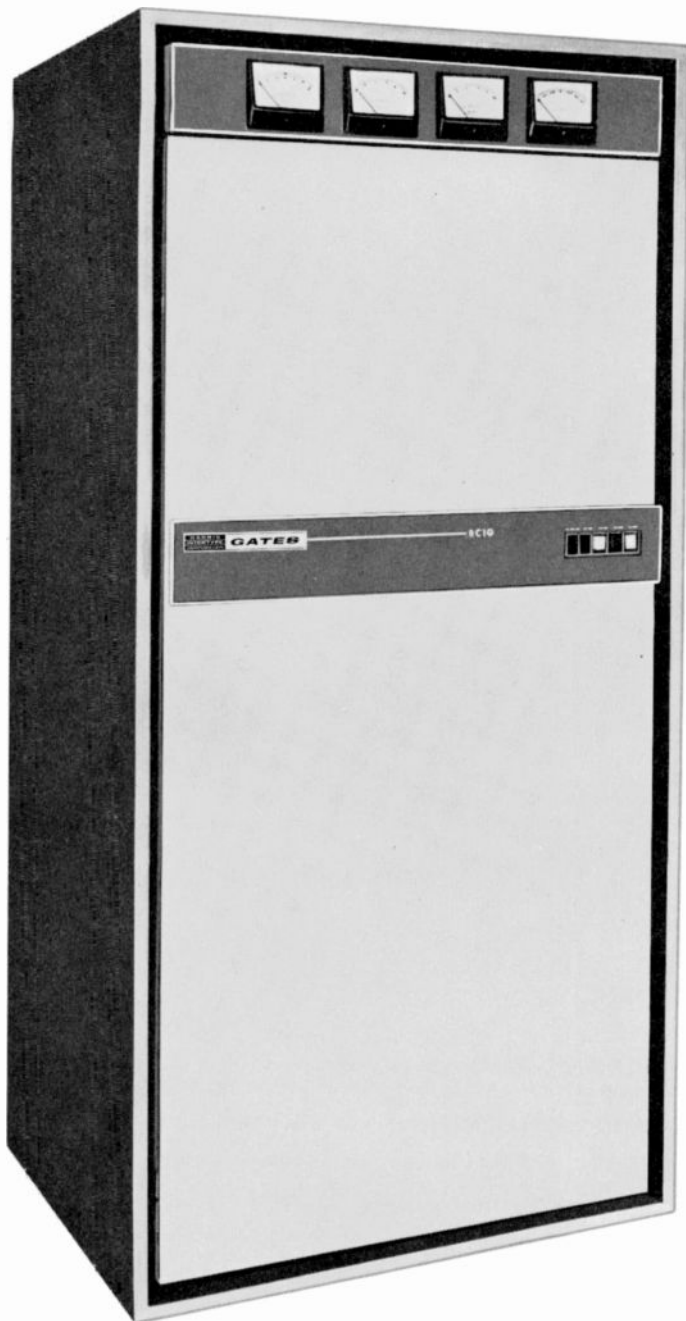

MODEL BC-1G

The "Big G" offers you all of the really important features you look for in a 1 kW AM transmitter . . . such as wide frequency response, great reliability and low operating costs. Another big feature is the high fidelity sound, achieved through low distortion—sound with an unusually rich quality that has become a "Big G" trade-mark.



AUDIO SECTION: Wider frequency response, low harmonic distortion, and low noise . . . the basis of the "Big G's" fine sound . . . result from a unique circuit arrangement. A new low leakage modulation transformer, combined with superb high frequency response has produced typical distortion readings of 1.5% or less at the critical 7000 Hz audio frequency. Push-pull 807 tubes modulate the husky 833A high level modulator tubes, producing an abundance of extra power to provide full performance as tubes age.

RF SECTION: Dual vacuum-type ovenless crystal units provide utmost stability. Frequency adjustment and crystal changeover are made from the front, as are all transmitter control functions. There are four RF stages to assure good frequency stability. Dual long-life 833A tubes feed a generous 1000 watts into a Tee network for exact loading and superior harmonic attenuation. The final amplifier and Tee network are tuned by large, variable edgewound coils.

BUILT-IN DUMMY ANTENNA: The BC-1G may be tested at a full 1 kilowatt output with 100% modulation, using this built-in antenna feature.

POWER REDUCTION: Class IV stations will particularly appreciate the quick and efficient way the BC-1G reduces power to 250 watts. Switching in the primary of the main plate transformer eliminates power consuming, voltage dropping resistors. Plate voltage is reduced on both the power amplifier and modulator tubes, resulting in the possibility of hundreds of added tube hours, as well as savings in power costs.

POWER AMPLIFIER TUBES: In search of the most reliable power tube, based both on performance and cost per hour, Gates engineers tested every known tube type available for this service. The result was the selection of the 833A tube for both RF and modulator circuits. The 833A provides a combined hourly tube cost of approximately 2¢, and has worldwide availability. Being a solid, husky triode, it is more tolerant to spurious emissions, and changing operating conditions caused by variances in load or fluctuations in cooling.

REMOTE CONTROL: Built-in metering kits are provided for both plate voltage and plate current. The use of relays throughout permits almost instantaneous adaption to remote control, and eliminates the need for outboard attachments. All electrical connections for remote controlling are brought out to terminal boards.

RECTIFIER SYSTEM: The BC-1G solid state model has three separate power supplies, all with large silicon rectifiers for lower power consumption, lifetime reliability. The three are: (1) main HV supply, (2) intermediate supply, and (3) bias supply.

1000/250 Watt AM Broadcast Transmitter-BC-1G

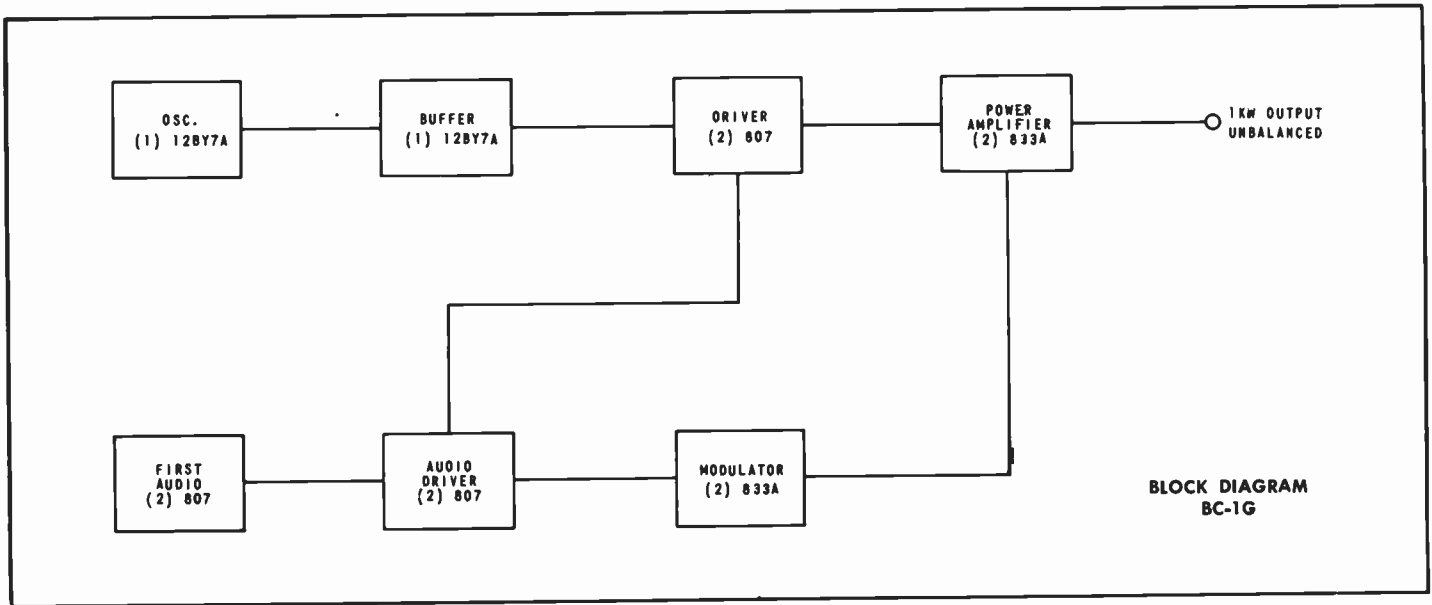

COOLING: The "Big G" was designed from the outset with ideal cooling as a major engineering objective. In the transmitter, parts location is of great importance, and is combined with an intelligent convection cooling system and suction fan ventilation in the top of the cabinet. Fresh air is drawn through dual removable filters at the back base of the transmitter, circulated through every part of the equipment, and then exhausted at the top. Heat generating power tubes are located in the direct air stream. Component and tube life are greatly lengthened by the cool-running operation.

GENERAL DESIGN: The transmitter is completely self-contained in a sturdy steel cabinet. An attractive front door is hinged on the left and opens to expose all tuning controls. Color-coded switches for start-stop and power change functions are accessible from the front when the door is closed. These switches illuminate to show the transmitter operating status at a glance. Behind the front door is a full-length perforated grill for protection when the transmitter is operating . . . it may be removed in seconds by means of snap locks. The back panel is easily removed by turning two thumb screws.

SPECIFICATIONS

POWER OUTPUT: 1000/250 watts. Capable output to accommodate phasor loss, etc., 1100 watts. Also available in a 1000/500 watt model.

RF FREQUENCY RANGE: 540-2000 kHz (as ordered).

RF OUTPUT IMPEDANCE: 50/70 ohms. Other output impedances available on special order.

FREQUENCY STABILITY: ± 5 Hz or better.

CARRIER SHIFT: 3% or less with adequate power mains. Typical is 2%.

MODULATION: High level Class B.

AUDIO RESPONSE: $\pm 1\frac{1}{2}$ dB 30-12,000 Hz 95% modulation. Under practical programming conditions $\pm 1\frac{1}{2}$ dB 30-16,000 Hz.

AUDIO DISTORTION: 3% or less 50-10,000 Hz 90% modulation. Under practical programming conditions 2% or less 50-16,000 Hz.

NOISE: (1000 watts) 60 dB or better below 100% modulation. (250 watts) 55 dB or better below 100% modulation.

AUDIO INPUT IMPEDANCE: 150 or 600 ohms at +16 dBm ± 2 dB.

POWER CONSUMPTION: 1 kW; 0 modulation, 2650 watts; program modulation, 3150 watts; 100% modulation, 3850 watts. 250 watts; 0 modulation, 1650 watts, programming modulation, 1825 watts; 100% modulation, 2050 watts.

POWER INPUT: 230 volt, 1 phase, 3 wire, 50/60 Hz. (208 volts also available when specified).

DUMMY ANTENNA: 50 ohms. Capable 100% program modulation continuous or 100% sine wave modulation for 20 minutes on and 5 minutes off.

TEMPERATURE: -20° to $+50^{\circ}$ C (silicon). $+5^{\circ}$ to $+50^{\circ}$ C (mercury rectifier).

SIZE: 78" high, 37" wide, 29" deep. Front door swing 32".

WEIGHT: Net, 1000 lbs. Domestic packed, 1140 lbs. Export packed, 1490 lbs. Cubage: 110.

TUBES: (2) 12BY7A crystal oscillator and buffer, (2) 807 intermediate driver amplifiers, (2) 833A RF power amplifiers, (2) 807 1st audio amplifiers, (2) 807 2nd audio amplifiers, (2) 833A modulators. If tube rectifier model purchased, add: (2) 8008 HV rectifiers, (2) 866/866A intermediate voltage rectifiers.

ORDERING INFORMATION

BC-1G transmitter, 1000/250 watts, solid state rectifier model, with tubes, and 1 vacuum crystal.....994-6245

BC-1G transmitter, 1000/250 watts, tube rectifier model, with tubes and 1 vacuum crystal.....994-6245B

Spare 100% tube complement for 994-6245 model.....990-0471

Spare 100% tube complement for 994-6245B model.....990-0472

Output power remote control kit.....994-6326

NOTES: (1) Be sure to specify carrier frequency when ordering. (2) Available for 208 volts, 3 wire, at slight additional cost. (3) Packed weight of 994-6245B tube rectifier model is 25 lbs. greater. (4) Power consumption of the BC-1G with tube rectifiers is slightly higher due to addition of filament transformers.

500 Watt AM Broadcast Transmitter

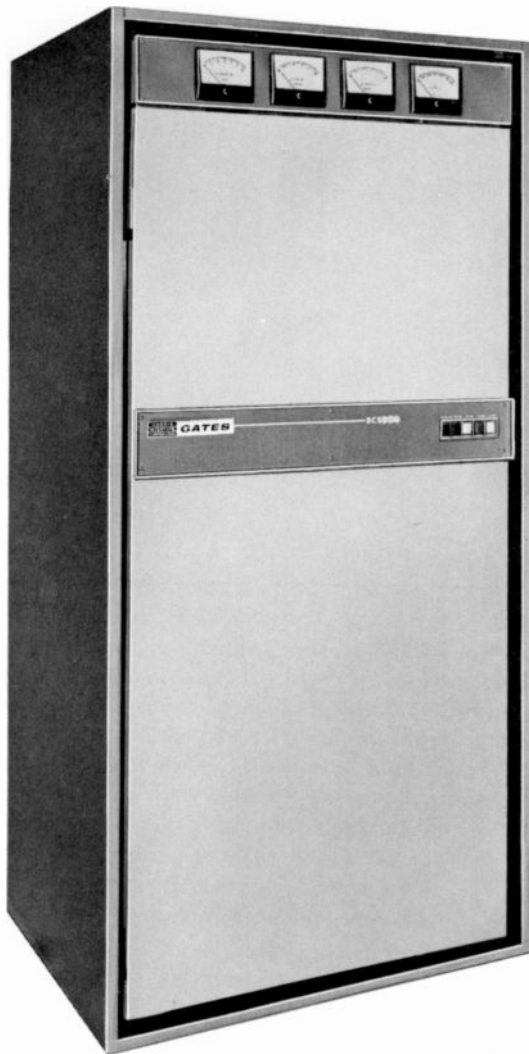

MODEL BC-500G

The B-500G broadcast transmitter is essentially the same transmitter as the BC-1G, 1,000 watt model described on pages 20 and 21. It differs only in the use of a single type 833A RF power tube. So complete is standardization that an increase to 1,000 watts at any later date is easily accomplished. As the basic design is around 1,000 watt construction, a bonus of conservatism is built into this 500 watt model.

All of the features found in the 1,000 watt BC-1G are also found in the BC-500G. These features include: a built-in dummy antenna for easier maintenance, solid state power supplies throughout, total accessibility from the front, modulation of the RF driver and power amplifiers, inverse feedback and lower distortion. RF harmonic reduction meets FCC regulations within the transmitter itself as the Pi-Tee output network does not assume that the outside antenna coupler will perform this function. The specifications herein are pertinent to the Model BC-500G, 500 watt transmitter. Any other data is the same as the Model BC-1G.

SPECIFICATIONS

POWER OUTPUT: FCC rated 500 watts. Copability 550 watts.
RF FREQUENCY RANGE: 540 kHz to 2000 kHz (as ordered).
RF OUTPUT IMPEDANCE: 50/70 ohms.
FREQUENCY STABILITY: ± 5 Hz.
CARRIER SHIFT: 3% or less at 100% modulation.
AUDIO RESPONSE: $\pm 1\frac{1}{2}$ dB, 30-12,000 Hz. (Typical: $\pm 1\frac{1}{2}$ dB, 30-16,000 Hz under practical programming conditions.)
AUDIO DISTORTION: 3% or less 50-10,000 Hz at 95% modulation.
NOISE: 60 dB, or better, below 100% modulation level.
AUDIO INPUT: 150 or 600 ohms, +9 dBm, ± 2 dB for 100% modulation.
POWER INPUT: 230 volts, 3 wire, 50/60 Hz single phase. Power consumption (0 modulation) 1900 watts; (program modulation) 2200 watts; (100% modulation) 2600 watts.
DUMMY ANTENNA: 50 ohms.
MONITORS: Will accommodate all current models. Gotes FCC approved M-4990 Frequency Monitor and M-6659 Modulation Monitor recommended.

SIZE: 78" high, 37" wide, 29" deep. Front door swing 32".
WEIGHT AND CUBAGE: (Domestic) 950 lbs. net., 1100 lbs. packed. (Export) 1350 lbs. packed. Cubage: 100.
FINISH: Two-tone beige-grey.
TUBES: 12BY7A oscillator, 12BY7A 1st IPA, (2) 807 2nd IPA, (1) 833A power amplifier, (2) 807 1st audio, (2) 807 2nd audio, (2) 833A modulators.

ORDERING INFORMATION

Model BC-500G AM broadcast transmitter, 500 watts, with tubes, one crystal, silicon rectifiers.....994-6333
Spare 100% tube complement for BC-500G.....990-0481
Recommended minimum spare tube kit for BC-500G.....990-0479

NOTES: (1) Be sure to specify carrier frequency when ordering. (2) Available for 208 volts, 3 wire, at slight additional cost. (3) Available on special order with tube rectifiers at no increase in price. (4) 500 watt stations may use a 1000 watt transmitter operated at 500 watts power. If 1000 watts is later contemplated, the customer should purchase the Model BC-1G.

250 Watt AM Broadcast Transmitter

MODEL BC-250GY

Gates 250 watt AM broadcast transmitter is a performance-plus, high fidelity transmitter, complete in every detail for today's modern broadcasting. Features include attractive shadow mold styling, vacuum crystal, and full size back door for 100% accessibility. Fully FCC type approved, Gates BC-250GY transmitter has a world-wide reputation for long, trouble-free service. From Greenland to the Marianas, broadcasters acclaim the excellence and simplicity of this most widely used 250 watt medium wave transmitter.

RADIO FREQUENCY AND AUDIO STAGES: The RF tube line-up consists of a 12BY7 in an oscillator circuit that utilizes a vacuum crystal. A second 12BY7 is used as an intermediate power amplifier to drive a rugged 813, which in turn feeds the parallel 810 power amplifiers. The audio section is push-pull with 6L6 driver tubes operating into the Class B 810 modulator tubes. Interchange of power amplifier and modulator tubes gives added economy and longer tube life.

OPERATING FEATURES: The emphasis is on accessibility, ease of service and well ventilated design. Convection cooling is employed. As a result, the BC-250GY transmitter is silent in operation, and may be operated adjacent to a microphone. Vertical construction permits "walk-in" access. The audio section is a hinged sub-section. Seven meters allow direct simultaneous reading of all important functions. For a conservative, superb performing transmitter, the Model BC-250GY will fill the needs of most discriminating broadcasters.

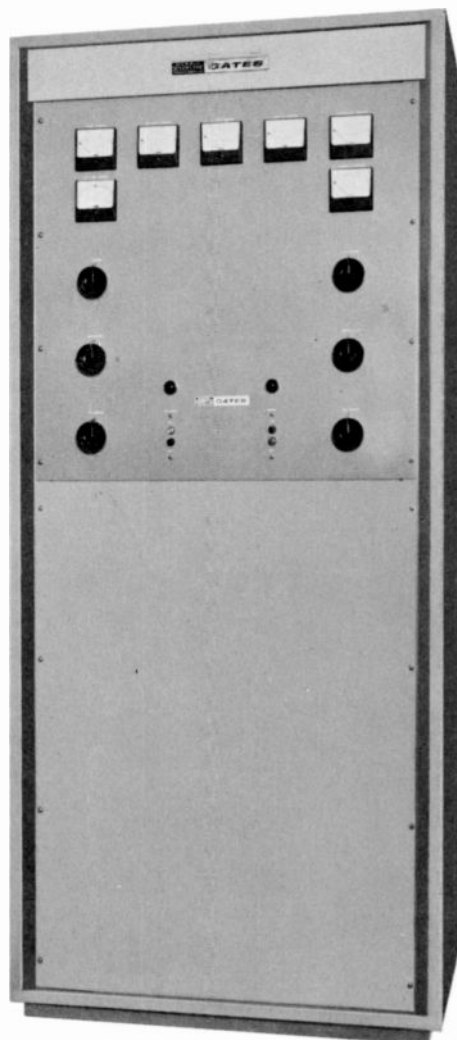

SPECIFICATIONS

POWER OUTPUT: Rated 250 watts, capable 280 watts.

FREQUENCY RANGE: 540-1620 kHz, as ordered.

RF OUTPUT IMPEDANCE: 30/300 ohms unbalanced, as ordered.

FREQUENCY STABILITY: ± 5 Hz.

CARRIER SHIFT: 3% or less, 100% modulation.

MODULATION: High-level plate.

AUDIO RESPONSE: ± 1.5 dB 30-10,000 Hz.

AUDIO DISTORTION: 3% or less, 50-7500 Hz at 90% modulation.

NOISE: 55 dB below 100% modulation.

AUDIO INPUT: 500/600 ohms ± 8 dBm ± 2 dB, 100% modulation.

POWER CONSUMPTION: 1.6 kW at 90% modulation.

POWER INPUT: 230 volts AC, 2 wire, single phase, 50/60 Hz.

POWER FACTOR: Better than 90%.

MONITORS: Will accommodate all modern frequency and modulation monitors.

SIZE: 78" high, 34" wide, 33" deep.

WEIGHT: Domestic, packed—770 lbs.; export—900 lbs.

CUBAGE: 112.

FINISH: Two-tone beige-grey.

TUBES: (4) 810, (2) 6L6, (2) 12BY7, (1) 813, (2) 8008, (1) 5Y4G.

ORDERING INFORMATION

BC-250GY Transmitter, 250 watts, complete with one set of tubes and one vacuum crystal.....994-3760

Spare 100% set of tubes.....990-0507

Recommended minimum set of spare tubes.....990-0508

NOTE: Please state carrier frequency and RF output impedance when ordering.

Antenna Phasing Equipment

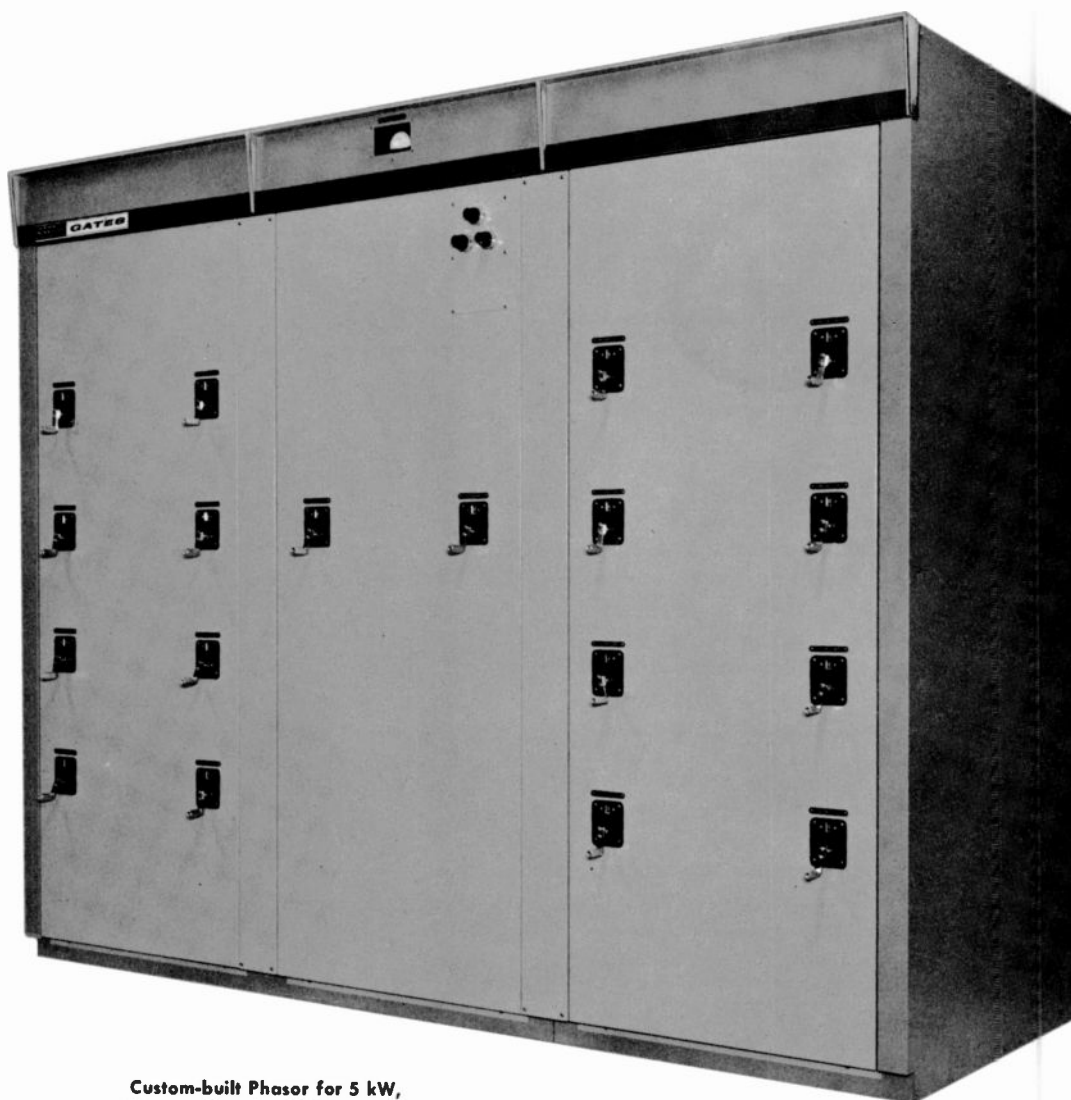

Custom-built Phasor for 5 kW,
5-tower directional AM station.

Gates phasing equipment is custom built, utilizing Gates manufactured inductors and other quality components for precise coverage patterns requiring a minimum of adjustment and a maximum of stability. Some of the most complex phasing systems in existence have been built by Gates.

ADVANCED RESEARCH: As the world leader in the design and manufacture of phasing equipment, Gates engages in highly advanced phasor research and development. All Gates phasing systems are computer designed to assure maximum accuracy and most efficient circuitry. Phasor construction is carried out by a group of design and production experts, with years of experience in specialized phasing equipment. This group is under the direction of a registered professional engineer.

CONSTRUCTION: Antenna tuning units are constructed as a panel and shelf type for wall mounting in a doghouse, or in weatherproof metal cabinets. Phasor cabinetry built to your specifications is available, and becomes an integral planning factor in the coordination of design and styling to reflect over-all system compatibility and appearance.

Gates manufactures phasing equipment for any power, for any number of towers; 250 watt to 250 kilowatt tuning units; diplexers for medium wave and for 2-30 MHz short wave; triplexers, rejection filters, and a wide range of radio frequency networks. Each is custom tailored for the particular application, to assure the broadcaster's complete satisfaction.

Antenna Phasing Equipment

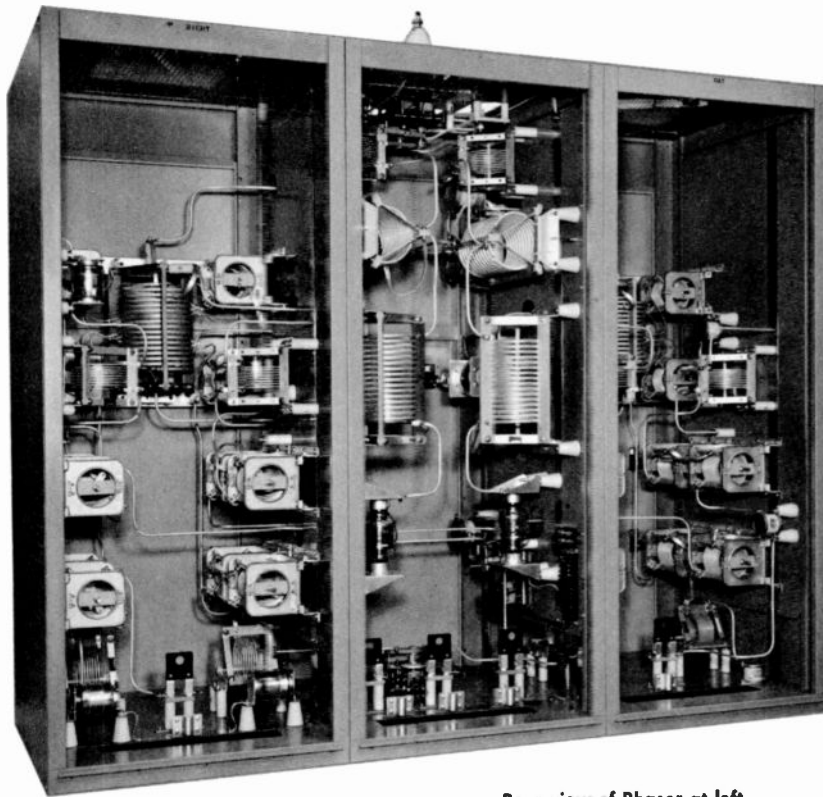

Rear view of Phasor at left, with panels removed. Note the clean mechanical layout.

STABILITY AND EFFICIENCY: All directional phasing equipment is designed to the parameters provided by the station's consulting engineer, and work is not initiated until the consultant and customer approve the design. To furnish custom designed phasors suited for specific broadcasting needs, Gates provides detailed specifications for your equipment, so you may determine exactly what you are buying. The full range of adjustment can be precisely determined by computer—before it is delivered. This avoids the possibility of having to replace inadequate components, or make costly field modifications of design to relieve difficult adjustment.

The careful design and construction practices maintained by Gates give you more than reasonable assurance of the best possible long term stability and efficiency. This avoids expensive readjustments and reproof of pattern later on.

Gates phasors are constructed to give a safety factor of 1.4 times on RMS current and four times on maximum RMS voltage based on expected operating adjustments.

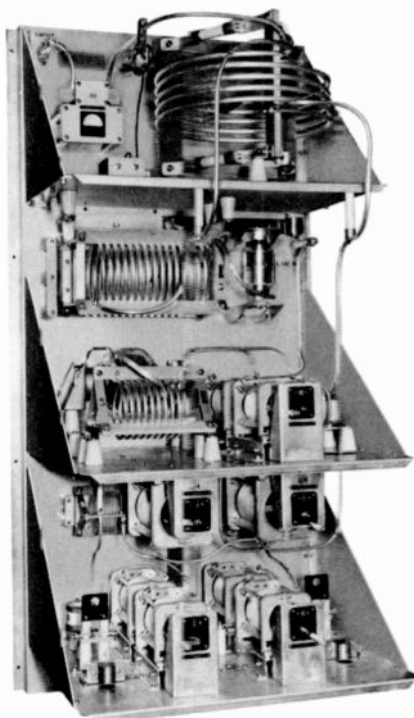

**CUSTOM-BUILT
OPEN PANEL
PHASOR.**

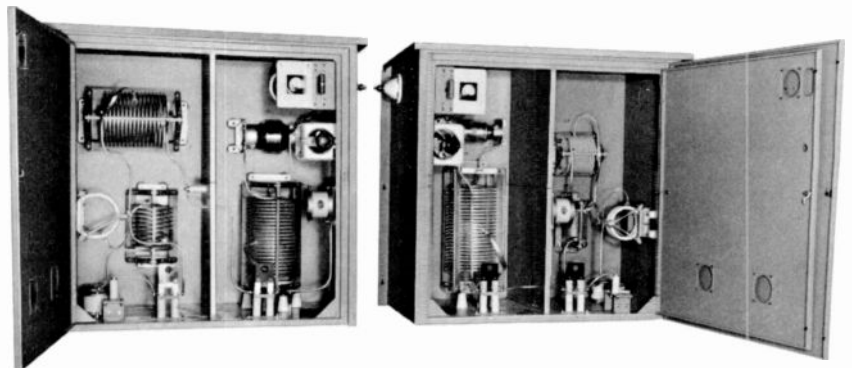

10 kW MEDIUM WAVE DIPLEXER

Numerous diplexers, triplexers, RF filters and custom designed networks are considered normal design and construction activity at Gates. The above illustrates a 10 kW medium wave diplexer that permits two AM transmitters to feed a common vertical radiator.

Common Point Impedance Bridge



An instrument for permanent installation in the common point of a directional antenna system. Permits the common point resistance and reactance to be measured during normal operation without transmitter shutdown. Panel ammeter reads common point current so that direct antenna power can be determined.

The Model CPB-1 and CPB-1A Common Point Impedance Bridges are operating impedance bridges similar to the Model OIB-1, but designed for permanent installation in your phasing equipment at the antenna common point. Instruments have two 4" dials calibrated directly in resistance and reactance. A panel meter is provided for a null detector. The R & X dials are manipulated as a normal bridge while the transmitter is operating at full or reduced power to give a null indication on the panel meter. The value of the common point resistance and reactance can then be read directly from the two dials.

It has been found that many directional antennas have common point impedances which vary from time to time due to seasonal changes in the ground system and minor tuning drift of the antenna parameters. On many occasions it was found from remeasurement of the common point impedance that the station had been transmitting with somewhat less than full power for some time because of these changes. The CPB-1 and CPB-1A permit the station operator to determine the common point impedance at any time, even during normal operating hours. By minor adjustment of the common point resistance control, he can maintain his radiated power at the full license value at all times. He also has a method of detecting changes in his antenna system which affect the common point. This may alert him to equipment faults and prevent citations for antenna misadjustment.

CPB-1 and CPB-1A bridges are normally supplied mounted on a standard 19" x 7" rack panel. A cutout can be made in

the antenna phasing equipment for mounting this panel. Both bridges are also available without the rack panel. A drill template is then supplied, permitting the station engineer to mount the bridge in the existing panel of the antenna phasor.

SPECIFICATIONS

FREQUENCY RANGE: 500-1650 kHz.

POWER RATING: CPB-1—5 kW—100% amp. mod. continuous. CPB-1A—50 kW—100% amp. mod. continuous.

RESISTANCE RANGE: 30-100 ohms.

REACTANCE RANGE: ± 50 ohms (1000 kHz).

ACCURACY: Resistance $\pm 2\% \pm 1$ ohm. Reactance $\pm 5\% \pm 1$ ohm. (Provision is made for your consultant to adjust the calibration to agree exactly with your licensed resistance value).

RF SOURCE: Your transmitter operating at normal or reduced power acts as source—no generator is required.

DETECTOR: Tuned internal detector with 25 ua panel meter—no external detector is required.

AMMETER: Panel hole is provided for Weston Model 308, 3½" square ammeter. A meter recessing bracket is supplied for high power applications. A matching meter for your power and resistance can be supplied.

TERMINALS: Screw terminals or standoff insulators at rear of bridge box for connection to tubing, strap, or jumper to coax is provided.

MOUNTING: Standard 7" x 19" engraved gray rack panel—can be supplied without panel for mounting behind your phasor panel (drill template supplied).

DIMENSIONS: Bridge box without panel: Height: 7", Width: 9", Depth: 9¼". Panel dimensions: 7" x 19".

ORDERING INFORMATION

CPB-1 Common Point Impedance Bridge, 5 kW.....700-0055
CPB-1A Common Point Impedance Bridge, 50 kW.....700-0056

Operating Impedance Bridge



- Measures "in circuit" operating impedance—500 kHz to 5 MHz.
- Handles through power up to 10 kW.
- No signal generator or external detector required for measurement under power.
- Can be used with signal generator and receiver as a normal bridge.
- Measures negative impedance loads.
- Ideal for use in adjusting multi-tower directional antennas.
- Based on new principle.

The Model OIB-1 Operating Impedance Bridge measures the operating impedance of the individual radiators, networks, transmission line sections, and common point of directional antenna systems while they are functioning normally and under power. This "operating impedance" cannot be measured by normal impedance bridge methods because the system characteristics are disrupted when the bridge is inserted in the circuit. The OIB-1 thus satisfies a critical requirement long felt by consulting and broadcast station engineers. In addition it has many applications in other fields that cannot be duplicated by any other instrument.

The OIB-1 is inserted directly in series with the transmission line, network, or antenna. The transmitter power is applied and a bridge balance is obtained by manipulating the R and X dials on the face of the bridge. Balance is indicated by a null reading on the meter which is mounted on the front panel

of the bridge. Operating resistance and reactance are then read directly from the bridge dials. The VSWR on a transmission line can be read directly from a scale on the meter.

SPECIFICATIONS

FREQUENCY RANGE: 500 kHz to 5 MHz.

THROUGH POWER RATING: 10 kW, carrier only, no modulation with VSWR 3:1.

INSERTION EFFECT: Equal to 9" of 150-ohm line.

FUNCTIONS: Direct reading in R, -400 to +400 ohms. Direct reading in X, -300 to +300 ohms. Measures VSWR, $Z_0=0$ to 400 ohms. Indicates relative forward and reflected power.

ACCURACY: R and X, $\pm 2\% \pm 1$ ohm. Dials individually calibrated and engraved.

RF SOURCE: Transmitter, transmission line, etc., or signal generator with adapting connector.

DETECTOR: Internal for high power source. Connector on front panel for external detector when used with signal generator. Amplifier for internal detector available as factory installed option if high sensitivity is desired.

TERMINALS: Input and output are large UHF receptacles (UG-357/U). 12" input and output clip leads are supplied as standard with bridge. 18" leads optional at no extra cost when specified with order. External detector connection is BNC.

ACCESSORIES: Aluminum polyurethane-lined transport case.

DIMENSIONS: 12½" x 9½" x 5¼" deep.

WEIGHT: 10 lbs.

ORDERING INFORMATION

Model OIB-1 Operating Impedance Bridge. Specify whether 12" or 18" leads are desired700-0063
D. C. Amplifier. Used to increase sensitivity of Bridge for use with power sources as low as 25 watts.....700-0064
TC-1 Transport Case. For OIB-1.....700-0065

AM Antenna Couplers

WEATHERPROOF SERIES—FED ANTENNA COUPLER, 1250 WATTS

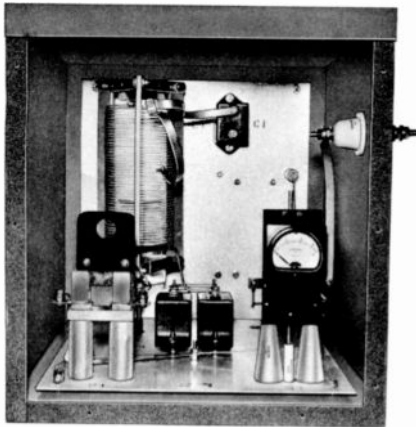

Recommended for broadcast transmitter powers of 1,000, 500 and 250 watts, 100% modulated. Heavy edgewound micaex insulated silver plated coil has generous inductance for a full Tee network along with fixed mica capacitors supplied. Extra room is provided to install either diode or thermocouple remote metering equipment. Heavy duty meter shorting switch eliminates antenna meter from the circuit when not in use for lightning protection. Meter is observed through plexiglass porthole. Front door of cabinet has been removed for illustrative purposes.

SPECIFICATIONS

CARRIER POWER: Up to 1250 watts AM.
FREQUENCY: 525-1700 kHz as ordered.
LINE IMPEDANCE: 40-230 ohms as ordered.
TO MATCH: Series-fed tower of from 70° to 95° electrical length.
CIRCUIT: Full Tee Network.
WEIGHT: 98 lbs.
SIZE: 20" high, 20 1/4" wide, 18 3/4" deep.

ORDERING INFORMATION

Antenna Coupler with antenna meter_994-3494
NOTE: When ordering, state transmission line impedance, frequency, tower height, and tower measurements, if known. For remote meters, see below. Couplers to match unusual loads such as short or tall towers, shunt feed, etc., are available on special order at extra cost.

SERIES AND SHUNT FED COUPLERS

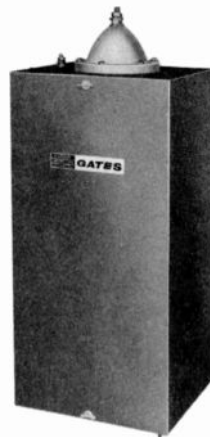

Both series and shunt fed models are constructed in a non-weatherproof cabinet with slip-off front door and large lead in bowl at top. Coil is micaex insulated edgewound silver plated and capacitors are supplied to tune to buyer's specific frequency. Size: 21" high, 10" wide, 9" deep. Usually mounted in small dog house at base of tower. Rating 1250 watts, 100% modulated.

***SERIES FEED MODEL:** Provides full Tee network inductance with capacitors to match wide range of input and output impedances. State frequency line impedance, and tower height when ordering. _____994-5178

***SHUNT FEED MODEL:** Includes inductor and capacitors to tune out reactance in shunt fed antenna coupling. If tower measurements are known, these are always especially helpful. State line impedance and frequency_994-5179

***NOTE: METER NOT INCLUDED.**

ISOLATION COIL

This isolation coil is quickly made to customer's order by carrying all basic materials in stock. The same type of coaxial cable is used in winding the coil as is used for sampling line. If the customer used Heliax sampling line, then the isolation coil would be wound with Heliax coaxial cable. Nominal inductance 85 uH. Available in weatherproof or open model. Sizes (weatherproof model), 20" wide, 12 1/2" high and 18 1/2" deep. (Open model), 16" wide, 10" high and 16" deep. When ordering, please state type or make of sampling line or preferred coaxial cable for coil construction. Resonating capacitor is not included.

ORDERING INFORMATION

Weatherproof isolation unit_____994-3073
 Open unit coil only, less cabinet_____994-4561

WEATHERPROOF 5-10 KW ANTENNA COUPLING UNITS

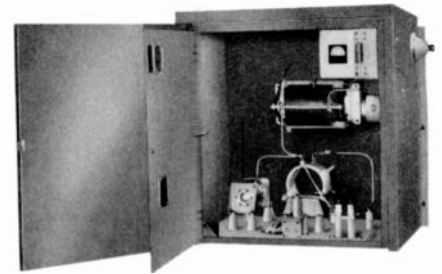

Housed in aluminum cabinet with double front doors. Porthole for meter reading and heavy duty meter shorting switch operates with doors closed. Large micaex insulated silver plated coils combined with capacitors of generous voltage and current ratings to assure a lifetime of service under extreme heat or cold. A large antenna lead in bowl is provided. Mounting is with metal flanges on the back of the tuning unit for attachment to wooden poles set in ground or for mounting on wall.

SPECIFICATIONS

CARRIER POWER: M-5309A 5,000 watts AM.
 M-5309B 10,000 watts AM.
FREQUENCY: 525-1,700 kHz as ordered.
LINE IMPEDANCE: 40-230 ohms as ordered.
TO MATCH: Series fed tower of from 70° to 95° electrical length.
CIRCUIT: Full Tee Network.
WEIGHT: Approximately 200 lbs.
SIZE: 38" high, 37" wide, 21 1/2" deep.

ORDERING INFORMATION

Antenna Coupling Unit, 5 kW_____994-5309A
 Antenna Coupling Unit, 10 kW_____994-5309B
NOTE: When ordering, state carrier frequency, transmission line impedance, power, tower height and tower measurements, if known. Couplers to match unusual loads such as short or tall towers, shunt feed, etc., are available on special order, at extra cost.

R. F. ANTENNA METERS

Internal thermocouple standard scale. Weston Model 308, three-inch square case. Other ranges not listed below are available with many carried in stock. Also expanded scale meters in inventory.

ORDERING INFORMATION

Meter, 0-3 R. F. amperes_____634-0206
 Meter, 0-6 R. F. amperes_____634-0238
 Meter, 0-8 R. F. amperes_____634-0209
 Meter, 0-10 R. F. amperes_____634-0210

DIODE TYPE REMOTE METER EQUIPMENT



For remote indication of RF current. Consists of a carefully constructed pickup loop attached through a short coaxial cable to a solid state rectifier assembly. RF current is measured without breaking the main lead. No AC power is required. May be used with any good 1 MA DC meter. Power range: 250 watts to 50,000 watts. Frequency range: 540 kHz to 1600 kHz.

ORDERING INFORMATION

Diode remote meter unit, less meter_____994-6112
 Meter 3" sq. case, scale 0-3 R. F. amperes_____632-0418
 Meter 3" sq. case, scale 0-5 R. F. amperes_____632-0419
 Meter 3" sq. case, scale 0-8 R. F. amperes_____632-0420
 Meter 3" sq. case, scale 0-10 R. F. amperes_____632-0421
 Meter 4" sq. case, scale 0-3 R. F. amperes_____632-0424
 Meter 4" sq. case, scale 0-8 R. F. amperes_____632-0426
 Meter 4" sq. case, scale 0-10 R. F. amperes_____632-0361
 Meter 4" sq. case, scale 0.15 R. F. amperes _____632-0428

NOTE: Other meter scale ranges available at extra cost. Above for use with diode remote unit, not thermocouple.

AM Antenna Coupling Accessories

SOLENOID TOWER CHOKES

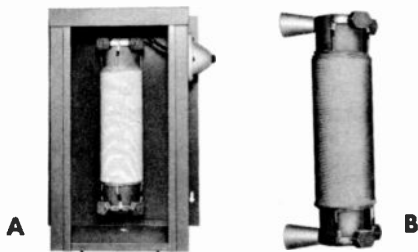

(20 AMP AC RATING)

Most popular of all tower light isolation chokes. Available in 2 or 3 section and in open type, or weatherproof as illustrated. Wound on heavy triple X tubing with micro-by-pass condensers on each circuit end. Inductance approximately 350 uH. 3" stand-off insulators are part of coil. (Weatherproof type), 24" high, 17 1/4" wide, 10 1/4" deep. Illustration to left shows weatherproof unit with front cover removed.

ORDERING INFORMATION

Tower Choke, 2 wire, weatherproof,
Fig. A.....994-3937
Tower Choke, 3 wire, weatherproof,
Fig. A.....994-3938
Tower Choke, 2 wire, open type,
Fig. B.....994-3935
Tower Choke, 3 wire, open type,
Fig. B.....994-3936

RADIO FREQUENCY CONTACTOR

A heavy duty solenoid operated RF contactor for most switching applications through 50 kW power. Available in either SPDT or DPDT types and in two voltage ratings. Will operate on 115/230 volts AC, latching type. Will handle up to 25 amperes RF per contact.

ORDERING INFORMATION

Contactor SPDT insulated 17 kV peak
voltage.....570-0001
Contactor DPDT insulated 17 kV peak
voltage.....570-0002
Contactor SPDT insulated 22 kV peak
voltage.....570-0003
Contactor DPDT insulated 22 kV peak
voltage.....570-0004

LARGE INVENTORY OF METERS

In the manufacture of transmitting and audio equipment for broadcasting, communications and defense, Gates is required to carry thousands of meters in inventory. Whether AC, DC, or RF, or microammeter, milliammeter or ammeter, it is very likely the meter you need in emergency or expansion is quickly available. Give us desired case size, range and type of movement and we will serve you speedily. Many meters are also carried at our Houston, Texas branch.

HEAVY DUTY SAMPLING LOOP



This is a very rugged fixed non-shielded RF sampling loop. It is heavily galvanized after welding, and is fitted with large steatite insulators and heavy duty tower leg clamps for easy and positive mounting. Complete with type "N" jack. For 50 to 70 ohm sampling line.

ORDERING INFORMATION

Heavy duty sampling loop.....994-6126

ROTATING PHASE SAMPLING LOOPS

This model is especially applicable where high current ratios are to be sampled. May be rotated so that phase monitor amplitude values are nearly equal. Electrostatically shielded and insulated from tower. May be used with or without isolation coil at base of tower. Coil is single loop, heavily insulated from base frame. Matches either 50 or 70 ohm line. Size: 48" wide, 32" high.

ORDERING INFORMATION

Rotating Sampling Loop.....994-3283

METER JACK AND SHORTING BAR-MOUNTING PLUG

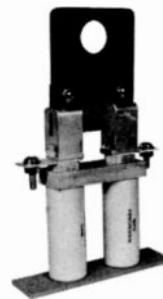

A great convenience to allow RF current measurements to be made by simply plugging in a meter. Will accommodate most 3" or 4" meters. A "must" in critical RF circuit areas in phasars, couplers, etc. Rating up to 50 kW on a 50 ohm line.

ORDERING INFORMATION

Meter jack and shorting bar.....994-3280
Meter mounting plug.....994-3281

METER SHORTING SWITCH



A heavy duty, make-before-break meter shorting switch of the plunger or push type. Heavy bronze tempered spring grips on both sides assure accuracy and durability.

ORDERING INFORMATION

Meter Shorting Switch, rating 40
amperes.....994-6527
Meter Shorting Switch, rating 15
amperes.....994-3493

AUSTIN RING TYPE TOWER CHOKE

Ring type tower choke is a transformer with clear air space between primary and secondary, and minimum antenna shunting effects. Independent of frequency. All models are for 115/230 volt primary and 115 volt secondary. Base insulator in photo for illustration purposes only.

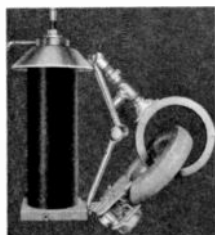

ORDERING INFORMATION

CAP-KVA	MFG. STYLE	LBS.	ATTACHMENTS	ORDER NO.
1-1.75	Side Bracket	81	none	710-0051
1-1.75	Side Bracket	85	lightning gap	710-0052
1-1.75	Pedestal	82	none	710-0053
1-1.75	Pedestal	86	lightning gap	710-0054
2-3	Side Bracket	188	none	710-0055
2-3	Side Bracket	201	lightning gap	710-0031
2-3	Pedestal	182	none	710-0056
2-3	Pedestal	200	lightning gap	710-0057

HARRIS
INTERTYPE
CORPORATION **GATES**

AM Modulation Monitor



MODEL M-6659

Gates' AM Modulation Monitor is an FCC type-accepted solid-state instrument designed to meet or exceed all requirements for measuring modulation percentages of broadcast and short-wave stations in the frequency range 540 kHz to 30 MHz. It will provide the accurate and dependable monitoring required by the FCC, and is suitable for proof-of-performance measurements.

CONTROLS: Three functional controls are located on the front panel, and mounted in-line for easy adjustment: (1) carrier-level setting, (2) a range selector control covering negative peak percentages, and (3) a modulation meter switch for choosing either negative or positive peaks. Switches and terminal connections are mounted on the rear of the chassis.

MONITOR ACCURACY: Gates monitors are factory calibrated by precision instruments and need no further adjustment. The monitor's solid-state circuits are not affected by ageing and the resulting change in circuit constants that normally affect calibration accuracy.

MODULATION METER: Correct positive or negative peak indications, even on program bursts as short as 40 to 90 milliseconds, assure true peak measurement regardless of the wave forms encountered.

OVER-MODULATION FLASHER: Operation of the flasher light is adjusted by the calibrated negative-peak control, and has the same superior accuracy as the meter.

AUDIO OUTPUTS: Proof-of-performance measurements can be taken from the monitor's high-fidelity output with absolute assurance that readings of transmitter performance are accurate. A 600-ohm audio output is also provided to supply aural monitoring in the control room.

REMOTE OPERATION: Modulation readings by meter and flasher at a distant location are obtainable with a Gates optional remote meter panel. Separate output circuits provide (1) a ballistically correct signal for a remote meter and (2) a remote flasher, connected by two loops with a length of up to 2,000 ft. of #22 or larger wire.

AM Modulation Monitor—M-6659

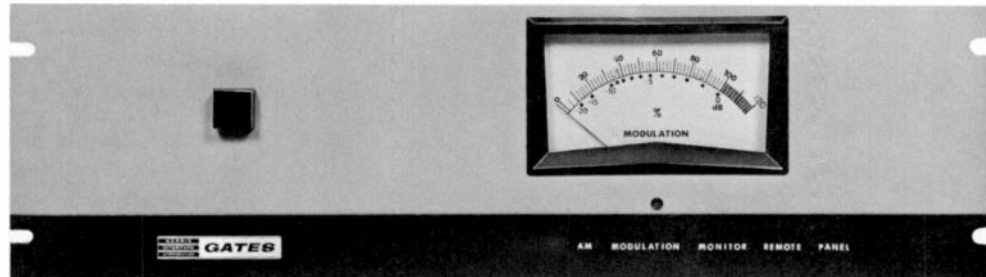

REMOTE METER AND FLASHER PANEL

SPECIFICATIONS

FREQUENCY RANGE: 540 kHz to 30.0 MHz.

RF INPUT: For 50/75 ohm line at 6 to 20 volts.

MODULATION INDICATION:

METER: 0% to 100% on negative peaks.
0% to 120% on positive peaks.

FLASHER: 50% to 100% in 5% steps on negative peaks. Flashes when negative modulation is within 2% of dial setting.

ACCURACY: Meter is $\pm 2\%$ of full scale at 1000 Hz. Flasher is $\pm 2\%$ at 1000 Hz.

RESPONSE TIME:

METER: Responds to within 90% of correct reading with a single 65 (± 25) millisecond pulse of modulation. Needle returns to 10% of reading in 650 (± 150) milliseconds after signal is removed.

FLASHER: Responds to less than one millisecond pulse of modulation and remains on for about 0.5 second.

AUDIO MONITOR OUTPUT:

FREQUENCY RESPONSE: ± 0.5 dB from 20 Hz to 20 kHz.

DISTORTION: Less than 0.3% with 600-ohm load at 100% modulation.

OUTPUT VOLTAGE: At 100% modulation, output is 0.55 volts into a 600-ohm load, approximately -10 dBm average.

OUTPUT IMPEDANCE: 600 ohms, unbalanced.

FIDELITY MEASURING OUTPUT:

FREQUENCY RESPONSE: ± 0.5 dB, 20 Hz to 20 kHz.

DISTORTION: Less than 0.3%.

OUTPUT VOLTAGE: At 100% modulation, output is 4.4 volts with a load resistance greater than 100,000 ohms.

OUTPUT IMPEDANCE: 4000 ohms, unbalanced.

NOISE: 70 dB below nominal outputs of both monitoring and fidelity outputs.

REMOTE OUTPUT: For meter and flasher indications at another location, use Gates remote meter panel: 994-6687.

PHYSICAL & MECHANICAL DIMENSIONS:

SIZE: 19" long x 7" high x 6" deep. Will mount in a standard relay rack.

WEIGHT: Domestic, 12 lbs. Export, 21 lbs. Cubage, 3. cu. ft.

POWER SOURCE: 105-125 volts, 50/60 Hz., 10 watts.

SERVICE CONDITIONS:

AMBIENT TEMPERATURE RANGE: -4° to 125° F. (-20° to 52° C.).

AMBIENT HUMIDITY RANGE: 0% to 95% relative humidity.

ALTITUDE: Sea level to 7500 feet.

ORDERING INFORMATION

Solid-State AM Modulation Monitor ----- 994-6659
Remote Meter Panel ----- 994-6687

AM Frequency Monitor

MODEL M-4990

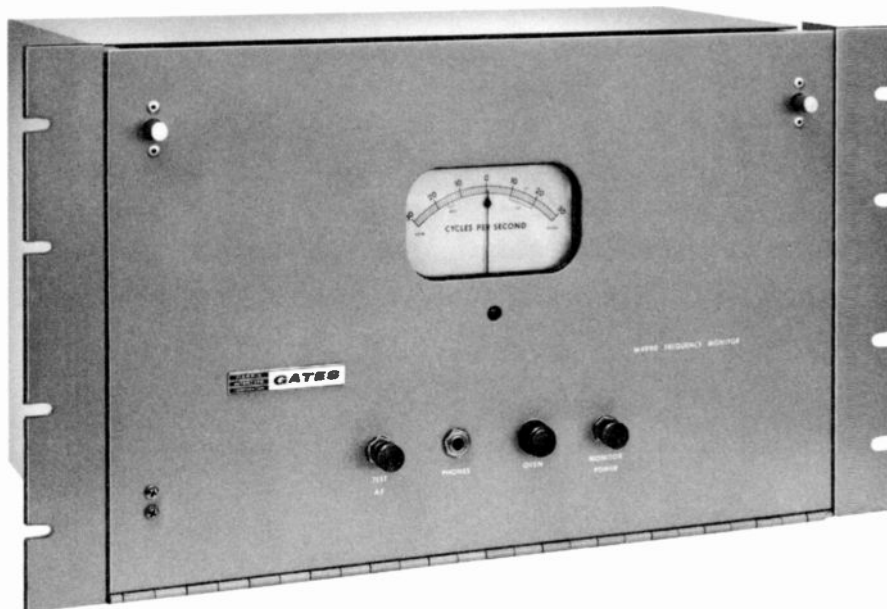

The major requirements of a broadcast frequency monitor are reliability, and extreme accuracy in indication of the carrier frequency. Progressive engineering has provided both in Gates FCC type approved M-4990 Frequency Monitor.

Significant improvements include an amplified intermediate frequency that is limited prior to the discriminator circuit. As a result, heavy modulation or a wide change in RF input level will have essentially no effect on the accuracy of the frequency meter reading. The precision vacuum type crystal easily meets FCC stability requirements, and is mounted in a temperature controlled chamber, along with oscillator components. This results in one-half part per million frequency accuracy. Another engineering improvement is the greatly simplified balanced discriminator circuit. The older and often troublesome meter reactance box has been discarded.

For remote control operation, the M-4990 Frequency Monitor may be operated as an off-the-air monitor, or over telephone lines when used with the Gates M-5631 Extension Meter Panel.

Frequency is direct reading. The same meter, by switching, also indicates; (a) carrier level, and (b) oscillator current. Controls include: AF level for correct input signal; phone jack for 1,000 Hz tone; power switch and OVEN ON pilot light.

SPECIFICATIONS

FREQUENCY RANGE: 540-1600 kHz (as ordered).

METER: Reads direct 30-0-30 Hz above and below carrier frequency.

OSCILLATOR AND STABILITY: Electron coupled, 1,000 Hz below assigned frequency. Accuracy of ± 0.5 parts per million. Over-all monitor stability, ± 2.0 parts per million.

INPUT: 50/70 ohms. Will operate on input as low as 5 mV. When direct connected, will accommodate input voltages from 5 to 50 volts. The input signal may be either modulated or unmodulated.

POWER INPUT: 105/125 volts, 50/60 Hz, 85 watts.

TUBES: (5) 6AU6, (3) 6AQ5, (2) 6AL5 and (1 each) 12BY7A, 6C4, 12AT7, 6X4, OB2 and 13-4 ballast tube.

FCC APPROVAL: No. 3-102.

MECHANICAL: 19" x 10½" x 10½" deep. Weight packed (domestic) 53 lbs., (export) 77 lbs. Cubage: 4. Finish: beige-gray.

ORDERING INFORMATION

Frequency Monitor with tubes.....	994-4990
Remote Control Extension Meter (see Page 71).....	994-5631
Spare 100% tube kit for monitor.....	990-0281

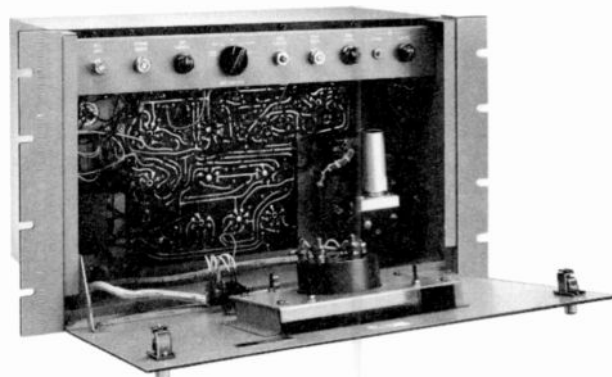

Front panel hinges down for easy maintenance and operating adjustments. Note the circular temperature-controlled oven containing all oscillator components and the precision vacuum type crystal. A slip-on dust cover protects tubes and terminations.

AM Accessories



PHASE MONITOR

A completely solid state AM phase monitor for directional systems up to 9 towers. Phase readings are not affected by modulation, and are accurate to $\pm 1^\circ$. Silicon transistors and taut-band meters assure greatest reliability. The Model 112 phase monitor is easy to operate, easy to read, and it is fully adaptable to remote control operation.

SPECIFICATIONS

FREQUENCY RANGE: 540-1600 kHz.
ACCURACY: $\pm 1^\circ$. Phase resolution: 0.5° .
INPUT IMPEDANCE: 50 or 75 ohms.
NUMBER OF INPUTS: Up to 9.
INPUT LEVEL: 1.5 to 20 volts RMS.
POWER REQUIRED: 115/230 VAC, 15 watts. 50/60 Hz.
SIZE: 19" W x 7" H x 14" D.
WEIGHT: 20 lbs.

ORDERING INFORMATION

Model 112 Phase Monitor (Stote number of towers).....731-020X

FIELD INTENSITY METER

The battery operated Model 120E field intensity meter is universally used to measure field strength in the 540-1600 kHz broadcast band. Accuracy of measurement is assured by a calibration method that compensates for variations in tube characteristics and for voltage variations in the self-contained battery power supply. The 120E is a necessary item for initial and periodic directional antenna measurement and proof of performance.

SPECIFICATIONS

FREQUENCY RANGE: 540-1600 kHz.
MEASUREMENT RANGE: 10 microvolts to 10 volts per meter.
ACCURACY: 2%.
OUTPUT INDICATOR: Direct reading. Provision for recorder.
TUBES: (4) 1T4, (2) 1R5, plus two IN34A diodes.
BATTERIES: (5) 1.5 volt flashlight type, (2) midget 67½ volt "B".

Note: These standard type universally available batteries are not supplied, but may be purchased locally.

SIZE: 9" high, 13" wide, 5¾" deep.
WEIGHT: 12½ pounds.



ORDERING INFORMATION

Model 120E Field Intensity Meter (less batteries).....700-0001

Dummy Antennas

The dummy antenna is perhaps the most needed test device in a broadcasting station. Principal use is tune-up and test without the signal being on the air. For daytime stations, this means routine work may be done after station sign off instead of after 1 a.m. The dummy antenna is most valuable in the event of a transmitting system malfunction. At this time the

5 KW AIR COOLED DUMMY ANTENNA

For use with standard broadcast transmitters in the 5 kW power range for tune-up and efficiency tests. Essentially non-reactive. Handles 5000 watts 100% sine wave modulated. For operation between 200 kHz and 2000 kHz. 27½" x 26" x 10¼" high. Available in 50 ohm (Model DU-551) and 70 ohm (Model DU-570).



first problem is always locating the source of the trouble. An open transmission line, a short in the coupler or phasor, a short in a tower light, etc., will usually react by operating the overload relay in the transmitter. By attaching the dummy antenna, the trouble spot is quickly isolated as either in the transmitter or elsewhere in the system.

10 KW AIR COOLED DUMMY ANTENNA

An air cooled 10,000 watt dummy antenna that will permit 100% sine wave modulation for long periods of time. Essentially non-reactive, it can be used at full rating between 200 kHz and 2000 kHz. Resistance, 50 ohms. This air cooled dummy antenna eliminates need for water connections and is a practical device for tune-up and measurement. 29½" x 26" x 16½" high. Model M-6107.



50 KW WATER COOLED DUMMY ANTENNA

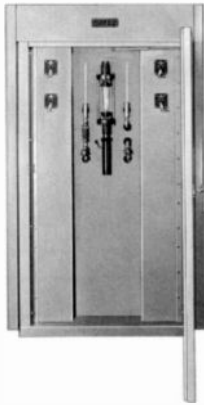

The Gates 50 kW water cooled dummy antenna is available either for medium wave or short wave application. The medium wave unit is essentially non-reactive in the 200-2000 kHz band, and does not usually require a matching network. Both models will easily handle a full 50 kW 100% modulated when provided with suitable water flow. Water of reasonable purity can be used; normal required flow is approximately 15 gallons per minute. Dual thermometers and flow meter

are provided for precise power measurement by the calorimetric method. Available in medium wave type with 50, 70, 150, 300 or 600 ohms input impedance as ordered. The high frequency model for operations between 2-30 MHz is available only for 300 or 600 ohms. Size: 78" high, 42" wide, 48½" deep.

100 KW WATER COOLED DUMMY ANTENNA



Designed for high power application, the Model WDL-1000A water cooled dummy load will dissipate a generous 100 kW AM at any frequency up to 30 MHz. Operating impedance is 300 ohms balanced. Other impedances available on special order. This model employs its own captive water system and an external heat exchanger. Water required for cooling need only be reasonably clean and free

from mineral content. Heat is dissipated in an external heat exchanger of the water-to-air type. Approximately 150 gallons of water fill the system.

Size, of the dummy load only, is approximately 4' wide, 5' high, 4' deep. Total weight, including heat exchanger, is 3850 pounds packed for shipment. Operates on 230 volts AC, single phase.

1 KW AIR COOLED DUMMY ANTENNA



This unit may be used for any medium wave transmitter at a maximum power rating of 1 kW, 100% modulated. Consists of non-inductive resistors heavily banded together to arrive at correct load resistance. For 200 kHz to 2000 kHz. 20¼" x 12½" x 5" high. Available in 50 ohm and 70 ohm models.

ORDERING INFORMATION

DU-551 Dummy Antenna, 5 kW, 50 ohms.....	994-3968-001
DU-570 Dummy Antenna, 5 kW, 70 ohms.....	994-3968-002
M-6107 Dummy Antenna, 10 kW, 50 ohms.....	994-6107
M-5497 Dummy Antenna, 50 kW, medium wave (see Note 1)	994-5497-001
M-5497A Dummy Antenna, 50 kW, high frequency (see Note 1).....	994-5497-002
Dummy Antenna, 100 kW, high frequency (see Note 2).....	WDL-1000A
DU-151 Dummy Antenna, 1 kW, 50 ohms.....	994-4354
DU-170 Dummy Antenna, 1 kW, 70 ohms.....	994-3483

NOTES: (1) Be sure to state resistance, such as 50 ohms. (2) Give power line frequency when ordering, such as 50 or 60 Hz, etc.

FM BROADCAST TRANSMITTERS



Solid State "DCFM" Exciter

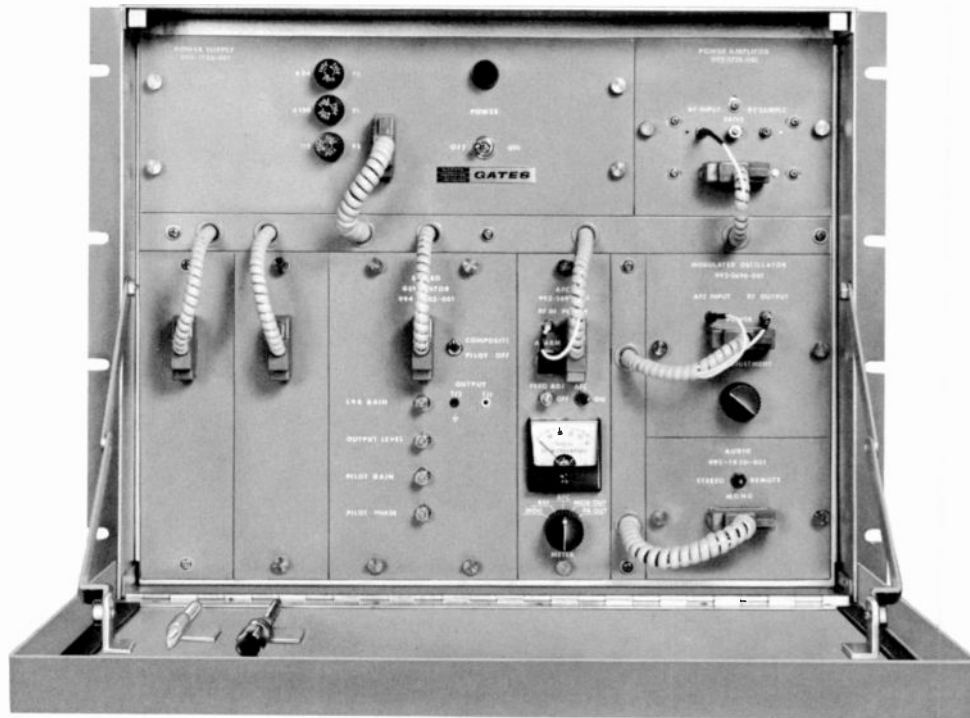

MODEL TE-3

Gates' advance-design solid state TE-3 Exciter, combining the superior stereo performance of Direct Carrier Frequency Modulation (DCFM) with the extreme frequency stability of Digital Automatic Frequency Control (DAFC), is the heart of every Gates "H3" transmitter.

The "H3" FM transmitter series is FCC type accepted, and thoroughly field tested. There are nine models, covering all power ranges:

- A one tube 250 watt FM transmitter
- A one tube 1000 watt FM transmitter
- A two tube 2000 watt FM transmitter
- A two tube 3000 watt FM transmitter
- A two tube 5000 watt FM transmitter
- A two tube 7500 watt FM transmitter
- A two tube 10,000 watt FM transmitter
- A three tube 20,000 watt FM transmitter
- A six tube 40,000 watt FM transmitter

FULL 10 WATTS OF RF SOLID STATE POWER: The Model TE-3 Exciter was designed to upgrade FM transmitter reliability by using solid state devices to reduce the greatest danger to electronic equipment—heat. Only performance-proven solid state devices and precision temperature-compensated components are used to assure continuous duty service. A full 10 watts of composite RF signal at carrier frequency is produced easily by this 100% transistorized exciter. The TE-3 can be used to drive most modern FM transmitters requiring 10 watts carrier frequency input.

ADVANCED DESIGN: The oscillator in the Model TE-3 Exciter operates at the carrier output frequency, eliminating

frequency multipliers. This, combined with Digital Automatic Frequency Control, means improved carrier stability and excellent frequency response. With this exciter, phase shift and distortion resulting from frequency multiplier tuned circuits are now a thing of the past. There is no longer a need to retune critical stages, which means more stable and efficient operation.

STEREO SEPARATION 35 DB MINIMUM: Optimum 35 dB separation is the result of Direct Carrier Frequency Modulation of the oscillator at the output frequency. As carrier generation and modulation take place "on frequency," the wide bandwidth needed for high fidelity reproduction is easily attained. The result is better FM stereo separation and minimum crosstalk between main channel and sub channels used for SCA and FM stereo.

MODULAR CONSTRUCTION: The Model TE-3 is composed of seven modules, each individually shielded, and connected within the exciter enclosure by an advanced intercabling technique. Connections are made at the front of each module with premium quality quick-disconnect plugs. Test voltage measurements and adjustments can be made easily by this advanced modular mechanical design. Modular construction allows the addition of stereo or SCA at a later date by simply plugging in the factory adjusted module(s).

SUPERB SCA OPERATION: In the TE-3 Exciter crosstalk from the main channel to the SCA channel is virtually eliminated through new filtering techniques, and cancellation of the second harmonic of the composite stereo signal.

Model TE-3 Exciter Modules



Modulated Oscillator Module

Operating at carrier frequency, the ultra stable modified Clapp oscillator is modulated by the direct application of mono, stereo and SCA input signals. For the most precise stability, the oscillator circuit is constructed with temperature compensated components and isolated by shock mounts. Gates "DCFM" is generated in this module, and feeds the solid state 10 watt amplifier module.

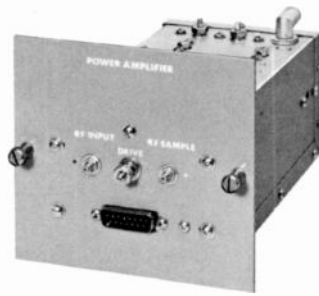

Power Amplifier Module

The power amplifier of the Model TE-3 FM Exciter is all solid state and provides a 10 watt signal at carrier frequency to the driver or final amplifier of Gates "H3" Series Transmitters. Amplifier bandwidth is approximately 3 MHz, which assures optimum stereo separation.



Stereo Generator Module (Optional)

With Gates solid state stereo generator, stereo separation left to right and right to left is always better than 35 dB from 50 Hz to 15 kHz. This performance is assured by the Gates "DCFM" exciter design. The modular construction allows you to order a Gates FM transmitter for monophonic operation, and add the factory aligned stereo generator later.



Automatic Frequency Control Module

Continuous carrier stability, within ± 1 kHz ($\pm .001\%$) of the assigned center frequency, is provided by a precision crystal controlled oscillator. Digital devices count down the output of the modulated oscillator and the crystal frequency for phase comparison. The two oscillators are then "phase locked" for error-free frequency control.

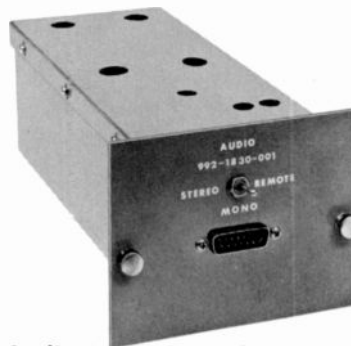

Audio Input Control Module

Control, processing and input switching of mono, stereo and 41 kHz SCA inputs to the modulated oscillator are provided in this module. During monophonic operation the right channel is automatically switched to the 41 kHz SCA input, which allows use of this program line for SCA operation.

Power Supply Module

The solid state regulated DC power supply provides 24 volts DC to all modules in the Model TE-3 Exciter. Temperature compensated zener diodes are used to provide constant zener voltages over a temperature range of -20° C to $+70^{\circ}$ C, and power line variations from 85 volts to 130 volts. Ample power is available for the optional stereo and SCA modules.

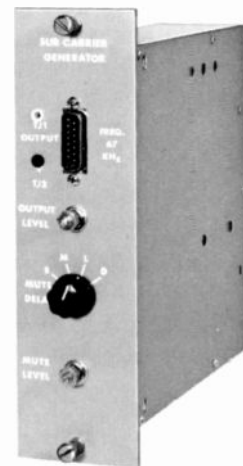

SCA Module (Optional)

Stable, self-excited oscillators are used to provide 41 kHz or 67 kHz SCA operation of excellent quality, with very low distortion. Automatic muting is included, with provision for control of both mute level and mute time constant. Factory pre-aligned SCA modules can be installed in the Model TE-3 Exciter by simply plugging into the space provided.

40,000 Watt FM Transmitter



MODEL FM-40H3

Gates largest standard model FM transmitter offers the ultimate in reliable performance, with superior FM monaural and multiplex operation. The FM-40H3 uses only six tubes to develop a 40 kW output, which, in combination with the appropriate antenna, is capable of producing the maximum effective radiated power permissible for a Class C station.

SOLID STATE "DCFM": Gates field proven 100% solid state TE-3 exciter, employing Direct Carrier Frequency Modulation and Digital Automatic Frequency Control, is the heart of the FM-40H3 transmitter. The modulated oscillator of the exciter operates at the carrier frequency for greatest stability and excellent frequency response. The 10 watt output of the exciter drives separate 10 watt solid state isolation amplifiers.

The isolation stages drive a pair of 4CX250B tubes in each driver amplifier, which produce 400 watts for each 4CX15000A power amplifier. Sufficient space is available to duplicate the exciter and isolation amplifiers if desired.

HIGH POWER PERFORMANCE: Modern ceramic tetrodes are used in the FM-40H3 for reliability and low cost operation.

Output tuning in each amplifier is accomplished with an inductively tuned silver plated tank circuit. This eliminates the need for vacuum capacitors in the tank circuit of the amplifier. Tee notch and harmonic filters on the output of each amplifier reduce harmonic radiation beyond the required minimum.

COMBINING NETWORK: Outputs of each 20 kW amplifier are fed through Tee notch and harmonic filters to the combining network. This hybrid network adds the two 20 kW signals to produce a 40 kW output to the transmission line. However, the two amplifiers remain isolated from each other. Should one power amplifier fail, the other will continue feeding the combining network, and the combiner will operate as a power divider. However, in this case, 10 kW is fed to the output transmission line, and 10 kW is fed into a 10 kW dummy load connected to the combiner. This is necessary to maintain almost complete isolation of the non-operating amplifier and to permit servicing without unwanted RF coupling.

The combining network, harmonic, and Tee notch filters, or "plumbing", can be physically tailored to fit specific installation requirements.

40,000 Watt FM Transmitter—FM-40H3

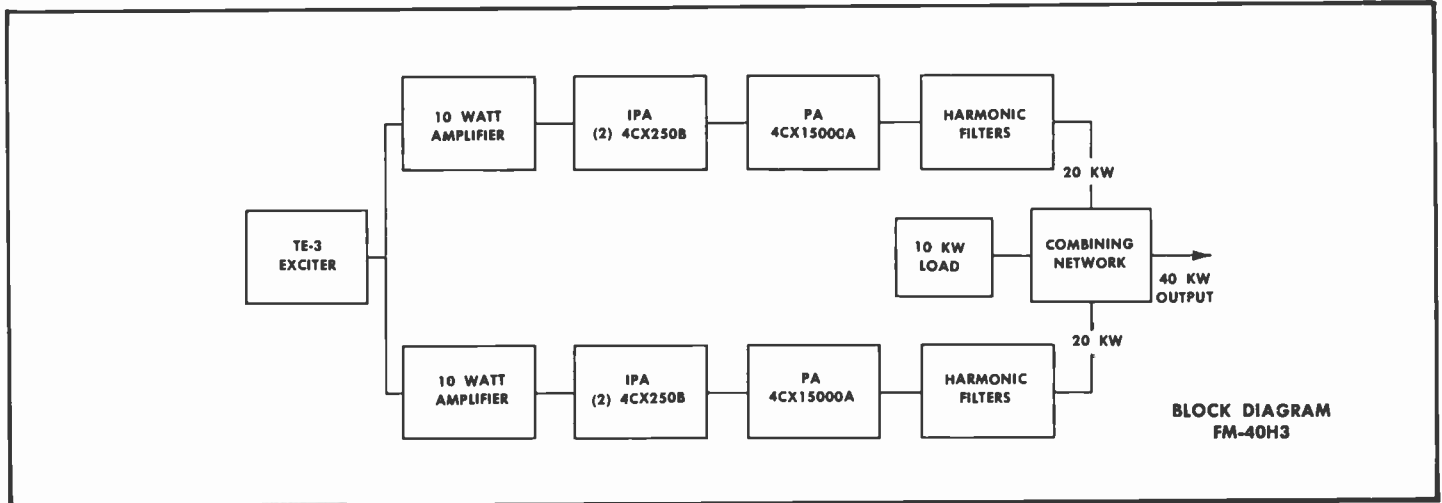

SPECIFICATIONS

GENERAL

POWER OUTPUT: 40 kW.
FREQUENCY RANGE: 87.5 to 108 MHz, tuned to specified operating frequency.
RF OUTPUT IMPEDANCE: 50 ohms.
OUTPUT TERMINATION: 3/4" EIA flange.
FREQUENCY STABILITY: .001% or better.
TYPE OF MODULATION: Direct Carrier Frequency Modulation.
MODULATION CAPABILITY: ± 100 kHz.
AC INPUT POWER: 208/240 V, 3 phase 60 Hz. Power consumption 61,000 watts (approx.). 115 V single phase, 60 Hz, 600 watts. (50 Hz available on special order.)
RF HARMONICS: Suppression meets all FCC requirements.
POWER SUPPLY RECTIFIERS: Silicon.
ALTITUDE: 7,500 feet.
BLOWERS: (2) 1,250 cfm @ 6.3 inches.
AMBIENT TEMPERATURE RANGE: -20°C to $+45^{\circ}\text{C}$.
MAXIMUM VSWR: 1.7 to 1.
OVER-ALL CABINET SIZE: Transmitter cabinet 84" W x 78" H x 32 3/4" D. HV power supply cabinet 30" W x 30" D x 49" H. (Two supplied).
FRONT DOOR SWING: 21".
FINISH: Two-tone beige-gray.
WEIGHT AND CUBAGE: Export: 4,600 lbs. Domestic: 4,000 lbs., 300 cu. ft.

MONAURAL MODE

AUDIO INPUT IMPEDANCE: 600 ohms balanced.
AUDIO INPUT LEVEL: +10 dBm ± 2 dB for 100% modulation at 400 Hz.
AUDIO FREQUENCY RESPONSE: Standard 75 microsecond, FCC pre-emphasis curve ± 1 dB, 30-15,000 Hz.
DISTORTION: 0.5% or less, 30-15,000 Hz.
FM NOISE: 65 dB below 100% modulation (ref. 400 Hz).
AM NOISE: 50 dB below reference carrier AM modulated 100%.

STEREOPHONIC MODE (Stereo Generator optional)

PILOT OSCILLATOR: Crystal controlled.

PILOT STABILITY: 19 kHz ± 1 Hz.

AUDIO INPUT IMPEDANCE: (left and right) 600 ohms balanced.

AUDIO INPUT LEVEL: (left and right) +10 dBm ± 1 dB for 100% modulation at 400 Hz.

AUDIO FREQUENCY RESPONSE: (left and right) Standard 75 microsecond, FCC pre-emphasis curve ± 1 dB, 50-15,000 Hz.

DISTORTION: (left or right) 1% or less, 50-15,000 Hz.

FM NOISE: (left or right) 60 dB minimum below 100% modulation, reference 400 Hz.

STEREO SEPARATION: 35 dB minimum 50-15,000 Hz.

SUB-CARRIER SUPPRESSION: 42 dB below 90% modulation.

CROSSTALK: (main to sub-channel or sub to main channel) 42 dB below 90% modulation.

SCA MODE (SCA Generator optional)

FREQUENCY STABILITY: ± 500 Hz.

FREQUENCY: Between 25 and 75 kHz.

OSCILLATOR TYPE: Two Colpitts heterodyned to produce desired output frequency.

MODULATION: Direct FM.

MODULATION CAPABILITY: ± 7.5 kHz.

AUDIO INPUT IMPEDANCE: 600 ohms balanced.

AUDIO INPUT LEVEL: +8 dBm, ± 3 dB, for 100% modulation at 400 Hz.

AUDIO FREQUENCY RESPONSE: 41 kHz and 67 kHz, 50 microsecond, modified pre-emphasis. 67 kHz response modified for proper operation when used with stereo to conform to FCC specifications.

DISTORTION: Less than 1.5% 30-7000 Hz.

FM NOISE: (Main channel not modulated) 55 dB minimum (ref. 100% modulation 400 Hz).

CROSSTALK: (sub-channel to main channel) - 60 dB or better.

CROSSTALK: (main channel to sub-channel) 50 dB below 100% modulation (ref. 400 Hz).

AUTOMATIC MUTE LEVEL: Variable from 0 to 40 dB below 100% modulation.

ORDERING INFORMATION

FM-40H3, 40,000 watt FM broadcast transmitter with TE-3 exciter.....	994-6746
FM-20/20H3, 20,000/20,000 watt FM broadcast transmitter, with TE-3 exciter. No combining network—feeds horizontal and vertical antennas separately.....	994-6770
Stereo Generator (add for stereo operation).....	994-6533
SCA Sub-carrier generator (add for SCA operation).....	994-6507

20,000 Watt FM Transmitter

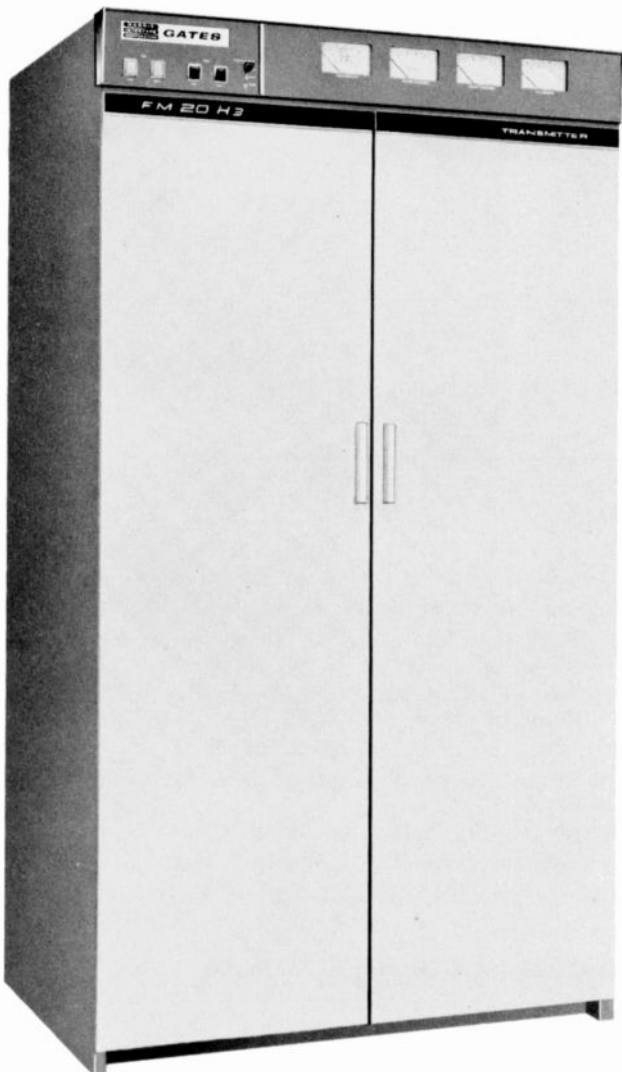

MODEL FM-20H3

The pace-setting engineering which produced Direct Carrier Frequency Modulation (DCFM), as employed in the FM-20H3, has made possible a three tube, 20,000 watt transmitter with the ultimate in performance standards. Fully FCC type accepted for stereo and monaural broadcasting in the 88 to 108 MHz FM band.

ONLY THREE TUBES: Solid state reliability is achieved, as the transmitter uses only three tubes for 20,000 watts output. The transistorized model TE-3 exciter delivers ten watts. This is followed by the only tubes employed—two parallel 4CX250B drivers and the rugged high-efficiency 4CX15000A single ended power amplifier.

POWER AMPLIFIER TUBE: The ceramic type 4CX15000A output tube assures excellent performance and long tube life for 20,000 watt FM service. This high power gain tetrode operates at a leisurely pace, dissipating little more than 5000 watts at a full 20,000 watts output.

SOLID STATE "DCFM" EXCITER: The 100% solid state model TE-3 exciter employs an advanced Gates design wherein the oscillator is modulated at the carrier frequency (DCFM). The result is improved carrier stability and unsurpassed frequency response. Modular construction of the TE-3 exciter allows plugging in of the solid state individually shielded stereo and SCA modules at any time.

PLUG-IN STEREO/SCA GENERATOR MODULES: To equip your FM-20H3 transmitter for stereo or SCA just plug the appropriate modules into the TE-3 exciter. For SCA you have your choice of 41 kHz and 67 kHz modules.

OPERATIONALLY TESTED: Environmental tests that surpass conditions of any location a transmitter is likely to encounter were imposed upon the FM-20H3 before it entered production. In addition, each transmitter is fully tuned and tested to the assigned frequency before shipment.

PUSHBUTTON OPERATION: On-off functions are controlled by lighted pushbuttons at the top left of the transmitter. These are plainly marked "filament on-off"; "plate on-off".

POWER OUTPUT CONTROL: In the FM-20H3 transmitter, Gates supplies a built-in motor-operated screen voltage control, for power output adjustment.

REMOTE CONTROL BUILT IN: All necessary functions can be remote controlled in the FM-20H3. No additional equipment is required for Gates remote control systems.

AUTOMATIC RECYCLING: In case of momentary overload, the FM-20H3 will recycle automatically. Should the overload reoccur in excess of the desired number of times preset in the transmitter, the transmitter will then remain off the air until reset locally or remotely.

HV SILICON POWER SUPPLIES: Two separate three-phase all-silicon power supplies are used in the FM-20H3. The 9000 volt supply, for PA plate voltage, is housed in a separate high voltage enclosure, and includes a manual switch to allow power cutback to approximately 5 kW. The other three-phase power supply, which powers the IPA plate and screen circuit, and also the PA screen, is housed in the main transmitter cabinet.

HANDSOME STYLING: The main transmitter cabinet is attractively, yet functionally styled, with double front doors, and an eye-catching meter panel framed in contoured brushed aluminum. The finish is in two-tone beige-gray. A separate enclosure for the HV power supply complements the main FM-20H3 cabinet.

20,000 Watt FM Transmitter—FM-20H3

HARMONIC FILTERS STANDARD EQUIPMENT: Included as standard equipment is a Tee type notch filter for second harmonic reduction, a micromatch VSWR section for direct meter reading on the transmitter of both power output and standing wave ratio, and a low pass filter which effectively eliminates third and higher order harmonics. Tuning and testing, which includes adjustment of filters for maximum harmonic attenuation, is accomplished at the factory on the customer's frequency.

EFFICIENT AIR COOLING: A heavy-duty impeller type blower was selected for use in the FM-20H3 to help increase component life. This blower moves up to 200% more air than required for normal heat dissipation of the transmitter when operating at altitudes up to 7500 feet—which means fast, efficient cooling for all components.

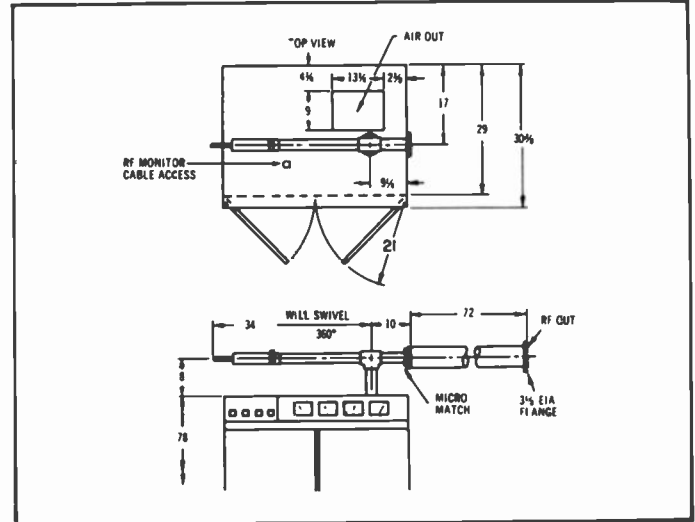

SPECIFICATIONS

GENERAL

POWER OUTPUT: 20 kW.
FREQUENCY RANGE: 87.5 to 108 MHz, tuned to specified operating frequency.
RF OUTPUT IMPEDANCE: 50 ohms.
OUTPUT TERMINATION: 3/4" EIA flange.
FREQUENCY STABILITY: .001% or better.
TYPE OF MODULATION: Direct Carrier Frequency Modulation.
MODULATION CAPABILITY: ± 100 kHz.
AC INPUT POWER: 208/240 V, 3-phase 60 Hz. Power consumption 30,000 watts (approx.). 115 V single phase, 60 Hz, 300 watts. (50 Hz available on special order.)
RF HARMONICS: Suppression meets all FCC requirements.
POWER SUPPLY RECTIFIERS: Silicon.
ALTITUDE: 7,500 feet.
BLOWER: 1,250 cfm @ 6.3 inches.
AMBIENT TEMPERATURE RANGE: -20°C to $+45^{\circ}\text{C}$.
MAXIMUM VSWR: 1.7 to 1.
OVER-ALL CABINET SIZE: Transmitter cabinet 42" W x 78" H x 32 1/4" D. HV power supply cabinet 30" W x 30" D x 49" H.
FRONT DOOR SWING: 21".
FINISH: Two-tone, beige-gray.
WEIGHT & CUBAGE: Export: 2,300 lbs. Domestic: 2,000 lbs. 150 cu. ft.

MONAURAL MODE

AUDIO INPUT IMPEDANCE: 600 ohms balanced.
AUDIO INPUT LEVEL: $+10$ dBm ± 2 dB for 100% modulation at 400 Hz.
AUDIO FREQUENCY RESPONSE: Standard 75 microsecond, FCC pre-emphasis curve ± 1 dB, 30-15,000 Hz.
DISTORTION: 0.5% or less, 30-15,000 Hz.
FM NOISE: 65 dB below 100% modulation (ref. 400 Hz).
AM NOISE: 50 dB below reference carrier AM modulated 100%.

STEREOPHONIC MODE (Stereo Generator optional)

PILOT OSCILLATOR: Crystal controlled.

PILOT STABILITY: 19 kHz ± 1 Hz.
AUDIO INPUT IMPEDANCE: (left and right) 600 ohms balanced.
AUDIO INPUT LEVEL: (left and right) $+10$ dBm ± 1 dB for 100% modulation at 400 Hz.
AUDIO FREQUENCY RESPONSE: (left and right) Standard 75 microsecond, FCC pre-emphasis curve ± 1 dB, 50-15,000 Hz.
DISTORTION: (left or right) 1% or less, 50-15,000 Hz.
FM NOISE: (left or right) 60 dB minimum below 100% modulation, reference 400 Hz.
STEREO SEPARATION: 35 dB minimum 50-15,000 Hz.
SUB-CARRIER SUPPRESSION: 42 dB below 90% modulation.
CROSSTALK: (main to sub-channel or sub to main channel) 42 dB below 90% modulation.

SCA MODE (SCA Generator optional)

FREQUENCY STABILITY: ± 500 Hz.
FREQUENCY: Between 25 and 75 kHz.
OSCILLATOR TYPE: Two Colpitts heterodyned to produce desired output frequency.
MODULATION: Direct FM.
MODULATION CAPABILITY: ± 7.5 kHz.
AUDIO INPUT IMPEDANCE: 600 ohms balanced.
AUDIO INPUT LEVEL: $+8$ dBm, ± 3 dB for 100% modulation at 400 Hz.
AUDIO FREQUENCY RESPONSE: 41 kHz and 67 kHz, 50 microsecond, modified pre-emphasis. 67 kHz response modified for proper operation when used with stereo to conform to FCC specifications.
DISTORTION: Less than 1.5% 30-7,000 Hz.
FM NOISE: (main channel not modulated) 55 dB minimum (ref. 100% modulation 400 Hz).
CROSSTALK: (sub-channel to main channel) -60 dB or better.
CROSSTALK: (main channel to sub-channel) 50 dB below 100% modulation (ref. 400 Hz).
AUTOMATIC MUTE LEVEL: Variable from 0 to 40 dB below 100% modulation.

ORDERING INFORMATION

FM-20H3, 20,000 watt FM broadcast transmitter, with TE-3 exciter.....	994-6745
100% spare tube kit.....	990-0552
Stereo generator (add for stereo operation).....	994-6533
SCA sub-carrier generator (add for SCA operation).....	994-6507

10,000 Watt FM Transmitter

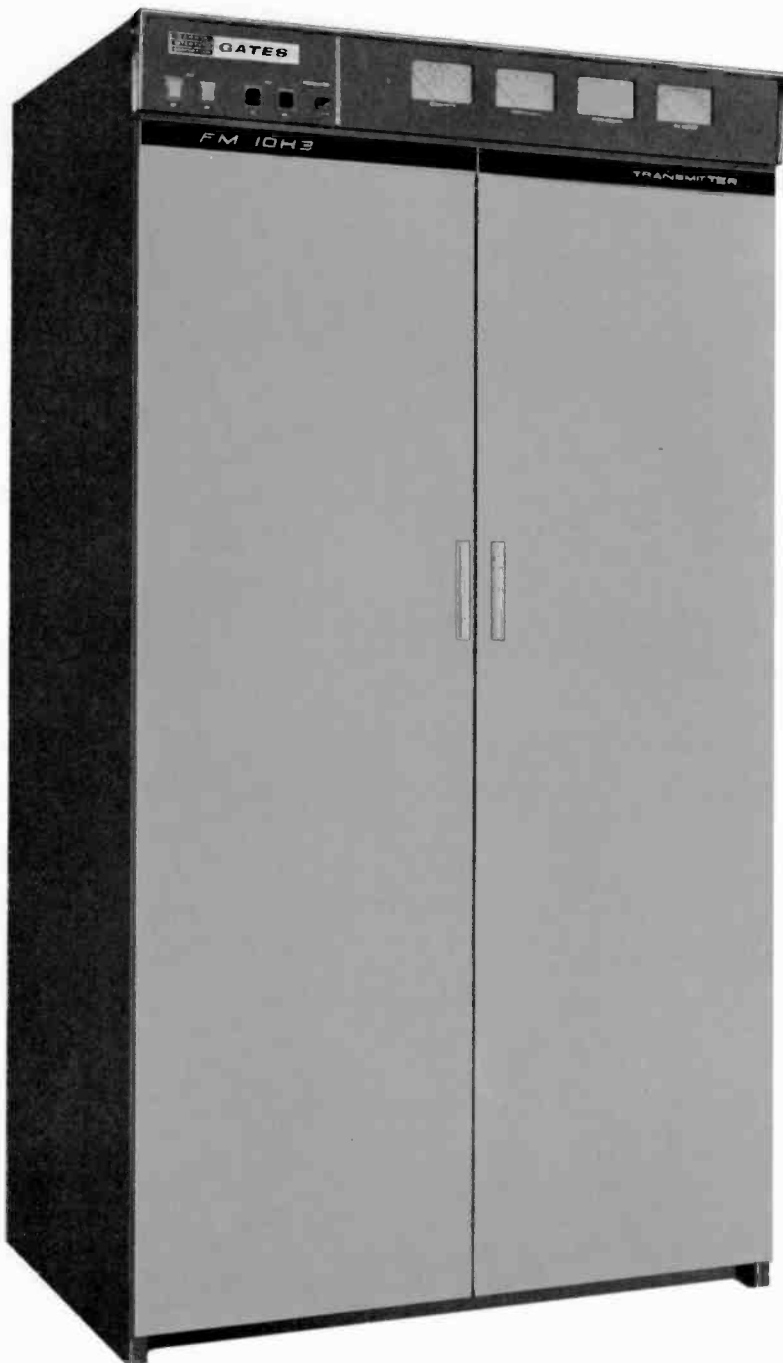

MODEL FM-10H3

Gates FM-10H3 is the most advanced 10,000 watt FM transmitter ever offered. It incorporates the TE-3 solid state "DCFM" exciter for unsurpassed stereophonic and monaural sound, and only two tubes are required to produce a full 10,000 watts. Gates model FM-10H3 is fully FCC type accepted for stereophonic (with optional stereo generator) and monaural FM broadcasting in the 88 to 108 MHz band.

TWO TUBES: Only two tubes are used in the entire transmitter. 10 watts is delivered from the model TE-3 transistorized exciter to the 4CX300A driver, which supplies a nominal 250 watts to drive the 4CX10,000D power amplifier. This power tetrode operates at a leisurely pace, providing ample power to deliver a high fidelity signal with proven economy.

TYPE 4CX10,000D POWER OUTPUT TUBE: Use of the power packed ceramic 4CX10,000D tube as the final amplifier assures excellent performance. It was selected because of its 10 kW plate dissipation, its ability to produce more power . . . and its proven longer, useful life.

SELF-CONTAINED: Except for the top-mounted Tee notch and low pass filters, the FM-10H3 transmitter is completely self-contained. The power transformer, solid state exciter, and optional stereo/SCA generating equipment are all housed in one attractively styled cabinet.

"DCFM" EXCITER: As in other "H3" series transmitters, the FM-10H3 employs the 100% solid state TE-3 exciter. An advanced design used first by Gates, the exciter employs Direct Carrier Frequency Modulation (DCFM) and Digital Automatic Frequency Control. This makes possible improved carrier stability and unsurpassed frequency response.

BUILT-IN REMOTE CONTROL: Connect the transmitter control unit to the transmitter, tie in the telephone line to the studio control unit, and you are ready for complete remote control operation. All necessary functions can be controlled remotely—and no additional equipment is required for a Gates remote control system.

POWER GUARD: The FM-10H3 employs a special power supply protective circuit, Power Guard, to assure maximum protection from transient voltages or on-off power surges.

AUTOMATIC RECYCLING: Should a momentary overload occur, the FM-10H3 will recycle automatically. If the overload reoccurs in excess of the number of times preset in the transmitter, the transmitter will remain off the air until it is reset, either manually or by remote control.

SILICON RECTIFIERS: For increased reliability, silicon power rectifiers are used in all FM-10H3 power supplies. Operated well below their rated levels, they provide years of dependable service in the transmitter. In the HV power supply, a generous number of 16 ampere silicon cells operate in a three phase bridge, and are so rugged that maximum transmitter current demand is only 50% of the peak rating of the supply. Three solid state power supplies are used; high voltage, bias, and exciter.

10,000 Watt FM Transmitter—FM-10H3

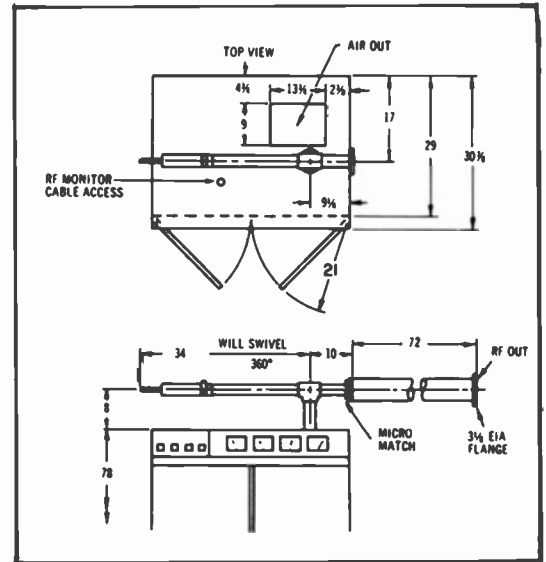
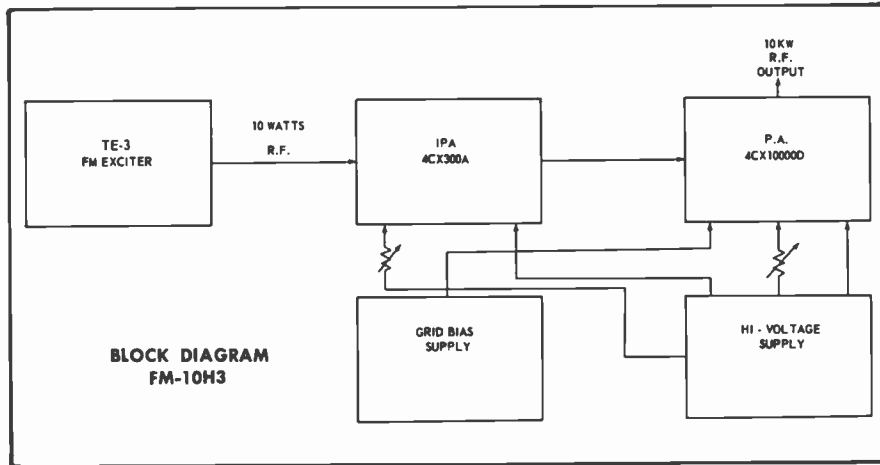

SPECIFICATIONS

GENERAL

POWER OUTPUT: 10 kW.
FREQUENCY RANGE: 87.5 to 108 MHz, tuned to specified operating frequency.
RF OUTPUT IMPEDANCE: 50 ohms.
OUTPUT TERMINATION: 3/4" EIA flange.
FREQUENCY STABILITY: .001% or better.
TYPE OF MODULATION: Direct Carrier Frequency Modulation.
MODULATION CAPABILITY: ±100 kHz.
AC INPUT POWER: 208/240 V, 3 phase, 60 Hz at 17 kW. 115 V, single phase, 60 Hz, 300 watts, (50 Hz available on special order.)
POWER SUPPLY RECTIFIERS: Silicon.
RF HARMONICS: Suppression meets all FCC requirements.
ALTITUDE: 7,500 feet.
BLOWER: 430 cfm @ 2.6 inches.
AMBIENT TEMPERATURE RANGE: -20°C to +45°C.
MAXIMUM VSWR: 1.7 to 1.
OVER-ALL CABINET SIZE: 42" W x 78" H x 32 3/4" D.*
 *32 3/4" is over-all depth dimension. With rear door and front door handles removed, minimum depth is 29 3/4".
FRONT DOOR SWING: 21".
FINISH: Two-tone, beige-gray.
WEIGHT & CUBAGE: Export: 975 lbs. Domestic: 825 lbs. 110 cu. ft.

MONAURAL MODE

AUDIO INPUT IMPEDANCE: 600 ohms balanced.
AUDIO INPUT LEVEL: +10 dBm ±2 dB for 100% modulation at 400 Hz.
AUDIO FREQUENCY RESPONSE: Standard 75 microsecond, FCC pre-emphasis curve ±1 dB, 30-15,000 Hz.
DISTORTION: 0.5% or less, 30-15,000 Hz.
FM NOISE: 65 dB below 100% modulation (ref. 400 Hz).
AM NOISE: 50 dB below reference carrier AM modulated 100%.

STEREOPHONIC MODE (Stereo Generator optional)

PILOT OSCILLATOR: Crystal controlled.
PILOT STABILITY: 19 kHz ±1 Hz.
AUDIO INPUT IMPEDANCE: (left and right) 600 ohms balanced.
AUDIO INPUT LEVEL: (left and right) +10 dBm ±1 dB for 100% modulation at 400 Hz.
AUDIO FREQUENCY RESPONSE: (left and right) Standard 75 microsecond, FCC pre-emphasis curve ±1 dB, 50-15,000 Hz.
DISTORTION: (left or right) 1% or less, 50-15,000 Hz.
FM NOISE: (left or right) 60 dB minimum below 100% modulation, reference 400 Hz.
STEREO SEPARATION: 35 dB minimum 50-15,000 Hz.
SUB-CARRIER SUPPRESSION: 42 dB below 90% modulation.
CROSSTALK: (main to sub-channel or sub to main channel) 42 dB below 90% modulation.

SCA MODE (SCA Generator optional)

FREQUENCY STABILITY: ±500 Hz.
FREQUENCY: Between 25 and 75 kHz.
OSCILLATOR TYPE: Two Colpitts heterodyned to produce desired output frequency.
MODULATION: Direct FM.
MODULATION CAPABILITY: ±7.5 kHz.
AUDIO INPUT IMPEDANCE: 600 ohms balanced.
AUDIO INPUT LEVEL: +8 dBm, ±3 dB for 100% modulation at 400 Hz.
AUDIO FREQUENCY RESPONSE: 41 kHz and 67 kHz, 50 microsecond, modified pre-emphasis. 67 kHz response modified for proper operation when used with stereo to conform to FCC specifications.
DISTORTION: Less than 1.5% 30-7000 Hz.
FM NOISE: (main channel not modulated) 55 dB minimum (ref. 100% modulation 400 Hz).
CROSSTALK: (sub-channel to main channel) -60 dB or better.
CROSSTALK: (main channel to sub-channel) 50 dB below 100% modulation (ref. 400 Hz).
AUTOMATIC MUTE LEVEL: Variable from 0 to 40 dB below 100% modulation.

ORDERING INFORMATION

FM-10H3, 10,000 watt FM broadcast transmitter, with TE-3 exciter.....	994-6744
100% spare tube kit.....	990-0551
Stereo generator (add for stereo operation).....	994-6533
SCA sub-carrier generator (add for SCA operation).....	994-6507

5000-7500 Watt FM Transmitters

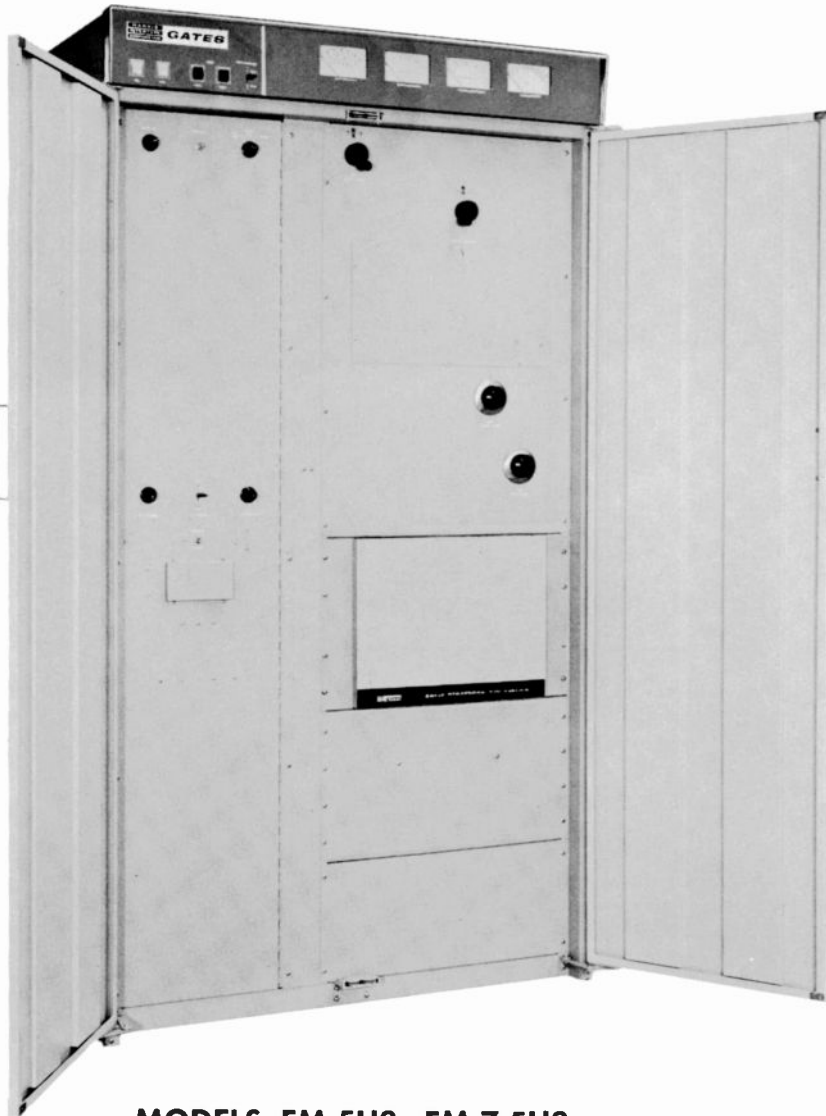

MODELS FM-5H3 - FM-7.5H3

Gates FM-5H3 and FM-7.5H3 transmitters provide 5,000-7,500 watts output with just two tubes—and feature the performance proven solid state TE-3 exciter, employing Direct Carrier Frequency Modulation. Quality all the way, both transmitters combine the reliability of solid state circuitry and the superb performance of "DCFM" for outstanding stereo (with optional stereo generator) and monaural transmission. Each transmitter is FCC type accepted for stereophonic and monaural FM broadcasting in the 88 to 108 MHz band.

ONLY TWO TUBES: With the transistorized 10 watt model TE-3 exciter incorporated into these transmitters, only two tubes are needed to produce a full 5,000 watts of power in the model FM-5H3, and a full 7,500 watts in the FM-7.5H3. A type 4CX250B tube amplifies the solid state exciter output and supplies a nominal 250 watts to drive the ceramic 4CX-5000A final tube. This power tetrode operates as a single ended amplifier to produce 5 to 7.5 kilowatts of power.

"DCFM" PERFORMANCE: The superior engineering design of Gates TE-3 exciter includes Direct Carrier Frequency Modulation for superior stereo performance and Digital Automatic Frequency Control for maximum stability.

In both the FM-5H3 and the FM-7.5H3 stereo separation is 35 dB minimum from 50 Hz to 15 kHz.

Self-contained within these transmitters, the "DCFM" exciter is of modular construction so that the solid state stereo and SCA modules may be plugged in at any time.

VARI-LINE TUNING: Field proven for dependability, Gates Vari-Line tuning is used in the FM-5H3 and the FM 7.5H3 transmitters. This is an advanced method of tuning a single ended FM amplifier to achieve optimum output efficiency.

HARMONIC REDUCTION: Included as standard equipment in the transmitters is a Tee type notch filter for second harmonic reduction, a micro-match VSWR section for direct meter reading of both power output and standing wave ratio, and a low pass filter which effectively eliminates third and higher order harmonics.

SPECIAL PROTECTIVE CIRCUIT: The FM-5H3 and the FM-7.5H3 are protected by Power Guard, a Gates developed power supply protective circuit, that provides maximum protection from transient voltages.

If a momentary overload occurs, the transmitter will recycle automatically up to the number of times preset.

For increased dependability, solid state rectifiers are standard in these transmitters.

OPERATING CONVENIENCE: "On-off" functions in the FM-5H3 and the FM-7.5H3 are controlled by two lighted push-buttons at the top left of the transmitter. The multimeter control switch is located just to the right of these pushbuttons.

Full metering is provided with four large, front panel meters, including a VSWR power indicator that permits direct reading of both power output and standing wave ratio.

SELF-CONTAINED: The power supply, exciter, power transformers and optional stereo generating/SCA equipment are all housed in one cabinet, for simplified transmitter installation.

REMOTE CONTROL: In both the FM-5H3 and the FM-7.5H3 all functions can be remote controlled. Simply connect the transmitter control unit of the Gates remote control system and remote operation is ready.

5000-7500 Watt FM Transmitters-FM-5H3-FM-7.5H3

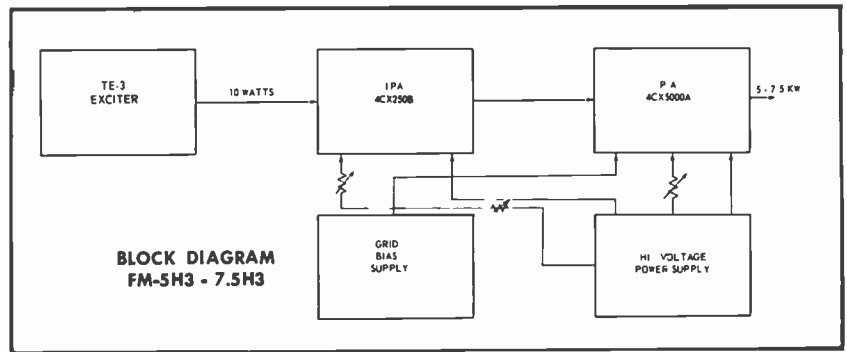
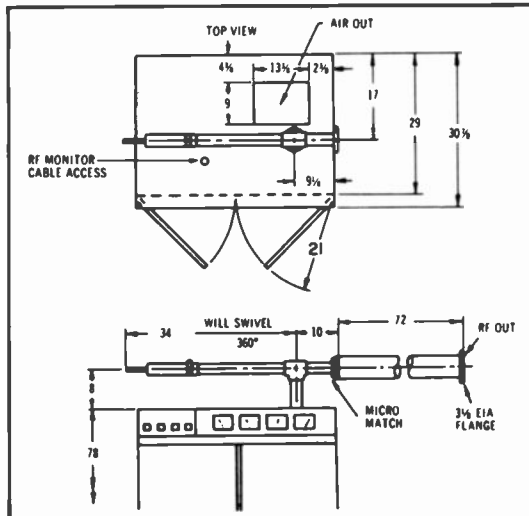

SPECIFICATIONS

GENERAL

- POWER OUTPUT:** 5 or 7.5 kW.
- FREQUENCY RANGE:** 87.5 to 108 MHz, tuned to specified operating frequency.
- RF OUTPUT IMPEDANCE:** 50 ohms.
- OUTPUT TERMINATION:** 3/4" EIA flange.
- FREQUENCY STABILITY:** .001% or better.
- TYPE OF MODULATION:** Direct Carrier Frequency Modulation.
- MODULATION CAPABILITY:** ±100 kHz.
- AC INPUT POWER:** 208/240 V, 3 phase. 10 kW consumption at 5 kW output. 15 kW consumption at 7.5 kW output. 115 V single phase, 60 Hz, 300 watts. (50 Hz available on special order.)
- POWER SUPPLY RECTIFIERS:** Silicon.
- RF HARMONICS:** Suppression meets all FCC requirements.
- ALTITUDE:** 7,500 feet.
- BLOWER:** 390 cfm @ 3.2 inches.
- AMBIENT TEMPERATURE RANGE:** -20°C to +45°C.
- MAXIMUM VSWR:** 1.7 to 1.
- OVER-ALL CABINET SIZE:** 42" W x 78"H x 32 3/4" D.*
*32 3/4" is over-all depth dimension. With rear door and front door handles removed, minimum depth is 29 3/4".
- FRONT DOOR SWING:** 21".
- FINISH:** Two-tone beige-grey.
- WEIGHT AND CUBAGE:** Export: 900 lbs. Domestic: 750 lbs. 110 cu. ft.

MONAURAL MODE

- AUDIO INPUT IMPEDANCE:** 600 ohms balanced.
- AUDIO INPUT LEVEL:** +10 dBm ±2 dB for 100% modulation at 400 Hz.
- AUDIO FREQUENCY RESPONSE:** Standard 75 microsecond, FCC pre-emphasis curve ±1 dB, 30-15,000 Hz.
- DISTORTION:** 0.5% or less, 30-15,000 Hz.
- FM NOISE:** 65 dB below 100% modulation (ref. 400 Hz).
- AM NOISE:** 50 dB below reference carrier AM modulated 100%.

STEREOPHONIC MODE (Stereo Generator optional)

- PILOT OSCILLATOR:** Crystal controlled.
- PILOT STABILITY:** 19 kHz ±1 Hz.
- AUDIO INPUT IMPEDANCE:** (left and right) 600 ohms balanced.
- AUDIO INPUT LEVEL:** (left and right) +10 dBm ±1 dB for 100% modulation at 400 Hz.
- AUDIO FREQUENCY RESPONSE:** (left and right) Standard 75 microsecond, FCC pre-emphasis curve ±1 dB, 50-15,000 Hz.
- DISTORTION:** (left or right) 1% or less, 50-15,000 Hz.
- FM NOISE:** (left or right) 60 dB minimum below 100% modulation, reference 400 Hz.
- STEREO SEPARATION:** 35 dB minimum 50-15,000 Hz.
- SUB-CARRIER SUPPRESSION:** 42 dB below 90% modulation.
- CROSSTALK:** (main to sub-channel or sub to main channel) 42 dB below 90% modulation.

SCA MODE (SCA Generator optional)

- FREQUENCY STABILITY:** ±500 Hz.
- FREQUENCY:** Between 25 and 75 kHz.
- OSCILLATOR TYPE:** Two Colpitts heterodyned to produce desired output frequency
- MODULATION:** Direct FM.
- MODULATION CAPABILITY:** ±7.5 kHz.
- AUDIO INPUT IMPEDANCE:** 600 ohms balanced.
- AUDIO INPUT LEVEL:** +8 dBm, ±3 dB for 100% modulation at 400 Hz.
- AUDIO FREQUENCY RESPONSE:** 41 kHz and 67 kHz, 50 microsecond, modified pre-emphasis. 67 kHz response modified for proper operation when used with stereo to conform to FCC specifications.
- DISTORTION:** Less than 1.5% 30-7000 Hz.
- FM NOISE:** (main channel not modulated) 55 dB minimum (ref. 100% modulation 400 Hz).
- CROSSTALK:** (sub-channel to main channel) -60 dB or better.
- CROSSTALK:** (main channel to sub-channel) 50 dB below 100% modulation (ref. 400 Hz).
- AUTOMATIC MUTE LEVEL:** Variable from 0 to 40 dB below 100% modulation.

ORDERING INFORMATION

FM-5H3, 5000 watt FM broadcast transmitter with TE-3 exciter.....	994-6736
FM-7.5H3, 7500 watt FM broadcast transmitter with TE-3 exciter.....	994-6743
100% spare tube kit for either of above.....	990-0549
Stereo generator (odd for stereo operation).....	994-6533
SCA sub-carrier generator (add for SCA operation).....	994-6507

3000 Watt FM Transmitter

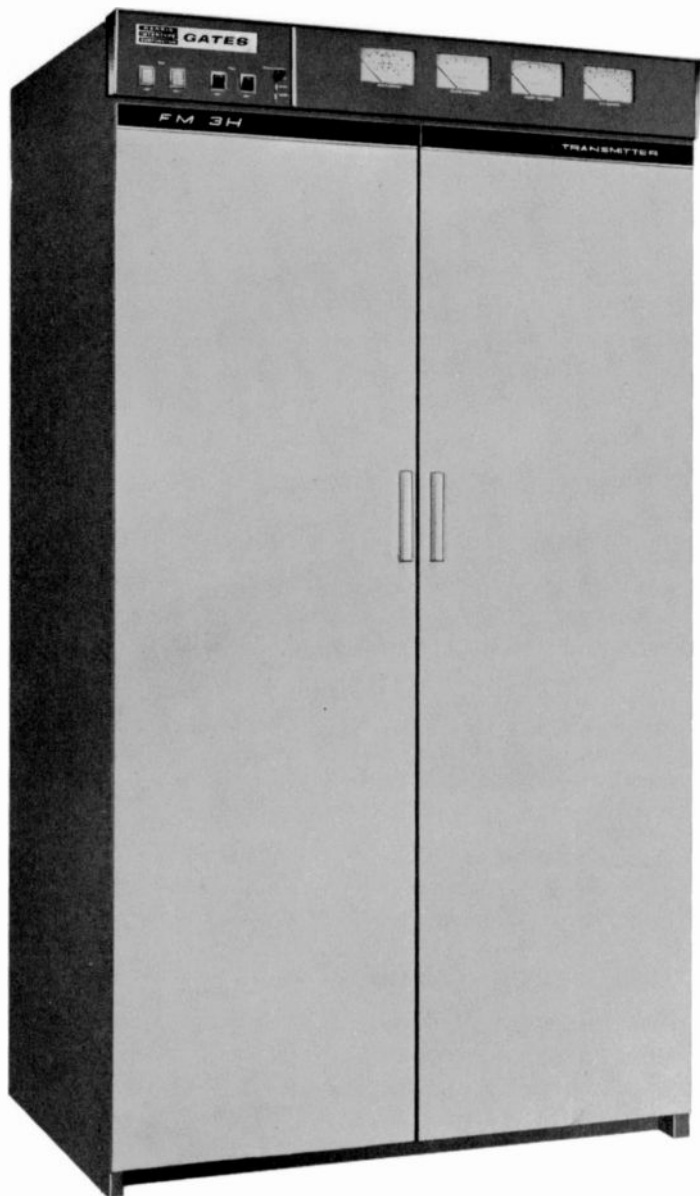

MODEL FM-3H3

This is the 3,000 watt version of Gates exciting line of advanced engineered FM transmitters featuring "DCFM". Modern in every way, model FM-3H3 incorporates the 100% solid state TE-3 exciter employing Direct Carrier Frequency Modulation, for superb stereo and monaural FM sound.

In the TE-3 exciter, carrier generation and modulation occur at the transmitter operating frequency. The result is greatly improved carrier stability and unsurpassed frequency response. Self-contained within the FM-3H3 transmitter, the TE-3 exciter is all solid state, and of modular construction to permit easy plug-in of optional stereo and SCA transistorized modules at any time.

Gates model FM-3H3 is FCC type accepted for both monaural and stereophonic broadcasting in the 88 to 108 MHz FM band.

LONG TUBE LIFE: This transmitter uses the 4CX5000A power tube which is standard in most modern 5,000 watt FM transmitters. As this modern ceramic tetrode operates well below its rated output, the tube coasts along in 3,000 watt service.

VARI-LINE TUNING: An advanced method of tuning a single ended FM amplifier for optimum output efficiency, Vari-Line is built into the FM-3H3. A portion of a parallel tubular transmission line is made variable to inductively tune the line to operating frequency. This means greater reliability as no mica or vacuum capacitors are needed in the tank circuit.

POWER GUARD: A Gates developed power supply protective circuit, Power Guard, assures maximum protection from transient voltages or on-off surges which might damage the power transformer and related electrical components.

EFFICIENT COOLING: A heavy-duty, impeller type self-cleaning blower provides effective component cooling throughout the FM-3H3. This blower moves up to 200% more air than required for normal heat dissipation of the transmitter when operating between sea level and 7,500 feet, and helps provide longer component life.

PUSHBUTTON OPERATION: Simplified "on-off" control is provided with lighted pushbuttons at the top left of the transmitter. These are "filament on-off"; "plate on-off". Just to the right of these is a switch for control of the multimeter. With this arrangement there is no need to open the front doors to operate the FM-3H3.

BUILT-IN REMOTE CONTROL: No additional transmitter equipment is needed for Gates remote control systems. Connect the FM-3H3 to a Gates transmitter control unit, and you are ready for remote control operation.

FILTERS ARE STANDARD EQUIPMENT: Included with the FM-3H3 transmitter is a Tee notch filter for second harmonic reduction and a low pass filter which substantially eliminates third and higher order harmonics. A micromatch VSWR section for direct meter reading of power output and standing wave ratio is also included.

AUTOMATIC RECYCLING: In case of momentary overload, the transmitter recycles automatically. However, should the overload reoccur in excess of the number of times preset in the transmitter, the FM-3H3 will remain off the air until it is reset.

3000 Watt FM Transmitter—FM-3H3

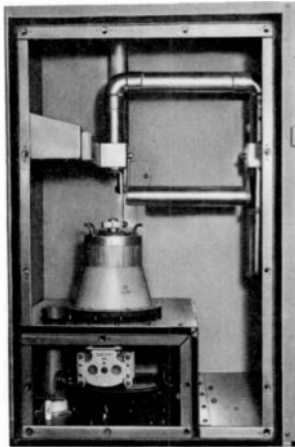

Driver amplifier located directly below the 4CX5000A power amplifier for added efficiency of operation.

TWO-TUBE DESIGN: From the TE-3 exciter to transmission line there are only two tubes in the FM-3H3. A type 4CX250B tube amplifies the ten watts from the solid state exciter and drives the 4CX5000A power tetrode.

STEREO SEPARATION: With a minimum stereo separation of 35 dB from 50 to 15,000 Hz, the FM-3H3 excels in stereophonic broadcasting, when equipped with the optional plug-in solid state stereo module. For monophonic service a full, rich response from 50 to 15,000 Hz, and extremely low distortion, assure superb audio quality.

SILICON POWER SUPPLY: This transmitter incorporates solid state rectifiers throughout. A generous number of silicon cells, operating in a three-phase bridge rectifier, are so rugged that maximum transmitter current demand is only 50% of the peak rating of the power supply. Exclusive use of silicon rectifiers and the 100% transistor exciter greatly enhance overall reliability.

SPECIFICATIONS

GENERAL

POWER OUTPUT: 3 kW.
FREQUENCY RANGE: 87.5 to 108 MHz, tuned to specified operating frequency.
RF OUTPUT IMPEDANCE: 50 ohms.
OUTPUT TERMINATION: 3/8" EIA female flange.
FREQUENCY STABILITY: .001% or better.
TYPE OF MODULATION: Direct Carrier Frequency Modulation.
MODULATION CAPABILITY: ± 100 kHz.
AC INPUT POWER: 208/240 V, 3-phase, 50/60 Hz. Power consumption 6800 watts (approx.). 115 V, 50/60 Hz, single phase, 300 watts.
POWER SUPPLY RECTIFIERS: Silicon.
RF HARMONICS: Suppression meets all FCC requirements.
ALTITUDE: 7,500 feet.
BLOWER: 390 cfm @ 3.2 inches.
AMBIENT TEMPERATURE RANGE: -20°C to $+45^{\circ}\text{C}$.
MAXIMUM VSWR: 1.7 to 1.
OVER-ALL CABINET SIZE: 42" W x 78" H x 32 3/4" D.*
*32 3/4" is over-all depth dimension. With rear door and front door handles removed, minimum depth is 29 3/4".
FRONT DOOR SWING: 21".
FINISH: Two-tone beige-gray.
WEIGHT & CUBAGE: Export: 875 lbs. Domestic: 725 lbs. 110 cu. ft.

MONAURAL MODE

AUDIO INPUT IMPEDANCE: 600 ohms balanced.
AUDIO INPUT LEVEL: $+10$ dBm ± 2 dB for 100% modulation at 400 Hz.
AUDIO FREQUENCY RESPONSE: Standard 75 microsecond, FCC pre-emphasis curve ± 1 dB, 30-15,000 Hz.
DISTORTION: 0.5% or less, 30-15,000 Hz.
FM NOISE: 65 dB below 100% modulation (ref. 400 Hz).
AM NOISE: 50 dB below reference carrier AM modulated 100%.

STEREOPHONIC MODE (Stereo Generator optional)

PILOT OSCILLATOR: Crystal controlled.
PILOT STABILITY: 19 kHz ± 1 Hz.
AUDIO INPUT IMPEDANCE: (left and right) 600 ohms balanced.
AUDIO INPUT LEVEL: (left and right) $+10$ dBm ± 1 dB for 100% modulation at 400 Hz.
AUDIO FREQUENCY RESPONSE: (left and right) Standard 75 microsecond, FCC pre-emphasis curve ± 1 dB, 50-15,000 Hz.
DISTORTION: (left or right) 1% or less, 50-15,000 Hz.
FM NOISE: (left or right) 60 dB minimum below 100% modulation, reference 400 Hz.
STEREO SEPARATION: 35 dB minimum 50-15,000 Hz.
SUB-CARRIER SUPPRESSION: 42 dB below 90% modulation.
CROSSTALK: (main to sub-channel or sub to main channel) 42 dB below 90% modulation.

SCA MODE (SCA Generator optional)

FREQUENCY STABILITY: ± 500 Hz.
FREQUENCY: Between 25 and 75 kHz.
OSCILLATOR TYPE: Two Colpitts heterodyned to produce desired output frequency.
MODULATION: Direct FM.
MODULATION CAPABILITY: ± 7.5 kHz.
AUDIO INPUT IMPEDANCE: 600 ohms balanced.
AUDIO INPUT LEVEL: $+8$ dBm, ± 3 dB for 100% modulation at 400 Hz.
AUDIO FREQUENCY RESPONSE: 41 kHz and 67 kHz, 50 microsecond, modified pre-emphasis. 67 kHz response modified for proper operation when used with stereo to conform to FCC specifications.
DISTORTION: Less than 1.5% 30-7,000 Hz.
FM NOISE: (main channel not modulated) 55 dB minimum (ref. 100% modulation 400 Hz).
CROSSTALK: (sub-channel to main channel) -60 dB or better.
CROSSTALK: (main channel to sub-channel) 50 dB below 100% modulation (ref. 400 Hz).
AUTOMATIC MUTE LEVEL: Variable from 0 to 40 dB below 100% modulation.

ORDERING INFORMATION

FM-3H3 3000 watt FM broadcast transmitter with TE-3 exciter.....	994-6742
100% spare tube kit.....	990-0549
Stereo generator (add for stereo operation).....	994-6533
SCA sub-carrier generator (add for SCA operation).....	994-6507

2000 Watt FM Transmitter

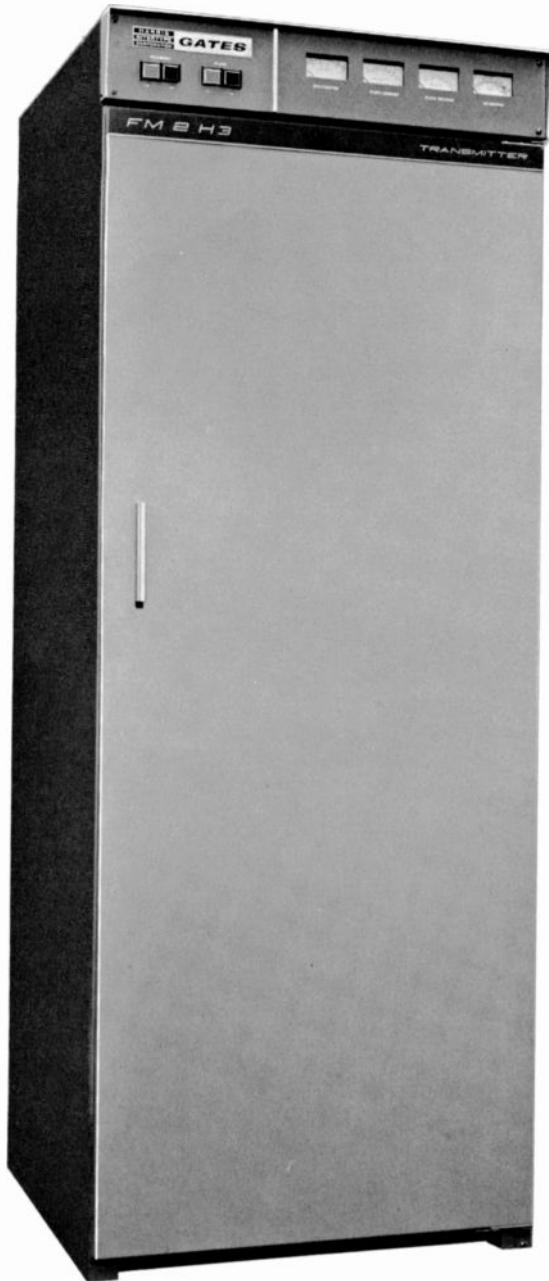

MODEL FM-2H3

The FM-2H3 employs only two tubes for an output of 2,000 watts. Driven by Gates' TE-3 solid-state exciter, the two stages are a 4X150A intermediate power amplifier, and a 5CX1500A single-ended final amplifier. A voltage regulated filament assures greater reliability, longer tube life.

Sophisticated broadband circuitry assures maximum stereo separation and minimum crosstalk to provide listeners with the finest sound in FM. The FM-2H3 is FCC type accepted for 2,000 watts output for both monaural and stereophonic transmission in the 88 to 108 MHz band.

STABLE, EASY OUTPUT TUNING: Plate tuning of the final amplifier is stable and easily adjusted. The plate circuit is a shorted, one-quarter wave-length configuration, with the plate-line operated at DC ground potential. Coarse plate tuning is pre-set for the operating frequency on the quarter wave plate circuit. Fine adjustment is made with the plate tuning knob on the front panel. Amplifier loading is changed by a variable output loading control.

POWER OUTPUT CONTROL: The transmitter has a built-in motor-operated rheostat connected to the screen supply for adjusting the power output. A built-in reflectometer with a VSWR power meter makes adjustments of the power output easy and accurate.

PUSHBUTTON OPERATION: Manual operation of the transmitter is simple. On-Off functions are controlled by lighted, dual pushbuttons at the top left of the cabinet. They are clearly marked Filament On and Off, Plate On and Off. After the filaments of the tubes are turned on, a time-delay relay allows the cathodes to reach operating temperatures before the Plate power can be turned on.

AUTOMATIC RECYCLING: In case of momentary overload, the transmitter will recycle automatically. If the overload repeats more than the desired number of times pre-set in the transmitter, the transmitter will then stay off the air until it is reset locally or by remote control.

REMOTE CONTROL: All necessary operating functions can be remote controlled. No additional equipment is required to adapt a Gates Remote Control System to the transmitter. Connections are easily made at a terminal on the side of the cabinet.

PLUG-IN STEREO AND SCA: A station engineer can equip the transmitter for stereo and/or SCA operation at any time. Gates' unique modular design of the TE-3 solid-state exciter makes this possible using plug-in units.

Initially, the transmitter can be ordered for monophonic service. Later, plug-in stereo and SCA can be added.

Stereo separation of 35 dB minimum from 50 to 15,000 Hz makes the FM-2H3 outstanding for stereophonic broadcasting.

HARMONIC FILTERS STANDARD: Supplied with a Gates-designed harmonic filter the transmitter fully meets FCC requirements for spurious radiation. All filtering is mounted inside the transmitter cabinet and provides rapid cut-off of second and higher order harmonics.

QUALITY COMPONENTS: Every transmitter component is conservatively operated and chosen to give optimum performance in continuous duty service. In Gates' TE-3 exciter, only performance-proven solid-state devices and precision temperature compensated components are used throughout.

2000 Watt FM Transmitter-FM-2H3

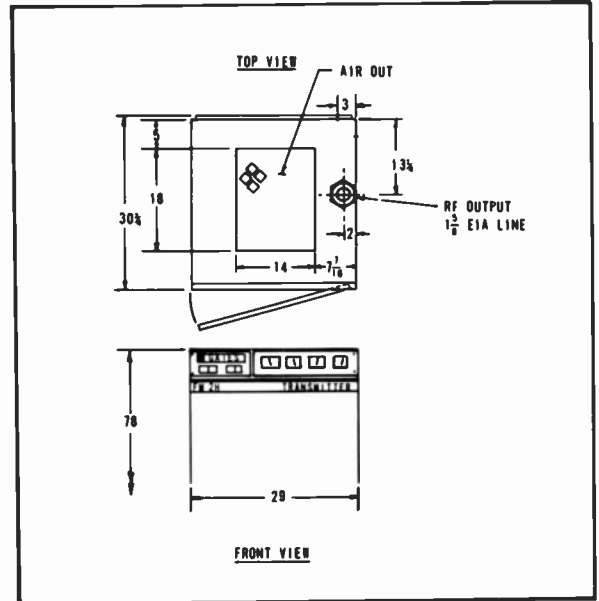
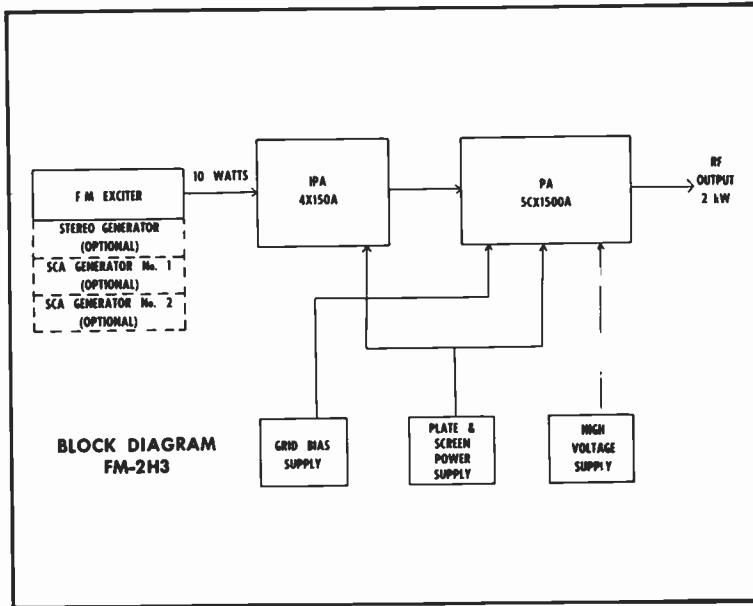

SPECIFICATIONS

GENERAL

POWER OUTPUT: 2 kW.
FREQUENCY RANGE: 87.5 to 108 MHz, tuned to specified operating frequency.
RF OUTPUT IMPEDANCE: 50 ohms.
OUTPUT TERMINATION: 1 1/2" EIA flange.
FREQUENCY STABILITY: .001% or better.
TYPE OF MODULATION: Direct Carrier Frequency Modulation.
MODULATION CAPABILITY: ± 100 kHz.
AC INPUT POWER: 197/250 V., 50/60 Hz, single phase, two wire. Power consumption: 4,200 watts (approx.). 115 V, 50/60 Hz, single phase, 100 watts.
RF HARMONICS: Suppression meets all FCC requirements.
POWER SUPPLY RECTIFIERS: Silicon.
ALTITUDE: 7,500 feet.
BLOWER: 140 cfm @ 1.8 inches.
AMBIENT TEMPERATURE RANGE: -20°C to $+45^{\circ}\text{C}$.
MAXIMUM VSWR: 1.7 to 1.
OVERALL CABINET SIZE: 29" W. x 78" H. x 33" D.
FRONT DOOR SWING: 29".
FINISH: Two-tone, beige-gray.
WEIGHT & CUBAGE: Export: 700 lbs. Domestic: 580 lbs. 65 cu. ft.

MONAURAL MODE

AUDIO INPUT IMPEDANCE: 600 ohms balanced.
AUDIO INPUT LEVEL: +10 dBm ± 2 dB for 100% modulation at 400 Hz.
AUDIO FREQUENCY RESPONSE: Standard 75 microsecond, FCC pre-emphasis curve ± 1 dB, 30-15,000 Hz.
DISTORTION: 0.5% or less, 30-15,000 Hz.
FM NOISE: 65 dB below 100% modulation (ref. 400 Hz).
AM NOISE: 55 dB below reference carrier AM modulation 100%.

STEREOPHONIC MODE

PILOT OSCILLATOR: Crystal controlled.

PILOT STABILITY: 19 kHz ± 1 Hz.
AUDIO INPUT IMPEDANCE: (left and right) 600 ohms balanced.
AUDIO INPUT LEVEL: (left and right) +10 dBm ± 1 dB for 100% modulation at 400 Hz.
AUDIO FREQUENCY RESPONSE: (left and right) Standard 75 microsecond, FCC pre-emphasis curve ± 1 dB, 50-15,000 Hz.
DISTORTION: (left or right) 1% or less, 50-15,000 Hz.
FM NOISE: (left or right) 60 dB minimum below 100% modulation. Reference 400 Hz.
STEREO SEPARATION: 35 dB minimum 50-15,000 Hz.
SUB-CARRIER SUPPRESSION: 42 dB below 90% modulation.
CROSSTALK: (main to sub-channel or sub to main channel) 42 dB below 90% modulation.

SCA SPECIFICATIONS

FREQUENCY STABILITY: ± 500 Hz.
FREQUENCY: Between 25 and 75 kHz.
OSCILLATOR TYPE: Two Colpitts heterodyned to produce desired output frequency.
MODULATION: Direct FM.
MODULATION CAPABILITY: ± 7.5 kHz.
AUDIO INPUT IMPEDANCE: 600 ohms balanced.
AUDIO INPUT LEVEL: +8 dBm, ± 3 dB for 100% modulation at 400 Hz.
AUDIO FREQUENCY RESPONSE: 41 kHz and 67 kHz, 50 microsecond, modified pre-emphasis. 67 kHz response modified for proper operation when used with stereo to conform to FCC specifications.
DISTORTION: Less than 1.5% 30-7,000 Hz.
FM NOISE: (main channel not modulated) 55 dB minimum (ref. 100% modulation 400 Hz).
CROSSTALK: (sub-channel to main channel): -60 dB or better.
CROSSTALK: (main channel to sub-channel): 50 dB below 100% modulation (ref. 400 Hz).
AUTOMATIC MUTE LEVEL: Variable from 0 to 40 dB below 100% modulation.

ORDERING INFORMATION

FM-2H3 2000 watt FM broadcast transmitter with TE-3 exciter.....	994-6741
100% spare tube kit.....	990-0587
Stereo generator (add for stereo operation).....	994-6533
SCA generator (add for SCA operation).....	994-6507

1000 Watt FM Transmitter

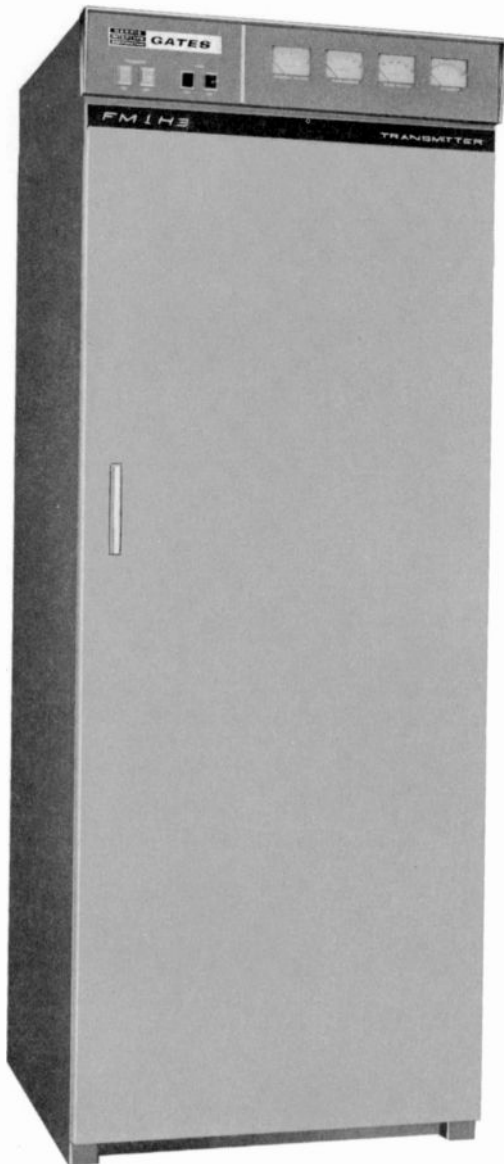

MODEL FM-1H3

Superb for stereo, multiplex or monaural sound, the one tube, 1000 watt model FM-1H3 transmitter incorporates the all solid state TE-3 exciter, employing Direct Carrier Frequency Modulation. The FM-1H3 is FCC type accepted for 1000 watt output for both monaural and stereophonic transmission in the 88 to 108 MHz band.

ONE TUBE DESIGN: Just one tube—a modern type 4CX1000A tetrode—is all that is needed to supply 1000 watts output in the FM-1H3. Driven directly by the 10 watt exciter, the 4CX-1000A serves as the power amplifier and is operated well within its ratings. A voltage regulated filament assures longer useful tube life, and greater on-the-air reliability.

STABILITY AND EFFICIENCY: Forced air cooled, the 4CX-1000A power amplifier stage is mounted in a fully shielded enclosure to eliminate power losses by radiation or interaction. A shorted quarter-wave type plate circuit reduces harmonics and spurious radiation to a minimum, and the entire amplifier has a high degree of stability.

ADVANCED TE-3 EXCITER: The 100% solid state Direct Carrier Frequency Modulation (DCFM) exciter provides a full 10 watts output, and is completely self-contained within the FM-1H3. With "DCFM" and Digital Automatic Frequency Control, highly improved carrier stability and excellent frequency response are assured.

STEREO/MULTIPLEX OPERATION: In the FM-1H3, stereo separation is 35 dB minimum from 50 to 15,000 Hz. Plugging in the optional stereo or SCA generators takes only a few seconds, as pre-wired spaces are provided in the TE-3 exciter for these modules.

SOLID STATE RECTIFIERS: Silicon rectifiers are standard equipment in this modern slimline transmitter. These dependable rectifiers provide generous voltage and current safety factors throughout.

HARMONIC FILTERS: Supplied with a Gates designed multi-section harmonic filter, the FM-1H3 transmitter fully meets FCC requirements regarding spurious radiation. The Tee filter section provides rapid cut off in the second harmonic region, and is located in the transmitter cabinet. The remaining filter elements, for further attenuation of the second and higher order harmonics, are housed in a six foot section of standard 3/8-inch transmission line. They may be considered as part of the over-all transmission line system for installation purposes.

READY FOR REMOTE CONTROL: Remote control capabilities are built into the FM-1H3 transmitter, including terminations to attach to most remote control equipment. A motor driven loading control to vary power output from the remote point is supplied as standard equipment.

AUTOMATIC RECYCLING: The FM-1H3 recycles and is again turned on in case of momentary overload. If, after three or four consecutive overloads, it fails to turn itself on, the transmitter remains off until the "Plate On" function is activated either locally or by remote control.

STEREO AND SCA MODULES: Operating flexibility is assured by the all solid state stereo and SCA modules. Plugging directly into the model TE-3 exciter, these units provide unexcelled performance standards for modern FM broadcasting.

1000 Watt FM Transmitter—FM-1H3

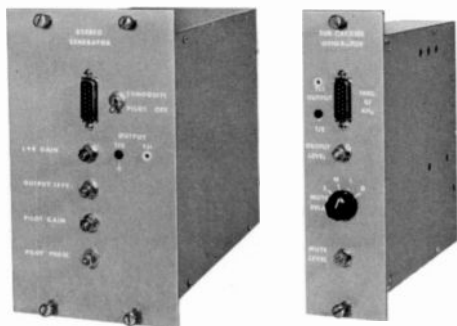

STEREO AND SCA MODULES: Plugging directly into the model TE-3 exciter, these units provide unexcelled performance for modern FM broadcasting.

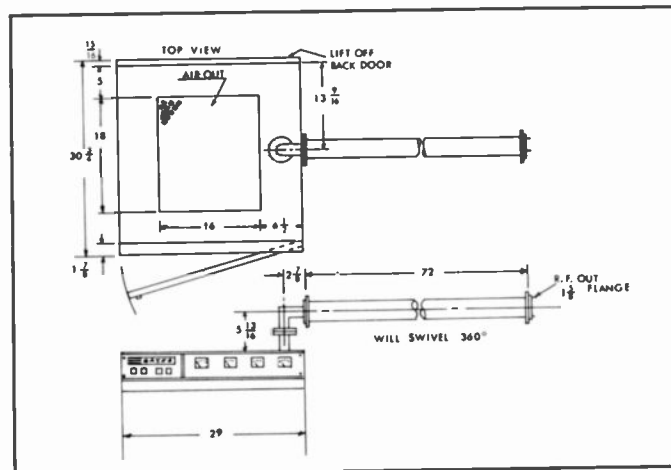

SPECIFICATIONS

GENERAL

POWER OUTPUT: 1 kW.
FREQUENCY RANGE: 87.5 to 108 MHz, tuned to specified operating frequency.
RF OUTPUT IMPEDANCE: 50 ohms.
OUTPUT TERMINATION: 1 1/2" EIA female flange.
FREQUENCY STABILITY: .001% or better.
TYPE OF MODULATION: Direct Carrier Frequency Modulation.
MODULATION CAPABILITY: ± 100 kHz.
AC INPUT POWER: 208/240 V, 50/60 Hz, single phase, 3 wire. Power consumption 2500 watts (approx.).
POWER SUPPLY RECTIFIERS: Silicon.
RF HARMONICS: Suppression meets all FCC requirements.
ALTITUDE: 7500 feet.
BLOWER: 115 cfm @ .45 inches.
AMBIENT TEMPERATURE RANGE: -20°C to $+45^{\circ}\text{C}$.
MAXIMUM VSWR: 1.7 to 1.
OVER-ALL CABINET SIZE: 29" W x 78" H x 32 3/4" D.
FRONT DOOR SWING: 29".
FINISH: Two-tone, beige-gray.
WEIGHT & CUBAGE: Export: 670 lbs. Domestic: 550 lbs. Cubage: 72.

MONAURAL MODE

AUDIO INPUT IMPEDANCE: 600 ohms balanced.
AUDIO INPUT LEVEL: $+10$ dBm ± 2 dB for 100% modulation at 400 Hz.
AUDIO FREQUENCY RESPONSE: Standard 75 microsecond FCC pre-emphasis curve ± 1 dB, 30-15,000 Hz.
DISTORTION: 0.5% or less, 30-15,000 Hz.
FM NOISE: 65 dB below 100% modulation (ref. 400 Hz).
AM NOISE: 50 dB below reference carrier AM modulated 100%.

STEREOPHONIC MODE (Stereo Generator optional)

PILOT OSCILLATOR: Crystal controlled.

PILOT STABILITY: 19 kHz ± 1 Hz.

AUDIO INPUT IMPEDANCE: (Left and right) 600 ohms balanced.
AUDIO INPUT LEVEL: (left and right) $+10$ dBm ± 1 dB for 100% modulation at 400 Hz.
AUDIO FREQUENCY RESPONSE: (Left and right) standard 75 microsecond, FCC pre-emphasis curve ± 1 dB, 50-15,000 Hz.
DISTORTION: (Left and right) 1% or less, 50-15,000 Hz.
FM NOISE: (Left and right) 60 dB minimum below 100% modulation, reference 400 Hz.
STEREO SEPARATION: 35 dB minimum 50-15,000 Hz.
SUB-CARRIER SUPPRESSION: 42 dB below 90% modulation.
CROSSTALK: (Main to sub-channel or sub to main channel) 42 dB below 90% modulation.

SCA MODE (SCA Generator optional)

FREQUENCY STABILITY: ± 500 Hz.
FREQUENCY: Between 25 and 75 kHz.
OSCILLATOR TYPE: Two Colpitts heterodyned to produce desired output frequency.
MODULATION: Direct FM.
MODULATION CAPABILITY: ± 7.5 kHz.
AUDIO INPUT IMPEDANCE: 600 ohms balanced.
AUDIO INPUT LEVEL: $+8$ dBm, ± 3 dB for 100% modulation at 400 Hz.
AUDIO FREQUENCY RESPONSE: 41 kHz and 67 kHz, 50 microsecond, modified pre-emphasis. 67 kHz response modified for proper operation when used with stereo to conform to FCC specifications.
DISTORTION: Less than 1.5% 30-7000 Hz.
FM NOISE: (Main channel not modulated) 55 dB minimum (ref. 100% modulation 400 Hz).
CROSSTALK: (Sub-channel to main channel) -60 dB or better.
CROSSTALK: (Main channel to sub-channel) 50 dB below 100% modulation (ref. 400 Hz).
AUTOMATIC MUTE LEVEL: Variable from 0 to 40 dB below 100% modulation.

ORDERING INFORMATION

FM-1H3, 1000 watt FM broadcast transmitter with TE-3 exciter.....	994-6740
100% spare tube kit.....	990-0550
Stereo generator (add for stereo operation).....	994-6533
SCA sub-carrier generator (add for SCA operation).....	994-6507

250 Watt FM Transmitter

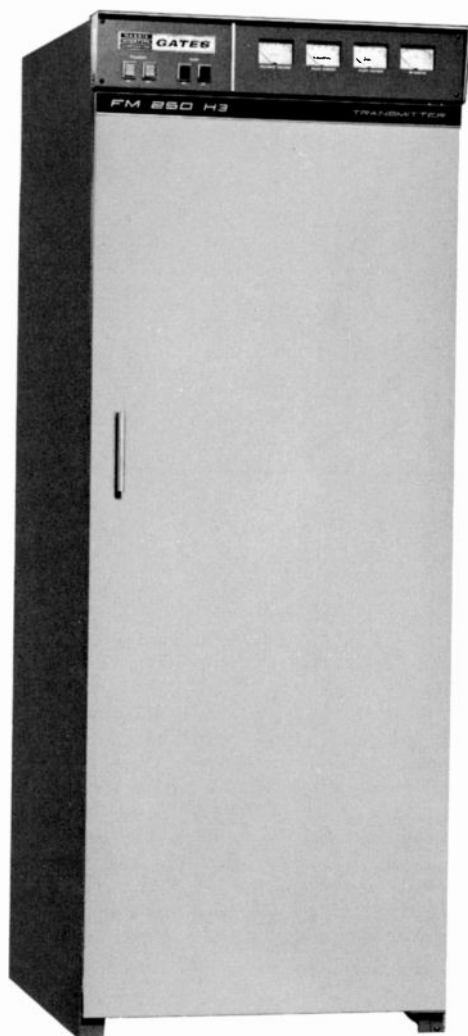

MODEL FM-250H3

Only one tube, a 4CX250B tetrode power amplifier, is used in the FM-250H3 for a full 250 watts power output. This transmitter incorporates Gates exclusive TE-3 exciter, employing Direct Carrier Frequency Modulation for unsurpassed audio fidelity in FM broadcasting. The FM-250H3 transmitter is fully FCC type accepted for stereophonic and monaural transmission in the 88 to 108 MHz FM broadcast band.

The TE-3 exciter is completely self-contained within the transmitter. Modular construction allows the addition of stereo and/or SCA at any time by simply plugging in the appropriate module. Stereo separation in the FM-250H3 is a minimum of 35 dB from 50 Hz to 15 kHz.

SOLID STATE RECTIFIERS: Transmitter reliability is greatly enhanced by the use of silicon diodes in all power supplies in the FM-250H3.

HARMONIC OUTPUT FILTER: Provided as standard equipment, the harmonic filter is contained within the FM-250H3 transmitter cabinet. Harmonics are attenuated well below FCC requirements.

AUTOMATIC RECYCLING: In case of momentary overload, the FM-250H3 will recycle automatically—a feature seldom provided in 250 watt FM transmitters.

REMOTE CONTROL: Wiring for remote control is built in, including a motor driven control to vary power output. No outboard components are needed in the transmitter, when used with a Gates remote control system.

SPECIFICATIONS

GENERAL

POWER OUTPUT: 250 watts.
FREQUENCY RANGE: 87.5 to 108 MHz, tuned to specified operating frequency.
RF OUTPUT IMPEDANCE: 50 ohms.
OUTPUT TERMINATION: Type N receptacle.
FREQUENCY STABILITY: .001% or better.
TYPE OF MODULATION: Direct Carrier Frequency Modulation.
MODULATION CAPABILITY: ± 100 kHz.
AC INPUT POWER: 115 volts, 60 Hz, 850 watts (approximate).
POWER SUPPLY RECTIFIERS: Silicon.
RF HARMONICS: Suppression meets or exceeds all FCC requirements.
ALTITUDE: 7,500 feet.

AMBIENT TEMPERATURE RANGE: -20°C to $+45^{\circ}\text{C}$.

MAXIMUM VSWR: 1.7 to 1.

OVER-ALL CABINET SIZE: 29" W x 78" H x 32 $\frac{1}{4}$ " D.

FINISH: Two-tone beige-gray.

WEIGHT AND CUBAGE: Export: 620 lbs. Domestic: 600 lbs. 6.5 cu. ft.

MONAURAL OPERATION

AUDIO INPUT IMPEDANCE: 600 ohms balanced.
AUDIO INPUT LEVEL: +10 dBm ± 2 dB for 100% modulation at 400 Hz.
AUDIO FREQUENCY RESPONSE: Standard 75 microsecond, FCC pre-emphasis curve ± 1 dB, 30-15,000 Hz.
DISTORTION: 0.5% or less 30-15,000 Hz.
FM NOISE: 65 dB below 100% modulation (ref. 400 Hz).
AM NOISE: 50 dB below reference carrier AM modulated 100%.

ORDERING INFORMATION

FM-250H3, 250 watt FM broadcast transmitter.....	994-6739
Spare tube 4CX250B.....	374-0081
Stereo generator (add for stereo operation).....	994-6533
SCA sub-carrier generator (add for SCA operation).....	994-6507

10 and 50 Watt FM Transmitters



Model BFE-10C Ten Watt FM Transmitter.



Front view (cover removed) of Model BFE-10C, ten watt FM transmitter. Models BFE-50C and BFR-50C are essentially the same in appearance.

THREE MODELS AVAILABLE

Gates has consistently offered the most complete line of low powered wide band FM broadcast transmitters in the industry. Especially designed for educational FM broadcasting and for STL (studio-transmitter link) service, three popular models featuring direct crystal controlled cascade modulation are available. Included are the 10 watt BFE-10C and 50 watt BFE-50C versions for the standard FM broadcast band of 88 to 108 MHz, and the 50 watt Model BFR-50C which operates in the 40 to 220 MHz FM band. The BFR-50C is specifically designed for high fidelity program relay and STL service and is very popular with broadcasters abroad. The same low distortion, wide frequency response and reliability, characteristic of Gates higher powered FM models, will be found in these three lower powered units.

Metering consists of an audio level meter to indicate proper modulation level and individual meters for RF output, plate current and plate voltage. The transmitters are 100% complete without external accessories other than antenna and audio equipment.

MODEL BFE-10C: The BFE-10C ten watt FM transmitter is FCC type approved for educational FM broadcasting and is equally excellent for STL service or in any applications where 10 watts FM output is required. A compact self-contained unit designed specifically for desk or wall mounting, this 10 watt model incorporates the M-6095 exciter featuring direct crystal controlled cascade modulation.

Immediate "full view" access is available by removing the front grill or the rear full length slip-off door. This complete

10 watt FM transmitter is used by many schools, colleges, universities and overseas broadcasters in conjunction with the Gates FM-11 single ring or the FM-22 double ring FM antenna.

MODEL BFE-50C: For 88 to 108 MHz FM service, the BFE-50C is similar in design to the BFE-10C transmitter but delivers 5 times as much power, or 50 watts. A 50 watt power amplifier is added to the 10 watt section to provide the higher powered output. The amplifier utilizes two 6146 tubes and a separate 600 volt power supply. Identical in appearance to the standard BFE-10C transmitter, the cabinet easily houses the 50 watt amplifier and power supply.

MODEL BFR-50C: This compact 50 watt transmitter is probably the world's most widely used FM relay transmitter. Designed to relay broadcast programs from studio to transmitter or between special program originating points, the Model BFR-50C operates on any one specific frequency (as ordered) within the 40 MHz to 220 MHz band. When operating below 80 MHz, the maximum deviation is ± 40 kHz. Above 80 MHz the frequency deviation is ± 75 kHz. The 50 watt amplifier consists of one radio frequency stage, powered by a 600 volt power supply. The range of this transmitter is greatly increased by use of a directional antenna. The corner reflector antenna, when used at both transmitting and receiving ends, will result in several hundred watts of effective power. A relay link up to nearly 100 miles is possible, depending on the antenna height of both transmitter and receiver, as well as the terrain.

10 and 50 Watt FM Transmitters



Left, FM-11 single ring omni-directional antenna with power gain of 0.8. Right, two bay FM-22 omni-directional antenna with gain of 1.6. These are broadband, easy to install antennas.

Front view (cover removed) of BFE-50C fifty watt FM transmitter.

SPECIFICATIONS

POWER OUTPUT: BFE-10C, 10 watts; BFE-50C, 50 watts; BFR-50C, 50 watts.
FREQUENCY RANGE: Models BFE-10C and BFE-50C, 88-108 MHz, as ordered. Model BFR-50C, 40 to 220 MHz, as ordered.
STABILITY: 0.001% or better.
MODULATION: Direct crystal controlled cascade modulation.
RESPONSE: Within 1 dB of standard 75 microsecond pre-emphasis curve or flat ± 1 dB, 50-15,000 Hz.
 Note: Will supply with 75 microsecond pre-emphasis curve unless ordered for flat curve.
FREQUENCY DEVIATION: ± 100 kHz; (± 75 kHz = 100% modulation in FM broadcasting). Model BFR-50C. Models below 80 MHz have maximum deviation of ± 40 kHz or less, as desired. Above 80 MHz may be ± 75 kHz or less, as desired.
DISTORTION: 1% or less 30-15,000 Hz. 0.5% 100-10,000 Hz.
RF HARMONICS: Suppression meets or exceeds all FCC requirements.
INPUT: +10 dBm ± 2 dB at 600 ohms impedance.
POWER: 117 volts, 50/60 Hz. BFE-10C, 120 watts; BFE-50C, 230 watts; BFR-50C, 230 watts.

RF OUTPUT: 50 ohms (Type N connector).
OSCILLATOR: Direct crystal controlled.
NOISE: 65 dB below 100% modulation (FM).
TEMPERATURE: -20° to $+45^{\circ}$ C.
TUBES:
 BFE-10C: (6) 6AU6, (3) 6J6, (3) 6201, (3) 7025, (2) OA2, and (1 each) 12AX7, 6AQ5, GZ34/5AR4, 6080, 6360.
 BFE-50C: Same as above, with (2) 6146 and (1) 5R4GYA tubes added.
 BFR-50C: Same as BFE-10C with (1) 5894, (1) 6AQ5, and (1) 5R4GYA tubes added.
ALTITUDE: 7500 feet.
FINISH: Gates two-tone beige gray with trim in brushed aluminum and black.
SIZE: 26½" high, 28" wide, 14" deep.
WEIGHT (Packed):
 BFE-10C (domestic) 100 lbs.; (export) 205 lbs.; 15 cu. ft.
 BFE-50C (domestic) 125 lbs.; (export) 230 lbs.; 16 cu. ft.
 BFR-50C (domestic) 125 lbs.; (export) 230 lbs.; 16 cu. ft.

ORDERING INFORMATION

BFE-10C, 10 watt FM transmitter, 88-108 MHz, with tubes and crystal.....994-5594
 Spare 100% tube kit for BFE-10C.....990-0391
 Manufacturer's recommended minimum tube kit for BFE-10C.....990-0488
 BFE-50C, 50 watt FM transmitter, 88-108 MHz, with tubes and crystal.....994-5595
 Spare 100% tube kit for BFE-50C.....990-0489

Manufacturer's recommended minimum tube kit for BFE-50C.....990-0490
 BFR-50C, 50 watt Relay Transmitter for 40-220 MHz, with tubes, crystal and oven.....994-5599
 FM-11 Single Ring Educational (88-108 MHz) FM Antenna.....710-0102
 FM-22 Double Ring Educational (88-108 MHz) FM Antenna.....710-0103

State carrier frequency when ordering all models and antennas and frequency swing desired when ordering Model BFR-50C transmitter.

FM Broadcast Link and Relay System

SYSTEM A

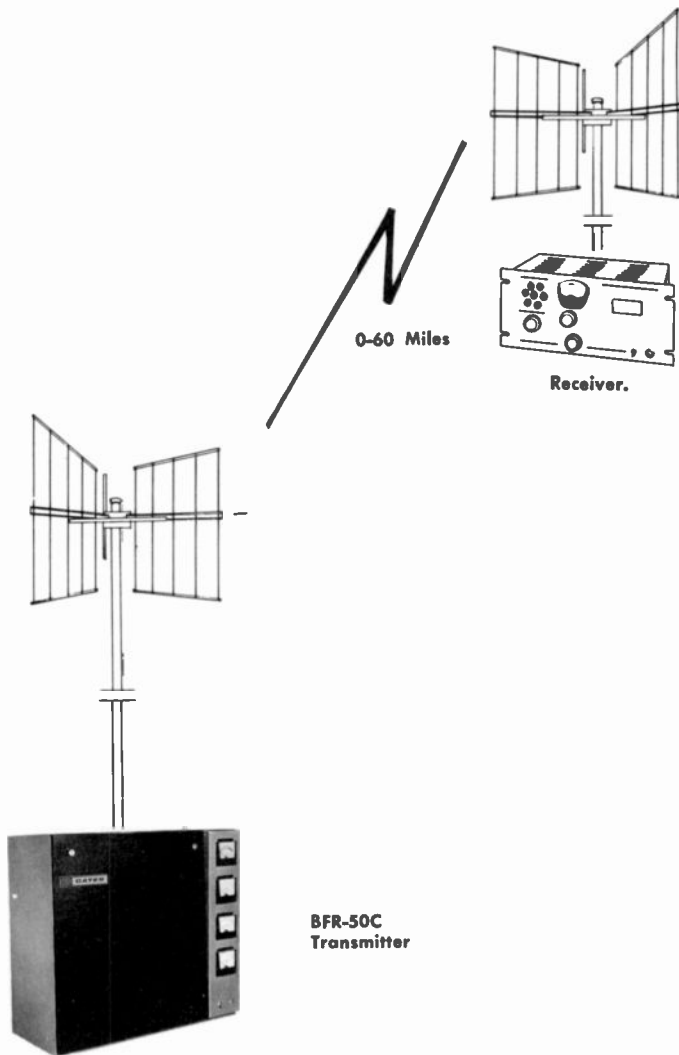

DIRECTIONAL: System A is a directional FM system operating in the 148-174 MHz band, which furnishes an effective 750 watt signal and will provide a line-of-sight high fidelity transmission link over distances up to 50 to 60 miles (subject to antenna heights and terrain). Applications include studio to transmitter link, point to point relay service, or remote pickup. Featured is the Gates BFR-50C, 50 watt Transmitter.

ORDERING INFORMATION

1—50 watt FM transmitter.....	BFR-50C
1—Receiver, 125-175 MHz.....	731-0009
2—Corner reflector, high gain, broadband antennas.....	3605A
100'—Coaxial Cable.....	RG-8/U
100'—Twin line 300 ohm.....	8235
Complete system as described above.....	FML-50D

SYSTEM B

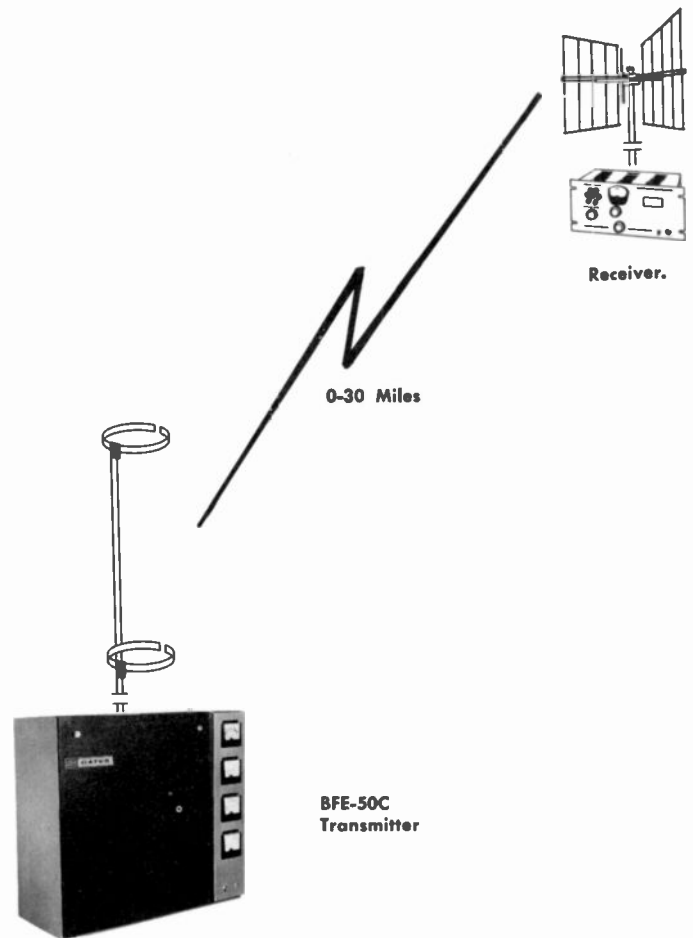

NON-DIRECTIONAL: System B is a non-directional 88-108 MHz FM system using a non-directional antenna for transmitting and a high gain directional antenna for receiving. This system provides a high fidelity studio-to-transmitter link, and, where regulations permit, allows simultaneous FM broadcasting of the AM program. The system features the Gates BFE-50C 50 watt transmitter, which has built-in RF output indicator and audio level meters. Line-of-sight reception with 50 watt transmitter is estimated at 30 miles.

ORDERING INFORMATION

1—50 watt FM transmitter.....	BFE-50C
1—Receiver, 88-125 MHz.....	731-0003
Alternate Transmitter for shorter distances: 10 watt FM transmitter, 88-108 MHz.....	BFE-10C
1—Two ring FM transmitting antenna, gain 1.6.....	FM-22
1—FM receiving antenna.....	LPL-FM-6
100'—Coaxial Cable, for transmitter.....	RG-8/U
100'—Twin line 300 ohm, for receiver.....	8235
Complete 50 watt system as described above.....	FML-50ND
Complete 10 watt system using alternate transmitter described above.....	FML-10ND

Circularly Polarized FM Antenna

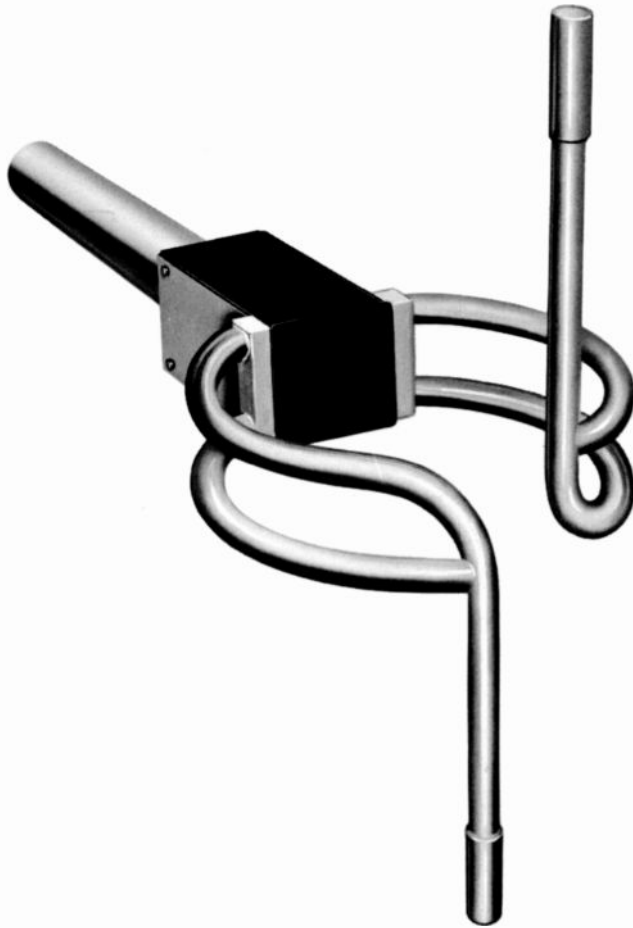

DUAL-CYCLOID FOR HIGHER POWER STATIONS

Gates Dual Cycloid FM Antenna with circular polarization has a radiation pattern intended to deliver an improved signal to FM receivers. A primary advantage of the Dual-Cycloid antenna is the reduction of antenna transmitting bays required when circular polarization is desired. Previously, individual elements, horizontal and vertical, and in most cases a power divider, had to be installed to obtain dual polarization. Now, only the Gates Dual-Cycloid is required.

Utilizing the time proven features of the Cycloid antenna, and other advantages of the Gates Type 300G vertical antenna, the Dual-Cycloid provides a radiating system with a low standing wave ratio over a bandwidth of 200 kHz. Ideal conditions are presented for the transmission of today's complex FM monaural, stereo, and SCA multiplex signals.

The Gates Dual-Cycloid Type FMC antenna transmits circular polarization as authorized by FCC rules and regulations. The station's effective radiated power will still be determined by the signal radiated in the horizontal plane. This is determined by the antenna gain (see table) in the horizontal plane multiplied by the power input to the antenna.

Any number of elements from one to sixteen may be utilized, providing maximum flexibility in the selection of power gain for a particular installation. Special antennas with null fill and beam tilt are available. Maximum power rating per bay is ten kilowatts; arrays will handle power inputs as high as forty kilowatts. De-icers are available and are recommended for climates that experience icing conditions.

The Dual-Cycloid consists of two basic parts: (1) the radiating element and, (2) the interconnecting transmission line sections. The radiating elements in an array are all identical electrically and mechanically. Utilizing the effective ring design of the Cycloid as the basic unit, two vertical elements have replaced the fixed end plates; the rear terminal block is now a matching balun mating the antenna impedance to the interconnecting transmission line.

The vertical sections have adjustable caps for a fine adjustment of the horizontal/vertical radiation ratio. Designed for rugged trouble-free operation, all antenna elements are fabricated of a durable weather resistant brass alloy with excellent electrical properties.

Antenna elements are normally spaced one wave-length apart with interconnecting transmission line sections and feed through a common system input termination of 50 ohms, which is a standard 3/8" EIA female flange.

MOUNTING: The antenna is mounted on a specially designed supporting bracket, fabricated to mate with the tower in a mounting arrangement specified by the purchaser. Antennas are usually mounted on the leg or tower face of a guyed or self supporting tower. Pole or top mounting is available on special order.

FEED POINT: Antennas of 9 bays or less are end fed through a 6 ft. transmission line section; 10 or more bays are usually center fed through a 6 ft. transmission line section, 90° elbow and coaxial "T" connector.

CIRCULARITY: Both the horizontal and vertical radiation pattern of the Dual-Cycloid antenna have been measured within ± 2 dB in free space. When side mounted, the antenna pattern will be somewhat affected by the supporting structure. This effect, however, has been minimized with the special supporting bracket and feed system which places the radiating element over 36" from the tower.

Supplied on a standard 3/8" EIA line, the antenna is complete with mounting brackets for standard AM and FM towers.

Circularly Polarized FM Antenna—Dual-Cycloid

Heavy-duty mounting brackets, designed to place the antenna element away from the supporting structure for the least effect on the radiation pattern, are supplied at no additional cost. Standard brackets are for use on tower legs or side mounting on the normal type AM radiator. A special quotation will be made for brackets on TV towers and non-standard radiators and poles.



SPECIFICATIONS

FREQUENCY RANGE: Factory tuned to one frequency in the 88 to 108 MHz band.

POLARIZATION: Circular, clockwise.

POWER GAIN (Over Dipole): Approximately equal to half the number of stacked bays for horizontal polarization; same for vertical polarization. See table below.

AZIMUTHAL PATTERN: Circular ± 2.0 dB in free space for horizontal polarization; same for vertical polarization. See table below.

VSWR AT INPUT (Without field trimming): Top mounting, 1.1:1 or better. Side mounting, 1.5:1 or better.

VSWR AT INPUT (With field trimming): Top or side mounting, 1.1:1 or better over ± 100 kHz.

INPUT IMPEDANCE: 50 ohms.

INPUT CONNECTION: 3/8-inch, 50 ohm EIA female flange.

POWER INPUT RATING: Approximately 10 kW per bay (see table).

WINDLOAD: 50 lbs. per square foot for flat surfaces; 33 lbs. per square foot for cylindrical surfaces.

DIMENSIONS: (One bay) 30 in. high, 45 1/2 in. long.

FEED POINT: One to nine bays, end fed. Ten bays and over, center fed with even number of bays, or at a point 1/2 bay below center with odd number of bays.

WEIGHT: Antenna bay, 41 lbs. (19 kg). Interconnecting feed line, 27.5 lbs. (12 kg). Mounting bracket, 22 lbs. (10 kg).

GATES TYPE	POWER GAIN		dB GAIN		FIELD GAIN ¹		POWER RATING	APPROX. ² LENGTH	WEIGHT ³ (lbs.)	WIND- ⁴ LOAD
	Horizontal	Vertical	Horizontal	Vertical	Horizontal	Vertical				
FMC-1	0.46	0.46	-3.37	-3.37	0.678	0.678	10 kW	0	41	172
FMC-2	1.0	1.0	0	0	1.0	1.0	20 kW	10 ft.	110	391
FMC-3	1.5	1.5	1.76	1.76	1.23	1.23	30 kW	20 ft.	178	610
FMC-4	2.1	2.1	3.22	3.22	1.45	1.45	40 kW	30 ft.	247	829
FMC-5	2.7	2.7	4.31	4.31	1.64	1.64	40 kW	40 ft.	315	1049
FMC-6	3.2	3.2	5.25	5.25	1.79	1.79	40 kW	50 ft.	384	1268
FMC-7	3.8	3.8	5.80	5.80	1.95	1.95	40 kW	60 ft.	452	1487
FMC-8	4.3	4.3	6.34	6.34	2.07	2.07	40 kW	70 ft.	520	1707
FMC-9	4.9	4.9	6.87	6.87	2.21	2.21	40 kW	80 ft.	589	1926
FMC-10	5.5	5.5	7.40	7.40	2.35	2.35	40 kW	90 ft.	658	2192
FMC-12	6.6	6.6	8.20	8.20	2.57	2.57	40 kW	110 ft.	795	2630
FMC-14	7.8	7.8	8.29	8.29	2.79	2.79	40 kW	130 ft.	931	3069
FMC-16	8.9	8.9	9.49	9.49	2.98	2.98	40 kW	150 ft.	1069	3507

Equipment furnished: antenna elements as required; antenna mounting hardware (specify tower manufacturer and type); interconnecting rigid coax transmission line section (6 ft.); standard 3/8-inch EIA female flange.

Accessory equipment: RF shielded deicer system, 300 watts per bay, 115 volts, 50/60 Hz . . . complete with conduit boxes and RF shielded interbay wiring harness. Thermo-switch for control of deicers. AC heater cable.

1. To obtain the effective free space field intensity at one mile in mv/m for one kilowatt antenna input power, multiply field gain by 138. 2. When determining coax line lengths on end feed antenna, add 6' to allow for matching stub. When determining coax line lengths on center feed antenna, termination will be 6' below center due to matching stub. 3. A typical leg mounting bracket weighs approximately 22 lbs. and is not included in weights given. 1 per bay required. Weights given included antenna bay and interconnecting feedline. 4. Based on 50 psf wind pressure on flat surfaces, 33 psf on cylindrical surfaces (110 mph actual wind velocity).

Directional Dual Cycloid FM Antenna

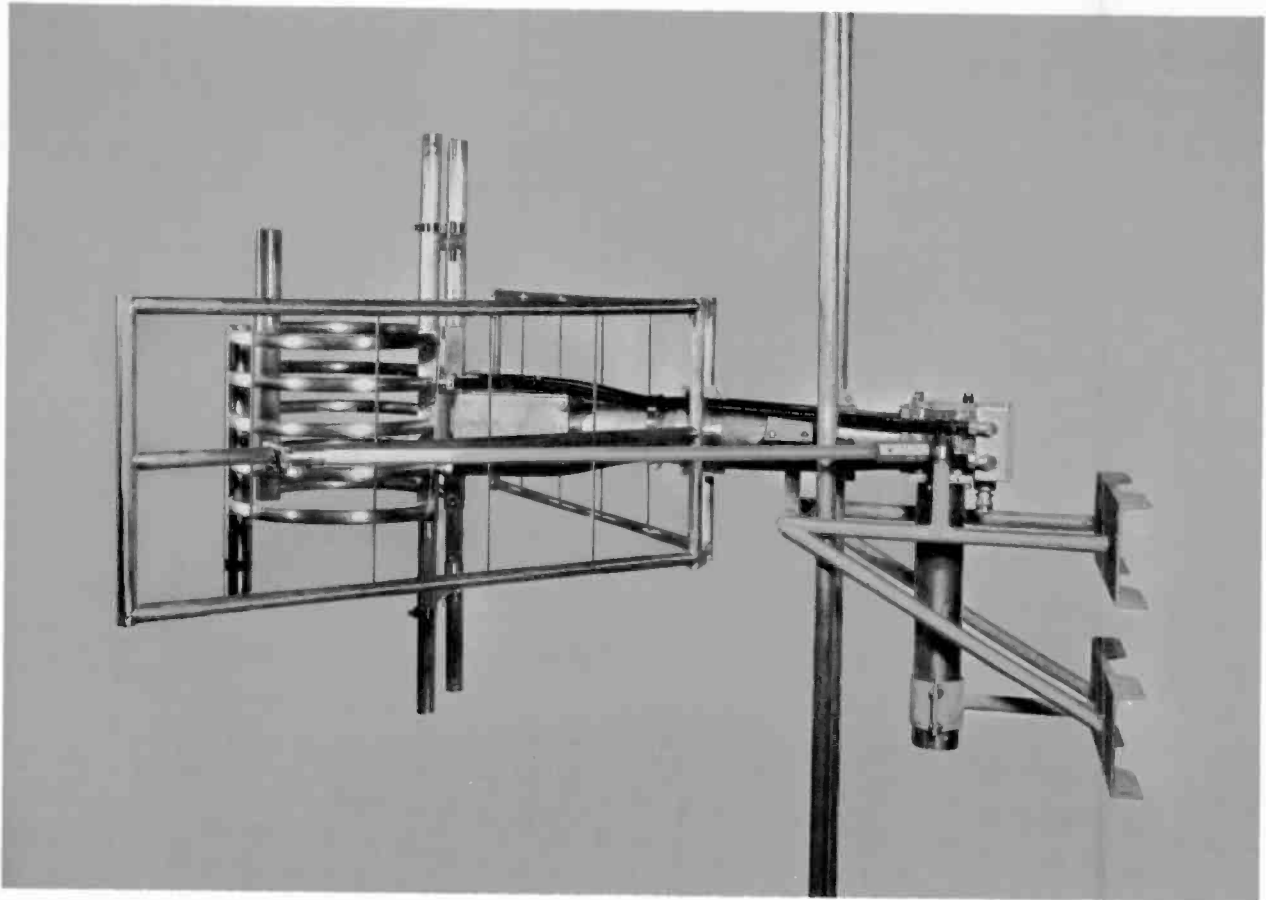

Gates' FMC-(X)DA is a directional dual polarized FM antenna designed for pole mounting. The antenna is available with up to eight bays (the X in the type number indicates the number of bays—the 4-bay antenna is FMC-4DA, etc.). The interbay transmission feed line uses 3/8-inch rigid coaxial line. Spacing between bays is one wavelength.

Typical horizontally measured relative field patterns for both polarizations are shown in the figures on the next page. Minor variations may be obtained, such as varying the null at 180°, decreasing or increasing the lobes at 90° and 270° by a small amount, or increasing or decreasing the lobe at 0° by a small amount. Any such changes would alter the power gain figures shown in the chart on the next page by a small amount. Extensive change of pattern is only available on a custom basis, and at added cost, since a special study would be required, including extensive pattern testing on the antenna range.

Each antenna bay uses a circularly polarized type driven element, plus one horizontal reflective screen and two parasitic vertical reflectors used for beam shaping to achieve the directional radiation pattern for both polarizations. The directional antenna patterns are developed by mechanical means, no special phasing lines being used. Thus, keeping the driven elements and beam shaping elements in good mechanical condition should be all that is required to maintain the pattern in adjustment.

Orders for the Gates Directional Dual Cycloid should stipulate the desired true azimuth orientation, radiated power limitations, transmitter power output capability, transmission line efficiency (or type and length of such line) and complete dimensions on the size of the pole to be used for the antenna mount. Antenna pattern requirements are normally stipulated by the station's consultant.

Each directional antenna is carefully patterned on an antenna range, not at the customer's site. A single bay of the antenna is mounted on a pole essentially identical in cross section to that on which the antenna is to be finally installed. Thus, it is necessary that the factory be supplied with complete data on pole diameters, step bolt size and location, and the location of any conduits and/or coaxial lines so that they may be duplicated during final testing.

The Directional Dual Cycloid can be equipped with factory installed heaters, and heaters are recommended for installations where icing may occur. A total of 900 watts of heat is used per antenna bay, which should assure proper deicing and maintenance of the antenna pattern during such weather conditions. Six 150-watt, 120-volt elements are used in each heater-equipped bay, and these individual elements may be replaced in the field. If a 240-volt supply for the heaters is desired, the order should so state so that heaters may be properly connected.

Directional Dual Cycloid FM Antenna

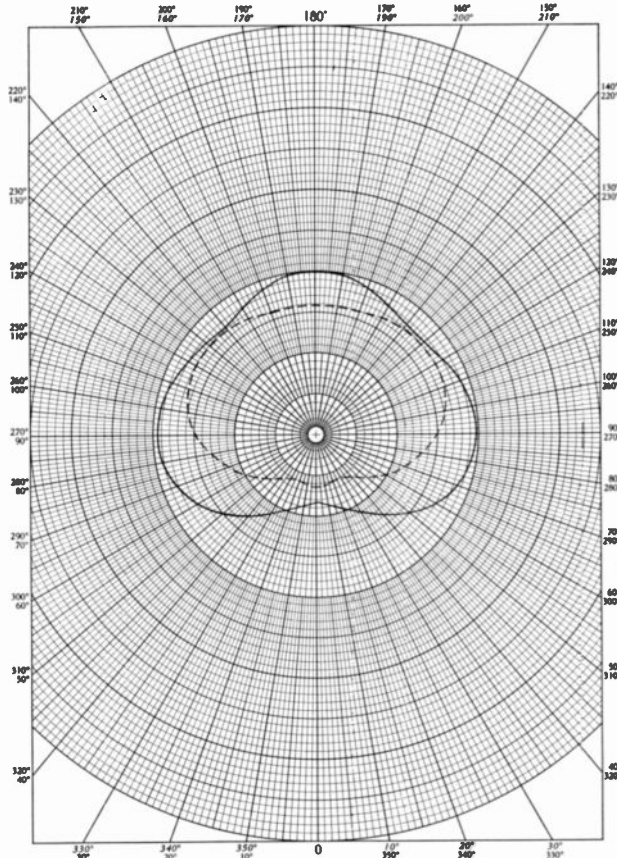

PATTERN "A"
Horizontal Relative Field Patterns

Solid line—horizontal polarization HRMS 0.830
Dashed line—vertical polarization HRMS 0.659

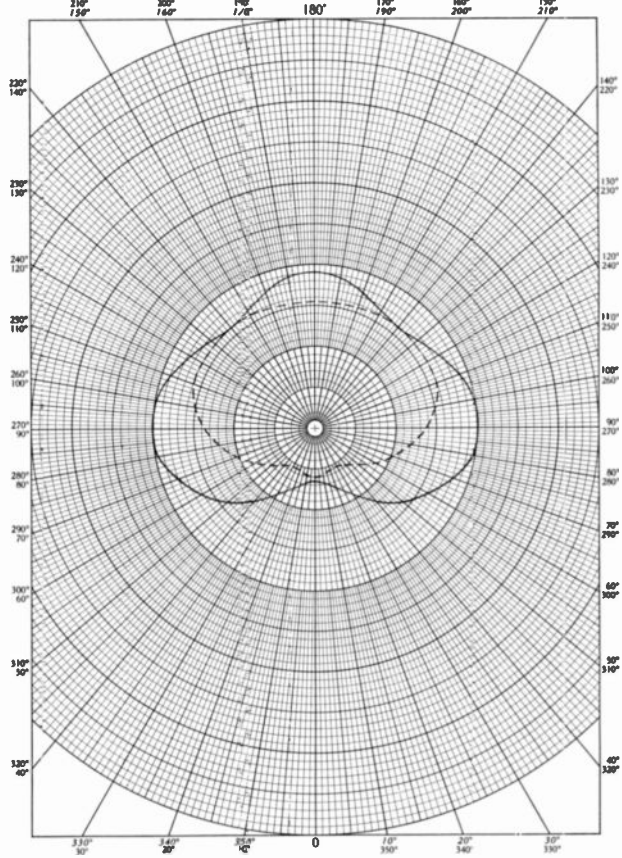

PATTERN "B"
Horizontal Relative Field Patterns

Solid line—horizontal polarization VRMS 0.798
Dashed line—vertical polarization VRMS 0.619

GATES TYPE	PATTERN "A"		PATTERN "B"		APPROX. WEIGHT*	CALCULATED WIND LOAD—50/33 PSF#
	Horiz. Pwr. Gain	Vert. Pwr. Gain	Horiz. Pwr. Gain	Vert. Pwr. Gain		
FMC-1DA	0.795	0.575	0.878	0.564	137 lbs.	354
FMC-2DA	1.71	1.23	1.89	1.21	284 lbs.	738
FMC-3DA	2.66	1.92	2.94	1.89	432 lbs.	1122
FMC-4DA	3.63	2.62	4.02	2.59	579 lbs.	1506
FMC-5DA	4.61	3.33	5.11	3.28	727 lbs.	1809
FMC-6DA	5.61	4.05	6.20	3.99	874 lbs.	2274
FMC-7DA	6.60	4.77	7.30	4.69	1022 lbs.	2658
FMC-8DA	7.60	5.49	8.42	5.41	1169 lbs.	3042

The above power gain figures will vary with the pattern shape. The power gain figures are given merely as a guide for roughly determining the number of bays required. Some variance may be expected in designing a given directional pattern, so that the exact gain figures are not known until the directional antenna pattern is finally achieved. Using pole mounting, the patterns should be quite similar to those patterns shown, but minor pattern changes may be achieved to fit given requirements.

* Weight includes interbay line, transformer section, brackets, heaters, heater junction boxes and heater wiring.

50 PSF wind pressure on flat surfaces, 33 PSF on cylindrical surfaces (110 MPH actual wind velocity). Wind load calculations include interbay line, transformer section, brackets, heater junction boxes and external heater wiring.

Circularly Polarized FM Antenna



DUAL-CYCLOID II FOR MEDIUM POWER STATIONS

Gates' Dual-Cycloid II circularly polarized FM antenna provides all of the electrical advantages of the Dual-Cycloid, in a lighter weight, low silhouette design for minimum windloading. The antenna features center feed for medium power handling capabilities—from four to twelve bays handle transmitter powers through 10 kilowatts. Antenna elements are normally spaced one wavelength apart with interconnecting transmission line sections and feed through a common antenna system input termination of 50 ohms, with a standard 3/8-inch EIA female flange.

The vertical sections have adjustable caps for the fine adjustment of the horizontal/vertical radiation ratio. All antenna elements are fabricated of a durable, weather-resistant brass alloy. Null fill and beam tilt available. Standard brackets for mounting the antenna on the tower leg are included with the antenna. Optional deicers consist of two 150-watt heating elements per bay, replaceable in the field. Interbay wiring is not included. Order Type FMC-(X)B. (X indicates the number of bays required.)

SPECIFICATIONS

FREQUENCY RANGE: Factory tuned to one specific frequency in the 88 to 108 MHz band.

POLARIZATION: Circular, clockwise.

FREE SPACE PATTERN: Horizontal component circular ± 2 dB.
Vertical component circular ± 2 dB.

VERTICAL TO HORIZONTAL POWER RATIO: Fixed at 50/50.

VSWR: 1.2 to 1 or better ± 200 kHz as tuned at the factory.

VSWR when tower mounted 1.5 to 1 or better ± 200 kHz. Capable of

adjustment 1.1 to 1 ± 100 kHz with field tuning.

POWER GAIN: Horizontal polarization: see table. Vertical polarization: see table.

POWER INPUT RATING: Maximum of 10 kW.

INPUT CONNECTION: 3/8" EIA female flange, 50 ohm.

WINDLOAD: Designed for 50 psf for flat surfaces, 33 psf for cylindrical surfaces.

GATES TYPE	POWER GAIN		dB GAIN		FIELD GAIN ¹		POWER RATING	APPROX. ² LENGTH	WEIGHT ³ (Lbs.)	WIND- ⁴ LOAD
	Horizontal	Vertical	Horizontal	Vertical	Horizontal	Vertical				
FMC-4B	2.025	2.025	3.064	3.064	1.423	1.423	10 kW	30	147	340
FMC-5B	2.577	2.577	4.111	4.111	1.605	1.605	10 kW	40	175	412
FMC-6B	3.134	3.134	4.961	4.961	1.770	1.770	10 kW	50	204	485
FMC-7B	3.695	3.695	5.676	5.676	1.922	1.922	10 kW	60	232	557
FMC-8B	4.258	4.258	6.292	6.292	2.063	2.063	10 kW	70	261	629
FMC-9B	4.823	4.823	6.833	6.833	2.196	2.196	10 kW	80	289	701
FMC-10B	5.390	5.390	7.316	7.316	2.322	2.322	10 kW	90	318	773
FMC-11B	5.958	5.958	7.751	7.751	2.441	2.441	10 kW	100	346	845
FMC-12B	6.527	6.527	8.147	8.147	2.555	2.555	10 kW	110	375	917

- To obtain the effective free space field intensity at one mile MV/M for one kilowatt antenna power, multiply field gain by 137.6.
- The feed point of center fed antennas is 10 ft. below the center of the antenna. Center fed antennas have a 3/8" line input.
- The weights given are less brackets, but the interbay transmission line, transformer section, the center fed tee section and elbow, are all included in the weight.
- Windload based on 50 psf on flat surfaces and 33 psf for cylindrical surfaces (actual wind velocity 110 mph). Computed for 100 MHz antenna less mounting brackets and less heater junction boxes and heater cables.

Circularly Polarized FM Antenna

DUAL-CYCLOID III

FOR STATIONS UP TO 5 KILOWATTS

Designed for lower power stations, Gates' Dual-Cycloid III circularly polarized FM antenna is an end-fed version of the Dual-Cycloid II—it is lighter in weight, and has less windloading. From one to eight bays handle transmitter powers through 5 kilowatts.

The antenna consists of a 1½-inch transmission line with individual bays separated by approximately one wavelength at the operating frequency. All antenna elements are fabricated of a durable, weather-resistant brass alloy. Null fill and beam tilt are not available on the Dual-Cycloid III.

Deicers consist of two 150-watt heating elements per bay—interbay wiring is not included. These elements are factory installed, and are replaceable in the field. Standard brackets for mounting the antenna on the tower leg are included with the antenna. Order Type FMC-(X)A. (X indicates the number of bays required.)



SPECIFICATIONS

FREQUENCY RANGE: Factory tuned to one specific frequency in the 88-108 MHz band.

POLARIZATION: Circular, clockwise.

FREE SPACE PATTERN: Horizontal component circular ± 2 dB.

Vertical component circular ± 2 dB.

VERTICAL TO HORIZONTAL RATIO: Fixed at 50/50.

VSWR: 1.2 to 1 or better ± 200 kHz as tuned at the factory. VSWR when tower mounted 1.5 to 1 or better ± 200 kHz. Capable of adjustment to 1.1 to 1 ± 100 kHz with field tuning.

POWER GAIN: Horizontal polarization: see table.

Vertical polarization: see table.

POWER INPUT RATING: Maximum of 5 kW for two to eight bays. 3 kW for single bay.

INPUT CONNECTION: A six foot transformer section is provided on the bottom of each antenna system which has a 1½" 50 ohm EIA female connector.

WINDLOAD: Designed for 50 psf for flat surfaces, 33 psf for cylindrical surfaces.

WEIGHT: Single bay 24 lbs., less brackets. 1½" interbay coaxial line weighs approximately 10 lbs. per section.

DIMENSIONS: Single bay height approximately 42". Length approximately 16".

GATES TYPE	POWER GAIN		dB GAIN		FIELD GAIN ¹		POWER RATING	APPROX. ² LENGTH	WEIGHT ³ (lbs.)	WIND- ⁴ LOAD
	Horizontal	Vertical	Horizontal	Vertical	Horizontal	Vertical				
FMC-1A	0.438	0.438	-3.585	-3.585	0.662	0.662	3 kW		24	54
FMC-2A	0.947	0.947	-0.237	-0.237	0.973	0.973	5 kW	10	53	126
FMC-3A	1.480	1.480	1.702	1.702	1.216	1.216	5 kW	20	81	198
FMC-4A	2.025	2.025	3.064	3.064	1.423	1.423	5 kW	30	110	271
FMC-5A	2.577	2.577	4.111	4.111	1.605	1.605	5 kW	40	138	343
FMC-6A	3.134	3.134	4.961	4.961	1.770	1.770	5 kW	50	167	414
FMC-7A	3.695	3.695	5.676	5.676	1.922	1.922	5 kW	60	196	486
FMC-8A	4.258	4.258	6.292	6.292	2.063	2.063	5 kW	70	225	558

1. To obtain the effective free space field intensity at one mile in MV/M for one kilowatt antenna power, multiply field gain by 137.6.

2. When determining coax length, add six feet to antenna length.

3. The weights given are less brackets, but the interbay transmission line and transformer section are all included in the weight.

4. Windload based on 50 psf on flat surfaces and 33 psf for cylindrical surfaces (actual wind velocity 110 mph). Computed for a 100 MHz antenna less mounting brackets and less heater junction boxes and heater cables.

Horizontally and Vertically Polarized FM Antennas



CYCLOID

Gates' Cycloid horizontally polarized FM antenna fills the need for a modern, easy to install and highly efficient antenna, with minimum standing wave ratio for FM stereo and monaural service. The field-proven Cycloid offers high gain and high power handling capabilities incorporated in an electrical design available exclusively from Gates.

The antenna is factory pretuned to the customer's frequency, assuring optimum on-the-air performance. Mounting brackets are supplied as a standard item. The Cycloid antenna is available with any number of bays from one to sixteen and with 1½-inch or 3½-inch line. See the price list for complete listing.

SPECIFICATIONS

FREQUENCY RANGE: Factory tuned to specified frequency in 88-108 MHz band.

POLARIZATION: Horizontal.

HORIZONTAL PATTERN: Circular, ± 1.0 dB in free space.

INPUT IMPEDANCE: 50 ohms, on 1½" or 3½" coax.

FEED POINT: 1 to 8 bays inclusive—end feed. 9 to 16 bays inclusive—center feed.

POWER RATING: 3 kW per section on 1½" line.

VSWR: (With field tuning) Top mounting, 1.1 to 1. Side mounting, 1.1 to 1. (Factory tuned) Top mounting 1.2 to 1. Side mounting, 1.5 to 1.

WINDLOAD: 20 lbs. per square foot.

DIMENSIONS: (One bay): Height (over-all), 6 inches. Ring diameter, approx. 18 inches (depends on frequency).

WEIGHT: Antenna, 25 lbs. per ring. 1½" line, 12½ lbs. per 10 ft. section. 3½" line, 27½ lbs. per 10 ft. section.

EQUIPMENT FURNISHED: Antenna mounting hardware (specify tower make, height and type number when ordering). Correct number of antenna elements as ordered. Interconnecting rigid coax (1½" or 3½") as ordered. Standard EIA (1½" or 3½") flanges as ordered.

ACCESSORY EQUIPMENT (Optional): Deicers: 300 watts (FMH-300). 600 watts (FMH-600). Antenna Heater Control.



TYPE 300G

The 300G vertically polarized FM antenna enables an FM station to transmit a supplemental vertically polarized signal to achieve elliptical or circular polarization as authorized in the FCC Rules and Regulations. It may be used in combination with any type of horizontally polarized FM antenna.

Both the 1½-inch and 3½-inch vertical antennas carry type number 300G. As these antennas are usually ordered as a system of several bays with connecting lines and breakers, the Gates price list is employed for more complete listings. Power division networks, both variable and fixed, are available to combine vertical and horizontal antennas, and are listed in the price list.

SPECIFICATIONS

FREQUENCY RANGE: Factory tuned to specified frequency in 88-108 MHz band.

POLARIZATION: Vertical.

POWER GAIN: Approximately equal to number of dipoles.

HORIZONTAL LINEARITY: Dipole circular ± 1 dB in free space.

INPUT IMPEDANCE: 50 ohms on 1½" or 3½" coax.

FEED POINT: For 9 bays or less, the antenna is end fed. For 10 bays or more, the antenna is center fed where number of bays is even, and for odd number of bays feed point is ½ bay length below center.

POWER RATING: 3 kW per dipole.

VSWR: Tuned to 1.1:1 or less; less than 1.5:1 when mounted on side of tower.

WINDLOAD: 60 psf. on flat surfaces, 40 psf. on cylindrical surfaces (123 mph actual wind velocity).

DIMENSIONS: Length of dipole—3.75 ft. From center of transmission line to center of dipole—2.83 ft.

WEIGHT: 1½" dipole—26.5 lbs. 3½" dipole—34.0 lbs. Typical mounting bracket—22.0 lbs. per bay.

DEICERS: Not required.

FM Isolation Transformers, Antenna Accessories

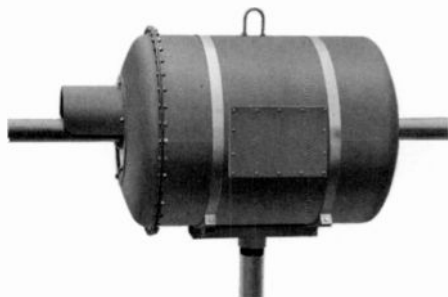

25 kW ISOLATION TRANSFORMER.

The FM isolation transformer is designed to couple FM transmitter power across the base of an insulated tower used jointly as an AM and FM radiator, without objectionable mismatch being introduced into the FM transmission line. Single AM antennas and antennas which are part of an AM directional antenna system are not affected when the isolation transformer is used.

SPECIFICATIONS

(7.5, 10 and 25 kW Units)

FREQUENCY: 88 to 108 MHz (adjusted to the customer's operating frequency of the factory).

VSWR: Less than 1.05 to 1 on specified frequency, ± 0.5 MHz when terminated in a matched 50 ohm load.

POWER RATING: (Into matched 50-ohm load)

Model 620-0397—7.5 kW
 Model 620-0415—10 kW
 Model 620-0444—25 kW

INSERTION LOSS: 0.10 dB or less.

INPUT AND OUTPUT: (7.5 kW unit) EIA 1 $\frac{1}{2}$ " flange, male* or female. (10 kW unit) EIA 3 $\frac{1}{4}$ -inch flange, female. (25 kW unit) 3 $\frac{1}{2}$ -inch 50 ohm EIA male flange will mate with the 3 $\frac{1}{4}$ -inch female flange such as the Andrew type 78-AR-F used on 3 $\frac{1}{4}$ -inch Heliax cable, or the flange on Andrew type 562A 50 ohm 3 $\frac{1}{4}$ -inch rigid coaxial transmission line.

*Box has EIA male connector. The male to male adapter may be removed if box connects to female fitting. Subtract 6" from flange to flange length for each adapter if removed.

WEIGHT: (7.5 and 10 kW units) 48 lbs. (25 kW unit) 255 lbs.

LENGTH: (7.5 and 10 kW units) 20" flange to flange. (25 kW unit) 39" flange to flange.

MOUNTING: (7.5 and 10 kW units) 2" pipe flange on bottom of box. (25 kW unit) Separate 3" pipe flange on bottom. Two stainless steel straps secure tank to cradle.

PRESSURIZATION: Designed for use in a pressure system with gas passing through the unit. (Normal pressure 3 to 5 lbs. per square inch using dry air or dry gas.)

ORDERING INFORMATION

7.5 kW Isolation Transformer, adjusted to the customer's operating frequency at the factory. Standard EIA 1 $\frac{1}{2}$ " flanges. For use with a maximum transmitter power of 7.5 kW.....620-0397

10 kW Isolation Transformer, adjusted to the customer's operating frequency at the factory. Standard 3 $\frac{1}{4}$ " flanges. For use with a maximum transmitter power of 10 kW.....620-0415

25 kW Isolation Transformer, adjusted to the customer's operating frequency at the factory. Standard EIA 3 $\frac{1}{2}$ " flanges. For use with a maximum transmitter power of 25 kW.....620-0444

FM ANTENNA ACCESSORIES



AUTOMATIC ANTENNA HEATER CONTROL SYSTEM: (shown above). Fully automated control of FM, TV and other types of electrically operated broadcast and communications antenna heater systems. Suitable alarms indicate visually and aurally existing weather conditions and register partial and total heater failure.

SPECIFICATIONS

POWER INPUT: 115 VAC, 60 Hz.

INPUTS: Temperature sensors; precipitation sensor; heater failure sensor.

INDICATORS: Rain, freeze, low temperature, heaters, heater fail. Selectable aural alarm for any or all of those listed.

MOUNTING: Standard 3 $\frac{1}{2}$ " x 19" rack panel. 8 inches deep.

OPTIONS: 12 VDC function outputs for telemetering status data. Model 2570-CA calibration box. Power contactors and enclosures.

ORDER NUMBER: (Antenna heater control system)..... 710-0139

REPLACEMENT ANTENNA HEATER ELEMENTS:

Dual-Cycloid Antennas (2 elements per bay).....710-0136
 Dual-Cycloid II (2 elements per bay).....710-0137
 Cycloid Antenna (2 elements per bay).....710-0138

AC HEATER CABLE AND CONDUIT:

Includes installation. Only available when a tower or FM antenna is being installed.

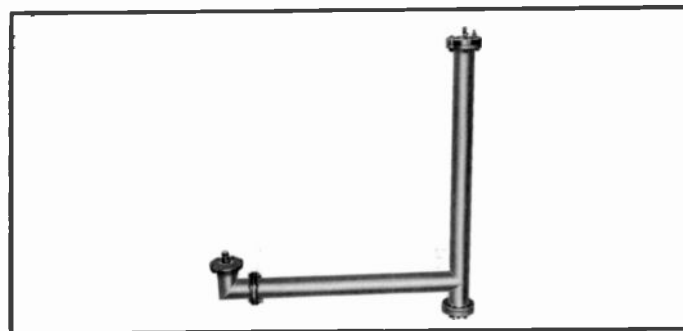

FIXED POWER DIVIDER: (shown above). Custom designed to divide power for vertical and horizontal antennas to customer's specifications. Special order.

With 3 $\frac{1}{8}$ " EIA input and 3 $\frac{1}{8}$ " EIA output for both horizontal and vertical antennas.

With 1 $\frac{1}{2}$ " EIA input and 3 $\frac{1}{8}$ " EIA output for both horizontal and vertical antennas.

With 3 $\frac{1}{8}$ " EIA input and 1 $\frac{1}{2}$ " EIA output for both horizontal and vertical antennas.

With 1 $\frac{1}{2}$ " EIA input and 1 $\frac{1}{2}$ " EIA output for both horizontal and vertical antennas.

FM Stereo Modulation Monitor



MODEL GTM-88S

The GTM-88S measures all modulation characteristics of an FM stereo or monaural signal in accordance with FCC requirements. All normal operating controls are accessible from the front panel. Instrument outputs for the right and left channels on the rear of the monitor can be connected to such auxiliary test equipment as oscilloscopes, distortion analyzers and frequency monitors, which may remain connected without affecting monitor performance or accuracy. Left channel instrument output is switchable to either channel by front panel control.

Printed circuit construction is used throughout, and, combined with the total solid state design, improves over-all dependability, and assures stable operation even under adverse operating conditions. Space age integrated circuits combine all circuit components into a single silicon semi-conductor device, thus eliminating many physical components as well as their associated interconnections, for the ultimate in performance and reliability. Provision has been made for the addition of an SCA adapter to measure SCA modulation in accordance with FCC rules and regulations.

SPECIFICATIONS

ELECTRICAL

OPERATING FREQUENCY: 87.5 to 108 MHz.
RF INPUT IMPEDANCE: 50 ohms, unbalanced.
RF INPUT SENSITIVITY: 0.1 to 1 watt.
COMP. INPUT SENSITIVITY: 0.7 V peak-to-peak for 100% modulation.
COMP. INPUT IMPEDANCE: 4000 ohms.
COMP. OUTPUT: 3 V peak-to-peak at 100% modulation.
COMP. OUTPUT IMPEDANCE: 600 ohms.
COMP. OUTPUT FREQ. RES.: ± 0.5 dB, 30 Hz to 100 kHz.
19 kHz OUTPUT: 0.75 V peak-to-peak into 20 K ohms load.
HEADPHONE OUTPUT: Levels for loads from 4 ohms to several megohms with distortion 1% or less. Separate level control.
POWER REQUIREMENTS: 100-130 VAC, 50/60 Hz, 40 watts.

INSTRUMENT OUTPUT (left or right)

IMPEDANCE: 20,000 ohms.
FREQUENCY RESPONSE: ± 0.5 dB, 50 Hz, to 15 kHz.
DISTORTION (Stereo): 0.5% or better from 50 Hz to 15 kHz at 100% modulation.
INTERNAL NOISE: -70 dB or better in mono or stereo below 100% modulation at 400 Hz.
CHANNEL SEPARATION: 35 dB or better 50 Hz to 15 kHz.

CROSSTALK CAPABILITY

MAIN TO SUB: 50 dB or better.
SUB TO MAIN: 55 dB or better.
SCA TO MAIN OR SUB: 70 dB or better.
SUBCARRIER SUPPRESSION: 50 dB or better with modulation from 5 to 15 kHz.

MODULATION METER

ACCURACY: $\pm 5\%$ or better.
BALLISTICS: Conform to FCC rules 73.322 (b).
PEAK MODULATION INDICATOR: Adjustable to indicate from 50% to 120% modulation.
AM NOISE MEASUREMENT: AM noise up to -70 dB from 30 Hz to 75 kHz.
FCC TYPE APPROVAL: No. 3-144.

MECHANICAL

RF INPUT CONNECTOR: UHF plug.
DIMENSIONS: 19" wide, 8 $\frac{3}{4}$ " high, 1 $\frac{1}{4}$ " deep.
WEIGHT: 26 lbs. (net).
AMBIENT TEMPERATURE: 10°C (50°F) to 55°C (131°F).
AMBIENT HUMIDITY: 0 to 95% relative.
ALTITUDE: Sea level to 10,000 feet.
MOUNTING: Standard 19" rack panel or free standing.

ORDERING INFORMATION

GTM-88S FM Stereo Modulation Monitor, complete with crystal, calibrated to specified operating frequency

994-6569

FM Monaural Modulation Monitor



MODEL GTM-88M

Incorporating all of the advanced performance features of the stereo unit, the GTM-88M monophonic monitor can be readily converted to stereo operation with full FCC type approval. Printed circuit modular construction used in the GTM-88M allows conversion to stereo operation with no wiring changes. The conversion is accomplished by plugging in the appropriate modules and filters, then calibrating for stereo operation. The design also provides for the addition of an adapter for measurement of SCA modulation.

Silicon solid state and silicon integrated circuits used in the monitor were selected for their dependability.

All normal operating controls are on the front panel, with other controls behind a hinged front panel. When converted to stereo, the monophonic monitor requires no control changes. The peak modulation indicator is adjustable in 10 degree steps from 50% to 120%.

Separate headphone and instrument outputs receive an FM signal with de-emphasis, while the modulation meter receives the complete signal with pre-emphasis to provide accurate modulation readings. Compact in size, the GTM-88M is designed for standard rack mounting.

SPECIFICATIONS

ELECTRICAL

OPERATING FREQUENCY: 87.5 to 108 MHz.
RF INPUT IMPEDANCE: 50 ohms, unbalanced.
RF INPUT SENSITIVITY: 0.1 to 1 watt.
HEADPHONE OUTPUT: Load levels from 4 ohms to several megohms with 1% or less distortion. Separate level control.
POWER REQUIREMENTS: 100 to 130 VAC, 50/60 Hz, 40 watts.

INSTRUMENT OUTPUT

IMPEDANCE: 20,000 ohms.
FREQUENCY RESPONSE: ± 0.5 dB, 50 Hz to 15 kHz.
DISTORTION: 0.25%, 50 Hz to 15 kHz at 100% modulation.
INTERNAL NOISE: -70 dB below 100% modulation at 400 Hz.

MODULATION METER

ACCURACY: $\pm 5\%$.
BALLISTICS: Meet FCC rule 73.322 (b).
PEAK MODULATION INDICATOR: Adjustable from 50 to 120% modulation.
AM NOISE MEASUREMENT CAPABILITY: -70 dB, 30 Hz to 75 kHz.
FCC TYPE APPROVAL: No. 3-145.

MECHANICAL

RF INPUT CONNECTOR: UHF plug.
DIMENSIONS: 19" wide, 8 $\frac{3}{4}$ " high, 1 $\frac{1}{4}$ " deep.
WEIGHT: 24 lbs. (net).
AMBIENT TEMPERATURE: 10° to 55°C, (50° to 131°F).
AMBIENT HUMIDITY: 0 to 95% relative.
ALTITUDE: Sea level to 10,000 feet.
MOUNTING: Standard 19" rack panel or free standing.

ORDERING INFORMATION

GTM-88M FM Monaural Modulation Monitor, complete with crystal, calibrated to specified operating frequency-----994-6581

SCA Modulation Monitor Adapter

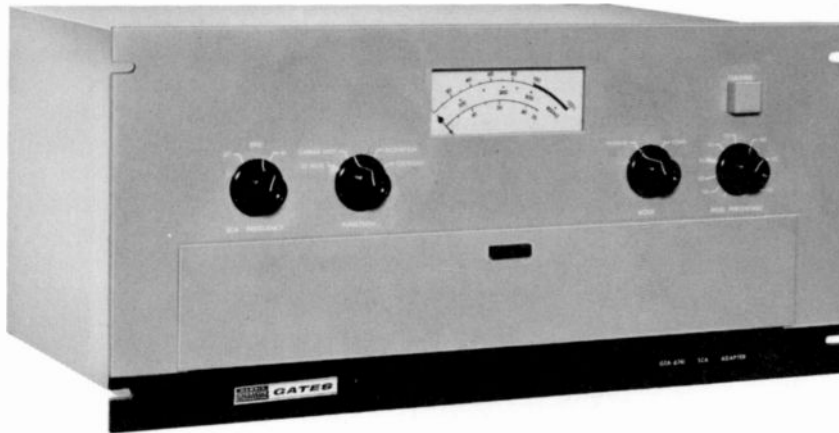

MODEL GTA-6741

Gates SCA modulation monitor adapter measures all modulation characteristics of an SCA signal when used in conjunction with Gates FM modulation monitors. This adapter can also be used with the GTA-88F SCA frequency comparator to measure the accuracy of SCA frequencies as specified by the FCC. Total solid state circuitry, plus integrated circuits throughout the GTA-6741, assures trouble-free operation.

A built-in peak modulation flasher provides indication of peak or over-modulation on the SCA channel. The GTA-6741 is also equipped with an instrument output for connection of external test equipment without affecting performance of the adapter. A separate audio output provides a +10 dBm signal to drive an external amplifier. A separate headphone jack is also provided.

Measurements that can be made using this SCA modulation monitor adapter and Gates GTM-88S stereo or GTM-88M monophonic modulation monitor include:

1. SCA channel modulation (41 and/or 67 kHz).
2. Crosstalk—SCA into main channel.
3. Crosstalk—SCA into stereo channel.
4. Crosstalk—Main into SCA channel.
5. Crosstalk—Stereo into SCA channel.
6. Crosstalk—67 kHz into 41 kHz SCA channel.
7. Crosstalk—41 kHz into 67 kHz SCA channel.
8. FM noise measurements—SCA channel.
9. SCA frequency accuracy (when used with Gates GTA-88F frequency comparator).
10. Distortion on the SCA channel (with external distortion analyzer).

SPECIFICATIONS

OPERATING FREQUENCY: 41 kHz and 67 kHz.

SCA PEAK MODULATION INDICATOR: Adjustable to indicate from 50% to 120% modulation. Meets FCC Rules 73.332D (4).

CROSSTALK CAPABILITY

SCA INTO MAIN OR SUB: (10% SCA) 70 dB or better.

MAIN INTO SCA: (SCA 8:1) 50 dB or better (30 Hz - 15kHz).

STEREO INTO SCA: (SCA 8:1) 40 dB or better (30 Hz - 15 kHz).

41 KHZ INTO 67 KHZ: (both SCA at 10%) 45 dB (30 Hz - 5 kHz).

67 KHZ INTO 41 KHZ: (both SCA at 10%) 45 dB (30 Hz - 5 kHz).

AUDIO OUTPUT

HEADPHONE OUTPUT: Provides sufficient level for headphones from 4 ohms to several megohms. Separate level control provided. ± 1 dB 30 to 7,500 Hz.

AUDIO OUTPUT: +10 dBm at 600 ohms (unbalanced).

INSTRUMENT OUTPUT

IMPEDANCE: 20,000 ohms.

DISTORTION: 1% or better (30 Hz - 7.5 kHz).

FREQUENCY RESPONSE: ± 0.5 dB (30 Hz - 7.5 kHz).

GENERAL

POWER SOURCE: All DC voltages provided from GTM-88M or GTM-88S FM modulation monitors.

SIZE: 19" wide, 8 $\frac{3}{4}$ " high, 11" deep. Including knobs and rear connectors, 13" deep.

WEIGHT: 20 lbs. (net).

AMBIENT TEMPERATURE: 10°C to 55°C (50°F to 131°F).

AMBIENT HUMIDITY: 0 to 95% relative.

ALTITUDE: Sea level to 10,000 feet.

MOUNTING: Standard 19-inch rack panel or free standing.

ORDERING INFORMATION

GTA-6741 SCA Modulation Monitor Adapter-----994-6591

FM Accessories

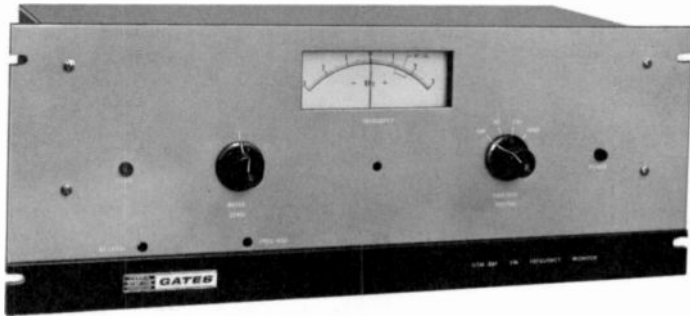

MODEL GTM-88F

FM FREQUENCY MONITOR

Gates new all solid state FM frequency monitor measures the precise operating frequency of the FM transmitter by utilizing pulse counting techniques. A crystal controlled wide band pulse signal is compared with the FM transmitter center frequency to determine any frequency deviation from the assigned operating channel. The pulse counting technique assures a measurement accuracy of better than 0.0001%, and full compliance with all FCC requirements.

FREQUENCY RANGE: 88 to 108 MHz (fixed).

POWER: 100 to 130 VAC, 50/60 Hz, 40 watts, 19" W x 7" H x 10" D.

GTM-88F FM frequency monitor, complete with crystal, calibrated to specified operating frequency.....994-6588

PILOT-SCA FREQUENCY COMPARATOR

Gates pilot-SCA frequency comparator determines the accuracy of the pilot frequency when used with Gates GTM-88S stereophonic modulation monitor, and SCA frequencies when used with the GTA-6741 SCA modulation adapter. Three integrated circuits, one transistor, and nine diodes (all silicon) are used for stability and reliability. The GTA-88F is factory calibrated, and will provide years of dependable service in full compliance with existing FCC rules.

OPERATING FREQUENCIES: 19, 41 and 67 kHz as supplied.

POWER: 100 to 130 VAC, 50/60 Hz, 10 watts. 19" W x 5 1/4" H x 6 3/4" D. (8 3/4" deep with knobs and rear connectors.)

GTA-88F 19 kHz pilot/SCA 41 and 67 kHz frequency comparator...994-6603



MODEL GTA-88F

FM RF AMPLIFIER

Designed to operate in conjunction with Gates FM frequency and modulation monitors, the GTM-88R amplifier is used at a remote location to provide sufficient RF power to drive the monitors. This is ideal for applications where the monitors are located at the studio and the transmitter is at a remote location. It permits the operator to monitor the frequency and modulation of the transmitter as required by FCC regulations. Solid state silicon circuitry plus extensive use of integrated circuits throughout assures dependable, trouble-free operation.

FREQUENCY RANGE: 87.5 to 108 MHz.

POWER: 115 V, 50/60 Hz, 12 watts. 19" W x 5 1/4" H x 10" D.

GTM-88R FM RF amplifier complete with antenna, less interconnecting cable.....994-6614



MODEL GTM-88R

FM Installations

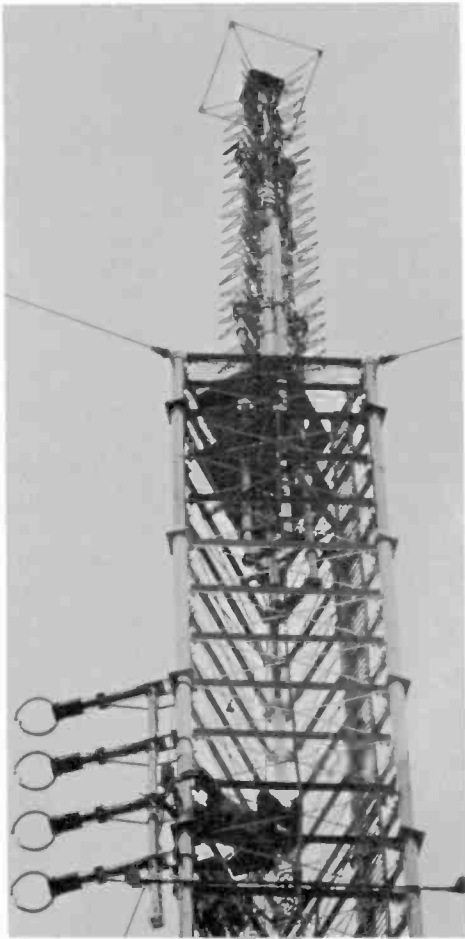

(Left) WGEM-FM, Quincy, Illinois utilizes a Gates 9-bay Dual Cycloid Antenna, leg mounted on the WGEM-TV tower. The top four bays are shown during installation.

(Right) A Directional FM Antenna, pole mounted, is used by Station WKZN-FM, Kenosha, Wisconsin. Each bay of the directional antenna is equipped with heaters (totaling 900 watts).

In the lower left photo, Frank Laughlin, of Station KGRC-FM, Hannibal, Missouri, makes a minor adjustment to the station's stereo-equipped FM-20H transmitter.

In the lower right photo, Chief Engineer George Watson, of Station WDRC-FM, Hartford, Connecticut, checks the FM-7.5H transmitter tuning. The transmitter is remote controlled from downtown Hartford, and feeds a Gates 5-bay Cycloid and 300G antenna combination.



**RADIO
BROADCAST
TRANSMITTER
ACCESSORIES**

**HARRIS
INTERTYPE
CORPORATION**

GATES®
A DIVISION OF HARRIS-INTERTYPE

Remote Control System



Fig. A. Studio unit provides complete metering and selection/operation of up to 23 control functions. Power supply is self-contained.

MODEL RDC-10AC

This Gates remote control equipment is a direct current system without tubes or transistors and has only one major moving part—the rugged gold contact stepper. Facilities are provided for as many as ten metering positions and 23 control functions. Capacity of the RDC-10AC equipment ranges from the one transmitter, one tower installation to a multi-tower directional system, as well as combination AM-FM separate transmitters with only one RDC-10AC system.

Standard equipment includes: (a) the studio control unit, Fig. A, (b) the transmitter control unit, Fig. B, (c) plate current and (d) plate voltage metering kits, plus (e) the tower light indicator unit. Studio and transmitter units are also available separately. Items (c), (d) and (e) are described on Page 71.

The studio control unit (Fig. A) has three large, easy-to-read meters that indicate plate voltage, plate current and AM antenna current or FM output. The meters may be switched

to several circuits on one or two transmitters, coupling units, etc. As an example, the tower light function can be indicated on the plate current meter. Many combinations are possible with the selection of the proper accessories as listed on Page 71. Relays are of highest quality to assure freedom from malfunction. A switch is provided on the transmitter control unit to transfer operation back to manual during transmitter maintenance or servicing.

Only two metallic telephone pairs are required. Usually the order phone between studio and transmitter is connected to one of the remote functions to eliminate the need for a third order phone line. The RDC-10AC system will operate on telephone lines up to 30 miles in length, or with 3000 ohms loop resistance, whichever is greater. Both studio and transmitter units are 19" wide, 8¾" high and 10" deep. Front panels drop down for easier servicing. Shipping weight: domestic, 50 lbs.; export, 85 lbs. Cubage: 4 cubic feet.

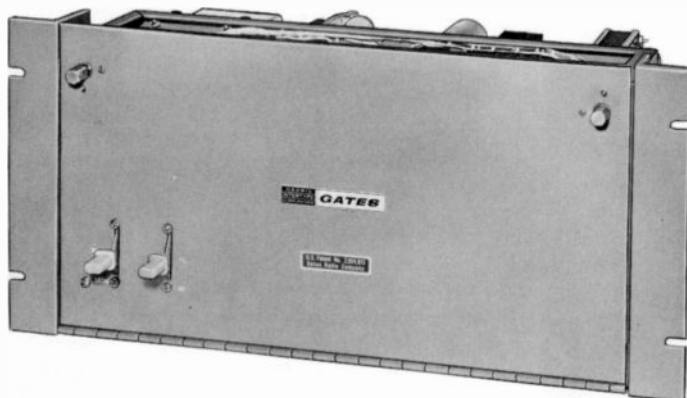

Fig. B. Transmitter unit may mount in a rack, or directly in most transmitters. Power supply is self-contained.

ORDERING INFORMATION

- (A) Complete RDC-10AC system includes studio and transmitter units and items I, J and K below.....994-5862-001
- (B) Studio and transmitter units only.....994-5862-002
- (C) Antenna diode to remote control antenna meter.....994-6112
- (D) Motor driven rheostat for power control of 250 watt transmitter.....994-4703-001
- (E) Motor driven rheostat for power control of 500 watt transmitter.....994-4703-002
- (F) Motor driven rheostat for power control of 1000 watt transmitter.....994-4703-003
- (G) Motor assembly to drive variable coil for load power adjustment such as for 5 kW or 10 kW transmitters. (Relay below necessary).....994-5066
- (H) Relay assembly to operate 994-5066 motor.....994-4806
- (I) Plate current unit to extend plate current readings.....994-4720
- (J) Plate voltage unit to extend plate voltage readings.....994-4719
- (K) Tower light indicator.....994-5145

IMPORTANT: When ordering, give as much transmitter detail as possible: (a) make and type number, (b) plate rheostat in ohms and watts. If not a Gates transmitter, state method of power output control such as rheostat, variable loading, etc. If you are in doubt, please contact us. Gates will gladly assist.

Remote Control System Accessories

FREQUENCY MONITOR EXTENSION METER

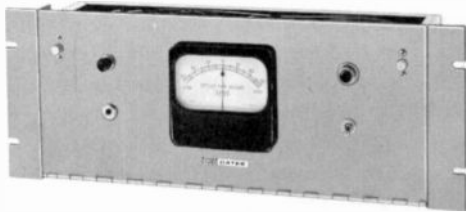

For M-4990 AM Frequency Monitor. Meter is exact duplicate of the M-4990 monitor for extending frequency indication to studios.
Extension meter.....994-5631

MONITOR EXTENSION METERS

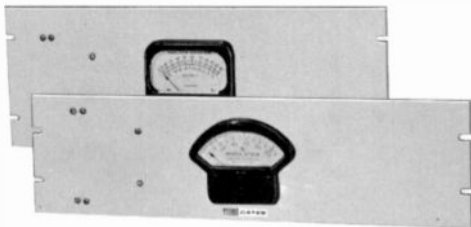

Several types available as listed below for extending modulation monitors. Mounted on standard 19" rack panel. 5 1/4" high.

Remote Meter for M-5774 modulation monitor.....994-5836B
Remote meter for extending Gates M-5693 modulation monitor.....994-5837

AUXILIARY RELAY ASSEMBLY



Auxiliary relay assembly to provide one on-off momentary switching facility. These relays provide two sets of double pole double throw contacts rated at 8 amperes, 115 volts AC.

Auxiliary Relay Assembly.....994-5249
Same as above but latching (holding) type with 10 ampere contacts.....994-5248

OUTPUT LOADING CONTROL KIT

Complete kit to control output loading of Gates BC-5P-2 and BC-5H 5 kW transmitters. It includes M-5066 and M-4806 relay and all necessary mounting hardware.

Output Loading Control Kit.....994-4848A

MOTOR OPERATED RHEOSTAT



Recommended for regulating the plate voltage in transmitters of 1 kW and less. Available in three sizes for 250, 500 and 1000 watt transmitters. Motor is one rpm and operates from 115 volts, 60 Hz.

Motor Rheostat for 250 watts.....994-4703A
Motor Rheostat for 500 watts.....994-4703B
Motor Rheostat for 1 kW.....994-4703C
Motor Control for Rheostat in BC-500G and BC-1G.....994-6326

TUNING MOTOR



This unit for tuning variable inductor, capacitor or other controls, has built-in limit switches. Five wire reversible motor 1 rpm. Requires M-4806 relay assembly for control. 115 volt, 50/60 Hz.

Tuning Motor.....994-5066

TUNING MOTOR ASSEMBLY

For operating rheostat, variable condenser, or any variable control. Three wire reversible motor 1 rpm. Torque 15 lb.-inches. 115 volts, 50/60 Hz.

Tuning Motor.....994-4800

AC RECTIFIER

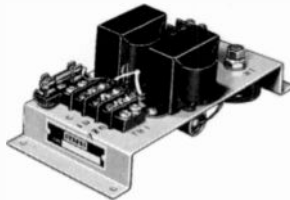

Rectifies the AC voltage, either line or filament, at the transmitter, and feeds back DC to studio unit for measuring AC by remote control.

AC Voltage Unit.....994-4825

PLATE CURRENT UNIT

Included with the Gates remote control system. Furnishes a sample of plate current which is returned to the studio unit and measured on the directly calibrated plate current meter. The unit is provided with a high voltage protective fuse, and can be used for current ranges of 0-0.8 and 0-3 amperes. Units can be used in parallel if higher current range is required.

Plate Current Unit.....994-4720A

TOWER LIGHT UNIT

This unit is used to provide a DC voltage for indication of proper tower light operation. Includes current transformer.

Tower Light Metering Kit.....994-5145

RF DIODE UNIT

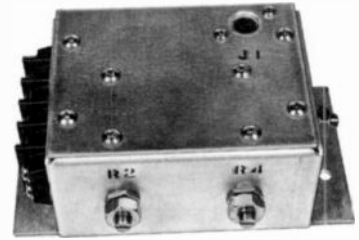

The M-6112 RF diode unit is designed for use as a remote RF indicating device in standard broadcast installations for sampling base currents or common point currents. It is not a directly calibrated RF ammeter, but is adjustable to indicate current linearity with the RF meter. It is not necessary to break the lead to the antenna to install the unit. The M-6112 RF diode consists of an inductive loop which is attached to a rectifier assembly, and is also clamped to the antenna lead. The M-6112 is a solid state device and requires no AC power.

POWER RANGE: 250 to 50,000 watts.

FREQUENCY RANGE: 540 to 1600 kHz.

RF Diode Unit.....994-6112

OVERLOAD RELAY

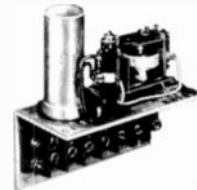

Replaces circuit breakers in current or older models, as circuit breakers are usually undependable for remote control. Tripping current adjustable. Inserted in cathode circuit of RF power amplifier. Some engineers prefer an additional unit in modulator circuit.

Overload Relay.....994-5129

FM OUTPUT INDICATOR

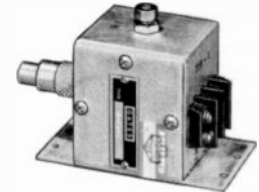

Designed to sample the 50 ohm transmission line of an FM transmitter for measuring transmitter output as required by FCC. Provides a DC voltage which is measured on the studio unit meter system. Solid state. Requires no AC power.

FM Output Indicator.....994-4845

PLATE VOLTAGE UNIT

Supplied with Gates remote control systems. One unit is used with voltages up to and including 6000 volts. For higher voltages, additional units may be connected in series. Also available as an accessory item for metering additional stages of transmitters.

Plate Voltage Unit.....994-4719A

Coaxial And Rigid Transmission Lines

FLEXIBLE COAXIAL CABLE

**AIR
DIELECTRIC**



Produced in continuous splice-free lengths, Heliax® low loss cable is ideally suited for any application where use of coaxial transmission line is indicated. For medium wave VHF and UHF applications, long, continuous lengths provide ease of installation and maintenance-free service. Corrugated copper conductors provide a combination of flexibility and low loss. For direct burial, exposure to rough handling, or where the outer conductor must be insulated, Heliax jacketed with polyethylene is available. Although Heliax connectors and fittings are easily attached, it is recommended that all cable assemblies be ordered with fittings factory attached with specialized manufacturing equipment. Please order by type number.

® Registered trademark, Andrew Corporation.

SPECIFICATIONS

SIZE:	7/8"	1 1/8"	3"	5"	8"
TYPE NUMBER, UNJACKETED:	H5-50	—	—	—	—
TYPE NUMBER, JACKETED:	HJ5-50	HJ7-50A	HJ8-50B	HJ9-50	HJ10-50
IMPEDANCE: OHMS	50	50	50	50	50
ATTENUATION @ 100 MHz, dB/100 FT.:	0.37	0.21	0.14	0.080	.052
VELOCITY: %:	91.6	92.1	93.3	93.0	94.0
AVERAGE POWER, @ 100 MHz-kw:	6.4	14.5	34.0	95.0	170.0
BEND RADIUS (MINIMUM)—INCHES:	10	20	30	50	72
NET WEIGHT—UNJACKETED: POUNDS/FT.:	.43	—	—	—	—
NET WEIGHT—JACKETED: POUNDS/FT.:	.51	.92	1.5	4.2	8.9

FOAM DIELECTRIC COAXIAL CABLE



Foam Heliax is used in those broadcast installations requiring low loss coaxial cable in which pressurizing is not desirable. A corrugated copper outer conductor and foam dielectric provide a combination of high strength, low loss and power handling not available in solid dielectric cables. The flexibility of foam Heliax provides maximum resistance to crushing, kinking or denting, and enables it to be pulled through conduits and around obstructions. Please order by type number.

SPECIFICATIONS

SIZE:	1/2"	7/8"
TYPE NUMBER:	FH4-50B	FH5-50A
TYPE NUMBER, JACKETED:	FHJ4-50B	FHJ5-50A
IMPEDANCE:	50 ohms	50 ohms
ATTENUATION @ 100 MHz, dB/100 FT.:	0.82	0.44
VELOCITY, %:	79	79
AVERAGE POWER, @ 100 MHz, kW	2.3	4.8
BENDING RADIUS (MINIMUM)—INCHES:	5	10
NET WEIGHT—POUNDS/FT.:	.125 lbs.	.32 lbs.
NET WEIGHT—JACKETED:	.185 lbs.	.42 lbs.

RIGID TRANSMISSION LINES



RIGID LINE







Teflon insulated rigid copper coaxial transmission lines for broadcast application. Line and connectors meet all EIA applicable standards. Mitered elbows are compensated to provide low VSWR. All rigid sections and components include inner connectors, "O" ring and hardware. Please order by type number, and specify frequency.

SPECIFICATIONS

SIZE:	7/8"	1 1/8"	3 1/8"
TYPE NUMBER:	560	561	562A
IMPEDANCE:	50 ohms	50 ohms	50 ohms
ATTENUATION @ 100 MHz, dB/100 FT.:	0.40	0.20	0.11
VELOCITY, %:	99.8	99.8	99.8
AVERAGE POWER, @ 100 MHz:	4.3 kW	15.0 kW	48.0 kW
NET WEIGHT—POUNDS/FEET:	.65	1.25	2.75

Coaxial Transmission Line Accessories

Fittings: Flanged items are EIA standard and include inner connector, "O" ring, silicon grease and hardware kit.





EIA FLANGE 	EIA FLANGE 	REDUCER CONNECTOR 	END TERMINAL 	TYPE N JACK 	SPLICE 
Use with copper Heliax cable.	Includes gas barrier.	Reduce cable size to EIA flange sizes.	For strap connection to center conductor.	Female, mates with (-).	Use with copper Heliax cable.

FOAM DIELECTRIC

1/2"	44AR	---	---	1/2"	44AT	(UG23)	44AN	44AZ
7/8"	45AR	---	---	7/8"	45AT	(UG21)	45AN	45AZ

AIR DIELECTRIC

7/8"	75AR	75AG	---	7/8"	75AT	(UG21)	75AN	75AZ
1 1/8"	87R	87G	1 1/8"-7/8" 87S	1 1/8"	87T	(UG21)	87N	87Z
3"	78ARM	78AGM	3 3/8"-1 1/8" 78AS	3"	(79ARM + 2062A)	---	---	78AZ
5"	79R	79G	6 1/8"-3 1/8" (79R+1872)	5"	(79R + 2073)	---	---	79Z
8"	80R	80G	6 1/8"-3 1/8" (80R+1872)	8"	(80R + 2073)	---	---	80Z

TYPE UHF JACK 	NON-INSULATED HANGER 	INSULATED HANGERS 	INSULATED HANGERS 	HANGER ADAPTERS
Female.	Kit of 10 hangers. Spacing 3' for 1 1/8" cables, 5' for 3" and 5" cables.	Use on insulated tower spacing 3 feet apart.	Use on insulated tower spacing 3' apart for 1 1/8", 5' for larger sizes.	INSULATED Adapters used to mount insulated hangers to tower without drilling. Angle Members 13555A Round Members up to 3" 13550
				NON-INSULATED Kit consists of 10 adapters to mount hangers to tower.
				ANGLE MEMBER TOWERS 1 1/8" hangers 31768 3" and 5" hangers 33981-1
				ROUND MEMBER TOWERS Use with 1 1/8" hangers: Member dia. 1"-2" 31670-1 2"-3" 31670-2 3"-4" 31670-3 4"-5" 31670-4 5"-6" 31670-5 Use with 3", 5" and 8" hangers: Member dia. 1"-3" 33984

FOAM DIELECTRIC

1/2"	44AU	WRAPLOCK	1/2"	11662-3	---
7/8"	45AU	12395-1	7/8"	11662-2	---













AIR DIELECTRIC

7/8"	75AU	WRAPLOCK	7/8"	11662-2	---
1 1/8"	87U	33598-1	1 1/8"	---	33948-3
3"	---	33598-3	3"	---	33948-2
5"	---	33598-5	5"	---	33948-1
8"	---	33598-9	8"	---	---

WRAPLOCK	GROUNDING KITS				HOISTING	
One hundred feet of stainless steel wraplock, complete with fasteners. Use at three-foot intervals for all cables 1 1/8" and smaller. Type 12395-1	Cable Size	Unjacketed	Jacketed	Unjacketed	Jacketed	
	1/2"	26892-1	26892-2	---	---	---
	7/8"	24810-1	24810-2	29958	---	19256B
	1 1/8"	---	24811-2	---	---	24312A
	3"	---	28708-2	---	---	26985A
	5"	---	30417-2	---	---	31031-1
	8"	---	30417-2	---	---	31031-2

Coaxial Transmission Line Accessories

Fittings: All flanged items are EIA standard and include inner connector, "O" ring, silicon grease and hardware kit. All hangers require round member or angle adapters for attachment to tower.

90° MITER ELBOW	GAS BARRIER	REDUCER	END TERMINAL	INNER CONNECTOR	ROUND MEMBER CLAMP																																				
																																									
<p>Brass construction with swivel flanges on both ends. Includes one inner connector.</p>	<p>With fixed male connector on both ends. May be used as gas inlet fitting.</p>	<p>Reduces line size.</p>	<p>For strap connection. Gas tight with vent plug. Includes inner connector.</p>	<p>With Teflon anchor bead.</p>	<p>Attaches hangers to tower members up to 3" diameter.</p>																																				
<table border="0"> <tr><td>7/8"</td><td>1060</td></tr> <tr><td>1 1/2"</td><td>1061</td></tr> <tr><td>3 1/2"</td><td>1062</td></tr> </table>	7/8"	1060	1 1/2"	1061	3 1/2"	1062	<table border="0"> <tr><td>7/8"</td><td>1260A</td></tr> <tr><td>1 1/2"</td><td>1261B</td></tr> <tr><td>3 1/2"</td><td>1262A</td></tr> </table>	7/8"	1260A	1 1/2"	1261B	3 1/2"	1262A	<table border="0"> <tr><td>7/8"-1 1/2"</td><td>1860A</td></tr> <tr><td>1 1/2"-3/4"</td><td>1861</td></tr> <tr><td>3 1/2"-6 1/8"</td><td>1872</td></tr> </table>	7/8"-1 1/2"	1860A	1 1/2"-3/4"	1861	3 1/2"-6 1/8"	1872	<table border="0"> <tr><td>7/8"</td><td>---</td></tr> <tr><td>1 1/2"</td><td>2061</td></tr> <tr><td>3 1/2"</td><td>2062</td></tr> </table>	7/8"	---	1 1/2"	2061	3 1/2"	2062	<table border="0"> <tr><td>7/8"</td><td>34389A</td></tr> <tr><td>1 1/2"</td><td>34660</td></tr> <tr><td>3 1/2"</td><td>15093A</td></tr> </table>	7/8"	34389A	1 1/2"	34660	3 1/2"	15093A	<table border="0"> <tr><td>7/8"</td><td>13550</td></tr> <tr><td>1 1/2"</td><td>13550</td></tr> <tr><td>3 1/2"</td><td>13550</td></tr> </table>	7/8"	13550	1 1/2"	13550	3 1/2"	13550
7/8"	1060																																								
1 1/2"	1061																																								
3 1/2"	1062																																								
7/8"	1260A																																								
1 1/2"	1261B																																								
3 1/2"	1262A																																								
7/8"-1 1/2"	1860A																																								
1 1/2"-3/4"	1861																																								
3 1/2"-6 1/8"	1872																																								
7/8"	---																																								
1 1/2"	2061																																								
3 1/2"	2062																																								
7/8"	34389A																																								
1 1/2"	34660																																								
3 1/2"	15093A																																								
7/8"	13550																																								
1 1/2"	13550																																								
3 1/2"	13550																																								
RIGID HANGER	SLIDING HANGER	SPRING HANGERS	INSULATED SLIDING HANGERS	INSULATED SPRING HANGER	ANGLE ADAPTER																																				
																																									
<p>Mounts to 3/16" diameter hole with 1 1/2" bolt or angle adapter. Use at 300' intervals.</p>	<p>7/8" size use at 6' intervals. 1 1/2" use at 10 foot intervals.</p>	<p>7/8" size use at 100' intervals. 1 1/2" size use at 50' intervals. 3 1/2" size use at 10' intervals.</p>	<p>Same as Type 14378 except includes insulator, 14063.</p>	<p>Same as spring hangers except includes insulator, 14063.</p>	<p>Galvanized clamp for attaching hangers to tower angle members up to 7/8" thick.</p>																																				
<table border="0"> <tr><td>7/8"</td><td>14328</td></tr> <tr><td>1 1/2"</td><td>13924</td></tr> <tr><td>3 1/2"</td><td>13927</td></tr> </table>	7/8"	14328	1 1/2"	13924	3 1/2"	13927	<table border="0"> <tr><td>7/8"</td><td>14327</td></tr> <tr><td>1 1/2"</td><td>14378</td></tr> <tr><td>3 1/2"</td><td>—</td></tr> </table>	7/8"	14327	1 1/2"	14378	3 1/2"	—	<table border="0"> <tr><td>7/8"</td><td>13889</td></tr> <tr><td>1 1/2"</td><td>14379</td></tr> <tr><td>3 1/2"</td><td>13925</td></tr> </table>	7/8"	13889	1 1/2"	14379	3 1/2"	13925	<table border="0"> <tr><td>7/8"</td><td>---</td></tr> <tr><td>1 1/2"</td><td>14442</td></tr> <tr><td>3 1/2"</td><td>---</td></tr> </table>	7/8"	---	1 1/2"	14442	3 1/2"	---	<table border="0"> <tr><td>7/8"</td><td>---</td></tr> <tr><td>1 1/2"</td><td>14441</td></tr> <tr><td>3 1/2"</td><td>13926</td></tr> </table>	7/8"	---	1 1/2"	14441	3 1/2"	13926	<table border="0"> <tr><td>7/8"</td><td>13555A</td></tr> <tr><td>1 1/2"</td><td>13555A</td></tr> <tr><td>3 1/2"</td><td>13555A</td></tr> </table>	7/8"	13555A	1 1/2"	13555A	3 1/2"	13555A
7/8"	14328																																								
1 1/2"	13924																																								
3 1/2"	13927																																								
7/8"	14327																																								
1 1/2"	14378																																								
3 1/2"	—																																								
7/8"	13889																																								
1 1/2"	14379																																								
3 1/2"	13925																																								
7/8"	---																																								
1 1/2"	14442																																								
3 1/2"	---																																								
7/8"	---																																								
1 1/2"	14441																																								
3 1/2"	13926																																								
7/8"	13555A																																								
1 1/2"	13555A																																								
3 1/2"	13555A																																								

INNER CONNECTOR ADAPTER, 50-51 ohms—7/8" size, Type 4850A; 1 1/2", Type 4851; 3 1/2", Type 4852.

HARDWARE KIT for use on one pair of flanges—7/8" size, Type 11381-5; 1 1/2" size, Type 11381-2, 3 1/2" size, Type 11381-3.

"O RING GASKET, 7/8" size, Type 10683-1; 1 1/2" size, Type 10683-2; 3 1/2" size, Type 10683-3.

Coaxial Transmission Line Accessories

PRESSURIZATION EQUIPMENT

Automatic Dehydrators—Types 1920A and 1930 are heatless, fully automatic dehydrators capable of delivering continuous supplies of dry air. No down time is necessary to activate the dry agent. Both units will operate over an ambient range of 0° to 120°F with an input humidity of 95%.



TYPE:	1920A	1930
OUTPUT:	1.2 CFM @ 4 psig	.2 CFM
POWER:	120V, 60 Hz	120V, 60 Hz
INTERNAL OPERATING PRESSURE:	60 psig	30 psig
OUTLET DEWPOINT:	Below -37°F	Below -20°F
DIMENSIONS, INCHES:	15½ x 24 x 14¼	13¼ x 7¼ x 14¾

DRY AIR HAND PUMP

Type 878A, dry air hand pump, pressurizes up to 1000 feet of 7/8" cable or 250 feet of 1½" line. One pound of silica gel and seven feet of hose is supplied.

Please order by type number.....878A



NITROGEN TANK FITTINGS

Type 858C, nitrogen tank fittings — includes pressure regulator, high and low pressure gauges and 10 feet of 3/8" O.D. poly tubing and fittings to fit 1/8" MPT.

Please order by type number.....858C



COAXIAL SWITCHING EQUIPMENT

These 1½", 3½" and 6½" coaxial transfer switches are used wherever RF power must be rerouted quickly. Should power fail, these motor driven switches may be cycled manually. Power source is 120V, 50/60 Hz.

LINE SIZE, INCHES:	1½"	3½"	6½"
TYPE NUMBER:	6730D	6740A	6750
FREQUENCY BAND MHz:	0-1000	0-1000	0-750
CURRENT REQUIREMENT, AMPS:	0.3	2.0	3.0
POWER PEAK* kW:	100	400	1500
VSWR, MAXIMUM:	1.03-500 MHz	1.02-500 MHz	1.05 to 750 MHz
SWITCHING TIME, SECONDS:	1	2	2
DIMENSION, INCHES:	8 x 8 x 10	14 x 14 x 14	24 x 24 x 24
WEIGHT, POUNDS:	13	65	250

* At unity VSWR and 40°C (104°F) ambient temperature.

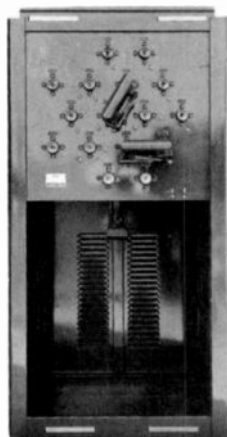

PATCH PANELS

A standard series of manual patch panels for 1½-inch and 3½-inch lines are offered in combinations up to 10 by 11. Typical specifications of the commonly used 1 by 2 and 2 by 2 are shown below.

TYPE NO.:	34600	34601	34602A	34603A
DESCRIPTION:	1 x 2	2 x 2	1 x 2	2 x 2
LINE SIZE:	1½"	1½"	3½"	3½"
VSWR:	-1.1 up to 1800 MHz		-1.05 up to 100C MHz	
SIZE, INCHES:	14" high x 19" wide x 14" deep			



Transmission Line Pressurization Systems

All air dielectric cable and rigid line should be pressurized with dry air or dry gas. Changes in temperature can cause moisture condensation from outside air and seriously impair the electrical efficiency of the line. For this reason, cable or rigid line should be under pressure at all times.

Pressurization can be accomplished by manual or automatic means, depending upon the amount of line in use at the station and whether or not the site is attended. Automatic electric dehydrators are recommended for unattended sites or those where larger amounts of cable or rigid line are employed. A dry air hand pump is usually satisfactory for attended sites using a relatively small amount of cable. A cylinder of dry nitrogen gas can also be used. All installations of air dielectric cable, line or microwave waveguide should be purged prior to putting the system in service and at any

time moist air enters the line. To purge the system, pressurize at the equipment end of the line (5-10 psig) with the Type 1920A automatic dehydrator, nitrogen gas cylinder, or Type 878 hand pump. Bleed the line using the gas port plug located at the antenna end of the line and allow the pressure to drop to zero.

Repeat this procedure three times to ensure that the moist air is replaced by dry air or dry gas.

When it is too difficult or inconvenient to bleed the air at the antenna end of the line, let the air escape at the transmitter or dehydrator end after pressurizing the line three times, allowing an hour each time for the air to mix.

Type 1920A dehydrator will automatically maintain from 3 to 8 psi while gas cylinder output pressure should be set between 2 and 10 psig.

Automatic Dehydrator System

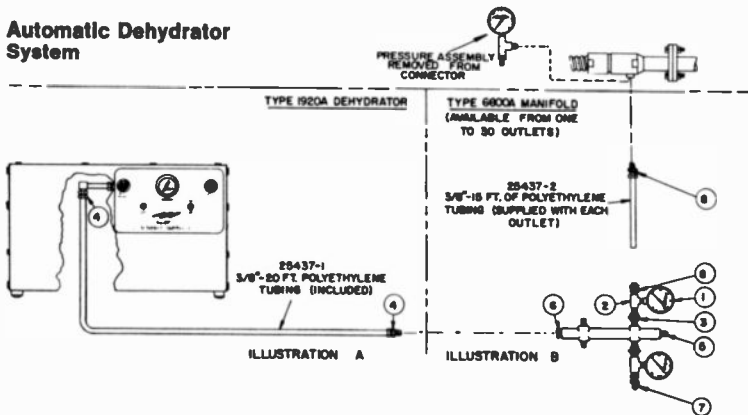

AUTOMATIC DEHYDRATOR SYSTEM

- 1) 3500 pressure gauge
- 2) 3028 tee (brass) 1/8 F.P.T. on all three
- 3) 4944 needle valve (40 P.S.I.) 1/8 male to 1/8 male
- 4) 25436-5 male fitting (brass) 3/8 tube to 1/8 M.P.T.
- 5) 9908-2 plug (brass) 1/4 M.P.T. Sq. Hd.
- 6) 4960 bushing (brass) 1/8 F.P.T. to 1/4 M.P.T.
- 7) 25436-1 cap (polyethylene) 3/8 O.D.
- 8) 25436-2 half union (brass) 3/8 tube to 1/8 M.P.T.

NOTE: For reference only. Parts listed are included with Types 1920A and 6600A.

Compressed Gas System

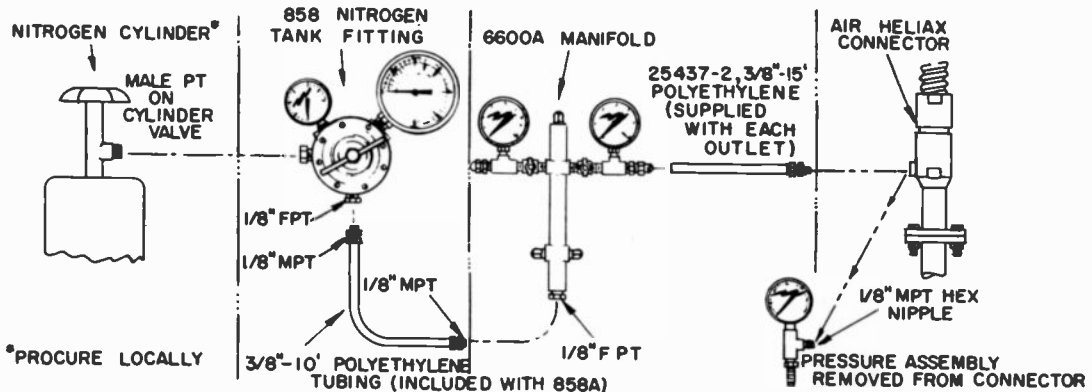

Manual System

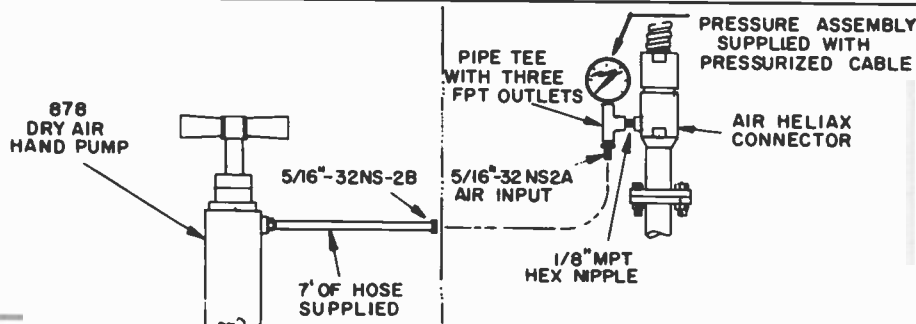

Open Wire Transmission Line

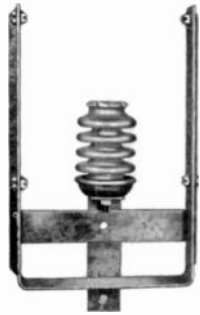

M-3327 Bracket.

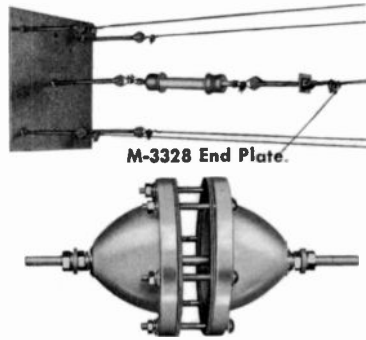

M-3328 End Plate.

M-2870D Feed-thru Bowl.



M-3322 Horn Gap.



M-3864 Center Post.

TRANSMISSION LINE BRACKET

For 5 or 6 wire transmission line. Rating up to 150 kW modulated. Made of 1/4" steel 3" wide with welded L section on each side to fully prevent twisting under ice or wind load. Supplied with 8 1/4" ribbed insulator, wire guides and all hardware. Galvanized throughout.

Line Bracket.....994-3327

LINE END PLATE

To terminate the open wire line at each end. Plate is 1/4" thick, 20" square. Fully galvanized. Includes turnbuckles, 25 1/2" strain insulator and all hardware. Rating up to 150 kW modulated.

End Plate.....994-3328

FEED-THRU BOWLS

A large feed-thru bowl with 50 kW modulated rating. Available in single and double units and with solid or hollow studs as listed below. Bowls are Alsimag. Hardware, heavy brass. Velutex seals are provided for weathertight installation.

Solid stud, 2 bowls, for walls to 10 1/2" thick.....994-2870

Same as above but hollow stud.....994-3254

Solid stud, single bowl, for walls 1" thick.....994-5280

Same as above but hollow stud.....994-5281

HORN GAP

A very desirable item where higher power is employed. Connects to hot side of line and ground to drain off lightning and heavy static discharges. Usually one is employed for each 200 feet of line. Insulator for 150 kW. Arc gaps heavy chrome plate. Galvanized throughout.

Horn Gap.....994-3322

CENTER POST ASSEMBLY

Has variety of uses such as end or corner angling of transmission line, support insulator for two wire line or rhombic antennas, and a guide insulator such as end of building or coupling unit. Rating 150 kW. Galvanized throughout.

Center Post Insulator.....994-3864

HARD DRAWN WIRE

If desired, when ordering transmission line components, Gates will gladly supply No. 6, 8 or 10 hard drawn copper wire at current market prices. State length in feet desired, remembering to multiply the length of line by the number of wires in line, either 5 or 6.

SPECIAL OPEN WIRE LINES

Gates engineers have designed many special open wire lines for both short and long distances. Most celebrated was a 30-mile line supplied for use in the Arctic Circle. Upon receipt of a sketch or word description of the requirements, Gates engineers will gladly submit layout and quotation.

DESIGN AND IMPEDANCE CHART

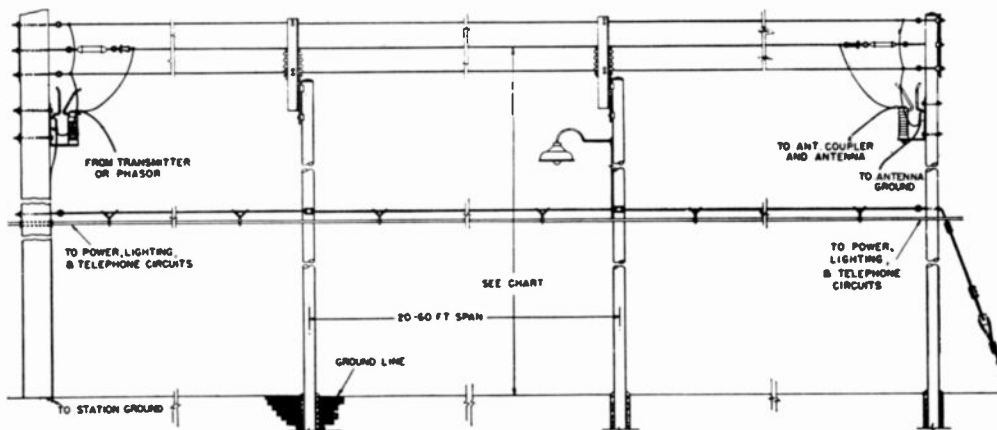

Chart above illustrates typical five or six wire open type transmission line. Table is provided to show impedances with various wire sizes at certain heights above ground. Transmission line brackets are M-3327, end plate M-3328. Horn gap is M-3322. The power, lighting and telephone circuits shown are optional, according to requirements of installation.

AVERAGE SURGE IMPEDANCE FOR 6 WIRE TRANSMISSION LINES

HEIGHT OF CENTER WIRE	WIRE SIZE		
	6	8	10
9'	232 Ω	246 Ω	250 Ω
10'	234 Ω	250 Ω	256 Ω
12'	240 Ω	252 Ω	260 Ω

AVERAGE SURGE IMPEDANCE FOR 5 WIRE TRANSMISSION LINES

HEIGHT OF CENTER WIRE	WIRE SIZE		
	6	8	10
9'	330 Ω	346 Ω	364 Ω
10'	333 Ω	350 Ω	365 Ω
12'	332 Ω	348 Ω	363 Ω

Antenna Towers

FOR AM, FM AND TV

Available in choice of design and exact height for your frequency and power.

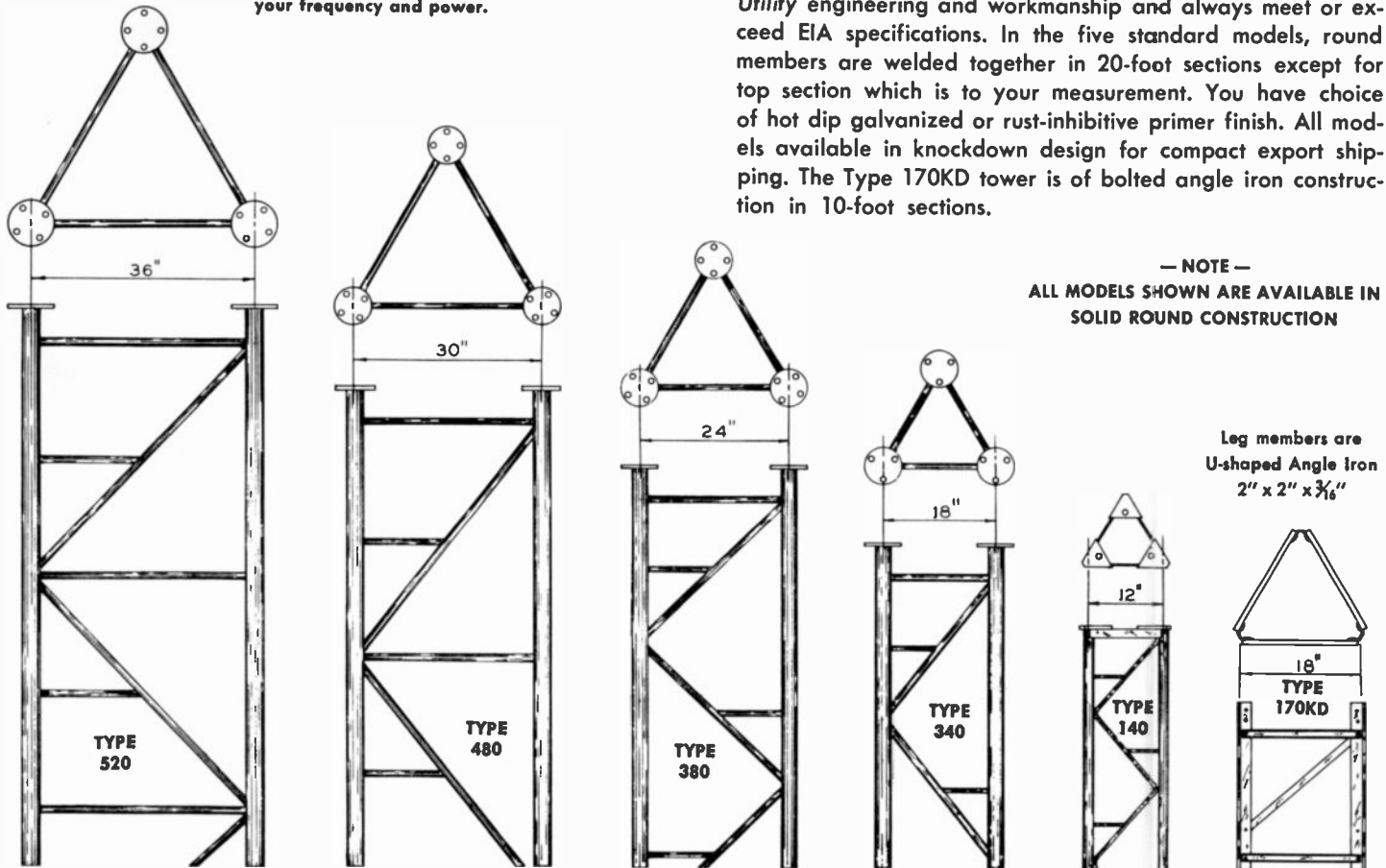

— NOTE —
ALL MODELS SHOWN ARE AVAILABLE IN SOLID ROUND CONSTRUCTION

Leg members are U-shaped Angle Iron 2" x 2" x 3/16"

RIGID ANCHOR BEAMS: Anchors are individually designed to meet the requirements of each tower installation. *Utility* uses the I-beam with its proven structural rigidity. When installed by *Utility* tower crews, on normal soil, this beam is imbedded in concrete slab reinforced with steel rods and with earth fill on top.

SOLID BASE INSULATORS: Insulated vertical radiators are equipped with the latest *Utility* 3401 or *Utility* 2201 pivot base insulators for positive insulation between base and ground. *Utility* base insulators have much higher compression rating than hollow insulators of similar size. They are resilient and shatter-proof. Each insulator is proof tested for a load approximately eight times greater than ever carried in normal broadcast service.

GALVANIZED HARDWARE: All *Utility* tower hardware is hot dipped galvanized to prevent rust and corrosion.

EASY MAINTENANCE: Round members and welded construction provide smooth surfaces for easy painting and servicing. Steps are built into bracing to eliminate need for scaffolding and to make entire height of tower easy for maintenance men to reach.

SPECIFICATIONS

TOWER TYPE	MAXIMUM RECOMMENDED HEIGHT	TOWER WIDTH	WEIGHT PER FOOT*	TYPE OF BASE INSULATION
520	500 FT.	36 IN.	31 LBS.	LOCKE OR LAPP
480	480 FT.	30 IN.	28 LBS.	LOCKE OR LAPP
380	400 FT.	24 IN.	19 LBS.	UTILITY 3401
340	350 FT.	18 IN.	17 LBS.	UTILITY 3401
140	200 FT.	12 IN.	12 LBS.	UTILITY 2201
170KD	320 FT.	18 IN.	17 LBS.	UTILITY 3401

*Tower steel only—Weight of guys, insulators, etc., not included.

ORDERING INFORMATION

Specify: Type of tower; tower height; insulated or non-insulated; galvanized or non-galvanized. Self-supporting, tall TV towers, or towers over 520' will be quoted upon request. Installation services for towers, FM, TV antennas, transmission line, AC lighting and ground systems also available on request.

Tower Lights And Accessories

BEACON FLASHERS

NON-FUS.	FUSED	DESCRIPTION	NO. OF SWITCHES	MAX. RATING WATTS/SWITCH	HOUSING TYPE	TAPS or K.O.	WEIGHT SHIP	(LBS.) NET
BF 60A-1 BF 60A-2 BF 60A-3	BF 60F-1 BF 60F-2 BF 60F-3	Single Pole, Single Throw 117 Volt, 60 Hz	ONE	2800	OUTDOOR INDOOR PANEL	¾"	12 11 4½	11 10 3
BF 61A-1 BF 61A-2 BF 61A-3	BF 61F-1 BF 61F-2 BF 61F-3	Single Pole, Double Throw (for Load Balance Resistor) 117 Volt, 60 Hz	ONE	1500	OUTDOOR INDOOR PANEL	¾"	12 11 4½	11 10 3
BF 62A-1 BF 62A-2 BF 62A-3	BF 62F-1 BF 62F-2 BF 62F-3	Single Pole, Single Throw 240 Volt, 60 Hz	ONE	2800	OUTDOOR INDOOR PANEL	¾"	12 11 4½	11 10 3
BF 63A-1 BF 63A-2 BF 63A-3	BF 63F-1 BF 63F-2 BF 63F-3	Double Pole, Single Throw 117 Volt, 60 Hz, or 120/240 Volt, 60 Hz	TWO	2800	OUTDOOR INDOOR PANEL	1"	13 11 5	12 10 3½
BF 64A-1 BF 64A-2 BF 64A-3	BF 64F-1 BF 64F-2 BF 64F-3	Two Circuit 117 Volt, 60 Hz, or 120/240 Volt, 60 Hz	TWO	2800	OUTDOOR INDOOR PANEL	1"	13 11 5	12 10 3½
BF 65A-1 BF 65A-2 BF 65A-3	BF 65F-1 BF 65F-2 BF 65F-3	Single Pole, Single Throw 240 Volt, 50 Hz	ONE	2800	OUTDOOR INDOOR PANEL	¾"	13 11 5	12 10 3½
BF 66A-1 BF 66A-2 BF 66A-3	BF 66F-1 BF 66F-2 BF 66F-3	Single Pole, Single Throw 117 Volt, 60 Hz with BY-PASS	ONE	1500	OUTDOOR INDOOR PANEL	¾"	28 23 9	23 18 6
BF 67A-1 BF 67A-2 BF 67A-3	BF 67F-1 BF 67F-2 BF 67F-3	Single Pole, Double Throw 117 Volt, 60 Hz with BY-PASS (for Load Balance Resistor)	ONE	1500	OUTDOOR INDOOR PANEL	¾"	28 23 9	23 18 6
BF 68A-1 BF 68A-2 BF 68A-3	BF 68F-1 BF 68F-2 BF 68F-3	Two Circuit, Double Pole 120/240 Volt, 60 Hz	FOUR	2800	OUTDOOR INDOOR PANEL	1¼"	36 25 10	29 21 7
BF 69A-1 BF 69A-2 BF 69A-3	BF 69F-1 BF 69F-2 BF 69F-3	Three Circuit 120/240 Volt, 60 Hz or 120/208 Volt, 3 PH.	THREE	2800	OUTDOOR INDOOR PANEL	1¼"	35 24 10	28 20 7
BF 70A-1 BF 70A-2 BF 70A-3	BF 70F-1 BF 70F-2 BF 70F-3	Four Circuit 120/240 Volt, 60 Hz or 120/208 Volt, 3 PH.	FOUR	2800	OUTDOOR INDOOR PANEL	1¼"	36 25 10	29 21 7

ACCESSORIES

TOWER LIGHTS: Single obstruction light, bottom entrance conduit fitting furnished with lamp receptacle to accommodate either a 100 or 111 watt, 115 V medium screw base lamp, or lumen pre-focus series lamp.

Single obstruction light.....710-0012

Single obstruction light, same as above, but side entrance conduit fitting. Order.....710-0013

Double obstruction light, with two lamp receptacles, each accommodating either 100 or 111 watts, medium screw base. Bottom entrance fitting type for one-inch conduit.

Double obstruction light.....710-0014

Clear traffic signal lamp. 107 watt, 115 V.

Signal lamp 107A21/TS.....396-0141

Code Beacon 300 MM, standard fully approved FCC and CAA model supplied with two red filters.

For 1" conduit, 3-wire Grn Ground.....710-0063

For 1" conduit, 4-wire Grn Ground.....710-0075

Beacon lamp, 620 watt 620P540.....396-0129

PHOTO-CELL UNIT: Single unit, indoor housing, lighting control unit with outdoor remote weather photo tube, includes complete code flasher for flashing of three towers and photo-electric cell control for automatic turning on and off. 115/230 V, 50/60 Hz.

Photo-cell unit.....LC-2077

Single unit, indoor housing, same as above, except for 4 towers...LC-2076

PHOTO-CELL AND BEACON FLASHER: A combination unit in weatherproof housing. Photo-cell may be rotated to north regardless of mounting position on tower. Turns on at 35 foot candles and off at 58 foot candles.

For 1 pole 30 amperes, flashes one circuit.....710-0058

FISHER-PIERCE PHOTO-CELL UNIT: A unit completely weatherproof, fully approved for turning on and off tower lights; has time delay of 5-7 seconds to prevent operation by chance.

For 105/130 V, 3000 watt rating, SPST, double break.....670-0007

Heavy Duty Inductors and Capacitors

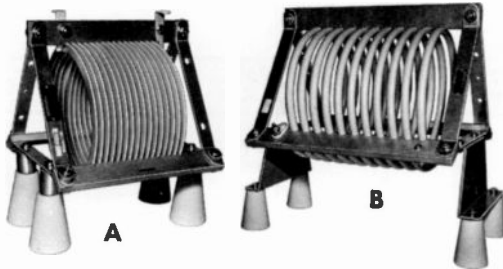

Gates manufactured inductors put the emphasis on solid mechanical construction. Variable coils have double gripping contact wheels. Other sizes and ratings available on special order.

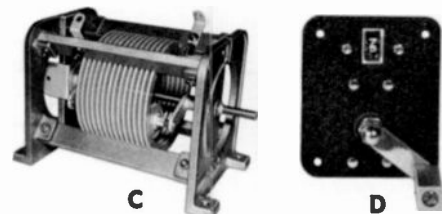

87	F	A	46	3	4	
Inductance in microhenries.	F—Fixed V—Variable	A— $\frac{1}{4}$ " B— $\frac{3}{8}$ " C— $\frac{1}{2}$ "	No letter here indicates ribbon. "T" indicates tubing.	Number of turns.	Pitch of winding in $\frac{1}{8}$ " for ribbon, $\frac{1}{4}$ " for tubing.	Inside diameter in inches.

SPECIFICATIONS AND ORDERING INFORMATION

ORDER NO.	TYPE NO.	FIG.	OVER-ALL LENGTH IN INCHES	ORDER NO.	TYPE NO.	FIG.	OVER-ALL LENGTH IN INCHES
931-6138-010	87FA4634	A	12	931-6337-003	32FBT1658	B	15
931-6138-039	6FC0854	A	6 $\frac{1}{4}$	931-6337-004	45FBT2158	B	18 $\frac{1}{2}$
931-6138-040	10FC0855	A	6 $\frac{1}{4}$	931-6372-002	65FBT2559	B	24 $\frac{1}{2}$
931-6138-041	13FC0856	A	6 $\frac{1}{4}$	931-6337-001	17FCT1178	B	14
931-6138-025	17FC1654	A	8 $\frac{1}{4}$	931-6372-001	35FCT1769	B	24 $\frac{1}{2}$
931-6138-026	24FC1655	A	8 $\frac{1}{4}$	931-6583-008	6VC0854	C	8
931-6138-027	32FC1656	A	8 $\frac{1}{4}$	931-6583-001	15VC1444	C	9
931-6138-036	42FC2266	A	12 $\frac{1}{2}$	931-6583-002	26VC2144	C	10 $\frac{1}{2}$
931-6138-030	67FC2856	A	13	931-6583-003	42VC2145	C	10 $\frac{1}{2}$
931-6337-007	10FBT1066	B	12 $\frac{1}{2}$	931-6583-004	62VC2845	C	12 $\frac{1}{2}$
931-6337-002	20FBT1656	B	15				

Coil clip for FA coils.....	402-0029
Coil clip for FC coils.....	402-0031
Coil clip for FBT coils.....	402-0033
Coil clip for FCT coils.....	402-0034

Counter dial for variable coils reads 1/10 turns. Size: 3" wide, 3 $\frac{1}{2}$ " high. Figure D. With removable crank handle.....	994-6233-001
With non-removable crank handle.....	926-5509-003



MICA CAPACITORS FOR TRANSMITTERS AND PHASORS

Designed for continuous service with each sheet of mica carefully gauged for thickness and inspected for absence of impurities. Tolerance plus or minus 5%. Cast end bells and ceramic insulated. Sizes over-all: Model G1: 3 $\frac{3}{4}$ " x 2 $\frac{1}{2}$ ". Model G2: 4 $\frac{1}{4}$ " x 3". Model G3: 6 $\frac{1}{2}$ " x 4". Model G4: 6 $\frac{1}{2}$ " x 5 $\frac{1}{4}$ ". Usually all sizes carried in stock. Please order by type number and capacity. Example: Model G2, capacity .0003 mfd. Other sizes and ratings available on special order.

CAPACITY mfd.	MODEL G1		MODEL G2		MODEL G3		MODEL G4	
	Amps	Volts	Amps	Volts	Amps	Volts	Amps	Volts
.0002	3	6000	4.3	10,000	5.6	20,000		
.00025			5.1	10,000			8.2	30,000
.0003			5.6	10,000	6.8	20,000	9.1	30,000
.0004	4.7	6000	6.2	10,000	8.2	20,000		
.0005	5.1	6000	6.8	10,000	9	20,000	12	30,000
.0008					12	20,000	15	30,000
.001	7.5	6000	10	10,000	13	20,000	16	30,000
.0015	9.1	6000	12	10,000	16	15,000	20	25,000
.002	11	6000	13	10,000	20	15,000	22	20,000
.003	13	6000	16	8,000	24	12,000	27	20,000
.004	15	6000	18	8,000	27	12,000	30	20,000
.005	16	4000	20	6,000	30	10,000	33	15,000
.006	18	4000	22	5,000	33	10,000	36	15,000
.008					36	10,000	39	12,000
.01	20	4000	24	5,000	39	8,000	43	10,000
.02					47	5,000		

**VHF AND UHF
TELEVISION
TRANSMITTERS
AND
ACCESSORIES**

**HARRIS
INTERTYPE
CORPORATION**

GATES®
A DIVISION OF HARRIS-INTERTYPE

35,000 Watt VHF Color Television Transmitters

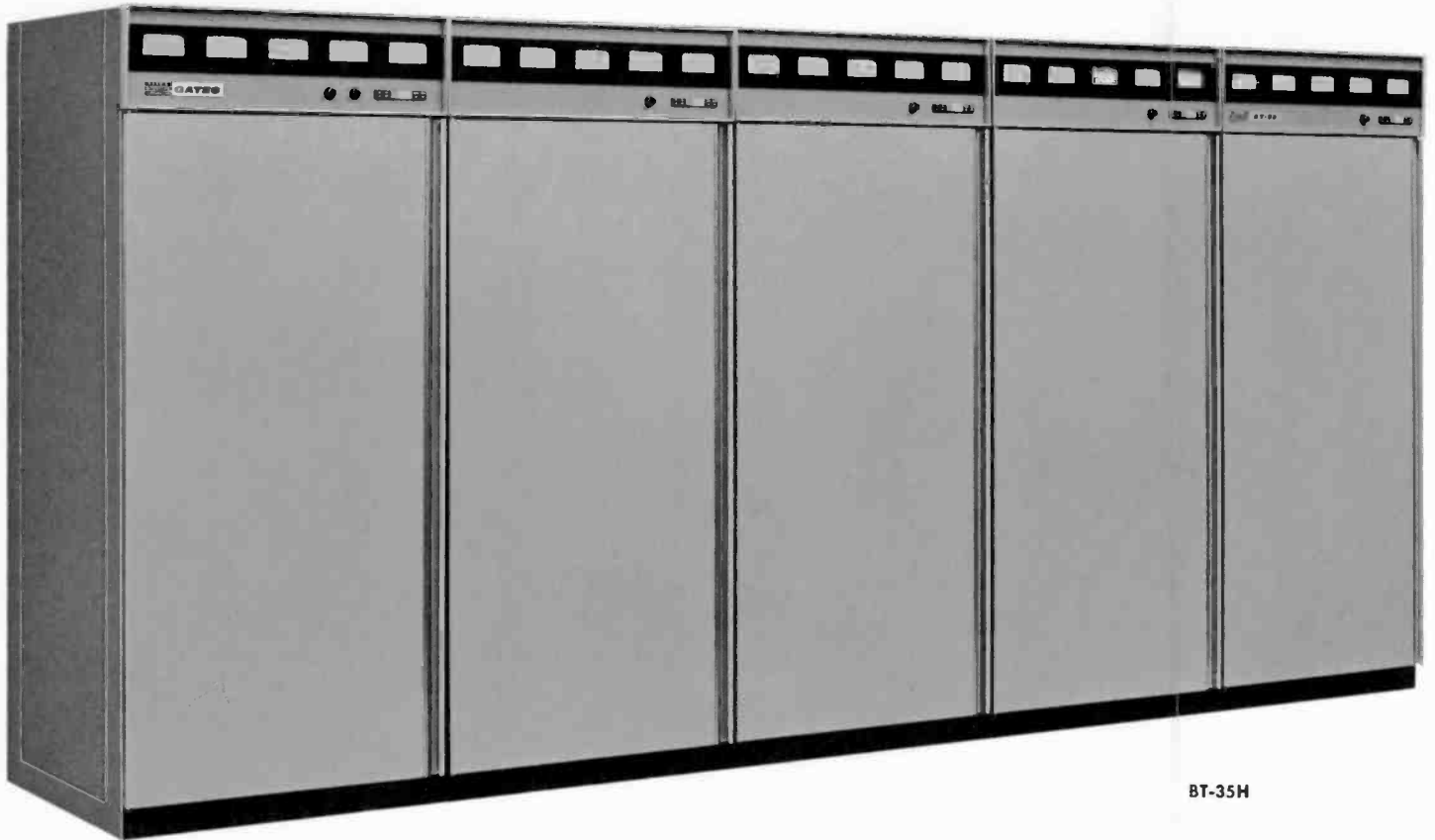

BT-35H

MODEL BT-35L LOW BAND

MODEL BT-35H HIGH BAND

With the introduction of its advanced line of color VHF television transmitters, featuring IF MODULATION, Gates made available to the broadcasting industry the first VHF equipment specifically developed and designed for color telecasting. The FCC type accepted BT-35H is the 35 kW high band model in this outstanding line. The 35 kW low band model is the BT-35L.

These 35 kW transmitters set new standards of excellence for color transmission through the achievement of four design objectives. These are: IF MODULATION, low-level vestigial side-band filtering, true linear operation of power amplifiers, and solid state visual and aural exciters.

IF MODULATION: Low-level IF MODULATION is a system wherein the picture and sound signals are processed, modulated and corrected at very low power levels (milliwatts) for proper transmission to the antenna. These signals are then increased in power through the use of extremely linear power amplifier tubes to the 35 kW power level.

Because it occurs at much lower power levels, intermediate frequency modulation needs fewer circuits in order to produce a fully processed, quality picture signal. Gates' system takes less than 1.0 volt of video signal to modulate the RF carrier, where other recent designs need as much as 200 volts for carrier modulation.

The simplicity of IF MODULATION results in nearly perfect signal linearity. Thus, predistortion circuitry which degrades color fidelity is practically eliminated.

The ring-modulator used in the BT-35 (and all Gates' VHF transmitters) allows modulation percentages to approximately 2%. This exceptional color performance, even with such colors as highly saturated yellow and cyan, is the result of excellent linearity and depth of modulation.

In addition, equalization of envelope delay occurs at the IF carrier frequency. This delay function is not fixed but continuously variable.

35,000 Watt VHF Color Television Transmitters

LOW-LEVEL VESTIGIAL SIDEBAND FILTERING: Another advantage of IF MODULATION is that in this system visual sidebands are shaped at the IF frequency, rather than "on frequency" at the full output power of the transmitter. This completely eliminates the need for a conventional bulky sideband filter which can cause a power loss, can sometimes arc over, and takes up valuable space in the transmitter building. The sideband filter used by Gates is a removable module housed in the visual exciter.

VISUAL AND AURAL EXCITERS: Picture and sound modulation take place in the independent solid-state visual and aural exciters. Both exciters produce fully processed carriers "on channel", leaving the stages which follow exclusively for power amplification. One knob on each exciter controls the visual or aural power of the transmitter without retuning of any kind.

In the visual and aural exciters, the carriers are generated by a system of three different signal frequencies. One is a reference signal whose frequency is determined by that of the assigned TV channel. It is combined with two fixed frequencies. The video information is amplitude modulated on an IF carrier and the audio is frequency modulated on a carrier spaced 4.5 MHz from the visual IF carrier. Mixing or up-converting the visual and aural signals with the reference signal results in the proper "on channel" frequency.

LONG-TERM STABILITY: The use of conservatively rated Type 8806 and 8807 ceramic tetrodes as VHF linear amplifiers, operating in a grounded grid and grounded screen configuration, provides true linearity and maximum stability and reliability.

CONTROL LOGIC AND PROTECTIVE CIRCUITRY: In the BT-35, each cabinet has its own independent control logic. Complete and fool-proof control of all transmitter functions is achieved through the use of solid-state memory, timing and logic circuits. An emergency battery supply is provided to maintain control logic memory during periods of power line failure.

REMOTE CONTROL: All transmitter control and monitoring circuits are designed for remote control and automatic logging. The power controls are motor driven and the necessary remote control sampling points are built in on accessible terminal boards.

POWER SUPPLY: The high-voltage power supply, including the transformer, is one externally-mounted assembly. The power supply circuit consists of two 3-phase full-wave 3500 volt rectifying systems in series, each system being driven by a separate secondary. Both systems combined have a total of twelve conduction periods in which the peaks of one system coincide with the troughs of the other. This 12-phase rectification has a very low ripple content of approximately 42 dB below the DC output before filtering takes place.

MODULAR TRANSMITTER DESIGN: Gates' BT-35 consists of five cabinets: (1) a complete 1.3 kilowatt transmitter (BT-1300) which serves as a driver for high power RF amplifiers (this is the basic unit for all Gates' higher powered VHF transmitters); (2) an aural power amplifier; (3) a visual driver; (4 & 5) two 18 kilowatt visual power amplifiers connected to an antenna through a combining network.

The building-block concept in Gates' line of VHF transmitters permits parallel operation for high power in the most economical and reliable manner possible.

EASE OF MAINTENANCE: The entire BT-35 is easily accessible from the front and back. Both visual and aural exciters slide out and can operate independently from the other transmitter stages outside the main cabinet. The various exciter circuits such as reference oscillator, visual oscillator, aural oscillator and modulator are of modular construction and can be removed for maintenance.

Tubes in the driver, and the visual and aural amplifiers can be removed by one man from the front of the transmitter.

Easy-to-read 4-inch meters are used in the meter panel located at the top of each cabinet. All meter panels are hinged for easy access.

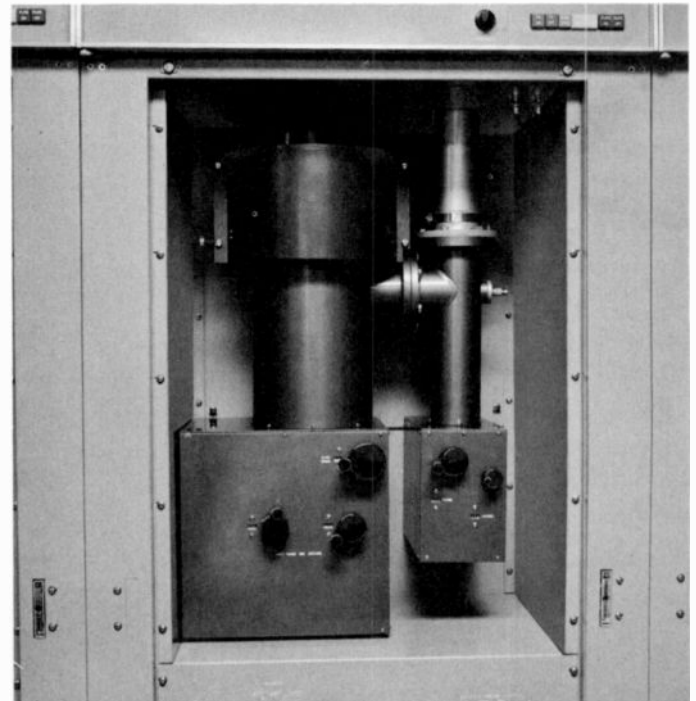

BT-35H 35 kW high band transmitter high-power cavity assembly with visual output coupler. Complete tuning controls are readily accessible from the front of the transmitter.

35,000 Watt VHF Color Television Transmitters

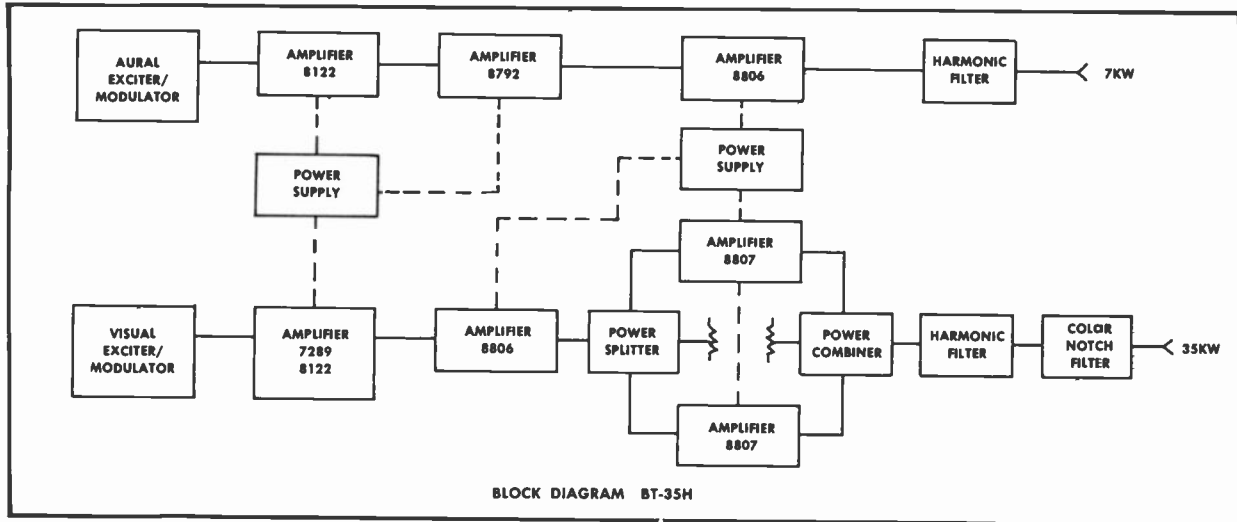

SPECIFICATIONS (CCIR specifications available)

VISUAL PERFORMANCE

- POWER OUTPUT:** 35 kW peak (FCC and CCIR "B").
- OUTPUT IMPEDANCE:** 50 ohms. Output connector: 3/8" EIA standard.
- FREQUENCY RANGE:** (BT-35L) 48 to 88 MHz (Channels 2 to 6). (BT-35H) 174 to 230 MHz (Channels 7 to 13).
- CARRIER STABILITY:** ± 250 Hz (maximum variation over 30 days).
- REGULATION OF RF OUTPUT POWER (Black to white picture):** Less than 3%.
- VARIATION OF OUTPUT:** Over one frame: less than 2%.
- VISUAL SIDEBAND RESPONSE:**
- | | | |
|----------------------|-------|-------------------|
| +4.75 MHz and higher | ----- | -20 dB or better. |
| Carrier to +4.18 MHz | ----- | +0.5, -1 dB. |
| Carrier | ----- | 0 dB reference. |
| Carrier to -0.5 MHz | ----- | +0.5, -1 dB. |
| -1.25 MHz and lower | ----- | -20 dB or better. |
| -3.58 MHz | ----- | -42 dB or better. |
- FREQUENCY RESPONSE VS. BRIGHTNESS:** ± 0.75 dB (measured at 65% and 15% of modulation. Reference 100% = peak of sync).
- VISUAL MODULATION CAPABILITY:** 3% or better.
- DIFFERENTIAL GAIN:** 0.5 dB or better (maximum variation of sub-carrier amplitude from 75% to 10% of modulation. Sub-carrier modulation percentage: 10% peak to peak.)
- LINEARITY (LOW FREQUENCY):** 0.5 dB or better.
- DIFFERENTIAL PHASE:** $\pm 3^\circ$ or better (maximum variation of sub-carrier phase with respect to burst for modulation percentage from 75% to 10%. Sub-carrier modulation percentage: 10% peak to peak.)
- SIGNAL-TO-NOISE RATIO:** -50 dB or better (RMS) below sync level.
- K FACTORS:** 2: 2%, 20: 3%.
- ENVELOPE DELAY:**
- | | | | |
|-----------------|-------------|---|----------------------------------|
| .05 to 2.1 MHz: | ± 70 ns | } | Reference to standard curve—FCC. |
| at 3.58 MHz: | ± 35 ns | | |
| at 4.18 MHz: | ± 70 ns | | |

- VIDEO INPUT:** Bridging, loop through input with -30 dB or better return loss up to 5.5 MHz, 75 ohm system.
- HARMONIC RADIATION:** -80 dB.

AURAL PERFORMANCE

- POWER OUTPUT:** 9 kW at diplexer output.
- AUDIO INPUT:** +10 dBm, ± 2 dB into 600 ohms.
- INPUT IMPEDANCE:** 600/150 ohms.
- PRE-EMPHASIS:** 75 microseconds.
- FREQUENCY RESPONSE:** ± 0.5 dB relative to pre-emphasis (30-15,000 Hz).
- DISTORTION:** 0.5% or less after 75 microseconds de-emphasis with ± 25 kHz deviation. 0.7% after 50 microseconds de-emphasis with ± 50 kHz deviation.
- FM NOISE:** -60 dB relative to ± 25 kHz deviation.
- AM NOISE:** -52 dB relative to 100% modulation (measured after de-emphasis).
- OUTPUT IMPEDANCE:** 50 ohms, output connector 3/8" EIA standard.
- FREQUENCY STABILITY:** ± 250 Hz (maximum variation over 30 days).

SERVICE CONDITIONS

- AMBIENT TEMPERATURE:** -18° to +50°C. (0° to 122°F.).
- AMBIENT HUMIDITY RANGE:** 0 to 100% relative humidity.
- ALTITUDE:** Sea level to 7500 feet.
- PHYSICAL AND MECHANICAL DIMENSIONS:** Size: 157 1/2" wide x 31 1/2" deep x 72" high. (Power supply: 43" wide x 42" deep x 34" high.) Weight: 4515 lbs. (approximate). (Power supply: 1950 lbs. approximate.)
- ELECTRICAL REQUIREMENTS:** 440/460/480 volts, 3 phase, 60 Hz. (380 volts, 50 Hz available.)

ORDERING INFORMATION

- BT-35L 35 kW VHF-TV transmitter (for Channels 2 to 6) with operating tubes, transistors, IC's, solid-state rectifiers, crystals, required pre-correction circuitry, low-level vestigial sideband filter, harmonic and color notch filters.....994-6697-001
- BT-35H 35 kW VHF-TV transmitter (for Channels 7 to 13) with all of above included.....994-6657-001

25,000 Watt VHF Color Television Transmitters

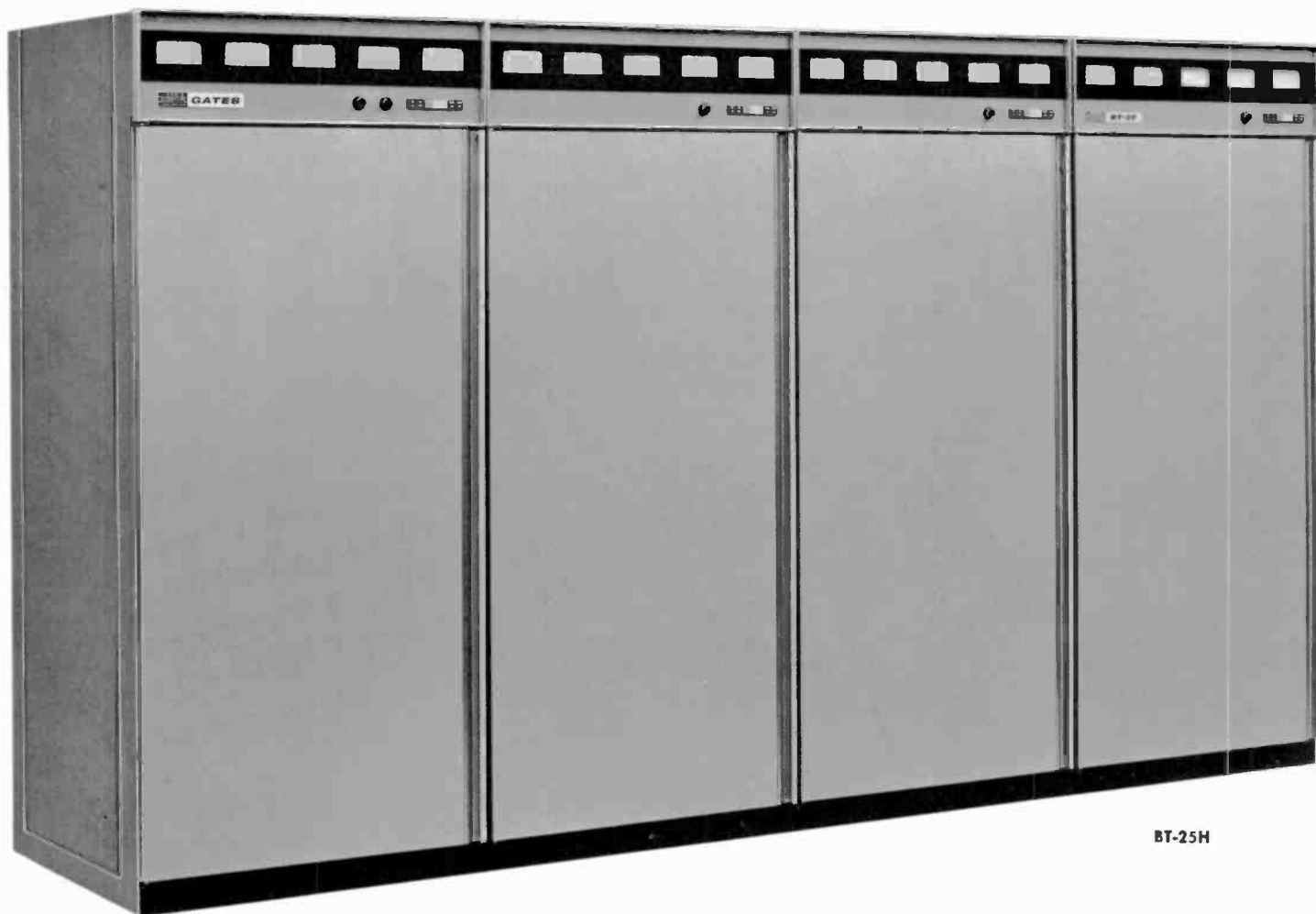

BT-25H

MODEL BT-25L LOW BAND

MODEL BT-25H HIGH BAND

Featuring IF MODULATION for superb color transmission, the BT-25L and BT-25H are the FCC type accepted 25 kilowatt models in Gates' advance-design lineup of VHF color television transmitters. The BT-25L is for operation on Channels 2 to 6, the BT-25H for Channels 7 to 13.

IF MODULATION of the visual carrier, low-level sideband filtering, true linear operation of power amplifiers and solid-state visual and aural exciters combine to set new standards of color performance for VHF transmitters. Operating specifications far exceed anything possible with conventional transmitters, even those using solid-state exciters.

In these 25 kW transmitters, as in Gates' entire VHF line, there are no excessive video envelope delay or phase matching networks to burden the generation and transmission of the color signal. Transmitter operation is simple and reliable.

Frequency adjustment, power output control and amplifier tuning are straightforward.

IF MODULATION: The outstanding feature of Gates' television transmitters, including the BT-25, is the low-level IF MODULATION design. For color transmission IF MODULATION excels in electrical performance, reliability and simplicity of operation.

Occurring at much lower power levels than conventional designs, intermediate frequency modulation needs fewer circuits to produce a fully processed, quality picture signal. Less than one volt of video signal is needed to modulate the RF carrier, as compared to the several hundred volts required by other recent designs.

Due to the low-level techniques, which include the use of devices such as an extremely linear broadband diode ring

25,000 Watt VHF Color Television Transmitters

modulator, active delay compensation, low-level sideband filtering and very linear broadband amplifiers, the broadcast signal is a faithful reproduction of the signal applied to the transmitter input. IF MODULATION results in the elimination of many transmission problems at their source, rather than using half-way measures to eliminate the effects of these problems later on.

LOW-LEVEL VESTIGIAL SIDEBAND FILTERING: Visual sidebands are shaped at the IF frequency, rather than "on frequency" at the full output power of the transmitter. Thus, there is no need for a bulky, conventional sideband filter, which can cause a power loss and takes up valuable space in the transmitter building. The sideband filter employed in the BT-25 is a removable module housed in the visual exciter.

VISUAL AND AURAL EXCITERS: Solid-state, self-contained visual and aural exciters furnish fully processed 1.0-watt visual and 10-watt aural signals. The output of these exciters is a complete TV signal ready for further amplification and "on channel" transmission for any specified channel.

A single knob on each exciter will set the level of transmitter power without any retuning. A similar procedure is used for adjusting the carrier frequency. The frequency of the master oscillator (located in the visual exciter) can be varied ± 500 Hz by means of a front panel control. With one knob the station engineer can make precise frequency adjustments to both the visual and aural carriers.

A switch mounted on the visual exciter panel permits readings of all parameters. A separate meter on the aural exciter permits monitoring of aural parameters.

CONTROL LOGIC AND PROTECTIVE CIRCUITRY: Solid-state memory, timing and logic circuits are employed for complete, fool-proof control of all transmitter functions. Each transmitter cabinet has its own independent control logic.

STABILITY: One factor insuring RF stability is the use of conservatively rated Type 8806 ceramic tetrodes operating as VHF linear amplifiers. These amplifier stages operate in a grounded grid and grounded screen configuration and tube neutralization is not required.

REMOTE CONTROL: Control circuit functions, metering and monitoring have all been designed specifically for remote control operation.

POWER SUPPLY: The unitized high-voltage power supply (including the transformer) is housed in a single assembly, mounted externally from the transmitter. Routine maintenance access is provided by a removable panel.

EASE OF MAINTENANCE: The BT-25 provides for quick accessibility to all components. Visual and aural exciters slide out, and various exciter circuits such as reference oscillator, visual oscillator, aural oscillator and modulator are modular in design for easy removal for maintenance.

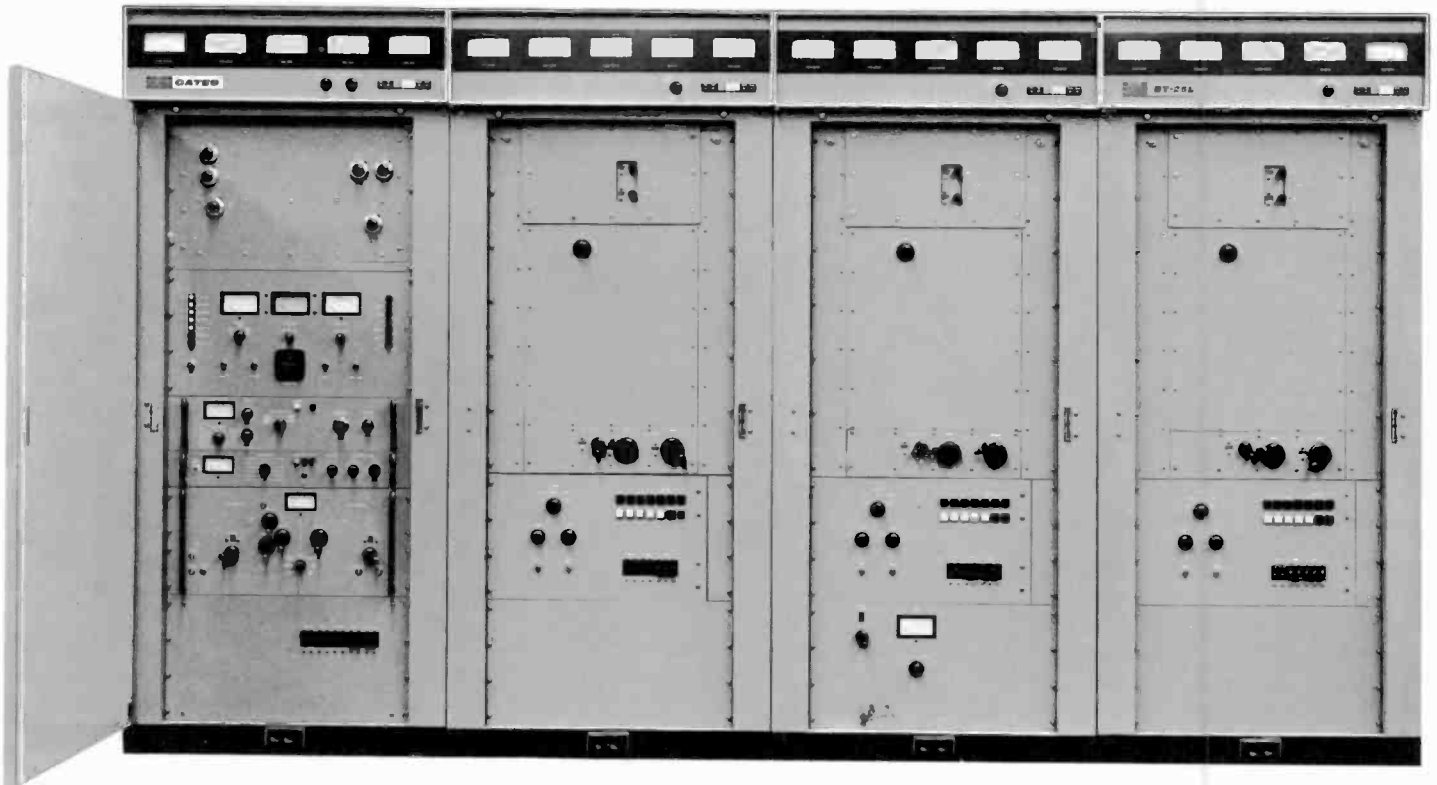

BT-25L 25 kW low band transmitter cabinet lineup, from left to right, includes: 1300-watt exciter/driver, aural power amplifier, and paralleled visual power amplifiers.

25,000 Watt VHF Color Television Transmitters

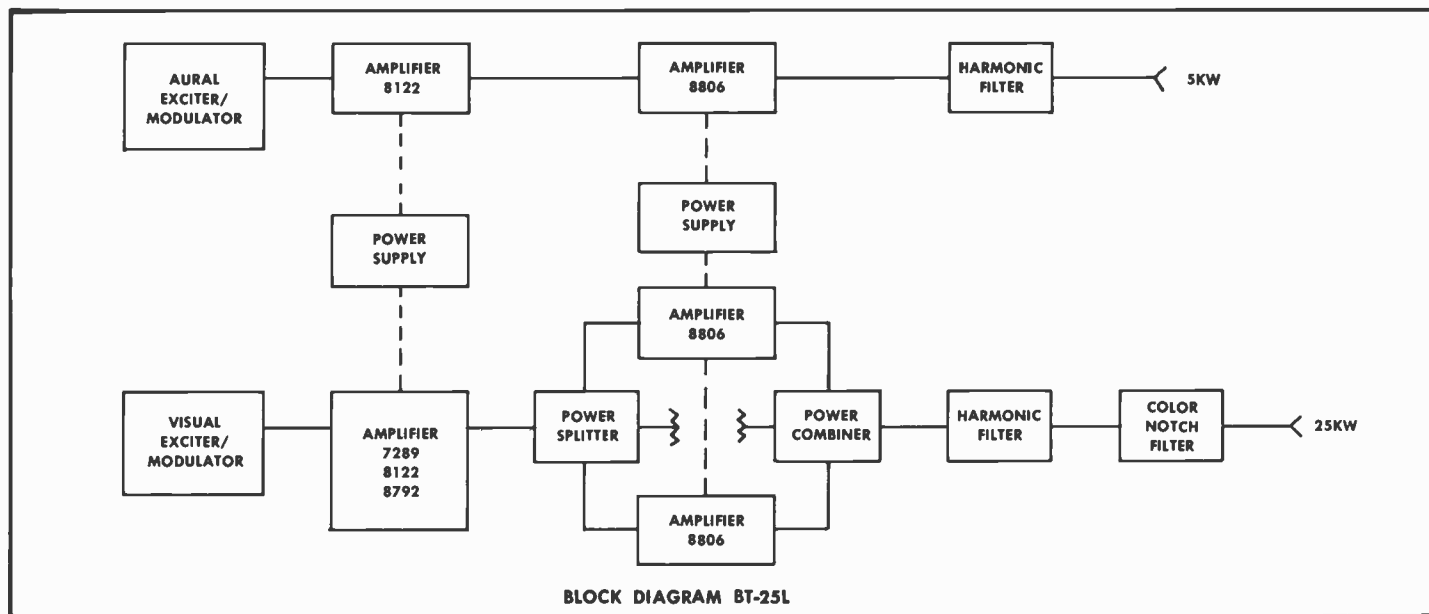

BLOCK DIAGRAM BT-25L

SPECIFICATIONS

(CCIR specifications available.)

VISUAL PERFORMANCE

POWER OUTPUT: 25 kW peak (FCC). 20 kW peak (CCIR "B").

OUTPUT IMPEDANCE: 50 ohms. Output connector: 3/8" EIA standard.

FREQUENCY RANGE: (BT-25L) 48 to 88 MHz (Channels 2 to 6). (BT-25H) 174 to 230 MHz (Channels 7 to 13).

CARRIER STABILITY: ± 250 Hz (maximum variation over 30 days).

REGULATION OF RF OUTPUT POWER (Black to white picture): Less than 3%.

VARIATION OF OUTPUT: Over one frame: less than 2%.

VISUAL SIDEBAND RESPONSE:

+4.75 MHz and higher	-----	-20 dB or better.
Carrier to +4.18 MHz	-----	+0.5, -1 dB.
Carrier	-----	0 dB reference.
Carrier to -0.5 MHz	-----	+0.5, -1 dB.
-1.25 MHz and lower	-----	-20 dB or better.
-3.58 MHz	-----	-42 dB or better.

FREQUENCY RESPONSE VS. BRIGHTNESS: ± 0.75 dB (measured at 65% and 15% of modulation. Reference 100% = peak of sync).

VISUAL MODULATION CAPABILITY: 3% or better.

DIFFERENTIAL GAIN: 0.5 dB or better (maximum variation of sub-carrier amplitude from 75% to 10% of modulation. Sub-carrier modulation percentage: 10% peak to peak).

LINEARITY (LOW FREQUENCY): 0.5 dB or better.

DIFFERENTIAL PHASE: $\pm 3^\circ$ or better (maximum variation of sub-carrier phase with respect to burst for modulation percentage from 75% to 10%. Sub-carrier modulation percentage: 10% peak to peak).

SIGNAL-TO-NOISE RATIO: -50 dB or better (RMS) below sync level.

K FACTORS: 2t 2%, 20t 3%.

ENVELOPE DELAY:

.05 to 2.1 MHz:	± 70 ns	} Reference to standard curve—FCC.
at 3.58 MHz:	± 35 ns	
at 4.18 MHz:	± 70 ns	

VIDEO INPUT: Bridging, loop through input with -30 dB or better return loss up to 5.5 MHz, 75 ohm system.

HARMONIC RADIATION: -80 dB.

AURAL PERFORMANCE

POWER OUTPUT: 5 kW at diplexer output.

AUDIO INPUT: +10 dBm, ± 2 dB into 600 ohms.

INPUT IMPEDANCE: 600/150 ohms.

PRE-EMPHASIS: 75 microseconds.

FREQUENCY RESPONSE: ± 0.5 dB relative to pre-emphasis (30-15,000 Hz).

DISTORTION: 0.5% or less after 75 microseconds de-emphasis with ± 25 kHz deviation. 0.7% after 50 microseconds de-emphasis with ± 50 kHz deviation.

FM NOISE: -60 dB relative to ± 25 kHz deviation.

AM NOISE: -52 dB relative to 100% modulation (measured after de-emphasis).

OUTPUT IMPEDANCE: 50 ohms, output connector 3/8" EIA standard.

FREQUENCY STABILITY: ± 250 Hz (maximum variation over 30 days).

SERVICE CONDITIONS

AMBIENT TEMPERATURE: -18° to $+50^\circ\text{C}$. (0° to 122°F).

AMBIENT HUMIDITY RANGE: 0 to 100% relative humidity.

ALTITUDE: Sea level to 7500 feet.

PHYSICAL AND MECHANICAL DIMENSIONS: Size: 126" wide x 31 1/2" deep x 72" high. (Power supply: 36" wide x 24" deep x 40" high). Weight: 3775 lbs. (approximate). (Power supply: 870 lbs. approximate.)

ELECTRICAL REQUIREMENTS: 208/240 volts ± 11 volts, 3 phase, 50/60 Hz.

ORDERING INFORMATION

BT-25L 25 kW VHF-TV transmitter (for Channels 2 to 6) with operating tubes, transistors, IC's, solid-state rectifiers, crystals, required pre-correction circuitry, low-level vestigial sideband filter, harmonic and color notch filters.....994-6696-001

BT-25H 25 kW VHF-TV transmitter (for Channels 7 to 13) with all of above included.....994-6656-001

18,000 Watt VHF Color Television Transmitters

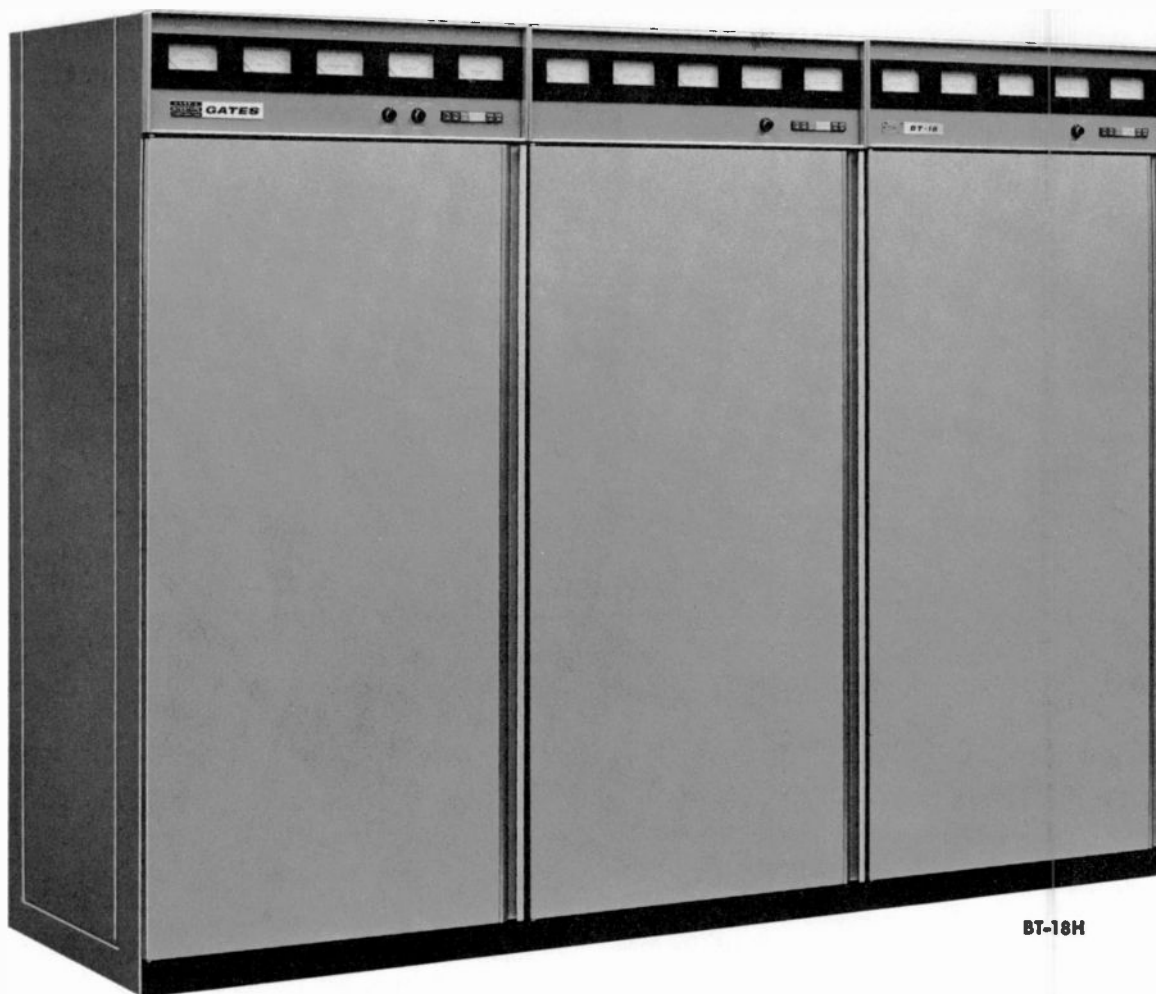

BT-18H

MODEL BT-18L LOW BAND

MODEL BT-18H HIGH BAND

The Gates system of IF MODULATION employed in the FCC type accepted BT-18H (and in the BT-18L, the 18 kW low band model) provides the highest degree of color quality available today. Low power solid-state circuitry is used in a simple, straightforward system to achieve outstanding color fidelity.

Only three cabinets are required to house each of these 18 kilowatt models. Gates' unique modularized building block concept allows a maximum utilization of valuable floor space.

IF MODULATION: In Gates' exclusive modulation system a fully processed video signal, along with an IF carrier signal, is applied to a balanced modulator. At the output of the modulator an ultra-linear, fully modulated double sideband signal appears. This signal is a perfect reproduction of the video input signal, raised to the IF frequency.

The modulated signal then passes through active color delay compensation circuitry and a low power sideband filter. The sideband filter shapes the visual signal so that it exhibits required bandpass characteristics. Not only is the lower sideband filtered but the upper sideband is also limited so that energy above 4.2 MHz does not pass through the sideband filter.

After the fully processed and modulated IF signal is generated it is simply inserted into an upconverter to arrive at the desired "on channel" output signal. This signal then passes through several stages of amplification and appears at the output of the transmitter at the 18 kW power level.

A direct FM 32.5 MHz IF system is used to generate the aural carrier. This IF signal is upconverted to the desired output channel.

18,000 Watt VHF Color Television Transmitters

VISUAL AND AURAL EXCITERS: Both the visual and aural exciters are mounted in pull-out drawers and may be operated outside the main transmitter for test purposes.

Each exciter constitutes a complete miniature "on channel" transmitter. The exciter output power may be adjusted at any level up to one watt visual and 10 watts aural with a front-panel control. Changing power level results only in an actual power change and does not influence signal modulation depth or linearity.

The visual and aural exciters both contain frequency determining circuitry which is housed in temperature controlled ovens. Digital phase-locked loops guarantee absolute frequency stability.

CONTROL LOGIC: Individual solid-state control and protective circuitry is provided for each transmitter cabinet. Semiconductors are used to eliminate conventional electro-mechanical devices. Extremely simple circuit design results in simulation of all relay-type contact arrangements without the normal maintenance and reliability problems associated with relay-type control logic.

STABILITY: Exclusive coaxial cavities are used in all high-level amplifier stages. The cavity design has inherently high isolation between input and output circuitry. High-efficiency, broadband ceramic tetrodes, operating grounded grid, are used in the cavities. These tubes are designed for full power operation up to 400 MHz. The excellent cavity isolation, coupled with the high frequency ceramic tetrodes, results in very stable operation, not requiring neutralization.

REMOTE CONTROL: Provision is made for convenient access to terminals for interfacing control and metering functions to a remote control system.

POWER SUPPLY: A highly efficient polyphase power supply, including silicon rectifiers, transient suppressors, filter capacitors, and transformers, is contained within a single externally-mounted cabinet.

The power supply circuit consists of two 3-phase full-wave rectifier systems in series, each system being driven by a set of three secondaries. Both systems combined have a total of twelve conduction periods in which the peaks of one system coincide with the troughs of the other.

INDICATORS: A complete system of meters and overload indicators is provided in each cabinet for monitoring transmitter operation. In the event of a transmitter malfunction, an examination of the indicators provided will locate the problem area.

ACCESSIBILITY: The entire transmitter is easily accessible, front and back. All components may be reached quickly through removable panels. Both the visual exciter and the aural exciter slide out, and various exciter circuits such as the reference oscillator, visual oscillator, aural oscillator and modulator are of modular construction and can be removed for maintenance. Tubes in the visual and aural high power amplifiers can be removed by one man from the front of the transmitter. Meter panels at the top of all cabinets are hinged for quick access.

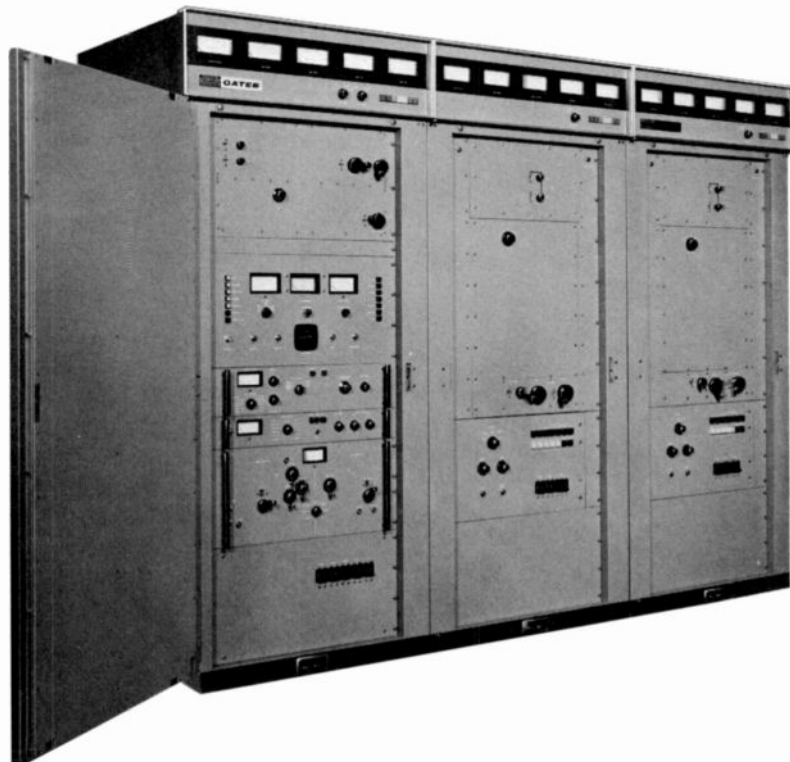

Front view, BT-18L, 18 kW low band transmitter, showing from left to right, the 1300-watt exciter/driver, the aural power amplifier and the 18 kilowatt visual power amplifier.

18,000 Watt VHF Color Television Transmitters

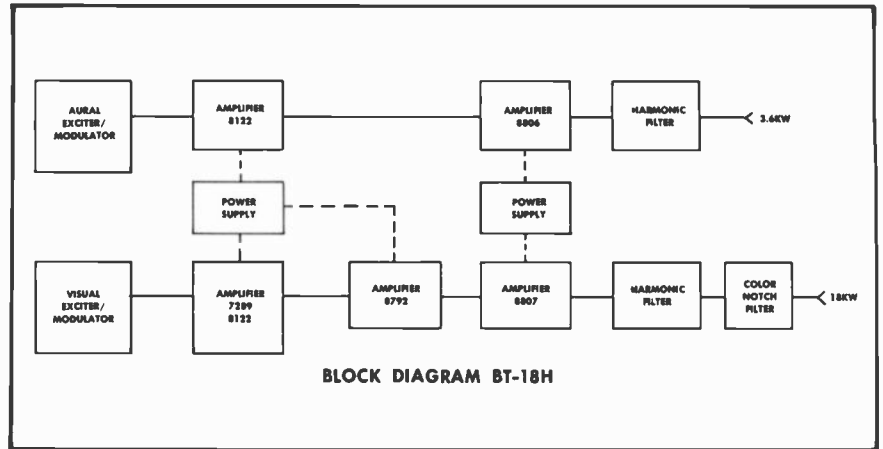
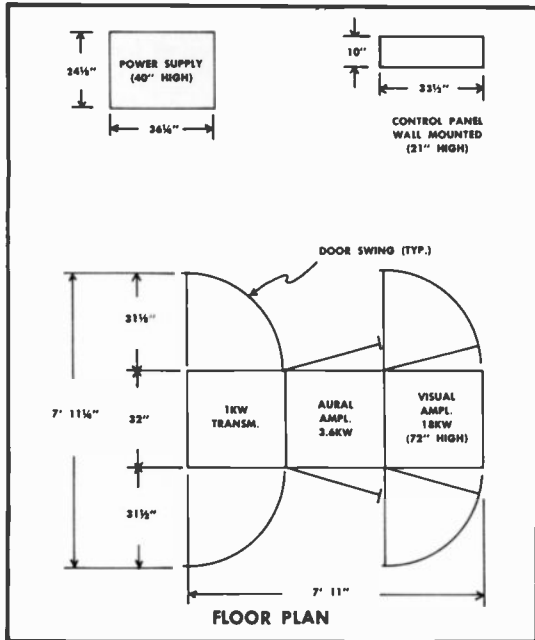

SPECIFICATIONS

(CCIR specifications available.)

VISUAL PERFORMANCE

- POWER OUTPUT:** 18 kW peak (FCC and CCIR "B")
- OUTPUT IMPEDANCE:** 50 ohms. Output connector: 3/8" EIA standard.
- FREQUENCY RANGE:** (BT-18L) 48 to 88 MHz (Channels 2 to 6). (BT-18H) 174 to 230 MHz (Channels 7 to 13).
- CARRIER STABILITY:** ± 250 Hz (maximum variation over 30 days).
- REGULATION OF RF OUTPUT POWER** (Black to white picture): Less than 3%.
- VARIATION OF OUTPUT:** Over one frame: less than 2%.
- VISUAL SIDEBAND RESPONSE:**
 - +4.75 MHz and higher.....-20 dB or better.
 - Carrier to +4.18 MHz.....+0.5, -1 dB.
 - Carrier.....0 dB reference.
 - Carrier to -0.5 MHz.....+0.5, -1 dB.
 - 1.25 MHz and lower.....-20 dB or better.
 - 3.58 MHz.....-42 dB or better.
- FREQUENCY RESPONSE VS. BRIGHTNESS:** ± 0.75 dB (measured at 65% and 15% of modulation. Reference 100% = peak of sync.)
- VISUAL MODULATION CAPABILITY:** 3% or better.
- DIFFERENTIAL GAIN:** 0.5 dB or better (maximum variation of sub-carrier amplitude from 75% to 10% of modulation. Sub-carrier modulation percentage: 10% peak to peak.)
- LINEARITY (LOW FREQUENCY):** 0.5 dB or better.
- DIFFERENTIAL PHASE:** $\pm 3^\circ$ or better (maximum variation of sub-carrier phase with respect to burst for modulation percentage from 75% to 10%. Sub-carrier modulation percentage: 10% peak to peak.)
- SIGNAL-TO-NOISE RATIO:** -50 dB or better (RMS) below sync level.
- K FACTORS:** 2 \pm 2%, 20 \pm 3%.
- ENVELOPE DELAY:**

.05 to 2.1 MHz:	± 70 ns	} Reference to standard curve—FCC.
at 3.58 MHz:	± 35 ns	
at 4.18 MHz:	± 70 ns	

VIDEO INPUT: Bridging, loop through input with -30 dB or better return loss up to 5.5 MHz, 75 ohm system.

HARMONIC RADIATION: -80 dB.

AURAL PERFORMANCE

- POWER OUTPUT:** 3.6 kW at diplexer output.
- AUDIO INPUT:** +10 dBm, ± 2 dB into 600 ohms.
- INPUT IMPEDANCE:** 600/150 ohms.
- PRE-EMPHASIS:** 75 microseconds.
- FREQUENCY RESPONSE:** ± 0.5 dB relative to pre-emphasis (30-15,000 Hz).
- DISTORTION:** 0.5% or less after 75 microseconds de-emphasis with ± 25 kHz deviation, 0.7% after 50 microseconds de-emphasis with ± 50 kHz deviation.
- FM NOISE:** -60 dB relative to ± 25 kHz deviation.
- AM NOISE:** -52 dB relative to 100% modulation (measured after de-emphasis).
- OUTPUT IMPEDANCE:** 50 ohms, output connector 3/8" EIA standard.
- FREQUENCY STABILITY:** ± 250 Hz (maximum over 30 days).

SERVICE CONDITIONS

- AMBIENT TEMPERATURE:** -18° to +50°C. (0° to 122°F.).
- AMBIENT HUMIDITY RANGE:** 0 to 100% relative humidity.
- ALTITUDE:** Sea level to 7500 feet.
- PHYSICAL AND MECHANICAL DIMENSIONS:** Size: 94 1/2" wide x 31 1/2" deep x 72" high. (Power supply: 36 1/4" wide x 24 1/4" deep x 40" high.) Weight: 3035 lbs. (approximate). (Power supply: 870 lbs. approximate.)
- ELECTRICAL REQUIREMENTS:** 208/240 volts ± 11 volts, 3 phase, 50/60 Hz. (380 volts, 50 Hz available.)

ORDERING INFORMATION

- BT-18L 18 kW VHF-TV transmitter (for Channels 2 to 6) with operating tubes, transistors, IC's, solid-state rectifiers, crystals, pre-correction circuitry, low-level vestigial sideband filter, harmonic and color notch filters.....994-6695-001
- BT-18H 18 kW VHF-TV transmitter (for Channels 7 to 13) with all of above included.....994-6655-001

13,000 Watt VHF Color Television Transmitters

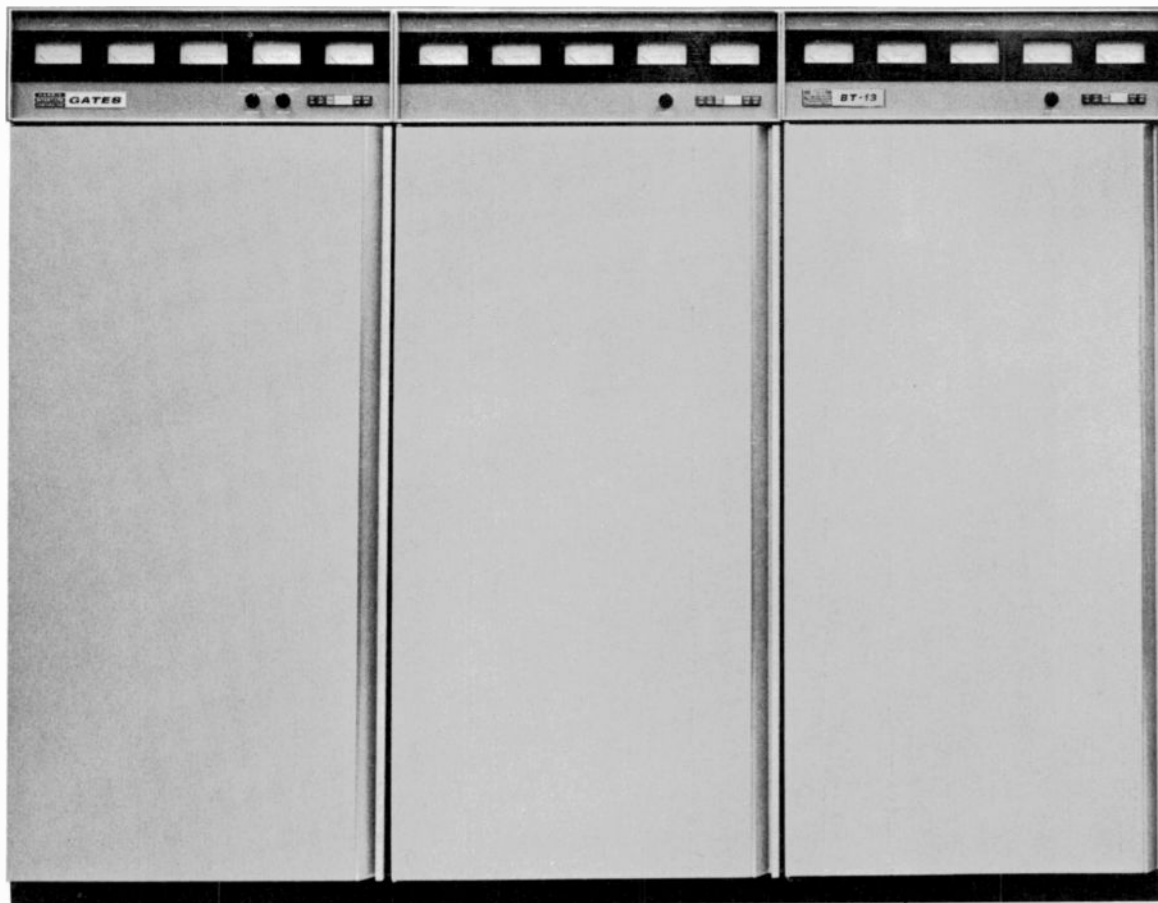

MODEL BT-13L LOW BAND MODEL BT-13H HIGH BAND

Utilizing Gates' advanced IF MODULATION concept, the BT-13L low band and FCC type accepted BT-13H high band 13 kW VHF TV transmitters provide superb color reproduction and highest reliability.

Controls are designed for simplicity of operation. Although each cabinet contains completely independent control logic, only one pushbutton, located on the front panel of the exciter/driver cabinet, need be depressed to place the transmitter on complete operational status.

Circuit design is straightforward, using a "building block" concept for ease of installation and maintenance. Extensive use of silicon transistors provides highly reliable, drift-free operation.

IF MODULATION: The modulation system employed in the transmitters uses advance-design techniques coupled with

solid-state circuitry for the finest color performance available today.

In IF MODULATION, all signal processing and shaping occurs at an extremely low power level. This eliminates many of the problems encountered with systems where less stable high power circuits are required for signal generation. Less than one volt is used in the visual modulation process, as compared to the much higher voltages required by other systems.

LINEAR AMPLIFIERS: The rugged ceramic coaxial tetrodes employed as grounded grid linear amplifiers provide truly linear operation, with extremely low intermodulation products. The tubes utilize a special internal element design which prevents them from being power limited.

ORDERING INFORMATION

BT-13L 13 kW VHF-TV transmitter (for Channels 2 to 6) with operating tubes, transistors, IC's, solid-state rectifiers, crystals, pre-correction circuitry, low-level vestigial sideband filter, harmonic and color notch filters..... 994-6694-001
BT-13H 13 kW VHF-TV transmitter (for Channels 7 to 13) with all of above included..... 994-6654-001

5,000 Watt VHF Color Television Transmitters



BT-5L
5 kW
low band VHF
TV transmitter.

MODEL BT-5L LOW BAND

MODEL BT-5H HIGH BAND

Gates' BT-5, 5 kW VHF television transmitter, featuring IF MODULATION for the highest quality color transmission, is available in two models. The BT-5L is for low band (Channels 2-6) service; the FCC type accepted BT-5H is for high band (Channels 7-13).

Providing 5000 watts visual and 1000 watts aural output, the BT-5 is contained in two cabinets, plus external power supply,

and occupies a total of less than 21 square feet of floor space. Visual power output is also 5 kW for CCIR "B" (Band I or Band III).

With the achievement of four design objectives—IF MODULATION, low-level vestigial sideband filtering, true linear operation of the power amplifier, and solid-state visual and aural exciters—Gates has provided the only truly modern television transmitter available today.

5,000 Watt VHF Color Television Transmitters

IF MODULATION: The use of IF MODULATION results in extremely efficient generation of a completely processed television signal at milliwatt power levels. In this system, picture and sound signals are processed, modulated and corrected at very low power levels for proper transmission to the antenna. These signals are then increased in power through the use of extremely linear power amplifiers to the 5 kW power level.

Because it occurs at milliwatt power levels, intermediate frequency modulation needs fewer circuits to produce a fully processed, quality picture signal. Gates' system takes less than 1.0 volt of video signal to modulate the RF carrier,

where other recent designs need as much as 200 volts for carrier modulation.

The simplicity of IF MODULATION results in nearly perfect signal linearity. Thus, predistortion circuitry which degrades color fidelity is practically eliminated.

The ring modulator used in the BT-5 allows modulation percentages to approximately 2%. The excellent linearity and depth of modulation results in exceptional color performance even with such colors as highly saturated yellow and cyan.

In addition, equalization of envelope delay occurs at the IF carrier frequency. This delay function is not fixed but continuously variable.

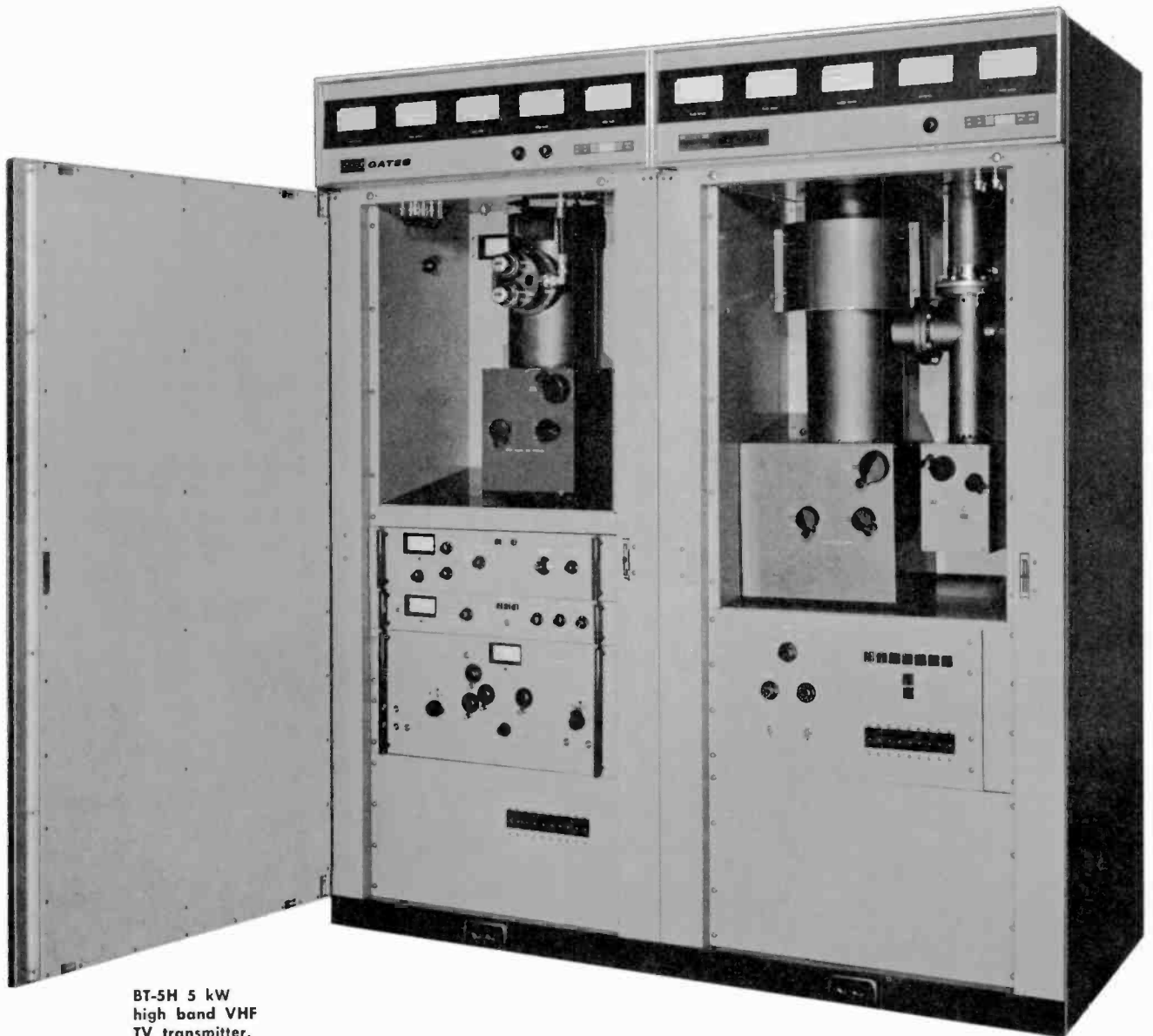

BT-5H 5 kW
high band VHF
TV transmitter.

5,000 Watt VHF Color Television Transmitters

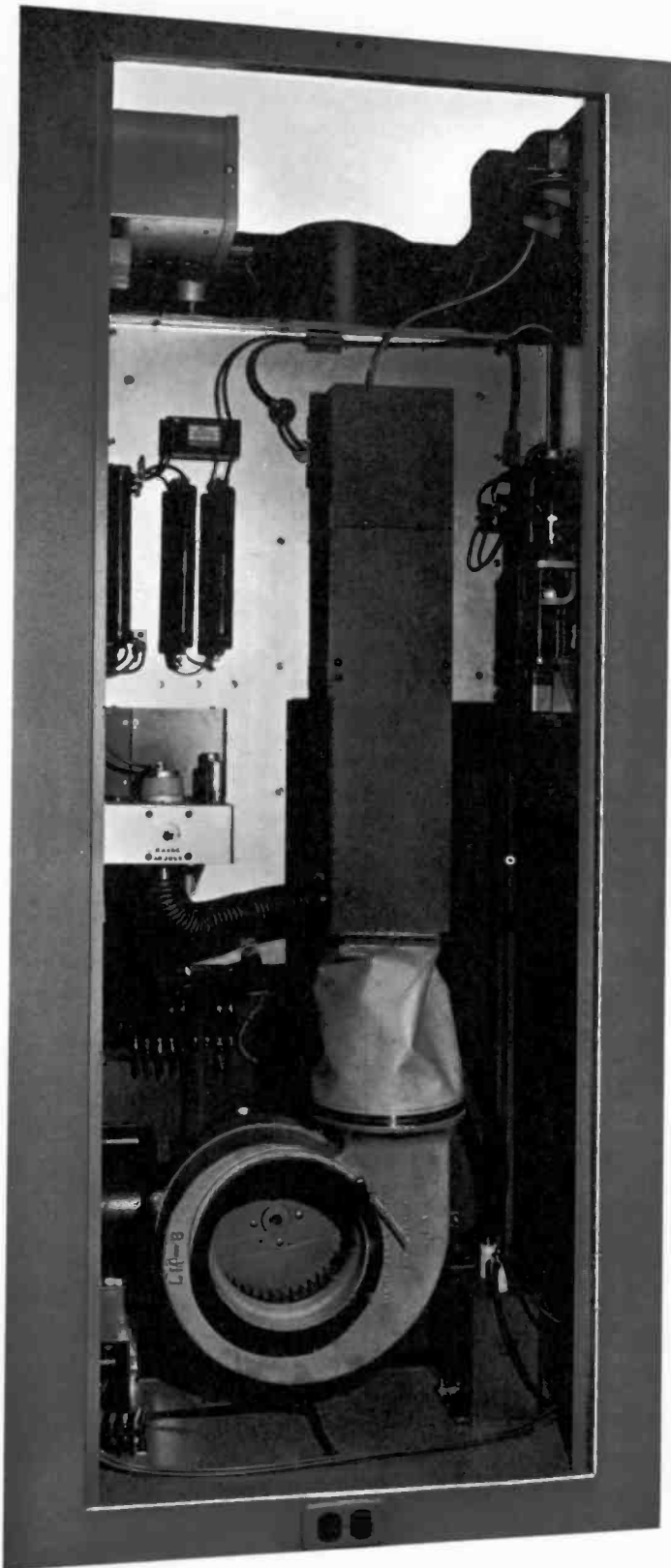

Rear view, visual power amplifier, BT-5H, 5 kW high band transmitter.

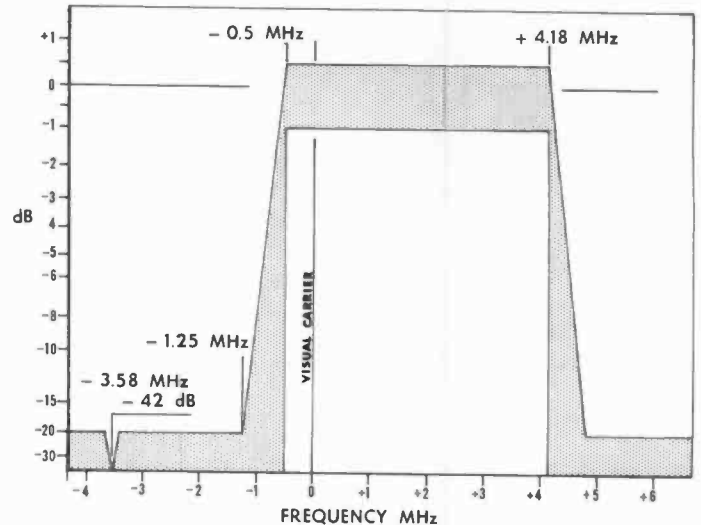

LOW-LEVEL VESTIGIAL SIDEBAND FILTERING: Another advantage of IF MODULATION is that in this system visual sidebands are filtered out at the IF frequency, rather than "on frequency" at the full output power of the transmitter. This completely eliminates the need for a conventional bulky sideband filter which can cause a power loss, can sometimes arc over, and takes up valuable space in the transmitter building. The sideband filter used by Gates is a removable module housed in the visual exciter.

VISUAL AND AURAL EXCITERS: Both the visual and aural exciters are mounted in pull-out drawers and may be operated outside the main transmitter for test purposes.

Each exciter constitutes a complete miniature "on channel" transmitter. The exciter output power may be adjusted at any level up to one watt visual and 10 watts aural with a front panel control. Changing power level results only in an actual power change and does not influence signal modulation depth or linearity.

CONTROL LOGIC: Individual solid-state control and protective circuitry is provided for each transmitter cabinet. Semiconductors are used to eliminate conventional electro-mechanical relays. Extremely simple circuit design results in simulation of all relay-type contact arrangements without the normal maintenance and reliability problems associated with relay-type control logic.

REMOTE CONTROL: Control circuit functions, metering and monitoring have all been designed specifically for remote control operation.

POWER SUPPLY: The unitized high-voltage power supply (including the transformer) is housed in a single assembly, mounted externally from the transmitter. Routine maintenance access is provided by a removable panel.

ACCESSIBILITY: The BT-5 provides for quick accessibility to all components. Visual and aural exciters slide out, and various exciter circuits such as reference oscillator, visual oscillator, aural oscillator, and modulator are modular in design for easy removal for maintenance.

5,000 Watt VHF Color Television Transmitters

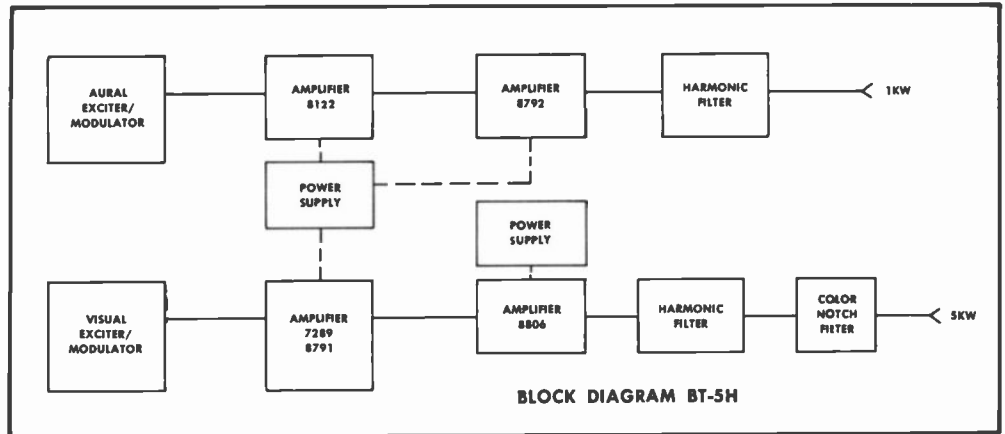
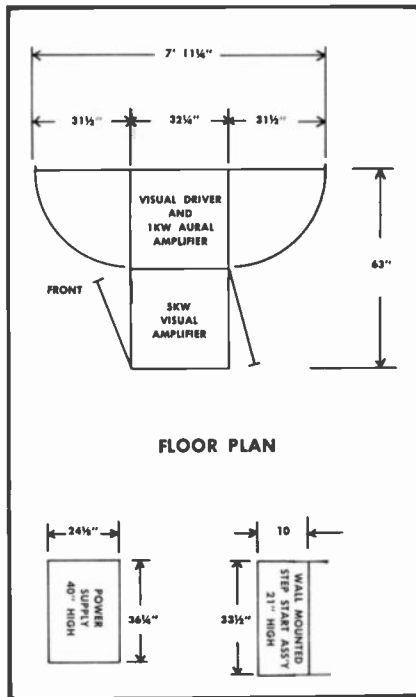

SPECIFICATIONS

(CCIR specifications available.)

VISUAL PERFORMANCE

- POWER OUTPUT:** 5 kW peak (FCC and CCIR "B").
- OUTPUT IMPEDANCE:** 50 ohms. Output connector: 1 1/2" EIA standard.
- FREQUENCY RANGE:** (BT-5L) 48 to 88 MHz (Channels 2-6). (BT-5H) 174 to 230 MHz (Channels 7-13).
- CARRIER STABILITY:** ±250 Hz (maximum variation over 30 days).
- REGULATION OF RF OUTPUT POWER** (Black to white picture): Less than 3%.
- VARIATION OF OUTPUT:** Over one frame: less than 2%.
- VISUAL SIDEBAND RESPONSE:**
 - +4.75 MHz and higher.....-20 dB or better.
 - Carrier to +4.18 MHz.....+0.5, -1 dB.
 - Carrier.....0 dB reference.
 - Carrier to -0.5 MHz.....+0.5, -1 dB.
 - 1.25 MHz and lower.....-20 dB or better.
 - 3.58 MHz.....-42 dB or better.
- FREQUENCY RESPONSE VS. BRIGHTNESS:** ±0.75 dB (measured at 65% and 15% of modulation. Reference 100% = peak of sync).
- VISUAL MODULATION CAPABILITY:** 3% or better.
- DIFFERENTIAL GAIN:** 0.5 dB or better (maximum variation of sub-carrier amplitude from 75% to 10% of modulation. Sub-carrier modulation percentage: 10% peak to peak).
- LINEARITY (LOW FREQUENCY):** 0.5 dB or better.
- DIFFERENTIAL PHASE:** ±3° or better (maximum variation of sub-carrier phase with respect to burst for modulation percentage from 75% to 10%. Sub-carrier modulation percentage: 10% peak to peak).
- SIGNAL-TO-NOISE RATIO:** -50 dB or better (RMS) below sync level.
- K FACTORS:** 2† 2%, 20† 3%.

ENVELOPE DELAY:

- .05 to 2.1 MHz: ±70 ns
 - at 3.58 MHz: ±35 ns
 - at 4.18 MHz: ±70 ns
- Reference to standard curve—FCC.

VIDEO INPUT: Bridging, loop through input with -30 dB or better, return loss up to 5.5 MHz, 75 ohm system.

HARMONIC RADIATION: -80 dB.

AURAL PERFORMANCE

- POWER OUTPUT:** 1 kW at diplexer output.
- AUDIO INPUT:** +10 dBm, ±2 dB into 600 ohms.
- INPUT IMPEDANCE:** 600/150 ohms.
- PRE-EMPHASIS:** 75 microseconds.
- FREQUENCY RESPONSE:** ±0.5 dB relative to pre-emphasis (30-15,000 Hz).
- DISTORTION:** 0.5% or less after 75 microseconds de-emphasis with ±25 kHz deviation, 0.75% after 50 microseconds de-emphasis with ±50 kHz deviation.
- FM NOISE:** -60 dB relative to ±25 kHz deviation.
- AM NOISE:** -50 dB relative to 100% modulation (measured after de-emphasis).
- OUTPUT IMPEDANCE:** 50 ohms. Output connector: HN female.
- FREQUENCY STABILITY:** ±250 Hz relative to frequency offset by 4.5 MHz from the visual carrier.

SERVICE CONDITIONS

- AMBIENT TEMPERATURE:** -18° to +50°C. (0° to 122°F.)
- AMBIENT HUMIDITY RANGE:** 0 to 100% relative humidity.
- ALTITUDE:** Sea level to 7500 feet.
- PHYSICAL AND MECHANICAL DIMENSIONS:** Size: 63" Wide x 31 1/2" Deep x 72" High. (Power supply: 36 1/4" W x 24 1/8" D x 40" H.) Weight 1424 lbs. (approximate). (Power supply: 800 lbs. approximate.)
- ELECTRICAL REQUIREMENTS:** 208/240 volts ±11 volts, 3 phase, 50/60 Hz.

ORDERING INFORMATION

- BT-5L 5 kW VHF-TV transmitter (for Channels 2 to 6) with operating tubes, transistors, IC's, solid-state rectifiers, crystals, required pre-correction circuitry, low-level vestigial sideband filter, harmonic and color notch filters.....994-6807-001
- BT-5H 5 kW VHF-TV transmitter (for Channels 7 to 13) with all of above included. Specify994-6765-001

1300 Watt VHF Color Television Transmitters



BT-1300H
1300-watt
high band
VHF TV
Transmitter.

MODEL BT-1300L LOW BAND

MODEL BT-1300H HIGH BAND

Gates' BT-1300 is a completely self-contained, one-cabinet, 1300-watt VHF television transmitter, featuring IF MODULATION for true color transmission. For low band (Band I) service, specify BT-1300L, and for high band (Band III), BT-1300H. Both models are FCC type accepted, and meet or exceed CCIR requirements.

The unsurpassed fidelity of the transmitter's fully processed carriers stems from the achievement of four design objectives: IF MODULATION of the visual and aural carriers; solid-state

visual and aural exciters; low-level vestigial sideband filtering; and true linear operation of amplifier stages.

With Gates' advanced circuitry, delay equalizers and differential phase and gain correctors are an integral part of the transmitter. There are no external video filter networks.

Operation of the transmitter—frequency adjustment, power output control and amplifier tuning—is simple and reliable. The result is outstanding color picture quality and power output stability.

1300 Watt VHF Color Television Transmitters

IF MODULATION: True low-level IF MODULATION provides unsurpassed modulation capability with precise linearity, offering color quality not found in other equipment available today.

In the BT-1300 (which is the basic driver unit for all Gates' higher powered VHF transmitters), the visual and aural exciters generate fully modulated low-level IF signals. The output of a common crystal controlled reference oscillator is used to raise the individual IF signal to the desired "on channel" output frequency. Less than 1.0 volt of video is needed to fully modulate the RF carrier.

The Gates ring modulator permits modulation percentages to approximately 2% without compromising transmitter performance—and eliminates most pre-distortion circuitry. This results in exceptional color performance and nearly perfect signal linearity. Even such colors as highly saturated as cyan and yellow are faithfully reproduced with IF MODULATION.

Another Gates engineering first is envelope delay compensation at the IF frequency. Continuously variable controls allow a precise delay correction not possible with conventional fixed-step systems.

VISUAL SIDEBAND FILTERING: Visual sideband filtering is performed on the IF frequency at milliwatt power levels. This contrasts with inefficient conventional high level methods accomplished "on channel" at kilowatt power levels, with associated performance and maintenance problems.

The sideband filter used by Gates is a small removable module housed in the visual exciter. It completely eliminates the conventional, space-consuming filtering device, with its inherent insertion losses.

VISUAL EXCITER: A totally solid-state, self-contained one-watt unit, the visual exciter incorporates a ring modulator and furnishes a fully processed visual signal ready for further amplification "on channel". A single knob, located on the front panel, is provided for adjusting both the visual and aural carrier frequencies ± 500 Hz. A 12-position switch permits readings of operating parameters.

The vestigial sideband filter and envelope delay circuit in the visual exciter can be by-passed by a switch mounted on the exciter control panel. This is useful in obtaining a visual display of the overall bandwidth during maintenance and tuning operations.

AURAL EXCITER: The aural exciter is 100% solid state. Its 10-watt output is an "on channel" carrier controlled by phase lock for maximum frequency stability. A meter permits monitoring of operating parameters.

A front panel control on both visual and aural exciters sets the transmitter power, without need for subsequent modulation adjustment or retuning.

SIGNAL FLOW: The visual exciter signal goes through two IPA stages: a type 7289 planar triode and a type 8122 tetrode, giving an output of approximately 100 watts. It then goes to the final power amplifier, an 8792 coaxial tetrode, that delivers 1300 watts peak power output.

The 10-watt output of the aural exciter drives an 8122 final amplifier, delivering 260 watts average power output.

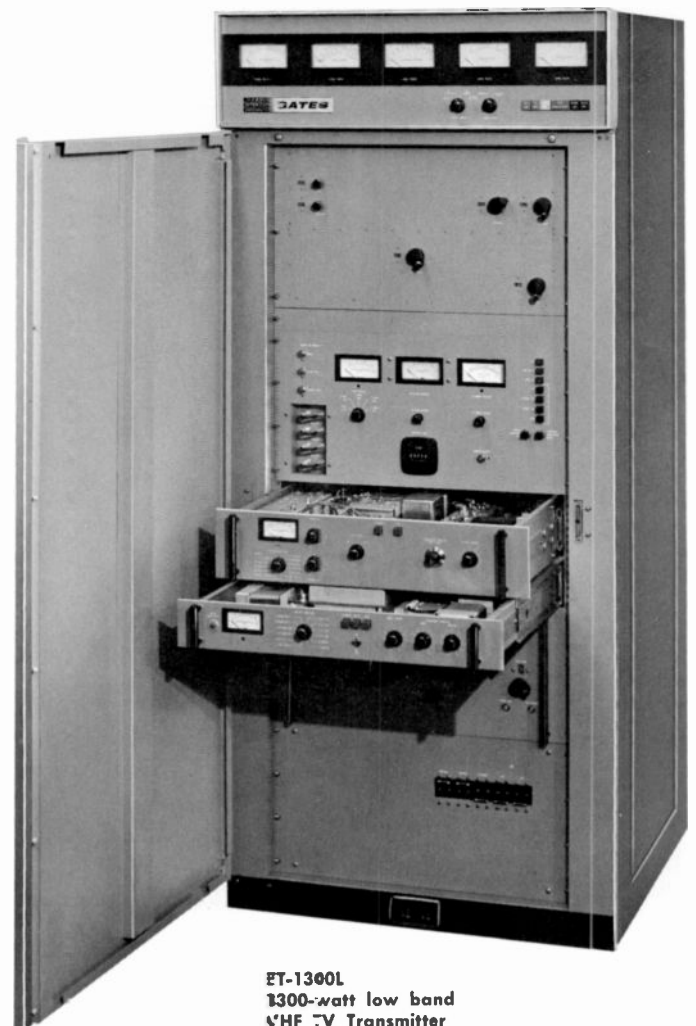

ET-1300L
1300-watt low band
VHF TV Transmitter

1300 Watt VHF Color Television Transmitters

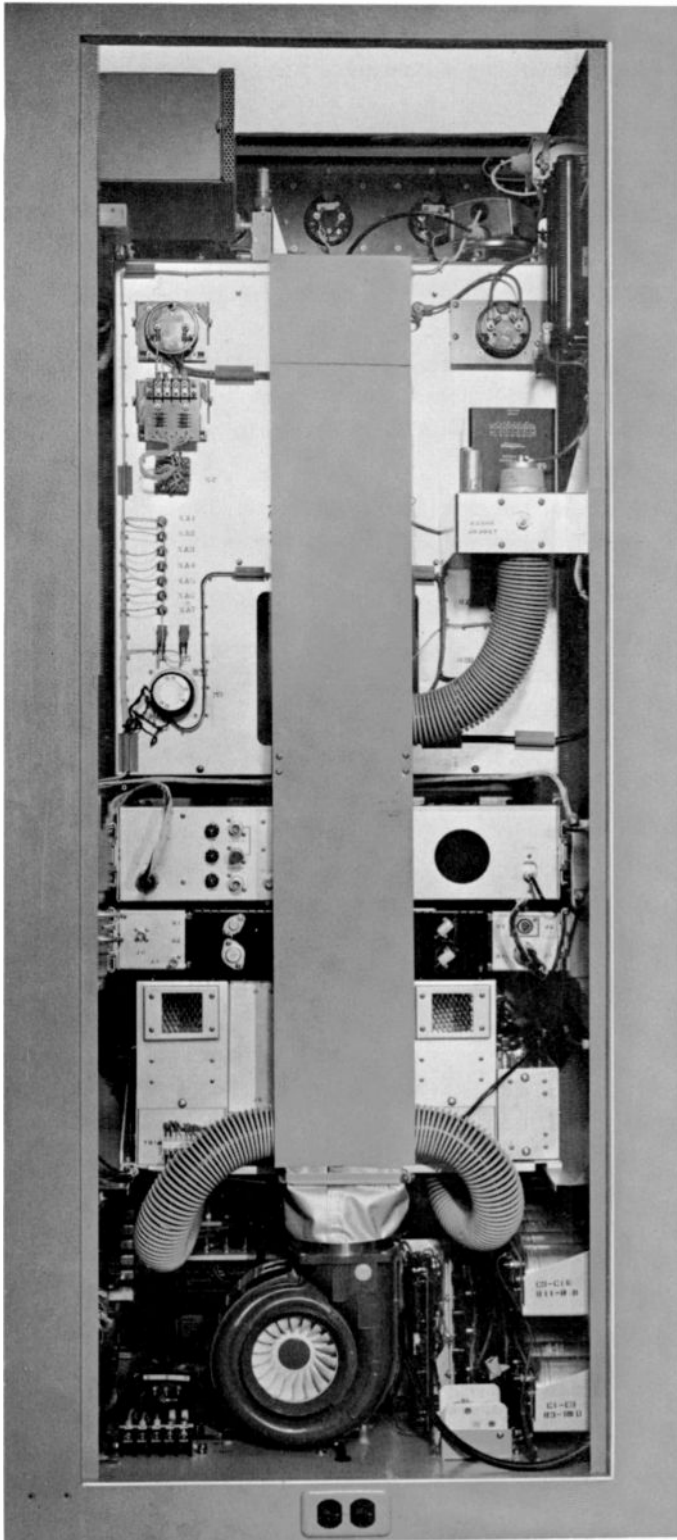

Rear view, door removed, BT-1300H, 1300-watt high band VHF transmitter.

CONTROL LOGIC: Complete and fool-proof control of all transmitter functions is achieved through the use of solid-state memory, timing and logic circuits. A self-charging emergency power source is provided to maintain control logic memory during periods of power-line failure.

The solid-state control logic and protective circuitry, in addition to commanding normal AC control functions, is also used to visually indicate, through pilot lights, the operating status of the transmitter system. The indicator lights allow easy isolation of circuit faults.

REMOTE CONTROL: All control, metering and monitoring circuits have been designed specifically for remote control operation. The power controls are motor driven and the necessary remote control sampling points are built-in on accessible terminal boards.

STABILITY: Advance-design ceramic tetrodes offer ultra-linear, inherently stable high power output.

ACCESSIBILITY: All components of the BT-1300—including visual and aural exciters, intermediate power amplifiers, final power amplifiers, sideband filter and power supply—are contained in a single cabinet, with total component accessibility provided front and back.

Visual and aural exciters slide out and can operate independently from the transmitter outside the main cabinet. Various exciter circuits, such as oscillators, modulators and processing circuitry, are of modular construction and can be removed for maintenance or replacement.

Easy-to-read, eye-level 4-inch meters are used to monitor required transmitter functions. The meter panel is of double-hinged construction for convenient fold-down access during maintenance.

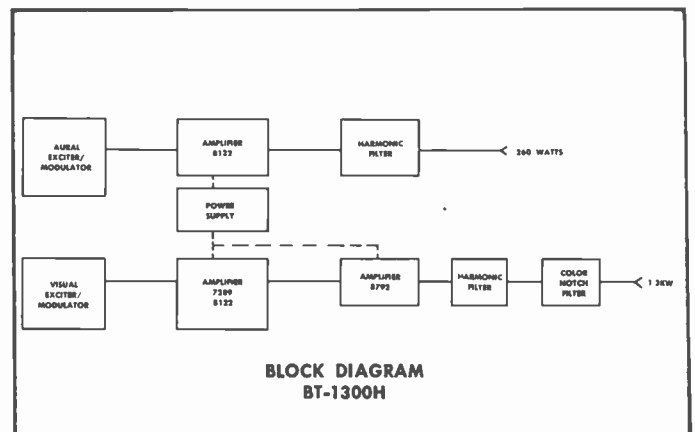

1300 Watt VHF Color Television Transmitters

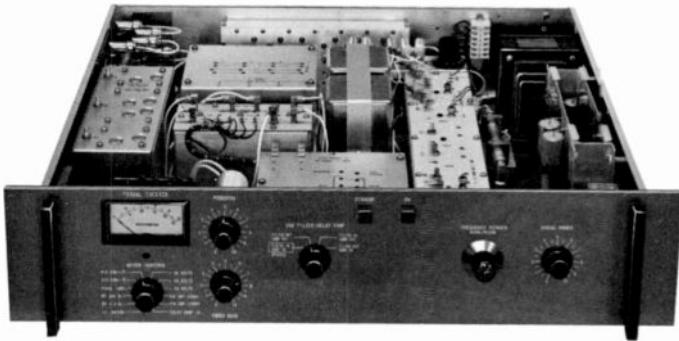

VISUAL EXCITER. Complete, self-contained one-watt, "on channel" signal source. Totally solid state. Modular construction.

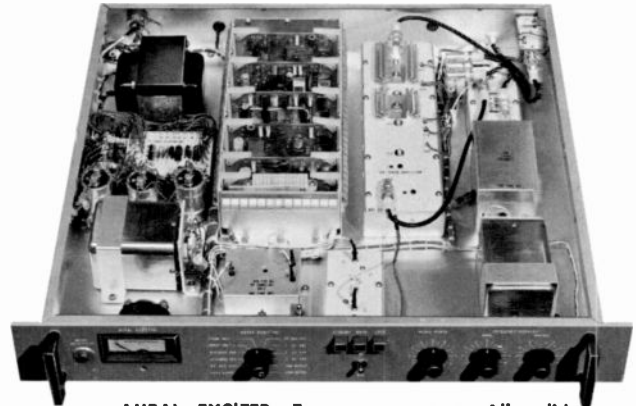

AURAL EXCITER. Ten watts output. All solid state. Phase-locked direct FM. Contains EBS carrier muting facilities.

SPECIFICATIONS

(CCIR specifications available.)

VISUAL PERFORMANCE

- POWER OUTPUT:** 1.3 kW peak (FCC). 1.0 kW peak (CCIR "B").
- OUTPUT IMPEDANCE:** 50 ohms. Output connector (Visual) Type "HN".
- FREQUENCY RANGE:**
 BT-1300L: 48 to 88 MHz (channels 2-6). (48.25 to 62.25 MHz for CCIR channels E2 to E4.)
 BT-1300H: 174 to 230 MHz (channels 7-13). (175.25 to 224.25 MHz for CCIR channels E5 to E12.)
- CARRIER STABILITY:** ± 250 Hz (maximum variation over 30 days).
- REGULATION OF RF OUTPUT POWER (Black to White Picture):** Less than 3%.
- VARIATION OF OUTPUT:** Over one frame: less than 2%.
- VISUAL SIDEBAND RESPONSE:**
- | | | |
|----------------------|-------|-------------------|
| +4.75 MHz and higher | ----- | -20 dB or better. |
| Carrier to +4.18 MHz | ----- | +0.5, -1 dB. |
| Carrier | ----- | 0 dB reference. |
| Carrier to -0.5 MHz | ----- | +0.5, -1 dB. |
| -1.25 MHz and lower | ----- | -20 dB or better. |
| -3.58 MHz | ----- | -42 dB or better. |
- FREQUENCY RESPONSE VS. BRIGHTNESS:** ± 0.75 dB (measured at 65% and 15% of modulation. Reference 100% = peak of sync).
- VISUAL MODULATION CAPABILITY:** 3% or better.
- DIFFERENTIAL GAIN:** 0.5 dB or better (Maximum variation of sub-carrier amplitude from 75% to 10% of modulation. Sub-carrier modulation percentage: 10% peak to peak.)
- LINEARITY (Low Frequency):** 0.5 dB or better.
- DIFFERENTIAL PHASE:** $\pm 3^\circ$ or better (Maximum variation of sub-carrier phase with respect to burst for modulation percentage from 75% to 10%. Sub-carrier modulation percentage: 10% peak to peak.)
- SIGNAL-TO-NOISE RATIO:** -50 dB or better (RMS) below sync level.
- K FACTOR:** 2 \pm 2%. 20 \pm 3%.

ENVELOPE DELAY:

.05 to 2.1 MHz:	± 70 ns	} Reference to standard curve—FCC.
at 3.58 MHz:	± 35 ns	
at 4.18 MHz:	± 70 ns	

VIDEO INPUT REQUIREMENTS: 1.0 volt peak to peak, sync negative ± 3 dB. Bridging, loop through input with -30 dB or better return loss up to 5.5 MHz, 75 ohm system.

HARMONIC RADIATION: -80 dB.

AURAL PERFORMANCE

- AUDIO INPUT:** +10 dBm, ± 2 dB.
- INPUT IMPEDANCE:** 600/150 ohms.
- PRE-EMPHASIS:** 75 microseconds.
- FREQUENCY RESPONSE:** ± 0.5 dB relative to pre-emphasis (30-15,000 Hz).
- DISTORTION:** .5% or less after 75 microsecond de-emphasis with ± 25 kHz deviation.
- FM NOISE:** -60 dB relative to ± 25 kHz deviation.
- AM NOISE:** -52 dB relative to 100% modulation (measured after de-emphasis).
- RF OUTPUT IMPEDANCE:** 50 ohms, Type "N" connector.
- FREQUENCY STABILITY:** ± 250 Hz over a 30-day period.

SERVICE CONDITIONS

- AMBIENT TEMPERATURE:** -10° to +50°C. (14° to 122°F.)
- AMBIENT HUMIDITY RANGE:** 0 to 100% relative humidity.
- ALTITUDE:** Sea level to 10,000 ft. (3048 meters).
- PHYSICAL AND MECHANICAL DIMENSIONS:** Size: 72" H x 31½" W x 31½" D. (182.9 cm x 80 cm x 80 cm). Weight: Approximately 800 lbs. or 360 kg.
- ELECTRICAL REQUIREMENTS:** 208/240 volts (± 11 volts) 50/60 Hz, single phase.

ORDERING INFORMATION

- BT-1300L 1300-watt VHF TV transmitter for Channels 2-6 (CCIR Channels E2 to E4), with operating tubes, transistors, IC's, solid-state rectifiers, crystals, required pre-correction circuitry, low-level vestigial sideband filter, harmonic and color notch filters 994-6693-001
- BT-1300H 1300-watt VHF TV transmitter for Channels 7-13 (CCIR Channels E2 to E4), with all of above included..... 994-6653-001

120 Watt VHF Color Television Transmitters

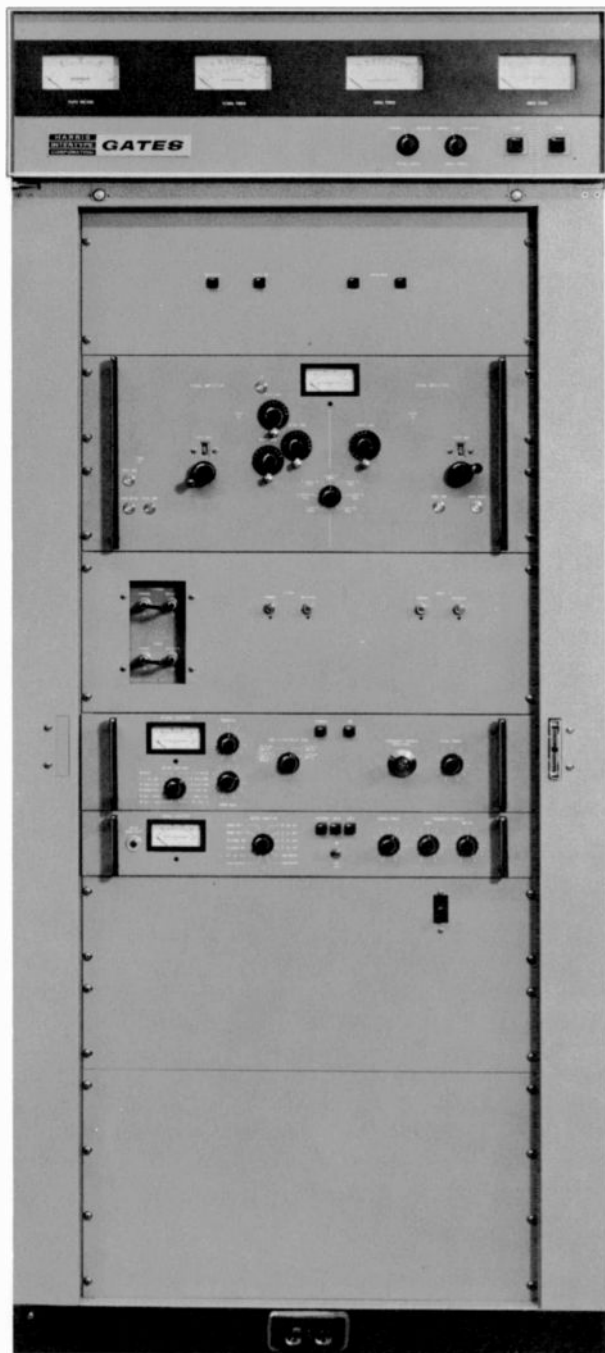

MODEL BT-100L LOW BAND

MODEL BT-100H HIGH BAND

Gates' BT-100 VHF color television transmitter, featuring IF MODULATION, is available in two models—BT-100L for low band (Band I) service, and BT-100H for high band (Band III) operation.

Both models will deliver 120 watts peak of sync visual (FCC) and 50 watts aural. Both fully meet or exceed CCIR requirements, and are FCC type accepted.

IF MODULATION: Low-level IF MODULATION, employed in the BT-100L and BT-100H, excels in electrical performance, reliability and simplicity of operation.

Due to the low-level techniques, which include the use of devices such as an extremely linear broadband diode ring modulator, active delay compensation, low-level sideband filtering and a very linear broadband amplifier, the broadcast signal is a faithful reproduction of the signal applied to the transmitter input.

The ring modulator allows modulation percentages to approximately 2%. This unusually good color performance, even with such colors as highly saturated yellow and cyan, is the result of excellent linearity and depth of modulation. Picture quality is superior to that provided by any other equipment currently available.

VISUAL AND AURAL EXCITERS: Both exciters are completely solid-state and have a drawer-like design for easy, slide-out accessibility. One knob on each exciter controls the visual and aural power output of the transmitter without retuning of any kind. A station engineer can also make precise frequency adjustments on both the visual and aural exciters by means of front-panel controls.

The visual and aural exciters furnish fully processed 1.0-watt visual and 10-watt aural signals. The output of these exciters is a complete TV signal that is ready for further amplification and "on channel" transmission.

In addition to the visual and aural exciters, amplifiers and power supplies, the cabinet also contains harmonic filters, color notch filter (external in the BT-100L), directional couplers and frequency monitor probes.

Separate aural and visual RF outputs are provided. If it is desired to feed a common antenna and transmission line with both visual and aural outputs, a diplexer will be required.

ACCESSIBILITY: The entire transmitter is easily accessible, front and back. Both visual and aural exciters slide out and can operate independently from the other transmitter stages outside the cabinet. Various exciter circuits such as reference oscillator, visual oscillator, aural oscillator and modulator are of modular construction and can be removed for maintenance.

Easy-to-read 4-inch meters are used in the meter panel located at the top of the cabinet. The meter panel is hinged for quick access.

120 Watt VHF Color Television Transmitters

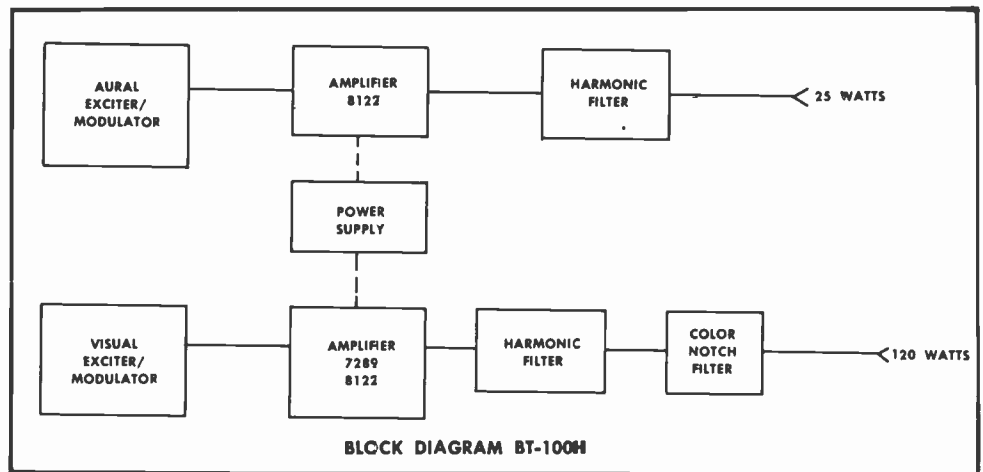
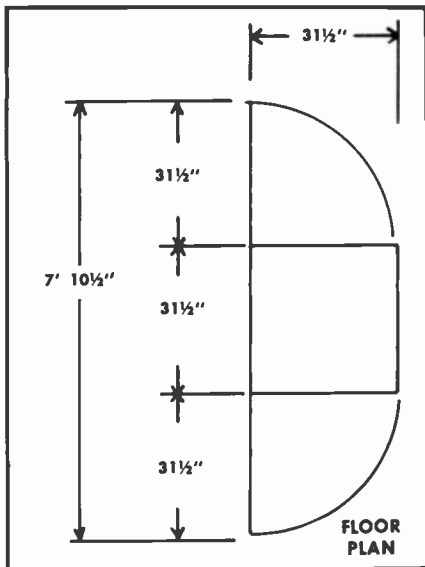

SPECIFICATIONS

(CCIR specifications available.)

VISUAL PERFORMANCE

POWER OUTPUT: 120 watts peak (FCC). 100 watts peak (CCIR "B").

OUTPUT IMPEDANCE: 50 ohms. Type "N" connector.

FREQUENCY RANGE:

BT-100L: 48 to 88 MHz (48.25 to 62.25 MHz for CCIR channels E2 to E4).

BT-100H: 174 to 230 MHz. (175.25 to 224.25 MHz for CCIR channels E5 to E12).

CARRIER STABILITY: ± 250 Hz (Maximum variation over 30 days).

REGULATION OF RF OUTPUT POWER (Black to White picture): Less than 3%.

VARIATION OF OUTPUT: Over one frame, less than 2%.

VISUAL SIDEBAND RESPONSE:

+4.75 MHz and higher.....	-20 dB or better.
Carrier to +4.18 MHz.....	+0.5, -1 dB.
Carrier.....	0 dB reference.
Carrier to -0.5 MHz.....	+0.5, -1 dB.
-1.25 MHz and lower.....	-20 dB or better.
-3.58 MHz.....	-42 dB or better.

(Response for system other than FCC to be scaled to appropriate corner frequencies of the applicable system.)

FREQUENCY RESPONSE VS. BRIGHTNESS: ± 0.75 dB.

VISUAL MODULATION CAPABILITY: 3% or better.

DIFFERENTIAL GAIN: 4% or better.

LINEARITY (LOW FREQUENCY): 0.5 dB or better.

DIFFERENTIAL PHASE: $\pm 3^\circ$ or better (Maximum variation of sub-carrier phase with respect to burst for modulation percentage from 75 to 10%. Sub-carrier modulation percentage: 10% peak to peak.)

SIGNAL-TO-NOISE RATIO: -50 dB or better (RMS).

K FACTOR: 2 \pm 2%; 20 \pm 3%.

ENVELOPE DELAY:

.05 to 2.1 MHz: ± 70 ns	} Reference to standard FCC curve. Comporable CCIR performance.
at 3.58 MHz: ± 35 ns	
at 4.18 MHz: ± 70 ns	

VIDEO INPUT: 1.0 volt peak to peak, sync negative ± 3 dB, bridging input with -30 dB or better return loss up to 5.5 MHz, 75 ohm system.

HARMONIC RADIATION: -60 dB.

AURAL PERFORMANCE

POWER OUTPUT: 50 watts.

OUTPUT IMPEDANCE: 50 ohms, type "N" connector.

AUDIO INPUT: +10 dBm, ± 2 dB into 600 ohms.

INPUT IMPEDANCE: 600/150 ohms, $\pm 10\%$ (30-15,000 Hz).

PRE-EMPHASIS: 50/75 or zero microseconds.

FREQUENCY RESPONSE: ± 0.5 dB relative to pre-emphasis (30-15,000 Hz).

DISTORTION: .5% or less after 75 microsecond de-emphasis with ± 25 kHz deviation. .7% after 50 microsecond de-emphasis with ± 50 kHz deviation.

FM NOISE: -60 dB relative to ± 25 kHz deviation.

AM NOISE: -52 dB relative to 100% modulation (measured after de-emphasis).

RF OUTPUT IMPEDANCE: 50 ohms. Type "N" connector. VSWR less than 1.3.

FREQUENCY STABILITY: ± 250 Hz over a 30-day period.

SERVICE CONDITIONS

AMBIENT TEMPERATURE: -10° to $+50^\circ$ C.

AMBIENT HUMIDITY RANGE: 0 to 100% relative humidity.

ALTITUDE: Sea level to 7500 ft., or 2300 meters.

SIZE: 72" H x 31 1/2" W x 31 1/2" D. 182.9 cm H x 80 cm W x 80 cm D.

WEIGHT: Approximately 800 pounds or 360 kg.

ELECTRICAL REQUIREMENTS: 208/240 volts (± 11 volts) 50/60 Hz, single phase. (115 volts available on special order.)

ORDERING INFORMATION

BT-100L VHF TV transmitter for Channels 2-6 (CCIR Channels E2 to E4), with operating tubes, transistors, IC's, solid-state rectifiers, crystals, required pre-correction circuitry, low-level vestigial sideband filter, harmonic and color notch filters..... 994-6692-001

BT-100H VHF TV transmitter for Channels 7-13 (CCIR Channels E5 to E12), with all of above included..... 994-6652-001

UHF Television Exciter/Driver



VISUAL EXCITER

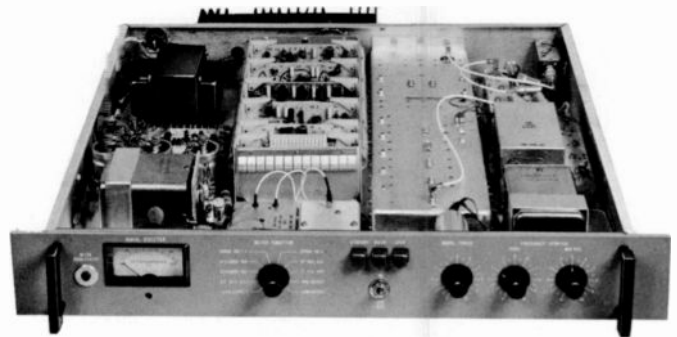

AURAL EXCITER

MODEL TD-2U

The TD-2U provides a nominal 2-watt television signal on any UHF channel, and is employed as the exciter/driver unit in all Gates' UHF transmitters. It consists of two drawer-mounted units, a visual exciter/modulator and an aural exciter/modulator, each employing a broadband stripline power amplifier.

These solid-state units may be used to drive amplifiers for any desired power output in updating older UHF transmitters, or may be used as a complete low power UHF transmitter.

Both exciters employ Gates' exclusive system of IF MODULATION to provide unsurpassed signal fidelity.

VISUAL EXCITER: This unit contains all the necessary sub-assemblies to generate, process and amplify video signals. Modulation, delay correction, linearity correction and vestigial sideband filtering occur at an IF frequency. An upconverter and a broadband, solid-state power amplifier provide the "on channel" output signal.

The signal system operates in the following manner: the video input is applied to a differential amplifier which provides cancellation of common mode signals. The differential amplifier drives several stages, which provide signal processing and clamping. Two identical, fully processed video signals are developed. One signal drives the ring modulator, the other signal provides output for monitoring video system performance.

The fully modulated double sideband IF signal that appears at the output of the ring modulator passes through the delay compensator, sideband filter, and linearity corrector before arriving at the "on channel" upconverter.

A precision crystal oscillator, operating in a temperature controlled environment, is used in conjunction with a digital harmonic generator, to develop a signal which drives the "on channel" upconverter.

Once the IF signal and the upconverter signal are mixed together, a bandpass filter is used to separate the desired signal from other mixing products. At this point a standard "on channel" vestigial sideband signal appears at a milliwatt power level. The signal then passes through an untuned, broadband, solid-state stripline amplifier, which provides the final two-watt, "on channel" output signal.

AURAL EXCITER: A direct FM varicap modulator generates the aural IF signal at 32.5 MHz. The entire aural modulator is housed in a temperature controlled oven to insure stability. A digital phase lock system is used to precisely control aural frequency.

The aural IF signal is combined with an upconversion signal supplied by the visual exciter to generate the "on channel" aural carrier. The signal is then amplified to a power level of five watts by an untuned, broadband, solid-state stripline amplifier. Special circuitry is provided to disable the aural amplifier during EBS tests.

OPERATING CONTROLS: Both exciters are provided with a full complement of operating controls. Motor driven video gain, pedestal, visual power and aural power controls are standard for remote control operation. The unique miniature motor drive used on the controls allows the use of auxiliary control knobs on the front panels.

Multi-turn indicating knobs are used on both the visual and aural exciters for adjusting frequency. The control on the visual exciter changes the master oscillator frequency, which results in an identical change in both visual and aural output frequencies. The control on the aural exciter adjusts the aural frequency for proper intercarrier separation of 4.5 MHz.

Front panel multimeters are used on both exciters for monitoring operating parameters.

UHF Television Exciter/Driver

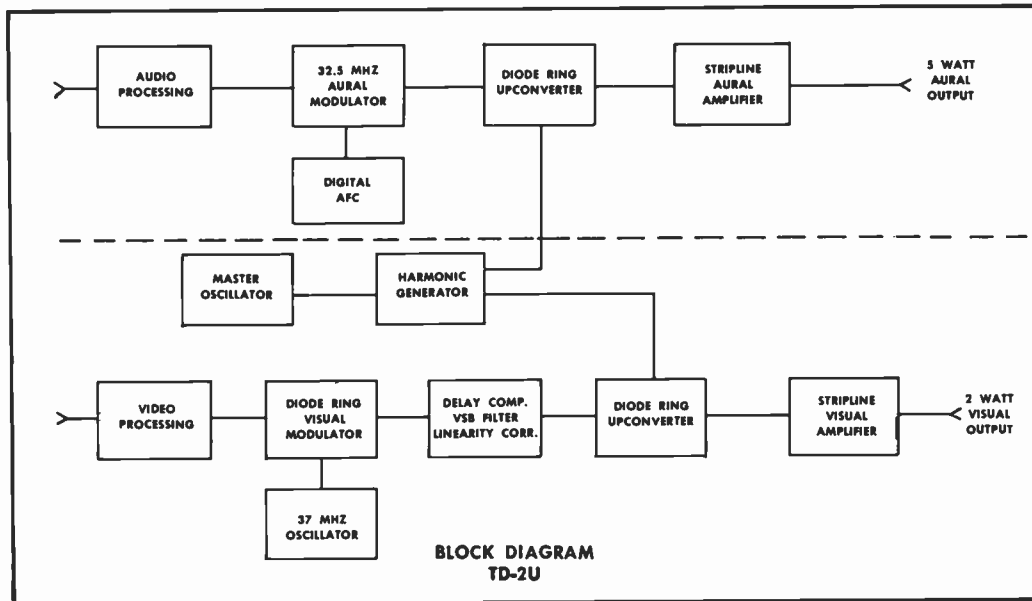

SPECIFICATIONS

VISUAL PERFORMANCE

OUTPUT POWER: 2 watts nominal (peak of sync).

OUTPUT IMPEDANCE: 50 ohms. Output connector: BNC.

FREQUENCY RANGE: 470-890 MHz (Channels 14-83). (CCIR bands IV, V.)

CARRIER STABILITY: ± 250 Hz (Maximum variation over 30 days).

REGULATION OF RF OUTPUT POWER (Black to white picture): Less than 3%.

VARIATION OF OUTPUT: Over one frame: less than 2%.

VISUAL SIDEBAND RESPONSE:

+4.75 MHz and higher.....	-20 dB or better.
Carrier to +4.18 MHz.....	+0.5, -1 dB.
Carrier.....	0 dB reference.
Carrier to -0.5 MHz.....	+0.5, -1 dB.
-1.25 MHz and lower.....	-20 dB or better.

FREQUENCY RESPONSE VS. BRIGHTNESS: ± 0.75 dB (Measured at 65% and 15% of modulation. Reference 100% = peak of sync.)

VISUAL MODULATION CAPABILITY: 3% or better.

DIFFERENTIAL GAIN: 0.2 dB or better (Maximum variation of sub-carrier amplitude from 75 to 10% of modulation. Sub-carrier modulation percentage: 10% peak to peak).

LINEARITY (LOW FREQUENCY): 0.1 dB or better.

DIFFERENTIAL PHASE: $\pm 2^\circ$ or better (Maximum variation of sub-carrier phase with respect to burst for modulation percentage from 75 to 10%. Sub-carrier modulation percentage: 10% peak to peak).

SIGNAL-TO-NOISE RATIO: -50 dB or better (RMS) below sync level.

K FACTORS: 2t 2%, 20t 3%.

ENVELOPE DELAY:

.05 to 2.1 MHz:	± 70 ns	} Reference to standard curve—FCC.
at 3.58 MHz:	± 35 ns	
at 4.18 MHz:	± 70 ns	

VIDEO INPUT LEVEL: 1.0 volt peak to peak ± 3 dB, sync negative.

HARMONIC RADIATION: -60 dB.

AURAL PERFORMANCE

AUDIO INPUT: +10 dBm, ± 2 dB into 600 ohms.

INPUT IMPEDANCE: 600/150 ohms.

PRE-EMPHASIS: 75 microseconds.

FREQUENCY RESPONSE: ± 0.5 dB relative to pre-emphasis (30-15,000 Hz).

DISTORTION: 0.5% or less after 75 microseconds de-emphasis with ± 25 kHz deviation.

FM NOISE: -60 dB relative to ± 25 kHz deviation.

AM NOISE: -60 dB relative to 100% modulation (measured after de-emphasis).

OUTPUT IMPEDANCE: 50 ohms, output connector BNC.

FREQUENCY STABILITY: ± 250 Hz (maximum variation over 30 days).

OUTPUT POWER: 5 watts.

SERVICE CONDITIONS

AMBIENT TEMPERATURE: -10° to +50°C. (14° to 122°F.)

AMBIENT HUMIDITY RANGE: 0 to 100% relative humidity.

PHYSICAL DIMENSIONS: Visual exciter: 5 $\frac{3}{8}$ " H. x 22 $\frac{1}{2}$ " D. x 24" W.
Aural exciter: 3 $\frac{1}{2}$ " H. x 20 $\frac{1}{4}$ " D. x 24" W.

WEIGHT: Visual exciter: 37 lbs. Aural exciter: 27 lbs.

AC INPUT POWER: 110/130 volts, single phase, 60 Hz.

AC POWER CONSUMPTION: Visual: 200 watts. Aural: 160 watts.

ORDERING INFORMATION

Model TD-2U UHF exciter/driver, includes visual exciter and aural exciter.....994-6806-001

55,000 Watt UHF Color Television Transmitter



MODEL BT-55U

Employing IF MODULATION for the finest color reproduction available today, Gates' FCC type accepted BT-55U 55 kW UHF transmitter is entirely solid state, except for klystron visual and aural output amplifiers.

Modulation of the visual and aural carriers occurs at a relatively low IF frequency, where all signal processing and shaping is accomplished at extremely low power levels. This exclusive Gates IF system establishes absolute control over all critical signal characteristics to provide superb transmission quality.

VISUAL AND AURAL EXCITERS: The BT-55U utilizes Gates' TD-2U exciter/driver, consisting of two drawer-mounted solid-state units. These units directly drive the visual and aural klystron amplifiers with a nominal 2-watt visual output and a 5-watt aural output. (See TD-2U, pages 102-103.)

KLYSTRONS: Two identical five-cavity vapor-cooled klystrons are used in the BT-55U. Each klystron requires less than one watt of drive power to develop full power output. The kly-

strons are housed in separate cabinets, containing identical control logic, magnet supplies and overload sensors, and operate independently of one another. Installation or replacement of klystrons can be accomplished rapidly by one man.

HEAT EXCHANGER: The BT-55U employs a unitized heat exchanger, which contains the cooling cores, blower and motor, circulating pump, storage tank, and control devices. The cooling system is a departure from conventional designs that use individual components that must be installed separately.

REMOTE CONTROL: All control circuitry in the BT-55U is of solid-state digital logic design, which simplifies remote control operation. All control commands require only a momentary contact closure. Remote metering samplers are provided for monitoring operating parameters. Several readily accessible terminal strips allow convenient connection to a remote control system.

INSTALLATION: The Gates "building block" concept of transmitter construction simplifies installation and minimizes floor space requirements.

55,000 Watt UHF Color Television Transmitter

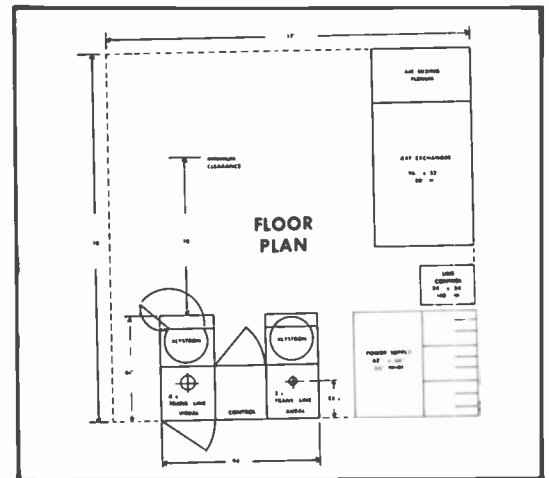
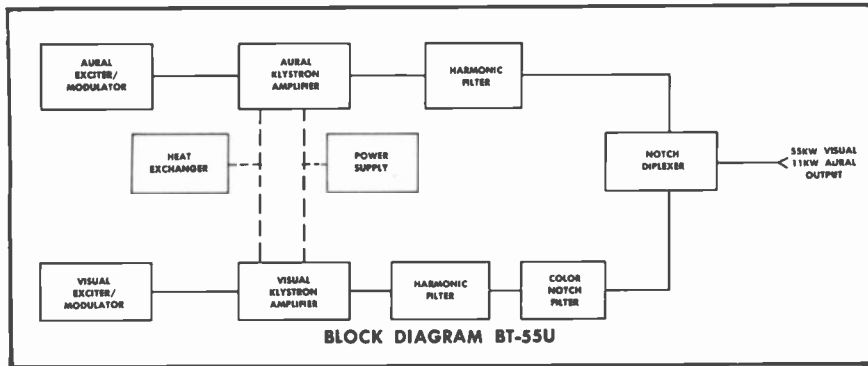

SPECIFICATIONS

VISUAL PERFORMANCE

OUTPUT POWER: 55 kW (Peak of Sync). (FCC and CCIR systems B, M.)
OUTPUT IMPEDANCE: 50 ohms. Output connector: 6 1/8" EIA std.
FREQUENCY RANGE: 470-890 MHz, (Channels 14-83). (CCIR bands IV, V.)
CARRIER STABILITY: ±250 Hz (Maximum variation over 30 days).
REGULATION OF RF OUTPUT POWER (Black to White Picture): Less than 3%.
VARIATION OF OUTPUT: Over one frame: less than 2%.

VISUAL SIDEBAND RESPONSE:

+4.75 MHz and higher	-----	-20 dB or better.
Carrier to +4.18 MHz	-----	+0.5, -1 dB.
Carrier	-----	0 dB reference.
Carrier to -0.5 MHz	-----	+0.5, -1 dB.
-1.25 MHz and lower	-----	-20 dB or better.
-3.58 MHz	-----	-42 dB or better.

Corner frequencies scaled to meet CCIR standards.

FREQUENCY RESPONSE VS. BRIGHTNESS: ±0.75 dB (Measured at 65% and 15% of modulation. Reference 100% = peak of sync.)

VISUAL MODULATION CAPABILITY: 3% or better.

DIFFERENTIAL GAIN: 0.5 dB or better (Maximum variation of sub-carrier amplitude from 75 to 10% of modulation. Sub-carrier modulation percentage: 10% peak to peak).

LINEARITY (LOW FREQUENCY): 0.5 dB or better.

DIFFERENTIAL PHASE: ±4° or better (Maximum variation of sub-carrier phase with respect to burst for modulation percentage from 75 to 10%. Sub-carrier modulation percentage: 10% peak to peak).

SIGNAL-TO-NOISE RATIO: -50 dB or better (RMS) below sync level.

K FACTORS: 2t 2%, 20t 3%.

ENVELOPE DELAY:

.05 to 2.1 MHz:	±70 ns	} Reference to standard curve—FCC.
at 3.58 MHz:	±35 ns	
at 4.18 MHz:	±70 ns	

VIDEO INPUT: Bridging, loop through input with -30 dB or better return loss up to 5.5 MHz, 75 ohm system.

VIDEO INPUT LEVEL: 1.0V Peak to Peak ±3 dB, sync negative.

HARMONIC RADIATION: -80 dB.

AURAL PERFORMANCE

AUDIO INPUT: +10 dBm, ±2 dB into 600 ohms.

INPUT IMPEDANCE: 600/150 ohms.

PRE-EMPHASIS: 75 microseconds.

FREQUENCY RESPONSE: ±0.5 dB relative to pre-emphasis (30-15,000 Hz).
DISTORTION: 0.5% or less after 75 microseconds de-emphasis with ±25 kHz deviation.

FM NOISE: -59 dB relative to ±25 kHz deviation.

AM NOISE: -55 dB relative to 100% modulation (measured after de-emphasis).

OUTPUT IMPEDANCE: 50 ohms, output connector 3 1/8" EIA std.

FREQUENCY STABILITY: ±250 Hz (Maximum variation over 30 days).

OUTPUT POWER: 5.5 kW to 11 kW (Measured at the output of the Diplexer).

SERVICE CONDITIONS

AMBIENT TEMPERATURE: +2° to +50°C. (36° to 122°F.)

AMBIENT HUMIDITY RANGE: 0 to 100% relative humidity.

ALTITUDE: Sea level to 7500 ft.

KLYSTRONS

TYPES:

Low Band (Channels 14-29) (470-566 MHz), VA 953B.
 Mid Band (Channels 30-51) (566-698 MHz), VA 954B.
 High Band (Channels 52-83) (698-890 MHz), VA 955B.

ELECTRICAL

AC INPUT POWER: 440/460/480 Volts, 3 Phase 60 Hz. (380 Volts 50 Hz available).

AC POWER CONSUMPTION (Black Picture): 20% Aural, 230 kW; 10% Aural, 210 kW. Power Factor: 100%. Regulation: 3%. Phase Unbalance: 2%.

DIMENSIONS

TRANSMITTER: 94 1/2" W. x 63" D. x 72" H. Weight: 4100 lbs.

POWER SUPPLY: 66" W. x 62" D. x 66" H. Weight: 9200 lbs.

HEAT EXCHANGER: 96" W. x 52" D. x 80" H. Weight 4000 lbs.

ORDERING INFORMATION

BT-55U 55 kW UHF-TV transmitter, with operating klystrons, transistors, IC's, solid-state rectifiers, crystals, required pre-correction circuitry, low-level vestigial sideband filter, harmonic and color notch filters and notch diplexer..... 994-6748-001

110,000 Watt UHF Color Television Transmitter



MODEL BT-110U

Gates' BT-110U includes two visual klystron cabinets, one aural klystron cabinet, two control cabinets, two high voltage power supplies and two unitized heat exchangers.

Three identical klystrons are used for the high power visual and aural amplifiers. Each of the visual amplifiers operates at a 55 kW power level, and the outputs are added together in a hybrid combiner to produce a total output of 110 kW. The aural klystron is capable of producing up to 22 kW at the output of the diplexer.

The paralleled visual amplifiers provide redundancy. If one visual stage should fail, output power will automatically drop to 25% of the total output power with no carrier interruption. The defective stage may be repaired with no loss of air time. Should the aural amplifier stage fail, the aural and visual exciters can be multiplexed through the visual amplifiers for emergency operation.

VISUAL AND AURAL EXCITERS (TD-2U): The visual exciter employs IF MODULATION and IF bandpass shaping to generate a standard vestigial sideband signal at an IF frequency of 37 MHz. A special corrector, operating at the IF frequency, compensates for inherent klystron non-linearities.

The diode ring modulator, exhibiting exceptionally good phase and linearity characteristics, modulates the IF carrier at low power levels for unsurpassed color performance. Modulation capability exceeds 3% for all video frequencies, so that even highly saturated yellow or cyan may be transmitted with no loss of fidelity.

A varicap modulated direct FM system generates a standard television aural signal at an IF frequency of 32.5 MHz in the aural exciter. Frequency response and distortion characteristics are excellent.

Both exciters utilize a common master oscillator to convert the IF signals up to the desired UHF channel. (For more complete information on Gates' TD-2U exciter/driver see pages 102-103.)

KLYSTRONS: High gain klystrons, containing five internal cavities, amplify the exciter outputs to the proper power levels. The klystrons are mounted in special mechanical assemblies which pivot to allow easy installation. Vapor cooling is used with two completely self-contained heat exchangers provided.

POWER SUPPLIES: Two unitized supplies are employed to power the BT-110U. Each polyphase supply contains a high voltage transformer, filter choke, filter capacitor, solid-state rectifiers and transient protectors—all sealed in oil for cooling and insulation. An access plate is provided for inspection and maintenance.

GENERAL: Gates' unique "building block" concept, in which major components are housed in functional modules, greatly simplifies transmitter assembly and installation, while providing total redundancy.

110,000 Watt UHF Color Television Transmitter

SPECIFICATIONS

VISUAL PERFORMANCE

OUTPUT POWER: 110 kW (peak of sync). (FCC and CCIR systems B, M.)
OUTPUT IMPEDANCE: 50 ohms. Output connector: 6 1/4" EIA std.
FREQUENCY RANGE: 470-890 MHz, (Channels 14-83). (CCIR bands IV, V.)
CARRIER STABILITY: ± 250 Hz (Maximum variation over 30 days).
REGULATION OF RF OUTPUT POWER (Black to White Picture): Less than 3%.
VARIATION OF OUTPUT: Over one frame: less than 2%.
VISUAL SIDEBAND RESPONSE:
 +4.75 MHz and higher ----- -20 dB or better.
 Carrier to +4.18 MHz ----- +0.5, -1 dB.
 Carrier ----- 0 dB reference.
 Carrier to -0.5 MHz ----- +0.5, -1 dB.
 -1.25 MHz and lower ----- -20 dB or better.
 -3.58 MHz ----- -42 dB or better.
 Corner frequencies scaled to meet CCIR standards.

FREQUENCY RESPONSE VS. BRIGHTNESS: ± 0.75 dB (Measured at 65% and 15% of Modulation. Reference 100% = peak of sync).

VISUAL MODULATION CAPABILITY: 3% or better.

DIFFERENTIAL GAIN: 0.5 dB or better (Maximum variation of sub-carrier amplitude from 75 to 10% of modulation. Sub-carrier modulation percentage: 10% peak to peak).

LINEARITY (LOW FREQUENCY): 0.5 dB or better.

DIFFERENTIAL PHASE: $\pm 4^\circ$ or better (Maximum variation of sub-carrier phase with respect to burst for modulation percentage from 75 to 10%. Sub-carrier modulation percentage: 10% peak to peak).

SIGNAL-TO-NOISE RATIO: -50 dB or better (RMS) below sync level.

K FACTORS: 2t 2%, 20t 3%.

ENVELOPE DELAY:

.05 to 2.1 MHz: ± 70 ns	} Reference to standard curve—FCC.
at 3.58 MHz: ± 35 ns	
at 4.18 MHz: ± 70 ns	

VIDEO INPUT: Bridging, loop through input with -30 dB or better return loss up to 5.5 MHz, 75 ohm system.

VIDEO INPUT LEVEL: 1.0V Peak to Peak ± 3 dB, sync negative.

HARMONIC RADIATION: -80 dB.

AURAL PERFORMANCE

AUDIO INPUT: +10 dBm, ± 2 dB into 600 ohms.

INPUT IMPEDANCE: 600/150 ohms.

PRE-EMPHASIS: 75 microseconds.

FREQUENCY RESPONSE: ± 0.5 dB relative to pre-emphasis (30-15,000 Hz).

DISTORTION: 0.5% or less after 75 microseconds de-emphasis with ± 25 kHz deviation.

FM NOISE: -59 dB relative to ± 25 kHz deviation.

AM NOISE: -55 dB relative to 100% modulation (measured after de-emphasis).

OUTPUT IMPEDANCE: 50 ohms, output connector 6 1/4" EIA std.

FREQUENCY STABILITY: ± 250 Hz (Maximum variation over 30 days).

OUTPUT POWER: 11 kW to 22 kW (Measured at the output of the Diplexer).

SERVICE CONDITIONS

AMBIENT TEMPERATURE: +2° to +50°C. (36° to 122°F.)

AMBIENT HUMIDITY RANGE: 0 to 100% relative humidity.

ALTITUDE: Sea level to 7500 ft.

KLYSTRONS

TYPES:

Low Band (Channels 14-29) (470-566 MHz), VA 953B.
 Mid Band (Channels 30-51) (566-698 MHz), VA 954B.
 High Band (Channels 52-83) (698-890 MHz), VA 955B.

ELECTRICAL

AC INPUT POWER: 440/460/480 Volts, 3 phase 60 Hz. (380 Volts 50 Hz available).

AC POWER CONSUMPTION (Black Picture): 20% Aural, 460 kW. 10% Aural, 430 kW. Power Factor: 100%. Regulation: 3%. Phase Unbalance: 2%.

DIMENSIONS

TRANSMITTER: 157 1/2" W. x 63" D. x 72" H. Weight: 6550 lbs.

POWER SUPPLIES (2): Each 66" W. x 62" D. x 66" H. Weight of each: 9200 lbs.

HEAT EXCHANGERS (2): Each: 96" W. x 52" D. x 80" H. Weight of each: 4000 lbs.

ORDERING INFORMATION

BT-110U 110 kW UHF-TV transmitter, with operating klystrons, transistors, IC's, solid-state rectifiers, crystals, required pre-correction circuitry, low-level vestigial sideband filter, harmonic and color notch filters and notch diplexer.....994-6749-001

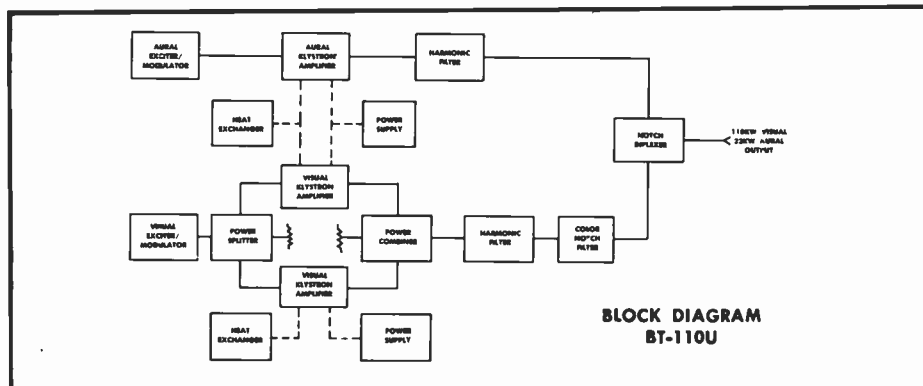

BLOCK DIAGRAM
BT-110U

220,000 Watt UHF Color Television Transmitter

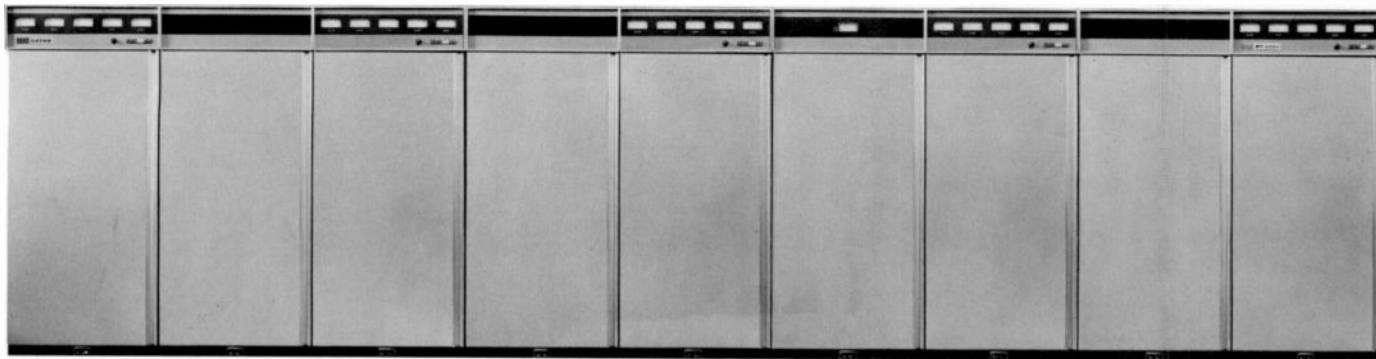

MODEL BT-220U

The BT-220U is the first 220 kW UHF television transmitter ever built. Featuring Gates' exclusive IF MODULATION for outstanding color performance, this transmitter provides 220,000 watts visual and 22,000 watts aural output with only five high gain klystron amplifiers. Except for the klystrons, all other circuitry in the BT-220U is solid-state for stable operation and highest reliability.

VISUAL: The visual amplifier system consists of four 55 kW klystrons operating in a parallel tandem configuration. Two klystrons are paralleled to produce a 110 kW output, which is combined with the output of the other two paralleled klystrons to produce a total output of 220 kW. Should one klystron fail, the transmitter will stay on the air, although the output power will automatically drop to 56% of its operating level.

Each klystron has completely independent control logic and high voltage switching so that one klystron may be removed from the system without disabling the transmitter. Individual klystron installation or replacement can be accomplished rapidly by one man.

Low level IF MODULATION is used to generate a high quality IF signal in the visual exciter. A unique linearity corrector processes the IF signal to compensate for inherent klystron non-linearities. This allows transmitter output power to be varied without requiring complete readjustment of the signal processing system.

AURAL: A single vapor-cooled klystron, with five internal cavities, is used as the aural amplifier. This klystron is identical to those used in the visual amplifier system. A solid-state direct FM exciter, with up to 5 watts output, provides the aural drive power.

For a complete description of the visual and aural exciters, see the TD-2U, pages 102-103.

PROTECTIVE CIRCUITRY: Maximum transmitter protection is provided by a complete system of voltage, current and temperature sensors. Solid-state control logic is used to drive high speed vacuum contactors, which provide instantaneous interruption of primary power to prevent transmitter damage due to an overload condition. The transmitter will automatically recycle three times. If a fourth overload occurs within a 60-second time period, the transmitter will shut down until the overload condition is corrected and the protective circuitry is reset.

METERING: Complete metering is provided to monitor transmitter operating parameters. The eye-level 4-inch meters are located on the front of the transmitter cabinets for easy reading. All meter panels are hinged to allow instant access for inspection and maintenance.

GENERAL: Individual unitized power supplies and heat exchangers are furnished for each visual klystron amplifier. The oil-filled power supplies contain a high voltage transformer, rectifier diodes, filter capacitor, filter choke and transient protective circuitry. The supplies utilize a polyphase rectifier system which provides an extremely pure DC output.

The heat exchangers are self-contained cooling systems. Each houses the cooling cores, a circulating pump, a blower, a storage tank, and temperature sensing control circuitry.

All connections for interfacing the BT-220U with a remote control system are provided on readily accessible terminal strips.

The entire transmitter is easily accessible from the front and back. Both visual and aural exciters slide out and can operate independently from the other transmitter stages outside the main cabinet.

220,000 Watt UHF Color Television Transmitter

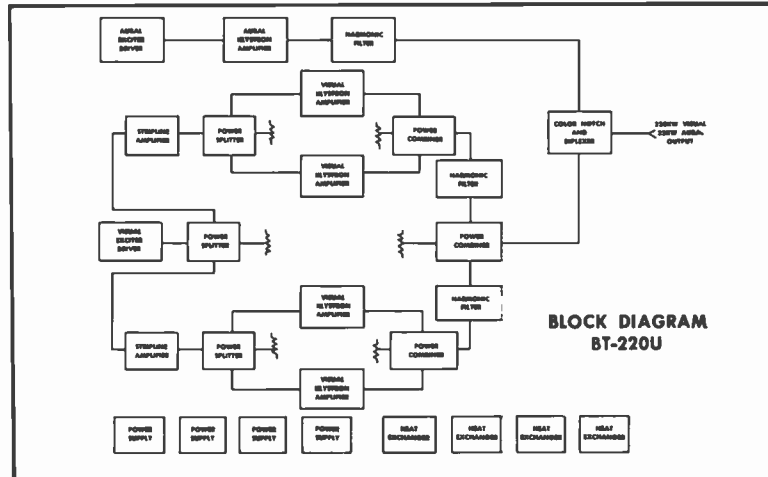

SPECIFICATIONS

VISUAL PERFORMANCE

OUTPUT POWER: 220 kW (peak of sync). (FCC and CCIR systems B, M.)
OUTPUT IMPEDANCE: 50 ohms. Output connector: 6 1/4" EIA std.
FREQUENCY RANGE: 470-890 MHz, (Channels 14-83). (CCIR bands IV, V.)
CARRIER STABILITY: ±250 Hz (Maximum variation over 30 days).
REGULATION OF RF OUTPUT POWER (Black to White Picture): Less than 3%.

VARIATION OF OUTPUT: Over one frame: less than 2%.

VISUAL SIDEBAND RESPONSE:

+4.75 MHz and higher	-20 dB or better.
Carrier to +4.18 MHz	+0.5, -1 dB.
Carrier	0 dB reference.
Carrier to -0.5 MHz	+0.5, -1 dB.
-1.25 MHz and lower	-20 dB or better.
-3.58 MHz	-42 dB or better.

Corner frequencies scaled to meet CCIR standards.

FREQUENCY RESPONSE VS. BRIGHTNESS: ±0.75 dB (Measured at 65% and 15% of Modulation. Reference 100% = peak of sync).

VISUAL MODULATION CAPABILITY: 3% or better.

DIFFERENTIAL GAIN: 0.5 dB or better (Maximum variation of sub-carrier amplitude from 75 to 10% of modulation. Sub-carrier modulation percentage: 10% peak to peak).

LINEARITY (LOW FREQUENCY): 0.5 dB or better.

DIFFERENTIAL PHASE: ±4° or better (Maximum variation of sub-carrier phase with respect to burst for modulation percentage from 75 to 10%. Sub-carrier modulation percentage: 10% peak to peak).

SIGNAL-TO-NOISE RATIO: -50 dB or better (RMS) below sync level.

K FACTORS: 2t 2%, 20t 3%.

ENVELOPE DELAY:

.05 to 2.1 MHz:	±70 ns	} Reference to standard curve—FCC.
at 3.58 MHz:	±35 ns	
at 4.18 MHz:	±70 ns	

VIDEO INPUT: Bridging, loop through input with -30 dB or better return loss up to 5.5 MHz, 75 ohm system.

VIDEO INPUT LEVEL: 1.0V Peak to Peak ±3 dB, sync negative.

HARMONIC RADIATION: -80 dB.

AURAL PERFORMANCE

AUDIO INPUT: +10 dBm, ±2 dB into 600 ohms.

INPUT IMPEDANCE: 600/150 ohms.

PRE-EMPHASIS: 75 microseconds.

FREQUENCY RESPONSE: ±0.5 dB relative to pre-emphasis (30-15,000 Hz).

DISTORTION: 0.5% or less after 75 microseconds de-emphasis with ±25 kHz deviation.

FM NOISE: -59 dB relative to ±25 kHz deviation.

AM NOISE: -55 dB relative to 100% modulation (measured after de-emphasis).

OUTPUT IMPEDANCE: 50 ohms, output connector 6 1/4" EIA std.

FREQUENCY STABILITY: ±250 Hz (Maximum variation over 30 days).

OUTPUT POWER: 22 kW (Measured at the output of the diplexer).

SERVICE CONDITIONS

AMBIENT TEMPERATURE: +2° to +50°C. (36° to 122° F.)

AMBIENT HUMIDITY RANGE: 0 to 100% relative humidity.

ALTITUDE: Sea level to 7500 ft.

KLYSTRONS

TYPES:

Low Band (Channels 14-29) (470-566 MHz), VA 953B.
 Mid Band (Channels 30-51) (566-698 MHz), VA 954B.
 High Band (Channels 52-83) (698-890 MHz), VA 955B.

ELECTRICAL

AC INPUT POWER: 440/460/480 Volts, 3 Phase 60 Hz. (380 Volts 50 Hz available.)

AC POWER CONSUMPTION (Black Picture): 10% aural, 920 kW. Power factor: 100%. Regulation: 3%. Phase Unbalance: 2%.

DIMENSIONS

TRANSMITTER: 29 1/2" W. x 63" D. x 72" H. Weight: 12,000 lbs.

POWER SUPPLIES (4): Each 66" W. x 62" D. x 66" H. Weight of each: 9200 lbs.

HEAT EXCHANGERS (4): Each 96" W. x 52" D. x 80" H. Weight of each: 4000 lbs.

ORDERING INFORMATION

BT-220U 220 kW UHF-TV transmitter, with operating klystrons, transistors, IC's, solid-state rectifiers, crystals, required pre-correction circuitry, low-level vestigial sideband filter, harmonic and color notch filters and notch diplexer.....994-6777-001

Television Accessory Equipment

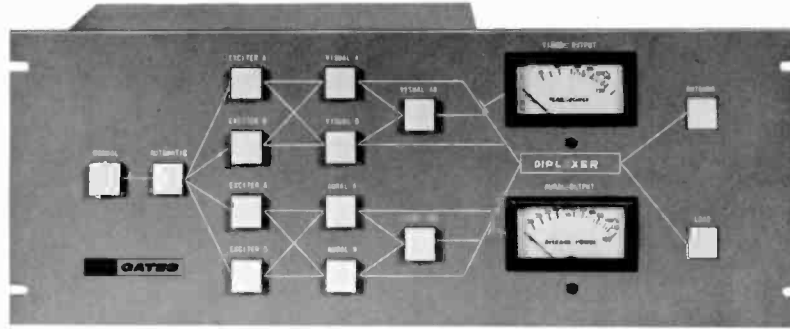

MULTIPLE TV TRANSMITTER SYSTEM CONTROL AND SWITCHING PANEL

The Transmitter System Control and Switching Panel is designed for use with multiple transmitter system installations:

- A. Main and standby transmitters.
- B. Parallel transmitters operating full power.
- C. Parallel transmitters operating half power.

(Similar control systems are available for: three transmitters—two operating full power with a spare third transmitter; or, three transmitters—two operating half power, and a spare third for full power or half power operation.)

A unique system control panel is used to select on-air transmitter combinations and show transmitter status by lighted pushbuttons. It also contains two meters for monitoring visual and aural combined transmitter output powers.

When used in a parallel transmitter system, one exciter will drive the transmitter or transmitters selected for operation

while the other exciter will be fed into a dummy load or the inoperative transmitter for testing.

Transmitter A, B or A+B can be selected for on-air operation by depressing the appropriate pushbutton and the desired system will be in operation in less than two seconds. If transmitter A is selected for operation, transmitter B is automatically routed to the dummy load and may be operated with the unused exciter for test purposes. Selecting transmitter B for on-air operation will allow A to be tested.

The system utilizes low power coaxial transmitter input switching; high power coaxial RF output switching; solid-state input and output switching control logic; RF phasing controls; and system interconnection circuitry.

ORDERING INFORMATION

Multiple TV Transmitter System Control and Switching Panel. Includes: system control panel, RF phasing panel, input switching and control logic housing, interconnecting cables and output combining and switching assembly-----

994-6798-000

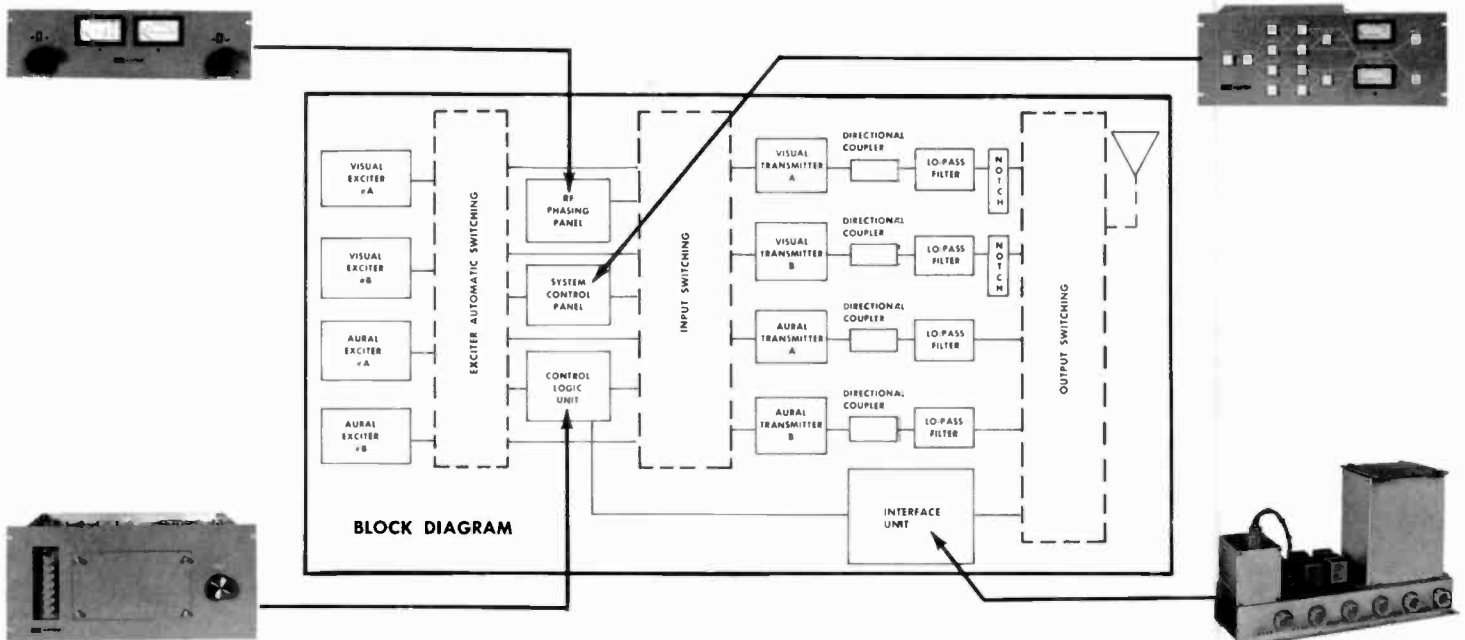

Television Accessory Equipment

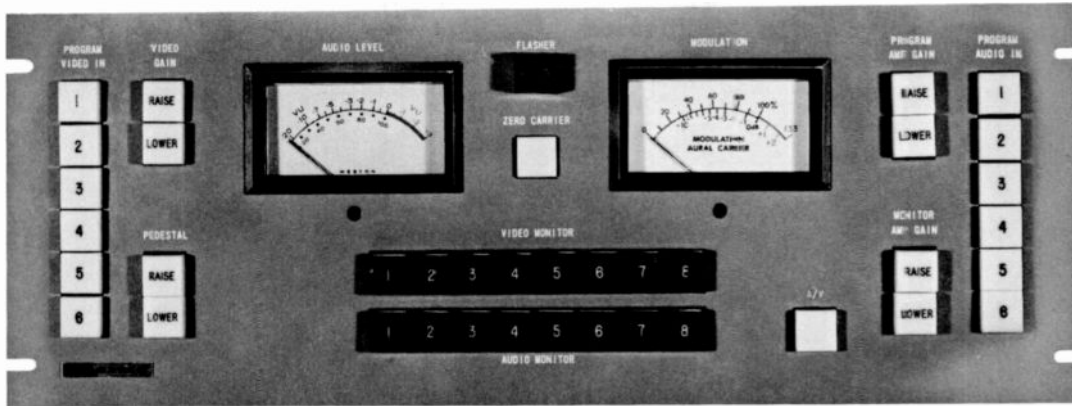

TV TRANSMITTER AUDIO/VIDEO PROGRAM CONTROL AND MONITORING PANEL

Gates' TV Transmitter Audio/Video Program Control Panel consists of a control panel and a rack-mounted electronics frame. The control panel contains pushbuttons for the control of six audio inputs, six video inputs, eight audio and eight video monitoring points as well as control of video level, pedestal level, audio gain and audio monitor gain. The panel

also contains meters for audio input and percentage of modulation along with an over-modulation percentage indicator.

The rack-mounted electronics frame houses all of the active circuit components to control the signals as commanded from the control panel.

SPECIFICATIONS

INPUTS: Six, 75 ohm video; six, high impedance audio; eight, 75 ohm video monitoring; eight, high impedance audio monitoring; VU meter; modulation percentage meter; over-modulation percentage indicator.

OUTPUTS: Two, 75 ohm video; two, 600 ohm audio; two, 75 ohm video monitor; and an 8 ohm, 10 watt audio monitor.

VIDEO INPUT LEVEL: 1.0 volt peak to peak.

AUDIO INPUT LEVEL: 0 dBm.

VIDEO MONITOR INPUT: 1.0 volt peak to peak.

AUDIO MONITOR INPUT: 0 dBm.

VIDEO OUTPUT: 1.0 volt peak to peak.

AUDIO OUTPUT: +10 dBm.

VIDEO MONITOR OUTPUT: 1.0 volt peak to peak.

AUDIO MONITOR OUTPUT: 10 watts into 8 ohms.

ORDERING INFORMATION

TV Transmitter Audio/Video Program Control and Monitoring Panel.....994-6795-000

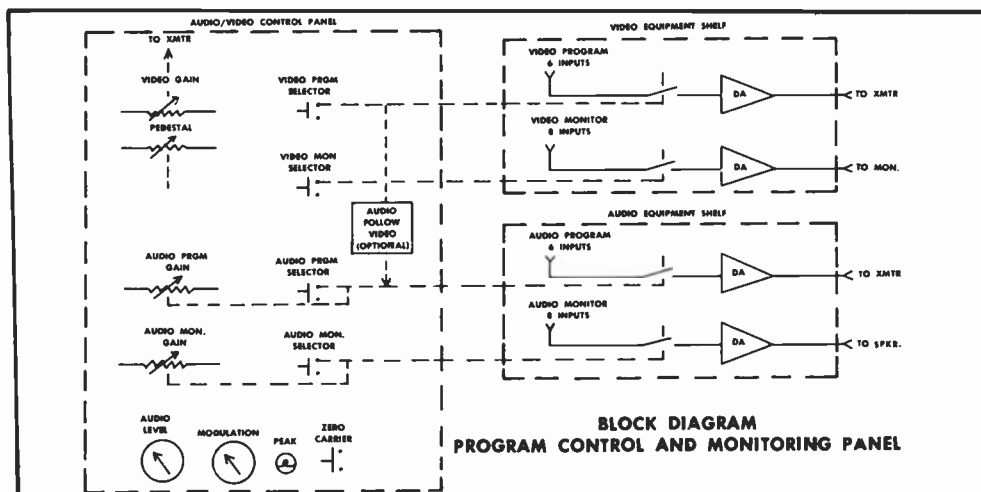

Television Accessory Equipment

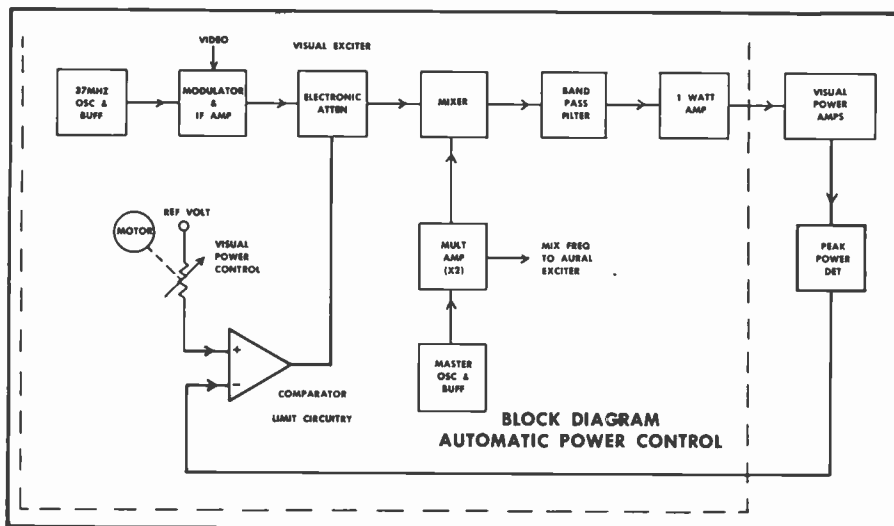

TV TRANSMITTER AUTOMATIC POWER CONTROL

Gates' TV transmitter Automatic Power Control will automatically maintain transmitter output power at a predetermined level. It may be used with either visual or aural transmitters in single or paired transmitter installations.

The device, by means of an electronic attenuator located in the IF signal path, automatically adjusts system gain so that the sample voltage from the peak power detector is exactly the same as the reference voltage from the power control.

Automatic control is limited to approximately 2 dB in the positive direction to warn of abnormal decreases in system gain. Once the upper limit is reached, the control supplies a contact closure or a voltage to trigger an alarm. The response time for power corrections is 100 milliseconds.

ORDERING INFORMATION

TV Transmitter Automatic Power Control.....994-6797-000

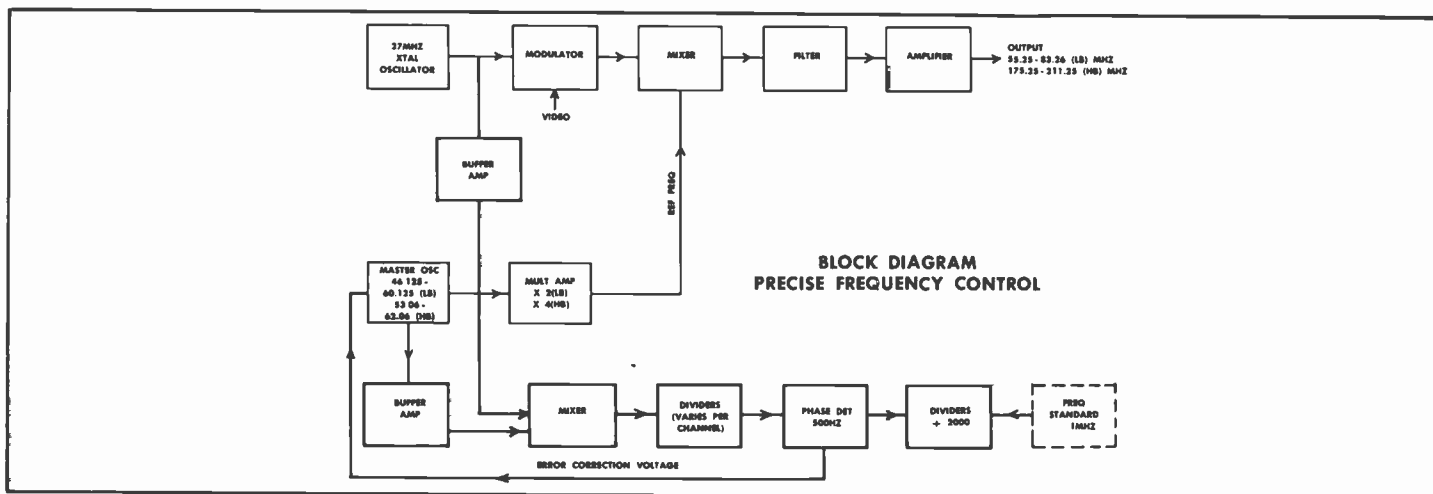

TV TRANSMITTER PRECISE FREQUENCY CONTROL

Extremely accurate control of the visual carrier is provided by the Gates Precise Frequency Control to minimize co-channel interference.

The visual carrier is phase locked to a customer-provided external standard reference oscillator. The reference standard operates near 1 MHz and is divided to approximately 15 kHz to control the carrier phase lock circuitry. The stability of the reference standard determines the final visual carrier stability.

The phase lock circuitry is designed so that a failure of the external reference will only result in the exciter returning to its original frequency-determining elements and there will be no loss of carrier.

Systems using dual visual exciters require separate precise offset control modules in each exciter.

ORDERING INFORMATION

TV Transmitter Precise Frequency Control.....994-6760-000

Television Accessory Equipment

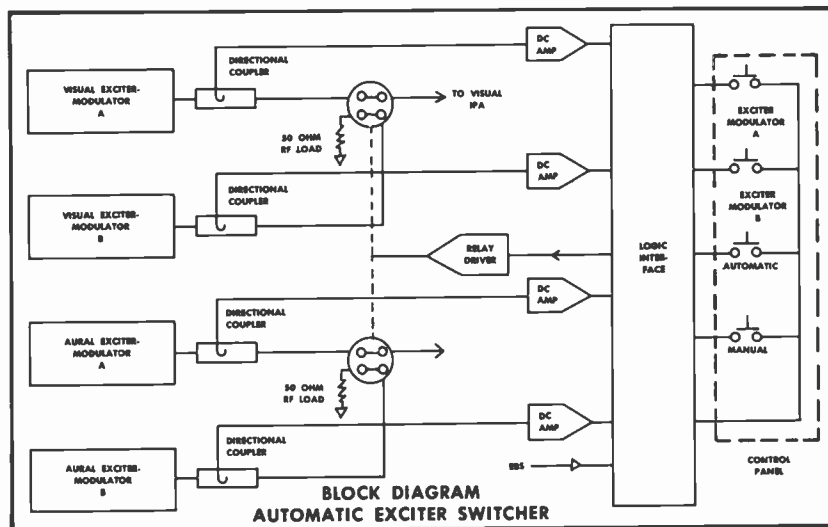

TV TRANSMITTER AUTOMATIC EXCITER SWITCHER

Gates' Automatic Exciter Switcher is designed to operate with two visual and two aural exciters. Exciter outputs are continuously monitored to detect operational status. Should the "on air" exciters fail, the standby exciter is immediately transferred to drive the transmitter. Complete switching is accomplished during one field of a standard television signal or in less than 20 milliseconds.

Only Gates can offer a system which will automatically and instantaneously switch a spare modulator, sideband filter,

delay compensator and phase-locked oscillator to an "on air" status without causing prolonged carrier interruptions.

Standby exciters are terminated in a small 50 ohm load which may be removed to connect the standby exciters to test or monitoring equipment.

ORDERING INFORMATION

Automatic Exciter Switcher.....994-6799-000

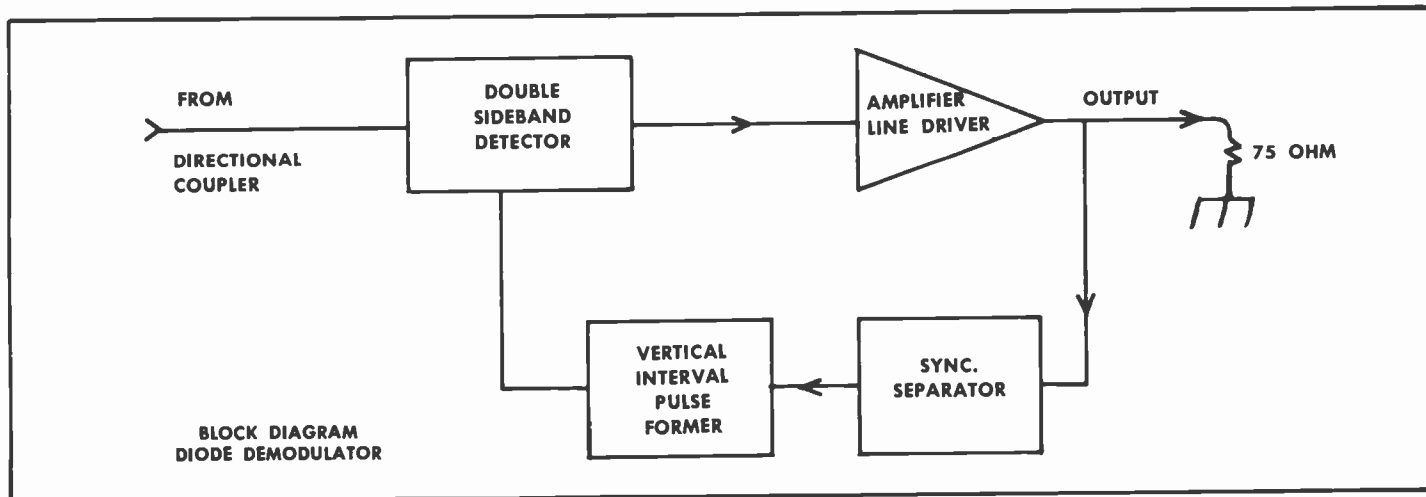

DIODE DEMODULATOR

This unit is a self-contained solid-state video detector. The video presentation from Gates' Diode Demodulator is a detected RF envelope for measuring modulation depth and for monitoring the RF output of a UHF or VHF visual television transmitter.

The depth of modulation is measured by comparing the instantaneous video waveform with a zero carrier reference pulse which occurs during the vertical blanking interval. The

reference pulse may be switched on or off manually or from a remote location.

A 4.5 MHz aural filter is provided to suppress the aural carrier. This filter may be switched in or out of the circuit. The Diode Demodulator is designed for continuous 24-hour-a-day operation.

ORDERING INFORMATION

Diode Demodulator.....994-6789-000

Television Accessory Equipment

RAK-80



Designed to complement Gates' television transmitter cabinetry, the RAK-80 is a highly flexible unit that can be used as a rack only, or as a complete cabinet with all accessories. Construction is extremely rugged, and there is not the slightest torsion in the doors or cabinet framework.

The basic RAK-80 cabinet assembly includes: two panel mounting angles; an air filter mounted in the rear of the cabinet base; convenient knock-outs for wiring in the bottom and sides of the base; and new EIA standard panel-mounting hole spacing.

The following are optional accessories with the RAK-80, and must be ordered separately: side panels; rear door with or without louvers; fan kit (includes 150-cfm base-mounted fan to maintain a constant, positive pressure inside the cabinet); and rear mounting angles.

SPECIFICATIONS

HEIGHT OVERALL: 72".

WIDTH: 22 $\frac{1}{8}$ " without side panels; 23 $\frac{1}{2}$ " with side panels.

DEPTH: 23 $\frac{3}{8}$ " with rear door; 24 $\frac{1}{8}$ " with front and rear door.

FINISH: Dark beige.

WEIGHT: (Maximum) 170 lbs.

ORDERING INFORMATION

Basic rack.....	994-6713-001
Side panel (fits right or left side).....	994-6714-001
Louvered top.....	994-6665-001
Door with louvers (fits front or rear, may be mounted to open right or left hand).....	994-6715-001
Door without louvers (fits front or rear, may be mounted to open right or left hand).....	994-6715-002
Fan kit.....	994-6717-001
Air filter (replacement).....	448-0288-001
Rear mounting angle kit (2 angles, No. 10 screws).....	994-6716-001

4 BY 1 RF MATRIX SWITCHER

The RF Matrix Switcher is designed to handle low level RF monitoring signals from 40 to 220 MHz. It contains relays to route signals from up to four RF monitoring probes into a common output.

Signals to the four inputs loop through the matrix and appear at the output only when a particular crosspoint is energized.

This enables RF probes to normally feed peak power indicators or test and monitoring equipment if the matrix crosspoints are activated.

The matrix may also be connected in reverse for feeding up to four test or monitoring inputs from one RF probe.

ORDERING INFORMATION

4 by 1 Matrix Switcher.....	994-6800-000
-----------------------------	--------------

Television Accessory Equipment

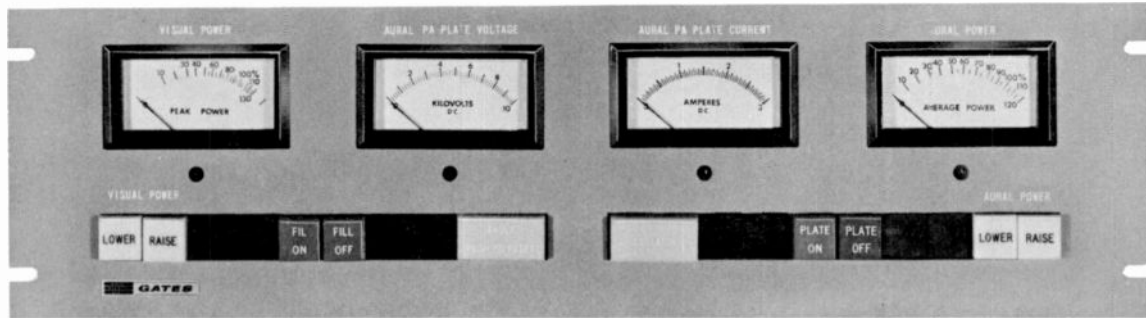

POWER CONTROL AND METERING PANEL

The Gates Power Control and Metering Panel affords complete operating control and monitoring of a television transmitter.

The panel allows the operator to control the aural and visual transmitters and make the required FCC meter readings at a point removed from the immediate transmitter location.

Four meters are included: visual power output meter, aural power output meter, PA plate voltage meter and aural PA plate current meter.

The control panel functions as an extension of the transmitter control logic and readily adapts itself for interfacing with a remote control system.

ORDERING INFORMATION

Power Control and Metering Panel.....994-6796-000

TOTAL SYSTEMS ENGINEERING

Gates not only manufactures the most modern television transmitters available today, but also supplies complete transmitter systems. Gates is ready to provide every item needed in a transmitter installation from antenna to STL, along with highly qualified technical support.

Each television transmitter installation includes tower, antenna, transmission line, transmitter, input, terminal and test equipment. These items must be compatible to function as a successful installation.

Tower, antenna and transmission line equipment should be carefully chosen to form a matched system. Tower height, antenna radiation characteristics and transmitter power determine station coverage, and must be optimized to efficiently reach a maximum number of viewers. Test, input, terminal and STL equipment should be selected to provide highly efficient operation and maximum control of the transmitter input signal. Gates' professional team of system engineers will provide assistance in selecting a tailored system to meet specific installation requirements and budgetary limits.

It is standard Gates procedure to test all television transmitters "on channel" at full rated power before shipment from the factory. After installation, every television transmitter receives on-site checkout by a field service engineer to certify proper installation and performance, and station engineers are given personalized instruction on transmitter operation.

Gates' staff of television field service engineers is immediately available to perform any on-site service from proof of performance to complete installation supervision. These engineers are equipped with the most modern test and measurement equipment to make complete on-site tests, including sophisticated antenna and transmission line measurements and analyses.

An extensive inventory of replacement parts is maintained throughout equipment service life. Emergency replacement parts and technical service are available on a continuous twenty-four hour basis.

Television Monitors

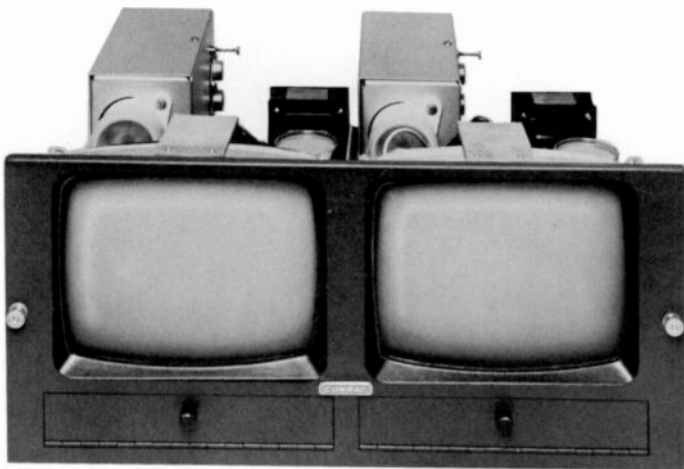

RND9/2R

Conrac RND9 series 9-inch transistorized monitors have high reliability, low power drain, small size, and generate a minimum of heat which could affect other equipment. They are full broadcast quality video monitors designed for continuous duty operation from broadcast, industrial or computer generated signals.

The RND9 series features a 9-inch Conrac-manufactured rectangular tube with excellent geometry and small spot size, assuring crisp 800 line center resolution and 700 line corner resolution.

SPECIFICATIONS

INPUT POWER: 65 watts at 120/240 volts 60 Hz (525/60 U.S.) or 50 Hz (625/50 CCIR). All performance specifications will be met while the line voltage varies from 105 to 130 or 210 to 260 volts AC. A three-wire line cord, 6 feet long, is provided.

VIDEO SIGNAL: 0.3 volt p-p (minimum for 50 volts at kinescope). Sync negative at monitor input.

VIDEO INPUT IMPEDANCE: High impedance bridging (equivalent to 100K in parallel with 22 pF) can be terminated by an internal 75 ohm load ($\pm 1\%$) through a switch located on rear apron.

VIDEO RESPONSE: 10 MHz ± 1 dB. Differential gain below 5% with 75 volts kinescope drive.

DC RESTORATION: 100% or zero, sync tip clamp.

EXTERNAL SYNC: 1 to 8 volts. Parallel connectors. Monitor will operate from either composite video and sync signals or separate external composite sync.

LINEARITY: Within 2% of picture height.

TRANSISTORS: The RND9 monitors utilize 30 transistors and 26 diodes on glass epoxy circuit boards. The high voltage rectifier is a 1B3/1G3.

KINESCOPE: 9SP4, 9-inch kinescope with laminated safety shield.

WEIGHT: Net, 50 lbs. Shpg. wt. 60 lbs.



RHA19

Conrac's RHA19 is a compact, 100% solid-state, professional color monitor designed to meet rigid broadcast studio requirements. It is available in a cabinet model, for mounting on slides in 19" racks (taking up only 21" of vertical space), or for pedestal or ceiling mounting. Its all solid-state circuitry provides maximum stability, long life, low power drain (250 watts) and a minimum of heat. Its modular design and quick-disconnect circuit boards permit rapid replacement of circuits and ease of maintenance.

A precision decoder allows reduction in operating controls to "Contrast" and "Brightness", while calibrated controls offer "pre-set" chroma and brightness positions. Both features make the RHA19 a standard for color setup.

SPECIFICATIONS

INPUT POWER: 250 watts at 120/240 volts 60 Hz (525/60 N.T.S.C.) or 50 Hz power input optional. All performance specifications will be met while the line voltage varies from 105 to 130 or from 210 to 260 volts AC. A three-wire line cord, six feet long, with twist lock disconnect, is furnished.

VIDEO SIGNAL: 0.35 volts p-p minimum. Sync negative at monitor input.

VIDEO INPUT IMPEDANCE: Two, high impedance bridging. Each can be terminated by an internal 75 ohm load through a switch located on the rear apron.

EXTERNAL SYNC: High impedance, 1-8 volts p-p, sync negative. Parallel co-ax input connectors.

VIDEO RESPONSE: Flat to 5 MHz in block and white position. A 3.58 MHz trap is automatically switched in during color operation while frequencies above 3.58 MHz are rolled off. Variable aperture correction from front panel controls.

LINEARITY: Within 2% of picture height.

KINESCOPE: A 19GWP22 tube, incorporating an etched laminated safety shield.

WEIGHT: Net, 101 lbs. Shpg. wt. 127 lbs.

Television Monitors

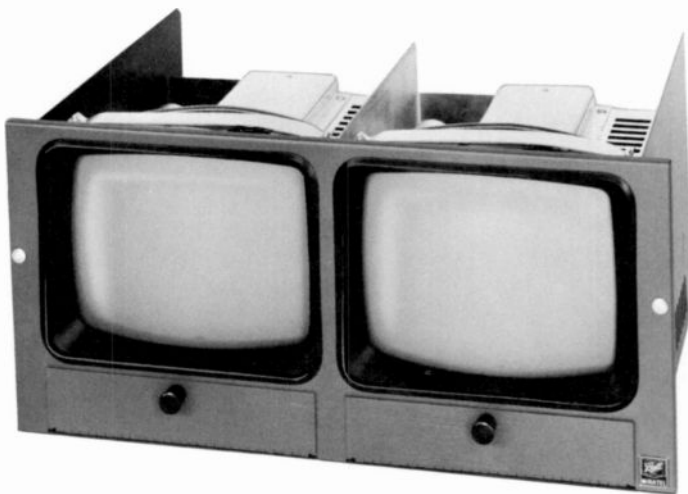

TE-9

Ball Brothers Research Corporation's TE-9 black and white monitor is a low cost, solid-state video monitor designed for utility applications in broadcast television, instructional television, visual information display and security television systems where reliability and high quality video reproduction are desired. The monitors feature a 9-inch "T-banded" cathode ray tube, with the remaining circuitry of solid-state construction.

SPECIFICATIONS

ELECTRICAL

Video Amplifier

INPUT IMPEDANCE: 15K ohms HI-Z—75 ohms LOW-Z.

INPUT CONNECTOR: UHF—looping.

INPUT LEVEL: 0.3 V to 2.0 V p-p.

DIFFERENTIAL GAIN: 5% maximum (linear mode) at 20 V p-p output.

DC RESTORER: Diode type.

VIDEO OUTPUT AMPLIFIER: Adjustable for different levels of gray scale definition or normal television signals.

BANDWIDTH: 10 MHz (-3 dB).

Synchronization

EXTERNAL SYNC CONNECTOR: Optional (UHF looping with rear panel external/internal switch; input level, 1.0 V to 4.5 p-p).

Display

PICTURE TUBE: 9-inch rectangular aluminumized.

RESOLUTION: 600 lines at 40 ft. Lombers.

GEOMETRIC DISTORTION: 2% maximum.

Power Supply

INPUT VOLTAGE: 105 V to 130 V rms., 60 Hz.

INPUT POWER: 45 watts.

MECHANICAL

CHASSIS SIZE WITH CRT (NOMINAL): Height, 8 $\frac{3}{4}$ "; Width, 8 $\frac{5}{8}$ "; Depth, 9 $\frac{1}{8}$ ".

CABINET SIZE (NOMINAL): Height, 9 $\frac{3}{8}$ " (includes $\frac{1}{4}$ " for handle and $\frac{3}{8}$ " for feet); Width, 8 $\frac{1}{16}$ "; Depth, 10 $\frac{1}{16}$ ".

WEIGHT: Approximately 12 lbs. for chassis with CRT. Approximately 15 $\frac{1}{2}$ lbs. for chassis with CRT and cabinet.



TCB-14R

Ball Brothers' TCB-14R color broadcast monitor is a transistorized, high performance monitor designed to solve two of the studio engineer's basic problems: placement and accessibility of controls. Brightness, contrast and on/off controls are located on the front panel of the TCB-14R. All other controls are located on an extendible printed circuit card located immediately behind the front control panel. A lock on the front control panel makes the controls on the extendible PC card virtually tamper-proof.

SPECIFICATIONS

VIDEO

INPUT LEVEL: 0.3 to 2.0 V p-p, sync negative.

INPUT IMPEDANCE: Switch selectable—15K ohms looping or 75 ohms terminated.

FREQUENCY RESPONSE: Amplifiers compensated for flat frequency response at face of CRT. For color, a trop is switched in to attenuate all frequencies above 3.58 MHz.

APERTURE CORRECTION: Variable.

DISPLAY

CRT: 15LP22, high brightness phosphors.

INTERLACE: 2:1 positive.

GEOMETRIC DISTORTION: Less than two percent.

FILAMENT: DC, regulated.

POWER

INPUT: 120 volts ± 10 percent 60 Hz and 400 Hz. 170 watts nominal.

GENERAL

TALLY LIGHT: Panel lamp with numbering provisions (external power required.)

EXTERNAL SYNC: Bridging internal/external switch selected, 4.0 volt nominal, ± 6 dB.

ENVIRONMENTAL

TEMPERATURE: 10°C to 45°C.

DIMENSIONS

SIZE: Height, 10 $\frac{1}{2}$ "; Width, 19"; Depth, 17 $\frac{3}{8}$ " excluding connectors.

WEIGHT: 60 pounds.

Television Installations

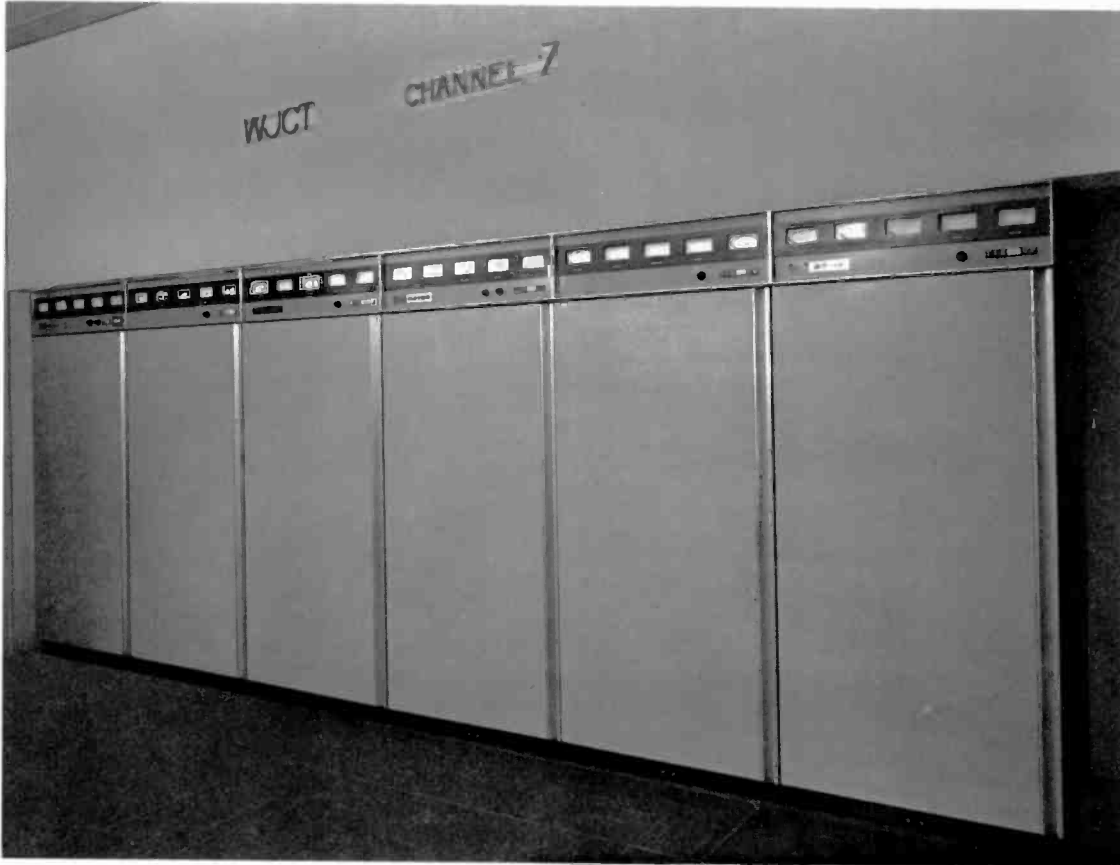

▲
A typical dual transmitter installation of parallel Gates BT-18H, 18 kW high band television transmitters at WJCT-TV, Jacksonville, Florida. The visual and aural sections of both transmitters operate in parallel for normal operation. Either transmitter may be operated independently into the antenna or a test load during an emergency condition by selecting the desired configuration on a push-button panel.

▶
Gates BT-35H, 35 kW high band television transmitter installation at WGEM-TV, Quincy, Illinois. Gates' compact modular construction allows maximum utilization of valuable floor space. Independent visual power amplifiers and solid-state IF exciters provide highly reliable operation.



**AUDIO
CONTROL
CONSOLES**

**HARRIS
INTERTYPE
CORPORATION**

GATES[®]
A DIVISION OF HARRIS-INTERTYPE

Dual Programming Transistor Console With Stereo



THE DUALUX II

One of the most versatile audio consoles on the market today, Gates Solid Statesman Dualux II is ideal for the broadcaster who wants to control AM, FM, FM Stereo and SCA from one control point during all or part of the broadcasting day.

With the extensive capabilities of the Dualux II, monophonic or stereophonic mixing can be done independently or simultaneously. Simplified control of any mode of broadcasting is achieved through the console's exclusive program output selector. An interlocking system guards against the programming of any unacceptable combinations.

WIDE CHOICE OF INPUTS: Twenty-two audio inputs can be fed to the Dualux II. These include: thirteen monophonic sources, six stereo sources, two automatic programming sources and an SCA channel. Four unwired utility keys allow the addition of sources of your choice.

MICROPHONE CHANNELS (1, 2 and 3): Four single monophonic microphones can be individually switched to channels 1 and 2. Either of two stereo microphone pairs can be mixed on channel 3, and a switch is provided to combine the output during monophonic broadcasting.

MEDIUM LEVEL CHANNELS (4, 5, 6, 7 and 8): Channels 4 and 5 will each mix four stereo sources, while channels 6 and 7 will mix four monophonic sources. These sources can be cartridge tape machines, reel-to-reel units or turntables.

Channel 8 will mix four remote monaural inputs and has a monaural network input. Cueing is provided on all medium level channels.

POSITIVE MIXING CONTROL: Low impedance ladder step type attenuators are used in the minimum loss mixing circuits. Large "feel-of-the-board" VA control knobs are used to make mixing more efficient. An illuminated key selector above each of the mixing knobs switches the mixer output to AM or FM.

Center position is off. Color inserts are provided for all mixer knobs to aid in identification.

MONITORING: The Dualux II has two solid state monitoring amplifiers for both stereo and mono monitoring. Monitoring outputs are for control rooms, Studio A, B, and lobby. Cue/intercom connections are provided to Studio A and B.

SOLID STATE MUTING: The Dualux II has Gates new "Micro-muting" which mutes loudspeakers in microseconds. The muting is so fast that a microphone placed directly in front of the monitor cannot possibly cause feedback. This instantaneous solid state muting is exceptionally quiet in operation.

OUTSTANDING AUDIO QUALITY: Audio response is excellent, with distortion at an unusually low level. Consequently, the Dualux II provides audio quality ideally suited to any type of broadcasting—AM, FM or FM Stereo/SCA.

AMPLIFIERS: The silicon transistor Solid-Statesman amplifiers used throughout provide high level, high fidelity output. Pre-amplifiers will provide a full +23 dBm output, and will handle input levels of -17 dBm without overload or distortion. The program amplifiers are capable of +32 dBm output, and the monitor amplifiers deliver +40 dBm (10 watts). All components are mounted on etched circuit boards for added reliability and excellent crosstalk and noise specifications. Silicon transistors are used to assure optimum console performance over a wide ambient temperature range.

All amplifiers are packaged in modular extruded aluminum housings, and are completely accessible when the top of the console is opened. Amplifiers and power supplies plug in for ease in servicing.

INTERCHANGEABILITY: Electrically, the program amplifiers, monitor amplifiers, and cue amplifier are identical, thus providing three backup program amplifiers as an integral part of the console.

Dual Programming Transistor Console With Stereo-Dualux II

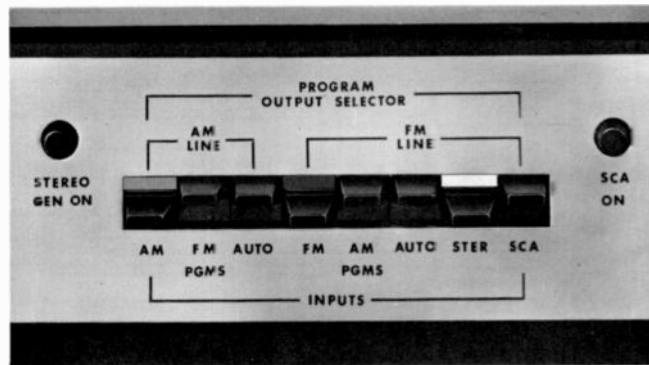

PROGRAM OUTPUT SELECTOR: Functions are logically presented and color-coded to channel keys and VU meter illumination for simplicity. Briefly, control provisions are: two separate transmitter inputs are marked "AM Line" and "FM Line." The AM transmitter may be programmed independently through any mixing channel when corresponding keys are operated to the left. Illuminated channel key, AM VU meter, and tab key #1 of the selector assembly are color-coded green.

Similarly, the FM transmitter may be programmed from the FM buss, when red tab key #4 is selected. In this mode FM may be stereo or mono, depending on the position of tab

key #7 of the program output selector. During non-stereo periods an SCA channel may be turned on and programmed from an external source by tab key #8. All keys are cleverly interlocked against any unacceptable combinations.

Either the AM or FM line may be programmed from external automation equipment by the mere flip of a tab key, without tying up a mixing channel. Dualux II provides a complete and economical means of complying with regulations on separate AM/FM programming. During other hours AM may program FM, or vice-versa, by selecting the appropriate key and operating the console conventionally.

SPECIFICATIONS

MIXING CHANNELS: Total 8. Two microphone—mono. One microphone—stereo. Two turntable/tape—stereo. Two turntable/tape—mono. One remote/network—mono.

AMPLIFIERS AND POWER SUPPLIES PROVIDED: Four preamplifiers, six output modules—program/monitor/cue (all interchangeable as supplied). Two muting modules, four power supply modules, and M-6556B transformer panel.

OPERATING MODE: Tri-channel—mono/stereo simultaneously.

INPUT CIRCUITS: Total 22. Four microphones—mono. Two microphones—stereo pair. Four turntable/tape—stereo pair. Four turntable/tape—mono. Four remote lines, one network, one SCA source—mono. One automation source—stereo pair. One automation source—mono.

OUTPUT CIRCUITS: Three program outputs @ +8 dBm, three record outputs @ -16 dBm, (bridged program line), two monitor speakers unmuted (left and right for lobby), six monitor speakers muted (left and right for Studios A & B & control room), two studio intercom outputs (Studio A, Studio B).

AUXILIARY INPUT/OUTPUT CIRCUITS SWITCHED THROUGH CONSOLE: Inputs: AM automation, FM—left automation (mono), FM—right automation (stereo), programming for SCA—41 kHz. Output: Programming for SCA—41 kHz.

MONITOR OUTPUT: 8 ohms nominal, for use as follows: (A) Single 8 ohm speaker. (B) Two 16 ohm speakers in parallel. (C) Up to six 48 ohm speak-

ers (using the 48/8 ohm transformer supplied) in parallel. (D) Any combination of speakers and/or transformers with a resultant network of 8 ohms or higher.

IMPEDANCES: Microphones: 30/50 or 150/250 ohms balanced. Turntable/tape: 150/250 ohms unbalanced. Network /remote: 500/600 ohms balanced. Record output: 600 ohms balanced.

GAIN: Microphone to line: 102 dB, ± 2 dB. Medium level to line: 60 dB, ± 2 dB.

RESPONSE: Program and monitor: ± 1.0 dB, 20 Hz to 20 kHz.

DISTORTION: Program circuits: 0.5% maximum, 20 Hz to 20 kHz @ +18 dBm. Monitor circuits: 1.0% maximum, 20 Hz to 20 kHz @ +40 dBm (10 watts).

NOISE: Program circuits: 74 dB below +18 dBm with -50 dBm input (-124 dBm equivalent input noise measured 20 Hz to 20 kHz). Monitor circuits: 74 dB below +40 dBm with -50 dBm input (-124 dBm equivalent input noise measured 20 Hz to 20 kHz). Medium level inputs: (Program) 74 dB below +18 dBm.

POWER: 117 volts, 50/60 Hz, 1-phase.

FINISH: Satin anodized aluminum panels, with lettering in black. Cabinet color—two-tone beige-gray.

SIZE: 51 $\frac{3}{4}$ " wide, 17" deep, 11 $\frac{1}{2}$ " high.

SHIPPING DATA: Packed weight: domestic, 140 lbs.; export, 220 lbs. Cube: 16 cubic feet.

ORDERING INFORMATION

Dualux II, eight channel mono/stereo console for tri-channel operation. Complete with four M-6549B preamplifiers, six M-6550B program/monitor/cue output modules (interchangeable), two M-6553 and M-6553A solid state muting modules, and M-6551A and M-6552 power supply modules. An M-6556B transformer panel and eight speaker transformers (478-0275) are also supplied with the console.

994-6542

Dual Programming Transistor Console With Stereo-Dualux II

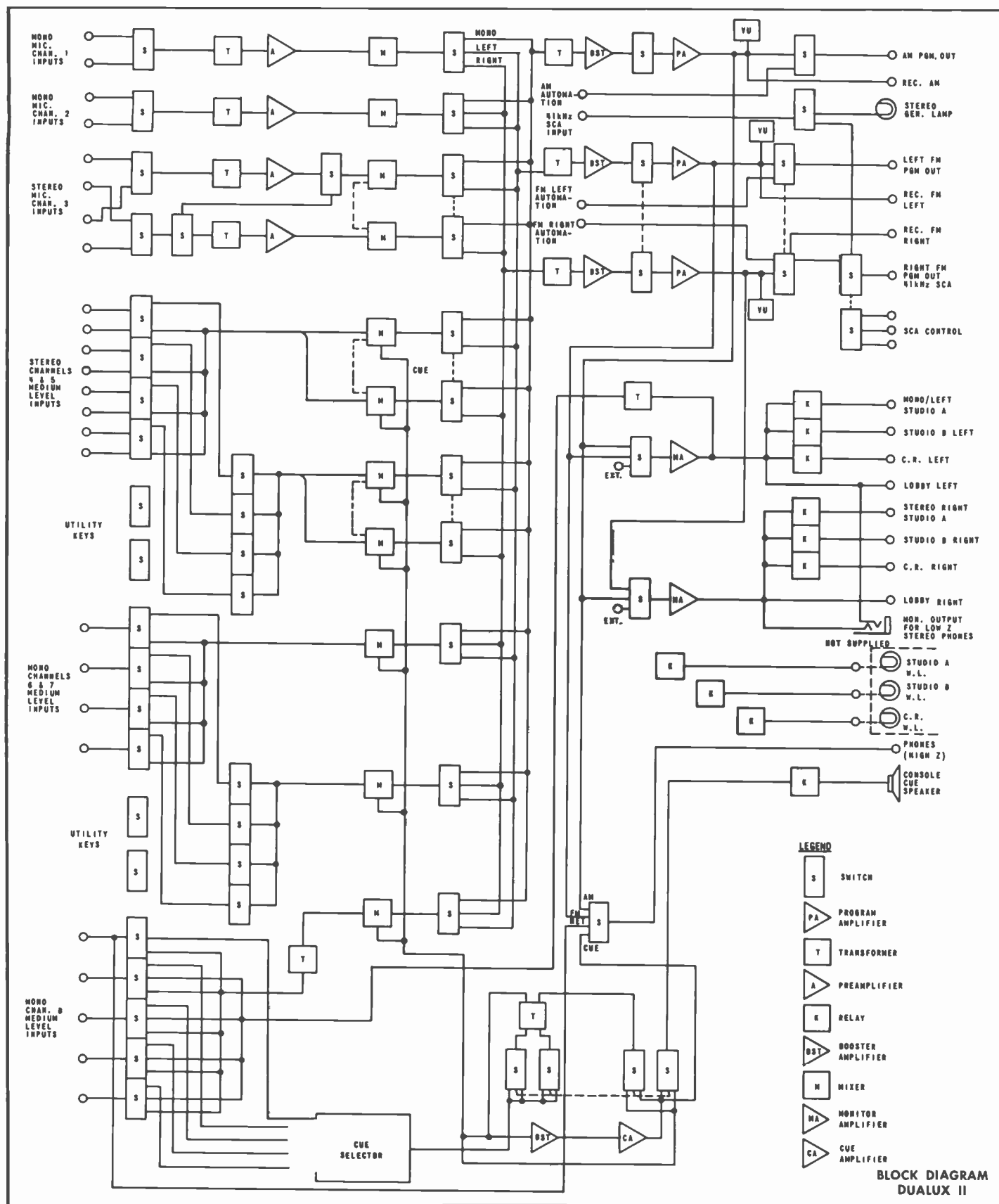

Eight Channel Monophonic Transistor Console



THE GATEWAY II

Field-proven successor to the world famous Gateway, the Gateway II blends excellent audio and unusual flexibility with handsome, functional styling. The result: a completely transistorized control board that gives you a wide choice of input facilities, plus operating simplicity.

Features include: eighteen inputs into eight mixing channels; inbuilt cue/intercom system; provision for remote announcer operation of studio microphone channels; a novel variable program equalizer which may be instantly switched into the circuit for special effects or line correction; instantaneous solid state "Micro-muting"; illuminated program keys; and large "feel-of-the-board" control knobs.

INPUTS: The versatility of the Gateway II is in its wide selection of inputs. Eighteen inputs can be switched into eight mixing channels. These include six microphones, four turntables, four tapes (cartridge or reel-to-reel), three remotes and network. Four unwired utility keys are provided for expansion.

MICROPHONE CHANNELS: Six microphones from control room and two studios may be mixed on channels 1, 2 and 3. A flexible muting assignment terminal strip allows the engineer to tailor loudspeaker muting and warning light controls to the channels which fit a particular programming situation. On-off control of one microphone channel may be given to the announcer through the addition of a simple relay module on channel 2 (optional). Input capability of the Solid Statesman preamplifiers is -17 dBm, making this audio control console virtually immune to microphone overload.

SOLID STATE MUTING: The Gateway II has Gates "Micro-muting" which mutes loudspeakers in microseconds—so fast that a microphone placed directly in front of the monitor speaker cannot feed back. This instantaneous solid state muting is exceptionally quiet in operation.

MEDIUM LEVEL CHANNELS: Four turntables or similar devices may be mixed in any combination through flexible input switching on channels 4 and 5. (The same four devices are controlled from either channel). Similarly, four cartridge or reel-to-reel tape recorders may be accommodated on channels 6 and 7. Channel 8 has input switching for three remote lines and network. All medium level faders are equipped with cue positions to the self-contained cue intercom amplifier.

PROGRAM EQUALIZER: An exclusive feature of the Solid Statesman Gateway II is an inbuilt equalizer for correcting response deficiencies of tapes, remotes, etc., and also for special effects. Both low and high frequency correction may be made with separate controls which tailor the over-all console response ± 10 dB at 100 Hz and 10,000 Hz. A three position lever key instantly switches in equalization, either continuously or momentarily. In the "out" position the Gateway II has a superb flat response from 20 to 20,000 Hz.

UNSURPASSED AUDIO: Gates advanced solid state plug-in amplifiers are one of the many reasons for the outstanding performance of the Gateway II. Audio response is excellent, with distortion at a very low level. Consequently, the Gateway II provides an audio quality which makes it the perfect console for high fidelity broadcasting.

MODULAR CONSTRUCTION: All amplifiers are packaged in extruded aluminum housings and use plug-in connections. All components are mounted on etched circuit boards to add reliability and contribute to the excellent crosstalk and noise specifications of the console. Silicon transistors are used to allow wide frequency response and assure optimum console performance over a wide ambient temperature range. All amplifiers are completely accessible when the top of the console is opened, simplifying maintenance.

Eight Channel Monophonic Transistor Console—Gateway II

HIGH LEVEL, HIGH FIDELITY OUTPUT: The wide dynamic range of the preamplifiers will accommodate microphone levels from -77 dBm to -17 dBm without overload or distortion. The program amplifiers deliver $+32$ dBm output and the monitor amplifiers $+40$ dBm, all with unsurpassed frequency response, low distortion and low noise.

STYLING: This "second generation" Solid-Statesman console is beautifully styled with anodized front panels, the exclusive Gates VA mixing control knobs, and a cabinet richly finished in beige-gray tones to complement any control room decor. Illuminated program keys complete the over-all leadership look of the Gateway II.

IMMEDIATE ACCESSIBILITY: You can reach every component in the Gateway II with ease. No console made is easier to maintain.

AMPLIFIER INTERCHANGEABILITY: Program, cueing and monitor amplifiers all have the same electrical design and construction and can be interchanged at random. As a result, three backup program amplifiers are provided as part of the console.



SPECIFICATIONS

MIXING CHANNELS: Total—8. Three microphone, two turntables, two tapes and one remote/network.

AMPLIFIERS AND POWER SUPPLIES PROVIDED: Three preamplifiers, three output modules—program, monitor and cue (interchangeable as supplied). Two muting modules (solid state speaker muting), three power supply modules.

OPERATING MODE: Single channel mono with audition positions.

INPUT CIRCUITS: Total—18. Six microphone, four turntables, four tapes, three remote lines, one network.

OUTPUT CIRCUITS: One program output @ $+8$ dBm, one audition output @ -14 dBm, one monitor speaker output unmuted for lobby, three monitor speakers muted, two studio intercom outputs (Studio A, Studio B), and one headphone output.

MONITOR OUTPUT: 8 ohms nominal, for use with only one of the following: (A) A single 8 ohm speaker. (B) Two 16 ohm speakers in parallel. (C) Up to six 48 ohm speakers (using the 48/8 ohm transformers supplied) in parallel. (D) Any combination of speakers and/or transformers with a resultant network impedance of 8 ohms or higher.

IMPEDANCES: Microphones: 30/50 or 150/250 ohms balanced. Turntable/tape: 150/250 ohms unbalanced. Network/remote: 500/600 ohms bal-

anced. Audition output: 600 ohms unbalanced. Monitor output: 8 ohms nominal unbalanced. Program output: 600/150 ohms balanced.

GAIN: Microphone to line: 100 dB ± 2 dB. Medium level to line: 60 dB, ± 2 dB.

RESPONSE: Program and monitor: ± 1.0 dB, 20 Hz to 20 kHz.

DISTORTION: Program circuit: 0.5% maximum, 20 Hz to 20 kHz @ $+18$ dBm. Monitor circuits: 1.0% maximum, 20 Hz to 20 kHz @ $+40$ dBm (10 watts).

NOISE: Program circuits: 74 dB below $+18$ dBm with -50 dBm input (-124 dBm equivalent input noise, measured 20 Hz to 20 kHz). Monitor circuits: 74 dB below $+40$ dBm with -50 dBm input (-124 dBm equivalent input noise, measured 20 Hz to 20 kHz). Medium level inputs: (Program) 74 dB below $+18$ dBm.

POWER: 117 volts, 50/60 Hz, 1-phase.

FINISH: Satin anodized aluminum panels, with lettering in black. Cabinet color—two tone beige-gray.

SIZE: 48 $\frac{1}{4}$ " wide, 17" deep, 8 $\frac{3}{4}$ " high.

SHIPPING DATA: Packed weight: Domestic, 210 lbs. Export, 250 lbs. Cubage, 17.5 cubic feet.

ORDERING INFORMATION

Gateway II, eight channel console, complete with three M-6549B preamplifiers, three M-6550B program/monitor/cue output modules (interchangeable), two M-6554A solid state muting modules, two M-6551B power supply modules, one M-6552 power supply module, one M-6556A transformer panel, and four speaker matching transformers (478-0275)-----994-6541

Eight Channel Monophonic Transistor Console-Gateway II

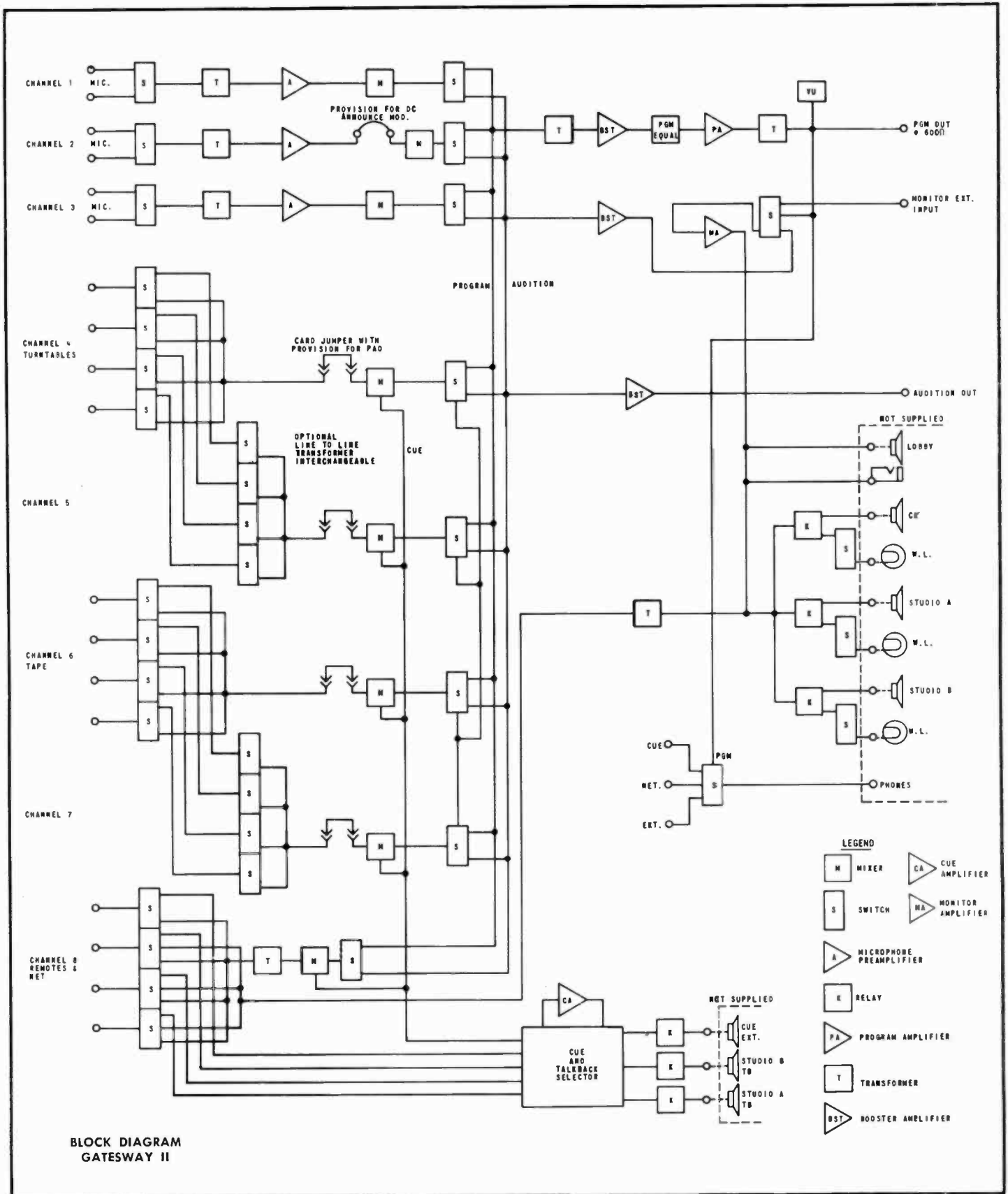

BLOCK DIAGRAM
GATEWAY II

Eight Channel Monophonic Transistor Console

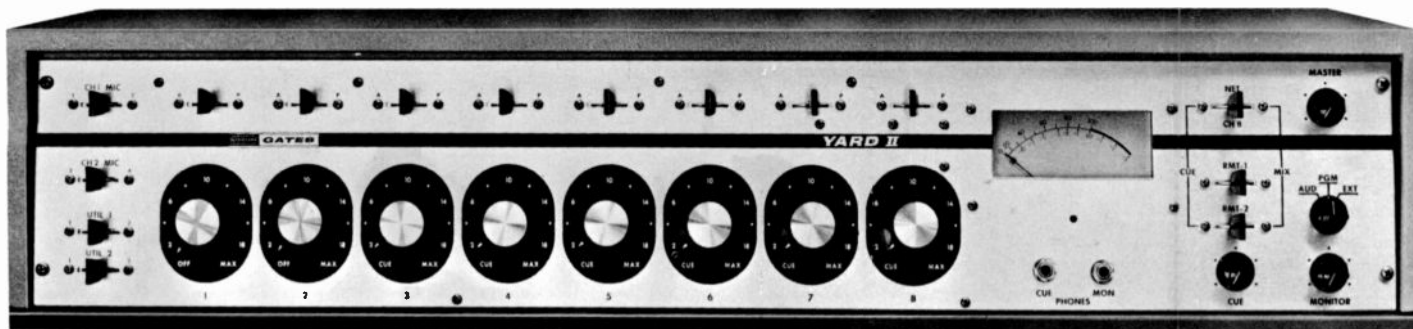

THE YARD II

Successor to the famous Yard console, the new Yard II now offers even greater versatility with the added reliability of total solid state design. Just over a yard wide, Gates Yard II console offers 12 inputs into 8 mixing channels. It is ideal as a full control facility for smaller AM and FM monophonic stations and a perfect submaster control or production console in larger operations. The low silhouette styling is a definite "plus" for television use.

Functionally arranged, the eight mixing channels are in the center of the board with the meter to the right, along with master gain controls. Preamplifiers used on microphone channels 1 and 2 may select from two low impedance microphones on each input. Five medium level channels can be used with any sources, such as turntables, tape recorders, etc. The eighth channel is specifically designed for use with network and two remote sources, and separate front panel switches provide selection of any of these inputs.

INDEPENDENT CHANNEL MONITORING AND RECORDING: Any of the 8 input channels may be switched to either the program or audition position to permit independent monitoring or recording of any incoming sources without disturbing programming.

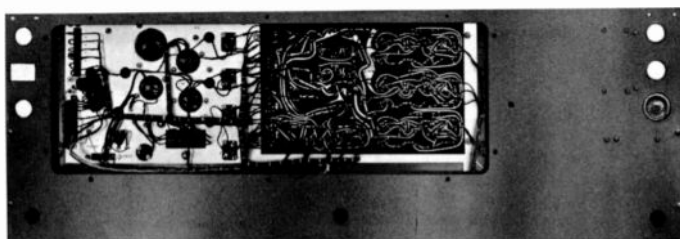

All wiring on the printed circuit board is accessible through a removable cover plate on the bottom of the console. The entire console is hinged to permit easy access.

HIGH FIDELITY PERFORMANCE: Frequency response of the Yard II is uniform ± 1 dB from 30 to 15,000 Hz. Noise is better than 73 dB below normal output with crosstalk below the noise at normal levels and control settings. Distortion is less than 0.75% from 30 to 15,000 Hz at a +18 dBm output.

LOW SILHOUETTE STYLING: Only 8½ inches high, the Yard II offers an excellent over the top view, especially adaptable for TV operation.

ACCESSIBILITY: All components can be quickly reached through the lift off top. The entire console is hinged at the rear for complete access to the under side of the console.

INPUTS: Four microphones, five medium level inputs, and three external line inputs. Cue bus is connected to mixers 3 through 8 to provide rapid cueing on all six channels.

CUE AMPLIFIER: Built-in cue speaker in the top of the console provides cue from channels 3 through 8 to either the speaker built into the console or through the separate cue headphone jack.

BOOSTER AMPLIFIER: A monitor booster amplifier is provided as standard equipment to allow switching the monitor amplifier from program to audition without changing level.

MUTING RELAYS: Two muting relays are supplied to operate warning lights as well as muting of the control room and studio speakers. A terminal strip on the console permits flexible selection of muting relay operation by simply changing jumper wires.

VU METER: A four-inch illuminated 'B' scale VU meter is flush mounted with the Yard II front panel for accurate level measurement.

COLOR CODED CONTROLS: Mixer knobs are supplied with various colored disc inserts to color code controls such as red for turntables, green for studio A, etc.

COMPACT AND LIGHTWEIGHT: The 38" Yard II console is one of the most compact, full facility consoles ever produced. It measures 38" wide, 8½" high, and 13" deep, and weighs only 54 pounds.

Eight Channel Monophonic Transistor Console—Yard II

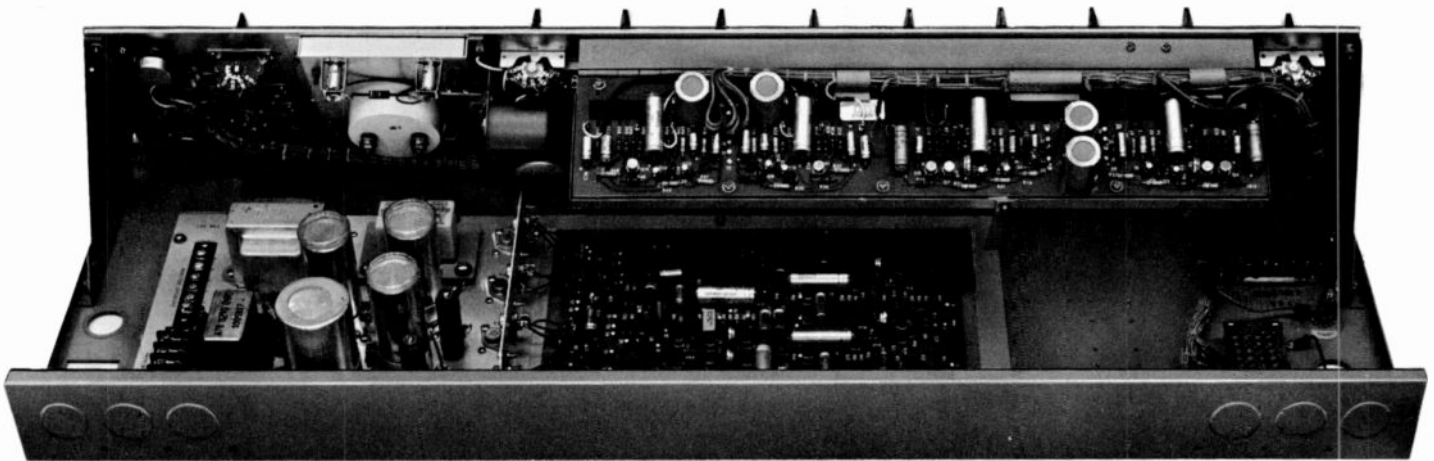

Complete access to all components is via the easily removed cover of the Yard II. All input and output connections can be made through the rear or the bottom of the console. Convenient knock-outs on the rear apron provide entry for wiring cables.

SPECIFICATIONS

GENERAL

MIXING CHANNELS: Total of eight, all monaural. Two microphone, five medium level, one network/remote.

AMPLIFIERS PROVIDED: Two preamplifiers, two booster amplifiers, one program amplifier, one monitor amplifier, and one cue amplifier.

OPERATING MODE: Monaural.

INPUT CIRCUITS: Four for microphones, two for turntables, two for tape, one utility, three for network/remote.

OUTPUT LINES: One program, two muted speaker, one non-muted speaker, one cue speaker (muted), two headphone (monitor and cue).

MICROPHONE (CH. 1 & 2) TO PROGRAM LINE OUT

MAXIMUM GAIN: 103 \pm 2 dB.

FREQUENCY RESPONSE: \pm 1 dB, 30 to 15,000 Hz.

DISTORTION: Less than 0.75%, 30 to 15,000 Hz, at +18 dBm output.

NOISE: More than 73 dB below +18 dBm output with -50 dBm input. Equivalent input noise is better than -123 dBm, 30 to 15,000 Hz.

CROSSTALK: Below noise level, with normal levels and control settings.

MICROPHONE IMPEDANCE: 30/50 or 150/250 ohms, balanced.

MEDIUM LEVEL (CH. 3-7) TO PROGRAM LINE OUT

MAXIMUM GAIN: 63 \pm 2 dB.

FREQUENCY RESPONSE: \pm 1 dB, 30 to 15,000 Hz.

DISTORTION: Less than 0.75%, 30 to 15,000 Hz at +18 dBm output.

NOISE: More than 73 dB below +18 dBm output with -10 dBm input, 30 to 15,000 Hz.

CROSSTALK: Below noise level, with normal levels and control settings.

INPUT IMPEDANCE: 150 ohms, unbalanced.

NETWORK/REMOTES (CH. 8) TO PROGRAM LINE OUT

MAXIMUM GAIN: 43 \pm 2 dB.

FREQUENCY RESPONSE: \pm 1 dB, 30-15,000 Hz.

DISTORTION: Less than 0.75%, 30 to 15,000 Hz at +18 dBm output.

NOISE: More than 73 dB below +18 dBm output with +10 dBm input, 30 to 15,000 Hz.

CROSSTALK: Below noise level, with normal levels and control settings.

INPUT IMPEDANCE: 600 ohms, balanced.

MONITOR CIRCUITS

*GAIN: Mic. -Pgm. -Mon. Out 124 \pm 2 dB

Mic. -Aud. -Mon. Out 106 \pm 2 dB

Med. -Aud. -Mon. Out 66 \pm 2 dB

Ext. Mon. -Mon. Out 46 \pm 2 dB

*Approximately 11 dB additional gain is available by shorting out the R37, 10,000 ohm resistor, connected between the Monitor Selector Switch and the Monitor Gain control.

FREQUENCY RESPONSE: \pm 1 dB, 30 to 15,000 Hz.

DISTORTION: Less than 1%, 30 to 15,000 Hz at +40 dBm (10 watts) output.

NOISE: More than 73 dB below +40 dBm (10 watts) output, 30 to 15,000 Hz.

CROSSTALK: Below noise level, with normal levels and control settings.

POWER REQUIREMENTS

LINE VOLTAGE AND FREQUENCY: 117V (as shipped) /234V, 50/60 Hz.

POWER CONSUMPTION: 60 watts, maximum.

PHYSICAL SIZE

CONSOLE: 38" wide, 13" deep, 8½" high.

CONSOLE WEIGHT: 54 lbs.

POWER TRANSFORMER: Approximately 6½" long x 4" wide x 3½" high.

ORDERING INFORMATION

Yard II Audio Console.....994-6616

Eight Channel Monophonic Transistor Console—Yard II

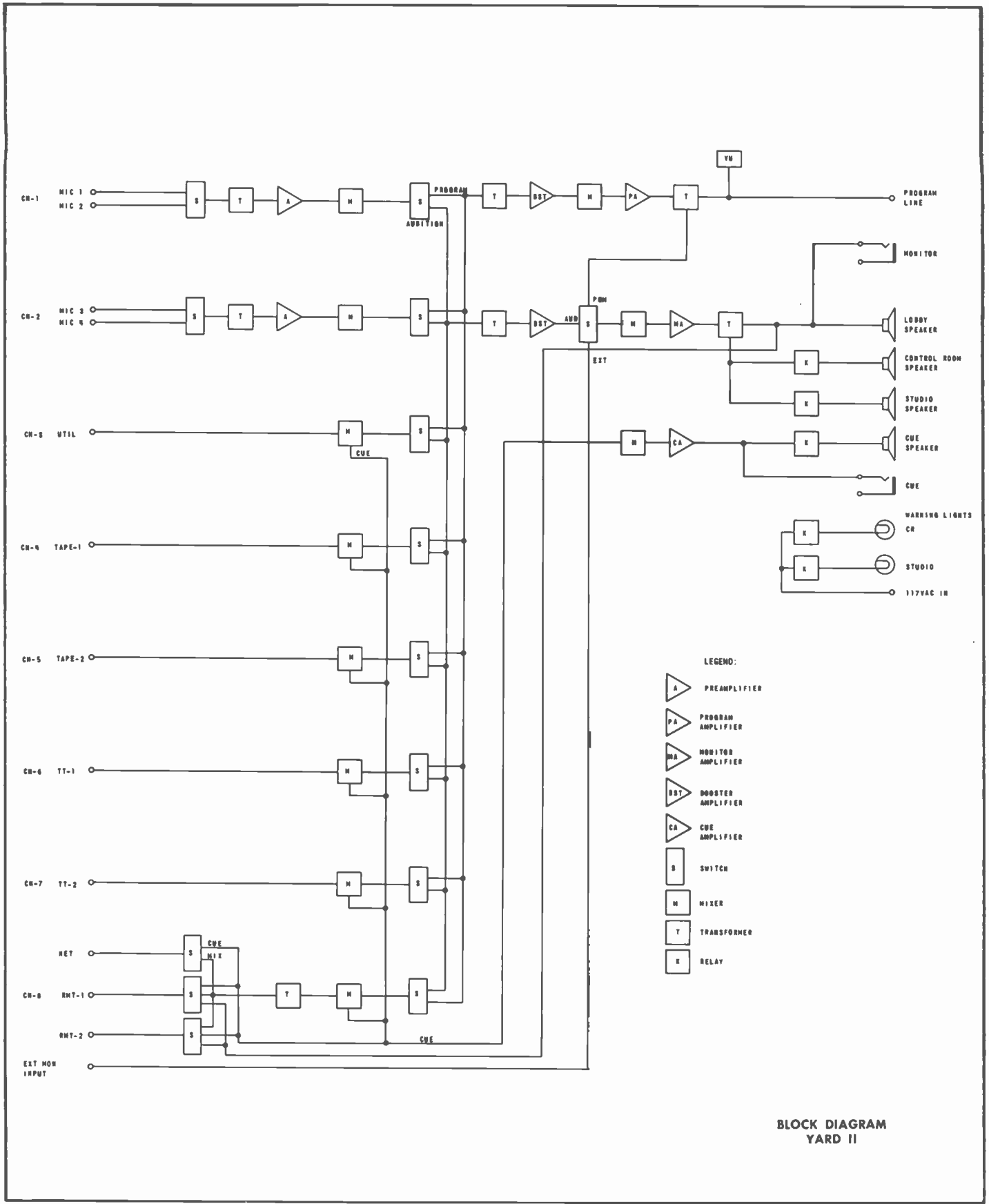

Five Channel Stereo Transistor Console

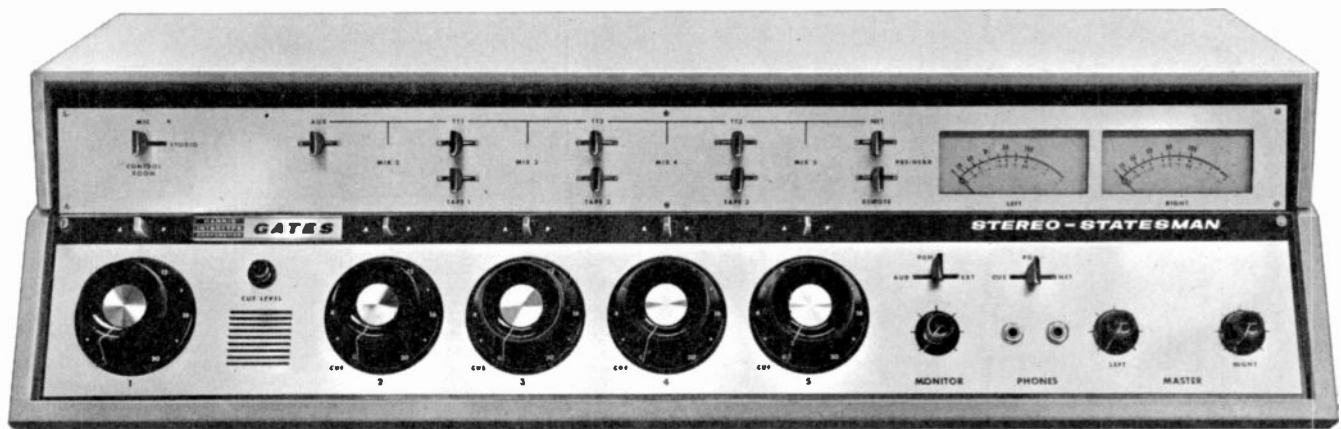

THE STEREO STATESMAN

Designed and built to provide the soundest sound for the new era of FM broadcasting, the completely transistorized Stereo Statesman console is equally at home in the studio of the small market broadcaster, or with the large, metropolitan broadcaster as a production or secondary control board.

The performance figures of this console are at the quality level which builds and holds listeners. Frequency response is 20 to 20,000 Hz with less than 1 dB variation. Distortion is less than 0.5% at all frequencies.

Other important features include: Full logic audio switching; cue/intercom to two studios; all solid state modular amplifiers with printed circuit boards; two monitor amplifiers; illuminated program keys; and Gates exclusive control knobs.

VERSATILE INPUT SWITCHING: Eleven inputs may be switched into the five stereo mixing channels in a manner that satisfies virtually any stereo programming requirement. These inputs can include: two stereo microphone pairs; three stereo turntables; three stereo tape reproducers; one remote; one network and one auxiliary stereo source.

MICROPHONE CHANNEL: Two stereo pairs of microphones may be selected into channel 1. One position is designated "Control Room" and the other position "Studio". Muting is automatically transferred when key is operated.

MEDIUM LEVEL CHANNELS: Channels 2, 3, 4 and 5 may be used for turntables, tape or other medium level inputs. Three tapes, three turntables and one auxiliary source may be switched into these four channels. Each tape and turntable input are switchable to either of two mixers, with tab switches for maximum flexibility. Channel 5 may also select from "Network" or "Remote". If these signals are monophonic, they may be split to drive both the right and left stereo mixer on that channel.

POSITIVE PROGRAM CONTROL: Three-position illuminated key switches above each mixing knob control program selection. The selector key glows green in "audition" position, red in "program" position and amber in center "off" position.

HIGH FIDELITY SOUND: The superb audio qualities of the Stereo Statesman—such as a frequency response of 20 to 20,000 Hz with less than 1 dB variation, and a signal to noise ratio of -74 dB—are achieved through the use of silicon transistors, and low impedance mixing.

AMPLIFIERS: All amplifiers are modular in construction, with plug-in connections for easy interchange and maintenance. Components are mounted on etched circuit boards to increase reliability and contribute to the excellent crosstalk and noise specifications of the console. Silicon transistors assure optimum console performance over a wide ambient temperature range. All amplifiers are completely accessible when the top of the console is opened, simplifying maintenance.

WIDE DYNAMIC RANGE: The preamplifiers in the Stereo Statesman will accommodate microphone levels from -77 to -17 dBm without overload or distortion. The program amplifiers deliver +32 dBm output and the monitor amplifiers +40 dBm output, all with excellent frequency response, low distortion and low noise.

MONITORING: Two monitor amplifiers, each capable of providing up to 10 watts each (+40 dBm) are included. Monitor input is selectable from "program", "audition" or "external source". Muting is provided for control room and studio loudspeakers and the console cue speaker. Conventional high impedance headset jacks for stereophonic headphones are provided on the front of the console and can be switched to monitor program, network or external.

Five Channel Stereo Transistor Console—Stereo Statesman

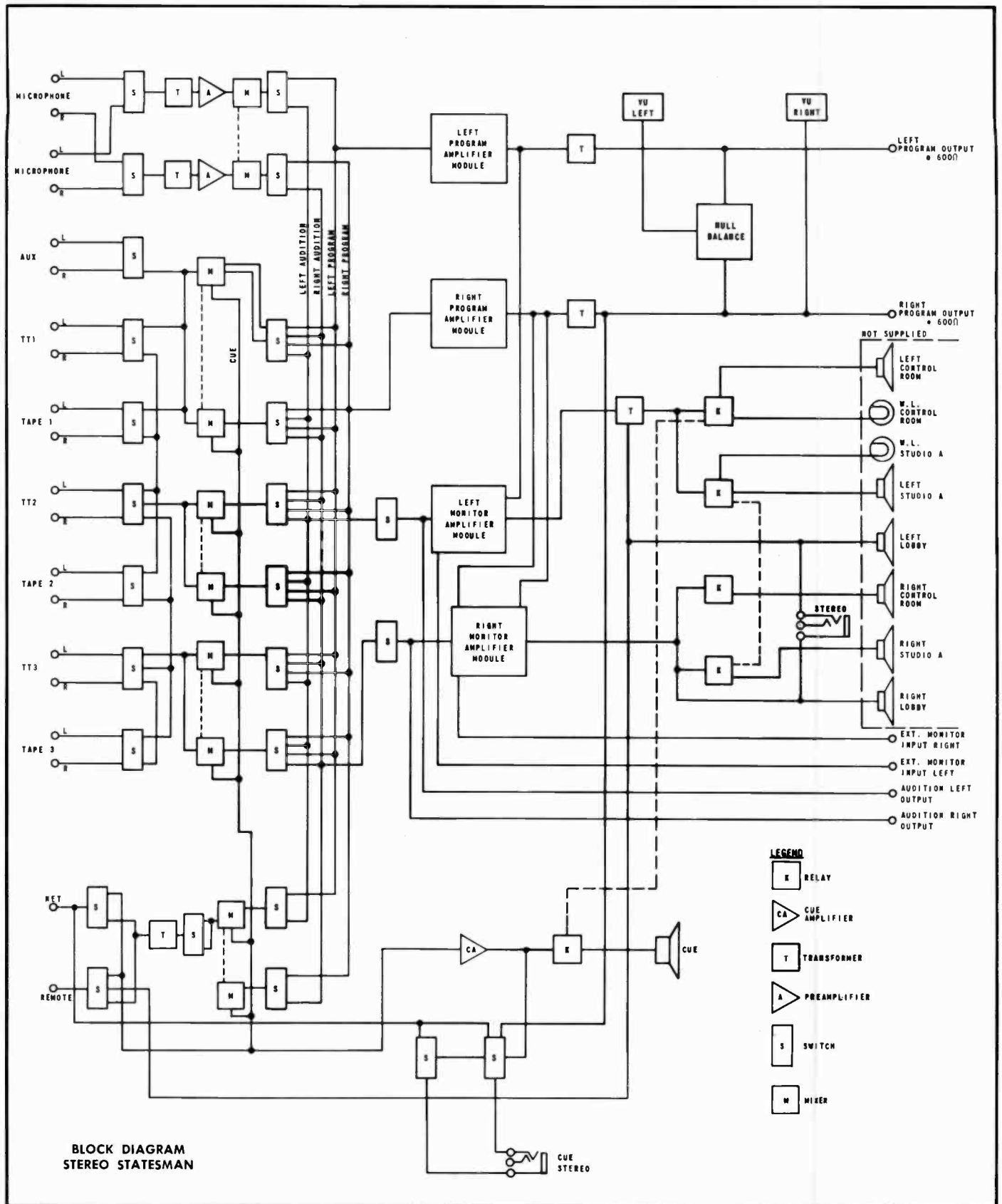

Five Channel Stereo Transistor Console—Stereo Statesman

SPECIFICATIONS

MIXING CHANNELS: Total—5. One microphone. Four tape, turntable, remote or network.

AMPLIFIERS AND POWER SUPPLIES PROVIDED: Two preamplifiers, five program/monitor/cue amplifiers (interchangeable as supplied), three power supply modules.

OPERATING MODE: Stereophonic.

INPUT CIRCUITS: Total—11. Two pairs of stereo microphones, three turntables, three tape, one remote, one network, one auxiliary.

OUTPUT CIRCUITS: Two program outputs at +8 dBm, two audition outputs at -12 dBm, two stereo pair muted speakers (control room, studio), one stereo pair unmuted speakers (lobby), headphone.

IMPEDANCES: Microphones: 30/50 or 150/250 ohms balanced. Turntable/tape: 150/250 ohms. Network/remote: 150/250 ohms. (478-0009 line matching transformer optional). Audition output: 600 ohms. Monitor output: 8 ohms nominal. Program output: 600/150 ohms balanced.

GAIN: Microphone to line: 102 dB, ± 2 dB. Medium level to line: 60 dB, ± 2 dB.

RESPONSE: Program and monitor: ± 1.0 dB, 20 Hz to 20 kHz @ +18 dBm.

DISTORTION: Program circuits: 0.5% maximum, 20 Hz to 20 kHz @ +18 dBm. Monitor circuits: 1.0% maximum, 20 Hz to 20 kHz @ +40 dBm.

NOISE: Program circuits: 74 dB below +18 dBm with -50 dBm input (-124 dBm equivalent input noise measured 20 Hz to 20 kHz). Monitor circuits: 74 dB below +40 dBm with -50 dBm input (-124 dBm equivalent input noise measured 20 Hz to 20 kHz). Medium level inputs: (Program) 80 dB below +18 dBm.

POWER: 117 volts, 50/60 Hz, 1 phase.

FINISH: Satin anodized aluminum panels with lettering in black. Cabinet color—two-tone beige-gray.

SIZE: 36 $\frac{3}{4}$ " wide, 17" deep, 8 $\frac{3}{4}$ " high.

SHIPPING DATA: Packed weight: Domestic, 170 lbs. Export, 210 lbs. Cube, 13 cubic feet.

ORDERING INFORMATION

Stereo Statesman, five channel stereophonic audio console, complete with two M-6549A preamplifiers, five M-6550A program/monitor/cue modules (interchangeable), one M-6551 and two M-6552 power supply modules, and one M-6556 transformer panel.....994-6540

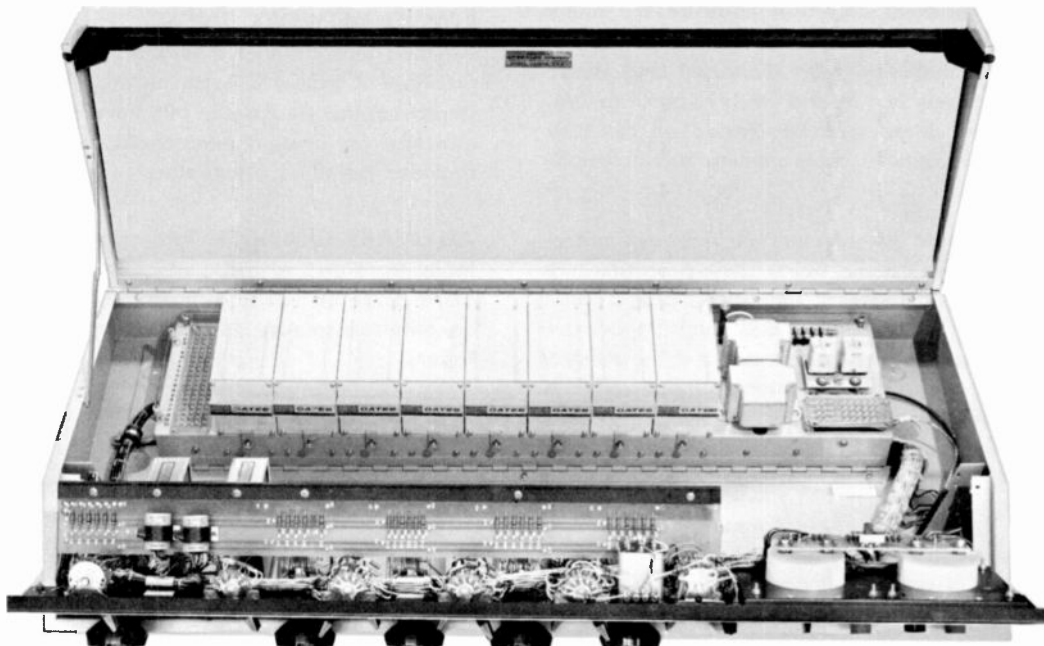

The Stereo Statesman top cover hinges up and the front panel swings down to reveal every "behind the panel" component. This layout and logical access is typical of the complete line of Gates consoles, and reflects the engineering and planning required for neat, professional installations.

Ten Channel Stereo Or Monaural Transistor Console

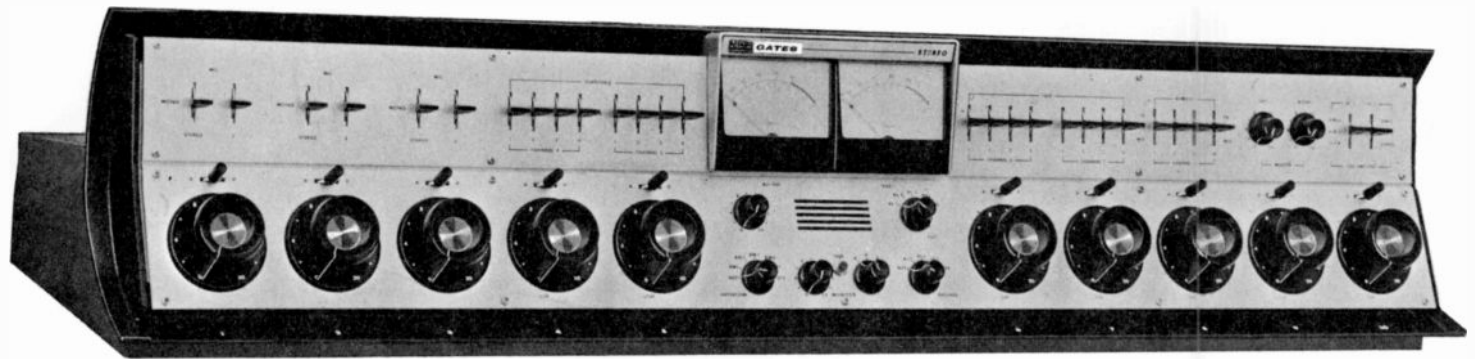

THE EXECUTIVE

With ten full stereo mixers, the dual channel Executive is one of the most complete transistorized audio consoles for stereo or monaural programming on the market today.

Amazingly versatile, this console is a member of Gates Solid-Statesman family—a term applied only to transistorized products that meet the most rigid engineering and manufacturing specifications.

STEREO AND MONAURAL: All ten mixing channels of the Executive are stereo, including network and remote inputs. These channels may also be operated monaurally. By simply adding a third plug-in program amplifier, a compatible "left plus right" signal is available to feed monaural and stereo programming simultaneously to AM and FM (monaural to AM, stereo to FM). Likewise, stereo may be carried on FM with completely different monophonic programming being broadcast on AM.

AMPLIFIERS: The amplifier complement includes six microphone preamplifiers (three stereo pairs), two program amplifiers, two high fidelity monitoring amplifiers, and a cue/intercom amplifier. Also supplied are two audition booster amplifiers, which are part of the internal circuit arrangement. Space is provided for two additional preamplifiers and one additional program amplifier. The power supply is also self-contained and is fully regulated. The amplifiers and power supply are completely solid state.

MIXING SYSTEM: The mixing system contains 10 channels, all with dual (stereo) controls. Channels 1, 2 and 3 are for microphones. Channels 4 and 5 will accept four stereo turntables in any combination, while channels 6 and 7 accommodate four stereo tape inputs. Channel 8 handles four remote lines, and channels 9 and 10 are network and auxiliary channels respectively. The separate fader for incoming network programming is especially convenient for taping delayed broadcast material without tying up the other high-level input to the console. Faders 4 through 10 are all cueing attenuators which feed the inbuilt cue/intercom system.

MICROPHONE INPUTS: Six preamplifiers in three stereo pairs are connected to dual-position input selector keys, permitting 12 microphones (6 stereo pairs) to be selected. Space is provided for two additional M-6034 preamplifiers.

TURNTABLE-TAPE INPUTS: Four turntables may be switched to mixers 4 and 5, and four tape sources may be switched into channels 6 and 7 in any sequence. All faders are stereo, and cue positions are provided on each of these attenuators.

REMOTE-NETWORK INPUTS: Four remote lines may be switched into channel 8 through a line isolation transformer provided. Channel 9 is for network input. Both channels are stereo control equipped, but have removable splitting pads attached for present monophonic signals. Cue positions are provided on these attenuators.

AUXILIARY CHANNEL: This tenth channel has dual line isolation transformers and is uniquely equipped to accommodate extra stereo or monaural functions, either in the studio or from an external source. A cue position is also provided on this fader.

CUE-INTERCOM SYSTEM: An inbuilt cue-intercom amplifier is included, with its speaker centered below the VU meters. The cue signals from mixers 4 through 10 feed the system. The cue-intercom also provides remote talk-back, studio intercom and network preview monitoring. The console muting system also protects against feedback from the cue-intercom speaker.

OPERATING MODES: Stereo only, or monaural only, may be fed to either program or audition mixer circuits. Likewise, monaural FM may be broadcast separately from monaural AM. When the optional M-5700 program amplifier is added, stereo FM and monaural AM may be broadcast either simultaneously, or separately.

Ten Channel Stereo Or Monaural Transistor Console—Executive

VU METERS: Dual 4-inch illuminated meters are provided. The left meter connects to the left channel, while the right meter connects to the right channel (or it may be switched to the output of the optional M-5700 program amplifier). The right meter also switches to parallel the left meter for stereo calibration or to check incoming network level. A third external VU meter, in an attractive "shadow mold" housing, is available for larger installations where simultaneous metering of three program channels is required.

MUTING RELAYS: Three are supplied to mute three pairs of loudspeakers. Warning light contacts are also provided. These relays operate from the microphone keys and cue-intercom system.

ADDITIONAL FACILITIES: These include: dual headphone jacks; a cue-intercom selector switch; left and right master gain controls for the program amplifier; a dual monitoring amplifier gain control; a fully regulated power supply; and 28 tab keys (top row) performing a large number of switching functions.

STYLING: Exclusively styled by one of America's leading industrial designers, the Executive's satin anodized aluminum control panel floats in a 3-dimensional setting, and the "shadow mold" styling is strikingly modern in appearance. The front panel hinges down and the cabinet top cover hinges up.

SPECIFICATIONS

MIXING CHANNELS: Total—10. All stereo. (3) microphone, (2) turntables, (2) tape or projectors, (1) remote, (1) network, (1) all purpose.

AMPLIFIERS PROVIDED: 2 program, 2 booster, 2 monitor, 6 preamplifiers (3 pairs), 1 cue amplifier. Space provided for two optional added preamplifiers and one optional added program amplifier.

OPERATING MODE: Stereo and monaural.

INPUT CIRCUITS: 12 for mics., 4 turntables, 4 tape/projectors, 4 remote lines, 1 network line, 1 all purpose utility.

OUTPUT LINES: 2 program, 6 muted speaker (3 pairs), 2 non-muted speaker, 2 intercom, 2 headphones, 2 record. NOTE: Add one more program output if optional program amplifier is purchased.

IMPEDANCES: Microphones: 30/50 or 150/250 ohms. Turntable/tape: 150/250 ohms unbalanced. Remote lines: 500/600 ohms, balanced. Network: 500/600 ohms. Utility: 500/600 ohms. Programming output: 500/600 ohms. Recording output: 500/600 ohms. Intercom output: 48 ohms. Monitor speaker output: 8/16 ohms.

GAIN: Turntable, tape, network (high level) input to program line output, 55 dB. To monitor amplifier output, 55 dB. From microphone input to program line output, 102 dB. To monitor amplifier output, 102 dB. NOTE: All measurements ± 2 dB.

RESPONSE: All segments of program circuit ± 1 dB, 30-15,000 Hz. Monitoring circuit $\pm 1\frac{1}{2}$ dB, 30-15,000 Hz. NOTE: Typical response all circuits: 20-20,000 Hz, ± 2 dB.

DISTORTION: Any segment of program circuit 0.5% or less between 30-15,000 Hz at +8 dBm output level or 0.5% at +18 dBm, 50-15,000 Hz. Monitor amplifier 1% at -39 dBm (8 watts).

NOISE: Program circuits 70 dB or better below +18 dBm output, with -50 dBm input (equivalent noise input is -120 dBm). Monitor circuits, 60 dB below +39 dBm output. Crosstalk: All circuits below noise level with normal gain settings for proper programming.

STEREO ISOLATION: Below noise level all channels.

POWER: 115 volts, 50/60 Hz, 1 phase. Power consumption, 50 watts at 60 Hz.

FINISH: Cabinet, beige-gray. Panel, natural anodized aluminum lettered in black. Knobs with decal color inserts.

SIZE: 53 $\frac{1}{2}$ " wide, 11 $\frac{1}{2}$ " high, 17 $\frac{1}{2}$ " deep.

SHIPPING DATA: Packed weight: Domestic, 220 lbs. Export, 270 lbs. Cubage: 27 cubic feet.

OPTIONAL ACCESSORIES: Space is provided to add two model 994-6034 preamplifiers, and one model 994-5700 program amplifier.

NOTE: For optimum performance the load on the monitor amplifier should not be less than 8 ohms. Where it is necessary to operate several loudspeakers on one amplifier, use the 478-0275 matching transformer. Four of these transformers are supplied with the console.

ORDERING INFORMATION

Executive Audio Console (includes 4 speaker matching transformers).....	994-6158
Optional Preamplifier.....	994-6034
Optional program amplifier.....	994-5700
Speaker matching transformer.....	478-0275
Optional 3rd VU meter.....	994-6208
Intercom sub-station.....	994-6424

Ten Channel Stereo Or Monaural Transistor Console-Executive

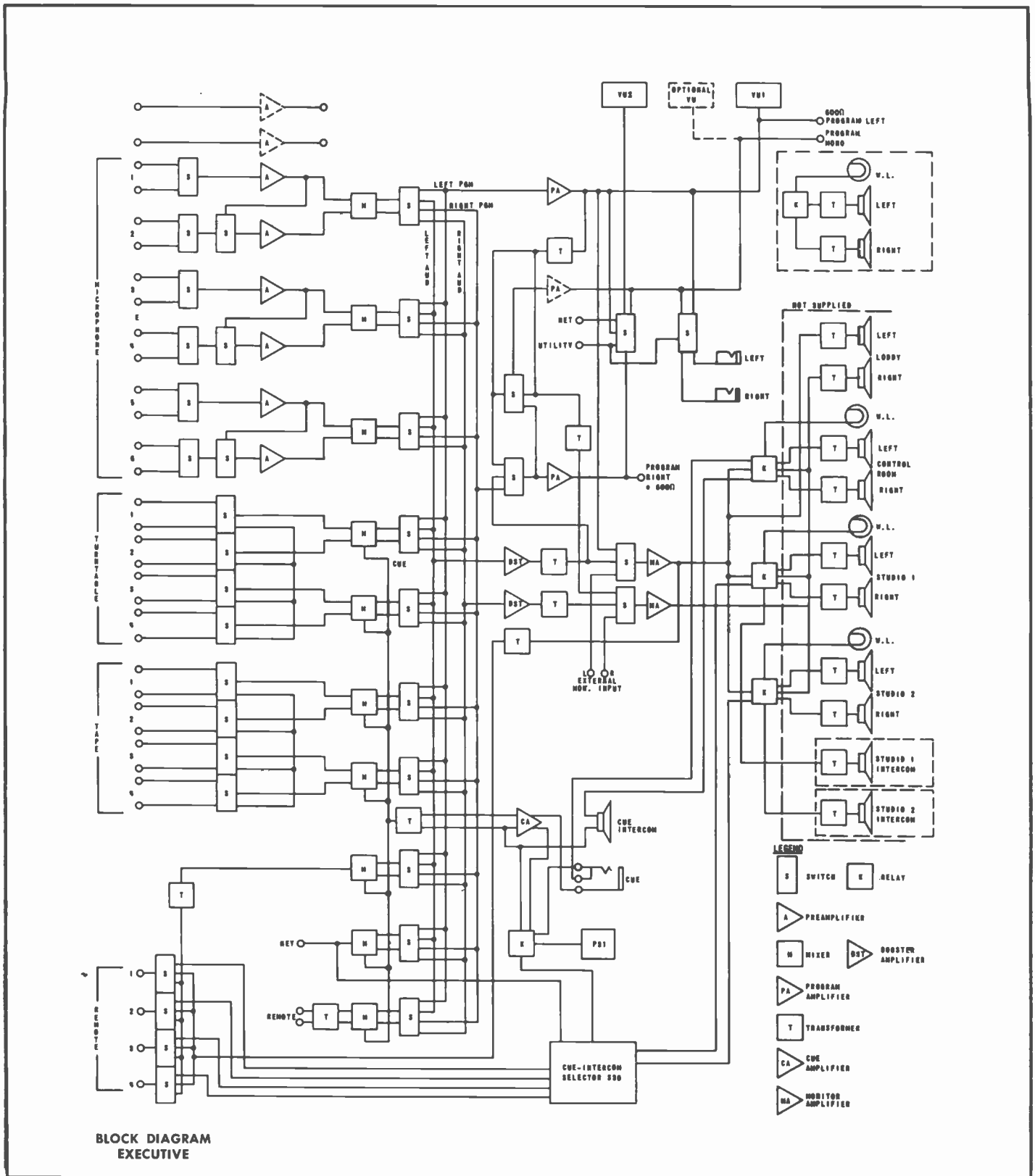

Dual Programming Ten Channel Transistor Console

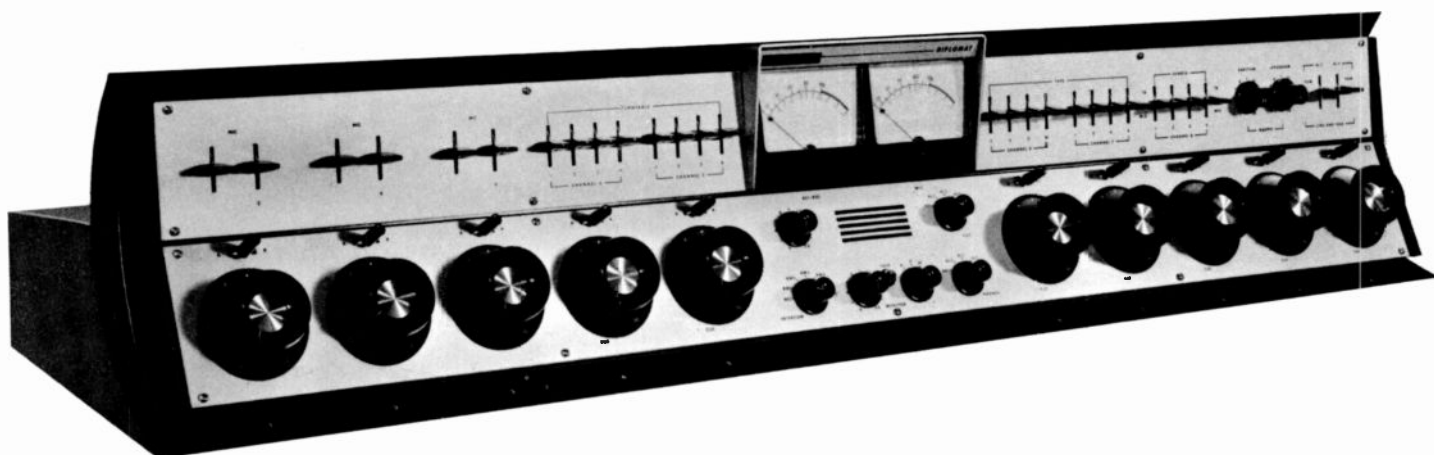

THE DIPLOMAT

The Diplomat is the senior partner in the fully transistorized Gates line of Solid-Statesman monaural consoles. This dual channel console has 10 mixing channels, cue-intercom, 28 upper level tab keys for nearly every conceivable input and output circuit function, and features the VA knob and "shadow mold" styling—designed exclusively for Gates by one of the country's leading industrial stylists.

MIXING SYSTEM: The mixing system is a ten channel, low impedance type, using ladder controls throughout in a minimum loss circuit design. The key switch above each channel control switches the mixer to either program amplifier.

MICROPHONE CHANNELS: Six microphones are tab key selected into 3 preamplifiers and associated mixing channels 1, 2 and 3. Channel keys operate the three muting relays.

TURNTABLE CHANNELS: Mixing channels 4 and 5 handle four turntables into either mixer in any sequence. Four upper level tab keys on each channel select the turntable to be used. Cue position on faders connects any turntable input to the cue amplifier.

TAPE CHANNELS: Mixing channels 6 and 7 handle four tape or projector inputs into either mixer in any sequence. Four upper level tab keys on each channel select the input to be used. Cue position on fader connects any tape input to cue amplifier.

REMOTE CHANNEL: Mixing channel 8 accommodates four remote lines by upper tab key selection. A line isolation transformer is part of this circuit. Cue position on fader connects any remote line to cue amplifier.

NETWORK CHANNEL: Mixing channel 9 is for network or similar input. Cue position on fader connects network to cue amplifier for preview.

AUXILIARY CHANNEL: Mixing channel 10 is for any input source such as a second network or much used remote. This auxiliary channel has a cue position on the fader connected to cue amplifier.

CUE-INTERCOM SYSTEM: The built-in intercom system provides network monitoring, remote over-ride, remote talk-back, studio intercom, turntable cueing, tape cueing and general previewing and cueing. The control room and studio speakers are muted by the channel keys and muting relays when there is a live microphone in any of these locations. The cue amplifier and speaker/microphone is self-contained, and the cue speaker/microphone is located directly under the VU meters.

PROGRAM SWITCHING FUNCTIONS: A single key changes the master operation of the console from simultaneous to separate operation as desired by the operator. Dual program amplifiers are standard equipment. Space is provided for an optional third program amplifier. If the third program amplifier is utilized, this will permit, for example, recording while broadcasting AM and FM simultaneously from the second of the dual channels.

VU METERS: Two 4" illuminated VU meters are supplied. The left meter is connected to program channel 1 at all times. The right meter may be switch selected to (a) program channel 1 for calibration, (b) program channel 2, (c) output of optional third program amplifier, (d) network input, or (e) external connections.

MONITORING AMPLIFIER: The self-contained 8 watt monitoring amplifier input may be switched to (a) output of master program channel, (b) output of program channel 2 or (c) external input. Amplifier output feeds the loudspeaker system.

MUTING RELAYS: Three relays mute speakers and operate studio warning lights in the control room and are controlled from microphone mixer channel keys. Intercom is also interlocked to prevent feedback.

Dual Programming Ten Channel Transistor Console—Diplomat

PHONE JACKS: Phone jacks are provided on a separate mounting plate which attaches to the desk, thus eliminating phone cords over the desk top.

POWER SUPPLY: The power supply is fully regulated and self-contained except for the small AC transformer, which is external to assure extremely low noise.

SERVICING: The Diplomat front panel hinges down and cabinet lid hinges up to expose all components for easy maintenance. All terminations are in the rear.

RECOMMENDED USE: The Diplomat may be described as an unusually wide facility audio console of network or large station caliber. It is excellent for TV as well as radio.

SPECIFICATIONS

MIXING CHANNELS: Total 10. Three microphone, two turntable, two tape/projector, one remote, one network and one auxiliary.

AMPLIFIERS PROVIDED: 2 program, 1 monitor, 3 preamplifiers, 1 cue amplifier. Room provided for 1 additional program amplifier and 2 additional preamplifiers.

OPERATING MODE: Dual channel monaural.

INPUT CIRCUITS: 6 for microphones, 4 turntables, 4 tape/projectors, 4 remote lines, 1 network line, 1 auxiliary line.

OUTPUT CIRCUITS: 2 program, 1 audition, 3 muted speakers, 1 non-muted speaker, 2 intercom, 2 headphones.

IMPEDANCES: Microphones: 30/50 or 150/250 ohms. Turntable: 600 ohms. Tape/projector: 600 ohms. Remote lines: 600 ohms. Network: 600 ohms. Auxiliary: 600 ohms. Programming output: 600 ohms. Audition output: 600 ohms. Intercom output: 48 ohms. Monitor speakers: 8/16 ohms. Recording outputs: 600 ohms.

NOTE: Where more than two loudspeakers are used, it is mandatory that the 478-0275 speaker matching transformer or similar be used with each loudspeaker. This assures correct loudspeaker performance and protects power transistors in the monitoring amplifier.

GAIN: Turntable, tape, network (medium level) input to program line output 55 dB. From microphone input to program line output 102 dB. All measurements ± 2 dB.

RESPONSE: All segments of program circuit ± 1 dB 30-15,000 Hz. Monitoring circuit $\pm 1\frac{1}{2}$ dB 30-15,000 Hz.

NOTE: Typical response: 20-20,000 Hz.

DISTORTION: Any segment of program circuit 0.5% or less between 30-15,000 Hz at +8 dBm output level, or at +18 dBm output 0.5% 50-15,000 Hz. Monitor amplifier 1% at +38 dBm (8 watts). Intermodulation distortion: 0.5% program and 1.0% monitor circuits.

NOISE: Program circuits: 70 dB or better below +18 dBm output, with -50 dBm input (equivalent noise input -120 dBm). Monitor circuits: 60 dB below +39 dBm output. Crosstalk: All circuits below noise level with normal gain settings for proper programming.

POWER: 117 volts, 50/60 Hz, 1 phase. Power consumption 34 watts at 60 Hz.

FINISH: Satin anodized aluminum panel with lettering in black. Cabinet in beige-gray, with shadow mold in black. Knob color insert decal kit included.

SIZE: 53½" wide, 11¾" high, 17¾" deep.

SHIPPING DATA: Packed weight: Domestic, 220 lbs.; export, 242 lbs. Cubage: 26 cubic feet.

ORDERING INFORMATION

Diplomat audio console complete with four speaker matching transformers	994-6377
Optional program amplifier	994-5700
Optional preamplifier	994-6034
Speaker matching transformer	478-0275
Spare 100% semi-conductor kit	990-0505
Studio cue/intercom speaker	994-6424

IMPORTANT: For optimum performance the load on the monitor amplifier should not be less than 8 ohms. Where it is necessary to operate several loudspeakers on one amplifier, use the 478-0275 matching transformer. Four of these transformers are supplied with the console.



STUDIO CUE-INTERCOM SPEAKER

Beautifully styled to match all Gates Solid Statesman products. Cast aluminum housing in non-reflecting black with heavy fabric grill cloth front. Speaker 600/48 ohms to match console intercom impedances. Size: 5½" wide, 6¾" high, 4" deep. ORDER MODEL 994-6424.

Dual Programming Ten Channel Transistor Console—Diplomat

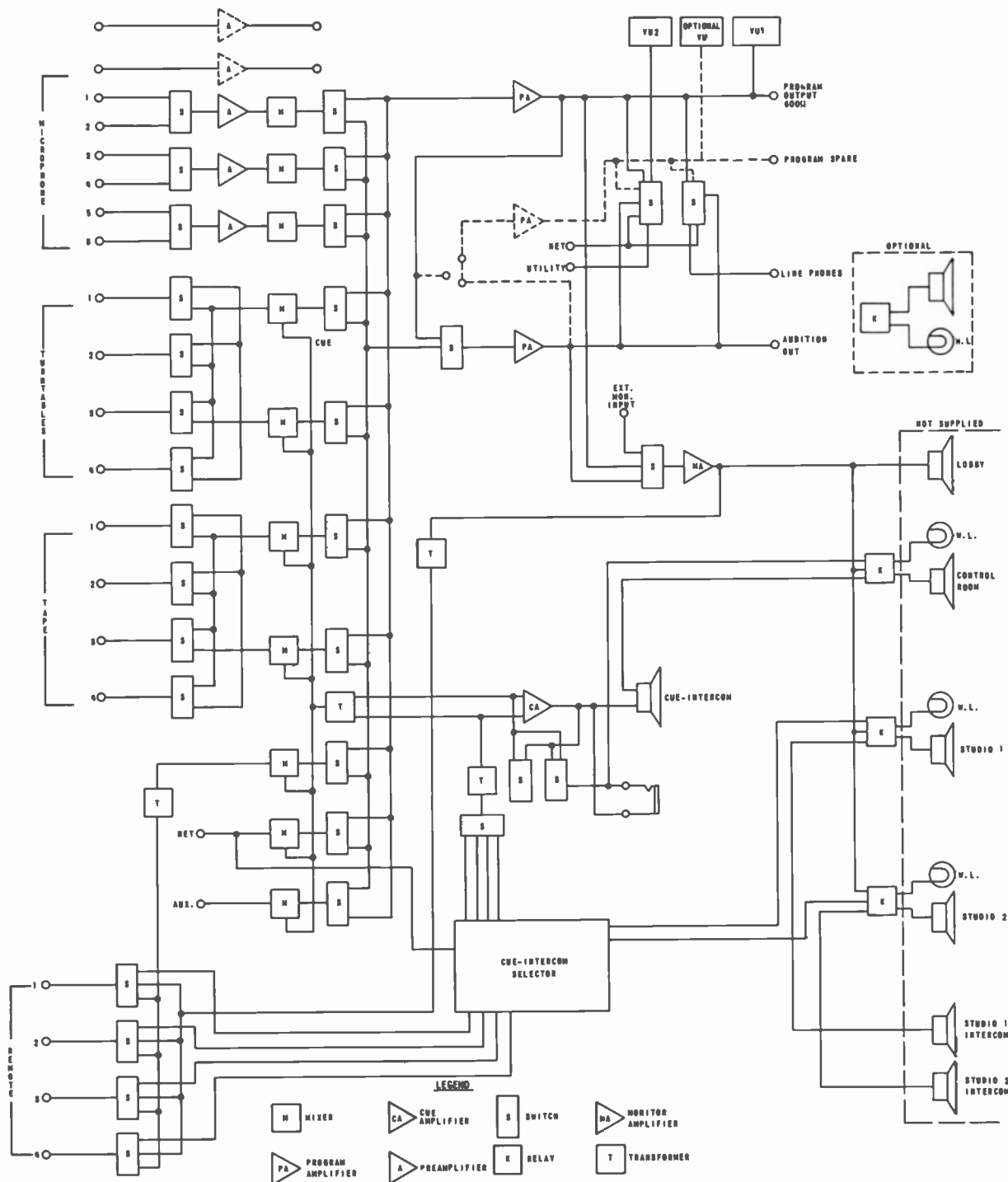

BLOCK DIAGRAM
DIPLOMAT

Dual Programming Eight Channel Transistor Console



THE PRESIDENT

The President is a completely transistorized dual channel, 8 mixer audio control console, featuring Gates unique Control Center, with its extreme versatility and operating simplicity. Control Center frees engineers from the mechanics of patching, yet all program inputs are available instantly.

With a full amplifier complement, the President console is particularly well suited for television operation. Six of twelve microphones can be mixed simultaneously, while still providing mixing facilities for the extensive medium level signals in television such as: film projectors, video tape recorders, auxiliary mixers, and the usual turntable, cartridge and reel-to-reel equipment.

MIXING SYSTEM: Eight monophonic mixing channels are provided, utilizing low impedance, ladder type controls. Key selection allows any mixer to feed either program channel. Cue positions are on several controls (see Cue-Intercom System).

MICROPHONE INPUTS: This standard console provides eight microphone inputs switchable into four mixing channels. Channels 3 and 8 each provide two medium level inputs, or may be converted to microphone level by use of the optional plug-in microphone preamplifiers. If the preamplifiers are connected ahead of the input selector switch on these channels, each fader can then fill the dual role of a microphone and medium level channel.

MEDIUM LEVEL INPUTS: Control Center consists of two banks of twelve push keys, plus OFF. The upper bank feeds the left mixer. The lower bank feeds the right mixer. Any push key when depressed automatically releases any other key in the same row. All push keys not in use automatically connect to the cue amplifier/speaker. Each bank of push keys has four red, four white, four blue colors, plus green for OFF.

They may be placed in any sequence, and illuminate when the respective key is depressed. Each push key is numbered with a large block figure. A typewritten identification card,

identifying each source in the system, may be substituted if desired.

Any of twelve medium level circuits may be punched into either mixing channel, assuring full fader control. Two faders do the work of twelve in the President Control Center. Isolation transformers are used in both circuit banks to assure balance, whether the input is in studio or out of studio.

Push key switches, utilizing gold program circuit contacts, provide reliable maintenance-free operation. Silver alloy DC switching contacts used to illuminate the "in use" stations also provide 30 volts DC for the control of external equipment. The Gates KCP-5 relay is available as optional equipment. It has D.P.D.T. contacts and requires 5 mA to operate.

CUE-INTERCOM SYSTEM: A fully interlocked cue-intercom system is incorporated. The cue position of mixing channels 3 and 8, the network input, or any of the twelve pushbutton stations may feed the cue amplifier, regardless of the position of the cue amplifier input selector switch. Completely self-contained, the cueing system also provides talk-back control to two studios and remote lines.

MUTING RELAYS: Speaker muting relays are provided for the control room and two studio speakers. These relays have extra intercom muting contacts to prevent feeding an intercom signal into the studios when a live microphone is in use. The control room muting relay is factory wired to mute the console speaker with any signal source when the control room microphone is in use. A cue phone jack permits headphone monitoring of the cue-intercom circuits at all times. Added contacts are provided for studio warning lights.

AMPLIFIER COMPLEMENT: The President is completely transistorized, incorporating Gates exclusive Solid-Statesman transistor amplifiers. The standard amplifier complement consists of four plug-in microphone preamplifiers, two plug-in program amplifiers, one cue-intercom amplifier, and an 8 watt transistorized monitoring amplifier. Space is provided for two optional additional preamplifiers. The power supply is self-contained and is fully regulated.

Dual Programming Eight Channel Transistor Console—President

The 10 dB overload capacity of the M-5700 program amplifiers used in the President, coupled with at least a 20 dB overload capacity in the microphone preamplifiers, makes the President almost impervious to excessive program levels. A 6 dB line isolation pad permits the connection of this console to highly reactive telephone lines without any noticeable interaction.

The +39 dBm (8 watts) rating of the transistor monitor amplifier is combined with flat response, and low harmonic and intermodulation distortion that is typical of Solid-Statesman engineering.

The regulated power supply protects the console amplifiers from variations due to line and load regulation. In addition, the power supply ripple is reduced to insure uniformly low noise in all of the console circuits. The power supply is short-circuit protected to prevent damage during operation or maintenance.

VU METERS: Four-inch, illuminated VU meters provide visual monitoring of both output channels. The meters can be mounted anywhere along the top rail of the console, or placed on the console desk.

SPECIFICATIONS

MIXING CHANNELS: Total—8. Monophonic.

AMPLIFIERS PROVIDED: 2 program, 1 monitor, 4 preamplifiers, 1 cue/intercom amplifier. (2 additional preamplifiers optional).

OPERATING MODE: Dual channel monaural.

INPUT CIRCUITS: 8 microphones into 4 preamplifiers, standard. 12 microphones into 6 preamplifiers, by use of two optional preamplifiers. 11 turntables, tape, projector or external inputs into 2 mixers. 4 remote lines. One network line into 1st "Control Center" push key.

OUTPUT LINES: 2 program lines, 3 muted speaker outputs, 1 unmuted speaker output, 2 interlocked studio intercom speakers, 1 intercom, 2 headphone outputs.

IMPEDANCES: (Input) Mics: 30/50 or 150/250 ohms. Mixing channels 3 and 8: 600 ohms unbalanced if optional preamplifiers are not used. (Output) 2 program lines each 500/600 ohms. Monitor amplifier: 8/16 ohms. Intercom speakers: 45 ohms.

GAIN: Microphone input to line output: 104 dB \pm 3 dB. Turntable input to line output: 56 dB \pm 2 dB. Microphone input to speaker output: 104 dB minimum. Turntable input to speaker output: 56 dB minimum.

RESPONSE: Rated \pm 1.0 dB from 30 to 15,000 Hz in all regular program circuits. Capable: 20-20,000 Hz. Rated \pm 1.5 dB from 30 to 15,000 Hz in all monitoring speaker circuits. Capable: 20-20,000 Hz.

DISTORTION: Rated 0.5% maximum, 30 to 15,000 Hz at +8 dBm output in all regular program circuits. Capable: 20-20,000 Hz. Rated 0.5% maximum, 50 to 15,000 Hz at +18 dBm output in all regular program circuits. Rated 1.0% maximum, 50 to 15,000 Hz at +39 dBm (8 watts) in speaker outputs. Capable: 1% or less 20-20,000 Hz at +38 dBm.

NOISE: Program circuits, 70 dB or better below +18 dBm with -50 dB input (equivalent noise input is -120 dBm). Turntable, tape and all Control Center input circuits 70 dB below +18 dBm output. Monitoring circuits 60 dB below +39 dBm output.

CROSSTALK: Below noise level in all channels.

POWER: 115 volts, 50/60 Hz, 44 watts.

FINISH: Panel, natural aluminum with knobs and lettering in black. Cabinet color—beige-grey. Mixer knobs supplied with decol color insert kit. Control Center knobs in four colors and illuminated.

SIZE: 52½" wide, 11½" high, 17½" deep.

SHIPPING DATA: Weight packed: domestic, 220 lbs.; export, 290 lbs. Cubage: 27 cubic feet.

OPTIONAL ACCESSORIES: Space provided for 2 added M-6034 plug-in amplifiers.

ORDERING INFORMATION

The President, dual channel audio control console, includes 2 external VU meters, 4 speaker matching transformers, 4 mic preamps, monitor amplifier, cue amplifier, and 2 program amplifiers

.....	994-6209
Optional plug-in microphone preamplifiers.....	994-6034
External VU meter with housing.....	994-6208
Intercom sub-station, deluxe.....	994-6424
Spare 100% semi-conductor kit.....	990-0503
Speaker matching transformer.....	478-0275
KCP-5 Relay, 30 volt D.P.D.T. to start-stop external equipment.....	994-6482

Five Channel Monophonic Transistor Console



THE AMBASSADOR

A premium quality Solid-Statesman console, the Ambassador features Gates exclusive Control Center, plus superb electrical performance and great operating versatility in a compact size.

The unique Control Center has two mixing channels doing the work of 12. This, combined with the multiple microphone facilities, cue-intercom and many other features, results in a fine console for use in AM, FM and TV broadcasting.

AMPLIFIER COMPLEMENT: The Ambassador is completely transistorized, incorporating Solid-Statesman plug-in transistor amplifiers to meet superior performance and reliability standards. It includes: (2) plug-in microphone preamplifiers (space provided for optional 3rd preamplifier), (1) plug-in program amplifier, (1) plug-in audition booster amplifier, (1) plug-in cue/intercom amplifier and (1) eight-watt monitoring amplifier. The preamplifiers have a full 20 dB overload capacity. The distortion is actually lower than that of many test oscillators. The program amplifier has a full 10 dB overload factor above the +14 dBm rating used to feed the 6 dB line isolation pad to the program line. Performance standards are not altered by substantial level variations and high telephone line reactances, and provide quality that only the more sophisticated test systems are capable of measuring.

The monitoring amplifier provides a full +39 dBm (8 watts) output to the speakers with low harmonic and intermodulation distortion. The response of all amplifiers is flat over a wide audio spectrum. An isolation transformer bridges the output of the monitor amplifier for emergency program feed and remote program cue. The cue-intercom system is peaked for maximum intelligibility.

A fully regulated power supply protects the console amplifiers from variations due to line and load regulation. Power supply ripple is reduced almost to the point of non-existence to assure uniformly low noise in all of the console circuits.

The power supply is also protected to prevent damage to any of the transistors in either the power supply or amplifiers from a momentary or sustained short in any of the load circuits.

MIXING SYSTEM: Five monophonic input mixing channels are provided, utilizing low impedance, ladder-type controls. The Ambassador accommodates 22 inputs with expansion facilities to 31 by using the three unwired utility switches left available for the user. Key selection allows any mixer to feed program amplifier or audition output through the audition booster amplifier.

CONTROL CENTER: The heart of the Ambassador is Control Center, operating into mixers 4 and 5. It consists of two rows of 12 push-keys, plus an OFF key, with the upper bank of 12 push-keys feeding the left mixer (#4) and the lower bank of 12 push-keys feeding the right mixer (#5). Any push-key, when depressed, automatically releases any other key in the same row. Any push-keys which are not feeding either mixer 4 or 5 are connected to the cue amplifier/speaker. Push-keys are color-coded for convenience in identifying inputs such as turntables, tapes, etc.

To further expand the medium level facilities in the Ambassador, push-key #1 selects from any one of four remote lines or network as switched by the upper row tab keys above the Control Center. A large, numbered designation strip between the push-key rows may be replaced with typewritten identification cards. Any of the 12 circuits may be switched into either mixing channel, assuring full fader control.

The 30 volt circuit for illumination of each push-key is also brought to a pair of terminals. In this manner, the push-keys may start a mechanical device such as a Criterion, projector or turntable at the same time as the audio is engaged. A relay kit (994-6482) is available for this service and is listed on the next page.

Five Channel Monophonic Transistor Console—Ambassador

Mixing channels one through three provide six more inputs for either microphone or medium-level signals. The standard Ambassador is equipped with two plug-in preamplifiers to accommodate up to four studio and control room microphones through faders 1 and 2. Fader 3 has a cueing attenuator and is for medium-level inputs. Provision for a third, optional, plug-in preamplifier is included. This optional 994-6034 preamplifier may be connected ahead of the input selector switch of channel three for a dual function of microphone input plus medium-level input—or, it may be wired after the input selector to provide two additional microphone inputs.

CUE/INTERCOM SYSTEM: The inbuilt cue/intercom system permits preview listening from all Control Center circuits such as remotes, network, turntables, tapes, projectors. In addition, preview from mixing channel 3 and auxiliary is provided. Talk back is possible to two studios, remote lines and a spare input circuit. The 994-6424 sub-station listed below is suggested for studio use in talk back service.

MUTING RELAYS: Three muting relays, energized by microphone channel keys, disconnect loudspeakers adjacent to a live microphone, provide contacts for warning lights and

additional contacts to mute the intercom system when a studio is in use. A cue phone jack is provided to allow headphone monitoring of cue circuits where necessary.

MOVABLE VU METER: Mounted in a cast aluminum housing, the illuminated VU meter may be located where desired—along the top rail of the console cabinet or at either side of the console. In this way, the VU meter may be placed in the most convenient visual location, which varies from one station to another. A connecting cable and plug is part of the meter assembly.

VERSATILITY: The creative design of the Ambassador makes it very nearly a custom console. Control Center, with its array of 24 illuminated touch control keys into two channels, plus 3 additional mixing inputs with their associated switching, and three utility keys, provides many exciting possibilities in audio control.

The VA mixer knob is used on all faders. Designed first in similar style for the Voice of America Studios, it is a substantial advance in the "feel-of-the-board" concept. "Shadow-mold" styling is from one of America's leading industrial stylists, engaged by Gates for the Solid-Statesman line of equipment.

SPECIFICATIONS

MIXING CHANNELS: Total—5. Monophonic.

AMPLIFIERS PROVIDED: 1 plug-in program, 1 plug-in booster, 1 eight-watt monitor, 2 plug-in preamplifiers, 1 plug-in cue amplifier.

OPERATING MODE: Single channel monaural.

INPUT CIRCUITS: 4 microphones into 2 preamplifiers, as supplied; 6 microphones into 3 preamplifiers, 3rd preamplifier optional; 12 turntables, tape, projector, or any medium-level input into 2 mixers; 4 remote lines; 1 network line.

OUTPUT LINES: 1 program, 1 audition, 3 muted speaker, 1 non-muted speaker, 2 studio intercom, 1 spare intercom.

IMPEDANCES: Microphones 30/50 or 150/250 ohms; turntable/tape 600 ohms unbalanced; remote lines 600 ohms; network 600 ohms; programming output 600 ohms; audition output 600 ohms; intercom output 45 ohms; monitor output 8-16 ohms.

GAIN: Turntable, tape, network (high level) input to program line output 56 dB. To monitor amplifier output 56 dB minimum. From microphone input to program line output 104 dB. To monitor amplifier output 104 dB minimum. Note: All measurements ± 2 dB.

RESPONSE: All segments of program circuit: ± 1.0 dB, 30-15,000 Hz. Ca-

pable: 20-20,000 Hz. Monitoring circuit ± 1.5 dB, 30 to 15,000 Hz. Copable: 20-20,000 Hz.

DISTORTION: Any segment of program circuit 0.5% or less between 30-15,000 Hz at +8 dBm output level. Copable: 20-20,000 Hz. Monitor amplifier: 1.0% between 30-15,000 Hz, at +39 dBm (8 watts output level). Capable: 20-20,000 Hz.

NOISE: Program circuits: -70 dB or better below +18 dBm output, with -50 dBm (equivalent noise input is -120 dBm). Monitor circuits: 60 dB below +39 dBm output. Crosstalk: All circuits below noise level with normal programming gain settings.

POWER: 117 volts, 50/60 Hz, single phase. Power consumption 40 watts at 60 Hz.

FINISH: Panel: Natural satin anodized aluminum with black nomenclature. Decal color insert kit supplied for mixer knobs. Cabinet: beige-gray with black trim.

SIZE: 37½" long, 11¾" high, 17¾" deep.

SHIPPING DATA: Packed weight: Domestic, 245 lbs.; export, 265 lbs. Cubage: 20.5 cubic feet.

OPTIONAL ACCESSORIES: Space is provided to add, when desired, one model 994-6034 preamplifier.

ORDERING INFORMATION

Ambassador, single channel console, complete with 2 preamplifiers and 4 speaker matching transformers.....	994-5564
Extra plug-in microphone preamplifier.....	994-6034
Intercom sub-station, deluxe.....	994-6424
Speaker matching transformer.....	478-0275
Relay kit for use with Control Center to start mechanical device.....	994-6482
Spare 100% semi-conductor kit.....	990-0499
Plug-in jumper board.....	913-6060

NOTES: (1) Four speaker matching transformers are supplied with each console. If more than 4 speakers are to be used, order an added 478-0275 transformer for each added speaker. (2) If it is desired to use mixing channels 1 or 2 as medium level inputs, order 913-6060 plug-in jumper board to replace preamplifiers.

Four Channel All-Purpose Console



THE STUDIOETTE

A single channel monophonic console with 13 inputs into four mixing channels, the Studioette has found wide application as a main console in modest sized stations, as a sub-console for large installations, or as a second console for independent programming or recording. The demand for an attractive, compact, large facility console has made the Studioette equally popular in mobile audio installations.

OPERATION: Completely self-contained including power supply, the Studioette provides 4 mixing channels with channel keys, and a row of 14 tab keys for multiple circuit combinations. Three utility keys are provided for specialized station needs and may be wired into any input. Step type ladder mixing controls, illuminated 4" VU meter, and the same quality amplifiers found on larger Gates consoles are all included in the Studioette.

Four microphones may be key selected into two preamplifiers. Three turntables, two tape/projectors, three remote lines and network are also accommodated. The 10 watt ultra-linear monitoring amplifier is standard equipment. Dual muting relays handle speaker and warning light functions. Space is provided for a third (optional) preamplifier. The Studioette is a functional all-purpose console, performance proven by hundreds of broadcasting and recording users around the world.

When mixing channels 3 and 4 are in cue position, they automatically connect to terminals from which a cueing amplifier may be fed. Gates 994-5377 cueing amplifier is ideal for this service. With this feature, all circuits feeding mixing channels 3 and 4 may be prechecked, including turntables, network, tape inputs and remote lines.

MONITOR BOOSTER: A two-stage amplifier is located between the audition bus of the mixer and input to the monitoring amplifier. This feature provides balanced level between the program and audition outputs so that there is no need for readjustment of gain settings when switching.

RELAYS: Two relays are supplied for operating warning lights and muting loudspeakers. There is also space for two additional relays. These relays operate in conjunction with the microphone keys and almost any muting arrangement is possible with this design.

ADDITIONAL FACILITIES: Additional facilities include an output emergency key for switching the program line to the monitoring amplifier output in case of a noisy tube, etc., in the program amplifier. A monitor selector key switches the monitoring amplifier input to: (1) program line for monitoring, (2) terminals for external monitor input, and (3) audition output of the mixing system. A headphone jack is always available across the program line. The 4" illuminated VU meter is flush mounted. This meter is connected to the program line to indicate +8 VU at 0 scale reading.

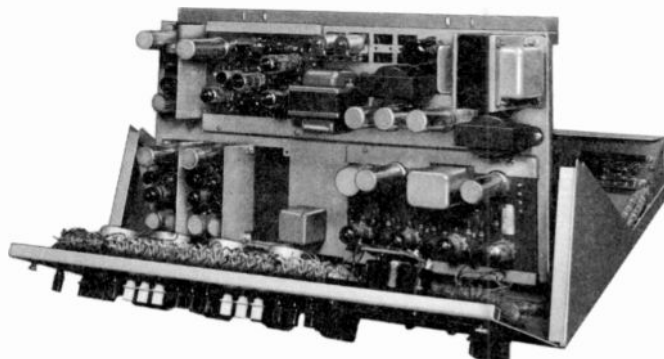

The Studioette top cover may be completely removed, and the front panel hinges out to reach every "behind the panel" component. The amplifier deck hinges up so that muting relay contacts are at your finger tips when touch-up burnishing is required.

Four Channel All-Purpose Console—Studioette

SPECIFICATIONS

MIXING CHANNELS: Total—4. Key selected to program or audition bus. Channels 1 and 2 for microphones, 3 and 4 for multi-input use such as turntables, tapes, etc. Cue position on faders 3 and 4.

AMPLIFIERS PROVIDED: 1 program, 1 monitor, 2 preamplifiers.

OPERATING MODE: Single channel monaural.

INPUT CIRCUITS: 4 microphones, 3 turntables, 2 tapes or projectors, 3 remote lines, 1 network line. (1 external monitor amplifier input).

OUTPUT LINES: 1 program, 1 audition, 2 muted speaker, 1 non-muted speaker, 1 turntable cue, 1 remote/tape cue.

IMPEDANCES: Microphones 30/50 or 150/250 ohms; turntable/tape 150/250 ohms unbalanced; remote lines 600 ohms; network 600 ohms; Programming output 600 ohms; audition output 20,000 ohms; monitor speakers 8/16 ohms. Note: Where more than two loudspeakers are used, the 478-0275 speaker matching transformer should be used.

GAIN: Turntable, tape, network (medium level) input to program line output 63 dB; to monitor amplifier output 100 dB. From microphone input to program line output 103 dB; to monitor amplifier output 103 dB. All measurements ± 2 dB.

RESPONSE: Program circuit $\pm 1\frac{1}{2}$ dB 30 to 15,000 Hz. Monitoring circuit ± 2 dB 30 to 15,000 Hz.

DISTORTION: Program circuit 1% or less between 30-15,000 Hz at +8 dBm output level. Monitor amplifier 2% at +40 dBm (10 watts).

NOISE: Program circuits: 70 dB or better below +18 dBm output, with -50 dBm input (equivalent noise input is -120 dBm). Monitor circuits: 55 dB below +40 dBm output. Crosstalk: all circuits below noise level with normal gain settings for proper programming.

POWER: 117 volts, 50/60 Hz, 1 phase. Power consumption 120 watts at 60 Hz.

FINISH: Panels, anodized black and gray. Cabinet, beige-gray.

SIZE: 24" wide, 8 $\frac{1}{4}$ " high, 17" deep.

SHIPPING DATA: Packed weight: Domestic, 70 lbs.; export, 110 lbs. Cubage: 12 cubic feet.

TUBES: (9) EF86/6267, (3) 12AX7, (2) EL84, (2) OAT and (1 each) 12AU7, GZ34.

OPTIONAL ACCESSORIES: Space is provided to add 1 model 994-5304 preamplifier and two 572-0072 muting relays.

ORDERING INFORMATION

Studioette audio console.....	994-5381
100% spare tube kit.....	990-0444
Optional preamplifier.....	994-5304
Speaker matching transformer.....	478-0275
Extra muting relay.....	572-0072
Optional cueing amplifier.....	994-5377

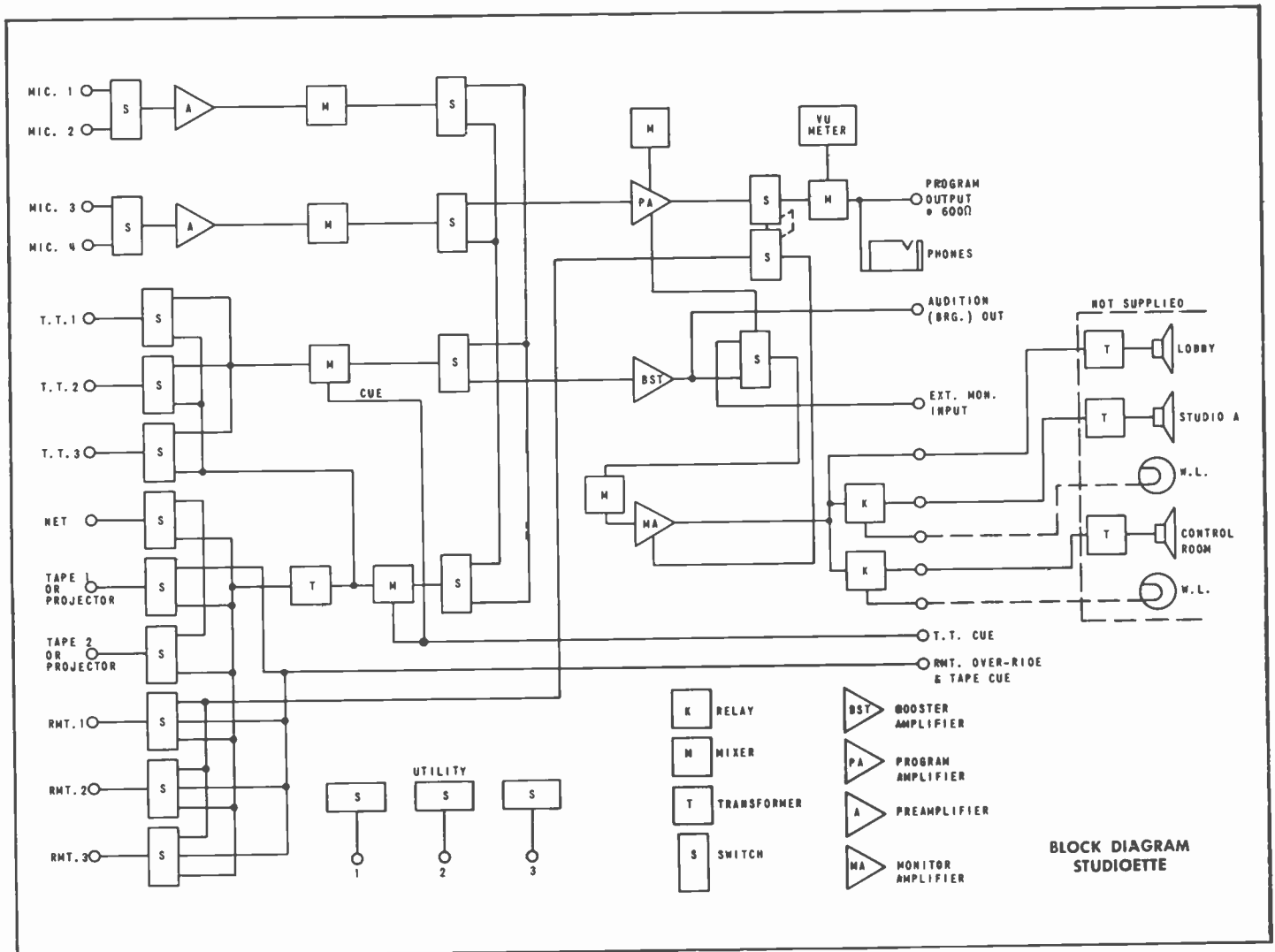

Four Channel Stereo Recording Mixer



THE STEREO PRODUCER

Gates' Stereo Producer is a solid-state four-channel stereo-phonetic production mixer, providing all facilities for direct recording, dubbing, sound-on-sound recording, editing and monitoring.

ADAPTABILITY: The Stereo Producer may be used in almost any situation not requiring a complete speech input console. It is small enough to take to sporting events, concerts, city council meetings, etc. for on-the-spot remote coverage. Ideal for stereo newscasts, and as a sub-studio console for programming outside the main control room.

SOUND-ON-SOUND: An important feature of the Stereo Producer is its ability to make sound-on-sound recordings. The monitoring amplifiers normally bridge the program amplifier outputs. However, if it is desired to add voice-over on a prerecorded music or voice track, the monitor amplifier is switched to either of the high-level inputs, ahead of the mixers, to prevent acoustic feedback.

STEREO BALANCING: Circuitry is provided to allow accurate stereo channel balancing, using the "null" method, with the aid of the large, 4-inch console VU meters.

INPUTS: The console has transformer-balanced inputs on each channel. Inputs include: six microphones into two faders, and ten turntable, cartridge or reel-to-reel recorders into two faders (for each stereo channel).

OUTPUTS: High-gain program amplifiers furnish 600-ohm balanced outputs at +8 VU, after an isolation pad. The monitor amplifiers provide +32 dBm (1½ watts) for driving monitoring loudspeakers. Monitor-speaker muting on the microphone channels is standard.

Large "feel-of-the-board" VA control knobs are used for speed and accuracy in mixing. Installation of the Stereo Producer is simple, with all cable connections made to barrier-type terminal strips. All components are readily accessible through the lift-off top.

Four Channel Stereo Recording Mixer—Stereo Producer

SPECIFICATIONS

MIXING CHANNELS: Total of 4. 2 microphone channels, 2 medium level (TT/Tape/Projector) channels. Cue provision on medium level channels.

AMPLIFIER SYSTEM: 2 identical printed-circuit board assemblies are used, 1 for each stereo channel. Each printed-circuit board contains 2 microphone preamps, 1 booster amp, 1 program amp, 1 monitor amp, and 1 power supply.

OPERATING MODE: Stereophonic.

INPUT CIRCUITS: 6 microphone or low-level, 10 medium level per stereo channel.

OUTPUT LINES: Stereo program line, stereo monitor output, and stereo high impedance headphone jack.

IMPEDANCES (All Balanced): Microphone, 30/50 or 150/250 ohms. Medium level, 150/600 ohms. Program output, 150/600 ohms. Monitor outputs, 8/16 ohms.

GAIN: Microphone input to line output, 100 dB \pm 3 dB.
Medium level input to line output, 55 dB \pm 3 dB.
Medium level input to monitor output, 80 dB \pm 3 dB.

RESPONSE: \pm 1.0 dB from 30 to 15,000 Hz in program circuits. \pm 1.5 dB from 30 to 15,000 Hz in monitoring circuits.

DISTORTION: Harmonic, 1.0% maximum, 50 to 15,000 Hz @ +18 dBm output in program circuits, and @ +32 dBm in monitor circuits. Inter-modulation, 1.0% maximum in program circuits.

NOISE: -120 dBm relative input noise on microphone channels. -75 dBm relative input noise on medium level channels.

CROSSTALK: 55 dB below -60 dBm input and +8 dBm output, 30 Hz to 15,000 Hz, microphone channels. 55 dB below -15 dBm input, +8 dBm output, 30 Hz to 15,000 Hz, medium level channels.

POWER: 117 volts, 50/60 Hz, power consumption 28 watts.

FINISH: Beige/gray with black trim.

SIZE: 28" long, 10½" high, 18" deep.

WEIGHT: 60 lbs.

SHIPPING DATA: Packed weight, domestic, 75 lbs.; export, 125 lbs., cubage, 5 cubic feet.

ORDERING INFORMATION

M-6642 Stereo Producer recording mixer, four channels complete with preamplifiers, program amplifiers, monitor amplifiers and self-contained power supplies ----- 994-6642

100% spare semi-conductor kit for the Stereo Producer ----- 990-0583

Speaker matching transformers for using external 8-ohm speakers, 48/8 ohms (two required for stereo) ----- 478-0291

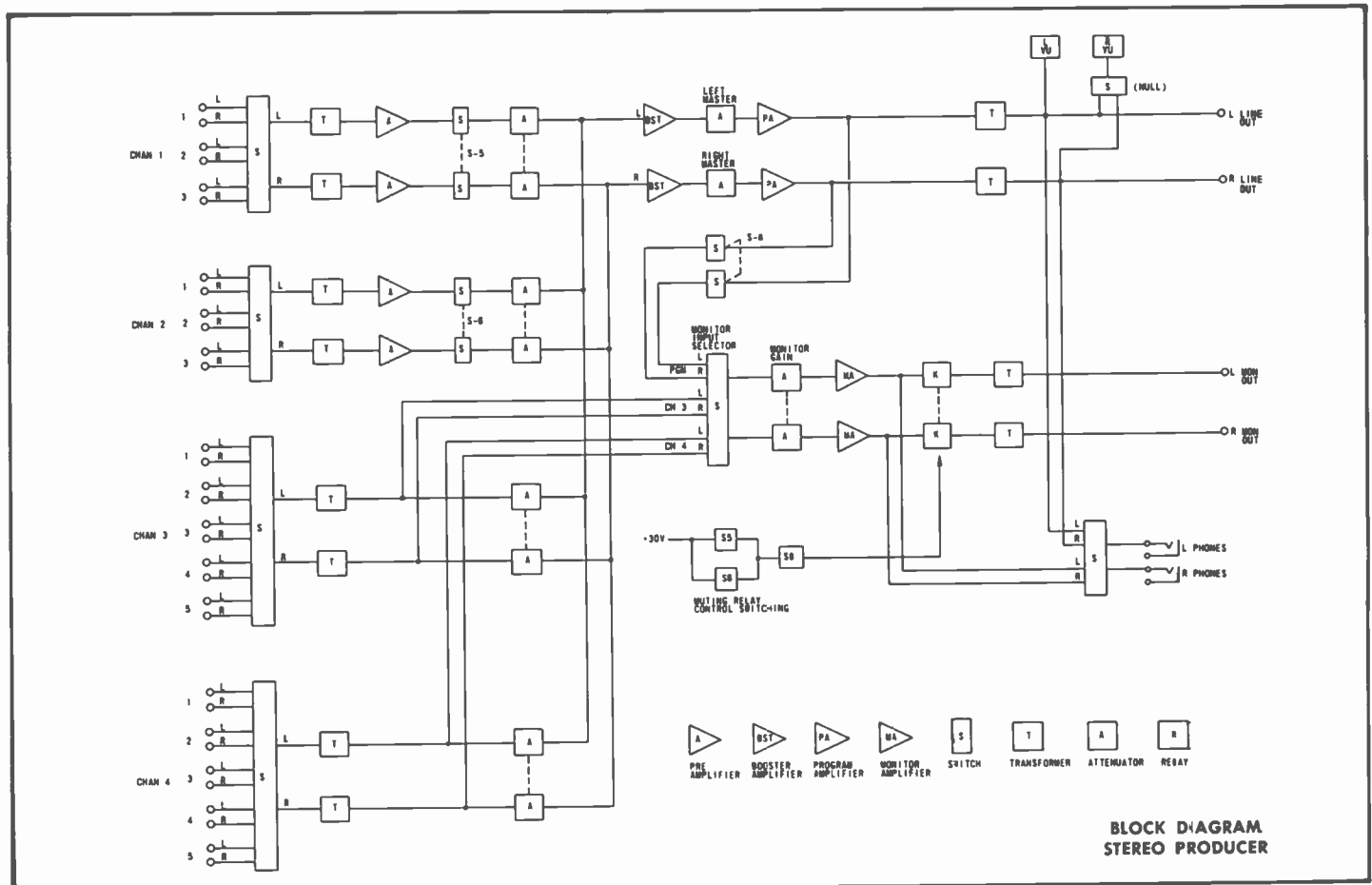

Four Channel Recording Mixer



THE PRODUCER

The rapid growth of cartridge tape recorders and increased use of reel-to-reel recorders in radio and television broadcasting demands an audio control system specifically designed for production mixing. Completely transistorized, Gates Producer provides the facilities for direct recording, dubbing, sound-on-sound recording, editing and monitoring. The use of the VA mixing control knob, the same as used on all Gates Solid Statesman consoles, adds to the accuracy and speed called for in the handling of a production operation.

ADAPTABILITY: Though designed primarily for recording, the Producer is adaptable to other services not requiring a complete speech input console. Such services might include news rooms, mobile units and small sub-stations.

INPUTS: Professional in every respect, the Producer provides transformer balanced inputs on each channel. Twelve inputs through the four mixing channels provide six microphones into two faders, plus six turntables, cartridges, or reel-to-reel recorders into two faders. Two-stage, 45 dB pre-amplifiers on microphone channels 1 and 2 provide high level mixing. Completely self-contained, the Producer also includes a high gain program amplifier which furnishes a 600 ohm balanced output at +8 VU, after a 6 dB pad. A monitor amplifier is provided, driving the 3" x 5" loudspeaker mounted internally (or an external speaker, if desired). Mon-

itor speaker muting on the microphone channels is standard. Muting defeat is also provided.

SOUND-ON-SOUND: An exclusive feature in the Producer is the ability to make "sound-on-sound" recordings with ease. The monitoring amplifier normally bridges the program amplifier output. If it is desired to add voice over a pre-recorded voice or music track, this amplifier is switched to monitor either high level input, ahead of the mixers, without fear of feedback.

A four-inch illuminated VU meter, a headphone monitor jack, and a self-contained power supply are all standard on the Producer.

DESIGN: This console is a fine example of functional design and versatility, tailored specifically for broadcast production requirements. All amplifier components are on two printed boards, one containing the two microphone preamplifiers and program amplifier, the other housing the monitor amplifier and power supply. All transistors are plug-in for ease of maintenance.

The regulated power supply is short-circuit protected by a self-restoring sealed circuit breaker, eliminating the need for fuses. Installation of the Producer is fast and simple, with all cable connections made to barrier-type terminal strips.

Four Channel Recording Mixer-Producer

Note complete transistorized construction and immediate access to all components. Self-contained 3" x 5" speaker located at top rear is ideal for cueing and production.

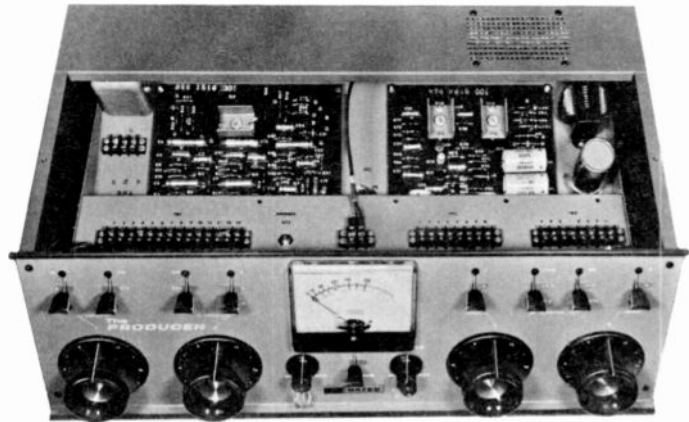

SPECIFICATIONS

MIXING CHANNELS: Total—4. 2 microphone channels, 2 TT/tape/projector channels. Cue provision on high level channels.

AMPLIFIERS PROVIDED: 1 program, 2 preamplifiers, 1 monitor amplifier and power supply.

OPERATING MODE: Single-channel monophonic.

INPUT CIRCUITS: 6 microphone or low level, 6 turntable/tape or high level.

OUTPUT LINES: 600 ohms balanced. One 45/48 ohm internal or external loudspeaker. One high-impedance headphone monitor.

IMPEDANCES: Microphone, 30/50 or 150/250 ohms. Turntable, tape, or cartridge, 150 or 600 ohms. Programming output, 600 ohms balanced. Loudspeaker, 45/48 ohms.

GAIN: Microphone input to line output, 100 dB \pm 3 dB. Turntable input to line output, 55 dB \pm 3 dB. Microphone input to speaker output, 125 dB \pm 3 dB. Turntable input to speaker output, 80 dB \pm 3 dB.

RESPONSE: \pm 1.0 dB from 30 to 15,000 Hz in program circuits. \pm 1.5 dB from 30 to 15,000 Hz in monitoring circuits.

HARMONIC DISTORTION: 0.5% maximum, 30 to 15,000 Hz at +8 dBm output in program circuits.

INTERMODULATION DISTORTION: 0.5% maximum in program circuits.

NOISE: -120 dBm relative input noise on microphone channels. -75 dBm relative input noise on turntable channels.

POWER: 117 volts, 50/60 Hz, power consumption 30 watts.

FINISH: Beige-gray with black trim.

SIZE: 24" long, 10½" high, 15" deep.

SHIPPING DATA: Packed weight, domestic, 50 lbs.; export, 80 lbs. Cubage; 4.6 cubic feet.

ORDERING INFORMATION

The Producer recording mixer.....994-6407
 100% spare semi-conductor kit.....990-0512
 Speaker matching transformer.....478-0275
NOTE: When using external monitoring loudspeakers, the 478-0275 matching transformer must be used to match the 45/48 ohm monitor output to the voice coil impedance of a loudspeaker.

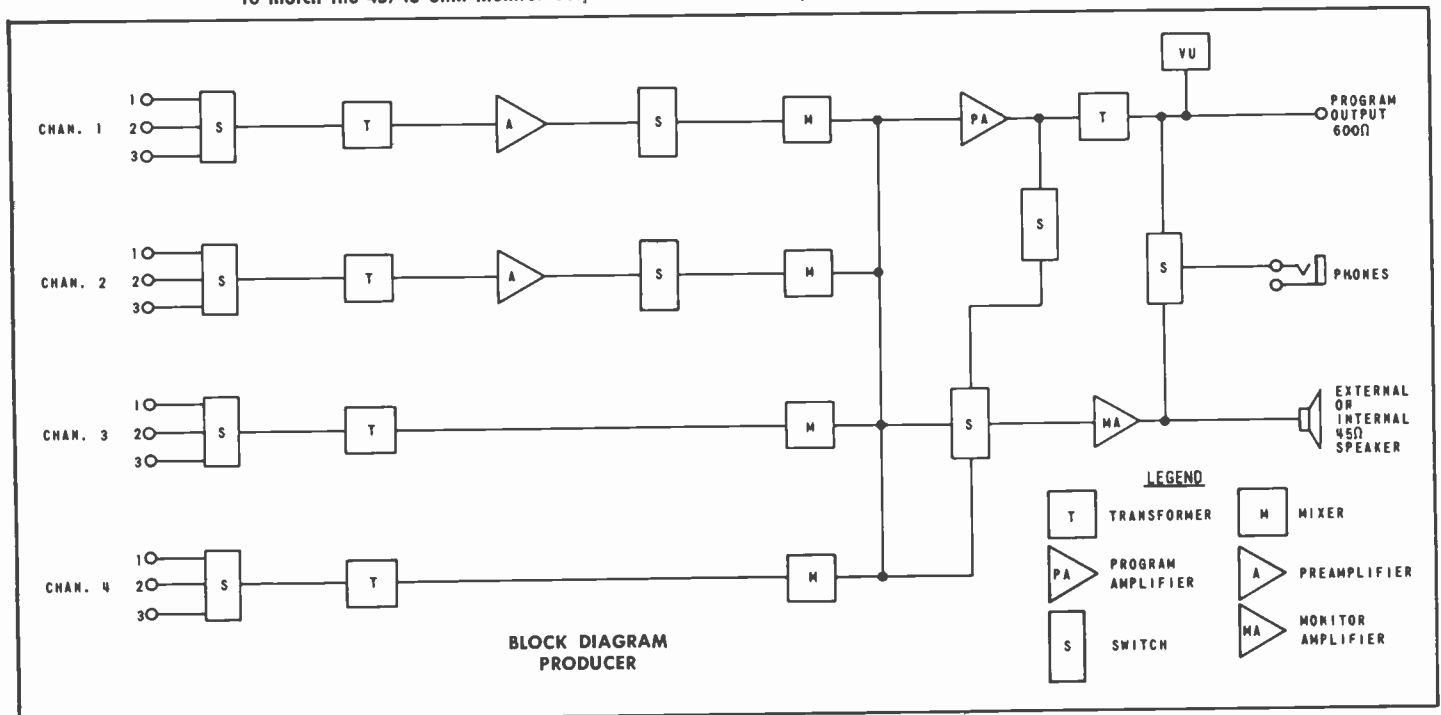

Audio Installations



STEREO STATESMAN CONSOLE AND GATES' CB-77 TURNTABLES
KCOR, SAN ANTONIO



TELEVISION AUDIO CONSOLE
CBS TELEVISION, NEW YORK

Gates standard and custom audio equipment is designed to meet the highest quality standards, with special attention given to both the performance and reliability of every unit. Because of this insistence on quality, and proven superior capabilities in design and manufacturing, Gates has long been the leader in filling the audio equipment needs of the entire broadcast industry—from the smaller individual stations to the largest major networks.

Photographs on this page illustrate how Gates audio systems contribute to the total communications flexibility of a dynamic media. In planning new installations, assistance is available to every AM, FM, TV, and educational station or government agency upon request.



GATESWAY II CONSOLE AND CARTRIDGE TAPE EQUIPMENT
WEEL, BOSTON



VOICE OF AMERICA
GATES' CUSTOM AUDIO SYSTEM

PROGRAM AUTOMATION

**HARRIS
INTERTYPE
CORPORATION** **GATES®**
A DIVISION OF HARRIS-INTERTYPE

Program Automation Systems

To offset rising costs of radio station operation . . . to improve program quality and content . . . and to provide additional statistical and control service . . . many broadcasters are employing Gates program automation systems on a full-time or part-time basis.

Modern program automation systems, properly employed, offer substantial advantages to most broadcast operations . . . large or small . . . AM or FM. These advantages include: more efficient utilization of available manpower, resulting in lower operating costs; relief of personnel from essentially mechanical tasks to allow more time for creative assignments and sales; and improved production, with better control over programming and the station image.

Gates program automation offers a realistic means of obtaining substantial operating economies, while building a superior and more saleable program product.

When considering automation, the broadcaster must exercise great care in selecting a system that fits his exact programming requirements. The philosophy behind Gates automation is to create a system to fit the format, rather than change a format to fit the system. At the same time, all Gates automation systems can be easily expanded as the station prospers . . . utilizing standard control components . . . at the lowest possible cost, consistent with quality.

To learn how Gates program automation can benefit your operation, contact your Gates District Manager, or a Gates Broadcast Automation Specialist.



Views of Gates automation demonstration studios and recording facilities in Quincy, Illinois. Ideally suited for management and engineering evaluation of broadcast automation techniques.



Program Automation Systems

These photographs are representative of the many Gates automation systems installed by broadcasters throughout the world. A complete users list of stations with Gates program automation is available on request.

A new 50 kW AM station in the western U.S. has employed this Gates system since its first day on the air. A variety of programming formats can be handled through the combination of reel-to-reel transports, Criterion 80 cartridge decks, and the Criterion 55 multiple cartridge reproducers. The system also employs automatic digital program logging (not shown).

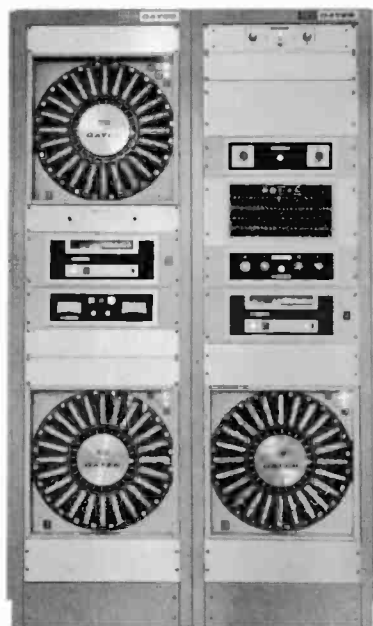
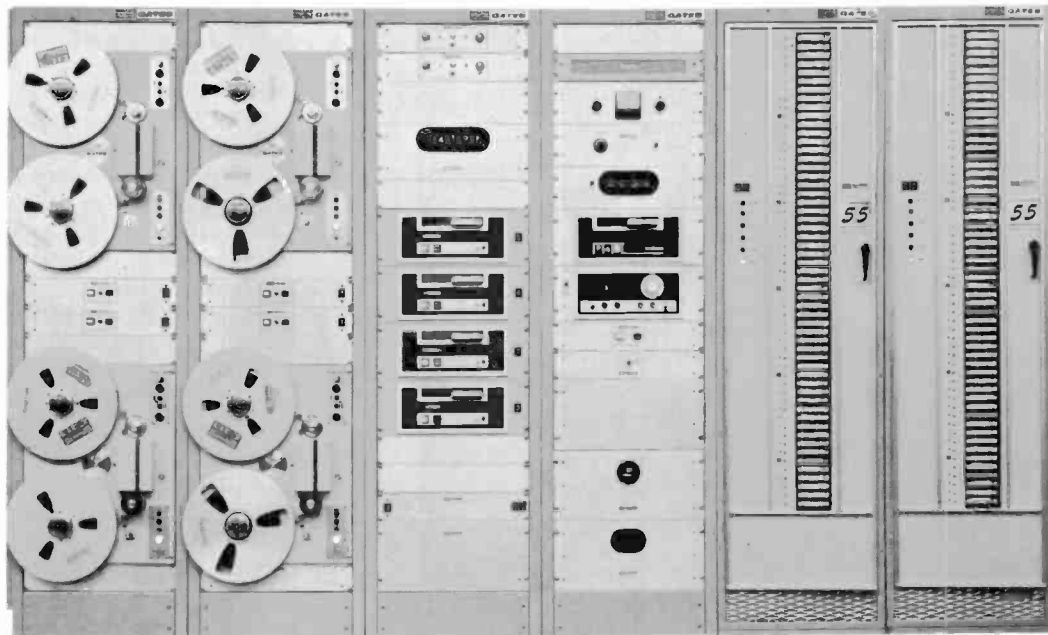

Small but highly flexible Gates automation system installed by FM stereo station on Florida Gulf Coast. This system can handle a "top 40" format and also perform "part-time" automation duties during portions of the broadcast day.

This economical system provides Gates GBR-15 tape transports for music programming and random access of tape cartridges for commercial announcements. Automatic time announcements and network joining featured in this unit are available in any Gates program automation system.

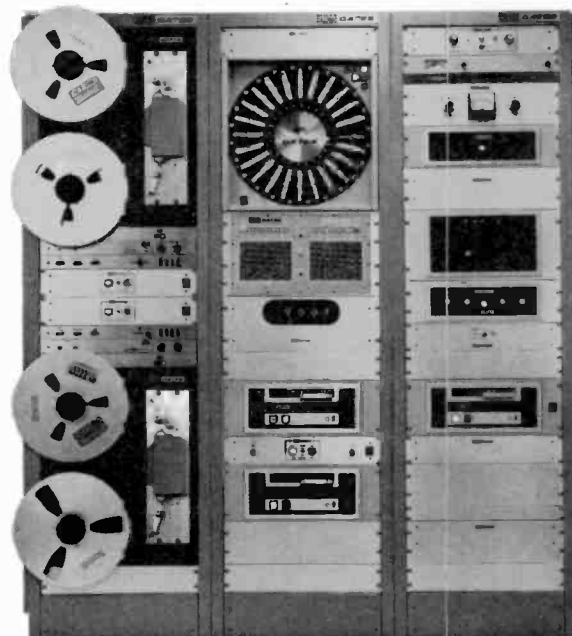

SP-10 And SP-19 Programmers



The SP-10 and SP-19 program control systems provide fully automatic control of audio automation systems. The SP-10 unit will function with up to 10 audio sources, and as many as 19 may be controlled with the SP-19 Programmer.

SP-10 and SP-19 Programmers utilize a standard magnetic tape cartridge to store sequential format information in a virtually unlimited pattern. Either system can also provide numerous exact time functions by addition of the TS-3 Time Selector accessory.

Storage of operating instructions is obtained by dialing digits associated with various audio sources onto the memory cartridge. Approximately 1000 instructions can be stored on a 31-minute cartridge, for extreme flexibility in hour to hour program variations. The system programmer establishes format, not content, allowing a wide variety of programming without change in the programmer cartridge. The programmer is a device which automatically channels the "End of Message" pulse to the start circuit of the next selected source. The switching concept, exclusive with Gates, prevents such errors as the accidental simultaneous start of two or three sources on the air.

Digital information dialed onto the tape cartridge is stored as a cluster of control tones. As an example, dialing a "6" for the audio source designated number six causes a cluster of tones to be recorded on the tape. Upon playback during automated programming, this and other digits are read from the tape and provide the sequential control required. The programmer reads each digit individually and shows this digit as the next source to be broadcast in the front panel readout. A "cue" or reference tone may be placed on the cartridge

to identify the beginning of various program segments within the controlled format. Other control tones are available for special switching applications, such as the TS-3 Time Selector accessory which permits time entries at any 15-second portion of an hour.

A unique feature of the Gates SP-10 and SP-19 system programmers is their ability to "skip" programmed events stored on the tape cartridge when exact time programming is required. An example is automatic network joining. To assure sufficient programming time during the program segment preceding network joining, it is desirable to schedule an extra selection or two of instrumental music. If the selections are not required to fill out the programming time, they are "skipped" and not used in the programming sequence. With this feature it becomes possible to pad a program time segment with "fill" music and obtain exact time programming without precisely timing each program element.

With the TS-3 digital Time Selector, SP-10 and SP-19 systems may perform a variety of precise time-controlled functions such as: "dead-roll" or "back-time" of theme music, for network joining; changing of formats; or commercial load throughout the broadcast schedule, etc.

SP-10 and SP-19 Program Control Packages consist of a control unit and related memory tape cartridge deck, plus an associated 10 or 19 channel audio switcher.

Accessory items include: TS-3 Time Selector; OPC-10 and OPC-19 Audio Overlap Controls; External Audio Adapters (for sources without end-of-message cueing); Fade-In and Fade-Out Audio Panels.

SPECIFICATIONS

INPUTS: SP-10 maximum of 10 sources—SP-19 maximum of 19 sources.
SOURCE SELECTION: By digits dialed with a standard telephone dial into a tape cartridge memory.
SEQUENTIAL EVENTS: Maximum of approximately 1000 before repetition.
TIME CORRECTIONS: Provided by program control package accessories.
CONTROL VOLTAGES: From self-contained power supply.
POWER SOURCE: 105/125 volts, 1 amp, 60 Hz. (50 Hz available).
RELAYS: Automatic Electric Class E telephone type—Automatic Electric stepping switch with gold-plated contacts.
HOUSING: Rack mount with a slide-out chassis.
DIMENSIONS: Control unit—7" high x 15" deep x 19" wide. Tape memory unit—7" high x 15" deep x 19" wide.

ORDERING INFORMATION

SP-10 Program Control System, 10-source. Includes: control panel; memory tape unit; and AMS-10 master switcher900-0257
SP-19 Program Control System. As above, except for up to 19 audio sources.....900-0258
OPC-10 Overlap Program Control accessory for SP-10. Provides audio overlap in automation system.....900-0059
OPC-19 Overlap Program Control. As above, used with SP-19 programmer900-0060
TS-3 Time Selector. Provides exact time controlled functions in either SP-10 or SP-19 system. (See specifications, page 157.)...900-0141

NOTE: Other associated control components may be needed to meet desired operating requirements.

SC-48 Simplex Programmer

This easy-to-operate programmer is readily adapted to a sophisticated program schedule to provide variety in generating a "live" sound. The unit controls as many as nine sources in any combination of cartridge and reel-to-reel units. Thumb-wheel selectors are used to sequentially select the order of source appearance in the program. Up to 48 events can be sub-divided into two, four, or eight program segments with 24, 12 or 6 events in each segment.

A time pulse generator associated with the SC-48 programmer is capable of providing up to four individual time corrections each hour. The actual correction time of each is determined by four rotary switches marked in five-minute increments. These switches are adjustable internally so that the exact time of correction may be offset from the true five-minute point. The rotary selector switch of each time correction point may be disabled if less than four corrections per hour are desired.

The program need not fade when it is time to make a time correction. Rather, after the selection playing is completed, the programmer will skip to the first event of the next program segment. In this way it is not necessary to exactly time program content and "fill" material can easily be added to each segment. Unused fill material is automatically skipped, assuring desired continuity.

OPC-3A accessory provides controlled audio overlap capability in SC-48 automation systems.

With additional optional equipment it is possible to use the SC-48 programmer in an exact time correction system which will fade program material immediately upon correction by the time pulse generator and skip to the first event of the next program segment, which could be either network news or a spot or cartridge into preceding network news. A system of this type is fully capable of joining a network during unattended operation.

No changes in internal programmer wiring are needed to add or change audio sources controlled by the SC-48. A

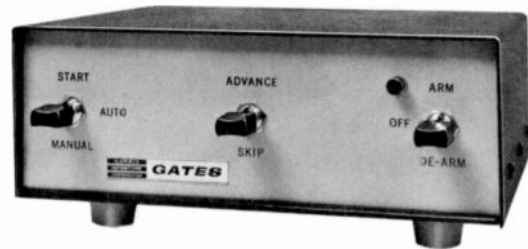

RC-48A Remote Control Unit. Provides manual control of primary SC-48 Programmer functions: Start/Stop; Advance/Skip; and Arm/De-Arm.

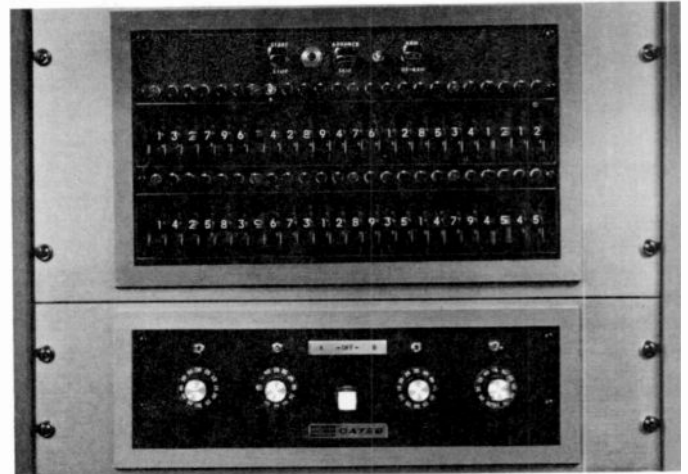

socket is provided for each source. To add or change sources, it is only necessary to plug-in the tape unit's connecting cable at the back of the unit.

All relays used in the programmer are plug-in and completely sealed to provide protection from dust and dirt. Relays have gold contacts to assure dependable operation and years of trouble free service, even under demanding broadcast reliability standards.

SPECIFICATIONS

INPUTS: Maximum of nine sources.

SOURCE SELECTION: Maximum of nine by thumbwheel switch.

SEQUENTIAL EVENTS: Forty-eight before repetition.

TIME CORRECTIONS: One, two, three or four may be inside each hour at any five-minute time during the hour.

SENSING: 25 Hz, left channel only (silence sensing on special order).

FILTERING: 25 Hz filter, left and right channel output (-8 dB at 50 Hz, -35 dB at 25 Hz).

CONTROL VOLTAGES: 24-volt DC self-contained power supply.

POWER SOURCE: 105-125 volts, 60 Hz. (50 Hz available)

RELAYS: Plug-in with dust covers. AE stepping switch with gold-plated contacts.

AUDIO OUTPUT: 600 ohms, balanced, -4 dBm.

AUDITION CIRCUIT: Headphone and rear panel output.

TIMER PULSE: One circuit each 2½ minutes. Two circuits vernier adjustable within 2½ minute increments.

HOUSING: Rack mount with slide-out chassis.

SIZE: (SC-48 w/25 Hz detector) 8¼" H x 19" W x 15" D.
(Time pulse generator) 5¼" H x 19" W x 15" D.

ORDERING INFORMATION

SC-48 Program Control System, 9-source. Includes: SC-48 control panel and TPG-2 time pulse generator.....	900-0225
OPC-3 Overlap Program Control accessory for SC-48. Provides audio overlap in automation system.....	900-0146
RC-48A Remote Control Unit	900-0089

Automation Systems Equipment

CRITERION 855

With ample capacity for broadcast and storage of 55 NAB type A tape cartridges, and using the performance-proven Criterion 80 playback unit, the Criterion 855 provides increased flexibility for automation systems, while assuring excellent audio broadcast quality. It can be added to any Gates automation system.

Up to 55 cartridges are placed in the rack in the exact order they appear on the broadcast schedule. The deck moves from top to bottom and stops only at the slots which have a cartridge. It pulls the cartridge into position on the deck, and positively locks it against the microset head assembly, assuring unsurpassed audio quality.

SPECIFICATIONS

AUDIO OUTPUT: 600 ohms +12 dBm maximum, (150 ohms optional) balanced.

FREQUENCY RESPONSE: ± 2 dB 70 to 12,000 Hz, ± 4 dB 50 to 15,000 Hz.

DISTORTION: Record to playback, 2% at 0 VU record level, 400 Hz.

NOISE: 55 dB below tape signal reference of 400 Hz with 3% THD.

RECYCLE TIME: 62 seconds from rejection of bottom cartridge until top cartridge is ready. Four seconds from shelf to shelf.

SIZE: 77 $\frac{1}{2}$ " high x 22" deep x 23 $\frac{3}{4}$ " wide. Net weight, 405 lbs.

ORDERING INFORMATION

Criterion 855-M Multiple Cartridge Unit, monophonic.....900-0028

Criterion 855-S Multiple Cartridge Unit, stereophonic.....900-0029

NOTE: Above units sold less side panels for installation in automation systems. If panels desired, use 2 each, RAK-70 side panels (see page 175).

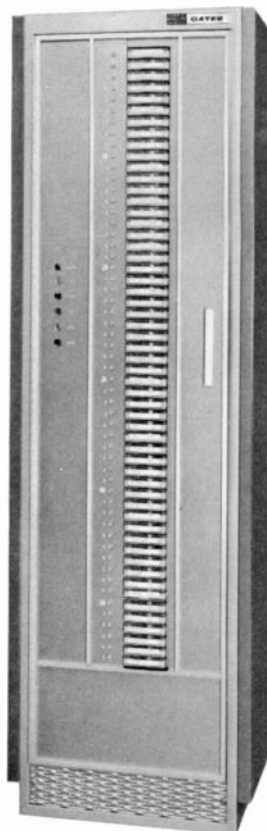

MULTIPLE CARTRIDGE REPRODUCER

Gates G-24 Carousel tape unit is a rotary drum mechanism for tape cartridges that can be operated by manual, automatic, and random access selectors. Each drum holds a maximum of 24 standard cartridges, and revolves to allow positioning of the cartridges against the stationary transport. The G-24 positions cartridges in sequence unless an optional random access unit is employed.

G-24 mono and stereophonic units are compatible with most existing automation systems. Modular solid-state electronics provide for the NAB standard controls of 1000 Hz, 150 Hz, and 8000 Hz. In addition, logic control of the start-stop functions may be used.

Exclusive Gates features adapted from the Criterion 80 cartridge machine for improved reliability include the microset head assembly and vapor-blasted large diameter capstan drive for increased torque and superior audio reproduction.

All units are Random Accessible with optional accessories. A manual remote control or a Random Access Programmer for automated use are available.

SPECIFICATIONS

AUDIO OUTPUT AND DISTORTION: +4 VU max. into 600 ohms (less than 1% THD) from NAB reference level tape.

FREQUENCY RESPONSE: +1 dB to -2 dB 50-12,000 Hz at 7 $\frac{1}{2}$ ips.

SIGNAL-TO-NOISE RATIO: -56 dB @ 7 $\frac{1}{2}$ ips (mono), -52 dB @ 7 $\frac{1}{2}$ ips (stereo).

SIZE: 19" wide x 19" deep x 19 $\frac{1}{4}$ " high. Net weight, 95 lbs.

ORDERING INFORMATION

G-24-M Multiple Cartridge Unit, monophonic.....900-0134-001

G-24-S Multiple Cartridge Unit, stereophonic.....900-0134-002

NOTE: Above units include Gates' exclusive features and Carousel Service Unit for extended logic and control in automation systems. Carousel Service Unit available separately (order 900-0206).



Random Access Programmers

MODEL RA-5

Gates Model RA-5 is a random access programmer designed to control as many as five Model G-24-M/S multiple cartridge reproducers.

This unit will program up to fifty events (individual shelf positions) on the machines it is associated with before recycle of the sequence. The event storage capacity may be extended in multiples of fifty by using the appropriate number of optional RA-5X event extenders.

Unique audio mixing is provided within the switching section of the RA-5, and overlap between any two inputs is available at the operator's option. The audio overlap is determined by the position and duration of the 150 Hz switching tone recorded during production.

A sophisticated feature of the RA-5 not found on similar random access equipment is the solid state logic and memory circuitry provided to cause "search ahead." During operation, the RA-5 will cause each cartridge reproducer to search and access the required shelf until it recognizes that the next machine to be searched has not yet played.

Two big advantages of the RA-5 are: simplicity in set-up over the method of having one programmer for each G-24; and the ease with which a system using less than five G-24 units may be expanded up to five (at the cost of the multiple cartridge units only).

Intended for rack mounting, the RA-5 measures 21" H x 19" W x 14" D (12 rack units). Power requirements are 115 volt AC, 60 Hz.

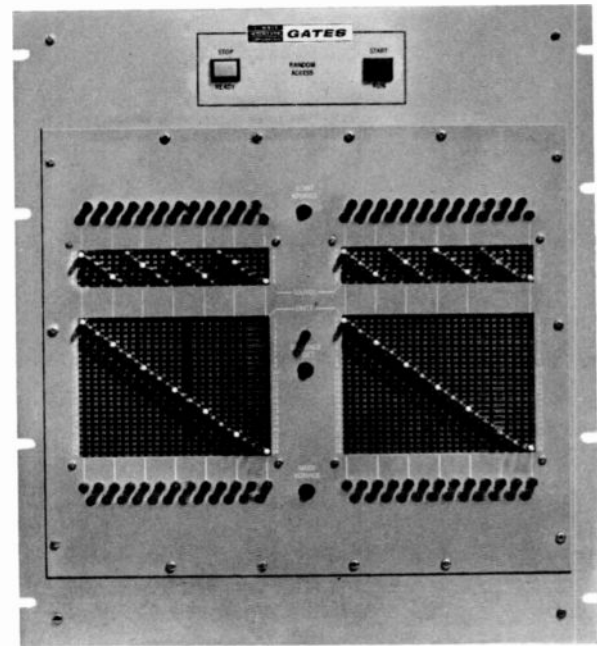

ORDERING INFORMATION

RA-5 random access programmer for use with G-24-M/S multiple cartridge units. Inputs for up to 5 Model G-24 units.....900-0137
RA-5X event extender for above unit. Any number of RA-5X units may be connected together to extend event storage of RA-5 in multiples of fifty. (Same size as RA-5, with plug-in connections).....900-0138

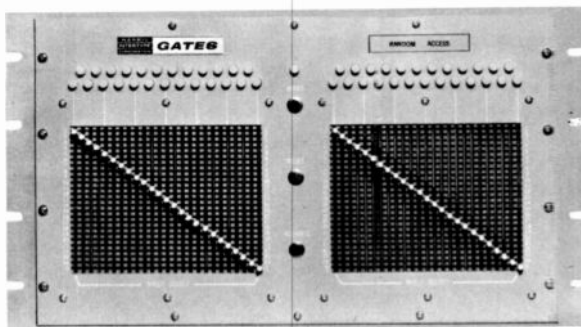

MODEL RA-1

Gates RA-1 random access unit is intended to provide random selection for a single Gates multiple cartridge reproducer (G-24-M/S).

Assignment of cartridge sequence is determined by the positions of fifty vertical slider switches located on the front panel of the equipment. Thus, fifty selections can be made from any of the 24 shelves in the G-24 before repetition or re-programming. The fifty step sequence is repetitive in that

step one follows step fifty, and the sequence may be shortened to less than fifty events by setting any of the sliders to the lowest, or 25th position. This is the "S" or SKIP position. The usual procedure for setting up the RA-1 involves setting slider number 1 (left side) to the shelf number containing the first desired tape cartridge. Each succeeding slider, in sequence, is set as required to indicate the desired sequence of shelf assignment for the G-24. The INDEX button is pressed once to initiate the action required to access the first selected tape cartridge.

It is possible to alter the sequence midway so that a cartridge already selected will be rejected. This may be accomplished through the use of the ADVANCE and INDEX buttons, even though a tape cartridge is playing at the time.

The RA-1 measures 10½" H x 19" W x 10" D. and is intended for standard rack mounting. The device is completely solid state, making use of SCR's for counting. Control signals and power are supplied from the service unit assembly of the G-24 unit.

ORDERING INFORMATION

RA-1 random access programmer for use with single G-24-M/S multiple cartridge reproducer.....900-0191



Automation Systems Equipment

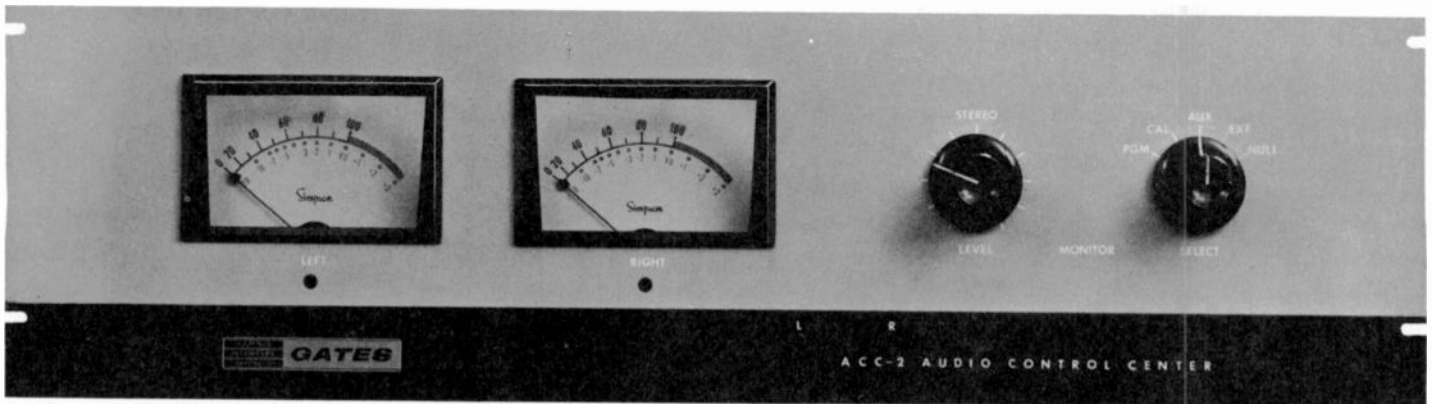

ACC-2
STEREO
AUDIO
CONTROL
CENTER

AUDIO CONTROL CENTER

The ACC-1 and ACC-2 audio control centers provide a consolidated program output and monitoring unit for Gates' program automation systems. Solid-state modular amplifiers, as used in Gates' studio audio consoles, provide outstanding performance, with program amplifier output capability up to +26 dBm (+8 dBm nominal), and plug-in monitoring amplifiers at 10 watts (+40 dBm) per channel.

Both the monophonic ACC-1 and stereophonic ACC-2 control centers accept 25 Hz high-pass filter(s) for use in automation systems with reel-to-reel tape audio sources. The ACC-2 stereo audio control center also provides for the installation of an optional L + R sum channel output amplifier. Power supplies and all modular amplifiers plug into the rack-mount chassis.

The audio control center front panel facilities include VU metering, monitor gain control, and meter/monitor selector switch for visually and aurally checking: PGM, program output; CAL, processing equipment such as overlap, etc.; AUD, audition; and EXT, external audio source such as an air monitor.

In stereophonic ACC-2 units, a fifth switch position (NULL) provides an accurate check of channel phasing. Adjustment of program output levels is by screwdriver through access holes in the front panel.

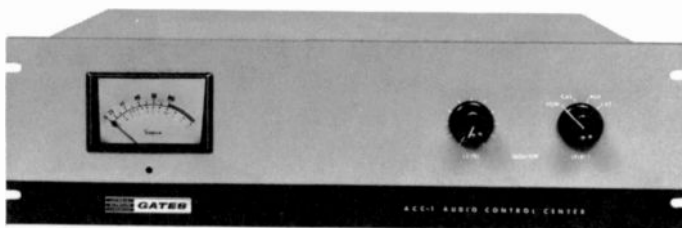

ACC-1 MONOPHONIC AUDIO CONTROL CENTER

The Gates ACC-1 monophonic audio control center is fully self-contained in a 5¼-inch rack-mounted unit. The ACC-2 stereophonic package includes a separate 3½-inch power supply panel which may be mounted adjacent to the ACC-2 control center or separated up to ten feet. External connections are to terminal strips in the rear of all units.

SPECIFICATIONS

PROGRAM INPUT: 600 ohms, balanced. -40 to -7 VU for full output level, +8 dBm nominal.

AUDITION/EXTERNAL INPUTS: Bridging or matching as a function of input pad configuration. -25 to +14 VU.

GAIN: System input to program output, 21 dB nominal, 41 dB \pm 2 dB maximum. Adjustment of fixed pads can accommodate input levels of -40 VU for systems with complex pre-processing losses.

RESPONSE: 30 to 15,000 Hz \pm 1 dB.

DISTORTION: Program circuits 0.5% maximum 30 Hz to 15 kHz @ +18 dBm output; 1.0% maximum @ +26 dBm output. Monitor circuits 1.0% maximum 30 Hz to 15 kHz @ +40 dBm output (10 watts).

NOISE: -75 dB or better, 30 Hz to 15 kHz on all circuits with normal levels and control settings (-30 dBm input and +18 dBm output for program channels).

POWER: 117 volts, 50/60 Hz, 1 phase. 100 watts maximum for full stereophonic package.

SIZE: ACC-1 (complete) and ACC-2 audio section—front panel 5¼ inches high, 19 inches wide, 15½ inches deep behind front panel. ACC-2 power supply—3½ inches high, 19 inches wide, 15½ inches deep.

ORDERING INFORMATION

- ACC-1 Audio Control Center, monophonic. Includes program amplifier. Less monitor amplifier, 25 Hz filter (order separately) 900-0273
- ACC-2 Audio Control Center, stereophonic. Includes two program amplifiers and power supply. Monitor amplifiers and 25 Hz filters must be ordered separately 900-0274
- ACC/MON Monitor Amplifier Module. Order 2 for stereo 900-0276
- ACC-F 25 Hz High-Pass Filter. For systems with reel-to-reel music sources. Two required for stereo 484-0066
- ACC/SCN Sum Channel Output Package. For ACC-2 units if L + R output desired. Includes 3rd program amplifier module 900-0277



Automation Systems Equipment

TIME ANNOUNCER

Gates' time announcer system provides pre-recorded time announcements automatically at the discretion of an operator or according to the pre-schedule of an automation system. Two standard Criterion 80 cartridge tape playback units are used (one for odd-minute announcements, one for even minutes), and are automatically synchronized by the TA-1 control unit. An external time pulse source is required by the TA-1. Systems with automatic program logging may utilize a digital clock, or order the TPM module listed below.

ORDERING INFORMATION

TA-1 Control Panel (also requires 2 Criterion 80 cartridge playback units and time pulse source).....	900-0056
TPM Time Pulse Module.....	900-0192



TS-3 TIME SELECTOR

The Gates TS-3 Time Selector is an exact time control device that performs a switching function on a time-programmed basis in Gates' SP-10 or SP-19 automation systems. "Time assignment" instructions are stored in the SP-10/19 memory tape cartridge and may be executed at any 15-second point of any minute in the hour. Real time information is provided by the DC-10 digital clock, which is required in a system incorporating the TS-3 time selector.

Typical operation of the TS-3 would consist of exact time operation of the automation system for network joining, exact time station identifications, to control back-timed audio sources, etc. The time selector will operate only in conjunction with a DC-10 digital clock and the SP-10/19 programmers.

ORDERING INFORMATION

TS-3 Time Selector.....	900-0141-000
DC-10 Digital Clock (60 Hz).....	900-0037-001
DC-10 Digital Clock (50 Hz).....	900-0037-002

NETWORK JOINING

Network joining with an automation system is accomplished by system logic apparatus synchronized by a real-time clock base associated with the system. Depending on the broadcaster's preference, network joining usually incorporates fade-in or fade-out of program material.

The Gates MDF-M (mono) and MDF-S (stereo) Motor-Driven Faders provide an economical method of smoothly fading down programming to skip and join a network or other source on an exact time basis.

The Gates F1-M (mono) and F1-S (stereo) Fade-In Units are designed to start a theme or other program material at a pre-determined interval before an exact-time event, and

smoothly fade into that source so that the material will conclude precisely before starting the next event, typically a network program. The fade-in unit is used with a specific audio source, normally a Criterion 80 tape cartridge unit, for playing the pre-timed music selections.

ORDERING INFORMATION

MDF-M Motor-Driven Fader, monophonic.....	900-0044-000
MDF-S Motor-Driven Fader, stereophonic.....	900-0067-000
F1-M Fade-In Unit, monophonic. (Requires Criterion 80 audio source).....	900-0255-001
F1-S Fade-In Unit, as above except stereo.....	900-0255-002

Automation Systems Equipment



Logging Encoder.



Digital Clock



Logging Printer.

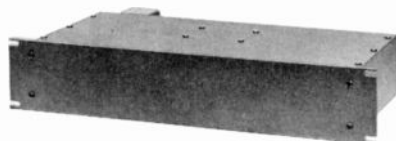

Logging Decoder.

AUTOMATIC PROGRAM LOGGING

Gates system of automatic program logging provides an accurate, printed record of programming actually broadcast. This system has been the basis for FCC license renewal at many automated broadcast stations and meets FCC log verification requirements. A logging printer, similar to an adding machine, prints the time at which each source in the system is started, along with a five digit code for all entries which require identification. If identification is not required, the code is automatically replaced by five zeros, making all logging complete.

The program logging equipment consists of a logging encoder for recording a five digit logging code on the control track of any tape cartridge; a logging decoder for reading the five digit code during playback; a digital clock to furnish time of broadcast; and a logging printer to print the broadcast time and the logging code.

SPECIFICATIONS

SYSTEM COMPONENTS: Logging encoder, logging decoder, digital clock and logging printer.

RECORD PRINT-OUT: Standard adding machine tape . . . may be set single, double or triple space.

PRINT-OUT INFORMATION: Time and five digit code.

TIME PRINT-OUT ACCURACY: Within 30 seconds of time shown on print-out tape.

OPERATION: Uses 8 kHz tone pulse clusters on cartridge control track to form digits.

POWER SOURCE: 105-125 volts, 2 amps, 60 Hz.

ORDERING INFORMATION

APL/SP-1015 Automatic Program Logging System (for use with SP-13 and SP-19 programming systems).....900-0034

APL/SC-48 as above, except for use with SC-48 programming systems.....900-0039

CG-8 Special Code Generator (optional). Provides 8 different five digit logging codes to identify non-cartridge automation sources such as network, live studio, etc.....900-0040



DC-10 DIGITAL CLOCK

The DC-10 digital clock is used as a centralized source of time information in Gates automated broadcast systems. It may also be used to control the operation of auxiliary apparatus within the program automation system, or external non-related equipment. Visual time information is displayed on the front of the unit, with rear chassis connections for operation of other equipment.

Use of the DC-10 digital clock to control all time related functions assures fully synchronized operation of the broadcast facility. 115 VAC power required. Dimensions: 7" high, x 19" wide x 11" deep.

DC-10 digital clock (60 Hz).....900-0037-001

DC-10 digital clock (50 Hz).....900-0037-002

GateSound Programming



OUTSTANDING PRE-RECORDED MUSIC

GateSound is designed to provide you with a basic taped music library of selections with the widest possible appeal. These tapes are intended as a starter package of musical programming for automation systems, and are appropriately named the "Prelude" series. They are equally suitable for any broadcaster wishing to expand a tape library simply and economically.

TYPE OF MUSIC: All-time country and western favorites, show tunes, motion picture sound tracks and great standards are presented in vocal and instrumental arrangements, carefully selected for "middle-of-the-road" content, to serve as a sound base on which to build your future programming. Selections likely to become outdated are not included, to assure a modern, up-to-date sound for your listeners.

PRODUCTION QUALITY: The "Prelude" series is produced exclusively for Gates by AltoFonic Programming, Inc. While these tapes are completely separate from the library services of AltoFonic, the same expert programming know-how and professional recording techniques are utilized to produce tapes of amazing fidelity and consistency. These tapes are exclusive through GateSound, and not available elsewhere.

BASIC CATEGORIES: GateSound "Prelude" series separates music into these categories:

- Prelude 200—Vocals, Male.
Up-tempo country and western selections.
- Prelude 300—Vocals, Male.
Medium and slow tempo country and western selections.
- Prelude 400—Vocals, Female and Group.
Mixed tempo country and western selections.

- Prelude 500—Instrumentals.
Mixed tempo country and western selections.
- Prelude 600—Instrumentals.
Standard and popular selections, M-O-R.
- Prelude 700—Instrumentals.
Standard and popular selections, M-O-R.
- Prelude 800—Vocals, Mixed.
Standard and popular selections, M-O-R.
- Prelude 900—Instrumentals, Mixed.
Mixed tempo conservative standard selections.

Comprehensive coverage of all recording companies provides the most extensive musical variety within the categories. Complete listings are available on request for ordering information.

TAPE DATA: "Prelude" tapes are unannounced for maximum flexibility in any operation, and allow the use of local voices if desired. All tapes are supplied on 1.0 mil polyester tape. Bi-directional tapes are supplied with metallic foil at both ends for reversing systems. All music is matched at both ends (no fading).

A 25 Hz tone, 5 dB below program reference level and 1.5 seconds long, appears 1.5 seconds before the end of each selection. This tone is followed by one second of silence, then the next selection begins exactly 2.5 seconds after the beginning of the tone. On stereo tapes the tone appears on the left channel only.

Tapes are available in 10½ or 14 inch reel sizes, and in any popular track configuration. The entire GateSound library is available in monaural or stereo.

Professional Tape Cartridge Systems



CRITERION 80

From the originators of the tape cartridge system for broadcasting comes the ultimate in cartridge equipment for professional use . . . the Criterion 80 series, with built-in performance-proven features. From sleek slide-out chassis for complete accessibility to the tape deck and all plug-in electronics, to better timing, lower wow and flutter, and dependable direct-capstan drive, Criterion 80 represents twelve years experience in the design, engineering and manufacturing of broadcast tape cartridge equipment.

Renowned for dependability and quality in broadcasting, Criterion units are in continuous service in the largest and most respected radio and television stations throughout the world.

MODELS AND TYPES: Criterion 80 models are available in playback only, or record/playback, in monophonic and stereophonic versions. The basic Criterion 80 unit is housed in a trim-line desk cabinet, and may be attractively rack-mounted using the optional 19-inch rack adapter panels. The primary 1 kHz cue tone is standard. Second and third cue tone operation is optional on all models with plug-in cue sensing kits. All versions of Gates Criterion 80 series meet or exceed National Association of Broadcasters' performance standards. Monophonic units are fully wired for immediate conversion to stereo.



PRECISION MECHANICAL CONSTRUCTION: The excellence of Criterion 80 performance lies in the outstanding engineering and quality of its tape deck, motor mechanism, and exclusive Micro-Set head assembly. The massive direct-drive capstan motor provides speed accuracy comparable to the finest reel-to-reel machines.

HIGH-QUALITY ELECTRONICS: All-silicon transistor amplifiers in Criterion 80 are on plug-in glass epoxy PC cards and are fully RFI-proofed for installation in the most demanding broadcast environments.

RECORDING UNITS: The Criterion 80 recording amplifier, like the playback unit, is housed in a trim-line desk console, and may be rack mounted with the appropriate adapter panel. Latest state-of-the-art circuitry in Criterion 80 electronics provides a master-quality recorder for professional use.

SPECIFICATIONS

PLAYBACK UNIT

POWER: 105-125 volts, 60 Hz or 50 Hz. 70 watts maximum.

FREQUENCY RESPONSE: ± 2 dB 50 to 15,000 Hz.

NOISE: 45 dB (stereo), 48 dB (mono) below NAB standard reference. 52 dB (stereo), 55 dB (mono) below tape signal reference of 400 Hz, 3% THD.

DISTORTION: Record to playback, less than 2% at 6 dB above NAB standard reference.

AUDIO OUTPUT: 600 ohms, balanced, 0 dBm nominal, +10 dBm maximum.

TAPE SPEED: 7½ inches per second.

TAPE DRIVE SYSTEM: Direct copstan drive, sealed ball bearings.

FLUTTER AND WOW: 0.2% or less.

TIMING ACCURACY: 0.1% or better.

TAPE START AND STOP TIME: Less than 0.1 second.

TAPE PULLING FORCE: 3 pounds.

DIMENSIONS AND WEIGHT: Desk top cabinet, 6" high, 13½" wide, 14" deep. With rack adapter, 7" high, 19" wide. Net weight, 30 lbs.

RECORDING AMPLIFIER

POWER SOURCE: From playback unit.

AUDIO INPUT: 600 ohms balanced line, input levels from -20 to +10 dBm, matching; +10 to +40 dBm bridging (20 K).

REMOTE CONTROL: All functions and lamp indications.

BIAS OSCILLATOR: Push-pull, 80 kHz.

DIMENSIONS AND WEIGHT: Desk top cabinet, 4" high, 13¼" wide, 12½" deep. With rack adapter, 5¼" high, 19" wide. Net Weight, 12 lbs.

ORDERING INFORMATION

Criterion 80 Playback, mono, 1-tone, desk mount.....	994-6701
As above, except stereo.....	994-6702
Criterion 80 Record/Playback, mono, 1-tone, desk mount.....	994-6729
As above, except stereo.....	994-6731
QS-150, 150 Hz cue sensor. Plugs into playback for 2-tone cueing	900-0154
QS-8, 8 kHz cue sensor. Plugs into playback for 3rd tone cueing	900-0155
TO-23, 150 and 8000 Hz cue oscillator assembly, plugs into record amplifier for conversion to either 2 or 3 tone.....	900-0165
RA-P Rack Adapter Kit, playback. For 19" rack mounting.....	994-6790
RA-A Rack Adapter Kit, record amplifier. For 19" rack mounting	994-6791

Professional Tape Cartridge Systems

CRITERION COMPACT PLAYBACK UNIT

The Criterion Compact is the newest, advance-design version of Gates' famous Criterion tape cartridge system. Designed for convenient installation in today's crowded studios, and to conserve valuable rack space in broadcast automation systems, the Criterion Compact playback retains all those features which have made Criterion the industry standard for cartridge machine excellence. These features include: rugged machined aluminum deck; massive 450 rpm direct drive capstan motor; and exclusive, improved Micro-Set precision head assembly. PLUS: new digital-logic cueing; single-card electronics for mono or stereo units; air-damped solenoid for whisper-quiet control room operation; and high-speed cueing (optional).

MODELS AND TYPES: The Criterion Compact playback is available for mono or stereo reproduction. Single or dual-channel playback amplifier cards plug into a common PC receptacle. For convenience, the Criterion Compact is designed for desk or rack mounting at the users' option. Two Compact series reproducers can be mounted side by side in a standard 19-inch equipment rack in the space normally required for a single machine. The Criterion Compact deck slides out of its housing for maintenance.

DIGITAL-CONTROLLED CUEING: 1 kHz primary, 150 Hz secondary, and 8 kHz tertiary cue tones are sensed on a single PC card, utilizing digital logic IC's. All Criterion Compact units are equipped for 3-tone cueing—simply plug in the appropriate relay for external control.

HIGH-SPEED CUEING: An optional feature for the Criterion Compact playback is a 4:1 (30 ips) high-speed drive for rapidly cueing cartridges to the 1 kHz primary cue tone after sensing the 150 Hz end-of-message signal. This can also be accomplished by manual override. The digital IC logic is automatically expanded for sensing in the cue mode, and



measures pulse width rather than frequency or level, for accurate control. All models are designed to add this feature when desired. See ordering information below.

SUPERB ELECTRONICS: Integrated circuits, digital logic, and silicon transistor audio circuitry are the basis for Criterion Compact's excellence in quality and reliability. Audio output capability is +18 dBm (+8 dBm nominal) to overcome losses in complex studio or system installations. Audio distortion is virtually unmeasurable, limited only by the recorded tape being played.

SPECIFICATIONS

POWER: 102-125 volts, 60 Hz (50 Hz on special order). 70 watts maximum.

FREQUENCY RESPONSE: ± 2 dB 50 to 15,000 Hz.

NOISE: 45 dB (stereo), 48 dB (mono) below NAB standard reference. 52 dB (stereo), 55 dB (mono) below tape signal reference of 400 Hz, 3% THD.

DISTORTION: Less than 1% at NAB standard reference level.

AUDIO OUTPUT: 600 ohms, balanced, +8 dBm nominal, +18 dBm maximum.

TAPE SPEED: 7½ inches per second. Optional 30 ips fast cue accessory available.

TAPE DRIVE SYSTEM: Direct capstan drive, sealed ball bearings.

FLUTTER AND WOW: 0.2% or less.

TIMING ACCURACY: 0.1% or better.

TAPE START AND STOP TIME: Less than 0.1 second.

TAPE PULLING FORCE: 3 pounds.

DIMENSIONS AND WEIGHT: Desk Mount: 5⅞ inches high, 8⅞ inches wide, 12½ inches deep. Net weight 20 pounds. Rack mount: 5¼ inches high, 19 inches wide (with rack mounting angles) for two Criterion Compact desk mount housings bolted side-by-side.

ORDERING INFORMATION

Criterion Compact Playback, monaural, desk mount.....994-6794
Criterion Compact Playback, stereo, desk mount.....994-6815
Rack Mounting Kit, for mounting two Criterion Compact play-
backs in a single 19" rack.....994-6812
Quick-Cue Kit for conversion of Criterion Compact to high-
speed cueing.....994-6816
2nd and 3rd Cue Tone Relay. Add one for each tone desired....574-0162

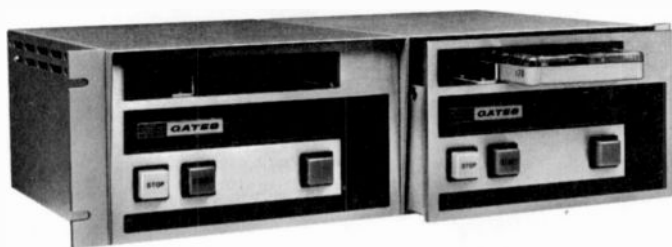

Tape Cartridge System Accessories



REMOTE CONTROL/TIMER

Most control functions of the Criterion 80 record/playback unit can be remotely controlled with this attractive and convenient unit. A built-in timer registers the elapsed time of recording, simplifying production of multi-cut tapes. Starting the machine automatically activates the timer elapsed-seconds register. Stop, Start, Record Set, and all cue-tone functions of the Criterion 80 recorder are provided. Illuminated pushbuttons. Desk top unit measures 7¼" W. x 8" H. x 4½" D.

RC-T-8 Remote Control with elapsed time indicator..... 900-0266



RECORD/PLAYBACK REMOTE CONTROL

All control functions of the Criterion 80 record/playback unit are remotely controlled from this desk-top unit. Stop/Start switches, also Record Set, Secondary Cue, and Auxiliary Cue functions. When used with Criterion 80 recorder in playback mode, pushbuttons illuminate as cue tones are detected to facilitate checking encoded cartridges. Size: 5¾ inches wide, 5½ inches high, 2¾ inches deep.

RC-RA-8 Remote Control..... 900-0267

PLAYBACK REMOTE CONTROL

For remotely operating up to four Criterion 80 or four Criterion Compact playback units. Operates start circuit only. Includes ready lights and start switches (illuminated). Size: 5¾" W. x 5½" H. x 2¾" D.

RC-P4-8 Playback Control for Criterion 80..... 900-0268

RC-P4-C Playback Control for Criterion Compact..... 994-6817

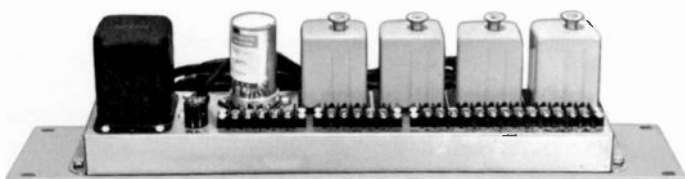

AUDIO SWITCHER PANEL

Up to four Criterion 80 units can be switched into one console input through this panel. Use two panels for stereo. Not for Criterion Compact.

AMS-4A Automatic Master Switcher..... 900-0024

Tape Cartridges And Accessories



Gates tape cartridges are designed and manufactured to provide you with the finest over-all cartridge performance available today. Each careful production step assures this same high quality performance on the first and one-thousandth use of the cartridge. These tape cartridges meet and exceed all industry standards, and are fully compatible with all NAB standard tape machines.

In the manufacturing process, only the finest quality lubricated tape is used. It is wound on a precision automatic tape winding machine, and carefully spliced with magnifying glass attention. Special polyurethane pressure pads are installed in each cartridge to reduce wow and flutter to a minimum, while providing optimum tape-to-head contact.

The final production steps include a careful checkout on a tape deck attached to a precision wow and flutter meter, and an additional test involving recording and playback to assure audio excellence. Only after these tests have been completed is the Gates "Label of Quality" added to each cartridge.

ORDERING INFORMATION

A-300, 40 second cartridge	900-0077
A-300, 70 second cartridge	900-0078
A-300, 100 second cartridge	900-0079
A-300, 2½ minute cartridge	900-0080
A-300, 3½ minute cartridge	900-0081
A-300, 5½ minute cartridge	900-0082
A-300, 10½ minute cartridge	900-0083
B-600, 16 minute cartridge	900-0084
C-1200, 31 minute cartridge	900-0085
A-300 Empty cartridge	732-0220
B-600, Empty cartridge	732-0221
C-1200, Empty cartridge	732-0222
Cartridge Pressure Pads—(50 replacement foam plastic pads)	994-6430
Cartridge labels, 1000 (yellow, red, green, and white)	900-0065
FAL-1A Test Cartridge. Full track, for mono or stereo systems. Includes tones for azimuth alignment, frequency response, and standard level reference	900-0090

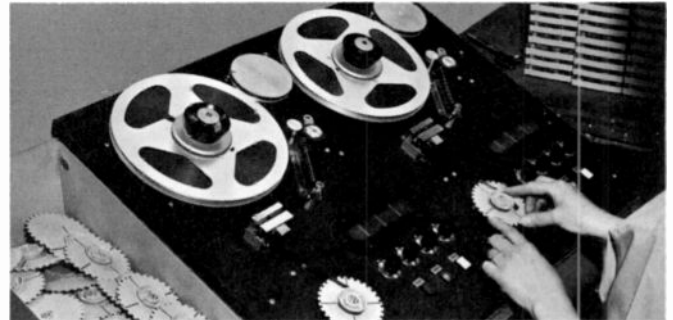

Tape is wound onto cartridge turntables with a precision tape winding machine to assure exact tape length and playing time.

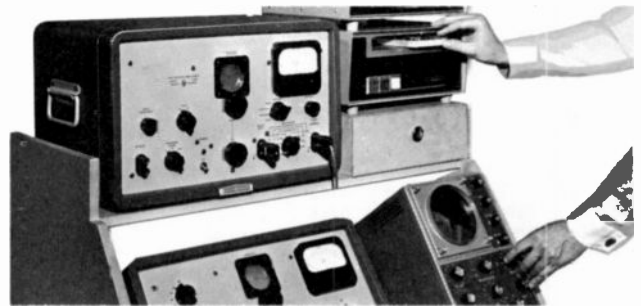

Each cartridge is tested for recovery level of recorded tone to assure stable levels from cartridge to cartridge.



TD-1 TAPE ERASER

Professional model bulk magnetic tape eraser. Recommended for all sizes of tape cartridges, and reels up to 10½ inches. Lowers residual noise 3 to 6 dB below comparable hand-held units. Pushbutton operation. 117 volts, 50/60 Hz. Weight is 9 pounds. Manufactured by Audiolab.

ORDERING INFORMATION

TD-1 Tape Eraser	732-0223
------------------------	----------



Tape Cartridge Storage Units



RM-100

M-5986 Storage Rack. Conveniently stores forty "Type A" Series 300 cartridges in only 10½" of standard rack space.

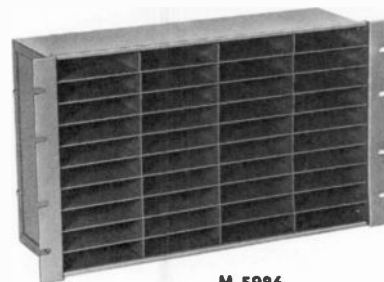

M-5986

RM-100 Wall Mount Cartridge Rack provides for storage of 100 Series 300 cartridges in minimum space. The unit can be wall or table top mounted. Walnut formica trim. Dimensions 2' H x 2' W x 4¾" D.

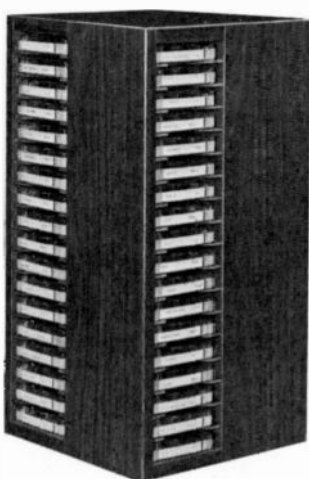

SECR-72

RS-200 Lazy Susan Revolving Cartridge Storage Rack—eight removable rack sections each store 25 "Type A" Series 300 cartridges, for a total of 200 for the unit. The RS-25 racks may be removed for use in other studios and are available separately.

SECR-72 Storage Cabinet. Attractive walnut formica trim blends with any decor. Storage space for 72 Series 300 cartridges. Cabinet rotates on ball bearings. Dimensions: 22" high x 11" wide x 11" deep.



RS-200

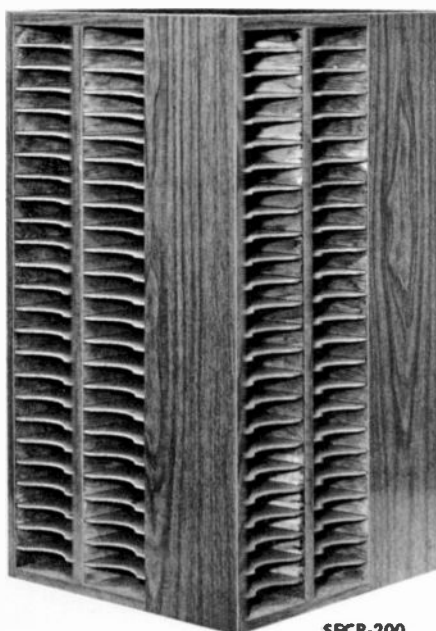

SECR-200

SECR-200 Storage Cabinet. Walnut formica trim for attractive over-all appearance. Capable of storing 200 Series 300 cartridges. Rotates on ball bearings. Dimensions: 29½" high x 15¾" wide x 15¾" deep.

ORDERING INFORMATION

M-5986 Storage Rack for 40 Series 300 cartridges.....	994-5986
RM-100 Storage Rack for 100 Series 300 cartridges.....	730-0834
RS-200 Storage Rack for 200 Series 300 cartridges.....	730-0835
RS-25 Storage Rack for 25 Series 300 cartridges (not shown).....	730-0836
SECR-72 Storage Cabinet for 72 Series 300 cartridges.....	900-0147
SECR-200 Storage Cabinet for 200 Series 300 cartridges.....	900-0148

AUDIO EQUIPMENT

HARRIS
INTERTYPE
CORPORATION

GATES[®]
A DIVISION OF HARRIS-INTERTYPE

AM Limiting Amplifier



MODEL M-6543

Designed to outperform all others, the Gates Solid Statesman Peak Limiting Amplifier ushers in a new age of advanced limiter capabilities.

PERFORMANCE: True limiting without peak clipping is achieved with an average 3 to 5 microsecond attack time. This eliminates the several milliseconds of clipping found in most limiters while the limiting action "catches up". Thus, in this new Peak Limiting Amplifier, even the most critical ear cannot detect the audible distortions that are apparent as a result of slow attack time.

LOW DISTORTION: Distortion is typically 0.2% at 30 Hz and 0.3% at 16 kHz with 10 dB of limiting, and is less than 1.0% with up to 30 dB of limiting. Frequency response remains uniform with or without limiting.

HIGHER MODULATION LEVELS: Fast attack time (in microseconds) and variable release time provide complete freedom from "pumping" with limiting of 15 to 20 dB on most program content. A 30:1 compression ratio allows 99.5% negative modulation without overmodulation. For AM stations,

asymmetrical limiting permits positive peak modulation levels of 110% or 120%, yet negative peaks are limited to 100% or less. This produces a louder-sounding signal.

AUTOMATIC PHASE REVERSAL: The highest peak of the audio signal is made positive to produce the highest AM modulation level in the transmitter. This asymmetrical limiting causes no base line shift in the limiter, and does not artificially alter the balance of the program content. It does permit greater modulation of the natural positive peaks with the resultant increase in transmitter power.

Symmetrical limiting is also available for operation where peaking and phasing of the signal are not desired. A front panel control also permits the limiter to be disabled for proof of performance tests.

CONTROLS: All operating controls are located behind the front access panel. Input and output connections are provided on a barrier terminal block, in addition to the AC power cord, on the rear of the unit.

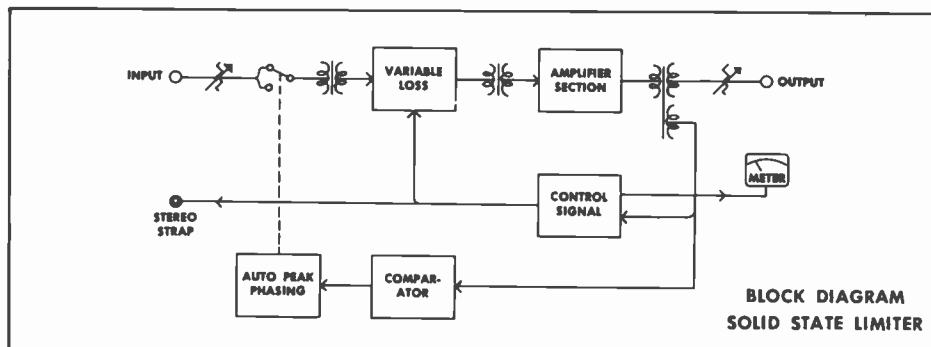

AM Limiting Amplifier

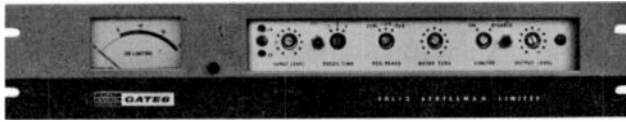

Front view, panel open.

The signal at "A" applied to a conventional limiter with a clipper produces output "B". Here the signal is first clipped, introducing distortion, and then several milliseconds later the true limiting is accomplished. Gates Solid Statesman Limiter completes the limiting action during the first half cycle of the pulse (output "C"). Any distortion produced would be during the first half cycle, and after that the signal would be truly limited without distortion.

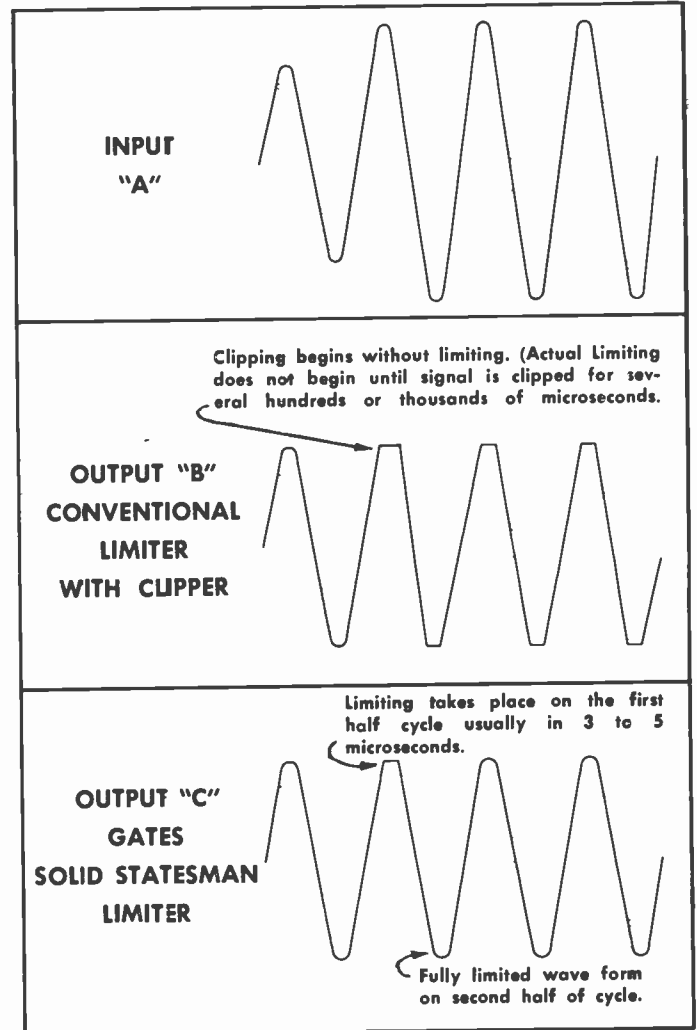

SPECIFICATIONS

GAIN: 50 dB, ± 2 dB max. @ 1 kHz. (May be reduced by built-in input and/or output attenuators).

FREQUENCY RESPONSE: ± 1.0 dB max., 30 to 16,000 Hz (with or without limiting).

HARMONIC DISTORTION: Less than 1.0% from 30 to 16,000 Hz, from 0 to 10 dB of limiting, except with fast recovery on low frequencies where there is partial recovery on each $\frac{1}{2}$ cycle.

NOISE: 70 dB below threshold of limiting, 30 to 16,000 Hz.

ATTACK TIME: Less than 10 microseconds (typical 3 to 5 microseconds).

RECOVERY OR RELEASE TIME: Gated to program content, with 3 positions for individual preferences.

AMOUNT OF LIMITING: 30 dB with a 30:1 compression ratio, an increase of 30 dB input level will increase output level 1 dB.

INPUT LEVEL: Adjustable -22 to $+18$ dBm for 5 dB of limiting.

OUTPUT LEVEL: Adjustable to $+23$ dBm maximum.

INPUT AND OUTPUT IMPEDANCE: 600 ohms, balanced or unbalanced.

TEMPERATURE RANGE: -20°C to $+55^{\circ}\text{C}$.

INPUT POWER: 115/230 volts, 50/60 Hz.

DIMENSIONS: $3\frac{1}{2}$ " H x 12" D x 19" W (standard rack).

WEIGHT: 13 lbs. net; 22 lbs. shipping.

ORDERING INFORMATION

AM Limiting Amplifier-----994-6543



FM Limiting Amplifier



MODEL M-6631

Gates' new Solid Statesman FM Limiter (M-6631) is designed to prevent FM over-modulation, while retaining the original fidelity of the program material. This is accomplished through a combination of limiting, pre-emphasis, instantaneous peak controlling and de-emphasis.

A wide control range, low distortion and rapid attack time are outstanding features of the M-6631—made possible by the extremely close balance of the "Differential Amplifier" used as the gain control device.

Another important feature is the selectable recovery time, which allows each station to choose the best recovery time (FAST, MEDIUM, SLOW) for its type of programming.

In the FAST mode of operation the FM Limiter has dynamic gated recovery. This permits very fast (200 millisecond) recovery times for the highest possible modulation levels, while distortion figures are almost as low at 30 Hz operation as at 1000 Hz.

The MEDIUM and SLOW positions are conventional and

offer slower recovery times for stations desiring protection from over-modulation, but more subtle operation.

The selectable frequency threshold for instantaneous peak controlling permits the local station to select the frequency at which the instantaneous peak controller starts operating. This control function is related to the FCC 75 microsecond pre-emphasis curve, and is intended to offer stations positive protection, but lesser amounts of control action if desired.

Two FM Limiters may be synchronized for stereo operation with a small phono-plug jumper supplied.

A front panel control permits the user to disable the unit for proof of performance tests.

Only 3½" of standard rack space is required for the M-6631 FM Limiter. All operating controls are located behind the easily removed front access panel. Circuit components are readily accessible by removing the top cover. Input and output connections are provided on a barrier terminal block on the rear of the unit along with the stereo sync jack and AC power and fuse.

FM Limiting Amplifier

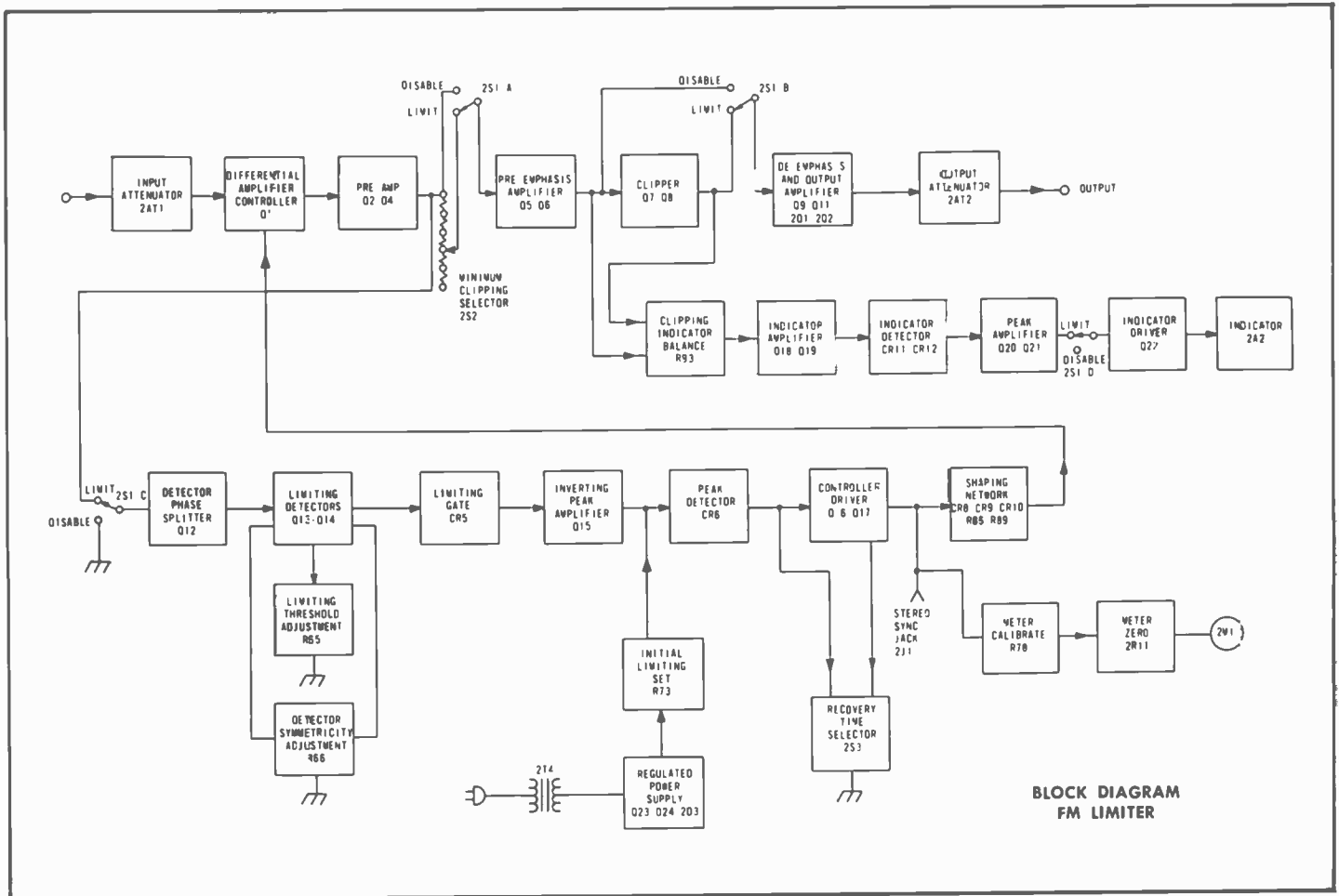

**BLOCK DIAGRAM
FM LIMITER**

SPECIFICATIONS

GAIN: 50 dB, ± 2 dB max. @ 1kHz. (May be reduced by built-in input and/or output attenuators).

FREQUENCY RESPONSE: ± 1.0 dB, 30 Hz to 16 kHz, below threshold of instantaneous limiting.

HARMONIC DISTORTION: 1% Max. 30 Hz to 16 kHz, below limiting, or at 10 dB of limiting in any recovery mode.

NOISE: 70 dB below the threshold of limiting. (Limiting Threshold 30 Hz to 16 kHz.)

ATTACK TIME: 40 microseconds, maximum (no "thumping").

RECOVERY TIME:—Selectable:

FAST: Dynamically Gated for 200 milliseconds

MEDIUM: 2 seconds

SLOW: 10 seconds

AMOUNT OF LIMITING: 30 dB.

LIMITING SLOPE: Better than 30:1. (A 30 dB increase in the input signal will produce less than a 1 dB rise in the output level.)

INPUT LEVEL: -17 dBm to $+23$ dBm for 10 dB of limiting.

OUTPUT LEVEL: Adjustable to $+23$ dBm maximum with limiting. $+30$ dBm amplifier maximum.

INPUT AND OUTPUT IMPEDANCE: 600 ohms, balanced or unbalanced.

DIMENSIONS: $3\frac{1}{2}$ " H x $13\frac{3}{4}$ " D x 19" W (standard rack).

WEIGHT: 14 lbs. net.; 23 lbs. shipping.

TEMPERATURE RANGE: -20°C to $+55^{\circ}\text{C}$. -4°F to $+131^{\circ}\text{F}$.

INPUT POWER: 115/230 volts, 50/60 Hz, 5 watts.

ORDERING INFORMATION

Solid Statesman FM Limiter.....994-6631-001
 Matched Pair of FM Limiters (for stereo).....994-6631-002

Automatic Gain Control Amplifier



MODEL M-6629

Gates Solid Statesman AGC Amplifier (M-6629) is the most versatile automatic gain control system available today. A wide range of control on the amplifier, and an adjustable attack/recovery time feature, insure programming flexibility. The high compression ratio and rapid attack time generate consistently high modulation levels, while the slow attack/recovery mode will maintain control over average program material and extend dynamic range.

The wider control range, lower distortion and rapid attack time are made possible by the use of a "differential amplifier" as the gain controlling device. Extremely close balance of this amplifier provides the desirable characteristics of the M-6629. Another feature is the selectable attack/recovery time which allows each station to select the control time best suited to its program format.

In the FAST mode, the reaction time is similar to that of other limiters now on the market. This operating mode is most desirable for those stations wanting the highest possible modulation levels.

In the MEDIUM and SLOW modes, reaction times are considerably slower. These operating modes are available to those stations which desire a lesser amount of control action than that found in the FAST mode.

Two Solid Statesman AGC Amplifiers may be synchronized for stereo operation. A small jumper cable is all that is required.

Front panel controls permit the user to disable both the expansion and compression functions separately for proof of performance tests. Under these conditions the unit has the same gain as when 15 dB of compression, the ideal operating point, is being used. This provides a test position and at the same time maintains system calibration.

Only 3½" of standard rack space is required for the M-6629. All operating controls are located behind the easily removable access panel. Circuit components are readily accessible by removal of the top cover. Input and output connections are provided on a barrier terminal block on the rear of the unit, along with the stereo sync jack and AC power and fuse.

Automatic Gain Control Amplifier

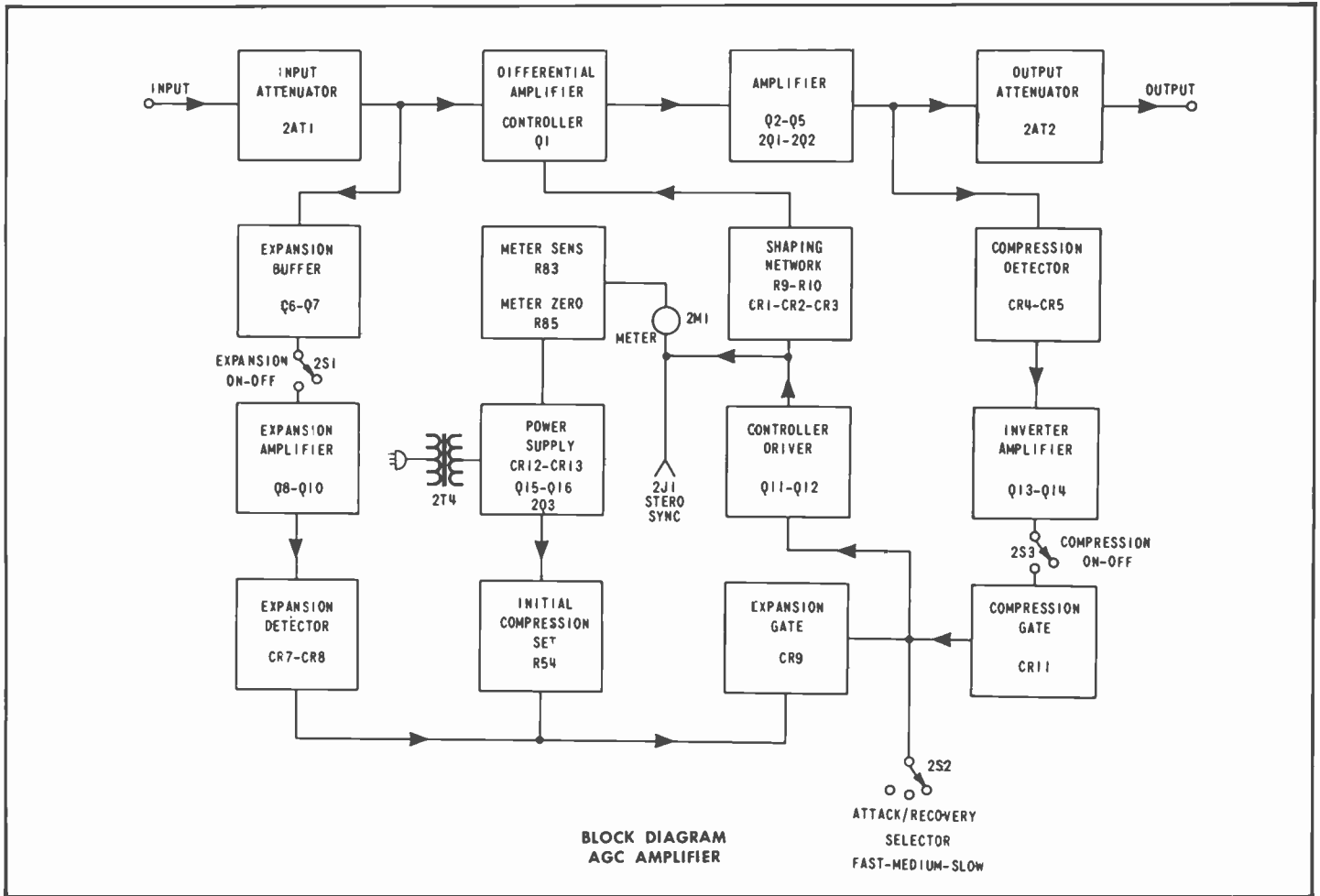

SPECIFICATIONS

GAIN: All figures given with no attenuation in input and output controls (wide open).

MAXIMUM GAIN: 50 dB \pm 2 dB @ 1 kHz with maximum expansion.

NOMINAL GAIN: 35 dB \pm 2 dB @ 1 kHz with nominal signal (15 dB of compression) or no signal condition.

MINIMUM GAIN: 20 dB \pm 2 dB @ 1 kHz with full (30 dB) compression.

FREQUENCY RESPONSE: \pm 1.0 dB, 30 Hz to 16 kHz with or without compression.

HARMONIC DISTORTION: Less than 1.0% from 30 Hz to 16 kHz. AGC on or off.

NOISE: 70 dB below the threshold of compression.

COMPRESSION ATTACK TIME: 30 dB, selectable. Fast: 100 μ Sec. Medium: 1-2 M Sec. Slow: 30 M Sec.

COMPRESSION RECOVERY TIMES: 30 dB, dependent upon compression attack time. Fast: 12 Sec. Medium: 22 Sec. Slow: 53 Sec.

EXPANSION ATTACK TIMES: 15 dB, dependent upon compression attack time. Fast: 7.5 Sec. Medium: 15 Sec. Slow: 35 Sec.

EXPANSION RECOVERY TIMES: 15 dB, dependent upon compression attack time. Fast: 4 Sec. Medium: 5 Sec. Slow: 10 Sec.

AMOUNT OF COMPRESSION: 30 dB.

AMOUNT OF EXPANSION: 15 dB.

COMPRESSION RATIO: Better than 30:1, a 30 dB increase in the input signal will produce less than 1 dB rise in the output level.

INPUT LEVEL: -15 dBm to +25 dBm for 15 dB of compression.

OUTPUT LEVEL: Adjustable to +20 dBm maximum with compression, +30 dBm amplifier maximum.

INPUT AND OUTPUT IMPEDANCE: 600 ohms, balanced or unbalanced.

DIMENSIONS: 3½" H x 13¾" D x 19" W (Standard rack).

WEIGHT: 14 lbs. net. 23 lbs. shipping.

TEMPERATURE RANGE: -20°C to +55°C. -4°F to +131°F.

INPUT VOLTAGE: 117/234 V, 50/60 Hz.

INPUT POWER: 5 watts.

ORDERING INFORMATION

Solid Statesman Automatic Gain Control Amplifier.....994-6629-001
Matched Pair AGC Amplifiers (for stereo).....994-6629-003

Premium Solid State Audio Amplifiers

6300 SERIES

Designed for custom audio equipment, these fully transistorized audio amplifiers incorporate engineering advances that provide excellent performance standards.

Thorough laboratory testing and extensive field use have proven the "6300" series amplifier family one of the finest in the broadcasting field.

"6300" amplifiers are noted for low noise, low distortion, wide frequency response and Solid-Statesman reliability.

Units may be installed in tandem with little or no equalizing, while maintaining an excellent signal-to-noise ratio. Modern plug-in design assures easy installation and maintenance.

Included in this complete line are: Preamplifier, program amplifier, program/AGC (automatic gain control) amplifier, power supplies, mounting trays and a compact shelf assembly for rack mounting.

For the most critical applications, Gates recommends the "6300" Solid-Statesman Series.



M-6313A



M6314A



Typical rear plug in detail.

TRANSISTORIZED PREAMPLIFIER SPECIFICATIONS

GAIN: 40 dB, or 46 dB (by receptacle strapping), ± 0.3 dB.

FREQUENCY RESPONSE: ± 0.5 dB from 20 to 20,000 Hz, or ± 0.25 dB from 30 to 15,000 Hz.

DISTORTION: 0.25% maximum from 30 to 15,000 Hz @ +20 dBm output.

NOISE: -123 dBm relative input noise, 30 to 15,000 Hz.

SOURCE IMPEDANCE: 150/600 ohms balanced or unbalanced, center tapped.

LOAD IMPEDANCE: 150/600 ohms, balanced or unbalanced.

POWER: 48 volts DC @ 30 mA.

CONNECTORS: 16 terminal, self-aligning, recessed to prevent accidental damage.

MONITORING: Indicator lamp provides warning of short-circuit condition.

TEST POINT: Pin jacks provide audio output monitoring.

MOUNTING TRAY: M-6341 tray and receptacle. Tray attaches to M-6689 panel and shelf assembly for mounting up to eight preamplifiers in 3½" of vertical rack space.

SIZE: 2" wide x 3¼" high x 14¾" long.

WEIGHT: 4½ lbs. net.

ORDER NUMBER994-6313A

TRANSISTORIZED PROGRAM/AUTOMATIC GAIN CONTROL AMPLIFIER SPECIFICATIONS

GAIN: 62 dB, ± 0.3 dB; or 80 dB, ± 0.5 dB (by receptacle strapping).

FREQUENCY RESPONSE: ± 0.5 dB from 20 to 20,000 Hz or ± 0.25 dB from 30 to 15,000 Hz (62 dB gain). ± 0.5 dB from 30 to 15,000 Hz (80 dB gain).

DISTORTION: 0.25% maximum from 30 to 15,000 Hz, (62 dB gain @ +32 dBm output level). 0.5% maximum from 30 to 15,000 Hz, (80 dB gain @ +32 dBm output level).

NOISE: -116 dBm relative input noise (62 dB gain mode) from 30 to 15,000 Hz. -118 dBm relative input noise (80 dB gain mode) from 30 to 15,000 Hz.

GAIN REDUCTION: (AGC): Amplifier input/output characteristics linear below threshold of AGC @ +20 dBm output level. 6 dB gain reduction maximum in 62 dB gain mode. After maximum of 6 dB AGC, amplifier input/output characteristics become linear again. An input level of -24 dBm will result in 6 dB gain reduction and an output level of +32 dBm. Approximately 21 dB AGC in the 80 dB gain mode. Amplifier characteristics linear below the threshold of AGC @ +20 dBm output level. An input level of -27 dBm will result in 21 dB gain reduction and an output level of +32

dBm. An external switch permits disabling the AGC action without thumps or clicks in the program circuit.

ATTACK TIME: AGC attack time = 25, ± 3 milliseconds.

RECOVERY TIME: AGC recovery time = 0.5, ± 0.1 second.

SOURCE IMPEDANCE: 150/600 ohms, balanced or unbalanced, center tapped.

LOAD IMPEDANCE: 150/600 ohms, balanced or unbalanced, center tapped.

POWER: 48 volts DC @ 140 mA.

CONNECTORS: 16 terminal, self-aligning, recessed to prevent accidental damage.

MONITORING: Indicator lamp provides warning of short-circuit condition.

TEST POINT: Pin jacks provide audio output monitoring.

MOUNTING TRAY: M-6342 tray and receptacle. Six PGM/AGC amplifiers mount in 3½" of vertical rack space.

SIZE: 2¾" wide x 3¼" high x 14¾" long.

WEIGHT: 5 lbs. net.

ORDER NUMBER994-6314A

Premium Solid State Audio Amplifiers



M-6338

TRANSISTORIZED POWER SUPPLY

SPECIFICATIONS

CAPACITY: Up to 50 M-6313 Transistor Preamplifiers, or up to 10 M-6314 Program/AGC amplifiers or any combination with a maximum rated current of 1.5 amps. Use for large systems or where growth is anticipated.

OUTPUT: 48 volts DC at 0 to 1.5 amps, continuous.

RIPPLE: Less than 1.0 mV from 0 to full load.

INTERNAL IMPEDANCE: 0.05 ohms.

REGULATION: 0.3%.

POWER: 117 volts nominal, 50/60 Hz, 130 watts maximum.

SHORT CIRCUIT PROTECTION: Resistive short circuit protection allows full operation to resume after momentary short circuits on the output. Primary fuse prevents component damage with sustained short circuits.

UNDERVOLTAGE ALARM: Self-contained relay actuates with approximately 10% undervoltage. Contacts are connected to the output plug to permit the operation of an external alarm.

CONNECTORS: 16 terminal, self-aligning, recessed to prevent damage.

SWITCH AND FUSE: Switch and illuminated indicating fuse holder located on the front escutcheon for AC control of the power supply.

MONITORING: Neon lamp (to indicate presence of AC supply voltage), and load lamp (to indicate output voltage). Output sampling jack located on the front escutcheon.

MOUNTING TRAY: M-6344 tray and receptacle. Four M-6338 power supplies mount in 3½" of vertical rack space.

SIZE: 4½" x 3½" high x 14¾" long.

WEIGHT: 7½ lbs. net.

ORDER NUMBER994-6338



M-6321

TRANSISTORIZED PROGRAM AMPLIFIER

SPECIFICATIONS

GAIN: 62 dB, ±0.3 dB, unterminated input.

FREQUENCY RESPONSE: ±0.5 dB from 20 to 20,000 Hz or ±0.25 dB, 30-15,000 Hz.

DISTORTION: 0.25% maximum from 30 to 15,000 Hz @ +32 dBm output.

NOISE: -116 dBm relative input noise, 30 to 15,000 Hz.

SOURCE IMPEDANCE: 150/600 ohms, balanced or unbalanced, center tapped.

LOAD IMPEDANCE: 150/600 ohms, balanced or unbalanced, center tapped.

POWER: 48 volts DC @ 140 mA.

CONNECTORS: 16 terminal, self-aligning, recessed to prevent damage.

MONITORING: Indicator lamp provides warning of short-circuit condition.

TEST POINT: Pin jacks provide audio output monitoring.

MOUNTING TRAY: M-6426 tray and receptacle for up to six program amplifiers in 3½" of vertical rack space.

SIZE: 2¾" wide x 3½" high x 14¾" long.

WEIGHT: 4½ lbs. net.

ORDER NUMBER994-6321



M-6421

TRANSISTORIZED POWER SUPPLY

SPECIFICATIONS

CAPACITY: Up to ten M-6313 preamplifiers, or two M-6314 Program/AGC amplifiers, or any system combination with a maximum rated current not exceeding 300 mA for use in smaller systems.

OUTPUT: 48 volts DC at 0 to 300 mA continuous.

RIPPLE: Less than 1.0 mV from 0 to full load.

INTERNAL IMPEDANCE: 0.05 ohms.

REGULATION: 0.3%.

POWER: 117 volts nominal, 50/60 Hz, 30 watts.

SHORT CIRCUIT PROTECTION: Resistive for momentary short circuits on output. Primary fuse prevents damage from sustained short circuits.

CONNECTORS: 16 terminal, self-aligning, recessed to prevent damage.

SWITCH AND FUSE: Located on front escutcheon.

MOUNTING TRAY: M-6422 tray and receptacle. Six M-6421 power supplies mount in 3½" of vertical rack space.

SIZE: 2¾" wide x 3½" high x 14¾" long.

WEIGHT: 5½ lbs. net.

ORDER NUMBER994-6421

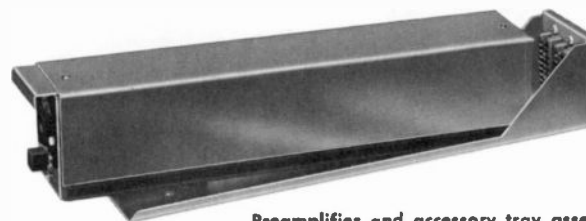

Preamplifier and accessory tray assembly. Plugs on all amplifiers are recessed to assure no damage to pins.

Audio Amplifier Accessories

ACCESSORIES

Complete mounting accessories are available for the "6300" series Solid-Statesman amplifiers. The M-6689 panel and shelf assembly unit occupies only 3½" x 19" of rack space. Built of heavy-gauge, plated, non-corrosive steel, finished in beige-gray, with hinged front panel. Individual mounting trays have been designed for each model amplifier and power supply.

In system practice a typical audio input signal may pass through four amplifiers, four faders, nine transformers, and be bridged a dozen or more times, yet the system performance at the output is equal to or better than any individual amplifier specification. Of particular importance is the higher rated output levels of both preamplifiers and program amplifiers to accommodate greater dynamic range at no increase in distortion.

NOTE: The source of load impedance of the amplifiers as listed in the specifications is the recommended impedance of the connecting device (such as a microphone, attenuator, line or loudspeaker). However, the input impedance of all four amplifiers is approximately ten times higher than the source impedance, giving the systems designer greater flexibility.

The output impedance is approximately 1/10 the load impedance, which permits multiple bridging without any degradation of the output signal.

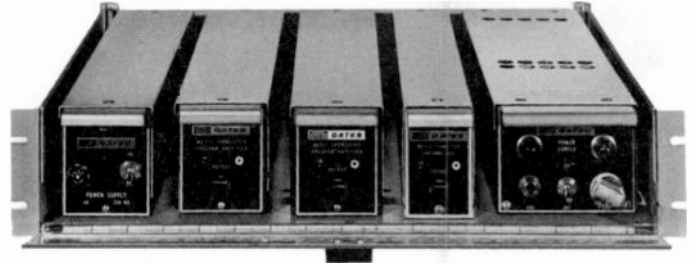

Above: M-6689 panel and shelf assembly, showing several "6300" series Solid-Statesman units. This assembly requires only 3½" x 19" of rack space.

ORDERING INFORMATION

Mounting tray for preamplifier	994-6341
Mounting tray for program amplifier	994-6426
Mounting tray for program/AGC amplifier	994-6342
Mounting tray for M-6421 power supply	994-6422
Mounting tray for M-6338 power supply	994-6344
Panel and shelf assembly	994-6689

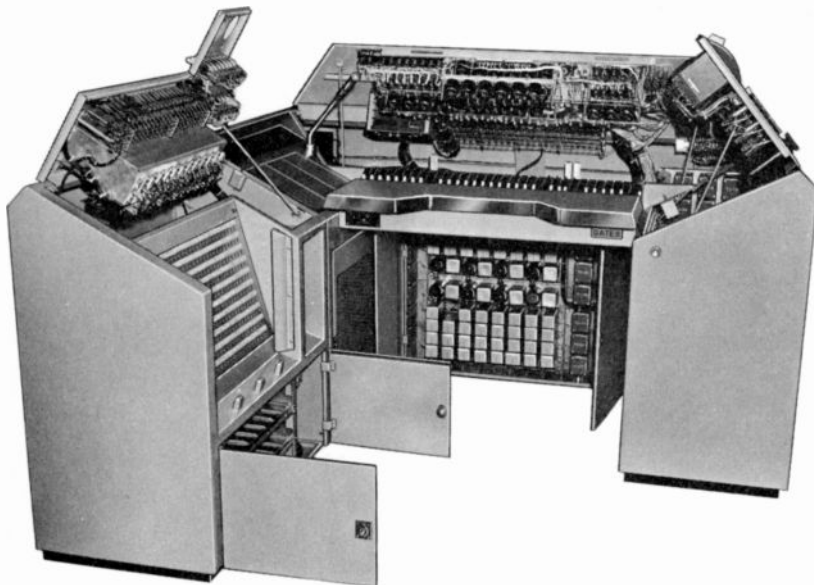

TELEVISION AUDIO CONSOLE

The production console at the left is now in use in a leading television network, and houses 57 of the "6300" series Solid-Statesman transistorized units. The remarkable capabilities of this completely self-contained console include: mixing from 25 input audio sources simultaneously into nine separate program channels, each with automatic level control; built-in video monitoring, ten audio monitoring channels; twelve microphone equalizers; two graphic program equalizers; five sound effects filters; two reverberation send and return channels; vertical attenuators; three video controlled audio channels, plus many other special features.

Rack Cabinets

RAK-70

Designed with the flexibility to accommodate all types of equipment. Whether used as a rack only, or a complete cabinet with all accessories, the RAK-70 can fill almost any special requirement of the individual broadcaster.

Mechanical construction of each component gives the RAK-70 ruggedness and rigidity. There is not the slightest torsion in the doors or cabinet framework.

The basic RAK-70 cabinet assembly includes: two panel mounting angles; an air filter mounted in the rear of the cabinet base, with provision for mounting an air filter in the base front; convenient knock-outs for wiring in the bottom and sides of the base; and new EIA standard panel-mounting hole spacing.

Optional accessories for the RAK-70 are: side panels; louvered top; rear door with or without louvers; fan kit (includes 200-cfm base-mounted fan to maintain a constant, positive pressure inside the cabinet); air filter kit (for installing air filter in base front); and rear mounting angles.

To order, see "Ordering Information" below.

SPECIFICATIONS

HEIGHT OVER-ALL: 78".
 WIDTH OVER-ALL: 23½".
 DEPTH OVER-ALL: 23⅝".
 PANEL SPACE: 19" × 70".

PANEL MOUNTING: New standard EIA rack multi-

ples, 10-32 mounting screws provided.
 FINISH: Beige-gray, smooth finish.
 WEIGHT: Net 160 lbs.; domestic packed, 175 lbs.;
 export packed, 275 lbs.; cubage, 28 cubic feet.
 TO ORDER: See "Ordering Information" below.

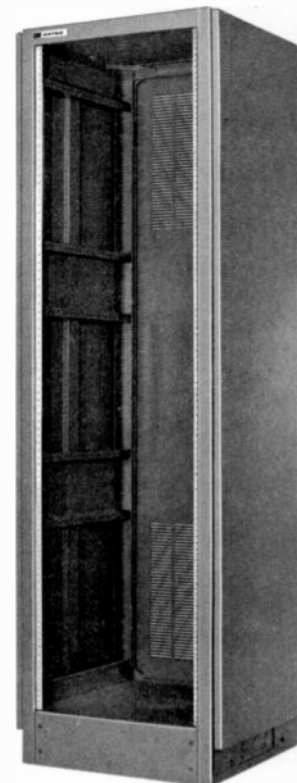

RAK-7

The RAK-7 is one of the finest solid side rack type cabinets designed specifically to accommodate all types of broadcast equipment. Built of lightweight steel, this cabinet has solid sides, a solid base, full size rear door with louvers at top and bottom for efficient ventilation.

SPECIFICATIONS

HEIGHT OVER-ALL: 78".
 WIDTH OVER-ALL: 23½".
 DEPTH OVER-ALL: 19½".
 DOOR SWING: 20½".
 PANEL SPACE: 19" × 71¾".
 CLEARANCE BEHIND PANEL: 17".

PANEL MOUNTING: Standard rack multiples 10-32 mounting screws provided.
 FINISH: Beige-gray.
 WEIGHT: Net 100 lbs.; Domestic packed 115 lbs.;
 Export packed 200 lbs.; Cubage: 18 cu. ft.
 TO ORDER: See "Ordering Information" below.

ORDERING INFORMATION

RAK-70:	
Basic cabinet assembly	994-6643-002
Side Panel	994-6664-001
Louvered top	994-6665-001
Door with Louvers	994-6671-001
Door without Louvers	994-6671-002
Key type lock for doors	448-0320-000
Fan kit	994-6666-001
Air filter kit	994-6668-001
Air filter (replacement)	448-0288-000
Rear mounting angle (two must be ordered)	827-4789-002

RAK-7	
Rack cabinet	994-5527-003
Joiner trim	994-5577-001

CR-70 (not shown)
 Waist-high rack cabinet. Heavy cold rolled furniture grade steel, resistance welded.
 Size 37¼" H x 23¾" W x 23" D. Rack space 33¼" x 19" 994-5651-001

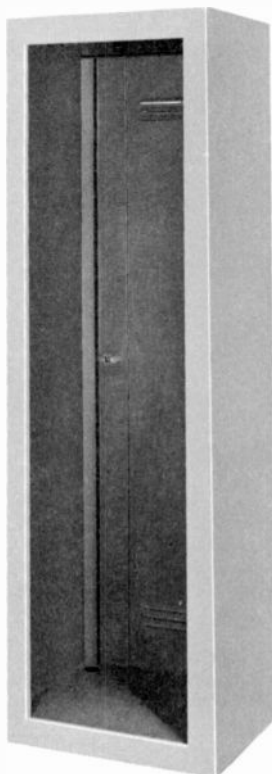

Program And Monitoring Amplifiers

PROGRAM OR LINE AMPLIFIER

Studio equipment facilities often may be expanded by adding a second or third program amplifier. In single channel consoles the audition bus may be used for separate programming of FM by inserting the M-5576B program amplifier between the bus and the line. For bridging, standby and network feeds, this amplifier mounted in the equipment rack is ideal.

This high gain, low distortion, 4-stage program amplifier includes a self-contained power supply and requires only 5¼" of rack space. A dual gain control with one section in the second stage grid and the other section in the third stage grid assures a low noise ratio at any gain setting.

SPECIFICATIONS

GAIN: 75 dB, ± 2 dB.

RESPONSE: $\pm 1\frac{1}{2}$ dB, 30-15,000 Hz.

DISTORTION: 0.75% at +12 dBm output, 30-15,000 Hz. 1% at +22 dBm output, 50-15,000 Hz.

NOISE: 60 dB below +12 dBm output or equal to -120 dBm relative input noise.



IMPEDANCES: Input and output: 150/250 or 500/600 ohms.

POWER: 117 volts, 50/60 Hz, 45 watts.

TUBES: (3) 6F86 and (1 each) 12AU7, 6X4.

MECHANICAL: 19" x 5¼" x 7½" deep. Weight packed (domestic), 27 lbs.; (export) 50 lbs. Cubage: 2 cubic feet. Finish: beige-gray.

ORDERING INFORMATION

Program amplifier with tubes.....994-5576B

Spare 100% tube kit.....990-0450



MONITORING AMPLIFIER

In quality audio systems, the need for excellence in loudspeaker distribution is paramount. Here is an outstanding ultra linear amplifier offering a variety of input impedances, very low distortion, excellent power output and high gain. Input impedances for matching 30/50 and 150/250 ohm lines or bridging at 30,000 ohms are available. An unusually high gain of 100 dB allows the M-5575 monitoring amplifier to be used directly from a mixer program bus, low level turntable output or a microphone. The distortion is less than 1%, though a full 10 watts of power is produced from a -60 dBm input.

SPECIFICATIONS

GAIN: 100 dB or bridging 50 dB.

RESPONSE: $\pm 1\frac{1}{2}$ dB, 30-15,000 Hz.

DISTORTION: 1% or less 50-15,000 Hz at +40 dBm (10 watts).

NOISE: 60 dB or better below +40 dBm, measured at -50 dBm input.

IMPEDANCES: (Input) 30/50 or 150/250 ohms at 100 dB gain. 30,000 ohms bridging at 50 dB gain. (Output) 8 and 16 ohms.

POWER: 117 volts, 50/60 Hz, 85 watts.

TUBES: (3) 12AX7, (2) EL84, (1) GZ34, (1) OA2, (1) OB2.

MECHANICAL: 19" x 7" x 8" deep. Weight packed (domestic), 34 lbs.; (export) 59 lbs. Cubage: 3 cubic feet. Finish: beige-gray.

ORDERING INFORMATION

Ultra linear monitoring amplifier, with tubes.....994-5575

Spare 100% tube kit.....990-0303

Speaker matching transformer.....478-0275



Monitoring And Utility Amplifiers

TRANSISTOR MONITOR AMPLIFIER

Offering the superb performance of transistors, Gates M-6108 professional 8-watt monitoring amplifier is designed for the exacting demands of modern broadcasting. Only 4½" x 8½" x 3½" including self-contained power supply, it will fit anywhere, even in the corner of a loudspeaker cabinet. The almost negligible operating temperature lends to its versatility.

The M-6108 will produce 20-20,000 Hz response within ±1 dB with no more than 1% distortion at a full eight watts output. Gain of 53 dB from a 600 ohm input or 39 dB from the 6,000 ohm bridging input assures wide versatility. The output of 4-16 ohms for direct speaker connection may be changed to other higher impedances through the use of an optional external matching transformer.



SPECIFICATIONS

GAIN: 53 dB using 600 ohm input; 39 dB using 6000 ohm bridging input.
RESPONSE: 20-20,000 Hz ±1 dB.
DISTORTION: 1% or less 8 watts output, 50-15,000 Hz. 1% or less 6 watts output, 30-15,000 Hz.
NOISE: 85 dB below +39 dBm output (8 watts).
IMPEDANCES: (Input) 600 ohms matching, 6000 ohms bridging, transformer input. (Output) 4 to 16 ohms.

POWER: 117 volts, 50/60 Hz, 18 watts.
SIZE: 4½" wide, 8½" long, 3½" high.
WEIGHT: 4 lbs. net.

ORDERING INFORMATION

Eight-watt transistorized monitor amplifier.....994-6108



SINGLE CHANNEL UTILITY AMPLIFIER

Often called the most important of amplifiers, as it fills almost any amplifier need. AC operated and completely self-contained, the M-5530 all purpose amplifier operates as (a) a single microphone remote amplifier, (b) turntable preamplifier with ample gain for passive equalizers, (c) standby program amplifier, and (d) a microphone amplifier for medium level tape recording. Mounts nicely in turntable cabinet. Ideal for permanent remotes.

SPECIFICATIONS

GAIN: 81 dB.
RESPONSE: 30-15,000 Hz ±1½ dB.
DISTORTION: 1% or less 50 to 15,000 Hz at +8 dBm output or 2% at +18 dBm.
NOISE: 60 dB below +8 dBm.
IMPEDANCES: (Input) 30/50 or 150/250 ohms. (Output) 150/250 or 500/600 ohms.
POWER: 115 volts, 50/60 Hz. Consumption 15 watts.
TUBES: (2) EF86/6267, and (1 each) 12AU7, 6X4.

SIZE: 11" x 5" x 5¾" deep.
WEIGHT: Net 9½ lbs. Packed 20 lbs. Cubage: 2 cubic feet.

ORDERING INFORMATION

Single channel utility amplifier with tubes.....994-5530
 Chassis connector (female).....612-0194
 Microphone connector (male).....610-0182
 Spare 100% tube kit.....990-0280



Audio Accessories

CUEING AMPLIFIER



Program preview of 10 audio circuits may be selected by a rotary switch with this high gain, compactly designed cueing amplifier. Requiring only 3½" of rack space, Gates Uni-Que amplifier has a self-contained loudspeaker and is easily adaptable to convenient desk mounting. High gain allows cueing direct from turntable, tape, projector circuits and microphone preamplifier outputs. Input is either low impedance or bridging. Speaker has terminals for muting when used in the control room. Front panel includes gain control, 10 selector switch (plus "off" position), power switch, pilot light and fuse.

SPECIFICATIONS

GAIN: 70 dB low impedance matching, 35 dB bridging, ± 2 dB.
INPUT LEVEL: -20 dBm matching or +22 dBm bridging.
RESPONSE: Peaked for high intelligibility.
IMPEDANCES: (Input) 30/50, 150/250 or 10,000 ohms bridging. (Output) to self-contained speaker with muting terminals external.
NOISE: 50 dB or better below speaker level of about +30 dBm.
POWER: 105/125 volts, 50/60 Hz, 25 watts.
POWER SUPPLY: Solid state, transformer input (not AC/DC).
TUBES: (1) 12AX7, (1) 50C5.
MECHANICAL: 19" x 3½" x 6½" deep. Weight packed: (domestic) 16 lbs., (export) 30 lbs. Cubage: 2 cubic feet. Finish: Beige-gray.

ORDERING INFORMATION

Cueing Amplifier with tubes.....994-5377
 Spare 100% tube kit.....990-0305

SWITCH AND FUSE PANEL



Each rack of audio and radio frequency equipment should have a master switch and fuse panel. Usually mounted at the bottom of the rack, the Gates M-4242 switch and fuse panel includes dual pilot lamps to indicate input and output voltage, dual fuses and D.P.D.T. primary switch. Rating 15 amperes at 115 volts, AC. Size: 19" x 3½" x 3" deep. Finish: Beige-gray. Weight packed: 10 lbs. Cubage: 1 cubic foot.

ORDERING INFORMATION

Switch and fuse panel.....994-4242



VU METER AND RANGE PANEL

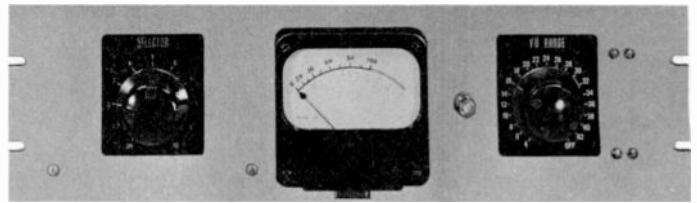

A 5% or better accuracy is maintained throughout the 2 VU per step, +4 to +42 VU range. The 10-position input selector switch permits permanent installation to regularly checked circuits. For proof of performance measurements, equipment calibration, input level measurements from remote circuits and output levels (up to 10 watts), the VU-22 meter panel offers complete versatility. Input: 7500 ohms to bridge a 500/600 ohm line. Frequency response: Flat 20-20,000 Hz. Size 19" x 5¼" x 3" deep. Finish: Beige-gray and black. Shipping weight packed: 12 lbs. Cubage: 1 cubic foot.

ORDERING INFORMATION

VU-22 VU meter and range panel.....994-4577
 Terminal board accessory for above.....994-4648

STUDIO WARNING LIGHTS



An unusually attractive studio fixture with edgewise lighting of a plexiglass transparent plate. Incandescent lamp is housed in gun-metal casing. Mounting is usually above studio door. "On Air" lettering is in red with other nomenclatures, such as Studio A", etc., supplied in black. Housing is well ventilated, without light leakage. Size: 18" wide, 3" front to back, and 6½" from bottom of glass to top of housing. 117 volts, 50 watts. UL approved.

ORDERING INFORMATION

LETTERING	ORDER
On Air (in red).....	406-0269
Special lettering up to 12 characters (specify).....	406-0278
On The Air (QF-15 Rollins).....	406-0285
Studio A (QF-15 Rollins).....	406-0280
Studio B (QF-15 Rollins).....	406-0281

Audio Accessories

VA PROGRAM FADER KNOBS



The VA program knobs are used on all Solid-Statesman consoles and are specifically recommended for mixer and master gain functions. Designed to meet human engineering concepts, these VA fader knobs are fashioned for the control operator's hands, where touch and feel are of major importance. Matching black anodized dial available.

ORDERING INFORMATION

VA knob only.....650-0130
 Dial for VA knob.....648-0045
 Knob decal kit (6 colors—5 of each).....646-0379

STUDIO CUE/INTERCOM SPEAKER

The studio cue/intercom speaker is a modern design, high efficiency cue speaker mounted in a cast aluminum housing and finished in black, with attractive grill. It may be used for cue listen or cue talk-back. Matches either 48 or 600 ohms. Size: 5½" wide, 6½" high and 4" deep, with a 30° slope when placed on desk.



ORDERING INFORMATION

Studio cue/intercom speaker.....994-6424

DESK OR CONSOLE TOP VU METER

Used on the President and Ambassador Solid-Statesman consoles, this completely housed VU meter is ideal for many audio applications. Standard scale B illuminated 4" VU meter in cast aluminum housing 5½" x 6½" x 4" deep.



ORDERING INFORMATION

VU meter (30° slope when placed on desk).....994-6208

SPEAKER MATCHING TRANSFORMER

Where many speakers are used, the normal 8 ohm voice coil impedance will cause a mismatch. This transformer has a primary of 48 ohms and a secondary of 8 ohms. Thus, six transformers in parallel will reflect the normal 8 ohms output impedance of the studio monitor amplifier.

Speaker matching transformer (not shown).....478-0275

PATCH PANELS AND CORDS

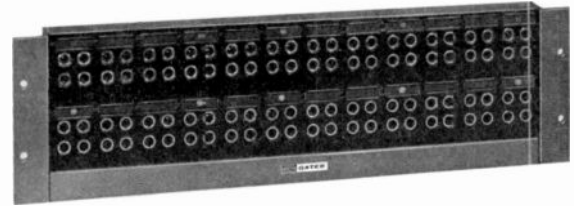

Illustrated above are two PJ-341 jack strips on a PD-2 jack mat to supply 48 pairs or 96 jacks on a 19" x 5¼" rack space.



Twenty-four pairs or 48 jacks is a PJ-341 jack strip on a PD-1 jack mat. Rack space 19" x 3½".



Shown above is the PJ-343 twenty-four jack, 12-pair unit requiring only 19" x 1¾" rack space. No jack mat is required.

Industry standard double jack panels. Jack strips and jack mats listed separately below for ease in ordering. Jacks are closed circuit type to normal through audio circuits when patch cord plugs are not inserted. Contacts are silver alloy with springs, non-aging, non-ferrous metal to assure lasting tension. Molded bakelit[®] form, steel reinforced. Individual designation strips with slip-in holders for each jack pair.



Patch cords have double plug each end, with cords in 4 lengths. Cords shielded and covered with double black braid, with extra reinforcement 6" from each plug end.

ORDERING INFORMATION

Jack strip only (PJ-343), 24 jacks or 12 pairs (no jack mat required).....612-0307
 Jack strip only, (PJ-341), 48 jacks or 24 pairs (less mat).....612-0306
 Jack mat for one PJ-341 jack strip (PD-1).....994-4399
 Jack mat for two PJ-341 jack strips (PD-2).....994-4400
 Jack mat for three PJ-341 jack strips (PD-3).....994-4401
 Double patch cord with 2' cord (PJ-12).....250-0002
 Double patch cord with 3' cord (PJ-13).....250-0003
 Double patch cord with 4' cord (PJ-14).....250-0004
 Double patch cord with 5' cord (PJ-15).....250-0005

Audio Accessories

TRANSCRIPTION STORAGE CABINETS

For convenient filing and protection of records or tapes, use modern Wallach storage cabinets. Models available for all

sizes of discs and tape reels. Modular systems for desk and floor mounting, with doors and locks, also available.

DISC CABINET



Protect those expensive and fragile 12" LP's as they should be. Holds 540 12" LP's with a heavy red wallet for each. Includes two sets of numbers, 1620 printed catalog cards and card file. Size: 60" x 29" x 14" deep. Double door with lock and key.

Disc cabinet448-0134

DOUBLE DOOR TAPE CABINETS, WITH LOCK

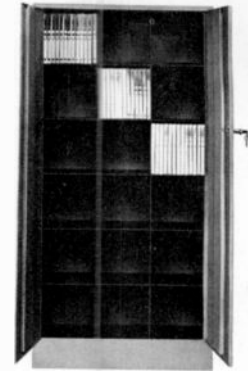

Cabinet for 7" reel boxes. 18 compartments — capacity to 288 reel boxes. 29" x 60" x 10" deep.

Cabinet448-0130

Cabinet for 10½" reel boxes. 12 compartments — capacity to 192 reel boxes. 29" x 60" x 10" deep.

Cabinet448-0178

LP ALBUM CABINET

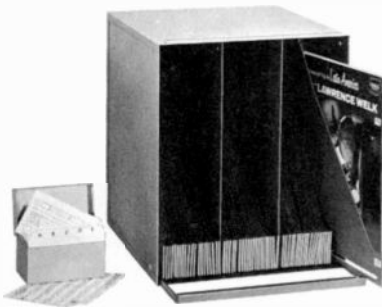

Holds sixty 7", 10" or 12" albums. Includes cataloging system with index cards for fingertip control. Size: 13½" x 15½" x 14" deep.

Cabinet for 60 albums448-0230
As above, with snap catch door448-0231

TAPE CABINETS



Holds 42 reel boxes of 7" tape reels. Has six compartments. May be stacked as desired. 13½" wide, 12½" high, 8½" deep.

Cabinet448-0043

Holds 21 reel boxes of 10½" tape reels. Has three compartments. May be stacked as desired. 13½" wide, 12½" high, 12" deep.

Cabinet448-0074

CONNECTORS

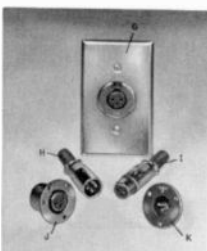

- (G) Single, 3 prong, female, 1 wall plate (XLR3-35)612-0188
- (H) Cable plug, 3 prong, male. (XLR3-12C)610-0182
- (I) Cable receptacle, female, 3 prong (XLR3-11X)612-0182
- (J) Chassis receptacle, female, 3 prong (XLR3-13)612-0194
- (K) Chassis receptacle, male, 3 prong (XLR3-14)610-0194

AUDIO TERMINAL BLOCK



For inter-rack or jack field wiring. Molded one-piece black phenolic with base 3½" x 6½". 3½" high. Plated brass terminals. Polished phenolic finish. Mounts in Gates RAK-1 rack cabinet with BRK-1 bracket. 120 terminals in six rows.

Audio terminal block.....614-0339

Audio Accessories

BOOM STANDS



Provide convenient and proper microphone placement where correct position cannot be reached with conventional stands. Boom length 62 inches, height adjustable from 4 ft to 6 ft. Base diameter 17 inches, tubular sections superchrome plated. "Snap On" hangers provided for microphone cable. Shipping weight 33 lbs.

Boom Stand without casters.....720-0061
 Boom Stand with silent casters.....720-0062

ADJUSTABLE MICROPHONE ARM



Flexo Mikester Mike Support Arm clamps or screws to any position. Swings to 36 inches fully extended. Mounts any microphone up to 4 lbs. Shipping weight 7 lbs.

Flexo Mikester.....720-0040

HEADPHONES



BA-200 Brush. Smartly styled, unusually sensitive high impedance crystal headset. Dual earpieces. Monophonic service.

Dual Headset.....721-0003
 BA-201 Brush. Single headpiece version of above. High impedance crystal type.

Single Headset.....721-0004
 TRIM economy headset. Featherweight dual earpiece model, recommended for utility monitoring use such as remotes, etc. Impedance 24,000 ohms.

Model 107 TRIM Dual Headset.....721-0006
 STEREPHONIC Headphones. High impedance dual headset for control room monitoring with stereophonic consoles such as the Gates Executive or Stereo Statesman.

BA-206B Stereo Headset.....721-0009
 511 TRIM Headphone Plug.....610-0273

DESK STANDS



Model 418. Heavy cast iron stand finished in medium gray. Specifically designed for microphones using small type stud such as Gates G-100 and G-200. Net weight 3 lbs.

Desk Stand.....720-0026
 Model 419. Heavy weight desk stand similar to the Model 418, but for use with the Gates G-300 or similar microphones.

Desk Stand.....720-0028
 DS-7. Adjustable desk stand for all popular microphones. Tubular section adjusts from 8 to 13 inches. Heavy chrome-plated stem and gray cast base with felt feet. Shipping weight 3 lbs.

Desk Stand.....720-0076
 DS-5. Non-adjustable desk stand. Chrome-plated tube 4" high. 6" diameter cast iron base with rubber feet. Weight 2 lbs.

Desk Stand.....720-0035
 TS-8. Banquet stand. Adjustable 14½" to 26". Chrome stem sections with velvet-action clutch adjustment. 8" diameter base. Wt. 5 lbs.

Banquet Stand.....720-0150

TAPE SPLICER



Deluxe "Stereo 4" tape splicer with integral tape dispenser for splicing tape. Two-position, replaceable cutting blades. Makes diagonal splice, cuts tiny trims on sides. Made of strong "Implex" plastic. With 100' roll of ½" splicing tape and instructions. Shipping wt., 1 lb. Made by Robbins.

"Stereo 4" Tape Splicer.....732-0099

EDIT-ALL PROFESSIONAL SPLICER



The standard editing device used by professional recording engineers. It is the only precision editing block especially designed with a curved groove to hold the tape firmly without damage. Designed by a network tape editor. Precision machined, will never wear out. Kit complete with block, Mylar splicing tape, blade, marking pencil, and instructions. Wt., 1 lb.

Edit-all Splicing Kit.....732-0167

FLOOR STANDS



MS-25. Professional microphone floor stand. "Air-Lock" cushion controls drop, prevents slippage and microphone damage. Adjusts from 37 to 66 inches. Heavy, triangular base 17 inches in diameter. Full chrome with medium gray base. Fits all microphones listed in this catalog. Weight, 25 lbs.

Professional Floor Stand.....720-0048
 MS-10C. Excellent for average weight microphones. Has 10" diameter base, chrome 2-section tube. Adjusts 35 to 64 inches. Wt., 13 lbs.

Utility Floor Stand.....720-0047
 BB-1. "Baby Boom" stand attachment. Converts any floor stand with ¾"-27 thread to boom-type stand. 32" boom, adjustable counter balance for various microphones. Wt., 6 lbs.

Baby Boom attachment (no stand).....720-0059
 NOTE: All mic stands on this page have ¾"-27 thread, which is standard in the industry.

BULK TAPE ERASER



Professional model HD-11M. Heavy duty unit erases entire reel of tape at once, in seconds. Lowers residual noise 3 to 6 dB below most erase-head levels. Recommended for tape cartridges or reels up to 10½". Adaptor hub available for 10½" NAB reels. 117 volts, 50/60 Hz. Weight, 9 lbs. Made by Microtran.

Bulk Eraser.....732-0096
 Adaptor Hub for 10½" reels.....732-0043

JIFFY TAPE ERASER



Compact unit erases tape conveniently. For cartridges or any size reel. Holds in hand, with momentary pushbutton operation. 117 volts, 60 Hz. Weight, 5 lbs.

Jiffy Hand-Type Tape Eraser.....730-0102

TAPE HEAD DEMAGNETIZER

Model 400. Removes residual magnetism from tape heads for optimum signal-to-noise ratio and protects tapes against deterioration. For 117 volts, 60 Hz. Wt., 1 lb.

Head Demagnetizer.....730-0180

Speakers and Speaker Systems

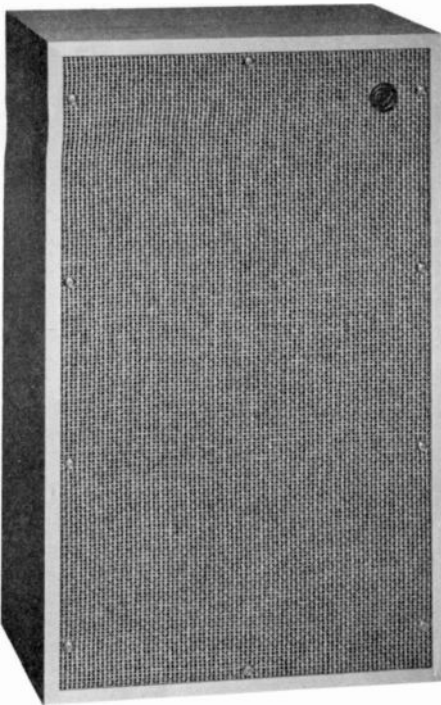

Sentry II
floor model.



Sentry I
wall or
ceiling model

STUDIO MONITOR SYSTEMS

Designed specifically for monitor use in recording and broadcast studios, these loudspeaker systems permit precise monitoring and equalization uncolored by monitor speakers. Precision driver components include 12" Radax loudspeaker, diffraction horn, high frequency driver and special crossover. Quality hardwood cabinet, sanded and sealed, ready for finishing. Neutral cane grill cloth.

SPECIFICATIONS

FREQUENCY RESPONSE: 30 to 20,000 Hz.

EIA SENSITIVITY RATING: 49 dB.

POWER CAPACITY: 20 watts.

IMPEDANCE: Tapped transformer accommo-
dates 16, 150 or 600 ohms.

ORDERING INFORMATION

FLOOR MODEL: Finished on all four
sides. Size: 32" x 20" x 13" deep.
Net weight: 63 lbs.

ORDER NUMBER.....722-0051

WALL MODEL: Size 21½" x 37" x
16½" deep. Net weight: 82 lbs.

ORDER NUMBER.....722-0044



GATESPEAKER 12

This is an ideal monitor speaker for the broadcaster, with high-quality, wide range performance, plus heavy duty construction. Thirteen watts power handling capability and response from 35 to 17,000 Hz. 5½" over-all depth. An excellent replacement speaker.

SPECIFICATIONS

MAGNET WEIGHT: 4.64.

POWER: 13 watts.

VOICE COIL IMPEDANCE: 8 ohms.

SIZE: 12 inches.

ORDERING INFORMATION

Gatespeaker 12722-1200



GATESPEAKER 8

Offering wide range, sturdy construction and minimum cost, the Gatespeaker 8 is one of the finest utility monitor speakers available. Will reproduce lows to 50 Hz and highs to 12,000 Hz.

SPECIFICATIONS

MAGNET WEIGHT: 2.64.

POWER: 11 watts.

VOICE COIL IMPEDANCE: 8 ohms.

SIZE: 8 inches.

ORDERING INFORMATION

Gatespeaker 8722-0800

SPEAKER TRANSFORMERS AND PADS

TR-15 matching transformer. 15 watt capacity. 35-20,000 Hz, ±2 dB. Pri 333/500/1000/2000 ohms. Sec 4/8/16 ohms.

Matching transformer TR-15.....478-0250

Transformer, primary 45/48 ohms, sec. 8 ohms.....478-0275*

Volume control, 8-ohm T-pad.....554-0227

Volume control, 4-ohm T-pad.....554-0180

*Use with Gates audio control consoles.

Wall and Corner Baffles



DWB-12A



DWB-8A

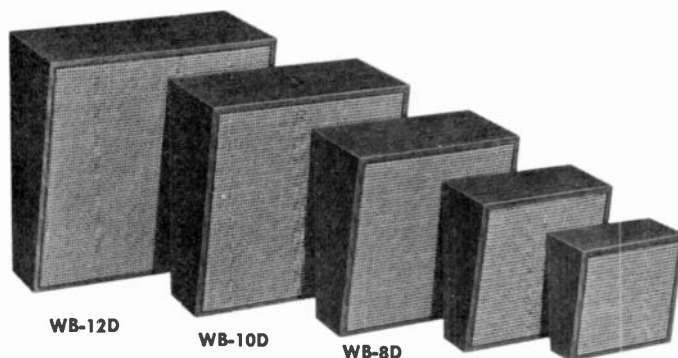

WB-12D

WB-10D

WB-8D

WB-6D

WB-4/5D

DELUXE WALL BAFFLES

Natural hardwood, richly finished in Dusk Walnut or Antique Birch . . . fits into the finest surroundings. Genuine birch has rich satin-smooth appearance. Grill cloth is attractive cane. Has many popular features for better sound and easy handling, including slanting front construction for increased cubic volume. Speaker hardware already firmly fixed in place. Mounting clip included.

DWB-8A—Takes 8-inch speaker, maximum speaker depth 4½".
Size: 10" x 10¾" x 6½". Shipping weight for 2, 5½ lbs. State
birch or walnut finish.....DWB-8A

DWB-12A—Takes 12" speaker, maximum speaker depth 6½".
Size: 13¾" x 14" x 9½". Shipping weight for 2, 9 lbs. State
birch or walnut finish.....DWB-12A

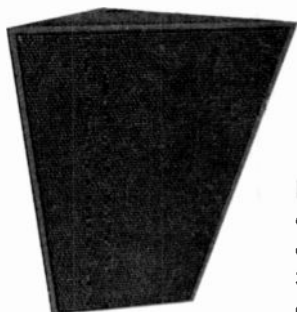

SLANTING CORNER BAFFLES

Rigid construction with wood-grain vinyl covering, and modern cane grill. Superb tone. Slant front aims sound down, corner location increases effective air mass.

Bass enhanced by acoustic padding. Bass reflex design. No screws to hold grill in place or mar its appearance. Mounting clips provide quick, sure, concealed mounting. All mounting hardware is included. State blond or walnut.

SCB-8D—Takes 8" speaker. Maximum speaker depth, 5½". Shipping weight 6 lbs.SCB-8D

SCB-12D—For 12" speaker. Maximum speaker depth, 6½". Shipping weight 8 lbs.SCB-12D

REGULAR WALL BAFFLES

Extremely durable, with rugged construction that not only increases rigidity but also eliminates the possibility of baffle resonance and sound distortion. A durable vinyl cover adds warmth and texture to the appearance. Cane grills provide a modern touch that blends with almost any installation decor. Topping off the appearance of these baffles is the sculptured look which dramatically frames the grill. Clips and all speaker hardware are included. Available in either blond or walnut wood-grained vinyl at the same price. State blond or walnut when ordering.

WB-4/5D—4" or 5" speaker, maximum speaker depth 2¾".
Shipping weight for 2, 3 lbs.WB-4/5D

WB-6D—For 6" speaker, maximum speaker depth 3¾". Shipping weight for 2, 4 lbs.WB-6D

WB-8D—For 8" speaker maximum speaker depth 4¾". Shipping weight for 2, 6 lbs.WB-8D

WB-10D—For 10" speaker, maximum speaker depth 5¾". Shipping weight for 2, 8 lbs.WB-10D

WB-12D—For 12" speaker, maximum speaker depth 6¾". Shipping weight for two, 11 lbs.WB-12D

Regular and Deluxe Baffle Speaker Size

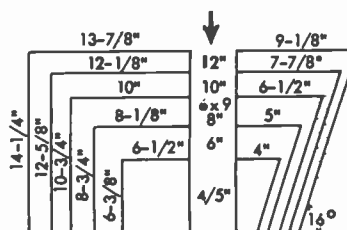

REDUCING RING

R-8/12—to mount 8" speaker in any 12" cabinet, console, or baffle. Made of ¾" plywood with all holes drilled and hardware included. Ship. Wt. 1 lb.R-8/12

Gates Professional Broadcast Microphones



MODEL
G-600

Gates' G-600 is a dynamic, omnidirectional microphone designed for exacting professional applications—ideally suited for film production, recording, FM, AM and TV broadcasting. The high output level and low sensitivity to mechanical shock make it excellent for pass around use in audience participation, for hand-held use by vocalists, or as a lavalier.

SPECIFICATIONS

TYPE: Dynamic.
FREQUENCY RESPONSE: 80-13,000 Hz.
POLAR PATTERN: Omnidirectional.
IMPEDANCE: Low (150 ohms).
OUTPUT LEVEL: -55 dB (0 dB=1 mw/10 dynes/cm²).
FINISH: Fawn charcoal.
CABLE: 18 ft. two-conductor, shielded.
ACCESSORIES: Lavalier neck cord assembly and 310 clamp furnished.

ORDERING INFORMATION

Gates' G-600 microphone -----720-0267



MODEL
G-700

Designed for professional use, FM, AM and TV broadcasting, the G-700 is a dynamic, omnidirectional microphone with outstanding performance characteristics. Wide frequency response, broad pickup range, and light weight make it excellent for TV staging and for pass around use.

SPECIFICATIONS

TYPE: Dynamic.
FREQUENCY RESPONSE: 50-15,000 Hz.
POLAR PATTERN: Omnidirectional, becoming slightly directional with increase in frequency.
IMPEDANCE: Matches all low impedances 50 through 250 ohms. Line balanced to ground and phased.
OUTPUT LEVEL: -57 dB (0 dB=1 mw/10 dynes/cm²).
FINISH: Fawn Charcoal.
CABLE: 18 ft. 3-conductor, shielded.
ACCESSORIES: Model 300 stand clamp (adapts to 1/2" or 5/8"-27 pipe thread), lavalier neck cord.

ORDERING INFORMATION

Gates' G-700 microphone -----720-0268



MODEL
G-800

The G-800 is a dynamic cardioid microphone created especially for professional applications requiring a sharply controlled super-cardioid directional pattern. The G-800 possesses a degree of directional control so effective that frequency response is virtually independent of location of sound source. An easily operated "bass-tilt" switch corrects spectrum balance for longer reach situations.

SPECIFICATIONS

TYPE: Dynamic.
FREQUENCY RESPONSE: 90-13,000 Hz.
POLAR PATTERN: Super cardioid.
IMPEDANCE: Lo-Z (150 ohms nominal).
OUTPUT LEVEL: -56 dB (0 dB=1 mw/10 dynes/cm²).
FINISH: Fawn charcoal.
CABLE: 18 ft. 2-conductor, shielded.
ACCESSORIES: 310 stand adapter, and protective metal carrying case.

ORDERING INFORMATION

Gates' G-800 microphone -----720-0269



MODEL
G-500

Dynamic lavalier microphone. A studio quality unit designed in size and performance for TV and similar applications where a miniature, tailored response microphone is required.

SPECIFICATIONS

RESPONSE: 50 to 12,000 Hz, rising to 6 kHz.
IMPEDANCE: 50-250 ohms.
OUTPUT LEVEL: -59 dB.
POLAR PATTERN: Omnidirectional.
FINISH: Non-reflecting gray with stainless steel grill.
CABLE: 30 foot, 2 conductor shielded.
DIMENSIONS: 3/32-inch diameter, 2 3/4" length.
NET WEIGHT: 2 ounces (less cable).

ORDERING INFORMATION

Gates G-500 dynamic lavalier microphone, with lavalier cord and clip--720-0197

STUDIO AND MICROPHONE CABLE

MIC-100 microphone cable. 2 conductor, stranded 20 AWG. Braided shield. Heavy rubber jacket-----250-0036

SH-2-20 General purpose audio cable. 2 conductor, stranded 20 AWG, with push-back braided shield. Not insulated-----253-0018

8450 Belden miniature audio cable. 2 conductor, 22 AWG. Drain wire, foil shield, vinyl jacket-----253-0054

8451 Belden miniature audio cable. As above, except solid conductor-----253-0059

Professional Broadcast Microphones



MODEL 642

Perfect for television, film, sports, or wherever a highly directional top quality microphone is required. Essentially cardioid unidirectional up to 500 Hz. Highly directional over balance of range. Working distance several times greater than conventional microphones. Excellent for boom use. Must be used with model 356 shock mount. Made by Electro-Voice.

SPECIFICATIONS

TYPE: Dynamic, modified cardioid.
RESPONSE: Flat 30 to 10,000 Hz or choice of 5 to 10 dB low frequency reduction steps by screwdriver adjustment.
IMPEDANCE: 50, 150 or 250 ohms.
OUTPUT LEVEL: -48 dB.
FINISH: Cast aluminum with non-reflecting gray finish.
SIZE: 17 $\frac{7}{8}$ " long; 3 $\frac{3}{8}$ " max. diameter.
WEIGHT: 3 lbs. 4 oz., net.

ORDERING INFORMATION

Model 642 microphone, complete with connector and 20-ft cable.....720-0163
 Model 356 shock mount (required).....720-0155



MODEL RE51

Unique dynamic microphone which allows hands-free use for sports announcing. Lightweight unobtrusive mike assembly clips on eyeglass frame or special headband furnished. Small battery-powered transistor amplifier clips to user's belt, has on/off switch, cough button, battery test lamp, cable connector. Screwdriver slot output level adjustment.

SPECIFICATIONS

TYPE: Dynamic
RESPONSE: 80 to 10,000 Hz.
IMPEDANCE: Matches all low impedance inputs.
OUTPUT LEVEL: -56 dB (Max.)
FINISH: Non-reflecting Black.
SIZE: 1/2" Dia. and 1" Long. Two microphone tubes (3 $\frac{1}{2}$ " and 4 $\frac{1}{2}$ " long) furnished.
WEIGHT: Less than 1/2 oz.

ORDERING INFORMATION

Model RE51 Microphone with two microphone tubes and battery-powered transistor amplifier.....720-0271

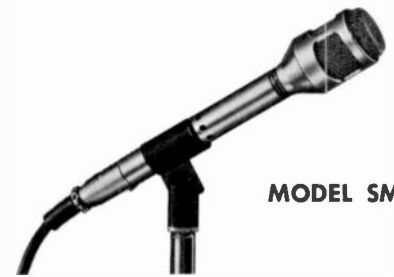

MODEL SM53

The frequency response of the SM53 is essentially flat across its broad frontal pickup area to the top end of the audible spectrum. Its response is natural, without strident peaks, without false coloration. Built-in low end roll-off filter switch. Soft, neutral glare-free finish is ideally suited for on-camera use.

SPECIFICATIONS

TYPE: Dynamic.
FREQUENCY RESPONSE: 70 to 16,000 Hz.
POLAR PATTERN: Cardioid (Unidirectional).
IMPEDANCE: 150 ohms to permit proper match with any input from 50 through 250 ohms.
OUTPUT LEVEL: -58.5 dB.
CABLE: 20-foot two-conductor shielded Broadcast type with Cannon XLR-3-11C connector attached on microphone end.
CONNECTOR: Cannon XLR-3-12 type in microphone.
FINISH: Motte metallic.
NET WEIGHT: (less cable) 8 ounces.

ORDERING INFORMATION

Model SM53 microphone.....720-0272



MODEL RE-15

ORDERING INFORMATION

Model RE-15 microphone, complete with 18-ft. cable, XLR3-11 connector, metal carrying case, and clamp 720-0240

The RE-15, by Electro-Voice, is a dynamic cardioid microphone created especially for the most exacting professional applications. The RE-15 features a degree of directional control so effective that response is independent of angular location of sound source. A super cardioid, this microphone provides the greatest possible rejection of unwanted sounds. An easily operated "bass tilt" switch corrects spectrum balance for boom use and other longer reach situations.

SPECIFICATIONS

FREQUENCY RESPONSE: 60-15,000 Hz.
POLAR PATTERN: Super Cardioid.
IMPEDANCE: 150 ohms.
OUTPUT LEVEL: -55 dB.
DIAPHRAGM: Acoustalloy.
DIMENSIONS: 6 $\frac{1}{8}$ " long, 1 $\frac{3}{8}$ " diam. (3/4" shank dia.).
FINISH: Non-reflecting matte satin nickel.
NET WEIGHT: 8 oz. (not including cable).
CABLE: 18 feet, 2-conductor, shielded, broadcast type cable, synthetic rubber jacketed with Cannon XLR3-11 connector.
ACCESSORIES FURNISHED: Protective metal carrying case, Model 310 clamp.

The Shure SM58 is ideal for remote news, sports, interviews, or wherever the announcer or performer may need to work close to the microphone. Built-in spherical windscreens minimizes or eliminates explosive breath "pop." Wide response with slight presence rise for clean, bright and natural sound. Convenient size and weight for comfortable hand-held use. Slip-in stand adapter included.



MODEL SM58

SPECIFICATIONS

FREQUENCY RESPONSE: 50-15,000 Hz.
POLAR PATTERN: Cardioid.
IMPEDANCE: Dual: 50 and 150 ohms.
OUTPUT LEVEL: -56 dB (0 dB = 1 milliwatt with 10 microbars).
DIMENSIONS AND WEIGHT: 6 $\frac{1}{2}$ " x 2" diam. (max.); 15 oz.

ORDERING INFORMATION

Model SM58, dynamic, cardioid, with built-in windscreens, cable, connector and stand adapter.....720-0228

Four Channel Solid Statesman Remote Amplifier



THE DYNAMOTE "70"

Broadcasting's finest remote amplifier—with such outstanding features as: completely transistorized circuits, designed to allow longer battery life; nine switchable inputs into four mixing channels; illuminated slide rule VU meter; built-in tone oscillator; PA feed; and amplified studio cue.

INPUT CIRCUITS: All mixing is high level. Four microphones feed four preamplifiers. All four preamplifier inputs are balanced and have input transformers as standard equipment. Five other input circuits are switch-selectable into the mixing system. These are: (1) tone oscillator, (2) dual turntable inputs, and (3) two high level inputs.

VERSATILE MIXING: Mixing channel 1 is for a microphone only; channel 2 accommodates a microphone or the built-in tone oscillator; channel 3, one microphone, one turntable or one high level input; and channel 4, one microphone, one turntable, or one high level input.

PROGRAM CUE: A front panel key switches the studio line into the Dynamote program amplifier and PA feed for ease in monitoring studio cues.

AMPLIFIERS: Four preamplifiers, each with transformer input, feed four mixing controls, which in turn feed the program amplifier. Distortion is 1% or less at +18 dBm output (10 dB overload) to the line (after 6 dB isolation pad).

FRONT PANEL CONTROLS: Four mixing channels are operated by specially-designed control knobs, created specifically for remote functions. Knobs are coordinated with the panel slope for positive-feel mixing. Other panel controls are (1) master gain, (2) PA gain control, (3) amplified cue selector control, (4) VU meter light control (the VU meter light operates from separate batteries), and (5) the slide rule VU meter.

REAR PANEL CONTROLS: All secondary switching is at the rear. The tone oscillator, dual turntable and dual high level inputs switch into mixing channels 2, 3 and 4. All input and output circuits connect to a recessed panel with standard XL-type receptacles for the microphones.

VU METER: The VU meter is of the slide rule type with full lateral scale area. Illumination is from two separate batteries, and the meter light may be turned on by pulling out on the PA feed control. Batteries will light the meter for 60 hours. A rear panel switch allows the meter to read either VU or battery condition.

PA FEED: The Dynamote "70" supplies an isolated output adjustable from the front panel to provide 0.5 volts into a 100,000 ohm unbalanced load.

Four Channel Solid Statesman Remote Amplifier

TERMINAL FEATURES: Ducl headphone jacks are provided for operator and director. The amplifier turns on when either headphone plug, or a dummy plug, is inserted. Microphone inputs are standard X1-type connectors. Jacks are provided for two turntables and two high level inputs, and terminals for telephone line and PA feed, and optional AC in-line power supply receptacle.

BATTERY AND AC POWER: Twelve "C" size standard 1½-volt dry batteries power the amplifier for 200 hours. As the amplifier design is based on full gain and output level at rated 1% distortion with as little as 12 volts, the useful life is greatly extended. The optional in-line power supply

operates about 2 volts above the batteries with diodes disabling the battery voltage. If power fails for any reason, batteries automatically take over without evidence in the program.

DYNAMOTE "70" PARALLELING: Any reasonable number of units may be paralleled for a large field broadcast. Rear panel jacks permit the feeding of additional Dynamotes directly to the mixer bus of the master Dynamote without losing a mixing channel on the master unit. For example, six Dynamotes will provide 24 microphone inputs—yet require only about 76 inches of width, or about 38 inches if two units are stacked on top of one another.



Rear view, Dynamote "70".

SPECIFICATIONS

OPERATING MODE: Single channel monaural.

MIXING CHANNELS: Total four; three switchable for other functions.

INPUT CIRCUITS: Channel 1, microphone input; Channel 2, microphone and tone oscillator; Channel 3, microphone, turntable and high level input; Channel 4, microphone, turntable and high level input. Input levels: Microphones -60 dBm, high level 600 ohm circuits rated -15 dBm to +8 dBm. Turntable inputs have RIAA equalization and accept standard VR-type phono cartridges without further preamplification.

OUTPUT CIRCUITS: 1 program line, 1 isolated PA feed, 1 mixer multiple output, 2 headphone monitoring jacks.

SOURCE IMPEDANCES: Microphones—30/50 and 150/250 ohms, balanced or unbalanced, with input transformers on all channels. High Level—600 ohms, unbalanced. (-15 dBm to +8 dBm input level.) Turntables—6200 ohms for VR type pickup cartridge equalization. Mixer Multiple Input—600,000 ohms.

INPUT IMPEDANCE: Preamplifiers, 1500 ohms or higher, 30-15,000 Hz.

LOAD IMPEDANCES: Program Output—600/150 ohms, balanced or unbalanced, (factory connected for 600 ohms). PA Feed—100,000 ohms unbalanced. Amplifier Paralleling—600,000 ohms bridging.

OUTPUT IMPEDANCE: Program Amplifier, 490 ohms nominal.

GAIN: Microphone input to line output, 97 dB \pm 2 dB.

RESPONSE: \pm 1½ dB, 25 to 16,000 Hz.

DISTORTION: 1.0% maximum, 30 to 15,000 Hz @ +18 dBm output (after 6 dB isolation pad).

NOISE: 62 dB or better below +8 dBm output with -60 dBm input. (Relative input noise -122 dBm.)

BATTERY COMPLEMENT: 12 Size "C" 1½ volt cells for amplifier. 2 Size "D" 1½ volt cells for VU light.

BATTERY LIFE: Approximately 200 hours for amplifier pack, and 60 hours for meter light.

EXTERNAL POWER: Four terminal plug on rear accepts optional 994-6435 in-line power pack for 117 volt AC operation.

CABINET DATA: Size: 12¾" wide, 4¾" high, 12½" deep. Finish: Charcoal gray vinyl with satin chrome trim accents. Weight: 12¼ pounds, including batteries.

SHIPPING DATA: Packed Weight: Domestic, 16 lbs.; Export, 35 lbs, Cubage, 2 cubic feet.

ORDERING INFORMATION

Dynamote "70" 4-channel remote amplifier, complete but less male microphone connectors and batteries.....	994-6434
Microphone plugs, male (four required).....	610-0182
Battery complement for Dynamote "70".....	994-6441
Vinyl cover with accessory pocket.....	725-0128
In-Line power supply for 117 volt operation.....	994-6435

Three Channel Solid Statesman Remote Amplifier



THE ATTACHE "70"

Unexcelled remote pickup performance is provided by this stylish, fully-transistorized audio remote amplifier. Attache "70" provides: three microphone channels with one magnetic phono and one high level input; 200-hour battery life; optional in-line AC power supply; slide rule VU meter; and superior performance with wider response, lower distortion.

INPUTS: Three channels, all with preamplifiers, include: channel 1, microphone only with input transformer; channel 2, microphone tone oscillator or high level input; channel 3, microphone or phono cartridge. The depth of only 12½" allows switching of secondary circuits such as turntable and high level inputs at the rear.

TOTAL FACILITY: The front panel contains specially styled mixing knobs for "touch control" fading, master gain control and isolated PA feed control. The optional power supply is diode protected from the batteries when in use. If power fails, batteries take over automatically.

PERFORMANCE: Distortion is 1% or less at +18 dBm output, with an extended response of 25-16,000 Hz.

DESIGN: The Attache "70" is smoothly styled in lightweight aluminum and vinyl clad steel. A snap-on cover protects mixing controls when the remote is not in use.



The rear panel shows the logical grouping of line terminations.

SPECIFICATIONS

OPERATING MODE: Monaural.

MIXING CHANNELS: 3, with channels 2 and 3 switchable to other functions.

INPUT CIRCUITS: Channel 1, microphone only, includes input transformer; Channel 2, microphone or 400 Hz tone oscillator or high level input; Channel 3, microphone or turntable.

OUTPUT CIRCUITS: Program line for 600/150 ohms, PA feed, and headphone monitoring jack.

SOURCE IMPEDANCES: Microphones, 30/50 ohms or 150/250 ohms. Turntable, 6200 ohms for VR pickup cartridges and RIAA equalized. High level, 600 ohms unbalanced -15 dBm to +8 dBm.

GAIN: Microphone input to program line output is 94 dB \pm 2 dB.

RESPONSE: \pm 1.5 dB 25-16,000 Hz.

DISTORTION: Less than 1% at +18 dBm output (10 dB overload) into the program line. (6 dB isolation pod incorporated).

NOISE: 62 dB below +8 dBm output with -60 dBm input. (Relative noise -122 dBm).

BATTERIES: 12 standard 1½-volt type "C" cells for amplifier and 2 standard 1½-volt type "D" cells for meter light.

AC POWER: Gates In-Line 994-6435 power pack for 117 volt, 50/60 Hz.

CABINET DATA: 10" wide, 4¾" high, 12½" deep. Finish: Charcoal gray, black and satin chrome. Net weight with batteries, 10 lbs. Packed weight: Domestic 20 lbs. Export 35 lbs. Cubage: 1.5 cubic feet.

ORDERING INFORMATION

Attache "70" 3-channel remote amplifier, less batteries.....	994-6433
Microphone connector, 3 required.....	610-0182
Battery Kit complete.....	994-6441
Optional microphone input transformer.....	478-0285
Power Supply, In-Line type.....	994-6435
Pliable vinyl cover.....	725-0127

Two Channel Solid Statesman Remote Amplifier



THE COURIER "70"

Studio console quality in an all-transistorized audio remote amplifier no larger than a modern camera carrying case. Perfect for inexpensively handling those many remote situations where normally no more than two microphones are required. Premium features include: separate preamplifier for each mixing channel; slide rule illuminated VU meter; long battery life; optional in-line AC power supply; 1% or less distortion at high output levels; 25-16,000 Hz frequency response; and total weight of 9 pounds with batteries.

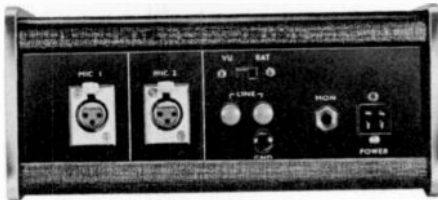

PERFORMANCE: The outstanding performance of the compact Courier "70" is a result of extensive product research. At full-rated +18 dBm output, distortion is less than 1%, even when full battery power is down more than 30%. Courier "70" battery life is normally in excess of 200 hours. Front panel controls in addition to mixers are: master gain control, meter light switch and slide-rule VU meter (which also checks battery condition).

POWER SUPPLY: An optional in-line AC power supply is diode protected from the batteries when in use. If power fails, change-over to batteries is instant and automatic. The amplifier turns on with the insertion of headphone plug or dummy plug.

STYLING: Sleek, flight-line styling in charcoal gray vinyl and satin aluminum, with special mixing knobs designed for "touch control" fading.

SPECIFICATIONS

OPERATING MODE: Monaural.

MIXING CHANNELS: 2 for microphones.

OUTPUT CIRCUITS: 1 program line, 1 headphone monitor.

SOURCE IMPEDANCE: Microphone 30/50 to 150/250 ohms, unbalanced. Input transformers optional.

LOAD IMPEDANCE: 600/150 ohms, balanced or unbalanced. Factory connected for 600 ohms.

MAXIMUM INPUT LEVEL: -35 dBm into either microphone channel.

MAXIMUM OUTPUT LEVEL: +18 dBm to program line. 6 dB line isolation pad built-in.

GAIN: Microphone input to line output, 94 dB \pm 2 dB.

RESPONSE: \pm 1½ dB, 25 to 16,000 Hz.

DISTORTION: 1% maximum, 30 to 15,000 Hz @ +18 dBm output.

NOISE: 62 dB or better below +8 dBm output with -60 dBm input. (Relative input noise -122 dBm).

BATTERIES: 12 size "C" cells for amplifier. 2 size "D" cells for VU light.

BATTERY LIFE: 200 hours or more for amplifier pack, and 60 hours for meter light.

AC POWER: Four-terminal plug on rear accepts external 994-6435 in-line power pack for 117 volt AC operation.

CABINET DATA: Size: 10" wide, 4½" high, 12½" deep. Finish: Charcoal gray vinyl with satin chrome trim. Weight: 8¾ lbs., including batteries. Packed weight (domestic), 14 lbs., (export), 32 lbs. Cubage, 1.5 cu. ft.

ORDERING INFORMATION

Courier "70" 2-channel remote amplifier, less batteries.....	994-6432
Microphone connectors, male (2 required).....	610-0182
Battery kit complete.....	994-6441
Optional microphone input transformer.....	478-0285
Power Supply, In-Line type for 117 volt AC operation.....	994-6435
Vinyl cover, with accessory pocket.....	725-0127

Single Channel Remote Or Microphone Amplifier



THE UNIMOTE "70"

Gates Unimote "70" is a transistorized single channel audio remote or utility amplifier, featuring compact, functional and attractive styling. Battery life is 300 hours or over (using standard "C" size flashlight cells). If AC power operation is desired, the in-line power unit is available. Smooth change-over to batteries occurs instantly and automatically in case of power failure. The printed circuit amplifier has less than 1% distortion at +18 dBm output.

DESIGN: All controls and terminations are on the front of the unit. Operation is of the turn on—turn off type after the gain control setting is determined. Unimote "70" may be desk mounted, attached to the wall by screws, mounted under a lectern or pulpit, or carried as easily as a camera case. This compact amplifier is a natural for church remotes, weather bureau, or other "set and forget" installations.

SPECIFICATIONS

OPERATING MODE: Monaural.

INPUT CIRCUIT: One 30/50 or 150/250 ohm microphone.

OUTPUT CIRCUITS: One program line, one headphone monitor.

LOAD IMPEDANCE: 600/150 ohms, balanced or unbalanced (factory connected for 600 ohms). 6 dB isolation pad self-contained.

GAIN: Microphone input to line output, 82 dB, ± 2 dB.

OUTPUT LEVEL: +18 dBm to program line.

RESPONSE: $\pm 1\frac{1}{2}$ dB 30 to 15,000 Hz.

DISTORTION: 1% maximum, 30 to 15,000 Hz @ +18 dBm output.

NOISE: -122 dBm relative input noise.

BATTERIES: 12 size "C" cells.

BATTERY LIFE: Approximately 300-400 hours, average duty cycle.

AC POWER: External 994-6435 in-line power pack for 117 volt AC operation.

CABINET DATA: Size: 10" wide, 5 $\frac{1}{4}$ " high, 4 $\frac{1}{4}$ " deep. Finish: anodized aluminum front panel with charcoal gray Royalite case. Weight: 5 lbs., including batteries. Shipping weight: packed 6 $\frac{1}{2}$ lbs. Cubage: 1 cu. ft.

ORDERING INFORMATION

Unimote "70" single channel remote amplifier, less batteries.....	994-6431
Microphone connector, male (1 required).....	610-0182
Battery complement for Unimote "70".....	994-6441
Optional input transformer.....	478-0285
In-line power supply for 117 volt operation.....	994-6435

IN-LINE POWER SUPPLY

Compact accessory power unit for any of Gates Solid-State-man remote amplifiers: Dynamote "70", Attache "70", Courier "70", and Unimote "70". In-Line type with six-foot line cord and four-foot output cord terminating in mating plug for all remote units. For 117 volt, 50/60 Hz operation of Gates remote amplifiers in permanent installations. Dual supply design provides power for amplifiers and VU meter illumination. Easily carried in accessory pocket of vinyl remote amplifier covers.

SPECIFICATIONS

POWER INPUT: 117 volts, 50/60 Hz.

POWER OUTPUT: 4 prong plug, mates with remote amplifier.

SIZE: 5 $\frac{1}{2}$ " x 4" x 1 $\frac{3}{4}$ " case. DC supply cable, 48" long. AC power cord, 72" long.

FINISH: Charcoal gray vinyl-clad steel.

WEIGHT: 2 lbs. net.

ORDERING INFORMATION

In-line Power Supply, complete.....	994-6435
-------------------------------------	----------



All Purpose Remote Amplifier

MODEL M-6600

A compact, lightweight remote amplifier, the M-6600 Solid-Statesman provides fine remote performance, and makes an ideal all-purpose amplifier. Battery operated and 100% self-contained, it may be quickly installed to fill many studio requirements. Use it to temporarily replace a faulty program amplifier, as a preamplifier for cartridge or reel tape recorders, or as one of several feeder amplifiers for the extravaganza type of pickup. These are just a few of the possibilities.

The housing is all aluminum, and ribbed for added strength, providing complete electrical isolation for the floating printed board internal assembly. The gain control and combined on-off switch are on one end of the amplifier, and the microphone receptacle, phone jack, and line terminals are on the opposite end. The output transformer is "T" pad isolated and wired for 600 ohms, but internally changeable to 150 ohms where desired. For the installation requiring a number of widely spaced microphones, the use of the M-6600 amplifier permits connection to the central control point with unshielded telephone type wire, and individual gain adjustment for each microphone.

Two 8.4 volt standard mercury batteries, available nationwide, provide about 50 hours of service. Total weight is less than 2½ pounds with batteries and microphone connector.



SPECIFICATIONS

GAIN: 82 dB \pm 3 dB at 150/250 ohms source impedance. 77 dB \pm 3 dB at 50 ohms source impedance.

NOTE: With gain control setting reduced about 14 dB, this permits 68 dB operating gain for correct output level.

RESPONSE: 30-15,000 Hz \pm 2 dB.

DISTORTION: 1% maximum at +18 dBm, 30-15,000 Hz.

NOISE: -122 dBm relative input noise, 30-15,000 Hz.

BATTERIES: Two 8.4 volt mercury Eveready E146X or Burgess H146X. Expected life at maximum amplifier performance, 50 hours under average programming.

SOURCE IMPEDANCE: 30/50 or 150/250 ohms unbalanced.

LOAD IMPEDANCE: 600/150 ohms balanced, wired for 600 ohms.

SIZE AND FINISH: 8¼" long, 2½" wide, 3" high. Finish: Natural aluminum.

WEIGHT: Net, with male connector, 2 lbs. Shipping weight 8 lbs.

ORDERING INFORMATION

Amplifier (less batteries).....994-6600
Battery.....66C-0022

Professional Transcription Turntables



This cut-away illustration of a Gates turntable shows the fine machining and workmanship in the equipment. Oilite bearings are used at all bearing points, including the large center spindle bearing. Speed shift linkages are through monoball self-aligning bearings for smooth, silent, trouble-free operation. There are no belts, planetary drives or gear trains to wear. Shift speeds to 78, 45 or 33½ rpm by simply moving shift lever to the desired index point. Then touch the mercury-type switch to either start or stop. Complete one-hand operation leaves the other hand free for cueing or control boards.

PRECISION ENGINEERED

Recent advances in recording techniques, as well as stereo requirements, now place stronger demands on today's reproducing equipment. To meet these improved performance standards, Gates offers two outstanding turntables (one 16-inch model, one 12-inch model), designed to reduce rumble to an all-time low, without the sacrifice of quick cue.

The heart of Gates turntable design is a drive hub, which is part of the turntable platter—and about one-half the radius of a 45 rpm disc. A single idler wheel for all speeds is floating and self-aligning—and a 600 rpm hysteresis synchronous motor with 3-speed pulley, engages the idler wheel to the inner hub.

The combination of lower motor speed (one-third that of other models) and a drive located inside the playing surface, results in remarkably low rumble.

Speed change is exact and functionally correct. All three speeds shift across a single indexed plate. A mercury-type start/stop switch illuminates when on. The smooth felt platter surface offers slip-cueing if desired. A captive pop-up spindle is provided for 45 rpm discs.

Every Gates turntable is totally hand-assembled, micrometer checked under rigid quality-control standards and then individually tested in our laboratory for wow, flutter, and speed consistency.

As Gates turntables are precision machined devices they are not the lowest in initial cost, but are far less expensive on the basis of per-hour cost.

DRIVE DESIGN PRINCIPLE

OLD METHOD

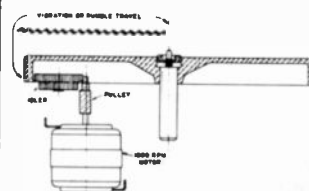

Rim drive turntables, as the word implies, drive against the outer rim of the platter. Vibration, commonly called rumble, is returned to the center spindle, or bearing, across the entire playing surface of the platter. This type of drive usually requires an 1800 rpm motor for proper speed ratios. The greater the motor speed, the greater the vibration. Also, higher motor speeds raise the audio frequency of this vibration or rumble.

GATES METHOD

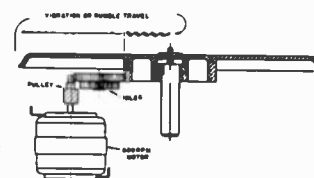

In both the 12- and 16-inch Gates turntables, the drive is against a solid inner hub, away from the usable playing surface of the platter. Likewise, any minute vibration or rumble is pushing against the center bearing instead of pulling away as in outer rim drive turntables. With this exclusive drive system, a 600 rpm hysteresis synchronous motor is used. Lower motor speed assures lower vibration or rumble. The lower speed substantially drops the audio frequency of this much-lower motor vibration so that nearly all of the rumble is in the sub-audible spectrum.

Professional Transcription Turntables—16-Inch



MODEL CB-500

Gates CB-500 is the most widely used 16-inch turntable in the broadcasting industry. Designed for continuous 24-hour commercial service, this turntable is ruggedly constructed to meet the strain of any control room operation, while maintaining its excellent quality of performance.

Time proven features include heavy machined aluminum platter, rubber-shock-mounted cast aluminum chassis, oilite hub bearing, self-centering neoprene idler wheel, monoball self-aligning speed shift bearings, and a functional speed selector mechanism. (Order pickup arm separately.)

SPECIFICATIONS

CHASSIS SIZE: 21¼" x 21¼" x 1½".

MOTOR HANG BELOW BOTTOM OF CHASSIS: 4¾".

CONSTRUCTION: Both platter and base of machined aluminum.

FINISH: Beige-gray with escutcheon in black and turntable platter cover in heavy gray felt.

PLATTER SIZE: 17".

STROBOSCOPE: Built-in on platter for all three speeds.

CENTER SPINDLE: Spring-locking type, snaps up for 45 rpm hub, locks down for smaller-spindle records.

CENTER BEARING: 1" diameter hardened steel, rotates in oilite bearing.

MOTOR: Hysteresis synchronous, single phase, 600 rpm, with 40°C temperature rise.

CUEING: At 33½ rpm, ½ turn. At 45 rpm, ¼ turn. At 78 rpm, 1¼ turn.

NOISE OR RUMBLE: At 33½ rpm, rated -45 dB. At 45 rpm, rated -40 dB. At 78 rpm, rated -35 dB.

WOW: Rated 0.1% at 33½ rpm, capable .08%.

FLUTTER: Rated 0.07% at 33½ rpm, capable .05%.

MOTOR START: Rocker-type illuminated mercury switch.

IDLER WHEEL: Special shear action neoprene, self-aligning.

SPEED CHANGE: To 33½, 45, or 78 rpm by single indexed lever control.

POWER: 117 volts, 60 Hz, 35 watts. (50 Hz available, see below.)

WEIGHT: Net: 34 lbs. Packed: domestic, 45 lbs.; export, 70 lbs. Cubage: 6 cubic feet.

ORDERING INFORMATION

CB-500 16-inch transcription turntable, chassis only, for 60 Hz.....994-5739-003

CB-500A 16-inch transcription turntable, chassis only, for 50 Hz.....994-5739-004

Professional Transcription Turntables—12-Inch



MODEL CB-77

Gates CB-77 is a professional 12-inch transcription turntable, with the same unique design principles as its companion 16-inch model. In the 12-inch CB-77 chassis will be found the same inner hub drive system, the same convenient speed change system, the same illuminated rocker arm on-off switch, etc. The only difference is the reduced size, affording broad-

casts a more compact turntable arrangement for today's busy control room, where space is at a premium.

The chassis is ready for you to attach the pickup arm of your choice (order separately), and is designed for 33 $\frac{1}{3}$, 45 and 78 rpm speeds.

SPECIFICATIONS

CHASSIS SIZE: 16" x 16" x 1 $\frac{1}{16}$ ". Motor hang below bottom of chassis: 5 $\frac{3}{4}$ ".

CONSTRUCTION: Platter and base of machined aluminum.

FINISH: Beige-gray with escutcheon in black and turntable platter cover in heavy gray felt.

PLATTER SIZE: 13 $\frac{3}{8}$ ".

STROBOSCOPE: Built-in for all 3 speeds.

CENTER BEARING: 1" diameter hardened steel, rotates in oilite bearing.

CENTER SPINDLE: Spring-locking type snaps up for 45 rpm, locks down for smaller spindle records.

MOTOR: Hysteresis synchronous, single phase, 600 rpm, with 40°C temperature rise.

CUEING: At 33 $\frac{1}{3}$ rpm, $\frac{1}{8}$ turn. At 45 rpm, $\frac{1}{4}$ turn. At 78 rpm, 1 turn.

NOISE OR RUMBLE: At 33 $\frac{1}{3}$ rpm, rated -45 dB. At 45 rpm, rated -40 dB. At 78 rpm, rated -35 dB. (Meets or exceeds NAB specifications for stereophonic reproduction.)

WOW: 0.1% maximum, capable .08%.

FLUTTER: .07% maximum, capable .05%.

MOTOR START: Rocker-type illuminated mercury switch.

IDLER WHEEL: Special shear action neoprene, self-aligning.

SPEED CHANGE: To 33 $\frac{1}{3}$, 45 or 78 rpm by single indexed lever control.

POWER: 117 volt, 60 Hz, 35 watts. (50 Hz model available, see below.)

WEIGHT: Net: 30 lbs. Packed: domestic, 40 lbs.; export, 65 lbs. Cubage: 3.6 cubic feet.

ORDERING INFORMATION

CB-77 12-inch transcription turntable, chassis only, 60 Hz.....994-5798-005

CB-77A 12-inch transcription turntable, chassis only, 50 Hz.....994-5798-006

Turntable System Components

16-INCH SYSTEM COMPONENTS

To make up a 16-inch turntable system, the following components are recommended:

MONOPHONIC SYSTEM

CB-500 turntable, 60 Hz (50 Hz available).....994-5739-003
 Gray 208-S 16" viscous damped tone arm.....723-0099
 or
 Gray 306 16" Micro-Trak tone arm.....723-0269
 Shure M-44-7 stereo dynetic cartridge w/.0007" diamond stylus 723-0236
 M-6244 equalized turntable preamplifier, transistorized.....994-6244
 NOTE: If Gray 208-SG tone arm is desired (723-0153), a General Electric VR-II turn-around cartridge should be used (723-0017).

STEREOPHONIC SYSTEM

CB-500 turntable, 60 Hz (50 Hz available)..... 994-5739-003
 Gray 208-S 16" viscous damped tone arm.....723-0099
 or
 Gray 306 16" Micro-Trak tone arm723-0269
 Shure M-44-7 stereo dynetic cartridge w/.0007" diamond stylus 723-0236
 M-6244 equalized turntable preamplifier, transistorized,
 (two required)994-6244
 NOTE: To order cabinet, see below.



12-INCH SYSTEM COMPONENTS

The following components are recommended to make up your 12-inch turntable system.

MONOPHONIC SYSTEM

CB-77 turntable, 60 Hz (50 Hz available).....994-5798-005
 Gray 206-S 12" tone arm.....723-0259
 or
 Gray 303 12" Micro-Trak tone arm.....723-0268
 Shure M-44-7 stereo dynetic cartridge w/.0007" diamond stylus 723-0236
 M-6244 equalized turntable preamplifier, transistorized.....994-6244
 NOTE: If Gray 206-SG 12" tone arm is desired (catalog number 723-0250), order General Electric VR-II turn-around cartridge (catalog number 723-0017).

STEREOPHONIC SYSTEM

CB-77 turntable, 60 Hz (50 Hz available)..... 994-5798-005
 Gray 206-S 12-inch tone arm.....723-0259
 or
 Gray 303 12" Micro-Trak tone arm723-0268
 Shure M-44-7 stereo dynetic cartridge w/.0007" diamond stylus 723-0236
 M-6244 equalized turntable preamplifier, transistorized,
 (two required)994-6244
 NOTE: To order cabinet, see below.



DUAL TURNTABLE CABINET

Beautifully styled, and dimensioned to accommodate either 12- or 16-inch Gates turntables. For description, see Page 201.

Dual turntable cabinet.....994-6449

SINGLE TURNTABLE CABINET

Fits any decor. Accommodates either 12-inch or 16-inch Gates turntable. For description, see page 201.

Single turntable cabinet.....994-6448

Transcription Tone Arms and Pickups



12" AND 16" MICRO-TRAK TONE ARMS

Especially designed for stereo, this durable arm will track distortion-free at micro-pressures of 1/10 gram. A new material never before used in a tone arm, wood impregnated with epoxy resins, was selected for this arm to achieve the extremely low tracking force and very low resonance characteristics. Sapphire bearings floating in a unique elastomer ring isolate the tone arm from its mounting and produce a tone arm with virtually no vertical friction.

Available for 12" and 16" turntables, this arm will accept any broadcast type stereo cartridge.

Gray 303 Micro-Trak 12" tone arm.....723-0268
 Gray 306 Micro-Trak 16" tone arm.....723-0269



12" AND 16" TONE ARMS

Models 206-S and 208-S viscous damped tone arms come with slide and modular weights for mounting single play stereo or monophonic cartridges. Designed specifically for the GE turnaround cartridges, the models 206-SG and 208-SG have a slot cut out in the front of the arm to clear the stem of the GE cartridge, and are specially balanced for this cartridge. Accessory weights are also available.

Gray 206-S, 12" viscous damped tone arm.....723-0259
 Gray 206-SG, 12" viscous damped tone arm for turnaround cartridge.....723-0250
 Gray 208-S, 16" viscous damped tone arm.....723-0099
 Gray 208-SG, 16" viscous damped tone arm for turnaround cartridge.....723-0153

STEREOPHONIC PICKUP CARTRIDGES



Model M44-7 stereo dynamic cartridge is recommended for faithful reproduction of both stereophonic and monophonic recordings. It offers superior stereo separation, smoother response, and is designed to complement the 15° effective cutting angle now being used on stereo recordings. The easily changed styli may be interchanged for various types of recordings.

SPECIFICATIONS

FREQUENCY RESPONSE: 20 to 20,000 Hz.
 CHANNEL SEPARATION: More than 25 dB at 1000 Hz.
 OUTPUT: 9 millivolts per channel at 1000 Hz at 5 cm/sec.
 LOAD IMPEDANCE: 47,000 ohms per channel.
 TRACKING: 1.5 to 3 grams.
 STYLUS: Features "no scratch" retractable design.
 INDUCTANCE: 680 millihenries.
 D. C. RESISTANCE: 650 ohms.
 MOUNTING: Standard 1/2" mounting center.
 WEIGHT: 7 grams net.

ORDERING INFORMATION

Shure M44-7 stereo Dynetic Cartridge with 0.0007" diamond stylus.....723-0236
 Replacement Stylus N-44-7 0.0007" diamond.....723-0237



The Model M93E Hi-Track Elliptical Cartridge is an outstanding performer in tone arms that track in the 1 1/2 to 3 grams range. While capable of reducing high frequency splatter, the M93E is rugged enough to withstand continued back-cueing.

M93E Hi-track Elliptical Cartridge 1 1/2 to 3 grams tracking.....723-0306
 N-93E Elliptical replacement stylus.....723-0307



The M75-6 has trackability specifications that assure you that this cartridge will track grooves cut to the theoretical limits of recording cutting velocity . . . throughout the audible spectrum. Ideal for use in upgrading tone arms.

M75-6 Hi-track Spherical Stylus Cartridge for 1 1/2 to 3 grams tracking.....723-0308
 N75-6 replacement stylus.....723-0309

Transistorized Turntable Preamplifiers



MONOPHONIC — STEREO

Single-channel preamplifier designed for use in broadcasting, recording, and general sound requirements where low distortion and exacting frequency response characteristics are demanded. Featuring self-contained power supply and transformer output. For stereo operation use two units. The input impedance of 47,000 ohms makes the M-6244 compatible with virtually all magnetic cartridges (including stereo).

SPECIFICATIONS

INPUT: 47,000 ohms.

OUTPUT: Adjustable from -22 dBm to -12 dBm with 12 mV input.

RESPONSE: Within ± 1 dB of RIAA/NAB standard curve. Additional high-frequency, roll-off filter position provided.

DISTORTION: Less than 0.5% at normal levels (-22 dBm to -12 dBm output). Less than 1.0% at 10 dB overload (above 12 mV input).

NOISE: 68 dB or lower, below -12 dBm output (with 12 mV input).

LOAD IMPEDANCE: 600 ohms or 150 ohms, balanced or unbalanced.

MAXIMUM OPERATING AMBIENT TEMPERATURE: +60°C (+140°F).

POWER: 115 volts, 50/60 Hz, 1 watt.

MOUNTING: Two holes for mounting to Gates turntable or inside of any cabinet. May be mounted in any position.

SIZE: 2 $\frac{3}{16}$ " wide, 8 $\frac{1}{2}$ " long, 2 $\frac{1}{8}$ " high.

WEIGHT AND CUBAGE: Net weight, 1 $\frac{1}{4}$ lbs. Packed weight, 8 lbs. Cubage, 1 cubic foot.

ORDERING INFORMATION

Transistor equalized turntable preamplifier (order two for stereo).....994-6244

WIRE — AUDIO



Gates Radio Company has a complete line of quality wire and cable to fill any broadcasting or communication need. Cable for every purpose—shielded, unshielded, multi-conductor, power, audio system and more.

The following wire recommended for microphone and shielded power supply cable has high abrasion resistance and extra flexibility. It is especially suited for installations where cable must take tight bends or lie perfectly flat. The cable has tinned conductors with tinned copper-braided shield.

8410 Belden single conductor shielded, black rubber jacket.....	250-0059
8412 Belden (Gates MIC-100) 2 conductor stranded 20 AWG Braided shield cotton wrap heavy rubber jacket.....	250-0036
8428 Belden neoprene jacketed heavy duty mic cable. 2 conductor 18 AWG braided shield.....	253-0024
SH-2-20 2 conductor stranded 20 AWG, 2/push back braided shield not insulated.....	253-0018
1261 2 conductor stranded 24 AWG, braided shield, not insulated.....	253-0001

The following are 2 conductor, color-coded broadcast audio cables which come in standard and miniature size. Type 8437 has a braided, tinned copper shield; types 8450 and 8451 have spiral-wrap aluminum-Mylar shields. All types have tinned drain wires. Available in 100, 500 or 1000 foot spools. Average shipping weight per 100 feet, 2 $\frac{1}{2}$ lbs. Type 8451 available in black vinyl or gray jacket.

8437 Belden 2 conductor 22 AWG solid, w/drain wire and braided shield, black vinyl jacket.....	253-0062
8450 Belden miniature audio cable 2 conductor, 22 AWG solid, drain wire, foil shield vinyl jacket.....	253-0054
8451 Belden miniature audio cable, 2 conductor 22 AWG stranded, drain wire, foil shield, vinyl jacket.....	253-0059
Cable 6 conductor, 3 pair, wire size 22 AWG.....	250-0081
Wire 18 AWG stranded, yellow.....	252-0247
High voltage wire 8 AWG 40 kV.....	255-0006

Modular Audio Equipment Cabinets



"Combo" desk system includes two dual pedestals (M-6449) and table top section (M-6450). Electronic equipment shown to demonstrate a typical installation.

MODERN, FLEXIBLE STYLING

The fullest flexibility of custom cabinetry, with the economy of standard production units, combine to offer broadcasters a totally modern concept in control room desks. Beautifully styled in walnut grain and textured Formica, these desks have the appearance of fine furniture, and the strength and durability to last for years.

"Building blocks" of single-width pedestal, double pedestal, uniform table top sections, plus two decorator leg sections can be assembled in dozens of configurations. Pedestal base sections have removable grill front and cabinet-finish rear doors that remove to reveal standard 19" rack mounting rails.

Cartridge tape equipment, leveling amplifiers, jack fields, etc., may be mounted for operator convenience. The interior of each cabinet is also finished, so cabinets may be used for disc or tape storage by removing the panels entirely.

When used with turntables, the pedestals conform to NAB standards for transcription cabinets. For console wiring, a cable trough is concealed under the table top section near the rear. The "horseshoe" or "combo" configuration shown above provides an attractive and functional control center in keeping with the aesthetic beauty of modern communications equipment.

ORDERING INFORMATION

Combo desk system, complete with 2 double pedestals and top section. For specifications on individual items that make up the system, see Page 201. Console, microphone and turntables pictured above are not included.

994-6454

Modular Audio Equipment Cabinets

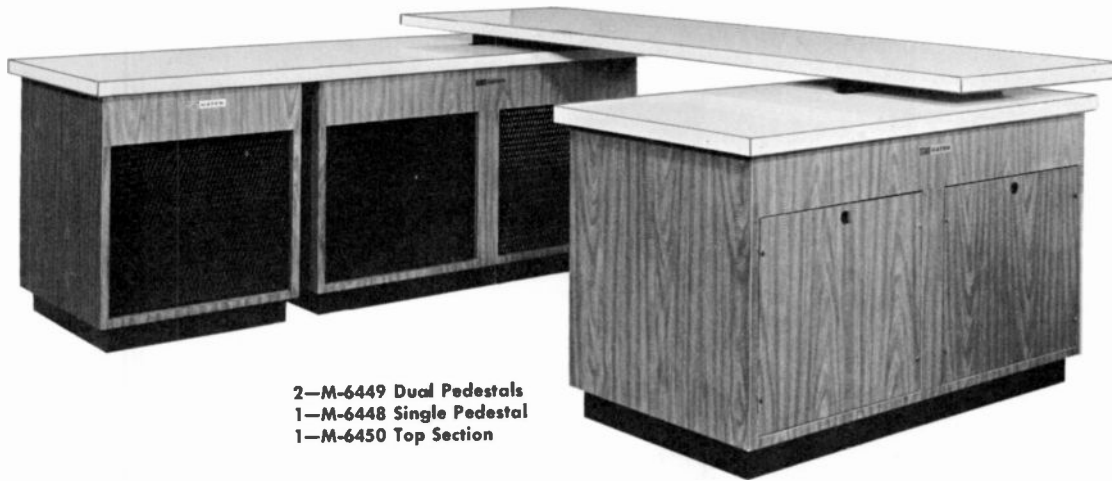

2—M-6449 Dual Pedestals
1—M-6448 Single Pedestal
1—M-6450 Top Section

WIDE VARIETY OF COMBINATIONS

By choosing combinations of modular desk components, large and complex control room arrangements are made possible. Shown above is a desk system with one extended "wing". This could easily accommodate an extra turntable, two-way radio, or other miscellaneous equipment. Or, the top can be left bare for counter space, with the grilled area used for mounting any rack-mounted equipment such as reel-to-reel recorders, utility amplifiers, etc.

Development of this tasteful equipment cabinetry encompassed human engineering studies, styling analysis and comparison with established mechanical specifications where available. For instance, the turntable pedestals conform to the height standards of the NAB, and are four inches lower than the desk top section for comfortable operation. Color and texture of the cabinets blend easily with any studio color scheme and provide a pleasant setting in keeping with the trend of modern office furniture.

Many interesting variations in control room desks allow tailor-made arrangements for specific station operations. The single pedestal, serving as a right hand desk base, may also provide rack space for Criterion tape cartridge equipment, reel-to-reel recorder or storage. All pedestals have sturdy black steel bases with leveling feet. Expanded metal grill or finished access door removes to reveal 16" of standard 19" rack space. Double and single leg assemblies are of sturdy 1" satin chrome square steel tubing with leveling feet. Both 12" and 16" Gates turntables and all types of speech input consoles may be used with these cabinets.

For ordering information and specifications on pedestals, top and leg assemblies see Page 201.



1—M-6449 Dual Pedestal
1—M-6450 Top Section
1—M-6456 Double Leg Assembly
1—M-6455 Single Leg Assembly

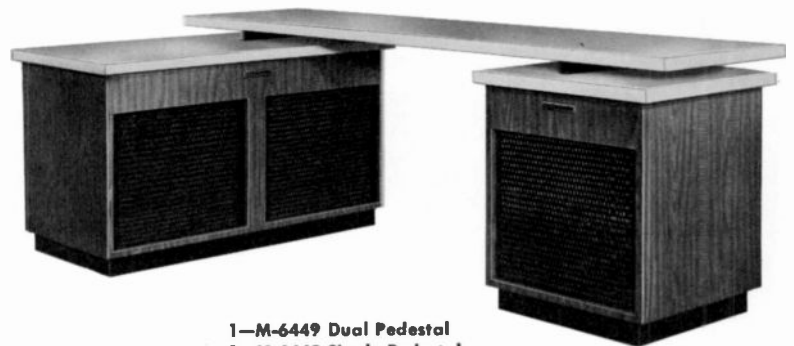

1—M-6449 Dual Pedestal
1—M-6448 Single Pedestal
1—M-6450 Top Section

Modular Audio Equipment Cabinets



1—M-6449 Dual Pedestal
1—M-6448 Single Pedestal
1—M-6450 Top Section

TYPICAL SELECTIONS

Gates modular equipment cabinetry shown here serves to suggest how a modular system may be assembled to fit specific studio requirements. Note the convenient storage area provided by the double and single turntable pedestals.

In addition to modular studio furniture Gates also offers the world's most complete selection of standard production audio equipment. A Gates District Manager will be happy to discuss

particular programming requirements with you, and recommend a complete control room package suited to your individual needs.

For ordering information and specifications on audio equipment cabinetry items, see Page 201. Console, turntables, microphone, and cartridge tape equipment shown here are not included with the cabinet equipment.



M-6449 Double Turntable Pedestal.



M-6448 Single Turntable Pedestal.

Modular Audio Equipment Cabinets



SINGLE PEDESTAL, M-6448

Mounts one 12" or 16" turntable. 16" rack mount space front with expanded metal grill. 16" rack mount space rear with wood-grain door. Constructed of 3/4" solid flake board, laminated with Formica. Furnished with 2 1/2" steel base and floor levelers.

FINISH: Walnut formica. Top in champagne formica and trim painted satin black.

SIZE: Height 26", width 23", depth 23".

WEIGHT: Net, 60 lbs.; packed 70 lbs.

CUBAGE: 12 cubic feet.

ORDER NUMBER.....994-6448



DOUBLE PEDESTAL, M-6449

Mounts two 12" or 16" turntables. Total 64" of 19" rack mount space available front and back, both sections. 3/4" flake board with Formica laminate. 2 1/2" steel base and floor levelers.

FINISH: Walnut formica. Top in champagne formica and trim painted satin black.

SIZE: Height 26", width 45", depth 23".

WEIGHT: Net, 108 lbs.; packed, 140 lbs.

CUBAGE: 18 cubic feet.

ORDER NUMBER.....994-6449

NOTE: Cabinets normally supplied less cut-outs for turntables. If cut-outs desired, an added cost is involved.

METAL GRILL REPLACEMENTS

Where the expanded metal grill used on cabinet fronts, such as the M-6448 or M-6449, is to be eliminated in part for rack mounted items, other size grills are listed below to fill the unused portion. Example: full grill is 16" high. If 5 1/4" rack space used, order 994-6453B to fill remaining space.

Grill 10 1/2" high.....994-6453B

Grill 5 1/4" high.....994-6453C

Grill 3 1/2" high.....994-6453D

UNIFORM TABLE TOP SECTION

Complete with wiring trough, and angle brackets for assembly with pedestals or legs. When assembled, desk surface is 29" from floor. (Not illustrated.)

FINISH: Neutral champagne formica.

SIZE: Length 84", depth 29", thickness 1 1/8". (Other lengths on special order.)

WEIGHT: Net, 55 lbs.; packed, 70 lbs.

CUBAGE: 7.5 cubic feet.

ORDER NUMBER.....994-6450



DOUBLE LEG, M-6456

For supporting top section. Square 1" steel welded construction with crossbrace. Complete with mounting flanges and floor levelers.

FINISH: Satin chrome steel.

SIZE: 1" x 1" x 28". Over-all width 21".

WEIGHT: Packed, 10 lbs.

CUBAGE: 2 cubic feet.

ORDER NUMBER.....994-6456



SINGLE LEG, M-6455

Mounts beneath desk top section. Square 1" steel tubing with mounting flange and floor leveler.

FINISH: Satin chrome steel.

SIZE: 1" x 1" x 28".

WEIGHT: Packed, 5 lbs.

CUBAGE: 1 cubic foot.

ORDER NUMBER.....994-6455

Portable Audio Turntable-Console



MODEL KD-20A

Rugged, compact, and all solid state, this economical unit is ideal for remote disc jockey shows and special on-the-spot broadcasts.

COMPLETE REMOTE CAPABILITY: Two high quality, three speed turntables, with individual mixing controls are provided. Two microphones and a remote input can also be mixed and are individually selectable by a three position switch. The remote input has a 50 dB pad which enables use of a high level source such as a tape recorder or remote amplifier, adding to the capability of the unit. Line feed and control, PA feed and monitoring are included.

COMPACT DESIGN: This unit is packaged for portability. Weighing only 68 pounds, the KD-20A has detachable legs which fasten underneath the base for ease in transporting. The base of this console is fiberglass to provide protection for the equipment. Side handles enable easy carrying, and the unit's over-all size enables it to fit into the rear of a standard size car.

EXCELLENT AUDIO: Both turntable channels have integral RIAA equalization to match their respective cartridges. Microphone channel frequency response is ± 2 dB from 50

15,000 Hz. Output level is +6 VU with 3% or less distortion from 50 to 10,000 Hz.

The KD-20A's output passes through a 3 dB pad before feeding the broadcast line. The output also passes through a resistive isolation network before going to the monitor phone jack. Feed to the PA system is isolated by a bridging transformer and a separate fader is used to control PA level.

SOLID STATE ELECTRONICS: All circuitry in this console from preamplifiers to power supply is solid state, using high quality, ruggedly mounted transistors and diodes. Etched wiring is used in all amplifiers. The full wave power supply is fully regulated.

EASE OF OPERATION: The control placement of this unit assures easy operation by one man. Faders for the two turntables and the microphone/remote input are on the lower portion of the control panel. The three position microphone/remote switch is in the center with the PA level control and master gain control to the right and left of the VU meter respectively. Cueing of the turntables can be accomplished through headphones; monitoring is done through the headphones or an external amplifier.

SPECIFICATIONS

MIXING CHANNELS: Four.

MODE: Monaural.

INPUTS: Total six—(2) turntables, (2) 50-250 ohm microphones, (1) high level 600 ohms, (1) medium level 600 ohms.

CUEING: Pushbuttons on turntable channels to headphone jack.

FREQUENCY RESPONSE: (Audio system), ± 2 dB, 50-15,000 Hz. (Pickups) Standard RIAA curve.

DISTORTION: 3% or less.

OUTPUT: 600 ohms @ +6 VU (after built-in 3 dB pad).

NOISE: (Microphone channel) -56 dB (relative input noise -106 dBm).

POWER: 117 volts, single phase, 60 Hz.

SIZE: 44" long, 16½" wide, 10" high.

WEIGHT: 68 pounds net.

ORDERING INFORMATION

Portable KD-20A audio turntable/console.....740-0032

Proof Of Performance Equipment



A



B



C

SA-131

A proof of performance package that assures accurate results and complete equipment to check audio and radio frequency performance. There are three basic units, plus two optional units: (A) type 210 audio oscillator, (B) M-3625 gain

set, (C) type 410 distortion meter, and optional RF pickup coil and diode rectifier for AM transmitter measurements. For FM transmitters the signal can be obtained directly from the modulation monitor for proof of performance tests.

AUDIO OSCILLATOR

Fig. A. An excellent source for audio signals from 10 to 100,000 Hz, the type 210 oscillator consists of an RC audio circuit followed by an amplifier of extremely low distortion. Response over the entire frequency range is ± 1 dB with wave form distortion of less than 0.2% at a 5 volt output. Calibration over the 10 to 100,000 Hz range is $\pm 2\%$. Output impedances are 600 ohms balanced, 600 ohms unbalanced and 150 ohms unbalanced. Maximum output is 10 volts into a 600 ohm load. The unit is 6" wide, 9" high and 12" deep, including a self-contained power supply. Weight is 11 pounds.

GAIN SET

Fig. B. The M-3625 gain measuring set consists of a VU meter with switching to accommodate all usable ranges for measuring purposes. The attenuation circuit includes a 10 step 2 dB per step variable attenuator of the balanced ladder type, and fixed plug-in pads which may be used in any number from 1 to 3. Pads are used for attenuation and impedance matching. Two are supplied, providing 40 dB attenuation at 600/600 ohms and one with 20 dB at 600/250 ohms, all balanced H. The gain set is completely shielded.

SPECIFICATIONS

INPUT IMPEDANCE: 600 ohms, balanced.
OUTPUT IMPEDANCE: Variable 30 to 600 ohms.
OUTPUT LEVEL: Variable from +21 dBm to -136 dBm.
RESPONSE: ± 0.5 dB, 30-15,000 Hz.
DISTORTION AND NOISE: Negligible.
SIZE: 12 $\frac{3}{4}$ " wide, 8 $\frac{3}{4}$ " high, 4" deep.

DISTORTION METER

Fig. C. The type 410 distortion meter measures audio distortion, noise level, audio gain or loss in decibels and AC voltages. This unit measures distortion on fundamental frequencies from 20 to 20,000 Hz and indicates harmonics up to 100 kHz. Distortion levels as low as 0.1% can be measured, and distortion measurements may be made on signal levels from 0.1 volt to 30 volts. For noise and response measurements the instrument is calibrated in 1 dB steps from 0 to -15 dB. The attenuator provides additional ranges from -60 dB to +50 dB in 10 dB steps. The unit is 11 $\frac{1}{2}$ " wide and 9" high. Weight is 11 pounds.

PICKUP COIL AND RECTIFIER

Optional accessory for AM transmitters only. Designed for use with the type 410 distortion meter, the pickup coil is supplied ready to couple to the tank circuit of an AM transmitter. It is supplied with 15 feet of coaxial cable that connects the coil to the diode rectifier unit. Complete RF filtering guarantees a pure audio output signal free from RF disturbances. 4" long, 2" wide, and 1 $\frac{1}{4}$ " high.

ORDERING INFORMATION

SA-131 proof of performance package, consists of one each
 Model 210, M-3625, and Model 410.....994-3663
 Model 210 audio oscillator.....730-0045
 Model 3625 gain set.....994-3625
 Model 410 distortion meter.....700-0040
 Pickup coil and rectifier (optional for AM only).....994-3626-002



Professional Tape Recorders

SPECIFICATIONS

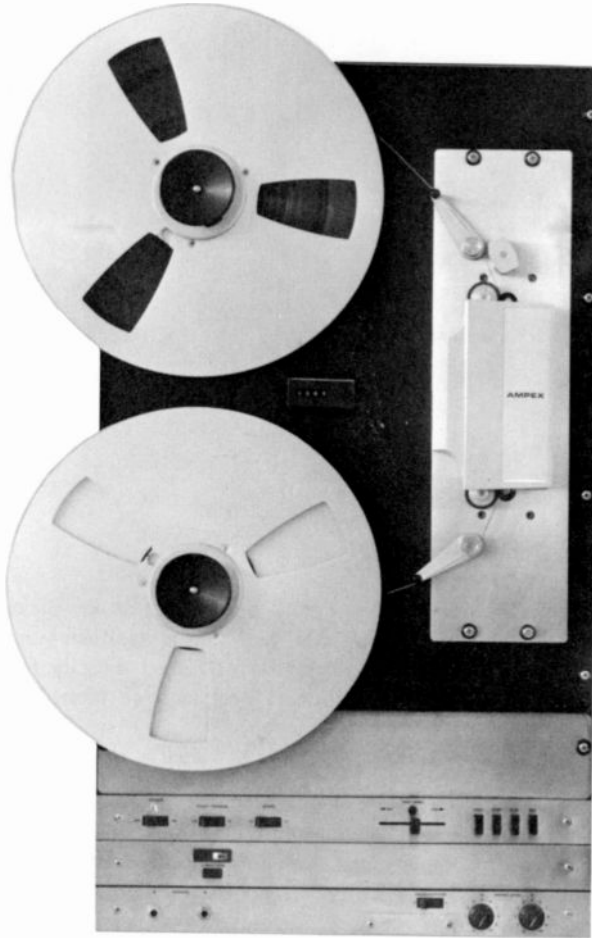

AMPEX ABR-10/ABR-15 SERIES

The new ABR Series recorder/reproducers have been designed specifically for the broadcaster.

The ABR-10 operates with reel sizes from 5 to 10½ inches. The ABR-15 is designed for reels of up to 15 inches for long-duration record or playback. ABR Series machines are available in either record/reproduce or playback-only configurations.

In the bidirectional configuration, Ampex ABR Series recorders are totally symmetrical machines. Separate capstan drive motors are used, one for each direction, allowing improved production and providing a full program automation capability. Tape is always pulled across the heads, thus improving head-to-tape contact.

Automatic reversing with the use of alternate tracks in each direction eliminates turning reels over and reueing. A new direct-drive system controlled by an electronic servo uses specially designed DC motors. This system eliminates several electrical and mechanical components that can affect tape speed stability and increase flutter. Tape speed is maintained regardless of voltage, frequency, and phase fluctuations from the input power line.

TAPE FORMAT: Full, half or quarter tracks on ¼-inch-wide tape, 1-mil or 1½-mil base. Specifications are based on Ampex recommended professional quality magnetic tape on 10½-inch aluminum reels.

TAPE SPEEDS: Standard, selectable pairs from 15/16, 1½, 3¾, 7½, or 15 ips for either unidirectional or bidirectional operation.

REEL SIZE: 5 inches to 10½ inches in diameter for Model ABR-10. 5 inches to 15 inches in diameter for Model ABR-15.

FREQUENCY RESPONSE: 15 ips: 30 to 18,000 Hz, ±3 dB; 7½ ips: 40 to 15,000 Hz, ±2 dB; 3¾ ips: 40 to 10,000 Hz, ±2 dB; 1½ ips: 40 to 10,000 Hz, ±3 dB; 15/16 ips: 100 to 5000 Hz, ±3 dB.

CROSSTALK REJECTION: 60 dB or better at 1000 Hz (2-track head stacks).

BIAS OSCILLATOR: Nominal bias/erase frequency: 100 kHz.

FLUTTER AND WOW: 15 ips: 0.1%; 7½ ips: 0.15%; 3¾ ips: 0.18%; 1½ ips: 0.25%; 15/16 ips: 0.4%.

SIGNAL-TO-NOISE RATIO:

Tape Speed	Full Track	Half Track	Quarter Track
15 ips	66 dB	63 dB	57 dB
7½ ips	66 dB	63 dB	57 dB
3¾ ips	63 dB	58 dB	51 dB
1½ ips		45 dB	42 dB
15/16 ips		40 dB	40 dB

(Peak record level to unweighted noise. Includes bias, erase, and playback amplifier noise.)

INPUT: 100,000 ohms unbalanced. Accepts line level from -17 dBm for recommended operating level.

OUTPUT: +4 dBm, balanced. +24 dBm clipping level. Amplifier total harmonic distortion at +20 dBm is less than 0.1%.

EQUALIZATION: 90 to 200 microseconds at 15/16, 1½, and 3¾ ips. NAB equalization for 7½ and 15 ips tape speeds.

FAST SPEED: Fast speed for rewind or search functions manually adjustable. Minimum rewind time: approximately 90 seconds for 2400-foot NAB reel. Approximately 3 minutes for 5000-foot, 14-inch reel.

START TIME: Operating speed obtained in 0.1 second or less; 3 seconds to normal flutter specification.

STOP TIME: At 15 ips (15-in. reel) tape moves 3 inches.

TAPE SPEED ACCURACY: Within ±0.08% from beginning to end of reel. With internal speed control, tape speed unaffected by line voltage or frequency fluctuations.

REFERENCE OSCILLATOR STABILITY: Bridge Oscillator: ±0.05%, 0° to 65°C. Crystal Oscillator: ±0.01%, -10° to 75°C.

CAPSTAN SPEED ACCURACY: Capstan speed as referred to the servo reference frequency shall be less than that shown as measured throughout any reel of tape:

TAPE SPEED	CAPSTAN POSITION ERROR
15 ips	± 75 microseconds
7½ ips	±150 microseconds
3¾ ips	±300 microseconds

POWER REQUIREMENTS: 105 to 125 VAC, 50/60 Hz.

POWER CONSUMPTION: 2.2 amps at 115 VAC.

SIZE AND WEIGHT: ABR-10, Tape Transport (bidirectional): 14 inches high x 19 inches wide; 42 pounds. ABR-15, Tape Transport (bidirectional): 24½ inches high x 19 inches wide; 50 pounds. Electronics and Control Units: 1¾ inches high x 19 inches wide (each unit); 4-6 pounds.

ORDERING INFORMATION AVAILABLE ON REQUEST.

Professional Tape Recorders



AMPEX 440-B TAPE SYSTEM

One of the finest commercial tape recorders available anywhere. The all-transistor Ampex 440-B series sets the highest standards in professional recording performance. Uncompromising quality characteristics, both electronic and mechanical, result in superiority of performance and long, trouble-free operation. Transport control buttons are recessed so that they cannot be accidentally pressed; all can be remote controlled. The 440-B is the professional broadcast version of Ampex recorders used by leading Hollywood recording companies. Rack, Portable, or Console mount, monophonic or stereophonic versions, dual speed: 7½-15, or 3¾-7½ ips.

Rigid die-cast frame provides absolutely flat mounting of all mechanical components for precise tape alignment. The AG-440-B has been designed for easy, rapid maintenance, and minimum downtime. Modular design with front panel plug-in circuit boards permits fast servicing and replacement. Individual head stacks can be replaced with a single screw and plug-in connector. Transport motors, guides, and major components can be quickly removed and replaced in exact alignment because of the precision milled transport casting. All relays plug-in and are fully interchangeable.

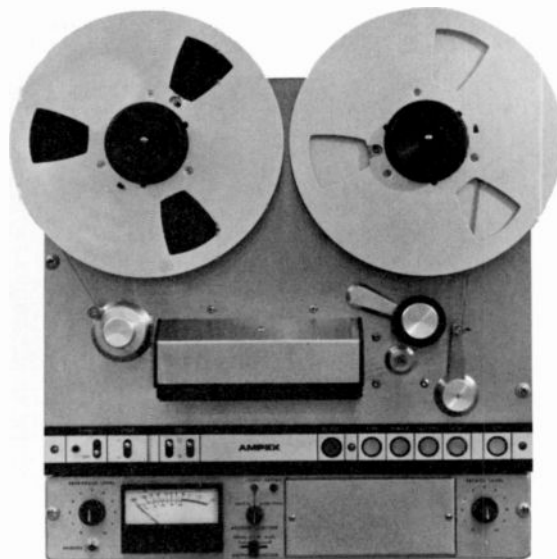

SPECIFICATIONS

TAPE SPEEDS: 7½ and 15 ips, or 3¾ and 7½ ips.
SIGNAL TO NOISE RATIO: 15 ips full track 68 dB, 2 track 60 dB; 7½ ips full track 68 dB, 2 track 60 dB; 3¾ ips full track 63 dB, 2 track 56 dB.
FREQUENCY RESPONSE (OVER-ALL): 15 ips ±2 dB, 30 to 18,000 Hz; 7½ ips ±2 dB, 40 to 10,000 Hz; 7½ ips +2 to -4 dB, 30 to 15,000 Hz; 3¾ ips ±2 dB, 50 to 7500 Hz.
FLUTTER: 15 ips below 0.08% rms; 7½ ips below 0.10% rms; 3¾ ips below 0.15% rms.
PLAYBACK OUTPUT: +8 dBm into 600 ohms—restrappable for +4 dBm output balanced or unbalanced. Maximum of +29 dBm before clipping.
RECORD INPUT: 100 K ohm unbalanced bridging with dummy plug or 20 K ohm bridging with plug-in transformer -17 dBm to produce recommended operating level.
START/STOP: Start, tape at full speed in less than 1/10 second. Stop, tape travel 2" or less after depressing stop button.
PLAYBACK TIMING ACCURACY: ±0.2% (±3.6 seconds in 30 minutes).
EQUALIZATION: NAB standard, CCIR on special order.
POWER REQUIREMENTS: 117 volts, 50 or 60 Hz @ 2.5 amp. for 2 channel.
DIMENSIONS: Transport, 19" wide x 15¾" high. Electronics, 19" wide x 3½" high.
MOUNTING CONFIGURATIONS: Portable, Console, or Unmounted.
REEL SIZE: Standard up to 10½ inch, adjustable up to 11½" reels.
 Complete specification on request.

ORDERING INFORMATION

AG-440B-1 (4010131-01) full track, unmounted, 7.5/15 IPS, 60 Hz.....	730-1164
AG-440B-1 (4010131-03) as above, console mounted.....	730-1165
AG-440B-1 (4010131-09) half track, console mounted, 7.5/15 IPS, 60 Hz.....	730-1168
AG-440B-2 (4010132-01) two track stereo, unmounted, 7.5/15 IPS, 60 Hz.....	730-1170
AG-440B-2 (4010132-03) as above, console mounted.....	730-1171
AG-440B-2 (4010132-13) two track stereo, plus quarter track playback, unmounted, 7.5/15 IPS, 60 Hz.....	730-1172
AG-440B-2 (4010132-15) as above, console mounted.....	730-1173
AG-440B-2 (4010132-07) two track stereo, unmounted, 3.75/7.5 IPS, 60 Hz.....	730-1174
AG-440B-2 (4010132-09) as above, console mounted.....	730-1175
AG-445B-1 (4010141-19) half track, unmounted, 3.75/7.5 IPS, 60 Hz.....	730-1181

Professional Tape Recorders



AMPEX AG-500 SERIES

The AG-500-1 is a versatile one-channel recorder with full or half-track heads. This portable single channel solid state unit has input controls that can mix two incoming line signals. Use of mike pre-amp accessory converts line inputs to accept low impedance microphones. Narration over music, music/voice mixing or special sound-on-sound capabilities are possible. Recorder will feed 600 ohm remote broadcast phone line.

SPECIFICATIONS

SPEEDS: 7½ and 15 ips, or 3¾ and 7½ ips (AG-500-4 for 4 track stereo, 3¾ and 7½ ips only).

FREQUENCY RESPONSE (OVER-ALL): 15 ips ±2 dB, 30 to 18,000 Hz; 7½ ips ±2 dB, 30 to 15,000 Hz; 3¾ ips +2 dB -4 dB, 40 to 8,000 Hz.

SIGNAL TO NOISE RATIO: 7½ and 15 ips, full track (60 Hz) 60 dB (50 Hz) 57 dB, half or two track 55 dB. 3¾ ips full track 55 dB, half and quarter track 50 dB.

WOW AND FLUTTER: 15 ips less than 0.15% rms, 7½ ips less than 0.18% rms, 3¾ ips 0.25% rms.

TIMING ACCURACY: ±0.25%, 7½ and 15 ips; ±0.40%, 3¾ ips.

OUTPUT: +4 dBm into 600 ohm balanced load.

POWER REQUIRED: 117 Volts, 60 Hz, 1.50 Amp. 230 Volts, 50 Hz, 0.75 Amp.

RACK SPACE: Transport, 8¾" H x 19" W x 6" D. Electronics, 3½" H x 19" W x 6" D.

WEIGHT: 1 channel portable 42 lbs., 2 channel portable 52 lbs.

ORDERING INFORMATION

AG-500-1 Single channel Full track, rack mount, 7.5/15 ips, 60 Hz.....	730-0963
AG-500-1 Same as above except half-track.....	730-0964
AG-500-1 Single channel, full track, rack mount, 3.75/7.5 ips, 60 Hz.....	730-0965
AG-500-1 Same as above except half-track.....	730-0966
AG-500-2 Stereo, 2 track, rack mount, 7.5/15 ips, 60 Hz.....	730-0967
AG-500-2 Stereo as above except 3.75/7.5 ips.....	730-0968
Portable Case for AG-500 single channel.....	730-0970
Portable Case for AG-500 two channel.....	730-0971



AMPEX AG-600

The AG-600 series is designed for broadcast, where compact lightweight professional quality recording equipment is needed or where budgets are limited.

SPECIFICATIONS

FREQUENCY RESPONSE: 7½ ips: ±2 dB from 60 Hz to 10 kHz; +2.4 dB from 40 Hz to 15 kHz. 3¾ ips: ±2 dB from 50 Hz to 7 kHz; +2.4 dB from 40 Hz to 8 kHz.

SIGNAL TO NOISE: 7½ ips: Full track 57 dB; Half track 55 dB; 3¾ ips: Full track 52 dB; Half track 50 dB.

CROSSTALK REJECTION: Better than 40 dB mid-frequency.

FLUTTER AND WOW: (Measured by ASA Standards) 7½ ips less than 0.17%; 3¾ ips less than 0.25%.

TIMING ACCURACY: 7½ ips ±0.2% (±3.6 seconds in 30 minutes). 3¾ ips ±0.4% (±7.2 seconds in 30 minutes).

FAST FORWARD OR REWIND TIME: 90 seconds for full 1200 foot reel.

SPEEDS: Dual speed, 3¾ and 7½ ips.

REEL SIZE: 5" and 7".

EQUALIZATION: 117 volt, 60 Hz models: 3¾ ips, 120 microsecond. 7½ ips, NAB. 115/230 volt, 50 Hz models: 3¾ ips, 120 or 200 microsecond. 7½ ips, NAB or CCIR.

POWER REQUIREMENTS: For 117 volt operation 0.5 amperes. For 230 volt operation 0.3 amperes.

WEIGHT: Single channel: 28 lbs. portable. Dual channel 42 lbs. portable.

ORDERING INFORMATION

AG-600-1 NAB equalization, full track, unmounted, 60 Hz, 117 Volt.....	730-1018
AG-600-1, as above in portable case.....	730-1019
AG-600-1, NAB equalization, half track, unmounted, 60 Hz, 117 Volt.....	730-1020
AG-600-1, as above in portable case.....	730-1021
AG-600-2, two-channel, two track, one-half track stereo, NAB equalization, unmounted, 60 Hz, 117 volts.....	730-1022
AG-600-2 same as above in portable case.....	730-1023
AG-600-4, two channel, four track, one-quarter track stereo, NAB equalization, unmounted, 60 Hz, 117 volt.....	730-1026
AG-600-4, Same as above in portable case.....	730-1027
AA-620 Portable speaker-amplifier for AG-600 and AG-500 series. 10" wafer, 3½" tweeter, 20 watt solid state amplifier in enclosure.....	730-1030

Professional Tape Recorders

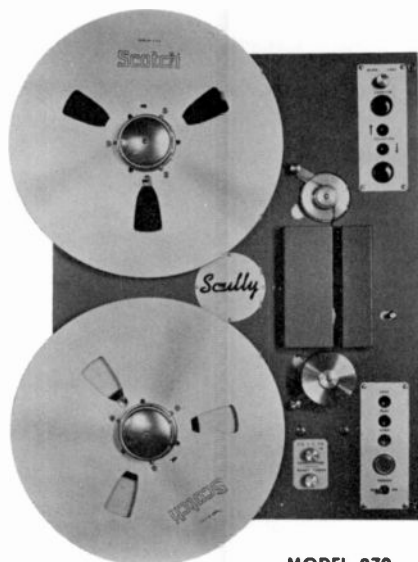

MODEL 270

SCULLY PRECISION TAPE EQUIPMENT

The portable Scully 270 Reproducer is intended for broadcasters, background music operators or any application where long life, reliability and exacting performance specifications in tape handling equipment are essential. The companion model 280 complete record/reproduce system has the same fine features plus quality all-transistor recording amplifier.

SPECIFICATIONS

Model 270

TAPE SPEEDS: 3¾ ips-7½ ips or 7½-15 ips.
TAPE SIZE: ¼" or ½".
HEAD CONFIGURATION: Monophonic half or full track; stereo 2, 3, or 4 channel.
REEL SIZE: Up to 14".
REEL HUBS: NAB, CCIR.
STARTING TIME: 1/10th second.
STOPPING TIME: 1/5th second.
FAST WIND TIME: 4800 foot reel—105 seconds.
PLAYING TIME: 14" reel, 4800 feet 1½ mil tape @ 3¾ ips—8 hrs. 7½ ips—4 hrs; 14" reel, 9600 feet ½ mil tape @ 3¾ ips—16 hours; @ 7½ ips—8 hours.
FREQUENCY RESPONSE: ±2 dB 50-7500 Hz @ 3¾ ips. ±2 dB 50-15,000 Hz @ 7½ ips. ±1½ dB 50-15,000 Hz @ 15 ips.
FLUTTER AND WOW: 0.2% RMS @ 3¾ ips. 0.1% RMS @ 7½ ips. .08% RMS @ 15 ips.
SIGNAL TO NOISE RATIO (FULL TRACK): -60 dB @ 7½ and 15 ips.
TIMING ACCURACY: Better than 99.8% (30 minute reel).
AMPLIFIER: Solid State, plug-in.
AMPLIFIER EQUALIZATION: Front panel switch.
AMPLIFIER OUTPUT: +18 dBm 600 ohms balanced line.
AMPLIFIER DISTORTION: Less than 0.5% total HD at +18 dBm.
OPERATING CONTROLS: Play, fast, Direction Change, Stop, Speed Selector, Equalization.
REMOTE FEATURES: All controls except motor speed change.
REVERSING: Foil using low current transistor switching, with mechanical memory.
MOTORS: Two torque and one hysteresis synchronous speed reversible capstan motor.
POWER REQUIREMENTS: 117 V, 50/60 Hz, 275 watts.



MODEL 280

CONTROL SYSTEM: All relays and solenoids 24 volts DC; plug-in relays.
CHASSIS FRAME: ¾" cast aluminum 2" depth.
MAIN PANEL: Precision aluminum plate.
FACE PLATE: Easily removable, permitting continuous operation.
BREAKING SYSTEM: Disc Type.
TAPE TENSION: Continuous adjustable electrical controls system.
WEIGHT: 79 lbs.
SHIPPING WEIGHT: 90 lbs.
SIZE: 19" x 24½" x 8¾".

ORDERING INFORMATION

Model 270-1 Rack mount reproducer, ½ track monophonic, 14" reel capacity. 7.5/15 ips.....730-0927
 Model 270-2 As above, except for stereophonic reproduction.....730-0928
 Model 280-1 Rack mount record/reproduce. ½ track monophonic, 10½ reel capacity. 7½-15 ips.....730-0923
 Model 280-2 As above, except for stereophonic.....730-0924
 Model 280-1 (SP-14) Rack mount model 280 monophonic recorder with 14" reel capacity.....730-0925
 Model 280-2 (SP-14) As above, except for stereo.....730-0926

Professional Tape Recorders



**MAGNECORD MODEL 1022
TRANSISTORIZED DUAL CHANNEL
RECORDER/REPRODUCER**

Model 1022 is a dual channel recorder/reproducer designed for professional applications requiring the ultimate in quality and reliability from a tape transport system. The two-channel amplifier is completely transistorized, equipped with a zener regulated power supply, and furnishes all the electronic functions of record, playback, high frequency bias and erase. Separate record and reproduce amplifiers allow simultaneous record and playback.

SPECIFICATIONS

TAPE SPEEDS: 7½ and 15 ips.
FLUTTER AND WOW: 0.17% rms at 7½ ips. 0.15% rms at 15 ips.
PLAYBACK TIMING ACCURACY: ±0.2%
FREQUENCY RESPONSE—OVER-ALL RECORD/REPRODUCE: ±2 dB 30 Hz to 16 kHz at 7.5 ips; ±2 dB 35 Hz to 22 kHz at 15 ips.
SIGNAL-TO-NOISE RATIO: 53 dB at 7.5 and 15 ips.
OUTPUTS: 150/600 ohm balanced (+4 dBm) auxiliary A and auxiliary B unbalanced.
HEADS: Erase head—half-track. Record head—half-track. Play head—half-track and quarter-track.
WEIGHT: Transport 33 pounds. Amplifier 14 pounds.
DIMENSIONS: Transport 19" wide, 10½" high, 7¼" deep; Amplifier 19" wide, 5¼" high, 12¼" deep. Transport Reel Overhang, 1¾" (7-inch reel).
POWER REQUIREMENTS: 110/130 V, 60 Hz, 180 watts.

ORDERING INFORMATION

1022-X—Fully transistorized, stereo, 7.5/15 ips, half track with extra quarter track playback head, rack mounting, manual operation 730-0419
 1022-RX—As above, with provisions for remote control 730-0829
 Remote Control Box, may be used with "RX" model above 730-0831
 A81D128-2 Transport Case 730-0425
 A81D129-2 Electronics Case 730-0426



**MAGNECORD MODEL 1021
TRANSISTORIZED MONOPHONIC
RECORDER/REPRODUCER**

Fully transistorized with a regulated power supply, the MagneCORD 1021 offers the stability of a two-speed hysteresis synchronous capstan motor plus separate reel drive motors. Equalization meets NAB standards. Input and output impedances are all balanced for broadcast equipment.

SPECIFICATIONS

TAPE SPEEDS: 3.75 and 7.5 ips.
FLUTTER AND WOW: 0.25% at 3.75 ips; 0.17% at 7.5 ips.
TIMING ACCURACY: ±0.2%.
FREQUENCY RESPONSE—OVER-ALL RECORD/REPRODUCE: 35 to 8000 Hz ±2 dB at 3.75 ips; 45 to 18,000 Hz ±2 dB at 7.5 ips.
SIGNAL-TO-NOISE RATIO: 53 dB, both speeds.
INPUTS—SWITCH SELECTED: Microphone, 150 ohms; Balanced Bridge; Unbalanced Bridge; Unbalanced Auxiliary.
OUTPUTS: 150/600-ohm balanced (+4 dBm), auxiliary A and auxiliary B unbalanced.
HEADS: Erase head—full-track. Record head—full-track. Play head—half-track.
WEIGHT: Transport 33 pounds. Amplifier 14 pounds.
DIMENSIONS: Transport, 19" wide, 10½" high, 7¼" deep; Amplifier, 19" wide, 5¼" high, 12" deep; Transport Reel Overhang, 1¾" (7-inch reel).
POWER REQUIREMENTS: 110/130 V, 60 Hz, 180 watts.

ORDERING INFORMATION

1021-X—Fully transistorized, monaural, 3.75/7.5 ips, full track erase and record, half track playback, rack mounting, manual operation 730-0418
 1021-RX—As above, with provisions for remote control 730-0828
 Remote Control Box, may be used with "RX" model above 730-0831
 A81D128-2 Transport Case 730-0425
 A81D129-2 Electronics Case 730-0426

HIGH FREQUENCY BROADCAST TRANSMITTERS



100 kW Short Wave Broadcast Transmitter

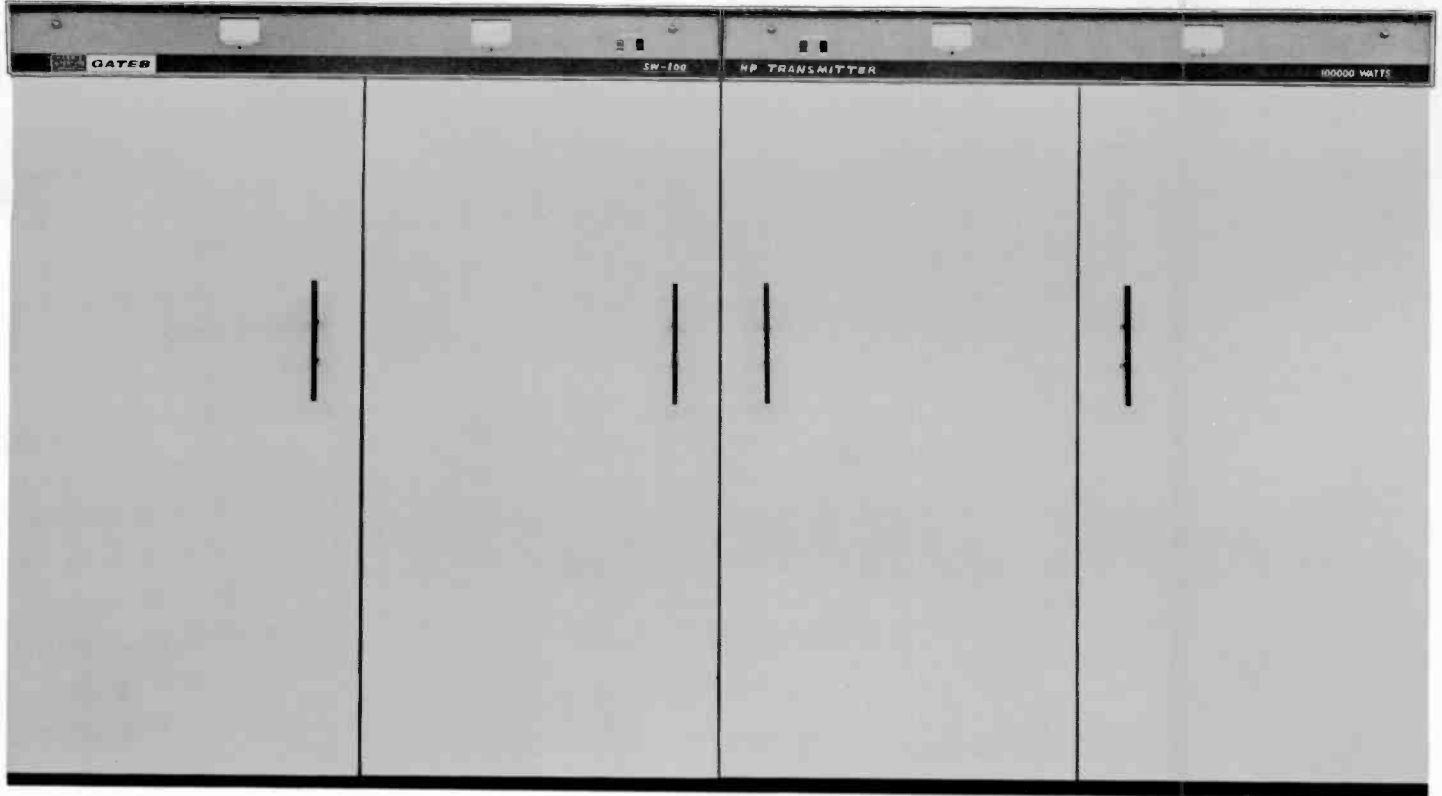

MODEL SW-100

Gates SW-100 provides overall performance superior to that of any other short wave broadcast transmitter in the same power range—and at significantly lower operating costs. This is made possible by Gates' exclusive high level Pulse Duration Modulator (U.S. Patent No. 3440566).

HIGH EFFICIENCY—EXCEEDS 60%: The Pulse Duration Modulator employed in the transmitter is almost 90% efficient (instead of the usual 50% or 60%), allowing an unusually high overall efficiency of more than 60%. This means about one-third less power consumption than that of other high level plate modulated 100 kilowatt transmitters.

ONLY FIVE TUBES: The transmitter employs just five tubes—with a modern ceramic 4CV50,000E power tetrode in the modulator and final RF power amplifier sockets. All power supplies utilize long-life solid-state silicon rectifiers. Highest quality components, conservatively rated, are used throughout the SW-100 to assure greatest reliability.

CONTINUOUS 100% MODULATION RATING: The high efficiency series type Pulse Duration Modulator permits continuous 100% sine wave or trapezoidal modulation. Another feature of this high efficiency series type modulator is convenient front panel carrier adjustment over a wide range.

PRE-SET TUNING: After the SW-100 has been tuned to the desired frequency manually, the exact position of each variable tuning element is stored in a simple "memory". Up to ten different frequencies from 3.2 to 26.5 MHz can be "remembered", which allows pushbutton re-tuning to any pre-set frequency without further manual tuning. Few controls and ample metering make this the easiest tuning 100 kW transmitter available.

QUIET VAPOR PHASE COOLING: Vapor phase cooling reduces noise by eliminating the need for large blowers moving high velocity air. One two-horsepower fan cools the heat exchanger and flushes the transmitter cabinets, resulting in whisper-quiet operation. Vapor phase cooling also extends tube life by helping to eliminate "hot spots" and maintaining anode temperatures far below those attained by other methods.

Ideal for use in all types of climate, this transmitter greatly reduces the problems of cleaning and filtering of outside air. With vapor phase cooling, ducting outside air into the transmitter is not necessary. Also, the cooling system requires little attention other than maintaining the proper purity and water level in the reservoir tank.

100 kW Short Wave Broadcast Transmitter

GREATLY REDUCED FLOOR SPACE: Due to the high efficiency of the transmitter and the elimination of large iron core components (no modulation transformer and reactor), the SW-100 requires only 7.0 square meters (76 square feet) of floor space. Careful cabinet design provides easy accessibility to all components.

TRANSMITTER LAYOUT: The standard layout of the transmitter consists of two cabinets, a heat exchanger designed for mounting on top of the cabinets, and an external high voltage power transformer. Front and rear doors, and meter panel are magnetically latched. External connections to the transmitter are made through the top so that floor ducts are not necessary.

SW-50: The SW-50 is the 50 kW version of the SW-100, and includes all of the features mentioned previously. These features include: the Pulse Duration Modulator, which allows an unusually high overall efficiency of more than 60%; five tube design—only five tubes in the entire transmitter for highest reliability; continuous 100% modulation rating; quiet Vapor Phase cooling; pre-set tuning; and reduced floor space, due to the elimination of large iron core components.

The SW-50 layout is identical to that of the SW-100 (two cabinets, heat exchanger and external high voltage power transformer).

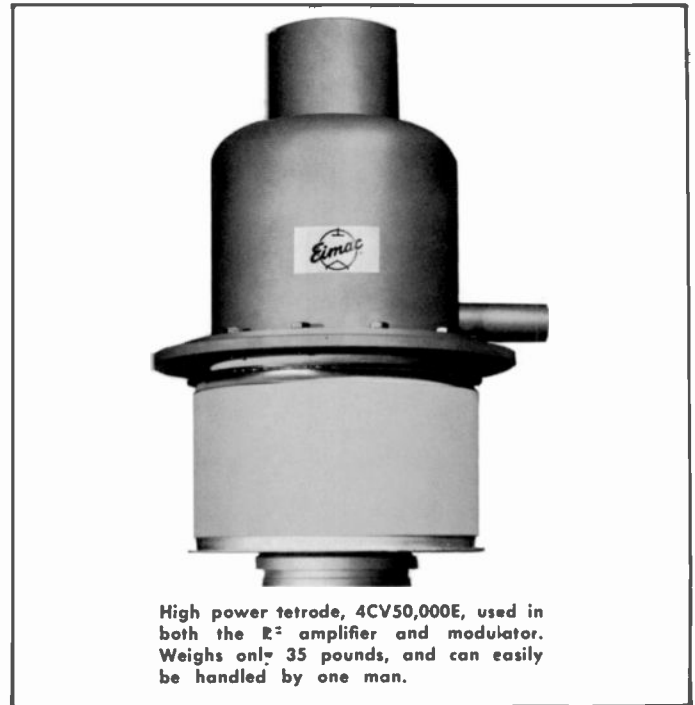

High power tetrode, 4CV50,000E, used in both the R² amplifier and modulator. Weighs only 35 pounds, and can easily be handled by one man.



SW-100, front doors removed.

100 kW Short Wave Broadcast Transmitter

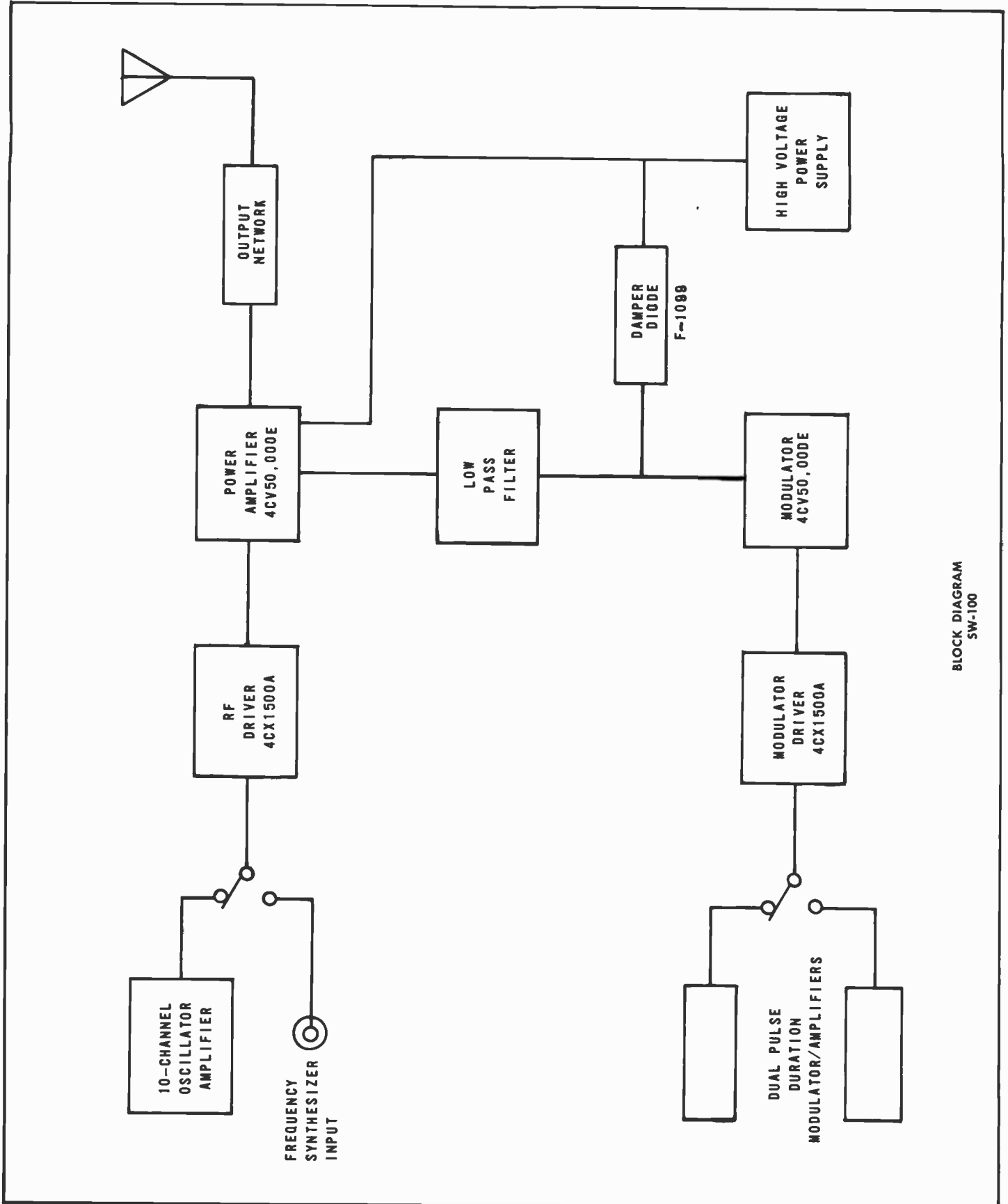

BLOCK DIAGRAM
SW-100

100 kW Short Wave Broadcast Transmitter



SW-100, with heat exchanger

SPECIFICATIONS

POWER OUTPUT: (SW-100) 100,000 watts nominal unmodulated; capable 110,000 watts. (SW-50) 50,000 watts nominal unmodulated; capable 55,000 watts.

RF FREQUENCY RANGE: 3.2 to 22.0 MHz. Optional 3.95 to 26.5 MHz.

METHOD OF TUNING: Manual, or selection of 10 pre-set channels.

RF OUTPUT IMPEDANCE: 300/600 ohms, balanced.

RF FREQUENCY STABILITY: $\pm 1 \times 10^{-4}$ (± 22 Hz at 22 MHz).

SPURIOUS AND HARMONIC EMISSION: Less than 50 mW.

CARRIER SHIFT: Less than 2% at 95% modulation. Less than 5% at 100% modulation.

AUDIO FREQUENCY RESPONSE: ± 1.5 dB from 50 to 10,000 Hz referenced to 1,000 Hz at 95% modulation.

AUDIO FREQUENCY DISTORTION: Less than 3% from 50 to 10,000 Hz at 95% modulation.

NOISE: 55 dB below 1,000 Hz, 100% modulated level.

AUDIO INPUT LEVEL: 0 dBm ± 2 dB for 100% modulation.

AUDIO INPUT IMPEDANCE: 600/150 ohms, balanced or unbalanced.

MODULATION LEVEL: 100% sinusoidal, continuous, 50-5000 Hz.

TRAPEZOIDAL MODULATION: Less than 5% tilt or overshoot, 100 Hz to 2000 Hz.

POWER INPUT: Any specified voltage 380 V to 480 V, 3 phase, 50 or 60 Hz.

POWER CONSUMPTION: (SW-100) 165 kW—no modulation; 170 kW—30% modulation; 250 kW—100% modulation. (SW-50) 90 kW—no modulation; 93 kW—30% modulation; 135 kW—100% modulation.

POWER FACTOR: Greater than 95%.

VOLTAGE REGULATOR: Electronic voltage regulation for all power supplies other than high voltage.

CROWBAR RESPONSE: Less than 5 microsecond operate time.

OVERALL EFFICIENCY: 60% @ average modulation.

TUBES: Two—4CV50,000E; two—4CX1500A; one—F-1099.

TEMPERATURE RANGE: 0 to +50°C ambient air temperature.

HUMIDITY: 95% relative humidity, maximum.

STORAGE TEMPERATURE: -35°C to +60°C.

ALTITUDE: Up to 1829 meters (6000 feet) above sea level.

CABINET DATA: (SW-100 and SW-50) Each of two cabinets measures 1.83 meters (6 feet) wide, 1.37 meters (4.5 feet) deep, and 1.98 meters (6.5 feet) high. The heat exchanger adds another 1.06 meters (3.5 feet) in height.

ORDERING INFORMATION

SW-100, 100,000 watt short wave broadcast transmitter.....994-6734-001

SW-50, 50,000 watt short wave broadcast transmitter.....994-6808-001

20,000 Watt HF Broadcast Transmitter



MODEL HF-20B

This remarkable transmitter, field proven in over 16 different countries, represents the ultimate in 20 kW high frequency transmitter performance. It is designed for continuous 24-hour-a-day operation in all parts of the world, including areas with tropical climates.

Air cooled and employing high level plate modulation, the HF-20B is tunable over the entire frequency spectrum between 4 and 22 MHz.

FAST TUNING: Once the frequency band is selected, transmitter tune-up can be made within one minute from front panel controls. Except for the final tank coil, all circuits are continuously variable and front panel tuned between 4 MHz and 22 MHz. Changing of the final tank coil, which sets on a sliding carriage in the PA tank frame assembly, is speedily accomplished. Five coils are supplied for full 4-22 MHz coverage. Counter type controls read to 1/10 turn to permit accurate logging of all tuned circuits and quick return to any previously employed frequency.

RADIO FREQUENCY AND AUDIO SECTIONS: A two-stage radio frequency exciter unit incorporates switching positions for four crystals and input provisions for an external VFO or frequency shift keyer. The 6146 straight amplifier or doubler stage is followed by two type 4-250A tubes which provide an abundance of RF drive to the final amplifier. Four 3X2500F3 triodes operate push-pull parallel in the power output stage. A superb audio system consisting of four stages, all push-pull, is employed in the HF-20B. Four type 3X3000F1 triodes operating push-pull are used as Class B modulators.

OUTPUT COUPLING: To accommodate a wide variety of transmission lines, a balanced matching output network is incorporated, using series variable coils and parallel variable vacuum capacitors designed to match 300 to 800 ohm resistive balanced lines (500 ohms, with VSWR 1.7 to 1). Both variable coils and capacitors have counter type tuning controls for accurate logging. (A 50 ohm unbalanced output is also available on special order).

20,000 Watt HF Broadcast Transmitter—HF-20B

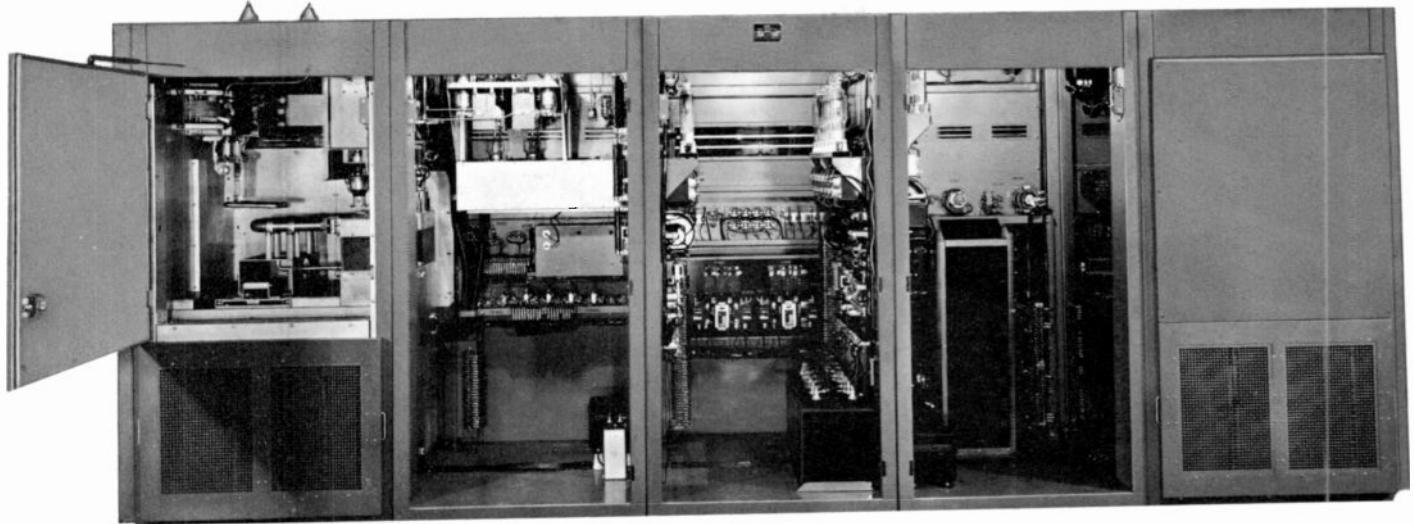

Rear view of the HF-20B.

POWER SUPPLIES: Five major power supplies deliver plate and bias voltages to the HF-20B transmitter. To assure greater reliability and better regulation, separate high voltage supplies are used for the modulator and power amplifier.

RELAYS AND PROTECTION: Magnetic AC contactors are inserted in all main primary lines. All major tubes are protected by individual supervisory overload relays. Protection devices included for door interlock and air failure.

MODEL HF-20BX: Identical to the HF-20B transmitter described herein, but has 400 word per minute keyer added. This model may be used for broadcasting, voice communications, telegraph, or with optional frequency shift keyer.

MODEL HF-20CX: The audio frequency response is for voice only in this model; otherwise it is the same as the HF-20BX, including keyer and provision for FSK. Audio response is rated 200-3,500 Hz ± 3 db.

SPECIFICATIONS

CARRIER POWER OUTPUT: 4-18 MHz, 20,000 watts. 18-22 MHz, 16,000 watts modulated (A3). Full 20 kW output 4-22 MHz telegraph.

FREQUENCY RANGE: 4-22 MHz.

RF STABILITY: .003% or better, with JK-09C oven.

OUTPUT IMPEDANCE: 300-800 ohms resistive balanced. (500 ohms, with VSWR 1.7 to 1.) (50 ohms unbalanced, optional).

POWER LINE REQUIREMENTS: 230 volts, 3 phase, 50/60 Hz. Other primary voltages or line frequencies available on special order.

POWER FACTOR: 90% or better.

POWER CONSUMPTION: 0% modulation, 37 kW. Average modulation, 43 kW. 100% modulation (sine wave), 55 kW.

POWER REDUCTION: Low power tune-up switch provided.

AUDIO RESPONSE: ± 1.5 dB, 50-10,000 Hz.

DISTORTION: 3% or less, 100-5000 Hz. 4% or less 50-7500 Hz.

NOISE: 55 dB or better below 100% modulation.

CRYSTAL POSITIONS: Four; input for external VFO or FSK provided.

KEYING: 400 wpm with essential square top wave form, on-off keying. Keyer supplied on Models HF-20BX and HF-20CX only.

TUBES: (RF section) 6AG7 oscillator, 6AG7 buffer, 6146 buffer/doubler, (2) 4-250A RF driver, (4) 3X2500F3 power amplifiers. (Audio section) (2) 6J7 first audio, (2) 807 second audio, (2) 845 audio driver, (4) 3X3000F1 modulators. (Power supplies) (12) 673 HV rectifiers, (4) 800B LV rectifiers, (2) 866A LV rectifiers. (Keyer) (1) 812 keyer tube.

SIZE: HF-20B and HF-20BX, 205" wide, 48½" deep, 78" high. Door swing, 40" front and rear. Floor space for external transformers: 10' x 9'. Largest cabinet size uncroted: 45" wide, 50" deep, 78" high. HF-20CX, 175" wide, 48½" deep, 78" high. Door swing, 40" front and rear. Floor space for external transformers: 5' x 6'.

WEIGHT: (Packed) domestic, 11,000 lbs.; export, 13,900 lbs. Cubage: 1050 cubic feet.

ORDERING INFORMATION

HF-20B, 20 kW broadcast transmitter, 4-22 MHz, with one set of coils, tubes, less crystals	994-4748
HF-20BX, 20 kW broadcast transmitter, with tubes and with keyer added, 4-22 MHz, less crystals	994-4778A
HF-20CX, 20 kW telephone and telegraph transmitter, with tubes and keyer, 4-22 MHz, less crystals	994-4778B
Spare 100% tube kit for HF-20B	990-0139
Spare 100% tube kit for HF-20BX	990-0140
Crystal and holder, .02% accuracy (specify operating frequency)	CR27A/U
Temperature controlled crystal oven holds two CR27A/U crystals for 0.003% accuracy	JK-09C

10,000 Watt High Frequency Broadcast Transmitter

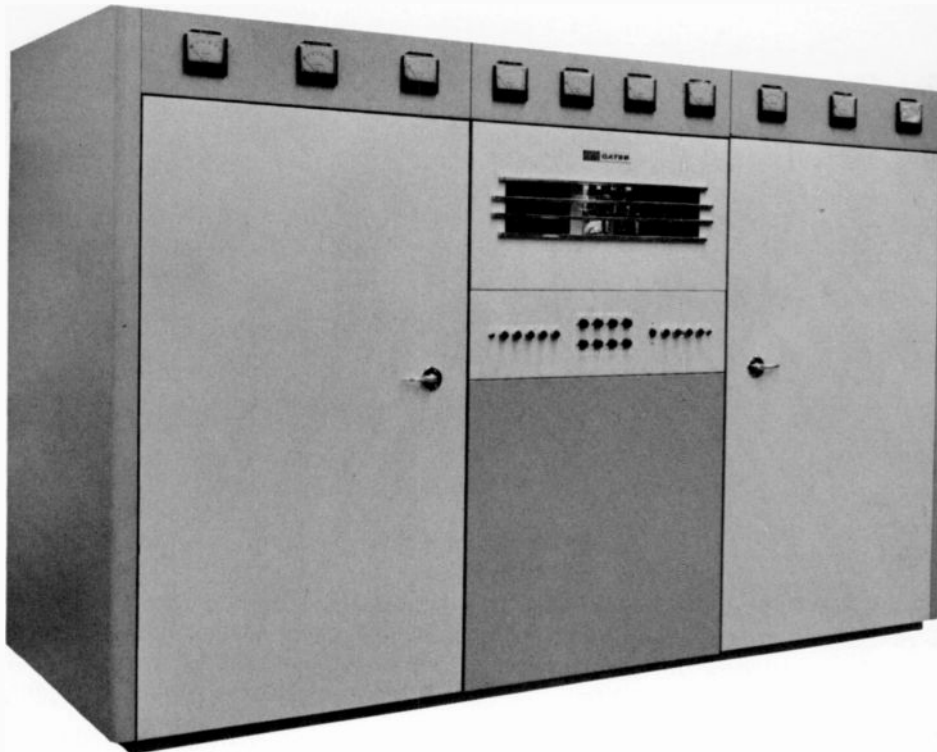

MODEL HF-10B

POWER OUTPUT: 10,000 watts.

FREQUENCY RANGE: 2-22 MHz. (4-30 MHz on special order).

TYPE OF EMISSION: (Model HF-10B) A3. (Models HF-10BX, HF-10CX) A1, A2, A3 and F1 with external frequency shift keyer.

FREQUENCY STABILITY: .003%, with oven.

CARRIER SHIFT: 5% or less at 100% modulation.

RF HARMONICS: Suppression of harmonics meets or exceeds CCIR requirements.

OUTPUT IMPEDANCE: 300 to 800 ohms resistive balanced. (500 ohms with VSWR 1.7 to 1). (50 ohms unbalanced on special order).

POWER LINE REQUIREMENTS: 230 volts, 3 phase, 50 or 60 Hz (as ordered). (Other voltages or line frequencies available on special order.)

POWER FACTOR: 90% or better.

POWER CONSUMPTION: 0% modulation, 21 kW. Average modulation, 23 kW. 100% modulation, 30 kW.

FREQUENCY RESPONSE: (Model HF-10B) ± 1.5 dB, 30-10,000 Hz. (Model HF-10CX) ± 3 dB, 150-4000 Hz.

DISTORTION: (Model HF-10B) 3% or less 50 to 7500 Hz. (Model HF-10CX) 10% or less 150-4000 Hz.

AUDIO INPUT: +15 dBm ± 2 dB.

NOISE: (Model HF-10B) 60 dB or better below 100% modulation. (Model HF-10CX) 45 dB or better below 100% modulation.

CRYSTAL POSITIONS: 4, front panel selected.

TUBES: (2) 6AG7, (2) 4-250A, (2) 6J7, (4) 845, (4) 3X2500F3, (4) 800B, (6) 673, (3) 807, (Keyer is type 812A).

SIZE: 125" wide, 78" high, 48½" deep. Front door swing, 19"; back door swing 40". Size of largest cubicle uncrated: 45" wide, 50" deep, 78" high. (Space required to accommodate optional external oil-filled magnetic components 8' x 3').

WEIGHT AND CUBAGE:

MODEL	DRY COMPONENTS
HF-10B	6600 lbs. domestic packed 6815 lbs. export packed 533 cu. ft.
HF-10CX	6150 lbs. domestic packed 6360 lbs. export packed 523 cu. ft.

ALTITUDE: 6000 feet. (Higher on special order.)

OIL-FILLED COMPONENTS

(Optional)
8000 lbs. domestic packed 10,174 lbs. export packed 566 cu. ft.
6950 lbs. domestic packed 9125 lbs. export packed 533 cu. ft.

ORDERING INFORMATION

HF-10B, 10 kW broadcast transmitter, with tubes, less crystals.....	994-3787
HF-10BX, 10 kW broadcast transmitter, with tubes, electronic keyer, less crystals.....	994-3789
HF-10CX, 10 kW communications telephone and telegraph transmitter, with tubes, less crystals.....	994-3793
HF-10TX, 10 kW communications telegraph transmitter, with tubes, less crystals.....	994-3795
Spare 100% tube kit for all models.....	990-0253
Crystal and holder (.02% accuracy) (specify operating frequency).....	CR27A/U
Temperature controlled oven, holds two CR27A/U crystals, (.003% accuracy).....	JK-09C

NOTES: (1) State line frequency as 50 or 60 Hz. (2) Above models are for 2-22 MHz and with self-contained dry type power components. (3) All models available for 4-30 MHz at slight extra cost. (4) All models available with external oil-filled plate transformer, modulation transformer, and modulation reactor at extra cost. (5) Be sure and state carrier frequency/s, primary voltage and frequency when ordering.

SINGLE SIDEBAND AND COMMUNICATIONS TRANSMITTERS

HARRIS
INTERTYPE
CORPORATION

GATES[®]
A DIVISION OF HARRIS-INTERTYPE

SG-75A/B Synthesized ISB High Frequency Exciter



Gates SG-75 frequency synthesized independent sideband exciter features total solid state design plus extensive use of integrated circuits. It provides a power output of 100 milliwatts over the 2 to 30 MHz range, and has six separate operating modes. Direct digital frequency adjustments on the front panel permit selection of 280,000 frequencies in 100 Hz increments.

A self-contained wideband frequency shift keyer provides a full carrier shifted in frequency ± 400 to 425 Hz about the center frequency. This eliminates the need for an external keyer or tone oscillator and provides the advantages of direct reading of center frequency.

Automatic gain control is used to control the inputs to balanced modulator stages. Controlled carrier level is provided in the lower, upper and independent sideband modes. This carrier level control is automatically turned off in the FSK mode. Carrier level control is on the front panel along with all normal operating controls. The FSK inputs allow polar, neutral and dry contact keying.

The "B" version of the SG-75 provides selectable carrier insertion compatible with CCIR recommendations.

SPECIFICATIONS

FREQUENCY RANGE: 2 to 29.9999 MHz in 100 Hz steps (280,000 channels).
OPERATING MODES: CW (A0, A1), FSK (F1); AME (A3h); USB, LSB (A3a, i); ISB (A3b).

RATED POWER OUTPUT: 100 mW PEP/CW.

FREQUENCY CONTROL: Digital control of stabilized VFO, synthesized.

OUTPUT IMPEDANCE: 50 ohms nominal.

GAIN CONTROL: Automatic with manual override.

TUNING TIME: 10 seconds.

METHOD OF TUNING: Automatic.

SIGNAL TO NOISE RATIO: In band 50 dB. Out of band 60 dB, exclusive of harmonics.

SIGNAL TO DISTORTION RATIO: 50 dB at rated output. (Distortion products: At rated output, 3rd and higher order products are at least 50 dB below either tone of a standard two-tone test signal).

CARRIER LEVEL: Selectable: SG-75A, 0, -6, -20, -55 dB. SG-75B, 0, -6, -16, -26, -55 dB.

STABILITY: 1×10^{-7} per day (optional 5×10^{-9} per day).

UNWANTED SIDEBAND REJECTION: 60 dB at 500 Hz.

AUDIO INPUT: Two independent 600 ohm channels balanced or unbalanced, -20 to +10 dBm for full RF output with independent AGC amplifiers.

AUDIO FREQUENCY RESPONSE: 250 to 3000 Hz or 250 to 6000 Hz with 3 dB maximum ripple.

FSK CAPABILITY: Wideband FSK built in, adjustable from ± 400 to ± 425 Hz (other shifts optional).

POWER INPUT: 115/230 volts, $\pm 10\%$, 47 to 400 Hz, 50 watts maximum, 2 wire, single phase. All power supplies regulated.

TEMPERATURE: 0° to $+50^\circ\text{C}$.

HUMIDITY: 0 to 95%.

ALTITUDE: Sea level to 10,000 feet.

OUTPUT CONNECTOR: Type BNC.

SIZE: 8 $\frac{3}{4}$ " high, 19" wide, 17" deep.

WEIGHT: 56 lbs. net; domestic pack 75 lbs.; export pack 110 lbs.; Cubage: 6 cubic feet.

OPTIONAL REMOTE CONTROL: Electronic with adapter.

COMPONENTS: All components meet MIL specifications where practicable.

NOTE: The SG-75 exciter operates with Gates 1, 3, or 10 kW linear power amplifiers.

ORDERING INFORMATION

SG-75A synthesized HF ISB exciter.....994-6562-003

SG-75B synthesized HF ISB exciter (CCIR compatible).....994-6562-004

SG-70 ISB High Frequency Exciter



Gates Model SG-70 ISB exciter is equipped to transmit single sideband, independent sideband, compatible AM, CW, MCW, or FSK with adapter. Provisions are incorporated for carrier suppression from -50 dB to 0 dB. A versatile and compact unit designed for accurate and rapid channel change and tune-up, the SG-70 has a self-contained silicon rectifier power supply, and requires only $8\frac{3}{4}$ inches in a standard 19-inch rack for mounting.

The input circuits of the SG-70 include two independent 600 ohm balanced or unbalanced input channels and one high impedance microphone channel. The 600 ohm channels will operate the exciter to full power with a minimum input audio level of -12 dB.

Mode selector switches are provided to switch all inputs to either upper sideband or lower sideband operation.

For the accurate and rapid tuning changes required in HF communications, Gates has designed the SG-70 sideband generator to provide increased utilization through simplified operation. Any one of ten crystal controlled channels may be selected immediately by the turn of a knob. A second selector switch chooses one of 15 frequency bands within the 2-32 MHz range.

Then two final adjustments remain, RF tune and injection tune and the exciter is operational. Exceptional frequency stability is achieved through the use of an oven containing the master solid state transistorized frequency oscillator. The absolute drift never exceeds 8 Hz at any point in the spectrum. The solid state power supply is self-contained. The three generator modules—IF frequency generator, RF section, and injection generator—are of the plug-in type.

SPECIFICATIONS

FREQUENCY RANGE: 2-32 MHz continuous, band switched.

POWER OUTPUT: 100 milliwatts PEP.

OUTPUT IMPEDANCE: 50 ohms nominal.

OPERATING MODES: USB, LSB, ISB, AME, CW, MCW, FSK with external adapter.

FREQUENCY CONTROL: Temperature controlled crystals, or optional external VFO or synthesizer.

CRYSTAL POSITIONS: 10. Selectable from front panel, with independent trimmer, or synthesizer.

STABILITY: Better than 1 PPM per day.

CARRIER SUPPRESSION: 0 to -50 dB.

SIGNAL TO DISTORTION RATIO: 45 dB @ rated output. (Distortion products: At rated output, 3rd and higher order products are at least 45 dB below either tone of a standard two-tone test signal.)

SIGNAL TO NOISE RATIO: 55 dB.

UNWANTED SIDEBAND REJECTION: 60 dB at 500 Hz.

AUDIO INPUT: Two independent 600 ohm channels balanced or unbalanced. -12 dBm for full RF output. One high impedance microphone channel requiring 1 mV for full PEP.

AUDIO RESPONSE: 250 to 6350 Hz with a 3 dB maximum ripple. Other bandwidths available.

ENVIRONMENTAL: 0° to -50°C operating, or -50° to $+70^{\circ}\text{C}$ non-operating.

POWER CONSUMPTION: 140 watts.

POWER INPUT: 115/230 volts, $\pm 5\%$, 50/60 Hz, 2 wire, single phase.

SIZE: 19" wide, $8\frac{3}{4}$ " high, 17" deep.

WEIGHT: 56 lbs. net; 90 lbs. export packed. Cubage: 7.5 cubic feet.

NOTE: The SG-70 exciter operates with Gates 1, 3, or 10 kW linear power amplifiers.

ORDERING INFORMATION

SG-70 ISB HF exciter.....994-6411
Complete set of spare tubes.....990-0517

10 kW Automatically Tuned ISB HF Power Amplifier

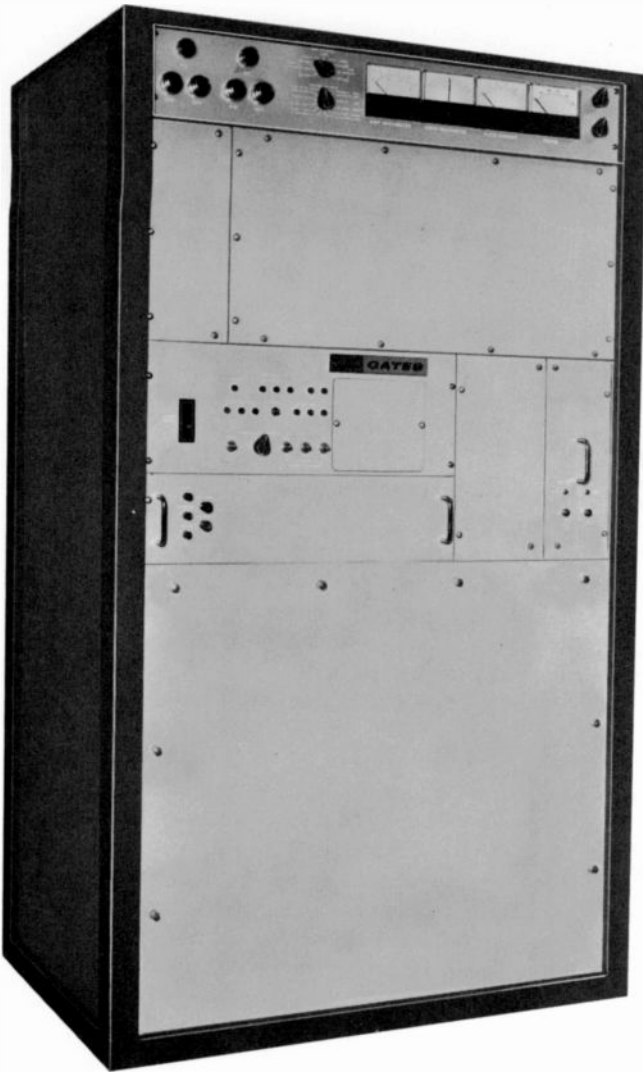

MODEL ATL-10

Designed for operation in high performance SSB transmitting systems, the Gates ATL-10 linear amplifier requires only 0.1 watt RF drive power to tune automatically from 2-30 MHz in 20 seconds or less. Power output is 10 kW peak envelope or average into an antenna load in any mode requiring linear amplification in a 16 kHz bandwidth. A reliable, simplified tune sequence control governs the automatic tuning circuits with a minimum of control information from the exciter. No band information is required. Prepositioning of the tuning elements is achieved directly from information taken from the input RF frequency, thus making the power amplifier suitable for use with any exciter capable of delivering 100 mW of drive power.

A unique feature of the ATL-10 is the use of DC torque motors to position the tuning elements. These are direct-drive motors

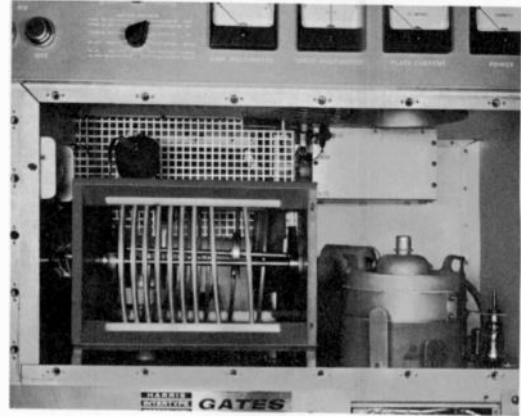

A single 8171/4CX10,000D ceramic tetrode, operating Class AB₁ in a grounded screen configuration, produces the full 10 kW PEP or CW output with maximum stability.

that eliminate much of the mechanical complexity heretofore inherent in automatically tuned equipment. As DC motors are insensitive to power line frequency, the Gates ATL-10 amplifier may be operated from various sources without the need for an optional frequency inverter.

The ATL-10 amplifier, when combined with the Gates SG-75A Exciter, offers full remote control capability. This optional remote control equipment is available to operate both units in a variety of configurations. Combining the SG-75A and ATL-10 produces the advanced STAR-10 sideband transmitter.

RF INPUT: A single type 8233 tube operating Class A in the broad-band input amplifier assures high gain with stability, while maintaining low distortion characteristics. A single type 8321/4CX350A second Class A amplifier also operates completely broad-band. The interstage networks up to and including the input to the driver amplifier are broad-banded and do not require servo tuning.

DRIVER AMPLIFIER: A pair of 8321/4CX350A tubes are operated Class AB₁ to develop satisfactory reserve drive power for the final amplifier grid. Efficiency of this stage is maximized by the use of a parallel tuned matching network to couple into the final amplifier. Approximately 8 dB of RF feedback is applied to the cathode of the driver from the plate circuit of the final amplifier to improve the linearity of these stages.

POWER AMPLIFIER: The final amplifier employs an 8171/4CX10,000D ceramic tetrode operating Class AB₁ in a grounded screen configuration for maximum stability. The grid drive network and plate tank circuits are automatically tuned to resonance by DC control amplifiers and torque motors. The output tuning and loading network is a pi-L filter designed for optimum harmonic rejection and load matching ability. This circuit is capable of matching into a 3:1 VSWR at a full rated power, with optimum loading obtained by the third DC motor and servo system.

10 kW Automatically Tuned ISB HF Power Amplifier—ATL-10

SPECIFICATIONS

- FREQUENCY RANGE:** 2 to 30 MHz.
- OPERATING MODES:** Dependent on type of exciter.
- RATED POWER OUTPUT:** 10 kW PEP or average.
- OUTPUT IMPEDANCE:** 50 ohms with VSWR up to 3:1.
- GAIN CONTROL:** Capable of automatic with proper exciter interface.
- GAIN VARIATION:** 4 dB maximum, 2-30 MHz.
- TUNING TIME:** 20 seconds maximum.
- METHOD OF TUNING:** Automatic, remote.
- HARMONIC OUTPUT:** 2nd, -56 dB below full output, all others 60 dB.
- SIGNAL TO NOISE RATIO:** 50 dB.
- SIGNAL TO DISTORTION RATIO:** Capable of 40 dB, 2 to 27.5 MHz; 38 dB, 27.5 to 30 MHz. Distortion products: At rated output, third and higher order distortion products are at least 40 dB below either tone of a standard two-tone test signal 2 to 26 MHz, and at least 36 dB 26 to 30 MHz.)
- BANDWIDTH:** 25 kHz; 1.5 dB ripple 2 to 4 MHz, 1.0 dB ripple 4 to 30 MHz.
- INPUT IMPEDANCE:** 50 ohms, 1.5:1 VSWR (maximum).
- INPUT CONNECTOR:** Type BNC.
- RF INPUT POWER:** 100 mW maximum for both tune and operate.
- POWER INPUT:** 200, 210, 220, 230, 240 and 250 volts, $\pm 10\%$, 3 phase, 47-63 Hz, 24 kVA at 0.95 power factor, at 10 kW CW.
- TEMPERATURE:** 0° to 50°C.
- HUMIDITY:** 0 to 95%.
- ALTITUDE:** Sea level to 10,000 feet.
- OUTPUT CONNECTOR:** 1½" EIA flange.
- REMOTE CONTROL:** Optional.
- COMPONENTS:** All components meet MIL specifications where practicable.
- SIZE:** 69" high, 40" wide, 27" deep.
- WEIGHT:** 1300 lbs. net. Domestic pack, 1545 lbs. Export pack, 1700 lbs. Cu-
bage: 88.7 cubic feet.

ORDERING INFORMATION

- ATL-10 10,000 watt automatically tuned ISB HF power amplifier, complete with cabinet.....994-6506
- 100% spare tube kit.....990-0574

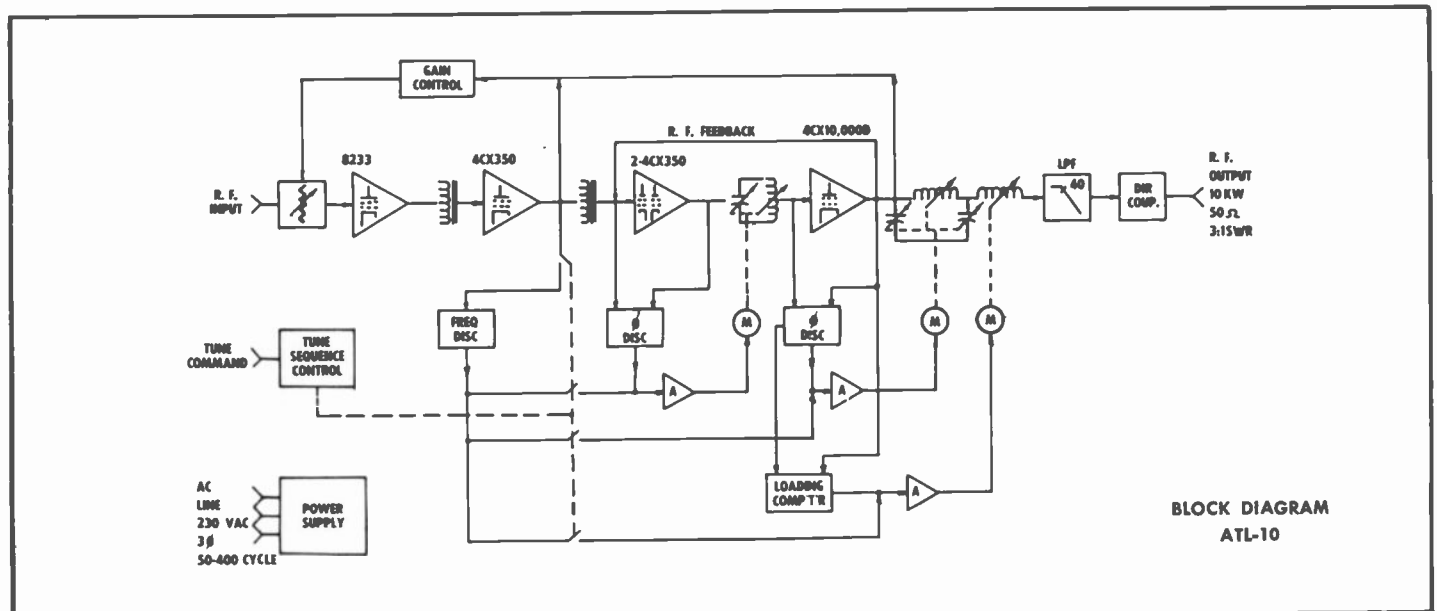
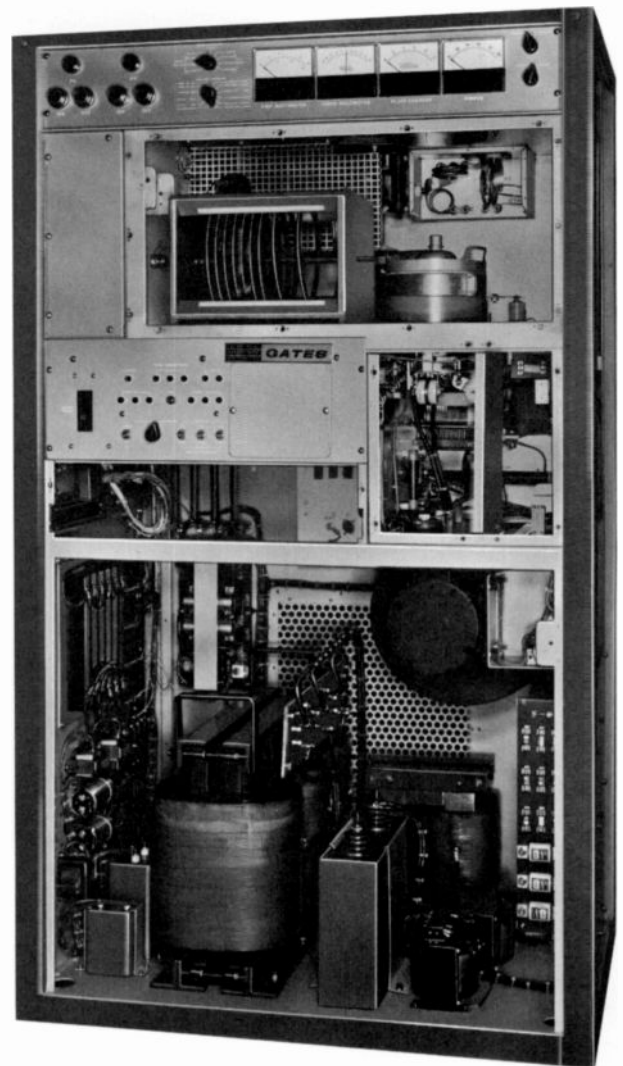

10 kW Automatically Tuned ISB HF Transmitter

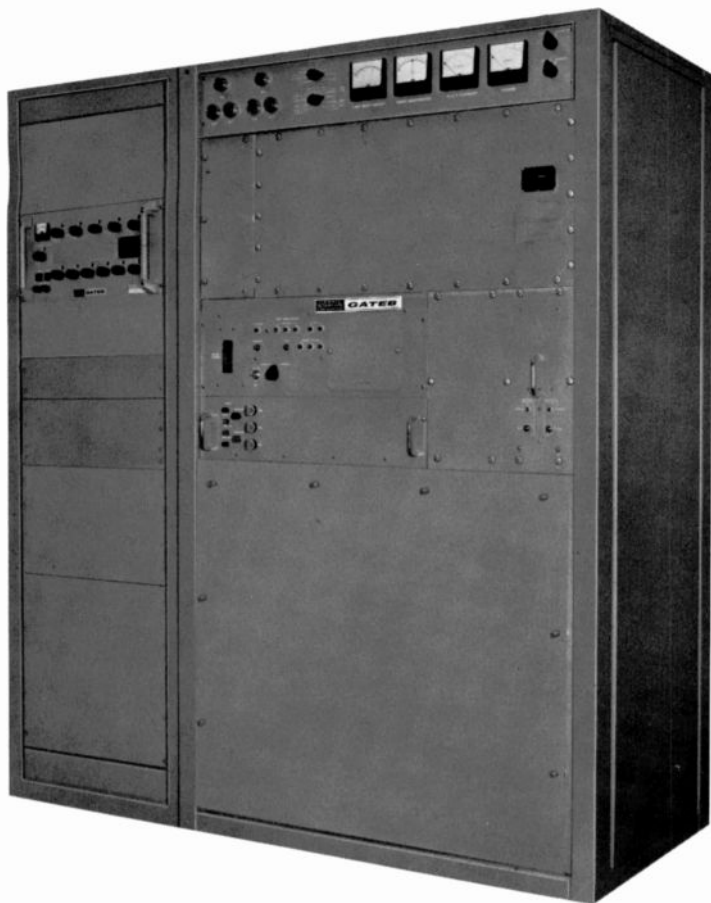

MODEL STAR-10

Totally modern in design, the STAR-10 is a complete 10 kW transmitter for HF communication service. It incorporates a synthesized exciter that generates a total of 280,000 discrete frequencies, spaced every 100 Hz in the 2-30 MHz band; and a linear power amplifier (ATL-10) which provides a full 10 kW on single tone, as well as 10 kW PEP.

An optional remote control system provides selection of ten preset channels. A second optional system provides remote selection of the full 280,000 discrete frequencies available from the exciter.

The STAR-10 can be retuned, and mode or power level changed in less than 25 seconds, from the time the remote control is actuated to the time the final loads.

All components are solid state except LPA tubes. Integrated circuits are used to control digital tuning of the synthesizer. Signal circuits of the exciter, plus the servo control circuit of the LPA, are discrete components.

LOW DISTORTION: Third order distortion products are at least 40 dB below either tone of a two-tone test at rated power output up to 27.5 MHz.



TUNING: Automatic frequency change is accomplished through a sequential control which is activated by a specific "Tune" command and a new reference frequency. The three DC servo motors are operated in closed loop proportional control servo systems to accomplish the actual adjustment. Tuning time is normally 20 seconds or less.

SENSORS AND DETECTORS: The change in frequency is sensed by a frequency discriminator which is coupled to the output of the second broad-band amplifier. This develops an analog signal from which coarse positioning of the tuning and loading components is accomplished. The output of both the driver and the final are sampled by phase detectors and compared with their input signals for a precise determination of resonance. This provides fine tuning adjustments for the plate tank circuit of the driver and final. Final amplifier loading is controlled by sensing the voltage gain of the output stage.

DC SERVO SYSTEMS: The input to the servo system is an operational amplifier with a feedback loop to shape the system response to an error signal. This method of response shaping reduces the system cost and complexity by replacing the tachometer generator with minor electrical components. The servo power amplifier is a direct coupled solid state DC proportional amplifier with a transistor bridge output which provides high efficiency and dynamic braking.

Use of direct-drive DC torque motors provide system stability due to the high torque to inertia ratio (T_a/J_a). Because the motors are directly coupled to the shafts there is no dead zone caused by gear backlash. Since there are no gears involved, and the motors turn at a relatively slow speed, no slip clutch is required.

RF INPUT: A unique light sensitive resistor and DC amplifier circuit in the input stage provides superior gain control while minimizing effects of distortion normally associated with less well isolated control circuits. A single type 8321/4CX350A, a second Class A amplifier, also operates completely broadband. The interstage networks up to and including the input to the driver amplifier are broad-banded and therefore do not require servo tuning.

DRIVER AND FINAL AMPLIFIER: A pair of 8321/4CX350A's, followed by an 8171/4CX10,000D are operated Class AB₁ in a grounded screen configuration for maximum stability. The grid drive network and plate tank circuits are automatically tuned to resonance by DC control amplifiers and torque motors. The output tuning and loading network is a pi-L filter designed for optimum harmonic rejection and load matching ability. This circuit is capable of matching into a 3:1 VSWR at a full rated power, with optimum loading obtained by the third DC motor and servo system.

RF PROTECTIVE DEVICES: All stages of the amplifier are protected against overloading and/or overdriving. The driver input is protected by grid leak biasing. An anode dissipation limiter is utilized to protect the PA from excessive dissipation.

10 kW Automatically Tuned ISB HF Transmitter—Star-10

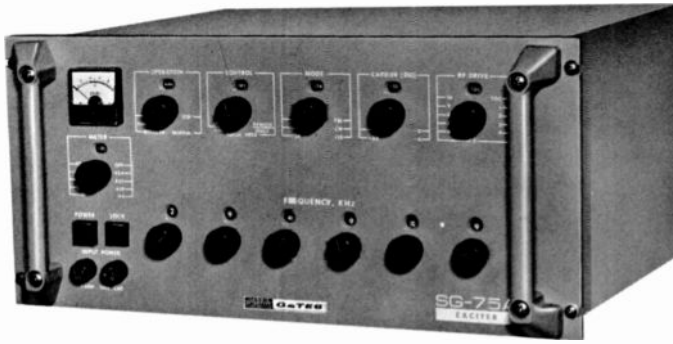

The SG-75A solid state synthesized exciter features front panel selection of 280,000 frequencies in the 2 to 30 MHz range. It operates in the ISB, LSB, USB, AME, CW and FSK modes.

The PA tube and plate supply are protected from current overload by a fast acting relay. A reflected power detector is used to unkey the amplifier and trigger an "excessive SWR" alarm. This protects the final stage against the effects of an SWR which exceeds 3:1.

ENCLOSURE: The entire ATL-10 linear amplifier is contained in a single enclosure measuring 40" wide, 69" high and 27" deep. The power supply is designed for immediate access from the front to all components. The servo control drawer is removable from the front panel and can be serviced while the amplifier is operating. The driver amplifier is also removable as a module for bench servicing. The final grid compartment as well as the final amplifier compartment are enclosed in air tight, RF tight enclosures, in which the cover panels may be removed for direct access.

COOLING: The air for cooling the ATL-10 amplifier is normally brought in through a filtered intake at the front or back of the cabinet. A blower forces the air up through the driver plenum, and into the power amplifier compartment. The majority of the air flows directly through the 8171/4CX-10,000D. The remainder of the air is used to circulate through the PA compartment. All air is exhausted horizontally at the top rear of the cabinet. The ATL-10A has a front air intake, and the ATL-10B has a rear air intake—otherwise the two amplifiers are identical.

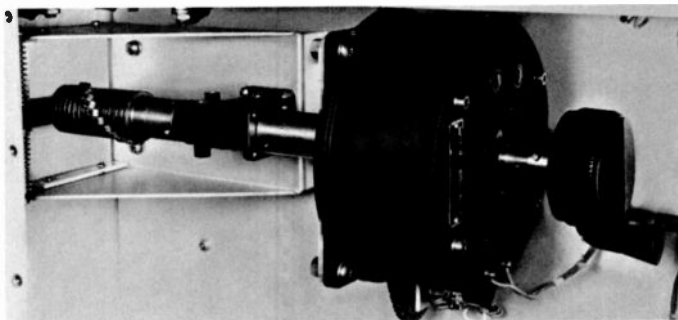

High torque DC servo motors direct coupled to PA circuits assure tuning accuracy. Reliability is enhanced through Gates design using fewer components.

SPECIFICATIONS

- FREQUENCY RANGE:** 29.9999 MHz in 100 Hz steps (280,000 frequencies).
- OPERATING MODES AND RATED POWER OUTPUT:**
- | | |
|------------------------|-------------|
| CW (Ao, A1)..... | 10 kW (av.) |
| FSK (F1)..... | 10 kW (av.) |
| AME (A3h)..... | 10 kW PEP |
| USB, LSB (A3a, j)..... | 10 kW PEP |
| ISB (A3b)..... | 10 kW PEP |
- FREQUENCY CONTROL:** Digital control of stabilized VFO, synthesized.
- OUTPUT IMPEDANCE:** 50 ohms with VSWR up to 3:1.
- GAIN CONTROL:** Automatic with manual override.
- LOAD CONTROL:** Peak power control.
- TUNING TIME:** 25 seconds maximum.
- METHOD OF TUNING:** Automatic, remote.
- HARMONIC OUTPUT:** 2nd, 56 dB below full output. All others, 60 dB.
- SIGNAL TO NOISE RATIO:** 50 dB.
- SIGNAL TO DISTORTION RATIO:** 40 dB. (Distortion products: At rated output at least 40 dB below either tone of a standard two-tone test signal up to 26 MHz and 36 dB 26 to 30 MHz).
- CARRIER LEVEL:** Selectable: 0, -6, -20, -55 dB, or 0, -6, -16, -26, -55 dB.
- CARRIER COMPRESSION:** 1 dB maximum.
- STABILITY:** 1×10^{-7} per day (optional 5×10^{-9} per day).
- UNWANTED SIDEBAND REJECTION:** 60 dB at 500 Hz.
- AUDIO INPUT:** Two independent 600 ohm channels balanced or unbalanced, with independent AGC, -20 to +10 dBm for full RF output.
- AUDIO FREQUENCY RESPONSE:** 250 to 3000 Hz or 250 to 6000 Hz, with 3 dB maximum ripple.
- FSK CAPABILITY:** Wideband FSK built in, adjustable from ± 400 to ± 425 Hz (other shifts optional).
- POWER INPUT:** 200, 210, 220, 230, 240, 250 volts, $\pm 10\%$, 3 phase, 47-63 Hz, 24 kVA at 0.95 power factor at 10 kW CW.
- TEMPERATURE:** 0° to +50°C.
- HUMIDITY:** 0 to 95%.
- ALTITUDE:** Sea level to 10,000 feet.
- OUTPUT CONNECTOR:** 1½" EIA flange.
- OPTIONAL REMOTE CONTROL:** Frequency, operating mode, carrier level, power output, plate on/off and keying.
- COMPONENTS:** All components meet MIL specifications where practicable.
- SIZE:** Amplifier, 69" high, 40" wide, 27" deep. Exciter, 8¾" high, 19" wide, 17" deep. (Exciter rack optional.)
- WEIGHT:** Amplifier; net 1300 lbs., domestic pack 1545 lbs., export pack 1700 lbs. Cubage: 88.7 cubic feet. Exciter; net 56 lbs., domestic pack 75 lbs., export pack 110 lbs. Cubage: 6 cubic feet.

ORDERING INFORMATION

- STAR-10 ISB HF Transmitter, with tubes and silicon rectifiers.....994-6566
- 100% tube kit.....990-0574
- Model CA-10 remote adapter for STAR-10. Permits selection of any one of ten preset frequencies by remote control.....994-6567A
- Model CA-280K remote adapter for STAR-10. Permits selection of 280,000 frequencies by remote control.....994-6567B

1000 Watt ISB HF Transmitter

MODEL ST-1A



A continuous duty sideband transmitter, the ST-1A is conservatively rated at 1000 watts CW as well as PEP. Powers up to 1500 watts (50% overload) may be handled on an intermittent basis without damage to the equipment. The ST-1A is continuously tunable over the entire 2 to 32 MHz range. All tuning can be accomplished in less than two minutes by means of convenient front panel controls.

Designed for operation on any one of 10 crystal controlled channels, with all tuning accomplished by only seven front panel controls and one band switch. The ST-1A will transmit USB, LSB, ISB, AME, CW, MCW and FSK with adapter. Third order distortion products are at least 35 dB below the level one tone of a two-tone test. At maximum power, each of the two independent sidebands has a full 6 kHz capability. Easy access to all components is assured with modular and tilt-over slide out construction used in the compact ST-1A. Maximum attention has been given to efficient cooling for the entire transmitter.

Exceptional frequency stability has been achieved by using a crystal oven containing a transistorized master frequency oscillator. Generator stability of two parts in 10^{-7} is approached at 32 MHz. Data and teletype tone transmission is possible since absolute drift never exceeds 8 Hz at any point in the operating spectrum.

A directional coupler and meter are provided in the ST-1A as standard equipment for power indications. Gates directional watt meter uses two separate circuits to measure forward and reflected RF power in the 50 ohm transmission line.

SPECIFICATIONS

FREQUENCY RANGE: 2-32 MHz continuous, band switched.

POWER OUTPUT: 1000 watts PEP, 1000 watts CW, continuous.

OUTPUT IMPEDANCE: 50 ohms; will match a VSWR up to 2:1.

OPERATING MODES: USB, LSB, ISB, AME, CW, MCW, FSK with external adapter.

FREQUENCY CONTROL: Temperature controlled crystals, or optional external VFO or synthesizer.

CRYSTAL POSITIONS: 10. Selectable from front panel, with independent trimmer, or synthesizer.

STABILITY: Better than 1 PPM per day.

CARRIER SUPPRESSION: 0 to -50 dB.

SIGNAL TO DISTORTION RATIO: 35 dB. (Distortion products: At rated output, 3rd and higher order products are at least 35 dB below either tone of a standard two-tone test signal.)

SIGNAL TO NOISE RATIO: 50 dB.

UNWANTED SIDEBAND REJECTION: 60 dB at 500 Hz.

HARMONICS: Second harmonic, at least 40 dB down; all higher order harmonics, at least 50 dB down.

AUDIO INPUT: Two independent 600 ohm channels balanced or unbalanced. -12 dBm for full RF output. One high impedance mic channel requiring 1 mV for full PEP.

AUDIO RESPONSE: 250 to 6350 Hz with 3 dB maximum ripple. Other bandwidths available.

AUTOMATIC LOAD CONTROL: Provided to limit distortion during high-drive peaks or load changes.

ENVIRONMENTAL: 0° to +50°C operating, or -50° to +70° C non-operating.

POWER CONSUMPTION: Key down CW 3.45 kw, @ approximately 90% power factor.

POWER INPUT: 115/230 volts, single phase, 3 wire, 50/60 Hz.

SIZE: Over-all with optional cabinet: 21" wide, 33 3/4" high, 23 1/2" deep. Amplifier: 12 3/4" high, standard 19" rack mount. Power supply: 8 3/4" high, standard 19" rack mount. Exciter: 8 3/4" high, standard 19" rack mount.

WEIGHT: 375 lbs. net. Domestic packed: 500 lbs. Export packed: 600 lbs. Cubage: 14 cubic feet.

ORDERING INFORMATION

ST-1A ISB HF communications transmitter with tubes and silicon rectifiers, less cabinet.....994-6418
Complete set of spare tubes.....990-0519
Optional ST-1A transmitter cabinet.....952-5967

3000 Watt ISB HF Transmitter

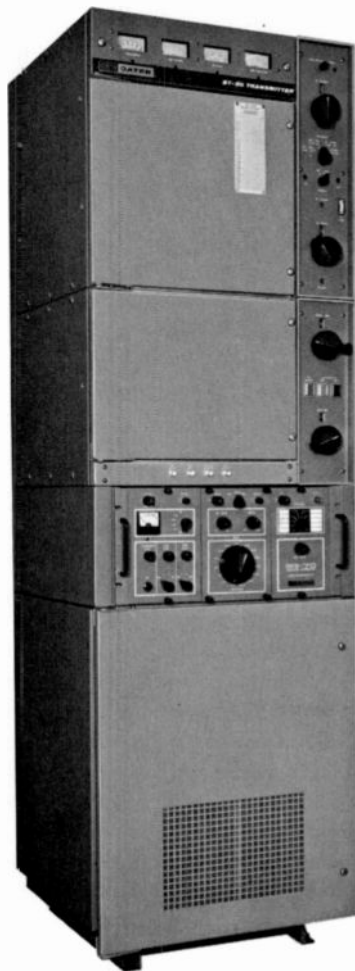

MODEL ST-3A

Gates offers an ISB transmitter with unexcelled performance for high frequency communications service in either fixed station or transportable operation. Conservatively rated at 3000 watts average as well as 3000 watts PEP, the ST-3A transmitter provides SSB, ISB, AME, CW, MCW, and FSK modes of operation.

The ST-3A is a complete transmitter consisting of the SG-70 ISB Exciter, power amplifier and solid state power supply, all in one extremely accessible cabinet.

Designed for operation on any one of 10 crystal controlled frequencies, all tuning is accomplished by only six front panel controls and one channel selector covering the 2 to 30 MHz frequency range.

Mode switches select operation on upper, lower or both sidebands. At maximum power, each of the two independent sidebands has a full 6 kHz capability. Flat crystal filter response provides the capability of effectively multiplexing four 3 kHz channels for voice and teletype communications. Third order distortion products are at least 40 dB below the level of one tone of a two tone test.

The ST-3A transmitter has been designed to provide accurate and rapid tuning. A compact and efficient turret tuner is used to switch each of the 10 crystal controlled positions into one of the 15 frequency bands. This permits tuning the transmitter to a pre-logged frequency, usually within one minute, and at widest extremes, no more than two minutes.

SPECIFICATIONS

FREQUENCY RANGE: 2-30 MHz continuous, band switched.
POWER OUTPUT: 3000 watts PEP, 3000 watts CW, continuous.
OUTPUT IMPEDANCE: 50 ohms; will match a VSWR up to 3:1.
OPERATING MODES: USB, LSB, ISB, AME, CW, MCW, and FSK with external adapter.
FREQUENCY CONTROL: Temperature controlled crystals or optional external VFO or synthesizer.
CRYSTAL POSITIONS: 10; selectable from front panel, with independent trimmer, or synthesizer.
STABILITY: Better than 1 PPM per day.
CARRIER SUPPRESSION: 0 to -50 dB.
SIGNAL TO DISTORTION RATIO: 40 dB. (Distortion Products: At rated output, 3rd and higher order distortion products are at least 40 dB below either tone of a standard two-tone test signal.)
SIGNAL TO NOISE RATIO: 50 dB.
UNWANTED SIDEBAND REJECTION: 60 dB at 500 Hz.

HARMONICS: Second harmonic, at least 50 dB down; all higher order harmonics, at least 60 dB down. Optional filter available.
AUDIO INPUT: Two independent 600 ohm channels balanced or unbalanced. -12 dBm for full RF output. One high impedance mic channel requiring 1 mV for full PEP.
AUDIO RESPONSE: 250 to 6350 Hz with 3 dB maximum ripple. Other bandwidths available.
AUTOMATIC LOAD CONTROL: Provided to limit distortion during high drive peaks or load changes.
ENVIRONMENTAL: 0° to +50°C operating, or -50° to +70°C non-operating.
POWER CONSUMPTION: Key down CW 7.5 kW, @ approx. 90% Power Factor.
POWER INPUT: 208/230/240 volts ±5% 50/60 Hz, 3-phase 3 or 4 wire, plus 115/230 volts, 2 wire.
SIZE: 22" Wide, 72" High, 24" Deep.
WEIGHT: 800 lbs. net. Domestic packed: 925 lbs. Export packed: 975 lbs. Cubage: 41 cubic feet.

ORDERING INFORMATION

ST-3A 3 kW ISB Transmitter with tubes, silicon rectifiers, less crystals.....	994-6492
ST-3A (same as above) with 78 dB factory installed harmonic filter.....	994-6492B
Spare tube kit for above.....	990-0520
HFT-5K 5 kW balun to match 50 ohms to 600 ohms.....	478-0246
Roll out base for ST-3A transmitter.....	994-6477

1000 Watt HF Linear Amplifier

MODEL HFL-1000



Gates HFL-1000 Linear Amplifier at 1000 watts PEP or 1000 watts CW is the smallest, completely self-contained amplifier in its power class. It features 90° tilt type slide mounting for the amplifier and a slide-out power supply which provides complete front panel servicing. Air intake is at the rear of the unit. The amplifier exhaust is on top, and the power supply exhaust is in the rear. The amplifier is designed to operate between 2.0 and 32 MHz and is capable of any type emission not exceeding its power and bandwidth capabilities. The final amplifier is operated class AB₁ at all times.

Ample metering is employed in the HFL-1000 linear amplifier to facilitate tuning and maintenance. A directional coupler with meter is provided as standard equipment for measuring forward or reflected power. The amplifier can be tuned and loaded to full rated output on any operating frequency, using only front panel controls. Tuning is continuous over the entire range without changing components. No air capacitors are used for tuning or loading. Loading is accomplished with band switched ceramic capacitors and a variable vacuum capacitor. Silicon rectifiers are used in all power supplies.

The amplifier and power supply may be mounted in any standard 19' relay rack, or in an optional cabinet.

The amplifier and power supply are manufactured for a wide range of temperature and humidity conditions and can be operated at altitudes up to 10,000 feet above sea level on a continuous basis.

SPECIFICATIONS

FREQUENCY RANGE: 2-32 MHz.

POWER OUTPUT: 1000 watts PEP, 1000 watts CW, continuous.

OUTPUT IMPEDANCE: 50 ohms; will match a VSWR up to 2:1.

OUTPUT CONNECTOR: Type UHF.

RF INPUT POWER: Less than 100 milliwatts driving power to obtain full rated output.

INPUT IMPEDANCE: 50 ohms, nominal.

INPUT CONNECTOR: Type BNC.

BANDWIDTH: 16 kHz or more to the 1 dB point.

HARMONICS: Second harmonic, at least 40 dB down; all higher order harmonics, at least 50 dB down.

SIGNAL TO DISTORTION RATIO: Capable of 35 dB. (Distortion products: At rated output, 3rd and higher order distortion products are at least 35 dB below either tone of a standard two-tone test signal.)

TUNING: Only four tuning controls, all on front panel and 1 band switch.

TUNING TIME: Maximum time required to change frequency between any two previously logged operating frequencies—two minutes.

AUTOMATIC LOAD CONTROL: Provided to limit distortion during high drive peaks or load changes.

POWER SUPPLY: Solid state.

DUTY CYCLE: Continuous at full rated output throughout the full environmental range specified.

ENVIRONMENTAL: 0° to +50°C; 0 to 95% humidity from sea level to 10,000 feet.

POWER INPUT: 115/230 volts, single phase, 3 wire, 50/60 Hz.

POWER CONSUMPTION: Key down CW 3.31 kW @ approximately 90% power factor.

SIZE: Amplifier, 12¼" high x 19" wide. Power supply, 8¾" high x 19" wide.

WEIGHT: 280 lbs. net; 350 lbs. export packed. Cubage: 8 cubic feet.

ORDERING INFORMATION

HFL-1000 1 kW linear amplifier with tubes and silicon rectifiers, less cabinet.....994-6161
Cabinet for HFL-1000.....952-5894
100% spare tube kit.....990-0447

3000 Watt HF Linear Amplifier

MODEL HFL-3000

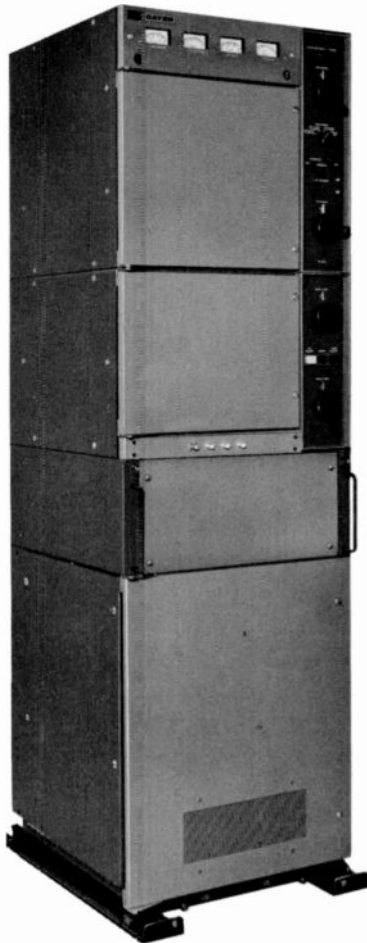

The Gates HFL-3000 linear amplifier is rated at 3000 watts CW/PEP, and is designed to operate between 2 and 30 MHz. It features continuously variable tuning over the entire range and may be excited by any suitable generating equipment delivering 100 mW of power into 50 ohms. Any type of emission not exceeding the amplifier power output or bandwidth ratings is possible.

Important where compactness is desired, such as in multi-transmitter operations or portable installation, the total size of the 3000 watt unit, including self-contained power supply, is only 72" high, 22" wide, and 24" deep. Designed for operation at altitudes up to 10,000 feet on a continuous basis.

The power amplifier operates class AB₁ for all modes of emission. A 4CX3000A power tetrode is used as the final amplifier of the HFL-3000. The amplifier may be quickly tuned and loaded to full rated output at any operating frequency between 2-30 MHz by front panel controls. RF feedback is employed. A directional coupler and meter are provided as standard equipment for measuring either forward or reflected power.

The Gates HFL-3000 RF linear amplifier may be remote controlled through its normal start-stop functions up to nominal distances of several hundred feet.

SPECIFICATIONS

FREQUENCY RANGE: 2-30 MHz.

POWER OUTPUT: 3000 watts PEP, 3000 watts CW, continuous.

OUTPUT IMPEDANCE: 50 ohms; will match a VSWR up to 3:1.

OUTPUT CONNECTOR: Type LC.

RF INPUT POWER: Less than 100 milliwatts driving power to obtain full rated output.

INPUT IMPEDANCE: 50 ohms, nominal.

INPUT CONNECTOR: Type BNC.

BANDWIDTH: 16 kHz or more to the 1 dB point.

HARMONICS: Second harmonic, at least 50 dB down; all higher order harmonics, at least 60 dB down. Optional 78 dB filter available.

SIGNAL TO DISTORTION RATIO: Capable of 40 dB. (Distortion products: At rated output, 3rd and higher order distortion products are at least 40 dB below either tone of a standard two-tone test signal.)

SIGNAL TO NOISE RATIO: 50 dB.

TUNING: Only four tuning controls, all on front panel.

TUNING TIME: Maximum time required to change frequency between any two previously logged operating frequencies—two minutes.

AUTOMATIC LOAD CONTROL: Provided to limit distortion during high drive peaks or load changes.

DUTY CYCLE: Continuous at full rated output throughout the full environmental range specified.

ENVIRONMENTAL: 0° to +50°C; 0 to 95% humidity from sea level to 10,000 feet.

POWER INPUT: 208/230/240 volts $\pm 5\%$, 50/60 Hz, 3-phase, 3 or 4 wire, plus 115/230 volts, 2 wire.

POWER CONSUMPTION: Key down CW 7.45 kW @ approximately 90% power factor.

SIZE: 22" wide, 24" deep, 72" high.

WEIGHT: 660 lbs. net; 930 lbs. export packed. Cubage: 61.4 cubic feet.

ORDERING INFORMATION

HFL-3000 3 kW linear amplifier complete with tubes, silicon rectifiers, less roll out base.....994-6466A
HFL-3000 with optional filter.....994-6466B
Roll out base for HFL-3000.....994-6477
Spare tube kit.....990-0531

Transmitter Control



TYPICAL SPECIFICATIONS

Transmitter control consoles are designed for use with any medium wave or short wave transmitter to provide a convenient and centralized "control center" to operate the transmitter. Gates can design and build consoles for high powered 50 kW or 100 kW transmitters, or for any special application.

AUDIO INPUTS: Three 600 ohm channels provided with line isolation transformers.
OUTPUT: 600 ohms.
MASTER GAIN: Balanced 30 steps, 1.5 dB per step.
VU METER: 4" square case with range control.
MODULATION METER: 4" square case illuminated.
PUSHBUTTONS: Four pairs provided for transmitter start-stop functions.
PILOT LIGHTS: Indicate transmitter filament and plate on.
FINISH: Medium hand rubbed gloss gray with escutcheons in black.

EXTENDED CONTROL AND METERING PANELS

Gates extended control and metering panels are designed to extend basic transmitter meter readings and control functions of a Gates transmitter from a room housing the transmitter to another room in the building. Interconnection over a reasonable distance between the panel and transmitter can be accomplished through the use of a multi-conductor cable. All units are standard 19-inch width for convenient rack mounting.

Metering is accomplished by three easy-to-read 4-inch meters. Plate voltage and plate current indications appear on separate meters. The third meter is used for indicating RF Amperes for an AM transmitter or RF output in kW for an FM transmitter. As remote meter sampling kits are included as standard items in current Gates transmitters, metering is

easily accomplished. For AM transmitters the Gates M-6112 diode units should be added for indication of RF Amperes. The M-6112 is described on page 71.

Control of transmitter filament and plate is facilitated through switches located below the meters. To comply with FCC regulations an additional switch is provided to activate a power raise/lower function. For some AM transmitters a motor-rheostat assembly is required—these units are described on page 71.

Ample space is provided on the panel so that a station can add additional switching or control functions, such as a stereo on-off switch.

ACCESSORY EQUIPMENT



Remote Pickup Equipment—150-450 MHz



M-30BT

NOTE: The M-30BT/TPS and M-20BT/TPS are available with choice of inputs of either 3 microphones, (1 push-to-talk), or 2 microphones (1 push-to-talk) and one 600 ohm line level input. Please specify choice of input configuration.

AVERAGE COVERAGE OVER FLAT TERRAIN OF M-30BT TRANSMITTER

RECEIVING ANTENNA HEIGHT	ANTENNA COMBINATIONS		EXPECTED COVERAGE IN MILES
* 75 ft.	Receiving	Transmitting	
** 150 ft.	5 Element Yagi	Single Ring	9
* 75 ft.	5 Element Yagi	Single Ring	13
** 150 ft.	Stacked 5 Element Yagi's	Single Ring	11
* 75 ft.	Stacked 5 Element Yagi's	Single Ring	15
** 150 ft.	5 Element Yagi	5 Element Yagi	14
* 75 ft.	5 Element Yagi	5 Element Yagi	18
** 150 ft.	Stacked 5 Element Yagi's	5 Element Yagi	16
* 75 ft.	Stacked 5 Element Yagi's	5 Element Yagi	20
** 150 ft.	RA-4 Antenna	Single Ring	10
*** 300 ft.	RA-4 Antenna	Single Ring	14
** 150 ft.	RA-4 Antenna	5 Element Yagi	16
*** 300 ft.	RA-4 Antenna	5 Element Yagi	20

The above measurements are based on a transmitting antenna height of 6 feet above surrounding objects.

CODE:

- * Measurement based on length of RG-8U Transmission Line not to exceed 80 ft.
- ** Measurement based on length of FHJ4 Transmission Line not to exceed 200 ft.
- *** Measurement based on length of 7/8" Heliax Line not to exceed 350 ft.

M-20BT SERIES TRANSMITTER

450-460 MHz

- RF OUTPUT: 20 watts, continuous.
- FREQUENCY RANGE: 450-460 MHz.
- CRYSTAL MULTIPLICATION: 108.
- SPURIOUS EMISSION: Spurious radiation attenuated at least 60 dB below carrier level. Harmonics suppressed at least 60 dB.
- FREQUENCY STABILITY: $\pm 0.0005\%$.
- TEMPERATURE RANGE: -30°C to $+60^{\circ}\text{C}$.
- MODULATION: 100F3 Maximum. (Normally adjusted for ± 20 kHz swing.)
- AUDIO INPUTS: Three. One for push-to-talk mike. Two for 50-150 ohm mike inputs or 600 ohm line input.
- AUDIO INPUT LEVEL: -70 dB.
- AUDIO CONNECTORS: (2) XLR-3-31 and (1) XLR-4-31.
- POWER REQUIREMENTS: 120 VAC and 12.6 VDC. (DC Transistorized Power Supply.)
- MODULATION CONTROL: Solid State Compressor/Limiter.
- NOISE LEVEL OF TRANSMITTER: Better than -45 dB.
- OVERALL RESPONSE WITH MATCHED RECEIVER: ± 2 dB from 60 to 12,500 Hz.
- DISTORTION: Less than 3%.
- FREQUENCIES POSSIBLE: Two: Max. Spacing 500 kHz.
- NET WEIGHT: 17 pounds.
- DIMENSIONS: Portable: 14" wide, 10" long, 7" high. Rack Mounted: 19" wide, 10" long, 10 1/2" high.
- TUBE COMPLEMENT: 16 Transistors, 6 Diodes, 1 Varactor, 6 tubes.

M-30BT SERIES TRANSMITTER

152-172 MHz

- RF OUTPUT: 30 watts, continuous.
- FREQUENCY: 152-172 MHz.
- CRYSTAL MULTIPLICATION: 36.
- SPURIOUS EMISSION: Spurious Radiation attenuated at least 70 dB below carrier level. Harmonics suppressed at least 60 dB.
- FREQUENCY STABILITY: $\pm 0.0005\%$.
- TEMPERATURE RANGE: -30°C to $+60^{\circ}\text{C}$.
- MODULATION: 30 F3 Maximum. (Normally adjusted for ± 7.5 kHz swing.)
- AUDIO INPUTS: Three. One for push-to-talk mike. Two for 50-150 ohm mike inputs or 600 ohm line input.
- AUDIO INPUT LEVEL: -70 dB.
- AUDIO CONNECTORS: (2) Cannon XLR-3-31 and (1) XLR-4-31.
- POWER REQUIREMENTS: 120 Volts AC or 12.6 Volts DC. (Transistorized)
- MODULATION CONTROL: Solid State Compressor/Limiter.
- NOISE LEVEL OF TRANSMITTER: Better than -45 dB.
- OVERALL RESPONSE WITH MATCHED RECEIVER: ± 2 dB from 60 to 7500 Hz.
- DISTORTION IN TRANSMITTER: Less than 3%.
- FREQUENCIES POSSIBLE: Two: Max. Spacing 120 kHz.
- NET WEIGHT: 16 pounds.
- DIMENSIONS: 14" wide, 10" long, and 7" high.
- TUBE COMPLEMENT: 16 Transistors, 6 Diodes, 6 Tubes.

Also available with return communications circuit—base to mobile.

Remote Pickup Equipment—150-450 MHz



MR-30/150 - 170 RECEIVER

SENSITIVITY: 0.6 microvolts or less for 20 dB SNR with low pass filter.
FREQUENCY RANGE: 152-172 MHz.
SELECTIVITY: -100 dB at ± 32 kHz. -6 dB or less at ± 15 kHz.
SPURIOUS RESPONSE: All spurious and image responses attenuated at least 90 dB.
OVERALL RESPONSE: ± 2 dB 60 to 7500 Hz with matching M-30BT transmitter.
FREQUENCY STABILITY: $\pm .0005\%$ with crystal oven.
TEMPERATURE RANGE: -30°C to +60°C.
AUDIO OUTPUT: +8 VU at 600 ohms.
METERING: Signal strength and VU brought out to test jacks. Visual metering optional.
POWER REQUIREMENTS: 120/240 VAC, 50/60 Hz.
DIMENSIONS: 10½" high, 19" wide, 9" deep.
PANEL FINISH: WE Hammertone Gray.
NET WEIGHT: 20 pounds.



MR-100/450 - 460 RECEIVER

SENSITIVITY: 0.6 microvolts or less for 20 dB SNR with low pass filter.
FREQUENCY RANGE: 450-460 MHz.
SELECTIVITY: -90 dB at ± 120 kHz. -6 dB or less at ± 40 kHz.
SPURIOUS RESPONSE: All spurious and image response attenuated at least 85 dB.
OVERALL RESPONSE: ± 2 dB, 60 to 12,500 Hz with matched M-20BT Transmitter.
FREQUENCY STABILITY: $\pm .0005\%$ with crystal oven.
TEMPERATURE RANGE: -30°C to +60°C.
AUDIO OUTPUT: +8 VU at 600 ohms.
METERING: Signal strength and VU brought out to test jacks.
POWER REQUIREMENTS: 120/240 VAC, 50/60 Hz.
DIMENSIONS: 10½" high, 19" wide, 9" deep. Panel finish grey.
NET WEIGHT: 20 pounds.

ORDERING INFORMATION TYPICAL ONE-WAY PACKAGES

150 MHz

1 — M-30BT/TPS Transmitter Portable-mobile, 30 watt, broadcast-quality with c/w tubes, crystal and tuned. 120 VAC and 12.6 VDC	731-0045
1 — TPS-TC mobile control for M-30BT/TPS transmitter.....	731-0047
1 — ASP-143 bumper mount for MA-1 antenna	710-0087
1 — MA-1 Mobile Single Ring Antenna.....	710-0089
1 — PA-1 Portable Single Ring Antenna.....	710-0088
1 — MR-30/150-170 Receiver, Rack Mount, broadcast-quality continuous-duty, with tubes, crystal and tuned. 120 VAC. 600 ohm output.....	731-0046
1 — RA-4 4-bay Base Antenna.....	710-0086
150 — Feet FHJ4-50B Heliac foam filled, ½", jacketed transmission line.....	618-0171
2 — 44AU UHF jack, for use with FHJ4-50B.....	620-0301
1 — PG-4A pigtail, 4' RG-8A/U cable with plugs.....	731-0218
1 — PG-4B pigtail, 4' RG-8A/U cable with connectors.....	731-0182

450 MHz

1 — M-20BT/TPS Transmitter, Portable-mobile, 20 watt, broadcast-quality, continuous-duty, with c/w tubes, crystal and tuned. 120 VAC and 12.6 VDC.....	731-0254
1 — TPS-TC mobile control for M-20BT/TPS transmitter.....	731-0047
1 — ASP-406 Rooftop antenna, mobile, vertically, polarized	710-0111
1 — MR-100/450-460 Receiver, Rack Mount, broadcast-quality, 120 VAC. 600 ohm output.....	731-0187
1 — ASP-313 Base Antenna, colinear, 6 dB gain.....	710-0112
2 — ASP-320 Mounting Clamps for ASP-298 and ASP-313.....	710-0113
150 — Feet FHJ5-50A heliac, ¾", 50 ohm jacketed.....	618-0172
2 — 45AU UHF jack, for use with FHJ5-50A.....	620-0317
1 — PG-4B pigtail, 4' RG-8A/U cable with connectors.....	731-0182
1 — PG-4C pigtail, 4' RG-8U with UG-21C/U and UG-23B/U connectors.....	731-0257

ACCESSORIES

SR-90R Turner microphone, carbon, for local control of M-25C.....	720-0187
RMC-1C remote control consolette, solid state, complete with transistors, power supply.....	731-0199
DFT Dual frequency kit for M-30BT, M-30BT/TPS and M-30BT/CD, less crystal.....	731-0162
DFR Dual Frequency kit for MR-30BT/150-170 and M-25/150-170C, less crystal.....	731-0163
XT-1A Hi-Accuracy Crystal for M-30BT/TPS, M-30BT/CD and M-25C.....	731-0165
XR-1A Hi-Accuracy Crystal for MR-30BT/150-170 and M-25/150-170C	731-0166

Studio-Transmitter Link—890-960 MHz



The Model PCL-303 Studio-Transmitter Link provides a high-quality audio channel between a broadcast studio and a remote transmitting site.

It has been developed specifically for application in broadcast service. Designed for continuous service, it operates in accordance with Subpart E, Part 74, of the FCC Rules and Regulations. It is available for all STL bands—domestic and foreign.

From the operational maintenance standpoint, multicircuit metering has been provided. Utilizing front panel meters, all significant circuits can be measured at the turn of a knob. The equipment is furnished with rack-mounted slides for easy inspection. Interstage shielding is used where required, with equipment covers—top and bottom—being provided for each unit.

TRANSMITTER: The true, direct FM principle of modulation is employed in these STL transmitters. To ensure the required output frequency stability, a thoughtfully-engineered auto-

matic frequency control (AFC) system is utilized. Here's how it works:

An extremely stable basic oscillator is modulated with a pair of variable capacitance (varicap) diodes. The frequency of this basic FM oscillator (approximately 78 MHz) is divided by 1024 using a binary divider chain which employs high-speed, integrated circuit (IC) elements.

This divided output is phase compared to the output of a reference crystal (oven-controlled) oscillator, and the resultant error voltage is used to phase lock the basic oscillator to the crystal. Low-frequency modulation components have negligible effect on the AFC lock as a result of the high-frequency division ratio (1024) employed in the basic oscillator. The phase-locked output of the direct FM basic oscillator is multiplied and power amplified; in the PCL-303 it is further tripled to the output frequency with a parametric multiplying diode.

An RF cavity filter at the transmitter output attenuates spurious signals to at least 60 dB below rated power output, and

Studio-Transmitter Link—890-960 MHz

an integral sampling probe feeds a panel meter to continuously monitor relative output power. A quiet, dependable, blower fan cools the final transistor power chain. The fully-regulated and protected power supply is self-contained and maintains stable power output with line voltage variations from 105 VAC to 130 VAC.

An input audio filter removes unwanted program components above 17 kHz. This effectively reduces the crosstalk (in all multiplex channels) which may be caused by spurious high-frequency noise in the program line.

Standard 75 microsecond pre-emphasis is also incorporated in the program input. BNC connectors, for inserting remote control and SCA subcarriers, and a 5-pin connector, used when the STL transmitter is remotely controlled, appear on the rear of the chassis.

RECEIVER: This is a conventional double-conversion, crystal-controlled, superheterodyne receiver with a self-contained, regulated power supply. Signals from the antenna input are passed through a five-cavity RF pre-selector which is used

ahead of a low-noise, input mixer diode (Schottky barrier type).

The first IF (72 MHz) section consists of a three-stage FET amplifier employing AGC and designed for low noise and medium bandwidth characteristics. The second IF section (10.7 MHz) is an amplifier exhibiting exceptionally sharp skirts and linear phase characteristics. These characteristics are achieved by a ten-pole, active filter slightly overcoupled to give the desired response. Less distortion to high-frequency modulation components are ensured by this design. The ratio detector affords better rejection of impulse noise and adjacent channel interference.

The audio section, utilizing an operational amplifier, is a wide-band, low-noise, low-distortion type amplifier incorporating a 75 microsecond de-emphasis network. A carrier-operated squelch relay silences all output should the carrier be lost or if the power fails. Contacts for external carrier alarm use are located on the back of the chassis, as are the two BNC connectors for subcarrier outputs. A 600 ohm output-to-line transformer and a 17 kHz low-pass elliptical filter complete this section.

SYSTEM SPECIFICATIONS

FREQUENCY RESPONSE: $\pm 1/2$ dB from 30 Hz to 15,000 Hz.
DISTORTION: Less than 0.5% from 50 Hz to 15,000 Hz.
SIGNAL-TO-NOISE RATIO: Better than 68 dB (–65 dB for PCL-202) below 100% modulation.

MODULATION CAPABILITY: One program and two subcarrier channels.
PRIMARY POWER SOURCE: 120/240 VAC, $\pm 10\%$ 50-60 Hz.
PANEL SPACE REQUIRED: 5 1/4" x 19"—transmitter or receiver.

OPERATING SPECIFICATIONS

TRANSMITTER

TYPE: Direct FM.
RF OUTPUT: 7 watts minimum; 8 watts maximum into nominal 50 ohm load—Type N female connector.
FREQUENCY STABILITY: Better than 0.001% (0° to 55°C); Crystal mounted in temperature controlled oven.
MULTIPLICATION: 12 times basic oscillator frequency.
AM NOISE: Better than 75 dB below carrier reference.
DEVIATION: ± 40 kHz for 100% modulation.
SPURIOUS EMISSIONS: More than 60 dB below carrier.
AUDIO INPUT: 600 ohms balanced; +10 dBm for 100% modulation.
MULTIPLEX INPUTS: Two BNC connectors provided for subcarrier channels in 25-100 kHz spectrum; approximately 1.0 volt rms for 20% deviation.
SOLID-STATE DEVICES: All silicon; 15 transistors (JEDEC), 14 diodes, 5 varicaps, 11 IC's, 1 varactor.
POWER SUPPLY: Fully regulated, self-contained.
COOLING: Convection and forced.
DIMENSIONS: 5 1/4" x 19" x 16".

RECEIVER

TYPE: Superheterodyne—double conversion and crystal controlled.
ANTENNA INPUT: Nominal 50 ohms impedance—Type N female connector.
SENSITIVITY: Less than 3 microvolts for 20 dB quieting. Requires only 35 microvolt signal for 60 dB quieting.
SELECTIVITY: 200 kHz.
AUDIO OUTPUT: 600 ohms balanced; +10 dBm.
MULTIPLEX OUTPUTS: Two BNC connectors; 1.0 volt peak-to-peak per subcarrier for 20% subcarrier injection at transmitter.
SOLID-STATE DEVICES: All silicon; 19 diodes, 21 JEDEC registered transistors (18 bi-polar, 3 field effect), 1 IC.
POWER SUPPLY: Zener regulated—self-contained.
DIMENSIONS: 5 1/4" x 19" x 14".

Transmitting and Receiving Tubes



8806



8807



4CX5000A



833-A

FAST-MOVING INVENTORY

Gates carries thousands of tubes in inventory—which, because of fast turnover, are always fresh. This is of vital importance, particularly for large transmitting tubes, where long shelf periods can make tubes gaseous. Listed below are a few of the popular tube types in stock—many others are also on hand. All tubes carry full warranty.

HOW TO ORDER

Tubes may be ordered from Quincy, Houston, or New York. Shipment will be made as you direct—air freight, rail express, etc. Prices are no more at Gates—and you have the assurance of tube freshness. Please place your order by tube type and IBM number. Example: Type 3CV30000CH3-----374-0108.

TRANSMITTING TUBES

Type	Number	Type	Number
3CV30000H3	374-0108	833A	374-0039
3CX2500A3	374-0094	845	374-0040
3CX2500F3	374-0093	866A	374-0042
4-125A	374-0008	872A	374-0043
4-250A	374-0009	885	378-0008
4-400A	374-0010	1612	370-0146
4CX250B	374-0081	1622	370-0149
4CX300A	374-0014	6076	374-0050
4CX1000A	374-0015	6146	374-0051
4CX3000A	374-0074	6360A	374-0054
4CX5000A	374-0016	6528	370-0160
4CX10000D	374-0077	7480	374-0107
4CX15000A	374-0097	8008	374-0058
4X250B	374-0019	8806	374-0118
575A	374-0026	8807	374-0119
673	374-0027	8122	374-0096
807	374-0030	8792	374-0117
810	374-0031	7289	374-0115
813	374-0034	WL5891	374-0067

RECEIVING TUBES

Type	Number	Type	Number
OA2	370-0144	6CA7	370-0066
OA3/VR75	370-0005	6CD6GA	370-0069
OD3/VR150	370-0008	6L6GC	370-0086
GZ34/5AR4	370-0133	6SH7	370-0093
5BP1A	378-0003	6SJ7	370-0094
5R4GY	374-0020	6SQ7	370-0098
5U4GB	370-0017	6V6GT	370-0102
5V4GA	370-0230	6X4	370-0105
5Y3GT	370-0020	6X5GT	370-0106
5749	370-0153	6080	370-0158
5879	370-0155	6386	370-0213
6AH6	370-0027	12A7	370-0112
6AL5	370-0030	12AU7A	370-0195
6AS7GA	370-0036	12AX7	370-0116
6BG6GA	370-0052	12AY7	370-0117
6C5	370-0065	12BY7A	370-0123

FCC AND FAA SPECIFICATIONS

This chart illustrates the requirements for the standard lighting of antenna towers and supporting structures in accordance with "Indicated paragraphs of FCC Form 715 and FCC Rules Part 17", and "FAA Standards for Marking and Lighting Obstructions to Air Navigation, Sept. 1962".

Aeronautical study by the FCC and FAA may determine that other than standard lighting is required for a specific tower installation. The FCC Construction Permit will specify the required lighting for each installation and should be carefully checked for this information.

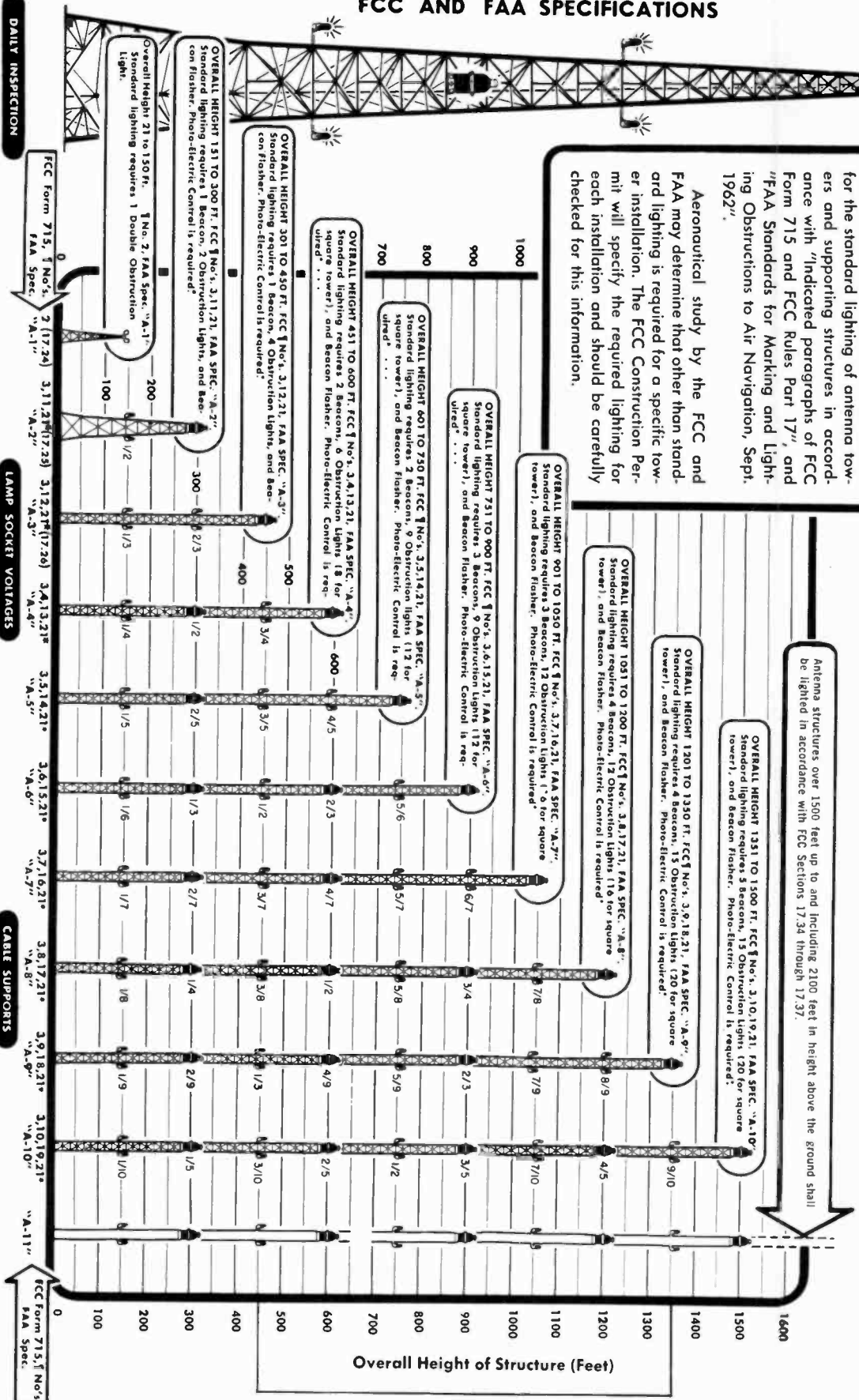

DAILY INSPECTION

FCC Form 715 Paragraph 21 states: "All lights shall burn continuously or shall be controlled by a light sensitive device . . ."

LAMP SOCKET VOLTAGES

FCC Form 715 Paragraph 21 states: "The lamp socket voltage shall be within 3% of the rated voltage of the lamp used."

CABLE SUPPORTS

The National Electric Code specifies that conductors in vertical runs shall be supported by cable supports at intervals not greater than 100 ft.

INDEX

Item	Page	Item	Page
AM Antenna Couplers, Accessories	28, 29	Cabinets, Tape	180
AM Broadcast Accessories	33	Cabinets, Transcription	180, 195, 198 thru 201
AM Frequency Monitor	32	Cable, Audio	197
AM Limiting Amplifier	166, 167	Cable, Coaxial	72
AM Modulation Monitor	30, 31	Capacitors, Mica	80
AM Transmitters	6 thru 23	Cartridge Recorder/Reproducer Equipment	154
Air Dielectric Coaxial Cable	72		160 thru 162
Ambassador Audio Console	140, 141	Cartridges, Pickup	196
Ampex Tape Recording Equipment	204 thru 206	Cartridges, Tape	163
Amplifiers, Audio Plug-In	172 thru 174	Chokes, Tower	29
Amplifiers, Cueing	178	Circularly Polarized FM Antennas	56 thru 61
Amplifiers, High Frequency Linear	220, 221, 226, 227	Coaxial Cable and Accessories	72 thru 75
Amplifiers, Limiting	166 thru 171	Coils, RF	80
Amplifiers, Monitor	176, 177	Coils, Isolation	28
Amplifiers, Program or Line	176	Common Point Impedance Bridge	26
Amplifiers, Remote Broadcast	186 thru 191	Communications Equipment	210 thru 228
Amplifier, RF FM	67	Connectors, Audio	180
Amplifiers, Transistorized—System Type	172 thru 174	Conrac TV Monitors	116
Amplifier, Utility (single channel)	177	Consoles, Audio Control	120 thru 147
Antenna Couplers	28	Console, Portable Audio	202
Antenna Diode Units for Remote Control	71	Consoles, Speech Input	120 thru 147
Antenna Meter, Remote	28	Consoles, Transmitter Control	228
Antenna Phasing Equipment	24, 25	Console Desks	198 thru 201
Antenna Towers, AM, FM, TV	78	Control, Remote	70, 71
Antenna Tower Accessories	79	Couplers, Antenna	28
Antenna Tuning Equipment	28, 29	Courier, 2-Channel Remote Amplifier	189
Antennas, Cycloid	62	Criterion Compact Tape Cartridge Equipment	161
Antennas, Dual-Cycloid	56 thru 61	Criterion 80 Tape Cartridge Equipment	160
Antennas, Dummy	34	Cueing Amplifier	178
Antennas, FM Circular	56 thru 61	Cue-Intercom Speaker	179
Antennas, FM Directional	58, 59	Cycloid Antenna	62
Antennas, FM Horizontal	62		
Antennas, FM Vertical	62	Desks, for Audio Control Consoles	198 thru 201
Arms, Pickup	196	Demagnetizer, Tape Head	181
Attache, 3-Channel Remote Amplifier	188	Desk Stands, Microphone	181
Audio Accessories	178 thru 185	Diode and Pickup Coil	28, 71
Audio Amplifiers, System Type	172 thru 174	Diplomat Audio Control Console	135 thru 137
Audio Consoles	120 thru 147	Directional Antenna, FM	58, 59
Audio Installations	148	Directional Antenna Phasing Equipment	24, 25
Audio Oscillator	203	Distortion Meter	203
Audio Terminal Blocks	180	Dual-Cycloid FM Antenna	56, 57
Automatic Gain Control Amplifier, Audio	170, 171	Dual-Cycloid II FM Antenna	60
Automation, Program Systems	150 thru 158	Dual-Cycloid III FM Antenna	61
		Dualux II Audio Control Console	120 thru 122
Baffles and Speakers	182, 183	Dummy Antennas	34
Base Station, Remote Pickup	230, 231	Dynamote 70, 4-Channel Remote Amplifier	186, 187
Base, Turntable	198 thru 201		
Beacon Flashers	79	Equalized Preamplifiers	197
Boom Stands	181	Eraser, Bulk-Type Tape	181
Broadcast Modulation Monitors	30, 31, 64 thru 66	Exciter, FM	36, 37
Bowls, Feed-Thru	77	Exciters, HF	218, 219
Broadcast Transmitters—AM, FM, TV	6 thru 23	Exciter/Driver, UHF-TV	102, 103
	38 thru 54, 82 thru 109	Executive Audio Control Console	132 thru 134
Cabinets, Console	198 thru 201	FM Antenna Towers	78
Cabinets, Compact Disc for LP Albums	180	FM Antennas	56 thru 62
Cabinets, Rack	114, 175	FM Exciter, DCFM	36, 37

INDEX

Item	Page	Item	Page
FM Frequency Comparator, Pilot-SCA	67	Meter, Remote Antenna	28
FM Frequency Monitor	67	Meter, VU, Desk or Console Top Mounting	179
FM Isolation Transformers	63	Meter, VU and Range Panel	178
FM Limiting Amplifier	168, 169	Meter Shorting Switch	29
FM Link and Relay Systems	55, 230 thru 233	Mica Capacitors	80
FM Monitors	64 thru 67	Microphone Accessories	181
FM RF Amplifier	67	Microphones	184, 185
FM Relay Receiver	55	Modular Audio Equipment Cabinets	198 thru 201
FM SCA Generator	37	Modulation Monitor, AM	30, 31
FM Stereo Generator	37	Modulation Monitors, FM	64 thru 66
FM Transmitters	38 thru 54	Monitor Amplifiers	176, 177
Fader Knobs	179	Monitor, Frequency, AM	32
Feed-Thru Bowls	77	Monitor, Frequency, FM	67
Field Intensity Meter	33	Monitor, Modulation, AM	30, 31
Flexible Coaxial Cable	72	Monitors, Modulation, FM	64 thru 66
Floor Stands, Microphone	181	Monitor, Phase	33
Foam Dielectric Coaxial Cable	72	Monitors, Television	116, 117
Frequency Comparator, FM Pilot-SCA	67	Multiplex Generator, SCA	37
Frequency Monitor, AM Model M4990	32	Music Tapes, Pre-recorded	159
Frequency Monitor Extension Meters	71		
Frequency Monitor, FM	67	Open Wire Transmission Line	77
Furniture, Control Room	198 thru 201	Operating Impedance Bridge	27
		Oscillator, Audio	203
Gain Measuring Set	203		
GateSound Tapes	159	Panel and Shelf Assemblies	174
Gatesway II Audio Control Console	123 thru 125	Patch Panels and Patch Cords	179
Generator, Stereo	37	Peak Limiting Amplifier	166, 167
Generator, Sub-Carrier	37	Phasing Equipment	24, 25
		Phase Monitor	33
High Frequency Exciters	218, 219	Pickup Arms	196
HF Transmitters, Broadcast	210 thru 216	Pickup Cartridges	196
HF Transmitters, Communications	218 thru 227	Pickup Coil and Rectifier	203
Headphones	181	Pilot-SCA Frequency Comparator	67
Heliac Coaxial Cable	72	Portable Turntable/Audio Console	202
High Frequency Linear Amplifiers	220, 221, 226, 227	Power Supply, Plug-In Audio Amplifiers	173
		Preamplifiers, Turntable	197
Inductors	80	President Audio Control Console	138, 139
Installations Audio	148	Pressurization Equipment	75, 76
Installations, Transmitter	68, 118	Producer, Audio Recording Mixer	146, 147
Intercom, Studio Sub-Station	179	Program Amplifiers, Rack Mount	172 thru 177
Isolation Coil	28	Program Automation Systems	150 thru 158
Isolation Transformers, FM	63	Program Logging, Automatic	158
		Program Tapes, Pre-recorded	159
Jack Strips and Accessories	179	Programmers, Automation System	152, 153
KD-20A Portable Console	202	Proof of Performance Equipment	203
Lights, Studio Warning	178	RF Amplifier, FM	67
Lights, Tower Accessories, etc.	79	RF Contactor	29
Limiting Amplifiers	166 thru 171	RF Meter	28
Linear Amplifiers, High Frequency	220, 221, 226, 227	RF Meter Jack	29
Load, Dummy Antenna	34	Rack Cabinets	114, 175
Loudspeakers & Enclosures	182, 183	Random Access Programmers	155
		Recorders, Audio	160, 204 thru 208
Magnecord Recorder/Reproducers	208	Recorders, Audio Cartridge	160
Meter, Field Intensity	33	Recorders, Reel-to-Reel	204 thru 208
Meter, RF	28	Relay System, FM	230 thru 233
		Remote Amplifiers, Audio	186 thru 191

INDEX

Item	Page	Item	Page
Transmitters (High Frequency Broadcast)		Unique, Cueing Amplifier	178
100,000 Watt Model SW-100 Transmitter ...	210 thru 213	Unimote 70, 1-Channel Remote Amplifier	190
50,000 Watt Model SW-50 Transmitter	211, 213	Utility Audio Amplifier	177
20,000 Watt Model HF-20B Transmitter	214, 215	VA Program Fader Knobs	179
10,000 Watt Model HF-10B Transmitter	216	Vertically Polarized FM Antenna	62
Transmitter, Remote Pickup	230, 231	VHF Television Transmitters	82 thru 101
Transmitter, STL	55, 232, 233	VP-100, 100,000 Watt AM Transmitter	6 thru 8
Transmitting Tubes	234	VP-50, 50,000 Watt AM Transmitter	9 thru 11
Tubes, Transmitting, Receiving	234	VU Meter, Desk or Console Top	179
Tuning Units, Antenna	28, 29	VU Meter and Range Panel	178
Turntable, Portable Audio Console	202	Wall Baffles	183
Turntable Preamplifiers	197	Warning Lights, Studio	178
Turntables and Accessories	192 thru 197	Yagi Antennas, Remote Pickup Equipment	230, 231
TV Towers	78	Yard II Audio Control Console	126 thru 128
UHF Television Transmitters	102 thru 109		

The mechanical and electrical design of the equipment described herein is subject to change without notice as deemed necessary by Gates Radio Company or its suppliers in the interest of advancing industry requirements or the state of the art.

INDEX

Item	Page	Item	Page
Remote Antenna Meter	28, 71	Transfer Switch, RF	75
Remote Control Accessories	71	Transformers, FM Isolation	63
Remote Control Systems	70, 71	Transformers, Ring	29
Remote Monitoring Meters	71	Transformer, Speaker Matching	179
Remote Pickup Equipment	55, 230, 231	Transistors	235
Rigid Transmission Line	72	Transmission Line, Coaxial	72
Ring Transformer	29	Transmission Line, Open Wire	77
Sampling Loops	29	Transmitters (Broadcast/AM)	
SCA Modulation Monitor	66	100,000 Watt Model VP-100 Transmitter	6 thru 8
SCA Multiplex Generator	37	50,000 Watt Model VP-50 Transmitter	9 thru 11
SCA Multiplex Monitor	66	20,000 Watt Model BC-20H Transmitter	12, 13
Scully Tape Recording Equipment	207	10,000 Watt Model BC-10H Transmitter	14 thru 16
Semiconductor Directory	235	5,000 Watt Model BC-5H Transmitter	17 thru 19
Sideband Generator	218, 219	1,000/250 Watt Model BC-1G Transmitter	20, 21
Single Sideband Generator, SG-70	219	500 Watt Model BC-500G Transmitter	22
Single Sideband Generator, SG-75A/B	218	250 Watt Model BC-250GY Transmitter	23
Single Sideband Transmitters	220 thru 227	Transmitters (Broadcast/FM)	
Solid Statesman Peak Limiting Amplifier	166, 167	40,000 Watt Model FM-40H3 Transmitter	38, 39
Speech Input Systems	120 thru 147	20,000 Watt Model FM-20H3 Transmitter	40, 41
Speakers and Baffles	182, 183	10,000 Watt Model FM-10H3 Transmitter	42, 43
Speaker Matching Transformer	179	5,000-7,500 Watt Models FM-5H/7.5H3 Transmitters	44, 45
Splicers, Tape	181	3,000 Watt Model FM-3H3 Transmitter	46, 47
Stands, Microphone	181	2,000 Watt Model FM-2H3 Transmitter	48, 49
Stereo Generator	37	1,000 Watt Model FM-1H3 Transmitter	50, 51
Stereo Modulation Monitor	64	250 Watt Model FM-250H3 Transmitter	52
Stereo Producer Audio Recording Mixer	144, 145	50 Watt Model BFE-50C Transmitter	53, 54
Stereo Statesman Audio Control Console	129 thru 131	50 Watt Model BFR-50C Transmitter	53, 54
STL Systems, FM	55, 232, 233	10 Watt Model BFE-10C Transmitter	53, 54
Studio Cue/Intercom Speaker	179	50 Watt FM Relay System	55
Studioette Audio Control Console	142, 143	50 Watt STL System	55
Studio Warning Lights	178	Transmitters (Communications)	
Sub-Carrier Generator	37	20,000 Watt Model HF-20CX Transmitter	215
Switch and Fuse Panel	178	10,000 Watt Model HF-10CX Transmitter	216
Switch, Meter Shorting	29	Transmitters (Single Sideband)	
Tape Cartridge Equipment	160 thru 164	10,000 Watt Model ATL-10 Transmitter	220, 221
Tape Cartridges and Accessories	163, 164	10,000 Watt Model STAR-10 Amplifier	222, 223
Tape Cartridge Storage Units	164	3,000 Watt Model ST-3A Transmitter	225
Tape Eraser, Bulk-Type	181	3,000 Watt Model HFL-3000 Amplifier	227
Tape Head Demagnetizer	181	1,000 Watt Model ST-1A Transmitter	224
Tape Recorders	204 thru 208	1,000 Watt Model HFL-1000 Amplifier	226
Tape Splicer	181	Transmitters (UHF Television)	
Television Accessory Equipment	110 thru 117	220,000 Watt Model BT-220U Transmitter	108, 109
Television Monitors	116, 117	110,000 Watt Model BT-110U Transmitter	106, 107
Television Transmitters	82 thru 109	55,000 Watt Model BT-55U Transmitter	104, 105
Terminal Blocks, Audio	180	Transmitters (VHF Television—High Band and Low Band)	
Test Equipment, Audio	203	35,000 Watt Model BT-35 Transmitter	82 thru 84
Tone Arms	196	25,000 Watt Model BT-25 Transmitter	85 thru 87
Tower Chokes	29	18,000 Watt Model BT-18 Transmitter	88 thru 90
Tower Lighting	236	13,000 Watt Model BT-13 Transmitter	91
Tower Lights and Accessories	79	5,000 Watt Model BT-5 Transmitter	92 thru 95
Towers, Antenna, AM, FM, TV	78	1,300 Watt Model BT-1300 Transmitter	96 thru 99
Transcription Turntables, Amplifiers and Accessories	192 thru 197	120 Watt Model BT-100 Transmitter	100, 101
Transcription Tone Arms and Pickups	196		



PRICE LIST

(Applies to Catalog #99, Effective January 1, 1971)

This is your price list for items listed in your Gates catalog. Each price has been carefully checked for accuracy. Rapidly changing conditions as well as the human element, will necessitate price changes or corrections from time to time. Therefore, the prices herein are subject to change without notice. — All prices are F. O. B. Quincy, Illinois or point of manufacture.

CAT. PAGE	TYPE NUMBER	PRODUCT DESCRIPTION	UNIT PRICE	CAT. PAGE	TYPE NUMBER	PRODUCT DESCRIPTION	UNIT PRICE
8	994-6561	Model VP-100 with one set of tubes and two crystals	120,000.00		990-0540	100% set spare transistors for BC-5H (diodes not included)	186.00
	990-0566	100% set spare tubes for VP-100 transmitter	6,206.00		994-6548	Kit for remote control of power output	375.00
	990-0567	Recommended minimum spare tubes for VP-100 transmitter	3,481.00	21	994-6245-001	BC-1G transmitter, 1000/250 watts, solid state rectifier model, with tubes, and 1 vacuum crystal	6,450.00
11	994-6523	Model VP-50 with one set of tubes and two crystals	97,500.00		994-6245-003	BC-1G transmitter, 1000/250 watts, tube rectifier model, with tubes and 1 vacuum crystal	6,250.00
	990-0537	100% set of spare tubes for VP-50 transmitter	3,395.00		990-0471	Spare 100% tube complement for 994-6245 model	310.00
	990-0538	Recommended minimum spare tubes for VP-50 transmitter	2,701.00		990-0472	Spare 100% tube complement for 994-6245B model	340.00
13	994-6669	Model BC-20H transmitter, consisting of two standard BC-10H 10 kW transmitters, a 20kW combiner and a common drive unit	51,450.00		994-6326	Output power remote control kit	185.00
16	994-6522	Model BC-10H transmitter with one set of tubes and two crystals	23,500.00	22	994-6333	Model BC-500G AM broadcast transmitter, 500 watts, with tubes, one crystal, silicon rectifiers	5,995.00
	990-0539	100% set spare tubes for BC-10H transmitter	870.00	22	990-0481	Spare 100% tube complement for BC-500G	218.00
	990-0540	Set of spare transistors for BC-10H (diodes not included)	186.00		990-0479	Recommended minimum spare tube kit for BC-500G	85.00
	994-6548	Kit for remote control of power output	375.00	23	994-3760-005	BC-250GY Transmitter, 250 watts, complete with one set of tubes and one vacuum crystal	4,995.00
19	994-6521-003	Model BC-5H transmitter with one set of tubes and two crystals	20,500.00		990-0507	Spare 100% set of tubes	185.00
	990-0535	100% set spare tubes for BC-5H transmitter	665.00		990-0508	Recommended minimum set of spare tubes	99.00

CAT. PAGE	TYPE NUMBER	PRODUCT DESCRIPTION	UNIT PRICE	CAT. PAGE	TYPE NUMBER	PRODUCT DESCRIPTION	UNIT PRICE
26	700-0055	CPB-1 Common Point Impedance Bridge, 5 kW ----	545.00				
	700-0056	CPB-1A Common Point Impedance Bridge, 50 kW ----	595.00				
27	700-0063	Model OIB-1 Operating Impedance Bridge. Specify whether 12" or 18" leads are desired -----	595.00				
	700-0064	D. C. Amplifier. Used to increase sensitivity of Bridge for use with power sources as low as 25 watts -----	63.00				
	700-0065	TC-1 Transport Case. For OIB-1 -----	90.00				
28	ANTENNA COUPLER 1250 WATTS						
	994-3494	44A, antenna coupling unit for 1000 watts or less. Note: Does not include tower chokes, diode or line current meter -----	595.00				
	SERIES & SHUNT FEED COUPLERS						
	994-5178	M-5178 antenna coupler for direct feed to series fed antenna. Note: For 250, 500 and 1000 watt transmitters, metering not included. Non-weatherproof.	310.00				
	994-5179	M-5179 antenna coupler for direct feed to shunt fed antenna. Note: For 250, 500 and 1000 watt transmitters, metering not included. Non-weatherproof.	310.00				
	ISOLATION COIL						
	994-3073-003	M-3073, using 1/2", 50 ohm foam heliax FH4, coil only on mfg. plate. In weatherproof housing ---	330.00				
	994-4561-003	M-4561, using 1/2", 50 ohm foam heliax FH4, coil only on mfg. plate. Less cabinet. -----	235.00				
28	5-10kW ANTENNA COUPLING UNITS						
	994-5309A	M-5309A (special) antenna coupling unit for 5000 watts AM. Note: Does not include tower chokes, diode or line current meter	1,100.00				
	994-5309B	M-5309B (special) antenna coupler for 10,000 watts A.M. Note: Does not include tower chokes, diode or line current meter ----	1,495.00				
						R.F. ANTENNA METERS	
				634-0206	308 Weston 0-3 RF Int. Thermo Std. Scale -----	49.00	
				634-0238	308 Weston 0-6 RF Int. Thermo Std. Scale -----	76.50	
				634-0209	308 Weston 0-8 RF Int. Thermo Std. Scale -----	49.00	
				634-0210	308 Western 0-10 RF Int. Thermo Std. Scale -----	49.00	
					DIODE TYPE REMOTE METER EQUIPMENT		
				994-6112	M-6112 solid state diode assembly. For all powers 250 watts through 50 kW. Meter not included -----	95.00	
				632-0418	Meter 0-1 MA DC, Westinghouse RX351. With 0-3 amps RF scale face, 3' case -----	40.00	
				632-0419	Same as above, 0-5 amp scale face -----	40.00	
				632-0420	Same as above, 0-8 amp scale face -----	40.00	
				632-0421	Same as above, 0-10 amp scale face -----	40.00	
				632-0424	Meter 0-1MA DC RX-371 Westinghouse with 0-5 amp scale face -----	45.00	
				632-0426	Same as above, 0-8 amp scale face -----	45.00	
				632-0361	Same as above, 0-10 amp scale face -----	45.00	
				632-0428	Same as above, 0-15 amp scale face -----	45.00	
				29	SOLENOID TOWER CHOKES		
				994-3937	M-3937 tower choke, 2 section weatherproof ----	160.00	
				994-3938	M-3938 tower choke, 3 section weatherproof ----	185.00	
				994-3935	M-3935 tower choke, 2 section unhusd -----	90.00	
				994-3936	M-3936 tower choke, 3 section unhusd -----	115.00	
				29	RADIO FREQUENCY CONTACTOR		
				570-0001	145-101-13, SPDT 17,000 peak voltage, 25 amps current -----	130.00	

CAT. PAGE	TYPE NUMBER	PRODUCT DESCRIPTION	UNIT PRICE	CAT. PAGE	TYPE NUMBER	PRODUCT DESCRIPTION	UNIT PRICE
570-0002	145-102-13,	DPDT 17,000 peak voltage, 25 amps current -----	145.00		710-0057	A-1973 transformer, 2-3 KVA, pedestal. With lightning gap -----	375.00
570-0003	145-201-13,	SPDT 22,000 peak voltage, 25 amps current -----	155.00	31	994-6659	Solid-State AM Modulation Monitor -----	795.00
570-0004	145-202-13,	DPDT 22,000 peak voltage, 23 amps current -----	175.00		994-6687	Remote Meter Panel -----	100.00
HEAVY DUTY SAMPLING LOOP				32	994-4990	Frequency Monitor with tubes -----	1,050.00
994-6126	Fixed, non-shielded sampling loop -----		190.00		994-5631	Remote Control Extension Meter -----	100.00
ROTATING PHASE SAMPLING LOOPS					990-0281	Spare 100% tube kit for monitor -----	17.00
994-3283	M-3283A sampling loop, shielded, insulated and adjustable 83-15 PN UHF type connector -----		195.00	33	PHASE MONITOR		
METER JACK AND SHORTING BAR-MOUNTING PLUG					731-0200	Phase Monitor, two towers, Clarke 112 -----	1,395.00
994-3280	M-3280 meter jack and shorting bar -----		17.00		731-0201	Phase monitor, three towers, Clarke 112 -----	1,445.00
994-3281	M-3281 meter mounting plug -----		12.00		731-0202	Phase monitor, four towers, Clarke 112 -----	1,495.00
994-6527	Meter shorting switch, rating 40 amperes -----		68.00		731-0203	Phase monitor, five towers, Clarke 112 -----	1,545.00
994-3493	Meter shorting switch, rating 15 amperes -----		38.00		731-0204	Phase monitor, six towers, Clarke 112 -----	1,595.00
RING TYPE TOWER CHOKE					FIELD INTENSITY METER		
710-0051	A-2100 transformer, 1-1.75 KVA side bracket. No lightning gap -----		319.00	700-0001	120E field intensity meter, less batteries -----		1,150.00
710-0052	A-2101 transformer, 1-1.75 KVA side bracket. With lightning gap -----		330.00	34	DUMMY ANTENNAS		
710-0053	A-2102 transformer, 1-1.75 KVA pedestal. No lightning gap -----		319.00	994-3968-001	DU-551 5 kW dummy antenna, air cooled, 50 ohm -----		450.00
710-0054	A-2103 transformer, 1-1.75 KVA pedestal. With lightning gap -----		330.00	994-3968-002	DU-570 as above, 70 ohm -----		450.00
710-0055	A-1970 transformer, 2-3 KVA, side bracket. Without lightning gap -----		357.00	994-6107	M-6107 10 kW dummy antenna, air cooled, 50 ohms -----		625.00
710-0031	A-1971 transformer, 2-3 KVA, side bracket. With lightning gap -----		375.00	994-5497-001	M-5497 50 kW dummy antenna, water cooled -----		5,000.00
710-0056	A-1972 transformer, 2-3 KVA, pedestal. No lightning gap -----		357.00	994-5497-002	M-5497A as above, 2-25 MHz -----		5,000.00
				WDL-1000A	Dummy antenna, 100kW, high frequency -----	On Request	
				994-4354	DU-151 1 kW dummy antenna, air cooled, 50 ohms -----		160.00
				994-3483	DU-170 Dummy Antenna, 1 kW, 70 ohms -----		160.00
				FM BROADCAST TRANSMITTERS			
				39	994-6746	FM-40H3, 40,000 watt FM broadcast transmitter with TE-3 exciter -----	59,990.00

CAT. PAGE	TYPE NUMBER	PRODUCT DESCRIPTION	UNIT PRICE	CAT. PAGE	TYPE NUMBER	PRODUCT DESCRIPTION	UNIT PRICE
	994-6770	FM-20/20H3, 20,000/20,000 watt FM broadcast transmitter, with TE-3 exciter. No combining network-feeds horizontal and vertical antennas separately -----	56,790.00	49	994-6741	FM-2H3 2000 watt FM broadcast transmitter with TE-3 exciter -----	9,995.00
	994-6533	Stereo Generator (add for stereo operation) -----	1,295.00		990-0587	100% spare tube kit -----	200.00
	994-6507	SCA Sub-carrier generator (add for SCA operation) --	595.00		994-6563	Stereo generator -----	1,295.00
41	994-6745	FM-20H3, 20,000 watt FM broadcast transmitter, with TE-3 exciter -----	27,995.00		994-6507	SCA sub-carrier generator ..	595.00
	990-0552	100% spare tube kit -----	766.00	51	994-6740	FM-1H3 1000 watt FM broadcast transmitter with TE-3 exciter -----	7,595.00
	994-6533	Stereo generator (add for stereo operation) -----	1,295.00		990-0550	100% spare tube kit -----	200.00
	994-6507	SCA sub-carrier generator (add for SCA operation) --	595.00		994-6533	Stereo generator (add for stereo operation) -----	1,295.00
43	994-6744	FM-10H3, 10,000 watt FM broadcast transmitter, with TE-3 exciter -----	19,995.00		994-6507	SCA sub-carrier generator (add for SCA operation) --	595.00
	990-0551	100% spare tube kit -----	629.00	52	994-6739	FM-250H3, 250 watt FM broadcast transmitter ----	5,995.00
	994-6533	Stereo generator (add for stereo operation) -----	1,295.00		374-0081	Spare tube 4CX250B -----	35.60
	994-6507	SCA sub-carrier generator (add for SCA operation) --	595.00		994-6533	Stereo generator (add for stereo operation) -----	1,295.00
45	994-6736	FM-5H3, 5000 watt FM broadcast transmitter with TE-3 exciter -----	15,595.00		994-6507	SCA sub-carrier generator (add for SCA operation) -----	595.00
	994-6743	FM-7.5H3, 7500 watt FM broadcast transmitter with TE-3 exciter -----	17,995.00	54	994-5594-003	BFE-10C 10 watt transmitter with one set of tubes, crystal and oven, 50/60 Hz -----	1,495.00
	990-0549	100% spare tube kit for either of above -----	530.00		990-0391	100% set spare tubes ----	42.00
	994-6533	Stereo generator (add for stereo operation) -----	1,295.00		990-0488	Mfg. recommended minimum tube kit -----	24.00
	994-6507	SCA sub-carrier generator (add for SCA operation) --	595.00		994-5595-003	BFE-50C, 50 watt FM transmitter, 88-108 MHz, with tubes and crystal -----	2,350.00
47	994-6742	FM-3H3 3000 watt FM broadcast transmitter with TE-3 exciter -----	12,595.00		990-0489	100% set spare tubes ----	54.00
	990-0549	100% spare tube kit -----	530.00		990-0490	Mfg. recommended minimum tube kit -----	30.00
	994-6533	Stereo generator (add for stereo operation) -----	1,295.00		994-5599	BFR-50C, 50 watt transmitter \pm 75 kHz swing, 130-170 MHz, 50/60 Hz operation -----	2,650.00
	994-6507	SCA sub-carrier generator (Add for SCA operation) --	595.00		710-0102	FM-11 Single Ring Educational (88-108 MHz) FM antenna -----	210.00
					710-0103	FM-22 Double Ring Educational (88-108 MHz) FM antenna -----	420.00

CAT. PAGE	TYPE NUMBER	PRODUCT DESCRIPTION	UNIT PRICE	CAT. PAGE	TYPE NUMBER	PRODUCT DESCRIPTION	UNIT PRICE
55	FM BROADCAST LINK & RELAY SYSTEM			FMC-8	8-Bay 3-1/8" line -----	7,450.00	
994-5599	BFR-50C 50 watt FM transmitter -----	2,650.00			Same as above, with heaters	9,050.00	
731-0009	Receiver, 125-175 MHz ... On Request		FMC-9	9-Bay 3-1/8" line -----	8,365.00		
3605A	2-Corner reflector, high gain, broadband antennas ... On Request			Same as above, with heaters	10,165.00		
RG-8/U	100'-Coaxial Cable ----- On Request		FMC-10	10-Bay 3-1/8" line -----	9,295.00		
8235	100'-Twin line 300 ohms ... On Request			Same as above, with heaters	11,295.00		
FML-50D	Complete system as described above ----- On Request		FMC-11	11-Bay 3-1/8" line -----	10,225.00		
994-5595	BFE-50C 50 watt FM transmitter -----	2,350.00		Same as above, with heaters	12,425.00		
731-0003	Receiver, 88-125 MHz ... On Request		FMC-12	12-Bay 3-1/8" line -----	11,150.00		
994-5594-003	BFE-10C Alternate Transmitter for shorter distances: 10 watt FM transmitter, 88-108 MHz -----	1,495.00		Same as above, with heaters	13,550.00		
710-0103	FM-22 Two ring FM transmitting antenna, gain 1.6 ...	420.00	FMC-13	13-Bay 3-1/8" line -----	12,075.00		
LPL-FM-6	1-FM receiving antenna ... On Request			Same as above, with heaters	14,675.00		
RG-8/U	100'-Coaxial Cable, for transmitter ----- On Request		FMC-14	14-Bay 3-1/8" line -----	13,020.00		
8235	100'-Twin line 300 ohms, for receiver ----- On Request			Same as above, with heaters	15,820.00		
FML-50ND	Complete 50 watt system described above ----- On Request		FMC-15	15-Bay 3-1/8" line -----	13,965.00		
FML-10ND	Complete 10 watt system using alternate transmitter described above ----- On Request			Same as above, with heaters	16,965.00		
57	DUAL CYCLOID CIRCULARLY POLARIZED FM ANTENNA			FMC-16	16-Bay 3-1/8" line -----	14,860.00	
FMC-1	1-Bay 3-1/8" line -----	1,050.00		Same as above, with heaters	18,060.00		
	Same as above, with heaters	1,250.00	59	DUAL CYCLOID DIRECTIONAL FM ANTENNA			
FMC-2	2-Bay 3-1/8" line -----	1,990.00	FMC-1DA	1-Bay -----	3,800.00		
	Same as above, with heaters	2,390.00		Same as above, with heaters	4,200.00		
FMC-3	3-Bay 3-1/8" line -----	2,790.00	FMC-2DA	2-Bay -----	5,200.00		
	Same as above, with heaters	3,390.00		Same as above, with heaters	6,000.00		
FMC-4	4-Bay 3-1/8" line -----	3,720.00	FMC-3DA	3-Bay -----	6,600.00		
	Same as above, with heaters	4,520.00		Same as above, with heaters	7,800.00		
FMC-5	5-Bay 3-1/8" line -----	4,650.00	FMC-4DA	4-Bay -----	8,000.00		
	Same as above, with heaters	5,650.00		Same as above, with heaters	9,500.00		
FMC-6	6-Bay 3-1/8" line -----	5,575.00	FMC-5DA	5-Bay -----	9,300.00		
	Same as above, with heaters	6,775.00		Same as above, with heaters	11,300.00		
FMC-7	7-Bay 3-1/8" line -----	6,510.00	FMC-6DA	6-Bay -----	10,700.00		
	Same as above, with heaters	7,910.00		Same as above, with heaters	13,100.00		
			FMC-7DA	7-Bay -----	12,100.00		
				Same as above, with heaters	14,900.00		
			FMC-8DA	8-Bay -----	13,500.00		
				Same as above, with heaters	16,600.00		
			60	DUAL CYCLOID II FM ANTENNA			
			FMC-4B	4-Bay -----	2,815.00		
				Same as above, with heaters	3,355.00		
			FMC-5B	5-Bay -----	3,420.00		
				Same as above, with heaters	4,095.00		
			FMC-6B	6-Bay -----	4,025.00		
				Same as above, with heaters	4,835.00		
			FMC-7B	7-Bay -----	4,630.00		
				Same as above, with heaters	5,575.00		

CAT. PAGE	TYPE NUMBER	PRODUCT DESCRIPTION	UNIT PRICE	CAT. PAGE	TYPE NUMBER	PRODUCT DESCRIPTION	UNIT PRICE
	FMC-8B	8-Bay ----- Same as above, with heaters	5,230.00 6,315.00		FMA-7A	Seven ring, 1-5/8" -----	3,865.00
	FMC-9B	9-Bay ----- Same as above, with heaters	5,840.00 7,055.00		FMA-7B	Seven ring, 3-1/8" -----	4,115.00
	FMC-10B	10-Bay ----- Same as above, with heaters	6,440.00 7,790.00		FMA-8A	Eight ring, 1-5/8" -----	4,360.00
	FMC-11B	11-Bay ----- Same as above, with heaters	7,045.00 8,530.00		FMA-8B	Eight ring, 3-1/8" -----	4,725.00
	FMC-12B	12-Bay ----- Same as above, with heaters	7,650.00 9,270.00		FMA-10A	Ten ring, 1-5/8" -----	5,460.00
					FMA-10B	Ten ring, 3-1/8" -----	5,880.00
					FMA-12A	Twelve ring, 1-5/8" -----	6,565.00
					FMA-12B	Twelve ring, 3-1/8" -----	7,090.00
61	DUAL CYCLOID III FM ANTENNA			62	CYCLOID ANTENNA HEATERS		
	FMC-1A	1-Bay ----- Same as above, with heaters	605.00 740.00		FMH-300	300 Watt heaters (per bay)	115.00
	FMC-2A	2-Bay ----- Same as above, with heaters	1,210.00 1,480.00		FMH-600	600 Watt heaters (per bay)	175.00
	FMC-3A	3-Bay ----- Same as above, with heaters	1,815.00 2,220.00		TYPE 300G FM ANTENNAS (no heaters required)		
	FMC-4A	4-Bay ----- Same as above, with heaters	2,415.00 2,995.00		300G-1	Single bay—1-5/8" ----- 3-1/8" -----	570.00 670.00
	FMC-5A	5-Bay ----- Same as above, with heaters	3,020.00 3,695.00		300G-2	Two bay—1-5/8" ----- 3-1/8" -----	1,100.00 1,175.00
	FMC-6A	6-Bay ----- Same as above, with heaters	3,625.00 4,435.00		300G-3	Three bay—1-5/8" ----- 3-1/8" -----	1,640.00 1,765.00
	FMC-7A	7-Bay ----- Same as above, with heaters	4,230.00 5,175.00		300G-4	Four bay—1-5/8" ----- 3-1/8" -----	2,185.00 2,350.00
	FMC-8A	8-Bay ----- Same as above, with heaters	4,830.00 5,915.00		300G-5	Five bay—1-5/8" ----- 3-1/8" -----	2,730.00 2,940.00
62	CYCLOID FM RING ANTENNA				300G-6	Six bay—1-5/8" ----- 3-1/8" -----	3,280.00 3,530.00
	FMA-1A	One ring, 1-5/8" -----	567.00		300G-7	Seven bay—1-5/8" ----- 3-1/8" -----	3,865.00 4,120.00
	FMA-2A	Two ring, 1-5/8" -----	1,105.00		300G-8	Eight bay—1-5/8" ----- 3-1/8" -----	4,360.00 4,725.00
	FMA-2B	Two ring, 3-1/8" -----	1,175.00		300G-10	Ten bay—1-5/8" ----- 3-1/8" -----	5,460.00 5,880.00
	FMA-3A	Three ring, 1-5/8" -----	1,640.00		300G-12	Twelve bay—1-5/8" ----- 3-1/8" -----	6,565.00 7,090.00
	FMA-3B	Three ring, 3-1/8" -----	1,765.00		63	FM ISOLATION TRANSFORMERS	
	FMA-4A	Four ring, 1-5/8" -----	2,185.00		620-0397	Isolation transformer, Type 402, standard EIA 1-5/8" adjusted to cus- tomer's operating fre- quency at factory, for use with a maximum transmit- ter power of 7.5 kW -----	1,000.00
	FMA-4B	Four ring, 3-1/8" -----	2,350.00				
	FMA-5A	Five ring, 1-5/8" -----	2,730.00				
	FMA-5B	Five ring, 3-1/8" -----	2,940.00				
	FMA-6A	Six ring, 1-5/8" -----	3,275.00				
	FMA-6B	Six ring, 3-1/8" -----	3,530.00				

CAT. PAGE	TYPE NUMBER	PRODUCT DESCRIPTION	UNIT PRICE	CAT. PAGE	TYPE NUMBER	PRODUCT DESCRIPTION	UNIT PRICE
	620-0415	Isolation transformer, Type 402, with standard 3-1/8" flanges, adjusted to customer's operating frequency, for use with a transmitter power up to and including 10kW -----	1,210.00				
	620-0444	25 kW Isolation transformer, Type 425, standard 3-1/8" flanges, adjusted to customer's operating frequency, for use with a transmitter up to and including 25 kW -----	2,940.00				
63	FM ANTENNA ACCESSORIES						
	710-0139	Antenna heater control system -----	875.00				
	710-0136	Dual-Cycloid replacement antenna heater elements (2 elements per bay) ----	65.00				
	710-0137	Dual-Cycloid II replacement antenna heater elements (2 elements per bay) -----	65.00				
	710-0138	Cycloid replacement antenna heater elements (2 elements per bay) -----	35.00				
64	FM MODULATION MONITORS						
	994-6569	Gates GTM-88S stereo modulation monitor, tuned to customer's operating frequency -----	2,495.00				
65	994-6581	Gates GTM-88M FM monophonic modulation monitor	1,695.00				
66	994-6591-003	GTA-6741 SCA Modulation adapter -----	1,650.00				
67	FM ACCESSORIES						
	994-6588	Gates GTM-88F FM frequency monitor, specify operating frequency -----	695.00				
	994-6603-003	Gates GTA-88F, 19 kHz, pilot and SCA 67 kHz and 41 kHz frequency comparator. Used in conjunction with Gates stereo and monaural modulation monitor -----	450.00				
	994-6614-003	GTM-88R FM RF amplifier complete with antenna, less interconnecting cable	650.00				
				70	REMOTE CONTROL SYSTEM		
					994-5862-001	RDC-10AC, remote control system including studio unit, transmitter unit, plate current and voltage kits and one tower light metering unit. Unit provides total of 23 control functions. Ten metering positions are available. Four are permanently used for the fundamental readings ---	1,390.00
					994-5862-002	RDC-10AC remote control system including studio unit and transmitter unit only .	1,250.00
					994-6112	M-6112 AM antenna diode for all powers. (Inductive coupled unit) -----	95.00
					994-4703-001	M-4703 motor and rheostat assembly for most 250 watt transmitters -----	160.00
					994-4703-002	M-4703 motor and rheostat assembly for most 500 watt transmitters -----	170.00
					994-4703-003	M-4703 motor and rheostat assembly for most 1000 watt transmitters ---	185.00
					994-5066	M-5066 tuning motor, 7 RPM, 5 wire (generally used for coupling to an existing variable capacitor or inductor, to control transmitter output or loading) -----	255.00
					994-4806	M-4806 relay assembly to control one 5 wire motor .	90.00
					994-4720-002	M-4720A plate current metering kit -----	72.00
					994-4719-002	M-4719A plate voltage metering kit -----	53.00
					994-5145	M-5145 tower light metering kit -----	74.00
				71			
					994-5631	M-5631 extension meter for Gates M-4990 frequency monitor -----	100.00
					994-5836-002	Remote Meter for M-5774 modulation monitor ----	130.00
					994-5837	M-5837 extension meter for Gates M-5693 modulation monitor -----	130.00

CAT. PAGE	TYPE NUMBER	PRODUCT DESCRIPTION	UNIT PRICE	CAT. PAGE	TYPE NUMBER	PRODUCT DESCRIPTION	UNIT PRICE
	994-5249	M-5249 auxiliary relay assembly to provide one "on-off momentary" switching facility -----	90.00	72-75		See Andrew Price List	
	994-5248	M-5248 auxiliary relay assembly to provide one "on-off holding" switching facility -----	90.00	77		OPEN WIRE TRANSMISSION LINE	
	994-4848-A	M-4848 complete kit to control output loading of Gates BC-5P-2 and BC-5H 5kW transmitters including motor, relay and all necessary mounting hardware --	395.00		994-3327	M-3327 transmission line bracket -----	68.00
71	994-4703-001	M-4703A motor and rheostat assembly for most 250 watt transmitters ----	160.00		994-3328	M-3328 end plate -----	72.00
	994-4703-002	M-4703B motor and rheostat assembly for most 500 watt transmitters -----	170.00		994-2870-004	M-2870 feed-through bowl. 2 bowls, solid stud, for walls to 10-1/2" thick ----	26.00
	994-4703-003	M-4703C motor and rheostat assembly for most 1000 watt transmitters ----	185.00		994-3254	M-3254 feed-through bowl. 2 bowls, hollow stud, for walls to 10-1/2" thick ----	30.00
	994-6326	M-6326 motor assembly for output control of BC-1G -----	185.00		994-5280	M-5280 feed-through bowl. Single bowl, solid stud, for walls to 1" thick -----	20.00
	994-5066	M-5066 tuning motor, 7 RPM, 5 wire (generally used for coupling to an existing variable capacitor or inductor, to control transmitter output or loading) -----	255.00		994-5281	M-5281 feed-through bowl. Single bowl, hollow stud, for walls to 1" thick -----	22.00
	994-4800	M-4800 tuning motor assembly, 3 wire motor, 1 RPM for a rheostat and other control (similar to that used on above motor and rheostat assemblies) .	120.00		994-3322	M-3322 horn gap -----	110.00
	994-4825	M-4825 AC voltage metering kit -----	74.00		994-3864	M-3864 center post assembly -----	42.00
	994-4720-002	M-4720A plate current metering kit -----	72.00	79		TOWER LIGHTS AND ACCESSORIES	
	994-6112	M-6112 AM antenna diode for all powers (Inductive coupled unit) -----	95.00		710-0012	OB-20-3 single obstruction light -----	14.00
	994-5129	M-5129 adjustable DC overload relay assembly -	45.00		710-0013	OB-21-4 single obstruction light -----	14.00
	994-4845	M-4845 FM output indicator (diode) -----	32.00		710-0014	OB-22-4 double obstruction light, medium screw ----	28.00
	994-4719-002	M-4719A plate voltage metering kit -----	53.00		396-0141	107A21-TS traffic signal lamp, 115 volts -----	.75
					710-0063	KG-114-3G code beacon 300 MM. 1" conduit top, 3 wire Grn. Ground ----	275.00
					710-0075	Kg-114-4G code beacon 300 MM. 1" conduit top, 4 wire Grn. Ground -----	275.00
					396-0129	620 P540 Beacon lamp, 620 watt -----	3.30
					710-0058	LC-700A-2 photo-cell and beacon flasher. Single circuit for one tower -----	127.50
					670-0007	63305DA Fisher-Pierce light control (110VAC) ---	95.00
				80		INDUCTORS	
					931-6138-010	87FA4634 87 UH, 12-1/6" l., 87RA4634 fixed 1/4" edgewise, 10 amp. rating.-	60.00

CAT. PAGE	TYPE NUMBER	PRODUCT DESCRIPTION	UNIT PRICE	CAT. PAGE	TYPE NUMBER	PRODUCT DESCRIPTION	UNIT PRICE
	931-6138-039	6FC0854 6UH, 6-1/2" l., fixed 1/2" edgewise, 20 amp rating -----	40.00		931-6583-002	26VC2144 26 UH, 10-3/4" l., 4" d., variable 1/2" edgewise, 20 amp rating _	85.00
	931-6138-040	10FC0855 10 UH, 6-1/4" l., 5" d., fixed 1/2" edgewise, 10 amp rating -----	39.00		931-6583-003	42VC2145 42 UH, 10-3/4" l., 5" d., variable 1/2" edgewise, 20 amp rating _	110.00
	931-6138-041	13FC0856 13 UH, 6-1/4" l., 6" d., fixed 1/2" edgewise, 20 amp rating -----	40.00		931-6583-004	62VC2845 62 UH, 11" l., 5" d., variable 1/2" edgewise, 20 amp rating _	94.00
	931-6138-025	17FC1654 17 UH, 8-3/4" l., 4" d., fixed 1/2" edgewise, 20 amp rating -----	48.00		402-0029	LC4 for 1/2" edgewise FA coils -----	.60
	931-6138-026	24FC1655 24 UH, 8-3/4" l., 5" d., fixed 1/2" edgewise, 20 amp rating -----	54.00		402-0031	LC8 for 1/2" edgewise FC coils -----	1.05
	931-6138-027	32FC1656 32 UH, 8-3/4" l., 6" d., fixed 1/2" edgewise, 20 amp rating -----	52.00		402-0033	RC6 for 3/8" tubing F8T coils -----	3.55
	931-6138-036	42FC2266 42 UH, 12-5/8" l., 6" d., fixed 1/2" edgewise, 20 amp rating -----	51.00		402-0034	RC8 for 1/2" tubing TCT coils -----	4.00
	931-6138-030	67FC2856 67 UH, 13-1/16" l., 6" d., fixed 1/2" edgewise, 20 amp rating -----	82.00		926-5509-003	M-5521 veeder counter geared type, reads to 1/10 turn, 3/8" shaft diameter. With non-removable crank handle -----	40.00
80	931-6337-007	10FBT1066 10 UH, 21-1/2" l., 6" d., fixed 3/8" copper tubing, 30 amp rating ----	71.00		994-6233-001	Same as above except with removable crank handle --	45.00
	931-6337-002	20FBT1656 20 UH, 15" l., 6" d. fixed 3/8" copper tubing, 30 amp rating ----	105.00	80	MICA CAPACITORS		
	931-6337-003	32FBT1658 32 UH, 15" l., 8" d., fixed 3/8" copper tubing, 30 amp rating ----	112.00	G1	.0002 mfd. -----	On Request	
	931-6337-004	45FBT2158 45 UH, 18-1/2" l., 8" d., fixed 3/8" copper tubing, 30 amp rating ----	187.00		.0004 mfd. -----	On Request	
	931-6372-002	65FBT2559 65 UH, 24-1/2" l., 9" d., fixed 3/8" copper tubing, 30 amp rating ----	138.00	G2	.0005 mfd. and .001 mfd. _	On Request	
	931-6337-001	17FCT1178 17 UH, 14" l., 8" d., fixed 1/2" copper tubing, 40 amp rating -----	110.00		.0015 mfd. and .002 mfd. _	On Request	
	931-6372-001	35FCT1769 35 UH, 24-1/2" l., 9" d., fixed 1/2" copper tubing, 40 amp rating ----	180.00		.003 mfd. thru .005 mfd. _	On Request	
	931-6583-008	6VCO854 6 UH, 8" l., 4" d., variable 1/2" edgewise, 20 amp rating -----	68.00	G3	.006 mfd. and .01 mfd. _ _	On Request	
	931-6583-001	15VC1444 15 UH, 10-3/4" l., 4" d., variable 1/2" edgewise, 20 amp rating _	66.00		.02 mfd. -----	On Request	
				G4	.0002 mfd. thru .0005 mfd. _	On Request	
					.001 mfd. thru .006 mfd. _ _	On Request	
					.01 mfd. -----	On Request	
					.0003 mfd. -----	On Request	
					.0004 mfd. thru .0008 mfd. _	On Request	
					.0001 mfd. thru .008 mfd. _	On Request	
					.01 mfd. -----	On Request	
					.02 mfd. -----	On Request	
					.00025 mfd. thru .0008 mfd. _	On Request	

CAT. PAGE	TYPE NUMBER	PRODUCT DESCRIPTION	UNIT PRICE	CAT. PAGE	TYPE NUMBER	PRODUCT DESCRIPTION	UNIT PRICE
		.001 mfd.thru .003 mfd.	On Request				
		.004 mfd.	On Request				
		.005 mfd.	On Request				
		.006 mfd.	On Request				
		.008 mfd.	On Request				
		.01 mfd.	On Request				
VHF TELEVISION TRANSMITTERS							
84	994-6697-001	BT-35L 35 kW VHF-TV low band transmitter (for specified Channel 2 to 6) with operating tubes, transistors, IC's, solid-state rectifiers, crystals, required pre-correction circuitry, low-level vestigial sideband filter, harmonic and color notch filters	On Request		994-6655-001	BT-18H 18 kW VHF-TV high band transmitter (for specified Channel 7 to 13) with operating tubes, transistors, IC's, solid-state rectifiers, crystals, pre-correction circuitry, low-level vestigial sideband filter, harmonic and color notch filters	On Request
	994-6657-001	BT-35H 35 kW VHF-TV high band transmitter (for specified Channel 7 to 13) with operating tubes, transistors, IC's, solid-state rectifiers, crystals, required pre-correction circuitry, low-level vestigial sideband filter, harmonic and color notch filters	On Request	91	994-6694-001	BT-13L 13 kW VHF-TV low band transmitter (for specified Channel 2 to 6) with operating tubes, transistors, IC's, solid-state rectifiers, crystals, pre-correction circuitry, low-level vestigial sideband filter, harmonic and color notch filters	On Request
	994-6656-001	BT-25H 25 kW VHF-TV high band transmitter (for specified Channel 7 to 13) with operating tubes, transistors, IC's, solid-state rectifiers, crystals, required pre-correction circuitry, low-level vestigial sideband filter, harmonic and color notch filters	On Request		994-6654-001	BT-13H 13kW VHF-TV high band transmitter (for specified Channel 7 to 13) with operating tubes, transistors, IC's, solid-state rectifiers, crystals, pre-correction circuitry, low-level vestigial sideband filter, harmonic and color notch filters	On Request
87	994-6696-001	BT-25L 25 kW VHF-TV low band transmitter (for specified Channel 2 to 6) with operating tubes, transistors, IC's, solid-state rectifiers, crystals, required pre-correction circuitry, low-level vestigial sideband filter, harmonic and color notch filters	On Request	95	994-6807-001	BT-5L 5 kW VHF-TV low band transmitter (for specified Channel 2 to 6) with operating tubes, transistors, IC's, solid-state rectifiers, crystals, required pre-correction circuitry, low-level vestigial sideband filter, harmonic and color notch filters	On Request
	994-6656-001	BT-25H 25 kW VHF-TV high band transmitter (for specified Channel 7 to 13) with operating tubes, transistors, IC's, solid-state rectifiers, crystals, required pre-correction circuitry, low-level vestigial sideband filter, harmonic and color notch filters	On Request		994-6765-001	BT-5H 5 kW VHF-TV high band transmitter (for specified Channel 7 to 13) with operating tubes, transistors, IC's solid-state rectifiers, crystals, required pre-correction circuitry, low-level vestigial sideband filter, harmonic and color notch filters	On Request
90	994-6695-001	BT-18L 18 kW VHF-TV low band transmitter (for specified Channel 2 to 6) with operating tubes, transistors, IC's, solid-state rectifiers, crystals, pre-correction circuitry, low-level vestigial sideband filter, harmonic and color notch filters	On Request	99	994-6693-001	BT-1300L 1300-watt VHF TV low band transmitter, for specified Channel 2 to 6 (CCIR Channel E2 to E4)	On Request
					994-6653-001	BT-1300H 1300-watt VHF TV high band transmitter, for specified Channel 7 to 13 (CCIR Channel E2 to E4)	On Request

CAT. PAGE	TYPE NUMBER	PRODUCT DESCRIPTION	UNIT PRICE	CAT. PAGE	TYPE NUMBER	PRODUCT DESCRIPTION	UNIT PRICE
101	994-6692-001	BT-100L VHF TV low band transmitter, for specified Channel 2 to 6 (CCIR Channel E2 to E4) -----	On Request	113	994-6799-000	Automatic Exciter Switcher	OnRequest
	994-6652-001	BT-100H VHF TV high band transmitter for specified Channel 7 to 13 (CCIR Channel E5 to E12) -----	On Request		994-6789-000	Diode Demodulator -----	OnRequest
UHF TELEVISION TRANSMITTERS				114	994-6713-001	RAK-80, Basic rack -----	OnRequest
103	994-6806-001	TD-2U UHF exciter/driver, includes visual exciter and aural exciter -----	On Request	994-6714-001	Side panel (fits right or left side) -----	OnRequest	
105	994-6748-001	BT-55U 55 kW UHF-TV transmitter, with operating klystrons, transistors, IC's, solid-state rectifiers, crystals, required pre-correction circuitry, low-level vestigial sideband filter, harmonic and color notch filters -----	On Request	994-6665-001	Louvered top -----	OnRequest	
107	994-6749-001	BT-110U 110 kW UHF-TV transmitter, with operating klystrons, transistors, IC's, solid-state rectifiers, crystals, required pre-correction circuitry, low-level vestigial sideband filter, harmonic and color notch filters -----	On Request	994-6715-001	Door with louvers (fits front or rear, may be mounted to open right or left hand) -----	OnRequest	
109	994-6777-001	BT-220U 220 kW UHF-TV transmitter, with operating klystrons, transistors, IC's, solid-state rectifiers, crystals, required pre-correction circuitry, low-level vestigial sideband filter, harmonic and color notch filters -----	On Request	994-6715-002	Door without louvers (fits front or rear, may be mounted to open right or left hand) -----	OnRequest	
TELEVISION ACCESSORY EQUIPMENT				994-6717-001	Fan Kit -----	OnRequest	
110	994-6798-000	Multiple TV Transmitter System Control and Switching Panel. Includes: system control panel, RF phasing panel, input switching and control logic housing, interconnecting cables and output combining and switching assembly -----	On Request	448-0288-001	Air filter (replacement)---	OnRequest	
111	994-6795-000	TV Transmitter Audio/Video Program Control and Monitoring Panel ----	On Request	994-6716-001	Rear mounting angle kit (2 angles, No. 10 screws) _	OnRequest	
112	994-6797-000	TV Transmitter Automatic Power Control -----	OnRequest	994-6800-000	4 by 1 Matrix Switcher ---	OnRequest	
	994-6760-000	TV Transmitter Precise Frequency Control -----	OnRequest	115	994-6796-000	Power Control and Metering panel -----	On Request
				116	Television Monitors -----	On Request	
				117	Television Monitors -----	On Request	
				AUDIO CONSOLES			
				121	994-6542	DUALUX II, M-6542, 8 channel mono/stereo console for tri-channel operation. With 4 preamps, 6 output modules, 2 muting modules, 4 power supply modules -----	4,595.00
				124	994-6541-002	GATESWAY II, M-6541A, 8 channel monophonic console complete with 3 preamps, 3 output modules, 1 muting module, 3 power supply modules -----	3,250.00
				127	994-6616	Yard II Audio Console complete with separate power transformer -----	2,295.00
				131	994-6540-003	STEREO STATESMAN, M-6540A 5 channel stereo console, complete with 2 preamps, 5 output modules, 3 power supply modules --	2,995.00
				133	994-6158-002	EXECUTIVE AUDIO CONSOLE (includes 4 speaker matching transformers) --	5,295.00

CAT. PAGE	TYPE NUMBER	PRODUCT DESCRIPTION	UNIT PRICE	CAT. PAGE	TYPE NUMBER	PRODUCT DESCRIPTION	UNIT PRICE
	994-6034	Optional preamplifier ----	95.00		478-0291	Speaker matching transformer -----	5.25
	994-5700-003	Optional program amplifier -----	245.00		994-6482	Relay kit for use with Control Center to start mechanical device -----	20.75
	478-0291	Speaker matching transformer -----	5.25		990-0499	TK-499, 100% semiconductor replacement kit ---	91.00
	994-6208	Optional 3rd VU meter ---	83.00		913-6060	Plug-in jumper board ----	8.50
	994-6424	Intercom sub-station ----	67.00	136	994-6377-002	Diplomat audio console complete with four speaker matching transformers ---	4,495.00
	994-6034	Optional preamplifier ----	95.00		994-5381	Studioette Audio Console --	1,395.00
	478-0291	Speaker matching transformer -----	5.25		990-0444	100% spare tube kit -----	22.50
	990-0505	TK-505, 100% semiconductor replacement kit ---	102.00		994-5304-002	Optional preamplifier ----	70.00
	994-6424	Studio cue/intercom speaker	67.00		478-0291	Speaker matching transformer -----	5.25
139	994-6209-003	The PRESIDENT, dual channel audio control console, includes 2 external VU meters, 4 speaker matching transformers, 4 mic preamps, monitor amplifier, cue amplifier, and 2 program amplifiers -----	3,995.00		572-0072	Extra muting relay -----	17.00
	994-6034	Optional plug-in microphone preamplifiers -----	95.00		994-5377	Optional cueing amplifier --	260.00
	994-6208	External VU meter with housing -----	83.00	145	994-6642	Stereo Producer, M6642, 4 channel stereo recording mixer, complete with preamplifiers, program amplifiers, monitor amplifiers and self-contained power supplies -----	1,450.00
	994-6424	Intercom sub-station, deluxe -----	67.00		990-0583	100% spare semiconductor kit for the Stereo Producer -----	61.00
	990-0503	Spare 100% semiconductor kit -----	106.00		478-0291	Speaker matching transformers for using external 8-ohm speakers, 48/8 ohms (two required for stereo) -----	5.25
	478-0291	Speaker matching transformer -----	5.25	147	994-6407	The Producer recording mixer -----	850.00
	994-6482	KCP-5 Relay, 30 volt D.P.D.T. to start-stop external equipment -----	20.75		990-0512	100% spare semiconductor kit -----	28.00
141	994-5564-003	Ambassador, single channel console, complete with 2 preamplifiers and 4 speaker matching transformers -----	3,195.00		478-0291	Speaker matching transformer -----	5.25
	994-6034	Extra plug-in microphone preamplifier -----	95.00	152	900-0257	PROGRAM AUTOMATION SP-10 Program Control System, 10-source. Includes: control panel memory tape unit; and AMS-10 master switcher. Systems programmer allows for the selection of an almost unlimited sequence of audio sources before sequence repetition. Design of unit provides for easy sequence changes as required by format and broadcast schedule. Controls ten audio sources. 60 Hz -----	3,445.00
	994-6424	Intercom sub-station, deluxe -----	67.00				

CAT. PAGE	TYPE NUMBER	PRODUCT DESCRIPTION	UNIT PRICE	CAT. PAGE	TYPE NUMBER	PRODUCT DESCRIPTION	UNIT PRICE
	900-0258	SP-19 Program Control System. As above, except for up to 19 audio sources	5,260.00		900-0191	RA-1 random access programmer for use with single G-24-M/S multiple cartridge reproducer	1,795.00
	900-0059	OPC-10 Overlap Program Control accessory for SP-10. Provides audio overlap in automation system	1,150.00	156	900-0273	ACC-1 Audio Control Center, monophonic. Includes program amplifier. Less monitor amplifier, 25 Hz filter (order separately)	650.00
	900-0060	OPC-19 Overlap Program Control. As above, used with SP-19 programmer	2,300.00		900-0274	ACC-2 Audio Control Center, stereophonic. Includes two program amplifiers and power supply. Monitor amplifiers and 25 Hz filters must be ordered separately	875.00
	900-0141-001	TS-3 Time Selector. Provides exact time controlled functions in either SP-10 or SP-19 system	1,175.00		900-0276	ACC/MON Monitor Amplifier Module. Order two for stereo	125.00
153	900-0225-001	SC-48 Program Control System, 9-source. Includes: SC-48 control panel and TPG-2 time pulse generator	2,585.00		484-0066	ACC-F 25 Hz High-Pass Filter. For systems with reel-to-reel music sources. Two required for stereo	45.00
	900-0146	OPC-3 Overlap Program Control accessory for SC-48. Provides audio overlap in automation system	435.00		900-0277	ACC/SCN Sum Channel Output Package. For ACC-2 units if L + R output desired. Includes 3rd program amplifier module	175.00
154	900-0028	Criterion 855-M Multiple Cartridge Unit, monophonic	3,095.00	157	900-0056	TA-1 Time Announced Control Panel. Automatically alternates two tape cartridge transports each minute to provide audio time source in an automated system. Must be used in conjunction with digital clock or TPM module and two Criterion 80 units	385.00
	900-0029	Criterion 855-S Multiple Cartridge Unit, stereophonic	3,295.00		900-0192	TPM Time Pulse Module	155.00
	900-0134-001	G-24-M Multiple Cartridge Unit, monophonic	1,775.00		900-0141-001	TS-3 Time Selector. TS-3 interprets and registers time correction information recorded on programmer cartridge of SP-10 and 19 programmers and must be used in conjunction with Digital Clock	1,175.00
	900-0134-002	G-24-S Multiple Cartridge Unit stereophonic	1,945.00		900-0037-001	DC-10 Digital Clock (60 Hz)	1,155.00
155	900-0137	RA-5 Randomax Random Access Programmer. To be used in conjunction with Gates G-24-M/S Carousel Multiple Cartridge Units (order separately). Programmer provides inputs for up to 5 G-24 units. 50 event storage capacity before recycle. One RA-5 and two G-24 units occupy one rack, (order separately). Rack space for RA-5—12 units (21")	3,995.00		900-0037-002	DC-10 Digital Clock (50 Hz)	1,165.00
	900-0138	RA-5X Event Extender for use with above unit. 50 additional events. Unit plugs into basic RA-5 programmer. Any number of RA-5X units may be connected together to extend event storage of RA-5 in multiples of fifty. Same rack space as RA-5 required	1,795.00		900-0044	MDF-M Motor-Driven Fader, monophonic	450.00
					900-0067	MDF-S Motor-Driven Fader, stereophonic	560.00

CAT. PAGE	TYPE NUMBER	PRODUCT DESCRIPTION	UNIT PRICE	CAT. PAGE	TYPE NUMBER	PRODUCT DESCRIPTION	UNIT PRICE
	900-0255-001	F1-M Fade-in Unit, mono- phonic (Requires Criterion 80 audio source) -----	675.00		994-6702-002	Basic Criterion 80 Play- back Unit, stereophonic, with primary 1000 Hz cue, desk mount, 60 Hz -----	975.00
	900-0255-002	F1-S Fade-In Unit, as above except stereo -----	785.00		994-6704-002	As above, except 50 Hz ..	985.00
158	900-0034	APL/SP-1019 Automatic Program Logging System (for use with SP-10 and SP- 19 programming systems) -	3,750.00		994-6729-001	Matched Criterion 80 Record/Playback Combin- ation, monophonic, with 1000 Hz cue, desk mount, 60 Hz -----	1,190.00
	900-0039	APL/SC-48 as above, ex- cept for use with SC-48 programming systems ---	3,850.00		994-6733	As above, except 50 Hz ..	1,200.00
	900-0040	CG-8 Special Code Gener- ator (Optional). Provides 8 different five digit logging codes to identify non- cartridge automation sources such as network, live studio, etc. -----	670.00		994-6731	Matched Criterion 80 Record/Playback Combin- ation, stereophonic, with 1000 Hz cue, desk mount, 60 Hz -----	1,560.00
	900-0037-001	DC-10 Digital Clock—Dig- ital timing unit designed to combine actual air time with numerical code infor- mation for print out by logging printer LP. Also serves as the time source to provide information for network joining, delayed broadcast tape recording and other timing appli- cations. 60 Hz -----	1,155.00		994-6707	Criterion 80 Record Amp- lifier only, monophonic, 1000 Hz cue, desk mount -	400.00
	900-0037-002	Same as above except 50 Hz -----	1,165.00		994-6708	Criterion 80 Record Amp- lifier only, stereophonic, 1000 Hz cue, desk mount -	585.00
159	GATESOUND PRELUDE SERIES TAPES To order an entire "Pre- lude" series (200, 300, etc.) simply specify: Series num- ber, reel size, mono or stereo, track configuration, and single or bi-directional. One series furnishes 24 hours of music. To order less than an entire series, you will find it more con- venient to use the special order form available on request from Gates.				900-0154	QS-150, 150 Hz cue sensor. Plugs into playback for 2- tone cueing -----	30.00
					900-0155	QS-8, 8 kHz cue sensor. Plugs into playback for 3rd tone cueing -----	40.00
					900-0165	TO-23, 150 and 8000 Hz cue oscillator assembly, plugs into record amplifier for conversion to either 2 or 3 tone -----	105.00
					994-6790	RA-P Rack Adapter Kit, playback. For 19" rack mounting -----	8.00
					994-6791	RA-A Rack Adapter Kit, record amplifier. For 19" rack mounting -----	5.00
160	CRITERION 80 TAPE CARTRIDGE SYSTEMS			161	994-6794	Criterion Compact Play- back, monaural, with 1000 Hz cue, desk mount, 60 Hz ..	690.00
	994-6701-002	Basic Criterion 80 Play- back Unit, monophonic, with primary 1000 Hz cue, desk mount, 60 Hz -----	790.00		994-6815	Criterion Compact Play- back, stereo, with 1000 Hz cue, desk mount, 60 Hz ---	1,090.00
	994-6703-002	As above, except 50 Hz ..	800.00		994-6812	Rack Mounting Kit, for mounting two Criterion Compact playbacks in a single 19" rack -----	10.00

CAT. PAGE	TYPE NUMBER	PRODUCT DESCRIPTION	UNIT PRICE	CAT. PAGE	TYPE NUMBER	PRODUCT DESCRIPTION	UNIT PRICE
	994-6816	Quick-Cue Kit for conversion of Criterion Compact to high-speed cueing ----	95.00		900-0085	C-1200, 31 minute cartridge	11.25
	574-0162	2nd and 3rd Cue Tone Relay. Add one for each tone desired -----	6.75		732-0220	A-300, Empty Cartridge ..	1.80
162	900-0266	RC-T-8 Remote Control w/ elapsed time indicator, for remote control of Criterion 80 record/playback System. Stop, Start, Record Set, and all cue-tone functions of the Criterion 80 recorder are provided ---	150.00		732-0221	B-600, Empty Cartridge ---	3.00
	900-0267	RC-RA-8 Remote Control panel with "Start", "Record Set", "Auxiliary Tone" and "Stop" buttons for control of one record/playback system from a remote point -----	65.00		732-0222	C-1200, Empty Cartridge --	4.45
	900-0268	RC-P4-8 Playback Control, for remotely operating up to four Criterion 80 playback units. Operates start circuit only ----	65.00		994-6430	Cartridge pressure pad (50 replacement foam plastic pads) -----	8.00
	994-6817	RC-P4-C As above, except for Criterion Compact ----	65.00		900-0065	Cartridge labels, 1000 (yellow, red, green, and white) specify color -----	7.90
	900-0024	AMS-4A Automatic Master Switcher automatically switches audio feed from 4 or less Criterion 80 Playback units into a single channel. Not for Criterion Compact -----	160.00		900-0090	FAL-1A test cartridge. Full track, for mono or stereo systems. Includes tones for Azimuth alignment, frequency response and standard level reference -----	30.00
163	TAPE CARTRIDGES AND ACCESSORIES				732-0223	TD-1 Professional model bulk magnetic tape eraser ..	41.50
	900-0077	A-300, 40 second cartridge ..	2.35	164	CARTRIDGE TAPE STORAGE UNITS		
	900-0078	A-300, 70 second cartridge ..	2.50		994-5986	Gates M-5986 storage rack. Mounts in 10-1/2" vertical rack space. Holds 40 A-300 cartridges.-----	50.00
	900-0079	A-300, 100 second cartridge -----	2.55		730-0834	RM-100 broadcast electronics wall mount cartridge rack. Stores 100 series A-300 cartridges. Size 2 ft. x 2 ft. x 4-3/8". Gray formica -----	47.50
	900-0080	A-300, 2-1/2 minute cartridge -----	2.75		730-0835	RS-200 lazy susan cartridge rack. Revolving floor type. Stores 200 A-300 cartridges. 51-1/4" high, 20-1/2" diameter -----	145.50
	900-0081	A-300, 3-1/2 minute cartridge -----	2.85		730-0836	RS-25, broadcast electronics wire-type storage. Holds 25, A-300 cartridges. Zinc plated. Size: 34" high, 5" square ea. -----	13.00
	900-0082	A-300, 5-1/2 minute cartridge -----	3.15		730-1189	SECR-72, cartridge storage cabinet-walnut formica trim for 72 series 300 cartridges. Rotates on ball bearings. Dimensions: 22" Hx11" W x11" D -----	79.00
	900-0083	A-300, 10-1/2 minute cartridge -----	4.20		730-1190	SECR-200, storage cabinet walnut formica trim. Capable of storing 200 series 300 cartridges. Rotates on ball bearings. Dimensions 29-1/2" H x 15-3/4" W x 15-3/4" D -----	116.00
	900-0084	B-600, 16 minute cartridge	6.95				

CAT. PAGE	TYPE NUMBER	PRODUCT DESCRIPTION	UNIT PRICE	CAT. PAGE	TYPE NUMBER	PRODUCT DESCRIPTION	UNIT PRICE
167		AMPLIFIERS			994-6668-001	Air Filter kit for RAK-70 ..	5.00
	994-6543	Solid Statesman AM Limiting Amplifier	695.00		448-0288-000	Air filter (replacement) for RAK-70	2.00
169	994-6631-001	Solid Statesman FM Limiter	750.00		827-4789-002	Rear mounting angle (two must be ordered) for RAK-70	7.50
	994-6631-002	Matched Pair of FM Limiters (for stereo)	1,500.00		994-5527	RAK-7 Rack Cabinet	150.00
171	994-6629-001	Solid Statesman Automatic Gain Control Amplifier ...	725.00		994-5577-001	Joiner trim for RAK-7 ...	17.00
	994-6629-003	Matched Pair AGC Amplifiers (for stereo)	1,430.00		994-5651-001	CR-70 Waist-high rack cabinet	90.00
172	994-6313-002	M-6313A Preamplifier ...	260.00	176		PROGRAM AND MONITORING AMPLIFIERS	
	994-6314-002	M-6314A Program/AGC Amplifier	400.00		994-5576-003	Program amplifier with tubes	365.00
173	994-6338	M-6338 48 volt power supply, 1.5 amp capacity	295.00		990-0450	100% spare tube kit	6.50
	994-6321	M-6321 Program Amplifier	320.00		994-5575	Ultra linear monitoring amplifier, with tubes	375.00
	994-6421	M-6421 48 volt power supply, 300 mA capacity	235.00		990-0303	Spare 100% tube kit	12.00
174	994-6341	Tray for M-6313A preamplifier	11.00		478-0291	Speaker matching transformer	5.25
	994-6426	Tray for M-6321A program amplifier	11.00	177	994-6108	Eight-watt transistorized monitor amplifier	200.00
	994-6342	Tray for M-6314A program AGC amplifier	13.00		994-5530	Single channel utility amplifier with tubes	160.00
	994-6422	Tray for M-6421 power supply	11.00		612-0194	Chassis connector female ..	3.05
	994-6344	Tray for M-6338 power supply	11.00		610-0182	Microphone connector (male)	1.90
	994-6689	Panel and shelf assembly ..	80.00		990-0280	Spare 100% tube kit	5.00
		RACK CABINETS		178		AUDIO ACCESSORIES	
175	994-6643-002	RAK-70 Basic Cabinet assembly	160.00		994-5377	Cueing Amplifier with tubes	275.00
	994-6664-001	Side Panel for RAK-70	30.00		990-0305	Spare 100% tube kit	2.50
	994-6665-001	Louvered top for RAK-70 ..	5.50		994-4242	Switch and fuse panel	63.00
	994-6671-001	Door with louvers for RAK-70	50.00		994-4577	VU-22 VU meter and range panel	167.00
	994-6671-002	Door without louvers for RAK-70	50.00		994-4648	Terminal board accessory for above	10.00
	448-0320-000	Key type lock for doors for RAK-70	4.95		406-0269	On Air (in red)	17.50
	994-6666-001	Fan kit for RAK-70	60.00		406-0278	Special lettering up to 12 characters (specify)	30.00
					406-0285	On The Air (QF-15 Rollins)	45.00
					406-0280	Studio A (QF-15 Rollins) ..	45.00
					406-0281	Studio B (QF-15 Rollins) ..	45.00

CAT. PAGE	TYPE NUMBER	PRODUCT DESCRIPTION	UNIT PRICE	CAT. PAGE	TYPE NUMBER	PRODUCT DESCRIPTION	UNIT PRICE
179	650-0130	VA knob only -----	3.75		610-0182	Cable plug, 3 prong, male, (XLR3-12C) -----	1.90
	648-0045	Dial for VA knob -----	2.50		612-0182	Cable receptacle, female, 3 prong (XLR3-11C) -----	2.15
	646-0379	Knob decal kit (5 ea. 6 colors) -----	3.25		612-0194	Chassis receptacle, female, 3 prong (XLR3-13) -----	3.05
	994-6424	Studio cue/intercom speaker. May be used for cue listen or cue talk-back -----	67.00		610-0194	Chassis receptacle, male, 3 prong (XLR3-14) -----	1.40
	994-6208	M-6208 external VU meter and housing -----	83.00		614-0339	PJ-106 audio terminal block, 120 terminals in 6 rows -----	9.45
	478-0291	Speaker matching transformer -----	5.25	181	720-0061	BS-36 boom stand -----	55.83
	612-0307	Jack strip only (PJ-343), 24 jacks or 12 pairs (no jack mat required) -----	25.14		720-0062	BS-36W boom stand w/ casters -----	63.33
	612-0306	Jack strip only (PJ-341), 48 jacks or 24 pairs (less mat) -----	42.75		720-0026	Model 418 -----	8.10
	994-4399	Jack mat for one PJ-341 jack strip (PD-1) -----	11.50		720-0028	Model 419 -----	8.10
	994-4400	Jack mat for two PJ-341 jack strips (PD-2) -----	17.95		720-0076	Model DS-7 (adjusts 8" to 13") -----	4.59
	994-4401	Jack mat for three PJ-341 jack strips (PD-3) -----	24.00		720-0035	Model DS-5 (non-adjustable) -----	2.84
	250-0002	Double patch cord with 2' cord (PJ-12) -----	6.75		720-0150	TS-8 banquet (adjusts 14-1/2" to 26") -----	8.51
	250-0003	Double patch cord with 3' cord (PJ-13) -----	6.90		720-0048	MS-25 -----	22.68
	250-0004	Double patch cord with 4' cord (PJ-14) -----	7.13		720-0047	MS-10C -----	8.67
	250-0005	Double patch cord with 5' cord (PJ-15) -----	7.28		720-0059	BB-1 baby boom only (no stand) -----	6.49
180	448-0134	C-540 disc cabinet holds 540 12" LP's -----	279.00		720-0040	Model #1 Flexo -----	10.77
	448-0230	LP-12 disc cabinet -----	39.00		732-0099	Tape splicer, Robins TS8D -----	9.97
	448-0231	LP-12D disc cabinet -----	46.50		732-0096	Microtran HD-11M bulk tape eraser, reel type -----	31.00
	448-0130	TR-72887" double-door reel storage cabinet -----	142.50		732-0043	Adapter hub for 10-1/2" reels, HD-11AD Microtran -----	3.15
	448-0178	TR-192 10-1/2" double-door reel storage cabinet -----	148.50		721-0003	BA-200 Brush -----	22.00
	448-0043	TR-742 sectional tape storage cabinet -----	16.50		721-0004	BA-201 Brush -----	18.70
	448-0074	Sectional tape storage cabinet -----	12.60		721-0006	107 Trimm headphone AH -----	7.20
	612-0188	Single, 3 prong, female, 1 wall plate (XLR3-35) -----	7.85		721-0009	BA-206B Brush stereo headset -----	39.00
					610-0273	#511 Trimm headphone plug -----	.80
					732-0167	KS-3 Edit-all tape splicer -----	10.00
					730-0102	Jiffy P-30 bulk tape eraser, hand type -----	17.25

CAT. PAGE	TYPE NUMBER	PRODUCT DESCRIPTION	UNIT PRICE	CAT. PAGE	TYPE NUMBER	PRODUCT DESCRIPTION	UNIT PRICE
	730-0180	Tape head demagnetizer, Audio Devices, Model 400	6.00		WB-12D	For 12" speaker, maximum speaker depth 6-3/8". Shpg. wt. for 2, 11 lbs. . . ea.	6.60
182	722-0051	Studio loudspeaker monitoring system (Electro Voice Sentry II) -----	180.00		725-0087	SCB-8D 8" slanting, corner (walnut) -----	9.85
	722-0044	Studio loudspeaker monitoring system (Electro Voice Sentry I) -----	180.00		725-0088	SCB-8D 8" slanting, corner (blond) -----	9.85
	722-1200	GRS-1200 12" 8 ohms 4.64 oz. magnet, 13 watts, 45-18,000 Hz -----	9.50		725-0105	SCB-12D 12" slanting, corner (blond) -----	13.50
	722-0800	GRS-800 8" 8 ohms 2.64 oz. magnet, 11 watts 50-12,000 Hz -----	8.95		725-0104	SCB-12D 12" slanting, corner (walnut)	13.50
	478-0250	Electro-Voice TR-15 speaker matching transformer. 15 watt capacity. Primary impedance 333, 500, 1000, 2000 ohms; 4, 8 and 16 ohms secondary impedances. ± 2 dB, 35-20,000 cps. insertion loss 0.8 dB . . .	4.80		MICROPHONES		
	478-0291	Speaker matching transformer for all Gates consoles 45 to 50 ohms pri; 8 ohms secondary -----	5.25	184	720-0267	G-600 Gates microphone, dynamic omnidirectional, response 80-13,000 Hz ---	48.50
	554-0227	T-8 Mallory 8 ohms speaker control (T-pad) -----	5.90		720-0286	G-700 Gates microphone, dynamic, omnidirectional, response 50-15,000 Hz ---	57.50
	554-0180	T-4 Mallory 4 ohms speaker control (T-pad) -----	5.90		720-0269	G-800 Gates microphone, dynamic cardioid, response 90-13,000 Hz -----	84.50
183	725-0012	DWB-8A 8" wood wall baffle (blond) -----	6.00		720-0197	G-500 Gates microphone, miniature lavaller, dynamic, response 50-12,000 Hz -----	49.50
	725-0011	DWB-8A 8" wood wall baffle (walnut) -----	6.00		250-0036	8412 Belden (Gates MIC-100) 2 conductor stranded 20 AWG Braided shield cotton wrap heavy rubber jacket ----- per ft.	.18
	725-0009	DWB-12A 12" wood wall baffle (blond) -----	8.75		253-0018	SH-2-20 2 conductor stranded 20 AWG, w/push back braided shield not insulated ----- per ft.	.06
	725-0028	DWB-12A 12" wood wall baffle (walnut) -----	8.75		253-0054	8450 Belden miniature audio cable 2 conductor, 22 AWG solid, drain wire, foil shield, vinyl jacket per ft.	.06
	WB-4/5D	For 4/5" speaker, maximum speaker depth 2-3/4". Shpg. wt. for 2, 3 lbs. . . ea.	3.23		253-0059	8451 Belden miniature audio cable 2 conductor 22AWG stranded, drain wire, foil shield, vinyl jacket ----- per ft.	.06
	WB-6D	For 6" speaker, maximum speaker depth 3-3/8". Shpg. wt. for 2, 4 lbs. . . ea.	3.90	185	720-0163	EV642 microphone, complete with connector and 20-foot cable -----	255.00
	WB-8D	For 8" speaker, maximum speaker depth 4-3/8". Shpg. wt. for 2, 6 lbs. . . ea.	4.65		720-0155	EV model 356 shock mount	31.50
	WB-10D	For 10" speaker, maximum speaker depth 5-1/4". Shpg. wt. for 2, 8 lbs. . . ea.	6.00		720-0271	Model RE-51 microphone with two microphone tubes and battery-powered transistor amplifier -----	134.00

CAT. PAGE	TYPE NUMBER	PRODUCT DESCRIPTION	UNIT PRICE	CAT. PAGE	TYPE NUMBER	PRODUCT DESCRIPTION	UNIT PRICE
	720-0272	Model SM-53 microphone, dynamic, cardioid -----	150.00	190	994-6431	Unimote "70", M-6431, single channel, transistor ---	200.00
	720-0240	Model RE-15 microphone, complete with 18-foot cable XLR3-11 connector, metal carrying case, and clamp -----	159.00		610-0182	Microphone connector, (1 required) -----	1.90
	720-0228	Model SM-58 microphone, dynamic, cardioid, with built-in windscreen, cable, connector and stand adapter -----	87.00		994-6441	Battery complement for Unimote "70" -----	4.20
187	REMOTE AMPLIFIERS				478-0285	Optional input transformer	25.00
	994-6434	Dynamote "70", M-6434, 4 channel, transistor, less batteries -----	725.00		994-6435	M-6435 in-line power supply for 117 VAC -----	75.00
	610-0182	Microphone plugs, male (four required) -----	1.90	191	994-6600	M-6600 single channel remote amplifier, less batteries -----	125.00
	994-6441	Battery complement for Dynamote "70" -----	4.20		660-0022	Battery for M-6600 (2 required) ----- ea.	2.25
	725-0128	Vinyl cover with accessory pocket -----	18.50	193	TRANSCRIPTION TURNTABLES		
	994-6435	M-6435 in-line power supply for 117 VAC -----	75.00		994-5739-003	CB-500, M-5739B, 16" turntable, chassis only, 60 Hz ..	325.00
188	994-6433	Attache "70", M-6433, 3 channel transistor, less batteries -----	525.00		994-5739-004	CB-500A, 16" turntable chassis only, 50 Hz -----	360.00
	610-0182	XLR-3-12C microphone connector (3 required) -----	1.90	194	994-5798-005	CB-77, 12" turntable, chassis only, 60 Hz -----	199.50
	994-6441	Battery Kit complete -----	4.20		994-5798-006	CB-77A, as above except 50 Hz -----	234.50
	478-0285	Optional microphone input transformer -----	25.00		16" MONOPHONIC SYSTEM COMPONENTS		
	994-6435	M-6435 in-line power supply for 117 VAC -----	75.00	195	994-5739-003	CB-500, 16" turntable, chassis only, 60 Hz (50 Hz. available) -----	325.00
	725-0127	Vinyl cover for Attache ---	17.50		723-0099	208-S Gray, 16" viscous damped tone arm -----	67.00
189	994-6432	Courier "70", M-6432, 2 channel, transistor, less batteries -----	425.00			Gray 306 Micro-trak, 16" tone arm -----	82.50
	610-0182	Microphone connectors, male (2 required) -----	1.90		723-0236	Shure M-44-7 stereo dynamic cartridge with .0007" diamond stylus -----	19.95
	994-6441	Battery kit complete -----	4.20		994-6244-004	M-6244 equalized turntable preamp transistorized monophonic -----	130.00
	478-0285	Optional microphone input transformer -----	25.00		16" STEREPHONIC SYSTEM COMPONENTS		
	994-6435	M-6435 in-line power supply for 117 VAC -----	75.00		994-5739-003	CB-500 turntable, 60 Hz ..	325.00
	725-0127	Vinyl cover for Courier ---	17.50		994-5739-004	CB-500A, 16" turntable, chassis only, 50 Hz -----	360.00
					723-0099	Gray 208-S 16" viscous damped tone arm -----	67.00
					723-0269	Gray 306 Micro-Trak, 16" tone arm -----	82.50

CAT. PAGE	TYPE NUMBER	PRODUCT DESCRIPTION	UNIT PRICE	CAT. PAGE	TYPE NUMBER	PRODUCT DESCRIPTION	UNIT PRICE
	723-0236	Shure M44-7 stereo dynetic cartridge w/.0007 diamond stylus -----	19.95		723-0099	208-S Gray, 16" viscous damped tone arm -----	67.00
	994-6244-004	M-6244 equalized turntable preamp transistorized, 2 required for stereo --ea.	130.00		723-0153	208-SG Gray, turnaround styli, 16" arm -----	67.00
	12" MONOPHONIC SYSTEM COMPONENTS				723-0236	Shure M44-7 stereo dynetic cartridge w/.0007 diamond stylus -----	19.95
	994-5798-005	CB-77, M-5798D, 12" turntable, chassis only. 60 Hz	199.50		723-0237	N-44-7 replacement stylus .0007 diamond -----	9.75
	994-5798-006	CB-77A, as above except 50 Hz -----	234.50		723-0306	M93E Hi-track Elliptical Cartridge 1-1/2 to 3 grams tracking -----	39.95
	723-0259	206-S Gray 12" arm -----	67.00		723-0307	N-93E Elliptical replacement stylus -----	19.50
	723-0268	Gray 303 Micro-Trak, 12" tone arm -----	72.50		723-0308	M75-6 Hi-track Spherical Stylus Cartridge for 1-1/2 to 3 grams tracking -----	24.50
	723-0236	Shure M44-7 stereo dynetic cartridge w/.0007 diamond stylus -----	19.95		723-0309	N-75-6 replacement stylus ..	11.35
	994-6244-004	M-6244 equalized turntable preamp transistorized monophonic -----	130.00	197	994-6244	M-6244 equalized turntable preamp transistorized, monophonic. (Two required for stereo) -----ea.	130.00
	12" STEREOHONIC SYSTEM COMPONENTS				AUDIO WIRE		
195	994-5798-005	CB-77, M-5798D 12" turntable, chassis only, 60Hz --	199.50		250-0059	8410 Belden single conductor shielded, black rubber jacket -----per ft.	.18
	994-5798-006	CB-77A, as above except 50 Hz -----	234.50		250-0036	8412 Belden (Gates MIC-100) 2 conductor stranded 20 AWG Braided shield cotton wrap heavy rubber jacket -----per ft.	.18
	723-0259	206-S Gray 12" arm -----	67.00		253-0024	8428 Belden neoprene jacketed heavy duty mic cable. 2 conductor 18 AWG braided shield -----per ft.	.24
	723-0268	Gray 303 Micro-Trak, 12" tone arm -----	72.50		253-0018	SH-2-20-2 conductor stranded 20 AWG, w/push back braided shield not insulated -----per ft.	.06
	723-0236	Shure M44-7 stereo dynetic cartridge w/.0007 diamond stylus -----	19.95		253-0001	1261 2 conductor stranded 24 AWG, braided shield, not insulated -----per ft.	.14
	994-6244-004	M-6244 equalized turntable preamp transistorized, 2 required for stereo	130.00		253-0062	8437 Belden 2 conductor 22 AWG solid, w/drain wire and braid shield, black vinyl jacket --per ft.	.08
	994-6449	M-6449, double turntable pedestal (walnut) -----	310.00		253-0054	8450 Belden miniature audio cable 2 conductor, 22 AWG solid, drain wire, foil shield, vinyl jacket -----per ft.	.06
	994-6448	M-6448, single turntable pedestal (walnut) -----	175.00				
196	723-0268	Gray 303 Micro-Trak, 12" tone arm -----	72.50				
	723-0269	Gray 306 Micro-Trak, 16" tone arm -----	82.50				
	723-0259	206-S Gray 12" arm -----	67.00				
	723-0250	206-SG Gray 12" arm, turnaround styli -----	67.00				

CAT. PAGE	TYPE NUMBER	PRODUCT DESCRIPTION	UNIT PRICE	CAT. PAGE	TYPE NUMBER	PRODUCT DESCRIPTION	UNIT PRICE
	253-0059	8451 Belden miniature audio cable, 2 conductor 22 AWG stranded, drain wire, foil shield, vinyl jacket -----per ft.	.06		994-3626-001	M-3626 Rectifier and pickup coil -----	75.00
	250-0081	Cable 6 conductor, 3 pair, wire size 22 AWG --per ft.	.19			TAPE RECORDERS	
	253-0247	Wire 18 AWG stranded, yellow -----per ft.	.24	204		ABR-10/ABR-15 Ordering information and prices available on request.	
	255-0006	High voltage wire 8 AWG 40kV -----per ft.	7.25	205	730-1164	AG-440B-1 (4010131-01) full track, unmounted, 7.5/15 IPS, 60 Hz -----	2,099.00
		AUDIO EQUIPMENT CABINETS			730-1165	AG-440B-1 (4010131-03) as above, console mounted	2,499.00
198	994-6454	M-6454 "Combo" system, complete with two double pedestals and top section. (Note: Combo systems shipped less cutouts) -----	700.00		730-1168	AG-440B-1 (4010131-09) half track, console mounted, 7.5/15 IPS, 60 Hz ---	2,499.00
201	994-6448-001	M-6448 single pedestal less cutouts -----	175.00		730-1170	AG-440B-2 (4010132-01) two track stereo, unmounted, 7.5/15 IPS, 60 Hz ----	2,799.00
	994-6449-001	M-6449 double pedestal, less cutouts -----	310.00		730-1171	AG-440B-2 (4010132-03) as above, console mounted	3,229.00
	994-6453-002	M-6453B, 10-1/2" metal grill. 90 day delivery ----	7.50	205	730-1172	AG-440B-2 (4010132-13) two track stereo, plus quarter track playback, unmounted, 7.5/15 IPS, 60 Hz -----	2,849.00
	994-6453-003	M-6453C, 5-1/4" metal grill. 90 day delivery ----	7.00		730-1173	AG-440B-2 (4010132-15) as above, console mounted	3,279.00
	994-6453-004	M-6453D, 3-1/2" metal grill. 90 day delivery ----	7.00		730-1174	AG-440B-2 (4010132-07) two track stereo, unmounted, 3.75/7.5 IPS, 60 Hz ---	2,799.00
	994-6450	M-6450 uniform top section, complete with mounting angles and cable trough	135.00		730-1175	AG-440B-2 (4010132-09) as above, console mounted	3,229.00
	994-6456	M-6456 double leg assembly -----	24.00		730-1181	AG-445B-1 (4010141-19) half track, unmounted, 3.75/7.5 IPS, 60 Hz -----	1,579.00
	994-6455	M-6455 single leg assembly	12.00	206	730-0963	AG-500-1, 4010048-02 full track, unmounted, 7.5/15 IPS, 60 Hz -----	1,275.00
202	740-0032	KD-20 portable console....	1,100.00		730-0964	AG-500-1, 4010048-04, as above, except half-track heads -----	1,275.00
203	994-3663	SA-131, proof of performance package. Includes M-3625 gain set; 210 audio oscillator, and 410 noise and distortion meter. Note: Does not include R. F. rectifier, see below -----	1,095.00		730-0965	AG-500-1, 4010048-06 full track, unmounted, 3.75/7.5 IPS, 60 Hz -----	1,275.00
	700-0045	210 audio oscillator ----	345.00		730-0966	AG-500-1, 4010048-08, as above, except half-track heads -----	1,275.00
	994-3625	M-3625 gain set -----	380.00				
	700-0040	410 noise and distortion meter -----	375.00				
	994-3626-002	M-3626A R. F. rectifier and pickup coil (low distortion)	160.00				

CAT. PAGE	TYPE NUMBER	PRODUCT DESCRIPTION	UNIT PRICE	CAT. PAGE	TYPE NUMBER	PRODUCT DESCRIPTION	UNIT PRICE
	730-0967	AG-500-2, 4010049-02 stereo. Two-track stereo, unmounted. 7.5/15 IPS, 60 Hz -----	1,495.00		730-1030	Model AA-620, speaker amplifier, portable. Ideal companion unit to AG-600, AG-500 series and other professional recorders. 10" woofer, 3-1/2" tweeter and 20 watt solid state amplifier in one enclosure. 4010070-01 -----	259.00
	730-0968	AG-500-2, 4010049-06 stereo, as above, except 3.75/7.5 IPS speed -----	1,495.00		207 730-0927	270-1 rack mount reproducer, mono, with 1/2 track head assembly. Solid state with 14" reel capability standard. Includes foil sensing and automatic reversing -----	1,691.00
	730-0970	4150161-01 portable case for AG-500 single channel recorders -----	105.00		730-0928	270-2 rack mount reproducer, stereo, for 14" reel -----	1,797.00
	730-0971	415023-01 portable case for AG-500-2, two channel recorders -----	130.00		730-0923	280-1 rack mount record/reproduce, mono, with 1/2 track head assembly, solid state, 10-1/2" reel capability -----	2,150.00
206	730-1018	AG-600-1 NAB equalization, full track, unmounted, 60 Hz, 117 volt. 4010063-01 -----	660.00		730-0924	280-2 as above except stereo -----	2,795.00
	730-1019	AG-600-1 NAB equalization, full track, portable, 60 Hz, 117 volt. 4010063-02 -----	720.00		730-0925	280-1 (SP-14) rack mount record/reproduce, mono, with 1/2 track mono head assembly, solid state, 14" reel capability -----	2,490.00
	730-1020	AG-600-1 NAB equalization, half track, unmounted, 60 Hz, 117 volt. 4010063-03 -----	660.00		730-0926	280-2 (SP-14) as above except stereo -----	3,060.00
	730-1021	AG-600-1 NAB equalization, half track, portable, 60 Hz, 117 volt. 4010063-04 -----	720.00	208	730-0418	1021X (manual operation) monaural, 3.75/7.5 full track record, full track erase, half track play (plays full or half track) less case -----	972.00
	730-1022	AG-600-2 2 channel, two track, one half track stereo. NAB equalization, unmounted, 60 Hz, 117 volt. 4010064-01 -----	915.00		730-0419	1022X (manual operation) stereo, 7.5/15 half track stereo, fourth head included for 1/4 track stereo play, less case -----	1,149.00
	730-1023	AG-600-2 two channel, two track, one half track stereo, NAB equalization, portable, 60 Hz, 117 volt. 4010064-02 -----	1,010.00		730-0425	A81D128-A transport case -----	50.00
	730-1026	AG-600-4, two channel, four track, one quarter track stereo. NAB equalization. Unmounted. 60 Hz 117 volt. 4010064-03 -----	915.00		730-0426	A81D129-1 electronics case -----	50.00
	730-1027	AG-600-4, two channel, four track, one quarter track stereo. NAB equalization. Portable, 60 Hz, 117 volt. 4010064-04 -----	1,010.00		HIGH FREQUENCY BROADCAST TRANSMITTERS		
				213	994-6734-001	SW-100, 100,000 watt short wave broadcast transmitter -----	On Request
					994-6808-001	SW-50, 50,000 watt short wave broadcast transmitter -----	On Request

CAT. PAGE	TYPE NUMBER	PRODUCT DESCRIPTION	UNIT PRICE	CAT. PAGE	TYPE NUMBER	PRODUCT DESCRIPTION	UNIT PRICE
215	994-4748	HF-20B shortwave broadcast transmitter, 4-22 MHz. For operation from 230 V, 3 phase, 50 Hz. Complete w/one set coils, one set tubes, less crystals -----	On Request		JK-09C	Temperature controlled oven, holds two CR27A/U crystals, (.003% accuracy)	30.00
	994-4778A	HF-20BX shortwave broadcast transmitter 4-22 MHz. For operation from 230 V, 3 phase 50 Hz. Complete w/one set coils, one set tubes, less crystals -----	On Request		SINGLE SIDEBAND AND COMMUNICATIONS TRANSMITTERS		
	994-4778B	HF-20CX, 20 kW telephone and telegraph transmitter, with tubes and keyer, 4-22 MHz, less crystals -----	On Request	218	994-6562-003	SG-75A synthesized comm. exciter, output 100 mw, frequency 2 MHz to 30 MHz in 100 Hz steps, rack mounting Qty. 1-4 ----- Qty. 5-9 ----- Qty. 10-25 -----	8,250.00 7,650.00 7,100.00
	990-0139	Spare 100% tube kit for HF-20B -----	2,315.00		994-6562-004	SG-75B (as above) except CCIR Compatible -----	On Request
	CR27A/U	Crystal and holder, .02% accuracy (specify operating frequency) -----	18.00	219	994-6411	SG-70 sideband generator without cabinet Qty. 1-4 ----- Qty. 5-9 ----- Qty. 10-25 -----	4,900.00 4,900.00 4,900.00
	JK-09C	Temperature controlled crystal oven holds two CR27A/U crystals for 0.003% accuracy.-----	30.00		990-0517	Complete set of spare tubes. TK-517 -----	63.00
216	994-3787	HF-10B complete broadcast model transmitter, 2-22 MHz. For operation from 230 V, 3 phase, 60 Hz. Complete w/coils, one set tubes, less crystals. W/oil filled external components	On Request	221	994-6506-003	ATL-10, 10,000 watt automatically tuned ISB, HF power amplifier, Qty. 1-4 ----- Qty. 5-9 ----- Qty. 10-25 -----	26,600.00 26,600.00 23,600.00
	994-3789	HF-10BX complete broadcast model transmitter, w/electronic keyer added, 2-22 MHz. For operation from 230 V, 3 phase, 60 Hz, complete w/coil set, one set tubes, less crystals ---	On Request		990-0574	100% spare tube kit -----	737.00
	994-3793	HF-10CX communications telephone and telegraph transmitter, 2-22 MHz. For operation from 230 V, 3 phase, 60 Hz. Complete w/coil set, one set tubes, less crystals -----	On Request	223	994-6566	STAR-10, 10,000 watt automatically tuned transmitter Qty. 1-4 ----- Qty. 5-9 ----- Qty. 10-25 -----	35,700.00 34,000.00 31,400.00
	994-3795	HF-10TX telegraph transmitter, 4-30 MHz. For operation from 230 V, 3 phase, 60 Hz. Complete w/one coil set, tubes, less crystals -----	On Request		990-0574	100% tube kit -----	737.00
	990-0253	Spare 100% tube kit for all models -----	1,260.00		994-6567A	Model CA-10 remote adapter for STAR-10. Permits selection of any one of ten preset frequencies by remote control -----	No Longer Available
	CR27A/U	Crystal and holder (.02% accuracy) (specify operating frequency) -----	18.00		994-6567B	Model CA-280K remote adapter for STAR-10. Permits selection of 380,000 frequencies by remote control -----	No Longer Available
				224	994-6418	ST-1A sideband transmitter, 1000 watt with tubes less crystals and cabinet. Equipped with slides for 19" rack mounting Qty. 1-4 ----- Qty. 5-9 ----- Qty. 10-25 -----	10,400.00 10,400.00 9,750.00

CAT. PAGE	TYPE NUMBER	PRODUCT DESCRIPTION	UNIT PRICE	CAT. PAGE	TYPE NUMBER	PRODUCT DESCRIPTION	UNIT PRICE
	990-0519	Spare tube kit, TK-519 ----	301.00		990-0531	TK-531 Spare 100% tube kit -----	454.00
	952-5967	Cabinet for ST-1A Qty. 1-4 -----	150.00				
		Qty. 5-9 -----	150.00				
		Qty. 10-25 -----	120.00	231	REMOTE PICKUP EQUIPMENT		
225	994-6492-002	ST-3A sideband transmitter, 3000 watts with tubes, less crystals for 3 phase power source, without roll out base Qty. 1-4 -----	17,450.00		731-0045	150 MHz M30BT/TPS Transmitter Portable-mobile, 30 watt, broadcast-quality with c/w tubes, crystal and tuned. 120VAC and 12.6 VDC -----	695.00
		Qty. 5-9 -----	17,450.00				
		Qty. 10-25 -----	16,350.00		731-0047	TPS-TC mobile control for M-30BT/TPS transmitter --	35.00
	994-6492B	ST-3A (same as above) with 78 dB factory installed harmonic filter -----	On Request		710-0087	ASP-143 bumper mount for MA-1 antenna -----	9.95
	990-0520	Spare 100% tube kit, TK-520 -----	512.00		710-0089	MA-1 Mobile Single Ring Antenna -----	19.95
	478-0246	HFT-5K, 5 kW transformers, 10 kW PEP, matching 50 ohms to 600 ohms -----	617.00		710-0088	PA-1 Portable Single Ring Antenna -----	19.95
	994-6477	Roll out base for HFL-3000 or ST-3A transmitter Qty. 1-4 -----	415.00		731-0046	MR-30/150-170 Receives, Rack Mount, broadcast-quality continuous-duty, with tubes, crystal and tuned. 120 VAC, 600 ohm output -----	375.00
		Qty. 5-9 -----	385.00				
		Qty. 10-25 -----	325.00		710-0086	RA-4 4-bay Base Antenna -	131.75
226	994-6161-003	HFL-1000, 1 kW linear amplifier, complete with tubes, less cabinet. Equipped with slides for 19" rack mounting Qty. 1-4 -----	5,200.00		618-0171	FHJ4-50B Heliax foam filled, 1/2", jacketed transmission line ----- per ft.	.66
		Qty. 5-9 -----	5,200.00				
		Qty. 10-25 -----	4,600.00		620-0301	44AU UHF jack, for use with FHJ4-50B -----	6.00
	952-5894	Cabinet for HFL-1000 transmitter Qty. 1-4 -----	150.00		731-0218	PG-4A pigtail, 4' RG-8A/U cable with plugs -----	3.75
		Qty. 5-9 -----	150.00				
		Qty. 10-25 -----	120.00		731-0182	PG-4B pigtail, 4' RG-8A/U with connectors -----	5.95
	990-0447	100% tube kit -----	237.00				
227	994-6466-005	HFL-3000, 3 kW linear amplifier, complete with tubes, less roll out base, with 3 phase power sources Qty. 1-4 -----	12,400.00	231	731-0254	450 MHz M-20BT-TPS Transmitter, Portable-mobile, 20 watt, broadcast-quality, continuous-duty, with c/w tubes, crystal and tuned. 120 VAC and 12.6 VDC -----	795.00
		Qty. 5-9 -----	12,400.00				
		Qty. 10-25 -----	11,300.00		731-0047	TPS-TC mobile control for M-20BT/TPS transmitter --	35.00
	994-6466B	HFL-3000 with optional filter -----	On Request		710-0111	ASP-406 Rooftop antenna, mobile, vertically polarized	26.95
	994-6477	Roll out base for HFL-3000 or ST-3A transmitter. Qty. 1-4 -----	415.00				
		Qty. 5-9 -----	385.00		731-0187	MR-100/450-460 Receiver, Rack Mount, broadcast-quality, 120VAC. 600 ohm output -----	425.00
		Qty. 10-25 -----	325.00				

CAT. PAGE	TYPE NUMBER	PRODUCT DESCRIPTION	UNIT PRICE	CAT. PAGE	TYPE NUMBER	PRODUCT DESCRIPTION	UNIT PRICE
	710-0112	ASP-313 Base Antenna, colinear, 6 dB gain -----	129.00		374-0015	Type 4CX1000A -----	200.00
	710-0113	ASP-320 Mounting Clamps for ASP-298 and ASP-313 ..	6.95		374-0074	Type 4CX3000A -----	420.00
	618-0172	FHJ5-50A Hellax, 7/8", 50 ohm jacketed --- per ft.	1.70		374-0016	Type 4CX5000A -----	495.00
	620-0317	45AU UHF Jack, for use with FHJ5-50A -----	15.00		374-0077	Type 4CX10000D -----	575.00
	731-0182	PG-4B pigtail, 4' RG-8A/U cable with connectors ----	5.95		374-0097	Type 4CX15000A -----	695.00
	731-0257	PG-4C pigtail, 4' RG-8U UG-21C/U and UG-23B/U connectors -----	6.25		374-0019	No Longer Available	
		ACCESSORIES			374-0026	Type 575A -----	35.60
	720-0187	SR-90R Turner microphone, carbon, for local control of M-25C -----	16.90		374-0027	Type 673 -----	21.00
	731-0199	RMC-1C remote control console, solid state, complete with transistors, power supply -----	189.50		374-0030	Type 807 -----	4.20
	731-0162	DFT Dual frequency kit for M-30BT, M-30BT/TPS and M-30BT/CD, less crystal -----	25.00		374-0031	Type 810 -----	30.75
	731-0163	DFR Dual Frequency kit for MR-30BT/150-170 and M-25/150-170C, less crystal -----	25.00		374-0034	Type 813 -----	25.85
	731-0165	XT-1A Hi-Accuracy Crystal for M-30BT/TPS, M-30BT/CD and M-25C -----	15.00		374-0039	Type 833A -----	69.95
	731-0166	XR-1A Hi-Accuracy Crystal for MR-30BT/150-170 and M-25/150-170C -----	15.00		374-0040	Type 845 -----	35.20
232		Studio-Transmitter Link-890-960 MHz -----	On Request		374-0042	Type 866A -----	3.75
233					374-0043	Type 872A -----	10.85
					378-0008	Type 885 -----	5.00
					370-0146	Type 1612 -----	5.80
					370-0149	Type 1622 -----	5.35
					374-0050	Type 6076 -----	338.00
					374-0051	Type 6146 -----	4.35
					374-0054	Type 6360A -----	6.00
					370-0160	Type 6528 -----	30.00
					374-0107	Type 7480 -----	1,590.00
					374-0058	Type 8008 -----	11.80
					374-0118	Type 8806 -----	760.00
					374-0119	Type 8807 -----	760.00
					374-0096	Type 8122 -----	35.00
					374-0117	Type 8792 -----	215.00
					374-0115	Type 7289 -----	26.50
					374-0067	Type WL5891 -----	1,895.00
						RECEIVING TUBES	
				234	370-0001	OA2 -----	1.50
					370-0005	Type OA3/VR75 -----	1.55
					370-0008	Type OD3/VR150 -----	1.45
234		TRANSMITTING TUBES					
	374-0108	Type 3CV30000H3 -----	620.00				
	374-0094	Type 3CX2500A3 -----	200.00				
	374-0093	Type 3CX2500F3 -----	205.00				
	374-0008	Type 4-125A -----	44.00				
	374-0009	Type 4-250A -----	48.00				
	374-0010	Type 4-400A -----	48.00				
	374-0081	Type 4CX250B -----	35.60				
	374-0014	Type 4CX300A -----	54.00				

CAT. PAGE	TYPE NUMBER	PRODUCT DESCRIPTION	UNIT PRICE	CAT. PAGE	TYPE NUMBER	PRODUCT DESCRIPTION	UNIT PRICE
	370-0133	Type GZ34/ 5AR4 -----	2.25		380-0015	2N553 -----	5.00
	378-0003	Type 5BP1A -----	38.85		380-0016	2N1539 -----	2.30
	374-0020	Type 5R4GY -----	2.03				
	370-0017	Type 5U4GB -----	1.38	235	(TRANSISTORS, CONTINUED)		
	370-0230	Type 5V4GA -----	2.15		380-0018	2N1307 -----	.87
	370-0020	Type 5Y3GT -----	1.30		380-0019	2N1483 -----	4.35
	370-0153	Type 5749 -----	2.20		380-0020	2N696 -----	.78
	370-0155	Type 5879 -----	2.38		380-0022	2N1183A -----	3.45
	370-0027	Type 6AH6 -----	2.60		380-0025	2N2082 -----	3.60
	370-0030	Type 6AL5 -----	1.35		380-0033	2N1306 -----	.93
	370-0036	Type 6AS7GA -----	5.91		380-0034	2N2869 -----	2.28
	370-0052	Type 6BG6GA -----	3.25		380-0035	2N3614 -----	2.10
	370-0065	Type 6C5 -----	2.68		380-0039	PT3134E -----	63.00
	370-0066	Type 6CA7 -----	2.68		380-0041	2N3054 -----	1.74
	370-0069	Type 6CD6GA -----	3.10		380-0042	2N697 -----	.95
	370-0086	Type 6L6GC -----	2.63		380-0043	2N3055 -----	3.10
	370-0093	Type 6SH7 -----	3.08		380-0044	40319 -----	1.74
	370-0094	Type 6SJ7 -----	2.45		380-0045	2N4036 -----	1.98
	370-0098	Type 6SQ7 -----	2.48		380-0046	2N708 -----	.75
	370-0102	Type 6V6GT -----	1.88		380-0047	2N3500 -----	16.90
	370-0105	Type 6X4 -----	1.38		380-0048	2N3118 -----	7.45
	370-0106	Type 6X5GT -----	1.65		380-0049	2N3053 -----	1.13
	370-0158	Type 6080 -----	5.35		380-0050	40317 -----	1.17
	370-0213	Type 6386 -----	8.00		380-0051	3N58 -----	5.10
	370-0112	Type 12AT7 -----	1.53		380-0053	40314 -----	1.40
	370-0195	Type 12AU7A -----	1.38		380-0054	2N2150 -----	33.75
	370-0116	Type 12AX7 -----	1.35		380-0056	40321 -----	1.90
	370-0117	Type 12AY7 -----	2.85		380-0057	40322 -----	4.30
	370-0123	Type 12BY7A -----	1.60		380-0058	2N3440 -----	2.73
235	TRANSISTORS				380-0060	U149 -----	9.75
	380-0011	2N214 -----	2.00		380-0061	2N1724A -----	51.75
	380-0012	2N1183 -----	2.70		380-0062	40310 -----	1.50
	380-0013	2N1225 -----	2.10		380-0063	SE4010 -----	1.50
	380-0014	2N1414 -----	.91		380-0065	2N3766 -----	3.15
					380-0066	2N3740 -----	4.35

CAT. PAGE	TYPE NUMBER	PRODUCT DESCRIPTION	UNIT PRICE	CAT. PAGE	TYPE NUMBER	PRODUCT DESCRIPTION	UNIT PRICE
	380-0067	2N3819 -----	2.25		384-0040	1002A -----	1.35
	380-0068	37913 -----	4.20		384-0066	1N39B -----	.80
	380-0069	DTG2400 -----	5.35		384-0094	D144 -----	1.25
	380-0070	PT2121D -----	30.00		384-0098	67-7297 -----	420.00
	380-0071	2N706A -----	1.80		384-0111	1N3495 -----	2.25
	380-0073	2N918 -----	4.95		384-0116	1N3494 -----	1.90
	380-0077	2N708 -----	.75		384-0117	MR325R -----	1.90
	380-0078	2N709 -----	3.75		384-0128	1N270 -----	.48
	380-0083	2N2369 -----	1.60		384-0132	T171 -----	1.25
	380-0086	2N4391 -----	6.30		384-0133	MDA952-1 -----	5.90
	380-0087	2N3702 -----	.56		384-0134	1N914 -----	.75
	380-0088	2N3704 -----	.50		384-0135	SG3209 -----	1.50
235	(TRANSISTORS, CONTINUED)				384-0143	1N485 -----	1.40
	380-0089	T1409 -----	.23		384-0149	7030A -----	45.00
	380-0091	2N4250 -----	1.15		384-0150	18DB10A -----	10.80
	380-0092	TN323 -----	2.35		384-0151	814-2540-001 -----	31.50
	380-0094	2N4360 -----	.81		384-0154	67-6036 -----	28.35
	380-0095	S59 -----	.68		384-0155	67-6037 -----	34.50
	380-0096	2N3903 -----	1.15	235	(SILICON DIODES, CONTINUED)		
	380-0097	40360 -----	1.35		384-0156	67-6035 -----	74.50
	380-0098	814-7550-001 -----	2.25		384-0159	67-6099 -----	57.75
	380-0099	2N3391A -----	1.05		384-0164	2N3528 -----	2.45
	380-0101	TIS43 -----	1.50		384-0165	1N4720 -----	1.10
	380-0103	UC734 -----	2.72		384-0166	1N643 -----	1.50
	380-0105	40242 -----	.78		384-0169	814-3336-001 -----	4.25
	380-0106	2N4427 -----	3.23		384-0178	1N1200A -----	2.50
	380-0107	2N4905 -----	4.45		384-0183	1N60 -----	1.00
	380-0108	2N4906 -----	5.78		384-0184	67-7747 -----	117.60
	380-0111	2N3417 -----	1.10		384-0185	67-7800 -----	176.40
	SILICON DIODES				384-0194	MR327R -----	3.75
	384-0006	1N54AS -----	.80		384-0195	1N914 -----	.75
	384-0018	1N2069 -----	.75		384-0197	1N3754 -----	.48
	384-0019	1N2070 -----	1.00		384-0198	BR82C -----	6.35
	384-0020	1N2071 -----	1.29		384-0199	67-6136 -----	8.50

CAT. PAGE	TYPE NUMBER	PRODUCT DESCRIPTION	UNIT PRICE	CAT. PAGE	TYPE NUMBER	PRODUCT DESCRIPTION	UNIT PRICE
	384-0018	-----	.75		386-0045	M24AZ -----	3.00
	384-0204	1N456A -----	.65		386-0046	6082 -----	5.25
	384-0205	1N914 -----	.75		386-0047	1N3582 -----	13.45
	384-0208	1N277 -----	.51		386-0053	1N4746 -----	1.95
	384-0210	1N541 -----	.50		386-0057	1N4736 -----	1.95
	384-0211	1N941 -----	4.80		386-0058	1N3024B -----	5.92
	384-0212	MDA920A-1 -----	2.15		386-0063	1N2813 -----	8.48
	384-0214	MQ2 -----	30.00		386-0066	1N4728 -----	2.50
	384-0215	1N1200 -----	2.15		386-0068	1N3006B -----	10.95
	384-0216	1N54A -----	.68		386-0069	1.5R33A -----	2.50
	384-0219	814-6407-001 -----	15.00		386-0072	1.5R45A -----	2.50
	384-0222	814-6679-001 -----	250.00		386-0073	6046 -----	5.95
	384-0225	T1D40 -----	3.70		386-0074	VR12A -----	1.50
	384-0235	67C100H20TTS -----	47.25		386-0075	15R43B -----	2.50
	384-0238	MV1642 -----	2.13		386-0077	1N4749A -----	2.95
	384-0239	S101 -----	15.00		386-0078	1N4734A -----	2.95
	384-0241	1N935 -----	3.45		386-0079	VR33A -----	1.50
	384-0242	MDA920-2 -----	2.54		386-0080	1N754 -----	3.00
235		ZENER DIODES			386-0081	1N4729A -----	2.95
	386-0016	1N2974 -----	8.25		386-0089	1N3331A -----	11.50
	386-0018	1N725 -----	2.80		386-0090	1N4756A -----	2.90
	386-0019	1N754 -----	3.00		386-0091	1N4738 -----	2.20
	386-0028	1N-2992B -----	10.95		386-0100	1N4747A -----	2.90
	386-0030	1N-3027B -----	5.92		386-0109	VR20 -----	1.50
	386-0032	1N747A -----	4.25		386-0111	MZ1000-24 -----	1.30
	386-0034	1N3031B -----	5.92		386-0112	1N4733 -----	1.95
	386-0043	1N2767 -----	13.50		386-0114	VR8.5A -----	1.50
	386-0044	1N821 -----	4.40		386-0115	1N2835A -----	7.65

Rapidly changing conditions may necessitate price corrections from time to time. Therefore, the prices herein are subject to change without notice. All prices are F.O.B. Quincy, Illinois or point of manufacture.

HOW TO ORDER

ORDERING PROCEDURE: All sales are made in accordance with the standard Gates Terms and Conditions of Sale. No order shall be binding upon Gates until accepted by the company in writing at its home office in Quincy, Illinois.

PRICES: Catalog prices are net, f.o.b. Quincy, Illinois, or point of shipment. Our prices are based on cash transactions and all applicable discounts have been deducted. Prices are subject to change without notice. Orders are filled at prices in effect at time of shipment. You will be billed for any price increase and credited for any price reduction. We reserve the right to add any federal, state, or local taxes required by law. If you have a tax exemption number, please include it with your order. These prices and terms apply only to the U.S. For prices and terms in other countries, please contact International Sales Department, Gates Radio Company.

PAYMENT: There are four ways to pay for your equipment purchases:

- (1) **CASH**—This means full payment with order.
- (2) **C.O.D.**—A 25% down payment is required on C.O.D. orders.
- (3) **OPEN ACCOUNT**—A 25% down payment is recommended. The balance is payable within 30 days of invoice date. If you do not have an established account, please provide a current financial statement, plus trade and bank references with your order. Allow at least two weeks for processing.
- (4) **GATES FINANCE PLAN**—On major purchases, by domestic customers, a portion of the cost may be financed through a monthly payment plan. Since Gates financing plans are subject to change from time to time, contact our Credit Manager or your nearest Gates District Manager for full information. The Gates finance plan applies only to the United States.

RETURNS AND EXCHANGES: Do not return any merchandise without our written approval and Return Authorization. We will provide special shipping in-

structions and a code number that will assure proper handling and prompt issuance of credit. Please furnish complete details as to circumstances and reasons when requesting return of merchandise. Custom built equipment or merchandise specially ordered for you is not returnable. Where return is at the request of, or for the convenience of the customer, a restocking fee of 15% will be charged. All returned merchandise must be sent freight pre-paid and properly insured by the customer. When writing to Gates Radio Company about your order, it will be helpful if you specify the Gates factory order number or invoice number.

SHIPPING: Please specify method of shipment on your order. Shipping charges, insurance, and C.O.D. fees (when applicable) will be collected at time of delivery when shipment is made by air, rail or motor freight, or express. If you request parcel post shipment, postage and insurance fees will be billed to your account. Purchaser assumes all responsibility for and risk of loss of, or damage to equipment upon shipment from Gates shipping point(s). Should you receive merchandise damaged in shipment, it is your responsibility to file a damage claim immediately with the delivering carrier. Export packing for overseas shipment is available at slight extra charge.

WARRANTY ADJUSTMENTS: In the event of equipment failure during the warranty period, replacement or repair parts may be provided in accordance with the provisions of the Gates Warranty. In most cases you will be required to return the defective merchandise or part to Gates f.o.b. Quincy, Illinois, for replacement or repair. Repairs, within the warranty period, will be done on a no charge basis. Warranty replacements of defective merchandise will be billed to your account. This billing will be cleared by a credit issued upon return of the defective item.

MODIFICATIONS: Gates reserves the right to modify the design and specifications of the equipment shown in this catalog without notice or to withdraw any item from sale, provided, however, that any modification shall not adversely affect the performance of the equipment so modified.



HOME OFFICE AND MAIN PLANT

QUINCY, ILLINOIS 62301
123 Hampshire Street
Phone: 222-8200, Area 217

DISTRICT OFFICES

NEW YORK, NEW YORK 10016
130 East 34th Street
Phone: 889-0790, Area 212

WASHINGTON, D. C. 20005
730 Federal Building
1522 K Street, N. W.
Phone: 223-5508, Area 202

LOS ANGELES, CALIFORNIA 90007
1945 South Figueroa
Phone: 747-7129, Area 213

SERVICE CENTERS

NEW YORK, NEW YORK 10016
130 East 34th Street
Phone: 889-0790, Area 212

HOUSTON, TEXAS 77027
4019 Richmond Avenue
Phone: 623-6655, Area 713

CANADIAN SALES GATES (CANADA)

Division of Harris-Intertype (Canada) Ltd.

MONTREAL OFFICE
212 Brunswick Boulevard
Pointe-Claire, Quebec, Canada
Phone: 695-3751, Area 514

TORONTO OFFICE
19 Lesmill Road
Don Mills, Ontario, Canada
Phone: 447-7234, Area 416

INTERNATIONAL SALES OFFICE

NEW YORK, NEW YORK 10016
130 East 34th Street
Phone: 725-9800, Area 212

HARRIS
INTERTYPE
CORPORATION

GATES
A DIVISION OF HARRIS-INTERTYPE

Quincy, Illinois 62301

HARRIS
INTERTYPE
CORPORATION

GATES[®]
A DIVISION OF HARRIS-INTERTYPE

GATES RADIO COMPANY
QUINCY, ILLINOIS, 62301 U.S.A.