

**TECHNICAL
MANUAL**

CRITERION 80



WARRANTY

Seller warrants new equipment manufactured by Gates Radio Company against defects in material or workmanship at the time for delivery thereof, that develop under normal use within a period of one year (6 months on moving parts) from the date of shipment, of which Purchaser gives Seller prompt written notice. Other manufacturers' equipment, if any, including electron tubes, and towers shall carry only such manufacturers' standard warranty.

Seller's sole responsibility for any breach of the foregoing provision of this contract, with respect to any equipment or parts not conforming to the warranty or the description herein contained, is at its option, (a) to repair or replace such equipment or parts upon the return thereof f.o.b. Seller's factory within the period aforesaid, or (b) to accept the return thereof f.o.b. Purchaser's point of installation, whereupon Seller shall either (1) issue a credit to Purchaser's account hereunder in an amount equal to an equitable portion of the total contract price, without interest, or (2) if the total contract price has been paid, refund to Purchaser an equitable portion thereof, without interest.

If the Equipment is described as used, it is sold as is and where is. If the contract covers equipment not owned by Seller at this date it is sold subject to Seller's acquisition of possession and title.

Seller assumes no responsibility for design characteristics of special equipment manufactured to specifications supplied by or on behalf of Purchaser.

Seller shall not be liable for any expense whether for repairs, replacements, material, service or otherwise, incurred by Purchaser or modifications made by Purchaser to the Equipment without prior written consent of Seller.

EXCEPT AS SET FORTH HEREIN, AND EXCEPT AS TO TITLE, THERE ARE NO WARRANTIES, OR ANY AFFIRMATIONS OF FACT OR PROMISES BY SELLER, WITH REFERENCE TO THE EQUIPMENT, OR TO MERCHANTABILITY, INFRINGEMENT, OR OTHERWISE, WHICH EXTEND BEYOND THE DESCRIPTION OF THE EQUIPMENT ON THE FACE HEREOF.

RETURNS AND EXCHANGES

Do not return any merchandise without our written approval and Return Authorization. We will provide special shipping instructions and a code number that will assure proper handling and prompt issuance of credit. Please furnish complete details as to circumstances and reasons when requesting return of merchandise. Custom built equipment or merchandise specially ordered for you is not returnable. Where return is at the request of, or for the convenience of the customer, a restocking fee of 15% will be charged. All returned merchandise must be sent freight prepaid and properly insured by the customer. When writing to Gates Radio Company about your order, it will be helpful if you specify the Gates Factory Order Number or Invoice Number.

WARRANTY ADJUSTMENTS

In the event of equipment failure during the warranty period, replacement or repair parts may be provided in accordance with the provisions of the Gates Warranty. In most cases you will be required to return the defective merchandise or part to Gates f.o.b. Quincy, Illinois for replacement or repair. Cost of repair parts or replacement merchandise will be billed to your account at the time of shipment and compensating credit will be issued to offset the charge when the defective items are returned.

MODIFICATIONS

Gates reserves the right to modify the design and specifications of the equipment shown in this catalog without notice or to withdraw any item from sale provided, however, that any modifications shall not adversely affect the performance of the equipment so modified.

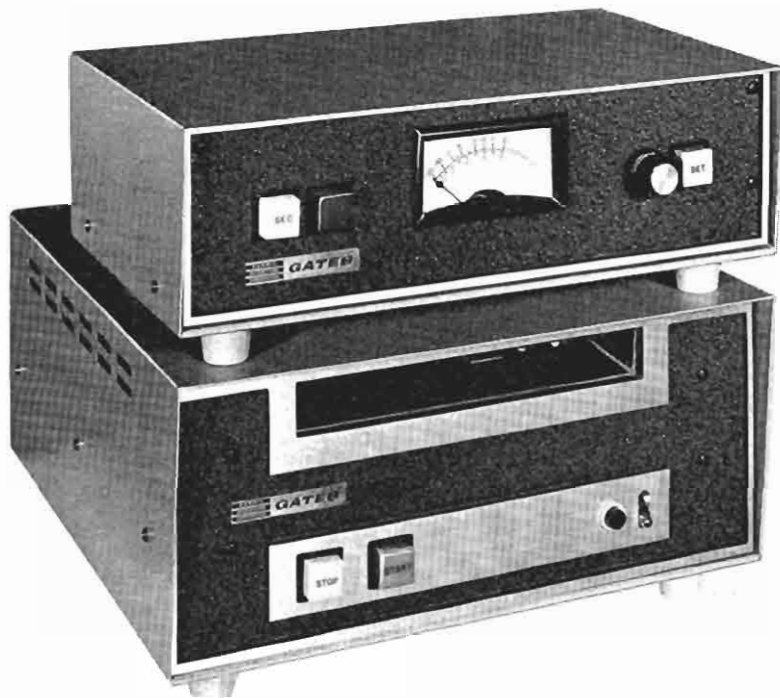

MONAURAL IN DESK MOUNT



STEREO IN RACK MOUNT

CRITERION 80

INTRODUCTION

CRITERION 80 is a fully NAB compatible tape cartridge system. The many features and options provide a model for every application.

PROPRIETARY DATA

This document contains proprietary data of Harris-Intertype Corporation.

No disclosure, reproduction, or use of any part thereof may be made except by written permission.

Price: \$10.00

888 1080 001

TABLE OF CONTENTS

SECTION		PAGE
1	INSTALLATION	1-1
	External Connections - Record	1-2
	External Connections - Playback	1-3
2	OPERATION	2-1
	Record Amplifier	2-1
	Playback	2-2
3	THEORY OF OPERATION.....	3-1
	Playback	3-1
	Record Amplifier	3-2
	Remote Controls	3-4
4	TECHNICAL DATA	4-1
5	MAINTENANCE & ADJUSTMENT	5-1
	Bias Adjustment	5-1
	Cue Record Levels	5-3
	Head Alignment	5-5
	Head Replacement	5-7
	Emergency Adjustments	5-11
	Deck Adjustments	5-12
	Maintenance Check Lists	5-15
6	SCHEMATICS	6-1
7	PARTS LIST	7-1

SECTION 1 - INSTALLATION

1.1 UNPACKING AND INSPECTION

Remove all packing material and carefully lift the units from the boxes. Check the equipment against the packing slips. Install the relays according to the enclosed set-up sheet. Visually inspect the units for any apparent damage and for missing or loose components. Check for proper operation of the front panel controls. Any claims for damage should be filed promptly with the transportation agency. If such claims are to be filed, all packing material must be retained.

1.2 INSTALLATION PROCEDURE

1.2.1 GENERAL

The location in an individual station will be determined by the arrangement of the main control room facilities. The placement of equipment and wiring should be planned carefully before any installation work is started. Care should be taken to provide for adequate ventilation.

1.2.2 PLAYBACK, MONOPHONIC

Connect a two-conductor shielded cable between the desired audio console input terminals and the 600 ohm program output terminals 3 and 5 of Playback connector J2. The shield of the cable should be connected to terminal 1. See Figure 1.2.

1.2.3 PLAYBACK, STEREO

Connections for the Stereo Left channel are the same as for monophonic audio channel. The Stereo Right channel is connected to terminals 4 and 6 with pin 2 for connection to the shield. Phasing should be carefully observed. Terminals 1-3-5 are identical to terminals 2-4-6 respectively. See Figure 1.2.

1.2.4 PLAYBACK – RECORD MONOPHONIC OR STEREO

Install the Playback-Amplifier interconnecting cable between connectors J3 of the Playback and J3 of the Recording Amplifier. Connect the audio input (monophonic or stereo Left channel) to terminals 3 and 5 of J1 with the shield connected to terminal 1. For stereophonic installations, connect the Right channel audio to terminals 4 and 6 of J1 and the shield to terminal 2. See Figure 1.1

1.2.5 REMOTE CONTROL CONNECTIONS

All control functions of both the Playback and Record Amplifier units may be remote controlled. See Charts 1.1 and 1.2 for proper connections.

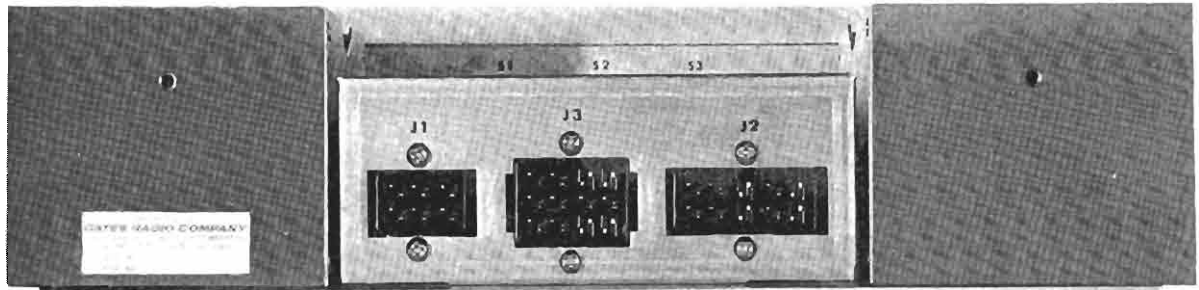

RECORD AMPLIFIER – REAR VIEW

FIG. 1-1

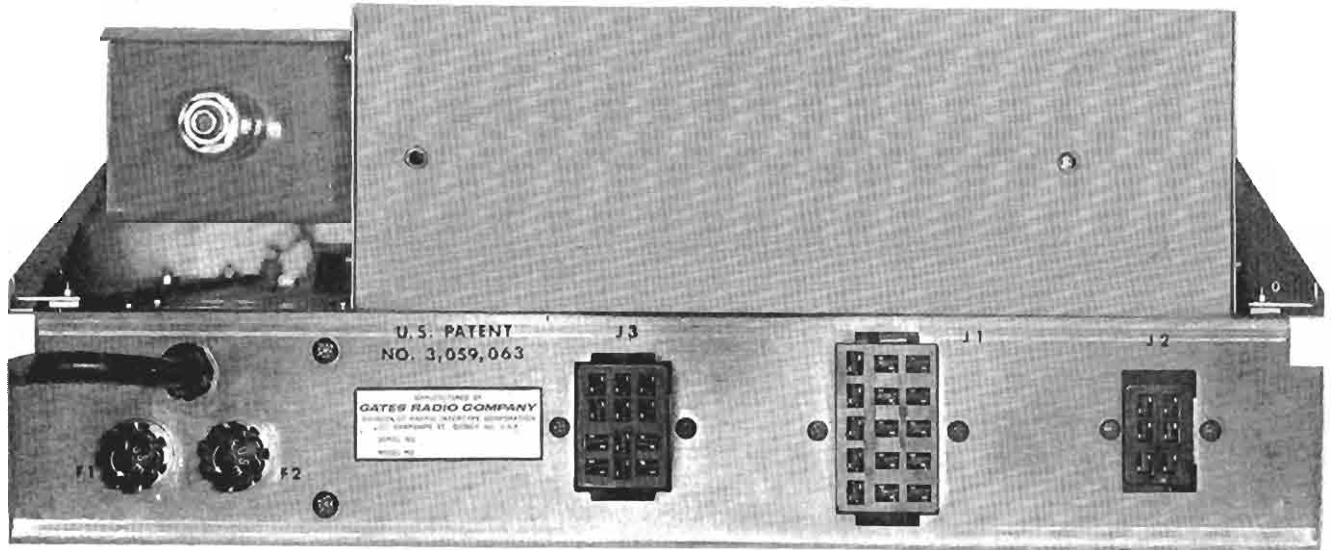

PLAYBACK – REAR VIEW

FIG. 1-2

EXTERNAL CONNECTIONS – RECORD AMPLIFIER	
CONNECTOR J1	
TERMINAL	FUNCTION
1	Shield Ground
3-5	Monophonic (or Left Stereo) Audio Input
2	Shield Ground
4-6	Right Stereo Audio Input (if used)
CONNECTOR J3	
	For Playback interconnecting cable
CONNECTOR J2	
1-2	Remote Record Set
3	Remote Set indication
5-8	Remote Secondary Tone keying
7-8	Remote Tertiary (auxiliary) Tone keying
4-6-9-10	No connection

CHART 1.1

EXTERNAL CONNECTIONS – PLAYBACK

CONNECTOR J1

TERMINAL

FUNCTION

1-2	Remote RUN indication
1	Ground
2-3	Remote Start
4-5	Remote Stop (see Note 1)
6-7	Auxiliary Start (closed momentarily as unit starts)
10-11	Auxiliary Switching (closed momentarily by Secondary tone)
12-13	Auxiliary Switching (closed momentarily by Tertiary tone)
14-3	Remote READY indication
15-1	Remote Tertiary cue indication
9-1	Remote Secondary cue indication

CONNECTOR J2

1	Shield Ground
3-5	Monophonic (or Left Stereo) Audio Output
2	Shield Ground
4-6	Right Stereo Audio Output (if used)

CONNECTOR J3

Record-Amplifier connecting cable

NOTE 1: *These terminals are strapped together (on the back of the connector) at the factory. Remove this strap if the REMOTE stop facility is used.*

CHART 1.2

SECTION 2 - OPERATION

2.1 RECORDING

2.1.1 RECORDING AMPLIFIER CONTROL FUNCTIONS

GAIN CONTROL: The Recording Amplifier gain control AT-1 is used for adjusting the recording level as indicated by the VU meter M1. Corresponding AT-2 and M2 are for the Right channel on stereo models.

RECORD SET: The Record Set pushbutton switch (SET) is used for placing the system in the recording mode.

SECONDARY CUE: The Secondary Cue pushbutton switch (SEC) is used for keying the 150 Hertz tone generator.

TERTIARY (AUXILIARY) CUE: The Tertiary, or auxiliary, Cue pushbutton switch (TER) is used for keying the 8000 Hertz tone generator.

2.1.2 RECORDING PROCEDURE

The procedure for recording one or more productions is as follows:

- a) Insert an ERASED tape cartridge into the right side of the cartridge slot in the Playback unit. Note that the STOP indicator is illuminated, indicating the cartridge is properly placed.
- b) Momentarily press the RECORD SET switch. The switch will be illuminated by the internal pilot lamp.
- c) Adjust the INPUT CONTROL so the program level reads "0" on the VU meter on program peaks.
- d) Press the START switch on the Playback unit and start recording immediately.
- e) Upon completion of the recorded production, momentarily press the STOP switch only if more than one production is desired on the same cartridge, allow the tape to continue running until it is stopped by the automatic cue tone.
- f) When recording more than one production on a single tape cartridge, follow the procedure listed in Steps c thru e for each recording. Upon completion of the final recorded production, allow the tape to continue running until it is stopped by the automatic cue tone.

The 1000 Hz Primary cue tone is recorded automatically at the beginning of the recording. If desired, the Secondary and Tertiary tones may be inserted after the message has been completely recorded. This permits monitoring and accurate placement of the tones.

2.2 **PLAYBACK**

2.2.1 **CONTROL FUNCTIONS**

ON—OFF: The ON—OFF switch applies power to the entire unit. The red neon lamp is illuminated when the unit is on.

START—RUN: The START switch causes the control circuits and the solenoid to be energized; and the tape to be set in motion. This switch is illuminated by an internal lamp when the tape is running in either the Playback or Record mode.

STOP—READY: The STOP switch is used to manually stop tape motion. This switch is illuminated by an internal lamp when a cartridge is properly inserted and the Playback is in the Ready mode.

PROGRAM GAIN: The Program Gain controls are mounted on the main chassis, and are used for adjustment of program output level. The Right Gain Control is not used in monophonic units.

CUE SENSITIVITY: The Cue Sensitivity controls are mounted on the respective circuit cards.

2.2.2 **PLAYBACK PROCEDURE**

The procedure for routine on-the-air playback of program material is as follows:

- a) Insert a recorded tape cartridge into the right side of the cartridge slot.
- b) Observe that the STOP—READY switch is illuminated, indicating the cartridge has been properly inserted, and that the unit is ready for on-the-air playback.
- c) Momentarily press the START switch. Tape motion will be started and will continue until the automatic cue tone is picked up by the cue head and the unit will stop in the correct position for the next playback.

SECTION 3 - THEORY OF OPERATION

GENERAL

PLAYBACK UNIT

The basic CRITERION 80 Playback unit is a solid state single-tone cue machine available in slide-out rack panel mounting or trimline desk console in either monophonic or stereophonic versions. Second and third tone operation is optional. All versions of the CRITERION 80 equipment meet NAB specifications and offer 24 volt DC external switching for safety in remote starting applications, and adaptability to automated systems. Electronics are of plug-in design; including relays, circuit cards, front panel switch assemblies and external connections. The high quality, laminated heads are built with an all metal face providing for long wear and low oxide accumulation. Improved solenoid action and shock mounted relays contribute to the quiet operation of the unit, and the proven full-swing pressure wheel linkage makes actual studio operation easy and fool-proof.

The heart of the CRITERION 80 Playback unit is a heavy-duty tape transport with its hysteresis synchronous positive speed direct capstan drive motor. The CRITERION 80 tape transport offers speed accuracy comparable to the finest reel-to-reel machines. Sealed precision instrument type ball bearings are used making transport flutter less than .2% rms.

Plug-in printed circuit boards offer the finest in advanced solid state design. Top quality epoxy glass board construction is used throughout for easy component access should maintenance be required. A regulated power supply is used to power all circuits assuring correct operating parameters and reliable operation at all times.

POWER CONTROL BOARD: This card contains the solenoid power supply and relay as well as a one-shot relay driver for an external "auxiliary start" output. The capstan motor may be connected to run continuously or to be switched by the deck micro-switch. Suppressor network R3 and C2 may be connected across the deck micro-switch or may be connected across the line.

POWER SUPPLY CARD: Diodes CR1 and CR2, together with C1, form the positive power supply which is applied to Q1 and Q2 in a compound connected series regulator. Diode CR3, with R1 and C4, form the current limited and filtered negative supply of approximately 8 volts used for reverse bias switching in the Record unit. Resistors R4 and R5 provide forward base bias to Q1, which is regulated at 24 volts by zener diode CR4. Capacitor C2 operates as a pre-filter for Q1 and as a delaying network to prevent high surge currents through Q1 and Q2. Resistor R2 limits the emitter current of Q1 and the base drive of Q2 for high current or short circuit protection. F1 is a quick acting instrument type fuse to assure protection for the power supply in case of shorts. At this point the voltage is +23 volts and is further filtered by R3 and C3 to supply the program amplifier cards.

PROGRAM AMPLIFIER: Transistors Q1 and Q2 are connected as a bootstrap amplifier for high DC stability. C3, R2, and R9 provide equalization, fixed for low frequencies of the NAB curve and adjustable at high frequencies to compensate for head losses and allow the choice of operating curves to match 3-3/4, 7-1/2, or 15 IPS requirements. R1 and R4 provide local AC feedback for these stages to increase AC stability. Q3 is a medium impedance

amplifier matching the gain control as an input load. R14 and R12 provide feedback for AC stability. Q4 is a Class A impedance matching output amplifier working into line transformer T1. R19 is a voltage dropping resistor for the lamp element of the LDR audio switch to allow operation from the +23 volts supply. The LDR provides a slight delay in the output of the program amplifier to suppress start-up noises.

1 kHz PRIMARY CUE: Q1 and Q2 comprise a broadband amplifier to provide high input impedance and high current gain suitable for driving all the cue sensors, which are compounded as a load. AC feedback for Q2 is provided by R5. Signal is coupled to the cue gain control R7, where cue sensitivity for the 1 kHz sensor is set. C7 allows low frequency degeneration for Q3, C8 provides high frequency limiting action. Q4 is a similarly tuned stage; the result is a passive two-stage amplifier at 1 kHz, with roll-off on either side at approximately 12 dB per octave. Q5 and Q6 operate as a signal rectifier and DC amplifier, with C13 providing a delaying action. Q6 is connected to the base of Q9 through a resistance bridging network. Q9 is a relay driver and is normally in saturation through bias resistors R21 and R29 to the positive supply. When a cue signal is detected, Q6 will remove the drive from Q9 and cause relay K1 to drop out; provided that Q7 is not conducting. The time delay/protect circuit receives run voltage from relay K1 through R33.

C14 charges through R32 to the avalanche voltage of uni-junction Q10. Q10 conducts, providing a gate signal for Q11; which fires, latches, and drops its anode voltage across R33 nearly to zero. During this timing interval Q8 is ON holding Q7 ON, which holds Q9 ON. In this way Q9 cannot be turned OFF by a cue signal until after the time delay cycle. A positive input to the base of Q8, through R26 from the 150 Hz sensor card, provides safety muting during reception of 150 Hz tones. R26 may be removed if this feature is not desired.

150 Hz SECONDARY CUE: The amplified cue signal is received from the 1 kHz card. R1, C1 and sensitivity control R2 form a low-pass network into the base of Q1. C14 provides low frequency degeneration and C3 provides high frequency attenuation for Q1. Q2 is in a similar circuit, resulting in a passive amplifier with slopes either side of center frequency of approximately 12 dB per octave. Q3 and Q4 operate as a signal rectifier and DC amplifier for the relay, with C9 providing a delaying action.

An output is taken from the collector of Q4 back to Q8 on the 1 kHz card for safety muting during the 150 Hz operation. The relay is normally returned to the anode of Q11 on the 1 kHz card to allow 150 cycle sensor operation only after the protect timer interval has passed.

8 kHz TERTIARY CUE: The amplified cue signal is received from the 1 kHz cue card. C1, C10 and sensitivity control R2 form a high pass network feeding Q1 in this circuit. The safety and inhibit functions utilized in the 150 Hz card are not utilized in this circuit, which otherwise functions the same as the 150 Hz cue circuit.

3.1.2 RECORD AMPLIFIER

The basic CRITERION 80 Recording Amplifier is a solid state, single-tone cue device for use in association with any monophonic model CRITERION 80 Playback. The Recording Amplifier is also available in slide-out rack panel mounting or trimline desk console in either monophonic or stereophonic versions. Second and third tone operation is optional. Operation on regulated

DC power from the associated Playback unit assures correct operating parameters at all times. The printed circuit board mounting of all components in the CRITERION 80 Recording Amplifier provides for easy and efficient maintenance. Pre-wired PC plugs permit easy field modification of any single-tone amplifier to three-tone operation.

RECORD AMP/METER AMP: Transistor Q1 is a common emitter amplifier with R2 providing local AC feedback. C2 slightly boosts high frequency gain to compensate for reactive losses in the input network. The output of Q1 feeds both the meter gain control (R13) and the pre-emphasis network consisting of C5, R6, C6, and R9. The input to the base of Q2 is fed from this network, and additionally shaped by C8, C9, and L1 to drive the recording head. L2 and C10 form a bias trap to limit bias on the collector of Q2. Transistors Q3 and Q4 make up a boot-strap amplifier, providing high input and low output impedance to drive the meter and its bridge rectifier.

BIAS OSCILLATOR: Transistors Q1 and Q2 operate as a Class AB push-pull oscillator, with transformer T1 and C4 as a tuned load. AC positive feedback is provided through C2 and C3. Negative feedback, for stability, is developed across R2 and R5. Output is taken from three taps on the transformer through resistors R8, R9, and R10, which provide resistive loads and current limiting while the switching transistors are AC grounded. Q3, Q4, and Q5 are saturated gates to allow selective application of bias to any of the three outputs. Trimmer C5, C6, and C7 provide independent bias adjustments for each head section. Diodes CR1 and CR2 turn on the bias oscillator by voltage from the SET button or the two-tone oscillator card, when keyed. DC reverse drive, to open the clamping gates, is derived from these same voltage sources. Resistor R1 and capacitor C1 filter the DC power applied to the oscillator circuit, to prevent false triggering.

1 kHz PRIMARY CUE OSCILLATOR: This card includes the 1 kHz oscillator and a timer circuit, which automatically applies a 1 kHz signal at the start of each recording operation. Transistor Q1 and associated components form a tunable shunt-fed Hartley oscillator. Potentiometer R5 is the primary cue level control, and serves as the oscillator load. The 1 kHz tone is coupled into amplifier Q2; the 150 Hz tone and the 8 kHz tone are also fed into the card through terminal 2 into Q2. Thus, Q2 acts as a common amplifier for all three tones, which are then coupled through the bias trap to the cue record head. The timer section of the card gets its power through terminal 12, which starts charging C10 through R14. When the charge on C10 reaches the avalanche point of Q3, the uni-junction will fire; applying a positive pulse to the base of Q4, which latches and remains on until power is interrupted again. During this timing period, transistor Q5 and Q6 are in the ON state, providing DC to power the 1 kHz tone oscillator. After the timing period, the power is dropped by Q4 through R19 to remove power from the oscillator.

2-TONE OSCILLATOR CARD: Both the 150 Hz and the 8 kHz oscillators are contained in this card. The circuits are similar to the 1 kHz card; being shunt fed Hartley oscillators, pushbutton controlled by application of DC power. The 150 Hz oscillator is turned ON by application of +23 volts through terminal 3, to the collector of Q1. The same voltage will pass through CR1 and out terminal 5 to trigger the bias oscillator, which will be gated to the cue head, along with the 150 Hz. The oscillator frequency is tuned by L1 and the level is controlled by potentiometer R7. The 8 kHz oscillator is identical in circuit configuration and operation, with the exception of a change in component values to change the frequency. Power is fed back through CR2 to turn on the bias whenever the 8 kHz cue tone is used.

SIGNAL INPUT CARD: This card contains the line transformer and impedance matching resistors. Options are provided for 600 ohm matching (with or without 30 dB attenuation) and 20 K ohm bridging inputs, by arranging the resistors on the card.

CONTROL CIRCUITS: The Record unit is interlocked so that it cannot be put into the Record mode while the Playback unit is running. This prevents accidental recording during Playback operations. Input plug J3, terminal 2 is supplied with +23 volts in the Ready condition, which drops to zero during the RUN condition. Action of the SET switch will apply power and energize relay K1. One set of contacts will supply power to pin C on the Record/Lock control card which will hold K1 in the Record mode after the Playback has started.

Pin D on the Record/Lock control card is supplied power from terminal 3 of J3, which remains positive until the Playback unit is stopped. This removes power from the emitter of Q1 and causes K1 to drop out. The unit cannot be set after the Playback is started, because the voltage on terminal 2 drops to zero when the Playback is in the RUN condition. J3, terminal 4 carries positive voltage when the Playback is in the RUN condition, which is applied to the 2-tone pushbuttons so that secondary and tertiary cue tones may be recorded at any time during Playback operations.

3.1.3 REMOTE CONTROLS

Three remote controls are offered to aid in the convenience and flexibility of CRITERION 80 operation. The RC-T provides all the controls and indicators of a Playback/Record installation as well as a timer to measure elapsed time in seconds.

This is an invaluable aid in production of cartridges. A connector is provided for the logging encoder, to put digital logging information on the cartridges.

The RC-RA provides all the features of the RC-T except the timer.

The RC-P-4 provides a START control with RUN and READY indicators for four Playback units.

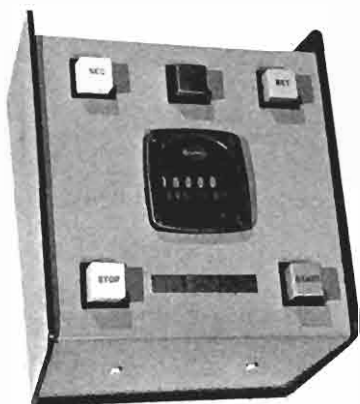

RC-T



RC-RA



RC-P4

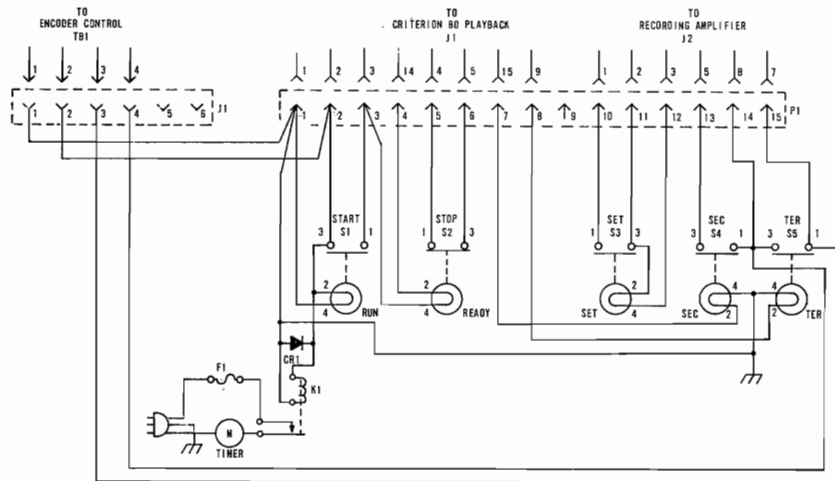

SCHEMATIC RC - T REMOTE CONTROL TIMER

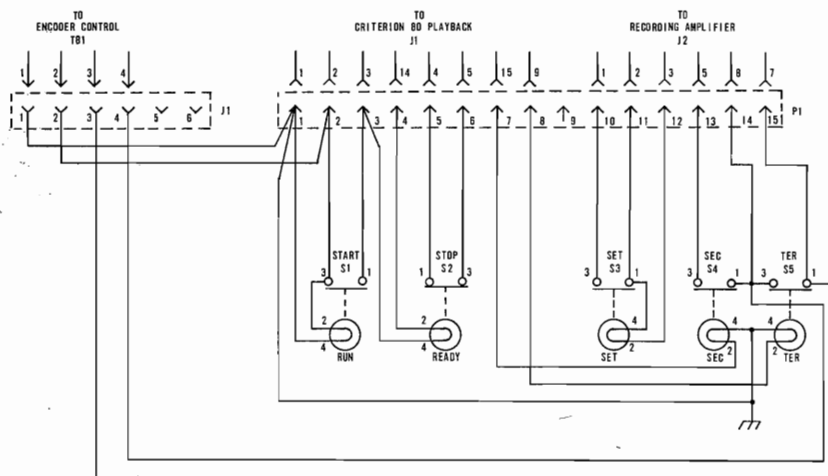

SCHEMATIC RC - RA REMOTE CONTROL

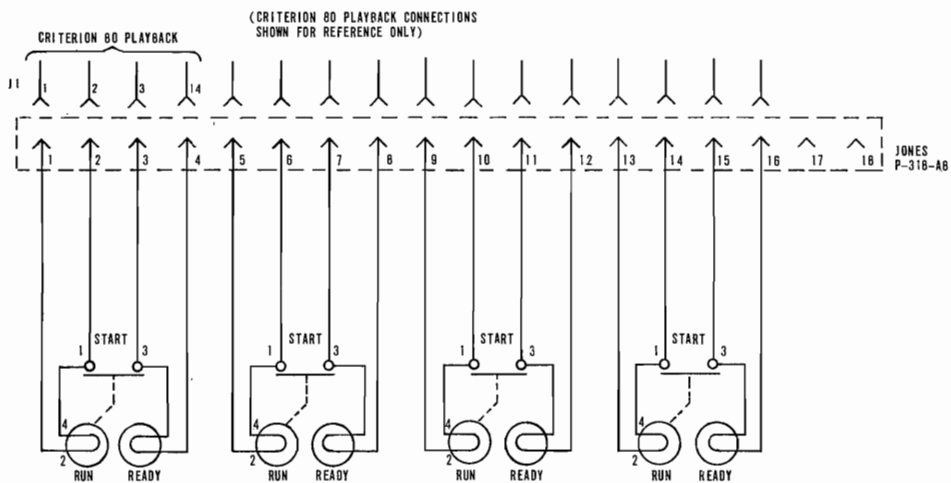

SCHEMATIC RC - P - 4 REMOTE CONTROL

SECTION 4 - TECHNICAL DATA

4.1 SPECIFICATIONS

4.1.1 PLAYBACK UNIT

POWER SOURCE:	117 volts, 60 Hz, 50 Hz on special order
POWER REQUIREMENTS:	65 watts maximum
FREQUENCY RESPONSE:	The overall Record/Playback response of the CRITERION 80 system is ± 2 dB from 50 to 15,000 Hz
NOISE:	55 dB (Mono), 52 dB (Stereo) below 3% THD at 400 Hz
DISTORTION:	Record to Playback, 3% maximum level at 6 dB above NAB Standard Reference level at 400 Hz
EQUALIZATION:	In accordance with NAB Cartridge Recording and Reproducing Standards. The recording amplifiers are equalized to maintain the required Playback characteristics
AMBIENT TEMPERATURE:	55 ^o C, maximum
OUTPUT PLAYBACK:	+12 dBm clipping point, normally 0 dBm with standard NAB level recording. 600 ohms balanced with 150 ohms as optional connection
CUE SIGNALS:	1000 Hz Primary Cue, 150 Hz Secondary and 8000 Hz Tertiary Cue Sensors are available as optional equipment
REMOTE CONTROL:	All control functions
TAPE SPEED:	7-1/2 inches per second, 3-3/4 and 15 on special order
TAPE DRIVE SYSTEM:	Direct capstan drive, sealed ball bearings. Tape START and STOP time: 0.1 second
WOW AND FLUTTER:	.2% or less
TIMING ACCURACY:	.1% or better
DIMENSIONS:	Rack mount, 7" high, 19" panel width, 13-1/2" deep Desk-Top Cabinet, 6-3/4" high, 13-1/2" wide, 14-1/2" deep
WEIGHT:	24 pounds, 35 pounds in rack mounting enclosure
HEADS:	In accordance with NAB Standards. Permits monitoring while recording

4.1.2 **RECORD AMPLIFIER**

POWER SOURCE:	From regulated supply of Playback unit
AUDIO INPUT:	-20 dBm min, +18 dBm max, 600 ohms balanced with 150 ohms as alternate connection
BIAS OSCILLATOR:	Push-Pull bias oscillator with isolated outputs, solid state switching to eliminate transients
TONE GENERATORS:	Individual tone oscillators with adjustable frequency and output level
AMBIENT TEMPERATURE:	55° C, max
REMOTE CONTROL:	All control functions
DIMENSIONS:	Rack mount, 5-1/4" high, 19" panel, 7-3/4" deep Desk-Top Cabinet, 4-7/8" high, 13-3/8" wide, 7-3/8" deep
WEIGHT:	15 pounds

SECTION 5 - MAINTENANCE & ADJUSTMENT

5.1 ADJUSTMENTS

5.1.1 RECORDING AMPLIFIER

BIAS LEVEL: When purchasing a new record amplifier or replacing record heads, it will be necessary to check the bias adjustment on the record amplifier. Since the inductance of the record heads may vary from head to head, bias voltage should be readjusted each time the record amplifier is used with a new replacement head (or a different Playback unit) in order to maintain proper recorded frequency response and output. The bias adjustment should be made using the type of tape which will normally be used. The following procedure should be used when bias adjustments are required:

SET-UP: The output of the Playback unit should be connected to a console or any convenient VU meter. Connect an audio oscillator to the Record amplifier input. For location of adjustment controls, see Record Amplifier Chassis Layout.

Steps to follow in adjustment —

- 1) Set the oscillator frequency at 1000 Hz.
- 2) Insert an erased 3-1/2 or 5-1/2 minute cartridge in the Playback unit.
- 3) On the Recording Amplifier — press the Record SET switch and adjust the Record level to -5 VU.
- 4) While recording, monitor the Playback output and adjust trimmer C-6; the middle trimmer on the bias card, with a non-magnetic screwdriver for maximum Playback level. For stereo recorders, repeat the adjustments on the right channel using C7, the bottom trimmer.

NOTE: *Erase cartridge if unit cues.*

- 5) On the Playback Unit Head Assembly: Unplug the green (Cue Play) head lead and insert the red (Program Play) head lead in its place. This permits monitoring of the cue track from the left Playback output while Cue Bias adjustments are made.
- 6) Extend the 1 kHz Cue Oscillator card using a 915-0675-001 extender card. (Connector on extender card must face same direction as components on circuit card.) Jumper B and D on extender card (9 and 11 on circuit card) to cause the 1 kHz to operate continuously.
- 7) While recording, adjust C5, top trimmer on the bias card, for maximum output on the program channel.
- 8) Return the head leads to their proper plugs (see Head Bracket assembly, Figure 5-1).

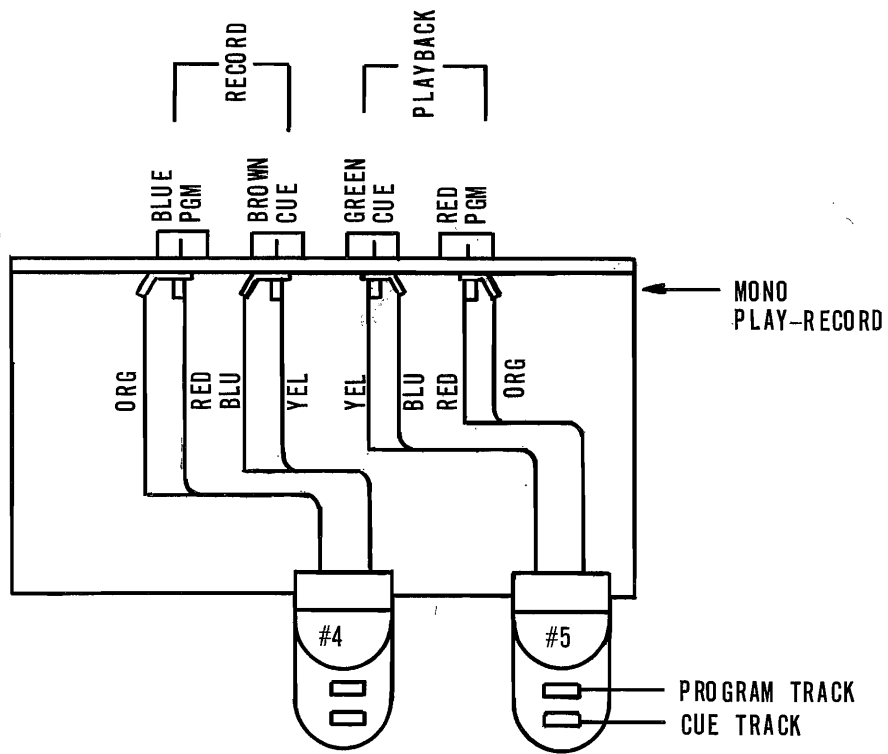
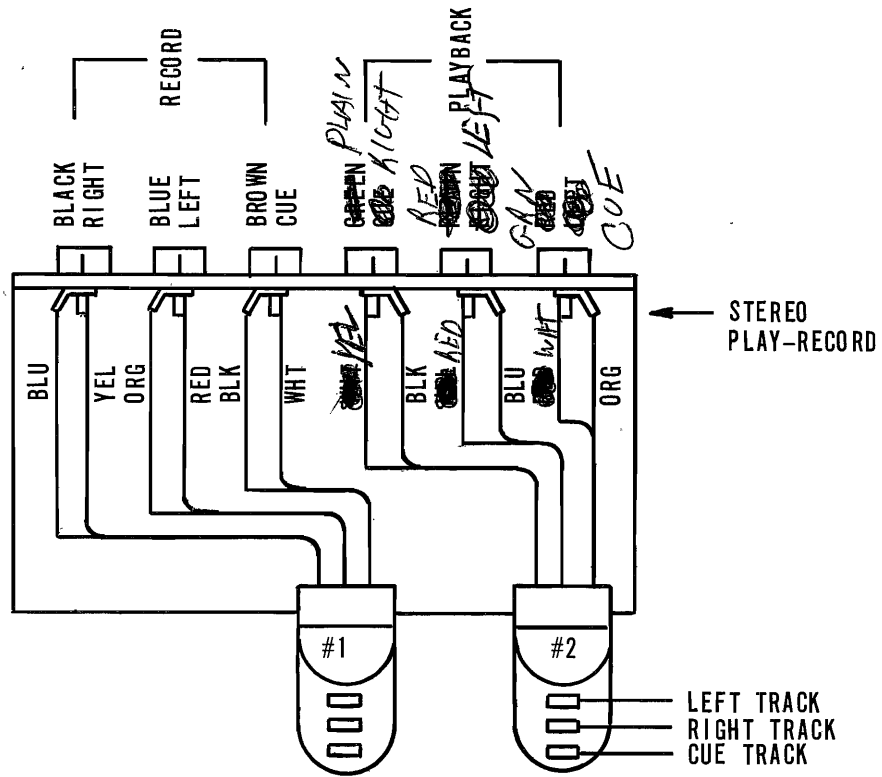

FIG. 5-1

CUE RECORD LEVELS: The Cue Record Levels are adjustable by potentiometers mounted on the oscillator cards. So long as replacement heads are of the same type as the original, no change in Cue Recording Levels should be necessary. Proper adjustment of the level controls (after Cue Bias adjustment has been performed in accordance with 5.1.1) should provide recovery levels from the Playback output as follows:

NAB Reference 400 Hz	0 dBm (Ref)
Primary (1 kHz)	+0.4 dBm
Secondary (150 Hz)	+6.1 dBm
Tertiary (8 kHz)	-9.4 dBm

CUE FREQUENCY: The Cue Frequencies are adjustable by means of the slug tuned coils on the cue oscillator cards. Adjustments of these coils are performed at the factory and should be attempted in the field only when proper equipment is available for accurately checking the oscillator frequencies.

5.1.2

PLAYBACK

See Playback Chassis Layout for location of adjustment controls, Figure 5-2.

CUE SENSITIVITY: The Cue Sensitivity is adjustable on each cue sensor card in the Playback unit. These controls are preset to barely trigger at 10 dB below the NAB standard levels at the factory and should require no further adjustment.

PROGRAM GAIN: The Program Gain controls are mounted on the main chassis of the Playback. The Right Gain Control is not used in monophonic units. The Program Gain is preset at the factory to produce 0 dBm output from a tape recorded at NAB standard reference level.

HEAD ALIGNMENT: Head Alignment should be checked in routine preventative maintenance, this topic is covered in Section 5 of this manual.

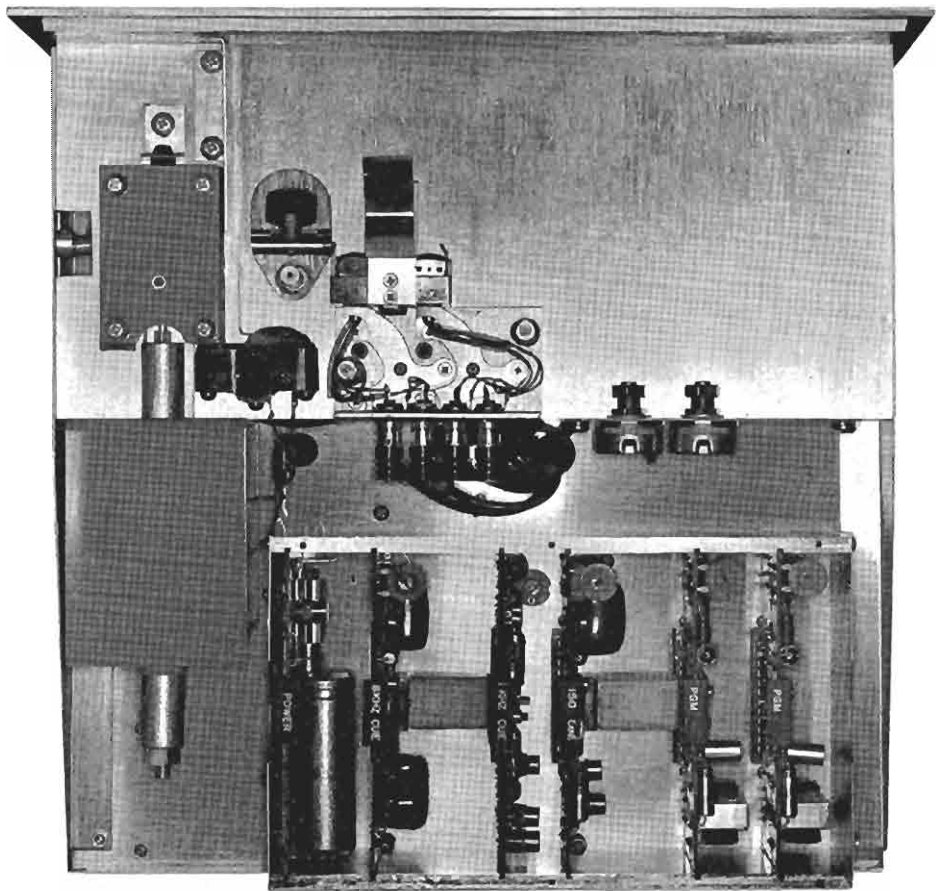

PLAYBACK CHASSIS - TOP VIEW
FIG. 5-2

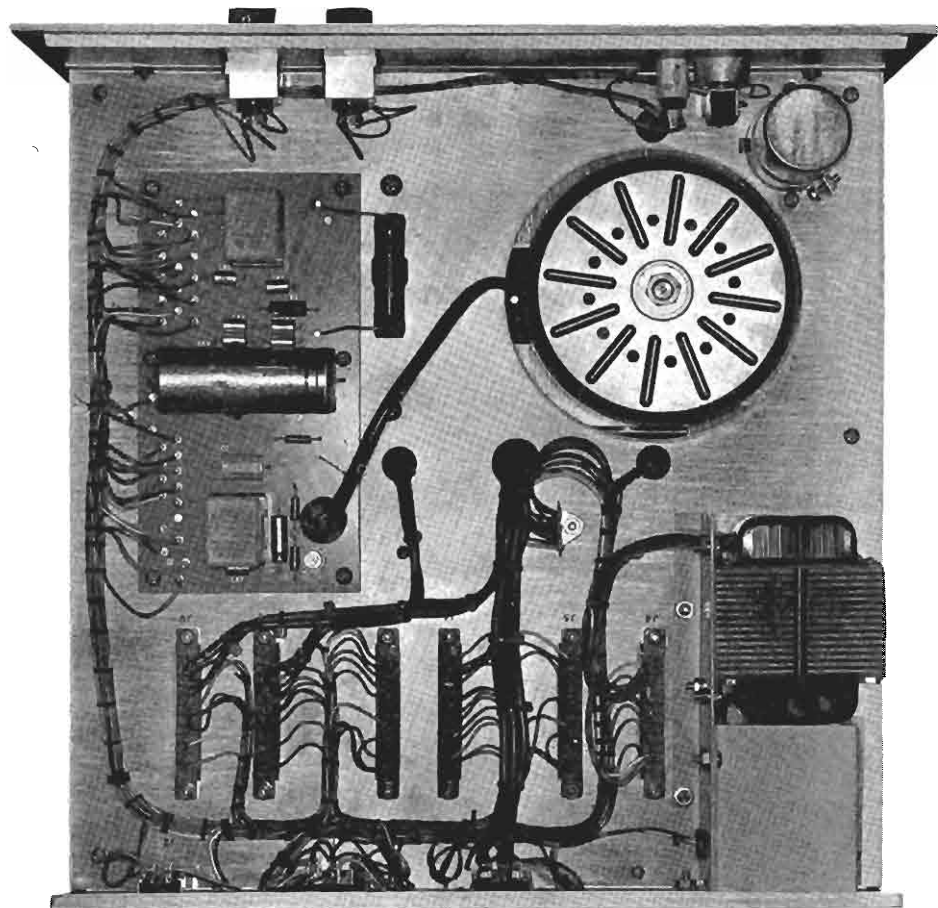

PLAYBACK CHASSIS - BOTTOM VIEW
FIG. 5-3

5.2 MAINTENANCE

5.2.1 RECORDING AMPLIFIER

Under normal operating conditions the Recording Amplifier requires no routine maintenance.

5.2.2 PLAYBACK UNIT

The CRITERION 80 Playback unit is factory adjusted to provide peak performance and under normal operating conditions should require no routine electrical maintenance.

HEADS: As with any quality tape equipment frequent checks of head alignment, condition and cleanliness are imperative for maximum performance and troublefree operation. Proper head care is especially important on the production equipment. Dirty, misaligned or worn heads are frequently at fault when problems are encountered in the areas of low program output, poor frequency response and false or missing cues. Cueing problems are easily detectable, therefore, and serve as good indicators for the need of head maintenance.

CAUTION: *In the majority of cases cueing problems are only compounded by readjustment of either Cue Record Level or Cue Sensitivity to settings other than those outlined in 5.1.1 and 5.1.2.*

- A. To facilitate easy head alignment checks, standard tapes should be recorded immediately upon receipt of the equipment. Tapes should be recorded as follows:
- 1) Record one cartridge with 15 kHz at a Record Level of -15 VU. Play the cartridge back, note and keep a log of the output level.
 - 2) Record one cartridge while operating the 1 kHz Cue Oscillator, with Pins 9 and 11 shorted on an extender card, in the Record Amplifier (no program input on this tape). This action records a continuous 1 kHz tone on the Cue track. Remove Cue Play head cable to prevent the Cue Sensor from stopping machine.
 - 3) Reverse the Cue Play and Program Play head cables. Play back the tape, and note and log the output level.
 - 4) While manually depressing the Secondary Cue (150 Hz) button on the Record Amplifier repeat Step 3 for one cartridge.
 - 5) While manually depressing the Tertiary Cue (8 kHz) button on the Record Amplifier repeat Step 3 for one cartridge.
 - 6) Using a clean 3-1/2 minute cartridge, record a single 1000 Hz cue tone (do not record program material on this tape). The tone is recorded automatically at the beginning of the recording process. Allow the machine to run until the tape cues. Rerun the tape, and log the exact time required for playback. This tape should be kept on hand as a timing standard.

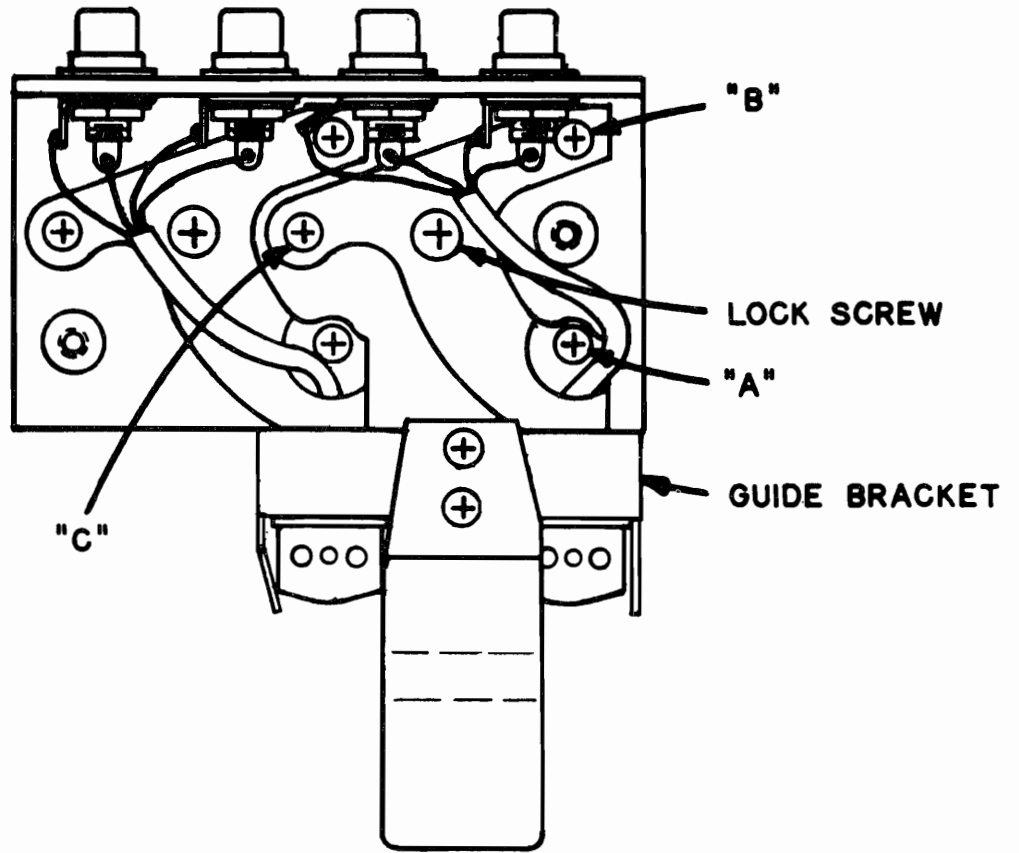

HEAD ASSEMBLY - ADJUSTMENT POINTS

FIG. 5-4

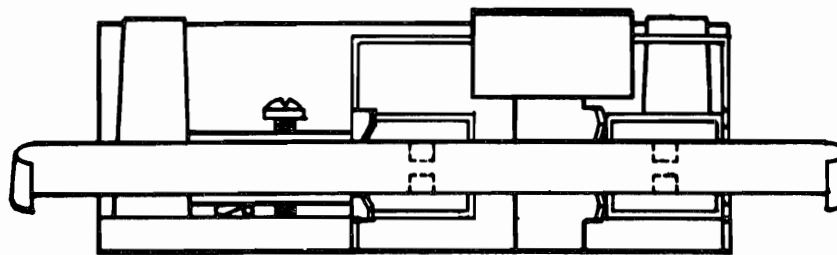

FIG. 5-5

- B. Of the various causes of cueing difficulties, that of head misalignment is most frequently encountered. The following discussion describes mounting and alignment of heads on the CRITERION 80 equipment.

Installation of Heads:

- 1) Install the thin lock nut on the head mounting stud.
- 2) Carefully thread the head leads through the head mounting hole. Use tubing over leads as protection against cutting wire insulation while threading in the head. Screw the head into the mounting hole until the apex of the head face is $27/32''$ plus or minus $1/32''$ from the front edge of the support member.

NOTES:

- a) *Do not twist or apply tension to the head leads.*
- b) *When tightening the head, apply pressure only to the boss located on the back of the head cup - not directly to the head.*
- c) *Solder the head leads only after completion of the installation. See Figure 5-1.*
- d) *Replace tape guide and cartridge hold-down spring. The bottom of all three fingers of the tape guide should rest on the deck surface.*

Height Adjustment:

Figure 5-4 illustrates the location of adjustment points, mounting screws and output connectors. The following steps outline proper adjustment procedures:

- 1) Turn the lock screw counterclockwise until the screw is well above the lock (maximum down) position.
- 2) Adjust screw A for $9/16''$ height of the top of the upper track above the deck surface. Gates gauge (Figure 5-9) can be used to make this setting. It can also be used to check the guide post height of cartridges.
- 3) Adjust screw B for exact perpendicularity between the deck surface and pole faces. This may be done using a metal gauge (Figure 5-6 or good quality machinist rule $3/4$ or 1 inch wide) which is known to be square. Resting one edge of the gauge on the deck surface, move the gauge against the face of the head. At the point of perpendicularity, no space should be visible between the head and gauge as the gauge is resting flat on the deck.
- 4) To facilitate fine adjustment of height, a strip of clear mylar may be prepared by removing the lubricant and oxide from a short length of $1/4''$ tape. Flex remover or shellac thinner (use in well ventilated area to prevent fire hazard) will suffice to loosen the oxide so it may be wiped off the transparent mylar base.

CAPSTAN ADJUSTMENT GAGE
815 1447

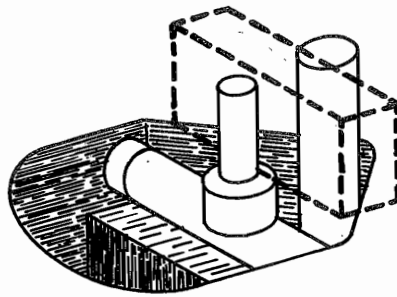
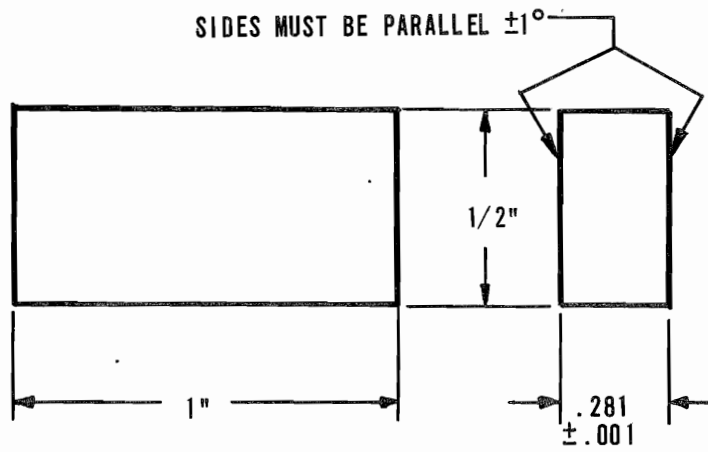
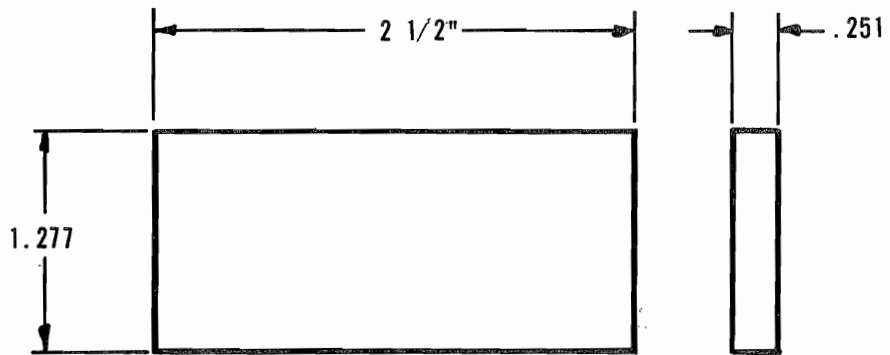

FIG. 5-6

HEAD ADJUSTMENT GAGE
815 0841



NOTE: ALL CORNERS $90 \pm 0.1^\circ$

FIG. 5-7

PINCH ROLLER - GO/NO GO
ADJUSTMENT GAGE
815 0844

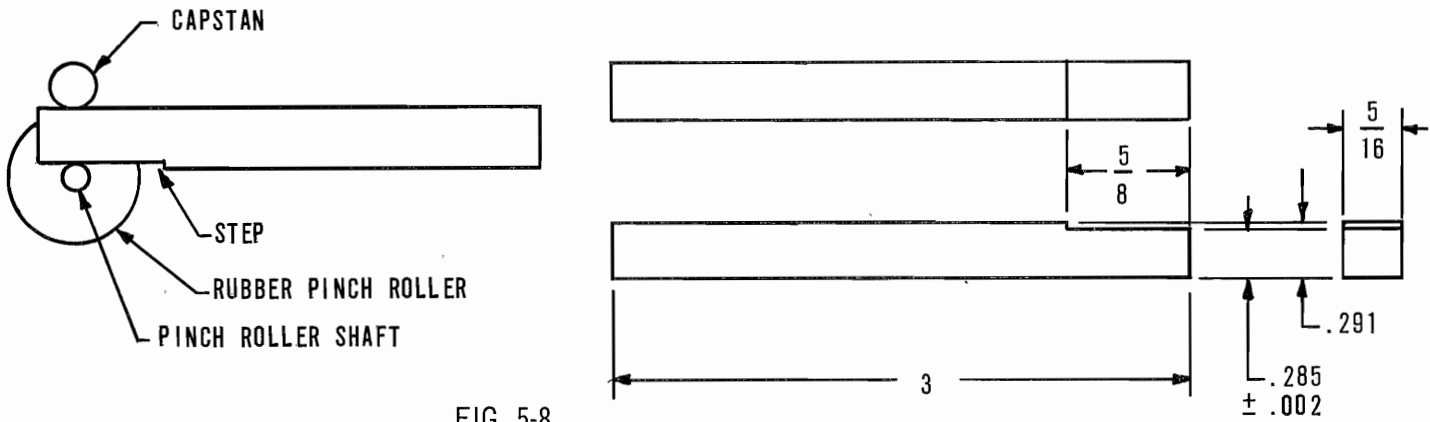

FIG. 5-8

HEAD/GUIDE HEIGHT GAGE
815 0842

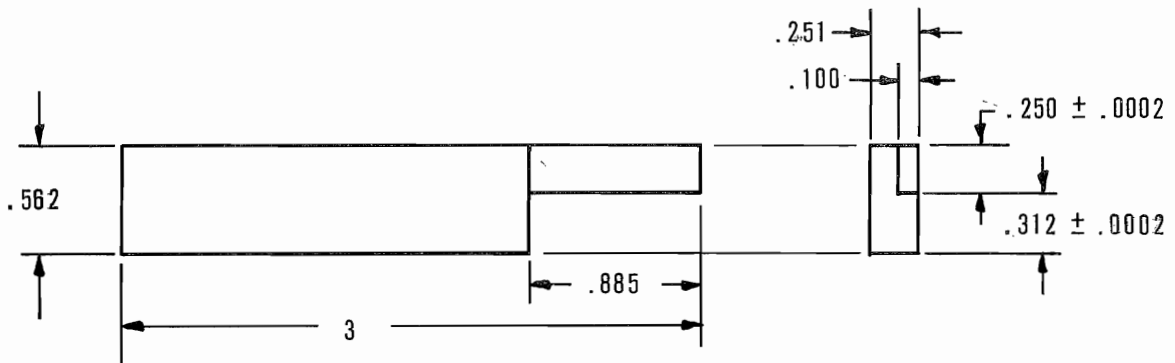

FIG. 5-9

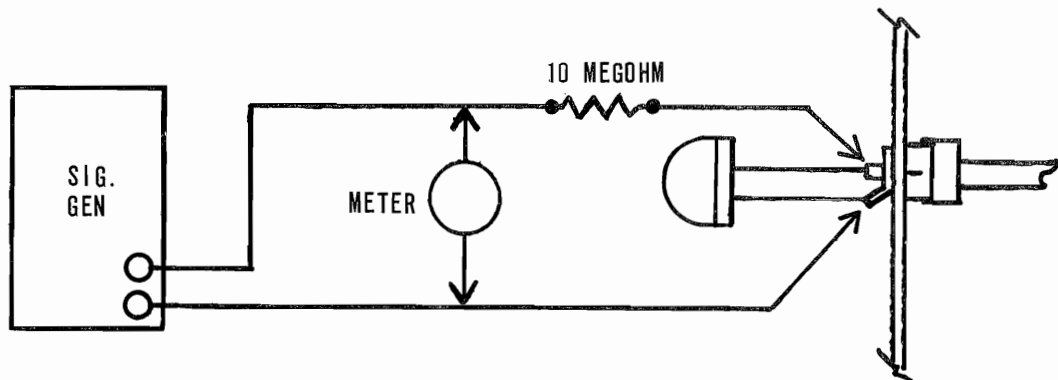

FIG. 5-10

- 5) Refer to Figure 5-5 and position the mylar across the head faces and properly engaged in the tape guides. This is the position of the tape when a cartridge is being played on the machine. To free one hand for adjustments, fasten the mylar to the opposite side of the guide bracket from the head which is being adjusted. Proper tape position in the tape guide is at the point where minimum distortion of the tape is observed. This distortion is due to the tape contacting the guide and is visible as a slight crinkle at either the top or bottom of the tape. With one hand, hold the mylar in a position contacting the heads as shown.
- 6) While holding the mylar in this position, alternately adjust screws A and B to position the tracks with respect to the tape. Screw A should be adjusted a small amount then B should be adjusted an equal amount in the same direction. This procedure is repeated until the correct height is obtained. Proper height is that height at which the top of the upper pole piece is at the same level as the top of the tape and the bottom of the lower pole piece is at the same level as the bottom of the tape.
- 7) Recheck perpendicularity (Step 3).

This completes the height and perpendicularity adjustments. The procedure should be repeated for the record head (if used). After adjustments are complete, the heads should be degaussed.

Azimuth Adjustment:

- 1) Remove the mylar and insert the tape which was recorded with the 15 kHz tone.
- 2) While monitoring the output of the Playback unit, adjust screw C of the Playback head for maximum output level.
- 3) Tighten the lock screw for this head.
- 4) To facilitate monitoring Playback from the Record head, the Program play (red) head lead and the Program record (blue) head lead should be reversed.
- 5) Align the Record head in the same manner as described in paragraphs 2 and 3 above. Output from the Record head will be slightly less than from the Playback head.
- 6) Return the head leads to their proper jacks and install the head cover.

NOTES:

As a check of azimuth on the production Playback, the following should be performed:

- a) *While recording a constant level of 15 kHz, monitor the output from the Playback head. Level should be about -15 dB.*
- b) *Carefully adjust the azimuth screw of the Record head for maximum output.*

Heads may be cleaned with a cotton swab and isopropyl alcohol. Care should be exercised to prevent misalignment of heads by excessive pressure.

PRESSURE ROLLER AND CAPSTAN SHAFT: Cotton swabs and isopropyl alcohol may also be used to remove deposits which accumulate on the pressure roller and capstan shaft. Care must be used to prevent liquid running down the capstan shaft into the motor bearings.

CUE SENSITIVITY LEVELS: When cue problems develop, a step-by-step analysis is helpful to rapidly ascertain the cause of difficulty. When such problems arise, the following procedure is recommended as a sample analysis:

As an example, consider a Playback unit which fails to respond to the 8 kHz cue tone:

- 1) Insert the 8 kHz standard cue tape recorded in 5.2 into the machine. Determine if the machine is cueing with the standard tape. If the unit does not cue, check head alignment with the standard 15 kHz tape.
- 2) Again insert the 8 kHz standard cue tape, and determine if the machine cues properly. Unless the heads are worn or the cue sensitivity level is low, the Playback should now cue properly.
- 3) If in Step 2, the unit did not cue properly, advance the cue sensitivity slightly and again determine if the Playback unit cues properly.

NOTE: *The cue sensitivity should be advanced ONLY following the performance of Steps 1 and 2 of this discussion.*

5.3 EMERGENCY ADJUSTMENT

In case where the equipment has been misadjusted, repaired, or a minimum of test equipment is available, the following procedure will suffice using a Simpson Model 260 Multimeter, Audio Signal Generator and a 10 megohm resistor. All voltage readings are RMS values.

5.3.1 PLAYBACK

- 1) Program Gain - Connect equipment as shown in Figure 5-10 across left head cable (leave head connected). Set signal generator at 400 Hz and 7.4 V as read on meter. Adjust Program Gain-L to read "0" dB or 0.78 V. on left PGM output. Be sure it is loaded with 600 ohms. Meter may be moved from input to output. Repeat for right channel on stereo models.
- 2) Primary Cue - Connect equipment as shown in Figure 5-10 across cue head cable. Set signal generator to 1 kHz and 3.20 V read on meter. Adjust R-7 (PRI CUE) on the 1 kHz Primary Cue board to barely trip and "cue-out" at this input level.
- 3) Secondary Cue - Change signal generator to 150 Hz and 2.60 V. Adjust R2 (SEC CUE) on the 150 Hz secondary cue board so that the relay barely trips.

The Program Amplifier is now set for a standard gain and can be used to set up the level of the cue oscillators. The cue sensors are set so that the sensitivity threshold is approximately 10 dB below NAB standard cue levels, the tapes made in Section 5.2.2 can now be used to check cue functions.

5.3.2 RECORDER

- 1) Connect the red L Play cable to the Cue Play head. Connect Simpson meter across audio output 600 ohm load.
- 2) SET and START Recorder, observe meter swing to about 0.75 V for a short pulse of 0.5 to 1 second. This is the automatic 1 kHz cue tone which is being recorded on the cue track and being played back through the Left Program Amplifier. If it is necessary to adjust the level of the 1 kHz Cue Oscillator, jumper Pin 9 to Pin 11 on the base of the 1 kHz cue card to cause the tone to operate continuously. SET and START the Recorder and adjust the Recorder Cue Tone Level to 0.75 V on the Simpson meter. Remove the jumper from 1 kHz cue card.
- 3) Depress SEC button and adjust SEC Cue Level for 1.5 V on Simpson meter.
- 4) Depress TER button and adjust TER Cue Level for 0.37 V on the Simpson meter.

The Cue Oscillators are now set to record cue tones at NAB Standard levels. Return head cables to normal and install an erased cartridge. SET and START Recorder. Depress SEC and TER buttons and listen for relay actions, allow the tape to run completely through to test the cue-out function.

5.4 DECK ADJUSTMENTS

This article is intended as a guide for maintenance of those portions of the deck assembly which affect tape drive. If wow and flutter or other tape drive problems are encountered, it should be determined that cartridges are not at fault before adjustments are made.

LINKAGE ASSEMBLY: The purpose of the linkage assembly is to convert the reciprocating movement of the solenoid to the revolving movement necessary for the cross shaft.

CROSS SHAFT ASSEMBLY: The pinch roller mounting shaft is pressed into the rotating cross shaft and, therefore, occupies a fixed position with respect to the cross shaft. Because of this the motor capstan must be adjusted relative to this assembly.

MOTOR POSITION: The position of the drive motor is adjustable by means of two mounting screws which are accessible from above the main deck structure. To provide access to the mounting screws, the head bracket should be removed; and to facilitate replacement of the bracket, its position should be marked on the main deck prior to removal. The motor assembly should be positioned to locate the capstan shaft as far toward the head bracket position as possible and 3-9/16 inches from the front edge of the deck (where it joins the back of the front panel). This can be set more precisely using Gates 815-1447 capstan adjustment gauge or a similar gauge made from information in Figure 5-6. To use this gauge, remove the rubber pinch roller and hold the



gauge as shown in Figure 5-6. With the two motor mounting screws loose, push the motor to the maximum distance from the solenoid; grasp the gauge and both shafts tightly so that they are parallel and touching. Tighten the motor mounting screws securely. Check to be sure that the gauge touches the capstan shaft along its entire length to insure that the pinch roller shaft is parallel with the capstan shaft. Replace the pinch roller. DO NOT ENERGIZE SOLENOID.

NYLON SLIDE BLOCKS: Refer to Figure 5-2. Loosen the four mounting screws. Separate the blocks at the solenoid end as far as possible. Snug the two screws on this end to hold the blocks in place. With the linkage in the rest (OFF) position, squeeze the opposite ends of the blocks against the aluminum slide without actually binding. Work the slide several times by hand to make certain no binding exists. Tighten the four mounting screws.

SOLENOID ADJUSTMENT: The adjustment of the set screw on the rear of the solenoid and the set screw on top of the slide cover determines the pinch roller pressure. The pinch roller shaft should come up to a distance of 0.285 to 0.290 measured between the top of the capstan shaft and the top of the pinch roller shaft with solenoid engaged and motor running.

A Go-No-Go gauge is described in Figure 5-8. If it is determined that solenoid adjustment is needed proceed as follows:

- a) Loosen locknut and set screw on rear of solenoid to within 1/2 turn from full out. Clip or tie the deck microswitch closed.
- b) Push START switch; then adjust the set screw on the top plate of the slide cover until the solenoid plunger barely bottoms in the bore. Operate STOP and START several times, allowing four or more seconds between operations. It will be necessary to manually pull the plunger assembly to the rest position. Tighten locknut when adjustment is complete.
- c) Turn the set screw on rear of solenoid in about three turns. Press the START switch and insert the 815-0844 gauge between the capstan and end of the pinch roller shaft as shown in Figure 5-8. Adjust the set screw until the gauge slips into the step - but not beyond.

CROSS SHAFT RETURN SPRING: The cross shaft return spring is located on the end of the shaft and is visible when viewing the machine from above the deck. This spring should be adjusted for a positive but not excessive return of the pressure roller.

RETURN LIMIT BUMPER: The return bumper is visible at the panel end of the slide assembly and may be adjusted by its support screw which is tapped into the main deck. The bumper limits the return travel of the pressure roller and should be adjusted along the solenoid axis to a point at which the top of the roller is not above, nor more than 1/16 inch below the deck surface.

BRONZE CUSHION SPRING: The bronze cushion spring is held in place between the limit bumper support bracket and the deck. The bronze leaf extends below the aluminum slide and is free to travel vertically in the deck slot. Adjustment of the leaf should be made from the underside of the deck. Proper adjustment is obtained by bending the spring upwards to slow the return of the slide so that it does not bounce when hitting the return bumper.

CARTRIDGE GUIDE GAGE
815 0961

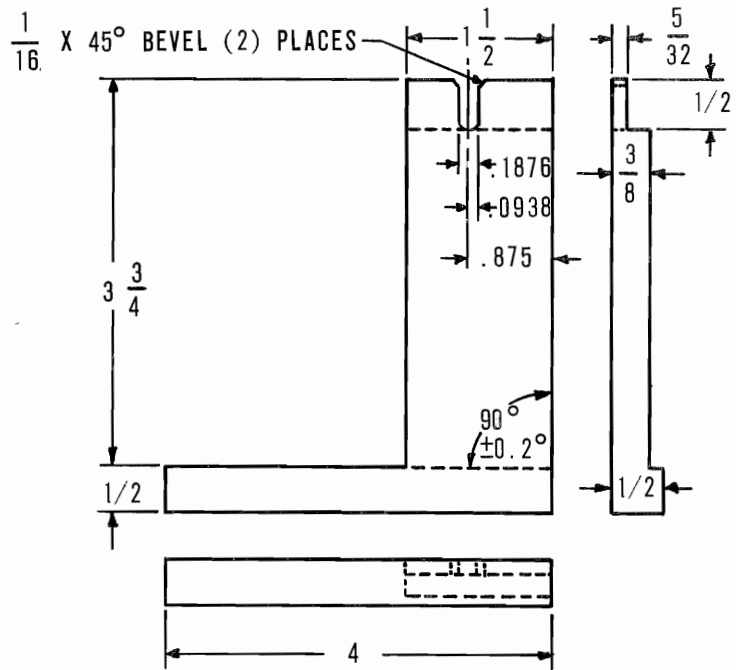

1. PLACE SLOT OF GAGE OVER PINCH ROLLER SHAFT - A
2. HOLD SHOULDER OF GAGE FIRMLY AGAINST DECK FRONT - B
3. POSITION CARTRIDGE GUIDE AGAINST GAGE AND TIGHTEN SCREWS - C

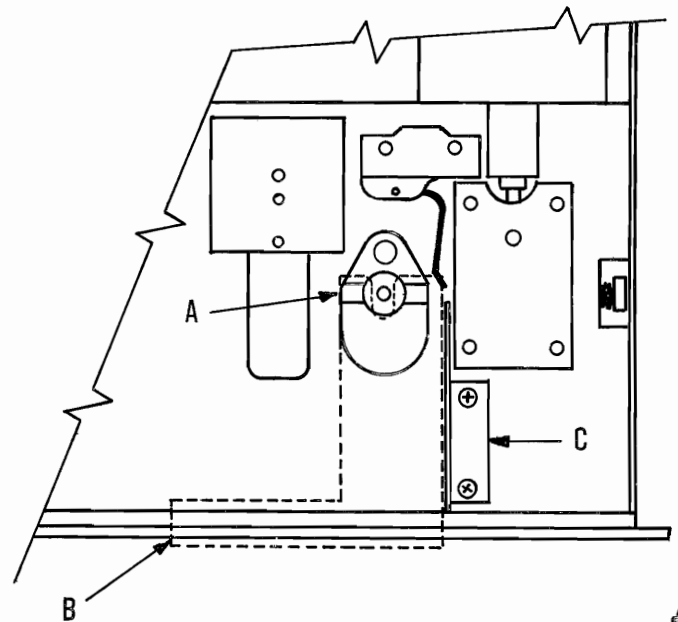

5.5

SUGGESTED MAINTENANCE CHECK LIST

5.5.1

DAILY

- 1) Clean heads as necessary. Dirty heads may usually be detected by visual inspection. Dirty heads will cause loss of audio level, poor response and missed cues.
- 2) Clean pressure roller and capstan. Dirty pressure rollers usually appear somewhat glazed and shiny. Poor tape drive and slippage will occur if this condition exists.
- 3) Check alignment of tape cartridge pressure pads. Check for forward and lateral adjustment. Check for loose or missing polyurethane. This should be done each time the cartridge is handled.
- 4) Run cartridge an instant before starting a recording. Through normal handling the tape may sag slightly in the cartridge. This will sometimes result in over-lapping of program and cue tracks, audible in Playback.
- 5) If a poor recording is noted, check:
 - a) Cartridge pressure pads.
 - b) Left-hand white guide post for proper seating.
 - c) Cartridge warpage. Make certain the Record and/or Playback heads are clean.

5.5.2

WEEKLY

- 1) Check heads for signs of excessive wear. This will cause poor frequency response in recording or reproducing and low cue sensitivity resulting in missed cues. Under average conditions the heads and pinch roller need replacement in 6 months to one year.
- 2) Play the 15 kHz test cartridge and check the Playback level. Any deterioration of the 15 kHz level would indicate a need for head alignment or replacement.
- 3) Carefully check the pinch roller adjustment with gauge 815-0844.
- 4) Using the timing standard cartridge, carefully measure the Playback time with a stop watch. If the Playback time is extended by two seconds or more, check the pinch roller and adjustment.
- 5) Lightly oil the pinch roller bearing. Be sure all lubricant is removed from the capstan shaft.

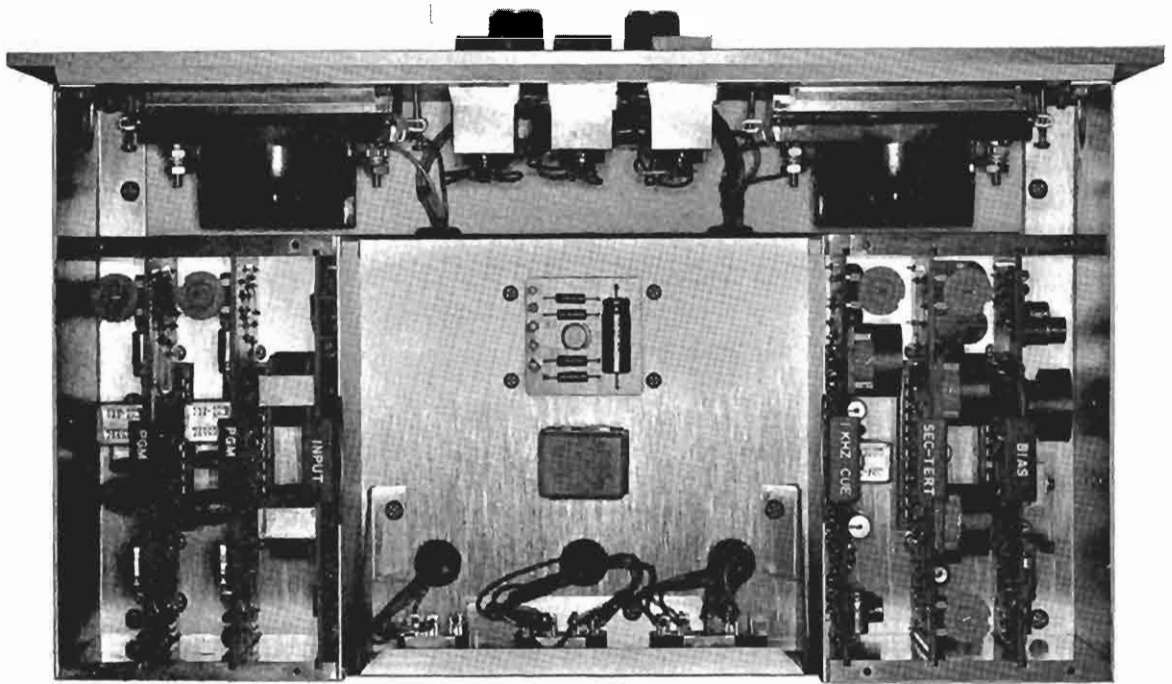

TOP VIEW STEREO RECORD AMPLIFIER

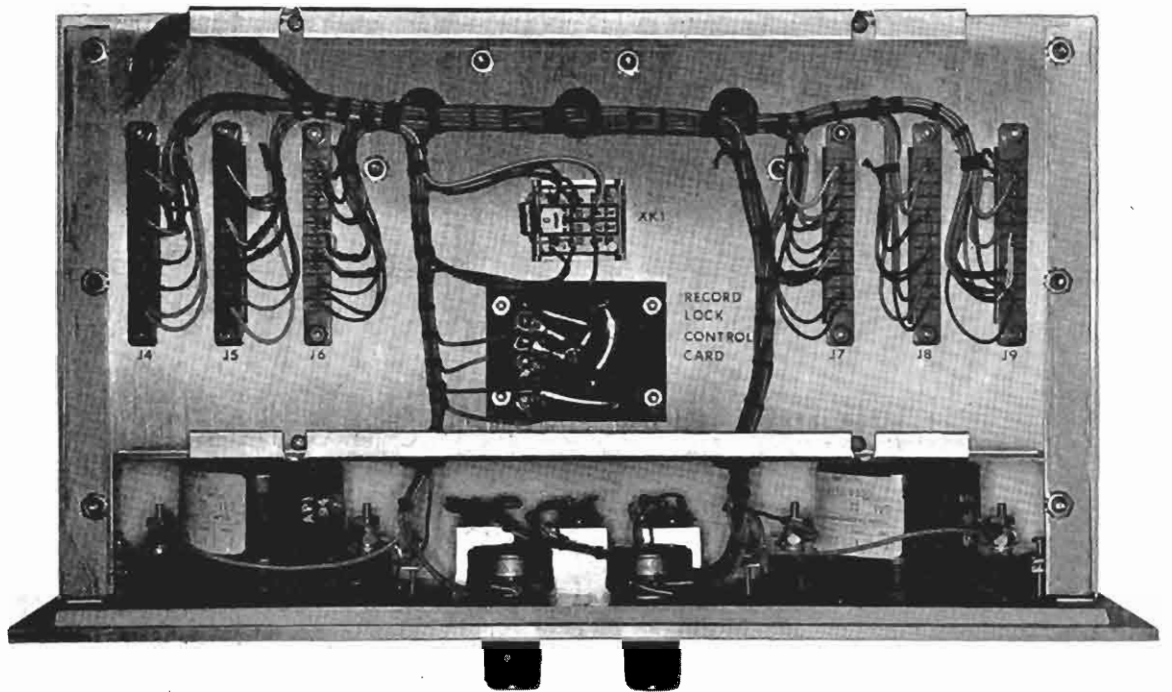

BOTTOM VIEW STEREO RECORD AMPLIFIER

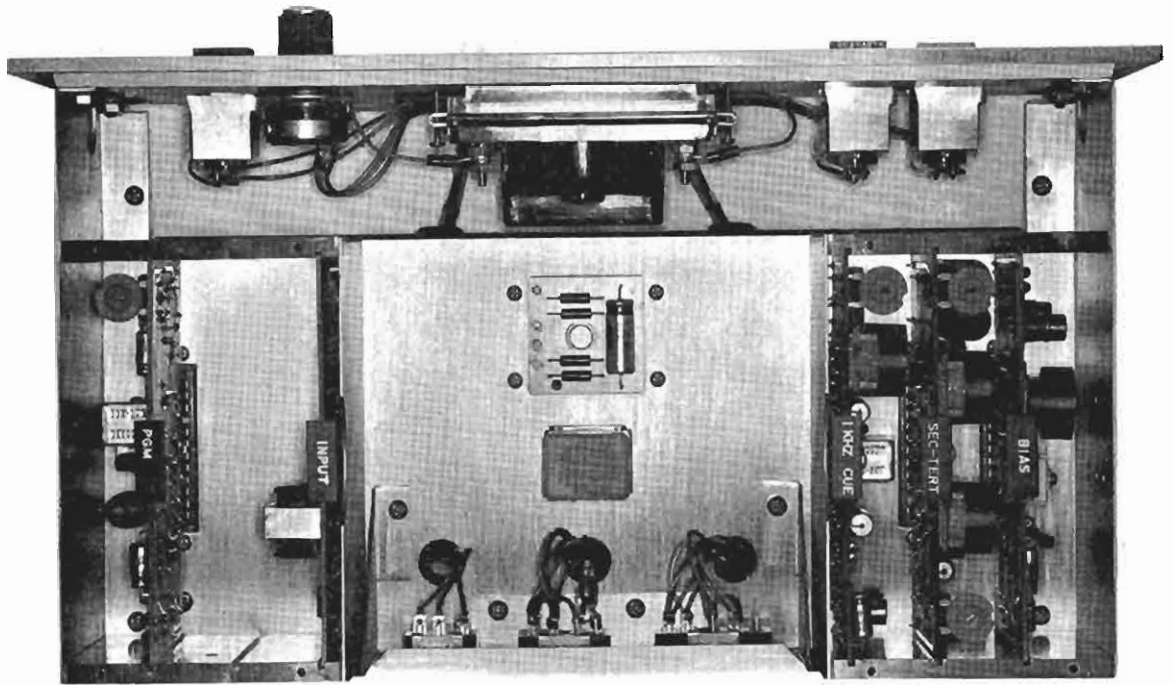

TOP VIEW MONO RECORD AMPLIFIER

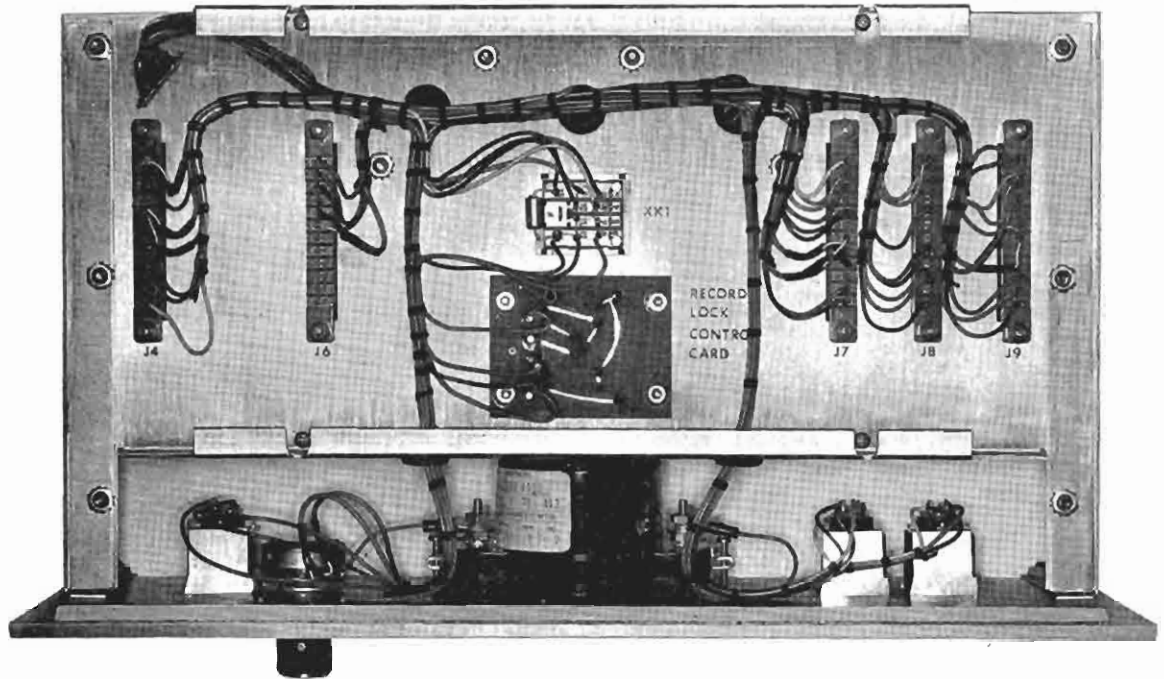

BOTTOM VIEW MONO RECORD AMPLIFIER

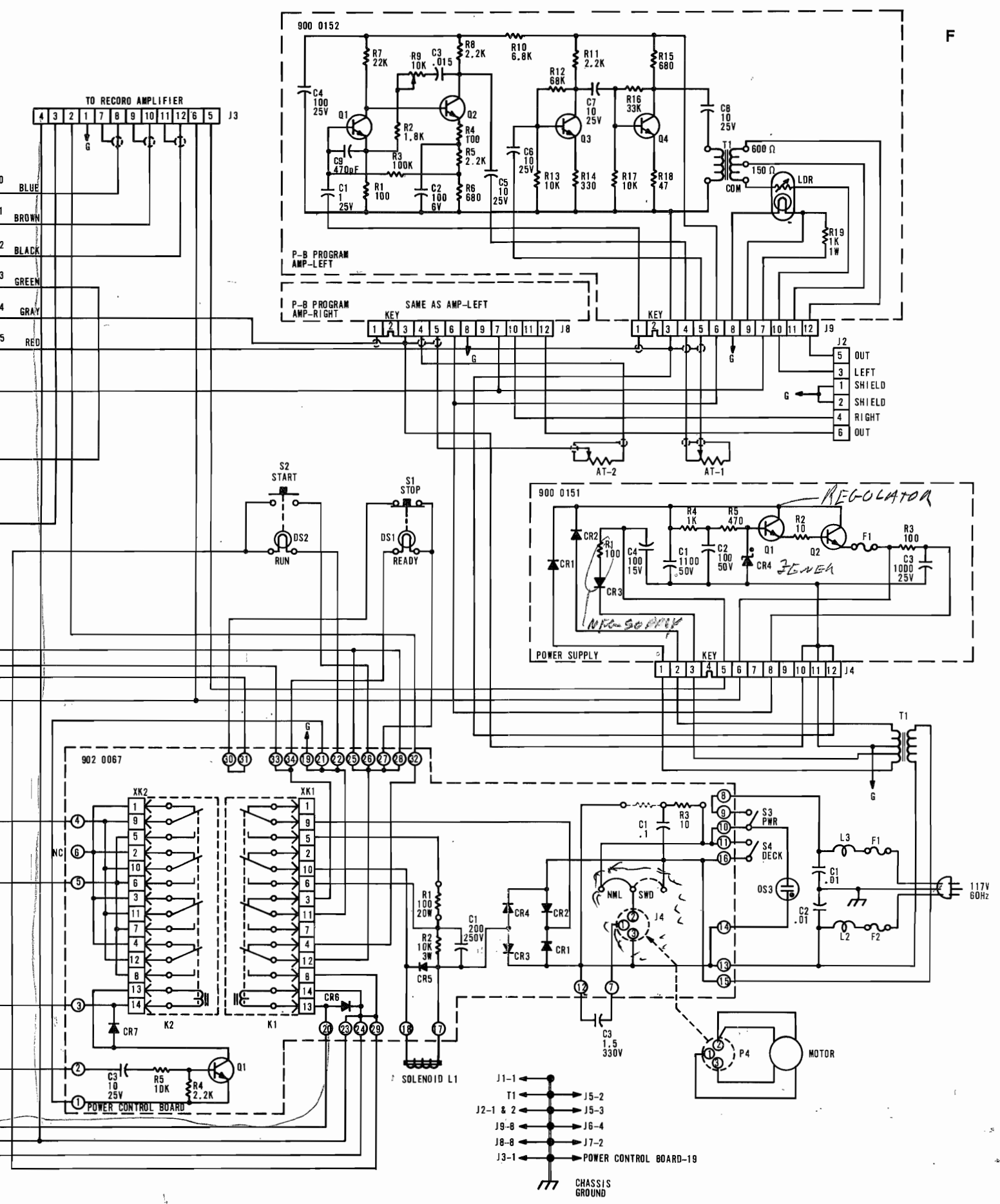

**SCHEMATIC PLAYBACK AMPLIFIER
CRITERION 80**

842 6203 001

SA 0515 (DA 200T)

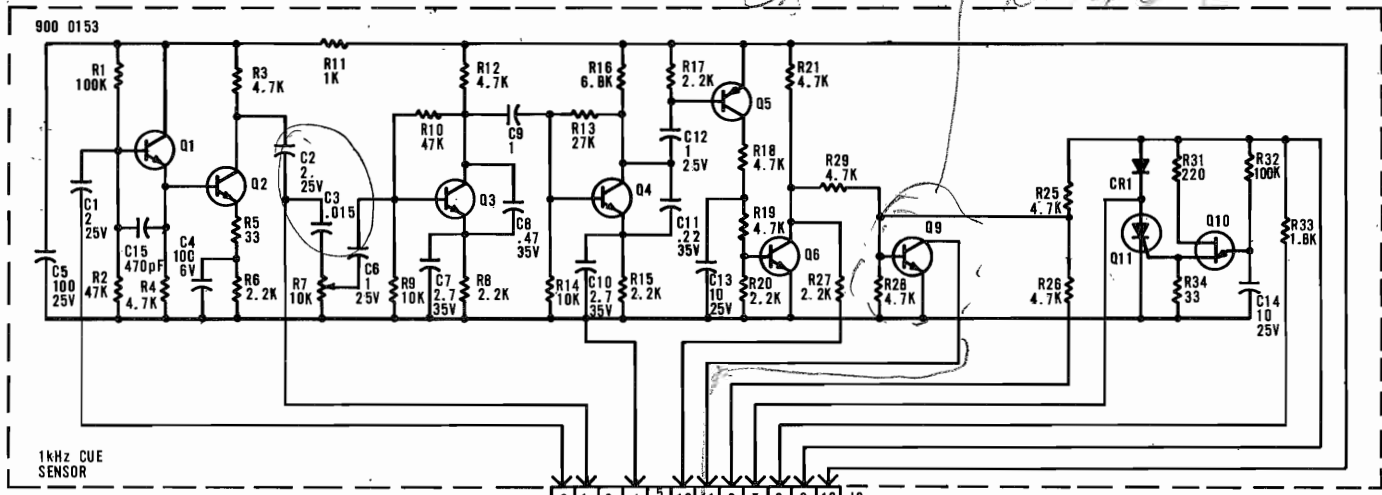

RECORD HEAD
PLAY HEAD

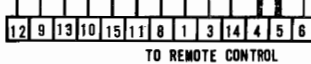
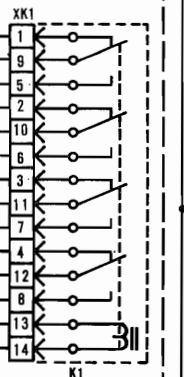
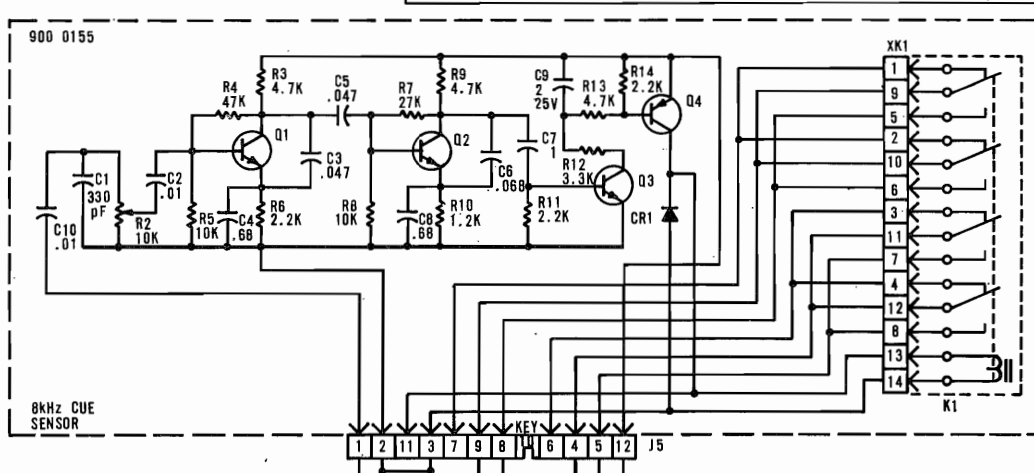
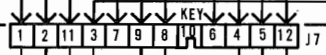
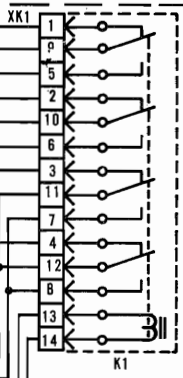
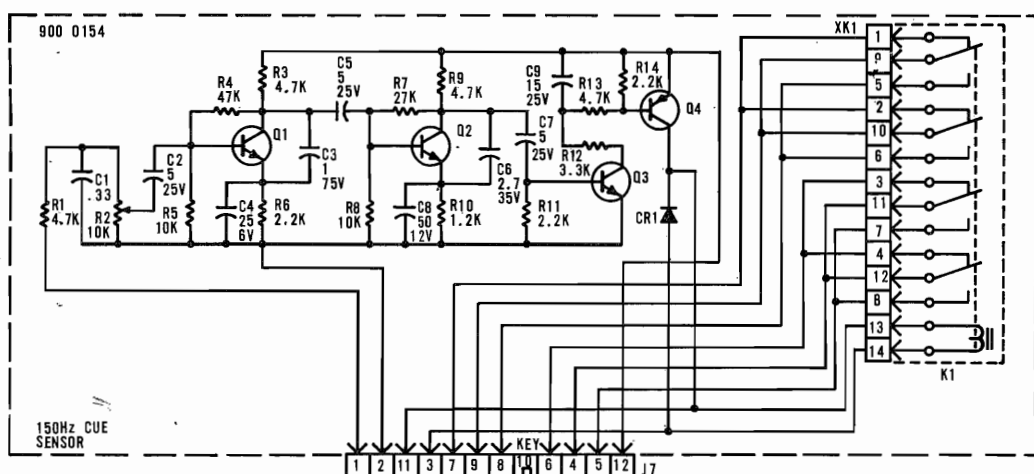
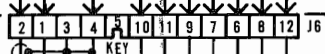

- 4. INDUCTANCE IN uH
 - 3. CAPACITANCE IN uF
 - 2. RESISTORS ARE 1/2 WATT
 - 1. RESISTANCE IN OHMS
- UNLESS OTHERWISE NOTED ALL:

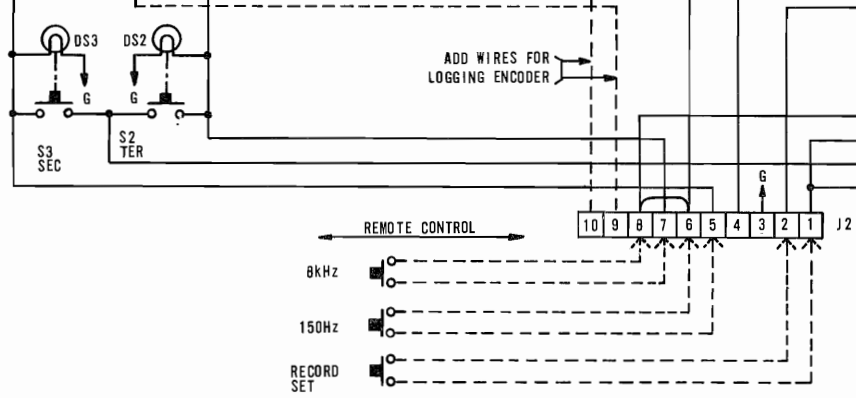
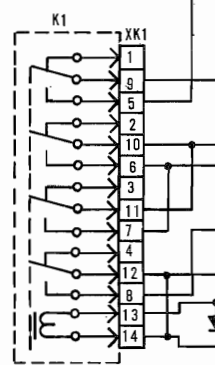
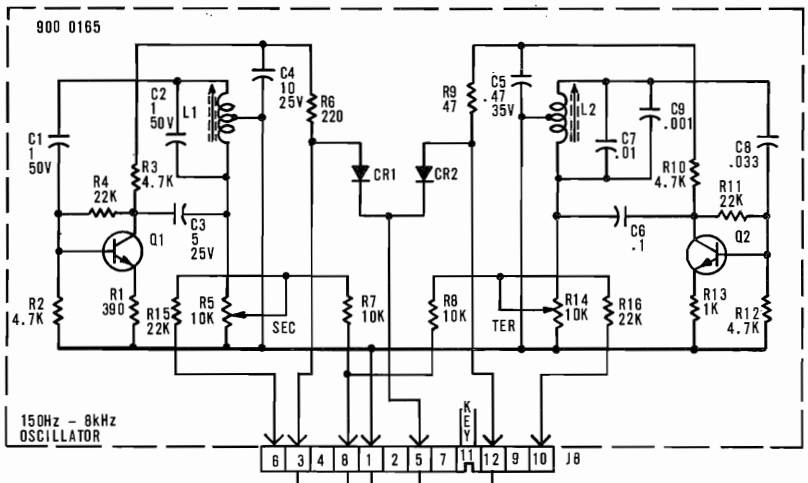
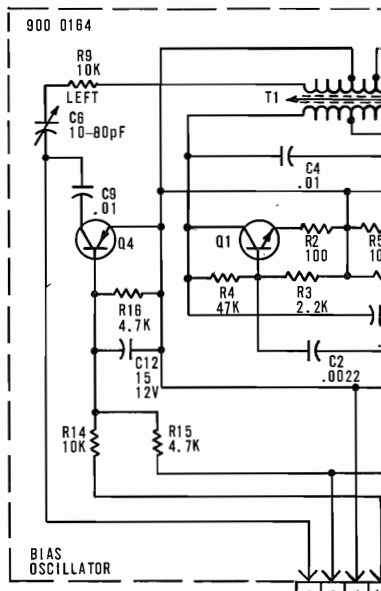
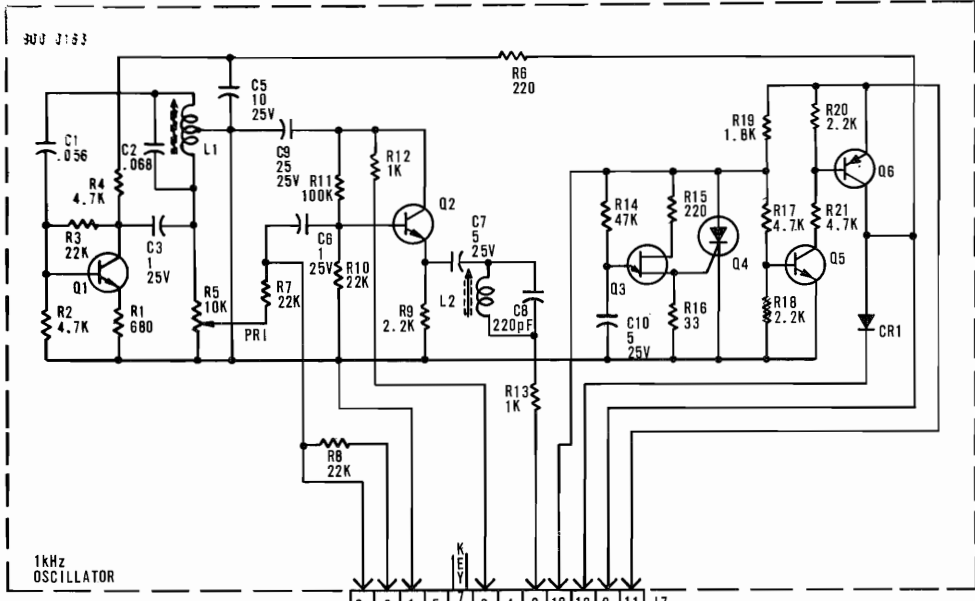

4. INDUCTANCE IN μ H
 3. CAPACITANCE IN μ F
 2. RESISTORS ARE 1/2 WATT
 1. RESISTANCE IN OHMS
 UNLESS OTHERWISE NOTED ALL

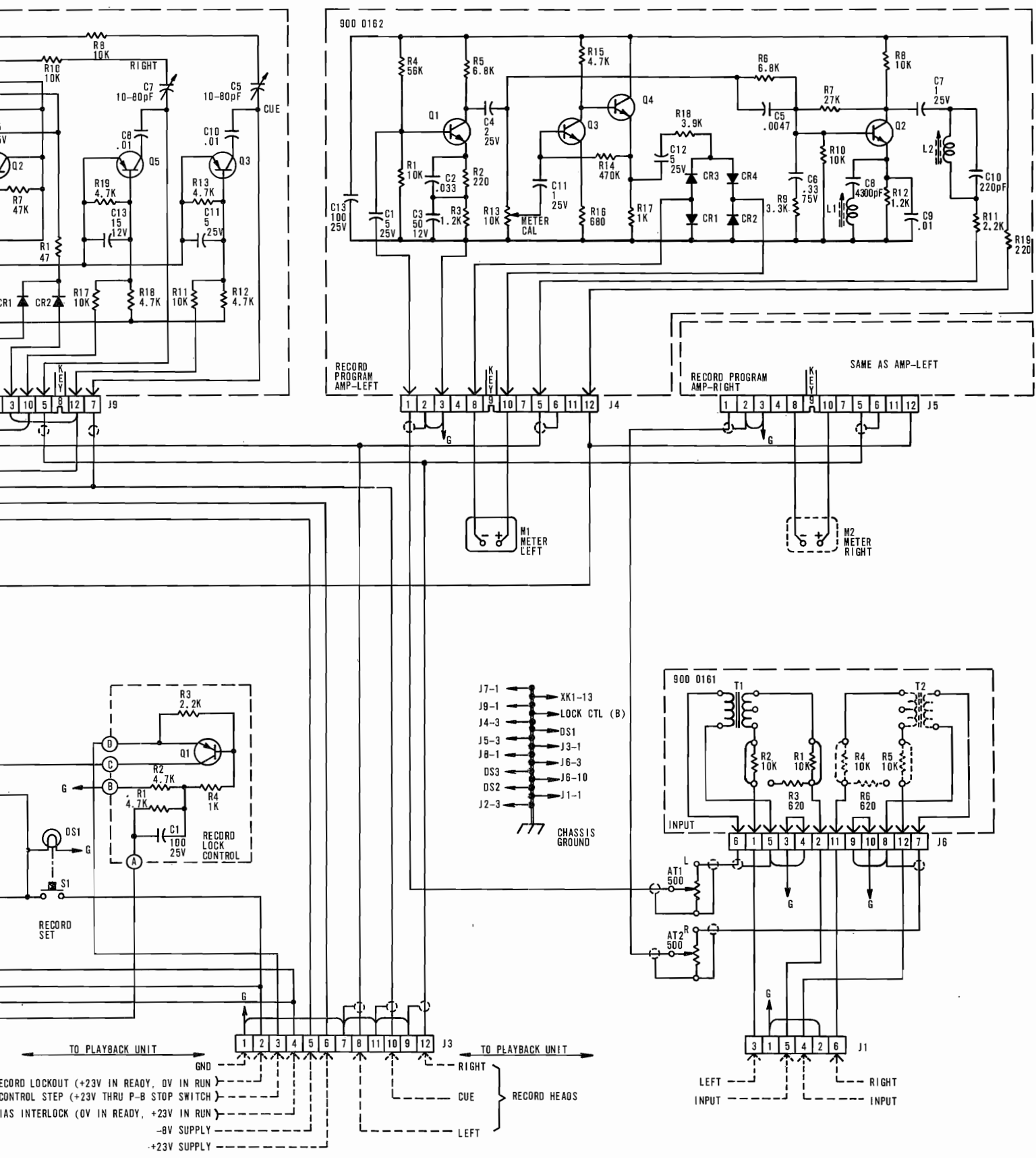

**SCHEMATIC RECORD AMPLIFIER
CRITERION 80**

842 6201 001

SECTION 7 - PARTS LIST

CIRCUIT CARDS

CRITERION 80

The following list of Plug-in Circuit Cards is used for a stereo, 3-tone, Record/Playback pair. Other configurations do not require all these cards.

A. PLAYBACK

2	P-B Program Amplifier	900-0152
1	1 kHz Cue Sensor	900-0153
1	150 Hz Cue Sensor	900-0154
1	8 kHz Cue Sensor	900-0155
1	Power Supply	900-0151

B. RECORDER

1	Input Card	900-0161
2	Record Program Amplifier	900-0162
1	Bias Oscillator	900-0164
1	1 kHz Oscillator	900-0163
1	150 Hz - 8 kHz Oscillator	900-0165

C. EXTENDER CARD

915-0675

PLAYBACK CHASSIS

SYMBOL	DESCRIPTION	GATES	PART NO.		SYMBOL	DESCRIPTION	GATES	PART NO.
AT1, AT2	Program Gain Pot 10 K ohm 2 W	550	0067 000		J3	Socket 12 Conductor	612	0464 000
C1,C2	Line Filter Cap .01 uF 1000 V	516	0081 000		J4 thru J9	Socket PC Board	612	0490 000
C3	Motor Cap 2.0 uF 330 V 50 Hz	524	0157 000		J10 thru J15	Socket 2 Conductor	612	0404 000
C3	Motor Cap 1.5 uF 330 V 60 Hz	524	0156 000		L2,L3	RF Choke 2.2 uH	494	0227 000
DS1, DS2	Lamp	396	0169 000		S1	Stop Switch	604	0453 000
DS3	Red Lamp Assy, Neon	406	0410 000		S2	Start Switch	604	0451 000
F1,F2	Fuse .8 Amp Slo Blo	398	0053 000		S3	Power Switch SPST	604	0435 000
J1	Socket 15 Conductor	612	0465 000			Lens, Green START	598	0133 000
J2	Socket 6 Conductor	612	0461 000			Lens, Yellow STOP	598	0134 000
					S4	Switch - See Deck Assembly		
					T1	Power Transformer	472	0648 000

SECTION 7 - PARTS LIST

POWER CONTROL BOARD - PLAYBACK CHASSIS

SYMBOL	DESCRIPTION	GATES PART NO.	SYMBOL	DESCRIPTION	GATES PART NO.
C1	Cap 200 uF 250 V	522 0411 000	R1	Res 100 ohm 20 W 10%	542 0119 000
C2	Cap .1 uF 400 V	506 0097 000	R2	Res 10 K ohm 3 W 5%	542 1141 000
C3	Cap 10 uF 25 V	522 0239 000	R3	Res 10 ohm ½ W 5%	540 0001 000
CR1 thru CR5	Diode RCA 1N3255	384 0263 000	R4	Res 2200 ohm ½ W 5%	540 0057 000
CR6, CR7	Diode RCA 1N3254	384 0258 000	R5	Res 10 K ohm ½ W 5%	540 0073 000
J4	Socket 3 Conductor	612 0488 000		<i>811-0045-401 CART HOLD SPRING DOWN</i>	
K1,K2	Relay 4 PDT 24 V	574 0162 000		Head, Playback Mono	730 1153 000
Q1	Transistor RCA 40311	380 0143 000		Head, Record Mono	730 1155 000
				Head, Playback Stereo	730 1156 000
				Head, Record Stereo	730 1157 000

DECK ASSEMBLY

ITEM	DESCRIPTION	GATES PART NO.	ITEM	DESCRIPTION	GATES PART NO.
1	Guide, Cartridge	811 0142 401	12	Cushion, Solenoid Plunger	811 0122 401
2	Slide Assy	911 0141 401	13 (L1)	Solenoid	923 0096 401
3	Guide, Slide, Left	811 0179 401	14	Plunger Assy, Solenoid	911 0133 401
4	Guide, Slide, Right	811 0113 401	15	Link, Drag Assy	911 0151 401
5	Spring, Slide Return	811 0121 401	16	Bumper, Rubber	424 0138 000
6	Holder, Return Spring	811 0148 401	17	Spring, Bumper	811 0152 401
7	Set Screw	811 0158 401	18	Pinch Roller, Replacement Kit	900 0259 001
8 (S4)	Deck Switch	911 0116 401	19	Roller Plate Assy	911 0185 401
9	Nut, Lock	304 0010 000	20	Pad, Cartridge	811 0044 401
10	Set Screw	344 0039 000	21	Motor, 60 Hz	923 0243 401
11	Spring, Solenoid Cushion	811 0123 401	21	Motor, 50 Hz	923 0243 402
			22	Bearing Assy	911 0127 401

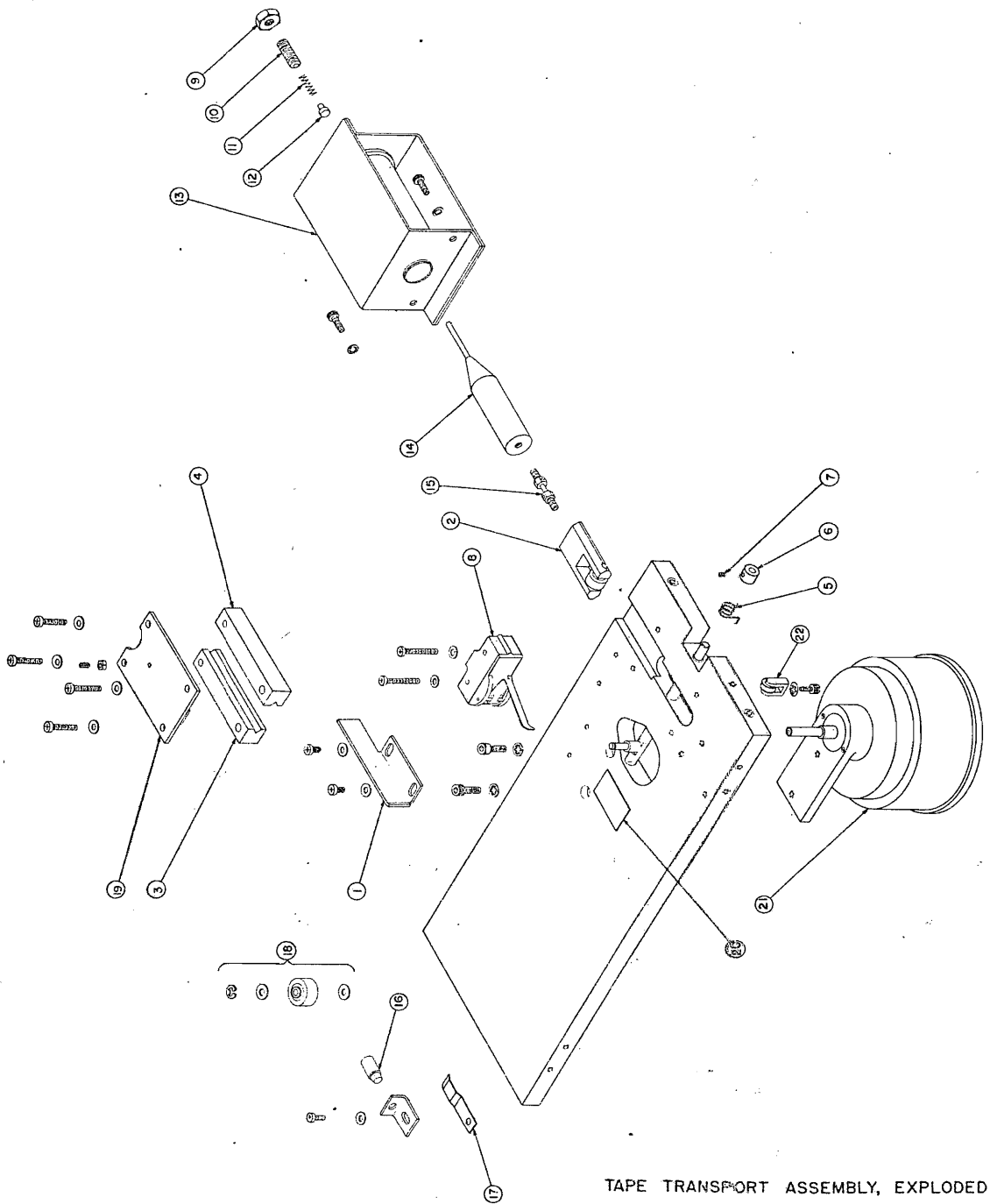

FIG 7-1

SECTION 7 - PARTS LIST
PLAYBACK CIRCUIT CARDS

P-B PROGRAM AMPLIFIER CARD 900 0152

SYMBOL	DESCRIPTION	GATES PART NO.		SYMBOL	DESCRIPTION	GATES PART NO.	
C1	Cap 1 uF 25 V	522	0232 000	R6	Res 680 ohm ½ W 5%	540	0045 000
C2	Cap 100 uF 6 V	522	0185 000	R7	Res 22 K ohm ½ W 5%	540	0081 000
C3	Cap .015 uF	508	0357 000	R8	Same as R5		
C4	Cap 100 uF 25 V	522	0246 000	R9	Pot 10 K ohm ¼ W	550	0272 000
C5 thru C8	Cap 10 uF 25 V	522	0239 000	R10	Res 6800 ohm ½ W 5%	540	0069 000
C9	Cap 470 pF, Mica	500	0908 000	R11	Same as R5		
LDR	Light Dependent Resistor	670	0015 000	R12	Res 68 K ohm ½ W 5%	540	0093 000
Q1 thru Q3	Transistor RCA 40397	380	0140 000	R13	Res 10 K ohm ½ W 5%	540	0073 000
Q4	Transistor RCA 40453	380	0139 000	R14	Res 330 ohm ½ W 5%	540	0037 000
R1	Res 100 ohm ½ W 5%	540	0025 000	R15	Same as R6		
R2	Res 1800 ohm ½ W 5%	540	0055 000	R16	Res 33 K ohm ½ W 5%	540	0085 000
R3	Res 100 K ohm ½ W 5%	540	0097 000	R17	Same as R13		
R4	Same as R1			R18	Res 47 ohm ½ W 5%	540	0017 000
R5	Res 2200 ohm ½ W 5%	540	0057 000	R19	Res 1000 ohm 1 W 5%	540	0468 000
				T1	Transformer Line-Line	478	0314 000

SECTION 7 - PARTS LIST
PLAYBACK CIRCUIT CARDS
1 kHz CUE SENSOR 900 0153

SYMBOL	DESCRIPTION	GATES	PART NO.	SYMBOL	DESCRIPTION	GATES	PART NO.
C1,C2	Cap 2 uF 25 V	522	0233 000	R7	Pot 10 K ohm ¼ W 5%	550	0272 000
C3	Cap .015 uF 200 V	508	0357 000	R8	Same as R6		
C4	Cap 100 uF 6 V	522	0185 000	R9	Res 10 K ohm ½ W 5%	540	0073 000
C5	Cap 100 uF 25 V	522	0246 000	R10	Same as R2		
C6	Cap 1 uF 25 V	522	0232 000	R11	Res 1000 ohm ½ W 5%	540	0049 000
C7	Cap 2.7 uF 35 V	526	0059 000	R12	Same as R3		
C8	Cap .47 uF 35 V	526	0017 000	R13	Res 27 K ohm ½ W 5%	540	0083 000
C9	Same as C6			R14	Same as R9		
C10	Same as C7			R15	Same as R6		
C11	Cap .22 uF 35 V	526	0013 000	R16	Res 6800 ohm ½ W 5%	540	0069 000
C12	Same as C6			R17	Same as R6		
C13,C14	Cap 10 uF 25 V	522	0239 000	R18,R19	Same as R3		
C15	Cap 470 pF Mica	500	0908 000	R20	Same as R6		
CR1	Diode RCA 1N3254	384	0258 000	R21	Same as R3		
Q1 thru Q4	Transistor RCA 40397	380	0140 000	R22	Not Used		
Q5	Transistor Motorola MPS-404-A	380	0145 000	R23	Same as R9		
Q6,Q9	Transistor RCA 40311	380	0143 000	R24	Not Used		
Q10	Transistor Motorola 2N4870	380	0141 000	R25,R26	Same as R3		
Q11	Rectifier Motorola 2N5061	384	0261 000	R27	Same as R6		
R1	Res 100 K ohm ½ W 5%	540	0097 000	R28,R29	Same as R3		
R2	Res 47 K ohm ½ W 5%	540	0089 000	R30	Not Used		
R3,R4	Res 4700 ohm ½ W 5%	540	0065 000	R31	Res 220 ohm ½ W 5%	540	0033 000
R5	Res 33 ohm ½ W 5%	540	0013 000	R32	Same as R1		
R6	Res 2200 ohm ½ W 5%	540	0057 000	R33	Res 1100 ohm 1 W 5%	540	0333 000
				R34	Same as R5		

SECTION 7 - PARTS LIST
PLAYBACK CIRCUIT CARDS
150 Hz CUE SENSOR 900 0154

SYMBOL	DESCRIPTION	GATES PART NO.		SYMBOL	DESCRIPTION	GATES PART NO.	
C1	Cap .33 uF 75 V	508	0373 000	R1	Res 4700 ohm ½ W 5%	540	0065 000
C2	Cap 5 uF 25 V	522	0236 000	R2	Pot 10 K ohm ¼ W	550	0272 000
C3	Cap 1 uF 75 V	508	0375 000	R3	Same as R1		
C4	Cap 25 uF 6 V	522	0178 000	R4	Res 47 K ohm ½ W 5%	540	0089 000
C5	Same as C2			R5	Res 10 K ohm ½ W 5%	540	0073 000
C6	Cap 2.7 uF 35 V	526	0059 000	R6	Res 2200 ohm ½ W 5%	540	0057 000
C7	Same as C2			R7	Res 27 K ohm ½ W 5%	540	0083 000
C8	Cap 50 uF 12 V	522	0208 000	R8	Same as R5		
C9	Cap 15 uF 25 V	522	0240 000	R9	Same as R1		
CR1	Diode RCA 1N3254	384	0258 000	R10	Res 1200 ohm ½ W 5%	540	0051 000
K1	Relay 4 PDT 24 V	574	0162 000	R11	Same as R6		
Q1,Q2	Transistor RCA 40397	380	0140 000	R12	Res 3300 ohm ½ W 5%	540	0061 000
Q3	Transistor RCA 40311	380	0143 000	R13	Same as R1		
Q4	Transistor RCA 40319	380	0044 000	R14	Same as R6		

8 kHz CUE SENSOR 900 0155

SYMBOL	DESCRIPTION	GATES PART NO.		SYMBOL	DESCRIPTION	GATES PART NO.	
C1	Cap 330 uF 500 V	500	0894 000	CR1	Diode RCA 1N3254	384	0258 000
C2	Cap .01 uF 200 V	508	0356 000	K1	Relay 4 PDT 24 V	574	0162 000
C3	Cap .047 uF 200 V	508	0363 000	Q1,Q2	Transistor RCA 40397	380	0140 000
C4	Cap .68 uF 75 V	508	0374 000	Q3	Transistor RCA 40311	380	0143 000
C5	Same as C3			Q4	Transistor RCA 40319	380	0044 000
C6	Cap .068 uF 200 V	508	0368 000				
C7	Cap .1 uF 200 V	508	0371 000				
C8	Same as C4						
C9	Cap 2 uF 25 V	522	0233 000				
C10	Same as C2						

SECTION 7 - PARTS LIST
PLAYBACK CIRCUIT CARDS

8 kHz CUE SENSOR 900 0155 - CONT'D.

SYMBOL	DESCRIPTION	GATES PART NO.	SYMBOL	DESCRIPTION	GATES PART NO.
R2	Pot 10 K ohm ¼ W	550 0272 000	R7	Res 27 K ohm ½ W 5%	540 0083 000
R3	Res 4700 ohm ½ W 5%	540 0065 000	R8	Same as R5	
R4	Res 47 K ohm ½ W 5%	540 0089 000	R9	Same as R3	
R5	Res 10 K ohm ½ W 5%	540 0073 000	R10	Res 1200 ohm ½ W 5%	540 0051 000
R6	Res 2200 ohm ½ W 5%	540 0057 000	R11	Same as R6	
			R12	Res 3300 ohm ½ W 5%	540 0061 000
			R13	Same as R3	
			R14	Same as R6	

POWER SUPPLY 900 0151

SYMBOL	DESCRIPTION	GATES PART NO.	SYMBOL	DESCRIPTION	GATES PART NO.
C1	Cap 1100 uF 50 V	522 0376 000	R1	Res 100 ohm ½ W 5%	540 0025 000
C2	Cap 100 uF 50 V	522 0394 000	R2	Res 10 ohm ½ W 5%	540 0001 000
C3	Cap 1000 uF 25 V	522 0417 000	R3	Same as R1	
C4	Cap 100 uF 15 V	522 0229 000	R4	Res 1000 ohm ½ W 5%	540 0049 000
CR1 thru CR3	Diode RCA 1N3254	384 0258 000	R5	Res 470 ohm ½ W 5%	540 0041 000
CR4	Diode IR 1N4749A	386 0077 000			
F1	Fuse 1 Amp	398 0115 000			
Q1	Transistor RCA 40311	380 0143 000			
Q2	Transistor RCA 40372	380 0137 000			

SECTION 7 - PARTS LIST
RECORD CHASSIS

SYMBOL	DESCRIPTION	GATES PART NO.	SYMBOL	DESCRIPTION	GATES PART NO.
AT1, AT2	Pot 500 ohm 2 W Record Level	550 0338 000	M1	Meter 0-200 Micro Amp	630 0136 000
C1	Cap 100 uF 25 V	522 0246 000	Q1	Transistor RCA 40319	380 0044 000
CR1	Diode RCA 1N3254	384 0258 000	R 1,R2	Res 4700 ohm ½ W 5%	540 0065 000
DS1 thru DS3	Lamp 387	396 0169 000	R3	Res 2200 ohm ½ W 5%	540 0057 000
J1	Socket 6 Conductor	612 0461 000	R4	Res 1000 ohm ½ W 5%	540 0049 000
J2	Socket 10 Conductor	612 0463 000	S1	Set Switch	604 0451 000
J3	Socket 12 Conductor	612 0464 000	S2	Tertiary Cue Switch	604 0451 000
K1	Relay 4 PDT, 24 V	574 0162 000	S3	Secondary Cue Switch	604 0451 000
				Lens, Orange SET	598 0131 000
				Lens, White SEC	598 0132 000
				Lens, Blue TER	598 0135 000
				Socket PC Board	612 0490 000

RECORD PLUG-IN CARDS
INPUT CARD 900 0161

SYMBOL	DESCRIPTION	GATES PART NO.	SYMBOL	DESCRIPTION	GATES PART NO.
R1,R2	Res 10 K ohm ½ W 5%	540 0073 000			
R3	Res 620 ohm ½ W 5%	540 0044 000			
R4,R5	Same as R 1				
R6	Same as R3				
T1,T2	Transformer Line-Line	478 0315 000			

SECTION 7 - PARTS LIST

RECORD PROGRAM AMPLIFIER 900 0162

SYMBOL	DESCRIPTION	GATES	PART NO.	SYMBOL	DESCRIPTION	GATES	PART NO.
C1	Cap 5 uF 25 V	522	0236 000	R9	Res 3300 ohm ½ W 5%	540	0061 000
C2	Cap .033 uF 200 V	508	0359 000	R10	Same as R1		
C3	Cap 50 uF 12 V	522	0208 000	R11	Res 2200 ohm ½ W 5%	540	0057 000
C4	Cap 2 uF 25 V	522	0233 000	R12	Same as R3		
C5	Cap .0047 uF 200 V	508	0361 000	R13	Pot 10 K ohm ½ W	550	0272 000
C6	Cap .33 uF	508	0373 000	R14	Res 470 K ohm ½ W 5%	540	0113 000
C7	Cap 1 uF 25 V	522	0247 000	R15	Res 4700 ohm ½ W 5%	540	0065 000
C8	Cap 4300 pF	500	0899 000	R16	Res 680 ohm ½ W 5%	540	0045 000
C9	Cap .01 uF 200 V	508	0356 000	R17	Res 1000 ohm ½ W 5%	540	0049 000
C10	Cap 220 pF 500 V	500	0893 000	R18	Res 3900 ohm ½ W 5%	540	0063 000
C11	Same as C7						
C12	Same as C1						
C13	Cap 100 uF 25 V	522	0246 000				
CR1 thru CR4	Diode Sylvania 1N276	384	0267 000				
L1,L2	Inductor Var 8K-20K uH	492	0363 000				
Q1 thru Q4	Transistor RCA 40397	380	0140 000				
R1	Res 10 K ohm ½ W 5%	540	0073 000				
R2	Res 220 ohm ½ W 5%	540	0033 000				
R3	Res 1200 ohm ½ W 5%	540	0051 000				
R4	Res 56 K ohm ½ W 5%	540	0091 000				
R5,R6	Res 6800 ohm ½ W 5%	540	0069 000				
R7	Res 27 K ohm ½ W 5%	540	0083 000				
R8	Same as R1						

SECTION 7 - PARTS LIST
RECORD PLUG-IN CARDS
BIAS OSCILLATOR 900 0164

SYMBOL	DESCRIPTION	GATES PART NO.		SYMBOL	DESCRIPTION	GATES PART NO.	
C1	Cap 25 uF 25 V	522	0242 000	R1	Res 47 ohm ½ W 5%	540	0017 000
C2,C3	Cap .0022 uF 200 V	508	0354 000	R2	Res 100 ohm ½ W 5%	540	0025 000
C4	Cap .01 uF 200 V	508	0356 000	R3	Res 2200 ohm ½ W 5%	540	0057 000
C5 thru C7	Cap Trimmer 10-80 pF	500	0909 000	R4	Res 47 K ohm ½ W 5%	540	0089 000
C8,C9, C10	Same as C4			R5	Same as R2		
C11	Cap 5 uF 25 V	522	0236 000	R6	Same as R3		
C12,C13	Cap 15 uF 12 V	522	0204 000	R7	Same as R4		
CR1, CR2	Diode RCA 1N3254	384	0258 000	R8 thru R11	Res 10 K ohm ½ W 5%	540	0073 000
Q1,Q2	Transistor RCA 40311	380	0143 000	R12,R13	Res 4700 ohm ½ W 5%	540	0065 000
Q3 thru Q5	Transistor Motorola MPS-404A	380	0145 000	R14	Same as R8		
				R15,R16	Same as R12		
				R17	Same as R8		
				R18,R19	Same as R12		
				T1	Transformer .285--.315 uH	478	0304 000

1 kHz OSCILLATOR 900 0163

SYMBOL	DESCRIPTION	GATES PART NO.		SYMBOL	DESCRIPTION	GATES PART NO.	
C1	Cap .056 uF 200 V	508	0366 000	CR1	Diode RCA 1N3254	384	0258 000
C2	Cap .068 uF 200 V	508	0368 000	L1	Inductor Var .475--.525 uH	492	0368 000
C3	Cap 1 uF 25 V	522	0232 000	L2	Inductor Var 8 K -- 20 K uH	492	0363 000
C4	Not Used			Q1	Transistor RCA 40311	380	0143 000
C5	Cap 10 uF 25 V	522	0239 000	Q2	Transistor RCA 40397	380	0140 000
C6	Same as C3						
C7	Cap 5 uF 25 V	522	0236 000				
C8	Cap 220 pF	500	0893 000				
C9	Cap 25 uF 25 V	522	0242 000				
C10	Same as C7						

SECTION 7 - PARTS LIST

RECORD PLUG-IN CARDS

1 kHz OSCILLATOR 900 0163 - CONT'D.

SYMBOL	DESCRIPTION	GATES	PART NO.	SYMBOL	DESCRIPTION	GATES	PART NO.
Q3	Transistor Motorola 2N4870	380	0141 000	R7,R8	Same as R3		
Q4	SCR, Motorola 2N5061	384	0261 000	R9	Res 2200 ohm ½ W 5%	540	0057 000
Q5	Same as Q1			R10	Same as R3		
Q6	Transistor RCA 40319	380	0044 000	R11	Res 100 K ohm ½ W 5%	540	0097 000
R1	Res 680 ohm ½ W 5%	540	0045 000	R12,R13	Res 1000 ohm ½ W 5%	540	0049 000
R2	Res 4700 ohm ½ W 5%	540	0065 000	R14	Res 47 K ohm ½ W 5%	540	0089 000
R3	Res 22 K ohm ½ W 5%	540	0081 000	R15	Same as R6		
R4	Same as R2			R16	Res 33 ohm ½ W 5%	540	0013 000
R5	Pot 10 K ohm ¼ W	550	0272 000	R17	Same as R2		
R6	Res 220 ohm ½ W 5%	540	0033 000	R18	Same as R9		
				R19	Res 1100 ohm 1 W 5%	540	0333 000
				R20	Same as R9		
				R21	Same as R2		

150 Hz – 8 kHz OSCILLATOR 900 0165

SYMBOL	DESCRIPTION	GATES	PART NO.	SYMBOL	DESCRIPTION	GATES	PART NO.
C1,C2	Cap 1 uF 50 V	508	0381 000	L1	Inductor Var 1,045–1,155 Hy	492	0369 000
C3	Cap 5 uF 25 V	522	0236 000	L2	Inductor Var 38 to 42 mH	492	0367 000
C4	Cap 10 uF 25 V	522	0239 000	Q1,Q2	Transistor RCA 40311	380	0143 000
C5	Cap .47 uF 35 V	526	0017 000	R1	Res 390 ohm ½ W 5%	540	0039 000
C6	Cap .1 uF 400 V	508	0371 000	R2,R3	Res 4700 ohm ½ W 5%	540	0065 000
C7	Cap .01 uF 200 V	508	0356 000	R4	Res 22 K ohm ½ W 5%	540	0081 000
C8	Cap .033 uF 200 V	508	0359 000	R5	Pot 10 K ohm ¼ W	550	0272 000
C9	Cap .001 uF 200 V	508	0352 000				
CR1,CR2	Diode RCA 1N3254	384	0258 000				

SECTION 7 - PARTS LIST

RECORD PLUG-IN CARDS

150 Hz — 8 kHz OSCILLATOR 900 0165 - CONT'D.

SYMBOL	DESCRIPTION	GATES PART NO.		SYMBOL	DESCRIPTION	GATES PART NO.
R6	Res 220 ohm ½ W 5%	540	0033 000			
R7,R8	Res 10 K ohm ½ W 5%	540	0073 000			
R9	Res 47 ohm ½ W 5%	540	0017 000			
R10	Same as R2					
R11	Same as R4					
R12	Same as R2					
R13	Res 1 K ohm ½ W 5%	540	0049 000			
R14	Same as R5					
R15,R16	Same as R4					

ADDENDA

CRITERION 80 INSTRUCTION BOOK

SCHEMATIC - PLAYBACK AMPLIFIER 842 6203 001

On 900 0153 change R33 from 1.8K to 1.1K.

SCHEMATIC - RECORD AMPLIFIER 842 6201 001

On 900 0163 change R19 from 1.8K to 1.1K

ECN-13313

Gates Radio Company
Quincy, Illinois

**HARRIS
INTERTYPE
CORPORATION**

GATES[®]

A DIVISION OF HARRIS-INTERTYPE

123 HAMPSHIRE ST. • QUINCY, ILLINOIS • 62301 • U.S.A.