



**audio  
equipment  
for  
am-fm-tv**

---

**GENERAL  ELECTRIC**

**AUDIO**

**EQUIPMENT**

**for AM-FM-TV**

TOM F. BOST, JR.  
GENERAL ELECTRIC CO.  
ELECTRONIC DEPT.  
187 SPRING ST., N. E.  
ATLANTA, GA.

*recd.  
Sept 13, 1950*

GENERAL  ELECTRIC

### **SCOPE OF SPECIFICATIONS**

In the construction of the equipment described, the full intent of the specifications will be met.

The General Electric Company, however, reserves the right to make any departure from the specifications for reason of improved design or operation.

# TABLE OF CONTENTS

	SECTION NUMBER
Job-Designed Equipment . . . . .	1
Console . . . . .	2
Transmitter Console . . . . .	3
Features of Rack-Mounted Equipment . . . . .	4
Amplifiers . . . . .	5
Power Supplies . . . . .	6
Panel-Mounted Accessories . . . . .	7
Cabinet Racks and Accessories . . . . .	8
Transformers . . . . .	9
Interconnecting Cable . . . . .	10
Microphone Accessories . . . . .	11
Loudspeakers . . . . .	12
Transcription Accessories . . . . .	13
Test Equipment . . . . .	14
Data . . . . .	15
Ordering Information . . . . .	16
Prices . . . . .	17
Index . . . . .	18



# General Electric "job-designed" equipment

Unusual speech-input requirements can always be met with General Electric "job-designed" equipment. Whenever special facilities are needed, custom installations can be built, wired, and factory tested to the user's own specifications, or a complete system study can be made and equipment engineered and produced at Electronics Park.

As a rule, these tailored systems are combinations of standard audio facilities supplemented by specially designed units to perform unusual switching jobs or to conform to unique space demands.



Fig. 1-2

The transmitter installation for WOR at North Bergen, N. J., is an excellent example of "job-designed" equipment. Both TV and FM transmitters can be supervised from a single control console.

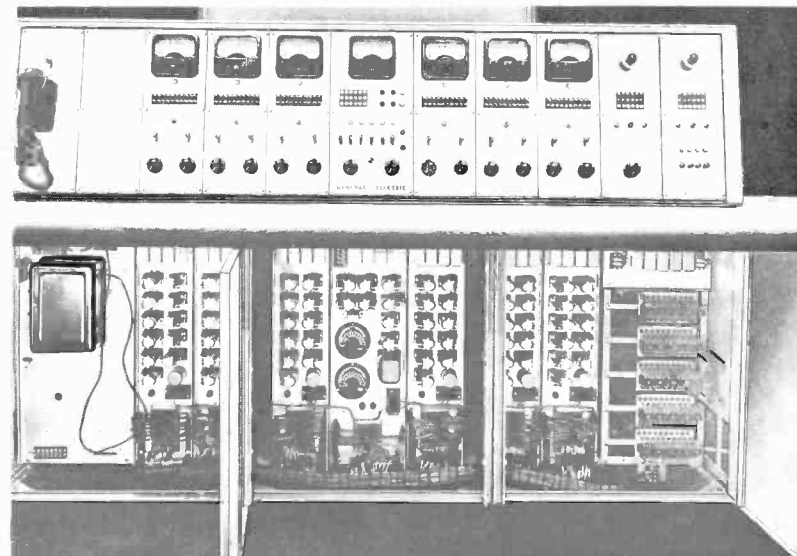

Fig. 1-1 A portion of the master control console for KWK, St. Louis. Complete facilities to operate ten studios into six lines on a preset basis reduces operator errors and increases effective utilization of station facilities.

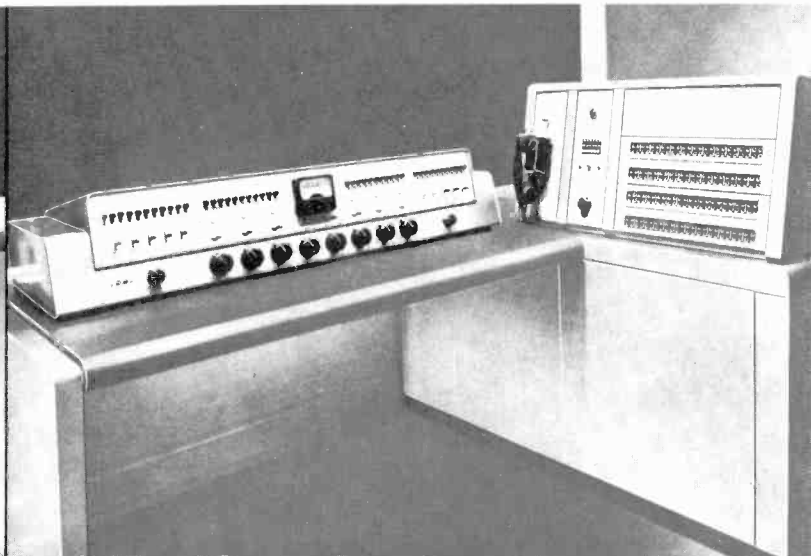

Fig. 1-3 Typical studio control at KWK consists of a standard G-E 2-Studio Console and a "job-designed" patching console to tie back to the master control system.

Fig. 1-4

KWK's studio control is centralized in these audio racks. Here, standard components—patch panels, power supplies, and amplifiers are supplemented by special devices such as the monitoring receivers. This equipment, completely assembled, wired, and tested at Electronics Park, reduced installation time and can result in material savings to the customer.

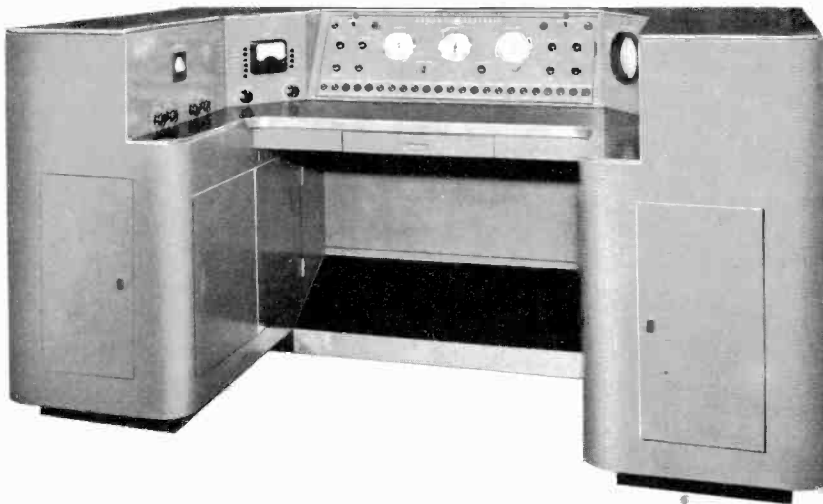
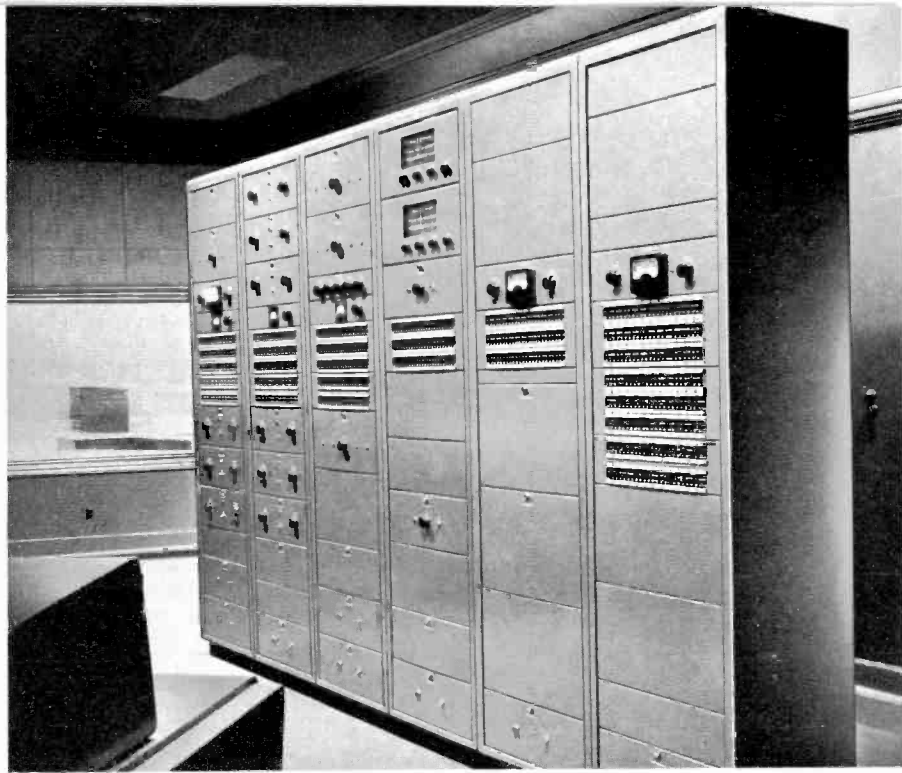

Fig. 1-5

This console is an example of "job design" for limited production. It is used with G-E 100-KW International Transmitters in every part of the world.

Fig. 1-6

Small stations, such as WMBO in Auburn, N. Y., have found that specialized equipment can improve their operation. Here, a 2-Studio Console incorporates control facilities for a Console Switching System for four output channels.



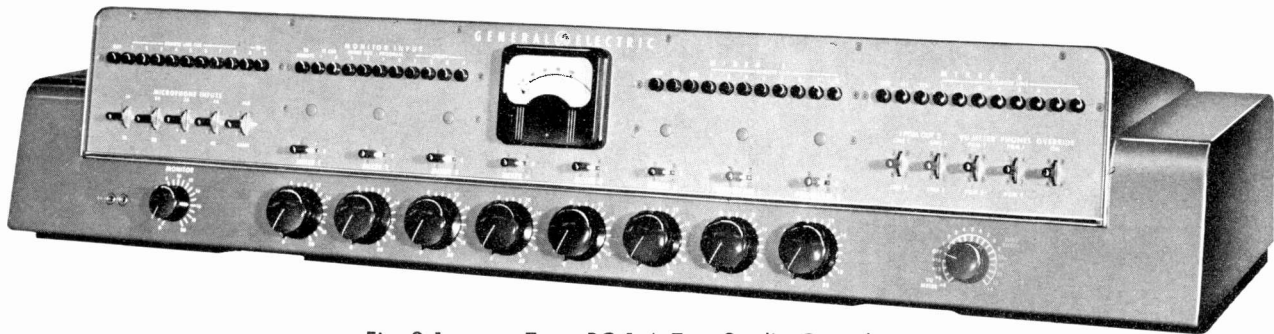

Fig. 2-1 Type BC-1-A Two-Studio Consolette

# Two-studio consolette Type BC-1-A

## FEATURES

- Two program amplifiers provide unusual flexibility
- Complete two-studio audio system for AM, FM, and TV
- Eight microphone inputs — four can be used simultaneously
- Ten-watt monitoring amplifier
- Inputs and mixing facilities for turntables and remote lines
- Low distortion over entire audio spectrum
- Built-in 6-db line pad
- Complete speaker interlocking prevents audio feedback
- seven reliable telephone-type relays used
- Separate power unit for external mounting removes heat and hum fields from amplifier unit
- Plug-in electrolytic capacitors used throughout
- Only three types of tubes required including power supply tubes
- High- and low-end frequency response may be modified to meet system requirements

## APPLICATION

The Type BC-1-A Two-Studio Consolette is a completely factory-wired unit containing all the necessary controls and amplifiers for an installation of two studios and announce booth. All the necessary functions of switching, mixing, and amplifying the audio outputs of microphones, transcription turntables and remote lines, plus auditioning and monitoring are handled in a single consolette.

This compact assembly is designed to exceed all FCC performance requirements for AM and FM broadcasting, as well as those of TV sound.

Two or more of these units are suitable for larger installations where a consolette is used for each studio or pair of studios to feed programs to the master control room.

## DESCRIPTION

The BC-1-A contains four pre-amplifiers, six mixers, two program amplifiers with master gain controls, and a ten watt monitor amplifier. Switching is provided at the pre-amplifier inputs so that a total of eight microphone channels are available. Four of these may be used simultaneously and by supplying pre-amplifiers for mixers 5 and 6 two additional microphone channels may be utilized. Eight remote lines and two turntables may be permanently connected and are selected by push-button switches. Two identical program amplifiers provide complete two channel operation. If only one is normally used, "on the air" reliability is assured since a program on one amplifier can be switched instantly to the second amplifier. It is also possible to feed the combined outputs of the two program amplifiers to a single line.

A large size, standard VU Meter is furnished. A range switch is provided to calibrate the 100 percent mark on the meter for +4, +8, +12 and +16 VU. The same switch has positions to meter the plate currents of all tubes in program circuits. A lever-key is provided to instantly switch the VU meter across either of the two program channels. An "external" position is also provided on this lever key for level checking of other circuits.

A headphone jack is provided to monitor each of the program amplifiers and a remote line. Either a single-plug or double-plug headphone may be accommodated. A lever-key switch selects the headphone. Talk-back and remote cue facilities are also included. Complete relay interlocking allows the operator to talk-back to studios used for audition but prevents accidental interruption of "on-air" studios. Program cue may be routed to any of the eight remote lines by pushing the proper Remote Line Cue button.

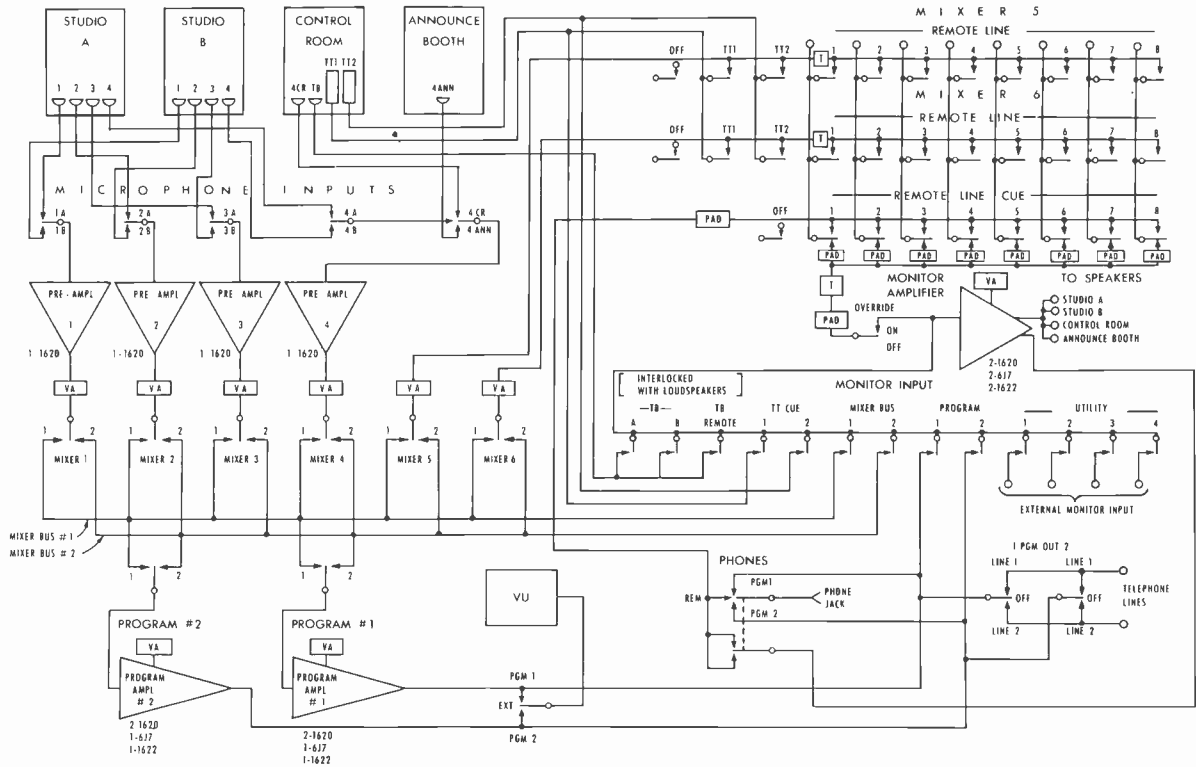

Fig. 2-2 Single Line Diagram for BC-1-A Consolette

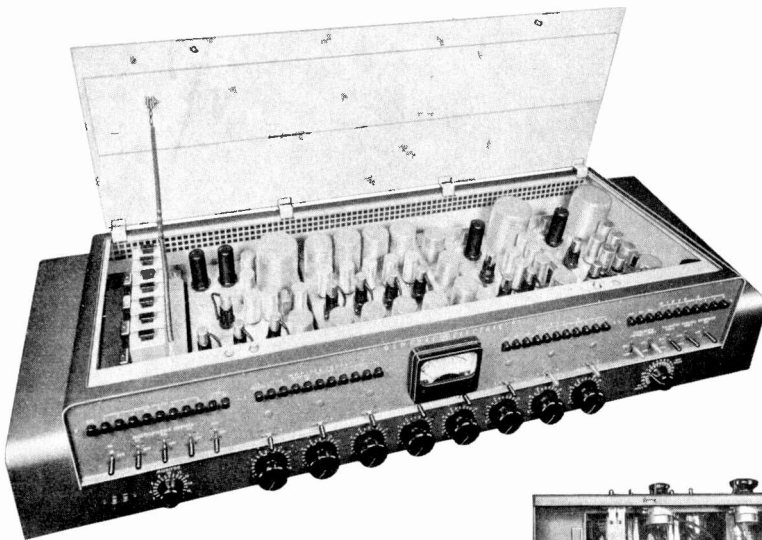
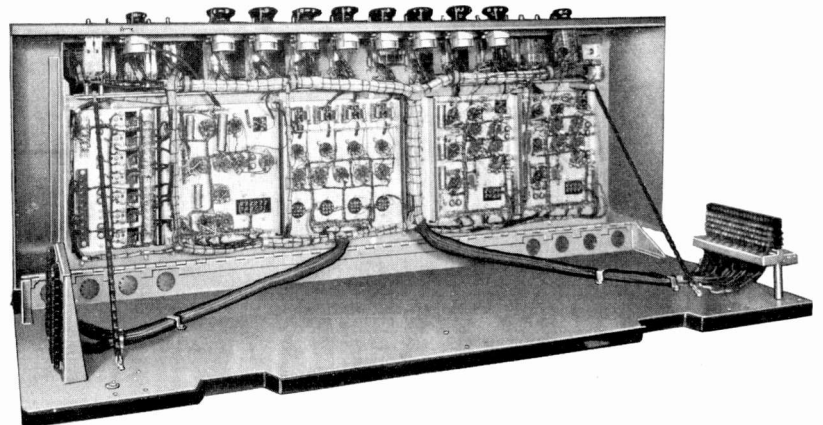

Fig. 2-3 Full-width cover of Consolette in open position

Fig. 2-4 Consolette cabinet raised for servicing



An over-ride circuit allows any remote to call in and over-ride the program being carried on the control room monitor speaker.

Mountings are provided for installing six telephone-type, slide-base lamp holders and lamps for a variety of signal operations. A pair of wires are installed from the external terminal board to each lamp mounting. The lamp end of each pair is taped to prevent shorting and is easily installed when required.

The consolette is of sturdy steel and aluminum construction. A top cover swings open to expose tubes, plug-in electrolytic capacitors, relay contacts, push-button switches, and lever-key switches. The entire chassis is hinged across the back to give easy access to the remainder of the components and to the external terminals. The entire unit is finished in two tones of blue mottletone enamel.

The necessary filament, plate, and relay power supplies are contained in the Power Unit of the consolette. Four separate rectifier circuits give excellent reliability. The Power Unit is housed in an attractive steel cabinet designed for wall mounting. The unit is finished in dark blue mottletone enamel. All components and terminals are easily accessible from the front by opening the hinged-front door and hinged chassis.

**SPECIFICATIONS**

	<u>Source Impedance</u>	<u>Input Impedance</u>
Microphones	30, 150, 250, or 600 ohms	unloaded input transformer
Remote Lines	600 or 150 ohms	600 or 150 ohms
Turntables	250 ohms	250 ohms
Talkback Microphone	150 or 250 ohms	unloaded input transformer
Monitor Utility Input	600, 250, or 150 ohm terminated lines	20,000 ohms bridging
<b>Load Impedance:</b>		
Program Lines	600 ohms	
Monitor	150 ohms (up to four 600-ohm speakers in parallel)	
Headphones	2000 ohms or higher	
<b>Output Level and Distortion:</b>		
Any pre-amp input to either program line output	1% rms maximum, 50 to 15,000 cycles for +18 dbm at output of 6-db line pad	
Any pre-amp input to monitor output (Monitor on program output)	3% rms maximum, 50 to 15,000 cycles for +40 dbm (10 watts) monitor output	
External monitor (utility) input to monitor output	1½% rms maximum, 50 to 15,000 cycles for +40 dbm (10 watts) monitor output	

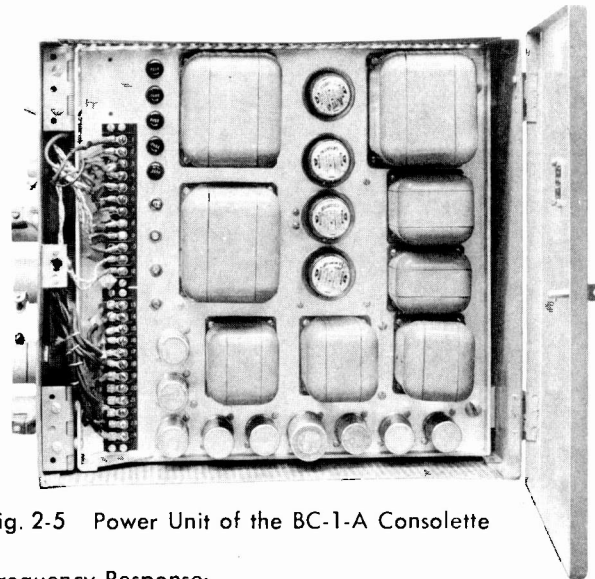

Fig. 2-5 Power Unit of the BC-1-A Consolette

**Frequency Response:**

Any pre-amp input to either program line output . . . . . ±1½ db, 50 to 15,000 cycles (provision for modifying this response is made)

Any pre-amp input to monitor output . . . . . ±2 db, 50 to 15,000 cycles

External Monitor (utility) input to monitor output . . . . . ±1 db, 50 to 15,000 cycles

**Gain (maximum):**

Any pre-amp input to either program output . . . . . 106 db (including loss of 6-db output pad)

Any transcription input to either program output . . . . . 76 db

Any remote line input to either program output . . . . . 49 db

Any external monitor (utility) input to a speaker . . . . . 25 db (bridging a 600-ohm line)

**Dimensions:**

	<u>Desk Unit</u>	<u>Power Unit</u>
Width	52 in.	17 in.
Depth	18 in.	8 in.
Height	10½ in.	17 in.
Weight	150 lbs.	68 lbs.

When ordering specify: Two-Studio Consolette, Type BC-1-A (order tubes separately)

**ACCESSORIES**

**Tube Complement:**

- 10-type 1620
- 4-type 1622
- 4-type 6J7
- 4-type 5R4GY

Relay Assembly . . . . . FA-20-A

## relay assembly Type FA-20-A

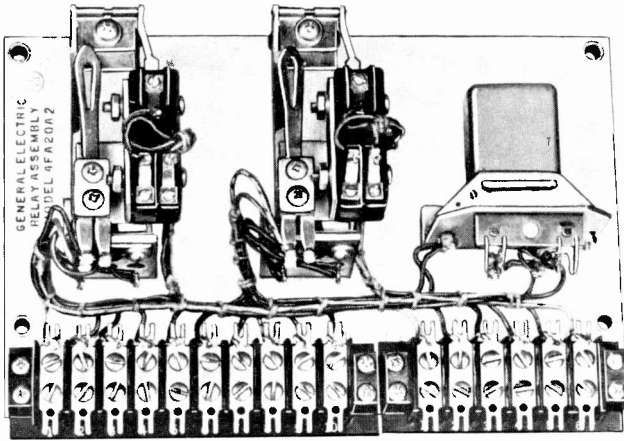

Fig. 2-6 Type FA-20-A Relay Assembly

A Type FA-20-A Relay Assembly consists of two relays and associated components mounted and wired on a flat-plate chassis. Each of the two relays is equipped with a single-pole, double-throw micro-switch for a 115-volt warning light circuit and a set of make-before-break contacts for a speaker, low-voltage indicating lamp, or other auxiliary circuit. Each relay coil is designed to operate from a 48-volt source.

Four of these assemblies should be used with a Two-Studio Consolette, Type BC-1-A, if warning lamp indication is desired in Studio A and B, announce booth, and control room. The BC-1-A consolette will furnish the required voltage and current for proper operation.

# Consolette switching system

### FEATURES

Eliminates need for master control operator

Complete local control of channel in use—interlocks prevent program interference or breaking circuit from another control point

Simple pre-set operations easily made

### APPLICATION

The Consolette Switching System is an electrically interlocked master control system with four inputs and four outputs. It consists of two, three, or four Two-Studio Consolettes, Model 4BC1A4, and one rack-mounted Output Switching Panel, Type FA-30-A. Certain accessories described below are also needed. The system is available on special order for existing installations.

Each switching point (4BC1A4 Consolette) controls the switching of one or two inputs to any of the four output

channels. Fig. 2-8 shows various combinations employing two to four consolettes and a network source.

### DESCRIPTION

A typical equipment list for an installation such as shown in Fig. 2-8A consists of:

Qty.	Type or Model No.
2	Two-Studio Consolette Model 4BC1A4
1	Output Switching Panel Type FA-30-A (12¼ inches high)
1	Relay Power Supply Type BP-5-A (7 inches high)
Plus amplifiers as follows:	
4	Program Amplifiers Type BA-2-A (7 inches high)

In place of the four Type BA-2-A Amplifiers the following plug-in type equipment may be substituted:

4	Plug-In Program/Monitor Amplifiers Type BA-12-A
4	Bridging Volume Controls for BA-12-A Amplifiers Type FA-35-D
4	Trays (for BA-12-A) Type FA-22-B
1	Shelf (will mount trays and plug-in amps) (7 inches high) Type FA-23-A
1	Power Supply (Either power supply, adjusted to run at 250 V output, will power four Type BA-12-A Amplifiers with ½% or less distortion at +30 dbm output). Type BP-8-A (rack-mounted 5¼" high) or Type BP-10-A (Plug-in)*

Note that tubes, wire, cabinet rack, pads, etc., will also be necessary.

\* If the BP-10-A Plug-in Power Supply is used, a mounting Tray, Type FA-22-C, and one additional Shelf, Type FA-23-A, will be needed.

### CONSOLETTTE

A Model 4BC1A4 Consolette is similar to the standard Type BC-1-A Consolette except that it contains four lever keys and eight indicator lamps mounted on the right end of the front panel. See Fig. 2-7. Four of the lamps indicate which channels are in use and are marked IN USE. The remaining four indicate the channel to which

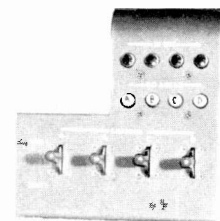

Fig. 2-7 Model 4BC1A4 Two-Studio Consolette

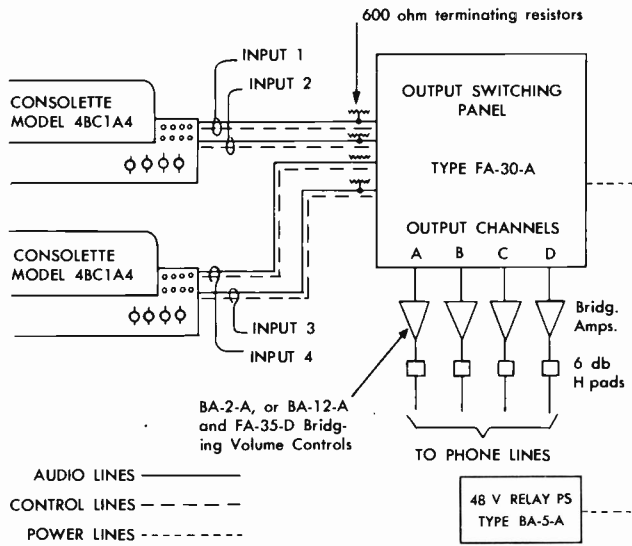

Fig. 2-8A Two Consolettes feeding output switching panel

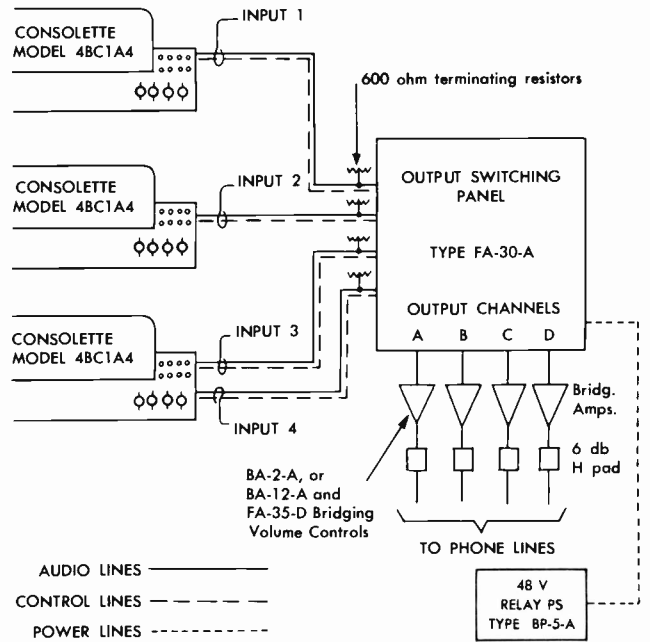

Fig. 2-8B Three Consolettes feeding output switching panel

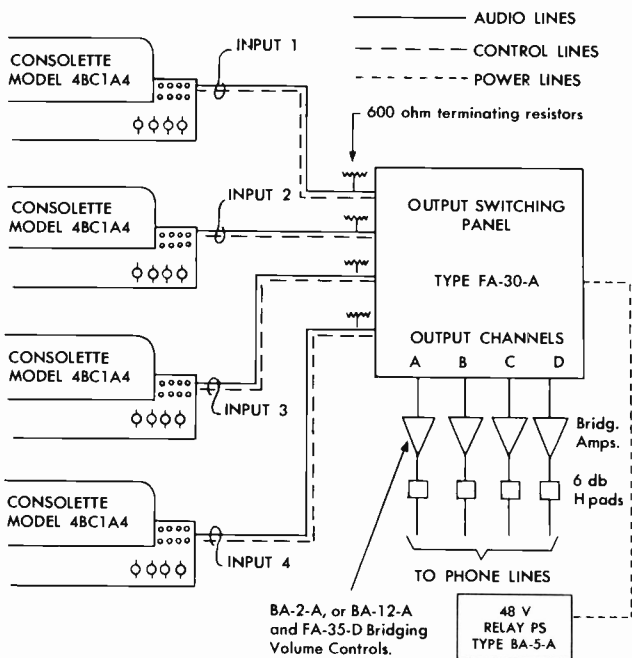

Fig. 2-8C Four Consolettes feeding output switching panel

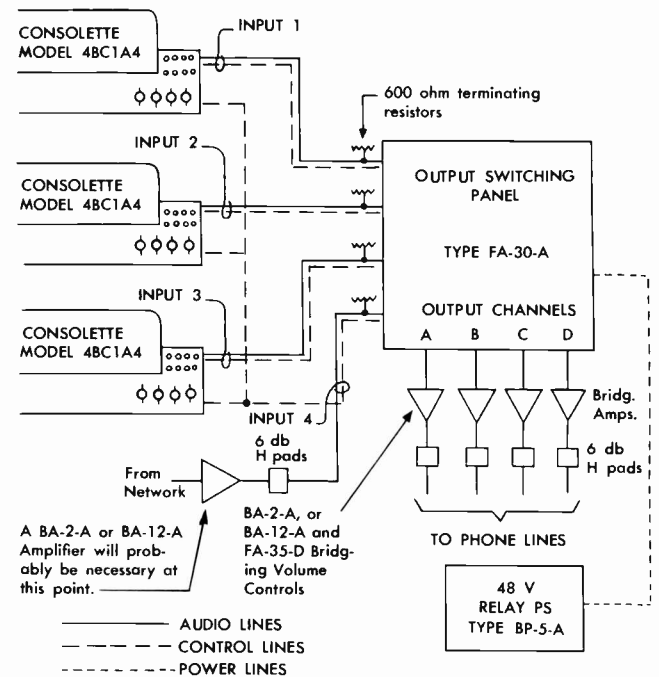

Fig. 2-8D Three Consolettes and network feeding output switching panel



that particular consolette is connected and are marked GO AHEAD. The four lever keys are three position keys. The center position is OFF. The up position of the first key connects line #1 of the consolette to outgoing channel #A by means of relays in the Output Switching Panel described later. The down position of the first key connects line #2 of the Consolette to outgoing channel #A in the same manner. The operation of the standard Type BC-1-A Consolette control circuits is in no way affected by the addition of the output switching keys and lamps.

**OUTPUT SWITCHING PANEL**

The rack-mounted Output Switching Panel, Type FA-30-A, includes sixteen telephone-type relays suitably wired to a standard telephone-type "Christmas Tree" terminal board. See Fig. 2-9 and Fig. 2-10

Contacts on the relays control the indicator lamps at the control stations so that the lamps indicate the actual status of the relays. The FA-30-A power requirements are .75 A @ 48 V DC. This can be obtained from a rack-mounted Type BP-5-A Relay Power Supply.

The FA-30-A Panel is designed to bridge the terminated outputs of the consolettes. It is recommended that Type BA-2-A or Type BA-12-A amplifiers, connected for bridging input, be used as channel amplifiers. Fig. 2-8B gives a suggested list of equipment needed for a typical Consolette Switching System.

**OPERATION**

**"In Use" Lamps**

IN USE lamps are duplicated on all of the consolettes. When an outgoing channel is in use, a corresponding lamp is lighted on each consolette. This indicates that it would be useless to try to pick up this channel. When this lamp is off any one control room may feed this channel by throwing a consolette output switching key up or down.

**"Go Ahead" Lamps**

The GO AHEAD lamps are individually connected, one to each relay. These lamps then show the status of each

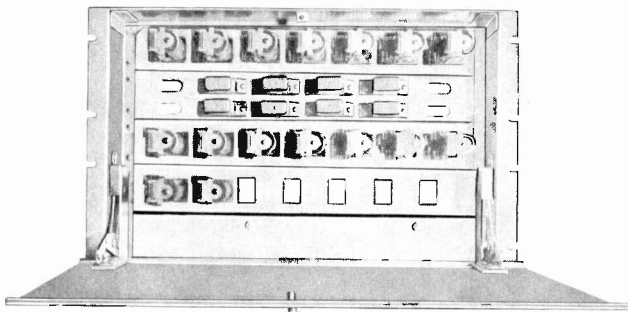

Fig. 2-9 Type FA-30-A Output Switching Panel

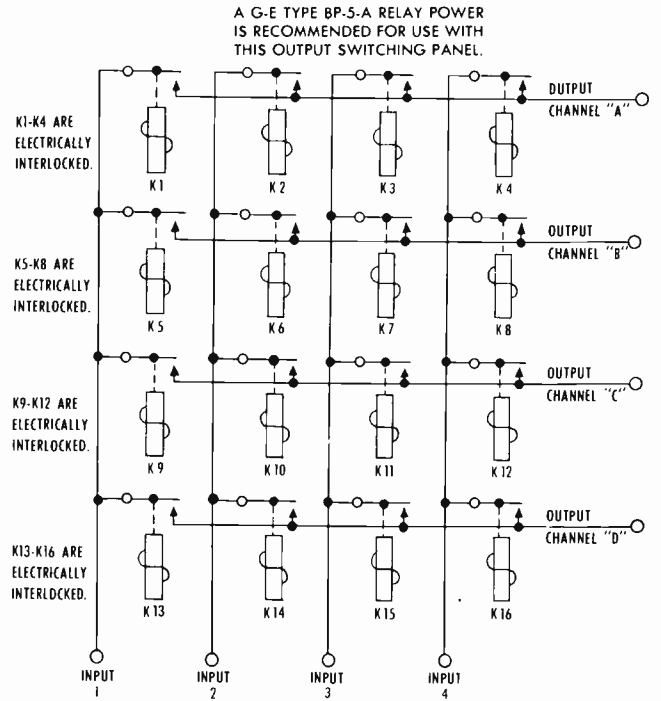

Fig. 2-10 Single Line Diagram for FA-30-A Panel

relay. When an IN USE lamp and the GO AHEAD lamp directly below it are lit, that consolette is connected to the indicated outgoing channel.

**"Channel Keys"**

An operator may connect his consolette to an outgoing channel, provided no other consolette is connected to that channel, by operating the channel key corresponding to the channel that he wishes to feed. In the case where the two consolettes are used as in Fig. 2-8A, when the channel key is up, line 1 of the consolette is feeding the channel corresponding to the key; when the channel key is down line 2 of the consolette is feeding that channel.

If an output channel is in use the next user may leave his output switching key up or down and, upon release of the channel by the previous user, this next user is automatically connected to the channel. Thus a degree of pre-set switching is provided which allows the user greater freedom to do other necessary operations at switching time.

Typical operating procedure would be to "pre-set" the channel key to the desired consolette line output position; e.g., Line 1, with Program Amplifier 1 on Mixer Bus 1 etc., but to leave the LINE 1 OUTPUT key in OFF position until both of the switching system lights come on indicating that your originating position is ready to go. Then the output key may be switched to Line 1 and you will be "On-the-Air."

Release of the channel to the next user is accomplished by placing the channel key in the center OFF position at the conclusion of your program.



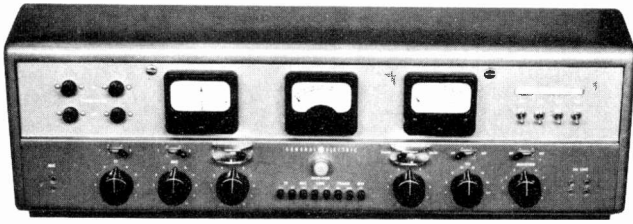

Fig. 3-1 Type BC-3-A Transmitter Console

# Transmitter console Type BC-3-A

## FEATURES

High degree of flexibility to meet operational requirements

Internally illuminated push-buttons for convenient control of transmitter

Easy to set up connections for "proof-of-performance" tests or routine measurements by means of tie-line jacks

Illuminated VU Meter with provision for two monitor meters

Hinged front-panel construction makes all components readily accessible for routine operational checks and maintenance

## APPLICATION

The Type BC-3-A Transmitter Console contains in one unit the external controls necessary for flexible operation of an AM or FM Broadcast Transmitter. It may be combined with the recommended rack-mounted equipment to provide complete transmitter audio facilities.

## DESCRIPTION

The Transmitter Console cabinet is of steel construction with two-tone blue finish and chromium trim, and is so proportioned that it will mount on a standard size desk. The front panel is hinged at the lower edge so that it may be tilted forward to permit internal inspection and servicing.

Variable attenuators are provided in the turntable, microphone, incoming line, program or master gain, and monitor circuits. Telephone-type lever keys are used for all transfer applications with guards provided on the more important keys. A mechanically and electrically interlocked push-button switch selects the various monitoring points. Individual level adjustment is provided for each monitor input. Two "on" and two "off" internally illuminated push-buttons are provided for control of transmitter power. Four

utility power switches are also provided and wired to terminal boards for such applications as control of power to tower lights, sleet melters, lightning trip circuits, carrier alarms, etc. Microphone input and tie-line jacks are provided on the front for maximum measurement convenience.

The Transmitter Console Type BC-3-A can be furnished with any of three combinations of meters. Therefore, the desired combination should be specified in the order.

Type BC-3-A combination 1 includes all of the facilities previously described and is supplied with a standard illuminated VU Meter. A step-range control is wired to this meter to provide full-scale measurement of audio levels from +4 to +14 VU. A transformer is installed to illuminate the meter. Handsome style plates cover the unused meter mountings.

Type BC-3-A combination 2 includes everything in combination 1 with the addition of a Frequency Deviation Meter and a Percentage Modulation meter for FM transmitters.

Type BC-3-A combination 3 includes everything in combination 1 with the addition of a Frequency Deviation Meter and a Percentage Modulation meter for AM transmitters.

## SPECIFICATIONS

### Input Impedances:

Lines Nos. 1 & 2	600 ohms, balanced
Turntables Nos. 1 & 2	600 ohms
Microphones 1 & 2	600 ohms
Master gain	600 ohms, balanced
Telephone set	600 ohms
VU Meter (external connections)	7500 ohms

### Output Impedances:

Program Circuit	600 ohms, balanced
Monitor Circuit	250 or 600 ohms, balanced

### Dimensions:

Width	40 in.
Depth	10 in.
Height	11-13/16 in.

Weight . . . . . approx. 55 lbs.

When Ordering Specify: Transmitter Console, Type BC-3-A (Specify if extension meters from station monitor are required. State type of monitor used.)

## ACCESSORIES

See page 3-3 for a list of equipment recommended to complement the BC-3-A Console.

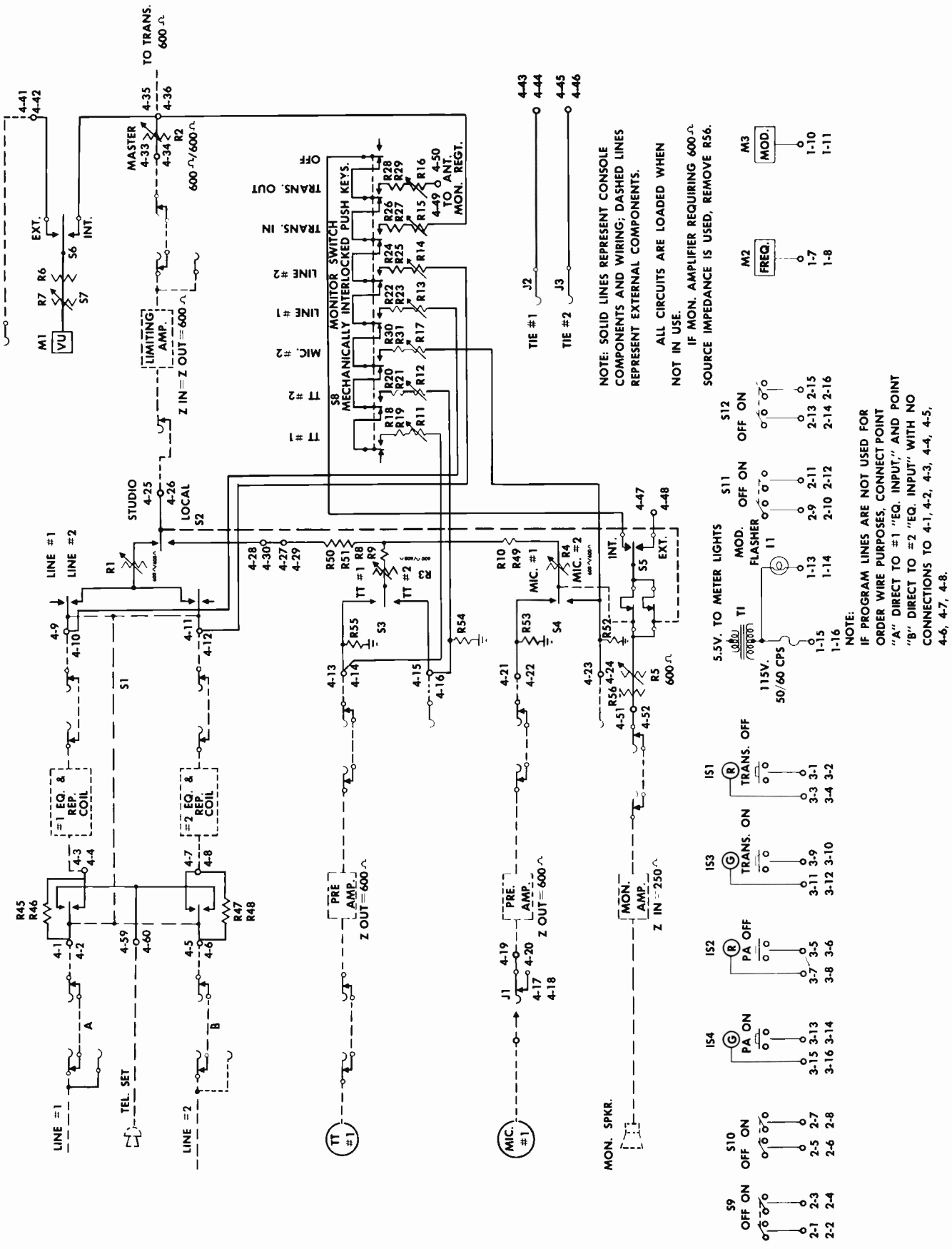

NOTE: SOLID LINES REPRESENT CONSOLE COMPONENTS AND WIRING; DASHED LINES REPRESENT EXTERNAL COMPONENTS.

ALL CIRCUITS ARE LOADED WHEN NOT IN USE.

IF MON. AMPLIFIER REQUIRING 600 Ω SOURCE IMPEDANCE IS USED, REMOVE R56.

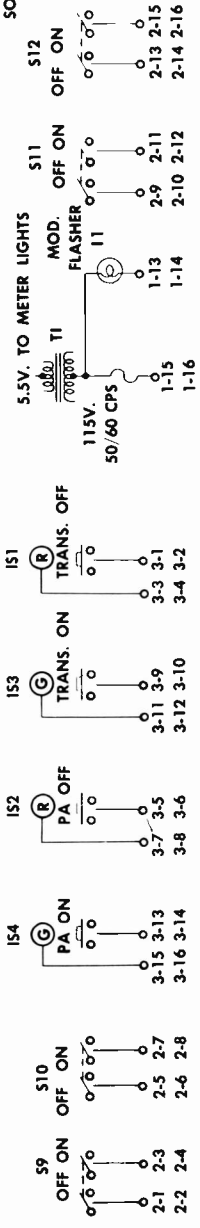

NOTE: IF PROGRAM LINES ARE NOT USED FOR ORDER WIRE PURPOSES, CONNECT POINT "A" DIRECT TO #1 "EQ. INPUT," AND POINT "B" DIRECT TO #2 "EQ. INPUT" WITH NO CONNECTIONS TO 4-1, 4-2, 4-3, 4-4, 4-5, 4-6, 4-7, 4-8.

Fig. 3-2 Simplified schematic of BC-3-A Transmitter Console

## deluxe combination Type BC-13-A

The Deluxe Combination is a complete four-unit package consisting of the following:

1. Type BC-3-A Transmitter Console (including extension meters)
2. Type FC-3-A Carrier Interruption Clock Panel for 60 cycles or Type FC-3-B for 50 cycles
3. Type FC-1-A Deluxe Desk
4. Type FC-2-A Deluxe Chair

This group is offered in the following combinations:

The Console included in BC-13-A combination 1 has only the standard VU Meter.

The Console included in BC-13-A combination 2 has in addition a Frequency Deviation meter and a Percentage Modulation meter for FM transmitters.

The Console included in BC-13-A combination 3 has in addition to the VU Meter a Frequency Deviation meter and a Percentage Modulation meter for AM transmitters.

## deluxe desk Type FC-1-A



Fig. 3-3 Type FC-1-A Deluxe Desk

The Type FC-1-A desk is modern, all-steel construction with a dark linoleum top and rounded corners. Special dark blue, baked-enamel finish gives unusual permanency and presents an attractive appearance in any Transmitter or Control Room.

Dimensions of the desk are sufficient to mount the Transmitter Console, Type BC-3-A, with ample clear desk space for studying of prints, for log pads, and for a desk telephone at either end of the BC-3-A console. This makes a convenient location for the telephones when they are not in use, as they do not obscure the controls and meters of the console.

Cut-outs, mounting holes, and wiring trough have been provided to permit easy mounting and wiring of the BC-3-A console unit. Wiring is completely concealed and space is provided to permit either trench or conduit type

of wiring. Dual convenience outlets are provided on each side of the desk to serve as sources of 115 volts a-c power for test equipment, lamps, etc.

The left-hand compartment houses the typewriter and its shelf. The right-hand compartment contains one small and one file drawer. A cylinder lock mounted on the large center drawer locks all drawers in the desk.

The desk is 60 inches long, by 34 inches deep, by 30½ inches high.

## deluxe chair Type FC-2-A



Fig. 3-4 Type FC-2-A Deluxe Chair

The FC-2-A chair has a modern streamlined appearance to complement the styling of the FC-1-A desk. It is swivel type with two arm rests and with adjustments for seat height and tilt tension. Metal parts are satin-aluminum finish and the upholstery is a long-wearing synthetic leather. The chair seat is filled with a sponge rubber for comfort.

## carrier interruption clock panel Types FC-3-A and FC-3-B

### APPLICATION

The Clock Panel, Type FC-3-A or FC-3-B, accurately indicates the station time and the time and duration of carrier outages. Use of this instrument permits the operator to devote his attention to getting the transmitter back on the air immediately instead of delaying to note the time before and after the failure.

### DESCRIPTION

The Clock Panel consists of two clocks, a timer, and their associated controls mounted on a panel for installation in a standard cabinet rack. Controls for setting, starting, and

stopping the clocks and timer are accessible from the front. The panel is finished in dark blue and the trim and control knobs are of polished chrome. Concealed clamps are used for mounting.

The clock at the left of the panel indicates STATION TIME. Provision is made for setting the minute, hour, and sweep second hand.

The clock in the center indicates TIME OF OUTAGE. Reset controls are provided as for the other clock.

The timer at the right of the panel indicates DURATION OF OUTAGE. If desired, the toggle switch may be used to prevent the timer from running when the transmitter is shut down.

**SPECIFICATIONS**

**Power Requirements:**

- Type FC-3-A.....115 volts, 60 cps, 20 watts
- Type FC-3-B.....115 volts, 50 cps, 20 watts

**Dimensions:**

- Width .....19 in.
- Height .....8-23/32 in.
- Depth .....3-5/8 in.

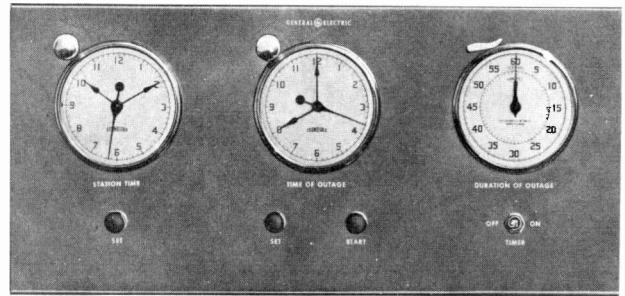

Fig. 3-5 Types FC-3-A or FC-3-B Carrier Interruption Clock Panel

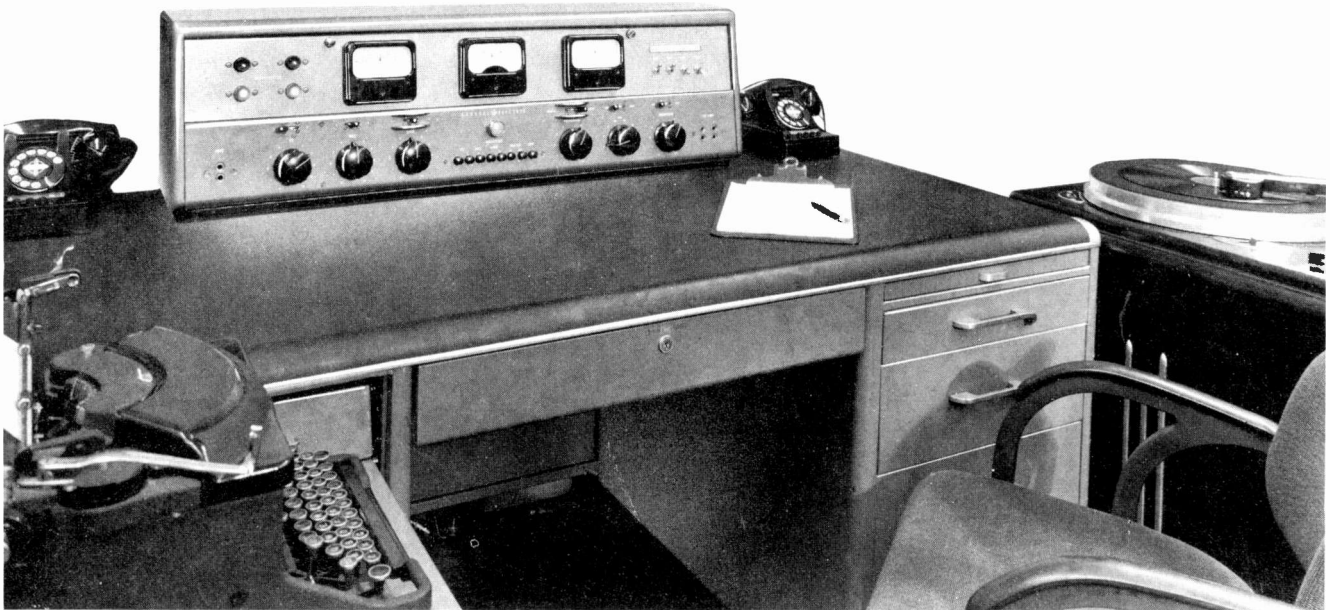

Fig. 3-6 Type BC-13-A Deluxe Combination. Clock Panel not shown

# hinged-front panel units

## FEATURES

Vertical-chassis construction gives excellent air circulation around tubes and transformers for cooling

Tubes and plug-in electrolytic capacitors are in direct view and readily accessible for checking and servicing from rear of cabinet rack

Small components and wiring are quickly accessible from front of cabinet rack by merely opening front panel

Complete unit may be serviced without removing from cabinet

Chassis mounting screws are concealed by front panel when closed — trim strips on cabinet rack are not required

Only one person required to install and service unit

Front panel always attached to chassis

Aluminum alloy panels and chassis are light weight and sturdy

## DESCRIPTION

General Electric rack-mounted equipment, including many amplifiers, utilizes a novel hinged-front panel construction.

Each unit has a recessed-type chassis equipped with mounting flanges for bolting the chassis vertically in a standard RMA 19-inch wide cabinet rack. A panel is attached to the chassis by means of concealed hinges. This front panel covers the recessed portion of the chassis and its mounting screws. Tubes, transformers, and large capacitors are mounted on the rear of the chassis so as to project out horizontally for easy maintenance. Small components, wiring, and terminal boards are contained within the recessed portion of the chassis thus making them readily accessible for servicing from the front of the cabinet when the front panel is opened. Front-of-panel controlled items such as potentiometers, attenuators, switches, and instruments are mounted directly on the hinged panel. A conduit hole is provided in each end of the chassis for entrance of external audio, power, and metering leads.

Most chassis and panels are constructed of aluminum alloy to afford minimum weight with the necessary rigidity and resistance to corrosion. The upper and lower edges of the panel are turned-in 90° for a depth of 5/16-inch to provide clearance for chassis mounting screws and to increase the sturdiness of the panel. Hinging of the panel to the chassis is accomplished by means of special hinges which allow the panel to be raised at the same time it tilts forward. This prevents interference between the panel

and rack and adjacent panels. The hinges are equipped with a stop so that the panel is horizontal when opened forming a convenient shelf.

# fixed front panel units

## FEATURES

Concealed mounting device presents neat panel appearance when mounted on rack

No screws show

Unlimited adjustment

Quickly and easily installed

## DESCRIPTION

The smaller General Electric rack-mounted equipments are mounted on flat panels which utilize a clamp-type mounting. The illustration, Fig. 4-1, shows how the panel is clamped to the mounting rack. This method of mounting eliminates unsightly front screws and permits unlimited vertical adjustment.

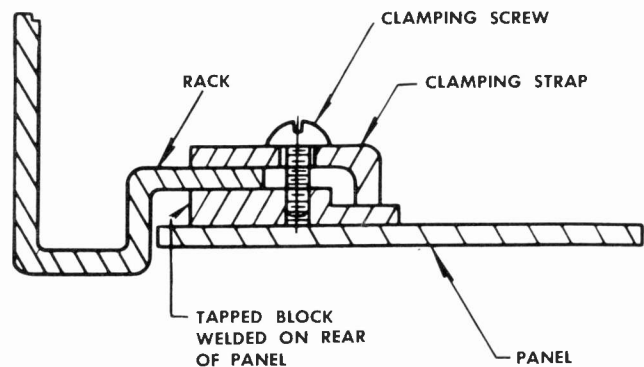

Fig. 4-1 Clamp mounting of fixed front panel units



# characteristics of G-E broadcast audio amplifiers

Type No. and Name	Use	Output (dbm)	Gain (db)	Source Impedance (ohms)	Load Impedance (ohms)	Gain Control (Self-contained)	Power Supply	Type of Mounting
BA-1-C Pre-Amplifier (Plug-in)	Pre-amplifier Booster Ampl. Program Ampl. Bridging Ampl.	+18	40 or 34	600/250/150/30 ----- 30,000 (Bridging Input)	600/150	No Use Bridging Volume Control Kit FA-35-E	Separate Use BP-1-A, BP-8-A or BP-10-A	Rack Mounting with FA-22-A Tray and FA-23-A Shelf Base Mounting with FA-22-A Tray
BA-1-D Pre-amplifier	Pre-amplifier Booster Ampl. Program Ampl. Bridging Ampl.	+18	40 ----- 0	600/250/150/30 ----- (Bridging Input)	600/150	No Use Bridging Volume Control Kit FA-35-A	Separate Use BP-1-A, BP-8-A or BP-10-A	Rack Mounting with BA-5-A Panel and Mounting
BA-2-A Program Amplifier	Program Ampl. Monitor Ampl. Bridging Ampl.	+33	60 ----- 39	600/150 ----- 40,000 (Bridging Input)	600/150	Yes	Internal AC	Rack Mounting
BA-3-A Equalized Transcription Pre-amplifier	Combined Transcription Equalizer and Pre-amplifier	-15VU from Typical Transcription	----- ----- 67	G-E Variable Reluctance Cartridge Type RPX-046	600/150 Also high impedance for cueing headphones	No	Internal AC	Base Mounting in T.T. cabinet
BA-4-D Monitoring Amplifier	Monitoring Cueing Talkback	+40	105 ----- 67	250/30 ----- 10,000 (Bridging Input)	600/150/ 8/2	Yes	Internal AC	Base Mounting in speaker cabinet
BA-4-E Monitoring Amplifier	Monitoring Cueing Talkback	+40	105 ----- 67	600/250/150/30 ----- 10,000 (Bridging Input)	600/150/ 8/2	Yes	Internal AC	Rack
BA-5-A Limiting Amplifier	Audio Peak Limiting	+12	44	600/150	600/150	Yes	Separate unit included	Rack
BA-6-A Portable Amplifier	Remote Pickups	+18	95	600/250/150/30 ----- 50 for P.A.	600/150 Line and 50 for P.A.	Yes	Internal AC and batteries	Portable carrying case
BA-10-A Utility Amplifier	Transcription and Microphone Pre-amplifier	+4	50	600/250/150/30	600/150	Yes	Internal AC	Base Mounting Rack Mounting with FA-5-A Panel and Mounting
BA-12-A Program/Monitor Amplifier (Plug-in)	Program Ampl. Monitor Ampl. Bridging Ampl.	+39	50 ----- 6	600/150 ----- 24,000 (Bridging Input)	600/150	No Use Volume Control Kit FA-35-F	Separate Use BP-8-A or BP-10-A	Rack Mounting with FA-22-B Tray and FA-23-A Shelf Base Mounting with FA-22-B Tray

# General discussion of ratings and terminology

General Electric broadcast amplifiers operate over a frequency range of at least 50 to 15,000 cycles and will deliver their full rated power throughout this range. The distortion and noise are reduced to values suitable for the most exacting service.

Much care has been taken in the design of these amplifiers to assure maximum reliability of operation as well as convenience for servicing.

The ratings given throughout this catalog use the following gain and level ratings:

db — refers to gain or loss

dbm — Single-frequency, sine wave power referred to 1 milliwatt

$$(\text{dbm} = 10 \log \frac{P}{.001})$$

VU — Program level as read on a standard VU Meter. Since program material is of a complex and transient nature, the VU meter indicates a level considerably under the instantaneous peak program level. In practical usage the amplifier dbm rating should exceed the VU level to be transmitted by at least 10 db.

The chart showing "Characteristics of G-E Broadcast Audio Amplifiers" lists the General Electric name and uses for each amplifier. The following uses are defined in RMA Standard TR-105B dated November 1949:

### **Preliminary Amplifier**

A preliminary amplifier is an amplifier which operates from a microphone or other low-level source. Its function is to amplify the microphone output or other signal to a level that can be fed into a subsequent circuit without the signal-to-noise ratio being degraded thereby.

### **Booster Amplifier**

A booster amplifier is an amplifier which is connected in the main program line between the preliminary amplifier and the program amplifier.

### **Program Amplifier**

A program amplifier is an amplifier which is connected in the main program channel and is capable of delivering standard output level.\*

### **Bridging Amplifier**

A bridging amplifier is an amplifier whose internal input impedance is such that it may be connected across a circuit without appreciably affecting the circuit performance in any respect. Its function is to operate into program circuits or similar loads.

### **Monitoring Amplifier**

A monitoring amplifier is an amplifier connected to a program circuit so as to provide a means of checking the program.

The term "Program Amplifier" is now used in place of the non-standard term "Line Amplifier" or "Main-Amplifier". The term "Bridging Amplifier" is now used in place of "Isolation Amplifier".

# discussion of gain ratings

As applied to a typical amplifier—General Electric Type BA-10-A

### **Unloaded-input Transformer (50-db gain)**

When the full generated voltage of a microphone, turntable pick-up, or similar device is applied to the input terminals of the amplifier which it is feeding, the operating conditions are referred to as those of an unloaded-input transformer since no resistance loading of the transformer, either primary or secondary, is used. Under these conditions the highest signal-to-noise ratio of a microphone-amplifier combination is obtained because the amplifier does not load the microphone.

Operating with an unloaded-input transformer, as explained above, the Type BA-10-A Utility Input Amplifier has a gain of 50 db. This gain is defined as the ratio of "power delivered to the load" to the "power which would be delivered to the load" if the pre-amplifier were replaced by an ideal transformer connected to match the load and source impedance. The gain is determined as follows:

\* +18 dbm to lines or +12 dbm to transmitters



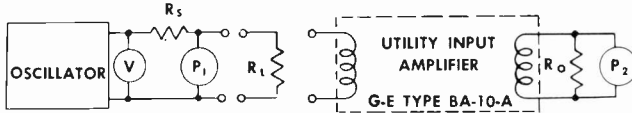

Fig. 5-1

A source resistance ( $R_s$ ) fed by an oscillator is connected to a load resistance ( $R_L$ ) of equal value. The oscillator output is adjusted until the power dissipated in  $R_L$  is  $-50$  dbm, as indicated by the power measuring instrument  $P_1$ . The output voltage of the oscillator, as indicated by voltmeter  $V$  is recorded,  $R_L$  is then disconnected from  $R_s$  and the oscillator, and the Utility Input Amplifier is connected in place of  $R_L$ . A tap on the input transformer of the amplifier is used which is equal to the value of  $R_s$  (150-ohm tap for 150-ohm  $R_s$ ). The output of the oscillator, as indicated by voltmeter  $V$ , is held constant at the value previously recorded. The resulting output as indicated by  $P_2$  which the amplifier will deliver to its proper load resistor  $R_o$  is "O" dbm.

Thus the gain of the amplifier is 50 db.

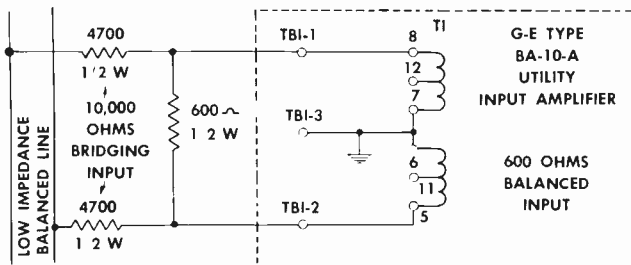

Fig. 5-2

**Matching Input (44-db gain)**

When the input circuit of an amplifier constitutes a resistive load equal in value to the impedance of the source feeding it, the amplifier is said to have a matching input. Under these conditions the voltage at the terminals of the input transformer of the amplifier is only one half the voltage generated by the source. This constitutes a 6-db drop in the voltage input to the amplifier which effectively produces a 6-db decrease in amplifier gain as compared with the gain obtained with unloaded-input transformer operation. Thus, the gain of the amplifier with matching input is 44 db.

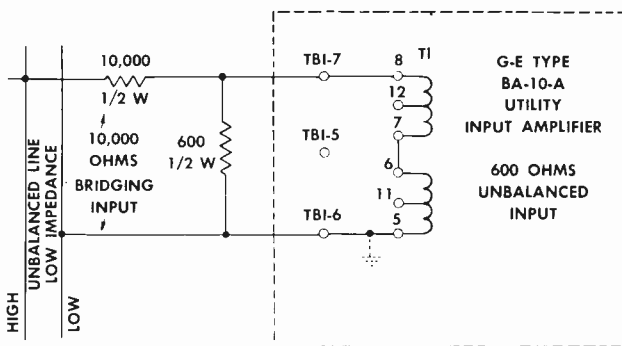

Fig. 5-3

**Bridging Input (20-db gain)**

When an amplifier or similar low-impedance device is connected across a low-impedance line in such a way that only a small fraction of the energy in the line (insufficient to affect the operation of the line) is diverted into the amplifier, the amplifier is said to employ a bridging input. This is accomplished by stepping up the input impedance

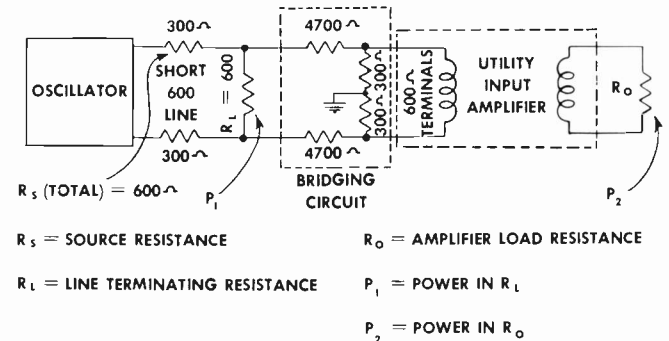

Fig. 5-4

of the amplifier (to 10,000 or 20,000 ohms, for example) so that in connecting it across the low-impedance line (0-1000 ohms) it has negligible effect.

Figs. 5-2 and 5-3 show the circuits of resistive pads either of which, when connected to the 600-ohm input terminals of the Type BA-10-A Utility Input Amplifier, converts the 600-ohm unloaded transmitter input to a 10,000-ohm resistive-input impedance. With such a pad the amplifier may be "bridged" directly across a low-impedance line.

Used as a bridging amplifier, the Utility Input Amplifier has a gain of 20 db, where the gain is defined as the ratio of the "power ( $P_1$ ) in the 600-ohm line terminating resistance ( $R_L$ )," to the "output power ( $P_2$ ) of the amplifier"; that is  $GAIN (db) = 10 \log P_2 \div P_1$ . Fig. 5-4 shows the circuit employed in measuring gain with bridging input.

# Two-stage pre-amplifier Type BA-1-D

**FEATURES**

- + 18 dbm output capability — does not overload when microphones are subjected to high-sound pressures
- Cross-talk at least 100 db below output level of adjacent amplifiers on common power supply
- Low hum — filament hum reduced by fully by-passing all cathodes -- B+ hum reduced by special feedback circuit so that plate-supply ripple may be as high as 100 millivolts with negligible hum output
- Isolation of 90 db or more when used for bridging
- Minimum of microphonics — uses quiet 1620's plus double shock mounting

Quick and easy servicing — flat-plate construction — plug-in electrolytic capacitors

### APPLICATION

The Type BA-1-D Two-Stage Pre-Amplifier is a high-fidelity, fixed-gain, extremely versatile, and compact unit recommended for use as a:

1. Microphone or transcription pre-amplifier
2. Booster amplifier between mixer and master gain controls
3. Program amplifier for medium level applications
4. Bridging amplifier with 10,000-ohm input impedance

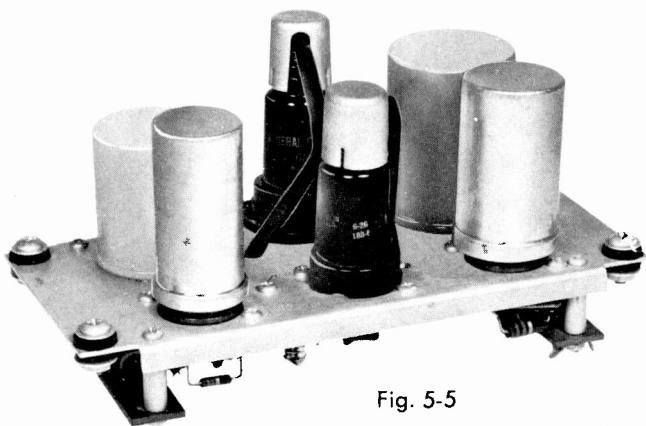

Fig. 5-5

Type BA-1-D Two-Stage Pre-Amplifier

### DESCRIPTION

The BA-1-D is constructed on a flat-plate chassis to achieve the utmost in accessibility of components and wiring. Solder-lug terminals are provided for audio input and output, power, and metering connections. Its first stage tube and the entire chassis are shock mounted to prevent microphonics.

The BA-1-D contains two resistance-coupled stages using type 1620 low-noise tubes. Feedback around both stages and the output transformer is accomplished by the use of a tertiary winding on the output transformer connected in series with the first tube cathode. This circuit eliminates the necessity of unby-passed cathode resistors with their attendant hum difficulties. Inclusion of the output transformer in the voltage feedback loop reduces transformer distortion and renders the amplifier practically immune to ripple and other disturbances which may be present on the B+ supply bus. Unloaded-transformer input is employed to give maximum gain and optimum signal-to-noise ratio from high-quality broadcast microphones.

The cathode resistors of both tubes are tapped to provide check voltages of 1.0 volt which are brought out to terminals. Tube condition and circuit performance may be quickly checked by connecting these to a Type FA-11-A DC Metering Panel, or some other suitable high-resistance voltmeter.

Fixed resistors are included in the amplifier to provide a 30,000-ohm input impedance when used as a bridging amplifier. Mounting holes are included on the chassis for the addition of the Type FA-35-A Bridging Volume Con-

trol. This unit provides a 10,000-ohm input impedance for use as bridging and a continuously variable input-volume control.

Each BA-1-D pre-amplifier is provided with four rubber shock-mounts and mounting screws. Up to 4 of these units can be mounted on a Type FA-5-A Panel and Mounting which occupies 8¾ inches of vertical rack space in a standard 19-inch wide cabinet rack. The small size and flat-plate chassis construction of the BA-1-D pre-amplifier makes it readily adaptable for mounting either vertically or horizontally in special cabinets, consoles, or frames.

### SPECIFICATIONS

For Microphone Input:

Source Impedance . . . . . 600/250/150/30 ohms (balanced or unbalanced)

Input Impedance . . . . . unloaded transformer

Gain . . . . . + 40 db

For Bridging Input (with bridging resistors supplied):

Input Impedance . . . . . 30,000 ohms

Gain . . . . . 0 db (bridging a 600-ohm line)

For Bridging Input (with FA-35-A Bridging Control):

Input Impedance . . . . . 10,000 ohms (balanced)

Maximum Gain . . . . . 10 db (bridging a 600-ohm line)

Maximum Input Level . . . + 40 dbm (bridging a 600-ohm line)

Output-load Impedance . . 600/150 ohms (balanced or unbalanced)

Output Level and Distortion (50-15,000 cycles):

with 300v d-c plate

supply . . . . . + 18 dbm, ½% or less distortion

with 250v d-c plate

supply . . . . . + 16 dbm, ½% or less distortion

Frequency Response . . . . ± 1 db, 50 to 15,000 cps with any combination of 600- and 150-ohm source and load impedances

Output Noise . . . . . - 80 dbm (Typical total noise at output is - 87 dbm. This consists essentially of 60 cycles and hiss. Other hum components are negligible. Amplifier is not, however, guaranteed to have output noise lower than - 80 dbm because of tube variations.)

Power Supply Requirements:

Plate Power . . . . . 6.5 ma at 250v d.c. or 8 ma at 300v d.c.

Filament Power . . . . . 0.6 ampere at 6.3v a.c. or d.c.

Dimensions:

Width . . . . . 3-13/16 in.

Height . . . . . 8-3/16 in.

Depth . . . . . 4-13/16 in. (over-all)

Weight . . . . . 3 lbs approx

When Ordering Specify: Two-Stage Pre-Amplifier, Type BA-1-D (Order tubes separately).

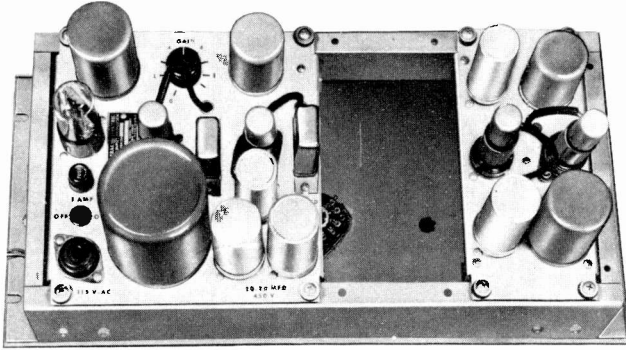

Fig. 5-6 Rear view of Type FA-5-A Panel and Mounting with BA-1-D and BA-10-A Amplifiers mounted

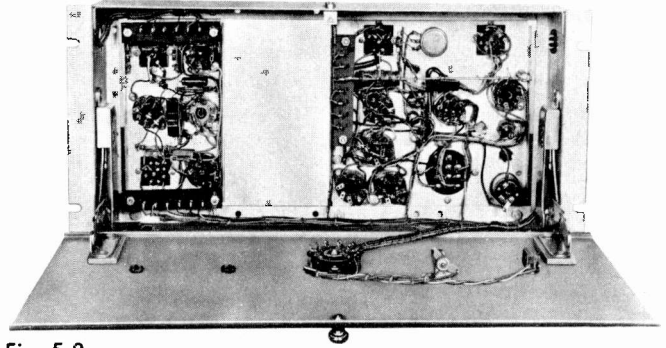

Fig. 5-8 Front view of Type FA-5-A Panel and Mounting with BA-1-D and BA-10-A Amplifiers mounted

**ACCESSORIES**

**Tube Complement**

consists of: 2-type 1620

Note: 6J7 tubes may be used when uniformity of characteristics and minimum of microphonics, hum, and distortion are not required.

Bridging Volume Control. . . FA-35-A

Power Supply. . . . . BP-1-A, BP-8-A

(for details see Power Supply Tabulation Chart)

DC Metering Panel. . . . . FA-11-A

Panel and Mounting. . . . . FA-5-A

(mounts up to 4 BA-1-D pre-amps in cabinet rack)

**bridging volume control  
Type FA-35-A**

**DESCRIPTION**

The FA-35-A Bridging Volume Control is designed specifically for mounting on the chassis of a G-E Type BA-1-B or BA-1-D Pre-amplifier to provide a balanced 10,000-ohm bridging-input circuit for the amplifier. The FA-35-A has a 30-db minimum insertion loss when used with a BA-1-B or BA-1-D amplifier. The FA-35-A contains a continuously variable dual-potentiometer for the 600-ohm output portion of the resistive network and thereby offers a means for control of gain when desired. The dual-potentiometer is of the solid-moulded type, with a resistor element that is not affected by heat, cold, moisture, or wear.

When Ordering Specify: Bridging Volume Control, Type FA-35-A.

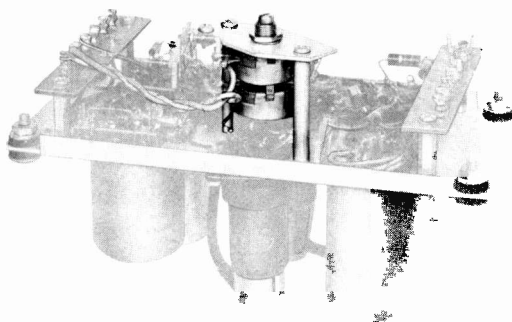

Fig. 5-7 Type FA-35-A Bridging Volume Control mounted on BA-1-D Amplifier

**Utility input  
amplifier  
Type BA-10-A**

**FEATURES**

- Compact — a-c operated self-contained power supply
- Easily installed — can be base mounted on a turntable or vertically mounted on a standard rack
- Plug-in electrolytic capacitors
- Low-noise level — magnetically shielded audio and power transformers
- Virtually no microphonics—first tube is shock mounted
- Tube-current check — provision for external metering

**APPLICATION**

High gain, interstage volume control, and self-contained power supply make the Type BA-10-A Utility Input Amplifier convenient for use as:

1. Microphone pre-amplifier
2. Booster amplifier between mixer and master gain control
3. Transcription pick-up amplifier in the turntable cabinet
4. Emergency announce-microphone amplifier at transmitter locations
5. Cueing amplifier between control room microphones and studio headphones
6. Isolation amplifier when equipped with suitable bridging resistors

**DESCRIPTION**

The BA-10-A is constructed on a flat plate chassis similar to the Type BA-1-D Pre-amplifier. Two resistance-capacitance coupled audio stages employ low noise type 1620 tubes with each stage included in a feedback loop. The continuously-variable interstage gain control uses a high-quality, solid-moulded type potentiometer. Hum is mini-

mized by the use of hum-balancing coil construction and alloy shields on input and output transformers and by the use of adequate cathode by-passing.

The cathode resistors of the amplifier tubes are tapped to provide check voltages of 1.0 volt. The connections from the taps are brought out to terminals. An external high-resistance voltmeter such as the Type FA-11-A DC Metering Panel may be used to check circuit performance.

A self-contained power supply eliminates the need for an external unit. The power transformer has been especially designed to have a minimum external field.

The BA-10-A may be base or rack mounted (horizontally or vertically). Each amplifier is provided with rubber shock mounts, mounting screws, and mounting brackets. Two of these units can be mounted on a Type FA-5-A Panel and Mounting which occupies 8¾ inches of vertical rack space in a standard 19-inch wide cabinet rack.

### SPECIFICATIONS

For microphone or Transcription Input:

Source Impedance . . . . .600/150/250/30 ohms (balanced or unbalanced)

Input Impedance . . . . .unloaded transformer

Maximum Gain . . . . .50 db

Maximum Input Level . . . -36 dbm

For Bridging Input (Using Bridging Volume Control FA-35-D):

Input Impedance . . . . .10,000 ohms (balanced)

Maximum Gain . . . . .20 db (bridging a 600-ohm line)

Maximum Input Level . . . +40 dbm (bridging a 600-ohm line)

Output Load Impedance . .600/150 ohms (balanced or unbalanced)

Output Level and Distortion . . . . . -2 dbm, ½% or less distortion

(50-15,000 cycles) . . . . . +4 dbm, 1% or less distortion

Frequency Response . . . . . ±1 db, 50 to 15,000 cps with any combination of 600- and 150-ohm source and load impedances

Output Noise . . . . . -70 db maximum

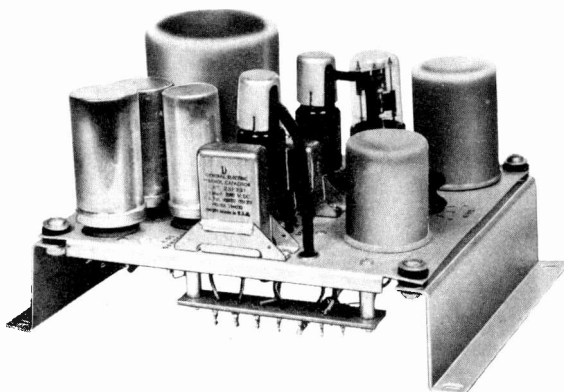

Fig. 5-9 Type BA-10-A Utility Input Amplifier

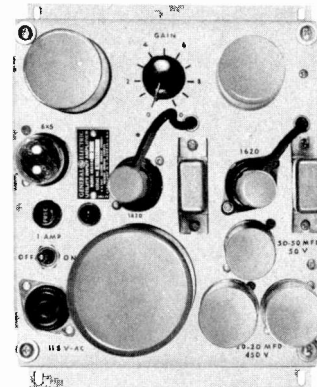

Fig. 5-10 Rear view of BA-10-A Amplifier

Gain Control . . . . .continuously variable log-taper potentiometer

Power Supply Requirements . . . . .105/115/125 volts, 50/60 cps, 20 watts

Dimensions:

Height . . . . .8-3/16 in. (9-1/16 in. including brackets)

Width . . . . .7-¾ in.

Depth . . . . .5 in. (over-all)

Weight . . . . .6-¼ lbs

When Ordering Specify: Utility Input Amplifier Type BA-10-A (order tubes separately)

### ACCESSORIES

Tube Complement

consists of: 2-type 1620

1-type 6X5-GT

Bridging Volume Control . .FA-35-D

DC Metering Panel . . . .FA-11-A

Panel and Mounting . . . .FA-5-A

## program amplifier Type BA-2-A

### FEATURES

High output level—low distortion and low noise  
Hinged panel permits easy access from front  
Plug-in electrolytic capacitors used throughout  
Accepts wide range of input levels without overload  
Dual step-type gain control provides accurate 3-db steps  
Vernier gain-control provides fine output adjustment  
Self-contained power supply

### APPLICATION

The Type BA-2-A Program Amplifier is an extremely ver-

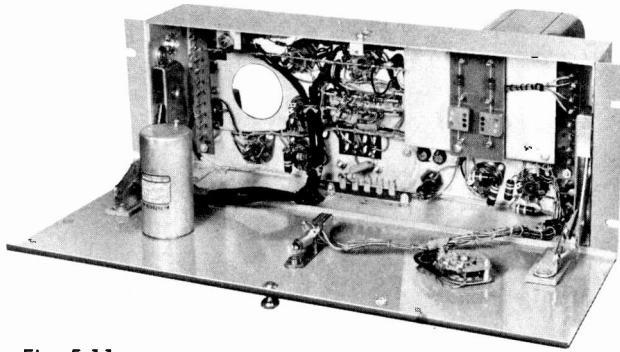

Fig. 5-11

Type BA-2-A Program Amplifier with front panel open

satellite unit recommended for use as a:

1. Program or Main Amplifier
2. Isolation or Bridging Amplifier
3. Line Amplifier
4. Medium-power monitoring or cueing amplifier

### DESCRIPTION

The BA-2-A embodies design and operational features which contribute much to simplified high-quality station operation.

Bridging and matching inputs and outputs which may be worked balanced or unbalanced make adaptation to new or existing circuits very easy.

The dual-section master gain control simultaneously adjusts the attenuation between the input transformer and first stage, and between first and second stages, to minimize input overloading and to reduce noise coming from the first stage.

The output circuits permit operation into lines with or without isolating pads, or operation of a loudspeaker where only moderate acoustic level is required.

The gain or output level of several Program Amplifiers may be adjusted to exactly the same values since the screw-driver operated vernier gain control overlaps the steps of the master gain control.

As shipped, the amplifier is connected for "flat" response, but provision is made for adding the necessary components to form a "boost" circuit which allows approximately a 3-db rise in response at 50 and/or 15,000 cycles.

A tube-check switch is included for easy connection of 1-volt cathode resistor taps to an external 5,000 ohms per volt 2-volt meter, such as is provided on the Type FA-11-A DC Metering Panel.

A well-filtered power supply is included on the amplifier chassis.

Vertical-chassis construction of the Type BA-2-A Program Amplifier permits great ease in servicing and adjustment. The hinged-front panel allows quick access for operation or maintenance. The master gain control, tube-check switch, ON-OFF switch, and indicator light are mounted on the panel. The screw-driver operated vernier gain control is mounted on the chassis and may be adjusted when the front panel is open. Removal of plug buttons at chassis ends exposes  $\frac{7}{8}$ -inch holes usable as convenient

wire entries to the amplifier. Solder-lug terminal boards within the chassis are used for external connections. A convenient shielded audio tie line connects right- and left-hand terminal boards. The power cord plugs into a flush-mounted, recessed male receptacle on the back of the chassis.

### SPECIFICATIONS

For Matching Input:

Source Impedance..... 600/150 ohms (balanced or unbalanced)

Input Impedance..... 600/150 ohms

Maximum Gain..... 60 db

Maximum Input Level.. +5 dbm

For Bridging Input:

Input Impedance..... 40,000 ohms (balanced or unbalanced)

Maximum Gain..... 39 db (when bridging a 600-ohm line)

Maximum Input Level.. +25 dbm (when bridging a 600-ohm line)

Output Load Impedance.. 600/150 ohms (balanced or unbalanced)

Output Level and Distortion:

+30 dbm (1 watt).....  $\frac{1}{2}$ % or less distortion

+33 dbm (2 watts)....  $1\frac{1}{2}$ % or less distortion

Above values with any combination of input and output connections and throughout 50 to 15,000 cps frequency range

Frequency Response.....  $\pm 1$  db, 50 to 15,000 cps

Output Noise ..... -53 dbm (for max gain)

Gain Control..... calibrated step-type, 3-db per step — also vernier-control overlapping steps of main control

Power Supply Require-

ments..... 105/115/125 volts, 50/60 cycles, 60 watts

Dimensions:

Width..... 19 in.

Height..... 7 in.

Depth.....  $7\frac{3}{4}$  in. (over-all)

Weight..... 20 lbs.

When Ordering Specify: Program Amplifier, Type BA-2-A (order tubes separately)

### ACCESSORIES

Tube Complement

consists of: 1-type 1620

1-type 6J7

1-type 1622

1-type 5Y3GT/G

DC Metering Panel.... FA-11-A

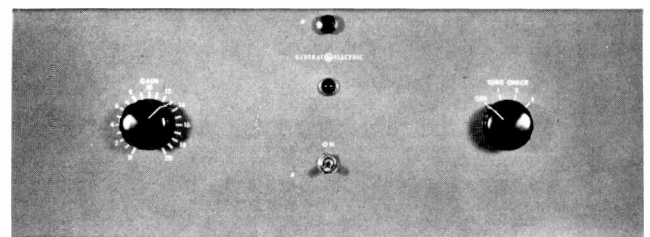

Fig. 5-12

Type BA-2-A Program Amplifier

# Monitoring amplifier Type BA-4-D

## FEATURES

- Ideal for base mounting — no front panel
- Excellent amplifier for mounting in speaker cabinet
- Includes remote volume control
- Outstanding circuit features which are similar to Type BA-4-E

## APPLICATION

The Type BA-4-D Monitoring Amplifier is similar in many respects to the Type BA-4-E described on the following page, except that it does not include a front panel. It may be base mounted horizontally, as in a speaker cabinet, or rack-mounted. A screw driver operated volume control and a power switch are mounted on the chassis with access from the rear (tube side).

## SPECIFICATIONS

- For Microphone or Transcription Input:
  - Source Impedance . . . . . 250 or 30 ohms
  - Input Impedance . . . . . unloaded transformer

- Maximum Input Level . . . +40 dbm (bridging a 600-ohm line)
- Output Load Impedance . . . 600, 150, 8 or 2 ohms
- Output Level and Distortion . . . . . +40 dbm, 1½% or less distortion (50-15,000 cycles) . . . . . +33 dbm, 1% or less distortion
- Frequency Response . . . . . ±1 db, 50 to 15,000 cps
- Output Noise . . . . . -18 dbm max (at full output the signal-to-noise ratio is 58 db. If a 20-db reduction in gain is effected by means of the interstage volume control, the signal-to-noise ratio is increased to 73 db)
- Gain Control . . . . . High-quality, solid-moulded continuously variable log-taper potentiometer
- Power Supply Requirements . . . . . 105/115/125 volts, 50 to 60 cycles, 85 watts

- Dimensions: (base mounted)
  - Length . . . . . 19 in.
  - Width . . . . . 8¾ in.
  - Height (over-all) . . . . . 7-13/16 in.
  - Weight . . . . . 21 lbs

When Ordering Specify: Monitoring Amplifier, Type BA-4-D (order tubes separately)



Fig. 5-13 Top view of Type BA-4-D Monitoring Amplifier

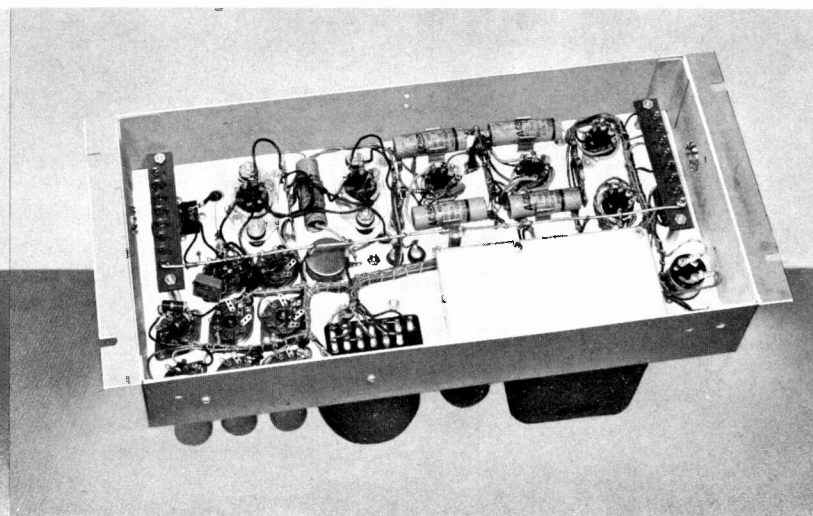

Fig. 5-14 Bottom view of Type BA-4-D Monitoring Amplifier

- Maximum Gain . . . . . 105 db
- Maximum Input Level . . . -27 dbm
- For Bridging Input (with Bridging Volume Control included):
  - Input Impedance . . . . . 10,000 ohms (balanced)
  - Maximum Gain . . . . . 67 db (bridging a 600-ohm line)

## ACCESSORIES

- Tube Complement
  - consists of: 2-type 1620
  - 2-type 6J7
  - 2-type 1622
  - 1-type 5U4G

# Monitoring amplifier Type BA-4-E

## FEATURES

- Compact — Requires only 7 inches of rack space
- High gain — useful for talk-back, transcription cue, and playback applications
- Easily serviced — all components readily accessible
- Separate bridging control for various monitoring applications
- High-quality components used throughout
- Separate output transformer windings for speaker and line
- 10 watts output

## APPLICATION

The Type BA-4-E Monitoring Amplifier is for use primarily in monitoring although it may be used in the program channel of a speech-input system. Because of the high inherent gain of the amplifier, it has other applications such as a control room-to-studio talk-back amplifier where the talk-back microphone feeds directly without pre-amplification, or as a transcription-cueing amplifier, again without pre-amplification.

## DESCRIPTION

The BA-4-E is designed for mounting in a standard cabinet rack. The front panel is hinged for instant interior accessibility. The power switch, indicator light, and gain control are all mounted on the front panel. A Bridging Volume Control (Type FA-35-D) is included for use when a bridging input is desired.

The amplifier circuit consists of a triode first stage, pentode second stage, dual-triode driver and phase-inverter with push-pull beam-power output. Resistance-capacitance coupling is used throughout. A gain control is connected between the first and second stages. Feedback is taken from a tertiary winding on the output transformer to the driver

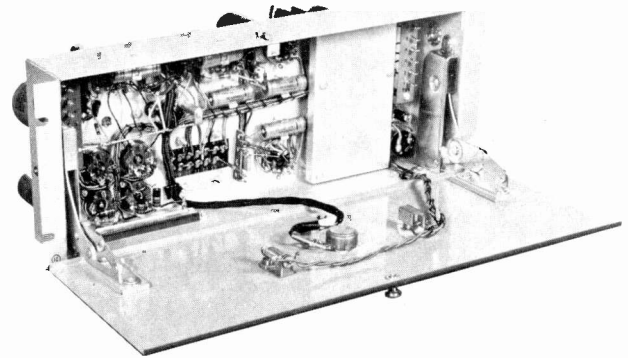

Fig. 5-15

Type BA-4-E Monitoring Amplifier with front panel open cathode. This provides low-output impedance for speaker damping, plus excellent frequency response, low distortion, and low-output stage hum level.

A self-contained power supply is provided. All filter capacitors are of the plug-in type.

## SPECIFICATIONS

For Microphone or Transcription Input:

- Source Impedance . . . . .600, 150, 250, or 30 ohms
- Input Impedance . . . . .unloaded transformer
- Maximum Gain . . . . .105 db
- Maximum Input Level . . . . .-27 dbm

For Bridging Input (with FA-35-D Bridging Volume Control supplied):

- Input Impedance . . . . .10,000 ohms (balanced)
- Maximum Gain . . . . . 75 db (bridging a 600-ohm line)
- Maximum Input Level . . . . .+40 dbm (bridging a 600-ohm line)

Output Load Impedance . . . . .600, 150, 8, or 2 ohms

Output Level and

- Distortion . . . . .+40 dbm, (10 watts) 1½% or less distortion
- (50-15,000 cycles) . . . . .+33 dbm, 1% or less distortion

Frequency Response . . . . .±1 db, 50 to 15,000 cps with any combination of 600- and 150-ohm source and load impedance

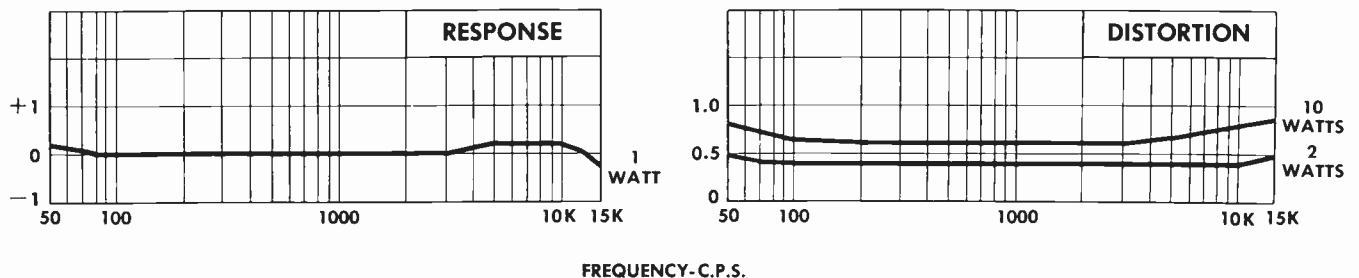

Fig. 5-16 Performance curves for BA-4-D and BA-4-E Amplifiers



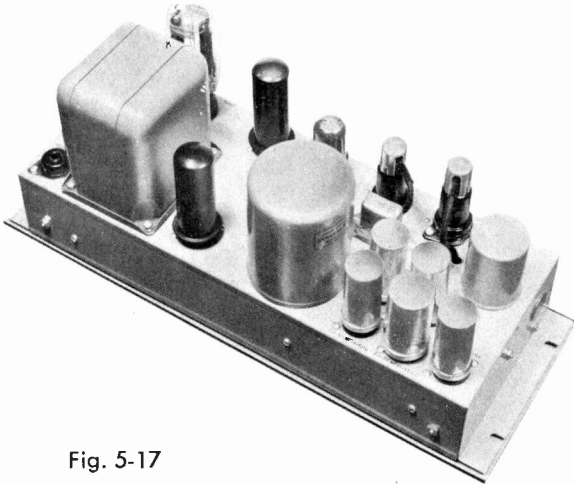

Fig. 5-17

Rear view of Type BA-4-E Monitoring Amplifier

Output Noise ..... — 18 dbm max (at full output the signal-to-noise ratio is 58 db. If a 20-db reduction in gain is effected by means of the interstage volume control, the signal-to-noise ratio is increased to 73 db)

Gain Control ..... continuously variable log-taper potentiometer

Power Supply Requirements ..... 105/115/125 volts, 50 to 60 cycles, 85 watts

## Dimensions:

Height ..... 7 in.

Width ..... 19 in.

Depth ..... 9-1/16 in. (over-all)

Weight ..... 23 lbs

When Ordering Specify: Monitoring Amplifier, Type BA-4-E (order tubes separately)

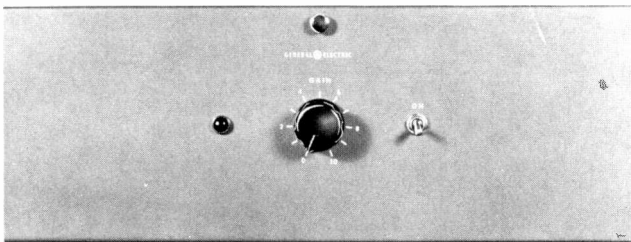

Fig. 5-18 Type BA-4-E Monitoring Amplifier

## ACCESSORIES

Tube Complement consists of: 2-type 1620  
1-type 6SN7GT  
2-type 1622  
1-type 5U4G

## bridging volume control Type FA-35-D

## DESCRIPTION

The FA-35-D Bridging Volume Control is intended to be used external to an amplifier. It converts the 600-ohm input of an amplifier to 10,000 ohms for balanced bridging service. The FA-35-D has a 30-db minimum insertion loss when used with a BA-4-E amplifier. The FA-35-D contains a long-life solid-moulded type dual potentiometer for the 600-ohm output portion of the resistive network and thereby offers a means for control of gain when desired. It can be installed in a studio control console, monitoring speaker cabinet, or at any other convenient location.

When Ordering Specify: Bridging Volume Control, Type FA-35-D

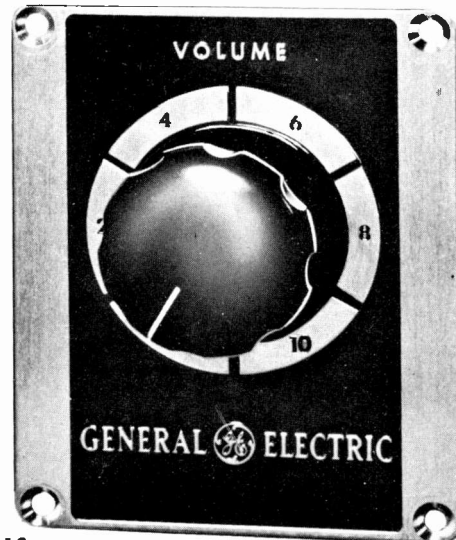

Fig. 5-19

Front view of Type FA-35-D Bridging Volume Control

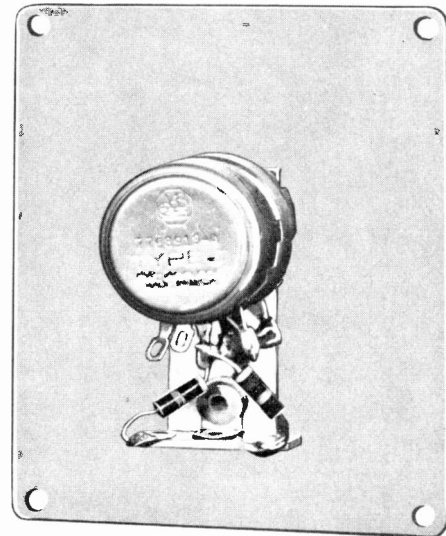

Fig. 5-20

Rear view of Type FA-35-D Bridging Volume Control



# Limiting amplifier

## Type BA-5-A

### FEATURES

- Extremely short attack time obtained by means of delay network plus high-speed bias generator
- Extremely low transient waveform distortion
- Very high compression above threshold of gain-reducing action
- "Motor-boating" impossible — high signal-to-noise "thump" ratio
- "Pumping" of program level minimized—recovery time on automatic function of program material
- Very low steady-state distortion and noise level — inverse feedback gain-reducing circuit
- Instant accessibility—vertical chassis with hinged dual front-cover panels

### APPLICATION

The Type BA-5-A Limiting Amplifier is used in both AM and FM stations. In AM operation the BA-5-A permits a substantial increase in average modulation level without overmodulation and without the effects of limiting becoming noticeable to the listener. In FM it helps to prevent overswing.

### DESCRIPTION

Behind the BA-5-A Limiting Amplifier's unequalled performance stands a unique combination of circuits, the initial development of which was done by the Columbia Broadcasting System technical staff. Control-bias generating circuits assure extremely fast development of the automatic-control voltage. Another circuit feature, a time-delay network in the signal channel, delays the signal until bias generator circuits have time to reduce the required amplifier gain. Audible "thump" also is greatly minimized with circuits that furnish an unusually high ratio of signal-voltage to control-voltage, especially for the first few db of gain reduction.

The common difficulty of "motor-boating" cannot occur, since the automatic-control voltage is not a function of the output voltage of the amplifier.

Further advantage of the Limiting Amplifier is that it will maintain a higher average modulation level without overmodulation of the main transmitter. With its higher compression ratio the amplifier's output level remains constant within 0.5 db for an input level increase of 12 db above the threshold value.

An "anti-pump" circuit provides an automatic adjustment of gain recovery time. Single program peaks (such as the sound of a gunshot) provide a gain recovery time of approximately ½ second but if several program peaks (such as an announcer talking above applause) should occur in rapid succession, the recovery time is lengthened. This feature minimizes the objectionable "pumping" usually associated with large amounts of limiting.

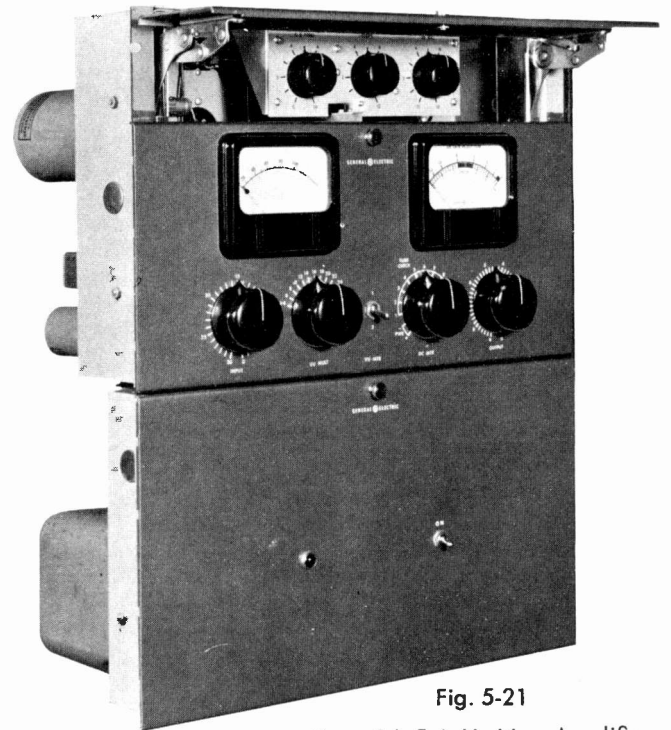

Fig. 5-21

Type BA-5-A Limiting Amplifier

Two separate units make up the BA-5-A Limiting Amplifier — an amplifier unit and a power supply.

The controls and meters used during normal operation are mounted directly on the hinged panels, and need not be removed or disturbed in any way when adjusting or servicing units in the rack. Several controls used only occasionally during adjustments of the amplifier are mounted on a sub-panel in the amplifier unit, behind a separate hinged-cover panel.

A gain reduction meter, mounted on the front panel of the amplifier will:

1. Indicate automatic-gain reduction directly in db
2. Indicate balance of various tubes
3. Measure tube-plate currents
4. Measure plate voltage

A panel-mounted rotary switch selects the desired meter function.

A standard VU meter is connected to a selector switch so that both input and output levels may be measured.

The power supply contains two separate regulated power supplies. These provide potentials of 250-volts positive and 250-volts negative, respectively. Constant d-c output voltages are maintained over a wide range of a-c line-voltage variations.

A power switch and a red-jewelled pilot lamp are mounted on the front-cover panel of the Power Supply Unit. Adjustment of d-c voltage in the power supplies is made by two controls on a sub-panel in the power supply chassis interior. This sub-panel also mounts a 5-ampere power fuse. Both voltage controls and fuse are readily accessible from the front of the unit by opening the hinged front-cover panel.

The two units may be separated physically as far as desired. The amplifier unit requires 12¼ inches of rack mounting space, and the power supply unit occupies 10½ inches.

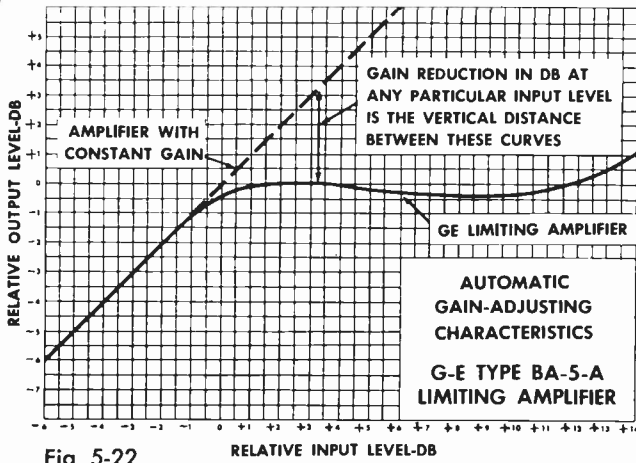

Fig. 5-22

**SPECIFICATIONS**

- For Matching Input:
  - Source Impedance . . . .600 or 150 ohms
  - Input Impedance . . . . .600/150 ohms
  - Gain . . . . .44 db
- Maximum Input Level:
  - At verge of gain reduction . . . . .-2 dbm
  - With 12 db of gain reduction . . . . .+ 10 dbm
- Minimum Input Level:
  - At verge of gain reduction . . . . .-32 dbm
  - Input level is adjustable in 1-db steps by means of the 30-step input-level control
- Output Load Impedance..600- or 150-ohms balanced or unbalanced
- Output Level and Distortion . . . . .+12 dbm, 1% or less distortion from 100-15,000 cps with 12 db of gain reduction - 1½% or less distortion from 50 to 100 cps with 12 db of gain reduction output level is adjustable in 0.2-db steps by means of the 45-step output-level control
- Frequency Response . . . . .±1 db, 50 to 15,000 cps under any condition of gain reduction
- Attack Time . . . . .effectively zero, due to unique circuits
- Recovery Time . . . . .automatic function of nature of program material

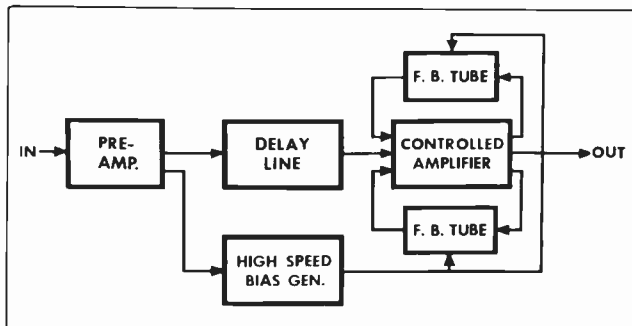

Fig. 5-23 Single line diagram of BA-5-A Amplifier

varies from ½ second for single short peaks to about 7 seconds for sustained or rapidly-recurring peaks.  
 Output Noise . . . . .70 db or more below output level at verge of gain reduction

**Dimensions:**

- Amplifier Unit
  - Width . . . . .19 in.
  - Height . . . . .12-¼ in.
  - Depth . . . . .8-⅝ in.
- Power Unit
  - Width . . . . .19 in.
  - Height . . . . .10-½ in.
  - Depth . . . . .8-⅝ in.

**Weight:**

- Amplifier Unit — 43 lbs
- Power Unit — 30 lbs

**Power Supply**

- Requirements . . . . .100-130 volts, 50/60 cps, 250 watts

When Ordering Specify: Limiting Amplifier, Type BA-5-A (order tubes separately)

**ACCESSORIES**

**Tube Complement**

Consists of the following:

- 3-type 6J7
- 3-type 6J5
- 5-type 6Y6-G
- 2-type 6X5-GT
- 1-type 6SN7-GT
- 3-type 1621
- 2-type 5R4-GY
- 2-type 6SL7-GT
- 2-type OD3/VR-150

# Plug-in amplifiers

General Electric Plug-In Amplifiers offer a successful and practical solution for an audio system where large numbers of amplifiers must be accommodated in a small space. The smallest or largest systems can be designed around only two basic units, the BA-1-C Pre-Amplifier and the BA-12-A Program/Monitor Amplifier.

Maintenance problems are minimized with the plug-in amplifiers since they can be easily removed from the racks and serviced at a test bench. Maintenance is further simplified since only two amplifiers are involved.

## Pre-amplifier Type BA-1-C

**FEATURES**

- Removable chassis side plate permits easy access to components and wiring
- May be connected for 40- or 34-db gain
- Bridging Volume Control available as accessory

+18-dbm output capability—reduces overload when microphones are subjected to high sound pressures

Cross-talk at least 100 db below output level of adjacent amplifiers on common power supply

Low hum—filament hum reduced by fully by-passing all cathodes - B+ hum reduced by special feedback circuit so that plate-supply ripple may be as high as 100 millivolts with negligible hum output

Isolation of 90 db or more when used for bridging

Minimum of microphonics — uses quiet 1620's plus shock mounting

**APPLICATION**

The Type BA-1-C Pre-amplifier is a high fidelity, dual-gain, versatile, and compact plug-in unit recommended for use as a:

1. Microphone or transcription pre-amplifier
2. Booster amplifier between mixer and master gain controls
3. Program amplifier for medium level applications
4. Bridging amplifier with fixed or variable gain

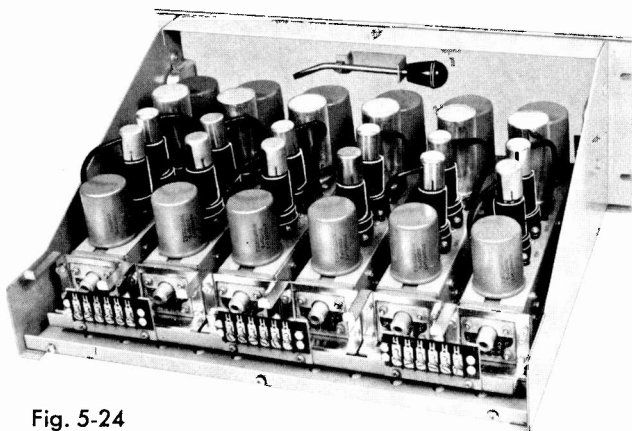

Fig. 5-24  
Six Type BA-1-C Amplifiers mounted on FA-23-A Shelf

**DESCRIPTION**

The BA-1-C contains two resistance-coupled stages using type 1620 low-noise tubes. Feedback around both stages and the output transformer is accomplished by the use of a tertiary winding on the output transformer which is connected in series with the first tube cathode. This circuit eliminates the necessity of unby-passed cathode resistors with their attendant hum difficulties. Inclusion of the output transformer in the voltage-feedback loop reduces transformer distortion and renders the amplifier practically immune to ripple and other disturbances which may be present on the B+ supply bus. Unloaded transformer input is employed to give maximum gain and optimum signal-to-noise ratio from high-quality broadcast microphones.

Fixed resistors are included in the BA-1-C to provide a 30,000-ohm input impedance when used as a bridging amplifier. A Type FA-35-E Bridging Volume Control is available as an accessory. This control mounts on the BA-1-C and provides a 10,000-ohm input impedance for use as a bridging or continuously variable-input volume control.

**SPECIFICATIONS**

For Microphone Input:

Source Impedance . . . .600/250/150/30 ohms  
(balanced or unbalanced)

Input Impedance . . . . .unloaded transformer

Gain . . . . .+40 db\*

For Bridging Input (with bridging resistors supplied):

Input Impedance . . . . .30,000 ohms

Gain . . . . .\*0 db (bridging a 600-ohm line)

For Bridging Input (with FA-35-E Bridging Control):

Input Impedance . . . . .10,000 ohms (balanced)

Maximum Gain . . . . .10\* db (bridging a 600-ohm line)

Maximum Input Level . . +40 dbm (bridging a 600-ohm line)

Output-load Impedance .600/150 ohms (balanced or unbalanced)

Output Level and Distortion (50-15,000 cycles):

with 300v d-c plate supply . . . . .+18 dbm, ½% or less distortion

with 250v d-c plate supply . . . . .+16 dbm, ½% or less distortion

Frequency Response . . . . ±1 db, 50 to 15,000 cps (with any combination of 600- and 150-ohm source and load impedances)

Output-noise . . . . .-80 dbm (typical total noise at output is -87 dbm — this consists essentially of 60 cycles and hiss — other hum components are negligible — amplifier is not, however, guaranteed to have output noise lower than -80 dbm because of tube variations)

Power Supply Requirements:  
Plate Power . . . . .6.5 ma at 250v d.c. or 8 ma at 300v d.c.  
Filament Power . . . . .0.6 ampere at 6.3v a.c. or d.c.

Dimensions:  
Length . . . . .9-7/8 in. (over-all)  
Width . . . . .2-1/4 in.  
Height . . . . .4-3/4 in.  
Weight . . . . .2-3/4 lbs

\* All gains may be reduced 6 db by reconnection of the feedback circuit. For instance, microphone input gain may be reduced from 40 to 34 db.

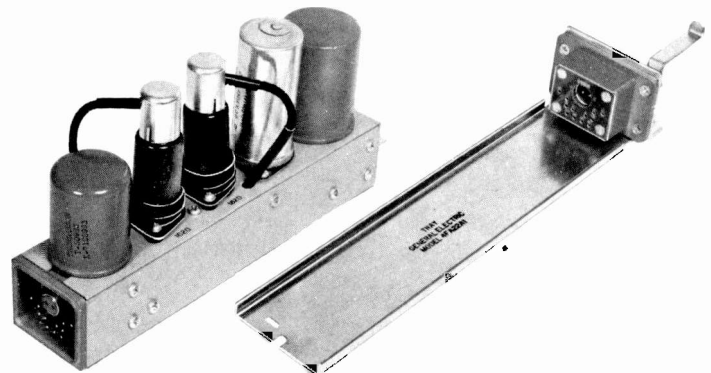

Fig. 5-25 Type BA-1-C Pre-Amplifier and Type FA-22-A Tray

When Ordering Specify: Pre-Amplifier, Type BA-1-C (order tubes separately)

### ACCESSORIES

#### Tube Complement:

Consist of: 2 -- 1620 tubes

Note: 6J7 tubes may be used when uniformity of characteristics and minimum of microphonics, hum, and distortion are not required.

Bridging Volume Control....FA-35-E

Power Supply .....BP-1-A, BP-8-A or BP-10-A  
(for details see Power Supply Tabulation Chart)

DC Metering Panel.....FA-11-A

Tray .....FA-22-A

Shelf .....FA-23-A

## tray Type FA-22-A

### APPLICATION

The Type FA-22-A Tray provides a means for making electrical connections to plug-in Pre-Amplifiers, Type BA-1-C, and for mounting these amplifiers in racks, cabinets, consoles, etc. One Tray is required for each Type BA-1-C Pre-Amplifier in service. The Type FA-23-A Shelf, which will accommodate six Type FA-22-A Trays complete with six Type BA-1-C Pre-Amplifiers, is recommended for mounting the Trays in a standard 19-inch wide cabinet or relay rack.

### DESCRIPTION

The FA-22-A consists of a metal plate with an attached Cannon receptacle which will mate with the plug on the rear of the Pre-Amplifier. This receptacle has gold-plated, non-oxidizing contact pins to give positive, dependable electrical connections to the amplifier plug. The solder end of each contact pin is tinned and will readily accommodate a wire of No. 16 AWG size or smaller. A small bracket is attached over the receptacle and serves as a cable support for the wires connected to the receptacle.

The two long sides of the plate are bent-up to form guiding flanges which facilitate plugging the amplifier into the Tray. Mounting holes are provided at the extreme front and rear ends of the Tray and mounting screws are furnished for fastening the Tray in Shelf Type FA-23-A for rack mounting. The Tray can be readily fastened on a simple angle-frame for mounting in special cabinets or consoles. A slot is provided at the front end of the Tray to serve as a fulcrum for the extractor tool when inserting or withdrawing the amplifier.

### Dimensions

Length	.....11-7/16 in. (not including cable support)
Width	.....2-1/4 in.
Height	.....2-3/8 in.
Weight	.....3/4 lb

## bridging volume control Type FA-35-E

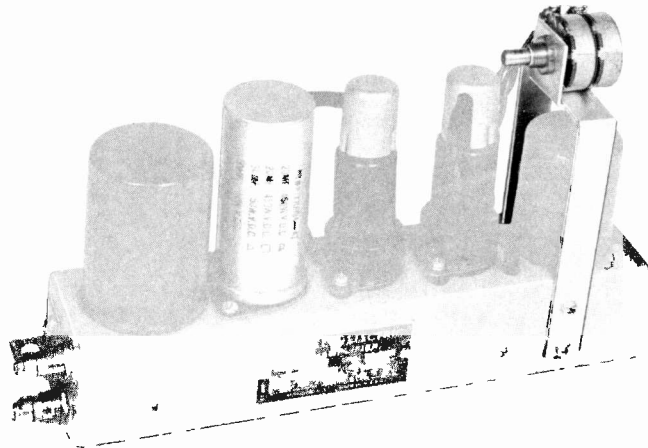

Fig. 5-26 Type FA-35-E Bridging Volume Control mounted on BA-1-C Amplifier

### DESCRIPTION

The Type FA-35-E Bridging Volume Control is designed specifically for mounting on the chassis of a BA-1-C Pre-Amplifier to provide a 10,000-ohm bridging-input circuit for the amplifier. The FA-35-E contains a continuously-variable dual-potentiometer for the 600-ohm output portion of the resistive network and thereby offers a means for control of gain when desired.

### SPECIFICATIONS

See the Type BA-1-C Pre-amplifier specifications

#### Dimensions:

Height	.....5-1/4 in.
Width	.....2-1/4 in.
Depth	.....1-3/4 in.
Weight	.....2-3/4 oz.

## Program/monitor amplifier Type BA-12-A

### FEATURES

Compact — four can be mounted in 7 inches of rack space

Simple Maintenance — plug-in construction permits easy removal for servicing

High-output Capability — suitable for feeding lines, loudspeakers, recorders, etc.

Versatile — fulfills all medium- and high-level requirements of an audio system

Excellent Frequency Response — provision for adjusting high- and low-frequency response for system equalization

Low crosstalk between units

High degree of isolation when used for bridging

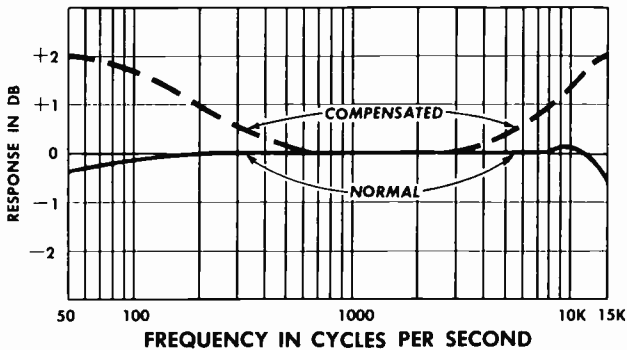

Fig. 5-27 Frequency response curve for BA-12-A Amplifier

### APPLICATION

The Type BA-12-A Program/Monitor Amplifier is a high fidelity, fixed-gain amplifier designed for a variety of high-level applications. This plug-in amplifier is especially recommended for use as the following:

1. Monitor amplifier for driving loudspeakers
2. Bridging amplifier
3. Program amplifier
4. Booster amplifier

### DESCRIPTION

The BA-12-A is a three stage amplifier employing a type 1620 pentode first stage, a triode-connected 6J7 cathode-follower, phase-inverter second stage, and a push-pull 6V6 tetrode output stage. Over-all feedback from the output stage to the first-stage cathode provides excellent frequency response with low noise and distortion.

Simple circuit changes permit the user to obtain a rise in response of approximately 2 db at 50 and/or 15,000 cps. This feature is useful in meeting over-all system frequency requirements when high- or low-frequency losses are introduced by lines or other associated equipment.

The amplifier input includes both low impedance and bridging connections. The output transformer has both high-fidelity, low-impedance windings and a utility winding for miscellaneous monitoring or cueing service.

### SPECIFICATIONS

For Matching Input:

Source Impedance . . . . .600/150 ohms (balanced or unbalanced)

Input Impedance . . . . .600/150 ohms

Gain . . . . .50 db

For Bridging Input (using internal bridging resistors):

Input Impedance . . . . .24,000 ohms (balanced)

Gain . . . . .6 db (bridging a 600-ohm line)

Output-load Impedance . . . . .600/150 ohms (balanced or unbalanced)

Utility Output . . . . .a balanced winding is provided which will deliver 6.9 volts across a minimum of 12,000 ohms when the program winding is delivering 8-watts output

Output Level and Distortion . . . . .

+30 dbm (1 watt), ½% or less distortion (300 or 250v)

+39 dbm (8 watts), 1% or less distortion (300 v)

+37 dbm (5 watts), 1% or less distortion (250v)

Frequency Response . . . ±1 db, 150 to 15,000 cps with any combination of 600 and 150 source and load impedances

Output Noise . . . . .-60 dbm maximum

Power Supply Requirements:

Plate Power . . . . .62.5 ma at 250v d.c.

73 ma at 300v d.c.

Filament Power . . . . .1.5 amps at 6.3v a.c. or d.c.

Dimensions:

Length . . . . .9-7/8 in.

Width . . . . .3-½ in.

Height . . . . .5-3/8 in.

Weight . . . . .6-¾ lbs

When Ordering Specify: Program/Monitor Amplifier, Type BA-12-A (order tubes separately)

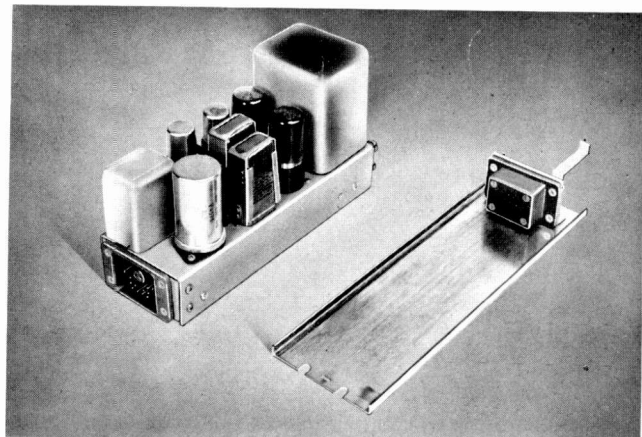

Fig. 5-28 Type BA-12-A Program/Monitor Amplifier and FA-22-B Tray

### ACCESSORIES

Tube Complement

consists of:

1 - Type 1620

2—type 6V6-GT

1 - Type 6J7

Volume Control . . . . .FA-35-F

DC Metering Panel . . . . .FA-11-A

Power Supply . . . . .BP-8-A or BP-10-A  
(for details see Power Supply Tabulation Chart)

Tray . . . . .FA-22-B

Shelf . . . . .FA-23-A

## tray Type FA-22-B

### APPLICATION

The Type FA-22-B Tray provides a means for making electrical connections to plug-in Program/Monitor Amplifiers, G-E Type BA-12-A, and for mounting these amplifiers in racks, cabinets, consoles, etc. One Tray is required for each Program/Monitor Amplifier, Type BA-12-A, in service. The Type FA-23-A Shelf, which will accommodate four Type FA-22-B Trays complete with four amplifiers, Type BA-12-A, is recommended for mounting the trays in a standard 19-inch wide cabinet or relay rack.

### DESCRIPTION

The FA-22-B Tray is constructed the same as the FA-22-A Tray except for dimensions. See page 5-14.

### SPECIFICATIONS

Dimensions:	
Length	.....11-7/16 in.
Width	.....3-1/2 in.
Height	.....2-3/8 in.
Weight	.....1 lb

## volume control Type FA-35-F

### DESCRIPTION

The Type FA-35-F Volume Control provides gain control for a Type BA-12-A Program/Monitor Amplifier. It consists of a 500,000-ohm log-taper potentiometer with screw-driver slot, a bracket for mounting on the Type BA-12-A

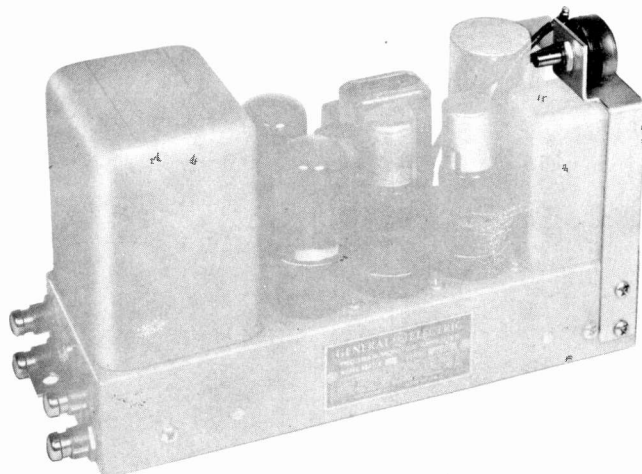

Fig. 5-29 Type FA-35-F Volume Control mounted on BA-12-A Amplifier

amplifier, plus necessary wiring to connect both internally, and to the tube grid. The potentiometer is connected between the secondary of the input transformer and the grid of the first tube. Connected across the secondary loading resistor it provides a maximum gain of 50 db with matching input (impedances of 600/150 ohms). Connected across the secondary of the input transformer with the loading resistor open-circuited, it provides a maximum gain of 56 db with unloaded input (input impedance is substantially higher than 600/150-ohm source impedances).

### SPECIFICATIONS

See the Type BA-12-A Program/Monitor Amplifier specifications

#### Dimensions:

Height	.....5-1/4 in.
Width	.....3-1/2 in.
Depth	.....1-1/2 in.
Weight	.....2-1/4 oz

## Portable amplifier Type BA-6-A

### FEATURES

Single unit contains amplifier, a-c power supply, and batteries

Four pre-amplifier channels with high-level mixing

Light weight — only 35 pounds including batteries

Electrical performance exceeds AM, FM, and TV requirements

Built-in test tone

Adjustable headphone level

"Battery-saver" filament switch

Complete accessibility of all components

VU meter dimmer control

Storage for power cord, spare tubes, and fuses

Step-type attenuators

Full 6-db line pad

### APPLICATIONS

The BA-6-A Portable Amplifier is a compact, easy-to-carry portable audio amplifier that will give studio-quality performance and eliminate the worry of power supply failure.

### DESCRIPTION

Each of the four microphone channels is equipped with an individual pre-amplifier. The outputs of the pre-amplifiers are connected to a four-channel, low-loss mixer, where they are mixed in the desired proportions, and fed to the main amplifier. The output of the main amplifier

feeds through a 6-db pad to the telephone lines. Selection of either of two output impedances, 150 or 600 ohms, is made by means of a screw-driver switch.

The output transformer is equipped with an isolated monitor winding. A microphone-level output is taken from this winding so that the broadcast program may be fed to a public address system or other amplifier. This output circuit provides balanced operation.

Three jacks are provided for headphone monitoring. One jack is connected on the line side of the output pad and is useful for receiving talkback and cue. The other two jacks are connected to the isolated monitor winding on the output transformer. One of these monitors is at normal line level, the other at 6 db higher than line level for use under high room-noise conditions. These latter two headphone outputs, since they are fully isolated, may be used to feed phono inputs of PA systems.



Fig. 5-30 Type BA-6-A Portable Amplifier



Fig. 5-31 Type BA-6-A Portable Amplifier with front cover removed

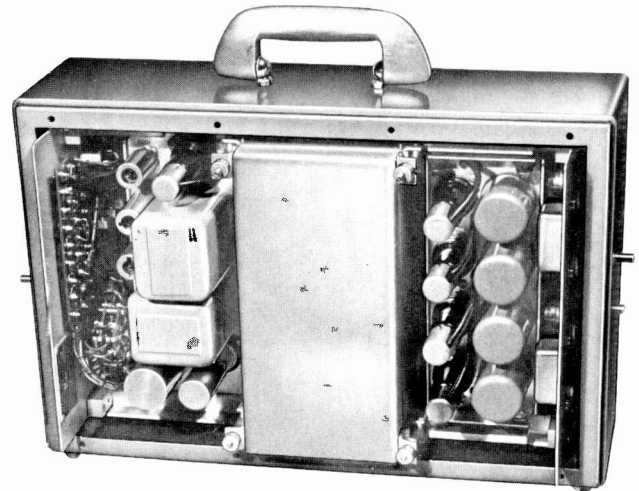

Fig. 5-32 Rear view of BA-6-A Amplifier with cover removed

A built-in audio oscillator is coupled into the input stage of the main amplifier so that the resulting output-tone level may be adjusted by means of the master gain control. This tone may be fed to the telephone line at reference level so that the remote line may be tested and the control room may adjust its equipment for proper operation, thereby eliminating the necessity for using a microphone to check peaks.

The BA-6-A includes a built-in a-c power supply plus accommodations for batteries. The internal battery complement is intended for use in case of a-c power interruption, but may be used for entire programs of relatively short duration. An external battery supply may be easily connected by the user.

A front panel switch is used to select either battery or a-c power operation. Four additional positions on this switch permit control of the number of pre-amplifiers in use on battery supply. This prolongs battery life by disconnecting filaments of pre-amplifiers not in use.

**SPECIFICATIONS**

- Number of microphone channels . . . . . 4
- Input Source Impedance. .600/250/150/30 ohms, balanced or unbalanced
- Output Load Impedance. .600/150 ohms, balanced or unbalanced
- Normal Output Level . . . less than 1% distortion 50-15,000 cycles, +18 dbm (program-level rating +8 VU)
- Emergency Output level. .quality will not be appreciably degraded at +14 VU program-level output

Mike Level Output . . . . .50 ohms, balanced, - 50 dbm  
 Mixing and Master Gain  
 Control . . . . .low-noise silver alloy step-type controls - 20 steps of 2 db per step tapered to infinity  
 Frequency Response . . . . . $\pm 1$  db - 50 to 15,000 cycles with any combination of 600- and 150-ohm input and output impedance  
 Gain . . . . .94 db at 1000 cycles  
 Noise Level . . . . .70 db below output level of +18 dbm at normal fader positions  
 Power Supply . . . . .117v, 50/60 cycles or internal batteries -- the power plug includes provisions for connection of external batteries

**Battery Complement:**

- "A" - 2 Eveready Type 774 or 2 Burgess Type F4P1 or equivalent, 6 v ea
- "B" - 3 Eveready Type 467 or 3 Burgess Type XX45 or equivalent, 67½ v ea
- Battery Life . . . . .Approximately three hours continuous (two pre-amplifiers in use). Longer when operated intermittently

**Dimensions:**

- Height . . . . .11-11/16 in. (case only), 14-9/16 in. (over-all)
- Length . . . . .17-9/16 in. (case only), 18-5/8 in. (over-all)
- Depth . . . . .8-5/8 in.

Weight: Approximately 30 lbs without batteries  
 Approximately 35 lbs with batteries

When Ordering Specify: Portable Amplifier, Type BA-6-A (order tubes and batteries separately)



Fig. 5-33 Output end of BA-6-A Amplifier with cover plate removed

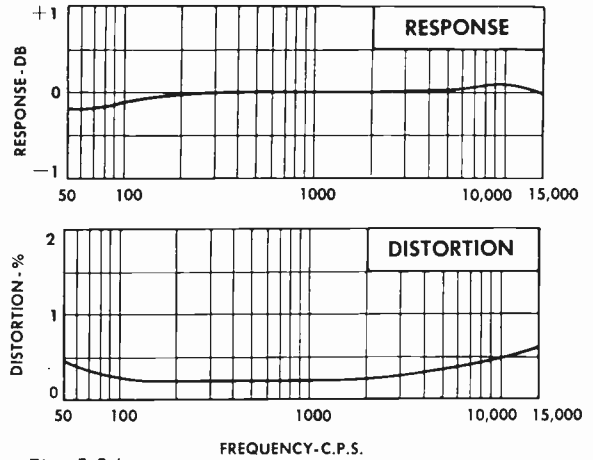

Fig. 5-34 Typical performance curves for BA-6-A Amplifier

**ACCESSORIES**

**Tube Complement**

- 5 - type 1620
- 1 - type 9001
- 1 - type 6AK6
- 1 - type 6X4

**Tube Complement alternate**

- consists of: (noise specifications are not guaranteed with this tube complement)
- 5 - type 6J7
  - 1 - type 9001
  - 1 - type 6AK6
  - 1 - Type 6X4

Fabric Protective Cover . . Type FA-24-A

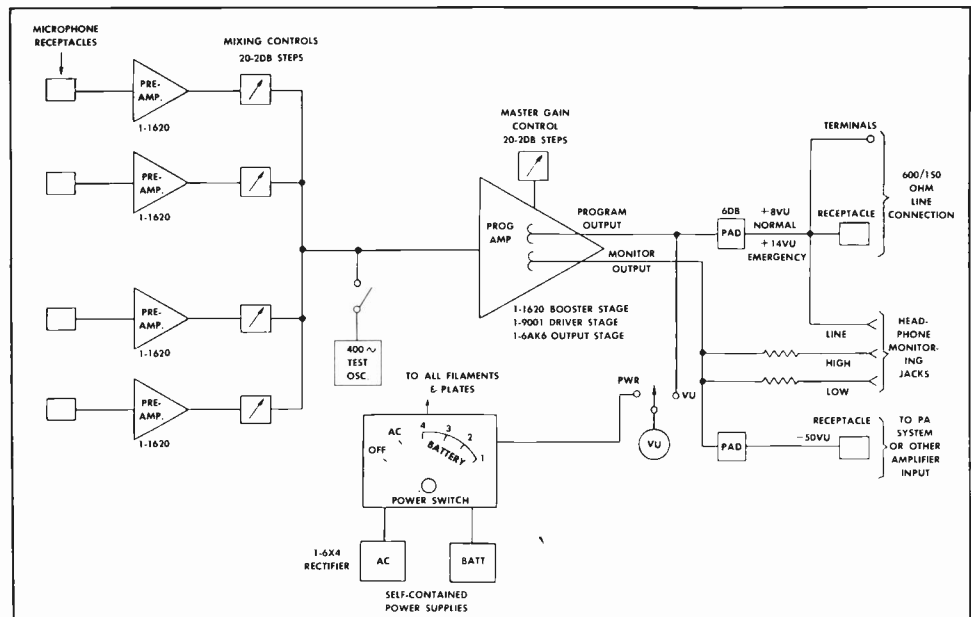

Fig. 5-35 Single line diagram of BA-6-A Amplifier



# Chart tabulation power supplies for audio facilities

Type	Primary Voltage	DC Output Plate Supply	AC Filament Supply	Mounting	Supply for Amplifiers
BP-1-A	105/115/125 50/60 cycles	Adjustable to 250v with loads from 5 to 50 ma; 225v to 60 ma	6.4v CT 3.6 amps	Rack	Type BA-1-B Type BA-1-C Type BA-1-D
BP-5-A	115 50/60 cycles	48 volts 1.2 amps for 95 F, ambient 0.5 amps for 122 F, ambient		Rack	Relays & Lamps
BP-8-A	110/117/125 50/60 cycles	Adjustable to 300v with loads from 40 to 230 ma	6.6v CT 15 amps	Rack	Type BA-1-D Type BA-1-C Type BA-12-A
BP-10-A	110/117/125 50/60 cycles	Adjustable to 300v with loads from 40 to 230 ma	6.4v 7.5 amps 60 cycles  6.4v 4.5 amps 50 cycles	Plug-In (FA-22-C Tray) (FA-23-A Shelf)	BA-1-C BA-12-A

## Pre-amplifier power supply Type BP-1-A

### FEATURES

Plug-in electrolytic capacitors used to allow ease of servicing

Hinged-front panel makes components, wiring, and controls readily accessible from front of rack

Well filtered d-c output assists in maintaining low-hum level in all types of pre-amplifiers

Rack-mounted chassis—mounting screws concealed by hinged-front panel—no cabinet trim strips required

### APPLICATION

Type BP-1-A Pre-Amplifier Power Supply is a rack-mounted unit designed to supply plate power for up to twelve Type BA-1-B Pre-Amplifiers, or up to eight Type BA-1-C or BA-1-D Pre-Amplifiers at 250 volts. It will supply filament power for up to six of the pre-amplifiers. A Filament Transformer Kit, Type FA-13-B, may be mounted on the Pre-Amplifier Power Supply chassis to supply filaments for an additional six pre-amplifiers.

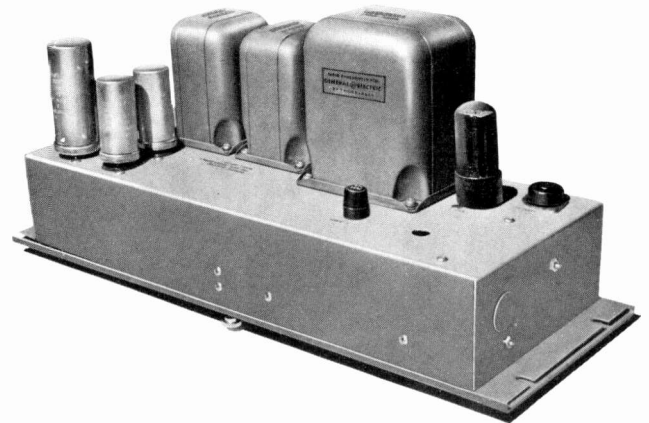

Fig. 6-1 Type BP-1-A Pre-Amplifier Power Supply

### DESCRIPTION

A full-wave rectifier circuit employing a 5Y3GT/G tube is used. Capacitor input plus two stages of L-C filter give an exceptionally low ripple content. A screw-driver adjustment provides d-c output-voltage control. The a-c filament supply is grounded through a screw-driver controlled hum balancing potentiometer.

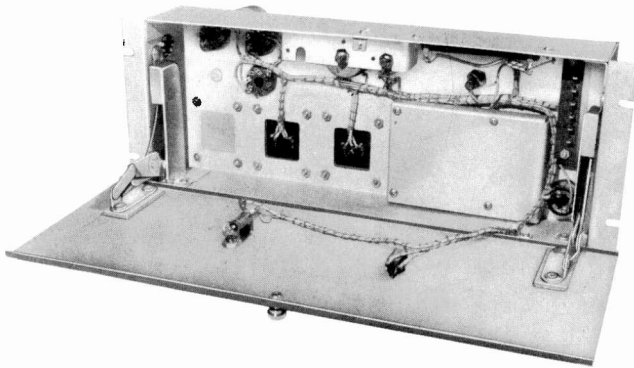

Fig. 6-2 Type BP-1-A Pre-Amplifier Power Supply with front panel open

### SPECIFICATIONS

Power Required .....105/115/125 v a.c., 50/60 cycles, 75 watts maximum

#### Output:

D-C Plate Supply.....adjustable to 250 volts with loads from 5 to 50 ma, 225v to 60 ma

Filament .....3.6 amps a.c. at 6.4 v

Output Hum Level.....approximately 134 db below 250 v at 50 ma

#### Dimensions:

Width .....19 in.

Height .....6-31/32 in.

Depth .....8-1/4 in.

Weight .....20 lbs

When Ordering Specify: Pre-Amplifier Power Supply, Type BP-1-A (order tubes separately)

### ACCESSORIES

#### Tube Complement

consists of:

1-type 5Y3GT/G

Filament Transformer Kit.. Type FA-13-B

## Relay power supply Type BP-5-A

The Type BP-5-A Relay Power Supply is a 48 volt, 1.2 ampere power supply for operating relays and indicator lamps.

### DESCRIPTION

The Relay Power Supply is of vertical-chassis construction with hinged-front panel for mounting in a standard cabinet or relay rack.

The circuit consists of a selenium rectifier in a bridge-type circuit fed from a tapped transformer; the rectifier feeds a choke-input, single-stage L-C filter. The primary of the transformer is fused to prevent overload. An a-c power switch and indicator light are mounted on the front panel.

### SPECIFICATIONS

Power Input.....115 volts, 50/60 cycles, 120 watts maximum

Output Voltage.....48 volts d.c. @ 1.2 amps

Output current.....1.2 amps for ambient temperatures of 95F or under  
0.5 amps for ambient temperatures of 122F

Regulation .....30-per cent full load to no load

Ripple .....approximately 0.4 volts RMS at full load

When Ordering Specify: Relay Power Supply, Type BP-5-A

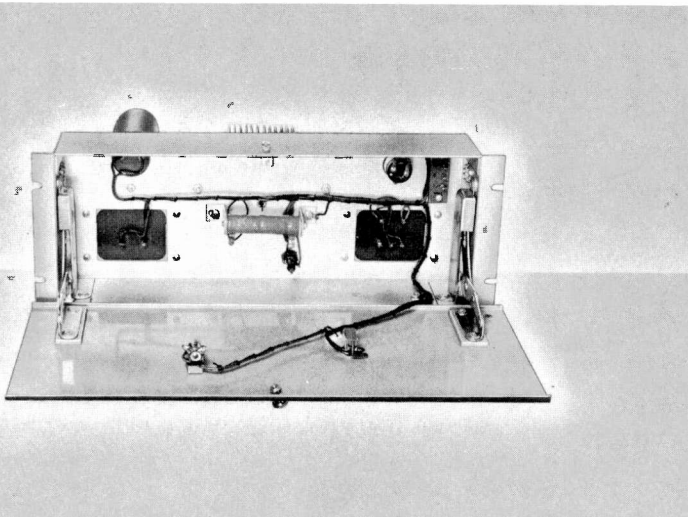

Fig. 6-3 Type BP-5-A Relay Power Supply with front panel open

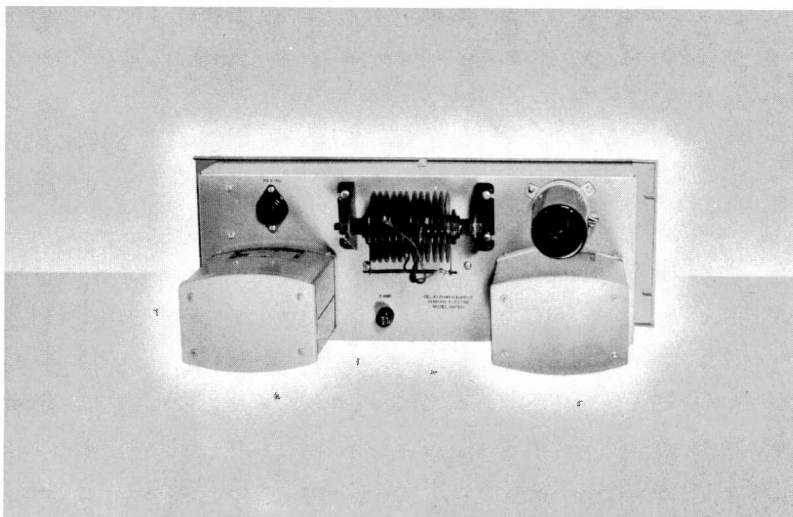

Fig. 6-4 Type BP-5-A Relay Power Supply

# Amplifier power supply Type BP-8-A

## FEATURES

- High current output in small rack space
- Hinged front-panel construction
- Plug-in capacitor
- Completely fused - B+ and a-c line
- Maximum accessibility

## APPLICATION

The Type BP-8-A Amplifier Power Supply is a rack-mounted unit which supplies plate power for up to three Type BA-12-A amplifiers, or up to 25 Type BA-1-C or BA-1-D amplifiers operating at 300 volts. When the d-c output voltage is adjusted to 250 volts, the plate power for additional amplifiers may be supplied. Filament power is also available.

## CIRCUIT

The circuit employs a full-wave rectifier using two 5Y3GT/G tubes in parallel followed by a two-stage choke input filter. A screw-driver adjustment provides an output-voltage control. The center tap of the a-c filament supply is biased 8 volts, positive, to assist in maintaining lowest hum output when supplying power to BA-12-A amplifiers.

## SPECIFICATIONS

Power Required . . . 110/117/125 v a.c., 50/60 cycles,  
250 watts

## Output:

D-C Plate Supply . . . d-c voltage adjustable to 300v with  
loads from 40 to 230 ma

Filament . . . . . 15 amps at 6.6 v

Ripple . . . . . 25 mv at maximum load

## Dimensions:

Width . . . . . 19 in.

Height . . . . . 5-7/32 in.

Depth . . . . . 11-13/16 in.

Weight . . . . . 36 lbs

When Ordering Specify: Amplifier Power Supply, Type  
BP-8-A (order tubes separately)

## ACCESSORIES

Tube Complement

consists of:

2-type 5Y3GT/G

# Plug-in power supply Type BP-10-A

## FEATURES

- Compact plug-in construction
- Easy to remove and service
- Conservatively rated components

## APPLICATION

The Type BP-10-A Plug-In Power Supply supplies plate power for up to three Type BA-12-A amplifiers, or up to 25 Type BA-1-C or BA-1-D amplifiers operating at 300 volts. When the d-c output voltage is adjusted to 250 volts, the plate power for additional amplifiers may be supplied. Filament power is also available.

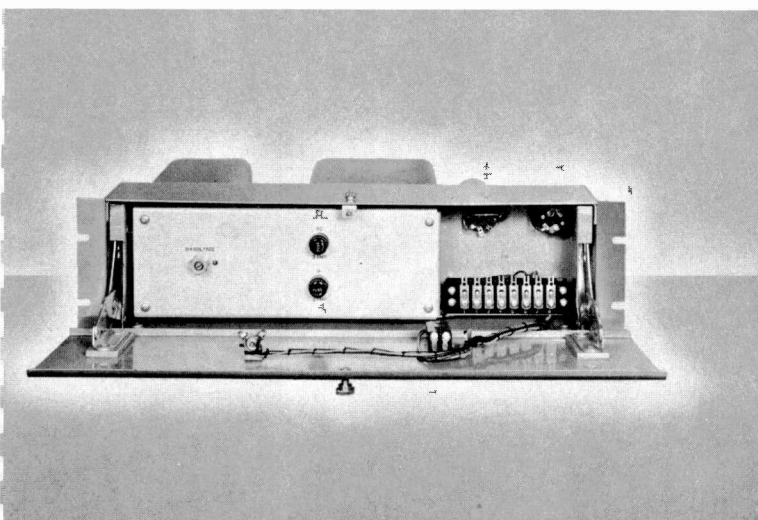

6-5 Type BP-8-A Amplifier Power Supply with front panel open

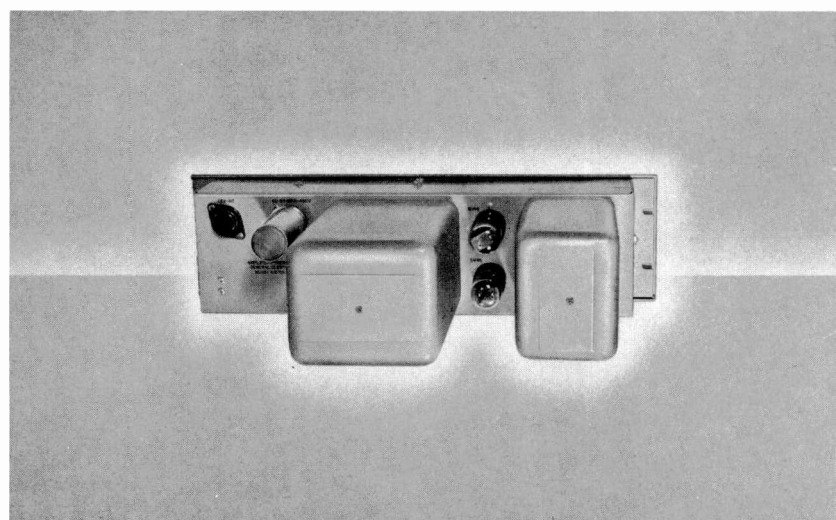

Fig. 6-6 Type BP-8-A Amplifier Power Supply

**DESCRIPTION**

The circuit of the BP-10-A employs a full-wave, single-phase rectifier using two type 5Y3GT/G tubes in parallel. The filter is capacitor input followed by one L-C stage. Screw-driver adjustment provides an output-voltage control. The center tap of the a-c filament supply is biased 8 volts, positive, to assist in maintaining lowest hum output when supplying power to BA-12-A amplifiers.

Plug-In Power Supply, Type BP-10-A, rests on a G-E Type FA-22-C Tray. Two trays mount on a Type FA-23-A Shelf.

**SPECIFICATIONS**

Power Required . . . . .110/117/125 v, 50/60 cycles,  
200 watts

**Output\***

D-C Plate Supply . . . . .d.c. voltages adjustable to  
300v with loads from 40 to  
230 ma

Filament . . . . .7.5 amps @ 6.4 v, 60 cycles  
4.5 amps @ 6.4 c, 50 cycles

Ripple . . . . .25 mv maximum at full load

**Dimensions:**

Width . . . . .7- $\frac{3}{8}$  in.

Height . . . . .5-15/16 in. max

Length . . . . .9-5/32 in.

Weight . . . . .21 lbs

When Ordering Specify: Plug-In Power Supply, Type BP-10-A (order tubes separately)

**ACCESSORIES****Tube Complement**

consists of . . . . .2-type 5Y3GT/G

Tray . . . . .Type FA-22-C

Shelf . . . . .Type FA-23-A

**tray  
Type FA-22-C****APPLICATION**

The Type FA-22-C Tray provides a means for making electrical connections to a Plug-in Power Supply, Type BP-10-A, and for mounting this power supply in racks, cabinets, consoles, etc. One Tray is required for each BP-10-A in service. The Type FA-23-A Shelf, which will accommodate two Type FA-22-C Trays complete with two BP-10-A power supplies, is recommended for mounting the trays in a standard 19-inch wide cabinet or relay rack.

**DESCRIPTION**

The FA-22-C Tray is constructed the same as the FA-22-A Tray except for dimensions. See page 5-14.

**SPECIFICATIONS****Dimensions:**

Length . . . . .11-7/16 in.

Width . . . . .7- $\frac{3}{8}$  in.

Height . . . . .2- $\frac{3}{8}$  in.

Weight . . . . .1- $\frac{1}{2}$  in.

When Ordering Specify: Tray, Type FA-22-C

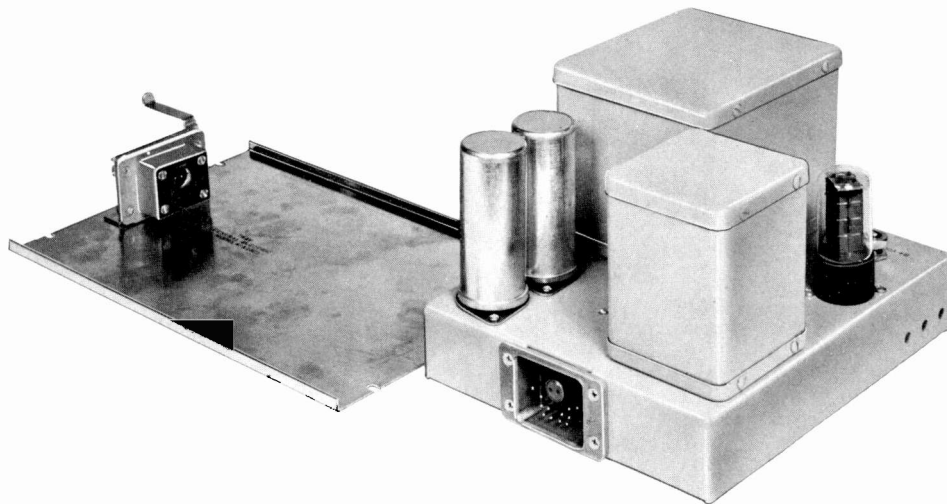

Fig. 6-7 Type BP-10-A Plug-in Power Supply and FA-22-C Tray

# Program level indicator panel Type FA-1-A

## FEATURES

- Measures levels from +4 to +42 VU
- May be switched to any of ten program lines
- Uses large size, standard VU meter
- Clamp-type mounting for easy installation

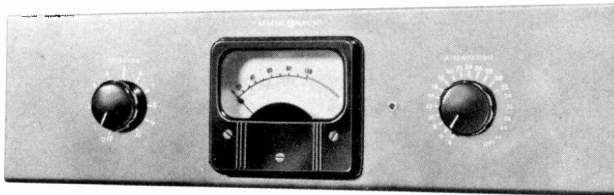

Fig. 7-1 Type FA-1-A Program Level Indicator Panel

## APPLICATION

The Type FA-1-A rack-mounted Program Level Indicator Panel provides a means of measuring accurately the program level of up to ten 600-ohm audio lines. The level of lines having other impedances may be measured by applying suitable correction factors. Program-level readings obtained with this unit are in "volume units" (VU). When used to make steady-state, single-frequency measurements, the readings obtained are in dbm.

## DESCRIPTION

The unit includes a two-circuit, ten-point selector switch (plus an OFF position), a variable step-type attenuator which provides readings of from +4 to +42 VU (or dbm) in 2-db steps, a VU meter, and a calibrating potentiometer for making a fine adjustment of the level reading over a range of  $\pm 1/2$  dbm.

The illuminated VU meter has two scales. The upper scale is calibrated in "percent", ranging from 0 to 100; the lower scale is calibrated in VU, ranging from -20 to +3. A source of 6.3 volts at 0.3 ampere is required for illumination.

## MOUNTING

The unit mounts on a standard 19-inch RMA relay or cabinet rack. A clamp-type mounting, which is not visible from the front, is provided to mount the panel in any desired location on the rack.

## SPECIFICATIONS

- Input Impedance . . . . . 7500 ohms
- Measurement Range . . . . . +4 to +42 VU (or dbm) in (600-ohm lines) 2-db steps
- Number of lines that may be measured . . . . . 1 to 10 inclusive
- Dimensions (over-all):
  - Height . . . . . 5-7/32 in.
  - Width . . . . . 19 in.
  - Depth . . . . . 3 $\frac{3}{8}$  in.
- Weight . . . . . 4 $\frac{1}{2}$  lbs
- When Ordering Specify: Program Level Indicator Panel, Type FA-1-A.

# dc metering panel Type FA-11-A

## FEATURES

- Provides measurement of amplifier tube-cathode voltages
- Gives indication of tube and circuit condition in up to ten circuits
- Terminal board makes wiring easy

## APPLICATION

Metering circuits are provided on all G-E rack-mounted and Plug-In Amplifiers (except Type BA-4-D and -E). Up to ten of these circuits may be wired to a DC Metering Panel. When amplifiers are operating normally, a 1-volt indication on the 2-volt FA-11-A meter scale is observed.

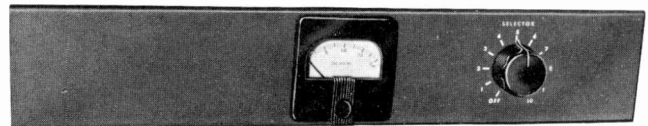

Fig. 7-2 Type FA-11-A DC Metering Panel

## DESCRIPTION

The FA-11-A DC Metering Panel consists of a 2-volt, 5000-ohms per volt d-c meter and a single-circuit, 10-position (plus OFF position) switch.

A terminal board is provided on the rear of the panel for connection to external circuits.

**MOUNTING**

A clamp-type mounting, not visible from the front, is provided to mount the panel on a standard 19-inch RMA relay or cabinet rack.

**SPECIFICATIONS**

DC Voltmeter.....0-2 vdc, 5000 ohms per volt  
Metering Switch.....10 position plus OFF

## Dimensions:

Height .....3-15/32 in.

Width .....19 in.

Depth .....3-3/16 in.

Weight .....1¼ lbs

When Ordering Specify: DC Metering Panel, Type FA-11-A

## Switch and fuse panel Type FA-4-A

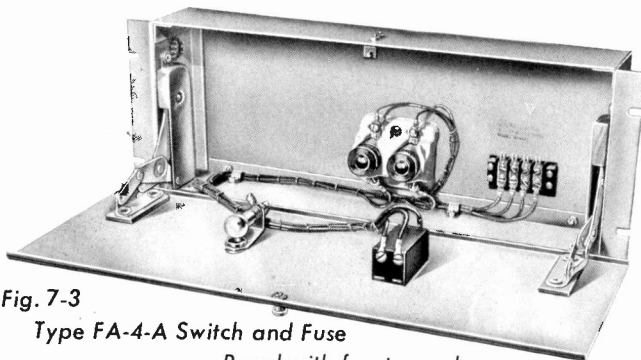

Fig. 7-3

Type FA-4-A Switch and Fuse  
Panel with front panel open

**FEATURES**

Easy access to fuse block through hinged-front panel  
Unused surface on removable back plate readily fitted with additional equipment

**APPLICATION**

The Type FA-4-A Switch and Fuse Panel provides a master power switch, indicator lamp, and fuse protection for an entire cabinet or relay rack.

**DESCRIPTION**

Power circuits running through the FA-4-A are activated by the switch. Dual fuses protect equipment from surges and shorts in the power line. The panel light indicates that the line is in use, or, with switch on and light out, indicates circuit trouble.

The hinged-front panel allows easy access to the fuse block on the inside back plate for inspection or replacement of fuses. Two fuses of the screw-plug type are required,

but are not furnished since their rating depends upon the load to be protected.

On the removable back plate are approximately 100 square inches of unused surface which may be used to mount filament or line transformers, line pads, equalizers, relays, etc.

A 7/8-inch diameter hole is provided at each end of the chassis for connecting external wires.

**MOUNTING**

The FA-4-A is designed for mounting in a standard 19-inch RMA cabinet or relay rack.

**SPECIFICATIONS**

Switch .....DPST, 20 amps, 125 v

Fuses (not furnished)...Plug type; rating dependent on equipment to be protected; 20 amps max

## Dimensions:

Width .....19 in.

Height .....6-31/32 in.

Depth (behind panel) 3¼ in.  
(over-all) ....4-5/16 in.

Weight .....5½ lbs

When Ordering Specify: Switch and Fuse Panel, Type FA-4-A

## Jack strip Type FA-2-A

**APPLICATION**

One or more Jack Strips are normally used in Broadcast Audio Facilities Systems to provide over-all operating flexibility. G-E Type FA-2-A Jack Strips are used in amplifier racks to permit rapid isolation, selection, and monitoring of individual amplifiers by means of patch cords. They are also used in studio and master control room consoles and racks to permit "patching" of the various remote, local, and audition programs into the desired transmitter, remote, and monitoring channels.

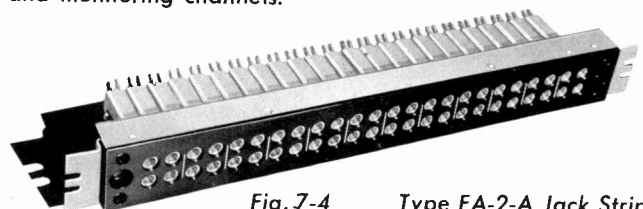

Fig. 7-4 Type FA-2-A Jack Strip

**DESCRIPTION**

The FA-2-A consists of two rows of 12 double jacks so mounted on a 3/8-inch thick by 2 1/8-inch wide black bakelite board that each jack is insulated from the others. The jack sleeves are flush with the front of the board and are mounted on 3/8-inch centers for use with G-E Type FA-7-A, -B, and -C Patch Cords, or for use with other manufacturers'

plugs with 5/8-inch pin spacing. All jacks are of the standard tip and sleeve type with normalled-through contact.

**MOUNTING**

Mounting brackets at the end of the strip are slotted to fit a standard 19-inch RMA cabinet or relay rack. Two No. 12-24 screws are supplied to mount each Jack Strip. Jack Panels, Type FA-3-A, -B, and -C, may be used with the FA-2-A to provide designation cards above and below each jack pair. See Fig. 7-6

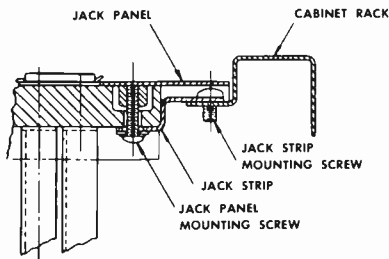

Fig. 7-5 Clamp Mounting for Jack Strips and Jack Panels

**SPECIFICATIONS**

- Number of Jack Pairs .....24
- Type of Jack .....Tip and sleeve with normalled-through contact
- Dimensions:
- Width .....18-13/16 in.
- Height .....2 1/8 in.
- Depth .....3 3/8 in. approx
- Weight .....5 1/2 lbs
- When Ordering Specify: Jack Strip, Type FA-2-A

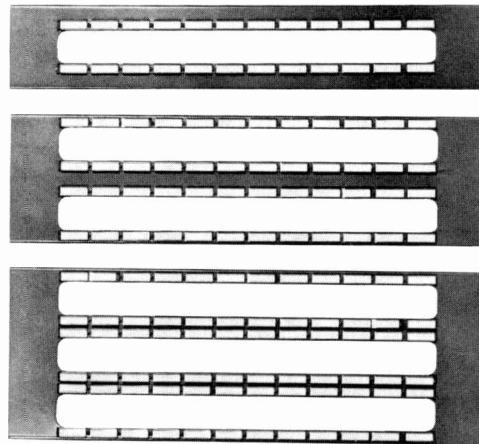

Fig. 7-6 Types FA-3-A, -B, and -C Jack Panels

**SPECIFICATIONS**

- Single Jack Panel, FA-3-A .....3-15/32 in. high;  
Weight: 1 1/4 lbs
- Double Jack Panel, FA-3-B .....5-7/32 in. high;  
Weight: 1 3/4 lbs
- Triple Jack Panel, FA-3-C .....6-31/32 in. high;  
Weight: 2 lbs

When Ordering Specify: Jack Panels, Type FA-3-A, -B, or -C.

**patch cords**  
**Type FA-7-A**  
**Type FA-7-B**  
**Type FA-7-C**

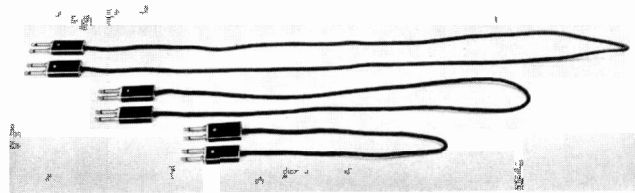

Fig. 7-7 Types FA-7-A, -B, and -C Patch Cords

General Electric Patch Cords consist of two insulated copper conductors shielded with tinned copper braid and covered with heavy black cotton braid. A six-inch length at either end is reinforced so that the two-conductor double plug may be securely mounted. The plug at either end is interchangeable with the W.E. Type 241-A double plug. The shield of the cord is connected to the sleeves of both plugs.

- Patch cords are available in the three sizes listed below:
- 2-Foot Cord Length: Type FA-7-A
- 4-Foot Cord Length: Type FA-7-B
- 6-Foot Cord Length: Type FA-7-C

When Ordering Specify: Patch Cords, Type FA-7-A, -B, or -C.

**jack panels**  
**Type FA-3-A (single)**  
**Type FA-3-B (double)**  
**Type FA-3-C (triple)**

Jack Panels are available for covering one, two, or three G-E Type FA-2-A Jack Strips. Designation cards inserted behind clear plastic strips are mounted on each panel above and below each pair of jack openings.

A mounting is furnished with each panel to secure it to the Jack Strip so that no mounting screws will be exposed.

# Equalizer unit Type FA-14-B

## FEATURES

- Equalizes up to 10,000 or 15,000 cycles depending on line length and termination
- Easily connected for equalization in steps of 3 db or less
- Small case mounts almost anywhere

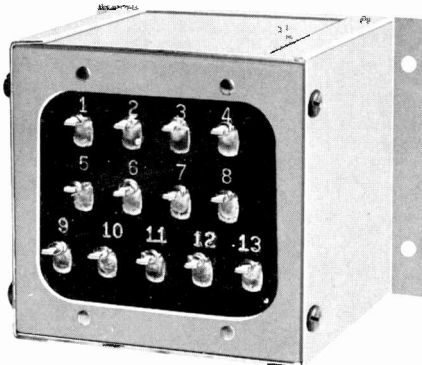

Fig. 7-8 Type FA-14-B Equalizer Unit

## APPLICATION

The Type FA-14-B Equalizer Unit is a semi-fixed unit recommended for use on lines which are permanently installed and continuously used, such as studio-to-transmitter lines and remote or "nemo" lines. It is designed to equalize non-linear characteristics of non-loaded telephone lines for substantially flat frequency response up to 10,000 or 15,000 cycles per second, depending on line characteristics and terminations.

## DESCRIPTION

The FA-14-B consists of a reactor, a capacitor, and associated resistors mounted in a rectangular metal case. A

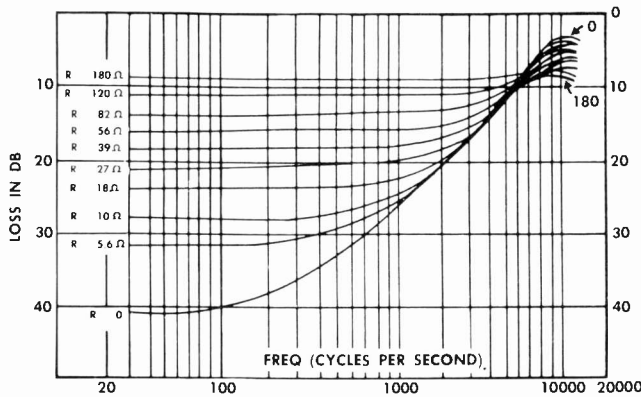

Fig. 7-9 Attenuation vs Frequency Characteristic Curves for FA-14-A and FA-14-B Line Equalizers (600-ohm load and source)

solder-lug terminal board is provided on one end of this case for adjusting the resistance and for connecting the unit to the line. Mounting feet on the opposite end of the unit make it adaptable for mounting on a flat surface.

## SPECIFICATIONS

- Line Impedance . . . . . 600 or 150 ohms
- Equalization Ability (dependent on line length):
  - Line termination 150 ohms . . . . . 30 to 15,000 cps
  - Line termination 600 ohms . . . . . 30 to 10,000 cps
- Insertion Loss (600-ohm source and load):
  - R = 0 ohms . . . . . 41-db max at 30 cycles, 2.5-db min at 11,000 cycles
  - R = 180 ohms . . . . . 8-db max at 30 cycles, 7-db min at 11,000 cycles
- Equalization Range . . . . . Refer to Frequency Characteristics curve

## Dimensions:

- Width (incl. mounting) . . 3<sup>7</sup>/<sub>8</sub> in.
- Depth . . . . . 3 in.
- Height . . . . . 3<sup>3</sup>/<sub>8</sub> in.
- Weight . . . . . 1<sup>1</sup>/<sub>2</sub> lbs
- When Ordering Specify: Equalizer Unit, Type FA-14-B

# Equalizer panel Type FA-14-A

## FEATURES

- Provides equalization for two lines
- Front-panel adjustment in steps of 3 db
- Equalizes short lines up to 15,000 cycles — longer lines up to 10,000 cycles
- Simple clamp-type rack mounting — no screws show

## APPLICATION

The Type FA-14-A Equalizer Panel is designed to equalize the non-linear characteristics of one or two non-loaded telephone lines for substantially flat frequency response to 10,000 or 15,000 cycles per second, depending on line characteristics and termination. The FA-14-A would normally be used on lines which are not continuously operating and, thus do not require the permanent installation of a fixed equalizer.

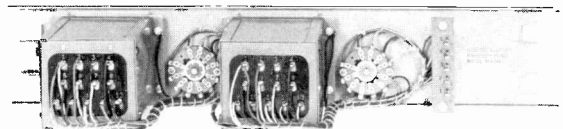

Fig. 7-10 Rear view of FA-14-A Equalizer Panel





Fig. 7-11 Front view of Type FA-14-A Equalizer Panel

**DESCRIPTION**

The FA-14-A consists of two separate and complete equalizers mounted on a single panel. Parallel-resonant circuits consisting of a capacitor, a reactor, and a logarithmically-tapered variable resistance are used in each equalizer unit. The variable resistance is adjusted by a switch operated by a knob on the front panel. Each of the equalizers on the panel may be externally patched to any of the program lines.

**MOUNTING**

The Equalizer Panel is designed for vertical mounting on a standard 19-inch RMA relay or cabinet rack. A clamp-type mounting, not visible from the front, is provided to mount the panel in any desired location on a rack.

**SPECIFICATIONS**

The electrical specifications for each of the sections of the Equalizer Panel are the same as the specifications for the Equalizer Unit, Type FA-14-B.

**Dimensions:**

- Width .....19 in.
- Height .....3-15/32 in.
- Depth .....4-15/16 in.
- Weight .....5 lbs

When Ordering Specify: Equalizer Panel, Type FA-14-A

made "bassy" or "tinny" and "telephone-quality" effects may be simulated.

**DESCRIPTION**

The FA-18-A consists of adjustable high- and low-pass filter sections mounted on a panel. Each of the filters are connected to a variable cut-off frequency-selector switch controlled by a front-panel knob. Each switch has eight cut-off positions (100, 250, 1000, 2000, 3000, 4000 and 5000 cycles) and an OFF position.

A key switch is provided to connect or disconnect the filter circuit so that the filter may be pre-set at any time for desired characteristics and inserted in the circuit when required.

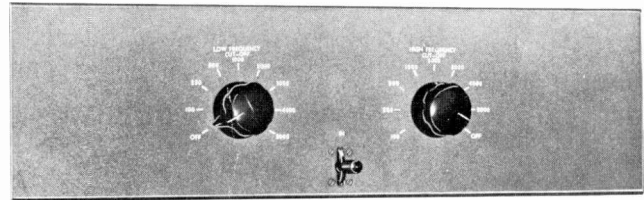

Fig. 7-12 Type FA-18-A Sound Effects Filter Panel

**MOUNTING**

The Sound Effects Filter Panel is designed for vertical mounting on a standard 19-inch relay or cabinet rack. A clamp-type mounting, not visible from the front, is provided to mount the panel in any desired location on a rack.

# Sound effects filter panel Type FA-18-A

**FEATURES**

- Simple control of desired bandwidth
- Gives variety of "bassy" or "tinny" effects
- Easy installation and operation

**APPLICATION**

The Type FA-18-A Sound Effects Filter Panel provides control of program bandwidth, thus enabling the user to obtain unusual sound effects. Speech and music may be

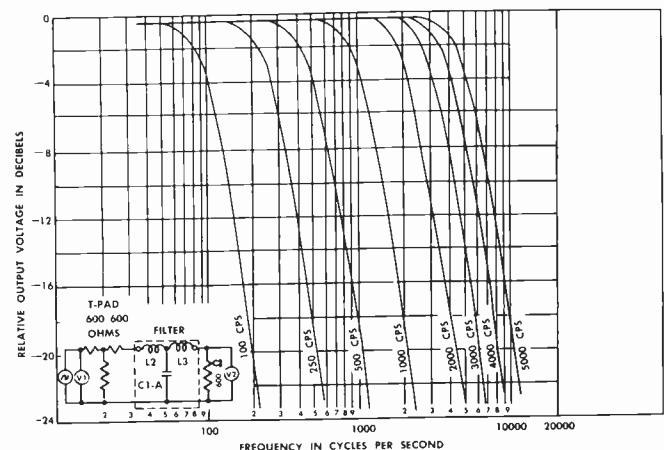

Fig. 7-13 Attenuation Characteristics of high-frequency cut-off section of FA-18-A

**SPECIFICATIONS**

Source Impedance.....600 ohms (unbalanced)  
 Operating Level.....-40 to +20 dbm  
 Load Impedance .....600 ohms (unbalanced)  
 Insertion Loss.....1 db or less at frequencies  
 remote from cut-off

**Dimensions:**

Width .....19 in.  
 Depth (incl. front panel  
 control) .....8-5/32 in.  
 Height .....7-7/32 in.  
 Weight .....9 lbs

When Ordering Specify: Sound Effects Filter Panel, Type FA-18-A

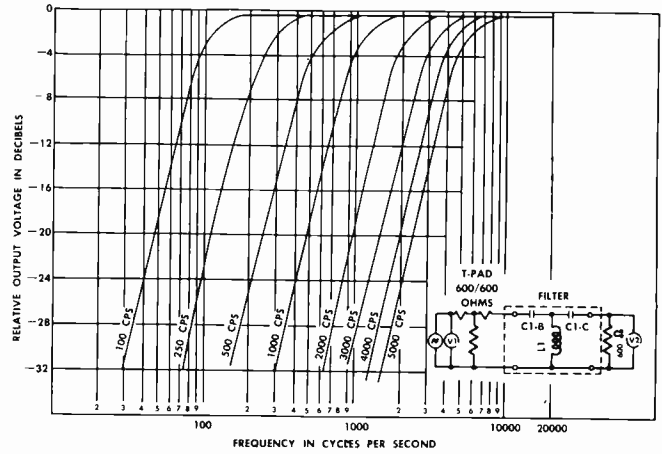

Fig. 7-14 Attenuation Characteristics of low-frequency cut-off section of FA-18-A

# Cabinet rack Type PR-1-A

## FEATURES

Versatile—adaptable for mounting either broadcast audio or television chassis and panels—removable front and rear doors arranged for left or right opening

Sturdy—welded skin construction with welded stiffeners in the doors

Attractive—panel edges concealed by recessed front mounting surface

Excellent ventilation—natural draft plus provision for connection to a pressurized system

Accessible—no awkward trim strips—convenient locations for terminal boards and wiring cables

## APPLICATION

The Type PR-1-A Cabinet Rack provides space for mounting any broadcast and television audio and video chassis and panels which are designed for installation in a standard 19-inch rack. The interior clearance depth is sufficient for mounting G-E television monitors without any front and rear extensions.

## DESCRIPTION

The PR-1-A Cabinet Rack consists of a rigid welded-sheet steel cabinet with an open front and a hinged-rear door. Two equipment mounting angles and two short terminal board frame mounting angles, each containing No. 12-24 tapped holes located in accordance with RMA standards, are provided with each rack. The front door is available as an accessory.

The outstanding feature of the PR-1-A is its versatility. Any combination of G-E audio and video chassis plus other manufacturer's rack equipment can all be mounted in the same rack. This is possible because of the three locations for the equipment mounting angles within the rack—front, intermediate, and rear. A neat and uniform appearance can be maintained even when units of different types are installed.

The front position of the mounting angle is for panel-mounted equipment that will be approximately flush with the front edge of the rack, without a front door, as in conventional audio practice. This position is  $\frac{1}{2}$ -inch behind the front surface of the cabinet shell so as to recess the audio panels slightly within the front surface of the cabinet and thus conceal the panel edges. The intermediate

position is  $4\frac{15}{16}$  inches behind the front surface of the cabinet shell and is intended for any standard panel-mounted units such as jack-panels, audio amplifiers, standard test equipment, and some front-mounted television units. With this type of mounting a front door can be used to screen an otherwise heterogeneous appearance and to provide a closed rack so that the pressurized ventilation would be more effective. The rear position is ideal for mounting television power supplies, video amplifiers, and other chassis-type television units when a front door is used. The mounting surface of the angle in this position is located  $11\frac{1}{8}$  inches behind the front surface of the cabinet shell. Combinations of front, intermediate and rear positions may also be used in the cabinet.

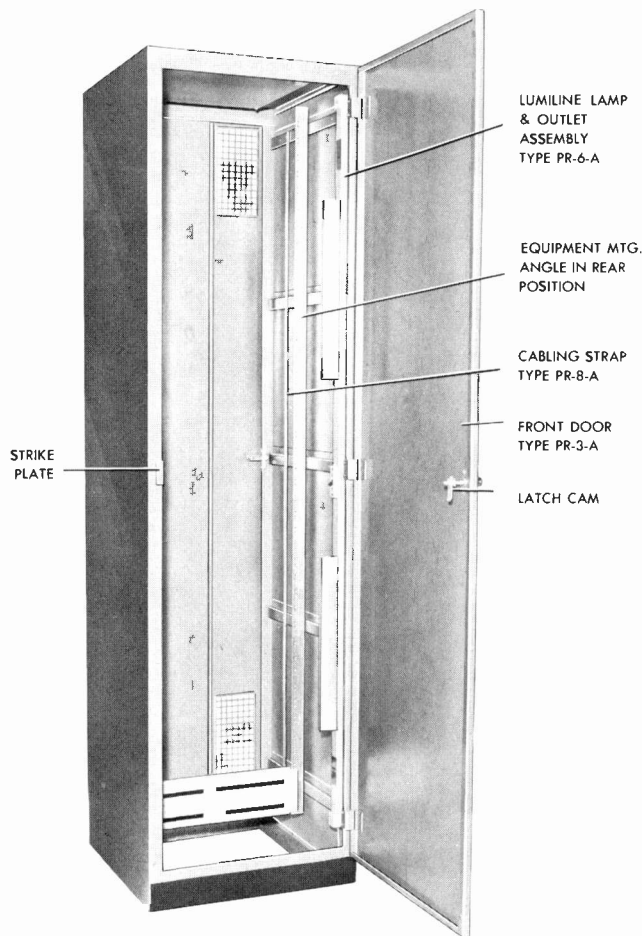

Fig. 8-1 Type PR-1-A Cabinet Rack and accessories

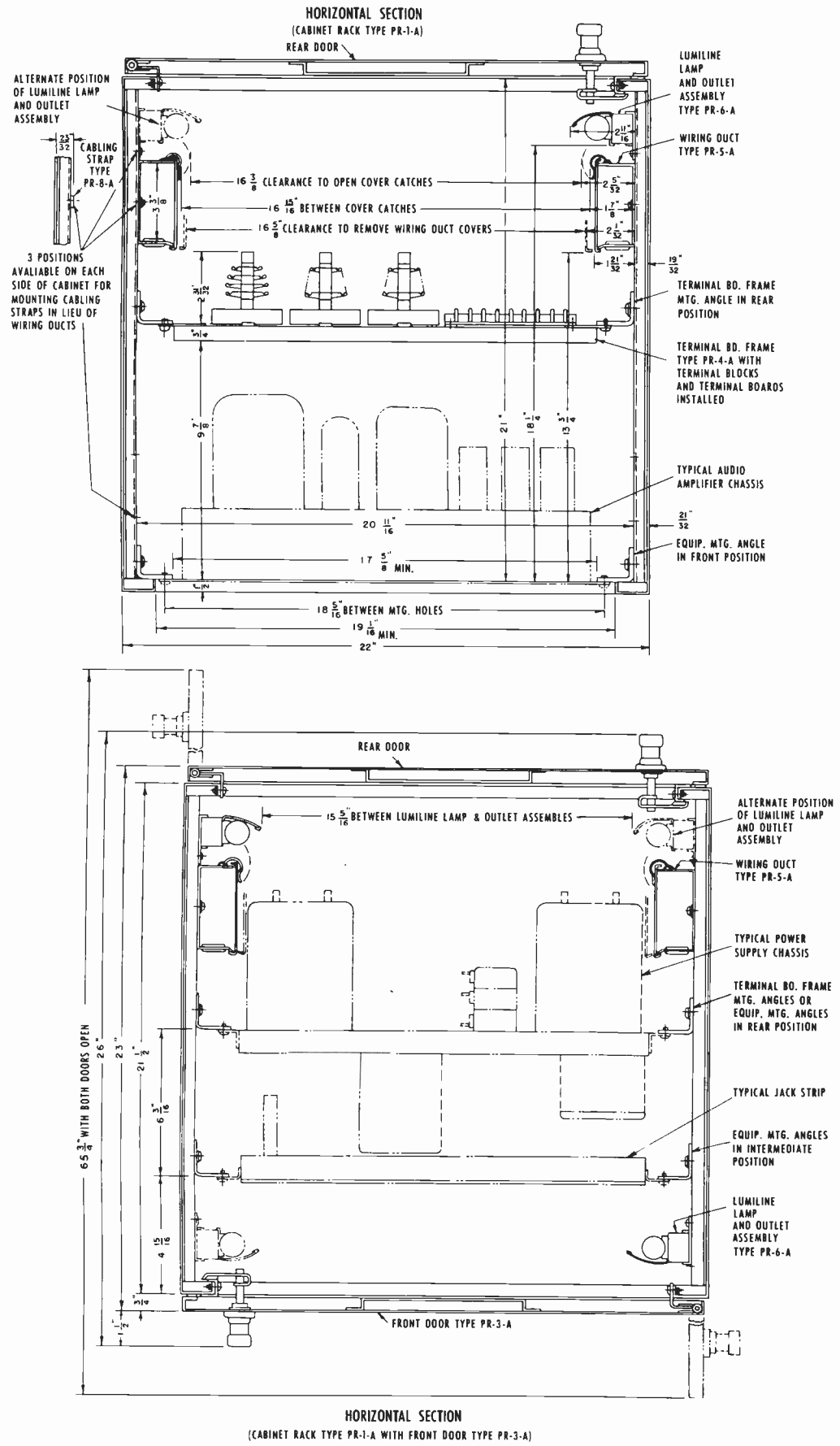

Fig. 8-2 Outline Drawing of PR-1-A Rack

The rear door is hinged on the right-hand side when the rack is shipped. As with the front door, the hinges may be reversed and the door swung from the left-hand side if desired.

Ventilation openings provided in the cabinet rack consist of four perforated grilles in the rear door, a large cut-out in the cabinet top, and the front cut-out in the cabinet base. A horizontal rectangular dust plate about 1 inch below the top cut-out protects equipment in the cabinet from dust and other foreign matter. This plate may be removed if an air duct or fan is attached to the cabinet top for forced ventilation.

Five horizontal mounting channels on each side of the cabinet interior with six tapped holes in each channel are used for mounting the vertical equipment mounting angles

in any of three locations and for mounting such cabinet accessory items as wiring ducts, cabling straps, and Lumiline\* lamps and outlet strips in several locations.

**MOUNTING**

The Cabinet Rack is bolted to the floor through six 5/8-inch diameter holes located in the base. See Fig. 8-2 for more specific information.

**SPECIFICATIONS**

- Dimensions (over-all):
  - Height .....83-1/3 in.
  - Width .....22 in.
  - Depth .....22-1/4 in. over rear door;
  - 23-11/16 in. over rear door handle
  - 43-3/8 in. with door fully open
- Weight .....170 lbs
- Mounting Space:
  - Height .....77 in.
  - Width .....19 in. for panels; 17-5/8 in. for chassis
  - Depth .....21 in.

When Ordering Specify: Cabinet Rack, Type PR-1-A

\*Registered trademark of General Electric Company.

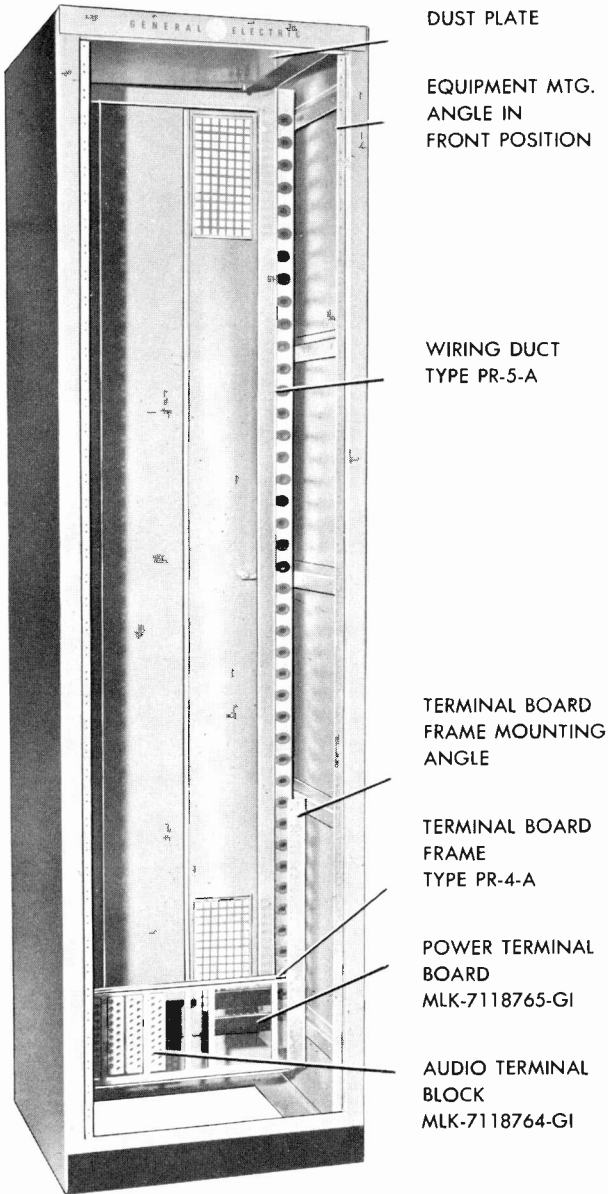

# Accessories for cabinet rack, Type PR-1-A

## front door Type PR-3-A

The front door is similar to the back door of the cabinet rack except for the omission of the perforated grilles and the addition of four nameplate mounting holes in both top and bottom flanges. The door weighs approximately 50 lbs and may be mounted on either the right or left side.

## terminal board frame Type PR-4-A

It is recommended that one terminal board frame be installed near the bottom of each cabinet rack to provide mounting facilities for the required terminal boards.

The PR-4-A frame provides mounting holes to accommodate three Audio Terminal Blocks and three Power Terminal Boards. By relocating the two middle straps to their alternate mounting holes, the frame is made suitable for mounting one Audio Terminal Block and six Power Terminal Boards. Four screws are supplied with each terminal board frame for attaching it to the mounting angles in the PR-1-A Cabinet Rack. The weight is 3 lbs.

Fig. 8-3 Type PR-1-A Cabinet Rack and accessories

## wiring duct Type PR-5-A

Designed for mounting within the PR-1-A Cabinet Rack, the General Electric Wiring Duct provides a convenient and accessible place for running wiring between various units mounted on the racks. A duct cover keeps the wiring protected and out of sight, thus eliminating the need for lacing or cabling of wires and assuring a neat installation. An outstanding feature of the Wiring Duct is the ease with which inter-unit wiring may be added or removed without disturbing other circuits.

The Wiring Duct consists of a U-shaped metal channel equipped with a readily removable full-length metal cover. In one side of the channel are slots, each fitted with a rubber grommet with  $\frac{5}{8}$ -inch diameter opening.

The duct mounts vertically in the Cabinet Rack with the slotted side facing the front of the cabinet. Mounting hardware is included with each duct.

It is recommended that two Wiring Ducts, Type PR-5-A, be used in each Cabinet Rack; one on the right-hand side (facing rear of cabinet) for audio and video inter-unit wiring, and one on the left-hand side for power, metering, and speaker inter-unit wiring.

### SPECIFICATIONS

Dimensions (over-all):	
Height	.....77-5/16 in.
Width	.....4 in.
Depth	.....1-7/8 in.
No. of slots in channel	....42
Weight	.....12 lbs

## Lumiline lamp and outlet assembly Type PR-6-A

The Type PR-6-A Lumiline Lamp and Outlet Assembly consists of a Wiremold channel complete with two plug receptacles, two pairs of Lumiline lamp receptacles, one switch, two reflectors, a BX connector at each end, and five mounting clips. Also furnished with the strip are two G-E 120-volt Lumiline lamps, four G-E lamp caps, and five mounting screws.

All wiring is completely enclosed within the channel. The power wires can be fed directly into the strip without first terminating at an exposed terminal board in the rack. This enables switching off all power to units within the cabinet and still keeps available power for the lights and soldering irons.

It is recommended that one assembly be used in the front and one in the rear. The PR-6-A weighs 5 lbs.

## mounting angles Type PR-7-A

The Type PR-7-A consists of a pair of 1½ by 1½ by 77½ inches long, zinc plated, steel equipment mounting angles and angle mounting hardware. These extra angles

are for use when it is desired to mount panels or chassis on two mounting locations at the same time. The mounting angle weighs 7 lbs.

## cabling straps Type PR-8-A

The Cabling Straps provide an inexpensive means for supporting cabinet inter-unit wiring. They consist of a pair of ½ x ½ x 73 inches long, zinc plated, steel straps each provided with five mounting holes and five mounting screws for attaching the strips to the cabinet. They are mounted vertically in the rear of the cabinet in place of wiring ducts.

## audio terminal block MLK-7118764-G1

The Audio Terminal Block provides terminating points for audio wires entering the Cabinet Rack and going to amplifiers and associated equipment mounted in the cabinet. It is an 80-terminal (4 rows of 20 each) solder-lug, telephone-type block, similar to WE Type 100-B.

Two screws and lockwashers are included with each block for mounting it on the Terminal Board Frame. The block weighs 1 lb.

## power terminal board MLK-7118765-G1

The Power Terminal Board provides terminating points for power, metering and speaker wires entering the Cabinet Rack and going to units mounted in the cabinet. It consists of an 8-terminal, screw-type terminal board, similar to Howard B. Jones Co. Type 8-142-MS. Each terminal has No. 8-32 screws, and is separated from the next terminal by an insulation barrier.

Four screws and lockwashers are supplied with each board for mounting it on the Terminal Board Frame. The board weighs ¼ lb.

### When Ordering Specify:

Front Door	.....Type PR-3-A
Terminal Board Frame	....Type PR-4-A
Wiring Duct	.....Type PR-5-A
Lumiline and Outlet Assembly	.....Type PR-6-A
Mounting Angles	.....Type PR-7-A
Cabling Straps	.....Type PR-8-A
Audio Terminal Block	....MLK-7118764-G1
Power Terminal Board	....MLK-7118765-G1

# Cabinet racks

## Types FA-8-C and FA-8-D

### FEATURES

- Sturdy, sheet steel construction
- No trim strips necessary — mounted surfaces recessed
- Excellent provision for ventilation
- Reinforced rear door
- Accessories easily mounted
- Attractive modern styling

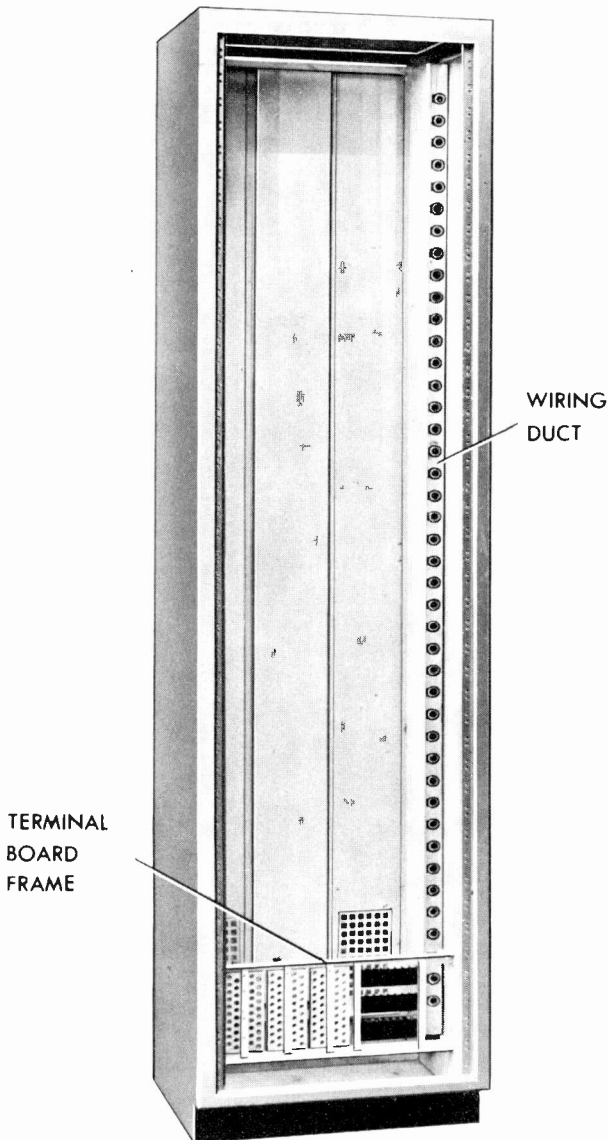

Fig. 8-4 Front view of Types FA-8-C and FA-8-D Cabinet Racks with accessories

### APPLICATION

The Types FA-8-C and FA-8-D Cabinet Racks provide space for mounting amplifiers, jack panels, indicator and metering panels, measuring apparatus, and other associated panel equipment designed for installation in a standard 19-inch rack.

### DESCRIPTION

The FA-8-C and the FA-8-D Cabinet Racks consist of sturdily constructed sheet steel cabinets with open front and hinged rear doors. The only difference between the two racks is in the size: the FA-8-C is 83 inches high; the FA-8-D is 75 inches high. Both racks are drilled and tapped in accordance with RMA standards for No. 12-24 mounting screws. The mounting surface is recessed  $\frac{1}{2}$  inch behind the front of the cabinet to conceal the edges of equipment panels.

Equipment mounted in the cabinets is ventilated by air entering through perforations in the lower part of the rear door and leaving through a rectangular opening in the cabinet top. A horizontal rectangular plate  $\frac{3}{4}$  of an inch below the top opening protects equipment in the cabinet from dust and other foreign material. This plate may be removed if an exhaust duct is attached to the cabinet top opening for forced ventilation.

Mounting facilities are provided for Cabinet Rack Accessories: a row of nuts is welded on each side of the interior of the cabinet for mounting the Wiring Ducts, and four tapped angle-brackets are attached to the cabinets for mounting a Terminal Board Frame. For convenient entrance of wires a rectangular cutout is provided in the base.

### MOUNTING

The Cabinet Racks are designed to be bolted to the floor through six  $\frac{5}{8}$ -inch diameter holes in the base. See Fig. 8-5 for specific mounting information.

### SPECIFICATIONS

#### Dimensions (over-all):

	FA-8-C	FA-8-D
Height	83 $\frac{1}{8}$ in.	75 in.
Width	21 $\frac{1}{8}$ in.	21 $\frac{1}{8}$ in.
Depth (exclusive of rear door handle which projects 1 $\frac{1}{2}$ " at rear)	18 $\frac{3}{8}$ in.	18 $\frac{3}{8}$ in.
Weight	150 lbs	139 lbs
Mounting Space:		
Height	77 $\frac{1}{8}$ in.	68 $\frac{3}{8}$ in.
Width	19 $\frac{1}{8}$ in.	19 $\frac{1}{8}$ in.

When Ordering Specify: Cabinet Rack, Type FA-8-C or Type FA-8-D

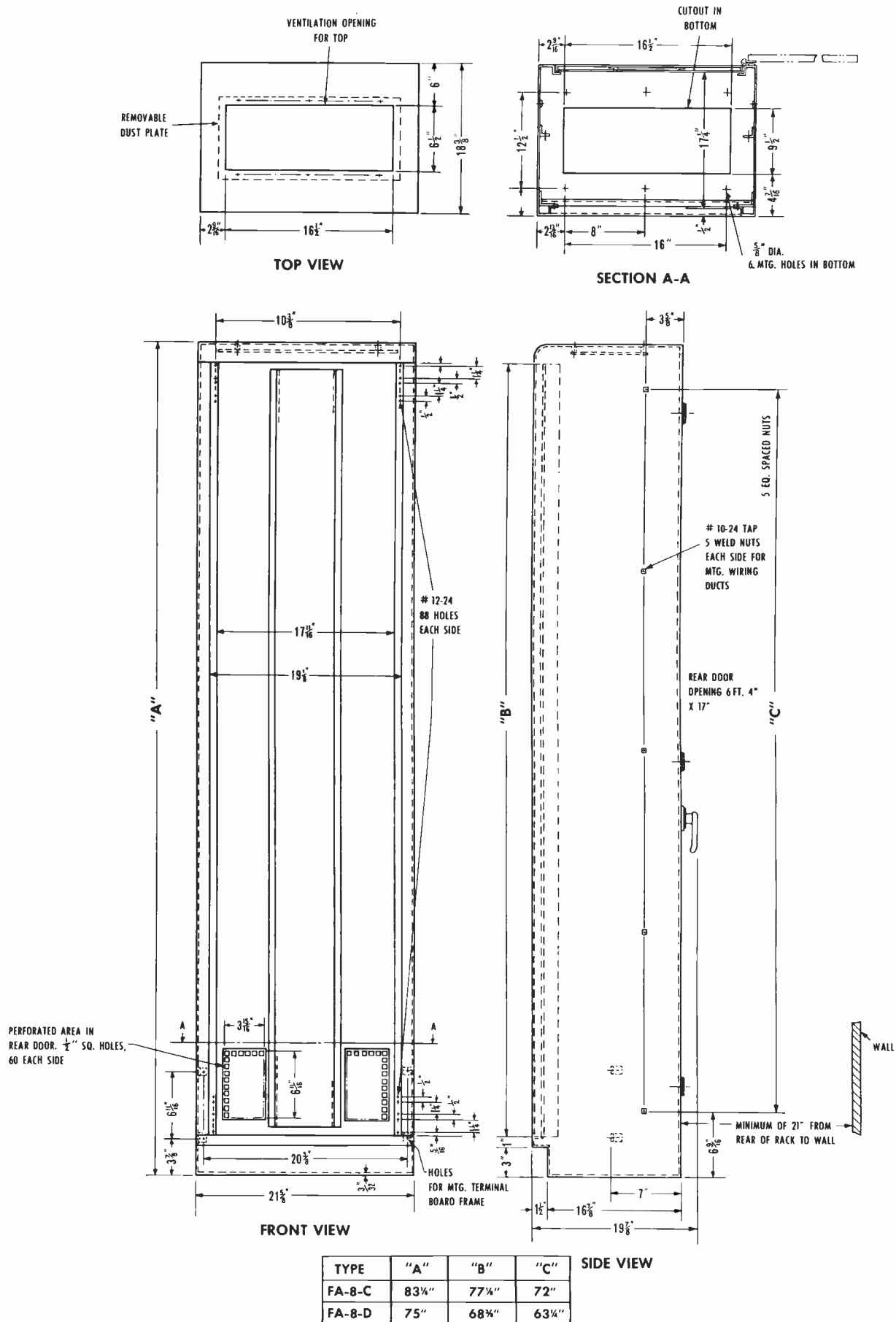

Fig. 8-5 Outline Drawing of FA-8-C and FA-8-D Racks



# Accessories for cabinet racks, Types FA-8-C and FA-8-D

## wiring duct

### ML-7767495-G1 (for FA-8-C) ML-7767495-G2 (for FA-8-D)

Designed for mounting within the FA-8-C or FA-8-D Cabinet Racks, the General Electric Wiring Ducts provide a convenient and accessible place for running wiring between various units mounted on the racks. A duct cover keeps the wiring protected and out of sight, thus eliminating the need for lacing or cabling of wires and assuring a neat installation. An outstanding feature of the Wiring Duct is the ease with which inter-unit wiring may be added or removed without disturbing other circuits.

The Wiring Duct consists of a U-shaped metal channel equipped with a readily removable full-length metal cover. In one side of the channel are slots, each fitted with a rubber grommet for 5/8-inch diameter opening.

The duct mounts vertically in the Cabinet Rack with the slotted side facing the front of the cabinet. Five screws and lockwashers are furnished with each duct to attach it to the weld nuts provided in the Cabinet Racks.

It is recommended that two Wiring Ducts be used in each Cabinet Rack: one on the right side (facing rear of cabinet) for audio inter-unit wiring, and one on the left side for power, metering, and speaker inter-unit wiring.

### SPECIFICATIONS

Dimensions (over - all):	ML-7767495-G1	ML-7767495-G2
Height	77-5/16 in.	68-9/16 in.
Width	3-7/8 in.	3-7/8 in.
Depth	1-7/8 in.	1-7/8 in.
No. of slots in channel	42	37
Weight	12 lbs	10 lbs

## terminal board frame ML-7769361-G1

It is recommended that one terminal board frame be installed near the bottom of each Cabinet Rack to provide mounting facilities for the required terminal boards.

The ML-7769361-G1 frame, of welded steel construction, provides mounting holes to accommodate up to three Audio Terminal Blocks and up to three Power Terminal Boards.

Four screws and lockwashers are supplied with each terminal board frame for attaching it to the mounting brackets in the FA-8-C or FA-8-D Cabinet Rack. The frame weighs 3 lbs.

## audio terminal block MLK-7118764-G1

The Audio Terminal Block provides terminating points for audio wires entering the Cabinet Rack and going to amplifiers and associated equipment mounted in the cabinet. It is an 80-terminal (4 rows of 20 each) solder-lug, telephone-type block, similar to WE Type 100-B.

Two screws and lockwashers are included with each block for mounting it on the Terminal Board Frame. The block weighs 1 lb.

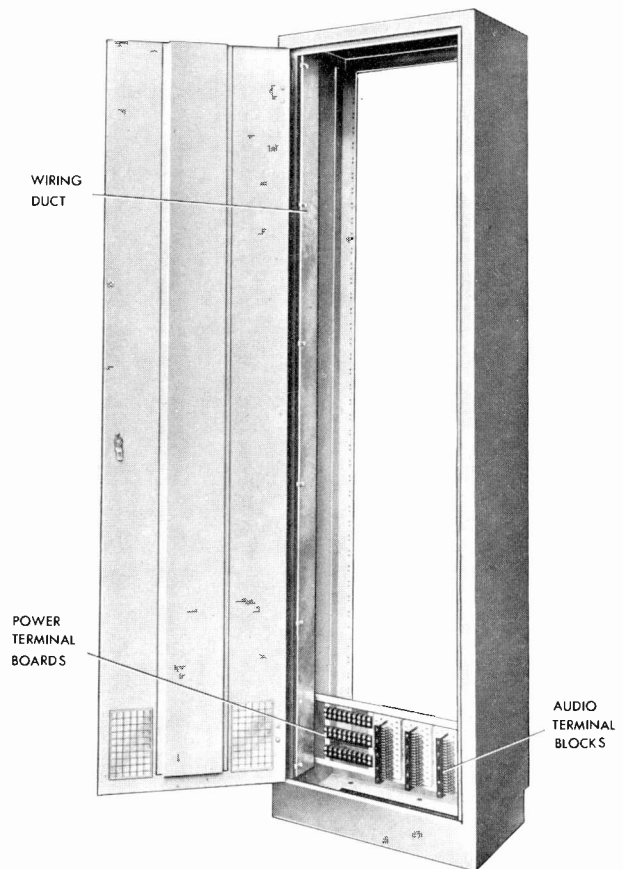

Fig. 8-6 Rear view of Type FA-8-C and FA-8-D Cabinet Racks, door open showing accessories

## power terminal board MLK-7118765-G1

The Power Terminal Board provides terminating points for power, metering, and speaker wires entering the Cabinet Rack and going to units mounted in the cabinet. It consists of an 8-terminal, screw-type terminal board, similar to Howard B. Jones Co. Type 8-142-MS. Each terminal has

No. 8-32 screws, and is separated from the next terminal by an insulation barrier.

Four screws and lockwashers are supplied with each board for mounting it on the Terminal Board Frame. The board weighs ¼ lb.

## Cabinet rack accessory kit Type FA-9-A, FA-9-B

Cabinet Rack Accessory Kits, Type FA-9-A and FA-9-B, provide complete sets of accessories most commonly used to equip Cabinet Racks FA-8-C and FA-8-D, respectively. A Cabinet Rack Accessory Kit consists of the following items:

FA-9-A Kit for FA-8-C Rack	FA-9-B Kit for FA-8-D Rack
Two Wiring Ducts (ML-7767495-G1)	Two Wiring Ducts (ML-7767495-G2)
One Terminal Board Frame (ML-7769361-G1)	One Terminal Board Frame (ML-7769361-G1)
Two Audio Terminal Blocks (MLK-7118764-G1)	Two Audio Terminal Blocks (MLK-7118764-G1)
Two Power Terminal Boards (MLK-7118765-G1)	Two Power Terminal Boards (MLK-7118765-G1)

When Ordering Specify: Cabinet Rack Accessory Kit, Type FA-9-A or FA-9-B

## blank panels Types FA-6-A through FA-6-G

General Electric maintains a complete line of 19-inch Blank Panels, ranging in height from 1-23/32 inches to 12-7/32 inches. These panels are primarily used for filling in unused mounting space on relay and cabinet racks, but may also be adapted as special metering, switching, or indicating panels simply by drilling for and mounting added components.

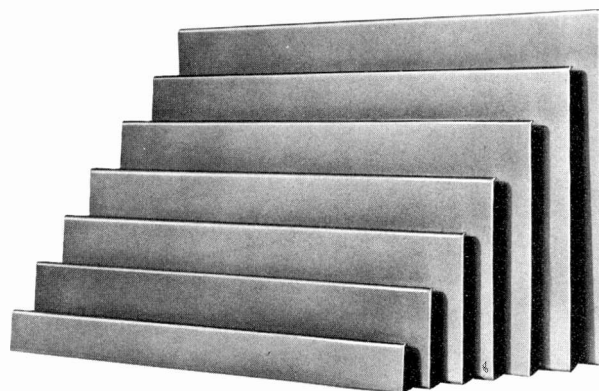

Fig. 8-7 Types FA-6-A through FA-6-G Blank Panels

The panels are constructed of 3/32-inch thick aluminum alloy. Upper and lower edges of each panel are turned in 90 degrees to increase rigidity and to give an effective panel thickness of 5/16 inch.

Clamp-type mounting hardware included with each blank panel is located on the rear so that no mounting screws are visible from the front of the cabinet rack, thus eliminating the need for cabinet trim strips. The front surface and edges of the panels are finished to match the finish on amplifier and associated equipment panels.

### PANEL SIZES

FA-6-A	.....1-23/32 in.
FA-6-B	.....3-15/32 in.
FA-6-C	.....5-7/32 in.
FA-6-D	.....6-31/32 in.
FA-6-E	.....8-23/32 in.
FA-6-F	.....10-15/32 in.
FA-6-G	.....12-7/32 in.

When Ordering Specify: Blank Panels, Type FA-6-A through FA-6-G

## panel and mounting Type FA-5-A

### FEATURES

- Convenient mounting for G-E Two-Stage Pre-Amplifiers and Utility Input Amplifiers
- Easy inspection and maintenance of mounted units because of hinged-front panel
- Rotary selector switch for quick circuit checks

### APPLICATION

The Type FA-5-A Panel and Mounting provides a means for mounting small, shallow, chassis in a standard RMA

19-inch cabinet. It is capable of mounting the following units:

- 4 — BA-1-D Two-Stage Pre-Amplifiers (see page 5-3)
- 2 — BA-10-A Utility Input Amplifiers (see page 5-5)
- 1 — BA-10-A Utility Input Amplifier plus 2—BA-1-D Two-Stage Pre-Amplifiers

### DESCRIPTION

The FA-5-A consists of a recessed chassis with open back and hinged-front panel. Flanges across the top and bottom of the open back serve as mounting surfaces to which units may be attached. Detachable plug buttons cover three large holes on either side of the chassis through which external wiring may be run to the mounted units.

The nine-position single-bank (eight active and one off) rotary selector switch mounted on the hinged-front panel is controlled by a front-panel knob to select any one of eight circuits to be checked.

Operating devices such as power switches, indicator lights, and potentiometers associated with mounted units may be installed in the four holes provided on the front panel for front-of-panel control and indication. Detachable plug buttons are furnished to cover these holes when not in use.

### MOUNTING

Four mounting screws are furnished to bolt the FA-5-A vertically to the Cabinet Rack.

### SPECIFICATIONS

Dimensions (over-all):

Height	.....8-23/32 in.
Width	.....19 in.
Depth	.....4-7/32 in. approx
Weight	.....3½ lbs
Switch (rotary)	.....9-position

When Ordering Specify: Panel and Mounting, Type FA-5-A

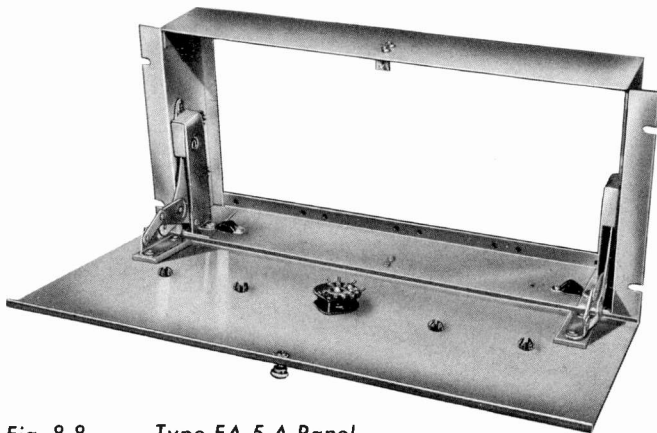

Fig. 8-8 Type FA-5-A Panel and Mounting with front panel open

## Panel and mounting Type FA-5-B

The FA-5-B Panel and Mounting provides a neat and convenient means for mounting small miscellaneous studio equipment in a standard 19-inch cabinet rack. Each FA-5-B consists of an open-back, recessed chassis with a hinged-front panel. Flanges with tapped inserts are provided on the rear of the chassis to serve as mounting surfaces.

### MOUNTING

The FA-5-B mounts vertically in a standard 19-inch cabinet rack. The chassis is bolted to the rack with mounting screws which are furnished.

### SPECIFICATIONS

Dimensions:

Height	.....6-31/32 in.
Width	.....19 in.
Depth	.....3-¼ in.
Weight	.....2-¾ lbs

When Ordering Specify: Panel and Mountings, Type FA-5-B

## Shelf Type FA-23-A

### FEATURES

Easy to service — hinged-front panel permits quick replacement of amplifiers and rapid tube check from front of rack

Extractor tool makes amplifier replacement easy  
Amplifier leads protected by cable-cover shield

### APPLICATION

The FA-23-A Shelf is used to mount G-E plug-in amplifiers and power supply Trays in a standard 19-inch cabinet rack. A maximum of six Pre-amplifiers, Type BA-1-C, four Program/Monitor Amplifiers, Type BA-12-A, two Power Supplies, Type BP-10-A or a combination of the above can be mounted in one Shelf.

The amplifiers and power supplies can be easily inserted or withdrawn from their mounting trays from the front of the rack by means of the extractor tool furnished with the Shelf.

**DESCRIPTION**

The FA-23-A consists essentially of a horizontal frame equipped with two vertical end-mounting brackets and a hinged-front panel. Mounting holes in the horizontal frame are provided for the attachment of the various combinations of the FA-22-A, FA-22-B, and FA-22-C Trays.

Three six-point terminal boards mounted along the rear edge of the Shelf are arranged for convenient paralleling of individual plate and filament leads from tray receptacles to power supply cables. A removable cable cover extends the full width across the rear of the Shelf to cover the terminal boards and external power, audio, and metering cables wired to the tray receptacles.

**MOUNTING**

The Shelf bolts to the cabinet rack with the No. 12-24 screws furnished. It may be mounted in any standard 19-inch wide rack which has at least 13 inches clear depth between the front mounting surface and the rear door. It is recommended, however, that the FA-8-C or FA-8-D Cabinet Racks, which have 17 inches clear depth, be used, since the additional depth will permit the installation and use of the wiring ducts which are part of the Accessory Kits, FA-9-A and FA-9-B.

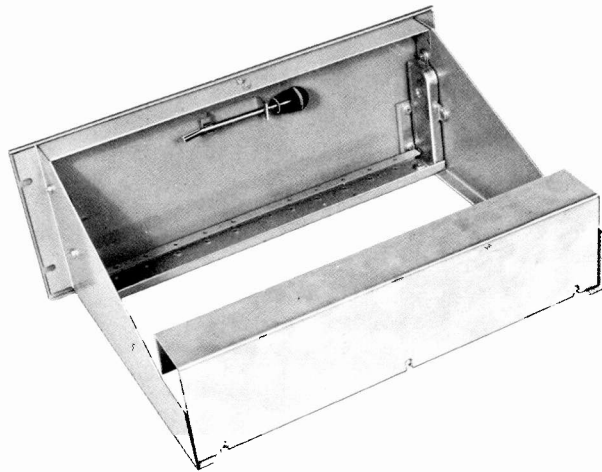

Fig. 8-9 Type FA-23-A Shelf

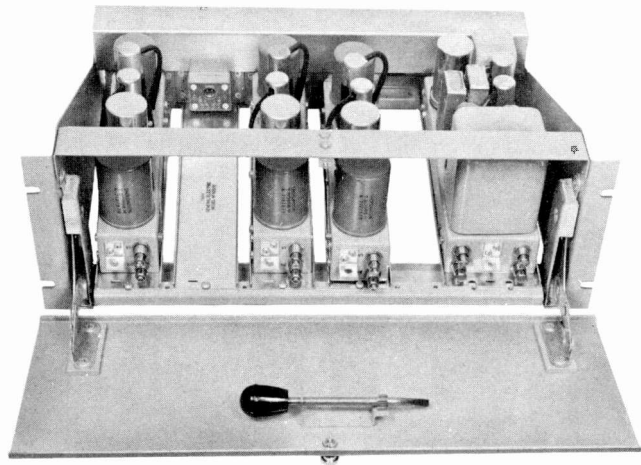

Fig. 8-10 Front view of FA-23-A Shelf, front panel open showing plug-in equipment mounted

**SPECIFICATIONS**

## Dimensions (over-all):

Height	.....	.6-31/32 in.
Width	.....	.19in.
Depth	.....	.13 in.
Inside Width	.....	.17 in.
Weight	.....	.5 lbs

When Ordering Specify: Shelf, Type FA-23-A

# line-to-line transformer Type FA-40-A

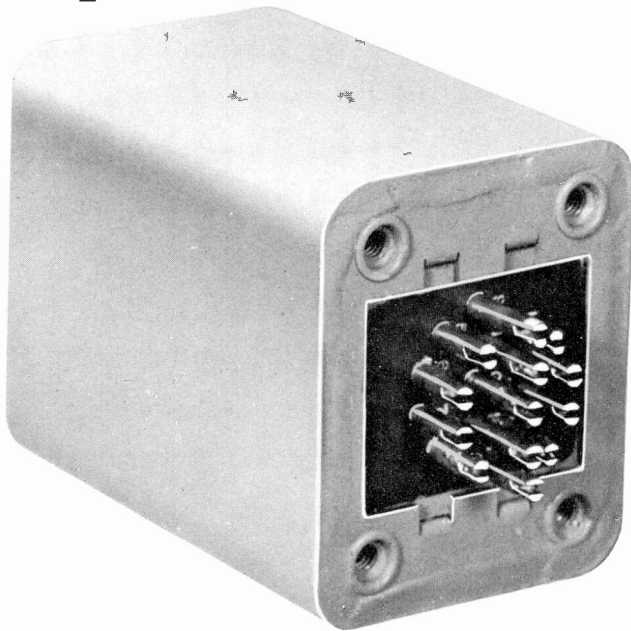

Fig. 9-1 Type FA-40-A Line-to-Line Transformer

The FA-40-A Line-to-Line Transformer is designed for use as a high quality repeat coil in telephone lines, or for isolation and impedance-matching in output circuits of low- and medium-level amplifiers.

### SPECIFICATIONS

- Frequency Range .....in excess of 50 to 15,000 cycles
- Maximum Operating Level .....+30 dbm at 50 cycles
- Insertion Loss .....less than 0.75 db
- Connections .....see Fig. 9-2
- Dimensions (over-all):
  - Height .....3-11/16 in. max
  - Width .....2 in. max
  - Depth .....2 3/8 in. max
  - Mounting .....tapped inserts

When Ordering Specify: Line-to-Line Transformer, Type FA-40-A

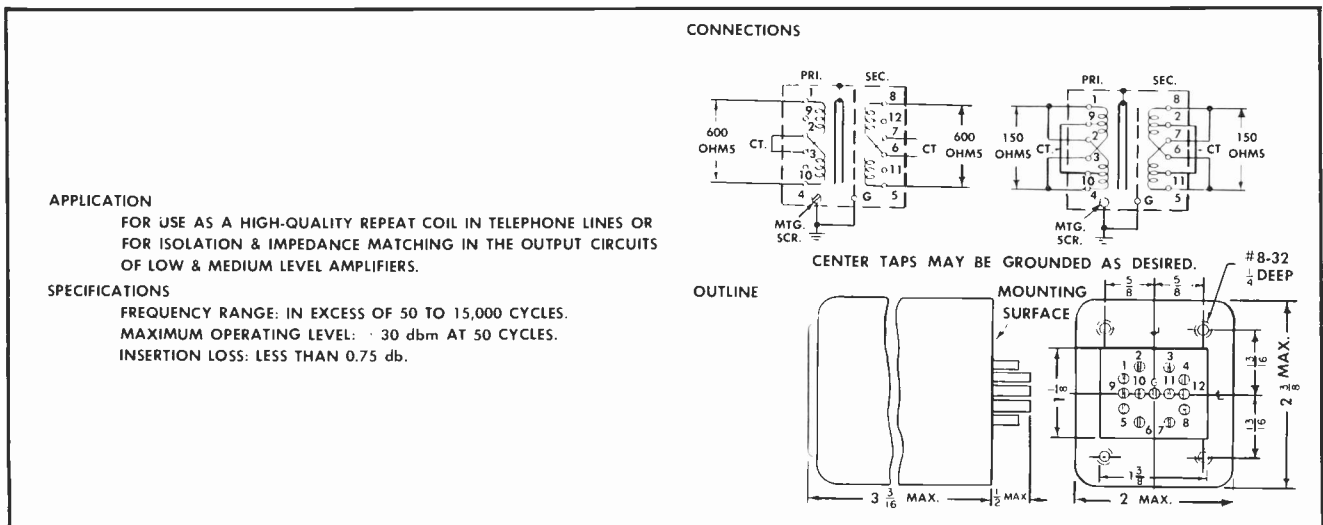

Fig. 9-2 Installation Drawing for FA-40-A Transformer

# bridging-to-line transformer Type FA-41-A

The FA-41-A Bridging-to-Line Transformer is designed for use in connecting a 600- or 150-ohm device across a low-impedance program circuit without appreciably affecting the performance of that circuit.

### SPECIFICATIONS

Frequency Range .....in excess of 50 to 15,000 cycles

Maximum Operating Level .....+15 dbm at 50 cycles on secondary (corresponds to approx 24 volts on 20,000-ohm primary)

Bridging Loss .....15 db (see Fig. 9-4)

Connections .....see Fig. 9-4

#### Dimensions (over-all):

Height .....3-3/16 in.  
Width .....1 7/8 in.  
Depth .....1 1/8 in.  
Mounting .....tapped inserts

When Ordering Specify: Bridging-to-Line Transformer, Type FA-41-A

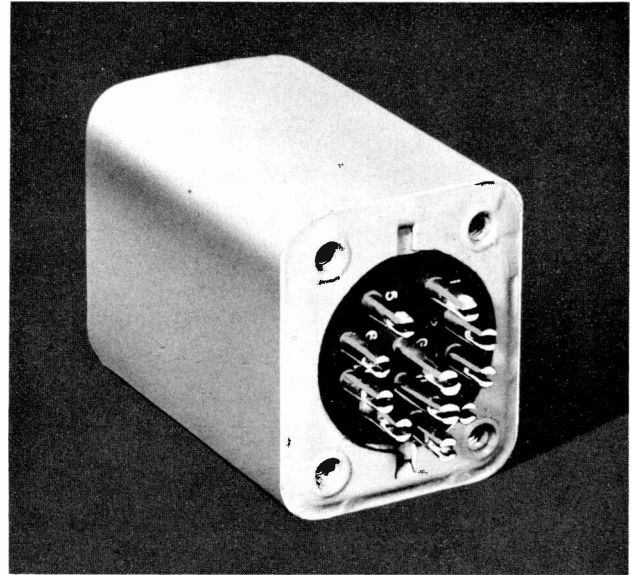

Fig. 9-3 Type FA-41-A Bridging-to-Line Transformer

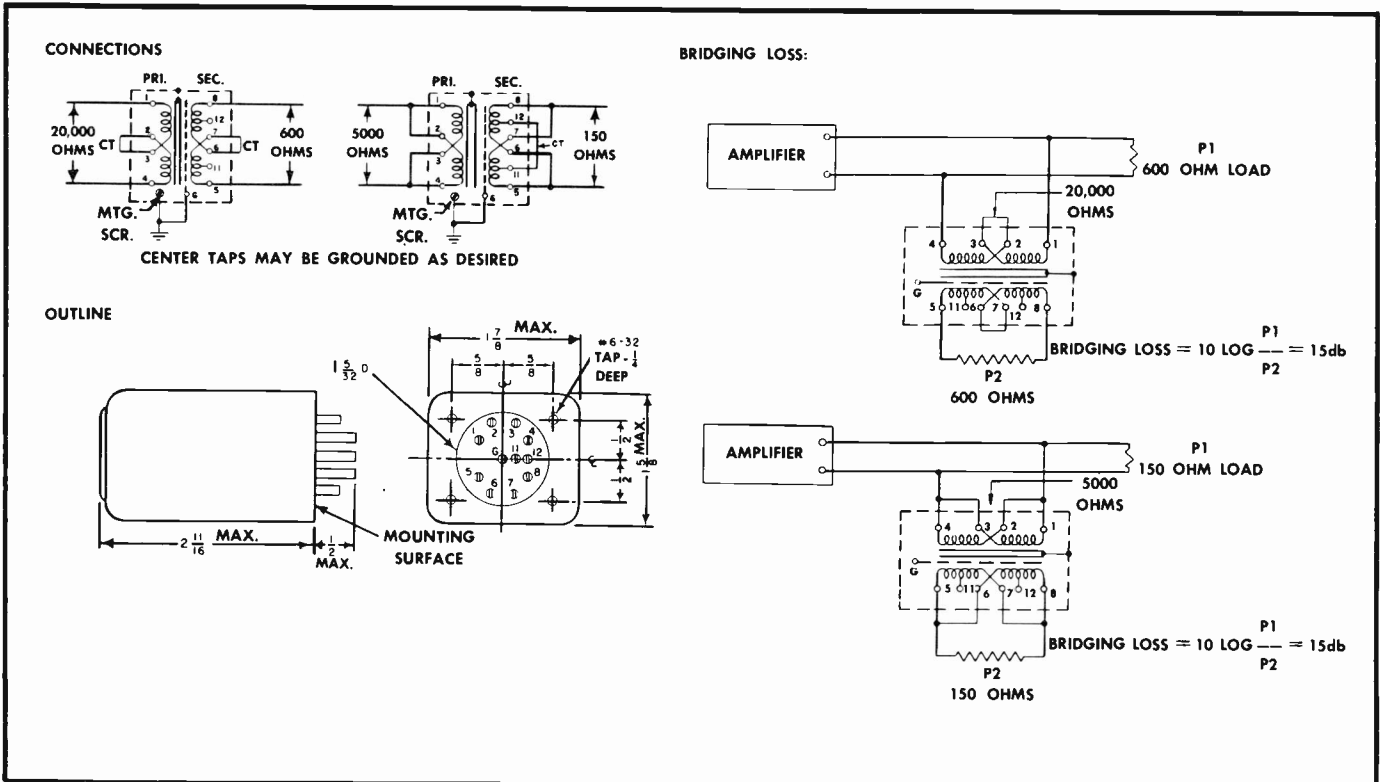

Fig. 9-4 Installation Drawing for FA-41-A Transformer

# Interconnecting cable

## Types FA-19-E, -F, -H, -J

General Electric's Interconnecting Cables are used for making audio, power, or control-circuit connections. All four types of interconnecting cable have special characteristics and recommended uses, but each is designed and manufactured to give efficient service and long life.

The cables consist of two tinned conductors, insulated with polyvinyl chloride compound, plus lacquered celanese braid coded red and black. A thin paper wrap and tinned copper braid shield cover the twisted insulated conductors. The FA-19-H Cable has an over-all impregnated jacket of black cotton braid.

All cables are stocked in 500-foot spools, and are sold only in spool lots. Spools are not returnable for credit.

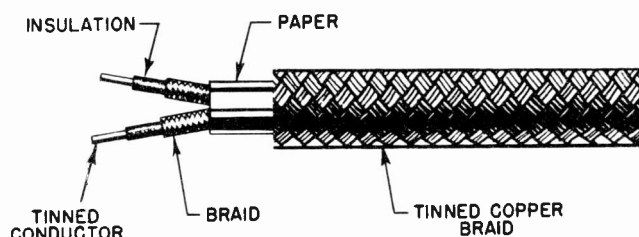

Fig. 10-1 Types FA-19-E, -F, and -J Interconnecting Cable

Cable Type Number	O.D.	Solid Conductor Size	Rating	Use
FA-19-E	0.171 in.	No. 22AWG, solid	400 v, 1.8 amp max	low/intermediate level audio connections inside cabinet racks
FA-19-F	0.201 in.	No. 18 AWG, solid	400 v, 5 amps max	general-purpose audio interconnecting cable for circuits within conduits, ducts, and cabinets
FA-19-H	0.226 in.	No. 18 AWG, solid	400 v, 5 amps max	low-level audio circuits within conduits, ducts, or cabinet racks where control of ground desired (shield-grounded at any desired point or points)
FA-19-J	0.245 in.	No. 16AWG, stranded	600 v, 8 amps max	power circuits, high-level audio circuits, etc. where shielding is desired

### recommended maximum number of cables in one conduit

Conduit Size (nominal)

Cable Type No.	½ in.	¾ in.	1 in.	1¼ in.	1½ in.	2 in.	2½ in.	3 in.	3½ in.	4 in.	4½ in.
FA-19-E	5	9	15	26	35	58	83	127	172	221	277
FA-19-F	4	6	11	19	25	42	60	92	124	160	200
FA-19-H	3	5	8	15	20	33	47	73	98	126	159
FA-19-J	2	4	7	13	17	28	40	62	83	107	135

When Ordering Specify: Interconnecting Cable, Type FA-19-E, -F, -H, or -J



Fig. 11-1 Types FA-16-A, -B, and -C Microphone Plugs and Receptacles

## Microphone plugs and receptacles Type FA-16-A, -B, and -C

All G-E Plugs and Receptacles are of the quick-disconnect type for ease in coupling and decoupling. They are all equipped with the standard three contacts, and are finished in satin chrome.

Type No.	Description	Mounting	Use
FA-16-A	male	integral cable clamp and locking device	microphone cables and extension cords
FA-16-B	female	integral cable clamp and locking device	microphone cables and extension cords
FA-16-C	female (including flush plate 4½ x 2¾)	single-gang, flush, wall-mounting; latch locking device	fits outlet box similar to G-E Outlet Box SP-5800

When Ordering Specify: Microphone Plug and Receptacle, Type FA-16-A, -B, -C

## Microphone cable Type FA-15-A

The FA-15-A Microphone Cable is a flexible, waterproof, shielded, two-conductor cable designed primarily for use with low-impedance microphones in broadcasting stations. It may also be used for making extension cords, for replacing old cables, etc.

The FA-15-A is made up of two stranded No. 20 rubber-insulated conductors covered with cotton braid and cotton filler and shielded with a tinned copper braid. Over the shield is a cotton wrap and a protective rubber jacket.

The Microphone Cable is stocked in 250-foot reels. Reels are not returnable for credit.

When Ordering Specify: Microphone Cable, Type FA-15-A

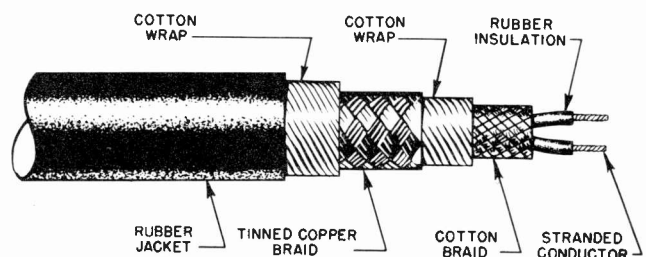

Fig. 11-2 Type FA-15-A Microphone Cable



# Monitoring speaker Type FS-1-A

## FEATURES

- Rich, full bass response is assured by ample cabinet volume and bass-reflex design
- Life-like treble response provided by a co-axial tweeter and efficient crossover network
- Contemporary cabinet styling and carefully selected woods complement the appearance of any studio
- Simplified installation is made possible by the clearly marked, open terminal board
- Low driving power required — highly efficient

## APPLICATION

The Type FS-1-A Monitoring Speaker is ideally suited for every application where pleasing, wide range response and good appearance are required.

## DESCRIPTION

The speaker unit is a single co-axial assembly which combines a horn-type high-frequency speaker with a low-frequency cone. Construction is greatly simplified by using a part of the cone to form the high-frequency horn.

An integral two-channel network provides excellent crossover characteristics to allow each section to operate at maximum efficiency. The permanent-magnet field supply simplifies installation and assures reliable, quiet reproduction. To complete the speaker unit, a high-quality line-matching transformer especially designed for the speaker is included.

The interior surfaces of the bass-reflex cabinet are treated with a special sound-absorbent material. By mounting the speaker on a Type FA-17-A base, the acoustic axis may be raised from 23½ inches to 38¾ inches. A G-E Type BA-4-D Monitoring Amplifier (described on page 5-8) may be installed in the FA-17-A base or in the FS-1-A cabinet.

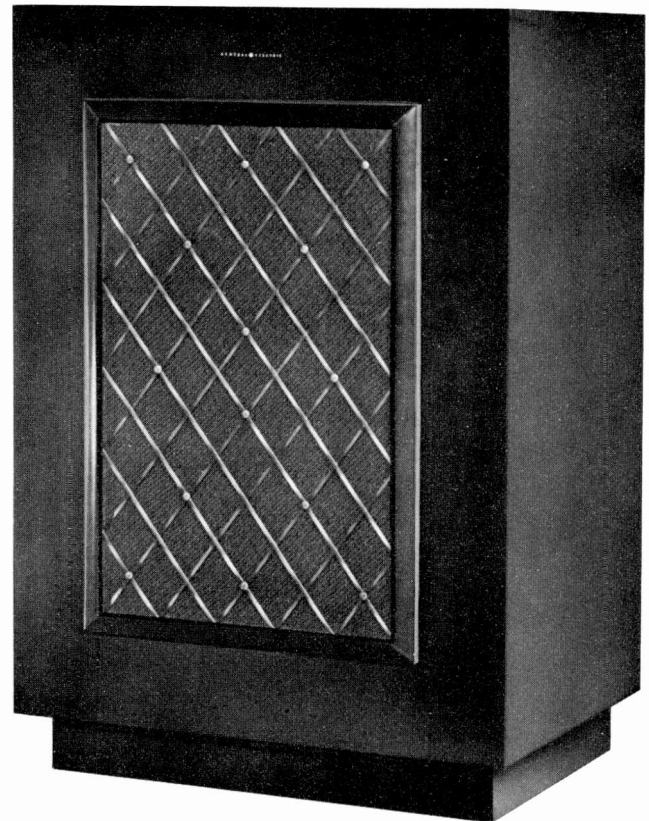

Fig. 12-1 Type FS-1-A Monitoring Speaker

## SPECIFICATIONS

- Frequency Response . . . . .50 to 15,000 cycles per second
- Power Rating . . . . .25 watts max, in speech and music systems
- Field . . . . .Permanent magnet
- Input Impedance . . . . .600/1200/1800/2400 ohms
- Dimensions:

  - Speaker . . . . .15 in.
  - Cabinet:

    - Width . . . . .25 in.
    - Depth . . . . .14½ in.
    - Height . . . . .26 in.
    - Weight . . . . .80 lbs

When Ordering Specify: Monitoring Speaker, Type FS-1-A

## ACCESSORIES

- Base . . . . .Type FA-17-A
- Speaker Control Plate. . . . .Type FA-10-A

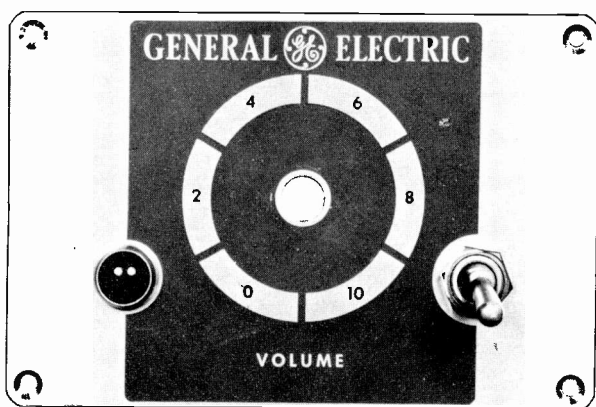

Fig. 12-2 Front view of Type FA-10-A Speaker Control Plate

## speaker control plate Type FA-10-A

### FEATURES

Centralizes speaker amplifier control at the speaker location

Compact design — may be mounted on speaker cabinet.

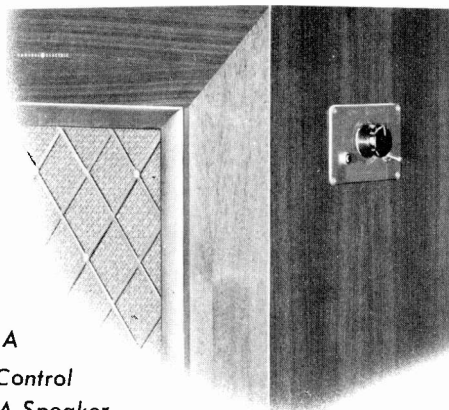

Fig. 12-3  
Type FA-10-A  
Speaker Control  
Plate and FA-35-A  
Bridging Volume Control  
mounted on FS-1-A Speaker

### DESCRIPTION

The Type FA-10-A Speaker Control Plate provides power control for an associated monitor amplifier. A red jewel light mounted on the front indicates whether power is on or off. A Bridging Volume Control which is furnished with the Monitoring Amplifier can be mounted on the back of the FA-10-A. Also, when the speaker is driven from a high-level bus, a power volume control can be mounted on the FA-10-A.

### SPECIFICATIONS

Height	.....	3 $\frac{3}{8}$ in.
Width	.....	5 $\frac{1}{8}$ in.
Depth (over-all)	.....	1 $\frac{3}{8}$ in.
Weight	.....	$\frac{1}{2}$ lb

When Ordering Specify: Speaker Control Plate, Type FA-10-A

## Studio wall speaker Type FS-2-A

### FEATURES

Sloping cabinet front for best sound distribution

12-inch General Electric speaker

Attractive walnut-finish wood cabinet

Line-to-voice-coil transformer built in

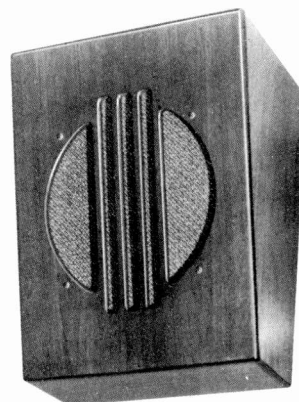

Fig. 12-4 Front view of Type FS-2-A Studio Wall Speaker

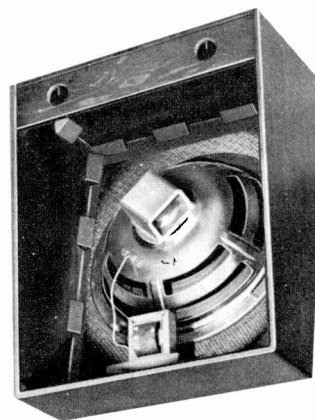

Fig. 12-5 Rear view of FS-2-A Studio Wall Speaker

### APPLICATION

The Type FS-2-A Studio Wall Speaker is a low-cost speaker for general use in studios, offices, and reception rooms of broadcasting stations.

### DESCRIPTION

The FS-2-A consists of a 12-inch speaker mounted in a walnut-finish wood cabinet constructed especially for wall mounting. The sloping cabinet front assures good sound distribution when the speaker is out of the way at ceiling level.

A line-to-voice-coil matching transformer is mounted in the cabinet, giving a choice of input impedances.

**SPECIFICATIONS**

Frequency Response .....60 to 8000 cycles per second  
 Power Rating .....10 watts max in speech and music systems  
 Field .....Alnico 5 permanent magnet  
 Input Impedance .....600/1200/1800/2400 ohms  
 Dimensions:  
 Width .....14 $\frac{1}{8}$  in.  
 Height .....18 in.  
 Depth .....9 $\frac{3}{4}$  in.  
 Weight .....10 lbs approx

When Ordering Specify: Studio Wall Speaker, Type FS-2-A

All-welded construction assures rigidity and provides optimum controlled flux density

Lustrous finish specially protected to preserve beauty and effectiveness

**APPLICATION**

General Electric loudspeakers may be used as original or replacement equipment and depended upon to provide unexcelled reproduction of both speech and music.

**Standard speakers**

(no enclosure)

**FEATURES**

Alnico 5 magnet material gives highest energy per unit volume of any material now available

Non-warping aluminum foil base voice coils provide high wattage handling capacity

Scientifically designed G-E cones assure faithful reproduction



Fig. 12-6  
Standard Speaker

**SPECIFICATIONS**

The following chart tabulates important characteristics of the loudspeakers:

**speaker characteristic table**

Type	Size	Universal Transformer Mounting Bracket	Mag. Wt. Ounces	Power Rating (Watts)	W. C. Dia.	V. C. Imped. Ohms
S400D	4"	✓	1.3	4	9/16"	3.2
S402D	4"	✓	1.	4	9/16"	3.2
S403D	4"	✓	.68	4	9/16"	3.2
S525D	5 $\frac{1}{4}$ "	✓	1.3	4	9/16"	3.2
S526D	5 $\frac{1}{4}$ "	✓	1.	4	9/16"	3.2
S527D	5 $\frac{1}{4}$ "	✓	.68	4	9/16"	3.2
S625D	6 $\frac{1}{2}$ "	✓	1.3	4	9/16"	3.2
S626D	6 $\frac{1}{2}$ "	✓	1.	4	9/16"	3.2
S650D	6 $\frac{1}{2}$ "	✓	2.98	8	3/4"	3.2
S703D	6" x 9"	✓	1.47	8	3/4"	3.2
S800D	8"	✓	2.98	8	3/4"	3.2
S810D	8"	✓	6.8	12	1"	3.2
S818D	8"	✓	6.8	12	1"	8.
S1000D	10"	✓	6.8	12	1"	3.2
S1001D*	10"		14.5	25	1 $\frac{1}{4}$ "	8.
S1003D	10"	✓	9.	25	1 $\frac{1}{4}$ "	8.
S1012D	10"	✓	3.16	12	1"	3.2
S1018D	10"	✓	6.8	12	1"	8.
S1200D	12"	✓	6.8	12	1"	3.2
S1201D*	12"		14.5	25	1 $\frac{1}{4}$ "	8.
S1203D	12"	✓	9.	25	1 $\frac{1}{4}$ "	8.
S1212D	12"	✓	3.16	12	1"	3.2
S1218D	12"	✓	6.8	12	1"	8.

\* DeLuxe



# transcription arm Type FA-21-A

## FEATURES

- Easy installation on popular turntables
- Clean quality—no arm resonances in audio range
- Tracks well—low-mass, low-friction arm
- Simple to operate—easy to spot in correct groove

## APPLICATION

The Type FA-21-A Transcription Arm which is designed to mount the G-E Variable Reluctance Pickup, Type RPX-046, is for use by broadcasting stations desiring the best in quality reproduction of lateral transcriptions and records.

## DESCRIPTION

The FA-21-A has been carefully designed for optimum performance of lateral disc recordings only. It contains no design compromises such as are necessary if vertical reproduction is also incorporated. To secure the best results from lateral recordings, the mass on the horizontal axis of the tone-arm is as low as possible, the bearing friction is a minimum, and the tone-arm is balanced about the horizontal axis.

The Type FA-21-A Transcription Arm will mount on transcription machines whose dimension from the center of turntable to edge of the mounting surface is approximately 15 inches or more.

Movement of the tone arm on the vertical and horizontal axis is particularly smooth because of the cone face ball-bearings. The combination of ball-bearings and leveling base results in a tracking which is substantially free of frictional or unbalance drag on the stylus.

The stylus is located by a line on the arm so that it may be accurately positioned on the transcriptions.

An adjustable spring tension device allows control of the stylus force.

When Ordering Specify: Transcription Arm, Type FA-21-A

## ACCESSORIES

Tone Arm Weight . . . . . Type RWP-001

This counterweight is for use with an FA-21-A Tone Arm to reduce stylus force to 6-8 grams in reproducing LP records.

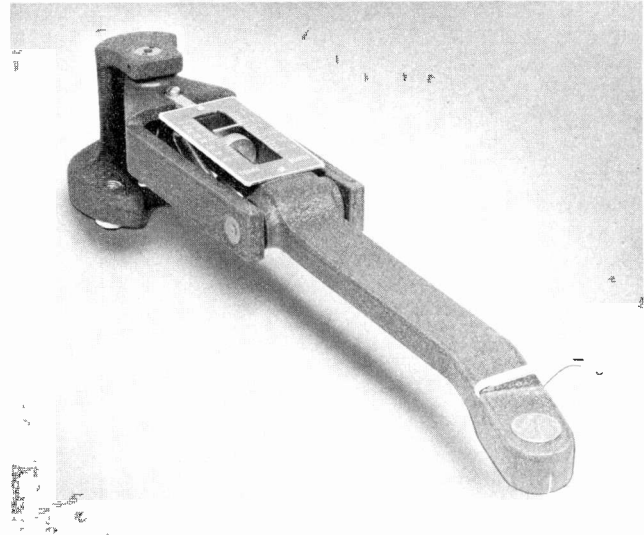

Fig. 13-1 Type FA-21-A Transcription Arm

# Variable reluctance cartridge Type RPX-046

## FEATURES

- High fidelity at low price
- Beautiful chrome finish
- Increases life of records
- Wide-range frequency response without peaks
- Low distortion

## APPLICATION

The Type RPX-046 Variable Reluctance Cartridge is a low impedance unit designed specifically for broadcast users. Smooth, wide-range frequency response, low cartridge mass and the high compliance stylus arm with which it is used assure that full benefit can be derived from recordings with a minimum of record wear.

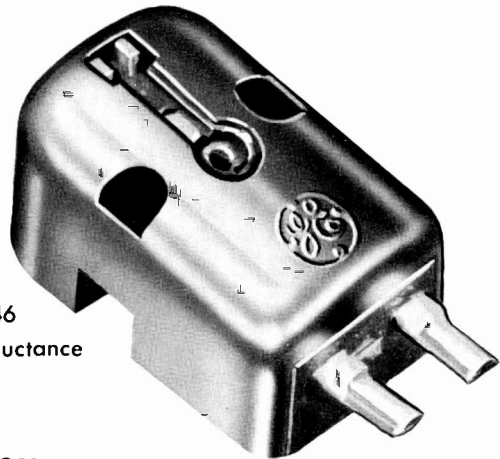

Fig. 13-2

Type RPX-046  
Variable Reluctance  
Cartridge

**DESCRIPTION**

Fig. 13-3 shows cartridge dimension and screw mounting centers of the RPX-046. Screws and stylus are shown in normal position. The cartridge, as supplied, does not include the stylus. Four screws are supplied separately so that mounting may be done either by 3-48 by 1/4-inch round-head or 4-40 by 1/4-inch filister-head machine screws.

The General Electric Type FA-21-A Tone Arm is recommended for professional and other high-quality installations. An adapter weight (RWP-001) permits proper operation with the 6-8 gram pressure cartridges.

**SPECIFICATIONS**

- Resistance (DC) .....220 ohms
- Inductance .....250 mh
- Output (average 1000 cycles):
  - Columbia 100003M, Standard Groove Record .....10 mv
  - Columbia RD90 Microgroove Record..8.5 mv
- Stylus Pressure:
  - With 2.5 mil or 3 mil stylus .....3/4 to 1 1/4 oz
  - With 1 mil stylus .....6 to 8 grams
- Dimensions:
  - Height .....9/16 in.
  - Width .....3/4 in.
  - Depth .....1-15/32 in.

When Ordering Specify: Variable Reluctance Cartridge,  
Type RPX-046

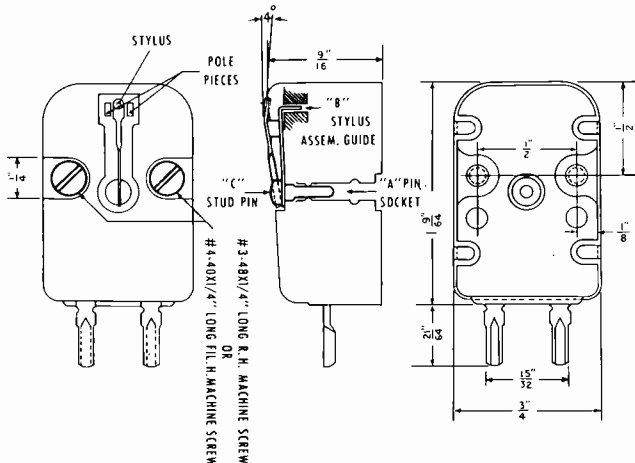

Fig. 13-3 Outline Drawing of Type RPX-046 Cartridge

**stylus**

Any of the styli listed below may be used with the RPX-046 cartridge and are replaceable when necessary. The choice of stylus assembly will depend upon the type of records (record groove width) and the normal life expectancy (number of plays) desired. Diamond stylus life is many times greater than that of the sapphire.

Following is a list of styli which can be used with the RPX-046 cartridge:

Type No.	Stylus	Stylus Radius in inches
RPJ-001	Sapphire	.003
RPJ-005	Sapphire	.001
RPJ-006	Sapphire	.0025
RPJ-002	Diamond	.0025
RPJ-003	Diamond	.003
RPJ-004	Diamond	.001

**Transcription  
equalizer  
Type FA-12-A**

**FEATURES**

- Full "NAB" low-frequency response—low distortion
- Adjustable high-frequency response, including "NAB" position
- Easy to install—single unit construction
- Low hum pickup because of mu-metal magnetic shielding
- Connections simplified—output may be run balanced or unbalanced
- Convenient to use—connects to any standard microphone pre-amplifier

**APPLICATION**

The Type FA-12-A Transcription Equalizer provides equalization for the G-E Variable Reluctance Pickup, Type RPX-046. It includes a four-position switch which allows control of high-frequency response. It connects to standard microphone pre-amplifiers.

**DESCRIPTION**

The FA-12-A is a single unit housed in a rectangular steel case which mounts underneath the top panel of a transcription machine. Mounting flanges are provided at the top (switch end) of the case. The switch shaft passes vertically through a clearance hole drilled in the top panel. The shaft is extra long in order to accommodate various thicknesses of transcription machine top panels. A knob and escutcheon plate are supplied for mounting above the equalizer on the control surface of the transcription machine panel. Although the equalizer components are completely enclosed in a protective metal case containing inner mu-metal shields, the removal of two case screws enables rapid access to the components should servicing be necessary.

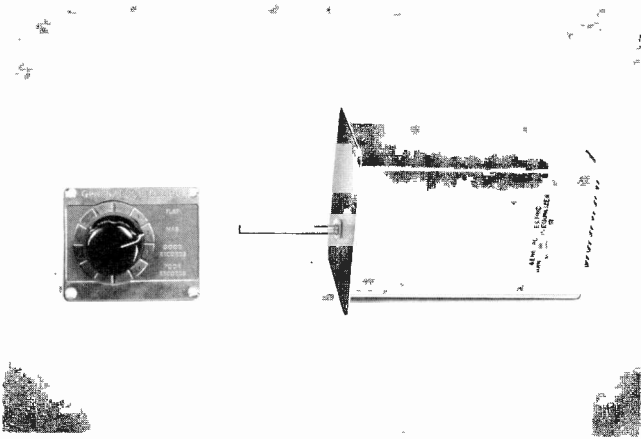

Fig. 13-4 Type FA-12-A Transcription Equalizer and escutcheon plate

The four positions of the switch are "Flat," "NAB," "Good Records," and "Poor Records." The "Flat" position provides essentially flat high-frequency response from material recorded at constant velocity. The "NAB" position provides essentially flat high-frequency response from material recorded in accordance with the "NAB" lateral curve. The "Good Records" position provides a high-frequency response somewhat more attenuated than that given by the "NAB" position. The fourth position, "Poor Records" provides a high-frequency response considerably more attenuated than that given by the "NAB" position. All switch positions provide low-frequency response essentially the complement of the "NAB" curve.

External connections to the pickup and to the amplifier are made on a terminal board located at the bottom of the equalizer case.

An output level of approximately  $-15$  VU is obtained when this equalizer is used in conjunction with a Variable Reluctance Pickup and an amplifier of 50-db gain such as the G-E Type BA-10-A.

#### SPECIFICATIONS

##### Output Circuits:

Load Impedance . . . . . will feed 250, 150, or 30 ohm microphone pre-amplifier inputs (unloaded transformer input)

Output Connections . . . . . balanced or unbalanced  
Output Level . . . . . when used with the G-E Variable Reluctance Pickup, Type RPX-046, playing 78 RPM phonograph records, the output will be approximately  $-65$  VU

##### Dimensions:

Width . . . . .  $6\frac{7}{8}$  in.  
Height . . . . .  $3\frac{3}{4}$  in.  
Depth . . . . . 3 in.  
Weight . . . . .  $3\frac{1}{2}$  lbs.  
When Ordering Specify: Transcription Equalizer, Type FA-12-A

## Equalized transcription pre-amplifier Type BA-3-A

#### FEATURES

- Full "NAB" low-frequency response—low distortion
- Adjustable high-frequency response, including "NAB" position
- Sufficient level to feed directly into conventional mixer systems
- Low-noise Type 1620 input tube
- Tubes and chassis both shock-mounted
- Magnetically shielded output and power transformers
- Plug-in electrolytic capacitors
- Provision for tube-current checks
- Output circuits may be run either balanced or unbalanced
- Cueing circuit for headphones

#### APPLICATION

The Type BA-3-A Equalized Transcription Pre-Amplifier is a high-quality, a-c operated, equalized audio amplifier. It provides equalization for the G-E Variable Reluctance Pickup, Type RPX-046. Approximately  $-15$  VU audio output is available for feeding console mixer systems.

For the convenience of the operator, the Type BA-3-A provides an isolated cueing circuit which will feed headphones independent of the program circuit.

#### DESCRIPTION

The amplifier is built on a flat-plate chassis which mounts inside the turntable cabinet. The four-position switch which allows control of the high-frequency response mounts on the turntable either at the top or the side. Included with the switch is an escutcheon plate and knob which mounts on the top of the turntable.

The four positions of the switch are "Flat," "NAB," "Good Records," and "Poor Records." The "Flat" position provides essentially flat high-frequency response from material recorded at constant velocity. The "NAB" position provides essentially flat high-frequency response from material recorded in accordance with the "NAB" lateral curve. The "Good Records" position provides a high-frequency response somewhat more attenuated than that given by the "NAB" position. The fourth position, "Poor Records," provides a high-frequency response considerably more attenuated than that given by the "NAB" position. All switch positions provide low-frequency response essentially the complement of the "NAB" curve.

Shielded leads are provided which connects the amplifier to the pickup and to the equalizer switch. If it is desirable, leads can be connected from the amplifier to a

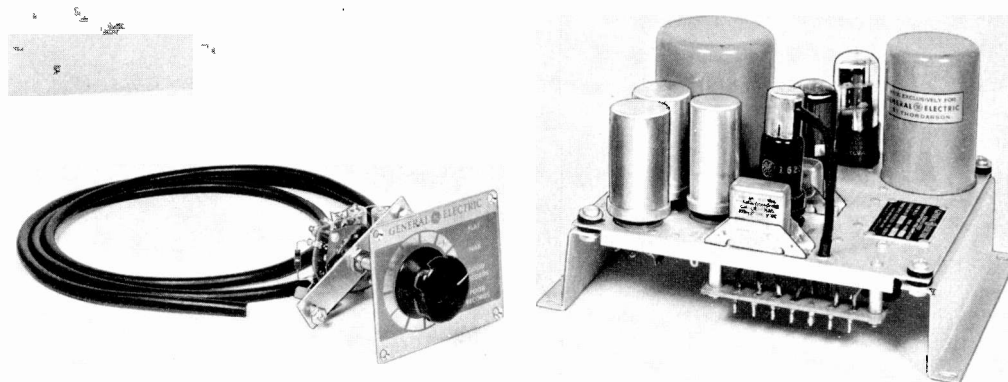

Fig. 13-5 Type BA-3-A Equalized Transcription Pre-Amplifier and escutcheon plate

headphone cueing jack. These are not furnished as part of the equipment.

The usual power and audio output leads interconnect with the station facilities. Terminals are provided for metering of tube cathode voltages. Connections may be made to a General Electric Type FA-11-A DC Metering Panel.

#### SPECIFICATIONS

Power Requirements	.....105/115/125 volts, 50/60 cycles, 20 watts
Load Impedance	.....600 or 150 ohms (balanced, or unbalanced)
Output Level	.....when used with the G-E Variable Reluctance Pickup, Type RPX-046, playing 78 RPM phonograph records, the output will be approx -15 VU
Distortion	.....0.5% or less, 50 to 15,000 cycles with up to -15 dbm output = 1% or less, 50 to 15,000 cycles with up to -5 dbm output
Noise Level	.....65 db below output level of -5 dbm

Cueing .....approx 1.5 volts, one side grounded, for use with standard headphones (medium and high impedance types)—output isolated from program circuit—cue output may be increased 6 or 10 db, if desired

#### Dimensions:

Height	.....5 in.
Width	.....9-1/16 in. (over-all)
Depth	.....7-3/4 in.
Weight	.....6 lbs.

When Ordering Specify: Equalized Transcription Pre-Amplifier, Type BA-3-A (order tubes separately)

#### ACCESSORIES

##### Tube Complement:

- 1 — type 1620\*
- 1 — type 6SN7-GT
- 1 — type 6X5

\*Type 6J7 may be used where a minimum of microphonics and hum are not required.



# distortion and noise analyzer

## Type YDA-1

### FEATURES

Four instruments in one—combines functions of:

- Distortion Meter
- Noise Meter
- Frequency Meter
- Vacuum Tube Voltmeter

Measures distortion down to 0.1 percent—voltages down to 100 microvolts

Meter readings in percent, volts, or DB

Provision for insertion of any desired frequency selective network

Balanced or single-ended input

Easy to operate

Case or rack panel mounting

### APPLICATION

The Type YDA-1 Distortion and Noise Analyzer is a high-quality, precision instrument designed especially for broadcast and laboratory use. Wherever information is required on distortion, audio noise, or hum, the YDA-1 will provide accurate measurement down to extremely low levels. It is easy to use and can be operated by untrained personnel.

### DESCRIPTION

The YDA-1 is suitable for portable use, or it may be removed from the cabinet for mounting in a standard 19-inch relay rack. Input connections are made to standard Western Electric jacks located on the front panel. A cable connector is provided at the rear of the chassis for making permanent connections to either input.

The Distortion and Noise Analyzer consists of the following principal circuit elements: output meter; high gain, stabilized audio-frequency amplifier; precision attenuator; "Bridged-T" filter circuit; input transformer and power supply.

Harmonic distortion is measured by comparing the voltage level of the signal with the fundamental present to the voltage level with the fundamental removed. Ideally this is achieved with a narrow rejection filter tuned to the fundamental frequency of the signal. The "Bridged-T" filter circuit is best suited to this application because it

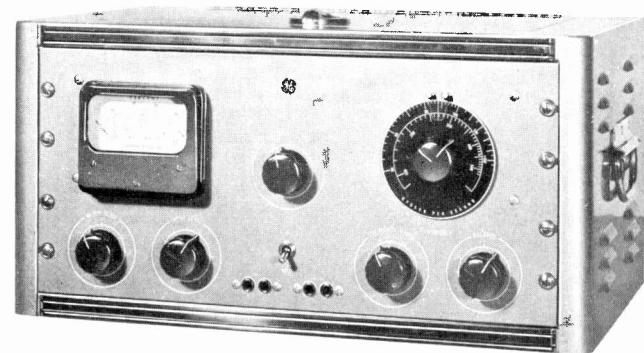

Fig. 14-1 Type YDA-1 Distortion and Noise Analyzer

provides practically infinite attenuation at the rejection frequency and permits level gain on either side. Most unique is the design of the filter circuit used in the YDA-1. A reactance tube is used as the variable inductive element in the "Bridged-T," and because of the novel, unusually high-Q reactance tube circuit employed, tuning is permitted through a wide range of frequency without loss of the desired sharp null.

The Indicating Circuit consists of a 200 microampere d-c instrument with illuminated scale for rapid and accurate measurements. It has three calibrated scales: two scales marked PERCENT are used for reading either percent distortion or absolute voltage; the third scale is calibrated in DECIBELS for reading noise or signal referred either to zero dbm or to an arbitrary input signal.

Several unusual features have been incorporated to make the instrument outstanding in its field. Among these is a balanced crystal-bridge rectifier to drive the output microammeter, an arrangement which permits wideband frequency response without need for zero adjustments. Amplifiers are designed with a large amount of negative feedback, to insure stability against line and tube variations. Generation of hum is avoided by supplying d-c heater current from a selenium rectifier to low level and other critical stages.

Another feature of special interest in broadcast and recording operations is the provision made for insertion of any desired 3-terminal network; such as, equalizers, tone controls, and other frequency weighing networks.

**SPECIFICATIONS****Distortion Measurements:**

Distortion Range .....1, 3, 10, 30 and 100% full scale

Accuracy .....5% of full scale plus 0.1% distortion

Frequency Range .....50 to 15,000 cycles

Input Voltage .....0.8 to 20 volts rms

**Absolute Noise or Voltage Measurements:**

Range .....+2 to -80 db referred to 1 milliwatt on 600 ohms or 1.0 volts to 100 microvolts, in 7 ranges

Frequency Range .....30 to 75,000 cycles per second for 100,000-ohms unbalanced input  
30 to 30,000 cycles per second for 600-ohms balanced input

Accuracy .....5% of full scale

**Relative Noise or Voltage Measurements:**

Range .....+2 to -80 db, in 7 ranges, referred to input signal

Input Voltage Range ..0.8 to 30 volts rms

Frequency Range .....30 to 75,000 cycles per second for 100,000-ohms unbalanced input  
30 to 30,000 cycles per second for 600-ohms balanced input

Accuracy .....5% of full scale

**Frequency Measurements:**

Range .....50 to 15,000 cycles in 5 ranges

Accuracy .....2%

Input Voltage .....0.8 to 20 volts rms

Input Impedance.....600 ohms unbalanced  
100,000 ohms unbalanced

**Ambient Temperature**

Range .....0 to 40C

Power Supply .....105-125 volts, 50/60 cycles commercial supply

Power Consumption... approx. 50 watts

**Dimensions:**

Width .....21 in.

Height .....10½ in.

Depth .....15 in.

Weight .....45 lbs approx

When Ordering Specify: Distortion and Noise Analyzer, Type YDA-1 (order tubes separately)

**ACCESSORIES****Tube Complement Consists of:**

3 — type 6SJ7

2 — type 6J5

1 — type 1620

1 — type 6SL7-GT

1 — type OD3/VR150

1 — type 5Y3GT

**Input Connectors**

1 — Western Electric Cat. DB-99

1 — Amphenol Cat. 80-MC2M

# Square wave generator Type YGL-1

**FEATURES**

Wide fundamental frequency range

Excellent wave form

Excellent stability

Step attenuator output control

Provisions for external synchronization

Electronically regulated power supply

Versatile mounting—supplied in cabinet but can be removed for mounting in a standard 19-inch relay rack

**APPLICATION**

The Type YGL-1 Square Wave Generator is a high-quality, precision-type instrument which produces a square wave of excellent form. It can be used for a wide variety of audio circuit testing.

**DESCRIPTION**

The YGL-1 delivers a rectangular wave output voltage with a negative pulse width of 25 percent. This relationship is desirable in that it assures the presence of both odd and even harmonics in the output, since a 50-percent relationship would eliminate the latter. The rise time of the leading edge of pulses is approximately .3 microsecond.

The circuit consists of two 6J5 tubes in a positive bias-type multivibrator circuit, followed by two 6AG7 clipper stages to improve the waveform. The self-contained power supply is electronically regulated to provide stable output under conditions of commercial line-voltage fluctuation.

The output may be synchronized to an external source if desired.

**SPECIFICATIONS**

Power Supply .....105-125 volts, 50-60 cycles commercial a-c; power consumption, 100 watts; self-contained, electronically regulated power supply



Fig. 14-2 Type YGL-1 Square Wave Generator

Pulse Characteristic . . . . .rectangular wave output with a 25% negative pulse  
 Rise Time . . . . .approximately .3 microsecond  
 Fundamental Frequency  
 Range . . . . .six overlapping ranges to give continuous coverage from 5 to 125,000 cycles  
 Output Voltage . . . . .variable from 0 to 5 volts, and in steps at 5, 10, 15, 25, 50, and 75 volts  
 Output Impedance . . . . .100 ohms at 5 volts, approximately 20 ohms/volts at all outputs  
 Synchronization . . . . .approximately 1.5 volts required for lock-in — higher voltages are required for lock-in with low-frequency sine waves—a "sync" input-level control is provided

Ambient Temperature . . . . .0 to 40C

#### Dimensions

##### Cabinet Model:

Height . . . . .10½ in.  
 Width . . . . .20¾ in.  
 Depth . . . . .14¾ in.

##### Rack Mounting:

Height . . . . .8¾ in.  
 Width . . . . .19 in.  
 Depth . . . . .11¼ in.

#### Weight:

Cabinet Model . . . . .48 lbs  
 Rack Mounting . . . . .44 lbs

When Ordering Specify: Square Wave Generator, Type YGL-1 (order tubes separately)

#### ACCESSORIES

##### Tube Complement

Consists of: 2 — type 6J5  
 2 — type 6AG7

# Oscilloscope Type ST-2A

#### FEATURES

- High sensitivity
- Exceptional stability
- Wide frequency response
- DC amplifier
- Excellent linearity
- Low capacity input probe (supplied as standard equipment)
- Z axis input
- Calibrating voltages provided
- Regulated power supply
- Safety window and rubber mounting for CR tube
- Direct connection to deflection plates

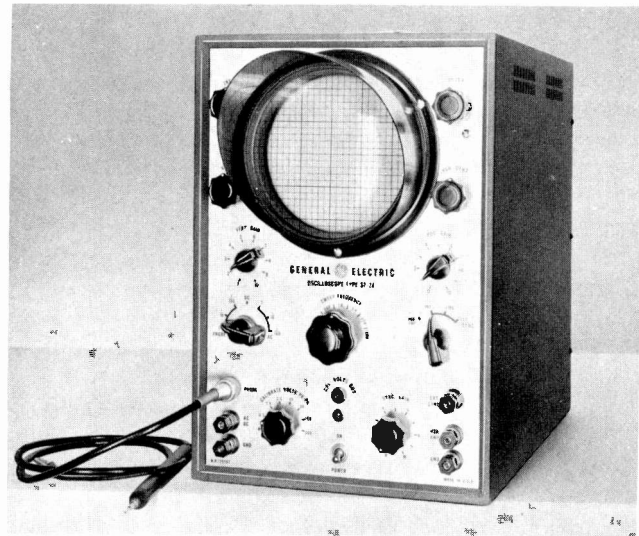

Fig. 14-3 Type ST-2A Oscilloscope

#### APPLICATION

The Type ST-2A Oscilloscope is a high-quality, 5-inch oscilloscope designed to fill the need for a general purpose instrument. Several special features including a DC amplifier are provided to adapt the equipment to a wide range of applications.

#### DESCRIPTION

The size and weight of the ST-2A have been held to a minimum consistent with good construction. The cathode ray tube is cradled in rubber and is provided with a ¼-inch thick safety window. The tube is a type 5UP1 which provides a very sharp and bright trace.

The controls are conveniently grouped according to their functions and a dual control is used for the sweep oscillator.

The input attenuator to the vertical amplifier has been especially designed to allow adaptation of the unit to many uses. This compensated attenuator will faithfully attenuate voltages by as much as 1000 to 1 without frequency discrimination. There is a probe input for testing circuits that withstand only a minimum of capacitive and resistive loading. Binding posts for both a-c and d-c amplifier inputs are provided.

The usefulness of this oscilloscope is increased because the vertical input circuit can handle direct voltages. This direct coupled input is very useful in testing industrial equipment and also for television and other circuits where both a d-c and an a-c component of voltage are present.

Adequate drive from the deflection amplifiers makes it possible to expand the pattern to several times the diameter of the tube. This permits better observation of short-duration pulses and allows closer observation of parts of a wave pattern.

Since the output stages of both the horizontal and vertical amplifiers are d-c coupled, the positioning controls are positive in their action and the trace responds immediately to any change in the positioning control settings. The am-

plifier circuits are not prone to overload and when overdriven, the recovery time is very rapid.

Wide frequency response is obtained without recourse to peaked amplifier coupling circuits. Straight resistive coupling is used and there is no positive slope to the frequency response curve, which falls off so gradually that the scope can be used on input frequencies up to 3 mc.

All low-level amplifier and sweep stages are supplied with d-c operating potentials from an electronically regulated power supply which allows the oscilloscope to be used under unusually severe power line fluctuations.

To aid in amplitude measurements of voltage under test, a standard voltage source is available from a pin-jack on the front panel. This calibrating voltage may be varied in seven steps—from .3 volts to 300 volts (peak-to-peak).

The intensity of the cathode ray beam may be modulated from a "Z Axis" input jack which is located on the back, along with the fuse, the power cord, and the astigmatism control. It is seldom necessary to adjust the astigmatism control but its availability is desirable if the 'scope is used at very high intensity levels such as might be required for group demonstrations.

The deflection plates of both the horizontal and vertical axis of the cathode ray tube are available at binding posts at the rear for direct connection. It is necessary only to turn a switch to cut out the amplifiers and connect to the plates direct.

## SPECIFICATIONS

(All ratings based on a nominal 117-volt line)

Input Impedance:

Vertical	AC Input—1 megohm shunted by 36 mmfd
	DC Input—1 megohm shunted by 80 mmfd at maximum gain setting
	Probe—1 megohm shunted by 10 mmfd
Horizontal	1 megohm shunted by 30 mmfd
Plates Direct	5 megohms shunted by 11 mmf

Frequency Response:

Vertical Amplifier	Probe and AC — +0, -20% from 20 cycles to 500 kc (square wave response 60 to 40,000 cycles) any gain setting
	+0, -50% from 20 cycles to 1 megacycle with gradual reduction in response beyond 1 megacycle
	DC — +0, -20% from 0 to 500 kc at full gain setting

Horizontal Amplifier .. +0, -20% from 20 to 100 kc at any gain setting

Sensitivity:

Vertical	AC Input — .015 volts rms per inch
	DC Input — 2.0 volts d-c per inch
	Probe — .20 volts rms per inch

Horizontal ..... 0.4 rms volts per inch

Maximum Input

Potential ..... 500 v peak, vertical

7 v peak, horizontal

Sweep Range ..... 10 cycles to 100 kc in six overlapping ranges

Synchronization ..... Internal, external, or power line

Linearity:

Vertical and

Horizontal ..... less than 10% non-linearity at full-scale deflection

Sweep ..... less than 15% non-linearity over 80% of forward sweep

Calibrating Voltages ... seven a-c voltages of power line frequency — .3, 1.5, 3, 15, 30, 150 and 300 volts with  $\pm 15\%$  accuracy

Ambient Temperature ... 0 to 40C

Power Requirements ..... 105-125 volts a.c., 50-60 cycle, 100 watts

Dimensions:

Height ..... 15½ in.

Width ..... 10 in.

Depth ..... 17 in.

Weight ..... 43 lbs

When Ordering Specify: Oscilloscope, Type ST-2A

## ACCESSORIES

Tube Complement

Consists of:	1—type 5UP1
	1—type 6SJ7
	1—type 5V4G
	1—type 6AS7G
	1—OA3/VR75
	1—type 6C4
	3—type 12AT7
	1—type 2X2A
	2—type 6SN7
	1—type 12AX7
	1—type 6Y6
	1—type 6SL7
	1—type OD3/VR150
	1—type 5Y3

# data

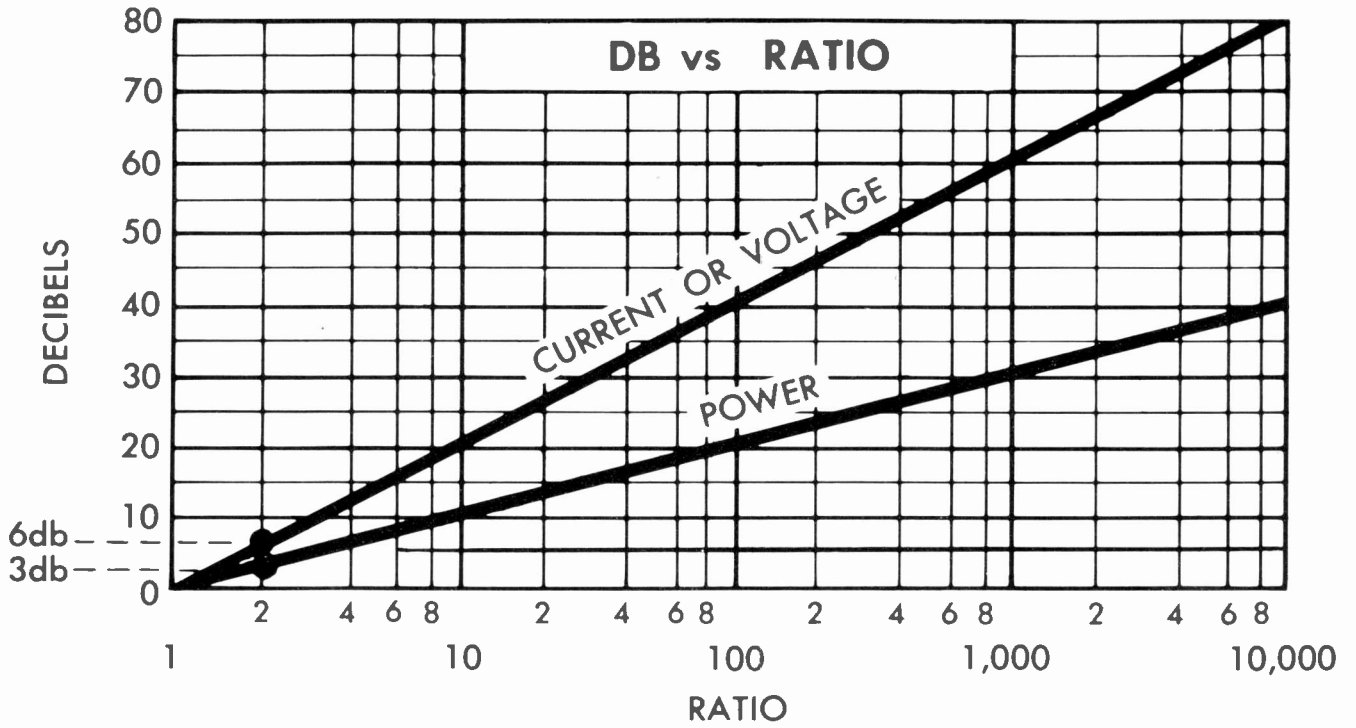

Fig. 15-1

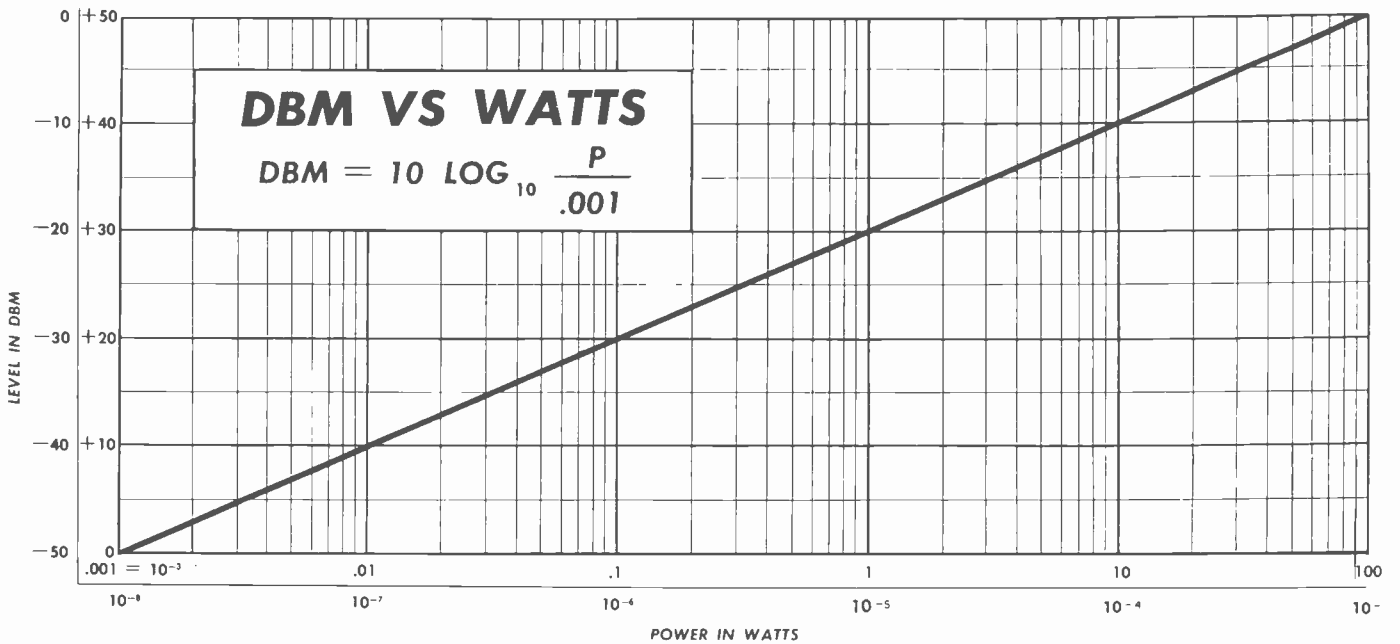
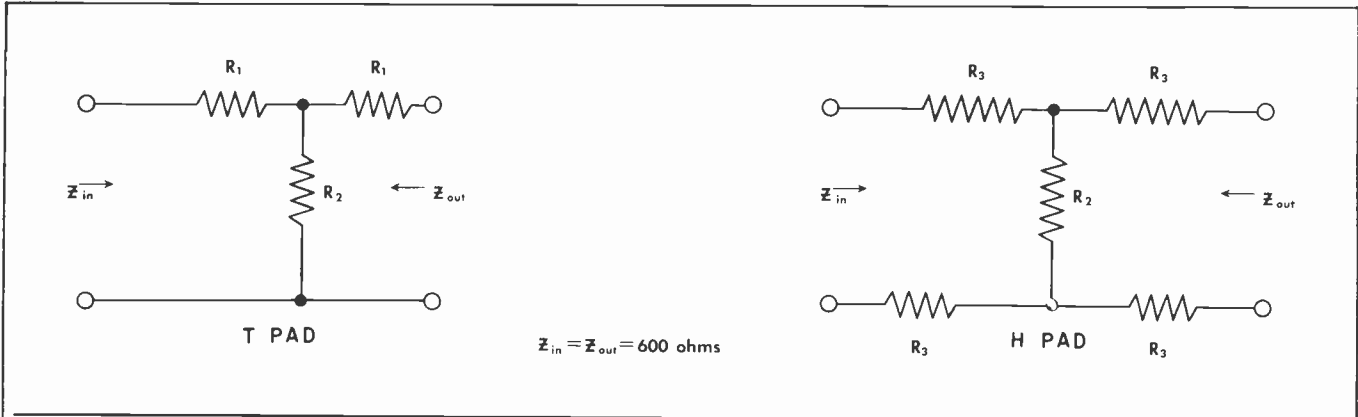

Fig. 15-2



Loss in DB	RMA Resistor Values*			Loss in DB	RMA Resistor Values*		
	R <sub>1</sub>	R <sub>2</sub>	R <sub>3</sub>		R <sub>1</sub>	R <sub>2</sub>	R <sub>3</sub>
1/2	18	10,000	8.2	16	430	200	220
1	36	5,100	18	17	470	180	220
2	68	2,700	36	18	470	150	240
3	100	1,800	51	19	470	130	240
4	130	1,200	68	20	510	120	240
5	160	1,000	82	22	510	100	270
6	200	820	100	24	510	75	270
7	220	680	110	26	560	62	270
8	270	560	130	28	560	47	270
9	300	470	150	30	560	39	270
10	300	430	160	32	560	30	300
11	330	360	160	34	560	24	300
12	360	330	180	36	560	18	300
13	390	270	200	38	560	15	300
14	390	240	200	40	560	12	300
15	430	220	200				

\*RMA resistor values nearest to the exact values are given

Fig. 15-3 Resistive pads

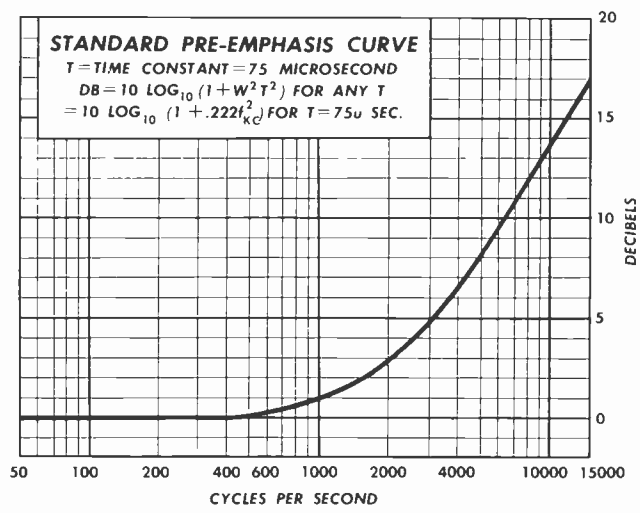

Fig. 15-4

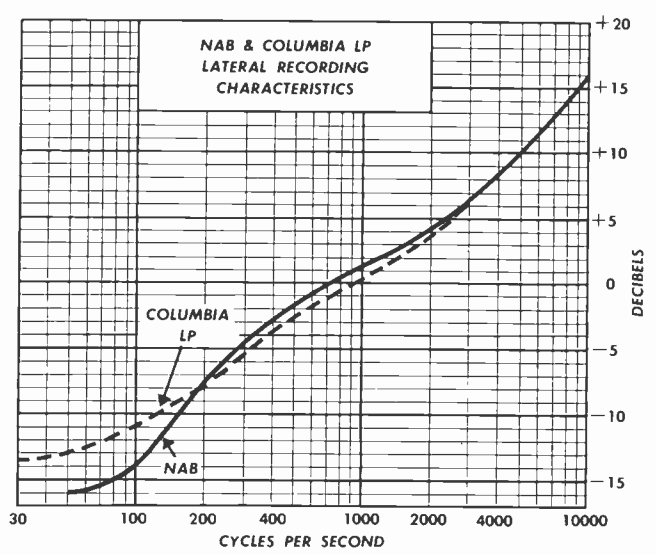

Fig. 15-5

# Use of limiter in fm systems

When using a limiting amplifier in a pre-emphasized system such as FM, special operating conditions prevail. These conditions necessitate consideration of whether the primary function of the limiting amplifier is to be (a) prevention of overmodulation, or (b) increase in average modulation.

## A. OVERMODULATION GUARD

In FM systems receiver distortion may become objectionable if the transmitter swing is appreciably greater than  $\pm 75$  KC at any time.

To prevent overswing, the limiter should be located after the pre-emphasis network (see Fig. 15-6). In this way program material containing high signal voltages at the higher frequencies (which frequently result when certain types of program material rich in highs are passed through the pre-emphasis network) will be effectively reduced in gain by the limiting amplifier. Thus overswing is prevented.

However, when the limiter follows the pre-emphasis network it is not feasible to employ a large amount of limiting

because the program will suffer changes in loudness without apparent good reason. This is the result of the pre-emphasis increasing the intensity of high-frequency components of the program material to such an extent that they initiate gain-reduction even when the mid, loudness-controlling frequencies do not require it.

## B. INCREASE OF AVERAGE MODULATION LEVEL

If the limiter is to be used primarily to increase the average modulation level of the FM transmitter, it should be located ahead of the pre-emphasis network (Fig. 15-7); that is, it should work in the flat portion of the audio system where gain-reduction is initiated by any peak above threshold. In practice, this means that gain reduction will generally be initiated by the mid, loudness-controlling frequencies.

It should be understood that such use seriously impairs the prevention of overmodulation by the limiter. This is because the controlled output of the limiting amplifier, which does not vary with frequency, is passed through pre-emphasis, causing the level fed to the transmitter to vary with frequency. When the limiting amplifier is located ahead of pre-emphasis, the transmitter operator must monitor the modulation level and maintain peaks within acceptable limits.

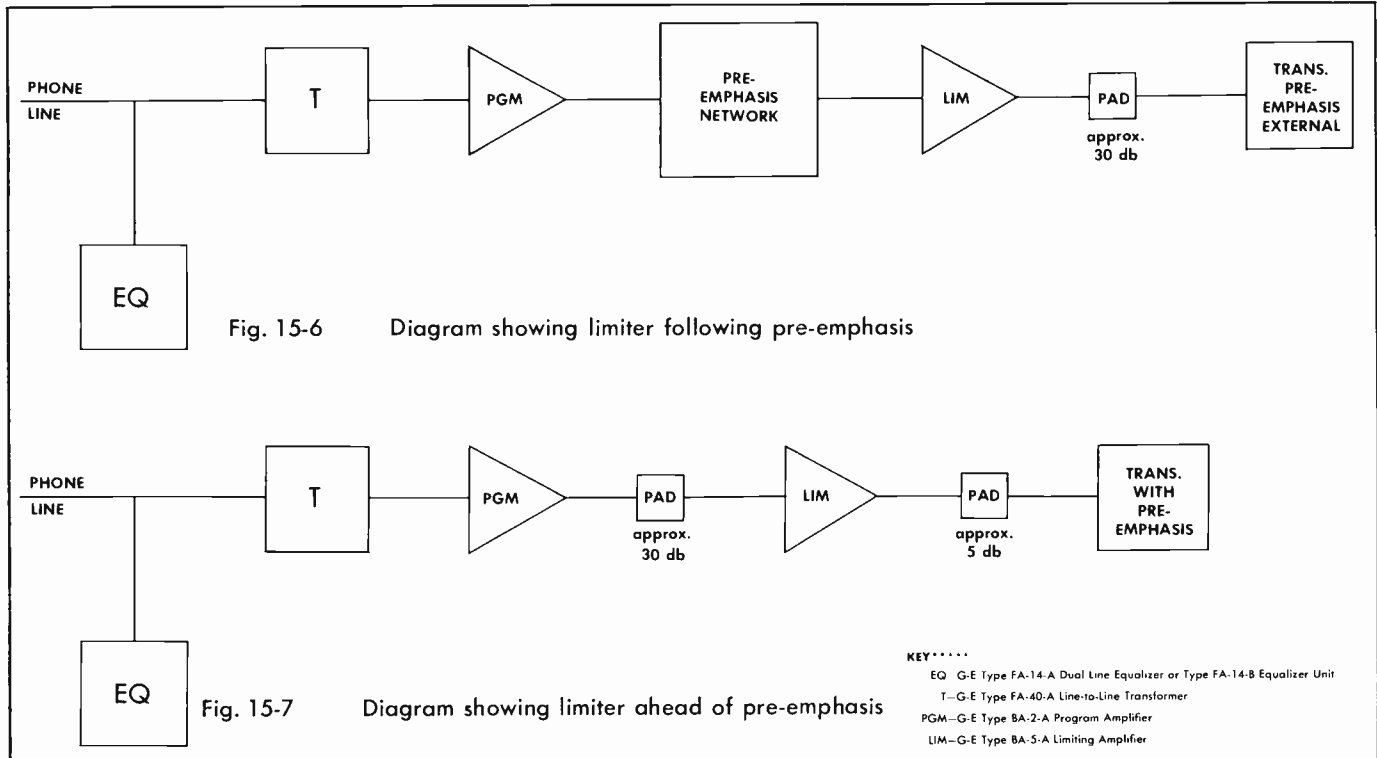

# Equipment list

## 1. studio audio facilities for am or fm

Suggested equipment list for handling two studios, control room, announce booth, two turntables, and equalization of remote lines.

Item	Quantity	Description
1	1	Two-Studio Console, Type BC-1-A
2	1	Set of tubes for BC-1-A
3	4	Relay Assembly, Type FA-20-A (for "On-Air" & "Audition" lights and announce speaker)
3A	2	"Audition" light
3B	4	"On-Air" light
4	1	Cabinet Rack, Type FA-8-C
5	1	Cabinet Rack Accessory Kit, Type FA-9-A
6	2	Double-row Jack Strips, Type FA-2-A
7	1	Double Jack Panel, Type FA-3-B
8	1	Equalizer Panel, Type FA-14-A
9	1	Monitoring Amplifier, Type BA-4-E (for house monitor)
10	1	Set of tubes for BA-4-E
11	1	Switch & Fuse Panel, Type FA-4-A
12	4	Blank Panel, Type FA-6-D
13	3	Blank Panel, Type FA-6-E
14	4	2 ft. Patch Cord, Type FA-7-A
15	2	Transcription Turntable
16	2	Transcription Arm, Type FA-21-A
17	2	RPX-046 Variable Reluctance Pick-up and Stylus
18		Either of the following equalizer combinations
	2	a) Equalized Transcription Pre-Amplifier, Type BA-3-A
	2	Set of tubes for BA-3-A
	2	b) Utility Input Amplifier, Type BA-10-A
	2	Sets of tubes for BA-10-A
	2	Transcription Equalizer, Type FA-12-A
19	2	Velocity Microphone
20	2	Directional Microphone
21	1	Pressure Microphone (for announce booth)
22	1	"Bantam" Velocity Microphone (for control room)
23	2	Program Stand
24	1	Floor Stand
25	1	Boom Stand
26	1	Desk Stand
27	1	Desk Stand for "Bantam" Microphone
28	6	Microphone Plugs, Type FA-16-A
29	6	Microphone Receptacle, Type FA-16-C
30	2	Monitoring Speaker, Type FS-1-A
31	2	Monitoring Speaker Base, Type FA-17-A
32	3	Studio Wall Speaker, Type FS-2-A
33	1	High-fidelity Headphones

34	1000 ft	Interconnecting Cable, Type FA-19-E (rack & general-purpose wiring)
35	500 ft	Interconnecting Cable, Type FA-19-F (speaker wiring)
36	500 ft	Interconnecting Cable, Type FA-19-J

## 2. audio remote equipment for am or fm

Item	Quantity	Description
1	1	Portable Amplifier, Type BA-6-A
2	1	Set of tubes for BA-6-A
3	1	Set of batteries for BA-6-A
4	1	Fabric Protective Cover for BA-6-A, Type FA-24-A
5	1 to 4	Microphones
6	1 to 4	Male Microphone Plug (for input receptacle)
7	2	Female Microphone Plug (for output receptacles)
8	250 ft	Microphone Cable, Type FA-15-A
9	as required	Portable or Collapsible Microphone Stand
10	1	High-fidelity Headphones

Note: To make up microphone-extension cable use one each of Items 6 and 7 and the required length of Item 8.

## 3. audio monitoring facilities at am or fm transmitter

(TRANSMITTER & STUDIOS AT DIFFERENT LOCATIONS)

Item	Quantity	Description
1	1	Transmitter Console, Type BC-3-A, with extension meters from station monitor
2	1	Cabinet Rack, Type FA-8-C
3	1	Cabinet Rack Accessory Kit, Type FA-9-A
4	2	Double Row Jack Strip, Type FA-2-A
5	1	Double Jack Panel, Type FA-3-B
6	1	Equalizer Panel, Type FA-14-A
7	1	Program Level Indicator Panel, Type FA-1-A
8	1	FM Station Monitor, Type BM-1-A (includes one set of tubes and one set of two crystals)
9	or 1	AM Modulation and Frequency Monitor (includes one set of tubes and one set of two crystals)
10	1	Monitoring Amplifier, Type BA-4-E
11	1	Set of Tubes for BA-4-E
12	1	Switch and Fuse Panel, Type FA-4-A
13	1	Program Amplifier, Type BA-2-A (for use as a phone line booster amplifier: (1) when equalized phone line level is low (AM or FM), or, (2) when limiter follows pre-emphasis (FM))
14	1	Set of Tubes for BA-2-A
15	1	Limiting Amplifier, Type BA-5-A (Program Amplifier, Type BA-2-A may be substituted)
16	1	Set of tubes for BA-5-A
17	1	Utility Input Amplifier, Type BA-10-A



18	1	Set of Tubes for BA-10-A	1	Set of Tubes for BA-10-A
19	1	Panel and Mounting, Type FA-5-A (for BA-10-A Amplifiers)	1	Transcription Equalizer, Type FA-12-A
20	4	2 ft. Patch Cord, Type FA-7-A	1	Transmitter Announce Microphone
21	1	Transcription Turntable	1	Desk Stand for Microphone
22	1	Transcription Arm, Type FA-21-A	1	Microphone Plug, Type FA-16-A
23	1	RPX-046 Variable Reluctance Pickup and Stylus	1	Microphone Receptacle, Type FA-16-C
24		Either of the following equalizer combinations:	1	Monitoring Speaker, Type FS-1-A
	1	a) Equalized Transcription Pre-Amplifier, Type BA-3-A (mount in TT cabinet)	1	Monitoring Speaker Base, Type FA-17-A
	1	Set of Tubes for BA-3-A	1	High-fidelity Headphone
	1	b) Utility Input Amplifier, Type BA-10-A (mount in TT cabinet)	1000 ft	Interconnecting Cable, Type FA-19-E (for rack and general-purpose wiring)
			500 ft	Interconnecting Cable, Type FA-19-F (for speaker wiring)
			500 ft	Interconnecting Cable, Type FA-19-J (for filament and power wiring)

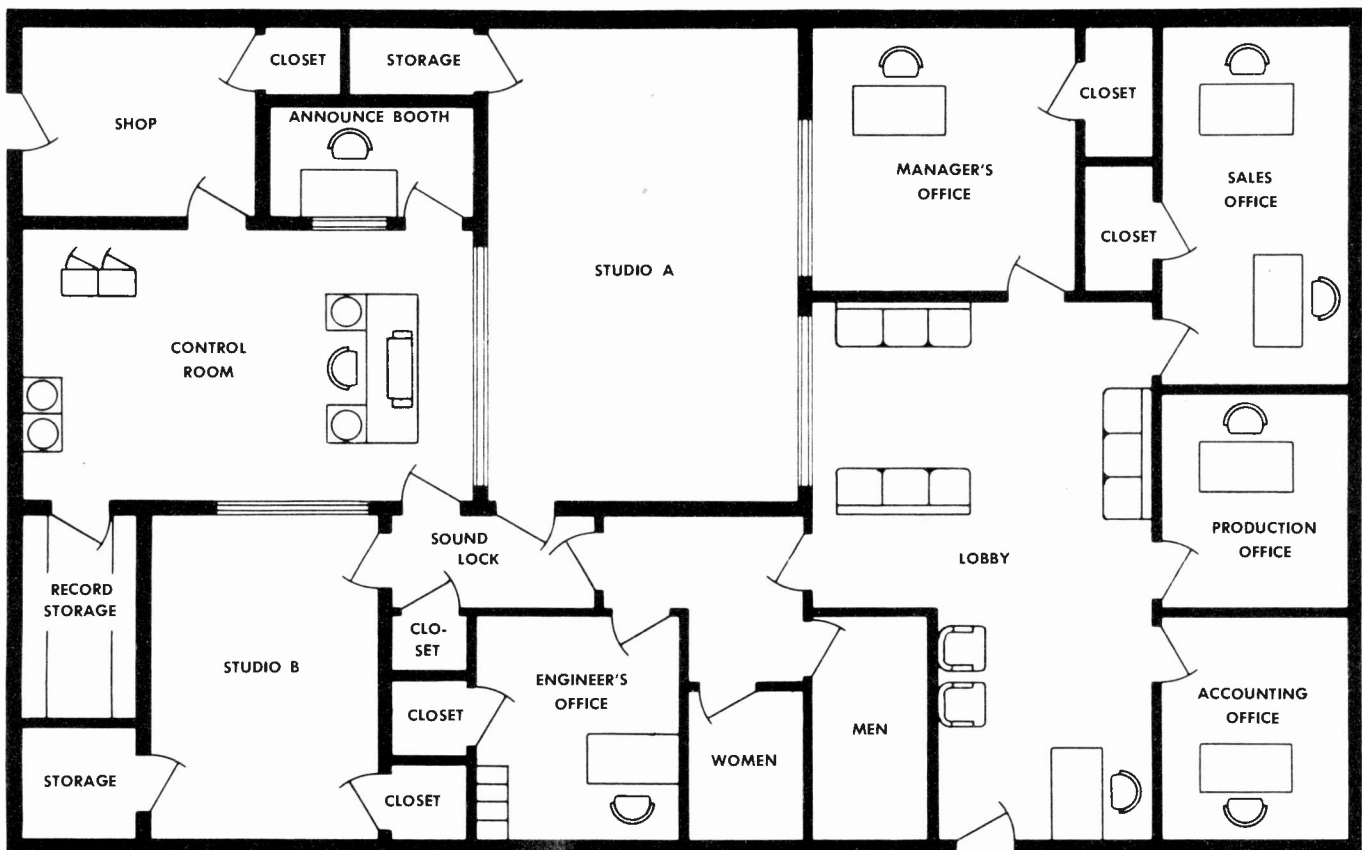

## SUGGESTED STUDIO LAYOUT

Fig. 15-8



# HOW TO ORDER GENERAL ELECTRIC AUDIO EQUIPMENT

The equipment listed in this catalog may be ordered by any of the following methods. Use the system that is most convenient and satisfactory to you.

## 1. TELEGRAPHIC ORDERS

Specify the equipment by type number and description, and also give your order number if an order number system is used at your station. Give complete shipping address and method of shipment required — that is, Air Express, Railway Express, etc. All telegraphic orders should be confirmed by a formal signed order as soon as possible. This formal order should be marked "Confirmation of Telegraphic Order Dated . . ."

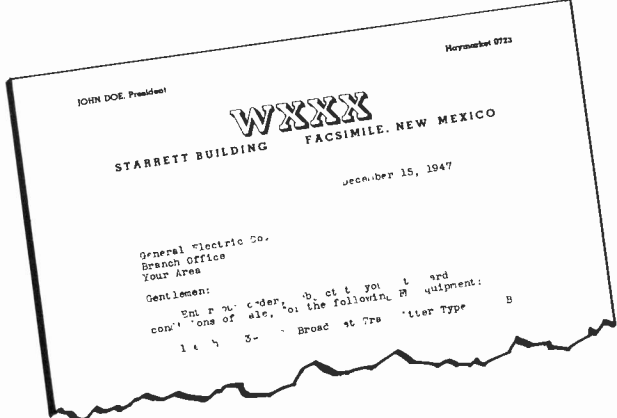
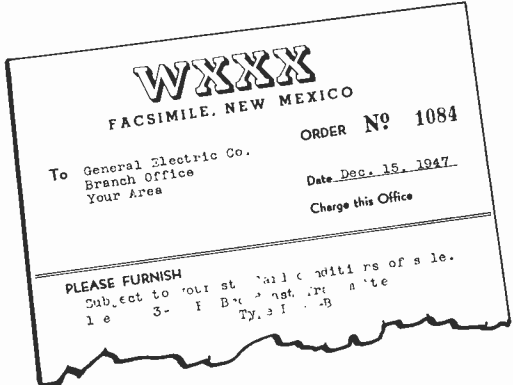
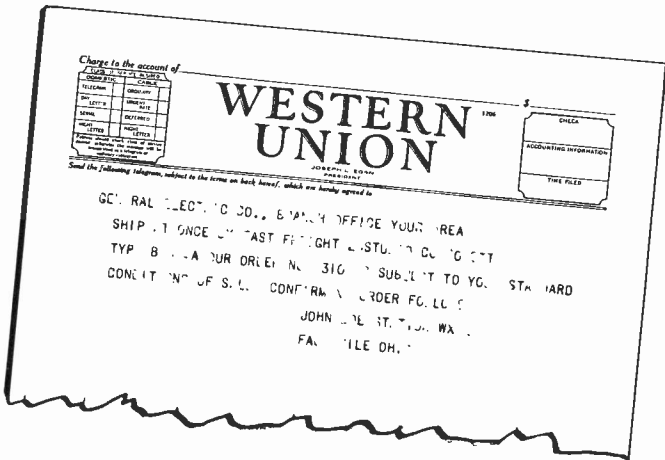

## 2. PURCHASE ORDERS

We suggest that you use either your station order blank or the convenient order blanks included in this catalog. All equipment ordered should be specified by type number and a complete description given in the space provided. Make certain your complete shipping address is shown and specify how the equipment should be shipped.

## 3. LETTER ORDERS

If you are temporarily out of order blanks, write us a letter stating the equipment you want. We will be glad to ship the equipment at the earliest possible date, subject to our standard conditions of sale.

See list of G-E district offices on back of this page

## **G-E OFFICES AT YOUR SERVICE**

### **ATLANTA 3, GEORGIA**

187 Spring Street, N.W.

### **BOSTON 1, MASSACHUSETTS**

140 Federal Street

### **CINCINNATI 2, OHIO**

215 West Third Street

### **CHICAGO 54, ILLINOIS**

1122 Merchandise Mart

### **CLEVELAND 14, OHIO**

710 Williamson Building  
Euclid Avenue and Public Square

### **DALLAS 2, TEXAS**

901 Ross Avenue

### **DENVER 2, COLORADO**

650 Seventeenth Street

### **DETROIT 26, MICHIGAN**

3037 Book Tower

### **KANSAS CITY 6, MISSOURI**

106 West Fourteenth Street

### **LOS ANGELES 14, CALIFORNIA**

530 West Sixth Street  
1300-01 Security Title Insurance Bldg.

### **MINNEAPOLIS 2, MINNESOTA**

12 South Sixth Street

### **NEW YORK 22, NEW YORK**

570 Lexington Avenue

### **PHILADELPHIA 2, PENNSYLVANIA**

1405 Locust Street

### **SALT LAKE CITY 9, UTAH**

200 South Main Street

### **SAN FRANCISCO 6, CALIFORNIA**

235 Montgomery Street

### **SEATTLE 4, WASHINGTON**

710 Second Avenue

### **SYRACUSE 1, NEW YORK**

Electronics Park

### **WASHINGTON 5, D. C.**

806 Fifteenth Street, N.W.

CUSTOMER'S PURCHASE ORDER

PLACED WITH

ELECTRONICS DEPARTMENT

**GENERAL ELECTRIC**

COMPANY

COMMERCIAL EQUIPMENT DIVISION, SYRACUSE, N. Y.

(LEAVE BLANK)

REQ'N NO.

DATE

CUSTOMER'S  
ORDER NO.

DATE

The warranty period referred to in the provisions entitled "WARRANTY" for the items described herein is one year.

CUSTOMER

\_\_\_\_\_  
\_\_\_\_\_  
\_\_\_\_\_

SHIP F.O.B. FACTORY TO

\_\_\_\_\_  
\_\_\_\_\_  
\_\_\_\_\_

TOM F. BOST, JR.  
GENERAL ELECTRIC CO.  
ELECTRONIC DEPT.  
187 SPRING ST., N. E.  
ATLANTA, GA.

SHIP VIA

QUANTITY ORDERED	TYPE NO.	DESCRIPTION	UNIT PRICE	TOTAL PRICE

CUSTOMER

BY

SIGNATURE



## STANDARD CONDITIONS OF SALE

**1. WARRANTY**—The Company warrants that the apparatus shall be of the kind and quality described in the specifications and free from defects in material or workmanship, and no other warranty, except of title, shall be implied. The conditions of any tests shall be mutually agreed upon, and the Company shall be notified of, and may be represented at, all tests that may be made. If any failure to comply with the specifications or if any defect in material or workmanship appears within the period specified on the front of this page, the Purchaser shall notify the Company thereof immediately and the Company shall correct the defect by repairing the defective part or by supplying a replacement therefor at the Company's expense. But if the apparatus is installed by the Company or its installation supervised by the Company, said warranty period shall run from the completion of installation, provided same is not unreasonably delayed by the Purchaser.

It is understood that any defective part will not be returned until authorized by the Company.

In lieu of the foregoing, the Company's standard published tube warranties in effect on the date hereof shall apply to any electronic tubes incorporated in or supplied with the apparatus.

The liability of the Company (except as to title) arising out of the supplying of said apparatus, or its use, whether on warranties or otherwise, shall be limited to the correction of defects as aforesaid and upon expiration of the warranty period all such liability shall terminate.

**2. PATENTS**—The Company shall defend any suit or proceeding brought against the Purchaser so far as based on a claim that any apparatus, or any part thereof, furnished under this contract constitutes an infringement of any patent of the United States, if notified promptly in writing and given authority, information and assistance (at the Company's expense) for the defense of same, and the Company shall pay all damages and costs awarded therein against the Purchaser. In case said apparatus, or any part thereof, is in such suit held to constitute infringement and the use of said apparatus or part is enjoined, the Company shall, at its own expense either procure for the Purchaser the right to continue using said apparatus or part; or replace same with non-infringing apparatus; or modify it so it becomes non-infringing; or remove said apparatus and refund the purchase price and the transportation and installation costs thereof. The foregoing states the entire liability of the Company for patent infringement by said apparatus or any part thereof.

**3. DELIVERY**—Unless otherwise specifically provided, delivery of the apparatus hereunder shall be made f.o.b. point of shipment. Shipping dates are approximate and are based upon prompt receipt of all necessary information.

The Company shall be liable for damages caused by delay in delivery when due to its fault or negligence, but it shall not be liable for delay due to causes beyond its reasonable control, such as acts of God, acts of the Purchaser, acts of civil or military authority, priorities, fires, strikes, floods, epidemics, quarantine restrictions, war, riots, delays in transportation, car shortages and

inability due to causes beyond its reasonable control to obtain necessary labor, materials, or manufacturing facilities. In the event of any such delay, the date of delivery shall be deferred for a period equal to the time lost by reason of the delay.

**4. PAYMENTS**—If, in the judgment of the Company, the financial condition of the Purchaser at any time does not justify continuance of production or shipment on the terms of payment specified, the Company may require full or partial payment in advance.

Pro rata payments shall become due as shipments are made and, if shipments are delayed by the Purchaser, such payments shall become due from the date when the Company is prepared to make shipment. If manufacture is delayed by the Purchaser, payment shall be made based on the contract price and the percentage of completion. Apparatus held for the Purchaser shall be at the risk and expense of the Purchaser. The Company reserves the right to ship to its order and make collection by sight draft with bill of lading attached.

**5. TITLE**—Title and right of possession of the apparatus sold hereunder shall remain with the Company and such apparatus shall remain personal property until all payments hereunder (including deferred payments whether evidenced by notes or otherwise) shall have been made in full in cash, and the Purchaser agrees to do all acts necessary to perfect and maintain such right and title in the Company. Risk of loss or damage, however, is on the Purchaser from delivery of the apparatus hereunder f.o.b. point of shipment.

**6. SALES AND SIMILAR TAXES**—The Company's prices do not include sales, use, excise or similar taxes. Consequently, in addition to the prices specified herein, the amount of any present or future sales, use, excise or other similar tax applicable to the sale of the apparatus hereunder shall be paid by the Purchaser, or in lieu thereof the Purchaser shall provide the Company with a tax-exemption certificate acceptable to the taxing authorities.

**7. CANCELLATION**—The Purchaser may cancel his order upon payment of reasonable cancellation charges which shall take into account expenses already incurred and commitments made by the Company.

**8. GENERAL**—In no event shall any claim for consequential damages be made by either party.

The Company will comply with all applicable federal, state and local laws.

No addition to or modification of any of the provisions upon the face or reverse hereof shall be binding unless made in writing and signed by an executive officer of the Company, or by the Manager or an Assistant Manager of its Electronics Department, or by the Manager or Manager of Sales of the Commercial Equipment Division of its Electronics Department.

Any provisions or conditions of the Purchaser's order which are in any way inconsistent with or in addition to these Standard Conditions of Sale (except additional provisions specifying quantity, character of the apparatus ordered, and shipping instructions) shall not be binding on the Company and shall not be considered applicable to this sale.

**CUSTOMER'S PURCHASE ORDER**  
 PLACED WITH  
 ELECTRONICS DEPARTMENT  
**GENERAL  ELECTRIC**  
 COMPANY  
 COMMERCIAL EQUIPMENT DIVISION, SYRACUSE, N. Y.

CUSTOMER'S  
ORDER NO.

DATE

(LEAVE BLANK)  <b>REQ'N NO.</b>  DATE
---

The warranty period referred to in the provisions entitled "WARRANTY" for the items described herein is one year.

CUSTOMER

---



---



---

SHIP F.O.B. FACTORY TO

---



---



---

**TOM F. BOST, JR.**  
 GENERAL ELECTRIC CO.  
 ELECTRONIC DEPT.  
 187 SPRING ST., N. E.  
 ATLANTA, GA.

SHIP VIA

QUANTITY ORDERED	TYPE NO.	DESCRIPTION	UNIT PRICE	TOTAL PRICE

\_\_\_\_\_  
 CUSTOMER  
  
 BY \_\_\_\_\_  
 SIGNATURE



## STANDARD CONDITIONS OF SALE

**1. WARRANTY**—The Company warrants that the apparatus shall be of the kind and quality described in the specifications and free from defects in material or workmanship, and no other warranty, except of title, shall be implied. The conditions of any tests shall be mutually agreed upon, and the Company shall be notified of, and may be represented at, all tests that may be made. If any failure to comply with the specifications or if any defect in material or workmanship appears within the period specified on the front of this page, the Purchaser shall notify the Company thereof immediately and the Company shall correct the defect by repairing the defective part or by supplying a replacement therefor at the Company's expense. But if the apparatus is installed by the Company or its installation supervised by the Company, said warranty period shall run from the completion of installation, provided same is not unreasonably delayed by the Purchaser.

It is understood that any defective part will not be returned until authorized by the Company.

In lieu of the foregoing, the Company's standard published tube warranties in effect on the date hereof shall apply to any electronic tubes incorporated in or supplied with the apparatus.

The liability of the Company (except as to title) arising out of the supplying of said apparatus, or its use, whether on warranties or otherwise, shall be limited to the correction of defects as aforesaid and upon expiration of the warranty period all such liability shall terminate.

**2. PATENTS**—The Company shall defend any suit or proceeding brought against the Purchaser so far as based on a claim that any apparatus, or any part thereof, furnished under this contract constitutes an infringement of any patent of the United States, if notified promptly in writing and given authority, information and assistance (at the Company's expense) for the defense of same, and the Company shall pay all damages and costs awarded therein against the Purchaser. In case said apparatus, or any part thereof, is in such suit held to constitute infringement and the use of said apparatus or part is enjoined, the Company shall, at its own expense either procure for the Purchaser the right to continue using said apparatus or part; or replace same with non-infringing apparatus; or modify it so it becomes non-infringing; or remove said apparatus and refund the purchase price and the transportation and installation costs thereof. The foregoing states the entire liability of the Company for patent infringement by said apparatus or any part thereof.

**3. DELIVERY**—Unless otherwise specifically provided, delivery of the apparatus hereunder shall be made f.o.b. point of shipment. Shipping dates are approximate and are based upon prompt receipt of all necessary information.

The Company shall be liable for damages caused by delay in delivery when due to its fault or negligence, but it shall not be liable for delay due to causes beyond its reasonable control, such as acts of God, acts of the Purchaser, acts of civil or military authority, priorities, fires, strikes, floods, epidemics, quarantine restrictions, war, riots, delays in transportation, car shortages and

inability due to causes beyond its reasonable control to obtain necessary labor, materials, or manufacturing facilities. In the event of any such delay, the date of delivery shall be deferred for a period equal to the time lost by reason of the delay.

**4. PAYMENTS**—If, in the judgment of the Company, the financial condition of the Purchaser at any time does not justify continuance of production or shipment on the terms of payment specified, the Company may require full or partial payment in advance.

Pro rata payments shall become due as shipments are made and, if shipments are delayed by the Purchaser, such payments shall become due from the date when the Company is prepared to make shipment. If manufacture is delayed by the Purchaser, payment shall be made based on the contract price and the percentage of completion. Apparatus held for the Purchaser shall be at the risk and expense of the Purchaser. The Company reserves the right to ship to its order and make collection by sight draft with bill of lading attached.

**5. TITLE**—Title and right of possession of the apparatus sold hereunder shall remain with the Company and such apparatus shall remain personal property until all payments hereunder (including deferred payments whether evidenced by notes or otherwise) shall have been made in full in cash, and the Purchaser agrees to do all acts necessary to perfect and maintain such right and title in the Company. Risk of loss or damage, however, is on the Purchaser from delivery of the apparatus hereunder f.o.b. point of shipment.

**6. SALES AND SIMILAR TAXES**—The Company's prices do not include sales, use, excise or similar taxes. Consequently, in addition to the prices specified herein, the amount of any present or future sales, use, excise or other similar tax applicable to the sale of the apparatus hereunder shall be paid by the Purchaser, or in lieu thereof the Purchaser shall provide the Company with a tax-exemption certificate acceptable to the taxing authorities.

**7. CANCELLATION**—The Purchaser may cancel his order upon payment of reasonable cancellation charges which shall take into account expenses already incurred and commitments made by the Company.

**8. GENERAL**—In no event shall any claim for consequential damages be made by either party.

The Company will comply with all applicable federal, state and local laws.

No addition to or modification of any of the provisions upon the face or reverse hereof shall be binding unless made in writing and signed by an executive officer of the Company, or by the Manager or an Assistant Manager of its Electronics Department, or by the Manager or Manager of Sales of the Commercial Equipment Division of its Electronics Department.

Any provisions or conditions of the Purchaser's order which are in any way inconsistent with or in addition to these Standard Conditions of Sale (except additional provisions specifying quantity, character of the apparatus ordered, and shipping instructions) shall not be binding on the Company and shall not be considered applicable to this sale.



CUSTOMER'S PURCHASE ORDER  
 PLACED WITH  
 ELECTRONICS DEPARTMENT  
**GENERAL  ELECTRIC**  
 COMPANY  
 COMMERCIAL EQUIPMENT DIVISION, SYRACUSE, N. Y.

CUSTOMER'S  
ORDER NO.

DATE

(LEAVE BLANK)

REQ'N NO.

DATE

The warranty period referred to in the provisions entitled "WARRANTY" for the items described herein is one year.

CUSTOMER

---



---



---

SHIP F.O.B. FACTORY TO

---



---



---

**TOM F. BOST, JR.**  
 GENERAL ELECTRIC CO.  
 ELECTRONIC DEPT.  
 187 SPRING ST., N. E.  
 ATLANTA, GA.

SHIP VIA

QUANTITY ORDERED	TYPE NO.	DESCRIPTION	UNIT PRICE	TOTAL PRICE

BY \_\_\_\_\_  
CUSTOMER  
SIGNATURE

## STANDARD CONDITIONS OF SALE

**1. WARRANTY**—The Company warrants that the apparatus shall be of the kind and quality described in the specifications and free from defects in material or workmanship, and no other warranty, except of title, shall be implied. The conditions of any tests shall be mutually agreed upon, and the Company shall be notified of, and may be represented at, all tests that may be made. If any failure to comply with the specifications or if any defect in material or workmanship appears within the period specified on the front of this page, the Purchaser shall notify the Company thereof immediately and the Company shall correct the defect by repairing the defective part or by supplying a replacement therefor at the Company's expense. But if the apparatus is installed by the Company or its installation supervised by the Company, said warranty period shall run from the completion of installation, provided same is not unreasonably delayed by the Purchaser.

It is understood that any defective part will not be returned until authorized by the Company.

In lieu of the foregoing, the Company's standard published tube warranties in effect on the date hereof shall apply to any electronic tubes incorporated in or supplied with the apparatus.

The liability of the Company (except as to title) arising out of the supplying of said apparatus, or its use, whether on warranties or otherwise, shall be limited to the correction of defects as aforesaid and upon expiration of the warranty period all such liability shall terminate.

**2. PATENTS**—The Company shall defend any suit or proceeding brought against the Purchaser so far as based on a claim that any apparatus, or any part thereof, furnished under this contract constitutes an infringement of any patent of the United States, if notified promptly in writing and given authority, information and assistance (at the Company's expense) for the defense of same, and the Company shall pay all damages and costs awarded therein against the Purchaser. In case said apparatus, or any part thereof, is in such suit held to constitute infringement and the use of said apparatus or part is enjoined, the Company shall, at its own expense either procure for the Purchaser the right to continue using said apparatus or part; or replace same with non-infringing apparatus; or modify it so it becomes non-infringing; or remove said apparatus and refund the purchase price and the transportation and installation costs thereof. The foregoing states the entire liability of the Company for patent infringement by said apparatus or any part thereof.

**3. DELIVERY**—Unless otherwise specifically provided, delivery of the apparatus hereunder shall be made f.o.b. point of shipment. Shipping dates are approximate and are based upon prompt receipt of all necessary information.

The Company shall be liable for damages caused by delay in delivery when due to its fault or negligence, but it shall not be liable for delay due to causes beyond its reasonable control, such as acts of God, acts of the Purchaser, acts of civil or military authority, priorities, fires, strikes, floods, epidemics, quarantine restrictions, war, riots, delays in transportation, car shortages and

inability due to causes beyond its reasonable control to obtain necessary labor, materials, or manufacturing facilities. In the event of any such delay, the date of delivery shall be deferred for a period equal to the time lost by reason of the delay.

**4. PAYMENTS**—If, in the judgment of the Company, the financial condition of the Purchaser at any time does not justify continuance of production or shipment on the terms of payment specified, the Company may require full or partial payment in advance.

Pro rata payments shall become due as shipments are made and, if shipments are delayed by the Purchaser, such payments shall become due from the date when the Company is prepared to make shipment. If manufacture is delayed by the Purchaser, payment shall be made based on the contract price and the percentage of completion. Apparatus held for the Purchaser shall be at the risk and expense of the Purchaser. The Company reserves the right to ship to its order and make collection by sight draft with bill of lading attached.

**5. TITLE**—Title and right of possession of the apparatus sold hereunder shall remain with the Company and such apparatus shall remain personal property until all payments hereunder (including deferred payments whether evidenced by notes or otherwise) shall have been made in full in cash, and the Purchaser agrees to do all acts necessary to perfect and maintain such right and title in the Company. Risk of loss or damage, however, is on the Purchaser from delivery of the apparatus hereunder f.o.b. point of shipment.

**6. SALES AND SIMILAR TAXES**—The Company's prices do not include sales, use, excise or similar taxes. Consequently, in addition to the prices specified herein, the amount of any present or future sales, use, excise or other similar tax applicable to the sale of the apparatus hereunder shall be paid by the Purchaser, or in lieu thereof the Purchaser shall provide the Company with a tax-exemption certificate acceptable to the taxing authorities.

**7. CANCELLATION**—The Purchaser may cancel his order upon payment of reasonable cancellation charges which shall take into account expenses already incurred and commitments made by the Company.

**8. GENERAL**—In no event shall any claim for consequential damages be made by either party.

The Company will comply with all applicable federal, state and local laws.

No addition to or modification of any of the provisions upon the face or reverse hereof shall be binding unless made in writing and signed by an executive officer of the Company, or by the Manager or an Assistant Manager of its Electronics Department, or by the Manager or Manager of Sales of the Commercial Equipment Division of its Electronics Department.

Any provisions or conditions of the Purchaser's order which are in any way inconsistent with or in addition to these Standard Conditions of Sale (except additional provisions specifying quantity, character of the apparatus ordered, and shipping instructions) shall not be binding on the Company and shall not be considered applicable to this sale.



CUSTOMER'S PURCHASE ORDER  
 PLACED WITH  
 ELECTRONICS DEPARTMENT  
**GENERAL  ELECTRIC**  
 COMPANY  
 COMMERCIAL EQUIPMENT DIVISION, SYRACUSE, N. Y.

(LEAVE BLANK)

REQ'N NO.

DATE

CUSTOMER'S  
 ORDER NO.

DATE

The warranty period referred  
 to in the provisions entitled  
 "WARRANTY" for the items  
 described herein is one year.

CUSTOMER

\_\_\_\_\_

\_\_\_\_\_

\_\_\_\_\_

TOM F. BOST, JR.  
 GENERAL ELECTRIC CO.  
 ELECTRONIC DEPT.  
 187 SPRING ST., N. E.  
 ATLANTA, GA.

SHIP F.O.B. FACTORY TO

\_\_\_\_\_

\_\_\_\_\_

\_\_\_\_\_

SHIP VIA

QUANTITY ORDERED	TYPE NO.	DESCRIPTION	UNIT PRICE	TOTAL PRICE

BY \_\_\_\_\_  
 CUSTOMER  
 SIGNATURE

RTD-540 (6-47) new

SUBJECT TO THE TERMS AND CONDITIONS PRINTED ON REVERSE SIDE

## STANDARD CONDITIONS OF SALE

1. **WARRANTY**—The Company warrants that the apparatus shall be of the kind and quality described in the specifications and free from defects in material or workmanship, and no other warranty, except of title, shall be implied. The conditions of any tests shall be mutually agreed upon, and the Company shall be notified of, and may be represented at, all tests that may be made. If any failure to comply with the specifications or if any defect in material or workmanship appears within the period specified on the front of this page, the Purchaser shall notify the Company thereof immediately and the Company shall correct the defect by repairing the defective part or by supplying a replacement therefor at the Company's expense. But if the apparatus is installed by the Company or its installation supervised by the Company, said warranty period shall run from the completion of installation, provided same is not unreasonably delayed by the Purchaser.

It is understood that any defective part will not be returned until authorized by the Company.

In lieu of the foregoing, the Company's standard published tube warranties in effect on the date hereof shall apply to any electronic tubes incorporated in or supplied with the apparatus.

The liability of the Company (except as to title) arising out of the supplying of said apparatus, or its use, whether on warranties or otherwise, shall be limited to the correction of defects as aforesaid and upon expiration of the warranty period all such liability shall terminate.

2. **PATENTS**—The Company shall defend any suit or proceeding brought against the Purchaser so far as based on a claim that any apparatus, or any part thereof, furnished under this contract constitutes an infringement of any patent of the United States, if notified promptly in writing and given authority, information and assistance (at the Company's expense) for the defense of same, and the Company shall pay all damages and costs awarded therein against the Purchaser. In case said apparatus, or any part thereof, is in such suit held to constitute infringement and the use of said apparatus or part is enjoined, the Company shall, at its own expense either procure for the Purchaser the right to continue using said apparatus or part; or replace same with non-infringing apparatus; or modify it so it becomes non-infringing; or remove said apparatus and refund the purchase price and the transportation and installation costs thereof. The foregoing states the entire liability of the Company for patent infringement by said apparatus or any part thereof.

3. **DELIVERY**—Unless otherwise specifically provided, delivery of the apparatus hereunder shall be made f.o.b. point of shipment. Shipping dates are approximate and are based upon prompt receipt of all necessary information.

The Company shall be liable for damages caused by delay in delivery when due to its fault or negligence, but it shall not be liable for delay due to causes beyond its reasonable control, such as acts of God, acts of the Purchaser, acts of civil or military authority, priorities, fires, strikes, floods, epidemics, quarantine restrictions, war, riots, delays in transportation, car shortages and

inability due to causes beyond its reasonable control to obtain necessary labor, materials, or manufacturing facilities. In the event of any such delay, the date of delivery shall be deferred for a period equal to the time lost by reason of the delay.

4. **PAYMENTS**—If, in the judgment of the Company, the financial condition of the Purchaser at any time does not justify continuance of production or shipment on the terms of payment specified, the Company may require full or partial payment in advance.

Pro rata payments shall become due as shipments are made and, if shipments are delayed by the Purchaser, such payments shall become due from the date when the Company is prepared to make shipment. If manufacture is delayed by the Purchaser, payment shall be made based on the contract price and the percentage of completion. Apparatus held for the Purchaser shall be at the risk and expense of the Purchaser. The Company reserves the right to ship to its order and make collection by sight draft with bill of lading attached.

5. **TITLE**—Title and right of possession of the apparatus sold hereunder shall remain with the Company and such apparatus shall remain personal property until all payments hereunder (including deferred payments whether evidenced by notes or otherwise) shall have been made in full in cash, and the Purchaser agrees to do all acts necessary to perfect and maintain such right and title in the Company. Risk of loss or damage, however, is on the Purchaser from delivery of the apparatus hereunder f.o.b. point of shipment.

6. **SALES AND SIMILAR TAXES**—The Company's prices do not include sales, use, excise or similar taxes. Consequently, in addition to the prices specified herein, the amount of any present or future sales, use, excise or other similar tax applicable to the sale of the apparatus hereunder shall be paid by the Purchaser, or in lieu thereof the Purchaser shall provide the Company with a tax-exemption certificate acceptable to the taxing authorities.

7. **CANCELLATION**—The Purchaser may cancel his order upon payment of reasonable cancellation charges which shall take into account expenses already incurred and commitments made by the Company.

8. **GENERAL**—In no event shall any claim for consequential damages be made by either party.

The Company will comply with all applicable federal, state and local laws.

No addition to or modification of any of the provisions upon the face or reverse hereof shall be binding unless made in writing and signed by an executive officer of the Company, or by the Manager or an Assistant Manager of its Electronics Department, or by the Manager or Manager of Sales of the Commercial Equipment Division of its Electronics Department.

Any provisions or conditions of the Purchaser's order which are in any way inconsistent with or in addition to these Standard Conditions of Sale (except additional provisions specifying quantity, character of the apparatus ordered, and shipping instructions) shall not be binding on the Company and shall not be considered applicable to this sale.

TYPE No.	DESCRIPTION	UNIT PRICE	TUBE PRICE (per set)
<b>B</b>			
BA-1-C	Plug-in Pre-Amplifier . . . . .	\$ 81.50	\$ 13.20
BA-1-D	Two-Stage Pre-Amplifier . . . . .	70.00	13.20
BA-2-A	Program Amplifier . . . . .	155.00	11.48
BA-3-A	Equalized Transcription Pre-Amplifier . . . . .	125.00	8.61
BA-4-D	Monitoring Amplifier . . . . .	145.00	20.77
BA-4-E	Monitoring Amplifier . . . . .	150.00	20.77
BA-5-A	Limiting Amplifier . . . . .	855.00	33.16
BA-6-A	Portable Amplifier . . . . .	595.00	38.44
BA-10-A	Utility Input Amplifier . . . . .	110.00	14.01
BA-12-A	Program/Monitor Amplifier . . . . .	94.50	11.64
BC-1-A	Two-Studio Console . . . . .	1,250.00	89.52
BC-1-A	Two-Studio Console, Model 4BC1A4 . . . . .	On Application	
BC-3-A	Transmitter Console . . . . .	375.00	
BC-3-A	Transmitter Console with Frequency Deviation and Percentage Modulation Instruments . . . . .	395.00	
BC-13-A	Transmitter Console Deluxe Combination . . . . .	750.00	
BP-1-A	Pre-Amplifier Power Supply . . . . .	80.00	.57
BP-5-A	Relay Power Supply . . . . .	150.00	
BP-8-A	Amplifier Power Supply . . . . .	115.00	1.26
BP-10-A	Plug-in Power Supply . . . . .	150.00	1.26

**F**

FA-1-A	Program Level Indicator Panel . . . . .	90.00	
FA-2-A	Jack Strips . . . . .	45.00	
FA-3-A	Jack Panel (single) . . . . .	8.00	
FA-3-B	Jack Panel (double) . . . . .	10.00	
FA-3-C	Jack Panel (triple) . . . . .	12.00	
FA-4-A	Switch and Fuse Panel . . . . .	30.00	
FA-5-A	Panel and Mounting . . . . .	15.00	
FA-5-B	Panel and Mounting . . . . .	15.00	
FA-6-A	Blank Panel . . . . .	3.00	
FA-6-B	Blank Panel . . . . .	4.00	
FA-6-C	Blank Panel . . . . .	4.00	
FA-6-D	Blank Panel . . . . .	4.00	
FA-6-E	Blank Panel . . . . .	4.50	
FA-7-A	Patch Cord . . . . .	7.80	
FA-7-B	Patch Cord . . . . .	8.30	
FA-7-C	Patch Cord . . . . .	8.50	
FA-8-C	Cabinet Rack . . . . .	165.00	
FA-8-D	Cabinet Rack . . . . .	165.00	
FA-9-A	Accessory Kit for Cabinet Rack FA-8-C . . . . .	42.00	
FA-9-B	Accessory Kit for Cabinet Rack FA-8-D . . . . .	42.00	
FA-10-A	Speaker Control Plate . . . . .	15.00	
FA-11-A	DC Metering Panel . . . . .	37.50	
FA-12-A	Transcription Equalizer . . . . .	57.50	
FA-14-A	Equalizer Panel . . . . .	45.00	

Prices are Net, F.O.B. factory.  
Sales, use, excise, or similar taxes are not included.

TYPE No.	DESCRIPTION	UNIT PRICE
FA-14-B	Equalizer Unit . . . . .	15.00
FA-15-A	Microphone Cable . . . . .	0.09 (per ft.)
FA-16-A	Microphone Plug . . . . .	2.35
FA-16-B	Microphone Plug . . . . .	4.00
FA-16-C	Microphone Receptacle . . . . .	5.50
FA-17-A	Speaker Base . . . . .	15.00
FA-18-A	Sound Effects Filter Panel . . . . .	125.00
FA-19-E	Interconnecting Cable . . . . .	40.00
FA-19-F	Interconnecting Cable . . . . .	50.00
FA-19-H	Interconnecting Cable . . . . .	66.00
FA-19-J	Interconnecting Cable . . . . .	66.00
FA-20-A	Relay Assembly . . . . .	35.00
FA-21-A	Transcription Arm . . . . .	41.00
FA-22-A	Tray . . . . .	9.75
FA-22-B	Tray . . . . .	9.75
FA-22-C	Tray . . . . .	9.75
FA-23-A	Shelf . . . . .	27.50
FA-30-A	Output Switching Panel . . . . .	On Application
FA-35-A	Bridging Volume Control . . . . .	9.75
FA-35-D	Bridging Volume Control . . . . .	12.00
FA-35-E	Bridging Volume Control . . . . .	13.75
FA-35-F	Volume Control . . . . .	6.50
FA-40-A	Line-to-Line Transformer . . . . .	20.00
FA-41-A	Bridging-to-Line Transformer . . . . .	20.00
FC-1-A	Transmitter Console Deluxe Desk . . . . .	150.00
FC-2-A	Transmitter Console Deluxe Chair . . . . .	75.00
FC-3-A	Carrier Interruption Clock Panel . . . . .	165.00
FC-3-B	Carrier Interruption Clock Panel . . . . .	165.00
FS-1-A	Monitoring Speaker . . . . .	145.00
FS-2-A	Studio Wall Speaker . . . . .	25.00

## M

ML-7767495-G1	Wiring Duct for Cabinet Rack FA-8-C . . . . .	15.00
ML-7767495-G2	Wiring Duct for Cabinet Rack FA-8-D . . . . .	15.00
ML-7769361-G1	Terminal Board Frame for Cabinet Racks FA-8-C and FA-8-D . . . . .	8.00
MLK-7118764-G1	Audio Terminal Block . . . . .	4.35
MLK-7118765-G1	Power Terminal Board . . . . .	2.00

## P

PR-1-A	Cabinet Rack . . . . .	175.00
PR-3-A	Front Door for Cabinet Rack PR-1-A . . . . .	50.00
PR-4-A	Terminal Board Frame for Cabinet Rack PR-1-A . . . . .	8.00
PR-5-A	Wiring Duct for Cabinet Rack PR-1-A . . . . .	15.00

TYPE No.	DESCRIPTION	UNIT PRICE
PR-6-A	Lumiline and Outlet Assembly . . . . .	48.00
PR-7-A	Mounting Angles for Cabinet Rack PR-1-A . . . . .	15.00
PR-8-A	Cabling Strap for Cabinet Rack PR-1-A . . . . .	7.50
<b>R</b>		
RPJ-001	Stylus . . . . .	2.10
RPJ-002	Stylus . . . . .	16.50
RPJ-003	Stylus . . . . .	16.50
RPJ-004	Stylus . . . . .	16.50
RPJ-005	Stylus . . . . .	2.10
RPJ-006	Stylus . . . . .	2.10
RWP-001	Stylus Adapter Weight . . . . .	3.85
RPX-046	Variable Reluctance Cartridge . . . . .	6.87
<b>S</b>		
ST-2A	Oscilloscope . . . . .	298.50
S400D	4-in. Speaker . . . . .	4.25
S402D	4-in. Speaker . . . . .	4.00
S403D	4-in. Speaker . . . . .	3.75
S525D	5¼-in. Speaker . . . . .	4.75
S526D	5¼-in. Speaker . . . . .	4.35
S527D	5¼-in. Speaker . . . . .	4.00
S625D	6½-in. Speaker . . . . .	5.50
S626D	6½-in. Speaker . . . . .	5.00
S650D	6½-in. Speaker . . . . .	6.75
S703D	6-in. x 9-in. Speaker . . . . .	7.50
S800D	8-in. Speaker . . . . .	8.95
S810D	8-in. Speaker . . . . .	12.00
S818D	8-in. Speaker . . . . .	12.50
S1000D	10-in. Speaker . . . . .	15.25
S1001D	10-in. Deluxe Speaker . . . . .	24.75
S1003D	10-in. Speaker . . . . .	18.50
S1012D	10-in. Speaker . . . . .	10.25
S1018D	10-in. Speaker . . . . .	15.75
S1200D	12-in. Speaker . . . . .	16.50
S1201D	12-in. Deluxe Speaker . . . . .	29.50
S1203D	12-in. Speaker . . . . .	20.50
S1212D	12-in. Speaker . . . . .	11.25
S1218D	12-in. Speaker . . . . .	17.00
<b>Y</b>		
YDA-1	Distortion and Noise Analyzer . . . . .	350.00
YGL-1	Square Wave Generator . . . . .	225.00

## TYPE NUMBER INDEX

TYPE NO.		SECTION and PAGE NO.
<b>B</b>		
BA-1-C	Plug-in Pre-Amplifier . . . . .	5-12
BA-1-D	Two-Stage Pre-Amplifier . . . . .	5-3
BA-2-A	Program Amplifier . . . . .	5-1
BA-3-A	Equalized Transcription Pre-Amplifier . . . . .	13-3
BA-4-D	Monitoring Amplifier . . . . .	5-8
BA-4-E	Monitoring Amplifier . . . . .	5-9
BA-5-A	Limiting Amplifier . . . . .	5-11
BA-6-A	Portable Amplifier . . . . .	5-16
BA-10-A	Utility Input Amplifier . . . . .	5-5
BA-12-A	Program/Monitor Amplifier . . . . .	5-14
BC-1-A	Two-Studio Console . . . . .	2-1
BC-1-A	Two-Studio Console, Model 4BC1A4 . . . . .	2-4
BC-3-A	Transmitter Console . . . . .	3-1
BC-13-A	Transmitter Console Deluxe Combination . . . . .	3-3
BP-1-A	Pre-Amplifier Power Supply . . . . .	6-1
BP-5-A	Relay Power Supply . . . . .	6-2
BP-8-A	Amplifier Power Supply . . . . .	6-3
BP-10-A	Plug-in Power Supply . . . . .	6-3
<b>F</b>		
FA-1-A	Program Level Indicator Panel . . . . .	7-1
FA-2-A	Jack Strips . . . . .	7-2
FA-3-A thru		
FA-3-C	Jack Panels . . . . .	7-3
FA-4-A	Switch and Fuse Panel . . . . .	7-2
FA-5-A	Panel and Mounting . . . . .	8-8
FA-5-B	Panel and Mounting . . . . .	8-9
FA-6-A thru		
FA-6-E	Blank Panels . . . . .	8-8
FA-7-A thru		
FA-7-C	Patch Cords . . . . .	7-3
FA-8-C	Cabinet Rack . . . . .	8-5
FA-8-D	Cabinet Rack . . . . .	8-5
FA-9-A	Accessory Kit for FA-8-C Cabinet Rack . . . . .	8-8
FA-9-B	Accessory Kit for FA-8-D Cabinet Rack . . . . .	8-8
FA-10-A	Speaker Control Plate . . . . .	12-2
FA-11-A	DC Metering Panel . . . . .	7-1
FA-12-A	Transcription Equalizer . . . . .	13-2
FA-14-A	Equalizer Panel . . . . .	7-4
FA-14-B	Equalizer Unit . . . . .	7-4
FA-15-A	Microphone Cable . . . . .	11-1
FA-16-A thru		
FA-16-C	Microphone Plugs and Receptacles . . . . .	11-1
FA-17-A	Speaker Base . . . . .	12-1
FA-18-A	Sound Effects Filter Panel . . . . .	7-5
FA-19-E, -F, -H, -J	Interconnecting Cable . . . . .	10-1
FA-20-A	Relay Assembly . . . . .	2-4



FA-21-A	Transcription Arm . . . . .	13-1
FA-22-A	Tray . . . . .	5-14
FA-22-B	Tray . . . . .	5-16
FA-22-C	Tray . . . . .	6-4
FA-23-A	Shelf . . . . .	8-9
FA-30-A	Output Switching Panel . . . . .	2-4
FA-35-A	Bridging Volume Control . . . . .	5-5
FA-35-D	Bridging Volume Control . . . . .	5-10
FA-35-E	Bridging Volume Control . . . . .	5-14
FA-35-F	Volume Control . . . . .	5-16
FA-40-A	Line-to-Line Transformer . . . . .	9-1
FA-41-A	Bridging-to-Line Transformer . . . . .	9-2
FC-1-A	Transmitter Console Deluxe Desk . . . . .	3-3
FC-2-A	Transmitter Console Deluxe Chair . . . . .	3-3
FC-3-A, -B	Carrier Interruption Clock Panel . . . . .	3-3
FS-1-A	Monitoring Speaker . . . . .	12-1
FS-2-A	Studio Wall Speaker . . . . .	12-2

## M

ML-7767495-G1	Wiring Duct for FA-8-C Cabinet Rack . . . . .	8-7
ML-7767495-G2	Wiring Duct for FA-8-D Cabinet Rack . . . . .	8-7
ML-7769361-G1	Terminal Board Frame for FA-8-C and FA-8-D Cabinet Rack . . . . .	8-7
MLK-7118764-G1	Audio Terminal Block . . . . .	8-4, 8-7
MLK-7118765-G1	Power Terminal Board . . . . .	8-4, 8-7

## P

PR-1-A	Cabinet Rack . . . . .	8-1
PR-3-A	Front Door for PR-1-A Cabinet Rack . . . . .	8-3
PR-4-A	Terminal Board Frame for PR-1-A Cabinet Rack . . . . .	8-3
PR-5-A	Wiring Duct for PR-1-A Cabinet Rack . . . . .	8-4
PR-6-A	Lumiline and Outlet Assembly . . . . .	8-4
PR-7-A	Mounting Angles for PR-1-A Cabinet Rack . . . . .	8-4
PR-8-A	Cablings Strap for PR-1-A Cabinet Rack . . . . .	8-4

## R

RPJ-001 thru RPJ-006	Styli . . . . .	13-2
RWP-001	Stylus Adapter Weight . . . . .	13-1
RPX-046	Variable Reluctance Cartridge . . . . .	13-1

## S

ST-2A	Oscilloscope . . . . .	14-3
S400D, etc.	Standard Speakers (no enclosure) . . . . .	12-3

## Y

YDA-1	Distortion and Noise Analyzer . . . . .	14-1
YGL-1	Square Wave Generator . . . . .	14-2

**ALPHABETICAL INDEX**

	<b>SECTION and PAGE NO.</b>
<b>A</b>	
Accessory Kit	
FA-9-A (for Cabinet Rack FA-8-C) . . . . .	8-8
FA-9-B (for Cabinet Rack FA-8-D) . . . . .	8-8
Amplifiers	
Chart Tabulation of . . . . .	5-1
Gain Ratings . . . . .	5-2
Limiting, BA-5-A . . . . .	5-11
Monitoring, BA-4-D . . . . .	5-8
Monitoring, BA-4-E . . . . .	5-9
Portable, BA-6-A . . . . .	5-16
Power Supply, BP-8-A . . . . .	6-3
Program, BA-2-A . . . . .	5-1
Program Monitor, BA-12-A . . . . .	5-14
Ratings and Terminology . . . . .	5-2
Utility Input, BA-10-A . . . . .	5-5
Audio Terminal Blocks, MLK-7118764-G1	
for Cabinet Racks FA-8-C and FA-8-D . . . . .	8-7
for Cabinet Rack PR-1-A . . . . .	8-4
<b>B</b>	
Blank Panels, FA-6-A thru FA-6-G . . . . .	8-8
Bridging-to-Line Transformer, FA-41-A . . . . .	9-2
Bridging Volume Controls	
FA-35-A (for Pre-Amplifier BA-1-D) . . . . .	5-5
FA-35-D (for Monitoring Amplifiers BA-4-D and BA-4-E) . . . . .	5-10
FA-35-E (for Pre-Amplifier BA-1-C) . . . . .	5-14
<b>C</b>	
Cabinet Racks	
FA-8-C . . . . .	8-5
FA-8-D . . . . .	8-5
PR-1-A . . . . .	8-1
Cabinet Rack Accessory Kits	
FA-9-A (for Cabinet Rack FA-8-C) . . . . .	8-8
FA-9-B (for Cabinet Rack FA-8-D) . . . . .	8-8
Cabling Straps, PR-8-A (for Cabinet Rack PR-1-A) . . . . .	8-4
Carrier Interruption Clock Panels, FC-3-A and FC-3-B . . . . .	3-3
Cartridge, Variable Reluctance, RPX-046 . . . . .	13-1
Chair, FC-2-A (for Transmitter Console) . . . . .	3-3
Charts	
Power Supply Data . . . . .	6-1
Tabulation of Amplifiers . . . . .	5-1
Clock Panel, Carrier Interruption, FC-3-A and FC-3-B . . . . .	3-3
Consolette, Two-Studio	
BC-1-A . . . . .	2-1
4BC1A4 . . . . .	2-4

<b>D</b>	
Data . . . . .	15-1
DC Metering Panel, FA-11-A . . . . .	7-1
Deluxe Combination, BC-13-A (for Transmitter Console) . . . . .	3-3
Desk, FC-1-A (for Transmitter Console) . . . . .	3-3
Distortion and Noise Analyzer, YDA-1 . . . . .	14-1
<b>E</b>	
Equalized Transcription Pre-Amplifier, BA-3-A . . . . .	13-3
Equalizer Panel, FA-14-A . . . . .	7-4
Equalizer, Transcription, FA-12-A . . . . .	13-2
Equalizer Unit, FA-14-B . . . . .	7-4
<b>F</b>	
Filter Panel, Sound Effects, FA-18-A . . . . .	7-5
Front Door, PR-3-A (for Cabinet Rack PR-1-A) . . . . .	8-3
<b>G</b>	
Gain Ratings, Amplifiers . . . . .	5-2
<b>I</b>	
Interconnecting Cable, FA-19-E, -F, -H, -J . . . . .	10-1
<b>J</b>	
Jack Panels, FA-3-A thru FA-3-C . . . . .	7-3
Jack Strips, FA-2-A . . . . .	7-2
Job-Designed Equipment . . . . .	1-1
<b>L</b>	
Limiting Amplifier, BA-5-A . . . . .	5-11
Line-to-Line Transformer, FA-40-A . . . . .	9-1
Lumiline and Outlet Assembly, PR-6-A (for Cabinet Rack PR-1-A) . . . . .	8-4
<b>M</b>	
Microphone Cable, FA-15-A . . . . .	11-1
Microphone Plugs and Receptacles, FA-16-A thru FA-16-C . . . . .	11-1
Monitoring Amplifiers	
BA-4-D . . . . .	5-8
BA-4-E . . . . .	5-9
Monitoring Speaker, FS-1-A . . . . .	12-1
Mounting Angles, PR-7-A (for Cabinet Rack PR-1-A) . . . . .	8-4

## O

Ordering Information . . . . .	16-1
Oscilloscope, ST-2A . . . . .	14-3
Output Switching Panel, FA-30-A (for BC-1-A Consolettes) . . . . .	2-4

## P

Panel and Mounting	
FA-5-A (for Amplifiers BA-1-A and BA-10-A) . . . . .	8-8
FA-5-B (for miscellaneous studio equipment) . . . . .	8-9
Patch Cords, FA-7-A thru FA-7-C . . . . .	7-3
Plug-in	
Power Supply, BP-10-A . . . . .	6-3
Pre-Amplifier, BA-1-C . . . . .	5-12
Program Monitor Amplifier, BA-12-A . . . . .	5-14
Plugs and Receptacles, FA-16-A thru FA-16-C . . . . .	11-1
Portable Amplifier, BA-6-A . . . . .	5-16
Power Supply	
Amplifier, BP-8-A . . . . .	6-3
Data, Chart Tabulation of . . . . .	6-1
Pre-Amplifier, BP-1-A . . . . .	6-1
Plug-in, BP-10-A . . . . .	6-3
Relay, BP-5-A . . . . .	6-2
Power Terminal Board, MLK-7118765-G1	
for Cabinet Racks, FA-8-C and FA-8-D . . . . .	8-7
for Cabinet Rack, PR-1-A . . . . .	8-4
Pre-Amplifiers	
Equalized Transcription, BA-3-A . . . . .	13-3
Plug-in, BA-1-C . . . . .	5-12
Power Supply, BP-1-A . . . . .	6-1
Two-Stage, BA-1-D . . . . .	5-3
Prices . . . . .	17-1
Program Amplifier, BA-2-A . . . . .	5-1
Program Level Indicator Panel, FA-1-A . . . . .	7-1
Program Monitor Amplifier, BA-12-A . . . . .	5-14

## R

Rack-Mounted Equipment, Features of . . . . .	4-1
Ratings and Terminology, Amplifiers . . . . .	5-2
Relay Assembly, FA-20-A . . . . .	2-4
Relay Power Supply, BP-5-A . . . . .	6-2

## S

Shelf, FA-23-A (for Power Supply BP-10-A) . . . . .	8-9
Sound Effects Filter Panel, FA-18-A . . . . .	7-5
Speakers	
Monitoring, FS-1-A . . . . .	12-1
Standard (no enclosure), S400D, etc. . . . .	12-3
Studio Wall, FS-2-A . . . . .	12-2
Speaker Base, FA-17-A . . . . .	12-1

Speaker Control Plate, FA-10-A . . . . .	12-2
Standard Speakers (no enclosure), S400D, etc. . . . .	12-3
Studio Wall Speaker, FS-2-A . . . . .	12-2
Styli, RPJ-001 thru RPJ-006 . . . . .	13-2
Stylus Adapter Weight, RWP-001 . . . . .	13-1
Square Wave Generator, YGL-1 . . . . .	14-2
Switch and Fuse Panel, FA-4-A . . . . .	7-2
<b>T</b>	
Terminal Board Frame	
ML-7769361-G1 (for Cabinet Racks FA-8-C and FA-8-D) . . . . .	8-7
PR-4-A (for Cabinet Rack PR-1-A) . . . . .	8-3
Transcription Arm, FA-21-A . . . . .	13-1
Transcription Equalizer, FA-12-A . . . . .	13-2
Transcription Pre-Amplifier, Equalized, BA-3-A . . . . .	13-3
Transformers	
Bridging-to-Line, FA-41-A . . . . .	9-2
Line-to-Line, FA-40-A . . . . .	9-1
Transmitter Console, BC-3-A . . . . .	3-1
Transmitter Console	
Chair, FC-2-A . . . . .	3-3
Deluxe Combination, BC-13-A . . . . .	3-3
Desk, FC-1-A . . . . .	3-3
Tray	
FA-22-A (for Pre-Amplifier BA-1-C) . . . . .	5-14
FA-22-B (for Program/Monitor Amplifier BA-12-A) . . . . .	5-16
FA-22-C (for Power Supply BP-10-A) . . . . .	6-4
Two-Stage Pre-Amplifier, BA-1-D . . . . .	5-3
Two-Studio Console	
BC-1-A . . . . .	2-1
4BC1A4 . . . . .	2-4
<b>U</b>	
Utility Input Amplifier, BA-10-A . . . . .	5-5
<b>V</b>	
Variable Reluctance Cartridge, RPX-046 . . . . .	13-1
Volume Control, FA-35-F (for Amplifier BA-12-A) . . . . .	5-16
Volume Controls, Bridging	
FA-35-A (for Pre-Amplifier BA-1-D) . . . . .	5-5
FA-35-D (for Monitoring Amplifiers BA-4-D and BA-4-E) . . . . .	5-10
FA-35-E (for Pre-Amplifier BA-1-C) . . . . .	5-14
<b>W</b>	
Wall Speaker, Studio, FS-2-A . . . . .	12-2
Wiring Ducts	
ML-7767495-G1 (for Cabinet Rack FA-8-C) . . . . .	8-7
ML-7767495-G2 (for Cabinet Rack FA-8-D) . . . . .	8-7
PR-5-A (for Cabinet Rack PR-1-A) . . . . .	8-4



**audio  
equipment  
for  
am-fm-tv**

---

**GENERAL  ELECTRIC**