Service Manual

Model

G24S/G16S

Recorder/Reproducer

FOSTEX®

TABLE OF CONTENTS

1. SPECIFICATIONS/SERVICE DATA	1
2. FUNCTIONS AND CONTROL	4
3. DEMO FUNCTION MODE	5
4. ADJUSTING PROCEDURE	6
5. EXPLODED VIEW, PCB ASSEMBLY AND PARTS LIST	30
6. CIRCUIT DIAGRAM	66
7. PIN INFORMATION FOR IC'S	94

NOTES

- * Adjustment procedures are given in this manual which also includes a Parts List and schematic diagrams to assist the service technician in maintaining the Model G24S/G16S. Please feel free to contact the nearest Fostex Dealer and Distributor, or write directly to a Fostex office, the addresses of which are printed on the back cover of this manual.
- * For the theory of operation of G24S/G16S, please refer to the G16 service manual (P/N 8288 721000).
- * The following accessories are supplied with G24S/G16S as the standard accessories.

Owner's manual: 1 copy (P/N 8288275000 export model)
 (P/N 8288276000 domestic model)

Wrench, Hex. 2 1 pc. (P/N 8204026001)

CAUTION

△Parts marked with this sign are safety critical components. They must always be replaced with identical components. Refer to the Fostex Parts List and ensure exact replacement.

1. SPECIFICATIONS / SERVICE DATA

TAPE	1 inch (25.4mm) tape width, 2.0mil (50 μ m) base	G24S	
	1/2 inch (12.7mm) tape width, 2.0mil (50 μ m) base	G16S	
TRACK FORMAT	24 track, 24 channel	G24S	
	16 track, 16 channel	G16S	
HEAD	Erase	24 track, 24 channel	G24S
		16 track, 16 channel	G16S
	Record/playback	24 track, 24 channel	G24S
		16 track, 16 channel	G16S
MOTOR	Capstan motor	1 pc.	DC print motor
	Reel motor	2 pcs.	DC motor
	Loading motor	1 pc.	DC motor
REEL SIZE	Up to 10-1/2 inch (27cm), NAB or EIA/CINE		
TAPE SPEED	15 ips (38cm/sec) \pm 0.2%		
PITCH CONTROL	More than \pm 12%		
LINE INPUT	-10dBV (0.3V), impedance: 30k Ω , unbalanced		
LINE OUT	-10dBV (0.3V), load impedance: 10k Ω or higher, unbalanced		
NOISE REDUCTION	DOLBY S NR (ON/OFF/Track 24 only OFF switchable)		
			G24S
	DOLBY S NR (ON/OFF/Track 16 only OFF switchable)		
			G16S
EQUALIZATION	15 ips (38cm/sec): ∞ + 35 μ sec		
RECORD LEVEL CALIBRATION	0dB referenced to 320nWb/m of tape flux		
WOW AND FLUTTER	\pm 0.05% peak WTD (IEC/ANSI), \pm 0.10% UNWTD for 15 ips, measured with flutter test tape, STL X-1453 (3,150 Hz)		
		Fostex 9101 (3,000 Hz)	G16S

START UP TIME	Less than 0.5 sec
FAST WIND SPEED	Less than 140 seconds for 2,500 ft. (740m) of tape
FREQUENCY RESPONSE (OVERALL)	40Hz ~ 18kHz, ± 3 dB for 15 ips (38cm/sec)
S/N (OVERALL)	84dB A weighted at 15 ips, referenced to 3% T.H.D. at 1kHz G24S 82dB A weighted at 15 ips, referenced to 3% T.H.D. at 1kHz G16S
T.H.D. (OVERALL)	Less than 1% at 1kHz, 0dB (NR OFF)
ERASURE	Better than 70dB at 1kHz (NR OFF)
CROSSTALK	Better than 55dB at 1kHz
POWER REQUIREMENTS	100V AC, 50/60Hz 145W G24S 120V AC, 60Hz 195W 220V AC, 50Hz 195W 240V AC, 50Hz 195W
	100V AC, 50/60Hz 100W G16S 120V AC, 60Hz 170W 220V AC, 50Hz 170W 240V AC, 50Hz 170W
DIMENSIONS	482 (W) x 488 (H) x 230 (D) (mm)
WEIGHT	35kg / 77lbs. G24S 32.5kg/72lbs. G16S

Specifications subject to change without notice.

*Dolby noise reduction manufactured under license from Dolby Laboratories Licensing Corporation.
"DOLBY" and the double-D symbol  are trademarks of Dolby Laboratories Licensing Corporation.

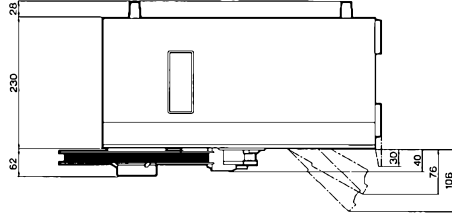
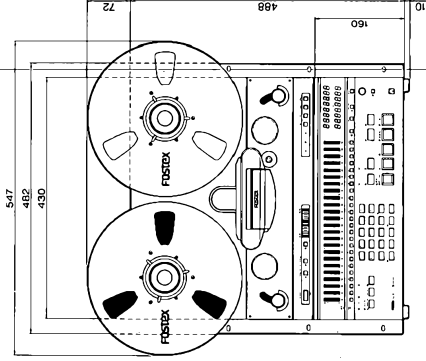

Front Panel

Control Panel (A)

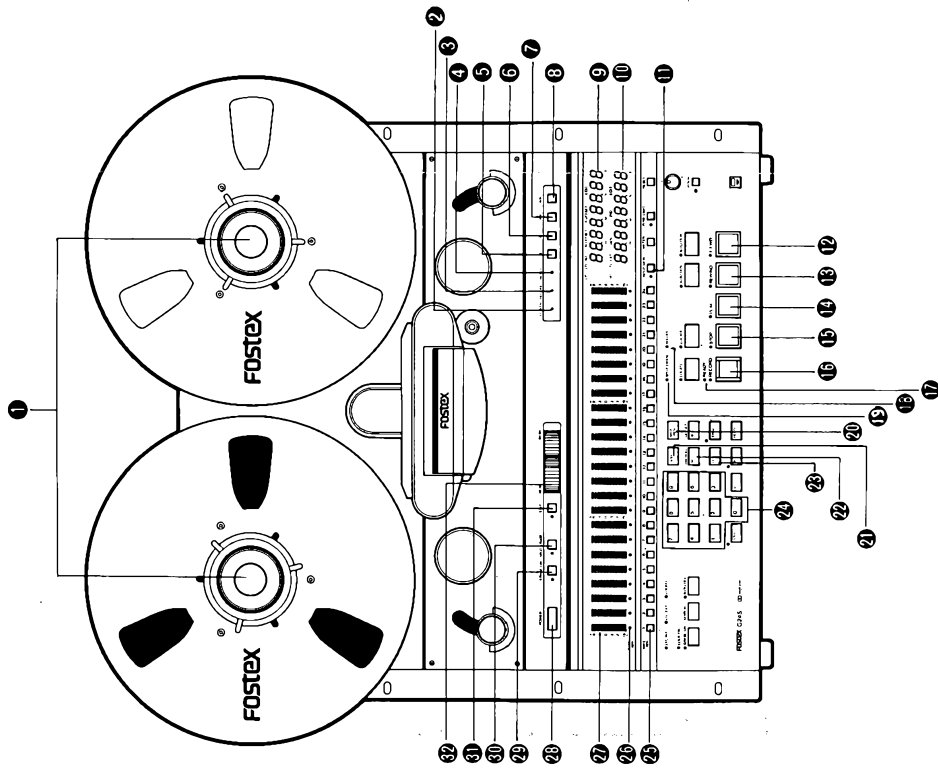

* The above illustration is for the G24S.

Control Panel (B)

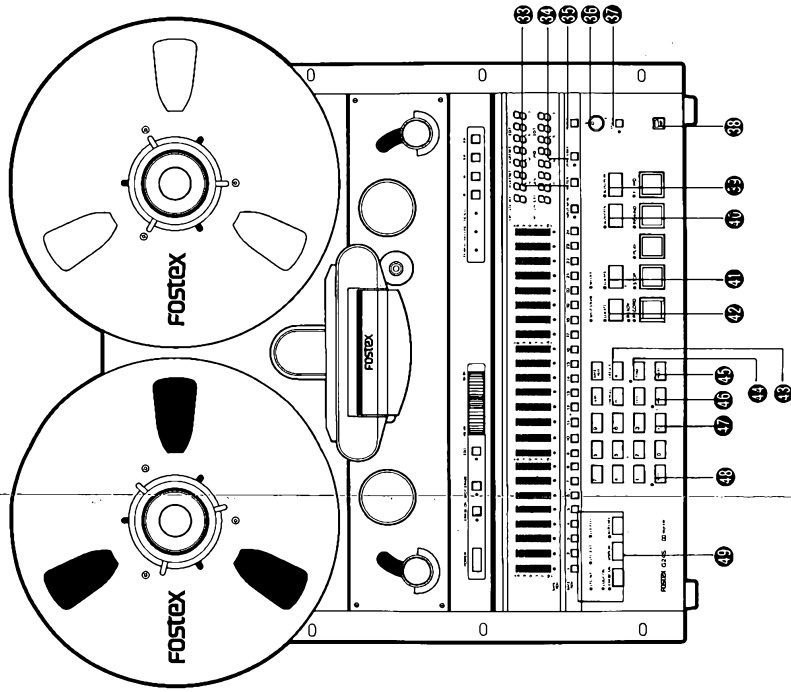

* The above illustration is for the G24S.

REAR PANEL

2. FUNCTIONS AND CONTROLS
[FRONT PANEL, CONTROL PANEL]

1. REEL CLAMPER
2. POWER LED
3. RECORD LED
4. READY LED
5. STOP BUTTON
6. PLAY BUTTON
7. REWIND BUTTON
8. FAST FORWARD BUTTON
9. TAPE TIME DISPLAY
10. MEMORY DISPLAY
11. INPUT MONITOR SWITCH/LED
12. FAST FORWARD BUTTON/LED
13. REWIND BUTTON/LED
14. PLAY BUTTON/LED
15. STOP BUTTON/LED
16. RECORD BUTTON/LED
17. READY LED
18. NOISE REDUCTION OFF LED
19. SPOT ERASE LED
20. SAFE/READY LED
21. PLUS 10 KEY
22. -/PREROLL KEY
23. CLEAR KEY
24. NUMERICAL KEYPAD
25. SAFE/READY SELECTORS
26. SAFE/READY LED
27. BARGRAPH LEVEL METERS
28. POWER SWITCH
29. ERASE ON BUTTON/LED
30. SPOT ERASE BUTTON/LED
31. EDIT BUTTON/LED
32. CUEING DIAL
33. METER BUTTON
34. ZONE LIMIT BUTTON/LED
35. RESET BUTTON
36. PITCH CONTROL KNOB
37. PITCH CONTROL BUTTON/LED
38. PANEL LOCK RELEASE KNOB
39. AUTO PLAY KEY/LED
40. AUTO RETURN KEY/LED
41. LOCATE 0 KEY/LED
42. LOCATE KEY/LED
43. PLUS/OFFSET KEY
44. TRIM KEY/LED
45. HOLD KEY
46. RECALL KEY/LED
47. PERIOD KEY
48. STORE KEY
49. OPTION KEY AREA
[REAR PANEL]
50. PUNCH-IN/OUT JACK
51. PLAY/LOCATE JACK
52. CONTROLLER CONNECTION TERMINAL
53. CONTROLLER UNIT SELECTION SWITCH
(FRONT/REAR)
54. ACCESSORY 1 TERMINAL
55. AC IN TERMINAL
56. DOLBY NR SWITCH
57. OUTPUT JACK
58. INPUT JACK

xx The following four functions are for G16S only
and are not applicable to G24S.

- A EXTERNAL NR CONNECTOR
- B INTERNAL/EXTERNAL NR SELECTING SWITCH
- C 16 OUT JACK
- D LOOP OUT 16 IN JACK

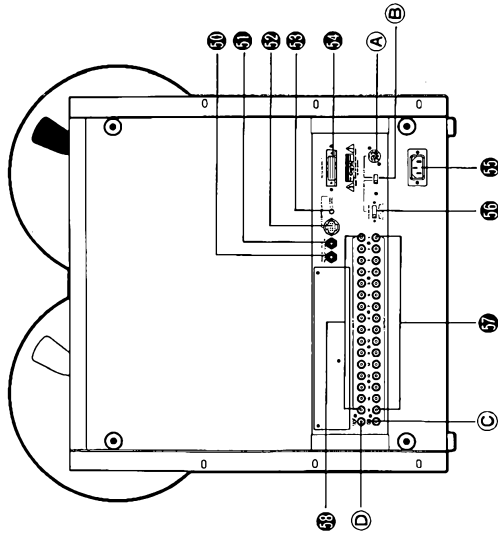

G16S

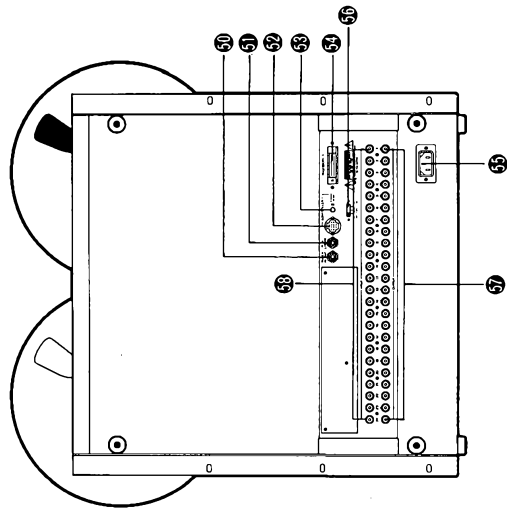

G24S

* Please take note the following modes on G24S/G16S as a service information since these functions are not described in the owner's manual.

3. DEMO FUNCTION MODE

1. Demo Function Mode 1

Graphic patterns appear on the G24S/G16S Controller bargraph LED meters and "G24" for G24S, "G16" for G16S are displayed a few seconds later when each power of G24S and G16S is switched on.

These indicate proper operations of the following:

- 1) CPU U1 on the Connector Board PCB
- 2) CPU U2 on the Controller PCB
- 3) Communication through the cable between U1 on the Connector Board PCB and U2 on the Controller PCB
- 4) Bargraph LED meter and drive circuit

2. Demo Function Mode 2

With power to G24S/G16S units switched on, when the Controller is connected to the main unit, a different graphic pattern (each line extended from both left and right ends connects at the center) will be displayed.

Due to this, it can be confirmed that the Controller is positively connected, CPU U2 on the Controller PCB has started functioning, and that serial data from CPU U1 on the Connector Board PCB is being received.

3. Demo Function Mode 3

- 1) The Demo Function Mode 3 can be entered by switching ON the power while depressing the STOP button on the Controller.

Every LED on the Controller (Except for the bargraph LED meter and "NR OFF" LED) will be lit.

- 2) The Demo Function Mode 3 will be proceeded by depressing the PLAY button on the Controller and the following can be checked.

- * Whether CPU U1 on the Controller PCB is functioning correctly or not.
- * Whether the 7 segments LED's and the drive circuit are in normal condition.

- 3) The Demo Function Mode 3 can be fast forwarded while the FF button on the Controller is kept depressed.

4) The Demo Function Mode 3 can be reversed while RWD button on the Controller is kept depressed.

5) The Demo Function Mode 3 can be stopped by depressing the STOP button on the Controller.

6) The Demo Function Mode 3 can be cancelled by depressing the RESET button on the Controller and then the machine enters normal mode.

The Demo Function Mode 3 test sequence continues forever, however, we understand it will be no problem as the Demo Function Mode 3 can be cancelled by depressing the RESET button.

4. ADJUSTING PROCEDURE

4.1. Test Equipment Required

Spring scale 0 ~ 4 Kg. (0 ~ 8 lbs.)
 0 ~ 300g. (0 ~ 10 ozs.)

Wow and Flutter Meter

Audio Oscillator

Frequency Counter

Band-pass Filter

AC Volt Meter (Level Meter)

Distortion Meter

Oscilloscope

Test Tape For reproduce alignment : MRL 41J326 G24S
 Fostex Model 9200 G16S

 For speed, Wow and Flutter measurement: STL X-1453 G24S
 Fostex Model 9201 G16S

Blank Tape: Ampex 456 is recommended

Empty Reel : Small (2 inch) Hub Type

Tape Tension Gauge: Tentel Model T2-H20-ML

Extension Card : Fostex P/N 8273617000

R/P Card Extraction Jig (to pull out the R/P Card) : Fostex P/N 8214180000

4.2 Transport Check and Adjustment

Note. When dismounting "Panel, transport, G" (P/N 8220633100), dismount "Guide, tension roller, G" (P/N 8212262000), "Pinch roller, C" (P/N 8260351000) for G24S/ "Pinch roller, B, 1/2" (P/N 8260203102) for G16S and "Panel, loading" (P/N 8220634200) first for easy dismounting.

4.2.1. Position of Brake Arm

The distance between Brake Arm (2) and Brake Slider (7) must be in 1 ± 0.5 mm as shown in Fig. 4.1. The distance can be adjusted by adjusting the position of Brake Arm (2) with two screws (5).

4.2.2. Brake Torque

The brake torque is applied mechanically. The pressure is set by variable spring force. While making these measurements and adjustments, be careful not to bend the brake bands. As brake torque will change after cleaning, brake drums and brake shoes should be cleaned only when absolutely necessary. If cleaning is required, use alcohol.
Brake adjustment is made with no power to G24S/G16S.

- 1) Place an empty 2" hub reel on the left reel table, and fasten one end of a 30" (1m) length of twine to the reel anchor.
- 2) Wind several turns of twine CCW around the hub and attach a suitable spring scale to the free end of the twine.
- 3) Read the scale only when the reel is in steady motion since the force required to overcome static friction will produce a false, excessively high initial reading.

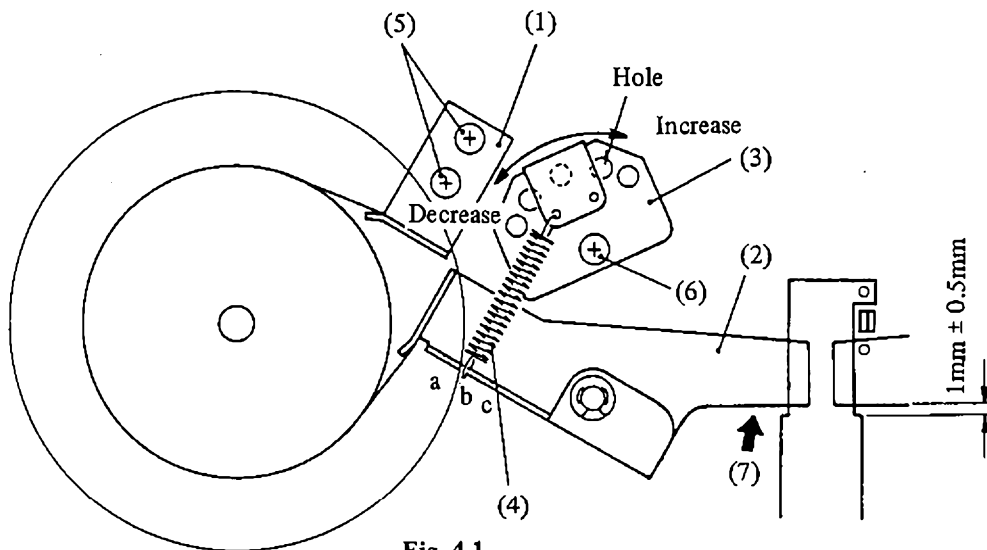
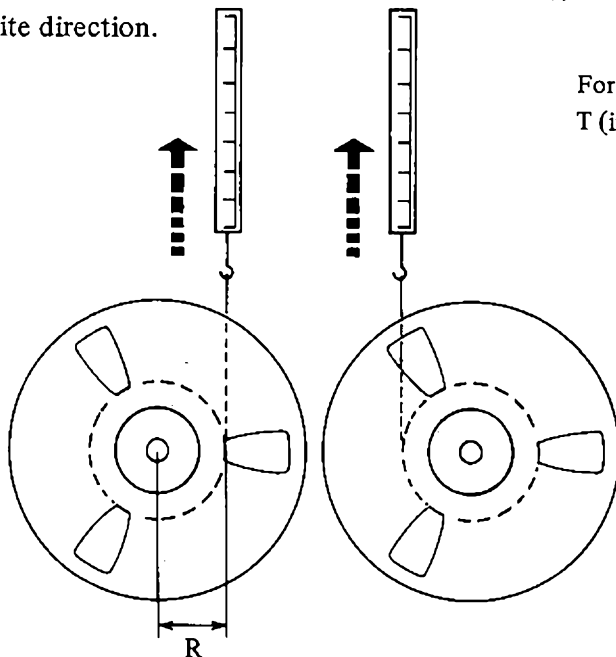

Fig. 4.1

- 4) The reading should be 1200 ~ 1800 g-cm (17 ~ 25 in. oz), and the difference of the torque at brake L and R is less than 20%.
- 5) If adjustment is required, loosen screw (6) of Fig. 4.1, and rotate the bracket (3) of Fig. 4.1. Rotate it to the right if torque is low and to the left if it is high for brake L.
- 6) The adjustment of brake R is the same with the exception that rotations are clockwise (wind string CLOCKWISE around the reel hub), and the rotation of the bracket is in opposite direction.



Formular for torque calculation:

$$T (\text{in-oz/g-cm}) = R \times W$$

R = Radius of hub (in/cm)

W = (oz/gm)

Fig. 4.2

4.2.3. Pinch Roller Pressure

Pinch roller pressure is supplied by PINCH ROLLER SPRING ① and SOLENOID, C ②.

- 1) First, loosen two screws A and B to secure that the SOLENOID, C ② is at free position.
- 2) Turn on the power of G24S and secure the left or right tension (shut off) arm in ON position (tension arm raised) without loading a tape on the transport.
- 3) Attach a suitable spring scale to the pinch roller shaft with a loop of twine. (shown in Fig. 4.3)
- 4) Put the G24S in the PLAY mode, and positioning the scale as illustrated in Fig. 4.3, slowly draw it in direction opposite the capstan until the pinch roller stops rotating.
- 5) The spring scale should indicate 2.5 ~ 3.0kg (5.5 ~ 6.6 lbs).
- 6) If the reading is off specification, loosen the screw C and move the BRACKET, SPRING ③ in direction of arrow shown in Fig. 4.4.

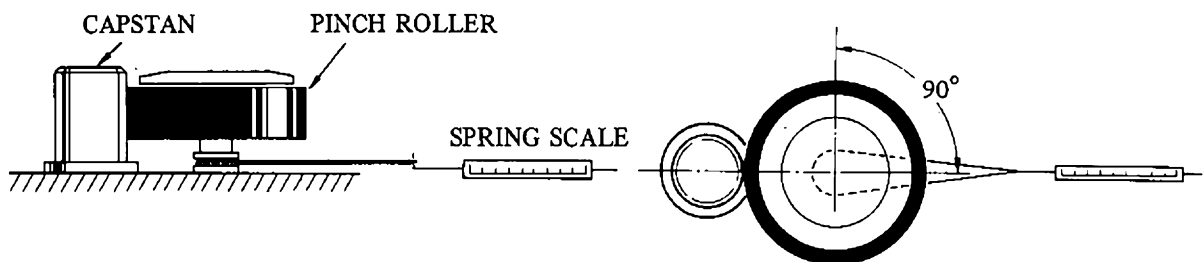

Fig. 4.3

****The following adjustments apply to G24S only.****

- 7) Turn off the power of G24S and rotate the CAM ASSY, LOADING ④ by hand until the CAM ASSY, LOADING ④ and ARM ASSY, JOINT, GA ⑤ reach the point within the arrow marked area as shown in Fig. 4.4.
- 8) At this condition, adjust the position of SOLENOID, C ② so that there is no gap X produced between the RUBBER ⑥ and SOLENOID, C ②. Then, holding both SOLENOID CORE ⑦ and SOLENOID, C ② and push the SOLENOID CORE ⑦ slightly to the arrow direction to eliminate the further play of the SOLENOID CORE ⑦ maintaining the engagement of CAM ASSY, LOADING ④ and ARM ASSY, JOINT GA ⑤ and then tighten the two screws A and B.

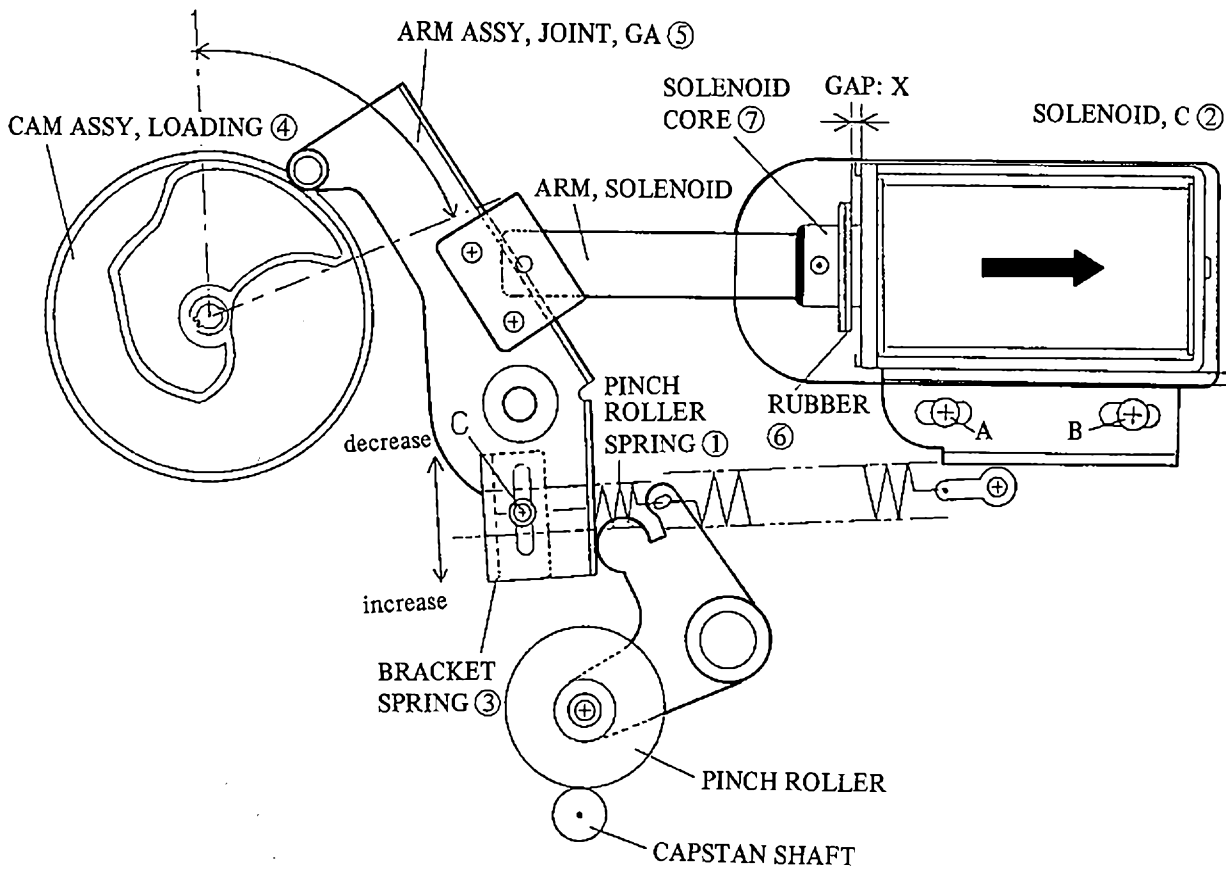

Fig. 4.4

4.2.4 Tension Roller Height Adjustment

If the tape travel is unsatisfactory due to a misaligned tension roller, its height must be corrected.

Load a tape and put the G24S/G16S in F.FWD and also in RWD modes.

If the tape moves up and down on the Guide roller (take up side) and the Footage roller (supply side) as shown in the Fig. 4.5 when repeated F. FWD and RWD modes, in other words, the position of tape path on the Rollers at F. FWD and RWD modes becomes different, the height of Tension arm will have to be adjusted by loosening the screw ① shown in the Fig. 4.5.

After the Tension arm height adjustment is completed, put the G24S/G16S in PLAY mode and confirm if the tape is travelling in the middle of the Reel.

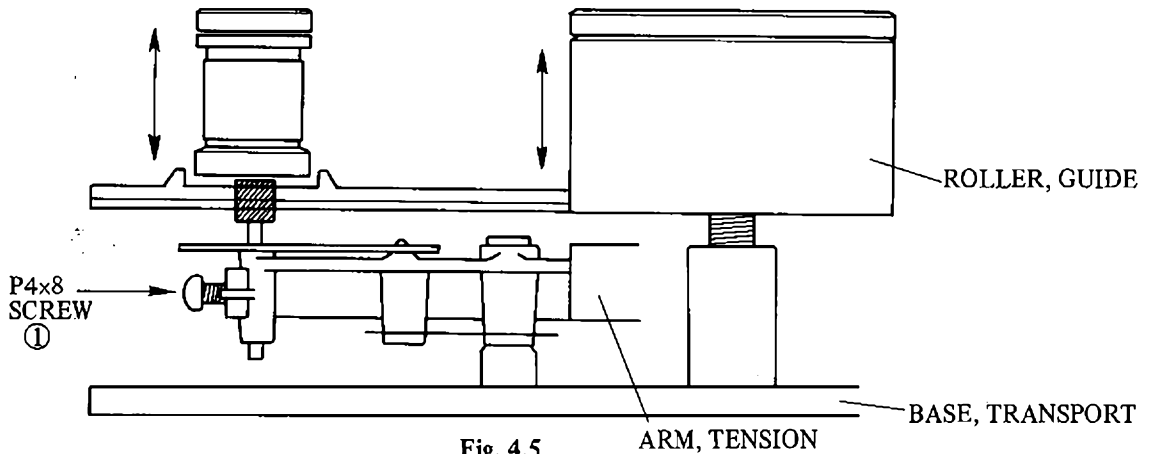

Fig. 4.5

** The following adjustment is applied to G24S only and there is no Reel table height adjustment for G16S required.

If the Reel height adjustment is necessary, the following procedure should be taken.

- 1) Loosen screw (A) (BOLT, HSB M4x10 8204027004). (two screws for one reel table).
- 2) Loosen screw (B) (SCREW, HSF 5x40 8204074003) by hex wrench (3mm) and take out washer (C) (WASHER, REEL CLAMPER 8223215000).
- 3) Then, adjust screw (D) (SCREW, HSC 5x8, BZn 8204076000) by hex wrench (2.5mm) so that the tape is travelling in the middle of the reel.
If the reel table is too high, turn the screw (D) CCW (counter clockwise).
If the reel table is too low, turn the screw (D) CW.

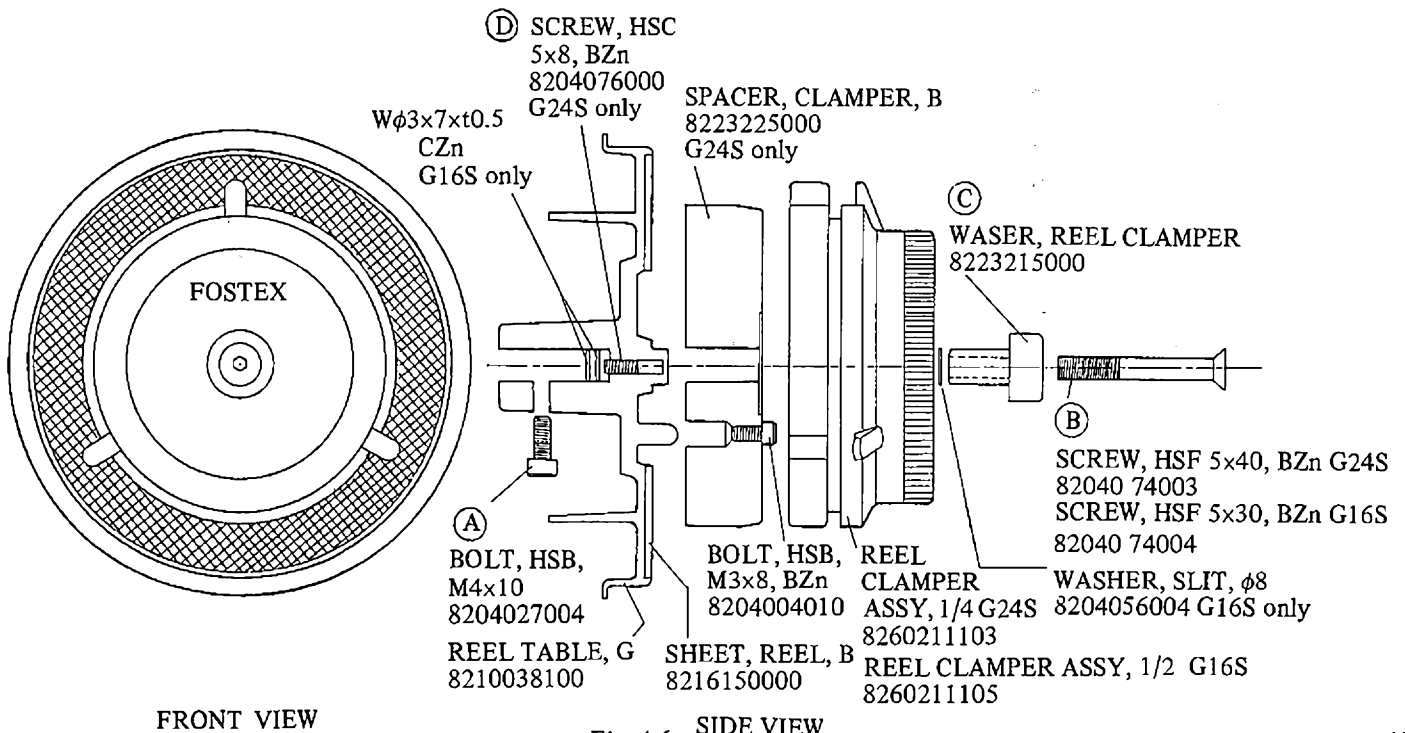

Fig. 4.6

4.2.5 Height Adjustment of the Head Assembly Guide

Height of the center guide in the head assembly must be adjusted when tape travel is unsatisfactory.

The height is adjusted by rotating the screw on the top of the guide with a 3mm box wrench while running a tape over a guide.

4.2.6 Reel Servo

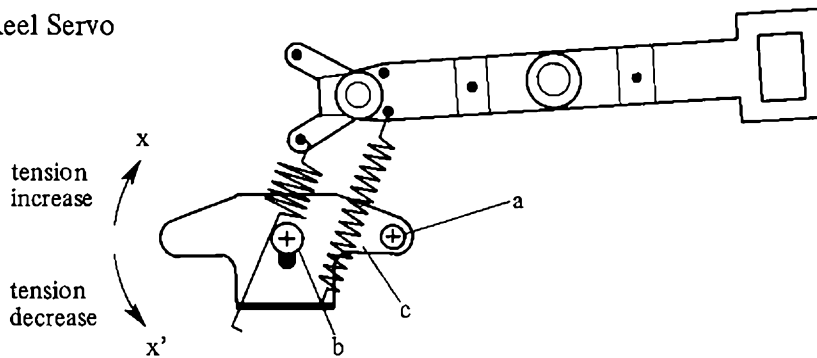

Fig. 4.7

4.2.6.1 Tools required for adjustment

Oscilloscope

Tape tension gauge : Tentel Model T2-H20-ML

Blank tape : 1" width, Ampex 456 G24S

1/2" width, Ampex 456 G16S

4.2.6.2 Procedure

- 1) Loosen the screws (a) and (b).
- 2) Tighten the screws (a) and (b) to hold the bracket (c) horizontally.
- 3) However, in case the optimum tension value cannot be obtained by adjusting the pots R1 thru R6 in the following tension adjustment procedures, loosen the screw (a) and (b) and adjust the position of the Tension arm bracket for x direction or x' direction for optimum tension value.

If the Tension arm bracket is adjusted too far x' direction, the shut off circuit may be activated.

4.2.6.3 Tape Tension Adjustment

Tape tension measurement will slightly differ due to scattered calibration figures of the tension gauge and ambient temperature differences from that at manufacture of the gauge. If the measurement is only for checking, it will be sufficient if preparations are made as in Item 4.2.6.4 and checked as explained in Item 4.2.6.9.

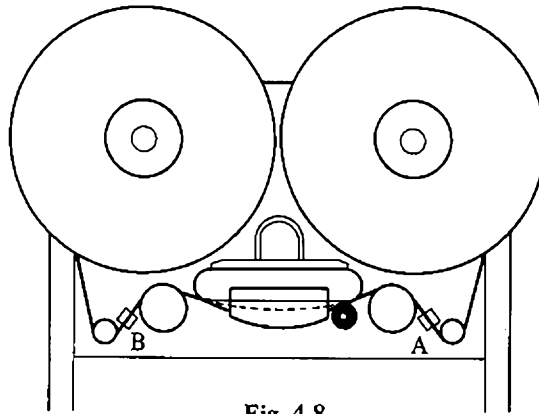

Fig. 4.8

4.2.6.4 Preparation

- 1) Load 10-½ inch reels wound with about the same amount of tape on both left and right reel turntables.
- 2) Disconnect the connector J4 on the DD CAPSTAN PCB to prevent the capstan motor from rotating.
- 3) Put the G24S/G16S in the 2nd mode by depressing the **STO** (store) button while holding down the **RCL** (recall) button. Then, put the G24S/G16S in MECHANISM-ADJUST mode by depressing the **STOP** button on the Controller while holding down the **HOLD** (hold) button.
- 4) With putting G24S/G16S on the horizontal position, pull the “Panel Lock Release Knob” on the Controller down to open up the Controller panel. (open the Controller panel fully to see and calibrate the pots of TENSION POD PCB) (shown in Fig. 4.9).

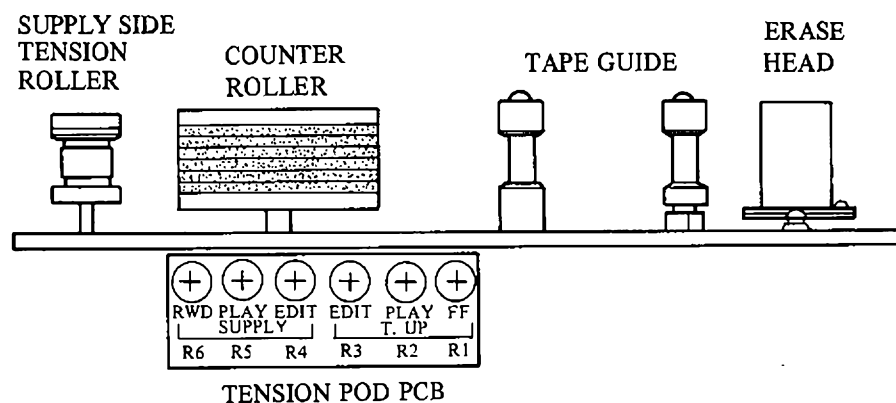

Fig. 4.9

4.2.6.5. At EDIT Mode

- 1) Under the MECHANISM-ADJUST mode, depress the **STOP** button on the main unit and put transport in the EDIT mode.

- 2) Insert the tension gauge at point "A" (shown in Fig. 4.8) and set R3 (EDIT-T. UP) for the reading of tape tension of 120g. Next, insert the tension gauge at point "B" and set R4 (EDIT-SUPPLY) so that the reading of tape tension is 120g.

4.2.6.6 At PLAY Mode

- 1) Put the transport in the PLAY mode by depressing the **PLAY** button on the main unit.
- 2) Set R2 (PLAY-T. UP) so that the reading of tape tension at "A" is 200g. In the same way, set R5 (PLAY-SUPPLY) so that the reading of tape tension at "B" is 160g.

4.2.6.7 At Fast Winding Mode

- 1) Put the transport in the F.FWD mode by depressing the **F. FWD** button on the main unit.
- 2) Set R1 (FF) so that the reading of tape tension at "A" is 350g.
- 3) Put the transport in the RWD mode by depressing the **REWIND** button on the main unit.
- 4) Set R6 (RWD) so that the reading of tape tension at "B" is 350g.

4.2.6.8 At EDIT mode

- 1) Put the transport into STOP mode by depressing **STOP** button on the main unit.
- 2) Depress **CLR** (clear) button of the controller to release the MECHANISM-ADJUST mode.
- 3) With putting G24S/G16S on the vertical position, put the connector J4 back on the DD CAPSTAN PCB.

4.2.6.9 Checking the Tape Tension (refer to Fig. 4.8)

- 1) Put the G24S/G16S in the MECHANISM-ADJUST mode (refer to 4.2.6.4 3))
- 2) Put the transport in the EDIT mode by depressing **STOP** button on the main unit.
- 3) Check the tension at "A" and "B". Tension at "A" and "B" should be 100 ~ 130g. And the difference of the tension between at "A" and "B" should be less than 5g.
- 4) Put the transport in the PLAY mode by depressing the **PLAY** button on the main unit. And confirm that tension at "A" is $190g \pm 10g$ and tension at "B" is $170 \pm 10g$. (Caution: since the capstan motor rotates at a speed of $3 \frac{3}{4}$ ips in the MECHANISM ADJUST mode, T.UP side tension should be 10g lower than the adjusted value in item 4.2.6.6, and supply side tension should be 10g higher than the adjusted value in item 4.2.6.6.

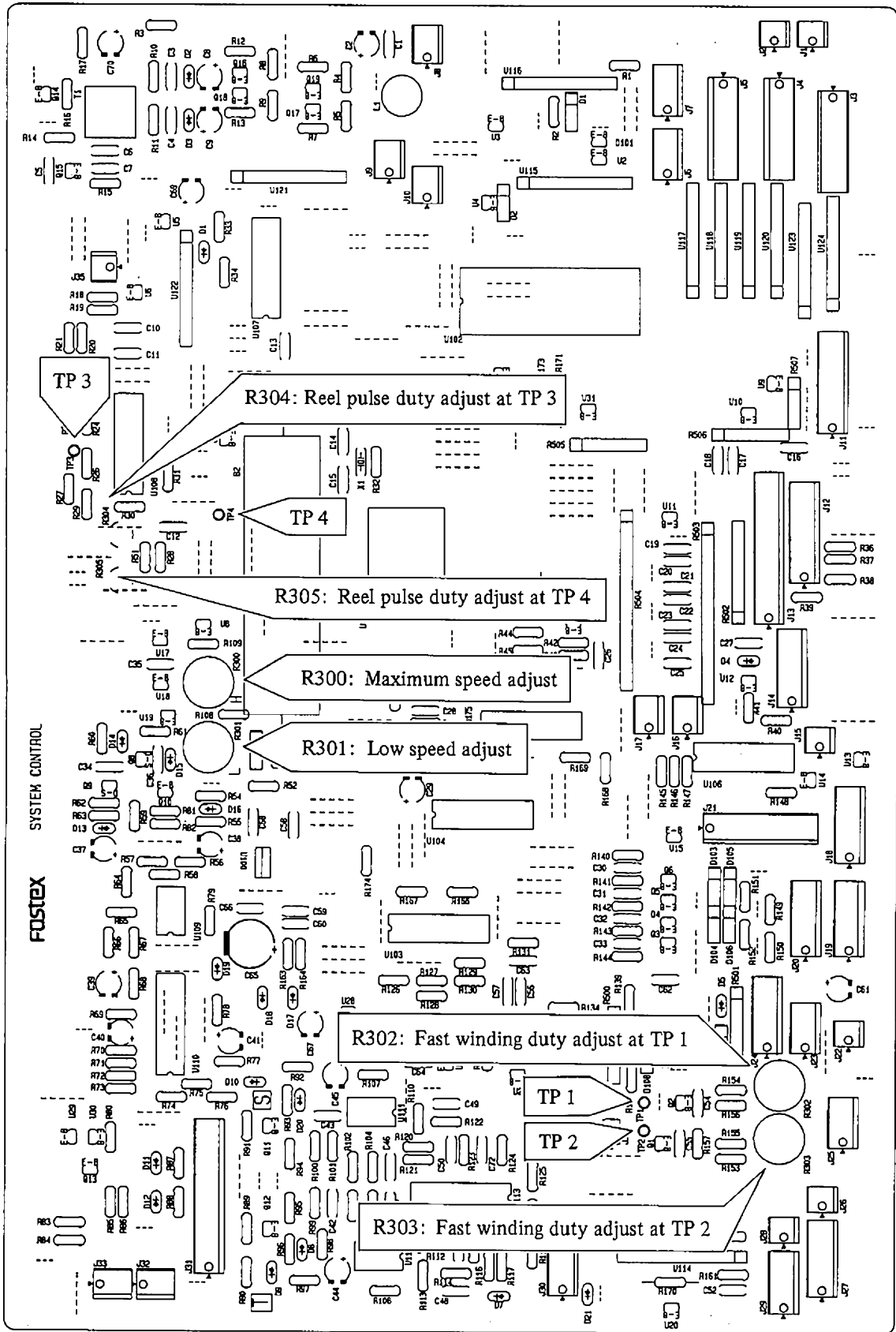

Fig. 4.10

- 5) Put the transport in the F.FWD or RWD mode by depressing the **F.FWD** or **REWIND** button on the main unit. Each tension at "A" or "B" should be $350 + 10, -20\text{g}$.
- 6) Depress the **CLR** (clear) button to release the "MECHANISM-ADJUST" mode.
- 7) Put the transport in EDIT mode by depressing the **EDIT** button of the G24S/G16S. Then, confirm that both T.UP reel and SUPPLY reel are in a steady state at the beginning of the tape and at the end of the tape. Also confirm if the tape travels are made smoothly for backward and when rotating the "JOG (EDIT) DIAL"

4.2.6.10 Adjusting the Count Pulse Duty and Fast Winding Speed.

- 1) First, take off the Rear panel and then swing open the SYSTEM CONTROL PCB by taking two screws out.
- 2) Rotate the R300 (H) fully CCW from the parts side of the PCB.
- 3) Put transport in the F. FWD or RWD mode.
- 4) Monitor the testpoint 1 waveform with an oscilloscope.
- 5) Adjust R302 on the SYSTEM CONTROL PCB for a 50% duty of the testpoint 1 waveform (shown in Fig. 4.11)
- 6) Monitor the testpoint 2 waveform with an oscilloscope.
- 7) Adjust R303 on the SYSTEM CONTROL PCB for a 50% duty of the test point 2 waveform. (shown in Fig. 4.11)
- 8) Confirm that there is 90° (degree) phase difference between test point 1 waveform and test point 2 wave form during the F. FWD or RWD mode. (shown in Fig. 4.11)

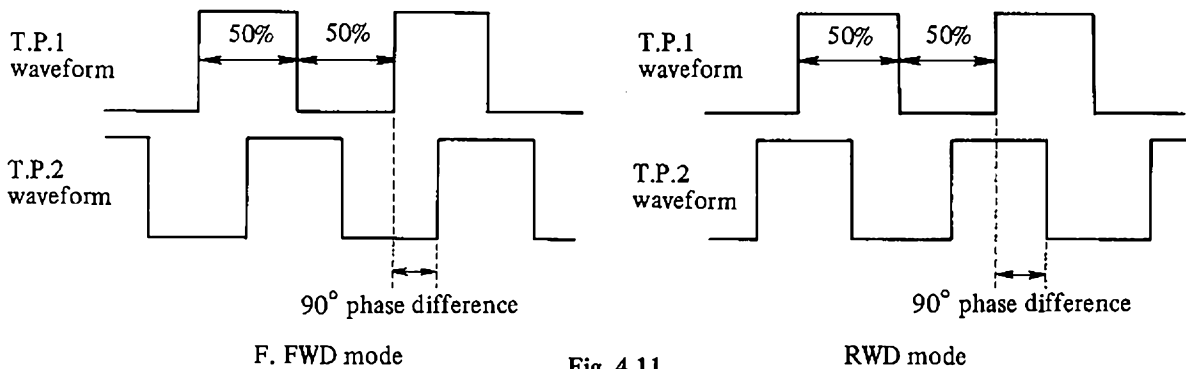

Fig. 4.11

- 9) Monitor the test point 1 waveform with an oscilloscope.
- 10) Put transport in F. FWD or RWD mode.

- 11) Adjust R300 (H) so that testpoint 1 wave length at maximum speed (winding the beginning of the tape in F. FWD or winding the end of the tape in RWD) is 0.65 msec. And confirm that the difference of the maximum winding speed in F. FWD and in RWD should be within 0.03 msec.
- 12) Holding the **F. FWD** or **REWIND** button of the controller down.
- 13) Adjust R301 (L) so that test point 1 wave length is 16 msec at the middle of the tape. And confirm that the difference of the winding speed in F. FWD and in RWD should be within 1 msec.

4.2.6.11 Adjusting the Reel Pulse Duty

- 1) Put transport in the F. FWD or RWD mode.
- 2) Adjust R304 on the SYSTEM CONTROL PCB for a 50% duty of the test point 3 waveform.
- 3) Adjust R305 on the SYSTEM CONTROL PCB for a 50% duty of the test point 4 waveform.

4.2.7 DD Capstan Servo Adjusting Procedure

4.2.7.1 Lock duty adjusting

- 1) Connect the oscilloscope probe to TP-2 on the DD CAPSTAN PCB.
- 2) Set transport in the PLAY mode and adjust R85 and R86 so that a square wave appears at TP-2.
- 3) Switch ON the **PITCH CONT** button and while watching the waveform of TP-2 on the oscilloscope, vary the SPEED by rotating the PITCH CONT KNOB from maximum through minimum. If the square wave duty changes as shown in Fig. 4.12, rotate R86 clockwise (CW), looking at it from the parts side of the DD CAPSTAN PCB, so that duty is about 50%. If the waveform is opposite to that in Fig. 4.12, then rotate R86 for a less than 50% waveform and R85 for a 50% duty.

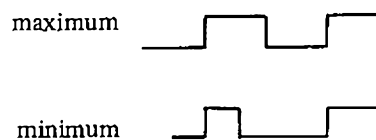

Fig. 4.12

- 4) Repeat above step 3) until the duty remains at about 50% when SPEED is changed from maximum through minimum.

4.2.7.2 Centering the Magnet FG and the Print Coil

This procedure is done at the factory and must not be done at routine maintenance and servicing.

When wow and flutter is extremely bad, it could be that the FG magnet and print coil are off center and therefore should be adjusted as follows:

- 1) Thread the Speed Tape (3KHz or 3150Hz) on the transport.
- 2) Loosen screws A and B just enough to allow shifting the PCB print coil.
- 3) Connect a wow and flutter meter to the reproduce output.
- 4) Put the transport in the PLAY mode and while reading the wow and flutter meter, slowly shift the PCB print coil to search for least amount of wow and flutter.
- 5) Carefully tighten screws A and B while checking the wow and flutter meters' best reading.

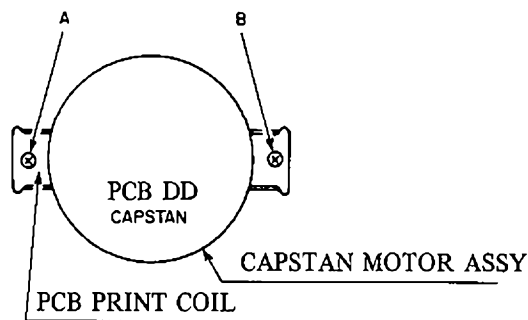

Fig. 4.13

- 6) It is considered as a normal condition if the value of the WOW & FLUTTER is measured as $\pm 0.05\%$ peak WTD (IEC/ASI) or less.

4.2.7.3 Adjusting the PITCH CON. Oscillator

- 1) Depress **RCL** (recall) button and then **PITCH** button on the Controller to see the "PITCH" display.
- 2) Turn the FRONT/REAR sw on the rear panel to REAR. (at this condition, PITCH CON. VR. on the Controller is not in operative condition).
- 3) Depress the **PITCH** button again and then PITCH LED starts blinking. In this condition, confirm that even if rotating the PITCH CON. KNOB, the PITCH value on the display never varies.
- 4) Adjust R87 on the DD CAPSTAN PCB assy so that the "PITCH" value on the display shows "0.0" (" -0.0" is no good).

- 5) Turn the FRONT/REAR SW to FRONT. Then, rotate and fix the PITCH CON. KNOB at the center position.
- 6) Adjust R101 on the CONTROLLER PCB (there is a hole provided on the back side of the Controller to rotate the pot) so that the PITCH value shows "0.0".

ADJUSTMENT ITEMS	ADJUSTING PART	ADJUSTMENT LOCATION	REF. CLAUSE
EDIT TENSION (T. UP)	EDIT R3 (4.7KΩB)	TENSION POD PCB	4.2.6.5
EDIT TENSION (SUPPLY)	EDIT R4 (4.7KΩB)		4.2.6.5
PLAY TENSION (T.UP)	PLAY R2 (47KΩB)		4.2.6.6
PLAY TENSION (SUPPLY)	PLAY R5 (100KΩB)		4.2.6.6
F.F. TENSION	FF R1 (22KΩB)		4.2.6.7
RWD TENSION	RWD R6 (22KΩB)		4.2.6.7
COUNT PULSE DUTY	R302 (33KΩB)	SYSTEM CONTROL PCB	4.2.6.10
COUNT PULSE DUTY	R303 (33KΩB)		4.2.6.10
WINDING SPEED HIGH	H R300 (100KΩB)		4.2.6.10
WINDING SPEED LOW	L R301 (330KΩB)		4.2.6.10
REEL PULSE DUTY L	R304 (47KΩB)		4.2.6.11
REEL PULSE DUTY R	R305 (47KΩB)		4.2.6.11
PITCH CONTROL DUTY	R85 (15KΩB)	DD CAPSTAN PCB	4.2.7.1
PITCH CONTROL DUTY	R86 (15KΩB)		4.2.7.1
PITCH CONTROL ADJ	R87 (1KΩB)		4.2.7.3
PITCH CONTROL ADJ	R101 (10KΩB)		4.2.7.3

4.3 Record / Reproduce Amplifier Checks and Adjustments

Reproduce Alignment Tape : MRL 41J326 G24S

Fostex 9200 G16S

Blank Tape: We would like to suggest that you use

AMPEX 456 1 inch tape for G24S and AMPEX 456 ½ inch tape for G16S.

4.3.1 Checking and Adjusting of Head

- 1) Connect a level meter and an oscilloscope to OUTPUT jack 1 and 24 (G24S) or OUTPUT jack 1 and 16 (G16S) for observing a lissajous waveform.
- 2) Tangency adjustment
If the head gap does not face the tape correctly as shown in the drawing below, a correct recording and/or playback level cannot be obtained.

And also there is considerable deterioration occurs in the high frequency range.

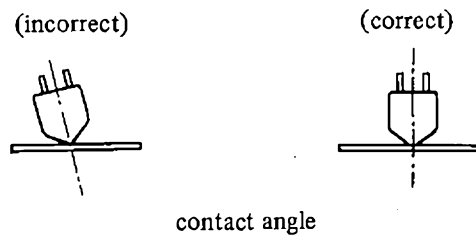

Load a Reproduce Alignment tape, MRL 41J326 for G24S/Fostex 9200 for G16S and playback the 10KHz/12.5KHz section. And then, adjust the tangency screws as shown in the Fig. 4.13 so that the reading of played back 10KHz/12.5KHz level will be the maximum. This is the point where the head gap faces the tape correctly.

3) Height/Tilt adjustment

The head height/tilt adjustment can be done with the two screws shown in the Fig. 4.14.

3)-1) Height adjustment

Incorrect adjustment of the head height will result in degraded Erasure, Crosstalk etc. The adjustment is as follows

Erase head . . . Head core edge slightly protrudes beyond the tape edge.

R/P head . . . Head core edge slightly recessed within the tape edge (core edge cannot be seen).

3)-2) Tilt adjustment

Tilt adjustment means that the head surface is so adjusted as to be parallel with the tape surface.

Improper tilt adjustment will cause a difference in pressure being applied to the head between the upper and lower edge of the tape.

Consequently, the head is apt to become worn into a trapezoid form.

Therefore, the head must be so adjusted that the head surface is parallel with the tape guide adjacent to it.

4) Azimuth phase adjustment

Load a Reproduce Alignment Tape, MRL41J326 for G24S/Fostex 9200 for G16S and playback the Head Azimuth and Frequency Response section of the test tape.

The Azimuth and Phase can be adjusted with the adjusting screw as shown in the Fig. 4.14.

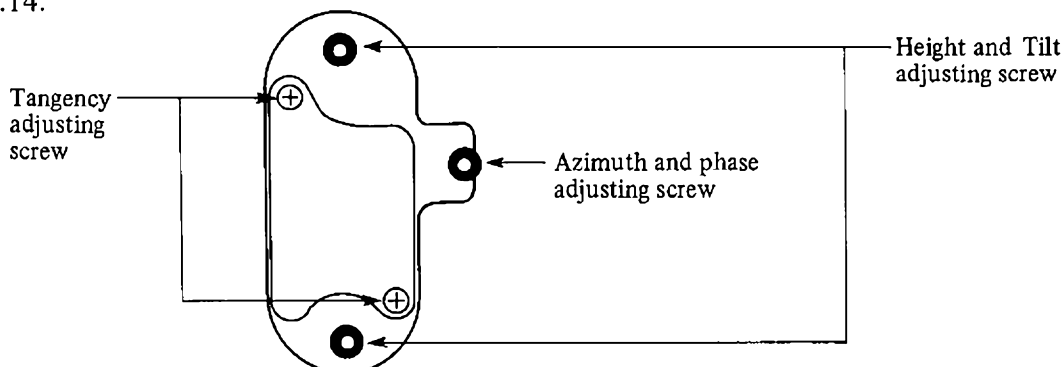

Fig. 4.14

Adjust the Azimuth and Phase Adjusting Screw for maximum reading on all 24/16 LED bargraph meters of the recorder.

Then, set the oscilloscope to XY mode to obtain a lissajous waveform to check the phase.

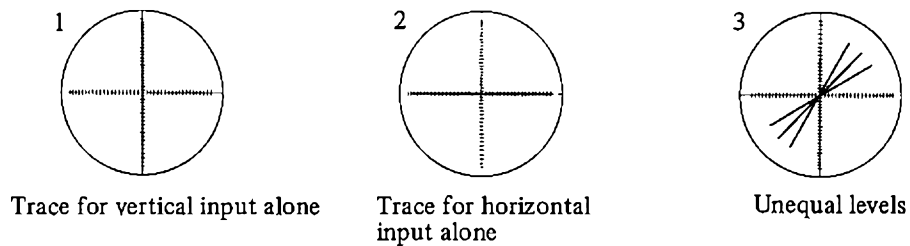

Fig. 4.15

If the trace length between (X) and (Y) are not the same, it means that the two inputs to the oscilloscope are not of the same level. Correct for equal lengths by the oscilloscope controls.

If the playback head azimuth is out of alignment, the following patterns will result:

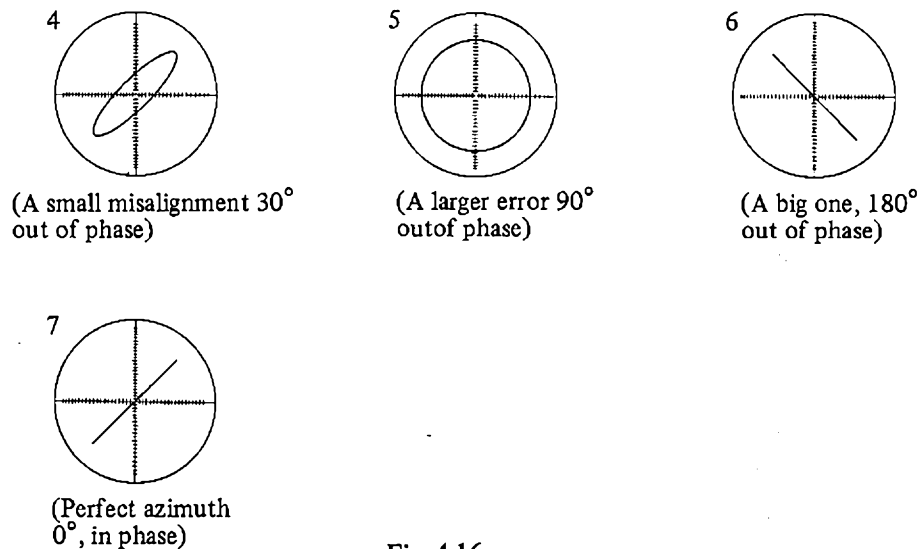

Fig. 4.16

As a result of phase check with a 12.5KHz signal, the adjustment is finished if the difference in phase is less than 75 degrees between tracks, and azimuth adjustment is at the best point.

4.3.2 Input Level and Meter Level Calibration

- 1) Put Dolby NR ON/OFF SW to OFF position.
- 2) Put Input Monitor Button to ON position so that the R/P amp enters into Input Monitor mode.
- 3) Plug in an audio oscillator output to the recorder rear panel INPUT jack 1 and apply a 1KHz, -10dBV (0.3V) signal.

- 4) Connect the level meter to OUTPUT jack 1 on the rear panel and check that the level here is -10dBV (0.3V) $\pm 0.5\text{dB}$.
- 5) After checking the OUTPUT jack 1 level, depress the **RCL** (recall) and **METER** (meter) key on the Controller. Then depress the **.** (period) key to select the "CAL" mode. The Memory Display changes the meter mode to

$\overline{\text{N}}\overline{\text{O}}\overline{\text{R}}\overline{\text{M}}\overline{\text{A}}\overline{\text{L}}$ (normal)
 $\overline{\text{T}}\overline{\text{E}}\overline{\text{M}}\overline{\text{P}}$ (temporary peak hold)
 $\overline{\text{P}}\overline{\text{A}}\overline{\text{R}}\overline{\text{M}}$ (permanent peak hold)
 $\overline{\text{C}}\overline{\text{A}}\overline{\text{L}}$ (calibration)

by depressing the **.** (period) key every time. To memorize the "CAL" mode, depress the **STO** (store) and then **METER** key. And adjust R201 (METER CAL) for a 0dB reading on the recorder LED bargraph meter.

- 6) Put the meter mode back to "NORMAL" mode:
- 7) Connect the level meter to test point TP-3 on the TRACK 1 of the R/P amplifier PCB Assy, and put the machine in the REC mode by depressing both REC and PLAY button simultaneously with turning the SAFE/READY SW to READY position. Then, adjust R202 (REC CAL) so that the level at TP-3 is -8.2dBV .
- 8) Calibrate the rest of the tracks in the same way.

4.3.3 Reproduce Level Calibration

- 1) Put Dolby NR ON/OFF SW to OFF position.
- 2) Playback the Reference Level Section (1KHz, -10dBV) of the Reproduce Alignment Tape, such as MRL 41 J326/Fostex 9200 test tape.
- 3) Connect a level meter to the recorder rear panel OUTPUT jack 1 and adjust R204 (REP LVL, NR OFF) so that the level is -10dBV (0.3V).
- 4) Put Dolby NR ON/OFF SW to ON position.
- 5) Connect the level meter to the test point TP-3 on the TRACK 1 of the R/P amplifier PCB Assy, and adjust R203 (REP LVL, NR ON) so that the level is -8.2dBV .
- 6) Connect the level meter to the recorder rear panel OUTPUT jack 1 again and confirm that the level is -10dBV ($\pm 0.5\text{dB}$).
- 7) After checking of the OUTPUT jack level, confirm that the meter reading is $0 \pm 1\text{dB}$.
If the reading is not $0\text{dB} \pm 1\text{dB}$, repeat the adjustments in the previous section, Item

4.3.2.5).

- 8) Calibrate tracks 2~24/2~16 in the same way.

4.3.4 Adjusting and Checking the Reproduce Frequency Response

- 1) Put Dolby NR ON/OFF SW to OFF position.

- 2) Playback the Frequency Response section of the Reproduce Alignment Tape.

*Caution: Please be careful that the Frequency Response section of the Reproduce Alignment Tape, MRL 41J326 is recorded 10dB lower than the Reference level position (1KHz).

- 3) Plug in a level meter to the OUTPUT jack.

- 4) Adjust R206 (REP EQ) so that the reproduce level at 10KHz is same as the level at 1KHz.

The normal playback frequency response should be within $\pm 3\text{dB}$ for a frequency range of 125Hz ~ 16KHz. If it is not within the spec, adjust R206 (REP EQ) again.

4.3.5 Bias Leakage Check

Two bias trap modules are provided for each channel. One is in the first stage of the reproduce amplifier and the other in the output stage of the record amplifier.

- 1) Reproduce bias trap module (U18)

To check bias leakage of TRACK 1, the oscilloscope probe is hooked to TP-2 and the probe ground clip to the GND pin. Put TRACK 1 in the reproduce mode, the adjacent TRACK 2 in the record mode and check bias leakage at TP-2.

It is considered as a normal condition if the bias leakage level is less than -10dBV .

(At checking TRACK 2, put adjacent TRACK 3 in the record mode).

If the bias leakage level is higher than the spec, it is adjusted to the minimum bias leakage level by rotating the center core of U18. But before doing this, check the frequency (100 KHz ± 0.5 KHz) of the erase/bias master oscillator. To check the oscillator frequency, pull out the R/P card of the G24S, and check the frequency at connector J 2-8 on the CONNECTOR BOARD PCB Assy.

- 2) Record bias trap module (U21)

To check bias leakage of TRACK 1, the oscilloscope probe is hooked to TP-4 and the probe ground clip to GND pin. Put TRACK 1 in the record mode and check bias leakage at TP-4.

It is considered as a normal condition if the bias leakage level is less than -8dBV .

If the bias leakage level is higher than the spec, it is adjusted to the minimum bias leakage level by rotating the center core of U21. But before doing this, check the frequency (100KHz \pm 0.5KHz) of the master oscillator. To check the oscillator frequency, pull out the R/P card of the G24S/G16S, and check the frequency at connector J2-8 on the CONNECTOR BOARD PCB Assy.

4.3.6 Erase Current Adjustment

*Caution: Since a multi-turn type pot is used for R209 (ERASE LVL) adjustment, it might give you a confusion to find out the setting of the maximum erase current level point.

In order to find out the maximum erase current level point, we would like to suggest that you rotate the pot clockwise and set to the point where just before the erase current drastically decreases.

- 1) In adjusting the erase current, put all the 24/16 tracks in the REC mode.
- 2) Rotate all the 24/16 tracks of the R209 (ERASE LVL) fully CW.
- 3) To adjust TRACK 1, for example, hook the hot side of the oscilloscope probe to TP-5 and ground clip of the probe to GND pin.
- 4) Set the core of T-1 (ERASE ADJ) so that voltage at TP-5 reaches the peak level point.
- 5) Then adjust R209 (ERASE LVL) so that the voltage at TP-5 is 37mVr.m.s. for G24S and 30mVr.m.s. for G16S or the maximum level you can get.
- 6) Calibrate tracks 2 ~ 24/2 ~ 16 in the same way.

4.3.7 Bias Current Adjustment

*Caution: Since a multi-turn type pot is used for R210 (BIAS LVL) adjustment, it might give you a confusion to find out the setting of the maximum bias current level point.

In order to find out the maximum bias current level point, we would like to suggest that you rotate the pot clockwise and set to the point where just before the bias current drastically decreases.

- 1) Rotate R205 (SYNC CROSSTALK CANCELLER POT) at the center position for all 24/16 tracks as shown in Fig. 4.17.

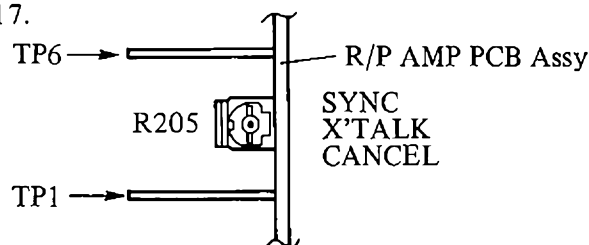

Fig. 4.17

- 2) Put all 24/16 tracks in the REC mode.
- 3) Set the core at T-2 (BIAS ADJ) to reach the peak level.
- 4) Then, adjust R210 (BIAS LVL) so that the level is 100mVr.m.s.

4.3.8 Record Level Calibration

- 1) Put Dolby NR ON/OFF SW to OFF position.
- 2) Load the blank tape (AMPEX 456) on the transport and apply an audio oscillator output of 1KHz, -10dBV (0.3V) to the INPUT jack on the recorder rear panel.
Also, plug in a level meter to the OUTPUT jack.
Taking TRACK 1 as an example, the connector number is "1" for both INPUT AND OUTPUT jacks.
- 3) Depress the RECORD TRACK 1 button, then, depress the RECORD and PLAY buttons to put TRACK 1 in the record mode.
When thus in the record mode, the meter will indicate the input level regardless of the position of the INPUT MON button. Check to see that the reading of this meter is 0dB \pm 1dB.
- 4) After recording a certain length of 1KHz, -10dBV signal, rewind tape to the starting point, put the transport in the PLAY mode and check the output level.
The INPUT MON switch must be at INDIV.
It is considered as a normal condition if the output level is -10dBV \pm 1dB.
If it is off spec, correct by adjusting R207 (REC LVL).
Calibrate tracks 2 ~ 24/2 ~ 16 in the same way.

4.3.9 Overall Frequency Response

- 1) Put Dolby ON/OFF switch to "ON" position.
- 2) Apply 1KHz and 10KHz, -35dBV signal repeatedly to the INPUT jack 1.
- 3) Put track 1 in the REC mode to record a certain length of the signal, rewind it to the start point, and playback the tape.
Then, adjust R208 (REC EQ) so that the difference of the reproduce level between 1KHz and 10KHz is 0 \pm 1dB.
- 4) Apply signals from 50 through 15KHz at -35dBV to the INPUT jack 1.
Record and reproduce the certain length of the signal. Confirm that frequency response is

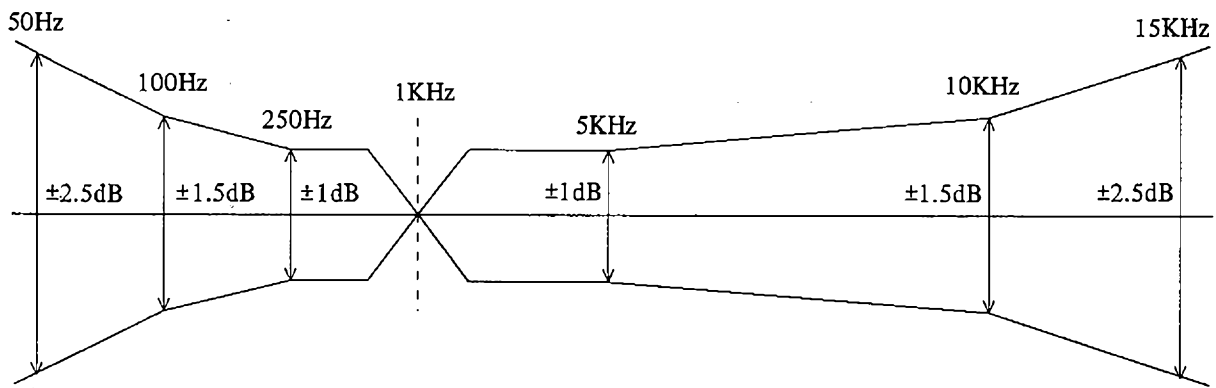

Fig. 4.18

as shown in Fig. 4.18.

If it does not fall within spec, correct it by slight rotation of R208 (REC EQ).

- 5) Put Dolby ON/OFF switch to "OFF" position.
- 6) Apply signals 40 through 18KHz at -10dBV. Record and playback the certain length of the signal.
It is considered as a normal condition if the frequency response from 40 through 18KHz is within $\pm 3\text{dB}$ against the 1KHz reference level.
- 7) Calibrate 2 ~ 24/2 ~ 16 tracks in the same way.

4.3.10 Overall S/N Measurement

- 1) Put NR ON/OFF switch to ON.
- 2) Upon completing checks up to Section 4.3.9 apply a 1KHz, -10dBV (0.3V) signal to the connector panel INPUT jack 1, for example, and record the signal onto a blank tape. Then, without stopping the tape, unplug the oscillator connected to the INPUT jack and further record a length of no-signal tape.
- 3) Plug a level meter into OUTPUT jack 1 and playback the recorded signal section to measure the noise level of the no-signal section against the 1KHz reference level. Calculate the difference between noise level and reference level, add 12dB to it and obtain the ratio between peak recording level and noise level.
Specification: 84dB weighted, 71dB unweighted G24S
82dB weighted, 69dB unweighted G16S

4.3.11 T.H.D. Measurement

- 1) Put NR ON/OFF switch to OFF.
- 2) To adjust TRACK 1, for example, apply a 1KHz, -10dBV (0.3V) test signal to INPUT

jack 1, record it, playback the recorded tape and apply its output from OUTPUT jack 1 to the distortion meter.

Specification: T.H.D. 1% or less

- 3) If it is not within spec, demagnetize the head, check the bias trap adjustment and record level.
If it still does not fall within spec after making the corrective measures above, readjust the bias current by the procedures in Section 4.3.7.
- 4) When the Section 4.3.7 adjustments are made, it is necessary to go through procedures in Sections 4.3.8 and 4.3.9.

4.3.12 Erasure Measurement

- 1) Put NR ON/OFF switch to OFF.
- 2) To adjust TRACK 1, for example, apply a 1KHz, 0dBV (1V) signal which is 10dB higher than the reference level, to INPUT jack 1 and put TRACK 1 in the record mode.
Partially rewind the tape to retain a section of the 1KHz signal and then record over the remaining section without any signal at the input.
- 3) Rewind to the start point of the recording, playback the tape and insert a 1KHz band-pass filter between OUTPUT 1 and the level meter to measure the output.
- 4) The level ratio between the 1KHz recording and the no-signal recording is the Erasure figure. It is considered as a normal condition if Erasure is higher than 70dB.
- 5) If it is off the spec, increase Erase current about 10% by the procedure of Section 4.3.6.
Monitor the Erase current waveform on the oscilloscope at adjusting and set the core just before the waveform begins to deteriorate.
A higher current will heat the Erase head and result in damage to the tape. And check the Head touch condition of tape.

4.3.13 Sync Crosstalk Check and Adjustment

- 1) Sync crosstalk is the relative figure, against the reference level, on how much of the recording signal from the track in the recording mode is leaking into the track being reproduced.
When sync crosstalk is excessively high, playback output during overdubbing will sound muddy by effect of the recording signal leakage or cause oscillation at ping-pong recording (where the playback output is transferred to another track).
- 2) Put NR ON/OFF switch to OFF.

- 3) Open the Controller Panel up, and take the "Panel Extension" out by unscrewing two screws.
- 4) Rotate the TRACK 1 R205 (SYNC CROSSTALK CANCELLER POT) on the R/P AMP PCB Assy to a point slightly CCW from the center position.
- 5) Turn the RECORD TRACK SAFE/READY SELECTOR of TRACK 1 to "SAFE" position.
- 6) Rotate the TRACK 2 R205 (SYNC CROSSTALK CANCELLER POT) to a point slightly CW from the full CCW position.
- 7) Plug in an audio oscillator output to the recorder rear panel INPUT jack 2 and apply a 1KHz, -10dBV (0.3V) signal.
- 8) Plug in a level meter to the recorder rear panel OUTPUT jack 1, and put TRACK 2 in the REC mode.
- 9) Rotate the TRACK 2 R205 (SYNC CROSSTALK CANCELLER POT) CW slowly and fix it at a point 3 ~ 5 dB above minimum point to obtain minimum sync crosstalk in the high frequency region.
- 10) Measure the OUTPUT level of TRACK 1 while sweeping the test signal frequency 20 ~ 20KHz. It is considered as a normal condition if the leaking level is less than -35dBV (18mV r.m.s.) at 1KHz and less than -4dBV (625mV r.m.s.) at worst peak point in high frequency region.
- 11) The remaining tracks 2 ~ 24/2 ~ 16 are adjusted in the same way.

4.3.14 Table of Adjustment Items and the Location/Typical Adjustment position of Pots on the R/P Amp.

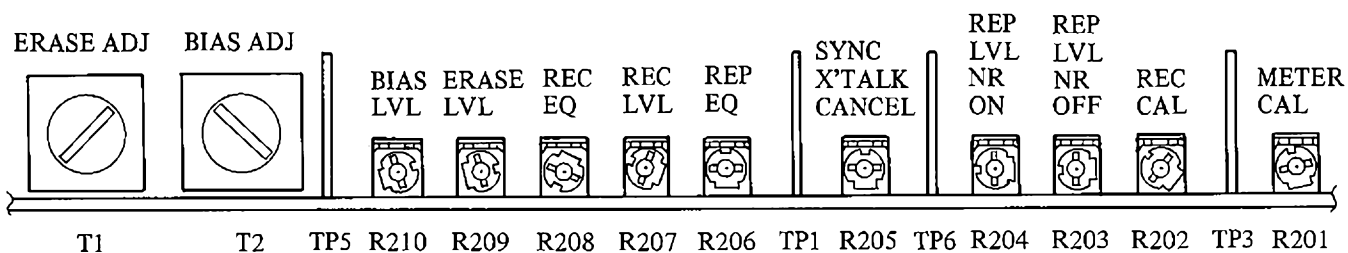

Fig. 4.19

ADJUSTMENT ITEMS	ADJUSTING PART	REF. CLAUSE
INPUT LEVEL	REC CAL (R202), 10KΩB	4.3.2
METER LEVEL	METER CAL (R201), 47KΩB	4.3.2
REPRO LEVEL NR OFF	REP LVL NR OFF (R204), 4.7KΩB	4.3.3
REPRO LEVEL NR ON	REP LVL NR ON (R203), 4.7KΩB	4.3.3
REPRO FREQ RESPONSE	REP EQ (R206), 4.7KΩB	4.3.4
REPRO BIAS LEAKAGE	REPRO BIAS TRAP (U18)	4.3.5
REC BIAS LEAKAGE	REC BIAS TRAP (U2)	4.3.5
ERASE CURRENT	T-1, ERASE LVL (R209, 10KΩB)	4.3.6
BIAS CURRENT	T-2, BIAS LVL (R210, 10KΩB)	4.3.7
REC LEVEL	REC LVL (R207), 4.7KΩB	4.3.8
OVERALL FREQ RESPONSE	REC EQ (R208), 10KΩB	4.3.9
SYNC CROSSTALK	SYNC X'TALK ADJ (R205, 220ΩB)	4.3.13

4.3.15 Dynamic Offset Adjustment

This adjustment is done at our factory and must not be done at routine maintenance and servicing. However, this adjustment is needed when replacing the DOLBY-S chip with new one for servicing.

Objective : The following adjustment so called Dynamic Offset adjustment is necessary in order to provide the transient response such as an attack response and a decay response of the source signal being input to the DOLBY S NR circuit in the optimum state as well as accurate state, in other words, put the G24S in the recording mode with the DOLBY S NR circuit under the best dynamic response state.

Tools required for adjustment:

Tone-burst generator (100 msec ON, 500 msec ~ 1 sec OFF)

Band-pass filter (BPF) with the corner frequencies at 20Hz and 200Hz and at least a 12dB/octave roll-off characteristics.

Extension card (P/N : 8273617000 supplied from service dept.)

Adjusting screw driver (P/N : 8286020000 supplied from service dept.)

Adjusting points : R211, R212

Connecting and adjusting method (Refer to Fig. 4.20 below)

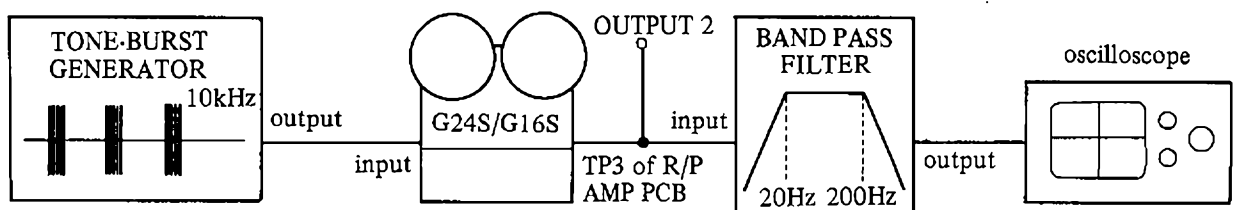

Fig. 4.20

- 1) Input a 10KHz signal through a tone-burst generator (100 msec ON, 500 msec ~ 1 sec OFF) and adjust the level of tone-burst signal for -50dBV at G24S/G16S output jack.
- 2) Route the signal at TP3 of R/P AMP PCB Assy through a band pass filter (BPF) with the corner frequencies at 20Hz and 200Hz and at least a 12dB/octave roll-off characteristics. Then, route the output signal from BPF to an oscilloscope.
- 3) Put G24S/G16S in the REC mode.
- 4) Adjust two pots R211 and R212 to minimize the peak-to-peak signal level as shown in Fig. 4.21.

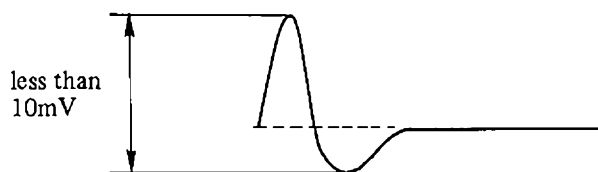

Fig. 4.21

* Note

If the BPF is not available at your hand, the Dynamic Offset adjustment can still be proceeded without BPF as follow.

Adjust two pots (R211 & R212) so that the signal level on the oscilloscope at output 2 is symmetrical with AC GND level as shown in Fig. 4.22.

Also please refer to Fig. 4.23 which shows the relationship between the pots (R211 & R212) and rotating direction (CW & CCW).

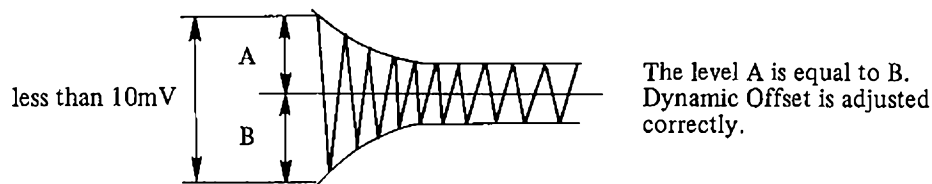

Fig. 4.22

Pot	Rotation	CW (clockwise)	CCW (counter-clockwise)
R211			
R212			

Fig. 4.23

Minimizing the initial transient response is particularly important as its spectrum contains higher-frequency information which is more audible when the Dynamic Offset is not made correctly.

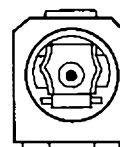

Fig. 4.24

Close look of the pots for Dynamic Offset adjustment

5. EXPLODED VIEW, PCB ASSEMBLY AND PARTS LIST

ASSEMBLING HARDWARE CODING LIST

All screws conform to ISO standards, and have crossrecessed heads, unless otherwise noted. ISO screws have the head inscribed with a point as in the figure to the right.

FOR EXAMPLE:

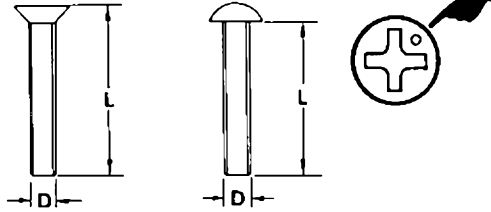
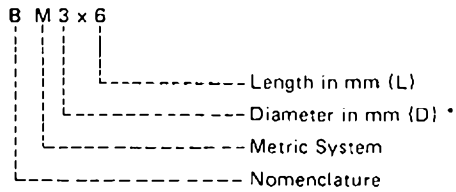

* Inner dia. for washers and nuts

	CODE	NAME	TYPE		CODE	NAME	TYPE
MACHINE SCREW	P	Pan Head Screw		WASHER, LUG, NUT	TW	Trim Washer (Countersunk)	
	T	Stove Head Screw (Truss)			N	Hex Nut	
	B	Binding Head Screw			L	Lug	
	F	Flat Countersunk Head Screw			THW	Thrust Washer (Poly Washer)	
	O	Oval Countersunk Head Screw		SETScrew	HSF	Hex Socket Setscrew (Flat Point)	
	PWH	Pan-Washer Head Screw			HSC	Hex Socket Setscrew (Cup Point)	
WOOD SCREW	RW	Round Head Wood Screw		SSF	Slotted Socket Setscrew (Flat Point)		
	FW	Flat Countersunk Wood Screw		SSC	Slotted Socket Setscrew (Cup Point)		
	OW	Oval Countersunk Wood Screw		BOLT	HSB	Hex Socket Head Bolt	
TAPPING SCREW	PTP	Pan Head Self Tapping Screw (B type)			HB	Hex Head Bolt	
	PTPWH	Pan-washer Head Self Tapping Screw (B type)		RING, PIN	ER	E-Ring (Retaining Washer)	
	TTP	Stove Head Self Tapping Screw (B type)			CRR	C-Ring (Inner)	
	FTP	Flat Countersunk Head Self Tapping Screw (B type)			CRS	C-Ring (Outer)	
TAPTITE SCREW	PTT	Pan Head Tapping Screw			GR	Seeger Ring	
	PTTWH	Pan-Washer Head Tapping Screw			SP	Spring Pin	
	TTT	Stove Head Tapping Screw			SR	Snap Ring	
	FTT	Flat Countersunk Head Tapping Screw			FINISH	Zn	Zinc plating
SEMS SCREW	PS	Pan Head Screw with Spring Washer				CZn	Colored zinc plating
	PSW	Pan Head Screw with Washer and Spring Washer		BZn		Black zinc plating	
WASHER, LUG, NUT	W	Flat Washer		Ni		Nickel plating	
	LW	Spring Washer		BNi		Black nickel plating	
	LWI	Internal Teeth Lock Washer		Cr		Chrome plating	
	LWE	External Teeth Lock Washer		BCr		Black chrome plating	

OVERALL EXPLODED VIEW

Ref. No.	Parts No.	Nomenclature	Ref. No.	Parts No.	Nomenclature
1.	8220 6331 00	Panel, transport, G	37.	8207 0006 02	Plasti rivet, #920
2.	8204 0230 05	Screw, buttonhead, HSB, M3x5, BZn	38.	8216 2840 00	Panel, rear, blank
3.	82163240 00	Sheet, blind, roller	39.	8220 6410 00	Bracket, PCB
4.	8220 6342 00	Panel, loading, G	40.	8273 5270 00	PCB assy, NR SWITCH
5.	8226 0191 00	Escutcheon, B	41.	8245 3400 00	Nut, phone jack
6.	8212 2620 00	Guide, tension roller, G	42.	8273 5920 00	PCB assy, IN/OUT, G24 G24S
7.	8204 0230 08	Screw, buttonhead, HSB, M3x10, BZn		8273 5280 00	PCB assy, IN/OUT, G16 G16S
8.	8223 1850 00	Cover, capstan	43.	8273 5290 00	PCB assy, ACCESSORY, G
9.	8204 0740 03	Screw, HSF 5x40, BZn – G24S	44.	8220 6210 00	Bracket, connector, 20P
	8204 0740 04	Screw, HSF 5x30, BZn – G16S	45.	8204 0130 02	Spacer, 3x3
10.	8223 2150 00	Washer, reel clamper	46.	8226 0621 00	Button, push, C-1
11.	8204 0560 04	Washer, slit, 8 – G16S only	47.	8216 3430 00	Sheet, insulation
12.	8204 0760 00	Screw, HSC 5x8, BZn – G24S only	48.	8220 7590 00	Plate, shield
13.	8260 2111 03	Reel clamper assy, 1/4 – G24S	49.	8220 7392 00	Bracket, AC INLET, B
	8260 2111 05	Reel clamper assy, 1/2 – G16S	50.	8245 1940 00	Connector, jack, INLET, ZUG2206-12A
14.	8223 2250 00	Spacer, clamper, B – G24S only	51.	8220 7401 00	Panel, AC INLET
15.	8204 0040 10	Bolt, HSB, M3x8, BZn – G24S only	52.	8276 6650 00	Cable assy, 12P, rear, G
16.	8216 2300 00	Collar, tape guide	53.	8276 8160 00	Cord, power, detachable, DM
17.	8260 3510 00	Pinch roller, C – G24S		8276 8170 00	Cord, power, detachable, USA/CND
	8260 2031 02	Pinch roller, B, 1/2 – G16S		8276 8180 00	Cord, power, detachable, EUR
18.	8212 2670 00	Panel, head, G		8276 8190 00	Cord, power, detachable, UK
19.	8220 7570 00	Weight, housing			
20.	8216 3030 00	Cushion, GF			
21.	8212 2631 00	Housing, head, G			
22.	8204 0660 01	Pin, 2x10			
23.	8214 1730 00	Spring, housing, G			
24.	8212 3041 00	Spacer, housing, G – G24S only			
25.	8276 6660 00	Cable assy, 12P, front, G			
26.	8216 3340 00	Washer, controller			
27.	8220 7321 00	Cover, heatsink – G24S only			
28.	8220 6320 00	Angle, 488			
29.	8216 3330 00	Cushion, side angle			
30.	8220 6300 00	Cover, rear, G			
31.	8207 0016 02	Foot, TL-027			
32.	8220 7330 00	Cover, bottom, GB			
33.	8220 7340 00	Foot, G – G24S			
	8207 0049 00	Foot, TL-043TK – G16S			
34.	8207 0049 00	Foot, TL-043TK			
35.	8220 7380 00	Panel, rear, G24 – G24S			
	8220 7480 00	Panel, rear, G16S – G16S			
36.	8220 6440 00	Bracket, rear panel			

OVERALL EXPLODED VIEW

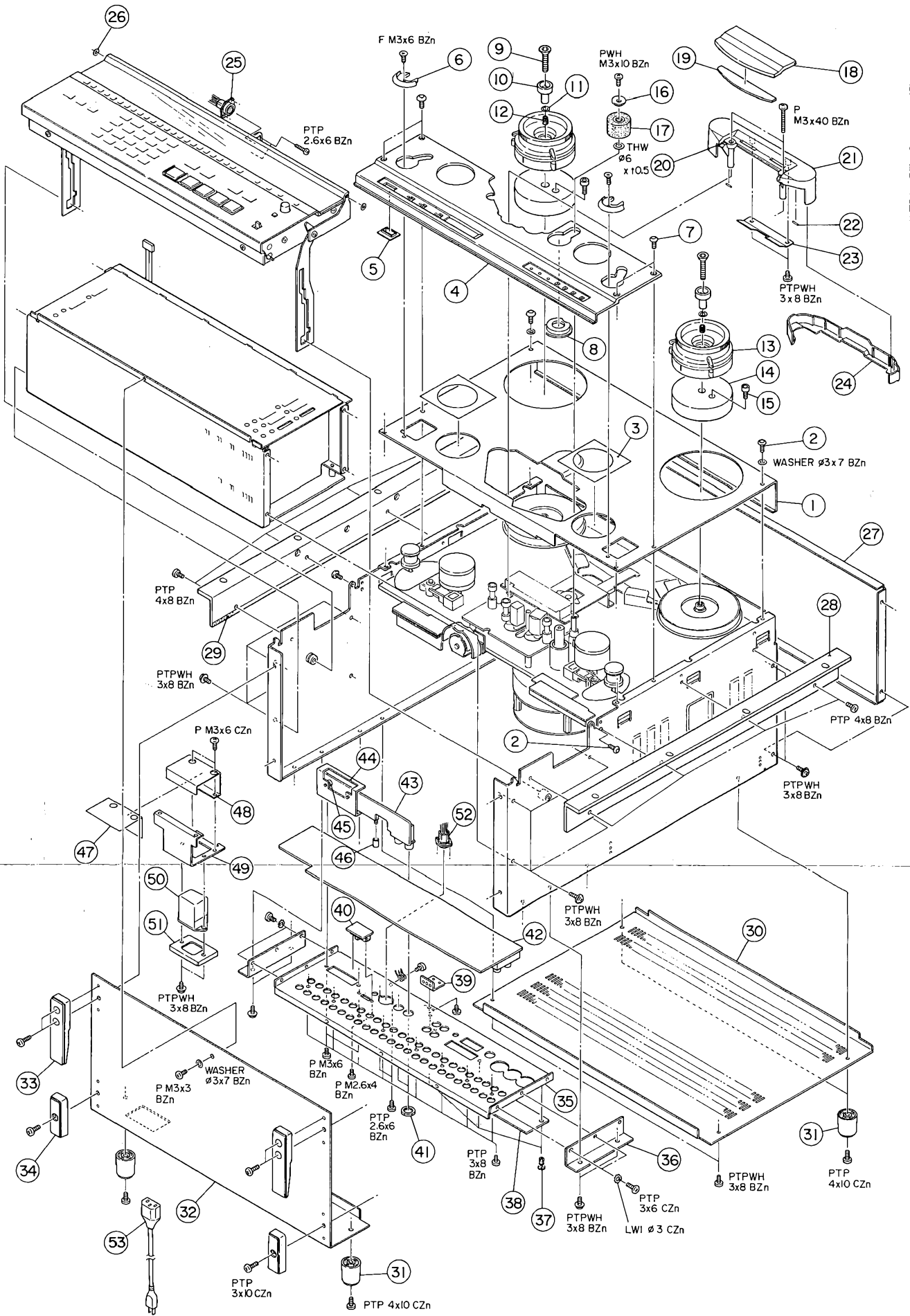

TRANSPORT EXPLODED VIEW I

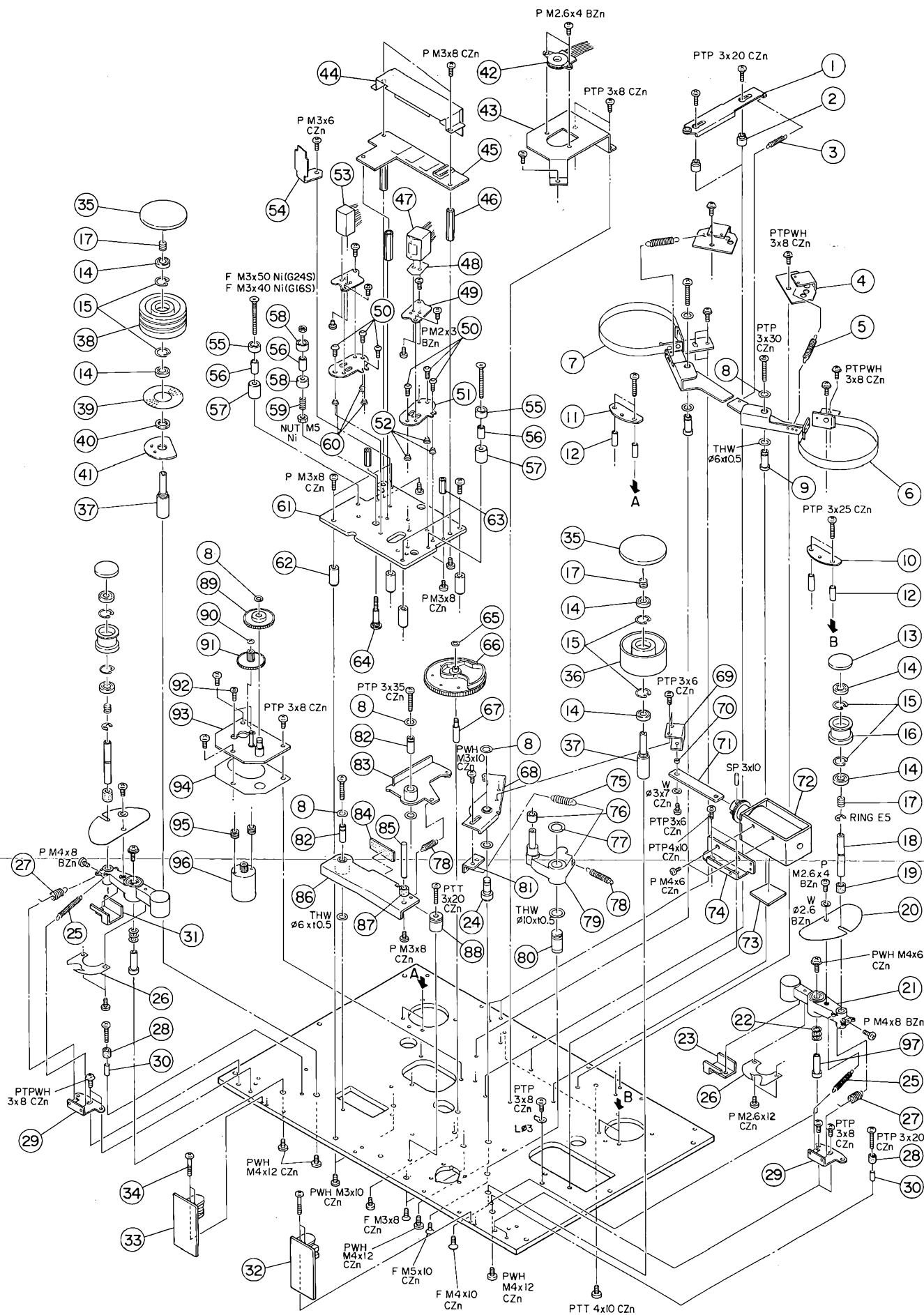

TRANSPORT EXPLODED VIEW 1

Ref. No.	Parts No.	Nomenclature	Ref. No.	Parts No.	Nomenclature	Ref. No.	Parts No.	Nomenclature	Ref. No.	Parts No.	Nomenclature
1.	8260 3251 00	Lever Assy, slide, G	33.	8273 6130 00	PCB Assy, TENSION SENSOR/S, G, G24	62.	8223 1940 00	Spacer, 19	95.	8216 0080 00	Bushing, rubber
2.	8223 1880 00	Shaft, slide		8273 5320 00	PCB Assy, TENSION SENSOR/S, G, G16	63.	8204 0090 05	Spacer, M3 x 15	96.	8270 5380 00	Motor Assy, loading, G
3.	8214 1560 00	Spring, slide		8204 0720 00	Screw, PTT, 2 x 20, CzN	64.	8223 2170 00	Shaft, guide, D	- G24S	8223 1900 00	Shaft, arm, E - G16S
4.	8220 3680 00	Bracket, spring, B		8223 1980 01	Shaft, footage roller, B - G16S	65.	8204 0560 02	Washer, slit, φ2.5	- G16S	8223 2160 00	Shaft, arm, G - G24S
5.	8214 1030 00	Spring, brake	34.	8223 1990 00	Cap, footage roller	66.	8260 2961 00	Cam Assy, loading			
6.	8260 1301 00	Band Assy, brake, R	35.	8223 2180 00	Roller, guide, B - G24S	67.	8223 1890 00	Shaft, cam, A			
7.	8260 1291 00	Band Assy, brake, L	36.	8223 2000 00	Roller, guide - G16S	68.	8260 3271 00	Arm Assy, joint, GA			
8.	8204 0560 03	Washer, slit, φ5	37.	8223 1980 02	Shaft, footage roller, C - G24S	69.	8220 7420 00	Bracket, solenoid	* G24S		
9.	8223 1870 00	Shaft, brake, arm	38.	8223 1980 01	Shaft, footage roller, B - G16S	70.	8204 0130 10	Spacer, 3 x 1.6	only		
10.	8273 5420 00	PCB Assy, REEL SENSOR/T, G	39.	8260 3350 00	Roller Assy, footage, B - G24S				* G24S		
11.	8273 5430 00	PCB Assy, REEL SENSOR/S, G	40.	8260 3310 00	Roller Assy, footage - G16S	71.	8220 7430 00	Arm, solenoid	only		
12.	8204 0130 16	Spacer, 3x20	41.	8218 1541 00	Sticker, strobe				* G24S		
13.	8223 2030 00	Cap, tension roller	42.	8204 0160 00	Nut, M9 x 0.75 x T2	72.	8249 0170 00	Solenoid, C	only		
14.	8204 0201 00	Bearing, 696ZZ	43.	8273 5380 00	PCB Assy, COUNT SENSOR, G				* G24S		
15.	8204 0240 01	Ring, CRR-15	44.	8253 9530 00	Switch, mode	73.	8273 5990 00	PCB Assy, SOLENOID, G24S	only		
16.	8223 2021 02	Roller, tension, B - G24S	45.	8220 6540 00	Bracket, mode SW				* G24S		
17.	8223 2022 01	Roller, tension, A - G16S	46.	8216 2861 00	Sheet, shield, head	74.	8220 3710 02	Bracket, solenoid, D	only		
18.	8214 1330 00	Spring, bearing, B	47.	8273 5930 00	PCB Assy, HEAD TERMINAL, G24				* G24S		
19.	8223 2190 00	Shaft, tension, B - G24S	48.	8273 5370 00	PCB Assy, HEAD TERMINAL, G	75.	8214 1741 00	Spring, pinch roller			
20.	8223 2010 00	Shaft, tension, A - G16S	49.	8204 0090 09	Spacer, M3 x 30	76.	8216 3350 00	Tube rubber, G			
21.	8216 3230 00	Tube, rubber, F - G24S	50.	8223 0750 10	Spacer, M3 x 17 - G16S	77.	8204 0560 04	Washer, slit, φ8			
22.	8216 2590 00	Tube, rubber, E - G16S	51.	8279 0260 00	Head Assy, R/P, G24 - G24S	78.	8214 1750 00	Spring, D			
23.	8216 3400 00	Plate, tension arm, B - G24S	52.	8279 0240 00	Head Assy, R/P, G16 - G16S	79.	8260 3282 02	Arm Assy, pinch roller, G24	- G24S		
24.	8216 2880 00	Plate, tension arm, A - G16S	53.	8220 7030 00	Shield base						
25.	8260 3571 00	Arm Assy, tension, B - G24S	54.	8220 6630 00	Bracket, head, D	80.	8260 3282 01	Arm Assy, pinch roller, G16	- G16S		
26.	8210 0102 00	Arm, tension - G16S	55.	8204 0230 08	Screw, burtonhead, HSB, M3 x 10, BZn	81.	8223 1910 00	Shaft, arm, F			
27.	8204 0750 00	Washer, spring, BD-10 - G24S	56.	8220 6620 00	Bracket, head, B	82.	8220 6550 00	Bracket, spring, C			
28.	THW φ6 x 10.5	- G16S	57.	8214 1740 00	Spring, head, D	83.	8223 1921 00	Shaft, lifter arm			
29.	Weight, tension, R * G16S	only	58.	8279 0270 00	Head Assy, E, G24 - G24S	84.	8260 3291 00	Arm Assy, joint, GB			
30.	Shaft, arm, E		59.	8279 0250 00	Head Assy, E, G16 - G16S	85.	8216 3320 00	Cushion, lifter	- G24S		
31.	Spring, tension, D		60.	8220 7440 00	Panel, blind, B - G16S	86.	8223 1930 02	Shaft, lifter, D	- G16S		
32.	Spring, tension, C - G16S		61.	8223 1970 00	Guide, tape, D - G24S	87.	8223 1930 01	Shaft, lifter, C			
33.	Tube, rubber, E		62.	8223 1960 02	Guide, tape, D - G16S	88.	8260 3300 00	Arm Assy, lifter, G			
34.	Bracket, Spring, D		63.	8223 1960 01	Guide, C - G16S	89.	8216 3230 00	Tube, rubber, F			
35.	Spacer, 3x10		64.	8223 1951 00	Guide, tape, E - G16S	90.	8212 2660 00	Shaft, slide, E			
36.	Weight, tension, L * G16S	only	65.	8223 1970 00	Guide, tape, F - G16S	91.	8204 0560 01	Washer, slit, φ2			
37.	PCB Assy, TENSION SENSOR/T, G, G24		66.	8214 0970 00	Spring, guide - G16S	92.	8204 0060 01	Shoulder, M3 x 4			
38.	PCB Assy, TENSION SENSOR/T, G, G16		67.	8214 1740 00	Spring, head, D - G24S	93.	8260 3260 00	Bracket Assy, gear			
39.	PCB Assy, TENSION SENSOR/T, G, G16		68.	8214 0990 00	Spring, head, B - G16S	94.	8216 2850 00	Cushion, GB			

TRANSPORT EXPLODED VIEW 2

Ref. No.	Parts No.	Nomenclature	Ref. No.	Parts No.	Nomenclature
1.	8220 6671 00	Heatsink, G	39.	8212 1131 00	Grip
2.	8239 0014 00	Insulator, AC238	40.	8212 2701 00	Boss, arm
3.	8207 0008 03	Stay, tapping support, 8N	41.	8220 6373 02	Chassis, side, R
4.	8273 5940 00	PCB assy, REGULATOR, M	42.	8220 6523 00	Base assy, transport, G
5.	8273 5950 00	PCB assy, REGULATOR, G24	43.	8220 6373 01	Chassis, side, L
6.	8220 6692 00	Heatsink, transistor	44.	8220 6410 00	Bracket, PCB
7.	8220 7470 00	Heatsink, transistor, B	45.	8220 6430 00	Bracket, system control
8.	8204 6270 04	Bolt, HSB, M4 x 10	46.	8273 5250 02	PCB assy, SYSTEM CONTROL, - G24S
9.	8216 1590 00	Sheet, reel, B		8273 5250 01	PCB assy, SYSTEM CONTROL, - G16S
10.	8210 0381 00	Table, reel, G		G16	
11.	8216 1090 00	Felt, brake, B	47.	8216 3311 00	Sheet, button, B
12.	8218 2640 00	Sticker, strobe, reel	48.	8273 5350 00	PCB assy, CONTROL SW, G
13.	8260 3371 00	Jog assy, shuttle	49.	8207 0020 02	Collar, TA-307
14.	8214 1920 00	Spring, jog, B	50.	8220 6592 00	Bracket, PCB, R
15.	8273 5340 00	PCB assy, JOG, G			
16.	8220 6570 00	Bracket, PCB, L			
17.	8216 3301 00	Sheet, button, A			
18.	8226 1192 00	Button, tact, C			
19.	8273 5330 00	PCB assy, SPOT/EDIT, G			
20.	8207 0020 03	Collar, TA-310			
21.	8207 0019 00	Bush, TB-300			
22.	8273 5360 00	PCB assy, TENSION POD, G			
23.	8242 1480 00	Transformer, power, G24 - G24S			
24.	8242 1371 00	Transformer, power, G16 - G16S			
25.	8220 6530 00	Angle, transport			
26.	8204 0290 00	Nut, flange, M4			
27.	8207 0073 00	Binder, PLT8H - G24S only			
28.	8220 7580 00	Cover, shield, transformer - G24S only			
29.	8249 0270 00	Motor, reel, CF - G24S			
30.	8249 0250 00	Motor, reel - G16S			
31.	8207 0046 02	Spacer, PCB, I4RT			
32.	8220 6680 00	Bracket, transformer			
33.	8245 0630 00	Voltage selector			
34.	8273 5960 00	PCB assy, POWER SUPPLY, G24 - G24S			
35.	8273 5960 01	PCB assy, POWER SUPPLY, G16S - G16S			
36.	8273 5910 00	PCB assy, STACK			
37.	8220 2631 00	Shield, D Motor			
38.	8220 2690 00	Plate, shield			
39.	8270 5710 01	Motor assy, direct capstan, G24 - G24S			
40.	8270 5710 02	Motor assy direct capstan, G16S - G16S			
41.	8273 5890 01	PCB assy, DD CAPSTAN, G24S/ G16S			
42.	8220 6400 00	Bracket, heatsink			

TRANSPORT EXPLODED VIEW 2

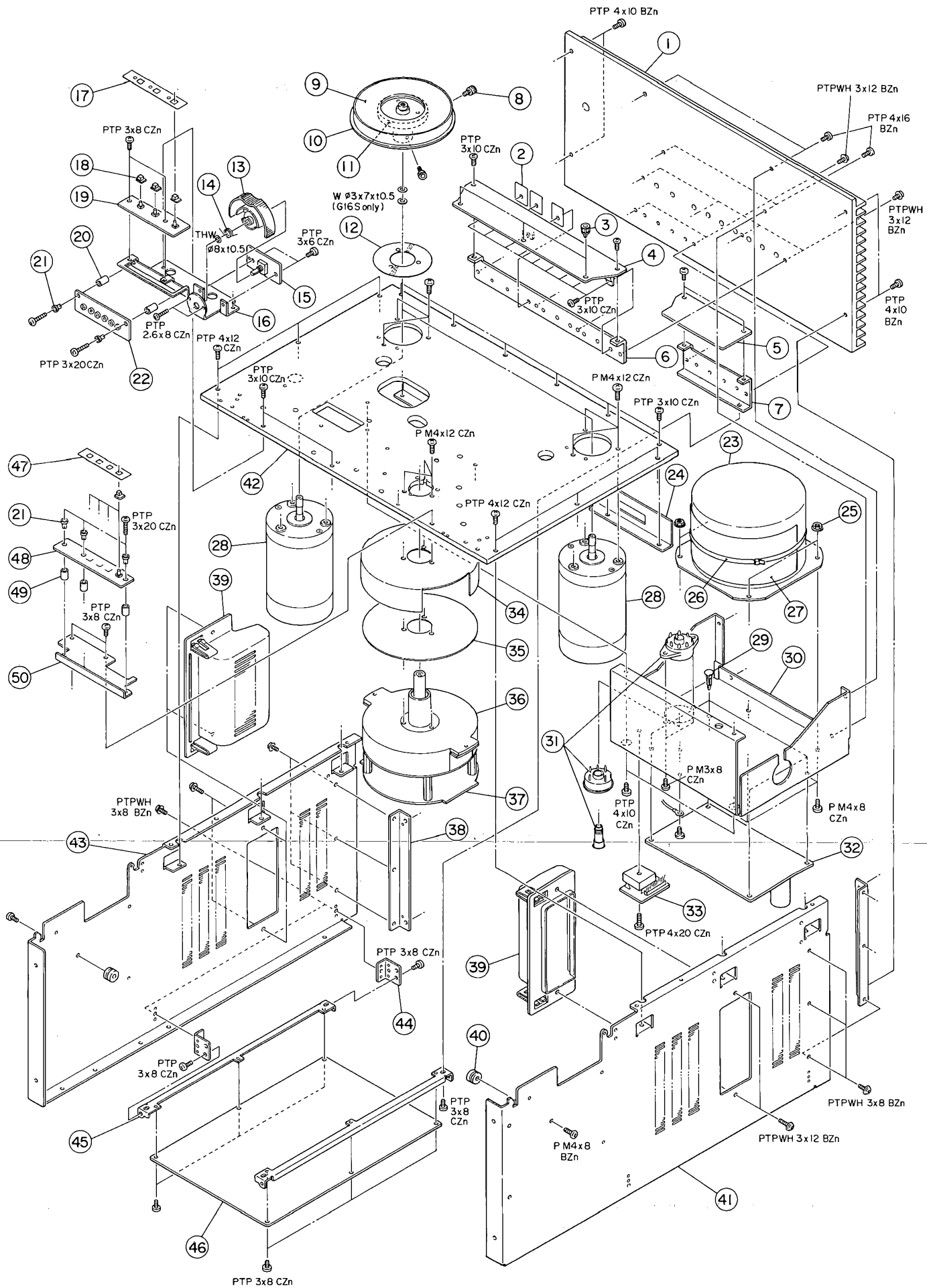

CONTROLLER/AMPLIFIER EXPLODED VIEW

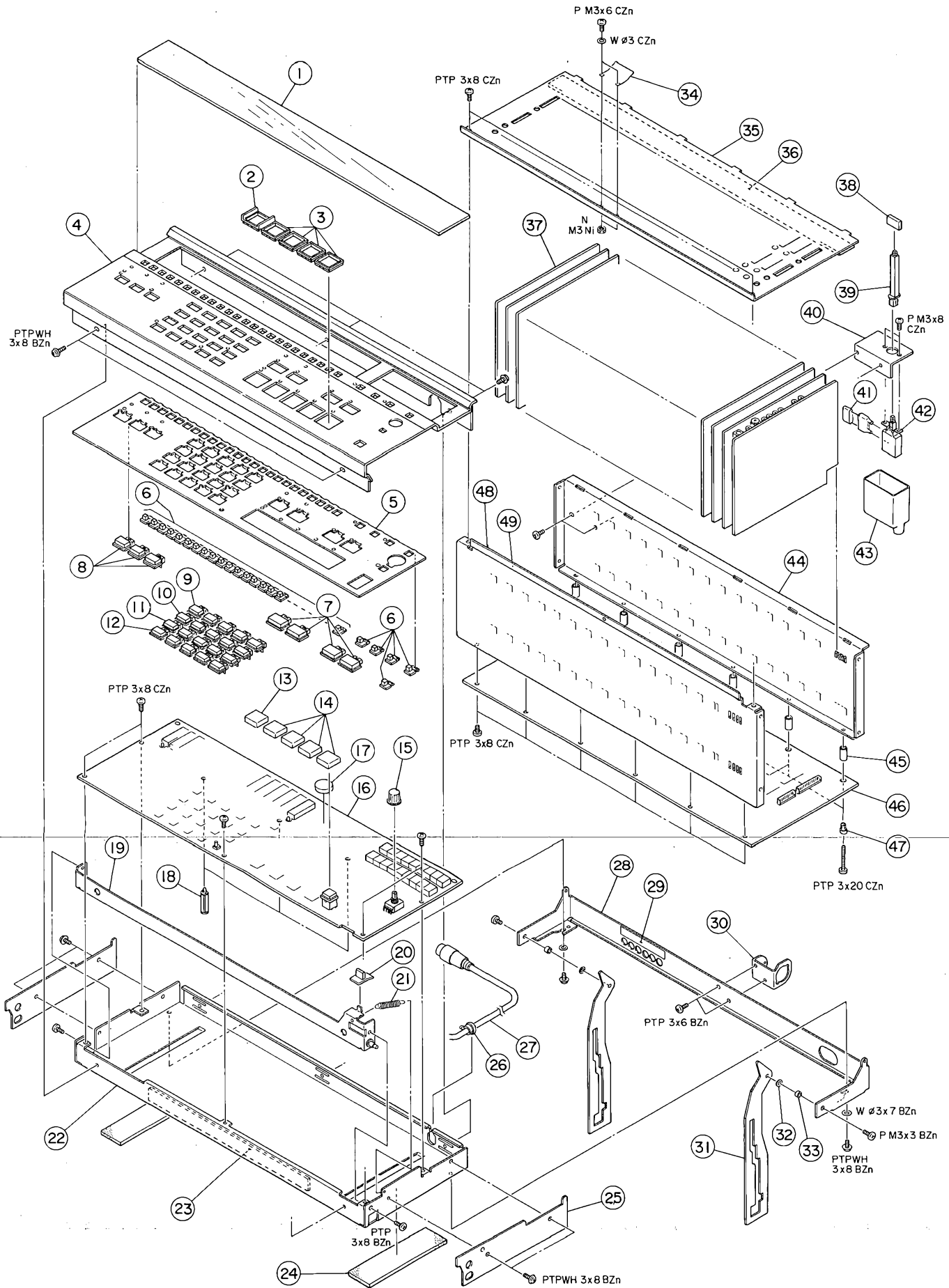

CONTROLLER/AMPLIFIER EXPLODED VIEW

Ref. No.	Parts No.	Nomenclature	Ref. No.	Parts No.	Nomenclature
1.	8212 3031 00	Panel, window, G24	40.	8220 6420 00	Bracket, power SW
	8212 2692 00	Panel, window	41.	8256 0750 05	Sparkkiller, universal, 0.047 μ F
2.	8226 1273 00	Escutcheon, control, A	42.	8253 4090 01	Switch, push, power, SDDF-3
3.	8226 1281 00	Escutcheon, control, B	43.	8207 0050 00	Cover, switch
4.	8220 7460 00	Panel, controller, G24S	44.	8220 7350 00	Bracket, amp, UP, 24
	8220 7490 00	Panel, controller, G16S	45.	8207 0020 04	Collar, TA-314
5.	8220 6720 00	Bracket, SW, A	46.	8273 5910 01	PCB assy, CONNECTOR BOARD, G24
6.	8226 1192 00	Button, tact, C			- G24S
7.	8226 1252 00	Button, tact, B		8273 5910 02	PCB assy, CONNECTOR BOARD, G16S
8.	8226 1243 00	Button, tact, A			- G16S
9.	8226 1243 04	Button, tact, A4	47.	8207 0019 00	Bush, TB-300
10.	8226 1243 03	Button, tact, A3	48.	8220 7360 00	Bracket, amp, DOWN, 24
11.	8226 1243 02	Button, tact, A2	49.	8218 6570 00	Label, channel, G24
12.	8226 1243 01	Button, tact, A1			
13.	8226 1231 01	Button, control, R			
14.	8226 1231 00	Button, control			
15.	8226 1210 00	Knob, pitch con.			
16.	8273 5240 02	PCB assy, CONTROLLER, G24			
		- G24S			
	8273 5240 01	PCB assy, CONTROLLER, G			
		- G16S			
17.	8216 0130 00	Leg, D12			
18.	8207 0048 00	Spacer, PCB, 2529			
19.	8260 3321 00	Arm assy, controller			
20.	8226 1220 00	Knob, eject			
21.	8214 1551 00	Spring, brake			
22.	8220 6700 00	Cover, bottom, controller			
23.	8216 2890 00	Cushion, GD			
24.	8216 2900 00	Cushion, controller			
25.	8220 6731 00	Panel, side, controller			
26.	8207 0002 14	Bushing, SR-5N-4			
27.	8276 6670 00	Cable assy, controller, G			
28.	8220 6490 00	Arm, controller			
29.	8218 6460 00	Label, tension pod			
30.	8220 6510 00	Bracket, connector, 12P			
31.	8220 6500 00	Arm, lock			
32.	8216 2931 00	Cushion, GE			
33.	8204 0130 10	Space, 3 x 1.6			
34.	8214 1930 00	Spring, open			
35.	8220 7411 00	Panel, extension, G24			
36.	8216 3420 00	Spacer, PCB			
37.	8273 5900 00	PCB assy, R/P AMP, S			- G24S
	8273 5900 01	PCB assy, R/P AMP,			- G16S
38.	8226 0130 03	Button, push, B, N			
39.	8212 0810 00	Joint arm			

G24S SYSTEM CONTROL PCB ASSEMBLY
G16S SYSTEM CONTROL PCB ASSEMBLY

G24S PCB Ass'y No. 8273 5250 02

G16S PCB Ass'y No. 8273 5250 01

Ref. No.	Parts No.	Nomenclature
U109	8236 0215 00	Analog, NJM2904D
U110	8236 0270 00	Analog, switch, 4066B
U111-112	8236 0215 00	Analog, NJM2904D
U113	8236 0292 00	Analog, NJM3403AD
U114	8236 0302 00	Analog, motor driver, LB1645N
U115-122	8236 0508 03	Digital, driver array, TD62554S
U123,124	8236 0508 03	Digital, driver array, TD62554S G24S
U123,124		(deleted) G16S

Ref. No.	Parts No.	Nomenclature
	8251 3531 00	Plain PCB, system control, G

IC's

U001	8236 0197 03	Driver, RN2003
U002	8236 0197 03	Driver, RN2003
U003	8236 0197 04	Driver, RN2004
U004	8236 0197 03	Driver, RN2003
U005	8236 0196 04	Driver, RN1004
U006	8236 0196 04	Driver, RN1004
U007	8236 0196 03	Driver, RN1003
U008	8236 0196 03	Driver, RN1003
U009-010	8236 0197 03	Driver, RN2003
U011	8236 0196 03	Driver, RN1003
U012	8236 0196 03	Driver, RN1003
U013	8236 0196 03	Driver, RN1003
U014	8236 0196 03	Driver, RN1003
U015	8236 0196 03	Driver, RN1003
U016	8236 0196 03	Driver, RN1003
U017	8236 0196 03	Driver, RN1003
U018	8236 0196 03	Driver, RN1003
U019	8236 0197 03	Driver, RN2003
U020	8236 0196 04	Driver, RN1004
U021	8236 0197 03	Driver, RN2003
U022	8236 0196 03	Driver, RN1003
U023	8236 0196 03	Driver, RN1003
U024	8236 0196 03	Driver, RN1003
U025	8236 0196 03	Driver, RN1003
U026	8236 0196 03	Driver, RN1003
U027	8236 0197 03	Driver, RN2003
U028	8236 0197 03	Driver, RN2003
U029	8236 0196 03	Driver, RN1003
U030	8236 0197 04	Driver, RN2004
U031	8236 0196 03	Driver, RN1003
U032	8236 0196 03	Driver, RN1003
U100	8236 0330 02	Analog, L78LR05-MA
U101	8236 0736 00	Digital, M37700M2A193FP
U102	8236 0571 00	Digital, M50782SP
U103	8236 0029 01	Digital, CMOS, 4050B
U104	8236 0028 01	Digital, CMOS, 4049UB
U105	8236 0028 01	Digital, CMOS, 4049UB
U106	8236 0005 01	Digital, CMOS, 4011B
U107	8236 0028 01	Digital, CMOS, 4049UB
U108	8236 0029 01	Digital, CMOS, 4050B

TRANSISTORS

Q001-002	8234 0002 07	2SC1815GR/BL
Q003-006	8234 1422 01	2SC752G-Y
Q007	8234 0002 07	2SC1815GR/BL
Q008-009	8234 0001 11	FET, 2SK117GR
Q010	8234 0003 03	2SA1015GR
Q011-012	8234 0002 07	2SC1815GR/BL
Q013	8234 0002 07	2SC1815GR/BL
Q014	8234 0002 04	2SC1815BL
Q015	8234 0002 04	2SC1815BL
Q016-017	8234 0037 02	2SC2655Y
Q018-019	8234 0038 02	2SA1020Y

DIODES

D001	8234 0088 00	GMB01-BT
D002-003	8234 0088 00	GMB01-BT
D004	8234 0088 00	GMB01-BT
D005	8234 0088 00	GMB01-BT
D006-016	8234 0088 00	GMB01-BT
D017-18	8234 0196 02	DSK10C-BT
D019-21	8234 0088 00	GMB01-BT
D101	8234 0039 00	Array, MA154WK
D102	8234 0040 00	Array, MA154WA
D103-104	8234 0040 00	Array, MA154WA
D105-106	8234 0039 00	Array, MA154WK
D107-108	8234 0040 00	Array, MA154WA
D109-110	8234 0039 00	Array, MA154WK
D111	8234 0040 00	Array, MA154WA

CARBON RESISTORS

All resistors 1/6W, ±5% unless otherwise noted.

R001	8230 1384 71	Flat mtg., 470Ω
R002	8230 1382 23	Flat mtg., 22kΩ
R003	8230 1381 81	Flat mtg., 180Ω
R004-005	8230 1381 09	Flat mtg., 1Ω
R006-007	8230 1385 62	Flat mtg., 5.6kΩ
R008-009	8230 1381 09	Flat mtg., 1Ω
R010-011	8230 1385 60	Flat mtg., 56Ω
R012-013	8230 1385 62	Flat mtg., 5.6kΩ

Ref. No.	Parts No.	Nomenclature
R014	8230 1382 20	Flat mtg., 22Ω
R015	8230 1381 24	Flat mtg., 120kΩ
R016	8230 1381 04	Flat mtg., 100kΩ
R017	8230 1381 03	Flat mtg., 10kΩ
R018-019	8230 1382 23	Flat mtg., 22kΩ
R020-021	8230 1381 03	Flat mtg., 10kΩ
R022	8230 1381 05	Flat mtg., 1MΩ
R023	8230 1381 04	Flat mtg., 100kΩ
R024	8230 1381 05	Flat mtg., 1MΩ
R025	8230 1381 04	Flat mtg., 100kΩ
R026	8230 1381 05	Flat mtg., 1MΩ
R027	8230 1381 04	Flat mtg., 100kΩ
R028	8230 1382 23	Flat mtg., 22kΩ
R029	8230 1381 03	Flat mtg., 10kΩ
R030	8230 1381 04	Flat mtg., 100kΩ
R031	8230 1381 05	Flat mtg., 1MΩ
R032	8230 1381 05	Flat mtg., 1MΩ
R033	8230 1381 02	Flat mtg., 1kΩ
R034	8230 1381 03	Flat mtg., 10kΩ
R035	8230 1381 04	Flat mtg., 100kΩ
R036-039	8230 1384 71	Flat mtg., 470Ω
R040	8230 1381 02	Flat mtg., 1kΩ
R041	8230 1382 23	Flat mtg., 22kΩ
R042	8230 1382 23	Flat mtg., 22kΩ
R043	8230 1382 23	Flat mtg., 22kΩ
R044-047	8230 1382 23	Flat mtg., 22kΩ
R048	8230 1381 03	Flat mtg., 10kΩ
R049	8230 1381 03	Flat mtg., 10kΩ
R050	8230 1381 02	Flat mtg., 1kΩ
R051	8230 1381 03	Flat mtg., 10kΩ
R052	8230 1384 73	Flat mtg., 47kΩ
R053	8230 1384 71	Flat mtg., 470Ω
R054	8230 1381 03	Flat mtg., 10kΩ
R055	8230 1381 04	Flat mtg., 100kΩ
R056	8230 1382 22	Flat mtg., 2.2kΩ
R057	8230 1382 22	Flat mtg., 2.2kΩ
R058	8230 1381 03	Flat mtg., 10kΩ
R059	8230 1382 23	Flat mtg., 22kΩ G24S
R059	8230 1381 03	Flat mtg., 10kΩ G16S
R060	8230 1386 21	Flat mtg., 620Ω
R061	8230 1381 03	Flat mtg., 10kΩ
R062	8230 1382 22	Flat mtg., 2.2kΩ
R063	8230 1381 02	Flat mtg., 1kΩ
R064	8230 1382 23	Flat mtg., 22kΩ
R065	8230 1382 23	Flat mtg., 22kΩ
R066	8230 1381 03	Flat mtg., 10kΩ G24S
R066	8230 1384 73	Flat mtg., 47kΩ G16S
R067	8230 1381 03	Flat mtg., 10kΩ
R068	8230 1382 22	Flat mtg., 2.2kΩ

Ref. No.	Parts No.	Nomenclature
R069	8230 1381 52	Flat mtg., 1.5kΩ
R070	8230 1382 23	Flat mtg., 22kΩ
R071	8230 1381 04	Flat mtg., 100kΩ
R072-074	8230 1382 23	Flat mtg., 22kΩ
R075	8230 1381 04	Flat mtg., 100kΩ
R076	8230 1381 04	Flat mtg., 100kΩ
R077	8230 1382 23	Flat mtg., 22kΩ
R078	8230 1381 02	Flat mtg., 1kΩ
R079	8230 1381 03	Flat mtg., 10kΩ G24S
R079	8230 1382 23	Flat mtg., 22kΩ G16S
R080	8230 1382 22	Flat mtg., 2.2kΩ
R081	8230 1382 23	Flat mtg., 22kΩ
R082	8230 1382 23	Flat mtg., 22kΩ
R083-084	8230 1382 21	Flat mtg., 220Ω
R085	8230 1382 23	Flat mtg., 22kΩ
R086	8230 1381 04	Flat mtg., 100kΩ
R087-09	8230 1383 02	Flat mtg., 3kΩ
R089	8230 1381 04	Flat mtg., 100kΩ
R090	8230 1381 04	Flat mtg., 100kΩ
R091	8230 1381 04	Flat mtg., 100kΩ
R092	8230 1384 73	Flat mtg., 47kΩ
R093	8230 1381 03	Flat mtg., 10kΩ
R094-095	8230 1381 02	Flat mtg., 1kΩ
R096	8230 1381 03	Flat mtg., 10kΩ
R097	8230 1384 73	Flat mtg., 47kΩ
R098	8230 1383 02	Flat mtg., 3kΩ G24S
R098	8230 1382 02	Flat mtg., 2kΩ G16S
R099-100	8230 1388 22	Flat mtg., 8.2kΩ
R101	8230 1383 02	Flat mtg., 3kΩ G24S
R101	8230 1382 02	Flat mtg., 2kΩ G16S
R102-103	8230 1381 03	Flat mtg., 10kΩ
R104-105	8230 1381 04	Flat mtg., 100kΩ
R106-107	8230 1381 00	Flat mtg., 10Ω
R108	8230 1384 74	Flat mtg., 470kΩ G24S
R108	8230 1385 64	Flat mtg., 560kΩ G16S
R109	8230 1381 03	Flat mtg., 10kΩ
R110	8230 1381 53	Flat mtg., 15kΩ
R111	8230 1384 73	Flat mtg., 47kΩ
R112	8230 1381 03	Flat mtg., 10kΩ
R113	8230 1381 53	Flat mtg., 15kΩ
R114	8230 1384 74	Flat mtg., 470kΩ
R115	8230 1381 04	Flat mtg., 100kΩ
R116	8230 1382 22	Flat mtg., 2.2kΩ
R117	8230 1383 32	Flat mtg., 3.3kΩ
R118-119	8230 1382 23	Flat mtg., 22kΩ
R120	8230 1381 03	Flat mtg., 10kΩ
R121	8230 1384 73	Flat mtg., 47kΩ
R122	8230 1384 74	Flat mtg., 470kΩ
R123	8230 1381 04	Flat mtg., 100kΩ
R124	8230 1383 32	Flat mtg., 3.3kΩ

Ref. No.	Parts No.	Nomenclature	Ref. No.	Parts No.	Nomenclature
R125	8230 1382 22	Flat mtg., 2.2k Ω	R504	8230 0701 04	Array, 1/4W, 100k Ω ×7, 5%, RKC-S
R126	8230 1381 05	Flat mtg., 1M Ω	R505	8230 0671 04	Array, 1/4W, 100k Ω ×3, 5%, RKC-S
R127	8230 1381 05	Flat mtg., 1M Ω	R506	8230 0671 03	Array, 1/4W, 10k Ω ×3, 5%, RKC-S
R128	8230 1884 73	Flat mtg., 47k Ω	R507	8230 0602 23	Array, 1/8W, 22k Ω ×3, 5%, RKC
R129	8230 1381 05	Flat mtg., 1M Ω			
R130	8230 1384 73	Flat mtg., 47k Ω			
R131	8230 1381 04	Flat mtg., 100k Ω			
R132	8230 1384 73	Flat mtg., 47k Ω			
R133	8230 1384 73	Flat mtg., 47k Ω			
R134	8230 1381 04	Flat mtg., 100k Ω			
R135-139	8230 1382 23	Flat mtg., 22k Ω			
R140-143	8230 1386 22	Flat mtg., 6.2k Ω			
R144	8230 1381 02	Flat mtg., 1k Ω			
R145-146	8230 1382 23	Flat mtg., 22k Ω			
R147-148	8230 1381 04	Flat mtg., 100k Ω			
R149-152	8230 1384 71	Flat mtg., 470 Ω			
R153	8230 1381 51	Flat mtg., 150 Ω			
R154-155	8230 1381 03	Flat mtg., 10k Ω			
R156-157	8230 1381 02	Flat mtg., 1k Ω			
R158-159	8230 1384 73	Flat mtg., 47k Ω			
R160-161	8230 1381 04	Flat mtg., 100k Ω			
R162	8230 1381 04	Flat mtg., 100k Ω			
R163-164	8230 1381 04	Flat mtg., 100k Ω			
R165	8230 1384 73	Flat mtg., 47k Ω			
R166	8230 1381 05	Flat mtg., 1M Ω			
R167	8230 1381 05	Flat mtg., 1M Ω			
R168	8230 1381 01	Flat mtg., 100 Ω			
R169	8230 1384 74	Flat mtg., 470k Ω			
R170	8230 0411 00	Flat mtg., 10 Ω , ¼W, nonflammable			
R171	8230 1382 23	Flat mtg., 22k Ω			
R172	8230 1381 03	Flat mtg., 10k Ω			
R173	8230 1381 04	Flat mtg., 100k Ω			
R174	8230 1381 02	Flat mtg., 1k Ω			
R175	8230 1382 23	Flat mtg., 22k Ω			
R176	8230 1382 23	Flat mtg., 22k Ω			
		CARBON POTS			
R300	8231 0031 04	Pot., semi-fixed, flat, 100k Ω , B			
R301	8231 0033 34	Pot., semi-fixed, flat, 330k Ω , B			
R302-303	8231 0033 33	Pot., semi-fixed, flat, 33k Ω , B			
R304-305	8231 0174 73	Pot., semi-fixed, metal, flat, 47k Ω , RH0621C			
R500	8230 0671 04	Array, 1/4W, 100k Ω ×3, 5%, RKC-S			
R501	8230 0522 23	Array, 1/8W, 22k Ω ×5, 5%, RKC			
R502	8230 0542 23	Array, 1/8W, 22k Ω ×7, 5%, RKC			
R503	8230 0701 03	Array, 1/4W, 10k Ω ×7, 5%, RKC-S			
		CAPACITORS			
		ALU = Electrolytic type			
		CER = Ceramic type			
		PES = Mylar type			
		PPR = Polypropylene type			
C001	8232 8031 03	CER, 50V, 0.01 μ F, +80-20%, YF			
C002	8232 1453 36	ALU, 35V, 33 μ F, 20%, SME-VB			
C003-004	8232 9011 03	PES, 50V, 0.01 μ F, 5%, AMZV			
C005	8232 9014 72	PES, 50V, 0.047 μ F, 5%, AMZV			
C006	8232 0318 22	PPR, 100V, 0.082 μ F, 5%, APS			
C007	8232 9011 02	PES, 50V, 0.001 μ F, 5%, AMZV			
C008	8232 1464 74	ALU, 50V, 0.47 μ F, 20%, SME-VB			
C009	8232 1464 74	ALU, 50V, 0.47 μ F, 20%, SME-VB			
C010-011	8232 8031 03	CER, 50V, 0.01 μ F, +80-20%, YF			
C012-013	8232 8031 03	CER, 50V, 0.01 μ F, +80-20%, YF			
C014-015	8232 0323 00	CER, 50V, 30pF, 5%, NPO			
C016-026	8232 8031 03	CER, 50V, 0.01 μ F, +80-20%, YF			
C027	8232 9014 73	PES, 50V, 0.047 μ F, 5%, AMZV			
C028	(deleted)				
C029	8232 1461 05	ALU, 50V, 1 μ F, 20%, SME-VB			
C030-033	(deleted)				
C034	8232 9013 32	PES, 50V, 0.033 μ F, 5%, AMZV			
C035	8232 9011 03	PES, 50V, 0.01 μ F, 5%, AMZV			
C036	8232 0321 00	CER, 50V, 10pF, \pm 5pF, NPO			

Ref. No.	Parts No.	Nomenclature	Ref. No.	Parts No.	Nomenclature
C037	8232 1464 75	ALU, 50V, 4.7 μ F, 20% SME-VB G24S			MISCELLANEOUS
C037	8232 1462 25	ALU, 50V, 2.2 μ F, 20% SME-VB G16S	E102	8239 0018 00	Battery, Ni-Cd, N-SB3
C038	8232 9011 04	PES, 50V, 0.1 μ F, 5%, AMZV	E501	8276 0020 02	Wire, jumper, 5mm, IPS-1041-2
C039	8232 1441 06	ALU, 25V, 10 μ F, 20%, SME-VB	E502	8276 0020 04	Wire, jumper, 10mm, IPS-1041-4
C040-041	8232 1463 34	ALU, 50V, 0.33 μ F, 20%, SME-VB	E503	8276 0010 00	Pin, header
C042-043	(deleted)		J001	8245 0530 02	Connector, jack, 8263, 2, straight, wht.
C044-045	8232 1441 06	ALU, 25V, 10 μ F, 20%, SME-VB	J002	8245 0530 22	Connector, jack 8263, 2, straight, red
C046-047	8232 9011 03	PES, 50V, 0.01 μ F, 5%, AMZV	J003	8245 0530 68	Connector, jack, 8263, 8, straight, yel. G24S
C048-049	8232 9011 54	PES, 50V, 0.15 μ F, 5% AMZV G24S	J003	(deleted)	G16S
C048-049	8232 9016 83	PES, 50V, 0.068 μ F, 5% AMZV G16S	J004	8245 0530 28	Connector, jack, 8263, 8, straight, red
C050-051	8232 9011 03	PES, 50V, 0.01 μ F, 5%, AMZV	J005	8245 0530 48	Connector, jack, 8263, 8, straight, blk.
C052	8232 8031 03	CER, 50V, 0.01 μ F, +80-20%, YF	J006	8245 0530 24	Connector, jack, 8263, 4, straight, red
C053	8232 8041 04	CER, 25V, 0.1 μ F, +80-20%, YF	J007	8245 0530 64	Connector, jack, 8263, 4, straight, yel.
C054-055	8232 9011 03	PES, 50V, 0.01 μ F, 5%, AMZV	J008	8245 0530 63	Connector, jack, 8263, 3, straight, yel.
C056-058	(deleted)		J009	8245 0530 43	Connector, jack, 8263, 3, straight, blk.
C059-060	8232 0324 70	CER, 50V, 47pF, 5%, NPO	J010	(deleted)	
C061	8232 1411 07	ALU, 6.3V, 100 μ F, 20%, SME-VB	J011	8245 0530 08	Connector, jack, 8263, 8, straight, wht.
C062-064	8232 8031 03	CER, 50V, 0.01 μ F, +80-20%, YF	J012	8245 0530 28	Connector, jack, 8263, 8, straight, red
C065	8232 1431 08	ALU, 16V, 1000 μ F, 20%, SME-VB	J013	8245 0530 12	Connector, jack, 8263, 12, straight, wht.
C066	8232 8031 03	CER, 50V, 0.01 μ F, +80-20%, YF	J014	8245 0530 06	Connector, jack, 8263, 6 straight, wht.
C067	8232 1431 06	ALU, 16V, 10 μ F, 20%, SME-VB	J015	8245 0530 62	Connector, jack, 8263, 2, straight, yel.
C068	(deleted)		J016	8245 0530 23	Connector, jack, 8263, 3, straight, red
C069	(deleted)		J017	8245 0530 23	Connector, jack, 8263, 3, straight, red
C070	8232 1453 36	ALU, 35V, 33 μ F, 20%, SME-VB	J018	8245 0530 46	Connector, jack, 8263, 6, straight, blk.
C071	8232 9011 03	PES, 50V, 0.01 μ F, 20%, AMZV	J019	8245 0530 26	Connector, jack, 8263, 6, straight, red
C072	8232 9011 03	PES, 50V, 0.01 μ F, 20%, AMZV	J020	8245 0530 66	Connector, jack, 8263, 6, straight, yel.
C073	8232 8031 03	CER, 50V, 0.01 μ F, +80-20%, YF	J021	8245 0530 69	Connector, jack, 8263, 9, straight, yel.

Ref. No.	Parts No.	Nomenclature
J022	8245 0530 02	Connector, jack, 8263, 2, straight, wht.
J023	8245 0530 24	Connector, jack, 8263, 4, straight, red
J024	8245 0530 26	Connector, jack, 8263, 6, straight, red
J025	8245 0530 44	Connector, jack, 8263, 4, straight, blk.
J026	8245 0530 42	Connector, jack, 8263, 2, straight, blk.
J027	8245 0530 06	Connector, jack, 8263, 6, straight, wht.
J028	8245 0530 22	Connector, jack, 8263, 2, straight, red
J029	8245 0530 05	Connector, jack, 8263, 5, straight, wht.
J030	8245 0530 07	Connector, jack, 8263, 7, straight, wht.
J031	8245 0530 32	Connector, jack, 8263, 12, straight, red
J032	8245 0530 23	Connector, jack, 8263, 3, straight, red
J033	8245 0530 63	Connector, jack, 8263, 3, straight, yel.
J034	8245 1761 02	Connector, jack, IMSA-9202B-102-T
J035	8245 0530 42	Connector, jack, 8263, 2, straight, blk. G24S
J035	(deleted)	G16S
L001	8242 0530 00	Coil, 150UH
T001	8242 0940 00	Transformer, Master OSC
X001	8256 0550 00	Ceramic resonator, 8MHz

Ref. No.	Parts No.	Nomenclature
J005	8245 0530 62	Connector, jack, 8263, 2, Straight, yel.
J006	8245 0530 22	Connector, jack, 8263, 2, Straight, red
J007	8245 0530 03	Connector, jack, 8263, 3, Straight, wht.
J008	8245 0530 23	Connector, jack, 8263, 3, Straight, red
J009	8245 0530 63	Connector, jack, 8263, 3, Straight, yel.
J010	8245 0530 06	Connector, jack, 8263, 6, Straight, wht.
J011	8245 0530 12	Connector, jack, 8263, 12, Straight, wht.
J012	8245 2730 01	Connector, jack, FC, HIF3BA20PA-DS(11)
S001	8253 1180 01	Switch, push, SPUP
W001	8276 6510 15	Cable Assy, earth-lug, D3, 150mm

NR SWITCH PCB ASSEMBLY

PCB Ass'y No. 8273 5270 00

Ref. No.	Parts No.	Nomenclature
	8251 8701 08	Plain PCB, NR switch
S001	8253 6630 01	Switch, slide, 2-3, non-shorting, SSSB023, L=6
W001	8276 2360 24	Cable Assy, 4P wht., 240mm

G24S TENSION SENSOR/T, G PCB ASSEMBLY
G16S TENSION SENSOR/T, G PCB ASSEMBLY

G24S PCB Ass'y No. 8273 6120 00

G16S PCB Ass'y No. 8273 5310 00

ACCESSORY PCB ASSEMBLY

PCB Ass'y No. 8273 5290 00

Ref. No.	Parts No.	Nomenclature
	8251 8701 01	Plain PCB, accessory
E101	8276 0020 02	Wire, jumper, 5mm, IPS-1041-2
J001-002	8245 3390 03	Connector, phone jack, YKB21-5010
J003	8245 0530 43	Connector, jack, 8263, 3, Straight, blk.
J004	8245 0530 02	Connector, jack, 8263, 2, Straight, wht.

Ref. No.	Parts No.	Nomenclature
B101	8251 8701 03	Plain PCB, tension sensor/T
IC		
U001	8234 0198 00	Opt., photo-interrupter, GP-IS52
TRANSISTOR		
Q001	8234 0001 21	FET, 2SK117GR, BL
DIODES		
D001-003	8234 0088 00	GMB01-BT

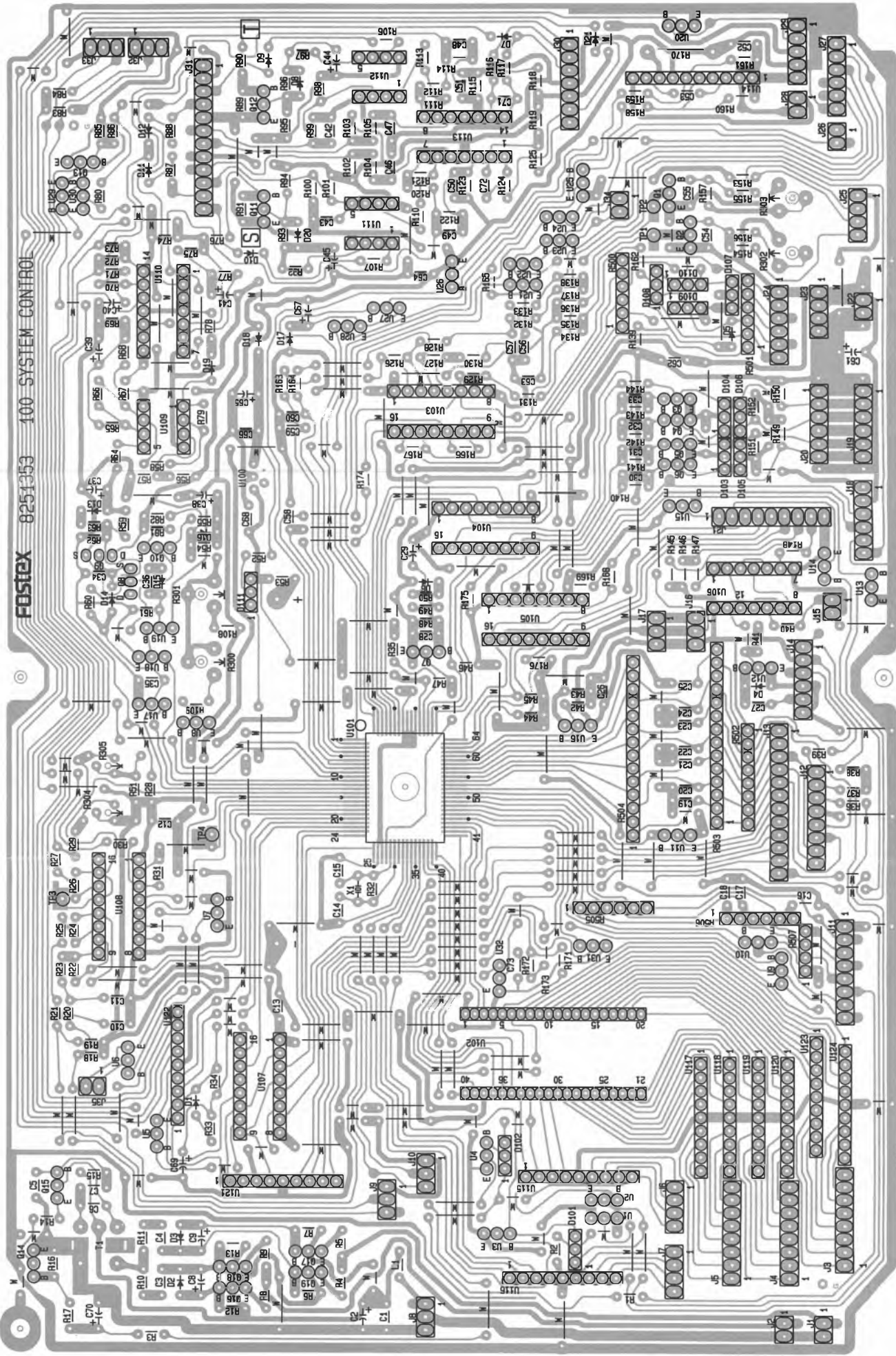

NR SWITCH
 ACCESSORY
 TENSION SENSOR/T, G
 TENSION SENSOR/S, G
 TENSION POD
 SPOT/EDIT
 JOG
 CONTROL SWITCH

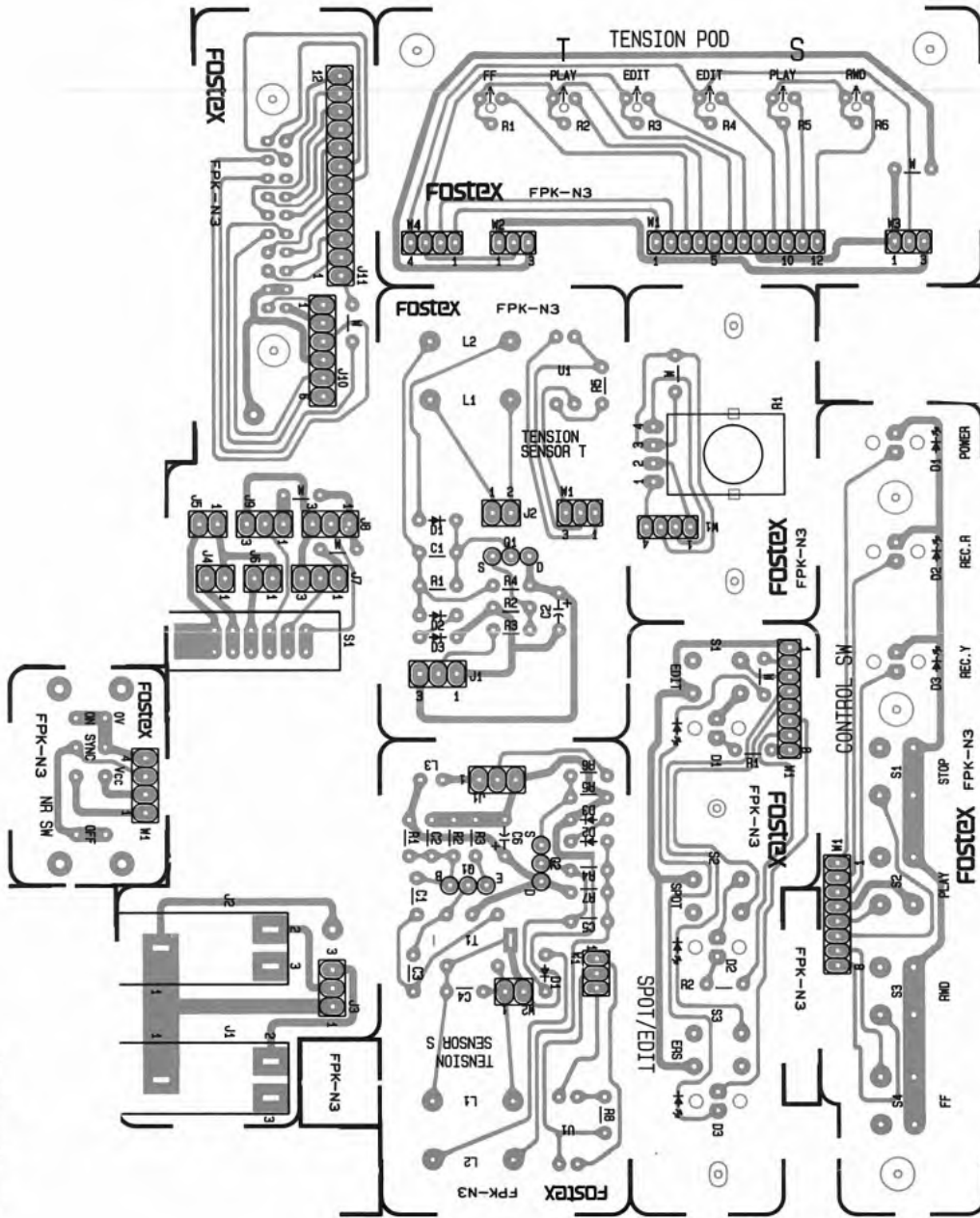

Ref. No.	Parts No.	Nomenclature
CARBON RESISTORS		
All resistors 1/6W, ±5%		
R001	8230 1381 04	Flat mtg., 100kΩ
R002	8230 1382 22	Flat mtg., 2.2kΩ
R003	8230 1382 22	Flat mtg., 2.2kΩ G24S
R003	8230 1381 02	Flat mtg., 1kΩ G16S
R004	8230 1388 23	Flat mtg., 82kΩ
R005	8230 1383 31	Flat mtg., 330Ω
CAPACITORS		
ALU = Electrolytic type PES = Mylar type		
C001	8232 9011 04	PES, 50V, 0.1μF, 5%, AMZY
C002	8232 1451 06	ALU, 35V, 10μF, 20%, SME-VB
MISCELLANEOUS		
J001	8245 0870 03	Connector, jack, 8263, 3, right-angle, wht.
J002	8245 0530 02	Connector, jack, 8263, 2, straight, wht.
L001-002	8242 0950 02	Coil, servo, E
W001	8276 6842 65	Cable ASSY, 3P, 8263 red-9073, 650mm G24S
G24S TENSION SENSOR/S, G PCB ASSEMBLY		
G24S PCB Ass'y No. 8273 6130 00		
G16S TENSION SENSOR/S, G PCB ASSEMBLY		
G16S PCB Ass'y No. 8273 5320 00		
Ref. No.	Parts No.	Nomenclature
B101	8251 8701 02	Plain PCB, tension sensor/S
IC		
U001	8234 0198 00	Opt., photo-interrupter, GP-1SS2
TRANSISTORS		
Q001	8234 0002 03	2SC1815GR
Q002	8234 0001 21	FET, 2SK1176 GR, BL
DIODE		
D001-003	8234 0088 00	GMB01-BT
CARBON RESISTORS		
All resistors 1/6W, ±5% unless otherwise noted.		
R001	8230 1386 83	Flat mtg., 68kΩ

Ref. No.	Parts No.	Nomenclature
R002	8230 1385 62	Flat mtg., 5.6k Ω
R003	8230 1382 20	Flat mtg., 22 Ω
R004	8230 1381 04	Flat mtg., 100k Ω
R005	8230 1382 22	Flat mtg., 2.2k Ω
R006	8230 1382 22	Flat mtg., 2.2k Ω G24S
R006	8230 1381 02	Flat mtg., 1k Ω G16S
R007	8230 1388 23	Flat mtg., 82k Ω
R008	8230 1383 31	Flat mtg., 330 Ω

CAPACITORS

ALU = Electrolytic type
 PES = Mylar type
 PPR = Polypropylene type

C001	8232 9011 02	PES, 50V, 0.001 μ F, 5%, AMZV
C002	8232 9015 62	PES, 50V, 0.0056 μ F, 5%, AMZV
C003	8232 0312 22	PPR, 100V, 0.0022 μ F, 5%, APS
C004	8232 0311 23	PPR, 100V, 0.012 μ F, 5%, APS
C005	8232 9011 04	PES, 50V, 0.1 μ F, 5%, AMZV
C006	8232 1451 06	ALU, 35V, 10 μ F, 20%, SME-VB

MISCELLANEOUS

J001	8245 0870 23	Connector, jack, 8263, 3, right-angle, red
L001-002	8242 0950 02	Coil, servo, E
L003	8242 0530 00	Coil, 150 μ H
T001	8242 1040 00	Transformer, OSC, 70kHz
W001	8276 6842 45	Cable ASSY, 3P, 8263 red-9073, 450 wht.
W002	8276 3910 50	Cable ASSY, shield wht. 2P wht- 5395, 500mm

SPOT/EDIT, G PCB ASSEMBLY

PCB Ass'y No. 8273 5330 00

Ref. No.	Parts No.	Nomenclature
	8251 8701 05	Plain PCB, spot/edit
D001-003	8234 0100 00	Opt., LED, org, GL-2HD6
R001	8230 1384 71	Resistor, carbon, 1/6W, 470, flat mtg., 5%

Ref. No.	Parts No.	Nomenclature
R002	8230 1384 71	Resistor, carbon, 1/6W, 470, flat mtg., 5%
E101	8276 0020 02	Wire, jumper, 5mm, IPS-1041-2
S001-003	8253 1130 11	Switch, tact, SOA-142HS
W001	8276 6890 40	Cable ASSY, 8P, 8263 wht. 9073, 400mm
Y101	8207 0051 01	Spacer, LED, 5

JOG PCB ASSEMBLY

PCB Ass'y No. 8273 5340 00

Ref. No.	Parts No.	Nomenclature
	8251 870106	Plain PCB, jog
R001	8240 1700 16	Pot., 11, 20k Ω , flat mtg.
W001	8276 7250 15	Cable ASSY, 4P, 9073-9073 flat mtg., 150mm

CONTROL SWITCH PCB ASSEMBLY

PCB Ass'y No. 8273 5350 00

Ref. No.	Parts No.	Nomenclature
	8251 8701 07	Plain PCB, control SW

DIODES

D001	8234 0191 00	Opt., LED, grn., GL-2EG6
D002	8234 0100 00	Opt., LED, org., GL-2HD6
D003	8234 2037 00	Opt., LED, yel., GL-2HY6
S001-004	8253 1130 11	Switch, tact, SOA-142HS
W001	8276 6892 70	Cable Assy, 8P, 8263 red- 9073, 700mm
Y101	8207 0051 01	Spacer, LED, 5

TENSION POD PCB ASSEMBLY

PCB Ass'y No. 8273 5360 00

Ref. No.	Parts No.	Nomenclature
	8251 8701 04	Plain PCB, tension pod

METAL RESISTORS

R001	8231 0172 23	Pot., semi-fixed, metal, 22k Ω
R002	8231 0174 73	Pot., semi-fixed, metal, 47k Ω
R003	8231 0174 72	Pot., semi-fixed, metal, 4.7k Ω
R004	8231 0174 72	Pot., semi-fixed, metal, 4.7k Ω

Ref. No.	Parts No.	Nomenclature
R005	8231 0171 04	Pot., semi-fixed, metal, 100kΩ
R006	8231 0172 23	Pot., semi-fixed, metal, 22kΩ

MISCELLANEOUS

E101	8276 0020 02	Wire, jumper, 5mm, IPS-1041-2
W001	8276 6932 65	Cable Assy, 12P, 8263 red 9073, 650mm
W002	8276 6840 50	Cable Assy, 3P, 8263 wht. 9073, 500mm
W003	8276 6842 17	Cable Assy, 3P, 8263 red 9073, 170mm

COUNT SENSOR

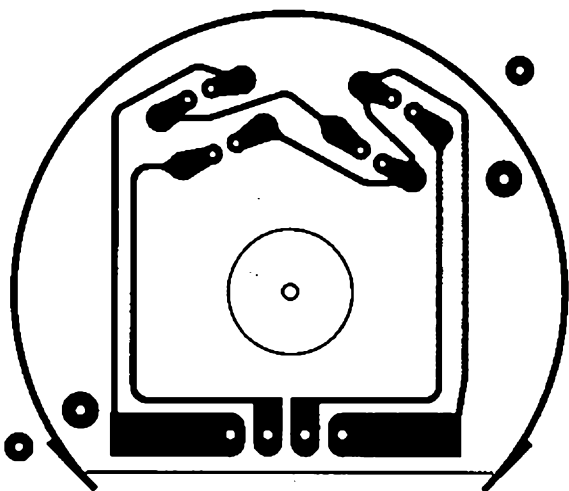

COUNT SENSOR PCB ASSEMBLY

PCB Ass'y No. 8273 5380 00

Ref. No.	Parts No.	Nomenclature
	8251 3361 00	Plain PCB, count sensor, G
U001-002	8234 0182 04	Opt., photo-interrupter, GP-2S04, B
W001	8276 2820 50	Cable Assy, 4P blk, 500mm

REEL SENSOR / T, G PCB ASSEMBLY

PCB Ass'y No. 8273 5420 00

Ref. No.	Parts No.	Nomenclature
	8251 3370 00	Plain PCB, reel sensor G
U001	8234 0182 04	Opt., photo-interrupter, GP-2S04, B

REEL SENSOR

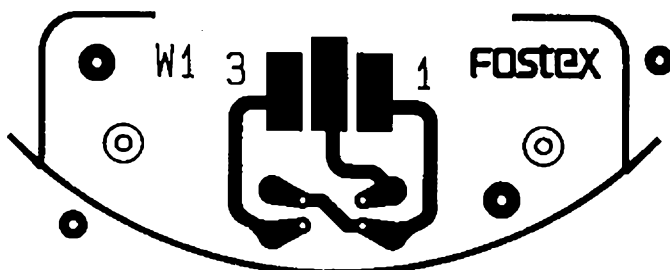

Ref. No.	Parts No.	Nomenclature
W001	8276 2400 75	Cable Assy, 3P red, 750mm

REEL SENSOR/S, G PCB ASSEMBLY

PCB Ass'y No. 8273 5430 00

Ref. No.	Parts No.	Nomenclature
	8251 3370 00	Plain PCB, reel sensor
U001	8234 0182 04	Opt., photo interrupter, GP-2S04, B
W001	8276 2810 55	Cable Assy, 3P yel. 550mm

DD CAPSTAN PCB ASSEMBLY

Ass'y No. 8273 5890 01

Ref. No.	Parts No.	Nomenclature
B101	8251 3601 00	Plain PCB, DD Capstan
		IC's
U001	8236 0209 00	Analog, NJM4559DF
U002	8236 0028 01	Digital, CMOS, 4049UB
U003	8236 0270 00	Analog SW, 4066B
U004	8236 0292 00	Analog, NJM3403AD
U005	8236 0215 00	Analog, NJM2904D
U006-008	8236 0007 01	Digital, CMOS, 4013B
U009	8236 0288 00	Analog, Timer, 555
U010	8236 0031 01	Digital, CMOS, 4069UB
U011	8236 0001 01	Digital, CMOS, 4001B
U012	8236 0062 00	Digital, CMOS, 4520B
U013	8236 0505 01	Driver, UN1211
U014	8236 0505 03	Driver, UN1213
U015	8236 0505 01	Driver, UN1211
U016	8236 0505 01	Driver, UN1211
U017	8236 0505 02	Driver, UN1212
U018-020	8236 0505 03	Driver, UN1213
U021	8236 0313 00	Analog, 79L09A
U022-024	8236 0505 03	Driver, UN1213

Ref. No.	Parts No.	Nomenclature	Ref. No.	Parts No.	Nomenclature
TRANSISTORS					
Q001	8234 0001 21	2SK117GR, BL	R034	8230 1382 24	Flat mtg., 220k Ω
Q002	8234 0003 04	2SA1015Y, GR	R035	8230 1382 73	Flat mtg., 27k Ω
Q003	8234 0001 21	2SK117GR, BL	R036	8230 1384 74	Flat mtg., 470k Ω
Q004	8234 0006 02	2SC2878B	R037	8230 1382 24	Flat mtg., 220k Ω
Q005	8234 0037 02	2SC2655Y	R038	8230 1384 73	Flat mtg., 47k Ω
Q006	8234 0038 02	2SA1020Y	R039	8230 1383 92	Flat mtg., 3.9k Ω
Q007	8234 0001 21	2SK117GR, BL	R040	8230 1381 53	Flat mtg., 15k Ω
Q008-009	8234 0003 03	2SA1015GR	R040	8230 1381 23	Flat mtg., 12k Ω
DIODES					
D001-010	8234 0088 00	GMB01-BT	R041	8230 1381 02	Flat mtg., 1k Ω
D011	8234 0019 10	Zener, 05AZ5.1Z	R042	8230 1381 03	Flat mtg., 10k Ω
D012	8234 0088 00	GMB01-BT	R043	8230 1382 72	Flat mtg., 2.7k Ω
D013	8234 0196 02	DSK10C-BT	R044	8230 1382 02	Flat mtg., 2k Ω
D014	8234 0088 00	GMB01-BT	R045	8230 1381 01	Flat mtg., 100 Ω
CARBON RESISTORS					
All resistors 1/6W, \pm 5% unless otherwise noted.					
R001-002	8230 1382 22	Flat mtg., 2.2k Ω	R046	8230 1381 01	Flat mtg., 100 Ω
R003	8230 1381 02	Flat mtg., 1k Ω	R047	8230 0354 78	Cement, 2W, 0.47 Ω , 10%
R004	8230 1381 03	Flat mtg., 10k Ω	R048	8230 1382 23	Flat mtg., 22k Ω
R005	8230 1381 05	Flat mtg., 1M Ω	R049	8230 1382 23	Flat mtg., 22k Ω
R006	8230 1381 04	Flat mtg., 100k Ω	R050	8230 1381 02	Flat mtg., 1k Ω
R007-008	8230 1381 03	Flat mtg., 10k Ω	R051	8230 1382 04	Flat mtg., 200k Ω
R009	8230 1381 05	Flat mtg., 1M Ω	R052	8230 1386 81	Flat mtg., 680 Ω
R010	8230 1381 03	Flat mtg., 10k Ω	R053	8230 1381 02	Flat mtg., 1k Ω
R011	8230 1382 23	Flat mtg., 22k Ω	R054	8230 1381 03	Flat mtg., 10k Ω
R012	8230 1382 23	Flat mtg., 22k Ω	R055	8230 1381 03	Flat mtg., 10k Ω
R013	8230 1381 02	Flat mtg., 1k Ω	R056	8230 1381 03	Flat mtg., 10k Ω
R014	8230 1382 24	Flat mtg., 220k Ω	R057	8230 1388 22	Flat mtg., 8.2k Ω
R015	8230 1386 81	Flat mtg., 680 Ω	R058	8230 1384 71	Flat mtg., 470 Ω
R016	8230 1381 03	Flat mtg., 10k Ω	R059	8230 1384 72	Flat mtg., 4.7k Ω
R017-018	8230 1381 04	Flat mtg., 100k Ω	R060	8230 1385 63	Flat mtg., 56k Ω
R019	8230 1384 73	Flat mtg., 47k Ω	R061	8230 1381 04	Flat mtg., 100k Ω
R020	8230 1383 33	Flat mtg., 33k Ω	R062	8230 1382 24	Flat mtg., 220k Ω
R021-022	8230 1381 03	Flat mtg., 10k Ω	R063	8230 1381 03	Flat mtg., 10k Ω
R023	8230 1384 73	Flat mtg., 47k Ω	R064-065	8230 1381 04	Flat mtg., 100k Ω
R024	8230 1381 04	Flat mtg., 100k Ω	R066	8230 0231 03	Metal, 1/4W, 10k Ω , 1%, ver.
R025	8230 1381 03	Flat mtg., 10k Ω	R067	8230 1384 72	Flat mtg., 4.7k Ω
R026	8230 1381 03	Flat mtg., 10k Ω	R068	8230 1381 03	Flat mtg., 10k Ω
R027	8230 1381 03	Flat mtg., 10k Ω	R069	8230 0232 22	Metal, 1/4W, 2.2k Ω , 1%, ver.
R028	8230 1382 23	Flat mtg., 22k Ω	R070	8230 1382 23	Flat mtg., 22k Ω
R029	8230 1382 23	Flat mtg., 22k Ω	R071	8230 1381 04	Flat mtg., 100k Ω
R030	8230 1381 04	Flat mtg., 100k Ω	R072	8230 1382 23	Flat mtg., 22k Ω
R031	8230 1386 81	Flat mtg., 680 Ω	R073	8230 1381 03	Flat mtg., 10k Ω
R032	8230 1381 03	Flat mtg., 10k Ω	R074	8230 1382 23	Flat mtg., 22k Ω
R033	8230 1384 73	Flat mtg., 47k Ω	R075	8230 1381 04	Flat mtg., 100k Ω
			R076	8230 1381 02	Flat mtg., 1k Ω
			R077	8230 0331 06	Metal, 1/4W, 10M Ω , 5%, straight
			R078	8230 1381 04	Flat mtg., 100k Ω
			R079	8230 1381 03	Flat mtg., 10k Ω
			R080	8230 1381 03	Flat mtg., 10k Ω
			R081	8230 1382 24	Flat mtg., 220k Ω
			R082	8230 1381 04	Flat mtg., 100k Ω

Ref. No.	Parts No.	Nomenclature	Ref. No.	Parts No.	Nomenclature
R083	8230 1381 04	Flat mtg., 100k Ω	C019	8232 9001 52	PEP, 50V, 0.0015 μ F, 5%, AWS
R084	8230 1381 05	Flat mtg., 1M Ω	C020	8232 0313 91	PPR, 100V, 390pF, 5%, APS
R085	8231 0031 53	Semi-fixed, flat mtg., 15k Ω , H1051A	C021	8232 8031 03	CER, 50V, 0.01 μ F, +80-20%, YF
R086	8231 0031 53	Semi-fixed, flat mtg., 15k Ω , H1051A	C022	8232 0320 50	CER, 50V, 5pF, 5%, NPO
R087	8231 0011 02	Semi-fixed, flat mtg., 1k Ω H1021A	C023	8232 0325 60	CER, 50V, 56pF, 5%, NPO
R088	8230 1386 81	Flat mtg., 680 Ω	C024	8232 1461 05	ALU, 50V, 1 μ F, 20%, SME-VB
R089	8230 1384 72	Flat mtg., 4.7k Ω	C025	8232 9011 04	PES, 50V, 0.1 μ F, 5%, AMZV
R090	8230 1381 04	Flat mtg., 100k Ω	C026	8232 8031 03	CER, 50V, 0.01 μ F, +80-20%, YF
R091	8230 1384 72	Flat mtg., 4.7k Ω	C027	8232 1441 07	ALU, 25V, 100 μ F, 20%, SME-VB
R092	8230 1381 04	Flat mtg., 100k Ω	C028	8232 8031 03	CER, 50V, 0.01 μ F, +80-20%, YF
R093	8230 1382 02	Flat mtg., 2k Ω	C029-030	8232 1451 06	ALU, 35V, 10 μ F, 20%, SME-VB
CAPACITORS			C031	8232 8001 04	CER, 16V, 0.1 μ F, +80-20%, YF
ALU = Electrolytic type			C032-038	8232 8031 03	CER, 50V, 0.01 μ F, +80-20%, YF
CER = Ceramic type			C039	8232 8021 01	CER, 50V, 100pF, 10%, SL
PES = Mylar type			C040	8232 9014 71	PES, 50V, 470pF, 5%, AMZV
PPR = Polypropylene type			C041	8232 9014 73	PES, 50V, 0.047 μ F, 5%, AMZV
C001	8232 1441 06	ALU, 25V, 10 μ F, 20%, SME-VB	C042-049	(deleted)	
C002	8232 1501 06	ALU, 16V, 10 μ F, 20%, BP SME-VB	C050	8232 1433 36	ALU, 16V, 33 μ F, 20%, SME
C003	8232 0322 71	CER, 50V, 270pF, 5%, NPO	C051	8232 8031 03	CER, 50V, 0.01 μ F, +80-20%, YF
C004	8232 0315 61	PPR, 100V, 560pF, 5%, APS	C052	8232 8031 03	CER, 50V, 0.01 μ F, +80-20%, YF
C005	8232 0322 21	CER, 50V, 220pF, 5%, NPO	C053	8232 1441 06	ALU, 25V, 10 μ F, 20%, SME
C006	8232 9011 03	PES, 50V, 0.01 μ F, 5%, AMZV	MISCELLANEOUS		
C007	8232 9013 32	PES, 50V, 0.0033 μ F, 5%, AMZV	E501	8276 0010 00	Pin, header
C008	8232 0313 31	PPR, 100V, 330pF, 5%, APS	E502	8245 0740 01	Connector, plug, 9067
C009	8232 0315 61	PPR, 100V, 560pF, 5%, APS	J001	8245 0530 62	Connector, jack, 8263, 2, straight, yel.
C010	8232 9011 03	PES, 50V, 0.01 μ F, 5%, AMZV	J002	8245 0530 03	Connector, jack, 8263, 3, straight, wht.
C011	8232 9013 32	PES, 50V, 0.0033 μ F, 5%, AMZV	J003	8245 0530 22	Connector, jack, 8263, 2, straight, red.
C012	8232 9011 02	PES, 50V, 0.001 μ F, 5%, AMZV	J004	8245 0530 04	Connector, jack, 8263, 4, straight, wht.
C013	8232 9011 83	PES, 50V, 0.018 μ F, 5%, AMZV	J005	8245 0530 62	Connector, jack, 8263, 2, straight, yel.
C014	8232 0315 61	PPR, 100V, 560pF, 5%, APS	J006	8245 0530 42	Connector, jack, 8263, 2, straight, blk.
C015	8232 0322 21	CER, 50V, 220pF, 5%, NPO			
C016	8232 9011 03	PES, 50V, 0.01 μ F, 5%, AMZV			
C017	8232 9013 32	PES, 50V, 0.0033 μ F, 5%, AMZV			
C018	8232 0313 31	PPR, 100V, 330pF, 5%, APS			

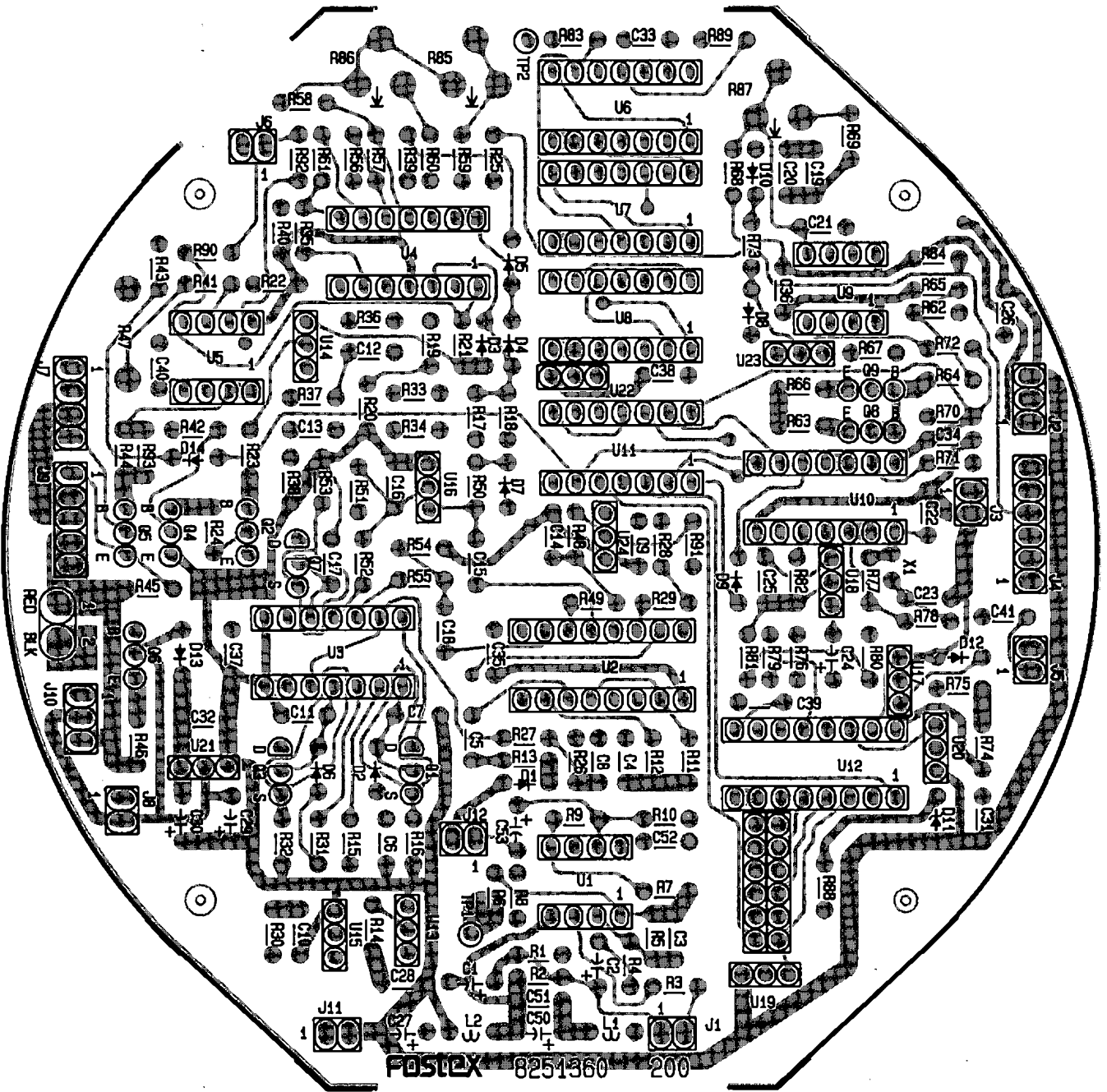

Ref. No.	Parts No.	Nomenclature	Ref. No.	Parts No.	Nomenclature
J007	8245 0530 04	Connector, jack, 8263, 4, straight, wht.	J012	8245 0530 02	Connector, jack, 8263, 2, straight, wht.
J008	8245 0530 22	Connector, jack, 8263, 2, straight, red.	J013	8245 0530 02	Connector, jack, 8263, 2, straight, wht.
J009	8245 0530 05	Connector, jack, 8263, 5, straight, wht.	J014	8245 0732 12	Connector, jack, 12P, 9067 2 gangs
J010	8245 0530 63	Connector, jack, 8263, 3, straight, yel.	L001	8242 0530 00	Coil, 150μH
J011	8245 0530 42	Connector, jack, 8263, 2, straight, blk.	L002	8242 0530 00	Coil, 150μH
			X001	8239 0016 00	Crystal, 38.4kHz

G24S R/P AMPLIFIER, S PCB ASSEMBLY
G16S R/P AMPLIFIER, 16S PCB ASSEMBLY

G24S PCB Ass'y No. 8273 5900 00

G16S PCB Ass'y No. 8273 5900 01

Ref. No. Parts No. Nomenclature

D003	8234 7500 00	ISS187
D004	8234 7500 00	ISS187
D005	8234 7500 00	ISS187
D006	8234 7500 00	ISS187
D007	8234 7500 00	ISS187
D008	8234 7500 00	ISS187
D009	8234 7502 01	Zener, DZD9.1Y <i>GS-013</i>
D010	8234 7500 00	ISS187
D012	8234 7500 00	ISS187
D013	8234 7500 00	ISS187
D014	8234 7501 01	U1BC44

Ref. No. Parts No. Nomenclature

B101	8251 8780 01	Plain PCB, R/P Amplifier, S IC's
U001	8236 7200 00	Analog, BA15218F
U002	8236 7200 00	Analog, BA15218F
U003	8256 0880 00	Module, dolby S, SBX1654
U004	8236 5000 00	CMOS, 4066BF
U005	8236 7201 00	Analog, NJM3404AM
U006	8236 7202 00	Analog, IR9358N
U007	8236 0734 00	Digital, UPD17108GS-711
U008	8236 5702 01	Driver, DTC314TK
U009	(deleted)	
U010	8236 5703 01	Driver, DTC323TK
U011	8236 5701 03	Driver, DTC114TK
U012	8236 5701 03	Driver, DTC114TK
U013	8236 5700 01	Driver, DTC113ZK
U014	8236 5701 03	Driver, DTC114TK
U015	8236 5701 03	Driver, DTC114TK
U016	8236 5701 03	Driver, DTC114TK
U017	8236 7000 01	Regulator, 78L05UA
U018	8256 0790 00	Module, trap S, 100kHz, 10mH
U019	8256 0810 00	Module, low pass filter
U020	8256 0810 00	Module, low pass filter
U021	8256 0790 00	Module, trap S, 100kHz, 10mH
U023	8236 5701 03	Driver, DTC114TK
U022	(spare)	
U024	8236 5702 01	Driver, DTC314TK

TRANSISTORS

Q001	8234 0091 01	FET, 2SK170GR
Q002	8234 6000 05	2SC4116GR/BL
Q004	8234 1903 03	2SK364V
Q005	8234 1903 03	2SK364V
Q006	8234 7000 02	2SK209GR
Q007	8234 6001 02	2SC2882Y
Q008	8234 6001 02	2SC2882Y
Q009	8234 6001 02	2SC2882Y
Q010	8234 6001 02	2SC2882Y
Q011	8234 6000 05	2SC4116GR/BL

DIODES

D001	8234 7500 00	ISS187
D002	8234 7500 00	ISS187

CARBON RESISTORS

All resistors 1/10W, ±5% unless otherwise noted.

R001	8230 5001 02	Flat mtg., 1kΩ,
R002	8230 5005 10	Flat mtg., 51Ω
R003	8230 5001 00	Flat mtg., 10Ω
R004	8230 5001 03	Flat mtg., 10kΩ
R005	8230 5003 32	Flat mtg., 3.3kΩ
R006	8230 5015 12	Metal, 5.1kΩ, 1%
R007	8230 5012 21	Metal, 220Ω, 1%
R008	8230 5001 01	Flat mtg., 100Ω
R009	8230 5002 73	Flat mtg., 27kΩ
R010	8230 5001 03	Flat mtg., 10kΩ
R011	8230 5003 33	Flat mtg., 33kΩ
R012	8230 5003 91	Flat mtg., 390Ω
R013	8230 5004 74	Flat mtg., 470kΩ
R014	8230 5002 71	Flat mtg., 270Ω
R015	8230 5001 82	Flat mtg., 1.8kΩ
R016	8230 5001 53	Flat mtg., 15kΩ
R017	8230 5004 71	Flat mtg., 470Ω
R018	8230 5008 23	Flat mtg., 82kΩ
R019	8230 5001 09	Flat mtg., 1Ω
R020	8230 5002 73	Flat mtg., 27kΩ
R021	8230 5001 04	Flat mtg., 100kΩ
R022	8230 5001 03	Flat mtg., 10kΩ
R023	8230 5001 03	Flat mtg., 10kΩ
R024	8230 5003 93	Flat mtg., 39kΩ
R025	8230 5002 22	Flat mtg., 2.2kΩ
R026	8230 5002 22	Flat mtg., 2.2kΩ
R027	8230 5003 93	Flat mtg., 39kΩ
R028	8230 5002 72	Flat mtg., 2.7kΩ
R029	8230 5001 53	Flat mtg., 15kΩ
R030	8230 5001 82	Flat mtg., 1.8kΩ
R031	8230 5004 73	Flat mtg., 47kΩ
R032	8230 5001 02	Flat mtg., 1kΩ
R033	8230 5001 02	Flat mtg., 1kΩ
R034	8230 5003 92	Flat mtg., 3.9kΩ
R035	8230 5001 53	Flat mtg., 15kΩ
R036	8230 5004 72	Flat mtg., 4.7kΩ

Ref. No.	Parts No.	Nomenclature	Ref. No.	Parts No.	Nomenclature	
R037	8230 5004 72	Flat mtg., 4.7k Ω	R087	8230 5002 22	Flat mtg., 2.2k Ω	
R038	8230 5001 04	Flat mtg., 100k Ω	R088	8230 5002 23	Flat mtg., 22k Ω	
R039	8230 5001 04	Flat mtg., 100k Ω	R089	8230 5001 23	Flat mtg., 12k Ω	
R040	8230 5001 04	Flat mtg., 100k Ω	R090	8230 5006 82	Flat mtg., 6.8k Ω	
R041	8230 5005 61	Flat mtg., 560 Ω	R091	8230 5004 73	Flat mtg., 47k Ω	
R042	8230 5003 92	Flat mtg., 3.9k Ω	R092	8230 5004 72	Flat mtg., 4.7k Ω	
R043	8230 5001 04	Flat mtg., 100k Ω	R093	(deleted)	G24S	
R044	8230 5001 04	Flat mtg., 100k Ω	R093	8230 5008 22	Flat mtg., 8.2k Ω	G16S
R045	8230 5001 04	Flat mtg., 100k Ω	R094	8230 5002 72	Flat mtg., 2.7k Ω	
R046	8230 5002 21	Flat mtg., 220 Ω	R095	8230 5001 20	Flat mtg., 12 Ω	G24S
R047	8230 5001 04	Flat mtg., 100k Ω	R095	8230 5002 20	Flat mtg., 22 Ω	G16S
R048	8230 5001 04	Flat mtg., 100k Ω	R096	8230 5002 22	Flat mtg., 2.2k Ω	
R049	8230 5002 23	Flat mtg., 22k Ω	R097	8230 5002 70	Flat mtg., 27 Ω	
R050	8230 5002 23	Flat mtg., 22k Ω	R098	8230 5002 03	Flat mtg., 20k Ω	
R051	8230 5002 23	Flat mtg., 22k Ω	R099	8230 5003 32	Flat mtg., 3.3k Ω	
R052	8230 5001 04	Flat mtg., 100k Ω	R100	8230 5004 73	Flat mtg., 47k Ω	
R053	8230 5004 31	Flat mtg., 430 Ω	R101	8230 5002 03	Flat mtg., 20k Ω	
R054	8230 5001 09	Flat mtg., 1 Ω	R102	8230 5001 52	Flat mtg., 1.5k Ω	
R055	8230 5002 23	Flat mtg., 22k Ω	R103	8230 5001 23	Flat mtg., 12k Ω	
R056	8230 5002 23	Flat mtg., 22k Ω	R104	8230 5008 22	Flat mtg., 8.2k Ω	
R057	8230 5001 53	Flat mtg., 15k Ω G24S	R105	8230 5002 72	Flat mtg., 2.7k Ω	
R057	8230 5001 33	Flat mtg., 13k Ω G16S	R106	8230 5004 70	Flat mtg., 47 Ω	
R058	8230 5003 92	Flat mtg., 3.9k Ω	R107	8230 5006 81	Flat mtg., 680 Ω	
R059	8230 5001 83	Flat mtg., 18k Ω	R108	8230 5002 70	Flat mtg., 27 Ω	
R060	8230 5001 82	Flat mtg., 1.8k Ω	R109	(spare)		
R061	8230 5001 52	Flat mtg., 1.5k Ω	R110	8230 5001 81	Flat mtg., 180 Ω	
R062	8230 5003 33	Flat mtg., 33k Ω	R111	8230 5001 03	Flat mtg., 10k Ω	
R063	8230 5001 03	Flat mtg., 10k Ω	R112	8230 5004 73	Flat mtg., 47k Ω	
R064	8230 5003 92	Flat mtg., 3.9k Ω	R113	8230 5001 00	Flat mtg., 10 Ω	
R065	8230 5002 73	Flat mtg., 27k Ω	R114	8230 5001 53	Flat mtg., 15k Ω	
R066	8230 5001 04	Flat mtg., 100k Ω	R115	8230 5001 03	Flat mtg., 10k Ω	
R067	8230 5001 83	Flat mtg., 18k Ω	R116	8230 5001 04	Flat mtg., 100k Ω	
R068	8230 5004 73	Flat mtg., 47k Ω	R117	8230 5001 00	Flat mtg., 10 Ω	
R069	8230 5002 23	Flat mtg., 22k Ω	R118	8230 5001 03	Flat mtg., 10k Ω	
R070	8230 5002 24	Flat mtg., 220k Ω	R119	8230 5001 04	Flat mtg., 100k Ω	
R071	8230 5001 02	Flat mtg., 1k Ω	R120	8230 5001 00	Flat mtg., 10 Ω	
R073	(spare)		R121	(spare)		
R074	8230 5001 09	Flat mtg., 1 Ω	R122	(spare)		
R075	8230 5002 23	Flat mtg., 22k Ω	R123	8230 5001 04	Flat mtg., 100k Ω	
R076	8230 5004 73	Flat mtg., 47k Ω	R124	8230 5001 01	Flat mtg., 100 Ω	
R077	8230 5001 04	Flat mtg., 100k Ω	R125	8230 5004 72	Flat mtg., 4.7k Ω	
R078	8230 5001 04	Flat mtg., 100k Ω	R126	8230 5002 23	Flat mtg., 22k Ω	
R079	8230 5001 04	Flat mtg., 100k Ω	R127	8230 5002 23	Flat mtg., 22k Ω	
R080	8230 5001 04	Flat mtg., 100k Ω	R128	8230 5001 04	Flat mtg., 100k Ω	
R081	8230 5001 04	Flat mtg., 100k Ω	R129	8230 5001 04	Flat mtg., 100k Ω	
R082	8230 5001 04	Flat mtg., 100k Ω	R130	8230 5004 31	Flat mtg., 430 Ω	
R083	8230 5002 03	Flat mtg., 20k Ω	R131	8230 5002 22	Flat mtg., 2.2k Ω	
R084	8230 5005 62	Flat mtg., 5.6k Ω	R132	8230 5006 81	Flat mtg., 680 Ω	
R085	8230 5001 04	Flat mtg., 100k Ω	R133	8230 5001 09	Flat mtg., 1 Ω	
R086	8230 5001 83	Flat mtg., 18k Ω	R201	8231 5004 73	Metal, semi-fixed, 47k Ω , RH03AVA, ver.	

Ref. No.	Parts No.	Nomenclature	Ref. No.	Parts No.	Nomenclature
R202	8231 5001 03	Metal, semi-fixed, 10k Ω RH03AVA, ver.	C012	8233 6013 92	FLM, 50V, 0.0039 μ F, 5%, ECW-U
R203	8231 5004 72	Metal, semi-fixed, 4.7k Ω RH03AVA, ver.	C013-015	8233 0031 06	ALU, 16V, 10 μ F, 20%, MF
R204	8231 5004 72	Metal, semi-fixed, 4.7k Ω RH03AVA, ver.	C016	8233 0034 76	ALU, 16V, 47 μ F, 20%, MF
R205	8231 5002 21	Metal semi-fixed, 220 Ω RH03AVA, ver.	C017	8233 0031 06	ALU, 16V, 10 μ F, 20%, MF
R206	8231 5004 72	Metal, semi-fixed, 4.7k Ω RH03AVA, ver.	C018	8233 6012 22	FLM, 50V, 0.0022 μ F, 5%, ECW-U
R207	8231 5004 72	Metal, semi-fixed, 4.7k Ω RH03AVA, ver.	C019	8233 6013 92	FLM, 50V, 0.0039 μ F, 5%, ECW-U
R208	8231 5001 03	Metal, semi-fixed, 10k Ω RH03AVA, ver.	C020	8233 0052 25	ALU, 35V, 2.2 μ F, 20%, MF
R209	8231 5001 03	Metal, semi-fixed, 10k Ω RH03AVA, ver.	C021	8233 0052 25	ALU, 35V, 2.2 μ F, 20%, MF
R210	8231 5001 03	Metal, semi-fixed, 10k Ω RH03AVA, ver.	C022	8233 0034 76	ALU, 16V, 47 μ F, 20%, MF
R211	8231 5011 04	Metal, semi-fixed, 100k Ω RH03AYA, flat mtg.	C023	8232 1562 27	ALU, 10V, 220 μ F, 20%, SRA
R212	8231 5011 04	Metal, semi-fixed, 100k Ω , RH03AYA, flat mtg.	C024	8233 0031 06	ALU, 16V, 10 μ F, 20%, MF
			C025	8233 0031 06	ALU, 16V, 10 μ F, 20%, MF
			C026	8233 0031 06	ALU, 16V, 10 μ F, 20%, MF
			C027	8233 0031 06	ALU, 16V, 10 μ F, 20%, MF
			C028	8233 0033 36	ALU, 16V, 33 μ F, 20%, MF
			C029	8233 0031 06	ALU, 16V, 10 μ F, 20%, MF
			C030	8233 0033 36	ALU, 16V, 33 μ F, 20%, MF
			C031	8233 0031 06	ALU, 16V, 10 μ F, 20%, MF
			C032	8233 0031 06	ALU, 16V, 10 μ F, 20%, MF
			C033	8233 0031 06	ALU, 16V, 10 μ F, 20%, MF
			C034	8233 6013 93	FLM, 50V, 0.039 μ F, 5%, ECW-U
			C035	8233 5013 30	CER, 50V, 33pF, 5%, CG21
			C036	8233 6012 22	FLM, 50V, 0.0022 μ F, 5%, ECW-U
			C037	8233 0062 24	ALU, 50V, 0.22 μ F, 20%, MF
			C037	8233 0061 54	ALU, 50V, 0.15 μ F, 20%, MF
			C038	8232 1031 06	ALU, 16V, 10 μ F, 20%, LL
			C039	8233 6012 22	FLM, 50V, 0.0022 μ F, 5%, ECW-U
			C040	8233 0064 74	ALU, 50V, 0.47 μ F, 20%, MF
			C041	8233 5001 02	CER, 50V, 0.001 μ F, 5%, SL21
			C042	8233 0061 05	ALU, 50V, 1 μ F, 20%, MF
			C043	8233 6006 83	FLM, 25V, 0.068 μ F, 5%, ECW-V
			C044	8233 0061 05	ALU, 50V, 1 μ F, 20%, MF
			C045	8233 0061 05	ALU, 50V, 1 μ F, 20%, MF
			C046	8233 5021 04	CER, 50V, 0.1 μ F, +80, Y5V21
			C048	8233 6001 04	FLM, 25V, 0.1 μ F, 5%, ECW-V
			C049	8233 6008 23	FLM, 25V, 0.082 μ F, 5%, ECW-V
C001	8233 6011 23	FLM, 50V, 0.012 μ F, 5%, ECW-U			
C002	8233 6011 02	FLM, 50V, 0.001 μ F, 5%, ECW-U			
C003	8233 5001 01	CER, 50V, 100pF, 5%, SL21			
C004	8232 1571 07	ALU, 16V, 100 μ F, 20%, SRA			
C005	8233 3042 25	TNT, 20V, 2.2 μ F, 20%			
C006	8233 5002 71	CER, 50V, 270pF, 5%, SL21			
C007	8233 0034 76	ALU, 16V, 47 μ F, 20%, MF			
C008	8233 6011 53	FLM, 50V, 0.015 μ F, 5%, ECW-U			
C009	8233 5002 20	CER, 50V, 22pF, 5%, SL21			
C010	8233 0031 06	ALU, 16V, 10 μ F, 20%, MF			
C011	8233 6012 22	FLM, 50V, 0.0022 μ F, 5%, ECW-U			

CAPACITORS

ALU = Electrolytic type

CER = Ceramic type

PES = Mylar type

PPR = Polypropylene type

FLM = Film type

TNT = Tantalum type

G24S

G16S

R/P AMPLIFIER

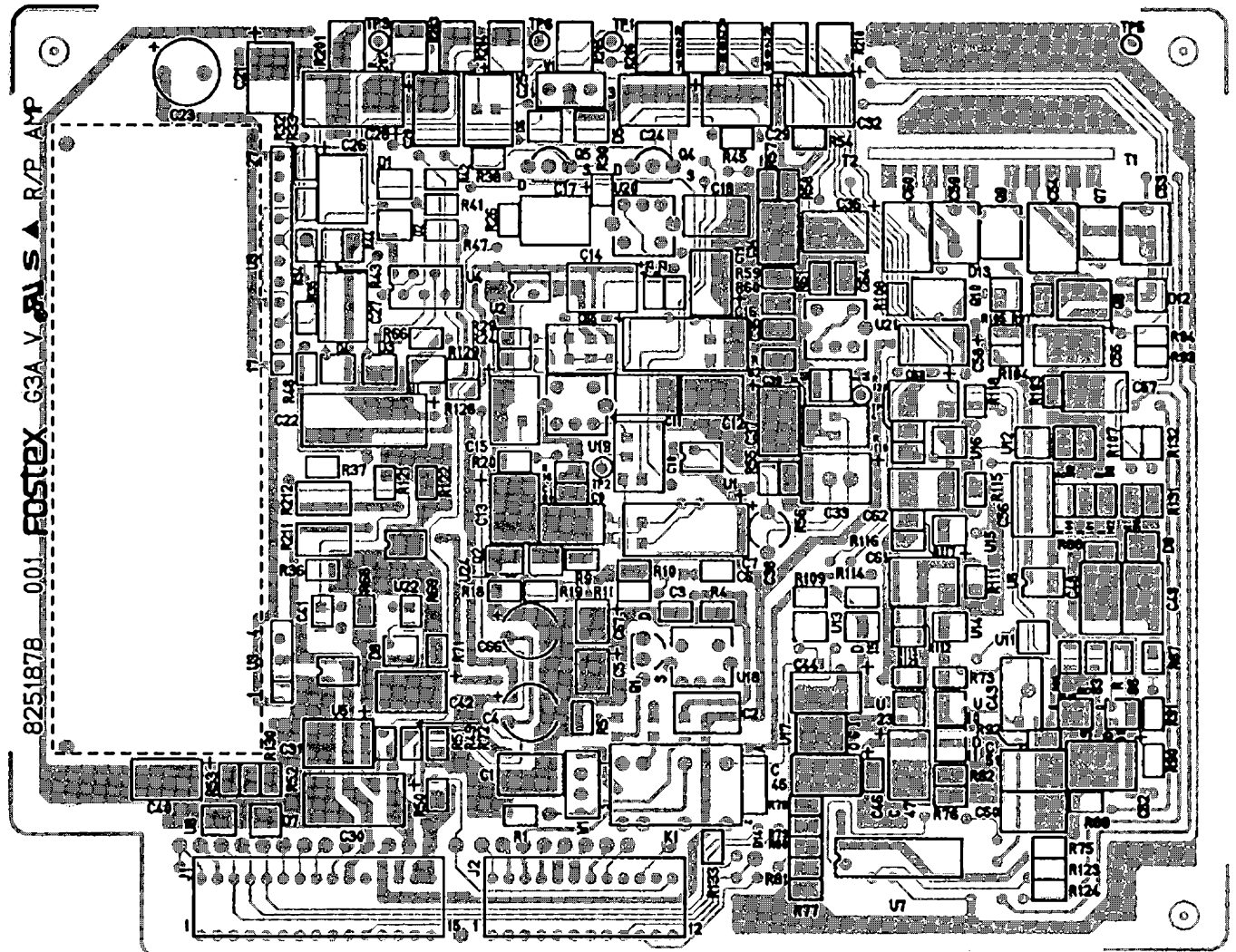

Ref. No.	Parts No.	Nomenclature	Ref. No.	Parts No.	Nomenclature
C050	8233 6011 03	FLM, 50V, 0.01 μ F, 5%, ECW-U	C064	8233 5001 01	CER, 50V, 100pF, 5%, SL21
C051	8233 6011 03	FLM, 50V, 0.01 μ F, 5%, ECW-U	C065	8233 0031 06	ALU, 16V, 10 μ F, 20%, MF
C052	8233 0031 06	ALU, 16V, 10 μ F, 20%, MF	C066	8232 1571 07	ALU, 16V, 100 μ F, 20%, SRA
C053	8232 0315 62	PPR, 100V, 0.0056 μ F, 5%, APS G24S	C067	8233 3042 25	TNT, 20V, 2.2 μ F, 20%
C053	8232 0316 82	PPR, 100V, 0.0068 μ F, 5%, APS G16S	MISCELLANEOUS		
C054	8233 0044 75	ALU, 25V, 4.7 μ F, 20%, MF	E601	8276 0010 00	Pin, header
C055	8233 0061 05	ALU, 50V, 1 μ F, 20%, MF	J001	8245 5220 15	Connector, jack, IL-SDD-15S- S2L2
C056	8233 6001 04	FLM, 25V, 0.1 μ F, 5%, ECW-V	J002	8245 5220 12	Connector, jack, IL-SDD-12S- S2L2
C057	8233 6011 03	FLM, 50V, 0.01 μ F, 5%, ECW-U	K001	8248 0070 00	Relay, G5A-1002H
C058	8233 0061 05	ALU, 50V, 1 μ F, 20%, MF	W001	8276 2450 12	Cable ASSY, shield 2 core, red, 3P wht, male, 120mm
C059	8232 0312 22	PPR, 100V, 0.0022 μ F, 5%, APS	Y2301	8220 7600 00	Cover, relay, shield
C060	8233 0044 75	ALU, 25V, 4.7 μ F, 20%, MF			

G24S CONTROLLER PCB ASSEMBLY
G16S CONTROLLER PCB ASSEMBLY

G24S PCB Ass'y No. 8273 5240 02

G16S PCB Ass'y No. 8273 8920 00

Ref. No.	Parts No.	Nomenclature
	8251 3500 00	Plain PCB, controller, G IC's
U001	8236 0556 00	Digital, MTC1R, MN17581
U002	8236 0568 00	Digital, FCG1, UPD78C12AGF
U003-004	8236 0567 00	Digital, driver, array, TD62309P
U005-029	8236 0510 01	Digital, driver, UN1111
U030	8236 0028 01	CMOS, 4049UB
U031-032	8236 0567 00	Driver, array, TD62309P
U033-048	8236 0510 01	Driver, UN1111
U049	(deleted)	

TRANSISTOR

Q001 8234 1422 01 2SC752G-Y

DIODES

Ref. No.	Parts No.	Nomenclature
D001-014	8234 0088 00	GMB01-BT
D015	(deleted)	
D016-038	8234 0088 00	GMB01-BT
D063	8234 0088 00	GMB01-BT G24S
D063	(deleted)	G16S
D064-079	8234 0088 00	GMB01-BT
D080-086	8234 0088 00	GMB01-BT G24S
D080-086	(deleted)	G16S
D087-096	8234 0088 00	GMB01-BT
D200-203	8234 0191 00	Opt., LED, grn., GL-2EG6
D204-205	8234 0191 00	Opt., LED, grn., GL-2EG6
D206-207	8234 0191 00	Opt., LED, grn., GL-2EG6
D208	8234 2037 00	Opt., LED, yel., GL-2HY6
D209-213	8234 0100 00	Opt., LED, org., GL-2HD6
D214-215	(deleted)	
D216-218	8234 0100 00	Opt., LED, org., GL-2HD6
D219-221	8234 0191 00	Opt., LED, grn., GL-2EG6
D222-223	8234 0100 00	Opt., LED, org., GL-2HD6
D224	8234 2037 00	Opt., LED, yel., GL-2HY6
D225	8234 2027 00	Opt., LED, grn.-red, GL3ED8 G24S
D225	(deleted)	G16S
D226-241	8234 2027 00	Opt., LED, grn.-red, GL3ED8

Ref. No.	Parts No.	Nomenclature
D242-248	8234 2027 00	Opt., LED, grn.-red, GL3ED8 G24S
D242-248	(deleted)	G16S
D249	8234 2023 00	Opt., LED, bargraph, 12 dot, SLA-5672-10 G24S
D249	(deleted)	G16S
D250-265	8234 2023 00	Opt., LED, bargraph, 12 dot, SLA-5672-10
D266-272	8234 2023 00	Opt., LED, bargraph, 12 dot, SLA-5672-10 G24S
D266-272	(deleted)	G16S
D273-290	8234 2028 00	Opt., LED, 7 segment, red, GL8D040)
D291	8234 0100 00	Opt., LED, org., GL-2HD6

CARBON RESISTORS

All resistors 1/6W, ±5% unless otherwise noted.

R001,038	8230 1387 53	Flat mtg., 75kΩ
R002	8230 1384 72	Flat mtg., 4.7kΩ
R003-010	8230 1384 70	Flat mtg., 47Ω
R011-014	8230 1384 70	Flat mtg., 47Ω
R015-022	8230 1384 70	Flat mtg., 47Ω
R023-026	8230 1384 70	Flat mtg., 47Ω
R027	8230 1389 11	Flat mtg., 910Ω
R028-029	8230 1381 02	Flat mtg., 1kΩ
R030	8230 1386 82	Flat mtg., 6.8kΩ
R031-032	8230 1381 02	Flat mtg., 1kΩ
R033-036	8230 1384 71	Flat mtg., 470Ω
R037	8230 1382 42	Flat mtg., 2.4kΩ
R039,066	8230 0950 01	Array, 1/8W, 22kΩ/100kΩx4, 5%, RKL-E
R040-055	8230 1381 01	Flat mtg., 100Ω
R056-057	8230 0362 21	Array, 1/8W, 220Ωx4, 5%, RKC
R058-063	(deleted)	
R064-065	8230 1381 03	Flat mtg., 10kΩ
R067	8230 0372 23	Array, 1/8W, 22kΩx8, 5%, RKC
R068	8230 1381 03	Flat mtg., 10kΩ

CARBON POTS

R100	8240 1700 14	Pot., 10kΩB, flat
R101	8231 0141 03	Pot., semi-fixed, flat, 10kΩ

CAPACITORS

ALU = Electrolytic type
CER = Ceramic type
PES = Mylar type
PPR = Polypropylene type

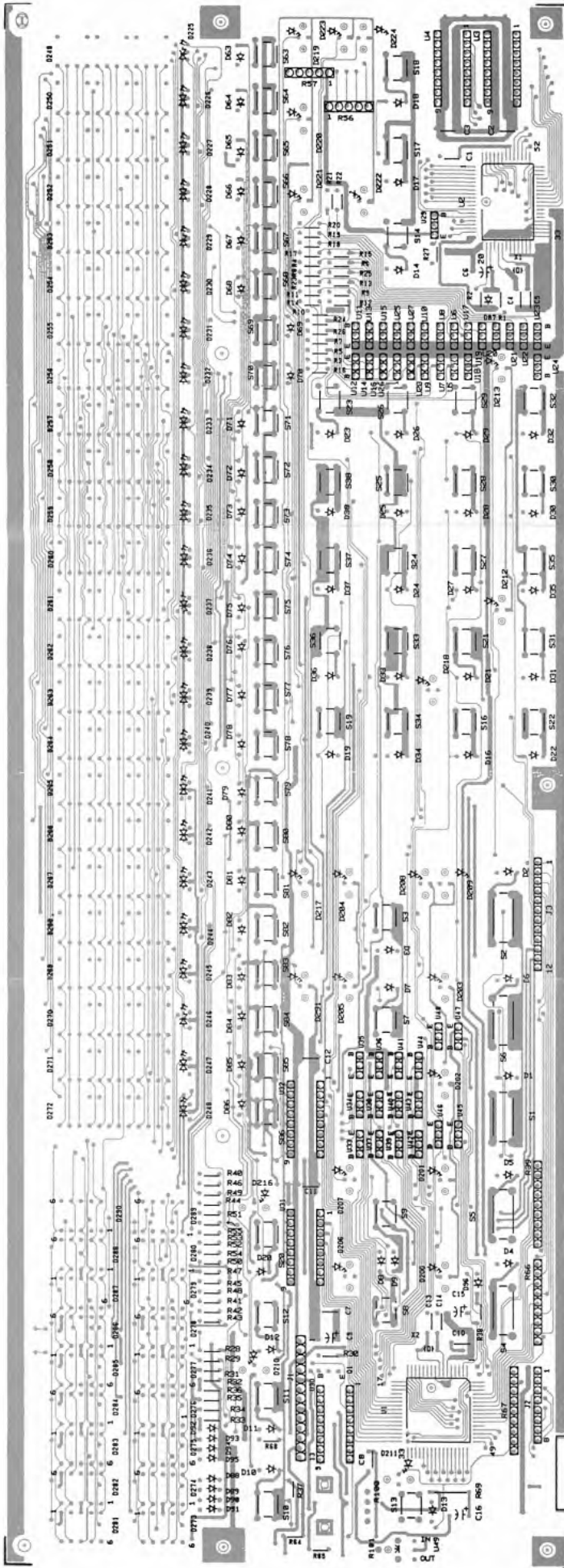

ERASE, S, PCB ASSEMBLY

G24S PCB Ass'y No. 8273 6810 00
G16S PCB Ass'y No. 8273 5980 00

Ref. No.	Parts No.	Nomenclature
B101	8251 8800 01	Plain PCB, erase, S
T001	8242 1630 00	Transformer, erase
T001	8242 1360 00	Transformer, erase
T002	8242 1490 00	Transformer, bias

ERASE



Ref. No.	Parts No.	Nomenclature
C001-003	8232 8001 04	CER, 16V, 0.1µF, +80 -20%,
	YF	
C004-005	8232 0323 00	CER, 50V, 30pF, 5%,
	NPO	
C006-015	8232 1604 74	ALU, 50V, 0.47µF, 20%,
	SRA	
C007-008	8232 8001 04	CER, 16V, 0.1µF, +80 -20%,
	YF	
C009	8232 1554 76	ALU, 6.3V, 47µF, 20%,
	SRA	
C010-012	8232 8001 04	CER, 16V, 0.1µF, +80 -20%,
	YF	
C013-014	8232 0323 00	CER, 50V, 30pF, 5%,
	NPO	
C016	(deleted)	
MISCELLANEOUS		
S001-002	8253 1150 00	Switch, push, SKEJAB
S003	8253 1130 11	Switch, tact, SOA-142HS
S004-006	8253 1150 00	Switch, push, SKEJAB
S007-014	8253 1130 11	Switch, tact, SOA-142HS
S015	(deleted)	
S016-038	8253 1130 11	Switch, tact, SOA-142HS
S039-062	(deleted)	
S063	8253 1130 11	Switch, tact, SOA-142HS
S063	(deleted)	
S064-079	8253 1130 11	Switch, tact, SOA-142HS
S080-086	8253 1130 11	Switch, tact, SOA-142HS
S080-086	(deleted)	
Y201	8207 0032 03	Spacer, LEDES-15
Y201	(deleted)	
Y701	8207 0032 03	Spacer, LEDES-15
Y702	8212 2720 00	Spacer, LED, 8
W001	8276 6670 00	Cable ASSY, controller, G
X001	8256 0780 00	Ceramic resonator, 12MHz
X002	8256 0550 00	Ceramic resonator, 8MHz

CONNECTOR BOARD

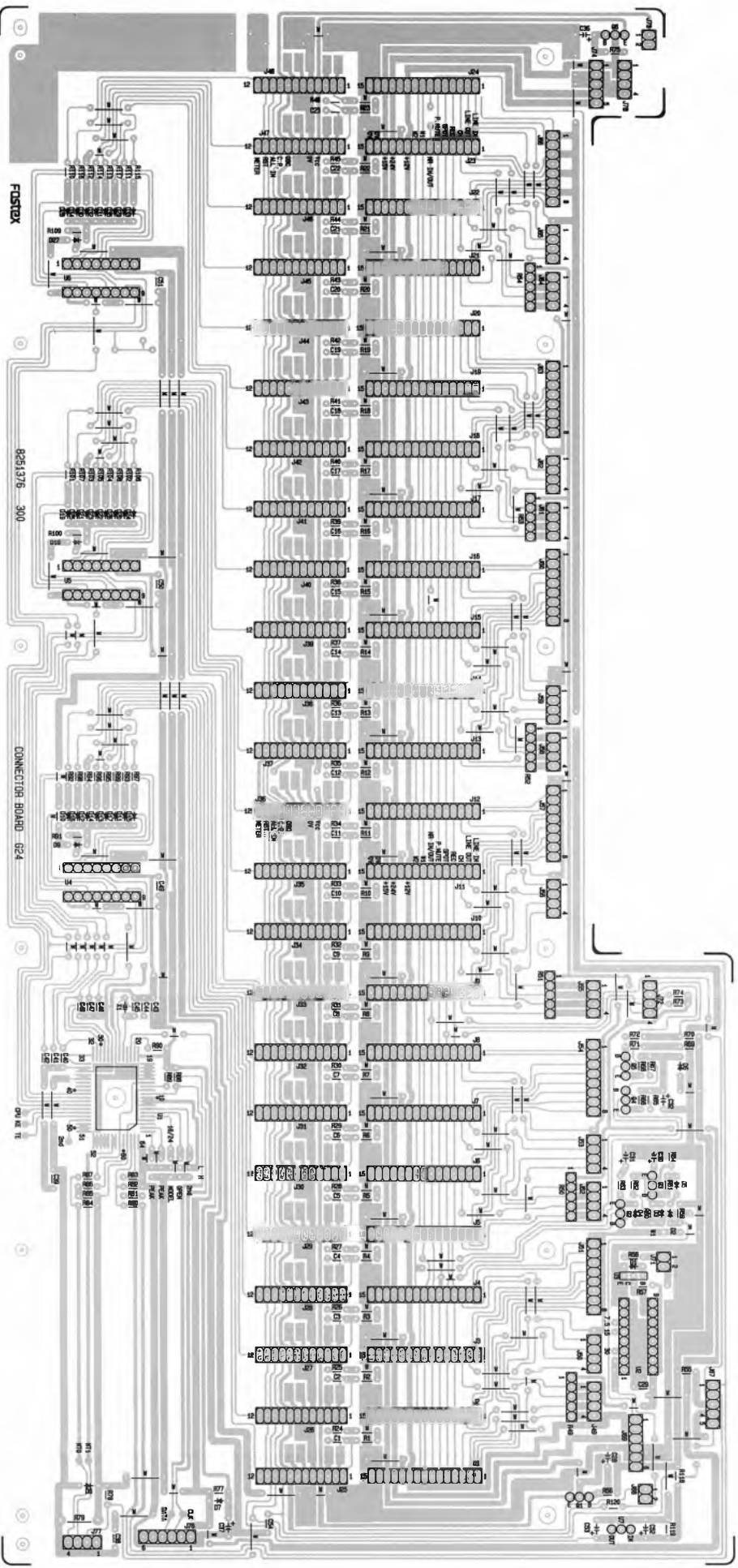

CONNECTOR BOARD PCB ASSEMBLY

G-24S Ass'y No. 8273 5910 01
G-16S Ass'y No. 8273 5910 02

Ref. No.	Parts No.	Nomenclature
B101	8251 3763 00	Plain PCB, connector board, G24S
		IC's
U001	8236 0568 00	Digital, UPD78C12AGF-E12-3BE
U002	8236 0024 00	Digital, CMOS, 4040B
U003	8236 0505 04	Digital, driver, UN1214
U004	8236 0328 00	Analog, multiplexer, 4052B
U005	8236 0328 00	Analog, multiplexer, 4052B
U006	8236 0328 00	Analog, multiplexer, 4052B G24S
U006	(deleted)	G16S
U007	8236 0570 01	Digital, reset, PST523D

TRANSISTORS

Q001	8234 0096 02	2SC732TM-BL
Q002	8234 0003 03	2SA1015GR
Q003	8234 0003 03	2SA1015GR
Q004	8234 0003 03	2SA1015GR
Q005	8234 0003 03	2SA1015GR
Q006	8234 0096 02	2SC732TM-BL G24S
Q006	(deleted)	G16S

DIODES

D001	8234 0088 00	GMB01-BT
D002	8234 0019 13	Zener, 05AZ9.1Y
D003	8234 0088 00	GMB01-BT
D004	8234 0196 02	DSK10C-BT
D005-026	8234 0088 00	GMB01-BT
D027-035	8234 0088 00	GMB01-BT G24S
D027-035	(deleted)	G16S

CARBON RESISTORS

All resistors 1/6W, ±5% unless otherwise noted.

R001-015	(spare)	
R016-023	(spare)	
R024-038	(spare)	
R039-046	(spare)	
R047-048	(deleted)	
R049-050	8230 0362 23	Array, 1/8W, 22kΩ×4, 5%, RKC
R051-052	8230 0362 23	Array, 1/8W, 22kΩ×4, 5%, RKC

Ref. No.	Parts No.	Nomenclature
R053-054	8230 0362 23	Array, 1/8W, 22kΩ×4, 5%, RKC G24S
R053-054	(deleted)	G16S
R055	8230 1381 02	Flat mtg., 1kΩ
R056	8230 1382 22	Flat mtg., 2.2kΩ
R057	8230 1382 23	Flat mtg., 22kΩ
R058	8230 1382 23	Flat mtg., 22kΩ
R059	8230 1381 04	Flat mtg., 100kΩ
R060	8230 1382 24	Flat mtg., 220kΩ
R061	8230 1382 23	Flat mtg., 22kΩ
R062	8230 1384 72	Flat mtg., 4.7kΩ
R063	(spare)	
R064	8230 1384 71	Flat mtg., 470Ω
R065	8230 1381 04	Flat mtg., 100kΩ
R066	8230 1382 72	Flat mtg., 2.7kΩ
R067	8230 1381 04	Flat mtg., 100kΩ
R068	8230 1384 71	Flat mtg., 470Ω
R069-070	8230 1382 23	Flat mtg., 22kΩ
R071-072	8230 1382 23	Flat mtg., 22kΩ
R073	8230 1382 23	Flat mtg., 22kΩ
R074	8230 1382 23	Flat mtg., 22kΩ
R075	8230 1382 22	Flat mtg., 2.2kΩ G24S
R075	(deleted)	G16S
R076	(deleted)	
R077	8230 1387 53	Flat mtg., 75kΩ
R078	8230 1382 22	Flat mtg., 2.2kΩ
R079	8230 0394 70	Flat mtg., 1/4W, 47Ω, nonflammable
R080	8230 1381 04	Flat mtg., 100kΩ
R081	8230 1381 04	Flat mtg., 100kΩ
R082	8230 1385 13	Flat mtg., 51kΩ
R083	8230 1385 13	Flat mtg., 51kΩ
R084	8230 1382 22	Flat mtg., 2.2kΩ
R085	8230 1382 23	Flat mtg., 22kΩ
R086	8230 1381 04	Flat mtg., 100kΩ
R087	8230 1382 22	Flat mtg., 2.2kΩ
R088	8230 1382 42	Flat mtg., 2.4kΩ
R089	8230 1382 42	Flat mtg., 2.4kΩ
R090	8230 1384 72	Flat mtg., 4.7kΩ
R091	8230 1381 02	Flat mtg., 1kΩ
R092-099	8230 1381 03	Flat mtg., 10kΩ
R100	8230 1381 02	Flat mtg., 1kΩ
R101-108	8230 1381 03	Flat mtg., 10kΩ
R109	8230 1381 02	Flat mtg., 1kΩ G24S
R109	(deleted)	G16S
R110-117	8230 1381 03	Flat mtg., 10kΩ G24S
R110-117	(deleted)	G16S
R118	8230 1381 03	Flat mtg., 10kΩ
R119	8230 1386 22	Flat mtg., 6.2kΩ
R120	(spare)	

Ref. No.	Parts No.	Nomenclature
CAPACITORS		
		ALU = Electrolytic type
		CER = Ceramic type
		PES = Mylar type
		PPR = Polypropylene type
C001-007	(spare)	
C008-015	(spare)	
C016-023	(spare)	
C024	(deleted)	
C025	(deleted)	
C026	(deleted)	
C027	(deleted)	
C028	8232 1434 76	ALU, 16V, 47 μ F, 20%, SME-VB
C030	8232 1433 36	ALU, 16V, 33 μ F, 20%, SME-VB
C031	8232 1433 37	ALU, 16V, 330 μ F, 20%, SME-VB
C032	8232 1461 05	ALU, 50V, 1 μ F, 20%, SME-VB
C033	(deleted)	
C034	(deleted)	
C035	(deleted)	
C036	8232 1434 76	ALU, 16V, 47 μ F, 20%, SME-VB G24S
C036	(deleted)	G16S
C037	8232 1464 74	ALU, 50V, 0.47 μ F, 20%, SME-VB
C038	8232 8001 04	CER, 16V, 0.1 μ F, +80-20, YF
C039	8232 8001 04	CER, 16V, 0.1 μ F, +80-20, YF
C040	8232 8011 81	CER, 50V, 180pF, 5%, SL
C041	8232 8011 81	CER, 50V, 180pF, 5%, SL G24S
C041	(deleted)	G16S
C042	8232 8011 81	CER, 50V, 180pF, 5%, SL G24S
C042	(deleted)	G16S
C043	8232 8001 04	CER, 16V, 0.1 F, +80-20, YF
C044	8232 0323 00	CER, 50V, 30pF, 5%, NPO
C045	8232 0323 00	CER, 50V, 30pF, 5%, NPO
C046	8232 8011 81	CER, 50V, 180pF, 5%, SL
C047	8232 8011 81	CER, 50V, 180pF, 5%, SL
C048	8232 8011 81	CER, 50V, 180pF, 5%, SL
C049	8232 8001 04	CER, 16V, 0.1 μ F, +80-20, YF
C050	8232 8001 04	CER, 16V, 0.1 μ F, +80-20, YF
C051	8232 8001 04	CER, 16V, 0.1 μ F, +80-20, YF G24S
C051	(deleted)	G16S
C053	8232 1431 06	ALU, 16V, 10 μ F, 20%, SME-VB
C054	(spare)	

Ref. No.	Parts No.	Nomenclature
MISCELLANEOUS		
E401		Wire, jumper, 5mm, IPS-1041-2
E402		Wire, jumper, 10mm, IPS-1041-4
J001-008	8245 5210 15	Connector, jack, IL-SDD-15P- S2T2
J009-016	8245 5210 15	Connector, jack, IL-SDD-15P- S2T2
J017-024	8245 5210 15	Connector, jack, IL-SDD-15P- S2T2 G24S
J017-024	(deleted)	G16S
J025-032	8245 5210 12	Connector, jack, IL-SDD-12P- S2T2
J033-040	8245 5210 12	Connector, jack, IL-SDD-12P- S2T2
J041-048	8245 5210 12	Connector, jack, IL-SDD-12P- S2T2 G24S
J041-048	(deleted)	G16S
J049	8245 0530 64	Connector, jack, 8263, 4, straight, yel.
J050	8245 0530 04	Connector, jack, 8263, 4, straight, wht.
J051	8245 0530 08	Connector, jack, 8263, 8, straight, wht.
J052	8245 0530 24	Connector, jack, 8263, 4, straight, red
J053	8245 0530 44	Connector, jack, 8263, 4, straight, blk.
J054	8245 0530 48	Connector, jack, 8263, 8, straight, blk.
J055	8245 0530 04	Connector, jack, 8263, 4, straight, wht.
J056	8245 0870 24	Connector, jack, 8263, 4, right-angle, red
J057	8245 0870 28	Connector, jack, 8263, 8, right-angle, red
J058	8245 0870 44	Connector, jack, 8263, 4, right-angle, blk
J059	8245 0870 64	Connector, jack, 8263, 4, right-angle, yel.
J060	8245 0870 68	Connector, jack, 8263, 8, right-angle, yel.
J061	8245 0870 24	Connector, jack, 8263, 4, right-angle, red G24S
J061	(deleted)	G16S
J062	8245 0870 04	Connector, jack, 8263, 4, right-angle, wht. G24S
J062	(deleted)	G16S
J063	8245 0870 08	Connector, jack, 8263, 8, right-angle, wht. G24S
J063	(deleted)	G16S

Ref. No.	Parts No.	Nomenclature	Ref. No.	Parts No.	Nomenclature
J064	8245 0870 04	Connector, jack, 8263, 4, right-angle, wht. G24S	J071	8245 0530 02	Connector, jack, 8263, 2, straight, wht.
J064	(deleted)	G16S	J072	8245 0530 24	Connector, jack, 8263, 4, straight, red
J065	8245 0870 44	Connector, jack, 8263, 4, right-angle, blk. G24S	J073	8245 0530 22	Connector, jack, 8263, 2, straight, red
J065	(deleted)	G16S	J074	8245 0530 05	Connector, jack, 8263, 5, straight, wht.
J066	8245 0870 48	Connector, jack, 8263, 8, right-angle, blk. G24S	J075	(deleted)	
J066	(deleted)	G16S	J076	8245 0530 46	Connector, jack, 8263, 6, straight, blk.
J067	8245 0530 05	Connector, jack, 8263, 5, straight, wht. G16S	J077	8245 0530 64	Connector, jack, 8263, 4, straight, yel.
J067	8245 0530 04	Connector, jack, 8263, 4, straight, wht. G24S	J078	(deleted)	G24S
J068	8245 0530 02	Connector, jack, 8263, 2, straight, wht.	J078	8245 0530 24	Connector, jack, 8263, 4, straight, red G16S
J069	8245 0530 06	Connector, jack, 8263, 6, straight, wht.	W001	8276 6510 15	Cable ASSY, earth-lug, D3, 150mm
J070	(deleted.)		X001	8256 0780 00	Ceramic resonator, 12MHz

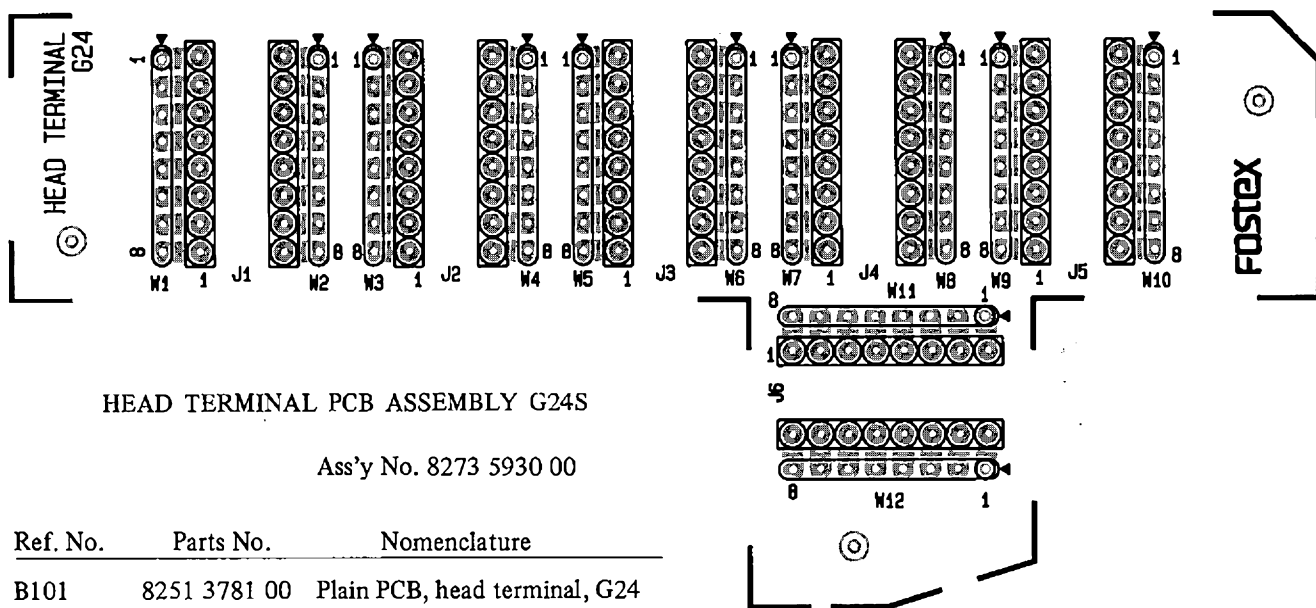

HEAD TERMINAL PCB ASSEMBLY G24S

Ass'y No. 8273 5930 00

Ref. No.	Parts No.	Nomenclature
B101	8251 3781 00	Plain PCB, head terminal, G24
J001-006	8245 1950 01	Connector, IC socket, 16P, N
W001,003	8276 3211 55	Cable ASSY, shield, 2 core, 8P red male, 550mm
W005	8276 3211 55	Cable ASSY, shield, 2 core, 8P, red male, 550mm
W002,004	8276 3201 55	Cable ASSY, shield, 2 core, 8P wht. male, 550mm
W006	8276 3201 55	Cable ASSY, shield, 2 core, 8P wht. male, 550mm
W007,009	8276 3231 55	Cable ASSY, shield, 8P red male, 550mm
W011	8276 3231 55	Cable, shield, 8P red male, 550mm

Ref. No.	Parts No.	Nomenclature
W008,010	8276 3221 55	Cable, shield, 8P wht male, 550mm
W012	8276 3221 55	Cable ASSY, shield, 8P wht. male, 550mm

HEAD TERMINAL PCB ASSEMBLY G16S

PCB Ass'y No. 8273 5370 00

Ref. No.	Parts No.	Nomenclature
	8251 3520 00	Plain PCB, head terminal, G
J001-004	8245 1950 01	Connector, IC Socket, 16P, N
W001,003	8276 3211 55	Cable Assy, shield 2 core, 8P red male-pin, 550mm
W002,004	8276 3201 55	Cable Assy, shield 2 core, 8P wht male-pin, 550mm
W005,007	8276 3231 55	Cable Assy, shield, 8P red male-pin, 550mm
W006,008	8276 3221 55	Cable Assy, shield, 8P wht. male-pin, 550mm

REGULATOR M PCB ASSEMBLY

Ass'y No. 8273 5940 00

Ref. No.	Parts No.	Nomenclature
B101	8251 8790 02	Plain PCB, regulator M
		IC's
U001	8236 0332 08	Analog, L7815ML
U002	8236 0332 08	Analog, L7815ML
U003	8236 0321 09	Analog, NJM7824FA
U004	8236 0332 07	Analog, L7812ML

TRANSISTORS

Q001	8234 1241 00	2SB883
Q002	8234 0002 06	2SC1815Y/GR/BL
Q003	8234 0003 03	2SA1015GR
Q004	8234 1725 02	2SD1264A-P
Q005	8234 1725 02	2SD1264A-P
Q006	8234 1720 00	2SD1047-E
Q007	8234 1720 00	2SD1047-E

DIODE

D001	8234 1966 02	Array, 10DL2CZ41A
------	--------------	-------------------

CARBON RESISTORS

All resistors 1/6W, ±5% unless otherwise noted.

R001	8230 1384 73	Flat mtg., 47kΩ
R002	8230 0572 02	Straight, 1/2W, 2kΩ, 5%
R003	8230 1382 23	Flat mtg., 22kΩ
R004	8230 1381 03	Flat mtg., 10kΩ

Ref. No.	Parts No.	Nomenclature
R005	8230 0321 08	Cement, 5W, 0.1Ω, 10%
R006		(spare)
R007	8230 1381 03	Flat mtg., 10kΩ
R008	8230 1381 52	Flat mtg., 1.5kΩ
R009	8230 1381 52	Flat mtg., 1.5kΩ
R010	8230 0571 01	Straight, 1/2W, 100Ω, 5%
R011	8230 0571 01	Straight, 1/2W, 100Ω, 5%
R012	8230 0323 38	Cement, 5W, 0.33Ω, 10%
R013	8230 0323 38	Cement, 5W, 0.33Ω, 10%
R014	8230 0572 02	Straight, 1/2W, 2kΩ, 5%

CAPACITORS

ALU = Electrolytic type

C001-008	8232 1461 05	ALU, 50V, 1μF, 20%, SME-VB
C009	8232 1464 76	ALU, 50V, 47μF, 20%, SME-VB
C010	8232 1462 24	ALU, 50V, 0.22μF, 20%, SME-VB
C011	8232 1462 24	ALU, 50V, 0.22μF, 20%, SME-VB

MISCELLANEOUS

E201	8276 0020 02	Wire, jumper, 5mm, IPS-1041-2
E202	8276 0020 04	Wire, jumper, 10mm, IPS-1041-4
J001	8245 0530 63	Connector, jack, 8263, 3, straight, yel.
J002	8245 0530 05	Connector, jack, 8263, 5, straight, wht.
J003	8245 0530 06	Connector, jack, 8263, 6, straight, wht.
J004	8245 0870 04	Connector, jack, 8263, 4, right angle, wht.
J005	8245 0870 03	Connector, jack, 8263, 3, right angle, wht.
J006	8245 0870 07	Connector, jack, 8263, 7, right-angle, wht.
J007	8245 0870 03	Connector, jack, 8263, 3, right-angle, wht.
W001	8276 7340 10	Cable ASSY, 10P, 8263 wht. 5395 #22, 100mm
W002	8276 7310 09	Cable ASSY, 7P, 8263 wht. 5395 #22, 90mm

REGULATOR PCB ASSEMBLY

POWER SUPPLY PCB ASSEMBLY

SOLENOID PCB ASSEMBLY G24S

Ass'y No. 8273 5950 00

G24S Ass'y No. 8273 5960 00
G16S Ass'y No. 8273 5960 01

(G24S only) Ass'y No. 8273 5990 00

Ref. No.	Parts No.	Nomenclature
B101	8251 8790 03	Plain PCB, regulator
U001	8236 0332 08	IC's
U002	8236 0362 02	Analog, L7815ML
U003	8236 0570 01	Digital, reset, PST523D
U004	8236 0362 01	Analog, PQ05RF2
U005	8236 0348 06	Regulator, 7915FA
Q001	8234 0038 02	2SA1020Y
TRANSISTOR		
CARBON RESISTORS		
All resistors 1/6W, ±5% unless otherwise noted.		
R001	8230 1381 02	Flat mtg., 1kΩ
R002	8230 1383 92	Flat mtg., 3.9kΩ
R003	8230 1381 03	Flat mtg., 10kΩ
R004	8230 0574 71	Straight, 1/2W, 470Ω, 5%
CAPACITORS		
ALU = Electrolytic type		
C001-008	8232 1461 05	ALU, 50V, 1μF, 20%, SME-VB
MISCELLANEOUS		
E101	8276 0020 02	Wire, jumper, 5mm, IPS-1041-2
E102	8276 0020 04	Wire, jumper, 10mm, IPS-1041-4
J001	8245 0870 22	Connector, jack, 8263, 2, right-angle, red
J002	8245 0870 42	Connector, jack, 8263, 2, right-angle, blk.
J003	8245 0870 05	Connector, jack, 8263, 5, right-angle, wht.
J004	8245 0870 24	Connector, jack, 8263, 4, right-angle, red
J005	8245 0870 42	Connector, jack, 8263, 2, right-angle, blk.
J011	8245 0870 65	Connector, jack, 8263, 5, right-angle, yel.
W001	8276 7330 15	Cable ASSY, 9P, 8263 wht. 5395, #22, 150mm

Ref. No.	Parts No.	Nomenclature
B101	8251 8791 01	Plain PCB, power supply
DIODES		
D001	8234 0086 02	Stack, KBU6D
D002	8234 0086 02	Stack, KBL6D
D002	(deleted)	
D003	8234 0086 02	Stack, KBU6D
D004	8234 0175 02	Stack, KBU8D
D005	8234 0160 02	DSC30TC-FD1
D006	8234 0160 02	DSC30TC-FD1
D007	8234 0088 00	GMB01-BT
D008	8234 0088 00	GMB01-BT
CARBON RESISTORS		
All resistors 1/6W, ±5% unless otherwise noted.		
R001	8230 1384 73	Flat mtg., 47kΩ
R002	8230 1384 73	Flat mtg., 47kΩ
R003	8230 0321 09	Cement, SW, 1Ω, 10%
R004	(spare)	
CAPACITORS		
ALU = Electrolytic type		
PES = Mylar type		
C001	8232 2026 88	ALU, 50V, 6800μF, 20%, SMH-VNSN-25D
C002	8232 1931 09	ALU, 25V, 10000μF, 20%, SMH-VNSN-22D
C003	8232 1991 59	ALU, 35V, 15000μF, 20%, SMH-VNSN-30D
C004	8232 1974 78	ALU, 35V, 4700μF, 20%, SMH-VNSN-22B
C005	8232 1974 78	ALU, 35V, 4700μF, 20%, SMH-VNSN-22B
C005	(deleted)	
C006	8232 2064 78	ALU, 63V, 4700μF, 20%, SMH-VNSN-25D
C007	8232 1981 09	ALU, 35V, 10000μF, 20%, SMH-VNSN-25D
C008	8232 9011 54	PES, 50V, 0.15μF, 5%, AMZV
C009	8232 1464 74	ALU, 50V, 0.47μF, 20%, SME-VB
C010	8232 0851 05	ALU, 50V, 1μF, 20%, BP, LR
C011	8232 1463 34	ALU, 50V, 0.33μF, 20%, SME-VB

Ref. No.	Parts No.	Nomenclature
MISCELLANEOUS		
E201	8276 0020 04	Wire, jumper, 10mm, IPS-1041-4
J001	8245 0530 07	Connector, jack, 8263, 7, straight, wht.
J002	8245 0530 09	Connector, jack, 8263, 9, straight, wht.
J003	8245 0530 22	Connector, jack, 8263, 2, straight, red
J004	8245 0530 10	Connector, jack, 8263, 10, straight, wht.
J005	(spare)	
J006	8245 0530 02	Connector, jack, 8263, 2, straight, wht.
Y401	8239 0002 00	Holder, fuse, S-NS057
Y402	8276 1590 10	Cable ASSY, RED/WHT, 100mm
F001	8239 1008 09	Fuse, multi, anti-rush, 8A, DM/USA/CND
F002	8239 0007 63	Fuse, time lag, 6.3A, EUR/UK
F002	8239 1008 09	Fuse, multi, anti-rush, 8A, DM/USA/CND
F003	8239 0007 63	Fuse, time lag, 6.3A, EUR/UK
F003	8239 1004 09	Fuse, multi, anti-rush, 4A, DM/USA/CND
F004	8239 0007 40	Fuse, time lag, 4A, EUR/UK
F004	8239 1004 09	Fuse, multi, anti-rush, 4A, DM/USA/CND
F005	(deleted)	
F005	8239 0007 40	Fuse, time lag, 4A, EUR/UK
F005	(deleted)	
F005	8239 1002 09	Fuse, multi, anti-rush, 2A, DM/USA/CND
F006	8239 0007 20	Fuse, time lag, 2A, EUR/UK
F006	8239 1004 09	Fuse, multi, anti-rush, 4A, DM/USA/CND
F006	8239 0007 40	Fuse, time lag, 4A, EUR/UK
STACK PCB ASSEMBLY		
Ass'y No. 8273 5970 00		
Ref. No. Parts No. Nomenclature		
B101	8251 8790 04	Plain PCB, stack
D001	8234 0084 02	Diode, stack, 15D4B41
W001	8276 6680 01	Cable ASSY, 5395-5395, 12P, 80mm

Ref. No.	Parts No.	Nomenclature
B101	8251 8790 05	Plain PCB, solenoid, G24S
D101	8234 0196 02	Diode, DSK10C-BT
W001	8276 2390 40	Cable ASSY, 2P red, 400mm
EXTERNAL NR SWITCH PCB ASSEMBLY G16S		
(G16S only) Ass'y No. 8273 6000 00		
Ref. No. Parts No. Nomenclature		
B101	8251 8790 06	Plain PCB, EXT NRSW
E101	8276 0020 02	Wire, jumper, 5mm, IPS-1041-2
J001	8245 4550 00	Connector, jack, DIN 8P, TCS 5033-18-2011
J002	8245 0530 04	Connector, jack, 8263, 4, straight, wht.
J003	8245 0530 05	Connector, jack, 8263, 5, straight, wht.
J004	8245 0530 24	Connector, jack, 8263, 4, straight, red
S001	8253 0410 02	Switch, slide, SSB342, non-shorting

- REGULATOR
- REGULATOR-M
- POWER SUPPLY
- STACK
- EXT NR SWITCH
- SOLENOID

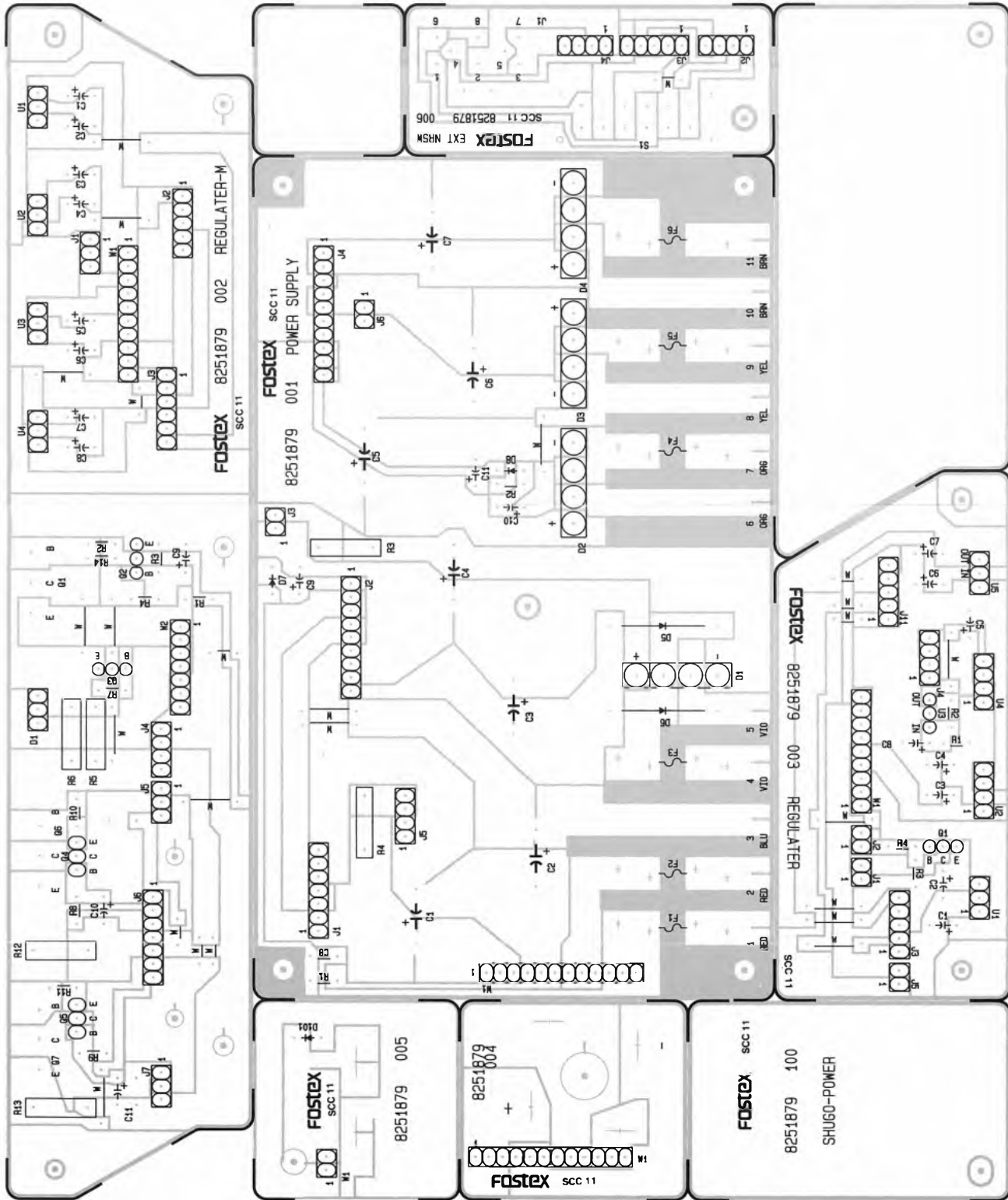

- REGULATOR
- REGULATOR-M
- POWER SUPPLY
- STACK
- EXT NR SWITCH
- SOLENOID

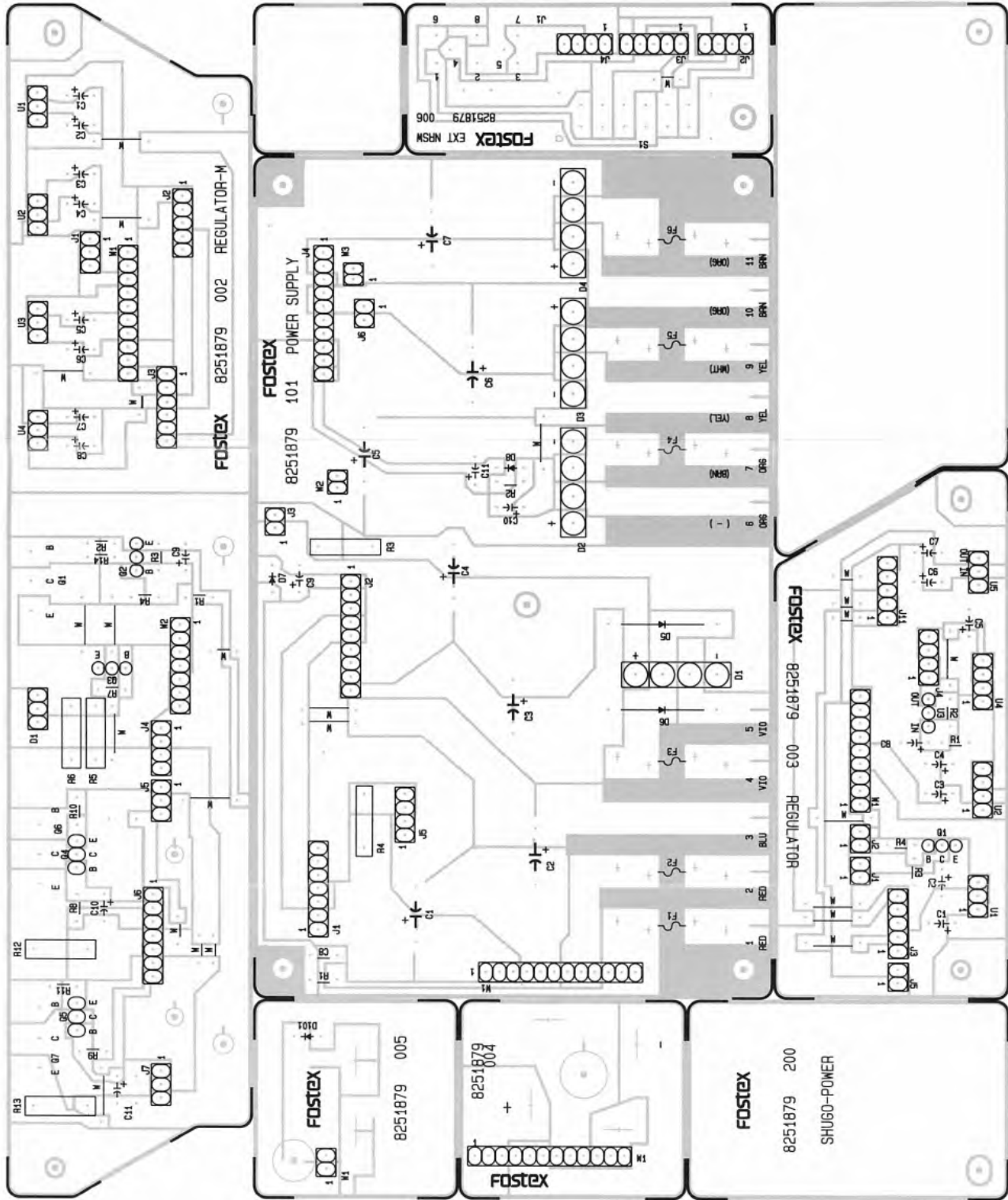

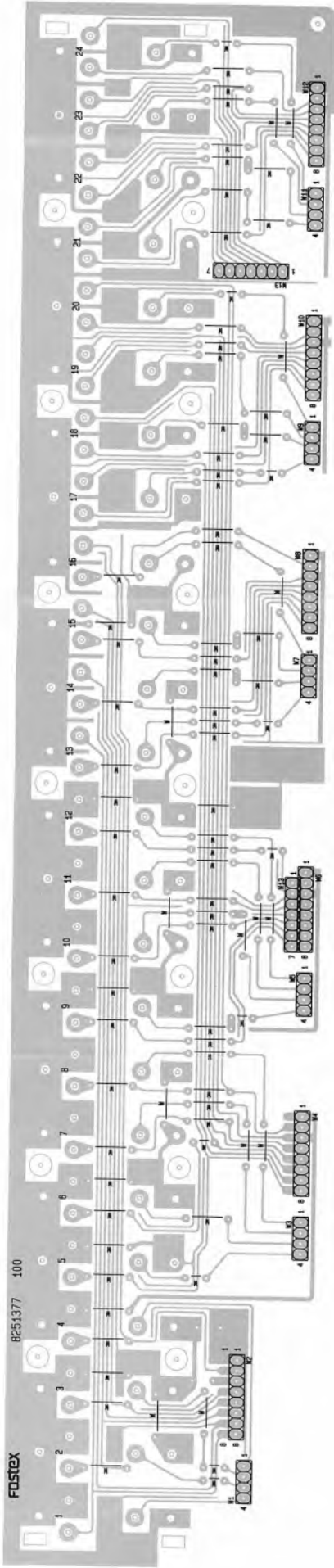

IN/OUT PCB ASSEMBLY G24S

Ass'y No. 8273 5920 00

Ref. No.	Parts No.	Nomenclature
B101	8251 3771 00	Plain PCB, IN/OUT, G24S
E101	8276 0020 02	Wire, jumper, 5mm, IPS-1041-2
E102	8276 0020 04	Wire, jumper, 10mm, IPS-1041-4
J001-008	8245 2161 00	Connector, pin jack, 6P, blk., with SW
W001	8276 2360 27	Cable ASSY, 4P, wht., 270mm
W002	8276 3260 25	Cable ASSY, 8P, wht., 250mm
W003	8276 2820 26	Cable ASSY, 4P, blk., 260mm
W004	8276 3550 25	Cable ASSY, 8P, blk., 250mm
W005	8276 2410 20	Cable ASSY, 4P, red, 200mm
W006	8276 3540 20	Cable ASSY, 8P, red, 200mm
W007	8276 2950 20	Cable ASSY, 4P, yel., 200mm
W008	8276 7240 20	Cable ASSY, 8P, yel., 200mm
W009	8276 2360 24	Cable ASSY, 4P, wht., 240mm
W010	8276 3260 20	Cable ASSY, 8P, wht., 200mm
W011	8276 2820 20	Cable ASSY, 4P, blk., 200mm
W012	8276 3550 20	Cable ASSY, 8P, blk., 200mm
W013	8276 1600 22	Cable, flat, 3P, 220mm
W014	8276 1610 20	Cable, flat, 4P, 200mm

IN/OUT PCB ASSEMBLY G16S

Ass'y No. 8273 6160 00

Ref. No.	Parts No.	Nomenclature
B101	8251 3541 00	PCB, IN/OUT, G16
E101	8276 0020 02	Wire, jumper, 5mm, IPS-1041-2
E102	8276 0020 04	Wire, jumper, 10mm, IPS-1041-4
J001-005	8245 2161 00	Connector, pin jack, 6P, blk., with SW
J006-007	8245 2191 00	Connector, pin jack, 2P, blk., with SW
W001	8276 2360 35	Cable ASSY, 4P, wht., 350mm
W002	8276 3260 35	Cable ASSY, 8P, wht., 350mm
W003	8276 2820 30	Cable ASSY, 4P, blk., 300mm
W004	8276 3550 30	Cable ASSY, 8P, blk., 300mm
W005	8276 2410 30	Cable ASSY, 4P, red, 300mm
W006	8276 3540 30	Cable ASSY, 8P, red, 300mm
W007	8276 2950 30	Cable ASSY, 4P, yel., 300mm
W008	8276 7240 30	Cable ASSY, 8P, yel., 300mm

6. CIRCUIT DIAGRAM

RECORDER, G24S 1/3

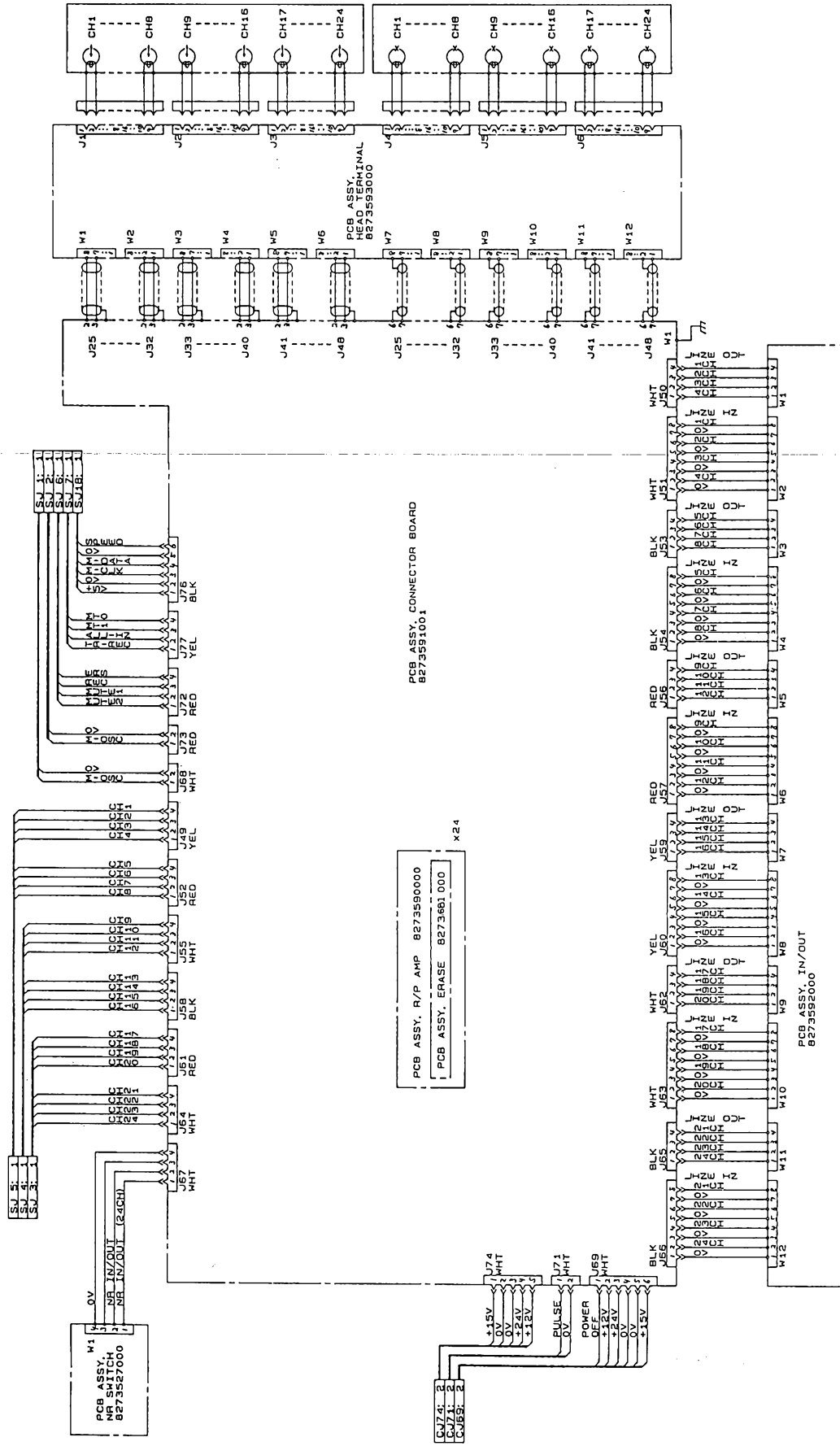

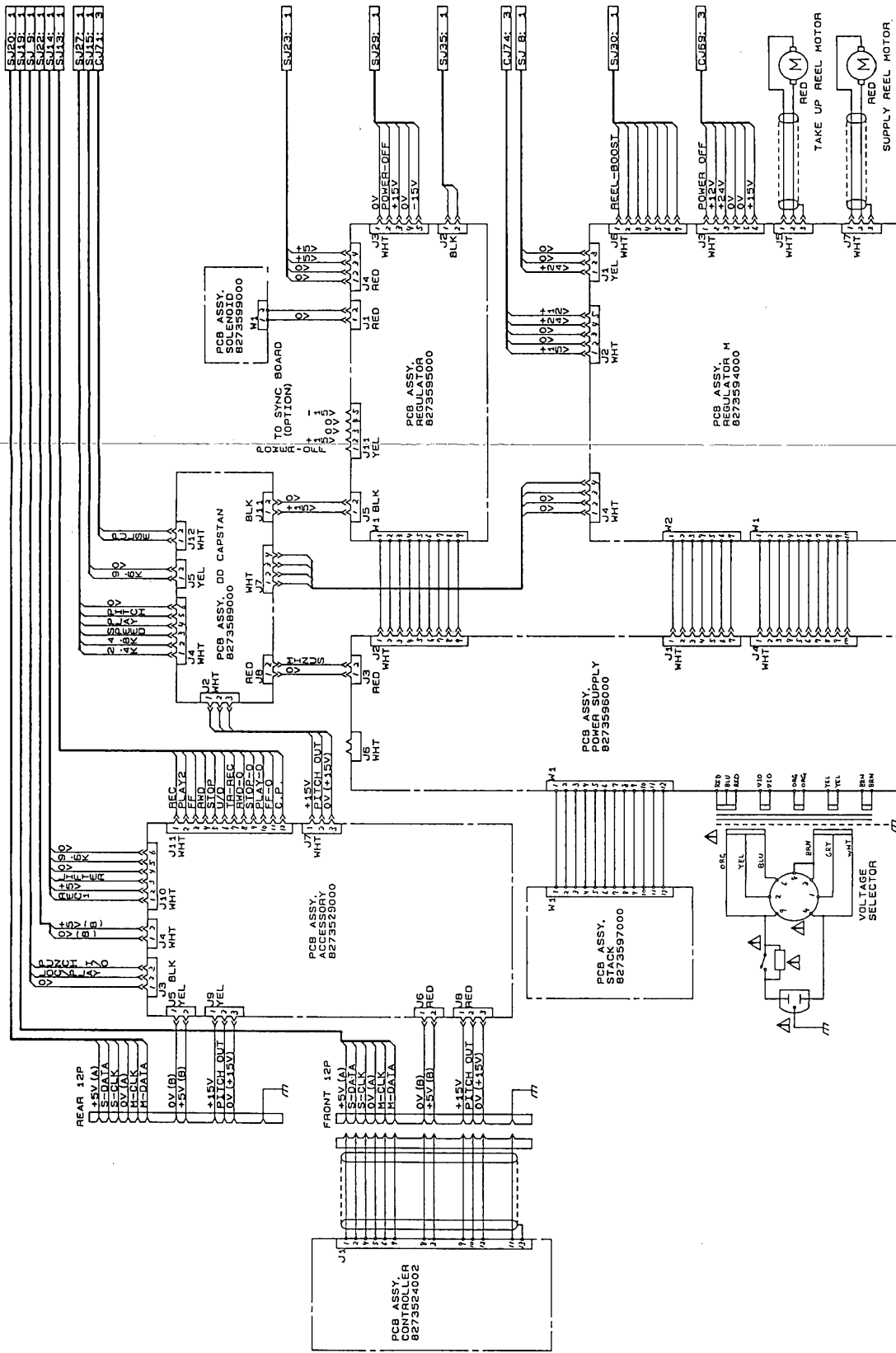

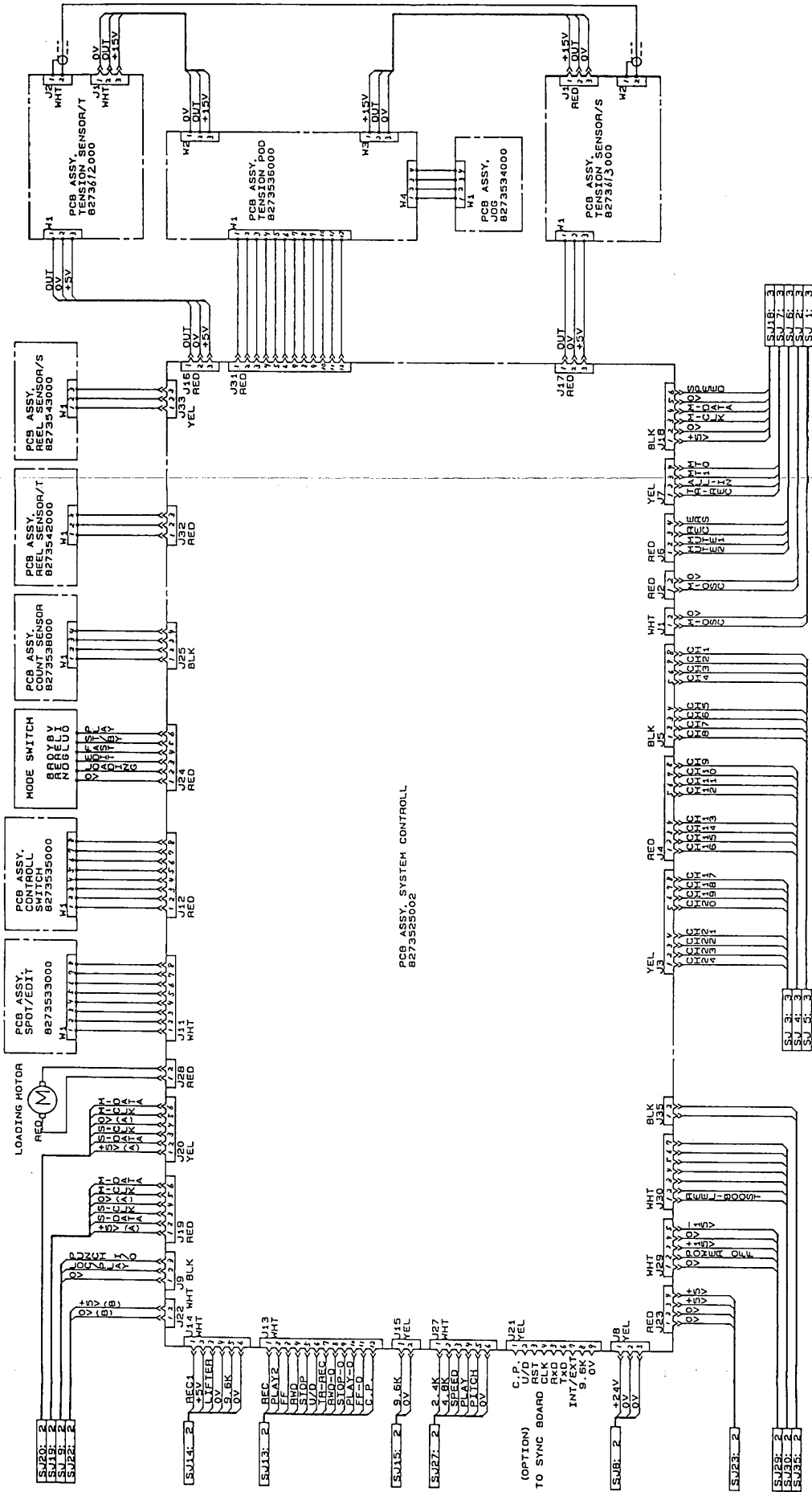

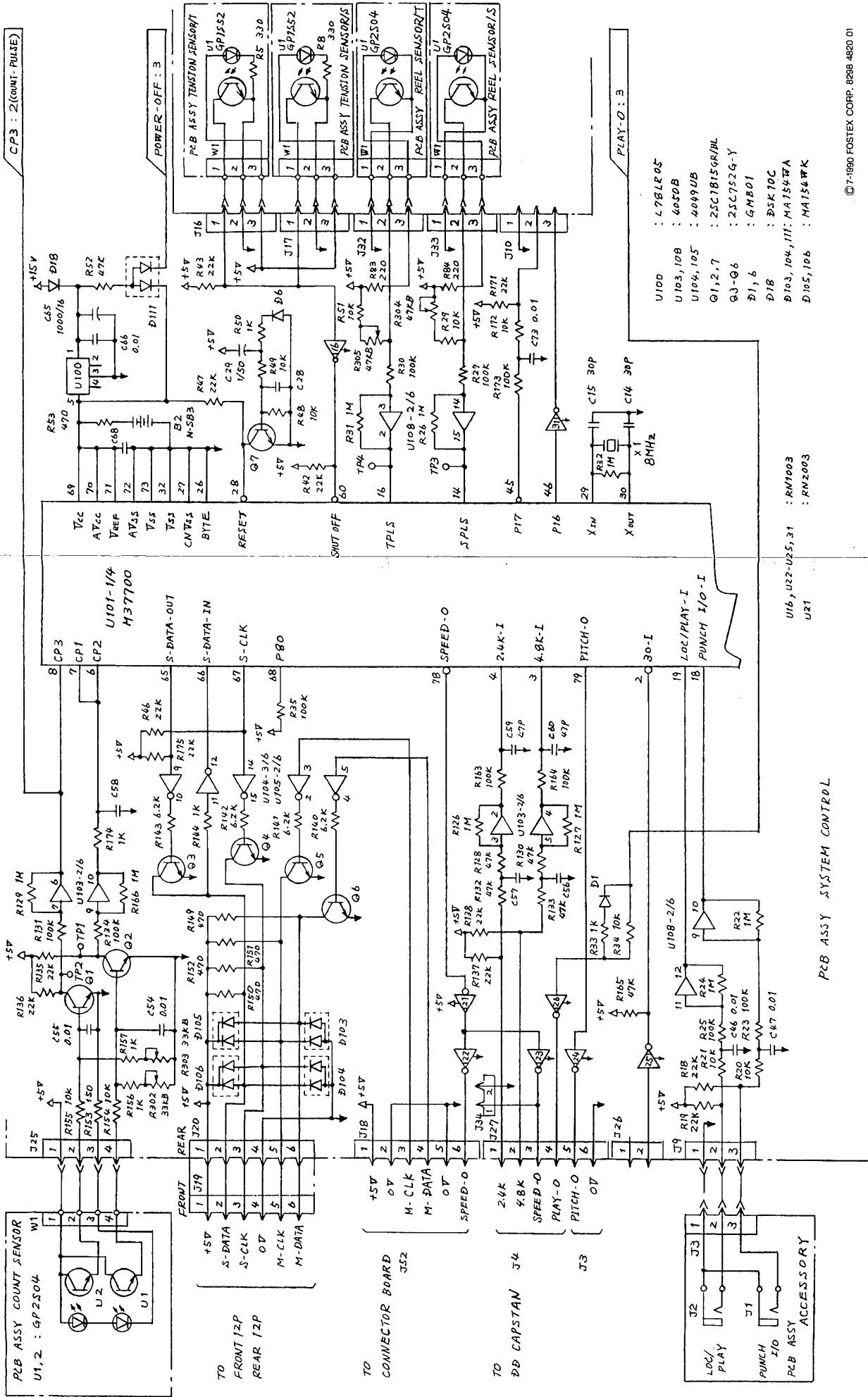

U100 : 74LS05
 U103, 10B : 4050B
 U104, 105 : 4049UB
 Q1, 2, 7 : 2SC1815GR/BL
 Q3-Q6 : 2SC752G-Y
 D1, 6 : GMB01
 D7B : 2SK70C
 D103, 104, 111: MA154WA
 D105, 106 : MA154WK

U16, U22-U25, 31 : RM1003
 U27 : RM2003

P/B ASSY SYSTEM CONTROL

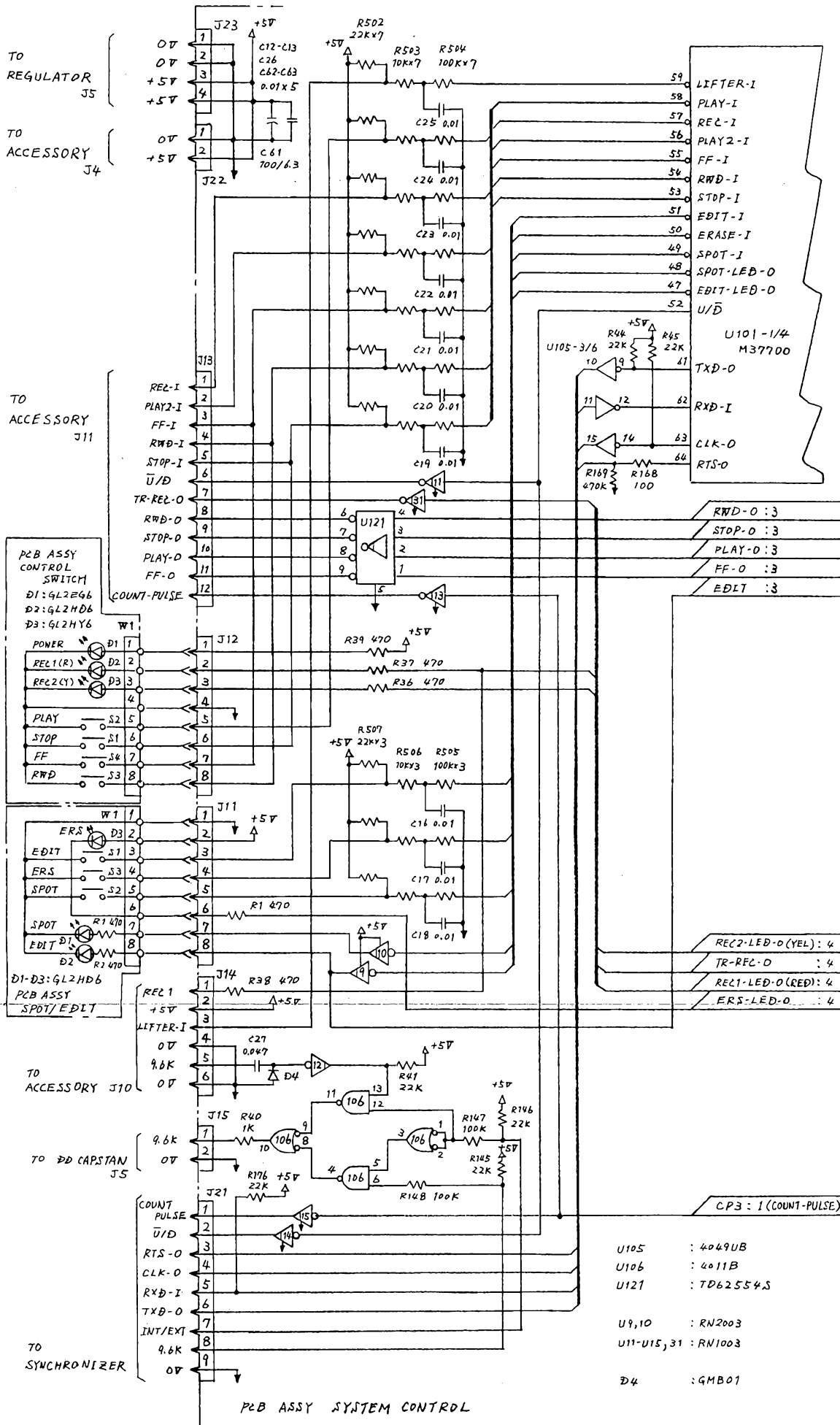

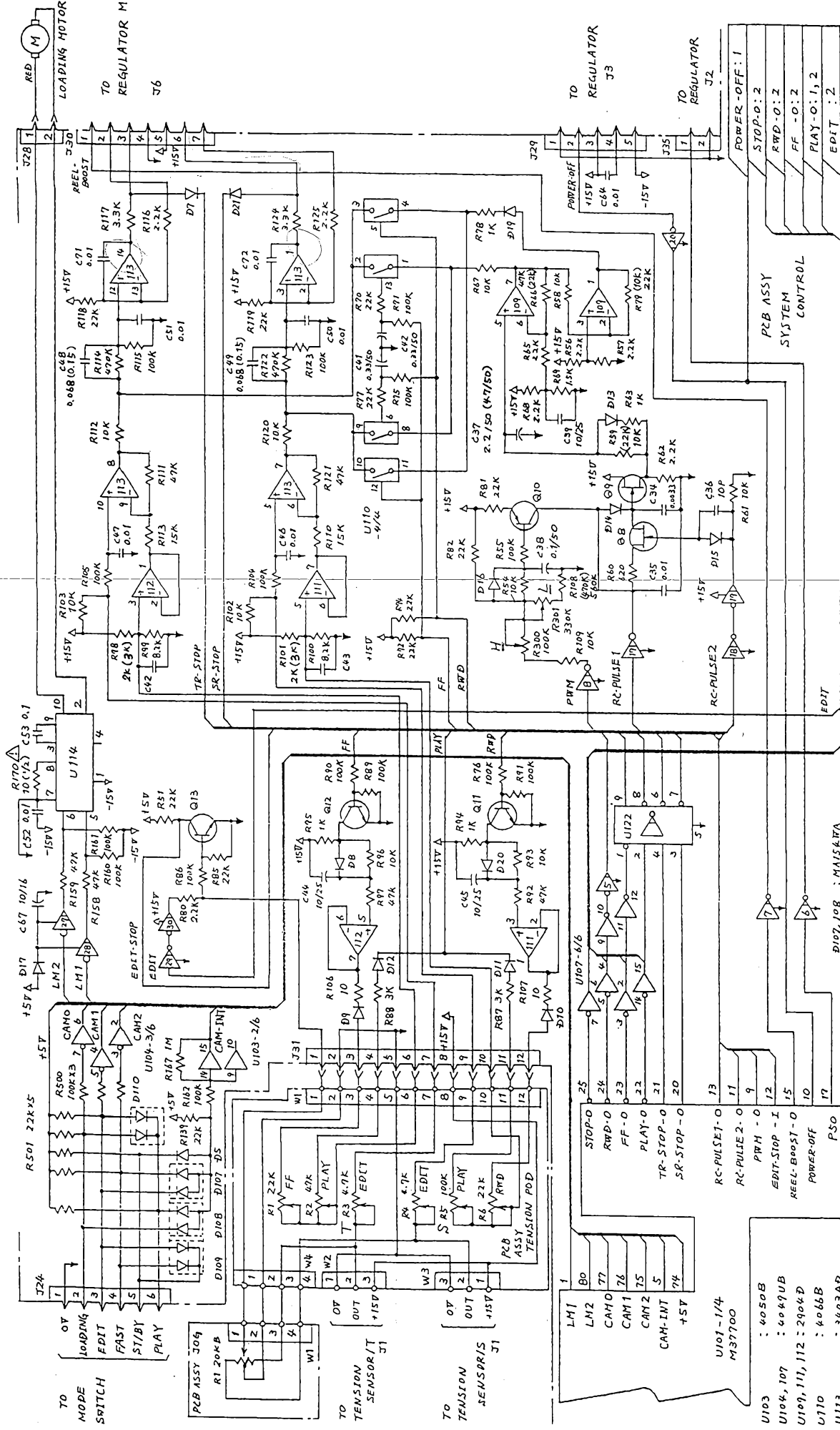

NOTE: () IN G24S

D107, 108 : MA15KTA
D109, 110 : MA15KWK

- U103 : 4050B
- U104, 107 : 4069UB
- U109, 111, 112 : 2904D
- U110 : 4066B
- U113 : 3603AD
- U114 : LB165N
- U122 : 70425545
- Q8, 9 : 25K1174R
- Q10 : 25A1015GR
- Q11-Q13 : 25C1B15GRBL
- U5, 6, 20 : RN1004
- U7, 8, 17, 18, 29 : RN1003
- U19, 21, 28 : RN2003
- U30 : RN2004
- D5, D7-D16, D19-D21 : 4M801
- D17 : DSX10C

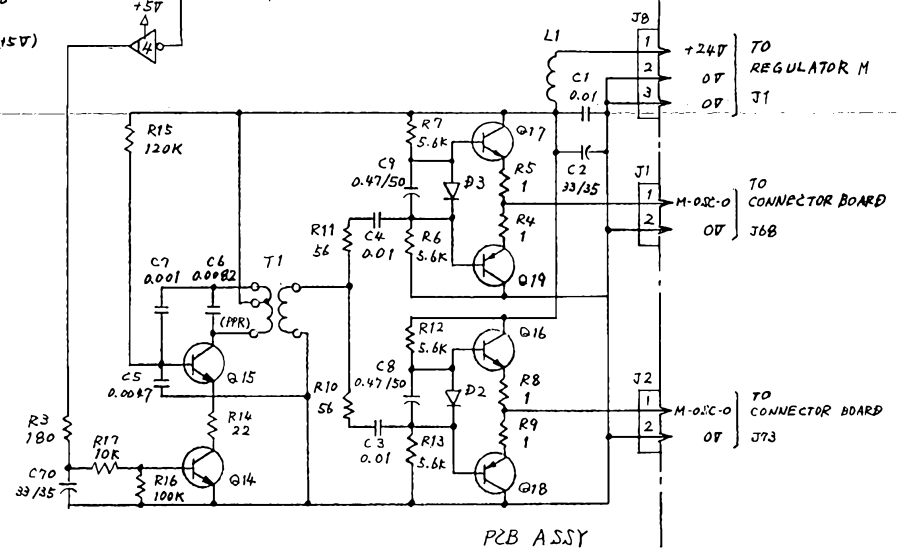
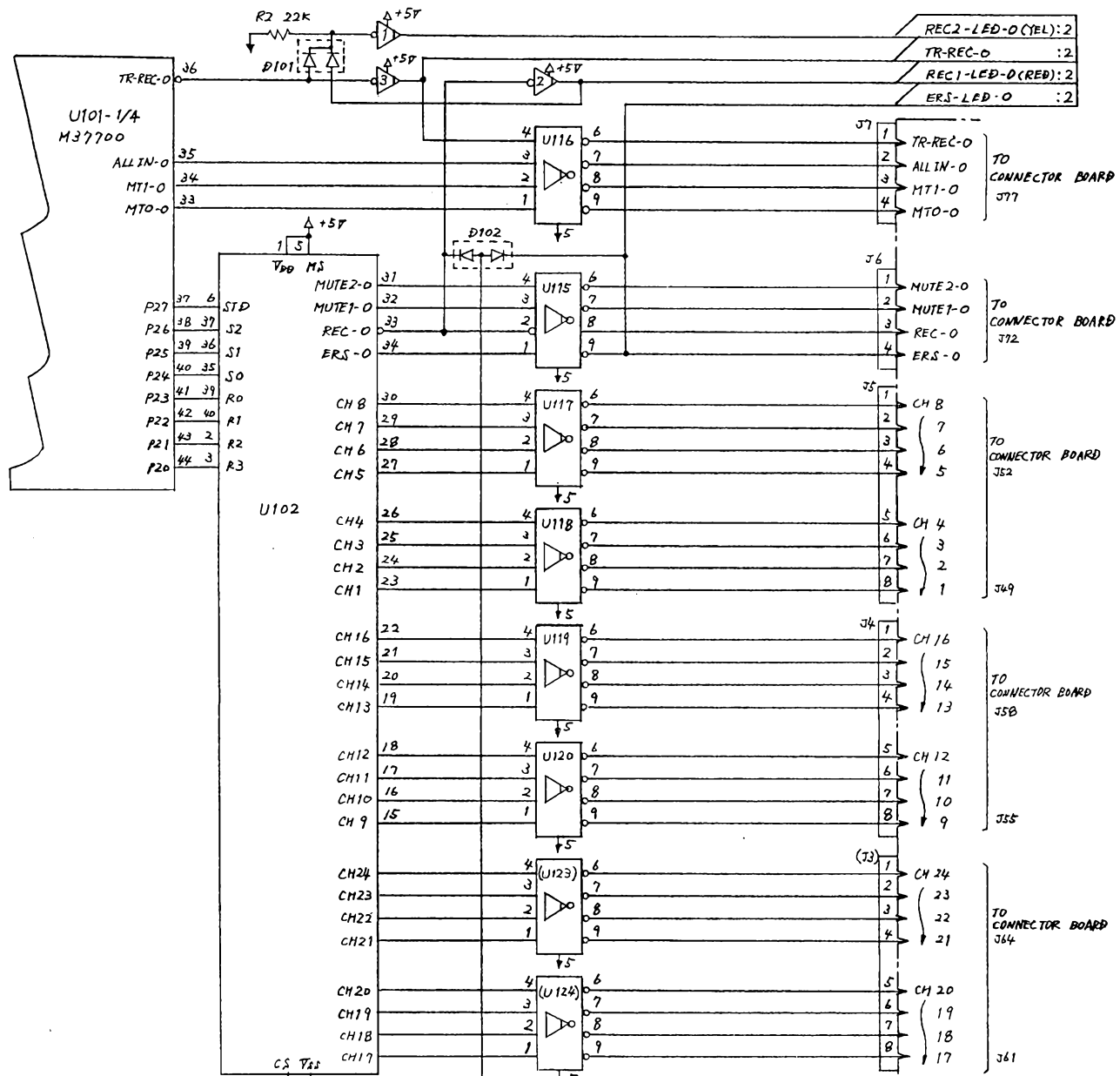

© 3-1991 FOSTEX CORP. 8298 5000 04

- U102 : MS0782AP
- U115~U120 : TD62554S (U123~U124)
- U1~U2, U4 : RN2003
- U3 : RN2004
- Q14, 15 : 2SC1815BL
- Q16, 17 : 2SC2655Y
- Q18, 19 : 2SA102DY
- D101 : MA154WK
- D102 : MA154WA
- D2, 3 : GMB01

NOTE: () IN G24S

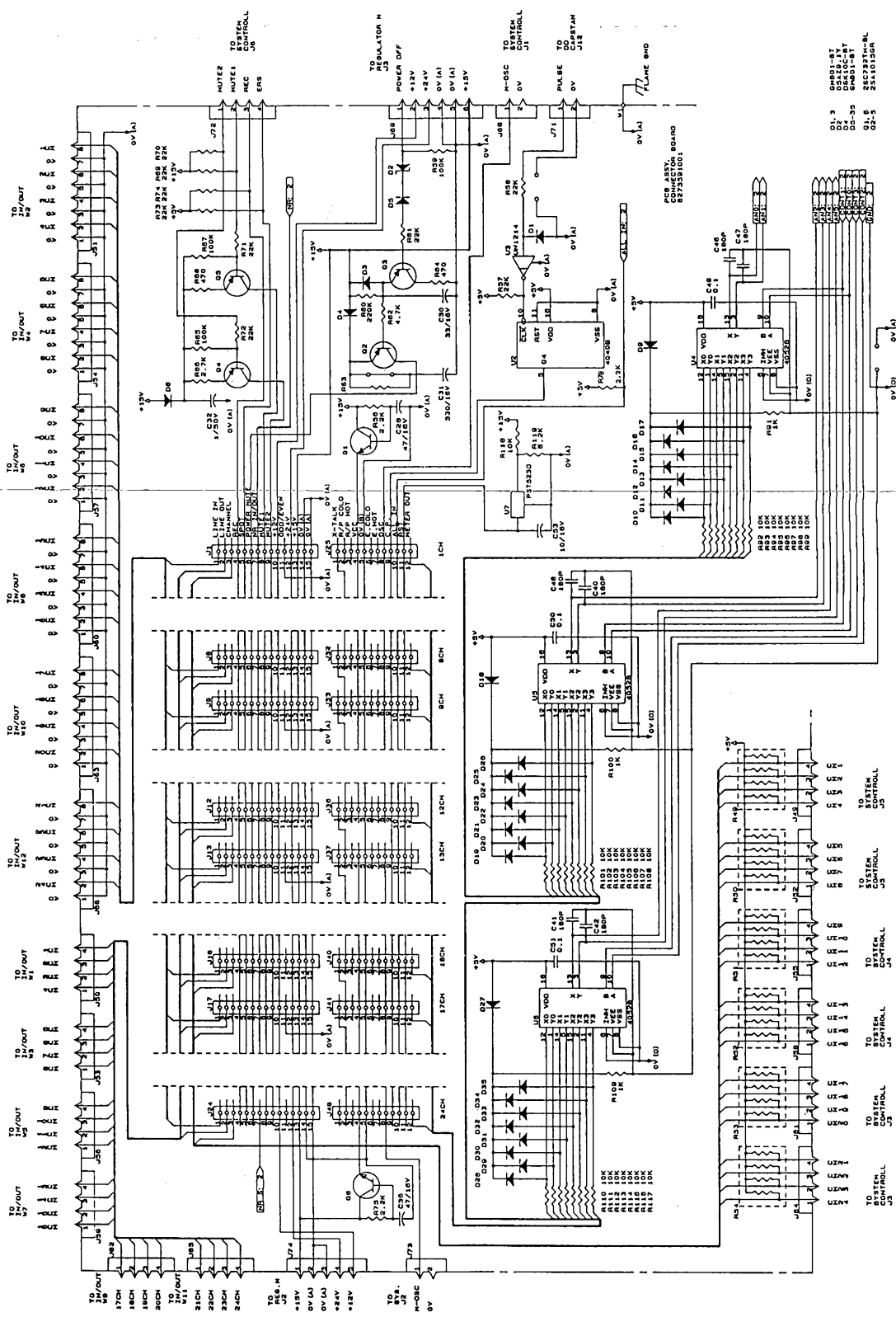

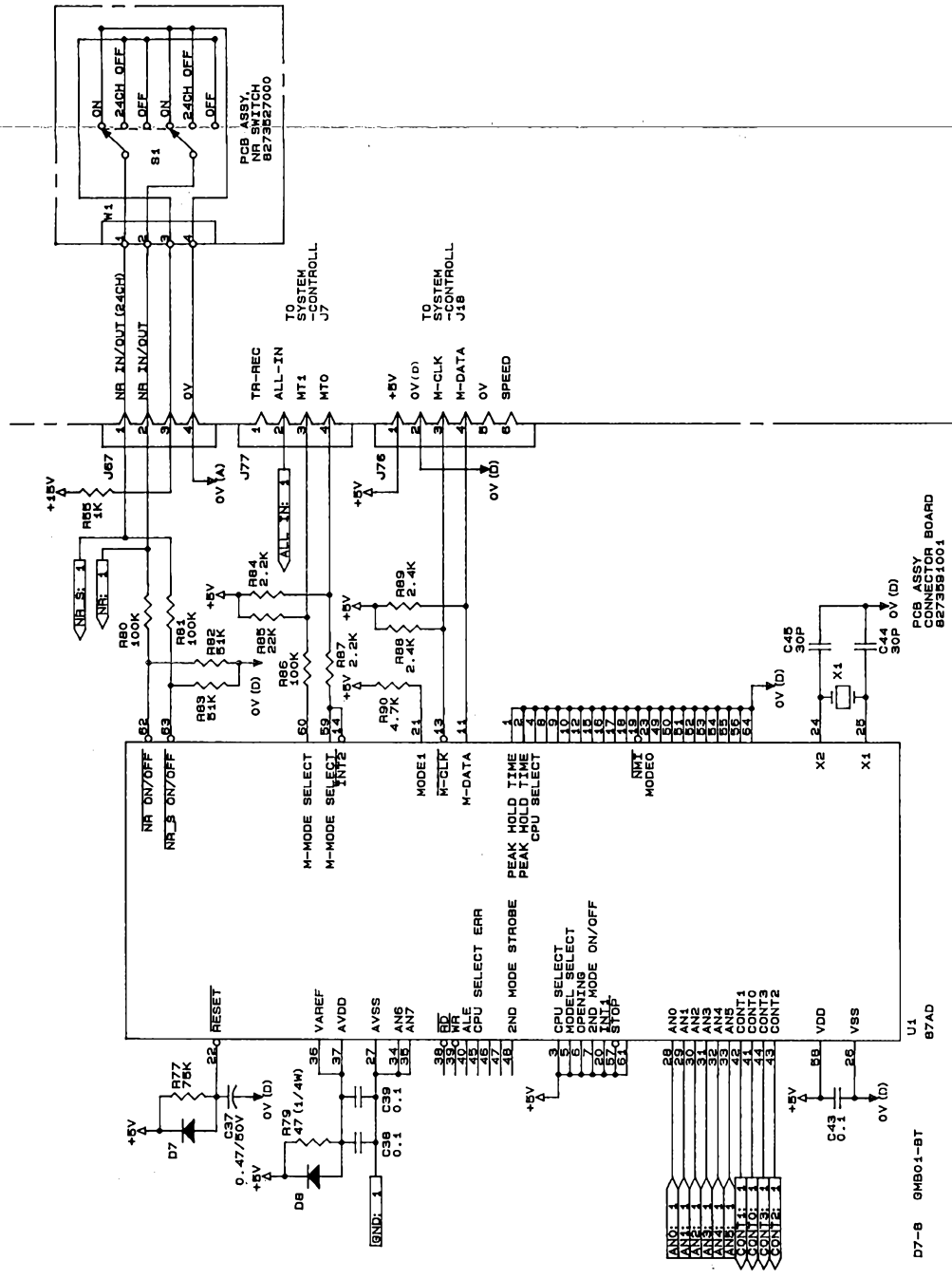

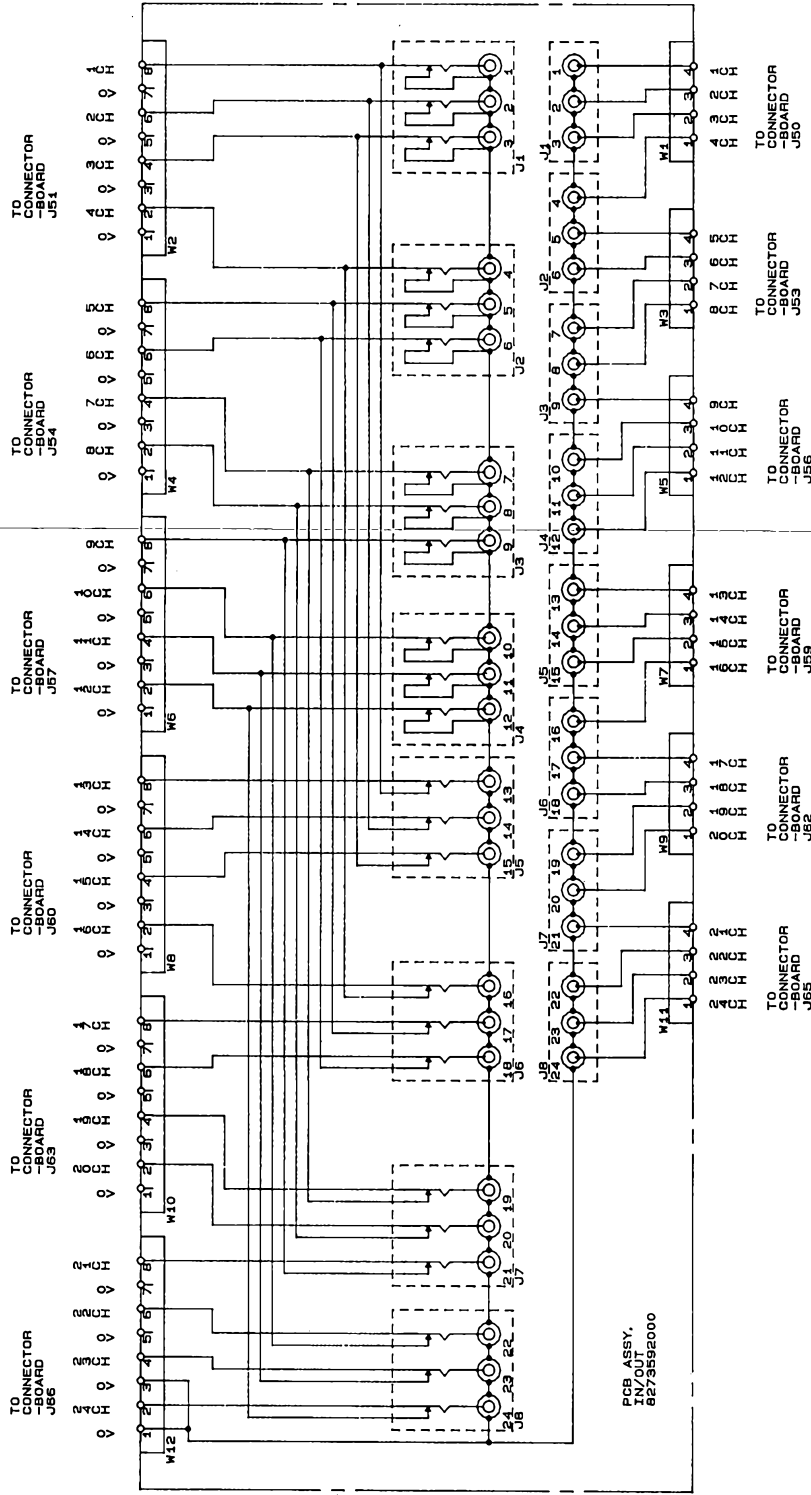

© 3-1991 FOSTEX CORP. 8238-5060 00

POWER SUPPLY, G24S

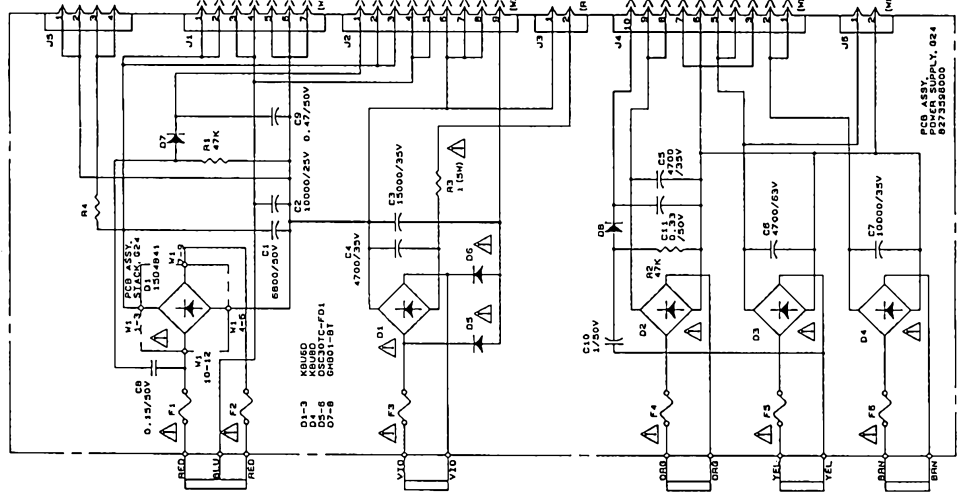

77

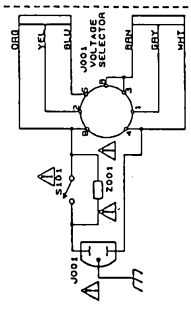

	PCB ASSY, 150-941	REV. 024	6375338000
F1	RA	16.3A	
F2	RA	16.3A	
F3	4A	1.4A	
F4	4A	1.4A	
F5	2A	1.2A	
F6	4A	1.4A	

77

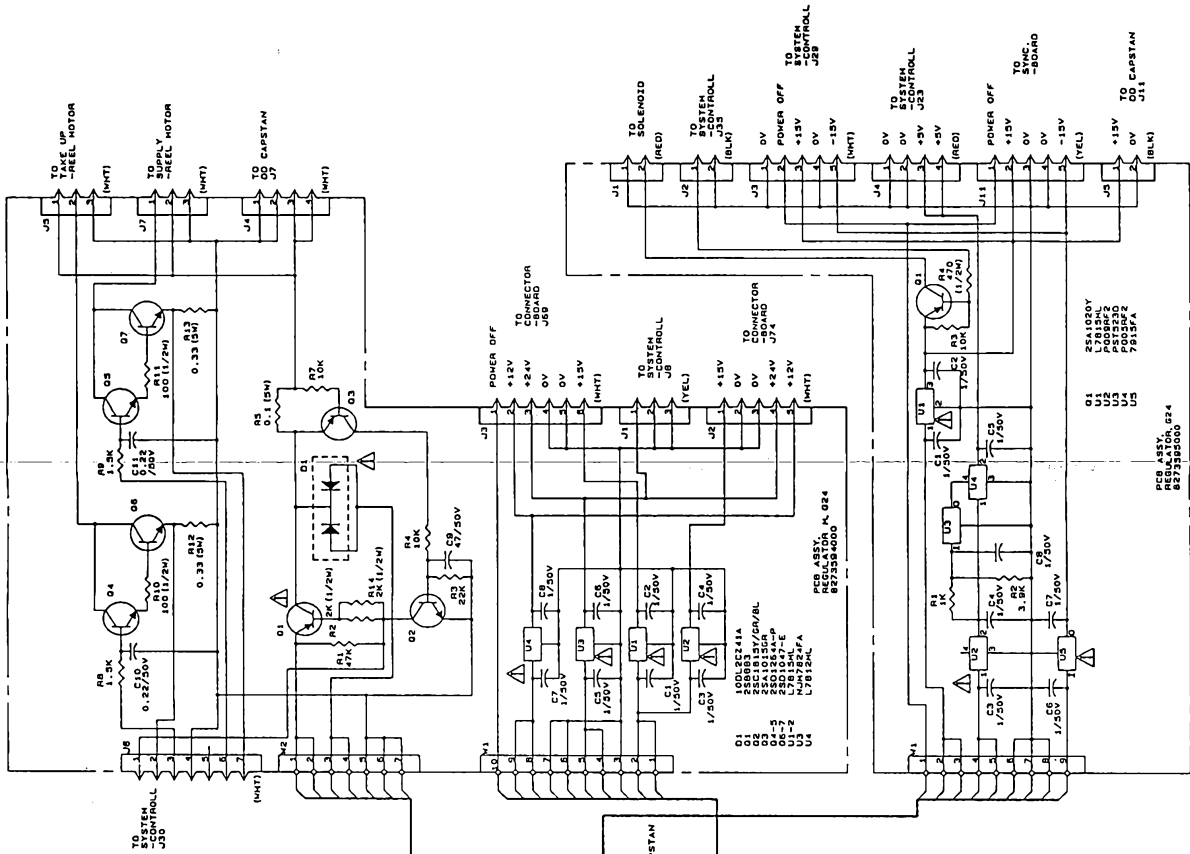

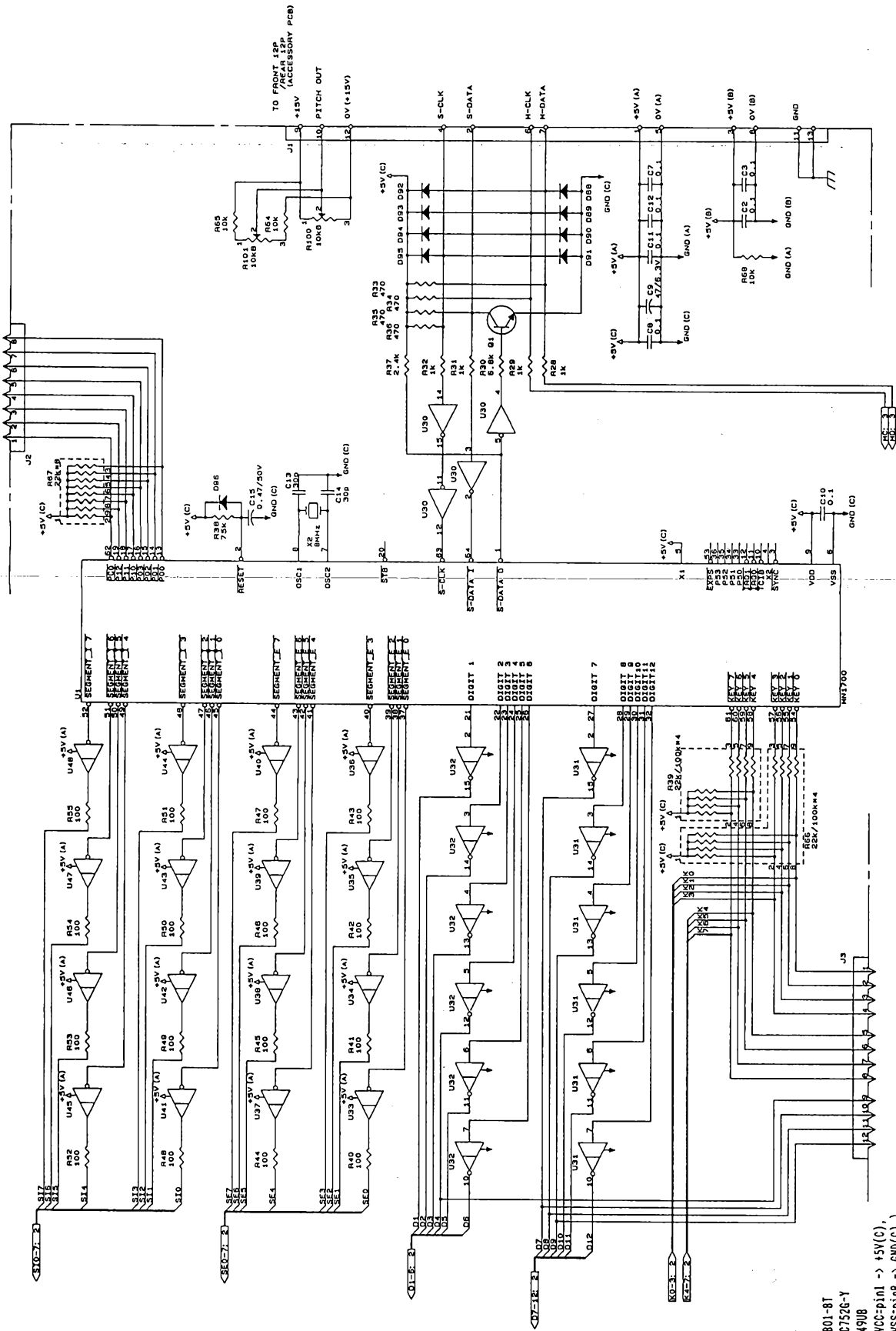

- D88-96
- 01
- U30
- U31-32
- U33-48
- GH801-8T
- ZSC7526-Y
- 4049UB
- (VCC-pin1 -> +5V(C),
VSS-pin8 -> GND(C))
- T062309P
- (VCC-pin16 -> +5V(A),
GND-pin8 -> GND(A))
- UM1111

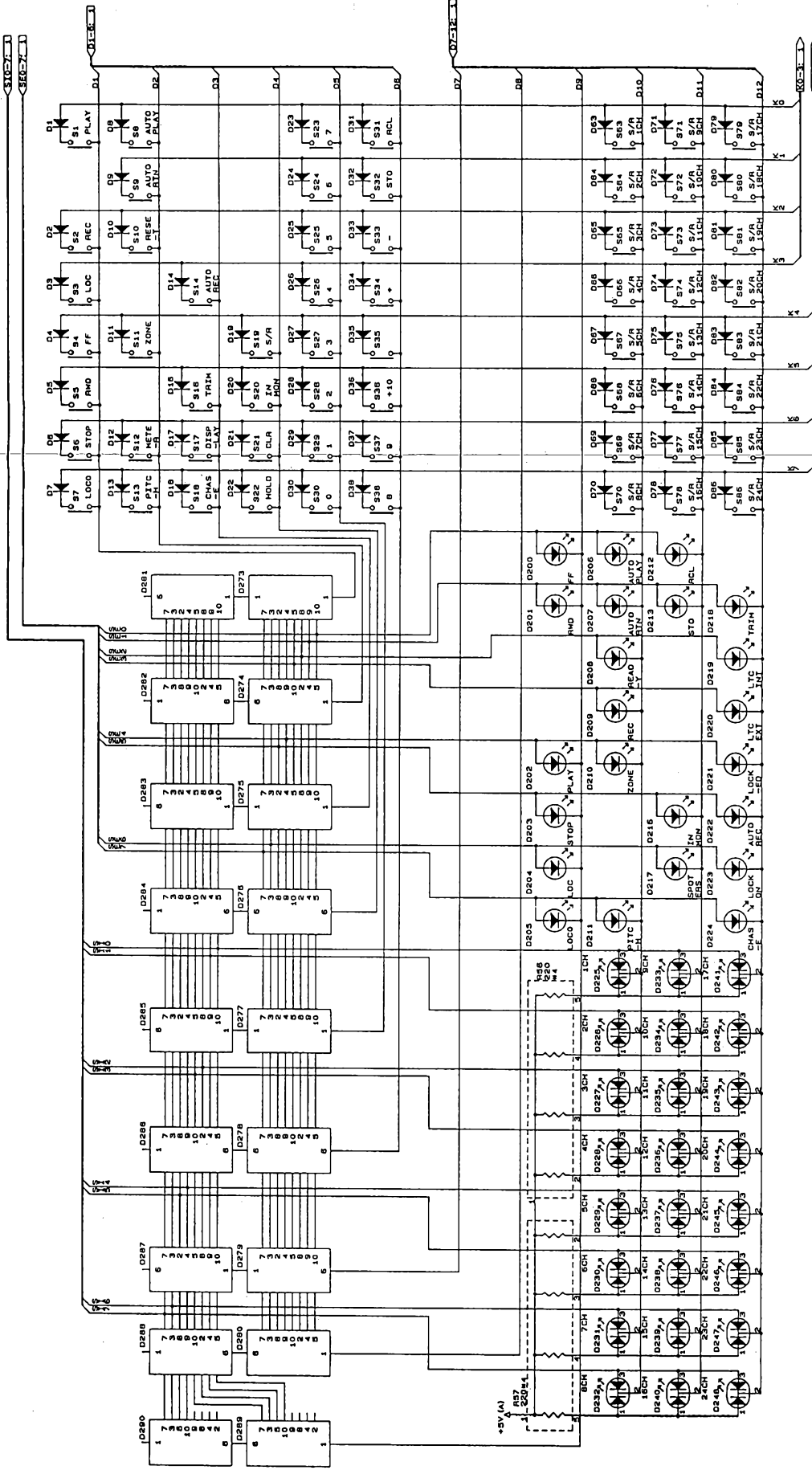

- D1-14, 16-38, 64-79 GM801-R1
- D200-207, 219-221 GL2EG6
- D209-213, 216-218, 222-223 GL2HD6
- D208, 224 GL2HY6
- D225-248 GL3ED8
- D273-290 GL80040 (pin1, 6-COMMON)

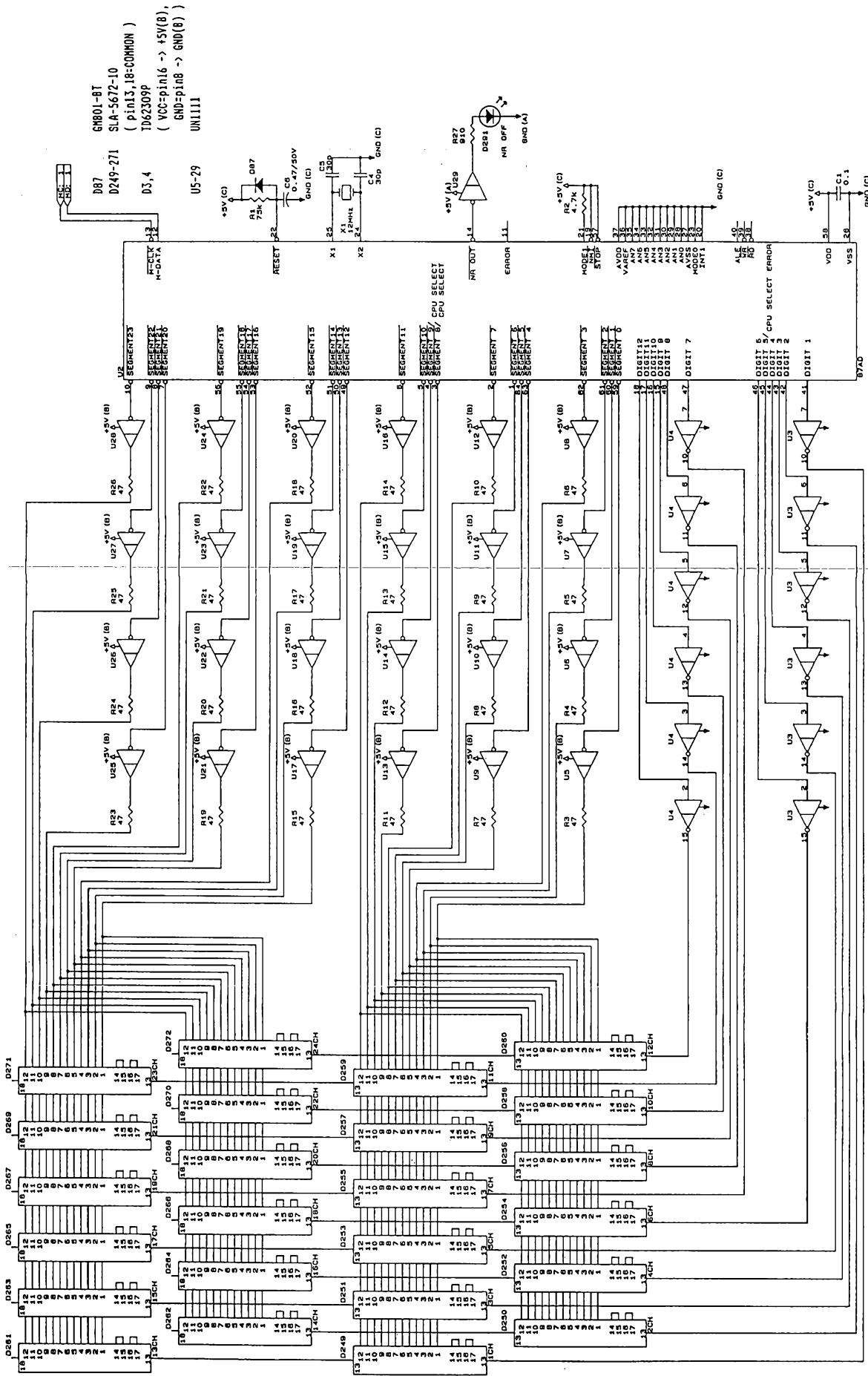

GM801-BT
SLA-5672-10
(pin13,18-COMMON)
TD62309P
(VCC-pin16 -> +5V(B),
GND-pin8 -> GND(B))
UN11111

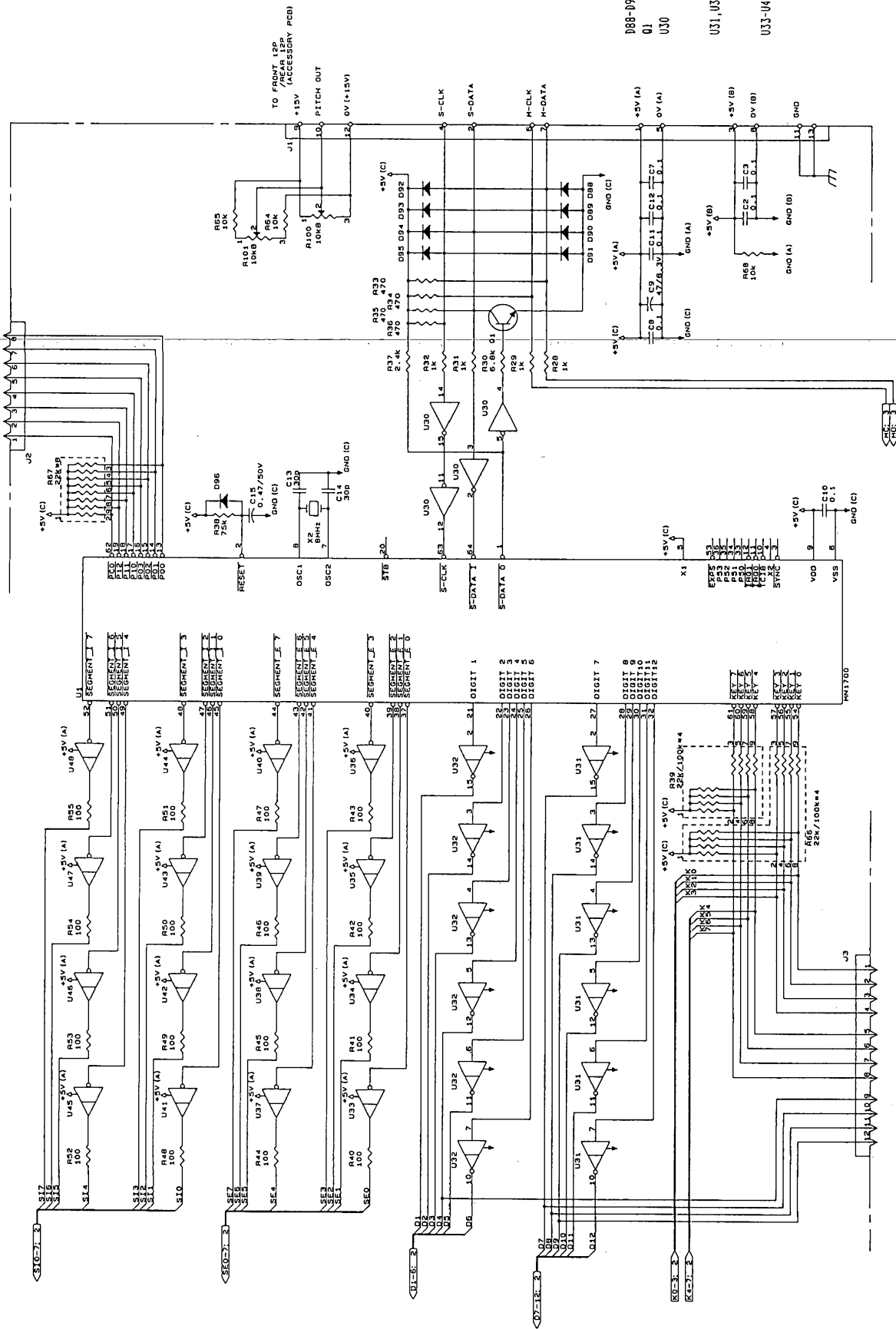

GM801-BT
2SC7520-Y
4049UB
(VCC-pin18 -> +5V(C),
VSS-pin18 -> GND(C))
T062309P
(VCC-pin16 -> +5V(A),
GND-pin18 -> GND(A))
UN1111

D88-D96
01
U30
U31, U32
U33-U48

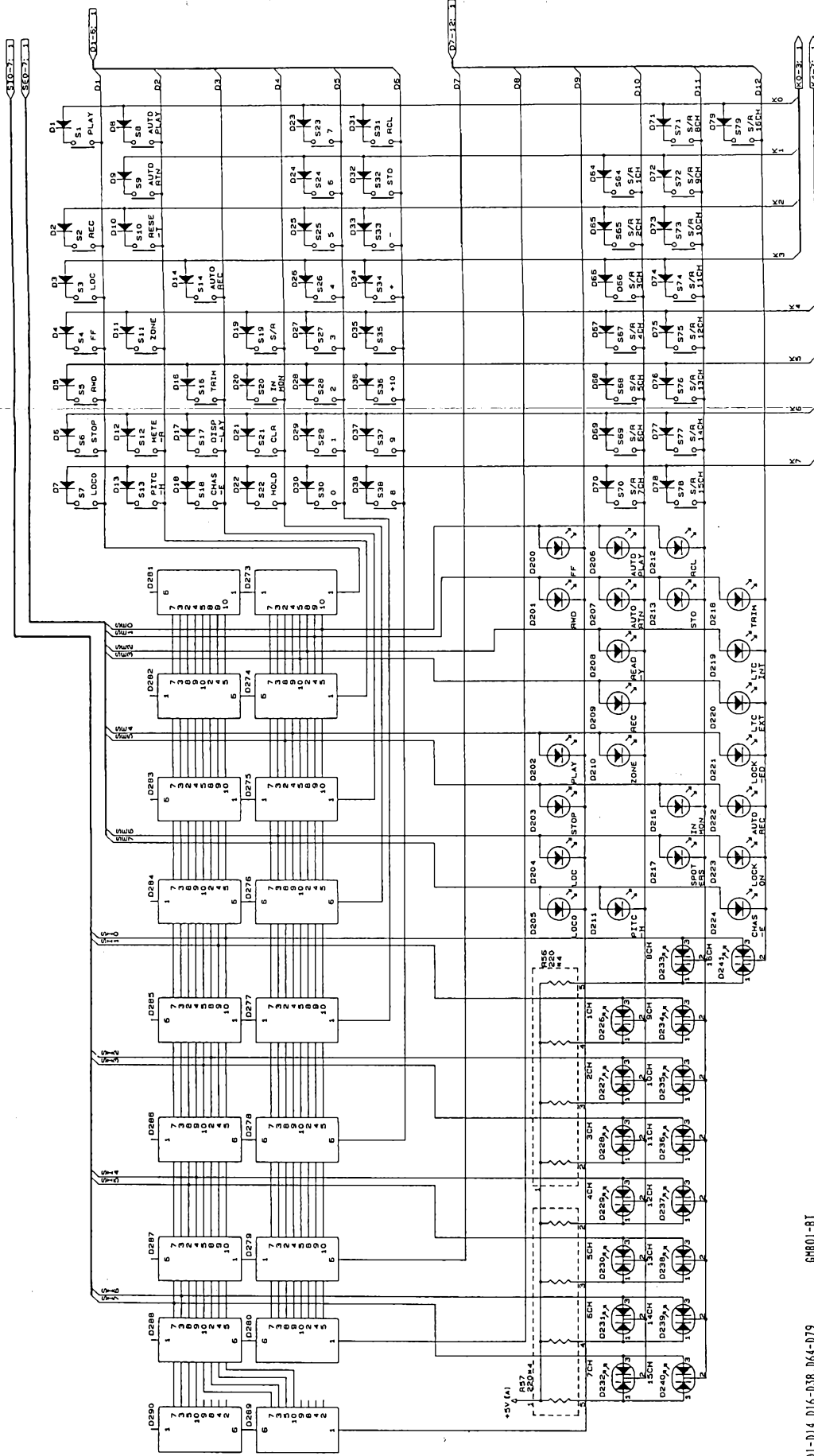

- D1-D14, D16-D38, D64-D79 CH801-8T
- D200-D207, D219-D221 6L2E66
- D209-D213, D216-D218, D227-D223 6L2H06
- D208, D224 6L2HY6
- D226-D241 6L3E08
- D273-D290 6L80040 (pin1, pin6-COMMON)

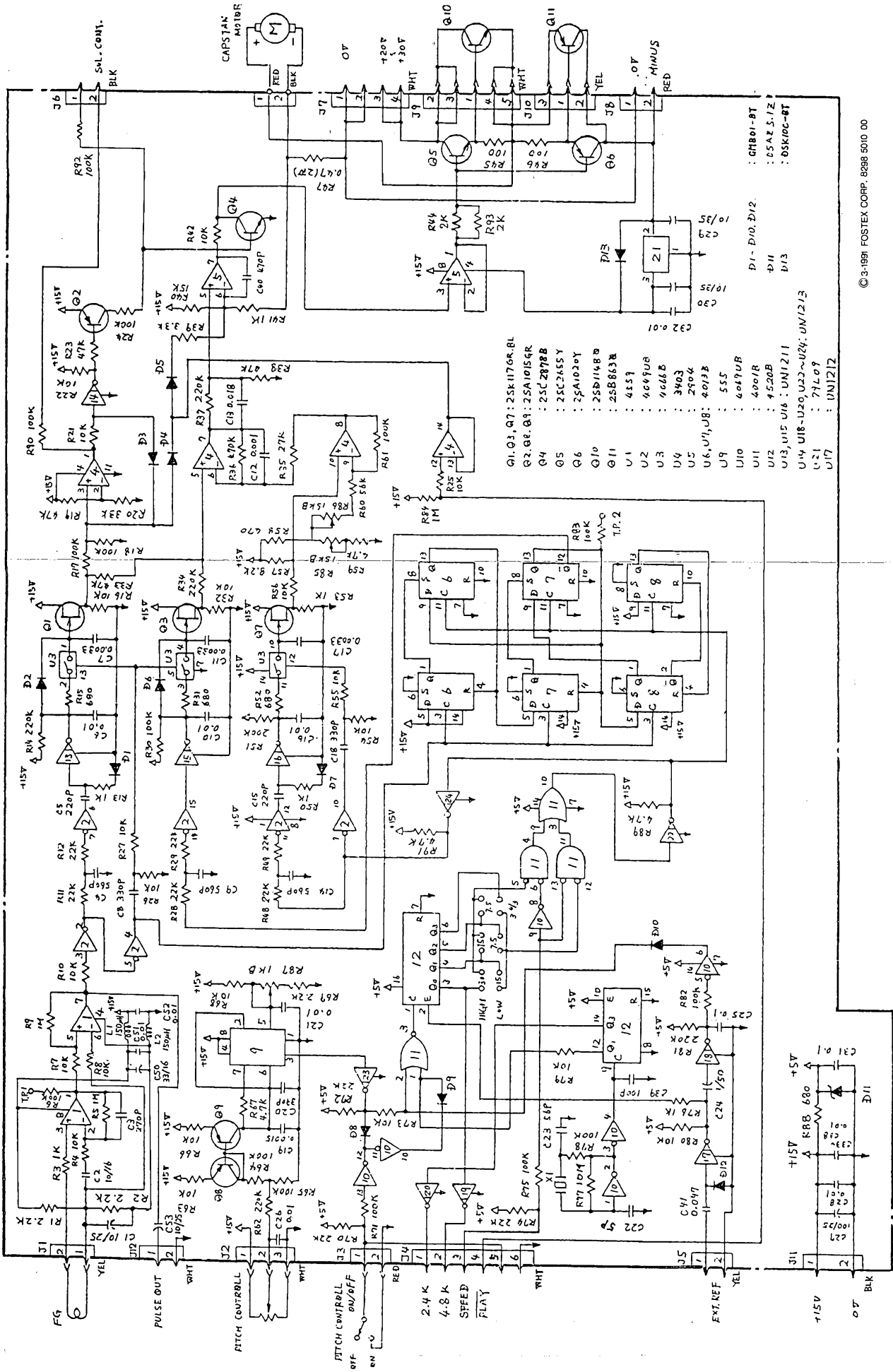

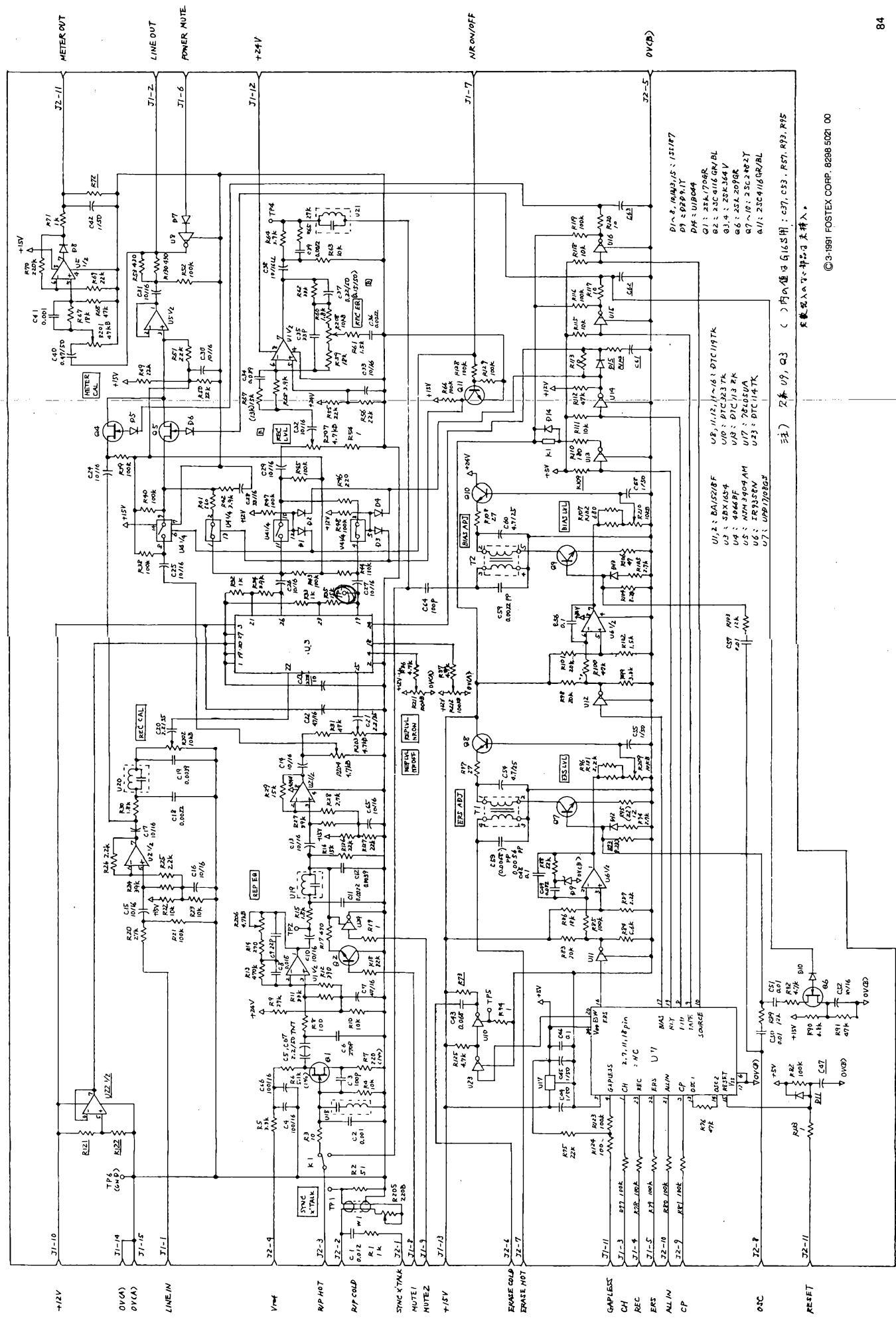

D1: 10A10/1.5 : 1521P7
 D2: 2929 K11
 D3: 25K179BR
 D4: 25C416 GN/BL
 D5: 25K364V
 D6: 252 207GR
 D7~10: 25C2402J
 D11: 25C416GR/BL

U1: 2. BA1528F
 U2: 58X1634
 U3: 4044BF
 U4: 20M3904AM
 U5: 2835SRV
 U6: 2835SRV
 U7: 2835SRV
 U8: 1121/1-61 DTC117K
 U9: 1121/1-61 DTC117K
 U10: 1121/1-61 DTC117K
 U11: 2835SRV
 U12: 2835SRV
 U13: 2835SRV
 U14: 2835SRV
 U15: 2835SRV
 U16: 2835SRV
 U17: 2835SRV
 U18: 2835SRV
 U19: 2835SRV
 U20: 2835SRV
 U21: 2835SRV
 U22: 2835SRV
 U23: 2835SRV
 U24: 2835SRV
 U25: 2835SRV
 U26: 2835SRV
 U27: 2835SRV
 U28: 2835SRV
 U29: 2835SRV
 U30: 2835SRV
 U31: 2835SRV
 U32: 2835SRV
 U33: 2835SRV
 U34: 2835SRV
 U35: 2835SRV
 U36: 2835SRV
 U37: 2835SRV
 U38: 2835SRV
 U39: 2835SRV
 U40: 2835SRV
 U41: 2835SRV
 U42: 2835SRV
 U43: 2835SRV
 U44: 2835SRV
 U45: 2835SRV
 U46: 2835SRV
 U47: 2835SRV
 U48: 2835SRV
 U49: 2835SRV
 U50: 2835SRV
 U51: 2835SRV
 U52: 2835SRV
 U53: 2835SRV
 U54: 2835SRV
 U55: 2835SRV
 U56: 2835SRV
 U57: 2835SRV
 U58: 2835SRV
 U59: 2835SRV
 U60: 2835SRV
 U61: 2835SRV
 U62: 2835SRV
 U63: 2835SRV
 U64: 2835SRV
 U65: 2835SRV
 U66: 2835SRV
 U67: 2835SRV
 U68: 2835SRV
 U69: 2835SRV
 U70: 2835SRV
 U71: 2835SRV
 U72: 2835SRV
 U73: 2835SRV
 U74: 2835SRV
 U75: 2835SRV
 U76: 2835SRV
 U77: 2835SRV
 U78: 2835SRV
 U79: 2835SRV
 U80: 2835SRV
 U81: 2835SRV
 U82: 2835SRV
 U83: 2835SRV
 U84: 2835SRV
 U85: 2835SRV
 U86: 2835SRV
 U87: 2835SRV
 U88: 2835SRV
 U89: 2835SRV
 U90: 2835SRV
 U91: 2835SRV
 U92: 2835SRV
 U93: 2835SRV
 U94: 2835SRV
 U95: 2835SRV
 U96: 2835SRV
 U97: 2835SRV
 U98: 2835SRV
 U99: 2835SRV
 U100: 2835SRV

注) 凡本图中 () 内之器件均用 G16S 用 : G27, C53, R57, R93, R95
 凡本图中 () 内之器件均用 G16S 用 : G27, C53, R57, R93, R95

© 1991 FOSTEX CORP. 8288 5021 00

HEAD TERMINAL, G24S

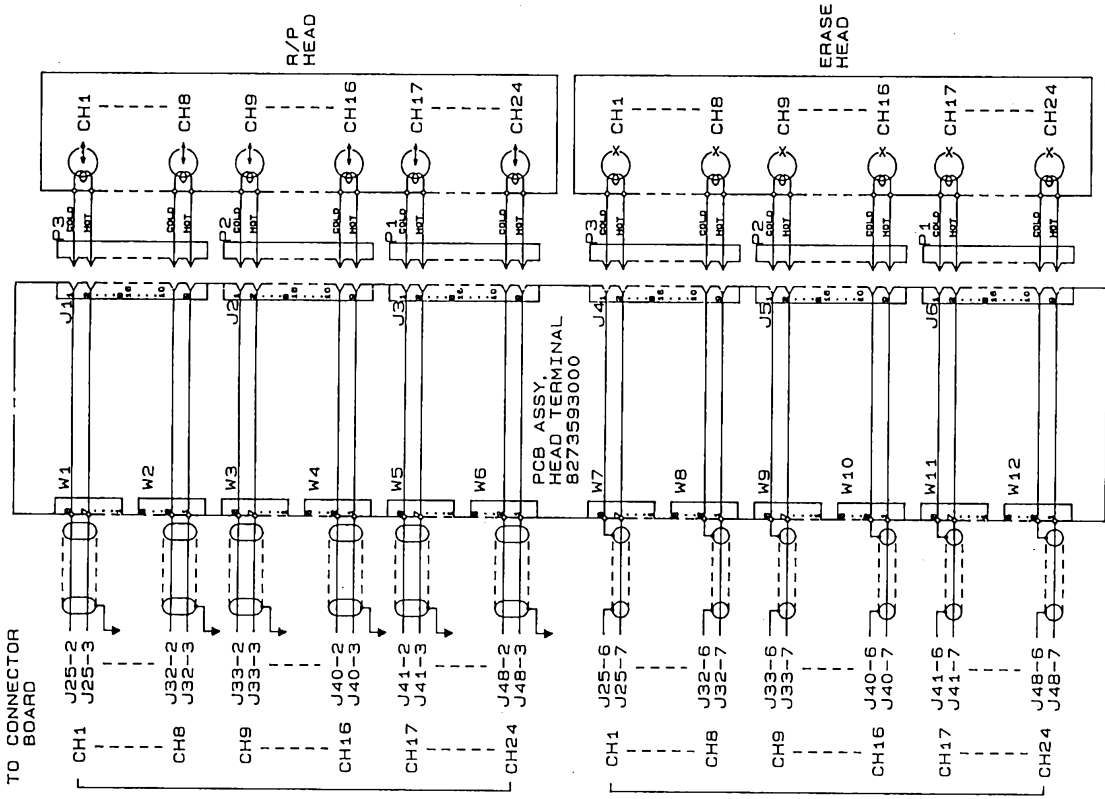

©1-1991 FOSTEX CORP. 8298 5040 00

TENSION SENSOR, G24S/G16S

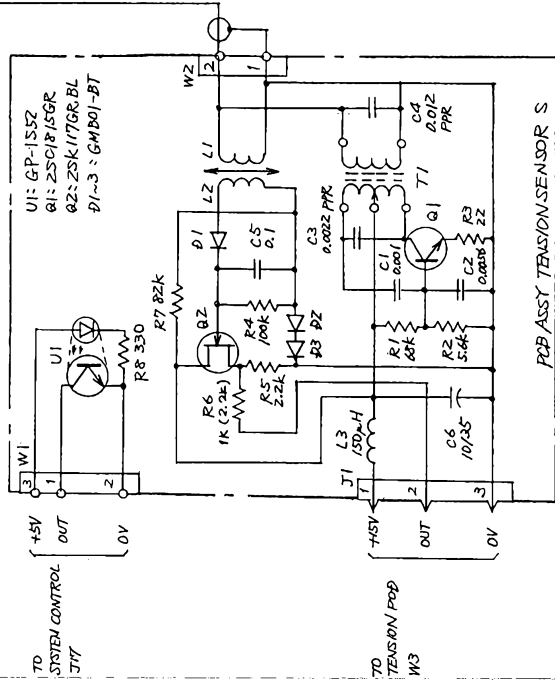
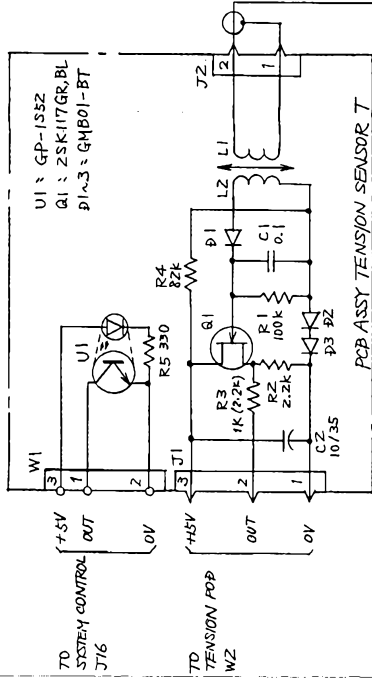

NOTE: () PARTS Q24.S

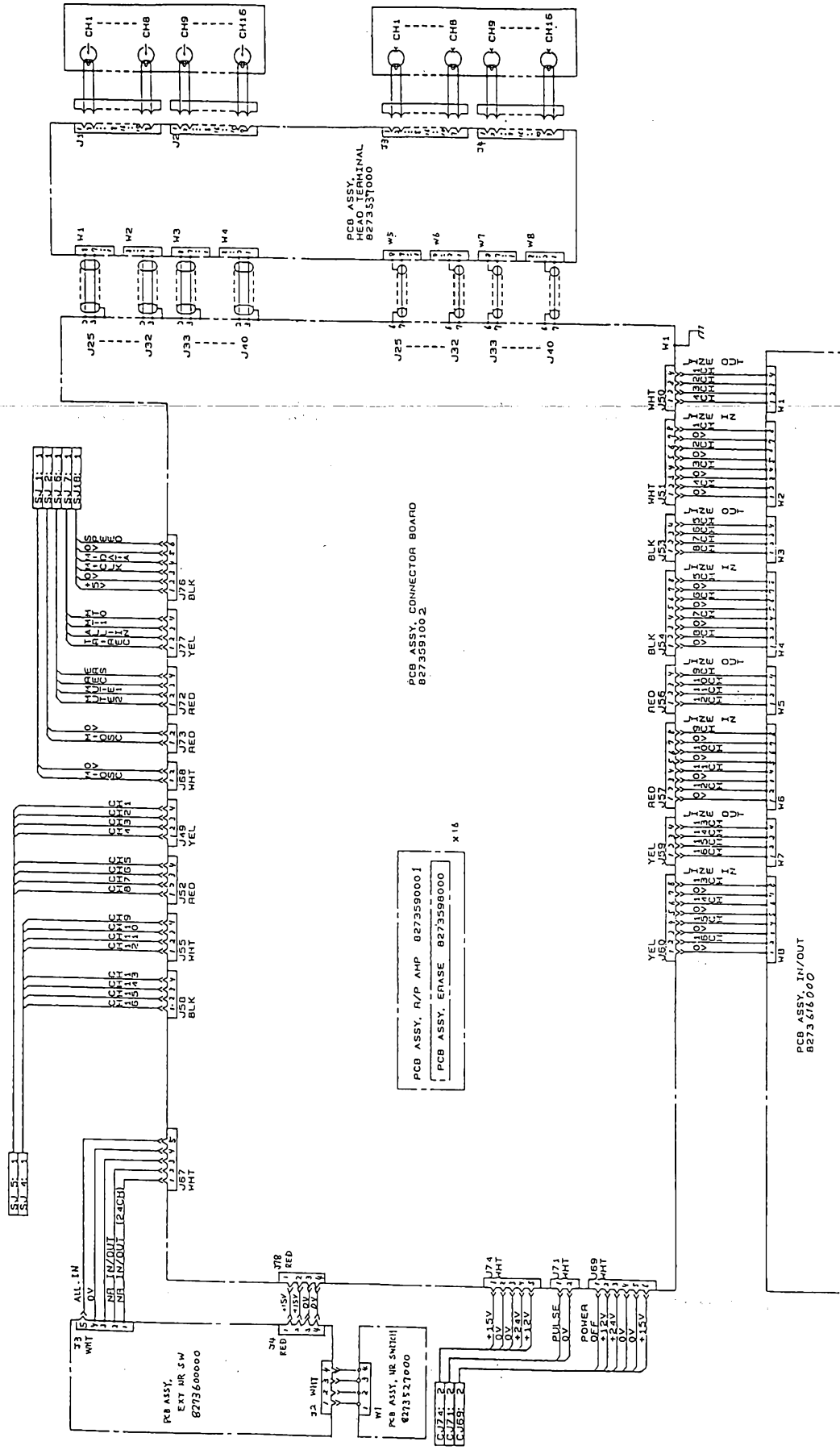

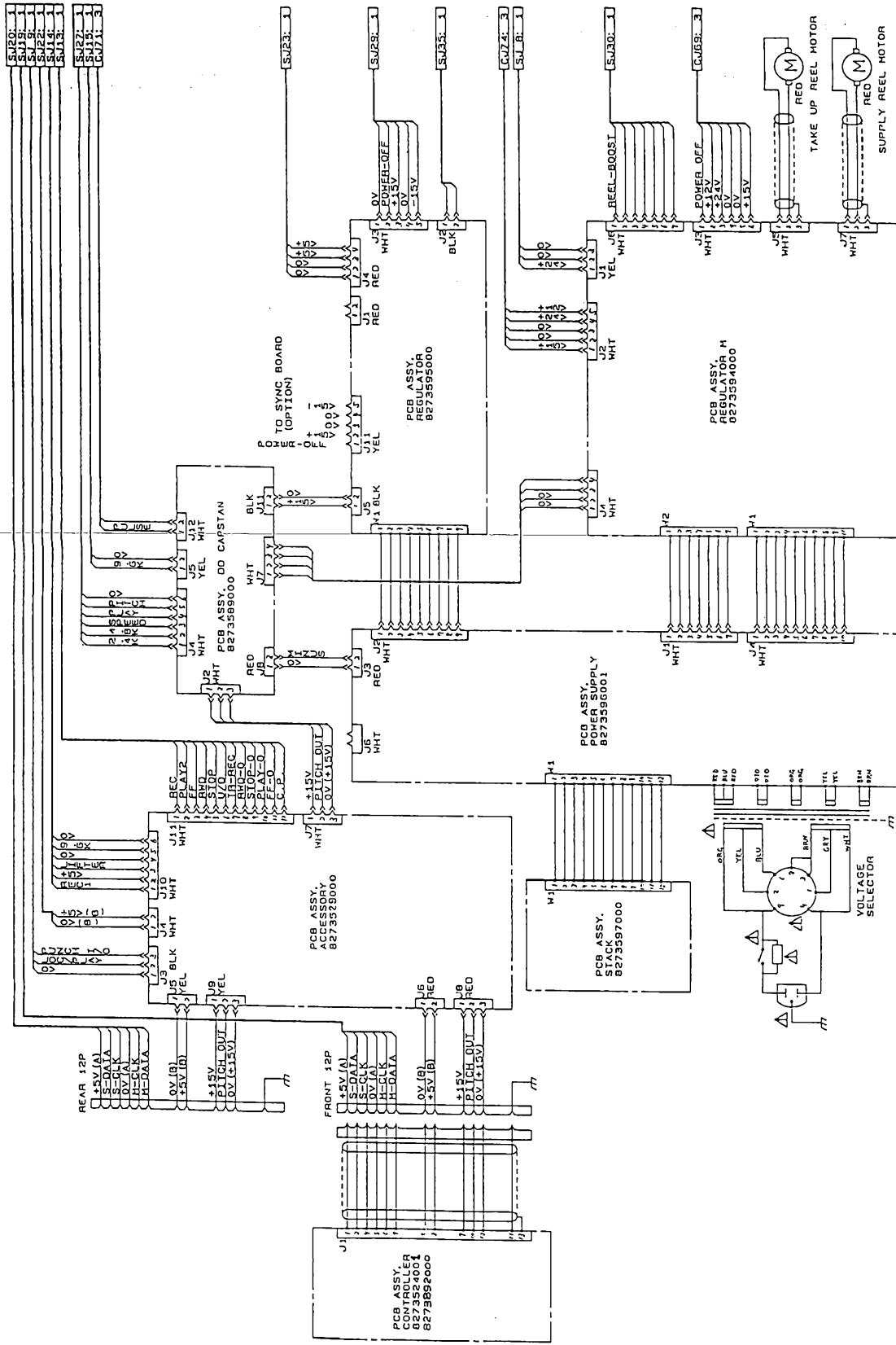

© 3-1991 FOSTEX CORP. 8298 5160 02

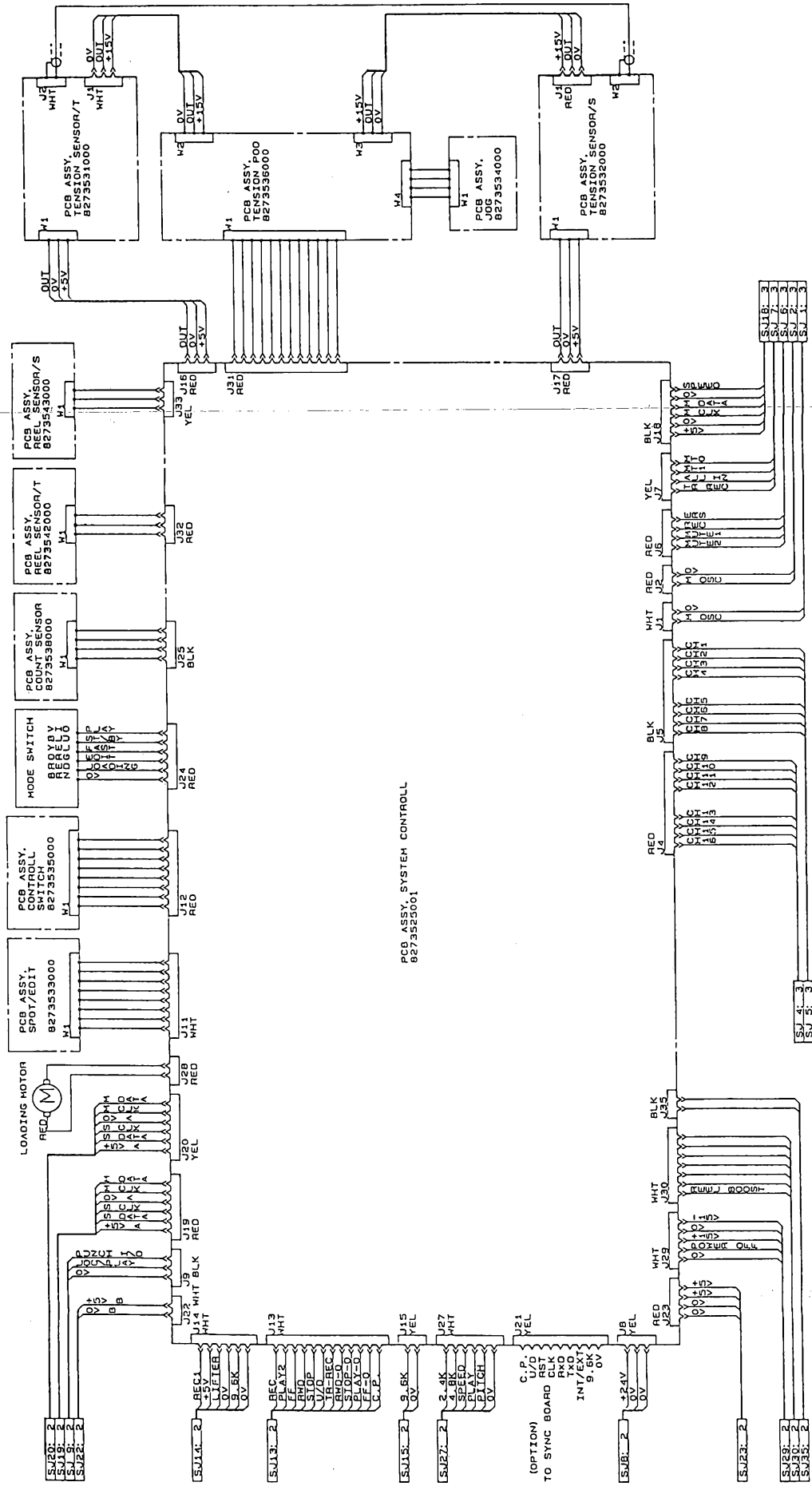

CONNECTOR BOARD, G16S 1/2

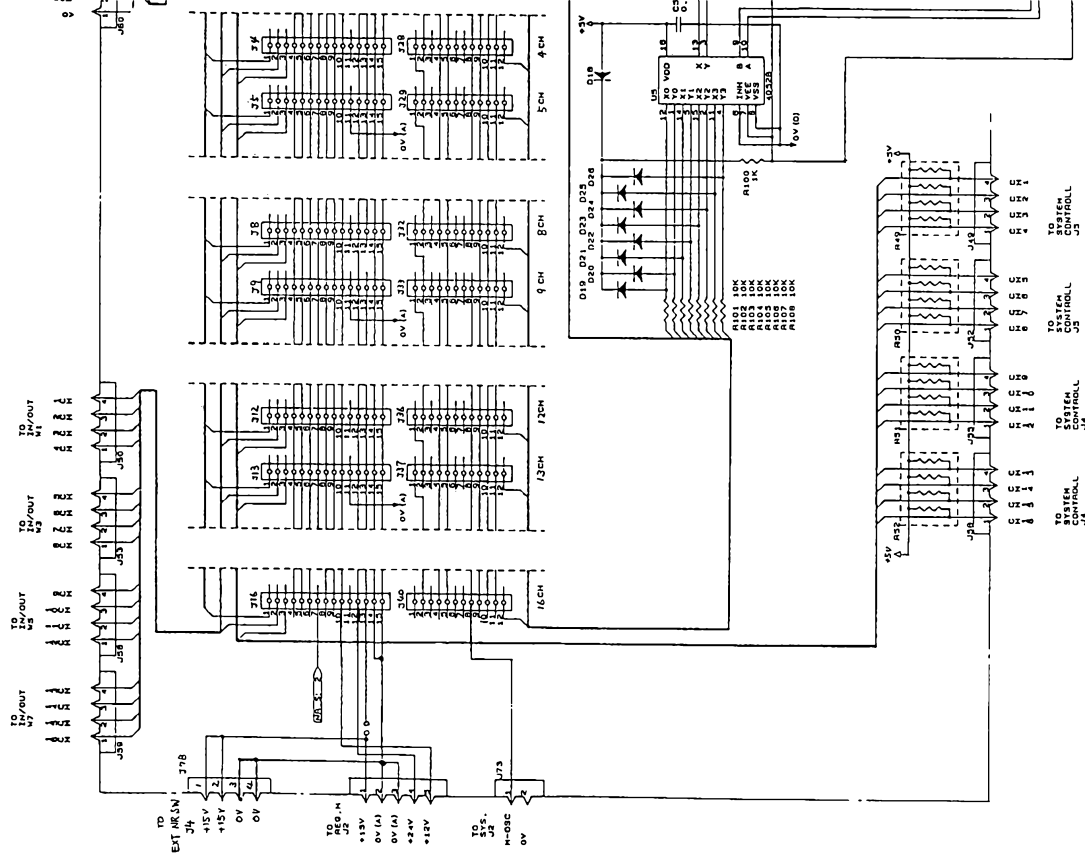

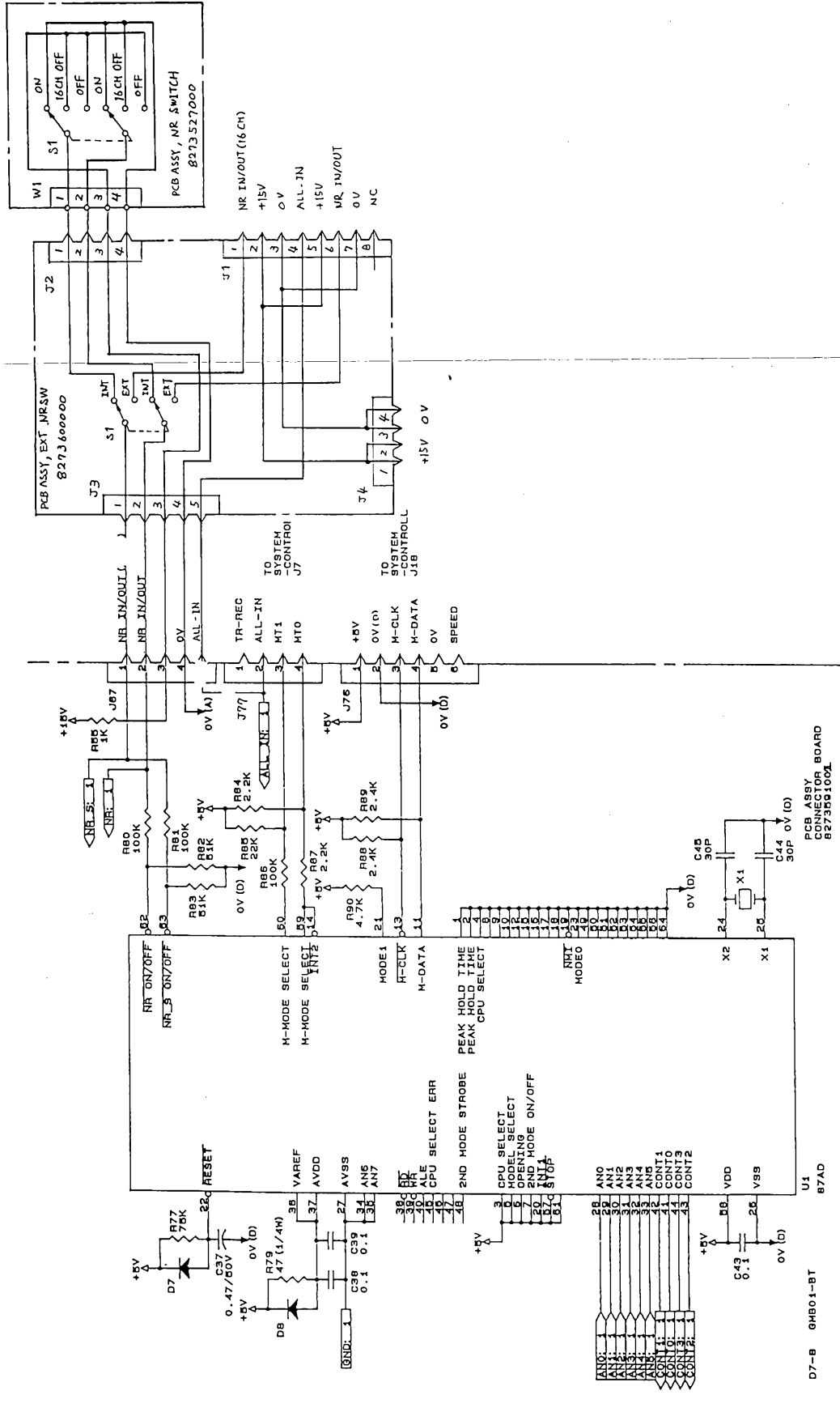

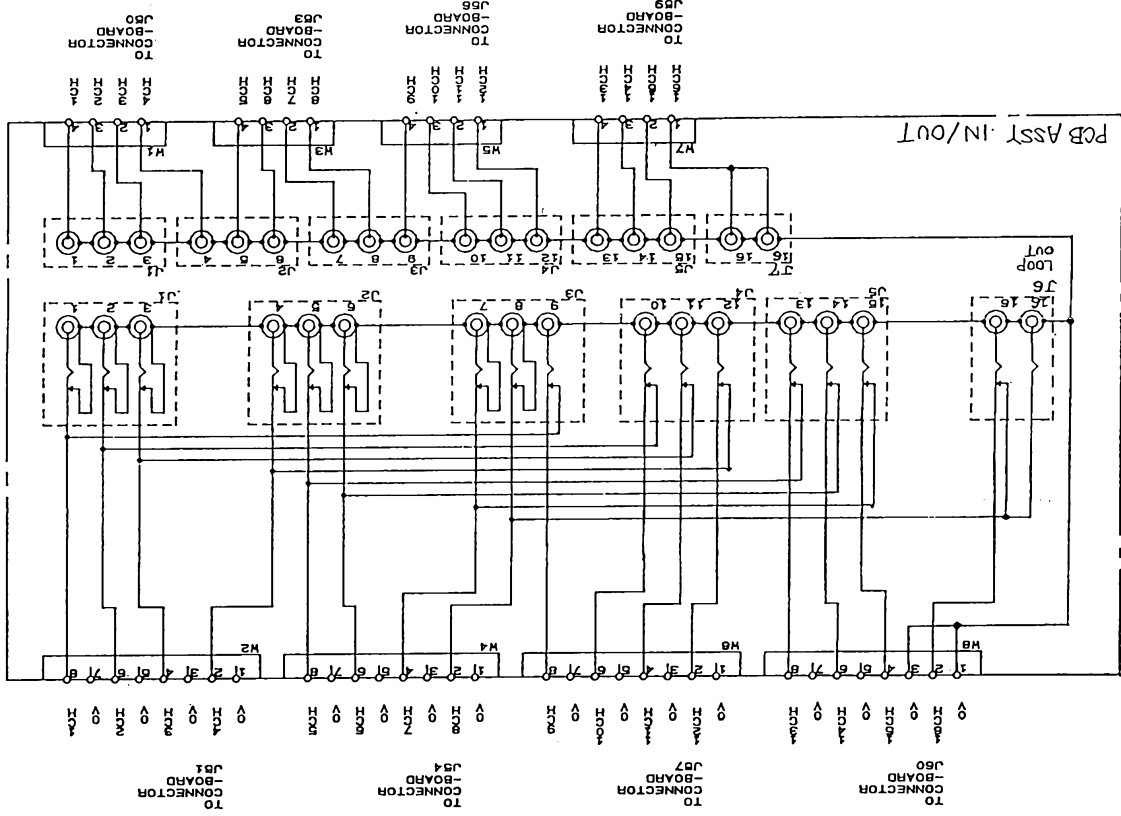

HEAD TERMINAL, G16S

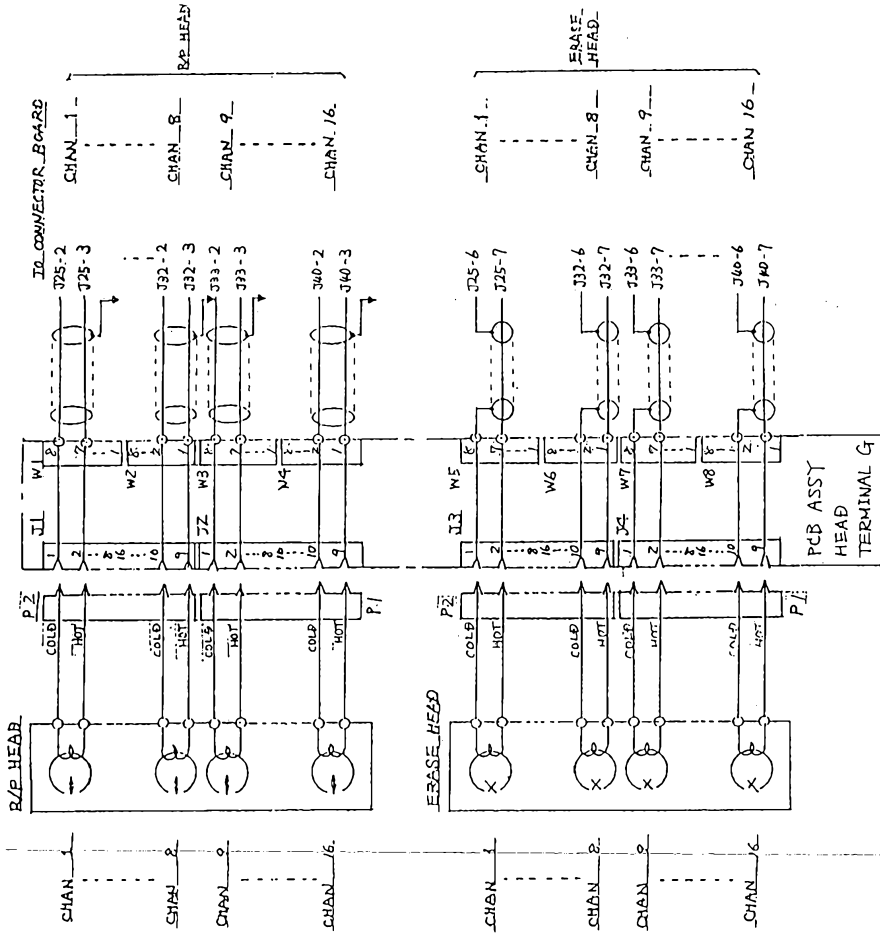

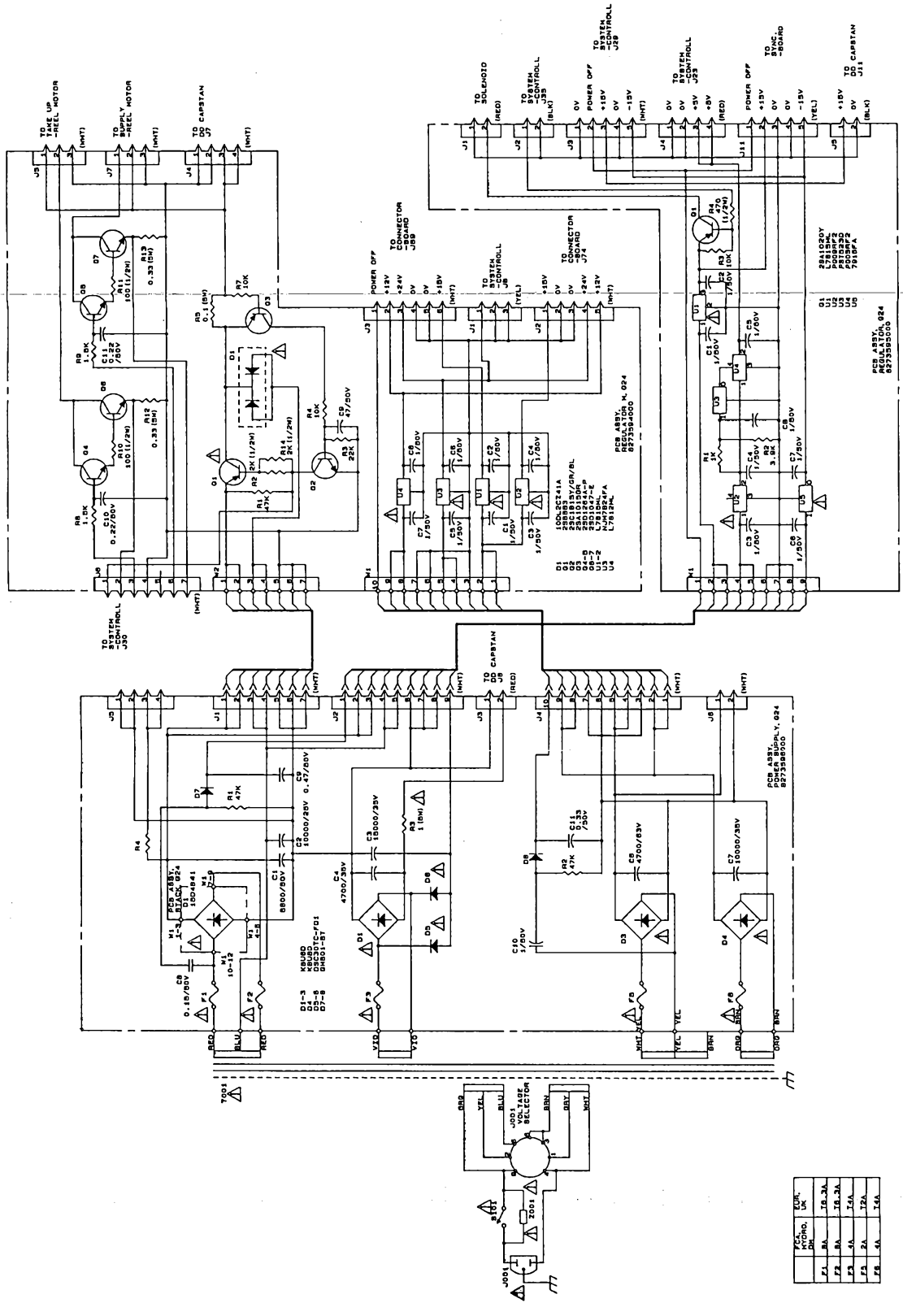

SYNCHRO, G24S/G16S

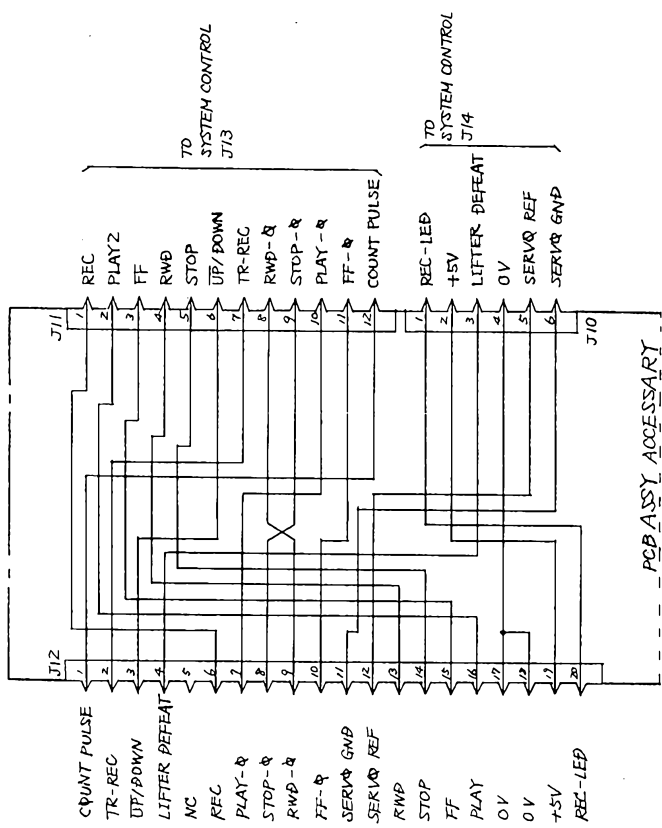

© 7-1990 FOSTEX CORP. B298 4890 00

ACCESSORY, G24S/G16S

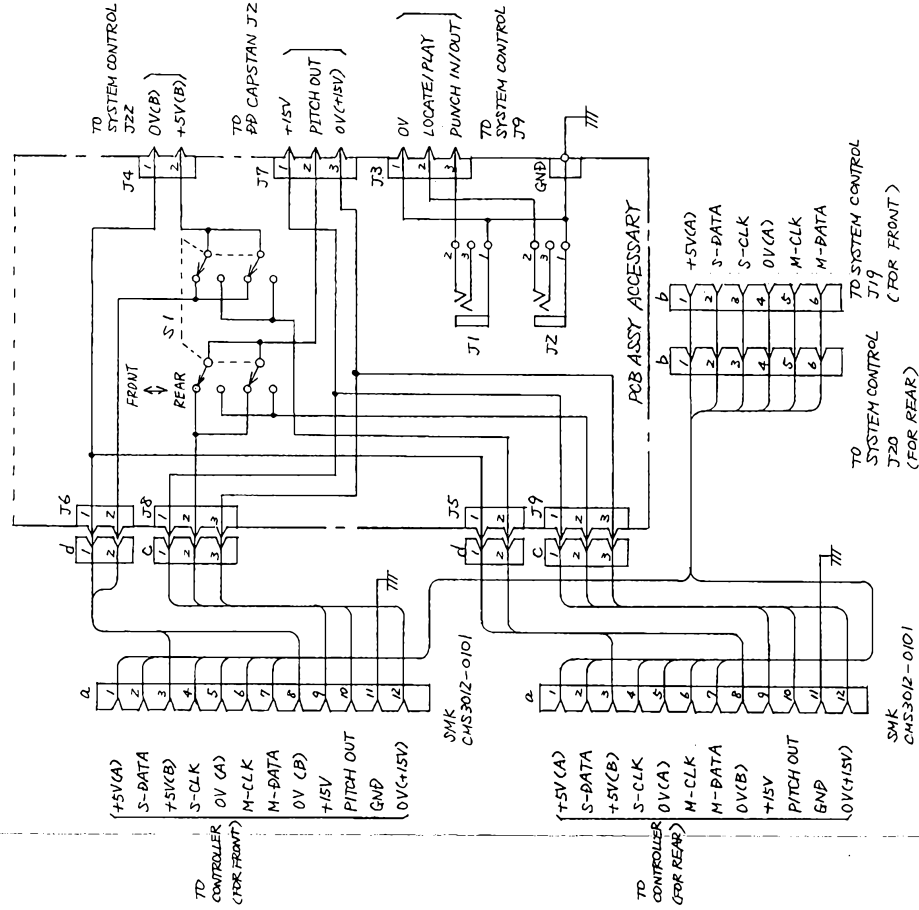

7. PIN INFORMATION FOR IC'S

4 BIT SINGLE-CHIP MICRO CONTROLLER

μPD17108GS:711 P/N: 8236 0734 00

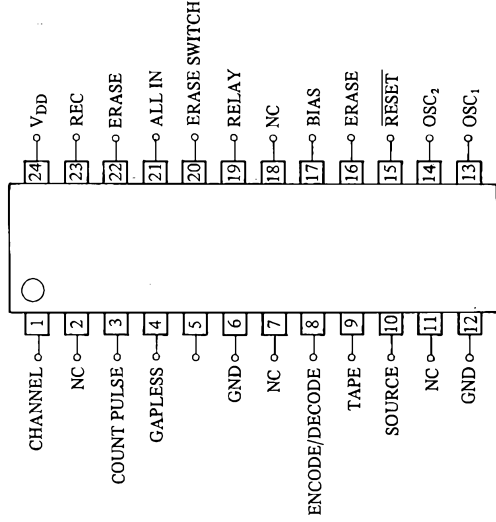

NJM3404AM DUAL SINGLE SUPPLY
OPERATIONAL AMPLIFIER P/N: 8236 7201 00

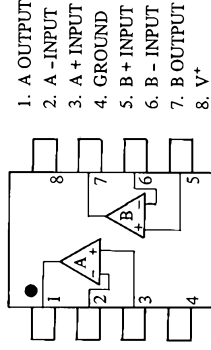

BA15218F DUAL HIGH SLEW RATE,
LOW NOISE OPERATIONAL AMPLIFIER

P/N: 8236 7200 00

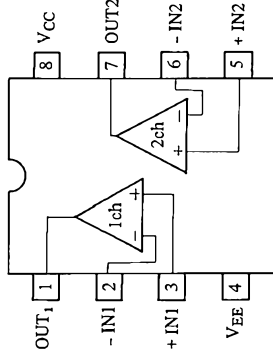

TC4066 BF QUAD BILATERAL SWITCH

P/N: 8236 5000 00

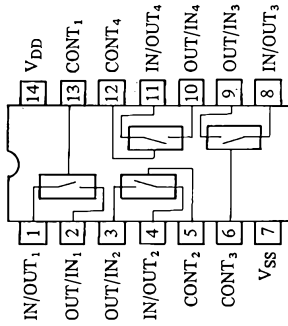

25B883 TRANSISTOR P/N: 8234 1241 00



IR9358N GENERAL-PURPOSE DUAL
OPERATIONAL AMPLIFIER

P/N: 8236 7202 00

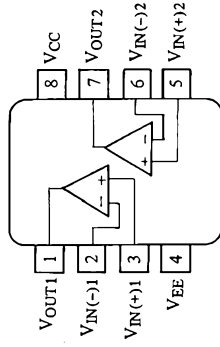

DTC323TK DIGITAL TRANSISTOR (INCLUDES RESISTOR)

P/N: 8236 5703 01

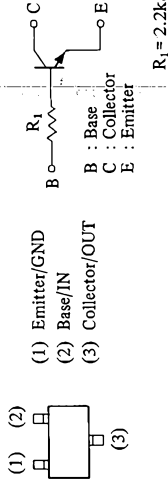

DTC114TK DIGITAL TRANSISTOR (INCLUDES RESISTOR)

P/N: 8236 5701 03



DTC314TK DIGITAL TRANSISTOR (INCLUDES RESISTOR)

P/N: 8236 5702 01



DTC113ZK DIGITAL TRANSISTOR (INCLUDES RESISTOR)

P/N: 8236 5700 01

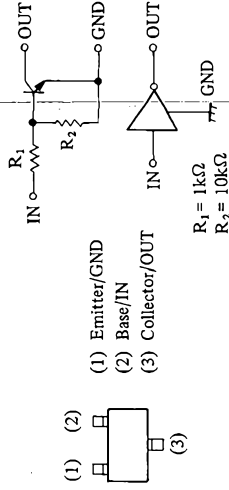

IC L7812ML 3-TERMINAL POSITIVE
VOLTAGE REGULATOR

P/N: 8236 0332 07

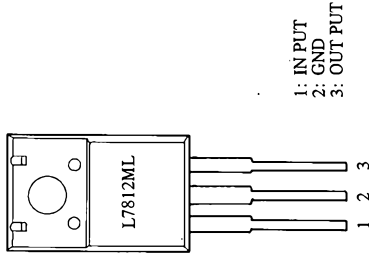

2SD1264A-P POWER TRANSISTOR

P/N: 8234 1725 02

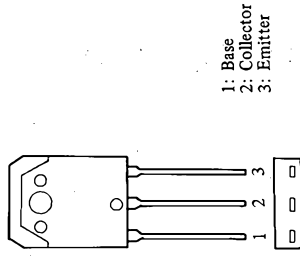

NJM78L05 UA 3-TERMINAL POSITIVE
VOLTAGE REGULATOR

P/N: 8236 7000 01



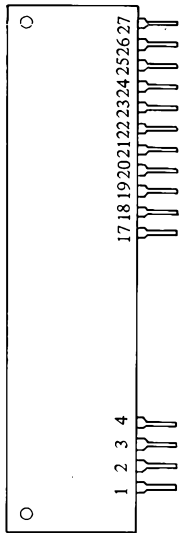

Pin Description

Pin No.	Symbol	Description
1	GND	GND
2	V _{EE}	Negative power supply
3	V _{CC}	Positive power supply
4	ADJ H	Dynamic offset adjustment (for high level stage)
17	GND	GND
18	ADJ L	Dynamic offset adjustment (for low level stage)
19	REC OUT	Recording output (encode output)
20	GND	GND
21	REC FB	Recording feedback
22	REC IN	Recording input
23	PB FB	Playback feedback
24	MODE	Recording/Playback switching
25	PB IN	Playback input
26	LINE OUT	Line output (decode output)
27	GND	GND

ENCODER BLOCK DIAGRAM

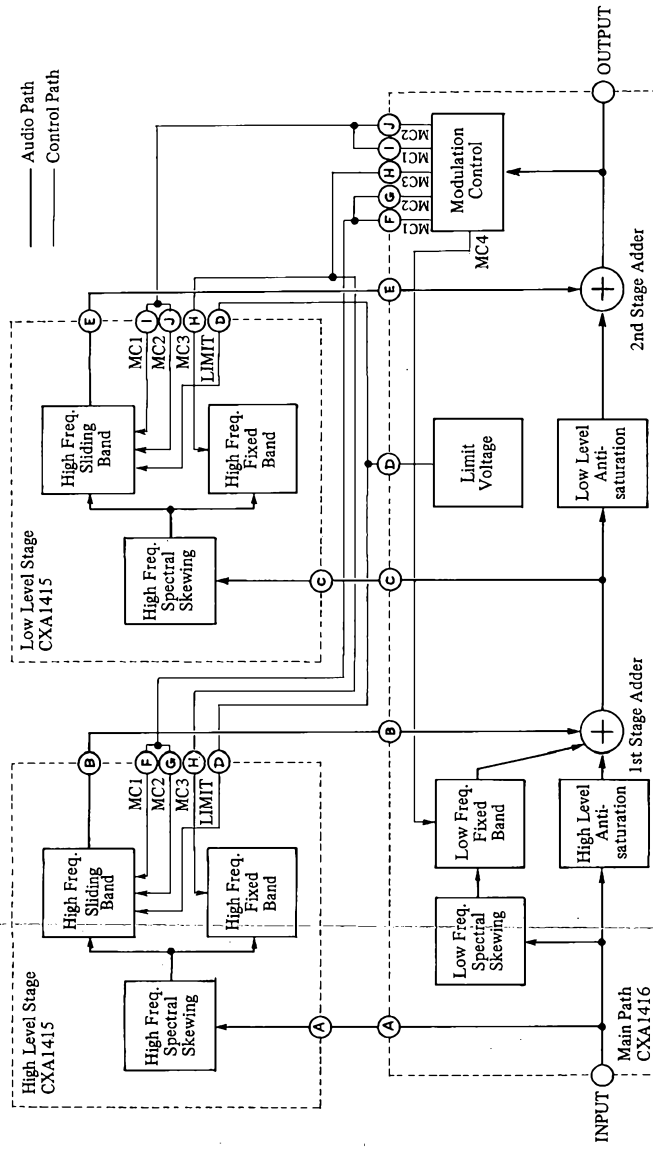

MC14040B 12-BIT BINARY COUNTER P/N: 8236 0024 00

LOGIC DIAGRAM

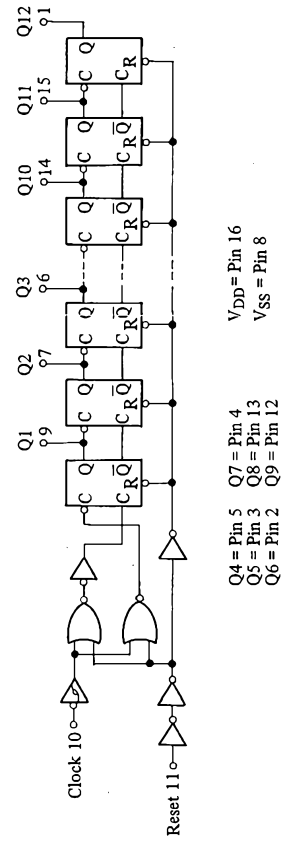

TRUTH TABLE

CLOCK	RESET	OUTPUT STATE
0	0	No Change
0	1	Advance to next state
x	x	All Outputs are low

x = Don't Care

Q4 = Pin 5 Q7 = Pin 4
 Q5 = Pin 3 Q8 = Pin 13
 Q6 = Pin 2 Q9 = Pin 12
 V_{DD} = Pin 16
 V_{SS} = Pin 8

FOStex®

FOSTEX CO. 3-2-35 Musashino, Akishima, Tokyo, Japan 196-0021
FOSTEX AMERICA 15431 Blackburn Ave., Norwalk, CA 90650, U.S.A.

© PRINTED IN JAPAN AUG. 1991 8288723000