

PETRODES

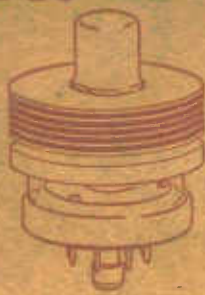

4-85A



4X100A



4-125A



4X150A



4-250A



4-400A



4X500A

TRIODES



4X500F



4-1000A



25T



3C24



35T



35TG



75T



2C39



100T



152T



250T



304T



450T



75T



1000T



1500T



2000T



3X2500A3

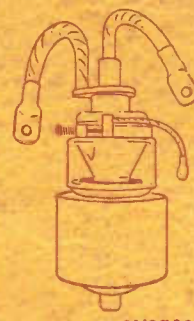

3X2500F3



3X12500A3



3X2000T

RECTIFIERS

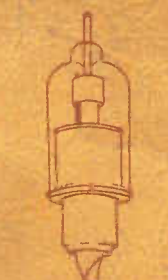

2-01C



855A



R2



2-1

CAPACITORS



250R



Variable Vacuum Capacitor



VC, Fixed Vacuum Capacitor

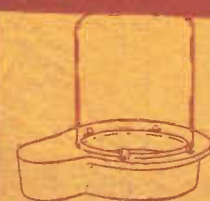

Air-system Sockets



HR, Heat Dissipating Connectors



Diffusion Pump



Vacuum Sockets

Eimac
TUBES

EITEL-McCULLOUGH, INC
San Bruno, California

EITEL-McCULLOUGH, INC.

TETRODES



4-65A

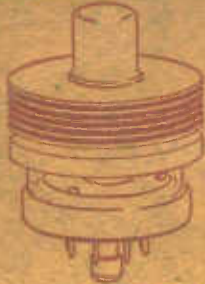

4X100A



4-125A



4X150A



4-250A



4-400A

TRIODES



4X300F



4-1000A



25T



3C24



35T



35TG



2C39



100T



152T



250T



304T



450T



1000T



1500T



2000T



3X2500A3

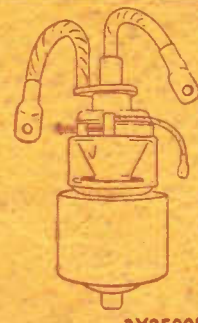

3X2500F3



3X12500A3

RECTIFIERS



201C



866A



8X



CAPACITORS



250R



Variable Vacuum Capacitor



VC Fixed Vacuum Capacitor



Air-system Sockets



HR, Heat Dissipating Connectors



Diffusion Purifier

Eimac
TUBES

EITEL-McCULLOUGH, INC.
San Bruno, California

VACUUM TUBES			
TUBE TYPE	PRICE	TUBE TYPE	PRICE
2-01C	13.75	25T	8.00
2-25A	10.00	35T	9.50
2-50A	12.50	35TG	10.00
2-150D	17.50	75TH	12.00
2-240A	60.00	75TL	12.00
2-2000A	195.00	100R	13.50
2C39	33.00	100TH	16.50
2C39A	33.00	100TL	16.50
3C24	8.00	152TH	26.00
3W10000A3	870.00	152TL	26.00
3X2500A3	180.00	250TH	30.00
3X2500F3	180.00	250TL	30.00
3X12500A3	875.00	250R	20.00
4-65A	14.50	253	18.50
4-125A	27.50	304TH	55.00
4-250A	37.50	304TL	55.00
4-400A	55.00	450TH	70.00
4-1000A	120.00	450TL	70.00
4E27A/5-125B	32.50	592/3-200A3	27.50
4X100A	48.00	750TL	125.00
4X150A	48.00	866A	1.95
4X150G	54.00	872A	8.20
4X500A	110.00	1000T	125.00
4X500F	85.00	1500T	200.00
KY21A	12.00	2000T	250.00
RX21A	8.00		

Heat Dissipating Connectors			
TYPE	PRICE	TYPE	PRICE
HR-1	.60	HR-6	.80
HR-2	.60	HR-7	1.60
HR-3	.60	HR-8	1.60
HR-4	.80	HR-9	3.00
HR-5	.80		

AIR SYSTEM SOCKETS	
TYPE	PRICE
4-400A/4000	16.00
4-400A/4006	6.00
4-1000A/4000	22.50
4-1000A/4006	7.50
4X150A/4000	19.50 / 8

VACUUM CAPACITORS			
TYPE	PRICE	TYPE	PRICE
VC6-20	13.50	VC50-20	22.00
VC6-32	15.50	VC50-32	25.00
VC12-20	15.00	VVC60-20	60.00
VC12-32	18.00	VVC2-60-20	134.00
VC25-20	18.00	VVC4-60-20	258.00
VC25-32	21.00		

VACUUM PUMP & GAUGE	
TYPE	PRICE
HV-1	125.00
Pump Oil - Qt.	5.00
100 IG	22.50

VACUUM SWITCH	
	PRICE
VS-2	12.00

EIMAC TRANSMITTING TUBES

TUBE TYPES	MAXIMUM RATINGS						ELECTRICAL CHARACTERISTICS							DIMENSIONS		TUBE PRICE	RECOMMENDED HR. HEAT DISSIPATING CONNECTORS		
	PLATE DISSIPATION, WATTS	PLATE VOLTAGE	PLATE CURRENT MILLIAMPERES	GRID DISSIPATION, WATTS	SCREEN VOLTAGE	SCREEN DISSIPATION, WATTS	FILAMENT, VOLTS	FILAMENT, AMPERES	AMPLIFICATION FACTOR	GRID-PLATE, MMF	INPUT, MMF	OUTPUT, MMF	TRANSCONDUCTANCE, UMHOS	LENGTH, INCHES	DIAMETER, INCHES		PLATE	GRID	
TETRODES	4-65A	65	3000	150	5	400	10	6.0	3.5	5	0.08	8.0	2.1	4000	4.25	2.31	14.50	HR6
	4X100A*	100	1000	250	2	300	15	6.0	2.8	4.5	0.02	14.1	4.7	12,000	2.87	1.64	48.00
	4-125A	125	3000	225	5	400	20	5.0	6.5	6.2	0.05	10.8	3.1	2450	5.69	2.87	27.50	HR6
	4X150A*	150	1000	250	2	300	15	6.0	2.8	4.5	0.02	14.1	4.7	12,000	2.47	1.64	48.00
	4-250A	250	4000	350	5	600	35	5.0	14.5	5.1	0.12	12.7	4.5	4000	6.38	3.56	37.50	HR6
	4-400A	400	4000	350	5	600	35	5.0	14.5	5.1	0.12	12.5	4.7	4000	6.38	3.56	55.00	HR6
	4X500A*	500	4000	350	10	500	30	5.0	13.5	6.2	0.05	12.8	5.6	5200	4.75	2.63	110.00
	4X500F*	500	4000	350	10	500	30	5.0	12.2	6.2	0.05	11.1	3.7	5200	5.38	2.75	85.00
4-1000A	1000	6000	700	25	1000	75	7.5	21	7.2	0.24	27.2	7.6	10,000	9.5	5.12	120.00	HR8	
TRIODES	25T	25	2000	75	7	6.3	3.0	24	1.5	2.7	0.3	2500	4.38	1.43	8.00	HR1
	3C24	25	2000	75	8	6.3	3.0	23	1.5	1.7	0.3	2500	4.38	1.43	8.00	HR1	HR1
	35T	50	2000	150	15	5.0	4.0	39	1.8	4.1	0.3	2850	5.5	1.81	9.50	HR3
	35TG	50	2000	150	15	5.0	4.0	39	1.8	2.5	0.4	2850	5.75	1.81	10.00	HR3	HR3
	75TH	75	3000	225	16	5.0	6.25	20	2.3	2.7	0.3	4150	7.25	2.81	12.00	HR3	HR2
	75TL	75	3000	225	13	5.0	6.25	12	2.4	2.6	0.4	3350	7.25	2.81	12.00	HR3	HR2
	2C39*	100	1000	100†	3	6.3	1.1	100	1.9	6.5	0.03	17,000	2.75	1.26	33.00
	100TH	100	3000	225	20	5.0	6.3	40	2.0	2.9	0.4	5500	7.75	3.19	16.50	HR6	HR2
	100TL	100	3000	225	15	5.0	6.3	14	2.0	2.3	0.4	2300	7.75	3.19	16.50	HR6	HR2
	152TH	150	3000	450	30	5 or 10	12.5 or 6.2	20	4.8	5.7	0.8	8300	7.63	3.0	26.00	HR5	HR6
	152TL	150	3000	450	25	5 or 10	12.5 or 6.2	12	4.4	4.5	0.7	7150	7.63	3.0	26.00	HR5	HR6
	250TH	250	4000	350	40	5.0	10.5	37	2.9	5.0	0.7	6650	10.13	3.81	30.00	HR6	HR3
	250TL	250	4000	350	35	5.0	10.5	14	3.1	3.7	0.7	2650	10.13	3.81	30.00	HR6	HR3
	304TH	300	3000	900	60	5 or 10	25 or 12.5	20	10.2	13.5	0.7	16,700	7.63	3.56	55.00	HR7	HR6
	304TL	300	3000	900	50	5 or 10	25 or 12.5	12	9.1	8.5	0.6	16,700	7.63	3.56	55.00	HR7	HR6
	450TH	450	6000	600	80	7.5	12.0	38	5.0	8.8	0.8	6650	12.63	5.13	70.00	HR8	HR8
	450TL	450	6000	600	65	7.5	12.0	18	5.2	7.3	0.9	6060	12.63	5.13	70.00	HR8	HR8
	750TL	750	10,000	1000	100	7.5	21.0	15	5.8	8.5	1.2	3500	17.0	7.13	125.00	HR8	HR8
	1000T	1000	7,500	750	80	7.5	17.0	35	5.1	9.3	0.5	9050	12.63	5.13	125.00	HR9	HR9
	1500T	1500	8,000	1250	125	7.5	24.0	24	7.2	9.9	1.5	10,000	17.0	7.13	200.00	HR8	HR9
2000T	2000	8,000	1750	150	10.0	25.0	23	8.5	12.7	1.7	11,000	17.75	8.13	250.00	HR8	HR9	
3X2500A3*	2500	6,000	2000	150	7.5	48	20	20	48	1.2	20,000	9.0	4.16	180.00	
3X2500F3*	2500	6,000	2000	150	7.5	48	20	20	48	1.2	20,000	9.0	4.16	180.00	
3X12500A3*	12,500	6,000	8000	600	7.5	192	20	95	240	5	80,000	9.5	11.06	875.00*	
3X20000A3*	20,000	6,000	12,000	900	7.5	288	20	120,000	10.0	12.5	1275.00**	

*Special leads requiring toroid-alloying
†Grid-Plate Current

**115% credit for return of radiator and mechanical assembly and crate in good condition, 25% credit for return of crate in good condition.
***125% credit for return of radiator and mechanical assembly and crate in good condition, 45% credit for return of crate in good condition.

EIMAC RECTIFIERS

	MERCURY VAPOR RECTIFIERS				HIGH VACUUM RECTIFIERS			
	866A (866)	RX21A (RX21)	872A (872)	KY21A (KY21) (Grid Control)	2-01C	100-R	2-150D (152-RA)	250-R
Filament Voltage	2.5	2.5	5.0	2.5	5.3	5.0	5.0	5.0
Filament Current	5.0 amp.	10 amp.	7.5 amp.	10 amp.	0.4	6.5	13.0	10.5
Peak Inverse Voltage	10,000	11,000	10,000	11,000	1000	40,000	30,000	60,000
Peak Plate Current	1.0 mp.	3 amp.	5.0 amp.	3 amp.	0.010
Average Plate Current	25 amp.	.75 amp.	1.25 amp.	.75 amp.100 amp.	.150 amp.	.250 amp.
Price	\$1.95	\$8.00	\$8.20	\$12.00	\$13.75	\$13.50	\$17.50	\$20.00

EIMAC VACUUM CAPACITORS

Type	VARIABLE	FIXED							
	VVC60	VC6-20	VC12-20	VC25-20	VC50-20	VC6-32	VC12-32	VC25-32	VC50-32
Capacity	10-60 mmf	6-mmf	12-mmf	25-mmf	50-mmf	6-mmf	12-mmf	25-mmf	50-mmf
Rating	20-KV	20-KV	20-KV	20-KV	20-KV	32-KV	32-KV	32-KV	32-KV
RF Peak
Price	\$60.00	\$13.50	\$15.00	\$18.00	\$22.00	\$15.50	\$18.00	\$21.00	\$25.00

HEAT DISSIPATING CONNECTORS

Type	Hole Dia.	Price	HR-5	HR-6	HR-7	HR-8	HR-9
HR-1	.052	\$.60	.125	.360	.125	1.60	1.60
HR-2	.0625	.60	.125	.570	.570	1.60	3.00
HR-3	.070	.60	.570
HR-4	.1015	.80

FUSION PUMP

HV-1 Diffusion Pump An air-cooled, oil diffusion type, vacuum pump. Ultimate vacuum, 4x10 ⁻⁶ mm of mercury. Speed (without baffle) approx. 67 liters/seconds.	\$125.00
100 IG, Ionization Gauge An electronic vacuum pressure gauge. Filament voltage 3.5 to 7.5 volts.	\$22.50
Eimac Pump Oil A	\$5.00 qt.

AIR-SYSTEM SOCKETS

Complete Assembly	
4-400A/4000	16.00
4-1000A/4000	22.50
Replacement Chimney	
4-400A/4006	6.00
4-1000A/4006	7.50

EIMAC VACUUM SWITCHES

Type	General Data	Price
VS-2	Single pole double throw switch within a high vacuum adaptable for high voltage switching. Contact spacing .015". Switch will handle R-f potentials as high as 20 Kv. In DC switching will handle approximately 1.5 Amps at 5 Kv.	\$12.00
VS-1	Same as above except for slightly smaller glass tubulation.	\$12.00

EITEL-McCULLOUGH, INC. • SAN BRUNO, CALIFORNIA

Export Agents: FRAZAR & HANSEN, 301 Clay Street, San Francisco, California, U. S. A.



TETRODES



4-65A

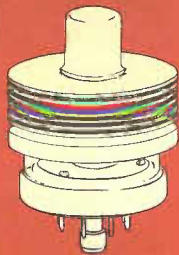

4X100A



4-125A

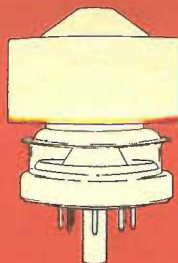

4X150A



4-250A

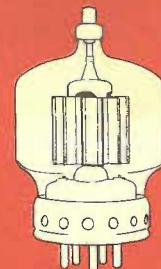

4-400A

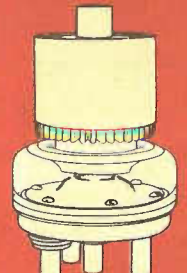

4X500A

TRIODES



4X300F



4-1000A

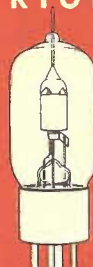

25T

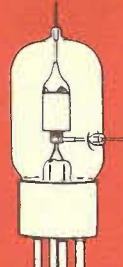

3C24



35T

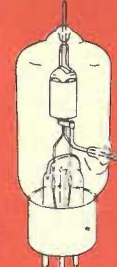

35TG

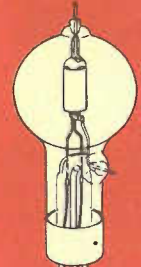

75T



2C3P

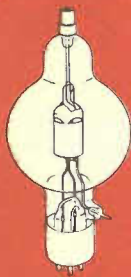

100T



152T



250T



304T



450T



750T



1000T



1500T

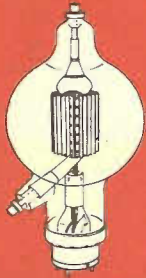

2000T

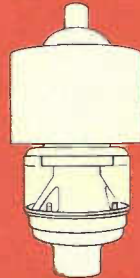

3X2500A3

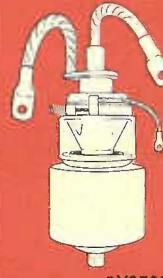

3X2500F3



3X12500A3

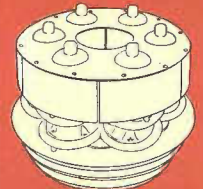

3X20000A3

RECTIFIERS



2-01C

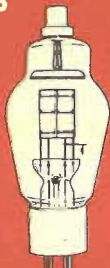

866A



RX21A



872A

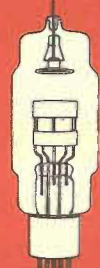

KY21A



100R

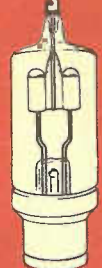

2-150D

CAPACITORS

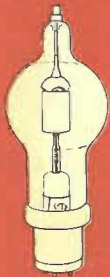

250R



Variable Vacuum Capacitor

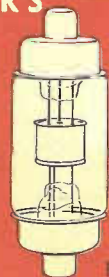

VC, Fixed, Vacuum Capacitor



Air-system Sockets



HR, Heat Dissipating Connectors

MISCELLANEOUS



Diffusion Pump

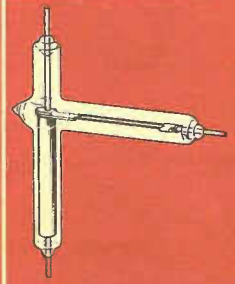

Vacuum Switch

AN EIMAC DISTRIBUTOR IS NEAR YOU

For Your Assurance to Obtain The Most Modern, Guaranteed Eimac Tubes—Purchase Only from These Authorized Distributors

ALASKA

Anchorage

Alaska Radio Supply, Inc.
Box 2279

Fairbanks

Yukon Radio Supply
655-6th Ave.
P. O. Box 1385

ALABAMA

Birmingham

Ack Radio Supply Co.
2205-3rd Ave. N.

James W. Clary Co.
2024 North 4th Ave.

Forbes Distributing Co.
2600 3rd Ave. S.

Mobile

Harris Supply Co.
10 N. Water St.
PO Box 1009

Montgomery

Nolin-McInnis, Inc.
205 Commerce St.
PO Box 2229

Southeastern Radio Parts Co.
210 N. Court St.

ARIZONA

Phoenix

Radio Parts of Arizona
36 West Madison St.

Radio Specialties &
Appliance Corp.
401 W. Jackson St.

Tucson

Elliott Electronics
418 N. 4th Ave.

ARKANSAS

Blytheville

Blytheville Radio Supply
112 South First St.

Ft. Smith

Wise Radio Supply
1001 Towson St.

Little Rock

Carlton Wholesale Radio, Inc.
109 W. 9th St.

Southern Radio Supply
1419 Main St.

Texarkana

Lavender Radio Supply Co.
PO Box 596

CALIFORNIA

Bakersfield

Valley Radio Supply
716 Baker St.

Burbank

Valley Electronic Supply Co.
1302 W. Magnolia Blvd.

Fresno

Arbuckle Radio Mfg. Co.
2330 Kern St.

Glendale

Hagerly Radio Supply
6826 San Fernando Road

Los Angeles

Henry Radio
11240 West Olympic

Kierulff & Company
820 West Olympic Blvd.

Radio Products Sales Co.
1501 South Hill

Radio Specialties Co.
1956 So. Figueroa St.

Radio Television Supply Co.
341 W. 18th St.

Shelley Radio Co.
2008 Westwood Blvd.

Long Beach

Fred S. Dean Co.
969 American Ave.

Larry Lynde Radio Supply Co.
853 Pine Ave.

Scott Radio Supply
266 Alamitos Ave.

Modesto

Jack Warren Wholesale
Radio Supply
907 Yosemite Blvd.

Oakland

W. D. Brill Co.
198 10th St.

Electric Supply Co.
149 - 12th St.

Pasadena

Dow Radio Supply Co.
1759 E. Colorado St.

Electronic Supply Corp.
150 W. Green St.

Sacramento

E. M. Kemp Co.
1115 R Street

Sacramento Elec. Supply Co.
1219 "S" St.

Santa Ana

Radio & Television Equipment Co.
207 Oak St.

Santa Barbara

Channel Radio Supply Co.
434 State St.

San Bernardino

Electronic Equipment Distributors
1123 W. Base Line at "L" St.

Inland Electronic Supply
843 Colton Ave.

San Diego

Electronic Equipment Distributors
1228-2nd Ave.

Western Radio & Television
Supply Co.
1415 India St.

San Francisco

Associated Radio Distributors
1251 Folsom St.

San Francisco Radio Supply Co.
1284 Market St.

Zack Radio Supply Co.
1426 Market St.

San Jose

Frank Quement, Inc.
161 W. San Fernando St.

Stockton

B. J. DeJarnatt Wholesale Co.
515 N. Hunter St.

COLORADO

Colorado Springs

Murray Radio Co.
502 W. Colorado Ave.

Denver

Inter-State Radio & Supply Co.
1639 Tremont Place

Radio Products Sales Co.
1237 - 16th St.

L. B. Walker Radio Co.
854 Broadway

Pueblo

L. B. Walker Radio Co.
218 W. 8th St.

CONNECTICUT

Bridgeport

Hatry & Young, Inc.
1700 Main St.

Hartford

Hatry & Young, Inc.
203 Ann St.

R. G. Sceli Co.
317 Asylum St.

New Britain

United Radio Supply Co.
47-53 East Main St.

New Haven

Thomas H. Brown Co.
15-25 Whiting St.

Congress Radio Co.
207 Congress Ave.

Hatry & Young, Inc.
77 Broadway

New London

Hatry & Young of
New London, Inc.
428 Bank Street

Stamford

Hatry & Young Inc.
97 Main St.

Stamford Radio Supply
562 Atlantic St.

Waterbury

The Bond Radio Supply
439 W. Main St.

Hatry & Young, Inc.
89 Cherry St.

DELAWARE

Wilmington

Almo Radio
6th & Orange St.

Radio Electric Service Co.
4th & Tatnall St.

FLORIDA

Jacksonville

Kinkade Radio Supply
1402 Laura St.

Thurow Distributors, Inc.
15 - 17 E. Church St.

Lakeland

Radio Accessories Co.
1050 S. Florida Ave.

Miami

Electronic Supply Co.
61 N. E. 9th St.

Thurow Distributors, Inc.
420 South West 8th St.

Orlando

Hammond-Morgan, Inc.
9 South Terry St.
PO Box 3162

Thurow Distributors, Inc.
131 S. Court St.

Pensacola

Gulf Electric Supply
115 E. Gregory St.

St. Petersburg

Cooper Radio Co.
648 Second Ave., So.

Welch Radio Supply
408 - 9th St. S.

Tallahassee

Thurow Distributors, Inc.
739 Monroe St.

Tampa

Kinkade Radio Supply
402 W. Fortune St.

West Palm Beach

Thurow Distributors, Inc.
509 Clematis St.

GEORGIA

Atlanta

Concord Radio Corp.
265 Peachtree St.

Southeastern Radio Parts Co.
442 W. Peachtree St. N. W.

Specialty Distributing Co.
957 Waverly Way N. E.

The Yancey Co., Inc.
340 W. Peachtree St. N. W.

Augusta

Specialty Distributing Co.
644 Reynolds St.

Albany

Specialty Distributing Co.
104 Pine Ave.

Columbus

Radio Sales & Service Co.
1326 First Ave.

Macon

Specialty Distributing Co.
519 Arch St.

Savannah

Southeastern Radio Parts Co.
38 Montgomery St.

Specialty Distributing Co.
223 E. Broughton St.

HONOLULU, T. H.

Radio Wholesale & Supply Co.
817 Alakea St.
P. O. Box 3768

IDAHO

Boise

Craddock's Radio Supply
1522 State St.

ILLINOIS

Chicago

Allied Radio Corporation
833 W. Jackson Blvd.

Chicago Radio Apparatus
Co., Inc.
415 So. Dearborn St.

Concord Radio Corp.
901 W. Jackson Blvd.

Green Mill Radio Supply
145 West 111th St.

Lukko Sales Corp.
5024 Irving Park Rd.

Newark Electric Co.
323 West Madison St.

Walker Jimieson
311 So. Western Ave.

Peoria

Klaus Radio & Electric Co.
707 Main St.

Quincy

Cooper Supply Co.
935 Main St.

Rockford

H & H Electronic Supply, Inc.
510 Kishwaukee St.

Art A. Johnson Sales & Service
1117 Charles St.

Mid-West Associated Distributors
506 Walnut St.

Rock Island

Tri-City Radio Supply
1919 Fourth Ave.

Springfield

Harold Bruce
120 N. 1st St.

Wilson Supply Co.
108 W. Jefferson St.

INDIANA

Anderson

Seyberts Radio Supply
1331 Main St.

Angola

Lakeland Radio Supply
525 South West St.

Evansville

Wesco Radio Parts
428-430 Pennsylvania St.

EIMAC TUBES ARE THE COUNTERSIGN OF DEPENDABILITY IN ANY ELECTRONIC EQUIPMENT

Fort Wayne

Pemberton Laboratories
236 East Columbia @ Barr St.
Protective Electric Supply
130 W. Columbia St.
Warren Radio Company
720 S. Clinton St.

Gary

Cosmopolitan Radio
524 Washington St.

Indianapolis

Radio Distributing Co.
1013 N. Capitol Ave.
Van Sickle Radio Supply Co.
102 S. Pennsylvania St.

Kokomo

George's Radio & Appliances
125 N. Buckeye St.

Lafayette

Holmes Radio Supply Co., Inc.
217 Main St.
Lafayette Radio Supply
408 E. North St.

Muncie

Radio Supply of Muncie
108 N. Walnut St.
Standard Radio Parts Co., Inc.
718 South Walnut St.

Peru

Clingaman Radio
814 W. Main St.

South Bend

Radio Distributing Co.
Monroe & Carroll Sts.

Terre Haute

Archer & Evinger
1348 Wabash Ave.
Terre Haute Radio
501 Ohio St.

IOWA

Cedar Rapids

Gifford Brown Inc.
106-108 First St., S. W.

Council Bluffs

World Radio Laboratories, Inc.
744 West Broadway

Des Moines

Gifford Brown, Inc.
1216 Grand Ave.
Radio Trade Supply Co.
1224 Grand Ave.

Dubuque

Boe Distributing Co.
498 N. Grandview Ave.

Ottumwa

Radio Trade Supply Co.
115 W. 2nd St.

Sioux City

Dukes Radio Co.
209 - 11 Sixth St.
Power City Radio Co.
513 Seventh St.

Waterloo

Farnsworth Radio & Television
623 Jefferson St.
Ray-Mac Radio Supply
613 Water St.

KANSAS

Pittsburg

Pittsburg Radio Supply
212 S. Broadway
Box 434

Topeka

Acme Radio Supply
516 Quincy St.
John A. Costelow Co. Inc.
125 Kansas Ave.

The Overton Electric Co. Inc.
522 Jackson St.

Wichita

Amateur Radio Equip. Co., Inc.
1215 East Douglas
Interstate Distributors, Inc.
1236 East Douglas
Radio Supply Co.
1125 - 27 E. Douglas

KENTUCKY

Lexington

Electronic Distributors
134 West 3rd St.
PO Box 55
Kentucky Radio Supply
351 W. Short St.
Radio Equipment Co.
480 Skain St.

Louisville

P. I. Burks & Co., Inc.
911 West Broadway
Universal Radio Supply Co.
533 S. 7th St.

LOUISIANA

Alexandria

Central Radio Supply Co.
509 Monroe St.
PO Box 1688

Baton Rouge

Electronic Supply Co.
1751-53 N. 21st St.
P. O. Box 1671

Lake Providence

F. H. Schneider & Sons, Inc.

Monroe

Hale & McNeil

New Orleans

Radio Parts, Inc.
807 Howard Ave.
Shuler Supply Co.
415 Dryades St.
Southern Radio Supply Co.
1900 Tulane Ave.

Shreveport

Inter-state Electric Co. of
Shreveport, Inc.
Koelemay Sales Co.
220 Crockett St.

MAINE

Auburn

Radio Supply Co. Inc.
28 Cross St.

Bangor

Radio Service Laboratory
76 Exchange St.

Portland

Maine Electronic Supply Corp.
13 Deer St.
Radio Service Laboratory
45 A Free St.

MARYLAND

Baltimore

Henry O. Berman Co.
12 E. Lombard St.
Kann-Ellert Electronics Inc.
9 South Howard St.
Radio Electric Service Co.
3 North Howard St.
Wholesale Radio Parts Co., Inc.
311 West Baltimore St.

Cumberland

Zimmerman Wholesalers
301 Baltimore Ave.

Hagerstown

Zimmerman Wholesalers
114 E. Washington St.

Salisbury

Standard Electronics Supply Co.
Ocean City Road

MASSACHUSETTS

Boston

DeMambro Radio Supply Co.
1111 Commonwealth Ave.
Hatry & Young, Inc.
42 - 44 Cornhill
A. W. Mayer Co.
895 Boylston St.
Radio Shack Corp.
167 Washington St.
Radio Wire Television, Inc.
110 Federal St.

Brockton

Ware Radio Supply Co.
913 Center St.

Cambridge

The Eastern Co.
620 Memorial Drive

Holyoke

Oakes Electrical Supply Co.
271 Appleton St.
Springfield Radio Co.
93 High St.

Lawrence

Hatry & Young, Inc.
639 Essex St.

New Bedford

C. E. Beckman Co.
11 Commercial St.

Pittsfield

Pittsfield Radio Co.
44 West St.

Springfield

T. F. Cushing
349 Worthington St.
Riga Electrical Corp.
376 Worthington St.
Springfield Radio Co.
405 Dwight St.

Worcester

Radio Electronics Sales Co.
46 Chandler St.
Radio Maintenance Supply Co.
19-25 Central St.

MICHIGAN

Ann Arbor

Wedemeyer Electronic Supply Co.
215 N. Fourth Ave.

Bay City

Kinde Distributing Co.
504 Washington Ave.

Battle Creek

Electronic Supply Co.
185 W. Michigan Ave.

Detroit

M. N. Duffy & Co.
2040 Grand River Ave.
Radio Electronic Supply Co.
1112 Warren Ave. West
Radio Specialties Co.
456 Charlotte Ave.

Flint

Lifsey Distributing Co.
730 N. Saginaw St.
Shand Radio Specialties
203 W. Kearsley St.

Grand Rapids

Radio Electronic Supply Co.
443 S. Division

Jackson

Fulton Radio Supply Co.
265 W. Cortland St.

Kalamazoo

Ralph M. Ralston Co.
201 N. Park St.

Lansing

Wedemeyer Electronic Supply Co.
2005 E. Michigan Ave.

Larim

Northwest Radio

Muskegon

Industrial Electric Supply Co.
1839 Peck St.

Pontiac

Electronic Supply Co.
248 E. Pike St.

MINNESOTA

Duluth

Lew Bonn Company
228 E. Superior St.
Northwest Radio
109 E. First St.

Minneapolis

Lew Bonn Company
1211 La Salle Ave.
Northwest Radio & Electronic
Supply
52 So. 12th St.
Stark Radio Supply Co.
71 S. Twelfth St.

St. Paul

Lew Bonn Co.
141 - 147 West Seventh St.
Hall Electric
386 Minnesota St.
Northwest Radio & Electronic
Supply Co.
194 W. 4th St.

MISSISSIPPI

Greenville

The Goyer Supply Co.
Radio Parts Dept.

Jackson

Ellington Radio, Inc.
816 South Gallatin St.

MISSOURI

Butler

Henry Radio
211 North Main

Joplin

4-State Radio & Supply Company
201 Main St.

Kansas City

Burstein-Applebee Co.
1012 - 14 McGee St.
Radiolab
1612 Grand Ave.

Poplar Bluff

Tri-State Radio & Supply
136 Bartlett St.

Springfield

Harry Reed Radio & Supply Co.
805 Boonville Ave.

St. Joseph

Acme Radio Supply
110 North 9th St.

St. Louis

Walter Ashe Radio Co.
1125 Pine St.
Van Sickle Radio Co.
1113 Pine St.

MONTANA

Billings

Electronic Supply Co.
214 Eleventh St., West

Great Falls

Geo. Lindgren Co.
P. O. Box 966

NEBRASKA

Lincoln

Leuck Radio Supply
243 So. 11th St.

- Omaha**
J. B. Distributing Co.
2855 - 57 Farnam St.
Omaha Appliance Co.
18th & St. Mary's
Radio Equipment Co.
2820 - 22 Farnam St.
- NEVADA**
Las Vegas
Metcalf's Radio Supply
1117 South Main St.
Reno
Ed. Heim Radio & Electronics
124 N. Virginia St.
E. M. Kemp Co.
1027 East 4th St.
- NEW HAMPSHIRE**
Concord
Evans Radio
P. O. Box 312
Dover
American Radio Corp.
510 Central Ave.
Manchester
Radio Service Laboratory
1191 Elm St.
- NEW JERSEY**
Atlantic City
Almo Radio Co.
4401 Ventnor Ave.
Radio Electric Service Co.
406 N. Albany Ave.
Camden
Radio Electric Service Co.
513 Cooper St.
Clifton
Eastern Radio Corp.
637 Main Ave.
Jersey City
Nidisco
713 Newark Ave.
New Brunswick
William Radio Supply Co.
210 French St.
Newark
Continental Sales Co.
195 - 197 Central Ave.
Electronic Marketers, Inc.
415 Halsey St.
Aaron Lippman & Co.
246 Central Ave.
Radio Wire-Television, Inc.
24 Central Ave.
Trenton
Allen and Hurley
25 South Warren St.
- NEW MEXICO**
Albuquerque
Radio Equipment Co.
523 East Central Ave.
L. B. Walker Radio Co., Inc.
114 W. Granite St.
P. O. Box 921
Roswell
Supreme Radio Supply
129 W. 2nd St.
- NEW YORK**
Albany
Fort Orange Distributing Co., Inc.
642 - 44 Broadway
E. E. Taylor Co.
465 Central Ave.
Amsterdam
Adirondack Radio Supply
54 Market St.
Binghamton
Federal Radio Supply Co.
188 State St.
- Brooklyn**
Peerless Electronics Distributors
Corp.
76 Willoughby St.
Buffalo
Dymac, Inc.
2329 Main St.
Radio Equipment Corp.
147 - 151 Genesee St.
Cortland
C. A. Winchell Radio Supply Co.
37 Central Ave.
Ithaca
Stallman of Ithaca
123 So. Tioga St.
P. O. Box 306
Long Island
Harrison Radio Corp.
172 - 31 Hillside Ave.
Jamaica, 3
Norman Radio Distributors, Inc.
94 - 29 Merrick Rd.
Jamaica
Peerless Radio Distributors, Inc.
92 - 32 Merrick Rd.
Jamaica
Standard Parts Corp.
235 Main St.
Hempstead
Mamaroneck
The Technical Materiel Corp.
121 Spencer Place
Mt. Vernon
Davis Radio Distributing Co.
66 E. 3rd St.
Radelco, Inc.
246 West 1st St.
- New York City**
Arrow Electronics Co.
82 Cortlandt St.
Calvert Electronics Co.
1947 Broadway
H. L. Dalis, Inc.
17 Union Square
Federated Purchaser
66 Dey St.
Grand Central Radio
124 E. 44th St.
Harrison Radio Corp.
12 W. Broadway
Harvey Radio Co., Inc.
103 W. 43rd St.
Metropolitan Radio-Electronics
Corp.
17 Union Square
Milo Radio & Electronics Corp.
200 Greenwich St.
New Yorker Electronics Co.
40 East 21st St.
Newark Electric Co., Inc.
242 - 50 West 55th St.
Niagara Radio Supply Corp.
160 Greenwich St.
Radio Ham Shack, Inc.
189-191 Greenwich St.
Radio-Wire Television, Inc.
100 Sixth Ave.
Sanford Electronics Corp.
136 Liberty St.
Sun Radio & Electronics Co., Inc.
122 - 24 Duane St.
Technical Equipment Co.
135 Liberty St.
Terminal Radio Corp.
85 Cortlandt St.
- Rochester**
Beaucaire, Inc.
114 Monroe Ave.
Hunter Electronics
233 East Ave.
Rochester Radio Supply Co.
114 St. Paul St.
- Niagara Falls**
Niagara Radio & Parts Co.
1518 Main St.
- Syracuse**
W. E. Berndt
655 S. Warren St.
Radio Supply Co.
200 Walton St.
Stewart W. Smith, Inc.
325 E. Water St.
- Utica**
Vaeth Elec. Co.
35 Genesee St.
- White Plains**
Westchester Electronic Supply Co.
420 Mamaroneck Ave.
- NORTH CAROLINA**
Asheville
Freck Radio & Supply Co.
38 Biltmore Ave.
Charlotte
Dixie Radio Supply Co., Inc.
715 W. Morehead
Shaw Distributing Co.
205 W. First St.
Greensboro
Johannesen Electric Co.
312 - 14 N. Eugene St.
Raleigh
Carolina Radio Equipment Co.
105 East Martin St.
Southeastern Radio Supply Co.
411 Hillsboro St.
- Wilmington**
French Radio Co.
1220 Dock St.
- Winston-Salem**
Dalton-Hege Radio Supply Co.
340 Brookstown Ave.
- NORTH DAKOTA**
Fargo
Fargo Radio Service Co.
515 Third Ave. N.
- OKLAHOMA**
Oklahoma City
Radio Supply, Inc.
724 N. Hudson
Box 1972
Tulsa
Harrison Equipment Co. Inc.
1124 East 4th St.
Radio, Inc.
1000 S. Main St.
S & S Radio Supply Co.
721 S. Detroit St.
- OHIO**
Akron
The Sun Radio Co.
110 East Market St.
Ashtabula
Morrison's Radio Supply
331 Center St.
Canton
Armstrong Radio Supply
226 - 28 Second St. S. E.
Cincinnati
Herrlinger Distributing Co.
15th & Vine Sts.
Hughes-Peters Inc.
1128 Sycamore St.
Steinberg's Inc.
633 Walnut St.
- The Mytronic Co.
121 West Central Parkway
United Radio, Inc.
1314 Vine St.
- Cleveland**
Northern Ohio Laboratories
2073 W. 85th St.
Pioneer Radio Supply Corp.
2115 Prospect Ave.
The Progress Radio Supply Co.
415 Huron Rd.
Radio & Electronics Part Corp.
3235 Prospect Ave.
Winteradio, Inc.
1468 W. 25th St.
- Columbus**
Hughes-Peters, Inc.
111 - 117 East Long St.
Thompson Radio Supplies
218 E. Gay St.
- Dayton**
Hughes-Peters, Inc.
300 W. 5th at Perry
Srepco, Inc.
135 E. Second St.
- East Liverpool**
D & R Radio Supply
631 Dresden Ave.
- Lima**
Lima Radio Parts Co.
641 N. Main St.
- Springfield**
Eberlie's Radio Supply
522 West Main St.
- Steubenville**
D & R Radio Supply
156 S. 3rd St.
- Toledo**
The H & W Auto Accessories Co.
26 N. 11th St.
Warren Radio Co.
1320 Madison Ave.
- Youngstown**
Radio Parts Co.
390 W. Commerce St.
Ross Radio Company
325 W. Federal St.
- OREGON**
Eugene
United Radio Supply, Inc.
179 W. 8th St.
Medford
Verl G. Walker Co.
205 West Jackson
Portland
Bargelt Supply Co.
1131 SW Washington
Harper-Meggee Co.
1506 N W Irving St.
Pacific Stationery Wholesale
Radio Dept.
414 S. W. 2nd Ave.
Northwest Radio Supply Co.
717 S W Ankeny St.
Stubbs Electric Co.
33 N W Park Ave.
United Radio Supply, Inc.
22 N. W. Ninth Ave.
- Salem**
United Radio Supply, Inc.
976 S. Commercial St.
- PENNSYLVANIA**
Allentown
Radio Electric Service Co.
1042 Hamilton St.
Easton
Radio Electric Service Co.
9 N. 2nd St.

Erie

J. V. Duncombe Co.
1011 W. 8th St.
Warren Radio, Inc.
12th & State Sts.

Harrisburg

Radio Distributing Co.
140 S. Second St.

Lancaster

George D. Barbey Co.
29 E. Vine St.

Philadelphia

Almo Radio Co.
509 Arch St.
Consolidated Radio Co.
612 Arch St.
Herbach & Rademan Co.
522 Market St.
M & H Sporting Goods Co.
512 Market St.
Radio Electric Service Co.
5133 Market St.
Radio Electric Service Co.
N. W. Corner 7th & Arch Sts.
Radio Electric Service Co.
3145 N. Broad St.
Radio Electric Service Co.
of Pa., Inc.
3412-14 Germantown Ave.
Eugene G. Wile
218 South 11th St.

Pittsburgh

Cameradio
963 Liberty Ave.
M. V. Mansfield Co.
937 Liberty Ave.
Tydings Company
632 Grant St.

Reading

George D. Barbey Co.
2nd & Penn Sts.

Scranton

Fred P. Purcell
548 - 550 Wyoming Ave.
Scranton Radio & Television
Supply Co.
519 Mulberry St.

Williamsport

Williamsport Radio Supply
518 W. Third St.

York

York Radio & Refrigeration Parts
263 W. Market St.

RHODE ISLAND

Providence

Wm. Dandreta & Co.
129 Regent Ave.
DeMambro Radio Supply Co.
90 Broadway
W. H. Edwards Co.
94 Broadway

SOUTH CAROLINA

Columbia

Dixie Radio Supply Co., Inc.
1700 Laurel St.

Charleston

Radio Laboratories
215 King St.

Greenville

Dixie Radio Supply Co.
22 S. Richardson St.
Gilliam Radio Co.
117 W. Coffee St.

SOUTH DAKOTA

Sioux Falls

Power City Radio Co.
209 So. First Ave.

TENNESSEE

Chattanooga

Specialty Distributing Co.
709 Chestnut St.

Jackson

L. K. Rush Company
206 E. Baltimore St.
Box 1418

Knoxville

Chemcity Radio & Electric Co.
12 Emory Park
PO Box 3131
Roden Electrical Supply Co.
808 N. Central Ave.

Memphis

Bluff City Distributing Co.
905 Union Ave.

Nashville

Braid Electric Co.
109 Eleventh Ave. So.
Electra Distributing Co.
1914 West End Ave.

TEXAS

Abilene

R. & R. Electronic Co.
1074 N. 1st St.

Amarillo

R. & R. Electronic Co.
412 W. 10th St.
West Texas Radio Supply
1026 W. 6th St.

Austin

The Hargis Co.
706 - W. 6th St.

Beaumont

Montague Radio Distributing Co.
760 Laurel St.
PO Box 3045

Corpus Christi

Electronic Equipment &
Engineering Co.
1310 So. Staples St.
Wicks-DeVilbiss Co.
516 - 18 South Staples St.

Dallas

Crabtree's Wholesale Radios
2608 Ross Ave.
Harrison Equipment Co. Inc.
6234 Peeler St.
Ra-Tel, Inc.
2409 Ross Ave.

Southwest Radio Supply

1820 N. Harwood St.
Wilkinson Bros.
PO Box 1169

Denison

Denison Radio Supply
310 W. Woodard St.

El Paso

Midland Specialty Co.
427 W. San Antonio St.
Reeves-Elliott Co.
720 N. Stanton St.

Fort Worth

Electronic Equipment Co.
301 E. 5th St.
Ft. Worth Radio Supply Co.
1201 Commerce St.

Houston

Benjamin Distributing Co.
P. O. Box 1104
Busacker Electronic Equipment
1721 Waugh Drive
Geophysical Supply Co.
1311 Dallas Ave.
P. O. Box 2214
Gulf Coast Electronics
1110 Winbern St.
Harrison Equipment Co.
1422 San Jacinto St.
Houston Radio Supply Co., Inc.
Clay at LaBranch
Lenert Company
2213 Congress Ave.
Sterling Radio Products Co.
1602 McKinney Ave.

Straus-Frank Company
4000 Leeland Ave.

Laredo

Radio & Electronics Supply Co.
1219 Lincoln St.

Lubbock

R & R Supply Co., Inc.
706 Main St.

McAllen

Rio Radio Supply Co.
P. O. Box 168

San Antonio

Amateur Headquarters & Supply
125 Fredericksburg Rd.
Amateur Radio Supply Co.
746 E. Myrtle St.
Straus-Frank Company
301 S. Flores St.

Tyler

Lavender Radio Supply Co.
110 Swann St.

Waco

The Hargis Co., Inc.
1305 Austin St.

Wichita Falls

Clark & Gose Radio Supply
1204 Ohio St.

UTAH

Salt Lake City

O'Laughlin's Radio Supply Co.
113 East Third South
Radio Supply Co.
45 East Fourth South
S. R. Ross, Inc.
1212 S. State St.
Standard Supply Co.
531 So. State St.

VIRGINIA

Arlington

R & M Radio Co.
2701 Wilson Blvd.

Lynchburg

Eastern Electric Co.
920 Commerce St.
P. O. Box 943

Norfolk

Radio Equipment Co.
821 West 21st St.

Richmond

The Arnold Company
2810 W. Marshall St.

WEST VIRGINIA

Charleston

Chemcity Radio & Electric Co.
1225 E. Washington St.

Clarksburg

Trenton Radio Co.
791 Pike St.

Huntington

Electronic Supply, Inc.
422 Eleventh St.
King & Irwin Inc.
316 Eleventh St.
Box 1248

Wheeling

General Distributors
26 Tenth St.

WASHINGTON

Bellingham

Waitkus Supply Co.
110 Grand Ave.

Everett

Pringle Radio Wholesale Co.
2514 Colby Ave.

Seattle

Alaska Radio Supply, Inc.
2701 California Ave.
Harper-Meggee, Inc.
960 Republican St.
Radio Products Sales Co.
1214 - 1st Ave.
Seattle Radio Supply, Inc.
2117 - 2nd Ave.
Western Electronic Supply Co.
2609 First Ave.
Herb E. Zobrist Co.
2121 Westlake Ave.

Spokane

Columbia Electric & Mfg. Co.
So. 123 Wall St.
Harper-Meggee Co.
N. 734 Division
Northwest Electronics Co.
North - 102 Monroe St.

Tacoma

C & G Radio Supply Co.
2502-6 Jefferson Ave.
A. T. Stewart Co.
743 Broadway

Walla Walla

Kar Radio & Electric Co.
12th & Pine Sts.
PO Box 676

Yakima

Lay & Nord
112 South Second St.

WASHINGTON D. C.

Capitol Radio Wholesalers
2120 - 14th St. N. W.
Electronic Wholesalers Inc.
2010-14th St. N. W.
General Electric Supply Corp.
705 Edgewood St. N. E.
Kenyon Radio Supply Company
2214 - 14th Street, N. W.
Rucker Radio Wholesalers
1312 - 14th St. N. W.
Sun Radio
938 "F" St. N. W.

WISCONSIN

Appleton

Appleton Radio Supply Co.
1217 N. Richmond St.
Valley Radio Distributors
518 N. Appleton St.

Madison

Satterfield Radio Supply
326 W. Gorham St.

Marinette

G. M. Popkey Co.
Main at 9th St.

Milwaukee

Central Radio Parts Co.
1723 W. Fond du Lac Ave.
Electro-Plance Distributors, Inc.
2458 W. Lisbon Ave.
Radio Parts Co., Inc.
536 - 38 West State St.

Wausau

Radio Service & Supply Co.
615 - 3rd St.

WYOMING

Cheyenne

Houge Radio & Supply Co.
2008 Carey Ave.

TUBE REPLACEMENT CHART

Tubes in the column marked "TYPE REPLACED" should be replaced with "EIMAC TUBE TYPE" shown in first column. Replacement with the EIMAC TUBE TYPE will require no reductions in voltages or power input or changes in mechanical connections.

Tubes under the heading "NEAR EQUIVALENT" can be replaced with EIMAC tubes provided changes are made in the electrical values or mechanical connections. Where an "X" appears in the "REQUIRED CHANGES" column some change is indicated.

TRIODES

Eimac Tube Type	Type Replaced	NEAR EQUIVALENT					
		Type	REQUIRED CHANGES				
			FIL. V	BIAS	SOCKET	PLATE CONNECTOR	GRID CONNECTOR
2C39	3X100A11 GL2C39 ZP572						
3C24	25TG 3-25D3 VT204 24G DR24G PE130A	3C28 TUF20 PE130B		X	X	X	X X X
3C37	3X150A3						
3X2500A3		7C24 7C25 WL473	X X X		X X X	X X X	X X X
25T	3-25A3 3C34 24 PE130C	HY30Z NU30Z 809 GL809 NU809 WL809 1623 GL1623 NU1623		X X X X X X		X X X X X X X X X	
35T	3-50A4 PE35T	HY40 T40 NU40T HY40Z TZ40 NU40TZ T55 811 DR811 GL811 NU811 WL811 812 812H DR812 GL812 NU812 WL812	X X X X X X X X X X X X X	X X X		X X X X X X X X X X X	
35TG	3-50D4	4C25 54 356A 808 DR808		X X X X	X	X X X X	X X X X
UH50	3-50G2 BW11 304B 834						



TUBE REPLACEMENT CHART TRIODES (Continued)

Eimac Tube Type	Type Replaced	NEAR EQUIVALENT					
		Type	REQUIRED CHANGES				
			FIL. V	BIAS	SOCKET	PLATE CONNECTOR	GRID CONNECTOR
75TH	3-75A3	HY51A NU51A HY51B HY51Z TW75 8005	X X X X X X	 X		X X X X X X	X X X X X X
75TL	3-75A2 75T						
100TH	3-100A4 VT218 RK38 DR100TH	4C22 HF100 T125 254 810 GL810 WL810	X X X X X X	X X X X	 X X X	X X X X X X X	X X X X X X
100TL	3-100A2 RK36 50T	8000	X		X	X	X
152TH	3-150A3 152H						
152TL	3-150A2 152L 152T						
250TH	3-250A4 VT220 RK36 454H	4C32 TW150 354E 354F WL463 PE530 GL592 822S	X X X X X	 X X X	 X X	X X X X X X X	X X X X X X X
250TL	3-250A2 VT130 150T 454L	4C34 HV18 KU23 DR200 EE200 HF200 NU200 T200 DR300 EE300 HF300 NU300 354C 354D WL460 806 GL806 WL806	X X X X X X X X X X X X X X X X X X	 X	 X	X X X X X X X X X X X X X X X	X X X X X X X X X X X X X X X
304TH	3-300A3 VT254 304H WL535						
304TL	3-300A2 VT129 304L 304T WL525						
450TH	3-450A4 VT108 WL450 F450TH 854H	357A 833A DR833A GL833A ML833A WL833A	X X X X X X		X X X X X	X X X X X	X X X X X X



TUBE REPLACEMENT CHART TRIODES (Continued)

Eimac Tube Type	Type Replaced	NEAR EQUIVALENT					
		Type	REQUIRED CHANGES				
			FIL. V	BIAS	SOCKET	PLATE CONNECTOR	GRID CONNECTOR
450TL	3-450A2 300T 854L						
750TL	3-750A2 1054L						
1000T	3-1000A4 1000UHF						
1500T	3-1500A3						
2000T	3-2000A3	HF3000 ZB3200	X X	X	X X	X X	X X

TETRODES

Eimac Tube Type	Type Replaced	NEAR EQUIVALENT					
		Type	REQUIRED CHANGES				
			FIL. V	BIAS	SOCKET	PLATE CONNECTOR	GRID CONNECTOR
4-125A	4D21 4D23 AT340 PE340	4E27		X	X	X	
		RK65			X	X	
		257		X	X	X	
		257B		X	X	X	
		AT257C		X	X	X	
		PE257C		X	X	X	
		813	X	X	X	X	
		GL813	X	X	X	X	
		ML813	X	X	X	X	
		NU813	X	X	X	X	
		WL813	X	X	X	X	
8001			X	X	X		
4-250A	5D22 5D24	363A	X		X	X	
		GL592	X	X	X	X	X
4X500A		RK6D22	X	X	X	X	X

RECTIFIERS

Eimac Tube Type	Type Replaced
2-150A 2-150D RX21A KY21A 100R	2-100A GL451 WL578 8020 DR8020 GL8020
250R	2-250A TR40M 371B DR371B NU371B
866A	866 UE966 UE966A
872A	872 UE972

VACUUM CAPACITORS

EIMAC VAC CAP	TYPE REPLACED	NEAR EQUIVALENT		
		TYPE NO.	REQUIRED CHANGES	
			CONNECTORS	SPACING
VC6-20	VC6			
VC12-20	VC12	GL1L21	X	X
		GL1L25	X	X
VC25-20	VC25	GL1L22	X	X
		GL1L36	X	X
VC50-20	VC50	GL1L23	X	X
		GL1L38	X	X
VC250				
VC1000				
VC6-32	VC6			
VC12-32	VC12			
VC25-32	VC25			
VC50-32	VC50			



TUBE REPLACEMENT CHART—CROSS INDEX

FOR TYPE NO.	USE EIMAC	FOR TYPE NO.	USE EIMAC	FOR TYPE NO.	USE EIMAC	FOR TYPE NO.	USE EIMAC
GL1L21	VC12-20	KU23	250TL	VT220	250TH	809	25T
GL1L22	VC25-20	24	25T	254	100TH	GL809	25T
GL1L23	VC50-20	24G	3C24	VT254	304TH	NU809	25T
GL1L25	VC12-20	DR24G	3C24	257	4-125A	WL809	25T
GL1L36	VC25-20	25TG	3C24	257B	4-125A	810	100TH
GL1L38	VC50-20	HY30Z	25T	PE257B	4-125A	GL810	100TH
2-100A	100R	NU30Z	25T	AT257C	4-125A	WL810	100TH
2-250A	250R	PE35T	35T	PE257C	4-125A	811	35T
GL2C39	2C39	RK36	100TL	DR300	250TL	DR811	35T
3-25A3	25T	RK38	100TH	EE300	250TL	GL811	35T
3-25D3	3C24	HY40	35T	HF300	250TL	NU811	35T
3-50A4	35T	HY40Z	35T	NU300	250TL	WL811	35T
3-50D4	35TG	NU40T	35T	300T	450TL	812	35T
3-50G2	UH50	NU40TZ	35T	304B	UH50	812H	35T
3-75A2	75TL	T40	35T	304H	304TH	DR812	35T
3-75A3	75TH	TR40M	250R	304L	304TL	GL812	35T
3-100A2	100TL	TZ40	35T	304T	304TL	NU812	35T
3-100A3	100TH	50T	100TL	AT340	4-125A	WL812	35T
3-150A2	152TL	HY51A	75TH	PE340	4-125A	813	4-125A
3-150A3	152TH	HY51B	75TH	354C	250TL	GL813	4-125A
3-250A3	250TL	HY51Z	75TH	354D	250TL	ML813	4-125A
3-250A4	250TH	NU51A	75TH	354E	250TH	NU813	4-125A
3-300A2	304TL	54	35TG	354F	250TH	WL813	4-125A
3-300A3	304TH	T55	35T	356A	35TG	822S	250TH
3-450A2	450TL	RK63	250TH	357A	450TH	833	450TH
3-450A4	450TH	RK65	4-125A	363A	4-250A	833A	450TH
3-750A2	750TL	75T	75TL	371B	250R	DR833A	450TH
3-1000A4	1000T	TW75	75TH	DR371B	250R	GL833	450TH
3-1500A3	1500T	DR100TH	100TH	NU371B	250R	ML833A	450TH
3-2000A3	2000T	HF100	100TH	F450	450TH	WL833A	450TH
3C28	3C24	VT108	450TH	WL450	450TH	834	UH50
3C34	25T	T125	100TH	GL451	100R	854H	450TH
3X100A11	2C39	VT129	304TL	454H	250TH	854L	450TH
3X150A3	3C37	PE130A	3C24	454L	250TL	1000UHF	1000T
4C22	100TH	PE130B	3C24	WL460	250TL	1054L	750TL
4C25	35TG	PE130C	25T	WL463	250TH	1623	25T
4C32	250TH	VT130	250TL	WL473	3X2500A3	GL1623	25T
4C34	250TL	150T	250TL	WL525	304TL	NU1623	25T
4D21	4-125A	TW150	250TH	PE530	250TH	HF3000	2000T
4D23	4-125A	152H	152TH	WL535	304TH	8000	100TL
4E27	4-125A	152L	152TL	ZP572	2C39	8001	4-125A
5D22	4-250A	152T	152TL	WL578	100R	8005	75TH
5D24	4-250A	DR200	250TL	GL592	4-250A	8020	100R
RK6D22	4X500A	EE200	250TL	GL592	250TH	DR8020	100R
7C24	3X2500A3	HF200	250TL	806	250TL	GL8020	100R
7C25	3X2500A3	NU200	250TL	GL806	250TL		
BW11	UH50	T200	250TL	WL806	250TL		
HV18	250TL	VT204	3C24	808	35TG		
TUF20	3C24	VT218	100TH	DR808	35TG		

CLASS C AMPLIFIER CALCULATIONS WITH THE AID OF CONSTANT CURRENT CHARACTERISTICS

In calculating and predicting the operation of a vacuum tube as a class-C radio frequency amplifier, the considerations which determine the operating conditions are plate efficiency, power output required, maximum allowable grid and plate dissipation, maximum allowable plate voltage and maximum allowable plate current. The values chosen for these factors will depend both on the demands of a particular application and the tube selected to do the job.

The plate and grid currents of a class-C amplifier are periodic pulses, the durations of which are always less than 180 degrees. For this reason the average plate and grid currents, power output, driving power, etc., cannot be directly calculated but must be determined by a Fourier analysis from points selected along the line of operation as plotted on the constant-current characteristics. This may be done either analytically or graphically. While the Fourier analysis has the advantage of accuracy, it also has the disadvantage of being tedious and involved.

An approximate analysis which has proven to be sufficiently accurate for most purposes is presented in the following material. This system has the advantage of giving the desired information at the first trial. The system, which is an adaptation of a method developed by Wagener¹, is direct because the important factors, power output, plate efficiency and plate voltage may be arbitrarily selected at the beginning.

In the material which follows, the following set of symbols will be used. These symbols are illustrated graphically in Figure 1.

Symbols

- P_i = Plate power input
- P_o = Plate power output
- P_p = Plate dissipation
- n = Plate efficiency expressed as a decimal
- E_{bb} = D-c plate supply voltage
- E_{pm} = Peak fundamental plate voltage
- e_{bmin} = Minimum instantaneous plate voltage
- I_b = Average plate current
- I_{pm} = Peak fundamental plate current
- i_{bmax} = Maximum instantaneous plate current
- θ_p = One-half angle of plate current flow
- E_{cc} = D-c grid bias voltage (a negative quantity)
- E_{c2} = D-c screen voltage

¹ W. G. Wagener "Simplified Methods for Computing Performance of Transmitting Tubes," Proc. I.R.E., Vol. 25, p. 47, (Jan. 1937).

(Reprinted from the Eimac News Industrial Edition, March 1945)

Indicates Revision 11-10-49

- E_{gm} = Peak fundamental grid excitation voltage
- e_{cmp} = Maximum positive instantaneous grid voltage
- I_c = Average grid current
- i_{cmax} = Maximum instantaneous grid current
- P_d = Grid driving power (including both grid and bias losses)
- P_g = Grid dissipation
- μ = Amplification factor of triode
- μ_{12} = Grid-screen amplification factor of tetrode

Method

The first step in the use of the system to be described is to determine the power which must be delivered by the class-C amplifier. In making this determination it is well to remember that ordinarily from 5 to 10 per cent of the power delivered by the amplifier tube or tubes will be lost in well-designed tank and coupling circuits at frequencies below 20 Mc. Above 20 Mc. the tank and coupling circuit losses are ordinarily somewhat above 10 per cent.

The plate power input necessary to produce the required output is determined by the plate efficiency:

$$P_i = \frac{P_o}{n}$$

For most applications it is desirable to operate at the highest possible efficiency. High-efficiency operation usually requires less expensive tubes and power supplies, and the amount of artificial cooling needed is frequently less than for low-efficiency operation. On the other hand, high-efficiency operation often requires more driving power and higher operating plate voltages. Eimac triodes and tetrodes will operate satisfactorily at 80 per cent efficiency at the highest recommended plate voltages and at 75 per cent efficiency at medium plate voltages.

The first determining factor in selecting a tube or tubes for any particular application is the maximum allowable plate dissipation. The total plate dissipation rating for the number of tubes used must be equal to or greater than that calculated from

$$P_p = P_i - P_o$$

After selecting a tube or tubes to meet the power output and plate dissipation requirements it becomes necessary to determine from the tube characteristics whether the tube selected is capable of the required operation and, if so, to determine the driving power, grid bias and grid current.

The complete procedure necessary to determine the class-C-amplifier operating conditions is as follows²:

1. Select plate voltage, power output and efficiency.
2. Determine plate input from

$$P_i = \frac{P_o}{\eta}$$

3. Determine plate dissipation from

$$P_p = P_i - P_o$$

P_p must not exceed maximum rated plate dissipation for tube or tubes selected.

4. Determine average plate current from

$$I_b = \frac{P_i}{E_{bb}}$$

I_b must not exceed maximum rated plate current for tube selected.

5. Determine approximate i_{bmax} from

$$\begin{aligned} i_{bmax} &= 4.5 I_b \text{ for } \eta = 0.80 \\ i_{bmax} &= 4.0 I_b \text{ for } \eta = 0.75 \\ i_{bmax} &= 3.5 I_b \text{ for } \eta = 0.70 \end{aligned}$$

6. Locate the point on constant-current characteristics where the constant plate current line corresponding to the approximate i_{bmax} determined in step 5 crosses the line of equal plate and grid voltages ("diode line") in the case of triodes; or in the case of tetrodes where the plate current line turns rapidly upward. Read e_{bmin} at this point.³

7. Calculate E_{pm} from

$$E_{pm} = E_{bb} - e_{bmin}$$

8. Calculate the ratio $\frac{I_{pm}}{I_b}$ from

$$\frac{I_{pm}}{I_b} = \frac{2\eta E_{bb}}{E_{pm}}$$

9. From the ratio of $\frac{I_{pm}}{I_b}$ calculated in step 8 determine the

ratio $\frac{i_{bmax}}{I_b}$ from Chart 1.

10. Calculate a new value for i_{bmax} from ratio found in step 9.

$$i_{bmax} = (\text{ratio from step 9}) I_b$$

11. Read e_{cmp} and i_{cmax} from constant current characteristics for values of e_{bmin} and i_{bmax} determined in steps 6 and 10.

12. Calculate the cosine of one-half the angle of plate current flow from

$$\cos \theta_p = 2.3 \left(\frac{I_{pm}}{I_b} - 1.57 \right)^4$$

13. Calculate the grid bias voltage from

$$E_{cc} = \frac{1}{1 - \cos \theta_p} \left[\cos \theta_p \left(\frac{E_{pm}}{\mu} - e_{cmp} \right) - \frac{E_{bb}}{\mu} \right], \text{ for triodes;}$$

$$\text{or } E_{cc} = \frac{1}{1 - \cos \theta_p} \left[-e_{cmp} \cos \theta - \frac{E_{c2}}{\mu_{12}} \right], \text{ for tetrodes.}$$

14. Calculate the peak fundamental grid excitation voltage from

$$E_{gm} = e_{cmp} - E_{cc}$$

15. Calculate the ratio $\frac{E_{gm}}{E_{cc}}$ for values of E_{cc} and E_{gm} found in steps 13 and 14.

16. Read ratio $\frac{i_{cmax}}{I_c}$ from Chart 2 for ratio $\frac{E_{gm}}{E_{cc}}$ found in step 15.

17. Calculate average grid current from ratio found in step 16 and value of i_{cmax} found in step 11.

$$I_c = \frac{i_{cmax}}{\text{ratio from step 16}}$$

18. Calculate approximate grid driving power from

$$P_d = 0.9 E_{gm} I_c^5$$

19. Determine grid dissipation from

$$P_g = P_d + E_{cc} I_c$$

P_g must not exceed the maximum rated grid dissipation for the tube selected.

Example

A typical application of this procedure is shown in the example below.

1. Desired power output..... 1250 watts
Desired plate voltage..... 4000 volts
Desired plate efficiency..... 75 per cent ($\eta = 0.75$)

$$P_i = \frac{1250}{0.75} = 1670 \text{ watts}$$

3. $P_p = 1670 - 1250 = 420 \text{ watts}$

Try type 450TL; Max. $P_p = 450W$; $\mu = 18$

4. $I_b = \frac{1670}{4000} = 0.417 \text{ ampere}$

(Max. I_b for 450TL = 0.600 ampere)

5. Approximate $i_{bmax} = 4.0 \times 0.417 = 1.67 \text{ ampere}$

6. $e_{bmin} = 315 \text{ volts (see figure 2)}$

7. $E_{pm} = 4000 - 315 = 3685 \text{ volts}$

8. $\frac{I_{pm}}{I_b} = \frac{2 \times 0.75 \times 4000}{3685} = 1.63$

9. $\frac{i_{bmax}}{I_b} = 3.45 \text{ (from Chart 1)}$

10. $i_{bmax} = 3.45 \times 0.417 = 1.44 \text{ amperes}$

11. $e_{cmp} = 280 \text{ volts}$

$$i_{cmax} = 0.330 \text{ amperes (see figure 3)}$$

12. $\cos \theta_p = 2.32 (1.63 - 1.57) = 0.139$

13. $E_{cc} = \frac{1}{1 - 0.139} \left[0.139 \left(\frac{3685}{18} - 280 \right) - \frac{4000}{18} \right]$
 $= -270 \text{ volts}$

14. $E_{gm} = 280 - (-270) = 550 \text{ volts}$

15. $\frac{E_{gm}}{E_{cc}} = \frac{550}{-270} = -2.04$

16. $\frac{i_{cmax}}{I_c} = 5.69 \text{ (from Chart 2)}$

17. $I_c = \frac{0.330}{5.69} = 0.058 \text{ amperes}$

18. $P_d = 0.9 \times 550 \times 0.058 = 28.7 \text{ watts}$

19. $P_g = 28.7 + (-270 \times 0.058) = 13.0 \text{ watts}$
(Max P_g for 450TL = 65 watts)⁶

² In the case of push-pull or parallel amplifier tubes the analysis should be carried out on the basis of a single tube, dividing P_i , P_o and P_p by the number of tubes before starting the analysis and multiplying I_b , I_c and P_d by the same factor after completing the analysis.

³ In a few cases the lines of constant plate current will deflect sharply upward before reaching the diode line. In these cases e_{bmin} should not be read at the diode line but at the point where the plate current line intersects a line drawn from the origin through these points of inflection.

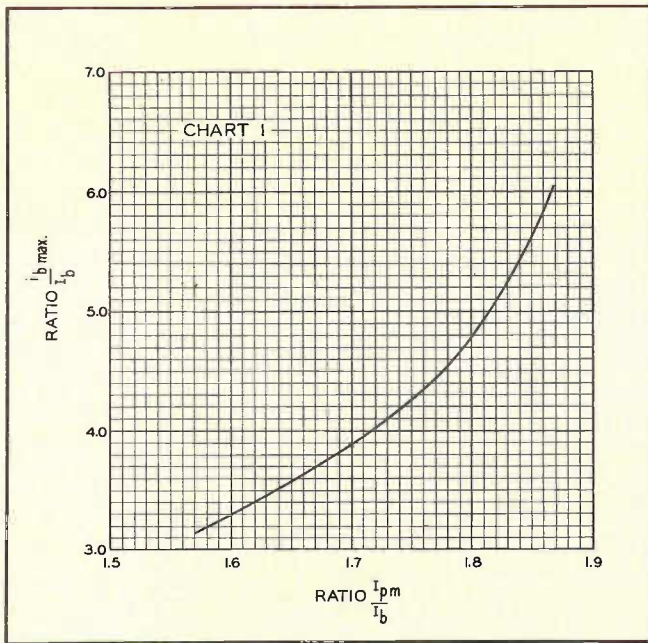

Chart 1

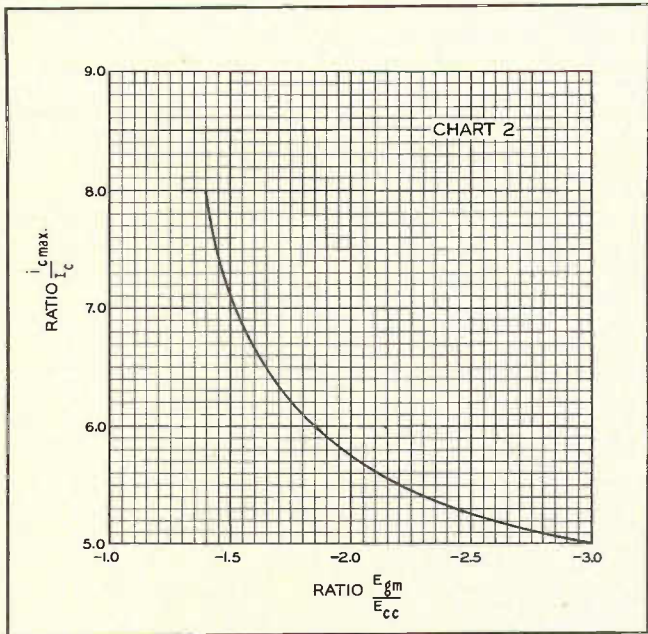

Chart 2

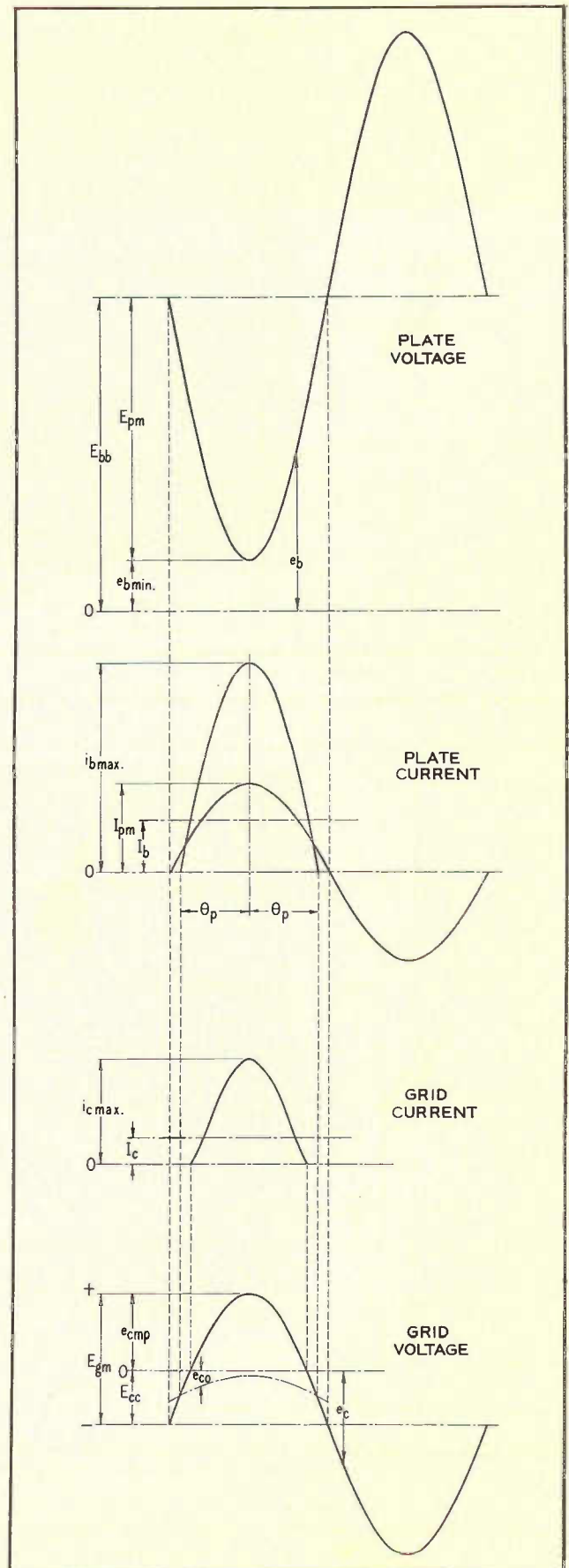

Figure 1. Symbols

4 If this calculation gives $\text{Cos } \theta_p$ as zero or a negative quantity class-B operation is indicated and new operating conditions should be chosen on a basis of higher efficiency (less plate dissipation, more power output or less power input).

5 The calculated driving power is that actually used in supplying the grid and bias losses. Suitable allowance in driver design must be made to allow for losses in the coupling circuits between the driver plate and the amplifier grid.

6 "Vacuum Tube Ratings" Eimac News, Industrial Edition, Jan. 1945.

(Reprinted from January, 1945 industrial edition of the Eimac News)

Vacuum Tube Ratings

COPYRIGHT, 1945
EITEL-McCULLOUGH, INC.
SAN BRUNO, CALIF.

Vacuum Tube Ratings

The data presented on tube data sheets are usually divided into three categories, (1) Electrical and Mechanical Characteristics, (2) Maximum Ratings and (3) Typical Operating Conditions. Electrical and mechanical characteristics are self-explanatory. The typical operating conditions are intended to guide the user in application of the tube under certain "typical" conditions. Several typical operating conditions for each class of service are usually given, with plate voltage as the independent variable. The conditions are chosen so that maximum performance is obtained for each value of plate voltage.

The conditions indicated as "typical" are not the only ones under which the tube can be used, however, and for this reason maximum ratings are given, so that if the user desires to choose his own conditions he will know the maximum capabilities of the tube in regard to certain restricting factors.

Maximum ratings are set solely on a basis of expected tube life. Each rating has been carefully determined by the tube manufacturer as the maximum value which will still permit a reasonable life expectancy for the tube.

Ordinarily the manufacturer sets each limit on an individual basis without regard to any other limit except where such limits are by their nature interdependent within the tube itself. Where the limits are interdependent in this way simultaneous operation at the maximum ratings involved is assumed in setting the limits, which may then be used as individual maximums.

Maximum Plate Dissipation

The plate dissipation of all radiation-cooled Eimac tubes is limited by plate temperature and its effects on parts of the tube other than the plate. The plates of all radiation-cooled Eimac tubes will withstand several times their maximum rated plate dissipation, but the heat generated by such operation has a considerable effect on other parts of the tube. The radiant heat from the plate causes the grid, filament and envelope to become heated, while heat conducted away from the plate by the plate lead contributes to the heating of the plate seal.

These effects are not ordinarily instantaneous, however, and for this reason all radiation-cooled Eimac tubes may be momentarily subjected to plate dissipation in excess of the maximum rating. The maximum plate dissipation rating is intended to set a point where continuous operation may be carried out without damage to any part of the tube, even though the other portions may at the same time be operating at their maximum ratings.

Regardless of other conditions, the maximum plate dissipation rating should not be exceeded in continuous operation. Plate dissipation in excess of the maximum rating is permissible for short periods of time with all Eimac radiation-cooled types.

Maximum Plate Voltage

Since Eimac tubes have no internal insulators, the only purpose of the maximum plate voltage limitation is to set a point above which the glass envelope will become damaged from dielectric losses or to set indirectly a limit to the r.f. charging current flowing in the plate and filament leads. The charging current is a function of the r.f. plate voltage, which is in turn a function of the d.c. plate voltage; this makes it possible to set an adequate limit on r.f. plate current without requiring the difficult task of determining the current directly. Most Eimac maximum plate voltage ratings fall in the r-f-plate-current-limit category. However, an example of the glass-stress type of limit may be seen in the UH-50 data. This tube has the same electrode structure as the 75TL. Due to the fact that its grid and plate leads are adjacent at the top of the envelope, however, the UH-50 has a maximum plate voltage rating of 1250 volts, whereas its counterpart, the 75TL, which has widely separated electrode terminations, has a maximum plate voltage rating of 3000 volts.

Regardless of other conditions, the maximum plate voltage rating should not be exceeded.

Maximum Plate Current

The maximum d-c plate current limit on Eimac tubes is based on the available filament emission. The maximum figure is intended to set a value which may be easily realized throughout the life of the tube. There has been no conclusive indication to date that excessive current has any direct effect on the life of the filament, although there is a certain amount of evidence to support such a belief. However, if operating conditions are chosen which require that the maximum plate current limitation be exceeded at the start of tube life, it may become increasingly difficult to maintain the excessive plate current as the tube ages.

Regardless of other conditions, the maximum plate current rating should not be exceeded.

Maximum Grid Ratings

Maximum grid current ratings, when coupled with maximum bias voltage or maximum r-f grid voltage ratings could conceivably limit grid dissipation. In many tubes, however, there is little justification for an independent grid bias or r-f grid voltage rating from a practical standpoint. Actually, of course, excessive r-f or bias voltage could cause excessive seal heating or breakdown of glass insulation. On most Eimac tubes these limitations are more academic than actual, since the magnitudes of voltage required to damage the tube are far in excess of those needed in practice, and their use results in no advantage to the tube user.

In the practical sense, the only grid limitation for most Eimac tubes is grid dissipation. Excessive grid dissipation can result in either primary (thermionic) emission from the grid or in deformation or melting of the grid through overheating. Most Eimac tubes now have non-emissive grids,

so that deformation or melting is usually the only result of excessive grid dissipation.

In the past, maximum grid dissipation has been more or less implied, rather than stated, on the Eimac tube data sheet by indicating a maximum grid current value. It was assumed that the tube user would not be likely to use more grid bias than necessary, since this would result in an increase in driving power without other compensating advantages, and that with a maximum grid current rating grid dissipation was thereby limited by practical considerations rather than by a definite statement. When the limit of grid dissipation was exceeded the user was usually made aware of the fact through a falling off of grid current as primary grid emission started to take place. The grid-emission phenomena is characteristic of tubes which do not employ special non-emissive grids, and its meaning is generally understood by the great majority of tube users.

The introduction of the non-emissive grid has led to difficulties with the maximum-grid-current rating, since there is generally little sign of grid emission in these tubes up to the point where the grid is permanently deformed by overheating. Obviously a new system of maximum grid ratings is required.

While it would be possible to set a limit on grid dissipation by giving maximum figures for both grid current and bias or peak r-f voltage, this has not been considered to be advisable since it places unnecessary and artificial restrictions on the application of the tubes. The new method of rating will consist only of a maximum on grid dissipation, and, in a few cases where glass-stem insulation is involved, a limit on r-f grid voltage. This grid-rating system will be used on all future printings of Eimac tube data sheets.

The influence of plate dissipation on grid temperature has been taken into consideration in setting up the grid dissipation maximums. The maximum grid dissipation figure given for each tube may be used simultaneously with maximum rated plate dissipation.

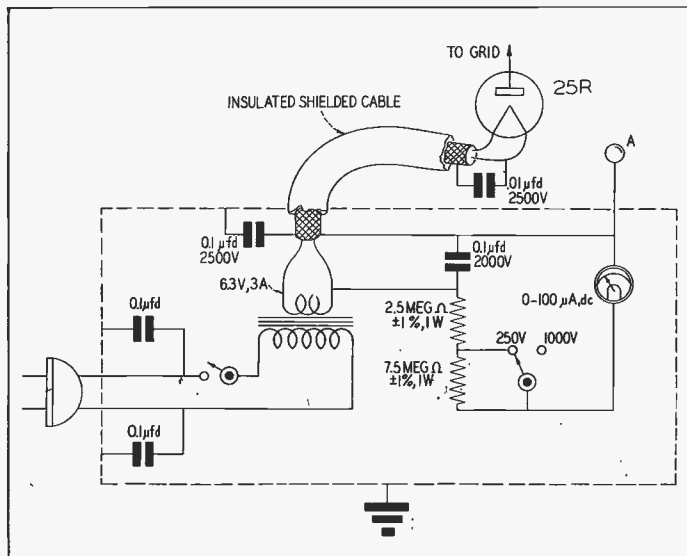

Figure 1. Peak vacuum tube voltmeter for making E_{gm} or e_{cmp} measurements.

Grid Dissipation Measurement

The obvious objection to grid-dissipation ratings is the necessity of determining the actual value of grid dissipation. Since grid dissipation is always equal to the total grid driving power less the power lost in the bias source, it is a simple matter to determine grid dissipation if the driving power is known. Driving power is equal to the driver output less the loss in the coupling circuits between the driver and the amplifier grid circuit (the coupling circuits include the driver plate tank, the coupling transmission line, and the amplifier grid tank, if one is used). Ordinarily, the losses in the coupling circuits will amount to about 30 per cent of the driver output. If this method is used:

$$P_g = N (P_{o \text{ driver}}) - E_c I_c$$

Where P_g = Grid Dissipation

N = Coupling Efficiency (Ordinarily $N = 0.7$)

$P_{o \text{ driver}}$ = Driver output power

E_c = D-C Bias Voltage

I_c = D-C Grid Current

Another method of determining grid dissipation is to subtract the bias loss from the driving power calculated by Thomas' formula¹:

$$P_d = E_{gm} I_c$$

Where E_{gm} = Peak R-F grid voltage

Grid dissipation is then approximately equal to:

$$P_g = I_c (E_{gm} - E_c) \text{ or alternatively}$$

$$P_g = e_{cmp} I_c^2$$

Where e_{cmp} = Peak Positive Grid Voltage

In order to use these expressions for P_g it is necessary to determine either E_{gm} or e_{cmp} . A suitable peak voltmeter for this purpose is shown in figure 1. When terminal (A) is connected to the negative end of the C-bias supply the meter reads E_{gm} . With (A) connected to ground, the meter indicates e_{cmp} . The first method of connection is most useful in measuring total grid driving power. When used to determine grid dissipation or driving power on a push-pull stage by measuring the voltage on each grid separately it may be advisable to shunt the "free" side of the grid tank circuit with a small capacitor having a capacitance equal to that introduced by the v.t.v.m.

The following is a tabulation of the maximum allowable grid dissipation for a group of Eimac tubes:

TYPE	MAX P _g (WATTS)	TYPE	MAX P _g (WATTS)
*25T	7	250TL	35
3C24	8	304TH	60
**35T	15	304TL	50
35TG	15	450TH	80
UH50	13	450TL	65
75TH	16	750TL	100
75TL	13	1000T	80
152TH	30	1500T	125
152TL	25	2000T	150
250TH	40		

*Max. E_{gm} 500 v.

**Max. E_{gm} 500 v.

Regardless of other conditions, the maximum grid dissipation rating should not be exceeded.

1. Thomas, "Determination of Grid Driving Power in Radio Frequency Amplifiers," Proc. I.R.E., Vol. 17, p. 1134 (1933).

2. Everitt, "Communication Engineering" p. 562; McGraw-Hill.

TENTATIVE DATA

EITEL-McCULLOUGH, Inc.
SAN BRUNO, CALIFORNIA

4E27A/5-125B

POWER PENTODE
MODULATOR
OSCILLATOR
AMPLIFIER

The Eimac 4E27A/5-125B is a power pentode having a maximum plate dissipation rating of 125 watts. Due to its high power-gain, it will deliver relatively large output with low driving-power. The low grid-plate capacitance of the 4E27A/5-125B makes neutralization unnecessary in most cases, and simplifies it in other cases. Type 4E27A/5-125B unilaterally replaces type 4E27.

Cooling of the 4E27A/5-125B is accomplished by radiation from the plate, which operates at a visible red color at maximum dissipation, and by air circulation through the base (unique base design permits unrestricted air-flow) and around the envelope.

GENERAL CHARACTERISTICS

ELECTRICAL

Filament: Thoriated tungsten	
Voltage	5.0 volts
Current	7.5 amperes
Grid-Screen Amplification Factor (Average)	5.0
Direct Interelectrode Capacitances (Average)	
Grid-Plate (without shielding, base grounded)	0.08 $\mu\mu\text{fd}$
Input	10.5 $\mu\mu\text{fd}$
Output	4.7 $\mu\mu\text{fd}$
Transconductance ($i_b = 50\text{ma.}$, $E_b = 2500\text{v.}$, $E_{c2} = 500\text{v.}$, $E_{c3} = 0\text{v.}$)	2150 μmhos
Frequency for Maximum Ratings	75 Mc.

MECHANICAL

Base 7 pin	Fits Ventilated Giant 7-pin Socket
Basing	RMA type 7BM
Mounting	Vertical, base down
Cooling	Convection and Radiation
Maximum temperature of seals	225°C
Maximum temperature of bulb	250°C
Recommended Eimac Heat Dissipating Connector:	
Plate	HR-5
Maximum Overall Dimensions	
Length	6.19 inches
Diameter	2.75 inches
Net Weight	6.7 ounces
Shipping Weight (Average)	1.5 pounds

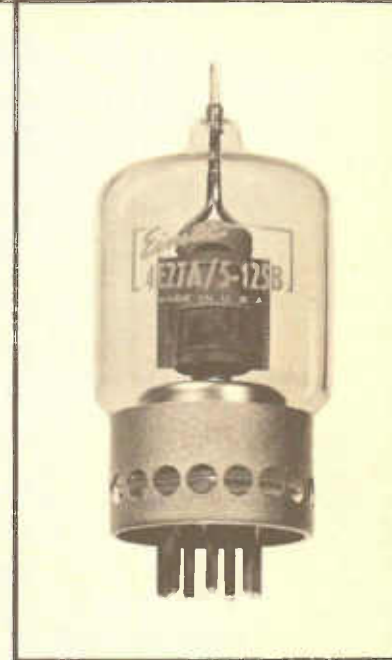

RADIO FREQUENCY POWER AMPLIFIER AND OSCILLATOR

Class-C Telegraphy or FM Telephony
(Key-down conditions, 1 tube)

MAXIMUM RATINGS

D-C PLATE VOLTAGE	4000 MAX. VOLTS
D-C SCREEN VOLTAGE	750 MAX. VOLTS
D-C GRID VOLTAGE	-500 MAX. VOLTS
D-C PLATE CURRENT	200 MAX. MA.
PLATE DISSIPATION	125 MAX. WATTS
SCREEN DISSIPATION	20 MAX. WATTS
SUPPRESSOR DISSIPATION	20 MAX. WATTS
GRID DISSIPATION	5 MAX. WATTS

TYPICAL OPERATION (Frequencies below 75 Mc.)

D-C Plate Voltage	1000	1500	2000	2500	3000	Volts
D-C Screen Voltage	500	500	500	500	500	Volts
D-C Suppressor Voltage	60	60	60	60	60	Volts
D-C Grid Voltage	-120	-130	-150	-170	-200	Volts
D-C Plate Current	167	200	200	186	167	Ma.
D-C Screen Current	11	11	11	7	5	Ma.
D-C Suppressor Current	6	5	4	3	3	Ma.
D-C Grid Current	6	8	8	7	6	Ma.
Peak R-F Grid Input Voltage	170	200	222	240	260	Volts
Driving Power (approx.)	1.0	1.6	1.8	1.7	1.6	Watts
Screen Dissipation	5.5	5.5	5.5	3.5	2.5	Watts
Grid Dissipation	.3	.6	.6	.5	.6	Watts
Plate Power Input	167	300	400	465	500	Watts
Plate Dissipation	47	85	100	115	125	Watts
Plate Power Output	120	215	300	350	375	Watts

AUDIO FREQUENCY POWER AMPLIFIER AND MODULATOR

Class-B (Sinusoidal wave)

MAXIMUM RATINGS (Per Tube)

D-C PLATE VOLTAGE	4000 MAX. VOLTS
D-C SCREEN VOLTAGE	750 MAX. VOLTS
D-C GRID VOLTAGE	-500 MAX. VOLTS
D-C PLATE CURRENT	200 MAX. MA.
PLATE DISSIPATION	125 MAX. WATTS
SCREEN DISSIPATION	20 MAX. WATTS
SUPPRESSOR DISSIPATION	20 MAX. WATTS
GRID DISSIPATION	5 MAX. WATTS

TYPICAL OPERATION (Frequencies below 75 Mc.)
Suppressor Grounded. 750 Screen Volts.

D-C Plate Voltage	1000	1500	2000	2500	3000	Volts
D-C Screen Voltage	750	750	750	750	750	Volts
D-C Grid Voltage	-170	-180	-200	-225	-250	Volts
D-C Plate Current	160	200	200	186	167	Ma.
D-C Screen Current	21	24	22	12	9	Ma.
D-C Grid Current	3	6	6	4	3	Ma.
Peak R-F Grid Input Voltage	205	235	257	270	290	Volts
Driving Power (approx.)	.6	1.4	1.5	1.1	.9	Watts
Screen Dissipation	16	18	17	9	7	Watts
Grid Dissipation	.1	.4	.3	.2	.2	Watts
Plate Power Input	160	300	400	465	500	Watts
Plate Dissipation	45	85	100	115	125	Watts
Plate Power Output	115	215	300	350	375	Watts

TYPICAL OPERATION (Frequencies below 75 Mc.)

Suppressor Grounded. 500 Screen Volts.

D-C Plate Voltage	1000	1500	2000	2500	3000	Volts
D-C Screen Voltage	500	500	500	500	500	Volts
D-C Grid Voltage	-120	-130	-150	-170	-200	Volts
D-C Plate Current	145	180	200	184	167	Ma.
D-C Screen Current	17	20	23	18	12	Ma.
D-C Grid Current	6	8	11	9	7	Ma.
Peak R-F Grid Input Voltage	170	200	240	250	270	Volts
Driving Power (approx.)	1.0	1.6	2.6	2.3	1.9	Watts
Screen Dissipation	8.5	10	12	9	6	Watts
Grid Dissipation	.3	.6	1.0	.8	.5	Watts
Plate Power Input	145	270	400	460	500	Watts
Plate Dissipation	55	95	125	125	125	Watts
Plate Power Output	90	175	275	335	375	Watts

PLATE MODULATED RADIO FREQUENCY AMPLIFIER

Class-C Telephony (Carrier conditions)

MAXIMUM RATINGS (Per Tube)

D-C PLATE VOLTAGE	3200 MAX. VOLTS
D-C SCREEN VOLTAGE	750 MAX. VOLTS
D-C GRID VOLTAGE	-500 MAX. VOLTS
D-C PLATE CURRENT	160 MAX. MA.
PLATE DISSIPATION	85 MAX. WATTS
SCREEN DISSIPATION	20 MAX. WATTS
SUPPRESSOR DISSIPATION	20 MAX. WATTS
GRID DISSIPATION	5 MAX. WATTS

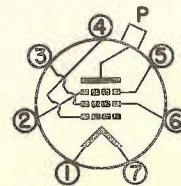
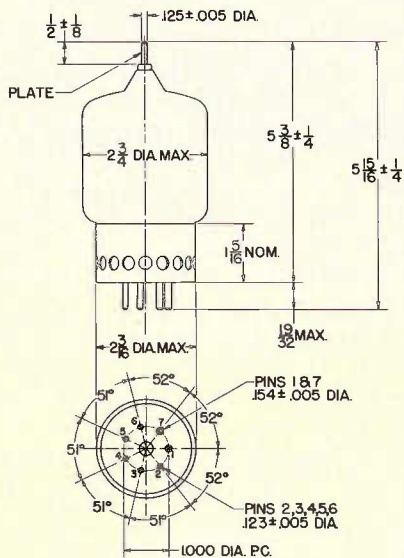
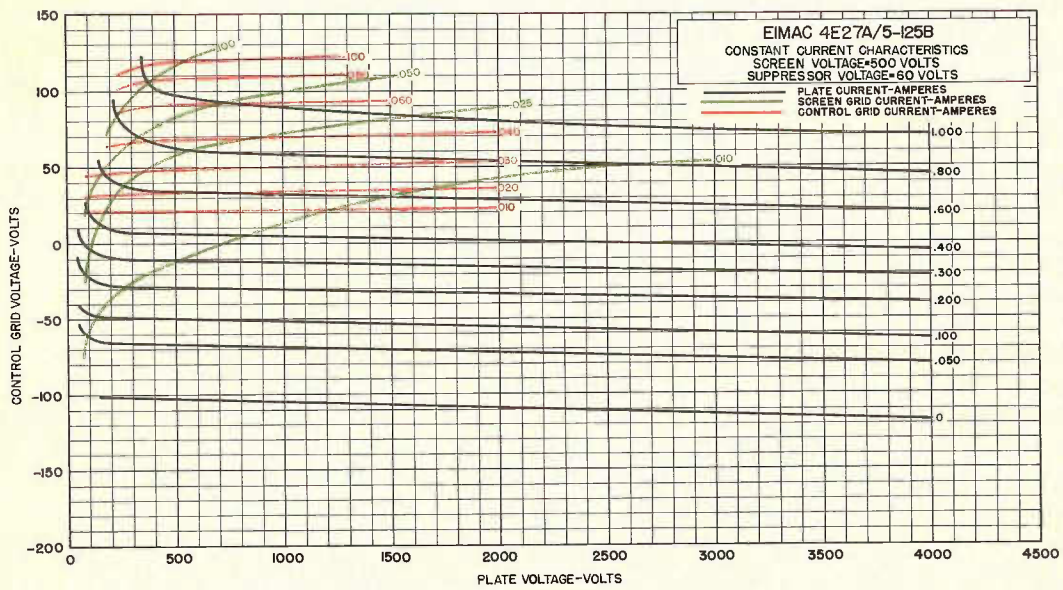
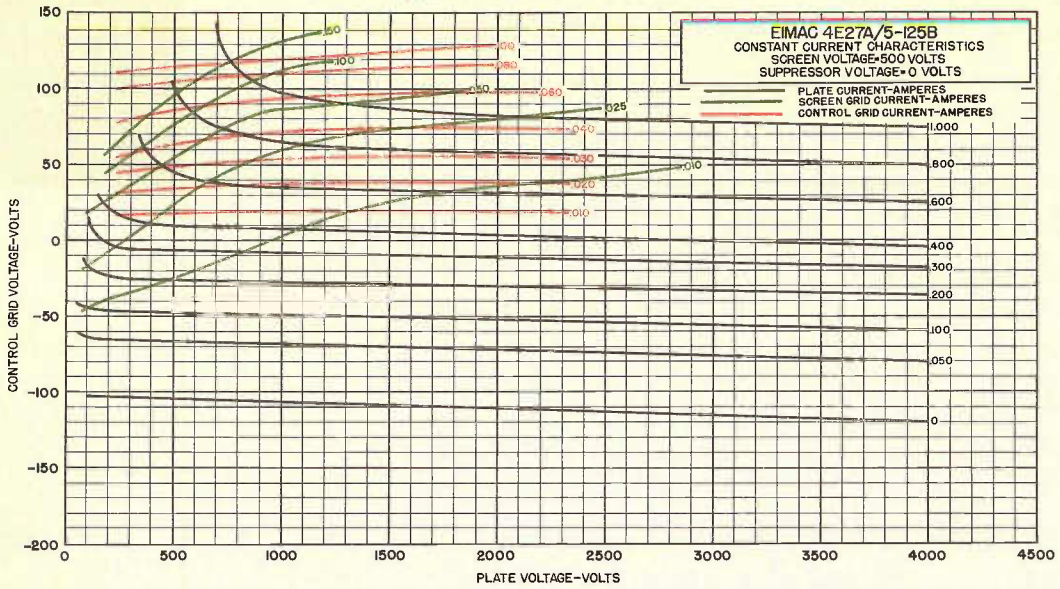

The Eimac 4-65A is a small radiation-cooled transmitting tetrode having a maximum plate dissipation rating of 65 watts. The plate operates at a red color at maximum dissipation. Short, heavy leads and low interelectrode capacitances contribute to stable efficient operation at high frequencies.

Although it is capable of withstanding high plate voltages, the internal geometry of the 4-65A is such that it will deliver relatively high power output at a low plate voltage.

The quick-heating filament allows conservation of power during standby periods in mobile applications.

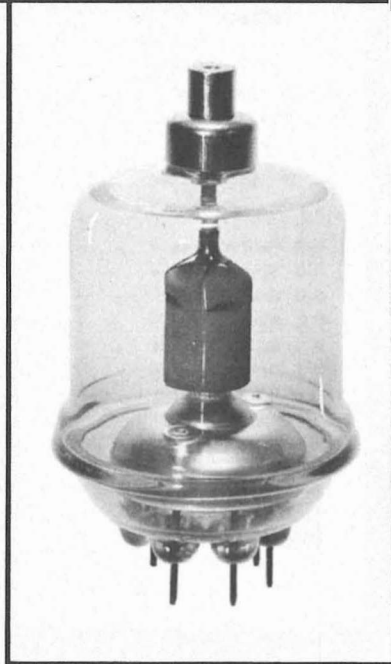

GENERAL CHARACTERISTICS

ELECTRICAL

Filament: Thoriated tungsten	
Voltage	6.0 volts
Current	3.5 amperes
Grid-Screen Amplification Factor (Average)	5
Direct Interelectrode Capacitances (Average)	
Grid-Plate	0.08 $\mu\mu\text{f.}$
Input	8.0 $\mu\mu\text{f.}$
Output	2.1 $\mu\mu\text{f.}$
Transconductance (ib = 125 ma., Eb = 500 v., E _{c2} = 250 v.)	4000 μmhos

MECHANICAL

Base	5-pin—Fits Johnson 122-101 Socket
Mounting	Vertical, base down or up
Cooling	Convection and Radiation
Maximum Overall Dimensions	
Length	4.25 inches
Diameter	2.31 inches
Net Weight	3 ounces
Shipping Weight (Average)	1.5 pounds

IF IT IS DESIRED TO OPERATE THIS TUBE UNDER CONDITIONS WIDELY DIFFERENT THAN THOSE GIVEN UNDER "TYPICAL OPERATION," POSSIBLY EXCEEDING MAXIMUM RATINGS, WRITE EITEL-McCULLOUGH, INC., FOR INFORMATION AND RECOMMENDATIONS.

RADIO FREQUENCY POWER AMPLIFIER AND OSCILLATOR Class-C Telegraphy or FM Telephony

MAXIMUM RATINGS (Key-down conditions, per tube)

D-C PLATE VOLTAGE	- - - - -	3000 MAX. VOLTS
D-C SCREEN VOLTAGE	- - - - -	400 MAX. VOLTS
D-C GRID VOLTAGE	- - - - -	-500 MAX. VOLTS
D-C PLATE CURRENT	- - - - -	150 MAX. MA.
PLATE DISSIPATION	- - - - -	65 MAX. WATTS
SCREEN DISSIPATION	- - - - -	10 MAX. WATTS
GRID DISSIPATION	- - - - -	5 MAX. WATTS

TYPICAL OPERATION

D-C Plate Voltage	- - - -	600	1000	1500	2000	3000	Volts
D-C Screen Voltage	- - - -	250	250	250	250	250	Volts
D-C Grid Voltage	- - - -	-50	-70	-75	-80	-90	Volts
D-C Plate Current	- - - -	140	150	150	150	115	Ma.
D-C Screen Current	- - - -	40	40	35	30	20	Ma.
D-C Grid Current	- - - -	13	15	14	12	10	Ma.
Peak R-F Grid Input Voltage (approx.)	- - - -	145	170	180	175	170	Volts
Driving Power (approx.)	- - - -	1.9	2.5	2.5	2.1	1.7	Watts
Screen Dissipation	- - - -	10	10	9	8	5	Watts
Plate Power Input	- - - -	84	150	225	300	345	Watts
Plate Dissipation	- - - -	30	45	55	65	65	Watts
Plate Power Output	- - - -	54	105	170	235	280	Watts

HIGH-LEVEL MODULATED RADIO FREQUENCY AMPLIFIER Class-C Telephony (Carrier conditions unless otherwise specified, 1 tube)

MAXIMUM RATINGS

D-C PLATE VOLTAGE	- - - - -	2500 MAX. VOLTS
D-C SCREEN VOLTAGE	- - - - -	400 MAX. VOLTS
D-C GRID VOLTAGE	- - - - -	-500 MAX. VOLTS
D-C PLATE CURRENT	- - - - -	120 MAX. MA.
PLATE DISSIPATION	- - - - -	45 MAX. WATTS
SCREEN DISSIPATION	- - - - -	10 MAX. WATTS
GRID DISSIPATION	- - - - -	5 MAX. WATTS

TYPICAL OPERATION

D-C Plate Voltage	- - - -	600	1000	1500	2000	2500	Volts
D-C Screen Voltage	- - - -	250	250	250	250	250	Volts
D-C Grid Voltage	- - - -	-100	-110	-125	-125	-150	Volts
D-C Plate Current	- - - -	117	120	120	120	108	Ma.
D-C Screen Current	- - - -	40	40	35	33	16	Ma.
D-C Grid Current	- - - -	11	12	12	12	8	Ma.
Screen Dissipation	- - - -	10	10	9	8	4	Watts
Grid Dissipation	- - - -	1.0	1.2	1.2	1.1	.7	Watts
Peak A-F Screen Voltage, 100% Modulation	- - - -	175	175	175	175	175	Volts
Peak R-F Grid Input Voltage (approx.)	- - - -	190	210	225	225	235	Volts
Driving Power (approx.)	- - - -	2.1	2.5	2.7	2.6	1.9	Watts
Plate Power Input	- - - -	70	120	180	240	270	Watts
Plate Dissipation	- - - -	20	25	35	40	45	Watts
Plate Power Output	- - - -	50	95	145	200	225	Watts

AUDIO FREQUENCY POWER AMPLIFIER AND MODULATOR Class-AB₁ (Sinusoidal wave, two tubes unless otherwise specified)

MAXIMUM RATINGS

D-C PLATE VOLTAGE	- - - - -	3000 MAX. VOLTS
D-C SCREEN VOLTAGE	- - - - -	600 MAX. VOLTS
MAX-SIGNAL D-C PLATE CURRENT, PER TUBE	- - - - -	150 MAX. MA.
PLATE DISSIPATION, PER TUBE	- - - - -	65 MAX. WATTS
SCREEN DISSIPATION, PER TUBE	- - - - -	10 MAX. WATTS

TYPICAL OPERATION

D-C Plate Voltage	- - - -	1000	1500	1750	Volts
D-C Screen Voltage	- - - -	500	500	500	Volts
D-C Grid Voltage (approx.)*	- - - -	-85	-85	-90	Volts
Zero-Signal D-C Plate Current	- - - -	30	30	20	Ma.
Max-Signal D-C Plate Current	- - - -	170	180	170	Ma.
Zero-Signal D-C Screen Current	- - - -	0	0	0	Ma.
Max-Signal D-C Screen Current	- - - -	24	14	17	Ma.
Effective Load, Plate-to-Plate	- - - -	9000	15,000	20,000	Ohms
Peak A-F Grid Input Voltage (per tube)	- - - -	85	85	90	Volts
Driving Power	- - - -	0	0	0	Watts
Max-Signal Plate Dissipation (per tube)	- - - -	45	63	62	Watts
Max-Signal Plate Power Output	- - - -	80	145	175	Watts

*Adjust to give stated zero signal plate current.

The effective grid circuit resistance for each tube must not exceed 250,000 ohms.

AUDIO FREQUENCY POWER AMPLIFIER AND MODULATOR Class-AB₂ (Sinusoidal wave, two tubes unless otherwise specified)

MAXIMUM RATINGS

D-C PLATE VOLTAGE	- - - - -	3000 MAX. VOLTS
D-C SCREEN VOLTAGE	- - - - -	600 MAX. VOLTS
MAX-SIGNAL D-C PLATE CURRENT, PER TUBE	- - - - -	150 MAX. MA.
PLATE DISSIPATION, PER TUBE	- - - - -	65 MAX. WATTS
SCREEN DISSIPATION, PER TUBE	- - - - -	10 MAX. WATTS

TYPICAL OPERATION

D-C Plate Voltage	- - - -	600	1000	1500	1800	Volts
D-C Screen Voltage	- - - -	250	250	250	250	Volts
D-C Grid Voltage (approx.)**	- - - -	-30	-30	-35	-35	Volts
Zero-Signal D-C Plate Current	- - - -	60	60	60	50	Ma.
Max-Signal D-C Plate Current	- - - -	300	300	250	220	Ma.
Zero-Signal D-C Screen Current	- - - -	0	0	0	0	Ma.
Max-Signal D-C Screen Current	- - - -	60	45	30	25	Ma.
Effective Load, Plate-to-Plate	- - - -	3600	6800	14,000	20,000	Ohms
Peak A-F Grid Input Voltage (per tube)	- - - -	120	105	100	90	Volts
Max-Signal Peak Driving Power	- - - -	6.2	5.0	3.2	2.2	Watts
Max-Signal Nominal Driving Power (approx.)	- - - -	3.1	2.5	1.6	1.1	Watts
Max-Signal Plate Dissipation (per tube)	- - - -	45	65	63	63	Watts
Max-Signal Plate Power Output	- - - -	90	170	250	270	Watts

**Adjust to give stated zero signal plate current.

**RADIO FREQUENCY LINEAR POWER AMPLIFIER
SINGLE SIDE BAND SUPPRESSED CARRIER
Class-B (One tube)**

MAXIMUM RATINGS

D-C PLATE VOLTAGE	- - - - -	3000 MAX. VOLTS
D-C SCREEN VOLTAGE	- - - - -	600 MAX. VOLTS
PLATE DISSIPATION	- - - - -	65 MAX. WATTS
SCREEN DISSIPATION	- - - - -	10 MAX. WATTS
GRID DISSIPATION	- - - - -	5 MAX. WATTS

*Adjust to give stated zero-signal plate current.
**Due to intermittent nature of voice average dissipation is considerably less than Max-Signal Dissipation.

TYPICAL OPERATION

D-C Plate Voltage	- - - - -	1500	2000	2500	Volts
D-C Screen Voltage	- - - - -	300	400	500	Volts
D-C Grid Voltage (approx.)*	- - - - -	-50	-75	-100	Volts
Zero-Signal D-C Plate Current	- - - - -	33	25	20	Ma.
Max-Signal D-C Plate Current	- - - - -	200	270	230	Ma.
Zero-Signal D-C Screen Current	- - - - -	0	0	0	Ma.
Max-Signal D-C Screen Current **	- - - - -	35	50	35	Ma.
Max-Signal Peak R. F. Grid Voltage	- - - - -	190	270	300	Volts
Max-Signal Avg. Grid Current	- - - - -	13	17	6	Ma.
Max-Signal Avg. Driving Power	- - - - -	2.4	4.6	1.8	Watts
Max-Signal Plate Dissipation**	- - - - -	105	190	225	Watts
Average Plate Dissipation	- - - - -	60	65	65	Watts
Max-Signal Useful Power Output	- - - - -	150	300	325	Watts

APPLICATION

MECHANICAL

Mounting—The 4-65A must be mounted vertically, base up or base down. The socket must provide clearance for the glass tip-off which extends from the center of the base. A flexible connecting strap should be provided between the plate terminal and the external plate circuit, and the Eimac HR6 cooler used on the tube plate lead. The socket must not apply lateral pressure against the base pins. The tube must be protected from severe vibration and shock.

Adequate ventilation must be provided so that the seals and envelope under operating conditions do not exceed 225°C. For operation above 50 Mc., the plate voltage should be reduced, or special attention should be given to seal cooling.

In intermittent-service applications where the "on" time does not exceed a total of five minutes in any ten minute period, plate seal temperatures as high as 250°C are permissible. When the ambient temperature does not exceed 30°C it will not ordinarily be necessary to provide forced cooling of the bulb and plate seal to hold the temperature below this maximum at frequencies below 50 Mc, provided that a heat-radiating plate connector is used, and the tube is so located that normal circulation of air past the envelope is not impeded.

ELECTRICAL

Filament Voltage—The filament voltage, as measured directly at the filament pins, should be between 5.7 volts and 6.3 volts.

Bias Voltage—D-C bias voltage for the 4-65A should not exceed 500 volts. If grid-leak bias is used, suitable protective means must be provided to prevent excessive plate or screen dissipation in the event of loss of excitation.

Grid Dissipation—Grid dissipation for the 4-65A should not be allowed to exceed five watts. Grid dissipation may be calculated from the following expression:

$$P_g = e_{c,mp} I_c$$

where P_g = Grid dissipation,
 $e_{c,mp}$ = Peak positive grid voltage,
and I_c = D-C grid current

$e_{c,mp}$ may be measured by means of a suitable peak voltmeter connected between filament and grid*

Screen Voltage—The D-C screen voltage for the 4-65A should not exceed 400 volts except in the case of class-AB audio operation and Single Side Band R-F amplifier operation where it would not exceed 600 volts.

Screen Dissipation—The power dissipated by the screen of the 4-65A must not exceed 10 watts. Screen dissipation is likely to rise to excessive values when the plate voltage, bias voltage or plate load is removed with filament and screen voltages applied. Suitable protective means must be provided to limit screen dissipation to 10 watts in the event of circuit failure.

Plate Voltage—The plate-supply voltage for the 4-65A should not exceed 3,000 volts. Above 50-Mc. it is advisable to use a lower plate voltage than the maximum, since the seal heating due to R-F charging currents in the screen leads increases with plate voltage and frequency. See instructions on seal cooling under "Mechanical" and "shielding."

Plate Dissipation—Under normal operating conditions, the plate dissipation of the 4-65A should not be allowed to exceed 65 watts in unmodulated applications.

In high-level-modulated amplifier applications, the maximum allowable carrier-condition plate dissipation is 45 watts.

Plate dissipation in excess of maximum rating is permissible for short periods of time, such as during tuning procedures.

OPERATION

Class-C FM or Telegraphy—The 4-65A may be operated as a class-C FM or telegraph amplifier without neutralization up to 110 Mc. if reasonable precautions are taken to prevent coupling between input and output circuits external to the tube. In single ended circuits, plate, grid, filament and screen by-pass capacitors should be returned through the shortest possible leads to a common chassis point. In push-pull applications the filament and screen terminals of each tube should be by-passed to a common chassis point by the shortest possible leads, and short, heavy leads should be used to interconnect the screens and filaments of the two tubes. Care should be taken to prevent leakage of radio-frequency energy to leads entering the amplifier, in order to minimize grid-plate coupling between these leads external to the amplifier.

Where shielding is adequate, the feedback at frequencies above 110 Mc. is due principally to screen-lead inductance effects, and it becomes necessary to introduce in-phase voltage from the plate circuit into the grid circuit. This can be done by adding capacitance between plate and grid external to the tube. Ordinary, a small metal tab approximately $\frac{3}{4}$ " square and located adjacent to the envelope opposite the plate will suffice for neutralization. Means should be provided for adjusting the spacing between the neutralizing capacitor plate and the envelope. An alternate neutralization scheme for use above 110 Mc., is illustrated in the diagram on page 4. In this circuit, feedback is eliminated by series-tuning the screen to ground with a small capacitor. The socket screen terminals should be strapped together as shown on the

*For suitable peak V.T.V.M. circuits see, for instance, "Vacuum Tube Ratings," Eimac News, January 1945. This article is available in reprint form on request.

Indicates change from previous sheet.

diagram, by the shortest possible lead, and the lead from the mid point of this screen strap to the capacitor, C, and from the capacitor to ground should be made as short as possible.

Driving power and power output under maximum output and plate voltage conditions are shown on page 2. The power output shown is the actual plate power delivered by the tube; the power delivered to the load will depend upon the efficiency of the plate tank and output coupling system. The driving power is likewise the driving power required by the tube (includes bias loss). The driver output power should exceed the driving power requirements by a sufficient margin to allow for coupling-circuit losses. The use of silver-plated linear tank-circuit elements is recommended for all frequencies above 75 Mc.

Class-C AM Telephony—The R-F circuit considerations discussed above under Class-C FM or Telegraphy also apply to amplitude-modulated operation of the 4-65A. When the 4-65A is used as a class-C high-level-modulated

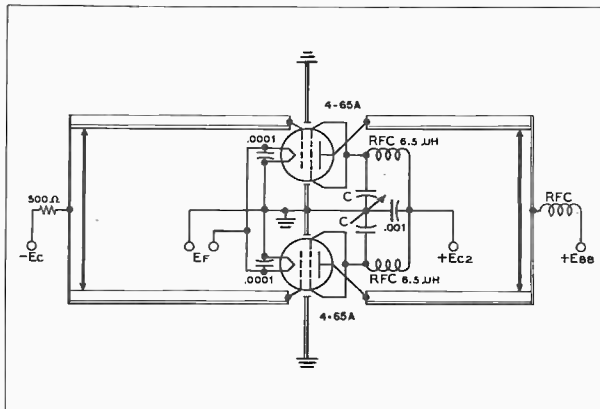

Screen-tuning neutralization circuit for use above 100 Mc.

C is a small split-stator capacitor.

$$C_{(u/d)} = \frac{640,000}{f^2 (\text{Mc.})}, \text{ approx.}$$

amplifier, both the plate and screen should be modulated. Modulation voltage for the screen is easily obtained by supplying the screen voltage via a series dropping resistor from the unmodulated plate supply, or by the use of an audio-frequency reactor in the positive screen-supply lead, or from a separate winding on the modulation transformer. When screen modulation is obtained by either the series-resistor or the audio-reactor methods, the audio-frequency variations in screen current which result from the variations in plate voltage as the plate is modulated automatically give the required screen modulation. Where a reactor is used, it should have a rated inductance of not less than 10 henries divided by the number of tubes in the modulated amplifier and a maximum current rating of two to three times the operating D-C screen current. To prevent phase-shift between the screen and plate modulation voltages at high audio frequencies, the screen by-pass capacitor should be no larger than necessary for adequate R-F by-passing.

For high-level modulated service, the use of partial grid-leak bias is recommended. Any by-pass capacitors placed across the grid-leak resistance should have a reactance at the highest modulation frequency equal to at least twice the grid-leak resistance.

Class-AB₁ and Class-AB₂ Audio—Two 4-65As may be used in a push-pull circuit to give relatively high audio output power at low distortion. Maximum ratings and typical operating conditions for class-AB₁ and class-AB₂ audio operation are given in the tabulated data.

Screen voltage should be obtained from a source hav-

ing reasonably good regulation, to prevent variations in screen voltage from zero-signal to maximum-signal conditions. The use of voltage regulator tubes in a standard circuit should provide adequate regulation.

Grid bias voltage for class AB₂ service may be obtained from batteries or from a small fixed-bias supply. When a bias supply is used, the D-C resistance of the bias source should not exceed 250 ohms. Under class-AB₁ conditions the effective grid-circuit resistance should not exceed 250,000 ohms.

The peak driving power figures given in the class-AB₂ tabulated data are included to make possible an accurate determination of the required driver output power. The driver amplifier must be capable of supplying the peak driving power without distortion. The driver stage should, therefore, be capable of providing an undistorted average output equal to half the peak driving power requirement. A small amount of additional driver output should be provided to allow for losses in the coupling transformer.

In some cases the maximum-signal plate dissipation shown under "Typical Operation" is less than the maximum rated plate dissipation of 4-65A. In these cases, with sine wave modulation, the plate dissipation reaches a maximum value, equal to the maximum rating, at a point somewhat below maximum-signal conditions.

The power output figures given in the tabulated data refer to the total power output from the amplifier tubes. The useful power output will be from 5 to 15 per cent less than the figures shown, due to losses in the output transformer.

Because of the intermittent nature of the voice, and the low average power, it is possible in cases where size and weight are important to operate a class-AB stage at higher peak power values than those indicated for sine wave.

In order to obtain peak power above that shown for sine wave (peak is twice average for sine wave), the plate-to-plate load impedance must be made proportionately lower than the value shown for a particular plate voltage. Also, more peak driving power will be required. At no time should the average plate or grid dissipation exceed the maximum values shown.

KEYING THE TETRODE AMPLIFIER

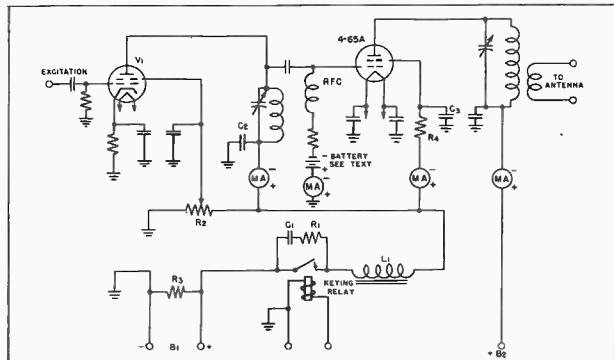

Tetrode Keying Circuit

The flow of plate current in an R-F tetrode amplifier depends not only on the control grid bias and excitation, but also on the voltage applied to the screen grid.

One easy method of keying is to remove the excitation and screen grid voltage simultaneously, while leaving the plate voltage still applied to the amplifier stage. This method also has an advantage in that the final tube can be made to draw a safe amount of current key-up position, maintaining a steadier drain on the power supply while keying. This tends to minimize "blinking lights" on weak AC supply lines when using moderate power. By properly

choosing the values of L, C, and R, in the circuit, perfectly clean-cut highest speed hand keying can easily be obtained that is entirely devoid of clicks.

The keying circuit is shown in the diagram and V_1 is the driver tube, which may be any one of the small tetrodes such as an 807, 6L6 or 6F6, used either as a frequency multiplier or a straight-through amplifier. This tube should furnish about five watts of output power which allows ample driving power for one 4-65A, including circuit losses. Capacitance coupling is shown in the diagram, but this, of course, could just as well be link coupling.

Steady driving power is fed to the grid of V_1 from the exciter. The keying circuit controls the plate and screen voltages on V_1 , as well as the screen voltage on the 4-65A, all obtained from a common power supply B. This supply should furnish sufficient voltage to the plate of V_1 to obtain the necessary driving power. Normally this voltage will be about the correct voltage for the screen of the 4-65A and resistor R₂ may be omitted.

When the key is up there is no excitation to the 4-65A, and consequently no grid leak bias. At the same time, the screen voltage has also been removed so that very little current is drawn by the plate. With plate voltages up to 2000 volts, the amount of current drawn is not sufficient to heat the plate beyond its rated plate dissipation and a fixed bias is not required. However, with plate voltages over 2000 volts, a small fixed bias supply is needed to keep the plate dissipation within the rated limit. An ordinary 22½ volt C battery in the control grid circuit will furnish sufficient bias to completely cut the plate current off at 3000 volts, while some lower value of bias can be used to permit a safe amount of current to flow in key-up position, presenting a more constant load to the power supply.

A tapped resistor R₂ serves to supply screen voltage to V_1 and by adjusting this tap, the excitation to the 4-65A may be easily controlled. This method of controlling the output of a tetrode is not recommended in the larger tetrodes, however, as it is wasteful of power and the lowered power output obtained is due to a loss in efficiency. R₂ also serves as a means of keeping the screen of the 4-65A at ground potential under key-up conditions, stabilizing the circuit. R₂ is the normal power supply bleeder.

The keying relay must be insulated to withstand the driver plate voltage. Key clicks may be completely eliminated by the proper selection of L₁, R₁ and C₁ in series with and across the relay. In many applications values of 500 ohms for R₁ and 0.25 ufd for C₁ have been found entirely satisfactory. Choke L₁ is best selected by trial and usually is on the order of 5 henries. A satisfactory choke for this purpose can be made by using any small power-supply choke, capable of handling the combined current of the final screen grid and the driver stage, and adjusting the air gap to give the proper inductance. This may be checked by listening for clean keying on the "make" side of the signal or by observation in a 'scope.

R-F by-pass condensers C₂ and C₃ will have some effect on the required value of L₁ as well as C₁. These by-pass condensers should be kept at as small a value of capacity as is needed. In most cases .002 ufd. is sufficient.

SHIELDING

The internal feedback of the tetrode has been substantially eliminated, and in order to fully utilize this advantage, it is essential that the design of the equipment completely eliminates any feedback external to the tube. This means complete shielding of the output circuit from the input circuit and earlier stages, proper reduction to low values of the inductance of the screen lead to the R-F ground, and elimination of R-F feedback in any common power supply leads.

Complete shielding is easily achieved by mounting the socket of the tube flush with the deck of the chassis as shown in the sketch.

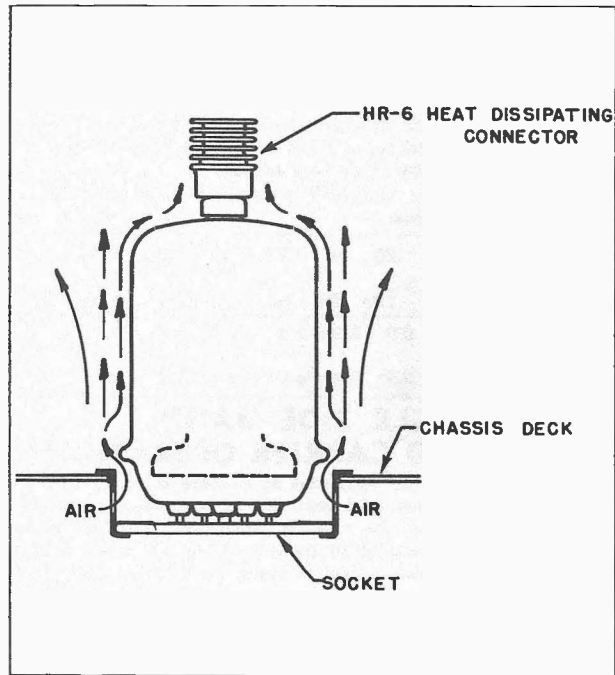

The holes in the socket permit the flow of convection air currents from below the chassis up past the seals in the base of the tube. This flow of air is essential to cool the tube and in cases where the complete under part of the chassis is enclosed for electrical shielding, screened holes or louvers should be provided to permit air circulation. Note that shielding is completed by aligning the internal screen shield with the chassis deck and by proper R-F by-passing of the screen leads to R-F ground. The plate and output circuits should be kept above deck and the input circuit and circuits of earlier stages should be kept below deck or completely shielded.

DIFFERENT SCREEN VOLTAGES

The published characteristic curves of tetrodes are shown for the commonly used screen voltages. Occasionally it is desirable to operate the tetrode at some screen voltage other than that shown on the characteristic curves. It is a relatively simple matter to convert the published curves to corresponding curves at a different screen voltage by the method to be described.

This conversion method is based on the fact that if all inter-electrode voltages are either raised or lowered by the same relative amount, the shape of the voltage field pattern is not altered, nor will the current distribution be altered; the current lines will simply take on new proportionate values in accordance with the three-halves power law. This method fails only where insufficient cathode emission or high secondary emission affect the current values.

For instance, if the characteristic curves are shown at a screen voltage of 250 volts and it is desired to determine conditions at 500 screen volts, all voltage scales should be multiplied by the same factor that is applied to the screen voltage (in this case—2). The 1000 volt plate voltage point now becomes 2000 volts, the 50 volt grid voltage point, 100 volts, etc.

The current lines then all assume new values in accordance with the 3/2 power law. Since the voltage was increased by a factor of 2, the current lines will all be increased in value by a factor of 2^{3/2} or 2.8. Then all the current values should be multiplied by the factor 2.8. The 100 ma. line becomes a 280 ma. line, etc.

Likewise, if the screen voltage given on the characteristic curve is higher than the conditions desired, the voltages should all be reduced by the same factor that is used to obtain the desired screen voltage. Correspondingly, the current values will all be reduced by an amount equal to the 3/2 power of this factor.

For convenience the 3/2 power of commonly used factors is given below:

Voltage Factor	.25	.5	.75	1.0	1.25	1.50	1.75
Corresponding							
Current Factor	.125	.35	.65	1.0	1.4	1.84	2.3
Voltage Factor	2.0	2.25	2.5	2.75	3.0		
Corresponding							
Current Factor	2.8	3.4	4.0	4.6	5.2		

SINGLE SIDE BAND SUPPRESSED CARRIER OPERATION

The 4-65A may be operated as a class B linear amplifier in SSSC operation and peak power outputs of over 300 watts per tube may be readily obtained. This is made possible by the intermittent nature of the voice. If steady audio sine wave modulation is used, the single side band will be continuous and the stage will operate as a C-W class-B amplifier. With voice modulation the average power will run on the order of 1/5th of this continuous power.

The same precautions regarding shielding, coupling between input and output circuits, and proper R-F bypassing must be observed, as described under Class-C Telegraphy Operation.

Due to the widely varying nature of the load imposed on the power supplies by SSSC operation, it is essential that particular attention be given to obtaining good regulation in these supplies. The bias supply especially, should have excellent regulation, and the addition of a heavy bleeder to keep the supply well loaded will be found helpful.

Under conditions of zero speech signal, the operating bias is adjusted so as to give a plate dissipation of 50 watts at the desired plate and screen voltages. Due to the intermittent nature of voice, the average plate dissipation will rise only slightly under full speech modulation to approximately 65 watts. At the same time, however, the peak speech power output of over 300 watts is obtained.

SSSC TUNING PROCEDURE

Tuning the SSSC transmitter is best accomplished with the aid of an audio frequency oscillator and a cathode-ray oscilloscope. The audio oscillator should be capable of delivering a sine wave output of a frequency of around 800 to 1000 cycles so that the frequency will be somewhere near the middle of the pass-band of the audio system. Since successful operation of the class-B stage depends on good linearity and the capability of delivering full power at highest audio levels, the final tuning should be made under conditions simulating peak modulation conditions. If a continuous sine wave from the audio oscillator is used for tuning purposes, the average power at full modulation would be about five times that of speech under similar conditions of single side band operation and the final amplifier would be subjected to a heavy overload. One method of lowering the duty cycle of the audio oscillator to closer approximate speech conditions would be to modulate the oscillator with a low frequency.

An alternate method would be to use the continuous audio sine wave, making all adjustments at half voltages and half currents on the screen and plate, thus reducing the power to one quarter. The stand-by plate dissipation under these conditions should be set at about 10 watts. Following these adjustments, minor adjustments at full voltages and 50 watts of stand-by plate dissipation could then be made, but only allowing the full power to remain on for ten or fifteen second intervals.

The first step is to loosely couple the oscilloscope to the output of the exciter unit. The final amplifier with its filament and bias voltages turned on should also be coupled to the exciter at this time. With the audio oscillator running, adjust the exciter unit so that it delivers double side band signals. Using a linear sweep on the oscilloscope, the double side band pattern will appear on the screen the same as that obtained from a 100% sine wave modulated AM signal. Next vary the audio gain control so that the exciter can be checked for linearity. When the peaks of the envelope start to flatten out the upper limit of the exciter output has been reached and the maximum gain setting should be noted. The coupling to the final stage should be varied during this process and a point of optimum coupling determined by watching the oscilloscope pattern and the grid meter in the final stage.

Next, adjust the exciter for single side band operation and if it is working properly, the pattern on the oscilloscope will resemble an unmodulated AM carrier. The phasing controls should be adjusted so as to make the envelope as smooth on the top and bottom as possible. If the above conditions are satisfied, the exciter unit can be assumed to be operating satisfactorily.

Next, loosely couple the oscilloscope link to the output of the final amplifier and again adjust the exciter unit to give double side band output.

If the reduced duty cycle method is used, the following tuning procedure may be followed:

1. Cut the audio output to zero.
2. Apply 120 volts of bias to the 4-65A control grid.
3. Apply the operating plate voltage followed by the operating screen voltage.
4. Reduce bias voltage to obtain 50 watts of stand-by plate dissipation.
5. Increase audio gain, checking the oscilloscope pattern for linearity as in the case of the exciter, and adjust for optimum antenna coupling.
6. Re-adjust exciter unit for single side band operation.
7. Disconnect test signal and connect microphone.
8. Adjust the audio gain so that the voice peaks give the same deflection on the oscilloscope screen as was obtained from the test signal peaks.

If the alternate method is used with a 100% duty cycle from the audio oscillator, then step 3 should be to apply half voltages and the stand-by plate dissipation should be set at 10 watts.

After the audio oscillator is disconnected and step 8 completed at half voltages, the full voltages can then be applied and the stand-by plate dissipation adjusted for 50 watts.

It is essential that the microphone cable be well shielded and grounded to avoid R-F feedback that might not occur when the lower impedance audio oscillator is used as an audio source.

Typical operational data are given for SSSC in the first part of this data sheet.

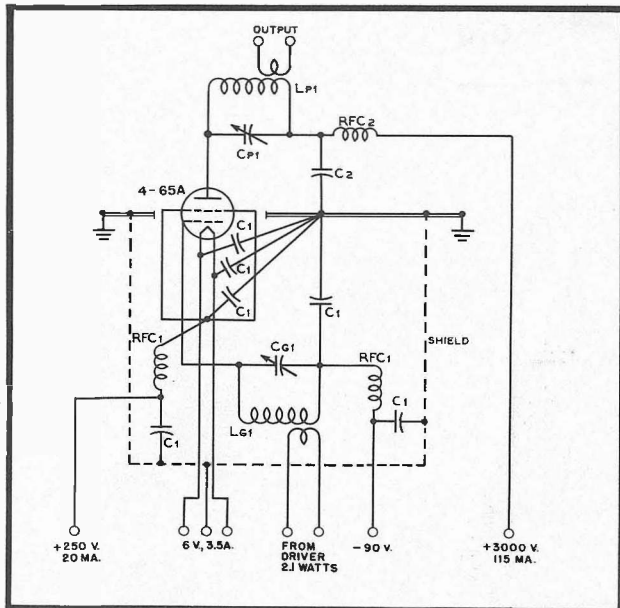

Typical radio-frequency power amplifier circuit, Class-C telegraphy, 345 watts input.

COMPONENTS FOR TYPICAL CIRCUITS

- $L_{p1} - C_{p1}$ — Tank circuit appropriate for operating frequency; $Q=12$. Capacitor plate spacing = .200".
- $L_{p2} - C_{p2}$ — Tank circuit appropriate for operating frequency; $Q=12$. Capacitor plate spacing = .200".
- $L_{p3} - C_{p3}$ — Tank circuit appropriate for operating frequency; $Q=12$. Capacitor plate spacing = .375".
- $L_{g1} - C_{g1}$ — Tuned circuit appropriate for operating frequency.
- $L_{g2} - C_{g2}$ — Tuned circuit appropriate for operating frequency.
- C_1 — .002 ufd. 500V Mica
- C_2 — .002 ufd. 5000V Mica
- C_3 — .001 ufd. 2500V Mica
- C_4 — .1 ufd. 1000V paper
- C_5 — .1 ufd. 600 V paper
- C_6 — 16 ufd. 450V Electrolytic
- C_7 — 10 ufd. 100V Electrolytic
- R_1 — 53,000 ohms 200 watt—60,000 ohm adjustable
- R_2 — 250,000 ohms 1 watt
- R_3 — 5,000 ohms 5 watt
- R_4 — 25,000 ohms 2 watts
- R_5 — 26,500 ohms 200 watts—30,000 ohm adjustable
- R_6 — 2,500 ohms 5 watts
- R_7 — 750 ohms 5 watts
- RFC_1 — 2.5 mhy. 125 ma. R-F choke
- RFC_2 — 1 mhy. 500 ma. R-F choke
- T_1 — 150 watt modulation transformer; ratio primary to secondary impedance approx. 1:1.1 Pri. impedance 15,000 ohms, sec. impedance 16,700 ohms.
- T_2 — 5 watt driver transformer impedance ratio primary to 1/2 secondary 1.5:1.
- T_3 — 300 watt modulation transformer; impedance ratio pri. to sec. approx. 2.4:1; Pri. impedance = 20,000 ohms, sec. impedance = 8,333 ohms.

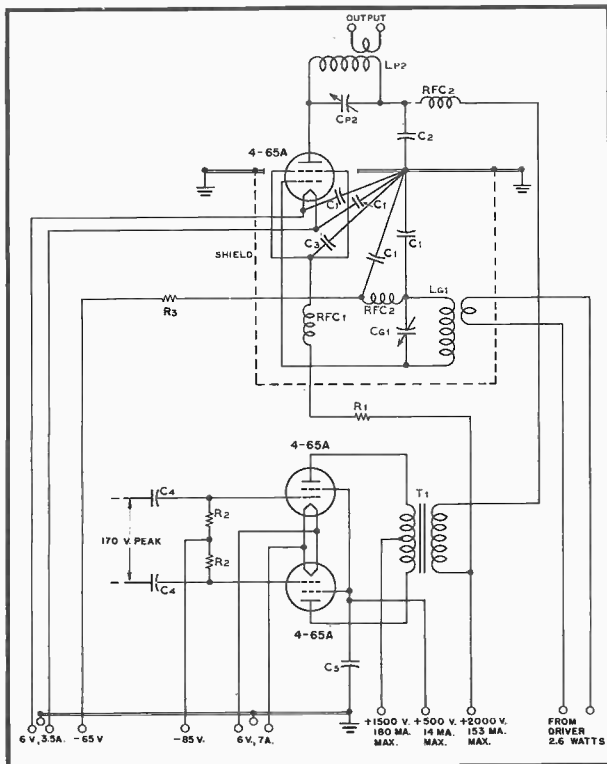

Typical high-level-modulated R-F amplifier, 240 watts plate input. Modulator requires zero driving power.

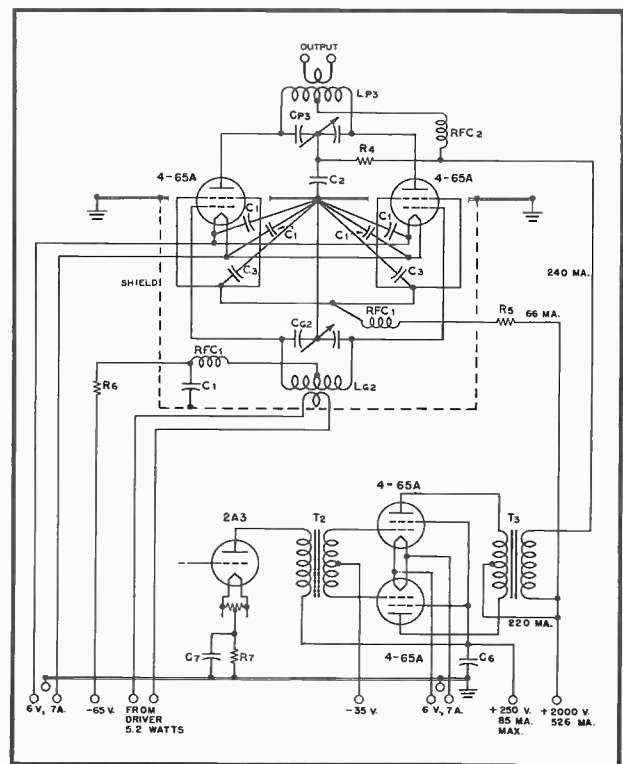

Typical high-level-modulated R-F amplifier circuit, with modulator and driver stages, 480 watts plate input.

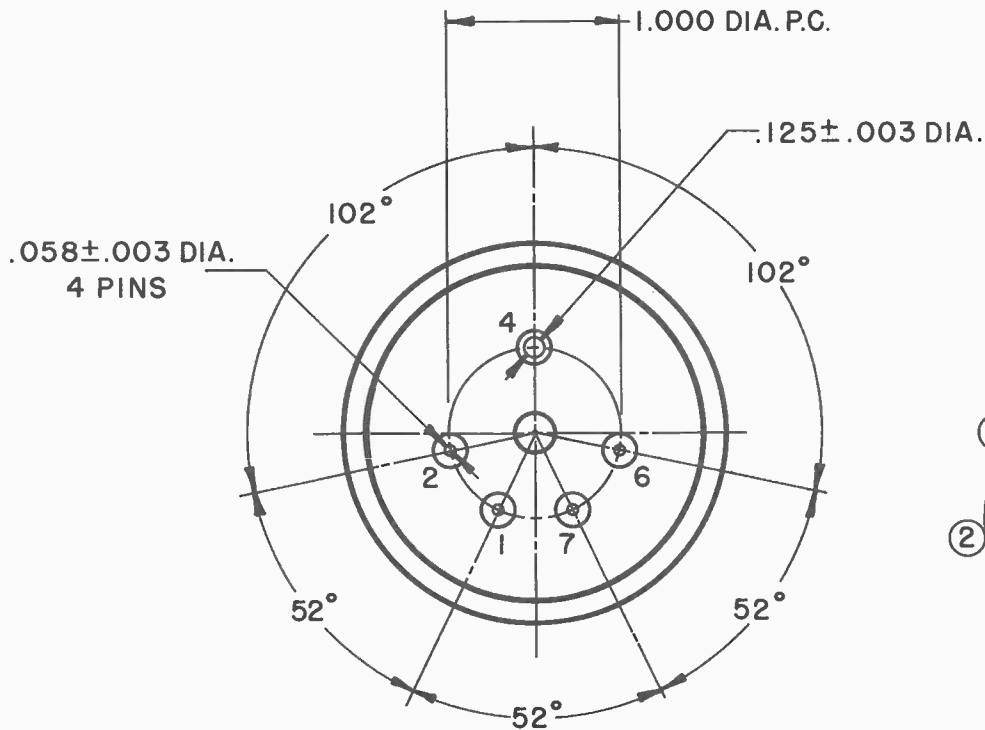
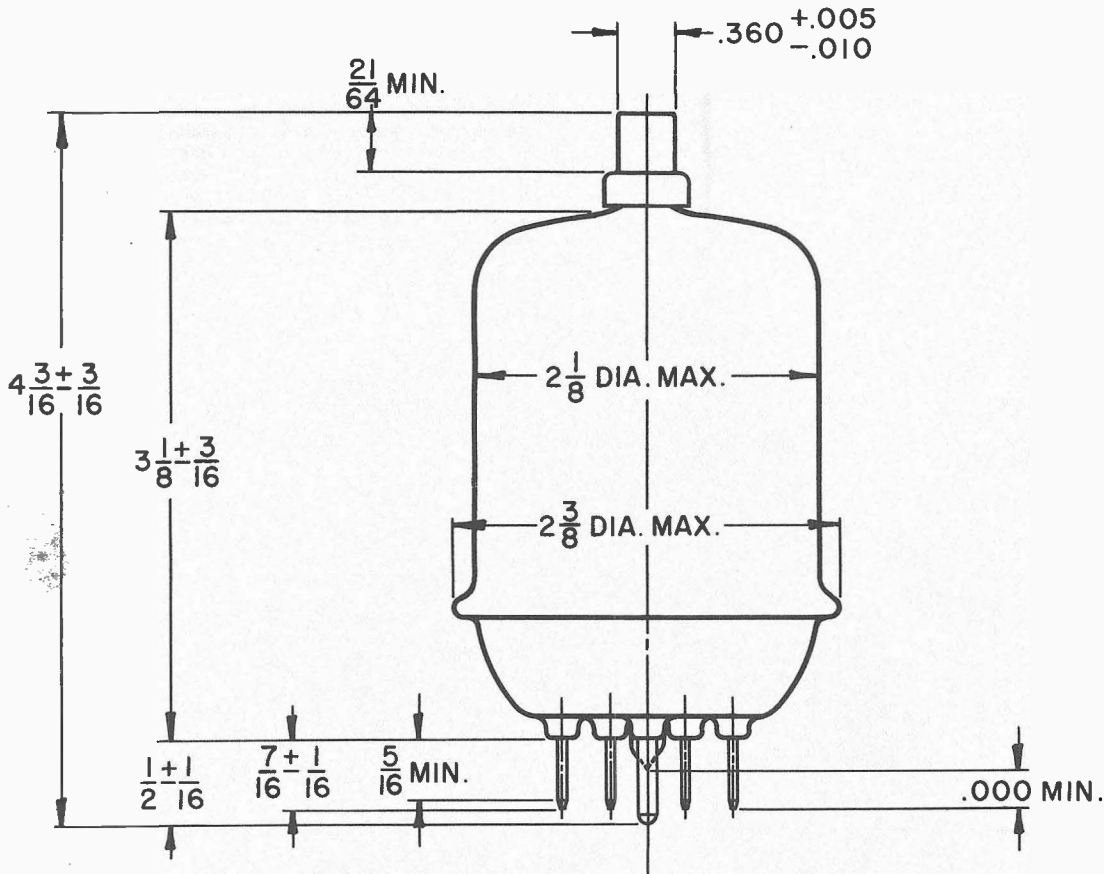

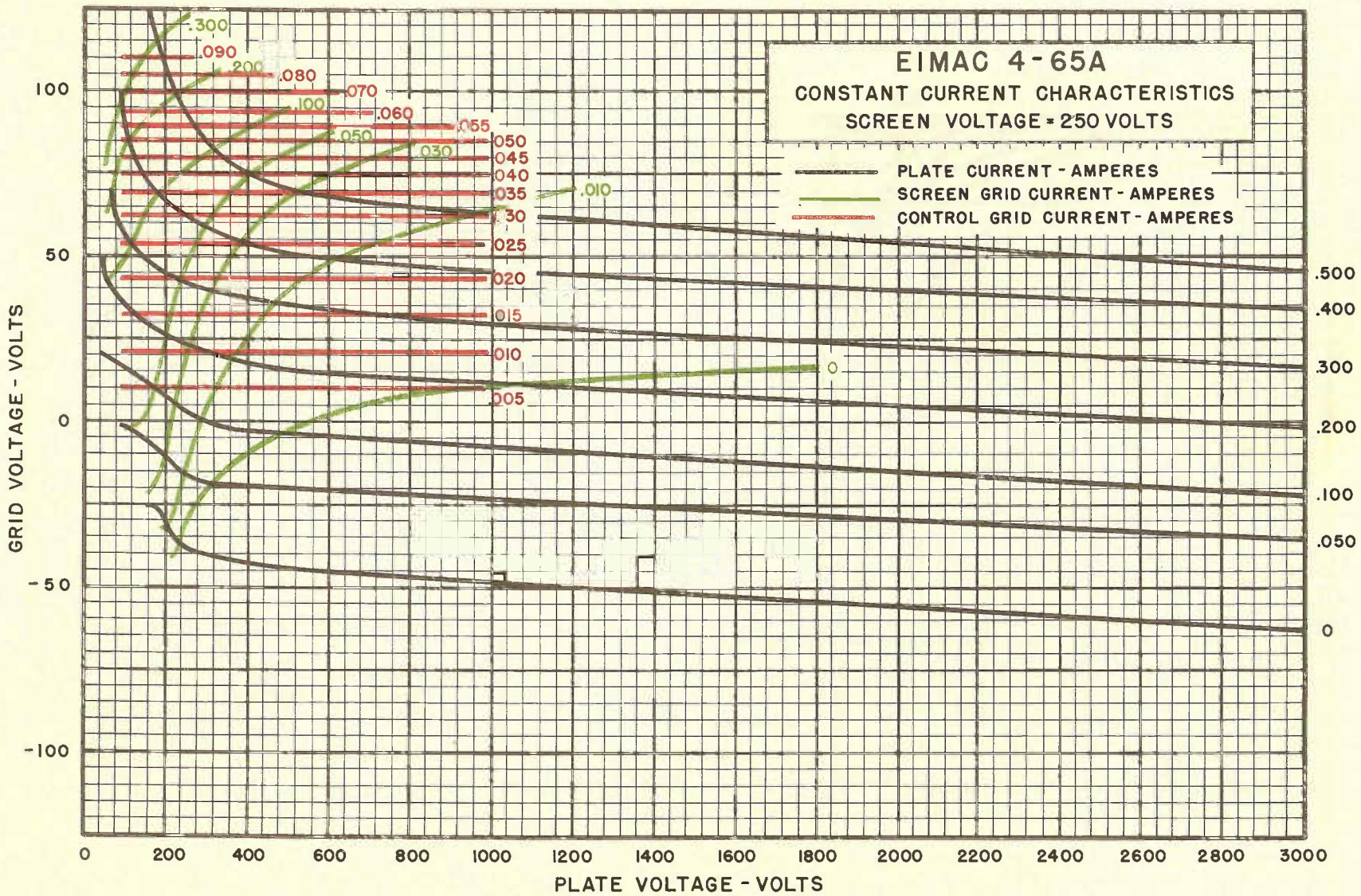

Simplic
 4-65A

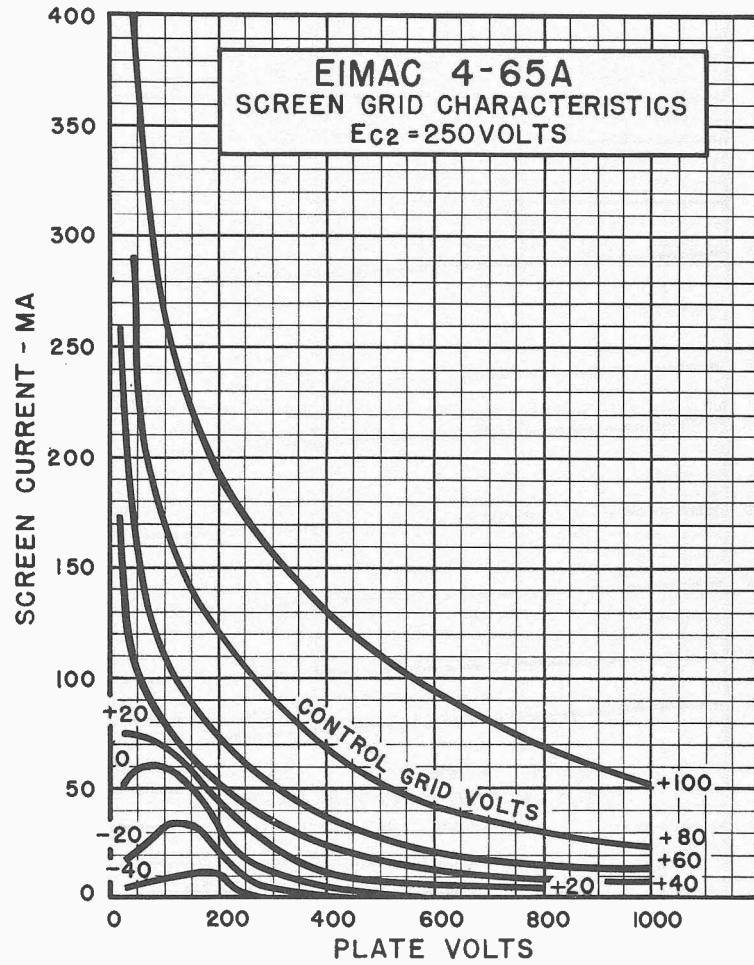
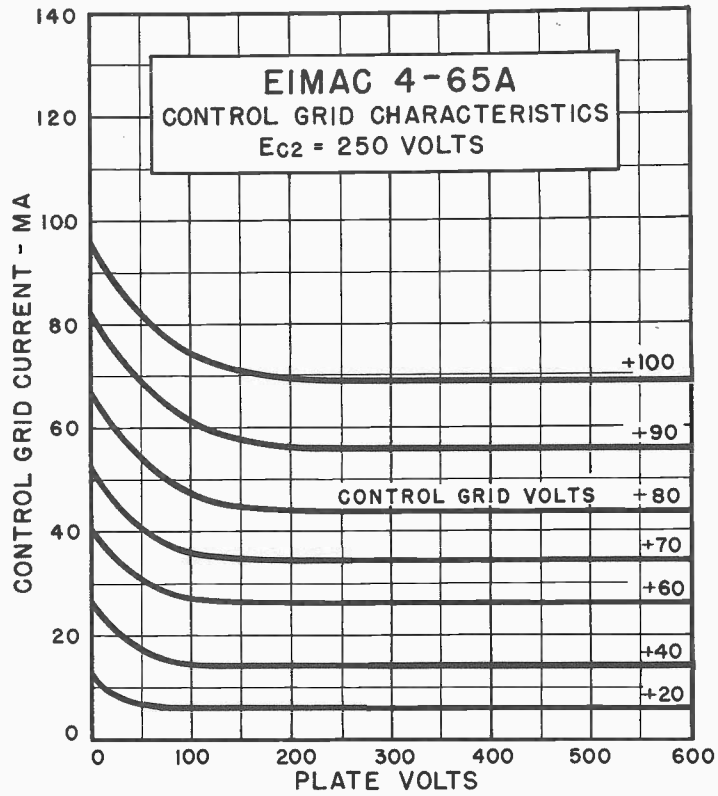

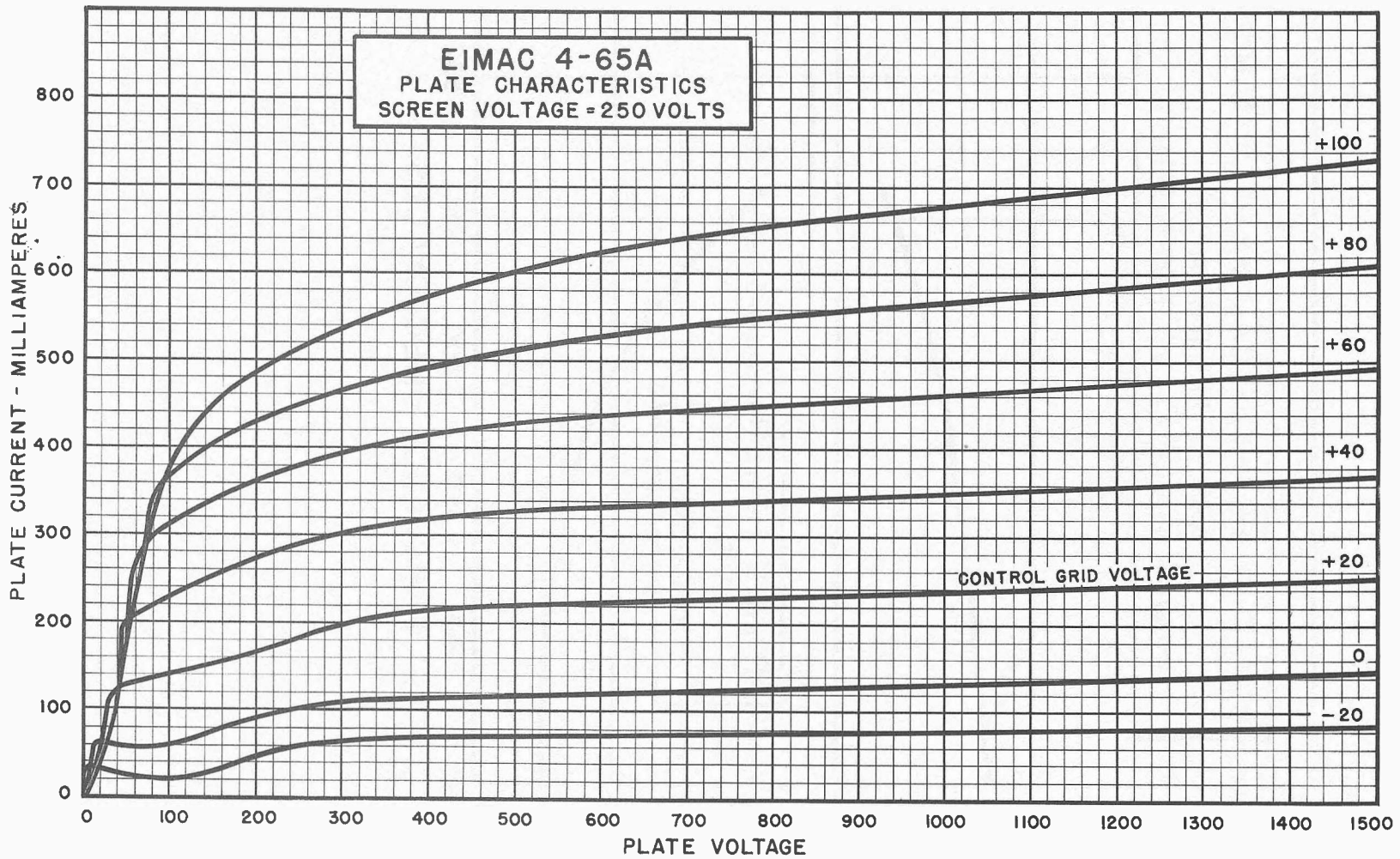

Eimac
 4-65A
U.S. PAT. OFF.

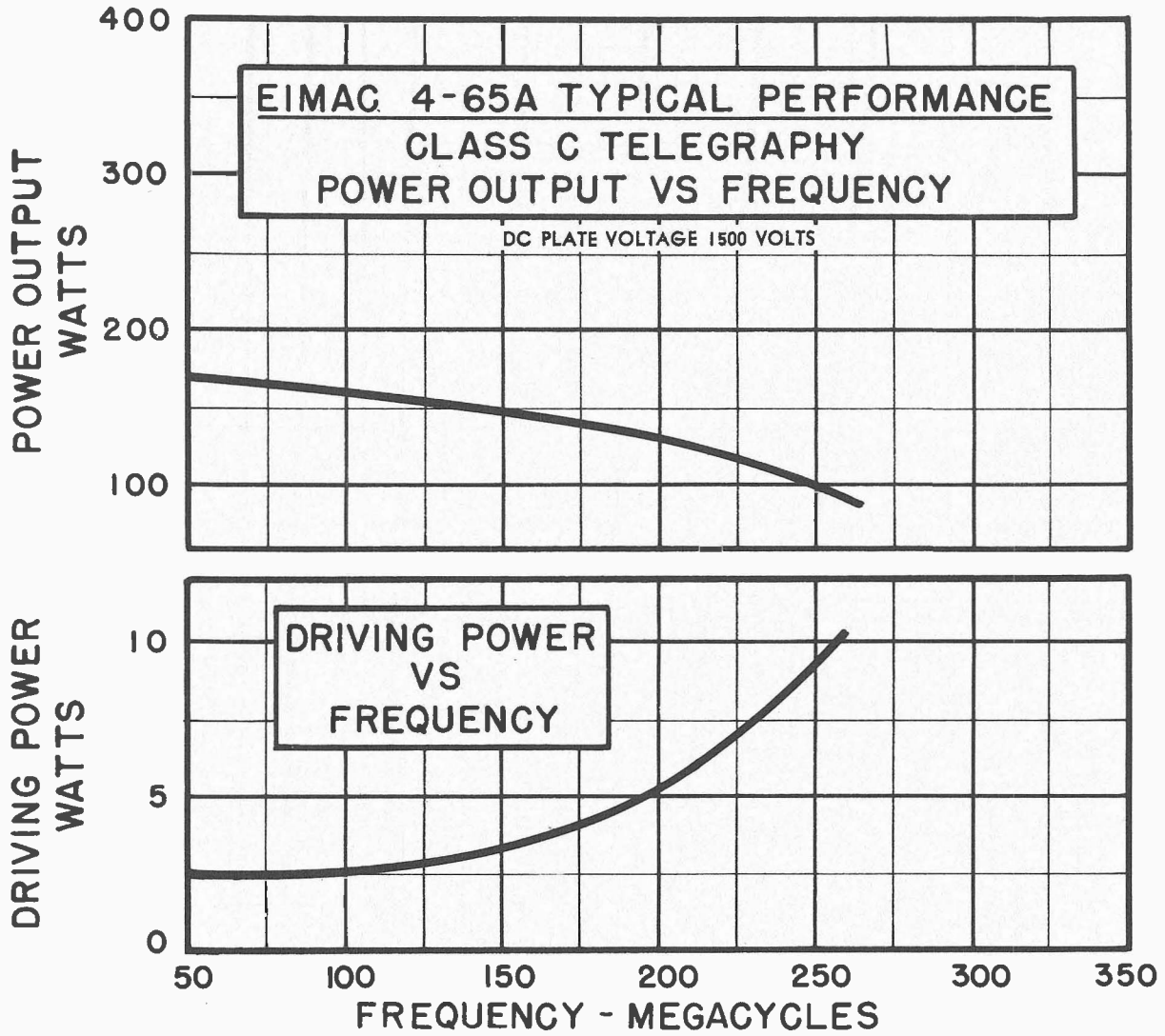

Eimac
EITEL-McCULLOUGH, INC.
 SAN BRUNO, CALIFORNIA

4-125A

(RMA 4D21)

POWER TETRODE

•
**MODULATOR
 OSCILLATOR
 AMPLIFIER**

The Eimac 4-125A is a power tetrode having a maximum plate dissipation rating of 125 watts, and is intended for use as an amplifier, oscillator or modulator. Due to its high power sensitivity, it will deliver relatively large output with low driving power. The low grid-plate capacitance of the 4-125A makes neutralization unnecessary in most cases, and simplifies it in other cases. The compact construction of this tube permits its operation at full input up to frequencies as high as 120 Mc.

Cooling of the 4-125A is accomplished by radiation from the plate, which operates at a visible red color at maximum dissipation, and by air circulation through the base and around the envelope.



GENERAL CHARACTERISTICS

ELECTRICAL

Filament: Thoriated tungsten

Voltage	-	5.0	volts
Current	-	6.5	amperes

▶ Grid-Screen Amplification Factor (Average)	-	5.9	
--	---	-----	--

Direct Interelectrode Capacitances (Average)

Grid-Plate (without shielding, base grounded)	-	0.05	μfd.
Input	-	10.8	μfd.
Output	-	3.1	μfd.

Transconductance ($i_b=50$ ma., $E_b=2500$ v., $E_{c2}=400$ v.)	-	2450	μmhos
--	---	------	-------

MECHANICAL

Base	-	5-pin metal shell, No. 5008B	
Basing	-	RMA type 5BK	
Cooling	-	Radiation and forced air	
Maximum Overall Dimensions:			
Length	-	5.69	inches
Diameter	-	2.72	inches
Net Weight	-	6.5	ounces
Shipping Weight (Average)	-	1.5	pounds

IF IT IS DESIRED TO OPERATE THIS TUBE UNDER CONDITIONS WIDELY DIFFERENT THAN THOSE GIVEN UNDER "TYPICAL OPERATION," AND WHICH POSSIBLY EXCEED MAXIMUM RATINGS, WRITE EITEL-McCULLOUGH, INC., FOR INFORMATION AND RECOMMENDATIONS.

RADIO FREQUENCY POWER AMPLIFIER AND OSCILLATOR
 Class-C Telephony or FM Telephony (Key-down conditions, 1 tube)

MAXIMUM RATINGS

D-C PLATE VOLTAGE	- - - - -	3000 MAX. VOLTS
D-C SCREEN VOLTAGE	- - - - -	400 MAX. VOLTS
D-C GRID VOLTAGE	- - - - -	-500 MAX. VOLTS
D-C PLATE CURRENT	- - - - -	225 MAX. MA.
PLATE DISSIPATION	- - - - -	125 MAX. WATTS
SCREEN DISSIPATION	- - - - -	20 MAX. WATTS
GRID DISSIPATION	- - - - -	5 MAX. WATTS

TYPICAL OPERATION (Frequencies below 120 Mc.)

D-C Plate Voltage	- - - - -	2000	2500	3000	volts
D-C Screen Voltage	- - - - -	350	350	350	volts
D-C Grid Voltage	- - - - -	-100	-150	-150	volts
D-C Plate Current	- - - - -	200	200	167	ma.
D-C Screen Current	- - - - -	50	40	30	ma.
D-C Grid Current	- - - - -	12	12	9	ma.
Screen Dissipation	- - - - -	18	14	10.5	watts
Grid Dissipation	- - - - -	1.6	2	1.2	watts
Peak R-F Grid Input Voltage (approx.)	-	230	320	280	volts
Driving Power (approx.) ²	- - - - -	2.8	3.8	2.5	watts
Plate Power Input	- - - - -	400	500	500	watts
Plate Dissipation	- - - - -	125	125	125	watts
Plate Power Output	- - - - -	275	375	375	watts

AUDIO FREQUENCY POWER AMPLIFIER AND MODULATOR
 Class-AB₂ (Sinusoidal wave, two tubes unless otherwise specified)

MAXIMUM RATINGS

D-C PLATE VOLTAGE	- - - - -	3000 MAX. VOLTS
D-C SCREEN VOLTAGE	- - - - -	600 MAX. VOLTS
MAX-SIGNAL D-C PLATE CURRENT, PER TUBE	- - - - -	225 MAX. MA.
PLATE DISSIPATION, PER TUBE	- - - - -	125 MAX. WATTS
SCREEN DISSIPATION, PER TUBE	- - - - -	20 MAX. WATTS

TYPICAL OPERATION

D-C Plate Voltage	- - - - -	1500	2000	2500	volts
D-C Screen Voltage	- - - - -	600	600	600	volts
D-C Grid Voltage ²	- - - - -	-90	-94	-96	volts
Zero-Signal D-C Plate Current	- - - - -	60	50	50	ma.
Max-Signal D-C Plate Current	- - - - -	222	240	232	ma.
Zero-Signal D-C Screen Current	- - - - -	-1.0	-0.5	-0.3	ma.
Max-Signal D-C Screen Current	- - - - -	17	6.4	8.5	ma.
Effective Load, Plate-to-Plate	- - - - -	10,200	13,400	20,300	ohms
Peak A-F Grid Input Voltage (per tube)	- - - - -	90	94	96	volts
Driving Power	- - - - -	0	0	0	watt
Max-Signal Plate Dissipation (per tube)	- - - - -	87.5	125	125	watts
Max-Signal Plate Power Output	- - - - -	158	230	330	watts
Total Harmonic Distortion	- - - - -	5	2	2.6	per ct.

¹ Above 120 Mc. the maximum plate voltage rating depends upon frequency see page 8.

HIGH-LEVEL MODULATED RADIO FREQUENCY AMPLIFIER
 Class-C Telephony (Carrier conditions unless otherwise specified, 1 tube)

MAXIMUM RATINGS

D-C PLATE VOLTAGE	- - - - -	2500 MAX. VOLTS
D-C SCREEN VOLTAGE	- - - - -	400 MAX. VOLTS
D-C GRID VOLTAGE	- - - - -	-500 MAX. VOLTS
D-C PLATE CURRENT	- - - - -	200 MAX. MA.
PLATE DISSIPATION	- - - - -	85 MAX. WATTS
SCREEN DISSIPATION	- - - - -	20 MAX. WATTS
GRID DISSIPATION	- - - - -	5 MAX. WATTS

TYPICAL OPERATION (Frequencies below 120 Mc.)

D-C Plate Voltage	- - - - -	2000	2500	volts
D-C Screen Voltage	- - - - -	350	350	volts
D-C Grid Voltage	- - - - -	-220	-210	volts
D-C Plate Current	- - - - -	150	152	ma.
D-C Screen Current	- - - - -	33	30	ma.
D-C Grid Current	- - - - -	10	9	ma.
Screen Dissipation	- - - - -	11.5	10.5	watts
Grid Dissipation	- - - - -	1.6	1.4	watts
Peak A-F Screen Voltage, 100% Modulation	- - - - -	210	210	volts
Peak R-F Grid Input Voltage (approx.)	- - - - -	375	360	volts
Driving Power (approx.) ²	- - - - -	3.8	3.3	watts
Plate Power Input	- - - - -	300	380	watts
Plate Dissipation	- - - - -	75	80	watts
Plate Power Output	- - - - -	225	300	watts

AUDIO FREQUENCY POWER AMPLIFIER AND MODULATOR
 Class-AB₂ (Sinusoidal wave, two tubes unless otherwise specified)

MAXIMUM RATINGS

D-C PLATE VOLTAGE	- - - - -	3000 MAX. VOLTS
D-C SCREEN VOLTAGE	- - - - -	400 MAX. VOLTS
MAX-SIGNAL D-C PLATE CURRENT, PER TUBE	- - - - -	225 MAX. MA.
PLATE DISSIPATION, PER TUBE	- - - - -	125 MAX. WATTS
SCREEN DISSIPATION, PER TUBE	- - - - -	20 MAX. WATTS

TYPICAL OPERATION

D-C Plate Voltage	- - - - -	1500	2000	2500	volts
D-C Screen Voltage	- - - - -	350	350	350	volts
D-C Grid Voltage	- - - - -	-41	-45	-43	volts
Zero-Signal D-C Plate Current	- - - - -	87	72	93	ma.
Max-Signal D-C Plate Current	- - - - -	400	300	260	ma.
Zero-Signal D-C Screen Current	- - - - -	0	0	0	ma.
Max-Signal D-C Screen Current	- - - - -	34	5	6	ma.
Effective Load, Plate-to-Plate	- - - - -	7200	13,600	22,200	ohms
Peak A-F Grid Input Voltage (per tube)	- - - - -	141	105	89	volts
Max-Signal Avg. Driving Power (approx.)	- - - - -	2.5	1.4	1	watts
Max-Signal Peak Driving Power	- - - - -	5.2	3.1	2.4	watts
Max-Signal Plate Dissipation (per tube)	- - - - -	125	125	122	watts
Max-Signal Plate Power Output	- - - - -	350	350	400	watts
Total Harmonic Distortion	- - - - -	2.5	1	2.2	per ct.

² The effective grid circuit resistance for each tube must not exceed 250,000 ohms.

³ Driving power increases above 70 Mc. See Page Eight.

APPLICATION

MECHANICAL

Mounting—The 4-125A must be mounted vertically, base up or base down. The socket must provide clearance for the glass tip-off which extends through the center of the base. The metal base shell should be grounded by means of suitable spring fingers. A flexible connecting strap should be provided between the plate terminal and the external plate circuit. The socket must not apply excessive lateral pressure against the base pins. The tube must be protected from severe vibration and shock.

Cooling—Adequate cooling must be provided for the seals and envelope of the 4-125A. In continuous-service applications, the temperature of the plate seal, as measured on the top of the plate cap, should not exceed 170° C. A relatively slow movement of air past the tube is sufficient to prevent seal temperatures in excess of maximum at frequencies below 30 Mc. At frequencies above 30 Mc., radio-frequency losses in the leads and envelope contribute to seal and envelope heating, and special attention should be given to cooling. A small fan or centrifugal blower directed toward the upper portion of the envelope will usually provide sufficient circulation for cooling at frequencies above 30 Mc., however.

In intermittent-service applications where the "on" time does not exceed a total of five minutes in any ten-minute period, plate seal temperatures as high as 220° C. are permissible. When the ambient temperature does not exceed 30° C. it will not ordinarily be necessary to provide forced cooling to hold the temperature below this maximum at frequencies below 30 Mc., provided that a heat-dissipating plate connector is used, and the tube is so located that normal circulation of air past the envelope is not impeded.

Provision must be made for circulation of air through the base of the tube. Where shielding or socket design makes it impossible to allow free circulation of air through the base, it will be necessary to apply forced-air cooling to the stem structure. An air flow of two cubic feet per minute through the base will be sufficient for stem cooling.

ELECTRICAL

Filament Voltage—For maximum tube life the filament voltage, as measured directly at the filament pins, should be the rated value of 5.0 volts. Unavoidable variations in filament voltage must be kept within the range from 4.75 to 5.25 volts.

Bias Voltage—D-c bias voltage for the 4-125A should not exceed 500 volts. If grid-leak bias is used, suitable protective means must be provided to prevent excessive plate or screen dissipation in the event of loss of excitation.

Screen Voltage—The d-c screen voltage for the 4-125A should not exceed 400 volts, except for class-AB₁ audio operation.

Plate Voltage—The plate-supply voltage for the 4-125A should not exceed 3000 volts for frequencies below 120 Mc. The maximum permissible plate voltage is less than

3000 volts above 120 Mc., as shown by the graph on page 8.

Grid Dissipation—Grid dissipation for the 4-125A should not be allowed to exceed five watts. Grid dissipation may be calculated from the following expression:

$$P_g = e_{cmp} I_c$$

where P_g = Grid dissipation,

e_{cmp} = Peak positive grid voltage, and

I_c = D-c grid current.

e_{cmp} may be measured by means of a suitable peak voltmeter connected between filament and grid³.

Screen Dissipation—The power dissipated by the screen of the 4-125A must not exceed 20 watts. Screen dissipation is likely to rise to excessive values when the plate voltage, bias voltage or plate load are removed with filament and screen voltages applied. Suitable protective means must be provided to limit screen dissipation to 20 watts in the event of circuit failure.

Plate Dissipation—Under normal operating conditions, the plate dissipation of the 4-125A should not be allowed to exceed 125 watts in unmodulated applications.

In high-level-modulated amplifier applications, the maximum allowable carrier-condition plate dissipation is 85 watts. The plate dissipation will rise to 125 watts under 100% sinusoidal modulation.

Plate dissipation in excess of the maximum rating is permissible for short periods of time, such as during tuning procedures.

OPERATION

Class-C Telephony or FM Telephony—The 4-125A may be operated as a class-C telegraph or FM telephone amplifier without neutralization up to 100 Mc. if reasonable precautions are taken to prevent coupling between input and output circuits external to the tube. A grounded metallic plate on which the socket may be mounted and to which suitable connectors may be attached to ground the tube base shell provides an effective isolating shield between grid and plate circuits. In single-ended circuits, plate, grid, filament and screen by-pass capacitors should be returned through the shortest possible leads to a common chassis point. In push-pull applications the filament and screen terminals of each tube should be by-passed to a common chassis point by the shortest possible leads, and short, heavy leads should be used to interconnect the screens and filaments of the two tubes. Care should be taken to prevent leakage of radio-frequency energy to leads entering the amplifier, to prevent grid-plate coupling between these leads external to the amplifier.

Above 100 Mc., or at lower frequencies if shielding is inadequate, it is necessary to neutralize the 4-125A in ordinary applications.

Where shielding is adequate, the feed-back at frequencies above 100 Mc. is due principally to screen-lead-inductance effects, and it becomes necessary to introduce

³ For suitable peak v.t.v.m. circuits see, for instance, "Vacuum Tube Ratings," Eimac News, January, 1945. This article is available in reprint form on request.

in-phase voltage from the plate circuit into the grid circuit. This can be done by adding capacitance between plate and grid external to the tube. Ordinarily, a small metal tab approximately 3/4-inch square connected to the grid terminal and located adjacent to the envelope opposite the plate will suffice for neutralization. Means should be provided for adjusting the spacing between the neutralizing capacitor plate and the envelope, but care must be taken to prevent the neutralizing plate from touching the envelope. An alternative neutralization scheme is illustrated in the diagram below. In this circuit feed-back is eliminated by series-tuning the screen to ground with a small capacitor. The socket screen terminals should be strapped together, as shown on the dia-

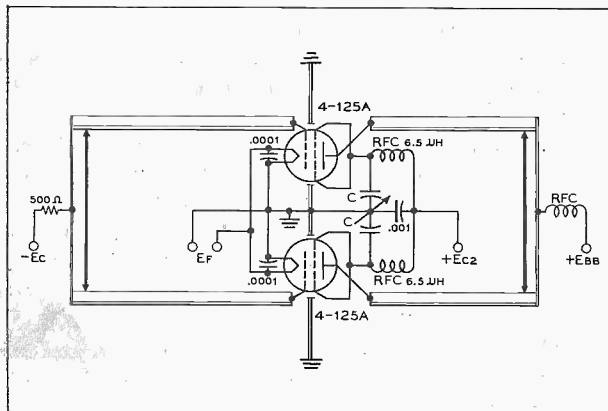

Screen-tuning neutralization circuit for use above 100 Mc.

C is a small split-stator capacitor.

$$C_{(uH/d)} = \frac{640,000}{f^2 (Mc.)^2} \text{ approx.}$$

gram, by the shortest possible lead, and the leads from the screen terminal to the capacitor, C, and from the capacitor to ground should be made as short as possible. All connections to the screen terminals should be made to the center of the strap between the terminals, in order to equalize the current in the two screen leads and prevent overheating one of them. The value for C given under the diagram presupposes the use of the shortest possible leads.

At frequencies below 100 Mc., and where shielding is inadequate, ordinary neutralization systems may be used. With reasonably effective shielding, however, neutralization should not be required below 100 Mc.

The driving power and power output under typical operating conditions, with maximum output and plate voltage, are shown on page 8. The power output shown is the actual plate power delivered by the tube; the power delivered to the load will depend upon the efficiency of the plate tank and output coupling system. The driving power is likewise the driving power required by the tube (includes bias loss). The driver output power should exceed the driving power requirement by a sufficient margin to allow for coupling-circuit losses. These losses will not ordinarily amount to more than 30 or 40 per cent of the driving power, except at frequencies above 150 Mc. The

use of silver-plated linear tank-circuit elements is recommended at frequencies above 100 Mc.

Conventional capacitance-shortened quarter-wave linear grid tank circuits having a calculated Z_0 of 160 ohms or less may be used with the 4-125A up to 175 Mc. Above 175 Mc. linear grid tank circuits employing a "capacitor"-type shorting bar, as illustrated in the diagram below, may be used. The capacitor, C_1 , may consist of two silver-plated brass plates one inch square with a piece of .010-inch mica or polystyrene as insulation.

Class-C AM Telephony—The r-f circuit considerations discussed above under Class-C Telegraphy or FM Telephony also apply to amplitude-modulated operation of the 4-125A. When the 4-125A is used as a class-C high-level-

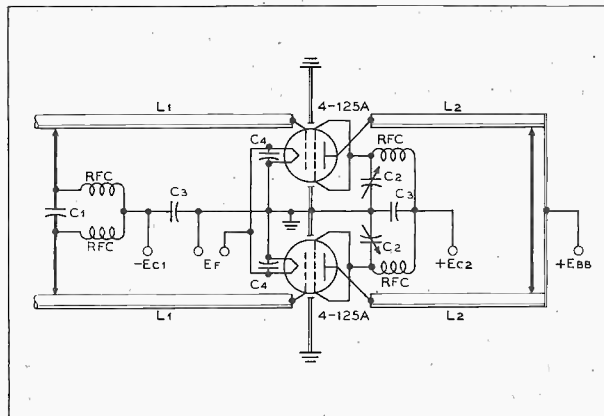

Typical circuit arrangement useful for frequencies above 175 Mc.

- C₁—See above.
- C₂—Neutralizing capacitor.
- C₃—.001 ufd.
- C₄—100 uufd.

- L₁—3/8" dia. copper spaced, 1" center-to-center, 6" long.
- L₂—7/8" dia. brass, silver plated, spaced 1/2" center-to-center, 14" long.

modulated amplifier, modulation should be applied to both plate and screen. Modulation voltage for the screen may be obtained from a separate winding on the modulation transformer, by supplying the screen voltage via a series dropping resistor from the unmodulated plate supply, or by the use of an audio-frequency reactor in the positive screen-supply lead. When screen modulation is obtained by either the series-resistor or the audio-reactor method, the audio-frequency variations in screen current which result from variations in plate voltage as the plate is modulated automatically give the required screen modulation. Where a reactor is used, it should have a rated inductance of not less than 10 henries divided by the number of tubes in the modulated amplifier and a maximum current rating of two or three times the operating d-c screen current. To prevent phase shift between the screen and plate modulation voltages at high audio frequencies, the screen by-pass capacitor should be no larger than necessary for adequate r-f by-passing. Where screen voltage is obtained from a separate winding on the modulation transformer, the screen winding should be designed to deliver the peak screen modulation voltage given in the typical operating data on page 1.

For high-level modulated service, the use of partial grid-leak bias is recommended. Any by-pass capacitors placed across the grid-leak resistance should have a reactance at the highest modulation frequency equal to at least twice the grid-leak resistance.

Class-AB₁ and Class-AB₂ Audio—Two 4-125A's may be used in a push-pull circuit to give relatively high audio output power at low distortion. Maximum ratings and typical operating conditions for class-AB₁ and class-AB₂ audio operation are given in the tabulated data.

When type 4-125A tubes are used as class-AB₁ or class-AB₂ audio amplifiers at 1500 plate volts, under the conditions given under "Typical Operation," the screen voltage must be obtained from a source having reasonably good regulation, to prevent variations in screen voltage from zero-signal to maximum-signal conditions. The use of voltage regulator tubes in a standard circuit will provide adequate regulation. The variation in screen current at plate voltages of 2000 and above is low enough so that any screen power supply having a normal order of regulation will serve. The driver plate supply makes a convenient source of screen voltage under these conditions.

Grid bias voltage for class-AB₂ service may be obtained from batteries or from a small fixed-bias supply. When a bias supply is used, the d-c resistance of the bias source should not exceed 250 ohms. Under class-AB₁ conditions the effective grid-circuit resistance for each tube should not exceed 250,000 ohms.

The peak driving power figures given in the class-AB₂ tabulated data are included to make possible an accurate determination of the required driver output power. The driving amplifier must be capable of supplying the peak driving power without distortion. The driver stage should, therefore, be capable of providing an undistorted average output equal to half the peak driving power require-

ment. A small amount of additional driver output should be provided to allow for losses in the coupling transformer.

The power output figures given in the tabulated data refer to the total power output from the amplifier tubes. The useful power output will be from 5 to 15 per cent less than the figures shown, due to losses in the output transformer.

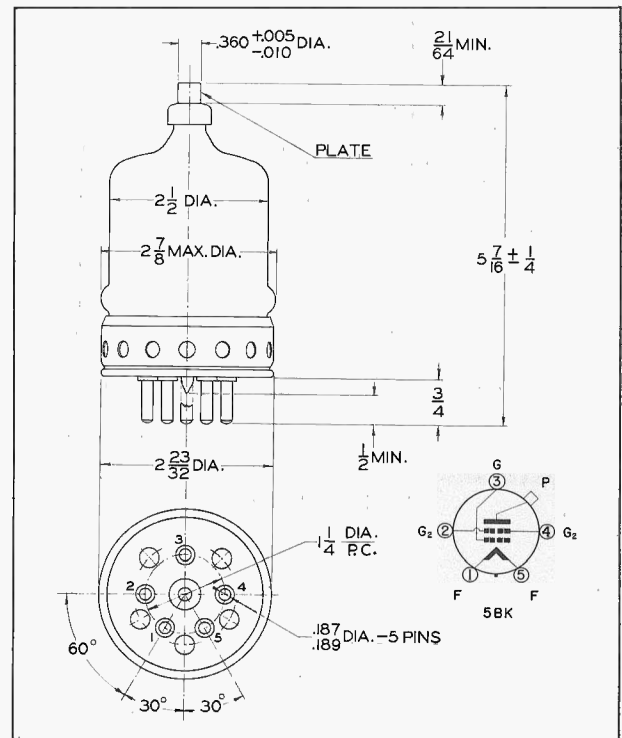

COMPONENTS FOR TYPICAL CIRCUITS

(Diagrams, Page 6)

- | | |
|---|--|
| $L_{p1} - C_{p1}$ — Tank circuit appropriate for operating frequency; $Q = 12$. Capacitor plate spacing = .200". | R_2 — 70,000 ohms, 100 watts |
| $L_{p2} - C_{p2}$ — Tank circuit appropriate for operating frequency; $Q = 12$. Capacitor plate spacing = .200". | R_3 — 3500 ohms, 5 watts |
| $L_{p3} - C_{p3}$ — Tank circuit appropriate for operating frequency; $Q = 12$. Capacitor plate spacing = .375". | R_4 — 35,000 ohms, 200 watts |
| $L_{p4} - C_{p4}$ — Tank circuit appropriate for operating frequency; $Q = 12$. Capacitor plate spacing = .375". | R_5 — 560 ohms, 1 watt |
| $L_{g1} - C_{g1}$ — Tuned circuit appropriate for operating frequency. | R_6 — 25,000 ohms, 2 watts |
| $L_{g2} - C_{g2}$ — Tuned circuit appropriate for operating frequency. | R_7 — 1500 ohms, 5 watts |
| C_1 — .002-ufd., 500-v. mica | RFC_1 — 2.5-mhy., 125-ma. r-f choke |
| C_2 — .002-ufd., 5000-v. mica | RFC_2 — 1-mhy., 500-ma. r-f choke |
| C_3 — .001-ufd., 2500-v. mica | T_1 — 10-watt driver transformer; ratio pri. to $\frac{1}{2}$ sec. approx. 2:1. |
| C_4 — 16-ufd., 450-v. electrolytic | T_2 — 200-watt modulation transformer; ratio pri. to sec. approx. 1:1; pri. impedance = 16,200 ohms, sec. impedance = 16,500 ohms. |
| C_5 — 10-ufd., 25-v. electrolytic | T_3 — 5-watt driver transformer; ratio pri. to $\frac{1}{2}$ sec. approx. 1.1:1. |
| R_1 — 7000 ohms, 5 watts | T_4 — 400-watt modulation transformer; ratio pri. to sec. approx. 2.7:1; pri. impedance = 22,200 ohms, sec. impedance = 8300 ohms. |

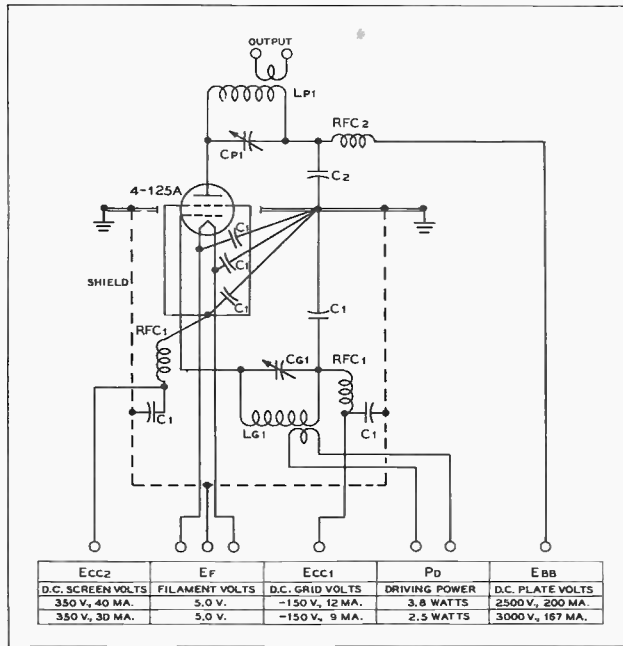

Typical radio-frequency power amplifier circuit, Class-C telegraphy, 500 watts input.

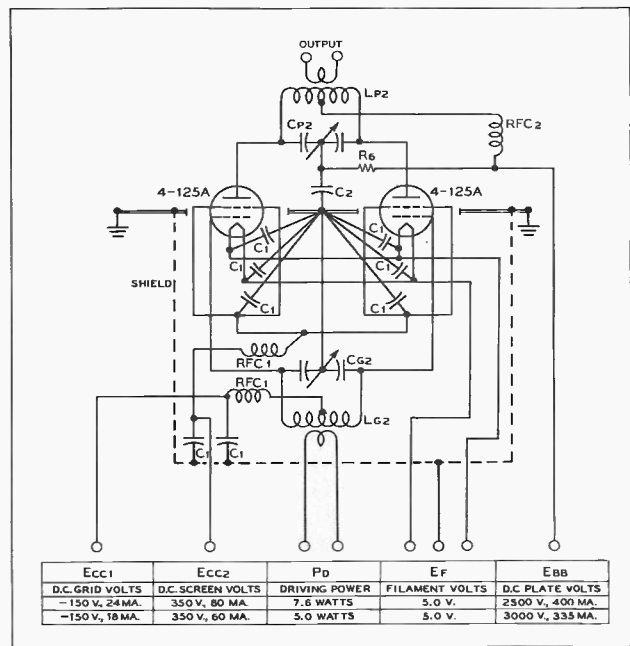

Typical radio-frequency power amplifier circuit, Class-C telegraphy, 1000 watts input.

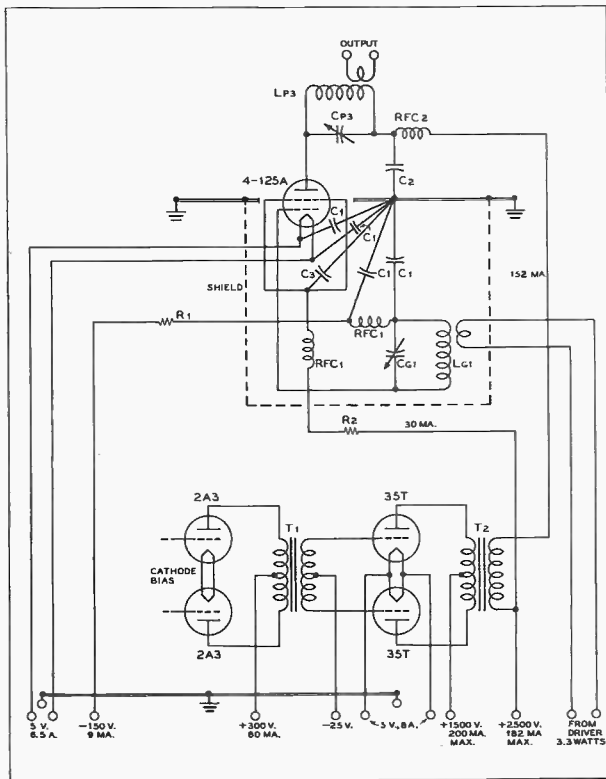

Typical high-level-modulated r-f amplifier circuit, with modulator and driver stages, 380 watts plate input.

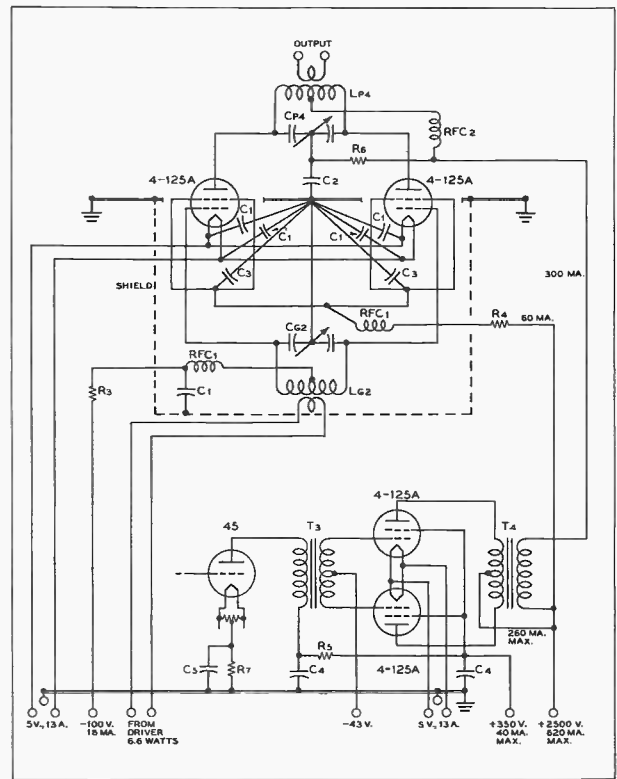

Typical high-level-modulated r-f amplifier circuit, with modulator and driver stages, 750 watts plate input.

SEE PRECEDING PAGE FOR LIST OF COMPONENTS

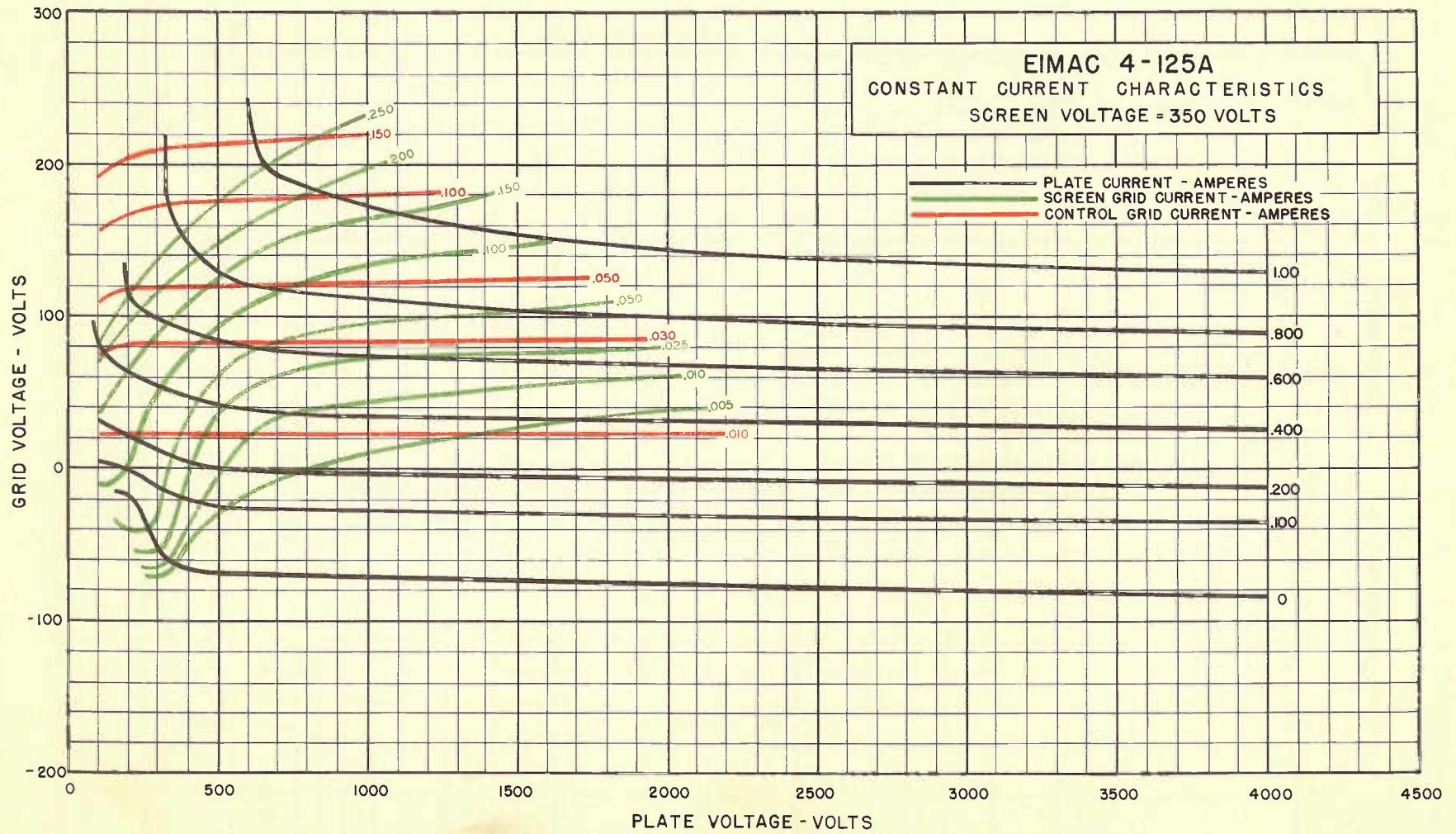

Sylvania
 4-125A
 (RMA 4021)

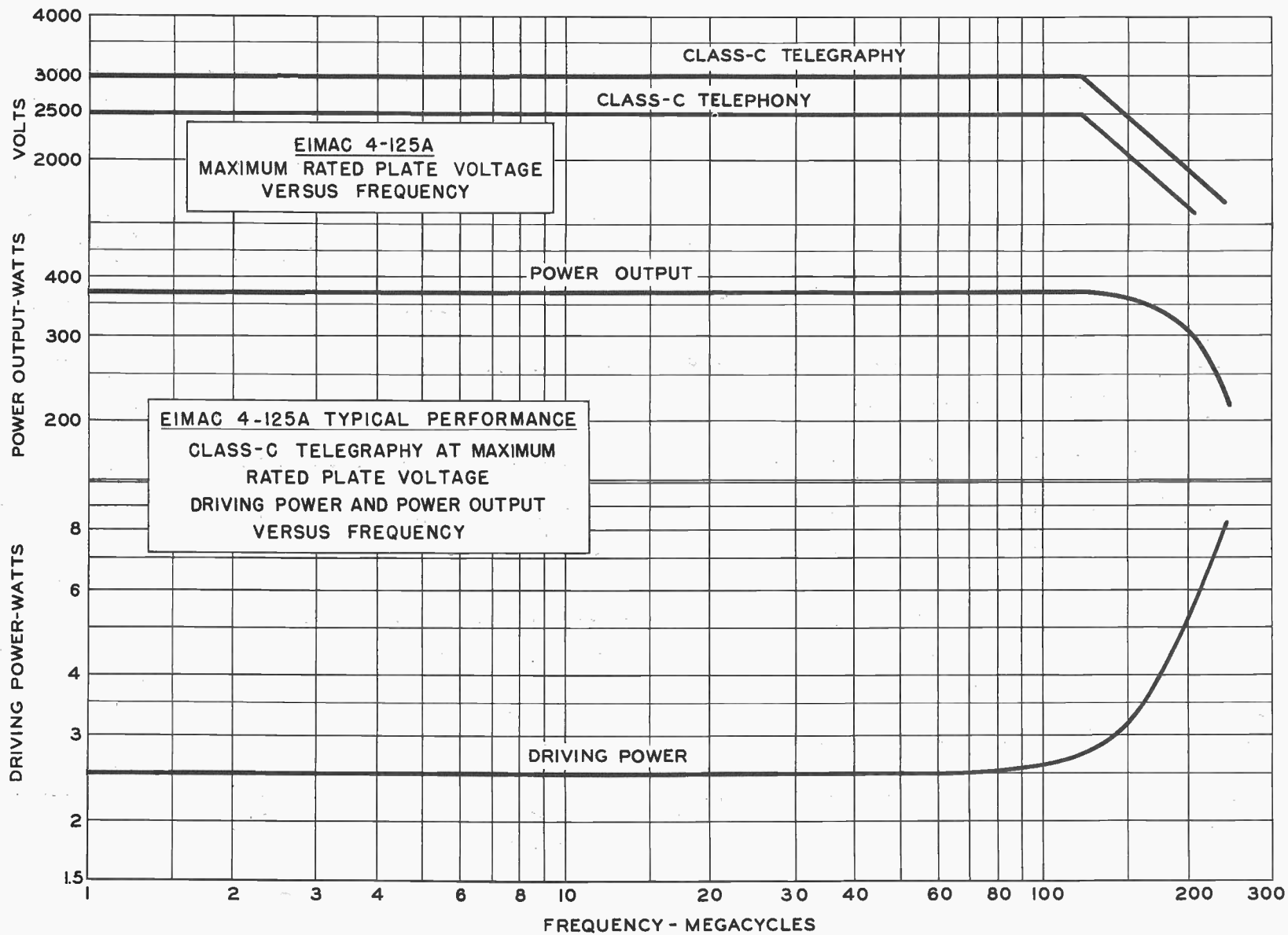

TENTATIVE DATA

EITEL-McCULLOUGH, Inc.
SAN BRUNO, CALIFORNIA

4X150A
POWER TETRODE

SUPERCEDES DATA SHEET DATED 4-15-47

The Eimac 4X150A is an extremely compact external-anode tetrode intended for use as a radio-frequency amplifier or oscillator at frequencies well into the uhf region or as an amplifier in any service requiring a high-gain tube capable of delivering high-power output at low plate voltage. Although it is capable of withstanding relatively high plate voltages, the 4X150A operates well at plate voltages of 400 to 500 volts, making it particularly well suited for high-power mobile applications. The combination of a high ratio of transconductance to capacitance and a maximum plate dissipation capability of 150 watts makes the tube an excellent wide-band amplifier for video applications.

The 4X150A is based in a manner which allows it to be used with a ceramic loktal socket. The base pins are arranged for maximum convenience in using the tube with either coaxial or linear tank circuits at uhf. To provide maximum circuit isolation at these frequencies, the screen is terminated in a contact ring located between the anode and the base. For low-frequency applications, a base pin is provided for the screen termination.

A single 4X150A operating in a coaxial amplifier circuit will deliver as high as 140 watts useful output at 500-Mc.

GENERAL CHARACTERISTICS

ELECTRICAL

Cathode: Coated Unipotential	
Heater Voltage	6.0 volts
Heater Current	2.6 amperes
Minimum Heating Time	30 seconds
Screen-Grid Amplification Factor (Average)	5.0
Direct Interelectrode Capacitances (Average)	
Grid-Plate (without shielding)	0.02 $\mu\mu\text{f.}$
Input	16.1 $\mu\mu\text{f.}$
Output	4.7 $\mu\mu\text{f.}$
Transconductance ($i_b=250 \text{ ma.}, e_1=500 \text{ v.}, E_{c2}=250 \text{ v.}$)	12,000 μmhos

MECHANICAL

Cooling	Forced Air ¹
Mounting Position	Any
Maximum Overall Dimensions	
Length	2.47 inches
Diameter	1.63 inches
Maximum Seated Height	1.91 inches
Net Weight	5.2 ounces
Shipping Weight (average)	1.6 pounds

RADIO FREQUENCY POWER AMPLIFIER OR OSCILLATOR

Class-C Telegraphy or FM Telephony

MAXIMUM RATINGS: (Frequencies up to 500-Mc.)

D-C PLATE VOLTAGE	1250 MAX. VOLTS
D-C SCREEN VOLTAGE	300 MAX. VOLTS
D-C GRID VOLTAGE ²	-250 MAX. VOLTS
D-C PLATE CURRENT	250 MAX. MA.
PLATE DISSIPATION ¹	150 MAX. WATTS
SCREEN DISSIPATION	15 MAX. WATTS
GRID DISSIPATION	2 MAX. WATTS

TYPICAL OPERATION

Single tube, frequencies below 165-Mc.

D-C Plate Voltage	600	750	1000	1250	volts
D-C Plate Current	200	200	200	200	ma.
D-C Screen Voltage	250	250	250	250	volts
D-C Screen Current	37	37	31	20	ma.
D-C Grid Voltage	-75	-80	-80	-90	volts
D-C Grid Current	11	11	10	11	ma.
Peak R-F Grid Voltage (Approx.)	91	96	95	106	volts
Driving Power (Approx.)	1.0	1.1	1.0	1.2	watts
Power Input	120	150	200	250	watts
Power Output	85	110	150	195	watts
Heater Voltage	6.0	6.0	6.0	6.0	volts

Single tube, 500-Mc. (Coaxial cavity)³

D-C Plate Voltage	600	800	1000	1250	volts
D-C Plate Current	170	200	200	200	ma.
D-C Screen Voltage	250	250	250	280	volts
D-C Screen Current	6	7	7	5	ma.
D-C Grid Voltage	-110	-110	-110	-115	volts
D-C Grid Current	6	10	11	10	ma.
Driver Output Power (Approx.)	15	20	25	30	watts
Power Input	102	160	200	250	watts
Power Output	50	96	122	140	watts
Heater Voltage	5.2	5.2	5.2	5.2	volts

HIGH-LEVEL-MODULATED RADIO FREQUENCY AMPLIFIER

Class-C Telephony (Carrier conditions)

MAXIMUM RATINGS (Frequencies up to 500-Mc.)

D-C PLATE VOLTAGE	1000 MAX. VOLTS
D-C SCREEN VOLTAGE	300 MAX. VOLTS
D-C GRID VOLTAGE ²	-250 MAX. VOLTS
D-C PLATE CURRENT	200 MAX. MA.
PLATE DISSIPATION	100 MAX. WATTS
SCREEN DISSIPATION	15 MAX. WATTS
GRID DISSIPATION	2 MAX. WATTS

¹ At 150 watts plate dissipation a minimum flow of 5.6 cubic feet of air per minute must be passed through the plate cooler. The pressure drop across the cooler at this flow equals 0.26" of water. Forced air cooling of the base terminal assembly must be provided. In no case should the temperature of the base seals be allowed to exceed 150 degrees C.

² Maximum permissible grid circuit resistance 25,000 ohms.

³ Due to transit time back heating effects, the heater voltage should be reduced at UHF. At 500-Mc., under typical operating conditions, heater voltage should be approximately 5.2 volts.

At lower plate current or lower frequency less reduction of heater voltage is required.

► Indicates change from sheet dated 4-15-47.



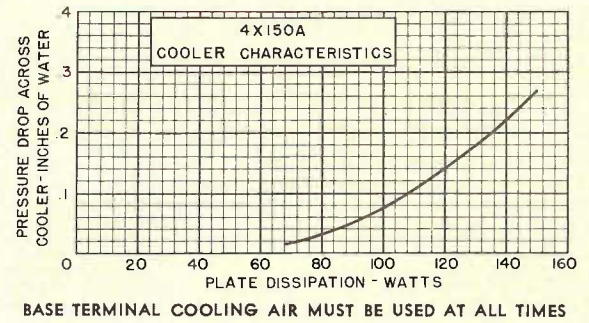
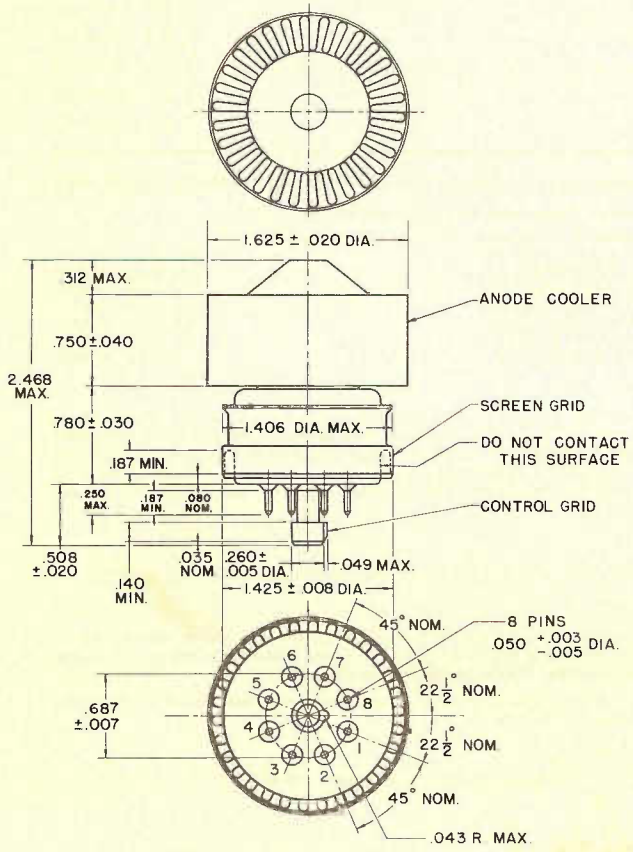
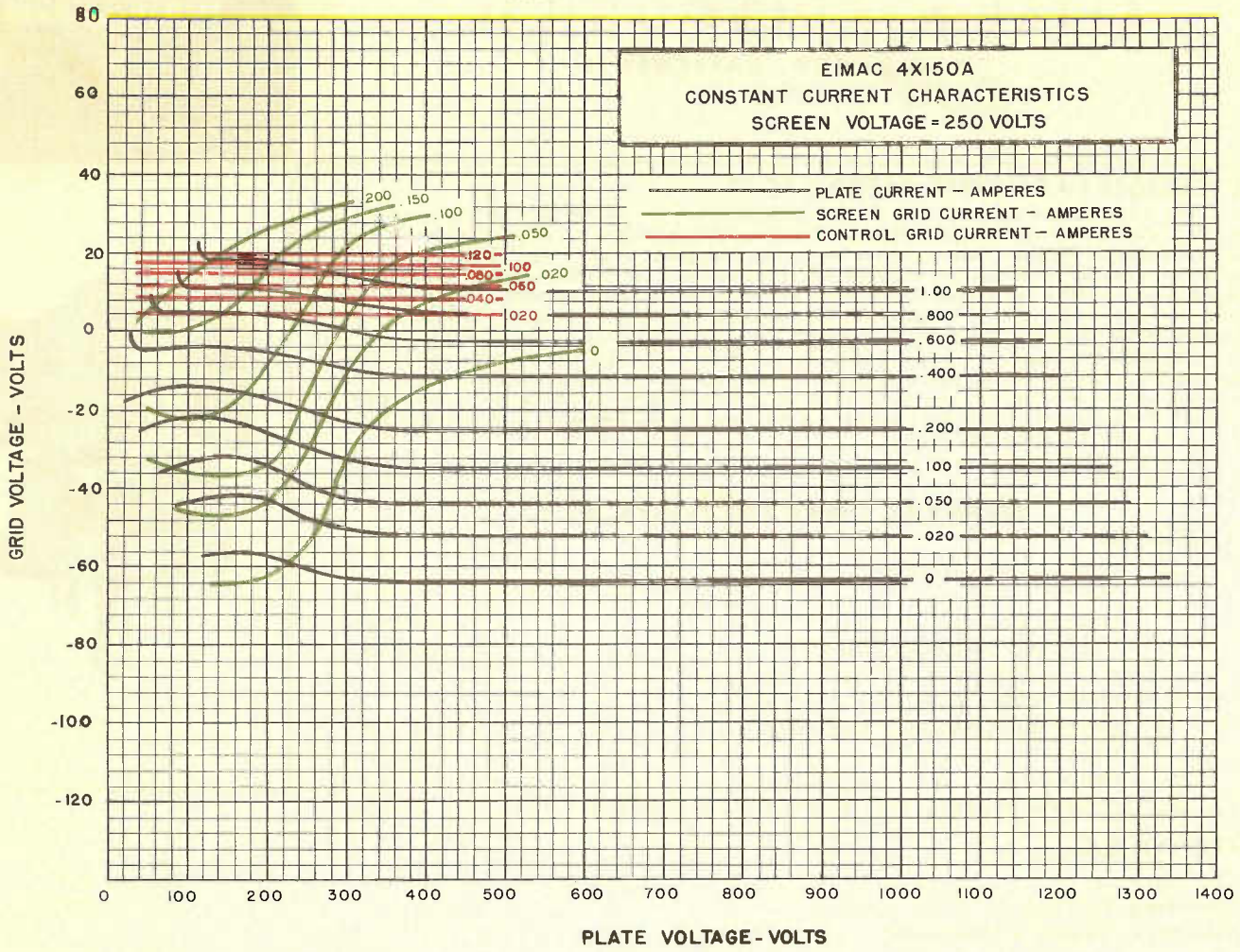

- PIN NO. 1 SCREEN GRID
 - " " 2 CATHODE
 - " " 3 HEATER
 - " " 4 CATHODE
 - " " 5 I.C. (DO NOT USE FOR EXTERNAL CONNECTION)
 - " " 6 CATHODE
 - " " 7 HEATER
 - " " 8 CATHODE
- CENTER PIN CONTROL GRID

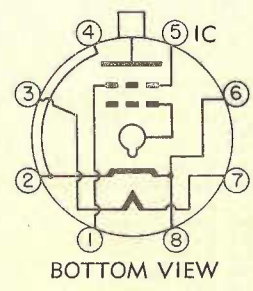

4X150A 4000 AIR SYSTEM SOCKET

The Eimac 4X150A/4000 air system socket was developed in order to provide adequate air cooling of the Eimac 4X150A tetrode. In addition the air-system socket makes possible improved circuit arrangements in high frequency applications.

AIR COOLING SYSTEM

The air stream is introduced into the socket from the underside and cools the grid, cathode and screen seals. It then flows over the glass envelope and through the anode cooler.

The air-system socket may be used in two types of circuit construction:

(1) **In co-axial line circuits.** The air system socket is mounted on the coaxial input line and air may be introduced by pressurizing the input cavity, the walls of the output cavity confine the flow and force it through the anode cooler.

(2) **In chassis construction.** A pressurized chamber below the socket is required. Such a chamber or closed chassis is commonly employed for electrical shielding and only slight modifications should be necessary to make it serve also for air cooling. For confining the air above the chassis a special "Pyrex" glass chimney is available to direct the air flow through the anode cooler.

In both constructions the required cooling air is 6 cubic feet per minute at a pressure of 0.75 inches of water.

SCREEN BYPASS CAPACITOR

A screen bypass capacitor with a capacitance of 3750 $\mu\mu\text{f}$ is built into the socket flange. The metal portions of the socket provide the connections to the screen and cathode terminals of the socket, thereby reducing the lead inductance to a minimum.

CAUTION: Holes must not be drilled through the socket flange to avoid damaging the bypass capacitor.

GRID CONNECTION

The grid terminal is on the center line of the socket and is provided with a threaded hole for direct connection to a coaxial grid line, or a terminal lug.

MOUNTING

With coaxial line cavities the air-system socket may be mounted directly on the end of the coaxial input line. The lower skirt of the socket fits directly over a cylinder of $1\frac{5}{8}$ " outside diameter, and four mounting holes are provided.

For chassis mounting a $2\frac{1}{4}$ " diameter hole should be cut into the deck and the socket secured by the three mounting clips provided. **DO NOT DRILL THROUGH THE SOCKET FLANGE.**

In circuits where the cathode of the tube is not at ground potential, or chassis potential, provision must be made to insulate the air-system socket from the chassis. This may be done by placing an insulating ring between the socket flange and chassis and also insulating the mounting clips from the flange.

MATERIAL

The insulating material used in the construction of the socket has very low R-F losses to well above 800 Mc. and is mechanically strong, non-porous, non-hygroscopic, and unaffected by high temperatures.

The contact fingers are of beryllium copper and all metal parts are silver plated to reduce R-F losses.

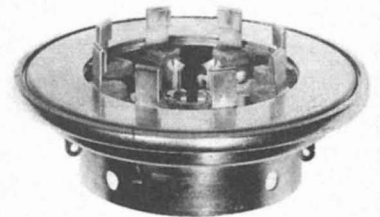

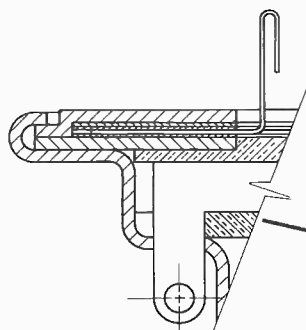

SECTION THRU SCREEN
GRID BY-PASS CAPACITOR

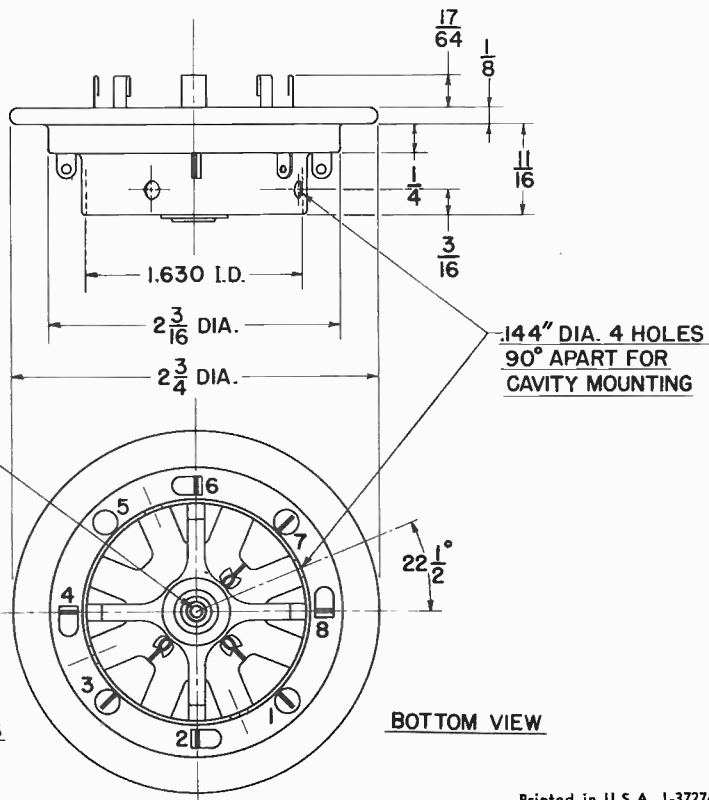

*6-32 THREAD FOR
CONTROL GRID
CONNECTION

- | | | |
|----------------|---|---------------|
| CONNECTION NO. | 1 | SCREEN GRID |
| " | 2 | CATHODE |
| " | 3 | HEATER |
| " | 4 | CATHODE |
| " | 5 | NO CONNECTION |
| " | 6 | CATHODE |
| " | 7 | HEATER |
| " | 8 | CATHODE |

DIMENSIONS
IN INCHES

BOTTOM VIEW

TENTATIVE DATA

Eimac
EITEL-McCULLOUGH, INC.
SAN BRUNO, CALIFORNIA

4X150G
POWER TETRODE

The Eimac 4X150G is an extremely compact external-anode tetrode intended for use as a radio-frequency amplifier, frequency multiplier, or oscillator at frequencies well into the UHF region or as an amplifier in any service requiring a high-gain tube capable of delivering high power-output at low plate-voltage. The combination of a high ratio of transconductance to capacitance and a plate dissipation capability of 150 watts makes the tube an excellent wide-band amplifier for video applications.

The cathode, grid and screen electrodes are mounted on conical and cylindrical supports giving a minimum of circuit discontinuities and lead inductance. The rugged cylindrical terminals, progressively larger in size, allow the tube to be inserted in coaxial line cavities. The screen support and terminal provide maximum isolation between the grid-cathode terminals and the plate circuit.

In amplifier service at 500 megacycles, output power of 140 watts per tube, with a stage power-gain of 20, can be obtained. At 1000 megacycles an output power of 50 watts per tube is obtained with a power-gain of five.

GENERAL CHARACTERISTICS

ELECTRICAL

Cathode: Coated Unipotential	
Heater Voltage	2.5 volts
Heater Current	6.25 amperes
Minimum Heating Time	30 seconds
Screen-Grid Amplification Factor (Average)	5.0
Direct Interelectrode Capacitances (Average)	
Grid-Plate (without shielding)	0.02 $\mu\mu\text{f}$
Input	16.1 $\mu\mu\text{f}$
Output	4.7 $\mu\mu\text{f}$
Transconductance ($i_b=250$ ma., $e_b=500$ v., $E_c=250$ V.)	12,000 μmhos

MECHANICAL

Cooling	Forced Air
At 150 watts plate dissipation, a minimum flow of 5.6 cubic feet of air per minute must be passed through the anode cooler. The pressure drop across the cooler at this flow equals 0.26 inches of water. Forced-air cooling of the base terminal assembly must be provided. In no case should the temperature of the metal-to-glass seals or the core of the anode cooler exceed 150° C.	
Mounting position	Any
Maximum Overall Dimensions	
Length	2 $\frac{5}{8}$ inches
Diameter	1 $\frac{5}{8}$ inches
Maximum Seated Height	1-27/32 inches
Net Weight	6 ounces
Shipping Weight (Average)	1.6 pounds

RADIO FREQUENCY POWER AMPLIFIER OR OSCILLATOR

Class-C Telephony or FM Telephony (Key-down conditions, per tube)

MAXIMUM RATINGS

D-C PLATE VOLTAGE	1250 MAX. VOLTS
D-C SCREEN VOLTAGE	300 MAX. VOLTS
D-C GRID VOLTAGE*	-250 MAX. VOLTS
D-C PLATE CURRENT	250 MAX. MA.
PLATE DISSIPATION	150 MAX. WATTS
ANODE-COOLER CORE TEMPERATURE	150 MAX. °C
SCREEN DISSIPATION	15 MAX. WATTS
GRID DISSIPATION	2 MAX. WATTS

*Maximum permissible grid circuit resistance 25,000 ohms

TYPICAL OPERATION

Single tube, frequencies below 165-Mc.

D-C Plate Voltage	600	750	1000	1250	Volts
D-C Plate Current	200	200	200	200	Ma.
D-C Screen Voltage	250	250	250	250	Volts
D-C Screen Current	37	37	31	20	Ma.
D-C Grid Voltage	-75	-80	-80	-90	Volts
D-C Grid Current	11	11	10	11	Ma.
Peak R-F Grid Voltage (Approx.)	91	96	95	106	Volts
Driving Power (approx.)	1.0	1.1	1.0	1.2	Watts
Power Input	120	150	200	250	Watts
Power Output	85	110	150	195	Watts
Heater Voltage ¹	2.5	2.5	2.5	2.5	Volts

Single tube, 750-Mc. (Coaxial cavity)

D-C Plate Voltage	1250	Volts
D-C Plate Current	200	Ma.
D-C Screen Voltage	250	Volts
D-C Screen Current	5	Ma.
D-C Grid Voltage	-60	Volts
D-C Grid Current	5	Ma.
Peak R-F Grid Voltage (approx.)	85	Volts
Driving Power (approx.)	9	Watts
Power Input	250	Watts
Power Output	100	Watts
Heater Voltage ¹	See note	

(Effective 2-15-50) Copyright 1950 by Eitel-McCullough, Inc.

PLATE MODULATED RADIO FREQUENCY AMPLIFIER

Class-C Telephony

MAXIMUM RATINGS (Carrier Conditions)

D-C PLATE VOLTAGE	1000 MAX. VOLTS
D-C SCREEN VOLTAGE	300 MAX. VOLTS
D-C GRID VOLTAGE*	-250 MAX. VOLTS
D-C PLATE CURRENT	200 MAX. MA.
PLATE DISSIPATION	100 MAX. WATTS
ANODE-COOLER CORE TEMPERATURE	150 MAX. °C
SCREEN DISSIPATION	15 MAX. WATTS
GRID DISSIPATION	2 MAX. WATTS

*Maximum permissible grid circuit resistance 25,000 ohms

PLATE PULSED RADIO FREQUENCY AMPLIFIER OR OSCILLATOR

MAXIMUM RATINGS

PULSED PLATE VOLTAGE	7000 MAX. VOLTS
PULSED SCREEN VOLTAGE	1500 MAX. VOLTS
D-C GRID VOLTAGE	-500 MAX. VOLTS
MAXIMUM PULSE DURATION	5 MICROSECONDS
PULSED CATHODE CURRENT	7 MAX. AMPS
AVERAGE POWER INPUT	250 MAX. WATTS
PLATE DISSIPATION	150 MAX. WATTS
ANODE-COOLER CORE TEMPERATURE	150 MAX. °C
SCREEN DISSIPATION	15 MAX. WATTS
GRID DISSIPATION	2 MAX. WATTS

TYPICAL PULSE OPERATION

Single tube oscillator, 1200-Mc.

Pulsed Plate Voltage	5	7	Kilovolts
Pulsed Plate Current	4.0	6.0	Amps.
Pulsed Screen Voltage	800	1000	Volts
Pulsed Screen Current	0.3	0.4	Amps.
D-C Grid Voltage	-200	-250	Volts
Pulsed Grid Current	0.5	0.6	Amps.
Pulse Duration	4	4	Microseconds
Pulse Repetition Rate	2500	1250	Per second
Peak Power Output	10	20	Kilowatts
Heater Voltage ¹			See Note ¹

¹Heater Voltage—Due to transit time back heating effects, the heater voltage should be reduced when operating at frequencies above 400 Mc. This voltage reduction should be made after dynamic operation of the tube has started. Since back heating is a function of frequency, grid current, grid bias, circuit design and circuit adjustment, the amount of back heating varies considerably with different methods of operation. The following table is an approximate guide for normal tube operation:

Frequency	up to 400 Mc.	400 to 1000 Mc.	1000 to 1500 Mc.	above 1500 Mc.
Heater Voltage	2.5 v	2.2 v	2.0 v	1.8 v



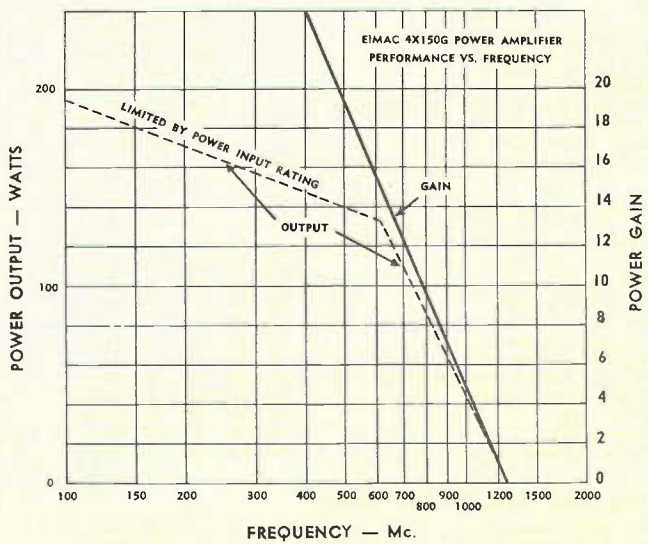
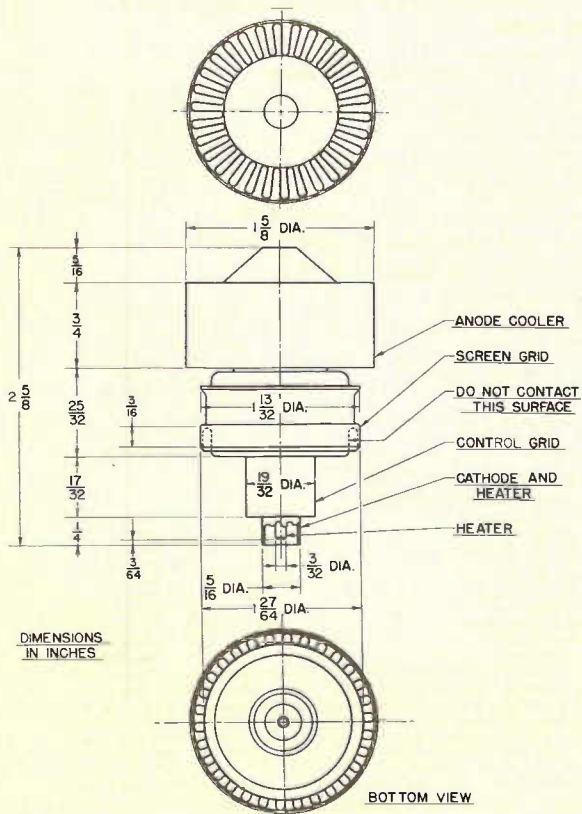
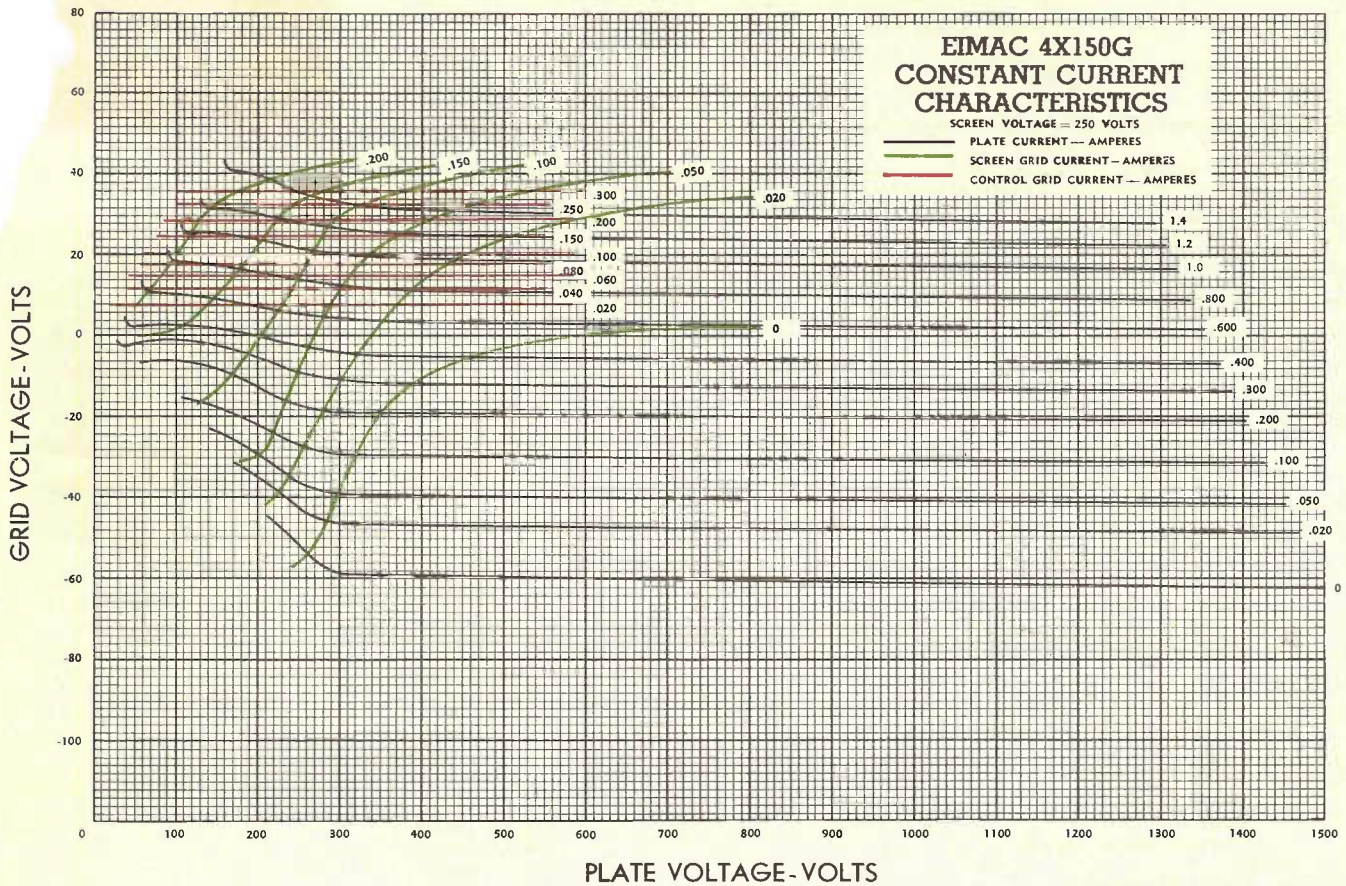

EITEL-McCULLOUGH, INC.

SAN BRUNO, CALIFORNIA

4-250A

(RMA 5D22)

**POWER TRODE
•
MODULATOR
OSCILLATOR
AMPLIFIER**

The Eimac 4-250A is a high-vacuum power tetrode having a maximum plate dissipation rating of 250 watts. It is intended for amplifier, oscillator and modulator service. Cooling of the 4-250A is accomplished by radiation from the plate, which operates at a visibly red temperature at maximum dissipation, and by forced air circulation through the base and around the envelope.

The low driving power required by the 4-250A, together with its low grid-plate capacitance and compact and rugged construction, allows considerable simplification of the associated circuits and the driver stage.

ELECTRICAL

Filament: Thoriated tungsten	
Voltage	5.0 volts
Current	14.5 amperes
Grid-Screen Amplification Factor (Average) - - - - - 5.1	
Direct Interelectrode Capacitances (Average)	
Grid-Plate (without shielding, base grounded)	0.12 $\mu\mu\text{fd.}$
Input	12.7 $\mu\mu\text{fd.}$
Output	4.5 $\mu\mu\text{fd.}$
Transconductance ($i_b = 100 \text{ ma.}, E_b = 2500 \text{ v.}, E_{c2} = 500 \text{ v.}$) - 4000 μmhos	

MECHANICAL

Base	5-pin metal shell, No. 5008B
Basing	RMA type 5BK
Cooling	Radiation and forced air
Maximum Overall Dimensions:	
Length	6.38 inches
Diameter	3.56 inches
Net Weight	8.0 ounces
Shipping Weight (Average)	2.5 pounds

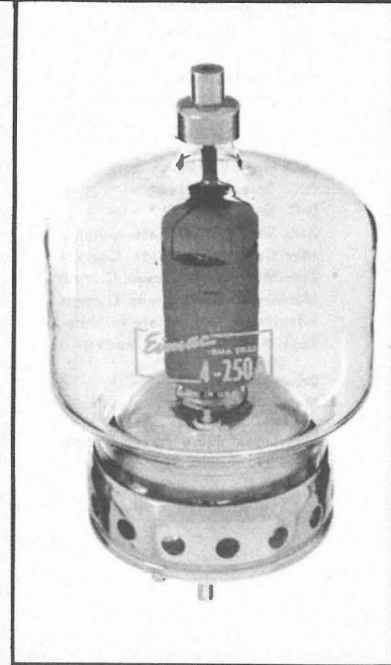

RADIO FREQUENCY POWER AMPLIFIER AND OSCILLATOR

Class-C FM or Telegraphy (Key-down conditions, 1 tube)

MAXIMUM RATINGS

D-C PLATE VOLTAGE ¹	4000 MAX. VOLTS
D-C SCREEN VOLTAGE	600 MAX. VOLTS
D-C GRID VOLTAGE	-500 MAX. VOLTS
D-C PLATE CURRENT	350 MAX. MA.
PLATE DISSIPATION	250 MAX. WATTS
SCREEN DISSIPATION	35 MAX. WATTS
GRID DISSIPATION	5 MAX. WATTS

▶ TYPICAL OPERATION (Frequencies below 75 Mc.)

D-C Plate Voltage	2500	3000	4000	volts
D-C Screen Voltage	500	500	500	volts
D-C Grid Voltage	-150	-180	-225	volts
D-C Plate Current	300	345	312	ma.
D-C Screen Current	60	60	45	ma.
D-C Grid Current	9	10	9	ma.
Screen Dissipation	30	30	22.5	watts
Grid Dissipation	0.35	0.8	0.46	watts
Peak R-F Grid Input Voltage (approx.)	220	265	303	volts
Driving Power (approx.) ²	1.70	2.6	2.46	watts
Plate Power Input	750	1035	1250	watts
Plate Dissipation	175	235	250	watts
Plate Power Output	575	800	1000	watts

▶ Indicates change from sheet dated 9-1-46.

(Effective 4-15-47) Copyright, 1947 by Eitel-McCullough, Inc.

HIGH-LEVEL-MODULATED RADIO FREQUENCY AMPLIFIER

Class-C Telephony (Carrier conditions unless otherwise specified, 1 tube)

MAXIMUM RATINGS

D-C PLATE VOLTAGE ¹	3200 MAX. VOLTS
D-C SCREEN VOLTAGE	600 MAX. VOLTS
D-C GRID VOLTAGE	-500 MAX. VOLTS
D-C PLATE CURRENT	275 MAX. MA.
PLATE DISSIPATION	165 MAX. WATTS
SCREEN DISSIPATION	35 MAX. WATTS
GRID DISSIPATION	5 MAX. WATTS

▶ TYPICAL OPERATION (Frequencies below 75 Mc.)

D-C Plate Voltage	2500	3000	volts
D-C Screen Voltage	400	400	volts
D-C Grid Voltage	-200	-310	volts
D-C Plate Current	200	225	ma.
D-C Screen Current	30	30	ma.
D-C Grid Current	9	9	ma.
Screen Dissipation	12	12	watts
Grid Dissipation	1.8	2.7	watts
Peak R-F Grid Input Voltage (approx.)	255	365	volts
Driving Power (approx.)	2.2	3.2	watts
Plate Power Input	500	675	watts
Plate Dissipation	125	165	watts
Plate Power Output	375	510	watts

¹ Above 75 Mc. the maximum plate voltage rating depends upon frequency, see page six.

▶ ² Driving power increases above 40 Mc. See Page Six.

AUDIO FREQUENCY POWER AMPLIFIER AND MODULATOR

Class-AB₁ (Sinusoidal wave, two tubes unless otherwise specified)

MAXIMUM RATINGS

D-C PLATE VOLTAGE	4000 MAX. VOLTS
D-C SCREEN VOLTAGE	600 MAX. VOLTS
MAX-SIGNAL D-C PLATE CURRENT, PER TUBE	350 MAX. MA.
PLATE DISSIPATION, PER TUBE	250 MAX. WATTS
SCREEN DISSIPATION, PER TUBE	35 MAX. WATTS

TYPICAL OPERATION

D-C Plate Voltage	1500	2000	2500	3000	volts
D-C Screen Voltage	500	500	500	500	volts
D-C Grid Voltage ²	-64	-88	-90	-93	volts
Zero-Signal D-C Plate Current	120	110	120	120	ma.
Max-Signal D-C Plate Current	400	405	430	417	ma.
Zero-Signal D-C Screen Current	-0.4	-0.3	-0.3	-0.2	ma.
Max-Signal D-C Screen Current	23	22	13	10.5	ma.
Effective Load, Plate-to-Plate	6250	9170	11,400	15,000	ohms
Peak A-F Grid Input Voltage (per tube)	64	88	90	93	volts
Driving Power	0	0	0	0	watt
Max-Signal Plate Dissipation (per tube)	145	175	225	250	watts
Max-Signal Plate Power Output	310	460	625	750	watts
Total Harmonic Distortion	4	2.5	2	2.5	per cent

² The effective grid-circuit resistance must not exceed 250,000 ohms.

AUDIO FREQUENCY POWER AMPLIFIER AND MODULATOR

Class-AB₂ (Sinusoidal wave, two tubes unless otherwise specified)

MAXIMUM RATINGS

D-C PLATE VOLTAGE	4000 MAX. VOLTS
D-C SCREEN VOLTAGE	600 MAX. VOLTS
MAX-SIGNAL D-C PLATE CURRENT, PER TUBE	350 MAX. MA.
PLATE DISSIPATION, PER TUBE	250 MAX. WATTS
SCREEN DISSIPATION, PER TUBE	35 MAX. WATTS

TYPICAL OPERATION

D-C Plate Voltage	1500	2000	2500	3000	volts
D-C Screen Voltage	300	300	300	300	volts
D-C Grid Voltage	-48	-48	-51	-53	volts
Zero-Signal D-C Plate Current	100	120	120	125	ma.
Max-Signal D-C Plate Current	485	510	500	473	ma.
Zero-Signal D-C Screen Current	0	0	0	0	ma.
Max-Signal D-C Screen Current	34	26	23	33	ma.
Effective Load, Plate-to-Plate	5400	8000	10,900	16,000	ohms
Peak A-F Grid Input Voltage (per tube)	96	99	100	99	volts
Max-Signal Avg. Driving Power (approx.)	2.1	2.3	2.2	1.9	watts
Max-Signal Peak Driving Power	4.7	5.5	4.8	4.6	watts
Max-Signal Plate Dissipation (per tube)	150	185	205	190	watts
Max-Signal Plate Power Output	428	650	840	1040	watts
Total Harmonic Distortion	3	4	4	4.5	per cent

APPLICATION

MECHANICAL

Mounting—The 4-250A must be mounted vertically, base up or base down. The socket must provide clearance for the glass tip-off which extends through the center of the base. The metal base shell should be grounded by means of suitable spring fingers. A flexible connecting strap should be provided between the plate terminal and the external plate circuit. The socket must not apply excessive lateral pressure against the base pins. The tube must be protected from severe vibration and shock.

Adequate cooling must be provided for the seals and envelope of the 4-250A. Forced-air circulation in the amount of five cubic feet per minute through the base of the tube is required. This air should be applied simultaneously with filament power. The temperature of the plate seal, as measured on the top of the plate cap, should not exceed 170° C in continuous-service applications.

A relatively slow movement of air past the tube is sufficient to prevent a plate seal temperature in excess of maximum at frequencies below 30 Mc. At frequencies above 30 Mc., radio-frequency losses in the leads and envelope contribute to seal and envelope heating, and special attention should be given to bulb and plate seal cooling. A small fan or centrifugal blower directed toward the upper portion of the envelope will usually provide sufficient circulation for cooling at frequencies above 30 Mc., however.

In intermittent-service applications where the "on" time does not exceed a total of five minutes in any ten-minute period, plate seal temperatures as high as 220° C are permissible. When the ambient temperature does not exceed 30° C it will not ordinarily be necessary to pro-

Indicates change from sheet dated 9-1-46.

vide forced cooling of the bulb and plate seal to hold the temperature below this maximum at frequencies below 30 Mc., provided that a heat-radiating plate connector is used, and the tube is so located that normal circulation of air past the envelope is not impeded.

ELECTRICAL

Filament Voltage—The filament voltage, as measured directly at the filament pins, should be between 4.75 and 5.25 volts.

Bias Voltage—D-c bias voltage for the 4-250A should not exceed 500 volts. If grid-leak bias is used, suitable protective means must be provided to prevent excessive plate or screen dissipation in the event of loss of excitation.

Grid Dissipation—Grid dissipation for the 4-250A should not be allowed to exceed five watts. Grid dissipation may be calculated from the following expression:

$$P_g = e_{cmp} I_c$$

where P_g = Grid dissipation,
 e_{cmp} = Peak positive grid voltage, and
 I_c = D-c grid current.

e_{cmp} may be measured by means of a suitable peak voltmeter connected between filament and grid³.

Screen Voltage—The d-c screen voltage for the 4-250A should not exceed 600 volts.

Screen Dissipation—The power dissipated by the screen of the 4-250A must not exceed 35 watts. Screen dissipa-

³ For suitable peak v.t.v.m. circuits see, for instance, "Vacuum Tube Ratings," Eimac News, January, 1945. This article is available in reprint form on request.

tion is likely to rise to excessive values when the plate voltage, bias voltage or plate load is removed with filament and screen voltages applied. Suitable protective means must be provided to limit screen dissipation to 35 watts in the event of circuit failure.

Plate Voltage—The plate-supply voltage for the 4-250A should not exceed 4000 volts for frequencies below 75 Mc. Above 75 Mc., the maximum permissible plate voltage is less than 4000 volts, as shown by the graph on page 6.

Plate Dissipation—Under normal operating conditions, the plate dissipation of the 4-250A should not be allowed to exceed 250 watts in unmodulated applications.

In high-level-modulated amplifier applications, the maximum allowable carrier-condition plate dissipation is 165 watts.

Plate dissipation in excess of the maximum rating is permissible for short periods of time, such as during tuning procedures.

OPERATION

Class-C FM or Telegraphy—The 4-250A may be operated as a class-C FM or telegraph amplifier without neutralization up to 30 Mc. if reasonable precautions are taken to prevent coupling between input and output circuits external to the tube. A grounded metallic plate on which the socket may be mounted and to which suitable connectors may be attached to ground the tube base shell, provides an effective isolating shield between grid and plate circuits. In single-ended circuits, plate, grid, filament and screen by-pass capacitors should be returned through the shortest possible leads to a common chassis point. In push-pull applications the filament and screen terminals of each tube should be by-passed to a common chassis point by the shortest possible leads, and short, heavy leads should be used to interconnect the screens and filaments of the two tubes. Care should be taken to prevent leakage of radio-frequency energy to leads entering the amplifier, in order to minimize grid-plate coupling between these leads external to the amplifier.

At frequencies from 30 Mc. to 45 Mc. ordinary neutralization systems may be used.

Where shielding is adequate, the feed-back at frequencies above 45 Mc. is due principally to screen-lead-

inductance effects, and it becomes necessary to introduce in-phase voltage from the plate circuit into the grid circuit. This can be done by adding capacitance between plate and grid external to the tube. Ordinarily, a small metal tab approximately $\frac{3}{4}$ -inch square connected to the grid terminal and located adjacent to the envelope opposite the plate will suffice for neutralization. Means should be provided for adjusting the spacing between the neutralizing capacitor plate and the envelope. An alternative neutralization scheme is illustrated in the diagram below. In this circuit, feed-back is eliminated by series-tuning the screen to ground with a small capacitor. The socket screen terminals should be strapped together, as shown on the diagram, by the shortest possible lead, and the leads from the screen terminal to the capacitor, C, and from the capacitor to ground should be made as short as possible.

Driving power and power output under maximum output and plate voltage conditions are shown on page 6. The power output shown is the actual plate power delivered by the tube; the power delivered to the load will depend upon the efficiency of the plate tank and output coupling system. The driving power is likewise the driving power required by the tube (includes bias loss). The driver output power should exceed the driving power requirement by a sufficient margin to allow for coupling-circuit losses. The use of silver-plated linear tank-circuit elements is recommended for all frequencies above 75 Mc.

Class-C AM Telephony—The r-f circuit considerations discussed above under Class-C FM or Telegraphy also apply to amplitude-modulated operation of the 4-250A. When the 4-250A is used as a class-C high-level-modulated amplifier, modulation should be applied to both plate and screen. Modulation voltage for the screen may be obtained from a separate winding on the modulation transformer, by supplying the screen voltage via a series dropping resistor from the unmodulated plate supply, or by the use of an audio-frequency reactor in the positive screen-supply lead. When screen modulation is obtained by either the series-resistor or the audio-reactor method, the audio-frequency variations in screen current which result from the variations in plate voltage as the plate is modulated automatically give the required screen modulation. Where a reactor is used, it should have a rated inductance of not less than 10 henries divided by the number of tubes in the modulated amplifier and a maximum current rating of two or three times the operating d-c screen current. To prevent phase shift between the screen and plate modulation voltages at high audio frequencies, the screen by-pass capacitor should be no larger than necessary for adequate r-f by-passing.

For high-level modulated service, the use of partial grid-leak bias is recommended. Any by-pass capacitors placed across the grid-leak resistance should have a reactance at the highest modulation frequency equal to at least twice the grid-leak resistance.

Class-AB₁ and Class-AB₂ Audio—Two 4-250A's may be used in a push-pull circuit to give relatively high audio output power at low distortion. Maximum ratings and typical operating conditions for class-AB₁ and class-AB₂ audio operation are given in the tabulated data.

Screen voltage should be obtained from a source having reasonably good regulation, to prevent variations in screen voltage from zero-signal to maximum-signal conditions. The use of voltage regulator tubes in a standard circuit should provide adequate regulation.

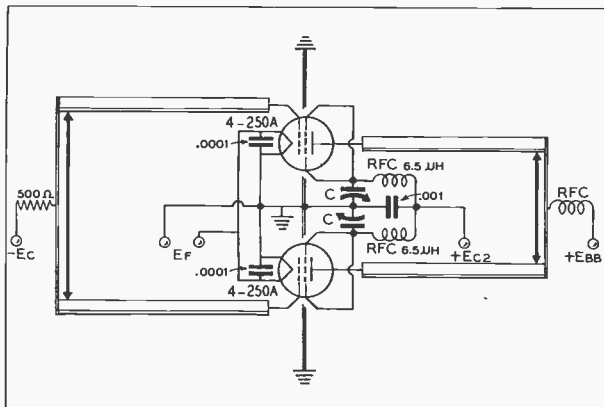

Screen-tuning neutralization circuit for use above 45 Mc.
C — Approximately 100 $\mu\mu$ fd. per section, maximum.

Grid bias voltage for class-AB₂ service may be obtained from batteries or from a small fixed-bias supply. When a bias supply is used, the d-c resistance of the bias source should not exceed 250 ohms. Under class-AB₁ conditions the effective grid-circuit resistance should not exceed 250,000 ohms.

The peak driving power figures given in the class-AB₂ tabulated data are included to make possible an accurate determination of the required driver output power. The driver amplifier must be capable of supplying the peak driving power without distortion. The driver stage should, therefore, be capable of providing an undistorted average output equal to half the peak driving power requirement. A small amount of additional driver output should be provided to allow for losses in the coupling transformer.

In some cases the maximum-signal plate dissipation shown under "Typical Operation" is less than the maximum rated plate dissipation of the 4-250A. In these cases, the plate dissipation reaches a maximum value, equal to the maximum rating, at a point somewhat below maximum-signal conditions.

The power output figures given in the tabulated data refer to the total power output from the amplifier tubes. The useful power output will be from 5 to 15 per cent less than the figures shown, due to losses in the output transformer.

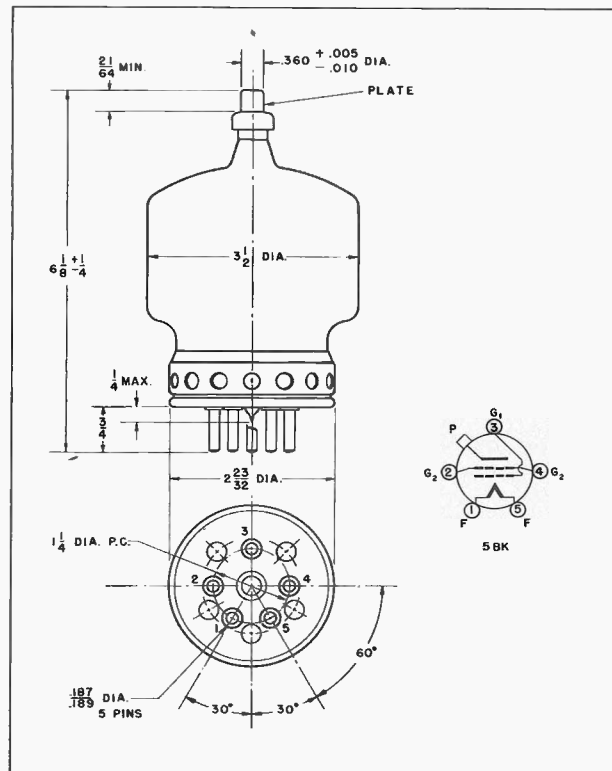

COMPONENTS FOR TYPICAL CIRCUITS

$L_{p1} - C_{p1}$ — Tank circuit appropriate for operating frequency;
 $Q = 12$. Capacitor plate spacing = .200".

$L_{p2} - C_{p2}$ — Tank circuit appropriate for operating frequency;
 $Q = 12$. Capacitor plate spacing = .200".

$L_{p3} - C_{p3}$ — Tank circuit appropriate for operating frequency;
 $Q = 12$. Capacitor plate spacing = .375".

$L_{g1} - C_{g1}$ — Tuned circuit appropriate for operating frequency.

$L_{g2} - C_{g2}$ — Tuned circuit appropriate for operating frequency.

C_1 — .002-ufd., 500-v. mica

C_2 — .002-ufd., 5000-v. mica

C_3 — .001-ufd., 2500-v. mica

C_4 — .1-ufd., 1000-v. paper

C_5 — .1-ufd., 600-v. paper

C_6 — .5-ufd., 600-v. paper

C_7 — .03-ufd., 600-v. paper

C_8 — .1-ufd., 1000-v. paper

C_9 — .25-ufd., 1000-v. paper

R_1 — 86,700 ohms, adjustable 100,000 ohms, 100 watts

R_2 — 250,000 ohms, 1/2 watt

R_4 — 15,000 ohms, 5 watts

R_5 — 25,000 ohms, 2 watts

R_6 — 2,500 ohms, 5 watts

R_7 — 35,000 ohms, 160 watts

R_8 — 250,000 ohms, 1/2 watt

R_9 — 200,000 ohms, 2 watts

R_{10} — 500 ohms, 1/2 watt

R_{11} — 1 megohm, 1/2 watt

R_{12} — 100,000 ohms, 1 watt

R_{13} — 200,000 ohms, 1/2 watt

R_{14} — 10,000 ohms, 1/2 watt

R_{15} — 50 ohms, 10 watts

R_{16} — 100,000 ohms, 100 watts

RFC_1 — 2.5-mhy., 125-ma. r-f choke

RFC_2 — 1-mhy., 500-ma. r-f choke

T_1 — 350-watt modulation transformer; ratio pri. to sec. approx. 1.5 : 1; pri. impedance 20,300 ohms, sec. impedance 13,300 ohms.

T_2 — 600-watt modulation transformer; ratio pri. to sec. approx. 1.8 : 1; pri. impedance 11,400 ohms, sec. impedance 6,250 ohms.

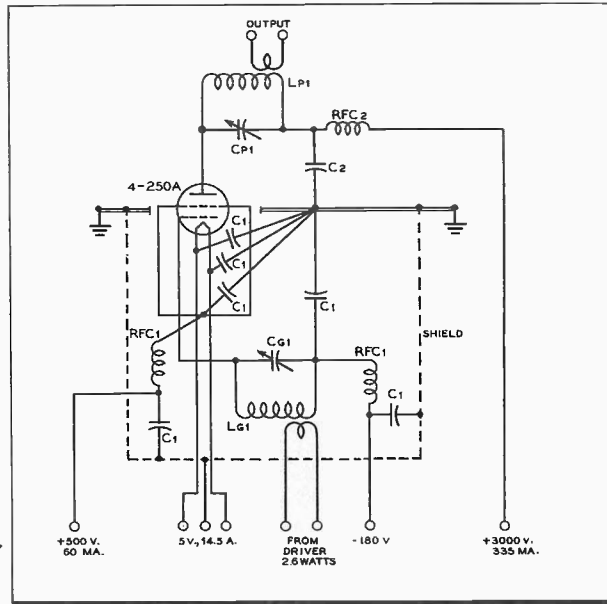

Typical radio frequency power amplifier circuit, Class-C telegraphy, 1000 watts input.

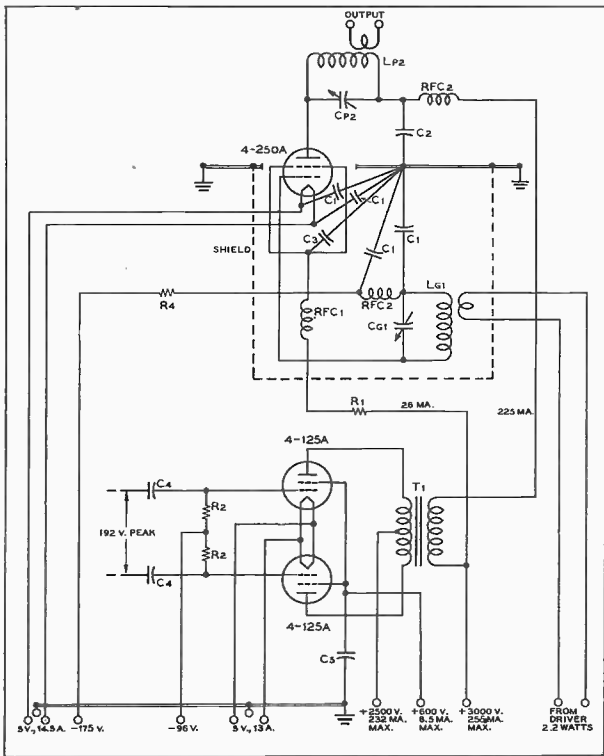

Typical high-level-modulated r-f amplifier circuit, with modulator stage, 675 watts input.

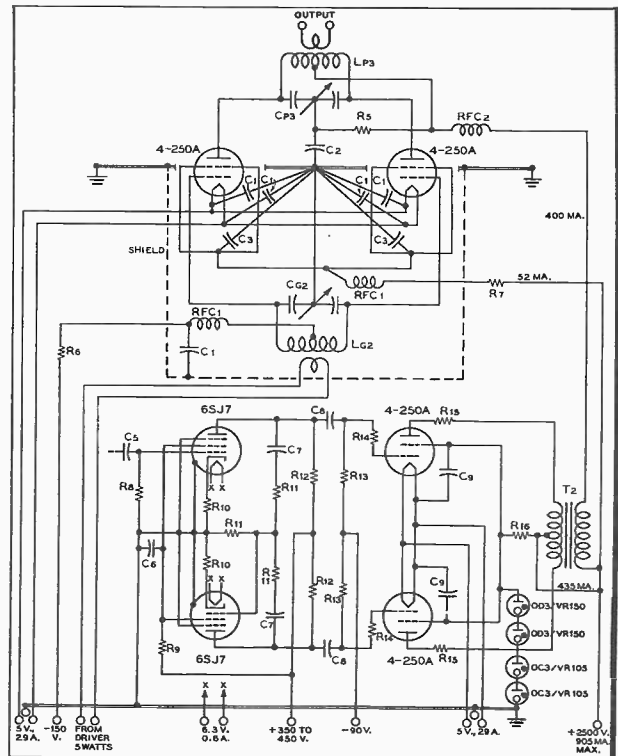

Typical high-level-modulated r-f amplifier circuit, with modulator and driver stages, 1000 watts input.

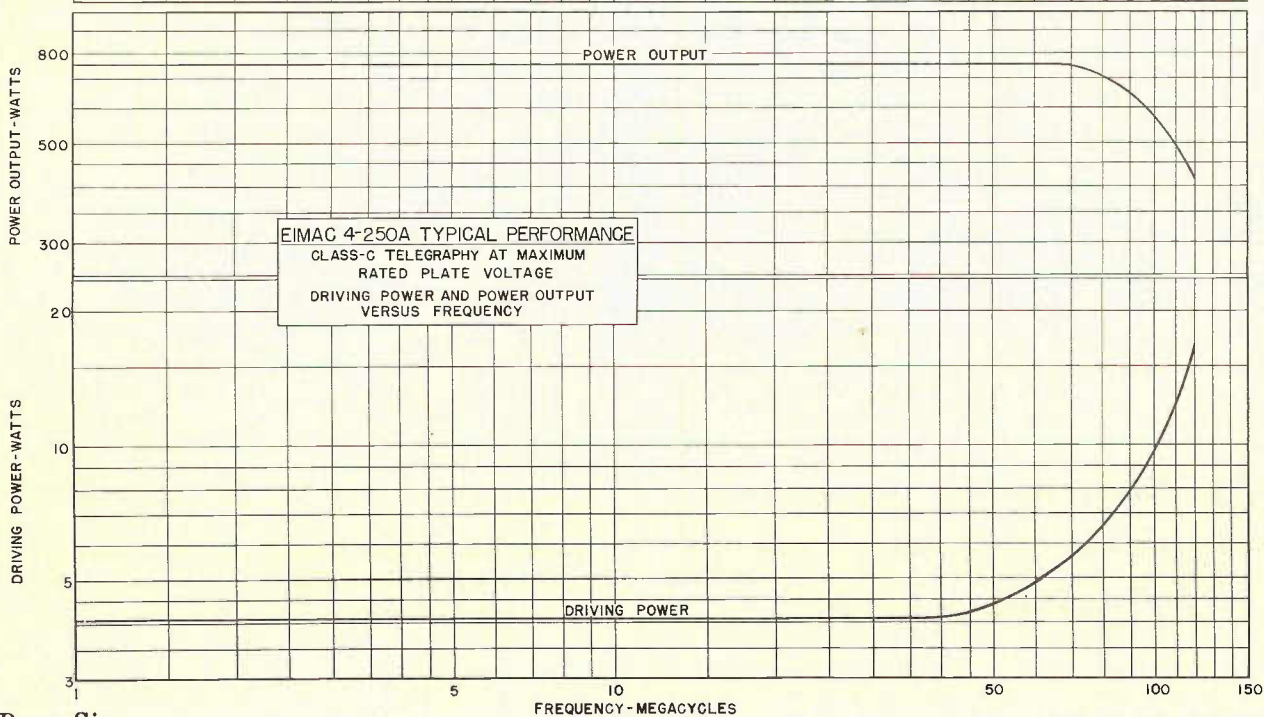
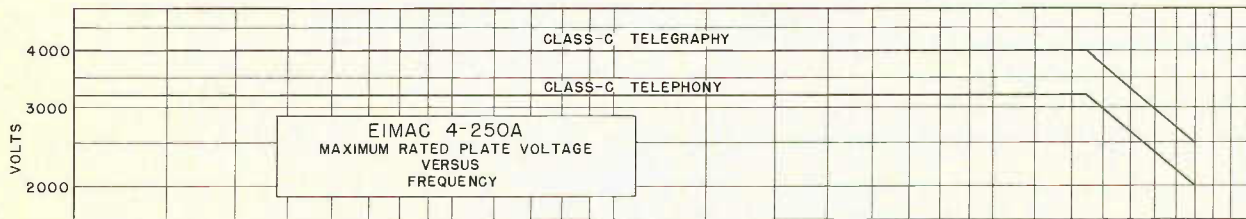
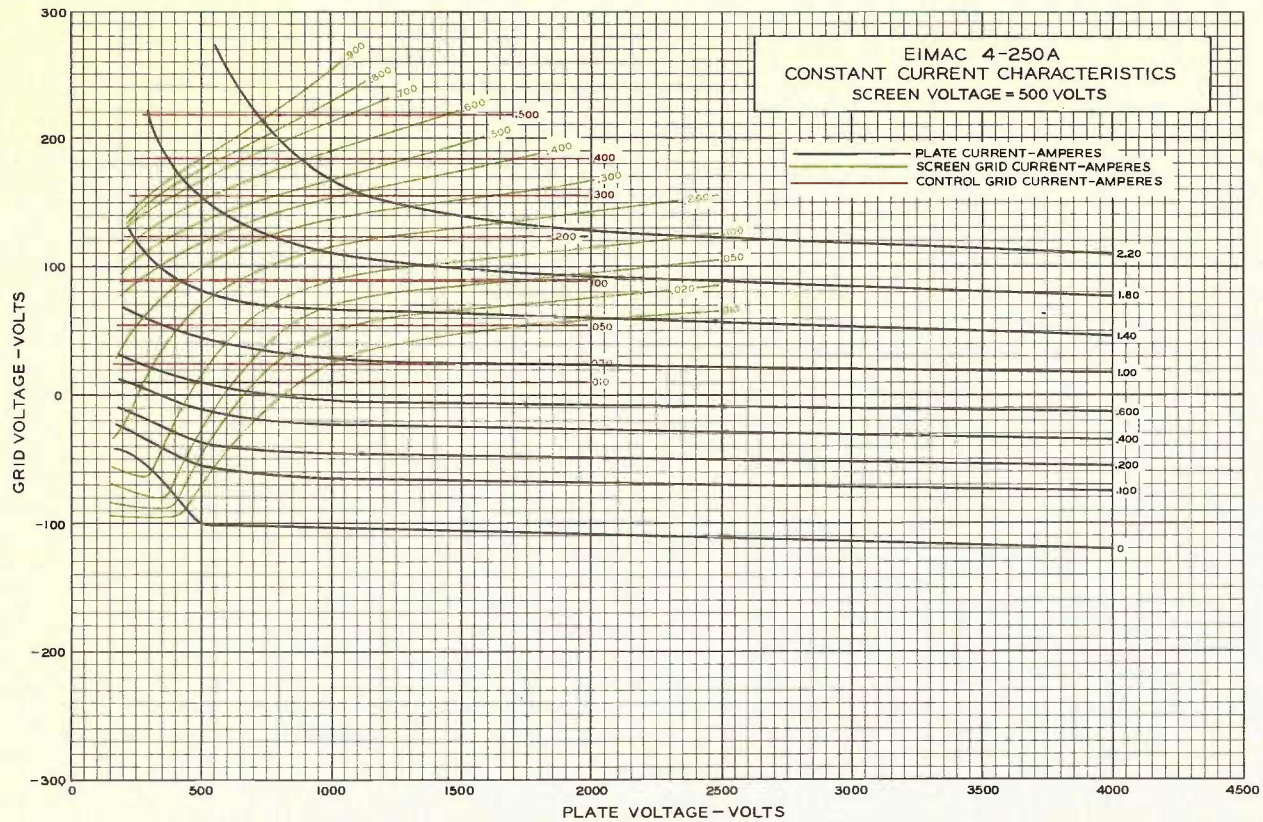

Eimac
EITEL-McCULLOUGH, Inc.
 SAN BRUNO, CALIFORNIA

4-400A

POWER TETRODE

•

RF

AMPLIFIER

The Eimac 4-400A is a high vacuum power tetrode having a maximum plate dissipation rating of 400 watts. It is intended for power amplifier service in 1 kw FM broadcast transmitters on the 88-108 Mc. band. Two tubes operating in this service will deliver a useful power output in excess of 1000 watts while operating under conservative conditions and with low driving-power requirements. The 4-400A is of compact and rugged construction and its low grid-plate capacitance coupled with its low driving power requirement allows considerable simplification of the associated circuit and driver stage.

Cooling of the 4-400A is accomplished by radiation from the plate and with circulation of forced-air through the base around the envelope and over the plate seal. The problem of cooling is greatly simplified by using an Eimac Air-System Socket and its accompanying glass chimney. This system is designed to efficiently maintain the correct balance of cooling air between the component parts of the tube.*†

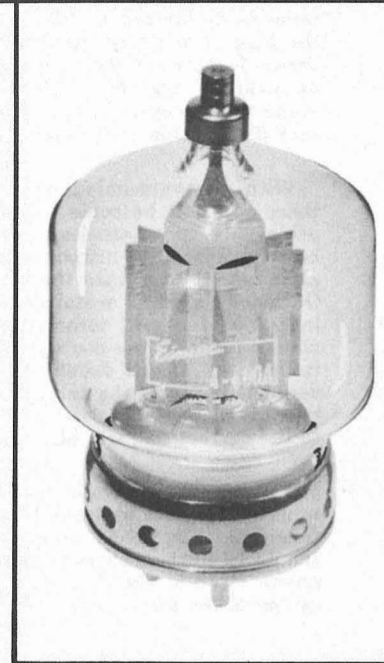

GENERAL CHARACTERISTICS

ELECTRICAL

Filament: Thoriated tungsten	
Voltage - - - - -	5.0 volts
Current - - - - -	14.5 amperes
Grid-Screen Amplification Factor (Average) - - - - -	5.1
Direct Interelectrode Capacitances (Average)	
Grid-Plate (without shielding, base grounded) -	0.12 $\mu\mu\text{fd}$
Input - - - - -	12.5 $\mu\mu\text{fd}$
Output - - - - -	4.7 $\mu\mu\text{fd}$
Transconductance ($i_b=100 \text{ ma.}$, $E_b=2500\text{V.}$, $E_{c2}=500\text{V.}$) -	4,000 μmhos

MECHANICAL

Base - - - - -	5-pin metal shell, No. 5008B
Basing - - - - -	RMA type 5BK
*Cooling - - - - -	Radiation and forced air.

When the Eimac Air-System Socket 4-400A/4000 is used, 14 cu. ft. of air per minute at 1/4 inch pressure as measured in the socket, is required per tube.

Maximum Overall Dimensions:	Tube Only	Tube with Socket, Chimney and HR-6 Plate Connector
Length - - - - -	6.38 inches	8.00 inches
Diameter - - - - -	3.56 inches	5.44 inches
Net Weight - - - - -	9. ounces	
Shipping Weight (Avg.) - - - - -	2.5 pounds	

RATINGS

RADIO-FREQUENCY POWER AMPLIFIER

Class-C FM Telephony or Telegraphy(Key-down conditions, 1 tube)

MAXIMUM RATINGS (Frequencies up to 110-Mc.)

D-C PLATE VOLTAGE - - - - -	4000 MAX VOLTS
D-C PLATE CURRENT - - - - -	350 MAX. MA.
D-C SCREEN VOLTAGE - - - - -	600 MAX. VOLTS
D-C GRID VOLTAGE - - - - -	-500 MAX. VOLTS
PLATE DISSIPATION - - - - -	400 MAX. WATTS
SCREEN DISSIPATION - - - - -	35 MAX. WATTS
GRID DISSIPATION - - - - -	5 MAX. WATTS

*Guarantee applies only when the 4-400A is used as specified with adequate air in the 4-400A/4000 Air-System Socket or equivalent.

†The Radio-frequency losses in a vacuum tube increase with frequency (Effective 3-1-48) Copyright 1948 by Eitel-McCullough, Inc.

TYPICAL OPERATION (110-Mc., Two Tubes)

D-C PLATE VOLTAGE - - - - -	3500	4000	VOLTS
D-C PLATE CURRENT - - - - -	500	540	MA.
D-C SCREEN VOLTAGE - - - - -	300	300	VOLTS
D-C SCREEN CURRENT - - - - -	40	45	MA.
D-C GRID VOLTAGE - - - - -	-170	-170	VOLTS
D-C GRID CURRENT - - - - -	20	20	MA.
DRIVING POWER (APPROX.) - - - - -	20	20	WATTS
PLATE POWER OUTPUT (APPROX.) - - - - -	1300	1600	WATTS
USEFUL POWER OUTPUT - - - - -	1160	1440	WATTS

and at 110-Mc. become an appreciable source of heat. Since these losses occur mainly in the leads and the glass surrounding these leads, adequate cooling must be provided to prevent the deterioration of the envelope at the point where the leads go through the glass.

APPLICATION

Conventional capacitance-shortened quarter wave linear grid and plate tank circuits may be used at 110-Mc. The circuit elements should be silver-plated for best results at this frequency. The 4-400A screen lead inductance is minimized by two screen leads brought through the base of the tube. In order to take advantage of this design feature the screen lead terminals on a socket must be strapped together and all R-F connections must be made to the center of this strap to provide balanced current distribution to ground.

With adequate shielding on frequencies above 30-Mc. there will still be some feed-back present, which is due principally to screen-lead-inductance effects. This may be neutralized by introducing inphase voltage from the plate circuit back into the grid circuit of the same tube. Ordinarily a small metal tab 1 inch by 1½ inches connected to the grid terminal and located parallel to the plate outside of the cooling chimney will suffice for neutralization. Means should be provided for adjusting the distance between the tab and the plate until the correct amount of neutralization is obtained. Trimming the tab to the correct size will also accomplish the same result.

An alternate neutralization method would be to series-tune each screen to ground by means of a small variable capacitor. The leads to each capacitor and to ground should be kept as short as possible and the lead from the screen strap to the capacitor should be brought from the center of the screen strap as previously mentioned.

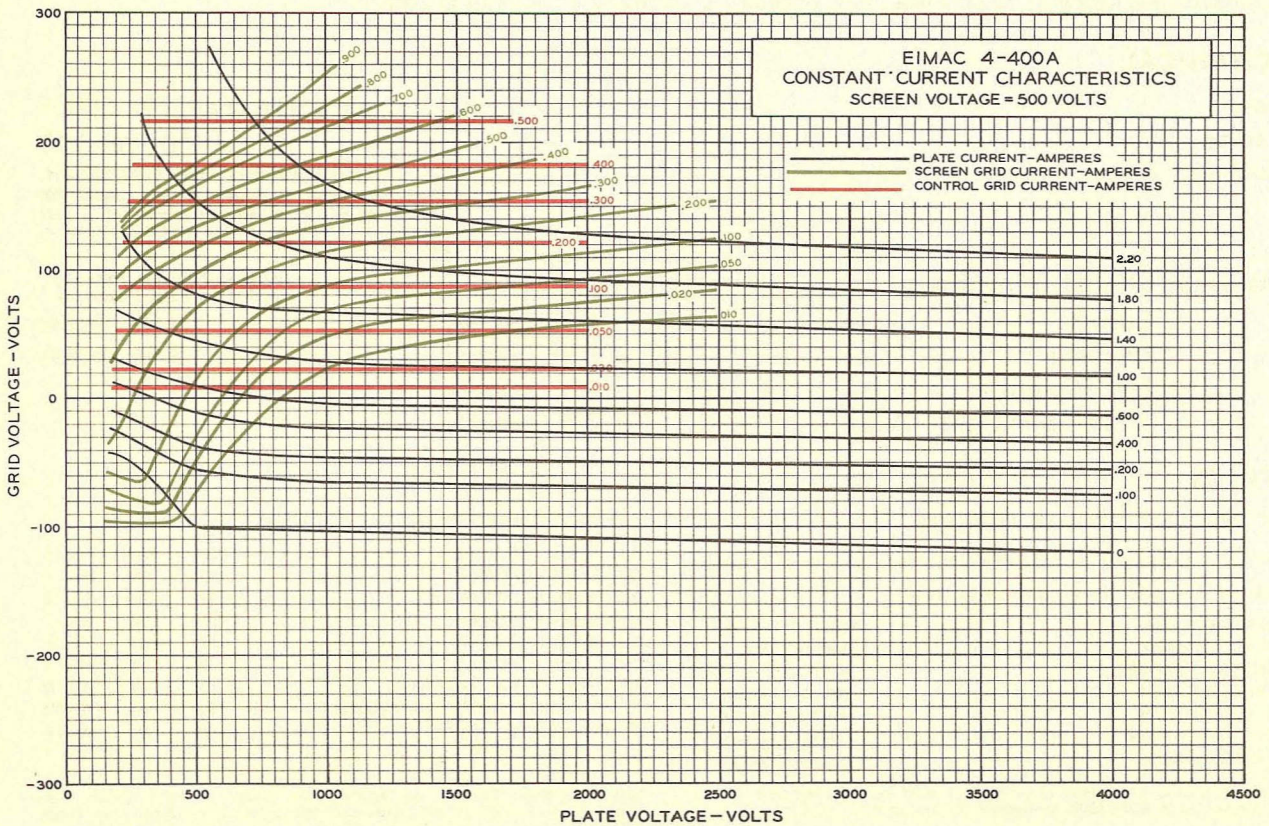
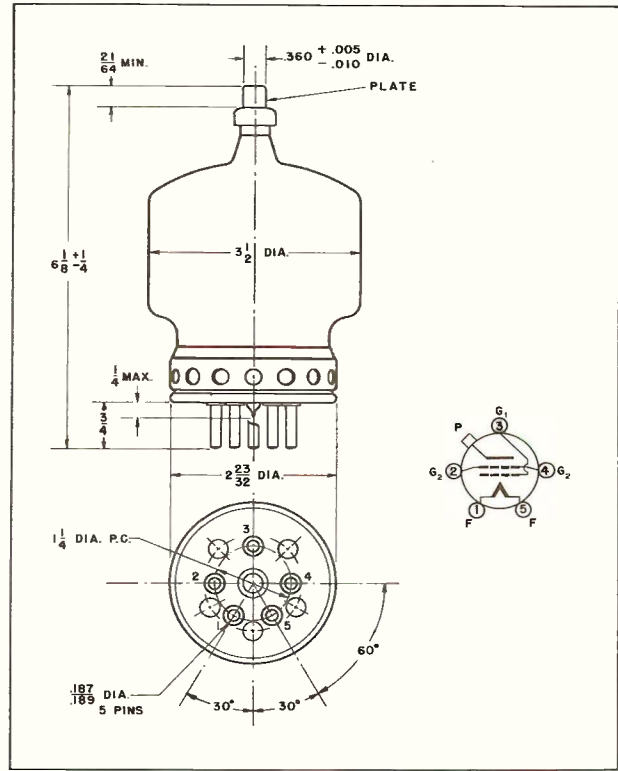

Eimac
EITEL-McCULLOUGH, INC.
SAN BRUNO, CALIFORNIA

4-400A/4000

AIR-SYSTEM
SOCKET

In order to simplify the cooling problem of the Eimac 4-400A Tetrode and assure adequate air-flow to the various seals, the Eimac Air-System Socket was developed. This system is so designed that the correct amount of cooling air is distributed to the various seals in the right proportion.

The system consists of two parts: a specially designed cooling socket and a glass chimney that fits over the tube envelope. The air is introduced into the system at a single port in the socket and then circulates through and around the base, cooling the base pins and seals. It then flows over the envelope, the plate seal and finally exhausts at the chimney top.

A $\frac{1}{4}$ inch diameter hole tapped 28 threads per inch is provided in the socket for the purpose of reading the static air pressure. Under full operating conditions at 110-Mc, with an ambient temperature of 25 degrees Centigrade, each tube requires cooling air at the rate of 14 cu. ft. per minute into the system with a static pressure of 0.25 inches of water as measured at the socket measuring port.

In selecting a blower, allowance should be made for pressure drop occurring in the duct and manifold between the blower and the socket. This drop will, of course, depend on the length and diameter of the air duct and manifold between the blower and the socket.

These air requirements are readily furnished by a small centrifugal blower of the dual type, with the output of each blower going to a socket. The single motor of this type of blower need require only 65 watts of power while furnishing 14 cu. ft. per minute air-flow at $\frac{1}{2}$ inch pressure from each of two blowers.

The 4-400A/4000 Air-System Socket can also be used without modification for the Eimac 4-250A and 4-125A Tetrodes.

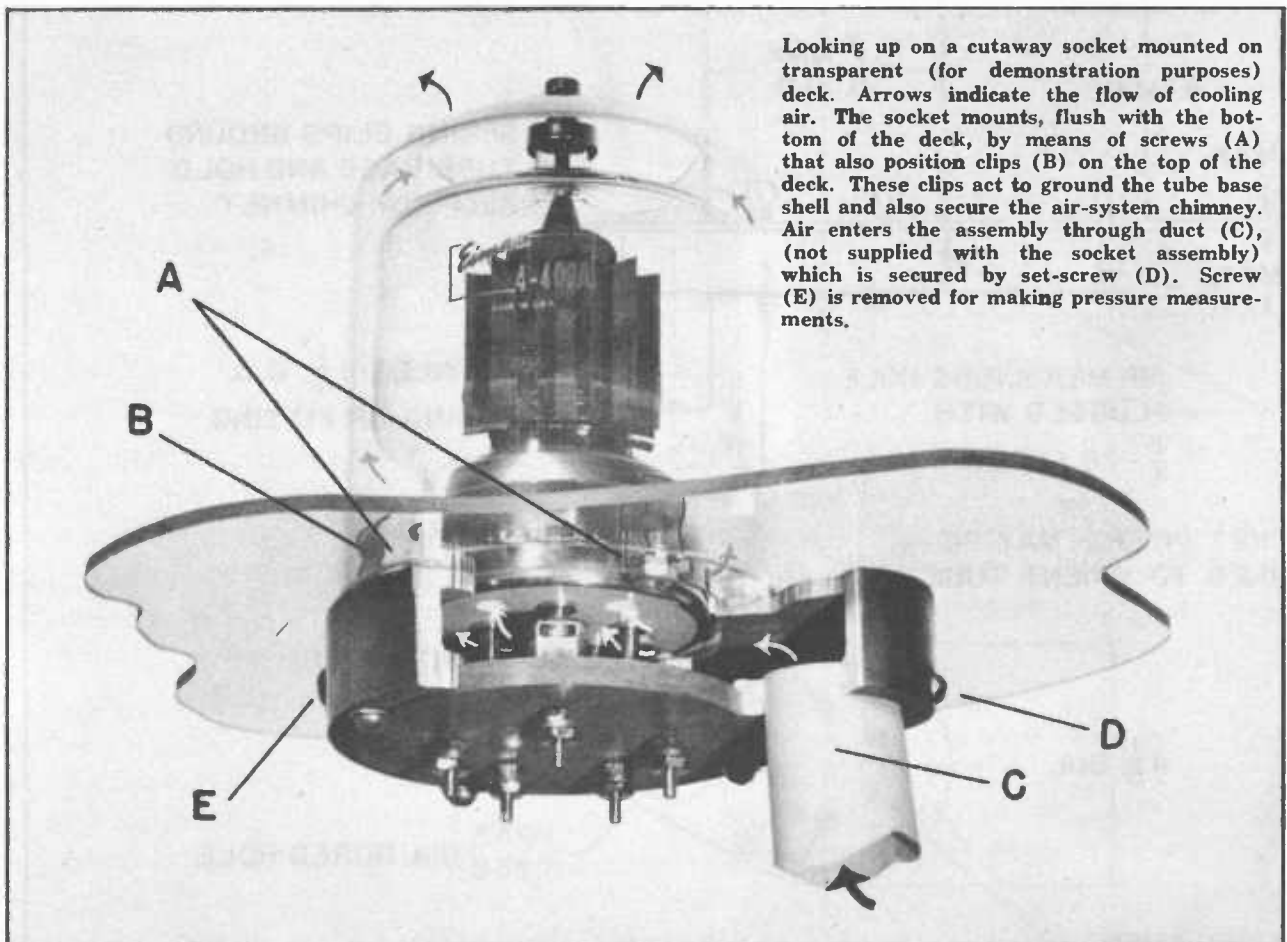
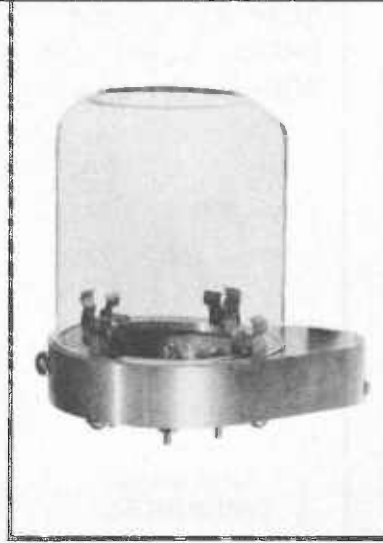

Looking up on a cutaway socket mounted on transparent (for demonstration purposes) deck. Arrows indicate the flow of cooling air. The socket mounts, flush with the bottom of the deck, by means of screws (A) that also position clips (B) on the top of the deck. These clips act to ground the tube base shell and also secure the air-system chimney. Air enters the assembly through duct (C), (not supplied with the socket assembly) which is secured by set-screw (D). Screw (E) is removed for making pressure measurements.

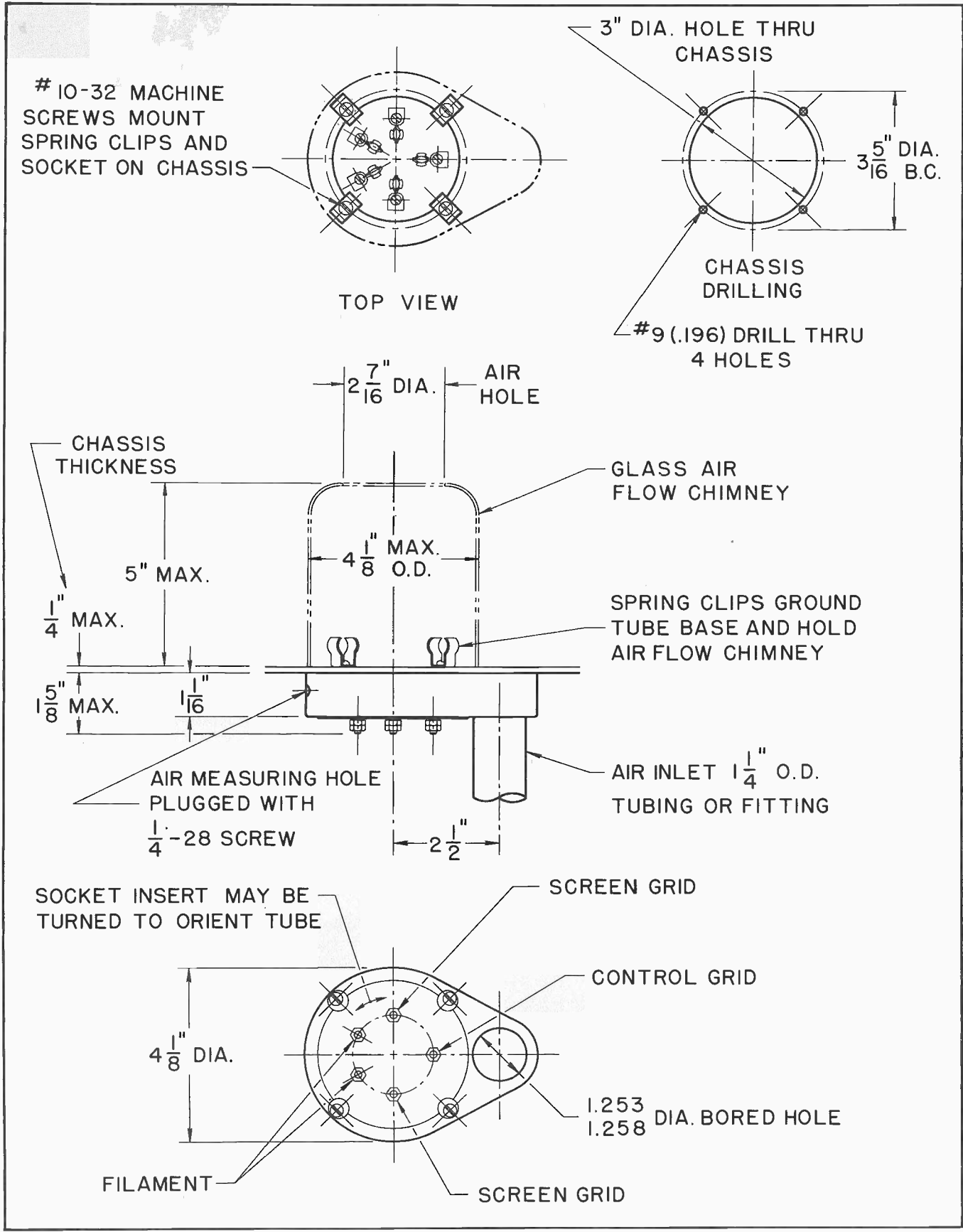

TENTATIVE DATA

EITEL-McCULLOUGH, INC.
SAN BRUNO, CALIFORNIA

4X500A

POWER TETRODE

The Eimac 4X500A is an external-anode tetrode having a maximum plate dissipation rating of 500 watts. Its small size and low-inductance leads permit efficient operation at relatively large outputs well into the VHF region. The screen grid is mounted on a disc which terminates in a connector ring located between grid and plate, thus making possible effective shielding between the grid and plate circuits. The grid terminal is located at the center of the glass base, to facilitate single-tube operation in coaxial circuits.

The combination of low grid-plate capacitance, low screen-lead inductance and functionally located terminals contributes to the stable operation of the 4X500A at high frequencies, making neutralization unnecessary in most cases and greatly simplifying it in others.



GENERAL CHARACTERISTICS

ELECTRICAL

Filament: Thoriated Tungsten	
Voltage - - - - -	5.0 volts
Current - - - - -	13.5 amperes
Screen Grid Amplification Factor (Average) - - - - -	6.2
Direct Interelectrode Capacitances (Average)	
Grid-Plate - - - - -	0.05 $\mu\mu\text{fd}$
Input - - - - -	12.8 $\mu\mu\text{fd}$
Output - - - - -	5.6 $\mu\mu\text{fd}$
Transconductance ($i_b=200$ ma., $e_b=2500$ v., $E_{c2}=500$ v.) -	5200 μhms

MECHANICAL

Maximum Overall Dimensions:	
Length - - - - -	4.375 inches
Diameter - - - - -	2.563 inches
Net Weight - - - - -	1.17 pounds
Shipping Weight (Average) - - - - -	6 pounds
Mounting Position: - - - - -	Vertical, Base up or down

RADIO FREQUENCY POWER AMPLIFIER AND OSCILLATOR

Class-C FM or Telegraphy (Key-down conditions, 1 tube)

MAXIMUM RATINGS (Frequencies up to 120 Mc.)

D-C PLATE VOLTAGE - - - - -	4000 MAX. VOLTS
D-C SCREEN VOLTAGE - - - - -	500 MAX. VOLTS
D-C GRID VOLTAGE - - - - -	-500 MAX. VOLTS
D-C PLATE CURRENT - - - - -	350 MAX. MA.
PLATE DISSIPATION ¹ - - - - -	500 MAX. WATTS
SCREEN DISSIPATION - - - - -	30 MAX. WATTS
GRID DISSIPATION - - - - -	10 MAX. WATTS

TYPICAL OPERATION

(Two-Tubes, push-pull amplifier, 110 Mc.)

D-C Plate Voltage - - - - -	2500	3000	volts
D-C Plate Current - - - - -	690	600	ma.
D-C Screen Voltage - - - - -	500	400	volts
D-C Screen Current - - - - -	100	95	ma.
D-C Grid Voltage - - - - -	-250	-200	volts
D-C Grid Current - - - - -	40	45	ma.
Driving Power (approx.) - - - - -	20	18	watts
Plate Power Output (approx.) - - - - -	1300	1320	watts
Useful Power Output - - - - -	1150	1180	watts

TYPICAL OPERATION

(Four tubes, push-pull-parallel amplifier, 110 Mc.)

D-C Plate Voltage - - - - -	4000	volts
D-C Plate Current - - - - -	1.25	amp.
D-C Screen Voltage - - - - -	500	volts
D-C Screen Current - - - - -	160	ma.
D-C Grid Voltage - - - - -	-250	volts
D-C Grid Current - - - - -	70	ma.
Driving Power (approx.) - - - - -	50	watts
Plate Power Output (approx.) - - - - -	3900	watts
Useful Power Output - - - - -	3500	watts

¹A minimum flow of 22 cubic feet of air per minute must be passed through the plate cooler. The pressure drop across the cooler at this flow equals 1.4 inches of water. The glass at the base of the tube must be cooled by passing air at a minimum velocity of 1000 feet per minute

across the base. Sufficient air for this purpose will ordinarily be obtained from a small fan or low-pressure centrifugal blower. Cooling air must be supplied to both the plate cooler and base before applying filament voltage.

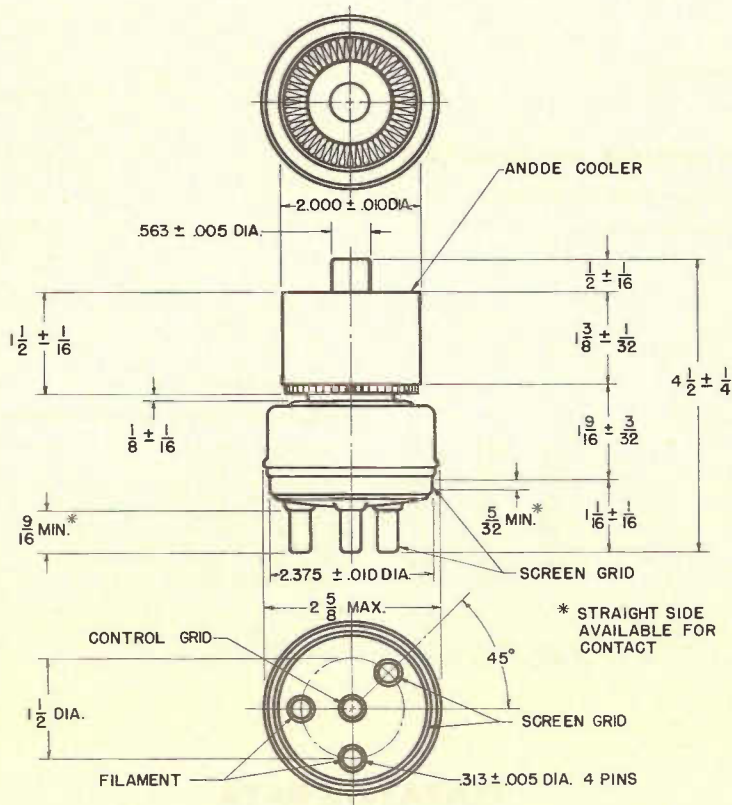
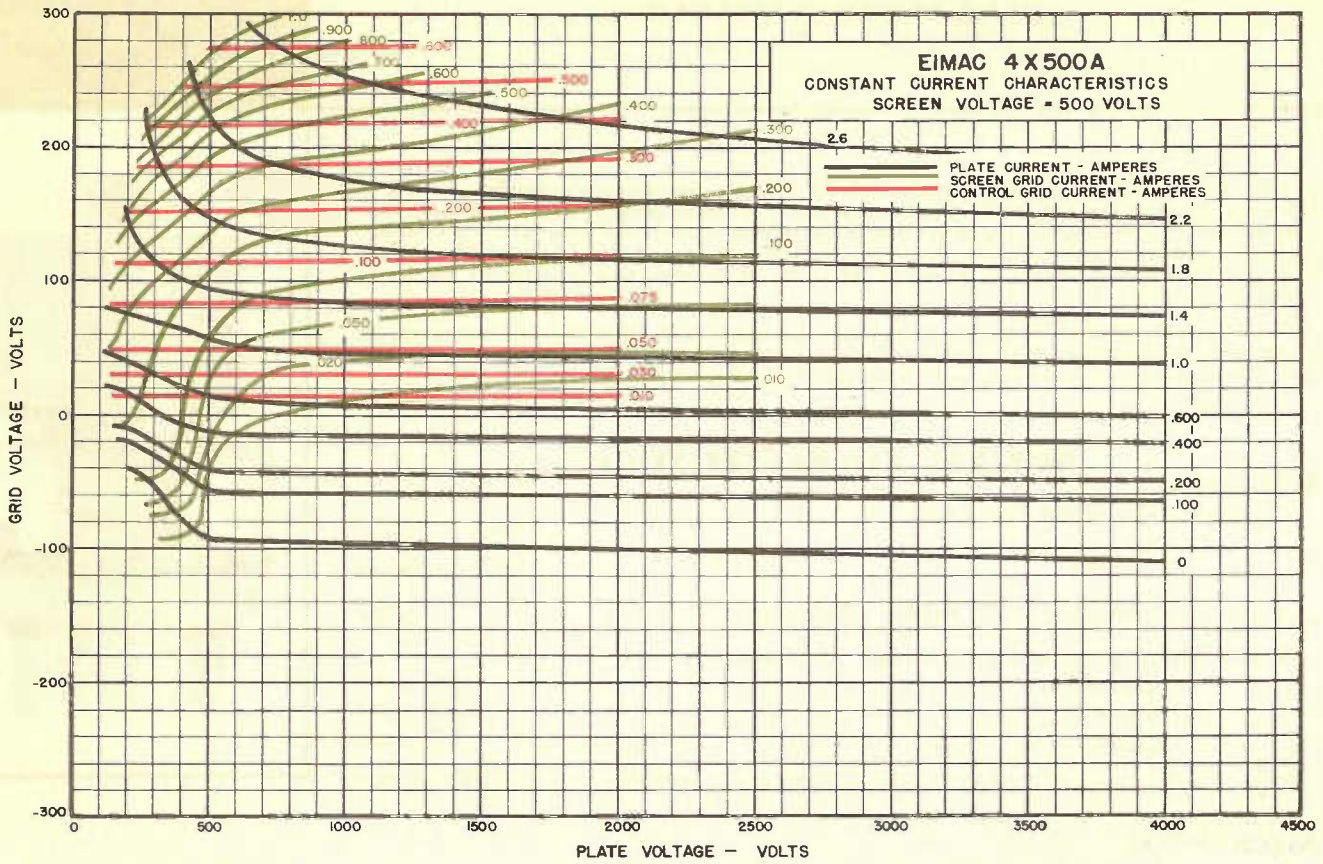

TENTATIVE DATA

EITEL-McCULLOUGH, Inc.

SAN BRUNO, CALIFORNIA

4-1000A
SUPERSEDES TYPE 4-750A

POWER TETRODE
MODULATOR
OSCILLATOR
AMPLIFIER

The Eimac 4-1000A is a power tetrode having a maximum plate dissipation of 1000 watts. Cooling of the 4-1000A is accomplished by radiation from the plate and by forced-air circulation around the glass envelope and through the compact low-inductance base structure. At maximum dissipation the plate operates at a red-orange color.

The 4-1000A permits a single-stage gain of more than 230 times up to approximately 30 Mc., or from 14 watts driving power to over 3 KW power output per tube. This output can be obtained at frequencies well into the VHF range. At 100 Mc. a pair of 4-1000A's will deliver a useful power output of more than 4000 watts.



GENERAL CHARACTERISTICS

ELECTRICAL

Filament: Thoriated tungsten	
Voltage	7.5 volts
Current	21 amperes
Grid-Screen Amplification Factor (Average)	7.2
Direct Interelectrode Capacitances (Average)	
Grid-Plate (without shielding, base grounded)	0.24 μmfd
Input	27.2 μmfd
Output	7.6 μmfd
Transconductance ($i_b=300 \text{ ma.}, E_b=2500 \text{ v.}, E_{c2}=500 \text{ v.}$)	10,000 μmhos

MECHANICAL

Base	5-pin metal shell, (see dwg.)
Basing	RMA type 5BK
Cooling	Radiation and forced air ¹
Mounting position	Vertical, base down or up
Maximum Overall Dimensions	
Length	9.25 inches
Diameter	5 inches
Net Weight	1.5 pounds
Shipping Weight (Average)	12 pounds

RADIO FREQUENCY POWER AMPLIFIER AND OSCILLATOR

Class-C Telephony (Key-down conditions, per tube)

MAXIMUM RATINGS

D-C Plate Voltage	6000 Max. Volts
D-C Screen Voltage	1000 Max. Volts
D-C Grid Voltage	-500 Max. Volts
D-C Plate Current	700 Max. ma
Plate Dissipation	1000 Max. Watts
Screen Dissipation	75 Max. Watts
Grid Dissipation	25 Max. Watts

TYPICAL OPERATION (Frequencies below 40 Mc.)

D-C Plate Voltage	3000	4000	5000	6000	Volts
D-C Screen Voltage	500	500	500	500	Volts
D-C Grid Voltage	-150	-150	-200	-200	Volts
D-C Plate Current	693	700	665	681	ma
D-C Screen Current	146	137	125	141	ma
D-C Grid Current	38	39	37	41	ma
Screen Dissipation	73	69	63	71	Watts
Grid Dissipation	5.4	5.5	5.3	6.1	Watts
Peak R-F Grid Input Voltage (approx.) ²	292	292	342	348	Volts
Driving Power (approx.) ²	11.1	11.4	12.7	14.3	Watts
Plate Power Input	2079	2800	3325	4086	Watts
Plate Dissipation	667	700	715	746	Watts
Plate Power Output	1412	2100	2610	3340	Watts

RADIO FREQUENCY POWER AMPLIFIER

FM Telephony or Class C Telephony

MAXIMUM RATINGS (Per tube at 110 Mc.)

D-C Plate Voltage	5000 Max. Volts
D-C Screen Voltage	1000 Max. Volts
D-C Grid Voltage	-500 Max. Volts
D-C Plate Current	700 Max. ma
Plate Dissipation	1000 Max. Watts
Screen Dissipation	75 Max. Watts
Grid Dissipation	25 Max. Watts

TYPICAL OPERATION (Two Tubes Push-Pull at 110 Mc.)

D-C Plate Voltage	4000	5000	Volts
D-C Screen Voltage	350	330	Volts
D-C Grid Voltage	-350	-487	Volts
D-C Plate Current	1.1	1.22	Amp
D-C Screen Current	290	250	ma.
D-C Grid Current	70	65	ma.
Screen Dissipation	100	83	Watts
Driving Power (approx.) ²	200	250	Watts
Plate Power Input	4400	6100	Watts
Plate Dissipation (per tube)	565	670	Watts
Useful Power Output	3050	4400	Watts

¹ Adequate cooling must be provided for the seals and envelope of the 4-1000A. Forced air circulation in the amount of 70 cubic feet per minute through the base of the tube is required. This air should be applied simultaneously with filament power. The temperature at the top of

the plate terminal and on the pins at the base of the tube should not exceed 150 degrees centigrade in continuous-service applications.

² Driving power increases for frequencies above approximately 30 Mc.

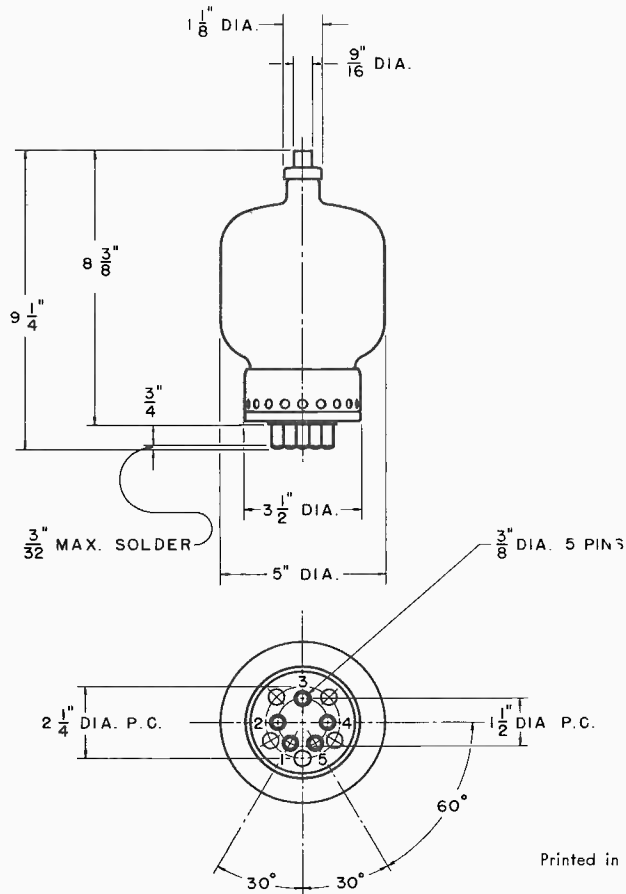
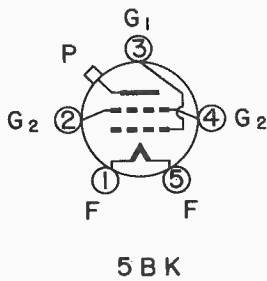
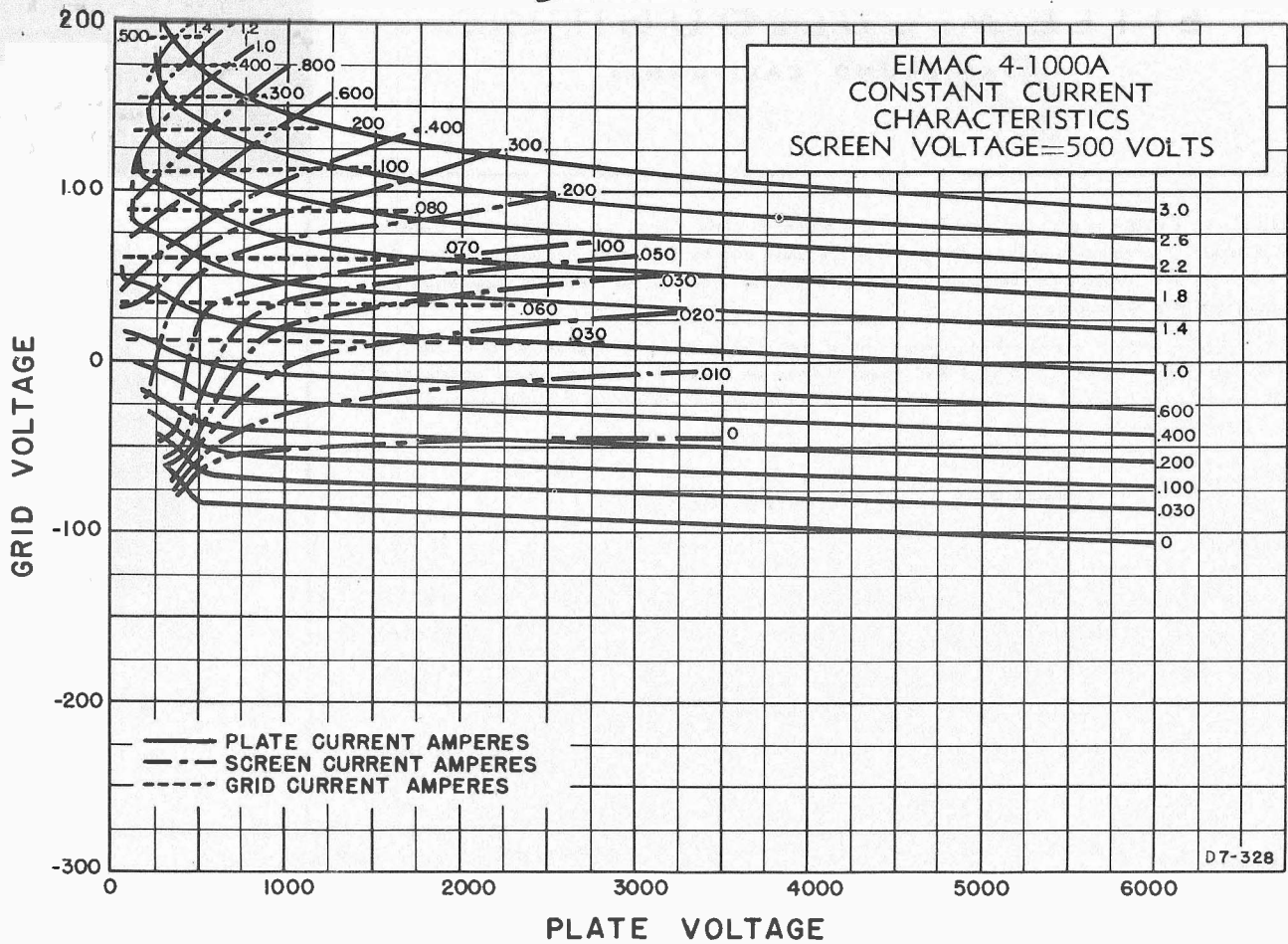

Eitel-McCullough
EITEL-McCULLOUGH, INC.
 SAN BRUNO, CALIFORNIA

25T

MEDIUM-MU TRIODE
 •
 MODULATOR
 OSCILLATOR
 AMPLIFIER

GENERAL CHARACTERISTICS

ELECTRICAL

Filament: Thoriated tungsten	
Voltage - - - - -	▶ 6.3 volts
Current - - - - -	3.0 amperes
Amplification Factor (Average) - - - - -	24
Direct Interelectrode Capacitances (Average)	
Grid-Plate - - - - -	1.5 $\mu\mu\text{f}$
Grid-Filament - - - - -	2.7 $\mu\mu\text{f}$
Plate-Filament - - - - -	0.3 $\mu\mu\text{f}$
Transconductance ($I_b=25$ ma., $E_b=1000$, $e_c=-15$) - - -	2500 μmhos

MECHANICAL

Base - - - - - (Small 4-pin bayonet, ceramic)	RMA type M8-071
Basing - - - - -	RMA type 3G
Maximum Overall Dimensions:	
Length - - - - -	4.50 inches
Diameter - - - - -	1.44 inches
Net weight - - - - -	1.00 ounce
Shipping weight (Average) - - - - -	1.25 pounds

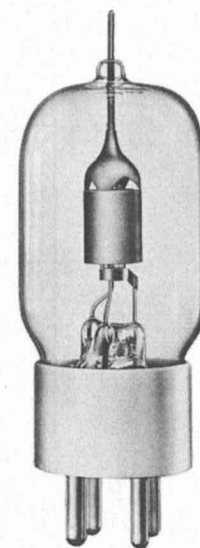

**AUDIO FREQUENCY POWER AMPLIFIER AND MODULATOR
 Class B**

	TYPICAL OPERATION—2 TUBES				MAX. RATING
D-C Plate Voltage - - - - -	750	1000	1500	2000	2000 volts
Max.-Signal D-C Plate Current, per tube* - -	•	•	•	•	75 ma.
Plate Dissipation, per tube* - - - - -	•	•	•	•	25 watts
D-C Grid Voltage (approx.) - - - - -	-20	-30	-55	-80	volts
Peak A-F Grid Input Voltage - - - - -	205	210	230	270	volts
Zero-Signal D-C Plate Current - - - - -	43	32	21	16	ma.
Max.-Signal D-C Plate Current - - - - -	133	120	94	80	ma.
Max.-Signal Driving Power (approx.) - - - -	1.4	1.2	0.8	0.7	watts
Effective Load, Plate-to-Plate - - - - -	9200	15800	33700	55500	ohms
Max.-Signal Plate Power Output - - - - -	50	70	90	110	watts

*Averaged over any sinusoidal audio frequency cycle.

**RADIO FREQUENCY POWER AMPLIFIER AND OSCILLATOR
 Class-C *Telegraphy
 (Key down conditions without modulation)**

	TYPICAL OPERATION—1 TUBE			MAX. RATING
D-C Plate Voltage - - - - -	1000	1500	2000	2000 volts
D-C Plate Current - - - - -	72	67	63	75 ma.
D-C Grid Current - - - - -	9	13	18	25 ma.
D-C Grid Voltage - - - - -	-70	-95	-130	volts
Plate Power Output - - - - -	47	75	100	watts
Plate Input - - - - -	72	100	125	watts
Plate Dissipation - - - - -	25	25	25	25 watts
Peak R. F. Grid Input Voltage, (approx.) - -	170	195	245	volts
Driving Power, (approx.) - - - - -	1.3	2.2	4.0	watts

*The above figures show actual measured tube performance, and do not allow for variation in circuit losses.
 ▶Corrects typographical error on sheet dated 8-15-44.

Simat
25T

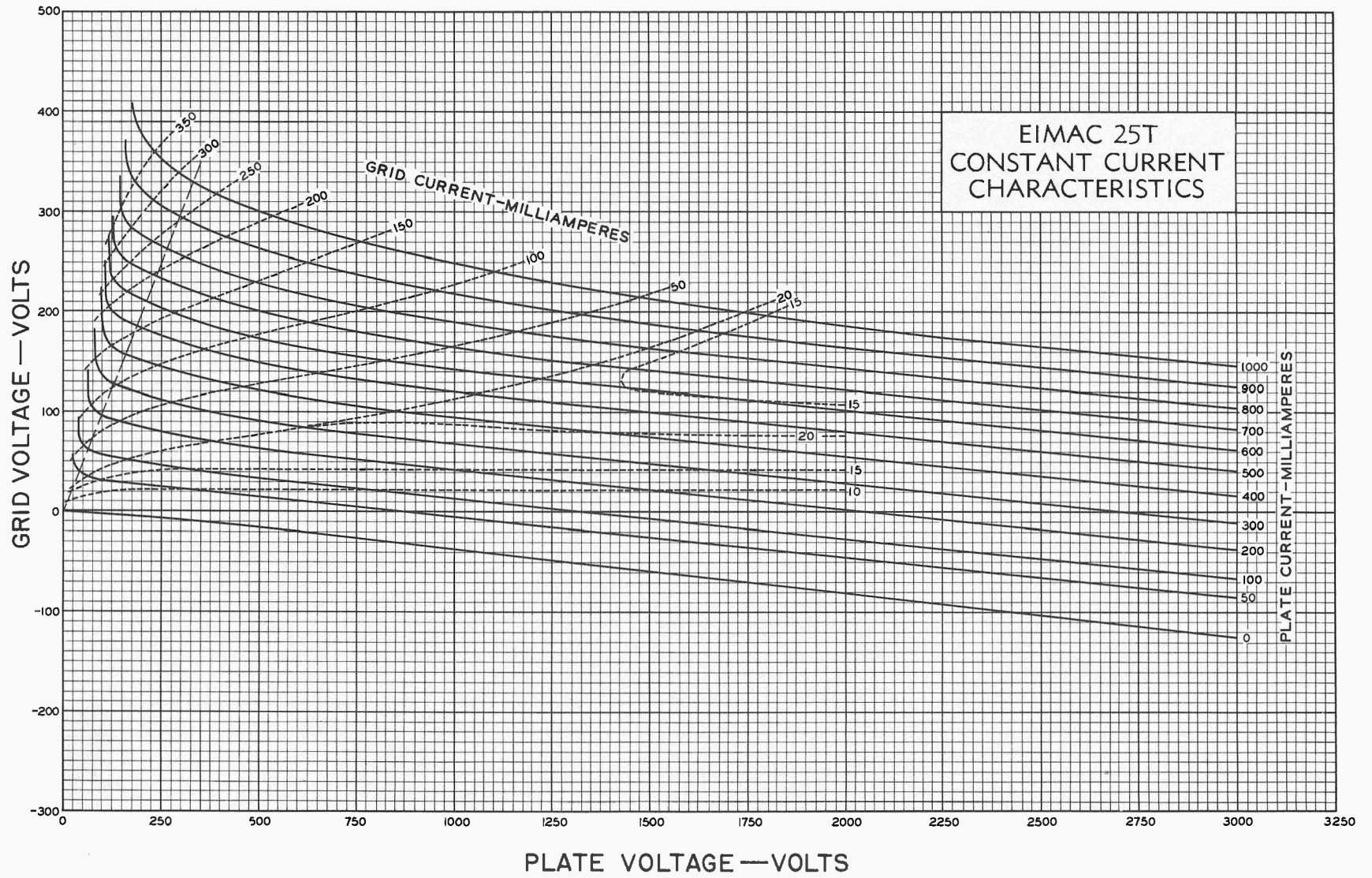

DRIVING POWER vs. POWER OUTPUT

The three charts on this page show the relationship of plate efficiency, power output and grid driving power at plate voltages of 1000, 1500 and 2000 volts. These charts show combined grid and bias losses only. The driving power and power output figures do not include circuit losses. The plate dissipation in watts is indicated by P_p .

Points A, B, and C are identical to the typical Class C operating conditions shown on the first page under 1000, 1500, and 2000 volts respectively.

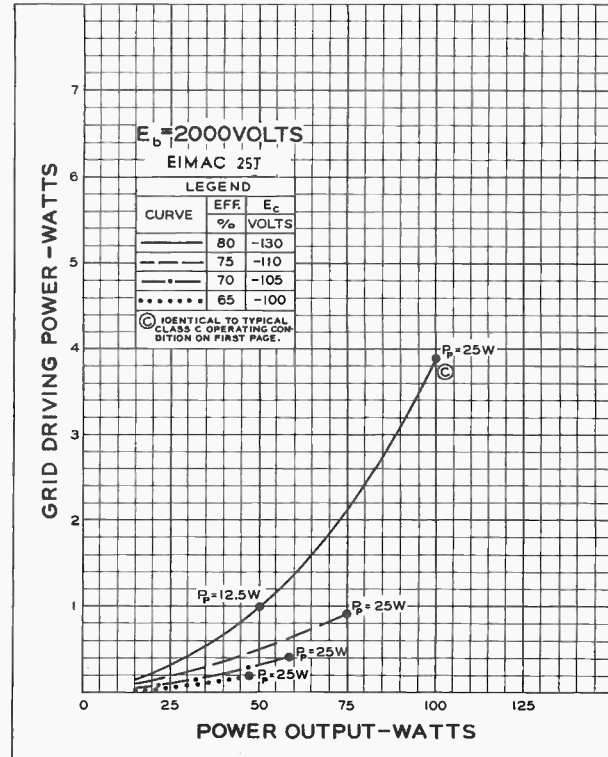
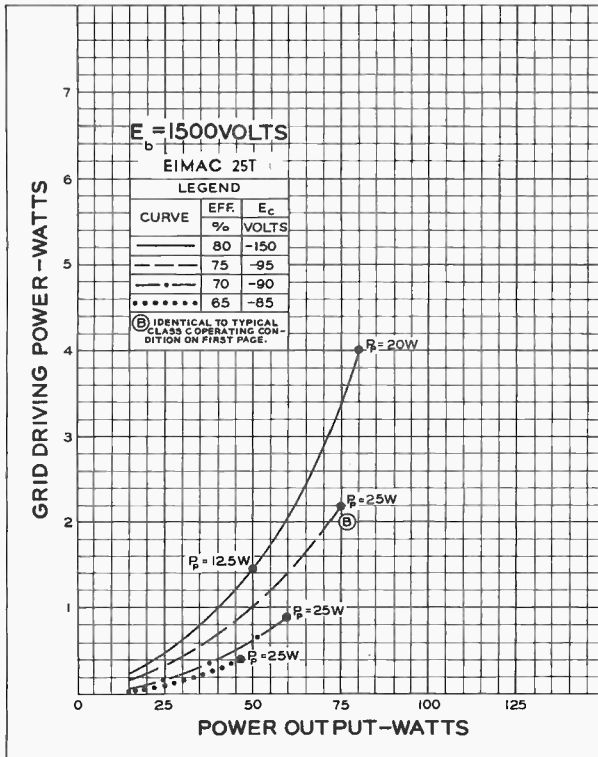
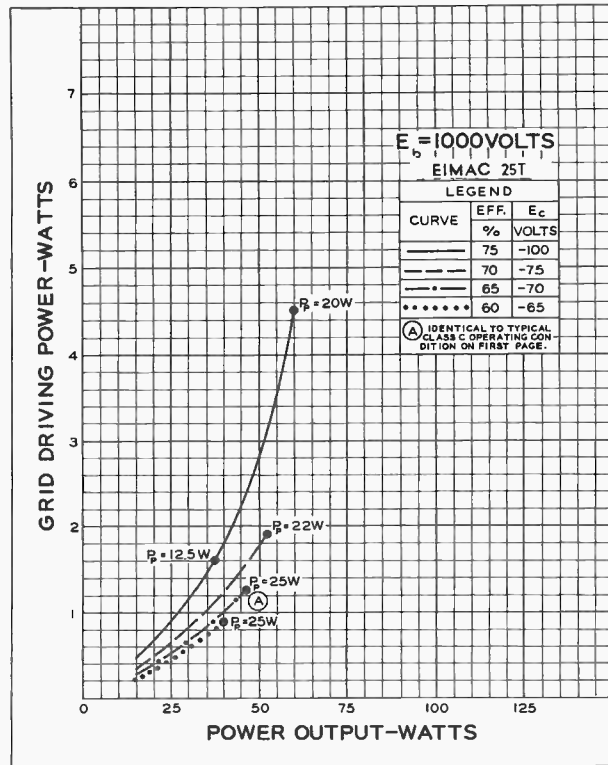

$.048 \pm .003$

PLATE

$\frac{5}{16}$ MIN.

$1\frac{7}{16}$ MAX.

$3\frac{9}{16} \pm \frac{3}{16}$

RMA BASE
NO. M8-071

$4\frac{3}{16} \pm \frac{3}{16}$

GRID

FILAMENT

NC

FILAMENT

3G



EITEL-McCULLOUGH, INC.

SAN BRUNO, CALIFORNIA

3 C 2 4

MEDIUM-MU TRIODE

MODULATOR
OSCILLATOR
AMPLIFIER

GENERAL CHARACTERISTICS

ELECTRICAL

Filament: Thoriated tungsten		
Voltage - - - - -	6.3	volts
Current - - - - -	3.0	amperes
Amplification Factor (Average) - - - - -		23
Direct Interelectrode Capacitances (Average)		
Grid-Plate - - - - -	1.5	$\mu\mu\text{f}$
Grid-Filament - - - - -	1.7	$\mu\mu\text{f}$
Plate-Filament - - - - -	0.3	$\mu\mu\text{f}$
Transconductance ($I_b=25 \text{ ma.}, E_b=1000, e_c=-20$)		2500 μmhos

MECHANICAL

Base - - - - -	(Small 4-pin bayonet)	RMA type M8-071
Basing - - - - -		RMA type 2D
Maximum Overall Dimensions:		
Length - - - - -	4.38	inches
Diameter - - - - -	1.44	inches
Net weight - - - - -	1.00	ounce
Shipping weight (Average) - - - - -	1.25	pounds

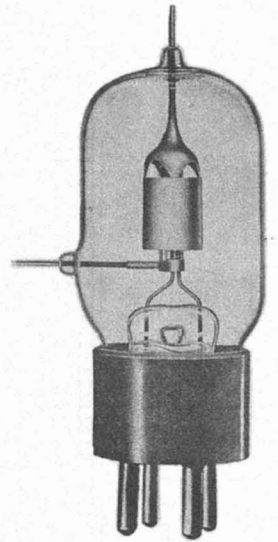

AUDIO FREQUENCY POWER AMPLIFIER AND MODULATOR Class B

	TYPICAL OPERATION—2 TUBES				MAX. RATING
	750	1000	1500	2000	
D-C Plate Voltage - - - - -	750	1000	1500	2000	2000 volts
Max.-Signal D-C Plate Current, per tube* - - -	•	•	•	•	75 ma.
Plate Dissipation, per tube* - - - - -	•	•	•	•	25 watts
D-C Grid Voltage (approx.) - - - - -	-20	-30	-60	-85	volts
Peak A-F Grid Input Voltage - - - - -	230	230	250	290	volts
Zero-Signal D-C Plate Current - - - - -	43	32	21	16	ma.
Max.-Signal D-C Plate Current - - - - -	133	120	94	80	ma.
Max.-Signal Driving Power (approx.) - - - - -	2.0	1.7	1.2	1.1	watts
Effective Load, Plate-to-Plate - - - - -	9200	15800	33700	55500	ohms
Max.-Signal Plate Power Output - - - - -	50	70	90	110	watts

*Averaged over any sinusoidal audio frequency cycle.

RADIO FREQUENCY POWER AMPLIFIER AND OSCILLATOR Class-C *Telegraphy (Key down conditions without modulation)

	TYPICAL OPERATION—1 TUBE			MAX. RATING
	1000	1500	2000	
D-C Plate Voltage - - - - -	1000	1500	2000	2000 volts
D-C Plate Current - - - - -	72	67	63	75 ma.
D-C Grid Current - - - - -	15	15	17	25 ma.
D-C Grid Voltage - - - - -	-80	-110	-170	volts
Plate Power Output - - - - -	47	75	100	watts
Plate Input - - - - -	72	100	125	watts
Plate Dissipation - - - - -	25	25	25	25 watts
Peak R. F. Grid Input Voltage, (approx.) - - -	200	225	295	volts
Driving Power, (approx.) - - - - -	2.6	3.1	4.5	watts

*The above figures show actual measured tube performance, and do not allow for variations in circuit losses.

Eimac
3C24

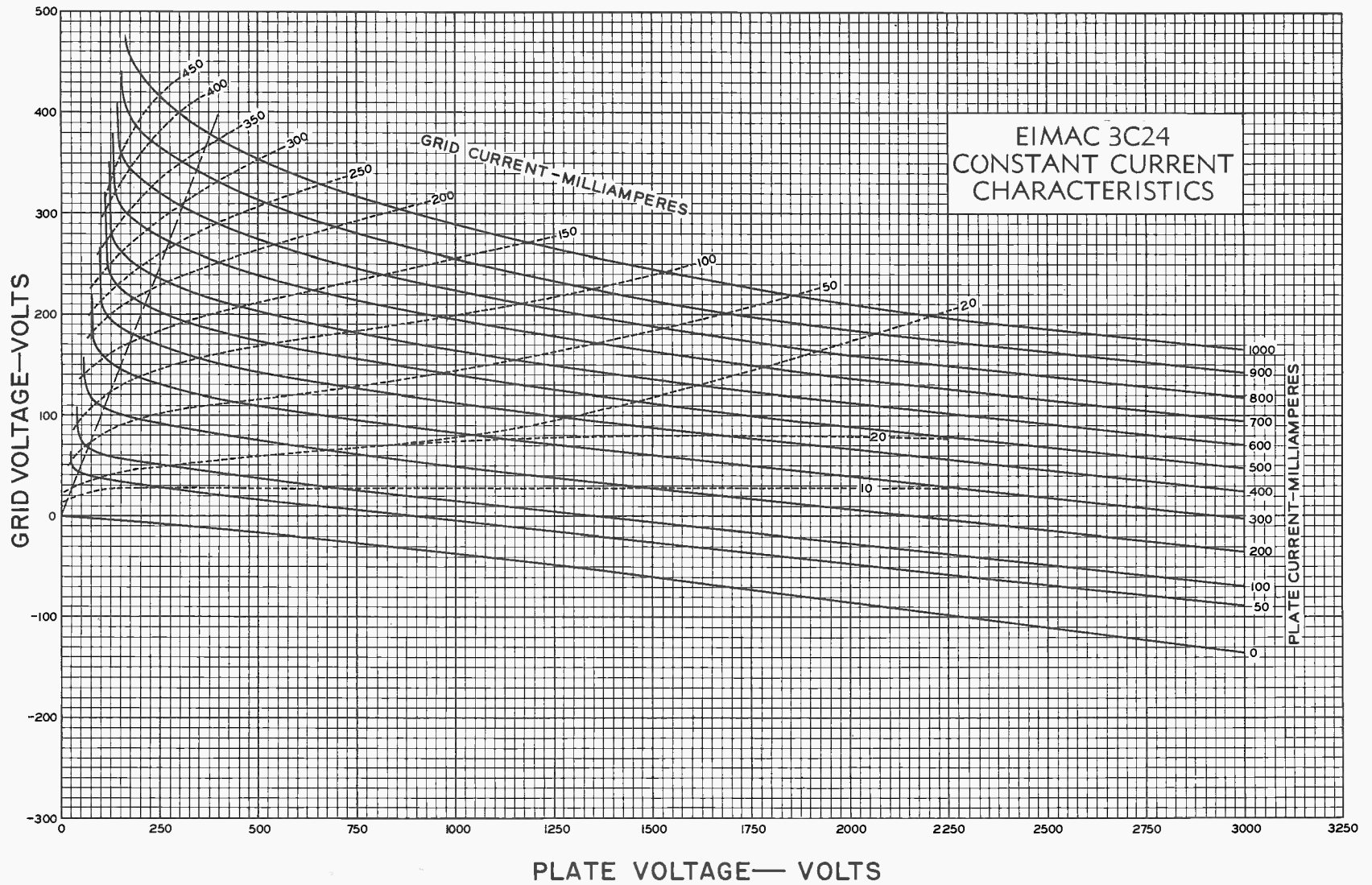

DRIVING POWER vs. POWER OUTPUT

The three charts on this page show the relationship of plate efficiency, power output and grid driving power at plate voltages of 1000, 1500 and 2000 volts. These charts show combined grid and bias losses only. The driving power and power output figures do not include circuit losses. The plate dissipation in watts is indicated by P_p .

Points A, B, and C are identical to the typical Class C operating conditions shown on the first page under 1000, 1500, and 2000 volts respectively.

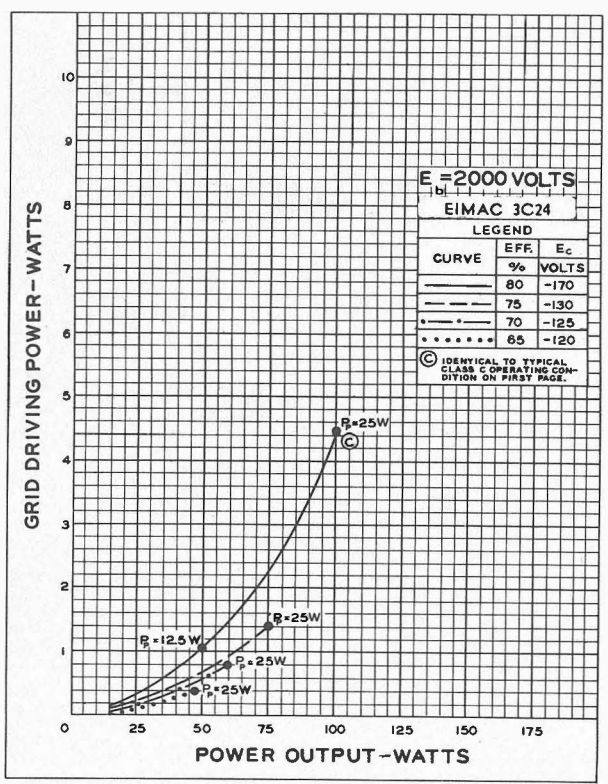
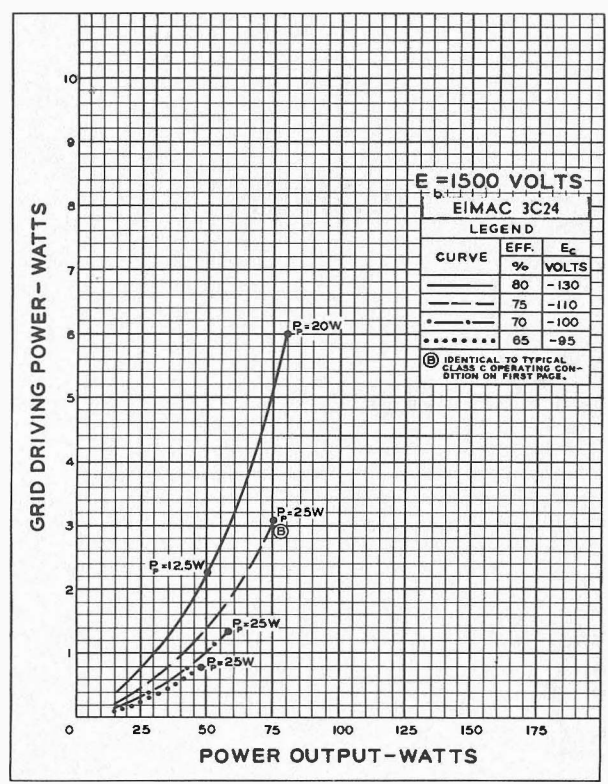
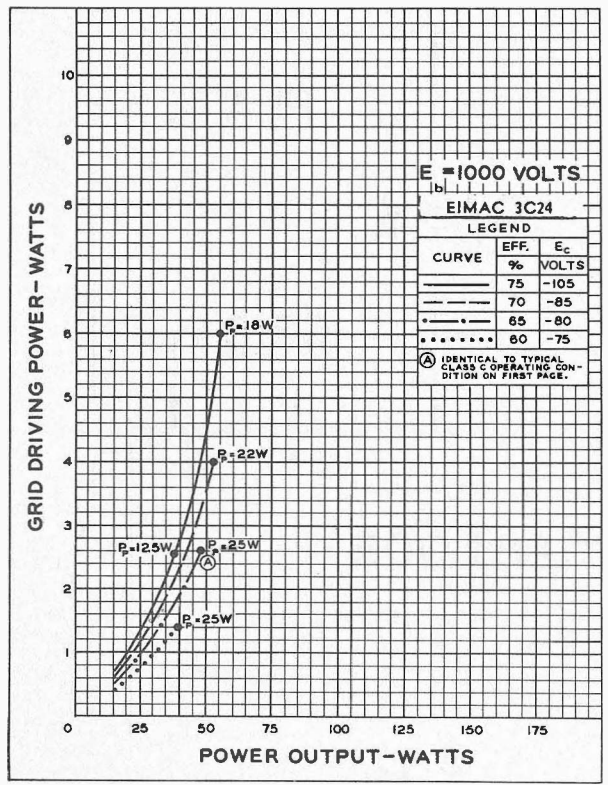

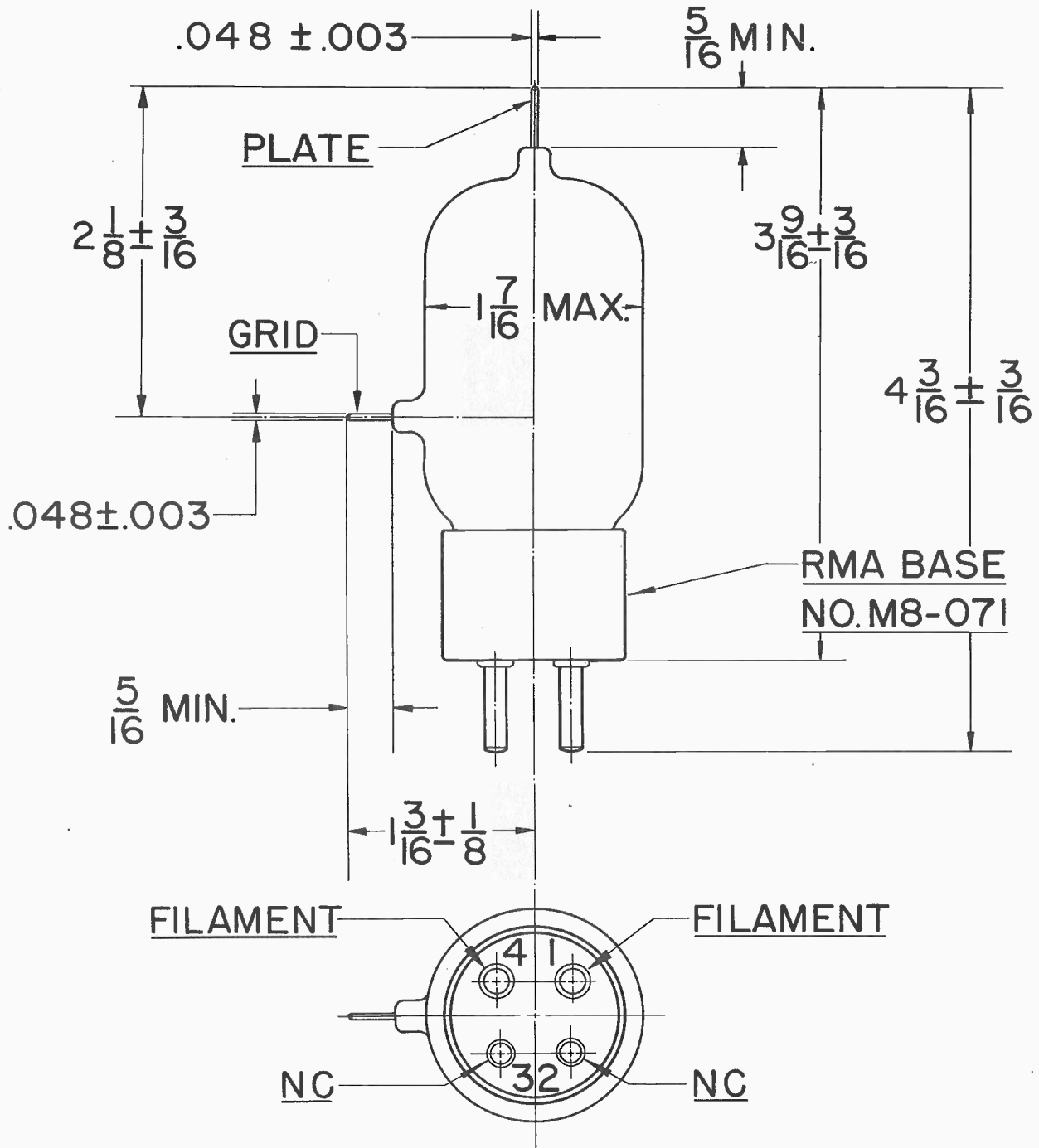

2D



Eitel-McCullough
EITEL-McCULLOUGH, INC.
 SAN BRUNO, CALIFORNIA

3 5 T

HIGH-MU TRIODE
 MODULATOR
 OSCILLATOR
 AMPLIFIER

GENERAL CHARACTERISTICS

ELECTRICAL

Filament: Thoriated tungsten	
Voltage - - - - -	5.0 volts
Current - - - - -	4.0 amperes
Amplification Factor (Average) - - - - -	39
Direct Interelectrode Capacitances (Average)	
Grid-Plate - - - - -	1.8 $\mu\mu\text{f}$
Grid-Filament - - - - -	4.1 $\mu\mu\text{f}$
Plate-Filament - - - - -	0.3 $\mu\mu\text{f}$
Transconductance ($I_b=100$ ma., $E_b=2000$, $e_c=-30$)	2850 μmhos
Frequency for Maximum Ratings - - - - -	100 mc.

MECHANICAL

Base - - - - -	(Medium 4-pin bayonet, ceramic)	RMA type M8-078
Basing - - - - -		RMA type 3G
Maximum Overall Dimensions:		
Length - - - - -		5.5 inches
Diameter - - - - -		1.81 inches
Net weight - - - - -		2.5 ounces
Shipping weight (Average) - - - - -		1.25 pounds

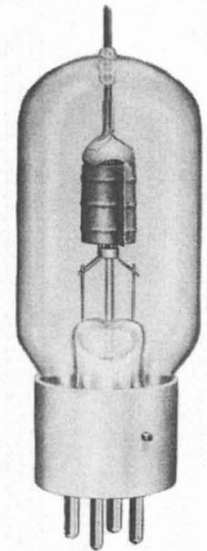

AUDIO FREQUENCY POWER AMPLIFIER AND MODULATOR

Class B

	TYPICAL OPERATION—2 TUBES			MAX. RATING	
	1000	1500	2000		
D-C Plate Voltage - - - - -	1000	1500	2000	2000	volts
Max.-Signal D-C Plate Current, per tube* - - -	•	•	•	150	ma.
Plate Dissipation, per tube* - - - - -	•	•	•	50	watts
D-C Grid Voltage (approx.) - - - - -	-8	-25	-40		volts
Peak A-F Grid Input Voltage - - - - -	240	250	255		volts
Zero-Signal D-C Plate Current - - - - -	67	45	34		ma.
Max.-Signal D-C Plate Current - - - - -	240	200	167		ma.
Max.-Signal Driving Power (approx.) - - - - -	7	5	4		watts
Effective Load, Plate-to-Plate - - - - -	7900	16200	27500		ohms
Max.-Signal Plate Power Output - - - - -	140	200	235		watts

*Averaged over any sinusoidal audio frequency cycle.

RADIO FREQUENCY POWER AMPLIFIER AND OSCILLATOR

Class-C *Telegraphy

(Key down conditions without modulation)

	TYPICAL OPERATION—1 TUBE			MAX. RATING	
	1000	1500	2000		
D-C Plate Voltage - - - - -	1000	1500	2000	2000	volts
D-C Plate Current - - - - -	125	125	125	150	ma.
D-C Grid Current - - - - -	40	40	45	50	ma.
D-C Grid Voltage - - - - -	-60	-120	-135		volts
Plate Power Output - - - - -	87	141	200		watts
Plate Input - - - - -	125	188	250		watts
Plate Dissipation - - - - -	38	47	50	50	watts
Peak R. F. Grid Input Voltage, (approx.) - - -	165	250	285		volts
Driving Power, (approx.) - - - - -	7	9	13		watts

*The above figures show actual measured tube performance, and do not allow for variations in circuit losses.

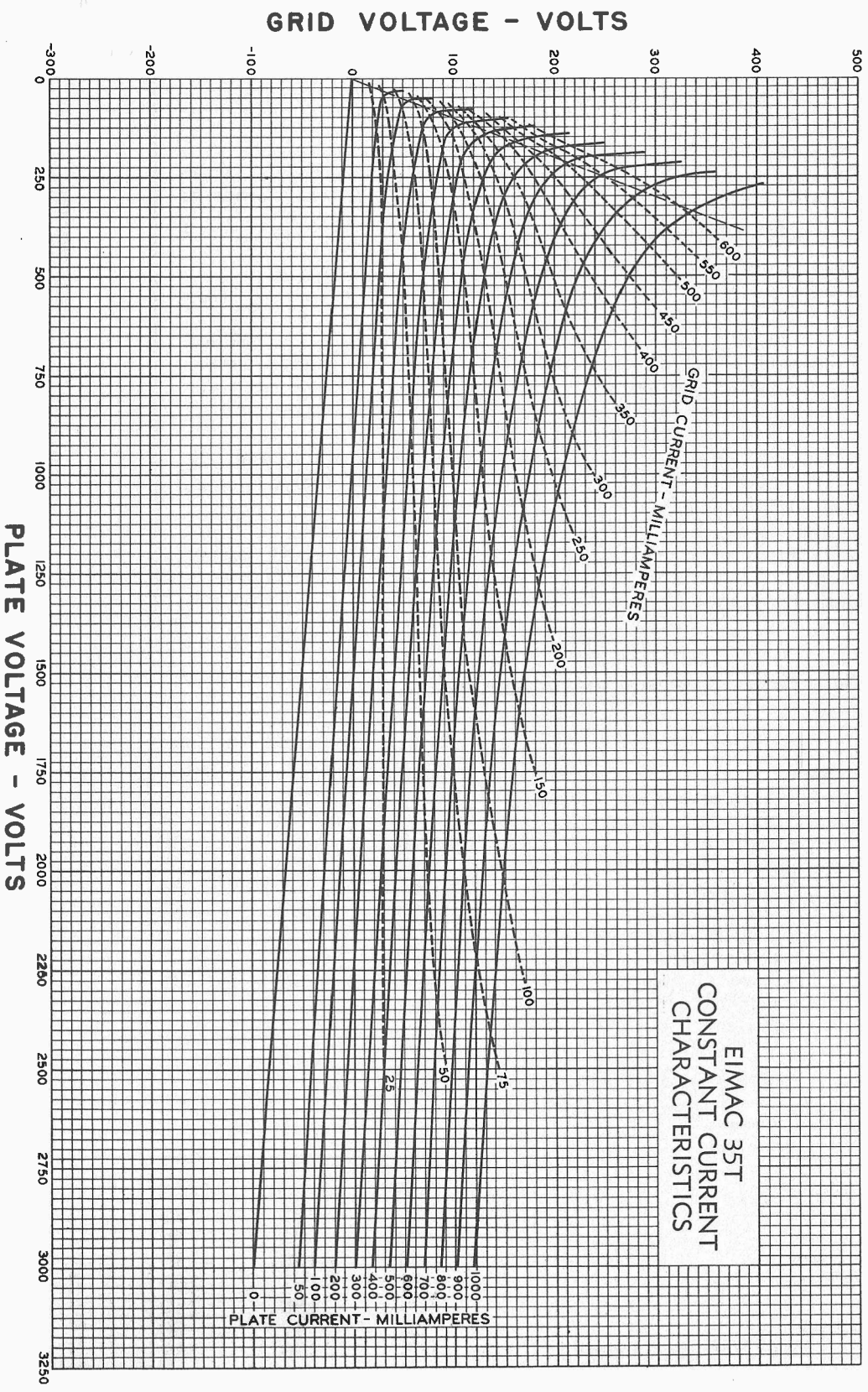

DRIVING POWER vs. POWER OUTPUT

The three charts on this page show the relationship of plate efficiency, power output and grid driving power at plate voltages of 1000, 1500 and 2000 volts. These charts show combined grid and bias losses only. The driving power and power output figures do not include circuit losses. The plate dissipation in watts is indicated by P_p .

Points A, B, and C are identical to the typical Class C operating conditions shown on the first page under 1000, 1500, and 2000 volts respectively.

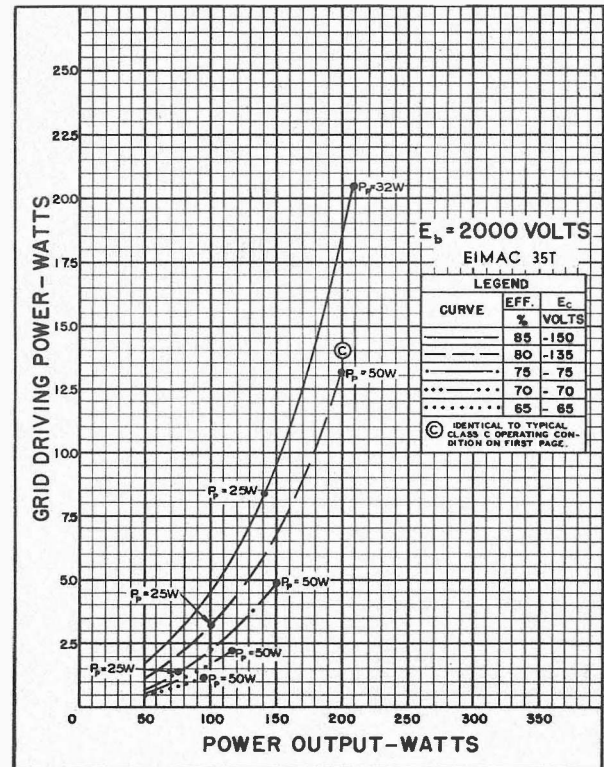
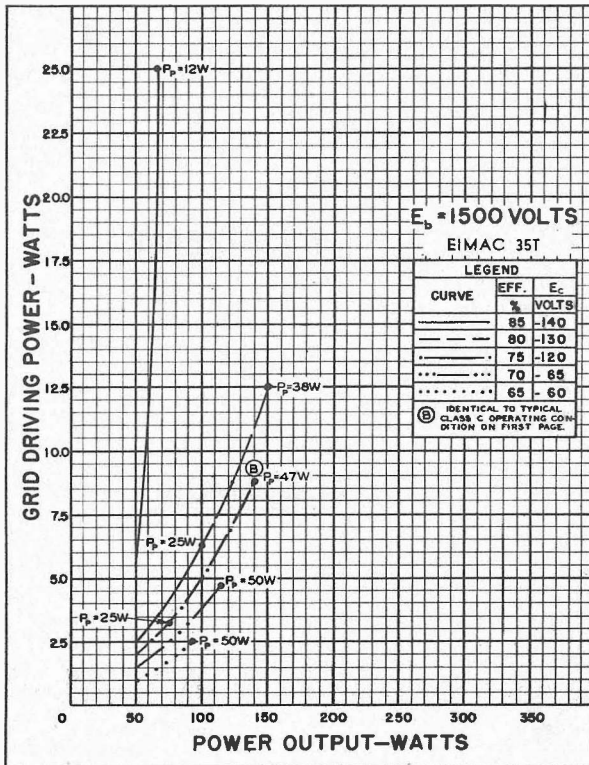
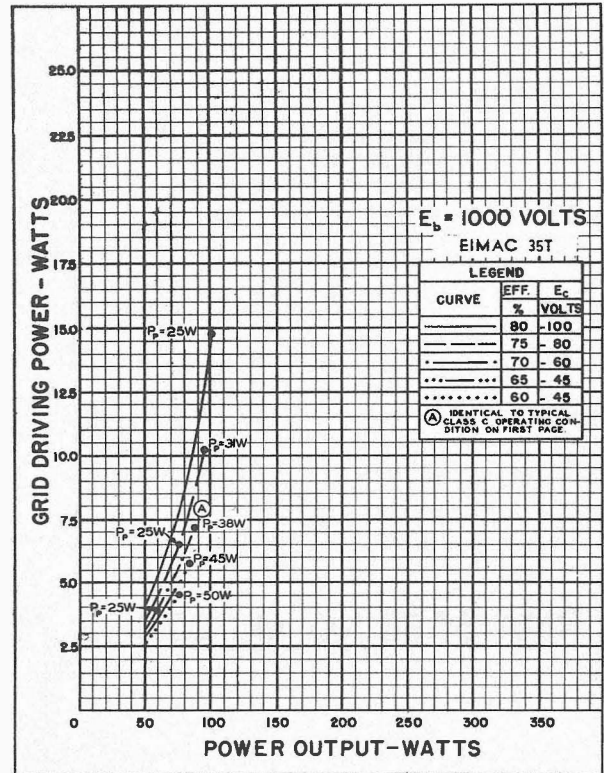

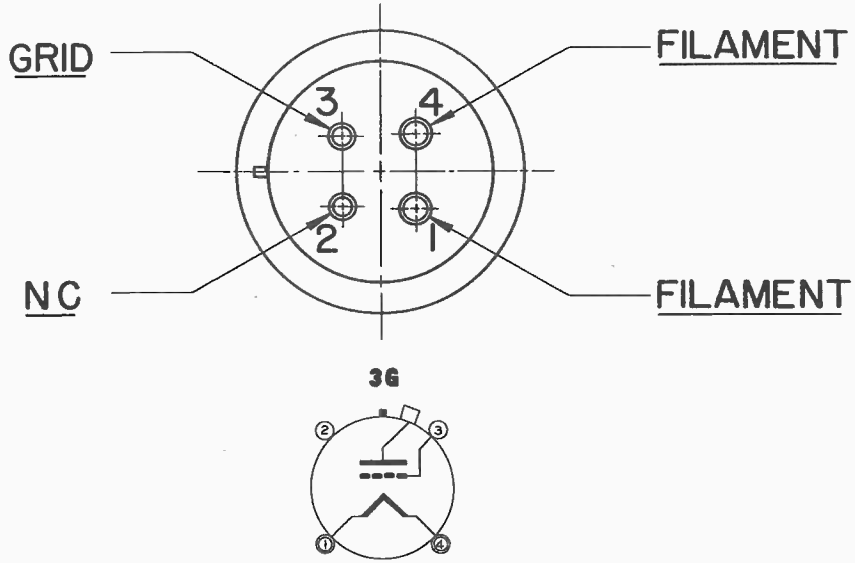
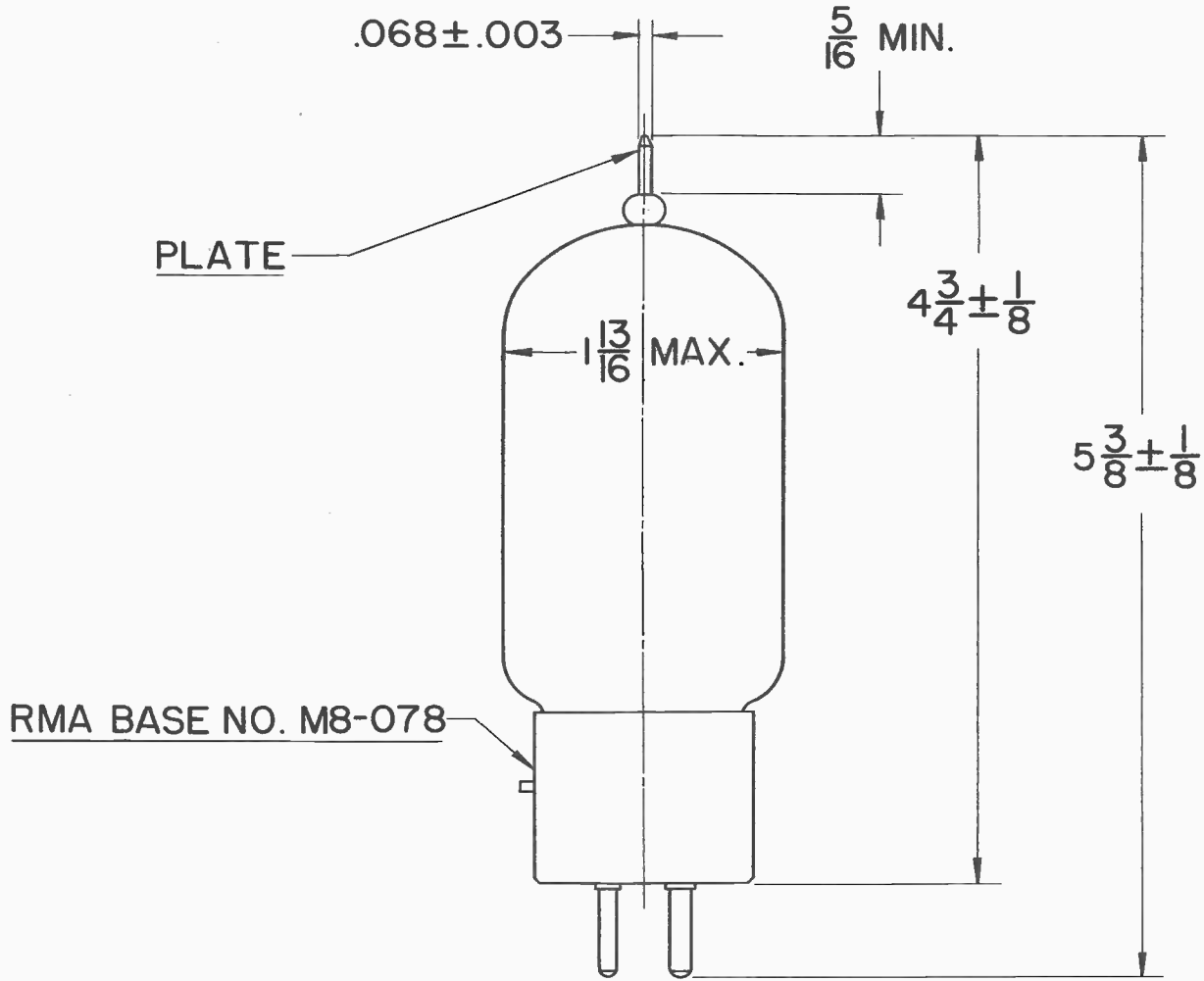

EITEL-McCULLOUGH, INC.

SAN BRUNO, CALIFORNIA

35TG

HIGH-MU TRIODE
 MODULATOR
 OSCILLATOR
 AMPLIFIER

GENERAL CHARACTERISTICS

ELECTRICAL

Filament: Thoriated tungsten		
Voltage - - - - -	5.0	volts
Current - - - - -	4.0	amperes
Amplification Factor (Average) - - - - -	39	
Direct Interelectrode Capacitances (Average)		
Grid-Plate - - - - -	1.8	$\mu\mu\text{f}$
Grid-Filament - - - - -	2.5	$\mu\mu\text{f}$
Plate-Filament - - - - -	0.4	$\mu\mu\text{f}$
Transconductance ($I_b=100$ ma., $E_b=2000$, $e_c=-30$)	2850	μmhos
Frequency for Maximum Ratings - - - - -	100	mc.

MECHANICAL

Base - - - - - (Medium 4-pin bayonet, ceramic)	RMA type M8-078
Basing - - - - -	RMA type 2M
Maximum Overall Dimensions:	
Length - - - - -	5.75 inches
Diameter - - - - -	1.81 inches
Net weight - - - - -	2.5 ounces
Shipping weight (Average) - - - - -	1.25 pounds

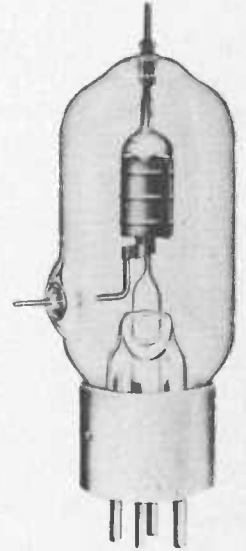

AUDIO FREQUENCY POWER AMPLIFIER AND MODULATOR

Class B

	TYPICAL OPERATION—2 TUBES			MAX. RATING	
	1000	1500	2000		
D-C Plate Voltage - - - - -	1000	1500	2000	2000	volts
Max.-Signal D-C Plate Current, per tube* - - -	•	•	•	150	ma.
Plate Dissipation, per tube* - - - - -	•	•	•	50	watts
D-C Grid Voltage (approx.) - - - - -	-8	-25	-40		volts
Peak A-F Grid Input Voltage - - - - -	240	250	255		volts
Zero-Signal D-C Plate Current - - - - -	67	45	34		ma.
Max.-Signal D-C Plate Current - - - - -	240	200	167		ma.
Max.-Signal Driving Power (approx.) - - - - -	7	5	4		watts
Effective Load, Plate-to-Plate - - - - -	7900	16200	27500		ohms
Max.-Signal Plate Power Output - - - - -	140	200	235		watts

*Averaged over any sinusoidal audio frequency cycle.

RADIO FREQUENCY POWER AMPLIFIER AND OSCILLATOR

Class-C *Telegraphy

(Key down conditions without modulation)

	TYPICAL OPERATION—1 TUBE			MAX. RATING	
	1000	1500	2000		
D-C Plate Voltage - - - - -	1000	1500	2000	2000	volts
D-C Plate Current - - - - -	125	125	125	150	ma.
D-C Grid Current - - - - -	40	40	45	50	ma.
D-C Grid Voltage - - - - -	-60	-120	-135		volts
Plate Power Output - - - - -	87	141	200		watts
Plate Input - - - - -	125	188	250		watts
Plate Dissipation - - - - -	38	47	50	50	watts
Peak R. F. Grid Input Voltage, (approx.) - - -	165	250	285		volts
Driving Power, (approx.) - - - - -	7	9	13		watts

*The above figures show actual measured tube performance, and do not allow for variations in circuit losses.

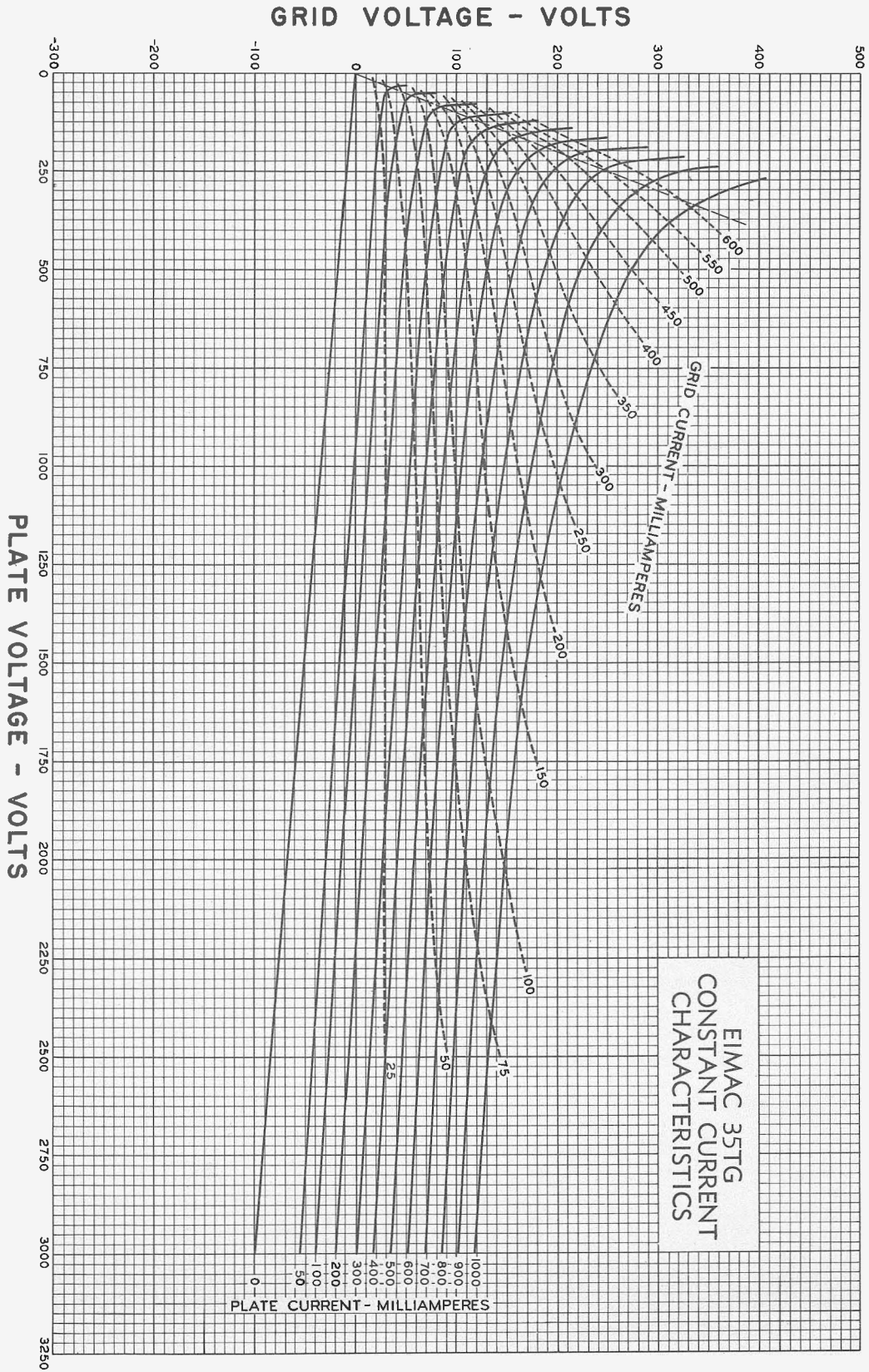

DRIVING POWER vs. POWER OUTPUT

The three charts on this page show the relationship of plate efficiency, power output and grid driving power at plate voltages of 1000, 1500 and 2000 volts. These charts show combined grid and bias losses only. The driving power and power output figures do not include circuit losses. The plate dissipation in watts is indicated by P_p .

Points A, B, and C are identical to the typical Class C operating conditions shown on the first page under 1000, 1500, and 2000 volts respectively.

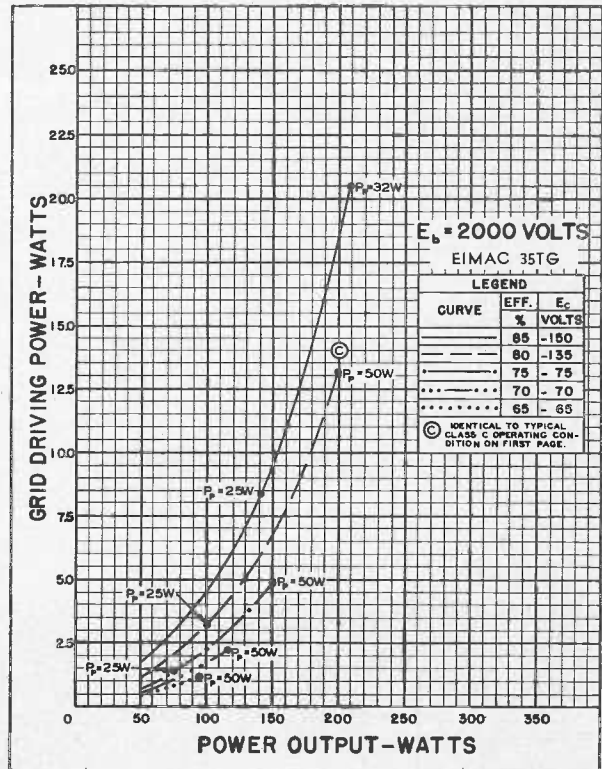
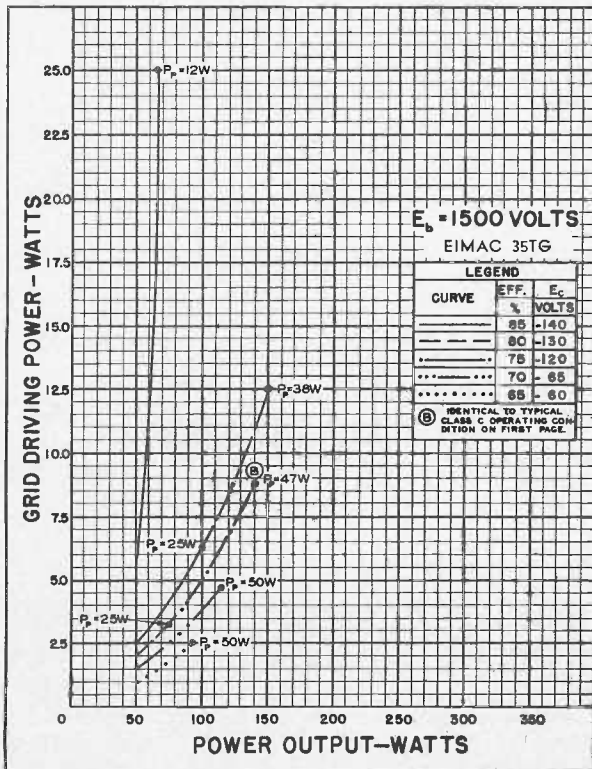
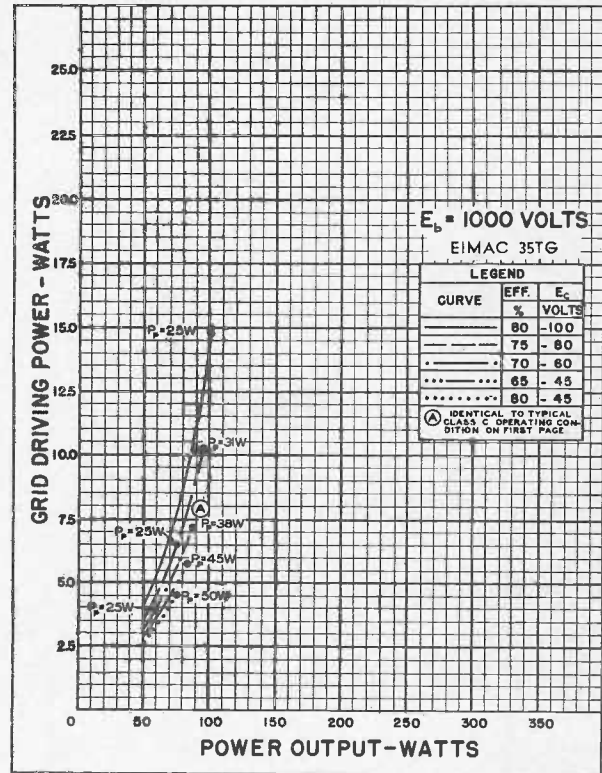

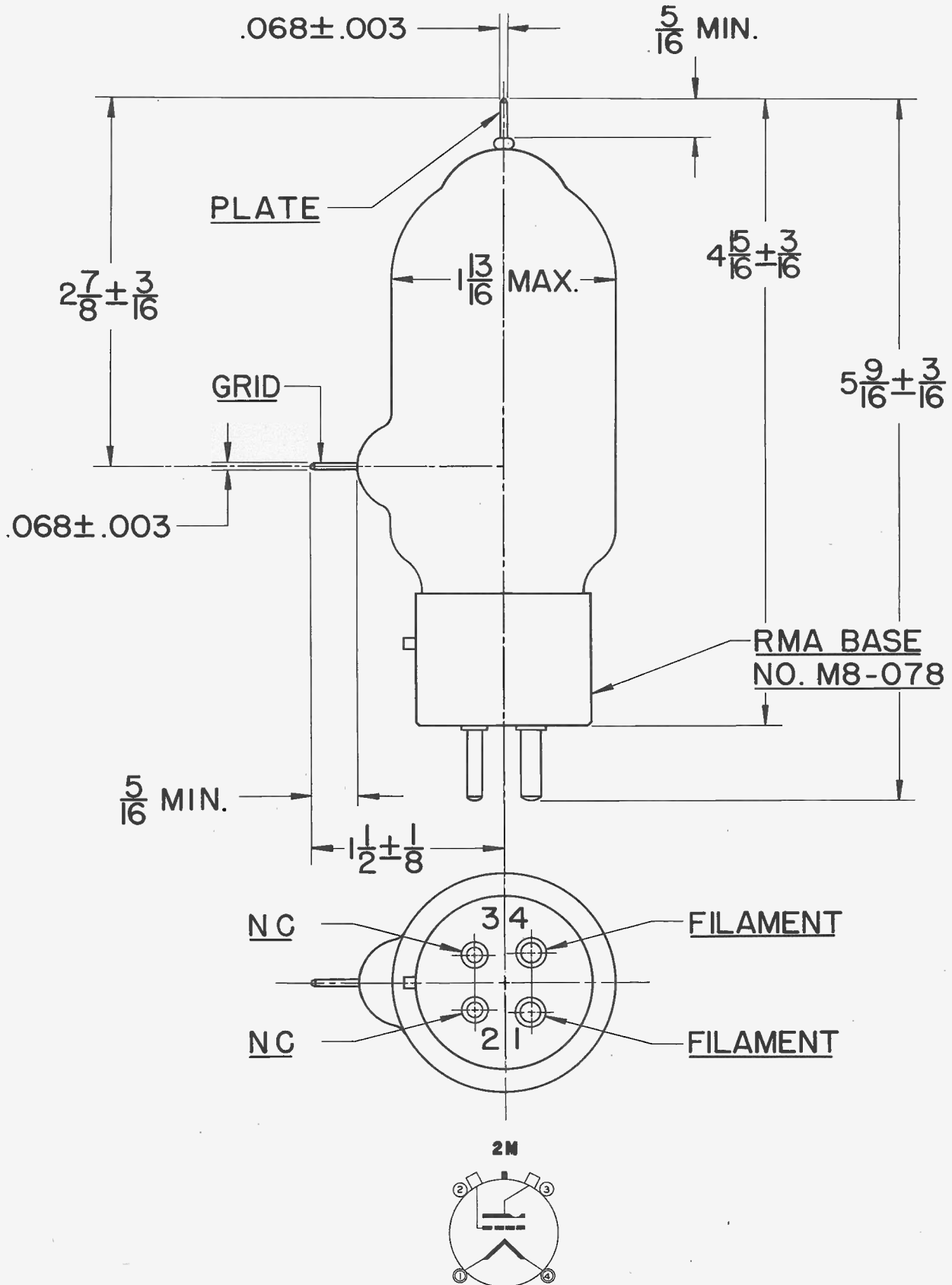

The Eimac 75TH is a medium-mu, high-vacuum transmitting triode intended for amplifier, oscillator and modulator service. It has a maximum plate dissipation rating of 75 watts. Cooling of the 75TH is accomplished by radiation from the plate, which operates at a visibly red temperature at maximum dissipation, and by air circulation around the envelope.

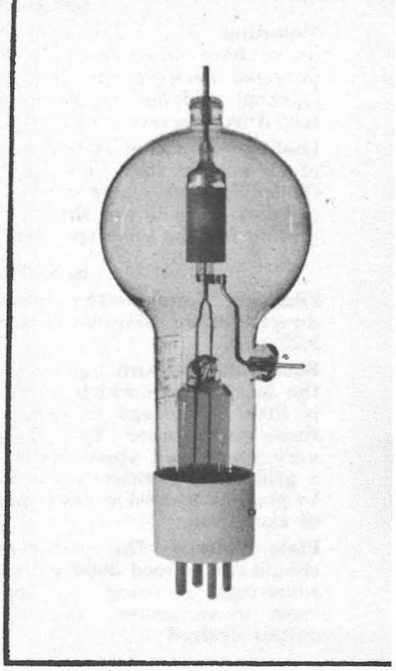

GENERAL CHARACTERISTICS

ELECTRICAL

Filament: Thoriated tungsten	
Voltage	5.0 volts
Current	6.25 amperes
Amplification Factor (Average) 20	
Direct Interelectrode Capacitances (Average)	
Grid-Plate	2.3 $\mu\mu\text{fd.}$
Grid-Filament	2.7 $\mu\mu\text{fd.}$
Plate-Filament	0.3 $\mu\mu\text{fd.}$
Transconductance ($i_b=225 \text{ ma.}, E_b=3000 \text{ v.}, E_c=-40 \text{ v.}$) 4150 μmhos	

MECHANICAL

Base	Medium 4-pin bayonet, ceramic, RMA type M8-078
Basing	RMA type 2M
Cooling	Radiation and air circulation
Maximum Overall Dimensions:	
Length	7.25 inches
Diameter	2.81 inches
Net Weight	3 ounces
Shipping Weight (Average)	1.5 pounds

RADIO FREQUENCY POWER AMPLIFIER AND OSCILLATOR

Class-C Telegraphy (Key-down conditions, 1 tube)

MAXIMUM RATINGS (Frequencies below 40 Mc.)

D-C PLATE VOLTAGE	3000 MAX. VOLTS.
D-C PLATE CURRENT	225 MAX. MA.
PLATE DISSIPATION	75 MAX. WATTS
GRID DISSIPATION	16 MAX. WATTS

TYPICAL OPERATION (Frequencies below 40 Mc.)

D-C Plate Voltage	1000	1500	2000	volts
D-C Grid Voltage	-80	-125	-200	volts
D-C Plate Current	215	167	150	ma.
D-C Grid Current	40	30	32	ma.
Peak R-F Grid Input Voltage (approx.)	290	250	325	volts
Driving Power (approx.)	9	6	10	watts
Plate Power Input	215	250	300	watts
Plate Dissipation	75	75	75	watts
Plate Power Output	140	175	225	watts

AUDIO FREQUENCY POWER AMPLIFIER AND MODULATOR

Class-B (Sinusoidal wave, two tubes unless otherwise specified)

MAXIMUM RATINGS

D-C PLATE VOLTAGE	3000 MAX. VOLTS
MAX-SIGNAL D-C PLATE CURRENT, PER TUBE	225 MAX. MA.
PLATE DISSIPATION, PER TUBE	75 MAX. WATTS
GRID DISSIPATION, PER TUBE	16 MAX. WATTS

TYPICAL OPERATION

D-C Plate Voltage	1000	1500	2000	volts
D-C Grid Voltage (approx.)	-25	-65	-90	ma.
Zero-Signal D-C Plate Current	90	67	50	ma.
Max-Signal D-C Plate Current	350	267	225	ma.
Effective Load, Plate-to-Plate	5300	11,400	19,300	ohms
Peak A-F Grid Input Voltage (per tube)	175	165	175	volts
Max-Signal Driving Power (approx.)	7	4	3	watts
Max-Signal Plate Dissipation (per tube)	75	75	75	watts
Max-Signal Plate Power Output	200	250	300	watts

APPLICATION

MECHANICAL

Mounting—The 75TH must be mounted vertically, base up or base down. Flexible connecting straps should be provided between the grid and plate terminals and the external grid and plate circuits. The tube must be protected from severe vibration and shock.

Cooling—Provision should be made for ample circulation of air around the 75TH. In the event that the design of the equipment restricts natural circulation, a small fan or centrifugal blower should be used to provide additional cooling for the envelope and plate and grid seals.

ELECTRICAL

Filament Voltage—The filament voltage, as measured directly at the filament pins, should be between 4.75 and 5.25 volts.

Bias Voltage—Although there is no maximum limit on the bias voltage which may be used on the 75TH, there is little advantage in using bias voltages in excess of those given under "Typical Operation," except in certain very specialized applications. Where bias is obtained by a grid leak, suitable protective means must be provided to prevent excessive plate dissipation in the event of loss of excitation.

Plate Voltage—The plate-supply voltage for the 75TH should not exceed 3000 volts. In most cases there is little advantage in using plate-supply voltages higher than those given under "Typical Operation" for the power output desired.

Grid Dissipation—The power dissipated by the grid of the 75TH must not exceed 16 watts. Grid dissipation may be calculated from the following expression:

$$P_g = e_{c,mp} I_c$$

where P_g = Grid dissipation,

$e_{c,mp}$ = Peak positive grid voltage, and

I_c = D-c grid current.

$e_{c,mp}$ may be measured by means of a suitable peak voltmeter connected between filament and grid.¹ In equipment in which the plate loading varies widely, such as oscillators used for radio-frequency heating, care should be taken to make certain that the grid dissipation does not exceed the maximum rating under any condition of loading.

Plate Dissipation—Under normal operating conditions, the power dissipated by the plate of the 75TH should not be allowed to exceed 75 watts. Plate dissipation in excess of the maximum rating is permissible for short periods of time, such as during tuning procedures.

¹ For suitable peak v.t.v.m. circuits see, for instance, "Vacuum Tube Ratings," Eimac News, January, 1945. This article is available in reprint form on request.

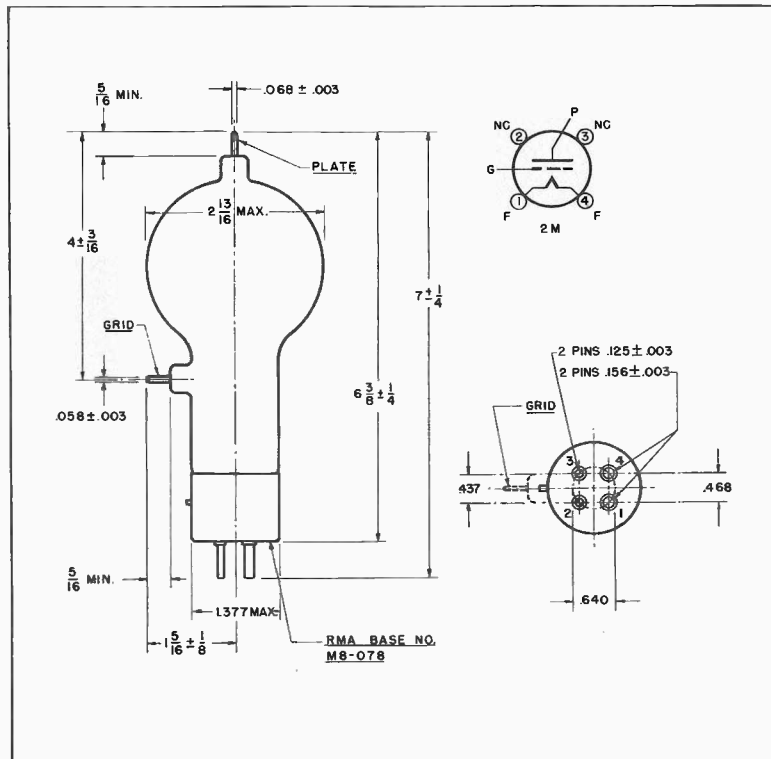

DRIVING POWER vs. POWER OUTPUT

The three charts on this page show the relationship of plate efficiency, power output and grid driving power at plate voltages of 1000, 1500 and 2000 volts. These charts show combined grid and bias losses only. The driving power and power output figures do not include circuit losses. The plate dissipation in watts is indicated by P_p .

Points A, B, and C are identical to the typical Class C operating conditions shown on the first page under 1000, 1500, and 2000 volts respectively.

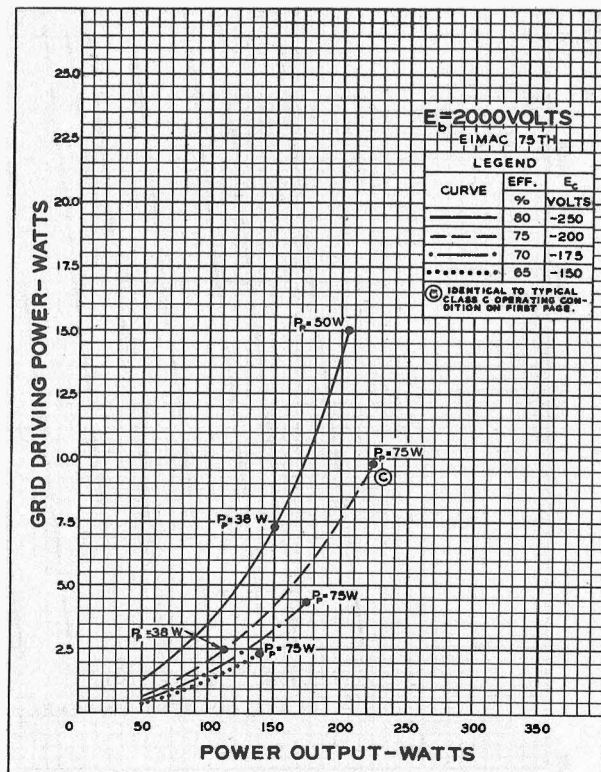
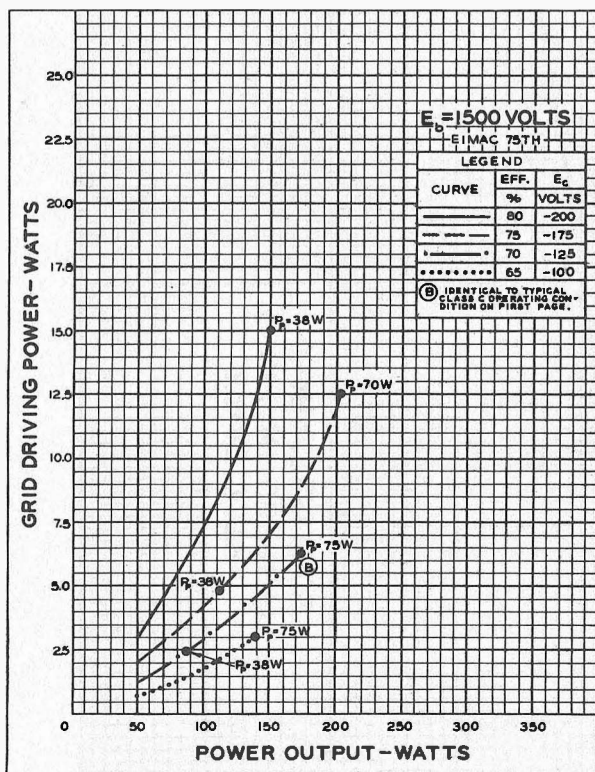
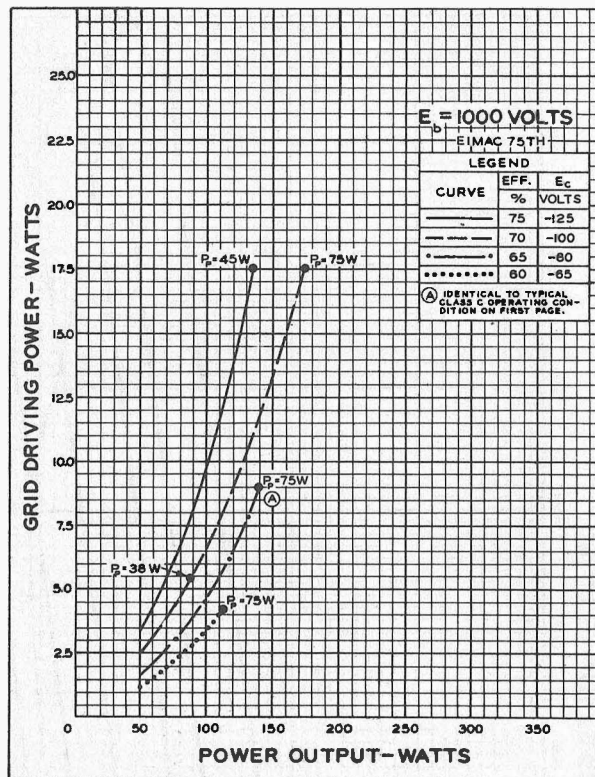

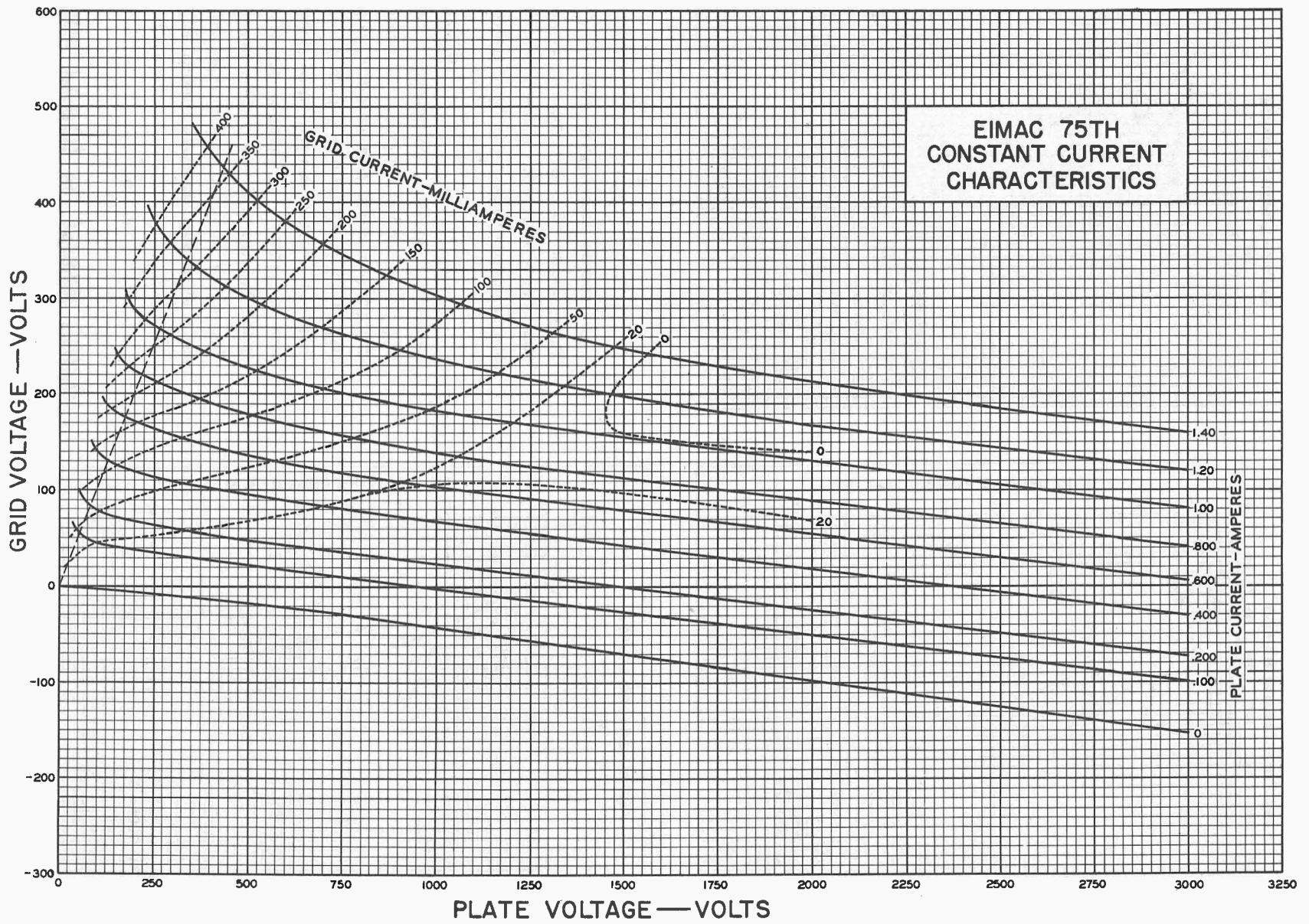

Eitel-McCullough, Inc.

SAN BRUNO, CALIFORNIA

75TL

LOW-MU TRIODE
MODULATOR
OSCILLATOR
AMPLIFIER

The Eimac 75TL is a low-mu, high-vacuum transmitting triode intended for amplifier, oscillator and modulator service. It has a maximum plate dissipation rating of 75 watts. Cooling of the 75TL is accomplished by radiation from the plate, which operates at a visibly red temperature at maximum dissipation, and by air circulation around the envelope.

GENERAL CHARACTERISTICS

ELECTRICAL

Filament: Thoriated tungsten	
Voltage	5.0 volts
Current	6.25 amperes
Amplification Factor (Average)	12
Direct Interelectrode Capacitances (Average)	
Grid-Plate	2.4 $\mu\mu\text{fd.}$
Grid-Filament	2.6 $\mu\mu\text{fd.}$
Plate-Filament	0.4 $\mu\mu\text{fd.}$
Transconductance ($i_b = 225\text{ma.}$, $E_b = 2500\text{v.}$, $E_c = -182\text{v.}$)	3350 μmhos

MECHANICAL

Base	Medium 4-pin bayonet, ceramic, RMA type M8-078
Basing	RMA type 2M
Cooling	Radiation and air circulation
Maximum Overall Dimensions:	
Length	7.25 inches
Diameter	2.81 inches
Net weight	3 ounces
Shipping weight (Average)	1.5 pounds

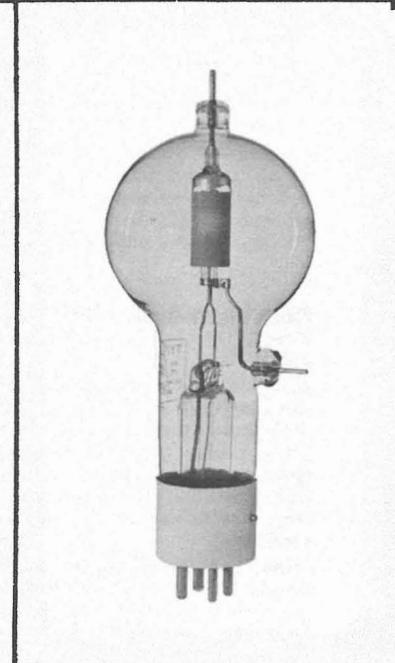

RADIO FREQUENCY POWER AMPLIFIER AND OSCILLATOR

Class-C Telegraphy (Key-down conditions, 1 tube)

MAXIMUM RATINGS (Frequencies below 40 Mc.)

D-C PLATE VOLTAGE	3000 MAX. VOLTS
D-C PLATE CURRENT	225 MAX. MA.
PLATE DISSIPATION	75 MAX. WATTS
GRID DISSIPATION	13 MAX. WATTS

TYPICAL OPERATION (Frequencies below 40 Mc.)

D-C Plate Voltage	1000	1500	2000	volts
D-C Plate Current	215	167	150	ma.
Plate Dissipation	75	75	75	watts
D-C Grid Voltage	-150	-250	-300	volts
D-C Grid Current	28	22	21	ma.
Peak R-F Grid Input Voltage (approx.)	320	355	425	volts
Driving Power, (approx.)	8	6	8	watts
Plate Power Input	215	250	300	watts
Plate Power Output	140	175	225	watts

AUDIO FREQUENCY POWER AMPLIFIER AND MODULATOR

Class-AB₁ (Sinusoidal wave, two tubes unless otherwise specified)

MAXIMUM RATINGS

D-C PLATE VOLTAGE	3000 MAX. VOLTS
MAX-SIGNAL D-C PLATE CURRENT, PER TUBE	225 MAX. MA.
PLATE DISSIPATION, PER TUBE	75 MAX. WATTS

¹ The effective grid-circuit resistance for each tube must not exceed 250,000 ohms.

AUDIO FREQUENCY AMPLIFIER (Continued)

TYPICAL OPERATION

D-C Plate Voltage	1500	2000	volts
D-C Grid Voltage ¹	-105	-160	volts
Peak A-F Grid Input Voltage (per tube)	105	160	volts
Zero-Signal D-C Plate Current	67	50	ma.
Max-Signal D-C Plate Current	143	130	ma.
Driving Power	0	0	watt
Effective Load, Plate-to-Plate	10,200	21,200	ohms
Max-Signal Plate Power Output	64	110	watts
Max-Signal Plate Dissipation (per tube)	75	75	watts

AUDIO FREQUENCY POWER AMPLIFIER AND MODULATOR

Class-B (Sinusoidal wave, two tubes unless otherwise specified)

MAXIMUM RATINGS

D-C PLATE VOLTAGE	3000 MAX. VOLTS
MAX-SIGNAL D-C PLATE CURRENT, PER TUBE	225 MAX. MA.
PLATE DISSIPATION, PER TUBE	75 MAX. WATTS
GRID DISSIPATION, PER TUBE	13 MAX. WATTS

TYPICAL OPERATION

D-C Plate Voltage	1000	1500	2000	volts
D-C Grid Voltage	-65	-105	-160	volts
Peak A-F Grid Input Voltage (per tube)	205	225	267	volts
Zero-Signal D-C Plate Current	100	67	50	ma.
Max-Signal D-C Plate Current	350	285	250	ma.
Max-Signal Avg. Driving Power (approx.)	7	6	5	watts
Max-Signal Peak Driving Power	26	23	19	watts
Effective Load, Plate-to-Plate	5,300	11,000	18,000	ohms
Max-Signal Plate Power Output	200	280	350	watts
Max-Signal Plate Dissipation (per tube)	75	75	75	watts

APPLICATION

MECHANICAL

Mounting—The 75TL must be mounted vertically, base up or base down. Flexible connecting straps should be provided between the grid and plate terminals and the external grid and plate circuits. The tube must be protected from severe vibration and shock.

Cooling—Provision should be made for ample circulation of air around the 75TL. In the event that the design of the equipment restricts natural circulation, a small fan or centrifugal blower should be used to provide additional cooling for the envelope and plate and grid seals.

ELECTRICAL

Filament Voltage—The filament voltage, as measured directly at the filament pins, should be between 4.75 and 5.25 volts.

Bias Voltage—Although there is no maximum limit on the bias voltage which may be used on the 75TL, there is little advantage in using bias voltages in excess of those given under "Typical Operation," except in certain very specialized applications. Where bias is obtained by a grid leak, suitable protective means must be provided to prevent excessive plate dissipation in the event of loss of excitation.

Plate Voltage—The plate-supply voltage for the 75TL should not exceed 3000 volts. In most cases there is little advantage in using plate-supply voltages higher than those given under "Typical Operation" for the power output desired.

Grid Dissipation—The power dissipated by the grid of the 75TL must not exceed 13 watts. Grid dissipation may be calculated from the following expression:

$$P_g = e_{cmp} I_c$$

where P_g = Grid dissipation,

e_{cmp} = Peak positive grid voltage, and

I_c = D-c grid current.

e_{cmp} may be measured by means of a suitable peak voltmeter connected between filament and grid.² In equipment in which the plate loading varies widely, such as oscillators used for radio-frequency heating, care should be taken to make certain that the grid dissipation does not exceed the maximum rating under any condition of loading.

Plate Dissipation—Under normal operating conditions, the power dissipated by the plate of the 75TL should not be allowed to exceed 75 watts. Plate dissipation in excess of the maximum rating is permissible for short periods of time, such as during tuning procedures.

² For suitable peak v.t.v.m. circuits see, for instance, "Vacuum Tube Ratings," Eimac News, January, 1945. This article is available in reprint form on request.

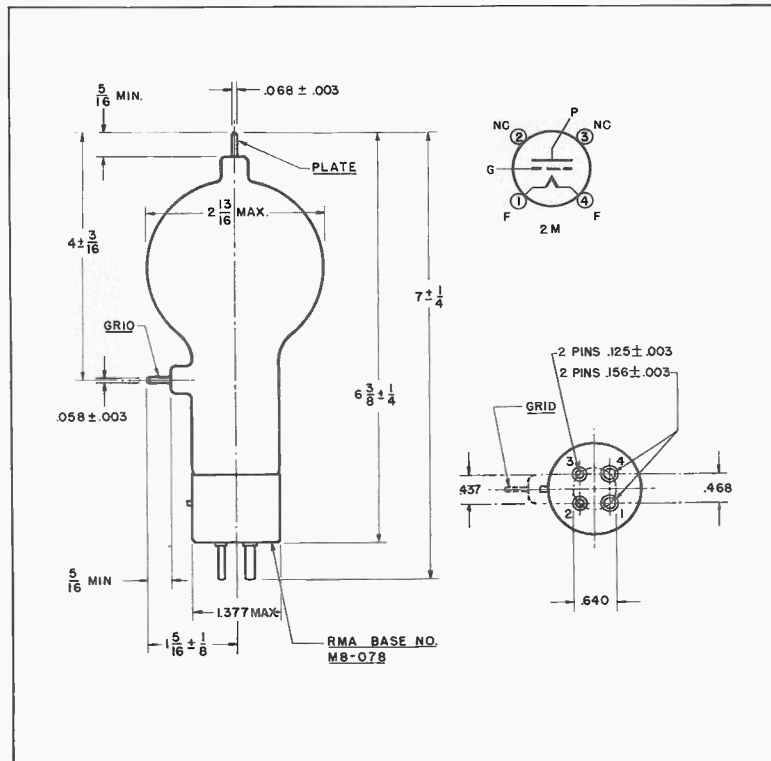

DRIVING POWER vs. POWER OUTPUT

The three charts on this page show the relationship of plate efficiency, power output and grid driving power at plate voltages of 1000, 1500 and 2000 volts. These charts show combined grid and bias losses only. The driving power and power output figures do not include circuit losses. The plate dissipation in watts is indicated by P_p .

Points A, B, and C are identical to the typical Class C operating conditions shown on the first page under 1000, 1500, and 2000 volts respectively.

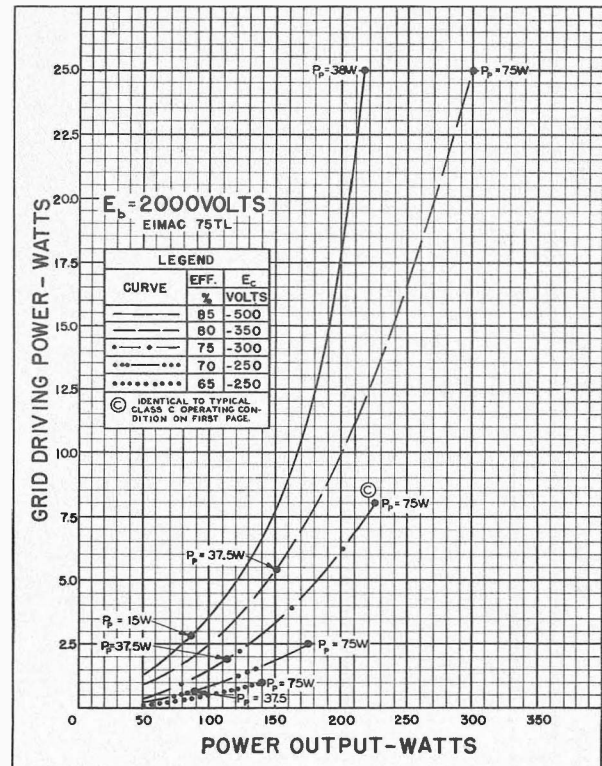
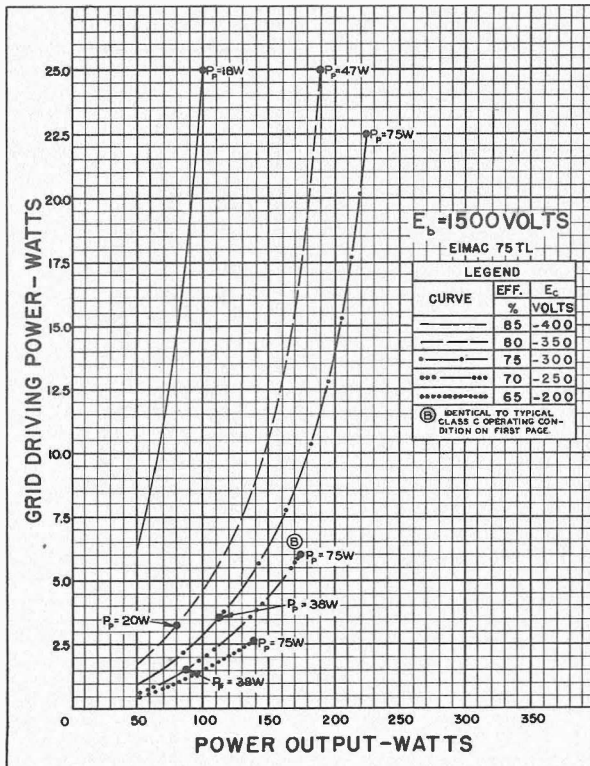
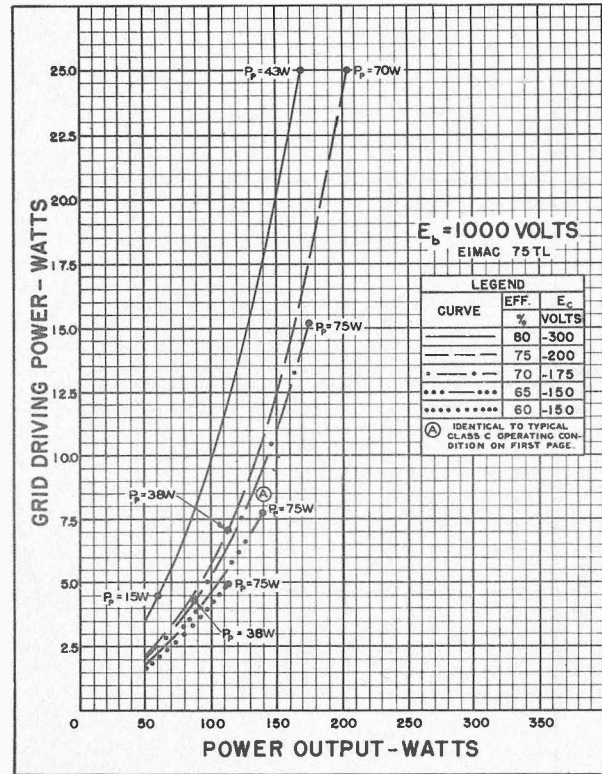

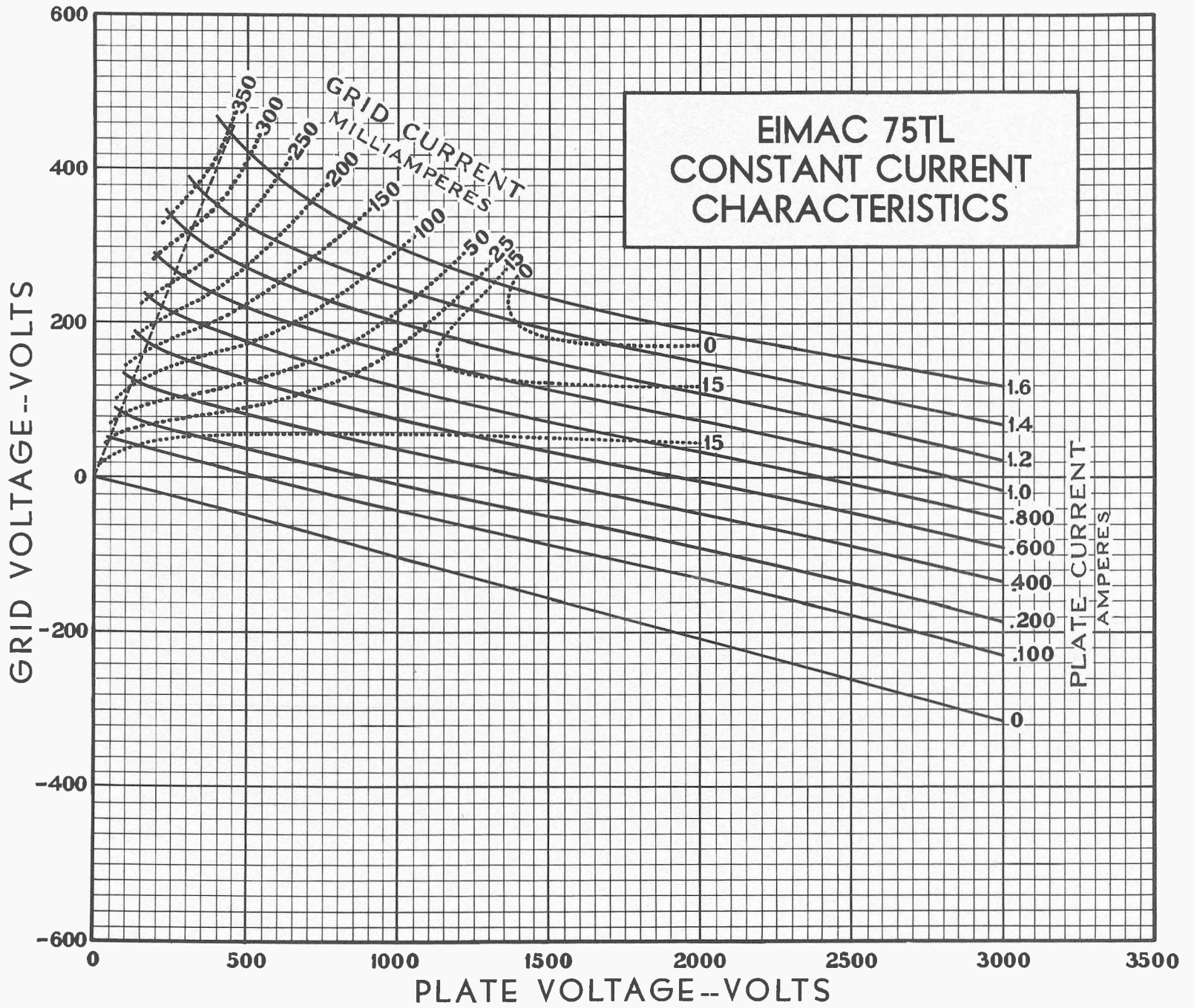



2C39A

HIGH-MU TRIODE

Supersedes
Types

2C38 - 2C39

► The Eimac 2C39A is a high-mu, forced-air cooled, transmitting triode designed for use as a power amplifier, oscillator, or frequency multiplier from low frequencies to above 2500 megacycles. Its small size, rugged construction, unusually high transconductance and relatively high plate-dissipation make possible the manufacture of compact equipment for moderate power output in either fixed or mobile service.

Because of the design and planar construction of the Eimac 2C39A, with the grid connection between anode and cathode connections, "grid-isolation" circuits can be employed. The electrode terminals are short cylinders of increasing diameters so that the tube may be readily inserted in cavity type circuits.



GENERAL CHARACTERISTICS

► ELECTRICAL

Cathode: Coated Unipotential		
Heater Voltage	- - - - -	6.3 volts
		See Application Notes
Heater Current	- - - - -	1.0 amperes
Amplification Factor	- - - - -	100
Transconductance ($I_b=70$ ma., $E_b=600$ v.)	- - - - -	22,000 umhos average
Direct Interelectrode Capacitances		
Grid-Plate	- - - - -	1.95 $\mu\mu\text{f}$
Grid-Cathode	- - - - -	6.50 $\mu\mu\text{f}$
Plate-Cathode	- - - - -	0.035 $\mu\mu\text{f}$ max.

MECHANICAL

Cooling: Anode	- - - - -	Forced Air
Grid and Cathode Seals	- - - - -	Forced Air
Maximum Overall Dimensions		
Length	- - - - -	2.75 inches
Diameter	- - - - -	1.26 inches
Net Weight	- - - - -	2.8 ounces
Shipping Weight	- - - - -	7 ounces

(Effective 2-15-50) Copyright 1950 by Eitel-McCullough, Inc.

► Indicates change from sheet dated 4-1-46.

▶ **RADIO FREQUENCY POWER AMPLIFIER AND MODULATOR** (Key-down conditions, per tube)

MAXIMUM RATINGS

D-C PLATE VOLTAGE	- - - - -	1000	VOLTS
D-C CATHODE CURRENT	- - - - -	125	MA.
D-C GRID VOLTAGE	- - - - -	-150	VOLTS
D-C GRID CURRENT	- - - - -	50	MA.
HEATER VOLTAGE	- - - - -	SEE APPLICATION NOTES	
PEAK POSITIVE R-F GRID VOLTAGE	- - - - -	30	VOLTS
PEAK NEGATIVE R-F GRID VOLTAGE	- - - - -	-400	VOLTS
PLATE DISSIPATION	- - - - -	100	WATTS
GRID DISSIPATION	- - - - -	2	WATTS

TYPICAL OPERATION

(Power Amplifier "Grid-Isolation" Circuit CW Operation 500 Megacycles.)

D-C Plate Voltage	- - - - -	800	Volts
D-C Plate Current	- - - - -	80	Ma.
D-C Grid Voltage	- - - - -	-45	Volts
D-C Grid Current	- - - - -	45	Ma.
Driving Power (approx.)	- - - - -	6	Watts
Useful Power Output	- - - - -	27	Watts
Heater Voltage	- - - - -	See Application Notes	

TYPICAL OPERATION

(R-F Oscillator—2500 Megacycles)

D-C Plate Voltage	- - - - -	900	Volts
D-C Cathode Current	- - - - -	90	Ma.
D-C Grid Voltage	- - - - -	-22	Volts
D-C Grid Current	- - - - -	27	Ma.
Useful Power Output	- - - - -	12	Watts
Heater Voltage	- - - - -	See Application Notes	

Note: These conditions are for "interrupted oscillation" performance, and conform to the minimum requirements of the JAN specifications for the 2C39A.

"Interrupted oscillations" are those which are periodically interrupted at an audio or radio frequency rate. Usually such action is related to the high time constant of the grid-leak resistor and associated bypass capacitors which prevents the developed bias-voltage from following, rapidly enough, the random changes in amplitude of the oscillations.

▶ **PLATE MODULATED OSCILLATOR OR AMPLIFIER 100% MODULATION**

MAXIMUM RATINGS

(Note: For less modulation a higher D-C plate voltage may be used if the sum of the peak positive-audio voltage and D-C voltage does not exceed 1200 volts.)

D-C PLATE VOLTAGE	- - - - -	600	VOLTS
D-C CATHODE CURRENT	- - - - -	100	MA.
D-C GRID VOLTAGE	- - - - -	-150	VOLTS
D-C GRID CURRENT	- - - - -	50	MA.
HEATER VOLTAGE	- - - - -	SEE APPLICATION NOTES	
PEAK POSITIVE R-F GRID VOLTAGE	- - - - -	30	VOLTS
PEAK NEGATIVE R-F GRID VOLTAGE	- - - - -	-400	VOLTS
PLATE DISSIPATION	- - - - -	100	WATTS
GRID DISSIPATION	- - - - -	2	WATTS

▶ **APPLICATION**

MECHANICAL

Mounting—The 2C39A may be operated in any position.

Contact to anode, grid, cathode, and heater terminals should be made by means of spring collets or spring fingers acting on the cylindrical surface of the terminals. The tube should enter the socket and be seated against the "anode flange" which is so labelled on the outline drawing. The tube should not be seated or stopped by any other surfaces.

To hold the tube in the socket against vibra-

tion, the retaining clamps should act against the anode flange surface. No clamping action should be made on any of the terminal surfaces.

Cooling—The anode, heater-seal, grid-seal and cathode-seal of the 2C39A normally require forced-air cooling. A suitable arrangement for an anode cooling-cowling is shown on the next page. An air-flow through this cowling of 12.5 cubic feet per minute is required for operation up to the maximum rated dissipation. The heater-seal, cathode-seal and grid-seal must be cooled so that the temperature of the metal does not exceed 175° C under any operating conditions.

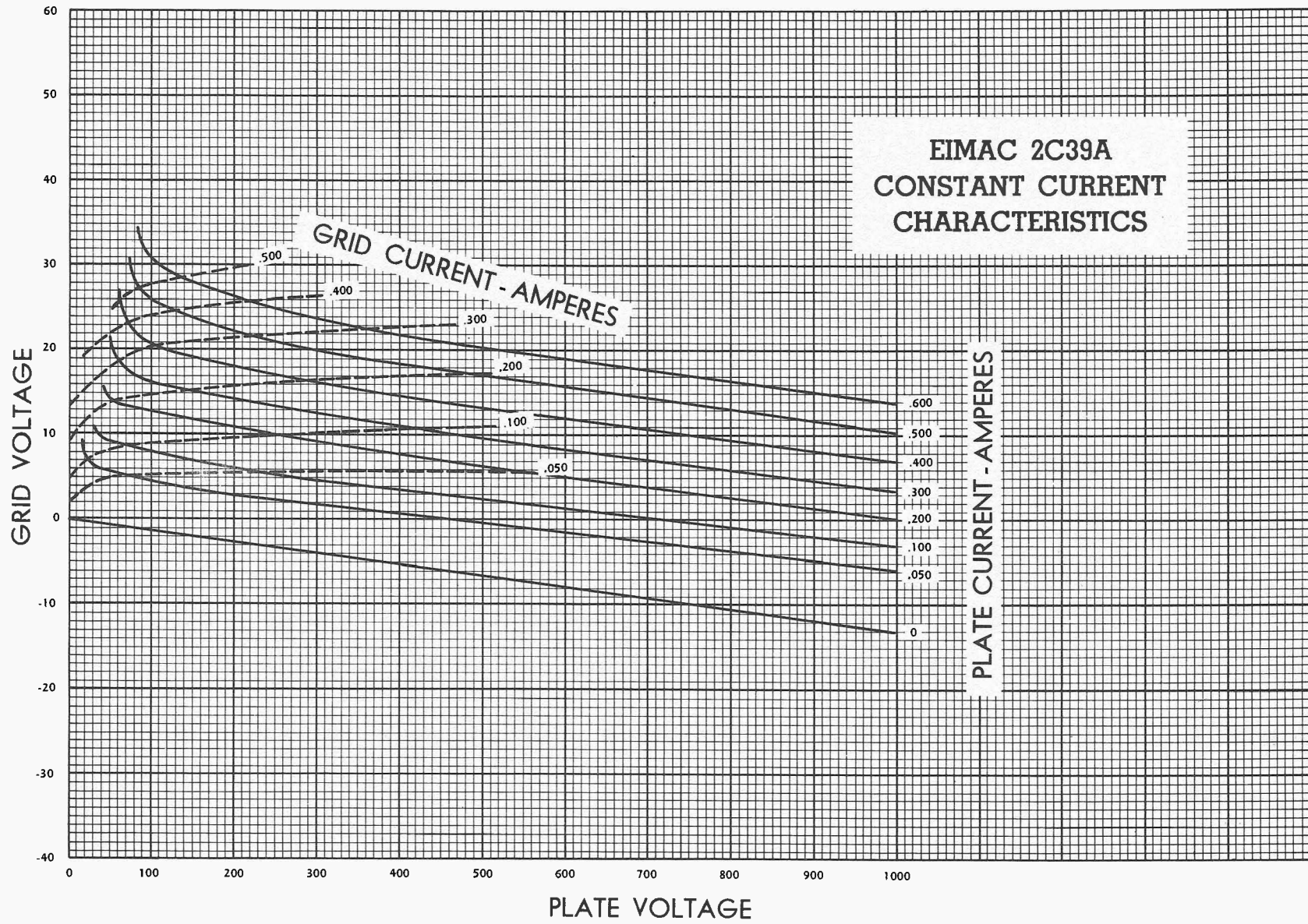

Eitel-McCullough, Inc.

SAN BRUNO, CALIFORNIA

100TH

HIGH-MU TRIODE
MODULATOR
OSCILLATOR
AMPLIFIER

The Eimac 100TH is a high-mu power triode having a maximum plate dissipation rating of 100 watts, and is intended for use as an amplifier, oscillator, or modulator. It can be used at its maximum ratings at frequencies as high as 40-Mc.

Cooling of the 100TH is accomplished by radiation from the plate, which operates at a visible red color at maximum dissipation, and by means of air circulation by convection around the envelope.

GENERAL CHARACTERISTICS

ELECTRICAL

Filament:	Thoriated tungsten	
	Voltage - - - - -	5.0 volts
	Current - - - - -	6.3 amperes
▶ Amplification Factor (Average)	- - - - -	38
Direct Interelectrode Capacitances (Average)		
	Grid-Plate - - - - -	2.0 $\mu\mu\text{f}$
	Grid-Filament - - - - -	2.9 $\mu\mu\text{f}$
	▶ Plate-Filament - - - - -	0.3 $\mu\mu\text{f}$
▶ Transconductance ($i_b=200$ ma., $E_b=3000$ v., $e_c=-5$ v.)	- - - - -	4500 μmhos
Frequency for Maximum Ratings - - - - -	- - - - -	40 Mc.

MECHANICAL

Base - - - - -	(Medium 4-pin bayonet, ceramic)	RMA type M8-078
Basing - - - - -	- - - - -	RMA type 2M
▶ Mounting - - - - -	- - - - -	Vertical, base down or up.
▶ Cooling - - - - -	- - - - -	Convection and Radiation.

▶ Recommended Heat Dissipating Connectors:

Plate - - - - -	Eimac HR-6
Grid - - - - -	Eimac HR-2

Maximum Overall Dimensions:

Length - - - - -	7.75 inches
Diameter - - - - -	3.19 inches
Net weight - - - - -	4 ounces
Shipping weight (Average) - - - - -	1.5 pounds

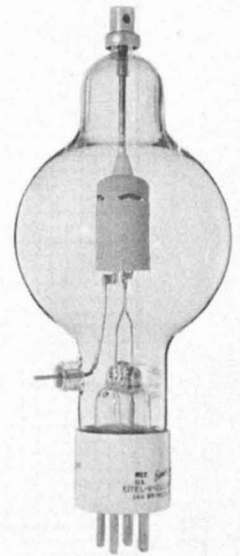

AUDIO FREQUENCY POWER AMPLIFIER AND MODULATOR

Class-AB₂ (Sinusoidal wave, two tubes unless otherwise specified)

MAXIMUM RATINGS

D-C PLATE VOLTAGE - - - - -	3000 MAX. VOLTS
MAX-SIGNAL D-C PLATE CURRENT, PER TUBE - - - - -	225 MAX. MA.
PLATE DISSIPATION, PER TUBE - - - - -	100 MAX. WATTS

▶ TYPICAL OPERATION

D-C Plate Voltage - - - - -	1500	2000	2500 Volts
D-C Grid Voltage (approx.)* - - - - -	-20	-35	-50 Volts
Zero-Signal D-C Plate Current - - - - -	80	60	48 Ma.
Max-Signal D-C Plate Current - - - - -	320	280	250 Ma.
Effective Load, Plate-to-Plate - - - - -	8800	15,000	22,000 Ohms.
Peak A-F Grid Input Voltage (per tube) - - - - -	145	150	155 Volts
Max-Signal Peak Driving Power - - - - -	18	19	15 Watts
Max-Signal Nominal Driving Power (approx.) - - - - -	9	9.5	7.5 Watts
Max-Signal Plate Power Output - - - - -	280	360	425 Watts

*Adjust to give stated zero signal plate current.

RADIO FREQUENCY POWER AMPLIFIER AND OSCILLATOR

Class-C Telephony or FM Telephony (Key-down conditions, per tube)

MAXIMUM RATINGS

D-C PLATE VOLTAGE - - - - -	3000 MAX. VOLTS
D-C PLATE CURRENT - - - - -	225 MAX. MA.
PLATE DISSIPATION - - - - -	100 MAX. WATTS
▶ GRID DISSIPATION - - - - -	20 MAX. WATTS

TYPICAL OPERATION

D-C Plate Voltage - - - - -	1500	2000	3000 Volts
D-C Grid Voltage - - - - -	-65	-80	-200 Volts
D-C Plate Current - - - - -	190	165	165 Ma.
D-C Grid Current - - - - -	48	39	51 Ma.
Peak R-F Grid Input Voltage - - - - -	230	230	385 Volts
Driving Power (approx.) - - - - -	10	8	18 Watts
Grid Dissipation - - - - -	7	5	10 Watts
Plate Power Input - - - - -	285	335	500 Watts
Plate Dissipation - - - - -	100	100	100 Watts
Plate Power Output - - - - -	185	235	400 Watts

▶ PLATE MODULATED RADIO FREQUENCY AMPLIFIER

Class-C Telephony (Carrier conditions, per tube)

MAXIMUM RATINGS

D-C PLATE VOLTAGE - - - - -	2500 MAX. VOLTS
D-C PLATE CURRENT - - - - -	180 MAX. MA.
PLATE DISSIPATION - - - - -	65 MAX. WATTS
GRID DISSIPATION - - - - -	20 MAX. WATTS

TYPICAL OPERATION

D-C Plate Voltage - - - - -	1500	2000	2500 Volts
D-C Grid Voltage - - - - -	-150	-200	-250 Volts
D-C Plate Current - - - - -	160	150	140 Ma.
D-C Grid Current - - - - -	46	41	40 Ma.
Peak R-F Grid Input Voltage - - - - -	325	375	425 Volts
Driving Power (approx.) - - - - -	15	15.5	17 Watts
Grid Dissipation - - - - -	8	7.3	7 Watts
Plate Power Input - - - - -	240	300	350 Watts
Plate Dissipation - - - - -	65	65	65 Watts
Plate Power Output - - - - -	175	235	285 Watts

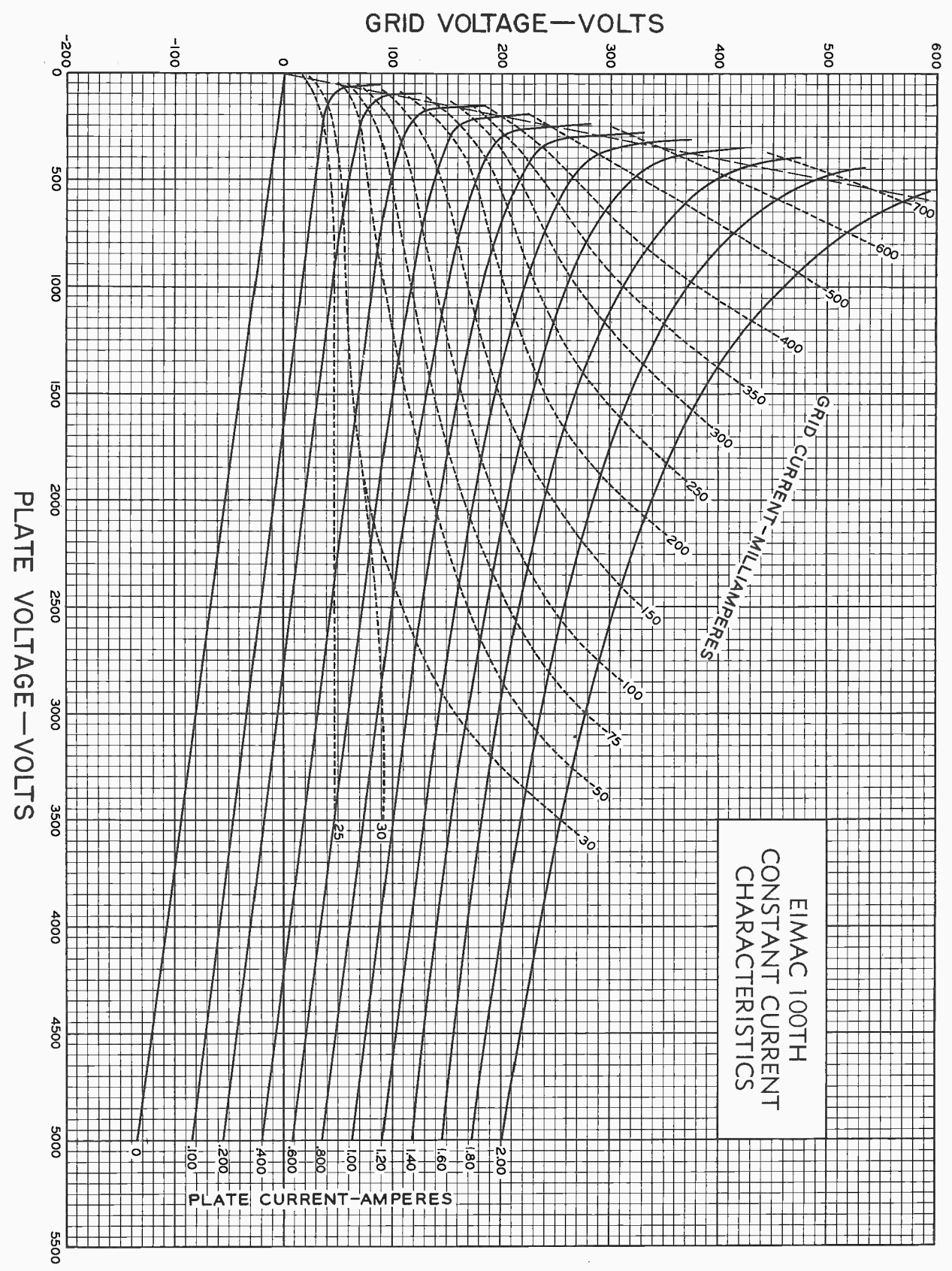

DRIVING POWER vs. POWER OUTPUT

The three charts on this page show the relationship of plate efficiency, power output and grid driving power at plate voltages of 1500, 2000 and 3000 volts. These charts show combined grid and bias losses only. The driving power and power output figures do not include circuit losses. The plate dissipation in watts is indicated by P_p .

Points A, B, and C are identical to the typical Class C operating conditions shown on the first page under 1500, 2000, and 3000 volts respectively.

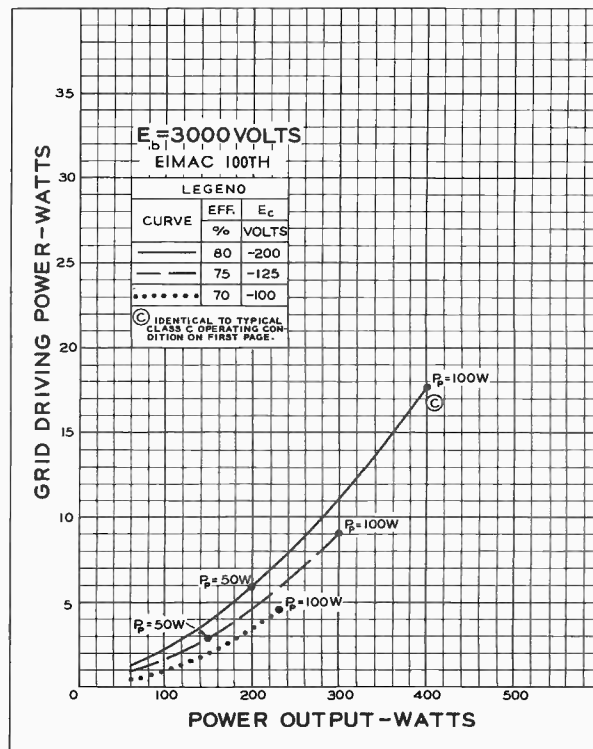
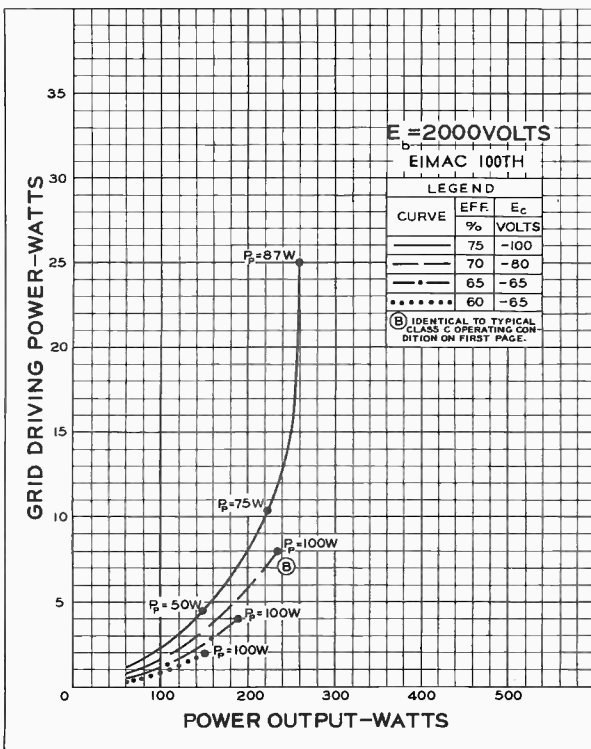
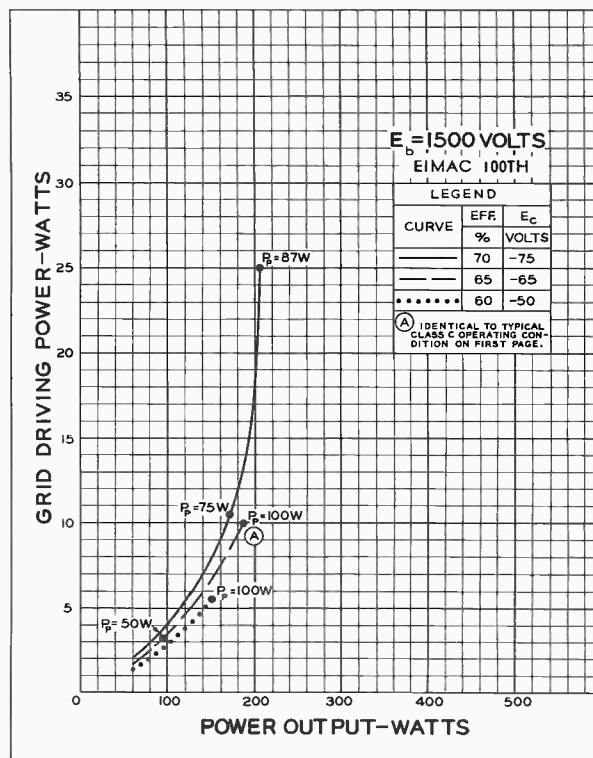

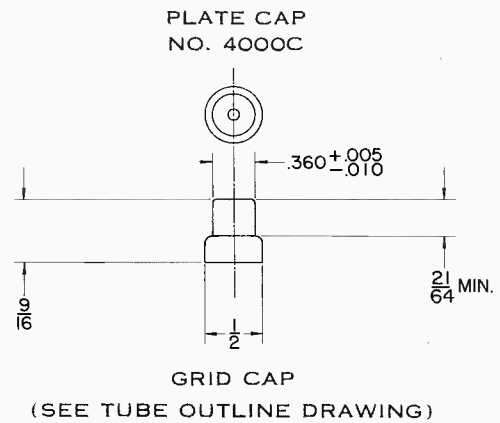
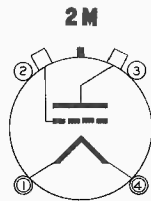
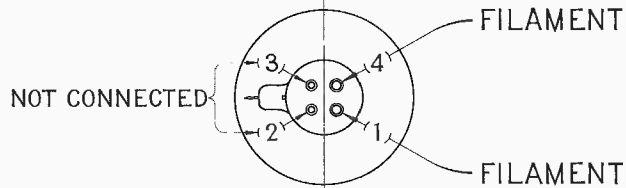
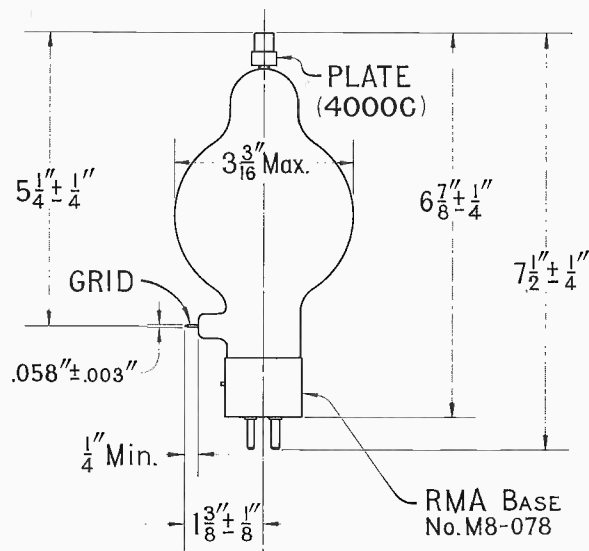

EITEL-McCULLOUGH, Inc.

SAN BRUNO, CALIFORNIA

100TL

LOW-MU TRIODE
•
MODULATOR
OSCILLATOR
AMPLIFIER

The Eimac 100TL is a low-mu power triode having a maximum plate dissipation rating of 100 watts, and is intended for use as an amplifier, oscillator or modulator. It can be used at its maximum ratings at frequencies as high as 40-Mc.

Cooling of the 100TL is accomplished by radiation from the plate, which operates at a visible red color at maximum dissipation, and by means of air circulation by convection around the envelope.

GENERAL CHARACTERISTICS

ELECTRICAL

Filament:	Thoriated tungsten	
	Voltage - - - - -	5.0 volts
	Current - - - - -	6.3 amperes
Amplification Factor (Average)	- - - - -	14
Direct Interelectrode Capacitances (Average)		
	Grid-Plate - - - - -	2.0 $\mu\mu\text{f}$
	Grid-Filament - - - - -	2.3 $\mu\mu\text{f}$
	Plate-Filament - - - - -	0.4 $\mu\mu\text{f}$
▶ Transconductance ($i_b=225$ ma., $E_b=3000$ v., $e_c=-90$ v.)	- - - - -	3000 μmhos
Frequency for Maximum Ratings	- - - - -	40 Mc.

MECHANICAL

Base - - -	(Medium 4-pin bayonet, ceramic)	RMA type M8-078
Basing - - -	- - - - -	RMA type 2M
▶ Mounting - - -	- - - - -	Vertical, base down or up.
▶ Cooling - - -	- - - - -	Convection and Radiation.

▶ Recommended Heat Dissipating Connectors:

Plate - - - - -	- - - - -	Eimac HR-6
Grid - - - - -	- - - - -	Eimac HR-2
Maximum Overall Dimensions:		
Length - - - - -	- - - - -	7.75 inches
Diameter - - - - -	- - - - -	3.19 inches
Net weight - - - - -	- - - - -	4 ounces
Shipping weight (Average) - - - - -	- - - - -	1.5 pounds

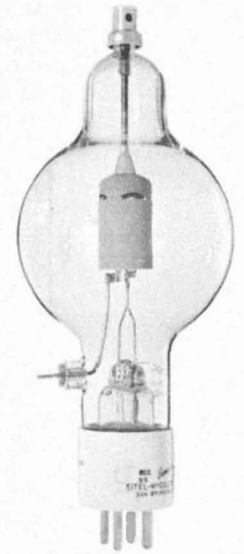

AUDIO FREQUENCY POWER AMPLIFIER AND MODULATOR

Class-AB₂ (Sinusoidal wave, two tubes unless otherwise specified)

MAXIMUM RATINGS

D-C PLATE VOLTAGE - - - - -	3000 MAX. VOLTS
MAX-SIGNAL D-C PLATE CURRENT, PER TUBE - - - - -	225 MAX. MA.
PLATE DISSIPATION, PER TUBE - - - - -	100 MAX. WATTS

▶ TYPICAL OPERATION

D-C Plate Voltage - - - - -	1500	2000	2500 Volts
D-C Grid Voltage (approx.)* - - - - -	-65	-110	-145 Volts
Zero-Signal D-C Plate Current - - - - -	80	60	48 Ma.
Max-Signal D-C Plate Current - - - - -	320	280	250 Ma.
Effective Load, Plate-to-Plate - - - - -	8800	15,000	22,000 Ohms
Peak A-F Grid Input Voltage (per tube) - - - - -	235	270	290 Volts
Max-Signal Peak Driving Power - - - - -	21	22	20 Watts
Max-Signal Nominal Driving Power (approx.) - - - - -	10.5	11	10 Watts
Max-Signal Plate Power Output - - - - -	280	360	425 Watts

*Adjust to give stated zero signal plate current.

RADIO FREQUENCY POWER AMPLIFIER AND OSCILLATOR

Class-C Telegraphy or FM Telephony (Key-down conditions, per tube)

MAXIMUM RATINGS

D-C PLATE VOLTAGE - - - - -	3000 MAX. VOLTS
D-C PLATE CURRENT - - - - -	225 MAX. MA.
PLATE DISSIPATION - - - - -	100 MAX. WATTS
▶ GRID DISSIPATION - - - - -	15 MAX. WATTS

TYPICAL OPERATION

D-C Plate Voltage - - - - -	1500	2000	3000 Volts
D-C Grid Voltage - - - - -	-175	-225	-400 Volts
D-C Plate Current - - - - -	190	165	165 Ma.
D-C Grid Current - - - - -	37	28	30 Ma.
Peak R-F Grid Input Voltage - - - - -	425	450	650 Volts
Driving Power (approx.) - - - - -	14	11	20 Watts
Grid Dissipation - - - - -	7.5	5	8 Watts
Plate Power Input - - - - -	285	335	500 Watts
Plate Dissipation - - - - -	100	100	100 Watts
Plate Power Output - - - - -	185	235	400 Watts

▶ PLATE MODULATED RADIO FREQUENCY AMPLIFIER

Class-C Telephony (Carrier conditions, per tube)

MAXIMUM RATINGS

D-C PLATE VOLTAGE - - - - -	2500 MAX. VOLTS
D-C PLATE CURRENT - - - - -	180 MAX. MA.
PLATE DISSIPATION - - - - -	65 MAX. WATTS
GRID DISSIPATION - - - - -	15 MAX. WATTS

TYPICAL OPERATION

D-C Plate Voltage - - - - -	1500	2000	2500 Volts
D-C Grid Voltage - - - - -	-300	-400	-500 Volts
D-C Plate Current - - - - -	160	150	140 Ma.
D-C Grid Current - - - - -	32	31	31 Ma.
Peak R-F Grid Input Voltage - - - - -	530	655	750 Volts
Driving Power (approx.) - - - - -	17	20	23 Watts
Grid Dissipation - - - - -	8	7.5	7.5 Watts
Plate Power Input - - - - -	240	300	350 Watts
Plate Dissipation - - - - -	65	65	65 Watts
Plate Power Output - - - - -	175	235	285 Watts

Simulac
100TL

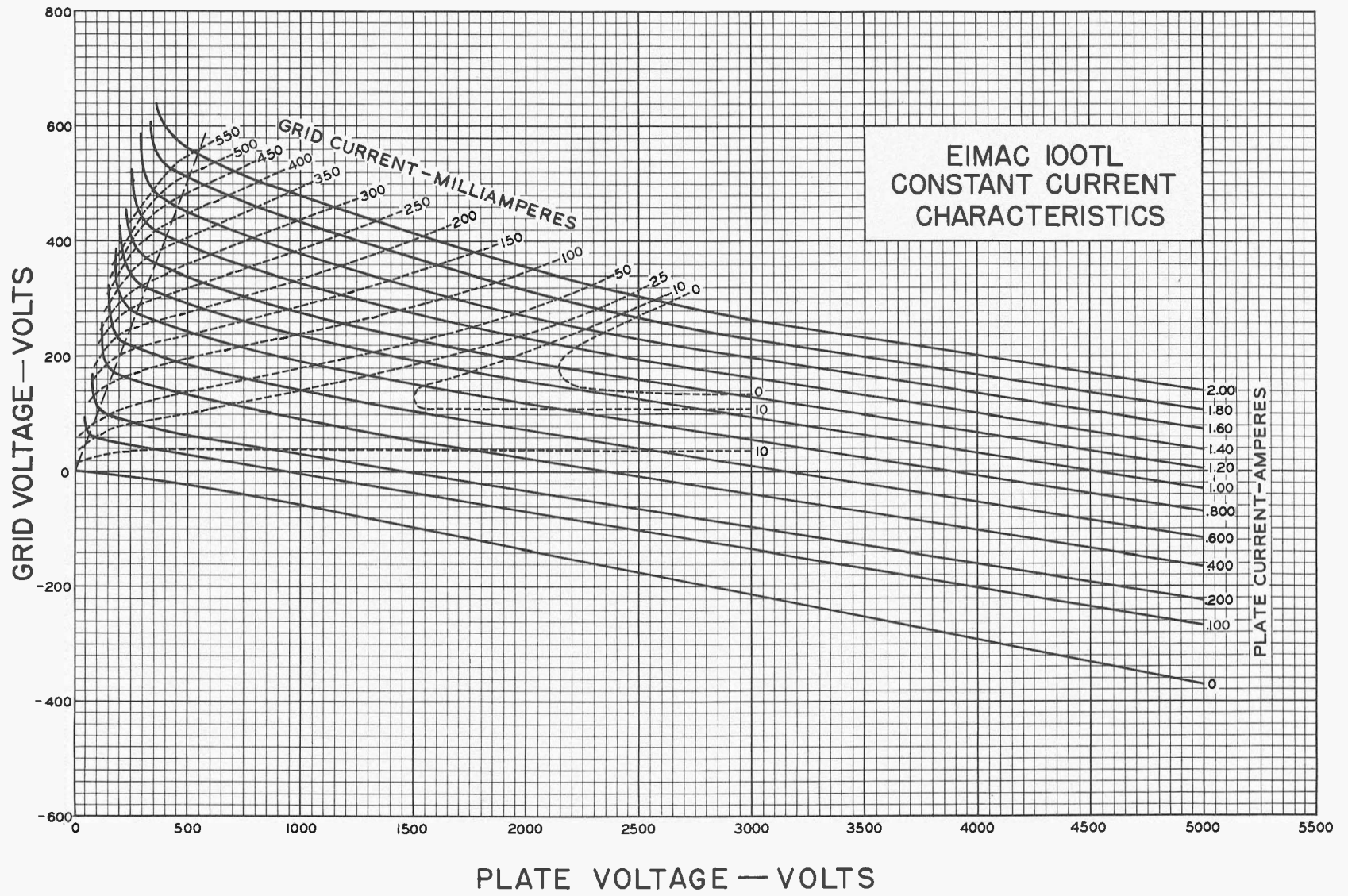

DRIVING POWER vs. POWER OUTPUT

The three charts on this page show the relationship of plate efficiency, power output and grid driving power at plate voltages of 1500, 2000 and 3000 volts. These charts show combined grid and bias losses only. The driving power and power output figures do not include circuit losses. The plate dissipation in watts is indicated by P_p .

Points A, B, and C are identical to the typical Class C operating conditions shown on the first page under 1500, 2000, and 3000 volts respectively.

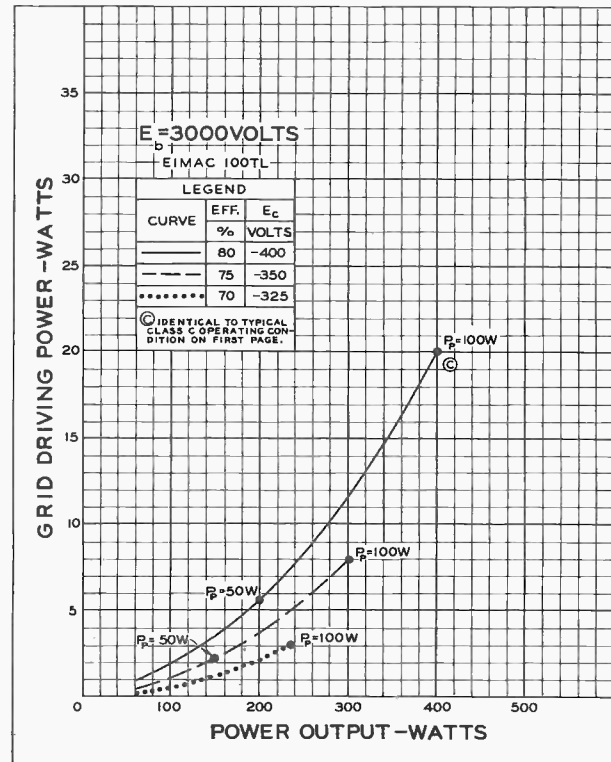
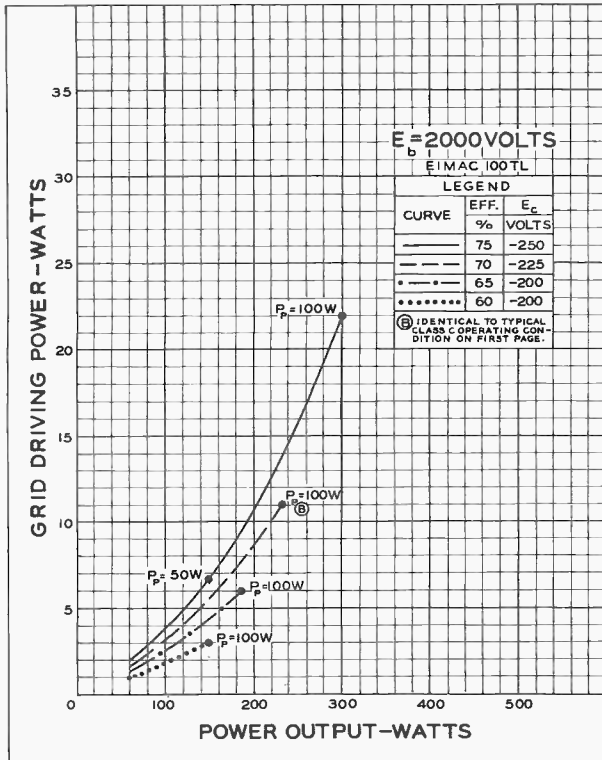
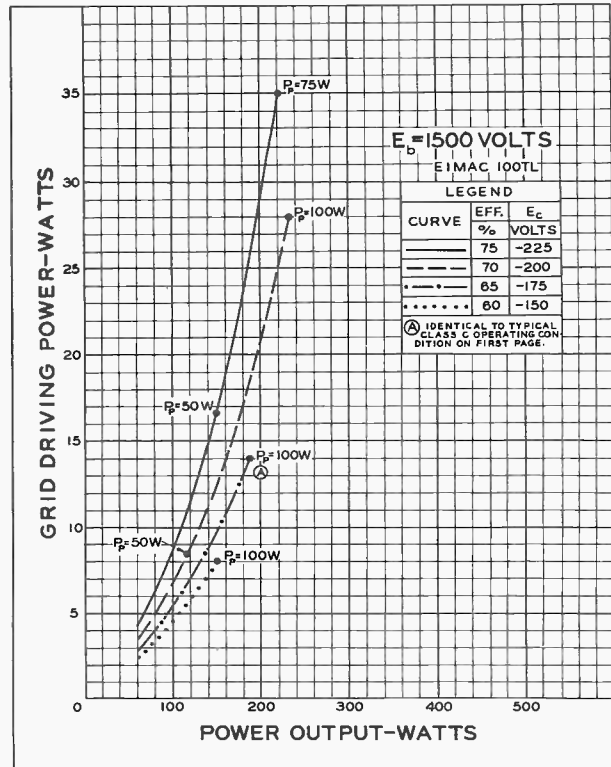

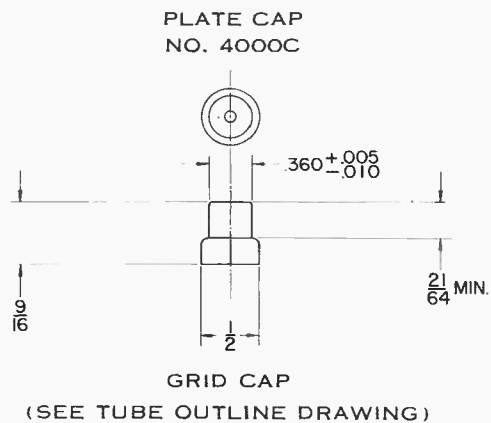
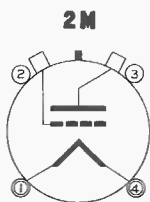
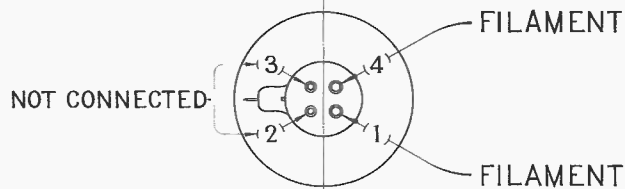
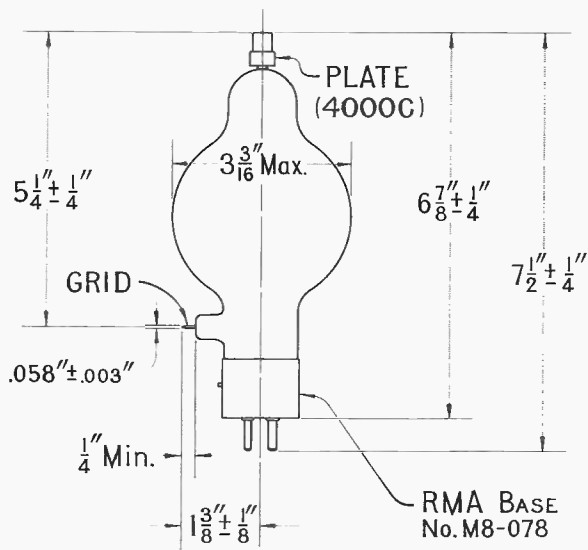

GENERAL CHARACTERISTICS

ELECTRICAL

Filament: Thoriated tungsten	
Voltage - - - - -	5.0 or 10.0 volts
Current - - - - -	12.5 or 6.25 amperes
Amplification Factor (Average) - - - - -	20
Direct Interelectrode Capacitances (Average)	
Grid-Plate - - - - -	4.8 $\mu\mu\text{f}$
Grid-Filament - - - - -	5.7 $\mu\mu\text{f}$
Plate-Filament - - - - -	0.8 $\mu\mu\text{f}$
Transconductance ($i_b = 500 \text{ ma.}$, $E_b = 3000 \text{ v.}$, $E_c = -40 \text{ v.}$)	8300 μmhos
Frequency for Maximum Ratings - - - - -	40 mc

MECHANICAL

Base - - - - -	Special 4 pin, No. 5000B
Basing - - - - -	RMA type 4BC
Maximum Overall Dimensions:	
Length - - - - -	7.625 inches
Diameter - - - - -	2.563 inches
Net weight - - - - -	7 ounces
Shipping weight (Average) - - - - -	2.0 pounds

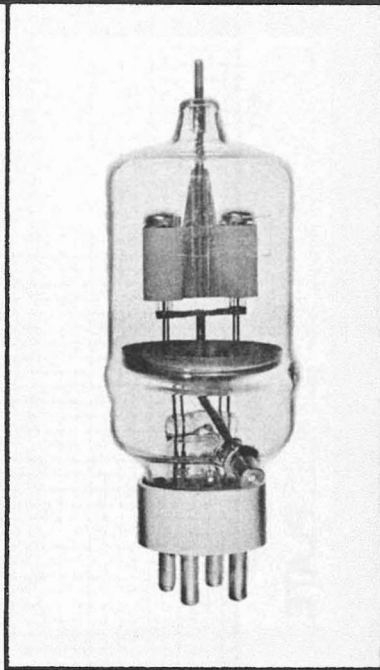

AUDIO FREQUENCY POWER AMPLIFIER AND MODULATOR

Class B

	TYPICAL OPERATION—2 TUBES			MAX. RATING
D-C Plate Voltage - - - - -	1500	2000	3000	3000 volts
Max.-Signal D-C Plate Current, per tube* - - -	•	•	•	450 ma.
Plate Dissipation, per tube* - - - - -	•	•	•	150 watts
D-C Grid Voltage (approx.) - - - - -	-65	-90	-150	volts
Peak A-F Grid Input Voltage - - - - -	340	350	430	volts
Zero-Signal D-C Plate Current - - - - -	133	100	67	ma.
Max.-Signal D-C Plate Current - - - - -	535	450	335	ma.
Max.-Signal Driving Power (approx.) - - - - -	9	6	3	watts
Effective Load, Plate-to-Plate - - - - -	5700	9600	20300	ohms
Max.-Signal Plate Power Output - - - - -	500	600	700	watts

*Averaged over any sinusoidal audio frequency cycle.

RADIO FREQUENCY POWER AMPLIFIER AND OSCILLATOR

Class-C *Telegraphy

(Key down conditions without modulation)

	TYPICAL OPERATION—1 TUBE			MAX. RATING
D-C Plate Voltage - - - - -	1500	2000	3000	3000 volts
D-C Plate Current - - - - -	333	300	250	450 ma.
D-C Grid Current - - - - -	58	74	70	85 ma.
D-C Grid Voltage - - - - -	-125	-200	-300	volts
Plate Power Output - - - - -	350	450	600	watts
Plate Input - - - - -	500	600	750	watts
Plate Dissipation - - - - -	150	150	150	150 watts
Peak R. F. Grid Input Voltage, (approx.) - - -	267	334	410	volts
Driving Power, (approx.) - - - - -	13	20	27	watts

*The above figures show actual measured tube performance, and do not allow for variations in circuit losses.

Eimac
152TH

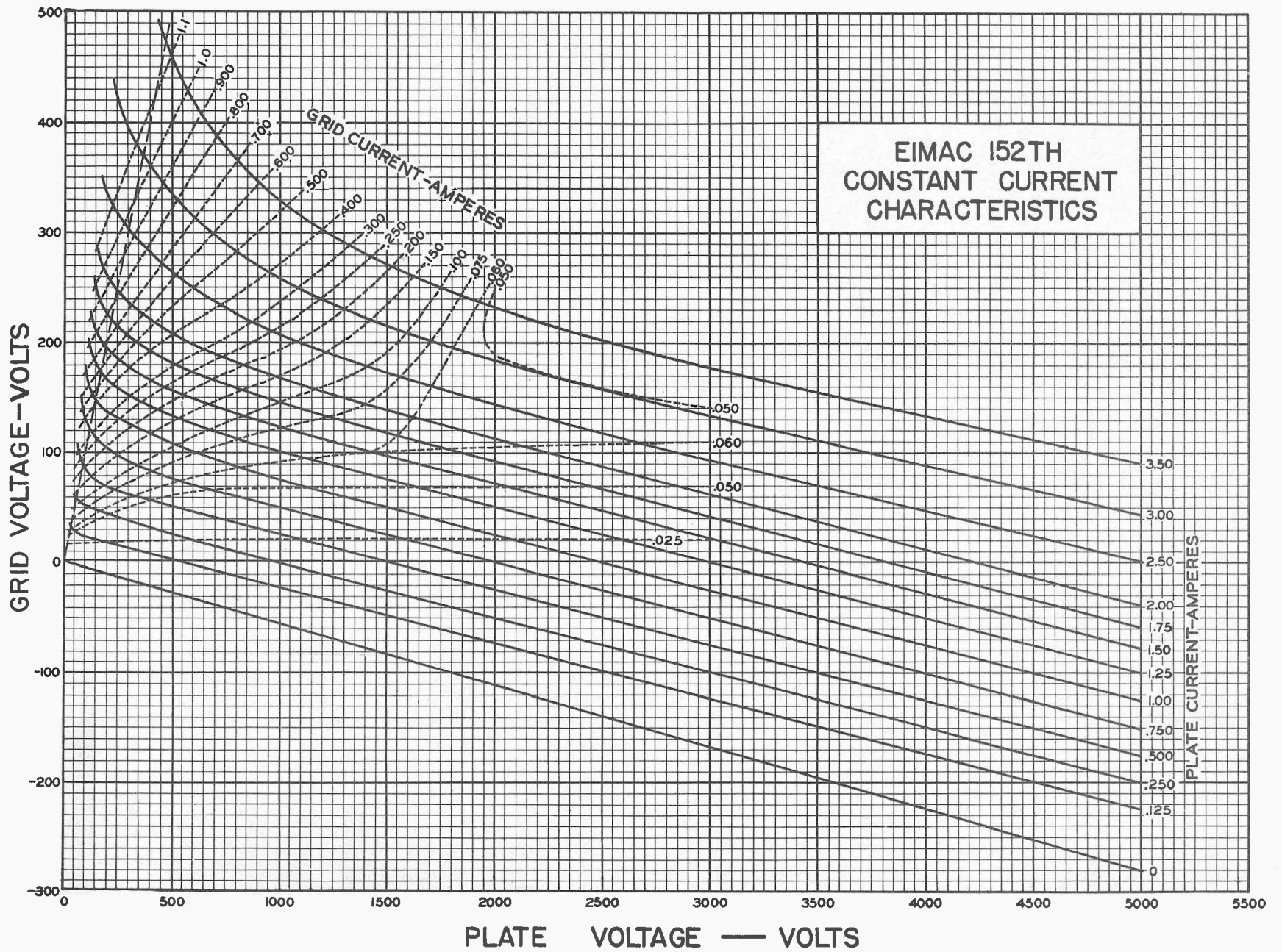

DRIVING POWER vs. POWER OUTPUT

The three charts on this page show the relationship of plate efficiency, power output and grid driving power at plate voltages of 1500, 2000 and 3000 volts. These charts show combined grid and bias losses only. The driving power and power output figures do not include circuit losses. The plate dissipation in watts is indicated by P_p .

Points A, B, and C are identical to the typical Class C operating conditions shown on the first page under 1500, 2000, and 3000 volts respectively.

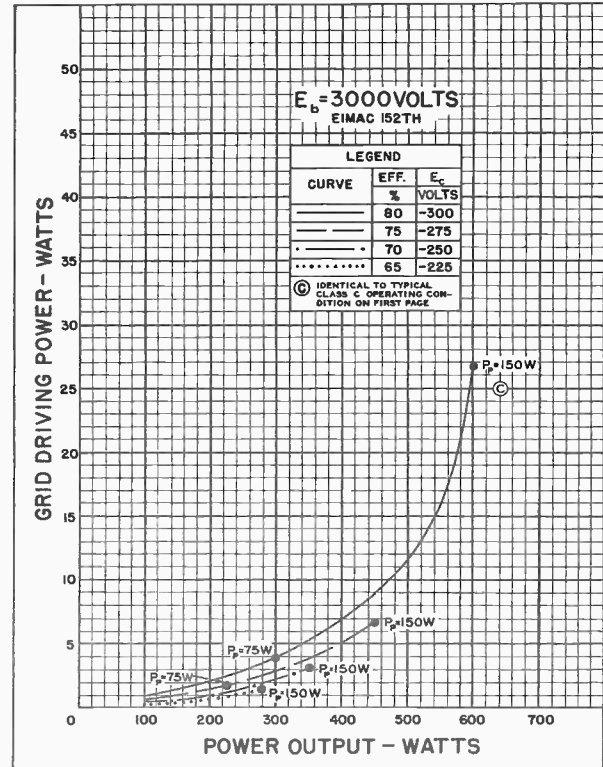
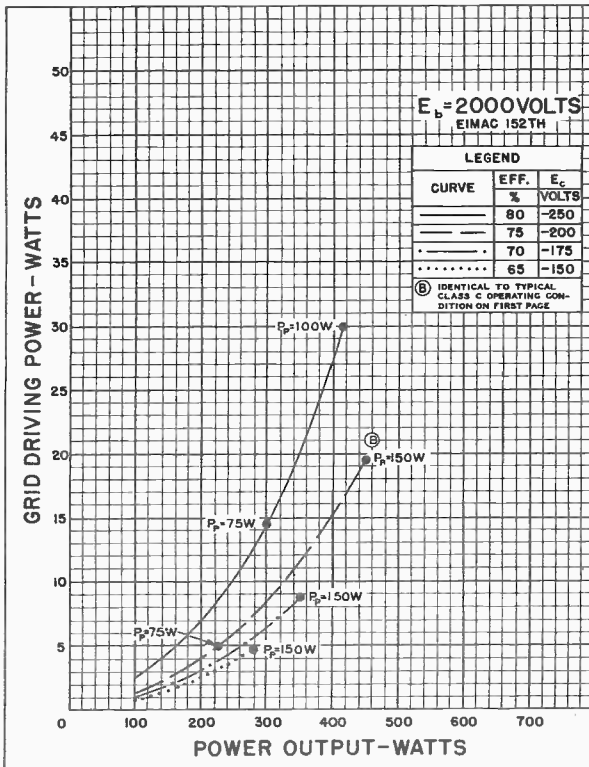
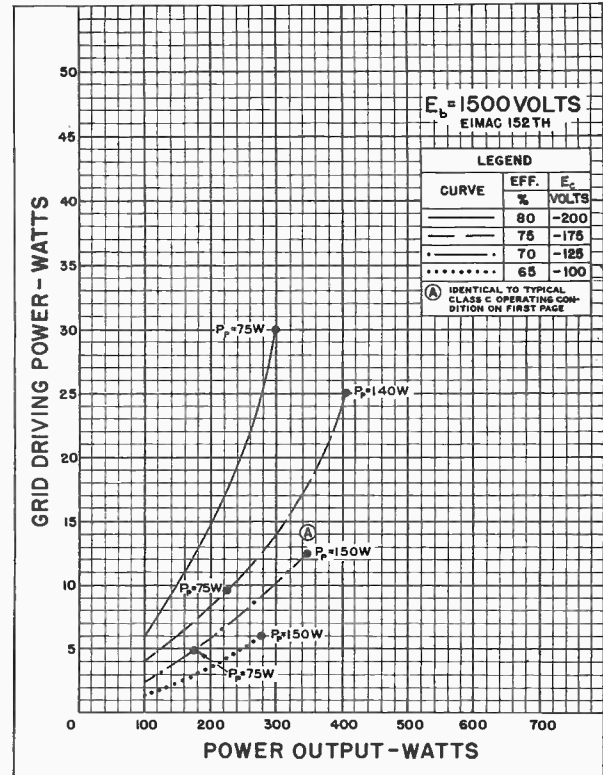

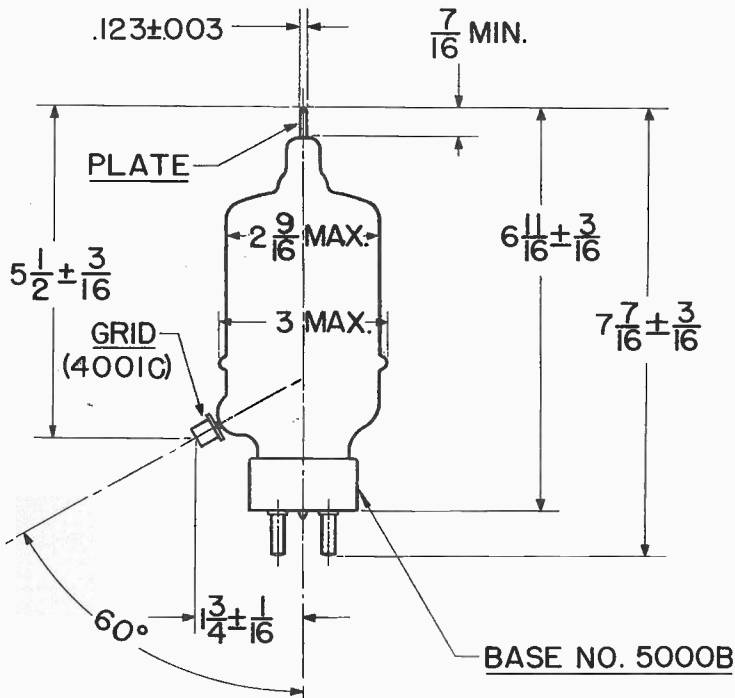
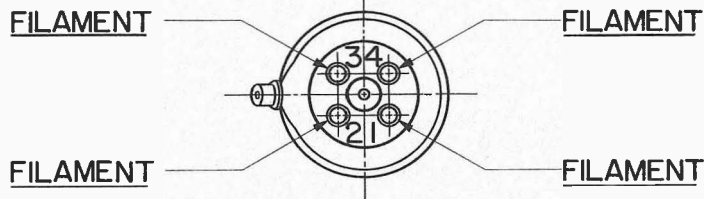
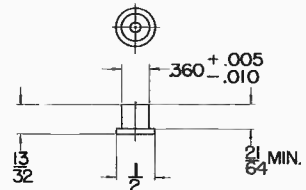
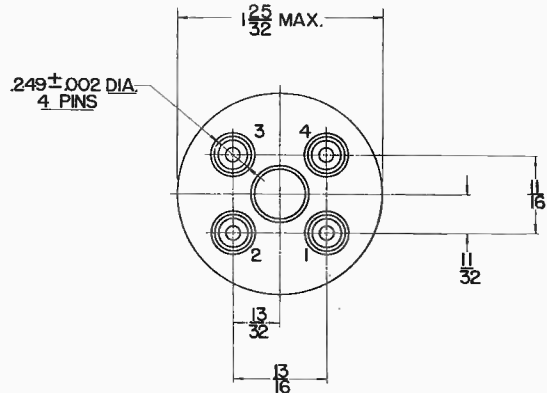
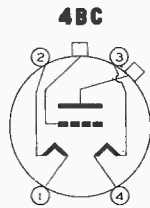
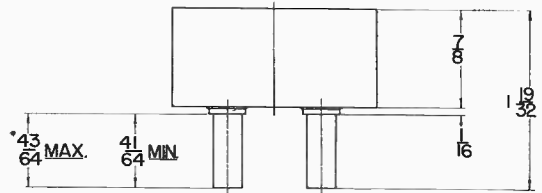

PLATE CAP
 (SEE TUBE OUTLINE DRAWING)

GRID CAP
 NO. 4001C



BASE NO. 5000B



*ON FINISHED TUBE ADD .060 FOR SOLDER

Eitel
EITEL-McCULLOUGH, Inc.
 SAN BRUNO, CALIFORNIA

152TL

**LOW-MU TRIODE
 MODULATOR
 OSCILLATOR
 AMPLIFIER**

GENERAL CHARACTERISTICS

ELECTRICAL

Filament: Thoriated tungsten	
Voltage - - - - -	5.0 of 10.0 volts
Current - - - - -	12.5 or 6.25 amperes
Amplification Factor (Average) - - - - -	12
Direct Interelectrode Capacitances (Average)	
Grid-Plate - - - - -	4.4 $\mu\mu\text{f}$
Grid-Filament - - - - -	4.5 $\mu\mu\text{f}$
Plate-Filament - - - - -	0.7 $\mu\mu\text{f}$
Transconductance ($i_b = 500 \text{ ma.}, E_b = 3000 \text{ v.}, E_c = -85 \text{ v.}$)	7150 μmhos

MECHANICAL

Base - - - - -	Special 4 pin, No. 5000B
Basing - - - - -	RMA type 4BC
Maximum Overall Dimensions:	
Length - - - - -	7.625 inches
Diameter - - - - -	2.563 inches
Net weight - - - - -	7 ounces
Shipping weight (Average) - - - - -	2.0 pounds

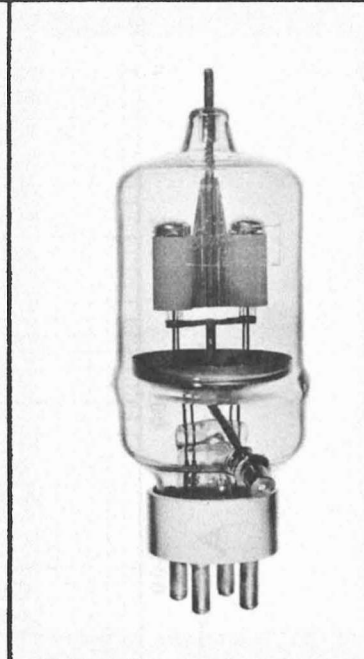

**AUDIO FREQUENCY POWER AMPLIFIER AND MODULATOR
 Class B**

	ZERO GRID CURRENT OPERATION—2 TUBES			TYPICAL OPERATION 2 TUBES			MAX. RATING	
	1500	2000	3000	1500	2000	3000		
D-C Plate Voltage - - - - -	1500	2000	3000	1500	2000	3000	3000	volts
Max.-Sig. D-C Plate Current, per tube*	•	•	•	•	•	•	450	ma.
Plate Dissipation, per tube* - - -	•	•	•	•	•	•	150	watts
D-C Grid Voltage (approx.) - - - -	-105	-160	-260	-105	-160	-260		volts
Peak A-F Grid Input Voltage - - - -	210	320	520	500	620	675		volts
Zero-Signal D-C Plate Current - - -	135	100	65	135	100	65		ma.
Max.-Signal D-C Plate Current - - -	286	260	220	570	500	335		ma.
Max.-Signal Driving Power (approx.)	0	0	0	15	13	3		watts
Effective Load, Plate-to-Plate - - -	5100	10500	24000	5500	9000	20400		ohms
Max.-Signal Plate Power Output - - -	130	220	370	560	700	700		watts

*Averaged over any sinusoidal audio frequency cycle.

**RADIO FREQUENCY POWER AMPLIFIER AND OSCILLATOR
 Class-C *Telegraphy**

(Key down conditions without modulation)

	TYPICAL OPERATION—1 TUBE			MAX. RATING
D-C Plate Voltage - - - - -	1500	2000	3000	3000 volts
D-C Plate Current - - - - -	333	300	250	450 ma.
D-C Grid Current - - - - -	45	42	40	75 ma.
D-C Grid Voltage - - - - -	-250	-300	-400	volts
Plate Power Output - - - - -	350	450	600	watts
Plate Input - - - - -	500	600	750	watts
Plate Dissipation - - - - -	150	150	150	150 watts
Peak R. F. Grid Input Voltage, (approx.) - - -	400	455	550	volts
Driving Power, (approx.) - - - - -	16	18	20	watts

*The above figures show actual measured tube performance, and do not allow for variations in circuit losses.

Eimac
152TL

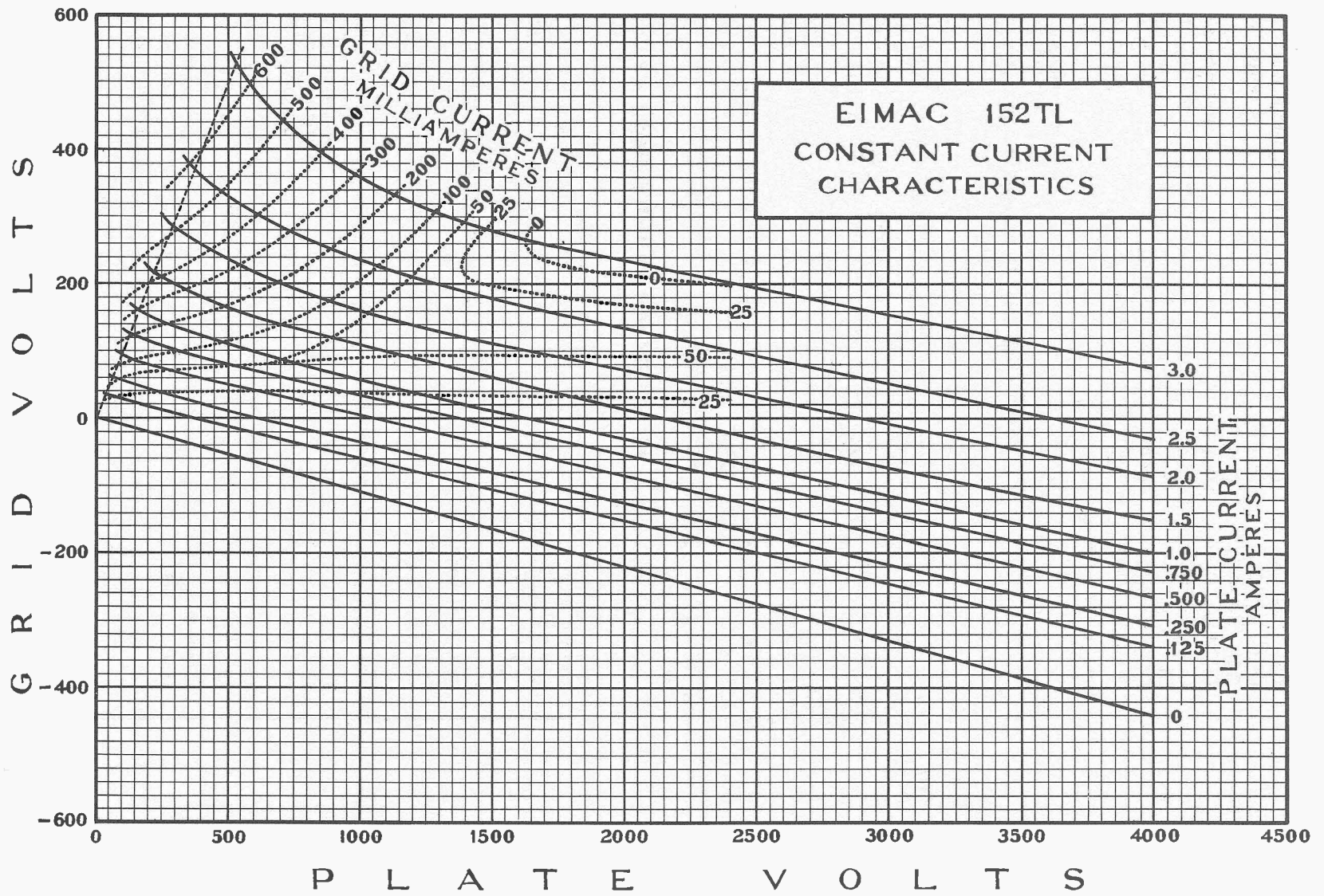

DRIVING POWER vs. POWER OUTPUT

The three charts on this page show the relationship of plate efficiency, power output and grid driving power at plate voltages of 1500, 2000 and 3000 volts. These charts show combined grid and bias losses only. The driving power and power output figures do not include circuit losses. The plate dissipation in watts is indicated by P_p .

Points A, B, and C are identical to the typical Class C operating conditions shown on the first page under 1500, 2000, and 3000 volts respectively.

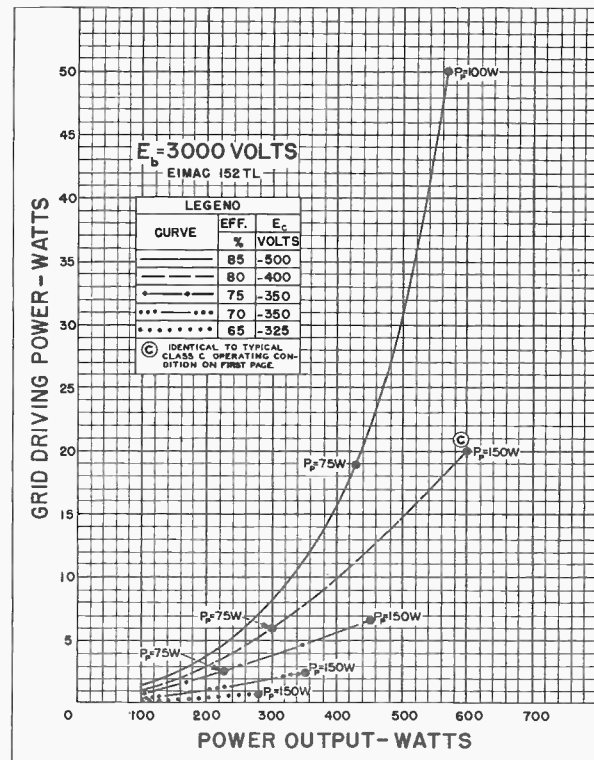
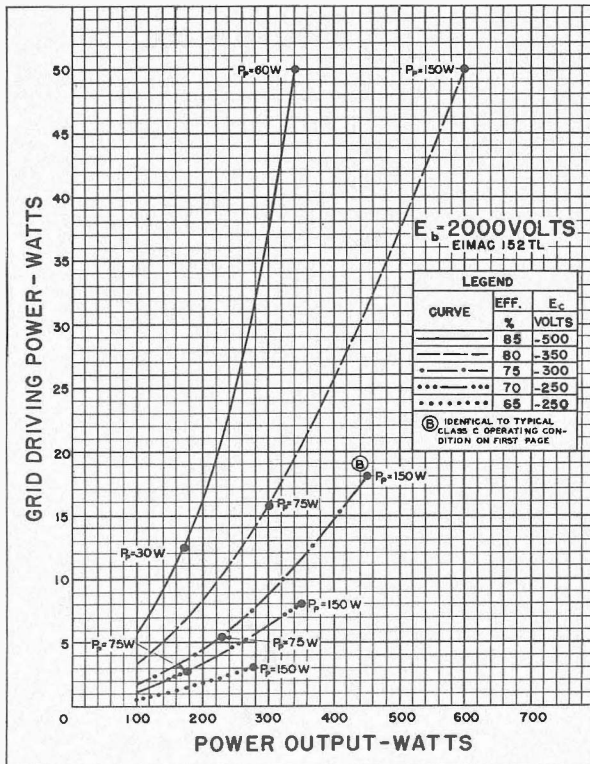
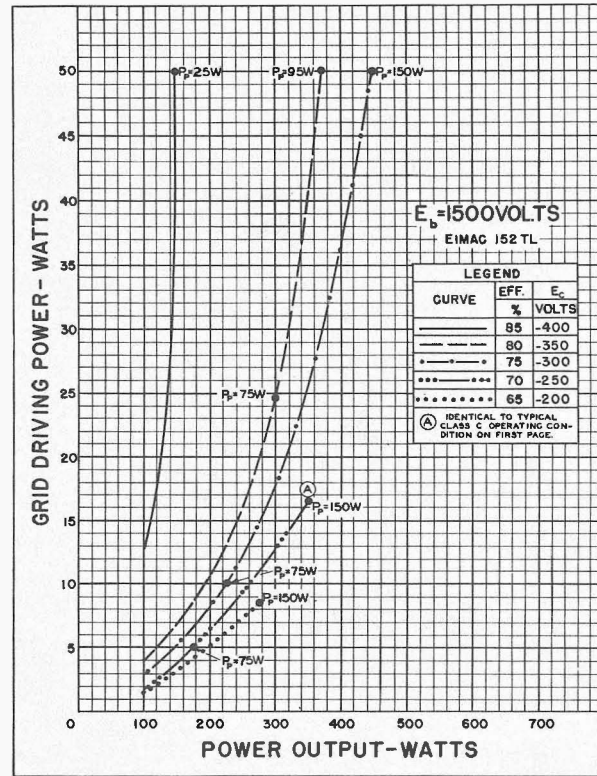

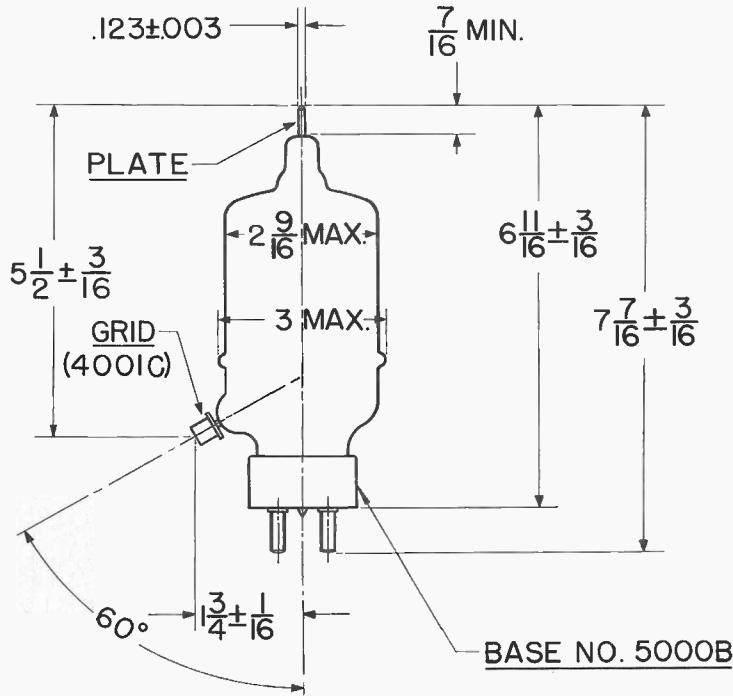
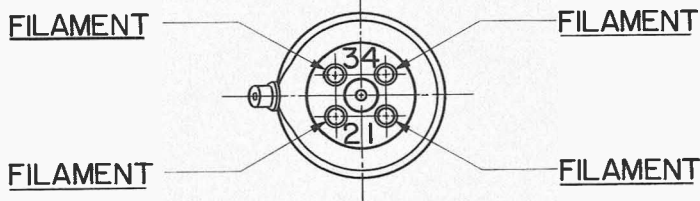
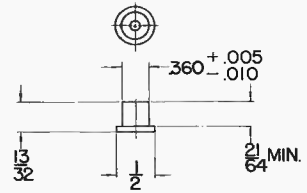
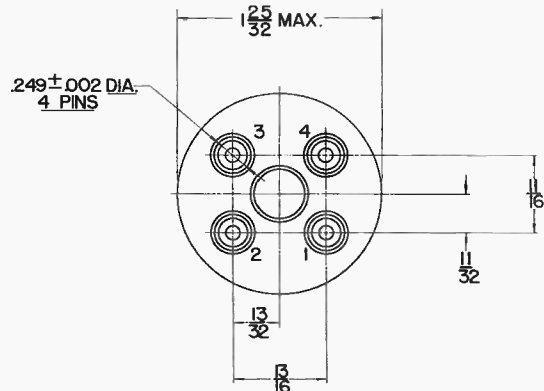
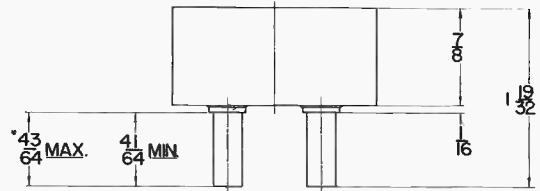

PLATE CAP
 (SEE TUBE OUTLINE DRAWING)

GRID CAP
 NO. 4001C



BASE NO. 5000B



*ON FINISHED TUBE ADD .060 FOR SOLDER

TENTATIVE DATA

EITEL-McCULLOUGH, INC.
SAN BRUNO, CALIFORNIA

592/3-200A3

MEDIUM-MU TRIODE

MODULATOR
OSCILLATOR
AMPLIFIER

The Eimac 592/3-200A3 is a medium-mu power triode having a maximum plate dissipation rating of 200 watts, and it is intended for use as a power amplifier, oscillator, or modulator. It can be used at its maximum ratings at frequencies as high as 150 Mc.
Cooling of the 592/3-200A3 is accomplished by radiation from the plate, which operates at a visible red color at maximum plate dissipation, and by means of forced-air circulation around the envelope.

GENERAL CHARACTERISTICS

ELECTRICAL

Filament: Thoriated tungsten	
Voltage	10.0 volts
Current	5.0 amperes
Amplification Factor (Average)	25
Direct Interelectrode Capacitances (Average)	
Grid-Plate	3.3 $\mu\mu\text{f}$
Grid-Filament	3.6 $\mu\mu\text{f}$
Plate-Filament	0.29 $\mu\mu\text{f}$
Transconductance ($i_b=200 \text{ ma.}, E_b=3000 \text{ v.}$)	3600 μmhos
Frequency for Maximum Ratings	150 Mc.

MECHANICAL

Mounting	Vertical
Maximum Overall Dimensions:	
Length	6.0 inches
Diameter	3-13/32 inches
Net Weight (approx.)	6 ounces
Shipping Weight (approx.)	1 1/2 pounds

COOLING

An air-flow of 15 cubic feet per minute should be directed at the bulb from a 2-inch diameter nozzle located about 3 inches from the center line of the tube. The center line of the nozzle should be located about 2 inches down from the top of the plate terminal. The incoming air temperature should not exceed 50° C. Other methods of cooling may be used provided maximum bulb and seal temperatures are not exceeded. An 8-inch fan located about 10 inches from the tube is one alternate method.

Maximum bulb temperature	225° C	Maximum seal temperature	175° C
--------------------------	--------	--------------------------	--------

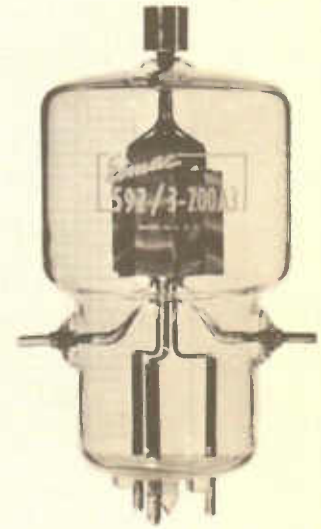

AUDIO FREQUENCY POWER AMPLIFIER AND MODULATOR—CLASS B

MAXIMUM RATINGS, PER TUBE

D-C PLATE VOLTAGE	3500 MAX. VOLTS
MAX-SIGNAL D-C PLATE CURRENT	250 MAX. MA.
PLATE DISSIPATION	200 MAX. WATTS
GRID DISSIPATION	25 MAX. WATTS

TYPICAL OPERATION

Sinusoidal wave, two tubes unless otherwise specified.			
D-C Plate Voltage	2000	2500	3000
D-C Grid Voltage (approx.)*	-50	-70	-90
Zero-Signal D-C Plate Current	120	100	80
Max-Signal D-C Plate Current	500	450	400
Effective Load, Plate-to-Plate	8500	12,600	18,000
Peak A-F Grid Input Voltage (per tube)	260	270	270
Max-Signal Peak Driving Power	50	52	40
Max-Signal Nominal Driving Power (approx.)	25	26	20
Max-Signal Plate Power Output	600	725	820

*Adjust to give stated zero-signal plate current.

PLATE MODULATED RADIO FREQUENCY AMPLIFIER

Class-C Telephony (Carrier conditions, per tube)

MAXIMUM RATINGS

D-C PLATE VOLTAGE	2600 MAX. VOLTS
D-C PLATE CURRENT	200 MAX. MA.
PLATE DISSIPATION	130 MAX. WATTS
GRID DISSIPATION	25 MAX. WATTS

TYPICAL OPERATION

D-C Plate Voltage	2000	2500	3000
D-C Plate Current	200	200	200
D-C Grid Voltage	-250	-300	-300
D-C Grid Current	35	35	35
Peak R-F Grid Input Voltage	480	535	535
Driving Power	17	19	19
Grid Dissipation	8	9	9
Plate Power Input	400	500	500
Plate Dissipation	115	125	125
Plate Power Output	285	375	375

The output figures do not allow for circuit losses.

RADIO FREQUENCY POWER AMPLIFIER AND OSCILLATOR

Class-C Telegraphy or FM Telephony (Key-down conditions, per tube)

MAXIMUM RATINGS

D-C PLATE VOLTAGE	3500 MAX. VOLTS
D-C PLATE CURRENT	250 MAX. MA.
PLATE DISSIPATION	200 MAX. WATTS
GRID DISSIPATION	25 MAX. WATTS

TYPICAL OPERATION

D-C Plate Voltage	2000	2500	3000	3500
D-C Plate Current	250	228	222	228
D-C Grid Voltage	-150	-180	-220	-270
D-C Grid Current	32	28	25	30
Peak R-F Grid Input Voltage	380	400	440	505
Driving Power	12	11	11	15
Grid Dissipation	7	6	5.5	7
Plate Power Input	500	570	666	800
Plate Dissipation	200	200	200	200
Plate Power Output	300	370	466	600

The output figures do not allow for circuit losses.

(Effective 2-15-50) Copyright 1950 by Eitel-McCullough, Inc.

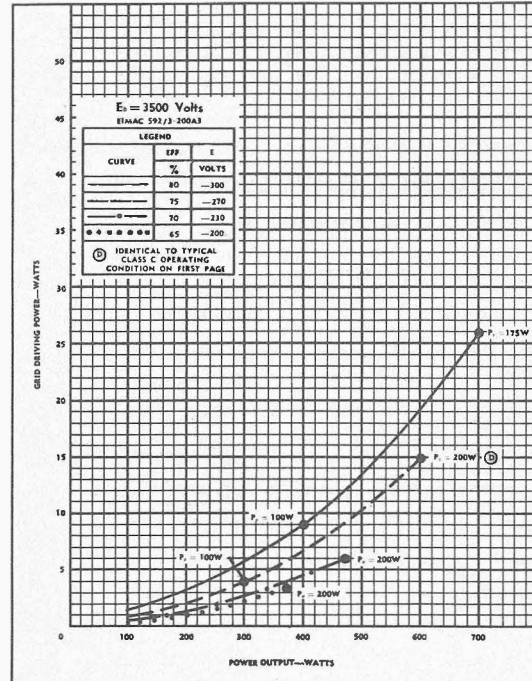
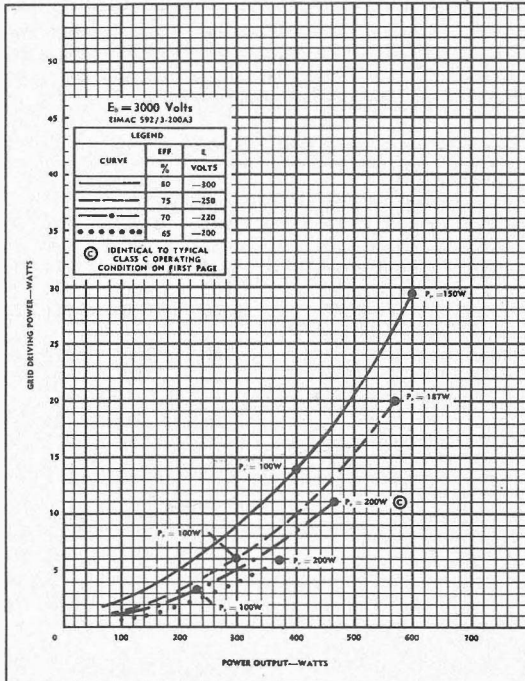
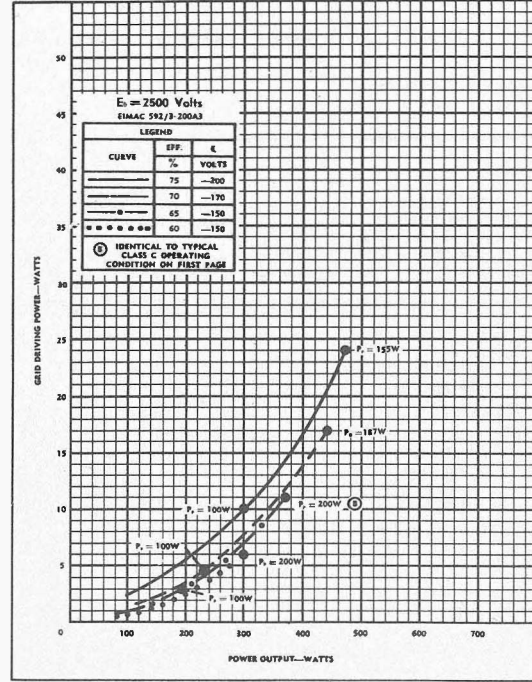
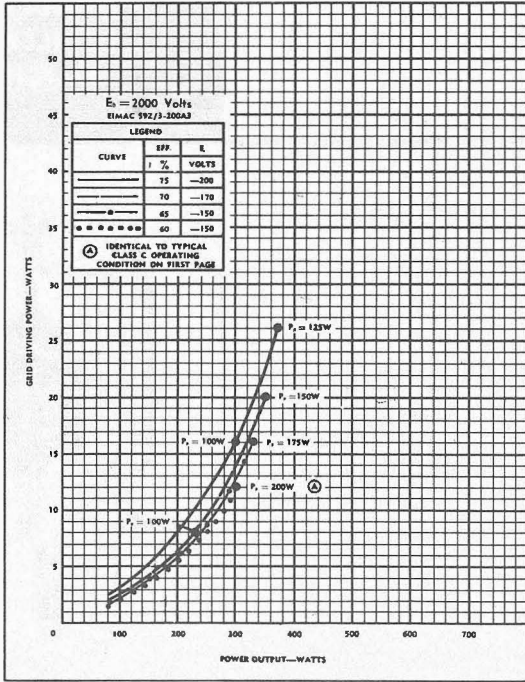

DRIVING POWER vs. POWER OUTPUT

The four charts on this page show the relationship of plate efficiency, power output and grid driving power at plate voltages of 2000, 2500, 3000 and 3500 volts. These charts show combined grid and bias losses only. The driving power and power output figures do not include circuit losses. The plate dissipation in watts is indicated by P_p .

Points A, B, C, and D are identical to the typical Class C operating conditions shown on the first page under 2000, 2500, 3000 and 3500 volts respectively.

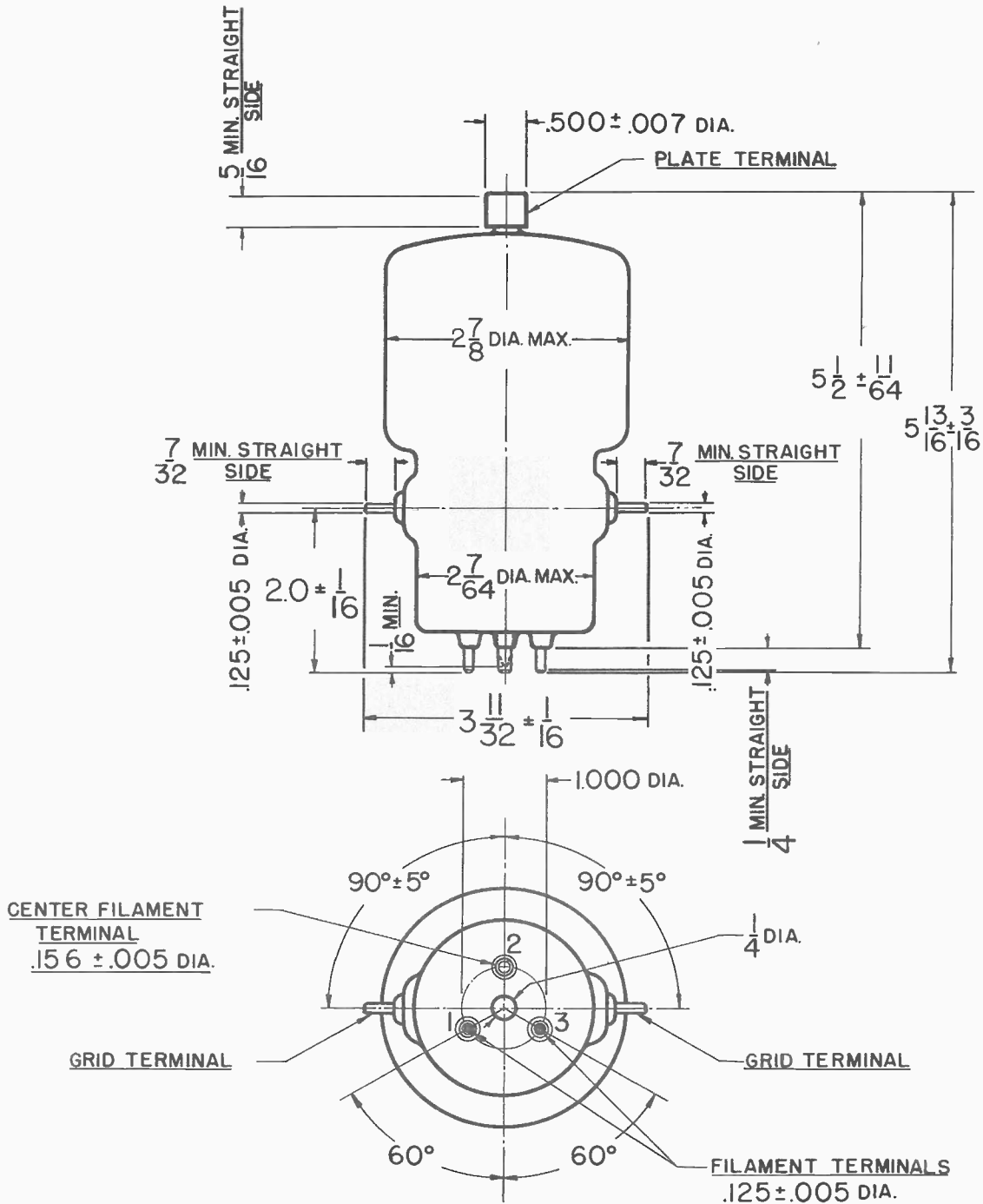

**DIMENSIONS
 IN INCHES**

BOTTOM VIEW

NOTE: CENTER FILAMENT TERMINAL, FILAMENT TERMINALS, AND TUBULATION ARE SO ALIGNED THAT THEY CAN BE FREELY INSERTED INTO A GAGE $\frac{1}{4}$ " THICK WITH HOLE DIA. $.186$ ", $.155$ ", & $.350$ " RESPECTIVELY, LOCATED ON THE TRUE CENTERS BY THE GIVEN DIMENSIONS.

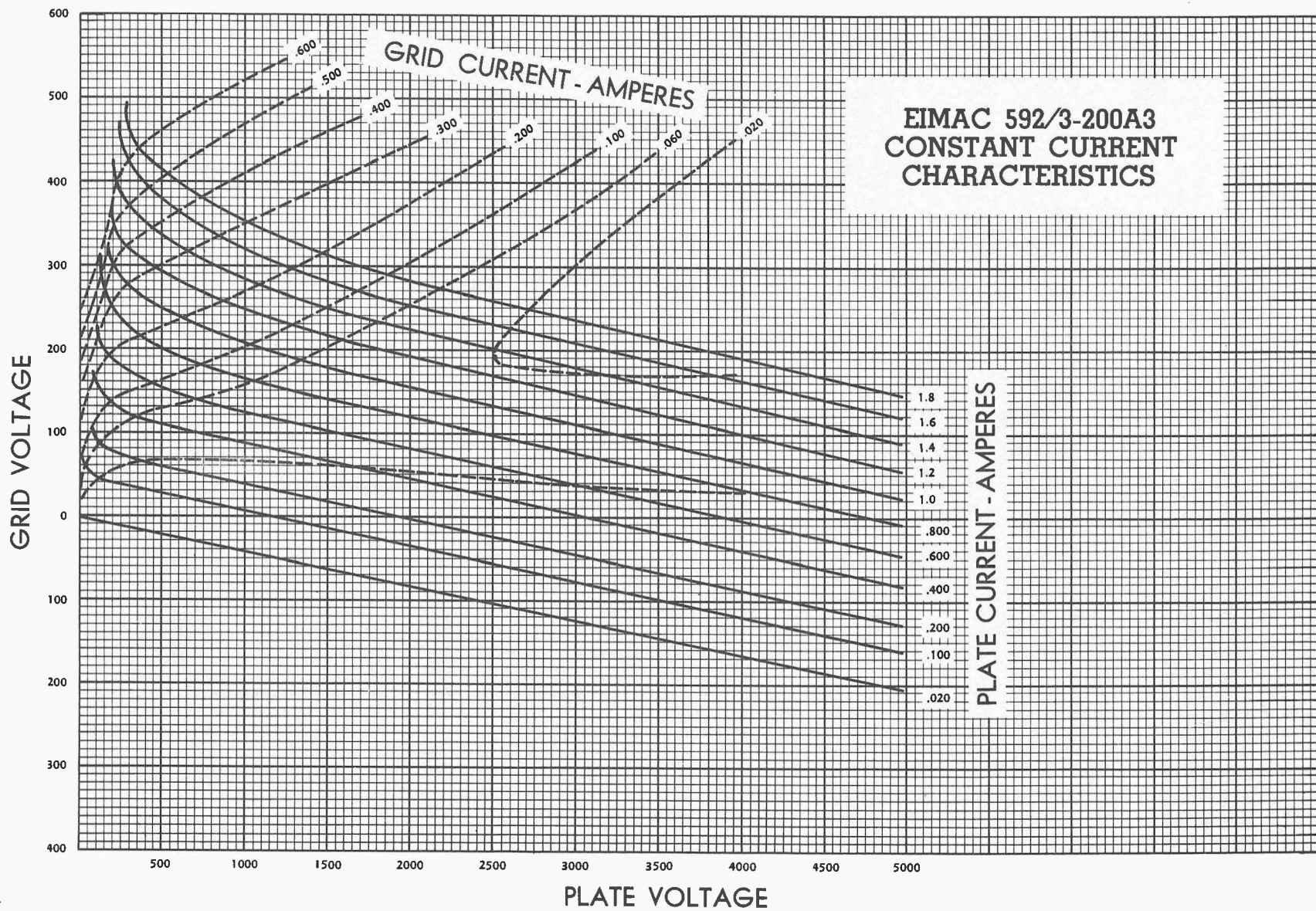

Eitel
EITEL-McCULLOUGH, Inc.
 SAN BRUNO, CALIFORNIA

250TH
 HIGH-MU TRIODE
 •
 MODULATOR
 OSCILLATOR
 AMPLIFIER

GENERAL CHARACTERISTICS

ELECTRICAL

Filament: Thoriated tungsten		
Voltage - - - - -	5.0	volts
Current - - - - -	10.5	amperes
Amplification Factor (Average) - - - - -		37
Direct Interelectrode Capacitances (Average)		
Grid-Plate - - - - -	2.9	uuf
Grid-Filament - - - - -	5.0	uuf
Plate-Filament - - - - -	0.7	uuf
Transconductance ($I_b=300$ ma., $E_b=3000$, $e_c=-20$)	6650	umhos
Frequency for Maximum Ratings - - - - -		40 mc.

MECHANICAL

Base - - - - -	4 pin, No. 5001B
Basing - - - - -	RMA type 2N
Maximum Overall Dimensions:	
Length - - - - -	10.125 inches
Diameter - - - - -	3.813 inches
Net weight - - - - -	12 ounces
Shipping weight (Average) - - - - -	2.25 pounds

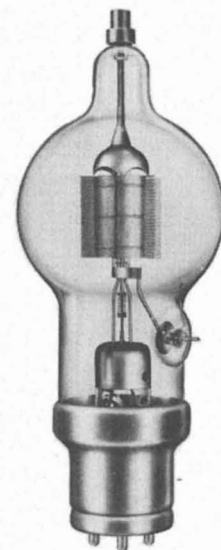

AUDIO FREQUENCY POWER AMPLIFIER AND MODULATOR

Class B

	TYPICAL OPERATION—2 TUBES			MAX. RATING	
D-C Plate Voltage - - - - -	1500	2000	3000	3000	volts
Max.-Signal D-C Plate Current, per tube* - - -	•	•	•	350	ma.
Plate Dissipation, per tube* - - - - -	•	•	•	250	watts
D-C Grid Voltage (approx.) - - - - -	0	-30	-65		volts
Peak A-F Grid Input Voltage - - - - -	410	460	460		volts
Zero-Signal D-C Plate Current - - - - -	220	140	100		ma.
Max.-Signal D-C Plate Current - - - - -	700	700	560		ma.
Max.-Signal Driving Power (approx.) - - - - -	36	34	24		watts
Effective Load, Plate-to-Plate - - - - -	4300	6000	12250		ohms
Max.-Signal Plate Power Output - - - - -	650	900	1150		watts

*Averaged over any sinusoidal audio frequency cycle.

RADIO FREQUENCY POWER AMPLIFIER AND OSCILLATOR

Class-C *Telegraphy

(Key down conditions without modulation)

	TYPICAL OPERATION—1 TUBE			MAX. RATING	
D-C Plate Voltage - - - - -	2000	3000	4000	4000	volts
D-C Plate Current - - - - -	357	333	313	350	ma.
D-C Grid Current - - - - -	94	90	93	100	ma.
D-C Grid Voltage - - - - -	-100	-150	-220		volts
Plate Power Output - - - - -	464	750	1000		watts
Plate Input - - - - -	714	1000	1250		watts
Plate Dissipation - - - - -	250	250	250	250	watts
Peak R. F. Grid Input Voltage, (approx.) - - -	345	395	470		volts
Driving Power, (approx.) - - - - -	29	32	39		watts

*The above figures show actual measured tube performance, and do not allow for variations in circuit losses.

Simul
250TH

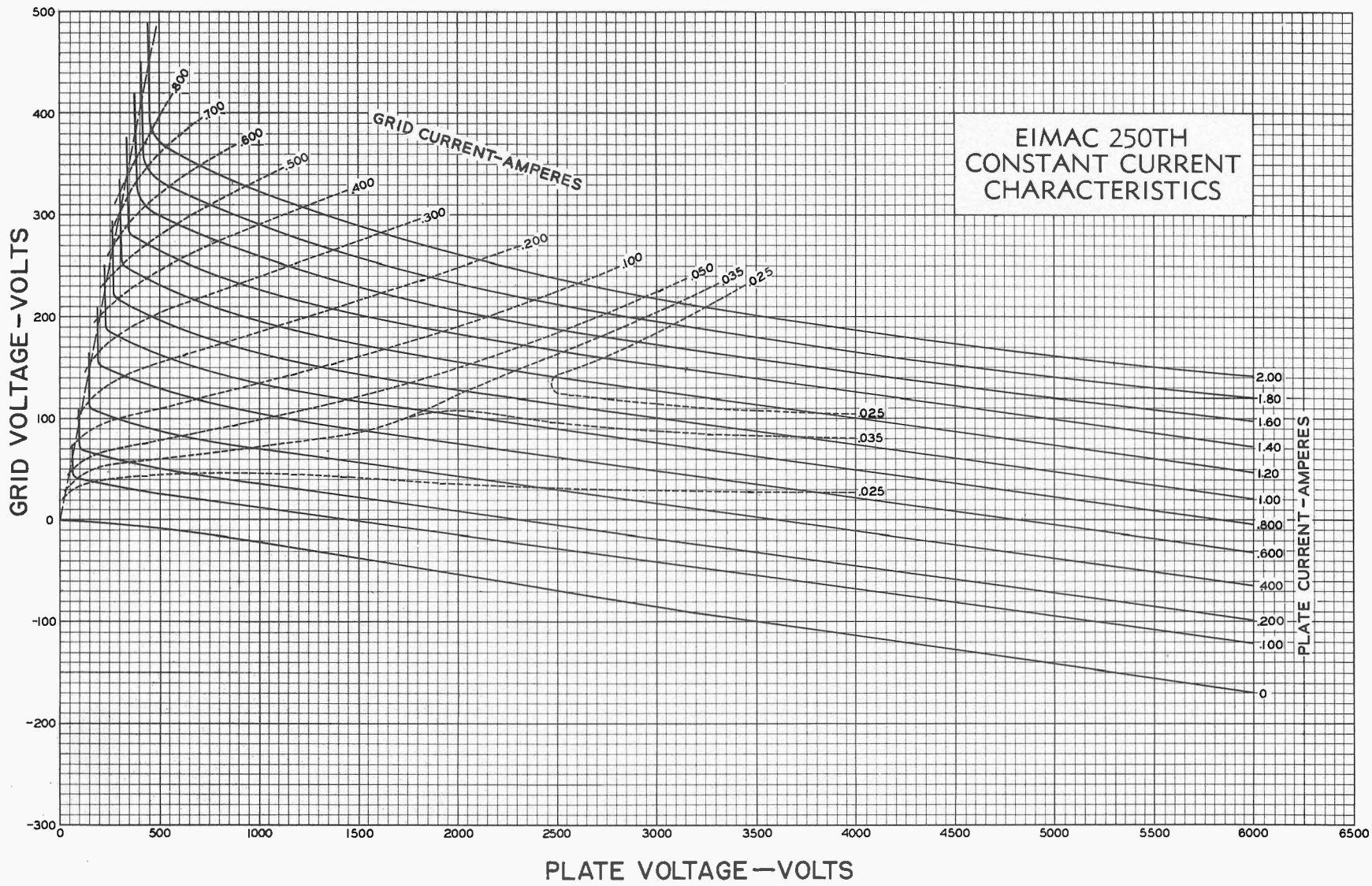

DRIVING POWER vs. POWER OUTPUT

The three charts on this page show the relationship of plate efficiency, power output and grid driving power at plate voltages of 2000, 3000, and 4000 volts. These charts show combined grid and bias losses only. The driving power and power output figures do not include circuit losses. Points A, B, and C are identical to the typical Class C operating conditions shown on the first page under 2000, 3000, and 4000 volts respectively.

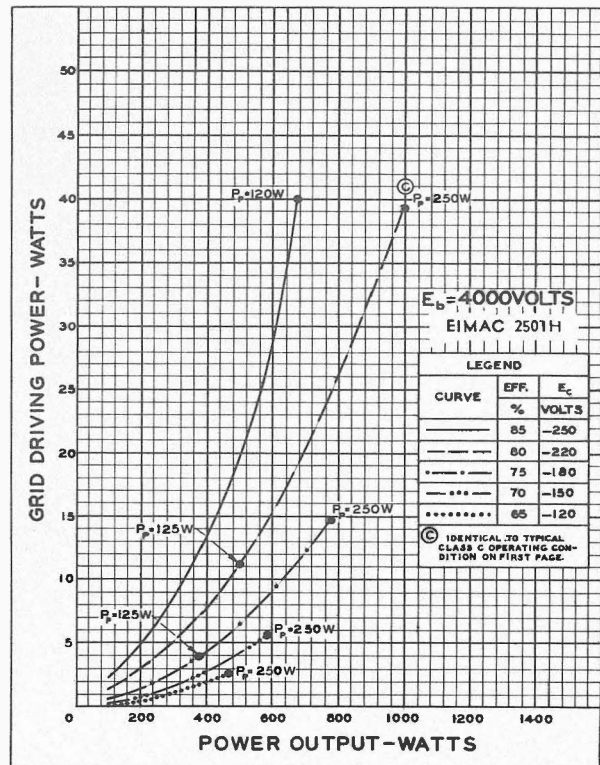
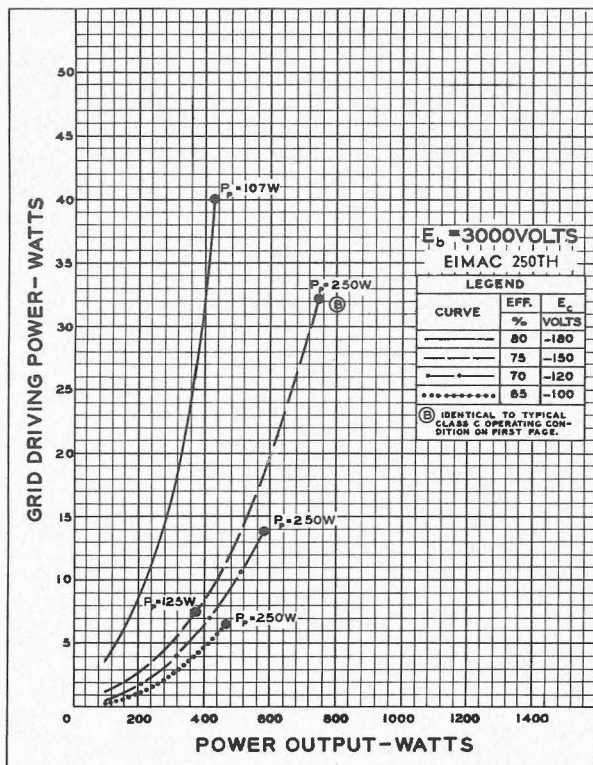
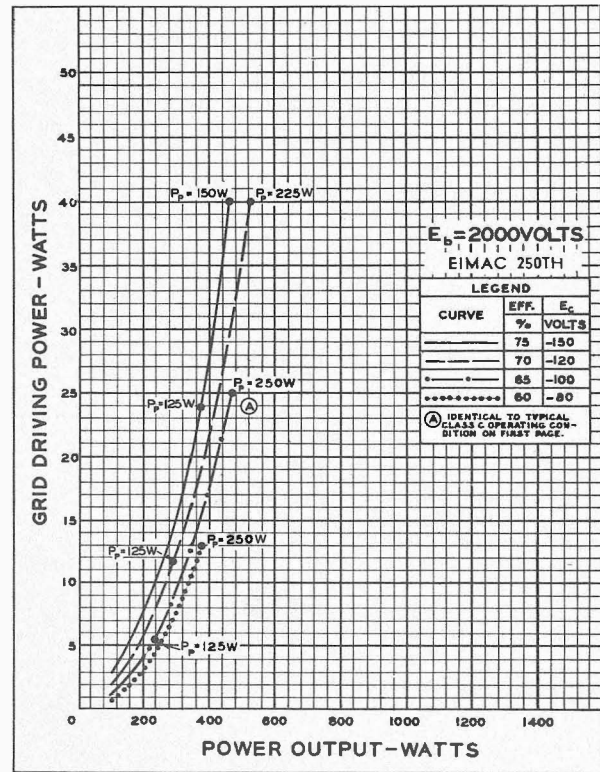

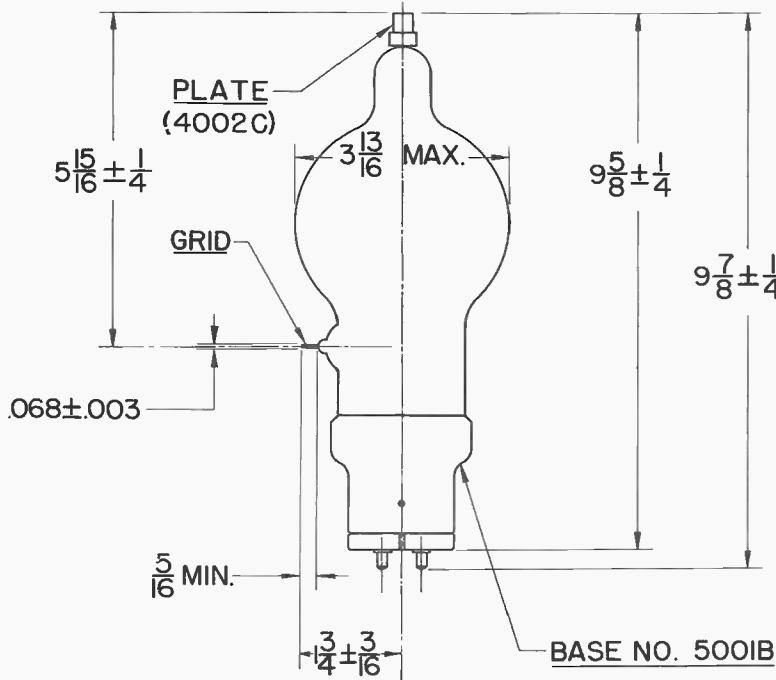

CAPS
 PLATE
 CAP NO. 4002C

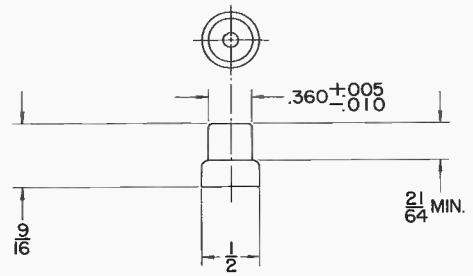

GRID

(SEE TUBE OUTLINE DRAWING)

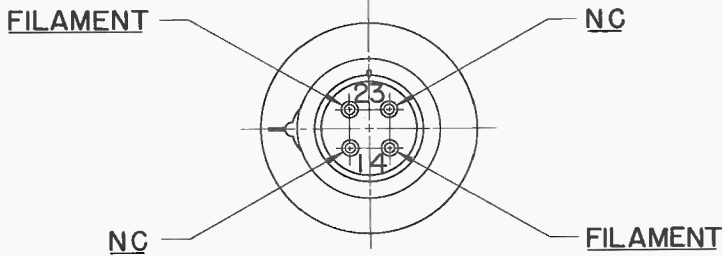

BASE NO. 500IB

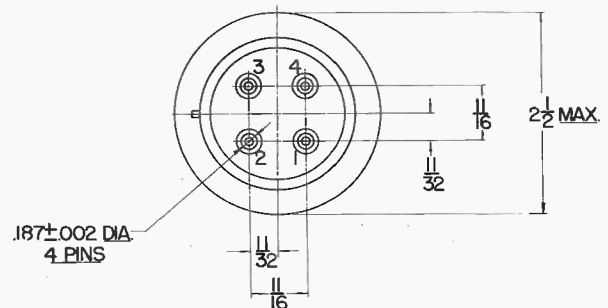
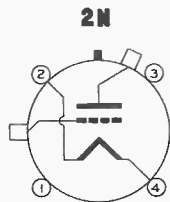
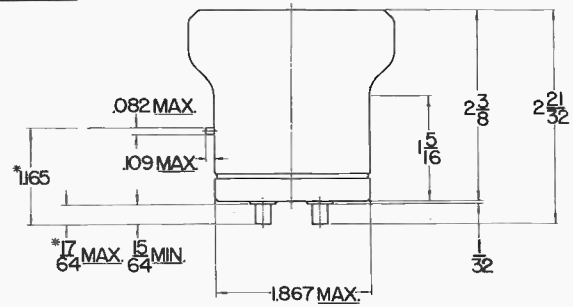

*ON FINISHED TUBE ADD .060 FOR SOLDER

Eitel-McCullough
EITEL-McCULLOUGH, INC.
 SAN BRUNO, CALIFORNIA

250TL

**LOW-MU TRIODE
 MODULATOR
 OSCILLATOR
 AMPLIFIER**

GENERAL CHARACTERISTICS

ELECTRICAL

Filament: Thoriated tungsten	
Voltage - - - - -	5.0 volts
Current - - - - -	10.5 amperes
Amplification Factor (Average) - - - - -	14
Direct Interelectrode Capacitances (Average)	
Grid-Plate - - - - -	3.1 $\mu\mu\text{f}$
Grid-Filament - - - - -	3.7 $\mu\mu\text{f}$
Plate-Filament - - - - -	0.7 $\mu\mu\text{f}$
Transconductance ($I_b=350 \text{ ma.}, E_b=3000, e_c=-130$)	2650 μmhos
Frequency for Maximum Ratings - - - - -	40 mc

MECHANICAL

Base - - - - -	4 pin, No. 500IB
Basing - - - - -	RMA type 2N
Maximum Overall Dimensions:	
Length - - - - -	10.125 inches
Diameter - - - - -	3.813 inches
Net weight - - - - -	12 ounces
Shipping weight (Average) - - - - -	2.25 pounds

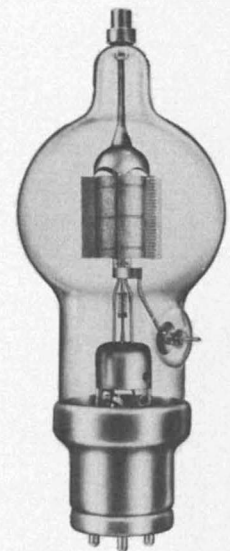

**AUDIO FREQUENCY POWER AMPLIFIER AND MODULATOR
 Class B**

	TYPICAL OPERATION—2 TUBES			MAX. RATING
D-C Plate Voltage - - - - -	1500	2000	3000	3000 volts
Max.-Signal D-C Plate Current, per tube* - - -	•	•	•	350 ma.
Plate Dissipation, per tube* - - - - -	•	•	•	250 watts
D-C Grid Voltage (approx.) - - - - -	-40	-80	-175	volts
Peak A-F Grid Input Voltage - - - - -	770	800	840	volts
Zero-Signal D-C Plate Current - - - - -	200	150	100	ma.
Max.-Signal D-C Plate Current - - - - -	700	650	500	ma.
Max.-Signal Driving Power (approx.) - - - - -	32	28	17	watts
Effective Load, Plate-to-Plate - - - - -	3700	6150	13000	ohms
Max.-Signal Plate Power Output - - - - -	580	800	1000	watts

*Averaged over any sinusoidal audio frequency cycle.

**RADIO FREQUENCY POWER AMPLIFIER AND OSCILLATOR
 Class-C *Telegraphy
 (Key down conditions without modulation)**

	TYPICAL OPERATION—1 TUBE			MAX. RATING
D-C Plate Voltage - - - - -	2000	3000	4000	4000 volts
D-C Plate Current - - - - -	350	335	310	350 ma.
D-C Grid Current - - - - -	45	45	40	50 ma.
D-C Grid Voltage - - - - -	-200	-350	-500	volts
Plate Power Output - - - - -	455	750	1000	watts
Plate Input - - - - -	700	1000	1250	watts
Plate Dissipation - - - - -	245	250	250	250 watts
Peak R. F. Grid Input Voltage, (approx.) - - -	575	720	900	volts
Driving Power, (approx.) - - - - -	22	29	33	watts

*The above figures show actual measured tube performance, and do not allow for variations in circuit losses.

Simul
250TL

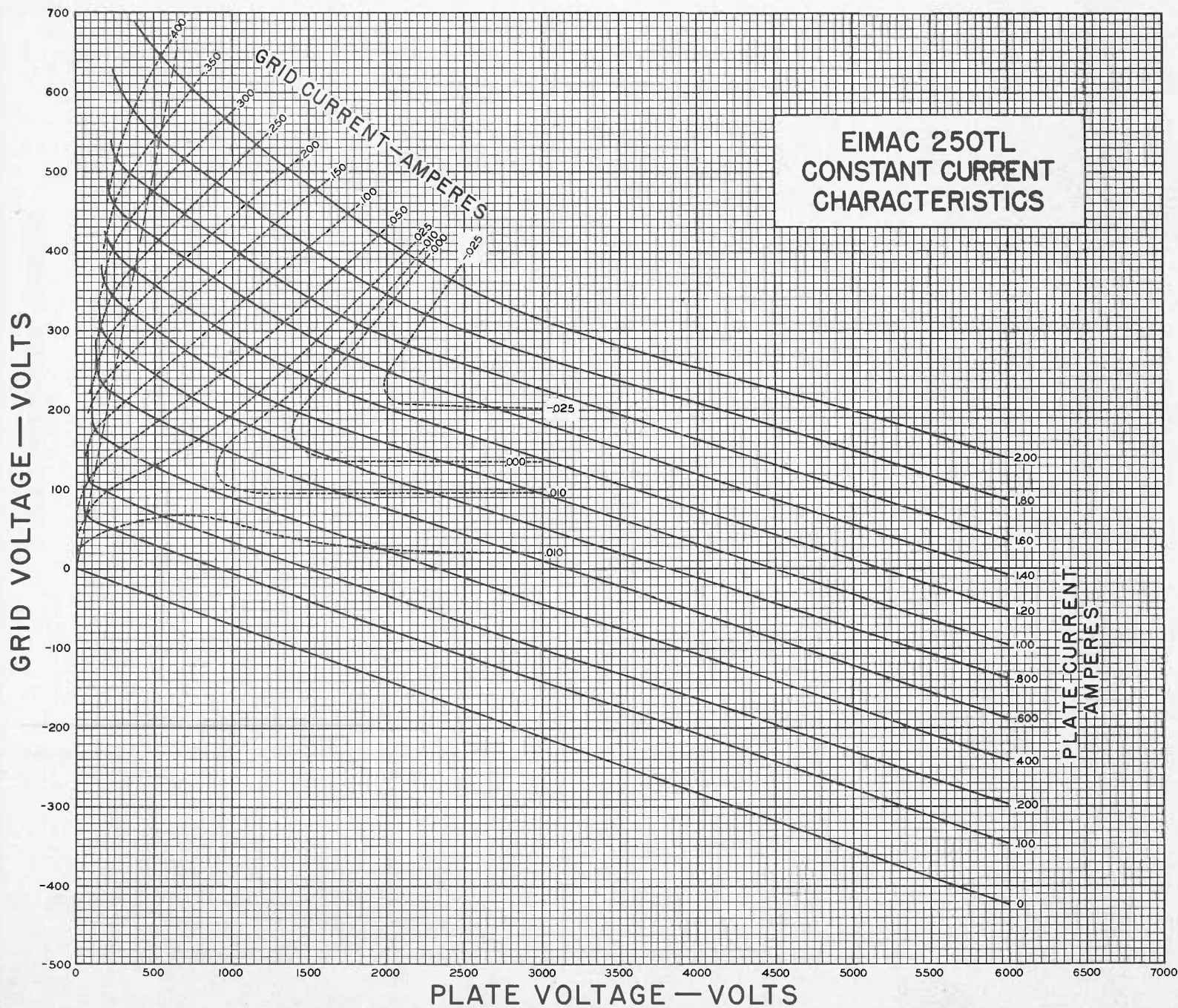

DRIVING POWER vs. POWER OUTPUT

The three charts on this page show the relationship of plate efficiency, power output and grid driving power at plate voltages of 2000, 3000 and 4000 volts. These charts show combined grid and bias losses only. The driving power and power output figures do not include circuit losses. The plate dissipation in watts is indicated by P_p .

Points A, B, and C are identical to the typical Class C operating conditions shown on the first page under 2000, 3000, and 4000 volts respectively.

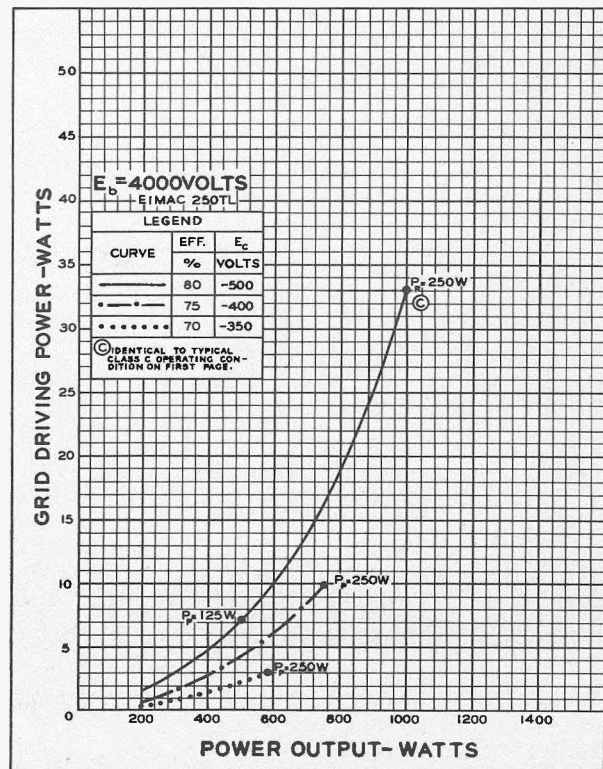
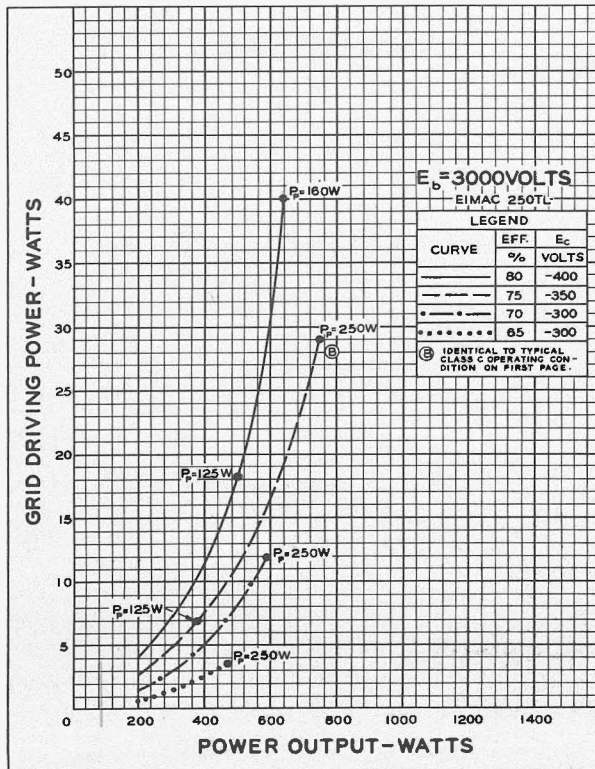
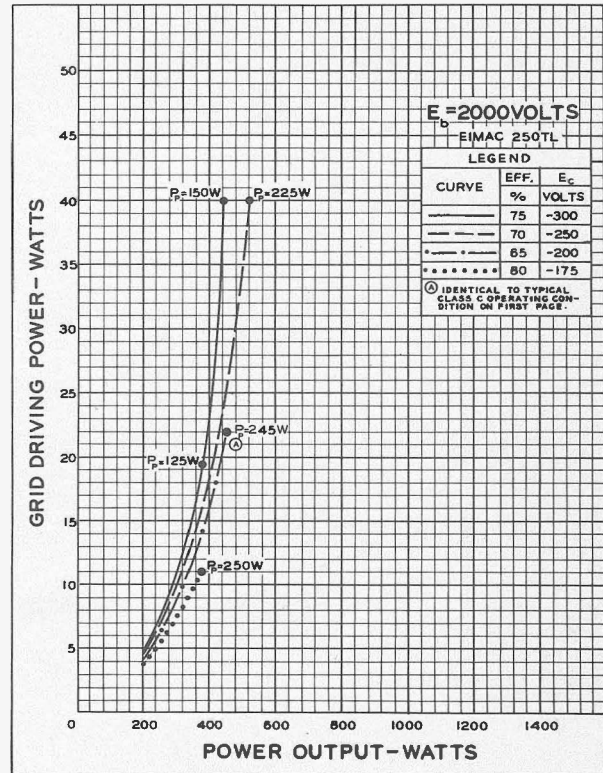

Eitel-McCullough
EITEL-McCULLOUGH, INC.
 SAN BRUNO, CALIFORNIA

304TH

MEDIUM-MU TRIODE
 •
 MODULATOR
 OSCILLATOR
 AMPLIFIER

GENERAL CHARACTERISTICS

ELECTRICAL

Filament: Thoriated tungsten	
Voltage - - - - -	5.0 or 10.0 volts
Current - - - - -	25.0 or 12.5 amperes
Amplification Factor (Average) - - - - -	20
Direct Interelectrode Capacitances (Average)	
Grid-Plate - - - - -	10.2 $\mu\mu\text{f}$
Grid-Filament - - - - -	13.5 $\mu\mu\text{f}$
Plate-Filament - - - - -	0.7 $\mu\mu\text{f}$
Transconductance ($I_b=1.0$ amp., $E_b=3000$, $e_c=-40$)	16,700 μmhos
Frequency for Maximum Ratings - - - - -	40 mc

MECHANICAL

Base - - - - -	Special 4 pin, No. 5000B
Basing - - - - -	RMA type 4BC
Maximum Overall Dimensions:	
Length - - - - -	7.625 inches
Diameter - - - - -	3.563 inches
Net weight - - - - -	12 ounces
Shipping weight (Average) - - - - -	3.0 pounds

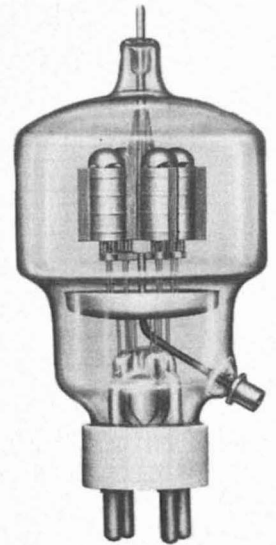

AUDIO FREQUENCY POWER AMPLIFIER AND MODULATOR

Class B

	TYPICAL OPERATION—2 TUBES			MAX. RATING	
D-C Plate Voltage - - - - -	1500	2000	3000	3000	volts
Max.-Signal D-C Plate Current, per tube* - -	•	•	•	900	ma.
Plate Dissipation, per tube* - - - - -	•	•	•	300	watts
D-C Grid Voltage (approx.) - - - - -	-65	-90	-150		volts
Peak A-F Grid Input Voltage - - - - -	330	350	420		volts
Zero-Signal D-C Plate Current - - - - -	267	200	134		ma.
Max.-Signal D-C Plate Current - - - - -	1066	900	667		ma.
Max.-Signal Driving Power (approx.) - - - -	17	12	6		watts
Effective Load, Plate-to-Plate - - - - -	2840	4820	10200		ohms
Max.-Signal Plate Power Output - - - - -	1000	1200	1400		watts

*Averaged over any sinusoidal audio frequency cycle.

RADIO FREQUENCY POWER AMPLIFIER AND OSCILLATOR

Class-C *Telegraphy

(Key down conditions without modulation)

	TYPICAL OPERATION—1 TUBE			MAX. RATING	
D-C Plate Voltage - - - - -	1500	2000	3000	3000	volts
D-C Plate Current - - - - -	667	600	500	900	ma.
D-C Grid Current - - - - -	115	125	135	170	ma.
D-C Grid Voltage - - - - -	-125	-200	-300		volts
Plate Power Output - - - - -	700	900	1200		watts
Plate Input - - - - -	1000	1200	1500		watts
Plate Dissipation - - - - -	300	300	300	300	watts
Peak R. F. Grid Input Voltage, (approx.) - -	250	325	395		volts
Driving Power, (approx.) - - - - -	25	39	53		watts

*The above figures show actual measured tube performance, and do not allow for variations in circuit losses.

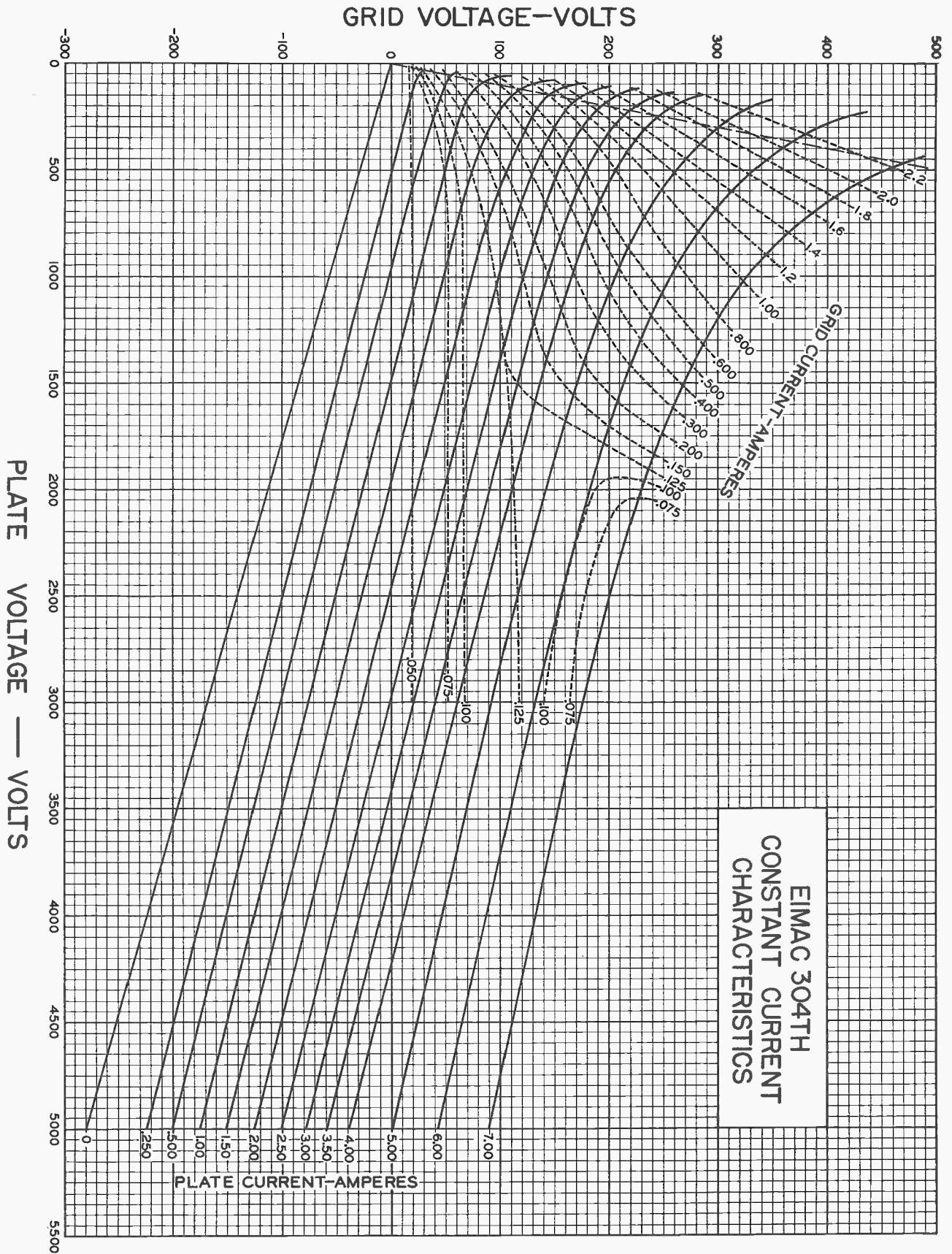

DRIVING POWER vs. POWER OUTPUT

The three charts on this page show the relationship of plate efficiency, power output and grid driving power at plate voltages of 1500, 2000 and 3000 volts. These charts show combined grid and bias losses only. The driving power and power output figures do not include circuit losses. The plate dissipation in watts is indicated by P_p .

Points A, B, and C are identical to the typical Class C operating conditions shown on the first page under 1500, 2000, and 3000 volts respectively.

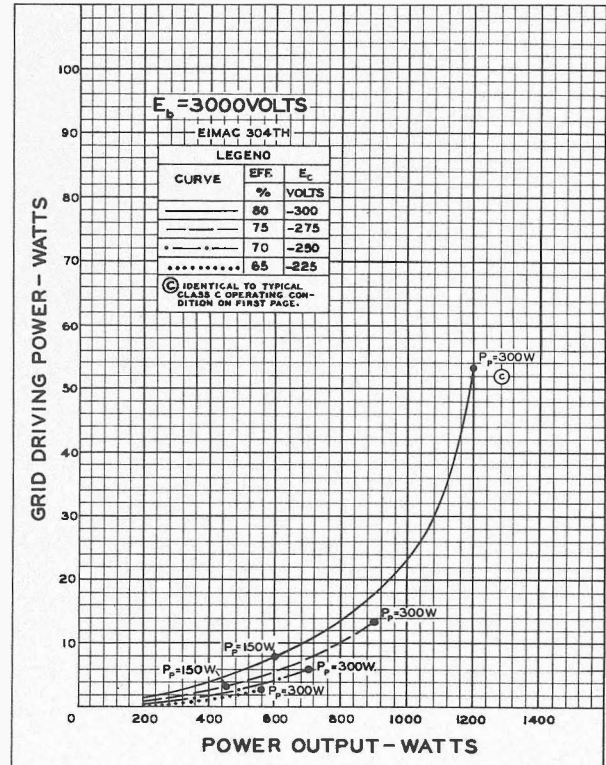
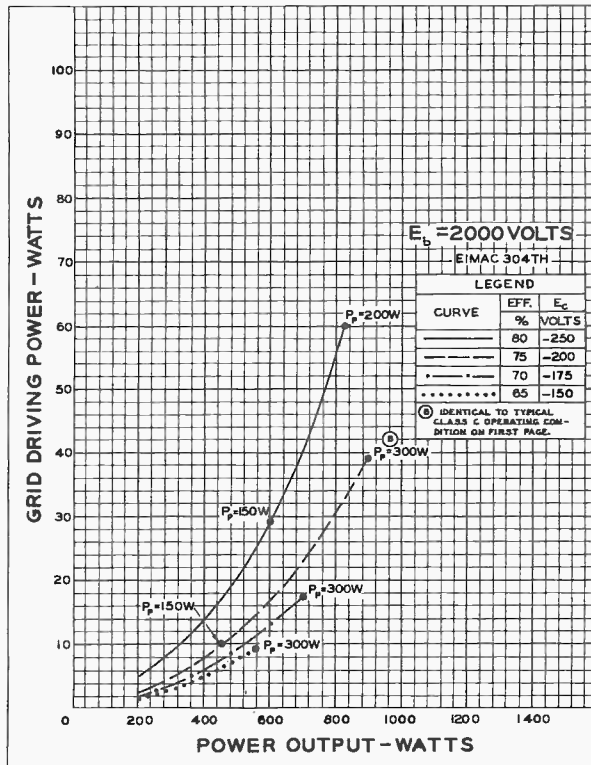
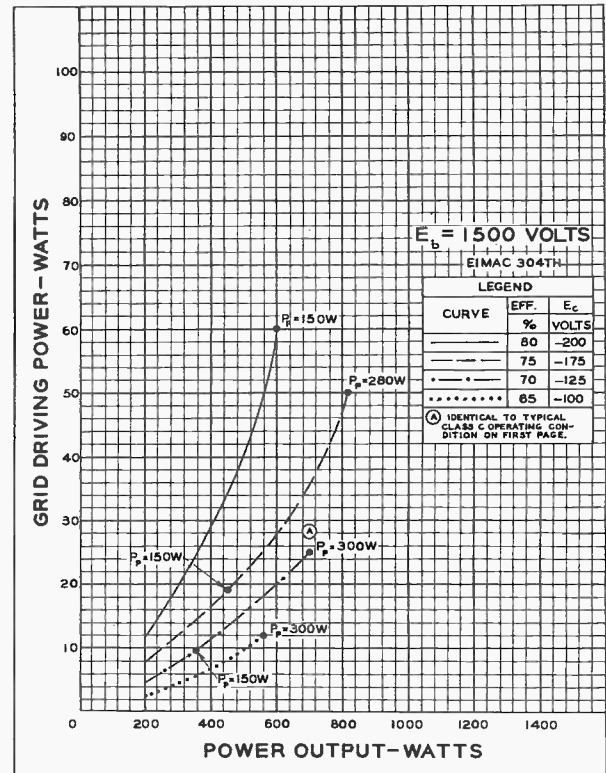

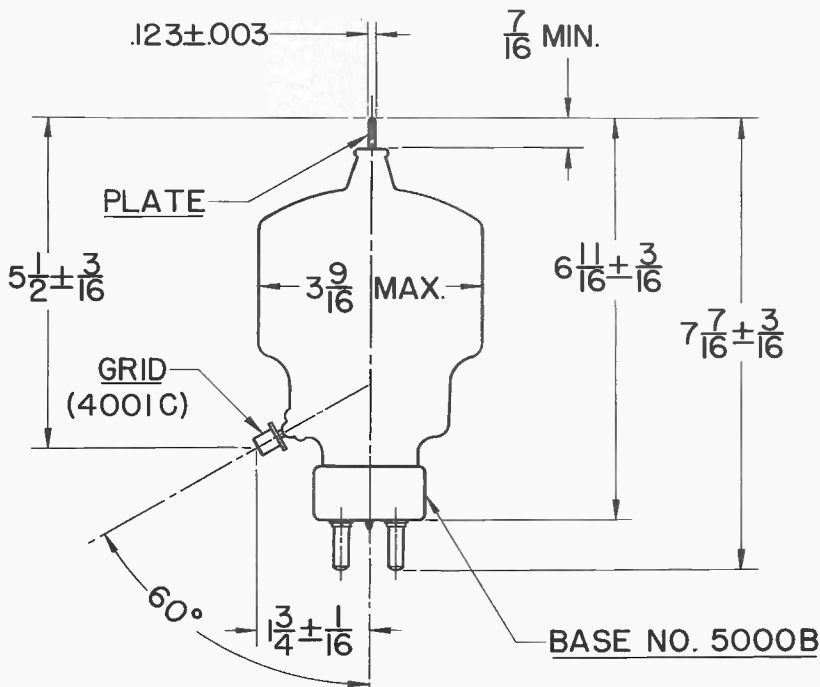
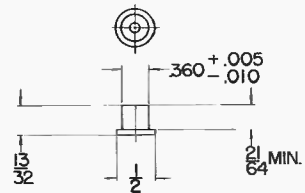
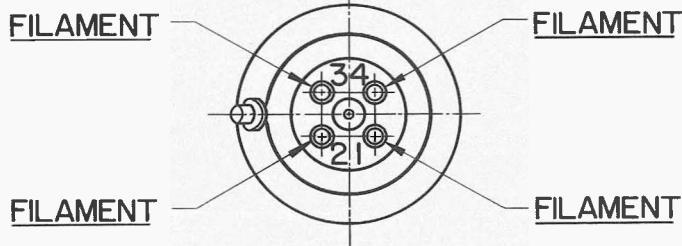
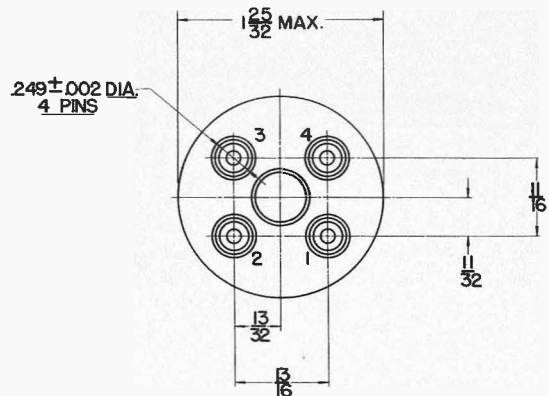
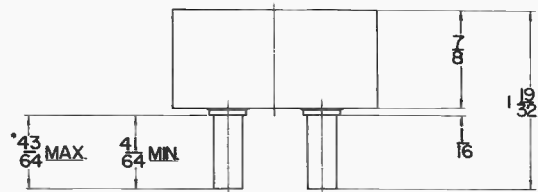

PLATE CAP
 (SEE TUBE OUTLINE DRAWING)

GRID CAP
 NO. 4001C



BASE NO. 5000B



*ON FINISHED TUBE ADD .060 FOR SOLDER

Eitel-McCULLOUGH, Inc.

SAN BRUNO, CALIFORNIA

304TL

LOW-MU TRIODE

MODULATOR
OSCILLATOR
AMPLIFIER

The Eimac 304TL is a low-mu, power triode having a maximum plate dissipation rating of 300 watts, and is intended for use as an amplifier, oscillator or modulator, where maximum performance can be obtained at low plate voltage. It can be used at its maximum ratings at frequencies as high as 40-Mc. Cooling of the 304TL is accomplished by radiation from the plate, which operates at a visible red color at maximum dissipation, and by means of air convection around the envelope.

GENERAL CHARACTERISTICS

ELECTRICAL

Filament: Thoriated tungsten	
Voltage - - - - -	5.0 or 10.0 volts
Current - - - - -	25.0 or 12.5 amperes
Amplification Factor (Average)	12
▶ Direct Interelectrode Capacitances (Average)	
Grid-Plate - - - - -	8.6 $\mu\mu\text{f}$
Grid-Filament - - - - -	12.1 $\mu\mu\text{f}$
Plate-Filament - - - - -	.8 $\mu\mu\text{f}$
▶ Transconductance ($i_b = 1.0$ amp., $E_b = 3000$ v., $e_c = -175$ v.)	16,700 μmhos
Frequency for Maximum Ratings	40 Mc.

MECHANICAL

Base - - - - -	Special 4 pin, No. 5000B
Basing - - - - -	RMA type 4BC
▶ Mounting - - - - -	Vertical, base down or up
▶ Cooling - - - - -	Convection and Radiation
▶ Recommended Heat Dissipating Connectors:	
Plate - - - - -	HR-7
Grid - - - - -	HR-6
Maximum Overall Dimensions:	
Length - - - - -	7.625 inches
Diameter - - - - -	3.563 inches
▶ Net weight - - - - -	9 ounces
▶ Shipping weight (Average) - - - - -	2 pounds



AUDIO FREQUENCY POWER AMPLIFIER AND MODULATOR

Class B (Sinusoidal wave, two tubes unless otherwise specified)

MAXIMUM RATINGS

D-C PLATE VOLTAGE - - - - -	3000 MAX. VOLTS
MAX-SIGNAL D-C PLATE CURRENT, PER TUBE - - - - -	900 MAX. MA.
PLATE DISSIPATION, PER TUBE - - - - -	300 MAX. WATTS

▶ TYPICAL OPERATION, CLASS AB₁

D-C Plate Voltage - - - - -	1500	2000	2500	3000	Volts
D-C Grid Voltage (approx.)* - - - - -	-118	-170	-230	-290	Volts
Zero-Signal D-C Plate Current - - - - -	270	200	160	130	Ma.
Max-Signal D-C Plate Current - - - - -	572	546	483	444	Ma.
Effective Load, Plate-to-Plate - - - - -	2540	5300	8500	12,000	Ohms
Peak A-F Grid Input Voltage (per tube) - - - - -	118	170	230	290	Volts
Max-Signal Peak Driving Power - - - - -	0	0	0	0	Watts
Max-Signal Plate Power Output - - - - -	256	490	610	730	Watts

*Adjust to give stated zero-signal plate current. The effective grid circuit resistance for each tube must not exceed 250,000 ohms.

▶ TYPICAL OPERATION, CLASS AB₂

D-C Plate Voltage - - - - -	1500	2000	2500	3000	Volts
D-C Grid Voltage (approx.)* - - - - -	-118	-170	-230	-290	Volts
Zero-Signal D-C Plate Current - - - - -	270	200	160	130	Ma.
Max-Signal D-C Plate Current - - - - -	1140	1000	900	800	Ma.
Effective Load, Plate-to-Plate - - - - -	2750	4500	6600	9100	Ohms
Peak A-F Grid Input Voltage (per tube) - - - - -	245	290	340	390	Volts
Max-Signal Peak Driving Power - - - - -	78	87	95	110	Watts
Max-Signal Nominal Driving Power (approx.) - - - - -	39	44	48	55	Watts
Max-Signal Plate Power Output - - - - -	1100	1400	1650	1800	Watts

*Adjust to give stated zero-signal plate current.

▶ PLATE MODULATED RADIO FREQUENCY AMPLIFIER

Class-C Telephony (Carrier conditions, per tube)

MAXIMUM RATINGS

D-C PLATE VOLTAGE - - - - -	2500 MAX. VOLTS
D-C PLATE CURRENT - - - - -	700 MAX. MA.
PLATE DISSIPATION - - - - -	200 MAX. WATTS
GRID DISSIPATION - - - - -	50 MAX. WATTS

TYPICAL OPERATION (Power input limited to 500 and 1000 watts)*

D-C Plate Voltage - - - - -	2000	2000	2500	2500	Volts
D-C Plate Current - - - - -	250	500	200	400	Ma.
Total Bias Voltage - - - - -	-500	-500	-525	-550	Volts
Fixed Bias Voltage - - - - -	-410	-275	-300	-300	Volts
Grid Resistor - - - - -	3000	3000	12,500	5000	Ohms
D-C Grid Current - - - - -	30	75	18	50	Ma.
Peak R-F Grid Input Voltage - - - - -	615	690	620	715	Volts
Driving Power - - - - -	18	52	11	36	Watts
Grid Dissipation - - - - -	3	15	2	9	Watts
Plate Power Input - - - - -	500	1000	500	1000	Watts
Plate Dissipation - - - - -	90	190	75	170	Watts
Plate Power Output - - - - -	410	810	425	830	Watts

*The figures are for convenience in obtaining a 500 or 1000 Watt carrier input per tube to the modulated amplifier. The output figures do not allow for circuit losses.

TYPICAL OPERATION*

D-C Plate Voltage - - - - -	1500	2000	2500	Volts
D-C Plate Current - - - - -	520	525	450	Ma.
Total Bias Voltage - - - - -	-370	-500	-550	Volts
Fixed Bias Voltage - - - - -	-160	-260	-440	Volts
Grid Resistor - - - - -	2800	3000	2000	Ohms
D-C Grid Current - - - - -	75	80	55	Ma.
Peak R-F Grid Input Voltage - - - - -	545	695	720	Volts
Driving Power - - - - -	41	55	40	Watts
Grid Dissipation - - - - -	13	15	10	Watts
Plate Power Input - - - - -	780	1050	1125	Watts
Plate Dissipation - - - - -	200	200	200	Watts
Power Output - - - - -	580	850	925	Watts

*The figures are for one tube operating at maximum plate dissipation as a plate modulated Class C amplifier. The output figures do not allow for circuit losses.

**RADIO FREQUENCY POWER AMPLIFIER
AND OSCILLATOR**

Class-C Telephony or FM Telephony
(Key-down conditions, per tube)

MAXIMUM RATINGS

D-C PLATE VOLTAGE	- - - -	3000 MAX. VOLTS
D-C PLATE CURRENT	- - - -	900 MAX. MA.
PLATE DISSIPATION	- - - -	300 MAX. WATTS
GRID DISSIPATION	- - - -	50 MAX. WATTS

TYPICAL OPERATION*

D-C Plate Voltage	- - - -	1500	2000	3000	Volts
D-C Grid Voltage	- - - -	-250	-300	-400	Volts
D-C Plate Current	- - - -	665	600	500	Ma.
D-C Grid Current	- - - -	90	85	80	Ma.
Peak R-F Grid Input Voltage	- - - -	430	480	575	Volts
Driving Power (approx.)	- - - -	33	36	40	Watts
Grid Dissipation	- - - -	11	11	8	Watts
Plate Power Input	- - - -	1000	1200	1500	Watts
Plate Dissipation	- - - -	300	300	300	Watts
Plate Power Output	- - - -	700	900	1200	Watts

*The figures show actual measured tube performance, and do not allow for circuit losses.

► Indicates change from sheet dated 1-1-44

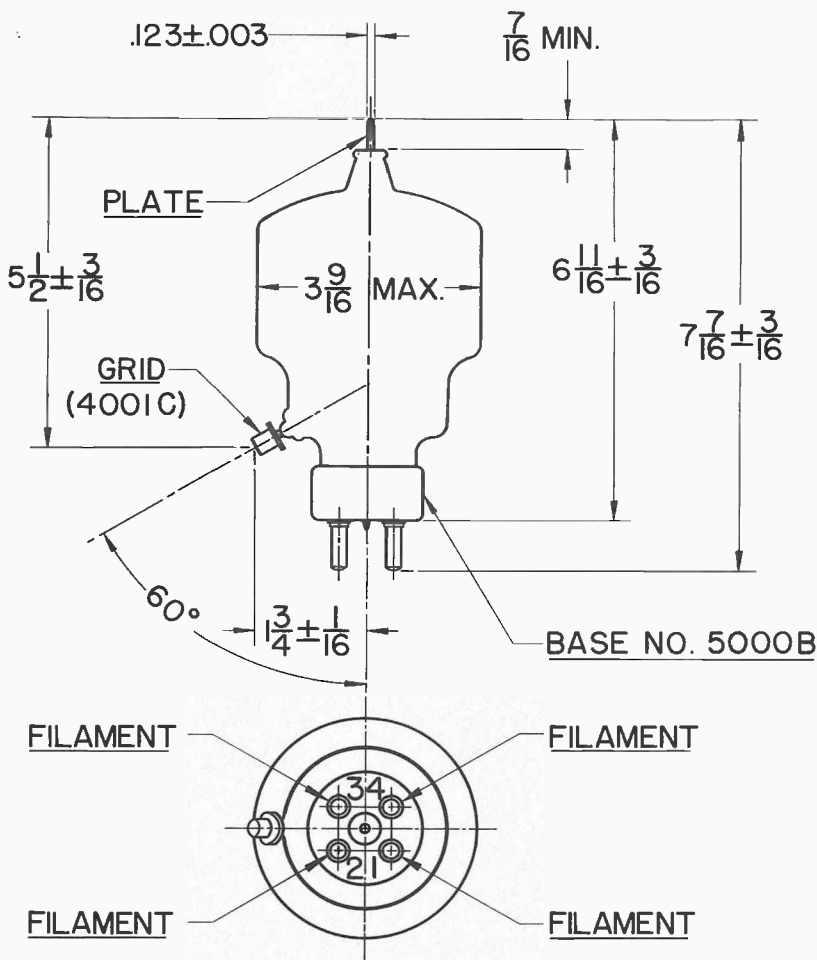

GRID CAP
NO. 4001C

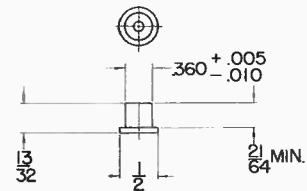

BASE NO. 5000B

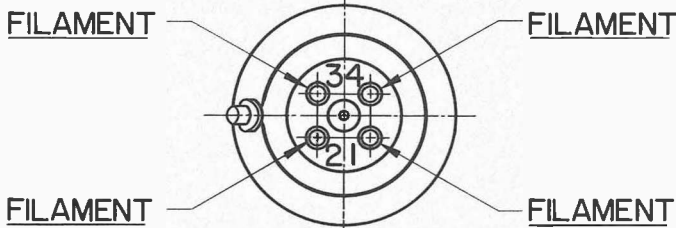
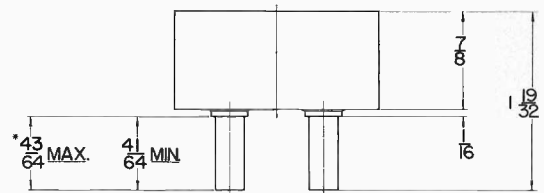

4BC

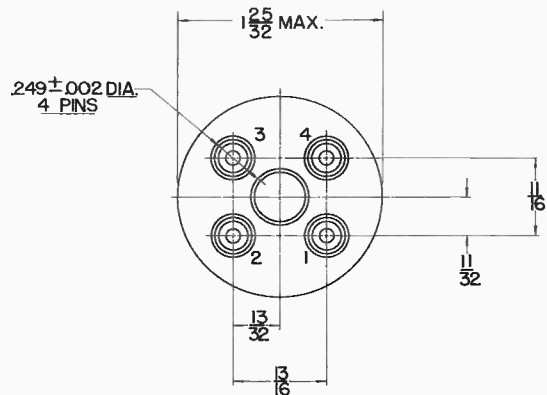
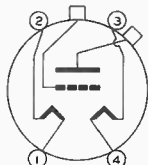

*ON FINISHED TUBE ADD .060 FOR SOLDER

DRIVING POWER vs. POWER OUTPUT

The three charts on this page show the relationship of plate efficiency, power output and grid driving power at plate voltages of 1500, 2000 and 3000 volts. These charts show combined grid and bias losses only. The driving power and power output figures do not include circuit losses. The plate dissipation in watts is indicated by P_p .

Points A, B, and C are identical to the typical Class C operating conditions shown on the first page under 1500, 2000, and 3000 volts respectively.

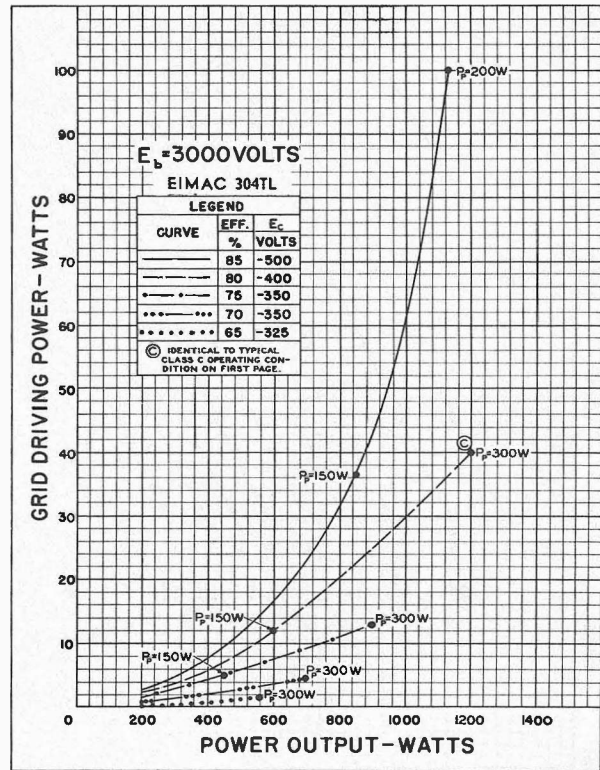
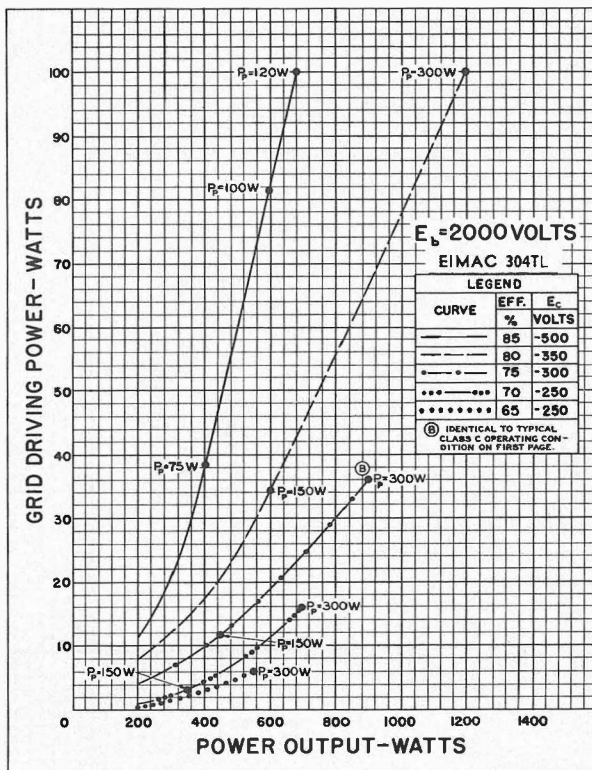
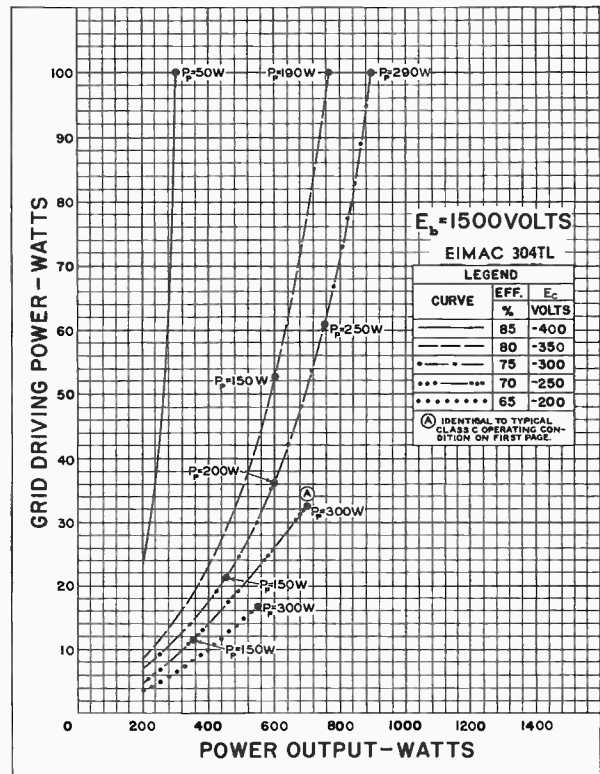

Eimac
304TL

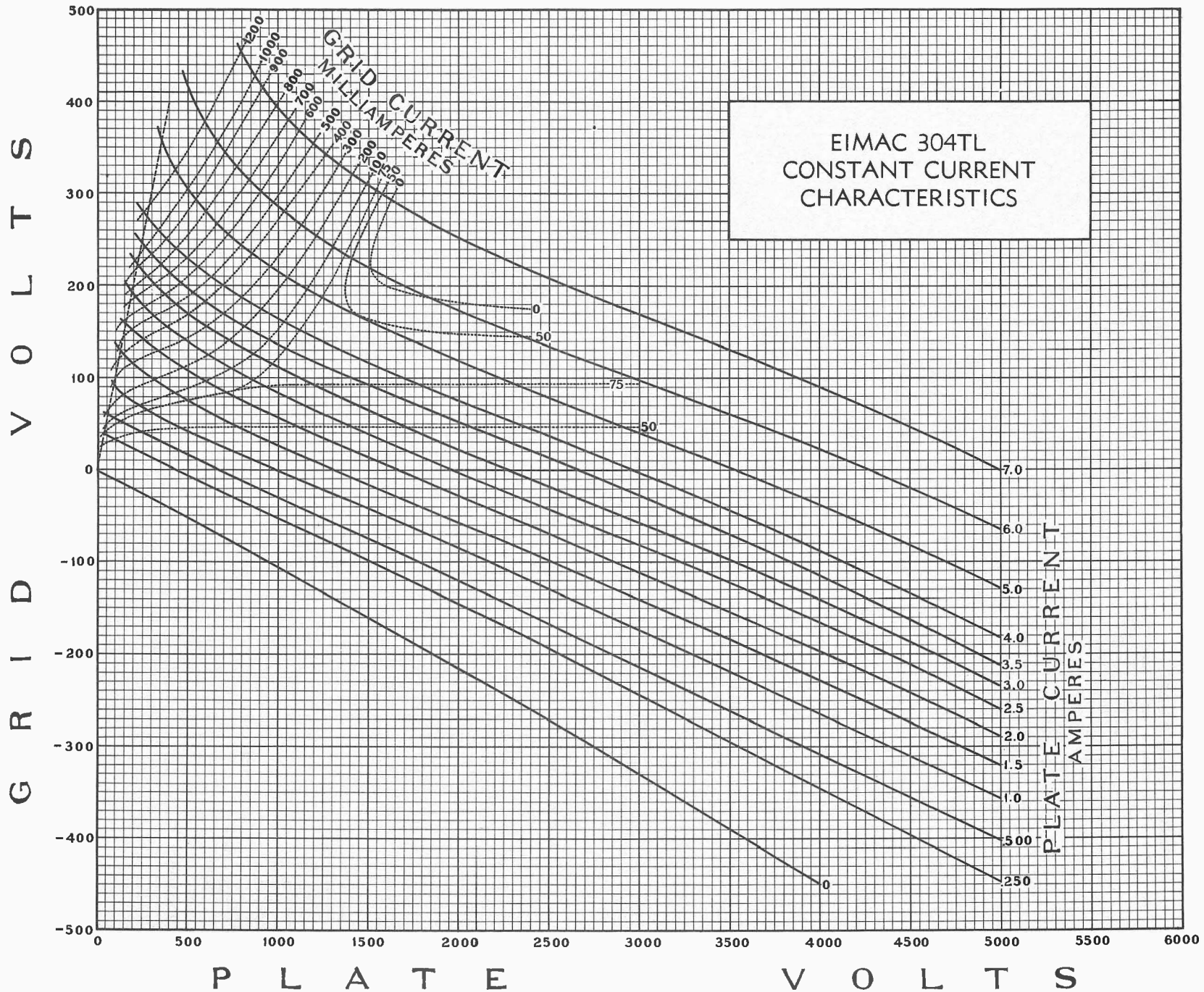

Note:

Dual connections for each filament lead are provided within the base of each 450TH and 450TL (see basing diagram within the data sheet). Corresponding socket terminals must be connected in parallel to provide proper distribution of filament and RF charging currents. Adequate ventilation or air cooling must be provided so that the seals and envelope do not exceed 200° C. under operating conditions.



450TH

**HIGH-MU TRIODE
MODULATOR
OSCILLATOR
AMPLIFIER**

GENERAL CHARACTERISTICS

ELECTRICAL

Filament: Thoriated tungsten		
Voltage - - - - -	7.5	volts
Current - - - - -	12.0	amperes
Amplification Factor (Average) - - - - -	38	
Direct Interelectrode Capacitances (Average)		
Grid-Plate - - - - -	5.0	$\mu\mu\text{f}$
Grid-Filament - - - - -	8.8	$\mu\mu\text{f}$
Plate-Filament - - - - -	0.8	$\mu\mu\text{f}$
Transconductance ($I_b=500$ ma., $E_b=4000$, $e_c=-45$)	6650	μmhos
Frequency for Maximum Ratings - - - - -	40	mc

MECHANICAL

Base - - - - -	4 pin, No. 5002B
Basing - - - - -	RMA type 4AQ
Maximum Overall Dimensions:	
Length - - - - -	12.625 inches
Diameter - - - - -	5.125 inches
Net weight - - - - -	1 pound
Shipping weight (Average) - - - - -	4 pounds

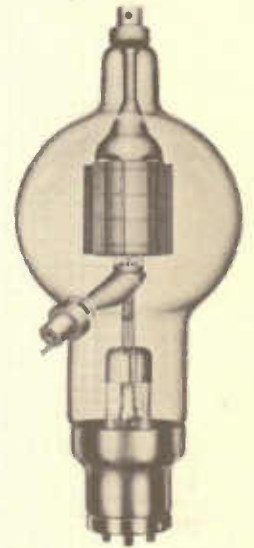

**AUDIO FREQUENCY POWER AMPLIFIER AND MODULATOR
Class B**

	TYPICAL OPERATION—2 TUBES			MAX. RATING
D-C Plate Voltage - - - - -	3000	4000	5000	6000 volts
Max.-Signal D-C Plate Current, per tube* - -	•	•	•	600 ma.
Plate Dissipation, per tube* - - - - -	•	•	•	450 watts
D-C Grid Voltage (approx.) - - - - -	-50	-85	-115	volts
Peak A-F Grid Input Voltage - - - - -	450	470	535	volts
Zero-Signal D-C Plate Current - - - - -	200	150	120	ma.
Max.-Signal D-C Plate Current - - - - -	770	675	620	ma.
Max.-Signal Driving Power (approx.) - - - -	17	14	10	watts
Effective Load, Plate-to-Plate - - - - -	7800	12800	18600	ohms
Max.-Signal Plate Power Output - - - - -	1400	1800	2200	watts

*Averaged over any sinusoidal audio frequency cycle.

**RADIO FREQUENCY POWER AMPLIFIER AND OSCILLATOR
Class-C *Telegraphy
(Key down conditions without modulation)**

	TYPICAL OPERATION—1 TUBE			MAX. RATING
D-C Plate Voltage - - - - -	3000	4000	5000	6000 volts
D-C Plate Current - - - - -	500	450	450	600 ma.
D-C Grid Current - - - - -	95	85	90	125 ma.
D-C Grid Voltage - - - - -	-175	-200	-300	volts
Plate Power Output - - - - -	1050	1350	1800	watts
Plate Input - - - - -	1500	1800	2250	watts
Plate Dissipation - - - - -	450	450	450	450 watts
Peak R. F. Grid Input Voltage, (approx.) - -	400	410	570	volts
Driving Power, (approx.) - - - - -	35	35	46	watts

*The above figures show actual measured tube performance, and do not allow for variations in circuit losses.

Eimac
450TH

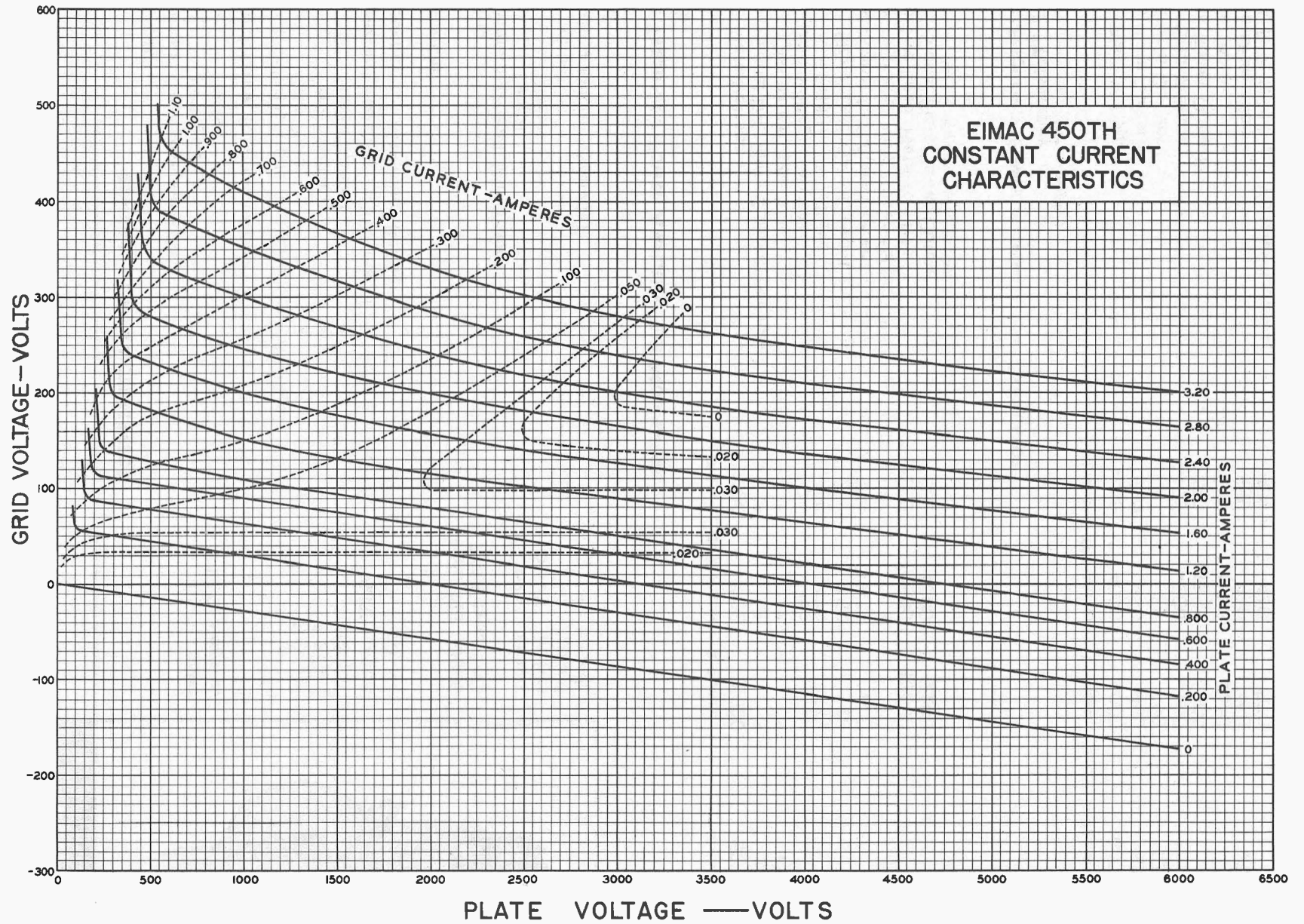

DRIVING POWER vs. POWER OUTPUT

The three charts on this page show the relationship of plate efficiency, power output and grid driving power at plate voltages of 3000, 4000, and 5000 volts. These charts show combined grid and bias losses only. The driving power and power output figures do not include circuit losses. The plate dissipation in watts is indicated by P_p .

Points A, B, and C are identical to the typical Class C operating conditions shown on the first page under 3000, 4000, and 5000 volts respectively.

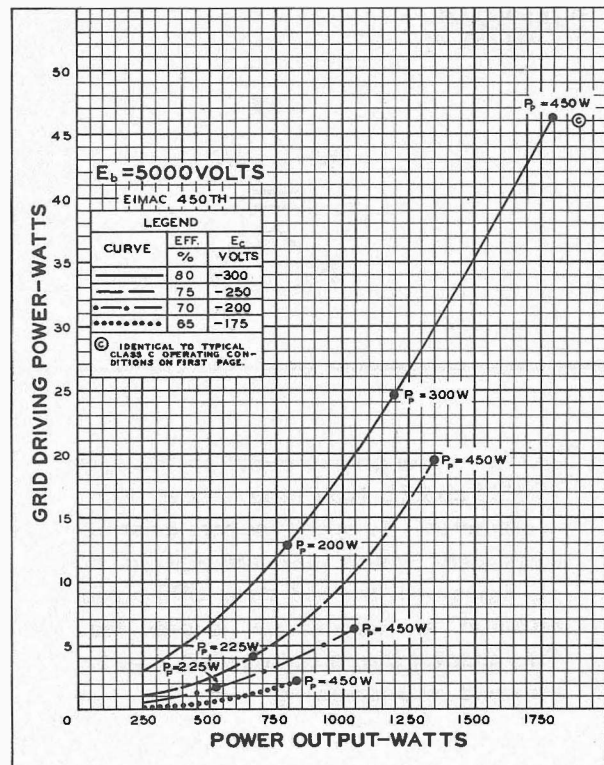
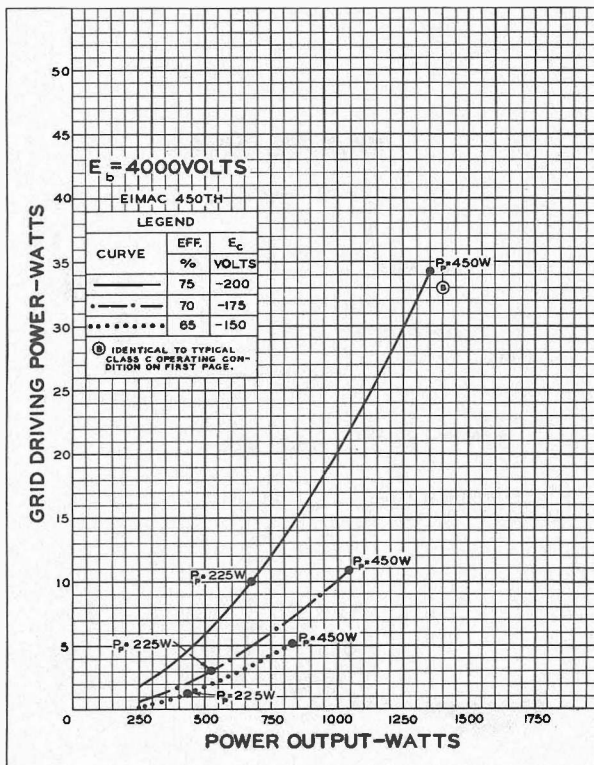
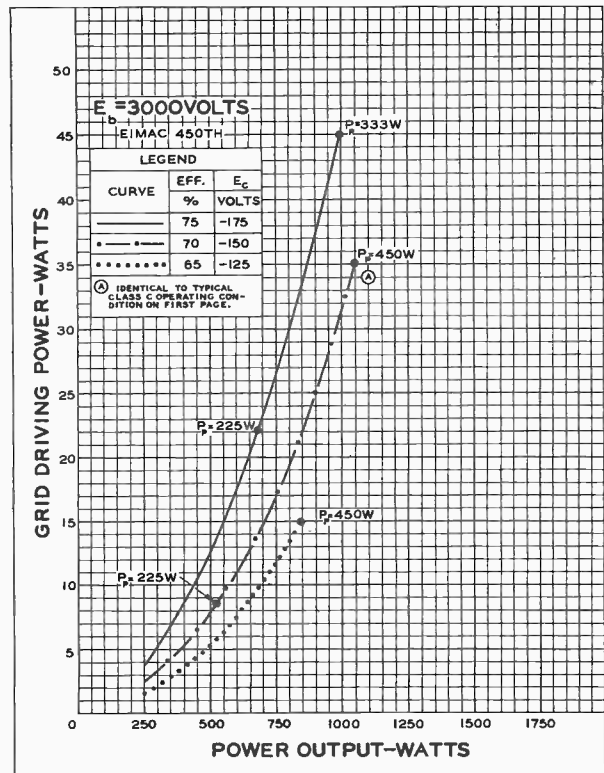

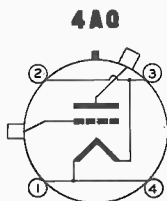
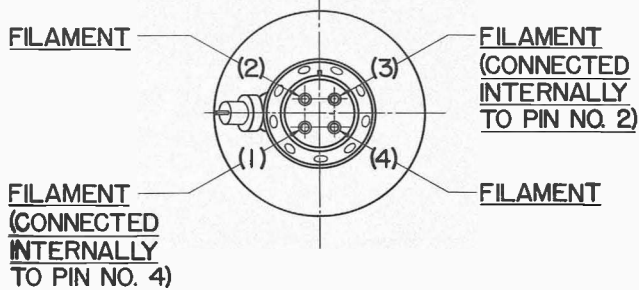
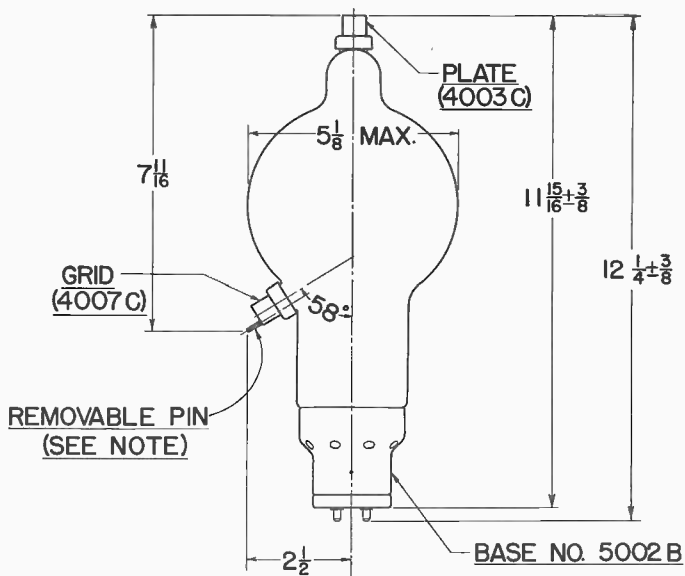
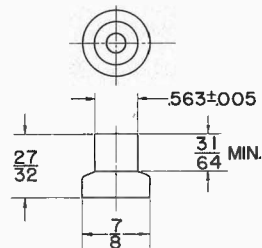
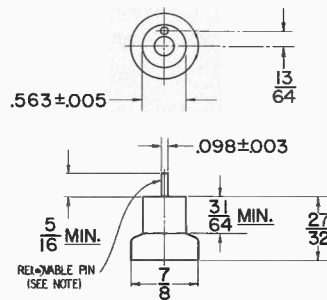

PLATE CAP NO. 4003C



GRID CAP NO. 4007C



BASE NO. 5002 B

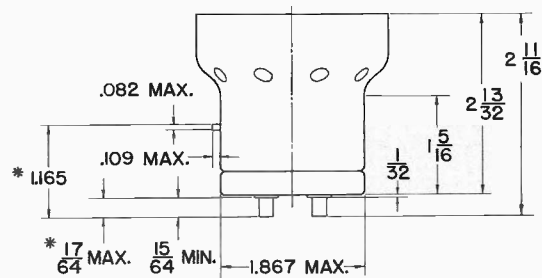

* ON FINISHED TUBE
 ADD .060 FOR SOLDER

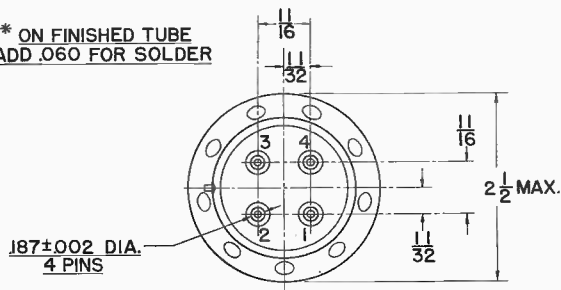

NOTE:—The grid terminal on the new 450TH and TL type tube is now .563" in diameter. To accommodate existing equipment which uses the 450TH or TL tubes with the old style .098" grid terminal, an adaptor pin is provided. This adaptor pin, if not needed, may be removed by unscrewing.

Eitel-McCullough, Inc.

SAN BRUNO, CALIFORNIA

450TL

MEDIUM-MU TRIODE

MODULATOR
OSCILLATOR
AMPLIFIER

The Eimac 450TL is a medium-mu power triode having a maximum plate dissipation rating of 450 watts, and is intended for use as an amplifier, oscillator and modulator. It can be used at its maximum ratings at frequencies as high as 40-Mc.

Cooling of the 450TL is accomplished by radiation from the plate, which operates at a visible red color at maximum dissipation, and by means of air circulation around the envelope.

GENERAL CHARACTERISTICS

ELECTRICAL

Filament: Thoriated tungsten	
Voltage	7.5 volts
Current	12.0 amperes
Note: Dual connections for each filament lead are provided within the base of the tube (see basing diagram). Corresponding socket terminals must be connected in parallel to provide proper distribution of filament and R-F charging currents.	
Amplification Factor (Average)	18
Direct Interelectrode Capacitances (Average)	
Grid-Plate	4.5 $\mu\mu\text{f}$
Grid-Filament	6.8 $\mu\mu\text{f}$
Plate-Filament	0.8 $\mu\mu\text{f}$
Transconductance ($i_b=500\text{ma}$, $E_b=4000\text{v}$, $e_c=-75\text{v}$.)	5000 μmhos
Frequency for Maximum Ratings	40-Mc.

MECHANICAL

Base	Special 4 pin, No. 5002B
Basing	RMA type 4AQ
Mounting	Vertical, base down or up
Cooling	Radiation and air circulation

Note: Adequate ventilation or air cooling must be provided so that the seals and envelope do not exceed 200°C under operating conditions.

Socket Johnson Type No. 211 or National Type No. XM50 or equivalent.

Recommended Heat Dissipating Connectors:

Plate	Eimac HR-8
Grid	Eimac HR-8

Note: The grid terminal of the 450TL is now .560" in diameter. To accommodate existing equipment designed for the older style 450TL having .098" diameter grid terminals, an adapter pin is provided with the newer tubes. This adapter pin is threaded so that it may be removed from the grid terminal of the tube. The small grid terminal, if used, requires an HR-4 heat dissipating connector. (See outline drawing.)

Maximum Overall Dimensions:

Length	12.625 inches
Diameter	5.125 inches
Net weight	1.3 pounds
Shipping weight (Average)	5.6 pounds

AUDIO FREQUENCY POWER AMPLIFIER AND MODULATOR

Class AB₂ (Sinusoidal wave, two tubes unless otherwise specified)

MAXIMUM RATINGS

D-C PLATE VOLTAGE	6000 MAX. VOLTS
MAX-SIGNAL D-C PLATE CURRENT PER TUBE	600 MAX. MA.
PLATE DISSIPATION, PER TUBE	450 MAX. WATTS

TYPICAL OPERATION—2 TUBES

D-C Plate Voltage	3000	4000	5000	Volts
D-C Grid Voltage (approx.)*	-110	-175	-240	Volts
Zero-Signal D-C Plate Current	200	150	120	Ma.
Max-Signal D-C Plate Current	770	675	620	Ma.
Effective Load, Plate-to-Plate	7700	12,800	18,500	Ohms
Peak A-F Grid Input Voltage (per tube)	325	365	430	Volts
Max-Signal Peak Driving Power	40	33	56	Watts
Max-Signal Nominal Driving Power (approx.)	20	17	28	Watts
Max-Signal Plate Power Output	1400	1800	2200	Watts

*Adjust to give stated zero-signal plate current.

RADIO FREQUENCY POWER AMPLIFIER AND OSCILLATOR

Class-C Telegraphy or FM Telephony (Key-down conditions, per tube).

MAXIMUM RATINGS

D-C PLATE VOLTAGE	6000 MAX. VOLTS
D-C PLATE CURRENT	600 MAX. MA.
PLATE DISSIPATION	450 MAX. WATTS
GRID DISSIPATION	65 MAX. WATTS

TYPICAL OPERATION, PER TUBE*

D-C Plate Voltage	3000	4000	5000	Volts
D-C Grid Voltage	-275	-400	-500	Volts
D-C Plate Current	500	450	450	Ma.
D-C Grid Current	65	53	54	Ma.
Peak R-F Grid Input Voltage	640	740	870	Volts
Driving Power (approx.)	38	35	42	Watts
Grid Dissipation	20	13	15	Watts
Plate Power Input	1500	1800	2250	Watts
Plate Dissipation	450	450	450	Watts
Plate Power Output	1050	1350	1800	Watts

*The figures show actual measured tube performance and do not allow for circuit losses.

PLATE MODULATED RADIO FREQUENCY AMPLIFIER

Class-C Telephony (Carrier conditions, per tube)

MAXIMUM RATINGS

D-C PLATE VOLTAGE	4500 MAX. VOLTS
D-C PLATE CURRENT	500 MAX. MA.
PLATE DISSIPATION	300 MAX. WATTS
GRID DISSIPATION	65 MAX. WATTS

TYPICAL OPERATION, PER TUBE*

D-C Plate Voltage	3000	4000	4500	Volts
D-C Plate Current	380	340	345	Ma.
Total Bias Voltage	-400	-500	-550	Volts
Fixed Bias Voltage	-200	-250	-275	Volts
Grid Resistor	5000	7000	7500	Ohms
D-C Grid Current	40	36	36	Ma.
Peak R-F Grid Input Voltage	700	790	850	Volts
Driving Power	28	29	31	Watts
Grid Dissipation	12	11	11	Watts
Plate Power Input	1150	1360	1550	Watts
Plate Dissipation	300	300	300	Watts
Plate Power Output	850	1060	1250	Watts

*The figures are for one tube operating at maximum plate dissipation as a plate modulated Class-C amplifier. The output figures do not allow for circuit losses.

Indicates change from sheet dated 9-1-44.

(Effective 10-1-49) Copyright 1949 by Eitel-McCullough, Inc.

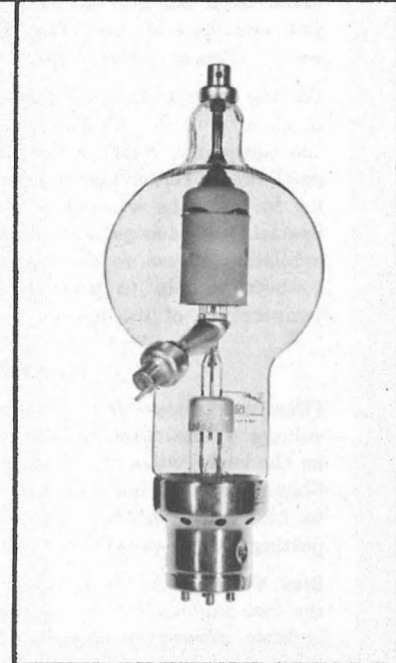

APPLICATION

MECHANICAL

Mounting—The 450TL must be mounted vertically, base up or base down. Flexible connecting straps should be provided from the grid and plate terminals to the external grid and plate circuits. The tube must be protected from severe vibration and shock.

Cooling—Provision should be made for ample circulation of air around the 450TL. In the event that the design of the equipment restricts natural circulation, the use of a small fan or centrifugal blower to provide additional cooling for the tube will aid in obtaining maximum tube life. Special heat-dissipating connectors (Eimac HR-8) are available for use on the plate and grid terminals. These connectors help to prolong tube life by reducing the temperature of the seals.

ELECTRICAL

Filament Voltage—For maximum tube life the filament voltage, as measured directly at the filament pins, should be the rated value of 7.5 volts. Unavoidable variations in filament voltage must be kept within the range from 7.03 to 7.88 volts. All four socket terminals should be used, putting two in parallel for each filament connection.

Bias Voltage—Although there is no maximum limit on the bias voltage which may be used on the 450TL, there is little advantage in using bias voltages in excess of those given under "Typical Operation," except in certain very specialized applications. Where bias is obtained by a grid leak, suitable protective means must be provided to prevent excessive plate dissipation in the event of loss of excitation.

Grid Dissipation—The power dissipated by the grid of the 450TL must not exceed 65 watts. Grid dissipation may be calculated from the following expression:

$$P_g = e_{emp} I_c$$

where P_g = Grid dissipation
 e_{emp} = Peak positive grid voltage, and
 I_c = D-c grid current.

e_{emp} may be measured by means of a suitable peak voltmeter connected between filament and grid.¹ In equipment in which the plate loading varies widely, such as oscillators used for radio-frequency heating, care should be taken to make certain that the grid dissipation does not exceed the maximum rating under any conditions of loading.

Plate Voltage—Except in very special applications, the plate supply voltage for the 450TL should not exceed 6000 volts. In most cases there is little advantage in using plate-supply voltages higher than those given under "Typical Operation" for the power output desired.

Plate Dissipation—Under normal operating conditions, the power dissipated by the plate of the 450TL should not be allowed to exceed 450 watts. At this dissipation the brightness temperature of the plate will appear a red-orange in color. The value of this color is somewhat affected by light from the filament as well as from external sources. Plate dissipation in excess of the maximum rating is permissible for short periods of time, such as during tuning procedures.

¹ For suitable peak v.t.v.m. circuits see, for instance, "Vacuum Tube Ratings," Eimac News, January, 1945. This article is available in reprint form on request.

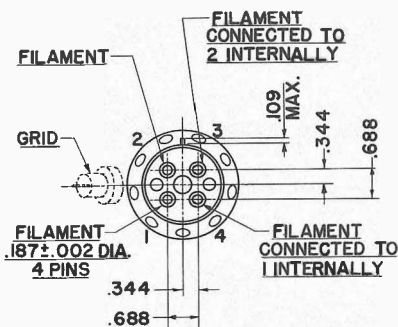
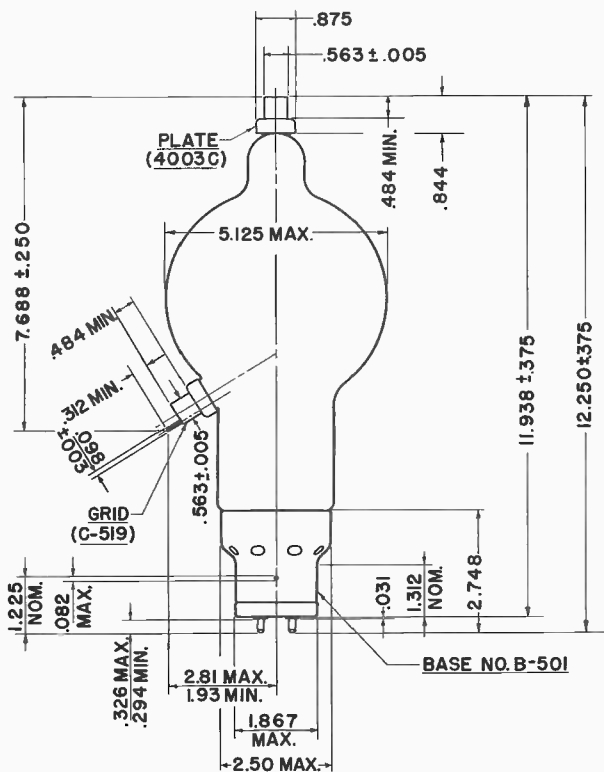

NOTE:—The grid terminal on the new 450TH and TL type tube is now .563" in diameter. To accommodate existing equipment which uses the 450TH or TL tubes with the old style .098" grid terminal, an adaptor pin is provided. This adaptor pin, if not needed, may be removed by unscrewing.

DRIVING POWER vs. POWER OUTPUT

The three charts on this page show the relationship of plate efficiency, power output and grid driving power at plate voltages of 3000, 4000, and 5000 volts. These charts show combined grid and bias losses only. The driving power and power output figures do not include circuit losses. The plate dissipation in watts is indicated by P_p .

Points A, B, and C are identical to the typical Class C operating conditions shown on the first page under 3000, 4000, and 5000 volts respectively.

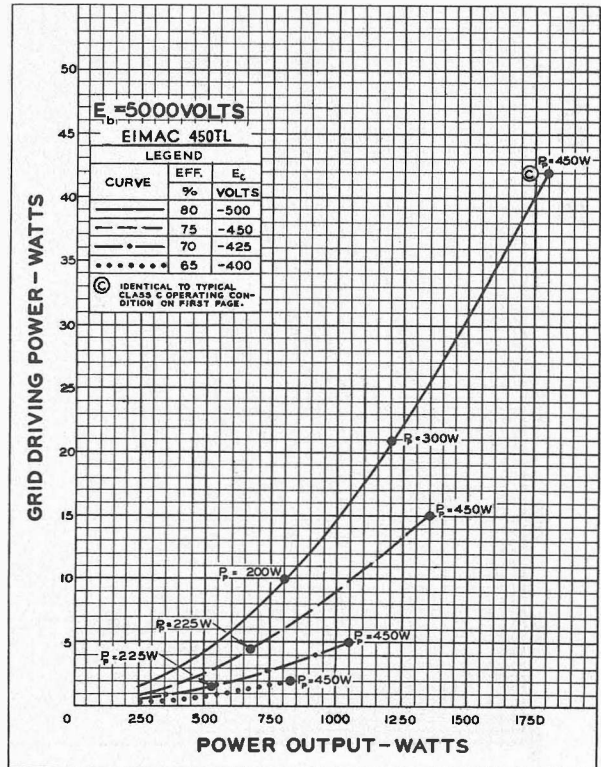
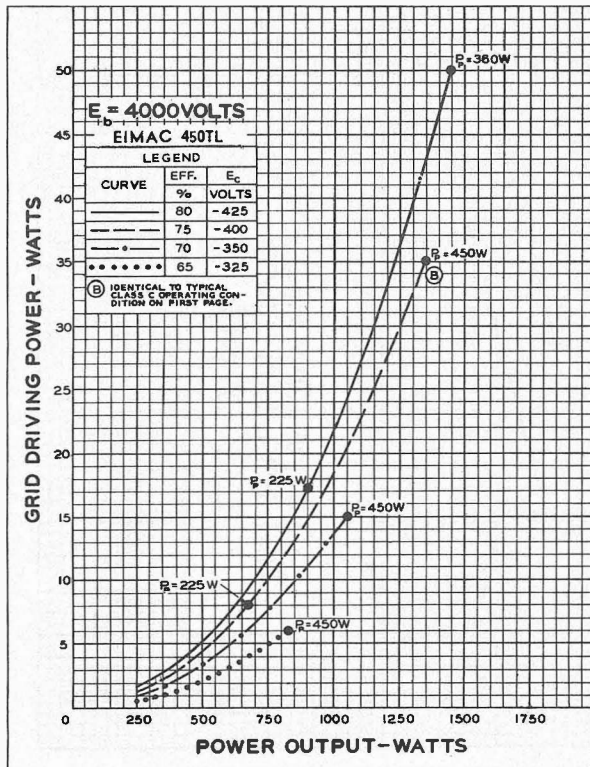
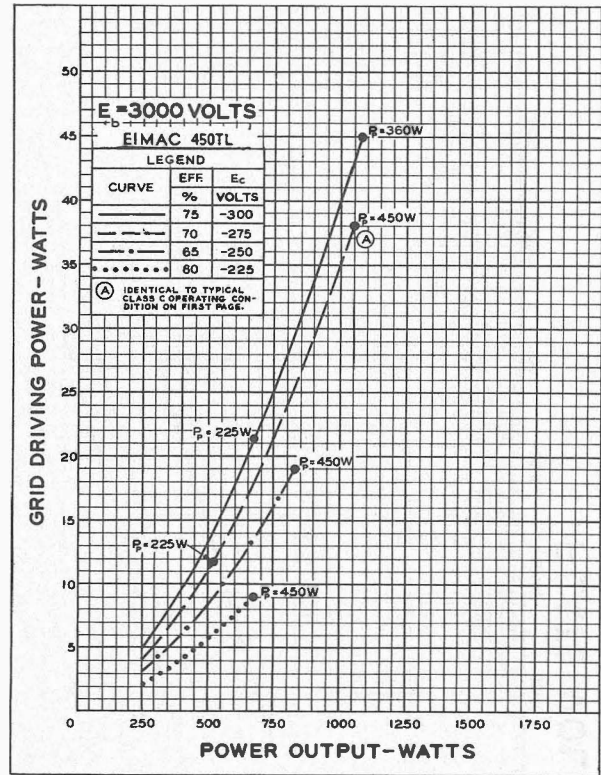

Simat
450TL

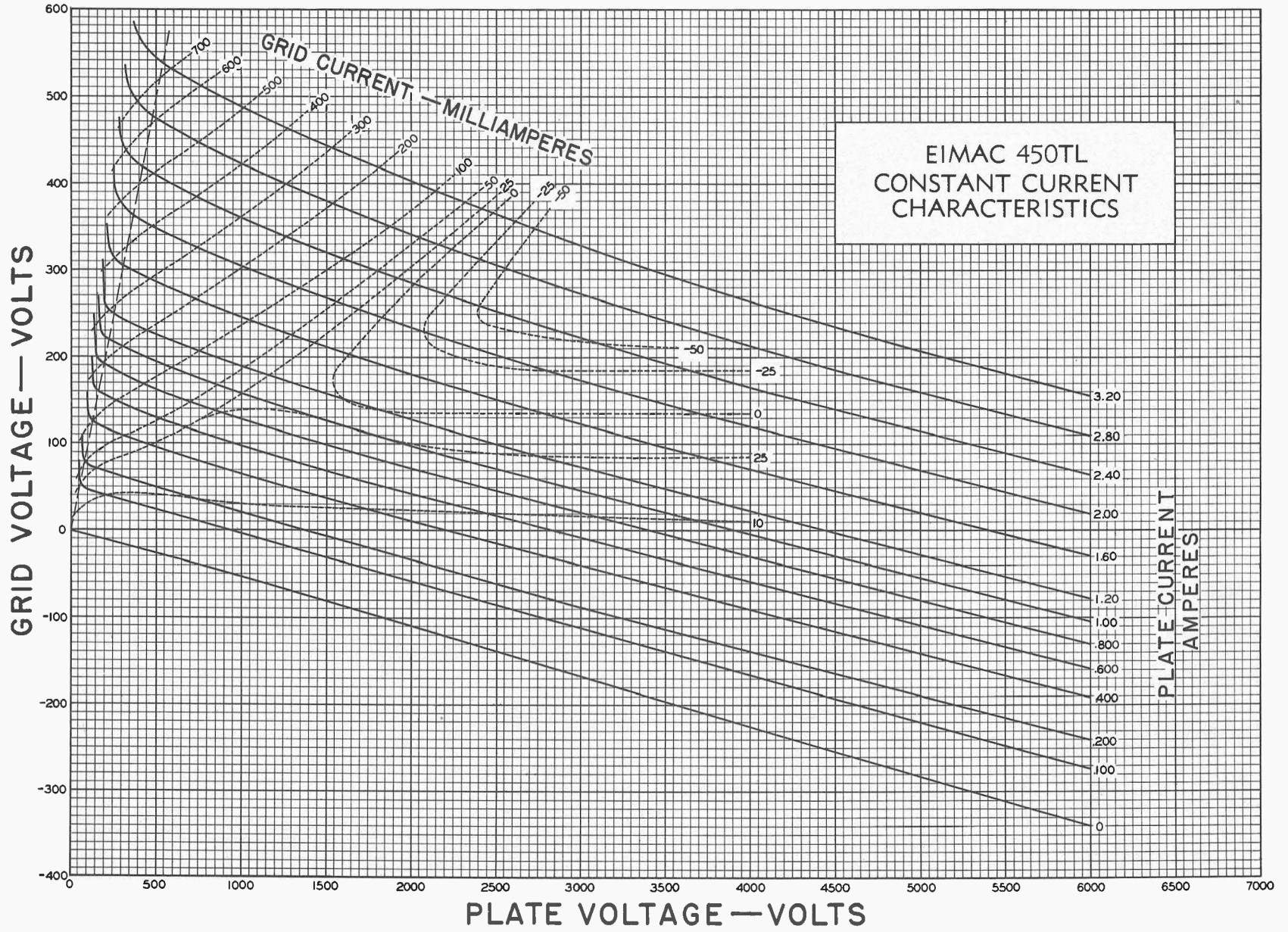

Eitel
EITEL-McCULLOUGH, Inc.
 SAN BRUNO, CALIFORNIA

750TL

**MEDIUM-MU TRIODE
 •
 MODULATOR
 OSCILLATOR
 AMPLIFIER**

GENERAL CHARACTERISTICS

ELECTRICAL

Filament: Thoriated tungsten		
Voltage	- - - - -	7.5 volts
Current	- - - - -	21.0 amperes
Amplification Factor (Average)	- - - - -	15
Direct Interelectrode Capacitances (Average)		
Grid-Plate	- - - - -	5.8 $\mu\mu\text{f}$
Grid-Filament	- - - - -	8.5 $\mu\mu\text{f}$
Plate-Filament	- - - - -	1.2 $\mu\mu\text{f}$
Transconductance ($I_{b1}=1.0$ amp., $E_{b1}=5000$, $e_c=-100$)		3500 μmhos
Frequency for Maximum Ratings	- - - - -	40 mc

MECHANICAL

Base	-	Special 4 pin, (Fits Johnson No. 214 Socket, or equal) No. 5003B
Basing	-	RMA type 4BD
Maximum Overall Dimensions:		
Length	- - - - -	17.0 inches
Diameter	- - - - -	7.125 inches
Net weight	- - - - -	2.75 pounds
Shipping weight (Average)	- - - - -	8.0 pounds

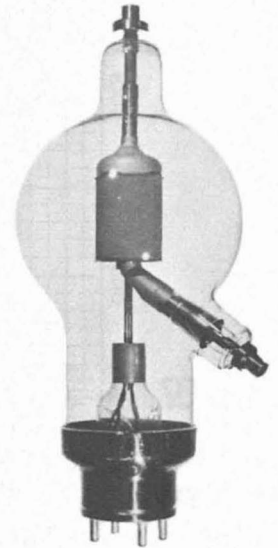

**AUDIO FREQUENCY POWER AMPLIFIER AND MODULATOR
 Class B**

	TYPICAL OPERATION—2 TUBES			MAX. RATING	
D-C Plate Voltage	4000	5000	6000	10000	volts
Max.-Signal D-C Plate Current, per tube*	•	•	•	1000	ma.
Plate Dissipation, per tube*	•	•	•	750	watts
D-C Grid Voltage (approx.)	-200	-285	-350		volts
Peak A-F Grid Input Voltage	910	1060	1200		volts
Zero-Signal D-C Plate Current	.250	.200	.166		amps.
Max.-Signal D-C Plate Current	.950	.860	.834		amps.
Max.-Signal Driving Power (approx.)	24	23	30		watts
Effective Load, Plate-to-Plate	8270	12300	16300		ohms
Max.-Signal Plate Power Output	2300	2800	3500		watts

*Averaged over any sinusoidal audio frequency cycle.

**RADIO FREQUENCY POWER AMPLIFIER AND OSCILLATOR
 Class-C *Telegraphy
 (Key down conditions without modulation)**

	TYPICAL OPERATION—1 TUBE				MAX. RATING	
D-C Plate Voltage	3000	4000	5000	6000	10000	volts
D-C Plate Current	713	625	600	625	1000	ma.
D-C Grid Current	95	69	67	78	125	ma.
D-C Grid Voltage	-350	-450	-550	-700		volts
Plate Power Output	1390	1750	2250	3000		watts
Plate Input	2140	2500	3000	3750		watts
Plate Dissipation	750	750	750	750	750	watts
Peak R. F. Grid Input Voltage, (approx.)	860	900	1000	1120		volts
Driving Power, (approx.)	74	53	61	93		watts

*The above figures show actual measured tube performance, and do not allow for variations in circuit losses.

Simul
750TL

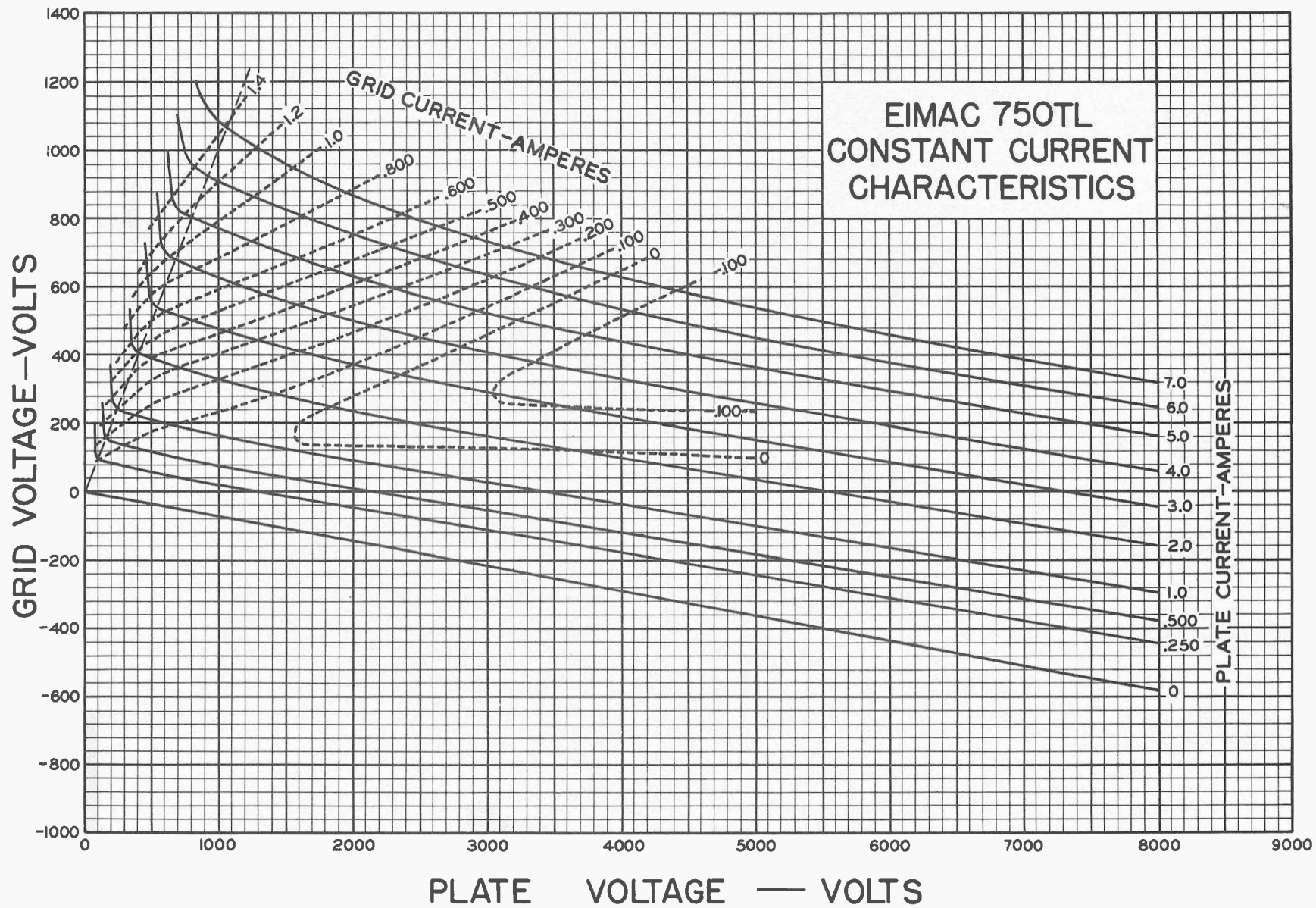

DRIVING POWER vs. POWER OUTPUT

The three charts on this page show the relationship of plate efficiency, power output and grid driving power at plate voltages of 4000, 5000, and 6000 volts. These charts show combined grid and bias losses only. The driving power and power output figures do not include circuit losses. The plate dissipation in watts is indicated by P_p . Points A, B, and C are identical to the typical Class C operating conditions shown on the first page under 4000, 5000, and 6000 volts respectively.

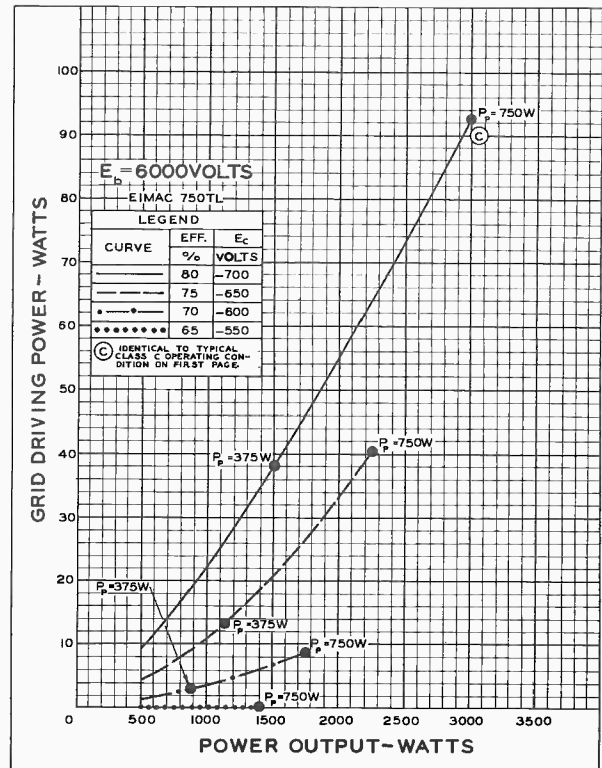
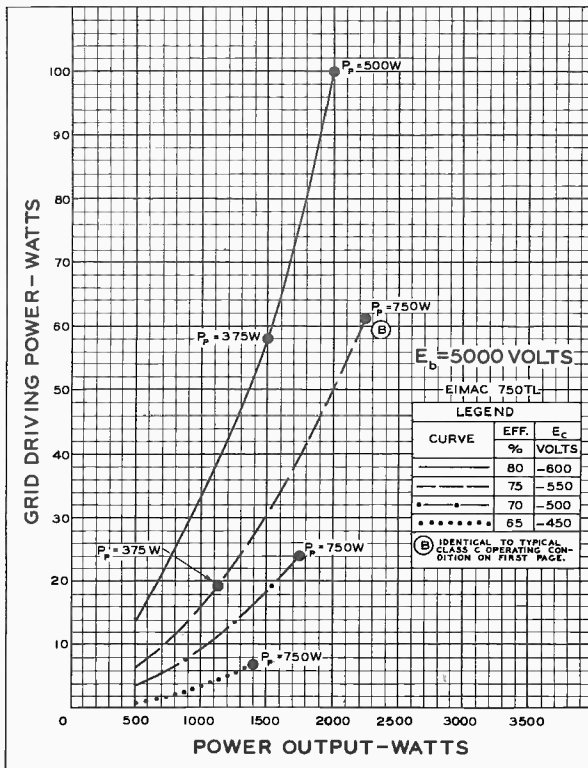
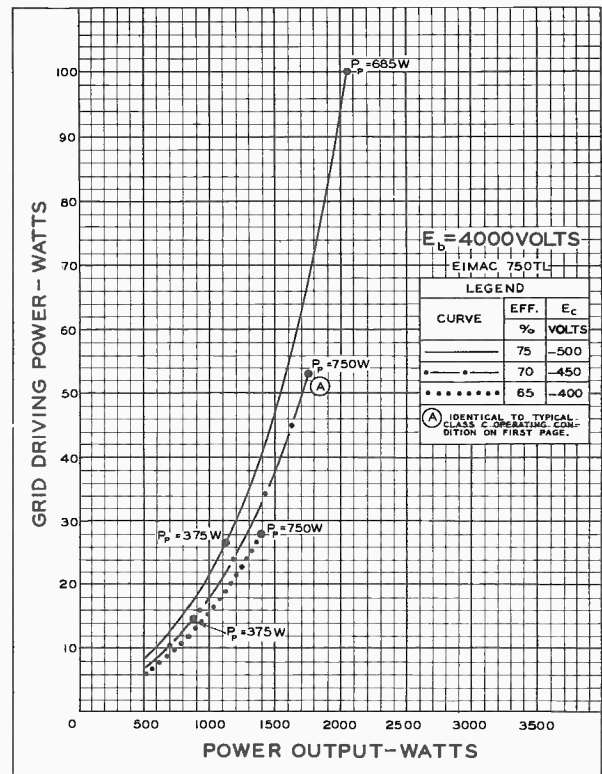

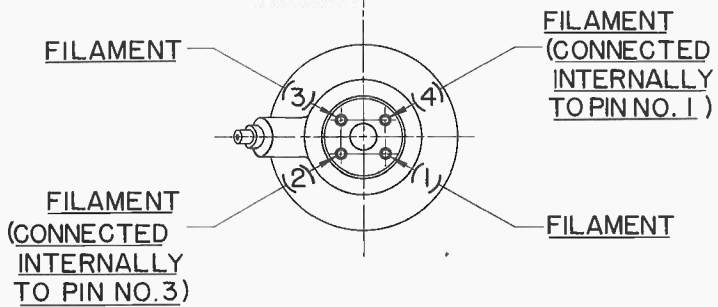
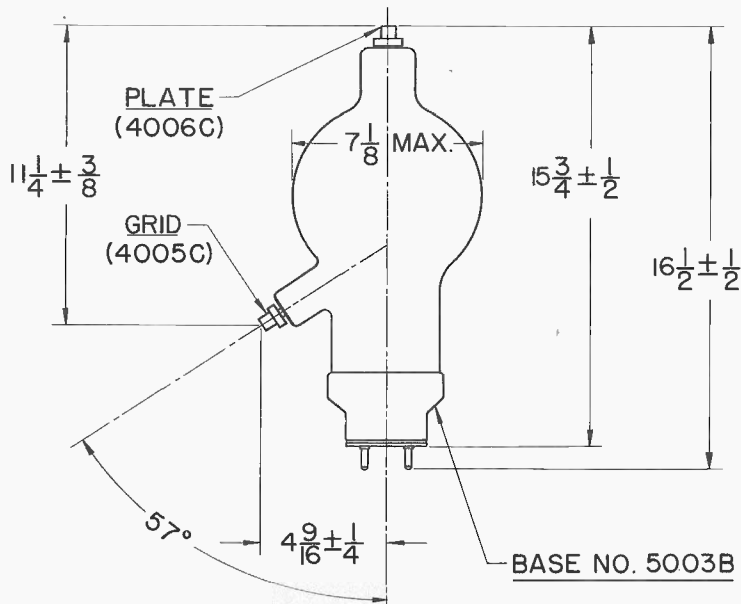

4BD

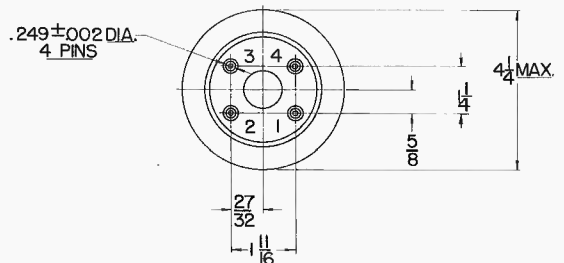
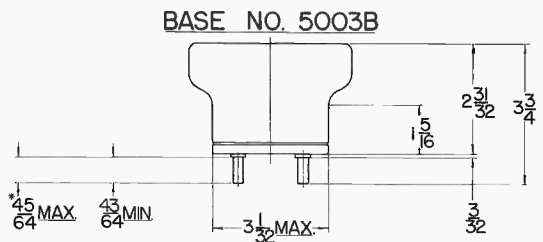
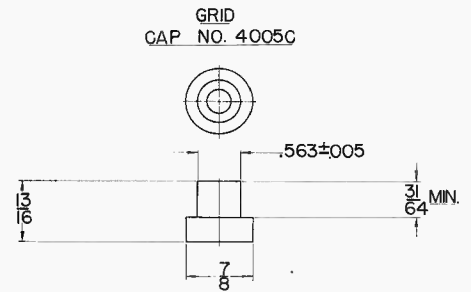
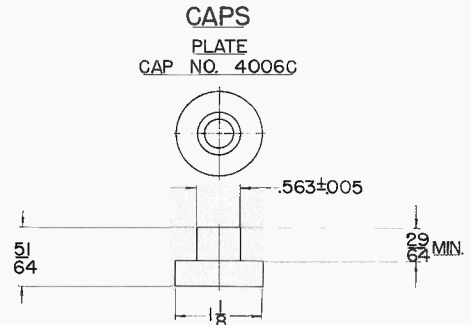
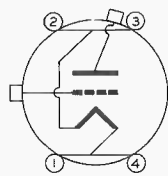

*ON FINISHED TUBE ADD .060 FOR SOLDER.

AIR COOLING

Provision should be made for ample circulation of air in the equipment employing this type tube.

EITEL-McCULLOUGH, INC.

SAN BRUNO, CALIFORNIA

1000T

HIGH-MU TRIODE
 •
 MODULATOR
 OSCILLATOR
 AMPLIFIER

GENERAL CHARACTERISTICS

ELECTRICAL

Filament: Thoriated tungsten		
Voltage	-	7.5 volts
Current	-	17.0 amperes
Amplification Factor (Average)		35
Direct Interelectrode Capacitances (Average)		
Grid-Plate	-	5.1 $\mu\mu\text{f}$
Grid-Filament	-	9.3 $\mu\mu\text{f}$
Plate-Filament	-	0.5 $\mu\mu\text{f}$
Transconductance ($I_b=750 \text{ ma.}, E_b=6000, e_c=-62$)		9050 μmhos
Frequency for Maximum Ratings		50 mc

MECHANICAL

Base	-	4-pin with tubing for forced air No. 5004B
Basing	-	RMA type 4AQ
Maximum Overall Dimensions:		
Length	-	12.625 inches
Diameter	-	5.125 inches
Net weight	-	1.25 pounds
Shipping weight (Average)	-	6.25 pounds

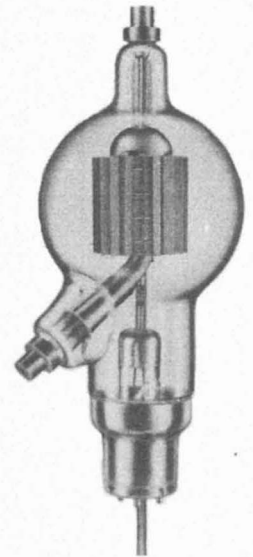

AUDIO FREQUENCY POWER AMPLIFIER AND MODULATOR

Class B

	TYPICAL OPERATION—2 TUBES			MAX. RATING	
	4000	5000	6000		
D-C Plate Voltage	-	-	-	7500	volts
Max.-Signal D-C Plate Current, per tube*	•	•	•	750	ma.
Plate Dissipation, per tube*	•	•	•	1000	watts
D-C Grid Voltage (approx.)	-70	-105	-135		volts
Peak A-F Grid Input Voltage	490	530	600		volts
Zero-Signal D-C Plate Current	.300	.240	.200		amps.
Max.-Signal D-C Plate Current	1.25	1.14	1.11		amps.
Max.-Signal Driving Power (approx.)	28	31	35		watts
Effective Load, Plate-to-Plate	6350	9250	12200		ohms
Max.-Signal Plate Power Output	3000	3700	4600		watts

*Averaged over any sinusoidal audio frequency cycle.

RADIO FREQUENCY POWER AMPLIFIER AND OSCILLATOR

Class-C *Telegraphy

(Key down conditions without modulation)

	TYPICAL OPERATION—1 TUBE				MAX. RATING	
	3000	4000	5000	6000		
D-C Plate Voltage	-	-	-	-	7500	volts
D-C Plate Current	750	713	667	667	750	ma.
D-C Grid Current	90	100	87	110	125	ma.
D-C Grid Voltage	-150	-150	-225	-350		volts
Plate Power Output	1350	1850	2333	3000		watts
Plate Input	2250	2850	3333	4000		watts
Plate Dissipation	900	1000	1000	1000	1000	watts
Peak R. F. Grid Input Voltage, (approx.)	350	365	420	610		volts
Driving Power, (approx.)	30	33	33	60		watts

*The above figures show actual measured tube performance, and do not allow for variations in circuit losses.

Eimac 1000T
VACUUM TUBE DIV. OF GENERAL ELECTRIC

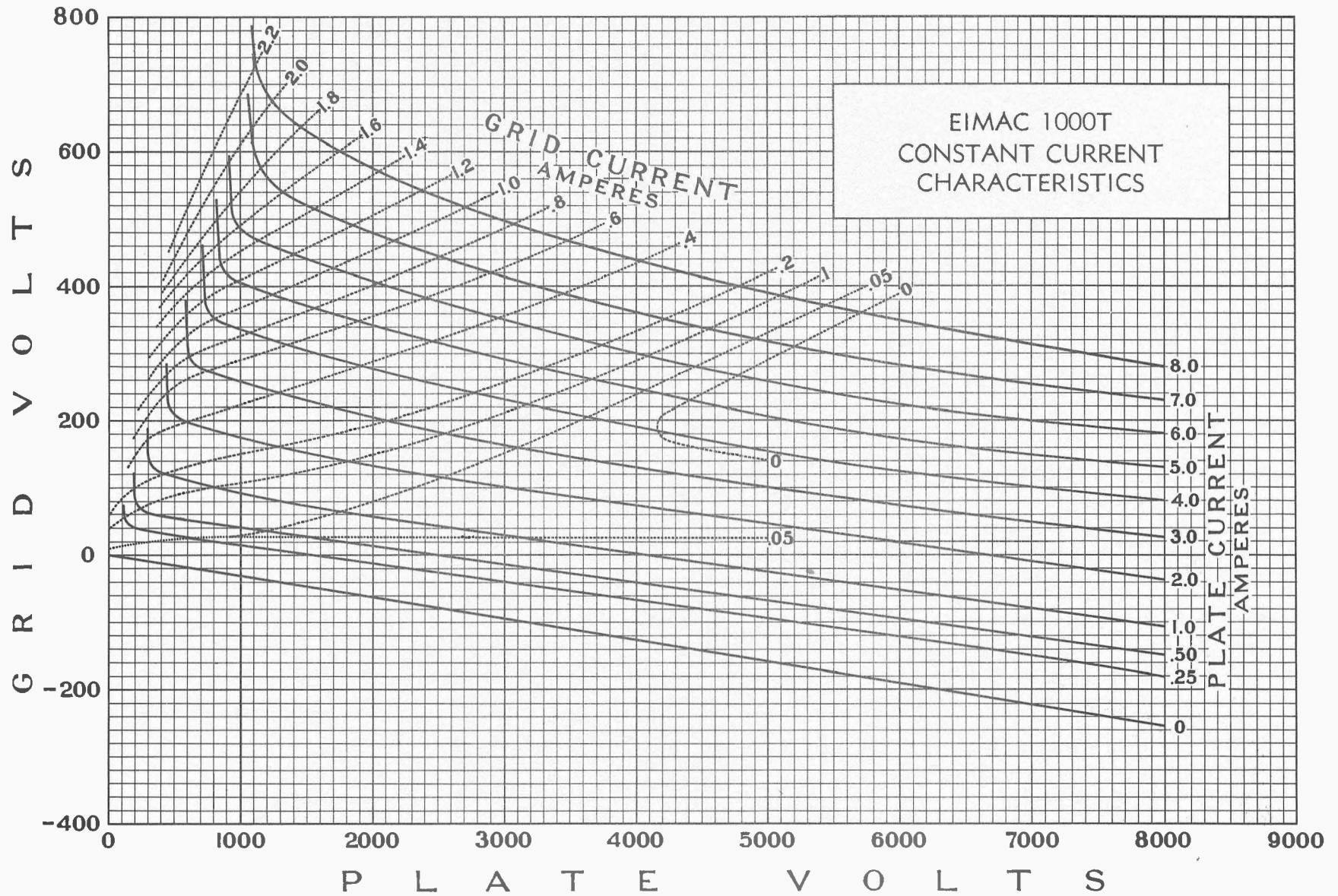

DRIVING POWER vs. POWER OUTPUT

The three charts on this page show the relationship of plate efficiency, power output and grid driving power at plate voltages of 4000, 5000 and 6000 volts. These charts show combined grid and bias losses only. The driving power and power output figures do not include circuit losses. The plate dissipation in watts is indicated by P_p . Points A, B, and C are identical to the typical Class C operating conditions shown on the first page under 4000, 5000, and 6000 volts respectively.

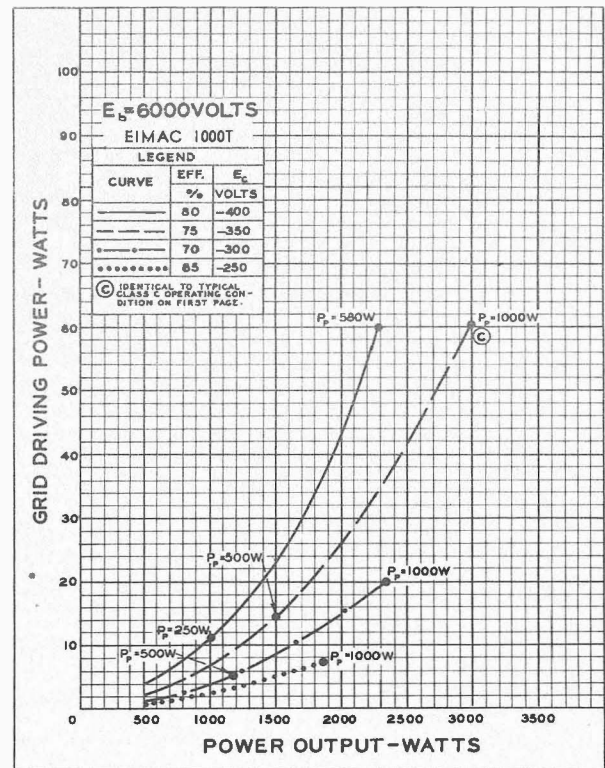
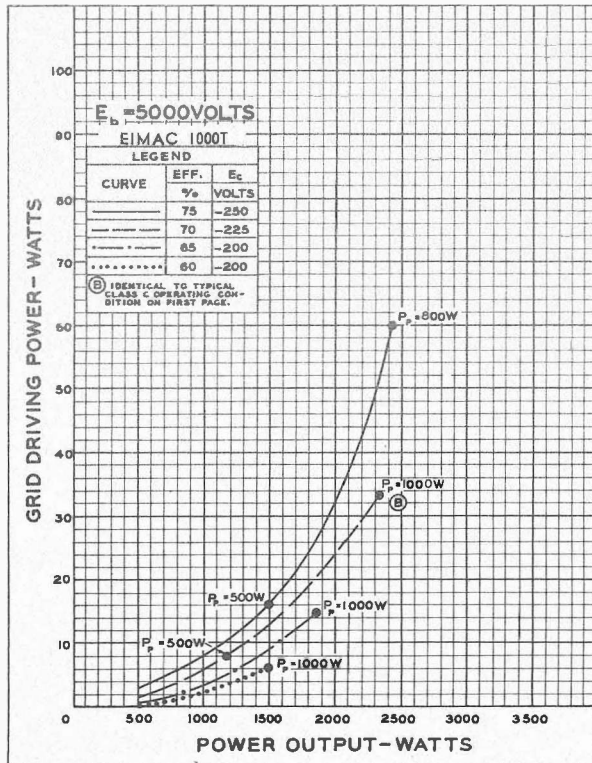
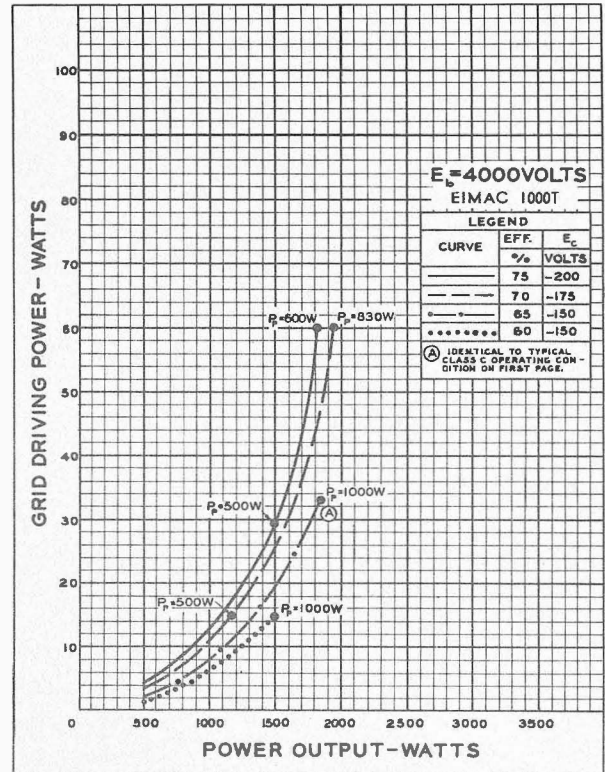

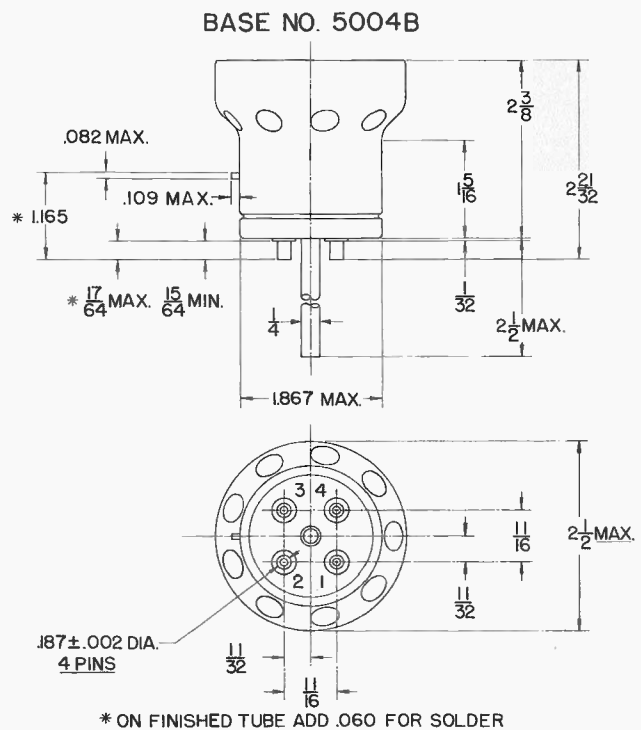
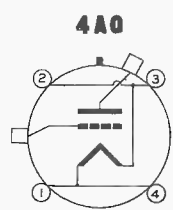
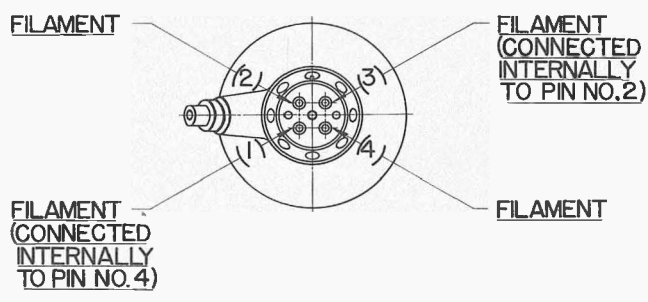
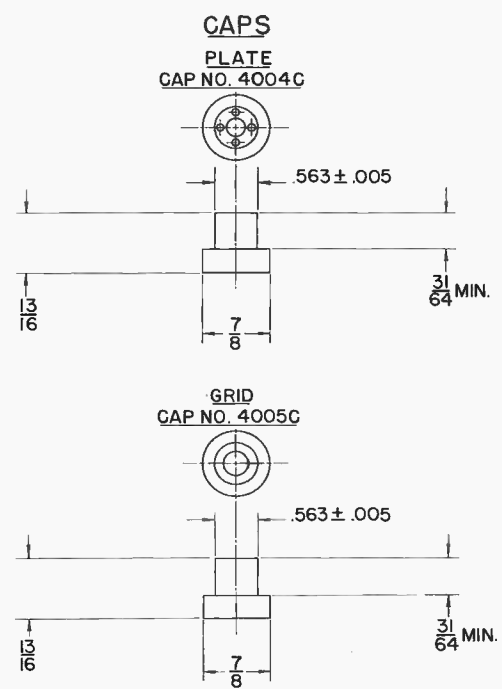
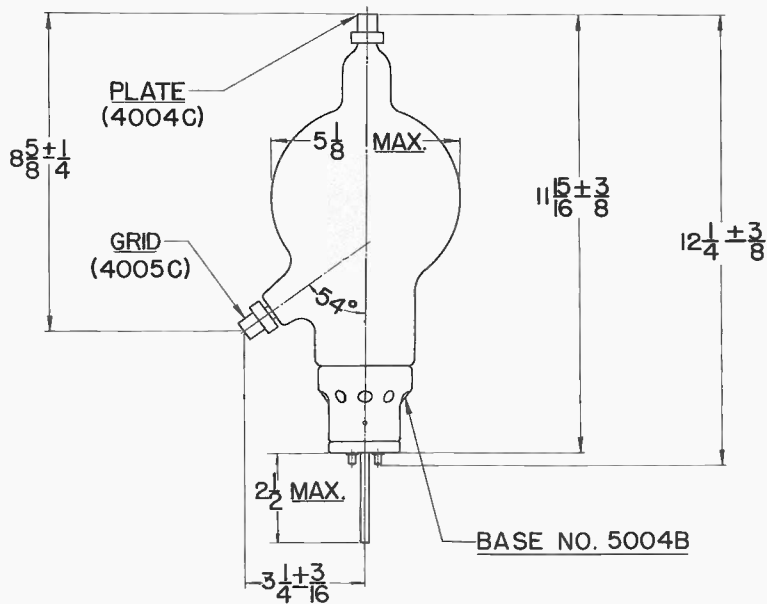

Forced air cooling on the seals of the Eimac 1000T, 1500T, and 2000T is recommended when tubes are operated under maximum conditions. We suggest the Roots Connersville blower unit No. 22. This blower when driven by a 1/4 H. P. motor at 1160 r.p.m. will deliver 13 cubic feet of air per minute at 1 pound pressure.

Each tube seal requires approximately 2 cubic feet per minute, therefore, one of these No. 22 blowers should handle any two of the above tubes.

We would suggest the outlet manifold, which is 1 inch in diameter, be kept to the shortest possible length—under 8 feet. It is also suggested 3/8 inch O.D. copper tubing be used from the outlet manifold to feed air to the various seals. It will be necessary to use an insulating type of tubing to actually connect to the tubes themselves. This tubing should have an I.D. of 5/16 inch.

Roots Connersville's plant is in Connersville, Indiana, with offices in most of the large cities.

Bulbs must be cooled with air equivalent to that supplied by standard 8" electric fan 12" from bulb.

Eimac
EITEL-McCULLOUGH, INC.
 SAN BRUNO, CALIFORNIA

1500T

MEDIUM-MU TRIODE

MODULATOR
 OSCILLATOR
 AMPLIFIER

The Eimac 1500T is a medium-mu, high-vacuum transmitting triode intended for amplifier, oscillator and modulator service. It has a maximum plate dissipation rating of 1500 watts. Cooling of the 1500T is accomplished by radiation from the plate, which operates at a visibly red temperature at maximum dissipation, and by means of forced air circulation around the envelope and at the seals.

GENERAL CHARACTERISTICS

ELECTRICAL

Filament: Thoriated tungsten	
Voltage - - - - -	7.5 volts
Current - - - - -	24.0 amperes
Amplification Factor (Average) - - - - -	24
Direct Interelectrode Capacitances (Average)	
Grid-Plate - - - - -	7.2 $\mu\text{fd.}$
Grid-Filament - - - - -	9.9 $\mu\text{fd.}$
Plate-Filament - - - - -	1.5 $\mu\text{fd.}$
Transconductance ($i_b = 1.25 \text{ amp.}, E_b = 6000 \text{ v.}, E_c = -155 \text{ v.}$)	10,000 μmhos

MECHANICAL

Base - - - - -	Special 4-pin, No. 5005B
Basing - - - - -	RMA type 4BD
Cooling - - - - -	Radiation and forced air
Maximum Overall Dimensions:	
Length - - - - -	17.0 inches
Diameter - - - - -	7.125 inches
Net Weight - - - - -	3.5 pounds
Shipping Weight (Average) - - - - -	8.5 pounds

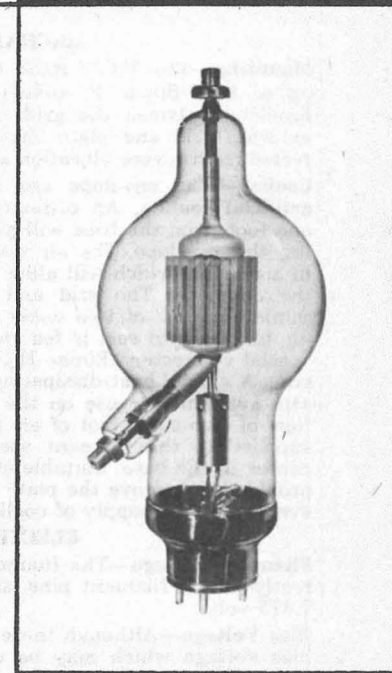

RADIO FREQUENCY POWER AMPLIFIER AND OSCILLATOR

Class-C Telegraphy (Key-down conditions, 1 tube)

MAXIMUM RATINGS (Frequencies below 40 Mc.)

D-C PLATE VOLTAGE - - - - -	▶ 8000 MAX. VOLTS
D-C PLATE CURRENT - - - - -	1.25 MAX. AMPS.
PLATE DISSIPATION - - - - -	1500 MAX. WATTS
GRID DISSIPATION - - - - -	125 MAX. WATTS

TYPICAL OPERATION (Frequencies below 40 Mc.)

D-C Plate Voltage - - - - -	5000	6000	7000	volts
D-C Grid Voltage - - - - -	-375	-600	-500	volts
D-C Plate Current - - - - -	1.00	1.00	.860	amps.
D-C Grid Current - - - - -	150	165	110	ma.
Grid Dissipation - - - - -	59	61	30	watts
Peak R-F Grid Input Voltage (approx.) -	850	1100	885	volts
Driving Power (approx.) - - - - -	115	160	85	watts
Plate Power Input - - - - -	5000	6000	6000	watts
Plate Dissipation - - - - -	1500	1500	1500	watts
Plate Power Output - - - - -	3500	4500	4500	watts

AUDIO FREQUENCY POWER AMPLIFIER AND MODULATOR

Class-B (Sinusoidal wave, two tubes unless otherwise specified)

MAXIMUM RATINGS

D-C PLATE VOLTAGE - - - - -	▶ 8000 MAX. VOLTS
MAX-SIGNAL D-C PLATE CURRENT, PER TUBE -	1.25 MAX. AMPS.
PLATE DISSIPATION, PER TUBE - - - - -	1500 MAX. WATTS
GRID DISSIPATION, PER TUBE - - - - -	125 MAX. WATTS

TYPICAL OPERATION

D-C Plate Voltage - - - - -	4000	5000	6000	volts
D-C Grid Voltage (approx.) - - - - -	-95	-145	-190	volts
Zero-Signal D-C Plate Current - - - - -	500	400	330	ma.
Max-Signal D-C Plate Current - - - - -	1.88	1.72	1.65	amps.
Effective Load, Plate-to-Plate - - - - -	4150	6150	8200	ohms
Peak A-F Grid Input Voltage (per tube) -	485	535	570	volts
Max-Signal Avg. Driving Power (approx.) -	95	105	115	watts
Max-Signal Plate Dissipation - - - - -	1500	1500	1450	watts
Max-Signal Plate Power Output - - - - -	4500	5600	7000	watts

(Effective 5-1-46) Copyright, 1946 by Eitel-McCullough, Inc.

▶ Indicates change from sheet dated 7-1-44.

APPLICATION

MECHANICAL

Mounting—The 1500T must be mounted vertically, base up or base down. Flexible connecting straps should be provided between the grid and plate terminals and the external grid and plate circuits. The tube must be protected from severe vibration and shock.

Cooling—The envelope and seals of the 1500T require artificial cooling. An ordinary 8- or 10-inch fan located one foot from the tube will provide sufficient air for cooling the envelope. The air should be directed at the tube in a manner which will allow the most uniform cooling of the envelope. The grid and plate seals each require a minimum flow of two cubic feet of air per minute. The air for the grid seal is fed through the grid connector. A special connector (Eimac HR-9) is available for this purpose. A special heat-dissipating connector (Eimac HR-8) is also available for use on the plate terminal. A minimum flow of two cubic feet of air per minute must likewise be supplied to the filament seals through the hole at the center of the base. Suitable electrical interlocks should be provided to remove the plate and filament voltages in the event that the supply of cooling air is interrupted.

ELECTRICAL

Filament Voltage—The filament voltage, as measured directly at the filament pins, should be between 7.125 and 7.875 volts.

Bias Voltage—Although there is no maximum limit on the bias voltage which may be used on the 1500T, there is little advantage in using bias voltages in excess of those given under "Typical Operation," except in certain very specialized applications. Where bias is obtained by a grid

leak, suitable protective means must be provided to prevent excessive plate dissipation in the event of loss of excitation.

Plate Voltage—The plate supply voltage for the 1500T should not exceed 8000 volts. In most cases there is little advantage in using plate-supply voltages higher than those given under "Typical Operation" for the power output desired.

Grid Dissipation—The power dissipated by the grid of the 1500T must not exceed 125 watts. Grid dissipation may be calculated from the following expression:

$$P_g = e_{\text{emp}} I_c$$

where P_g = Grid dissipation,
 e_{emp} = Peak positive grid voltage, and
 I_c = D-c grid current.

e_{emp} may be measured by means of a suitable peak voltmeter connected between filament and grid.¹ In equipment in which the plate loading varies widely, such as oscillators used for radio-frequency heating, care should be taken to make certain that the grid dissipation does not exceed the maximum rating under any condition of loading.

Plate Dissipation—Under normal operating conditions, the power dissipated by the plate of the 1500T should not be allowed to exceed 1500 watts. Plate dissipation in excess of the maximum rating is permissible for short periods of time, such as during tuning procedures.

¹ For suitable peak v.t.v.m. circuits see, for instance, "Vacuum Tube Ratings," Eimac News, January, 1945. This article is available in reprint form on request.

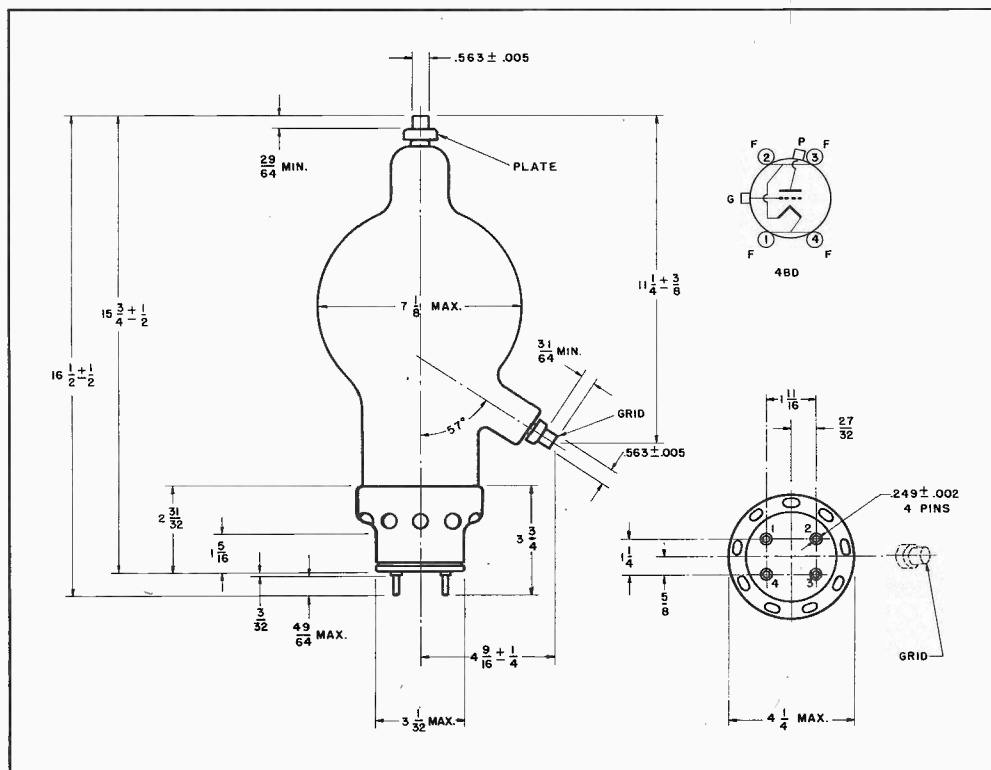

DRIVING POWER vs. POWER OUTPUT

The three charts on this page show the relationship of plate efficiency, power output and grid driving power at plate voltages of 5000, 6000, and 7000 volts. These charts show combined grid and bias losses only. The driving power and power output figures do not include circuit losses. The plate dissipation in watts is indicated by P_p .

Points A, B, and C are identical to the typical Class C operating conditions shown on the first page under 5000, 6000, and 7000 volts respectively.

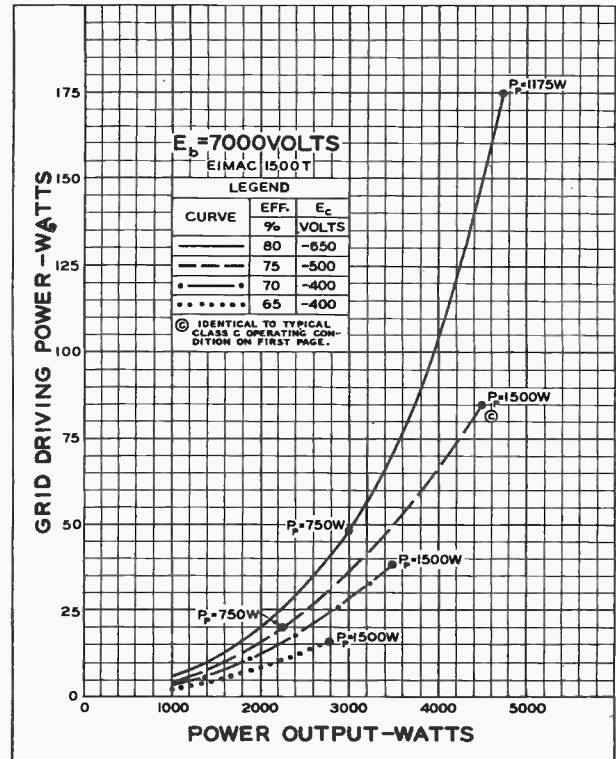
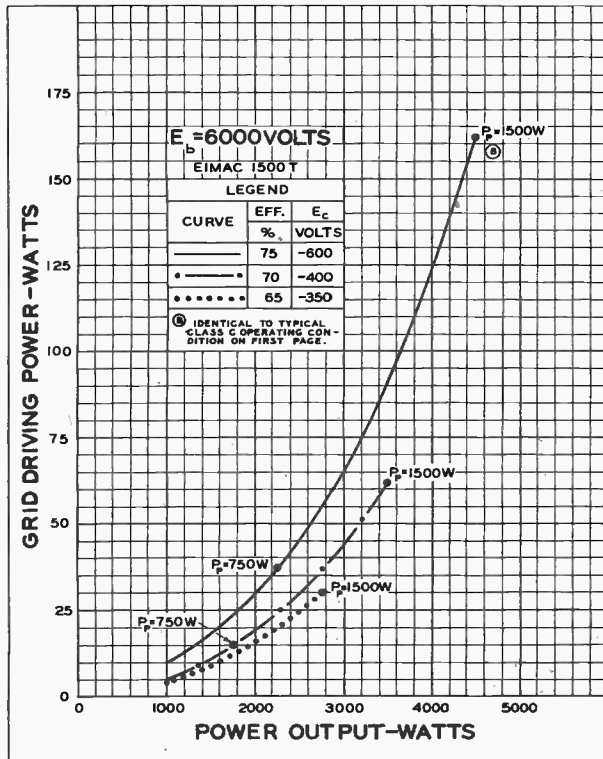
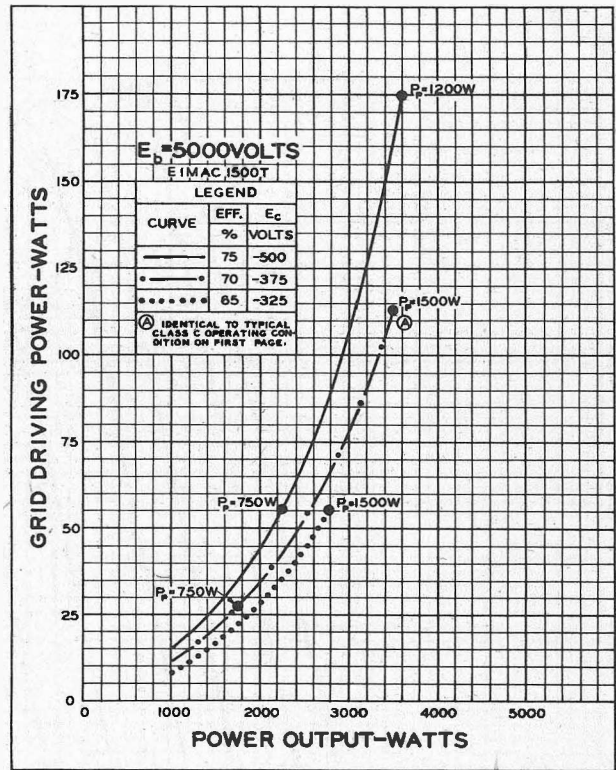

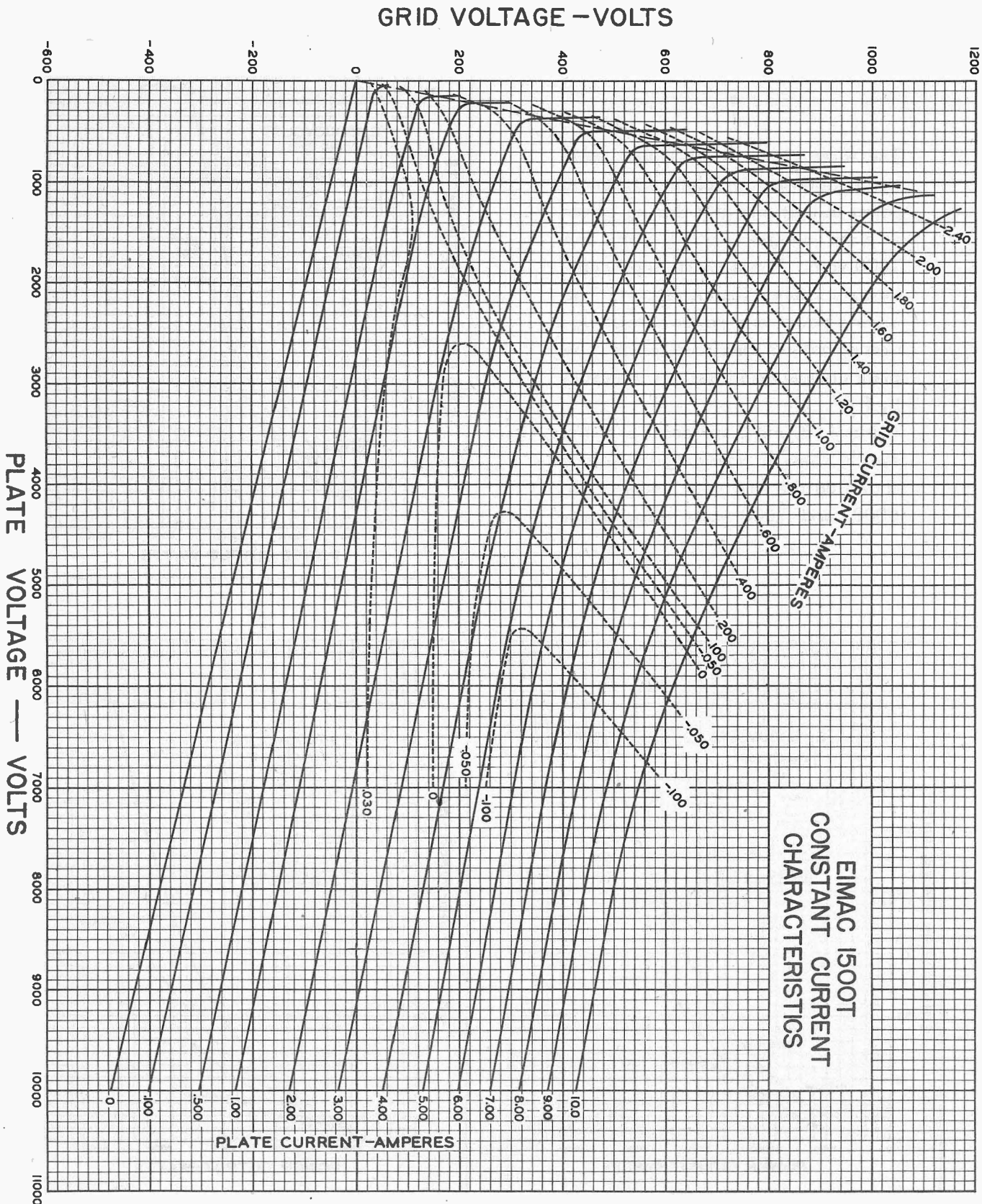

EITEL-McCULLOUGH, INC.

SAN BRUNO, CALIFORNIA

2000T

MEDIUM-MU TRIODE

MODULATOR
OSCILLATOR
AMPLIFIER

The 2000T is a medium-mu, high-vacuum transmitting triode intended for amplifier, oscillator and modulator service. It has a maximum plate dissipation rating of 2000 watts. Cooling of the 2000T is accomplished by radiation from the plate, which operates at a visibly red temperature at maximum dissipation, and by means of forced air circulation around the envelope and at the seals.

GENERAL CHARACTERISTICS

ELECTRICAL

Filament: Thoriated tungsten	
Voltage	10.0 volts
Current	25.0 amperes
Amplification Factor (Average) 23	
Direct Interelectrode Capacitances (Average)	
Grid-Plate	8.5 $\mu\mu\text{fd.}$
Grid-Filament	12.7 $\mu\mu\text{fd.}$
Plate-Filament	1.7 $\mu\mu\text{fd.}$
Transconductance ($i_b = 1.75 \text{ amp.}$, $E_b = 6000 \text{ v.}$, $E_c = -95 \text{ v.}$) 11,000 μmhos	

MECHANICAL

Base	Special 4-pin, No. 5006B
Basing	RMA type 4BD
Cooling	Radiation and forced air

Maximum Overall Dimensions:

Length	17.75 inches
Diameter	8.125 inches
Net weight	3.5 pounds
Shipping weight (Average)	8.5 pounds

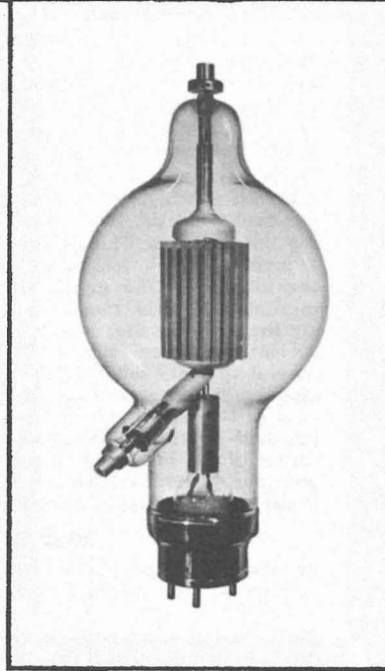

RADIO FREQUENCY POWER AMPLIFIER AND OSCILLATOR

Class-C Telegraphy (Key-down conditions, 1 tube)

MAXIMUM RATINGS (Frequencies below 40 Mc.)

D-C PLATE VOLTAGE	▶8000 MAX. VOLTS
D-C PLATE CURRENT	1.75 MAX. AMPS.
PLATE DISSIPATION	2000 MAX. WATTS
GRID DISSIPATION	150 MAX. WATTS

TYPICAL OPERATION (Frequencies below 40 Mc.)

D-C Plate Voltage	5000	6000	7000	volts
D-C Grid Voltage	-350	-500	-600	volts
D-C Plate Current	1.35	1.35	1.15	amps
D-C Grid Current	175	165	120	ma.
Grid Dissipation	79	78	43	watts
Peak R-F Grid Input Voltage (approx.)	900	1050	1060	volts
Driving Power, (approx.)	140	160	115	watts
Plate Power Input	6670	8000	8000	watts
Plate Dissipation	2000	2000	2000	watts
Plate Power Output	4670	6000	6000	watts

AUDIO FREQUENCY POWER AMPLIFIER AND MODULATOR

Class-B (Sinusoidal wave, two tubes unless otherwise specified)

MAXIMUM RATINGS

D-C PLATE VOLTAGE	▶8000 MAX. VOLTS
MAX-SIGNAL D-C PLATE CURRENT, PER TUBE	1.75 MAX. AMPS.
PLATE DISSIPATION, PER TUBE	2000 MAX. WATTS
GRID DISSIPATION, PER TUBE	150 MAX. WATTS

TYPICAL OPERATION

D-C Plate Voltage	5000	6000	7000	volts
D-C Grid Voltage	-180	-230	-290	volts
Zero-Signal D-C Plate Current	480	400	350	ma.
Max-Signal D-C Plate Current	2.00	1.88	1.86	amps.
Effective Load, Plate-to-Plate	4900	6650	8500	ohms
Peak A-F Grid Input Voltage (per tube)	470	525	590	volts
Max-Signal Avg. Driving Power (approx.)	50	60	75	watts
Max-Signal Peak Driving Power	178	184	212	watts
Max-Signal Plate Dissipation (per tube)	2000	1875	2000	watts
Max-Signal Plate Power Output	6000	7500	9000	watts

APPLICATION

MECHANICAL

Mounting—The 2000T must be mounted vertically, base up or base down. Flexible connecting straps should be provided between the grid and plate terminals and the external grid and plate circuits. The tube must be protected from severe vibration and shock.

Cooling—The envelope and seals of the 2000T require artificial cooling. An ordinary 8- or 10-inch fan located one foot from the tube will provide sufficient air for cooling the envelope. The air should be directed at the tube in a manner which will allow the most uniform cooling of the envelope. The grid and plate seals each require a minimum flow of two cubic feet of air per minute. The air for the grid seal is fed through the grid connector. A special connector (Eimac HR-9) is available for this purpose. A special heat-dissipating connector (Eimac HR-8) is also available for use on the plate terminal. A minimum flow of two cubic feet of air per minute must likewise be supplied to the filament seals through the hole at the center of the base. Suitable electrical interlocks should be provided to remove the plate and filament voltages in the event that the supply of cooling air is interrupted.

ELECTRICAL

Filament Voltage—The filament voltage, as measured directly at the filament pins, should be between 9.5 and 10.5 volts.

Bias Voltage—Although there is no maximum limit on the bias voltage which may be used on the 2000T there is little advantage in using bias voltages in excess of those given under "Typical Operation," except in certain very specialized applications. Where bias is obtained by a grid

leak, suitable protective means must be provided to prevent excessive plate dissipation in the event of loss of excitation.

Plate Voltage—The plate supply voltage for the 2000T should not exceed 8000 volts. In most cases there is little advantage in using plate-supply voltages higher than those given under "Typical Operation" for the power output desired.

Grid Dissipation—The power dissipated by the grid of the 2000T must not exceed 150 watts. Grid dissipation may be calculated from the following expression:

$$P_g = e_{cmp} I_c$$

where P_g = Grid dissipation,
 e_{cmp} = Peak positive grid voltage, and
 I_c = D-c grid current.

e_{cmp} may be measured by means of a suitable peak voltmeter connected between filament and grid.¹ In equipment in which the plate loading varies widely, such as oscillators used for radio-frequency heating, care should be taken to make certain that the grid dissipation does not exceed the maximum rating under any condition of loading.

Plate Dissipation—Under normal operating conditions, the power dissipated by the plate of the 2000T should not be allowed to exceed 2000 watts. Plate dissipation in excess of the maximum rating is permissible for short periods of time, such as during tuning procedures.

¹ For suitable peak v.t.v.m. circuits see, for instance, "Vacuum Tube Ratings," Eimac News, January, 1945. This article is available in reprint form on request.

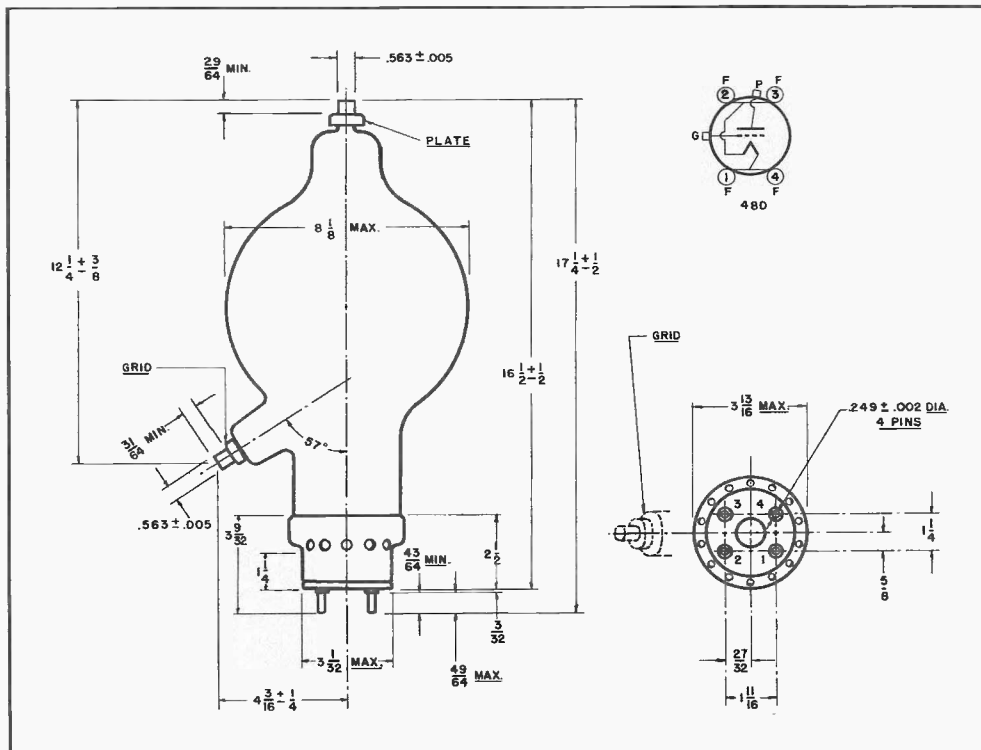

DRIVING POWER vs. POWER OUTPUT

The three charts on this page show the relationship of plate efficiency, power output and grid driving power at plate voltages of 5000, 6000, and 7000 volts. These charts show combined grid and bias losses only. The driving power and power output figures do not include circuit losses. The plate dissipation in watts is indicated by P_p .

Points A, B, and C are identical to the typical Class C operating conditions shown on the first page under 5000, 6000, and 7000 volts respectively.

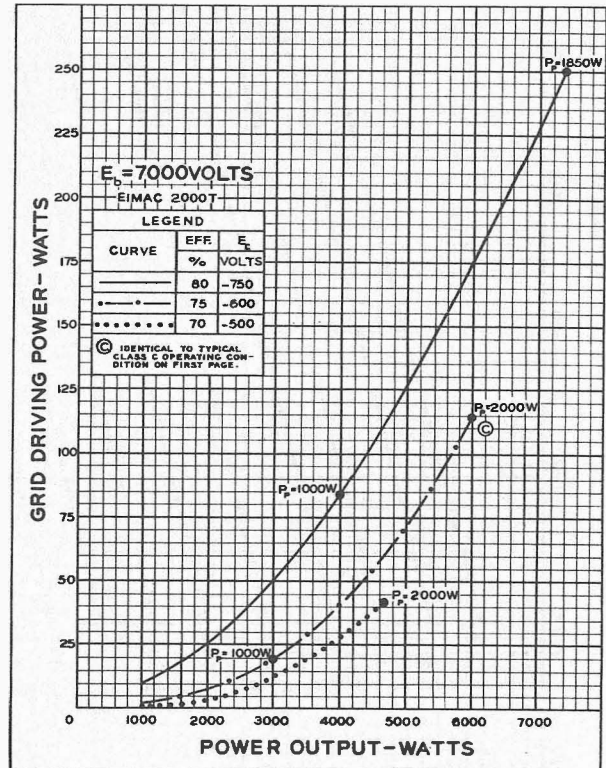
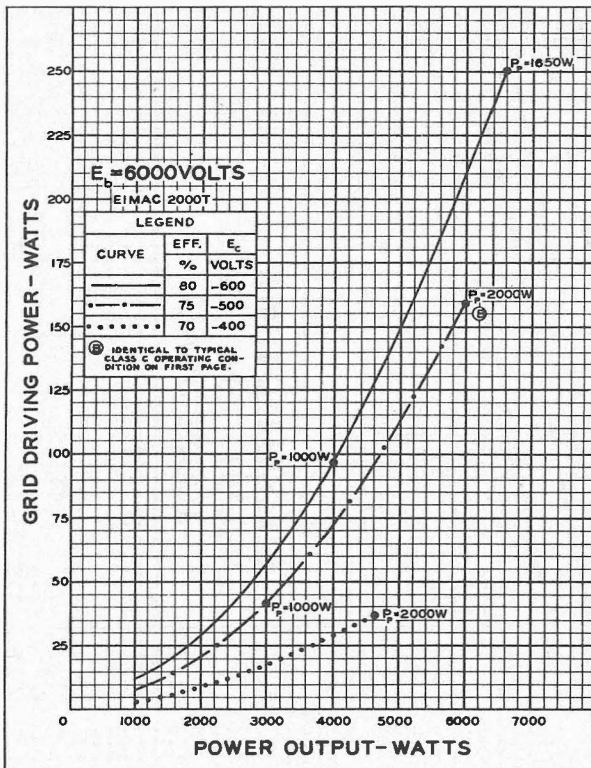
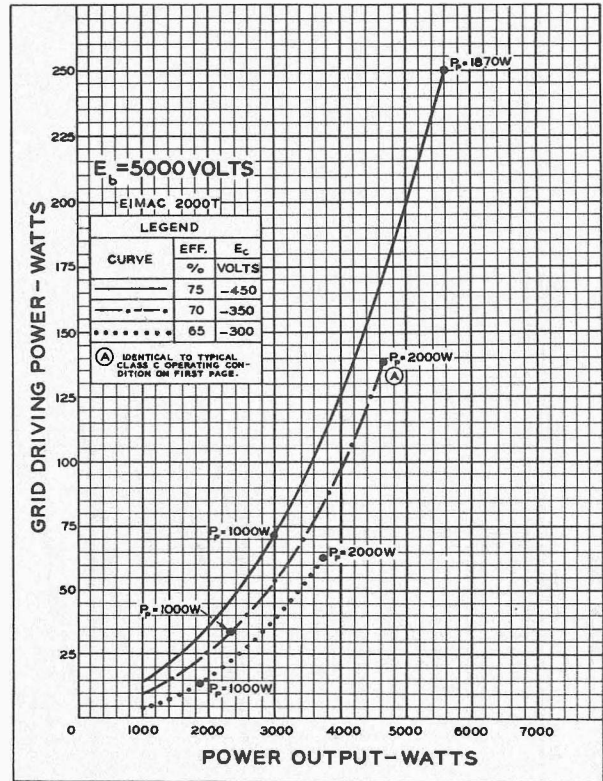

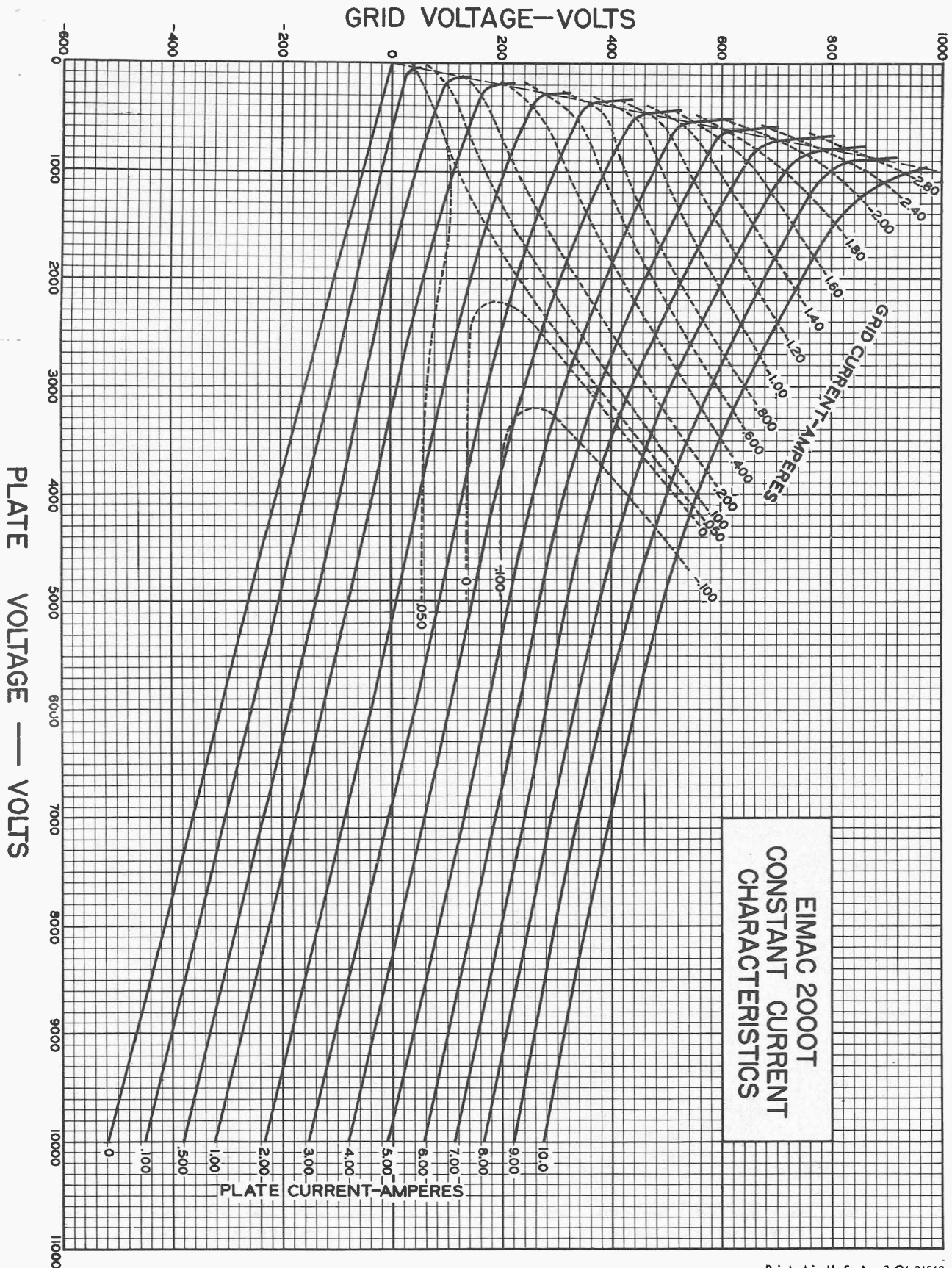

Eitel-McCULLOUGH, Inc.

SAN BRUNO, CALIFORNIA

3X2500A3

MEDIUM MU TRIODE

The Eimac 3X2500A3 is a medium-mu, forced-air cooled, external-anode transmitting triode with a maximum plate dissipation rating of 2500 watts. Relatively high power-output as an amplifier, oscillator or modulator may be obtained from this tube at low plate voltages. A single tube will deliver a radio-frequency output of 7500 watts at 4000 plate volts at frequencies up to 110 Mc., as well as at lower frequencies.

The tube has a rugged, low-inductance cylindrical filament-stem structure, which readily becomes part of a linear filament tank circuit for V.H.F. operation. The grid provides thorough shielding between the input and output circuits for grounded grid applications, and is conveniently terminated in a ring between the plate and filament terminals. As a result of the use of unique grid and filament terminal arrangements, it is possible to install or remove the 3X2500A3 without the aid of tools.

The approved Federal Communications Commission rating for the 3X2500A3 as a plate modulated amplifier is 5000 watts of carrier power.

GENERAL CHARACTERISTICS

ELECTRICAL

Filament: Thoriated tungsten	
Voltage - - - - -	7.5 volts
Current - - - - -	51 amperes
Maximum allowable starting current - - - - -	100 amperes
Amplification Factor (Average) - - - - -	20
Direct Interelectrode Capacitances (Average)	
Grid-Plate - - - - -	20 $\mu\mu^f$
Grid-Filament - - - - -	36 $\mu\mu^f$
Plate-Filament - - - - -	1.2 $\mu\mu^f$
Transconductance ($i_b=830$ ma., $E_b=3000$ v.) - - - - -	20,000 μ mhos
Frequency for Maximum Ratings - - - - -	75 Mc.

MECHANICAL

Base - - - - -	see drawing
Mounting - - - - -	Vertical, base down or up.
Maximum Overall Dimensions:	
Length - - - - -	9.0 inches
Diameter - - - - -	4.156 inches
Net Weight - - - - -	6.25 pounds
Shipping Weight (Average) - - - - -	17 pounds
COOLING - - - - -	Forced Air

A minimum flow of 120 cubic feet of air per minute must be passed through the anode cooler. The pressure drop across the cooler at this flow equals 1.0 inch of water. A minimum air-flow of 6 cubic feet per minute must also be directed toward the filament-stem structure, between the inner and outer filament conductors. Cooling air in the above quantities must be supplied to both anode cooler and filament seals before applying filament voltage and should be continued for five minutes after the filament power is removed. Anode-cooler core, grid and filament seal temperatures must not exceed 150° C. These figures are for an ambient temperature of 20° C at sea level and do not include duct or filter losses.



RADIO FREQUENCY POWER AMPLIFIER OR OSCILLATOR

(Conventional Neutralized Amplifier—Frequencies below 75 Mc.)

Class-C FM or Telegraphy (Key-down conditions, per tube)

MAXIMUM RATINGS

D-C PLATE VOLTAGE - - - - -	6000 MAX. VOLTS
D-C PLATE CURRENT - - - - -	2.5 MAX. AMPS
PLATE DISSIPATION - - - - -	2500 MAX. WATTS
PLATE COOLER CORE TEMPERATURE - - - - -	150 MAX. ° C
GRID DISSIPATION* - - - - -	150 MAX. WATTS

TYPICAL OPERATION (Frequencies below 75 Mc., per tube)

D-C Plate Voltage - - - - -	4000	5000	6000	Volts
D-C Plate Current - - - - -	2.5	2.5	2.08	Amps
D-C Grid Voltage - - - - -	—300	—450	—500	Volts
D-C Grid Current - - - - -	245	265	180	Ma.
Peak R-F Grid Input Voltage - - - - -	580	750	765	Volts
Driving Power (approx.) - - - - -	142	197	136	Watts
Grid Dissipation - - - - -	68	78	46	Watts
Plate Power Input - - - - -	10,000	12,500	12,500	Watts
Plate Dissipation - - - - -	2500	2500	2500	Watts
Plate Power Output - - - - -	7500	10,000	10,000	Watts

RADIO FREQUENCY POWER AMPLIFIER

Grounded-Grid Circuit

Class-C FM Telephony

MAXIMUM RATINGS (Frequencies between 85 and 110 Mc.)

D-C PLATE VOLTAGE - - - - -	4000 MAX. VOLTS
D-C PLATE CURRENT - - - - -	2.0 MAX. AMPS
D-C GRID CURRENT* - - - - -	200 MAX. MA.
PLATE DISSIPATION - - - - -	2500 MAX. WATTS
PLATE COOLER CORE TEMPERATURE - - - - -	150 MAX. ° C
GRID DISSIPATION* - - - - -	150 MAX. WATTS

*See application notes.

TYPICAL OPERATION (110 Mc., per tube)

D-C Plate Voltage - - - - -	3700	4000	Volts
D-C Grid Voltage - - - - -	—450	—500	Volts
D-C Plate Current - - - - -	1.8	1.85	Amps
D-C Grid Current - - - - -	190	190	Ma.
Driving Power (approx.) - - - - -	1600	1900	Watts
Useful Power Output - - - - -	6850	7500	Watts

▶ PLATE MODULATED RADIO FREQUENCY AMPLIFIER

(Conventional Neutralized Amplifier—Frequencies below 75 Mc.)

Class-C Telephony (Carrier conditions, per tube)

MAXIMUM RATINGS

D-C PLATE VOLTAGE	- - - -	5000	MAX. VOLTS
D-C PLATE CURRENT	- - - -	2.0	MAX. AMPS
PLATE DISSIPATION	- - - -	1670	MAX. WATTS
PLATE COOLER CORE TEMPERATURE	- - - -	150	MAX. ° C
GRID DISSIPATION	- - - -	150	MAX. WATTS

TYPICAL OPERATIONS (Frequencies below 75 Mc., per tube)

D-C Plate Voltage	- - -	4000	4500	5000	Volts
D-C Plate Current	- - -	1.67	1.55	1.45	Amps
Total Bias Voltage	- - -	-450	-500	-550	Volts
Fixed Bias Voltage	- - -	-230	-325	-410	Volts
Grid Resistor	- - -	1500	1500	1400	Ohms
D-C Grid Current	- - -	150	120	100	Ma.
Peak R-F Grid Input Voltage	- - -	680	720	760	Volts
Driving Power (approx.)	- - -	102	86	76	Watts
Grid Dissipation	- - -	35	26	21	Watts
Plate Power Input	- - -	6670	6970	7250	Watts
Plate Dissipation	- - -	1670	1670	1670	Watts
Plate Power Output	- - -	5000	5300	5580	Watts

▶ AUDIO FREQUENCY POWER AMPLIFIER AND MODULATOR

Class B (Sinusoidal wave, two tubes unless otherwise specified)

MAXIMUM RATINGS

D-C PLATE VOLTAGE	- - - -	6000	MAX. VOLTS
MAX.-SIGNAL D-C PLATE CURRENT, PER TUBE	- - - -	2.5	MAX. AMPS
PLATE DISSIPATION, PER TUBE	- - - -	2500	MAX. WATTS
PLATE COOLER CORE TEMPERATURE	- - - -	150	MAX. ° C

TYPICAL OPERATION CLASS AB₂ (Two tubes)

D-C Plate Voltage	- - -	4000	5000	6000	Volts
D-C Grid Voltage (approx.)*	- - -	-150	-190	-240	Volts
Zero-Signal D-C Plate Current	- - -	0.6	0.5	0.4	Amps
Max.-Signal D-C Plate Current	- - -	4.0	3.2	3.0	Amps
Effective Load, Plate to Plate	- - -	2200	3600	4650	Ohms
Peak A-F Grid Input Voltage (per tube)	- - -	340	360	390	Volts
Max.-Signal Peak Driving Power	- - -	340	230	225	Watts
Max.-Signal Nominal Driving Power (approx.)	- - -	170	115	113	Watts
Max.-Signal Plate Power Output	- - -	11,000	11,000	13,000	Watts

*Adjust to give stated zero-signal plate current.

TYPICAL OPERATION CLASS AB₂ (Two tubes)

(Modulator service for 4000 and 5000 volt operation, to modulate one or two tubes, as shown under "Plate Modulated Radio Frequency Amplifier.")

D-C Plate Voltage	- - -	4000	5000	4000	5000	Volts
D-C Grid Voltage (approx.)*	- - -	-155	-200	-145	-190	Volts
Zero-Signal D-C Plate Current	- - -	0.4	0.4	0.6	0.5	Amps
Max.-Signal D-C Plate Current	- - -	1.35	1.13	2.70	2.26	Amps
Effective Load, Plate to Plate	- - -	6600	10,000	3300	5000	Ohms
Peak A-F Grid Input Voltage (per tube)	- - -	240	275	285	310	Volts
Max.-Signal Peak Driving Power	- - -	42	40	134	118	Watts
Max.-Signal Nominal Driving Power (approx.)	- - -	21	20	67	59	Watts
Max.-Signal Plate Power Output	- - -	3700	4000	7400	8000	Watts
Will Modulate R. F. Final Input of	- - -	6670	7250	13,340	14,500	Watts

*Adjust to give stated zero-signal plate current.

APPLICATION

Filament Voltage—The filament voltage, as measured directly at the tube, should be 7.5 volts with maximum allowable variations due to line fluctuation of from 7.12 to 7.87 volts.

Bias Voltage—There is little advantage in using bias voltages in excess of those given under "Typical Operation", except in certain very specialized applications. Where bias is obtained from a grid resistor, suitable protective means must be provided to prevent excessive plate dissipation in the event of loss of excitation.

Plate Voltage—The plate supply voltage for the 3X2500A3 should not exceed 6000 volts. In most cases there is little advantage in using plate-supply voltages higher than those given under "Typical Operation" for the power output desired.

In Class-C FM or Telegraphy service, a 0.1 henry choke, shunted by a spark gap, should be series connected between the plates of the amplifier tubes and the high voltage plate supply capacitor to offer protection from transients and surges. In plate modulated service, where a plate modulation transformer is used, the protective choke is not normally required.

Grid Dissipation—The power dissipated by the grid of the 3X2500A3 must never exceed 150 watts. Grid dissipation may be calculated from the following expression:

$$P_g = e_{cmp} I_c$$

where P_g = Grid dissipation
 e_{cmp} = Peak positive grid voltage, and
 I_c = D-C grid current

e_{cmp} may be measured by means of a suitable peak voltmeter connected between filament and grid. Any suitable peak v.t.v.m. circuit may be used (one is shown in "Vacuum Tube Ratings", Eimac News, January 1945. This article is available, in reprint form on request).

In equipment in which the plate loading varies widely, such as oscillators used for radio-frequency heating, care should be taken to make certain that the grid dissipation does not exceed the maximum rating under any condition of loading.

In VHF operation, particularly above 75 Mc., the d-c grid current must not exceed 200 ma. under any conditions of plate loading. With lightly loaded conditions the grid driving-power should be reduced so that the grid current does not exceed one-tenth of the plate current.

► DRIVING POWER vs. POWER OUTPUT

The three charts on this page show the relationship of plate efficiency, power output and grid driving power at plate voltages of 4000, 5000 and 6000 volts. These charts show combined grid and bias losses only. The driving power and power output figures do not include circuit losses. The plate dissipation in watts is indicated by P_p .

Points A, B, and C are identical to the typical Class C operating conditions shown on the first page under 4000, 5000 and 6000 volts respectively.

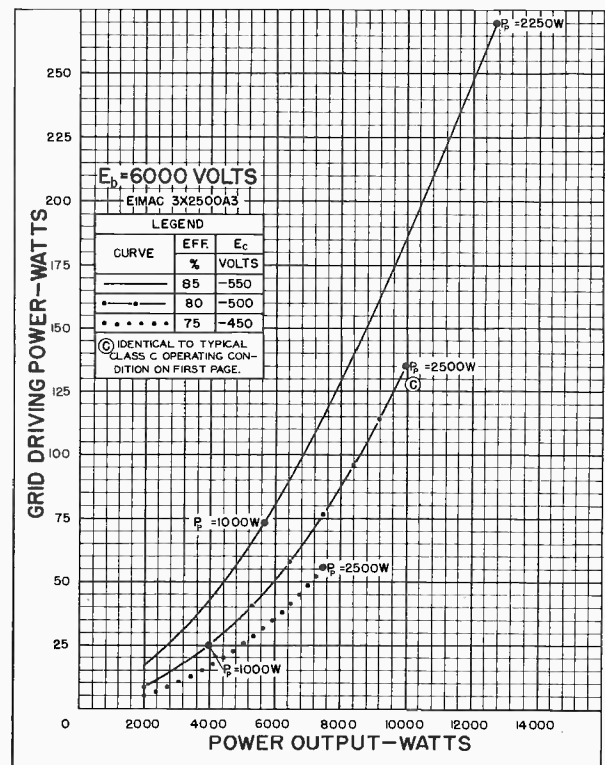
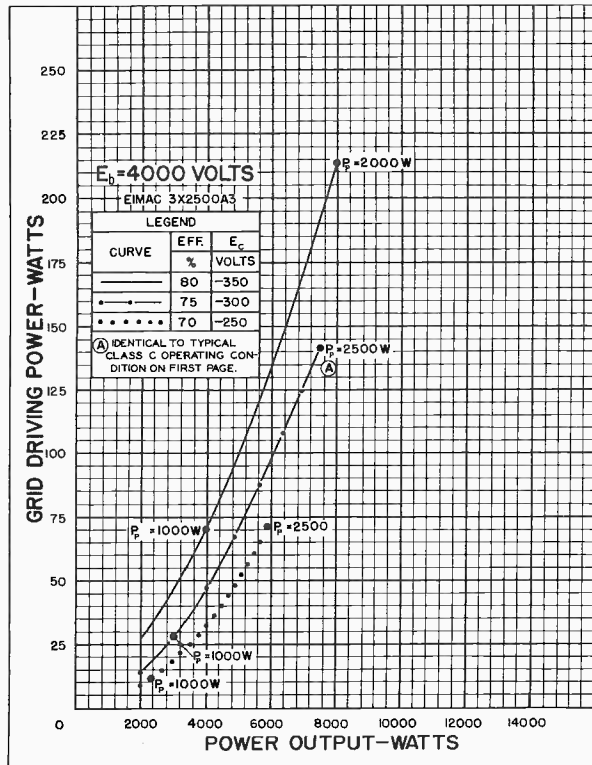
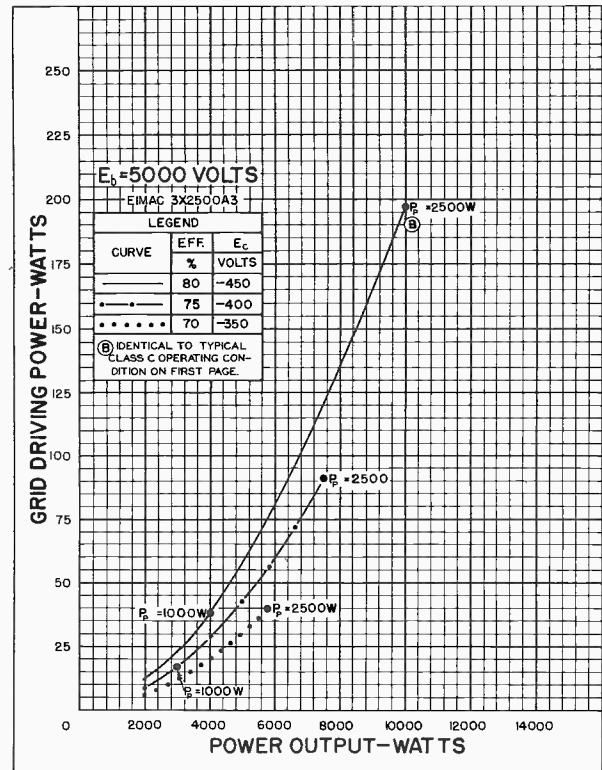

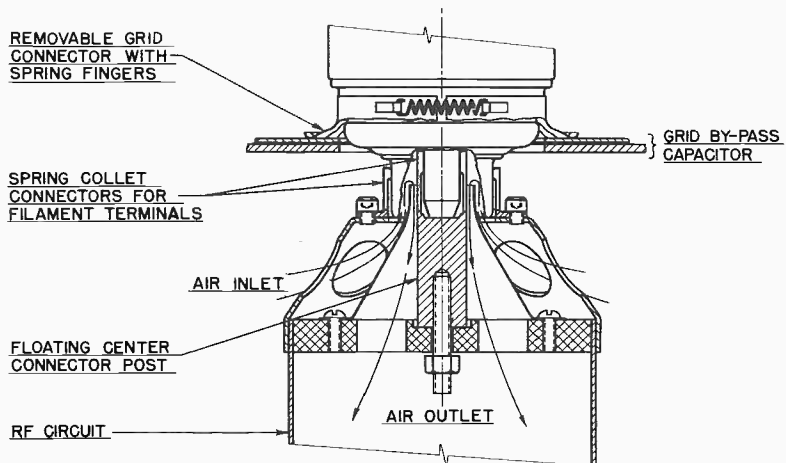
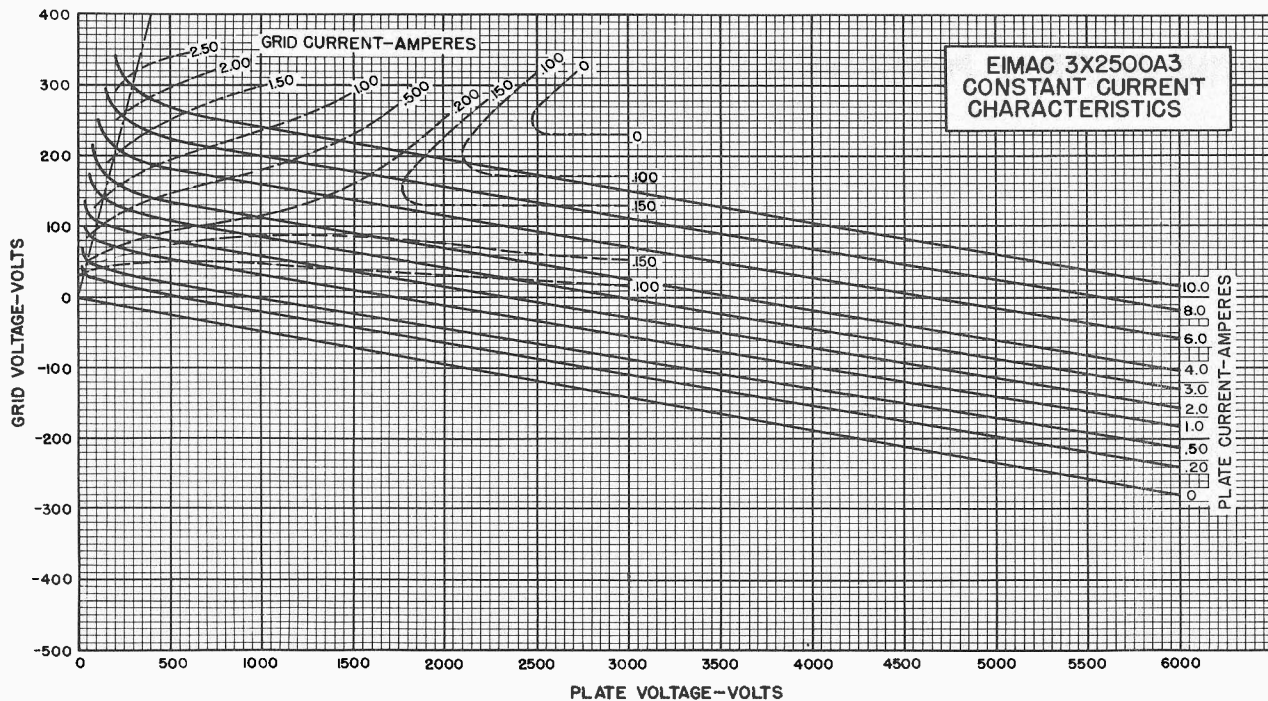

▶ TYPICAL TUBE CONNECTORS AND STEM COOLING

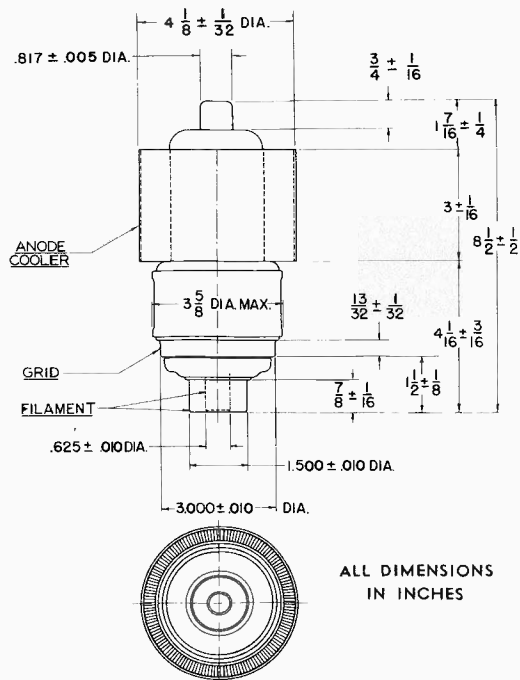

ALL DIMENSIONS IN INCHES

Eitel-McCullough, Inc.

SAN BRUNO, CALIFORNIA

3X2500F3

MEDIUM MU TRIODE

The Eimac 3X2500F3 is a medium-mu, forced-air cooled, external-anode power triode intended for amplifier, oscillator and modulator service. It has a maximum plate dissipation rating of 2500 watts and is capable of high output at relatively low plate voltages. A single 3X2500F3 will deliver a radio frequency plate power-output of 7500 watts at a plate voltage of 4000 volts.

The tube is equipped with flexible filament and grid leads which simplifies socketing and equipment design for industrial and communication frequencies below 30 Mc.

The approved Federal Communications Commission rating for the 3X2500F3 as a plate modulated amplifier is 5000 watts of carrier power.

GENERAL CHARACTERISTICS

ELECTRICAL

Filament: Thoriated tungsten	
Voltage	7.5 volts
Current	51 amperes
Maximum allowable starting current	100 amperes
Amplification Factor (Average)	20
Direct Interelectrode Capacitances (Average)	
Grid-Plate	20 $\mu\mu\text{f}$
Grid-Filament	36 $\mu\mu\text{f}$
Plate-Filament	1.2 $\mu\mu\text{f}$
Transconductance ($i_b = 830 \text{ ma.}, E_b = 3000 \text{ v.}$)	20,000 μmhos
Frequency for Maximum Ratings	30 Mc.

MECHANICAL

Base	See Drawing
Mounting	Vertical, base down or up.
Maximum Overall Dimensions:	
Length (Does not include filament connectors)	9.0 inches
Diameter	4.156 inches
Net weight	7.5 pounds
Shipping weight (Average)	17 pounds
Cooling	

A minimum flow of 120 cubic feet of air per minute must be passed through the anode cooler. The pressure drop across the cooler at this flow equals 1.0 inch of water. A minimum air-flow of 6 cubic feet per minute must also be directed toward the filament-stem structure, between the inner and outer filament conductors. Cooling air in the above quantities must be supplied to both anode cooler and filament seals before applying filament voltage and should be continued for five minutes after the filament power is removed. Anode-cooler core, grid and filament seal temperatures must not exceed 150° C. These figures are for an ambient temperature of 20° C at sea level and do not include duct or filter losses.

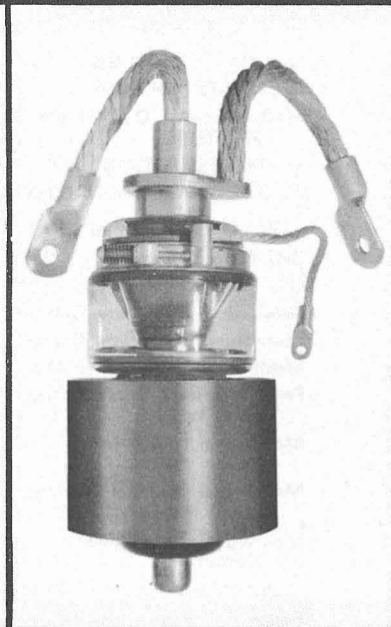

RADIO FREQUENCY POWER AMPLIFIER OR OSCILLATOR

(Frequencies below 30 Mc.)

Class-C FM or Telegraphy
(Key-down conditions, per tube)

MAXIMUM RATINGS

D-C PLATE VOLTAGE	6000 MAX. VOLTS
D-C PLATE CURRENT	2.5 MAX. AMPS
PLATE DISSIPATION	2500 MAX. WATTS
ANODE-COOLER CORE TEMPERATURE	150 MAX. °C
GRID DISSIPATION	150 MAX. WATTS

TYPICAL OPERATION

(Frequencies below 30 Mc., per tube)

D-C Plate Voltage	4000	5000	6000	Volts
D-C Plate Current	2.5	2.5	2.08	Amps
D-C Grid Voltage	-300	-450	-500	Volts
D-C Grid Current	245	265	180	Ma.
Peak R. F. Grid Input Voltage	580	750	765	Volts
Driving Power (approx.)	142	197	136	Watts
Grid Dissipation	68	78	46	Watts
Plate Power Input	10,000	12,500	12,500	Watts
Plate Dissipation	2500	2500	2500	Watts
Plate Power Output	7500	10,000	10,000	Watts

PLATE MODULATED RADIO FREQUENCY AMPLIFIER

(Frequencies below 30 Mc.)

Class-C Telephony
(Carrier conditions, per tube)

MAXIMUM RATINGS

D-C PLATE VOLTAGE	5000 MAX. VOLTS
D-C PLATE CURRENT	2.0 MAX. AMPS
PLATE DISSIPATION	1670 MAX. WATTS
ANODE-COOLER CORE TEMPERATURE	150 MAX. °C
GRID DISSIPATION	150 MAX. WATTS

TYPICAL OPERATION

(Frequencies below 30 Mc., per tube)

D-C Plate Voltage	4000	4500	5000	Volts
D-C Plate Current	1.67	1.55	1.45	Amps
Total Bias Voltage	-450	-500	-550	Volts
Fixed Bias Voltage	-230	-325	-410	Volts
Grid Resistor	1500	1500	1400	Ohms
D-C Grid Current	150	120	100	Ma.
Peak R. F. Grid Input Voltage	680	720	760	Volts
Driving Power (approx.)	102	86	76	Watts
Grid Dissipation	35	26	21	Watts
Plate Power Input	6670	6970	7250	Watts
Plate Dissipation	1670	1670	1670	Watts
Plate Power Output	5000	5300	5580	Watts

AUDIO FREQUENCY POWER AMPLIFIER AND MODULATOR

Class B (Sinusoidal wave, two tubes unless otherwise specified)

MAXIMUM RATINGS

D-C PLATE VOLTAGE - - - -	6000 MAX. VOLTS
MAX.-SIGNAL D-C PLATE CURRENT, PER TUBE - - - -	2.5 MAX. AMPS
PLATE DISSIPATION, PER TUBE - -	2500 MAX. WATTS
ANODE-COOLER CORE TEMPERATURE	150 MAX. °C

TYPICAL OPERATION CLASS AB₂ (Two Tubes)

D-C Plate Voltage - - -	4000	5000	6000	Volts
D-C Grid Voltage (approx.)*	-150	-190	-240	Volts
Zero-Signal D-C Plate Current	0.6	0.5	0.4	Amps
Max.-Signal D-C Plate Current	4.0	3.2	3.0	Amps
Effective Load, Plate to Plate	2200	3600	4650	Ohms
Peak A-F Grid Input Voltage (per tube) - - -	340	360	390	Volts
Max.-Signal Peak Driving Power - - - -	340	230	225	Watts
Max.-Signal Nominal Driving Power (approx.) - -	170	115	113	Watts
Max.-Signal Plate Power Output - - - -	11,000	11,000	13,000	Watts

*Adjust to give stated zero-signal plate current.

TYPICAL OPERATION CLASS AB₂ (Two Tubes)

Modulator service for 4000 and 5000 volt operation, to modulate one or two tubes, as shown under "Plate Modulated Radio Frequency Amplifier" (Page 1)

D-C Plate Voltage -	4000	5000	4000	5000	Volts
D-C Grid Voltage (approx.)* - - -	-155	-200	-145	-190	Volts
Zero-Signal D-C Plate Current - - - -	0.4	0.4	0.6	0.5	Amps
Max.-Signal D-C Plate Current - - - -	1.35	1.13	2.70	2.26	Amps
Effective Load, Plate to Plate - - - -	6600	10,000	3300	5000	Ohms
Peak A-F Grid Input Voltage (per tube)	240	275	285	310	Volts
Max.-Signal Peak Driving Power - -	42	40	134	118	Watts
Max.-Signal Nominal Driving Power (approx.) - - - -	21	20	67	59	Watts
Max.-Signal Plate Power Output - -	3700	4000	7400	8000	Watts
Will Modulate one Tube R. F. Final Input of - - - -	6670	7250			Watts
Will Modulate two tubes R. F. Final Input of - - - -			13,340	14,500	Watts

*Adjust to give stated zero-signal plate current.

APPLICATION

Filament Voltage—The filament voltage, as measured directly at the tube, should be 7.5 volts with maximum allowable variations due to line fluctuation of from 7.12 to 7.87 volts.

Bias Voltage—There is little advantage in using bias voltages in excess of those given under "Typical Operation", except in certain very specialized applications. Where bias is obtained from a grid resistor, suitable protective means must be provided to prevent excessive plate dissipation in the event of loss of excitation.

Plate Voltage—The plate supply voltage for the 3X2500F3 should not exceed 6000 volts. In most cases there is little advantage in using plate-supply voltages higher than those given under "Typical Operation" for the power output desired.

In Class-C FM or Telegraphy service, a 0.1 henry choke, shunted by a spark gap, should be series connected between the plates of the amplifier tubes and the high voltage plate supply capacitor to offer protection from transients and surges. In plate modulated service, where a plate modulation transformer is used, the protective choke is not normally required.

Grid Dissipation—The power dissipated by the grid of the 3X2500F3 must never exceed 150 watts. Grid dissipation may be calculated from the following expression

$$P_g = e_{cmp} I_c$$

where P_g = Grid dissipation

e_{cmp} = Peak positive grid voltage, and

I_c = D-C grid current

e_{cmp} may be measured by means of a suitable peak voltmeter connected between filament and grid. Any suitable peak v.t.v.m. circuit may be used (one is shown in "Vacuum Tube Ratings", Eimac News, January 1945. This article is available in reprint form on request).

In equipment in which the plate loading varies widely, such as oscillators used for radio-frequency heating, care should be taken to make certain that the grid dissipation does not exceed the maximum rating under any condition of loading.

▶ DRIVING POWER vs. POWER OUTPUT

The three charts on this page show the relationship of plate efficiency, power output and grid driving-power at plate voltages of 4000, 5000 and 6000 volts. These charts show combined grid and bias losses only. The driving power and power output figures do not include circuit losses. The plate dissipation in watts is indicated by P_p .

Points A, B, and C are identical to the typical Class C operating conditions shown on the first page under 4000, 5000 and 6000 volts respectively.

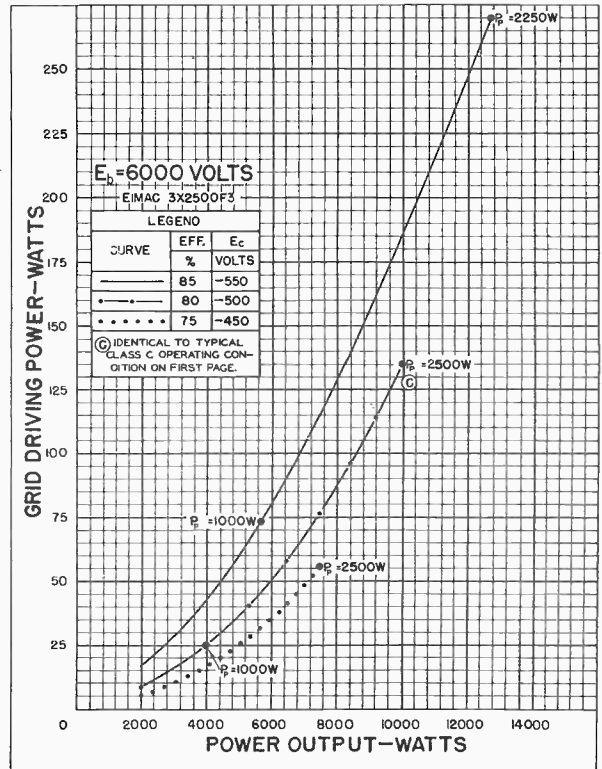
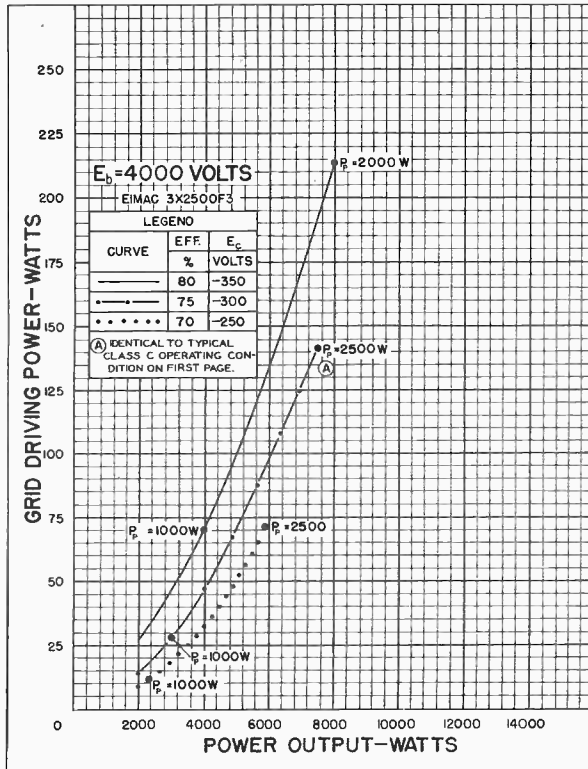
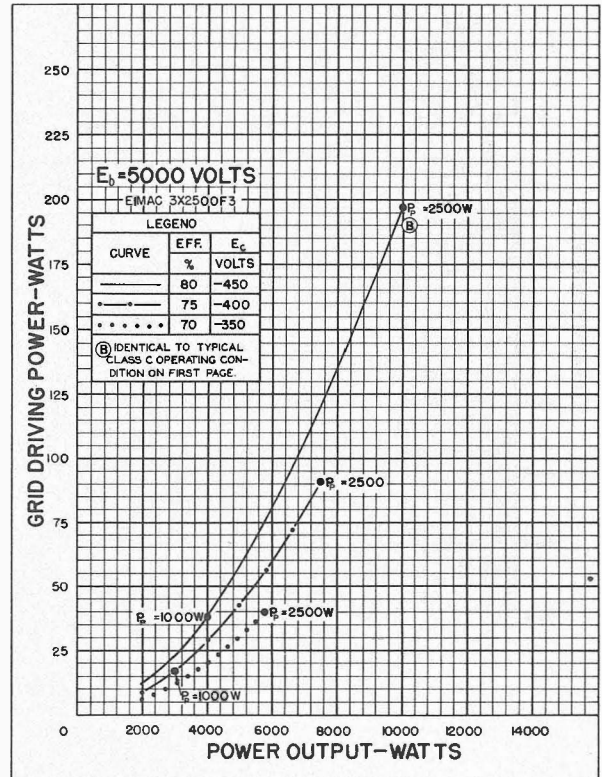

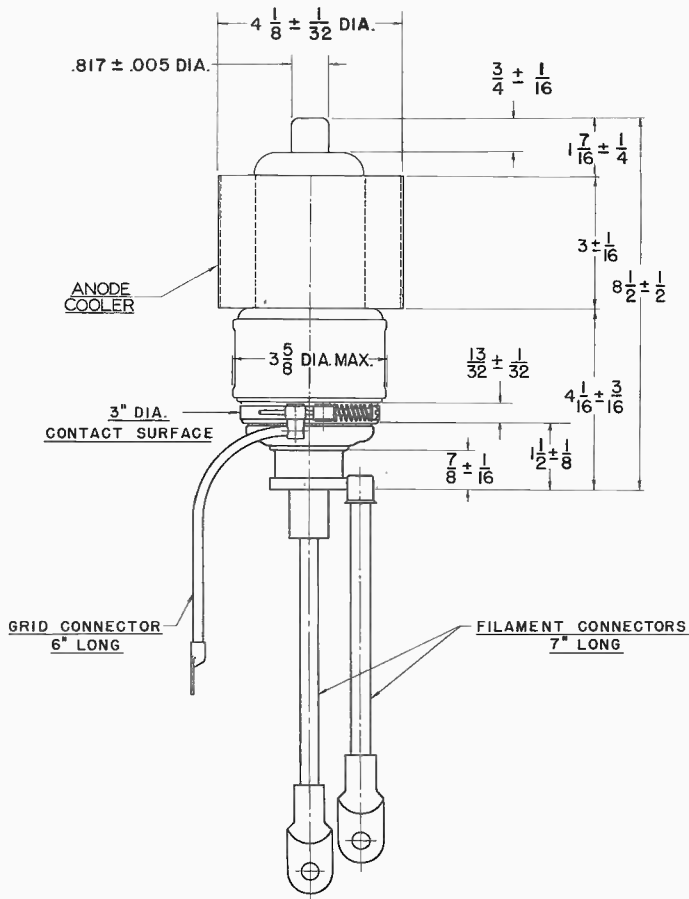
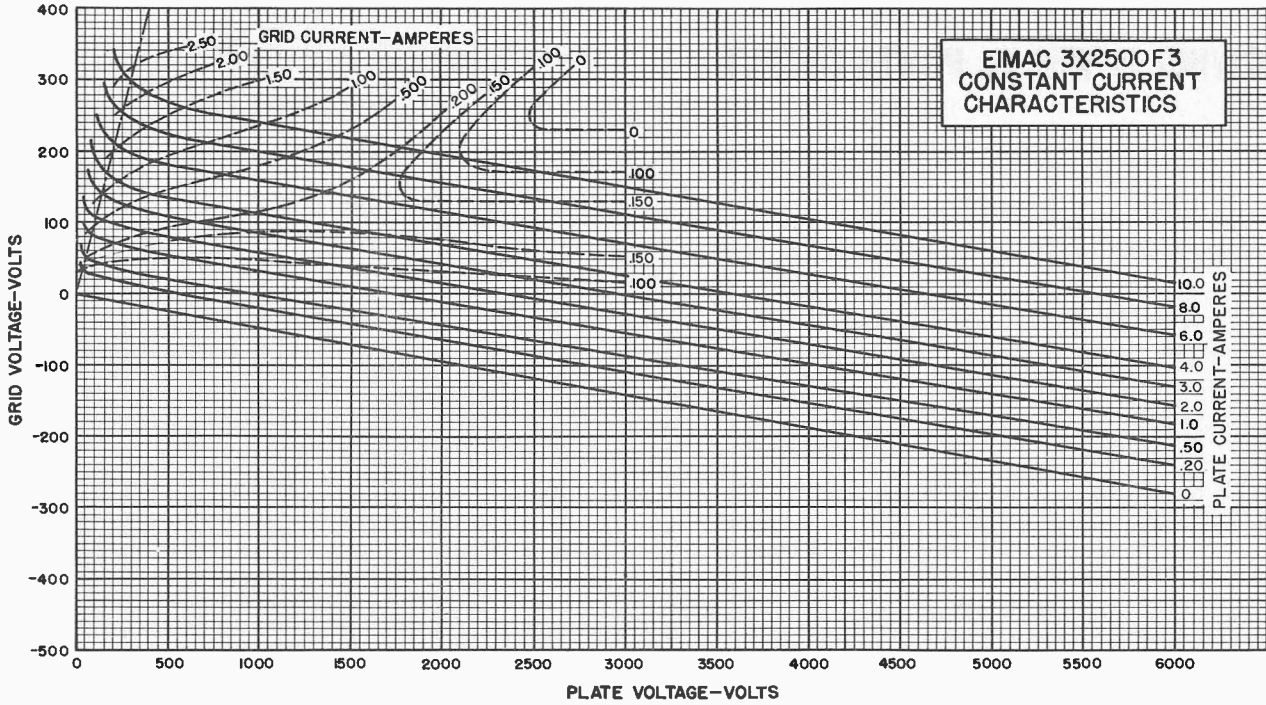

TENTATIVE DATA

EITEL-McCULLOUGH, Inc.
SAN BRUNO, CALIFORNIA

3W10000A3
VHF
POWER TRIODE

The Eimac 3W10000A3 is a high power, water cooled, external-anode transmitting triode having a maximum plate dissipation capability of 10 kilowatts. As a power amplifier the tube will operate efficiently at frequencies up to 250 Mc. A single 3W10000A3 operating as a television linear amplifier will deliver a synchronizing power-output of 5.5 kilowatts at 216 Mc. with a 5-Mc. bandwidth.

The coaxial terminal arrangement of the tube is ideally suited for use in cavity circuits. The cathode is a unipotential, indirectly heated, thoriated tungsten cylinder of rugged construction.

GENERAL CHARACTERISTICS

ELECTRICAL

Cathode: Indirectly heated thoriated tungsten (Note 1)			
Voltage, normal	- - - - -	1550	Volts D.C.
Current, normal	- - - - -	1.6	Amps. D.C.
Filament: Thoriated tungsten helix (Note 2)			
Voltage, starting	- - - - -	8.0	Volts A.C.
Voltage, operating	- - - - -	7.0	Volts A.C.
Current, starting	- - - - -	25	Amps.
Current, operating	- - - - -	15	Amps.
Amplification Factor (Average)	- - - - -	20	
Direct Interelectrode Capacitances (Average)			
Grid-Plate	- - - - -	30	$\mu\mu\text{f}$
Grid-Cathode	- - - - -	65	$\mu\mu\text{f}$
Plate-Cathode	- - - - -	3.5	$\mu\mu\text{f}$
Transconductance ($i_b = 3.3$ amp., $E_b = 3000$ v.)	- - - - -	55,000	μmhos

MECHANICAL

Cooling	- - - - -	Water and Forced Air (Note 3)
Mounting	- - - - -	Vertical, base down or up
Maximum Overall Dimensions:		
Length	- - - - -	13.0 inches
Diameter	- - - - -	5.0 inches
Net Weight	- - - - -	10.2 pounds
Shipping Weight (Average)	- - - - -	41 pounds

RADIO FREQUENCY POWER AMPLIFIER

Class-B Linear Amplifier-Television Service

MAXIMUM RATINGS (per tube)

D-C PLATE VOLTAGE	- - - - -	5 MAX KILOVOLTS
D-C PLATE CURRENT	- - - - -	10 MAX. AMPS.
PLATE DISSIPATION	- - - - -	10 MAX. KILOWATTS
GRID DISSIPATION	- - - - -	100 MAX. WATTS

TYPICAL OPERATION (Per tube, 5-Mc. Bandwidth, 216 Mc.)

Peak Synchronizing Level			
Load Impedance	- - - - -	560	280 Ohms
Effective Length of Plate Line	- - - - -	Quarter	Half Wave
D-C Plate Voltage	- - - - -	3250	2600 Volts
D-C Plate Current	- - - - -	4.25	6.0 Amps.
D-C Grid Voltage	- - - - -	-190	-160 Volts
D-C Grid Current	- - - - -	400	680 Ma.
Plate Power Input	- - - - -	13.8	15.6 Kw.
Plate Power Output	- - - - -	5.5	5.5 Kw.
Black Level			
D-C Plate Current (approx.)	- - - - -	3.18	4.5 Amps.
Plate Power Input	- - - - -	10.3	11.7 Kw.
Plate Dissipation	- - - - -	7.2	8.6 Kw.
Plate Power Output	- - - - -	3.1	3.1 Kw.
D-C Grid Voltage	- - - - -	-190	-160 Volts
D-C Grid Current	- - - - -	80	260 Ma.

Note 1: Cathode Heating Power—The cathode of the 3W10000A3 is a unipotential thoriated tungsten cylinder which is heated by electron bombardment of its inner surface. Bombardment is obtained by using the cylindrical cathode as the anode of a diode. A helical filament is mounted on the axis of the cathode cylinder to supply the bombarding electrons. A D.C. potential difference of approximately 1550 volts is applied between the inner filament and the cathode cylinder and

the recommended cathode heating power of 2500 watts is obtained with approximately 1550 volts D.C. and 1.6 amperes.

The inner filament is designed to operate under space charge limited conditions so that the cathode temperature may be varied by changing the voltage applied between the inner filament and the cathode cylinder. Since the cathode is connected to the negative terminal of the main plate supply, the inner filament may be at considerable negative potential with respect to ground. The filament transformer supplying the heating for the inner filament should be adequately insulated for this voltage.

Note 2: Filament Voltage and Regulation—The nominal value of filament voltage necessary for sufficient emission to start heating of the cathode is 8 volts. Once the cathode has reached operating temperature, heat is returned to the inner filament by radiation. Therefore, after the cathode power is applied, the inner filament voltage should be reduced to approximately 7 volts.

When the inner filament is first heated, the initial in-rush current must be limited to 40 amperes maximum. The current drawn by the filament at 8 volts, with the cathode cold, is about 25 amperes. After the cathode has reached temperature and the filament voltage has been reduced to 7 volts, the filament current drawn is approximately 15 amperes.

Note 3: Cooling—The water-cooled anode requires 2.1 gallons of cooling water per minute at an inlet pressure of 30 pounds per square inch, above discharge head, for the rated 10 Kw of plate dissipation. The outlet water temperature should not exceed 70°C.

The grid-terminal contact ring and adjacent glass must be cooled by high velocity air. The quantity, velocity and direction must be arranged to limit the maximum seal temperature to 175°C.

The cathode and filament-stem also require forced-air cooling. A minimum of 10 cubic feet per minute must flow through the three air holes in the center of the base of the tube to cool the glass parts supporting the filament. A minimum of 25 cubic feet per minute must flow up the outside of the two-inch diameter cathode contacting surface and into the space between this lead and the glass seal. The maximum safe operating temperature of the glass seal is 175°C. The air inside the cathode-lead cools only the filament assembly and does not cool the two-inch diameter cathode contacting surface.

Both air and water flow must be started before filament and cathode power are applied and maintained for at least one minute after the filament and cathode power have been switched off.

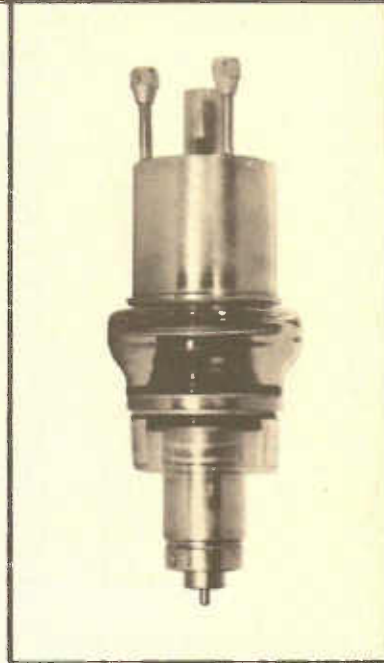

(Effective 2-15-50) Copyright 1950 by Eitel-McCullough, Inc.

TENTATIVE DATA

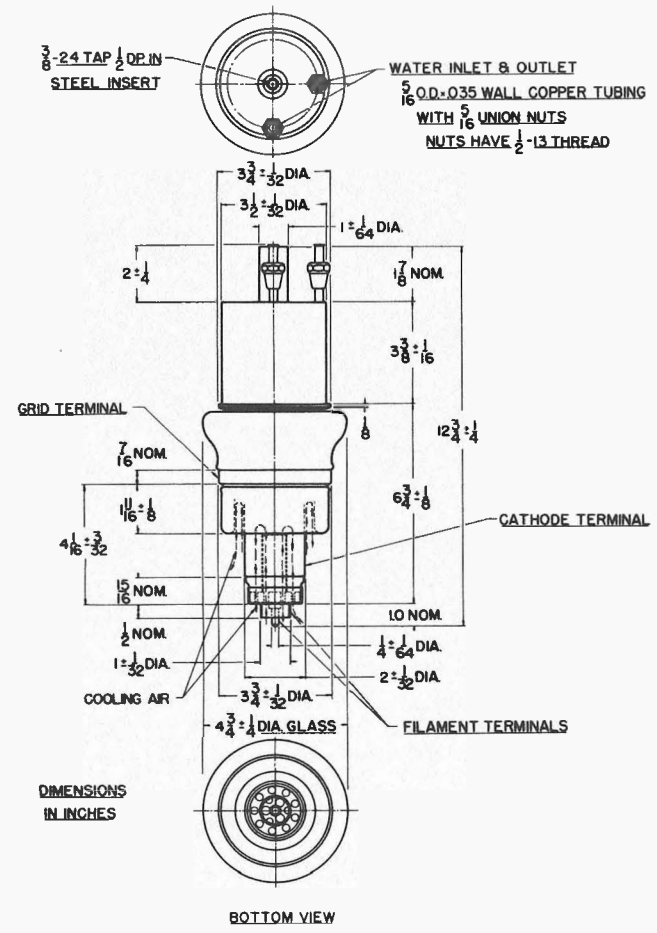
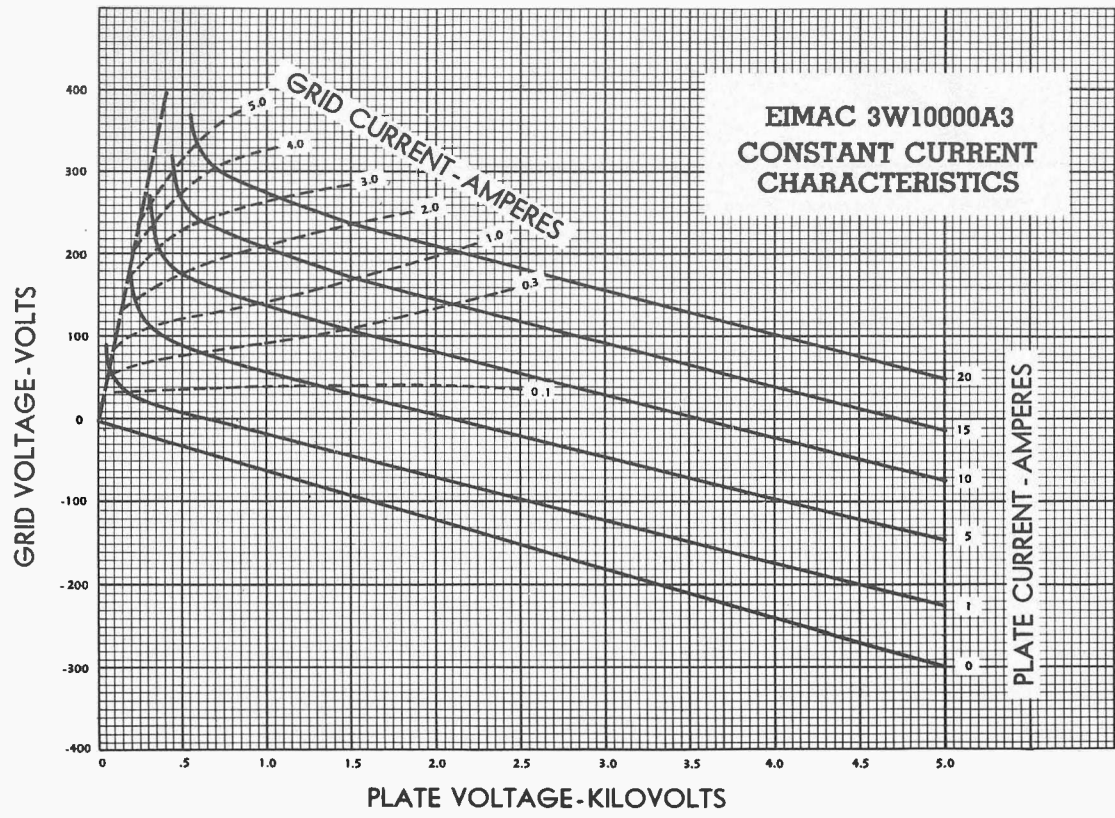

Eitel-McCullough, Inc.

SAN BRUNO, CALIFORNIA

VACUUM CAPACITORS

VC50-32	VC50-20
VC25-32	VC25-20
VC12-32	VC12-20
VC6-32	VC6-20

Eimac vacuum capacitors are small, vacuum-dielectric units intended principally for use as all or part of the plate tank capacitance in radio-frequency amplifiers or oscillators. They are also frequently used as high-voltage coupling and by-pass capacitors at high frequencies and as high-voltage neutralizing capacitors, when used in conjunction with small high-voltage variable capacitors having a small capacitance range. The use of a vacuum as a dielectric permits the construction of a comparatively small, lightweight capacitor for a given voltage rating and capacitance. In addition, the effects of dust and atmospheric conditions on the capacitor are eliminated by sealing the plates within a glass envelope.

These capacitors are manufactured in two maximum peak voltage ratings, 32,000 and 20,000 volts, and in capacitances of 6, 12, 25 and 50 μfd . All types have a maximum current rating of 28 amperes. Each of the capacitors may be operated at its full maximum voltage rating at any frequency below that at which the rms current through the capacitor is 28 amperes. Above this frequency, the r-f voltage across the capacitor must be reduced as the frequency increases, to prevent the current from exceeding the maximum rating. The graphs below show the maximum peak r-f voltage which may be applied to each type of capacitor at frequencies between 100 kilocycles and 50 megacycles. Curves are also shown which indicate the rms current flowing through the capacitor under maximum r-f voltage conditions at any frequency between 100 kilocycles and 50 megacycles. Where both r-f and d-c voltages are applied to the capacitor, the sum of the peak r-f and d-c voltages must not exceed the peak voltage rating of the capacitor.

Eimac vacuum capacitors are provided with terminals which allow the use of standard 60-ampere fuse clips for mounting. These clips must be kept clean and must at all times make firm and positive contact with the capacitor terminals. Failure to maintain a low-resistance contact to the capacitor terminals may result in excessive heating and permanent damage to the capacitor seals.

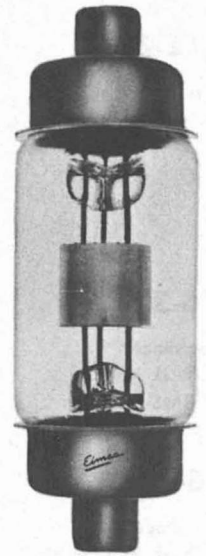

VC50-32

Capacitance* 50 μfd .
 Max. Peak Voltage 32,000 volts
 Max. RMS Current 28 amps.

VC50-20

Capacitance* 50 μfd .
 Max. Peak Voltage 20,000 volts
 Max. RMS Current 28 amps.

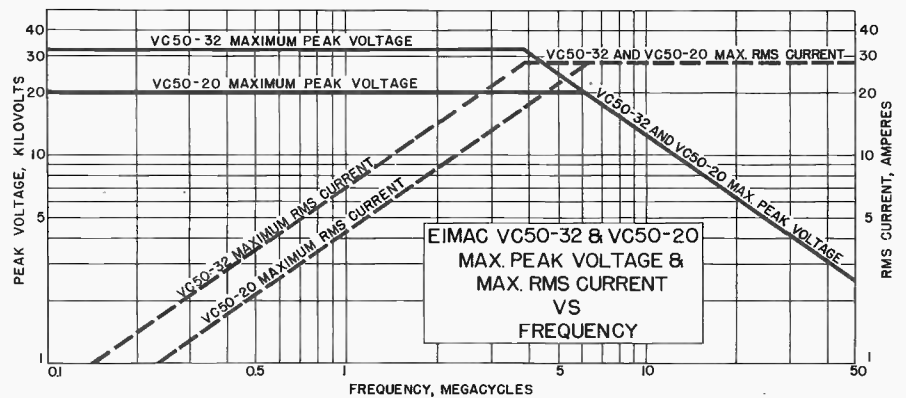

VC25-32

Capacitance* 25 μfd .
 Max. Peak Voltage 32,000 volts
 Max. RMS Current 28 amps.

VC25-20

Capacitance* 25 μfd .
 Max. Peak Voltage 20,000 volts
 Max. RMS Current 28 amps.

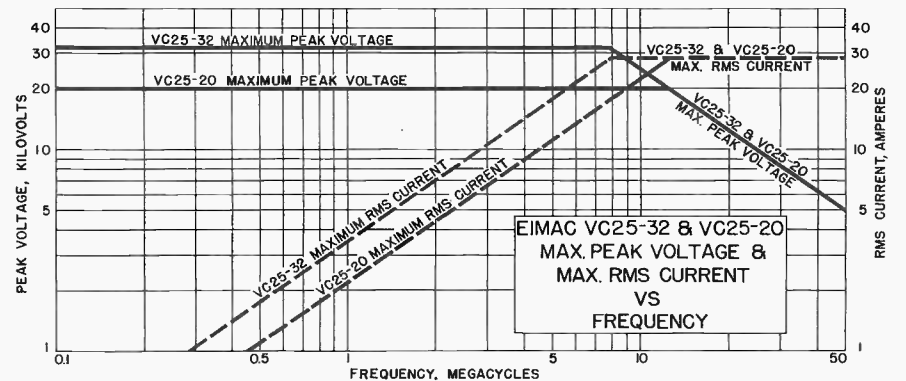

VC12-32

Capacitance* 12 $\mu\mu\text{fd}$.
Max. Peak Voltage 32,000 volts
Max. RMS Current 28 amps.

VC12-20

Capacitance* 12 $\mu\mu\text{fd}$.
Max. Peak Voltage 20,000 volts
Max. RMS Current 28 amps.

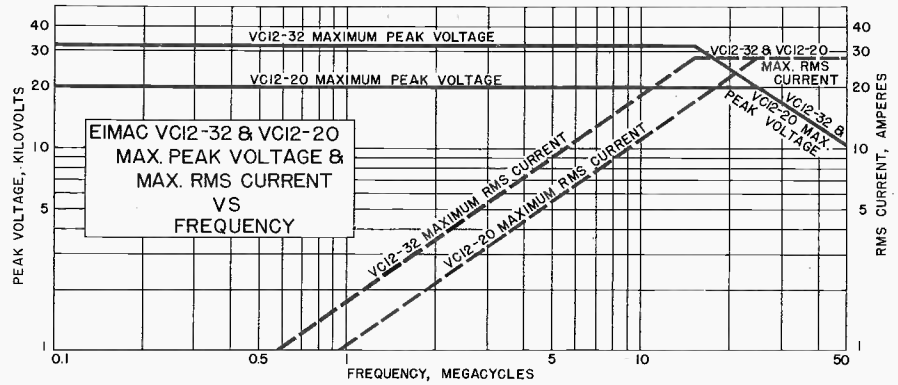

VC6-32

Capacitance* 6 $\mu\mu\text{fd}$.
Max. Peak Voltage 32,000 volts
Max. RMS Current 28 amps.

VC6-20

Capacitance* 6 $\mu\mu\text{fd}$.
Max. Peak Voltage 20,000 volts
Max. RMS Current 28 amps.

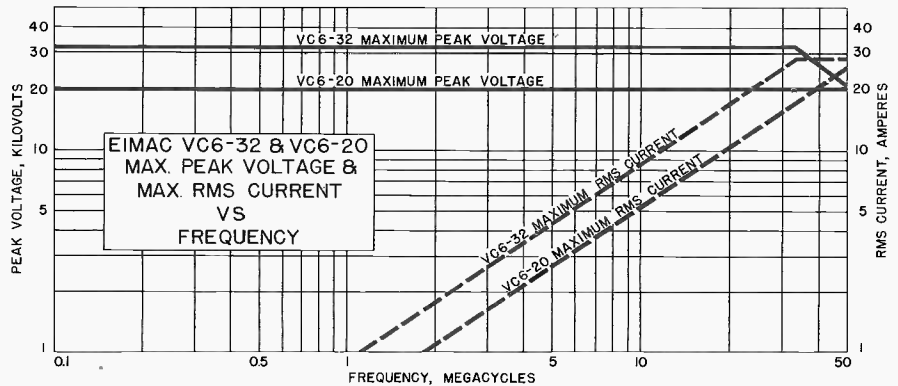

*Tolerances:

VC50-32, VC50-20 $\pm 1 \mu\mu\text{fd}$.; VC25-32, VC25-20 $\pm 1 \mu\mu\text{fd}$.; VC12-32, VC12-20 $\pm 1 \mu\mu\text{fd}$.; VC6-32, VC6-20 $\pm 0.5 \mu\mu\text{fd}$.

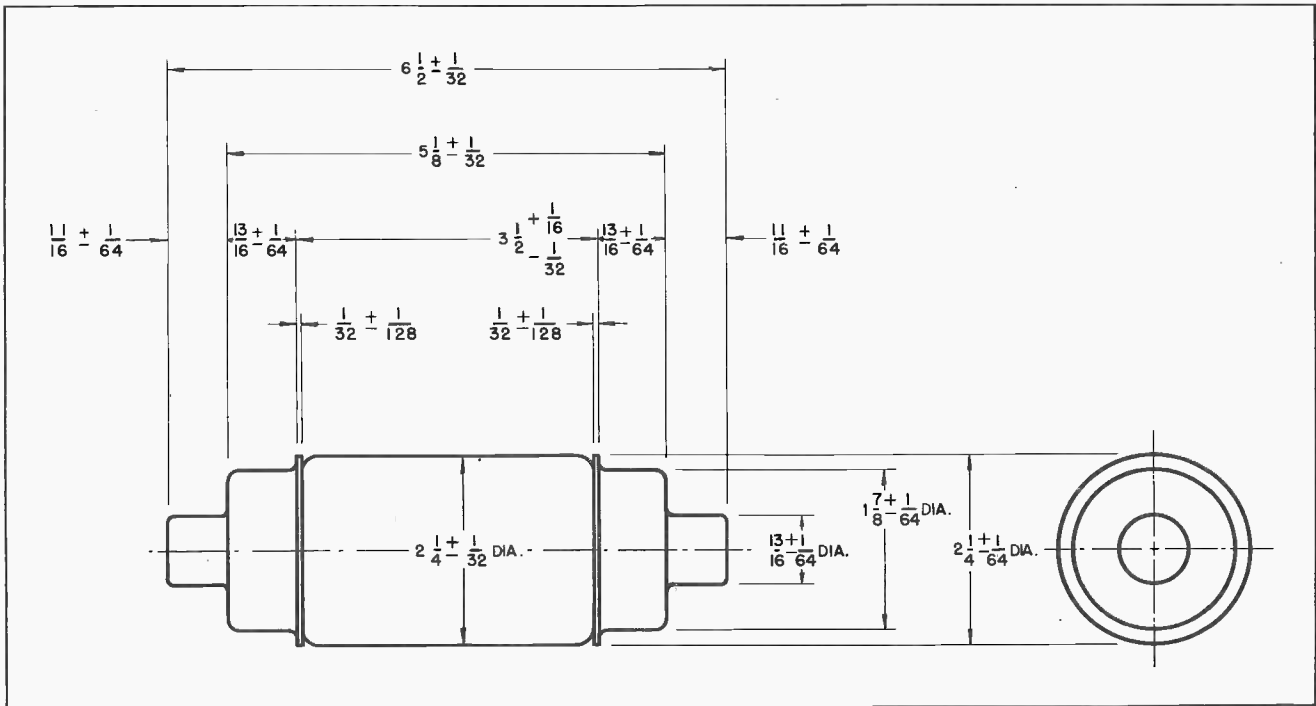

TYPES VVC 60-20 VVC2-60-20 VVC4-60-20

GENERAL

Eimac variable vacuum capacitors are intended principally for use as plate tank capacitors in radio frequency amplifiers and oscillators. The use of vacuum for the dielectric permits close spacing of the electrodes giving concentrated capacitance at high voltage. The variable vacuum capacitors are compact, lightweight, and eliminate the effects of dust and atmospheric conditions.

The basic capacitor unit (VVC60-20) has an RF peak voltage rating of 20,000 volts and a maximum current rating of 40 amperes RMS. Ganged multiple unit capacitors are available using two units (VVC2-60-20) or four units (VVC4-60-20). These multiple unit capacitors include a single mounting plate, gear train, and single tuning shaft. One end of each unit capacitor mounts on the common plate and one end is free. Thus the multiple capacitor may be connected with the units in parallel, as two series capacitors for "split-stator" work, or as multiple capacitors with one terminal common.

The capacitors may be operated at the maximum voltage rating at any frequency provided the current rating is not exceeded. Above a particular frequency the maximum current rating becomes the limitation and voltage values less than the maximum must be used. Curves are given for each capacitor showing maximum allowable current (RMS) vs frequency.

MOUNTING

The VVC60-20 is provided with a mounting plate on one end, which also serves as an electrical connection. If the circuit is such that one side of the capacitor is grounded, the mounting plate can be fastened directly to the panel or chassis. Four eyelets are provided on the mounting plate that accommodate No. 8-32 screws. If the unit is to be ungrounded the mounting should be on insulators and the tuning shaft broken with an insulating coupling and the dial portion of the shaft grounded.

The other end of the capacitor is provided with a large terminal that permits the use of a simple clamp or collet connector. This connector should be mounted flexibly to prevent undue mechanical strain being put on the capacitor seals. The connector must be kept clean and must at all times make a firm and positive contact with the capacitor terminal. Failure to maintain a low resistance contact to the capacitor terminal may result in excessive heating and permanent damage to the capacitor seals.

The multiple unit capacitor is designed so that it may be mounted readily on the chassis or from a panel. The mounting plate serves as one electrical connection and can be mounted directly at ground potential or insulated above ground. If the unit is ungrounded the tuning shaft should be broken with an insulating coupling and the dial portion of the shaft grounded.

The capacitors require normal circulation of air to keep the metal-to-glass seals below the maximum permissible temperature when carrying large values of current. In cases where the air flow is restricted or the ambient temperature is above room temperature a measurement of the seal temperature be made. Adequate cooling must be provided to keep the metal of the metal-to-glass seals below 150° centigrade.

The capacitance variation is linear with respect to shaft rotation, with the complete range being covered in seventeen revolutions of the shaft. Reference should be made to the tuning curve for each capacitor. A return to previously indexed settings is positive. The low-torque tuning mechanism provides easy hand operation of a dial directly on the shaft of either the single or multiple unit capacitors.

The variable vacuum capacitors have a low temperature coefficient resulting in a negligible change in capacitance due to variation in temperature. The actual coefficient values are given for each capacitor combination.

VVC 60-20
VARIABLE
VACUUM
CAPACITOR

Eimac
EITEL-McCULLOUGH, INC.
 SAN BRUNO, CALIFORNIA



The VVC60-20 is a single unit variable vacuum capacitor.

CHARACTERISTICS

ELECTRICAL

Capacitance		
Maximum		60 mmfd
Minimum		10 mmfd
Number of revolutions (See Curve)		17 turns
Maximum Peak R.F. Voltage		20 kilovolts
Maximum Current (RMS)		40 amperes
(See derating curve vs frequency)		
Temperature Coefficient		+ .004 mmfd/°C

MECHANICAL

Mounting	See Outline Drawing
Cooling	Air Convection
Maximum Seal Temperature	150°C.
Maximum Overall Dimensions	
Length	5-11/16"
Diameter	3- 1/16"
Net Weight	1 lb. 6 oz.
Shipping Weight (average)	2 lb.

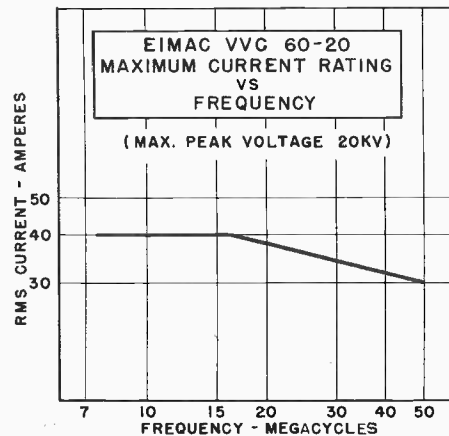
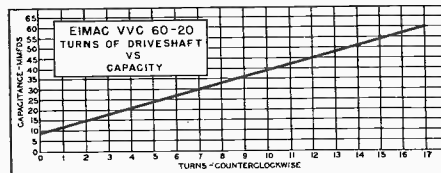
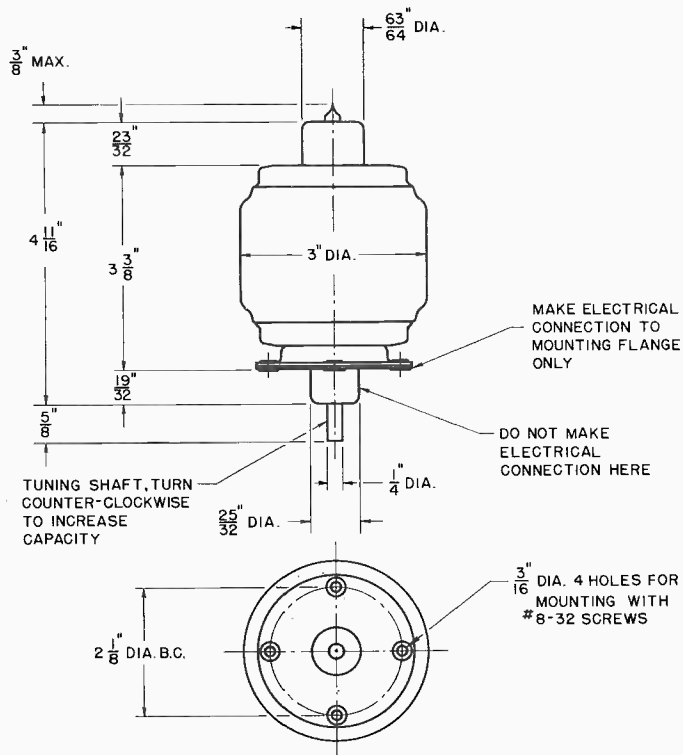

EITEL-McCULLOUGH, Inc.

SAN BRUNO, CALIFORNIA

VVC2-60-20

VARIABLE
VACUUM
CAPACITOR

The VVC2-60-20 is a dual unit variable vacuum capacitor consisting of two VVC60-20 units in a convenient gang-tuned mounting.

CHARACTERISTICS

ELECTRICAL

	Parallel	Split Stator
Capacitance		
Maximum	120	30 mmfd
Minimum	20	5 mmfd
Number of revolutions (See Curves)	17	17 turns
Maximum Peak R.F. Voltage.....	20	40 kilovolts
Maximum Current (RMS)	80	40 amperes
(See derating vs frequency)		
Temperature Coefficient	+ .008	+ .002 mmfd/°C

MECHANICAL

Mounting	See Outline Drawing
Cooling	Air Convection
Maximum Seal Temperature.....	150° C
Maximum Overall Dimensions	
Depth	6-9/32"
Height	3-1/8"
Width	8-1/8"
Net Weight	4 lbs.
Shipping Weight (approx.)	8 lbs.

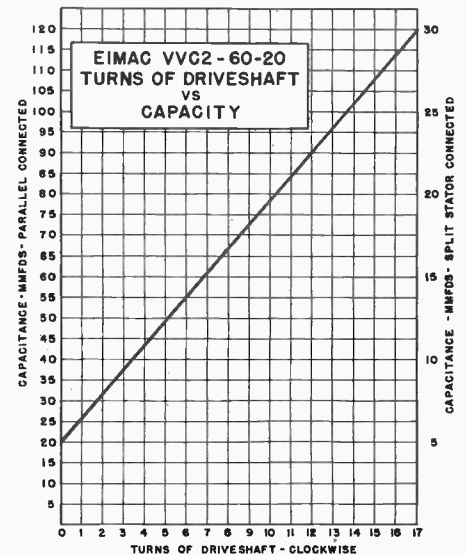
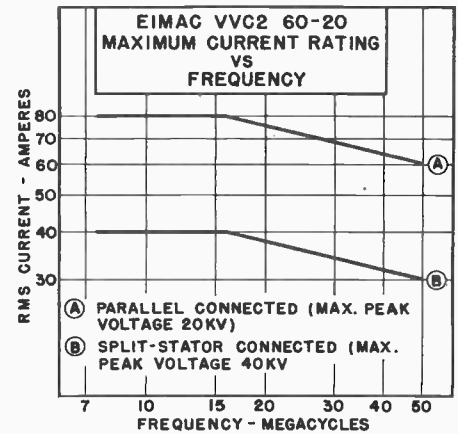
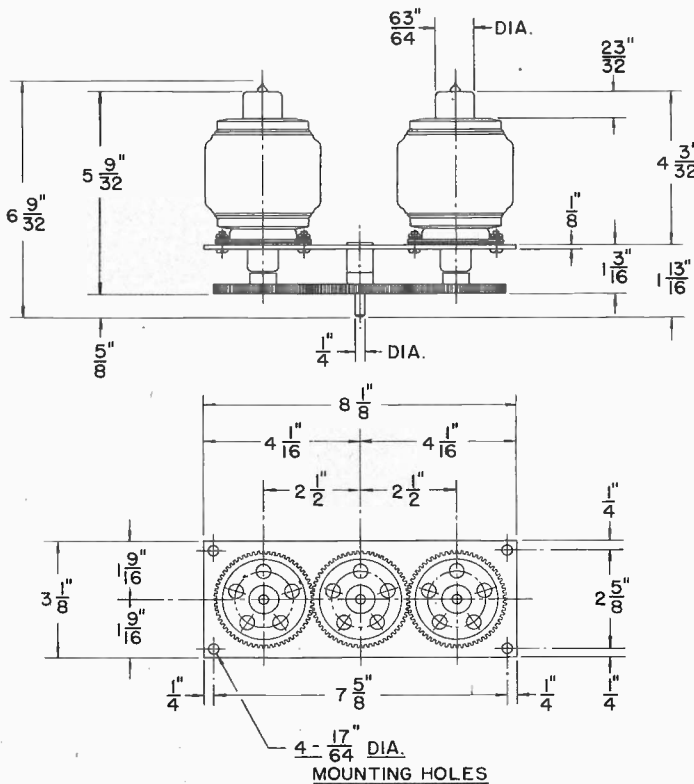
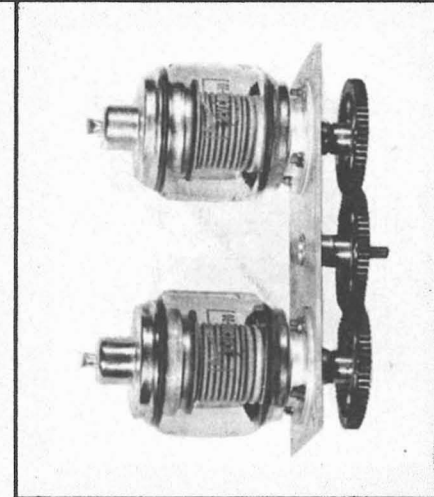

VVC4-60-20
VARIABLE
VACUUM
CAPACITOR

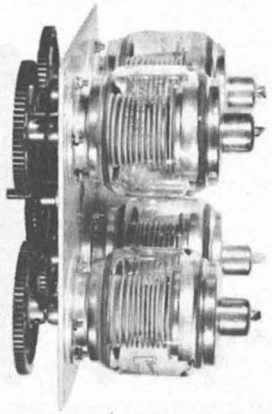

The VVC4-60-20 is a four unit variable vacuum capacitor consisting of four VVC60-20 units in a convenient gang-tuned unit.

CHARACTERISTICS

ELECTRICAL

	Parallel	Split Stator	
Capacitance			
Maximum	240	60	mmfd
Minimum	40	10	mmfd
Number of revolutions (See Curves)	17	17	turns
Maximum Peak R.F. Voltage.....	20	40	kilovolts
Maximum Current (RMS).....	160	80	amperes
(See derating curve vs frequency)			
Temperature Coefficient	+0.016	+0.004	mmfd/°C

MECHANICAL

Mounting	See Outline Drawing
Cooling	Air Convection
Maximum Seal Temperature.....	150°C
Maximum Overall Dimensions	
Depth	6- 9/32"
Height	7-13/16"
Width	7-13/16"
Net Weight	8 lbs.
Shipping Weight (approx.)	14 lbs.

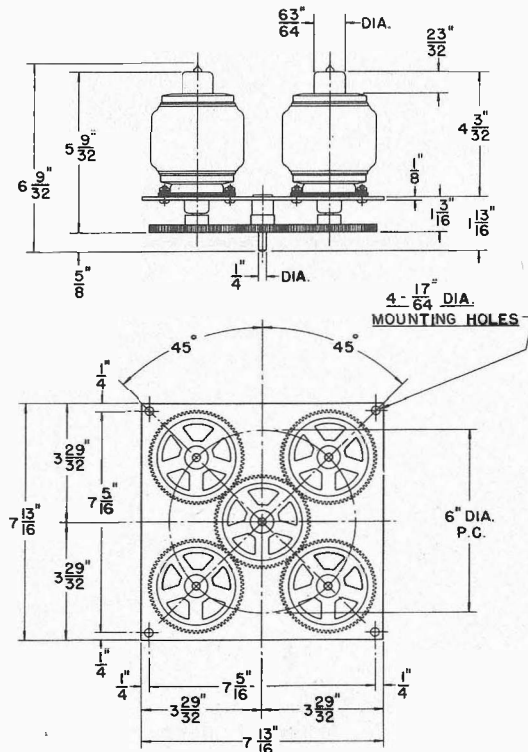
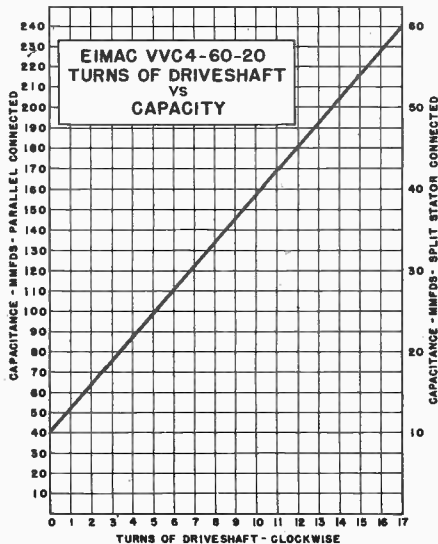
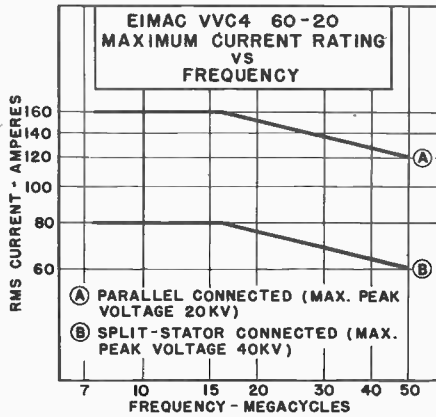

Summarized here are data on eight Eimac high vacuum rectifiers. The comprehensive series of tubes permits a choice of "per-tube" maximum ratings of D-C plate current from 50 ma. to 750 ma. and of maximum inverse plate voltage ratings from 15,000 to 75,000 volts.

Eimac high vacuum rectifiers can be operated in a variety of rectifying circuits and voltage multiplying circuits. By proper choice of circuit, considerably greater D-C output current and D-C output voltage can be had than is indicated by the ratings of the individual tubes. Also higher D-C current values can be had by simple parallel operation of the tube. No inherent difficulties are met in parallel operations because of the constancy of tube characteristics and freedom from the "uncertain firing voltage" found in gas and mercury vapor rectifiers.

The filaments of the Eimac high vacuum rectifiers reach operating temperature almost at once and therefore the plate voltage may be applied simultaneously with the filament voltage.

Eimac high vacuum rectifiers possess several advantages as compared with gas filled types because they will operate at higher voltages and higher frequencies and do not generate radio-frequency transients. They have no lower limit to the ambient operating temperature. The upper ambient operating temperature is limited solely by the need to keep seal and bulb temperatures below about 200°C. Full voltage ratings apply at all temperatures.

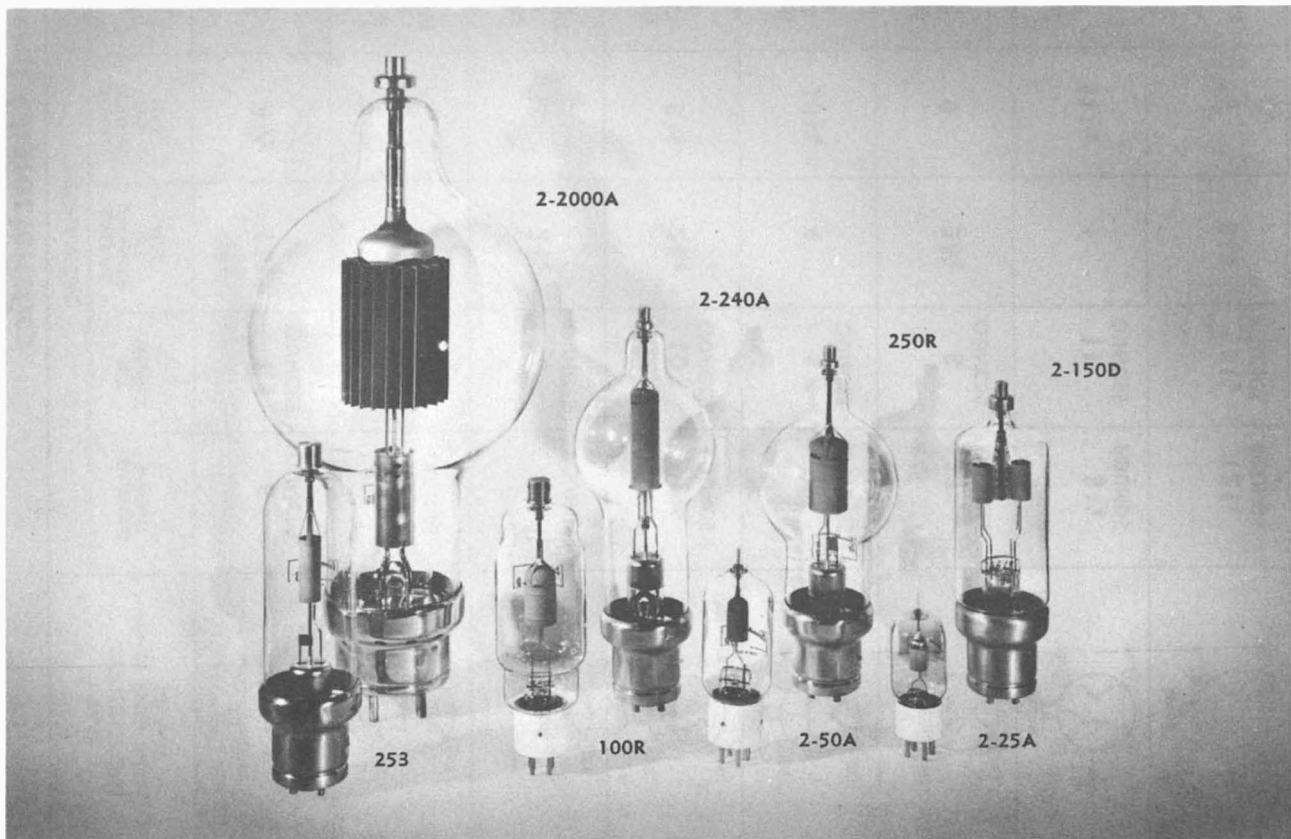

Detailed data sheets for individual rectifier tubes, giving complete operating procedures and applications, may be obtained by writing Eitel-McCullough, Inc.

EIMAC HIGH VACUUM RECTIFIERS : General Characteristics

Printed in U.S.A. 1-37276

TYPE	ELECTRICAL					MECHANICAL					BASE CONNECTIONS VIEWED FROM UNDERSIDE OF BASE
	AV. PLATE CURRENT MA. MAX.*	PLATE DISSIPATION WATTS MAX.	PEAK INVERSE VOLTAGE VOLTS MAX.	FILAMENT VOLTAGE VOLTS	FILAMENT CURRENT AMPERES	BASE	OVERALL LENGTH INS. MAX.	OVERALL DIAMETER INS. MAX.	NET WEIGHT	SHIPPING WEIGHT	
2-25A	50	15	25,000	6.3	3.0	SMALL 4 PIN	4½	1½	1.5 OUNCES	6 OUNCES	
2-50A	75	30	30,000	5.0	4.0	MEDIUM 4 PIN BAYONET	5¾	2	2.5 OUNCES	9 OUNCES	
100R	100	60	40,000	5.0	6.5	MEDIUM 4 PIN BAYONET	8	2¾	4 OUNCES	1 POUND	
2-150D	150	90	30,000	5.0	13.0	SKIRTED JUMBO 4 PIN	8⅞	2¾	10 OUNCES	1¼ POUNDS	
250R	250	150	60,000	5.0	10.5	SKIRTED JUMBO 4 PIN	10¼	4	1.5 OUNCES	6 OUNCES	
253	350	100	15,000	5.0	10.0	SKIRTED JUMBO 4 PIN	9	2¾	8 OUNCES	17 OUNCES	
2-240A	500	150	40,000	7.5	12.0	SKIRTED JUMBO 4 PIN	11¼	4	11 OUNCES	3¼ POUNDS	
2-2000A	750	1,200	75,000	10.0	25.0	SPECIAL 4 PIN No. 5006B	18	8¼	3½ POUNDS	12¾ POUNDS	

*MAXIMUM FOR INDUCTIVE INPUT FILTERS. FOR CAPACITOR INPUT FILTER CIRCUITS SEE INDIVIDUAL DATA SHEETS
 **TERMINALS 2 and 3 and 1 and 4 MUST BE PARRALLEL CONNECTED ON SOCKET.

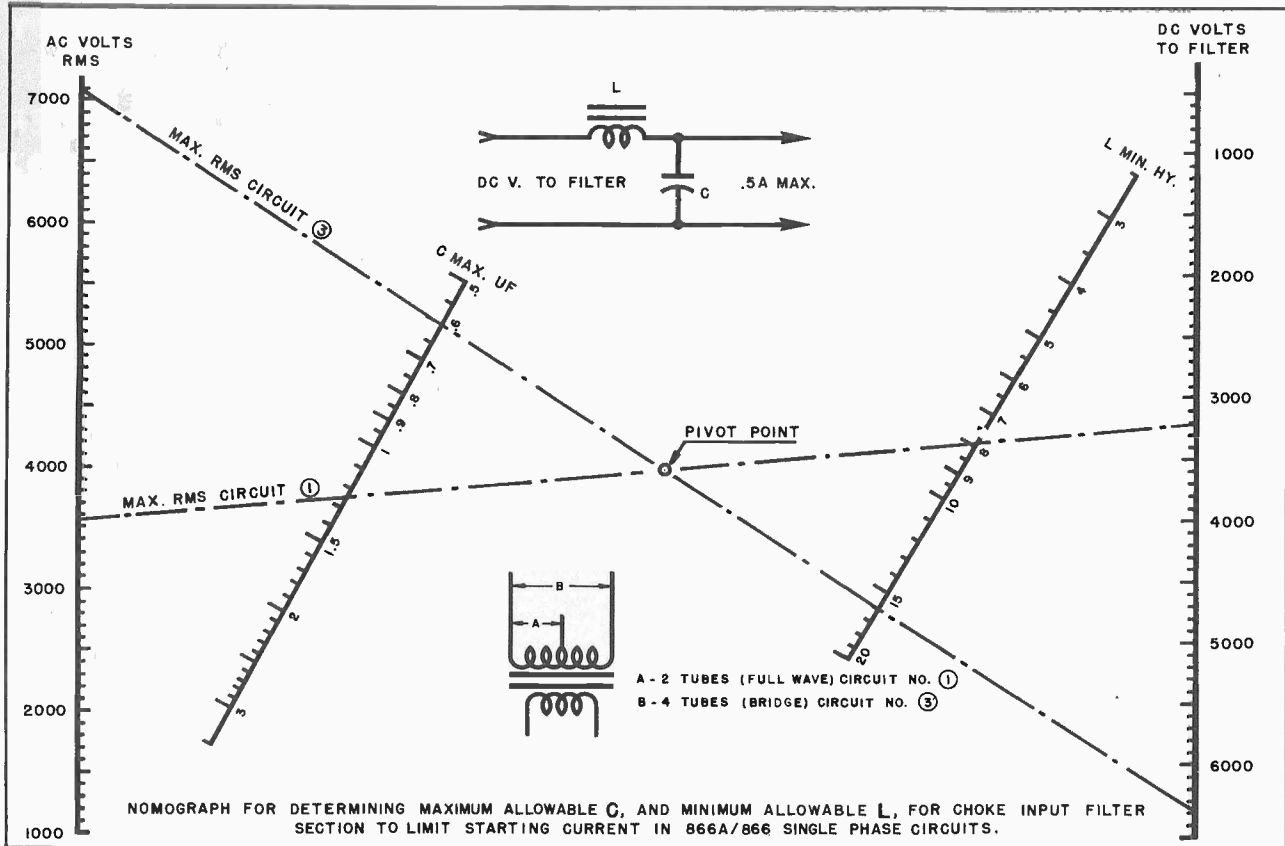

NUMBER	CIRCUIT	E AVERAGE	E INVERSE	I AVERAGE
①	SINGLE - PHASE FULL - WAVE 2 TUBES	0.318 E MAXIMUM 0.450 E RMS	3.14 E AVERAGE	0.636 I MAXIMUM
②	THREE - PHASE HALF - WAVE	0.827 E MAXIMUM 1.170 E RMS	2.09 E AVERAGE	0.827 I MAXIMUM
③	SINGLE - PHASE FULL - WAVE 4 TUBES	0.636 E MAXIMUM 0.900 E RMS	1.57 E AVERAGE	0.636 I MAXIMUM
④	THREE - PHASE FULL - WAVE	1.65 E MAXIMUM 2.34 E RMS	1.045 E AVERAGE	0.955 I MAXIMUM
⑤	THREE - PHASE DOUBLE - Y PARALLEL	0.827 E MAXIMUM 1.170 E RMS	2.09 E AVERAGE	1.91 I MAXIMUM

CONDITIONS ASSUMED
 (1) SINE WAVE SUPPLY (2) BALANCED PHASE VOLTAGES (3) ZERO TUBE DROP
 (4) PURE RESISTANCE LOAD (5) NO FILTER USED

CIRCUIT	A-C INPUT VOLTS** (RMS)	MAX. D-C OUTPUT VOLTS TO FILTER	CHOKE INPUT ONE-SECTION FILTER		MAX. D-C LOAD CURRENT amperes
			MIN. CHOKE (L) henrys	MAX. CONDENSER (C) uf	
THREE-PHASE HALF-WAVE CIRCUIT 2	per leg				
	4080	4780	3.2	1.4	0.75
	3000	3510	2.2	2.0	0.75
	2000	2340	1.4	3.0	0.75
THREE-PHASE FULL-WAVE CIRCUIT 4	per leg				
	4080	9570	1.8	0.5	0.75
	3000	7020	1.4	0.7	0.75
	2000	4680	0.9	1.2	0.75
THREE-PHASE DOUBLE-Y PARALLEL CIRCUIT 5	per leg				
	4080	4780	2.0	0.5	1.5
	3000	3510	1.5	0.7	1.5
	2000	2340	1.0	1.1	1.5
SINGLE PHASE FULL-WAVE (2 tubes) CIRCUIT 1*	per tube				
	3535	3950	—	—	0.25
	3000	3390	—	—	0.25
	2000	2260	—	—	0.25
1500	1700	—	—	0.25	

* With condenser input to filter.
 **For use under the conditions of the 10000-volt peak inverse rating. If the 866-A/866 is to be used under frequency and/or temperature conditions such that the peak inverse voltage is limited to 5000 volts, the a-c input voltage and d-c output voltage values in the table should be multiplied by a factor of 0.5 to give new values for the 5000-volt conditions.

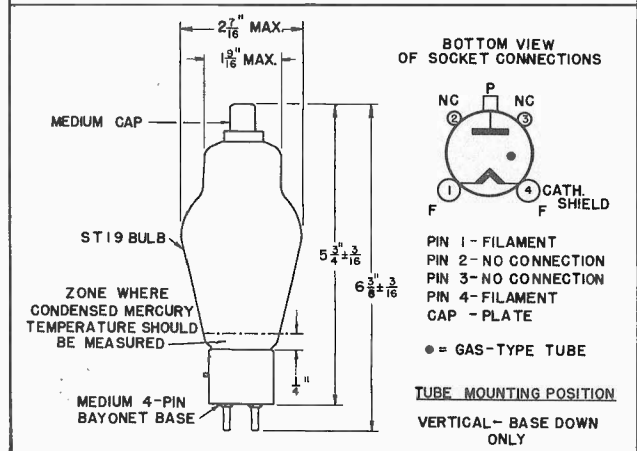

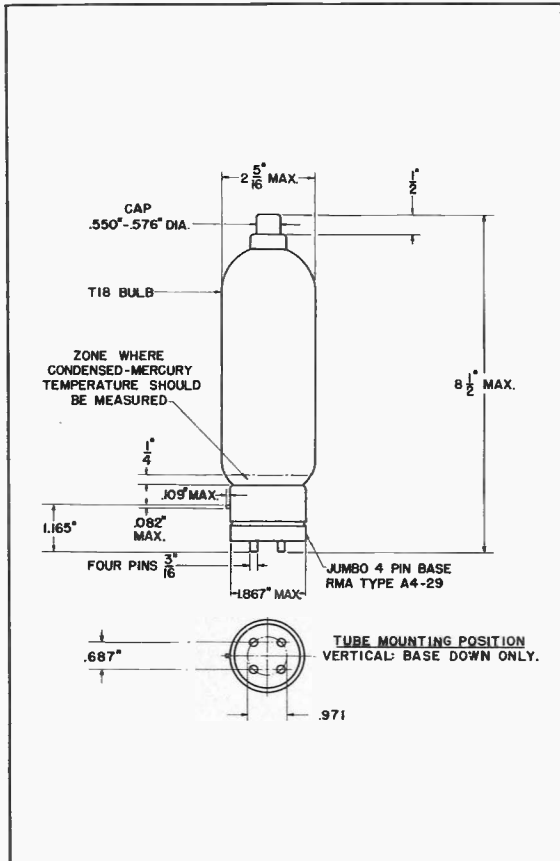
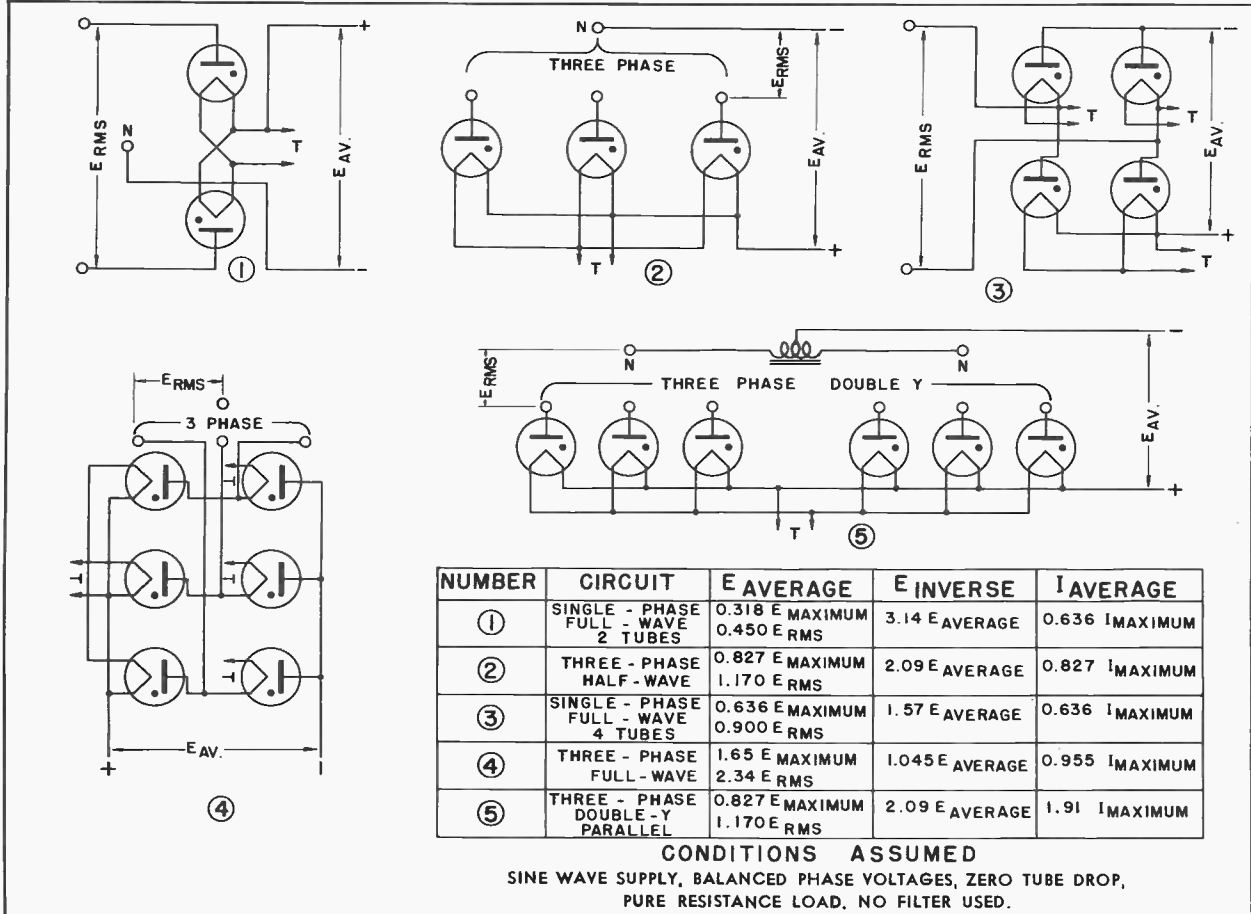

CIRCUIT	INPUT VOLTS/ MAXIMUM A-C (RMS)	APPROX. D-C OUTPUT VOLTS TO FILTER	MAXIMUM D-C OUTPUT CURRENT AMPERES
1	3535 per tube	3180	2.5
2	4080 per leg	4780	3.75
3	7070 total	6360	2.5
4	4080 per leg	9570	3.75
5	4080 per leg	4780	7.5

¹ Max. peak inverse voltage of 10,000 volts.

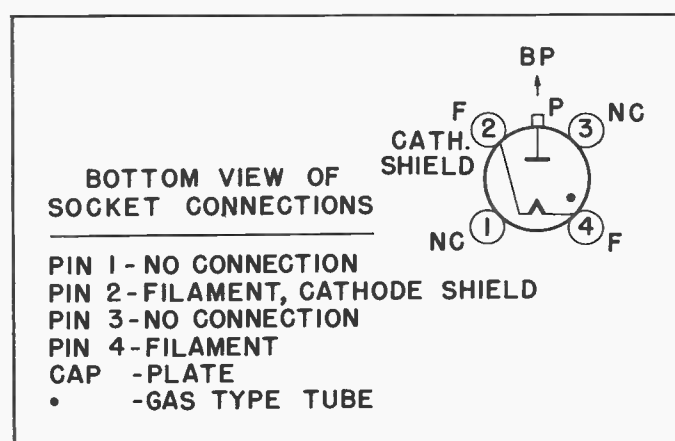

Eimac
EITEL-McCULLOUGH, INC.
 SAN BRUNO, CALIFORNIA

**HR HEAT
 DISSIPATING
 CONNECTORS**

Eimac HR Heat Dissipating Connectors are used to make electrical connections to the plate and grid terminals of Eimac tubes, and, at the same time, provide efficient heat transfer from the tube element and glass seal to the air. The HR connectors aid materially in keeping seal temperatures at safe values. However, it is sometimes necessary to forced-air-cool the connector by means of a small fan or blower. In such cases the air flow should be parallel with the fins of the connector. De-

signed for use on the larger tubes, the HR-9 Heat Dissipating Connector is provided with an air duct to conduct the cooling air directly to the glass seal.

HR Heat Dissipating Connectors are machined from solid dural rod, and are supplied with the necessary machine screws. The table below lists the proper connectors for use with each Eimac tube type.

TUBE	PLATE CONNECTOR	GRID CONNECTOR	TUBE	PLATE CONNECTOR	GRID CONNECTOR
25T	HR-1	2000T	HR-8	HR-9
3C24	HR-1	HR-1	4-65A	HR-6
35T	HR-3	4-125A	HR-6
35TG	HR-3	HR-3	4-250A	HR-6
UH50	HR-2	HR-2	4-400A	HR-6
75TH-TL	HR-3	HR-2	4-1000A	HR-8
100TH-TL	HR-6	HR-2	RX21A	HR-3
152TH-TL	HR-5	HR-6	KY21A	HR-3
250TH-TL	HR-6	HR-3	866	HR-8
304TH-TL	HR-7	HR-6	872A	HR-8
450TH-TL	HR-8	HR-8*	100-R	HR-8
750TL	HR-8	HR-8	2-150D	HR-6
1000T	HR-9	HR-9	250-R	HR-6
1500T	HR-8	HR-9			

*The grid terminal of the 450TH-TL type tube is now .560" in diameter. To accomodate existing equipment designed for the older style 450TH-TL having .098" diameter grid terminals, an adapter pin is provided with the newer tubes. This adapter pin is threaded so that it may be removed from the grid terminal of the tube. The small grid terminal requires an HR-4 connector.

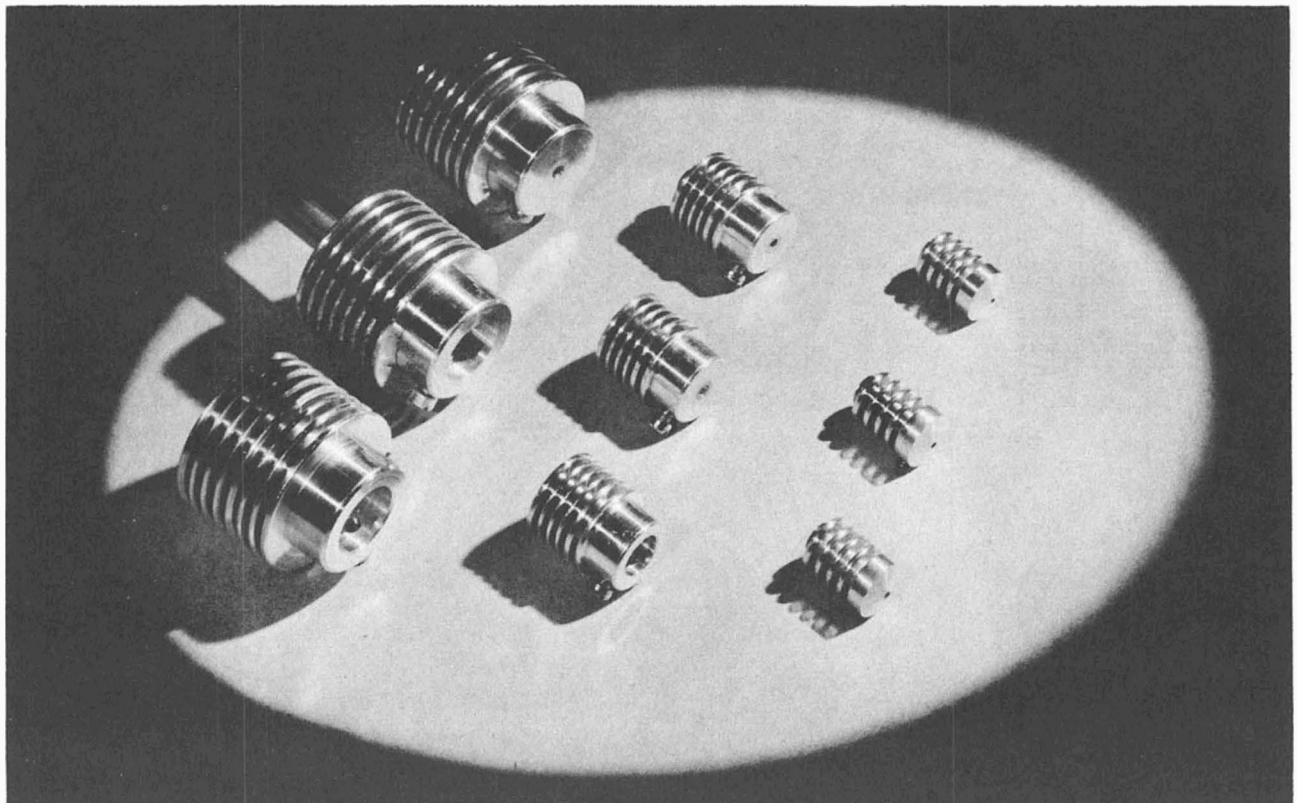

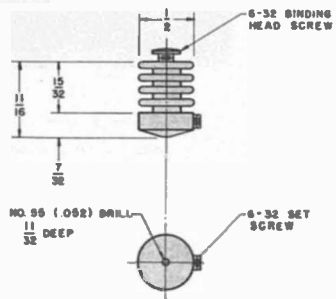

HR - 1

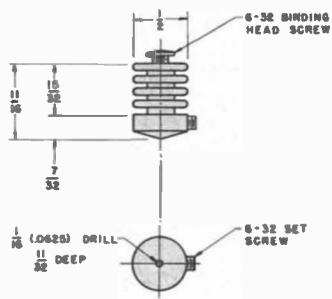

HR - 2

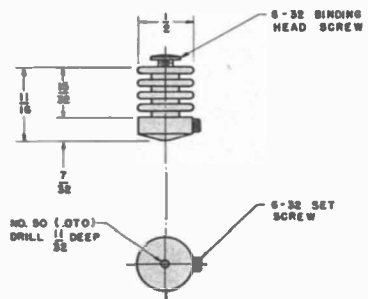

HR - 3

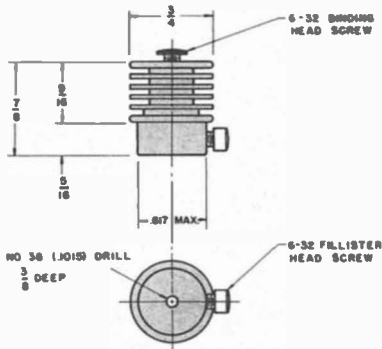

HR - 4

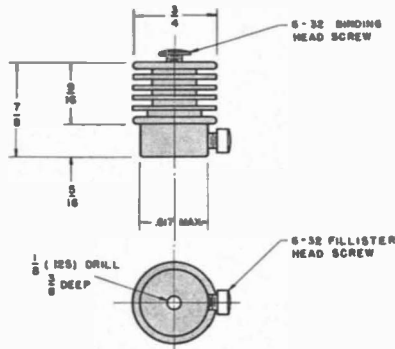

HR - 5

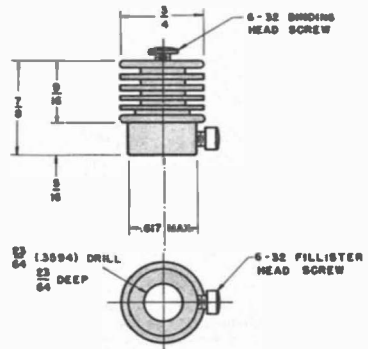

HR - 6

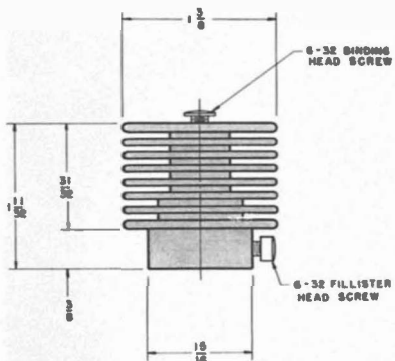

HR - 7

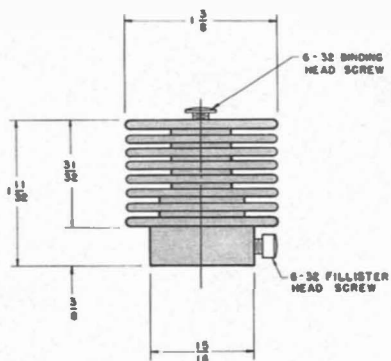

HR - 8

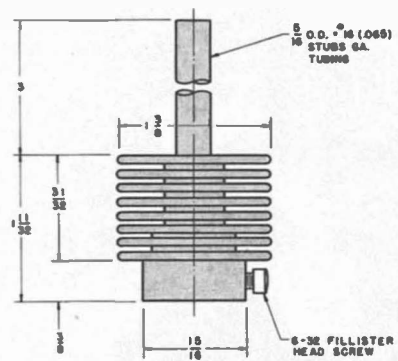

HR - 9

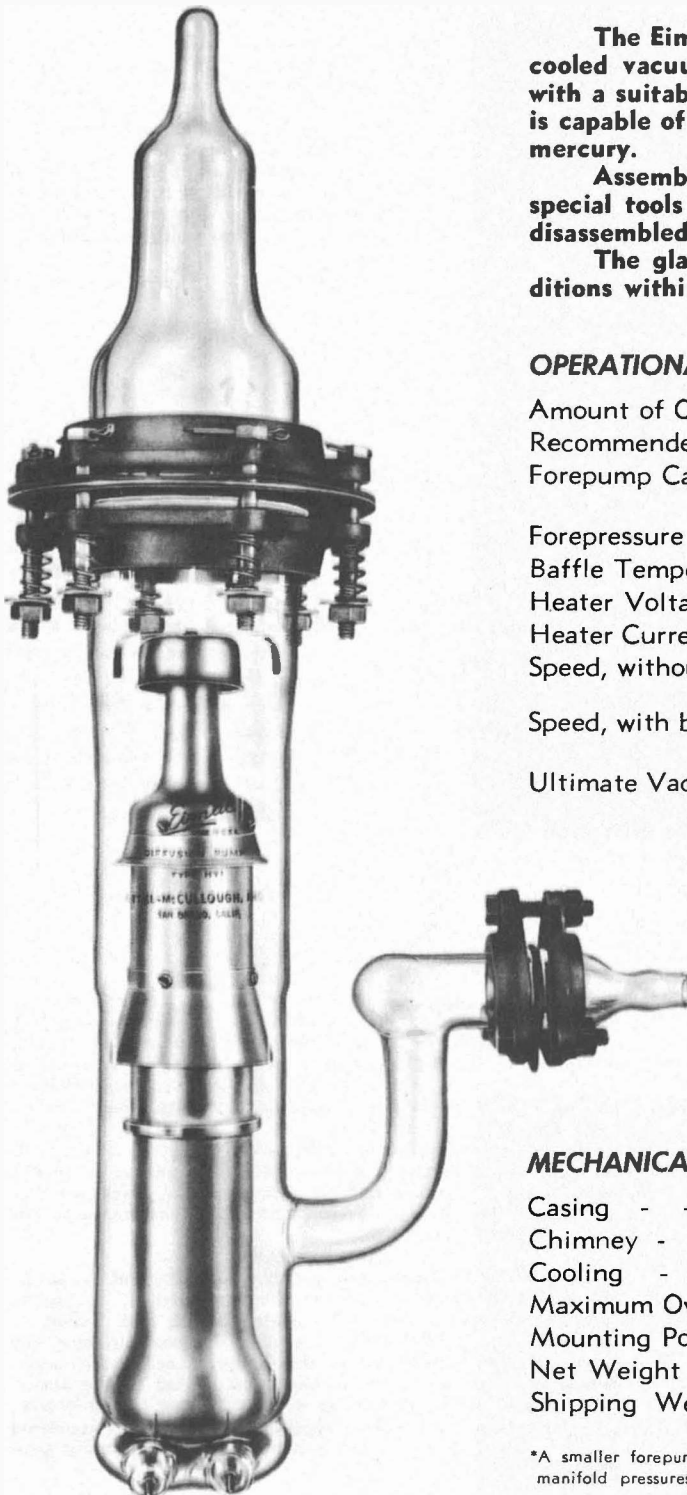

The Eimac HV-1 Diffusion Pump is a fast, triple-jet, air-cooled vacuum pump of the oil-diffusion type. When used with a suitable mechanical forepump and Eimac type A oil it is capable of reaching an ultimate vacuum of 4×10^{-7} mm of mercury.

Assembly of the pump is a simple operation, requiring no special tools or intricate adjustments. It can be completely disassembled for cleaning in five minutes or less.

The glass construction permits rapid inspection of conditions within the pump.

OPERATIONAL DATA

Amount of Oil	- - - - -	150 milliliters
Recommended Oil	- -	Eimac Diffusion Pump Oil, Type A
Forepump Capacity*	- - -	0.1 to 2.0 liters per second at 0.001 mm of mercury, or less
Forepressure (maximum)	- - - -	0.02 mm of mercury
Baffle Temperature	- - - - -	35° C or lower
Heater Voltage	- - - - -	100 to 110 volts
Heater Current (at 110 volts)	- - - - -	1.7 amperes
Speed, without baffle (approx.)*	- -	67 liters per second at 4×10^{-4} to 4×10^{-6} mm Hg
Speed, with baffle (approx.)*	- - -	32 liters per second at 4×10^{-4} to 4×10^{-6} mm Hg
Ultimate Vacuum, at 25° C (approx.)	- -	4×10^{-7} mm Hg when using recommended oil.

MECHANICAL DATA

Casing	- - - - -	Pyrex Glass
Chimney	- - - - -	3 Jet, Aluminum
Cooling	- - - - -	Air
Maximum Overall Dimensions	- - -	See Outline Drawing
Mounting Position	- - - - -	-Vertical, boiler down
Net Weight	- - - - -	6 pounds
Shipping Weight	- - - - -	18 pounds

*A smaller forepump may be used, but this will reduce the pumping speed at the higher manifold pressures.

OPERATION

The principle upon which the oil-diffusion pump operates may be explained as follows. The drawing on page three illustrates the accepted theory. Gas to be removed from the high-vacuum system enters the pump at the top, whence it moves into the region of the upper jet. Emerging from this jet is a stream of oil vapor which is generated by the electrically-heated oil boiler at the bottom of the pump. Molecules of the unwanted gas diffuse into this stream of oil vapor and are carried down and out toward the cooler glass-wall of the pump. Upon reaching the glass-wall, the oil vapor condenses to a film of liquid oil which runs down the wall and returns to the boiler. The gas molecules are forced downward by the oil vapor and gas above them and come under the influence of the middle jet, where they are again forced down toward the bottom of the pump by a stream of oil vapor.

in the system are to be avoided wherever possible. A short length of small-bore tubing can cause a considerable reduction in pumping speed.

Pumping speed is also affected by the capabilities of the forepump. The forepump must be able to remove the gas from the system while maintaining the required low pressure at its end of the diffusion pump.

Increased pumping speed may be obtained by operating several HV-1 units in multiple. The number of units which may effectively be used in multiple will be determined by the ability of the forepump to produce the required forepressure, and the ability of the manifold and tubulations to handle the desired pumping speed.

The HV-1 is capable of reaching an ultimate vacuum of 4×10^{-7} mm of mercury. To reach this low pressure, however, it is essential to avoid any contaminant in the high-vacuum system. Water, even in small amounts, or

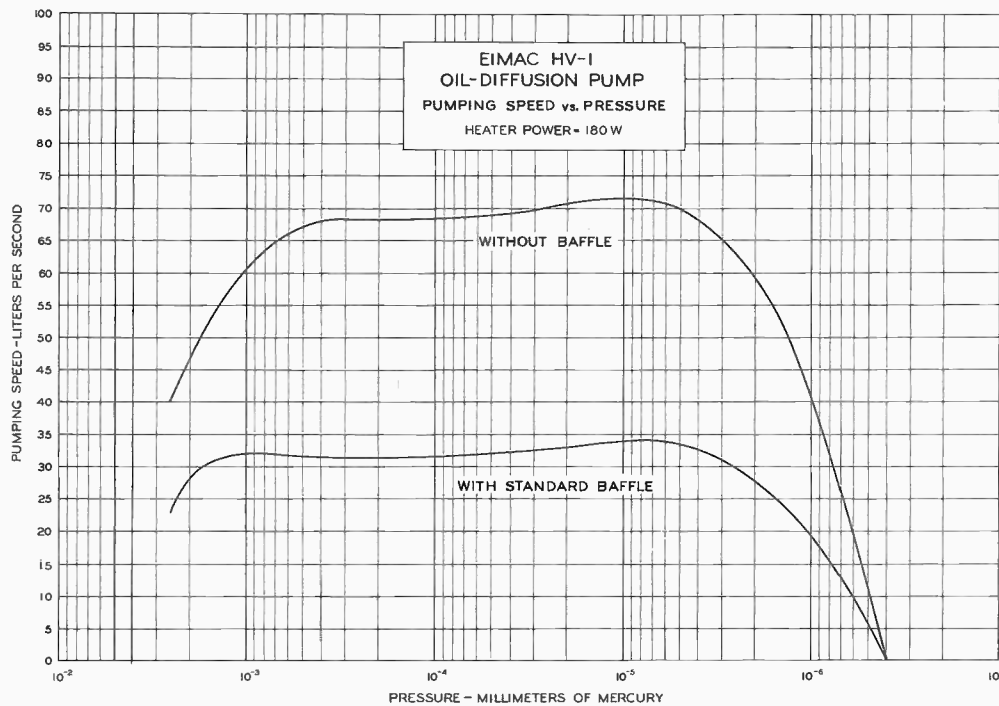

The curves at the left show the gas handling capabilities of the HV-1 over a range of pressures both with and without a baffle. These curves apply when a forepump with the required capacity is used. The rapid loss in pumping speed at the higher pressures is due to the inability of the forepump to handle the necessary volume of gas. With a larger forepump, the pumping speed would be maintained out to higher pressures.

The process of "packing" the molecules of gas down toward the bottom of the pump is again repeated at the bottom jet. During pumping, as the manifold pressure drops, the amount of oil issuing from the lower jet is sufficient to form a visible ring of oil on the wall of the pump at a point well below the bottom skirt. In this region the concentration of gas is great enough to raise the pressure to a point which will allow a mechanical forepump to effectively remove the gas from the system.

To prevent small amounts of oil vapor from finding their way back into the high-vacuum side of the system, a baffle is often employed between the diffusion pump and the high-vacuum system. In the HV-1 this baffle is a pair of aluminum discs which are kept relatively cool by the pump cooling fan. Oil vapor reaching the baffle condenses and is returned to the boiler. The baffle reduces the pumping speed by about one-half. If there are several bends in the high-vacuum manifold between the pump and the space to be evacuated, the baffle may be dispensed with, as the bends will serve to collect the oil vapor. However, the bends will also reduce the pumping speed. This is well illustrated in the curves. Constrictions

any hygroscopic matter should be carefully excluded. When so located as to be affected by heat, rubber is particularly objectionable, and a poor ultimate vacuum is likely to result if rubber gaskets are used in the diffusion pump. For this reason, Neoprene gaskets are supplied with the HV-1.

In systems employing stop-cocks, valves or gaskets, it is necessary that the stop-cock, valve or gasket lubricant have the minimum possible vapor pressure, because poor lubricants can easily destroy the high-vacuum capabilities of the pump.

APPLICATION

The HV-1 diffusion pump must be mounted securely, but not too rigidly. A satisfactory method of mounting consists of 1 X 1 X 1/8 inch angle shaped and drilled to pass four of the six spring loaded bolts used to join the large flanges at the top of the barrel (see illustration). When the desired manifold has been sealed to the manifold adapter (914 on outline drawing), the pump is prepared for operation (after rinsing thoroughly as specified under "cleaning") in accordance with the following procedure:

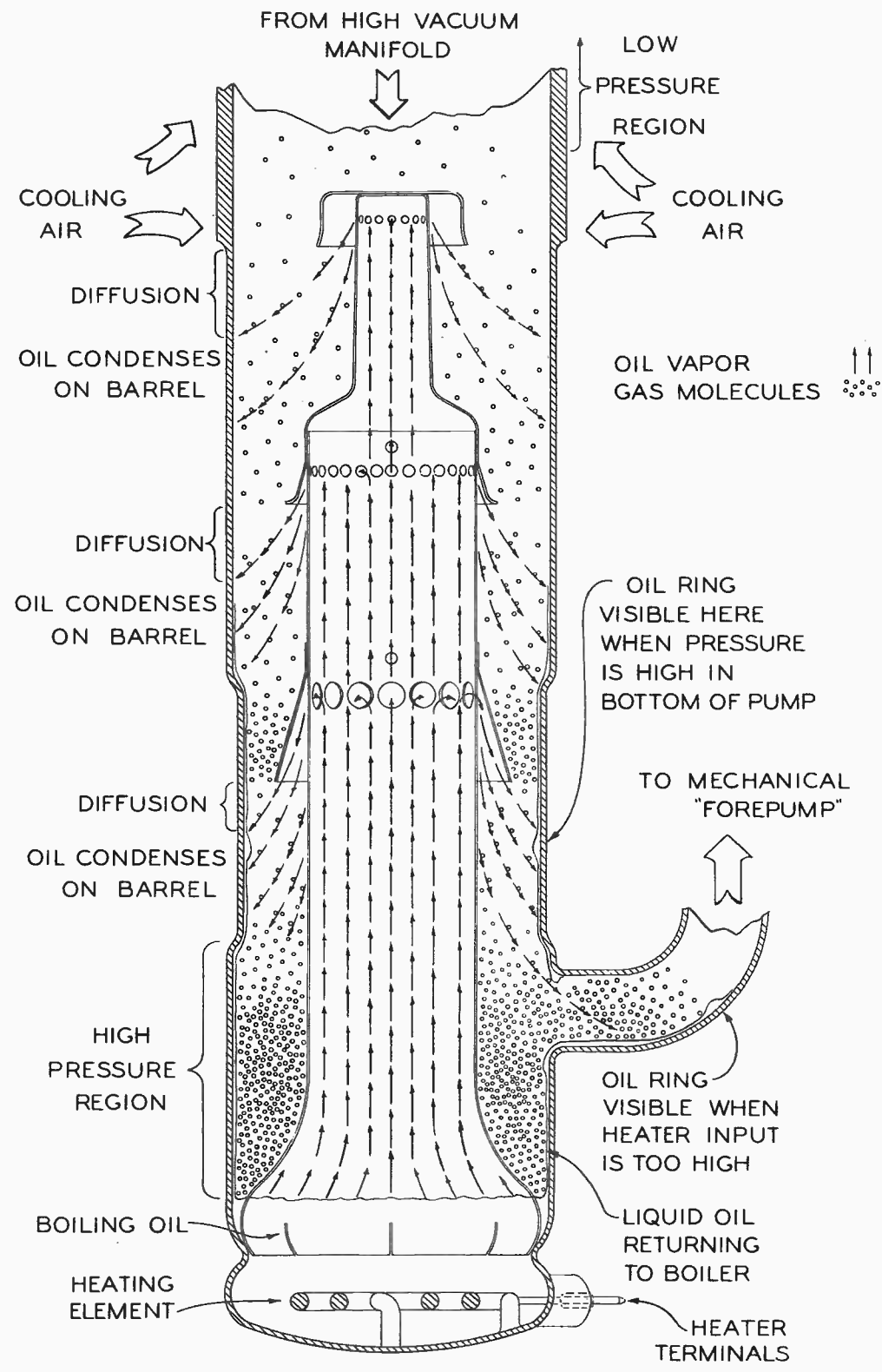

1. Pour 150 milliliters of Eimac Diffusion Pump Oil, Type A, into the pump barrel (917).
2. Insert the aluminum jet assembly (4911) into the pump barrel.
3. Assemble the pump carefully, moistening both sides of each gasket with pump oil, or with a thin layer of heavy-grade "Celvacene," or equivalent grease.
4. Install the pump in its mounting.
IMPORTANT: DO NOT START DIFFUSION PUMP HEATER UNTIL FOREPUMP IS IN OPERATION AND SYSTEM IS FREE OF LEAKS, TO AVOID PREMATURE HIGH TEMPERATURE AND DECOMPOSITION OF THE OIL.
5. After making certain that the forepump is connected to the nipple (8911) through the suitable flexible coupling (vacuum-hose or vacuum type bellows), start the forepump motor. Check the manifold with a Tesla or other high-voltage, high-frequency spark coil for leaks BEFORE CONTINUING.

The Tesla coil, with a flexible wire probe may be used to indicate the presence of leaks above the baffle. It is also valuable in estimating pressure in the manifold during the early stages of evacuation. **CAUTION:** Too high a voltage may puncture the manifold at its weak points, i. e. where the glass may be very thin or at a seal-off tubulation. A rough indication for a suitable Tesla voltage is that which will produce a corona of about one-eighth inch on the end of a No. 14 B & S probe wire, visible in the dark only, and a stringy spark not over five-eighths inch to a grounded metal surface.

If the system is known to be free of leaks, the forepump and HV-1 may be started together. However, to protect the system and its oil, the manifold first should be checked with the Tesla coil, with the HV-1 "off." When the cold oil stops bubbling and the pink glow is seen to be diminishing at a normal rate, the system may be assumed to be reasonably tight and the HV-1 may be started.

6. Connect the oil heater terminals via a switch to the source of power. The oil heater voltage should be set to between 100 and 110 volts for best results. An adjustable resistor or an auto transformer of the tapped or continuously variable types is recommended. The current at 110 volts is approximately 1.7 amperes.
7. The baffle assembly and upper end of the pump barrel should be kept cool (35° C or lower) by a small fan or blower (see illustration).

OIL—Eimac Type A Diffusion Pump Oil is a special petroleum product carefully processed by Eitel-McCullough, Inc. to afford the high-vacuum desired in diffusion pump work. The ultimate vacuum attainable for Type-A oil is on the order of 10^{-7} mm Hg. Its boiling-point at pressures on the order of 10^{-2} mm Hg is 135° C.

One noteworthy property of this oil is that under normal conditions, no particles of condensed oil will be found deposited in the high-vacuum manifold. This lack of condensation is indicative of the absence of "light ends." Such products of distillation usually must be barred from the high vacuum system by the use of liquid air or charcoal traps which invariably reduce the speed of any system and require extensive maintenance.

VACUUM GAGES—To properly evaluate the vacuum conditions at the manifold, a sensitive gage in the desired range is necessary. There are many systems used for this purpose, the most sensitive in the high-vacuum spectrum being the Ionization (or Ion) gage. Its range of usefulness extends from approximately 5 microns to a region in the upper experimental vacuum limits on the order of 10^{-6} microns (5×10^{-3} to 10^{-9} mm Hg). Recently, tubes and circuits have been developed which con-

tribute to the high stability of this instrument. The Eimac type 100-IG Ion Gage tube is designed to give the maximum internal leakage path, thus avoiding erratic readings due to possible contamination from the system.

LEAKS—If the system does not "clean-up" in a reasonable time, considering the nature and size of the manifold and connected chambers, a leak may be looked for by means of the Tesla coil. The probe should be run over the entire surface of the glass work involved. A "fast" leak will be indicated where sparks concentrate at a point on the glass and a pinkish glow takes place within the evacuated space.

Where a slow leak is suspected, before "bake-out" and where the vacuum is high but still not satisfactory, a solvent such as carbon tetrachloride may be applied to the manifold surface with an atomizer, a wad of cotton or brush. If a leak is found, the Tesla voltage will cause a marked bluish glow while the solvent is entering the aperture, or the ion gage reading will indicate increased pressure.

After "bake-out" or when the manifold is too hot for the application of liquids, illuminating gas or hydrogen may be applied to the surface from an unlighted torch. Gas entering the hole will effect the ionization gage reading immediately. A very small leak may be found in this way. If there are no leaks, the manifold and pump assembly is ready for use¹.

With the manifold at high vacuum, no ionization will be apparent from the effects of a Tesla probe held on the manifold (above the baffle). Below the baffle on the barrel of the HV-1 pump the probe will cause fluorescence of the oil vapors as well as a visible disturbance of the oil flow below the jets. The probe when touched to the HV-1 outlet will show a faint blue-violet glow. If these first two conditions are obtained, but a pinkish glow is present in the outlet, the mechanical pump and its coupling should be checked.

For new oil, or after an oil change, the pump will require about 24 hours of operation to condition the oil for optimum performance. Approximately 15 minutes heating time is required for the HV-1 to reach full efficiency from a cold start.

PRECAUTIONS

1—The vacuum system should not be opened "to air" when the diffusion pump is hot, to prevent oxidation of the pump oil. 2—If at any time a white vapor is visible in the HV-1, both pumps should be immediately shut off. The vapor is an indication of forepump failure or a very rapid leak. If the oil has become dark, the system may require complete cleaning. 3—Ground leads should be provided on both flange couplings to prevent the Tesla voltage from puncturing the Neoprene gaskets.

CLEANING

Diffusion pumps in continuous use should be cleaned at approximately one-month intervals. The materials and facilities required for cleaning are: Carbon tetrachloride and pentane (or acetone). An oven capable of temperatures up to 500° C will allow complete removal of carbonaceous deposits. The oven should be provided with an air inlet and outlet to allow the products of oxidation to be carried off. An accurate temperature control and indicator are advisable to prevent mishap to the glass parts. Where an oven is not available, steel wool, water and some abrasive cleanser such as diatomaceous earth

¹"Bake-out" consists of surrounding the manifold and work to be evacuated with an oven. The temperature is then raised and held just under the annealing point for the "softest" glass being used in the system (approximately 500 degrees C for Pyrex). The temperature is maintained for thirty minutes to an hour, or at least until the new glass in the system shows no fluorescence on application of the Tesla voltage. This "cleans up" the glass-ware to a point where it will not normally release further gas. An accurate thermocouple type temperature indicator and heater control are advisable to prevent mishaps to the system during "bake-out."

²Contamination in the system such as decomposed oil, or a source of high vapor pressure in the load will give "virtual leaks" or unfavorable maximum vacuum readings.



A typical vacuum pump system, utilizing an Eimac HV-1 Diffusion Pump.

The mechanical forepump should be shockmounted to minimize vibration. The large rubber tubing couplings between the forepump and the diffusion pump serve to prevent any movement of the forepump from being transmitted to the diffusion pump.

may be used. The procedure is given in the following paragraphs.

GLASS HOUSING BARREL—New housings should be given a rinse with a cup of pentane or acetone and then warm-air dried. (CAUTION: pentane and acetone are inflammable. Keep away from open flames.) Used, dirty housings should have the excess of oil fluid rinsed out with two or three flushings of about one cup (per rinse) of carbon tetrachloride. The last rinse may be saved for the first wash of the following pieces. To remove adhering carbonaceous matter after draining, the housing should be baked out in an oven up to 500° C. If the housing is not too caked, a rinse with pentane or acetone and gentle drying with warm air (in place of baking out in the oven) is sufficient.

ALUMINUM JET ASSEMBLY—The jet assembly may be cleaned at the same time that the glass housing barrel is cleaned by inserting the assembly into the glass housing, pouring in the rinse solution and closing the top opening with a stopper. Agitate the solution by tilting and shak-

ing the pump so that all parts are well washed over. Always remove the stopper and jet assembly after washing, prior to draining, baking or air drying. To further remove hard carbonaceous material, the assembly, less baffle, should be placed in an annealing oven and heated carefully to 475° C, then allowed to cool slowly in air.

BAFFLE—The baffle should be disassembled and all parts rinsed three times with pentane or acetone; the last two rinsings must be with clean solution. Follow with warm-air drying.

NEOPRENE GASKETS—Wash the gaskets in carbon tetrachloride or alcohol, then wipe with a clean cloth in place of warm-air drying.

GLASS MANIFOLDS—Use the same procedure as for the glass housing barrel when feasible. However, usually washing with pure water and alcohol, followed by warm-air drying, may be sufficient because there is less formation of carbonaceous matter here than in the case of the pump housing.

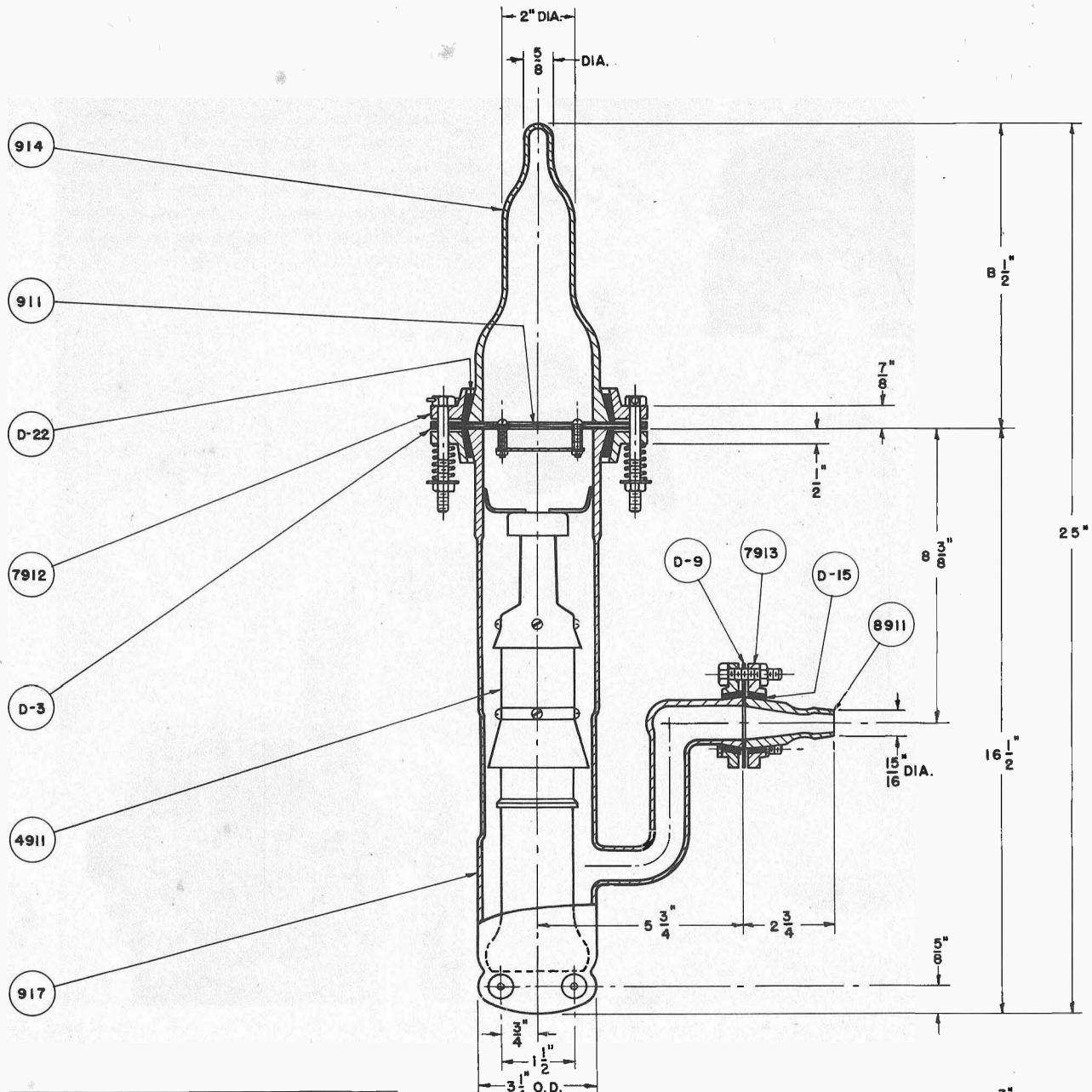

PART NO.	NO. REQD	ITEM
911	1	BAFFLE ASSEMBLY
914	1	MANIFOLD ADAPTOR
917	1	PUMP BARREL ASSEMBLY
4911	1	JET ASSEMBLY
7912	1	3" METAL FLANGE ASS'Y *
7913	1	1" METAL FLANGE ASS'Y *
8911	1	FORE-VAC NIPPLE
D-3	2	NEOPRENE GASKET-3" COUPLING
D-9	1	NEOPRENE GASKET-1" COUPLING
D-15	2	1" INSERT
D-22	2	3" INSERT

* EACH FLANGE ASSEMBLY INCLUDES NECESSARY FLANGES, GASKETS, INSERTS, BOLTS AND HARDWARE.

