

ALLIED Broadcast Equipment

THE BROADCAST INDUSTRY'S NUMBER ONE EQUIPMENT SUPPLIER

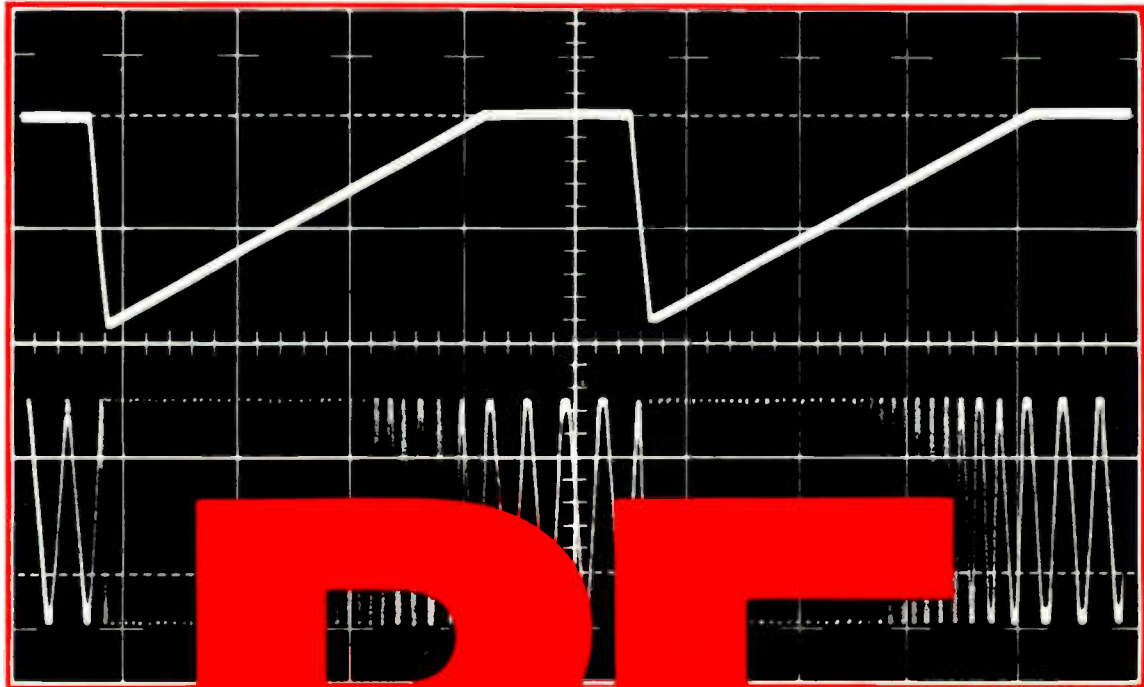

CATALOG II

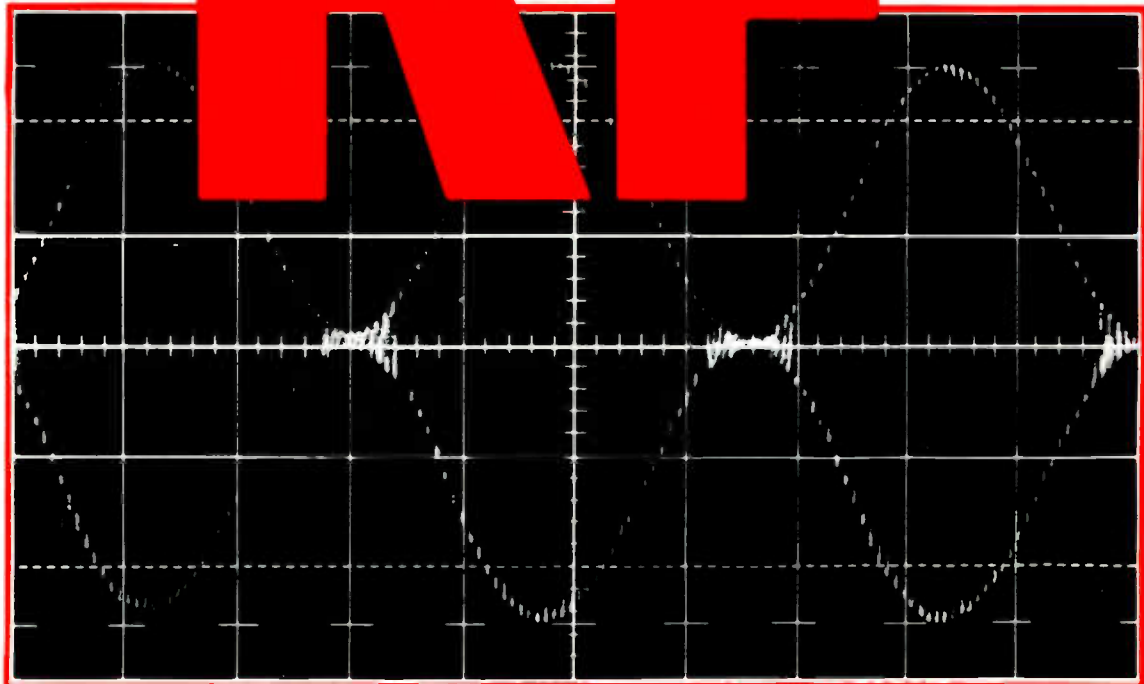

— PRODUCT CONTENT TABLE —

Coaxial Cable.....19, 21	Manual Patch Panel.....4
Coax Loads.....16	Miscellaneous RF, Coax, Waveguide.....17, 18
Coaxial Transfer Switch.....7, 8	Monitors.....27, 28, 29, 30
Copper.....7	Oscilloscope.....32
FM Antennas.....9, 10, 11, 12, 13, 14	Phase Converter.....25
FM Educational Antennas.....15	Phasors/LTU.....6
Frequency Counter.....19	RF Absorption Wattmeter.....34
Generator.....35	RF Ammeter.....22
Harmonic Filter Couplers.....5	RF Coaxial Load Resistor.....23, 24
Impedance Bridges.....31	Switching Combiner.....4
Insulators.....19, 21	Test Equipment.....30
Isocouplers.....20, 26	Toroidal Current Transformer.....22
Isolation Transformer.....20	Towers.....15
Load Resistors.....16	Transmitters.....1, 2, 3, 4
Low Pass Filter.....4	Wattmeter.....33

About the Allied "family" of Broadcast Equipment Divisions . . .

Allied has been a major distributor of professional broadcast equipment to radio stations, TV stations, and sound studios for over twelve years. For them, Allied has provided equipment from individual components to complete custom-designed studios and stations.

Representing over 220 product manufacturers, Allied's sales professionals have access to the latest state-of-the-art technology and can supply equipment that best suits the particular needs of their customers.

With offices in Richmond, IN, Chicago, IL, Seattle, WA, Dallas, TX, Los Angeles, CA and Atlanta, GA, Allied enjoys a geographic versatility that helps maintain efficient sales, service and distribution of its products with the personal attention of a cadre of dedicated personnel.

You'll enjoy your association with Allied Broadcast Equipment, the nation's number one independent distributor of broadcast equipment in the US and fast becoming a contender in the World Market Place. Allied serves broadcaster needs overseas through its Allied International office located in Richmond, IN with another 60 representatives throughout the world. Canadian broadcasters are serviced through offices located in Richmond Hill, Ontario. Allied also has a Satellite Equipment Division located in Richmond, IN to serve you in this rapidly expanding technology.

For your RF needs or any other broadcast equipment, contact one of the offices listed below:

SALES OFFICES

ATLANTA -----404-964-1464	RICHMOND-----317-962-8596
CHICAGO-----312-794-0224	SEATTLE-----206-838-2705
DALLAS-----214-423-8667	CANADA-----416-731-3697
LOS ANGELES-----818-843-5052	INTERNATIONAL-----317-935-1704

RF

**QUALITY PRODUCTS FOR YOU, PRODUCED
BY THE INDUSTRY'S BEST**

— offered by —

ALLIED 
Broadcast Equipment

**Receive personal service that you require and desire
when procuring your broadcast equipment.**

**Call Your Nearest Allied Professional
for specifications, pricing
and delivery parameters.**

CSI TRANSMITTERS

CSI's AM line of transmitters is available in power levels of from .25 to 10 kilowatts, all FCC type accepted. You may choose from several modifications including power cutbacks and conversion to a higher power in many cases.

In conjunction with a Pi-Rod tower array, Kintronic LTU's, and Cablewave or Andrew coaxial cable, Allied can supply a complete AM transmitting system of any size as directed by your consulting engineer.

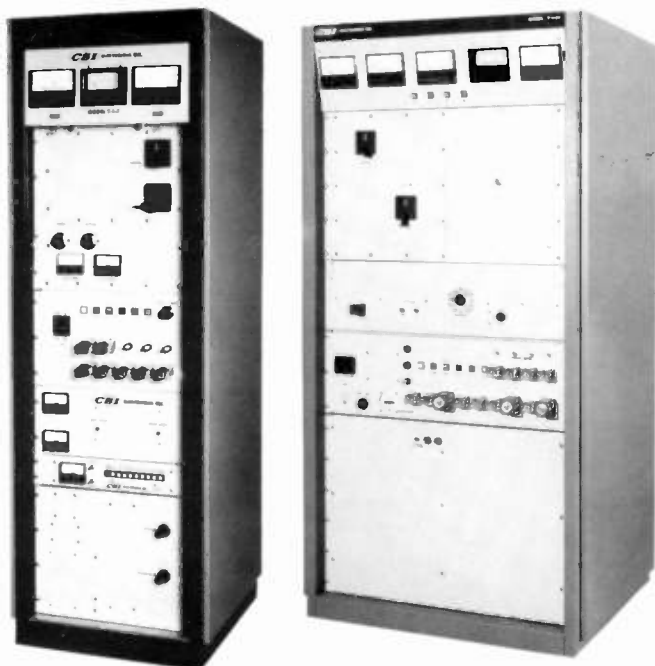

T-1-F

T-1-A1

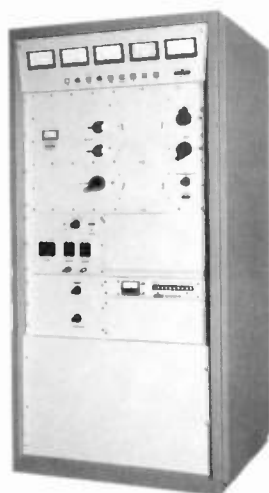

T-12-F1



(showing rear accessibility)

Model No.	Power Level Available
T-1-A	250 Watts
T-1-A	500 Watts
T-1-A	1KW
T-2.5-A1	2.5KW
T-5-A1	5KW
T-10-A1	10KW
T-25-A1	25KW
T-50-A1	50KW

FM transmitters from CSI feature grounded grid circuitry, excellent efficiency, time and field-proven exciters, and are completely ready to install when received.

*Levels range from 1KW to dual 20KW units which will produce a TPO of 40KW.

*A complete complement of accessories is also available which will permit you to custom modify the CSI transmitter of your choice to your exact requirements.

Models T-1-F1 through T-20-F1 are housed in a single cabinet. T-25-F is housed in two cabinets one of which is a stand-alone 3KW driver which can be used in emergencies in case of failure of the P.A.

Model No.	Power Level Available
T-1-F1	1KW, one tube transmitter, includes exciter
T-3-F1	3KW transmitter, includes exciter
T-5-F1	5KW transmitter, includes exciter
T-12-F1	12KW transmitter, includes exciter
T-20-F1	20KW transmitter, includes exciter
T-25-F1	25KW transmitter, includes independent 3KW driver and exciter

*All AM and FM transmitters require remote options for remote control use.

ALLIED

ELCOM BAUER TRANSMITTERS

All ELCOM BAUER AM transmitters listed below are complete with one set of operating tubes, two crystals and remote control interface. All transmitters are factory tuned and tested on single frequency and into an output impedance of 50 ohms unless otherwise specified by the customer. All AM transmitters include spare Oscillator, RF and Audio Driver cards.

OPERATIONAL BENEFITS FOR MOST AM MODELS

- 125% positive peak capability
- Stable high level plate modulation
- Solid-state low level Audio & RF stages
- Adaptable for AM stereo
- Oil filled modulation transformer
- Two (2) ovenless crystals switchable standard
- Automatic recycle with overload
- Remote resettable fault indicator
- Remote ready — wire or STL
- Interface for standard telemetry control equipment
- Unexcelled accessibility
- Single frequency: 540-1600 kHz, or 1.6 to 32 mHz

Model No.	Power Level Available
701B	1000 Watt
705C	5000 Watt
710C	10,000 Watt
715C	15,000 Watt
725	25,000 Watt
750	50,000 Watt

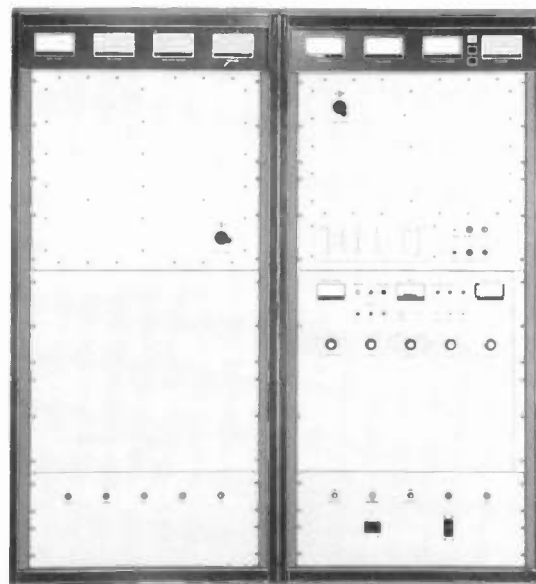

AM MODEL 710C

All ELCOM BAUER FM transmitters listed below are complete with FM Exciter, operating tubes, crystals, harmonic filter, remote control interface, VSWR protection and automatic power output control. All transmitters are tuned and tested on a frequency specified by the customer.

OPERATIONAL BENEFITS FOR MOST FM MODELS

- Solid-state direct FM phase lock loop exciter
- AFC status indication
- No neutralization required
- VSWR protection
- Automatic power output control
- Front panel circuit breaker
- Fuses with fault indicator
- FCC primary circuits metered and monitored
- Multimeter readout of secondary parameters
- Solid-state timing — diode logic and relays
- Tally light fault indicator with memory system
- Tuning controls with counter indicators

Model No.	Power Level Available
SS-250	250 Watt
601A	500 Watt
602A	1,000 Watt
603	1,750 Watt
605B	3,500 Watt
610A	7,000 Watt
625A	17,500 Watt
650	40,000 Watt

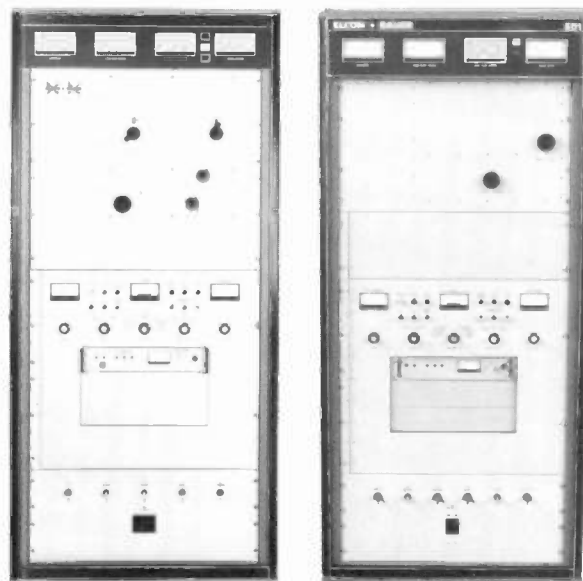

FM MODEL 603/605B FM MODEL 601A/602A

The new Model 6020 high performance exciter is the heart of ELCOM BAUER FM transmitters. Its advanced design provides frequency stability while delivering an exceptionally clean signal for further amplification. A single crystal frequency range of 87.5 to 108 mHz is continuously programmable in 100 kHz steps or 50 kHz steps with optional second crystal.



MODEL 6020

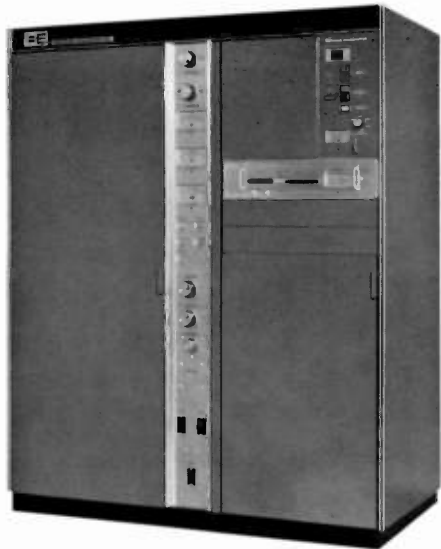

FM-30



FM-1.5A



FM-5A



FM-250



FM-300A

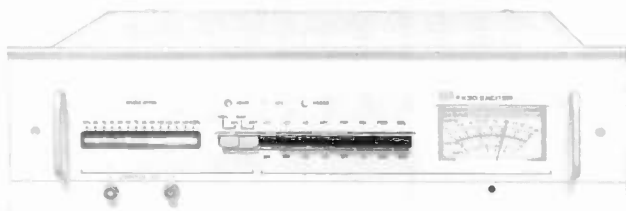

FX-30

BROADCAST ELECTRONICS FM-30 30KW SINGLE TUBE FM TRANSMITTER

The 30KW Model FM-30 is the most advanced transmitter since the advent of FM broadcasting.

The single tube FM-30 incorporates a unique folded half-wave cavity power amplifier design, digitally programmed FX-30 ultralinear exciter, solid-state IPA, and for the first time in a broadcast transmitter, a microprocessor based control system.

BROADCAST ELECTRONICS FM 1.5, 3.5 and 5 model one-tube transmitters also incorporate advanced engineering features including the patented unique folded half-wave cavity power amplifier, broadband solid-state IPA, digitally programmed FX-30 ultra-linear exciter and a digital control system producing a transmitter with optimum reliability and superb FM performance. Each model incorporates its own unique features (as its power rating dictates) as well as options for customizing to one's specified needs. All attain high overall efficiency for low operating cost. The FM-30 is now available in a 60KW configuration.

BROADCAST ELECTRONICS FM 100, 250 and 300 model high performance, ultra reliable, completely solid-state FM transmitters deliver a maximum watt RF output power, as defined by their model number, on a specified frequency in the 87.5 to 108 MHz range. They employ solid-state power amplifier(s) for the ultimate in signal fidelity and frequency stability. A low pass RF filter insures harmonic free distortion. All employ the FX-30 synthesized exciter to drive the amplifiers.

Model No.	Power Level Available
FM-60	60KW
FM-30	30KW
FM-5A	5.5KW
FM-3.5	3.5KW
FM-1.5	1.65KW
FM-100	100W
FM-250	250W
FM-300	300W

BROADCAST ELECTRONICS FX-30 EXCITER

The BROADCAST ELECTRONICS FX-30 Exciter offers performance so superior that it rivals the best hifidelity tuners available. Distortion in the FX-30 is extremely low, while programming is loud and clear. It has a frequency range of 87 mHz to 109 mHz with automatic power control, synthesized frequency control and low pass filter. Whether it is used in one of the new BROADCAST ELECTRONICS FM transmitters, or as a replacement for an existing exciter, the FX-30 is the new performance leader in FM broadcasting.

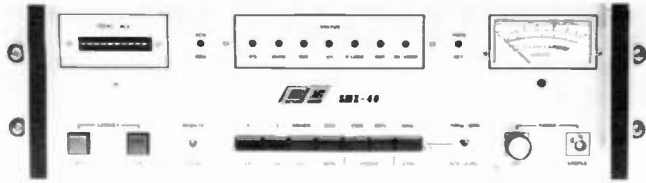

POWER PAK SMX-40

The SMX-40 is a full frequency synthesized world class FM exciter with variable power output, up to 30 watts of absolute RF drive power, extensive status indications and protection. It has very low noise levels and is frequency stable ± 300 Hz, 0° to 50°C . It has extensive filtering including harmonic output and RFI input. It is FCC type accepted and is covered by a full two-year warranty.

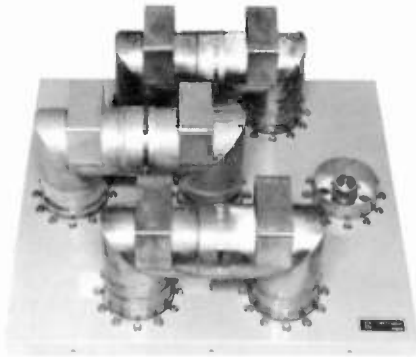

COMARK MANUAL PATCH PANEL

Coaxial Patch Panels are available in all standard transmission line sizes in three, four and seven port standard configurations. The patch link construction allows the patch link to self align with the panel ports for ease of operation.

- Self aligning
- Take apart patch links
- Handles for ease of patching

Model	Line Size	Poles	Links
CI-7511	1-5/8	3	1
CI-7512	1-5/8	4	2
CI-7513	1-5/8	5	2
CI-7514	1-5/8	7	3
CI-7541	3-1/8	3	1
CI-7542	3-1/8	7	3
CI-7543	6-1/8	3	1
CI-7544	6-1/8	7	3
CI-7545	3-1/8	4	2

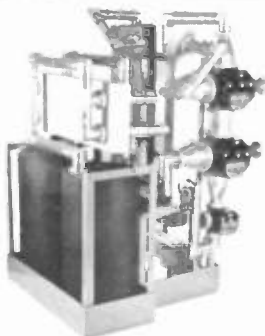

INTEGRATED SWITCHING COMBINER

COMARK 2300B & 2600 LOW PASS FILTER

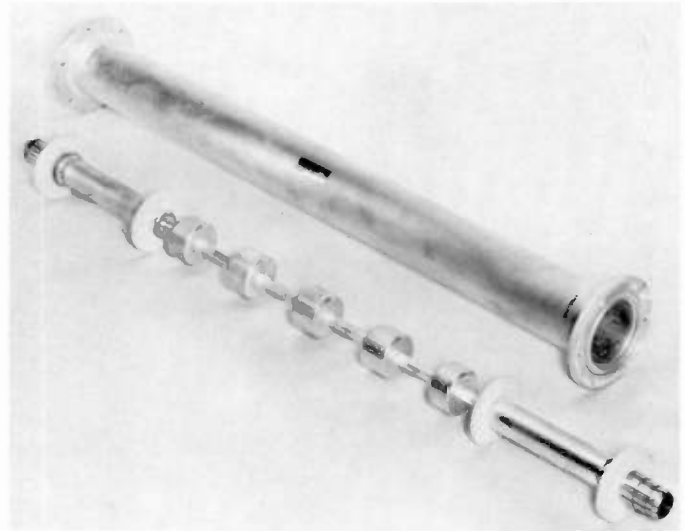

The COMARK Low Pass Filters are reactive type structures designed to attenuate the second, third and fourth harmonics at the transmitter output to ensure compliance with FCC regulations.

Each filter is manufactured for a single channel with an extremely low VSWR for system compatibility. Standard EIA flanges (one fixed and one swivel) are supplied with an anchor connector for simple installation.

FREQUENCY RANGE: Any single FM channel
CONNECTORS: Up to 6-1/8"
POWER: Up to 50KW

Model	Connectors	Frequency Band	Power Peak Sync.
CI-2310	3-1/8" EIA	UHF	30KW
CI-2311	3-1/8" EIA	VHF	35KW
CI-2312	3-1/8" EIA	VHF-FM	25KW(avg)
CI-2314	1-5/8" EIA	VHF-FM	3KW(avg)
CI-2610	6-1/8" EIA	UHF	60KW
CI-2611	6-1/8" EIA	VHF-FM	50KW

MICRO COMMUNICATIONS RF COMPONENTS

MICRO COMMUNICATIONS, INC. is a communications system oriented company and a manufacturer of equipment used extensively by the broadcasting industry.

- RF components of all types and sizes
- VHF and UHF duplexers with capabilities up to 220KW
- VHF, FM and UHF combiners with capabilities up to 220KW
- Filters, directional couplers, loads, hybrids, switching systems, etc.
- Master antennas
- Complete RF systems

BIRD® HARMONIC FILTER-COUPLERS

Filters are necessary. There was a time, however, when some responsible engineers did not agree. Early in the history of RF communications filters were called "a rubber glove for a leaky fountain pen." The implication was that with a properly designed and tuned transmitter, undesirable signals in the output could be kept low enough (for the requirements of that period) without using filters.

Today, keeping harmonics and spurious signals 40 dB below the level of the fundamental is no longer satisfactory. Requirements for 80 dB suppression are common and we have cooperated on a few requests for 100 and 120 dB. Just as a reminder, that means one trillionth of the main signal level, or a picowatt for every watt.

Attenuation is only one of the parameters. Some others are: insertion loss and VSRW, sharpness of cut-off, hi-pass, band-pass or low-pass, size and weight, power carrying capacity, connectors, paint, labeling and mounting features. While most wattmeters and terminating loads can be sold from stock, most filters are built to specifications on one or more of these parameters. Here are some pointers on specifying a filter to avoid over-design and to save.

BIRD® Harmonic Filters pack FCC required attenuation into small places. 300 watt to 50KW capacity. 10 inches to 56¾ inches long. A 5KW filter with harmonic attenuation of at least 55 dB is only 15-7/8 inches long. Certain models include integrated Directional Couplers. Special designs available — call ALLIED.

Model	Watts Average	Nominal Attenua. dB	Nominal Dimen. (in inches)	RF Connectors
5482	3KW	55	10x5x3	1-5/8" EIA Flg.
3111C	5KW	55	14½x5x3	1-5/8" Unfl.
3111H	5KW	55	15-7/8x5x3	1-5/8" EIA Flg.
5178	15KW	60	56¾x4½ dia	3-1/8" EIA Flg.
5177	30KW	60	56¾x6 dia	3-1/8" EIA Flg.
5179	50KW	60	56¾x7½ dia	3-1/8" EIA Flg.
3111A	5KW	60	14½x5x3	1-5/8" Unfl.
3111F	5KW	60	14½x5x3	1-5/8" EIA Flg.
3111B	5KW	60	14½x5x3	1-5/8" Unfl.
3111G	5KW	60	14½x5x3	1-5/8" EIA Flg.
3111E	5KW	60	14½x5x3	1-5/8" EIA Flg.
3111	5KW	60	14½x5x3	1-5/8" Unfl.
3108	5KW	60	16¼x5x3	1-5/8" EIA Flg.
3330A	15KW	60	59/16x4.5dia	3-1/8" Unfl.
3330E	15KW	60	59/16x4.5dia	3-1/8" Unfl.
3338	30KW	60	59x6 dia	3-1/8" Flg.
3339	50KW	60	59x7¼ dia	3-1/8" Flg.

PHASOR/LTU EQUIPMENT KINTRONICS



EXTERIOR OF LTU-1B

TECHNICAL DATA

Model	LTU-1B	LTU-5B	LTU-10B	LTU-50B
Carrier Power (100% Mod.)	1300 Watts	6000 Watts	12 Kilowatts	55 Kilowatts
Input Imped.	40 to 370 ohms	40 to 370 ohms	40 to 370 ohms	40 to 370 ohms
Antenna Imped.				
Resistance	10 to 1000	20 to 1000	20 to 1000	25 to 1000
Reactance	+j600 to -j500	+j600 to -j500	+j600 to -j500	+j600 to -j500
Circuit	Full Network	Full Network	Full Network	Full Network
Dimensions				
(W x H x D)	32"x28"x17"	36"x32"x24"	40"x35"x28"	Variable
Net Weight	85 Lbs.	110 Lbs.	125 Lbs.	750 Lbs.
Gross Weight				
Packed	100 Lbs.	130 Lbs.	150 Lbs.	1000 Lbs.

NOTE: Additional models available.

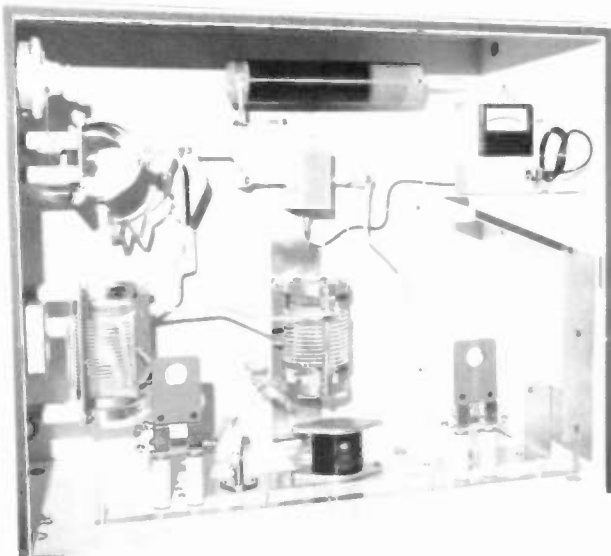

INTERIOR OF LTU-1B ANTENNA TUNING UNIT

In general these units are located near the base of the tower. Each unit is custom designed to provide coupling between the actual transmission line and the antenna to be used. A full "T" network is utilized with components conservatively rated to provide long life under 125% modulation conditions and a range of impedance tuning to meet any normal deviation in field installation conditions. The best commercial grade of components is used to construct these units. All capacitors are either Sangamo mica capacitors or ITT Jennings vacuum capacitors. The fixed and/or variable coils are all manufactured in-house using silver-plated copper ribbon or tubing and have demonstrated excellent long-term performance in the field. The "T" network is terminated with a double "J" plug in which a shorting bar and a meter plug are inserted. This allows for the RF meter to be left out of the circuit except when a base current reading is made so as to protect the meter from lightning damage. Meter switches may be installed as an alternate to the double "J" plug upon request. All interconnections between components are made either with silver-plated copper strap or tubing that has been treated to minimize tarnishing. All grounded components and transmission line clamps are connected on a common ground bus of copper strap which extends through the floor of the cabinet to a special connector to accommodate the strap from the antenna ground system. Transmission line clamps provide complete termination without the use of cable end terminations. A feed-through bowl insulator is used on one end to provide a terminal for interconnection to the antenna. Only non-ferrous materials are used in the construction of these units to provide long life. A key lock is provided on the hinged front door, and screen vents are used in the bottom and under the eaves of the housing to provide free air circulation.

ACCESSORIES

Static Drain Choke: This choke presents a high impedance to RF energy in the 500 to 1600 kHz range and are used to drain the static charge on towers when the charge is of too low a voltage to jump the tower horn gap.

RF Lighting Chokes: These chokes present a high impedance to RF energy in the 500 to 1600 kHz range and are used to isolate tower lights or FM antenna heaters from insulated AM towers. Two-wire (LC-2) or three-wire (LC-3) lighting chokes are available.

Remote Antenna Current Sensing Unit: This unit consists of a sampling loop which is to be mounted near the output connections to the antenna, which provides an RF voltage sample proportional to the antenna current. This RF voltage is fed to the sensing unit which provides a DC output voltage proportional to the antenna current. This output voltage may be used to drive a linear scale DC milliammeter having a scale range corresponding to the antenna current meter.

Remote Antenna Current Meter: This meter is a 3½" wide-vue, DC milliammeter and has a linear scale with current range corresponding to the range of the antenna current meter. Also available with this meter is a 4" x 19" rack panel for the mounting of the meter.

COPPER

ALLIED STOCKS AND SELLS MORE COPPER STRAP THAN ANY OTHER BROADCAST SUPPLIER. WE ALSO SUPPLY COPPER FLYSCREEN FOR ROOM OR EQUIPMENT SHIELDING AS WELL AS COPPER WIRE FOR CONSTRUCTION AND GROUNDSCREEN FOR COUNTERPOISE.

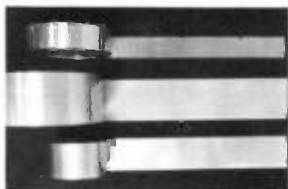

for RF Management,
COPPER STRAP
.020 or .032 thickness,
2, 3, 4, 6, 8 & 12" widths



for ground radials
SOFT #10 COPPER WIRE

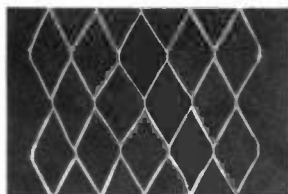

for tower counterpoise
COPPER GROUNDSCREEN



for equipment or room shielding
COPPER FLYSCREEN



COMARK MOTORIZED COAXIAL TRANSFER SWITCH

The 9301, 9302 and 9303 Coaxial Transfer Switches have been totally designed from the standpoint of the operator. Features such as watchband spring contacts in 3-1/8" and 6-1/8" models, visual status of position, and ease of maintenance provide a versatile switch for use in the "real world." Micro switch interlocks supplied are easily interfaced with any transmitter, for protection and control.

Features such as low VSWR and low insertion loss together with maximum isolation make these switches the ideal instrument for routing RF, especially in remote control applications. The positive action switching solenoid may be remotely controlled or manually overridden.

An optional control panel is available for remote RF switching that includes visual RF flow indication. The panel is 5 1/4" high and mounts in a standard 19" rack.

Watchband springs are used for all electrical connections to provide the most reliable contact possible. Three separate watchband springs are used for each inner conductor to further assure troublefree operation.

IMPEDANCE: 50 ohms

FREQUENCY RANGE: dc to 900 mHz

CONNECTORS:

CI-9100A	1-5/8"	EIA Fixed Flange
CI-9300A	3-1/8"	EIA Fixed Flange
CI-9600A	6-1/8"	EIA Fixed Flange

MCI COAXIAL TRANSFER SWITCH



MCI Coaxial Transfer Switches are designed primarily for application in television, FM and AM broadcast transmitter plants, and HF, VHF and UHF communications systems. As four-port transfer switches they will switch two signal sources between two loads. Since they can also be used as SPDT switches, complex switching matrices can be easily assembled.

MCI can furnish completely integrated switching systems and control/indicator panels to any degree of complexity. Outline your particular requirements for a prompt and comprehensive proposal.

- 6-1/8", 3-1/8" and 1-5/8" EIA
- Very fast switching
- Independent interlock/logic circuits
- Compatible with computer control
- Compact, lightweight

Model No.	Size
61103	1-5/8"
61104	3-1/8"
61105	6-1/8"

DELTA ELECTRONICS 6700 SERIES 1-5/8 & 3-1/8 INCH COAXIAL TRANSFER SWITCH



6730E

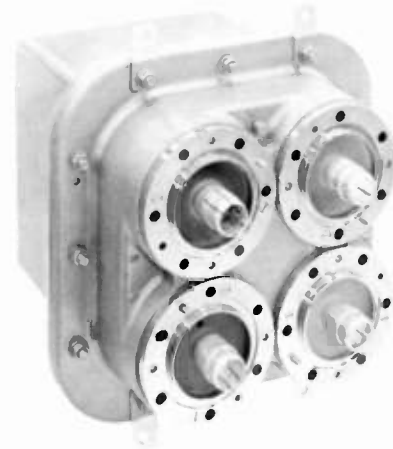

6740B

The 6700 Series of Coaxial Transfer Switches provides the engineer with the capability to switch between transmitters, antennas, or dummy loads with a minimum of off-the-air time. Both models can be operated by remote control or manually. Remote operation can be achieved using either 120V or 220/240V, 50/60 Hz. The transfer switch is fully interlocked with two isolated interlock circuits that duplicate the RF path exactly. The 6730/6732E is a 1-5/8" switch. The 6740B/6742B is a 3-1/8" switch and may be pressurized up to 15 lb./sq. in. A gas barrier is built into each terminal, and an air inlet port is also provided in the 6740B/6742B model.

Model No. for available equipment	Voltage
6730E	120 VAC
6732E	240 VAC
6740B	120 VAC
6742B	240 VAC
Control Panel Optional	



CETEC JSCP SERIES B — FM BROADCAST ANTENNA

The CETEC B Series JSCP antenna is an improved version of a circularly polarized FM broadcast antenna that has become one of the industry standards. Each bay consists of a radiating element with associated 3-1/8" flange, and both are supported by a heavy casting bolted to the mounting bracket for that bay. The interbay feed lines are joined by 3-1/8" flanges.

POWER RATING:

The JSCP is conservatively rated at 10KW per bay up to four bays, with a 40KW maximum rating for five bays and above.

VSWR RATING:

The JSCP antenna has excellent VSWR bandwidth. To assure lowest VSWR, each antenna is completely assembled and tuned at the factory on a structure similar to the end user's.

Type No. — Bays	Power Gain Ratio	Gain In dB	Field Gain	FS @ 1 mile 1KW, MV/M	Safe Power Rating	Net Weight w/ Mtg. Brackets	Windload*
JSCP-1 with deicers with radomes	0.46	— 3.37	0.678	93.2	10KW	25 lbs. 34 lbs. 55 lbs.	48 lbs. 57 lbs. 128 lbs.
JSCP-2 with deicers with radomes	1.0	0.0	1.0	137.6	20KW	125 lbs. 143 lbs. 185 lbs.	195 lbs. 219 lbs. 355 lbs.
JSCP-3 with deicers with radomes	1.5	1.76	1.23	168.4	30KW	199 lbs. 225 lbs. 289 lbs.	320 lbs. 368 lbs. 560 lbs.
JSCP-4 with deicers with radomes	2.1	3.22	1.45	199.2	40KW	274 lbs. 308 lbs. 394 lbs.	443 lbs. 516 lbs. 763 lbs.
JSCP-5 with deicers with radomes	2.7	4.31	1.64	225.2	40KW	350 lbs. 393 lbs. 500 lbs.	568 lbs. 664 lbs. 968 lbs.
JSCP-6 with deicers with radomes	3.2	5.05	1.79	246.0	40KW	498 lbs. 506 lbs. 678 lbs.	730 lbs. 851 lbs. 1210 lbs.
JSCP-7 with deicers with radomes	3.8	5.80	1.95	268.0	40KW	532 lbs. 591 lbs. 742 lbs.	854 lbs. 999 lbs. 1414 lbs.
JSCP-8 with deicers with radomes	4.3	6.34	2.07	285.2	40KW	609 lbs. 677 lbs. 849 lbs.	979 lbs. 1148 lbs. 1619 lbs.
JSCP-9 with deicers with radomes	4.9	6.90	2.21	303.8	40KW	713 lbs. 796 lbs. 1025 lbs.	1122 lbs. 1316 lbs. 1842 lbs.
JSCP-10 with deicers with radomes	5.5	7.40	2.35	322.4	40KW	774 lbs. 859 lbs. 1074 lbs.	1265 lbs. 1483 lbs. 2065 lbs.
JSCP-11 with deicers with radomes	6.0	7.78	2.45	336.8	40KW	868 lbs. 969 lbs. 1240 lbs.	1388 lbs. 1632 lbs. 2270 lbs.
JSCP-12 with deicers with radomes	6.6	8.20	2.57	353.2	40KW	929 lbs. 1032 lbs. 1289 lbs.	1514 lbs. 1780 lbs. 2475 lbs.
JSCP-14 with deicers with radomes	7.8	8.92	2.79	383.5	40KW	1051 lbs. 1158 lbs. 1473 lbs.	1760 lbs. 2077 lbs. 2885 lbs.

*based on 50/33 PSF @ 112 mph with mounting brackets

CETEC ELIPTICALLY POLARIZED PERFORMER FM ANTENNAS

Low Power Class A and educational broadcasting stations can take advantage of superior quality and craftsmanship of CETEC's latest contribution to FM broadcasting.

The JACP Series is rated at 3KW per bay up to a max of 10KW and is available in models from 1 to 12 bays. Low VSWR over 200 kHz provides excellent conditions for stereo broadcasting service.

These PERFORMER antennas are designed for low VSWR values. Each antenna is complete with a VSWR tuner, which is adjusted for best operation after installation. The antenna is

completely air tight and may be pressurized for long trouble free service.

Galvanized steel mounting brackets are included with each antenna for leg mounting on uniform cross section towers. Face mounting and tapered tower mounting brackets are priced on request. Other special mounting brackets are available.

The JLCP feed system consists of a vertical 1-5/8" line, across which are shunted the various bays. The input of the antenna is a 1-5/8" EIA flange.

Radomes are available at additional cost.

Type No. and Bays	Power Gain	Gain in dB	Field Gain	FS at 1 mile 1KW, MV/M	Net* Weight	Safe Power Rating	Windload* 50/33 PSF
JLCP-1	0.475	- 3.23	0.69	94.94	12 lbs.	3KW	15 lbs.
JLCP-2	0.955	- .20	0.977	134.44	51 lbs.	5KW	70 lbs.
JLCP-3	1.50	1.76	1.22	167.87	71 lbs.	6KW	130 lbs.
JLCP-4	2.05	3.12	1.43	196.77	90 lbs.	8KW	183 lbs.
JLCP-5	2.60	4.15	1.61	221.54	107 lbs.	10KW	242 lbs.
JLCP-6	3.15	4.98	1.77	243.55	132 lbs.	10KW	295 lbs.

*Mounting brackets not included in net weight or windloading.
No deicers available, 8, 10 and 12 bay available.

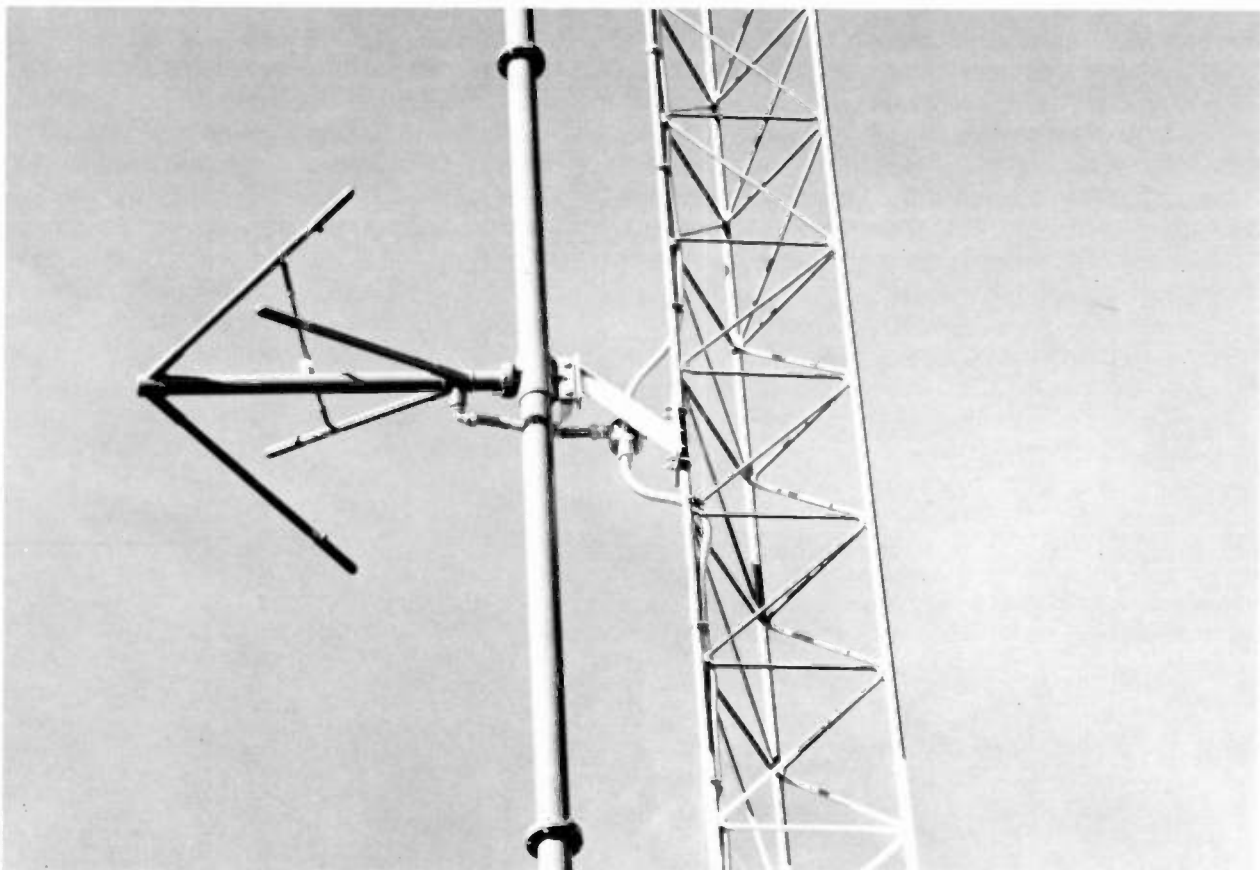

CETEC JHCP — FM BROADCAST ANTENNAS

Extremely high-power handling capacity, heavy-duty mechanical construction

The JHCP antenna is a circularly polarized FM antenna for the broadcaster who wants extremely high-input power capability, coupled with the patented design that has become an industry standard. Each bay consists of a radiating element with its associated 6-1/8" interbay feed line. The element and line are supported by a heavy brass casting which is attached to the support structure by its mounting bracket.

The radiating element consists of four 3" diameter quarter wave brass arms attached to a 3/4" brass support internal feed boom by brass castings. The interbay feed lines and boom are pressurized out to the feed point by the transmission line pressurization system.

POWER RATING:

The JHCP antenna is conservatively rated at 30KW per bay, with a maximum system rating of 80KW for three bays and above.

RADIATION PATTERN:

The circularity of the JHCP element is ± 1.0 dB in free space. CETEC pattern measurement service is recommended for this and all antennas to insure that there are no azimuth pattern nulls at the broadcaster's service area.

DEICING:

Deicing equipment is recommended for the JHCP in environments where regular icing and sleet conditions prevail in order to preserve the antenna's excellent VSWR specifications.

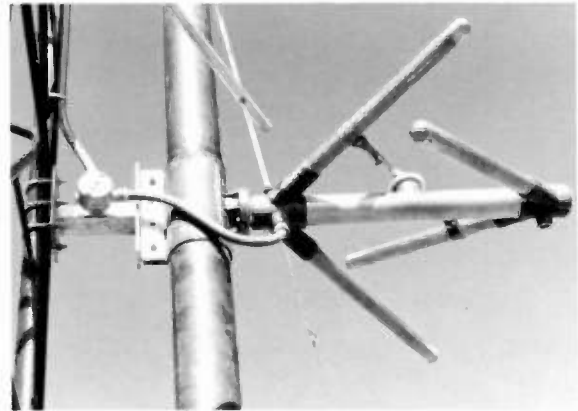

Radomes are also available for the JHCP antenna where electrical deicers are impractical.

BEAM TILT AND NULL FILL:

The JHCP antenna is optionally available with custom beam tilt and/or null fill to satisfy the requirements of the customer and consulting engineer, in order to optimize radiation toward the desired service area.

DIRECTIONAL ANTENNAS:

Custom Directional antenna patterns are available to meet FCC requirements, or for use in countries where such directional antennas are readily useable. Nulls may be produced depending on protection requirements of azimuth heading and null depth. Full-scale antenna range testing and pattern certification are offered for directional antennas. Specific details for special requirements available upon request.

Type No. and Bays	Power Gain	Gain in dB	Field Gain	FS @ 1 mile KW, MV/M	Net Weight	Safe Power Rating	Windload 50/33PSF
JHCP-1	.46	- 3.37	0.678	93.2	212 lbs.	30KW	269 lbs.
JHCP-2	1.0	0.	1.0	137.6	425 lbs.	60KW	540 lbs.
JHCP-3	1.6	1.98	1.25	172.0	634 lbs.	60KW	806 lbs.
JHCP-4	2.1	3.30	1.46	201.0	1007 lbs.	80KW	1254 lbs.
JHCP-5	2.7	4.35	1.65	227.0	1167 lbs.	80KW	1460 lbs.
JHCP-6	3.3	5.20	1.82	250.0	1320 lbs.	80KW	1662 lbs.
JHCP-7	3.9	5.90	1.97	271.0	1540 lbs.	80KW	1970 lbs.
JHCP-8	4.5	6.50	2.11	291.0	1758 lbs.	80KW	2245 lbs.
JHCP-10	5.7	7.53	2.38	328.0	2202 lbs.	80KW	2827 lbs.
JHCP-12	6.7	8.26	2.59	356.0	2640 lbs.	80KW	3410 lbs.

Deicers and Deicer Thermostat also available.

CETEC MODEL JBCP — FM ANTENNA

For the broadcaster who wishes to eliminate deicers and radomes in climates otherwise requiring them.

The CETEC Model JBCP antenna is a circularly polarized FM antenna designed for applications requiring relative insensitivity to icing along with high antenna input power. The antenna elements are fabricated of high strength thick wall copper with a 3-1/8" outside diameter. The JBCP antenna will handle up to 40KW per bay and up to 120KW per system. No deicers or radomes available.



CETEC PATTERN STUDY AND OPTIMIZATION SERVICE

These measured patterns were taken from actual production files, during antenna pattern correction service. They are typical of what can be expected when FM antennas are arbitrarily mounted on the leg or face of common size towers. The measured patterns resulting from "best guess" types of mounting, without any pattern correction, are shown as a dash line. The shaded areas indicate the minimum field strengths desired by the broadcaster. The solid line shows the measured field strength after the tower mounted antenna was pattern corrected with parasitic elements, mounted around the tower.

Pattern distortion is caused by the tower legs, horizontal and diagonal bracing, lighting conduits, coax lines, size and shape of the tower section, and other factors. Nulls as deep as 35dB have been measured (three hundredths of 1% power!). 20dB nulls are quite common (1% power). Only by actual azimuth pattern measurements, on the operating frequency, on the tower, or a replica of it, can the field pattern be determined accurately. Mounting the antenna on the side of the tower or pole nearest the service area does not guarantee best results. Nulls may be inadvertently pointed at the heart of the service area.

CETEC Antennas Pattern Optimization Service is used to improve the circularity of side-mounted CETEC FM antennas while repositioning the azimuth pattern null(s) to a heading that will be least detrimental to potential coverage.

The CETEC all-weather test range, located in the Sacramento Valley, is used for pattern measurement. One or more antenna bays are placed on an exact duplicate of the proposed antenna mounting structure for measurement, and parasitic elements are used to adjust the azimuth pattern in the horizontal polarization. Antenna positioning relative to the mounting structure is used to adjust the vertically polarized azimuth pattern. The parasitic elements are fabricated of steel and then hot dip galvanized for long life. Customized installation drawings are provided for ease of installation in the field. As a large number of variables, including number of antenna bays, mounting structure configuration and size, and orientation of the mounting structure relative to desired radiation directions, pricing for Pattern Optimization is on a custom basis.

Pricing may be obtained through ALLIED. CETEC stocks a number of standard mounting towers; where necessary, pricing will include any required tower duplication charges for proper testing.

DASH LINE - Original Pattern
SOLID LINE - After Optimization
SHADED AREA - Desired Coverage

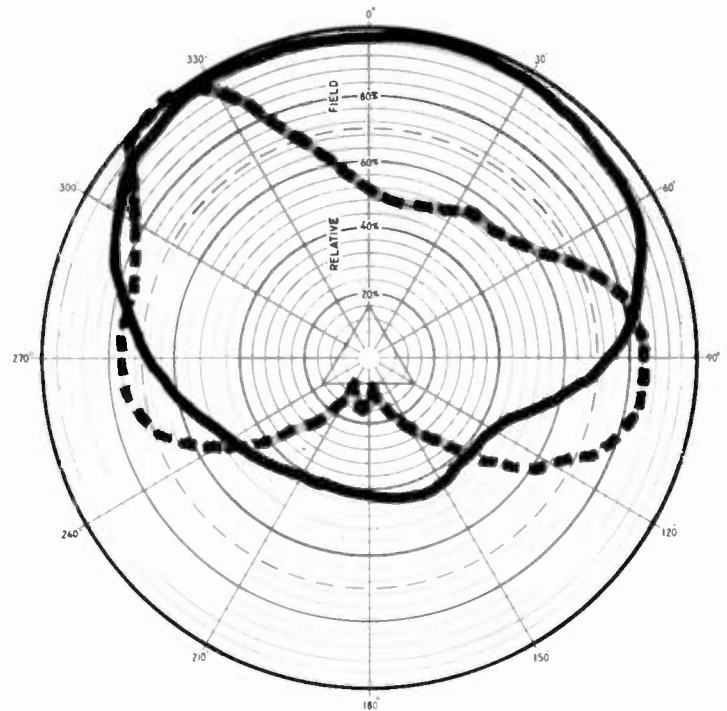

ACTUAL CASE TEST

Frequency = 94.5 MHz, Tower = 7 feet triangular,
Original Circuitry = ± 10.48 dB, Antenna Leg Mounted
After Adjustment, Circularity = ± 3.75 dB

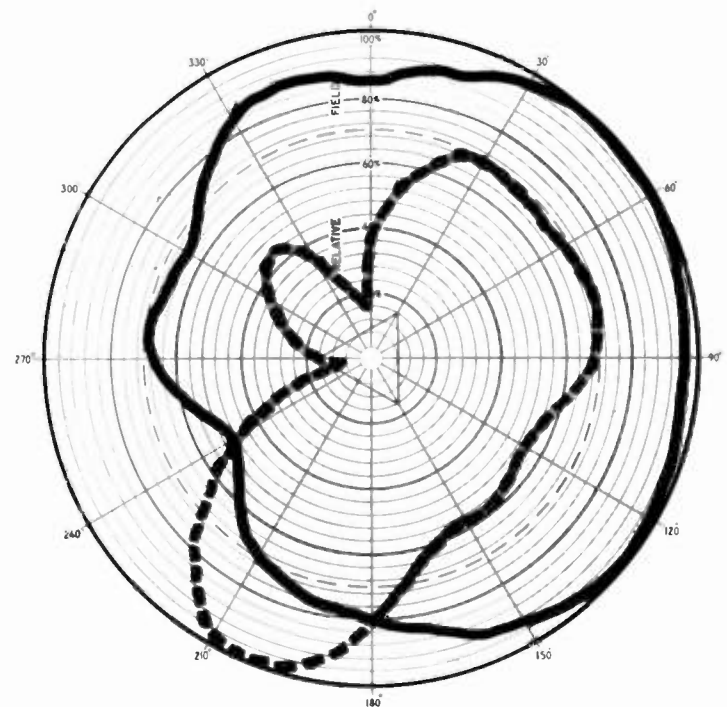

ACTUAL CASE TEST

Frequency = 102.5 MHz, Tower = 42 inch triangular,
Original Circuitry = ± 10.55 dB, Antenna Leg Mounted
After Adjustment, Circularity = ± 3.09 dB

COMARK CIRCULAR POLARIZED ANTENNAS

The series of FMC Circularly Polarized Antennas utilizes identical radiating elements for both the Lower Power (L) and High Power (H) series. The L series utilizes 1-5/8" feedline while the H series uses 3-1/8" feedline. Both series of antennas are available in systems that incorporate 1 to 14 elements. Normally, systems with eight or less elements are fed at the bottom while above eight, the system is fed from the center.

Each antenna contains a matching tuner which is approximately 6 feet long. It is extremely simple to adjust and has a foolproof method of adjustment without losing pressure. Mounting brackets are supplied with the antenna to assure proper mounting to the supporting structure.

Up to 6-1/8" input and feedline and up to 75KW power input on special order.

- Prices include complete mounting hardware for leg mounting on uniform guyed towers.
- Brackets for face mounting or self supporting towers are extra.
- Prices upon request.
- Antenna input flange on H series is 3-1/8" EIA Female. The L series is 1-5/8" EIA Female.
- Windload ratings are 50/33PSF, 110 miles per hour.
- Antenna weights include standard mounting hardware. Add 5 pounds per bay for deicers.
- Deicers require 230 volts, single phase balanced to ground with 400 watts consumption per bay.

FMC Model No. Stan. 1 ⁵ / ₈ - 3 ¹ / ₈ Input	Power Gain	Max. Input In KW	Net Wt. Pounds
FMLC-1	.44	5	40
FMHC-1	.47	10	60
FMLC-2	.97	10	90
FMHC-2	.99	10	140
FMLC-3	1.50	10	140
FMHC-3	1.54	15	220
FMLC-4	2.04	10	190
FMHC-4	2.14	20	300
FMLC-5	2.55	10	240
FMHC-5	2.70	25	380
FMLC-6	3.14	10	290
FMHC-6	3.30	30	460
FMLC-7	3.65	10	340
FMHC-7	3.84	35	560
FMLC-8	4.18	10	390
FMHC-8	4.30	40	640
FMLC-10	5.20	10	490
FMHC-10	5.40	40	570
FMLC-12	6.25	10	580
FMHC-12	6.54	40	730
FMLC-14	7.30	10	660
FMHC-14	7.70	40	860

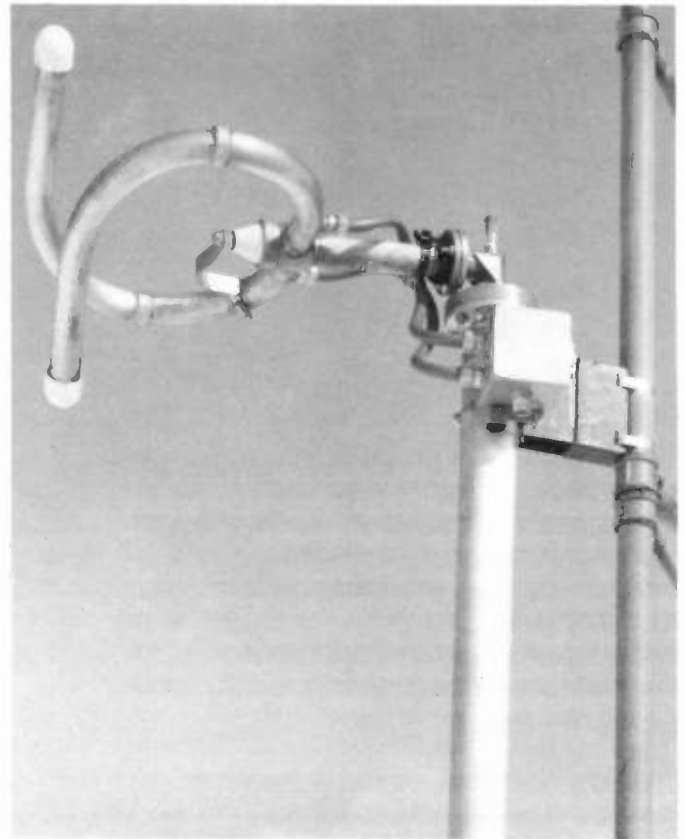

EDUCATIONAL SERIES

	Power Bays	Net Gain	Net Wt/lb	Nominal Pwr/KW	Wind load/lb
FMCE-1	1	.43	10	.5	20
FMCE-2	2	.90	22	.5*	40
FMCE-3	3	1.4	35	.5*	65
FMCE-4	4	1.92	47	.5*	88
FMCE-5	5	2.4	59	.5*	112
FMCE-6	6	2.9	68	.5*	135

* 2, 3, 4, 5 and 6 Bay will take .5KW more per bay (up to 3KW on 6 bay) with 1-5/8" input available.

Normally supplied with N fitting which will take Nominal .5KW input.

Interbay Feeds are of Flexible Cable.

FMCE 2 through FMCE 6 are center fed.

WHEN ORDERING BE SURE TO SPECIFY: Antenna type number - Deicers, if any - Frequency (between 88-108 mHz) - description of Tower - Make and Model.

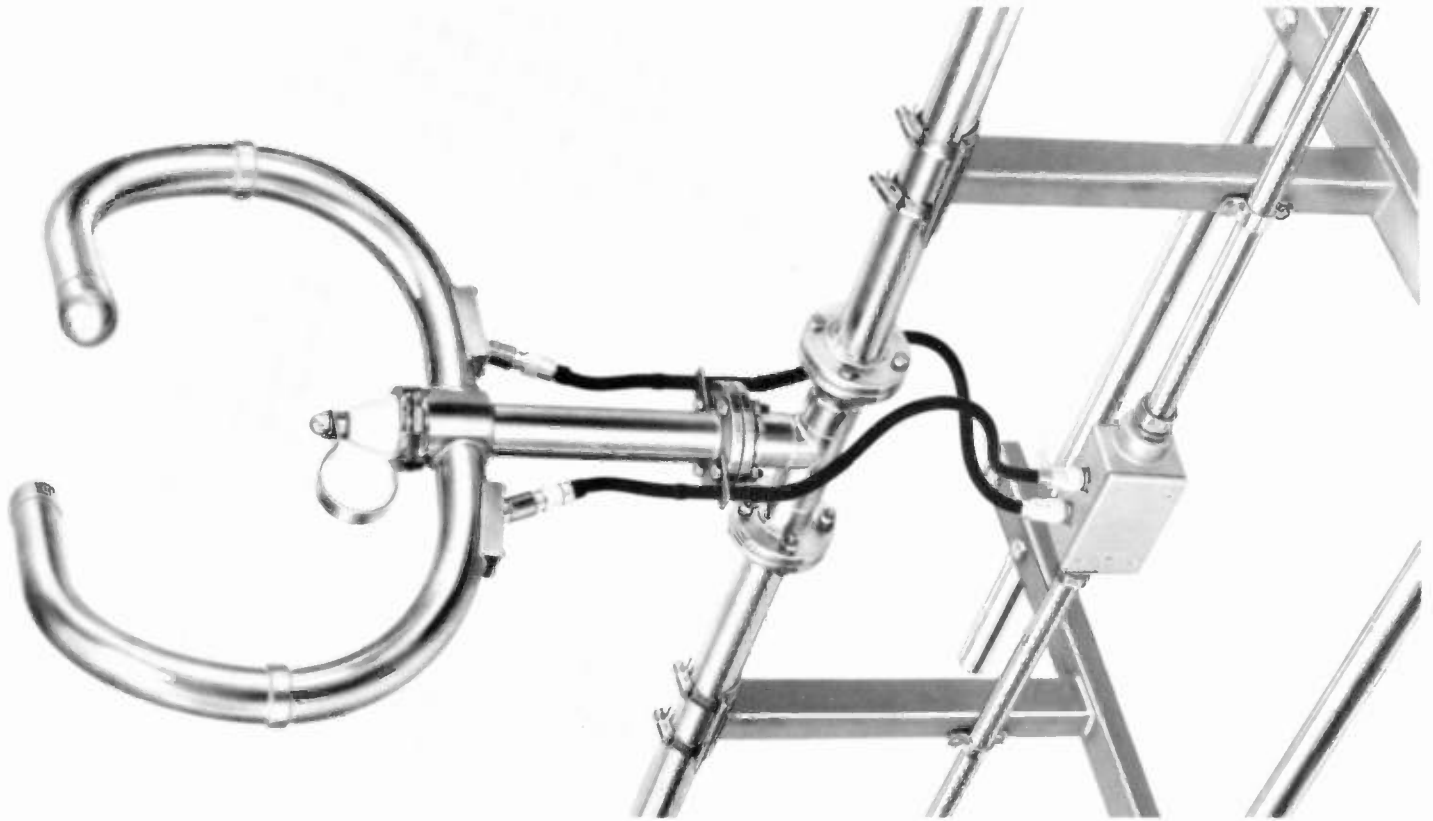

CELWAVE CIRCULARLY POLARIZED FM BROADCAST ANTENNAS

Standard circularly polarized FM antennas are fabricated of 1-5/8 O.D. copper tube formed into a 1½ turn helical radiating element. This element produces a transmitted signal that is circularly polarized in all directions in the azimuth plane.

Antennas are available with all elements fed in phase to produce maximum gain on the horizon with 1 through 8 elements end fed and 10 through 16 elements center fed. If beam tilt and/or null fill is required the multi-element array needed to produce the required pattern is center fed with appropriate power divider and phasor supplied.

Antenna weights include standard mounting hardware. Add 10 lbs. per bay for deicers. Deicers require 230 volts single phase balanced to ground with 500 watts consumption per bay.

When Ordering - Specify: Antenna type number, deicers, PD-1201, Frequency (88.1 to 107.9 MHz), 1-8 bays end fed, 10-16 bays center fed, Horizontal and Vertical Power Gains, Description of Tower - Make and Model, Beam Tilt and Null Fill, if required (extra), Thermostat and Control Box - PD-1202.

Type No. & Bays	Power Gain	Net/Wt. Lbs.	Power Rating/KW
CFM LP-1	.45	118	5
CFM HP-1	.475	178	5
CFM LP-2	.95	145	10
CFM HP-2	1.00	223	10
CFM LP-3	1.5	172	10
CFM HP-3	1.55	268	15
CFM LP-4	2.05	198	10
CFM HP-4	2.15	313	20
CFM LP-5	2.55	225	10
CFM HP-5	2.70	358	25
CFM LP-6	3.15	251	10
CFM HP-6	3.30	404	30
CFM LP-7	3.65	278	10
CFM HP-7	3.85	449	35
CFM LP-8	4.2	305	10
CFM HP-8	4.4	494	40
CFM LP-10	5.2	365	10
CFM HP-10	5.5	600	40
CFM LP-12	6.25	418	10
CFM HP-12	6.6	690	40

CFM LP = Circularly Polarized Low Power Shunt Fed with 1-5/8" Feed Line complete with 1-5/8" Fine Match.

CFM HP = Circularly Polarized High Power Shunt Fed with 3-1/8" Feed Line Complete with 3-1/8" Fine Match.

PI-ROD TOWERS

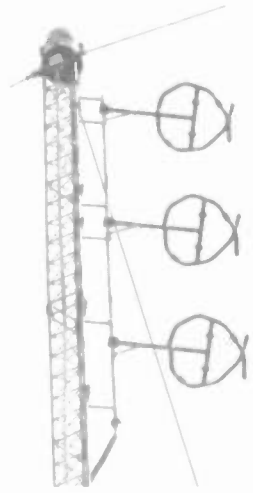

- Solid rod, all-welded construction provides greatest strength with minimum surface exposure to wind and icing conditions. Slim Line design offers minimized air resistance.
- A complete line of standard (proven performance) models.
- Computerized analysis of loading factors for structure conformity to meet and exceed customer specifications. Working with this data, licensed professional engineers review your specific requirements and determine the ultimate solution.

- Engineered concepts utilizing minimum space requirements. We design systems to meet critical space limitations, with 50% and small guy radii available.
- Minimized interference with reduced face width design improves transmissions . . . another PI-ROD engineering innovation.

UNION METAL POLES



Pole and accessories assembled on ground prior to erection.



Pole in position to be lowered on plumbing nuts.

UNION METAL's free-standing antenna support structures are ideally suited for commercial and industrial communication systems. Made of tapered, tubular steel, the poles are available in heights up to 300 feet and can be installed anywhere . . . on rooftops, confined areas, or just any place you want. These highly engineered poles for antennas offer numerous advantages over other types of structures:

- No guy wires required
- Minimum erection costs
- Low maintenance costs
- Aesthetic beauty
- Capacity for future needs
- Proven performance under extreme conditions
- Standard sizes available immediately

CELWAVE FM EDUCATIONAL ANTENNAS

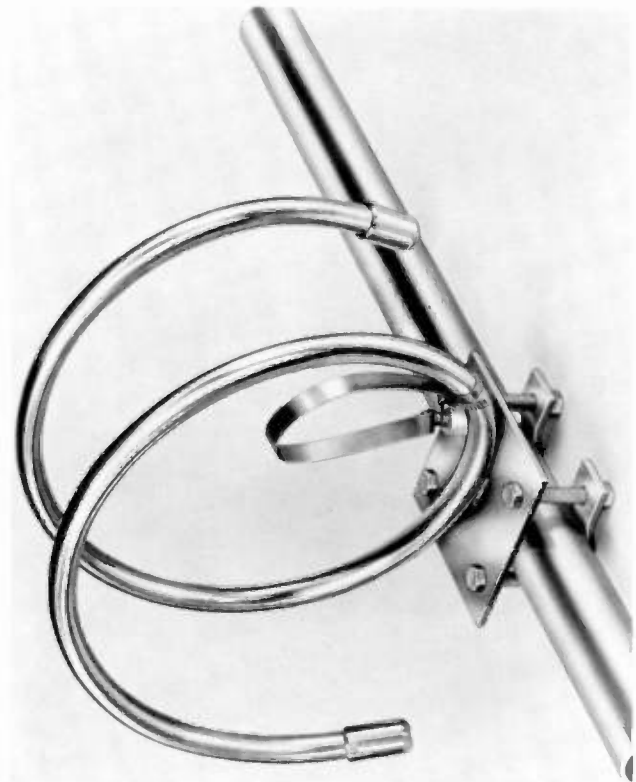

Educational FM antennas using the same general design concepts as the commercial High Power and Low Power antennas are available.

However, these antennas, because of the normally lower power required in the educational service, are fabricated of 7/8" stainless steel tube. The circularly polarized element has a U configuration. The educational antennas are complete with a matching harness of RG type cables and are designed to mount on tower legs or support pipes 1 1/4" to 2 1/4" diameters. The multi-element arrays have an element spacing of 10 feet.

- Educational FM Antennas are designed to mount on tower legs or support pipes having diameters up to 2 3/4". The spacing between bays is 10 feet.

- Educational FM Antennas are fed with RG-8 and RG-11 cables and all have a type N Male Input Connector.

Type No. & Bays	Power Gain	Net/Wt Lbs	Power Rating/KW
ECFM-1	.43	9	.2
ECFM-2	.90	21	.4
ECFM-3	1.42	32	.5
ECFM-4	1.95	43	.5
ECFM-6	2.99	65	.5

BIRD® 8645 25KW MODULOAD LOAD RESISTOR

- Power rating 25KW continuous duty up to 900 mHz
- Weight: 155 lbs.
- Distilled water or Ethylene Glycol
- 10KW and 80KW in this series plus 2½ to 7KW dry loads and Econo wet loads up to 80KW

CONTACT ALLIED FOR PRICING



BIRD® ELECTRONICS

BIRD® ELECTRONICS known for accuracy for more than a quarter of a century, offers thru-line RF directional watt meters, RF load resistors, up to 80KW, and "watcher®" protection systems.

ALLIED CARRIES THE ENTIRE
BIRD® PROFESSIONAL LINE.

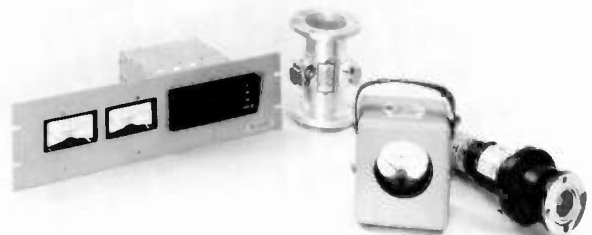

ELECTRO IMPULSE

RF Coaxial Loads - Air, oil, dry and water cooled of all sizes from .5 to 80KW.

Representative Models:

1500 watt oil dielectric cooled and self-contained
Model CPTN-1500 Good out to 1 GHz

10,000 watt dry load, forced air cooled and self-contained
Model DPTC-10KFM Good out to 110 mHz

25,000 watt dry load, forced air cooled and self-contained
Model DPTC-25KFM Good out to 110 mHz

80,000 watt water load, running-water cooled
Model CLW-84 Good out to 1 GHz

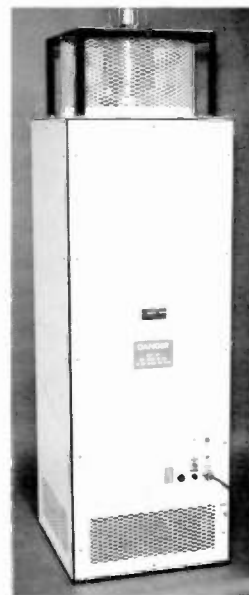

DPTC 50KFM



DPTC 10KFM

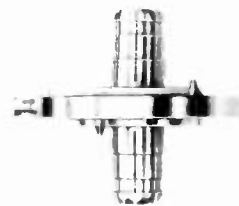

ANDREW



Cablewave Systems

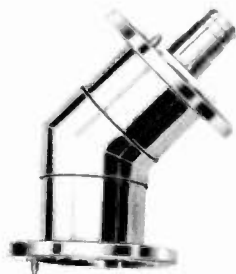

Directional Couplers	Low Pass Filters	Heliax Cable	Elbows
Diplexers	RF Patch Panels	Power Dividers	Switches
Tuners	Hangers	Flanges	Coax Power Combiner
Band Pass Cavities	Compact Preselectors	Pass-Reject Cavity	Notch Cavities
Connectors	Microwave Cables	Waveguide Flanges	Rigid Line Components

CELWAVE

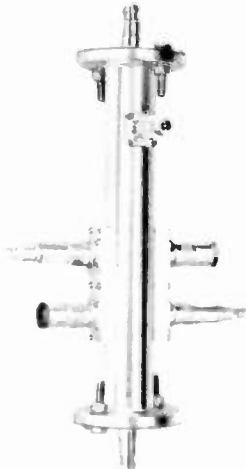

BIRD



Cetec



- | | | | |
|------------------------|---------------------|----------------------|------------------------|
| Anchor Connectors | Clamps | Ear Caps | Insulators |
| Phase Shifters | Sleeve Couplings | Coaxial trans. lines | Waveguide trans. lines |
| Gas Barriers | Terminals | RF Components | Combiner/Diplexer |
| Jogs | Low Loss Foam Cable | Quadrature Hybrids | Trap Filters |
| Base Station Duplexers | Helix Connectors | Radiax Accessories | Coaxial Cables |



COMARK



CABLEWAVE

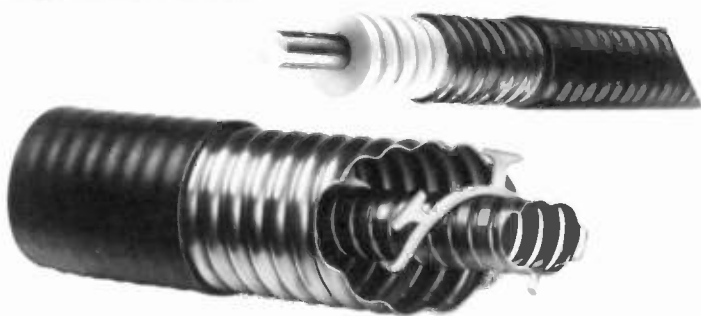

CABLEWAVE SYSTEMS coaxial cables feature flexibility, transverse stability, low attenuation, longitudinal precision and high power rating. Typical areas of application are: feedlines for broadcast antennas, feedlines for terrestrial microwave antennas, cabling of antenna arrays, and radio equipment interconnects. A full line of commonly used connectors featuring ease of assembly without special tools and reliable performance is available for all cables. Coaxial cables may be "phase stabilized" to provide a repetitive phase-temperature characteristic for reliable broadcast sampling line systems.

ALLIED CARRIES THE COMPLETE
CABLEWAVE LINE.

DIGIMAX D1200 FREQUENCY COUNTER

RANGE: 10 Hz - 1.2 GHz



The built-in .1 PPM (55° to 85° F) 10 mHz proportional oven OSC. and bright .5 in. LED readouts make the D1200 ideal for solving all those difficult bench and field problems. When checking audio frequency tones the D1200 will resolve 1/1000th Hz in ten seconds, 1/100th Hz in one second, and 1/10th Hz in only .1 second. This is made possible by the built-in audio multiplier. The D1200 also has a prescale input control — and the D1200 includes a 1.2 GHz prescaler. The D1200 will meet all FCC landmobile, broadcast, and telecommunications requirements.

SENSITIVITY: 50Hz to 25 mHz: 5 to 50 MV
25 mHz - 450 mHz: 15 to 50 MV
1 GHz: 50 to 75 MV
Power Req.: AC-12 Req. for 110 VAC,
8-15 VDC 500 MA

Accuracy as stated above equals ± 0.1 Hz @ 1 mHz
± 1.0 Hz @ 10 mHz
± 100 Hz @ 1 GHz

ANDREW

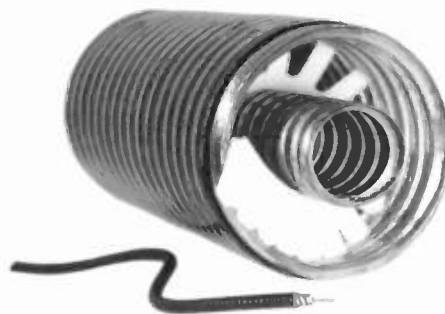

For more than 40 years, Andrew has offered a comprehensive line of broadcast products. These include both foam and air dielectric HELIAX™ flexible coaxial cables, rigid line components, pressurization equipment and installation accessories. Detailed information on the ANDREW line of products is available upon request.

ALLIED CARRIES THE COMPLETE ANDREW LINE.

DECCA AUSTIN

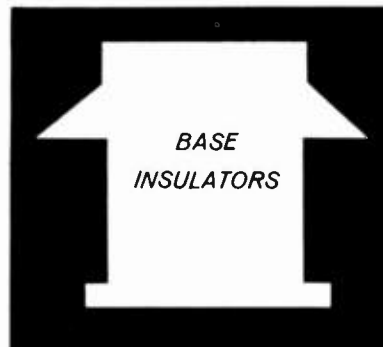
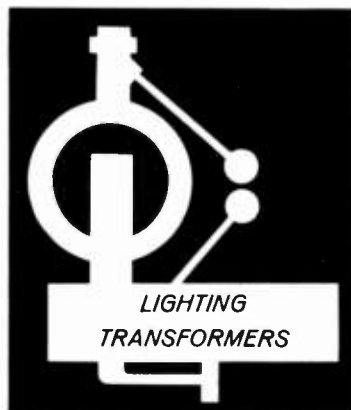

0.7 to 5Kva ring-type transformers. Insulating bases with a capacity of from 20,000 to 900,000 lbs. max. Guy strain insulators with working loads from 6,000 lbs. to 275,000 lbs. Strains include safety core, failsafe and failsafe breakups.
SEE PAGE 21.

MOSELEY ISOCOUPERS

The Model ICU Isocoupler Series is designated to facilitate the connection of a remote pickup transmitter or receiver, or an aural studio-transmitter or receiver to an antenna mounted on an ungrounded standard AM broadcast tower. As the capacitive loading presented to the broadcast tower is minimal, the effect on the base impedance will be negligible. The efficiency of the isocoupler at the designed operating frequency is greater than 90%. The isocoupler eliminates the need to employ a quarter-wavelength insulated transmission line section when installing either a remote pickup or STL antenna on a standard broadcast tower. The isocouplers are rated to withstand an instantaneous 15,000 volt peak. (Caution: In computing the electrical stress across the isocoupler, use the peak value, not RMS, and allow a margin for overmodulation peaks.) They are housed in rugged epoxy-fiberglass tubes. The end plates are sealed with epoxy glue, and the entire unit is painted with epoxy. Type N female RF fittings are used on all isocouplers.



Model	Operating Freq.*	Peak Voltage	Capacity**	Length	Diameter	Weight
ICU-1A	940-960 MHz	15,000	9 pf	5"	3"	¾ lb.
ICU-2A	450-470 MHz	15,000	3.5 pf	4"	3"	½ lb.
ICU-3A	148-172 MHz	15,000	3.5 pf	6½"	3"	½ lb.

*All isocouplers are designed to carry in excess of 60 watts continuous power at rated frequency.

**Measured between ends of isocoupler with center pin of UG-58A/U connector shorted to body.

ELECTRONIC RESEARCH ISOLATION TRANSFORMER — TYPE 425

The isolation transformer is designed to couple the FM power across the base insulator of a transmitting tower used jointly as an AM and FM radiator without introducing objectionable mismatch into the FM antenna feed line. An isolation transformer is especially desirable for feeding high impedance AM radiators or AM radiators which are part of an AM directional antenna system which might be adversely affected by a "bazooka" isolation system.

ELECTRICAL SPECIFICATIONS:

VSWR: Less than 1.05 to 1 at customer's frequency ± 0.5 MHz when terminated in a matched 50 ohm load.

Bandwidth: Over 2 MHz between 1.1 to 1 VSWR points when terminated in a matched 50 ohm load.

Power Rating into Matched 50 ohm load: 25KW.

Insertion Loss: Less than 0.1dB.

Input: 3-1/8" EIA 50 ohm male flange with captive bullet . . . output same.

AM Shunt Capacity to Ground: 60 to 70 pf.

AM Peak Voltage Rating: 40,000 volts.

Lightning Protection: Heavy duty D.C. shorts between the inner and outer conductors on both the input and output of the transformer.

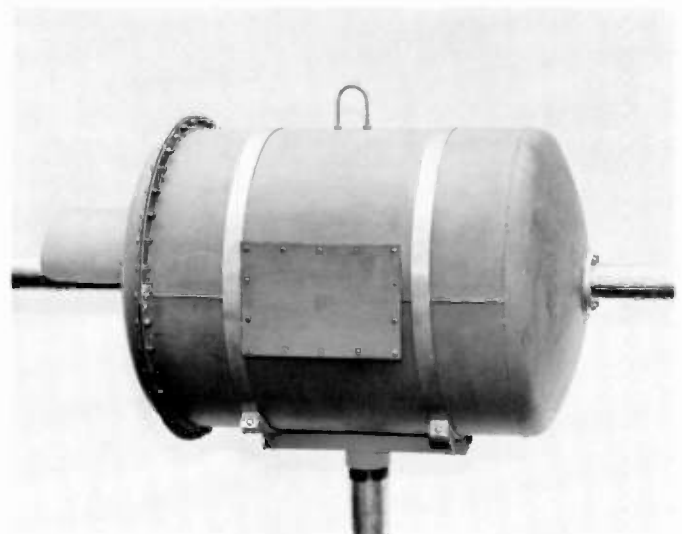

MECHANICAL SPECIFICATIONS:

Weight of Transformer and Cradle: 256 lbs.

Flange to Flange Length: 39" $\pm 1/8$ "

Maximum Diameter of Tank: 28½"

Designed for use in a pressurized system with gas passing through the unit.

AUSTIN RING TYPE ISOLATION TRANSFORMERS FOR RADIO TOWER AND MAST LIGHTING

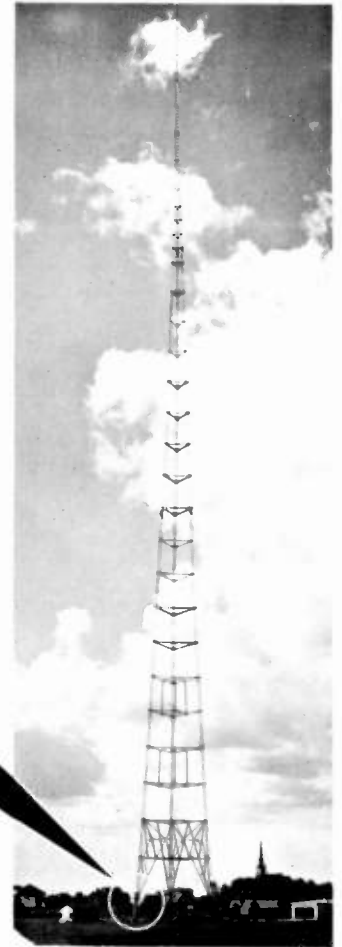
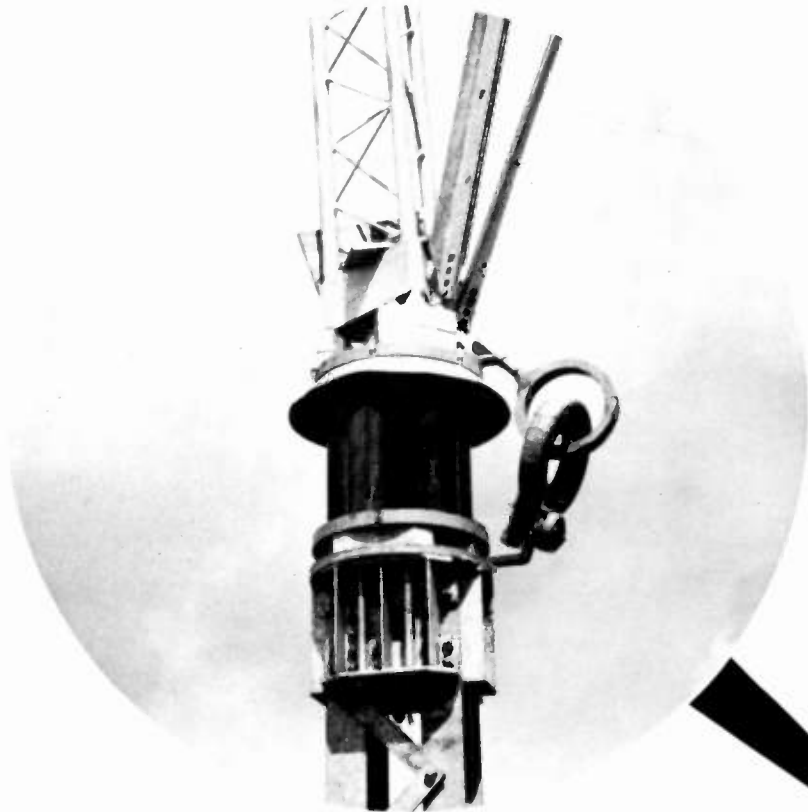
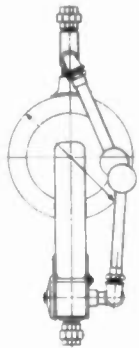

AIR INSULATION — Minimum RF loss
REGULATION — Better than 10% under normal load conditions
LOW CAPACITANCE — Minimum and stable effect on tuning.

EFFICIENCY — Better than 90% under normal load conditions
MOUNTING — Standard Pipe Unions supplied.
LIGHTING GAP — Supplied
 Up to 5 KVA available.

AUSTIN BASE INSULATORS FOR GUYED RADIO ANTENNA MASTS

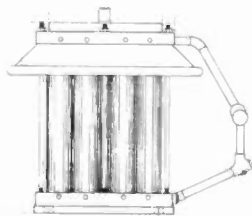

Oil filled to eliminate Radio Frequency loss due to water condensation on internal surfaces. Smooth insulator finish minimizes leakage and flashover due to surface contamination. Thermostatically controlled heaters available as an extra — these must be specified at time of ordering. Insulators for higher mechanical and electrical loads are readily available from standard AUSTIN designs. Up to 2.5 million pounds down working loads available.

BELDEN



BELDEN is recognized as the leader in the wire/cable/cord industry and manufactures thousands of different electronic cable and cord constructions utilized in a vast assortment of applications. Many cables are custom designed/manufactured for specific applications prior to becoming standardized for systems in data processing, computers, medical applications, broadcasting, etc. BELDEN Black 8451 is especially popular with broadcasters as well as 8728. With BELDEN in our "backyard," we offer you the world's largest inventory of wire/cable/cord available to anyone, anywhere.

DELTA ELECTRONICS TOROIDAL CURRENT TRANSFORMERS

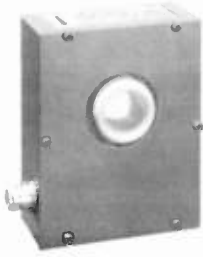

TCT-N

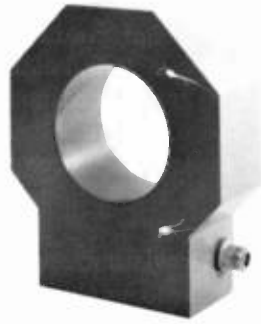

TCT-N-HV

The TCT-1, TCT-2 and TCT-3 are precision toroidal current transformers designed primarily for obtaining sampling voltages for phase and magnitude measurements on broadcast arrays. The units are housed in rectangular aluminum shield enclosures with a 1 1/4" teflon lined passhole through which the current carrying conductor is passed.

The TCT-1 and TCT-2 may both be used in the same system since they have identical tracking characteristics. The TCT-3 has somewhat different characteristics and preferably should not be mixed with the two types.

The TCT-N-HV specifies the current transformer is the high voltage type. The passhole in this transformer is 3/4". The conductor voltage to ground can be as high as 20 kV (RMS on modulation crests).

FREQUENCY RANGE:
.5 to 2 mHz

SOURCE IMPEDANCE:
50 ohms

SENSITIVITY:
TCT-1: .5V/ampere
TCT-2: .25V/ampere
TCT-3: 1V/ampere

CURRENT RANGE:
TCT-1: 0 - 40 amperes
TCT-2: 0 - 75 amperes
TCT-3: 0 - 25 amperes

ABSOLUTE MAGNITUDE ACCURACY:
±2%

ABSOLUTE PHASE ACCURACY:
TCT-1 and 2: ±2 degrees
TCT-3: ±3 degrees

MAGNITUDE TRACKING ACCURACY:
±1%

PHASE TRACKING ACCURACY:
TCT-1 and 2: ±0.5 degrees
TCT-3: ±1 degree

INSULATION:
10 kV

ELECTRIC FIELD REJECTION:
> 100 dB

RF AMMETER SYSTEMS



ABOUT THE TCA

The TCA (Transformer Coupled Ammeter) series uses a toroidal current transformer (TCT) to obtain a sample voltage proportional to the RF current flowing in a conductor. This sample is connected by a 50 ohm coaxial cable to a special rectifier circuit where it is converted to a DC current to drive the indicating instrument. A DC voltage output for driving a remote indicating instrument which may be calibrated to agree with the primary meter and used for remote indication is also provided.

THE COUPLING TRANSFORMER

The primary winding of the transformer is the current carrying conductor passed through the hole in the transformer box. This is usually a tubular lead feeding a tower base, a network lead, or the conductor connecting the transmitter output to the "common point" of the antenna phasing networks. The conductor size and its location in the passhole of the transformer have no practical effect on the meter calibration.

METER CIRCUIT

The meter circuit has a 50 ohm load resistor for proper termination of the cable. Thus, the cable is both source and load terminal for a match.

The rectifier filter circuit is designed to follow the modulation envelope accurately on both positive and negative excursions. The meter ballistics will give a stable carrier reading independent of modulation.

A switch is provided on all meters to remove and ground the rectifier portion of the circuit when not required.

METER CALIBRATION

Every TCA system is calibrated at an RF frequency of 1 mHz. Since the frequency response is extremely flat, accuracy is assured over the entire range of broadcast frequencies. The accuracy specification of ±2% of full scale is guaranteed without corrections. In addition, a correction curve is supplied with each meter for those users requiring even greater accuracy.

The calibration accuracy of TCA instruments is guaranteed for a period of one year under normal use conditions.

BIRD® TERMALINE® RF COAXIAL LOAD RESISTORS

BIRD® TERMALINE® Load Resistors are used in place of the antenna during testing, adjustment and alignment of 50 ohm coaxial RF transmitters.

Their low VSWR (1.1, or less, at mobile radio frequencies) assures an excellent match and the absorption of at least 99.75% of the RF energy generated.

The TERMALINE® Model 8135, shown is to Mobile RF Coaxial Load Resistors what the BIRD® Model 43 is to Directional Wattmeters — a “best buy.” This highly functional resistor is rated for 150W continuous dissipation. However, the rating may be exceeded for short periods (e.g. 250W max. for 5 minutes on, 30 minutes off). This feature eliminates the need

to purchase an additional termination where requirement for power up to 250W is sporadic.

BIRD® Electronic's traditional air cooled, liquid dielectric termination resistors are easily recognized by their light grey finish. These “standards of the industry” have been proven-in-use for nearly four decades. Their power ratings, as listed here, are conservative and may also be exceeded for short periods.

Most BIRD® TERMALINE® RF Coaxial Load Resistors are supplied with Quick Change (QC) type connectors. This allows use of connectors other than those “normally supplied.” Note that, unless a different connector style is requested at time of order, unit will be shipped with the one shown in the specifications.

ALL OPERATE IN HORIZONTAL POSITION ONLY!



Model No.	Power Rating	VSWR	Input Conn.	Weight
8135	150 Watts	1.1 max DC to 1000 mHz, 1.2 max 1000 to 2500 mHz, 1.3 max 2500 to 4000 mHz	QC Female N	6 lbs.
8141	250 Watts	1.1 max DC to 1000 mHz, 1.2 max 1000 to 2000 mHz, 1.3 max 2000 to 2500 mHz	QC Female N	10 lbs.
8201	500 Watts	1.1 max DC to 1000 mHz, 1.25 max 1000 to 2500 mHz	QC Female N	21 lbs.
8251	1000 Watts	1.1 max DC to 1000 mHz, 1.25 max 1000 to 2000 mHz, 1.3 max 2000 to 2400 mHz	QC Female LC	24 lbs.
8860	1500 Watts	1.1 max DC to 1000 mHz	QC Female LC	28 lbs.

BIRD® TERMALINE® — RF COAXIAL LOAD RESISTOR

Other BIRD® terminations have air dielectric ("dry load") and are identified by their black finish (10 watt units and higher). Air dielectric resistors offer the advantage of being able to be connected to a line in any position.

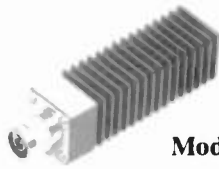

Model 8080



Model 8085

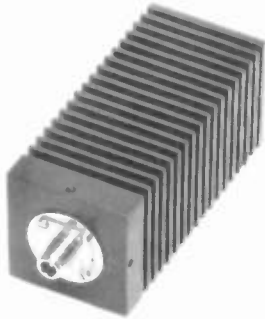

Model 8164



Model 8166



Model 8173

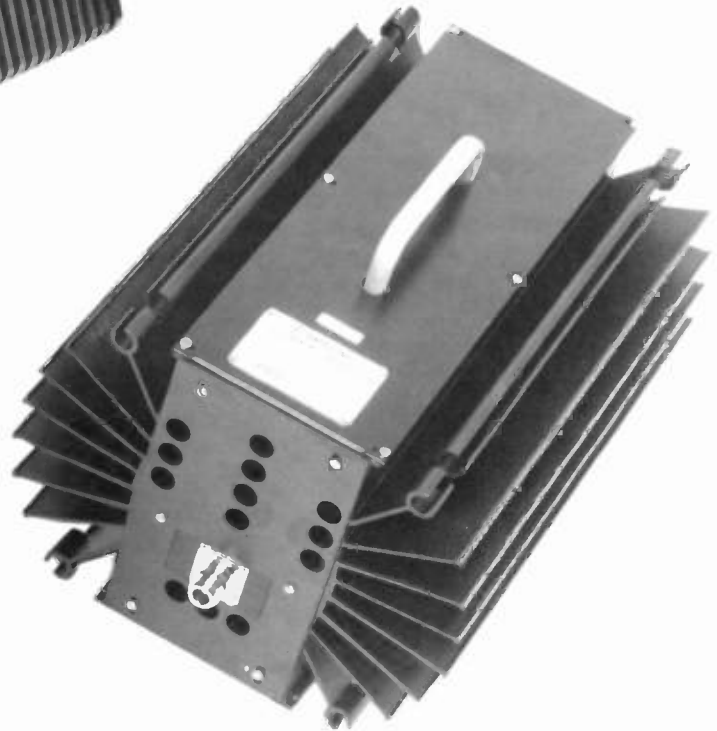

Model 8431



Model 8052-53



Series 80

Model No.	Power Rating	VSWR	Input Conn.	Weight
Series 80	5 Watts	1.1 max DC to 1000 mHz. 1.2 max 1000 to 3500 mHz. 1.3 max 3500 to 4000 mHz	Male/Female N	4 oz.
8052-53	10 Watts	1.1 max DC to 1000 mHz, 1.2 max 1000 to 3500 mHz	⁵² - Female N ⁵³ - Male N	4 oz.
8080	25 Watts	1.1 max DC to 1000 mHz. 1.25 max 1000 to 3500 mHz	QC Male N	9 oz.
8085	50 Watts	1.1 max DC to 1000 mHz. 1.25 max 1000 to 3500 mHz	QC Male N	15 oz.
8164	100 Watts	1.1 max DC to 1000 mHz. 1.2 max 1000 to 2500 mHz	QC Female N	48 oz.
8166	150 Watts	1.1 max DC to 1000 mHz. 1.2 max 1000 to 2500 mHz	QC Female N	96 oz.
8173	300 Watts	1.1 max DC to 1000 mHz, 1.25 max 1000 to 2000 mHz	QC Female N	6¼ lb.
8431	600 Watts	1.1 max DC to 1000 mHz, 1.25 max 1000 to 2500 mHz	SQC Female N	13 lb.

PHASEMASTER®



Economical, Reliable Conversion of Single-Phase and Regulation of Open Delta Service for 3-Phase Broadcast Operation

The Phasemaster® T-Series Rotary Phase Converter is specially engineered and manufactured for use with all types of radio and television transmitters. It converts single-phase power to 3-phase in locations not economically served by 3-phase lines.

Phasemaster® is particularly valuable in situations where the high cost of installing utility-supplied 3-phase power is prohibitive. A Phasemaster® T-Series Rotary Phase Converter can be installed for a fraction of the cost of obtaining 3-phase utility lines.

Utilities often use open delta systems to reduce distribution costs. However, the absence of a third transformer allows the line voltage to fluctuate excessively across the open leg. This condition is unacceptable for broadcast use. When used with open delta systems, the Phasemaster® closes the delta, eliminates undesirable fluctuations and regulates all three lines.

Phasemaster® is low in initial cost, high in performance and has a proven service record of more than 15 years in commercial broadcast installations worldwide. Phasemaster® has been sized and tested for compatibility with most makes and ratings of commercial transmitters.

PERFORMANCE

The Phasemaster® T-Series Rotary Phase Converter incorporates many superior performance benefits:

- Voltage produced through Phasemaster® is regulated within a range of 2-5% of the single-phase primary electrical supply.
- Output wave forms and phasing are nearly identical to utility-supplied 3-phase.
- The converter has the ability to buffer line transients and voltage spikes.
- Integral lightning protection adds to operating reliability.
- Systems are available to accommodate dual power output ratings, for example in daytime and nighttime transmission. Also available with automatically controlled high-low-power switching.
- The converter is designed to operate indefinitely on a continuous 24-hour-a-day basis, with or without a load, without injury to the converter.
- Units can be remotely controlled.
- Operating cost savings are realized by taking advantage of lower kilowatt-hour rate structures.

INFORMATION NEEDED FOR SIZING

To select the proper T-Series Phasemaster®, the following information is required:

- Type of broadcasting: AM, FM or television.
- Manufacturer, model number and KW rating of transmitter.
- AM transmitters: power consumption at average modulation and 100% modulation, in KW, KVA or amps.
- FM transmitters: power consumption at 110% current draw.
- Operating voltage.
- Elevation of transmitter installation.
- Any variations in power consumption due to broadcasting at different power levels, for example, daytime vs. night.
- Incoming service single-phase or open delta.

Model		T-1300	T-2000	T-2500	T-4000	T-5000	T-7500	T-8000	T-10000	T-12000	T-14000
Length	Inches	14.81	15.17	16.67	19.68	20.56	22.06	22.32	23.32	24.68	26.18
Width	Inches	15.09	16.72	16.72	19.00	22.06	22.06	23.66	23.66	25.81	29.96
Height	Inches	17.00	20.06	22.06	25.88	27.88	27.88	29.69	29.69	33.50	33.50
Shipping Weight	Pounds	145	190	227	365	430	497	640	788	905	950
Shipping Dim. (inches)	Height	28	28	28	37.5	37.5	37.5	40.5	40.5	40.5	40.5
	L x W	18x22	18x22	18x22	24.5x24.5	24.5x24.5	24.5x24.5	26.5x26.5	26.5x26.5	26.5x26.5	26.5x26.5

KINTRONIC LABORATORIES — ISOCOUPPLERS

The use of these units at the base of an AM tower permit the installation of an FM antenna and connecting transmission line on the tower without requiring insulation and tuning of the transmission line. Since the shunting capacity of these units across the base insulator of the AM tower is less than 150 PF, the effect on the base input impedance of the tower will be negligible for most single radiators or directional elements. The transmission line may be fastened to the tower for its full length permitting the tower to operate with normal radiation characteristics. Many of these isocouplers are now in service at permanent installations having stereo operation and judged by the user to be of superior quality. Four units available from 10 watts through 30 kilowatts.

KINTRONICS also offers sampling and transmission systems, control circuit cables, and phasing systems.



FMC-0.1

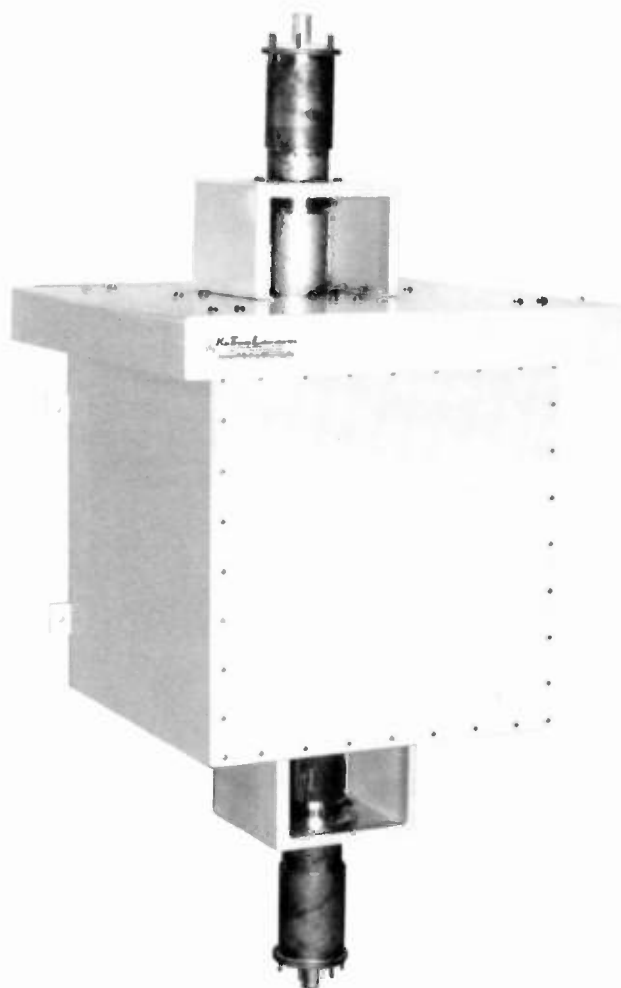

FMC-30



FMC-7.5



FMC-20

Model No.	Power Rating	Freq. Range	Input/Output Connection	Height-Width-Depth	Weight-Lbs.
FMC-0.5A	1500 W	35 to 87 mHz	N Female or 7/8" EIA Male Flange	34" x 13" x 13"	35
FMC-1.5	1500 W	88 to 149 mHz	N Female or 7/8" EIA Male Flange	28" x 12" x 12"	25
FMC-0.5B	500 W	150 to 699 mHz	Type N Female	24" x 12" x 12"	25
FMC-0.1	100 W	700 to 960 mHz	Type N Female	18" x 8" x 8"	10
FMC-7.5	7.5 KW	88 to 108 mHz	1 5/8" EIA Male Flange	43" x 16" x 16"	70
FMC-20	20 KW	88 to 108 mHz	3 1/8" EIA Male Flange	55" x 22" x 22"	125
FMC-30	30 KW	88 to 108 mHz	3 1/8" EIA Male Flange	64" x 30" x 30"	140
FMC-10	10 KW	54 to 216 mHz	1 5/8" EIA Male Flange	43" x 16" x 16"	70

1. Insertion loss at Fundamental Frequency = Less than 0.2 dB; Insertion loss at Second Harmonic = 20 dB or better
2. Output and Input Impedance = 50 ohms (other values available upon request)
3. VSWR within ± 0.5 mHz of operating frequency with a standard load impedance = Less than 1.05 to 1
4. Capacity between Input and Output Circuit = Less than 100 uuf; 150 uuf on 7.5, 10, 20 and 30 KW Models

BELAR AMM-3



The AMM-3 Modulation Monitor is basically the same as the AMM-2A except for an ability to read both positive and negative modulation peaks.

AMM-4



The AMM-4 Frequency Monitor is designed especially for ATS. Any frequency from 10 kHz to 50 MHz may be monitored for deviation.

AMM-2A

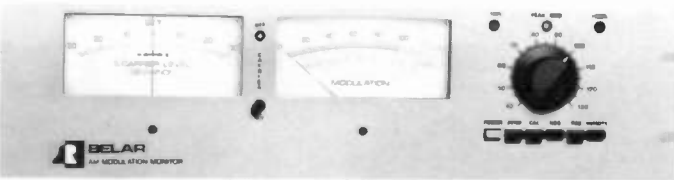

The AMM-2A Modulation Monitor sets standards in accurate AM monitoring. It's the first AM monitor to incorporate true ratio-type peak indicators. The AMM-2 contains a unique modulation cancellation scheme to recover unmodulated carrier to reference the modulation peaks to. Thus the instantaneous carrier without the need of time constants, as with AGC devices. True carrier is indicated with asymmetrical modulation encountered in today's high positive peak modulation, and peaks are automatically referenced to this true carrier to give the most accurate indication of program peaks.

RFA-1



The RFA-1 FM RF Amplifier allows for remote monitoring of the transmitter in conjunction with Main and SCA FM modulation monitoring equipment. It offers an RF input sensitivity of 100 microvolt for full output, 50 to 75 ohms of input impedance and operates from 88 to 108 MHz.

RFA-2



The RFA-2 AM RF Amplifier offers a selective, high gain, all silicon solid-state unit with AGC and makes it possible to monitor off-the-air AM signals accurately and conveniently without the problems associated with changes in transmitter power level, antenna patterns and signal fading. The RFA-2 when used in conjunction with AMM-2A, AMM-3 or AMM-4 allows monitoring of modulation characteristics at a remote point.

TVM-1



The TVM-1 Television Aural Modulation Monitor is a wide-band, all solid-state TV aural monitor designed to provide accurate modulation monitoring for the TV Broadcaster, UHF or VHF. The state-of-the-art TVM-1 measures *both* positive and negative peaks simultaneously and automatically selects and registers the higher of the two on *both* the true peak meter and peak flasher. Exclusive polarity lamps indicate the instantaneous polarity of the peaks registered on the peak meter and peak flasher. Calibration accuracy may be checked at any time with the front panel push-button modulation calibrator.

TVM-100



The BELAR Model TVM-100 Television Aural Modulation Monitor is a precision wide band monitor designed to measure the total modulation characteristics of mono as well as multi-channel television audio. Utilizing split sound and quasi-parallel detection modes, automatic deviation calibrators for 25 MHz (mono) and 73 MHz (BTSC Stereo) and a digital display for indication of actual deviation, the TVM-100 satisfies all requirements for mono and stereo baseband monitoring and test.

BELAR TVM-200



The BELAR Model TVM-200 TV Stereo Modulation Monitor is designed to operate in conjunction with the BELAR model TVM-100 TV Baseband Modulation Monitor to provide complete monitoring of BTSC stereo transmission systems. The test and measurement capabilities are enhanced by the integration of two auto-ranging voltmeters, allowing automatic measurement of channel separation, crosstalk, pilot phase and pilot level. An equivalent mode test function is also provided, which bypasses the DBX decoder for non-encoded transmitter testing. Multiple metering allows full-time monitoring of L + R and stereo composite modulation and selectable metering of total and L - R modulation along with left and right channel audio.

FMM-1



BELAR FM monitors are designed as a totally integrated, solid-state system to enable the broadcaster to fulfill his monitoring equipment requirements as the need arises. The FMM-1 Frequency and Modulation Monitor is a wideband, all solid-state FM monitor expressly designed to fulfill all the requirements for monaural monitoring as well as to provide a virtually pure, distortionless signal to drive the companion FMS-1 and SCM-1 for multiplex monitoring.

FMS-1



The FMS-1 when added to the FMM-1 provides complete monitoring and test functions to meet the daily requirements for stereo monitoring, and provides additional facilities for making the proper tests for weekly and monthly maintenance checks to insure maximum performance from stereo transmitters.

SCM-1



The SCM-1 SCA Frequency and Modulation Monitor, when added to the FMM-1 provides complete monitoring and test functions for SCA storecasting and remote telemetering applications. Up to four crystal switch positions allow four channels to be operated and tested.

FMM-2



The FMM-2 sets new standards in accurate FM monitoring. It's the first to incorporate a sample hold peak modulation meter circuit independent of modulation polarity to allow the meter to respond to program peaks of the shortest duration. The heart of the FMM-2 is an ultra-linear digital discriminator which provides a distortionless baseband signal for accurate monitoring as well as precise stereophonic and SCA decoding.

FMS-2



Working in conjunction with the FMM-2, the FMS-2 offers two independent peak modulation meters for simultaneous monitoring of left and right channels or L+R and L-R. It also has two independent auto-ranging voltmeters with LED displays for simplified automatic measurements of channel separation, crosstalk, sub-carrier suppression and noise.

QEI 691

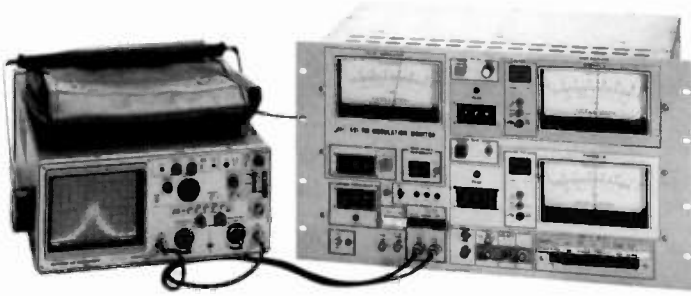

The 691 FM Monitor/Test Set is a high technology, precision instrument employing a combination of new techniques in a single, highly versatile, but very compact package. It was designed to be a complete FM test package with facilities for all proof-of-performance measurements and a wide range of trouble-shooting tests. Operator convenience and simplicity of use were primary considerations in the design of the system. Component selection and device ratings are such as to enhance the instrument's reliability even with adverse handling. It occupies only 10½" of vertical rack space in a standard 19" rack. NOTE: 691/01 with 1 ea. SCA, 691/02 with 2 ea. SCA.

GORMAN REDLICH CM

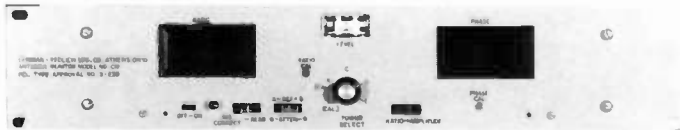

The Model CM is a stable, accurate monitor for DA installations not requiring telemetering of antenna readings. It offers true ratio readout. Non-reference and reference amplitudes are separately measured and divided electronically to give a digital readout that will not change with transmitter power and is exceptionally stable under conditions of asymmetric modulation. Stability of the readout makes readings accurate and easy to read.

CMR



The Model CMR is the latest in "developed technology" from G-R at a price comparable to analog monitors. With typical modulation, the CMR's true ratio readout is a factor of 10 more stable than instruments that measure normalized amplitude, and its phase readout is rock solid. Phase sign is automatic with no extra operations. Practically speaking, these features mean quick, accurate log or remote calibration readings. The CMR is fully remotable via land line or telemetry, using standard remote control equipment.

DAV TRONICS RFA-5



The RFA-5 AM RF Amplifier is designed to operate frequen-

cy and modulation monitors at a location remote from the transmitter, typically at the studio. When driven by a local antenna with an RF signal as low as 0.6 mv, the RFA-5 will drive most contemporary AM monitoring equipment, as well as providing a low-level output for an oscilloscope, and a clipped/limited output for a standard frequency counter.

DELTA DAM-1



The DAM-1 is a true digital antenna monitor designed specifically for measuring the parameters of broadcast frequency directional antenna systems. Digital data is not obtained by adding an A/D converter to the output of conventional analog circuitry. Instead, the latest digital techniques and TTL components are applied to achieve a truly digital approach to phase and current ratio measurements. Data is displayed on front panel seven-segment digital readouts to minimize reading error. A simplified selection system reduces operation of the DAM-1 to a straightforward procedure.

AAM-1

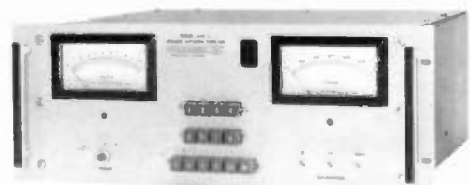

The AAM-1 Analog Antenna Monitor is designed specifically for measuring the parameters of AM broadcast frequency directional antenna systems. The monitor measures the relative current in each tower, the ratio of the current in each tower to that of a reference tower and the phase of the current in each tower relative to that of the reference tower. The AAM-1 can be equipped for up to eight input samples without external switching. Two reference towers can also be selected for DA-2 applications.

APC-1



The APC-1 Automatic Power Controller measures the operating power of an AM or FM station, and by interconnection to the transmitter's RAISE/LOWER controls causes the power to remain well within limits. The unit monitors a DC voltage from an external linear rectifier driven by an RF sample of the common point or base antenna current in AM applications, or a similar linear DC sample from the FM power meter or directional coupler. A special long time constant circuit removes modulation components and averages carrier shift variations in AM applications.

POTOMAC ANTENNA MONITORS AM-19



The AM-19 is the current model of the industry's most widely used solid-state antenna monitor. It provides direct meter readout of phase angle and loop current ratio. Tower selection is accomplished with push buttons on the front panel or by external contact closure in remote operation. Directional antenna arrays of from 2 to 12 towers with DA-1, DA-2 or DA-3 patterns may be monitored with this instrument. Compatible with virtually every type of wire or wireless remote control system, the AM-19 requires no external line interface equipment. Analog or digital remote metering panels are available for studio readout and may be added at any future date.

AM-19D



The AM-19D is identical to the AM-19 except for the digital panel meters and associated circuitry. Four digit LED numeric displays provide resolution of 1/10 of one degree (phase angle) and 1/10 of one percent (current ratio). The digital readout feature of this instrument virtually eliminates operator error related to meter interpretation. Remote switching and readout are accomplished as in the AM-19. Inherently stable circuit design, modular construction, simplicity of operation and moderate cost make the AM-19D the truly optimum monitor for directional stations utilizing lesser grade operators.

SMR-11

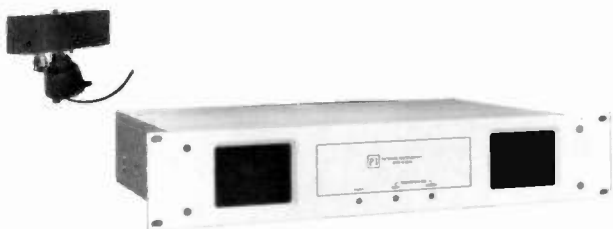

The SMR-11 is an AM broadcast band receiver of superior performance with many capabilities useful to the broadcaster. Receiver tuning is continuous from 530 to 1700 kHz, and can be locked with crystal accuracy at any desired frequency. The antenna can be a remotely located tunable ferrite rod unit (ANT-11), broadband wire or a whip. Bandwidth is determin-

ed by two switch-selected 455 kHz ceramic filters with bandwidths of 28 kHz and 12 kHz. Other special filters are available and can be installed.

Model	Description
SMR-11R	Rack mount version
SMR-11D	Desk mount version
ANT-11	Remote tunable ferrite rod antenna with internal, low noise preamplifier

POTOMAC TEST EQUIPMENT FIELD STRENGTH METERS



The POTOMAC line of field strength meters represent a new generation of precision instruments for direct measurement of electromagnetic fields in the 100 kHz to 960 mHz frequency spectrum. These units are intended for portable field use and include a laboratory quality receiver, integral shielded loop antenna, precision attenuator, internal calibration source, and voltage regulated battery power supply. An interlock switch prevents inadvertent battery discharge when the cover is closed. Batteries are not included.

Model	Description	Model	Description
FIM-21	535-1605 kHz	FIM-71	45-225 mHz
FIM-22	200-550 kHz	FIM-72	470-960 mHz
FIM-41	540-5000 kHz		

DELTA TEST EQUIPMENT MJ-50

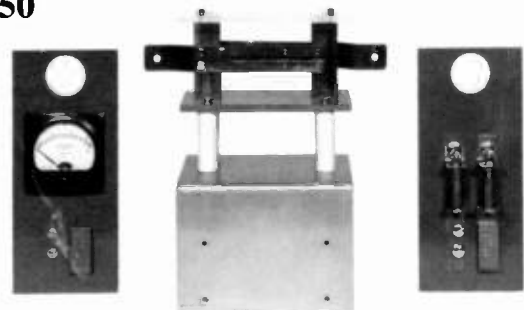

The DELTA Electronics Model MJ-50 Meter Jack is a make-before-break in-line jack assembly especially designed for permanent installation in broadcast antennas, transmission lines, and networks to permit the "hot" insertion of a DELTA OIB-1 Operating Impedance Bridge or ammeter without interruption to normal program operation. The Meter Jack is rated for continuous operation at currents of up to 50 amperes and is insulated for 10 kV RMS. Accessory plug panels are available for use with the OIB-1 and for all of the most commonly used ammeters.

DELTA ELECTRONICS TEST EQUIPMENT

OIB-3



The Model OIB-3 Operating Impedance Bridge measures the operating impedance of the individual radiators, networks, transmission line sections, and common point of directional antenna systems *while they are functioning normally and under power*. This "operating impedance" cannot be measured by normal impedance bridge methods because the system characteristics are disrupted when the bridge is inserted in the circuit. The OIB-3 thus satisfies a critical requirement long felt by consulting and broadcast station engineers. In addition it has many applications in other fields that cannot be duplicated by any other instrument. The OIB-3 is inserted directly in series with the transmission line, network, or antenna. The transmitter power is applied and a bridge balance is obtained by manipulating the R and X dials on the face of the bridge. Balance is indicated by a null reading on the meter which is mounted on the front panel of the bridge. Operating resistance and reactance are then read directly from the bridge dials.

The bridge has a built-in carrying case and RF amplifier for improved nulling.

- Frequency Range: 500 kHz to 5 MHz
- Through Power Rating: 5 kW Modulated 10 kW Carrier only
- Direct Reading in R: -1000 to +1000 ohms
- Direct Reading in X: -900 to +900 ohms
- Accuracy: R and X, 2%, ± 1 ohm

CPB-1



The Model CPB-1 and CPB-1A Common Point Impedance Bridges are operating impedance bridges designed for permanent installation in your phasing equipment at the antenna common point. The CPB-1 will handle common point powers up to 5 kW with 100% amplitude modulation on a continuous basis. The CPB-1A is designed for transmitter powers up to 50 kW. Both instruments have two 4" dials calibrated directly in resistance and reactance. A panel meter is provided for use as a null detector. The R and X dials are manipulated as a normal bridge to give a null indication on the panel meter while the transmitter is operating at full or reduced power. The value of the common point resistance and reactance can then be read directly from the two dials.

The CPB-1 and CPB-1A permit the station operator to determine the common point impedance at any time, even during normal operating hours. By minor adjustment of the common point resistance control, he can maintain radiated power at the full license value at all times.

- Frequency Range: 500 to 1640 kHz
- Power Rating: CPB-1, 5 kW; CPB-1A, 50 kW
- Resistance Measurements: 30 to 100 ohms Range $\pm 2\%$, ± 1 ohm accuracy
- Reactance Measurements: ± 50 ohms (1000 kHz) Range $\pm 2\%$, ± 1 ohm accuracy

RG-4



The RG-4 Receiver/Generator is designed as the ideal companion instrument for DELTA's OIB-1, OIB-2 and OIB-3 impedance bridges. These bridges and the RG-4 thus form a complete, portable impedance measuring system.

In noisy environments or under conditions of interfering signals, the generator can be modulated by an internal 50 Hz squarewave source and the receiver's coincidence detector circuit will provide clean positive nulls.

Frequency selection is accomplished by a front panel keypad assembly, controlling a precision Phase locked loop digital frequency synthesizer. Selected frequencies are displayed on a large LED readout panel.

Modern gel-cell batteries power the unit for field measurements for up to four hours from a full charge condition. The AC supply/charges operates from either 120 Vac or 240 Vac.

- Frequency Range: 100 kHz to 30 MHz
- Receiver/generator isolation: < 120 dB
- Generator output: to 10 VRMS into 50 Ω
- Modulation: 400 Hz, 90% AM, 50 Hz squarewave
- Receiver sensitivity: 5 micro V nominal

OIB-1



The Model OIB-1 Operating Impedance Bridge measures the operating impedance of the individual radiators, networks, transmission line sections, and common point of directional antenna systems *while they are functioning under normal power*. This "operating impedance" cannot be measured by usual impedance bridge methods because the system characteristics are disrupted when the bridge is inserted in the circuit.

The OIB-1 is inserted directly in series with the transmission line, network, or antenna. The transmitter power is applied and a bridge balance is obtained by manipulating the R and X dials on the face of the bridge. Balance is indicated by a null reading on the meter which is mounted on the front panel of the bridge. Operating resistance and reactance are then read directly from the bridge dials. The VSWR on a transmission line can be read directly from a scale on the meter.

- Frequency Range: 500 kHz to 5 MHz
- Through Power Rating: 5 kW Modulated 10 kW Carrier only
- Accuracy: R and X, 2%, ± 1 ohm
- Direct Reading in R: -400 to +400 ohms, standard
-1000 to +1000 ohms, optional
- Direct Reading in X: -300 to +300 ohms, standard
-900 to +900 ohms, optional
- Measures VSWR: $Z_0 = 0$ to 400 ohms

TEKTRONIX OSCILLOSCOPE



TEKTRONIX 2235 100 mHz OSCILLOSCOPE

Small Size:

5.4 in. high, 12.9 in. wide,

17.5 in. high

Lightweight:

15.7 lbs. with cover, probes & pouch

Trigger is sensitive to 0.3 div
at 10 mHz

2% Vertical and Horizontal
Accuracy (Normal)

Delay Jitter of 1:20,000 ensures
excellent timing measurement
resolution

With the 2235 and 2236 oscilloscopes, TEKTRONIX takes the high-value high-performance design concept of the 2200 Series even further. Both scopes feature a low price made possible by the 2200 Series' innovative, reduced-component architecture. (Yet both scopes offer advances in performance, operational simplicity and — not least — in solid reliability. All backed by the industry's first three-year warranty on all parts and labor, including the CRT). The 2236 introduces a new concept in waveform measurement: a counter/timer/DMM, integrated into

the scope's vertical, horizontal and trigger systems. Its capabilities simplify set-up, heighten measurement confidence and expand scope versatility in innumerable ways. The scope and DMM also can be applied simultaneously, with concurrent CRT and digital readout displays. DMM auto ranging simplifies set-up. An ohm-meter range of $2G\Omega$ — a hundred times the range of most such devices — lets the technician quickly pinpoint even small amounts of transformer leakage. The 2235 ensures measurement quality and reliability while reducing instrument cost.

TEKTRONIX 2236 100 mHz OSCILLOSCOPE

Small Size:

5.4 in. high, 12.9 in. wide,

17.5 in. high

Lightweight:

19.0 lbs. with cover, probes, test
leads & pouch

Microprocessor — driven
waveform analysis

Counter/Timer/DMM — type
measurements through the scope
system itself



THRULINE® RF DIRECTIONAL WATTMETERS 50 ohms NOMINAL

THE INDISPENSABLE MODEL 43 BY BIRD®

Range: 100 mW to 10,000 W

Affectionately referred to by radio engineers around the world as "The Bird," the low-cost Model 43 THRULINE® Directional Wattmeter has an unequalled history of reliability, durability and flexibility. Its in-the-field service record spans nearly three decades.

"The Bird" is a thoroughly engineered, portable, insertion-type instrument designed to measure both forward and reflected CW power in coaxial transmission lines. It gives accurate RF power flow readings under any load conditions.

The Model 43 THRULINE® Wattmeter is comprised of a line section and a direct-reading 3 scale meter housed in a rugged, corrosion-resistant aluminum case. QC (Quick Change) Type Connectors and a full range of Plug-In measuring elements (ordered separately now or later to meet your existing needs) give "The Bird" amazing flexibility and adaptability. Two extra elements can be stored in the housing, one on each side. The Model 43 is easy to use and simple to service in the field.

Line Section: A very precise 50 ohm coaxial air line is designed for insertion into the transmission line between transmitter and antenna or load. The line section is equipped with a socket into which the Plug-In element with the desired power and frequency range is inserted. It is also equipped with QC Connectors described below:

QC Type Connectors: The Bird® Model 43 is normally supplied with two Female N Connectors. However, at the time of ordering, other types of connectors may be specified including: Male or Female BNC, TNC, UHF, C, SC, LC, N, HN, LT, General Radio Type 874 and 7/8" EIA Flanged. All of these QC connectors are interchangeable in the field without affecting the instrument's calibration.

Indicating Meter: A shock-mounted 30 microampere meter with 3 expanded scales of 25, 50, 100 unit calibration to permit full scale direct power reading from 100 milliwatts to 10,000 watts.

Plug-In Elements: These elements read forward or reflected power as indicated by the direction in which the arrow is pointing. Frequency range and full scale power are marked on each element. Use a lower power element (e.g. 10:1) for increased resolution of reflected power readings.

Remote Installation: When it is more convenient, the RF line section can be easily removed from the Model 43 case and inserted at any desired point in the line. The meter may then be located at another point for optimum visibility. 32" of meter cable is supplied in the instrument housing for this purpose. Additional lengths available as required.



SPECIFICATIONS

Power Range: 0.1 W to 10 kW full scale using Bird Plug-In Elements. Accuracy not guaranteed with components not supplied by Bird.®

Usable over-range: To 120% of nominal full scale (for compliance with FCC 110% regulations without the need to buy and use higher power Elements)

Impedance: 50 ohms nominal

Insertion VSWR: with N Connectors 1.05 max.

Finish: Light Navy Grey Baked Enamel (MIL-E-15090)

Nominal Size: including connector 6 7/8" x 5 1/8" x 3 5/8"

Weight: 3 lbs.

Element Weight: 3 oz.

Accuracy: ±5% of full scale

BIRD® TERMALINE® RF ABSORPTION WATTMETERS — 50 ohms nominal

Absorption Wattmeters offer the convenience of a combination measuring and termination unit to engineers and technicians in STL and related fields. These TERMALINE® models are engineered for servicing 50 ohm-systems and keeping them at peak operation. They consist of a direct-reading meter and an integral liquid dielectric load resistor for dissipation of RF power during measurement.

Their individual frequency coverage is generally wider than that of a directional meter and they give RF readings directly in watts with an accuracy of $\pm 5\%$ of full scale to 512 mHz; $\pm 10\%$ of full scale to 1000 mHz.

Your attention is directed to the new 6730 Series Absorption Wattmeters. Each of them features a choice of three power ranges selected through a rotary switch. This desirable flexibility expands the utility of the TERMALINE® unit and eliminates the need to transfer the crystal diode. It makes measurement easier and frees one hand for equipment fine tuning or trouble-shooting.

The 6730 Series of five TERMALINE® Absorption Wattmeters offers a selection of top ranges: 250, 500 plus 1000, 1200 and 2500 watts. In this group, the Wattmeters and load sections are

joined with the patented BIRD® Quick-Change (QC) feature which permits easy separation into unlinked parts. This allows use of the resistor as an independent termination with an even lower VSWR and offers a choice of 15 other connector types where desired now or later.

Four low power wattmeters for servicing signal generators, oscillators, transceivers, and solid-state amplifiers are presented.

Their three power ranges (200mW/800mW/3W or 3W/10W/30W) are selected by a front-panel switch without the need to transfer crystals. They can further be expanded to higher power levels with TENU LINE® Attenuators, and all ranges are field-calibratable (e.g. for tighter accuracy at a specific frequency).

All units feature demodulated signal outputs for observation and measurement of AM envelopes. Models 6258 and 6259 also provide an RF signal sample for frequency and spectrum analysis. The wide frequency range accommodates communications measurements, all the way from 100 kHz to one gigahertz and all services in between.

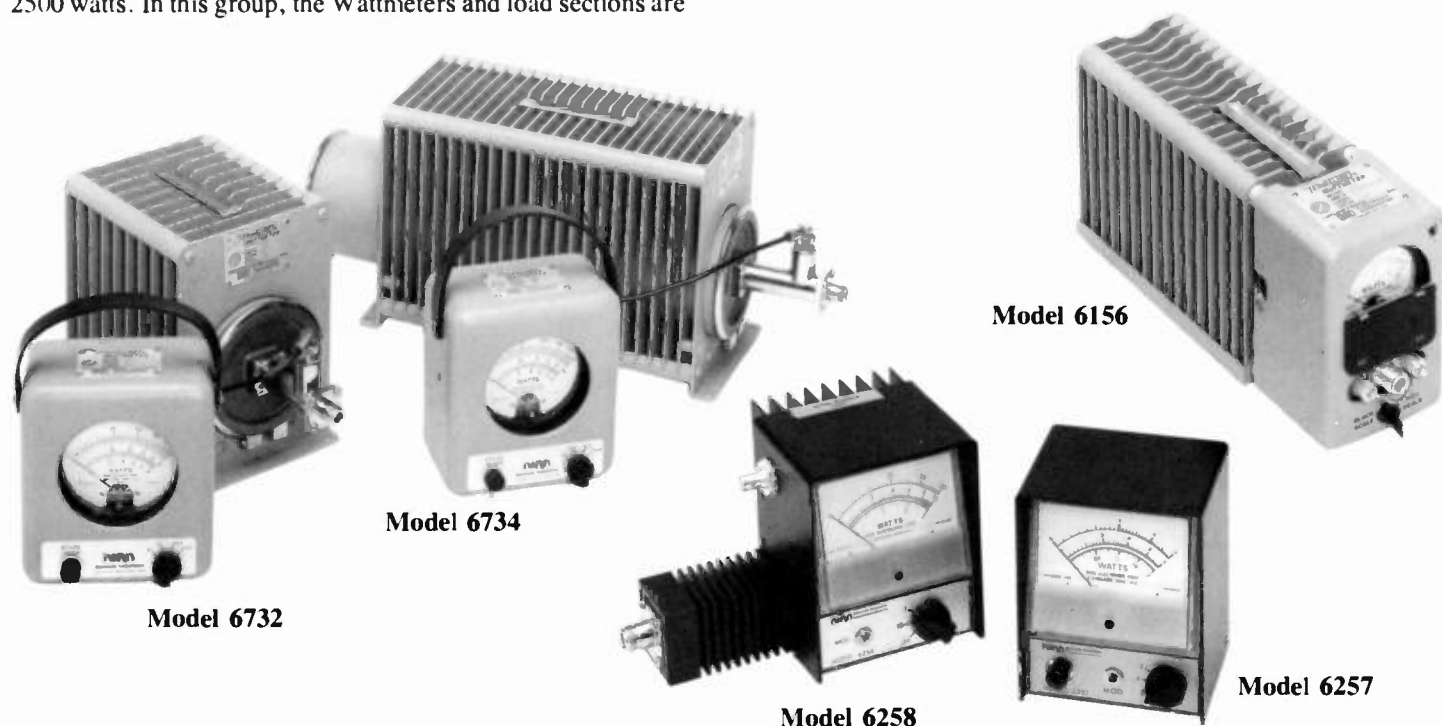

Model No.	Power Rating	Frequency Range	Power Scales	Weight
6256	3 watts	100 kHz - 512 mHz	0.2/0.8/3 watts	1 lb. 10 oz.
6257	3 watts	100 kHz - 1000 mHz	0.2/0.8/3 watts	1 lb. 10 oz.
6258	30 watts	25 - 512 mHz	3/10/30 watts	3 lbs.
6259	30 watts	25 - 512 mHz	3/10/30 watts	3 lbs.
6104	60 watts	25 - 512 mHz	0-2/0-6/0-20/0-60 watts	7 lbs.
6154	150 watts	25 - 1000 mHz	0-5/0-15/0-50/0-150 watts	8 lbs.
6156	150 watts	25 - 512 mHz	0-5/0-15/0-50/0-150 watts	8 lbs.
6732	250 watts	25 - 1000 mHz	0-10/0-50/0-250 watts	16 lbs.
6734	500 watts	25 - 1000 mHz	0-25/0-100/0-500 watts	27 lbs.

KOHLER — GENERATORS — FOR EMERGENCY STANDBY & PRIME POWER

FAST RESPONSE™ 180 KW to 275 KW

The most advanced generator design in the U.S. and on the international scene, KOHLER Fast-Response™ units have a combination of important performance advantages, including: 1. Exceptional motor starting; 2. Instant recovery from voltage transients; 3. Sustained short circuit protection.

In addition, Fast Response™ engine generators eliminate high frequency spikes thereby preventing disruption of telephone and electronic equipment.

Model	Standby Rating 60 Hz	Prime Rating 60 Hz	Dimensions L x W x H	Weight Lbs.
180ROZ	180 KW	180 KW	120x50x79 3/8"	5760
230ROZ	230 KW	205 KW	120x50x68 3/8"	5875
250ROZ	250 KW	225 KW	120x50x68 1/2"	5990
275ROZ	275 KW	250 KW	120x50x68 3/8"	5990

Available voltages: 120/240 1 phase through 100 KW, 120/208 3 phase, 4 wire through 347/600 3 phase, 4 wire all models.

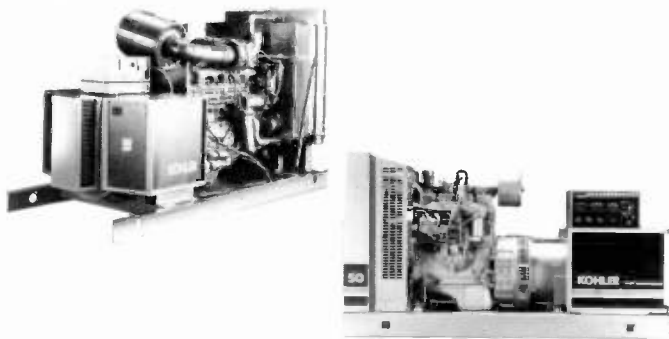

TR-SERIES™ 300 KW to 1000 KW

Diesel power with your choice of cooling, fuel system and exhaust system options. All models in this series are equipped with KOHLER's Microcomputer Decision Maker controller for full monitoring instrumentation, automatic protection features, and a broad range of accessories.

Engines for this series are supplied by Cummins. All are turbocharged, and the majority are also after-cooled.

With isochronous governors as standard equipment, steady-state frequency regulation from no load to full load is plus or minus .25%.

NEMA class F insulation system with epoxy coating for moisture and abrasion resistance.

Model	Standby Rating 60 Hz	Prime Rating 60 Hz	Dimensions L x W x H	Weight Lbs.
Brushless Liquid-Cooled Diesel				
300ROZ	300 KW	275 KW	120 1/2 x 45 1/2 x 70"	5525
350ROZ	350 KW	325 KW	120 1/2 x 45 1/2 x 70"	6650
400ROZ	400 KW	335 KW	133 x 45 1/2 x 79 1/2"	9500
450ROZ	450 KW	410 KW	142 1/4 x 59 1/4 x 96 5/8"	11550
500ROZ	500 KW	455 KW	145 5/8 x 59 1/4 x 82 3/4"	11850
600ROZ	600 KW	535 KW	145 x 62 x 87"	12465
750ROZ	750 KW	675 KW	177 x 67 x 45"	18400
800ROZ	800 KW	725 KW	177 x 67 x 95"	18400
1000ROZ	1000 KW	900 KW	213 1/2 x 84 x 112"	21000

Available voltages: 120/208 3 phase, 4 wire through 347/600 3 phase, 4 wire

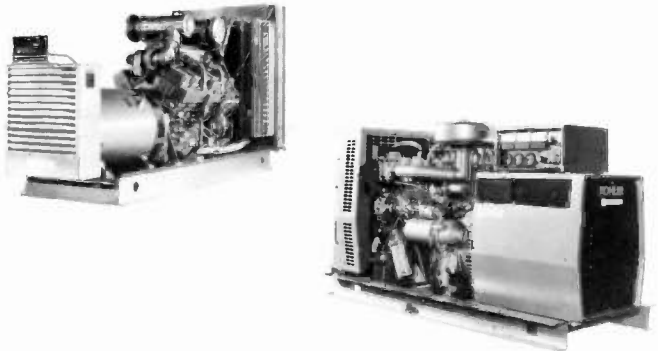

FAST RESPONSE II™ 20 KW to 150 KW

The KOHLER Fast Response II™ Engine Generator System: More advanced features, more reliability in a leaner, more efficient package.

KOHLER Fast Response II™ systems represent a highly refined second generation of the patented Fast Response™ design, offering these standard performance features: Instant response to load change, sustained short circuit capability, superior motor starting performance. KOHLER Fast Response II™ is America's first engine generator system to incorporate the reliability and efficiency of advanced microcomputer logic. The KOHLER Microcomputer Decision Maker™ executes instructions in *microseconds* and is virtually immune to false input signals.

Model	Standby Rating 60 Hz	Prime Rating 60 Hz	Dimensions L x W x H	Weight Lbs.
Fast Response II Liquid-Cooled Gas/Gasoline				
20RZ	20 KW	18 KW	72x29x43"	1142
30RZ	30 KW	27.5 KW	84x29x45"	1360
45RZ	45 KW	40 KW	84x29x45"	1465
60RZ	60 KW	54 KW	88 1/4 x 34 x 44"	2009
70RZ	70 KW	63 KW	88 1/4 x 34 x 44"	2100
80RZ	80 KW	72 KW	88 1/4 x 34 x 46"	2400
100RZ	100 KW	90 KW	88 1/4 x 34 x 46"	2550
Fast Response II Liquid-Cooled Diesel				
20ROZ	22 KW	20 KW	72x29x37.5"	1256
30ROZ	30 KW	27 KW	78x29x45"	1440
40ROZ	37 KW	34 KW	78x29x45"	1449
50ROZ	50 KW	46 KW	78x29x45"	1514
60ROZ	60 KW	54 KW	88 1/4 x 29 x 44"	1875
80ROZ	80 KW	72 KW	88 1/4 x 29 x 44"	2065
100ROZ	100 KW	90 KW	88 1/4 x 29 x 44"	2150
125ROZ	125 KW	112 KW	99x34x57 1/2"	3900
150ROZ	150 KW	135 KW	99x34x57 1/2"	3950

Available voltages: 120/240 1 phase, 120/208 3 phase, 4 wire through 347/600 3 phase, 4 wire all models.

R-SERIES™ 5 KW to 17.5 KW

R-Series™ generator sets above 10 KW provide many of the features of the Fast-Response models including voltage regulation with $\pm 2\%$, and a broad range of voltage combinations including 347/600. voltages from 120/240 through 277/480 are field reconnectable. The exclusive KOHLER solid-state volts-per-hertz regulator has three-phase sensing.

The standard controller is a relay model with a meter box option. An optional solid-state controller has a hospital lamp group to meet NFPA-76A.

Model	Standby Rating 60 Hz	Prime Rating 60 Hz	Dimensions L x W x H	Weight Lbs.
R-Series Air-Cooled Gas/Gasoline				
5RMY	5 KW		26 1/2 x 18 1/2 x 21 3/4"	234
7RMY	7 KW		28 1/2 x 21 1/2 x 26 1/2"	450
15RMY	15 KW		38 15/16 x 21 1/2 x 29 7/8"	696
R-Series Air-Cooled Diesel				
5RMOY	5 KW	5 KW	34 x 34 1/4 x 20"	547
10RMOY	10 KW	10 KW	46 x 26 x 41"	831
15RMOY	15 KW	14 KW	51 x 26 x 34 1/2"	965
R-Series Liquid-Cooled Gas/Gasoline				
7.5R	7.5 KW		43 1/4 x 19 1/4 x 25 1/2"	450
R-Series Liquid-Cooled Diesel				
17.5ROY	17.5 KW	15 KW	61 x 26 x 34 7/16"	940

Available voltages: 120/240 1 phase, 3 wire through 347/600 3 phase, 4 wire.

Models 5RMOY, 5RMY, 7RMY and 7.5R are 120 volt or 120/240 volt, 1 phase.

A-LINE
ADC
AKG
ALC
AMPEX
ANDREW
ANTENNA SPECIALISTS
APHEX
APT-HOLMAN
ARISTOCART
ARRAKIS
ASTROLITE
ATI
ATLAS
AUDICORD
AUDIO DIGITAL
AUDIOLAB
AUDIOMETRICS
AUDIO TECHNICA
AUDISAR
AUDITRONICS
AURATONE
AUTOGRAM
B & B SYSTEMS
BARCUS-BERRY
BELAR
BELDEN
BENCHMARK
BEYER DYNAMIC
BGE
BGW
BIRD
BONNEVILLE
BROADCAST AUDIO
BROADCAST ELECTRONICS
CABLEWAVE
CALZONE
CAPITOL
CATEL
CBS TEST RECORDS
CELWAVE
CETEC
CLEARCOM
COMARK
COMPUSONICS
COMPUTEMP
COMREX
COMTECH
CONEX
CRL
CROWN
CSI
DAV TRONICS
DBX
DECCA
DECIBEL
DELTA
DICTAPHONE
DIELECTRIC
DIGIMAX
DISCWASHER
DRAKE
DUROTEST
EDCOR
ELCOM BAUER

ELECTRO IMPULSE
ELECTRO VOICE
ELECTRONIC RESEARCH
ELECTROVERT
ELGIN
EMT
ESE
EVENTIDE
FIDELIPAC
FILMAGIC
GARNER
GENTNER
GKC
GORMAN REDLICH
HAFLER
HALLIKAINEN
HEACO
HENRY
H.O.M.E.
HOWE AUDIO
INTERSKIM
ITC
JAMPRO
JBL
KAHN
KAY
KEITH MONKS AUDIO
KINTRONICS
KLARK-TEKNIK
KOHLER
KOSS
LARUS
LEXICON
LITTLITE
LOFTECH
LPB
LUXO
M/A COM
MARANTZ
MARK PRODUCTS
MARTI
MAXELL
MAXITEL
McCURDY
MCI
McKAY DYMEK
MICRODYNE
MICROTRAK
MODULATION SCIENCES
MOSELEY
MOTOROLA
NAD
NAKAMICHI
NATIONAL ELECTROLAB
NEOTEK
NEUMANN
NUMARK
OMNIMOUNT
ONAN
ORBAN
OTARI
PERSONS
PHASE AUDIO
PHASEMASTER
PINZONE

PI ROD
POTOMAC
POWER PAK
PROTON
QEI
QRK
QUANTUM
RA-COM
RAMKO
RANE
REVOX
RTS
RUSLANG
RUSSCO
SCALA
SCOTCH
SCOTCHCART
SENNHEISER
SHIVELEY
SHURE
SIEMON
SIMPAC
SI-TEX
SME
SONEX
SONO MAG
SONY
SOUNDOLIER
SSAC
STANTON
STL
STRAIGHT WIRE AUDIO
STUDIO TECHNOLOGIES
SWITCHCRAFT
SYMETRIX
TAPCO
TAPECASTER
TEAC/TASCAM
TECHNICS
TEKTRONIX
TELEMIX
TELEX
TELFAX
TELLABS
TEPCO
TEXAR
TEXAS ELECTRONICS
TOA
TOPAZ
UNION METALS
UREI
UTAH SCIENTIFIC
VALLEY PEOPLE
VEGA
VIF
VOICE ACT
WEGENER
WESTCLOX
WEST PENN
WHITE INSTRUMENTS
WILL-BURT
WINGET
XEDIT
ZERCOM

SUBJECT TO CHANGE WITHOUT NOTICE

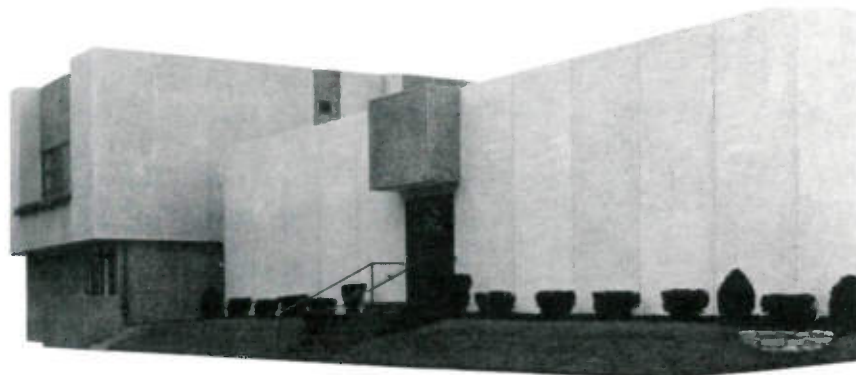



— SUBSIDIARIES —



3712 National Road - West • P. O. Box 1487 • Richmond, IN 47375
Phone 317-962-8596
Telex 810-345-1394, FAX 317-962-8961



3712 National Road - West • P. O. Box 1487 • Richmond, IN 47375
Telex 380474 ALLIED INT UD or 810-345-1394 ALLIED BRD RIC
Phone 317-935-1704 • Cable ALLIEDINTL



10 West Pearce Street • Unit 6 • Richmond Hill, Ontario L4B 1B6
Ontario & Quebec phone collect 416-731-3697
All other areas 1-800-268-6817



Corporate Office: 3712 National Road - West • P. O. Box 1487 • Richmond, IN 47375
TTY DDD 317-935-7466 • Telex 810-345-1394 • FAX 317-962-8961 • EZ LINK 621-267-20+

SALES OFFICES

RICHMOND, IN
(317) 962-8596

SEATTLE, WA
(206) 838-2705

CHICAGO, IL
(312) 794-0224

DALLAS, TX
(214) 423-8667

ATLANTA, GA
(404) 964-1464

LOS ANGELES, CA
(818) 843-5052

Illustrations, drawings, descriptions, measurements and weights are subject to change without notice due to technical improvements or modifications.
*certain products not available in all countries.