

TYPE 802A

FM BROADCAST SOLID STATE EXCITER

INSTRUCTION MANUAL

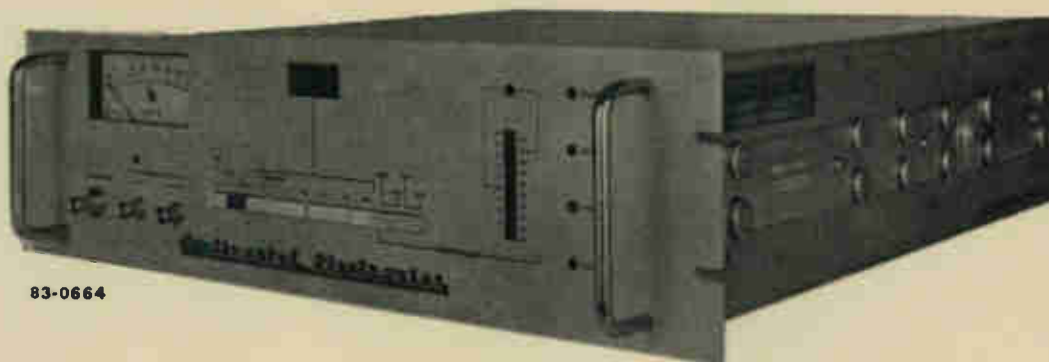

83-0664



Continental Electronics

a Division of Varian Associates

P.O. BOX 270879 DALLAS, TEXAS 75227 (214) 381-7161
CABLE ADDRESS: CONTRONICS TELEX ADDRESS: 73 - 398



TYPE 802A

FM BROADCAST SOLID STATE EXCITER

INSTRUCTION MANUAL

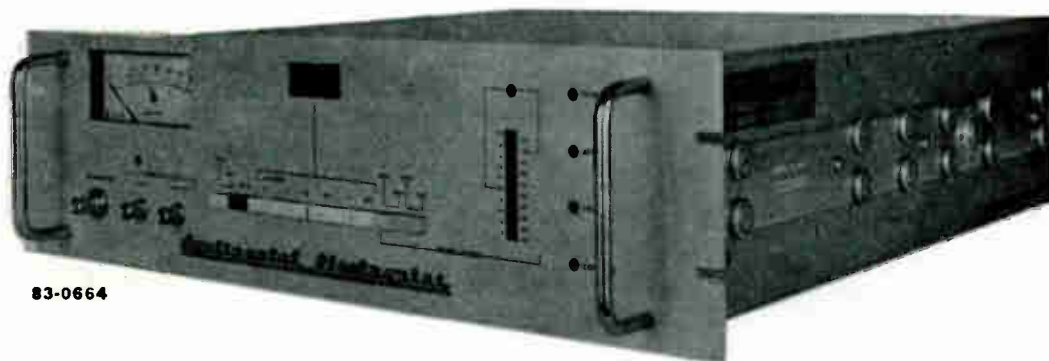

83-0664



varian

Continental Electronics

a Division of Varian Associates

P.O. BOX 270879 DALLAS, TEXAS 75227 (214) 381-7161
CABLE ADDRESS: CONTRONICS TELEEX ADDRESS: 73 - 398



RECORD OF CHANGES - 802A

<u>CHANGE NO.</u>	<u>DATE</u>	<u>EFFECTIVITY</u>
1	14 November 1983	All Transmitters
2	10 July 1984	SN 240 and Above

TABLE OF CONTENTS

SECTION 1 - GENERAL INFORMATION

<u>Paragraph</u>	<u>Title</u>	<u>Page</u>
1-1.	General	1-1
1-2.	Equipment Required or Suggested But Not Furnished	1-4

SECTION 2 - INSTALLATION

2-1.	Installation Procedure	2-1
------	------------------------	-----

SECTION 3 - OPERATION

3-1.	Controls And Indicators	3-1
3-2.	Operating Procedures	3-1

SECTION 4 - THEORY OF OPERATION

4-1.	Functional Description	4-1
4-1.1	AFC Circuits	4-1
4-1.2	Audio Circuits	4-6
4-1.3	Amplifier and Power Output Control Circuits	4-9
4-1.4	Power Supply Circuits	4-14
4-1.5	Metering and Monitoring Circuits	
4-2.	Detailed Circuit Description	4-22
4-2.1	Modulated Oscillator Assembly (A1)	4-22
4-2.2	Frequency Divider Assembly (A2)	4-23
4-2.3	Audio/AFC Assembly (A3)	4-24
4-2.4	Amplifier Assembly (AR1)	4-26
4-2.5	Amplifier Control Assembly (A5)	4-27
4-2.6	Modulation Display Assembly (A6)	4-28
4-2.7	Power Supply Assembly (A4)	4-30
4-2.8	Metering Network Assembly	4-30
4-2.9	Harmonic Filter Assembly	4-31

TABLE OF CONTENTS - Cont.

<u>Paragraph</u>	<u>Title</u>	<u>Page</u>
SECTION 5 - MAINTENANCE AND ALIGNMENT		
5-1.	General	5-1
5-2.	Power Supplies	5-2
5-3.	Modulated Oscillator and Frequency Divider	5-2
5-4.	Audio/AFC And Modulation Display	5-3
5-5.	Amplifier, Amplifier Control and Metering	5-4
5-6.	Harmonic Filter Alignment	5-6
SECTION 6 - VENDOR DATA		
6-1.	Solid State Component Layout	6-1

LIST OF ILLUSTRATIONS

<u>Figure</u>	<u>Title</u>	<u>Page</u>
1-1.	Type 802A FM Exciter	1-2
1-2.	Simplified Block Diagram	1-3
2-1.	Line Voltage Selector	2-2
2-2.	802A FM Exciter Connections	2-4
3-1.	Operating Controls	3-2
3-2.	802A FM Exciter, Top View	3-5
4-1.	AFC Circuits - Simplified Diagram	4-3/4-4
4-2.	AFC Circuits Location (Cover Removed)	4-5
4-3.	Audio Circuits - Simplified Diagram	4-6/4-7
4-4.	Amplifier and Power Control Circuits Location	4-10
4-5.	Amplifier and Power Output Control - - Simplified Diagram	4-11/4-12
4-6.	Power Supply Circuits - Simplified Diagram	4-15/4-16
4-7.	Power Supply Circuits - Parts Location	4-17
4-8.	Modulation Display - Simplified Diagram	4-19/4-20
4-9.	Metering and Monitoring Circuits	4-21
5-1.	Operating Adjustments Location	5-7
5-2.	Alignment Adjustments Location	5-8
5-3.	Alignment Adjustments Location	5-9
5-4.	Modulated Oscillator P.C. Card	5-10
5-5.	Modulated Oscillator Card Connections	5-11
5-6.	Frequency Divider Card	5-12
5-7.	Audio/AFC PC Card	5-13

LIST OF TABLES

<u>Table</u>	<u>Title</u>	<u>Page</u>
1-1.	Technical Characteristics	1-5
1-2.	Recommended Semi Conductor Spares List	1-8
3-1.	Operating Controls	3-3
3-2.	Typical AFC Voltage vs. Frequency	3-6
3-3.	Typical Amplifier Voltage and Current	3-7
5-1.	List of Schematics and Assembly Drawings	5-15
6-1.	Solid State Component Layouts	6-3

SECTION 1 - GENERAL INFORMATION

1-1. GENERAL

The Continental Electronics Type 802A FM Exciter (Figure 1-1) is a solid state, synthesized phase locked FM Exciter which provides FM output over the 87 MHz to 109 MHz frequency range in 10 KHz increments. The output frequency is selectable in BCD code on DIP rocker switches. Power output is adjustable from 5 watts to 50 watts.

Designed primarily as a driver for higher power transmitters, the 802A may also be used as a stand alone 50 watt transmitter.

The 802A is supplied with a balanced monophonic input, a balanced composite input and two balanced SCA inputs. The inputs may be driven from balanced or unbalanced sources.

The 802A is designed to mount in a standard 19 inch (483 mm) rack. Equipment slides are furnished with the exciter.

Table 1-1 lists the technical characteristics of the Type 802A FM Exciter. Figure 1-2 is a simplified block diagram of the exciter.

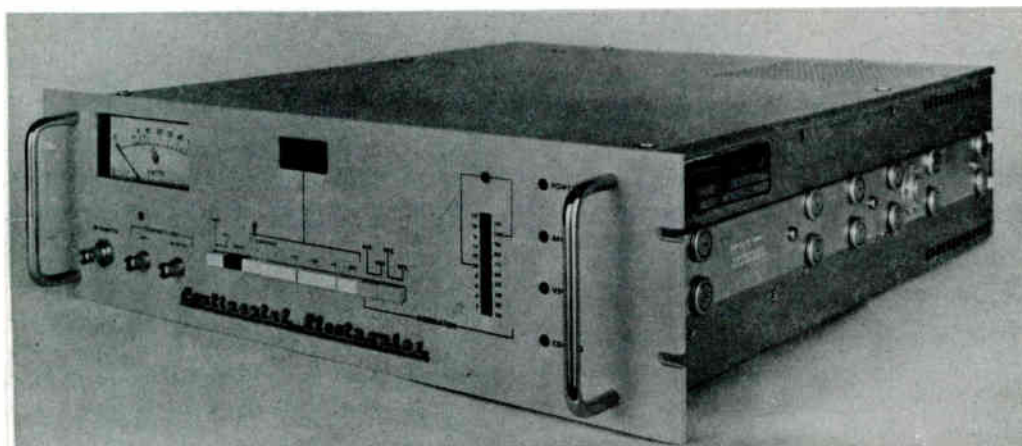

83-0665

Figure 1-1. Type 802A FM Exciter

LW1-1(14)

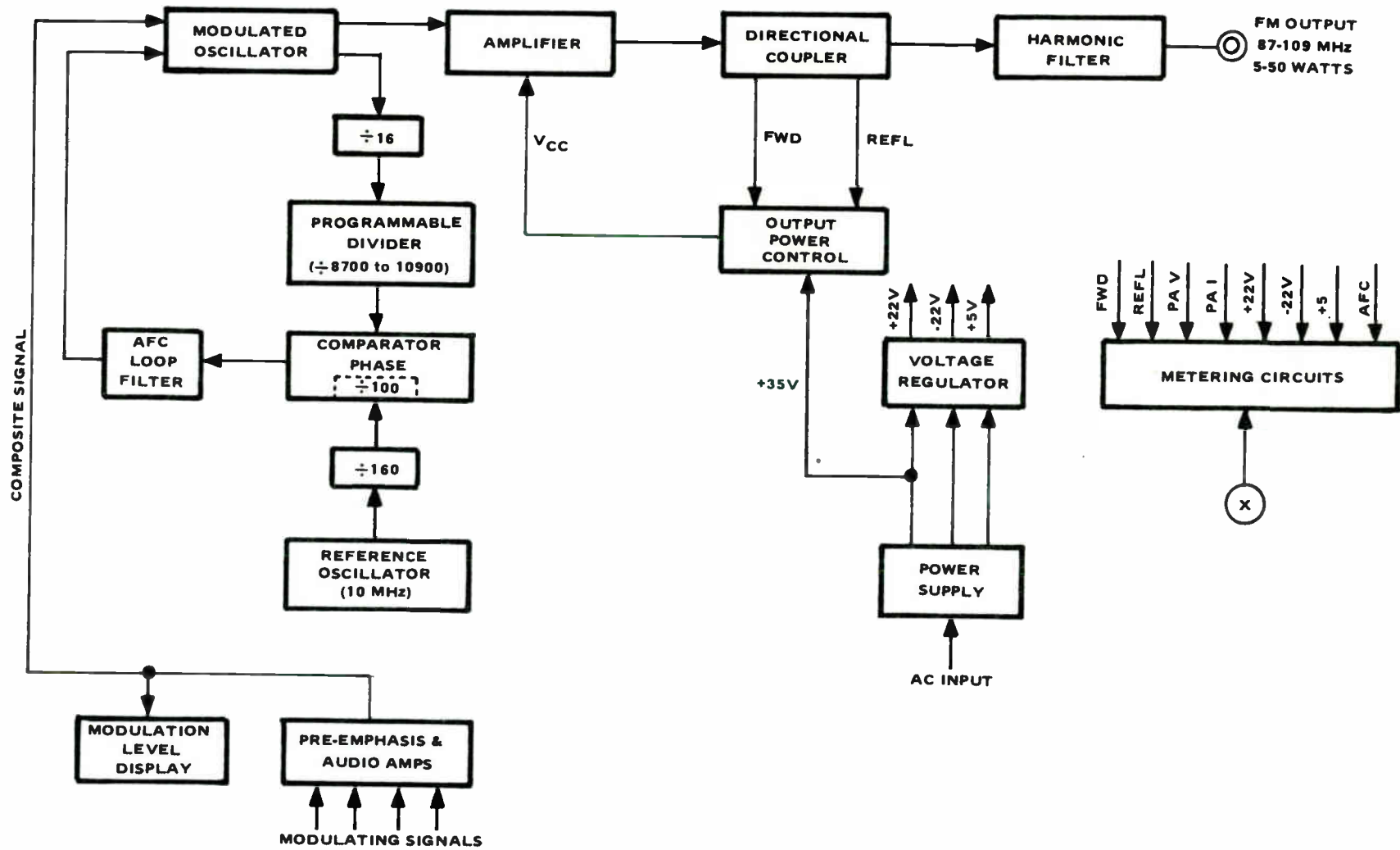

Figure 1-2. Simplified Block Diagram

1-2. EQUIPMENT REQUIRED OR SUGGESTED BUT NOT FURNISHED (OPTIONAL)

Recommended Semiconductor Spares Kit - 643-0055-002

100% Semiconductor Spares Kit - 643-0055-001

Blank Panels per customer rack.

TABLE 1-1. TECHNICAL CHARACTERISTICS

ELECTRICAL DATA -

Input Power:	115V or 230V $\pm 10\%$; 50/60 Hz $\pm 5\%$; single phase, 200 W. maximum
Power Output:	5 to 50 W, continuously adjustable
RF Harmonic & Spurious:	60 dB or more below rated output
Frequency Range:	87 to 109 MHz in 10 kHz steps
Frequency Control:	PLL Frequency Synthesis from high stability master oscillator
Frequency Stability:	± 250 Hz, 0° to 55°C .
Modulation Type:	Direct carrier frequency modulation
Modulation Indication:	Peak reading LED display with over- modulation indicator
Asynchronous AM S/N:	73 dB minimum, relative to carrier level
Synchronous AM S/N:	60 dB minimum, relative to carrier level

WIDEBAND OPERATION -

Composite Inputs:	Balanced and Test
Composite Input Impedance:	5 k ohms, nominal
Composite Input Level:	1.25V RMS (3.54 volts peak to peak) for ± 75 kHz deviation
Composite Amplitude Response:	± 0.1 dB, 20 Hz to 100 kHz
Composite Phase Response:	$\pm 0.5^\circ$, 20 Hz to 100 Hz
Composite Total Harmonic Distortion:	0.08% maximum

TABLE 1-1. TECHNICAL CHARACTERISTICS - Cont.

WIDEBAND OPERATION - Cont.

Composite Intermodulation Distortion:	0.08% maximum; 60 Hz/7 kHz, 4:1 ratio
Composite Transient IMD:	0.1% maximum
Composite FM S/N RATIO:	75 dB minimum below ± 75 kHz deviation
SCA Inputs:	Two, balanced
SCA Input Impedance:	50,000 ohms, nominal
SCA Input Level:	± 1.25 V RMS for ± 75 kHz deviation
SCA Amplitude Response:	± 0.3 dB, 40 kHz to 100 kHz

MONAURAL OPERATION -

Audio Input Impedance:	600 ohms, balanced
Audio Input Return Loss:	30 dB or better
Audio Input Level:	± 10 dBm (6.93 volts peak to peak @ 600 ohms) for ± 75 kHz deviation
Audio Frequency Response:	± 0.5 dB; flat, 25, 50 or 75 μ sec pre-emphasis 20 Hz to 15 kHz
Total Harmonic Distortion:	0.08% maximum; 20 Hz to 15 kHz
Intermodulation Distortion:	0.08% maximum; 60 Hz/7 kHz, 4:1 ratio
Transient IMD:	0.1% maximum
FM S/N Ratio:	75 dB minimum below ± 75 kHz deviation

TABLE 1-1. TECHNICAL CHARACTERISTICS - Cont.

PHYSICAL DATA -

Temperature Range:	0°C. to 55°C. (32°F. to 131°F.)
Altitude Range:	0 to 4600 M (0 to 15,100 ft.)
Relative Humidity Range:	0 to 95%
Size:	17-1/2" wide (444.5 mm) centered in a 19 inch wide (483 mm) rack-mounting panel; 5-1/4" (133.35 mm) high; 22" (558.8 mm) deep
Weight:	approximately 31.5 lbs. (14.3 kg) shipping: approx. 36 lbs. (16.5 kg)

TABLE 1-2. RECOMMENDED SEMICONDUCTOR SPARES LIST

REFERENCE DESIGNATOR	DESCRIPTION	PART NUMBER	QTY USED	MIN. RECOM
-	Recommended Spares Kit	643-0055-002		X
-	100% Spares Kit	643-0055-001	X	
A5VR2	Zener Diode, 1N4753A	353-6481-510	1	1
A6DS1, 2	Bar Graph Array HDSP-4840	262-5008-010	2	2
AR1Q1	Xstr, MJ3001	352-5016-010	1	1
CR1	Rectifier, MDA 2504	353-5017-010	1	1
AR1A1Q3	Xstr., MRF 315A	352-5016-020	1	1
AR1A1Q2	Xstr., PT9732	352-4009-010	1	1
AR1A1Q1	Xstr., 2N3553	352-0632-010	1	1
A7VR1	Diode, 1N4728A	353-6481-010	1	1
A6U4	I.C., LM555CN	351-1140-010	1	1
A6U2, 3	I.C., LM3914N	351-4709-010	2	1
A2DS1, 2 A3DS1, 2 A6DS6, 7	L.E.D. Grn.	353-0293-010	6	2
A6DS3, 4, 5	L.E.D. Red	353-0293-040	3	1
A1A1Q3, 4	Xstr. 2N5109	352-0863-020	2	1
A1A1Q1, 2	Xstr, U310	352-4005-000	2	1
A1A1CR7, 8 A6CR1-3 AR1A1CR1, 2	Diode, 5082-2800	353-0448-020	7	4
A1A1CR1-4	Varactor, KV2801	922-8004-010	4	4
A4U3	I.C., UA7805KC	351-1120-080	1	1
A1A1U1, A4U2	I.C., LM317T	351-1271-010	2	1
A4U1	I.C., LM377T	351-1345-030	1	1

TABLE 1-2. RECOMMENDED SEMICONDUCTORS SPARES LIST

A5VR1	Zener, 1N4752A	353-6481-490	1	1
A5U2	I.C., UA723PC	351-1035-060	1	1
A5Q1	Xstr., 2N6401	352-4008-010	1	1
A4CR5	Diode, 3N256	352-5015-010	1	1
A3VR1, 2	Zener, 1N4739A	353-6481-230	2	1
A3U11	I.C., UA 7915UC	351-1124-160	1	1
A3U10	I.C., UA7815UC	351-1120-050	1	1
A3U9, A6U1	I.C., LF347N	351-1370-020	2	1
A3U8	I.C., 4N28	351-0047-030	1	1
A3U6, A5U1, 3	I.C., LM358N	351-1211-040	3	1
A3U3, 4	I.C., CLM-51	352-4010-010	3	1
A3U2	I.C., LF353N	351-1370-040	1	1
A3U1	I.C., MC14568BCP	351-8883-010	1	1
CR2,3 A1A1CR5, 6 A3CR3-6 A4CR1-4, 6, 7	Diode, 1N4005	353-6442-050	14	10
A2CR1, 2 A3CR1, 2, 7-11 A5CR1-4 A6CR4-7	Diode, 1N4148	353-3763-010	17	10
A2U10	I.C., SN74LS90N	351-1711-050	1	1
A2U9	I.C., SN47LS93N	351-1171-060	1	1
A2U8	I.C., SN74121N	351-1187-010	1	1
A2U7	I.C., SN7420N	351-1548-090	1	1
A2U3-6	I.C., SN74LS190N	351-1171-010	4	2

TABLE 1-2. RECOMMENDED SEMICONDUCTORS SPARES LIST

A2U2, A3U5	I.C., SN74LS74AN	351-1710-020	2	1
A2U1	I.C., MC12011P	351-4708-010	1	1
A12Q1-4, A3Q1, 2 A5Q1 A6Q1	XSTR., 2N2222A	352-0661-020	8	4

SECTION 2 - INSTALLATION

2-1. INSTALLATION PROCEDURE

1. Remove crating and packing material and inspect for shipping damage.
2. Remove top cover and inspect for shipping damage, loose connectors, etc.
3. The 802A is shipped from the factory set for operation at 120 VAC unless directed otherwise by the customer. If operation at another line voltage is desired, pull the line voltage selector card (Figure 2-1) from the AC line connector and insert so that the desired voltage is visible on the card. If the line voltage is 220 or 240 VAC, replace the 3 ampere fuse in the AC line voltage connector with a 1.5 ampere fuse.
4. The 802A is shipped from the factory set to the customer's operating frequency. If the operating frequency was not specified, the 802A will be shipped set to 98.1 MHz. Refer to sections 5-2 and 5-3 for instructions when the frequency is to be changed.
5. The 802A is shipped from the factory with 75 μ sec pre-emphasis on the monophonic input unless directed otherwise by the customer. Flat, 25 μ sec or 50 μ sec may also be selected. Refer to Section 5-3.
6. Mount detachable halves of the 802A equipment slides in the equipment rack where the 802A is to be located and insert 802A into the slides.
7. Connect RF output, modulating signal lines, etc. Refer to Figure 2-2.
8. Place the mono/composite toggle switch in the desired position.

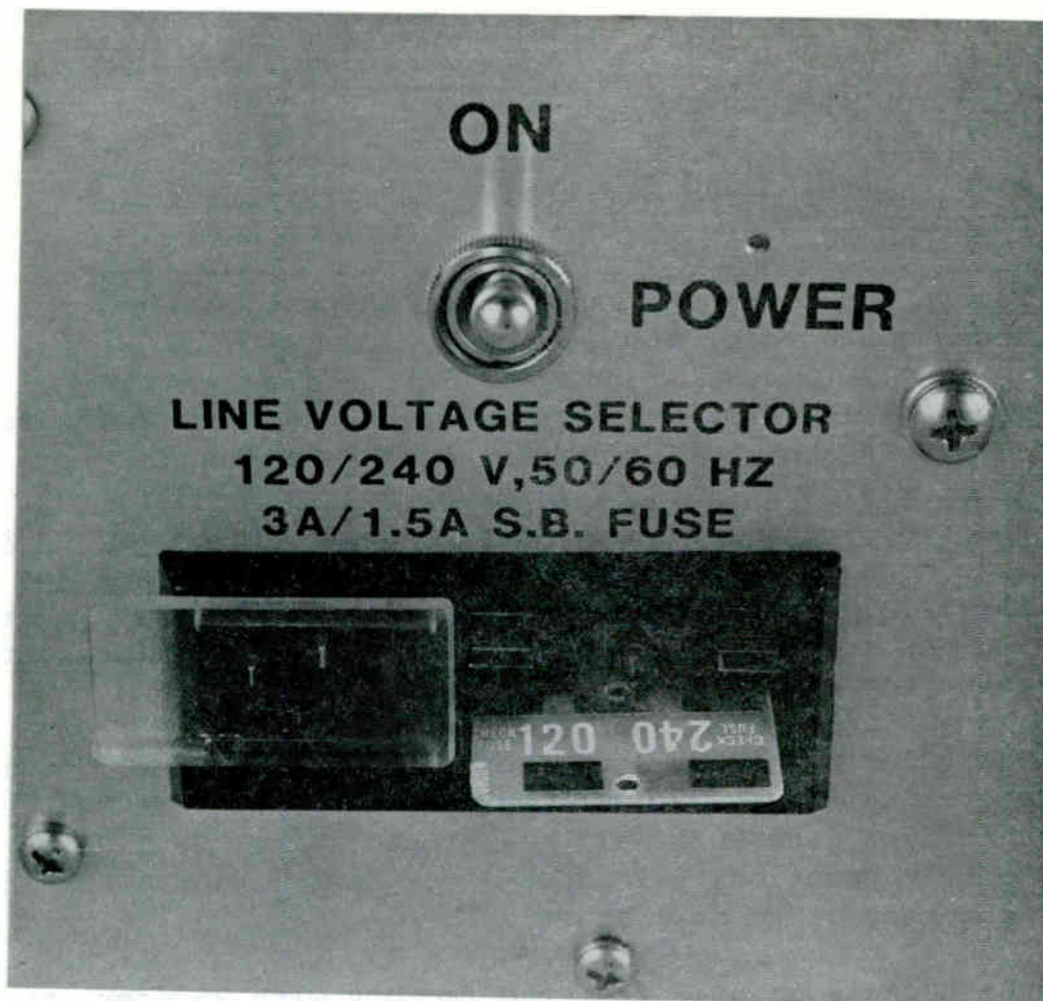

83-0671

LW1-1(19)

ACTUAL LINE VOLTAGESET AC LINE SELECTOR FOR

Below 110 VAC
 110 - 130 VAC
 Below 220 VAC
 220 - 250 VAC

100 V
 120 V
 220 V
 240 V

Figure 2-1. Rear Panel AC Power Setting

9. Terminate the RF output in a 50 ohm load (50 watt rating) and set POWER switch to ON. The POWER LED on the front panel will illuminate. After approximately 5 seconds, the AFC LED will illuminate and the forward power meter will indicate power output. Output power may be adjusted through the hole in the top cover. Verify the multimeter indications by checking against the factory test data sheets shipped with the 802A. Verify proper carrier frequency with the station frequency monitor.

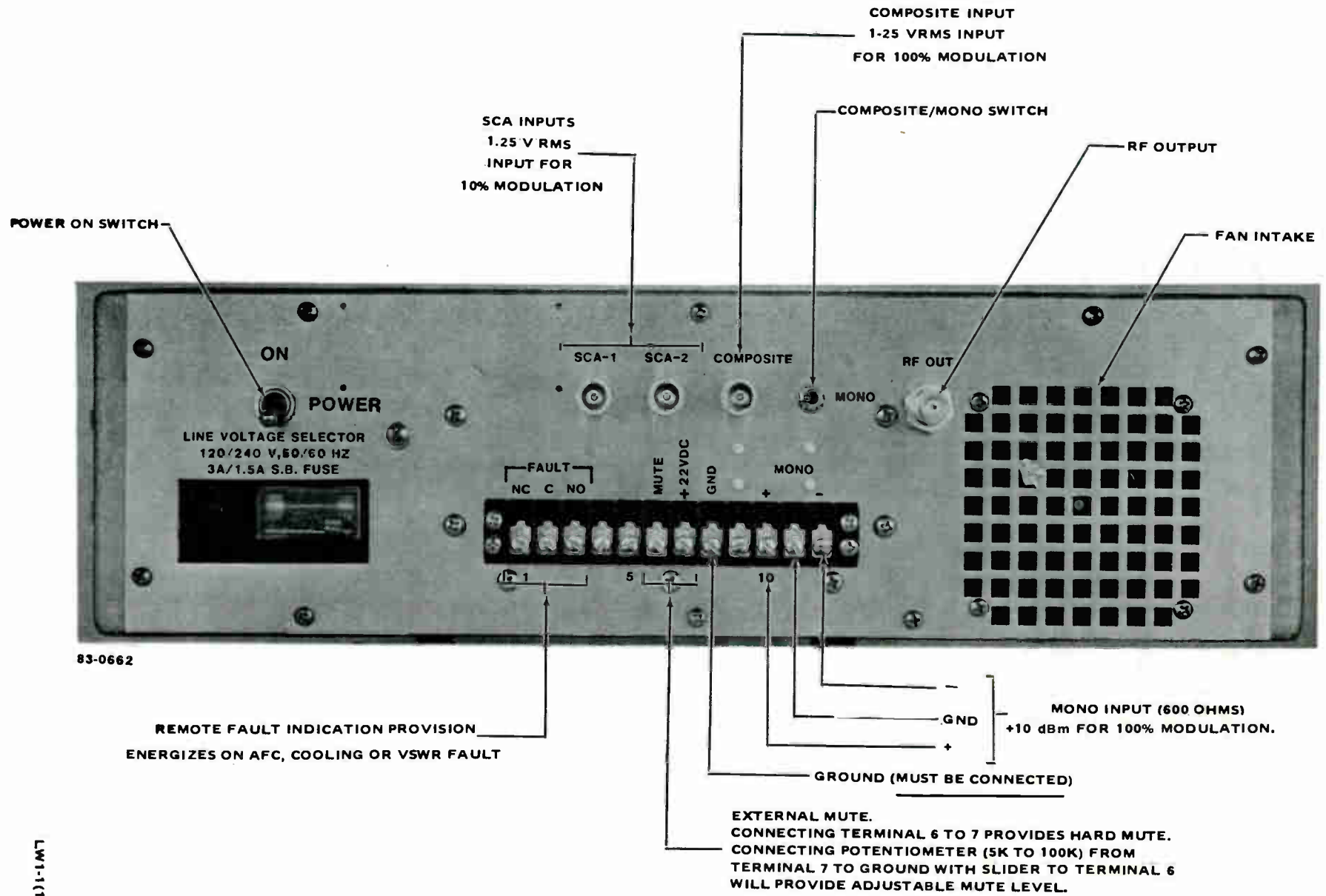

83-0662

LW1-1(10)

Figure 2-2. Type 802A Connections

SECTION 3 - OPERATION

3-1. CONTROLS AND INDICATORS

Table 3-1 describes the 802A operating features as shown in Figure 3-1. Figure 3-2 shows the location of the 802A major sub-assemblies.

3-2. OPERATING PROCEDURES

The 802A is placed in operation as follows:

1. Set Power switch to ON. The Power indicator LED will illuminate immediately. (The Power Switch may be left in the ON position and the exciter energized externally by filament auxiliary contacts or other means if desired.)
2. After a few seconds the AFC indicator LED will illuminate.
3. Verify programming by observing the modulation bar graph.
4. Verify Power output and proper load by noting Forward and Reflected power and the absence of VSWR indicator illumination.
5. Check meter readings.
 - a. The +22V should read 22V \pm 1.5V
 - b. The -22V should read 22V \pm 1.5V
 - c. The +5V should read 5V \pm 0.2V
 - d. AFC voltage is a function of operating frequency. Table 3-2 gives typical values. Refer to the factory test data for value applicable to a particular exciter.
 - e. Amplifier voltage and current is a function of frequency and power output. Table 3-3 gives typical values. Refer to factory test data for values applicable to a particular exciter.
6. To turn the 802A OFF, simply place the Power Switch in the OFF position. There are no circuits (such as crystal ovens) in the 802A that require standby power.

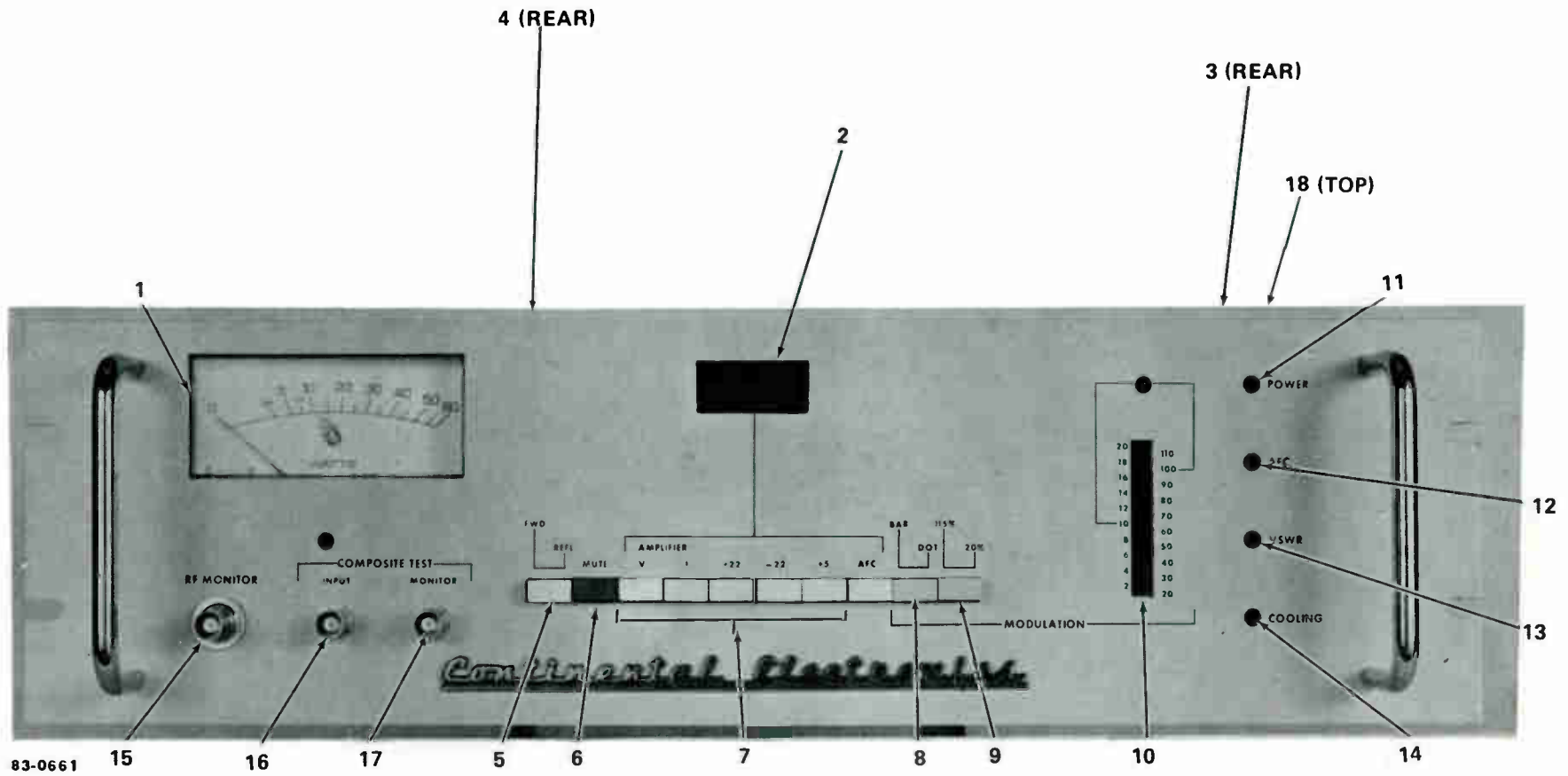

LW1-1(13)

Figure 3-1. Operating Controls & Indicators

TABLE 3-1. OPERATING CONTROLS

<u>ITEM</u>	<u>DESCRIPTION</u>	<u>FUNCTION</u>
1	ANALOG METER	Monitors Forward or Reflected RF Power
2	DIGITAL MULTIMETER	Displays Voltage or Current selected
3	TOGGLE SWITCH	Turns on Power (Located on rear)
4	TOGGLE SWITCH	Enables Pre-emphasized Mono Input (Located on rear)
5	PUSH-PUSH SWITCH	Selects Forward or Reflected (when depressed) for display on Item 1.
6	PUSH-PUSH SWITCH	Mutes Power Output when depressed
7	MULTIMETER SWITCH	Selects Power Amplifier Collector voltage, Power Amplifier Current, +22V, -22V, +5V or AFC voltage for display on Item 2. The switch positions are mechanically inter-locked.
8	PUSH-PUSH SWITCH	Selects bar or dot (when depressed) display mode on Item 10.
9	PUSH-PUSH SWITCH	Selects 115% (5% increments) or 20% (1% increments) scale for display on Item 10. The 20% scale (when switch is depressed) may be used to set SCA or pilot level.
10	BARGRAPH DISPLAY	20 segment display that monitors composite signal level to modulated oscillator. Calibrated in percent modulation.
11	GREEN LED	Illuminates to indicate power is ON
12	GREEN LED	Illuminates to indicate AFC loop is locked and exciter is on frequency

TABLE 3-1. OPERATING CONTROLS - Cont.

13	RED LED	Illuminates to indicate high VSWR condition at output.
14	RED LED	Illuminates to indicate over temperature condition on Power Amplifier.
15	BNC JACK	Provides sample of RF output. May be used to drive a frequency counter, etc.
16	BNC JACK	Composite input provided for test convenience.
17	BNC JACK	Provides sample of composite signal to modulated oscillator for test purposes.
18	POTENTIOMETER	Power output adjustment. Located on top of Unit. Clockwise rotation increases power output.

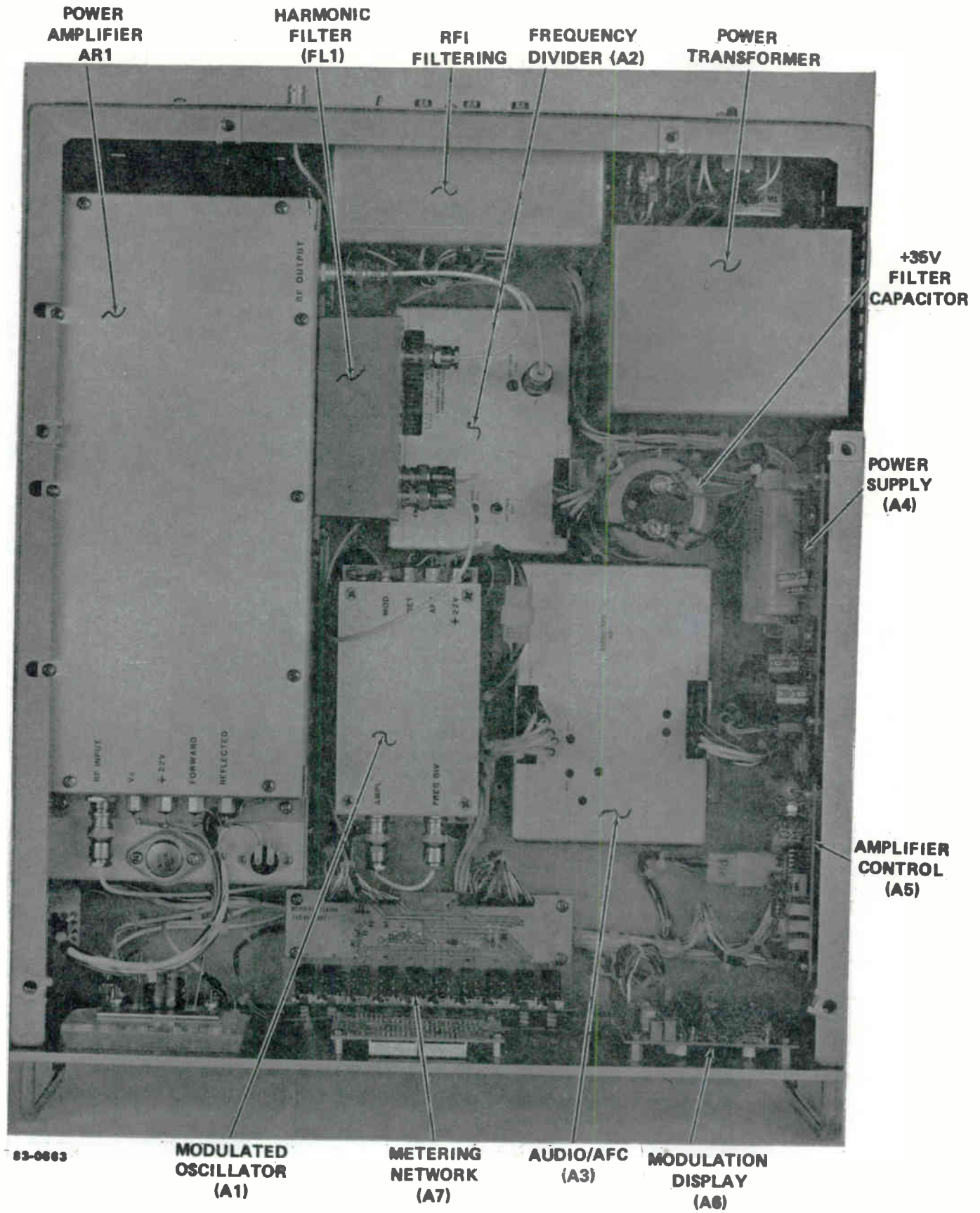

Figure 3-2. 802A, Top View

TABLE 3-2. TYPICAL AFC VOLTAGE vs FREQUENCY

<u>Fo MHz</u>	<u>AFC VOLTAGE</u>
87	3.5
88	4.0
89	4.4
90	4.9
91	5.4
92	5.9
93	6.4
94	6.9
95	7.4
96	8.0
97	8.7
98	9.7
99	11.0
100	5.7
101	6.1
102	6.5
103	6.9
104	7.3
105	7.7
106	8.1
107	8.7
108	9.2
109	10.0

TABLE 3-3. TYPICAL AMPLIFIER VOLTAGE AND CURRENT

<u>FREQUENCY</u>	<u>POWER OUTPUT</u>	<u>COLLECTOR VOLTAGE</u>	<u>COLLECTOR CURRENT (Amps)</u>
88.1 MHz	5	8.6	1.03
	10	10.9	1.54
	15	12.7	1.95
	20	14.4	2.31
	25	15.9	2.62
	30	17.4	2.92
	35	18.8	3.20
	40	20.1	3.44
	45	21.5	3.71
	50	22.7	3.94
98.1 MHz	5	8.4	.98
	10	11.1	1.49
	15	13.3	1.89
	20	15.2	2.23
	25	16.9	2.51
	30	18.5	2.78
	35	20.0	3.01
	40	21.4	3.23
	45	22.9	3.45
	50	24.4	3.65
107.9 MHz	5	9.7	.90
	10	13.4	1.37
	15	16.1	1.73
	20	18.5	2.03
	25	20.6	2.30
	30	22.6	2.54
	35	24.5	2.75
	40	26.4	2.94
	45	28.5	3.12
	50	30.4	3.27

SECTION 4 - THEORY OF OPERATION

This section describes the theory of operation of the 802A FM Exciter. A description of each functional circuit is followed by a more detailed description of each subassembly.

4-1. FUNCTIONAL DESCRIPTION

The 802A is described in terms of five functional circuit blocks. These are the AFC, Audio, Amplifier and Power Output Control, Power Supply and Metering Circuits. The following paragraphs provide a brief description of each functional circuit along with simplified diagrams where applicable.

4-1.1 AFC CIRCUITS

The Automatic Frequency Control circuits are comprised of the Modulated Oscillator Assembly (A1), Frequency Divider Assembly (A2) and the AFC loop filter portion of the Audio/AFC Assembly (A3). Figure 4-1 is a simplified diagram of the AFC circuitry. Figure 4-2 shows the location of these assemblies in the 802A.

The heart of the AFC system is the Modulated Oscillator Assembly. This assembly is comprised of an FET operated as a Hartley oscillator. Two pairs of varactor diodes are utilized. One pair (CR1 & CR2) is utilized for the AFC tuning voltage. The other pair (CR3 & CR4) is used for modulation and biased with a DC voltage. The DC bias voltage is changed at 100 MHz to optimize the AFC tuning voltage range. The modulated oscillator board is mounted in a rigid box and shock mounted to minimize susceptibility to vibration. The modulated oscillator has two outputs, one is used to drive the Power Amplifier (approximately 20 MW) and the other drives the Frequency Divider (approximately 10 MW).

The Frequency Divider (A2) contains the frequency divider chain which divides the carrier frequency down to the phase comparison frequency of 625 Hz and the 10 MHz Reference Oscillator and its frequency divider chain. The carrier frequency is first applied to High Frequency Counter U1 which divides the carrier frequency by eight. The carrier frequency is further divided by two via flip-flop U2 and applied to the BCD programmable frequency counter comprised of decade counters U3, U4, U5 and U6 and NAND gate U7. The counter may be programmed in 10 KHz increments to any frequency in the 87 to 109 MHz frequency range (divided by 8700 to 10900) by means of DIP Rocker switches, located on the frequency divider assembly. The output of each counter

is applied to the clock input of the succeeding counter. The maximum/minimum count signal of each decade counter is sensed and applied to NAND gate U7. When all four counters reach maximum/minimum count simultaneously, the output of U7 will go low. This signal is used to load the programmed count into the decade counters and the count sequence will then start again. The signal is also applied to one shot U8 which is used to stretch the very narrow pulse output of U7 to an approximately 50% duty cycle 625 Hz signal. The signal is applied to the AFC loop phase comparator located on the Audio/AFC Assembly. The inverse of the 625 Hz ($\overline{625}$ Hz) is rectified and used to drive VCO activity monitor DS1 via Q1 and Q2. DS1 will go out should the modulated oscillator or divider chain fail. The $\overline{625}$ Hz is also routed to the Audio/AFC Assembly for use in the AFC loss of lock circuits. The 100 MHz command to the programmable counter is also routed to the Audio/AFC assembly and used to change the bias on one pair of the Modulated Oscillator varactor tuning diodes. The 10 MHz reference oscillator is divided by 16 by U9 and further divided by 10 via U10. The 62.5 KHz output is routed to the AFC phase comparator located on the Audio/AFC Assembly and is also rectified and used to drive the Reference Oscillator activity monitor DS2. DS2 will go out should the Reference Oscillator or its divider chain fail.

The Audio/AFC Assembly, in addition to the audio circuits, contains the AFC phase comparator, loop filter, lock detector and Modulated Oscillator bias circuits. U1 comprises the AFC phase comparator. The 62.5 KHz reference signal is further divided by one hundred by U1 and compared against the 625 Hz signal from the Modulated Oscillator divider chain. The output of U1 will be high if the carrier frequency is higher than the reference frequency and low if the carrier frequency is lower than the reference frequency. If the carrier and reference frequency are the same, but different in phase, the output of U1 will be high for the time equal to the phase difference if the carrier leads the reference and low for the time equal to the phase difference if the carrier lags the reference frequency phase. If the carrier and reference frequency are the same frequency and in phase, the output of U1 will be 2.5 volts. The output of the phase comparator is applied to the AFC loop active filter comprised of integrator U2A and the 9.5 Hz Butterworth filter U2B. This high degree of filtering is necessary to remove the 625 Hz comparison frequency from the filter output. The loop filter output is then a DC voltage which will vary between 2.5 and 11.5 volts depending on frequency.

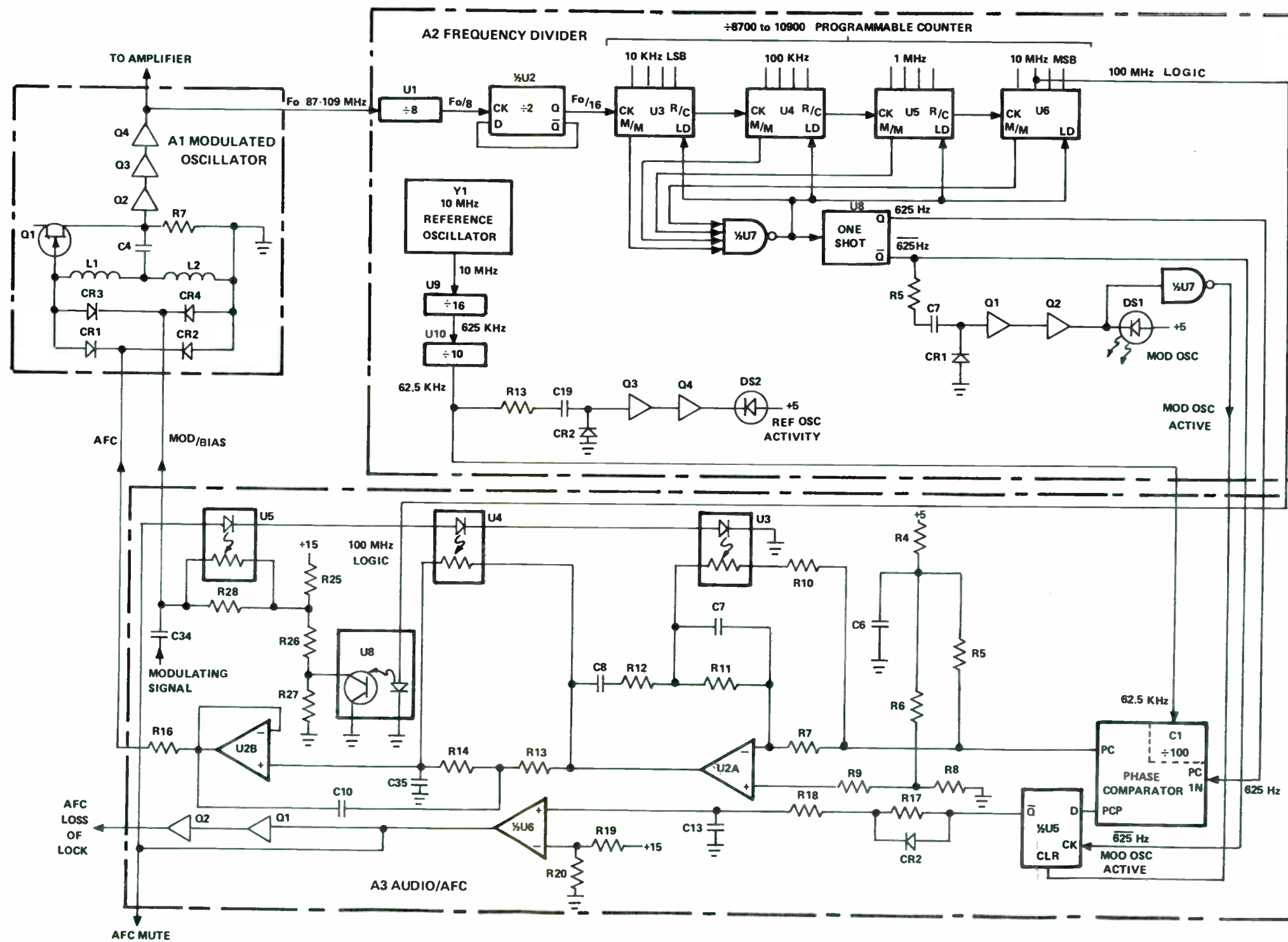

Figure 4-1. AFC Circuits - Simplified Diagram

LW1-1(2)

4-3/4-4

FREQUENCY DIVIDER A2

MODULATED
OSCILLATOR
A1

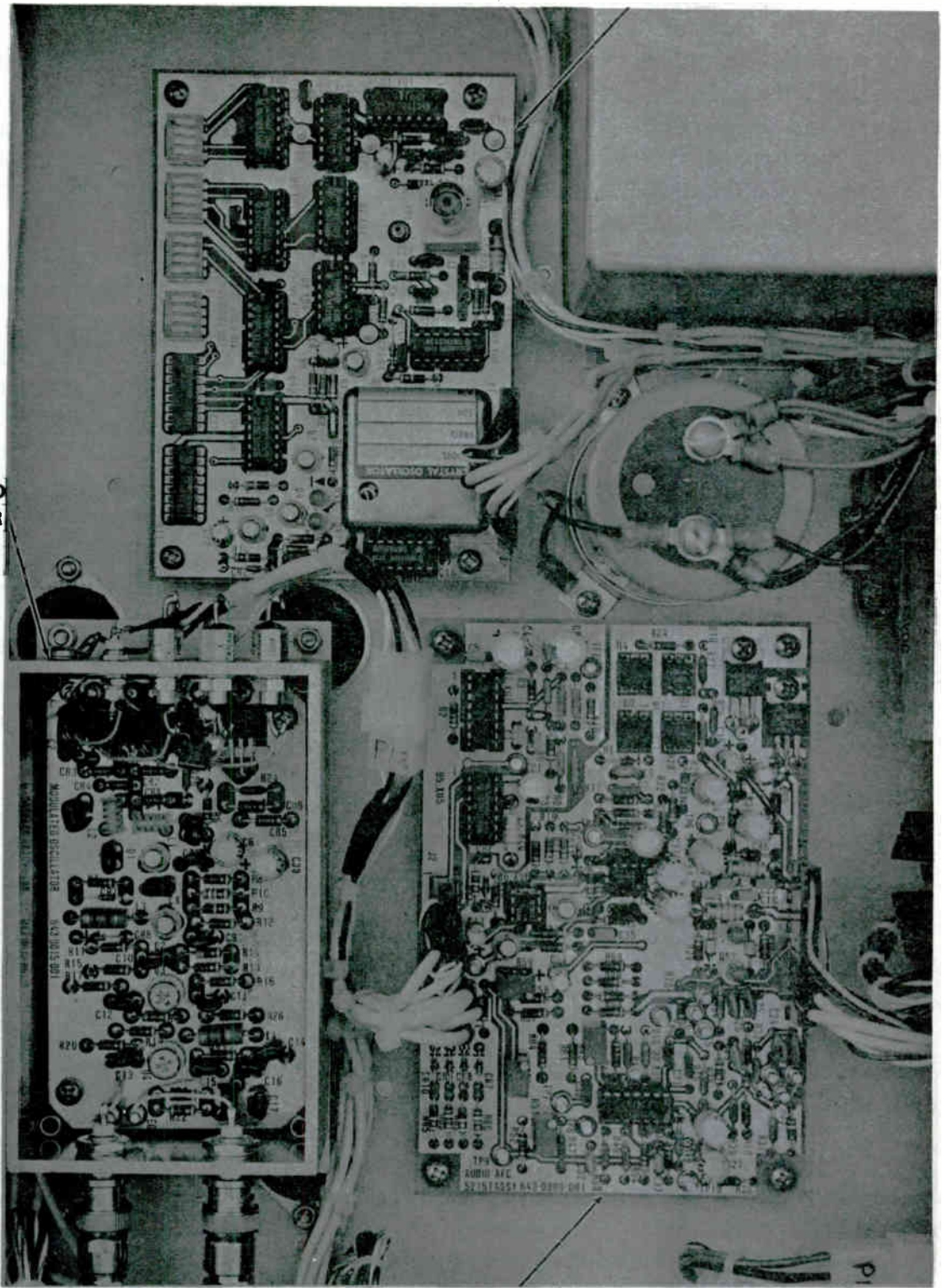

83-0709

AUDIO/AFC A3

LW1-1(15)

Figure 4-2. AFC Circuits Location (Cover Removed)

The AFC lock detection function is accomplished by flip-flop U5. An output from phase comparator U1 and the 625 Hz signal are compared in U5. The output from U1 is high if the carrier and reference frequency are in phase. The \bar{Q} output will be low. If the carrier and reference frequency are not in phase, the output from U1 will go low for a length of time equal to the phase difference. Since the inverted 625 Hz is applied to the lock detector U5, when the time that the U1 output is low exceeds 90° the \bar{Q} output of U5 will go high. This high signal is applied through the fast charge/slow discharge circuit formed by CR2, R17, R18 and C2 to lock driver U6. The output of U6 is used to mute the power amplifier output and extinguish the front panel AFC LED (via Q1 and Q2). The output of U6 is also used to drive optically coupled variable resistors U3 and U4. These resistors decrease in value when loss of lock is detected to speed up the loop filter response and decrease the amount of time required to achieve lock. Optically coupled variable resistor U5, also driven by U6, is used to allow the AFC bias to charge C34 (audio coupling capacitor) rapidly rather than through high value resistor R28. The AFC bias is changed at 100 MHz by shunting resistor R27 with optically coupled transistor U8 below 100 MHz. The bias voltage is approximately 2.8 VDC below 100 MHz and 5.8 VDC at 100 MHz and above.

4-1.2 AUDIO CIRCUITS

The Audio Circuits include the monophonic input, SCA inputs and composite input signal paths to the Modulated Oscillator. Figure 4-3 is a simplified diagram of the Audio Circuits.

The audio inputs first pass through RFI filters and are then routed to the Audio/AFC Assembly (A3). The mono input is also routed through switch S2. If S2 is in the mono position, the mono input is connected to the Audio/AFC assembly. This is done to obtain maximum separation when operating in the composite mode.

The balanced audio inputs are summed at the inverting input ports of U9A and U9B. U9A, U9B and U9C comprise a balanced to unbalanced amplifier circuit. R43 is used to balance the gain of U9A and U9B and thereby maximize common mode (hum) rejection. R51 is used to set the output level of buffer amplifier U9D at 2.25 VRMs. Diode pre-distortion is used to linearize the modulation characteristics of the varactor diodes in the modulated oscillator. R59 is used to adjust the amount of pre-distortion utilized. R56 is used to adjust the audio level to the modulated oscillator. A sample of the composite signal at U9D output is routed to the front panel composite monitor jack. The front panel composite test input is applied directly through R7 to U9D.

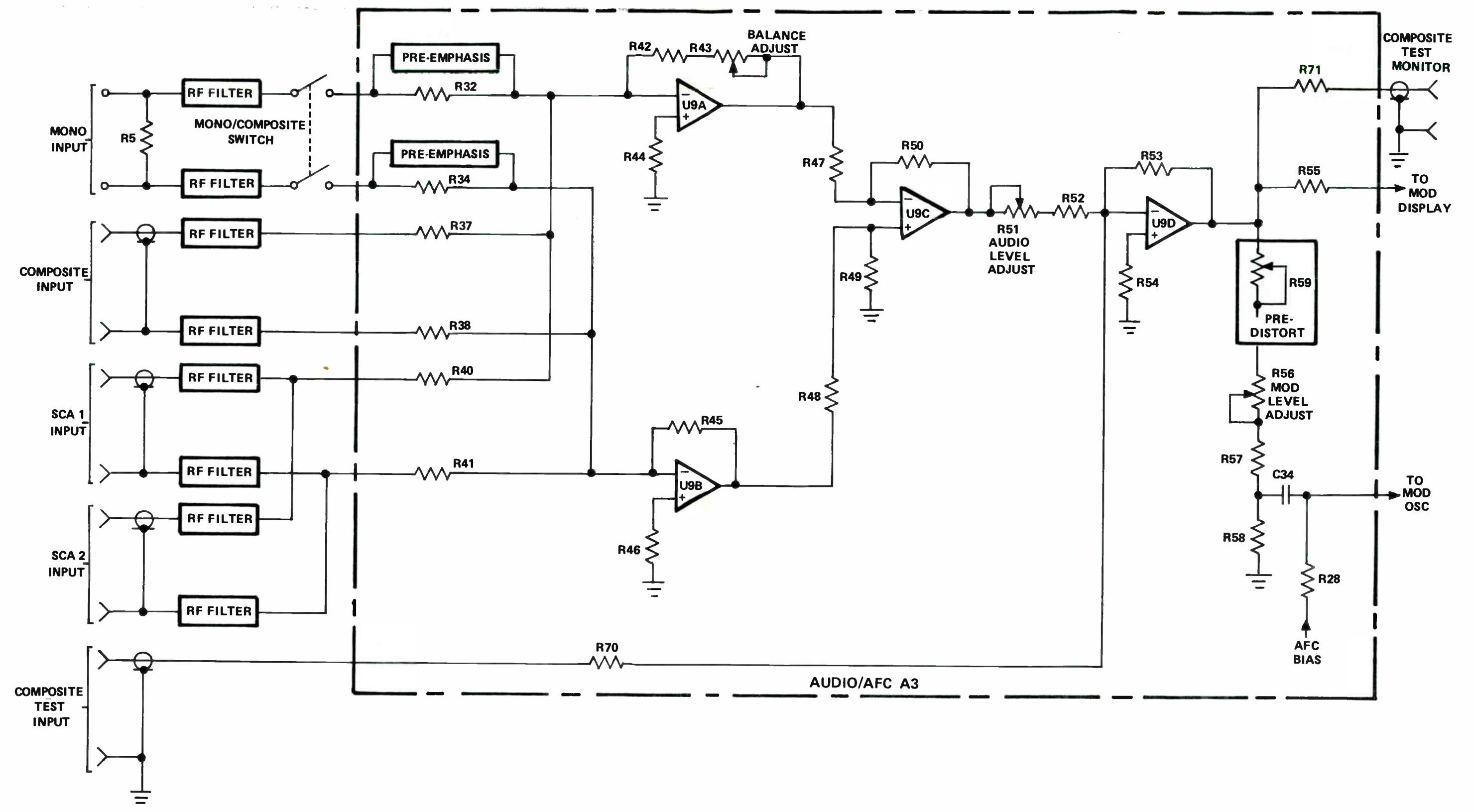

Figure 4-3. Audio Circuits – Simplified Diagram

LW1-1(4)

4-7/4-8

The 802A may be driven to 200% modulation with very little increase in distortion and is usable to frequencies below 2MHz input at full modulation capability without losing AFC lock. It is necessary to adjust R50 (predistortion) and R56 (mod level) at each carrier frequency to optimize distortion characteristics.

4-1.3 AMPLIFIER AND POWER OUTPUT CONTROL CIRCUITS

The Power Amplifier (AR1) amplifies the approximately 20 MW signal from the Modulated Oscillator to the 50 watt output level. A Harmonic Filter (FL1) follows the Power Amplifier. The Amplifier Control Assembly (A5) provides output power adjustment and protective features controlling the amplifier collector voltage. Figure 4-4 shows the location of these circuits in the 802A. Figure 4-5 is a simplified diagram of these circuits.

The Power Amplifier is a three stage solid state amplifier which operates broad band over the 87 to 109 MHz frequency range with no tuning. The amplifier PC board is mounted on a large heat sink for maximum cooling and transistor life. The first amplifier stage, a 2N3553, is matched to the fifty ohm input by means of a lumped constant network. This stage amplifies the signal to approximately a two watt level. The output of the first stage is matched to the input of the second stage, a PT9732, by means of a lumped constant network and a short strip line. This stage amplifies the signal to approximately a ten watt level. The output of the second stage is matched to the input of the third stage by a combination strip line and lumped constant network. The third stage, a MRF315A, amplifies the signal to the 50 watt level. The output network matches the 50 ohm output utilizing a strip line technique. Capacitors C11 and C34 provide harmonic rejection. The amplifier contains a stripline directional coupler which is used to detect both forward and reflected power at the output. Power output level is adjusted by controlling the collector voltage to the second and third stages. The series pass transistor for the collector voltage regulator is mounted on the amplifier heat sink. A thermal switch is also mounted to the amplifier heat sink and used to cut power back should the heat sink temperature rise too high (in the event of a fan failure for instance) and also activate the cooling LED on the front panel.

The Power Amplifier is followed by a harmonic filter which provides additional harmonic rejection.

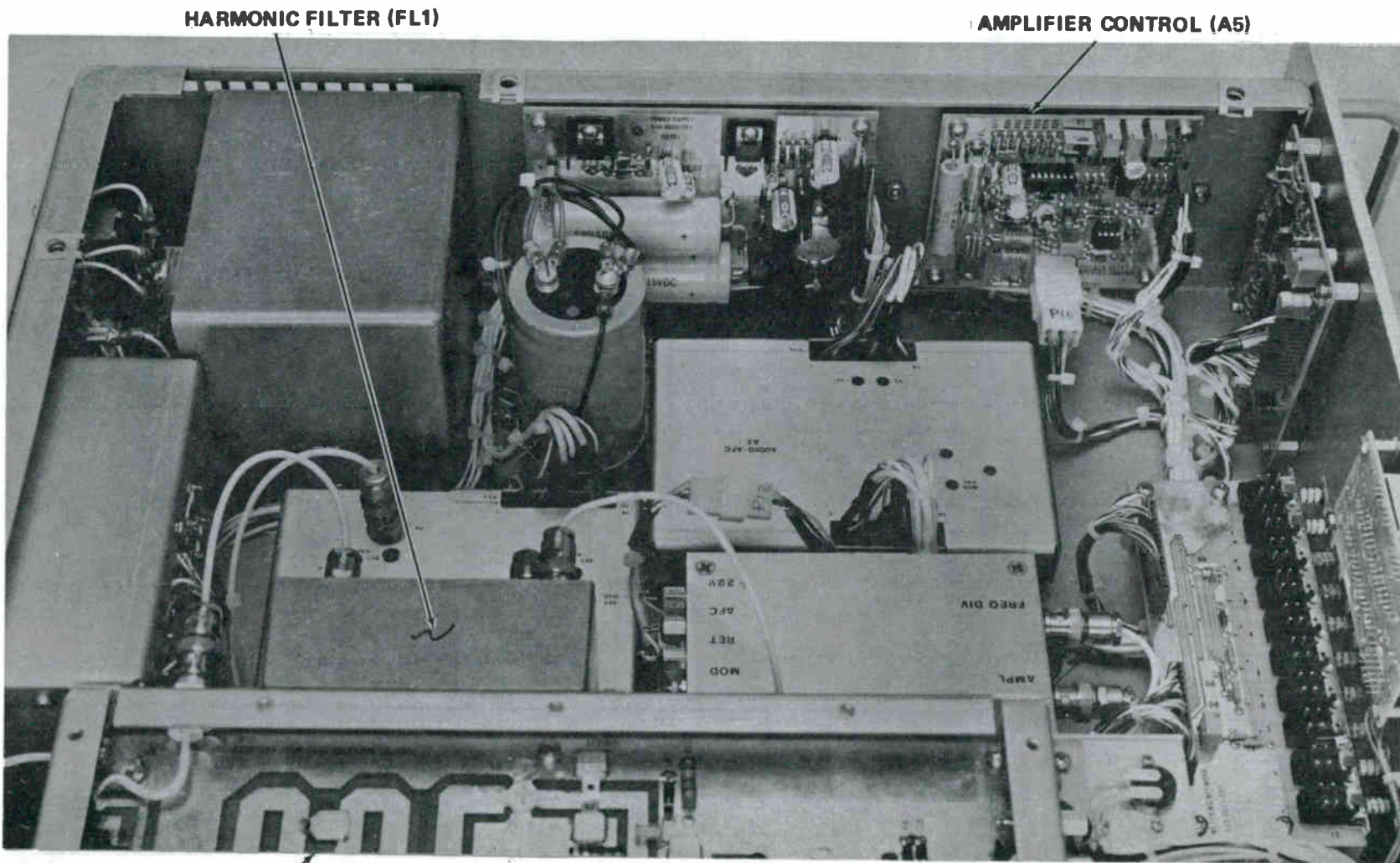

HARMONIC FILTER (FL1)

AMPLIFIER CONTROL (A5)

AMPLIFIER (AR1)

83-0668

LW1-1(12)

Figure 4-4. Amplifier & Power Control Circuit Location

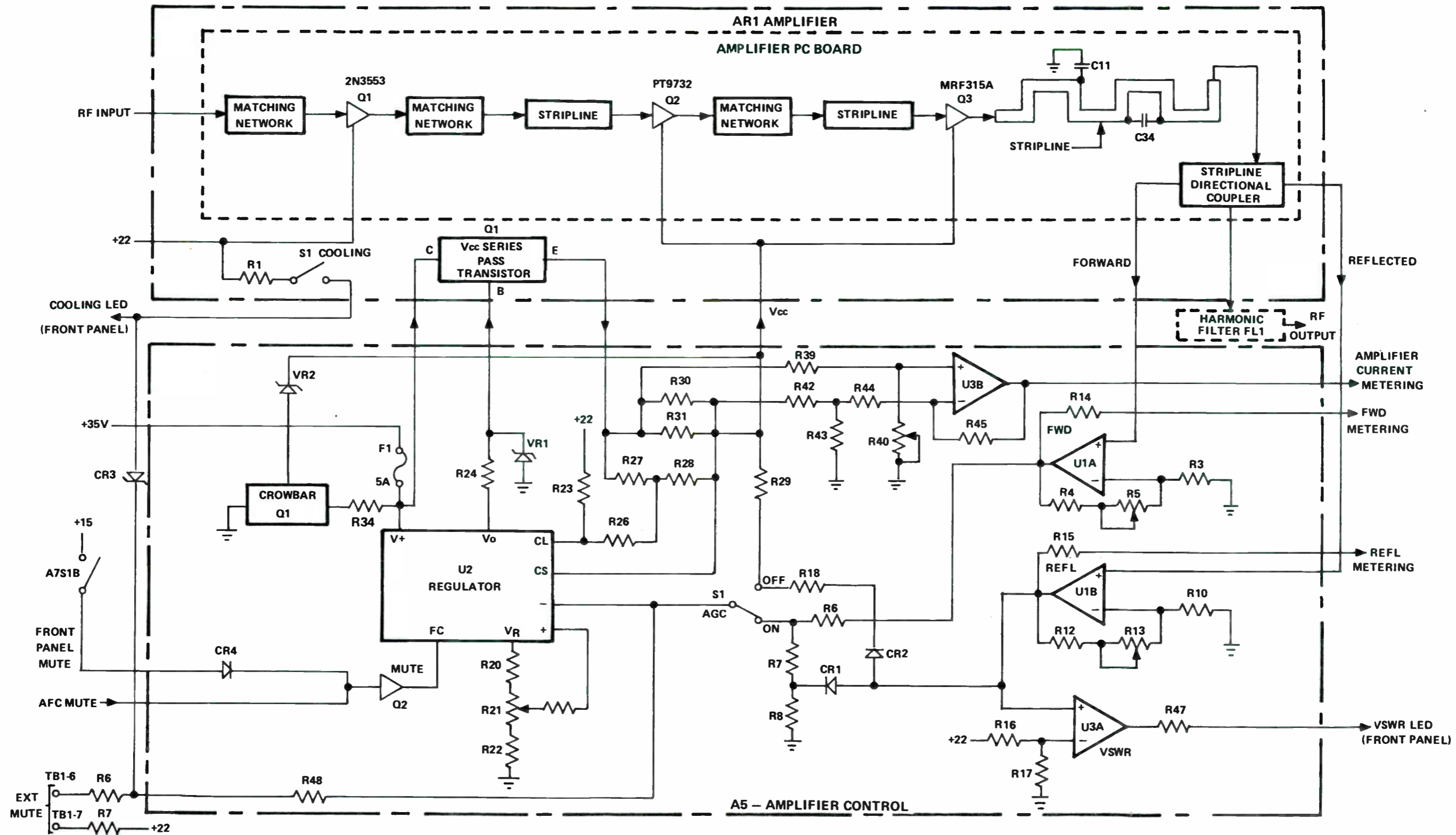

LW1-1(3)

Figure 4-5. Amplifier & Power Output Control - Simplified Diagram

4-11/4-12

The Amplifier Control Assembly (A5) contains the integrated circuit regulator which controls the Amplifier Collector voltage. The collector voltage regulator circuit may be operated in two modes; manual or automatic. In the manual mode, the collector voltage is adjusted for the desired power level using R21. Collector voltage is sensed via R29 and applied to the regulator via S1. Thus, the regulator serves to hold collector voltage constant. In the automatic (normal) mode, the directional coupler forward power signal is amplified by U1A and applied to the regulator via S1 and R6. Thus, the regulator serves to hold power output constant. Therefore, the power output will remain constant over temperature and slight load impedance changes. The directional coupler reflected power signal is amplified and used to protect the amplifier from damage when operating into a high VSWR. The reflected signal is coupled into the regulator via CR1 and CR2 and acts to reduce power output to a safe level. At approximately a 2 to 1 VSWR the output of U3A will go high and light the front panel VSWR indicator. Under open or short circuit conditions, power output is limited to approximately 8 watts. Over voltage protection for the amplifier is provided by Crowbar Q1. If the collector voltage to the amplifier exceeds the threshold voltage of VR2, the crowbar will fire, shorting the collector voltage feed through R34 and blowing fuse F1. Over current protection for the amplifier is provided by foldback current limiting in the 723 regulator U2. The voltage across low value resistors R30 and R31 is applied to the regulator via R27, R28 and R26. A positive bias voltage is also applied to the current limit input of the regulator via R23. This is to insure fast current limiting action in the event of a short circuit on the collector voltage feed to the amplifier.

The amplifier may be muted by depressing the mute switch on the front panel. This places a low on the regulator Frequency Compensation input, via CR4 and Q2, causing the regulator to take the collector voltage to approximately zero output. Loss of AFC lock is used to mute the amplifier in the same manner. An overtemperature condition will also mute the amplifier to approximately the 8 watt level (when operating at 50 watts output) via chassis components CR3 and A5R48. The front panel cooling LED indicator will illuminate when this occurs. The amplifier may be externally muted via TB1-6 and TB1-7 on the 802A rear panel. +22 VDC is present via R7 at TB1-7. If applied to TB1-6 via relay contacts this will cause a hard mute of the amplifier output. A potentiometer (5K to 100K) may be installed from TB1-7 to ground and the slider on the potentiometer applied to TB1-6 via relay contacts. The mute level may then be adjusted to the desired level by means of the potentiometer.

4-1.4 POWER SUPPLY CIRCUITS

Figure 4-6 is a simplified diagram of the 802A power supply circuits. Figure 4-7 shows the location of the major components of the Power Supply in the 802A.

The AC input is applied through the input connector to T1. The line voltage selector card is a part of the AC input connector. The input connector also contains an RFI filter. The exciter cooling fan is operated from a 115 volt winding on the primary of T1. The center tapped secondary of T1 is applied to full wave rectifier CR1 to obtain nominal +35V and -35V outputs. The +35V output is routed to the Amplifier Control Assembly (A5) and the Power Supply Assembly (through voltage dropping resistors R8 and R9) after filtering by C1. The -35V output is routed directly to the Power Supply Assembly as is the 8.4 volt output from the remaining transformer secondary.

The +35V input is passed through regulator U2 to obtain +22V output. This voltage is used to supply the first stage of the amplifier and other applications in the exciter where a very low noise voltage is not essential. This pre-regulated +22V is farther regulated to +15V in the modulated oscillator by U1. This +15V is used solely in the modulated oscillator to insure the outstanding noise characteristics of the 802A. The preregulated +22V and -22V are also regulated to +15V and -15V on the Audio/AFC Assembly (A3) by regulators U10 and U11. This is done to insure low noise and ripple on the supply voltage. Proper operation of the regulators U10 and U11 is indicated by LEDs DS1 and DS2. These indicators will illuminate when the 15V outputs are present. This $\pm 15V$ is also used to supply the amplifier on the Modulation Display Assembly (A6).

The 8.4VAC is rectified on the Power Supply Assembly by full wave bridge CR5 and applied to regulator U3. The +5V output from U3 is used to supply digital circuits throughout the 802A.

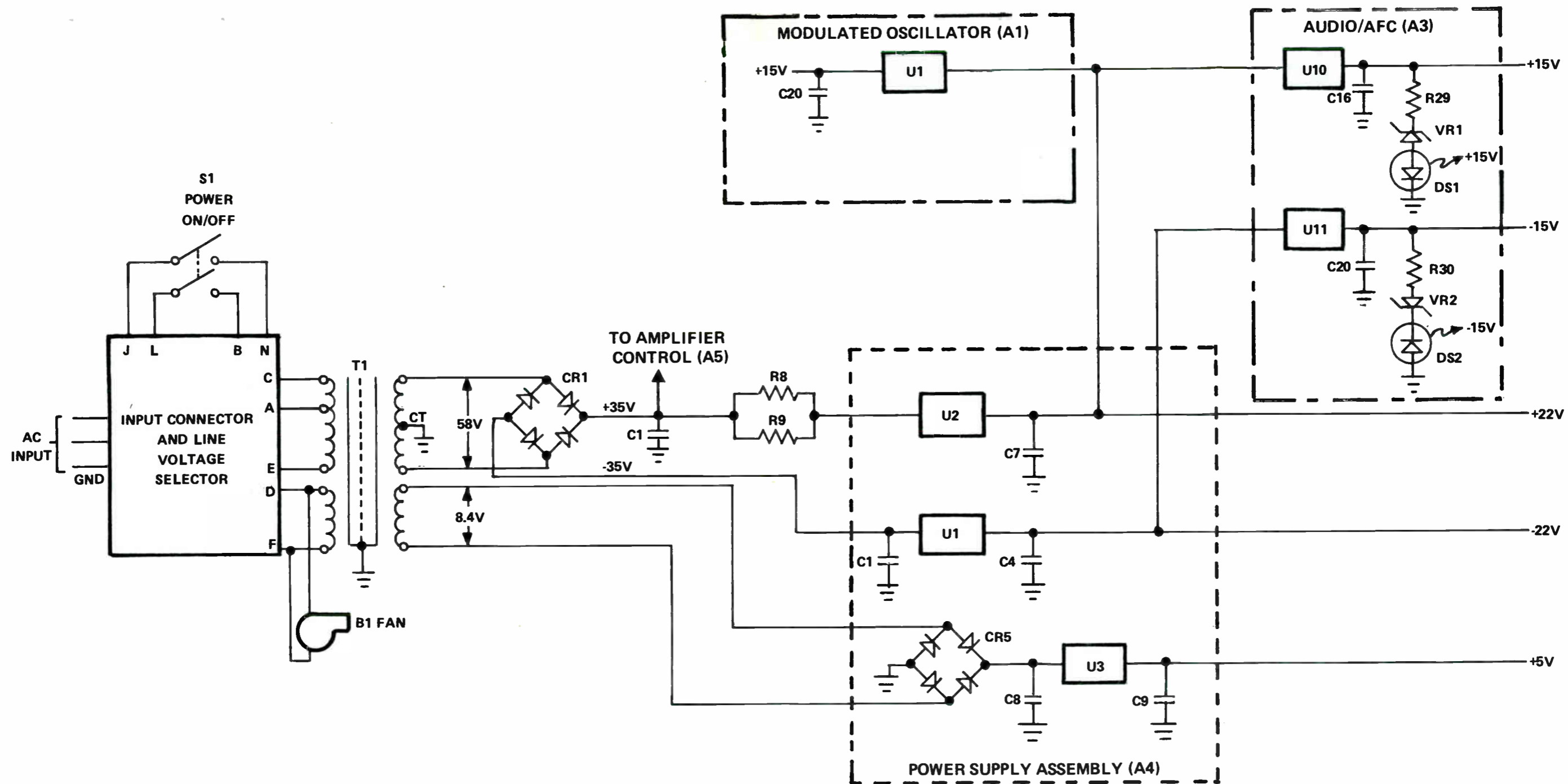

Figure 4-6. Power Supply Circuits - Simplified Diagram

LW1-1(5)

4-15/4-16

1950-1951



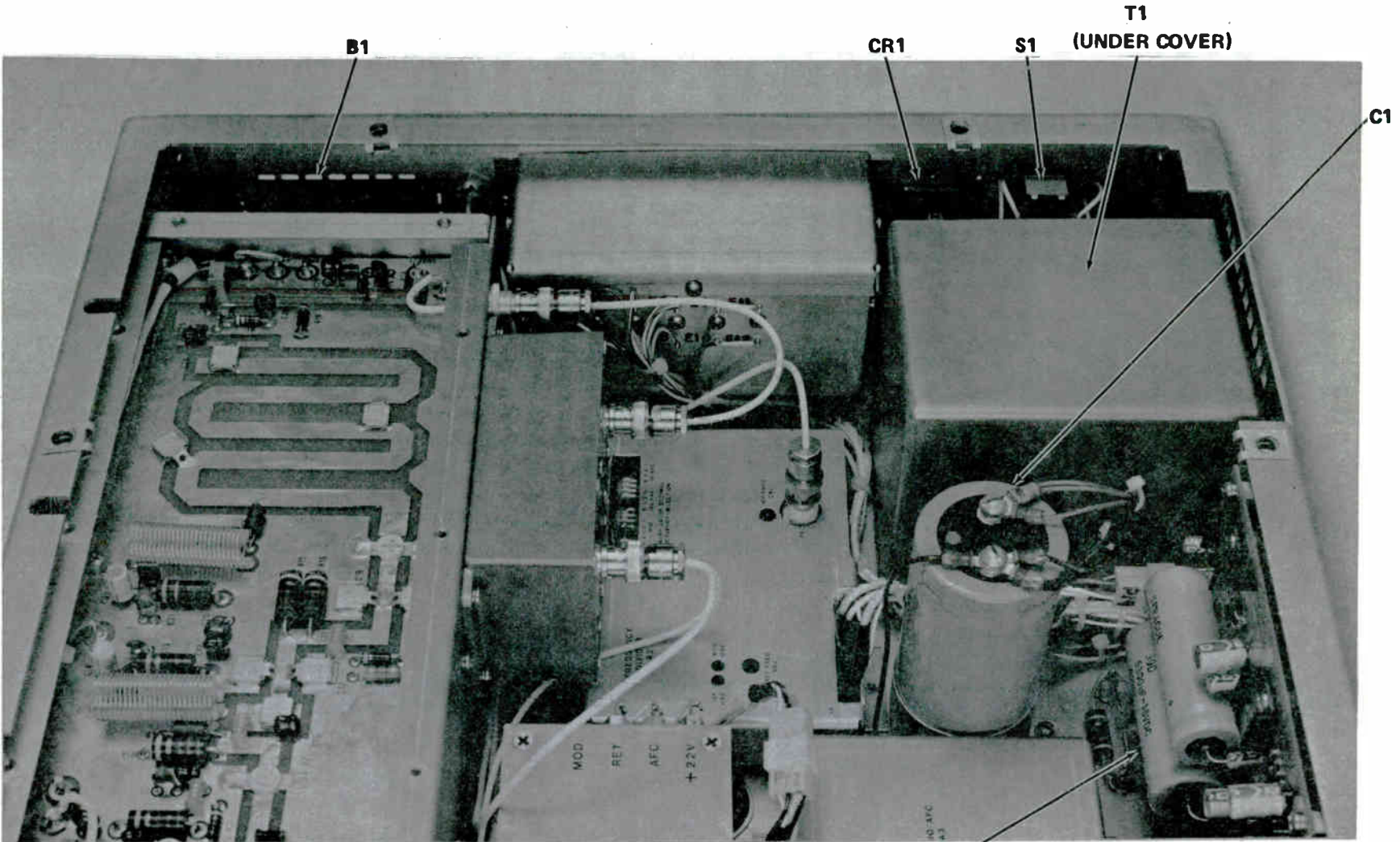

LW1-1(11)

83-0667

POWER SUPPLY ASSEMBLY (A4)

Figure 4-7. Power Supply Circuits - Parts Location

4-1.5 METERING AND MONITORING CIRCUITS

Three Metering and Monitoring devices are utilized in the 802A. The forward and reflected power is monitored on analog meter M1. The directional coupler signals from the power amplifier are amplified on the Amplifier Control Assembly and routed to the Metering Network Assembly (A7) which selects either forward or reflected power on M1.

Power Supply voltages and current are monitored on digital multimeter M2. These metered items are routed to voltage dividers on the Metering Network Assembly and selected for display on multimeter M2. Figure 4-9 shows the location of the metering and monitoring circuits.

The composite modulating signal to the Modulated Oscillator is detected and displayed on the bar graph on the front panel (calibrated in percent modulation). Figure 4-8 is a simplified diagram of the Modulation Display circuits. The composite modulating signal is applied to buffer amplifier U1A. R2 serves to calibrate the 115% full scale range of the display. U1B and U1C form an absolute value detector. This circuit detects both positive and negative peaks of the modulating signal. The detector is flat well beyond 100 KHz in order to respond to fast peaks in program material. The output of U1C is applied to the fast charge/slow discharge circuit formed by CR3, C4 and R12. U10 provides gain and buffering of the detected signal. A small amount of bias is applied via R13 to improve accuracy at low modulation levels. The signal is then applied to bar graph drivers U2 and U3 via the 20% scale calibration potentiometer R17. Either a bar or dot display mode may be selected from the front panel. The 10% LED when in the 20% full scale mode and the 100% LED when in the 115% full scale mode outputs of the bar graph drivers are sensed and used to trigger one shot U4 which drives the over-modulation indicator LED DS3.

The POWER ON, VSWR, COOLING and AFC LED indicators are located on the Modulation Display Assembly. The POWER ON LED is activated by the +5V supply. The COOLING, VSWR and AFC faults are summed and applied to Q3 which drives the remote fault relay K1.

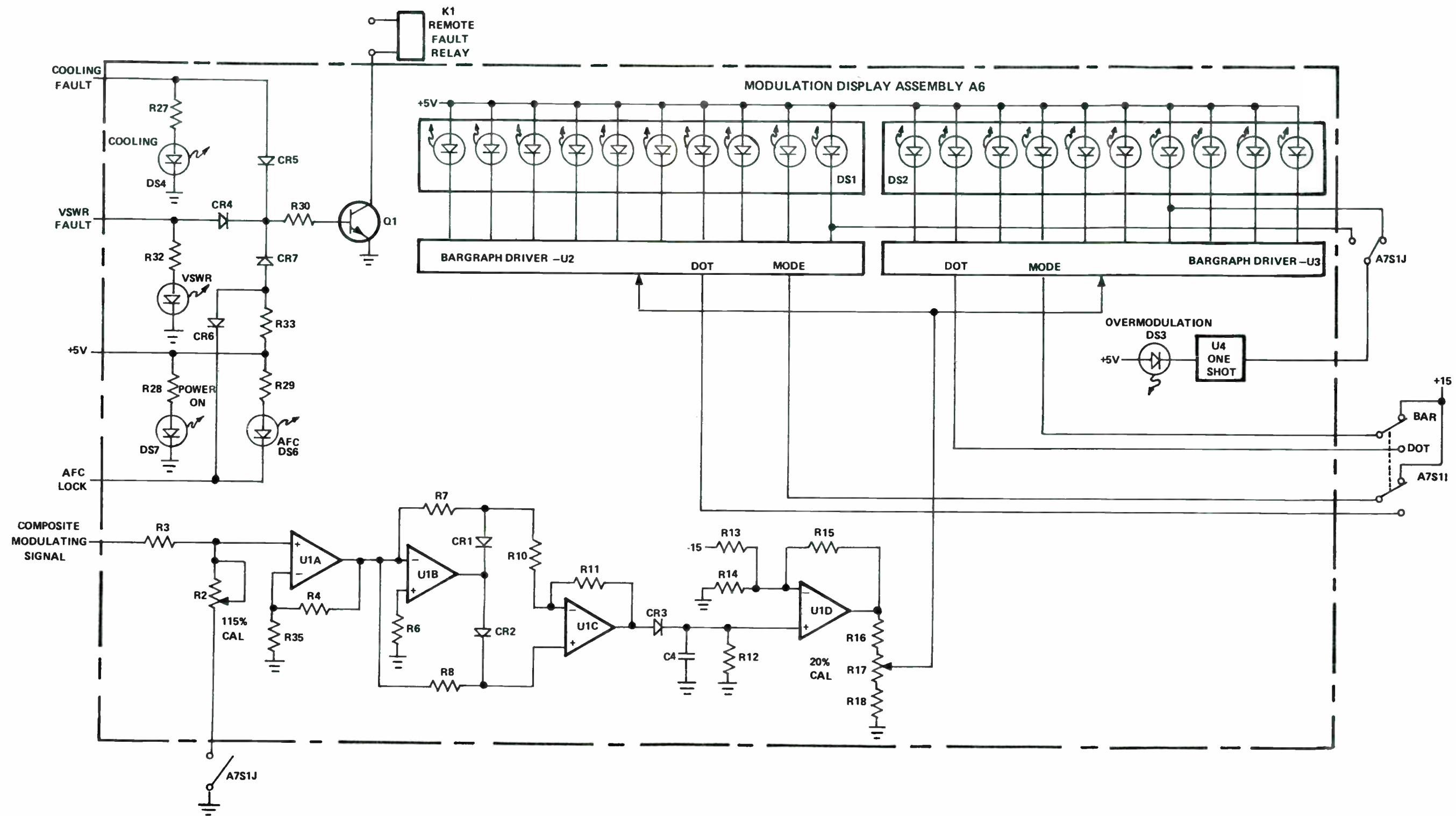

LW1-1(1)

Figure 4-8. Modulation Display - Simplified Diagram

4-19/4-20

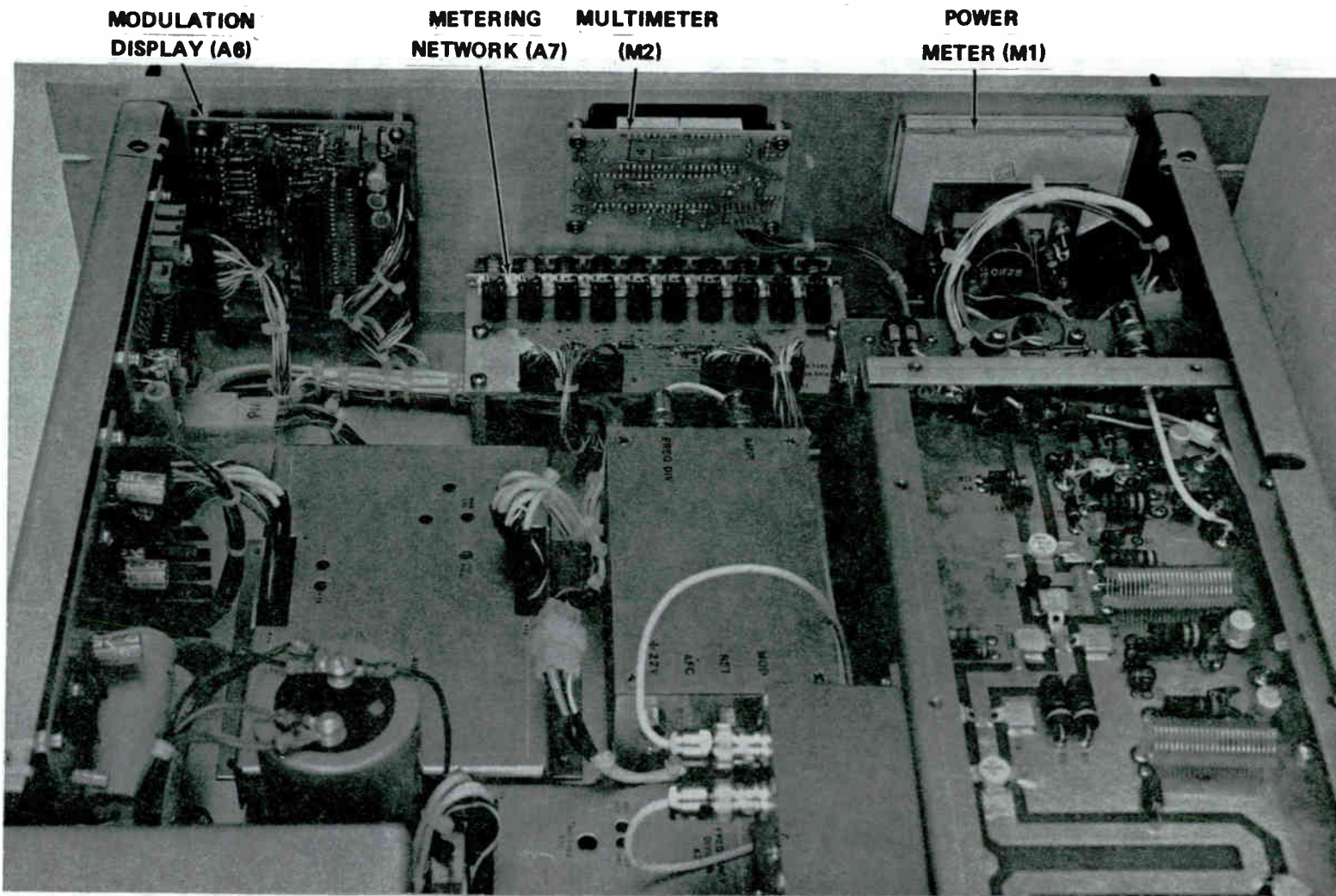

MODULATION
DISPLAY (A6)

METERING NETWORK (A7)
MULTIMETER (M2)

POWER
METER (M1)

4-21

802A

LW1-1(9)

83-0669

Figure 4-9. Metering & Monitoring Circuits, Location

4-2. DETAILED CIRCUIT DESCRIPTION

The following paragraphs provide a more detailed description of the assemblies which comprise the functional groups described in Section 4-1.

4-2.1 MODULATED OSCILLATOR ASSEMBLY (A1)

Refer to schematic 643-0016-001 and assembly drawings 643-0015-001 and 643-0052-001.

The Modulated Oscillator Assembly is comprised of the Modulated Oscillator PC Board (A1A1) and associated RFI filtering components and connectors. Capacitors C1, C2, C3, C4 and C5 along with L1, L2, L3 and L4 (ferrite beads) provide RFI filtering.

Supply voltage for the modulated oscillator is derived from the +22V supply by voltage regulator U1. R24 and R28 determine the output voltage of U1 (+15V). CR5 and CR6 provide transient protection. C18, C19 and C20 provide filtering to insure a very low noise, low ripple DC supply voltage for the oscillator.

The modulated oscillator is formed by JFET Q1 operating as a Hartley oscillator. The resonant tank circuit is comprised of L1, L2, CR1, CR2, CR3 and CR4. CR1-CR4 are varactor diodes used to modulate and tune the oscillator. Diode pair CR3 and CR4 are used for modulation and to bias the oscillator for the frequency ranges above or below 100 MHz. AFC tuning is accomplished by diode pair CR1 and CR2. An isolated return line is provided for the modulation and AFC inputs in order to minimize possible noise contributions from ground loops. Diodes CR7 and CR8 clamp the oscillator RF voltage and prevent rectification by the varactor diodes.

The output of oscillator Q1 is capacitively coupled via C8 to source follower Q2. Q2 in turn drives emitter follower Q3 through C10. These two high input impedance stages isolate the oscillator from the output load and prevent "pulling" of the oscillator due to output impedance changes. Q3 output drives amplifier Q4 via C12. Q4 is a conventional grounded emitter, Class A amplifier. C16, L5 and C17 provide harmonic rejection and impedance matching. The modulated oscillator has two outputs, one to drive the power amplifier and one to drive the frequency divider for the AFC circuits.

4-2.2 FREQUENCY DIVIDER ASSEMBLY (A2)

Refer to schematic 643-0004-001 and assembly drawing 643-0003-001.

The carrier frequency from the modulated oscillator is applied to ECL prescaler U1. U1 divides the carrier frequency by eight. U1 contains an ECL to TTL translator and the translator output is used to drive D flip-flop U2, half of which is used to further divide the carrier frequency by two. R1 provides a termination for the carrier signal input, R2 and C2 are required for U1 operation and R3 insures U1 stability. U3-U7 comprise the BCD programmable counter (\div 8700 to 10900) as previously described. Frequency is programmed via the DIP switches S1 thru S4. Integrated circuit resistor networks R11 and R12 act as pull up resistors. The programming is BCD code. To change frequency set the the switches for the BCD code of the frequency desired. For instance 103.14 MHz is

<u>10 MHz (S4)</u>	<u>1 MHz (S3)</u>	<u>100 MHz (S2)</u>	<u>10 XHz (S1)</u>
1010	0011	0001	0100
10	3	.1	.04

One shot U8 stretches the pulse from the programmable counter. R4 and C6 determine the output pulse width of U8.

The 10 MHz crystal oscillator Y1 is the reference oscillator for the AFC circuits. The AFC circuits phase lock the carrier frequency to the reference oscillator. The 10 MHz TTL output of Y1 is divided by 16 via U9 and further divided by 10 via U10. The \div 2 and \div 4 frequency outputs of U9 are applied to J3 along with the 10 MHz signal. Thus P1 may be used to select 2.5 MHz, 5 MHz or 10 MHz for access on TP1 to be used for frequency calibration.

The frequency divider operates from the +5V supply which is RFI filtered by C13, C14, C15 and L1. Further decoupling of the digital circuits from the supply is provided by capacitors placed close to the chip V_{CC} pins (C4, C5, C9, C10, etc.).

The Modulated Oscillator and Reference Oscillator and their respective divider chains are monitored for activity by identical circuits which drive LED indicators. The indicators are ON whenever activity is detected. Each activity monitor is coupled via a resistor capacitor network (R5, C7) to a diode detector (CR1) which drives an emitter follower stage (Q1) which in turn drives the LED driver (Q2). Should either oscillator or counter chain fail, the

activity monitor LED will extinguish and the AFC front panel LED will also extinguish.

4-2.3 AUDIO/AFC ASSEMBLY (A3)

Refer to schematic 643-0007-001 and assembly drawing 643-0006-001.

The Audio/AFC Assembly processes the audio inputs for application to the Modulated Oscillator and also contains the AFC phase comparator, loop filter and lock detector. The audio inputs (mono, composite and SCA) are applied to the balanced to unbalanced amplifier formed by U9A, U9B and U9C. Pre-emphasis is applied to the mono input by C23, C24, C25 and C26. By changing the jumpers on E1, E2, E3 and E4, E5, E6 flat, 25 μ sec, 50 μ sec or 75 μ sec pre-emphasis may be obtained. R43 is used to adjust the gain of U9A so that U9A and U9B have equal gain. This insures maximum common mode rejection (hum on the input lines for example). The output of U9A is inverted and summed with the output of U9B by U9C to provide the unbalanced signal required by the Modulated Oscillator. U9D acts as a buffer amplifier. The gain of U9D is adjusted by R51 to give 2.25 VRMS at U9D output. This level corresponds to 100% modulation. C30-C33 limit high frequency noise by reducing gain. The composite test input is applied to the inverting input of U9D. A sample of U9D output is routed to the Modulation Display Assembly and to the Composite Monitor jack on the front panel. Diode predistortion of the signal is used to compensate for the small non-linearity of the varactor diodes in the Modulated Oscillator. Diodes CR7, CR8, CR9 and CR10 are biased by their respective resistor networks and provide the predistortion. R59 is used to adjust the predistortion level for minimum distortion at the exciter output. R56 adjusts the signal level to achieve 100% modulation with 2.25 VRMS at TP9. R56 and R59 are adjusted at the carrier operating frequency and should be re-adjusted for optimum performance if the carrier frequency is changed. The modulating signal is coupled to the Modulated Oscillator through C34. The audio signal path is flat to beyond 100 KHz and usable to frequencies below 2 Hz.

To insure low noise power supplies for the operational amplifiers used in the audio and AFC circuits the pre-regulated +22 V and -22 V supplies are passed thru regulators U10 and U11 to obtain +15 V and -15 V. C15, C16, C19 and C20 provide filtering and CR3, CR4, CR5 and CR6 provide transient protection. The ± 15 V is also routed to the modulation display assembly. C17, C18, C21, C22, L2 and L3 provide decoupling for these outputs. The ± 15 V is monitored

by LEDs DS1 and DS2 through R29, R30 and zener diodes VR1 and VR2. Should the +15 V fail, DS1 will extinguish and should the -15 V fail, DS2 will extinguish.

Phase comparison for the AFC phase locked loop is provided by U1. The 625 Hz from the carrier frequency divider chain and the 62.5 KHz from the reference frequency divider chain are applied to U1. U1 further divides the 62.5 KHz by one hundred to 625 Hz. These two 625 Hz signals are phase compared in U1 and the output of the phase comparator (Pin 13) is applied to active filter U2A. R4, R8 and R5 bias the phase comparator output to 2.5 VDC so that the output phase comparator pulses will go high or low around the 2.5 VDC point depending on whether the carrier phase leads or lags the reference phase. R7 provides a small amount of offset bias (dead band) to insure that the phase comparator does not "hunt" around the in phase point. U2A is an integrator with a break frequency of approximately .05 Hz determined by C8 and R7. The output of the integrator is applied to the Sallen-Key type active Butterworth filter formed by U2B, R13, R14, C10 and C35. The output of U2B is then a DC voltage used for AFC tuning. Since the frequency response of the active filters U2A and U2B is very low, the AFC loop would take quite a long time to achieve lock when first turning on or changing frequency. Optically coupled variable resistors U3 and U4 are used to speed up the AFC filter response until phase lock is achieved at which time the filter response is returned to its normal frequency response. Bias is applied to the modulator pair of varactor diodes to optimize the AFC tuning curve and is applied to the Modulated Oscillator via R28. R28 is required to be a high value resistor to insure good low frequency modulation characteristics. The bias voltage is developed by the resistance voltage divider network formed by R25, R26 and R27. The bias voltage is changed whenever a frequency 100 MHz or above is selected by optically coupled transistor U8 which shorts out R27. As the time constant of R28 and modulation coupling capacitor C10 is long, optically coupled variable resistor U7 is used to short R28 with a low resistance value until lock is achieved.

The optically coupled variable resistors are driven by the output of buffer amplifier U6A. The lock detection function is performed by D flip-flop U5. An output from phase comparator U1 and the inverted 625 Hz carrier frequency signal are applied to U5. When the output from U1 goes low for a period of time equal to approximately 90° or more the \bar{Q} output of U5 will go high. This high signal (indicating loss of lock) is applied to U6A via the fast charge/slow discharge circuit formed by R16, CR2, R18 and C13.

This causes the output of U6A to go high which energizes the optically coupled variable resistors to speed up the AFC filter response and extinguishes the AFC front panel LED via Q1 and Q2.

4-2.4 AMPLIFIER ASSEMBLY (AR1)

Refer to schematic 643-0028-001 and assembly drawings 643-0027-001 and 643-0054-001.

The Power Amplifier consists of the amplifier PC board, which is mounted on a large heatsink, and RFI filtering. C1-C5 and L1-L4 (ferrite beads) perform RFI filtering. R1 provides +22 volts to the temperature switch S1 which monitors the amplifier heatsink temperature and will mute the output to a safe level in the event of excessive heat sink temperature (caused by a fan failure for instance).

The Amplifier PC board (AR1A1) contains the three stage amplifier which accepts the approximately 20 milliwatt input from the Modulated Oscillator and amplifies it to the 50 watt output level. The first stage utilizes a 2N3553 operated with approximately 1.6 VDC bias developed by R1, R2 and emitter resistor R3. C1, C2, L1, C35 and C36 match Q1 input impedance to the 50 ohm input. C3 provides RF ground for the emitter of Q1. The output of Q1 is matched to the input of Q2, a PT9732, by the matching network, comprised of L5, L15, C33, C9, L76 and a short strip line. C8 provides DC blocking while R4, R13 and L7 prevent parasitic oscillation.

The second stage, Q2, is operated with zero bias with the emitter at DC and RF ground. The output of Q2 is matched to the input of the third stage, a **MRF315A**, by the network comprised of C10, L8, C16, C17, C18, C19 and a short strip line. R15, R16, L11, L12 and R5 prevent parasitic oscillations and also prevent DC bias from developing at the base of Q3. C15 provides DC blocking. The output of Q3 is matched to the 50 ohm output impedance by the output strip line. C11 and C34 provide harmonic rejection. C23 provides DC blocking.

A directional coupler follows the output strip line. Both forward and reflected power are detected by the directional coupler strip lines, which are backward wave coupled to the 50 ohm output strip line. Capacitors C39 (forward) and C27 (reflected) compensate the directional coupler over the 87 to 109 MHz frequency range. R8 is adjusted to provide maximum directivity on the reflected power coupler. Diodes CR1 and CR2 detect the coupler outputs to provide a DC analog of forward and reflected power.

The collector of each amplifier stage is isolated from the collector of the other stages by decoupling circuits such as that formed by R7, L13, L14, C20, C22 and C32 for Q3. The first stage operates from the +22 V supply. The second and third stages operate from the variable voltage provided by the Amplifier Control Assembly.

The series pass transistor for the collector voltage regulator is also mounted on the amplifier heatsink.

4-2.5 AMPLIFIER CONTROL ASSEMBLY (A5)

Refer to schematic 643-0013-001 and assembly drawing 643-0012-001.

The primary function of the Amplifier Control Assembly is to regulate and control the level of the collector voltage of the final two stages of the power amplifier.

Unregulated supply voltage is routed thru fuse F1 and then applied to the collector of the series pass regulator Darlington transistor mounted on the amplifier heatsink. SCR Q1 provides over-voltage crowbar protection. Zener diode VR2 monitors the regulated voltage from the series pass transistor and will trigger Q1 should the collector voltage exceed 36V. R34 provides current limiting. F1 will open in the event the crowbar triggers. The regulated voltage from the series pass transistors is routed through current limiting and monitoring resistors R30 and R31 and applied to the amplifier. The voltage developed across R30 and R31 is sensed and applied to the current sense and limit inputs of the 723 regulator via R27 and R28. R28 provides a bias voltage to insure fast fold-back current limiting in the event of a short circuit. Operational amplifier U3B, operating with a non-inverting gain of 4, is connected to differentially amplify the voltage drop across R30 and R31 by a factor of two. Potentiometer R40 is used to adjust the output voltage of U3B to twice the voltage across the precision resistors R30 and R31. Thus, if the current to the amplifier is 4 amperes, the voltage across R30 and R31 will be .4 V and the output of U3B will be .8 V. The output voltage of U3B is routed to the Metering Network Assembly A7, adjusted and applied to the digital multimeter.

The internal reference voltage of the 723 regulator is applied to the non-inverting input of the regulator via R21. This voltage determines the output level of the regulator. In the manual mode, (AGC OFF) output voltage is applied to the inverting input of the regulator via R20 and the output voltage to the amplifier is maintained constant. In the automatic mode (AGC ON), the detected forward

power sample from the amplifier is amplified by U1A and applied to the inverting input of the regulator. Thus, the regulator acts to hold power output from the amplifier constant. VSWR protection is provided by U1B which amplifies the reflected power sample from the amplifier. This amplified voltage is routed through CR1 and summed with the forward power sample via R6, R7 and R8 and acts to reduce power output as VSWR increases. In the manual mode this reflected power signal is summed with the regulator output voltage via CR2, R35, R36 and R18 and acts in a similar manner to reduce power output as VSWR increases. Thus, the amplifier is protected from excessive VSWR conditions by controlling the collector voltage.

The output of U1A (forward power analog) is routed thru R14 to the Metering Network Assembly (A7) for application to the power meter. The reflected power signal is routed in a similar manner and is also applied to VSWR detector U3A. When the reflected power signal at the non-inverting input to U3A exceeds the bias voltage at the inverting input established by R16 and R17, the output of U3A will go high and cause the front panel VSWR LED indicator to illuminate and actuate the remote fault indication relay.

The output of the 723 regulator (U2) is applied to the base of the Darlington series pass transistor via current limiting resistor R24. Zener diode VR2 clamps the output of the regulator to prevent application of excessive voltage to the amplifier.

The AFC and front panel mute signals are applied to the base of Q2, turning Q2 ON and placing a low on the frequency compensation input to the regulator which causes the regulator to turn OFF. The external and cooling mute signals are applied to the inverting input of the regulator via R48 and act to reduce power output.

4-2.6 MODULATION DISPLAY ASSEMBLY (A6)

Refer to schematic 643-0019-001 and assembly drawing 643-0018-001.

The Modulation Display Assembly provides a bar graph display of the composite signal to the modulated oscillator. The display is calibrated in per cent modulation. The assembly also contains the LED indicators for POWER ON, AFC, VSWR and COOLING.

The composite signal is applied to buffer amplifier U1A. For the bar graph 20% full scale range, the gain is established by R4 and R35 at eleven (11). For the 115% full scale range potentiometer, R2 is connected to ground via the Metering Network Assembly switch and the gain set for 115% full scale by R2. U1B acts as an absolute value detector with negative peaks detected by CR1 and appearing at TP2 while positive peaks are deleted by CR2 and appear at TP3. R9 limits the gain of U1B when the signal is too small to cause CR1 and CR2 to conduct. The peak detected positive and negative signals are summed in U1C to provide a positive signal at U1C output. This signal is applied to the fast charge/slow discharge network comprised of CR3, CR4 and R12 and amplified by U10 for application to the bar graph drivers.

The bar graph drivers U2 and U3 each contain voltage comparators and linear voltage dividers which activate to drive 10 LEDs per driver. The comparators activate in sequence as the input signal is increased in level. The two bar graph drivers are connected in series to drive the two 10 element bar graph arrays DS1 and DS2. The detected composite signal from U1D is applied to the input of each driver at Pin 5. R17 adjusts the signal for 20% full scale. The reference voltage for the drivers is derived from the internal reference voltage of U3 via R20 and R21. The low end of U3 voltage divider network is applied to the high input end of the U2 voltage divider. R20 and R19 set the output sink current of the drivers so that each LED in the bar graph array pulls approximately 10 ma from the +5 V supply. SIP resistor networks R24-R26 limit power dissipation in the bar graph arrays.

The bar graph driver may be placed in the dot or bar display mode. This is accomplished by switching the mode input of the drivers (Pin 9) via the switch on the Metering Network Assembly. Timer U4 is connected as a one shot to actuate the over-modulation LED indicator DS3. R23 and C9 determine the output pulse duration (approximately 2.5 seconds). The trigger input of U4 is driven by the low signal which actuates the 100% or 10% LED in the bar graph array. The trigger input to U4 is switched via the Metering Network Assembly to the appropriate LED.

The LED indicators for POWER ON, AFC LOSS OF LOCK, VSWR FAULT and COOLING FAULT are also located on the Modulation Display Assembly. The POWER ON LED is operated by the +5 V power supply. The fault LED inputs are summed via CR4, CR7 and CR5 and used to turn on the remote fault relay via Q1. The collector of Q1 will go low to actuate the relay whenever a fault is detected.

4-2.7 POWER SUPPLY ASSEMBLY (A4)

Refer to schematic 643-0010-001 and assembly drawing 643-0009-001.

The approximately 8.4 VAC from the power transformer is applied to full wave bridge rectifier CR5. C8 provides ripple filtering. U3 regulates the output of CR5 to +5 VDC. CR6 and CR7 provide transient protection while C9 provides additional filtering.

The full wave rectified +35 volts from the chassis ripple filter C1 is applied to voltage regulator U2 to provide +22 VDC output. R3 and R4 set the output of U3 to +22 V. CR3 and CR5 provide transient protection while C5, C6 and C7 provide additional filtering.

The full wave rectified -35 volts from chassis rectifier CR1 is filtered by C1 and C2 and applied to voltage regulator U1. R1 and R2 set the output of U1 to -22 VDC. CR1 and CR2 provide transient protection while C3 and C4 provide additional ripple filtering.

4-2.8 METERING NETWORK ASSEMBLY (A7)

Refer to schematic 643-0025-001 and assembly drawing 643-0024-001.

The Metering Network Assembly comprises the front panel selector switch and associated metering resistor networks. Push-Push switch S1A selects forward or reflected power for display on M1. Mechanically interlocked S1C through S1H select either Amplifier Collector Voltage, Amplifier Collector Current, +22V, -22V, +5V or the AFC voltage for display on digital multimeter M2. R1 and R2 form the metering resistor network for Amplifier Voltage. R2 and R1, R3 and R1, R4 and R1 serve the same purpose for the +22V, -22V and +5V input respectively. R7 serves as the low end of the voltage divider network for the AFC voltage. R8 is used to calibrate the Amplifier Current.

Push-Push switch S1B (red button) provides front panel muting of the amplifier output. Push-push switch S1I selects the bar or dot mode for the modulation bar graph display and push-push switch S1J changes the bar graph display from 115% to 20% full scale. S1J also switches the trigger input of the over-modulation LED driver to the appropriate LED (i.e. 10% or 100%).

4-2.9 HARMONIC FILTER ASSEMBLY (FL1)

Refer to schematic 643-0022-001 and assembly drawing 643-0053-001.

The harmonic filter provides sufficient harmonic rejection to allow the 802A to be used as a stand-alone 50 watt transmitter. The filter is a five pole lumped constant filter. C2 and C4 are used to optimize filter input impedance and harmonic rejection. The voltage divider formed by R1 and R2 provides a sample of the RF output to the front panel monitor jack.

Faint, illegible text, possibly bleed-through from the reverse side of the page.

SECTION 5 - MAINTENANCE AND ALIGNMENT

5-1. GENERAL

The following paragraphs describe maintenance and alignment procedures for the Type 802A FM Exciter. Logical and methodical trouble shooting procedures should be used, proceeding from front panel indicators and meter readings to circuit checks and measurements. The 802A utilizes sockets for integrated circuits to enable rapid replacement should a failure occur. A data sheet is shipped with each exciter which gives the voltage and current levels as measured at final factory test. Periodic readings should be taken and compared to the data sheet values. Refer to Figure 5-1 through Figure 5-3 for the location of adjustable components in the 802A.

The PC board assemblies in the 802A may be removed by unplugging the connectors to the board and removing the four screws that mount each board to the chassis. The Frequency Divider and Audio/AFC boards have covers which are held in place by four screws accessible from the bottom of the exciter.

The top cover of the amplifier may be removed for in-place trouble shooting. The amplifier is removed by removing the screws from the exciter rear panel and laying it back. The six screws mounting the amplifier are accessible from the bottom of the exciter. Once the rear panel is laid back, the six bottom amplifier screws removed and the amplifier plug disconnected, the amplifier may be tilted to the right and lifted out. If Q2 or Q3 is to be replaced, the transistor should be mounted to the heat sink prior to soldering to the PC board in order to avoid undue stress on the transistor leads.

The power transformer is accessible by removing the mounting screws from its cover. The mounting screws are accessible from the bottom of the exciter. Turn the power OFF and disconnect the AC line cord prior to removing the transformer cover.

CAUTION

115/230 VAC IS PRESENT ON THE POWER TRANSFORMER,
POWER ON SWITCH AND AC LINE CONNECTOR WHEN THE
EXCITER IS OPERATING.

The following maintenance equipment is required:

Flat blade screwdriver
 Phillips screwdriver
 FM Monitor
 Audio Signal Generator
 Distortion Analyzer
 3-1/2 Digit DMM
 Calibrated in line 50 ohm Wattmeter

5-2. POWER SUPPLIES

The power supplies in the 802A contain no operating adjustments. The integrated circuit voltage regulators contain internal current limiting and over temperature protection. Clearing an overload condition will in most cases restore the regulators to normal operation.

5-3. MODULATED OSCILLATOR AND FREQUENCY DIVIDER

The Modulated Oscillator has no operating adjustments. The outputs may be open or short circuited without damage to the oscillator. The frequency divider cover is removed by extending the 802A on the slides and removing four screws from the bottom of the exciter. The 802A output frequency may be calibrated by means of the reference oscillator (this adjustment is accessible without removing the cover). A sample of the reference oscillator is provided at TP1. The frequency at TP1 may be selected by P1 to be 2.5, 5 or 10 MHz. A short wire may be inserted in TP1 and used with a standard receiver to calibrate output frequency. The operating frequency may be changed by programming the desired frequency, in BCD code, on the DIP switches. A DIP rocker switch in the OPEN position corresponds to a "1". For instance the BCD code for 88.37 MHz is:

<u>10 MHz</u>	<u>1 MHz</u>	<u>100 KHz</u>	<u>10 KHz</u>
1000	1000	0011	0111

Should either the reference oscillator or modulated oscillator fail, the appropriate on board LED indicator will extinguish. An oscilloscope probe may be used for trouble shooting the frequency divider chains. The pulses will be very narrow and will require a wide bandwidth oscilloscope.

5-4. AUDIO/AFC AND MODULATION DISPLAY

The Audio/AFC assembly contains two operating adjustments which are accessible without removing the cover. These are the modulation level and distortion null. These adjustments should be made to obtain best performance whenever the exciter operating frequency is changed. If the operating frequency is changed, only steps C and D in the following procedures need be performed. The cover may be removed from the audio/AFC assembly by extending the 802A on the slides and removing four screws from the bottom.

A. Balance Adjust

Apply a 400 Hz, +10 dBm, signal from an audio signal generator to TB1-10. Connect a clip lead or jumper from TB1-10 to TB1-12. This applies the same signal to both mono inputs. Connect an oscilloscope probe to TP8 and adjust R43 for minimum signal on the oscilloscope. (Mono/Composite Switch in MONO position).

B. Audio Level Adjust

Apply a 400 Hz, 1.25 VRMS, signal from an audio signal generator to the composite input. With a voltmeter or oscilloscope, adjust R51 for 2.25 VRMS (6.36 V peak to peak) at TP9. (Mono/Composite Switch in COMPOSITE position).

C. Modulation Adjust

Apply a 400 Hz, 1.25 VRMS, signal from an audio signal generator to the composite input. Connect the output of the exciter through a 30 dB attenuator to an FM monitor. Adjust R57 for 75 KHz deviation.

D. Distortion Null (Predistortion)

Connect the signal generator output from an audio analyzer such as the Sound Technology 1710A to the composite input of the exciter. Connect the exciter output through a 30 dB attenuator to a good quality FM monitor. Connect the FM monitor output to the distortion analyzer input of the audio analyzer. Configure the audio analyzer for a 1:1 IM measurement. Set the signal generator output for 75 KHz deviation. Adjust R59 for minimum IM distortion as indicated on the analyzer (typically less than 2%). Alternately, a 400Hz tone may be used to modulate the 802A and the output of the FM monitor displayed on an audio spectrum analyzer. The spectrum analyzer should have 80 dB dynamic range. R59 is then adjusted for minimum harmonic level of the 400 Hz

fundamental tone (each harmonic should be at least 75 dB below the fundamental 400 Hz tone).

The Modulation Display is calibrated following Steps A thru D. Step E (20% cal) must be performed prior to Step F (115% cal).

E. 20% Scale Adjust

Connect the output of the exciter through a 30 dB pad to an FM monitor. Apply a stereo pilot tone to the composite input and adjust the pilot tone level for 7.5 KHz deviation. Select the bar display mode and the 20% scale on the 802A front panel switch. Adjust R17 until the 10% LED just starts to glow. Verify adjustment by varying the pilot tone level above and below 7.5 KHz deviation. Verify that the over modulation indicator illuminates when the 10% LED turns on.

F. 115% Scale Adjust

Connect the exciter as in Step E and apply a stereo signal (400 Hz in the left channel) to the composite input. Adjust the signal level for 75 KHz deviation on the FM monitor. Select the bar display mode and the 115% scale on the 802A front panel switch. Adjust R2 until the 100% LED just starts to glow. The over-modulation indicator should illuminate when this occurs.

5-5. AMPLIFIER, AMPLIFIER CONTROL AND METERING

The output power adjustment is accessible through the top cover of the 802A by extending the exciter on the slide.

The Amplifier Assembly contains one adjustment which is used to set the output directional coupler to maximum directivity. This must be done prior to calibrating the reflected power meter, but need not be done again unless the directional coupler has failed and been repaired (diode failure for instance).

A. Direction Coupler Directivity

Remove the top cover from the Amplifier. Connect the output of the exciter to a 50 watt, 50 ohm termination. Select reflected power on the front panel switch and adjust R8 for minimum indication on the power meter.

B. Forward Power Calibration

Connect the exciter output through a calibrated 50 ohm, in line wattmeter to a 50 ohm termination. Place the AGC switch in the OFF position (Manual mode). Select forward power on the 802A front switch. Adjust the power output control (R21) for 40 watts on the external power meter. Adjust the forward power calibration potentiometer, R5, for 40 watts indication on the 802A front panel meter.

C. Reflected Power Calibration

Following calibration of the forward power meter, adjust the power level control for 5 watts output. Disconnect the 50 ohm termination from the exciter output. Select reflected power on the front panel switch and adjust R13 for 5 watts reflected power. Select forward power on the front panel switch and verify 5 watts forward. Repeat the process if necessary and adjust the power level control (R21) and reflected power calibration (R13) until 5 watts forward and reflected is obtained. Do not adjust the forward calibration (R5) during this process. The re-iteration of the reflected power calibration is necessary due to the fact that the VSWR protection is active at all times. Therefore, changing the gain of the reflected power amplifier will cause some change in power output. Connect the 50 ohm termination to the output of the exciter, set the AGC switch to the ON position (automatic mode) and adjust the power output control for the desired output level.

D. Amplifier Current Meter Calibration

Using a digital voltmeter (a 3-1/2 digit hand held DMM is adequate), record the voltage drop across R30 and R31 on the Amplifier Control Assembly. Be very careful not to short R30 and R31 to ground with the voltmeter terminals. Connect the digital voltmeter from J2-14 or R6 to ground. Adjust R40 until a voltage exactly twice that recorded across R30 and R31 is obtained. Select Amplifier current on the front panel switch. Adjust R8 on the Metering Network Assembly until a current reading in amperes equal to the voltage drop recorded across R30 and R31 is obtained. (That is, if a voltage drop of .300 volts is recorded across R30 and R31, adjust R8 for a current reading of 3.00 amperes.)

5-6. HARMONIC FILTER ALIGNMENT

The Harmonic Filter is aligned at the factory and will normally need no further adjustment. Connect the output of the exciter through a 50 watt, 30 dB attenuator to a spectrum analyzer with a frequency range extending to at least the tenth harmonic of the operating frequency. Adjust C2 and C5 for minimum reflected power and harmonic level. Several iterations of the adjustment may be necessary to achieve both minimum reflected power and optimum harmonic rejection. If operating frequency is changed, it may be necessary to adjust the Harmonic Filter for optimum harmonic rejection and minimum reflected power.

5-7

802A

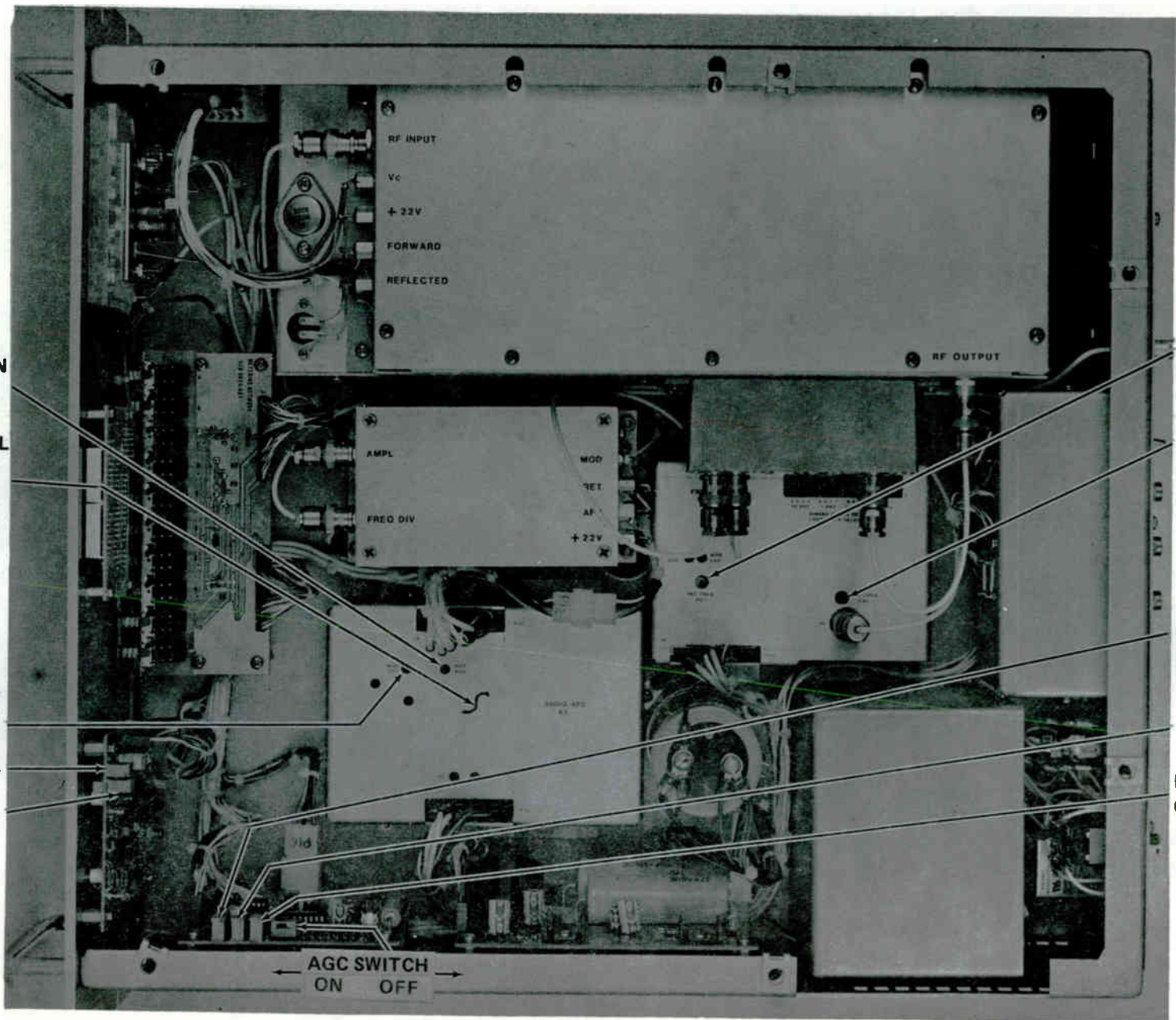

DISTORTION NULL

AUDIO LEVEL ADJUST AND BALANCE ADJUST UNDER COVER

MOD LEVEL ADJUST

115% CAL

20% CAL

AGC SWITCH ON OFF

RF INPUT
Vc
+22V
FORWARD
REFLECTED

RF OUTPUT

AMPL
MOD
RET
AF
+22V
FREQ DIV

REFERENCE OSCILLATOR ADJUST

REFERENCE OSCILLATOR CALIBRATION SAMPLE

REFLECTED POWER CALIBRATION

POWER OUTPUT ADJUST

FORWARD POWER CALIBRATION

83-0663

Figure 5-1. Operating Adjustments Location

5-8

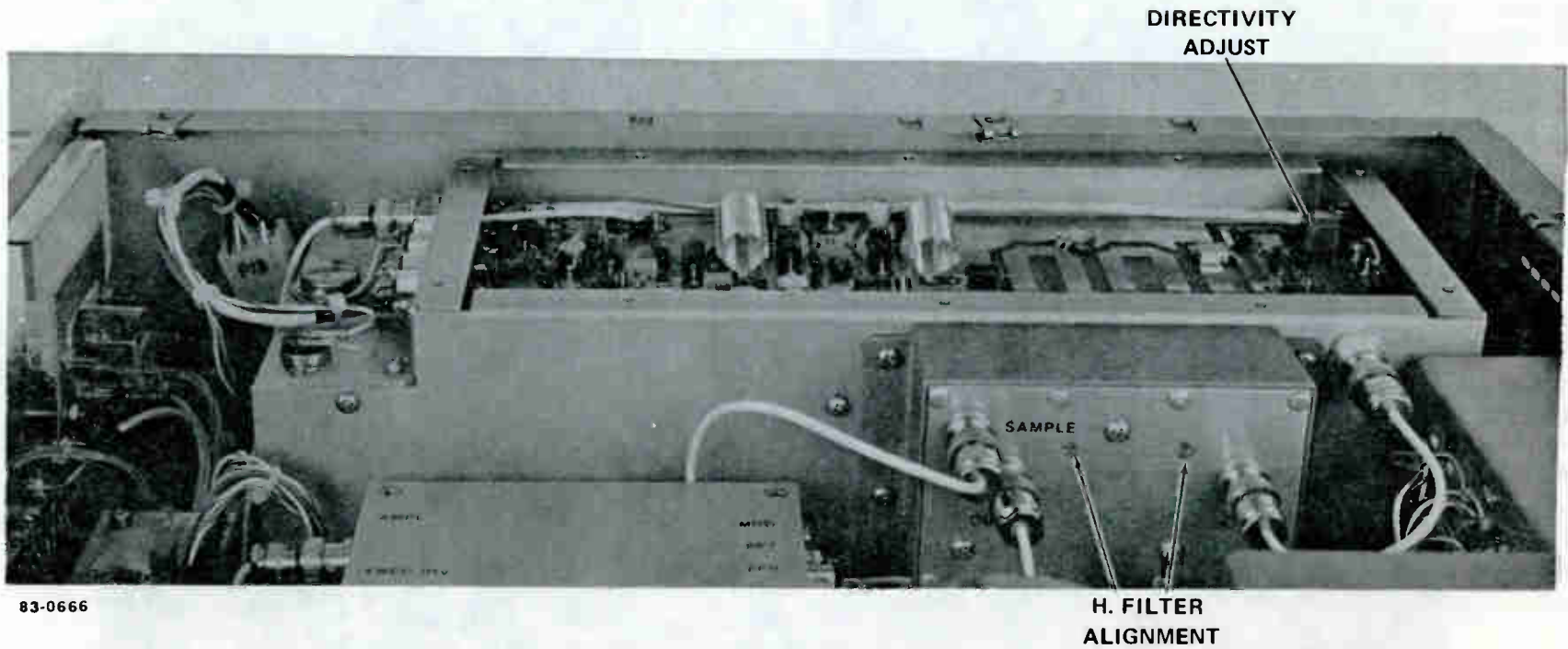

802A

LW1-1(8)

Figure 5-2. Alignment Location, Left Side, Top

AMPLIFIER
CURRENT CALIBRATION

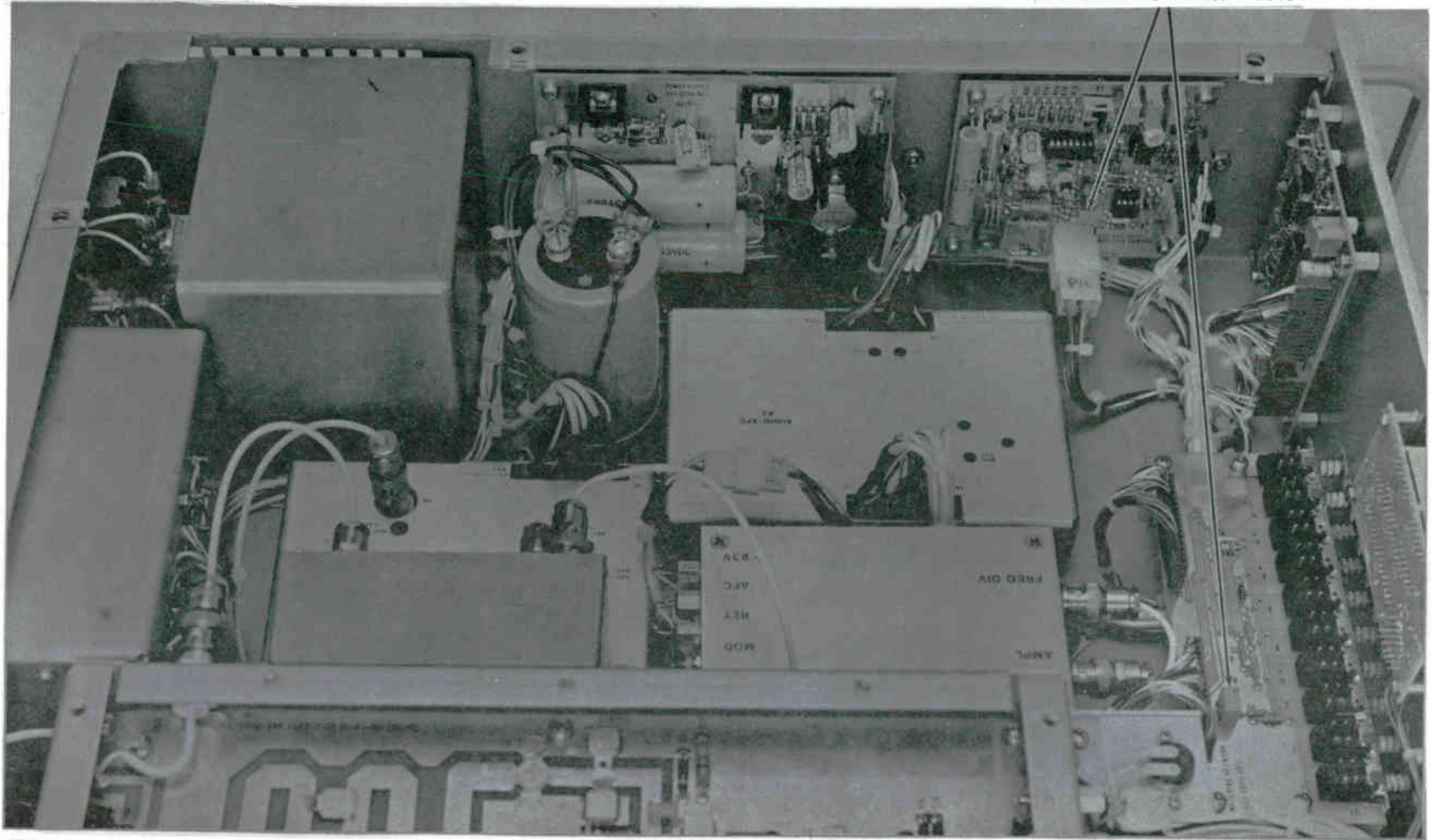

83-0888
LW1-1(7)

Figure 5-3. Alignment Location, Top View

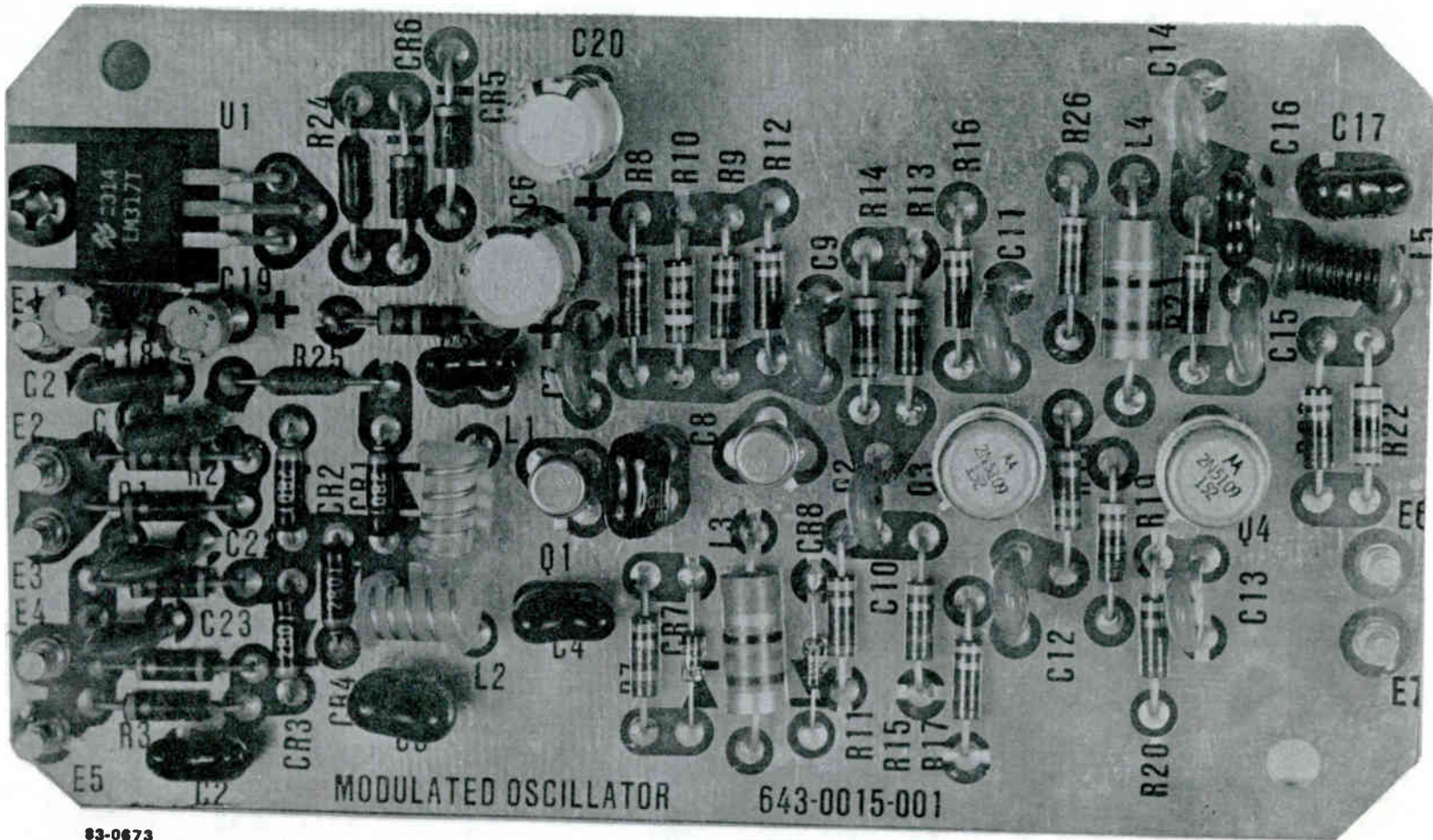

Figure 5-4. Modulated Oscillator P.C. Card

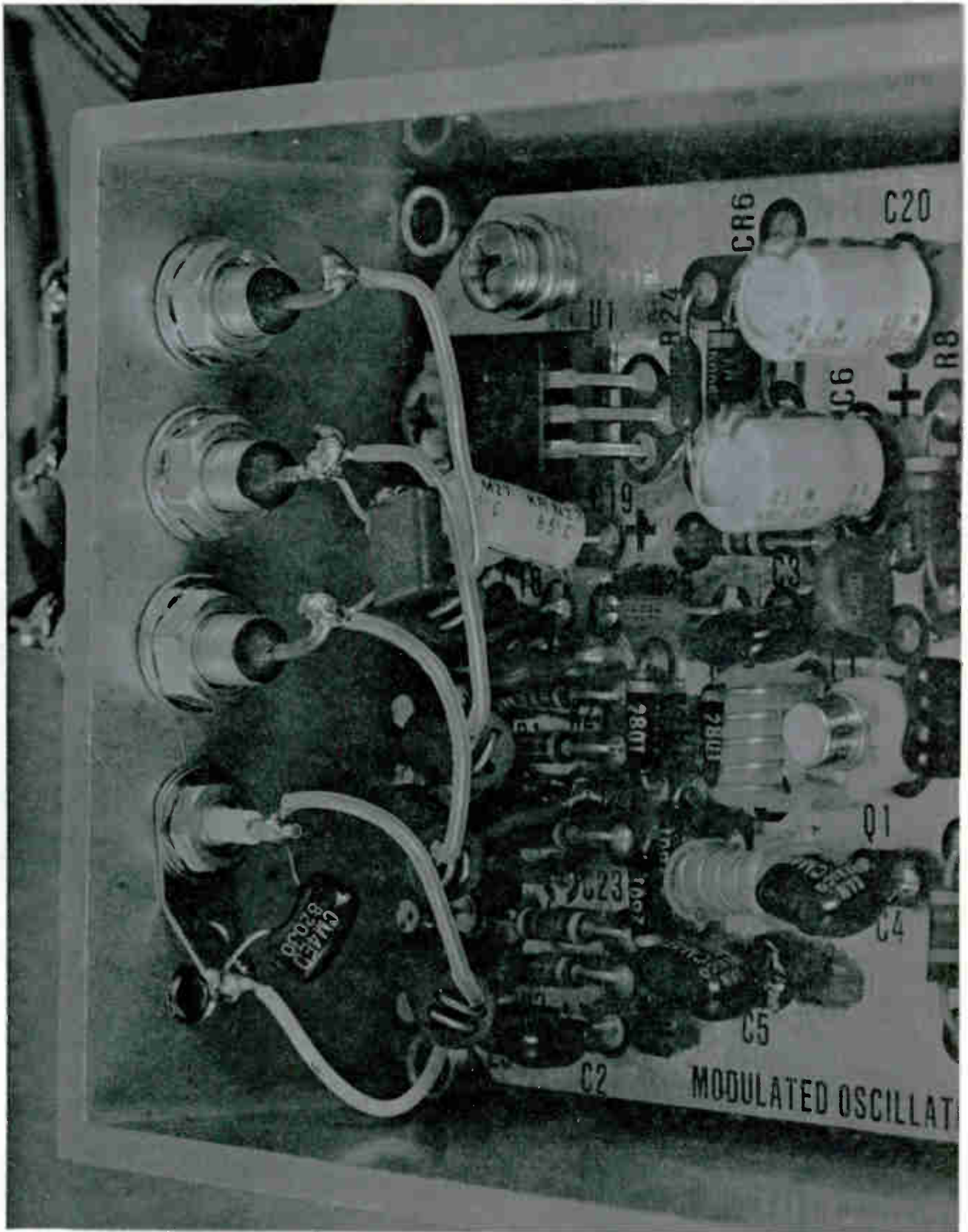
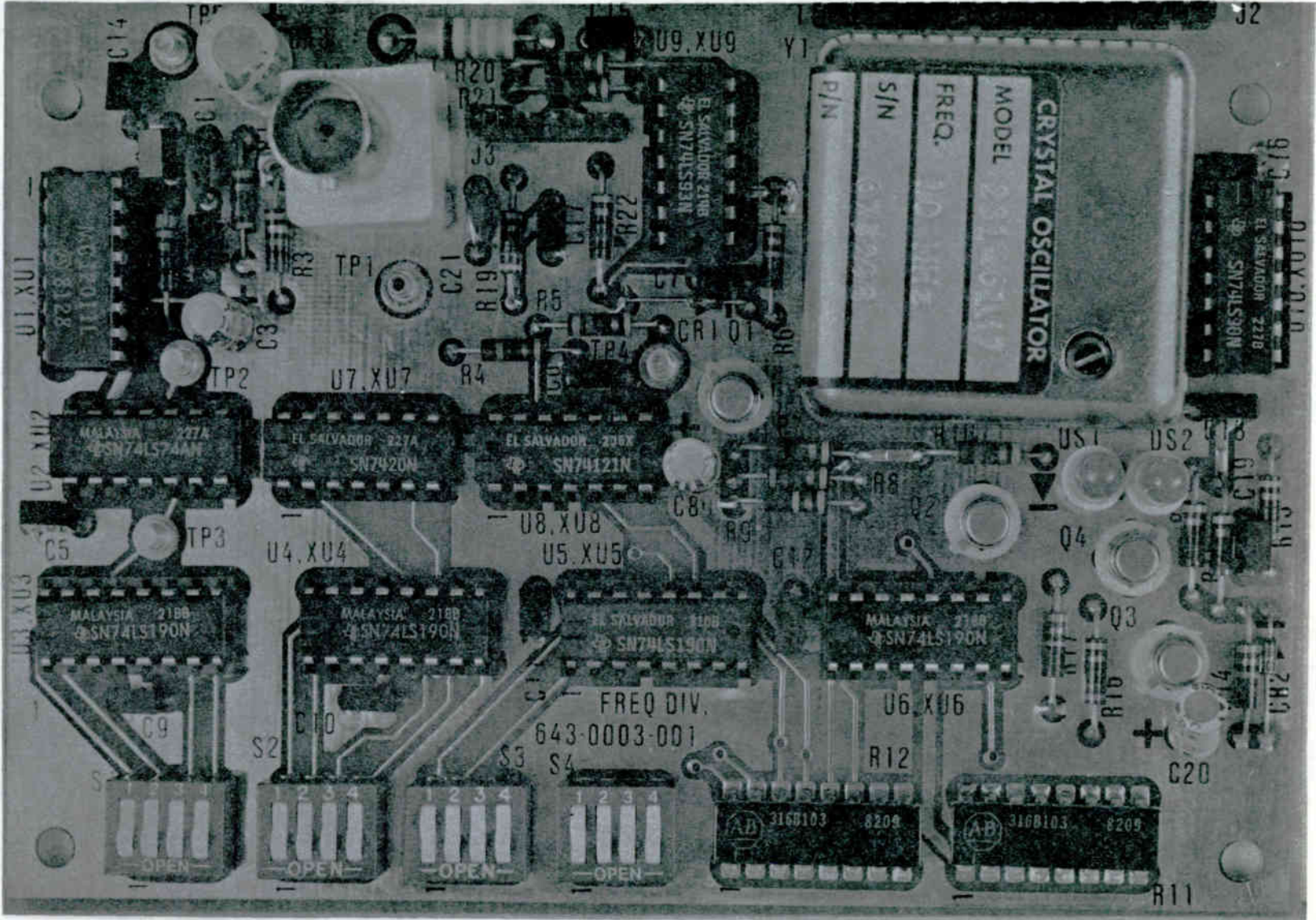

Figure 5-5. Modulated Oscillator Card Connections

83-0672

LW1-1(18)



83-0674

Figure 5-6. Frequency Divider Card

LW1-1(18)

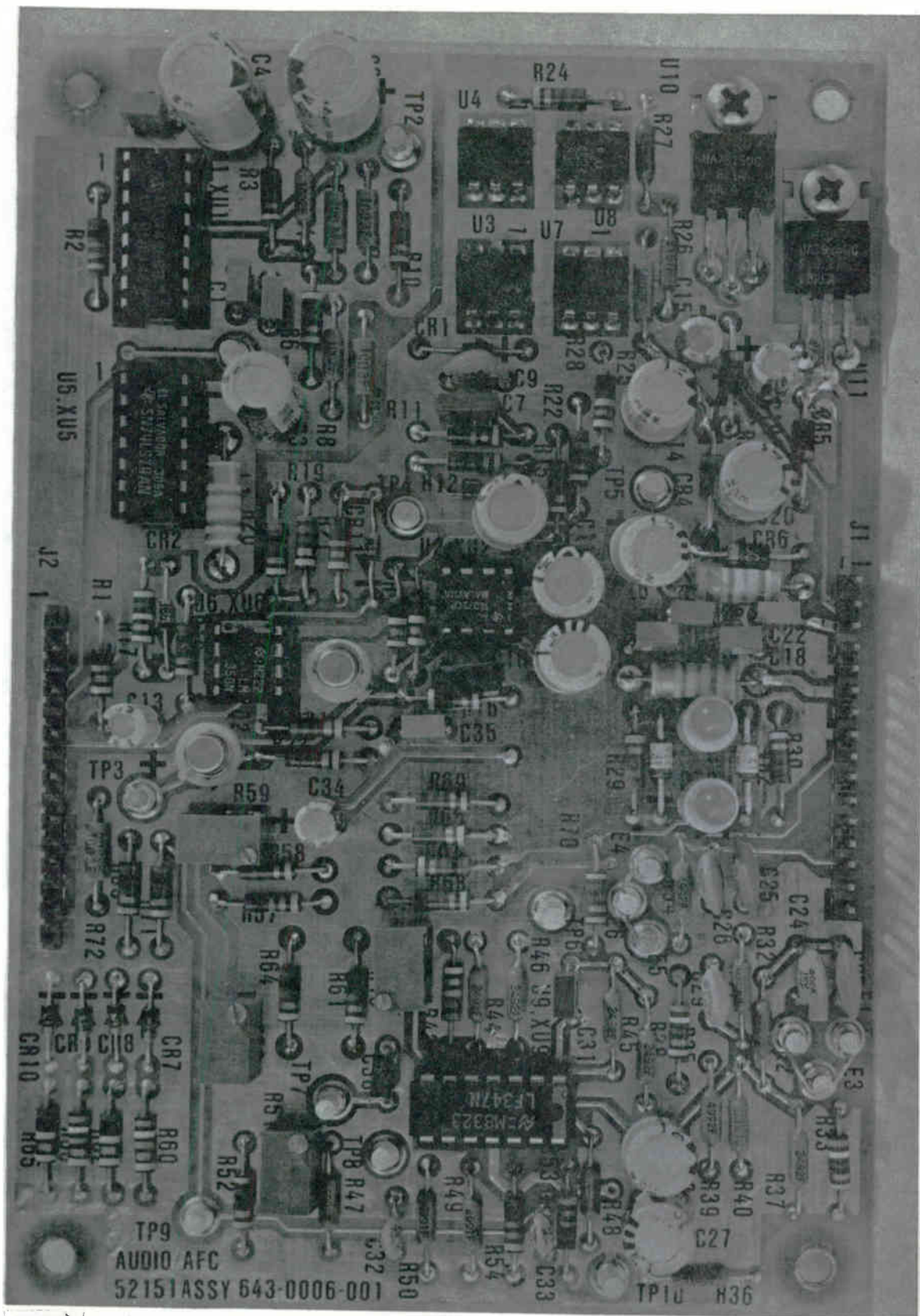

83-0710

LW1-1(20)

Figure 5-7. Audio/AFC PC Card

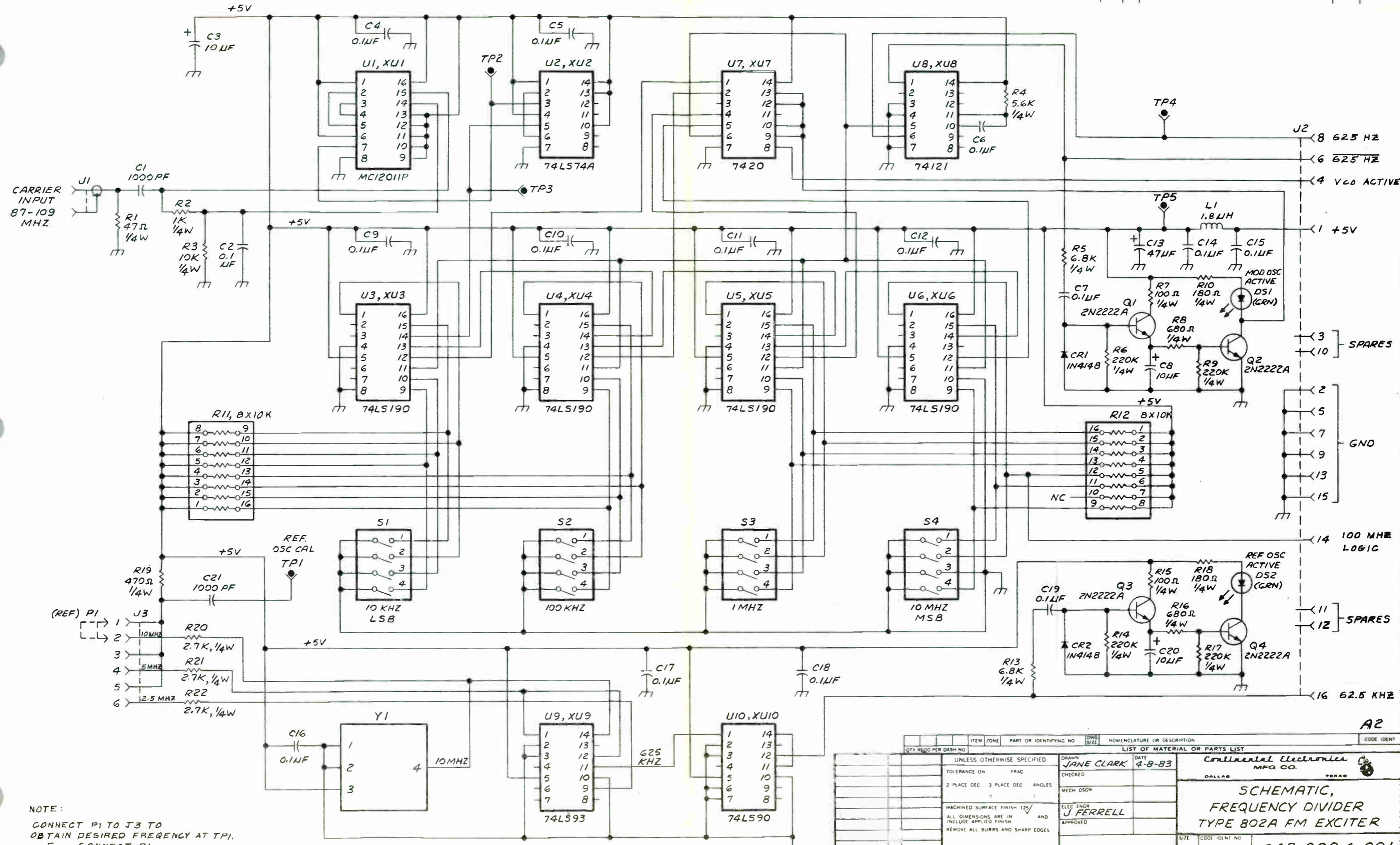

TABLE 5-1. LIST OF SCHEMATICS

<u>UNIT NO.</u>	<u>UNIT NAME</u>	<u>SCHEMATIC NO.</u>
—	Type 802A FM Exciter	643-0040-001
A1	Modulated Oscillator Assy.	643-0016-001
A1A1	Modulated Oscillator Card	643-0016-001
A2	Frequency Divider	643-0004-001
A3	Audio/AFC	643-0007-001
A4	Power Supply	643-0010-001
A5	Amplifier Control	643-0013-001
A6	Modulation Display	643-0019-001
A7	Metering Network	643-0025-001
AR1	Output Amplifier Assy.	643-0028-001
AR1A1	Amplifier Card	643-0028-001
FL1	Harmonic Filter Assy.	643-0022-001
FL1A1	Harmonic Filter Card	643-0022-001

PROPRIETARY NOTICE: THIS DOCUMENT AND THE SUBJECT MATTER HEREIN ARE THE PROPERTY OF CONTINENTAL ELECTRONICS MFG. CO. AND SHALL NOT BE REPRODUCED OR COPIED OR USED FOR THE PURPOSES OF MANUFACTURING OR SALE OF APPARATUS EXCEPT BY WRITTEN PERMISSION OF CONTINENTAL ELECTRONICS MFG. CO.

REVISIONS				
ZONE	LTR	DESCRIPTION	DATE	APPROVED



NOTE:
 CONNECT P1 TO J3 TO OBTAIN DESIRED FREQUENCY AT TP1.
 F CONNECT P1
 10 MHZ J3-1 & 2 (AS SHOWN)
 5 MHZ J3-3 & 4
 2.5 MHZ J3-5 & 6

ITEM		ZONE	PART OR IDENTIFYING NO.	QTY	UNLESS OTHERWISE SPECIFIED	DRAWN	DATE	NOMENCLATURE OR DESCRIPTION	CODE IDENT
643-0003-001		B02A			2 PLACE DEC 3 PLACE DEC ANGLES	JANE CLARK	4-8-83	Continental Electronics MFG CO.	A2
643-0004-001		B02A			MACHINED SURFACE FINISH 125/ AND INCLUDE APPLIED FINISH REMOVE ALL BURRS AND SHARP EDGES	J. FERRELL		SCHMATIC, FREQUENCY DIVIDER TYPE 802A FM EXCITER	
D 52151								643-0004-001	

[Faint, illegible text, possibly bleed-through from the reverse side of the page]

REVISIONS			
ZONE	LTR	DESCRIPTION	DATE
A			10/10/83
B			7/9/84
C		REVERSED POLARITY OF U11	2/28/84

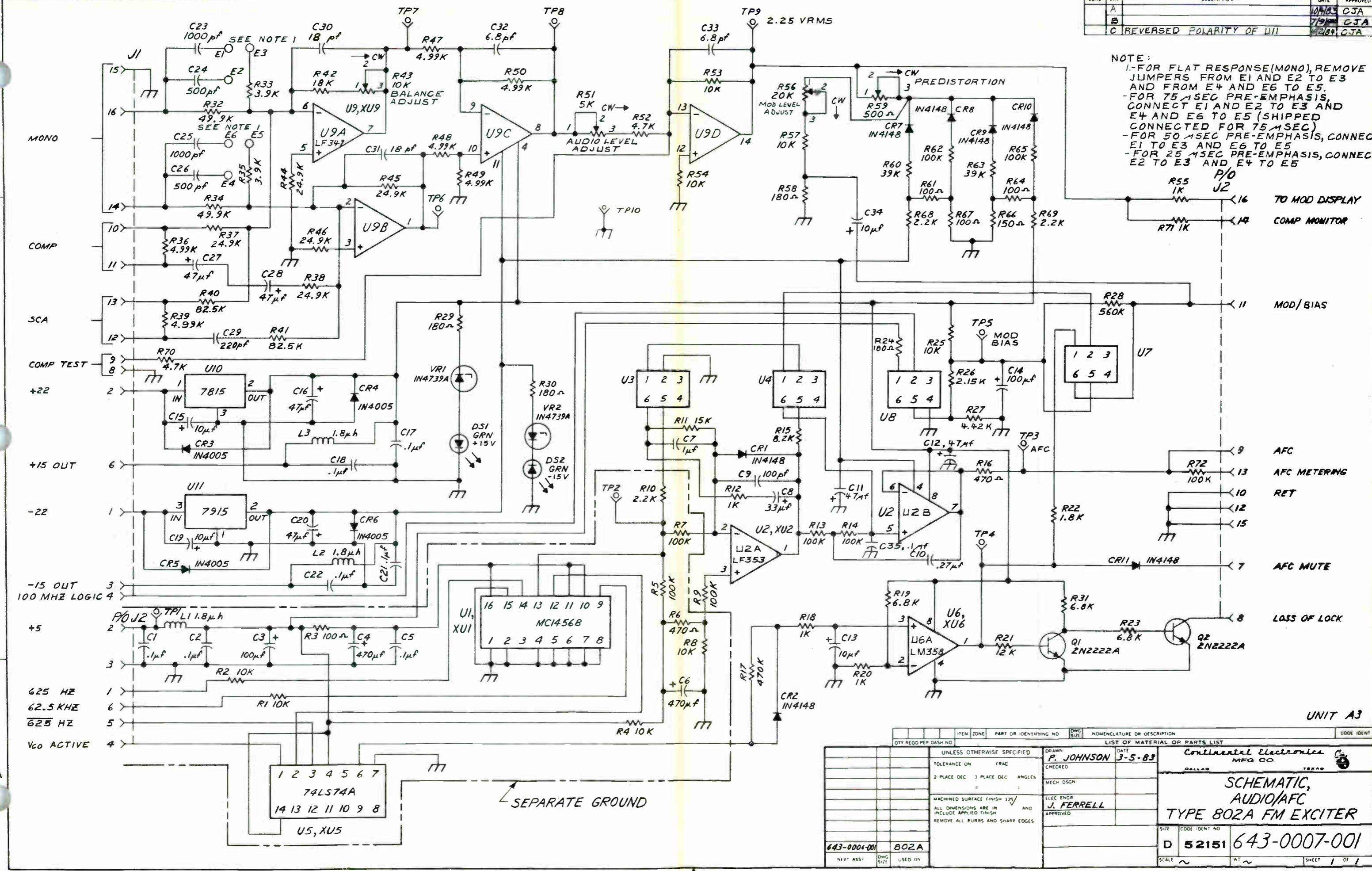

NOTE:
 1.- FOR FLAT RESPONSE (MONO), REMOVE JUMPERS FROM E1 AND E2 TO E3 AND FROM E4 AND E6 TO E5.
 - FOR 75 μSEC PRE-EMPHASIS, CONNECT E1 AND E2 TO E3 AND E4 AND E6 TO E5 (SHIPPED CONNECTED FOR 75 μSEC)
 - FOR 50 μSEC PRE-EMPHASIS, CONNECT E1 TO E3 AND E6 TO E5
 - FOR 25 μSEC PRE-EMPHASIS, CONNECT E2 TO E3 AND E4 TO E5

TO MOD DISPLAY
 COMP MONITOR

MOD/BIAS

AFC
 AFC METERING

RET

AFC MUTE

LOSS OF LOCK

UNIT A3

QTY	REQD PER DASH NO.	ITEM	ZONE	PART OR IDENTIFYING NO.	DWG SIZE	NOMENCLATURE OR DESCRIPTION	DATE	CODE IDENT
						UNLESS OTHERWISE SPECIFIED		
						TOLERANCE ON FRACTIONAL		
						2 PLACE DEC 3 PLACE DEC ANGLES		
						MACHINED SURFACE FINISH 125/		
						ALL DIMENSIONS ARE IN INCHES AND INCLUDE APPLIED FINISH REMOVE ALL BURRS AND SHARP EDGES		
643-0004-001		802A						

DRAWN	P. JOHNSON	DATE	3-5-83
CHECKED			
MECH DSGN			
ELEC ENGR	J. FERRELL		
APPROVED			

Continental Electronics MFG CO.	
DALLAS TEXAS	
SCHEMATIC, AUDIO/AFC	
TYPE 802A FM EXCITER	
SIZE	CODE IDENT NO.
D	52151
SCALE	WT

REVISIONS				
ZONE	LTR	DESCRIPTION	DATE	APPROVED
A	ADD	VR1	7/9/84	CJA

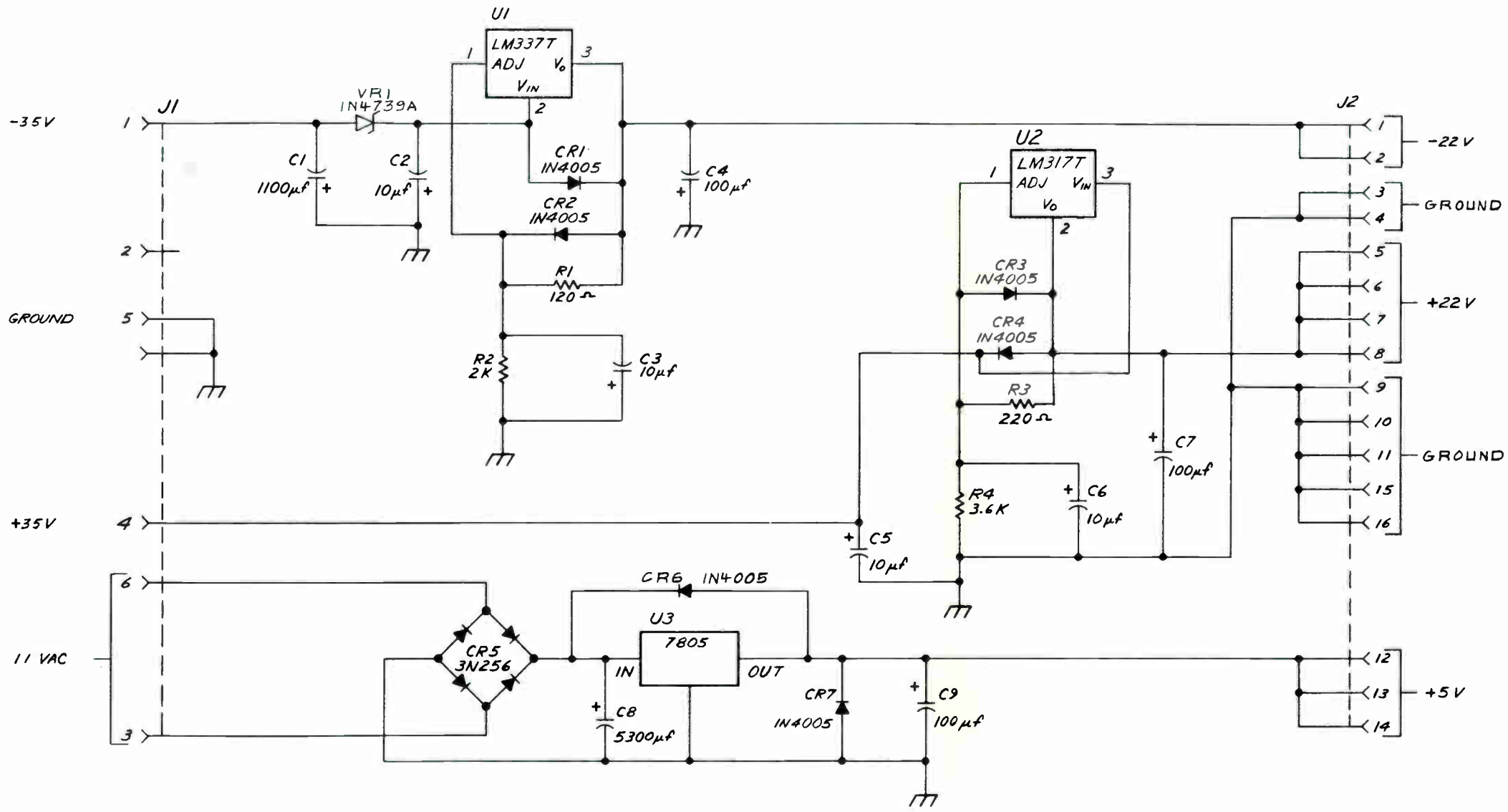

UNIT A4

QTY REQD PER ASSY NO.		ITEM	ZONE	PART OR IDENTIFYING NO.	DWG SIZE	NOMENCLATURE OR DESCRIPTION	CODE IDENT
LIST OF MATERIAL OR PARTS LIST							
		UNLESS OTHERWISE SPECIFIED		DRAWN		DATE	
TOLERANCE ON		FRAC		P. JOHNSON		4-7-83	
2 PLACE DEC		3 PLACE DEC		CHECKED			
ANGLES				MECH DSGN			
MACHINED SURFACE FINISH 125/				ELEC ENGR			
ALL DIMENSIONS ARE IN		AND		J. FERRELL			
INCLUDE APPLIED FINISH				APPROVED			
REMOVE ALL BURRS AND SHARP EDGES							
643-0009-001	802A						
NEXT ASSY	DWG SIZE	USED ON					
				Continental Electronics MFG CO		DALLAS TEXAS	
				SCHEMATIC-POWER SUPPLY			
				TYPE 802A FM EXCITER			
SIZE	CODE IDENT NO.						
D	52151	643-0010-001					
SCALE	WT	SHEET		OF			

PROPRIETARY NOTE: THIS DOCUMENT AND THE SUBJECT MATTER HEREIN ARE THE PROPERTY OF CONTINENTAL ELECTRONICS MFG. CO. AND SHALL NOT BE REPRODUCED OR COPIED OR USED FOR THE PURPOSE OF MANUFACTURE OR SALE OF APPARATUS EXCEPT BY WRITTEN PERMISSION OF CONTINENTAL ELECTRONICS MFG. CO.

REVISIONS				
ZONE	LTR	DESCRIPTION	DATE	APPROVED

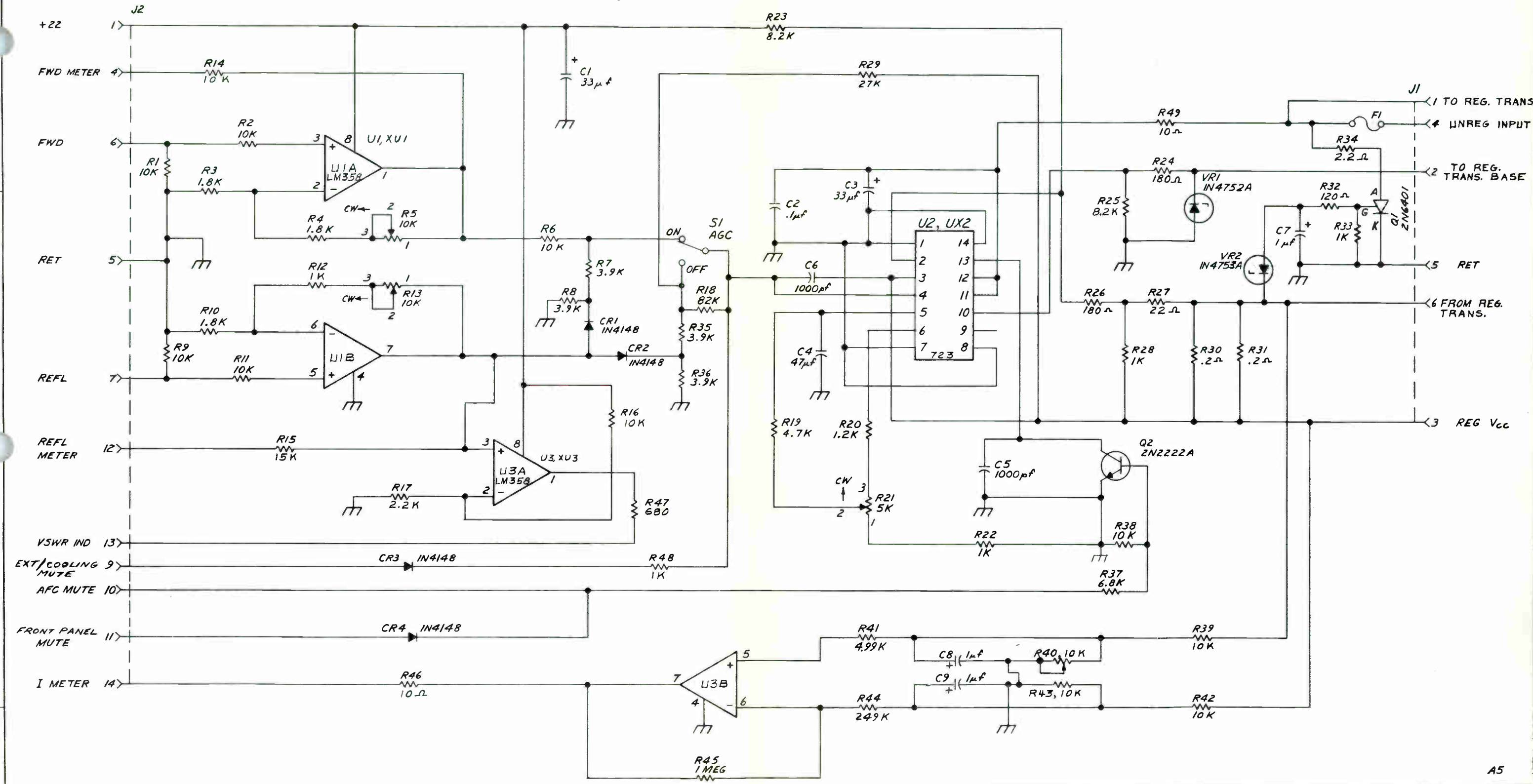

A5

QTY	REQD PER DASH NO	ITEM	ZONE	PART OR IDENTIFYING NO	DWG SIZE	NOMENCLATURE OR DESCRIPTION	DATE	CODE IDENT

UNLESS OTHERWISE SPECIFIED		DRAWN PAT JOHNSON 3-30-83	
TOLERANCE ON	FRAC	CHECKED	
2 PLACE DEC	3 PLACE DEC	MECH DSGN	
		ELEC ENGR	J. FERRELL
		APPROVED	

LIST OF MATERIAL OR PARTS LIST		Continental Electronics MFG CO	
		DALLAS TEXAS	
SCHEMATIC~ AMPLIFIER CONTROL TYPE 802A FM EXCITER			
SIZE	CODE IDENT		
D	52151	643-0013-001	
SCALE		WT	
			SHEET 1 OF 1

REVISIONS			
ZONE	LTR	DESCRIPTION	DATE

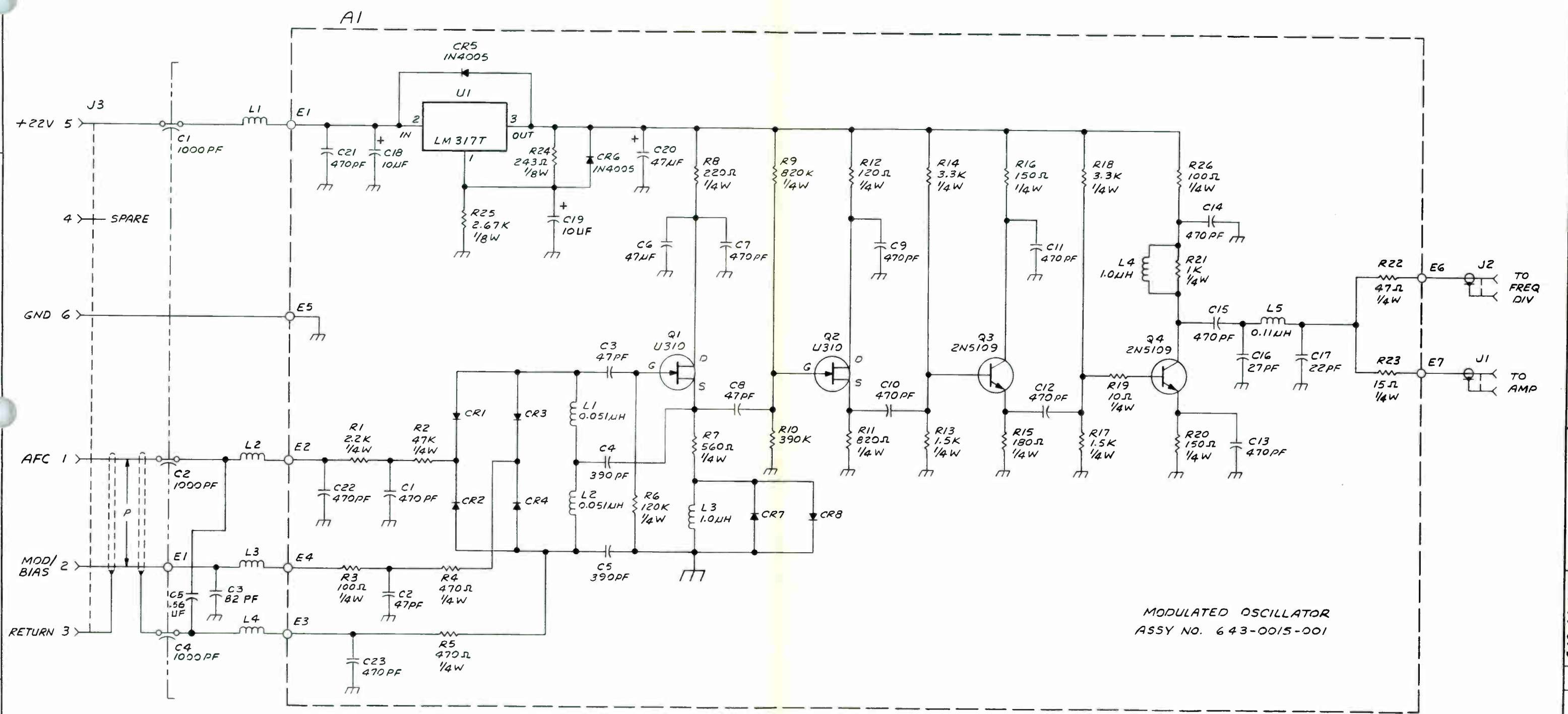

MODULATED OSCILLATOR
ASSY NO. 643-0016-001

QTY REQD PER DASH NO	ITEM	ZONE	PART OR IDENTIFYING NO	DWG SIZE	NOMENCLATURE OR DESCRIPTION	CODE IDENT

LIST OF MATERIAL OR PARTS LIST	
UNLESS OTHERWISE SPECIFIED	DATE 3-30-83
TOLERANCE ON FRACTION	DRAWN JANE CLARK
2 PLACE DEC 3 PLACE DEC ANGLES	CHECKED
MACHINED SURFACE FINISH 125/	MECH DSGN
ALL DIMENSIONS ARE IN INCHES AND	ELEC ENGR J. FERRELL
REMOVE ALL BURRS AND SHARP EDGES	APPROVED

643-0016-001	BOZA
NEXT ASSY	USED ON

SCALE	CODE IDENT NO	SIZE	DATE
	D 52151	643-0016-001	

PROPRIETARY NOTE: THIS DOCUMENT AND THE SUBJECT MATTER HEREIN ARE THE PROPERTY OF CONTINENTAL ELECTRONICS MFG. CO. AND SHALL NOT BE REPRODUCED OR COPIED OR USED FOR THE PURPOSE OF MANUFACTURING OR SALE OF APPARATUS EXCEPT BY WRITTEN PERMISSION OF CONTINENTAL ELECTRONICS MFG. CO.

REVISIONS				
ZONE	LTR	DESCRIPTION	DATE	APPROVED

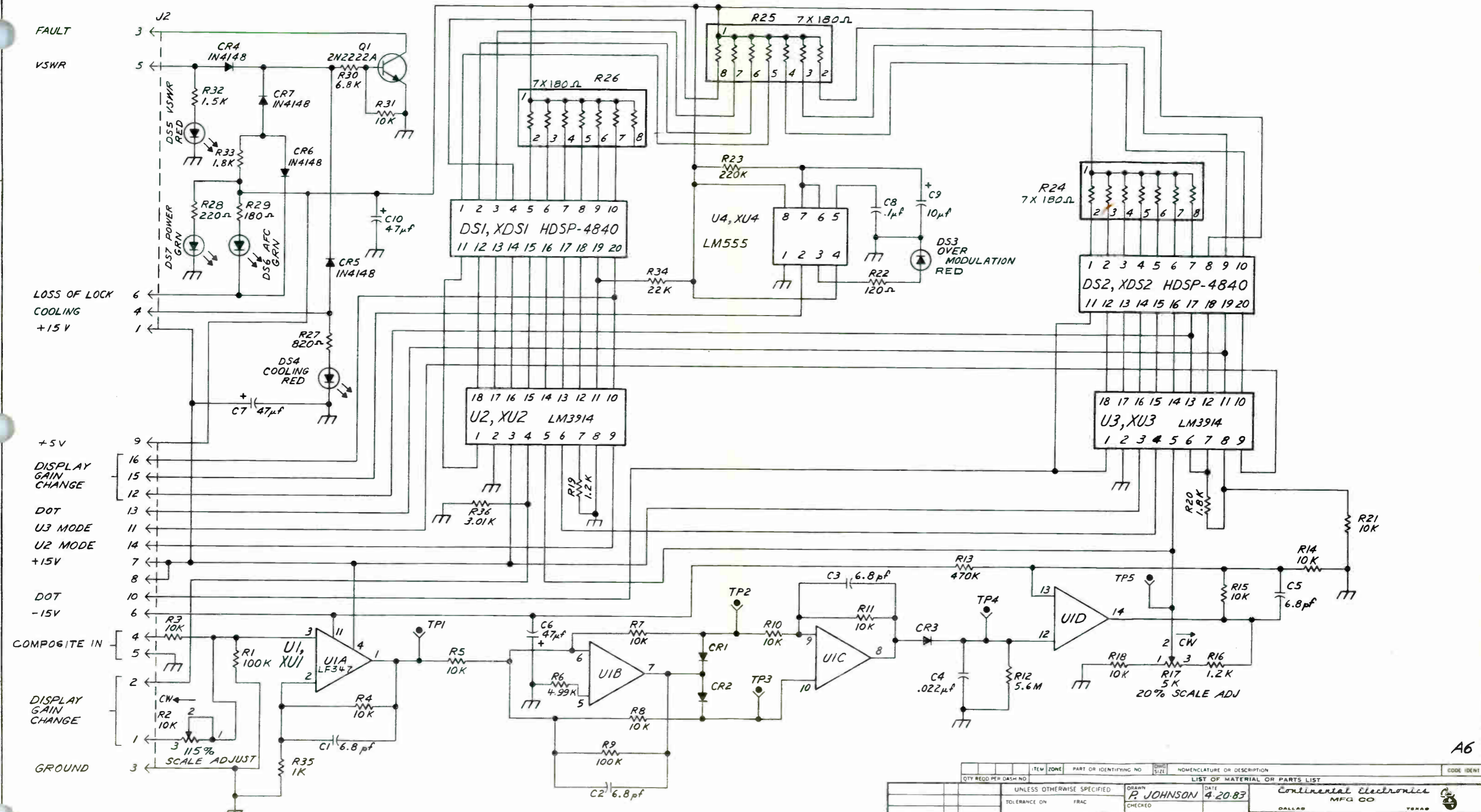

QTY REQD PER DASH NO.		ITEM	ZONE	PART OR IDENTIFYING NO.	QTY REQD PER DASH NO.	NOMENCLATURE OR DESCRIPTION	DATE	CODE IDENT

UNLESS OTHERWISE SPECIFIED		DRAWN		DATE		CONTINENTAL ELECTRONICS MFG CO	
TOLERANCE ON	FRAC	P. JOHNSON	4-20-83	DALLAS	TEXAS	SCHEMATIC MODULATION DISPLAY TYPE 802A FM EXCITER	
2 PLACE DEC	3 PLACE DEC	CHECKED					
		MECH DSGN					
MACHINED SURFACE FINISH 125/		ELEC ENGR					
ALL DIMENSIONS ARE IN		J. FERRELL					
INCLUDE APPLIED FINISH		APPROVED					
REMOVE ALL BURRS AND SHARP EDGES							

SIZE	CODE IDENT NO.	SCALE	WT	SHEET	OF
D	52151			643-0019-001	1 OF 1

PROPRIETARY NOTICE: THIS DOCUMENT AND THE SUBJECT MATTER HEREOF ARE THE PROPERTY OF CONTINENTAL ELECTRONICS MFG. CO. AND SHALL NOT BE REPRODUCED OR COPIED OR USED FOR THE PURPOSE OF MANUFACTURING OR SALE OF APPARATUS EXCEPT BY WRITTEN PERMISSION OF CONTINENTAL ELECTRONICS MFG. CO.

REVISIONS				
ZONE	LTR	DESCRIPTION	DATE	APPROVED

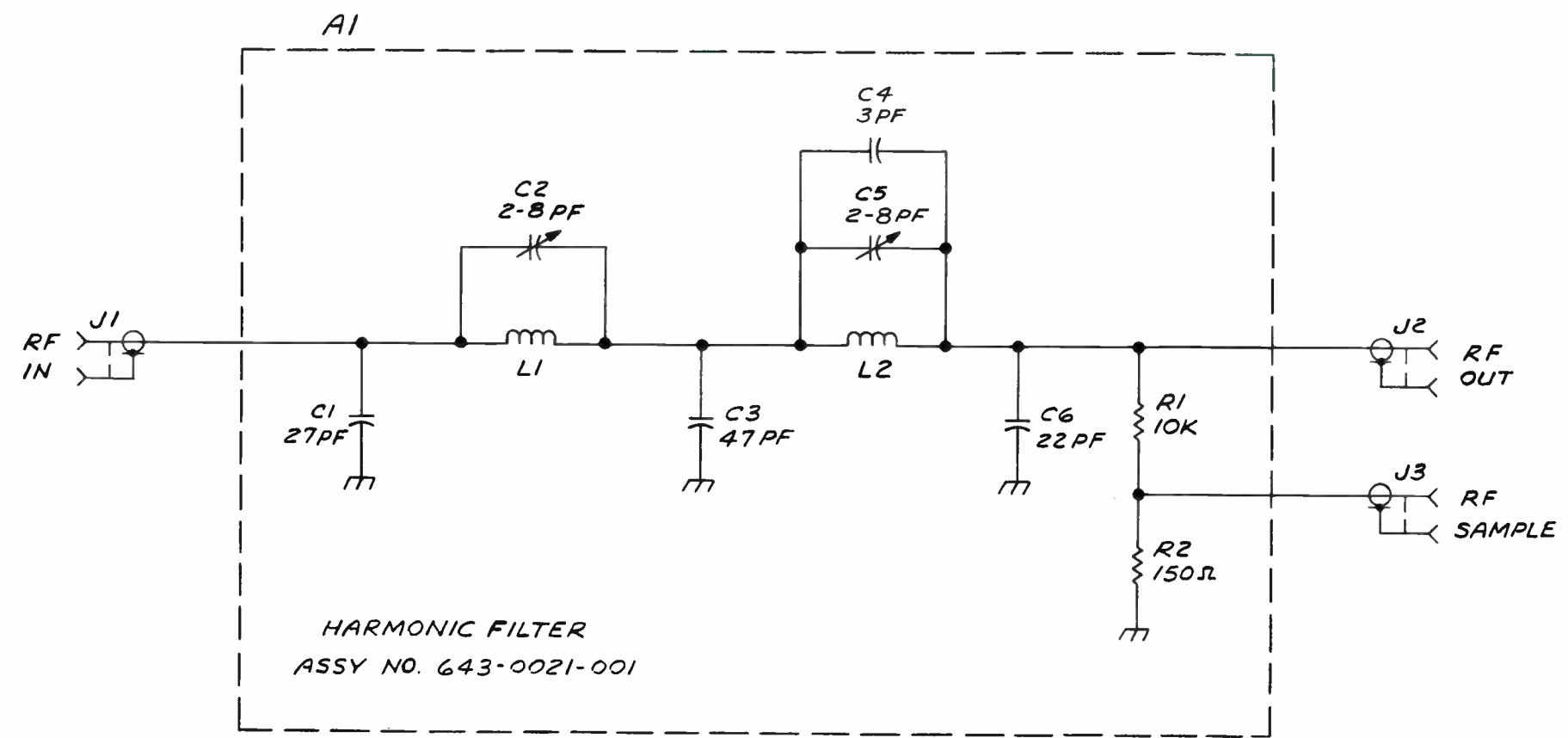

HARMONIC FILTER
ASSY NO. 643-0021-001

643-0022-001

FL1

QTY REQD PER DASH NO	ITEM	ZONE	PART OR IDENTIFYING NO	DWG SIZE	NOMENCLATURE OR DESCRIPTION	CODE IDENT
LIST OF MATERIAL OR PARTS LIST						
UNLESS OTHERWISE SPECIFIED				DRAWN	CONTINENTAL ELECTRONICS MFG. CO.	
TOLERANCE ON: FRAC				JANE CLARK	DALLAS TEXAS	
2 PLACE DEC 3 PLACE DEC ANGLES				CHECKED	SCHEMATIC, HARMONIC FILTER ASSY TYPE 802A FM EXCITER	
= = =				MECH DSGN		
MACHINED SURFACE FINISH 125/				ELEC ENGR		
ALL DIMENSIONS ARE IN				J. FERRELL	SIZE CODE IDENT NO	
INCLUDE APPLIED FINISH				APPROVED	C	52151
REMOVE ALL BURRS AND SHARP EDGES					643-0022-001	
643-0053-001			802A		SCALE: ~	WT ~
NEXT ASSY	DWG SIZE	USED ON			SHEET	OF

PROPRIETARY NOTE: THIS DOCUMENT AND THE SUBJECT MATTER HEREIN ARE THE PROPERTY OF CONTINENTAL ELECTRONICS MFG. CO. AND SHALL NOT BE REPRODUCED OR COPIED FOR USE FOR THE PURPOSE OF MANUFACTURE OR SALE OF APPARATUS EXCEPT BY WRITTEN PERMISSION OF CONTINENTAL ELECTRONICS MFG. CO.

REVISIONS				
ZONE	LTR	DESCRIPTION	DATE	APPROVED

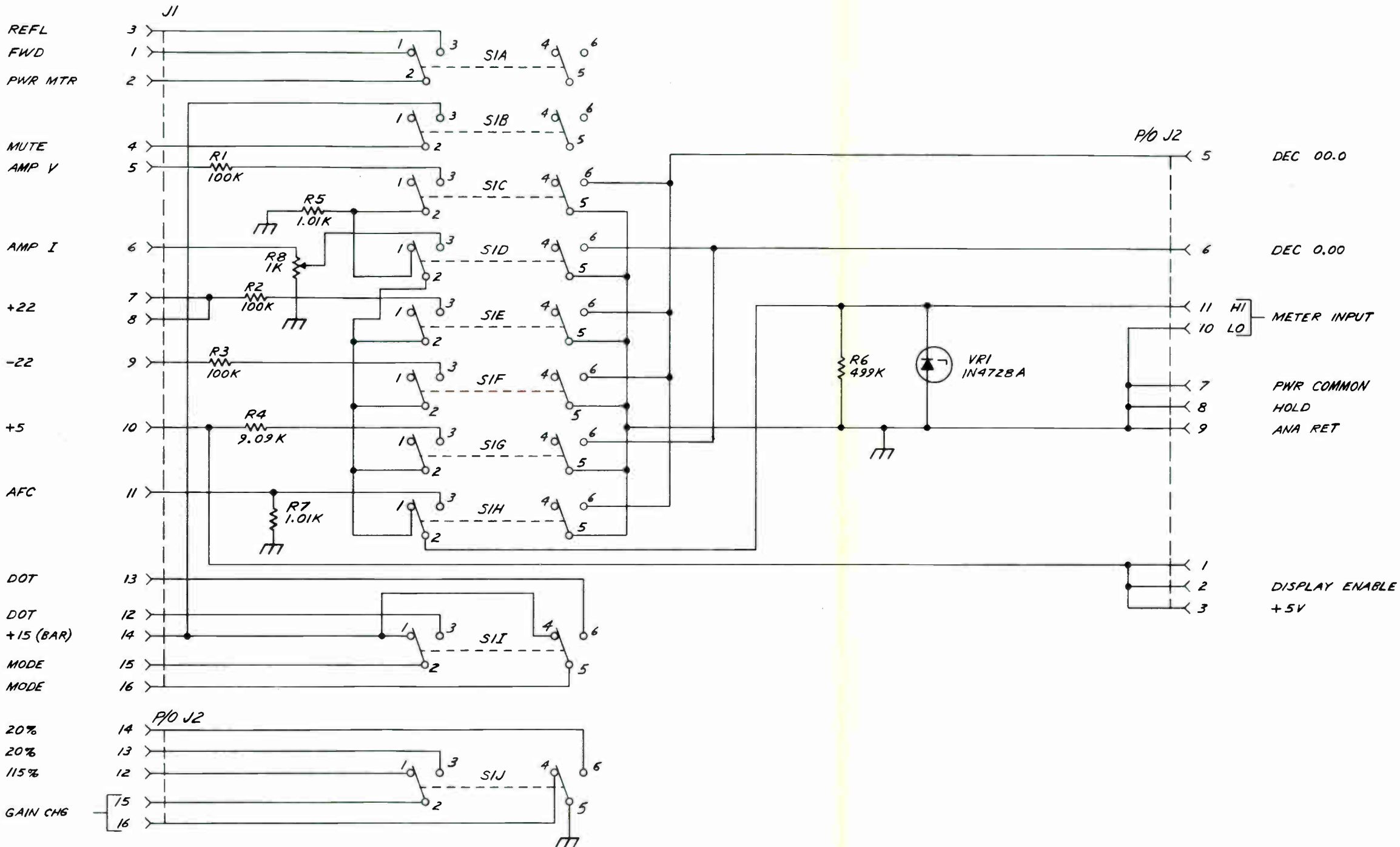

UNIT A7

QTY	REQD	PER	DASH	NO	ITEM	ZONE	PART OR IDENTIFYING NO	DWG. SIZE	NOMENCLATURE OR DESCRIPTION	DATE	CODE IDENT
LIST OF MATERIAL OR PARTS LIST											
UNLESS OTHERWISE SPECIFIED:										DRAWN PAT JOHNSON DATE 4-8-83	
TOLERANCE ON: FRACTIONAL										CHECKED	
2 PLACE DEC 3 PLACE DEC ANGLES										MECH DSGN	
MACHINED SURFACE FINISH 125/										ELEC ENGR J. FERRELL	
ALL DIMENSIONS ARE IN INCHES AND										APPROVED	
REMOVE ALL BURRS AND SHARP EDGES											
SCHEMATIC ~ METERING NETWORK TYPE 802A FM EXCITER											
Continental Electronics MFG CO											
DALLAS TEXAS											
SCALE ~											
SHEET 1 OF 1											

643-0025-001

PROPRIETARY NOTICE: THIS DOCUMENT AND THE SUBJECT MATTER HEREIN ARE THE PROPERTY OF CONTINENTAL ELECTRONICS MFG. CO. AND SHALL NOT BE REPRODUCED OR COPIED FOR ANY PURPOSES WITHOUT THE WRITTEN PERMISSION OF CONTINENTAL ELECTRONICS MFG. CO.

REVISIONS				
ZONE	LTR	DESCRIPTION	DATE	APPROVED

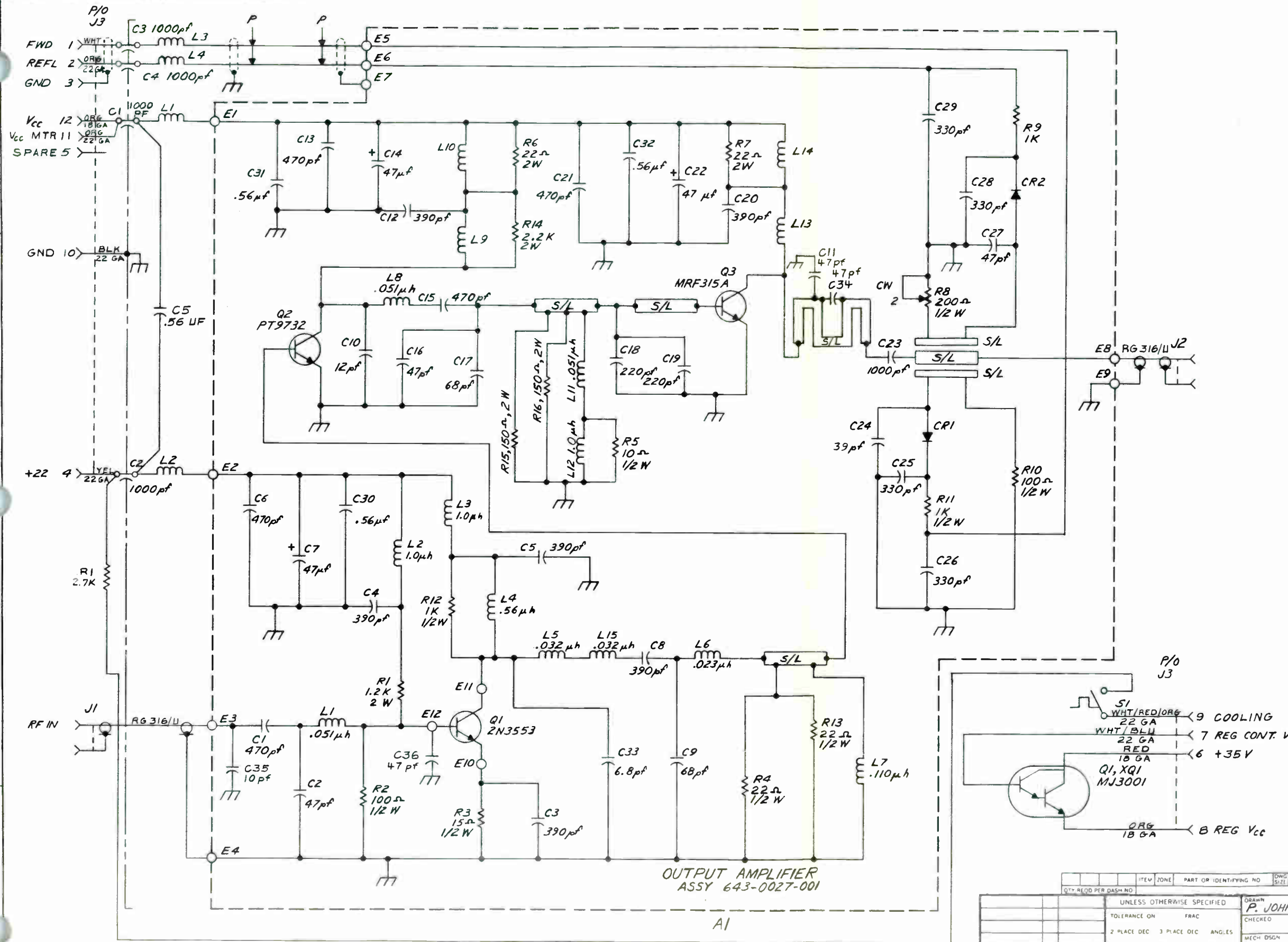

OUTPUT AMPLIFIER ASSY 643-0027-001

A1

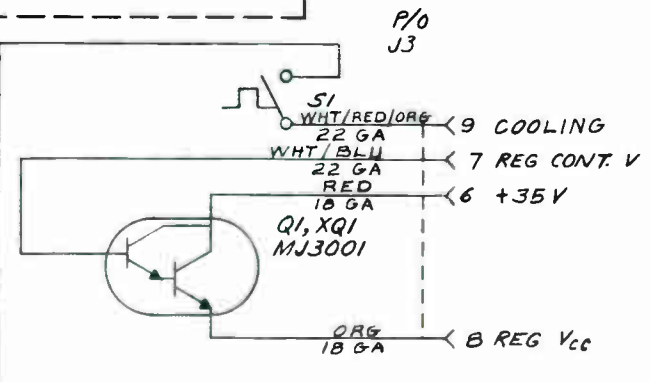

QTY	REV	ZONE	PART OR IDENTIFYING NO	DESC	DATE	CODE IDENT

UNLESS OTHERWISE SPECIFIED	DRAWN	DATE	Continental Electronics MFG. CO. DALLAS, TEXAS
TOLERANCE ON FRACTIONAL	P. JOHNSON	4-11-83	
2 PLACE DEC 3 PLACE DEC ANGLES	CHECKED		SCHEMATIC, AMPLIFIER TYPE 802A FM EXCITER
MACHINED SURFACE FINISH 125/ AND	MECH DSGN		
INCLUDE APPLIED FINISH REMOVE ALL BUMPS AND SHARP EDGES	ELEC ENGR		
	J. FERRELL		SIZE CODE IDENT NO D 52151 643-0028-001
			SCALE ~ ~ ~ SHEET 1 OF 1

ARI

643-0028-001

REV		ZONE	DESCRIPTION	DATE	APPROVED
2	1	SHT	REVISIONS		
			A	CHG R1-4 FROM 1K; C4-7 FROM 100PF	7/9/83
				CHG R8,9 FROM 47Ω	CJA

J1
INPUT POWER
CONNECTOR & FILTER

A4
POWER SUPPLY
ASSY DWG - 643-0009-001
SCHEMATIC - 643-0010-001

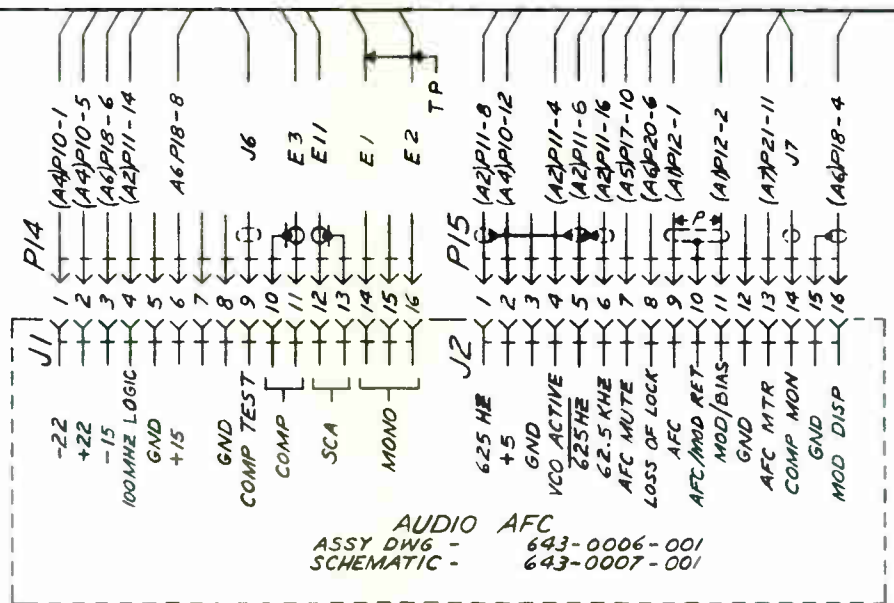
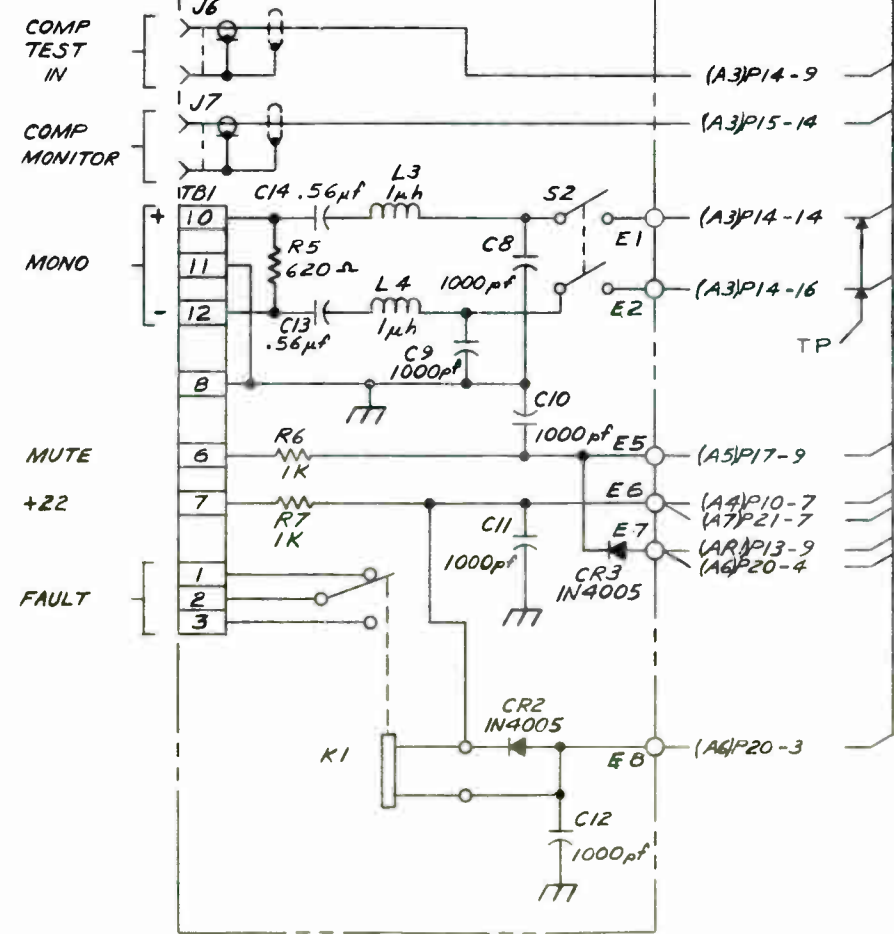
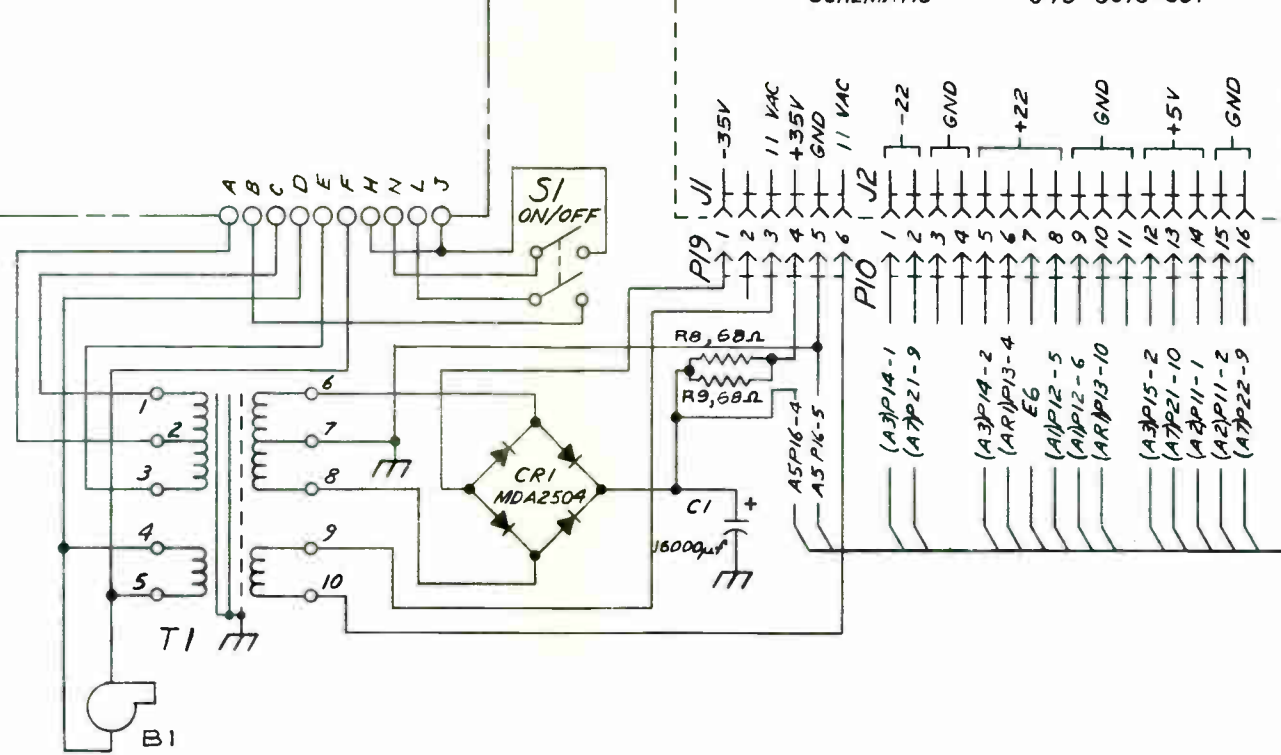
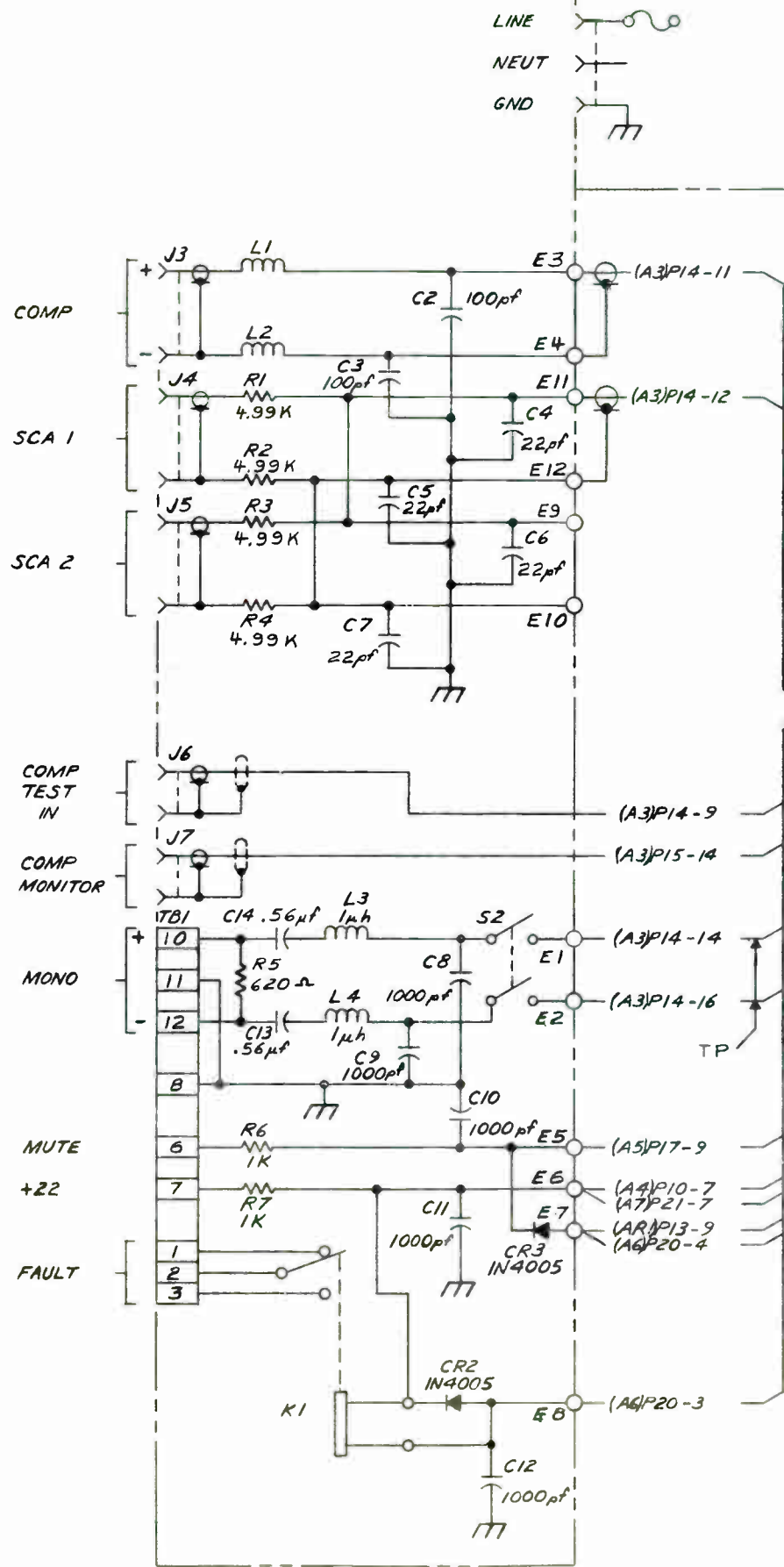

A3
AUDIO AFC
ASSY DWG - 643-0006-001
SCHEMATIC - 643-0007-001

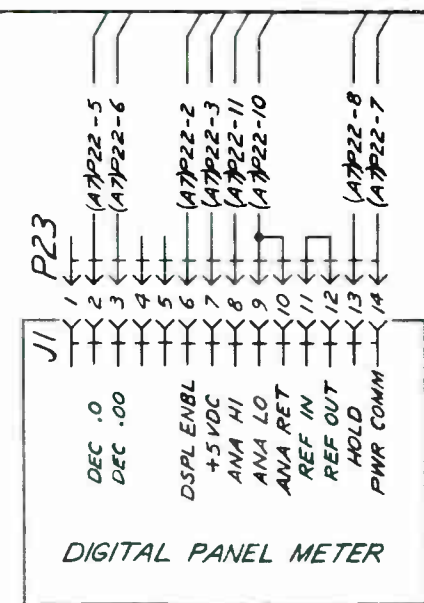

M2
DIGITAL PANEL METER

SEE SHT 2, ZONE C-8

ITEM	ZONE	PART OR IDENTIFYING NO	QTY REQD PER DASH NO	UNLESS OTHERWISE SPECIFIED	DRAWN	DATE	NOVENCULATURE OR DESCRIPTION	CODE IDENT
				TOLERANCE ON: 2 PLACE DEC 3 PLACE DEC ANGLES	R. JOHNSON	4-14-83	Continental Electronics MFG CO	
				MACHINED SURFACE FINISH 125/1000 AND ALL DIMENSIONS ARE IN INCHES UNLESS OTHERWISE SPECIFIED REMOVE ALL BURRS AND SHARP EDGES	CHECKED		SCHMATIC, TYPE 802A FM EXITER	
					MECH-DSGN			
					ELEC ENGR			
					J. FERRELL			
					APPROVED			
643-0001-001		802A					SIZE CODE IDENT NO	D 52151 643-0040-001
NEXT ASSY	DWG SIZE	USED ON					SCALE	SHEET 1 OF 2

REVISIONS				
ZONE	LTR	DESCRIPTION	DATE	APPROVED

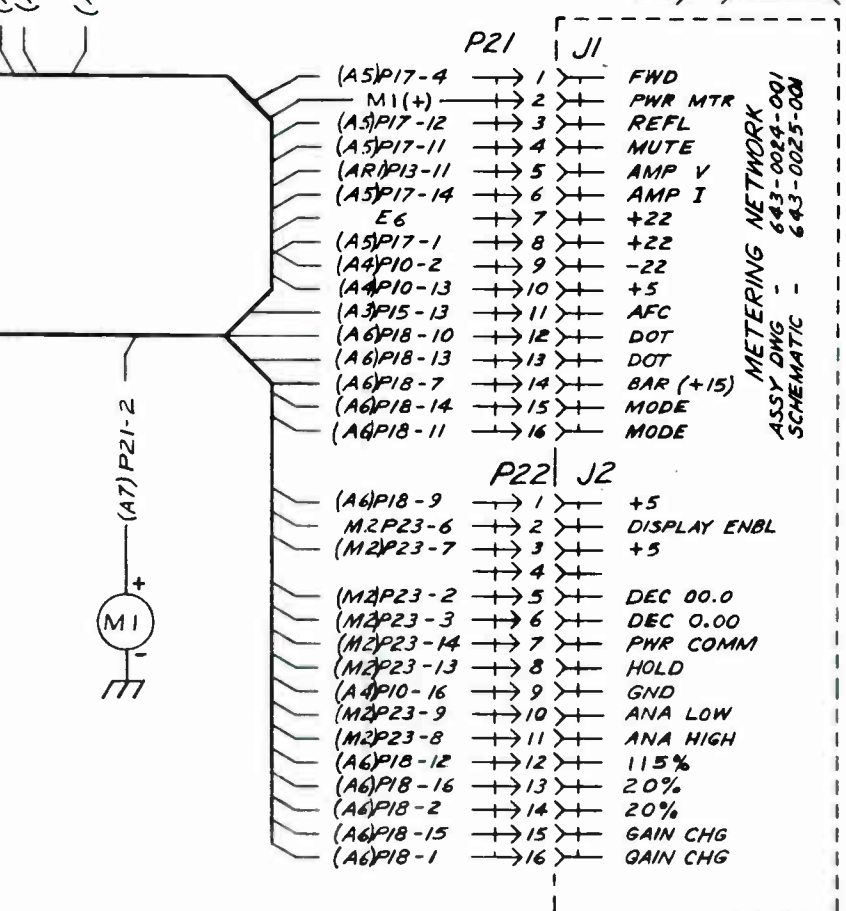
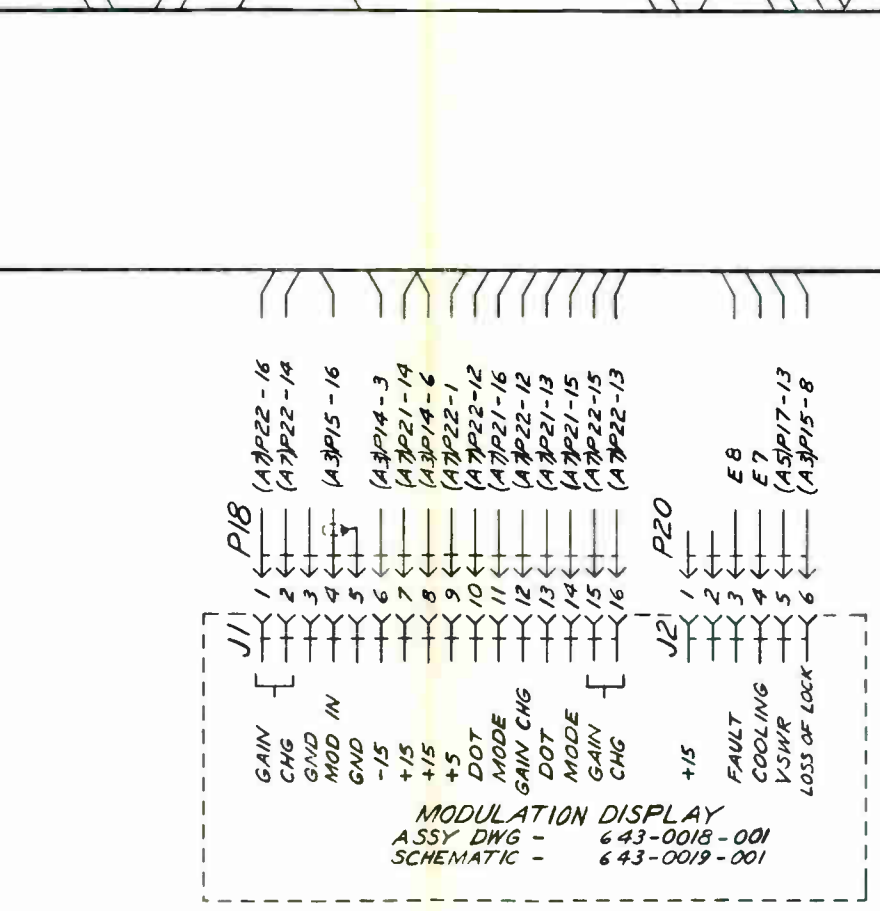
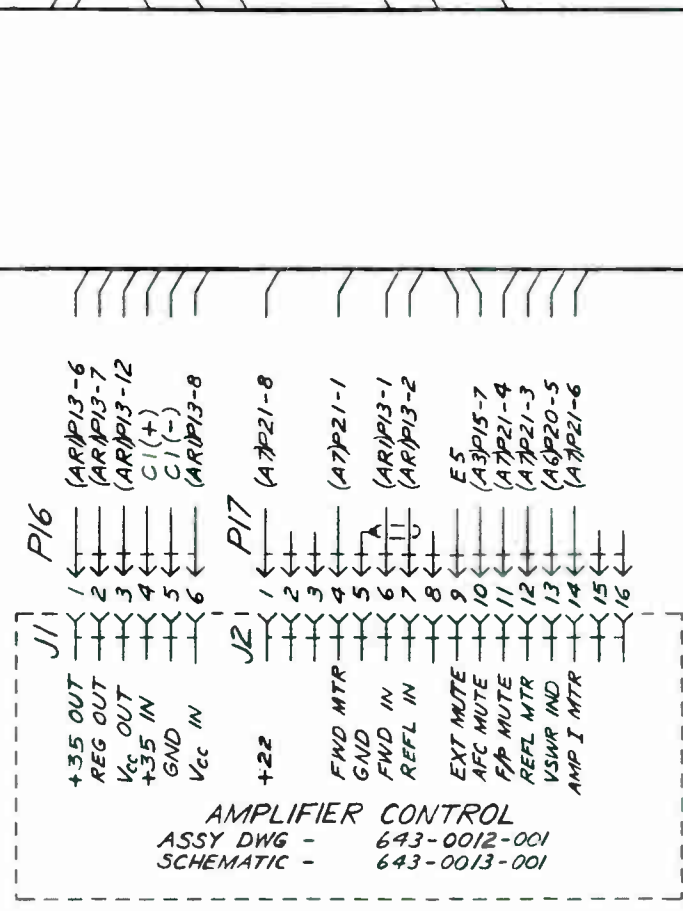
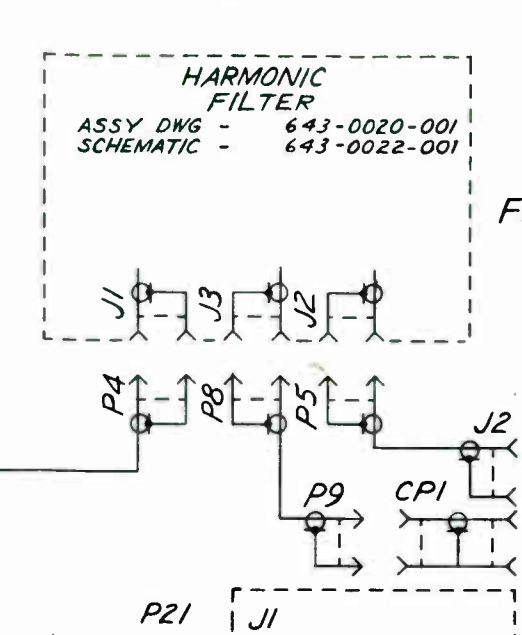
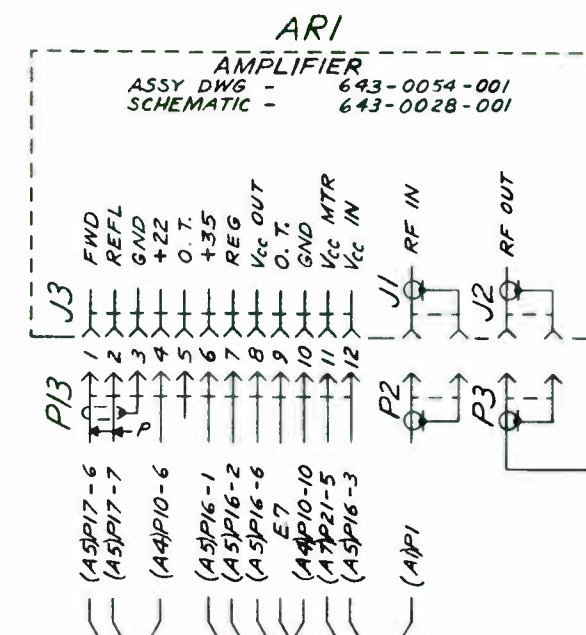
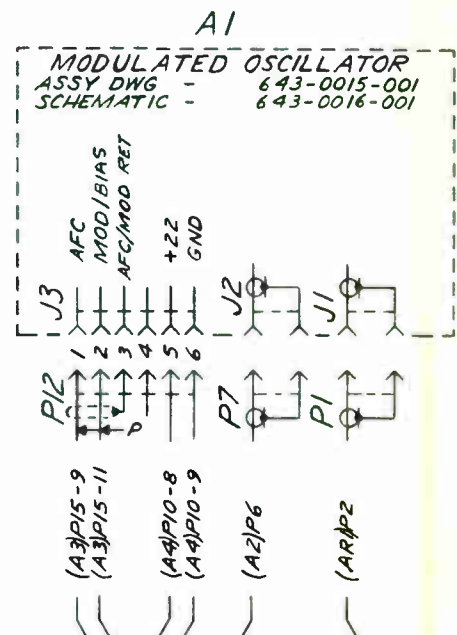
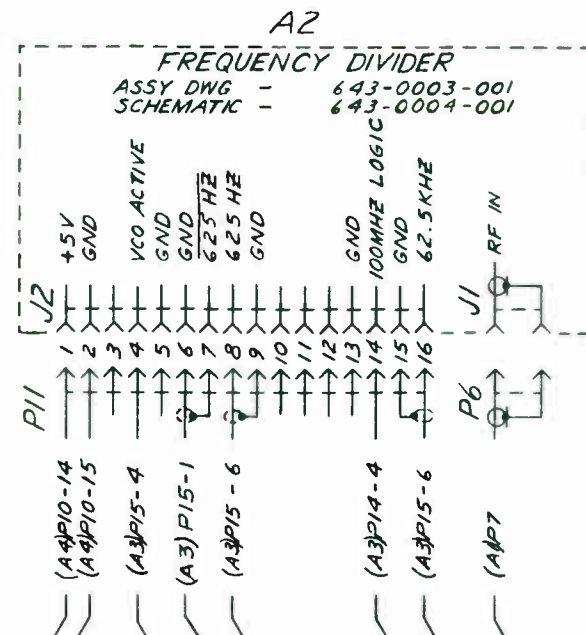

SEE SHEET 1 ZONE C-1

RF OUTPUT
 RF SAMPLE

QTY	REQO	PER	DASH	NO	ITEM	ZONE	PART OR IDENTIFYING NO	DWG SIZE	NOMENCLATURE OR DESCRIPTION	CODE IDENT

UNLESS OTHERWISE SPECIFIED	DRAWN P. JOHNSON	DATE 4-15-83
TOLERANCE ON FRACTIONAL	CHECKED	
2 PLACE DEC 3 PLACE DEC ANGLES	MECH DSGN	
MACHINED SURFACE FINISH 125	ELEC ENGR J. FERRELL	
ALL DIMENSIONS ARE IN INCHES UNLESS OTHERWISE SPECIFIED	APPROVED	
REMOVE ALL BURRS AND SHARP EDGES		

643-0001-001	D	B02A

Continental Electronics
 MFG CO
 DALLAS TEXAS

**SCHEMATIC,
 TYPE 802A
 FM EXITER**

SIZE CODE IDENT NO
D 52151 643-0040-001

SCALE ~ WT ~ SHEET 2 OF 2

SECTION 6 - PARTS LIST

6-1 GENERAL

This section contains a list of all repairable/replaceable electrical, and critical mechanical parts for the 802A Exciter.

6-2 REF DES

This column contains the electrical reference designators of all parts that have been assigned on schematics or wiring diagrams, and/or index numbers for all parts for which reference designators have not been assigned. When a reference designator, within a series of reference designators, has not been assigned a part number, the unassigned reference designator will be reflected as "NOT USED" in the DESCRIPTION column.

6-3 DESCRIPTION

This column contains the identifying noun or item name followed by a brief description. The description for electrical/electronic parts includes the application ratings and tolerances. For consecutively listed identical parts within an assembly, "SAME AS---" is reflected in the description of subsequent listings, referencing to the first listing within the assembly.

6-4 CEMC PART NUMBER

The CEMC Radio Specification or drawing number, for each item in the parts list, is reflected in this column.

6-5 ILLUSTRATIONS

All parts listed in the REF DES column are located on corresponding illustrations. The illustration always precedes the parts list. When a replaceable electrical item is hidden from view by structural parts of wiring, a dotted leader line is used to show the locations of the item on the illustration.

Type 802A FM EXCITER - PARTS LIST 643-0001-001

Page 1 of 2

<u>REF. DES.</u>	<u>DESCRIPTION</u>	<u>PART NUMBER</u>
A1	Modulated Oscillator Assembly	643-0052-001
A2	Frequency Divider Assembly	643-0003-001
A3	Audio/AFC Assembly	643-0006-001
A4	Power Supply Assembly	643-0009-001
A5	Amplifier Control Assembly	643-0012-001
A6	Modulation Display Assembly	643-0018-001
A7	Metering Network Assembly	643-0024-001
AR1	Amplifier Assembly	643-0054-001
B1	Fan	009-5007-001
C1	Capacitor, 16,000 μ f, 50V	183-5008-010
* C2, C3	Capacitor, 100pf	913-7007-010
* C4 - C7	Capacitor, 22pf	912-2768-000
C8 thru C12	Capacitor, 1000pf	913-1186-000
C13, C14	Capacitor, .57 μ f	913-5019-530
CP1	Adapter, BNC Bulkhead	357-6000-010
CR1	Bridge Rectifier	353-5017-010
* CR2, CR3	Diode, 1N4005	353-6442-050
F1	Fuse, 1.5A SB (240VAC)	264-0303-000
F1	Fuse, 3A SB (120VAC)	264-0306-000
FL1	Harmonic Filter Assembly	643-0053-001
J1	AC Line Connector	357-6601-010
J2	BNC Bulkhead Jack	357-6602-010
J3 thru J5	BNC Bulkhead Receptacle, Insulating	357-0076-010
J6, J7	BNC Bulkhead Receptacle	357-9607-000
K1	Relay	401-5011-010
L1, L2	RF Choke	240-2679-040
L3, L4	RF Choke	240-2715-530
M1	Analog Meter	458-5004-010
M2	Digital Meter	262-5007-010
* R1 thru R4	Resistor, 4.99K, 1/8W	705-3605-330
R5	Resistor, 620 ohms, 1/2 Watt	745-1343-000
R6, R7	Resistor, 1K, 1/2 Watt	745-0914-650
* R8, R9	Resistor,, 68 ohms, 2 Watt	745-5602-000
S1	Toggle Switch	266-9713-010
S2	Toggle Switch	266-3712-010
T1	Transformer	667-4001-010
TB1	Terminal Board	367-0020-000
W1	Power Cord	424-3000-010

TYPE 802A FM EXCITER - PARTS LIST 643-0001-000

Page 2 of 2

<u>REF. DES.</u>	<u>DESCRIPTION</u>	<u>PART NUMBER</u>
P1 thru P4	BNC Plug	357-7279-010
P10, P11, P14, P15, P17, P18 P21, P22	Connectors, 16 Pin	372-9604-010
P20	Connector, 6 Pin	372-9604-160
-	Terminals for Above Plugs	372-9604-080
P16	Connector, 6 Pin	372-9604-110
-	Terminal for P16	372-9604-050
P19	Connector, 6 Pin	372-9604-090
-	Terminal for P19	372-9604-010
P13	Connector, 12 Pin	372-5909-790
-	Terminal for P13	372-5904-060
P12	Connector, 6 Pin	372-9604-100
-	Terminal for P12	372-9604-030
P23	Connector, DIP	372-9605-010
-	Cover for P23	372-9605-020
-	Slide	015-9508-010
-	Vibration Isolator	200-0938-010
-	Clip-on Receptacle, 1/4 T Fastener	012-0050-050
-	1/4 T Fastener	012-1507-000
-	Retainer, 1/4 T Fastener	012-2782-000

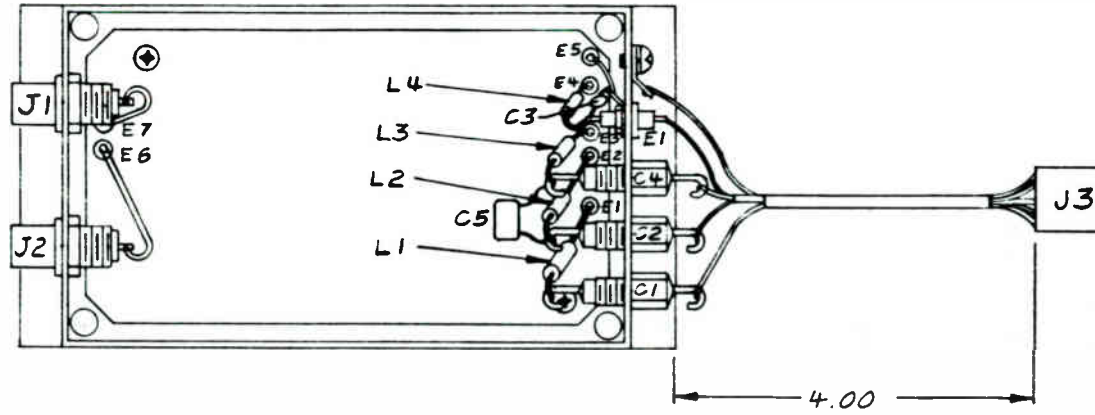
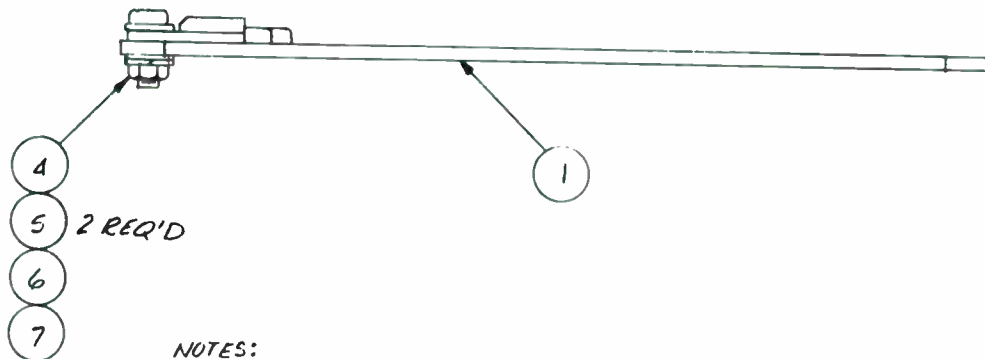
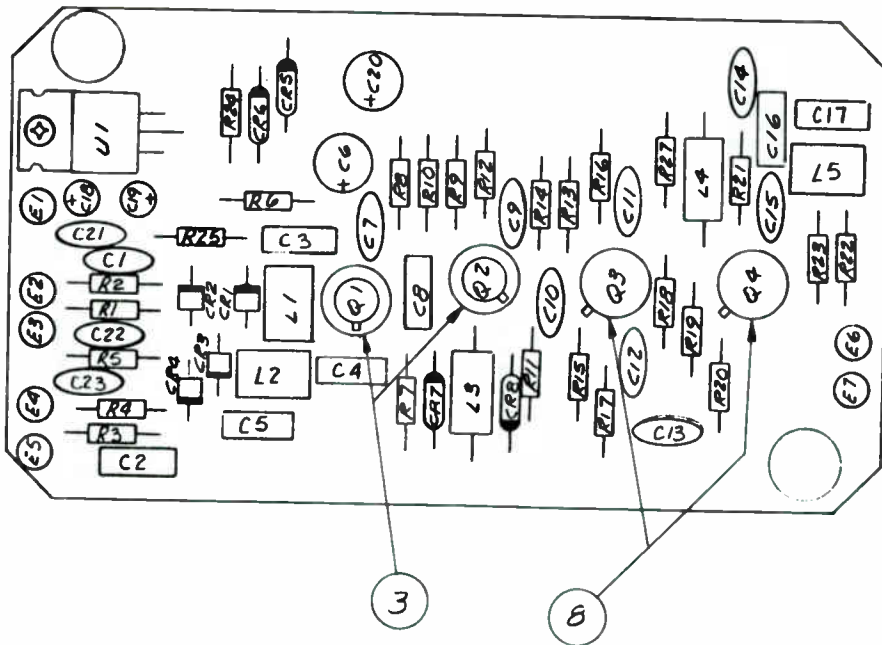

Figure 6-1. Modulator Oscillator Assembly, A1

A1 MODULATED OSCILLATOR ASSEMBLY - PARTS LIST 643-0052-001

<u>REF. DES.</u>	<u>DESCRIPTION</u>	<u>PART NUMBER</u>
A1	Card, Modulated Osc.	643-0015-001
C1, C2, C4	Feedthru Cap. 1000PF	913-4064-000
C3	Capacitor, 82PF	912-3873-000
C5	Capacitor, .56UF	913-5019-530
E1	Teflon Feedthru	306-3002-010
J1, J2	Connector	357-9670-000
J3	Connector Terminals	372-9604-020
J3	Connector	372-9604-090
L1, L2, L3, L4	RF Choke	240-2679-040
-	Box, Modulated Osc.	643-0041-001
-	Schematic	643-0016-001
-	Spacer	540-9209-003



NOTES:

- 1 PARTIAL REFERENCE DESIGNATIONS ARE SHOWN. PREFIX WITH UNIT NUMBER OR SUB-ASSEMBLY DESIGNATIONS OR BOTH FOR COMPLETE DESIGNATION.
- 2 CIRCUIT BOARD FABRICATION SHALL MEET OR EXCEED REQUIREMENTS OF MIL-P-55110B AND MIL-STD-275C.

Ref. 643-0015-001 Rev. -

Figure 6-2. Modulated Oscillator Bd, AlA1

AL1 MODULATED OSCILLATOR - PARTS LIST 643-0015-001

<u>REF. DES.</u>	<u>DESCRIPTION</u>	<u>PART NUMBER</u>
C1	Capacitor, 470PF	913-1189-000
C2, C3	Capacitor, 47PF	912-3856-000
C4, C5	Capacitor, 390PF	912-3921-000
C6	Capacitor, 47UF	183-5007-020
C7	Capacitor, 470PF	913-1189-000
C8	Capacitor, 47PF	912-3856-000
C9, C10	Capacitor, 470PF	913-1189-000
C11, C12	Capacitor, 470PF	913-1189-000
C13, C14	Capacitor, 470PF	913-1189-000
C15	Capacitor, 470PF	913-1189-000
C16	Capacitor, 27PF	912-3844-000
C17	Capacitor, 22PF	912-3842-000
C18, C19	Capacitor, 10UF	183-5007-060
C20	Capacitor, 47UF	183-5007-020
C21, C22	Capacitor, 470PF	913-1189-000
C23	Capacitor, 470PF	913-1189-000
CR1, CR2	Varactor, KV2801	922-8004-010
CR3	Varactor, KV2801	922-8004-010
CR4	Varactor, KV2801	922-8004-010
CR5, CR6	Diode, 1N4005	353-6442-050
CR7, CR8	Diode	353-0448-020
E1	Terminal	306-1126-000
thru E7		
L1, L2	RF Coil, .051UH	278-5042-040
L3, L4	RF Choke, 1.0UH	240-1590-000
L5	RF Coil, .11UH	278-5042-010
Q1, Q2	Transistor, U310	352-4005-000
Q3, Q4	Transistor, 2N5109	352-0863-020
R1	Resistor, 2.2K, 1/4Watt	745-0760-000
R2	Resistor, 47K, 1/2 Watt	745-0808-000
R3	Resistor, 100 Ohm, 1/4 Watt	745-0712-000
R4, R5	Resistor, 470 Ohm, 1/4 Watt	745-0736-000
R6	Resistor, 120K, 1/4 Watt	745-0823-000
R7	Resistor, 560 Ohm, 1/4 Watt	745-0739-000
R8	Resistor, 220 Ohm, 1/4 Watt	745-0724-000
R9	Resistor, 820K, 1/4 Watt	745-0853-000
R10	Resistor, 390K, 1/4 Watt	745-0841-000
R11	Resistor, 820 Ohm, 1/4 Watt	745-0745-000
R12	Resistor, 120 Ohm, 1/4 Watt	745-0715-000
R13	Resistor, 1.5K, 1/4 Watt	745-0754-000
R14	Resistor, 3.3K, 1/4 Watt	745-0766-000
R15	Resistor, 180 Ohm, 1/4 Watt	745-0721-000
R16	Resistor, 150 Ohm, 1/4 Watt	745-0718-000

A1A1 MODULATED OSCILLATOR - PARTS LIST 643-0015-001

<u>REF. DES.</u>	<u>DESCRIPTION</u>	<u>PART NUMBER</u>
R17	Resistor, 1.5K, 1/4 Watt	745-0754-000
R18	Resistor, 3.3K, 1/4 Watt	745-0766-000
R19	Resistor, 10 Ohm, 1/4 Watt	745-0676-000
R20	Resistor, 150 Ohm, 1/4 Watt	745-0718-000
R21	Resistor, 1K, 1/4 Watt	745-0748-000
R22	Resistor, 47 Ohm, 1/4 Watt	745-0700-000
R23	Resistor, 15 Ohm, 1/4 Watt	745-0682-000
R24	Resistor, 243 Ohm, 1/8 Watt	705-3600-670
R25	Resistor, 2.67K, 1/8 Watt	705-3605-200
R26	Resistor, 100 Ohm, 1/4 Watt	745-0712-000
U1	I.C., LM317T	351-1271-010
-	Pad	352-9552-620
-	Hex Nut, 6-32	313-0045-000
-	Lock Washer, No. 6	310-0071-000
-	Flat Washer, No. 6	310-0046-000
-	Screw, 6-32x3/8 PPH	343-0169-000
-	Pad	352-9552-120
-	Schematic	643-0016-001
-	Circuit Board	643-0014-001

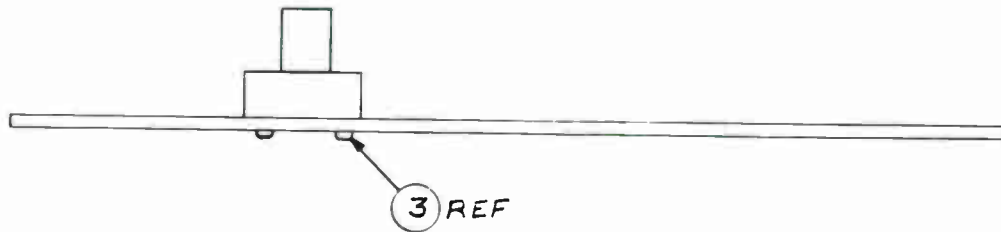
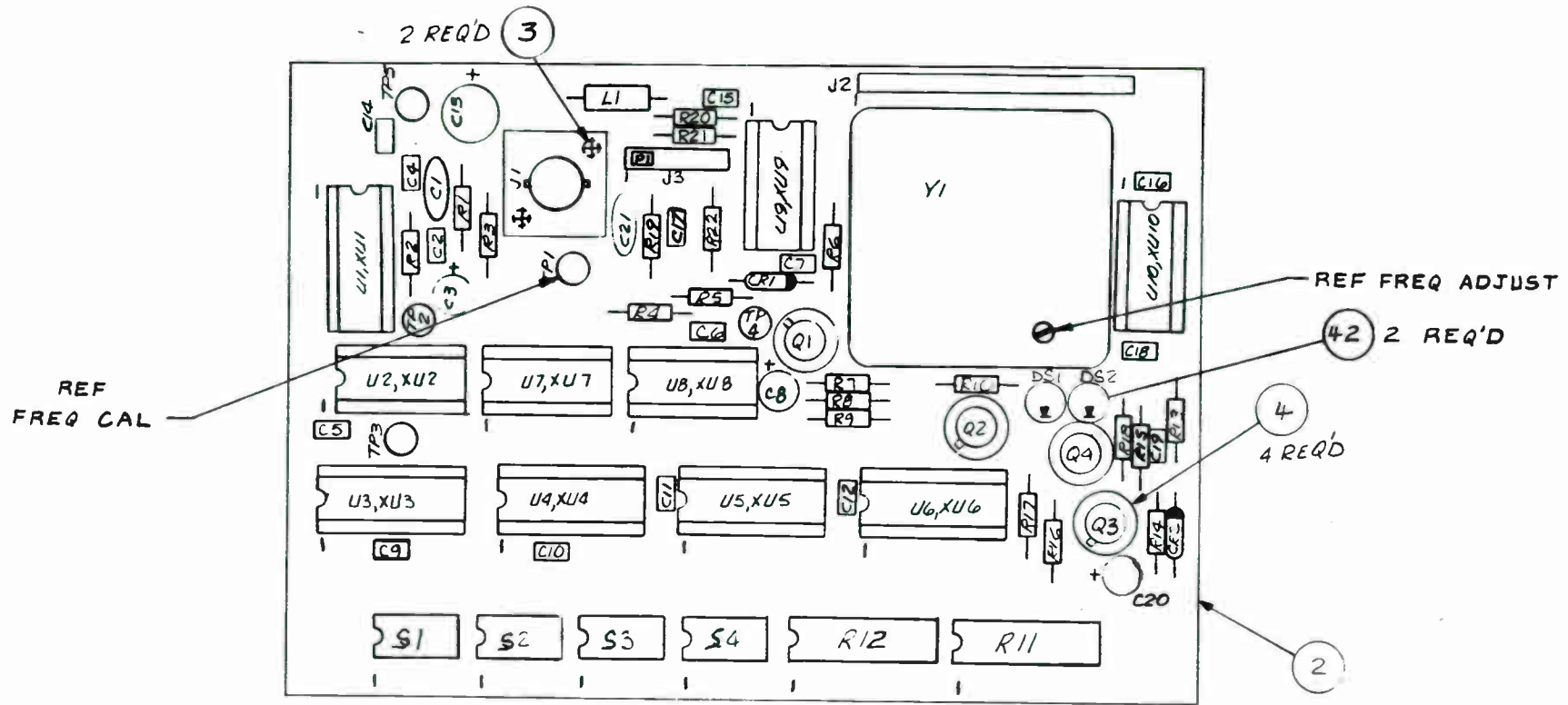

NOTES:

- 1 PARTIAL REFERENCE DESIGNATIONS ARE SHOWN. PREFIX WITH UNIT NUMBER OR SUB-ASSEMBLY DESIGNATIONS OR BOTH FOR COMPLETE DESIGNATION.
- 2 CIRCUIT BOARD FABRICATION SHALL MEET OR EXCEED REQUIREMENTS OF MIL-P-55110B AND MIL-STD-275C.

Ref. 643-0003-001 Rev. -

Figure 6-3. Frequency Divider Assembly, A2

A2 FREQUENCY DIVIDER - PARTS LIST 643-0003-001

<u>REF. DES.</u>	<u>DESCRIPTION</u>	<u>PART NUMBER</u>
C1	Capacitor, 1000PF	913-1186-000
C2	Capacitor, .1UF	913-5019-320
C3	Capacitor, 10UF	183-5007-060
C4, C5	Capacitor, .1UF	913-5019-320
C6, C7	Capacitor, .1UF	913-5019-320
C8	Capacitor, 10UF	183-5007-060
C9, C10	Capacitor, .1UF	913-5019-320
C11, C12	Capacitor, .1UF	913-5019-320
C13	Capacitor, 47UF	183-5007-020
C14, C15	Capacitor, .1UF	913-5019-320
C16, C17	Capacitor, .1UF	913-5019-320
C18, C19	Capacitor, .1UF	913-5019-320
C20	Capacitor, 10UF	183-5007-060
C21	Capacitor, 1000PF	913-1186-000
CR1, CR2	Diode,, 1N4148	353-3763-010
* DS1, DS2	LED, Green	353-0293-010
J1	Connector	259-5205-010
J2	Connector	372-9604-190
J3	Connector	372-9604-180
L1	RF Choke, 1.8UH	240-1571-000
P1	Connector	372-9604-150
Q1, Q2	Transistor, 2N2222A	352-0661-020
Q3, Q4	Transistor, 2N2222A	352-0661-020
R1	Resistor, 47 ohm, 1/4 Watt	745-0700-000
R2	Resistor, 1000 ohm, 1/4 Watt	745-0748-000
R3	Resistor, 10K, 1/4 Watt	745-0784-000
R4	Resistor, 5.6K, 1/4 Watt	745-0775-000
R5	Resistor, 6.8K, 1/4 Watt	745-0778-000
R6	Resistor, 220K, 1/4 Watt	745-0832-000
R7	Resistor, 100 ohm, 1/4 Watt	745-0712-000
R8	Resistor, 680 ohm, 1/4 Watt	745-0742-000
R9	Resistor, 220K, 1/4 Watt	745-0832-000
R10	Resistor, 180 ohm, 1/4 Watt	745-0721-000
R11, R12	Resistor, Network, 10K	350-4601-010
R13	Resistor, 6.8K, 1/4Watt	745-0778-000
R14	Resistor, 220K, 1/4 Watt	745-0832-000
R15	Resistor, 100 ohm, 1/4 Watt	745-0712-000
R16	Resistor, 680 ohm, 1/4 Watt	745-0742-000
R17	Resistor, 220K, 1/4 Watt	745-0832-000
R18	Resistor, 180 ohm, 1/4 Watt	745-0721-000
R19	Resistor, 470 ohm, 1/4 Watt	745-0736-000
R20, R21, R22	Resistor, 2700 ohm, 1/4 Watt	745-0763-000

A2 FREQUENCY DIVIDER - PARTS LIST 643-0003-001 (Continued)

<u>REF. DES.</u>	<u>DESCRIPTION</u>	<u>PART NUMBER</u>
S1, S2	Switch	266-0243-010
S3, S4	Switch	266-0243-010
TP1	Test Point	360-5003-010
TP2, TP3	Test Point	306-1126-000
TP4, TP5	Test Point	306-1126-000
U1	I.C., MC12011P	351-4708-010
U2	I.C., SN74LS74AN	351-1710-020
U3, U4	I.C., SN74LS190N	351-1711-010
U5, U6	I.C., SN74LS190N	351-1711-010
U7	I.C., SN7420N	351-1548-090
U8	I.C., SN74121N	351-1187-010
U9	I.C., SN74LS93N	351-1711-060
U10	I.C., SN74LS90N	351-1711-050
XU1	Socket, 16 Pin	220-0049-020
XU2	Socket, 14 Pin	220-0049-010
XU3, XU4	Socket, 16 Pin	220-0049-020
XU5, XU6	Socket, 16 Pin	220-0049-020
XU7, XU8	Socket, 14 Pin	220-0049-010
XU9, XU10	Socket, 14 Pin	220-0049-010
Y1	Crystal Oscillator	270-3003-010
-	LED Spacer	262-5006-010
-	Trans-Pad	352-9552-620
-	Screw No. 2 Self-Tapping	MS51861-2C
-	Circuit Board	643-0002-001
-	Schematic	643-0004-001

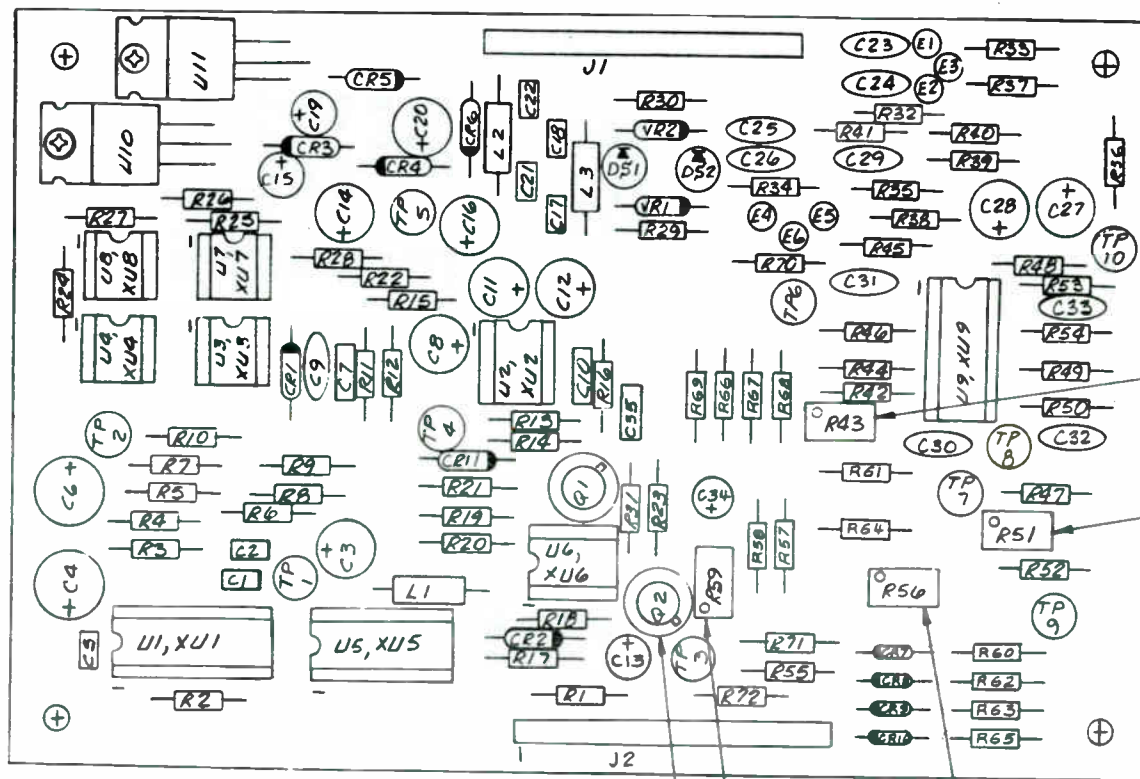
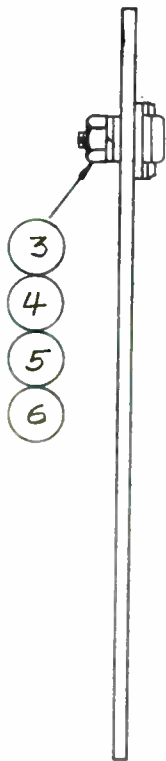

BALANCE
ADJUST

AUDIO LEVEL
ADJUST

MOD LEVEL ADJUST

PRE-DISTORT ADJUST
(DISTORTION NULL)

NOTE:

1. PARTIAL REFERENCE DESIGNATIONS ARE SHOWN. PREFIX WITH UNIT NUMBER OR SUB-ASSEMBLY DESIGNATIONS OR BOTH FOR COMPLETE DESIGNATION.
2. CIRCUIT BOARD FABRICATION SHALL MEET OR EXCEED REQUIREMENTS OF MIL-P-55110B AND MIL-STD-275C

802A

Figure 6-4. Audio/AFC Assembly, A3

Ref. 643-0006-001 Rev. -

A3 AUDIO/AFC ASSEMBLY - PARTS LIST 643-0006-001 REV. A

<u>REF. DES.</u>	<u>DESCRIPTION</u>	<u>PART NUMBER</u>
C1, C2	Capacitor, .1UF	913-5019-320
C3	Capacitor, 100UF	183-5007-050
C4	Capacitor, 470UF	183-5007-010
C5	Capacitor, .1UF	913-5019-320
C6	Capacitor, 470UF	183-5007-010
C7	Capacitor, 1UF	913-5019-560
C8	Capacitor, 33UF	183-5007-030
C9	Capacitor, 100PF	913-7007-010
C10	Capacitor, .27UF	913-5019-490
C11, C12	Capacitor, 47UF	183-5007-020
C13	Capacitor, 10UF	183-5007-060
C14	Capacitor, 100UF	183-5007-050
C15	Capacitor, 10UF	183-5007-060
C16	Capacitor, 47UF	183-5007-020
C17, C18	Capacitor, .1UF	913-5019-320
C19	Capacitor, 10UF	183-5007-060
C20	Capacitor, 47UF	183-5007-020
C21, C22	Capacitor, .1UF	913-5019-320
C23	Capacitor, 1000PF	913-7006-010
C24	Capacitor, 500PF	913-7006-020
C25	Capacitor, 1000PF	913-7006-010
C26	Capacitor, 500PF	913-7006-020
C27, C28	Capacitor, 47UF	183-5007-020
C29	Capacitor, 220pf	913-7006-060
C30, C31	Capacitor, 18PF	913-7006-050
C32, C33	Capacitor, 6.8PF	913-7006-030
C34	Capacitor, 10UF	183-5007-060
C35	Capacitor, .1UF	913-5019-320
CR1, CR2	Diode, 1N4148	353-3763-010
CR3, CR4	Diode, 1N4005	353-6442-050
CR5, CR6	Diode, 1N4005	353-6442-050
CR7, CR8	Diode, 1N4148	353-3763-010
CR9, CR10, CR11	Diode, 1N4148	353-3763-010
DS1, DS2	LED	353-0293-010
J1, J2	Connector	372-9604-190
L1, L2, L3	RF Choke, 1.8UHY	240-1571-000
Q1, Q2	Transistor, 2N2222A	352-0661-020
R1, R2	Resistor, 10K, 1/4Watt	745-0784-000
R3	Resistor, 100 ohm, 1/4 Watt	745-0712-000
R4	Resistor, 10K, 1/8 Watt	705-1454-630
R5	Resistor, 100K, 1/8 Watt	705-1092-000

*

A3 AUDIO/AFC ASSEMBLY - PARTS LIST 643-0006-001 REV. A (CONT.)

<u>REF. DES.</u>	<u>DESCRIPTION</u>	<u>PART NUMBER</u>
R6	Resistor, 470 ohm, 1/4 Watt	745-0736-000
R7	Resistor, 100K, 1/8 Watt	705-1092-000
R8	Resistor, 10K, 1/8 Watt	705-1454-630
R9	Resistor, 100K, 1/8 Watt	705-1092-000
R10	Resistor, 2.2K, 1/4 Watt	745-0760-000
R11	Resistor, 15K, 1/4 Watt	745-0790-000
R12	Resistor, 1K, 1/4 Watt	745-0748-000
R13, R14	Resistor, 100K, 1/4 Watt	745-0820-000
R15	Resistor, 8.2K, 1/4 Watt	745-0781-000
R16	Resistor, 470 ohm, 1/4 Watt	745-0736-000
R17	Resistor, 470K, 1/4 Watt	745-0844-000
R18	Resistor, 1K, 1/4 Watt	745-0748-000
R19	Resistor, 6.8K, 1/4 Watt	745-0778-000
R20	Resistor, 1K, 1/4 Watt	745-0748-000
R21	Resistor, 12K, 1/4 Watt	745-0787-000
R22	Resistor, 1.8K, 1/4 Watt	745-0757-000
R23	Resistor, 6.8K, 1/4 Watt	745-0778-000
R24	Resistor, 180 ohm, 1/4 Watt	745-0721-000
R25	Resistor, 10K, 1/8 Watt	705-1454-630
R26	Resistor, 2.15K, 1/8 Watt	705-1012-000
R27	Resistor, 4.42K, 1/8 Watt	705-1027-000
R28	Resistor, 560K, 1/4 Watt	745-0847-000
R29, R30	Resistor, 180 ohm, 1/4 Watt	745-0721-000
R31	Resistor, 6.8K, 1/4 Watt	745-0778-000
R32	Resistor, 49.9K, 1/8 Watt	705-3605-810
R33	Resistor, 3.9K, 1/4 Watt	745-0769-000
R34	Resistor, 49.9K, 1/8 Watt	705-3605-810
R35	Resistor, 3.9K, 1/4 Watt	745-0769-000
R36	Resistor, 4.99K, 1/8 Watt	705-3605-330
R37, R38	Resistor, 24.9K, 1/8 Watt	705-1063-000
* R39	Resistor, 4.99K, 1/8 Watt	705-3605-330
* R40, R41	Resistor, 82.5K, 1/8 Watt	705-1088-000
R42	Resistor, 18K, 1/4 Watt	745-0793-000
R43	Resistor, 10K, 1/2 Watt, VAR	382-1405-070
R44, R45, R46	Resistor, 24.9K, 1/8 Watt	705-1063-000
R47, R48	Resistor, 4.99K, 1/8 Watt	705-3605-330
R49, R50	Resistor, 4.99K, 1/8 Watt	705-3605-330
R51	Resistor, 5K, 1/2 Watt, VAR	382-1405-060
R52	Resistor, 4.7K, 1/4 Watt	745-0772-000
R53, R54	Resistor, 10K, 1/4 Watt	745-0784-000
R55	Resistor, 1K, 1/4 Watt	745-0748-000
R56	Resistor, 20K, 1/2 Watt, VAR	382-1405-080

A3 AUDIO/AFC ASSEMBLY - PARTS LIST 643-0006-001 REV. A (CONT.)

<u>REF. DES.</u>	<u>DESCRIPTION</u>	<u>PART NUMBER</u>
R57	Resistor, 10K, 1/4 Watt	745-0784-000
R58	Resistor, 180 ohm, 1/4 Watt	745-0721-000
R59	Resistor, 500 ohm, 1/2 Watt, VAR	382-1405-030
R60	Resistor, 39K, 1/4 Watt	745-0805-000
R61	Resistor, 100 ohm, 1/4 Watt	745-0712-000
R62	Resistor, 100K, 1/4 Watt	745-0820-000
R63	Resistor, 39K, 1/4 Watt	745-0805-000
R64	Resistor, 100 ohm, 1/4 Watt	745-0712-000
R65	Resistor, 100K, 1/4 Watt	745-0820-000
R66	Resistor, 150 ohm, 1/4 Watt	745-0718-000
R67	Resistor, 100 ohm, 1/4 Watt	745-0712-000
R68, R69	Resistor, 2.2K, 1/4 Watt	745-0760-000
R70	Resistor, 4.7K, 1/4 Watt	745-0772-000
R71	Resistor, 1K, 1/4 Watt	745-0748-000
R72	Resistor, 100K, 1/8 Watt	705-1092-000
TP1 thru TP10	Test Point	306-1126-000
U1	I.C. MC14568BCP	351-8883-010
U2	I.C., LF353N	351-1370-040
U3, U4	I.C., CLM-51	352-4010-010
U5	I.C., SN74LS74AN	351-1710-020
U6	I.C., LM358N	351-1211-040
U7	I.C., CLM-51	352-4010-010
U8	I.C., 4N28	351-0047-030
U9	I.C., LF347N	351-1370-020
U10	I.C., UA7815UC	351-1120-050
U11	I.C., UA7915UC	351-1124-160
VR1, VR2	Zener, 1N4739A	353-6481-230
XU1	Socket, 16 Pin	220-0049-020
XU2	Socket, 8 Pin	220-0049-100
XU5	Socket, 14 Pin	220-0049-010
XU6	Socket, 8 Pin	220-0049-100
XU9	Socket, 14 Pin	220-0049-010
XU3, 4, 7, 8	Socket, 6 Pin	220-6015-010
-	Spacer	262-5006-010
-	Mounting Pad	352-9552-620
-	Flat Washer, No. 6	310-0046-000
-	Lock Washer, No. 6	310-0071-000
-	Screw, 6-32x3/8	343-0169-000
-	Nut, 6-32	313-0045-000
-	Circuit Board	643-0005-001
-	Schematic	643-0007-001

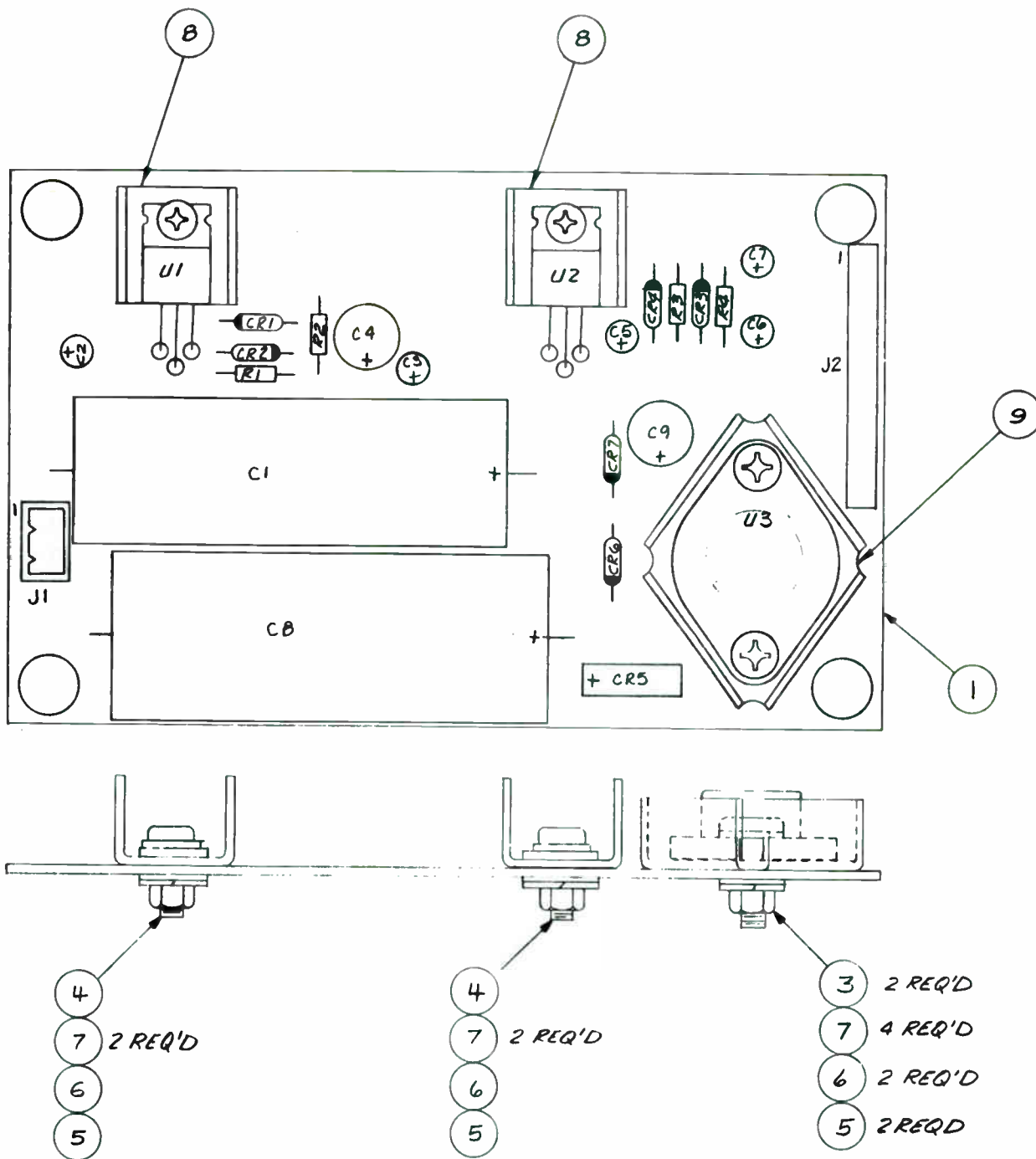

NOTES:

- PARTIAL REFERENCE DESIGNATIONS ARE SHOWN. PREFIX WITH UNIT NUMBER OR SUB-ASSEMBLY DESIGNATIONS OR BOTH FOR COMPLETE DESIGNATION.
- CIRCUIT BOARD FABRICATION SHALL MEET OR EXCEED REQUIREMENTS OF MIL-P-55110B AND MIL-STD-275C

Ref. 643-0009-001 Rev. -

Figure 6-5. Power Supply Assembly, A4

A4 POWER SUPPLY ASSEMBLY - PARTS LIST 643-0009-001

<u>REF DES.</u>	<u>DESCRIPTION</u>	<u>PART NUMBER</u>	
C1	Capacitor, 1100UF, 50V	183-5006-010	
C2, C3	Capacitor, 10UF	183-5007-060	
C4	Capacitor, 100UF	183-5007-040	
C5, C6	Capacitor, 10UF	183-5007-060	
C7	Capacitor, 100UF	183-5007-040	
C8	Capacitor, 5300UF	183-5006-020	
C9	Capacitor, 100UF	183-5007-040	
CR1, CR2	Diode, 1N4005	353-6442-050	
CR3, CR4	Diode, 1N4005	353-6442-050	
CR5	Diode, 3N256	352-5015-010	
CR6, CR7	Diode, 1N4005	353-6442-050	
J1	Connector	372-9604-100	
J2	Connector	372-9604-190	
R1	Resistor, 120 ohm, 1/4 Watt	745-0715-000	
R2	Resistor, 2000 ohm, 1/4 Watt	745-0759-000	
R3	Resistor, 220 ohm, 1/4 Watt	745-0724-000	
R4	Resistor, 3600 ohm, 1/4 Watt	745-0768-000	
U1	I.C., LM337T	351-1345-030	
U2	I.C., LM317T	351-1271-010	
U3	I.C., UA7805KC	351-1120-080	
VR1	Diode, Zener, 1N4739A	353-6481-230	*
-	Terminal for J1	372-9604-040	
-	Heatsink	352-4006-010	
-	1 each Heatsink	352-9638-110	*
-	1 each Heatsink	352-9638-120	*
-	1 each Heatsink	352-9638-140	*
-	Washer, Flat No. 6	310-0046-000	
-	Washer, Lock No. 6	310-0071-000	
-	Nut, Hex 6-32	313-0045-000	
-	Screw, 6-32x5/8 PPH	343-0173-000	
-	Screw, 6-32x1/2 PPH	343-0171-000	
-	Schematic	643-0010-001	
-	Circuit Board	643-0008-001	

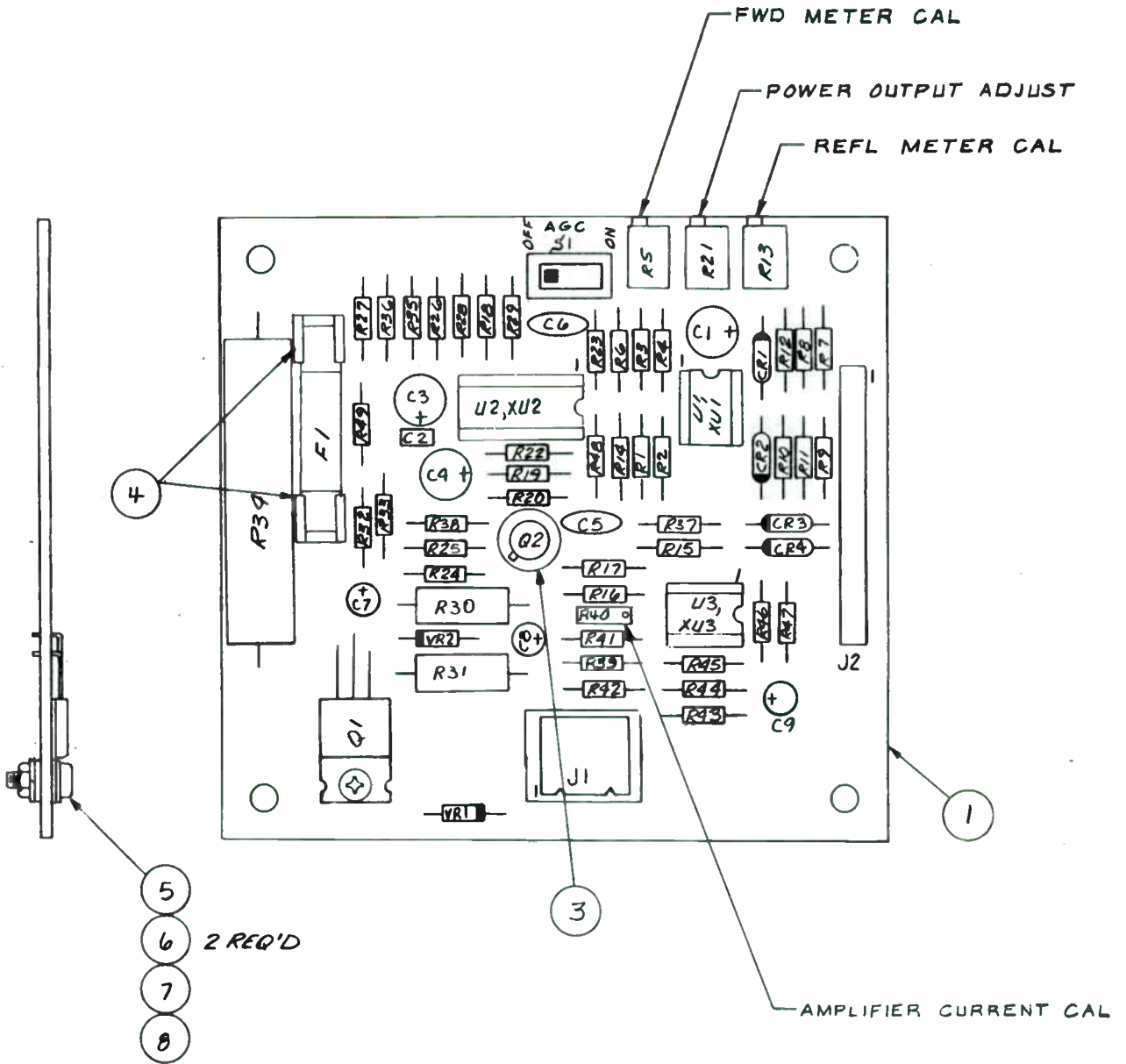

NOTES:

- 1 PARTIAL REFERENCE DESIGNATIONS ARE SHOWN. PREFIX WITH UNIT NUMBER OR SUB-ASSEMBLY DESIGNATIONS OR BOTH FOR COMPLETE DESIGNATION.
- 2 CIRCUIT BOARD FABRICATION SHALL MEET OR EXCEED REQUIREMENTS OF MIL-P-55110B AND MIL-STD-275C.

Ref. 643-0012-001 Rev. -

Figure 6-6. Amplifier Control Assembly, A5

A5 AMPLIFIER CONTROL ASSEMBLY - PARTS LIST 643-0012-001

<u>REF DES.</u>	<u>DESCRIPTION</u>	<u>PART NUMBER</u>
C1	Capacitor, 33UF	183-5007-030
C2	Capacitor, 0.1UF	913-5019-320
C3	Capacitor, 33UF	183-5007-030
C4	Capacitor, 47UF	183-5007-020
C5, C6	Capacitor, 1000PF	913-1186-000
C7, C8, C9	Capacitor, 1UF	184-9102-350
CR1, CR2	Diode, 1N4148	353-3763-010
CR3, CR4	Diode, 1N4148	353-3763-010
F1	Fuse 5 Amp	264-0726-000
J1	Connector	372-5909-770
J2	Connector	372-9604-190
Q1	SCR, 2N6401	352-4008-010
Q2	XSTR, 2N2222A	352-0661-020
R1, R2	Resistor, 10K, 1/4 Watt	745-0784-000
R3, R4	Resistor, 1.8K, 1/4 Watt	745-0757-000
R5	Resistor, 10K, 1/2 Watt VAR	382-1405-220
R6	Resistor, 10K, 1/4 Watt	745-0784-000
R7, R8	Resistor, 3.9K, 1/4 Watt	745-0769-000
R9	Resistor, 10K, 1/4 Watt	745-0784-000
R10	Resistor, 1.8K, 1/4 Watt	745-0757-000
R11	Resistor, 10K, 1/4 Watt	745-0784-000
R12	Resistor, 1K, 1/4 Watt	745-0748-000
R13	Resistor, 10K, 1/2 Watt, VAR	382-1405-220
R14	Resistor, 10K, 1/4 Watt	745-0784-000
R15	Resistor, 15K, 1/4 Watt	745-0790-000
R16	Resistor, 10K, 1/4 Watt	745-0784-000
R17	Resistor, 2.2K, 1/4 Watt	745-0760-000
R18	Resistor, 82K, 1/4 Watt	745-0817-000
R19	Resistor, 4.7K, 1/4 Watt	745-0772-000
R20	Resistor, 1.2K, 1/4 Watt	745-0752-000
R21	Resistor, 5K, 1/2 Watt, VAR	382-1405-210
R22	Resistor, 1K, 1/4 Watt	745-0748-000
R23	Resistor, 8.2K, 1/4 Watt	745-0781-000
R24	Resistor, 180 ohm, 1/4 Watt	745-0721-000
R25	Resistor, 8.2K, 1/4 Watt	745-0781-000
R26	Resistor, 180 ohm, 1/4 Watt	745-0721-000
R27	Resistor, 22 ohm, 1/4 Watt	745-0688-000
R28	Resistor, 1K, 1/4 Watt	745-0748-000
R29	Resistor, 27K, 1/4 Watt	745-0799-000
R30, R31	Resistor, 0.2 ohm, 3 Watt	725-3002-020
R32	Resistor, 120 ohm, 1/4 Watt	745-0715-000
R33	Resistor, 1K, 1/4 Watt	745-0748-000

A5 AMPLIFIER CONTROL ASSEMBLY - PARTS LIST 643-0012-001 (CONT.)

<u>REF. DES.</u>	<u>DESCRIPTION</u>	<u>PART NUMBER</u>
R34	Resistor, 2.2 ohm, 10 Watt	725-3002-010
R35, R36	Resistor, 3.9K, 1/4 Watt	745-0769-000
R37	Resistor, 6.8K, 1/4 Watt	745-0778-000
R38	Resistor, 10K, 1/4 Watt	745-0784-000
R39	Resistor, 10K, 1/8 Watt	705-1454-630
R40	Resistor, 10K, VAR	382-5001-010
R41	Resistor, 4.99K, 1/8 Watt	705-3605-330
R42, R43	Resistor, 10K, 1/8 Watt	705-1454-630
R44	Resistor, 249K, 1/8 Watt	705-1111-000
R45	Resistor, 1000K, 1/8 Watt	705-1117-000
R46	Resistor, 10 ohm, 1/4 Watt	745-0676-000
R47	Resistor, 680 ohm, 1/4 Watt	745-0742-000
R48	Resistor, 1K, 1/4 Watt	745-0748-000
R49	Resistor, 10 ohm, 1/4 Watt	745-0676-000
* S1	Switch, Slide, SPDT	266-9714-010
U1	I.C., LM358N	351-1211-040
U2	I.C., UA723PC	351-1035-060
U3	I.C., LM358N	351-1211-040
VR1	Zener Diode, 1N4752A	353-6481-490
VR2	Zener Diode, 1N4753A	353-6481-510
XU1	Socket, 8 Pin	220-0049-100
XU2	Socket, 14 Pin	220-0049-010
XU3	Socket, 8 Pin	220-0049-100
-	Hex Nut, 6-32	313-0045-000
-	Lock Washer, No. 6	310-0071-000
-	Flat Washer, No. 6	310-0046-000
-	Screw, 6-32x3/8 PPH	343-0169-000
-	Fuse Clip	265-9505-000
-	Mounting Pad	352-9552-620
-	Schematic	643-0013-001
-	Circuit Board	643-0011-001

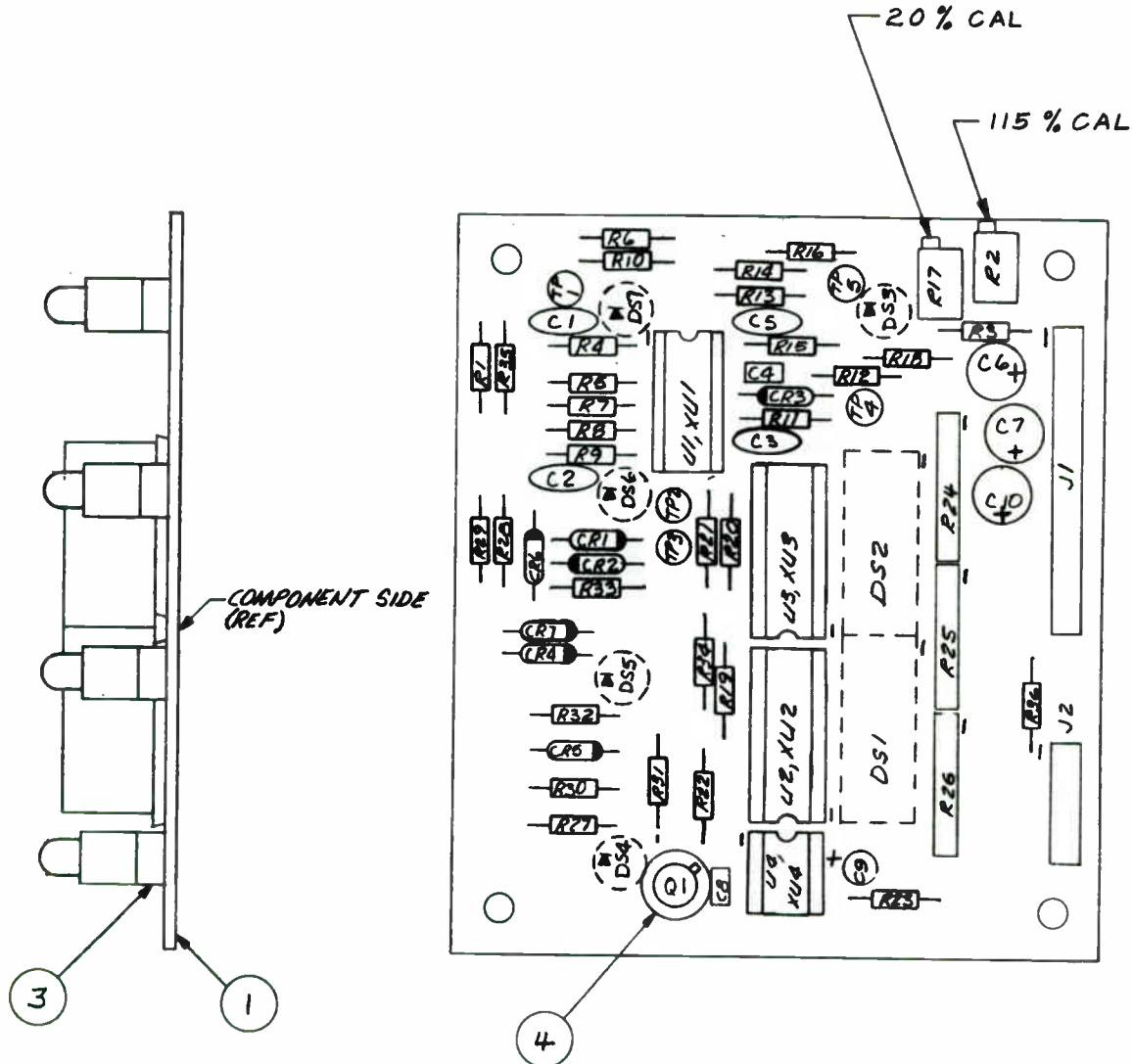

NOTES:

1. PARTIAL REFERENCE DESIGNATION ARE SHOWN, PREFIX WITH UNIT NUMBER OR SUB-ASSEMBLY DESIGNATIONS OR BOTH FOR COMPLETE DESIGNATION.
2. CIRCUIT BOARD FABRICATION SHALL MEET OR EXCEED REQUIREMENTS OF MIL-P-55110B AND MIL-STD-276C.

Ref. 643-0018-001 Rev. -

Figure 6-7. Modulation Display Assembly, A6

A6 MODULATION DISPLAY ASSEMBLY - PARTS LIST 643-0018-001

<u>REF. DES.</u>	<u>DESCRIPTION</u>	<u>PART NUMBER</u>
C1, C2, C3	Capacitor, 6.8PF	913-7006-030
C4	Capacitor, .002UF	913-5019-240
C5	Capacitor, 6.8PF	913-7006-030
C6, C7	Capacitor, 47UF	183-5007-020
C8	Capacitor, .1UF	913-5019-320
C9	Capacitor, 10UF	183-5007-060
C10	Capacitor, 47UF	183-5007-020
CR1, CR2, CR3	Diode	353-0448-020
CR4, CR5	Diode, 1N4148	353-3763-010
CR6, CR7	Diode, 1N4148	353-3763-010
DS1, DS2	Bar Graph Array	262-5008-010
DS3, DS4, DS5	L.E.D. Red	353-0293-040
DS6, DS7	L.E.D., Green	353-0293-010
J1	Connector	372-9604-190
J2	Connector	372-9604-180
Q1	XSTR, 2N2222A	352-0661-020
R1	Resistor, 100K, 1/4 Watt	745-0820-000
R2	Resistor, 10K, 1/2 Watt, VAR	382-1405-220
R3, R4, R5	Resistor, 10K, 1/8 Watt	705-1454-630
R6	Resistor, 4.99K, 1/8 Watt	705-3605-330
R7, R8	Resistor, 10K, 1/8 Watt	705-1454-630
R9	Resistor, 100K, 1/8 Watt	705-1092-000
R10, R11	Resistor, 10K, 1/8 Watt	705-1454-630
R12	Resistor, 5600K, 1/4 Watt	745-0883-000
R13	Resistor, 470K, 1/4 Watt	745-0844-000
R14, R15	Resistor, 10K, 1/4 Watt	745-0784-000
R16	Resistor, 1.2K, 1/4 Watt	745-0751-000
R17	Resistor, 5K, 1/2 Watt, VAR	382-1405-210
R18	Resistor, 10K, 1/4 Watt	745-0784-000
R19	Resistor, 1.2K, 1/4 Watt	745-0751-000
R20	Resistor, 1.8K, 1/4 Watt	745-0757-000
R21	Resistor, 10K, 1/4 Watt	745-0784-000
R22	Resistor, 120 ohm, 1/4 Watt	745-0715-000
R23	Resistor, 220K, 1/4 Watt	745-0832-000
R24, R25, R26	Resistor, Network 180 ohm	350-4600-010
R27	Resistor, 820 ohm, 1/4 Watt	745-0745-000
R28	Resistor, 220 ohm, 1/4 Watt	745-0724-000
R29	Resistor, 180 ohm, 1/4 Watt	745-0721-000
R30	Resistor, 6.8K, 1/4 Watt	745-0778-000
R31	Resistor, 10K, 1/4 Watt	745-0784-000
R32	Resistor, 1.5K, 1/4 Watt	745-0754-000
R33	Resistor, 1.8K, 1/4 Watt	745-0757-000

A6 MODULATION DISPLAY ASSEMBLY - PARTS LIST 643-0018-001 (CONT.)

<u>REF. DES.</u>	<u>DESCRIPTION</u>	<u>PART NUMBER</u>
R34	Resistor, 22K, 1/4 Watt	745-0796-000
R35	Resistor, 1K, 1/8 Watt	705-1454-390
R36	Resistor, 3.01K, 1/8 Watt	705-1019-000
TP1 thru TP5	Terminal	306-1126-000
U1	I.C., LF347N	351-1370-020
U2, U3	I.C., LM3914N	351-4709-010
U4	I.C., LM555CN	351-1140-010
XDS1, XDS2	Socket, 20 Pin	220-0049-090
XU1	Socket, 14 Pin	220-0049-010
XU2, XU3	Socket, 18 Pin	220-0049-060
XU4	Socket, 8 Pin	220-0049-100
-	XSTR Pad	352-9552-620
-	L.E.D. Spacer	262-5006-010
-	Schematic	643-0019-001
-	Circuit Board	643-0017-001

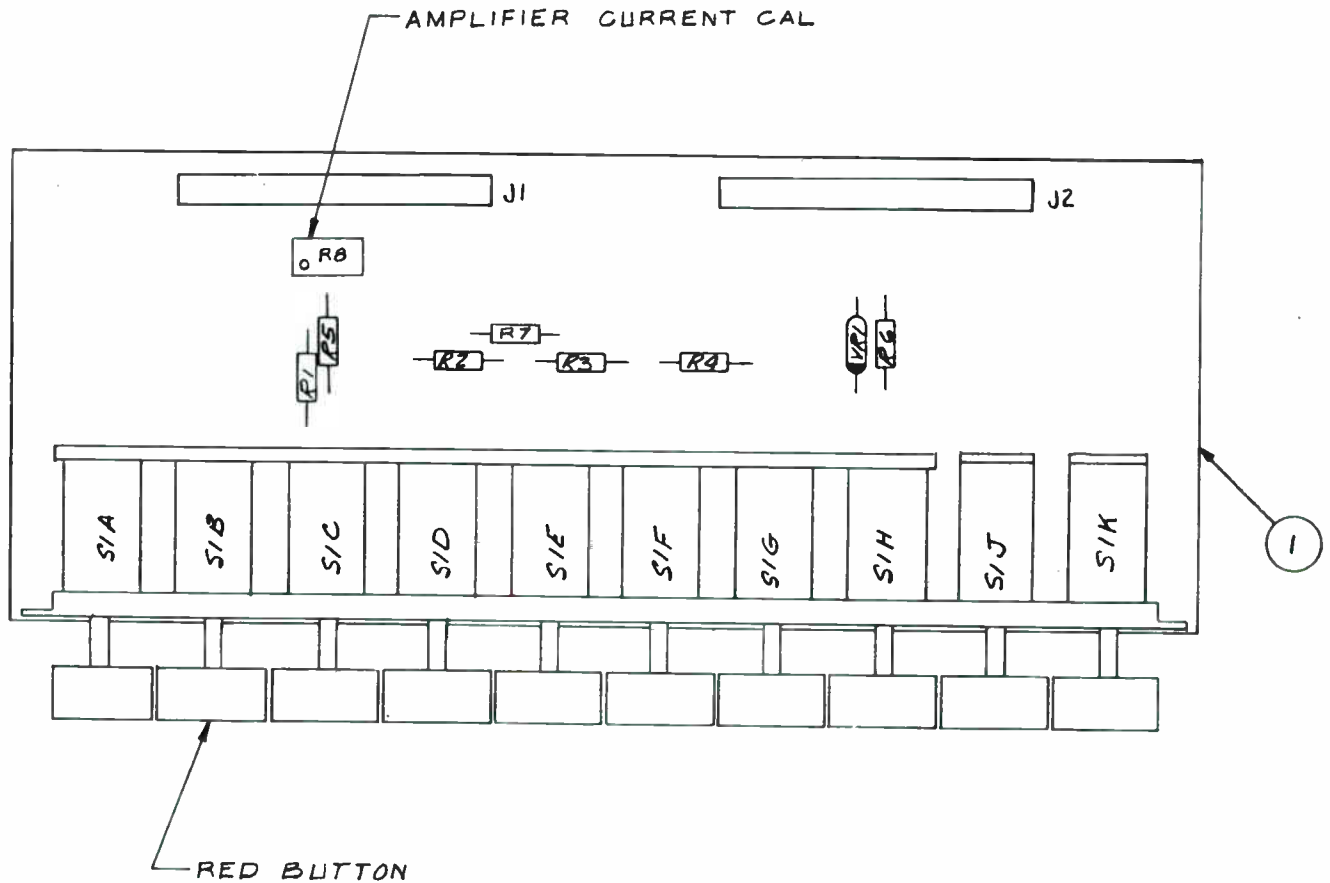

NOTES:

1. PARTIAL REFERENCE DESIGNATIONS ARE SHOWN. PREFIX WITH UNIT NUMBER OR SUB-ASSEMBLY DESIGNATIONS OR BOTH FOR COMPLETE DESIGNATION.
2. CIRCUIT BOARD FABRICATION SHALL MEET OR EXCEED REQUIREMENTS OF MIL-P-5510B AND MIL-STD-275C.

Ref. 643-0024-001 Rev. -

Figure 6-8. Metering Network Assembly, A7

A7 METERING NETWORK - PARTS LIST 643-0024-001

<u>REF. DES.</u>	<u>DESCRIPTION</u>	<u>PARTS NUMBER</u>
J1, J2	Connector	372-9604-190
R1, R2, R3	Resistor, 100K, 1/8 Watt	705-1092-000
R4	Resistor, 9.09K, 1/8 Watt	705-1042-000
R5	Resistor, 1.01K, 1/8 Watt	705-2502-010
R6	Resistor, 499K, 1/8 Watt	705-1118-000
R7	Resistor, 1.01K, 1/8 Watt	705-2502-010
R8	Resistor, Variable, 1K	382-1405-040
S1	Switch, 10 Station	266-9711-000
VR1	Diode, 1N4728A	353-6481-010
-	Schematic	643-0025-001
-	Circuit Board	643-0023-001

AR1, OUTPUT AMPLIFIER ASSEMBLY - PARTS LIST 643-0054-001

<u>REF. DES.</u>	<u>DESCRIPTION</u>	<u>PART NUMBER</u>
A1	Card, Output Amplifier	643-0027-001
C1, C2, C3, C4	Capacitor, Feedthru, 1000PF	913-4064-000
C5	Capacitor, .56 μ F	913-5019-530
J1, J2	Connector	357-7093-000
J3	Connector	372-5909-990
L1, L2, L3, L4	RF Choke	288-0842-100
Q1	XSTR, MJ3001	352-5016-010
R1	Resistor, 2.7K, 1/4 Watt	745-0910-750
S1	Temp. Switch	267-5001-000
XQ1	Socket, T0-3	220-0968-010
-	Cable Clamp	150-1540-000
-	XSTR Insulator	352-9655-040
-	Terminal for J3	372-9604-050
-	Spacer	643-0043-001
-	Output Amplifier Cover	643-0039-001
-	Front Heatsink Bracket	643-0038-001
-	Rear Heatsink Bracket	643-0037-001
-	Heatsink Support No. 2	643-0036-002
-	Heatsink Support No. 1	643-0036-001
-	Heatsink	643-0035-001

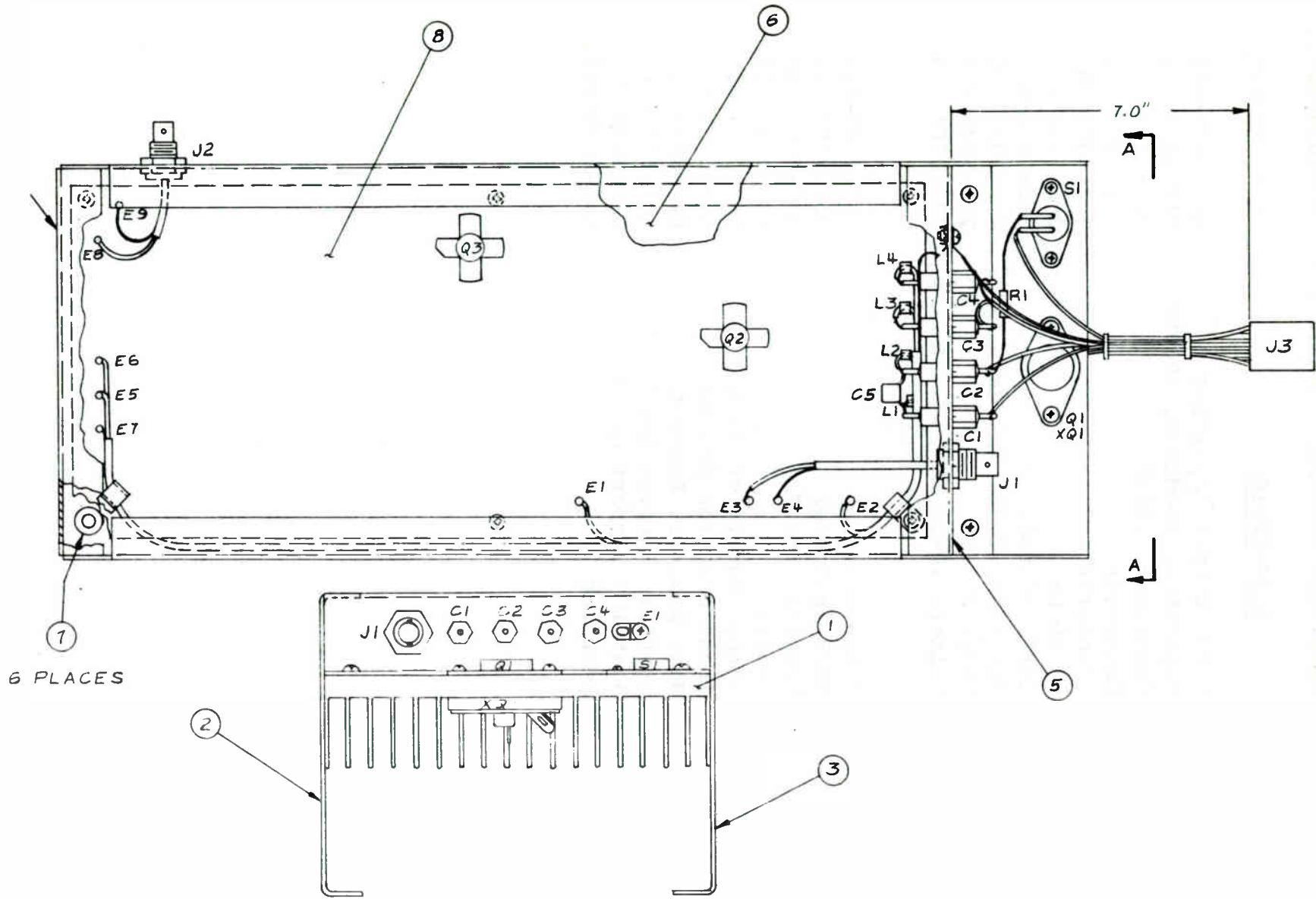

6 PLACES

VIEW A-A
ROTATED 30° CW

Ref. 643-0054-001 Rev. -

Figure 6-9. Output Amplifier Assembly, ARI

AR1A1 OUTPUT AMPLIFIER - PARTS LIST 643-0027-001

<u>REF. DES.</u>	<u>DESCRIPTION</u>	<u>PART NUMBER</u>
C1	Capacitor, 470PF	913-1189-000
C2	Capacitor, 47PF	912-3856-000
C3, C4, C5	Capacitor, 390PF	912-3921-000
C6	Capacitor, 470PF	913-1189-000
C7	Capacitor, 47UF	183-5007-020
C8	Capacitor, 390PF	912-3921-000
C9	Capacitor, 68PF	912-3867-000
C10	Capacitor, 12PF	912-3922-000
C11	Capacitor, 47PF	912-7025-030
C12	Capacitor, 390PF	912-3921-000
C13	Capacitor, 470PF	913-1189-000
C14	Capacitor, 47UF	183-5007-020
C15	Capacitor, 470PF	912-7025-060
C16	Capacitor, 47PF	912-7025-030
C17	Capacitor, 68PF	912-7025-040
C18, C19	Capacitor, 220PF	912-7025-050
C20	Capacitor, 390PF	912-3921-000
C21	Capacitor, 470PF	913-1189-000
C22	Capacitor, 47UF	183-5007-020
C23	Capacitor, 1000PF	912-7025-070
C24	Capacitor, 39PF	912-3853-000
C25, C26	Capacitor, 330PF	912-3915-000
C27	Capacitor, 47PF	912-3856-000
C28, C29	Capacitor, 330PF	912-3915-000
C30, C31, C32	Capacitor, .56UF	913-5019-530
C33	Capacitor, 6.8PF	913-7006-030
C34	Capacitor, 47PF	912-7025-030
C35	Capacitor, 10PF	912-3837-000
C36	Capacitor, 47PF	912-3856-000
CR1, CR2	Diode	353-0448-020
E1	Terminal	306-1126-000
thru		
E12		
L1	RF Coil, .051UH	278-5042-040
L2, L3	RF Choke, 1.0UH	240-1590-000
L4	RF Choke, .56UH	240-0874-050
L5	RF Coil, .032UH	278-5042-030
L6	RF Coil, .023UH	278-5042-020
L7	RF Coil, .11UH	278-5042-010
L8	RF Coil, .051UH	278-5042-040
L9	RF Choke	240-2679-040
L10	RF Choke	278-5041-000

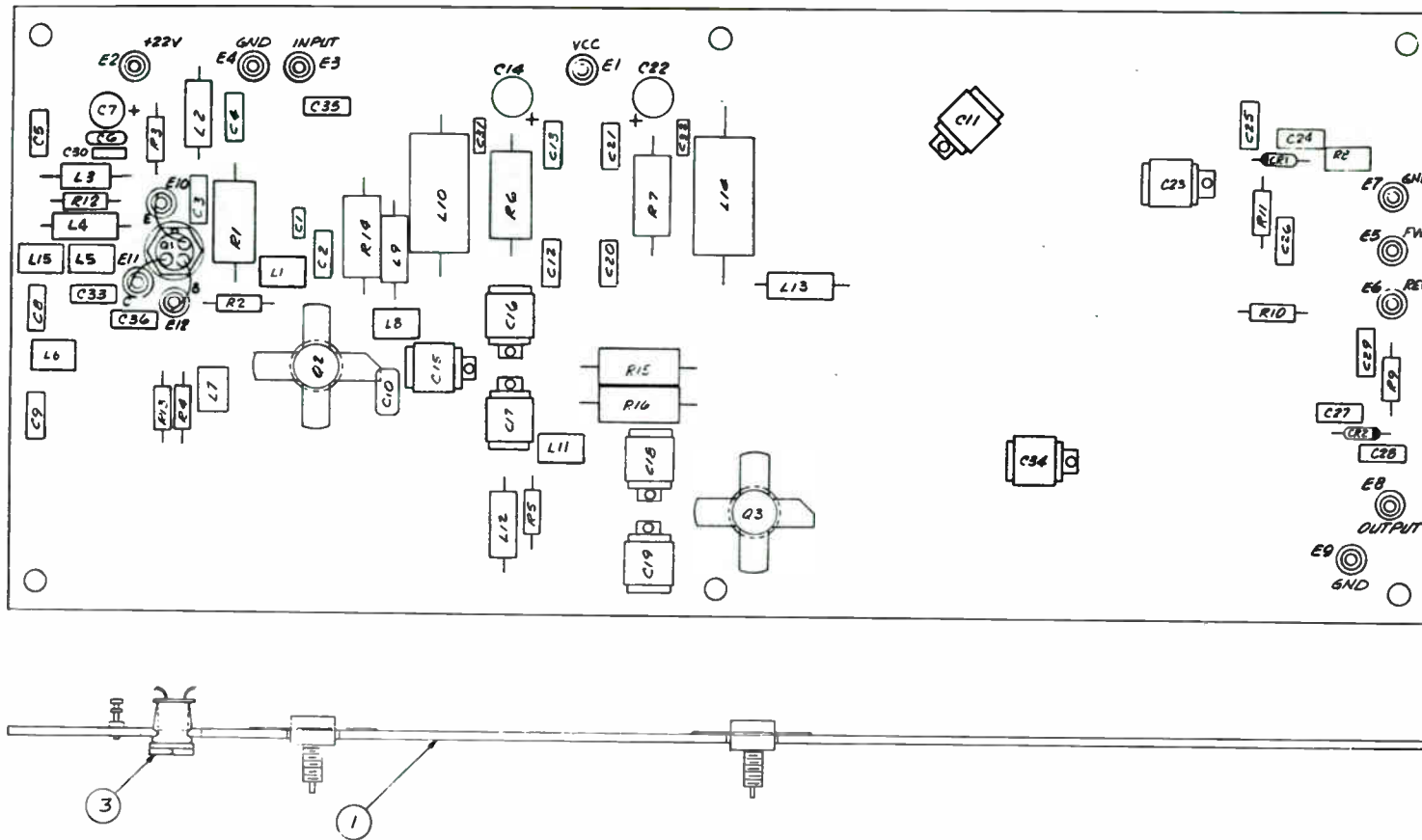

NOTES:

1. PARTIAL REFERENCE DESIGNATIONS ARE SHOWN. PREFIX WITH UNIT NUMBER OR SUB-ASSEMBLY DESIGNATIONS OR BOTH FOR COMPLETE DESIGNATION.
2. CIRCUIT BOARD FABRICATION SHALL MEET OR EXCEED REQUIREMENTS OF MIL-P-5510B AND MIL-STD-275C.
3. SOLDER Q2 & Q3 TO BOARD AFTER MOUNTING TO HEATSINK AT NEXT ASSEMBLY [6+3-005+03].

Ref. 643-0027-001

Figure 6-10. Output Amplifier, AR1A1

ARIAL OUTPUT AMPLIFIER - PARTS LIST 643-0027-001 (CONT.)

<u>REF. DES.</u>	<u>DESCRIPTION</u>	<u>PART NUMBER</u>
L11	RF Coil, .051UH	278-5042-040
L12	RF Choke, 1.0UH	240-1590-000
L13	RF Choke	240-2679-040
L14	RF Choke	278-5041-000
L15	RF Coil, .032UH	278-5042-030
Q1	XSTR, 2N3553	352-0632-010
Q2	XSTR, PT9732	352-4009-010
Q3	XSTR, MRF315A	352-5016-020
R1	Resistor, 1.2K, 2 Watt	745-5655-000
R2	Resistor, 100 ohm, 1/2 Watt	745-1309-000
R3	Resistor, 15 ohm, 1/2 Watt	745-1274-000
R4	Resistor, 22 ohm, 1/2 Watt	745-1281-000
R5	Resistor, 10 ohm, 1/2 Watt	745-1267-000
R6, R7	Resistor, 22 ohm, 2 Watt	745-5581-000
R8	Resistor, 200 ohm, 1/2W, VAR	382-1405-020
R9	Resistor, 1K, 1/2 Watt	745-1351-000
R10	Resistor, 100 ohm, 1/2 Watt	745-1309-000
R11, R12	Resistor, 1K, 1/2 Watt	745-1351-000
R13	Resistor, 22 ohm, 1/2 Watt	745-1281-000
R14	Resistor, 2.2K, 2 Watt	745-5665-000
R15, R16	Resistor, 150 ohm, 2 Watt	745-5616-000
-	Heatsink	352-4007-010
-	Schematic	643-0028-001
-	Circuit Board	643-0026-001

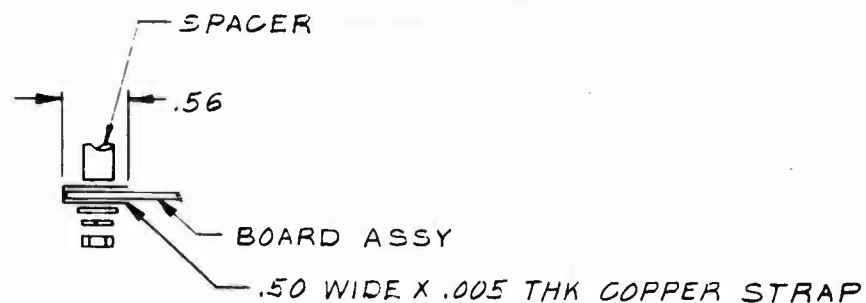

DETAIL A
2 PLACES

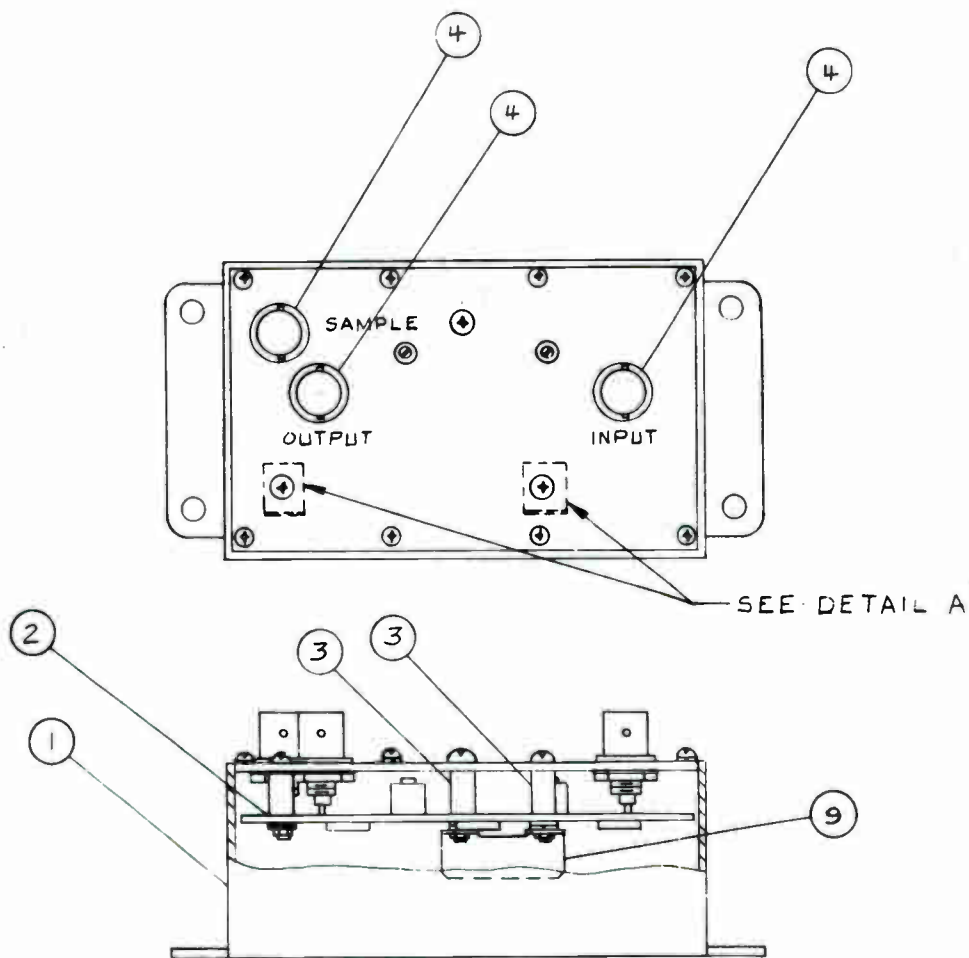

Ref. 643-0053-001 Rev. -

Figure 6-11. Harmonic Filter, FL1

SECTION 7 - VENDOR DATA

7-1. SOLID STATE COMPONENT LAYOUT

Table 7-1 contains connection layouts for the Solid State Components.



TABLE 7-1. SOLID STATE COMPONENT LAYOUTS

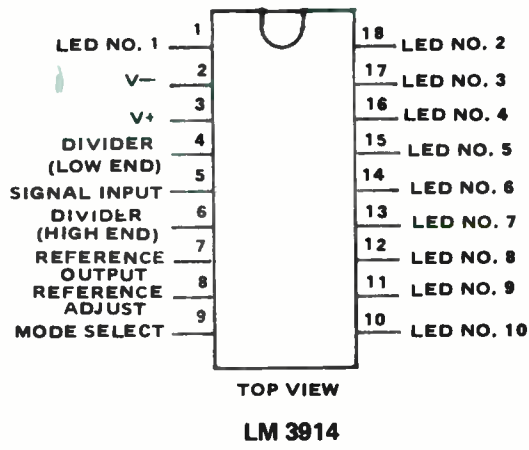
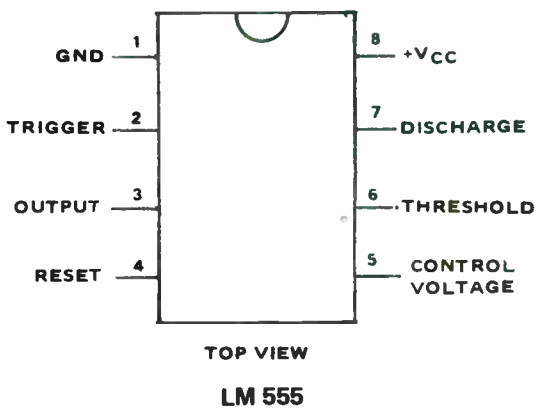
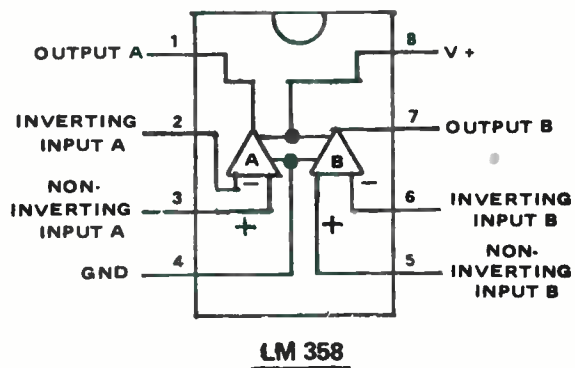
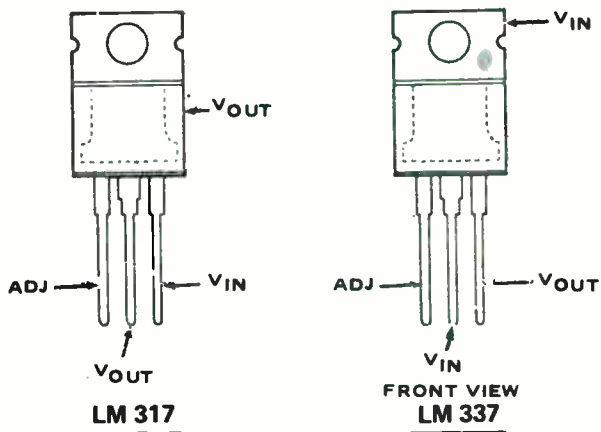
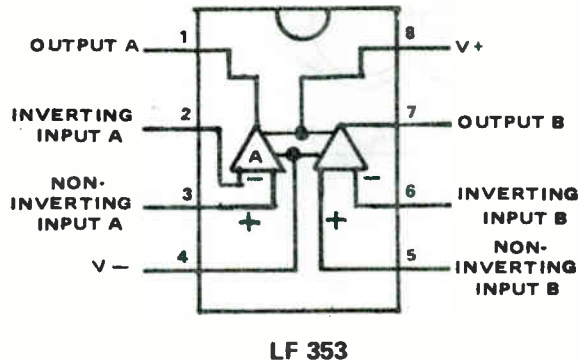
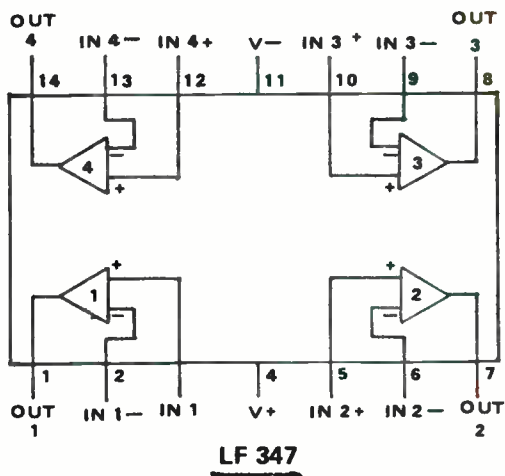
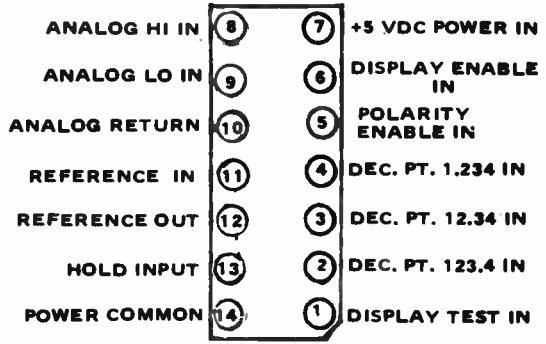
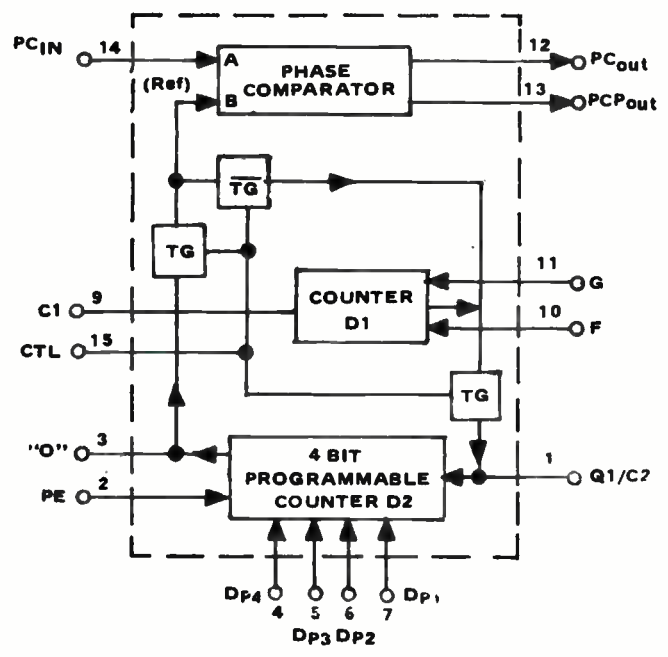
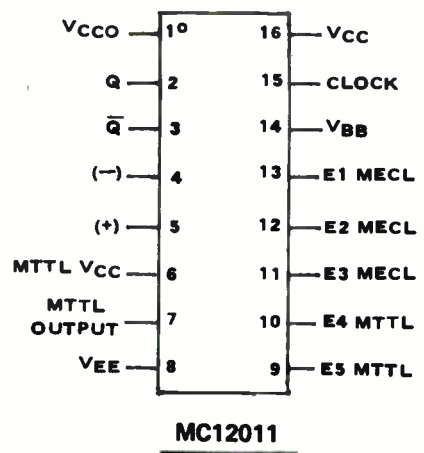
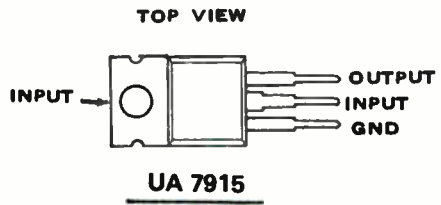
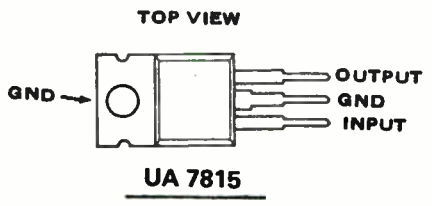
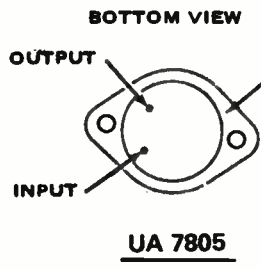

TABLE 7-1. SOLID STATE COMPONENT LAYOUTS - Cont.



M2 - DIGITAL MULTIMETER

V_{DD} = Pin 16
 V_{SS} = Pin 8
MC14568B

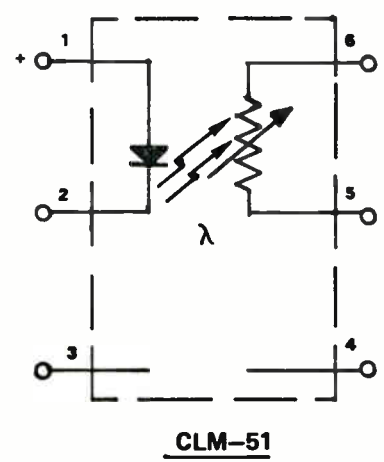
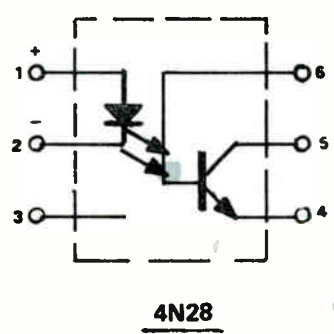
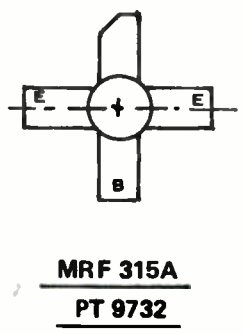
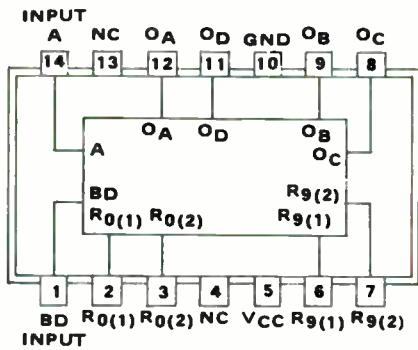
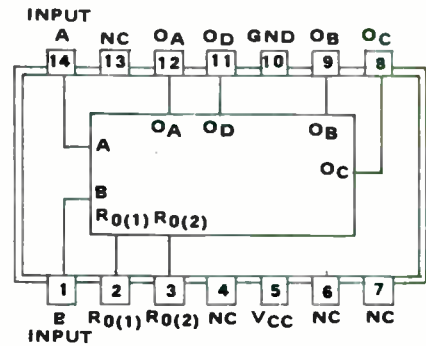

TABLE 7-1. SOLID STATE COMPONENT LAYOUT - Cont.



74LS90



74LS93

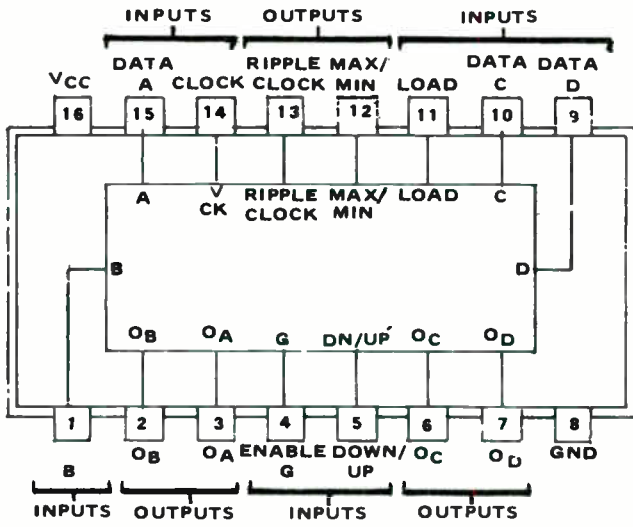

74LS190

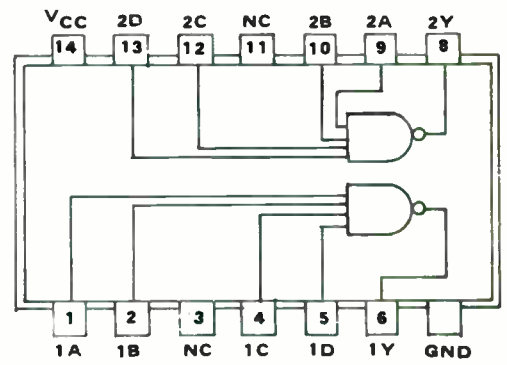

7420

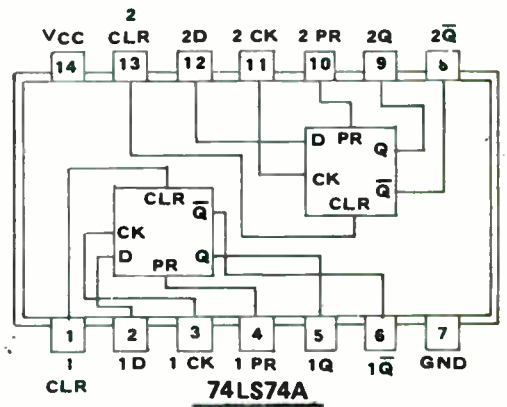

74LS74A

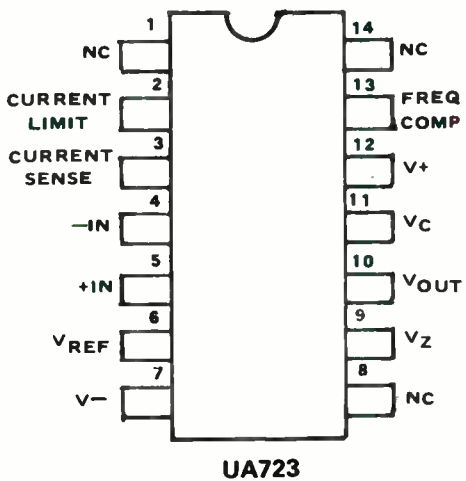

UA723

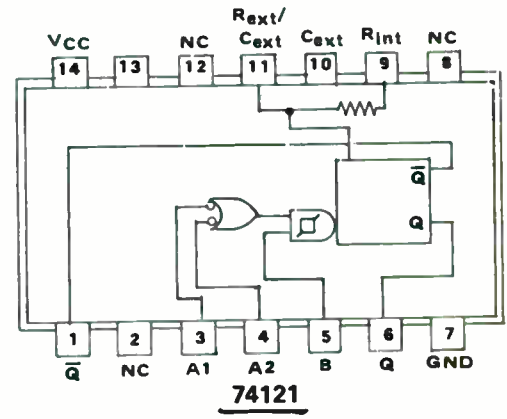

74121



[Faint, illegible handwritten text, possibly bleed-through from the reverse side of the page]

FACTORY TEST DATA
TYPE 802A 50 WATT FM EXCITER

SERIAL NO. 363 FREQUENCY 94.9 MHz
 STATION KJYK
 TESTED BY B. Loi DATE 5-15-85

MONO PERFORMANCE DATA

FREQUENCY (Hz)	DISTORTION (100% MOD)	RESPONSE (dB)	μ sec
50	0.04	0	
100	0.025	+0dB	
400	0.02	+0.2	
1,000	0.025	+1.0	
5,000	0.025	+8.4	
7,500	0.03	+11.4	
10,000	0.047	+13.6	
15,000	0.057	+16.6	

FM NOISE - 78 dB
 AM NOISE - 70 dB
 IM DISTORTION (4:1) 0.045%

COMPOSITE PERFORMANCE DATA

FREQUENCY (Hz)	DISTORTION (100% MOD)
50	0.04
1,000	0.042
10,000	0.043
20,000	0.035
40,000	0.035
75,000	0.048
100,000	0.075



FACTORY TEST DATA
TYPE 802A 50 WATT FM EXCITER

METER READINGS

+22	<u>21.3</u>	V
-22	<u>21.5</u>	V
+5	<u>4.93</u>	V
AFC	<u>8.0</u>	V

POWER OUTPUT

Vc (VOLTS)

Ic (AMPS)

50	<u>25.2</u>	<u>3.70</u>
45	<u>23.7</u>	<u>3.55</u>
40	<u>22.0</u>	<u>3.36</u>
35	<u>20.4</u>	<u>3.17</u>
30	<u>18.8</u>	<u>2.96</u>
25	<u>17.1</u>	<u>2.74</u>
20	<u>15.5</u>	<u>2.50</u>
15	<u>13.7</u>	<u>2.20</u>
10	<u>11.6</u>	<u>1.82</u>
5	<u>9.1</u>	<u>1.32</u>

