



FM Transmitters



The Collins Radio Company maintains three offices for your convenience:

CEDAR RAPIDS, IOWA (MAIN PLANT)
.11 WEST 42ND ST., NEW YORK 18, N. Y.
458 S. SPRING ST., LOS ANGELES 13, CAL.

At any one of these offices, qualified members of the Collins organization are prepared to give you immediate, reliable information regarding the fulfillment of your needs.

FOREWORD

In FM, as in AM, Collins transmitting equipment is thoroughly engineered to give you high performance with dependable, economical operation. The years of Collins experience in radio research, development, and manufacturing, and the widespread reputation of Collins radio equipment for advanced design and rugged dependability are your assurance that in your Collins transmitter you will have the best that can be had in FM equipment.

We are prepared to supply your entire requirements for transmitting equipment. Collins FM transmitters and speech equipment amply meet all FCC and RMA requirements and recommendations.

Our responsibility does not end with the delivery of the equipment. You have available the services of our engineering staff at all times, providing you the benefit of their skill and experience. You will have their assistance in getting your station on the air and operating efficiently in the shortest possible time.

COLLINS RADIO COMPANY • CEDAR RAPIDS, IOWA

11 W. 42ND ST. • NEW YORK 18, N.Y.

458 S. SPRING ST. LOS ANGELES 13, CAL.

Superior FEATURES

- | | |
|---------------------|-------------------------------|
| High efficiency | Vertical chassis construction |
| Simplified circuits | Low operating cost |
| Phasitron modulator | Thorough engineering |
| Motor tuning | Personnel protection |
| High stability | Harmonic attenuation |
| Accessibility | Centralized controls |
| Easy maintenance | Sturdy construction |
| Circuit protection | Heavy duty components |

* * *

Collins FM transmitting equipment is characterized by its unique engineering, combining originality in design with selected features that have been contributed to the radio field by outstanding scientists and engineers. The radically new and different Phasitron modulator circuit is employed, eliminating as many as ten tubes compared with former circuits, and resulting in far greater simplicity and operating reliability. Direct crystal control of the carrier frequency provides high stability without complexity of apparatus. A frequency multiplication of only 486 produces the carrier frequency. No frequency conversion or reference mechanisms are necessary. This new circuit, with fewer stages, fewer components, and

greater operating simplicity assures utmost dependability with a minimum of maintenance.

Each stage is individually engineered for its specific purpose. The complete equipment is an integrated unit, with all circuits performing in accordance with the overall plan. Spurious responses are nonexistent. Harmonic radiation is kept low through the use of push-pull output stages and electrostatic shielding of output coupling. Output stages are precisely tuned by motor driven elements that respond instantly to the operator. All controls are on the front panel.

A carrier control monitor is available which will protect the transmitter in case

of antenna or transmission line failure.

Receiving type tubes and high efficiency transmitting tubes are used to effect low operating cost. Tube types have been kept to a minimum, thus minimizing maintenance spares.

The transmitters described here are all cooled with filtered air. The cabinets are pressurized to exclude dust. An ambient temperature of +45°C is permissible, and room air may be recirculated for cooling both the 250 watt and the 1 kilowatt transmitters. It is advisable to draw in outside air for cooling the 3 kilowatt transmitter.

All power circuits include individual circuit breakers which open automatically under overload. Interlocking circuits prevent the application of plate voltages before the filaments have reached the specified operating temperature.

Particular attention has been given to accessibility. Vertical chassis construction is employed extensively. All tuning controls and the low voltage power circuits are accessible while the equipment is on the air. Centralized metering and controls

contribute to the overall ease of operation.

Maximum personnel protection is afforded by the use of electrical interlocks on doors opening to high voltage circuits, which are broken when the doors are opened. In addition, a grounding bar is mechanically operated to short out the circuits and trip the circuit breakers.

Sturdy construction, and heavy duty components in thoroughly engineered circuits assure long life with continuous operation.

These transmitters are designed as units, and may be combined with additional amplifier units to increase the power output and area coverage. The cabinets are attractively styled in three-tone gray. The design is such that each installation, irrespective of the number of cabinets, has a distinctive, integrated appearance.

SPEECH EQUIPMENT AND ACCESSORIES:

Complete studio facilities and transmitter accessories can be selected from the Collins Speech Equipment and Accessories booklet.

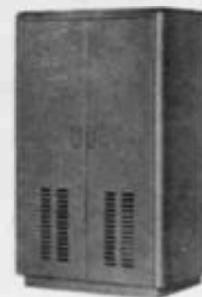
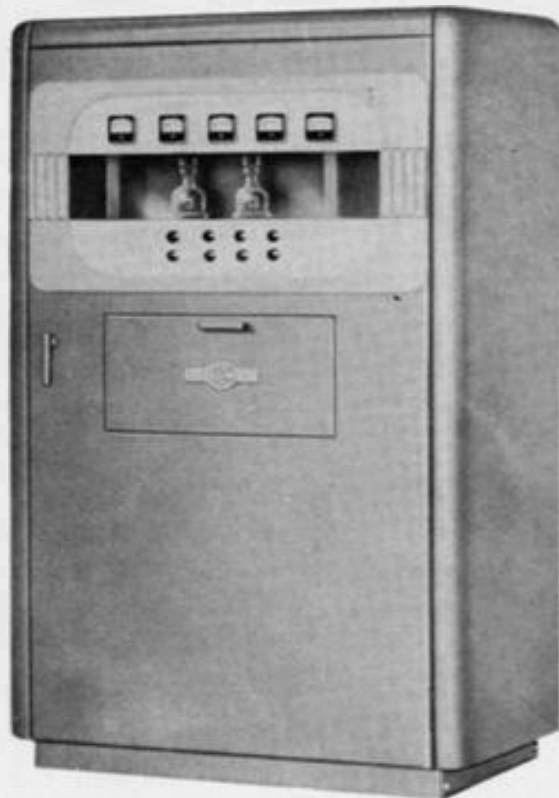

731A-1 SPECIFICATIONS

RANGE: Any specified channel between 88 mc and 108 mc.

POWER OUTPUT: 100 watts to 250 watts continuous duty operation.

LOAD: 40 to 80 ohm coaxial transmission line, power factor 0.866 to 1.0 (other arrangements are available).

STABILITY: Better than ± 1000 cps.

SWING: 0 to 120% modulation.

FREQUENCY RESPONSE: Flat within 1 db from 50 cps to 15,000 cps.

PRE-EMPHASIS: Standard 75 microsecond pre-emphasis network to be supplied for mounting in transmitter, or on 19" relay rack panel where transmitter is to be fed by compression amplifier.

DISTORTION: At 100% modulation 50 cps to 15,000 cps, less than 1.5%. Measurements in accordance with FCC re-

quirements.

AUDIO INPUT LEVEL: +12 dbm for 100% modulation at 400 cps.

AUDIO INPUT IMPEDANCE: 600 ohms and 150 ohms, balanced to ground.

NOISE LEVEL: a. Frequency modulation - better than 65 db below 100% modulation.

b. Amplitude modulation - better than 50 db below a level representing 100% amplitude modulation. (Measurements in accordance with FCC requirements.)

LINE VOLTAGE: 208/230 volts single phase.

VOLTAGE LIMITS: 190 to 250 volts.

LINE FREQUENCY: 60 cycle normal, 50 cycle on special order.

POWER DEMAND: 1.5 KVA 94% P. F. at maximum rated output.

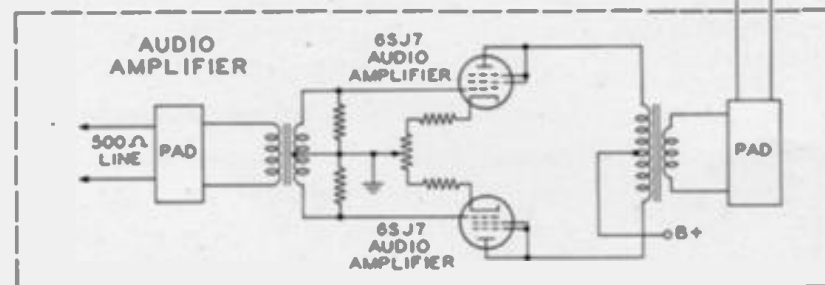
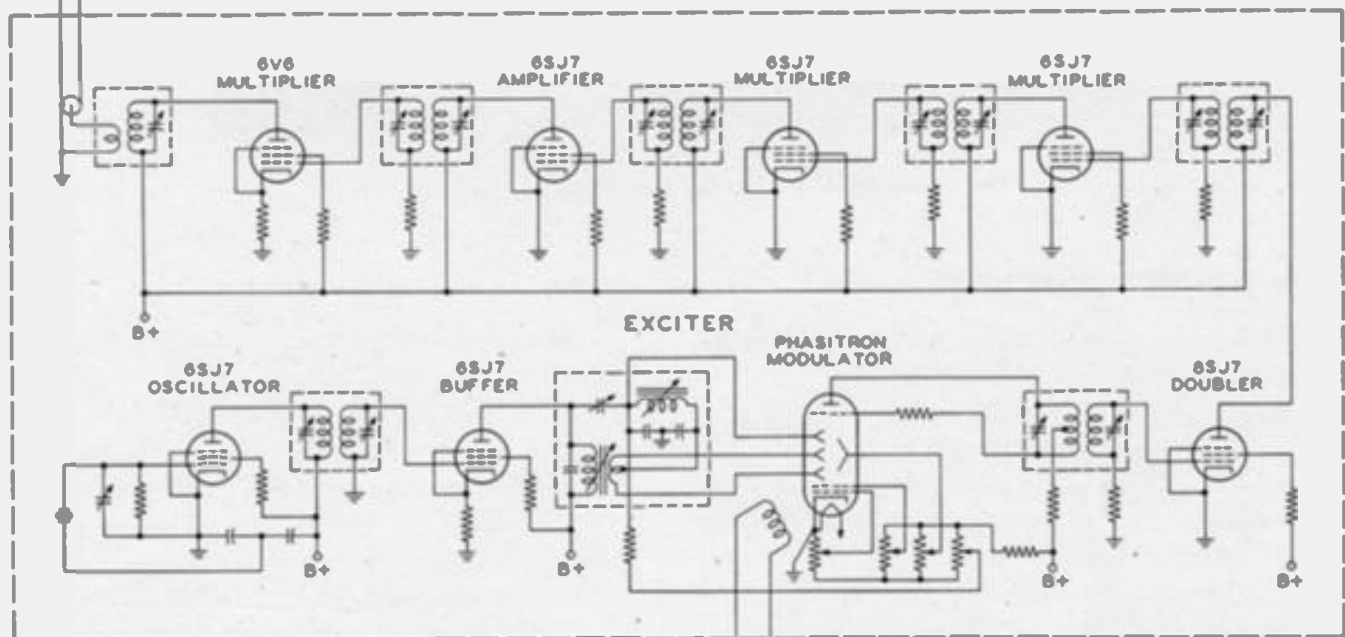
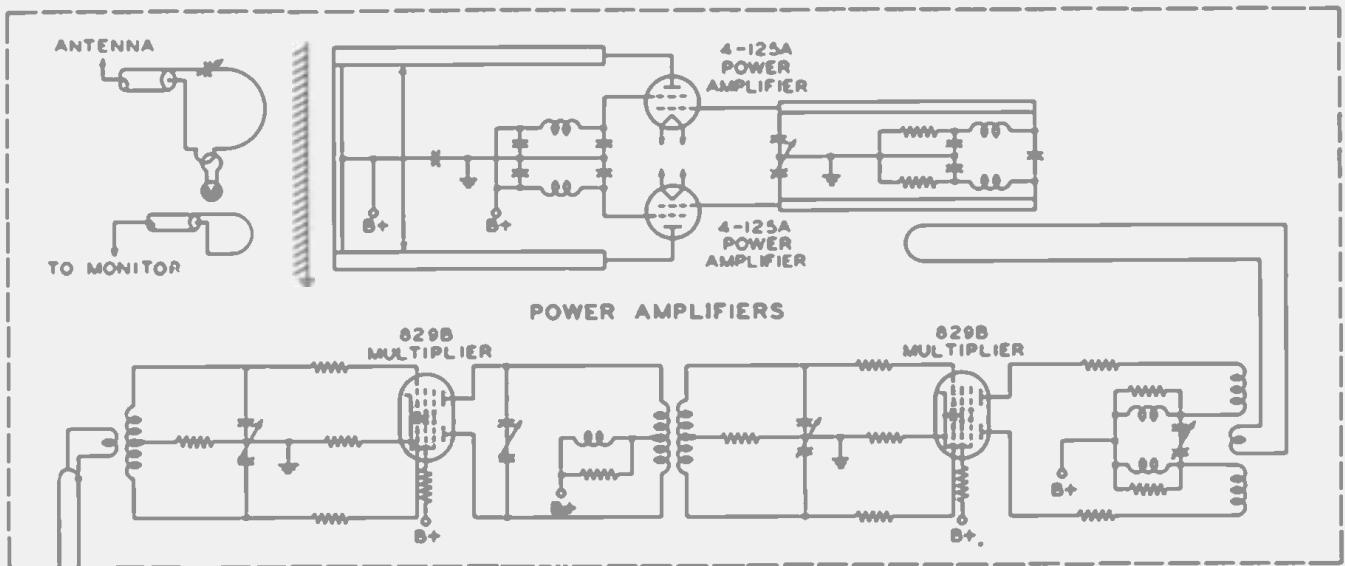

TYPE 731A
250 WATT F.M.
BROADCAST
TRANSMITTER



732A-1 SPECIFICATIONS

FREQUENCY RANGE: Any specified channel between 88 mc and 108 mc.

POWER OUTPUT: 250 watts to 1 kilowatt continuous operation.

LOAD: 40 to 80 ohm coaxial transmission line, power factor 0.866 to 1.0 (other output arrangements are available).

STABILITY: Better than ± 1000 cps.

SWING: 0 to 120% modulation.

FREQUENCY RESPONSE: Flat within 1 db from 50 cps to 15,000 cps.

PRE-EMPHASIS: Standard 75 microsecond pre-emphasis network to be supplied for mounting in transmitter, or on 19" relay rack panel where transmitter is to be fed by compression amplifier.

DISTORTION: At 100% modulation: 50 cps to 15,000 cps, less than 1.5%.

Measurements in accordance with FCC requirements.

AUDIO INPUT LEVEL: +12 dbm for 100% modulation at 400 cps.

AUDIO INPUT IMPEDANCE: 600 ohms and 150 ohms, balanced to ground.

NOISE LEVEL: a. Frequency modulation - better than 65 db below 100% modulation.

b. Amplitude modulation - better than 50 db below a level representing 100% amplitude modulation. (Measurements in accordance with FCC requirements.)

LINE VOLTAGE: 208/230 volts, 3 phase.

VOLTAGE LIMITS: 190 to 240 volts.

LINE FREQUENCY: 60 cycle normal, 50 cycle on special order.

POWER DEMAND: 3.0 KVA, 90% P. F. at maximum rated output.

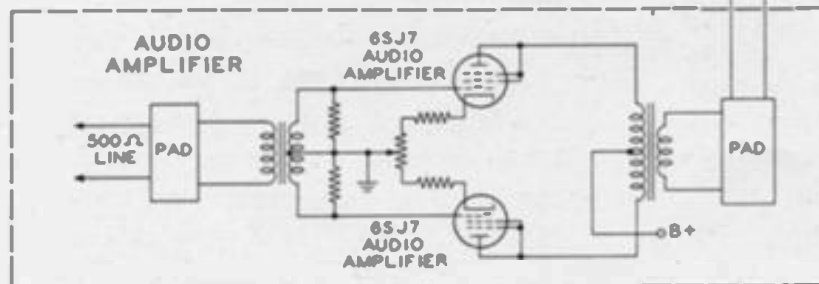
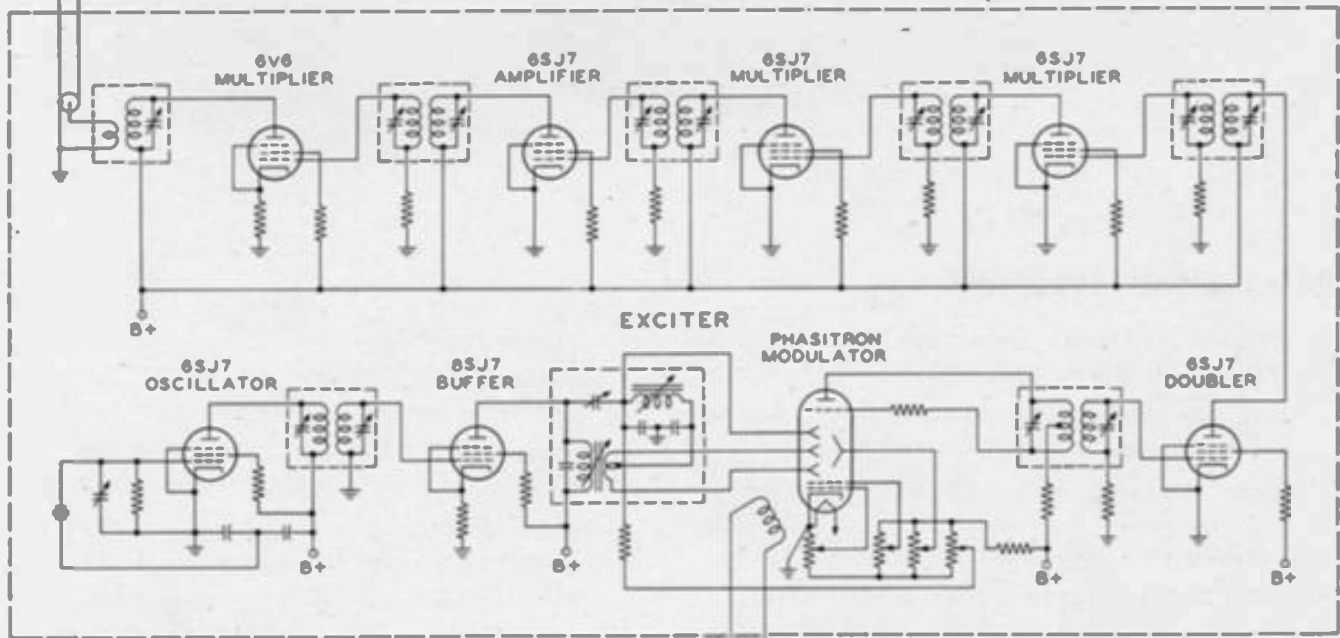
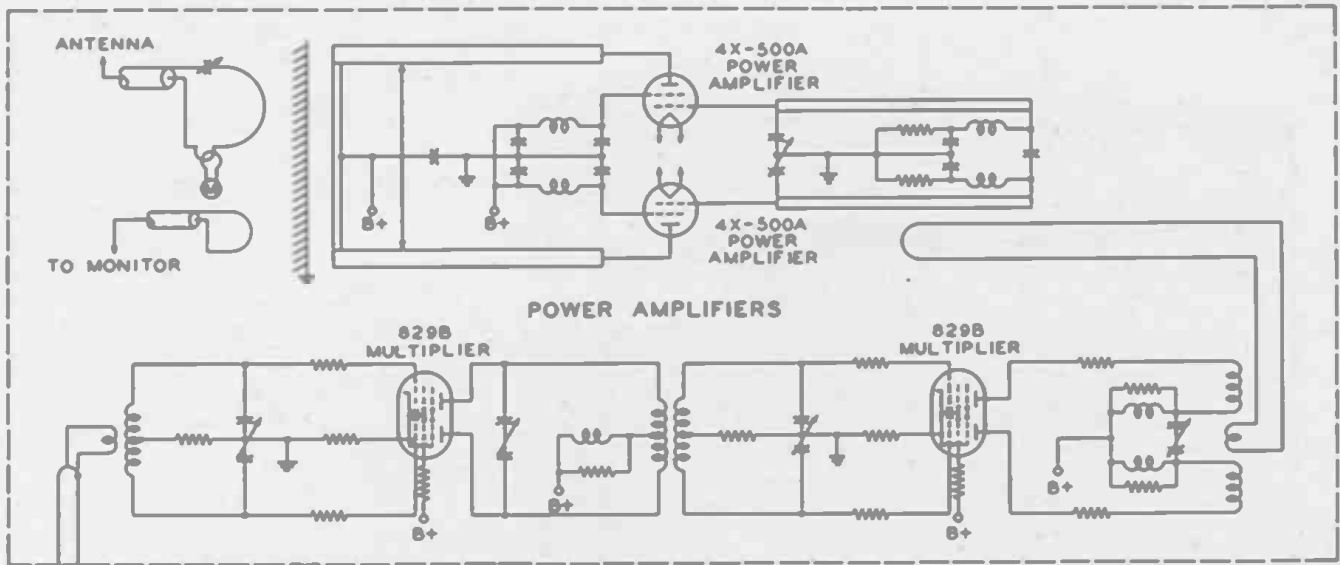

TYPE 732A
1000 WATT F.M.
BROADCAST
TRANSMITTER



733A-1 SPECIFICATIONS

FREQUENCY RANGE: Any specified channel between 88 mc and 108 mc.

POWER OUTPUT: 1 kilowatt to 3 kilowatts, continuous duty operation.

LOAD: 40 to 80 ohm coaxial transmission line, power factor 0.866 to 1.0 (other output arrangements are available).

STABILITY: Better than ± 1000 cps.

SWING: 0 to 120% modulation.

FREQUENCY RESPONSE: Flat within 1 db from 50 cps to 15,000 cps.

PRE-EMPHASIS: Standard 75 microsecond pre-emphasis network to be supplied for mounting in transmitter, or on 19" relay rack panel where transmitter is to be fed by compression amplifier.

DISTORTION: At 100% modulation: 50 cps to 15,000 cps, less than 1.5%. Measurements in accordance with FCC

requirements.

AUDIO INPUT LEVEL: +12 dbm for 100% modulation at 400 cps.

AUDIO INPUT IMPEDANCE: 600 ohms and 150 ohms, balanced to ground.

NOISE LEVEL: a. Frequency modulation - better than 65 db below 100% modulation.

b. Amplitude modulation - better than 50 db below a level representing 100% amplitude modulation. (Measurements in accordance with FCC requirements.)

LINE VOLTAGE: 208/230 volts, 3 phase.

VOLTAGE LIMITS: 190 to 240 volts.

LINE FREQUENCY: 60 cycle normal, 50 cycle on special order.

POWER DEMAND: 8.5 KVA, 90% P. F. at maximum rated output.

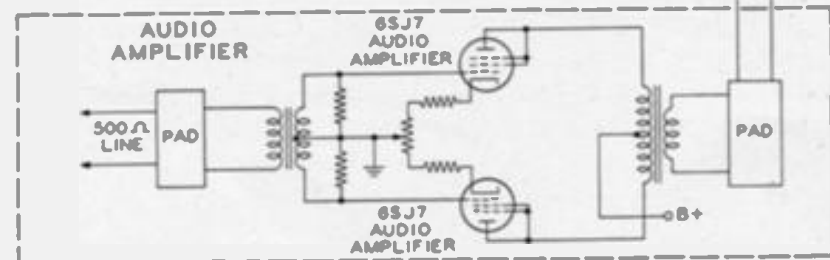
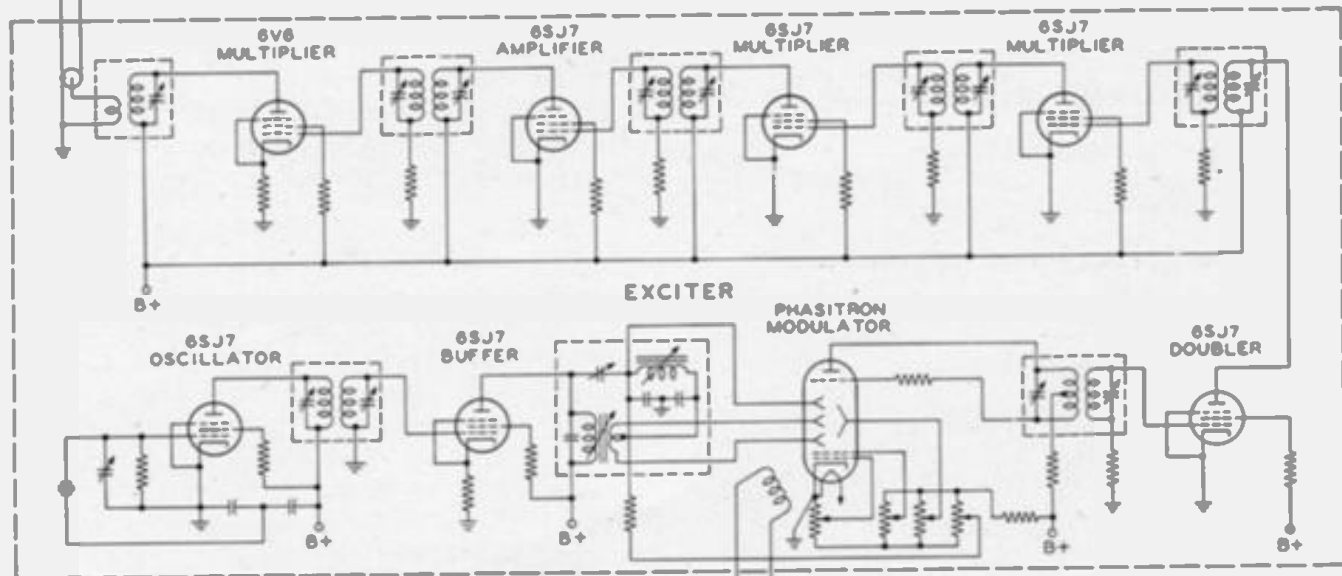
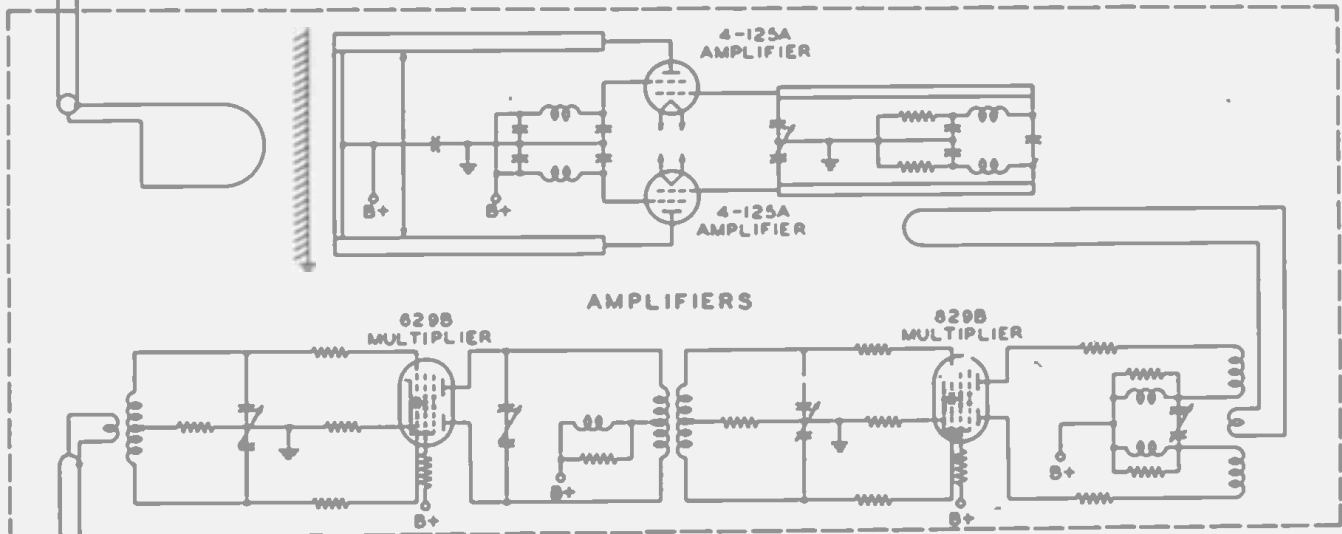
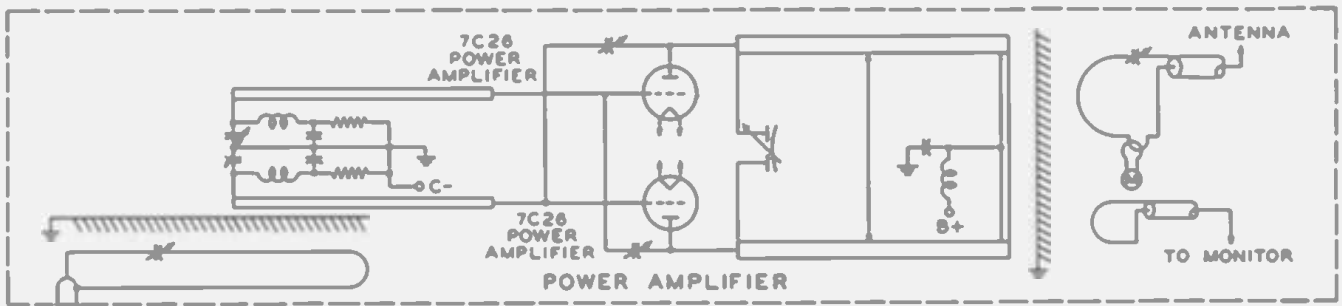

TYPE 733A
3000 WATT F.M.
BROADCAST
TRANSMITTER



For audio control in AM, FM and Television broadcasting.

FEATURES:

- 2 program amplifiers
- 10 independent input channels
- 6 remote lines
- monitor amplifier
- talkback circuits
- interlocked circuits
- on-the-air connections
- 2 VU meters
- can be tilted while in operation
- rotating chassis
- maximum accessibility
- 30 - 15,000 cps frequency response
- less than 1% distortion
- 5 speaker monitor output

The Collins 212A-1 speech input console is a packaged unit providing complete control of studio speech input equipment. Maximum versatility, simplicity of installation, convenience in operation, and extended high fidelity frequency response

combine to make the 212A-1 an outstanding contribution to FM, AM and Television broadcasting.

This console provides all facilities for auditioning or rehearsing, cueing, and broadcasting simultaneously from any combination of two studios, an announce booth, a control room announce microphone, two turntables, and six remote lines. Two program amplifiers are included in the 212A-1, making possible the feeding of two independent programs at once, or providing an emergency amplifier for normal use.

Advanced styling and construction provide an attractive appearance and quick, easy accessibility to all components and wiring. A novel rotating arrangement allows the entire unit to be tilted for access to the under side of the chassis *without requiring any additional space.* The 212A can be placed right up against a window, wall, or other obstructing surface without sacrificing accessibility, or requiring external support when the chassis is tilted.

The sloping front panel provides ease of reading and hand movements. Lever type positive action switches are employed in line switching circuits, and convenient push button controls are used to connect

remote lines. Attenuators have a smooth easy action.

Other salient features and specifications for the 212A-1 include:

1. 10 Independent input channels, including 6 microphone inputs and 2 low level transcription inputs (eight preamplifiers, one for each of the foregoing), as well as 2 independent channels for remote pickups.

2. Any one of six remote lines can be selected at will. Normal connections are supplied through the switches, so that override in the monitor amplifier is possible if desired. The remote channel provides the feedback of cue to the remote line selected.

3. Loudspeakers in all studios can be fed from the monitor amplifier, with selective talkback circuits interlocked to prevent program interruption. Talkback from the control room is possible into any one of three studios or into the remote lines by key switch control.

4. Connections are provided for external on-the-air light relays, with power furnished by the 212A-1 power supply.

5. Two VU meters are incorporated. One is bridged continuously across the program. Tube check is provided by a meter switch in the other VU circuit.

6. Jacks are provided for earphone monitoring of either program amplifier.

7. The construction permits easy access to tubes, attenuators, switches,

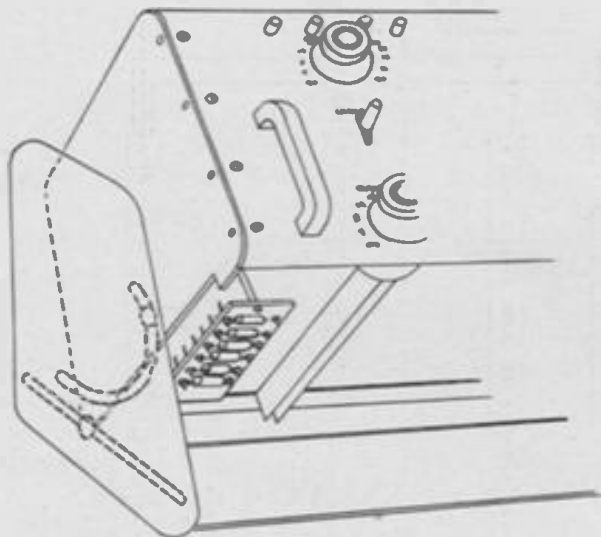

and other components and wiring without disassembly or deinstallation of the console.

8. The power supply is external, with provision for installation of duplicate power supplies. A single supply is capable of operating the equipment with adequate safety factors for long, trouble-free service. However, if two supplies are installed, a changeover is effected automatically in case of failure of the power supply in use.

SPECIFICATIONS:

FREQUENCY RESPONSE: Microphone to line or microphone to speaker, within 2 db total variation from 30 to 15,000 cps at normal gain control settings. Not more than $\pm 1/2$ db additional variation in frequency response over the above range at any other gain control setting.

INPUT IMPEDANCE: Microphones 30/50 or 200/250 ohms. Remote lines 150 or 600 ohms, with repeat coils self-contained. Turntables 250 ohms.

OUTPUT IMPEDANCE: Program line 500/600 ohms, balanced. Speaker - maximum of 5, each 600 ohms, unbalanced.

OUTPUT LEVEL: Program line output adjustable -4 to -26 dbm in 1db steps. Monitor output 8 watts.

DISTORTION: Less than 1.0% rms harmonic distortion at -16 dbm output. Less than 2.0% rms harmonic distortion at 8 watts output from monitor amplifier. In addition, combination tone distortion shall be of the same order at the same levels.

GAIN: Maximum, microphone to line, 110 db, line to line 50 db.

NOISE LEVEL: With the gain controls adjusted for normal operation with a low level microphone input (-60db) and with 12 dbm output, but with input terminated in an equivalent resistance, the combined hum and noise in the program output is at least 60 db down.

POWER INPUT: 115 volts 50/60 cycles a-c.

dbm: reference level 1 mw, 600 ohms.

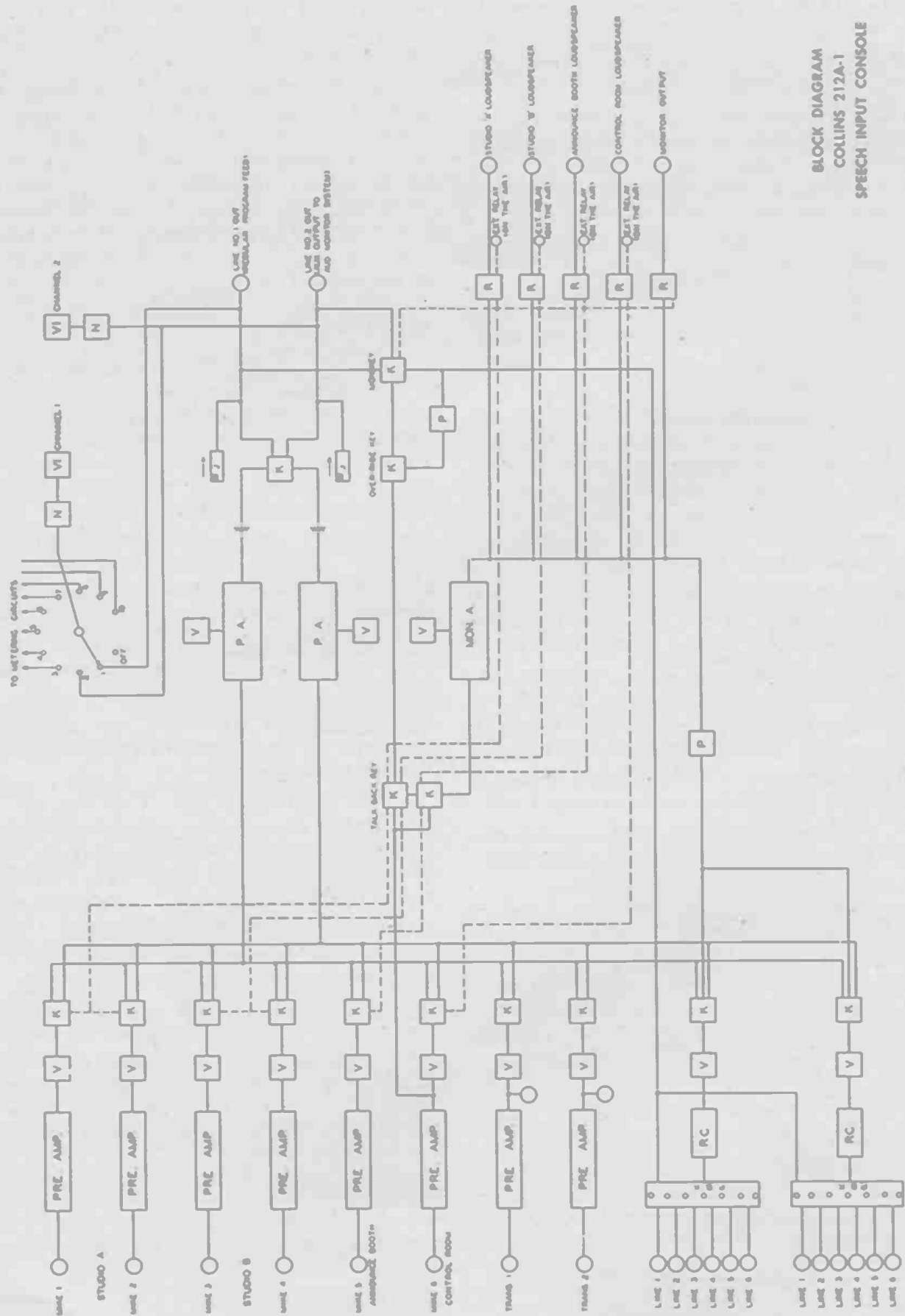

BLOCK DIAGRAM
COLLINS 212A-1
SPEECH INPUT CONSOLE



FEATURES:

- 7 independent input channels
- talkback circuits
- monitor amplifier
- interlocked circuits
- maximum accessibility
- 30-15,000 cps
- less than 1% distortion
- six remote lines
- rotating chassis
- 4 speaker monitor output

The Collins 212B-1 speech input console has the same superior quality, performance, and accessibility as the 212A-1 but is designed primarily for the smaller station where operational facilities are not so complex.

The 212B-1 provides complete control over simultaneous auditioning and broadcasting from any combination of two studios, a control room announce microphone, two turntables, and six remote lines. The

features of the 212B-1 that differ from those of the 212A-1 are:

1. 7 independent channels, including 4 microphone inputs each with its own preamplifier, 2 high level transcription inputs, and a remote pickup channel.

3. Loudspeakers in all studios can be fed from the monitor amplifier, with selective talkback circuits interlocked to prevent program interruption. Talkback from the control room into any one of two studios or into the remote lines by key switch control.

5. Tube check is quickly provided by a meter switch in the VU meter circuits.

8. An external power supply is provided with adequate safety factors for long, trouble-free service. Since the power supply is external, full size highest quality components are utilized in the speech console, with compact cabinet size and with all components and wiring easily accessible for maintenance.

9. Performance specifications of the 212B-1 and the 212A-1 are identical.

**BLOCK DIAGRAM
COLLINS 212B-1
SPEECH INPUT CONSOLE**

