

**SECRET**  
**CB**®



CONFIDENTIAL  
**FACTUAL**  
**REPORT**  
SCHEMATICS ETC.

## ACKNOWLEDGEMENTS

SECRET CB WISHES TO GRATEFULLY ACKNOWLEDGE THE FOLLOWING PEOPLE FOR THEIR HELP AND CONTRIBUTIONS TOWARD GETTING VOLUME 16 IN PRINT. THEIR ENCOURAGEMENT AND CONTRIBUTION OF MATERIAL HAS BEEN INVALUABLE.

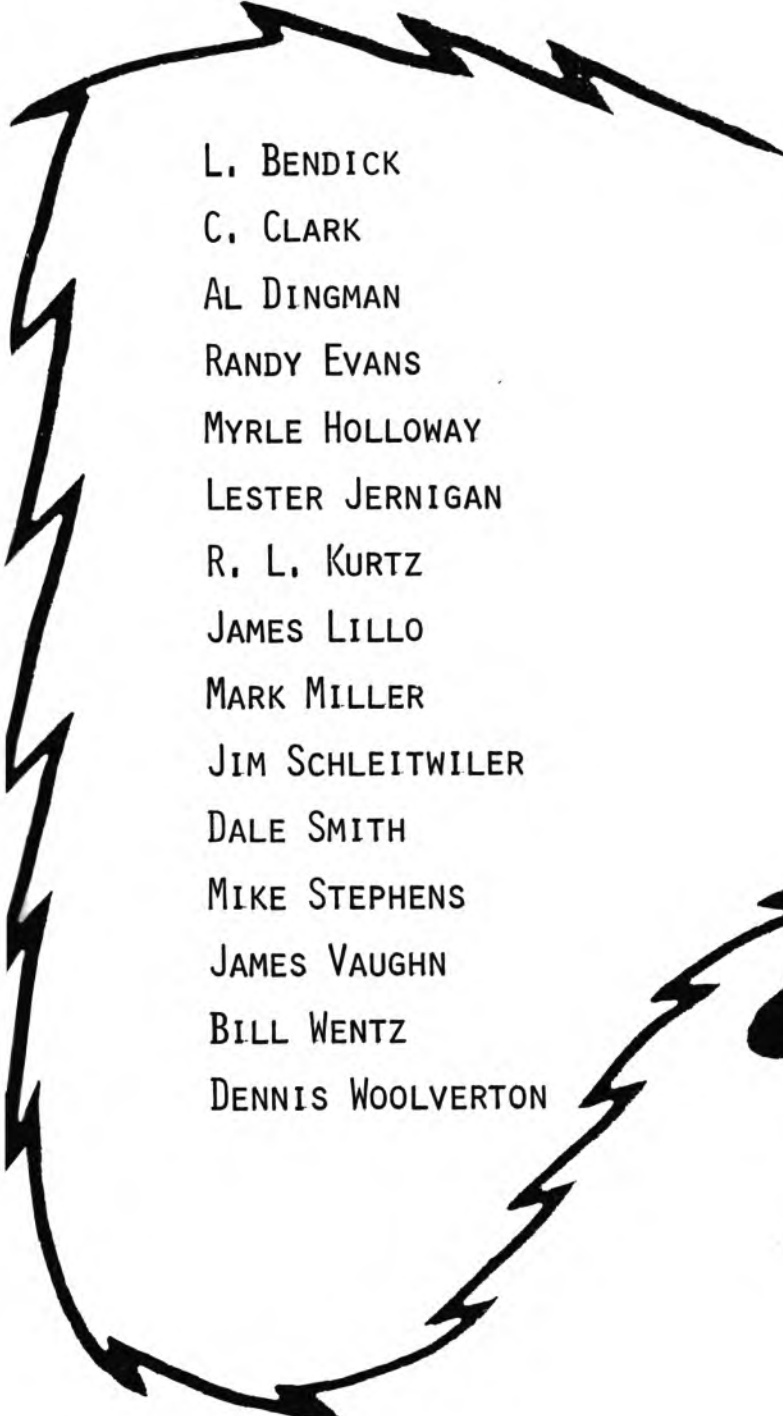

L. BENDICK  
C. CLARK  
AL DINGMAN  
RANDY EVANS  
MYRLE HOLLOWAY  
LESTER JERNIGAN  
R. L. KURTZ  
JAMES LILLO  
MARK MILLER  
JIM SCHLEITWILER  
DALE SMITH  
MIKE STEPHENS  
JAMES VAUGHN  
BILL WENTZ  
DENNIS WOOLVERTON

## WANTED

NEW MODIFICATIONS  
NEW CONVERSIONS  
TECHNICAL TIPS  
PROJECT PLANS  
ETC. ETC. ETC.



DORIS SAYS "THANKS" AND A FREE BOOK TO THE ABOVE PEOPLE.

## INTRODUCTION

A special thanks to our good friend, William G. Wentz, Jr., with his help we have been able to complete this Volume 16. All of our SECRET CB friends have been fantastic. With your patience and help we made it thru the past 6 months without a technician.

Because you all have waited so long for this volume we have packed it full. Bill and I know you are going to enjoy it.

Our "New Product Release" is about a new low kit for the TC9106, LC7130/7131, and uPD2814/2816C PLL Chips that also use a 10.7 ceramic or crystal filter in their receiver section.

There has been some installation problems with the VSB-1 (Kit #102) into the Cobra 2000 GTL. Included in this issue is some special hook-up instructions which solves the problem.

In this issue we have included the updated installation procedures for the Digital Processor Kit #146 and also the frequency chart.

Be sure to read about our NEWSLETTER and let us hear from you - pro or con!

When sending data in for Secret CB please print/give chassis #/ PLL type/ and especially PLL pin #'s.

Many thanks again to all of you who read and contribute to SECRET CB. We do appreciate all the information and helpful hints - KEEP THEM COMING. Volume 17 will be out sooner than you think! Scheduled for release in September.

Always Sincerely yours,



Doris Selman

# TABLE OF CONTENTS

PAGE #

ACKNOWLEDGEMENTS.....	1
INTRODUCTION.....	2
TABLE OF CONTENTS.....	3
NEWSLETTER.....	4-5
VSB-1 HOOK UP TO COBRA 2000GTL.....	6
SAMS CB MANUALS - OUT OF PRINT.....	7
!NEW PRODUCT RELEASE!.....	8
WEIRD CALL SIGNS.....	9
ZEBRA FREQUENCY CHART.....	10
ZEBRA ALPHA FREQUENCY CHART.....	11
ANCIENT FREQUENCY CHART.....	12
PENGUIN FREQUENCY CHART.....	13
EASY FREQUENCY CHART.....	14
MONGOOSE FREQUENCY CHART.....	15
WILD GOOSE FREQUENCY CHART.....	16
SCARECROW FREQUENCY CHART.....	17
ADAM FREQUENCY CHART.....	18
SLEEPER FREQUENCY CHART.....	19
DART FREQUENCY CHART.....	20
CUSTOM CONVERSION #2 - MIDLAND 76-858 - 02A PLL.....	21-24
CUSTOM CONVERSION #5 - Realistic TRC-448.....	25-30
HINTS / KINKS / GOOFS.....	31
SPECIFIC TUNE-UPS: GREAT Mdl. K605/GT-818, Royce I-580, Craig 4102, Beta 23 ch Deluxe, Coyote 23, Regency CR240, Tram XL-5, Realistic TRC-210.....	32
MODULATION ADJ/DEFEATS.....	32
M58472P PLL CHIP MODIFICATION.....	33
YOU CAN BUILD: OSCILLATOR CHECKER AND LOW CAPACITY PROBE...	34
TROUBLESHOOTING GUIDE.....	35-36
INTO THE KNOW WITH POTS.....	37
"MY WAY" SLIDE.....	38
COMMTRON XII ALIGNMENT & ADJUSTMENTS.....	39
COBRA 132XLR/135XLR UPDATE.....	39
MOTOROLA CC975AX.....	40
REALISTIC TRC-470.....	40
BLEED-OVER FILTER.....	40
ROAD RUNNER CB5000A.....	41
BRISTOL BCB-2271.....	41
LOOP FILTER-WHAT IS IT??.....	42
COLOR CODE GUIDE FOR CHOKES.....	42
COBRA 148GTL-DX ALIGNMENT PLL/RX/TX (EARLY).....	43-47
148GTL-DX BLOCK DIAGRAM (EARLY VERSION).....	48
148GTL-DX BLOCK DIAGRAM (LATER VERSION).....	49
148GTL-DX (EARLY) CLARIFIER MOD/TUNING.....	50-51
LAKE 400 (145106 PLL).....	52
COBRA 50XLR/55XLR (MB8719 PLL).....	53
"ANOTHER GOOD-1".....	54
COLT 1200 EXCALIBUR SERVICE TIP.....	55
TRS CHALLENGER 850/1400 UPDATE.....	55
TUNE UPS: LAFAYETTE CHB740, CHANNEL MASTER CB6830, MIDLAND 77-853	55
COBRA 148GTL-B Bulletin.....	55
PACIFIC SSB 800 Bulletin.....	56
ANTENNA INFORMATION.....	56
02A CLARIFIER & BANDSWITCH MODIFICATION.....	57-59
MIDLAND 6001 & 7001 (UPDATE).....	60-62
HIGH CURRENT METER AND "EL CHEEP-O" TEST LEADS.....	63-64
S.W.R. Vs. REFLECTED POWER %.....	65
"QUOTE-J.V." Re: THE BANDIT!.....	65
CUSTOM FREQUENCY STANDARD.....	66-67
SOMMERKAMP TRISTAR 747 (UPDATE).....	68
CHECKING MODULATION.....	69
DIGITAL PROCESSOR (KIT #146) DATA SHEET UPDATE.....	70
KIT #146 FREQUENCY CHART.....	71
"OOPS, WE GOOFED": Vol. 1, p. 61 - COURIER CENTURION.....	72
Vol. 13, p. 27 - RAY JEFFERSON.....	72
Vol. 12, p. 28 - REALISTIC TRC-57.....	72
Vol. 14, p. 22 - Step 3A.....	72
Vol. 14, p. 41 - GE 3-5813A/5869A.....	72
Vol. 15, p. 65 - AM POWER MOD.....	72
Vol. 15, p. 63 - TENNA POWER & FIELDMASTER.....	72
SECRET CB INDEX FOR VOLUMES 1 THRU 14.....	73-79
SECRET CB INDEX FOR VOLUME 15.....	80



"WANTED - FOR SALE - TRADE" NEWSLETTER

We have been asked about having advertising on radios, components, etc. in SECRET CB. This would suit no purpose as the time lag involved with printing of volumes.

So...have come up with a true, "Better Idea".

A "Newsletter" every two weeks, (Except Christmas/New Years Holidays). It will feature: Wanted, For Sale, Trade, etc., also any 'Late Breaking News' - Note: Like the Cobra 148GTL-DX's, (sources "dried-Up" within a month, and everyone lost out). In addition any particular problems that have been solved or have cropped up will be published...Newsletter will be limited to the CB and related Communications field only at this time. In the future it may, if subscribers want to expand, include other electronic fields.

To put this Newsletter into effect would need 100 initial subscribers at: \$15.00 for 24 issues (1st Class postage mailing every two weeks included). What we mean is that if we don't get 100 initial subscribers - the Newsletter idea; will be cancelled, and checks returned/or the next volume of SECRET CB shipped; at that "Special Price" only...(Your Choice)!

The 1st 100 subscribers can also place a free "80 character ad". Definition is by printed character; example: For Sale- 148GTL-DX, EX. Cond. \$200 ppd. J. Cornball; 123 Four St.; Corpus Christi, Tx 21119, 615-214-3162. (Don't count-Sale/Wanted/Trade, as will be coded) Count "Printed Material per Character"! Starting with the 1, in 148GTL, to the last 2 in phone number is 82 characters. The ad would cost \$1.64. At 2 cents per printed character. The ad will run for 3 issues, unless cancelled by phone or postcard. Minimum ad is \$1.00, no credit for un-used characters.

NOTE: Since speed of getting your ads published and in the mail is what the newsletter is all about we will accept checks for the newsletter and ads. (This policy is subject to change without notice.)

TO SUBSCRIBE: Send \$15.00 Check, Cash, or Money Order to Selman Enterprises, Inc., P.O. Box 8189, Corpus Christi, Texas 78412... If you wish to place an ad - send your ad and payment along with the subscription. If you are one of the first 100 you will be notified and your next ad will be free.

Newsletter cont.

If you want "Newsletter" only put SASE in envelope with payment and mark envelope "Newsletter" on lower left front corner. This will indicate you want to subscribe only, and check will be returned if Newsletter doesn't materialize. If you want "Newsletter" or Volume 17 of SECRET CB at 'Special Price' mark the envelope: "Newsletter/V-17" and forget the SASE...

Projected 1st issue is July 1, 1983, sooner if 100 subscribers materialize that quick (Note: this was written May 30th and have 8 subscribers from Nash/Tenn already!)

Price of ad is 2¢ per character. Send in your ad with your subscription so we will be ready to roll out the first Newsletter as soon as we get 100 subscribers.

WHEN SENDING IN ADS PLEASE PRINT CLEARLY ALL INFORMATION, NOT RESPONSIBLE FOR AUTHENTICITY OF ADS - WILL REPRINT OUR ERRORS AT NO CHARGE....

**!SPECIAL ACKNOWLEDGEMENT!**

"THANK YOU AGAIN, BILL WENTZ, FOR YOUR  
CONTRIBUTION TO THIS VOLUME OF SECRET CB"

USB-1 HOOK UP TO COBRA 2000GTL w/BYPASS SWITCH

XMTR

1. REMOVE C101

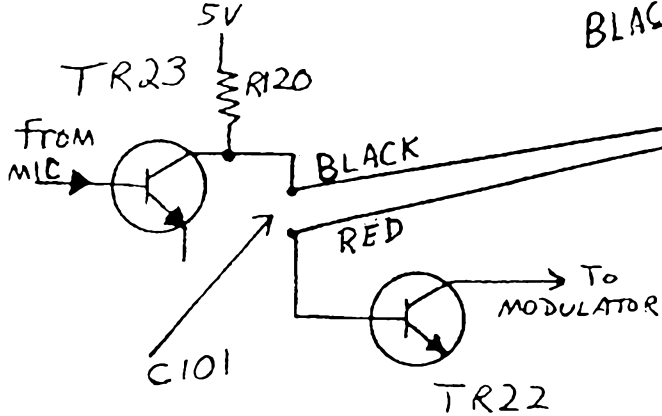

USB-1  
COMPRESSOR

BLACK - INPUT  
RED - OUTPUT

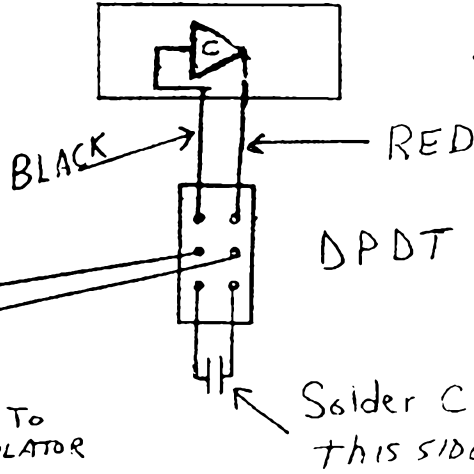

RECUR.

1. REMOVE C183
2. WIRE AS FOLLOWS
3. INSTALL IN914 AND 100K AS SHOWN IN RED LEAD FROM TR19

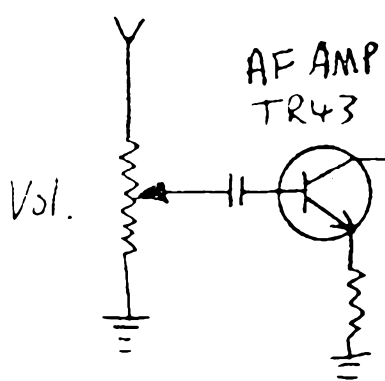

USB-1  
EXPANDOR

This diode ACTS AS A SWITCH TO PREVENT MODULATION ON XMIT FROM SHORTING THRU EXPANDER PORTION OF USB-1

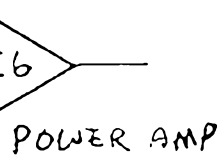
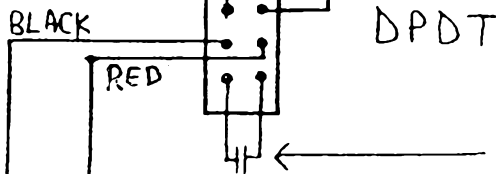
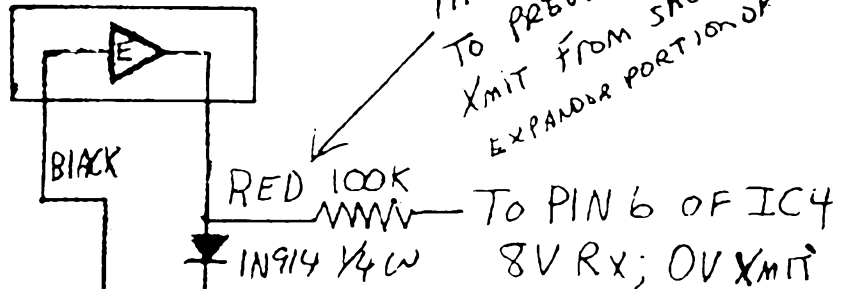

SAMS CB MANUALS - ONES OUT OF PRINT LINED OUT

~~1~~ 2 3 4 ~~5~~ ~~6~~ ~~7~~ ~~8~~ ~~9~~ ~~10~~ 11  
12 13 14 ~~15~~ 16 ~~17~~ 18 ~~19~~ ~~20~~ 21 22  
~~23~~ ~~24~~ 25 ~~26~~ ~~27~~ ~~28~~ 29 ~~30~~ 31 ~~32~~ ~~33~~  
34 ~~35~~ 36 37 ~~38~~ ~~39~~ 40 ~~41~~ 42 43 ~~44~~  
~~45~~ ~~46~~ 47 48 49 ~~50~~ 51 ~~52~~ ~~53~~ 54 ~~55~~  
~~56~~ 57 58 59 ~~60~~ ~~61~~ ~~62~~ ~~63~~ ~~64~~ 65 66  
~~67~~ 68 ~~69~~ 70 71 72 73 74 75 ~~76~~ 77  
78 79 ~~80~~ 81 82 ~~83~~ 84 ~~85~~ ~~86~~ 87 ~~88~~  
89 ~~90~~ ~~91~~ ~~92~~ ~~93~~ ~~94~~ ~~95~~ ~~96~~ ~~97~~ ~~98~~ ~~99~~  
~~100~~ ~~101~~ ~~102~~ 103 ~~104~~ ~~105~~ ~~106~~ ~~107~~ ~~108~~ 109 110  
111 ~~112~~ ~~113~~ ~~114~~ 115 116 ~~117~~ ~~118~~ ~~119~~ 120 121  
~~122~~ 123 ~~124~~ ~~125~~ 126 127 ~~128~~ 129 ~~130~~ ~~131~~ 132  
~~133~~ 134 ~~135~~ ~~136~~ ~~137~~ ~~138~~ 139 140 ~~141~~ ~~142~~ ~~143~~  
144 145 ~~146~~ ~~147~~ 148 ~~149~~ ~~150~~ ~~151~~ 152 ~~153~~ ~~154~~  
155 ~~156~~ ~~157~~ ~~158~~ ~~159~~ 160 ~~161~~ ~~162~~ ~~163~~ ~~164~~ 165  
~~166~~ ~~167~~ ~~168~~ ~~169~~ ~~170~~ ~~171~~ ~~172~~ ~~173~~ ~~174~~ ~~175~~ ~~176~~  
~~177~~ 178 179 ~~180~~ ~~181~~ 182 183 ~~184~~ ~~185~~ 186 ~~187~~  
~~188~~ ~~189~~ ~~190~~ ~~191~~ ~~192~~ ~~193~~ ~~194~~ ~~195~~ ~~196~~ ~~197~~ ~~198~~  
~~199~~ 200 201 ~~202~~ ~~203~~ ~~204~~ ~~205~~ ~~206~~ ~~207~~ 208 ~~209~~  
~~210~~ ~~211~~ ~~212~~ ~~213~~ ~~214~~ ~~215~~ ~~216~~ 217 ~~218~~ 219 ~~220~~  
~~221~~ 222 ~~223~~ ~~224~~ ~~225~~ 226 ~~227~~ 228 ~~229~~ ~~230~~ ~~231~~  
~~232~~ ~~233~~ ~~234~~ 235 236 237 ~~238~~ 239 ~~240~~ ~~241~~ ~~242~~  
~~243~~ ~~244~~ ~~245~~ 246 ~~247~~ ~~248~~ 249 ~~250~~ 251 ~~252~~ ~~253~~  
254 ~~255~~ 256 257 258 259 260 261 262 263 264  
265 266 ~~267~~ 268 269 270 271 272 273 274 275  
276 277 278 279 280 281 282 283 284 285 286  
287 288 289 290 291 292 293



## !NEW PRODUCT RELEASE!

COMING SOON!!

CARD-KIT DOES IT AGAIN:

Card-Kit Electronics has just announced that they will be releasing a new kit ("B" Kit) for marketing, approximately 1 July 1983. The kit will add low channels (26.955-26.510) and/or low half channels (26.950-26.510). This kit will fit practically all of the newer, single crystal, AM units. Specifically, those units employing the LC7130, LC7131, TC9106P, uPD2814C, and uPD2816C PLL Chips that also use a 10.7 Ceramic or Crystal filter in their receiver section.

Also there will be a modification made on the "A" Kit (covered in Volume 14) that will enable you to choose to obtain either full channels or half channels above channel 40.

Since this type of unit appeared in the market 4 years ago many theories have been discussed and almost as many experiments have been tried. Some of these experiments have been marketed but they like in full 40 channel coverage and will not track on frequency.

It turns out we all tried to make it more difficult than it was. Borrowing from the old practice of switching the TX and RX crystals on the old direct crystal units to allow the Civil Air Protrol to use a pair of channel 10 crystals to obtain their frequency (26.620) was the bases for this mod. This means all that was needed was to reverse the direction of shift of the PLL Chip. In order to receive the desired frequency all that was needed was to switch the filter that passed 10.695 and blocked the anti-image to a filter that passed the anti-image and blocked the 10.695. Simple huh? It is just as simple to use.

The installation of this kit into approximately 50 different units will be featured in SECRET CB Volume 17. DON'T MISS IT....

ORDER YOUR KITS NOW FROM SECRET CB....Catalog #136A or #136B. If you do not have a SECRET CB Catalog ask us for one.

## DO YOU HEAR THE "WEIRD" CALL SIGNS?

Not so "Weird"...! But "Custom" modified radios; with codes for frequency identification...!

Example: Recently heard 90 Zebra Alpha 1 talking with 28 Zebra 12. 16 told 90 to go to Red-32 USB, as 15 Zebra Alpha 218 monitored that frequency!.

Lost You - O.K.! Africa station talking to Texas; who wanted him to go to 26.325MHz-USB; so that Kentucky could get in on the conversation. The middle call sign (name) is actual frequency capability of radio. First number is Country/State of origin and last number is unit number.

There is only one common variation of all I know at present time, that is SKIP. SKIP means to go up 5KHz from whatever frequency on at time, most of these units are hand-held and AM.

Codes are listed below along with units used in if known (40 ch.)

ZEBRA/ZEBRA ALPHA - SSB Unit 26.085-28.045MHz (Alpha has 16 additional "channels")-used in 858 chip units.

ANCIENT - AM Unit 26.435-27.405MHz, 02A chip units.

PENGUIN - SSB Unit 26.815-28.085MHz, MB chassis (Note: there is also a PENGUIN ALPHA which starts at 26.175MHz and goes up to 28.085MHz, will find out for sure and pass along.)

EASY - SSB Unit 26.965-28.075MHz (Almost all are TRC-448's, Rec86345 chip)

MONGOOSE - AM Unit 26.425-27.555MHz (Ver-ry Fishy! as have found these are R/S TRC-424's modified by P.D.'s for undercover use. - have TX power turned down to about 1W.)

WILDGOOSE - AM Unit 26.325-27.405 (Also Fishy! as these are R/S TRC-431's modified for 100KHz lower range and nothing above 27.405MHz - full TX power.)

SCARECROW - AM Unit 25.905-27.865MHz, 858 chassis.

ADAM - SSB Unit 26.965-29.045MHz, 858 chassis.

SLEEPER - SSB Unit 26.525-27.795MHz, (Johnson 4730's)

DART - SSB Unit 26.325-28.225MHz, (Mostly RoadTalker's), below 26.965MHz, the frequency jumps are at 5KHz intervals!!

The following 11 charts are the frequency codes for all the known "custom codes" at this time:

### Zebra Frequency Chart

Frequency	Button	Selector	Frequency	Button	Selector	Frequency	Button	Select.
26.085	Red	11	26.775	Red-Ylw	37	27.505	Ylw	12
26.105	Red	12	26.785	Red-Ylw	38	27.515	Ylw	13
26.115	Red	13	26.795	Red-Ylw	39	27.525	Ylw	14
26.125	Red	14	26.805	Red-Ylw	40	27.535	Ylw	15
26.135	Red	15	26.855	Red-Grn	8	27.555	Ylw	16
26.155	Red	16	26.865	Red-Grn	9	27.565	Ylw	17
26.165	Red	17	26.875	Red-Grn	10	27.575	Ylw	18
26.175	Red	18	26.885	Red-Grn	11	27.585	Ylw	19
26.185	Red	19	26.905	Red-Grn	12	27.605	Ylw	20
26.205	Red	20	26.915	Red-Grn	13	27.615	Ylw	21
26.215	Red	21	26.925	Red-Grn	14	27.625	Ylw	22
26.225	Red	22	26.935	Red-Grn	15	27.635	Ylw	24
26.235	Red	24	26.955	Red-Grn	16	27.645	Ylw	25
26.245	Red	25	26.965	None-Reg.Ch.	1	27.655	Ylw	23
26.255	Red	23	26.975	None-Reg.Ch.	2	27.665	Ylw	26
26.265	Red	26	26.985	None-Reg.Ch.	3	27.675	Ylw	27
26.275	Red	27	27.005	None-Reg.Ch.	4	27.685	Ylw	28
26.285	Red	28	27.015	None-Reg.Ch.	5	27.695	Ylw	29
26.295	Red	29	27.025	None-Reg.Ch.	6	27.705	Ylw	30
26.305	Red	30	27.035	None-Reg.Ch.	7	27.715	Ylw	31
26.315	Red	31	27.045	Red-Grn	25	27.725	Ylw	32
26.325	Red	32	27.055	None-Reg.Ch.	8	27.735	Ylw	33
26.335	Red	33	27.065	None-Reg.Ch.	9	27.745	Ylw	34
26.345	Red	34	27.075	None-Reg.Ch.	10	27.755	Ylw	35
26.355	Red	35	27.085	None-Reg.Ch.	11	27.765	Ylw	36
26.365	Red	36	27.105	None-Reg.Ch.	12	27.775	Ylw	37
26.375	Red	37	27.115	None-Reg.Ch.	13	27.785	Ylw	38
26.385	Red	38	27.125	None-Reg.Ch.	14	27.795	Ylw	39
26.395	Red	39	27.135	None-Reg.Ch.	15	27.805	Ylw	40
26.405	Red	40	27.155	None-Reg.Ch.	16	27.855	Grn	8
26.455	Red-Ylw	8	27.165	None-Reg.Ch.	17	27.865	Grn	9
26.465	Red-Ylw	9	27.175	None-Reg.Ch.	18	27.875	Grn	10
26.475	Red-Ylw	10	27.185	None-Reg.Ch.	19	27.885	Grn	11
26.485	Red-Ylw	11	27.205	None-Reg.Ch.	20	27.905	Grn	12
26.505	Red-Ylw	12	27.215	None-Reg.Ch.	21	27.915	Grn	13
26.515	Red-Ylw	13	27.225	None-Reg.Ch.	22	27.925	Grn	14
26.525	Red-Ylw	14	27.235	None-Reg.Ch.	24	27.935	Grn	15
26.535	Red-Ylw	15	27.245	None-Reg.Ch.	25	27.955	Grn	16
26.555	Red-Ylw	16	27.255	None-Reg.Ch.	23	27.965	Grn	17
26.565	Red-Ylw	17	27.265	None-Reg.Ch.	26	27.975	Grn	18
26.575	Red-Ylw	18	27.275	None-Reg.Ch.	27	27.985	Grn	19
26.585	Red-Ylw	19	27.285	None-Reg.Ch.	28	28.005	Grn	20
26.605	Red-Ylw	20	27.295	None-Reg.Ch.	29	28.015	Grn	21
26.615	Red-Ylw	21	27.305	None-Reg.Ch.	30	28.025	Grn	22
26.625	Red-Ylw	22	27.315	None-Reg.Ch.	31	28.035	Grn	24
26.635	Red-Ylw	24	27.325	None-Reg.Ch.	32	28.045	Grn	25
26.645	Red-Ylw	25	27.325	None-Reg.Ch.	32			
26.655	Red-Ylw	23	27.335	None-Reg.Ch.	33			
26.665	Red-Ylw	26	27.345	None-Reg.Ch.	34			
26.675	Red-Ylw	27	27.355	None-Reg.Ch.	35			
26.685	Red-Ylw	28	27.365	None-Reg.Ch.	36			
26.695	Red-Ylw	29	27.375	None-Reg.Ch.	37			
26.705	Red-Ylw	30	27.385	None-Reg.Ch.	38			
26.715	Red-Ylw	31	27.395	None-Reg.Ch.	39			
26.725	Red-Ylw	32	27.405	None-Reg.Ch.	40			
26.735	Red-Ylw	33	27.455	Ylw	8			
26.745	Red-Ylw	34	27.465	Ylw	9			
26.755	Red-Ylw	35	27.475	Ylw	10			
26.765	Red-Ylw	36	27.485	Ylw	11			

Zebra Alpha Frequency Codes

Frequency	Button	Selector	Frequency	Button	Selector	Frequency	Button	Selector
26.085	Red	11	26.765	Red-Ylw	36	27.445	Blue	34
26.105	Red	12	26.775	Red-Ylw	37	27.455	Yellow	8
26.115	Red	13	26.785	Red-Ylw	38	27.465	Yellow	9
26.125	Red	14	26.795	Red-Ylw	39	27.475	Yellow	10
26.135	Red	15	26.805	Red-Ylw	40	27.485	Yellow	11
26.155	Red	16	26.815	Red-Ylw-Blu	31	27.505	Yellow	12
26.165	Red	17	26.825	Red-Ylw-Blu	32	27.515	Yellow	13
26.175	Red	18	26.835	Red-Ylw-Blu	33	27.525	Yellow	14
26.185	Red	19	26.845	Red-Ylw-Blu	34	27.535	Yellow	15
26.205	Red	20	26.855	Red-Grn	8	27.555	Yellow	16
26.215	Red	21	26.865	Red-Grn	9	27.565	Yellow	17
26.225	Red	22	26.875	Red-Grn	10	27.575	Yellow	18
26.235	Red	24	26.885	Red-Grn	11	27.585	Yellow	19
26.245	Red	25	26.905	Red-Grn	12	27.605	Yellow	20
26.255	Red	23	26.915	Red-Grn	13	27.615	Yellow	21
26.265	Red	26	26.925	Red-Grn	14	27.625	Yellow	22
26.275	Red	27	26.935	Red-Grn	15	27.635	Yellow	24
26.285	Red	28	26.955	Red-Grn	16	27.645	Yellow	25
26.295	Red	29	26.965	None-Reg.	Ch. 1	27.655	Yellow	23
26.305	Red	30	26.975	None-Reg.	Ch. 2	27.665	Yellow	26
26.315	Red	31	26.985	None-Reg.	Ch. 3	27.675	Yellow	27
26.325	Red	32	27.005	None-Reg.	Ch. 4	27.685	Yellow	28
26.335	Red	33	27.015	None-Reg.	Ch. 5	27.695	Yellow	29
26.345	Red	34	27.025	None-Reg.	Ch. 6	27.705	Yellow	30
26.355	Red	35	27.035	None-Reg.	Ch. 7	27.715	Yellow	31
26.365	Red	36	27.045	Red-Grn	25	27.725	Yellow	32
26.375	Red	37	27.055	None-Reg.	Ch. 8	27.735	Yellow	33
26.385	Red	38	27.065	None-Reg.	Ch. 9	27.745	Yellow	34
26.395	Red	39	27.075	None-Reg.	Ch.10	27.755	Yellow	35
26.405	Red	40	27.085	None-Reg.	Ch.11	27.765	Yellow	36
26.415	Red-Blue	31	27.105	None-Reg.	Ch.12	27.775	Yellow	37
26.425	Red-Blue	32	27.115	None-Reg.	Ch.13	27.785	Yellow	38
26.435	Red-Blue	33	27.125	None-Reg.	Ch.14	27.795	Yellow	39
26.445	Red-Blue	34	27.135	None-Reg.	Ch.15	27.805	Yellow	40
26.455	Red-Ylw	8	27.155	None-Reg.	Ch.16	27.815	Ylw-Blue	31
26.465	Red-Ylw	9	27.165	None-Reg.	Ch.17	27.825	Ylw-Blue	32
26.475	Red-Ylw	10	27.175	None-Reg.	Ch.18	27.835	Ylw-Blue	33
26.485	Red-Ylw	11	27.185	None-Reg.	Ch.19	27.845	Ylw-Blue	34
26.505	Red-Ylw	12	27.205	None-Reg.	Ch.20	27.855	Green	8
26.515	Red-Ylw	13	27.215	None-Reg.	Ch.21	27.865	Green	9
26.525	Red-Ylw	14	27.225	None-Reg.	Ch.22	27.875	Green	10
26.535	Red-Ylw	15	27.235	None-Reg.	Ch.24	27.885	Green	11
26.555	Red-Ylw	16	27.245	None-Reg.	Ch.25	27.905	Green	12
26.565	Red-Ylw	17	27.255	None-Reg.	Ch.23	27.915	Green	13
26.575	Red-Ylw	18	27.265	None-Reg.	Ch.26	27.925	Green	14
26.585	Red-Ylw	19	27.275	None-Reg.	Ch.27	27.935	Green	15
26.605	Red-Ylw	20	27.285	None-Reg.	Ch.28	27.955	Green	16
26.615	Red-Ylw	21	27.295	None-Reg.	Ch.29	27.965	Green	17
26.625	Red-Ylw	22	27.305	None-Reg.	Ch.30	27.975	Green	18
26.635	Red-Ylw	24	27.315	None-Reg.	Ch.31	27.985	Green	19
26.645	Red-Ylw	25	27.325	None-Reg.	Ch.32	28.005	Green	20
26.655	Red-Ylw	23	27.335	None-Reg.	Ch.33	28.015	Green	21
26.665	Red-Ylw	26	27.345	None-Reg.	Ch.34	28.025	Green	22
26.675	Red-Ylw	27	27.355	None-Reg.	Ch.35	28.035	Green	24
26.685	Red-Ylw	28	27.365	None-Reg.	Ch.36	28.045	Green	25
26.695	Red-Ylw	29	27.375	None-Reg.	Ch.37			
26.705	Red-Ylw	30	27.385	None-Reg.	Ch.38			
26.715	Red-Ylw	31	27.395	None-Reg.	Ch.39			
26.725	Red-Ylw	32	27.405	None-Reg.	Ch.40			
26.735	Red-Ylw	33	27.415	Blue	31			
26.745	Red-Ylw	34	27.425	Blue	32			
26.755	Red-Ylw	35	27.435	Blue	33			

### Ancient Frequency Chart

<u>Frequency</u>	<u>Code</u>	<u>Selector</u>	<u>Frequency</u>	<u>Code</u>	<u>Selector</u>
26.435	Red	10	26.965	None-Reg.Ch.1	1
26.445	Red	11	26.975	None-Reg.Ch.2	2
26.465	Red	12	26.985	None-Reg.Ch.3	3
26.475	Red	13	26.995	Green	31
26.485	Red	14	27.005	None-Reg.Ch.4	4
26.495	Red	15	27.015	None-Reg.Ch.5	5
26.505	Red	3	27.025	None-Reg.Ch.6	6
26.515	Red	16	27.035	None-Reg.Ch.7	7
26.525	Red	17	27.045	Green	36
26.535	Red	18	27.055	None-Reg.Ch.8	8
26.545	Red	19	27.065	None-Reg.Ch.9	9
26.555	Red	7	27.075	None-Reg.Ch.10	10
26.565	Red	20	27.085	None-Reg.Ch.11	11
26.575	Red	21	27.105	None-Reg.Ch.12	12
26.585	Red	22	27.115	None-Reg.Ch.13	13
26.595	Red	24	27.125	None-Reg.Ch.14	14
26.605	Red	25	27.135	None-Reg.Ch.15	15
26.615	Red	23	27.155	None-Reg.Ch.16	16
26.625	Red	26	27.165	None-Reg.Ch.17	17
26.635	Red	27	27.175	None-Reg.Ch.18	18
26.645	Red	28	27.185	None-Reg.Ch.19	19
26.655	Red	29	27.205	None-Reg.Ch.20	20
26.665	Red	30	27.215	None-Reg.Ch.21	21
26.675	Red	31	27.225	None-Reg.Ch.22	22
26.685	Red	32	27.235	None-Reg.Ch.24	24
26.695	Red	33	27.245	None-Reg.Ch.25	25
26.705	Red	34	27.255	None-Reg.Ch.23	23
26.715	Red	35	27.265	None-Reg.Ch.26	26
26.725	Red	36	27.275	None-Reg.Ch.27	27
26.735	Red	37	27.285	None-Reg.Ch.28	28
26.745	Red	38	27.295	None-Reg.Ch.29	29
26.755	Green	10	27.305	None-Reg.Ch.30	30
26.765	Green	11	27.315	None-Reg.Ch.31	31
26.785	Green	12	27.325	None-Reg.Ch.32	32
26.795	Green	13	27.335	None-Reg.Ch.33	33
26.805	Green	14	27.345	None-Reg.Ch.34	34
26.815	Green	15	27.355	None-Reg.Ch.35	35
26.835	Green	16	27.365	None-Reg.Ch.36	36
26.845	Green	17	27.375	None-Reg.Ch.37	37
26.855	Green	18	27.385	None-Reg.Ch.38	38
26.865	Green	19	27.395	None-Reg.Ch.39	39
26.885	Green	20	27.405	None-Reg.Ch.40	40
26.895	Green	21			
26.905	Green	22			
26.915	Green	24			
26.925	Green	25			
26.935	Green	23			
26.945	Green	26			
26.955	Green	27			

Penguin Frequency Chart

Frequency	Code	Selector	Frequency	Code	Selector
26.815	Blue	15	27.455	Blu-Ylw	15
26.835	Blue	16	27.475	Blu-Ylw	16
26.845	Blue	17	27.485	Blu-Ylw	17
26.855	Blue	18	27.495	Blu-Ylw	18
26.865	Blue	19	27.505	Blu-Ylw	19
26.885	Blue	20	27.525	Blu-Ylw	20
26.895	Blue	21	27.535	Blu-Ylw	21
26.905	Blue	22	27.545	Blu-Ylw	22
26.915	Blue	24	27.555	Blu-Ylw	24
26.925	Blue	25	27.565	Blu-Ylw	25
26.935	Blue	23	27.575	Blu-Ylw	23
26.945	Blue	26	27.585	Blu-Ylw	26
26.955	Blue	27	27.595	Blu-Ylw	27
26.965	None-Reg. Ch.	1	27.605	Blu-Ylw	28
26.975	None-Reg. Ch.	2	27.615	Blu-Ylw	29
26.985	None-Reg. Ch.	3	27.625	Blu-Ylw	30
26.995	Blue	31	27.635	Blu-Ylw	31
27.005	None-Reg. Ch.	4	27.645	Blu-Ylw	32
27.015	None-Reg. Ch.	5	27.655	Blu-Ylw	33
27.025	None-Reg. Ch.	6	27.665	Blu-Ylw	34
27.035	None-Reg. Ch.	7	27.675	Blu-Ylw	35
27.045	Blue	36	27.685	Blu-Ylw	36
27.055	None-Reg. Ch.	8	27.695	Blu-Ylw	37
27.065	None-Reg. Ch.	9	27.705	Blu-Ylw	38
27.075	None-Reg. Ch.	10	27.715	Blu-Ylw	39
27.085	None-Reg. Ch.	11	27.725	Blu-Ylw	40
27.095	Blue-Red	23	27.735	Blu-Ylw-Red	23
27.105	None-Reg. Ch.	12	27.745	Blu-Ylw-Red	26
27.115	None-Reg. Ch.	13	27.755	Blu-Ylw-Red	27
27.125	None-Reg. Ch.	14	27.765	Blu-Ylw-Red	28
27.135	None-Reg. Ch.	15	27.775	Ylw	15
27.155	None-Reg. Ch.	16	27.795	Ylw	16
27.165	None-Reg. Ch.	17	27.805	Ylw	17
27.175	None-Reg. Ch.	18	27.815	Ylw	18
27.185	None-Reg. Ch.	19	27.825	Ylw	19
27.205	None-Reg. Ch.	20	27.845	Ylw	20
27.215	None-Reg. Ch.	21	27.855	Ylw	21
27.225	None-Reg. Ch.	22	27.865	Ylw	22
27.235	None-Reg. Ch.	24	27.875	Ylw	24
27.245	None-Reg. Ch.	25	27.885	Ylw	25
27.255	None-Reg. Ch.	23	27.895	Ylw	23
27.265	None-Reg. Ch.	26	27.905	Ylw	26
27.275	None-Reg. Ch.	27	27.915	Ylw	27
27.285	None-Reg. Ch.	28	27.925	Ylw	28
27.295	None-Reg. Ch.	29	27.935	Ylw	29
27.305	None-Reg. Ch.	30	27.945	Ylw	30
27.315	None-Reg. Ch.	31	27.955	Ylw	31
27.325	None-Reg. Ch.	32	27.965	Ylw	32
27.335	None-Reg. Ch.	33	27.975	Ylw	33
27.345	None-Reg. Ch.	34	27.985	Ylw	34
27.355	None-Reg. Ch.	35	27.995	Ylw	35
27.365	None-Reg. Ch.	36	28.005	Ylw	36
27.375	None-Reg. Ch.	37	28.015	Ylw	37
27.385	None-Reg. Ch.	38	28.025	Ylw	38
27.395	None-Reg. Ch.	39	28.035	Ylw	39
27.405	None-Reg. Ch.	40	28.045	Ylw	40
27.415	Red	23	28.055	Ylw-Red	23
27.425	Red	26	28.065	Ylw-Red	26
27.435	Red	27	28.075	Ylw-Red	27
27.445	Red	28	28.085	Ylw-Red	28

### Easy Frequency Chart

Frequency	Code	Selector	Frequency	Code	Selector
26.965	Reg.Ch.	1	27.615	Red	2
26.975	Reg.Ch.	2	27.625	Red	3
26.985	Reg.Ch.	3	27.645	Red	4
27.005	Reg.Ch.	4	27.655	Red	5
27.015	Reg.Ch.	5	27.665	Red	6
27.025	Reg.Ch.	6	27.675	Red	7
27.035	Reg.Ch.	7	27.685	Red/Yellow	1
27.045	Yellow	1	27.695	Red	8
27.055	Reg.Ch.	8	27.705	Red	9
27.065	Reg.Ch.	9	27.715	Red	10
27.075	Reg.Ch.	10	27.725	Red	11
27.085	Reg.Ch.	11	27.735	Red/Yellow	5
27.095	Yellow	5	27.745	Red	12
27.105	Reg.Ch.	12	27.755	Red	13
27.115	Reg.Ch.	13	27.765	Red	14
27.125	Reg.Ch.	14	27.775	Red	15
27.135	Reg.Ch.	15	27.795	Red	16
27.155	Reg.Ch.	16	27.805	Red	17
27.165	Reg.Ch.	17	27.815	Red	18
27.175	Reg.Ch.	18	27.825	Red	19
27.185	Reg.Ch.	19	27.845	Red	20
27.205	Reg.Ch.	20	27.855	Red	21
27.215	Reg.Ch.	21	27.865	Red	22
27.225	Reg.Ch.	22	27.875	Red	24
27.235	Reg.Ch.	24	27.885	Red	25
27.245	Reg.Ch.	25	27.895	Red	23
27.255	Reg.Ch.	23	27.905	Red	26
27.265	Reg.Ch.	26	27.915	Red	27
27.275	Reg.Ch.	27	27.925	Red	28
27.285	Reg.Ch.	28	27.935	Red	29
27.295	Reg.Ch.	29	27.945	Red	30
27.305	Reg.Ch.	30	27.955	Red	31
27.315	Reg.Ch.	31	27.965	Red	32
27.325	Reg.Ch.	32	27.975	Red	33
27.335	Reg.Ch.	33	27.985	Red	34
27.345	Reg.Ch.	34	27.995	Red	35
27.355	Reg.Ch.	35	28.005	Red	36
27.365	Reg.Ch.	36	28.015	Red	37
27.375	Reg.Ch.	37	28.025	Red	38
27.385	Reg.Ch.	38	28.035	Red	39
27.395	Reg.Ch.	39	28.045	Red	40
27.405	Reg.Ch.	40			
27.415	Yellow	33			
27.425	Green	12			
27.435	Green	13			
27.445	Green	14			
27.455	Green	15			
27.475	Green	16			
27.485	Green	17			
27.495	Green	18			
27.505	Green	19			
27.525	Green	20			
27.535	Green	21			
27.545	Green	22			
27.555	Green	24			
27.565	Green	25			
27.575	Green	23			
27.585	Green	26			
27.595	Green	27			
27.605	Red	1			

Note: Some units may also have coverage in both Transmit and Receive on following:

28.055	Red/Yellow	33
28.065	Red/Yellow	34
28.075	Red/Yellow	35

MonGoose Frequency Chart

<u>Frequency</u>	<u>Code</u>	<u>Selector</u>	<u>Frequency</u>	<u>Code</u>	<u>Selector</u>
26.425	Red	9	27.025	None-Reg.Ch.	6
26.435	Red	10	27.035	None-Reg.Ch.	7
26.445	Red	11	27.055	None-Reg.Ch.	8
26.465	Red	12	27.065	None-Reg.Ch.	9
26.475	Red	13	27.075	None-Reg.Ch.	10
26.485	Red	14	27.085	None-Reg.Ch.	11
26.495	Red	15	27.105	None-Reg.Ch.	12
26.515	Red	16	27.115	None-Reg.Ch.	13
26.525	Red	17	27.125	None-Reg.Ch.	14
26.535	Red	18	27.135	None-Reg.Ch.	15
26.545	Red	19	27.155	None-Reg.Ch.	16
26.565	Red	20	27.165	None-Reg.Ch.	17
26.575	Red	21	27.175	None-Reg.Ch.	18
26.585	Red	22	27.185	None-Reg.Ch.	19
26.595	Red	24	27.205	None-Reg.Ch.	20
26.605	Red/Yellow	25	27.215	None-Reg.Ch.	21
26.615	Red/Yellow	23	27.225	None-Reg.Ch.	22
26.625	Red/Yellow	26	27.235	None-Reg.Ch.	24
26.635	Red/Yellow	27	27.245	None-Reg.Ch.	25
26.645	Red/Yellow	28	27.255	None-Reg.Ch.	23
26.655	Red/Yellow	29	27.265	None-Reg.Ch.	26
26.665	Red/Yellow	30	27.275	None-Reg.Ch.	27
26.675	Red/Yellow	31	27.285	None-Reg.Ch.	28
26.685	Red/Yellow	32	27.295	None-Reg.Ch.	29
26.695	Red/Yellow	33	27.305	None-Reg.Ch.	30
26.705	Red/Yellow	34	27.315	None-Reg.Ch.	31
26.715	Red/Yellow	35	27.325	None-Reg.Ch.	32
26.725	Red/Yellow	36	27.335	None-Reg.Ch.	33
26.735	Red/Yellow	37	27.345	None-Reg.Ch.	34
26.745	Red/Yellow	38	27.355	None-Reg.Ch.	35
26.755	Red/Yellow	39	27.365	None-Reg.Ch.	36
26.765	Red/Yellow	40	27.375	None-Reg.Ch.	37
26.785	Red/Yellow	12	27.385	None-Reg.Ch.	38
26.795	Red/Yellow	13	27.395	None-Reg.Ch.	39
26.805	Red/Yellow	14	27.405	None-Reg.Ch.	40
26.815	Red/Yellow	15	27.425	Yellow	12
26.835	Red/Yellow	16	27.435	Yellow	13
26.845	Red/Yellow	17	27.445	Yellow	14
26.855	Red/Yellow	18	27.455	Yellow	15
26.865	Red/Yellow	19	27.475	Yellow	16
26.885	Red/Yellow	20	27.485	Yellow	17
26.895	Red/Yellow	21	27.495	Yellow	18
26.905	Red/Yellow	22	27.505	Yellow	19
26.915	Red/Yellow	24	27.525	Yellow	20
26.965	None-Reg. Ch.	1	27.535	Yellow	21
26.975	None-Reg. Ch.	2	27.545	Yellow	22
26.985	None-Reg. Ch.	3	27.555	Yellow	24
27.005	None-Reg. Ch.	4			
27.015	None-Reg. Ch.	5			



### Wild Goose Frequency Chart

Frequency	Code	Selector	Frequency	(No Code-Reg.) (C.B. Freq.'s)
26.325	Blue	1	26.965	Selector- 1
26.335	Blue	2	26.975	2
26.345	Blue	3	26.985	3
26.365	Blue	4	27.005	4
26.375	Blue	5	27.015	5
26.385	Blue	6	27.025	6
26.395	Blue	7	27.035	7
26.415	Blue	8	27.055	8
26.425	Blue	9	27.065	9
26.435	Blue	10	27.075	10
26.445	Blue	11	27.085	11
26.465	Blue	12	27.105	12
26.475	Blue	13	27.115	13
26.485	Blue	14	27.125	14
26.495	Blue	15	27.135	15
26.515	Blue	16	27.155	16
26.525	Blue	17	27.165	17
26.535	Blue	18	27.175	18
26.545	Blue	19	27.185	19
26.565	Blue	20	27.205	20
26.575	Blue	21	27.215	21
26.585	Blue	22	27.225	22
26.595	Blue	24	27.235	24
26.605	Blue	25	27.245	25
26.615	Blue	23	27.255	23
26.625	Blue	26	27.265	26
26.635	Blue	27	27.275	27
26.645	Blue	28	27.285	28
26.655	Blue	29	27.295	29
26.665	Blue	30	27.305	30
26.675	Blue	31	27.315	31
26.685	Blue	32	27.325	32
26.695	Blue	33	27.335	33
26.705	Blue	34	27.345	34
26.715	Blue	35	27.355	35
26.725	Blue	36	27.365	36
26.735	Blue	37	27.375	37
26.745	Blue	38	27.385	38
26.755	Blue	39	27.395	39
26.765	Blue	40	27.405	40
26.785	Red	12		
26.795	Red	13		
26.805	Red	14		
26.815	Red	15		
26.835	Red	16		
26.845	Red	17		
26.855	Red	18		
26.865	Red	19		
26.885	Red	20		
26.895	Red	21		
26.905	Red	22		
26.915	Red	24		

ScoreCrow Frequency Chart

Frequency	Code	Selector	Frequency	Code	Selector	Frequency	Code	Selector
25.905	R-B	30	26.615	R-Y	21	27.295	None-CB	29
25.915	R-B	31	26.625	R-Y	22	27.305	None-CB	30
25.925	R-B	32	26.635	R-Y	24	27.315	None-CB	31
25.935	R-B	33	26.645	R-Y	25	27.325	None-CB	32
25.945	R-B	34	26.655	R-Y	23	27.335	None-CB	33
25.955	R-B	35	26.665	R-Y	26	27.345	None-CB	34
25.965	R-B	36	26.675	R-G-B	27	27.355	None-CB	35
25.975	R-B	37	26.685	R-G-B	28	27.365	None-CB	36
25.985	R-B	38	26.695	R-G-B	29	27.375	None-CB	37
25.995	R-B	39	26.705	R-G-B	30	27.385	None-CB	38
26.005	R-B	40	26.715	R-G-B	31	27.395	None-CB	39
26.015	R	5	26.725	R-G-B	32	27.405	None-CB	40
26.025	R	6	26.735	R-G-B	33	27.415	Y	5
26.035	R	7	26.745	R-G-B	34	27.425	Y	6
26.055	R	8	26.755	R-G-B	35	27.435	Y	7
26.065	R	9	26.765	R-G-B	36	27.455	Y	8
26.075	R	10	26.775	R-G-B	37	27.465	Y	9
26.085	R	11	26.785	R-G-B	38	27.475	Y	10
26.105	R	12	26.795	R-G-B	39	27.485	Y	11
26.115	R	13	26.805	R-G-B	40	27.505	Y	12
26.125	R	14	26.815	R-G	5	27.515	Y	13
26.135	R	15	26.825	R-G	6	27.525	Y	14
26.155	R	16	26.835	R-G	7	27.535	Y	15
26.165	R	17	26.855	R-G	8	27.555	Y	16
26.175	R	18	26.865	R-G	9	27.565	Y	17
26.185	R	19	26.875	B	27	27.575	Y	18
26.205	R	20	26.885	B	28	27.585	Y	19
26.215	R	21	26.895	B	29	27.605	Y	20
26.225	R	22	26.905	B	30	27.615	Y	21
26.235	R	24	26.915	B	31	27.625	Y	22
26.245	R	25	26.925	B	32	27.635	Y	24
26.255	R	23	26.935	B	33	27.645	Y	25
26.265	R	26	26.945	B	34	27.655	Y	23
26.275	R	27	26.955	B	36	27.665	Y	26
26.285	R	28	26.965	None-CB	1	27.675	G-B	27
26.295	R	29	26.975	None-CB	2	27.685	G-B	28
26.305	R	30	26.985	None-CB	3	27.695	G-B	29
26.315	R	31	26.995	B	39	27.705	G-B	30
26.325	R	32	27.005	None-CB	4	27.715	G-B	31
26.335	R	33	27.015	None-CB	5	27.725	G-B	32
26.345	R	34	27.025	None-CB	6	27.735	G-B	33
26.355	R	35	27.035	None-CB	7	27.745	G-B	34
26.365	R	36	27.055	None-CB	8	27.755	G-B	35
26.375	R	37	27.065	None-CB	9	27.765	G-B	36
26.385	R	38	27.075	None-CB	10	27.775	G-B	37
26.395	R	39	27.085	None-CB	11	27.785	G-B	38
26.405	R	40	27.105	None-CB	12	27.795	G-B	39
26.415	R-Y	5	27.115	None-CB	13	27.805	G-B	40
26.425	R-Y	6	27.125	None-CB	14	27.815	G	5
26.435	R-Y	7	27.135	None-CB	15	27.825	G	6
26.455	R-Y	8	27.155	None-CB	16	27.835	G	7
26.465	R-Y	9	27.165	None-CB	17	27.855	G	8
26.475	R-Y	10	27.175	None-CB	18	27.865	G	9
26.485	R-Y	11	27.185	None-CB	19			
26.505	R-Y	12	27.205	None-CB	20			
26.515	R-Y	13	27.215	None-CB	21			
26.525	R-Y	14	27.225	None-CB	22			
26.535	R-Y	15	27.235	None-CB	24			
26.555	R-Y	16	27.245	None-CB	25			
26.565	R-Y	17	27.255	None-CB	23			
26.575	R-Y	18	27.265	None-CB	26			
26.585	R-Y	19	27.275	None-CB	27			
26.605	R-Y	20	27.285	None-CB	28			

CODES: R-----Red  
 B-----Blue  
 Y-----Yellow  
 G-----Green

**ADAM Frequency Codes**

<u>Frequency</u>	<u>Code</u>	<u>Selector</u>	<u>Frequency</u>	<u>Code</u>	<u>Selector</u>	<u>Frequency</u>	<u>Code</u>	<u>Selector</u>
26.965	None	1	27.695	B	29	28.455	B-R	8
26.975	None	2	27.705	B	30	28.465	B-R	9
26.985	None	3	27.715	B	31	28.475	B-R	10
27.005	None	4	27.725	B	32	28.485	B-R	11
27.015	None	5	27.735	B	33	28.505	B-R	12
27.025	None	6	27.745	B	34	28.515	B-R	13
27.035	None	7	27.755	B	35	28.525	B-R	14
27.055	None	8	27.765	B	36	28.535	B-R	15
27.065	None	9	27.775	B	37	28.555	B-R	16
27.075	None	10	27.785	B	38	28.565	B-R	17
27.085	None	11	27.795	B	39	28.575	B-R	18
27.105	None	12	27.805	B	40	28.585	B-R	19
27.115	None	13	27.855	Y	8	28.605	B-R	20
27.125	None	14	27.865	Y	9	28.615	B-R	21
27.135	None	15	27.875	Y	10	28.625	B-R	22
27.155	None	16	27.885	Y	11	28.635	B-R	24
27.165	None	17	27.905	Y	12	28.645	B-R	25
27.175	None	18	27.915	Y	13	28.655	B-R	23
27.185	None	19	27.925	Y	14	28.665	B-R	26
27.205	None	20	27.935	Y	15	28.675	B-R	27
27.215	None	21	27.955	Y	16	28.685	B-R	28
27.225	None	22	27.965	Y	17	28.695	B-R	29
27.235	None	24	27.975	Y	18	28.705	B-R	30
27.245	None	25	27.985	Y	19	28.715	B-R	31
27.255	None	23	28.005	Y	20	28.725	B-R	32
27.265	None	26	28.015	Y	21	28.735	B-R	33
27.275	None	27	28.025	Y	22	28.745	B-R	34
27.285	None	28	28.035	Y	24	28.755	B-R	35
27.295	None	29	28.045	Y	25	28.765	B-R	36
27.305	None	30	28.055	R	8	28.775	B-R	37
27.315	None	31	28.065	R	9	28.785	B-R	38
27.325	None	32	28.075	R	10	28.795	B-R	39
27.335	None	33	28.085	R	11	28.805	B-R	40
27.345	None	34	28.105	R	12	28.855	Y-R	8
27.355	None	35	28.115	R	13	28.865	Y-R	9
27.365	None	36	28.125	R	14	28.875	Y-R	10
27.375	None	37	28.135	R	15	28.885	Y-R	11
27.385	None	38	28.155	R	16	28.905	Y-R	12
27.395	None	39	28.165	R	17	28.915	Y-R	13
27.405	None	40	28.175	R	18	28.925	Y-R	14
27.455	B	8	28.185	R	19	28.935	Y-R	15
27.465	B	9	28.205	R	20	28.955	Y-R	16
27.475	B	10	28.215	R	21	28.965	Y-R	17
27.485	B	11	28.225	R	22	28.975	Y-R	18
27.505	B	12	28.235	R	24	28.985	Y-R	19
27.515	B	13	28.245	R	25	29.005	Y-R	20
27.525	B	14	28.255	R	23	29.015	Y-R	21
27.535	B	15	28.265	R	26	29.025	Y-R	22
27.555	B	16	28.275	R	27	29.035	Y-R	24
27.565	B	17	28.285	R	28	29.045	Y-R	25
27.575	B	18	28.295	R	29			
27.585	B	19	28.305	R	30			
27.605	B	20	28.315	R	31			
27.615	B	21	28.325	R	32			
27.625	B	22	28.335	R	33			
27.635	B	24	28.345	R	34			
27.645	B	25	28.355	R	35			
27.655	B	23	28.365	R	36			
27.665	B	26	28.375	R	37			
27.675	B	27	28.385	R	38			
27.685	B	28	28.395	R	39			
			28.405	R	40			

Codes: B-Blue  
R-Red  
Y-Yellow

Sleeper Frequency Codes

<u>Frequency</u>	<u>Code</u>	<u>Selector</u>	<u>Frequency</u>	<u>Code</u>	<u>Selector</u>	<u>Frequency</u>	<u>Code</u>	<u>Selector</u>
26.525	W	17	27.155	None-Reg	Ch 16	27.765	B-Y	36
26.535	W	18	27.165	None-Reg	Ch 17	27.775	B-Y	37
26.545	W	19	27.175	None-Reg	Ch 18	27.785	B-Y	38
26.565	W	20	27.185	None-Reg	Ch 19	27.795	B-Y	39
26.575	W	21	27.205	None-Reg	Ch 20			
26.585	W	22	27.215	None-Reg	Ch 21			
26.595	W	24	27.225	None-Reg	Ch 22			
26.605	W	25	27.235	None-Reg	Ch 24			
26.615	W	23	27.245	None-Reg	Ch 25			
26.625	W	26	27.255	None-Reg	Ch 23			
26.635	W	27	27.265	None-Reg	Ch 26			
26.645	W	28	27.275	None-Reg	Ch 27			
26.655	W	29	27.285	None-Reg	Ch 28			
26.665	W	30	27.295	None-Reg	Ch 29			
26.675	W	31	27.305	None-Reg	Ch 30			
26.685	W	32	27.315	None-Reg	Ch 31			
26.695	W	33	27.325	None-Reg	Ch 32			
26.705	W	34	27.335	None-Reg	Ch 33			
26.715	W	35	27.345	None-Reg	Ch 34			
26.725	W	36	27.355	None-Reg	Ch 35			
26.735	W	37	27.365	None-Reg	Ch 36			
26.745	W	38	27.375	None-Reg	Ch 37			
26.755	W	39	27.385	None-Reg	Ch 38			
26.765	W	40	27.395	None-Reg	Ch 39			
26.775	Y-W	33	27.405	None-Reg	Ch 40			
26.785	Y-W	34	27.415	Y	33			
26.795	Y-W	35	27.425	Y	34			
26.805	Y-W	36	27.435	Y	35			
26.815	Y-W	37	27.445	Y	36			
26.825	Y-W	38	27.455	Y	37			
26.835	Y-W	39	27.465	Y	38			
26.845	B-W	17	27.475	Y	39			
26.855	B-W	18	27.485	B	17			
26.865	B-W	19	27.495	B	18			
26.885	B-W	20	27.505	B	19			
26.895	B-W	21	27.525	B	20			
26.905	B-W	22	27.535	B	21			
26.915	B-W	24	27.545	B	22			
26.925	B-W	25	27.555	B	24			
26.935	B-W	23	27.565	B	25			
26.945	B-W	26	27.575	B	23			
26.955	B-W	27	27.585	B	26			
26.965	None-Reg	Ch 1	27.595	B	27			
26.975	None-Reg	Ch 2	27.605	B	28			
26.985	None-Reg	Ch 3	27.615	B	29			
26.995	B-W	31	27.625	B	30			
27.005	None-Reg	Ch 4	27.635	B	31			
27.015	None-Reg	Ch 5	27.645	B	32			
27.025	None-Reg	Ch 6	27.655	B	33			
27.035	None-Reg	Ch 7	27.665	B	34			
27.045	B-W	36	27.675	B	35			
27.055	None-Reg	Ch 8	27.685	B	36			
27.065	None-Reg	Ch 9	27.695	B	37			
27.075	None-Reg	Ch 10	27.705	B	38			
27.085	None-Reg	Ch 11	27.715	B	39			
27.105	None-Reg	Ch 12	27.725	B	40			
27.115	None-Reg	Ch 13	27.735	B-Y	33			
27.125	None-Reg	Ch 14	27.745	B-Y	34			
27.135	None-Reg	Ch 15	27.755	B-Y	35			

Codes: W-White  
Y-Yellow  
B-Blue

(\* ) Some unit may not transmit above 27.705MHz, without complete modification...

### DART Frequency Chart

Freq.	Code	Select	Freq.	Code	Select	Freq.	Code	Select	Freq.	Code	Select
26.325	R	1	26.675	R-Y	6	27.085	None	11	27.795	Y	16
26.330	R	2	26.680	R-Y	7	27.105	None	12	27.805	Y	17
26.335	R	3	26.690	R-Y	8	27.115	None	13	27.815	Y	18
26.345	R	4	26.695	R-Y	9	27.125	None	14	27.825	Y	19
26.350	R	5	26.700	R-Y	10	27.135	None	15	27.845	Y	20
26.355	R	6	26.705	R-Y	11	27.155	None	16	27.855	Y	21
26.360	R	7	26.715	R-Y	12	27.165	None	17	27.865	Y	22
26.370	R	8	26.720	R-Y	13	27.175	None	18	27.875	Y	24
26.375	R	9	26.725	R-Y	14	27.185	None	19	27.885	Y	25
26.380	R	10	26.730	R-Y	15	27.205	None	20	27.895	Y	23
26.385	R	11	26.740	R-Y	16	27.215	None	21	27.905	Y	26
26.395	R	12	26.745	R-Y	17	27.225	None	22	27.915	Y	27
26.400	R	13	26.750	R-Y	18	27.235	None	24	27.925	Y	28
26.405	R	14	26.755	R-Y	19	27.245	None	25	27.935	Y	29
26.410	R	15	26.765	R-Y	20	27.255	None	23	27.945	Y	30
26.420	R	16	26.770	R-Y	21	27.265	None	26	27.955	Y	31
26.425	R	17	26.775	R-Y	22	27.275	None	27	27.965	Y	32
26.430	R	18	26.780	R-Y	24	27.285	None	28	27.975	Y	33
26.435	R	19	26.785	R-Y	25	27.295	None	29	27.985	Y	34
26.445	R	20	26.790	R-Y	23	27.305	None	30	27.995	Y	35
26.450	R	21	26.795	R-Y	26	27.315	None	31	28.005	Y	36
26.455	R	22	26.800	R-Y	27	27.325	None	32	28.015	Y	37
26.460	R	24	26.805	R-Y	28	27.335	None	33	28.025	Y	38
26.465	R	25	26.810	R-Y	29	27.345	None	34	28.035	Y	39
26.470	R	23	26.815	R-Y	30	27.355	None	35	28.045	Y	40
26.475	R	26	26.820	R-Y	31	27.365	None	36			
26.480	R	27	26.825	R-Y	32	27.375	None	37			
26.485	R	28	26.830	R-Y	33	27.385	None	38			
26.490	R	29	26.835	R-Y	34	27.395	None	39			
26.495	R	30	26.840	R-Y	35	27.405	None	40			
26.500	R	31	26.845	R-Y	36	27.425	B	12			
26.505	R	32	26.850	R-Y	37	27.435	B	13			
26.510	R	33	26.855	R-Y	38	27.445	B	14			
26.515	R	34	26.860	R-Y	39	27.455	B	15			
26.520	R	35	26.865	R-Y	40	27.475	B	16			
26.525	R	36	26.875	R-B-Y	12	27.485	B	17			
26.530	R	37	26.880	R-B-Y	13	27.495	B	18			
26.535	R	38	26.885	R-B-Y	14	27.505	B	19			
26.540	R	39	26.890	R-B-Y	15	27.525	B	20			
26.545	R	40	26.900	R-B-Y	16	27.535	B	21			
26.555	R-B	12	26.905	R-B-Y	17	27.545	B	22			
26.560	R-B	13	26.910	R-B-Y	18	27.555	B	24			
26.565	R-B	14	26.915	R-B-Y	19	27.565	B	25			
26.570	R-B	15	26.925	R-B-Y	20	27.575	B	23			
26.580	R-B	16	26.930	R-B-Y	21	27.585	B	26			
26.585	R-B	17	26.935	R-B-Y	22	27.595	B	27			
26.590	R-B	18	26.940	R-B-Y	24	27.605	Y	1			
26.595	R-B	19	26.945	R-B-Y	25	27.615	Y	2			
26.605	R-B	20	26.950	R-B-Y	23	27.625	Y	3			
26.610	R-B	21	26.955	R-B-Y	26	27.645	Y	4			
26.615	R-B	22	26.960	R-B-Y	27	27.655	Y	5			
26.620	R-B	24	26.965	None	1	27.665	Y	6			
26.625	R-B	25	26.975	None	2	27.675	Y	7			
26.630	R-B	23	26.985	None	3	27.695	Y	8			
26.635	R-B	26	27.005	None	4	27.705	Y	9			
26.640	R-B	27	27.015	None	5	27.715	Y	10			
26.645	R-Y	1	27.025	None	6	27.725	Y	11			
26.650	R-Y	2	27.035	None	7	27.745	Y	12			
26.655	R-Y	3	27.055	None	8	27.755	Y	13			
26.665	R-Y	4	27.065	None	9	27.765	Y	14			
26.670	R-Y	5	27.075	None	10	27.775	Y	15			

CODES: R-Red  
 B-Blue  
 Y-Yellow

Note: Some units may operate above 28.045 by using B-Y and start at 12 on the selector.

The following conversion is reprinted by permission of "Custom Conversions" and its author...

## CUSTOM CONVERSION #2

(Code Name: Ancient)

CHASSIS: Midland 76-858; O2A PLL

"This is basic O2A Hygain chassis; so with the exception of wire colors; switch wiring to chip and alignment can be used on any similar chassis."

Parts Cost: \$10 +, including SAMS.

Time to Modify: Varies, initial unit-3 Hrs.

Gain in Unit: Frequency coverage range (26.435-27.405MHz)

High Frequency Audio Filter

"Illegal Frequency Alert"

Loss in Unit: P.A. Capability

Follow directions to the letter, and you will have 91 "channel" unit to be proud of..

Use Ancient Code Chart on the previous pages for frequency selection.

Frequency is determined by the main channel selector and the frequency range selectors - at any time you are capable of transmitting on an "Illegal Frequency", the RF/S meter light will be out.

An amplified microphone may be used with CAUTION! If used as a mobile; the popular "Bandit" antenna; will cover the frequency range with no SWR problems.

Initial conversion performed on S/N S01026XXX..

Read thru this and write down all parts you will need to perform the conversion before attempting! DO NOT ATTEMPT TO CONVERT WITHOUT THE FOLLOWING: SAMS #177, Dummy Load, Frequency Counter, and Power/Modulation Meter are the minimum needed.

1. Remove Top and Bottom covers (Caution on the speaker terminals!)
2. Plug in an external speaker at EXT jack, will remain till finished with conversion.
3. Check Q-5 (Final); if insulator is grey plastic looking wafer; change to mica washer. (Varies, some are mica!)
4. Do a complete line-up per SAMS-177.
5. Cut all cable ties on wire around PCB.
6. Remove EXT CB switch from chassis.
7. Cut Gray and Brown wires from switch.
8. Trace Gray back to microphone jack-unsolder/delete.  
(Note: Sams, says Blue wire?)
9. Solder Brown to microphone jack where Gray deleted.
10. Cut Orange and Violet wires at switch.
11. Trace Orange back to microphone jack-unsolder/delete.  
(Note: Sams, says Gray wire?)
12. Solder Violet to microphone jack where Orange deleted.
13. Cut Pink wire off switch. Trace back to PT. 26 on PCB, delete.
14. Carefully, completely clean switch, set aside.
15. Remove HI FLT switch from chassis.
16. Cut Blue/White wire off switch.
17. Trace Blue/White wire back to Pt. 17 at PCB, strip about 1 1/2" of insulation off cut end. Wirewrap to Pt. G4 on PCB. (Located near Audio chip, black wires on it)
18. Cut Black wire at switch, Label 'G'.
19. Carefully, completely clean switch, set aside.
20. Turn unit on, check all functions (No PA Capability).
21. Remove R-77 carefully from PCB (150 ohm wirewound).
22. Trace Red wire on meter lamp back to PCB; (should have gone to point where R-77 taken out); unsolder.

23. Solder Red wire from meter lamp to one side of R-77 and sleeve joint/resistor with heat shrink. (See below)

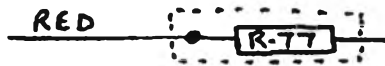

24. Go to PLL chip and cut etch EXACTLY as shown below: Bridge cuts with 4.7K 1/2w in exact places.

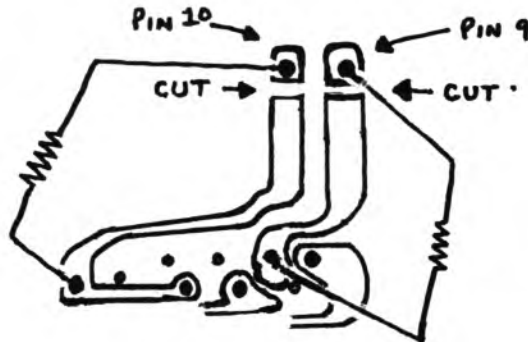

25. Wire up switches EXACTLY as shown below; Black wire 'G', and R-77 will be soldered last. Red, Yellow, and Orange wires; should be solid wires; 12" long. Switches are labeled as to designation for replacing into chassis. Label the Red, Yellow, and Orange wires.

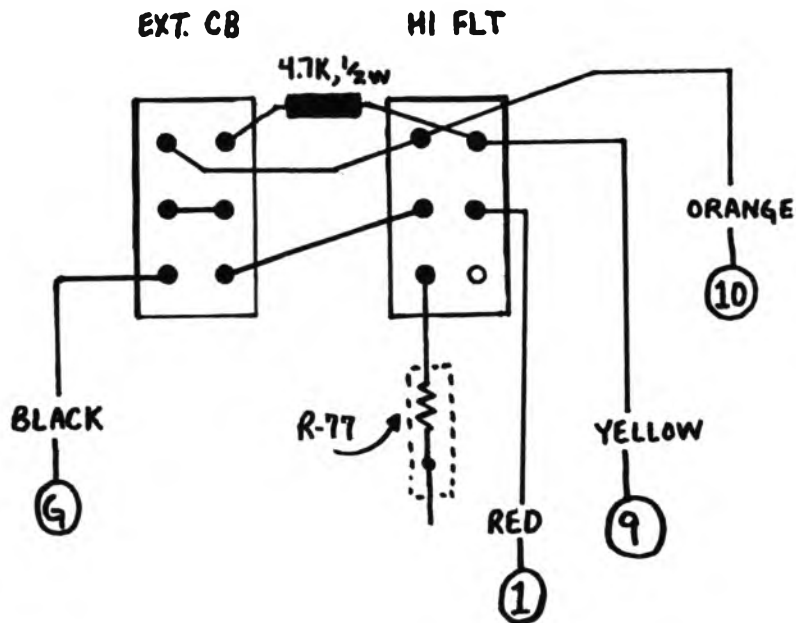

26. When finished mount switches in chassis in correct correlation with front panel.
27. Turn unit on, both switches down: light on S/RF Meter. Either up or both up, light off on S/RF meter.
28. Run the Red, Yellow and Orange Wire to the PLL Chip and solder to PLL chip pins as labeled. (See step 24 diagram)
29. Both switches down, check for normal 40 ch. frequencies, All!



30. HI FLT switch UP, EXT CB switch DOWN; (Code Green on Freq. chart); Check all frequencies. (See Step 32, if problem).
31. HI FLT switch DOWN, EXT CB switch UP; (Code Red on Freq. chart); Check all frequencies. (See Step 32, if problem).
32. If Frequency Range will not go down to 26.435MHz, retune L-1 and L-2. (Slightly, don't over-do it!)
33. Repeak T-4, L-7, L-11, and L-12 for Maximum Power Out; at 26.905MHz!
34. Broadband the output power across the entire frequency range using L-5 and T-3.
35. Adjust modulation to 100% using RV-2. DO NOT PULL C-96, OR DEFEAT ALC!
36. Add High Frequency Audio Filter across speaker terminals; in the case: (See below)

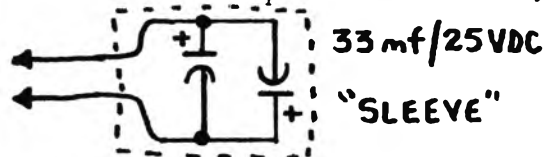

37. Lace up all wires carefully!
38. Disconnect external speaker, put unit back into case. (Don't forget to hook up speaker wires)
39. Using colored electrical tape (Red and Green), and paper punch. Punch out Red hole, put over EXT CB on case. Punch out Green hole, put over HI FLT on case.
40. Recheck everything, ENJOY...

The following conversion is reprinted by permission of "Custom Conversions" and its author...

### CUSTOM CONVERSION #5

(Code Name: Easy)

CHASSIS: Realistic TRC-448 (21-1561); Rec 86345 PLL

"This is a talking fool when modified correctly! Bonus is that most people don't know what to do with this unit and can be bought for a song..TILL NOW!

Parts Cost: \$12 +, including SAMS.

Time to Modify: Varies, initial unit-6 Hrs.

Gain in Unit: Frequency coverage range (26.965-28.075MHz\*)

Variable Transmit Frequency

High Frequency Audio Filter

"Illegal Frequency Alert"

Loss in Unit: P.A. and Monitor capability

Follow directions carefully and you will have a nice 101 "channel" SSB unit to play with...CHEAP...

Use Easy Code Chart on the previous pages for frequency selection.

Frequency is determined by the main channel selector and the frequency range selectors - at any time you are capable of transmitting on an "Illegal Frequency", the left meter light will be out.

An amplified microphone is not necessary and should be avoided if possible. A "Bandit" antenna will cover the frequency range with no problems.

Initial conversion performed on S/N 012XXX, Run #9A7

Read thru this and write down all parts you will need to perform the conversion before attempting! DO NOT ATTEMPT TO CONVERT WITHOUT THE FOLLOWING: SAMS #251, Dummy Load, Frequency Counter, and Power/Modulation Meter are the minimum needed.

1. Remove Top and Bottom cover. (Mark speaker wire polarity on cover, sleeve both wires so they won't short during conversion).
2. If any power transistors have NOT got thin mica insulators on them; change over to mica. (Note this unit O.K., but have seen some that had wrong insulators.)
3. Do a complete line-up per SAMS #251 (Exception on this unit, Tune everything that calls out a certain channel at Ch. 40!)  
Note: If you have modulation problems; first pull D-28, if still won't come up pull C-104.
4. Undo all plastic ties inside unit, save for re-use. Carefully remove all knobs on front panel.
5. Carefully, unsolder the Red and Black wires to meter; sleeve so won't short and tuck out of the way.
6. Remove front panel and label all switches on chassis front.
7. Remove the covers on the VCO Oscillators and AM/SSB Oscillators.
8. Un-solder carefully the bottom cover on PLL board.
9. Loosen screws holding switches (PA-Mon-CB; and NB).
10. Remove entire switch bracket from chassis, pull gently forward, so you have enough room to cut wires on NB switch.
11. Cut Blue wire, delete.
12. Cut Violet wire, delete.
13. Cut Brown Cable-trace back to PCB and remove. Jumper the points where the cable removed. (Use solid buss wire, jumper shield and center points, sleeve.)
14. Remove PA-MON-CB switch from bracket and follow instructions to the letter. NO DEVIATION! (See Switch Chart for wire color in case of change-wires are lettered according to step also.)
  - A. Cut Yellow wire, delete.
  - B. Cut Brown wire-move out of way-label "B".
  - C. Cut Red wire, trace to Mode switch and gently unsolder, clean out hole.

This Drawing to be used in correlation with Step 14.  
 Wire/Cable colors are given, exact points of conversion listed.  
 Double Check in case colors are different!

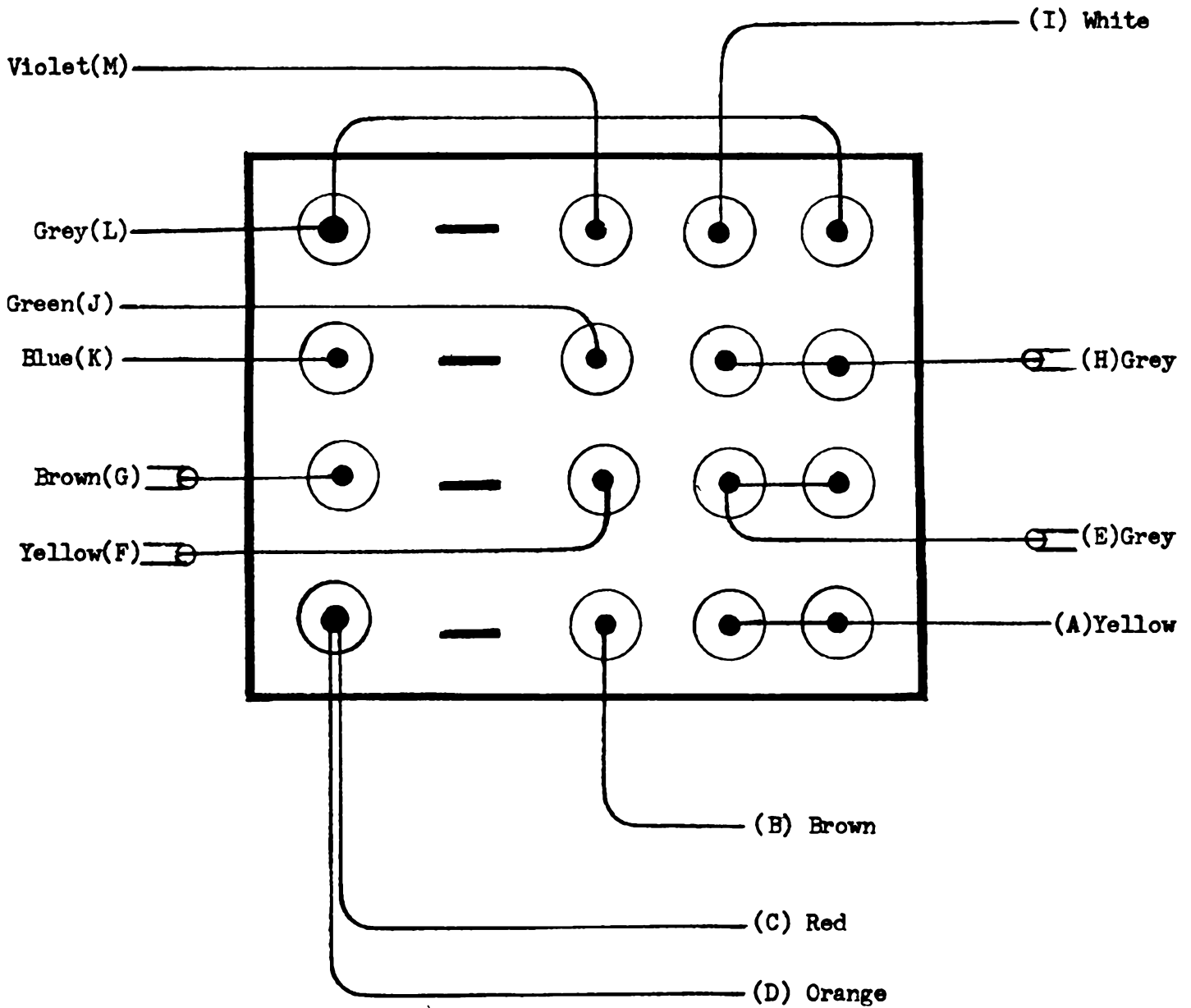

- D. Cut Orange wire, resolder both the Orange wire and Brown wire labeled "B" to place on Mode switch where wire in Step C removed. Sleeve first then solder to post carefully!
  - E. Cut Grey Cable, trace to PCB. (Note: was taped to Brown Cable in this unit; gently undo tape and unsolder the "Hot" side of Grey; CUT the shield of Grey as close as possible-use tape and rewrap to prevent short).
  - F. Cut Yellow Cable, trace to PCB-remove, clean out holes.
  - G. Cut Brown Cable, re-route to where Yellow Cable deleted. Strip wire, use shield and solder in as Yellow was- PCB silkscreen correct.
  - H. Cut Grey Cable, delete.
  - I. Cut White wire, delete.
  - J. Cut Green wire, trace to PCB, remove, clean out hole.
  - K. Cut Blue wire, re-route to where Green wire was, and solder.
  - L. Cut Grey wire, trace to PCB-remove, clean out hole.
  - M. Cut Violet wire, re-route to where Grey wire was and solder.
15. Turn unit on-check out all modes-NO PA...
  16. Remove D-12, replace with ECG-5072A, or 8.2V 1W Zener, sleeve.
  17. Unsolder L-18 from PCB; (Cut Green wire about 1" from choke; sleeve with heat shrink; tuck into wire bundle).
  18. Cut sleeving off L-18, unsolder Green wire. Solder Blue wire deleted in Step 11 to that leg. Resleeve choke and resolder into PCB.
  19. Route Blue wire between the shields of PLL Oscillator and AM/SSB Oscillators; between the PCB boards to etch side; under the shield to etch of Emitter Q-229.
  20. Remove D-15, no replacement.
  21. Remove VR-1, no replacement.
  22. Remove C-46, no replacement.
  23. Turn VR-2, FULLY CLOCKWISE.
  24. Turn unit on, check for slide-approximately:(-.6KH, +2.3KH).
  25. Clean completely both switches, holes also.
  26. On cover bottom install a 33MF/50V "non-polarized" electrolytic capacitor across the speaker (sleeve leads).

27. Mount the cleaned switches in bracket exactly as shown below, tighten screws.
28. Wire switches exactly as shown below, sleeve where possible.

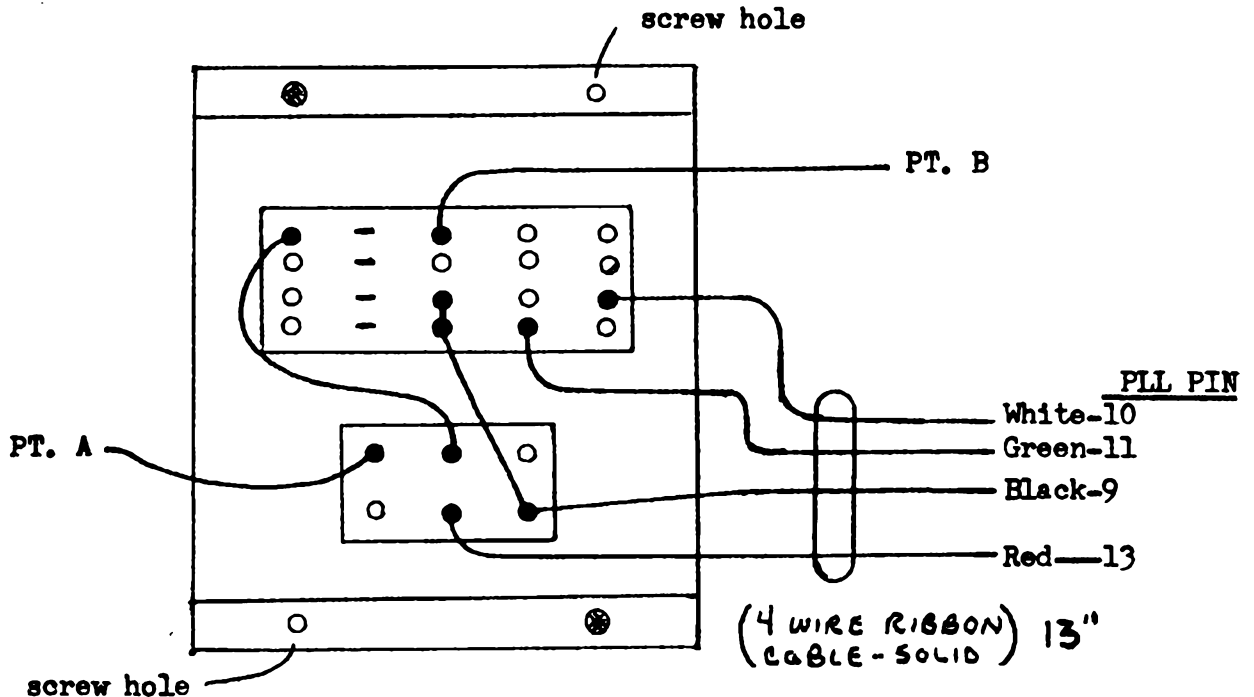

29. Cut White wire on lamp nearest the place where switches taken out approximately 3" from lamp. Strip and tin 1/8" both ends.
30. Place switch bracket into chassis (feed ribbon cable down to etch side), leave loose and solder White lamp wire that comes from PCB to Pt. B.
31. Solder White wire from lamp to Point A. Install bracket tighten down.
32. Turn unit on and check that light is out in any position except; when switches are both at extreme right.
33. Mark bracket front as follows: MON-PA-CB to Red-Green-CB; NB-Off to Yellow-Off.
34. Solder wires of ribbon cable exactly as designated by drawing in Step 28. Numbers are PLL Pin numbers-solder to etch in all cases but Pin 10(use extreme caution on pin-10). Route wire so that PLL shield will fit. CAUTION: Use isolated tip iron or battery operated soldering gun when soldering wires around PLL.
35. Turn unit on, Switches to CB and Off-check for normal CB frequencies..

36. Keep following in mind when doing Frequency alignment:  
 THIS UNIT WILL NOT HAVE A FLAT POWER OUTPUT: Example, initial unit.  
 AM Power almost at max setting, SSB Power at max!

Freq.	AM	SSB	Freq.	AM	SSB	Freq.	AM	SSB
26.965	2.0	3.0	27.405	5.8	9.7	27.805	6.0	10.0
27.075	4.1	8.5	27.585	6.5	11.0	27.905	4.0	8.0
27.215	5.0	9.0	27.705	7.0	12.0	28.045	2.2	3.8

---Use only a Plastic Tuning Tool for all adjustments!---

Using Frequency Chart, in AM Mode; see how high unit will go without falling out. (Initial unit dropped out at 27.865) All frequency range tuning will be done with T-201 thru T-204 and TC3 at this time only! Set for 27.585 and max tune the T-20's. Set for 28.045 and slowly adjust TC3 till you get an output-recheck bottom. If bottom fell out you are going to have to go back and retune the T-20's and possibly TC3. PATIENCE; is the key; I usually spend more time here than rest of the conversion.

After you get power output across the whole band; go to USB mode; should have power also.

Now go to LSB; DO NOT TOUCH T-201 thru T-204; adjust TC2 ONLY!  
 Adjust for power output across the whole band.

Recheck for Power Output, All Modes, Complete Frequency Range.

Repeat T-205, T-206, T-207, T-208; for maximum power across the whole band.

On Frequency Chart check to see if you have the top frequency of 28.075, if you do-good-if not-forget it!

37. Solder shield in place on bottom of PLL board, carefully!
38. Put Foam pad on front of switches; reinstall the front panel.
39. Solder wires back onto the meter carefully!
40. Using a kid's paper punch and colored electrical tape, punch out holes for color coding the switches (Put circles below the switches) MON-Red, PA-Green, and NB-Yellow.
41. Turn unit on and see that unit works, check meter for RX and TX.
42. Calibrate TX on meter for just coming into the red on the highest power point in SSB Mode, re-check against AM point.
43. Calibrate the Clarifier knob to be at center frequency when "Ident" is at 12 o'clock position. Replace remainder of knobs.
44. Turn off, replace covers on VCO's and Oscillators.
45. Carefully, lace up all wiring-use originals taken off also.
46. Solder speaker wires on and replace covers.
47. Turn on and double check unit for everything. Enjoy!

## HINTS / KINKS / GOOFS

(This will be a new feature in SCB for the working tech especially!  
for obvious reasons we will have to suspend our offer of free volume  
to published contributors..This applies to this column only!!!)

INFORMATION IN THIS COLUMN WILL NOT BE INDEXED\*\*\*

Problem: Squeal on Centurian 40D in SSB only! (Ampl. mike used)

Solution: changed R-86 to 20K-no change; checked driver/final bias-OK;  
finally found it...Slug nearest FET-5 of L-24 was tuned  
wrong and wrong size (scoped it and found was on a harmonic).  
Someone had busted original and replaced with wrong size.

Problem: TRC-449; Power switch on early production runs-if it is an  
exposed switch-the contacts will not take the current and build  
up carbon.

Solution: Check when you get one in and replace if old type, size is  
a problem in front panel (R/S PN is RRVY271001, on/off-vol)  
If they don't want to change it, remind them, Pay me now or  
a lot more later!

Problem: MB8719 chassis-units with AMC transistor pulled (TR-32);  
distortion/all sorts of noises in TX. Intermittent and not  
in all units...

Solution: AMC sensor transistor (TR-33) heating up-removed and cured.

Problem: Busted cores in cans.

Solution: Remove from PCB and get to from bottom, first hit it with a  
little heat to break up the glue.

Problem: Return of your repair jobs, that look like someone has had  
the "screwdriver" put to it. But you can't prove it!

Solution: Seal the unit with destroy tags; same kind your local Super  
Market uses; put them on and initial. Give a warning that  
if seals removed-they eat the repair bill!

Problem: "Off-the-wall" conversion by prior "UFO's"..Nuff said!!

Solution: Try to help by putting a tag on inside cover as to a refer-  
ence modification (SCB Vol/pg.; CC#; or phone no.)

Problem: Commtron XII (AM/FM only unit); drivers going bad!

Solution: Seems that this is a factory problem in production..Drivers  
are torqued down too tight-crack nut insulator and transistor.  
Cronic problem-check before you sell and change both.

Problem: HyGain Afterburner Linears

Solution: Remove TVI trap (a small P.C. board); cures most of problems;  
and increases power.

Problem: Cobra 2000, 148GTL - popping/cracking when mod limiter (TR-24)  
removed.

Solution: Remove C-232 electrolytic capacitor.

GOOF....Don't pass up R/S Engineer's Notebook Vol.2, has more than  
Vol. 1. Also don't throw away Vol. 1, as Vol-2 deleted some of it.  
A lot of good stuff in them, especially when stumped on circuit  
design.

HINT....When tuning-adjust for modulation without a test tone by using  
an AH-H-H-H into the microphone. Always tune for max forward power.  
If you have to whistle, go buy a dog!

Problem: 858 chassis, blows fuse when keyed-suspected final-but good!

Solution: C179 (2.2Mfd/25V tantalum), changed to higher voltage/same  
value-cured problem. Suggest changing on units...



SPECIFIC TUNE-UPS

GREAT Md1. K605/GT-818 (CCI 3002 PLL)

VR1-IF Gain           VR5-AGC  
VR6-TX Mtr            VR4-Sq Rng  
VR7-RX Mtr            VR8-AMC, (don't defeat)  
Peak: L901, L903, L905 (Some have 2SC1678, 10W final-Push!)

ROYCE I-580

VR201-AMC, VR202-TX Mtr, VR104-RX Mtr, VR103-Sq Rng.  
Peak: T201, T202, L203, L204, & CT201

CRAIG 4102

VR4-AMC, VR6-TX Mtr, VR3-Sq Rng, VR5-RX Mtr.

BETA 23 ch DELUXE

R78-AMC (defeat/remove), R65-TX Mtr, R66-RX Mtr, R26-Sq Rng

COYOTE 23

VR103-AMC(SSB), VR206-AMC(AM), VC201-AM Pwr, VC104-SSB Pwr

REGENCY CR-240

VR213-AMC (defeat, C293), VR14-AM Pwr, VR11 & L217-SSB Pwr

TRAM XI-5

R616-AMC, L106-AM Pwr, R130-SSB Pwr.

REALISTIC TRC-210 (21-1661) 40ch. Walkie-Talkie (TC9109BP PLL)

VR1-Sq Rng, VR2-Low Pwr Adj, VR3-Hi Pwr Adj. RX-adj T1, T2, T3,  
for max signal. TX-T5, T6, T7, L11, L12, L8, VR4 max pwr on  
field strength meter with antenna extended. Pull R-77 for max  
mod. - Unit has 16W final push it!

Note: Custom Conversion #20 avail. (5KHz jump +)

---

MODULATION ADJ/DEFEATS

JC Penny 981-6221, and Sears 934:38110700

D501-limiter....Zapper 9000 will install at C307.

Great GT-838

D17-Limiter

Craig 4104

R192-AMC

Unimetrics Mako-1

RV6-AMC

Cobra 20LTD

D13-Limiter

Cobra 28A

CD28 & 29, Limiters

Cobra 21X

VR207-AMC

Lake 5000

VR402-AMC

Siltronix Apache(AM-1)

VR7-AMC

Siltronix Mohawk(AM-2)

VR7-AMC

K-Mart, D-40

VR202-AMC

Palomar 49

D217-Limiter

Palomar 410C

RV2-AMC

Pearce-Simmon SuperLynx

C103-Limiter

Pioneer GT-600

D8-Limiter

## M58472P PLL Chip Modification

This PLL chip isn't too versatile, and used in only about 10 units. Known are following: GE- 3-5801A/5800A/5810A/5821A/5871A; Teaberry-Racer 'T', 'T' Charlie; Channel Master- CB6830/6834/6835.

Unit used for this modification was: GE 3-5801A S/N:01084XXX (SAMS-144) Chassis has PLL circuitry on a raised/separate PCB, mounted up off the main PCB. No problem on this modification-unless radio is busted to start with. Quick-ie Line-up in case you don't have SAMS: VR1-AGC, VR3-Sq Rng, VR4-RX Mtr, VR7-AMC (limiter-C507), VR5-TX Mtr...If you have to align PLL-get SAMS. RX-align in this order:T304, T303, T302, T301, L103, L102, L101. TX-peak, L901, L903, L905.

In this unit the ANL switch is utilized for modification. Remove R513; and replace with solid buss wire; this enables the ANL permanently. The ANL switch and wires can all be removed now. Obtain a 3 pole - 3 position switch, preferably a slide type that will fit perfect into position on the front panel.

Remove the Green wire from pin on PLL board, trace to selector and unsolder carefully. Replace with 7" piece of Green wire-soldered to selector switch where other removed, solder other end of wire to center pole of switch. Solder Green wire with slip-on connector to wiper of the switch. Solder a Black 7", and Red 7" piece to other poles of switch, install switch into panel-make sure that the black wire side is to the left in relation with panel front. (See below).

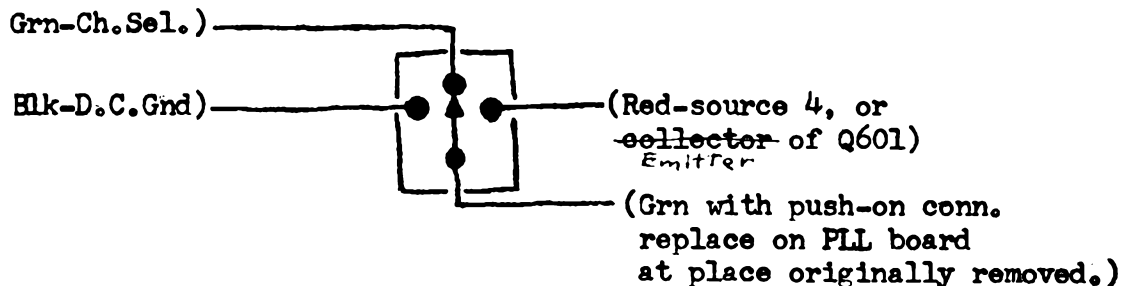

Wire up per above drawing the remaining wires...cut all wires to length.

Middle position on switch-normal C.B. frequencies.

Left position on switch-NEW frequencies only per selector:

Selector pos. 12	- 26.945MHz
13	- 26.955
16	- 26.995
20	- 27.045

Right position on switch-NEW frequencies only per selector:

Selector pos. 3	- 27.145MHz	32	- 27.485MHz
7	- 27.195	33	- 27.495
23	- 27.415	34	- 27.505
26	- 27.425	35	- 27.515
27	- 27.435	36	- 27.525
28	- 27.445	37	- 27.535
29	- 27.455	38	- 27.545
30	- 27.465	39	- 27.555
31	- 27.475	40	- 27.565

This is just about all the chip is capable of unless you want 26.935 (Pin 3 of PLL - Blue wire, break line and will have at 23 of the selector position).

# OSCILLATOR CHECKER

THIS RF PROBE IS HANDY FOR OSCILLATOR CHECKS:

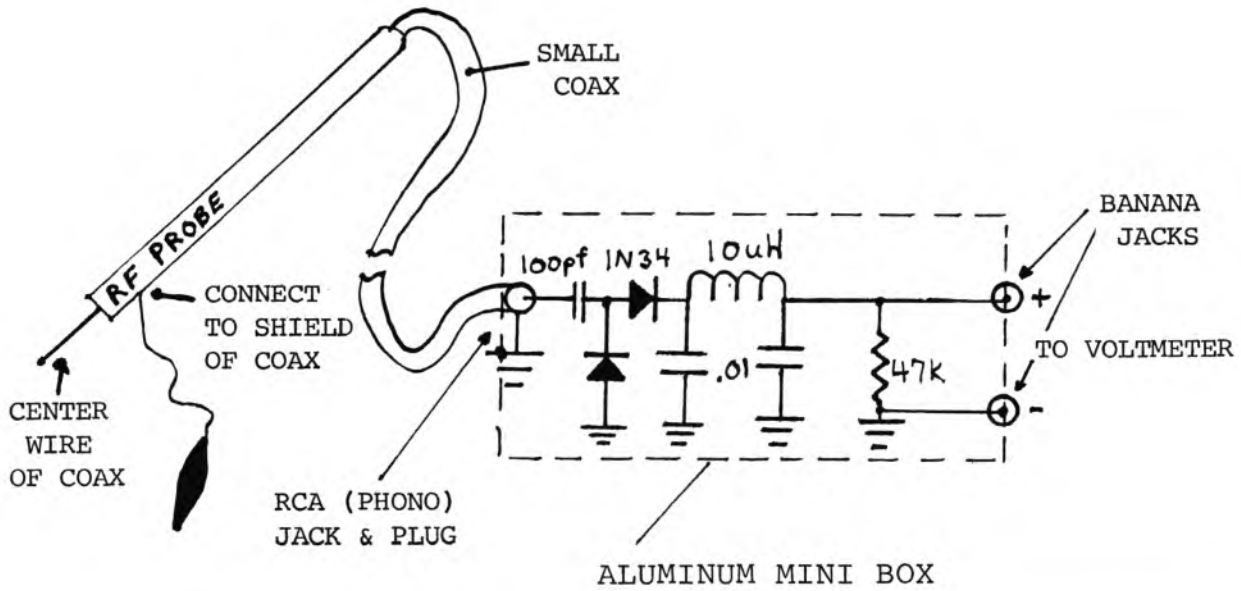

## LOW CAPACITY PROBE

A necessity for RF work, prevents loading. Put in a shielded tube.

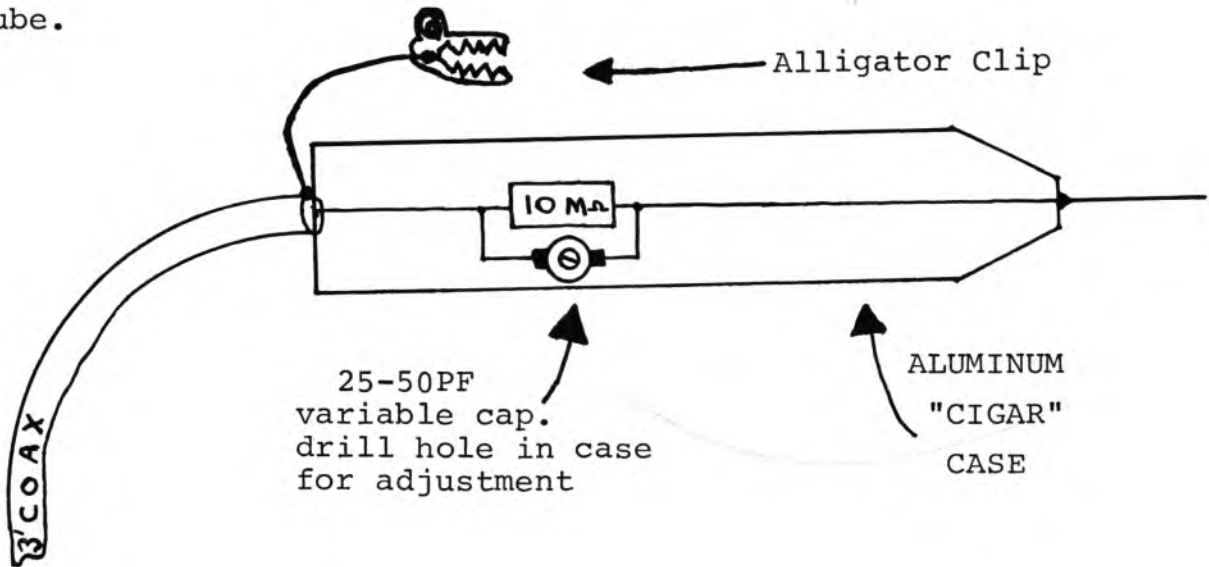

Feed in square wave signal and adjust trimmer cap for best waveform:

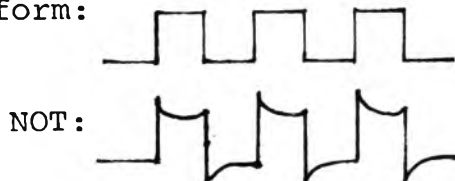

## TROUBLESHOOTING GUIDE

### UNIT WILL NOT TURN ON:

- \* Blown Fuse
- \* Defective ON/OFF Switch
- \* Power Cable or Source Defective or low voltage
- \* Reversed Polarity
- \* Internal Damage, Shorts or Opens (burned PC traces, wiring, chokes, cold solder joints, etc.)

### FUSE BLOWS IMMEDIATELY:

- \* Hooked Up backwards
- \* Polarity Protection Diode Shorted
- \* Incorrect Fuse Rating (AM units generally use a 2amp fuse; SSB's 5amp.)
- \* Component shorted (zener, regulator transistor, final or IC chip bad.)

### NO AUDIO FROM SPEAKER; S METER SHOWS SIGNAL PRESENT:

- \* Bad Speaker
- \* Defective Squelch Circuit
- \* Microphone not plugged in or defective mic.
- \* Volume Control defective
- \* Audio Amp defective

### NO RX. AUDIO/NO MOD.:

- \* Audio Amp.
- \* Microphone bad (cartridge or cord)

## TROUBLESHOOTING GUIDE cont'd.

### RX OK; BLOWS FUSE ON XMIT:

- \* Driver or final Shorted
- \* Modulator Defective
- \* TX Voltage Circuit defective

### RX AUDIO OK/NO MOD.:

- \* Microphone bad (cord, cartridge, battery)
- \* Mic Amp bad

### NO RX/NO TX:

- \* Crystal or PLL unit defective
- \* Voltage Reg. bad
- \* Unit in PA instead of CB Mode

### POOR RECEPTION /LOW RF OUTPUT:

- \* Low Voltage
- \* Antenna, coax, connector defective

### POOR SENSITIVITY:

- \* RF AMP Transistor or FET Bad
- \* Alignment (if tampered with)
- \* Coils open

Any intermittent type of symptom may be caused by cold solder joints, broken parts or thermally defective components. Trouble is especially bad in high vibration installations such as in diesels. Also be wary of double sided boards - a real pain. I have found a lot of these with hairline cracks and bad solder joints on top-bottom pc jumper. (Midland 79-900 and Pace 1000 were bad ones for this!)

# INTO THE KNOW WITH POTS

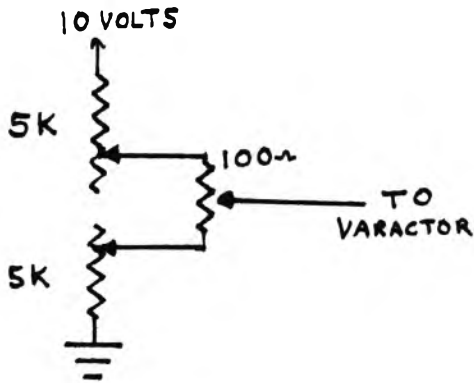

5K Pot is a Dual Pot. Resolution of above circuit is about 4 times better than a 10 Turn Pot! (If you can live with that many adjustments.)



10 Turn Pot- A good choice for accurate, single knob clarification

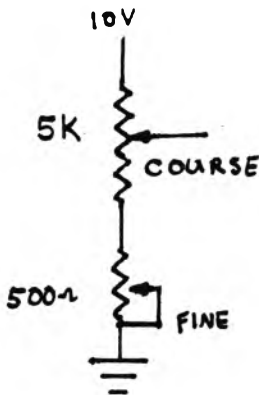

This circuit has somewhat less resolution of 3 Pot configuration, but is less expensive.

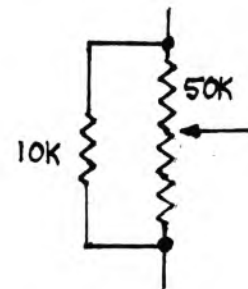

Here is what you can do if you need a 10K Pot, but all you have is a 50K.

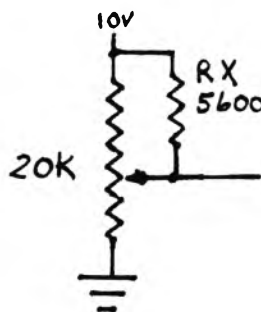

Here is the circuit you often see in CB's. RX is a "LINEARIZING" resistor. Usually about 20-30% of pot value.

"My Way" Slide  
by D.W.

Clarifier modification for Colt 480/485/1000/1200 (02A PLL).

I never have been satisfied with all the work necessary to get these chassis to slide more than 5KHz. It just seems to be too much hassle to take them all apart, put in variable caps, and chokes, etc..for just 10 to 12KHz of slide. With this in mind I decided to do it "My Way".

The schematic below shows the modifications that I made to get -2.5KHz to +24KHz (That's correct, no typing error!) and it takes about 15 minutes to do without having to tear the whole radio down.

First I do the standard clarifier modification for 5KHz of slide. Remove D5. Trace wire from center lug of clarifier control back to PCB and unsolder. Resolder wire to cathode of D4. Solder a piece of wire to emitter of Q44 and other end to the unused lug of clarifier control. If everything still works O.K.; let's go!!

Remove D3 and C18. Replace D3 with a Super Clarifier Diode, observe the same polarity as before. On etch side solder one leg of C18 to Q3, solder a 20pf cap to other leg of C18. The other leg of 20pf cap solder to D.C. Ground. Cut the circuit board trace between CT1 and X1, solder a .001mfd cap to the free end of X1 and the other end to the D3/R22 junction. THAT'S IT---ALL DONE, plenty of slide without major surgery.....

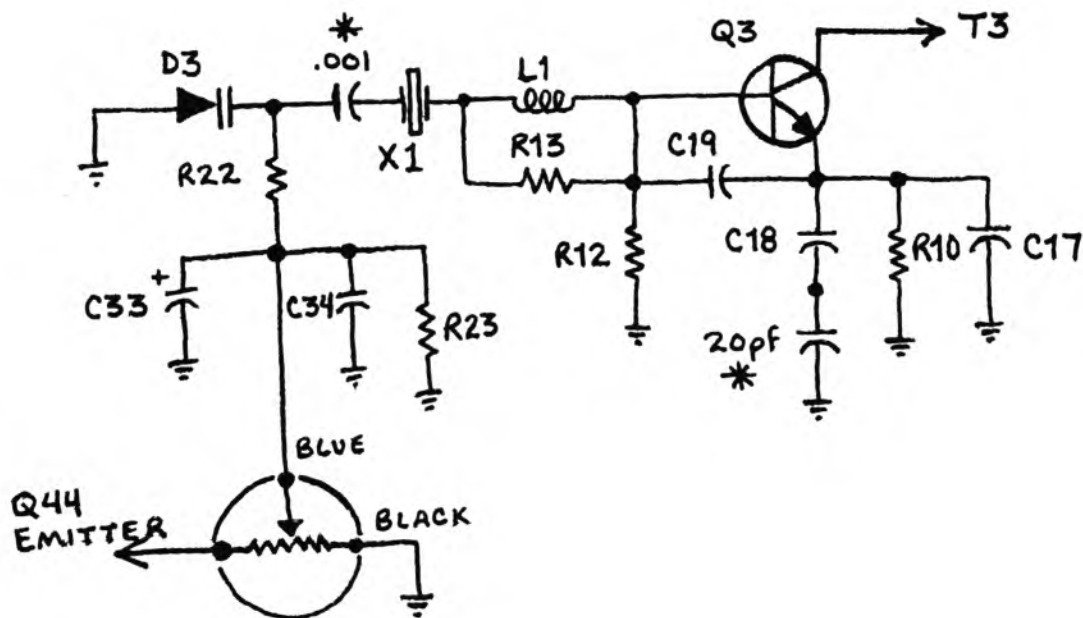

---Clarifier Circuit after modifications: new parts--\*  
 .001mfd cap  
 20pf cap  
 D3-changed to Super Clarifier Diode

COMMTRON XII - 120 channel, AM/FM (LC7120 PLL)

This is a GREAT little unit, with AM/FM and a frequency range from: 26.515-26.955, normal C.B. frequencies, 27.415-27.855MHz. (120 chnl.) This unit has been given a thorough going over by contributor, and the following alignment has been wrote up. (Also see HINTS-..)

AMC is RV201 (Note: do not remove the modulation limiter!)

RF Mtr.-RV202, SQ. Rng.-RV101, S Mtr.-RV103..

TX Adjustments: L304, L305, L306, L303, L302, L301; max output...

F.M. Deviation: (RV501) adjust to obtain 1.7KHz deviation with 20mv, 1KHz signal injected at Mic input

RX Adjustments:-Sig.Gen.-set to 27.185MHz, 1KHz/30% modulation; unit to Ch. 19-AM...

1. Adjust for max audio - L204, L101, L102, L103, L104, L105, L106, L107...  
-Set Sig. Gen. at 27.185MHz, 1KHz/1.7KHz deviation for FM. Set unit to FM...
2. Adjust for max audio - L501 and T501..

Notes: This is a fine radio; performance/price wise; if you want FM-but no SSB... Another EXPORT unit for England, made in Korea.. Prices vary per availability/under \$200 from most sources..... Anyone having Schematic/Factory Service Manual, SCB needs for file..

UPDATE

COBRA 132XLR/135XLR (TC5080P PLL)

This conversion does allow frequency coverage up to 28.025MHz, but-no more going below 26.965! No crystal switching is required, just change crystal permanently...

1. Remove 17.0555 Xtal...
2. Replace with 17.255MHz Xtal...
3. Cut trace to pin 8 of PLL (in effect Isolate, but leave some etch for soldering-so you won't have to solder directly to pin).
4. Solder a 4.7K resistor from pin 8 of PLL, to D.C. ground.
5. Obtain two SPST switches for selectors or preferably, permanently "hardwire" some existing switch functions and use those.
6. Follow diagram below and install the wiring to points indicated..
7. For alignment follow directions in previous issues: See Index....

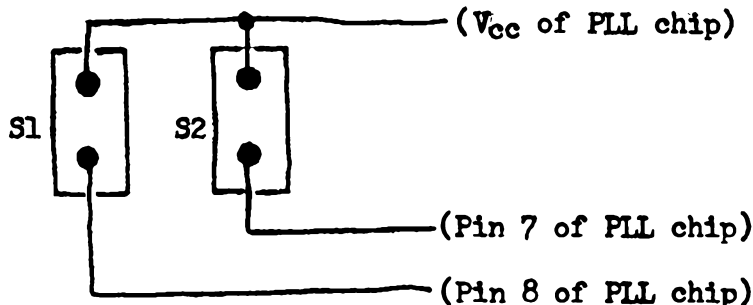

S1 On - 27.415-27.845MHz  
S2 On - 27.425-27.585MHz  
Both On - to 28.025MHz

Note: No chart was provided, and didn't have unit around to check F<sub>o</sub> per selector.....



MOTOROLA CC975AX

Nothing but what is printed was received - here goes!  
SAMS is not available on this unit, but #243 close.  
AMC is VR501, defeat is D501.  
Locate wiring harness from channel selector to PLL box..  
Wire up a SPST switch as shown below: Suggest going to point of  
origin on selector switch instead of "tacking" into the wire though!  
Remember, don't ask me what it gives!!!

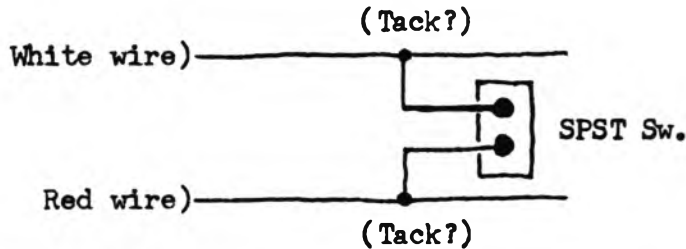

---

REALISTIC TRC-470 (IC7110 PLL)

Note: This is-In/Under dash-AM/FM Stereo/C.B. combo came out  
in '79..  
Carefully tack solder a 4.7K resistor to pin 13 of PLL chip..  
Locate Blue wire from channel selector switch to the PLL box,  
cut this wire and install SPST switch in line..  
Another SPST switch must be installed from the resistor to D.C.  
Ground... See drawing below:

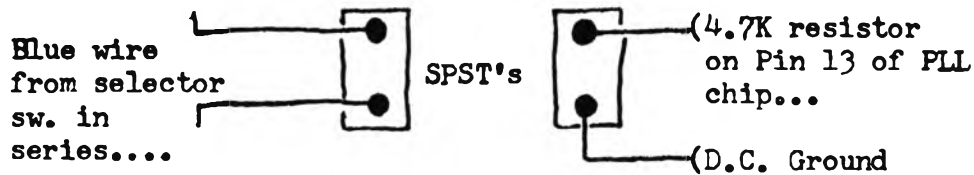

Combinations of these switches will yield from 26.785-27.999MHz!  
VCO coil must be retuned-T802....Mod. Limiter-Q509.....

Note: This same conversion technique has been done on GE 3-5804A  
and GE 3-5871B, others using this chip are: Sanyo TA2000,  
TA4000, TA6000; and Realistic TRC-454...

---

\*\*\* BLEED-OVER FILTER \*\*\*

This was to have been a SECRET, but 2 different sources sent it in!  
Has been used to cut down on bleedover on many O2A SSB units.  
No problem with parts, as most are in those junk units probably  
laying around. Remove existing 455KHz filter from unit and replace  
with two....See below: .....Experiment a bit-in for a surprise!!

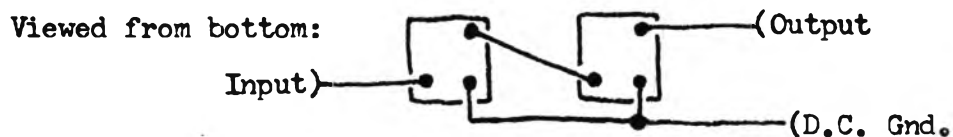

Glue together to save space....

ROAD RUNNER CB5000A (MSM5807 PLL)

Again-this is all we got; no tune-up spec's or particulars....

Remove PLL box from chassis and cut trace to Pin 4 of PLL chip..  
Cut trace going to Pin 2 of PLL chip, and bridge with 4.7K resistor..

Wire up a 6 position/2 pole switch as below; diodes are 1N914 or like item.....when finished wire up to indicated PLL chip pins..

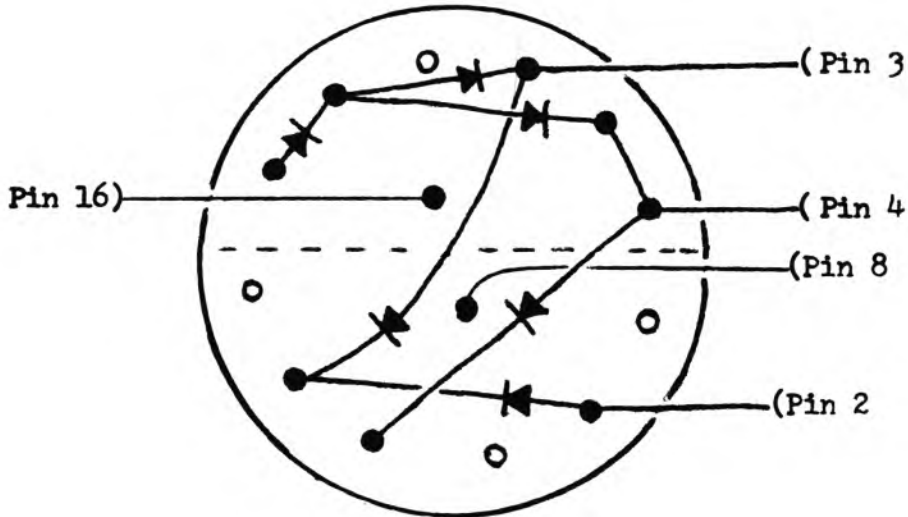

- Switch Positions:
- 1 - Normal C.B.
  - 2 - 27.425-27.595MHz, selector 12-27
  - 3 - 27.605-28.045MHz, selector 1-40
  - 4 - Dead Space - used to separate Hi/Lo F<sub>o</sub>.
  - 5 - 26.645-26.955MHz, selector 1-27
  - 6 - 26.325-26.765MHz, selector 1-40

This same PLL chip is also used in following: FieldMaster Micro-Mini-40, Alaron B-4900, Palomar 49, Kraco KCB-4000, Tenna 10901/10902/11302, and Realistic TRC-205..

BRISTOL ECB-2271 (MSM5907 PLL)

AMC-VR487, defeat is D481 and D482....Change final to 2SC1306...  
(Note: This is not a true PLL Chip, but Phase Detector/Programmable Divider).....the same type as found in following AM tube types; Teaberry Model 'T', Robyn T-240D, Gemtronics GTX4040/GTX-5000, and Shakespeare GBS-240..also a seldom heard of Colt 'Midnite Special' Mdl. 900..

Conversion is simple, using a SPDT center-OFF toggle switch(below)

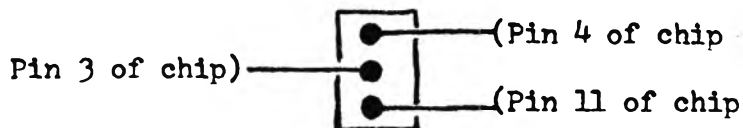

- Switch Up - 27.405-27.595MHz; selector 11-27
- Switch Center---Normal C.B.
- Switch Down - 26.645-26.965MHz..

## LOOP FILTER-WHAT IS IT??

Ever since the Digi-Scan Frequency Controller became available we became aware of the 10K-10mfd, "Loop Filter" and it's associated problems.

Below is a loop filter circuit from the Cobra 148GTL:

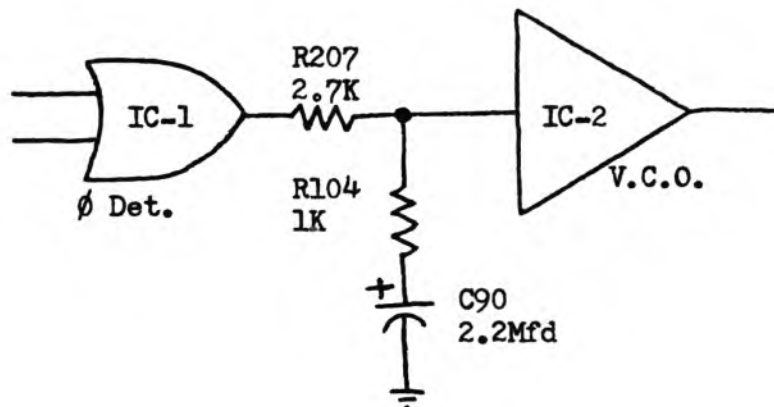

As simple as it might seem, the loop filter is the single most important part of the PLL system. It determines the "Settling Time" and the "Damping" of the loop. In diagram, R207 and C90 determine the Settling time. The ratio of R207 to R104 determine the Damping. R104 will be between 10-33% of R207. If R104 is too small, bounce, overshoot or oscillation might result. If R104 is too large, the loop may take a long time to lock in on a new frequency input. When divide by N counters are used, a long settling time is needed. A high quality, low leakage type capacitor must be used for C90....

---

### COLOR CODE GUIDE FOR CHOKES

Black - - - 0	<u>Multiplier Band</u>
Brown - - - 1	Black - - X1
Red - - - 2	Brown - - X10
Orange - - 3	Red - - - X100
Yellow - - 4	Orange - - X1000
Green - - - 5	
Blue - - - 6	
Violet - - 7	
Gray - - - 8	
White - - - 9	

MIL SPEC I.D. is a wide Silver band (or large dot on a small unit), at the end of the coil.

Three narrow bands (or small dots), will follow:

If the 1st or 2nd band is Gold, value is less than 10UH, and the remaining are the specific value figures...

Above 10UH, the first two bands are specific value figures, the 3rd band is the multiplier, and 4th band of Silver will indicate a 10% tolerance...

If you didn't know by now -- here it is: TWO different versions of this unit exist!! The 'Early' version is serial numbered from 03000001-4498 to 13000001-1504. Have no starting serial number for the 'Later' version at present time...

Major differences between versions are shown in the 'Early' and 'Later' version Block Diagrams - which are further on in this text.

\* \* \* \* \*

This is something everyone has been calling and asking about,

Complete Alignment Procedures for the 'Early' Version of 148GTL-DX.

PLL/OSCILLATOR ALIGNMENT

Equipment Needed: Oscilloscope, DC Voltmeter, Frequency Counter..

Step	Control Settings	Adjust	Perform/Check for
A	CH: 19 RX Mode AM Mode Voice Lock-Center Band: Mid	L14	Connect scope to TP4* (* in this case-lead of R83). Adjust for max indication on scope...
B	Same as above, CHANGE to: CH: 40	L15	Connect DC Voltmeter to TP2 (lead of R93). Adjust for 5.4V reading on DC Voltmeter.
C	Step A Settings	L16	Connect scope to TP3 (lead of R101). Adjust for max indication on scope...
D	Step A Settings	L31	Connect Freq. Counter to TP3 (Lead of R101). Adjust for 16.490MHz, +/- 20Hz.
E	Step A Settings CHANGE to: CH: 40 Mode: USB	L32	Leave Counter in place, adjust for 16.4925MHz, +/- 20Hz.
F	Step A Settings CHANGE to: CH: 40 Mode: LSB	L33	Leave Counter in place, adjust for 16.4875MHz, +/- 20Hz.

## 148GTL-DX...PLL/OSCILLATOR ALIGNMENT...Cont.

Step	Control Settings	Adjust	Perform/Check for
G	Step A Settings CHANGE to: CH: 40 Mode: LSB TX Mode	VR6	Leave Counter in place, adjust for 16.4875MHz, +/- 20Hz.
H	Step A Settings CHANGE to: CH: 40 Band: LOW	L22	Leave Counter in place, adjust for 16.040MHz, +/- 20Hz.
I	Step A Settings CHANGE to: CH: 40 Band: LOW Mode: USB	L23	Leave Counter in place, adjust for 16.0425MHz, +/- 20Hz.
J	Step A Settings CHANGE to: CH: 40 Band: LOW Mode: LSB	L24	Leave Counter in place, adjust for 16.0375MHz, +/- 20Hz.
K	Step A Settings CHANGE to: CH: 40 Band: HI	L40	Leave Counter in place, adjust for 16.940MHz, +/- 20Hz.
L	Step A Settings CHANGE to: CH: 40 Band: HI Mode: USB	L41	Leave Counter in place, adjust for 16.9425MHz, +/- 20Hz.
M	Step A Settings CHANGE to: CH: 40 Band: HI Mode: LSB	L42	Leave Counter in place, adjust for 16.9375MHz, +/- 20Hz.
N	Step A Settings CHANGE to: CH: 40 TX Mode	L47	Connect Frequency Counter to TP4* (*in this case lead of R114). Adjust for 10.695MHz, +/- 5Hz.
O	Step A Settings CHANGE to: CH: 40 Mode: USB	L48	Connect Frequency Counter to TP5 (lead of R39). Adjust 10.6925MHz, +5Hz, -0Hz.
P	Step A Settings CHANGE to: CH: 40 Mode: LSB	L49	Leave Counter in place, adjust for 10.6975MHz, +0Hz, -5Hz.

End of this alignment... PLL/Osc. ckts.

RECEIVER ALIGNMENT

Equipment Needed: 27MHz Band Signal Generator, Oscilloscope, Audio Frequency VTVM (Across 8 oz. speaker), Deviation Meter.

Step	Control Settings	Adjust	Perform/Check for
A	CH: 19 Band: MID AM Mode Tone: HI NB/ANL: OFF Volume: CW RF Gain: CW Coarse: Center Squelch: CCW CH 9 SW: OFF		DOUBLE CHECK ALL SETTINGS!
B	Same as above	L4	Turn core of L4 to the bottom..
C	Step A Settings	L3, L5, L6, L7, L8, L17 L18 and L4	Adjust for maximum reading and readjust L4 for maximum reading..
D	Step A Settings CHANGE to: NB/ANL: ON	L1, L2	Set SigGen on Mid, CH18 F <sub>o</sub> (27.175MHz). Note unit is still on CH:19. No modulation.. Connect scope to D2 and adjust coils for max reading. Set SigGen level to 5uV, and readjust both coils. ( D2 is TP1)
E	Step A Settings CHANGE to: Squelch: CW	VR2	Set the SigGen to Mid, CH19 F <sub>o</sub> (27.185MHz). 30% modulation at 1000uV level. Adjust VR2 until signal appears on scope. Tight Squelch Adjust..
F	Step A Settings	VR1	Set SigGen output level to 1000uV, no modulation. Adjust VR1 for S-9 reading on unit's meter
G	Step A Settings CHANGE to: Mode: FM	L9, L10	Set SigGen to 10uV with no modulation. Connect scope to lead of R279, and adjust coils for maximum reading. (Pin 1 & 2 of IC2).

Step	Control Settings	Adjust	Perform/Check for
H	Step A Settings CHANGE to: Mode: FM	L11	Set SigGen to 1mV with 1.5KHz deviation/1KHz. Adjust L11 for max sine-wave on scope.

End of this alignment... Receiver circuits

### TRANSMITTER ALIGNMENT

Equipment Needed: DC Ammeter, RF VTVM, Deviation Meter, Frequency Counter, Power Meter, Oscilloscope, 50 ohm Dummy Load.

Step	Control Settings	Adjust	Perform/Check for
A	CH: 19 TX Mode Mode: USB Mic Gain: Min	VR10	Remove PC-843 (PCB) and connect Ammeter to TP8 (+) and TP7 (-). Adjust for 8ma reading.
B	Same as Above	VR9	Connect DC Ammeter to TP8 (+) and TP6 (-) and adjust for 100ma reading.
C	Step A Settings CHANGE to: Mic input: 30mv 1KHz	L65	Restore PC-834. Turn core of L65 to the bottom of coil.
D	Step A Settings CHANGE to: Mic input: 30mv 1KHz	L64, L66 L67.	Adjust for maximum reading on RF VTVM (across 50 ohm Dummy Load).
E	Step A Settings CHANGE to: Mic Input: 30mv 1KHz	L65	Set the Band: HI, CH: 40, and adjust for maximum reading on RF VTVM. Turn Band: LO, CH: 1, readjust for equalized output power.
F	Step A Settings CHANGE to: Mode: AM Mic Input 90%	L54	Adjust for maximum reading on RF VTVM (Final Output Adjustment)
G	Step A Settings CHANGE to: Mic Input: 30mv 1KHz	VR7	Adjust ALC for 24.5V reading on RF VTVM (12W/50 ohm Single Tone).

148GTL-DX... TRANSMITTER ALIGNMENT... Cont.

Step	Control Settings	Adjust	Perform/Check for
H	Step A Settings!	VR4	Adjust for minimum reading on scope for both USB and LSB. (Minimum Carrier Adjust)
I	Step A Settings CHANGE to: Mode: AM	VR11	Adjust for 5.0W reading on RF Power Meter (AM carrier output adjustment).
J	Step A Settings CHANGE to: Mode: AM	VR8	Set the meter SW to S/RF. Adjust VR8 so radio's meter reads 5W (between Green and Red zones). "RF meter adjust".
K	Step A Settings CHANGE to: Mode: AM Mic Input: 30mv 1KHz	VR5	Adjust for 90% modulation on oscilloscope. (AM modulation adjust).
L	Step A Settings CHANGE to: Mode: FM Band: LOW CH: 40 Mic Input: 30mv 1KHz	VR3	Adjust for 4.5KHz deviation (FM deviation adjust).
M	Step A Settings CHANGE to: Mode: CW Band: LOW CH: 40 Mic Input: 30mv 1KHz	VR12	Adjust 0.2V reading on AF VTVM when CW key is keyed. (Side tone adjust)
N	Step A Settings CHANGE to: CH 9 SW: CH 9	None	Check that the output frequency is 27.065MHz on Frequency Counter...

End of the alignment... Transmitter circuits

\* \* \* \* \*

At present time am trying to locate alignment procedures for 'Later' version of 148GTL-DX. Will publish as soon as possible. The following Block Diagrams are of the 'Early' and 'Later' versions - 148GTL-DX.....





# BLOCK DIAGRAM (LATER VERSION)

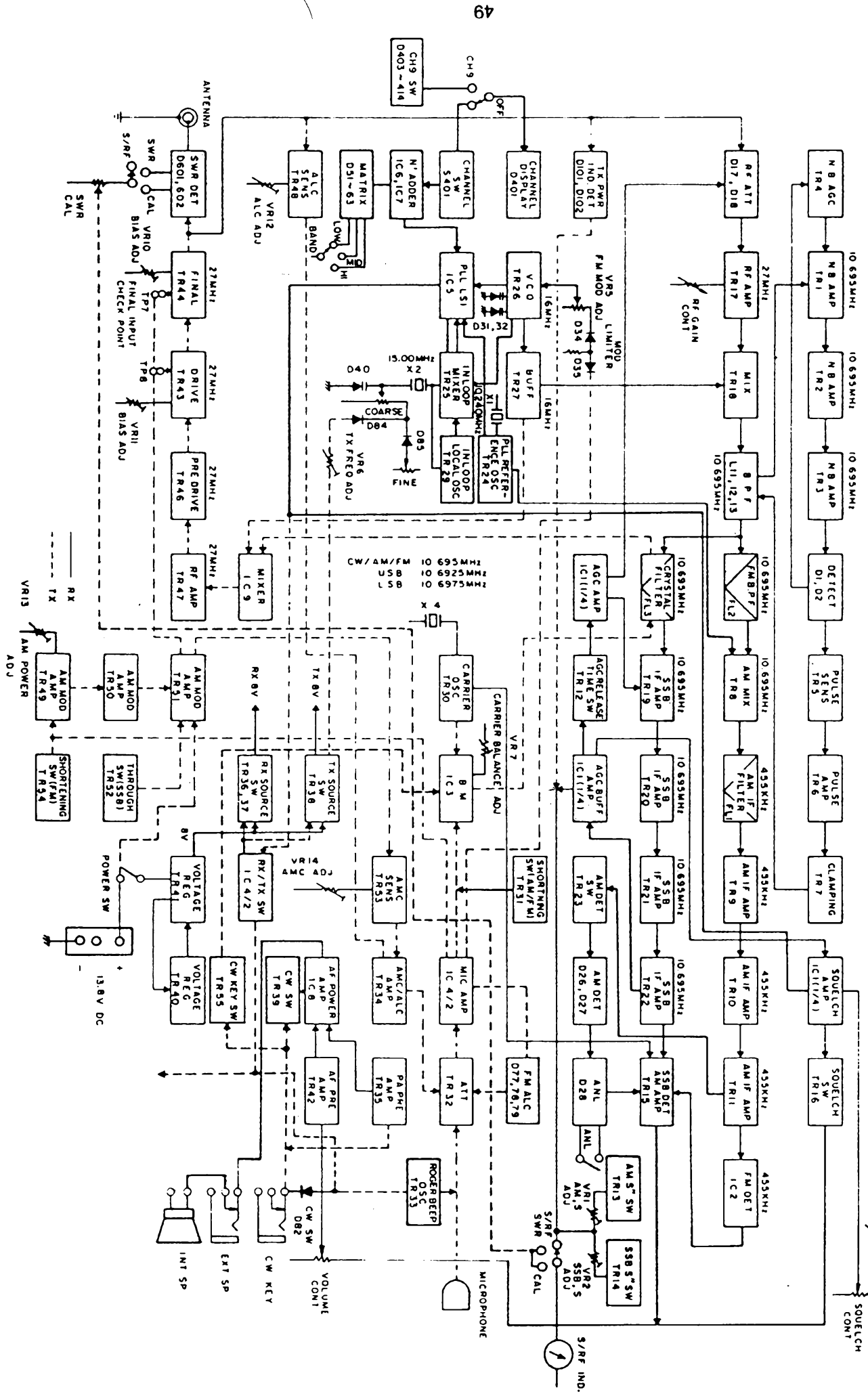

148GTL-DX (EARLY) LATE

This is a 'Proven' modification for the Clarifier and alignment for improving the SSB use.. As you probably are aware of, this unit uses a two-part clarifier-but only the COARSE section is unlocked as designed. Because of the detent on the COARSE potentiometer, synchronizing the RX and TX frequencies is usually very difficult.. The following 'mod.', and alignment solves all the problems: D.S.

*This Sucks Too*

1. Remove D84.
2. Move Blue wire at top end of VR307 (FINE) from TR36 Collector to TR36 Emitter.

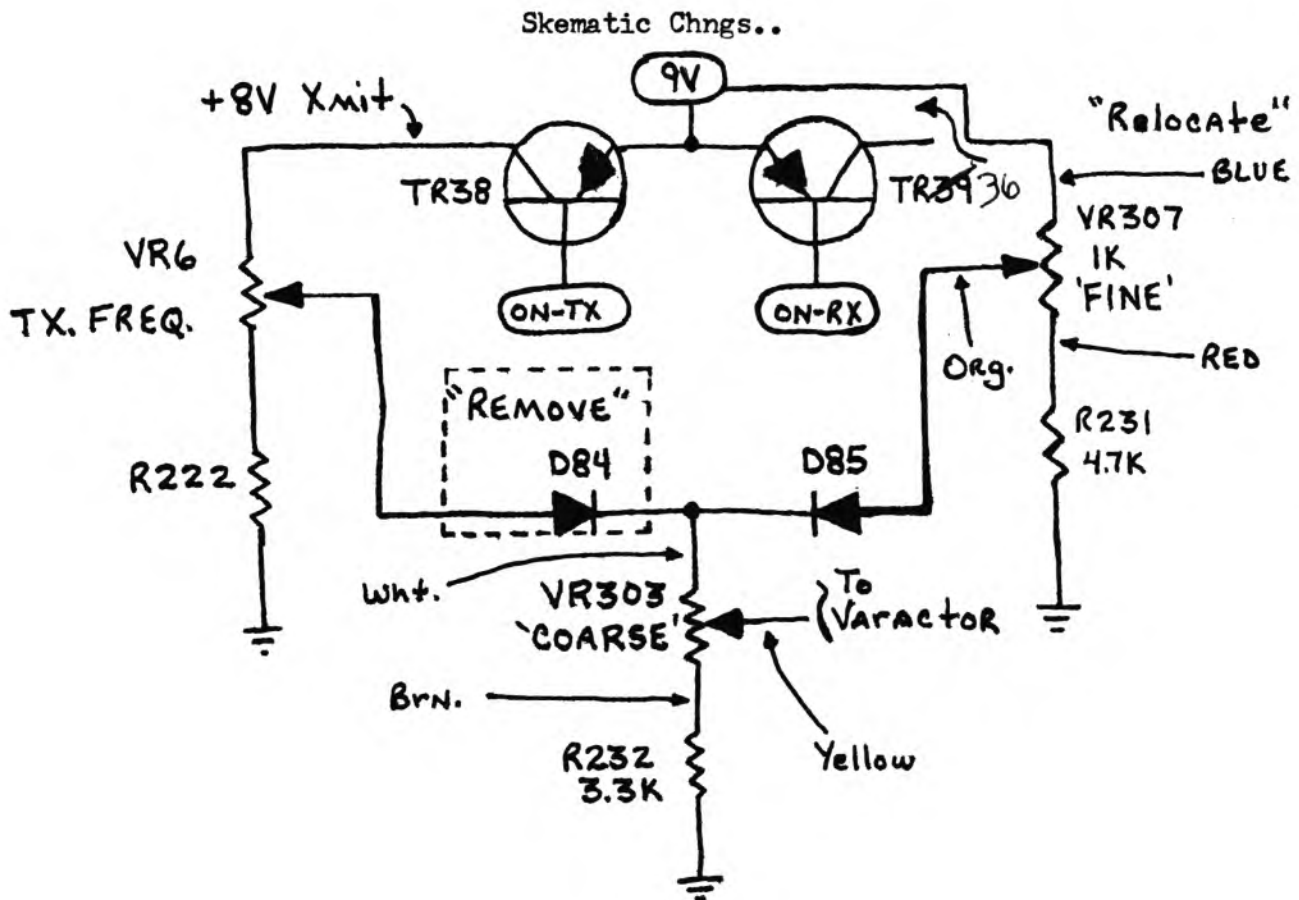

"FOLLOW ALIGNMENT ON NEXT PAGE - EXACTLY AS WRITTEN!"

148GTL-DX (~~EARLY~~) *GATE*.....

3. Realign as follows:

- A. Select CH. 39, MID band.
- B. Monitor TP3 with frequency counter.
- C. Adjust L21 for 16.700000MHz, AM Mode
- D. Adjust L22 for 16.702500MHz, USB Mode
- E. Adjust L23 for 16.697500MHz, LSB Mode
- F. Adjust L17 for maximum RF at TP4 (Rec).
- G. Adjust L19 for maximum RF at TP3 (Rec).
- H. On CH. 40, adjust L18 for 2.5VDC at TP2.
- I. Adjust L52, L53, and L55 for max power output; Xmt on CH. 40, AM.
- J. Adjust VR7 to null carrier on LSB Xmit.
- K. Adjust VR8 for correct output power reading on TX PWR MTR.
- L. Adjust VR13 for 6 watt output power (AM).
- M. Adjust the following in Receive for max S-meter reading:  
L7, L8, L9, L11, L12, L13, L14, L15...
- N. With 100 microvolt input adjust the following:  
VR2 for S9 reading in AM Mode.  
VR1 for S9 reading in SSB Mode.

---

MIDLAND 151M (77-151) LC7131 PLL

See drawing below for adjusts - No VR #'s on PCB.....  
View is from front of unit...(Need a skem. for our files!)

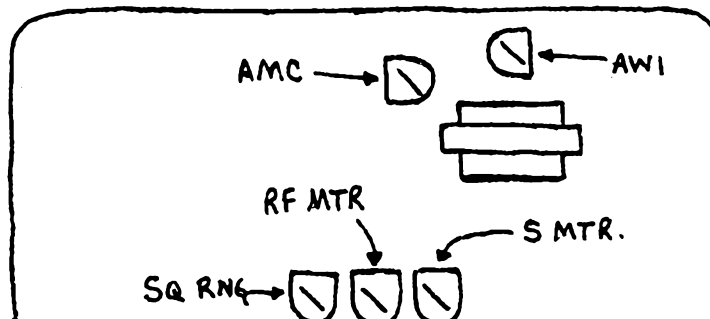

LAKE 400 (145106 PLL)

Other units using this same chip include: LAKE 600, ROBYN 440,  
REGENCY CB501, DAK MARK V & MARK IX, PALOMAR SSB-500B (Late),  
BROWNING GOLDEN EAGLE MARK IVA...

....Frequency chart below is for the Lake 400 (Proven), but you  
can experiment!

OPEN PIN 11 FOR LOW CHANNELS..used ANL switch..

<u>Selector</u>	<u>Frequency</u>	<u>Selector</u>	<u>Frequency</u>
1	1	21	26.895
2.....	2	22.....	26.905
3	3	23	26.935
4.....	4	24.....	26.915
5	26.695	25	26.925
6.....	26.705	26.....	26.945
7	26.715	27	26.955
8.....	26.735	28.....	1
9	26.745	29	2
10.....	26.755	30.....	3
11	26.765	31	26.995
12.....	26.785	32.....	4
13	26.795	33	33
14.....	26.805	34.....	34
15	26.815	35	35
16.....	26.835	36.....	36
17	26.845	37	37
18.....	26.855	38.....	38
19	26.865	39	39
20.....	26.885	40.....	40

NOTE: If Pin 6 is tied high, try taking low for 5KHz steps;

It does not work all the time!!

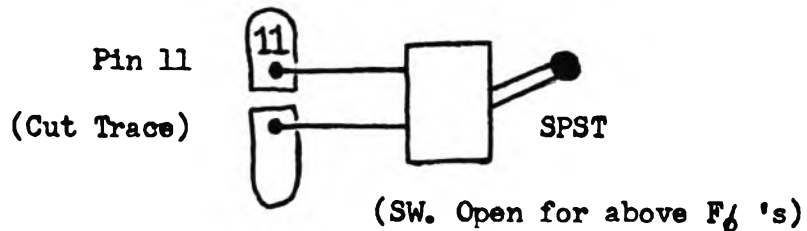

COBRA 50XLR/55XLR (MB8719 PLL)

A-Open Pin 10

B-Open Pins 10 and 11

C-Open Pin 10, and Pin 10 tied to Pin 17

Frequency Chart starts at selector position 16 (NO error)....

<u>Channel Selector</u>	<u>A</u>	<u>B</u>	<u>C</u>
16	26.515	26.835	27.795
17	26.525	26.845	27.805
18	26.535	26.855	27.815
19	26.545	26.865	27.825
20	26.565	26.885	27.845
21	26.575	26.895	27.855
22	26.585	26.905	27.865
23	26.615	26.935	27.895
24	26.595	26.915	27.875
25	26.605	26.925	27.885
26	26.625	26.945	27.905
27	26.635	26.955	27.915
28	26.645	1	27.925
29	26.655	2	27.935
30	26.665	3	27.945
31	26.675	26.995	27.955
32	26.685	4	27.965
33	26.695	5	27.975
34	26.705	6	27.985
35	26.715	7	27.995
36	26.725	27.045	28.005
37	26.735	8	28.015
38	26.745	9	28.025
39	26.755	10	28.035
40	26.765	11	28.045

"ANOTHER GOOD-1 FROM JIM"

Recently a customer asked us to come up with some sort of "battery eliminator" for his SEE Sidebander II equipped with a Astatic D104M Power Mic. The solution that we devised works so well that we would like to share it with you and your readers. The only drawback is that it will only work on radios which incorporate "relay" switching.

Operation: During receive, the capacitor charges thru diode. In Transmit, diode isolates capacitor from ground, and amplifier receives power from stored charge. Most Mics will operate for 30-40 seconds on 5,000MFD cap. When charge is depleted; simply release and capacitor will recharge; rekey and keep talking. (Charge time is so fast that all you have to do is unkey and key up again...) Beat's buying batteries.....

See schematic below:

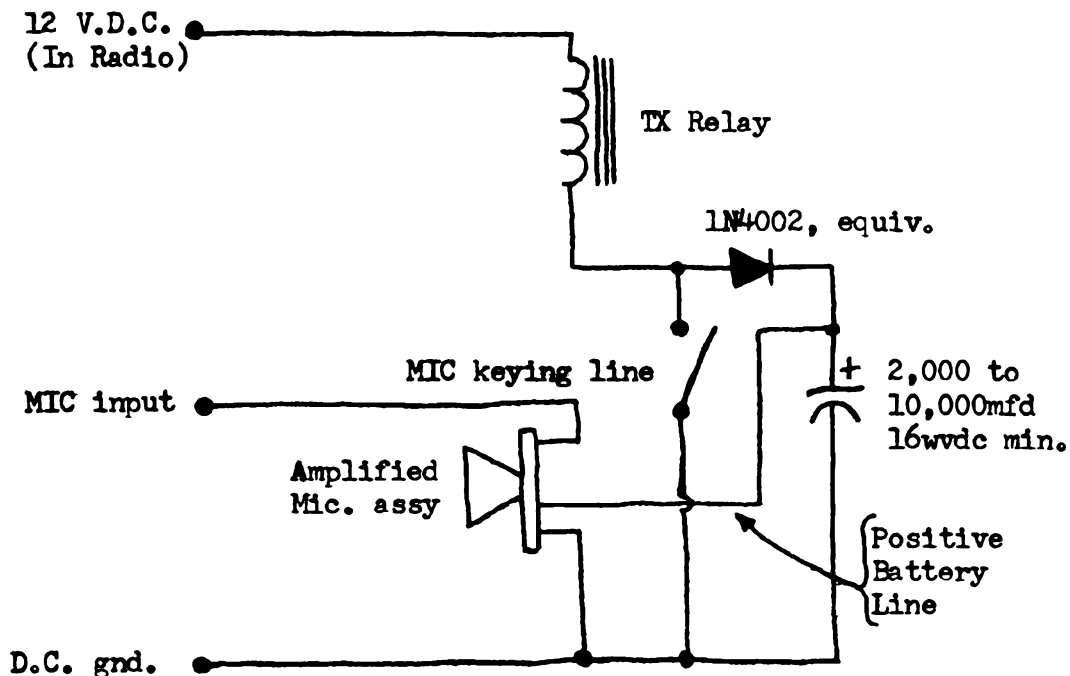

## COLT 1200 EXCALIBUR

**SERVICE TIP:** Replace small wires from PCB to Power Supply with 18 ga wire, and shorten to only length needed....

---

### TRS CHALLENGER 850/1400-UPDATE

1. Refer to Vol 4 for Freq/Slide modifications.
2. For -5KHz shift wire as follows:

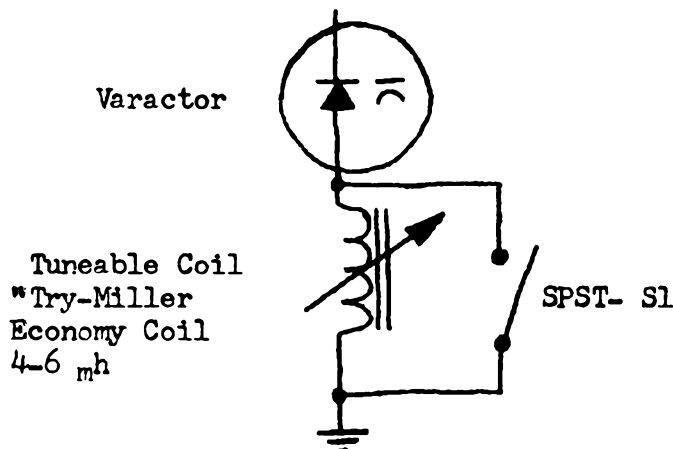

- A. Adjust center slots for center clarifier position with S1 closed.
- B. Open switch and adjust coil for -5KHz shift at center clarifier position

(Note: On 850-NB/ANL switches perfect for channel mod/shift.)

---

### LAFAYETTE CHE740

See PLL02A info: Vol. 4 for Freq. mod.  
Peak L7, L11, L12-max RF. RV4-TX Mtr. RV1-Sq Rng.  
RV2-AMC (C96, defeat) RV3-S Mtr.

### CHANNEL MASTER CB6830

AMC defeat is C511, 3.3mf/50VDC, located near VR7...

### MIDLAND 77-853

Peak L205, L903, L901 for max RF. VR1-AGC VR7-AMC  
VR5-TX Mtr.

---

### COERA 148GTL-B

Another EXPORT unit, this is all I know at present: Cybernet Chassis; goes to 27.605MHz in original form; (with readout on the chassis). Built-in SWR meter; switches all over the front. Made in Japan! Has 2SC1969(20W/6A Final) --For Tune-up and extras refer to HYGAIN V..Out of box operation is sloppy about 5½ AM, and 10 SSB....Have also heard other RUMORS, like don't ask COERA for a manual???



PACIFIC SSB 800

Another EXPORT unit; no direct readout, some say it has the 858 PLL and others the MC145106(MM55106/116/126) PLL. It uses Xtal switching for the extra channels? RF Gain is a switch? RF Final again is 2SC1969(20W/6A). Built-in SWR meter. Mike gain is on the mike. Supposed to have a good receiver. Unit is also relay switching..That's all I got-sorry.....

Letter from: J.L.

I, by accident came across a sure fire way to get ALL mobile antennas that are in the range of 1.5 to 2.0 down to a 1:1 match. This is done without the use of "liar" match boxes which only fool your SWR meter, I don't know if any of you have already tried this one. I have found in most cases that CB antenna manufacturers make great antennas if you have a 12-meter rig. Mid-way up the 11-meter and the higher and closer you get to 10-meter the higher the SWR. It has always been said and I believe it to be true that a top loaded antenna would be the best but of course it isn't practical.

I created my own top tuning coil for antennas that just won't come down to a good match. I find that most of the mobile antennas that have had a bad match were too short in length, even if they had never been cut-straight out of the box.

Try the following on your next 'problem', will be in for a surprise...also brings in 2-3db more receive....

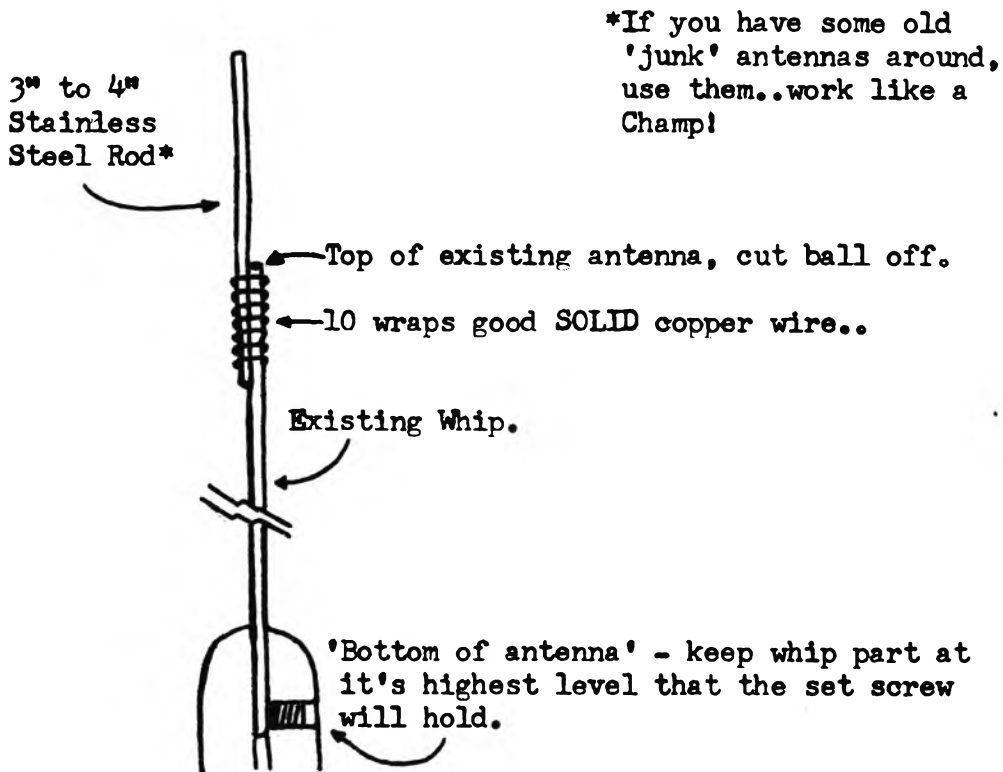

Now to set SWR just move the 3" or 4" rod at the top up or down. When desired match is attained, solder in place with propane torch and "ACID" core solder.... Top match is easy and not too noticeable if done neatly....

## O2A CLARIFIER & BANDSWITCH MODIFICATION

Modification O2A chassis clarifier circuit, to prevent loss of power caused by large amounts of clarifier swing over 5KHz...

1. Disconnect the collector of Q4
2. Remove C20.
3. Remove CT1 and SAVE!
4. Remove C18 and SAVE!
5. R11, R12, C19, and the base of Q3; all form a junction point.  
Also L1 and R13 - opposite X1 - form another junction point.  
Open the circuit between these two junction and insert C18 across the open.
6. Connect the collector of Q4 to the junction of C19, R10, C17 and the emitter of Q3, through a 6 pf capacitor.
7. Connect the removed CT1 from the collector of Q4 to the junction of C19, R10, C17 and the emitter of Q3.
8. Connect a 1K resistor to the junction of X1, L1, and R13.
9. Connect a 150 UH RF Choke between the open end of the resistor and ground.
10. Open the circuit between X1 and the junction of L1, R13, and the 1K resistor you added in Step 8.
11. Place a 1N4448 diode across the open, anode towards X1.  
\*If band switching is desired, see schematic of how crystals should be added at this point.\*
12. Connect the open end of X1 to the junction of CT2 and C21.
13. Connect the junction of R22 and D3 to the other end of CT2 and C21 junction, through a 2.2 UH choke.
14. Build a 9 volt regulated supply as illustrated on the schematics.
15. Apply the 9 volts from this supply to the anode of the diode you installed in Step 11, through a 1K resistor.

02A Clarifier & Bandswitch Modification...Cont.

15. --Cont. \*If band switching is used, -see schematic of switching arrangement for crystals.\*
16. Apply the regulated 9 volts to the unused side of the clarifier potentiometer.
17. Connect the other end to ground through a 1N4148 diode, cathode to ground. Leave the center wire connected as is!
18. Disconnect R24 and D5...

02A Clarifier Mod./Power supply schematic:

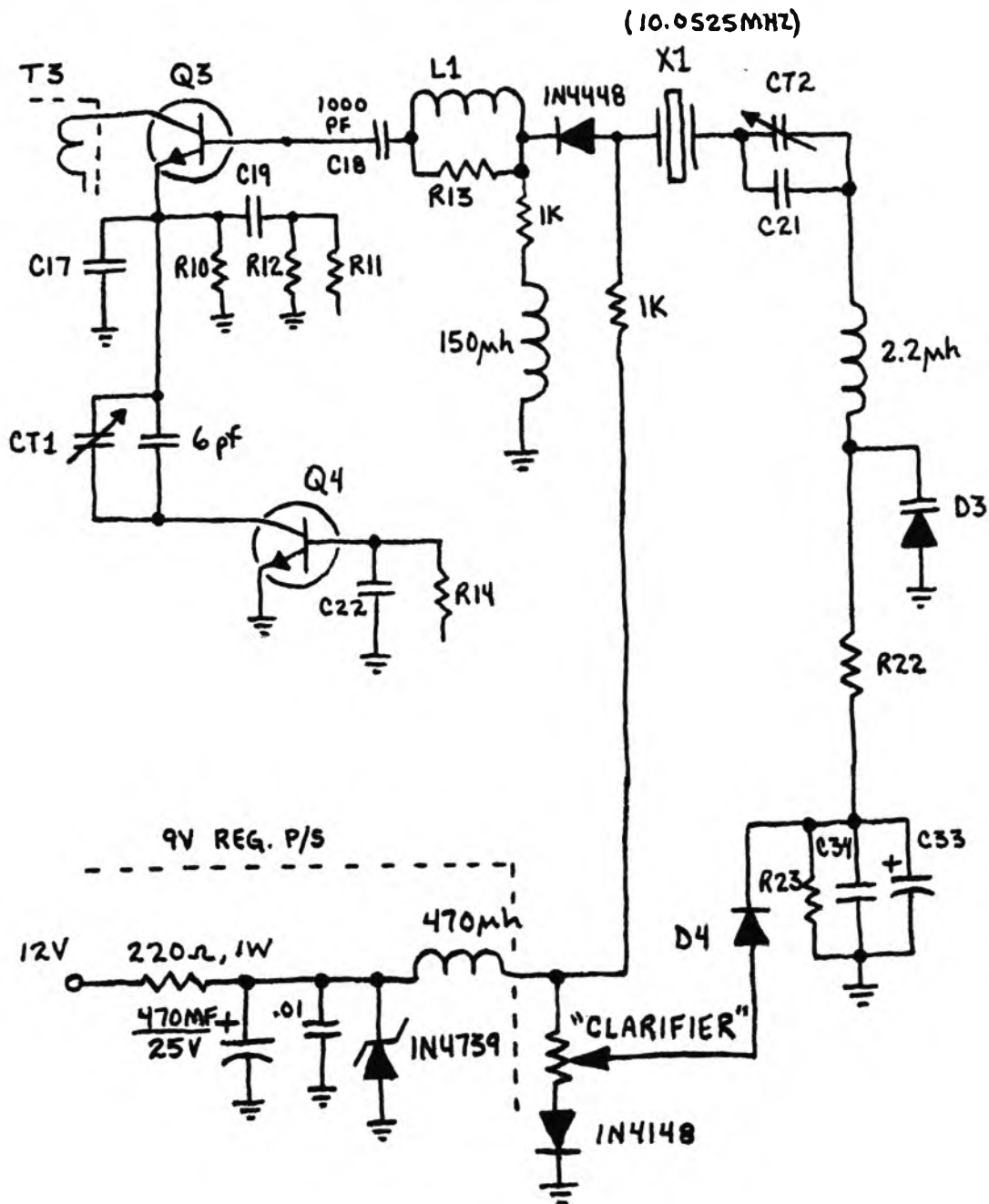

02A Clarifier & Bandswitch Modification...Cont.

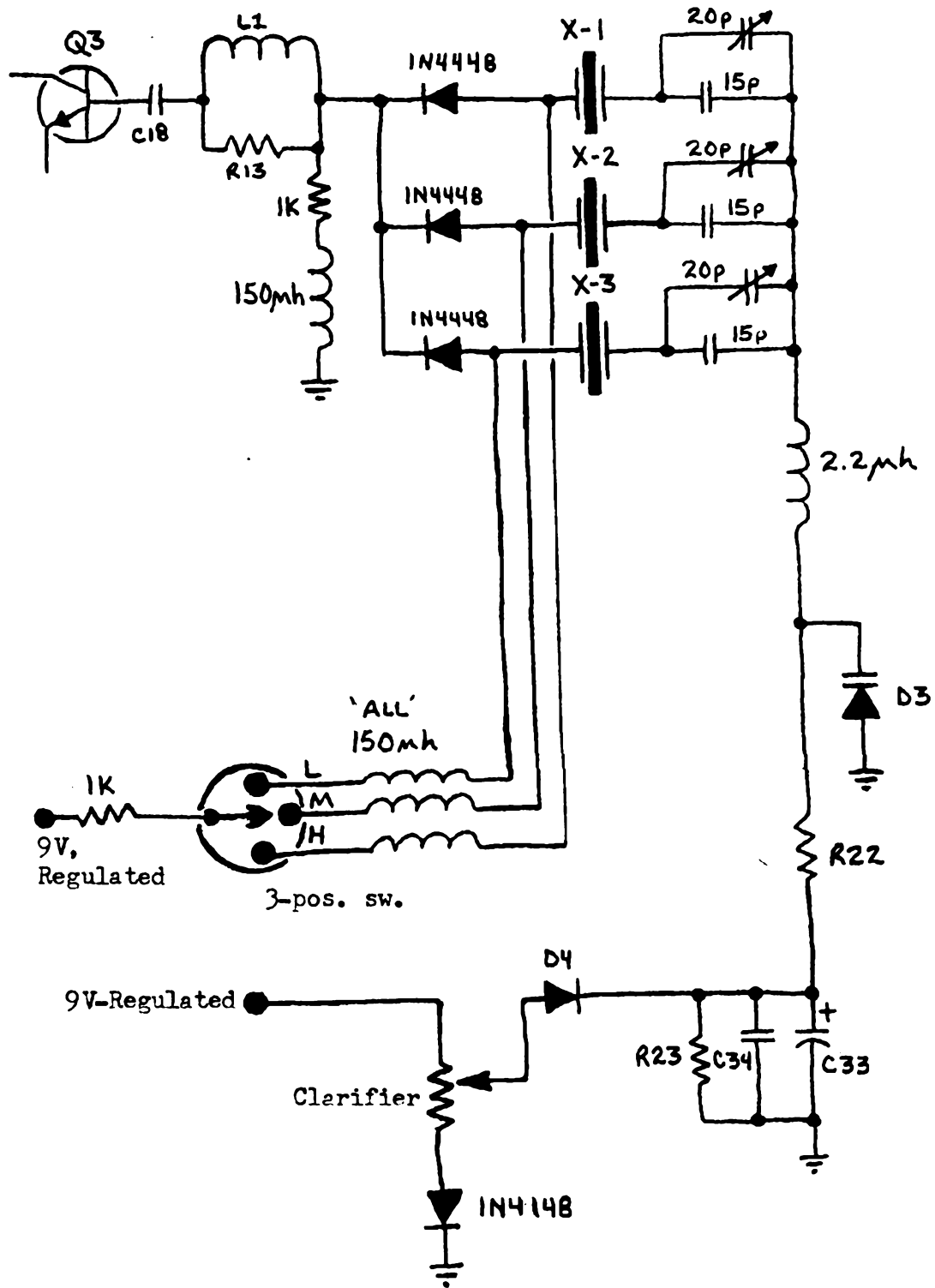

- X1 - 10.2725MHz
- X2 - 10.0525MHz
- X3 - 9.8325MHz

Bandswitch Skem.

## MIDLAND 6001 & 7001 (UPDATE)

This procedure gives maximum slide without loss of power on extreme ends of the slide, and gives upper frequencies without crystal switching. The only drawback is; that the upper freqs. come out on the zero-instead of fives; and must slide to reach. (This conversion does require a bit more parts than usuall, but the results are worthwhile)... Parts list follow: \*See Text..

100pf disc NPO capac.	2.7K $\frac{1}{4}$ W resistor	
4.7 UH RF Choke	7 UH RF Choke	
100 ohm $\frac{1}{2}$ W resistor	1N4739 Zener Diode/ECG 139A	
10K $\frac{1}{4}$ W resistor	.01 UF disc capac.	
.047 UF disc capacitor	100 UH RF Choke	
220 UF 25WVDC Elec.Cap.	10.695MHz, or 10.681MHz Xtal (See Note 4 - HC18U case..)	
*SPST switch	*47 ohm 1/4W resistor	*3pf disc, NPO
*5.6 UH RF Choke	*Super Diode	*20K 1/4W resistor
*MPS05A transistor/ECG 123AP		

### \* \*CLARIFIER INSTRUCTIONS\* \*

1. Remove R148, D49, C22, C23, C30, C29, R21, C21, C26...
2. Replace C27 with 100pf NPO capac.
3. Replace R14 with 2.7K resistor.
4. Replace D50 with 4.7 UH RF choke.
5. Replace L3 with 7 UH RF Choke.
6. Replace D4 with Super Diode, or place 5.6 UH RF choke between D4's Anode and ground...(Go with the diode..E/P)
7. Replace R20 with 10K resistor.
8. Build the 9 volt regulated supply as illustrated on skem..
9. Connect 9 Volt supply to unused terminal of the clarifier.
10. Run jumper to the junction of CT1, CT2, and CT3 from the cathode of D4..

There's the slide....

### \* \*FREQUENCY MOD. INSTRUCTIONS\* \*

1. Remove X2, replace with the 10.695MHz Xtal (See Note 4)..
2. Isolate Pin 9 of PLL IC from D.C. Ground..
3. Connect a wire from Pin 9 of PLL to one side of SPST sw.. (Suggest using an existing switch, use the center leg)..

Midland 6001 & 7001 (Update)..Cont.

4. Connect a wire from ground to the other side of the sw. (or outer leg of existing switch).
5. When switch is shorted/closed the radio will yield 27.420-27.860MHz.. SEE NOTE 4...

NOTE 1 - If power is not sufficient on upper freqs: parallel R33 with a 47 ohm resistor, and R129 with a 20K.

NOTE 2 - If with the new crystal, can't resume center slot. Isolate X2 from the junction of CT1, CT2, CT3, and D4. Bridge the open with a 3pf NPO disc capacitor. This will give a little more up slide.

NOTE 3 - If gain is low at TP3 after retuning of T1. Try replacing Q3 with an MPS05A/ECG 123AP..

CAUTION-Note B-C-E leads may not be the same..!

NOTE 4 - It has come to my attention that a heterodyne whistle may be encountered in some radios. If this is the case with your radio..These are two things you can do to correct it.

#1.. Don't do the clarifier mod listed here, - But, if you want the big slide you will have to!

#2.. Instead of replacing X2, simply make it switchable with a 10.681MHz crystal. This will make Ch. 1 start at 27.395MHz. But the squeal is eliminated.. This arrangement will also give frequencies below Ch. 1,-when the 10.46667MHz crystal is on line, and the switch on Pin 9 is activated..

See Schematic for drawing changes/9 Volt power supply.....

Clarifier/Power Supply Skem.

R & C #'s in parentheses, are changed items per instructions

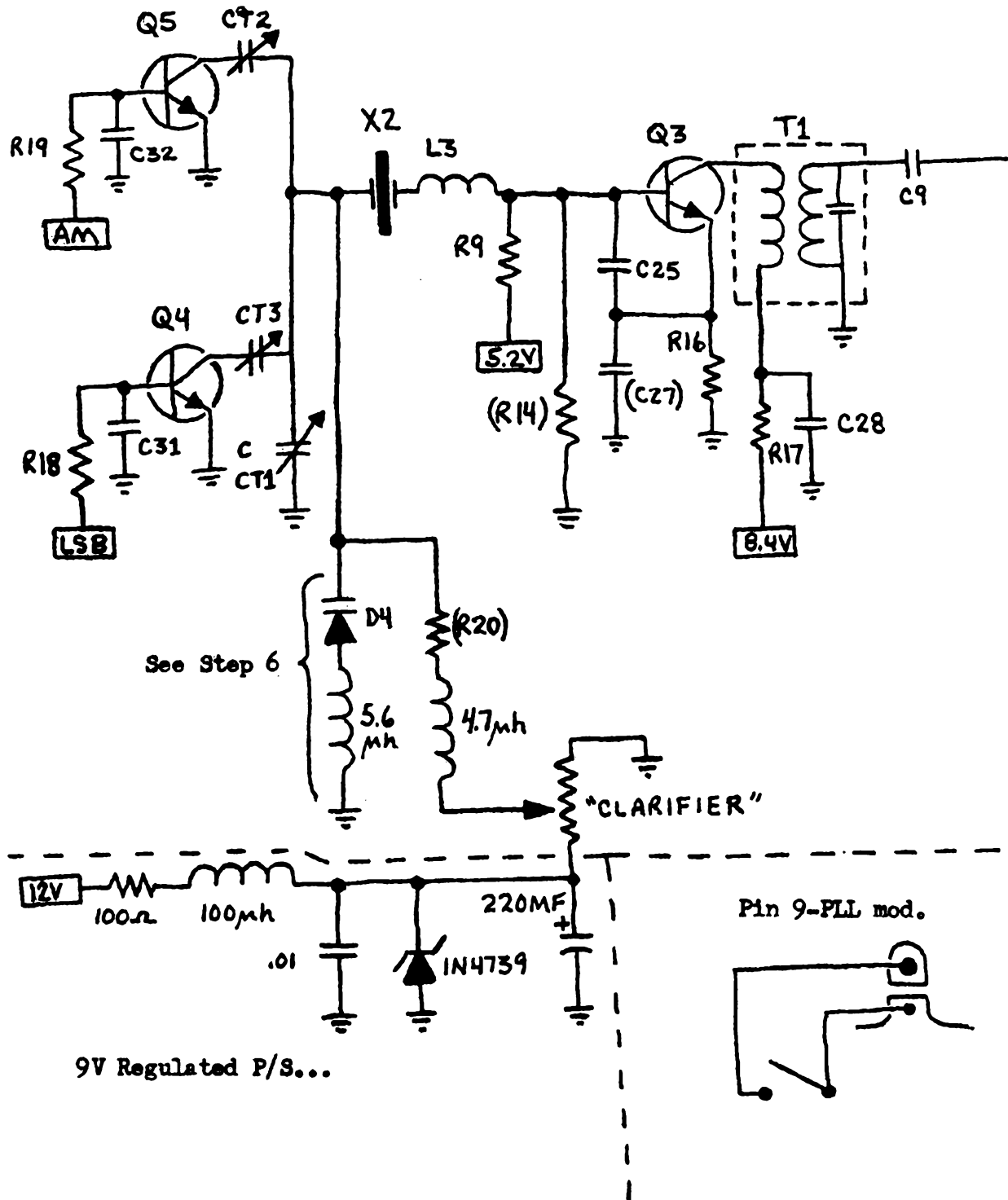

## HIGH CURRENT METER

A low-cost milliammeter can be easily converted to read high current by using a shunt across the meter movement. As you know currents in parallel resistors divide, the lower resistance getting the heaviest current flow. The shunt is an extremely low resistance, usually consists of a copper or brass bar across the meter terminals. It must be accurate if your meter is going to read correct.

1. Determine internal resistance of the meter.
2. Calculate the "SHUNT RESISTANCE".

HOW TO FIND THE INTERNAL RESISTANCE:

Wire up a test circuit as shown below:

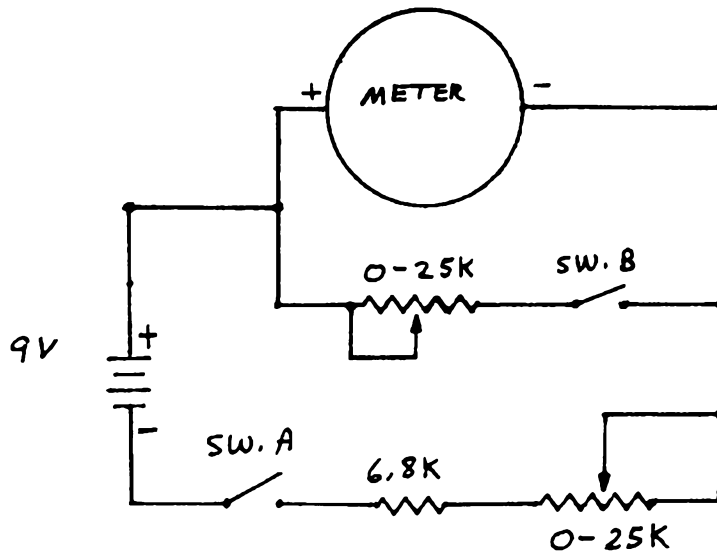

- A. Leaving switch B open, close switch A.
- B. Adjust VR1 to get a full scale deflection on the meter.
- C. Close switch B and adjust VR2 for a half scale reading on the meter.

Since  $I = E/R$  and  $R = E/I$  and the currents are the same through the meter and VR2, the resistance of VR2 equals the internal meter resistance. Measure VR2 with an ohmmeter (with switch B open). This is the internal meter resistance.

Continued on next page.



HIGH CURRENT METER Continued:

NEXT we will calculate the required shunt. The easiest way to explain this is with an actual example.

In our example, our VR2, and hence our meter resistance, turned out to 358 ohms. The voltage drop across  $R_L$  was 3.7V, so  $I = 3.7/6.8K = 544 \text{ uA}$  for full scale meter current. Now lets suppose we want the 544 uA meter to read 0-10 amps. So for 10 amps to flow, 9.999456 amps will be diverted by the shunt.  $R = .0194798 \text{ ohms}$ .

$$E = I \times R = 544 \text{ uA} (358 \text{ ohm}) = .1947878.$$

$$R \text{ shunt} = \frac{E}{I} = \frac{.1947878}{9.999456} = .0194798 \text{ ohm}.$$

So, for a full scale reading of 10 amps we need a .019 ohm shunt across the meter coil. Custom meters can now be designed for what ever purpose you desire. The only hard part is making the precision resistor required for an accurate reading. Use wire tables which give resistance per foot for custom shunts. A "low ohms adapter" for a digital multimeter works well for measuring these low resistance accurately.

---

---

#### "EL CHEEP-O" TEST LEADS

O.K., So--- they were cheap to start with! But not worth a d—. Replace the wire with good 22 gauge insulated wire. Those skinny little wires won't hold up. Nothing is more frustrating than an open test lead when jumpering for PLL logic checking!

S.W.R. Vs. REFLECTED POWER %

<u>S.W.R.</u>	<u>Reflected Power %</u>
1.0 : 1	0
1.1 : 1 .....	.3
1.2 : 1	.8
1.3 : 1 .....	1.7
1.4 : 1	2.7
1.5 : 1 .....	3.6
1.6 : 1	5.0
1.8 : 1 .....	8.0
2.0 : 1	11.0
2.6 : 1 .....	20.0

The above chart will give you a true idea of what a so-called "High S.W.R.", really is... It never ceases to amaze me the knowledge of people about their antenna's SWR. - It seems that according to the EXPERTS (everyone is one) anything over a 1.3 to 1 will blow up your radio.

Example: 2.0 : 1 SWR is good for 11% loss-at 4.0W AM and 12W SSB, the real output power would be 3.56W AM and 10.68W SSB. Which is really not enough to worry about.. That is why I tell everyone to just keep it below 2.0 : 1... (I have been running my own rig at 1.8 for over 3 years and no damage to it yet!)

---

"QUOTE-JAMES VAUGHAN"....Re: BANDIT..!

"I would also like to comment on the Bandit Antenna. I recently installed one on a customer's car, and I think it is one of the BEST antennas I have ever installed or seen anywhere. My customer was really pleased. He has tried all the other major brands and wasn't satisfied until he purchased a BANDIT."

## CUSTOM FREQUENCY STANDARD

This handy and accurate little frequency standard can be made very cheaply. I used "junk box" parts for most of the components. The crystal was 'appropriated' years before when I did some R & D work. (Seems they would grind up the crystals that didn't pass MIL SPEC, and I turned out to be the grinder-upper for about a month). The antenna feature is an 'extra'; not necessary; scrounged from old R/S weather cube. There are no critical parts, and can be breadboarded at this frequency range. The only calibration point is at Pin 14 of chip, adjust the variable cap. for exact frequency.

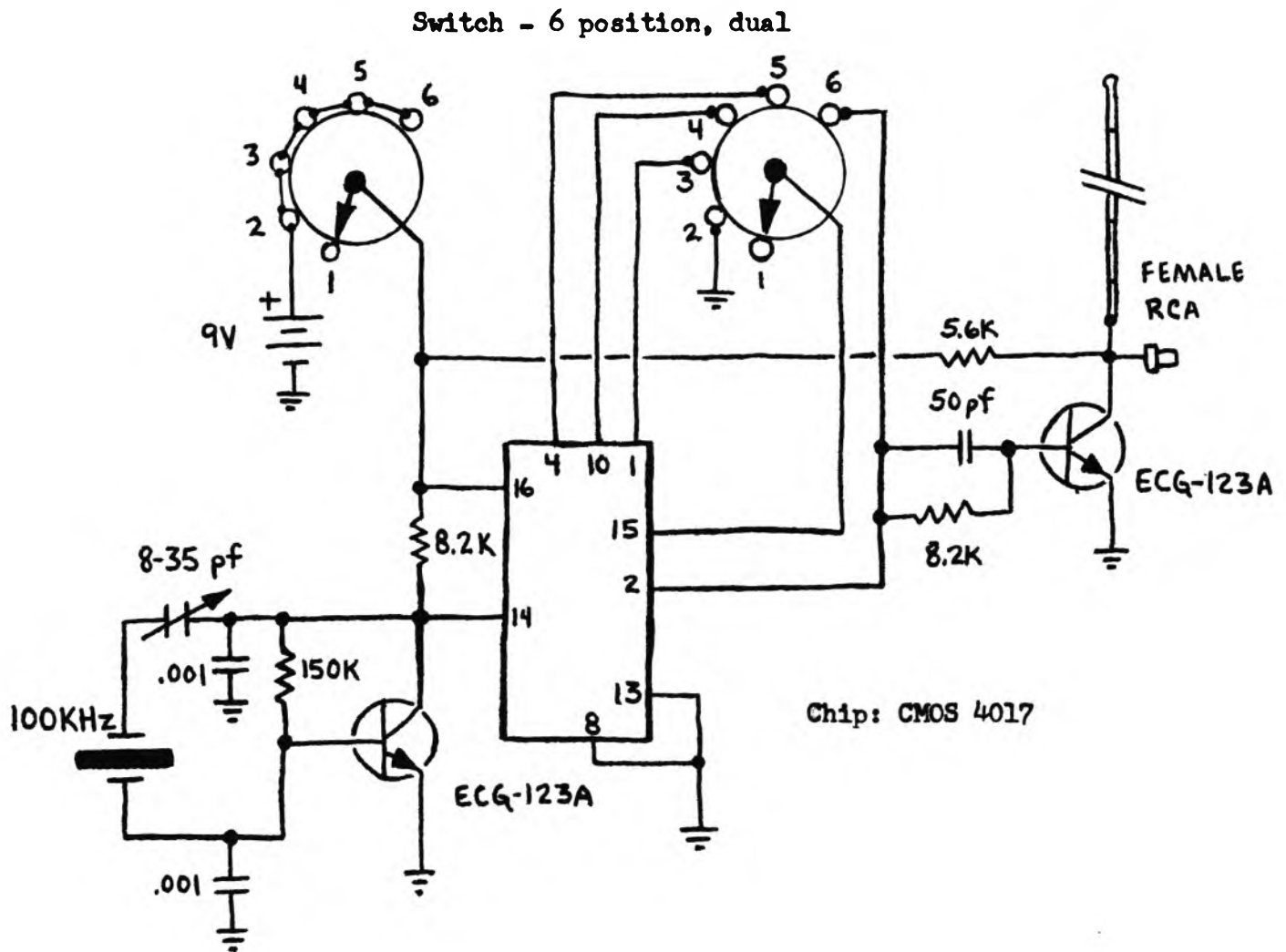

Custom Frequency Standard...Cont.

With the 100KC Xtal, frequency outputs are: Pos. 1 - Off  
2 - 10KHz  
3 - 20KHz  
4 - 25KHz  
5 - 50KHz  
6 - 100KHz

The chip is CMOS, so suggest using a socket. Decade Counter/Divider, R/S 276-2417 (\$1.50). With the paper work provided can use other output pins - for other frequencies. Also can switch crystal to the limit of transistors and chip. The limit is up to you.... Note: All grounds are D.C.; not case! The only thing at case ground is the RCA female jack. Experiment with it, this is one unit that is very useful..... The original unit I built all fit into a 3 1/4 x 2 1/8 x 4" mtl. box-R/S 270-251.

\* \* \* Note: If enough request-will try to have a different  
QUALITY piece of test equipment per issue \* \* \* \* \*

---



SOMMERKAMP TRISTAR 747 (UPDATE)

FOLLOW THE DRAWING FOR THIS ONE: No pin number given for mod..?

Printed as sent in - didn't have unit on hand to check out...

Cut etch on PCB as shown. (Open the feed from selector switch line)..

Existing Yellow wire on TONE switch was moved to where the BLACK wire is, the prongs were then separated for using on side of sw...

This section of switch is wired for picking up the missing F<sub>0</sub>'s

LO position is normal operation and HI position is used for the missing. (Note: Still missing will be 27.855-27.885MHz)

DRAWING: PCB/SW.

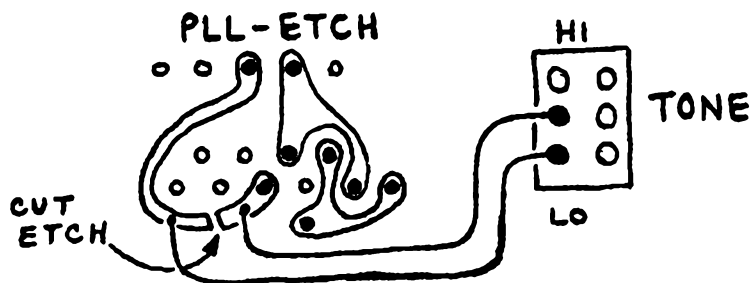

New frequencies with TONE Sw. in High position!

<u>Selector Pos.</u>	<u>BAND</u>	<u>Frequency</u>
3	LO	26.965
7	LO	26.745
28	LO	26.995
33	LO	27.045
38	LO	27.095
3	MID	27.145
28	MID	27.445
33	MID	27.495
38	MID	27.545
43	HI	27.595
47	HI	27.645
68	HI	27.895

Continue to 79 HI band 28.005 MHz

## CHECKING MODULATION

Low priced meter-type modulation indicators lack accuracy. Also, they cannot tell you if parasitics are present in the signal.

The best way to measure modulation and evaluate the quality of the transmitted signal is by using a 30MHz Scope. I use a Tektronix type 545A. The RF output of some sets get quite nasty when not properly aligned. (I just finished a realignment on a Midland 2001 that a trucker tried to tune up himself. Signal had a bad parasitic and even the V.C.O. had been misadjusted, causing lower 8 channels to receive on one channel!)

If you have a scope, but it is not good up to 30MHz, you can bypass the vertical amplifier (and its limitation) and go directly to the vertical deflection plates. See Volume 7, page 73.

If a high frequency scope is not available, you can build a detector for use with any DC scope.

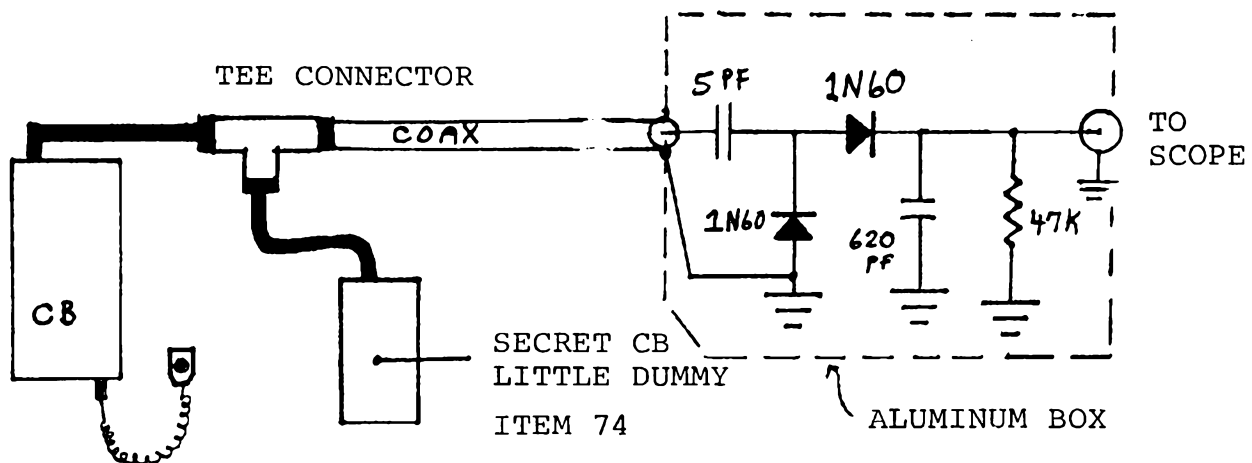

The above detector was built into a small aluminum mini box with an S0239 on one end and a cable to the scope on the other end.

Here is how to use this detector with your scope.

1. Adjust position control with no RF present to position the trace on the first line near the bottom of screen. This is the reference line.
2. Now key up transceiver with no modulation and adjust gain so trace is in center of screen.
3. Now modulate the transceiver. At 100% modulation you will get a level shift twice that in step 2.

## KIT #146 - DATA SHEET (UPDATE)

THIS KIT IS INTENDED TO EXPAND RECEIVE FREQUENCIES ONLY. WE ASSUME NO RESPONSIBILITY FOR MODIFICATIONS TO TRANSMITTERS RESULTING IN ILLEGAL OPERATION ON UNAUTHORIZED FREQUENCIES..

### INSTALLATION INSTRUCTIONS FOR THE DIGITAL PROCESSOR

The following pin numbers refer to the 2824 PLL chip.

1. Isolate pin 10 by removing the jumper (JP41) located between IC2 and D33 on the component side of the board.
2. Solder the Brown wire to ground (Pin 21)
3. Solder the Red wire to 5 volts (Pin 11)
4. Solder the Orange wire to Pin 14
5. Solder the Yellow wire to pin 10 in the hole where the jumper JP41 was.
6. Solder the Green wire to the other hole where the jumper JP41 was - next to C72..
7. Carefully remove C72 and save, clean out hole and solder the 1pf capacitor that comes with kit in place.
8. Remove C73, replace with the capacitor you took out of C72 position.
9. Change R106 (100 ohm to a 47 ohm) provided in kit; located by L18/X1.

### ALIGNMENT

- A. With switch in the center position, check for regular 1-40 channel operation..
- B. With switch in DOWN position, adjust the tripler L13 for 27.285 on channel 1. (If installed according to  $F_o$  chart drawing.)
- C. With switch in UP position, check for 27.605-28.045. The VCO (L14) may have to be adjusted.

NOTE: The tuning is very critical but, with a little patience, can be adjusted for full range.

### CLARIFIER MODIFICATION

1. Lift the Anode of D30 and connect the Super Slide in series.

This gives 5KHz slide.  
(For 13KHz slide, change D30 to a Super Clarifier Diode)..

2. Connect control to 8V source. Ground other end.
3. Remove D32...

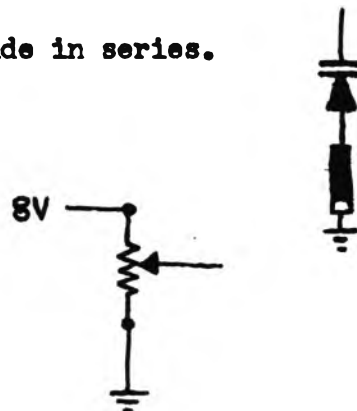

KIT #146 FREQUENCY CHART

Frequency correlation is referenced to the switch mounting position shown in drawing:

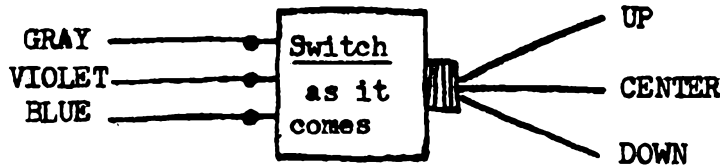

SW. DOWN -	SELECTOR -	FREQUENCY	SW. UP -	SELECTOR -	FREQUENCY
	1	27.285		1	27.605
	2	27.295		2	27.615
	3	27.305		3	27.625
	4	27.325		4	27.645
	5	27.335		5	27.655
	6	27.345		6	27.665
	7	27.355		7	27.675
	8	27.375		8	27.695
	9	27.385		9	27.705
	10	27.395		10	27.715
	11	27.405		11	27.725
	12	27.425		12	27.745
	13	27.435		13	27.755
	14	27.445		14	27.765
	15	27.455		15	27.775
	16	27.475		16	27.795
	17	27.485		17	27.805
	18	27.495		18	27.815
	19	27.505		19	27.825
	20	27.525		20	27.845
	21	27.535		21	27.855
	22	27.545		22	27.865
	23	27.575		23	27.895
	24	27.555		24	27.875
	25	27.565		25	27.885
	26	27.585		26	27.905
	27	27.595		27	27.915
	28	27.605		28	27.925
	29	27.615		29	27.935
	30	27.625		30	27.945
	31	27.635		31	27.955
	32	27.645		32	27.965
	33	27.655		33	27.975
	34	27.665		34	27.985
	35	27.675		35	27.995
	36	27.685		36	28.005
	37	27.695		37	28.015
	38	27.705		38	28.025
	39	27.715		39	28.035
	40	27.725		40	28.045



## "OOPS, WE GOOFED"

- Vol. 1, p. 61: COURIER CENTURION, Step 3: Change wire color green to yellow.
- Vol. 12, p. 27: RAY JEFFERSON - Correction for Step 3 & 4 and drawing:  
3. Bridge cut of no. 9 with 3K resistor.  
4. Wire up a DPDT Center-Off Switch as shown:

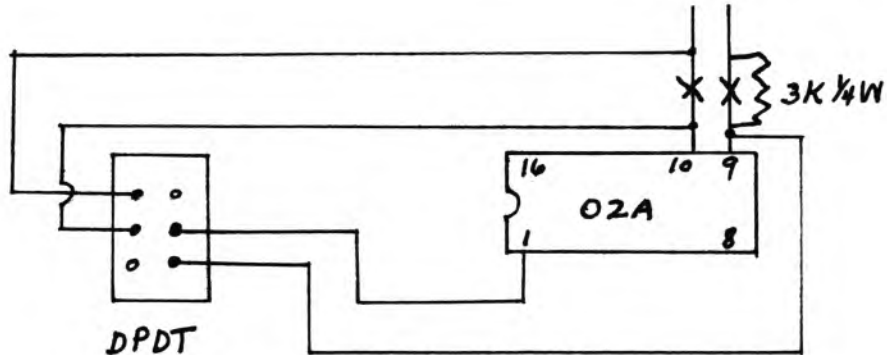

- Vol. 12, p. 28: REALISTIC TRC-57 - Somethin' wrong - put this one on hold, till get's double-checked! Will print correction ASAP.....
- Vol. 14, p. 22: Add a new step: 3A. Run a wire from L to the yellow dot post on epoxy pak.
- Vol. 14, p. 41: G.E. 3-5813A/5869A, ADD: Change 03A chip to 02A chip first!
- Vol. 15, p. 65: AM POWER MOD., Step 8: Leave 470pf (C146) AS IS. DO NOT REPLACE with the 100pf.
- Vol. 15, p. 63: TENNA POWER #10901 & FEILDMASTER TR-40 - delete from title: Midland 102M(77-102). The TUNE UP information is meant for the MIDLAND 102M.



# SECRET CB INDEX

## VOLUMES I THRU 14

<u>CONVERSIONS:</u>	<u>VOL/PG</u>	<u>CONVERSIONS:</u>	<u>VOL/PG</u>	<u>CONVERSIONS:</u>	<u>VOL/PG</u>	<u>CONVERSIONS:</u>	<u>VOL/PG</u>
<u>CONVERSION tips for</u> all SSB radios.....9/7		<u>COURIER</u> Centurion PLL.....1/31,61-62		<u>JOHNSON</u> 242-4730.....10/49-51		<u>PRESIDENT (cont.)</u> Washington w/11.1125	
"A" Channel Mod. for all SSB.....9/16-17		.....5/57		4125/4174.....13/61		(NEW).....10/28-29	
Cybernet Freq. Mod.....8/18		Centurion 40D.....10/53		4740 (NDC40013).....11/12		Zachary T.....1/60	
Uniden 8719PLL Mod.....8/15		Galaxy.....5/53-54,7/18-22		<u>KENWOOD</u>			
MB8719 Mod.....10/25-26		Gladiator PLL.....1/31,61-62		TS-120S.....12/22			
MB8719 w/11.1125 Mod. .....11/15, UPDATE.14/11-12		.....5/55-57		TS-130.....12/23		<u>RCA</u>	
PLL01A MOD.....9/15-17		Spartan.....1/61-62		TS-820S.....14/7-8		14T302.....5/11,39	
PLL02A Mod..4/54-55,3/13-15		.....5/30,53,55,57				14T302 (PLL 02AG).....4/36	
23 Ch. PLL02A AM Conv. 26.645 to 27.275.....12/32		<u>CPI</u>		<u>KRACO</u>			
Tech tips on the 858 Chassis.....10/55		300.....8/21		KCB2330A.....9/15		<u>REALISTIC</u>	
Uniden 858 update...9/8-11		400.....8/21		<u>LAFAYETTE</u>		TRC-57.....12/28	
How to get on 28 & 29 MHz w/uPD858 PLL.....11/4-7		2000.....3/25		SSB75.....14/9		TRC-431.....7/23-24	
uPD858 AM Conv.....11/35		2000 Low.....9/23		<u>MECTRON</u>		TRC-448 (REC86345).....11/19	
Receiver Widebanding for 858 Chassis.....13/34		2500.....5/37-38		ME502.....14/41		TRC-450.....10/31	
NEW Thumbwheel Conversion for 858 Chassis...13/35-37		<u>CRAIG</u>		<u>MIDLAND</u>		TRC-451.....12/10-13	
How to increase ANL efficiency 70%.....11/8		LL31 & L231.....9/12-14		CAP 858.....5/30		TRC-455 (SM5104).....12/30	
Ham Radio Crystal Selector.....12/24		LL32 & L232.....9/12		13-857.....11/36		TRC-457.....10/36	
<u>BOWMAN</u>		L232 & LL32 w/uPD824C Chip.....10/47,11/10		13-862.....14/48-49		TRC-459.....10/32-35	
CB910.....11/41,13/58		L321.....14/12		13-882C (02A).....13/62		TRC-480.....10/37-38	
CB920.....14/43		<u>DAK</u>		13-883B (uPD858).....12/4		TRC-490.....12/14-15	
CB930.....3/21		IX.....5/21-23		77-861.....12/26		<u>RAY JEFFERSON</u>	
CB950.....5/39		IX Mod. Update.....9/18-19		78-574.....14/10		CB845 (02A).....12/27	
<u>BROWNING</u>		X.....4/39-46		79-893.....2/20		<u>ROBYN</u>	
Mark III.....6/28		<u>DELCO</u>		79-900.....5/47		GT-440D.....1/23	
Mark IV.....6/29-30		Delco Factory AM/FM/CB Combo Unit.....11/38-40		6001.....11/16		SB-505.....5/41-42	
Mark IVA.....14/5		DM83.....12/26		7001.....8/21,11/16		SB-520D.....2/21-22	
Mark IV, IVA.....7/8-14		90BFMCl.....12/26		<u>MORSE</u>		SB-540D.....5/19,36,7/25-28	
Sabre.....1/27		90BFPCl.....12/26		3005.....2/27		WV-23.....1/24-25	
<u>CHANNEL MASTER</u>		91YFMCl.....12/26		<u>MOTOROLA</u>		WV-110 (SM5104).....12/31	
CB6830.....14/41		<u>DEMCO</u>		CB555 (TC9105P).....12/7		<u>ROYCE</u>	
<u>COBRA</u>		Star II.....5/60		T4025A.....10/46		1-601.....1/26	
CAM89.....14/45-46		Super Satellite.....5/60		<u>NESCO</u>		1-612.....5/45-46	
32XLR.....4/47		<u>FANON</u>		1249.....6/38		1-632.....11/21	
132B.....1/53		Fanfare 350.....5/57		<u>PACE</u>		1-632 Update.....13/23	
132XLR.....4/47		<u>FIELDMASTER</u>		8092.....6/35-36		1-641.....11/20	
135B.....1/53		Micro Mini 40.....11/37		<u>PALOMAR</u>		1-642.....13/24	
135XLR.....4/38		<u>GENERAL ELECTRIC</u>		500....4/19-20,5/32-36,8/21		<u>SANKYO</u>	
135XLR Update.....10/43-46		Superbase 3-5875/A...10/48		<u>PANASONIC</u>		SCS-555.....11/40	
138XLR.....1/20-23		3-5813A/3-5869A.....14/41		RJ3600.....10/57		<u>SBE</u>	
139XLR.....1/20-23		<u>GEMTRONICS</u>		RJ3700.....13/16-17		Console IV.....2/28-35	
140GTL3/19-20,4/50,10/28-29		GTX77.....5/39		<u>PEARCE-SIMPSON</u>		Console V.....2/28-37	
142GTL.....4/50,10/28-29		<u>HALLICRAFTERS</u>		Cheetah PLL.....1/31-32		Console VI.....8/14	
146GTL.....11/17-18		HCM271.....5/50-51,6/39		Simba PLL.....1/31-32		Cortez 21CB.....14/56-57	
148GTL.....8/16		<u>HYGAIN</u>		<u>PRESIDENT</u>		Formula D.....1/49	
2000 (C.A.P.).....6/23		I-A.....1/22		Adams.....2/16,13/18-20		LCBS-4.....7/29-33	
2000GTL.....5/20,7/15-17		PLL.....1/32		ARL44.....11/17-18		LCMS-4.....7/34-37	
<u>COLT</u>		II.....8/20		Grant.....1/22-23,5/9		Sidebander II.....2/28-35	
SK33.....3/4-7		<u>ITT</u>		.....2/17,23-26		Sidebander V.....2/36-37	
290.....3/4-7		CB-4000M.....13/61		Grant (NEW).....5/24-27		Sidebander VI.....8/14	
390.....3/4-7		CB-4400M.....4/17-18		.....13/21-22,14/13-17		Touch Com.....1/50-51	
480.....3/8-15,5/39		<u>J.C. PENNEY</u>		Honest Abe.....1/60		<u>SEARS</u>	
485.....3/8-15		6246.....13/61		John Q.....1/60		D63911 w/uPD861C.....12/26	
800.....3/4-7		6248.....8/24		Madison w/11.3258.....10/30		562-38220700.....10/56	
1000.....3/8-15				McKinley.....4/12-13		663-3810 w/2824.....11/22	
				McKinley w/11.1125.....10/29		934-3677150.....12/16-17	
				Teddy R.....1/60		934-36772600.....12/16-17	
				Washington.....1/22-23,5/9		934-38260700.....6/26-27	
						934-38260700 Update.....11/23	
						934-38270700.....5/28-29	
						934-38270700 Update.9/20-22	
						<u>SHARP</u>	
						CB-5470 HD42851B3.....11/24	

<u>CONVERSIONS:</u>	<u>VOL/PG</u>	<u>SLIDE MODIFICATIONS:</u>	<u>VOL/PG</u>	<u>SLIDE MODIFICATIONS:</u>	<u>VOL/PG</u>	<u>SLIDE MODIFICATIONS:</u>	<u>VOL/PG</u>
<u>SILTRONIX</u>		<u>BOWMAN</u>		<u>MIDLAND (cont.)</u>		<u>SANKYO</u>	
1011C.....	1/46	950.....	4/49	13-892.....	4/48,11/13	SCS-555.....	11/40
1011D.....	1/46			13-893.....	4/51		
		<u>COBRA</u>		13-898.....	1/36	<u>SBE</u>	
<u>SCMMERKAMP</u>		29GTL.....	13/57	13-898B.....	1/35	Console II.....	1/48
TS-788DX.....	13/25-30	132-A.....	1/28	78-574.....	14/10	Console IV.....	2/34,38-40
		132XLR.....	10/45-46	78-999.....	12/5	Console V.....	2/34,38-40
<u>SONAR</u>		135-A.....	1/28	79-891.....	12/6	LCBS-4.....	7/30
PS-2340.....	5/31	135-B.....	1/29	79-892.....	11/14	LCMS-4.....	7/34
		135XLR.....	4/38,8/38,10/45-46	79-900.....	5/47	Sidebander II.....	1/47
<u>SPARKOMATIC</u>		138.....	1/28	6001.....	11/16	Sidebander IV.....	2/34,38-40
CB4020S.....	14/41	138XLR.....	1/23	7001.....	8/21,11/16	Sidebander V.....	2/34,38-40
		139.....	1/30				
<u>STANDARD HORIZON</u>		139XLR.....	1/23	<u>MOTOROLA</u>		<u>SEARS</u>	
29-A.....	5/59,13/63	140GTL.....	4/50,6/64,10/28	CB-555.....	12/7	23 Ch. SSB.....	1/44
		142GTL.....	4/50,6/64			Roadtalker SM5104.....	12/18
		.....	8/35-37,10/28	<u>N.D.I.</u>		663-3810.....	11/22
<u>STONER</u>		146GTL.....	10/41,11/17	PC-201 (NDC40013PLL)...	12/8	934-3677150.....	12/17
Pro-40.....	4/52-53	148GTL.....	8/16			934-36772600.....	12/17
		2000GTL.....	12/20,13/40	<u>PACE</u>		934-38260700.....	10/52
<u>SUPERSCOPE AIRCOMMAND</u>				1000.....	1/37-38	934-38270700.....	5/28,9/20
CB340.....	8/19	<u>COLT</u>		DX1023B.....	1/39	934-38310700.....	5/19,9/22
CB340 (861 Update).....	9/24	480.....	3/11	8092.....	6/37		
		485.....	3/11,4/49	8193 (CC13001).....	12/9	<u>SHARP</u>	
<u>SWAN SIGNET</u>		1000.....	3/11			CB5470.....	11/24
270.....	5/58			<u>PALOMAR</u>			
		<u>COORIER</u>		500.....	4/19,5/32,35	<u>SILTRONIX</u>	
<u>TEABERRY</u>		Centurion.....	1/61,5/55			SSB.....	1/45
52 Ch. Capability.....	1/43	Centurion 40D.....	10/53	<u>PANASONIC</u>			
CAP Mod.....	5/30	Galaxy.....	5/53,7/19	RJ-3700.....	13/16-17	<u>STONER</u>	
Model T.....	4/3-4	Gladiator PLL.....	1/61,5/55			Pro-40.....	4/52,53
Racer T.....	1/58	Spartan.....	1/61,5/55	<u>PEARCE-SIMPSON</u>			
Ranger T.....	4/1-2,6/24-25			Bengal.....	1/40	<u>TEABERRY</u>	
Stalker I.....	1/57,4/5-6,10-11	<u>CPI</u>		Cheetah.....	1/40	Stalker IX.....	4/7-8
Stalker IX.....	4/7-9	2500.....	5/37	Simba.....	1/40	Stalker XV.....	4/7-8
Stalker XV.....	4/7-9,10/39					Stalker XV.....	10/39
Stalker XX.....	10/40	<u>CRAIG</u>		<u>PRESIDENT</u>		Stalker XX.....	10/40
T Bear.....	4/14-15	L-131.....	9/12-14	AR144.....	10/41	Stalker 101/202.....	4/10
T Dispatch.....	4/14-15	L-132 uPD2824C.....	9/12,10/47	Adams.....	1/16		
Titan T.....	4/14-15	L-231.....	9/12-14,12/3	Adams 858.....	13/18-20	<u>TRAM</u>	
		L-232.....	9/12,10/47,11/10	Grant.....	1/59,2/23	D60.....	1/52
		L321.....	14/12	Grant (NEW).....	5/24,8/34	D62.....	10/45-46
<u>TRAM</u>				Grant MB8719.....	13/21-22	D64.....	13/31
D12.....	10/56	<u>DAK</u>		Madison (NEW).....	10/30	D300.....	12/19
D42.....	4/47,5/40	X.....	4/45	McKinley.....	4/12,6/64		
D60.....	1/53	<u>FANON</u>		McKinley (NEW).....	10/29	<u>TRS CHALLENGER</u>	
D64.....	13/31	Fanfare 350F.....	5/55	Washington.....	1/59	850/1400.....	4/33
D80.....	10/30			Washington (NEW).....	6/64		
D201.....	1/56,3/22-23,4/48	<u>GENERAL ELECTRIC</u>		.....	8/33-34,10/28	<u>TRUETONE</u>	
D201A Update.....	10/54	3-5875A.....	10/48	<u>RCA</u>		CYJ4837A-87.....	11/14
D300.....	8/11-13			14T302.....	4/49	<u>WARDS</u>	
		<u>GEMTRONICS</u>				GEN-719A.....	11/10
<u>TRS CHALLENGER</u>		GTX-77.....	4/49	<u>REALISTIC</u>		*****	
850/1400.....	4/21-27,32-35			TRC-47.....	1/41		
		<u>HYGAIN</u>		TRC-48.....	1/42	<u>SPECIFIC RADIO TUNEUPS:</u>	
<u>VECTOR</u>		V.....	11/11	TRC-57.....	12/28		
770.....	4/56-57	623.....	1/33	TRC-448.....	11/19	<u>AIR COMMAND</u>	
790.....	4/58-59	674-A.....	4/60	TRC-450.....	10/31	CB640.....	5/38
				TRC-451.....	12/10		
<u>WARDS</u>		<u>J.C. PENNEY</u>		TRC-457.....	10/36	<u>ALARON</u>	
719A w/uPD2824.....	11/10	Pinto SSB.....	1/44	TRC-458.....	8/39-40	B-4075.....	9/30
		6248.....	13/14-15	TRC-459.....	10/34	B-4900.....	9/30
<u>YAESU</u>		981-6247.....	13/13	TRC-480.....	10/38	B-5050A.....	9/30
101.....	5/58			TRC-490.....	12/14-15	B-5200.....	3/41
FT-7B.....	7/38-41	<u>JOHNSON</u>					
FT-707.....	10/20-24	242-4730.....	10/50	<u>ROBYN</u>		<u>AMERICAN MOTORS</u>	
FT-901.....	6/3-12	352.....	1/34	SB-505.....	5/41	3221847/48/49/50.....	12/34
*****		4740.....	11/12	SB-540D.....	5/19		
				T240D.....	13/63	<u>AUDIOVOX</u>	
		<u>LAFAYETTE</u>				MCB750.....	3/41
		SSB75.....	14/9	<u>ROYCE</u>		MCB5000.....	11/42
				1-632.....	5/14,11/21,13/23	MDV6000.....	6/18
		<u>MIDLAND</u>		1-641.....	4/51,11/20		
		13-883B.....	12/4	1-642.....	13/24		

SPECIFIC RADIO TUNEUPS:

VOL/PG

AUTOMATIC  
CBH2265.....3/41

BOUMAN  
CB555.....3/44  
CB750.....2/43  
CB755.....14/44  
CBH900.....3/44  
CB910.....1/21,3/44  
CB920.....1/21,14/43  
CB930.....1/21,3/44  
CB950.....3/43  
CBH990.....5/43  
CBR9600.....2/42,3/41  
CBR9940.....3/44  
CBR9950.....10/58

BROWNING  
SABRE.....14/42

CHANNEL MASTER  
CB6834.....14/44  
CB6835.....6/18

CHRYSLER  
4048076/8077.....6/18

CLARION  
DMA066.....3/45  
JC202E.....3/45  
RCJ003.....3/45  
TC203E.....6/18

COBRA  
CAM89.....14/45  
19.....7/51  
19GTL.....12/34  
21GTL.....3/41,58  
21XLR.....1/20  
21XLR Update.....10/58  
25GTL.....3/41,58  
29GTL.....3/45,14/42  
29LTD.....13/59  
29XLR.....1/20  
32XLR.....3/58  
45XLR.....12/34  
46XLR.....3/43  
47XLR.....3/45  
50XLR.....3/43  
55XLR.....3/43  
66GTL.....10/58  
77X.....9/30  
78X.....4/49,6/19,8/44  
86XLR.....3/45  
87GTL.....6/19  
89GTL.....6/18  
132XLR.....3/45  
135XLR.....3/45,4/38  
138XLR.....1/20  
139.....1/20  
139XLR.....1/20  
140GTL.....3/20,58,4/50  
142GTL.....4/50  
146GTL.....10/41  
148GTL.....6/19  
1000GTL.....6/18,14/42

COLT  
222.....6/20  
290.....3/4  
350.....14/46  
390.....3/4  
480.....3/8,58  
485.....3/8,6/19

SPECIFIC RADIO TUNEUPS:

VOL/PG

COLT (cont.)  
800.....3/4  
800 Update.....10/58  
1000.....3/8,58  
1200.....9/30-31

COMMANDO  
2340.....1/21

CONVOY  
CON-400.....3/58

CPI  
CP400.....10/59

COURIER  
Blazer 40D.....3/58  
Centurion 40D...10/53,13/10  
Classic PLL40.....3/43  
Classic PLL40 Update..10/59  
Galaxy.....5/53  
Nightrider 40DR.....3/46  
Rangler 40D.....3/58  
Redball.....1/21  
Renegade 40.....3/46  
Rouge 40.....3/43

CRAIG  
L101.....6/20,11/42  
L102.....6/20  
L131.....10/59  
L132.....9/12,10/47  
L231 (AM,SSB).....10/60  
L232.....10/47,11/10

DAK  
Mark II.....10/60  
Mark V.....12/34  
Mark X.....4/45

DELCO  
70BFMC3.....2/43  
80BCB2.....6/20  
90BCB1.....10/60  
90BFMC1.....12/26  
90BFPC1.....12/26  
90BFTCL (FM,AM,CB)....10/60  
91YFMCl.....12/26

FANON  
10-40.....6/20  
Fanfare 125F.....3/43  
Fanfare 182F.....3/41  
Fanfare 184DF.....3/47  
Fanfare 185PLL.....3/46  
Fanfare 190DF....3/47,7/51  
Fanfare 350F....3/47,13/12

FORMAC  
40.....10/60

GENERAL ELECTRIC  
3-5800A.....3/50  
3-5804B.....6/21  
3-5804F.....10/61  
3-5804G.....12/35  
3-5805A.....9/31,10/61  
3-5811B.....9/31,10/61  
3-5812A.....10/61  
3-5814B.....6/21  
3-5817A.....7/51  
3-5818A.....2/42  
3-5819A.....11/42  
3-5821A.....9/31

SPECIFIC RADIO TUNEUPS:

VOL/PG

GENERAL ELECTRIC (cont.)  
3-5821B.....3/54  
3-5825A.....9/31-32  
3-5830.....3/42  
3-5869A.....2/42  
3-5871A.....13/60  
3-5871B.....3/46  
3-5875A.....9/32,10/48  
3-5900A.....12/35

GEMTRONICS  
GT44.....2/42  
GT55.....3/48  
GTX66.....6/21  
GTX77.....6/21  
GTX4040.....3/48  
GTX5000.....3/42,13/60

GENERAL MOTORS  
CBD-20U (PLL03A).....12/36  
CBD-203.....3/48  
4120.....3/46  
4145.....9/32  
4175.....3/46

HYGAIN  
VIII.....3/59  
674A.....4/60  
V674B.....1/21  
2701.....2/42  
2702.....3/48  
2703.....3/48  
2716.....12/36

ITT  
4000M.....13/61  
4400M.....4/17

J.C. PENNEY  
6246.....13/61  
981-6204.....9/32  
981-6225.....14/47  
981-6248.....13/14-15  
981-7461.....9/32  
981-8360.....10/61

JIL  
615CB.....11/42

JOHNSON  
123A.....1/21  
4125/4174.....13/61  
Messenger 40.....12/36  
Messenger 50.....7/51  
Messenger 80.....7/51  
Messenger 4120.....3/47  
Messenger 4135.....3/48  
Messenger 4140/4145....3/54  
Messenger 4170/4175....3/47  
.....Update.....11/43  
Messenger 4250.....3/48  
Viking 200.....12/36  
Viking 260/270.....3/49  
Viking 4330/4360.....11/43  
Viking 4740.....11/12

KRACO  
KB4045.....14/47  
KCB-2340.....2/42  
KCB-4000.....11/43  
KCB-4003.....3/42  
KCB-4005.....9/38,11/43  
KCB-4020.....3/49  
KCB-4030.....8/44  
KCB-4088.....3/50

SPECIFIC RADIO TUNEUPS:

VOL/PG

KRIS  
XL25.....2/43

LAFAYETTE  
Constat.....11/45  
Dyna-Ccm 40.....11/44  
HB640.....2/43  
LM-100 (PLL02A).....12/36  
LM-300.....12/37  
SSB75.....14/9  
SSB140.....11/44  
Telestat 1240.....5/14

LAKE  
410.....12/37  
450.....12/37  
600.....12/37

MEDALLION  
63-240.....3/50

MIDLAND  
100M.....10/67  
102M.....14/42  
150M.....7/52  
13-858.....14/42  
13-862.....14/48  
13-867.....13/62  
13-879.....14/50  
13-882C.....13/62  
13-892.....4/48  
13-893.....4/51  
63-445.....11/45  
76-858.....3/49  
76-860.....14/51  
76-863.....3/50,9/33  
77-101B.....8/44  
77-101C.....12/38  
77-821.....3/42  
77-824.....8/44  
77-824B.....12/38  
77-824C.....12/39  
77-838.....9/33  
77-849.....3/50  
77-856.....11/45  
77-861.....3/50  
77-861B.....11/45  
77-865.....9/33  
77-899.....9/33  
77-963.....3/42  
78-574.....9/38,12/39,14/10  
78-999 (02A).....12/5  
79-891 (02A).....12/5  
79-892.....3/49  
79-893.....2/20  
79-900.....9/33-34  
3001.....12/37  
4001 (77-004).....7/52  
5001.....12/37  
6001.....11/16  
7001.....11/16  
7001 (79-007).....11/45-46

MOPAR  
4094173.....3/51  
4094176.....3/51  
4094177.....3/49  
4094178.....3/60

MORSE  
2001.....12/42

MOTOROLA  
CB555.....12/7  
CF925AX.....11/46

SPECIFIC RADIO TUNEUPS:

	<u>VOL/PG</u>
<u>MOTOROLA (cont.)</u>	
Mocat 40.....	11/46
T4000A/05A/10A/20A.....	3/50
<u>N.D.I.</u>	
PC-102.....	11/46
PC-200.....	7/52
PC-201.....	12/8
<u>PACE</u>	
CB144.....	14/42
8003.....	11/47
8008.....	2/43
8016.....	11/47
8046.....	9/33
8113.....	12/39
8117.....	11/47
8155.....	9/34,12/40
8193.....	7/52
<u>PALOMAR</u>	
49.....	3/60
500.....	4/19,5/32
4100.....	3/54
<u>PANASONIC</u>	
CR-B474EU (AM,FM,CB)...	9/34
RJ-3200.....	14/42
RJ-3250.....	11/47
RJ-3600.....	11/48
RJ-3660.....	14/52
RJ-3700.....	13/17
<u>PEARCE-SIMPSON</u>	
Cougar 23.....	14/53
Leopard B.....	3/49
Puma 23B.....	13/62
Supertiger 40A.....	3/60
Tiger 40A.....	9/34
<u>PIONEER</u>	
GT-100G (AM,FM,CB)....	10/62
<u>PRESIDENT</u>	
AR-7.....	12/40
AR-44.....	10/63
AR-144.....	10/41
AR-711.....	12/34
AX-7.....	12/45
AX-11.....	12/45
AX-14.....	12/45
AX-44.....	12/45
AX-52.....	12/45
AX-55.....	12/45
AX-144.....	12-45
AX-711.....	12/40,45
Adams.....	2/16
Andrew J.....	9/34
Dwight D.....	10/62,14/54
Grant.....	1/22
Grant (NEW).....	5/24
James K.....	7/52
James K (NEW).....	12/40
McKinley.....	4/12
Old Hickory.....	9/34
Washington.....	1/22
Zachery T.....	14/54
<u>RAY JEFFERSON</u>	
CB-845.....	11/48
<u>RCA</u>	
14T270.....	9/36
14T300.....	2/43

SPECIFIC RADIO TUNEUPS:

	<u>VOL/PG</u>
<u>RCA (cont.)</u>	
14T302.....	3/53
14T303.....	11/48
<u>REALISTIC</u>	
TRC-45A.....	4/37
TRC-47.....	1/21
TRC-57.....	1/21,12/28
TRC-99A.....	4/37
TRC-100.....	4/37
TRC-180.....	4/37
TRC-200.....	4/37
TRC-200 Update.....	10/63
TRC-204.....	10/63
TRC-205.....	12/40
TRC-206.....	14/55
TRC-209.....	10/63
TRC-209(GRE7189PLL-VC)12/49	
TRC-410.....	12/29
TRC-420.....	12/41
TRC-421.....	8/44,12/41
TRC-421A.....	9/35
TRC-422.....	8/45
TRC-422A.....	10/64,67
TRC-424.....	3/57,9/35
TRC-425.....	7/53,10/67
TRC-426.....	10/64
TRC-427.....	8/45
TRC-428.....	11/48
TRC-431.....	4/37
TRC-432.....	11/48
TRC-440.....	8/45,9/35
TRC-441.....	10/67,11/49
TRC-448.....	3/51,10/64,11/19
TRC-449.....	3/51,9/35-36
TRC-451.....	12/10
TRC-452.....	1/21,3/52
TRC-454.....	8/45
TRC-455.....	3/60
TRC-456.....	10/67
TRC-457.....	9/35-36,10/36
TRC-458.....	9/35
TRC-459.....	10/34
TRC-461.....	3/51
TRC-462.....	9/36
TRC-466.....	3/51
TRC-468.....	3/57
TRC-470.....	9/39,12/41
TRC-471.....	8/45
TRC-480.....	7/53,10/37
TRC-490.....	11/49,12/15
<u>ROBERTS</u>	
40 Ch.....	14/42
<u>ROBYN</u>	
007-140.....	3/52
AM500D.....	3/52
DG130D.....	3/56
GT-410D.....	3/57
LB120.....	3/52
SB-505.....	5/42
SB-520D.....	2/22
SX-401.....	3/57
SX-402D.....	3/57
T240D.....	3/56,13/60,63
WV110.....	3/56
WV110 Update.....	11/50
<u>ROYCE</u>	
582 (PLL3001).....	12/42
604.....	3/56-57
607.....	12/42
611.....	14/55
1-617.....	3/52

SPECIFIC RADIO TUNEUPS:

	<u>VOL/PG</u>
<u>ROYCE (cont.)</u>	
1-619.....	3/56
1-621.....	3/57
1-625.....	3/56
1-632.....	11/21
1-639.....	12/41
1-641.....	3/60,4/51,11/20
1-642.....	13/24
1-650.....	14/42
1-651.....	7/55
1-655.....	11/50
1-660.....	2/42
1-673.....	3/52
1-675.....	3/53
1-680.....	3/52
<u>SBE</u>	
21-CB Cortez.....	14/56
26CB1A.....	3/61
42CB Cortez 40.....	3/61
43CB.....	3/53
44CB.....	9/36
45CB Trinidad III.....	3/61
47CB.....	3/53
49CB Tahoe 40.....	3/53
LCB-8 (uPD2826C).....	12/43
LCBS-4.....	7/32
LCM-5 Land Command.....	9/36
LCM-8.....	9/36
LCM-8 (PLL03A).....	12/42
LCMS-4.....	7/35
LCMS-8 (uPD2816C).....	12/43
<u>SEARS</u>	
CM-6000LA.....	3/59
CM-6000LC.....	3/59
Roadtalker 40.....	2/43
370-38050700.....	3/54
562-38200700.....	3/55
663-38020800.....	7/53
663-38070700.....	3/61
663-3810.....	11/22
663-381050.....	11/21
934-3677150.....	12/16
934-36772600.....	12/16
934-38061700.....	11/50
934-38062700.....	10/65
934-38080700.....	9/37
934-38081700.....	9/38
934-38120700.....	3/61
934-38260700.....	7/53
934-38270700.....	7/54
934-38310700.....	7/54-55
<u>SHAKESPEARE</u>	
GBS240.....	3/53
<u>SHARP</u>	
CB-23.....	13/63
CB-800.....	2/42
CB-2170.....	12/43
CB-4370.....	12/43
CB-4470.....	12/44
CB-4670.....	7/55
CB-5470.....	11/24
<u>SONAR</u>	
FS-2340.....	5/31
<u>SPARKOMATIC</u>	
SR-42/CBM.....	3/54
<u>STANDARD</u>	
29.....	1/22
29A(uPD857).....	13/63

SPECIFIC RADIO TUNEUPS:

	<u>VOL/PG</u>
<u>SUPERSCOPE</u>	
Aircommand CB1040.....	14/57
<u>SURVEYOR</u>	
620.....	3/55
2610.....	3/54
<u>TEABERRY</u>	
Model T.....	3/55
Racer T.....	3/55
Stalker II.....	1/21
Stalker III.....	7/55
Stalker IV.....	12/44
Stalker V.....	7/55
Stalker VIII.....	10/65
Stalker IX.....	10/65
Stalker XII.....	7/56
Stalker XV.....	10/39
Stalker XX.....	10/40
T Charlie.....	10/65
T Command.....	3/55
T Dispatch.....	3/55
<u>TENNA</u>	
10901.....	10/58
10902.....	10/65
11302 (AM,FM,CB).....	9/37
<u>TRS</u>	
Challenger 432.....	4/23
Challenger 460.....	14/59
Challenger 600.....	9/37
Challenger 850.....	4/32,7/55
Challenger 1200.....	12/44
<u>TRAM</u>	
D12.....	3/54
D64.....	13/31
<u>TRUETONE</u>	
CYJ4832-A-87.....	2/43
CYJ4837-A-87.....	3/59
CYJ4862-A-87.....	9/39
MCC4434A-57.....	14/60
<u>UTAC</u>	
TRX-400.....	3/59
TRX-500.....	5/56
<u>VECTOR</u>	
X.....	2/43
770.....	9/37
790.....	9/37
<u>WARDS</u>	
GEN-680A.....	14/61
GEN-696A.....	14/61
GEN-719A.....	11/10
GEN-775A.....	3/61
<u>XTAL</u>	
XSSB10.....	1/22
*****	

VOLUME 1

	PAGE #
GOLDEN EAGLE MARK IV PING MODIFICATION.....	20
CRYSTAL CROSS REFERENCE GUIDE.....	5-10
LETTER CHART FOR CRYSTAL FREQ. CORRELATION.....	11-18
GENERAL INFORMATION.....	63-67
LINEARS.....	68-70

\*\*\*\*\*

VOLUME 2

	PAGE #
NEW CRYSTAL CROSS REFERENCE GUIDE.....	5-9
LETTER CHART FOR CRYSTAL FREQ. CORRELATION.....	10-13
PRESIDENT GRANT RF GAIN & ADJACENT CH. REJ. MOD.....	18-19
ROBYN 510D/520D NOISE BLANKER ALIGNMENT.....	25-26
COBRA 139XLR SERVICE BULLETIN ON CRYSTAL DRIFT	
PROBLEM & PCB CRACKING.....	45-50
SERVICE BULLETIN ON SIDEBANDER II & CONSOLE II FOR	
IMPROVING CROSS MODULATION REJECTION.....	51
SERVICE BULLETIN-COBRA 29 ON MODULATION	
IMPROVEMENT, ALSO NOISE BLANKER.....	52
ANTENNA REPORTS.....	53-55
BETA-COM INFO (UPGRADING 23 CHANNEL RADIOS).....	57-87

\*\*\*\*\*

VOLUME 3

	PAGE #
PRESIDENT MADISON FREQ. COUNTER MOD.....	16-18
NOISE WHINE CURE.....	24
MICROPHONE WIRING INSTRUCTIONS.....	26-32
PLL CHANNELIZER.....	33-40
ANTENNA SECRETS (K40 STUD MOUNT FOR BIG STICK).....	63-64
SPECIAL SECTION ON LINEAR AMPLIFIERS:	
50-70W MOBILE.....	66
300-400W BASE.....	67-69
70W BASE.....	70-71
EAGLE 200.....	72
EAGLE 500.....	73
CONVERSION FROM AMATEUR TRANSMITTER TO LINEAR AMP...	74
LINEAR AMP PROBLEMS & SOLUTIONS.....	75-76

\*\*\*\*\*

VOLUME 4

	PAGE #
HOW TO BUILD YOUR OWN RELAY MODULE.....	16
02A CHIP INFORMATION.....	54-55
HINTS & KINKS ON COBRA 62XLR & 142GTL.....	61
TURNER MIC EXPANDER (500AMC DISABLE).....	62
K40 BLINKIE.....	63
SUNSPOT PREDICTION CHART.....	64
LINEAR REPORT SECTION:	
D & A MAVERICK.....	65
D & A 500 TRIPLE CONVERSION.....	65
EAGLE 515 MODIFICATION.....	66-67
UNIDEN SSB 10METER POWER CONVERSION.....	68-70
SUPER CLARIFIER DIODE.....	71

\*\*\*\*\*

VOLUME 5

	PAGE #
10 METER CONV. MICROCOMPUTER (MICROMONITOR PLL).....	1-5
ECHO BOX.....	6
250 WATT DUMMY LOAD - "SECRET CB'S LITTLE DUMMY"....	7
BUILT IN POWER MIKE.....	8-9
5-MILE SIMULATOR.....	10
RECEIVER PRE-AMP.....	11
GLEN DIGITAL CONTROLLER.....	12-13
GETTING SWR DOWN ON BASE ANTENNAS.....	15
APARTMENT ANTENNA.....	16
GROUNDING MOBILE RADIOS.....	17
OOPS! WE GOOFED!	
VOL. 1, PAGE 23.....	18
VOL. 2, PAGE 20 & 21.....	18
VOL. 3, PAGE 4, 7, 11, 25, 33.....	18
VOL. 4, PAGE 5, 45, 50.....	17

VOLUME 5 (cont.)

	PAGE #
DAK MARK IX POWER MODIFICATION.....	21-23
SUPER POWER MODULATION MOD. FOR BOWMAN BASE CBH990..	43
THE ART OF WIDEBANDING 858 CHIP.....	44
CONVERSION KIT + MARS & CAP FOR SSB.....	48-49
CONVERSION OF AM/SSB TO 10 METER AMATEUR.....	52
REDCO UFO INSTALLATIONS.....	61-69
HINTS & KINKS - COBRA 140/142/148GTL REGUALTOR	
IC SHORTING OUT.....	70
SLIDE INCREASE, ALL SSB RADIOS.....	71
RADAR COMMUNICATOR.....	72-73

\*\*\*\*\*

VOLUME 6

	PAGE #
PLL CRYSTAL CROSS REFERENCE GUIDE.....	1-2
SECRET CB TEST TONE.....	13
ERRONEOUS SIGNAL LOCATOR.....	14
LOW COST AMATEUR CONVERSION FOR 10 METERS.....	15
BASE ANTENNA GROUNDING.....	16-17
SUPER CLARIFIER 10-TURN POT.....	22
OOPS! WE GOOFED!	
VOL. 5, PAGE 19, 20, 28.....	25
THUMBWHEEL 200 CHANNEL CONVERSION FOR 858 CHASSIS..	31-34
REDCO UFO APPLICATIONS.....	40-52
SPECIAL SECTION ON LINEAR AMPLIFIERS:	
PDX 400.....	54
D & A MAVERICK 250.....	55
MACO DUSTER 300, 750 & 1000 TRANSMITTER.....	56-57
MACO 75.....	58
500 CX & 700 CX 10 to 11 METER CONVERSIONS.....	58
RDX-75.....	59
HDX-50.....	59
MDX-200.....	60
PDX-400.....	61
10 METER EXPERIMENTER BOARD INFORMATION.....	62-63
HOW TO MAKE CYBERNET CHASSIS SLIDE.....	65
HOW TO HOOK UP GLEN 310 TO PRESIDENT WASHINGTON....	67
SUPER CLARIFIER HINTS.....	66
REDCO DX-50.....	68-70

\*\*\*\*\*

VOLUME 7

	PAGE #
HOW TO MAKE YOUR EAGLE SCREAM.....	14
IMPROVED SLIDE MODIFICATION FOR 02A SSB RADIOS.....	42
UPDATED 200 CHANNEL AMATEUR CONVERSION FOR 858 CHIP	43-48
10 METER CONVERSION FOR SSB RADIOS USING MB8719....	49-50
HOW TO MAKE YOUR 858 CHASSIS SLIDE.....	56
LINEAR AMPLIFIER NOTES.....	57
RECEIVE AMP - SILTRONIX.....	58-59
ECHO BOX SPEECH PROCESSING FOR TRC-449.....	60
ADDING PING.....	61
CORRECTION TO THUMBWHEEL 200 CHANNEL CONVERSION....	62-63
MICROMONITOR TECH NOTES.....	64-69
MICROMONITOR INSTALLATION for RADIOS USING 858....	70-71
AMP FOR RF PROBE.....	72
OSCILLOSCOPE MOD. FOR RF & MODULATION DISPLAY.....	73
THE "BANDIT" ANTENNA.....	74-76
SECRET CB'S OWN "TROUBLESHOOTER".....	77

\*\*\*\*\*

VOLUME 8

	PAGE #
WHAT'S NEW ON THE ELECTRONICS HORIZON?.....	1-6
UHF FM CB (GMRS).....	7-10
UNIDEN MB8719 PLL CHIP FREQUENCY CONVERSION.....	15
FREQUENCY MOD. FOR J.C. PENNEY, COLT, LAFAYETTE,	
HYGAIN, ETC.....	18
BROWNING MARK IVA MOD. & UFO INSTALLATION.....	22-23
BROWNING MARK IV TRANSMITTER TROUBLESHOOTING.....	25-32
OOPS! WE GOOFED!	
VOL. 5, PAGES 31, 32, 33, 34.....	41
VOL. 7, PAGES 31, 37.....	42-43

LINEAR AMPLIFIER NOTES:  
 INSTALLING & TROUBLESHOOTING LINEAR AMPS..... 47-49  
 10 METER AMP BOARD MOD. TO UPRIGHT DRIVER..... 50  
 YOU CAN BUILD IT:  
 TWO-TONE GENERATOR..... 51  
 YAESU 601 (B) FREQ. COUNTER MOD. TO READ  
 CB LOW, MIDDLE, HIGH FREQ..... 52-54  
 RF TEST METER..... 56-57  
 REDCO UFO MODIFICATION (FROM 20 to 29.995 MHz)..... 55  
 SECRET CB'S POWER VECTORING..... 58  
 HOW THE ECHO BOX CAN ACTUALLY SURPASS THE POWER  
 OF A LINEAR IN SSB..... 59  
 MICROMONITOR QUESTIONS..... 60-62  
 MICROMONITOR INSTALLATION INSTRUCTIONS:  
 SM5104 PLL..... 63-64  
 ICOM 22S..... 65-67  
 NEW PRODUCT RELEASE:  
 ZAPPER 9000 MOD. & REFERENCE CHART..... 68-69  
 REDCO DIGI-SCAN UFO ELITE..... 70  
 CHOPPER CHARLIE ANTENNA, MODEL 64#5..... 71  
 TROUBLESHOOTER..... 73  
 AMATEUR VSB-1 (VOICE SIGNAL BOOSTER)..... 82

VOLUME 9

SSB'ER LOSE OUT AGAIN..... 1  
 FCC ANOUNCES PLANS FOR SIDEBAND..... 2-3  
 FCC DELAYS NPRM: SSB FREQS. DOUBTFUL..... 3-4  
 SPEED-O-MATIC "SPEEDO-1" X-BAND RADAR GUN..... 5-6  
 CONVERSION TIPS FOR ALL SSB RADIOS..... 7  
 RELAY CRYSTAL SWITCHING..... 25-26  
 LETTER FROM A FRIEND..... 27-28  
 HINTS & KINKS-ELECTRONIC CRYSTAL SWITCHING..... 29  
 OOPS! WE GOOFED! VOL. 8, PAGE 17..... 29  
 SOLVING T.V.I..... 40-42  
 RADACRUZ..... 42  
 IMPORTANT FACTS ABOUT ECHO BOXES..... 43-44  
 OOPS! WE GOOFED! VOL. 4, PAGE 51..... 44  
 VOICE SIGNAL BOOSTER (VSB-1) INSTALLATION..... 45-48  
 POWER SUPPLY MODIFICATION FOR REALISTIC PRE-AMP  
 NOISE-CANCELLING MIKE #21-1175..... 49-50  
 HINTS & KINKS - SWITCHABLE MODULATION INCREASE..... 51  
 RF ATTENUATOR..... 52-54  
 PRESIDENT SERVICE BULLETINS..... 55-61  
 INDEX VOLUMES 1 THRU 8..... 62-70

VOLUME 10

SECRET CB TROUBLESHOOTER..... 2-4  
 VOICE SIGNAL BOOSTER - VSB-1..... 5-19  
 REPLACING MB8734 with MB8719..... 35  
 uPD2816C PLL PIN OUT..... 42  
 TECH TIPS ON 858..... 55  
 UNCONVERTIBLE CHIP LIST..... 66  
 LINEAR SUGGESTIONS..... 68-69  
 ZAPPER 9000 INSTALLATION HINTS..... 70  
 OOPS! WE GOOFED!  
 VOL. 3, PAGE 33..... 71  
 VOL. 5, PAGE 24, 28, 48..... 72  
 VOL. 8, PAGE 16, 17..... 72-73  
 VOL. 9, PAGE 9, 51..... 74-75  
 VOL. 9, PAGE 29..... 72  
 CB PARABOLIC TYPE ANTENNA..... 77

VOLUME 11

CPI ALC MODIFICATION FOR INCREASED SSB POWER..... 9  
 HOW TO ADD RF GAIN CONTROL TO A CPI 300/400..... 11  
 VSB-1 UPDATE..... 25-26  
 NEW FRONTIER: FM CB..... 27-29  
 NEW PRODUCT: DIGI-SCAN DS-400..... 30-31

COMING ATTRACTIONS - SERIAL DATA/PLL  
 FREQUENCY SYNTHESIZERS..... 32  
 UNCONVERTIBLE AT THIS TIME -GE 3-5900A TC9101P.... 33  
 ADD CH. 9 & 19AT TO COLT 210..... 33  
 ZAPPER 9000 INSTALLATION UPDATES..... 34  
 RADIO MODULATION ADJUSTMENTS FOR VARIOUS MODELS... 51-53  
 HINTS ON SERVICING..... 54  
 SERVICE NOTES-GOLDEN EAGLE MARK IV TRANSMITTER... 55  
 D104 & D104M6 ASTATIC MIKE MODIFICATION..... 55  
 HOW TO SOLVE NOISE PROBLEMS..... 56-57  
 MORE ON THE "TROUBLESHOOTER"..... 57  
 NOISE IN DIESEL TRUCKS..... 58  
 IN HOUSE VALUE LISTING..... 59  
 TRUCKERS SPECIAL POLARITY PROTECTOR WITH SMARTS... 60  
 HOW TO BUILD:  
 LOW PASS FILTER..... 61  
 20db ATTENUATION PAD..... 61  
 BALUN COIL..... 62  
 1000Hz TONE..... 63  
 ADD A SECOND BATTERY..... 64  
 20 AMP POWER SUPPLY..... 65  
 SIGNAL INJECTOR..... 66  
 CMOS LOGIC PROBE..... 67  
 REFERENCE OSC-DIVIDER..... 68  
 READOUT MODIFICATION..... 69  
 ASTATIC MIC MOD..... 70  
 BILATERAL SWITCH..... 71  
 PLL PINOUT DIAGRAMS..... 72-77  
 THE "BANDIT" ANTENNA..... 53  
 OOPS! WE GOOFED!  
 VOL. 3, PAGE 25..... 78  
 VOL. 6, PAGE 32..... 78  
 VOL. 7, PAGE 43, 53, 63..... 78  
 VOL. 8, PAGE 52..... 78  
 VOL. 10, PAGE 2..... 78

VOLUME 12

SIMPLE CURE FOR RX-TX TRACKING PROBLEMS..... 21  
 HAM RADIO CRYSTAL SELECTOR GUIDE..... 24  
 VSB-1 HOOK-UP:  
 TEABERRY STALKER XX..... 25  
 REALISTIC TRC-490..... 25  
 WARDS GEN-719A..... 25  
 MODULATION ADJUSTMENTS FOR VARIOUS REALISTICS..... 33  
 ZAPPER 9000 REDERENCE CHART..... 46  
 ZAPPER TROUBLESHOOTING HINTS..... 47-48  
 TC9106 PLL OPERATION ANALYSIS..... 50-53  
 THE "SPREAD EAGLE" ANTENNA BREAK-THRU FOR TRUCKERS. 54-55  
 BASIC PLL..... 56  
 ELECTRONIC TERMINOLOGY..... 57  
 SCANNER PROGRAMMING TIPS..... 58  
 INTO THE KNOW WITH JAPANESE SEMICONDUCTORS..... 59  
 TRANSISTOR SPECIFICATIONS..... 60  
 RESISTOR COLOR GUIDE..... 61-62  
 CAPACITOR CODES..... 62  
 YOU CAN BUILD IT:  
 "SECRET CB'S" SUPER-DUPER POWER  
 SUPPLY CONTROLLER..... 63  
 AUDIO TEST STATION..... 64  
 POWER LINE FILTER - T.V.I. FILTER..... 65  
 OOPS! WE GOOFED!  
 VOL. 4, PAGE 38..... 66  
 VOL. 10, PAGE 10, 16, 28..... 66  
 VOL. 11, PAGE 3, 10, 15, 16, 71..... 66  
 INDEX VOLUMES 1 THRU 11..... 67-78

VOLUME 13

PAGE #

INTRODUCING THE SOMMERKAMP TS-788DX..... 4-9  
 MB8719 PINOUT..... 32  
 AGC SELECTOR SWITCH..... 38  
 CYBERNET 02A CHASSIS..... 39  
 HOW TO HOOK UP A 10 TURN POT TO 2000 GTL..... 40  
 2824C OPERATION ANALYSIS..... 41-43  
 VSB-1 HOOK-UP: TRC-448 & MIDLAND 77-0004 4001.... 43-44  
 TROUBLESHOOTING CLARIFIER PROBLEMS ON THE 858..... 45-47  
 SUPER REGULATOR..... 48  
 BUILD A RECEIVER PREAMP..... 49  
 LINEAR NOTES..... 50-51  
 MODULATED GUNN OSCILLATER..... 52-56  
 CYBERNET 02A AM POWER INCREASE..... 59  
 REALISTIC DX300 (20-204)..... 64  
 BEARCAT 250..... 65  
 OOPS! WE GOOFED!  
 VOL. 4, PAGE 39..... 66  
 VOL. 6, PAGE 3 & 12..... 66  
 VOL. 7, PAGE 54..... 66  
 VOL. 10, PAGE 25 & 48..... 66-67  
 VOL. 11, PAGE 4, 6, 10, 41, 75..... 67  
 INDEX VOLUMES 1 THRU 12..... 68-80

VOLUME 14

PAGE #

MB8719/11.3258 TRUTH TABLE..... 15-17  
 NEW PRODUCT: FM-30B THRU-LINE FREQ. COUNTER..... 18-19  
 NEW! "KIT A" FOR LC7130/7131 & TC9106P  
 CHIPS & INSTALLATION ISNTRUCTIONS..... 20-40  
 BROWNING PING INFORMATION..... 41  
 25-29 MHZ FREQUENCY ASSIGNMENTS..... 62-63  
 ELECTRONIC TERMINOLOGY..... 63  
 YOU CAN BUILD IT!  
 FET RECEIVER PRE-AMP..... 64  
 BUILD YOUR OWN SPACE SOUND..... 65  
 BUILD AN AMPLIFIER..... 66-67  
 INDEX FOR VOLUMES 1 THRU 13..... 68-80

\*\*\*\*\*

NOTE: SEE NEXT PAGE FOR VOLUME 15 INDEX.

# NOTES



ACKNOWLEDGEMENTS.....	1
INTRODUCTION.....	2
TABLE OF CONTENTS.....	3
BANDIT GOES FIBERGLASS.....	4
NEW MICROSCAN PLUS SYSTEM.....	5-6
BREAKING THAT CHIP.....	7-11
02A TRUTH TABLE.....	12-13
CDE MARK 26 (uPD861).....	14
CLARIFIER SOLUTION FOR COBRA 132/135XLR.....	15-17
CLARIFIER SOLUTION FOR BROWNING BARON & TRAM D-62.....	15-17
HOW TO MEASURE FREQUENCY ON YOUR SCOPE.....	17
COBRA 146GTL.....	18-19
PM77 POWER MODULATOR KIT.....	19
COBRA 148GTL-DX EXPORT MODEL.....	20-24
COBRA 2000GTL.....	25-28
DIGITAL PROCESSOR KIT FOR uPD2824 CHIP.....	28
GEMTRONICS GTX-2325.....	29
J.C. PENNEY 981-6203 (861 CHIP).....	30
DECIMAL EQUIV. OF # DRILLS FOR PC WORK IN INCHES.....	30
JOHNSON 4140 & OTHERS USING MOTOROLA SC42502P PLL.....	31
KENWOOD TS-530S.....	32
KENWOOD TS-820S.....	33-34
MIDLAND 13-882C.....	35
MIDLAND 79-892.....	36-38
PACE 1000MC-1000BC (NDC40013).....	39-41
WIRE GAUGE CONVERSION CHART.....	41
PACE 166 (23 CHANNEL VERSION).....	42
PACE 8155/8010A/9015A.....	43
PACE 8025 and 166 (40 Channel).....	44
PALOMAR SSB-500 - MCL45106P.....	45
RAIDER 4060 - MSM5807.....	46
ROYCE 1-655.....	47
ROYCE 1-639, PACE 8093 (CC1-3001).....	48
SBE-16CB Console II.....	49
STALKER IX (FM EXPORT ONLY MODEL).....	50-54
TEABERRY MODEL STALKER IX.....	55-57
TRISTAR 747.....	58
AM FREQ. EXP. FOR KRACO KCB4806 & 23 Ch AM 02A UNITS.....	59
23 CHANNEL 02A AM MODIFICATION.....	59
AM TUNE-UPS: AUDIOVOX MDU-6000, K40, LAFAYETTE CHB740.....	60
AM TUNE-UPS: PACE CB166 (40 ch.), Realistic TRC-411..	60
AM TUNE-UPS: TEABERRY TITAN "T", TRUETONE MIC4726A-67	61
MODULATION ADJ. for: COBRA 85, GEMTRONICS GTX-23, MIDLAND	61
13-881, SBE CONSOLE V, SBE TRINIDAD, TEABERRY BIG T....	61
MAKE YOUR "DWIGHT D" SLIDE.....	62
TENNA POWER #10901, FEILDMASTER TR-40, MIDLAND 102M..	63
CRYSTAL CONVERSION.....	64
POWER MODIFICATION FOR AM UNITS.....	65
PRO-22 POCKET SCAN AM/FM.....	66-69
"OOPS, WE GOOFED": VOL. 12, PAGE 7 - MOTOROLA CM555..	69
VOL. 13, PAGE 63 - ROBYN T240D....	69
VOL. 14, PAGE 12 - CRAIG L321.....	69
POINTER'S ON WHAT TO DO BEFORE CONV./MOD./TUNE UPS....	70
HOW TO CONVERT A SALVAGED METER TO A VOLT METER.....	71
STATE & INTERNATIONAL LOCATION DESIGNATORS.....	72
SECRET CB INDEX FOR VOLUMES 1 THRU 14.....	73-79
ORDER FORM FOR "SECRETS OF SATELLITE TV" VOLUME 2.....	80