

DECEMBER 1980

50p



Citizens' Band

THE MAGAZINE FOR THE TWO-WAY RADIO ENTHUSIAST

Build your own SWR meter

Base station antennas

CB and customising

CB soapbox

PLUS:

CB CLUB DIRECTORY

SPECIAL OFFERS

CB COMPETITION

NEW
From the publishers of
HOBBY ELECTRONICS

CB RADIO ACCESSORIES

THE LARGEST DISTRIBUTORS OF CB ACCESSORIES IN THE U.K.

Come and see the biggest and best selection of CB Radio Accessories from all the leading manufacturers, including:

HI HARADA

**TELECOM
CB PRODUCTS**



SIRTEL

WT

TURNER

CB

by ARISTA

K40

COMMUNICATION
ANTENNAS Y Y Y
hump

TELEX



SWR METERS
Including RAMA, HANSEN etc.

AGENTS THROUGHOUT THE UK

- ABERDEEN: Cheyne Electronics, Crossfields, Turiff, Aberdeenshire. (08886) 254
- BLACKPOOL: ADS Electronics, The Ledger Centre, 239 Dickson Road, Northshore, Blackpool.
- BRISTOL: CB Centre, 0272 554868
- BURY, LANCs: B & H Electronics, 183 The Rock, Bury, Lancs. 061 761 6144
- BURY ST. EDMUNDS: Denver Autos (Skid Parish), Troston, Bury St. Edmunds, Suffolk. Honnington 506
- CARLISLE: R & S Supplies, 29 Lamb Street, Uppery, Carlisle, Carlisle 38172
- CHELTONHAM: Breakers Yard, 1 Moorend Terrace, Croft Street, Cheltonham, Glos. (0242) 39783
- DERBY: RTS, 60 Osmaston Road, Derby, 0332 41235
- EAST BARNET: Autospar, 271 East Barnet Rd, East Barnet, Herts. 01 449 5070
- GRANTHAM: Castlegate TV, 64 Castlegate, Grantham, 0476 66869
- GREENFORD: Sound Around, 114 Ruislip Road, Greenford, Middlesex. 01-576 5030
- ISLE OF WIGHT: Electronic Pastimes, 29 North Road, Shanklin, Isle of Wight. (098386) 6103
- LEEDS: Hi Fi Servicing, 26 Moreland Grove, Leeds 17. (0532) 886960
- LONDON (West End): Sonic Sound Audio, 249-256 Tottenham Court Rd, London. W1. 01-637 1908
- NORTHAMPTON: Motorsound, 196A Kettering Road, Northampton.
- N. IRELAND: J.C. Patterson, The Corner House, Lisburn, NI. 08462 2034/5
- N. IRELAND: Mc. Neulty & Sons, Belmore St, Enniskillen, N. Ireland. (0365) 4443
- ORPINGTON: CB Shack, 16 Mount View Rd, Orpington, Kent. (66) 32411
- SCOTLAND (Greenock): Motor Accessory Centre, 1 Regent St, Greenock, Scotland. (0475) 25399
- SHEFFIELD: Steel City Custom, 132 Pennstone Rd North, Sheffield. (0742) 346234
- STOKE ON TRENT: HSBG, 27 Hope Street, Hanley, Stoke on Trent. (0782) 273815
- TUNBRIDGE WELLS: Charlie Bravo, 103 Camden Road, Royal Tunbridge Wells. 0892 34207
- WATFORD: Component Centre, 7 Langley Rd, Watford, Herts. (92) 46335
- WATFORD: Custom Plates, 867 St Albans Rd, Garston, Watford. 05273 61673
- WALES: Garys CB Shop, 101 Alexandra Road, Newport, Wales. 0633 213332
- WIGAN: Car Radio, 8 Darlington Street, East Wigan, Lancs. (0942) 43101
- WORCESTER: DAD, 23 Blackfriars Square, Worcester. (0905) 21919

*TRADE ENQUIRIES WELCOME at BLACKPOOL, BURY and **Mura**

**SHOP OPEN
9.00 - 5.30**

Mura 

MURA ELECTRONICS (U.K.) LTD
79 Church Road, Hendon,
London NW4 Tel: 01 203 5277/8



CB Band

Editor:
Rick Maybury
Group Art Editor:
Paul Wilson-Patterson

Advertisement Sales Executive:
Roy Perryment
Managing Director:
T.J. Connel



Get Your Ears On	5
Are you sitting comfortably, then I'll begin	
Update	7
The Latest CB News from home and abroad	
Coming Next Month	9
New of next month's mag	
Mack Chat	11
Mack The Hack has something to say	
SWR Project	12
Keep it clean	
CB And Custom Cars	16
British Graffiti?	
Competition	21
A real winner	
Base Station Antennas	22
The low down on the high ups	
Specials From Modmags	24
They are too	
CB Handbook	25
They're selling fast!	
Special Offers	26
We've got it monitored and taped	
CB Soapbox	28
Tell us what you think	
Subscriptions	30
Don't miss out	
Club Directory	32
Band together	

Copyright. All material in this publication is subject to world-wide copyright protection. Permission to reproduce any material in part or whole must be sought from the publisher. All reasonable care has been taken in the preparation of this magazine to ensure accuracy but Modmags cannot be held legally responsible for any omissions or mistakes that may occur. © 1980 Modmags Ltd.

CITIZENS BAND is normally published on the third Friday of Each Month prior to cover date.

CITIZENS BAND, 145 Charing Cross Road, London WC2H 0EE. 01-437-1002. Published by Modmags Ltd. Distributed by Argus Press Sales & Distribution Ltd., 12-18 Paul Street, London EC2A 4JS. Printed by QB Ltd., Colchester.

The publishers of CITIZENS BAND would like to point out that it is a contravention of the Wireless Telegraphy Act of 1949 and 1968 to use, manufacture, install or import CB transmitting equipment. It is not the intention of Modmags Ltd to incite, encourage or condone the use of such equipment.

The first major British CB enterprise

WE HAVE AN EXTENSIVE
RANGE OF CB ACCESSORIES
IN STOCK — ALL LEADING
MAKES INCLUDING:

TWEETY BIRD TBI amazing
microphone, noise generator
..... **£13.75**

FULLY RETRACTABLE dis-
guise antennas from **£22.50**

SWR's High-quality SWR and
field strength meter **£12.95**

HY-GAIN SLIDE MOUNT —
the best around — unbelievable
price **£4.05**

TURNER microphones — 12
models in stock from **£18.40**

AVANTI

ASTRO FANTOM ½ wave
mounts on glass **£22.50**
MOBILE MOONRAKER.
Moon magnet or hole mount.
The ultimate in mobile antenna
from **£44.95**
ASTRO BEAM. More forward
gain (11 d.B) than many 4 or 5
element beams! **£79.45**

All our retail prices are inc.
of VAT, subject to
availability and correct at
the time of going to press.

MISCELLANEOUS

SYMTEK RF PRE-AMP. Gives
a receiver real punch **£12.95**

25 WATT. Base/mobile
power amplifier **£34.90**

GP 27. Indoor or mast mount
mini ground plane antenna
..... **£35.00**

SUPER SAVERS

The famous **ANTENNA
SPECIALISTS M400** Star-
duster d.B Gain Base Station
Antenna **£19.95**

SHAKESPEARE Super Big
Stick Base Station Antenna
..... **£26.95**

FIRESTIK Mobile ½ Wave
Top-Loaded Mobile Whips from
..... **£6.95**

JAWS MARK II AVAILABLE LAST WEEK OCTOBER
WE STOCK 120 VARIETIES OF CB ANTENNAS
SOLE UK DISTRIBUTORS FOR



It is at present an offence under the Wireless
Telegraphy Acts 1949 to 1967 to manufacture
and/or use Citizens' Band radio transceivers and
such equipment is not licensable for use in the U.K.

We welcome Trade Enquiries. Trade Counter open 9.30 a.m.-7 p.m. Mon.-Sat.

For price list
please send
8" x 5" S.a.e.

CITIZENS' BAND
Radio Centre Ltd. 
337 Kenton Road, Harrow, Middlesex. Tel: 01-907 1106/7.

CITIZENS' BAND Radio Centre Ltd.

337 Kenton Road, Harrow, Middlesex. Tel: 01-907 1106/7.

We have the components in stock for the famous

JAWS MARK 2 CB Radio

- ★ 40 CHANNEL
- ★ 4-10 WATT OUTPUT
- ★ SQUELCH
- ★ EXTERNAL SPEAKER
& EXT PA FACILITY

Contact us for
further information

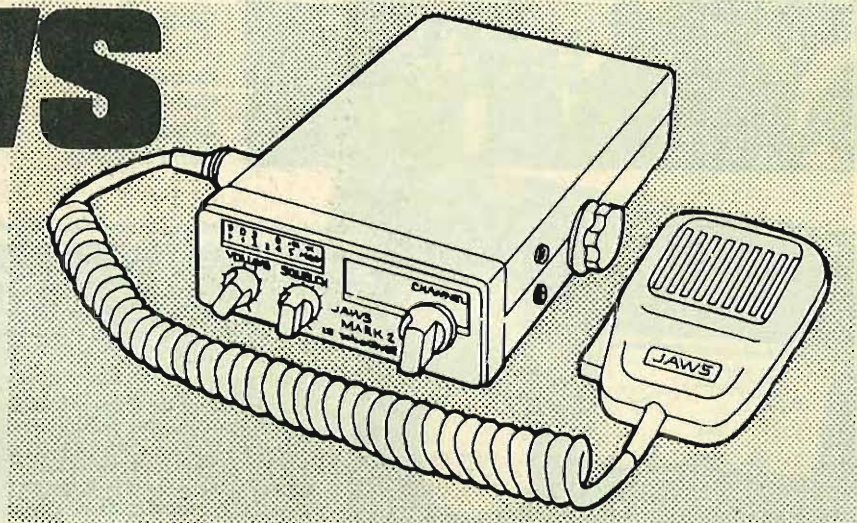

It is an offence under the wireless telegraphy acts 1949 & 1967 to manufacture
Citizens' Band radio transceivers and such equipment is not licensable for use in
the U.K.

EDITORIAL

Everyone knows by now that CB is illegal in this country. So why are we producing a monthly magazine on such a controversial subject? The answer is simple. Something like a half a million people in the British Isles think it is worth risking a £400 fine and up to six months' imprisonment just to talk to each other. Whilst we cannot condone any form of lawbreaking we do believe that those people have a right of access of the airwaves, the same right that is accorded to a significant proportion of the world's population. We would like to see that freedom available to everyone in this country with all the benefits that accompany a cheap, easy-to-use and freely available public two-way radio system. Although we won't be campaigning for a specific frequency we would like to see:

- a system that does not interfere with any other sector of the population
- a practical frequency which will allow the service to function adequately.

This does not infer we are in any way satisfied with 928 MHz nor does it imply we think 27 MHz is suitable. Either of these two frequencies (or any other frequency for that matter) that can meet these basic requirements and still be cheap to buy will fit the bill. I'm sure that most CBers would agree with this.

So much for the speeches, time now for a word or three on the magazine. CITIZENS BAND has been produced as a result of repeated requests from readers of our sister magazine HOBBY ELECTRONICS to deal with the subject of CB in greater depth. For some time now it has been apparent that the limited space in HE just wasn't enough. Earlier this year we took the decision to publish a monthly magazine which at that time we thought would coincide with the introduction of CB in this country. Alas that was not to be: continual back-pedalling by the Government and the dubious Open Channel document means that it will be some time before we get a workable system. So here we are, just like the thousands of breakers on channel we couldn't wait either.

Each month we will be bringing you the very latest CB news. Mack The Hack will be giving us, in his own unique style, his view of the month's happenings. Our technical staff in this country and abroad will be testing out the latest equipment. CB Soapbox will allow anyone with something to say make their point and the Club Directory will have all of the latest news from up and down the country plus the most up-to-date listing of CB clubs ever published. The icing on the cake will be our regular monthly project, From the workshops of Hobby Electronics and our overseas magazines will come cheap and simple-to-build electronic projects. This month we proudly present an SWR meter: look out for a base station power supply, antenna pre-amplifier and much, much more in the coming months.

All that remains now is for me to say welcome to CITIZENS BAND. I hope you enjoy it enough to become a regular reader. See you next month. Stay lucky.

Rick Mayhew

BIG EARS the shop

341-5 Roman Road, LONDON E.3.

Telephone 01-980-3534.

We have possibly the LARGEST RETAIL STOCK in the country.

DV27N	£10	Extension speaker	
DV27XN	£15	internal	£7
T27E	£15	Extension speaker	
3 ft Firestick	£15	external	£7
Rebel 500	£15	P.A. Speakers	£10
Mag Mount	£15		
TriwayAM/FM	£25		
SWRmeter78	£12		

*Special Offer from Big Ears Ltd.
Leicester: The Big Ears T. Shirt!
1 Gnome Logo Small, Med. & Large.
2 Legalise 27MHz Small, Med. & Large.
Both Black gold print only*

*£2.95 inc.
post+packing*

STOP PRESS. .
WALES & WEST
BIG EARS RANGE NOW AT:
Rigsby C.B. Centre
418 CHEPSTOW RD. NEWPORT.GWENT
TELEPHONE 0633 279192

Big Ears Ltd.
68 NARBOROUGH RD. LEICESTER.
TELEPHONE 0533 546031

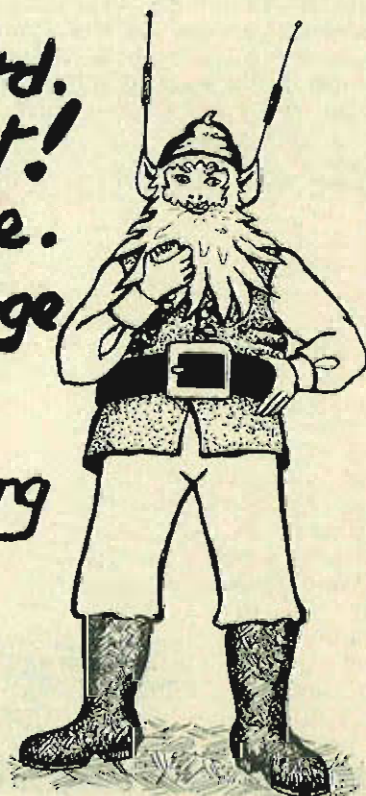

UPDATE

News from the world of CB

Frequency Band

Frequency 27 is the name of a new shop just opened in St James Street Walthamstow (London). Mark Gurney is the man to see (that's Mark at the wheel of his neat looking panel van). Mark has a very creditable range of accessories including some very interesting antennas and fixtures. Actually Mark got into CB via the TV aerial installation trade so there's not much he doesn't know about antennas. Although Frequency 27 has only been open a few weeks Mark is already firmly established as one of the most popular dealers in North London and he's regularly to be found at local club meetings. You can find him most Thursday evenings at the Big Eyeball Club in Tottenham. Mark's shop is at number 28 St James Street and that is just opposite James Street station for those without wheels.

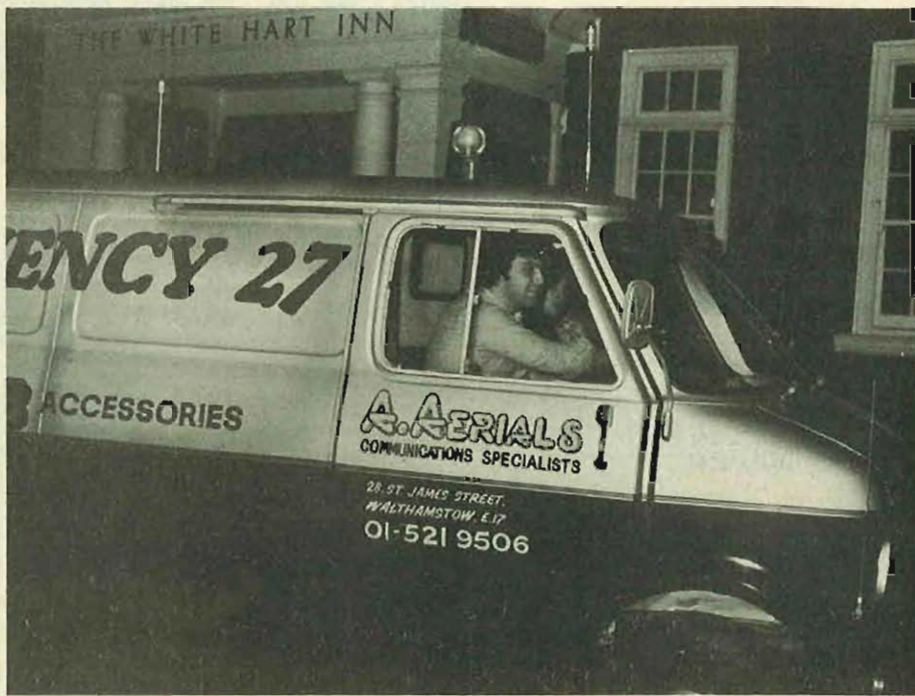

Radio Control Move

The news that radio control is about to be allocated another frequency has come none too soon. The suggestion that R/C was to be re-sited on or around 35 MHz has been confirmed although there was some doubt as to whether it would be the same as the international standard used by other countries around the world. Although this move would to a large extent, help alleviate the massive interference problem on 27 MHz the new frequencies would only be available to airborne models. Recent rumours are now suggesting that the new allocation on 35 MHz will in fact conform to the international standard.

New Catalogue

We have just received a very impressive looking new catalogue from Grove House Electronics. The catalogue contains just about every conceivable accessory from plugs to antennas and all at very reasonable prices. For your copy write to Grove House Electronics at: 14 Arcade Chambers, High Street, Bognor Regis, West Sussex or phone 0243 861705 for details.

Mounting interest

The famous Firestik company have released details of their new Flat Universal Mount. This new mount is specifically designed as a mirror mount on vehicles with flat mirror mount braces. These are usually only fitted to large trucks

but now some of the bigger pickups are fitting this kind of mirror.

There are two models available, the K124 which has a bayonet type connector and the K124A with a PL-259 type connector. No prices as yet but your nearest Firestik dealer should be able to help you.

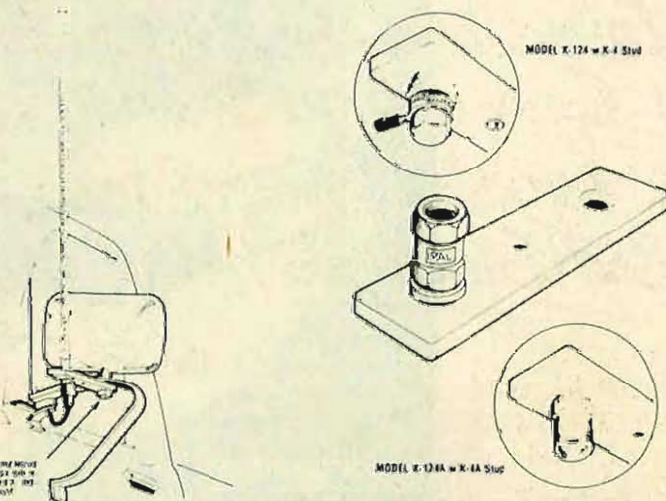

Breadboard 80

A few days after this magazine appears we will be staging our annual electronics exhibition

called Breadboard '80. This year the emphasis is on CB. At least one, possibly two American CB companies are booking stands.

CHELSEA CB CENTRE

73-77 BRITANNIA ROAD FULHAM LONDON SW6

Specialists in Antenna Fitting and In Car Entertainment

COME TO OUR NEW CB COUNTER FOR ALL YOU REQUIRE IN ACCESSORIES

Electric Retractable Tribander MS264 and other inconspicuous CB Aerials

Send Sae for our catalogue we stock almost everything including a full range of base station equipment



OPEN 7.45 TILL 4.30
MONDAY TO FRIDAY AND
10 TILL 5 SATURDAY

SPECIAL OFFER!!

Set up your winter base station
Ariel (Mini GP) 3.5 amp power supply,
17ft co ax with 2 PL 259
£47.50 + £5 P&P whilst stocks last

DISCOUNTS GIVEN
TO CLUB MEMBERS
WITH CLUB CARDS



WE DO NOT SELL
NOR CAN WE SUPPLY
RIGS 'UNTIL LEGAL'

01-731 0027

ASK FOR STEVE OR TONY
Trade enquiries welcome

CB NEXT MONTH

ON SALE FRIDAY 19th DECEMBER

Yes, CB Magazine is a monthly, not a quarterly or bi-monthly, we'll be on the bookstands regularly each month with the news, views, and opinions that the other magazines dare not print. CB magazine will also be the only national CB mag to present projects that are easy to build and of interest to CBers and radio enthusiasts alike. Just look at what's in store next month.

BASE STATION POWER SUPPLY

At last, a really practical circuit that will allow you to derive a 13.5 volt DC supply from the mains. This unit will happily power most of your in-car entertainment equipment. This unit is simple and cheap to build and will make a worthwhile addition to any workshop as a bench power supply and will happily deliver up to 3 amps.

CB ACCESSORIES

With a little luck (and with the wind in the right direction) one of the countries leading accessory dealers will be giving us his very own personal view from the other side of the counter plus a few hints and tips on how to spend your hard earned overdraft.

REGULAR FEATURES

We hope to be starting a new regular feature where we publish your letters and answer any technical queries you may have. If you feel like putting pen to paper then write to us at our usual address (see page 3) and mark your envelope 'Backchat'.

Our club listing is the most comprehensive and up-to-date in the country if you would like to see your club mentioned then see page 32 in this issue for details.

And finally, don't miss our monthly news page for all of the latest goings on in the world of CB, Open Channel and two-way radio.

CB SOAPBOX

Next month's 'Soapbox' has been handed over to Pete Christy, one of the countries leading radio control modellers. Pete's opinion of CB and how it affects his hobby makes compulsive reading. Be sure you don't miss this important feature next month.

MACK CHAT

You can't keep a good breaker down, Mack The Hack will be telling us of his own experiences of 'Hazzard County' right here in England!

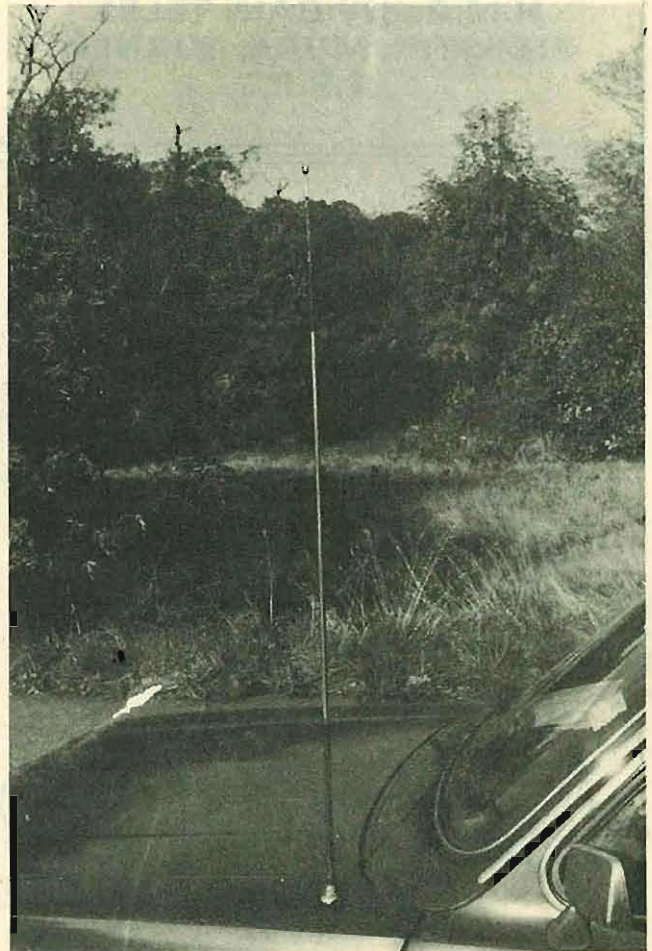

Circumstances may affect the actual contents

Spares 'N' Repairs

Suppliers of Quality CB Antennas
and Accessories

79 Far Gosford Street
Coventry
Telephone: (0203) 29567

All leading brands in stock

**H.M.P., HY-GAIN TELEX
FIRESTIK, MURA, TURNER
A.S.P.**



RUBBER DUCK CALLING LOGI
BAIRD — "SAY MAC WHERE DO I
GET R.F. TRANSISTORS 2.30
MHz. CIRCUIT BOARDS AND
APPLICATION NOTES?"

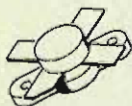
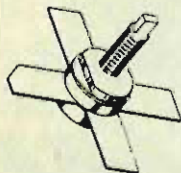

GAILAN OF COURSE!! THEY'VE
ALWAYS GOT WHAT I WANT.
MOTOROLA, M.R.F. AND
JAPANESE REPLACEMENT
TYPES



BUROETT ROAD, WISBECH
CAMBS PE13 2PS

TEL: 0945 63281
TELEX 32630

SRU AUTOS

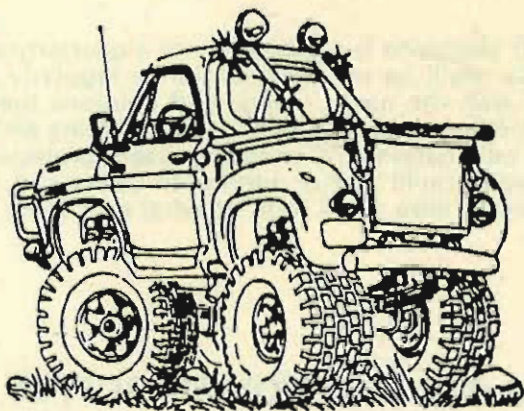

Citizen Band, Antennas and Accessories
for Marine, RV, Truck, Auto, Van
Motorcycles . . . Mobile and Indoor/
Outdoor Base Applications

10-4 Good Buddies

'Firestik'[®]
ANTENNAS

K40

SPECIAL OFFER!

Automatic electric aerial AM, FM, CB. Complete
with splitter box and safety relay which enables
use of CB only when fully extended. **£29.95**
+ £2 P&P. Fully guaranteed.

**229 CHERTSEY ROAD
ADDLESTONE, SURREY**

TEL.
CHERTSEY (STD 09328) 62556

UNTIL C B IS LEGALISED WE
DO NOT SUPPLY RIGS



Mack Chat

Every month Mack The Hack – one of CBs most famous personalities will give us his own very personal view of the CB scene.

YOU all got your ears on? Then I'll begin. "Introduce yourself", I was told, "write about yourself and CB for the first issue". For those of you that have not copied me before in the pages of HE, I say shame on you. Through the pages of HE and other CB journals, I have been named as a "personality" and "A legendary figure". Are you not supposed to be dead to be a legend? Well I'm not really any of those, I'm just a normal guy with a love for CB radio and like to write about my thoughts and adventures on the subject.

So why does a 40 year old married man with two teenage children and a big dog that will bite if anyone touches me or my property (HO warning) play with CB radio? Of course I am aware of the consequences if I was ever to get caught. I would lose a £50 rig, and lets say a £150 fine. That's the going rate in my 20 at the moment. I have been on channel for about two years, I work that out at 4 pints of beer or 60 cigarettes a week. So it's not a high price to pay for the pleasure that I've had so far from CB. Is it such a crime to modulate on 27MHz, what harm does it do? I believe that people that allow their dogs to foul the pavements cause more harm and that's also a crime.

Do not give me any rubbish about knocking aircraft out of the sky, I was losing my own model aircraft due to interference many years before CB was even thought of in this country. As for causing interference with hospital paging systems, how about hospital paging systems interfering with model aircraft, or why doesn't GPO paging interfere with hospitals or whatever way around you want it? Some of the equipment used in hospital radiology departments knock out 1-2 kilowatts plus, and this operates on 27 MHz. I bet that could cause some interference all round. I know that GPO paging interferes with CB and I wish they would stop it or give us a legal VHF frequency. Personally I

hate 27MHz, I believe it is well out of date for a CB system, and although we have been told many times by the powers that be that it would never be legalised on 27MHz. Did they not once say that we would never go to war against Germany, or that we would never be allowed to join the common market, or better still they said that woman would never be allowed to vote? I have recently heard a few rumours but I ain't saying nothing.

But back to my reasons why I use CB. Well, like many other buddies I spend many hours behind the steering wheel, I have helped others as they have helped me with traffic reports, directions to strangers in town that are looking for routes. I like radio and messing about with antennas and making other bits and pieces. Wow! I can hear some of you saying why don't I take the Radio amateurs' exam for a licence if I am that keen on radio? Well that's another story that I hope to write and tell you about in the very near future.

Mack the Hack

Over the past couple of years Mack The Hack has become one of CB's best known personalities. During that time Mack has helped to form at least two CB clubs, attended countless demonstrations and meetings and generally made himself a nuisance with the Home Office by writing to them at least once a week. Few people can claim to have as much experience with CB as Mack, with this in mind we have 'persuaded' him to share his expertise with you. If you have any kind of CB related problem then why not write to Mack The Hack at our usual address. We will forward on any letters, if you require a reply then please enclose a stamped addressed envelope.

If you have been a regular reader of Hobby Electronics over the past two years then you will know that Mack doesn't mince words. It occurs to us that sooner or later he's going to upset someone so to keep us out of jail we have to make the following disclaimer:

The views expressed by Mack The Hack are not necessarily those of the Editor or Publishers.

OK, nuff said, look out for another Mack Chat next month.

SWR METER PROJECT

CB MAGAZINE will be the first national monthly CB mag to publish construction projects. Each month we shall publish at least one simple to build project that should be of interest to both CBers and radio enthusiasts alike. We set the ball rolling with this simple yet highly effective Standing Wave Ratio (SWR) meter.

There are plenty of SWR meters on the market for CBers and amateurs at prices ranging from about £15 for simple 'economy' instruments right up to £100 for multi-function, almost 'professional' type instruments.

However, there's a certain satisfaction obtained from "rolling your own", be it clothes, furniture, fags, model aeroplanes – or CB accessories. Not only that, but you can save yourself money!

This little SWR meter project can be built for less than the economy model instruments around, and from experience, it works even better!

Construction

This is very straightforward. It is recommended that you use the printed circuit board designed for this project.

The circuit diagram of the instrument is shown in Figure 1. You can relate this to the component layout shown in Figure 4. For this project the components are mounted on the copper side of the printed circuit board.

Commence construction by winding 40 turns of the enamelled copper wire around the circumference of the ferrite 'toroid' ring. Then, cut a 45mm length of 50 ohm coax and cut back the braid and insulation as illustrated in Figure 2.

Slip the toroid over the piece of coax and position it centrally

between the ends. Fix it in place using a small amount of Evostick or other similar pliable compound sealer/cement. Solder this assembly onto the PC board as illustrated in Figure 4. Fix the toroid to the PC board with more glue. Only a small amount is necessary, don't overdo it.

All the other components can be mounted following this. Take care with the diodes D1 and D2.

The printed circuit board is assembled into a suitable metal box on which are mounted the meter (M1), the potentiometer (RV1), the switch (SW1) and the two coax sockets.

Assembly

All the major components should be mounted on the box panels once they have been drilled. The two PC board mounting bolts should also be secured to the back panel and two nuts added on to each bolt so that they will be beneath the PC board when it is assembled onto two coax sockets.

The PC board is soldered to the coax socket centre pins, before it is mechanically secured with nuts to the mounting bolts.

A PL259 plug should be screwed into the two coax sockets before soldering the PC board IN and OUT pads to the socket's centre pins. Make sure that a good fillet of solder secures each socket pin to the PC board pads. Don't overdo this though or the PC board may be damaged by excessive heat during the soldering process.

Once this has been

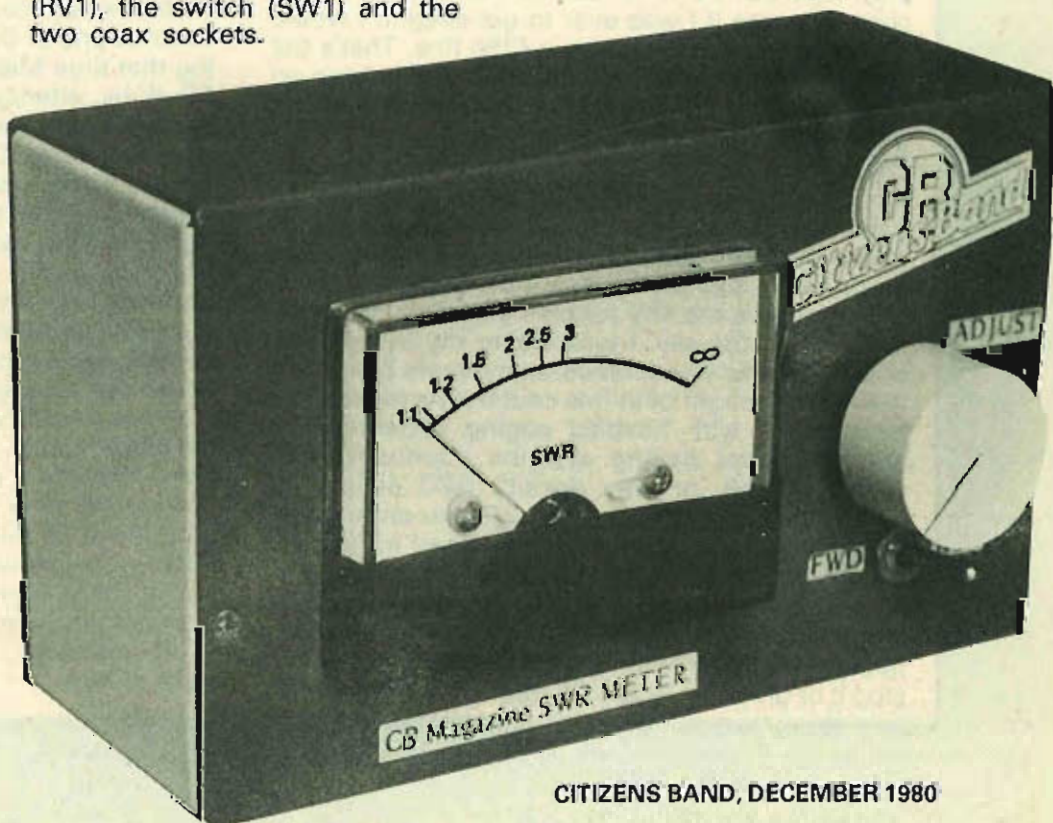

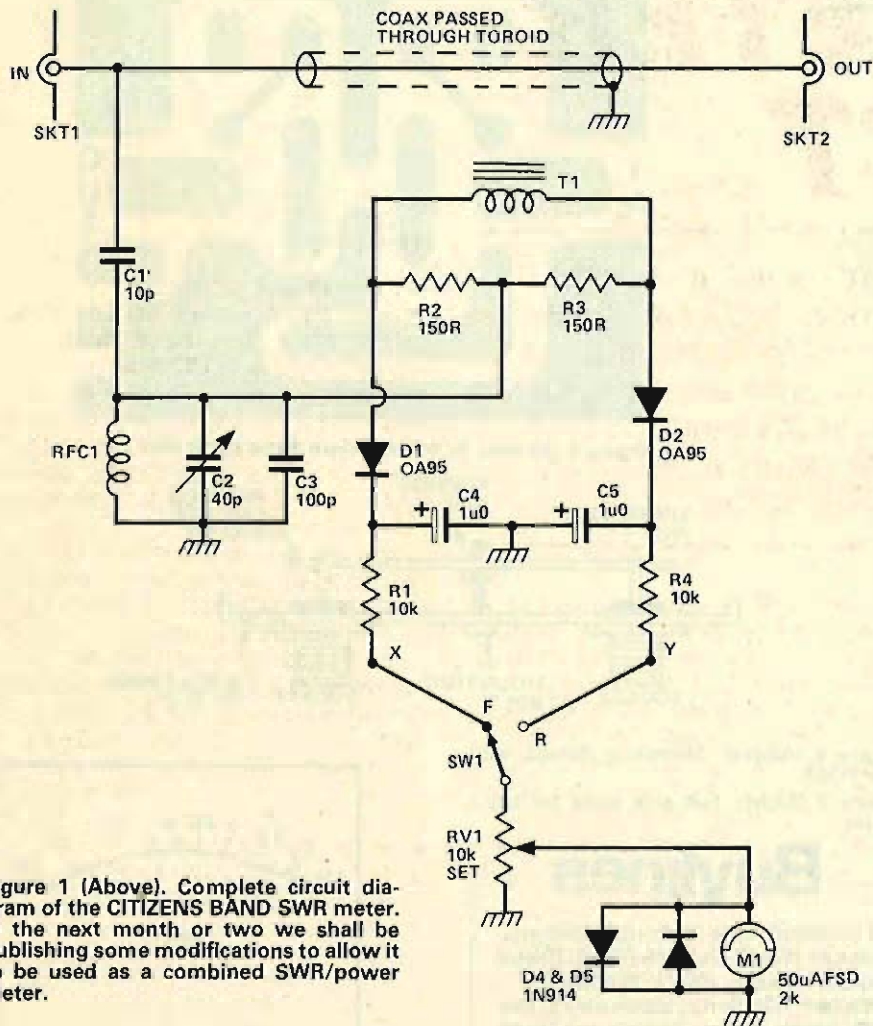

Figure 1 (Above). Complete circuit diagram of the CITIZENS BAND SWR meter. In the next month or two we shall be publishing some modifications to allow it to be used as a combined SWR/power meter.

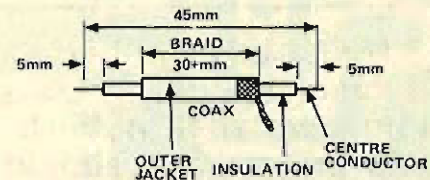
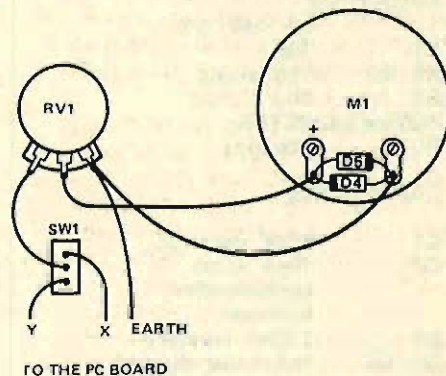

Figure 2 (Above). Cutting diagram for the coaxial cable.

Figure 3 (Below). Interconnection diagram for the meter, switch and potentiometer.



How it Works

For the interest of readers who may have an awakening or already established interest in the 'workings' of electronics and communications, here is a simple run down on how this SWR meter works.

The short length of coax cable is modified so that only the magnetic field of the RF currents passing through it is coupled to the 'toroid' ring (T1) placed over the cable.

The toroid is made of ferrite, a synthetic material which has the ability to concentrate a magnetic field. A number of turns of wire are wound around the circumference of the toroid to detect the magnetic field picked up by the toroid from the RF currents passing through the short length of coax.

The forward and reflected components of the RF in the coax pass effectively in different directions and have a phase difference of 180°—

that is, the reflected wave has the opposite phase to the forward wave.

The winding on T1 is connected to a 'reference' circuit which taps off a small amount of the RF from the input — C1 and C2-C3. This allows the forward and reflected currents to be obtained from T1, which flow through R2 and R3. The RF voltages that appear across R2 and R3 are rectified by D1 and D2 to provide appropriate dc voltages representing the forward and reflected components of the RF flowing through the coax line. The RF choke, RFC1, provides a dc return for the signal rectifiers D1 and D2.

The switch selects the output from the detectors enabling the forward component to be calibrated and the SWR value to be read from the meter scale. The diodes D4 and D5 provide overload protection for the meter.

successfully accomplished the two nuts on the mounting bolts, beneath the board, can be screwed up to lightly secure it. Another nut should then be screwed onto each mounting bolt on top of the board to finally secure it.

Once the mounting of the printed circuit board has been completed, the wiring of the switch, sensitivity potentiometer and meter should be completed with short lengths of hookup wire.

You may have noticed a couple of positions on the PCB remain unused. These are for a couple of extra components that will turn the SWR meter into a combined swr/power meter. We'll be telling you how to do this in the next few weeks.

SWR METER PROJECT

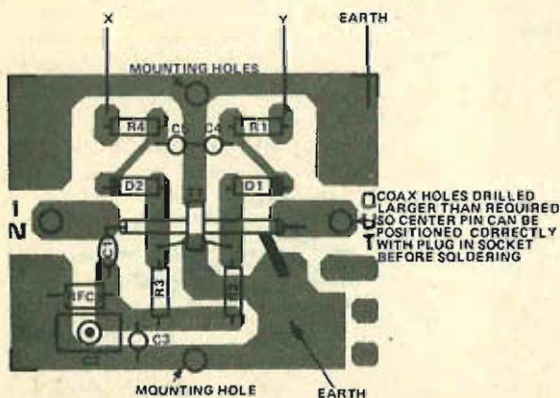

Figure 4 (Above). Overlay diagram for the CB SWR meter.

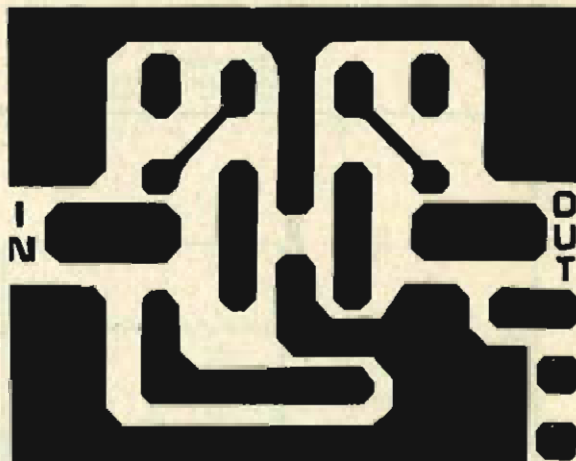

Figure 5 (Above). PCB foil pattern shown full size.

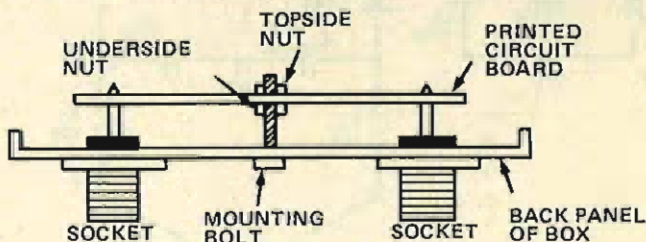

Figure 6 (Above). Mounting details for the PCB.

Figure 7 (Right). Full size scale for the meter.

Parts List

RESISTORS

	all 1/4W, 5%
R1	10K
R2, R3	150 ohms
R4	10 k
POTENTIOMETER	
RV1	10k pot.

CAPACITORS

C1	10pF ceramic
C2	40pF mica compression trimmer
C3	100pF ceramic
C4, C5	1 μ F solid dipped tantalum

SEMICONDUCTORS

D1, D2	OA 95
D4,5	1N914

MISCELLANEOUS

RFC1	Any moulded RF choke, 1mH or more (value not critical)
SW1	Single pole, double throw toggle switch
T1	40 turns of 35 gauge enamelled wire wound around circumference of toroid type T50-40 available from Ambit Ltd.
M1	50 μ A meter, 1k2 resistance.
Coax socket	Chassis-mount type (as shown) or single-hole type.

Two 25 mm long bolts with three nuts and two lock washers each; nuts and bolts for coax sockets (if required), short length of 50 ohm coax, hookup wire, etc.

Buylines

Toroidal ring: Ambit International, North Service Road, Brentwood, Essex (0277 230909).
Meter: Magenta Electronics Ltd, 98 Calais Road, Burton-on-Trent, Staffs. (0283 65435).

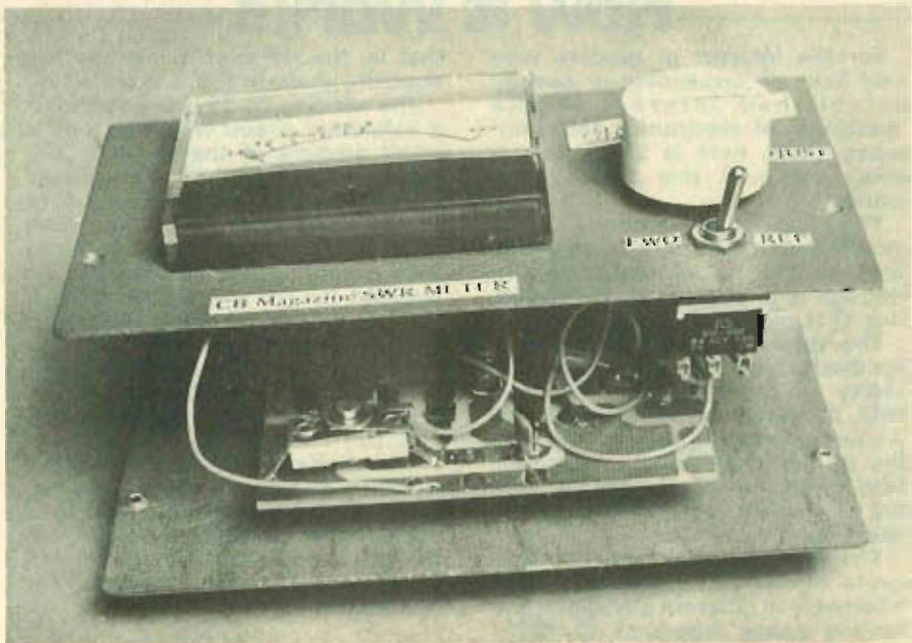
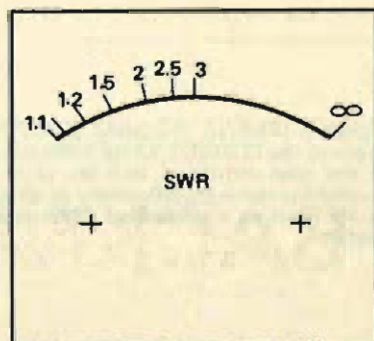

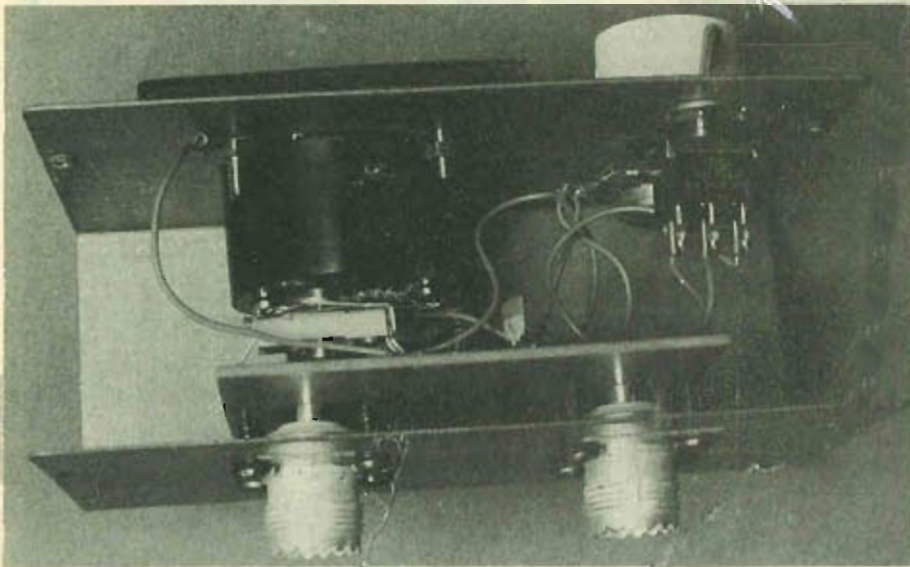

Calibration

A dummy load is required to complete the calibration of the SWR meter. These are obtainable for a few pounds from most CB accessory shops.

Connect the IN socket to an amateur transceiver with a short 'patch' cable and screw the dummy load into the OUT socket.

Set the sensitivity potentiometer to minimum (fully anti-clockwise). Set the switch to 'Forward'.

Set your transceiver to the AM mode and hold down the push-to-talk button. Rotate the sensitivity control clockwise so that the meter reads full scale. Switch to 'Reverse'. Adjust the trimmer capacitor on the PC board, C2, to get a minimum meter reading. Increase the sensitivity as you do this so that the actual minimum reading is obtained. You should be able to get the meter to read very close to zero by adjusting C2.

This completes the calibration and you can now use your meter to measure SWR.

CB

TABLE 1

SWR	SCALE READING
3:1	0.5 FULL SCALE
2.5:1	0.42 FULL SCALE
2:1	0.34 FULL SCALE
1.5:1	0.2 FULL SCALE
1.2:1	0.1 FULL SCALE
1.1:1	0.05 FULL SCALE

Left, Table showing relationship of meter scale relative to different SWR readings.

BACKNUMBERS FROM



Confidence (*konfidens*) *n* trust, reliance; lack of fear, selling backnumbers in the first issue.

Yes, we're confident alright. Although we haven't actually got any backnumbers to sell we just might have next month. Every month we'll hold back a few issues (if we can) so that people who might have missed a particular issue can still complete their collection. This number will be strictly limited so remember, the only way to keep up to date with the CB scene is to place a regular order with your newsagent or take out a subscription.

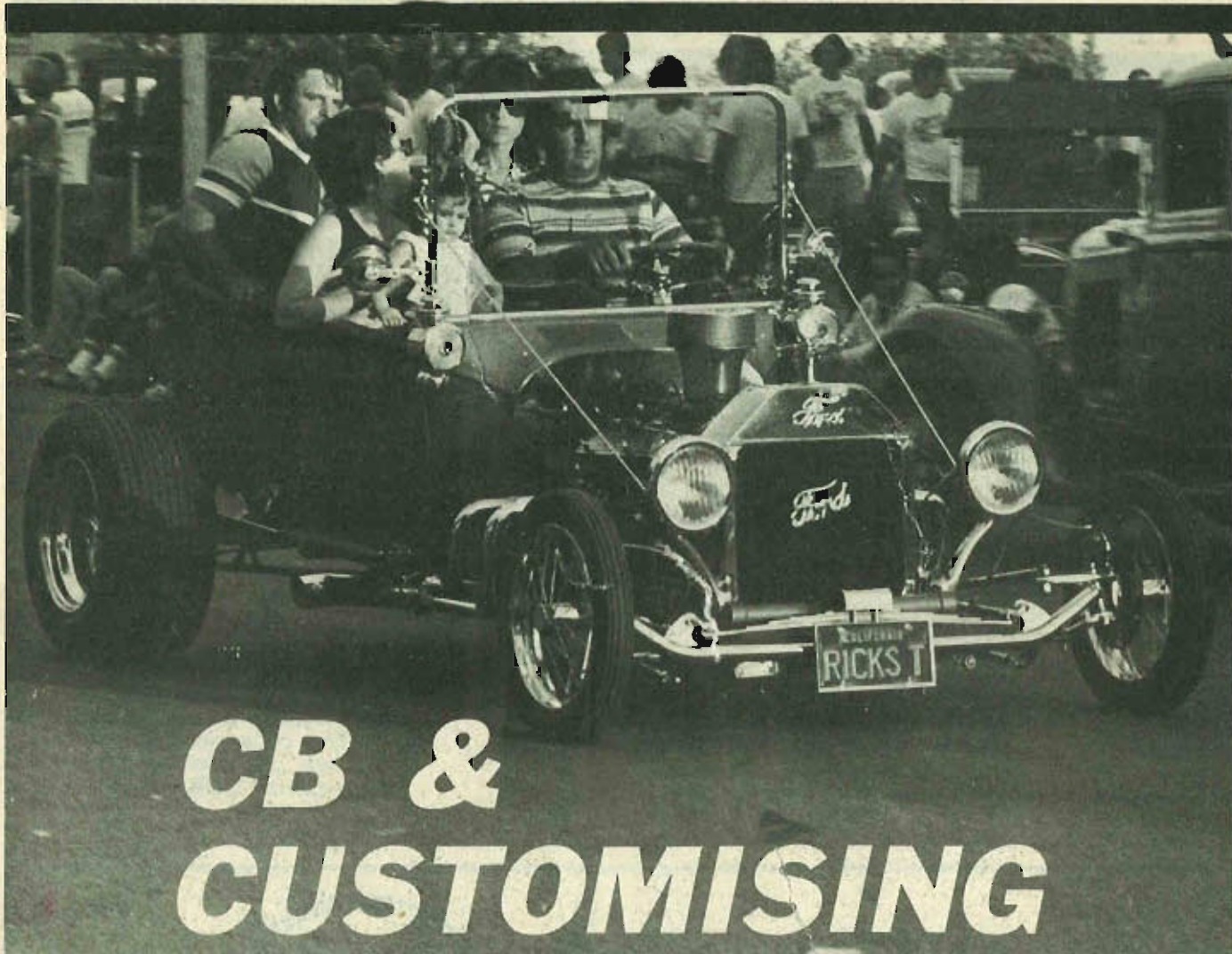

CB & CUSTOMISING

Like so many of our other recent 'cults' CB has been imported from the USA. Terry Bentley – a leading motoring journalist – discusses the connections between the current craze for CB in the world of car customising.

The true roots of the association between Citizens' Band radio and the world of freaky cars might be found somewhere in the muddled and confusing jungle that was American urban society in the Forties and Fifties, but its emergence in tangible form is a much more recent and homely happening. To trace the origins of the two separate cults – cars and CB – you'd need to be a sociologist with extensive awareness of the varying street cultures both in the US and in the UK over all of the last 35 years. I'm not a sociologist and I'm not even old enough to remember a great deal that's relevant from the formative years – but fortunately it doesn't take that much specialised knowledge to assemble a reasonably valid overall perspective on the subject.

Although the realisation of this

story is British, one thing it's important to understand is the Stateside orientation of the whole background. That's not to suggest that there is no native British tradition of modifying and restyling cars, nor is it to ignore the enthusiastic fraternity of radio amateurs that has flourished since time immemorial when cats' whiskers ruled the earth, but both of these turned out to be almost irrelevant as the transatlantic trends took hold.

American Influence

When our most troublesome ex-colony first began to exert a powerful cultural magnetism on the impressionable youth of Britain and Europe? I'd venture to suggest that it was in the early Hollywood era, but whether before or after the advent of the

talkies I couldn't tell you. The point is that there has long been an extremely powerful American flavour to many of the dreams and aspirations of young people in this country and elsewhere. First through the movies and subsequently through television, successive generations of Europeans (particularly British, in view of the lesser language barrier) were programmed to accept and ultimately to emulate 'the American way'. Just as Westerns painted a romantic picture of American history, detective stories and suchlike glamorised contemporary American life.

Britain after World War Two was a pretty downbeat, drab place, with rationing lingering on and luxuries generally in short supply. The USA that was visible on the cinema and TV screens appeared very different. It was pros-

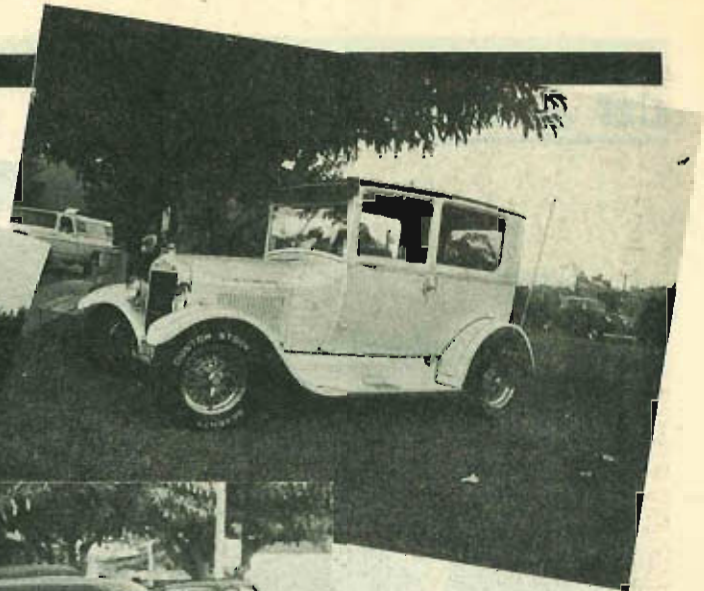

perous, lively and self-confident, full of optimism and style. It was brash, vulgar and superficial, of course, but above all it looked as though it was fun.

In several aspects the manufactured images told the truth. The Fifties were boom years for American industry and commerce. The consumer society was in full swing and increasing affluence brought the Hollywood lifestyle within the grasp of millions of real people. Even kids fresh from high school had money to burn and time to kill.

America was the land of the automobile from the very beginning. Wide open spaces, long distances between towns and cheap, abundant petrol ensured that cars became more dominant in everyday living than anywhere else.

It was natural that the teenagers would cruise the main drags of their towns in the evenings, looking for some action – and it was just as natural that some form of competitiveness should attach to the cars they drove. So it was that, from the infancy of hot rodding in the Thirties and Forties, street rods, machines and customs evolved, along with their own sport, drag racing.

While the racing quite quickly moved on to disused airstrips for the sake of legality, the cars and the cruising remained on the streets where their flamboyance soon caught the eyes of the film and TV producers. Shows like '77, Sunset Strip' with its famous 'Kookie car' Model T were imported to the UK, and the concept, if not for quite some time the reality, of the hot rod had arrived in Blighty.

Since then, of course, modified American cars of one kind or another have seldom been off our screens. Whole films have been devoted to specific areas of automotive culture – Two Lane Blacktop, American Graffiti, Boulevard Nights, to name but three successful pictures of recent years – and 'hot' machinery has even edged its way into the equipment of the cops'n'robbers, as in the TV series 'Starsky and Hutch'.

Fed on this rich diet of US material and encouraged from an early stage by the magazine 'Custom Car', the UK rodding scene has progressed well from its stuttering beginnings in the Sixties. As in the States, the various distinct types of cars have become established – e.g. street rods, street machines, mild and wild customs, lowriders – along with ▶

CB & CUSTOMISING



Above and left. Street cruisers in Los Angeles. Spot any CB aerials?



custom motorcycles, vans and pickups. Quality of design and execution has improved noticeably in the last couple of years, as cheap fares on transatlantic flights have enabled British enthusiasts to see for themselves how things ought to be done. The magazines, of which there are now four covering different aspects of the hobby, have helped raise standards, too, by presenting noteworthy examples as objectives at which to aim. 'Hot Rod & Custom' is widely acknowledged to be the leading publication in the field and features most of the best material from home and abroad.

Wireless Wheels.

The same factors which brought

about the car's leading role in American society later played a considerable part in establishing Citizens' Band radio as an integral part of ordinary people's lives. In such a big country, the nearest 'phone might be many miles away when it was needed, in sparsely populated areas, and the usefulness of an easily available mobile communication system was clearly evident. Initial legalisation by the Federal Communications Commission came in 1958 and CB deservedly grew and flourished. It became, particularly with the increase in number of channels and development of sideband in the late Seventies, the tool and toy of all kinds of people for all sorts of purposes, and of course it was de-

picted in all the pulp TV shows, many of which reached the eyes of intrigued British audiences.

The essential asset of CB is its mobility. Base stations in homes and offices have their obvious functions but would be threequarters redundant without mobile users to talk to. It needs no acrobatics of logic to understand how it was that those who depended on being mobile for a livelihood, principally the truckers, were most enthusiastic in equipping themselves with rigs in their cabs and quickly became the system's leading exponents. It was largely among the long-haul interstate truck drivers that the specialised vocabulary was created, and it was they who gave

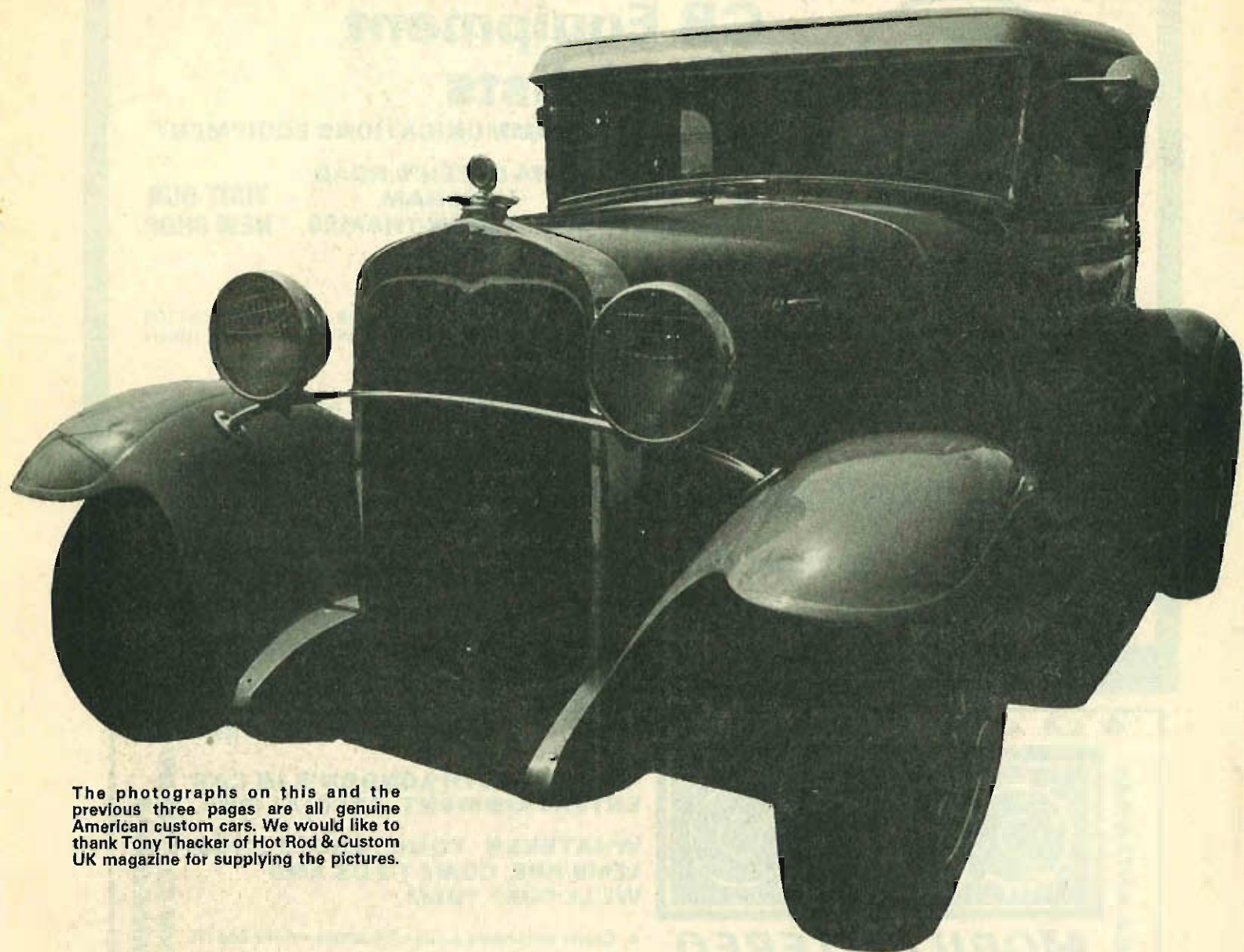

The photographs on this and the previous three pages are all genuine American custom cars. We would like to thank Tony Thacker of Hot Rod & Custom UK magazine for supplying the pictures.

CB an appealing tinge of anti-authoritarianism by using it to warn one another of police speed traps and so forth.

A kind of mystique grew around the truckers, with their colourful private argot and their ability to lead the establishment 'heavies' a dance, and the whole thing was heaved into the limelight by the infamous 'Convoy' film and hit record. Undoubtedly this was the major catalyst for the mushrooming of the previously small underground CB cult in Great Britain. Every adolescent enjoys a chance to indulge in a little undermining of repressive authority, and many of us go on feeling that way when we're supposed to be grown up! The illegality of such an obviously

harmless and indeed socially useful device as CB undoubtedly gave it greater impetus than it would otherwise have achieved in the UK.

Bearing in mind the preferences and susceptibilities of those already attracted to one chunk of Americana, i.e. rodding and customising, it was no surprise that many of the same people grabbed the chance to carve off another slice of fantasy-fulfilment by joining in the CB underworld. That's really the end of the tale. There really weren't any special developmental ties between customising and CB in the States, though rodders and customisers use the facility like everyone else. Over there is was the truckers' special

baby, and still is. The connection with wild cars on this side of the pond is 99% a domestic phenomenon, and even then it's not all it seems.

A final fact to take account of (note this, any Customs & Excise men looking for pointers): due to the current legal position and the conspicuousness of the vehicles, many of the base-loader antennae-festooned rods and machines around today are nothing but posers. In view of all the publicity ballyhoo, most actual 27MHz users are much more discrete and tend to do their thing in self-effacing vehicles like Vauxhall Vivas and Ford Cortinas. Maybe they even drive two cars – one for show and one with ears on **CB**

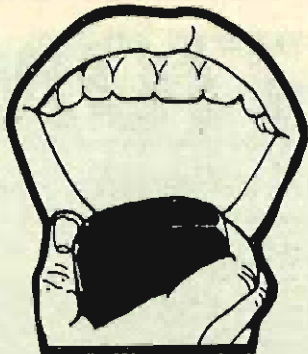

CB Equipment Specialists

SUPPLIERS OF COMMUNICATIONS EQUIPMENT

VISIT OUR
NEW SHOP

72-74 QUEEN'S ROAD
HERSHAM
WALTON-ON-THAMES
SURREY

VISIT OUR
NEW SHOP

ANTENNAS

M264 Disguise. SA300 Disguise. Hy-Gain Electric Disguise. Harada Electric Disguise. Harada TU11 Disguise. HMP K27 Disguise. CV Test Secret Antenna. Intenna. DV27. CX27%. T27; B27. DV27RN. DV27HN. Pal Firestik. Big Momma. Trucker Twins. Base Loaders. Mag Mounts. Starduster. Magnums. Power Pole. Hy-Gain Base. Dipoles. Many others.

MICROPHONES

Turner +2. Turner +3. Turner ssk. Magic Mike. Mura PRX. JMR 40. Denzai. Hy-Gain 611. Telephone Handsets. Motorcycle Sets. Others.

SPECIAL OFFER IF YOU BRING THIS ADVERT WITH YOU.

DV27 complete £5.75 inc. VAT

TEST EQUIPMENT

SWR-25. SRW-15. Hansen 50B. Hansen 5E. CB1105. JD310. CBM-20. CBT-15. CBT-25. CBM-40. Others. Dummy Loads.

MISCELLANEOUS

PL259/6. PL259/6. Reducers. Females. Back to Backs. SO-209 - 3.5mm jack. Splices. Mike Plugs. RG58/U. RG8/U. Patch Cables. Extension Cables. Mike Cables. 25 Amp Power Supplies. 5 Amp Power Supplies. Suppression Kits. Suppression Parts. Extension Speakers. PA Horns. Others. Linear Amplifiers to 1000w. RF Pre-Amps, etc.

IF WE HAVEN'T GOT IT—WE CAN GET IT

Mail order expressed by Red Star, all goods returnable, if not satisfied. Phone your requirements, quoting your Access or Barclaycard number for immediate dispatch. We will help with any problems by phone if at all possible.

Send a SAE for our
new Comprehensive Catalogue

10-21 Walton-on-Thames (09-322) 47395 9.30-6 Monday-Saturday

● C.B. AERIAL ● EVERYTHING BUT RIGS ● PLUGS ● SWR METERS ●

MOBILE ANTENNAE



MOBILE STEREO

Dept. CB, 360 York Road, London, SW18
Telephone 01-870 7362

Free fitting on all units purchased from us

● BASE ANTENNAE ● RAIN CAPS ● MICROPHONES ● CB SUPPRESSORS

WE ARE SOUTH LONDON'S IN CAR ENTERTAINMENT SPECIALISTS.

WHATEVER YOUR AUDIO PROBLEMS ARE, COME TO US AND WE'LL CURF THEM.

★ Come and have a cup of coffee while we fit your stereo

★ Wide range of fitting kits and aeriols ★

BOOST 20RF ●
IMPEDANCE MATCHER

Please mention
CITIZENS BAND
when replying to
advertisements

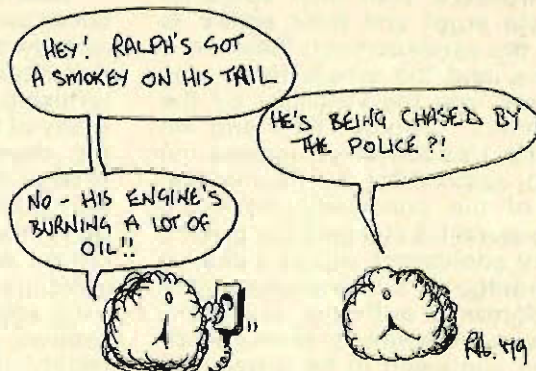

CB COMPETITION

First Prize: Binatone Programmable TV Game

Second Prize: Tenna CB Monitor

Third Prize: One years subscription to CB



Three fabulous prizes have to be won in this month's CB Competition. We wouldn't really start a new magazine without having a competition now could we? This free to enter competition is designed to test your general knowledge of CB. There are only five questions and you should be able to answer all of them if you have been a regular reader of *Hobby Electronics* or actively involved with CB over the past few months. We will be drawing the winning entry from the **CITIZENS BAND** hat on December the 12th so you'll have to hurry. Here are the questions.

- (1) Referring to the Green Paper 'Open Channel' what is the range of a transceiver operating at 900 MHz with 25 watts power between a mobile to fixed station?
- (2) What is the name of the American gentleman generally acknowledged to be the 'father of CB'?
- (3) What type of aerial is a DV27? Is it:
 - (a) Half Wave dipole
 - (b) $\frac{3}{8}$ wave helical
 - (c) Yagi array
 - (d) $\frac{5}{8}$ wave folded dipole
- (4) What is the maximum permitted output under FCC regulation for a single sideband rig?
- (5) What do the following abbreviations stand for?
 - (a) SWR
 - (b) ATU
 - (c) ERP
 - (d) MHz

Well, that was the easy bit, all you have to do now is to write down your answers on a post card, together with your name and address and send it to:

CITIZENS BAND COMPETITION
145 Charing Cross Road,
London WC2H 0EE.

We cannot enter into any correspondence regarding this competition. The Editor's decision will be final.

All entries must reach us no later than December 12th 1980.

BASE STATION ANTENNAS

And now for our regular monthly equipment review feature. We begin with a comparison of two of the most popular base-station antennas. Our technical reviewer 'Typewriter' has been trying out the Starduster and Firestik Macho-base somewhere on the continent.

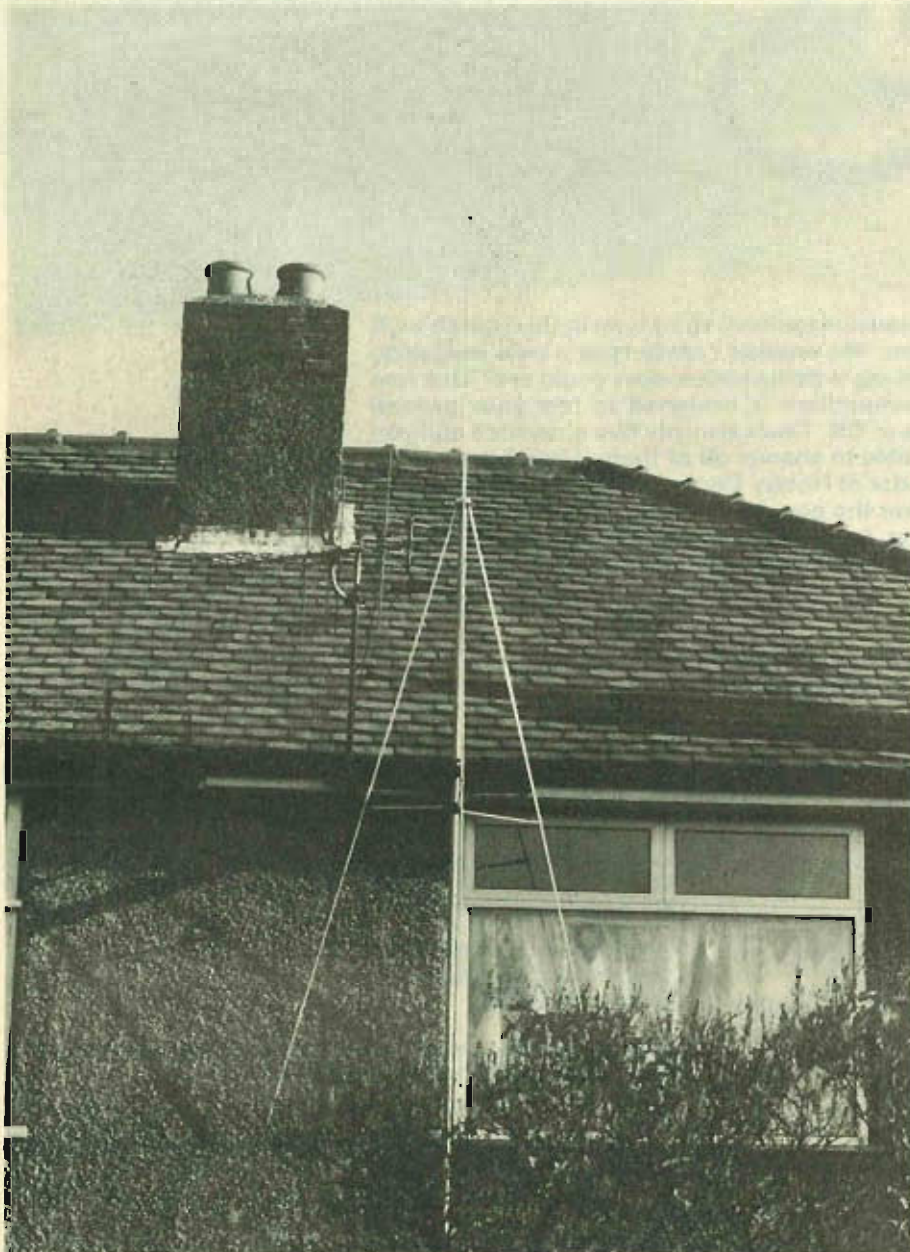

Spot the Starduster!! A most aptly named piece of equipment.

The only thing the Starduster M-400, made by The Antenna Specialists Co., and the Macho-base, made by 'Firestick' Antenna Co., have in common is that both are *ground-plane* antennas. While M-400 is intended for outdoor use, the Macho-base can be tucked away in a room or in a loft.

Let's have a look at both, starting at square one – unpacking and assembly.

Starduster M-400

When it arrives in its box, the size of the M-400 is deceptive. What comes out of the box is an assortment of aluminium rods, a circular aluminium base, some plastic component parts and an assortment of screws (a hexagonal-head key is provided for use with some of these).

As it goes together, the size of the M-400 becomes apparent. In fact, with an overall height of around 5½m (18 feet) it is an outside construction job. I found some of the self-tapping screws difficult to thread into the aluminium rods, and managed to nick myself with the screwdriver as I tightened one. (Moral: keep your fingers clear – especially on round-section rod!) This difficulty was overcome with a small box spanner.

Once assembled, the antenna *can* be stood on the ground on the tripod formed by its ground-plane radials but it's not very stable. As it is intended for mast-mounting, it is best to screw the base on to the end of a 1 inch inside-diameter or 1¼ inch outside-diameter steel pipe (known as 'barrel' in the Trade). The feeder is plugged into the

centre of the base and is run down the inside of the pipe. Thus the plug and socket are protected from the elements. A 6.4 m (21 foot) length of pipe was used with our test antenna.

No problem fitting the antenna to the pipe, but how do you hold twenty-odd feet of heavy steel pipe vertically? Guide ropes could have been used, but another (and safer) method chosen was to anchor the top of the pipe to the fascia of our host's house, with the pipe spaced clear of the gutter. The bottom end of the pipe was mounted in a solid base, knocked together from odds and ends of wood to hand. Because the coaxial feeder comes down the centre of the pipe, it was necessary to first cut a groove in the wooden base to avoid the edge of the pipe gulleting the feeder.

Total construction time was about one day, with much improvisation over the mounting. For safety's sake, elevation and mounting must be done by two people.

The manufacturer gives plenty of warnings in its literature about the hazards of mounting the antenna in the vicinity of power lines, and other warnings about the maximum safe height when close to an airport. Guidelines on the correct methods of mounting under these circumstances are also provided.

Macho-base

Six component parts comprise the Macho-base: a $\frac{1}{4}$ -wave helical antenna about 1½m (5 feet) in length, a heavy magnetic circular base fitted with 3 m (10 feet) of coaxial feeder, and four chrome-plated steel square-section rods, each 0.76 m (2½ feet) long.

Assembly time, it is claimed by Firestik, is: '... just one minute' and we found this to be true. The first step is to screw the antenna rod into the magnetic base, and then arrange the four chrome-plated rods — termed ground-plane stabilisers — in the form of a cross on the floor. The base is brought up to the meeting point of the rods and 'clunk-click' — the base and rods clamp together under magnetic attraction. So powerful is this magnet that it tends to upset the carefully laid-out cross pattern, which may need re-adjustment.

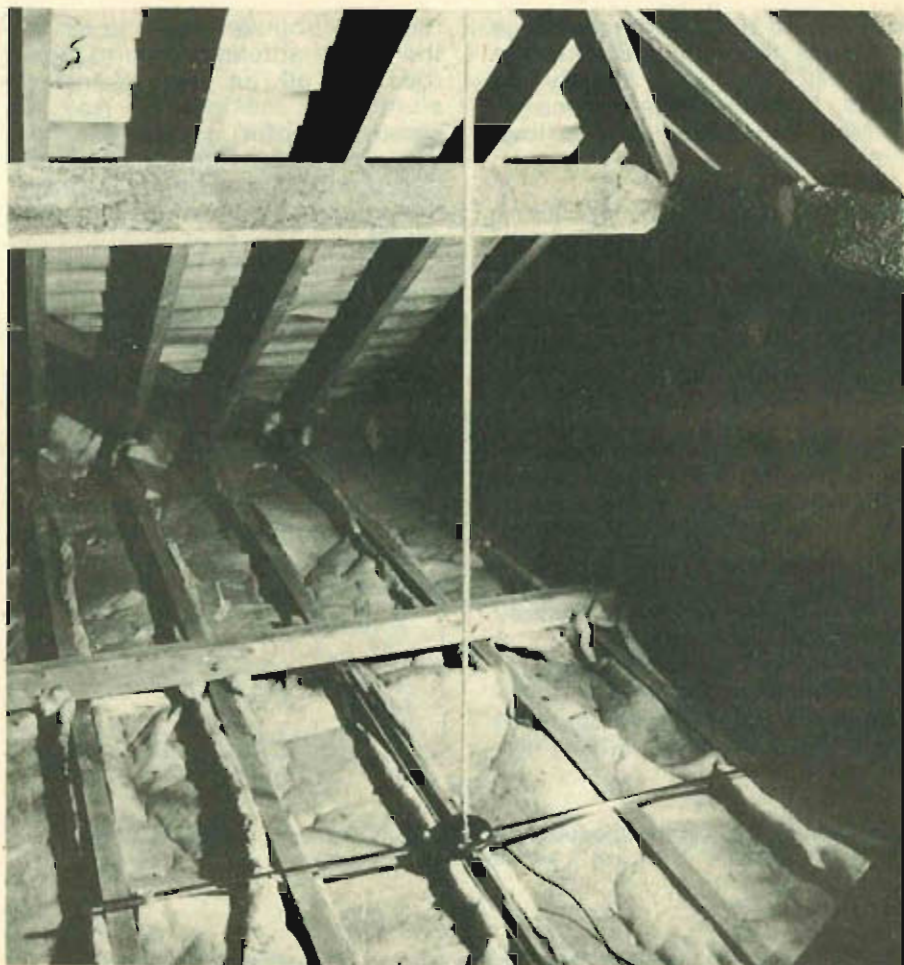

The Firestik Macho Base in position in a loft space.

After this, all that is necessary is to connect the coaxial feeder to the rig.

Obvious advantages of the Macho-base antenna are its ease of construction and small size, compared with the M-400. It can sit quite comfortably in the corner of a room but its efficiency may be affected by the screening effect of any metal gridding in reinforced-concrete walls. Many breakers prefer to site these Macho-bases in the loft, and this is where we placed our test model.

Macho test

In the test set-up we used, the M-400 was mounted on the 21 foot pipe, as described earlier, attached to the side of the house. The radiating element was at roof level. We placed the Macho-base in the centre of the loft space of the house. Coaxial feeders from both antennas were taken to the ground floor of the house, and connected to the two inputs of a

Defender TS-1, a combined VSWR (voltage standing wave ratio), power, modulation and antenna matching unit. (The Defender, from Shakespeare Electronics and Fibreglass Div., enables a transceiver to be switched between two antennas.) The test rig was run from a regulated supply, and had an RF power input of 3.4W.

A carrier was fed to each antenna, and transmissions were made on channel 5 (27.015 MHz) and channel 33 (27.335 MHz).

With the antennas matched-up for lowest VSWR, transmissions were monitored from a mobile rig at positions determined more from signal strength than distance.

The surprising outcome of these tests was the similarity in results. Differences of up to 11 dB at ½ mile range were recorded on the mobile test rig (biggest difference occurring at the higher frequency), but at around 2 miles the results were within 1 dB. We had no op-

portunity to test maximum range or assess radiation patterns. (As many of you will already be aware, the 'skip' interference on 27 MHz can easily swamp low-level signals!)

Which is best?

Final choice between the two depends largely on which you could accommodate and afford! Independent reports received on the Starduster M-400 have been very encouraging, and it was noticed that, at the base station, a definite boost in the incoming signal strength took place when switching over from the Macho-base to the M-400. But it does require mounting methods similar to those described earlier and, with a length of 18 feet, it is a very conspicuous antenna!

Some reports have been received on the Macho-base, particularly with regard to the apparent small size of the ground-plane ele-

ments. A popular trick is to mount the whole antenna, ground-plane rods and all, on a large area of aluminium cooking foil (say 30 square feet of it), spread out over the joists in the loft. We didn't try this, but it was claimed to improve the antenna's performance significantly.

A word about VSWR. I mentioned earlier that both antennas were matched-up on the Defender. This unit (which will be reviewed in a future issue) does an admirable job, but costs around £40. Supposing you fed the antennas straight into your rig without any matching?

We measured the unmatched VSWR of both antennas at the two spot frequencies, and it came out as follows:

Antenna	Channel	
	5	33
M-400	1.49	1.2
Macho-base	3	2.7

Right. Close up detail of the Starduster 'business end'. We're not too sure what the tri-lobal 'thingummy' is for but it certainly looks impressive.

Below. Mounting the Starduster to the side of a house. The batten shown fixes the Starduster to the fascia panel below the guttering.

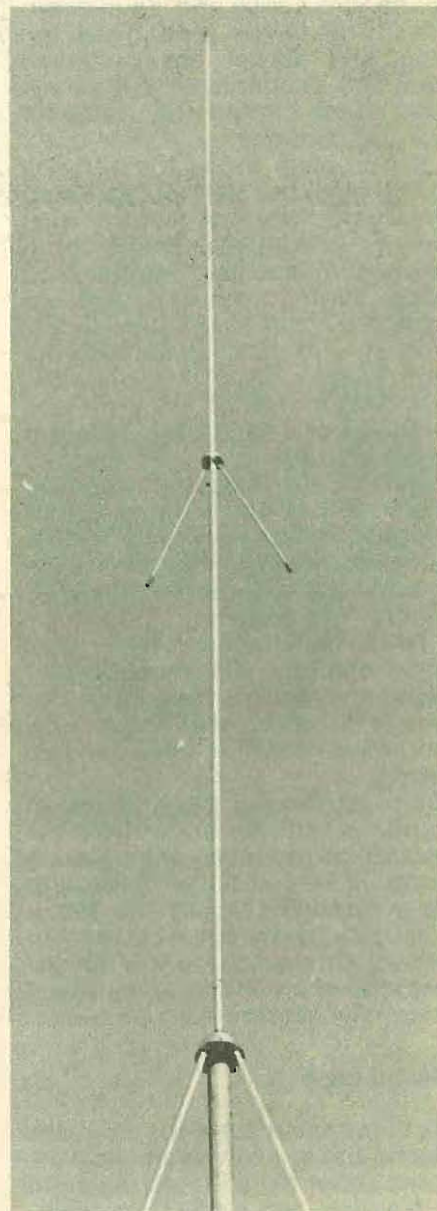
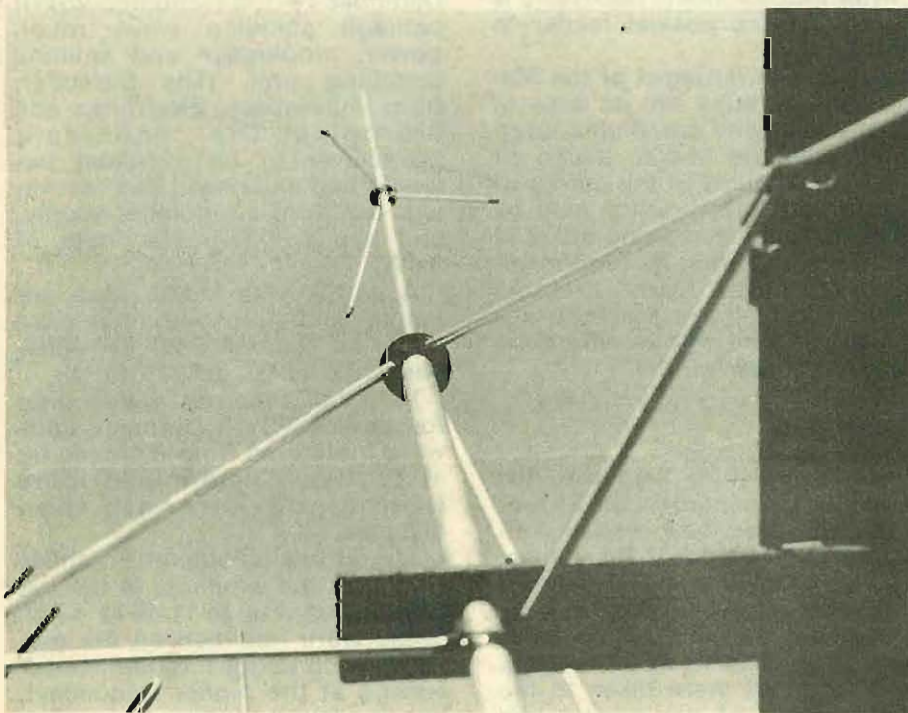

The significantly-worse figures for the Macho-base may have been the result of the long feeder we were using (although roughly the same length was used for the M-400) but, more likely, the antenna itself was in need of adjustment. (Details of how to do this are given in the literature.)

We would like to acknowledge Wintjoy Ltd., of 103 High Street, Shepperton, Middlesex for its assistance and loan of the antennas and equipment described in this article. Prices for the antennas were given as £24.75 for the M-400 and £31.50 for the Macho-base. (These prices are exclusive of VAT.)

CB

See your 'Handle' in print!

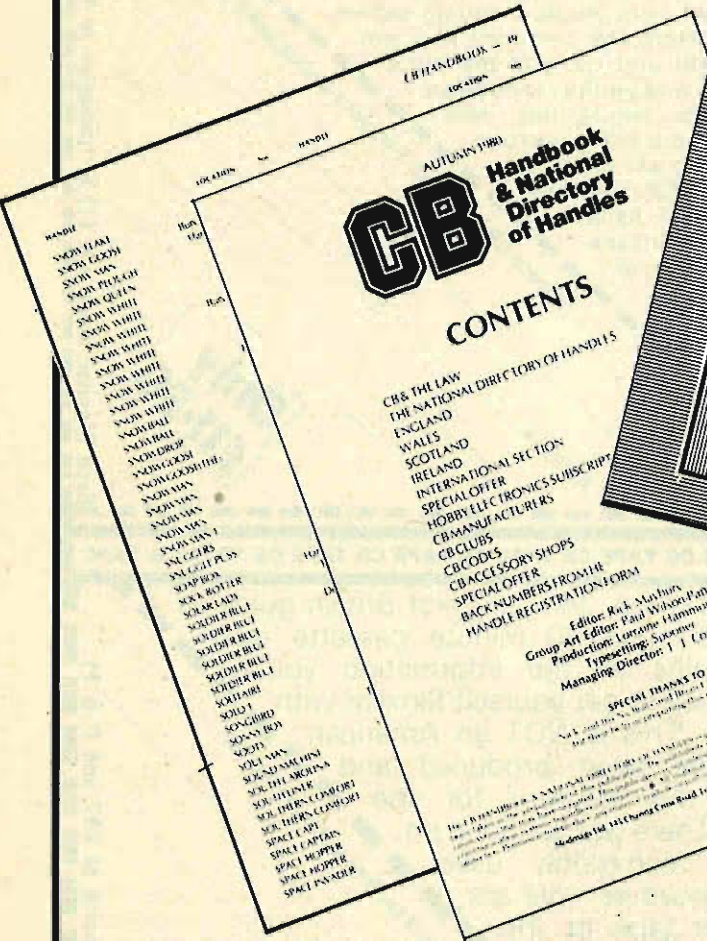
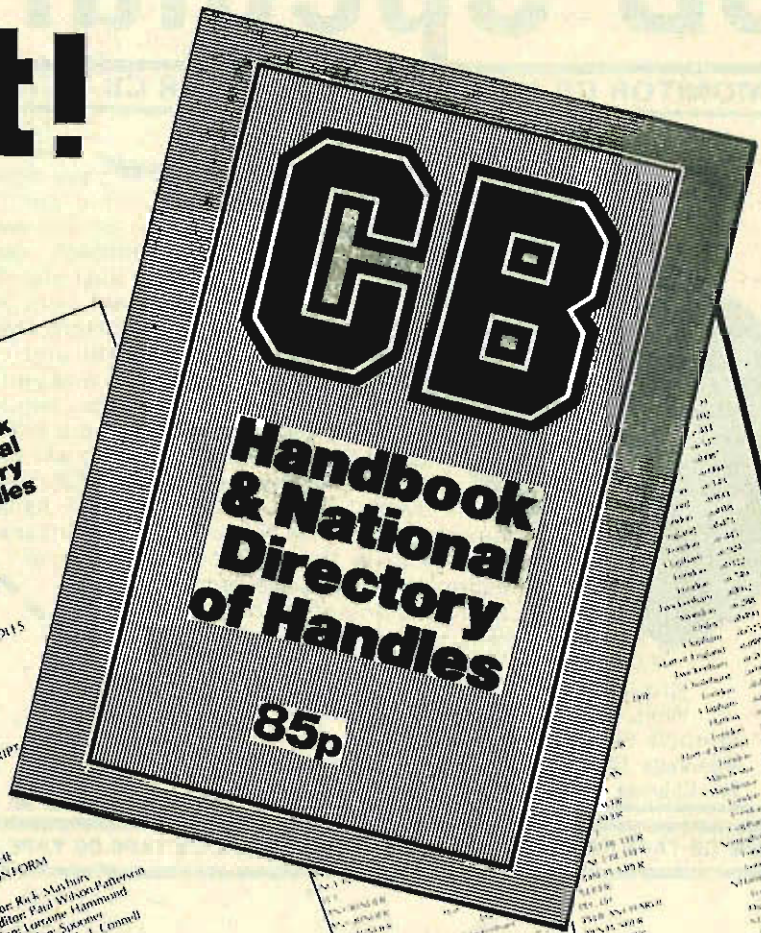

Did you send in your Handle for registration? If you did then you'll be glad to know that the CB Handbook & National Directory Of Handles is finally ready. Even if you missed the first edition it's not too late because inside the Handbook you'll find a registration form enabling you to get your Handle into the second issue and remember this is absolutely FREE.

Apart from the Handles Directory each Handbook contains hundreds of useful hints and tips as well as scores of addresses for clubs and CB manufacturers.

Each copy costs just 85 pence to personal callers or £1.00 inclusive of post and packing.

This is a strictly limited edition. To avoid disappointment place your order today.

Please send me..... Handbook(s).
 I enclose a cheque/Postal Order for £.....

Name

Address

Send this form, together with your remittance to:
 CB Handbooks, Modmags Sales Office, 145 Charing
 Cross Road, London WC2H 0EE.

Please allow 21 days for delivery.

CB Special offers

CB MONITOR CB MONITOR CB MONITOR CB MONITOR CB MONITOR CB MONITOR

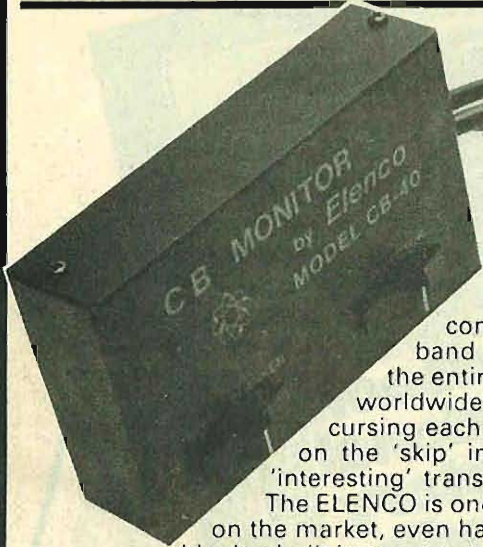

LEGAL CB, right, that's got your attention, now we can tell you all about this month's Very Special Offer.

For just £11.50 (all inclusive) you can be the proud owner of one of these ELENCO (no rubbish 'ere mate!) CB Monitor Converters. Just slip the plug from your existing car aerial into the appropriate socket, plug the lead from the unit into your car radio aerial socket and connect the black wire up to +12 volts and you're ready to go. The eight transistor circuit has now converted your AM car radio into a narrow-band Short Wave receiver. It will tune over the entire 40 channels used by CB networks worldwide. Thrill to the sound of Italians cursing each other, listen to the Americans on the 'skip' in the evenings, all sorts of 'interesting' transmissions may be heard! The ELENCO is one of the best converters on the market, even has a switchable noise blanker built in to cut out the irritating background hiss.

Well, what are you waiting for? Fill in the coupon today.
Modmags (Sales Office) Ltd.
 145 Charing Cross Road, London WC2H 0EE

Please send me.....

Name.....

Address.....

Elenco CB Monitors. I enclose a cheque/PO for.....

Only £11.50

Each Monitor costs just £11.50 (inclusive of VAT and P&P)

CB TAPE CB TAPE CB TAPE CB TAPE CB TAPE CB TAPE CB TAPE CB TAPE CB TAPE CB TAPE CB TAPE CB TAPE

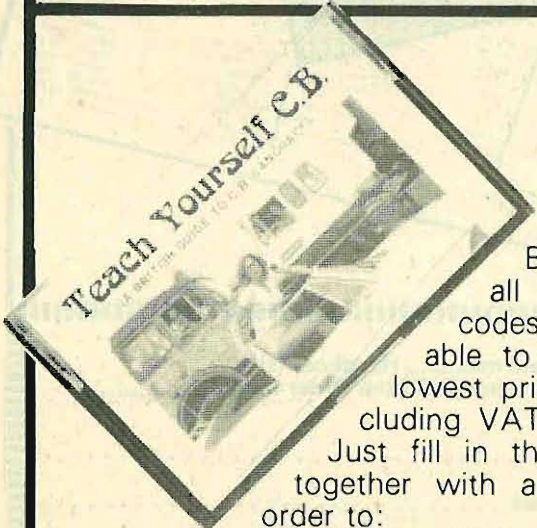

At last, the very first British guide to CB. This 40 minute cassette tape contains all the information you'll ever need to get yourself familiar with CB radio. This is NOT an American tape, it has been produced and recorded in this country for the British market. There are sections on all of the most commonly used codes, slang and procedure. We are able to offer you this tape at the lowest price possible, just £2.75 including VAT, postage and Packing. Just fill in the form and send it, together with a cheque or postal order to:

Modmags Ltd (Sales Office)
CB Tape Offer
 145 Charing Cross Road
 London WC2H 0EE
 Please allow 21 days for delivery.

Please send me.....

Name.....

Address.....

CB Tapes. I enclose a cheque/PO for.....

£2.75

Each tape costs £2.75 (inclusive of VAT and P & P)

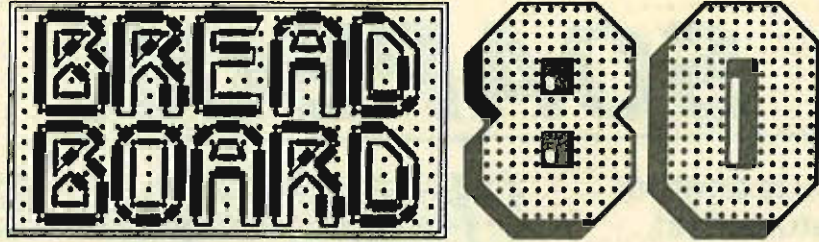

COMPONENTS DEMONSTRATIONS SPECIAL OFFERS MAGAZINES BOOKS



It's all at Breadboard '80

This is **the** exhibition for the electronics enthusiast. From November 26 -30 there is only one place in the universe for the electronics enthusiast to be — Breadboard '80, at the Royal Horticultural Hall in London. The majority of leading companies will be exhibiting, including all the top monthly magazines in the field. There will be demonstrations on most stands and many feature special offers that are EXCLUSIVE to Breadboard!

All aspects of this fascinating field are catered for, from CB to home computing, so whether you want to buy a soldering iron or a synthesiser — or just keep up to date with your hobby — don't miss Breadboard '80.



Royal Horticultural Halls
 Elverton Street
 Westminster London SW1
 November 26-30 1980

26th Nov — WEDNESDAY — 10am-6pm
 27th Nov — THURSDAY — 10am-8pm
 28th Nov — FRIDAY — 10am-6pm
 29th Nov — SATURDAY — 10am-6pm
 30th Nov — SUNDAY — 10am-4pm

Send to: Advance Tickets, Madman Ltd, 165 Chancery Lane, London WC2H 0LL

AVOID QUEUES — GET ADVANCE TICKETS

Please send: tickets @ £1.00 (Student/Child/DAP)

tickets @ £1.50

Enclose P.O./Cheque for £

CB SOAPBOX

CB Soapbox is another regular feature that will allow anyone to publicly voice their opinions. Our first contributor is no less than Keith Townsend. If you would like to have a go then write to us at the address on page three and mark your envelope 'CB Soapbox'.

During the last couple of years an ever-growing section of the motoring public has discovered a new sport. Bored with evading radar traps and cursing traffic wardresses they have turned to the thrills of 'meany' dodging.

Originally imported from Europe, this pastime has become uniquely British as, one by one the various European governments have accepted CB as a legitimate form of communication.

The rules of the game are pretty simple. The first thing a would-be player has to do is to equip his car with a Citizens Band radio transceiver and a suitable antenna. Thus kitted out our hero must select a code-name or 'handle' by which he intends to be recognised by other players. Before entering the game in a full role he must have at least a working knowledge of the phraseology common to all initiates. (Shades of the Brownies?) Now he may enter the game proper by climbing into his car and driving around discussing all manner of things with his fellow players, known to one and all as 'breakers'.

Any game worth the playing must include an opposing team and this game is no exception. The breakers' opponents, drawn mainly from the ranks of the Post Office, who, in the main, enjoy the



challenge which the sport provides. Faced with the almost impossible task of trying to be everywhere at once the aim of these gentlemen is to win the game by capturing our hero and separating him from his little black box. The rules are weighted in favour of the Post Office team, known to all players as 'meanies' or 'breaker takers', in that they may call up reinforcements from HM Customs and Excise and even the local village bobby.

Having effected their capture the meanies take the vanquished CBer to see the referee, in the form of the local magistrate, whose task is to set the level of the forfeit (more shades of the Brownies?) that the loser must pay. Dependent upon the degree of sympathy the hapless individual can extract from the magistrate the forfeit may be a mere conditional discharge or, if he is less fortunate, he may find himself with an empty piggy-bank as well as the loss of his radio under that section of the rules which says that a penalty must be paid merely for owning the goodies needed in order to play the game.

This light-hearted appraisal of the current status of Citizens Band radio, whilst not entirely representative of the facts, shows how a sort of sub-culture has developed

around what, in more enlightened countries, is seen as a healthy pastime and a useful emergency aid.

The most unfortunate effect of this cat and mouse game is that the true potential of public communication has not been realised.

Imagine for a moment that you are stranded on a motorway with a simple broken fan-belt. It is late at night and the weather is dreadful. Under current law you have two choices. You can either stay in your car until the rain stops or face an uncomfortable walk to the nearest phone, fervently hoping that it works when you get there.

Now imagine yourself in a similar predicament in a country which permits everyone the use of radio communication. All you now need to do is inform someone else of your difficulty for a message to be passed to the appropriate rescue service. Soon you can resume your journey with the minimum of discomfort.

In America, the home of Citizens Band, its introduction was viewed with the utmost suspicion by various police forces who feared that its only benefit would be to the criminal classes, whose nefarious schemes would come to fruition more easily through their increased ability to communicate. These fears soon proved groundless and today the majority of American police forces equip their patrol cars with CB in the knowledge that better contact with the motorist means greater road safety.

One American police chief has stated publicly that '3,000 accidents per year just don't happen now that we've got CB'.

Social Need

Besides having its serious uses CB fulfils a worthwhile social function. Simply stated it is fun. It makes no difference whether you are young or old, fit or ill, all you need is the strength to talk. You only need to visit a CB club to see that somehow this little black box has totally destroyed the class-consciousness of the traffic-light grand prix. At any mass eyeball you will see Rolls-Royces, Lincolns and Ferraris happily hob-

nobbing with the humble Mini and even the odd motor-bike, while nearby a majestic big-wheeler towers above a gold metaflake Transit designed and adapted with tender loving care by a buddy who would join the Foreign Legion rather than part with his pride and joy.

The first thing that strikes the casual observer as he enters the room is the cosmopolitan atmosphere in which the Rolls owner discusses the best features of the K40 with a couple of truckers while his XYL sips Martini with a beaver in T shirt and jeans. Teenagers and senior citizens can relax and share a common interest.

In time I am sure that the British motorist will come to view CB as the greatest thing since the starting handle (Hey fellas, hows about a campaign for the return of that little gem?) Gone will be the days of the endless traffic jam, the long, slow crawl home because some idiot dug a dirty great hole and forgot to take it with him when he left. Offering to let your wife operate the rig might even give you a rest from the back-seat driving.

Unfortunately these simple pleasures continue to be denied to us. Cat and mouse games are fun for a while but the average CBer waits eagerly for the day when he can announce his 10-20 and arrange an eyeball without the fear that such a small oversight might lead to a distinct reduction in his finances.

Amateur Objections

We've looked at the subject for its entertainment value and for the serious possibilities it can offer. Let's look at some of the reasons why it has not yet found official approval and examine the motives of some of the objectors.

The average R/C modeller may claim a valid objection when in reality his sole objection is to the use of a frequency already allocated to him. Whatever our views on the vagaries of British frequency allocation we must admit he has a point. If I'd spent the sort of money involved in some



models I'd feel like protecting my investment, too.

The radio amateur is a bird of a different colour. Whilst most 'hams' appreciate that CB and amateur radio are two distinct fields there remains a small but vocal group of erudite gentlemen to whom the allocation of any frequency to us lesser mortals would represent a threat to the whole of mankind. 'Gad, sir, it just wouldn't be cricket. What!' Don't spread it around but I have heard it whispered that these worthies meet once a year, at the dead of night on Salisbury Plain, to hold a requiem for the passing of the valve. In dismissing their objections as mere elitist bigotry we should remember that at times they have been obliged to fight for improvements to their own service.

What about the bureaucrats? The faceless mandarins who rule from beneath their bowler hats, through a haze of cigar smoke? Let's not kid ourselves that they really want to see a CB service in this country. The main function of a Civil Servant, as everyone knows, is to drink copious quantities of Government issue tea and the work involved in regulating our hobby could seriously in-

terfere with this important task.

Their masters are, however, beginning to realise that they can't succeed where Canute failed. Since the formation of the All-party Commons Committee we have seen the official attitude undergo subtle but definite changes. A definite 'No' has become a definite 'Maybe' in under twelve months. When you consider just what they were up against this reflects a great deal of credit on the hard work done by Mr Patrick Wall and his boys.

The Establishment is not yet finally convinced of the rightness of our case. Many notables have not yet caught up with what is going on around them. If they don't take their heads out of the sand pretty quickly they will end up with a carbon copy of the Australian situation. If and when this happens perhaps I will be excused if I say 'we told you so!'

The final, and most forgettable body of objectors is the gang of know-alls who claim that the general public doesn't have the sense to use the airwaves in a responsible manner. Funny, ain't it, how this same bunch pop their heads up every time somebody suggests we should enjoy ourselves. The simple answer to their argument is: Give us the chance to show that we're responsible.

Sure there are plenty of cowboys on the air at the moment. They are the inevitable product of prohibition and I'll lay odds that a legal facility would hold few attractions for them. Every serious enthusiast will be glad to see the back of those who claim that CB will no longer be fun once it's legal. These people will pirate any available frequency, just because it's there and many of them make a nuisance of themselves on the amateur bands. They are not what CB is about and it would be wrong to suggest that the majority must forgo their freedom on account of these few.

So where do we go from here? The long-awaited Green Paper has finally arrived and the attendant hullabaloo has died down. All it appears to offer is the vague suggestion that some eminent un-

CB SOAPBOX

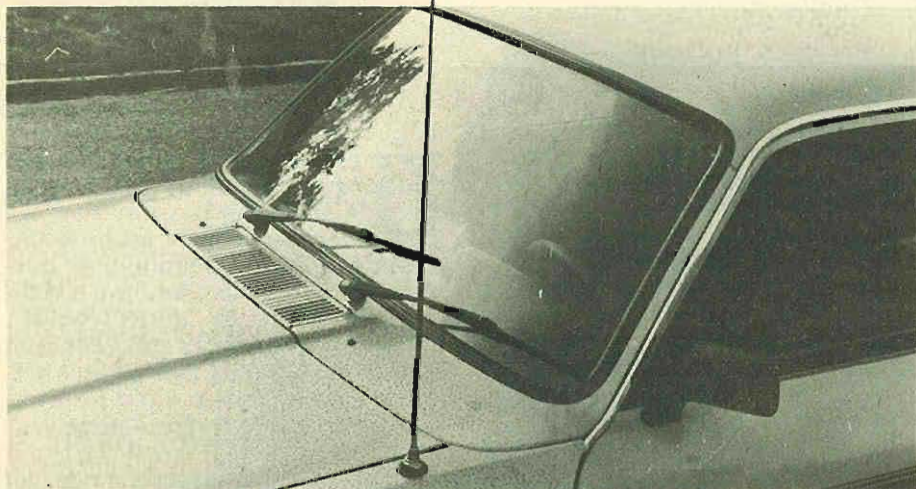

suitable frequency might become our own at some far distant time.

For myself I can only repeat what I said to Mack the Hack after reading the proposals for the first time. Me, I'm gonna buy myself a bloody great megaphone. I reckon I could shout further with it than I could transmit a signal at those sort of frequencies.

Proposals like these can only

have one result. Many of those who have waited patiently for the long-promised legalisation will wait no longer. The sale of 27 MHz rigs will grow even faster than before and the game of spot the yellow van will attract an even larger number of players ready to face the inherent risks in the frustrated belief that this offers the only chance of proving their determina-

tion to achieve their particular freedom. Who knows? Maybe they're right.

Personally I prefer to believe that there is still some mileage to be gained from continued discussion.

The choice is simple. Either we wear them down or we allow them to wear us down. We now command a degree of support that few would have believed possible a few short months ago. Organisations such as the GLC and the Mobile Radio Users Association have been joined by a large number of radio manufacturers eager to reap the benefits of an entirely new market. These are people capable of presenting a lobby that cannot be ignored and their help will shorten the battle.

Like everyone else I was disappointed that the Green Paper offered no quick solution to the problem but I'll keep on fighting just because my pride won't accept that you can't beat the system.

CB

CBs sent by post for £8.25

It's true, in fact the Post Office are helping us by delivering them to your door.

By sending us just £8.25 plus your name and address we'll send you the latest copy of CITIZENS BAND each month for one year. Now there won't be any excuse for missing a single issue just because your local newsagent has sold out.

Fill out the form below and send it, together with your cheque or postal order to:

CITIZENS BAND SUBSCRIPTION SERVICE

**PO Box 35,
Bridge Street,
Hemel Hempstead,
Herts.**

I would like to take out a year's subscription to CITIZENS BAND starting with the issue. I enclose a cheque/Postal Order for £.....

Name

Address

.....

.....

Applies only to UK, overseas and airmail rates on application.

Hobby Electronics

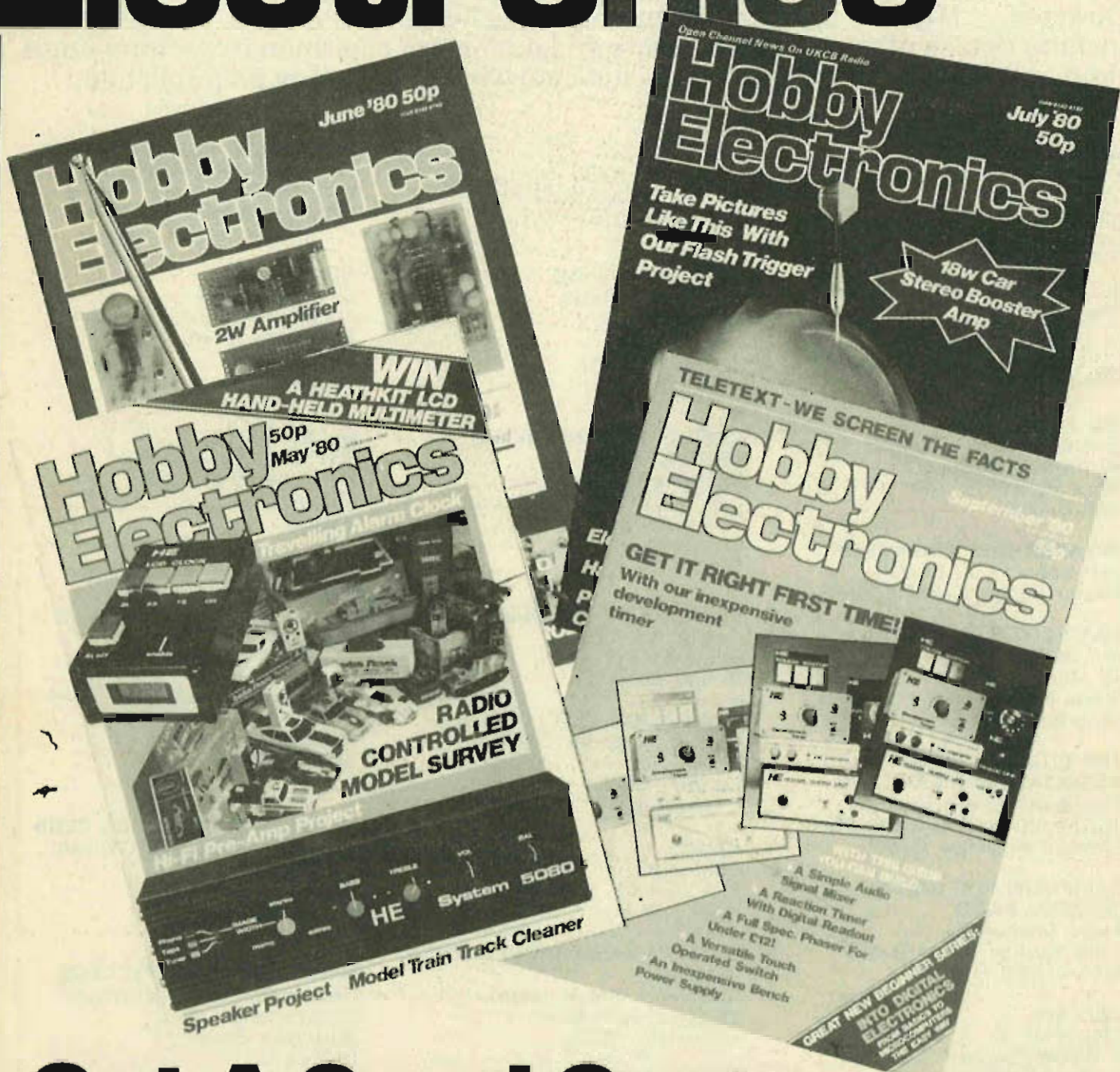

**Get A Good Copy
Every Month**

55p

CLUB DIRECTORY

This club directory is the most comprehensive and up-to-date listing ever published. If your local club has not been included then write to us at: Club Directory, CITIZENS BAND, 145 Charing Cross Road, London WC2H OEE. Please include details of membership, name and address of chairman or secretary plus time and place of meetings. Please indicate which items may be published.

ANGLIA BREAKERS CLUB
C/o Great White Horse Hotel,
Tavern Street,
Ipswich,
Suffolk

BIG EYEBALL BREAKERS
Alan Suleyman,
53 Church Crescent,
Finchley,
London N20.

BIG FOUR CLUB
'Secretary, Steve Barker,
40 Brunswick Square,
Hove BN3 1EF,
East Sussex

BREAKER ONE FOUR CLUB
Secretary: O. K. Corral,
Napier Barracks, BFPO 20

CBA SCOTTISH REGION
Ron Warbrick,
10 Manse Road,
Stone House,
Lanarkshire

THE CITIZENS BAND ASSOCIATION (CBA)
President: James Bryant,
16 Church Road, St Marks Road,
Cheltenham, Glos G151

CAMPAIGN FOR BRITISH CITIZENS BAND
Keith Townsend,
1163 Yardley Wood Road,
Birmingham B14 4LE

CBA SW,
Chairman: D. J. Bennet,
7 Wookey Hole Road,
Wells, Somerset

CBCB CLUB
Chairman: A. Scott Foster,
103 Southwood Road,
Downside,
Dunstable,
Beds.

CBCB
Chairman: Keith Townsend
1163 Yardley Wood Road
Birmingham B14 4LE

CB MUSKETEERS
Pro: J. L. Smith,
61 Gibbwin,
Great Linford,
Milton Keynes,
Bucks.

CHELTENHAM BREAKERS ASSOCIATION
Chairman: John Baxter,
c/o The Crown & Cushion,
Vath Road,
Cheltenham,
Glocs.

CLOG TOWN BREAKERS
Secretary: CBC,
c/o Astley Bridge,
Bolton B4 6PX

CRAIGAVON CB CLUB
Chairman: Steve Cairns,
Room 101,
Country Club,
Craigavon

CB-NE,
Chairman: Ian Morrison,
P.O. Box 61, Sunderland,
Tyne and Wear, SR3 1EZ

CITIZENS BAND RADIO ACTION GROUP
Chairman: Steve James,
55 Dartmouth Road,
Forest Hill SE23

DON VALLEY BREAKERS
282 Eccleshall Road,
Sheffield S11 8PE

EAST ANTRIM CB CLUB
PO. Box 4,
Antrim,
Northern Ireland

EDINBURGH CB RADIO CLUB
Secretary: Jim Martin
22 Ross Gardens,
Edinburgh, EH9 3BR

GBA
Chairman: Bob
Coronation Service Station,
Middleton Road,
Heywood,
Lancs.

GLASGOW CB CLUB
President: Ian Patterson,
147 Trassachs Road,
Rutherglen,
Glasgow

GLASGOW CB CLUB (CBA)
Chairman: Normund Cram,
3 Erskine Road, Whitecraigs,
Glasgow G46 6TQ

GRAMPIAN BREAKERS CLUB
Secretary: R. T. Strachan,
59 Jasmine Terrace,
Aberdeen

HART OF ENGLAND CB CLUB
Secretary: Mrs S. K. Wilson,
58 Clarendon Road,
Hinckley,
Leicestershire

HINCKLEY BREAKERS CLUB
Secretary: Miles Richardson,
8 Gladstone Close,
Swallows Green,
Hinckley,
Leics.

HARROW AND WEMBLEY CITIZENS BAND GROUP
Secretary: Bill Ridgeway,
7 Sandringham Crescent, Harrow,
Middlesex HA2 9BW

KENT & ESSEX BREAKERS ASSOCIATION

Secretary: Charlie,
c/o 24 Mill Lane,
West Thurrock,
Grays, Essex

LAGAN VALLEY CB CLUB

Poste Restante,
GPO,
Lisburn,
N. Ireland

LEICESTERSHIRE CB'ers

Chairman: Crapshooter,
c/o Modern Motoring Ltd.,
68 Narborough Road,
Leicester LE3 0BR

MID KENT CB CLUB

Chairman: Colin McKay,
18 High Street,
Charing,
Ashford,
Kent

MCBRC

Chairman: R. Hopkins,
85 Allens Lane,
Pelsall,
Walsall,
West Midlands

NORTH BIRMINGHAM CB CLUB

Secretary: Bob Barber,
58 Fowlmere Road,
Great Barr,
Birmingham B24 2EA

NORTH COTSWOLD CB CLUB,

23 Green Hill St.,
Stratford-on-Avon

NORTH MANCHESTER CB CLUB

Pro: Blaster Bates,
Belmont Hotel,
Middleton Road,
Crumpsall,
Manchester 8
(Meet alternate Mondays 8pm)

**OPEN CHANNEL CB CLUB,
PRESTON AND DISTRICT**

(Formerly Preston CB Club)
Chairman: F. W. McKeown,
Secretary: S. J. Battersby (address
below)
17 Coronation Street,
Blackburn, BB1 6BS

PRESTON CB CLUB

Chairman: F. W. McKeown,
29 Russell Avenue,
Preston,
Lancs.

**SOUTH BIRMINGHAM CB CLUB
(SBCBC)**

Secretary: R. A. Smith,
14 Delrene Road,
Solihul,
West Midlands B90 2HH

STEEL CITY CB CLUB

Chairman: Alan Taylor,
SSCBC,
P.O. Box 123,
Reading

TELFORD CB RADIO CLUB

Chairman: P. McGuinness,
192 Bishopdale,
Brookside, Telford

10-4 CLUB,

Secretary Ian Leslie,
BN/10.4
London WC1

UNITED BREAKERS ASSOCIATION (UBA)

Chairman: Andy Donovan,
50 Gaskell Street,
Clapham SW4

UBA (ESSEX)

Chairman: Ted Cheneler,
24 Bryony Close,
Witham, Essex

UBA (NE)

Chairman: B. D. Low,
53 Mayfield Avenue,
Lancaster

UNITED KINGDOM CITIZENS BAND CAMPAIGN

Chairman: Bernie Murray,
32 Downbank Avenue,
Barnehurst, Kent DA7 6RP

WEST GLAMORGAN BREAKERS ASSOCIATION

Secretary: G. Bunce,
25 Plas Newydd,
Baglan Moors,
Port Talbot,
West Glamorgan SA12 7DF

THE WEYMOUTH CB CLUB,

Chairman: Ray Howes
39 St Thomas Street, Flat 1,
Weymouth, Dorset

WYE FOREST BREAKERS

Chairman: C. Cox,
19 Chowson Pleck,
Chowson Estate, Droitwich

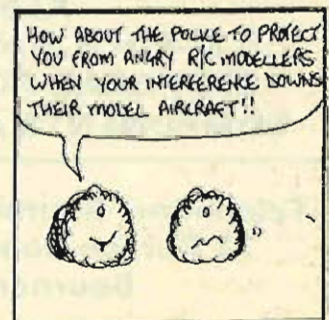
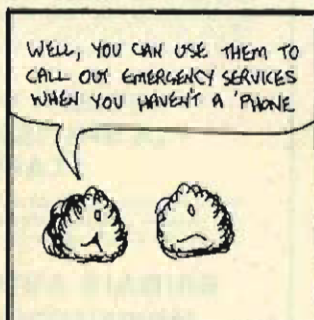
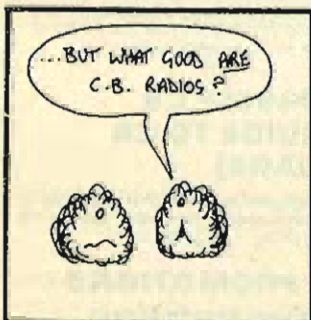



85 Ash Hill Road
Ash, Aldershot
Hants
Tel: 0252 318141

For the finest selection of C.B. accessories at the keenest. Prices call in or contact us between 10.30-6.00 Mon-Sat (closed Wed.)

If we haven't got it — we can usually get it.

We also stock an increasing range of amateur radio equipment and "in-car entertainment"

"SKYWAVE"

FOR

COMMUNICATION ANTENNAS BY H.M.P.



ALSO:

**C.B.-V.H.F. AMATEUR AND
TEST GEAR ACCESSORIES
COMPONENTS AND SURPLUS**

Telephone: Bournemouth 302080
73 Curzon Road, Boscombe
Bournemouth

CALLERS WELCOME

BREAKERWAY

CB Centre

The Future.

NOW!

**The Professional
CB Specialists**
101 Alexandra Road, Newport, Gwent
Tel: 0633-213332
©COPYRIGHT 1980 BREAKAWAY LTD

Teach Yourself C.B.

(A BRITISH GUIDE TO C.B. LANGUAGE)



**GOT YOUR EARS ON? DO YOU
COPY?**

Don't be a 'RUBBERBANDER!' Discover the difference between a 'BEAVER' and 'SMOKEY BEAR' or a 'GRANNY' and a 'FRONT DOOR.' Learn the colourful, crazy language of CB NOW with this educational and entertaining cassette tape. Learn also the more serious aspect of Citizens Band Radio. For example: How to deal with an emergency situation. In fact everything you need to know from choosing a 'HANDLE' and 'BREAKING A CHANNEL' to going 'DOWN THE OTHER SIDE.' Be an 'ACE' in time for legislation THEN join a convoy with confidence.

**TEACH YOURSELF CB
(A BRITISH GUIDE TO CB
LANGUAGE)**

Also included is a reference list of traditional ten code, phonetic alphabet and glossary of familiar phrases. SEND cheque or money order to the value of £2.99 (special introductory price) + 25p P&P to:

BRIDAIR AUDIO PROMOTIONS

BASEMENT STUDIOS, 158 NEW BRIDGE STREET
NEWCASTLE-UPON-TYNE NE1 2TE

Trade enquiries welcome Tel: 0632 22331 Allow 28 days for delivery



CBCBCB

**ACCESSORIES ACCESSORIES
LARGEST STOCKS IN THE MIDLANDS
WHOLESALE + RETAIL
SUPPLIED**

YES, WE CARRY LARGE STOCKS OF CB Equipment including over 50 TYPES of ANTENNA, SWRS, BURNERS, SPEAKERS, POWER SUPPLYS, SUPPRESSORS, PRE-AMPS, CABLES, ETC., PLUS LOTS LOTS MORE!!!

★ REMEMBER—We are Direct Importers and therefore can offer the BEST PRICES AROUND

THIS MONTH'S SPECIAL OFFERS

Fully retractable
AM/FM/CB Antenna
with Splitter. **Only £18.95**
3/5 amp Power Supply.
Only £16.95

DV27 **Only £5.95**
Magmount
Antenna
Complete **£8.95**

*** TRADE ENQUIRIES INVITED ***

**EM AUDIO
VISUAL**

27 HOPE STREET
HANLEY
STOKE-ON-TRENT ST1 5BT
Telephone: 0782 273815



THE CB ANTENNA
THAT REALLY "ZAPS"
IT OUT

'Firestik'[®]
ANTENNAS

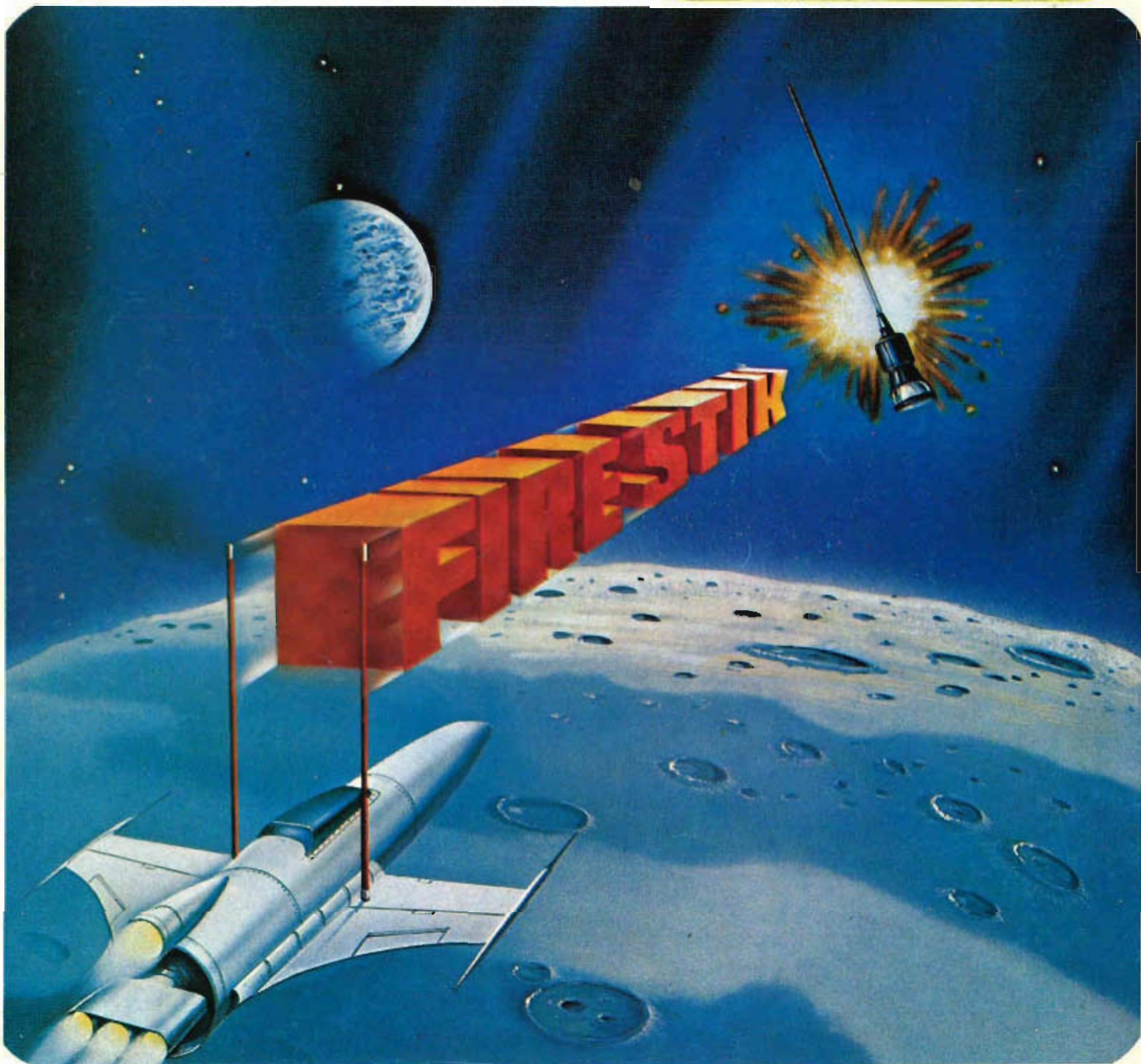

WINTJOY

THE 'CB' PEOPLE

WRITE OR CALL FOR FULL INFORMATION FROM:

WINTJOY LTD

TEL: WALTON ON THAMES
(STD 09322) 48145

103 HIGH STREET
SHEPPERTON
MIDDLESEX TW17 9BL
ENGLAND

See us at Breadboard 1980
26th to 30th November
Royal Horticultural Hall
London SW1
Stand C5 to C10