





"Interactive video games.  
So we can cream my cousin Ralph  
in San Diego at Sonic the Hedgehog.™"

There's been a lot of hype about the information superhighway.  
But for many companies, it's not just hype. They're on the verge of  
delivering broadband services. And we're the ones who are helping them do it.

Only AT&T Network Systems has the total solutions you need to get over  
the formidable hurdles associated with building new networks. From highly  
trained salespeople who understand your business, to the engineering expertise  
of Bell Labs. From planning and manufacturing to installation and service. Plus  
the systems integration to tie in any mix of analog and digital, wired and wireless  
networks and the operations systems to manage them.

And we back it all with the reliability we're famous for.

---

**Thousands of people ready to spend millions  
on new services.**

**(Our total solutions let you deliver, fast.)**

---

The biggest difference is that when you choose AT&T's total solutions  
you know your investment is protected. We bring you products that grow  
with your network. Like the world's only evolvable ATM technology—the  
AT&T GlobeView™-2000 Broadband System. And regional interconnects based  
on SONET and digital compression technology, to accommodate a virtually  
endless stream of new services.

So you can add capabilities and capacity, year after year.

Our total solutions approach is why cable TV, phone and media companies  
in the U.S. and throughout the world have selected AT&T Network Systems to be  
their strategic partner. So don't upgrade or build your network with just anybody.  
After all, people out there are demanding new broadband services. With our  
end-to-end solutions in place, you can start  
giving them what they want right away.

Before somebody else does.

**AT&T TOTAL SOLUTIONS  
MORE THAN JUST EQUIPMENT  
WHAT YOU NEED TO COMPETE**



**AT&T**  
Network Systems

Circle Reader Service No. 1

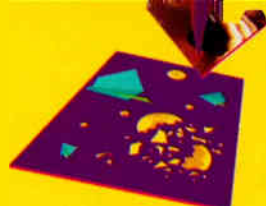

**WHO**

**BUILDS**

**THE MOST**

**COMPLETE**

**RESIDENTIAL**

**BROADBAND**

**NETWORK**

**DELIVERABLE**

**TODAY?**





# ADC. THE HOME





# OF BROADBAND.



**End-To-End Broadband Solutions**  
There's only one company that delivers the complete global end-to-end solutions you need for today's converging world of video, data and telephony. ADC. Our innovative Homeworx™ access platform features today's most advanced hybrid fiber/coax (HFC) architecture plus the flexibility to provide integrated wireline or wireless support for analog and digital video, telephony and data services.

**Systems Engineering Expertise**  
ADC's ability to integrate product solutions gives you single-source simplicity for building or upgrading your broadband network. And our engineering support is with you every step of the way, whether you're bringing service to the home of the future, or to the business of tomorrow, ADC is where you'll find the most flexible, practical broadband solutions. For more information call us at **1 800 366-3891**.

**ADC Telecommunications**

# Innovative Solutions For Delivering Residential Broadband Services.

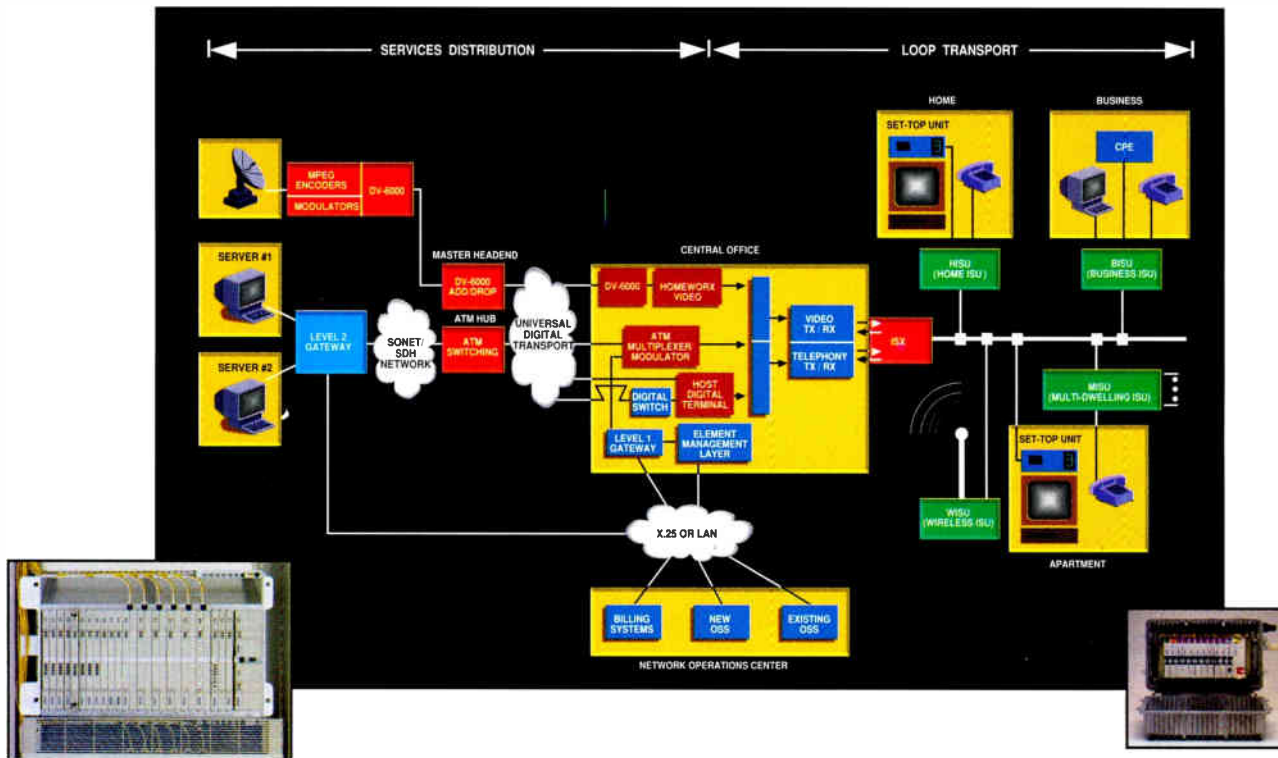

ADC is the leader in the development, design and deployment of residential broadband networks. Whether you're upgrading an existing telephony or video network or building it from scratch, ADC's Homeworx HFC access platform is the most cost effective, end-to-end transport solution available today. With flexible sizing and service components, the Homeworx platform permits a "pay-as-you-go" method of responding to changing technology and market demands.

Maximum deployment flexibility is ensured with the fiber-fed Homeworx ISX integrated services access node. Surrounding the ISX package is the video services node cabinet, an aluminum housing for the RF amplifier, power supply, transmitters, receivers and status monitoring modules.



For regional video networks and video trunking, ADC's digital transmission system provides unmatched flexibility. Compatible with the widest range of video formats and scrambling techniques, the

system carries up to 16 channels of digitized, uncompressed video over fiber at speeds up to 2.4 Gbps.

To manage your network, ADC offers a complete suite of broadband service assurance hardware and software. These systems integrate seamlessly into any service environment.

And the software-based, centralized administration and management system also improves performance, allowing preemptive responses to problems before they impact users.

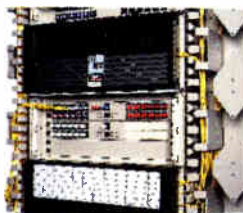

ADC's high performance video signal distribution coax interface products provide critical test and access points for broadband and baseband RF transmission signals.

Committed to innovative practical solutions, ADC is the home of broadband. For more information on end-to-end solutions for residential broadband services, call us at 1 800 366-3891.





With a majority of the regional Bell operating companies now confused over how to rebuild their networks to support video, many in the cable TV industry are taking a collective sigh of relief. But in California, there's going to be precious little time to breathe.



## Poised for competition in California

Pacific Bell is busily constructing a hybrid fiber/coax network in four key regions throughout the state. So far, a lack of a Section 214 waiver from the FCC has the RBOC hamstrung—it cannot hook anyone up to the network or start selling video services yet—but 2,000 people are busy digging trenches and stringing fiber and coax, preparing for the green light.

In many ways, the network will look like a state-of-the-art, 750 MHz two-way cable TV system—but there are some tricks up PacBell's sleeve, courtesy of the fact the RBOC can start its network build from scratch.

For example, broadcast analog channels will be secured via interdiction technology presently under development by AT&T Network Systems. This will allow PacBell to offer most of its channels in the most consumer-friendly method found to date. Interdiction, which jams video carriers to non-subscribing households at the control unit located on the side of the house, delivers the full range of authorized channels simultaneously. There's no need for a set-top (except for digital services), and all TV and VCR features and functions are supported. The impact of this shouldn't be underestimated. Consumers who have been exposed to interdiction love it.

But there's an added wrinkle PacBell has thrown in. Later this year, the company will begin taking delivery of a low-power network interface unit (NIU). Enough intelligence has been built into the unit to allow the network to monitor its performance. If anyone tampers with the device, if the quality of video begins to degrade or if the signal is lost completely, a technician can be dispatched immediately.

But that's not all. Within the NIU is a diplex filter that can be remotely opened and closed. With it, non-interactive subscribers can effectively be "removed" from the return portion of the network, which promises to eliminate most of the ingress problems that plague traditional return systems. When problems do occur, each switch can be polled—a process that takes just 100 milliseconds—until the offending unit is found.

It's true that PacBell isn't saying how much it will cost to build in these improvements. Certainly it will be expensive. But the telco knows that anything less reliable could erode its reputation for high quality service and reliability.

Cable companies had better sit up and take notice. It's difficult to say whether cash-strapped MSOs will be able to compete with anything comparable—and therein lies the danger. What PacBell has engineered is an elegant solution to several vexing problems. Cable TV engineers should pass the word along to their CEOs.

Competition is coming, and it shouldn't be taken lightly. PacBell, at least, knows what it's doing.

Roger Brown  
Editor

## ◆ CED MAGAZINE

### VP Group Publisher

William McGorry

### Publisher

Robert C. Stuehrk

### Editor

Roger Brown, Rbrowner@aol.com

### Managing Editor

Dana Cervenka

### Contributing Editors

Leslie Ellis, Ellis299@aol.com  
Fred Dawson

### CONSULTING ENGINEERS

#### Chairman

Wendell H. Bailey, NCTA VP,  
Science and Technology

#### MEMBERS

Jim Chiddix, Senior VP, Engineering and  
Technology, Time Warner Cable

Stephen D. Dukes, VP Engineering, TCI  
Technology Ventures

David Fellows, Sr. VP, Engineering and  
Technology, Continental Cablevision

Tom Jokerst, Sr. VP, Engineering, Charter  
Communications

Earl Langenberg, Executive Director, Growth  
Division, US West Communications

Dave Large, Principal, Media Connections  
Group

Robert Luff, Chief Technical Officer,  
Broadband Division, Scientific-Atlanta

Pete Smith, VP Engineering, Rifkin &  
Associates

Joe Van Loan, Sr. VP, Engineering, CableVision  
Industries

#### National Sales Manager

Cathy Wilson

#### Advertising/Marketing Manager

Scott C. Snyder, SSnyderCED@aol.com

#### Classified Sales Manager

Tim Reeder  
800/866-0206

#### Assistant to the Publisher

Michelle Pazar

#### Production Manager

Elaine Callahan

#### Art Director

Don Ruth

#### Address

600 S. Cherry St., Suite 400  
Denver, CO 80222  
303/393-7449

#### Circulation Director

Maria Gottlieb

#### Fulfillment Manager

Mary Keane

#### Subscriber services

CED  
P.O. Box 7699  
Riverton, NJ 08077-7699  
Telephone: 609/786-0501  
Fax: 212/887-8493

#### CHILTON PUBLICATIONS

Leon C. Hufnagel, Jr., President  
Donald W. Chestnut, Sr. VP, Ops/Admin.  
Christopher M. Savine, Sr. VP Finance  
Bill O'Brien, Sr. VP Communications Group



# Power To The Cable.



The power of cable is the key that unlocks the mysteries of the Infobahn. It is the power of possibilities. Of seeing a world of opportunities brought into every home through cable. It will be an evolution that will bring forth a sweeping revolution. A renaissance at the speed of light. It is the stuff that dreams are made of. But it is not a dream. It is here, it is now, it is reality. The dawn of the interactive age is upon us. And Motorola's CableComm technology is the empowering force on the horizon heralding this bright, new age.

**CableComm**



**The World Is Cable Ready.**



Multimedia Group

Circle Reader Service No. 2

For more information and a free Power To The Cable poster, call 708-632-3409.

Motorola and  are registered trademarks of Motorola Inc. CableComm is a trademark of Motorola Inc. ©1995 Motorola Inc.





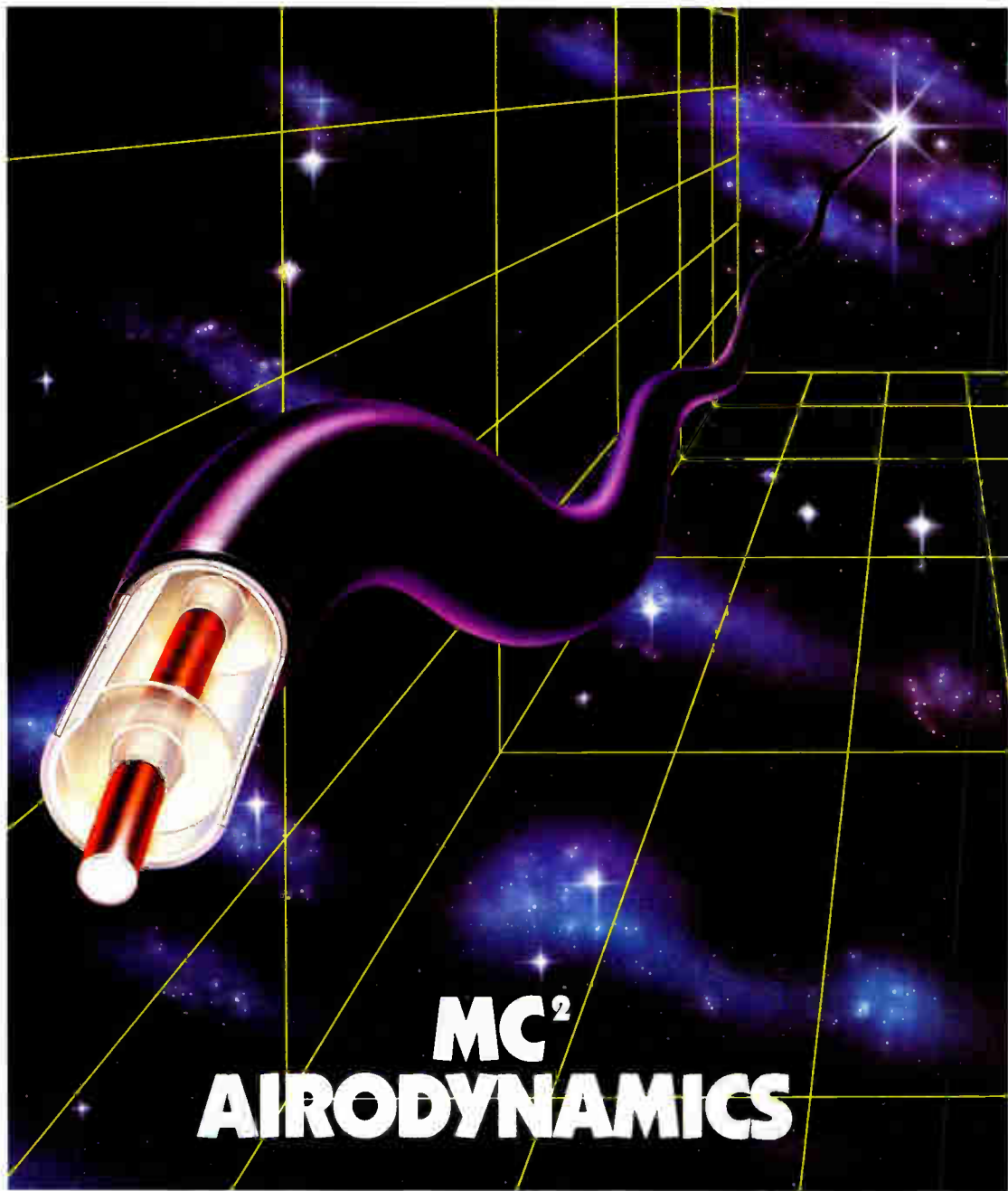

# MC<sup>2</sup> AIRODYNAMICS

## Perfection in Dielectrics.

Trilogy Communications built a better coaxial cable – MC<sup>2</sup> – and the CATV industry is letting us know about it.

The MC<sup>2</sup> air dielectric combines excellent product durability and flexibility with air-tight fully-bonded construction. Our 93% velocity of propagation provides the purest signal over the longest distance – fewer amplifiers

means immediate savings.

All this plus the highly respected Trilogy program of delivery and service provides our customers with the attention and performance that are second to none.

Our most prized dynamics are your acceptance of our best effort so far – MC<sup>2</sup> air dielectric coaxial cables.

QUALITY  
TECHNOLOGY  
SERVICE



Circle Reader Service No. 3

# Trilogy

COMMUNICATIONS INC.

Call or write for our free sample and brochure: TRILOGY COMMUNICATIONS INC. 2910 Highway 80 East, Pearl, Mississippi 39208  
800-874-5649 • 601-932-4461 • Fax: 601-939-6637

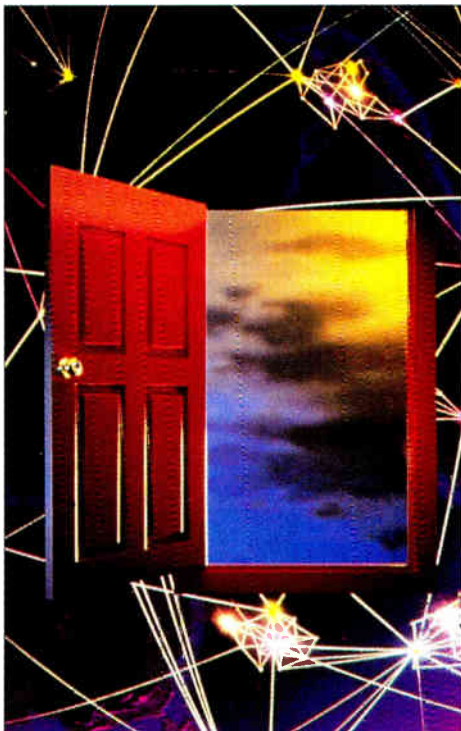

## 30 Opening the door to interactivity

By Roger Brown

Although there has been an explosion in the number of companies designing set-tops, the promise of true, digital interactivity has yet to be realized—and may still be years away.



*CED magazine is recognized by the Society of Cable Telecommunications Engineers.*

## FEATURES

### 40 CDMA for HFC

By Gihad Ghaibeh, Ericsson-Raynet Corp.

Code Division Multiple Access (CDMA) may be an alluring option for combating problems with the upstream path, but does it work in HFC networks?

### 54 Backbone of interactivity

By Ed Means, CableData

A sophisticated operational support system (OSS) will be required to manage the transaction complexity of interactive broadband networks.

### 60 PCs rule?

By Roger Brown

This Q&A with Avram Miller, vice president of corporate business development at Intel Corp., presents an alternative interactive future, one in which the PC will control the home.

### 64 Training for interactivity

By Dana Cervenka

With Time Warner's launch of its Full Service Network, the MSO has established a training program to make sure that technicians and installers are schooled not only in the technological "how" of interactivity, but also the business case "why."

### 1995 Frequency chart

By CED staff

Special with this issue is the annual Frequency Allocation Chart, which can be used as a handy wall reference.

### 74 Telecom Perspective

By Fred Dawson

Although some telcos seem to be backing off on the deployment of hybrid fiber/coax, Pacific Bell and SNET are charging ahead with broadband plans.

### 79 1995 salary survey

By Dana Cervenka

What do the industry's technical personnel fear the most? Being gobbled up by bigger fish. CED's annual salary survey presents a picture of what life is like for engineers, technicians and technical management.



## About the Cover

Photo courtesy of the St. Louis Convention & Visitors Commission.

## DEPARTMENTS

5 In Perspective

12 Capital Currents

14 Color Bursts

18 Spotlight

20 Frontline

22 Farmer's Market

24 FiberLine

66 Back to Basics

76 Ad Index

84 Product Showcase

87 Return Path

89 In the News

90 What's Ahead

92 New Products

94 Classifieds

100 My View

◆ ◆ ◆  
 ©1995 Capital Cities Media, Inc. All rights reserved. CED is a registered trademark of Capital Cities Media, Inc. CED (USPS 330-510) (ISSN 1044-2871) is published monthly except twice in May by Chilton Publications, A Capital Cities/ABC Publishing Group, 825 7th Ave., New York, NY 10019. Volume 21, Number 3. U.S. domestic subscriptions are \$48. Outside USA, subscriptions are \$69 for surface delivery or \$96 for air speed delivery, prepaid in U.S. funds drawn on a U.S. branch bank. Second-class postage paid at New York, NY 10019 and additional mailing offices. CED is published on behalf of the cable television and broadband communications industries. POSTMASTER: Please send address changes to CED Circulation, P.O. Box 7699, Riverton, NJ 08077-7699. MEMBERS OF THE BPA. Canada Post International Publications Mail Product (Canadian distribution) Sales Agreement No. 649945. Printed in U.S.A.



## The TVM550 expands bandwidth to make agile modulation hotter than ever.

Standard's TVM450 was a revolution – the first frequency agile, PLL-controlled, broadband heterodyne modulator capable of near-crystal performance without heavy post-filtering.

Now the TVM550 is making agile modulation hotter than ever.

With the TVM550, you get a re-broadcast quality modulator with noise- and spurious-free RF output and ultra-stable, artifact-free agile PLL synthesized tuning anywhere from 54 to 550 MHz. So you can cover a much bigger slice of the broadband spectrum with one device.

And if that's not enough to make the TVM550 sizzle, there's more.

### Talk about integration.

Short on rack space (and who isn't)? The TVM550 is designed to accept the seamless integration of options, including the CSG60 BTSC/MTS stereo generator and automatic high-level I.F. switching. By eliminating separate components for these functions, the TVM550 saves



rack space, external wiring and AC power requirements, and reduces heat generated in the headend.

### A few refinements.

The TVM550 also offers some very refined, practical features to make operations simple and obvious.

Video and RF test ports, a seven-segment deviation meter and BTSC indicator are all conveniently located on the front panel, while preprogrammed FCC frequency offsets are microprocessor controlled for exact system requirements.

The TVM550's advanced circuitry, slim-line design and high level performance characteristics make it the hot choice of cable MSOs.

### Get it while it's hot.

When you add up all the TVM550 can do, it's easy to see why it's becoming a very hot seller. But you don't have to take our word for it. Call us, and we'll send you complete specs and pricing. And if that's not enough to convince you, we'll set it up and show you – in your facility or ours.

Call today. We want to prove the TVM550 is one hot idea where you won't get burned.

*The Right Technology for Right Now.*



**SATELLITE & BROADBAND  
PRODUCTS DIVISION**

P.O. Box 92151 • Los Angeles, CA 90009-2151  
310/532-5300 ext. 280 • Toll Free 800/745-2445  
Fax: 800/722-2329 (Toll Free) • 310/532-0397 (CA & Int'l Only)

Canadian Address: 41 Industrial Pkwy S., Units 5 & 6  
Aurora, Ontario Canada L4G-3Y5  
905/841-7557 Main • Fax: 905/841-3693  
Sales: 800/638-4741

# Hot idea.





## ***A Natural Migration***

Leadership and vision. That's what sets us apart in today's environment of converging technologies. ADC Video Systems is leading the migration to advanced video and telephony network services with a clear vision and solution for your future – all while meeting your most demanding requirements today.

ADC Video Systems offers complete end-to-end solutions in hybrid fiber/coax video/telephony transport and distribution, high speed digital fiber backbone transport, distance learning,

Px64 multipoint videoconferencing, TV1 broadcast quality video and cellular telephone transport.

The flexibility to meet the needs of today's market will ultimately determine tomorrow's success. Whether you're migrating to digital video and telephony services, rebuilding your CATV network, installing state-of-the-art distance learning facilities or building videoconferencing networks, ADC Video Systems has the technology you need. Call us to find out why the future is real. We'll help keep you flying in the right direction.

**ADC Video Systems**

*Formerly American Lightwave Systems, Inc.*

999 Research Parkway Meriden, CT 06450 (800) 504-4443 • FAX (203) 630-5701



# THE FUTURE IS REAL

## The ADC Family of Products

- Homeworx™ 750 MHz Hybrid Fiber/Coax Transmission System
- DV5000™ Digital Video Transmission System
- PixNet™ Multipoint Videoconferencing System
- Network Monitoring and Control System
- FiberFrame™ Fiber Management System
- Soneplex™ DS1/DS3 Transport System
- CityCell™ Cellular Telephone Transport
- FN6000™ TV1 Broadcast Quality Video



Circle Reader Service No. 5

U.S. Sales Offices in California, Colorado, Connecticut, Florida, Georgia, Illinois, Massachusetts, Minnesota, Texas and Virginia. International Sales Offices in Australia, Belgium, Canada, China, Mexico, Singapore, South Korea, United Kingdom and Venezuela.

# Looking through a dim crystal ball



By Jim Farmer,  
Chief Technical Officer,  
Antec Technology Center  
jfarmer@ix.netcom.com

From time to time, I'm asked to peer into my crystal ball to predict the future services that cable will offer, and what operators should be doing to get ready for them. Unfortunately, the thing my crystal ball does best is to obfuscate. Be that as it may, there are a few general things to be said, and hopefully, you'll forget this column before I'm proved wrong.

The industry seems to be shifting its expectations for digital compression to the home a little. The technology is just about here and will work, but the cost is higher than people expected, and there are questions about the digital readiness of in-house wiring. Some manufacturers continue to develop digital set-top convertors, and others are proposing boxes on the side of the house to convert high density modulation such as 64 QAM to other modulation formats. The philosophy is that home wiring will work better, and multiple digital services will be cheaper to offer. We need both approaches for now, in order to find out what will best serve in the future.

The trend to smaller nodes in hybrid fiber/coax systems is valid no matter how fast compression to the home catches on. Most people seem to be designing for carrier-to-noise ratios in the very high 40s (51 dB is the record

we've heard), which can be done with HFC networks. And 750 MHz seems to make sense in most places, regardless of what you believe about the near term future of digital to the home.

## Protecting the return

The return band is the most interesting portion of the spectrum right now. With telephony, data, interactive games, energy management (again), switched video services and more, we expect to see activation of the return plant soon. The home seems to be the most common point of ingress into the return plant, with the drop coming in second. If you can protect the plant from ingress in the home and drop, you will have a clean plant capable of handling a lot of return data.

Protecting the plant from the dastardly things that happen in the home may mean high pass filtering at the ground block, which has implications for return services originating from inside the house. For this and other reasons, we see a lot of interest in network interfaces located on the side of the house. The best bet for keeping the drop from causing trouble is to use the best cable and the best connectors, applied using the best techniques. Do this when installing or replacing drops. This practice will pay, not cost.

A couple of things don't seem to work for the future. Many sweep systems interfere with digital sig-

nals, and there is no such thing as sweeping through during the VBI, or sweeping so fast that no one sees it. Return path AGC is out, because it doesn't work with a lot of signals, many having requirements to control the signal strength at the source.

Headend interconnection has been discussed a lot, and some systems are moving in this direction. Interconnection can be accomplished either digitally or through analog means, or perhaps using a hybrid. Generally, we prefer digital interconnection because of the typically long distances involved and the versatility that digital affords. However, where distances are moderate and quality objectives can be met, using analog for broadcast services may make sense.

For digital interconnection, there is a choice of proprietary digital systems or a standard called Sonet. Sonet is an acronym for Synchronous Optical Network, a standardized method for transporting digital signals on optical fiber at speeds up to 2.4 gigabits per second, with faster speeds coming. While Sonet equipment is initially a bit more costly than is proprietary equipment, you can do a lot more with a Sonet network. It can handle telephony, data and video.

## Equipment management

Headend space requirements are increasing. You may be adding more equipment to accommodate more channels, and as you add services such as telephony and data, you must add headend equipment to support them. And power. And cooling. In the future, not everything will fit into 19-inch racks.

When you add telephony equipment, you may find yourself dealing with boxes that are either 19 or 23 inches wide, as high as necessary, but no more than 12 inches deep. The telephony and cable industries have developed different philosophies regarding efficient use of space: telephony considers height of equipment to be of secondary importance, while depth is critical because of the traditional layout of telephone switching offices. Their equipment can't exceed 12 inches in depth, including connections. Both 19- and 23-inch widths are used. Cable, on the other hand, worries about the height of equipment, but doesn't mind if it is up to about 24 inches deep. Only 19-inch racks are used.

Soon you'll be adding operational support systems (OSS), networks of computers which monitor and control subsystems such as telephony. They will report problems up to higher levels of the OSS to generate alarms when something fails or goes out of tolerance. They will also allow a degree of control over the network from a central location. You need these systems if you're to approach the reliability demanded of communications systems today.

Change is coming, but probably not as fast and as radically as some are predicting. Competition is coming, too, and is real. You can handle the changes and the competition, but only if you get better. Courses, independent study and SCTE meetings are all good sources of the training you need to survive. **CED**



# channel Surfing



**New**

## MicroStealth Multi-Channel Testing -- for under \$900



**The Faster, Easier,  
Comprehensive signal level meter  
for cable TV installers.**

**Multi-Featured...** For the first time, installers can check all channels quickly and accurately- ensuring

FCC compliance and reducing subscriber callbacks. MicroStealth's scan mode displays multiple channels simultaneously on a single screen. Plus, measure up to 890 MHz for today's high bandwidth cable systems.

**Easy Viewing...** View the signal levels on a detailed, high resolution LCD display -- a feature, up until now, only available on higher priced signal level meters.

**Easy to Use...** With the press of a single button, cable installers can easily get a snapshot of the system's performance. There is even a one button *Go/No-Go* function so you can be sure you are within FCC compliance on every installation. MicroStealths are lightweight, rugged and water resistant, to withstand the abuse of every-day field use.



**MicroPriced...** The new MicroStealths are yours at unbelievably low prices. Even the enhanced MicroStealth MS1200 with 890 MHz frequency extensions, full scan mode, FCC *Go/No-Go*, and printer driver capability, is about half the price you would expect.

All the accuracy, speed and ease of use at a price you expect from a leader.

**Call 1-800-622-5515**

**WAVETEK**

*Wavetek...partners in productivity for over 25 years.*

©Wavetek Corp., 1995

# PacBell poised and ready to proceed with HFC network; awaits FCC OK

Bell Atlantic and US West may have pulled their applications for Section 214 waivers, and Ameritech may have decided to enter the video business as a cable operator and not a video dialtone provider, but Pacific Bell remains steadfast in its resolve to build a hybrid fiber/coax network and offer it to all content providers.

That was the message offered in late June when the RBOC opened its broadband laboratory to the press and demonstrated how its network, which will offer integrated telephony,

effectively reduced to 100 homes each through the use of signal upconversion—where some return signals in the 5 MHz to 40 MHz band are shifted higher in the spectrum.

Although PacBell will initially roll out set-tops from Scientific-Atlanta, the company intends to ultimately deploy side-of-home network interface units (the NIUs are scheduled to be tested this month) in conjunction with interdiction technology to provide a demarcation point and offer traditional analog video in the most consumer-friendly way possible. This

Within the NIU is a unique switched duplex filter that promises to reduce ingress in the reverse direction and help PacBell troubleshoot the network (see “In Perspective” on page 5). Whenever ingress becomes a problem, the switches can be remotely opened and closed until the offending unit is effectively “removed” from the network (see Figure 1).

Power will be derived from the network, although the NIUs and single-port interdiction units will be powered by the home, Cambron said. The power solution chosen is 90-volt, 1 Hertz. To battle the increased corrosion, PacBell has tested 2,600 combinations of connectors and cable to determine the effects of dissimilar metals coming together. Furthermore, buried cable is going underground in conduits only, Cambron said.

Already, PacBell has 2,000 people on the streets doing walkouts and stringing cable. As of the end of May, the company had placed 5.7 million feet of coax in the air and another 600,000 feet in the ground. It has already passed about 130,000 homes on the way to 500,000 by the end of 1995.

Figure 1: Network interface unit functional diagram

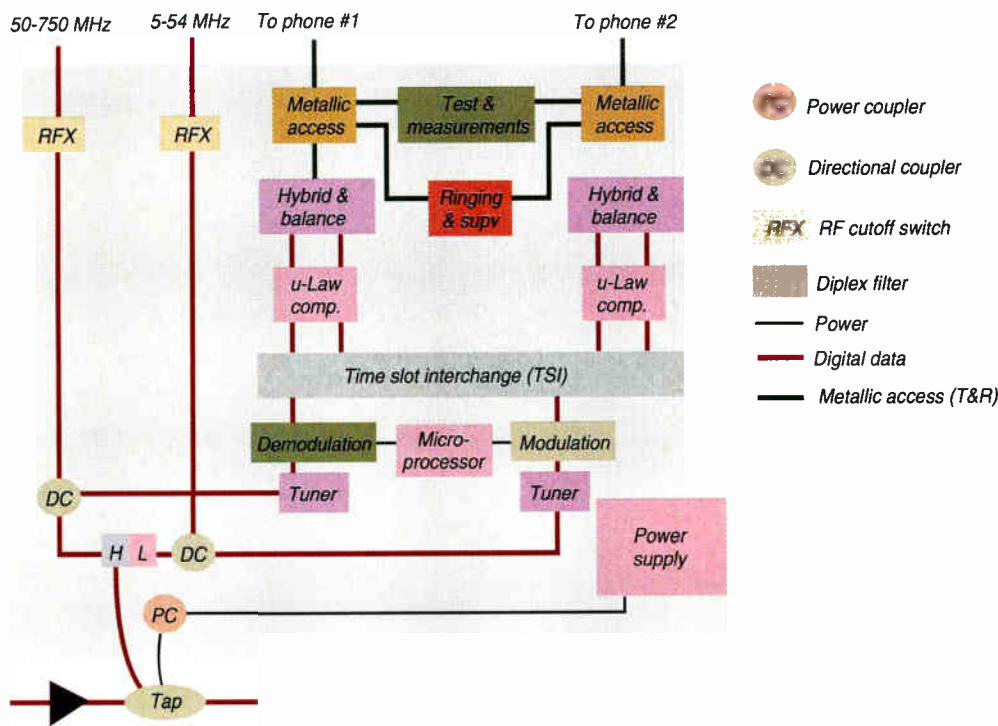

video and data services, works in a real environment. The demonstration was performed over a “closed” HFC network that serves just one node adjacent to the Concord, Calif. lab because the company was still awaiting FCC approval to attach customers to it.

PacBell, which has tied its rebuild business case to operational savings said to amount to \$50 per year per customer, is building a 750 MHz, HFC network with nodes serving 480 homes, on average. With coaxial cable feeding pockets of 125 homes each, the company has a clear migration path when it becomes economically feasible to add more fiber.

In the reverse direction, nodes have been

is in stark contrast to Tele-TV partners Nynex and Bell Atlantic, who once were committed to set-tops and now are focusing efforts on a switched digital solution.

In fact, PacBell hasn't even shared the details of its network design with Nynex or Bell Atlantic, according to Keith Cambron, director of systems engineering and the network's chief architect. Cambron said Tele-TV's main focus is on content development and file server platforms tied to ATM technology. He added that although there have been high-level discussions among the partners, there are fundamental differences in philosophy and motivation.

## Interactive group accelerates practices

Participants in the Interactive Multimedia Association (IMA) have taken some initial steps toward developing common protocols that would allow multimedia data to be shared across different computing platforms.

The first working meeting of the IMA's Interactive Media Forum announced delivery schedules for recommended practices for two major initiatives: Multimedia Data Exchange and Multimedia System Services, both of which are expected to help ease integration of various multivendor interactive information delivery solutions.

Specifically, Multimedia Data Exchange facilitates the development of content by specifying a flexible file container format and framework for implementation by developers that enables data exchange across multiple computing platforms. This document will be submitted to the Society of Motion Picture and Television Engineers for review.

Simultaneously, the IMF reviewed a final draft of the Multimedia System Services' recommended practices, specifying requirements for the synchronization of client/server multimedia, and the separation of media streams to support interactivity over multiple computing platforms. After completion last month, the document was slated to be submitted to DAVIC



# Thanks To Sharon Roberts, The Chair Orders Kept Stacking Up.

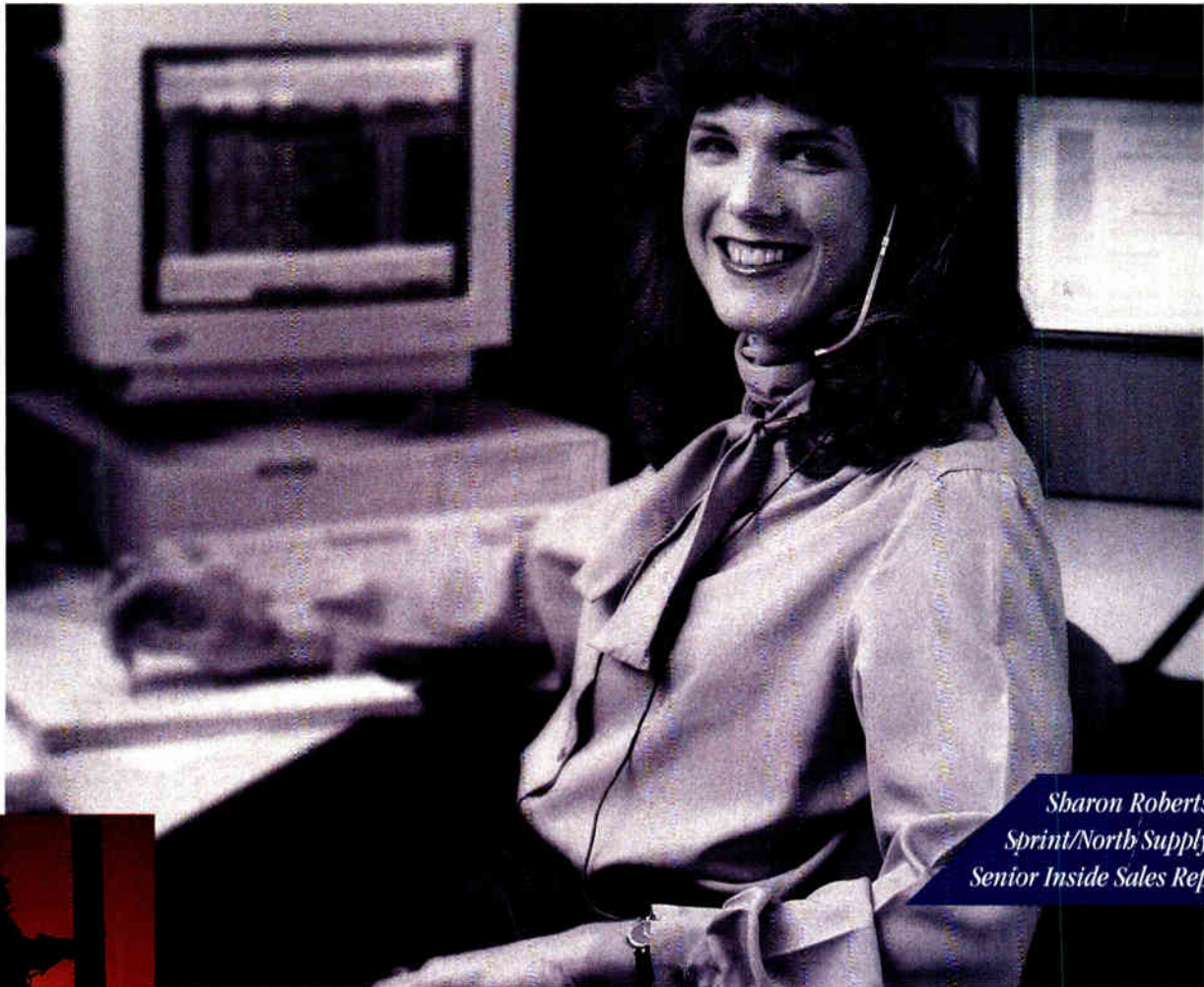

*Sharon Roberts  
Sprint/North Supply  
Senior Inside Sales Rep*



American Cablevision had a seating problem. They had to make an emergency replacement of their data lines to a national stacking chair manufacturer. But it was Saturday – and with business booming, computer downtime was out of the question. So Sharon Roberts, senior inside sales rep at Sprint/North Supply, sat down and worked out a solution.

Sharon coordinated a major weekend maneuver to deliver fiber optic cable to American Cablevision. First she contacted the Sprint/North Supply product manager, who advised her what to order. Then Sharon checked availabilities at our 10 distribution centers across the country and chose the closest one. The distribution center staff found a carrier, who delivered the cable on time for the big weekend replacement.

With the new data lines in place, the chair orders kept on coming – thanks to Sharon's stand-up performance. It's typical of the can-do approach that's an everyday thing for us. So when you need broadband product, call Sprint/North Supply, your full-line national distributor – we never sit down till the job's done right.

FREE SUBSCRIPTION. Call and order your FREE fax HotSheet, with the product and service information you need now. NO OBLIGATION.

**1-800-639-CATV**

On Line, On Call, On Time

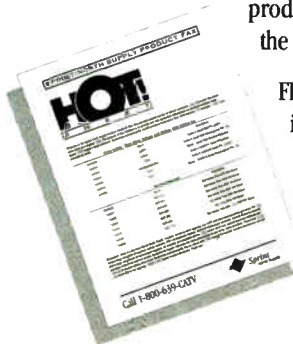

for review and inclusion in that standard.

During the meeting, members also discussed the Parallax Project, IMA's effort to improve consumers' experiences with CD-ROM titles as they hook up personal computers. The attendees discussed recommended practices for CD-ROM developers, a uniform label for CD-ROM packaging and a software program that prints labels consumers can take to retail outlets to help match CD-ROM titles with specific system configurations.

Also, meeting host Digital Equipment Corp. provided attendees with updates on the development of Digital Storage Media Command and Control and DAVIC standards.

## Zing, 3 MSOs agree to distribution deal

Zing Systems has signed agreements with cable TV partners TCI, Comcast and Continental whereby the MSOs will distribute Zing encoded TV signals over their networks. The three powerful operators combined serve 20 million subscribers—nearly 35 percent of the nation's cable TV households.

Zing technology allows producers of television programs to encode interactive data into the vertical blanking interval of any program or commercial. That data is received by a set-top decoder, which passes the info along to a remote control unit. Viewers provide feedback through the ZingDialer, an infrared modem, by simply pushing a button. Content can be recorded on VCRs, and Zing interactive videos can be rented or purchased.

In addition, the three partners have committed to fund the production of the in-home ZingDecoder, the dialer and the handheld remote unit. Furthermore, the agreement allows the MSOs to integrate Zing hardware into digital set-tops (Zing already has agreements with both General Instrument and Hewlett Packard to include the technology in their upcoming set-tops).

The MSOs hope to use the Zing technology to derive additional revenue by rolling out interactive programs and commercials—without having to wait for a new generation of set-top box. It is hoped that consumers will be more likely to actually watch the interactive programs and stay tuned to those networks that run interactive commercials—and actually channel surf, looking for interactive commercials.

Zing already has 12 networks committed to providing interactive programming and additional announcements adding more broadcast and cable programmers to the fold will come out prior to Zing's autumn launch, executives said.

## Studies predict how ITV will take shape

A new research study from Andersen Consulting shows that major communication companies know they'll have to partner with other companies to offer interactive services, but few are confident those partnerships will be successful.

More than 100 chief executive officers from cable MSOs, telcos and other carriers were surveyed in the spring by Andersen.

Ninety-two percent said future "winners" will be a product of partnerships between large companies like themselves and new entrants. But 54 percent thought the long-term prospects for today's partnerships were only "fair," and nine percent said they were "poor." Just 34 percent thought they were good, and just two percent said they were "excellent."

According to Andersen executives, the survey points out the truth of most mergers. Data shows that 50 percent of alliances between large and small firms involved in technology usually survive just four years—typically because the partners have unrealistic expectations.

Meanwhile, a study from Probe Research predicts that operators of networks that offer interactive services such as home shopping, interactive advertising, games and a variety of video entertainment services will reap an average of \$33.64 per month per subscriber the first year, with revenue growing to \$47.24 per month per sub in year seven.

The report predicts that interactive services will initially be driven by video-on-demand and near-video-on-demand services as well as a proliferation of niche channels and info services.

## Clarification

It has long been a policy at *CED* to remove references to commercial products, when possible, from articles contributed by outside authors. However, because of an editing error, several sentences in the story, "Optimizing the return path," which appeared in the July 1995 issue, were incorrect. Here are the corrected passages:

Page 52: "If no test point exhibited a S/N ratio worse than 10 dB for all return signals (it would normally be much better), a single Trilithic 9580 headend unit, for example, could monitor up to 32 fiber receivers with full accuracy. (The test point "manager" built into that unit enables it to analyze signals from each of eight test points individually or as a group.)"

Page 54: "The field unit offered by the authors' company can display sweep data as a

flatness graph compared to a reference, or as calculated values for gain and tilt."

Page 54: "The return maintenance system from the authors' company contains one, but a standalone unit can be used for many of the tests."

Page 54: "The maintenance system from the authors' company has an RF switcher which allows each node to be analyzed individually, and automatically provides the appropriate data to the field units currently working on that node. Essentially, the operator sees the same ingress spectrum that this company's headend unit "sees" and so can observe his own progress."

Pages 54/56: "Fortunately, they do so gradually, so regular monitoring of all return paths for increasing levels of noise or ingress, using the authors' company's headend unit or a spectrum analyzer, will identify problems before they become serious. Remote measurements at unattended headends can be made at intervals using this headend unit or a data logging SLM and reported via phone lines."

*CED* regrets these errors and any confusion or misunderstanding they may have caused.

## Jottings

**BellSouth Interactive Media Services** has chosen to deploy the Cheetah video server from The Network Connection as part of the personal computer services portion of the telco's upcoming video on demand trial outside Atlanta. With the server, consumers will be able to execute PC commands or play computer games over a video network. The server, which supports both data and video transfer, is based on Microsoft's NT server platform and the client/server model . . .

The SCTE has issued a call for papers to be presented at the 1996 Conference on Emerging Technologies, which will be held Jan. 8-10 in San Francisco. The Society seeks papers on digital compression and transmission, telephony, multimedia and future technologies. Abstracts are due by Sept. 1. Fax submissions to 610/363-5898 . . . **The International**

**Telecommunications Union** study group responsible for setting world standards in cable TV unanimously adopted regional standards for Japan, Europe and the U.S., all of which employ 64 QAM technology. The group was chaired by CableLabs President Richard Green and included personnel from Zenith, Ameritech and CableLabs . . . **Samsung Electronics** has licensed DigiCipher II technology from **General Instrument** and plans to develop dual mode MPEG-2/DigiCipher II decompression chips. Samsung last year licensed 64 QAM technology from GI . . . **CED**



# In network monitoring, it's the A.M. of a new age.

AM Communications offers a decade of experience in cable network monitoring. More than 400 AM systems are at work today, under our own name or within the products of some pretty famous strategic allies.

Our new products include not only Echo, a low-cost end-of-line monitor, but also a truly exciting second generation cable network monitoring system featuring easy-to-use OmniVu software. It's a Windows-based, open architecture system that's powerful, rich in

features, and distinctly affordable in price.

AM's total monitoring solutions include hardware, software, and technical service that's in-depth and on time. Please call (215-536-1354, 1-800-248-9004), fax (215-536-1475), or write (1900 AM Drive, Quakertown, PA 18951-9004). And give us the opportunity to do a little crowing

about what we can do for you.



**COMMUNICATIONS**

GUARDRAILS FOR THE INFORMATION SUPERHIGHWAY



Echo™ and OmniVu™ are trademarks of AM Communications, Inc.  
Windows™ is a trademark of Microsoft® Corp.

# Something that happened to LANcity founder and CEO Rouzbeh Yassini about six years ago gave him an inkling of the uphill battle ahead. He was extolling the virtues of transmitting data over the broadband cable network to an audience of university academics when one of them raised his hand. The Ph.D. announced to the assembled audience that the cable TV network was like a sewer system, and was just about as well-equipped to carry data communications traffic.

## Data crusader rails against vaporware



Rouzbeh Yassini

Fortunately for Yassini, he's not easily discouraged. At 37, he heads a company that has grown in five years from zero to \$12 million in gross revenues and which employs 48 people. He crusades for high-speed data connectivity over cable TV, and against those who would promote "vaporware" to the industry and to consumers. For the cable industry, he believes that data—and not telephony—is the industry's goldmine. In his own words, "There is no phone company on the face of the earth which can compete with a cable operator's delivery of data."

Yassini's corporate mission fits well with his personal goals. He believes that creating citywide information networks would help to solve the world's pollution problems by greatly reducing the need for the workforce to commute.

In fact, the company's projects have included tying together an Indiana school district's computers for better operational efficiency; enhancing a private, manufacturing network for Xerox Corp. in Rochester, N.Y.; and linking city departments and networks in Concord, N.H. to a nationwide E-mail network.

### The path to data

A 15-year veteran of the communications industry, Yassini initially came to the attention of his first employer, General Electric, in 1980 when, as a West Virginia University senior majoring in electrical engineering, he helped to create the school's first satellite downconverter. At the time, GE was very interested in DBS, so when Yassini mentioned his senior project during the course of an interview, the company quickly recruited him to work on cable television technology and digital signal processing.

After six years with GE, the president of startup company Proteon Inc. snared Yassini to design and develop LAN products using Token-Ring technology. Ironically, he almost turned the job down because he knew nothing about data. It wasn't long, though, before he not only mastered the art of data communications, but he also began to question why no one had tried to merge data with the broadband cable pipe. And

that question led Yassini to the doors of Applitek Corp., a manufacturer of terminal servers, bridges, routers and gateways, where he would serve as vice president of engineering and direct the company's private data network projects. To fully realize his vision, Yassini founded LANcity Corp. in June of 1990, to extend the reach of local area networks city-wide via the cable plant.

Now, Yassini spends a great deal of time making a case to the industry about the benefits of data. A fear of vaporware, coupled with a search for the right business model, he feels, are holding MSOs back from throwing their energies into data communications. While the difference between "reality and vaporware" will become apparent by the end of the year, says Yassini, there are also regulatory issues holding the movement back, including privacy and data security.

"Because we are trying to build a high-speed private network in the public domain," explains Yassini, "we need regulatory help to make sure that people do not pick up each other's information, just as they would not pick up someone else's mail out of their home mailbox."

### Nurturing new business

On a more personal note, Yassini is afraid that the general business climate is becoming more and more hostile to future cable entrepreneurs. "The model of success that this country has had is falling apart, in the sense of its complexities and market requirements," he laments. However, the industry can help to make capital available to struggling entrepreneurs, says Yassini, and industry trade associations and trade publications could take the lead in recognizing worthwhile new endeavors.

He knows firsthand about the sacrifices entrepreneurs must make to succeed: Yassini puts in 18- to 20-hour days, seven days per week, and penny-pinching is a way of life at his company. "Those sacrifices are very expensive, especially as you get older," he reflects. "You can only do this once in your career, and I am determined to get results." He's quick to point out that he doesn't do it alone, though, crediting a talented, dependable workteam, and his very supportive family.

His family supports his other creative ventures, too. Yassini and his father have started a Christmas tree farm in their picturesque New England backyard, though neither one of them may ever find it in their hearts to part with a single tree.

A nature lover at his core, Yassini also likes to paddle his canoe in the quiet Boxford, Mass. rivers, and wakes up everyday to the songs of cardinals, blue jays and golden finches.

"When you're canoeing, and listening to the birds, you can really see the value of keeping nature exactly as it is," notes Yassini, "letting communication flow through the wire, and keeping people out of their cars." **CED**

—Dana Cervenka





**The AM Series**  
*Standby Power Supply*



**The BPS Series**  
*Broadband Power Systems*



**The APC Series**  
*Non-Standby Power Supply*



**The FM Series**  
*Uninterruptible DC Power Supply*

# The World Leader in Reliable Power



**Enclosures**  
*For Cable Television Applications*



**The CFR Series**  
*UPS Systems for Headend & Office*

**A**s cable television audiences around the world have come to expect reliable service, operators have come to depend on Alpha. The XM Series CableUPS® was the first UPS for broadband applications and has become the world standard for reliable communications powering, including the newest architectures. With a complete line of cable TV powering products ranging from power supplies to Amp Clamp™ surge suppressors and cable TV specific batteries, Alpha provides the world's cable operators with complete power solutions... and peace of mind. For more information, call:

**1-800-421-8089**



**Batteries**  
*Cable Television Specific Batteries*



**The XM Series**  
*60 & 90 VAC CableUPS® Power Supplies*



**The Amp Clamp™**  
*Surge Suppression Product*

*Sales & service offices throughout the world*

▶ **USA & LATIN AMERICA**

Alpha Technologies  
Tel: (360) 647-2360  
Fax: (360) 671-4936

▶ **CANADA & PAC RIM**

Alpha Technologies  
Tel: (604) 430-1476  
Fax: (604) 430-8908

▶ **UK & EUROPE**

Alpha Technologies  
Tel: +44-1279-422110  
Fax: +44-1279-423355

▶ **GERMANY**

Alpha Technologies  
Tel: +49-9122-997303  
Fax: +49-9122-997321

▶ **MIDDLE EAST**

Alphatec  
Tel: +357-5-375675  
Fax: +357-5-359595

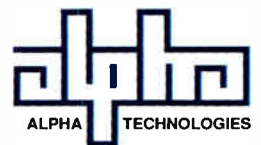

# A feast for the eyes and service, too



By Wendell Bailey,  
VP of Science  
and Technology, NCTA

One thing that most of us engineers have in common is that we eat out a lot. This is good for our taste buds but not so good for our waist lines. This gastronomic burden is due, no doubt, to the amount of travel that is involved in most technical jobs. In my case, the added burden of Washington social events and daily lunches with this or that visiting dignitary also exposes me to more than my share of eateries.

Since I discovered a long time ago that it is almost impossible to dine in a restaurant without overhearing someone discuss cable television, I think that it is only fair for those of us in the cable television business to discuss restaurants, and while we do, let's see if they provide any lessons for the conduct of our own business.

## Here to serve

We (restaurants and cable) are both in the service business. We are capital intensive, with a large part of our expenses going for the consumable items (food for them, programming for us), and we each have to figure out how to attract new customers while hanging on to our existing ones to enjoy a successful run.

In both cases, we depend on a mix of entry-level employees and skilled craftsmen to make it all work, and a

portion of our effort is always wasted on those who do not know what their job is all about, and thus, do not help us satisfy our customers.

## Computerized hospitality

Recently, I discovered two entirely different restaurants in the Washington, D.C. area that pleased me greatly. They both had good food, which was well prepared and fairly priced, and even though the type of food was different in the two places, the feel of the places was quite similar. It took me several visits to each place before I noticed that they both used a service technique where all of the wait persons helped out on all of the tables. No one walked past a customer without looking to see if there was anything that needed to be done.

At first, I thought that this was just a well-trained staff, but then I noticed that the computer system that was used at the cashiers' locations was also used for making notes about the needs of customers at specific tables.

When a service person was heading in the direction of the table so noted, they would make a point of bringing the water or coffee or whatever was needed. The fact that both of these places seemed to be using the same computer program prompted me to ask the

manager of one of them what the program was, and how it worked (everyone knows that engineers are shameless question askers). In the course of the conversation that followed, I discovered that the two restaurants were owned by the same company.

At first I was surprised, but on reflection I realized that the techniques that were used at each place were exactly alike, and that the only differences were the locations and the type of cuisine served. I also learned that the company has three other restaurants in the Washington, D.C. area, and each is completely different in decor, cuisine, style and ambiance, yet each shares the same commitment to a concept known as "team service."

## Changing the menu

What can the cable industry learn from a group like this? One could say that they have found a formula for eating places that produces good results, but that is too pat of an answer. The restaurant business is tough. In a city like D.C., they come and go with alarming regularity. So anyone who has a clue also has something to teach others.

The programs that we choose to supply to our subscribers are like the food that a restaurant serves. The responsiveness that we show to our subs is like the attention that a server or group of servers focuses on a dinner. Could we develop a service technique like "team service" in a typical cable system?

We have certainly made some headway in this regard. The industry-wide customer service guarantee program is one example. The software programs for keeping track of the physical location of service technicians seem to me to be a close analogy to the service concept in use in the chain of restaurants that I mentioned.

New designs for the distribution plant will make it possible for us to "change our menu" to suit our subscribers' changing tastes and expectations. All in all, this is not too different from how one must think about running any service-oriented enterprise.

## The best is yet to come

When all of the competitors who are launching services, and all of the groups that are yet to come are offering to beat our price and beat our service, will we have the staying power that a well-run restaurant has, or will we be like those that come and go?

When I visit companies in our business to talk about the future that we face, I see evidence of the effort and desire that surviving in that game takes. I see new tools and techniques from our vendors; I see new efforts in training; and I see a real commitment to the level of service that we give to our customers.

All of this makes me think that the people that consume entertainment TV will continue to find that we represent a good place to dine.

Just wait until they see what we will be serving them for dessert. **CED**





**GLOBAL  
NETWORK  
POWERING  
SOLUTIONS**

Communication superhighways demand highly reliable powering networks. Power Guard is a world leader in supplying simple solutions to these complex powering issues. Call today to discuss your powering requirements.



801 Fox Trail  
P.O. Box 2796  
Opelika, AL 36803  
800 288-1507  
205 742-0055  
205 742-0058 Fax



# Cable piracy and the schizoid FCC

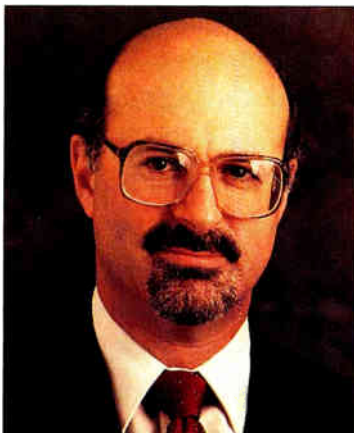

By Jeffrey Krauss, interpreter of techno-babble and President of Telecommunications and Technology Policy

Cable signal piracy is illegal. So you would think that the FCC would have rules against the sale of pirate descramblers. But it doesn't. So FCC staffers made one up. This is the story of Everquest, a company that tried to get an FCC equipment authorization for what appeared to the FCC to be pirate descramblers.

In FCC terminology, cable convertors and descramblers are called "cable system terminal devices" (CSTD), and Part 15 of the FCC Rules contains certain technical specifications that CSTDs have to meet before they can be sold. The specifications are purely technical and don't take usage into account. Part 15 primarily limits radio frequency emissions from the chassis and the output signal power. There are no other FCC Rules that apply to the manufacture and sale of descramblers. Once the FCC reviews the test measurements and issues an equipment authorization to the manufacturer, there are no FCC regulations against the sale of those units.

Cable signal theft is illegal. Section 633 of the Communications Act of 1934 also makes it illegal to manufacture and sell equipment used for cable piracy. But the FCC never bothered to adopt regulations as part of its equipment authorization rules that deal with this.

Because the FCC's equipment authorization rules deal with purely technical issues, a product that meets the applicable technical standards will be granted an equipment authorization, and the manufacturer can start selling it, even if it is likely to be used illegally. The product carries a label saying that it complies with the FCC rules. And who knows, that might be enough to convince a local judge that signal theft isn't illegal because the product is approved by the FCC.

## The Everquest case

Everquest Inc., a Nebraska company, submitted several equipment authorization applications to the FCC. The FCC staff saw that these were component descramblers, not integrated with a convertor but rather connected to it. These devices are known today as "pancakes" and are a typical equipment configuration for cable piracy.

After some correspondence, the FCC learned that these devices were intended to be used in addressable cable systems, but were not themselves addressable. In other words, they descrambled all programming wherever they were installed, so the FCC staff figured something unusual was going on.

In order to avoid granting an equipment authorization to boxes that appeared to be typical pirate pancake descramblers, the staff made up a rule against authoriz-

ing non-addressable descramblers.

By the way, Everquest is appealing. Everquest claims that these descramblers have a lawful purpose, and that distribution could be controlled by marketing them only to small cable systems and approved distributors. Everquest believes it has potential customers among small cable systems that will buy its descramblers because they are cheaper than major brands. We'll see whether any cable systems step forward and testify on their behalf. And I wonder who qualifies as "approved distributors."

The FCC staffers figured out the possible piracy aspect by accident. Everquest revealed more information than was necessary. Nothing in the FCC's equipment authorization rules requires an applicant to disclose whether the unit is addressable or not. Eyebrows were raised initially because the products were component descramblers, as opposed to the integrated convertor/descramblers which are normally used by cable companies. An integrated convertor/descrambler would have slipped through the equipment authorization process, no questions asked. Who knows, maybe some already have.

## FCC policy deficiencies

The FCC staffers may have been morally right in rejecting the Everquest applications, but legally, they were wrong. They simply made up a new policy. FCC Commissioners can make policies and rules, but staffers cannot. The Commissioners might issue a "Declaratory Order" that adopts a new policy or rule, but it would only be issued after interested parties had the opportunity to debate the pros and cons. There was no public debate over the staffers' decision—they simply did it.

The FCC staff is schizoid when it comes to cable signal theft. While this Everquest decision probably helps the fight against piracy, other FCC actions seem to promote signal theft. Most notably, the clear anti-scrambling influence in the May 1994 Docket No. 93-7 First Report and Order on cable and TV set equipment compatibility shows that some FCC staffers would like to eliminate scrambling and have all programming delivered in the clear. Everquest cites this decision in its favor.

And there is the recent Docket No. 95-61 Notice of Inquiry on competition in the delivery of video programming, which seems to push for retail sales of cable set-top boxes without considering the security implications.

The law is clear. Cable signal theft is illegal. But when it comes to policy and rules, the FCC is deficient. We need rules against the authorization and sale of pirate equipment. We need FCC staff to better understand the security risks of prohibiting scrambling, and allowing customer ownership of descramblers. We need a consistent governmental approach to signal piracy, backed by FCC rules and regulations. The law is clear on signal piracy, but the FCC is not. **CED**



# LECTRO

# PUSH IT

*The Lectro ZTT Power Supply Ensures Continuous Power*

# TO THE

*For Your Digital Or Analog Signals...Zero Transfer Time!*

# Limit

**The Lectro ZTT**

**60/90 VAC  
Field Selectable  
NOW AVAILABLE**



  
**LECTRO**  
A AMETEK COMPANY

**800-551-3790**  
Lectro Products, Inc.  
420 Athena Drive  
Athens, Georgia 30603

# A field-installable No epoxy, no polish needed fusion connector

By Rodney Throckmorton,  
Siecor Corp., and Rudolf  
Brugger, Siemens AG

As usage of field-installable connectors continues to increase, the desired performance of these connectors is approaching that of a factory-installed connector. Reflectance performance over temperature is especially important when considering the use of both higher transmission rates and connectors in the outside plant.

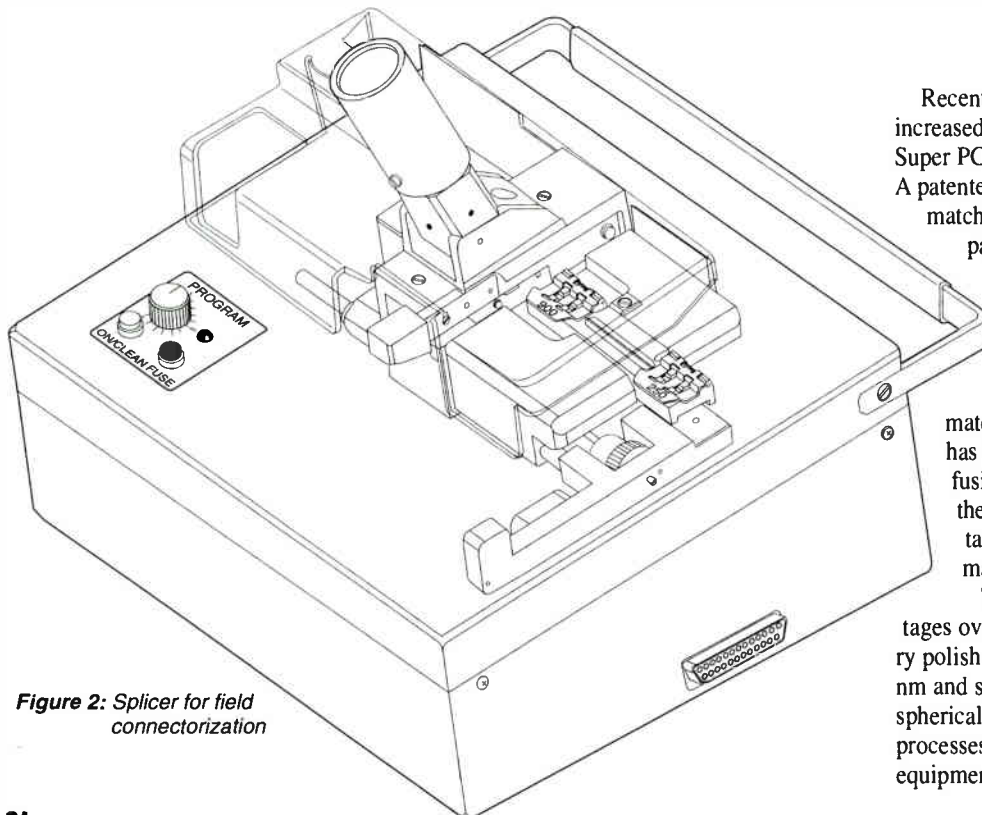
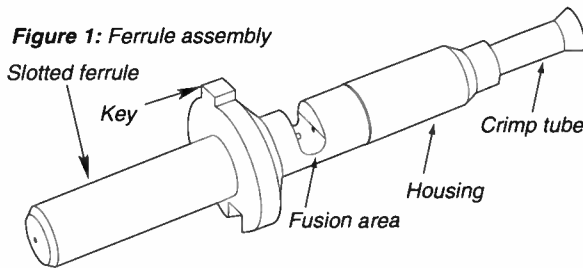
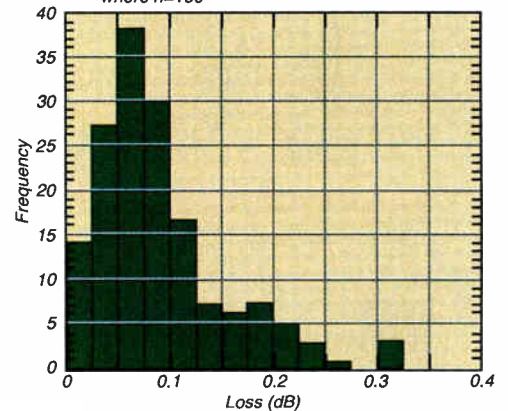

Figure 2: Splicer for field connectorization

The polishing process performed in the factory controls the connector end face geometry to ensure physical contact over a wide temperature range. One way to obtain this factory polish in the field is to use a pre-polished stubbed connector.

A no-epoxy, no-polish, crimp connector<sup>1</sup> has been in use for more than three years, in both singlemode and multimode versions. This connector uses the concept of mechanically splicing a near zero length pigtail. A short fiber stub is epoxied into a ceramic ferrule, and the end face factory polished to the required specifications. This connector uses a precision "V" groove and top flat to align and secure the stub and field fibers. The splice area contains an index matching material which has created some concern with reflectance performance over the -40°C to +75°C temperature range.

Figure 3: Splice loss histogram at 1310 nm wavelength where n=160



Recent improvements in this connector have increased the temperature range for which it meets Super PC (-40 dB) or Ultra PC (-55 dB) performance. A patented design to control the flow of the index matching material and prevent the occurrence of particle occlusion<sup>2</sup> has also been incorporated into this splice. Even so, concerns over index matching material still exist.

## Design

To address these concerns about index matching material, a new field-installable connector has been developed. This connector design allows fusion splicing within the physical boundaries of the connector, resulting in a near zero length pigtail. Additionally, no epoxy, polish, or matching material are required for installation.

This connector design provides several advantages over other field-installable connectors. The factory polish controls fiber extension on the order of  $\pm 50$  nm and symmetry, or apex offset, of the fiber and spherical dome to  $< 50 \mu\text{m}$ . Even if factory polishing processes are deployed in the field, the inspection equipment to continuously guarantee these end face



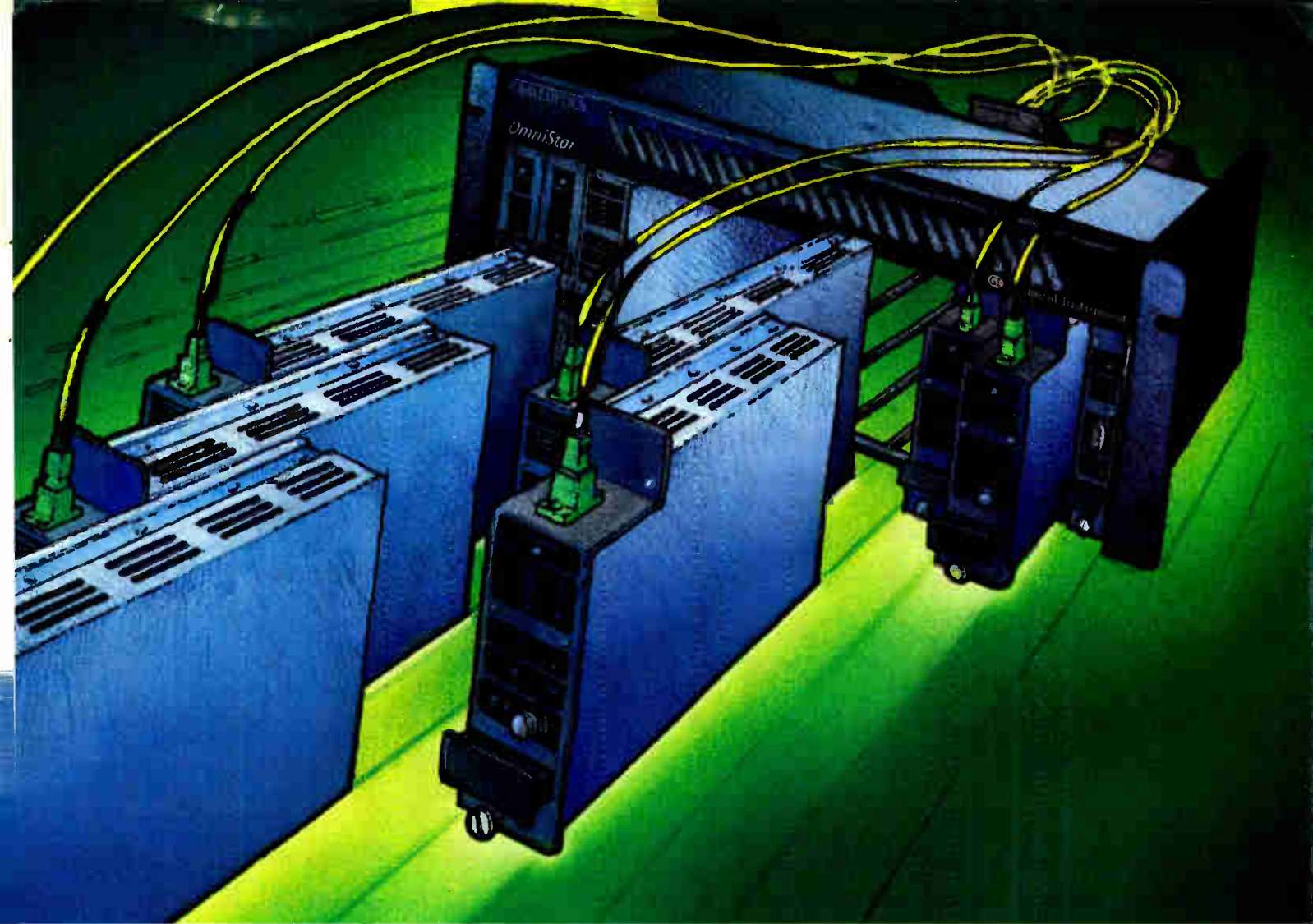

# More Fiber. Less Fat.

Pump up your network with OmniStar™, the high-laser-density broadband platform from GI.

Here's the next generation broadband laser platform you've been waiting for. Supported end-to-end by the worldwide leader, General Instrument.

OmniStar's built lean. Built to perform. Built to set the standard in high laser density, so it takes up less space in your headend, central office, hub, or OTN. OmniStar packs in more laser power per inch of rack space – an unequaled achievement in optical engineering and efficient packaging.



*The GI OmniStar Cableoptics Platform*

With OmniStar you get unprecedented freedom to mix-and-match our family of forward and return laser transmitters, forward and return laser receivers, redundancy switching modules, and power supplies. All front loadable in a space-saving package with network monitoring capabilities built in. No other broadband solution comes close.

So, if you want more fiber and less fat, call today for more information on OmniStar, the leanest star in broadband.

**GI** General Instrument

(215) 674-4800 (worldwide) • (800) 523-6678 (toll-free in U.S.) • (215) 956-6497 (fax worldwide)

Circle Reader Service No. 12

parameters are met would be impractical.

The absence of index matching gel eliminates any concerns about reflectance performance in the outside plant. The fused connector also has advantages over factory connectors. Cut-to-length jumpers, which eliminate the need for slack storage, can be quickly and easily produced with near factory connector performance. Repairs and upgrades to improve reflectance can be quickly performed any-

where without sacrificing performance.

The core component for all versions, SC, FC, and ST, is the ferrule assembly. This assembly consists of a short length of fiber precision cleaved at one end and epoxied into a zirconia ceramic ferrule. The ferrule incorporates an extended length and a transverse slot, into which the end of the stub fiber with the precision cleave protrudes (see Figure 1). This ferrule assembly also includes a key for align-

ing eccentricities, and a housing which couples the crimp tube to the ferrule to provide strain relief against torsional and tensile forces.

### Splicer

To simplify installation of this connector, a unique fusion splicer has been developed (see Figure 2). This splicer provides the ability to fuse within the transverse slot of the ferrule. The splicer incorporates a pivoting arm that

positions and orients the connector between the electrodes. Insertion and positioning of the bare field fiber has been simplified by a hand actuated translation stage. Angled optics provide viewing of a projection image of the fibers from 10 inches away. A telescoping tube provides shading of the

**Fiber alignment is provided by the micro-holes that hold the stub and field fiber**

view to allow splicing in direct sunlight.

An integral crimping mechanism performs the 900  $\mu$ m crimp immediately after splicing to ensure a zero stress condition beyond the buffer. Additionally, standard fiber-to-fiber splicing can be performed by simply attaching an adapter unit, which takes less than 30 seconds.

Sixteen preset splicing programs are accessible using a simple rotary switch. Programs included are for singlemode and multimode splicing, for both connectorization and fiber-to-fiber splicing. Additionally, a fiber burn back program is included as part of splicer maintenance, which is recommended by Bellcore. An optional programming module is available which allows modification of the individual splicing parameters.

### Installation

Installation of this connector consists of inserting the ferrule assembly into the splicer, stripping, cleaning and cleaving the field fiber to a predetermined length, and then fusing the fibers together. Fiber alignment is provided by the micro-holes that hold the stub and field fiber. After fusing, the 900  $\mu$ m crimp is then performed while the connector remains in the



**Lindsay**  
**SUBSCRIBER AMPLIFIER**

- 8 and 15 dB gain
- 5-42 MHz Reverse
- Low Noise
- 53-1000 MHz Forward

CALL NOW FOR YOUR CLOSEST STOCKING DISTRIBUTOR

**800-465-7046**  
**Phone: 705-324-2196**  
**Fax: 705-324-5474**



# WHEN IT COMES TO OPTICAL FIBER WE'VE GOT YOUR NUMBER.

# NOW HERE'S OURS.

Cable TV technicians and engineers  
already know that Corning's consistent and  
field-friendly fiber provides the industry's  
lowest splice loss numbers.

Now, when it comes to timely information  
for cable TV fiber applications, here's the  
only number you'll need.

Call the Corning  
Optical Fiber  
Information Center  
800-525-2524  
Ext. 538

Everything you want to know  
about optical fiber.  
All from the most extensive fiber  
reference source in cable television.

**CORNING**

*Specify Corning. Fiber you can count on.*

Circle Reader Service No. 14

Corning Optical Fiber

Count on Corning Fiber

splicer. This prevents coupling of any torsional or tensile forces to the splice joint. The connector is then removed from the splicer and the associated outer hardware, dependent on connector type, is snapped into place.

If the installation is on single fiber cable, a single crimp is performed with a hand tool that captures both the aramid yarn and jacket. The boot is then slid into place, and the connector is ready to use. Typical installation time,

whether installing 50 connectors or just one, is only three minutes for 900  $\mu\text{m}$  buffered fiber or five minutes for single fiber cable.

### Test results

Splice loss for 160 assemblies is shown in Figure 3. Values at 1310 nm wavelength show a mean splice loss of 0.09 dB. This loss distribution implies that mated pair losses will be comparable to factory pigtailed with their asso-

ciated fusion splice.

Results from thermal cycling per GR-326 show maximum insertion loss delta of 0.15 dB which occurs at the cold temperature extreme. This loss signature is shown in Figure 4 and is typical of that seen for a factory connector.

### Modal interference

Because modal interference can exist with closely spaced joints, loss will vary with

wavelength in stubbed connectors. Improved core alignment, along with the selection of a stub fiber for parameters such as cutoff wavelength, mode field diameter and concentricity error, minimizes any loss variation due to modal interference.<sup>3</sup> This variation, which has

**Typical installation time is only three minutes for 900  $\mu\text{m}$  buffered fiber**

been characterized both theoretically and empirically, is a maximum 11 percent of the incoherent (mean) loss, as shown in Figure 5.

### Conclusion

With this new fused connector, near factory performance can be achieved with a field-installable singlemode connector. Reflectance performance over the full  $-40^{\circ}\text{C}$  to  $+75^{\circ}\text{C}$  temperature range is achieved by providing a factory polish and fusion splicing, eliminating the need for an index matching material. With the addition of this connector, a joining point solution for every connectorization or splicing need is now available. **CED**

### References

1. M. deJong, "Cleave and crimp fiber optic connector for field installation," Tech. Dig. Conf. on Optical Fiber Commun., paper ThA1, pp. 139-141, 1990.
2. G. Kiss and A. Pellegrino, "Erratic loss and reflectance behavior in mechanical splices due to particulate occlusion," Proc. 6th NFOEC, pp. 5.2.1-5.2.12, 1990.
3. R.A. Throckmorton and D.O. Harris, "Modal interference in field installable single-mode fiber-optic connectors," Proc. 10th NFOEC, pp. 399-406, 1994.

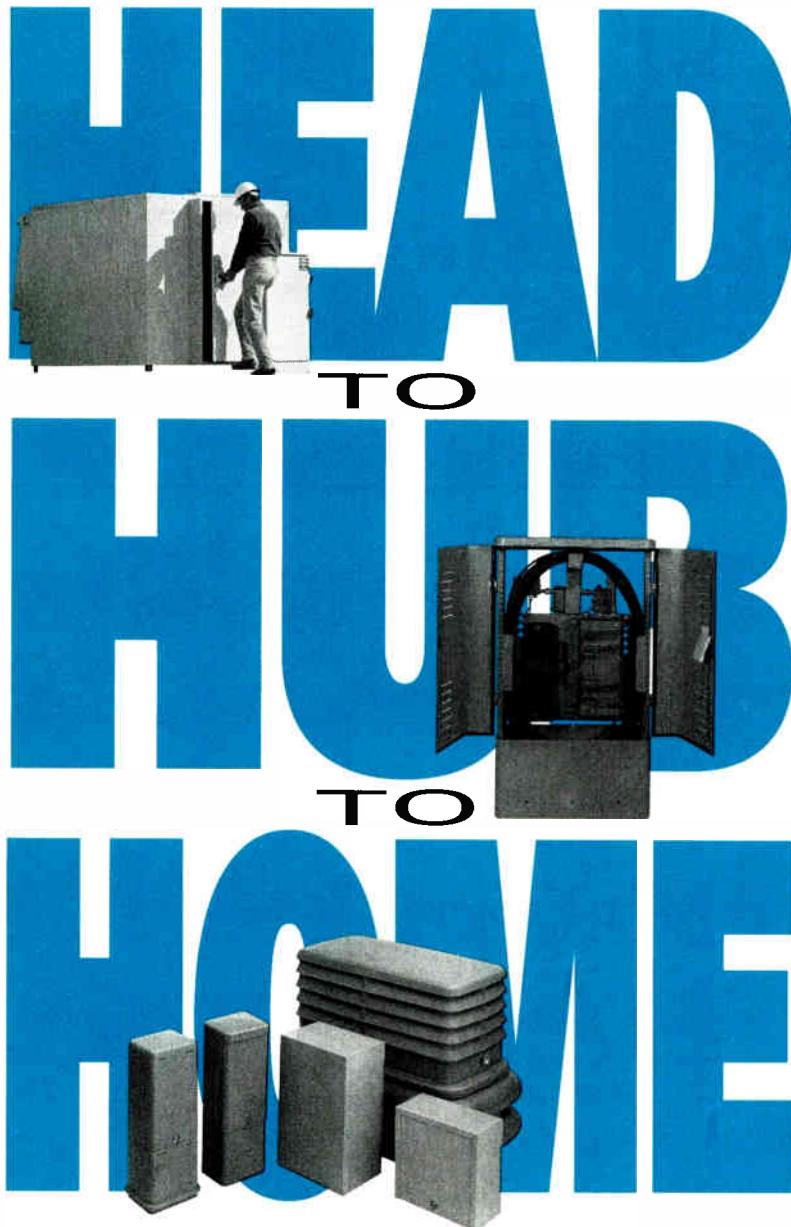

For all your broadband enclosure needs call 708-455-8010 or your authorized distributor.

**RELIANCE  
COMM/TEC**

INTEGRATED ACCESS SOLUTIONS™

Circle Reader Service No. 15



## Databases available for marketing and direct mail. Reach all or a selection of the nation's cable systems and MSOs!

### The CableFile System Database

- The most complete, up-to-date file of US cable operations available anywhere.
- Each listing contains key personnel and plant information.
- Updated on a daily basis as changes occur. Complete quarterly updates done as well.
- Entire Database or Customized Database available.
- Receive quarterly, semi-annual or annual updates with the CableFile Update Program.

### The CableFile MSO Database

- Provides pertinent information about corporate operations.
- Each listing contains names of 10 key personnel—**DECISION MAKERS.**
- Includes company-wide subscriber counts, pay subs, pay units and homes passed.

### For More Information...

- Please send complete information for CableFile Research.
- Please have a sales person call me with all the details.

Name \_\_\_\_\_ Title \_\_\_\_\_  
 Company \_\_\_\_\_  
 Address \_\_\_\_\_  
 City \_\_\_\_\_ State \_\_\_\_\_ Zip \_\_\_\_\_  
 Phone \_\_\_\_\_ Fax \_\_\_\_\_

Mail to: CommPerspectives • 600 S. Cherry St., Suite 400 • Denver, CO 80222  
 Fax to: 303/329-3453 • Questions? Call 303/393-7449

**CableFile Research is a product of the  
Chilton Communications Group.**

## Convergence '95™ Conference Series

The Convergence '95™ Conference Series will keep you up to date on all the latest in the converging marketplace. Conference topics for the remainder of 1995 include:

- Interactive Television Conference & Expo
- Convergence Technology
- Safety/Training '95

Each conference is an independent presentation. You can attend any or all of the conferences.

### For More Information...

- Please send information on the Convergence '95™ Conferences that I have indicated.

Name \_\_\_\_\_ Title \_\_\_\_\_  
 Company \_\_\_\_\_  
 Address \_\_\_\_\_  
 City \_\_\_\_\_ State \_\_\_\_\_ Zip \_\_\_\_\_  
 Phone \_\_\_\_\_ Fax \_\_\_\_\_

Mail to: CommPerspectives • 600 S. Cherry St., Suite 400 • Denver, CO 80222  
 Fax to: 303/329-3453 • Questions? Call 303/393-7449

## The Interactive Television Conference & Expo

September 25-28, 1995 • San Jose Convention Center

**PLUS...**

**The Second DAVID  
Developers Conference**  
 Co-hosted by CommPerspectives  
 and Microware

The *Convergence '95™ Interactive Television Conference & Expo* is the premier event for the rapidly developing interactive television industry. This conference, part of the acclaimed *Convergence '95™ Conference Series*, delves into the issues at the heart of interactive television today. *Convergence '95™* provides you the insights and networking opportunities you need by bringing together a concentrated audience of people, companies and programs that are central to this growing industry. **Finally, a conference undiluted with those only on the fringes of interactive television!**

*Sessions you can't afford to miss!*

*Exhibits of the best and most promising interactive networks, technologies, products and services!*

### For More Information...

- Send me a complete program and registration information for the Interactive Television Conference & Expo and DAVID Developers Conference.

Name \_\_\_\_\_ Title \_\_\_\_\_  
 Company \_\_\_\_\_  
 Address \_\_\_\_\_  
 City \_\_\_\_\_ State \_\_\_\_\_ Zip \_\_\_\_\_  
 Phone \_\_\_\_\_ Fax \_\_\_\_\_

Mail to: CommPerspectives • 600 S. Cherry St., Suite 400 • Denver, CO 80222  
 Fax to: 303/329-3453 • Questions? Call 303/393-7449



NO POSTAGE  
NECESSARY  
IF MAILED  
IN THE  
UNITED STATES

**BUSINESS REPLY MAIL**  
FIRST-CLASS MAIL PERMIT NO. 162 DENVER, CO

MultiChannel  
**CommPerspectives**

600 S. Cherry St., Suite 400  
Denver, CO 80222-9721



NO POSTAGE  
NECESSARY  
IF MAILED  
IN THE  
UNITED STATES

**BUSINESS REPLY MAIL**  
FIRST-CLASS MAIL PERMIT NO. 162 DENVER, CO

MultiChannel  
**CommPerspectives**

600 S. Cherry St., Suite 400  
Denver, CO 80222-9721

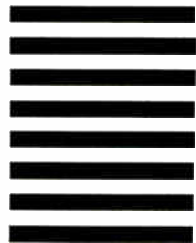

NO POSTAGE  
NECESSARY  
IF MAILED  
IN THE  
UNITED STATES

**BUSINESS REPLY MAIL**  
FIRST-CLASS MAIL PERMIT NO. 162 DENVER, CO

MultiChannel  
**CommPerspectives**

600 S. Cherry St., Suite 400  
Denver, CO 80222-9721

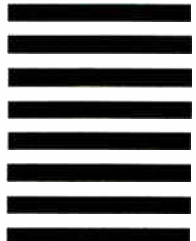



Figure 4: Typical temperature cycling data; 72 hours shown

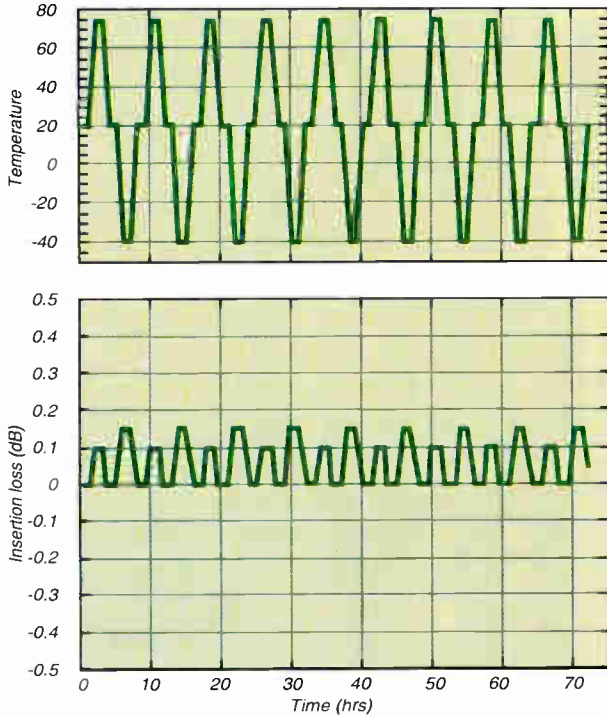
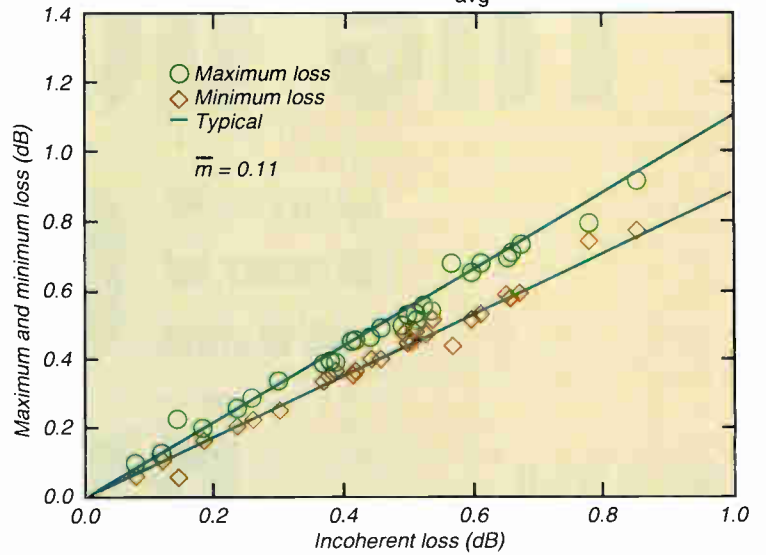

Figure 5: Extreme values of insertion loss vs. incoherent loss within the  $1310 \pm 20$  nm operating window for field-installable connectors incorporating fiber stubs with a low cutoff wavelength. Discrete points represent measured extreme values, while the solid lines are typical extremes calculated as  $(1 \pm m_{avg}) \times (\text{incoherent loss})$ .



# WE'VE GOT THE POWER ⚡

We offer the most complete line of 75 Ohm application specific and standard switches, attenuators and hybrids in the industry.

**JFW...The Power Leader**

For more information or for a free catalog, contact:

**JFW Industries, Inc.**  
5134 Commerce Square Drive  
Indianapolis, Indiana 46237

Tele. (317) 887-1340 Fax (317) 881-6790

Circle Reader Service No. 16

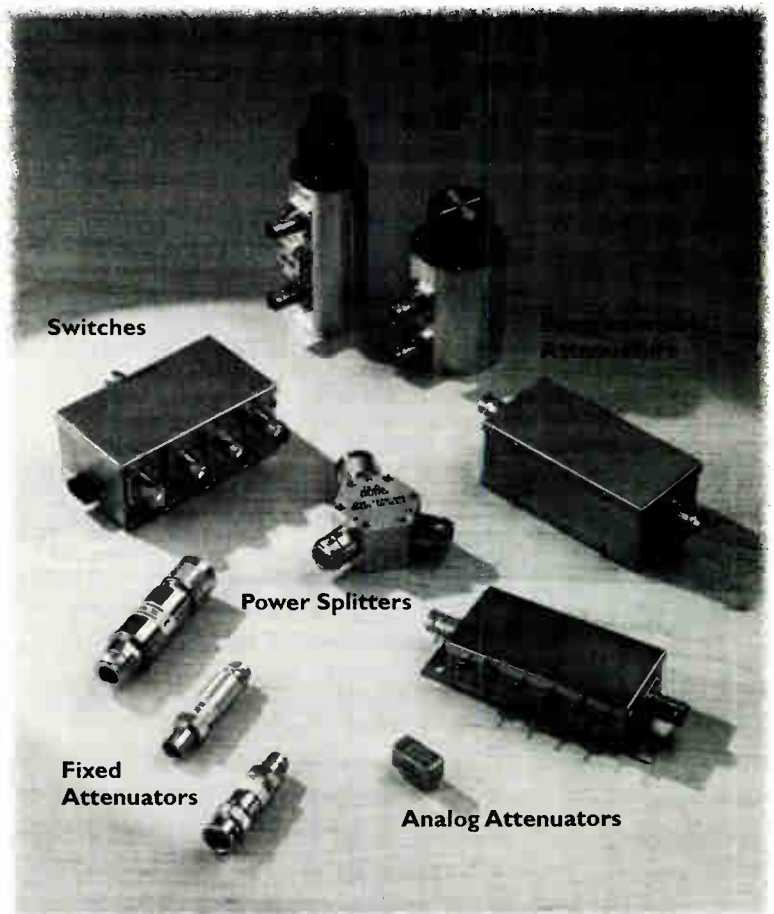

navigator. No major customers have yet been announced, but company executives said one should be forthcoming.

But the company throws cold water on digital enthusiasts. Over the next couple of years, Pioneer will be working with one cable TV MSO to develop a box and test feature sets with consumers before it commits to a huge production run, says Jim Slade, director of sales and marketing. "There's too much uncertainty over what it needs to do," says Slade in reference to the box. "Everyone has a different idea, so you end up with a



The DigiCable set-top from General Instrument.

very expensive set-top."

Pioneer believes it could be a long time before the economics for interactive TV are right. "People were way overoptimistic" when they talked about set-top prices, says Slade. "I'm not sure why. Maybe they wanted to believe it would work."

Regardless of price issues, Slade is critical of the lack of a deployed digital set-top in the cable industry. "It's difficult to understand why because there's clearly a market for them (he cites the success of the RCA DBS unit) but the cable industry has yet to deliver its first. They ought to be out there now—and they're not. Not even in field test quantities."

## Check your guns at the door, folks

One of the keys to making the advent of interactive digital television a success is interoperability across all kinds of varying platforms, whether they be operated by a cable MSO, a telephone company, or some other entity. On the micro level, components that go into hardware should also be able to support similar feature sets and speak the same language. But developing relationships between traditional competitors and whole new industries is often time consuming and inefficient.

Enter the Oracle Set-top Alliance.

Oracle, which one could argue has an agenda in that it wants ubiquity for its Oracle Media information handling solutions, nevertheless saw the need for a bridge between industries, manufacturers and the standards-making bodies, according to Jeff Cirese, director of set-top relations for Oracle.

"I view our work as complementary" to that of the standards groups like DAVIC, MPEG and others, says Cirese. "We're not attempting to set standards ourselves on features and functions of the set-top."

Instead, the Alliance brings set-top vendors up to date in standards developments by inviting speakers from those entities or through reports offered by Oracle representatives to those stan-

## The newcomers

Certainly no newcomer to the industry has been more successful than Hewlett Packard, which has already received commitments for 1 million analog/digital set-tops from TCI, Comcast and Cox for its Kayak unit. HP has licensed GI's DigiCipher II access control technology and will be fully compatible with TCI's Headend in the Sky program.

The first generation Kayak will support on-screen guides from TV Guide, Prevue and StarSight as well as NVOD. Play-along game applications will be available using the Zing technology.

HP has elected to use the Motorola 68ECXXX family of microprocessors for the main CPU and has reached an agreement with Broadcom to use its 64 QAM format. It too is built around the pSOS+ embedded operating system.

"There hasn't been a lot of news from us because we have our noses to the grindstone," reports Casey Sheldon, brand manager for HP's home products division. Specifically, HP is working on GI interoperability issues, making sure Kayak works as advertised with GI headend equipment.

Mitsubishi Electronics America made good on its 1994 promise when it unveiled its first digital set-top, an ADSL-based unit that features the Microware OS/9 DAVID operating system during this year's National

dards bodies. For example, Bob Luff of DAVIC and Frank Schwartz of VESA recently spoke to the group. In addition, the companies that actually buy the units have an active role in the group. For example, Ken Van Meter of Tele-TV, the consortium of Bell Atlantic, Pacific Bell and Nynex, recently addressed the group and discussed his needs.

The Alliance was formed in early 1994 because prior to that time there was no vehicle by which companies interested in interactivity could come together and talk about myriad issues. "We felt it would benefit all of us to create such a forum so we could talk about various key issues," Cirese notes.

About a dozen companies formed the core group and began meeting for about half a day every quarter or so. "We began by trying to encourage the rapid growth of the interactive industry," Cirese says. To that end, the Alliance focused on three major barriers: standards, compatibility and interoperability. "Vendors weren't talking with the content community, the network providers or government regulators" so the group brought in speakers to address those areas, Cirese adds.

Since then, the Alliance has evolved into a communications vehicle, or forum, to discuss open issues and/or problems. "This will be more of a focus in the future," Cirese notes, as networks get more complicated with the addition of servers, switches and new content developers. —R.B.

**The Alliance focused on three major barriers: standards, compatibility and interoperability**



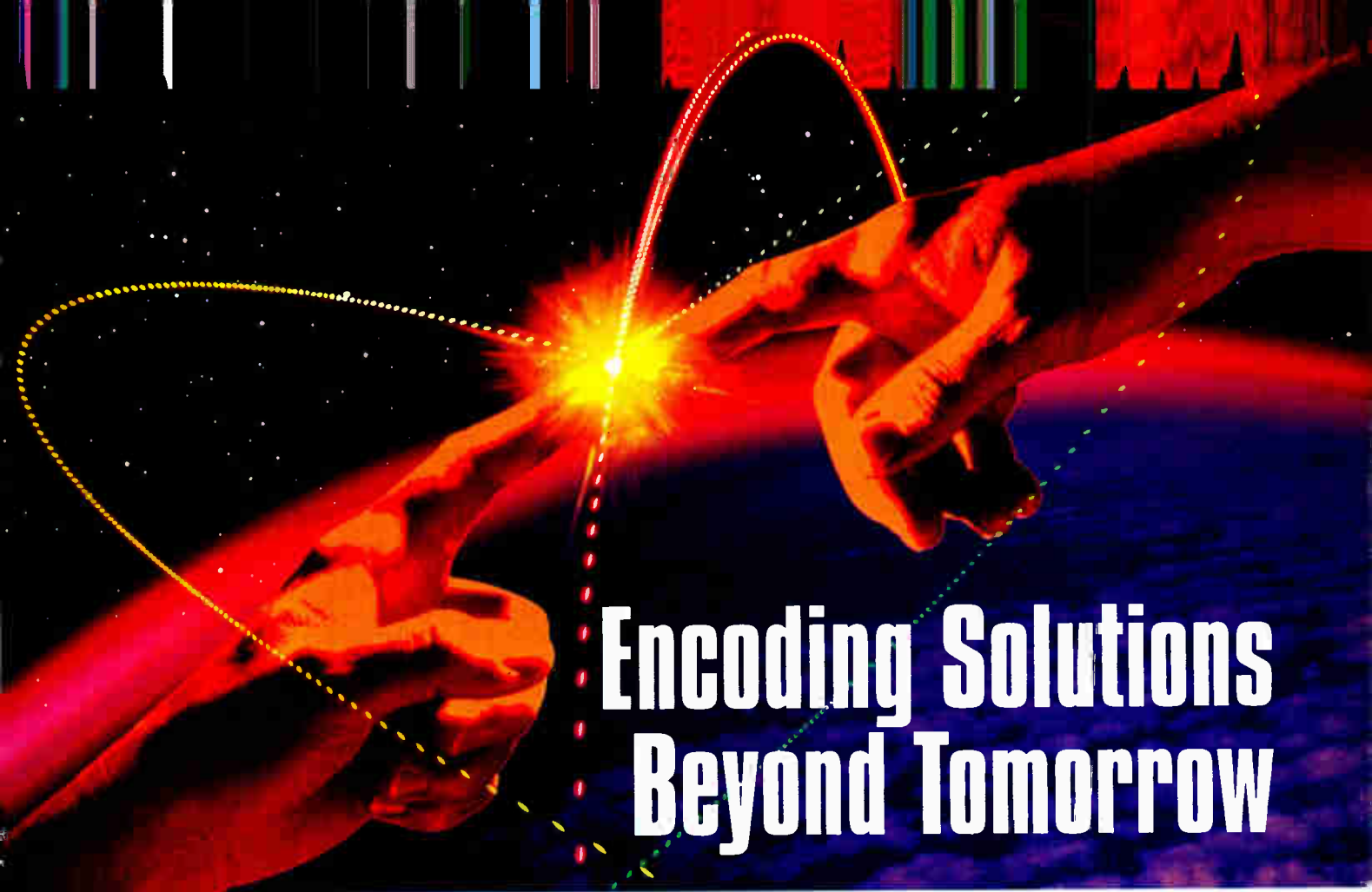

# Encoding Solutions Beyond Tomorrow

*Looking for affordable MPEG-2 encode/compression technology? Vela Research, Inc. can provide it today.*

## **REAL TIME MPEG-1 AND MPEG-2 ENCODING**

Vela Research MPEG-2 Encoders are capable of real time compression of video information into either the MPEG-1 ISO 11172 standard or the MPEG-2 ISO 13818 standard. This feature allows full interoperability with the next generation of MPEG-2-compliant decoder technology while offering full compatibility with today's MPEG-1-based PC and CD technologies.

## **VERSATILITY**

Vela's MPEG encoders accept a variety of video standards such as NTSC and PAL, and input signal formats that include composite, S-Video, Y/U/V or Digital D-1. This flexibility eliminates the need for expensive digital conversion electronics necessary to interface much of today's analog composite and component equipment to tomorrow's digital MPEG

encoding technology. The encoders support resolutions from SIF to ITU-R 601 at data rates from 1.158Mb/sec. to 15Mb/sec. A variety of audio signal formats are available from analog inputs to digital inputs based on the AES/EBU standards. The encoding workstation can be directly interfaced with computer/networking equipment such as Ethernet, Fast Ethernet, FDDI, CDDI, ATM and SCSI-2.

## **PROFESSIONAL WORKSTATION INCLUDED**

Vela Research MPEG encoder systems were designed and developed by digital encoding professionals with the video production professional in mind. An example of this attention to professional needs is found in the full-featured workstation included with the encoder. The workstation allows for complete external

control of a variety of VTRs, VCRs and laser disc players with on-screen controls for fast-forward, rewind, stop, play, cue and shuttle to timecode number. The internal 36GB disk capacity provides for capture and storage of compressed digital video files for later distribution.

## **CHECK US OUT**

Vela's MPEG encoders are available and shipping today! Call our Director of Sales,

Rick Chile, at (813) 572-1230, ext. 7171, to explore the "Encoding Solutions for Tomorrow" that

Vela Research can

provide today.

or write:

Vela Research, Inc. • P.O. Box 9090  
Clearwater, FL 34618-9090

**Meeting Tomorrow's Needs - Today<sup>SM</sup>**

Circle Reader Service No. 19



Show. The STB-1000 can also be configured to support HFC networks and ATM-based systems, says Dwain Aidale, vice president and general manager of Mitsubishi America.

In this first of a promised family of product, Mitsubishi has chosen to use Motorola's 68000 micro-processor family, but is considering use of the PowerPC processor in future models, Aidale adds. This first unit, which is scheduled to be delivered in production quantities next April, offers 2 Mbytes of RAM, an MPEG-1 video stream, a 64 QAM receiver and VSB communication interface.

Mitsubishi is building its units based on the DET/NIM (digital entertainment terminal/network interface module) model specified in telco RFPs (see sidebar below), and plans to offer a full range of NIMs, including DBS, MMDS, ATM, FTTC and HFC. The company even anticipates a day when its set-top could act as a base station for PCS handsets or as a wireless interface to devices like personal digital assistants. "To be successful, you have to play in them all," notes Michael Rude, senior strategic marketing manager at Mitsubishi. "We're here for a multiple play, not just to build set-tops. That's just an entree point."

## What's in a NIM?

*Less than six months after the term "NIM," for network interface module, appeared on the digital set-top scene, it's already fading, according to manufacturing and network executives familiar with the technology.*

*The term started cropping up in February, when the "Tele-TV" telco consortium of Bell Atlantic, Pacific Bell and Nynex issued a request for proposals for digital set-tops.*

*Because at least two of those RBOCs are chasing different network architectures—Bell Atlantic emphatically embracing switched digital video, and Pacific Bell just as emphatically deploying hybrid fiber/coax—the consortium needed a way to bring down set-top costs by triggering mass purchases, while still bridging the gap between their topological decisions.*

*That's where the NIM comes in. It is described in the Tele-TV RFP as a "replaceable unit which can be located physically within the digital entertainment terminals and allows for interfacing with hybrid fiber/coax, asymmetric digital subscriber line and fiber-to-the-curb networks." In short, the telcos wanted to bridge the network gaps with a slide-in board housing signal tuning, signal demodulation, access control and encryption. In scale, they asked for just over 2.2 million of the so-called "DET/NIM" boxes, over a three-year period.*

*But that plan might be changing, both in scope and timing. Tele-TV issued a brand-new RFP, this time for an end-to-end MMDS network, including set-tops, as a result of telcos buying up MMDS networks. Because the same people have to work on both RFPs, the original set-top request has been back-burnered for now.*

*Perhaps more notably, Pacific Bell engineers said during a press briefing last month that they'll use a set-top approach that does not support the NIM concept.*

*"We're not doing a NIM split," explained Keith Cambron, chief network architect and director of systems engineering for Pacific Bell. Cambron does eventually want to get to a point where*

*there is an open interface in Tele-TV homes, but "we don't view the digital entertainment terminal/network interface module [structure] as a keystone of the future wired industry."*

*Ditto the manufacturing community, apparently. While most all set-top makers say that, as always, they'll build what customers ask for, several have concerns about the additional cost of making a set-top that separates out key functions like demodulation, access control and security.*

*At the recent SCTE Cable-Tec Expo, for example, General Instrument showed off a digital set-top with an integrated network card, and said that the integrated approach is what the manufacturer is pursuing near term.*

*Indeed, the NIM panacea may be more complicated—and more costly—than it appears. "We don't think [the NIM concept] is quite that simple," says Bill Luehrs, vice president of network systems operations for Zenith Electronics, noting that before a removable network card can become reality, the industry has to come to a consensus on several issues, like memory and decompression specifications.*

*"What [Tele-TV] specified is actually what the industry needs—it's just that its requirements in terms of memory, functions and capability ended up with a box that's three times the price point they needed," Luehrs continues.*

*Gene Lew, director of Tele-TV's advanced technology group, disagrees, noting that he has a short list of companies that can meet a much lower price point. "The people you're talking to must have a disadvantage" in their manufacturing capability or component costs, he says.*

*Scientific-Atlanta, which owns the lion's share of telco set-top orders, does not currently separate out network interface elements, says David Levitan, vice president and general manager of subscriber systems for S-A. Instead, S-A is pursuing an approach that electronically breaks the set-top into three pieces: the network interface; the media platform, including graphics and software environment; and the security system.*

— Leslie Ellis

**The NIM may be more complicated—and more costly—than it appears**



# Our Inserters have a head start, before they get to your headend.



Testing our systems is something we take very seriously at SDI. That's why every StarNet Digital Inserter runs and verifies thousands of spots— before they're shipped. Our quality control department loads each system with commercials and connects it to the live tone feed. And the

testing is not done until the system verifies insertions at over 99% accuracy.

We think our testing and quality control is the best in the industry. If you don't believe us, just ask our customers. With over 35 systems installed, SDI is a leader in the digital insertion market.



404 W. Ironwood Drive, Salt Lake City, UT 84115  
(801) 464-1600 · Fax (801) 464-1699  
Circle Reader Service No. 20

**During its first trip to a cable TV trade show, Sony offered up a "concept" set-top**

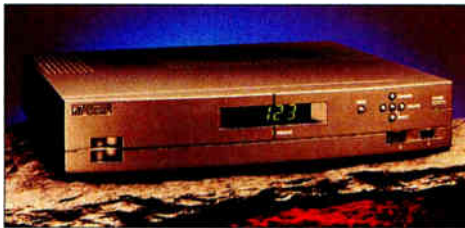

*A prototype of Scientific-Atlanta's digital terminal.*

Mitsubishi also took a financial stake in Stellar One, a separate company that was selected by Bell Atlantic for its ADSL video network. The relationship also details set-top manufacturing for existing contracts, technology licensing and joint bidding, according to Steven Voit of Stellar One.

These units also utilize the OS/9 operating system and offer 2 Mbytes of downloadable DRAM. It decompresses MPEG-1 video and offers MPEG-2 transport. Additionally, two connectors on the back of the unit allow direct connection to personal computer serial ports and parallel inputs or outputs.

Japanese computer and communications giant NEC has quietly thrown its hat into the set-top ring and presently has two development activities ongoing, says Leslie Giesler, strategic marketing manager at NEC America. As one of the world's largest suppliers of DRAM, and a manufacturer of MPEG, ATM and graphics chips, NEC believes it has the expertise in-house to build set-tops for network operators.

NEC is working on a DET/NIM type unit that features Microware's OS/9-DAVID real-time operating system, a PowerPC computing engine and MPEG-2 transport that is scheduled to be mass produced in the first quarter of 1996. Initial network interface modules will not support HFC networks, however. Instead, they will be aimed at telco customers who are building fiber-to-the-curb networks with ATM transport. In addition, a twisted pair NIM will be offered for ADSL applications, according to Giesler.

At the same time, NEC is building a set-top that closely adheres to the specifications laid out by Microsoft for its ATM-based foundational system, called the Microsoft Interactive Television system. NEC is actually one of at least four partners working with Microsoft to develop such set-tops, the others being Sony, General Instrument and Hewlett Packard. NEC has a long history of collaboration with Microsoft on the personal computing side of the house, Giesler says.

Already, NEC's first set-tops are being tested in its lab, and by the end of the year, will be used in Microsoft's Redmond, Washington campus. The company is also pursuing participation in a number of Microsoft trials. It is anticipated that the first real products will be offered in early 1996.

**Sony? No boloney!**

When Thomson sold its millionth DBS receiver, Sony became the second supplier of digital receivers, and the company hopes to use that as a springboard to even bigger things, judging from interviews with company representatives.

During its first trip to a cable TV trade show, Sony offered up a "concept" set-top that actually consisted of a "media unit" that would reside in a central location in the home, such as a closet or in a basement. Tied to that via cable would be any number of satellite RF

receivers that sit on the top of the TV. Dubbed "Pecchi" (Japanese for "penguin"), the media unit was conceived with the idea it would house an Intel 486 class micro-processor running at 66 MHz, with perhaps 8 Mbytes of RAM, although those specs are subject to change.

The small RF receivers, which in Sony's mock-up actually resembled small penguins, transport commands from the handheld remote, which does double duty as a telephone, to the central unit. Sony chose to use RF instead of infrared so that the system could be controlled from any location in the home, said Koichiro Tsujino, a project manager for Sony.

Because Sony was present in Dallas mainly to garner input from network operators, no specifics were given regarding price, availability dates or trials. However, Tsujino said he hopes to participate in several interactive trials once prototype products become available.

Although they aren't interactive, Thomson Consumer Electronics has a huge lead on everyone when it comes to building digital receivers, having done so for more than a year now for the DirecTV DBS service. Sold under the RCA DSS brand name, Thomson can count nearly a million in-field units.

Just two months ago, the company announced plans to work with BroadBand Technologies, a developer of fiber-to-the-curb and switched digital networks, to build a low-cost, open interface set-top box "at a price from \$50 to \$90 less than the equivalent HFC solutions," according to BBT.

Primarily aimed at the telco market, these set-tops will support fiber-to-the-curb and switched digital video applications. The units will be designed in a "standard format, with a standard network interface provided by BroadBand's FLX platform," according to a release.

BBT expects to use standards such as ATM and 16-CAP (carrierless amplitude and phase modulation) encoding to offer low-cost alternatives. In essence, the cost reduction will come from a more simple network to set-top connection. "Using low frequency, baseband transmission eliminates the need for forward error correction, adaptive equalization and demodulation," BBT said in a statement. "The result would be a product designed to maximize performance while using fewer components and realizing significant savings."

Waiting in the wings are companies like Samsung, Sharp and Apple who have interactive TV interests of their own that vary from a desire to manufacture set-top components, operating systems and perhaps, the set-tops themselves. Only time will tell if they become influential market forces.

**Conclusion**

With literally millions of manhours and dollars sunk into the development of digital set-tops designed for interactive TV, the day when at least a few people can decide what to watch and when to watch it isn't far off. But mass deployment is another matter entirely. The manufacturers say there might be 3 million such units in the field four years from today. That's a long way from a revolution. **CED**



# Introducing Zenith MultiMedia. Power your way to new cable revenues. Today.



Zenith Network Systems has developed the first real-time, two-way interactive analog system that offers you nearly every revenue-generating service associated with digital.

And, since it's analog, you can install it at a fraction of the cost.

What's more, it's technology that's here, technology you understand, technology that's ready to install. Today.

## The MM2500™ Set-Top

Our MM2500 set-top is an addressable, broadband, stereo-compatible unit that offers you two distinct advantages.

It is the only fully-downloadable, software-driven set-top, so you get full, diverse control from the headend.

And the MM2500 set-top is the only analog unit that supports revenue-generating real-time, two-way interactive services...the unregulated sources of revenue so essential to your growth and survival in today's competitive environment.

## The ScreenPlay™ Authoring Tool

The ScreenPlay Authoring Tool is an easy-to-learn, easy-to-use Windows™ based system that lets



you creatively customize on-screen displays downloaded to the MM2500 set-top.

It comes with a wide variety of characters and other graphic devices built-in, while allowing you to scan in virtually any graphic you might choose.

## Real Revenues Today. And Tomorrow.



While getting ready for the digital future, the MM2500 set-top can begin to generate new sources of real revenues today.

- Expanded promotion of PPV
- Interactive program guides
- Bulletin boards and messaging
- Interactive shopping and games
- New advertising options
- Near video-on-demand

Equally important, the MM2500 set-top can be a pathway for you — and your customers — to the digital future.

## Plug In To The Power.™

New technologies make way for new ways of making profits. And leading the way in technological advancements is, of course, something Zenith has been doing for over 75 years — another reason to plug in to the power of Zenith.

To learn more and to receive our free information kit, just call us today at 1-800-239-0900.



# Is CDMA a viable Modulation on HFC choice for the upstream path?

By Gihad Ghaibeh, Senior Systems Specialist, Ericsson-Raynet Corp.

Whether spin casting for Megabytes on the World Wide Web, or video conferencing from home, hybrid fiber/coax (HFC) networks must provide reliable communications in both the upstream and downstream paths.

Unfortunately, the upstream path is littered with obstacles to error-free transmission. Some of these are inherent to the network, such as upstream noise funneling and ingress [ref. 2] as well as medium access contention; others are vestiges of the cable TV services and deployments, such as a narrow upstream bandwidth and unpredictable diplexer group delay. An appropriate upstream modulation scheme and medium access technique is therefore the key ingredient in enabling trouble-free service.

Several upstream medium access schemes and modulation methods have been employed in such systems, the most common being a combination of Time Division Multiple Access (TDMA) and Frequency Division Multiplexing (FDM). The allure of Code Division Multiple Access (CDMA) proves too strong to resist investigating, however, especially with its claims for interference rejection, simultaneous medium access for multiple users, and more.

To illustrate a common setup, in Figure 1, an HFC system shows multiple subscribers sharing the coax cable. The upstream bandwidth available to digital subscribers is limited to the 18 MHz to 42 MHz band, as the spectrum below that is occupied generally with set-top box upstream signaling carriers, and above that by conventional cable TV channels. This leaves approximately 24 MHz for

upstream services on each coax cable tree originating at a Broadband Optical Network Unit (BONU).

This system employs a combination of TDMA and FDM to share the upstream band among the subscribers. Essentially, a group of subscribers are assigned a common carrier, and each subscriber transmits only during a predefined recurring time slot, thereby avoiding contention. Such a system, however, remains vulnerable to the occasional narrow-band interference and impulse noise that plague the upstream band. How well and under what conditions can CDMA improve performance? The answer requires digging a little deeper into the inner workings of CDMA.

## CDMA overview

Just as TDMA separates different channels and users by allocating each user a specific group of time slots, or Frequency Division Multiple Access (FDMA) allocates each user a unique frequency band, Code Division Multiple Access (CDMA) assigns each user or channel a code sequence by which only that user's data is modulated (coded) and decoded from the assembly of other signals.

In CDMA (Figure 2), channels occupy the same bandwidth and time but are effectively separated in the amplitude plane using a code for each channel. Two types of CDMA modulation may be distinguished: Frequency hop-

Figure 1: Ericsson-Raynet HFC system

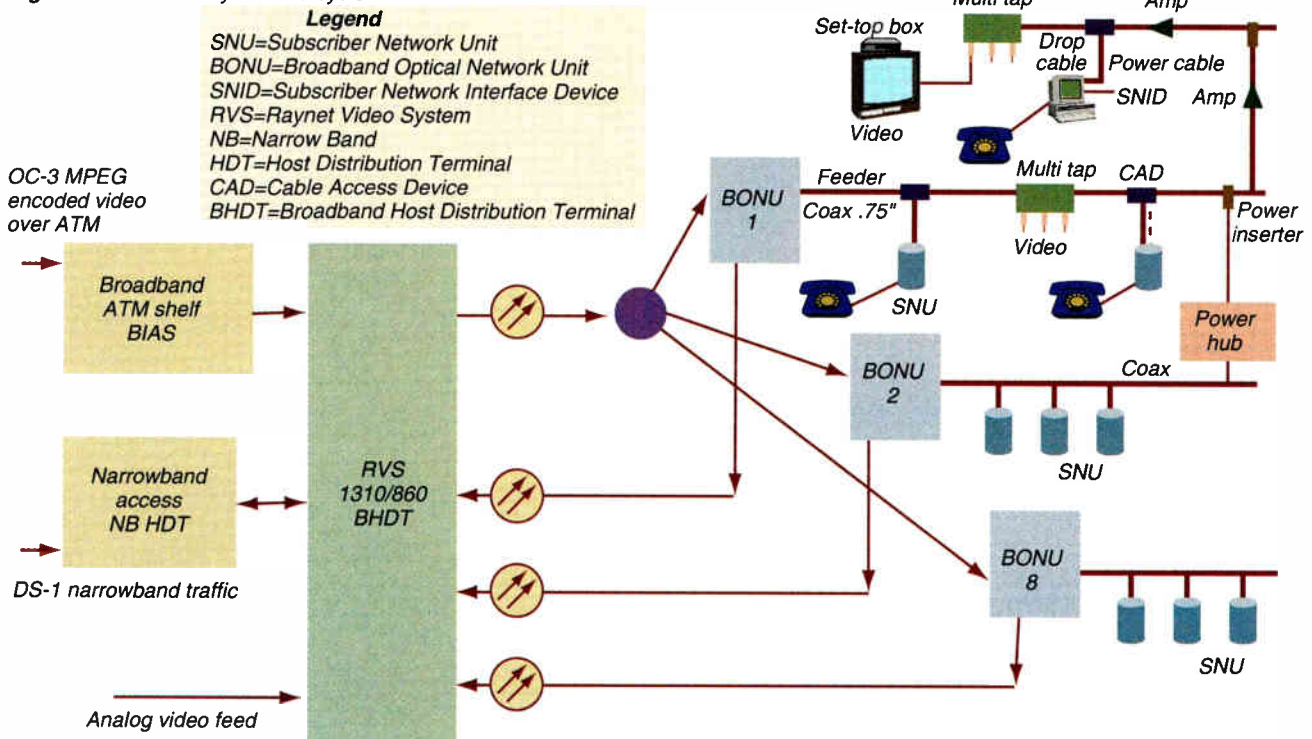



# Can Your Architecture Stand the Test of Time?

Can your broadband architecture support video on demand, targeted ads and telephony — as well as help you compete effectively? Scientific-Atlanta's Fiber-to-the-Serving Area architectures not only accommodate today's expanded bandwidth needs, but offer the built-in flexibility and reliability for the interactive future.

And we provide much more than advanced architectures. It's a complete end-to-end solution. Fiber optic, distribution and headend systems to implement your new FSA architecture at a low life-cycle cost. With subscriber systems to bring it all home.

So make sure your broadband network will stand the test of time. Call Scientific-Atlanta today at 800-433-6222 or fax us at 404-903-3088.



**Scientific  
Atlanta**



Atlanta 1996

EMERSON

Official Sponsor of the  
1996 Atlanta Olympic Games

## ◆ CODE DIVISION MULTIPLE ACCESS

ping and Direct Sequence (DS) spreading. The latter is of interest to this study and is described below.

To illustrate a simple CDMA setup, an example network consisting of four users or channels communicating upstream over a shared medium (coaxial cable in this case) is shown in Figure 3. For direct sequence spreading, a set of binary codes is chosen, and one code is assigned to each channel or user. The codes are chosen such that ideally they result in zero cross channel interference after demodulation (more on this later), which requires that any two codes differ from each other by exactly half the number of bits in the code word.

The code rate is chosen to be several multiples larger than the original data rate, i.e., each data bit is encoded with several code bits (four in this example). The code set selected for this example is shown in Table 1.

At each user, the unique fixed length code is added modulo 2 (xor'd) with each bit in the data stream. Therefore, a code bit of (1) will invert the data bit, while a code bit of (0) will not change the data. The resulting sequence is transmitted along with (summed with) the

spread data from other modulators occupying the transmission medium (Figure 3). For clarity, it's easier to illustrate the fundamental concepts by encoding the data as +1 for a 1 and (-1) for a (0). The xor operation is then transformed to a multiply operation.

The spreading of user #2 data is shown in Table 2 and results in the spread sequence shown before being added to the rest of the channels. In binary, the spread sequence = 1100 1100 1100, which occupies four times the bandwidth of the original data! The signals from all the channels are summed on the transmission medium, and the result is a composite multilevel waveform of:

22-22 0400 000-4 (nine possible discrete levels in the general [four user] case spanning -4 to +4 in unity increments).

To demodulate, the modulated signal is multiplied by the code sequence for that channel bit-by-bit. A code bit of (0) multiplies the signal by (-1), while a code bit of (1) multiplies the signal by (+1). The result is summed over each chirp (bit time), effectively correlating the received signal with the local user code. This process is shown in Figure 4.

From the above example it can be seen that

Figure 2: Modulation formats

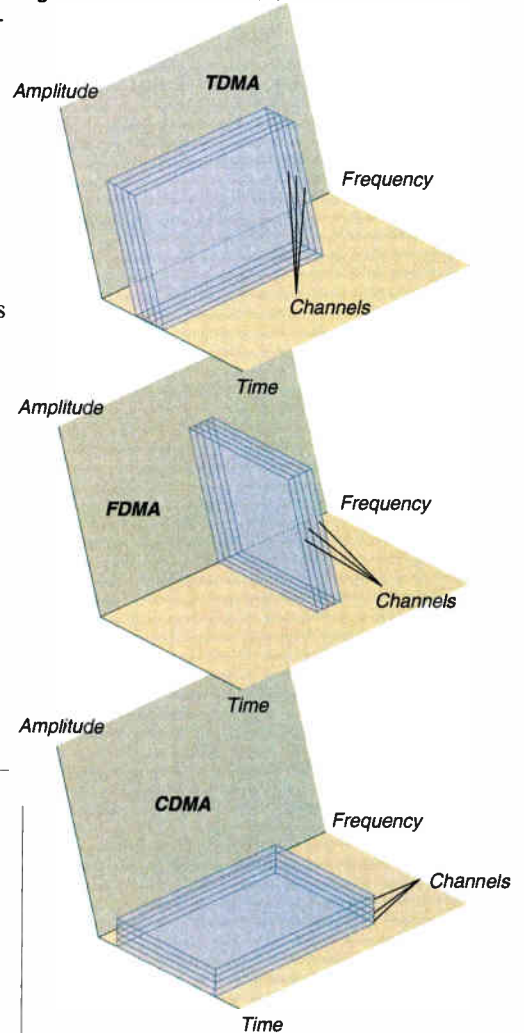

if the demod code matches the modulation code, all chirp bits will be (+1) for an original bit = 1; and (-1) for an original bit = 0, resulting in a sum of +4 for a 1 and -4 for a 0. In this case the demodulated waveform results in (-4 -4 -4) levels representing binary 0 0 0 which is the recovered user #2 data.

As far as the effect on other channels on the demodulated waveform, if the modulation and demodulation codes are not the same, exactly half the code word bits will be mismatched (from the properties of the code set) and the recovered waveform will be all zero, contributing no crosstalk into the user channel. Table 3 shows the channel 2 spread sequence effect (crosstalk) on the channel 3 demodulator output.

Transmitting several channels over the same medium is now possible by encoding each channel with a different code and adding all the channels (each code mismatches the other codes by half the bits in the code). Demodulating with a mismatched code will

# QINTAR®



1 GHz splitters



1 GHz taps

---



1 GHz 2-way amps



1 GHz A/B switches

In stock • Low cost • 5 year warranty

Qintar, Inc. • 700 Jefferson Ave.  
Ashland, OR 97520-3703 • U.S.A.

Ph. (503) 488-5500 • Fax (503) 488-5567





## Make Your Quality Cable Connection With Pirelli.

As an ISO 9001 registered company, Pirelli manufactures a full range of fiber optic cables for the cable television industry. Make your quality cable connection by calling these Pirelli representatives:

### Communications Supply Group

680 Industrial Cir S  
Shakopee MN 55379  
1-800-451-9032 · FAX 612-445-8423  
CO, IA, MN, ND, NE, NM, SD, WI, WY

### dB Communications

4007 Skippack Pike  
PO Box 1268  
Skippack PA 19474  
1-800-526-2332 · FAX 610-584-7875  
CT, DE, MA, MD, ME, NH, NJ,  
NY, PA, RI, VA, VT, WV

### B.E. Duval Company

347 W 6th St  
PO Box 5255  
San Pedro CA 90733  
310-833-0951 · FAX 310-832-9970  
AZ, CA, HI, NV

### Glade Communication Equipment Company

2691 151st Place NE  
Redmond WA 98052  
1-800-347-0048 · FAX 206-869-4119  
AK, ID, MT, OR, UT, WA

### MicroSat

4343 Shallowford Rd Ste F3  
Marietta GA 30062  
1-800-438-0812 · FAX 404-643-0899  
AL, AR, FL, GA, KS, LA, MS, NC, OK,  
SC, TN, TX

### W. Whitaker & Associates

120 Professional Park Ste 1  
PO Box 6327  
Lafayette IN 47903  
1-800-433-8775 · FAX 317-447-5064  
IL, IN, KY, MI, MO, OH

**PIRELLI**  
FIBER OPTIC CABLES

1-800-669-0808 · 803-951-4800

## ◆ CODE DIVISION MULTIPLE ACCESS

Table 1: Example set of spreading code words for four users

User #	Spreading code word (Binary)	Spreading code word (Bipolar)
0	0000	-1-1-1-1
1	0101	-1 1-1 1
2	0011	-1-1 1 1
3	0110	-1 1 1-1

result in a sum of 0 over each bit time and will not affect the result of the matched code sums. Codes with this property are termed "orthogonal" as separate signals may be modulated using these codes without interfering with each other at the demodulator output.

Spread spectrum signals in general are particularly immune to narrowband interference, i.e., interfering signals with a much narrower bandwidth than the spread signal. The DS demodulator in effect "gathers" the DS signal from a large bandwidth into a narrow one, and at the same time "disperses" the narrowband interfering signal or noise into a wide bandwidth. The noise power remaining in the despread signal spectrum is reduced to only a fraction of the original noise.

For a quantitative view and to get a little more insight into this process, start with a data sequence with the power spectrum shown in Figure 5. A spread sequence is generated, resulting in a signal shown in Figure 6 with the same power ( $P_{wS}$ ) but with bandwidth that has been expanded by the factor ( $F_s/F_u = G_s$ ) termed the spreading gain, where  $F_s$  is the bandwidth after spreading, and  $F_u$  is the unspread bandwidth.

This signal is transmitted over a noisy channel. If a narrowband jamming signal with power ( $P_{wJ}$ ) and bandwidth lying entirely inside the spread signal band is inserted in the channel, the signal-to-noise ratio (SNR) will be: channel SNR =  $SNR_c = P_{wS}/P_{wJ}$ .

This is exactly what would be expected for a conventionally modulated signal. The difference occurs, however, after despread the signal, as shown in Figure 7. The signal bandwidth is reduced to its original size while the jamming signal is spread by the spreading gain value  $G_s = F_s/F_u$ . The net effect is that the noise remaining within the signal bandwidth has been reduced by the spreading gain  $F_s/F_u$ . Therefore, the SNR after despread is increased by the spreading gain as follows: despread (SNR<sub>d</sub>) = channel (SNR<sub>c</sub>) \* spreading gain ( $F_s/F_u$ ) for  $F_j \ll F_s$  (i.e., the jamming signal is much narrower than the spread

signal bandwidth).

It is important to note that the power of all jamming signals lying inside the spread band ( $F_s$ ) will be spread and added as shown above. The net effect is that the total noise power inside the spread band ( $F_s$ ) is smoothed out, removing any peaks or narrowband signals and spreading the noise power evenly over the whole spread band ( $F_s$ ).

### Modulator synchronization

The degree of interchannel interference is determined by the set of codes used and the synchronization of the system. The system shown in Figure 8 consists of a number of modulators, each with a distinct code, sharing a transmission medium. Modems may be synchronous or asynchronous and possess the following properties and requirements.

#### Synchronous codes:

- ✓ Require code and bit synchronized modulators and demodulators.
- ✓ Achieve zero inter-channel interference.
- ✓ Achieve the highest density channels (modulators) for a given code size.
- ✓ Number of channels (modulators) is normally equal to the number of bits in the code word.

For example, a typical choice of synchronous codes would be a set of Walsh codes which is generated in an  $N \times N$  matrix (square), meaning the number of entries in the code table equals the number of bits in each code (the number of entries is always a power of 2).

A Walsh matrix for a four-bit code would be:

0000 = code #1  
0101 = code #2  
0011 = code #3  
0110 = code #4

Therefore, four users may share the medium by using a four-bit code. Assuming the data baud rate at the input to the modulator is 100 bps, the spread baud rate would be 400 bps due to the spreading gain (chirp size) of four. With a modulation efficiency of 1 bit/hertz/second, the transmitted bandwidth will expand from 100 Hz to 400 Hz but will carry four users. It is important to note that no inherent increase in capacity has been achieved over other conventional modulation schemes.

#### Asynchronous codes:

In the limit, using random codes, modulators transmitting asynchronously may be modeled as random noise interference to each



# All the right ingredients!

**Strong, cost effective  
Christy Grade Level Boxes...  
now available from Channell.**

Christy Concrete Products, Inc. has been manufacturing boxes for underground construction of water systems and utilities for nearly four decades. Now, they've teamed up with Channell Commercial to provide their concrete and Fibrelyte™ products to the telecommunications and broadband communications industries.

Christy uses an automated "dry tamp" process to manufacture its concrete boxes. To provide additional strength, fibers are added to the concrete mix. Additionally, a unique, thermoplastic ring assures proper fit of the non-skid lid and also protects the top edge of the box from chipping. The result is less breakage during shipment and reduced liability problems with installed boxes.



Christy's Fibrelyte boxes and lids complement the concrete product line. Constructed of proprietary composite materials, these lightweight and high strength Fibrelyte boxes offer many advantages over precast concrete. In many applications, Christy's concrete and Fibrelyte boxes and lids can be intermingled, providing numerous combinations for added strength while providing low cost product solutions.

Christy quality concrete and tough Fibrelyte grade level boxes—the right ingredients for your underground plant requirements. Call Channell toll free today for complete information.



**Christy Concrete Products, Inc.**  
44100 Christy Street, Fremont, CA 94538

**Marketed exclusively by Channell Commercial Corporation**

U.S.A. 800/423-1863 • 909/694-9160 FAX: 909/694-9170  
CANADA 800/387-8332 • 905/567-6751 FAX: 905/567-6756  
U.K. +1 44 171 589 3304 FAX: +1 44 171 589 1021  
ISRAEL 972 4 341329 FAX: 972 4 341387

Circle Reader Service No. 26

## ◆ CODE DIVISION MULTIPLE ACCESS

other. Each user contributes  $P \cdot F_u / F_s$  noise power into the other channels. Therefore, a receiver's SNR will deteriorate as:  $SNR = (n-1) \cdot F_u / F_s$  where  $n$  = number of simultaneous users and  $F_u / F_s = 1/\text{spreading gain (Gs)}$ . A set of asynchronous codes may be chosen, however, to possess low auto and cross correlation values, and therefore will cause much less interchannel interference.

Generally, asynchronous codes have the following properties:

- ✓ Do not require code synchronization between simultaneous modulators.
- ✓ Interchannel interference is nonzero and depends on the code set.
- ✓ Interchannel interference severely limits the number of users sharing the medium.
- ✓ For a given code size (and spreading gain), the number of simultaneous users is much smaller than a code synchronous system.

For example, when a number of users share a common band using random asynchronous

CDMA codes (as opposed to low cross correlation codes) with spreading gain of 100, assuming an otherwise noiseless channel, the SNR due to the interchannel interference resulting from two users sharing the band will be  $10 \cdot \log(1/100) = -20 \text{ dB}$ .

### CDMA power and SNR advantages

The average power transmitted in a CDMA system is larger than a TDMA system for a given transmitter power. This is because a transmitter in a CDMA system operates continuously, while a TDMA transmitter is only active during its designated time slot. The average power and SNR in a CDMA or FDM medium is therefore  $(n)$  times the total transmitted power in a TDMA medium for a given transmitter power, where  $(n)$  is the number of transmitters sharing the medium. This is a significant advantage for systems that are transmitter power limited such as satellite and mobile transmitters. Cable systems, however,

are also receiver power limited and therefore cannot benefit fully from this property.

A CDMA receiver is effective in rejecting large narrowband interfering signals when the spreading gain is high. If the interference is broadband and evenly distributed over the receiver RF bandwidth, however, the advantage over an FDMA or TDMA system is severely reduced or eliminated completely.

### Multipath fading and echoes

Echoes return a portion of the signal to the receiver after a delay, causing Inter Symbol Interference (ISI) in a conventional receiver. A delayed CDMA signal appears as an out-of-phase sequence to the CDMA receiver and will have a similar effect as interfering noise on the signal. A code with a low autocorrelation value would be suitable to such an environment.

The amount of echo suppression will therefore depend on the spreading gain and the cor-

Figure 3: Direct sequence spreading

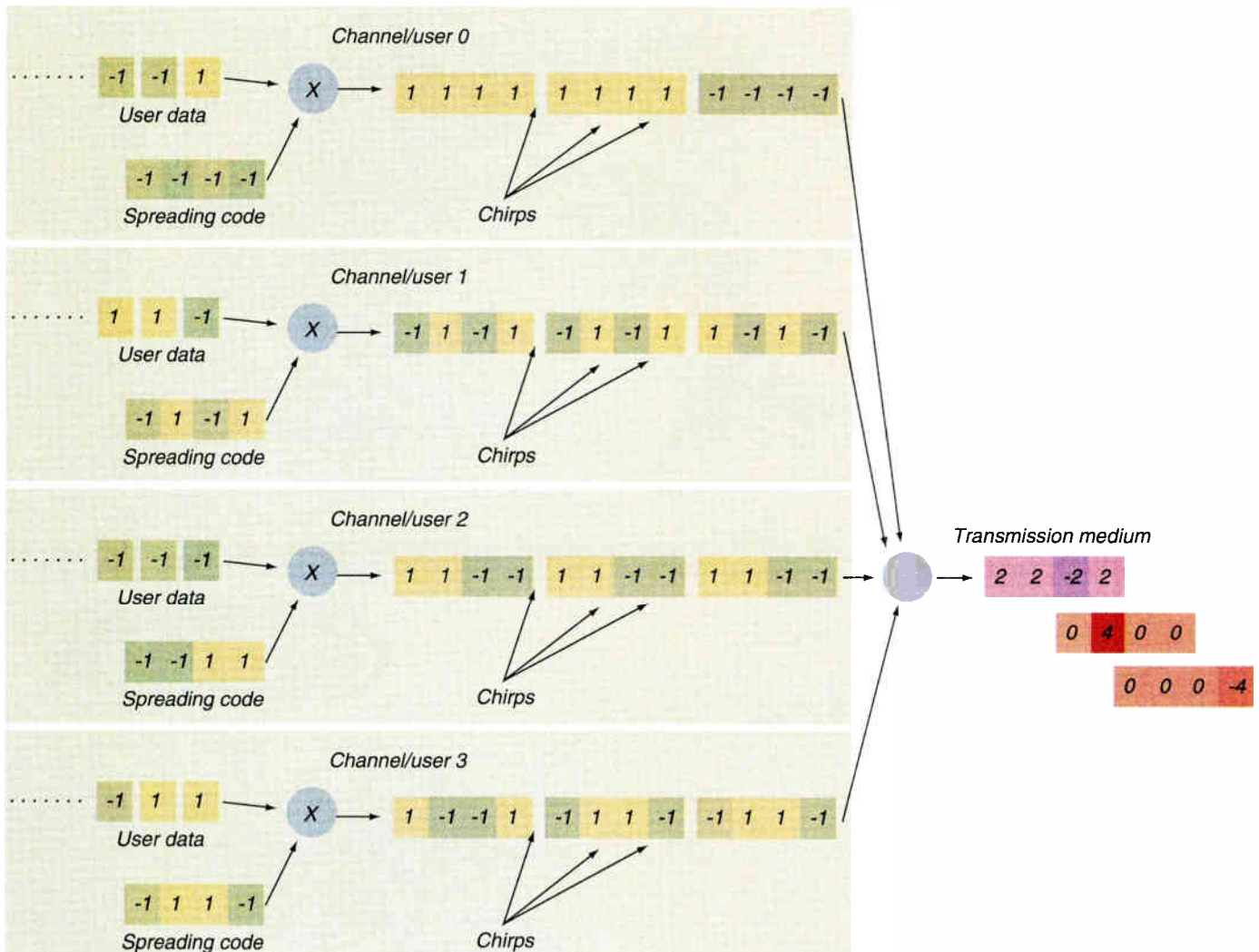



Now's not the time to be scratching your head with questions.

HP Callan 6000  
for cable  
television head  
end equipment

Get set up with your head end  
and have you automated the line  
that outputs your cable test equip-  
ment. After that your equipment is  
ready to go.

Two easy-to-use, row buttons per  
channel give you accurate and  
repeatable results every time you  
take a reading. Plus, its abundant  
data storage capacity lets you

2000 Hewlett-Packard Company

capture the results of tough tests  
automatically for in-depth analysis in  
the comfort of your office.

Get the only Head End about  
these measurements in the cable test  
industry there.

What's more, our three test mea-  
surements can help ensure don't have  
the same wire you're looking for, but  
instead the line technicians will

provide you with



HP Callan 6000  
for cable test other  
quality assurance



HP Callan 6000  
for all HP test equip-  
ment

work around  
whatever you

what you need them from

To find out how HP Callan can  
improve your cable TV testing  
ability (and maybe even get you  
some money) call HP Callan at  
1-800-432-4644, Ext. 3244.

© 2000 Hewlett-Packard Company

There is a better way.



**TULSAT**

### AD-1 AGILE DEMODULATOR

**\$399**

- \* Nyquist SAW Filter
- \* 4.5 Sub Carrier Output
- \* PLL Synthesized Tuning
- \* UHF, VHF & Cable Input
- \* Synchronous Video Detector
- \* Optional T-Channel Input

**BLONDER  
TONGUE**

**800-331-5997**

**TULSAT**

### VCRS PLUS

(Call for Latest Price)

**\$139.00  
HALFSIZE VCII CHASSIS**

**THERMOSTAT CONTROLLED FAN  
SAVES RACK SPACE**

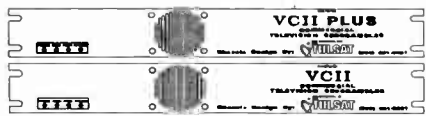

**(800) 331-5997**

**TULSAT**

### LARGE INVENTORY CONNECTORS

Popular & Hard to Find Sizes

Gilbert LRC  
Pyramid PPC Others

**TAPs DCs LEQs**

Magnavox SA Millenium  
Regal Eagle Jerrold Others

**TRAPs**

Positive Negative Tiering  
Eagle Arcom  
Pico Intercept Others

**800-331-5997**

## CODE DIVISION MULTIPLE ACCESS

Table 2: Output sequence (spread sequence)

	Bit time #1	Bit time #2	Bit time #3
Channel 2 data	-1	-1	-1
Channel 2 code	-1-1 1 1	-1-1 1 1	-1-1 1 1
Channel 2 spread data	1 1-1-1	1 1-1-1	1 1-1-1

relation properties of the code set utilized. Normally synchronous codes have high auto and cross correlation values and therefore will not benefit as much as asynchronous codes which are chosen specifically for these properties.

### CDMA in an HFC system

A great deal of insight may be obtained now by comparing an HFC system using FDMA/TDMA in the upstream path (toward the headend), with a CDMA system.

For a fully populated bandwidth (the available information bandwidth is fully utilized), the CDMA power (and SNR) advantage over pure TDMA (mentioned above) is severely diluted, if not completely lost. Digital RF carrier levels are limited by performance limitations in the analog video receivers, not the digital transmitters. Excessive digital carrier levels would cause cross channel interference as well as nonlinear distortion effects in the analog channels. Therefore, any SNR gain resulting from the CDMA power advantage mentioned earlier cannot be utilized effectively.

To support the number of potential users on a single coax (more than 150), synchronous CDMA codes would be required. This imposes severe synchronization requirements on each Subscriber Network Unit (SNU) or modulators. Bit timing between SNUs will have to be synchronized to within a 1/4 bit time. While not impossible, this imposes severe stability requirements on the timing generator module in the Host Distribution Terminal (HDT) at the headend. A TDMA system, on the other hand, does not require the simultaneous bit sync of all transmitters on the net; synchronization only requires that a given transmitter does not transmit during the wrong time slot. Several bits worth of guard band (dark space) may be inserted between TDMA slots, allowing for almost two orders of magnitude relaxation in sync accuracy.

Figure 4: DS demodulator

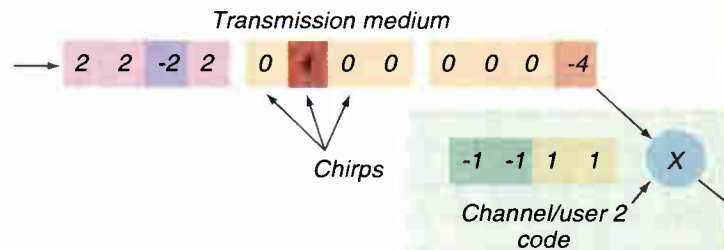



**Table 3: Unmatched code demodulator**

	Bit time #1	Bit time #2	Bit time #3
Channel 2 spread data	1 1-1-1	1 1-1-1	1 1-1-1
Channel 3 code	-1 1 1-1	-1 1 1-1	-1 1 1-1
Multiplier result	-1 1-1 1	-1 1-1 1	-1 1-1 1
Sum level	0	0	0
Crosstalk into channel 3	none	none	none

For a 40 megabaud rate, symbol time is 25 nanoseconds, and timing will have to be stable to within 6.25 nanoseconds at the SNU transmitters. Assuming 10,000-foot coax cable at 1.5 ns/foot propagation, the nearest and farthest SNUs must receive timing accurate to within 6.25 nsec during the delay of  $10,000 \times 1.5 \text{ ns} = 15 \text{ } \mu\text{seconds}$ . If the HDT derives its timing from a DS-1 interface with a Peak-Peak jitter spec of 5 Unit Intervals (UIs), the HDT PLL would have to have a step response (first order linear approximation) rise time on the order of  $(6.25e-9/15e-6) \times (5/1.544e6) = 128 \text{ seconds}$ . PLLs with such a narrow bandwidth have been realized using digital control loops (filters) but tend to be complex and expensive. The alternative would be to split up the 40 Mbps into multiple sub channels, at a lower data rate; each would then require a separate demod with reduced sync specs.

To further complicate matters, initial sign-on and phase adjustment (to compensate for the cable delays to various SNUs) of a new SNU might require the use of a separate channel with the identical delay characteristics of the main CDMA channel and could be implemented by reserving a time slot in each frame for clear TDMA traffic. This adds a whole new dimension of complexity to the system, not counting the added cost of a modem with such capabilities. An alternative method would use an asynchronous DS code possessing low cross correlation values with the synchronous codes, as the sign-on channel. Given that enough such codes exist to satisfy the simultaneous sign-on of several SNUs, the matter of modem complexity is still a major concern.

*Channel 2 demodulator*

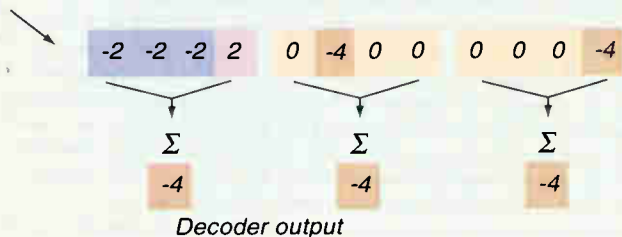

**OVERSTOCK SPECIALS**

**TAPs & DCs**

Scientific Atlanta

	NEW	USED
DCs	\$18.50	\$8-\$12
2-Ways	CALL	\$8-\$12
3-Ways	\$22.50	\$8-\$12
Taps	CALL	\$3-\$10

**TRAPs**

Used Neg Ch 2,5,6,A	\$1.50	All Swept 100 Min
New Neg Ch C,E,G	\$2.50	100 Min
Tiering Trap Ch AB	\$2.85	NEW USED \$1.95

**800-331-5997**

**SUB-BAND**

**Modulators DeModulators**

T-Channels, 4.5mhz & Agiles

**BT-2001 IRD'S**  
**BT-6185 IRD'S**  
Standard, Plus, VCRS or No Card Available

**BLONDER TONGUE**

**800-331-5997**

**NEW COMMERCIAL**

950-1450 mhz

**Satellite Receiver**

**\$249.00**

Crystal Synthesizer  
Narrow/Wide Band Audio  
3-Year Warranty

**BLONDER TONGUE**

**800-331-5997**

**TULSAT**

**TULSAT**

**TULSAT**

# ◆ CODE DIVISION MULTIPLE ACCESS

**Figure 5:** Power spectral density of data sequence before spreading

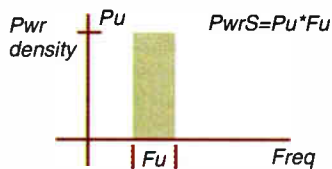

$u$ =unspread  
 $P_u$ =Power density of unspread signal  
 $PwrS$ =Original signal power  
 $F_u$ =unspread frequency bandwidth

**Figure 6:** Power spectrum after spreading

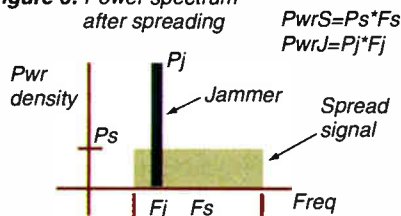

$s$ =Spread signal  
 $j$ =Jammer  
 $P_s$ =Power density of spread signal  
 $PwrS$ =Original signal power  
 $PwrJ$ =Jamming signal power  
 $F_j$ =Jammer signal bandwidth

**Figure 7:** Despreading (demodulation) including effect on jammer

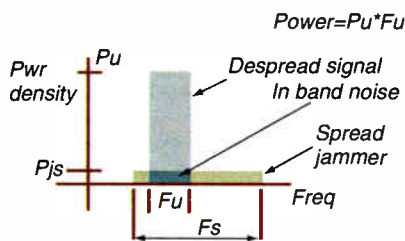

**Figure 8:** Synchronization model

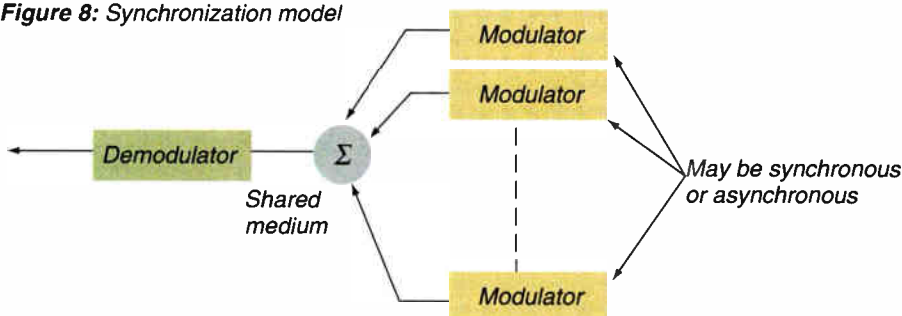

## Interference rejection

A fundamental point must be noted regarding CDMA. With all the available information bandwidth occupied with information, there is no increase in overall transmission bandwidth compared to a TDMA/FDMA system. Because spreading gain = 1, no overall spreading has occurred with zero corresponding increase in SNR after despreading (or decrease in error rate) measured across all the channels.

If, however, only a portion of the available information bandwidth is used, a certain amount of spreading gain may be realized with corresponding improvements in SNR and BER.

Consider, as an example, an HFC system where upstream transmission bandwidth is 6 Mbps per channel with 36 Mbps total upstream bandwidth available and only one channel in service. If a narrowband interfering signal falls inside the active channel's bandwidth, causing an SNR of 6 dB, the BER would fall to worse than  $10e-3$  assuming FDMA/PSK modulation. If, however, CDMA/PSK were used, the spreading gain possible (again 1 channel used only) is approximately  $10 \times \log(36/6) = 7.8$  dB, resulting in an SNR after demodulation of  $(6+7.8 = 13.8$  dB), and the resulting BER would be better than  $10e-9$ , assuming that overall channel power levels are maintained.

Of course, the FDMA system could detect the impaired performance and shift the channel to another band, incurring a period of errors in the process, whereas the CDMA system would incur almost no errors and require no BER monitoring for frequency management.

CDMA inherently does not provide any improvement in impulse noise immunity, and must be used in conjunction with a forward error correcting code such as a Reed-Solomon code, possibly in addition to interleaving to combat impulse noise effects.

CDMA provides significant performance advantages in an HFC environment only if the average information bandwidth is significantly smaller than the available channel information

bandwidth, and significantly large levels of narrowband interference or multipath must be rejected.

A typical application would be the upstream path in a concentrated HFC system. Here, the term "concentrated" is used to describe a channel or band shared by a number of users, only a portion of which are actively using the channel at the same time.

The channel bandwidth would be chosen to accommodate peak user traffic. No additional interference rejection performance is gained under these peak conditions. However, when traffic subsides to average rates and utilizes only a portion of the available bandwidth, narrowband interference rejection would be greatly enhanced, assuming that power control is used to maintain the overall channel power (sum of all active modulators) at maximum level.

Due to the large levels of broadband interference in the form of impulse noise, additional forward error correction codes should be incorporated into the coding scheme.

## Conclusion

CDMA may be used to gain significant narrowband interference rejection over conventional modulation schemes when used in a transmission channel such as the upstream path in a concentrated HFC network.

Formidable penalties are paid, however, in the form of synchronization requirements, which grow more stringent with higher bit rates, as well as modem complexity and cost. In most HFC applications, FDMA/TDMA access schemes can offer similar performance at a reduced cost. **CE**

## References

1. D.P. Whipple, "The CDMA standard," *Applied Microwave and Wireless*, 1994.
2. CableLabs, "Two-way transmission characteristics of cable systems," 1994.
3. J.G Proakis, "Digital Communications," second edition, McGraw Hill Book Co., 1989.



# SystemSelect™

FOR INTELLIGENT SOLUTIONS

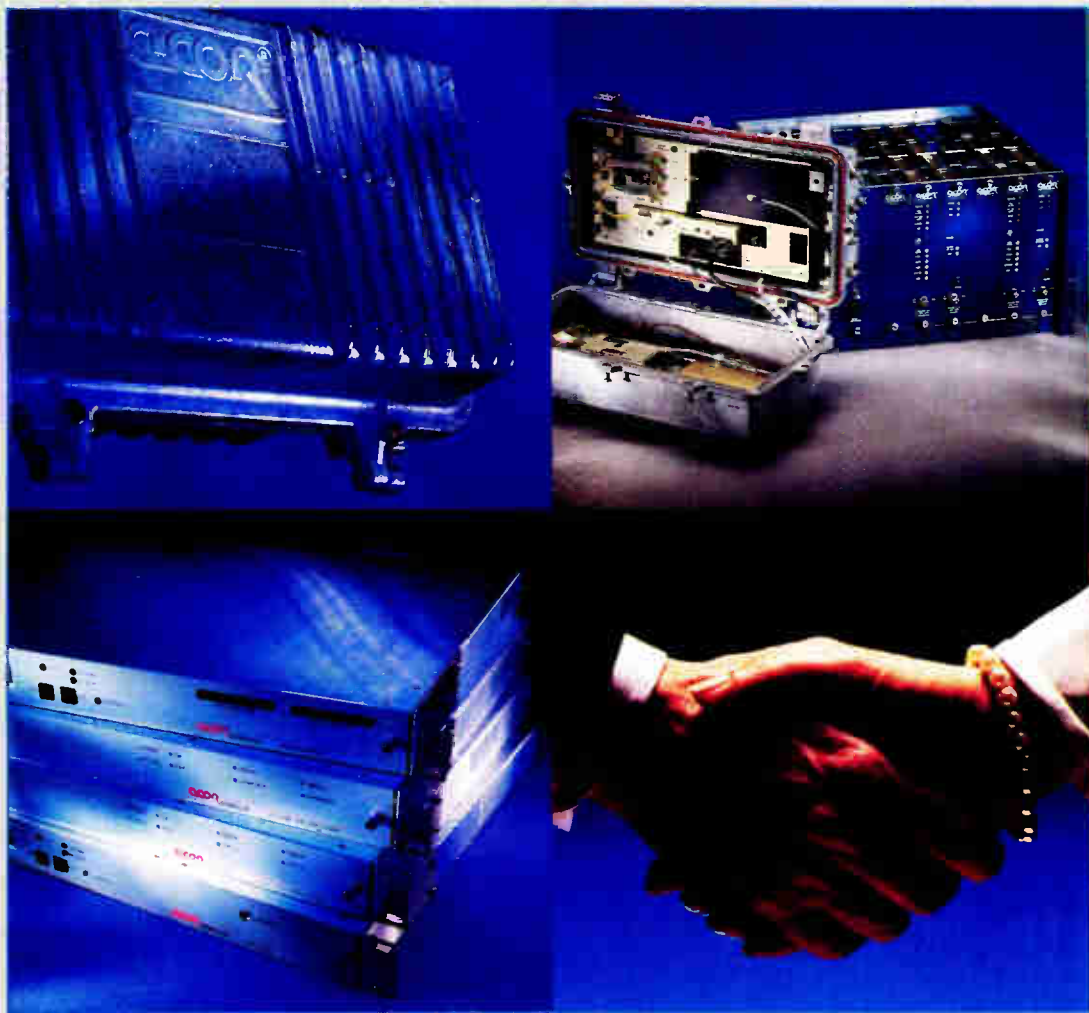

**SystemSelect™, C-COR's platform for a full range of network solutions for the cable television, telephone, and broadcast industries.**

Call now,  
**800-233-2267,**  
for more  
information  
about  
SystemSelect™.



C-COR's fiber optic and RF products offer advanced networking capabilities for today's hybrid fiber/coax architectures.

**POWERFUL**...LinkNet™ AM fiber optic equipment offers 750 MHz capability on single or dual fibers: redundant optical backup; a flexible, modular, upgradable platform; and the network management option.

**FLEXIBLE**...FlexNet™ RF amplifiers offer cost-effective, flexible capability from basic service to interactive multimedia. FlexNet™ 750 MHz amplifiers come in a 1 GHz housing and are backed by C-COR's extended warranty.

**RELIABLE**...Multi and single channel uncompressed digital video fiber optic systems provide highly-reliable, cost-effective delivery of video, audio, and data over long distances with no signal degradation.

Network analysis, design, installation and maintenance assistance, repair, training, and a 24-hour technical support hotline are also part of SystemSelect™.

**For Intelligent Solutions!**



60 Decibel Road  
State College, PA 16801  
814-238-2461  
800-233-2267  
Fax 814-238-4065

**CALIFORNIA OFFICE**  
47323 Warm Springs Boulevard  
Fremont, CA 94539-7462  
510-440-0330  
Fax 510-440-0218

**DENVER OFFICE**  
12742 East Caley Ave. / Suite A  
Englewood, CO 80111  
303-799-1100  
Fax 303-643-1743

**INTERNATIONAL OFFICE**  
P.O. Box 10,265, 1301 AG Almere  
The Netherlands  
31-36-536 4199  
Fax 31-36-536 4255

**CANADIAN OFFICE**  
377 Mackenzie Avenue, Unit 5  
Ajax, Ontario L1S 2G2, Canada  
905-427-0366 / 800-427-2559  
Fax 905-428-0927

# Not everyone out there has a need for interactive video.

## But not everyone can see the whole world at once.

**V**ideo is big. And not just video on demand, but interactive video. Video games, telecommuting, telemedicine, distance learning, the works.

Fujitsu's Broadway™ line of broadband products meets the demand. Our star architecture was specifically selected because it offers the capacity needed to move signals from the home as well as to the home — the key to interactivity.

It's time to get serious about providing video. Do you really want an architecture that lays all bets on that one "killer" application, like video on demand? Or would you rather depend on an architecture that gives your customers choices?

Ask them. After all, it's an odd creature that doesn't want to interact.

**BROADWAY™**  
THE BROADBAND YOUR AUDIENCE DEMANDS™

1-800-777-FAST ask for  
"Broadway"

[fujitsu\\_trans@msmail.fnts.com](mailto:fujitsu_trans@msmail.fnts.com)

Circle Reader Service No. 31

**FUJITSU**

