

# CED

COMPLIANCE



ENGINEERS AT THE MAGAZINE OF BROADBAND TECHNOLOGY / AUGUST 1989

career opportunities exist with one of the industry's leading cable television companies. Immediate openings in our VA, NC, SC, TN and GA operations for strong, motivated individuals with engineering and construction backgrounds to fill the following positions:

**Reward, respect & recognition: Searching for job satisfaction**

5 years experience in CATV maintenance. Oversee technical activities, verify progress, keep system records, etc. Send resume to:  
Cable Company  
Box 29  
Los Angeles, CA 90000

## SERVICE TECHNICIAN

Cable system in Northeast looking for technician who can trouble shoot and has knowledge of test equipment. Long hours, low pay. Little opportunity for advancement. Price experience a must.  
Jersey Cable  
Box 889  
Jersey City, NJ 43568

**SENIOR ENGINEER**-Must be a graduate engineer with 5 years construction and technical management experience. Organizational skills are a must. Benefits including dental, vision and company vehicle.  
Send resume to: Director of Engineering, Cable TV, Box 34, Vennice, VA 22189

## Chief Engineer

**Syndex: What it means to engineers**  
**Should cable develop own HDTV standard?**

**Vice President of Engineering**  
Immediate opening for VP of Engineering at large, urban cable system in the west. Applicant must be well-versed technically, have 10 or more years of industry experience, possess construction supervision and technical operations experience. BS degree in electrical or mechanical engineering required. Advanced written and interpersonal skills also required. Excellent salary and benefits. \$75,000 plus benefits. Send resume, complete with industry reference to: Personnel Department, Cable TV, Box J0501, Phoenix, AZ 56437.

end, earth station, construction and maintenance. FCC compliance a must. Position requires written and oral communication skills and ability to supervise others. Prior experience in cable television a plus. Send resume to: Director of Personnel, Cable TV System

**Technician**  
Cable television company seeks a qualified technician to design, implement and maintain microwave and satellite systems for CATV operations. Qualifications include 4+ years related experience, high school diploma or equiv. and knowledge of systems and equipment. Industry education/certification desired. Salary: \$26K.  
Send letter of application to:  
Cable Television  
Box M3000

## TECHNICAL SUPERVISOR

Growing MSO needs a strong individual who has 4 to 6 years of technical supervisory experience. Responsible for maintaining high quality cable operations, supervision and training of 14-16 technical staff and related administrative functions. Supervisory experience in a union environment helpful. Send resume and salary requirements to: Personnel Department, Growing Cable Company, 1332 West Point Ave, Baker, VA 59002

Director of Personnel  
Cable TV System



# Panasonic Built. From The Inside Out.

Every time you install a Panasonic® CATV converter, you're assured of uncompromised quality and performance. Because Panasonic CATV converters are designed and manufactured by its parent company, Matsushita Electric. Which means each CATV converter is Panasonic built. From the inside out.

Take the Panasonic TZ-PC140/170 Series. Employing the latest in manufacturing technology, Panasonic converters are built to exceptionally high quality standards. It's the quality your subscribers have grown to expect from Panasonic. And that will help avoid costly service calls.

And to provide today's subscribers with the sophistication they associate with all Panasonic video products, the TZ-PC140/170 Series provides features like BTSC stereo compatibility, skip-scan tuning and remote volume control (170 Series), to name a few.

Panasonic CATV converters. Built for you and your subscribers the way all converters should be. From the inside out.

## Panasonic Video Communications

For more information call:  
Northeast 609-589-3063 Midwest 513-530-9216  
Southeast 404-925-6845 West 415-947-0147

Reader Service Number 1

# MC<sup>2</sup> AIR-TIGHT CASES

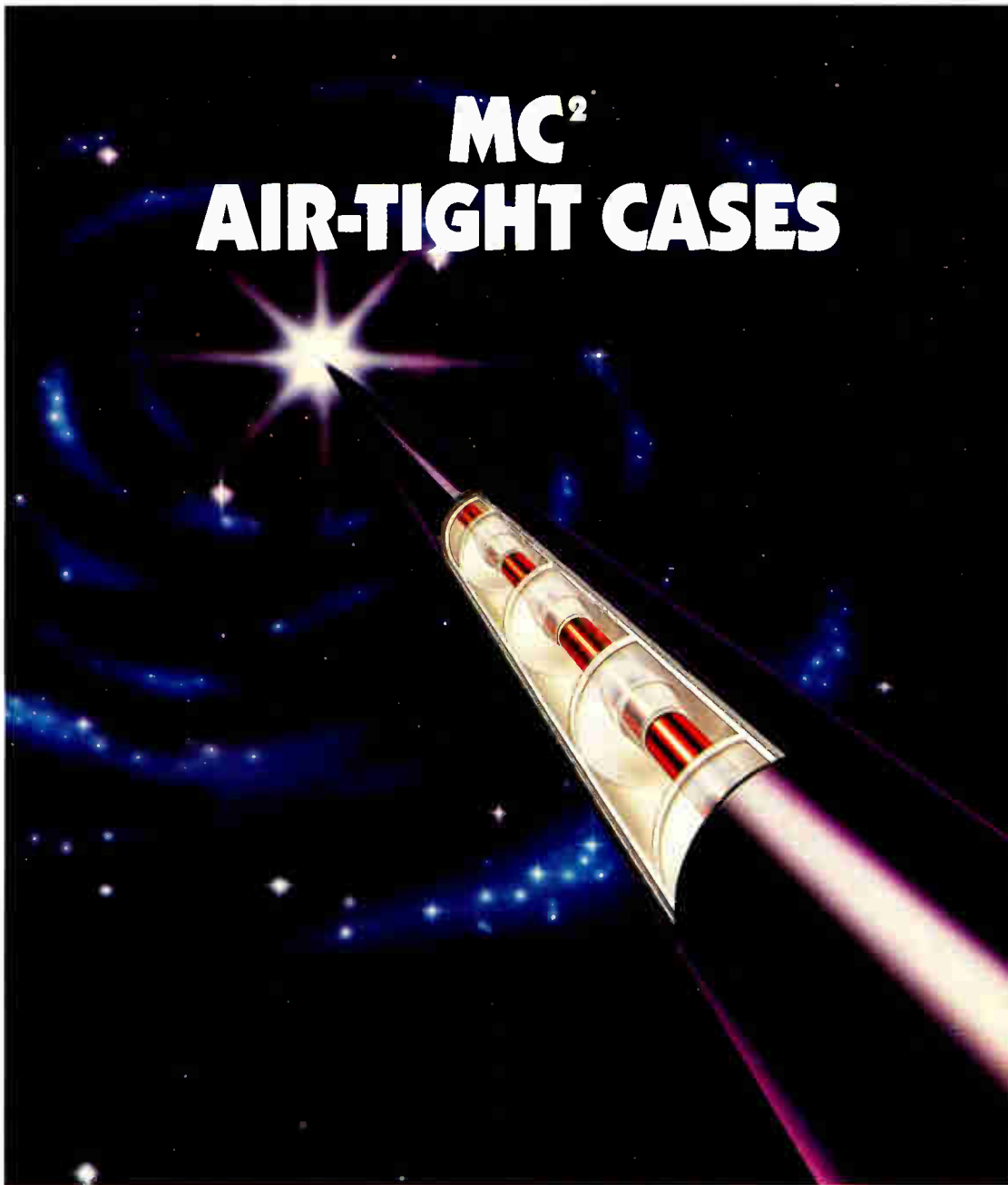

## Facts For The Perfect Offense.

With MC<sup>2</sup>, the facts speak for themselves:

**Fact:** Hermetically-sealed, compartmentalized structure makes moisture ingress unlikely—highly localized, if at all.

**Fact:** The 93% velocity of propagation allows one size smaller diameters than foam cables—more MC<sup>2</sup> per duct.

**Fact:** Superior attenuation allows about 20% fewer amplifiers in new-builds—stronger signals in rebuilds and upgrades.

**Fact:** Total bonding assures maximum loop-strength and minimum suck-out. Exceptional bending ability.

Case closed.

**The Choice Stops Here**



## Trilogy

COMMUNICATIONS INC.

Call or write for our free sample and brochure: TRILOGY COMMUNICATIONS INC., 2910 Highway 80 East, Pearl, Mississippi 39208  
800-874-5649 • 601-932-4461 • 201-462-8700

Reader Service Number 2

... construction, basic plant design, and system activation and  
 ... for these positions in VA and NC.

... salaries and benefits including dental, vision and company vehicle.

... of Engineering, Cable TV, Box 34, Vennice, VA 22189

**Chief Engineer**  
 ... will be responsible for en-  
 ... g and technical issues at local  
 ... vision site. Assistance with  
 ... 's efforts for technical devel-  
 ... thru policies and practice re-  
 ... Working knowledge of head-  
 ... station

**Vice President of Engineering**  
 ... immediate opening for VP of Engineering at large, urban cable system in  
 ... be well-versed technically, have 10 or more years of industry experie  
 ... nction supervision and technical operations experience. BS degree in  
 ... engineering required. Advanced written and interpersonal skills also  
 ... ed. \$75,000 plus benefits. Send resume, complete with indust  
 ... the MSO, Box J0501, Phoenix, AZ 56437.

**SERVICE**  
 Cable system in Nor  
 who can trouble shoot  
 of test equipment  
 little opportunity for a  
 experience a must.  
 Jersey Cable  
 Box 889  
 Jersey City, NJ

**Cable isn't what it used to be** 34  
 The second annual salary and job satisfaction survey discovers that relations between technicians and their managers aren't as rosy as they could be.

**About the Cover:**  
*This year's salary and job satisfaction survey uncovers strong undercurrents of dissension in the technical ranks. Just what do techs want? What are their concerns? Read the survey to see what's on their minds this year. Photo by Bob Sullivan.*

**Setting a de facto standard for HDTV** 44  
 Although much of the talk surrounding HDTV has died down recently, work on proponents is still forging ahead. This paper explores the possibility of cable setting its own standard—without waiting for an FCC decision.

**CLI COMPLIANCE**

**Frequency Allocation Chart** 51  
 Here it is! The updated annual Frequency Allocation Chart. Pull it out and save it.



DEPARTMENTS

- In Perspective . . . . .8
- Color Bursts . . . . .12
- Spotlight . . . . .16
- Frontline . . . . .20
- From the Headend . . .24
- Capital Currents . . . .26
- NCTA Notes . . . . .28
- SCTE Focus . . . . .30
- Back to Basics . . . . .98
- What's Ahead . . . . .104
- In the News . . . . .105
- Classifieds . . . . .112
- Ad Index . . . . .113

**How high? How fast?** 68  
 With all the talk of 1 GHz amplifiers, this article focuses on the need for the new electronics and what manufacturers are doing to develop the product.

**MultiPort: is it finally here?** 74  
 After a germination stage that has lasted years, MultiPort is finally about to be tested in the field. This story talks to the operators who have already begun small tests.

**Syndex and its technical implications** 78  
 Because of the impending deadline for syndex, operators are focusing on a solution. Just what syndex means technologically and what the manufacturers are doing is the thrust here.

*Planning on using a flyover? See page 88.*

**Looking at leakage from above and below** 88  
 In this month's CLI feature, Chris Duros with CableTrac and Edwin Dickinson with Dovetail examine airborne leakage data and sources.

©1989 by International Thomson Communications Inc. All rights reserved. CED (USPS 330-510) (ISSN 1044-2871) is published monthly except twice in May by International Thomson Communications Inc., 600 S. Cherry St. Denver, CO 80222. ©August 1989, Volume 15, Number 9. Subscriptions free to qualified industry readers. All other one-year subscriptions are \$36, prepaid in U.S. funds only. Second-class postage paid at Denver, CO, and additional mailing offices. CED is published on behalf of the cable television and broadband communications industries. POSTMASTER: Please send address changes to CED Circulation, 600 S. Cherry St., Suite 400, Denver, CO 80222. MEMBERS OF THE BPA.

# A reliable member of your community

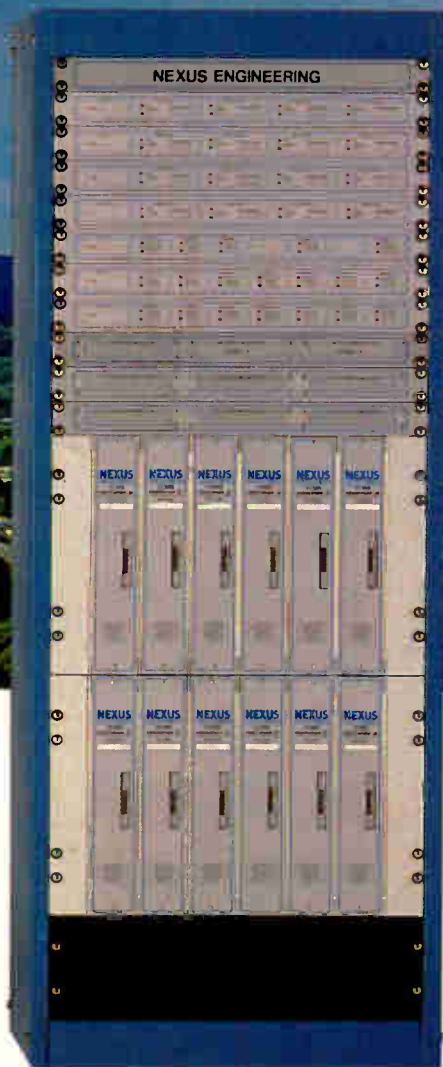

## NX-100 CATV HEADEND

*This 21 channel headend consists of:*

- 14 Satellite receivers
- 12 VideoCipher II<sup>®</sup> descramblers
- 14 Television modulators
- 7 Off air processors

*All in only 49" of rack space.*

Looking for a reliable, cost-effective headend? Look no further. The Nexus NX-100 integrated headend provides you with the solution. The NX-100 is based on the Nexus Series 100 product line, and features the revolutionary VCMB VideoCipher<sup>®</sup> Mainframe. The VCMB houses 6 VCII<sup>®</sup> descramblers in 12" of rack space.

The NX-100:

- sets a new standard for reliability
- is compact and easy to install
- offers unbeatable value.

The NX-100 — the complete solution to all your headend requirements. And like all of our products, it is covered by the famous Nexus five-year warranty. Call or write for details.

**Nexus** — Definitely Ahead of Our Time

TEL: (206) 644-2371 BELLEVUE, WA. or (604) 420-5322 BURNABY, BC. FAX: (604) 420-5941  
WRITE: NEXUS ENGINEERING CORP., 7000 LOUGHEED HWY., BURNABY, BC. V5A 4K4

**NEXUS**  
ENGINEERING CORP.  
PERFORMANCE  
YOU CAN SEE.

*rely on*

# Integral and **Setting the s undergro**

*1/4" Duct with  
.750 coax*

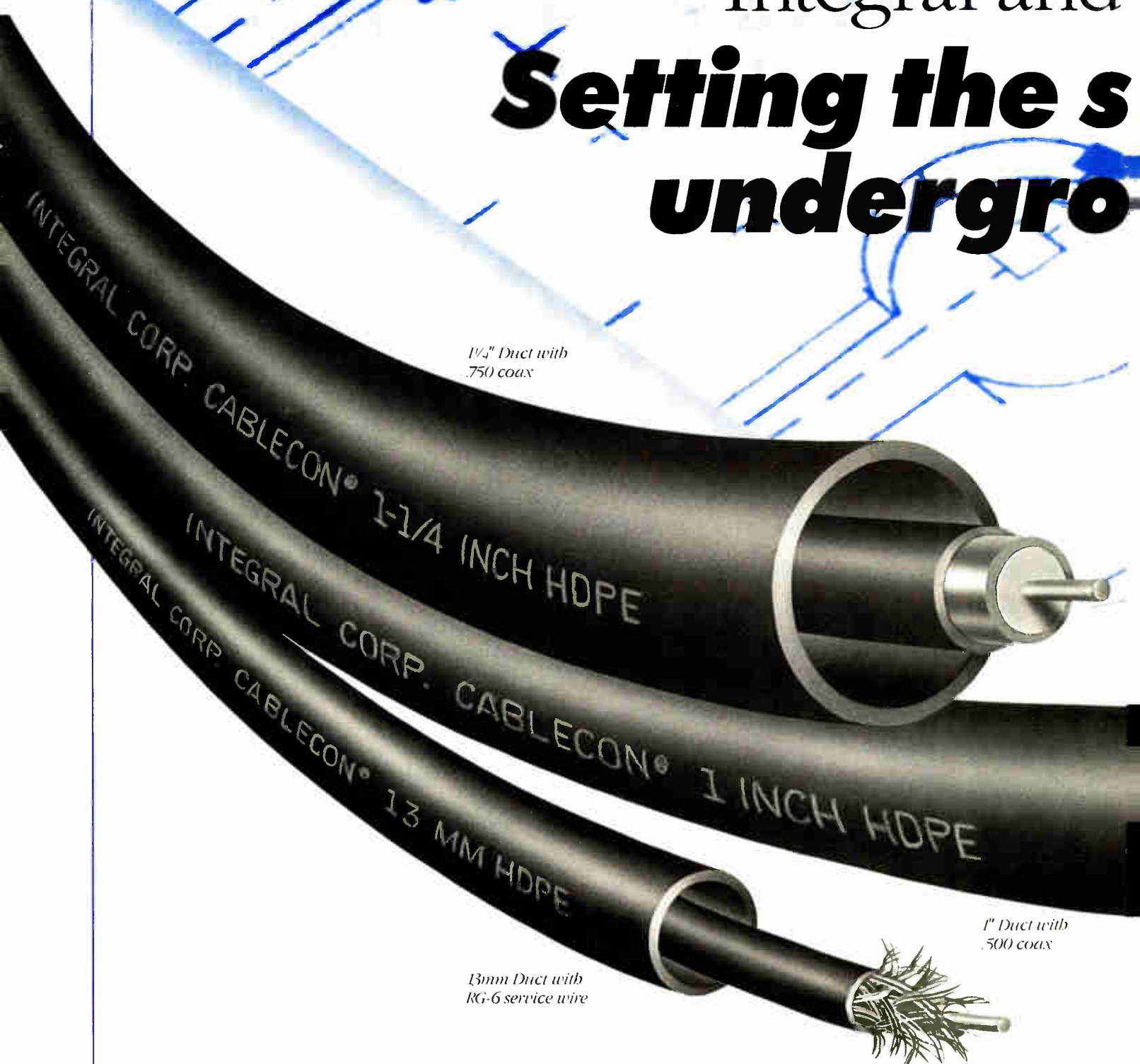

*1" Duct with  
.500 coax*

*13mm Duct with  
RG-6 service wire*

 **Integral  
Corporation**

**MARKETED EXCLUSIVELY BY**

Channell Commercial Corporation

**800/423-1863**

**800/345-3624**

**in CA**



# Channell... standards for underground plant.

Integral and Channell have been setting industry standards together for over 8 years. Our association has made us the leaders in providing underground materials for Cable Television plant: Integral's Cablecon® Cable-in-Conduit (CIC),

Drop-in-Duct (DID), and Fiber-in-Duct (FID); and

Channell's free-breathing above grade pedestals and airtight, watertight below grade enclosures.

To make it easier to order our complete line of high quality CATV products and to increase your construction efficiency, we would like to send you our new designer template — **FREE!** It contains all of the

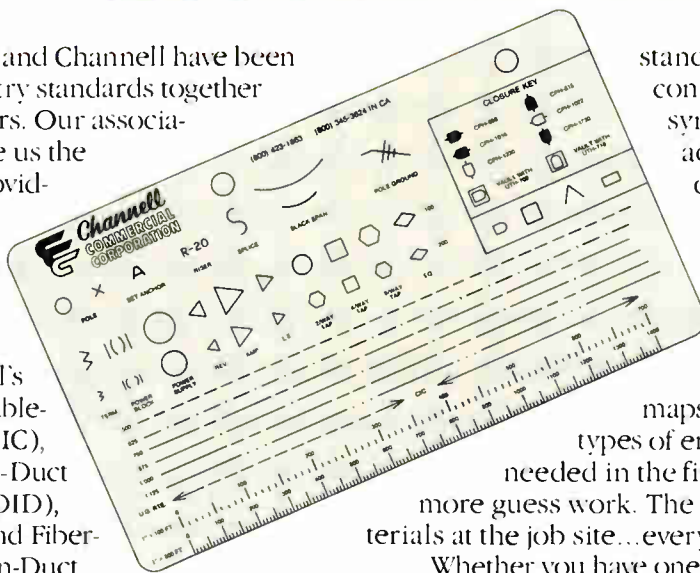

standard construction symbols adopted by our industry, plus new symbols that allow you to show on your base maps the exact types of enclosures

needed in the field. No more guess work. The correct materials at the job site...every time!

Whether you have one mile or a 100 miles of underground plant to build this year, why not buy direct from the Integral and Channell team? You'll save big bucks and be supported by one of the industry's largest direct sales forces in the U.S. and Canada.

Put our high standards to work for you today. Call **800/423-1863 (800/345-3624 in CA)**, or write for your **FREE** designer template and information on the complete line of Integral's Cable-in-Conduit products and Channell's above and below grade pedestals and enclosures.

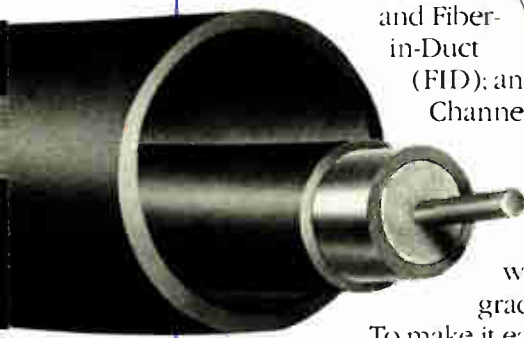

## Are you getting what you pay for?

Upon reading the results of this year's salary and job satisfaction survey (see page 34), it doesn't take long to realize there are strong undercurrents of dissension swirling under what appear to be still waters. A disturbing number of people are beginning to doubt they have much of a future in CATV—a surprise for an industry that has always been known for its optimism (perhaps only second to Realtors).

Managers say there are too many hassles; technicians grumble about poor wages. Everyone agrees that cable TV, which used to be a fun industry to work in and where everyone knew everyone else, became much more complicated as it grew to the point where it's now found in the majority of American homes. Regulations, competition, finding qualified, dedicated employees; it's all become too much, they say.

If cable plans to win its share of future battles and beat back competitors, it cannot allow its best people to leave and take their talents elsewhere. An industry that loses its seasoned veterans has to train newcomers from the beginning over and over again; it's like taking a team of rookies to the Super Bowl after your veterans got you through the playoffs.

So what can be done to keep the dissension from growing? The most obvious answer is to ante up to the players. Employees who work hard without positive reinforcement (bonuses, promotions, etc.) eventually wonder why they should labor so hard if they are never shown an opportunity to advance.

There are also ways to increase morale without boosting the payroll. Building employee teams to solve problems can make work *fun*. Providing forums for dissatisfied employees to get things off their chests can be both therapeutic for the employee and a real eye-opener for the employer. Simply *listening* to your employees and treating them with the respect they deserve could go a long way to building a satisfied, cohesive team.

Like cannibalistic animals that eat their young, the cable TV industry is in danger of reducing its ranks and allowing others to take over the fertile feeding grounds it fought so long and hard to get. Technical managers should assess their current problems, contrast those with what it is they want to achieve and ask themselves if they're aren't getting exactly what they're paying for.

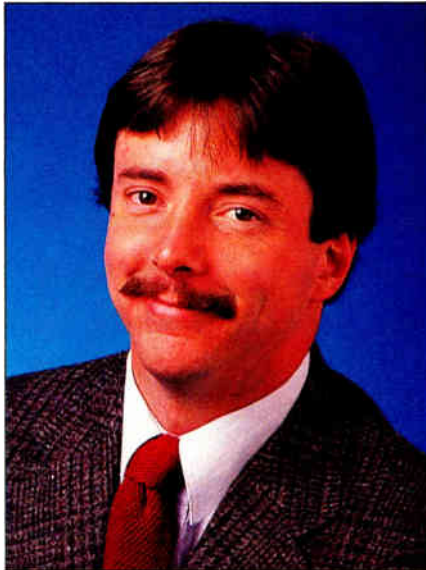

*Roger J. Brown*

Roger Brown  
Editor

William McGorry, Group Publisher  
Robert C. Stuehrk, Associate Publisher

**EDITORIAL**

Roger Brown  
Editor

Kathy Berlin  
Managing Editor

George Sell  
Contributing Editor

**CONSULTING ENGINEERS**

Chairman

Wendell H. Bailey, NCTA VP, Science and Technology

Members

Jim Chiddix, Senior VP, Engineering and Technology, ATC

John Dawson, Engineering Consultant

Roy Ehman, Director of Engineering, Jones Intercable

Tom Elliot, Director of Research and Development, Tele-Communications Inc.

Jim Farmer, Principal Engineer, Scientific-Atlanta

Paul Helmbach, VP Engineering, Home Box Office

Fred Kaiser, President, Alpha Technologies

Dave Large, Director, Video Product Planning, Raynet Inc.

Robert Luff, VP Technology, Jones Intercable

Steve Raimondi, VP Engineering, UA Cablesystems Corp.

Joe Van Loan, Engineering Consultant

**PRODUCTION**

Jeff Knight, Production Director

Don Ruth, Art Director

Elaine Callahan, Production Manager

Dick Benson, Circulation Director

**ADVERTISING**

Cathy Wilson, National Sales Manager

Judy Medley, Account Executive

Curt Stocker, Classified Sales Manager

**MARKETING AND SUPPORT**

Michelle Pazar, Author Support and Quality Assurance

Linda Hendrick, SCTE Chapter Support

**OFFICE**

Denver 600 S. Cherry Street, Suite 400, Denver, CO 80222 (303) 393-7449. Fax (303) 393-6654.

**ITCI**

INTERNATIONAL THOMSON  
COMMUNICATIONS INC.



The problem with separate receivers and descramblers is that by the time you have one of each, you don't have enough rack space left to mount a sheet of paper.

Enter the Agile 40C/K-IRD Integrated Receiver/Descrambler.

A single unit contains both the Standard Agile 40C/K and a VideoCipher® commercial descrambler. So you save about eight inches of rack space for every one you buy.

But don't let the small size fool you. The 40C/K-IRD is built to give you top perfor-

mance 24 hours a day. The unmodified receiver and a more efficient descrambler are completely RF isolated and have separate power supplies and heat sinks to decrease internal heat and greatly increase reliability.

It's also easy to set up and maintain. The proven Agile 40 C/K receiver has all the features cable operators need most: rock solid 100 KHz PLL tuning, 70 MHz IF with a front-panel test point to help minimize terrestrial interference, and Standard's internal 950-1450 MHz active loop-thru design to eliminate signal splitters. In addition,

the IRD front panel keeps the familiar commercial VideoCipher Power, Sync, Authorize and Bypass status lights.

Your local Standard representative has the full story.

But you might start thinking now about what you'll do with all that available space.

 **Standard**  
Communications  
SATCOM Division

P.O. Box 92151  
Los Angeles, CA 90009-2151  
Telephone: (800) 243-1357  
In California: (800) 824-7766  
(213) 532-5300 • Telex: 67-7173

Represented in Canada by:  
DGH Communication Systems Ltd.  
Scarborough, Ontario • 416/499-4746

Specifications subject to change without notice.



Space  
available.

SUPERIOR  
BILLBOARD CO.

## COLOR BURSTS

### CableData alters product offerings

In a significant move with both hardware and software implications, CableData has announced it plans to alter its product line to include a new Tandem computer and new software to replace its QuickData and QBS package. The decision was made because operators expressed strong desires for increased flexibility and more ability to share subscriber information with other computer systems, according to Nancy Frank, director of marketing.

As part of its new strategy, CableData will immediately offer cable operators the option of using Tandem's 2-year-old CLX 600 and 700 series computer system, which will support cable systems with up to 300,000 subscribers, in addition to the Tandem TXP product which has been installed at numerous cable TV sites. Both Tandem offerings are compatible with CableData's DDP software, which is scheduled to have a new update released on Sept. 1. The CLX computer is comparably priced to the QuickData hardware, said Frank.

In the longer term, CableData will be working on a new software package that will incorporate many of the most popular features of QBS and yet feature an open architecture that will allow operators to add data and "move it around" for greater utility with different vendors' hardware and software. This feature will allow MIS managers to get the flexibility and custom reports many of them desire.

The new software, to be called DDP/SQL (Structured Query Language), will be written in C language and is expected to be released sometime in the next 18 to 24 months, said Frank.

Regardless of the new focus, CableData's proprietary QuickData hardware, already installed in 80 U.S. systems and about a dozen European sites, will continue to be supported for "as long as they want to use that system," which will probably be a period of three to five years, Frank said. It will still be strongly marketed to the U.S. TVRO market as well as the European cable and DBS markets.

### Uniden enters cable TV market

Uniden, a well-known consumer electronics manufacturer, has extended its tentacles to include the SMATV and cable television hardware market. The company's initial offerings



*The Uniden CAT 50 modulator.*



*The Uniden CAT 100 receiver.*

will be a satellite receiver and a modulator with built-in stereo generator, which will be introduced at the Private Cable Show in Las Vegas. After that, an additional modulator, another receiver and one demodulator will be introduced into Uniden's product line, according to Rick Hebert, national sales manager of commercial products.



## Choosing the right cable and a white decision. Call MIDWEST

Need it now? Then call Midwest CATV. Full line inventory backed by great service.

Strand (foreign and domestic), trunk, feeder and drop. From a variety of manufacturers, in a variety of sizes.

Corporate Office  
Charleston, WV  
304 343-8874

Central Region  
Lafayette, IN 800 382-7526  
Outside IN 800 428-7596

Clarksburg, V  
Outside V



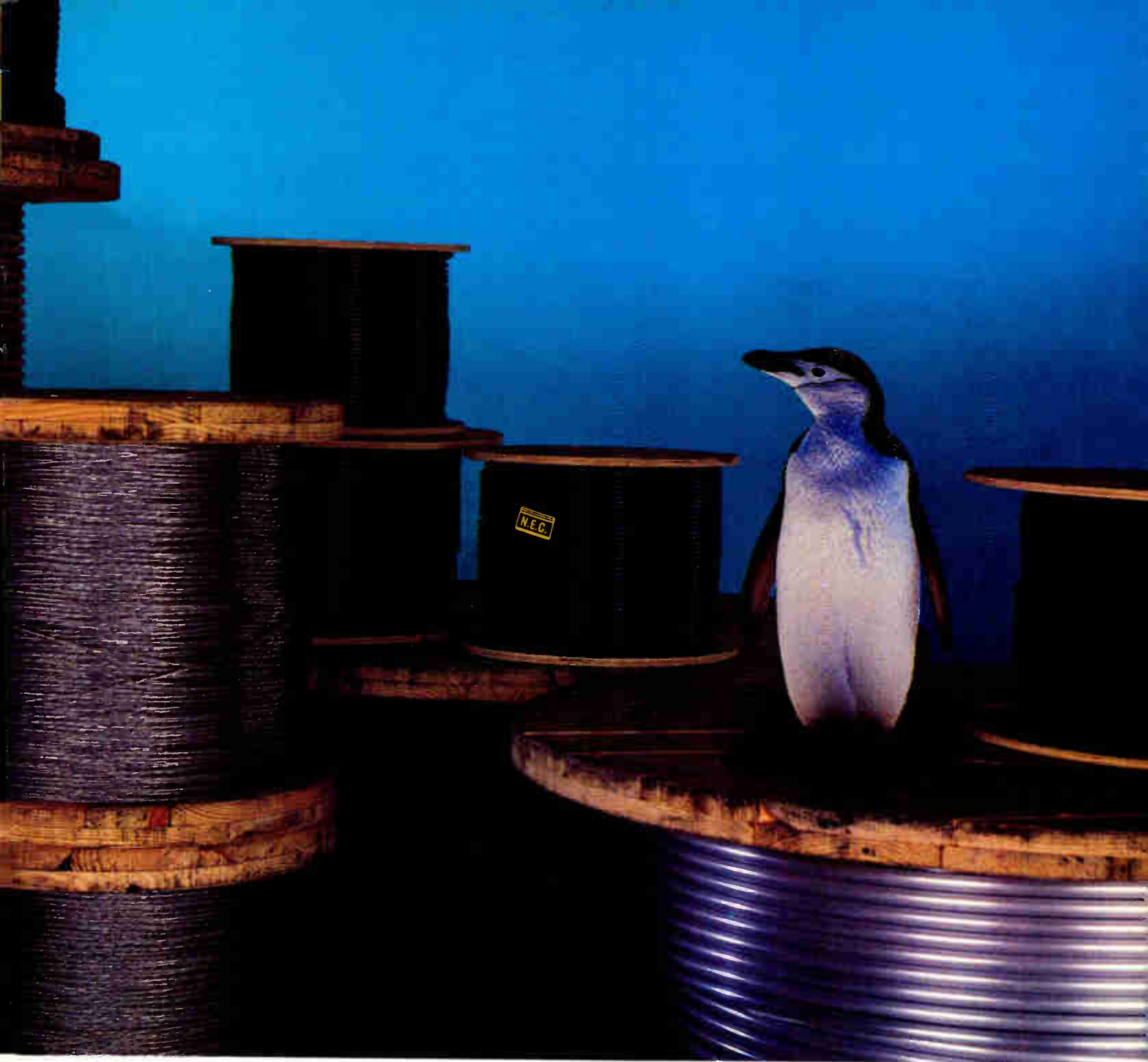

# rand supplier isn't always a black and T CATV first and see why.

Ready to ship from any of our nationwide warehouses.

Call the Midwest CATV office nearest you. Just tell 'em a little bird told you where to find the best service.



A division of Midwest Corporation

*More than supplies. Solutions.*

Reader Service Number 6

**ern Region**  
4 624-5459  
0 532-2288

**Northeastern Region**  
Pottstown, PA 215 970-0200  
Outside PA 800 458-4524

**Southern Region**  
Ocala, FL 800 433-4720  
Outside FL 800 433-3765

**Southwestern Region**  
Dallas, TX 214 271-8811  
Outside TX 800 421-4334

**Western Region**  
Denver, CO 800 232-9378  
Phoenix, AZ 800 782-4566

Uniden decided to enter the commercial side of the market after examining existing product and determining most of it utilizes "old technology" and yet commands premium prices. "Essentially, we found some companies charging more than \$1,000 for 1980 technology," said Hebert.

The CAT 100R is a frequency agile C-/Ku-band satellite receiver with tunable stereo outputs and built-in terrestrial interference filter. The two-inch high unit offers a threshold of better than 7 dB, selectable bandwidth (24 MHz and 32 MHz) and direct entry of desired frequency.

Uniden's other product—the CAT 50 stereo agile modulator—combines signal modulation and stereo signal generation in a single device that will be priced at about \$800, said Hebert.

Uniden already owns about 40 percent of the consumer satellite receiver market, said Hebert, and "we want to own a big hunk of this market too."

## Jones activates CAN in Augusta

The first leg of Jones Intercable's unique Cable Area Network hybrid fiber/coaxial cable system was acti-

vated in Jones' Augusta, Ga. system in late June. The nine-mile long trunk line serves nearly 7,000 subscribers and is this country's first deployment of a video network utilizing both AM and FM transmission schemes.

The CAN architecture used in Augusta is a variation of the one designed for Jones' Broward County, Fla. rebuild (*CED*, 2/89, p.27). FM links were added to the design to provide better performance into the AM portions of the plant and to the outer reaches of the system, which serves 59,000 subscribers.

The CAN system was designed to implement numerous fiber nodes into a cable system to reduce amplifier cascades (in this case from 42 amps to between five and 16), which improves signal-to-noise ratios, reduces system degradations and increases channel capacity. The architecture calls for the existing coaxial cable and microwave equipment to be left in place for backup purposes, greatly increasing system reliability.

By next spring, when the project is expected to be completed, a total of 17 AM and six FM lasers will send video signals over 179 miles. The rebuild cost is expected to be about \$300 per subscriber, according to Bob Luff, group vice president of technology at Jones.

At the press conference, Luff explained the benefits of the fiber system. A demonstration of the system was held on the lawn of one of the system's subscribers and direct comparisons were made between the fiber and coax delivery mechanisms.

Fiber hardware for the project is being provided by Anixter Cable TV (Synchronous equipment for the FM portions, AT&T electronics for the AM); plant construction is being done by Kennedy Cable Construction. Both firms provided hardware and services ahead of schedule, allowing Jones to activate the plant sooner than planned.

## Kahn pulls plug on NYT overbuild

Irving Kahn's dream of a fiber optic overbuild in southern New Jersey turned into a regulatory nightmare and is now apparently dead. Choice Cable Corp., of which Kahn is chairman, withdrew its 11 cable television franchise applications and abandoned plans to overbuild NYT Cable because Kahn saw no end to "government inaction and red tape at the state level," he said.

Saying he had "never walked away from a project before in my life," Kahn lambasted the New Jersey State Office of Cable Television for allowing the hearing process to become so protracted and NYT Cable for utilizing legal actions to delay competition.

"In response to NYT Cable's maneuvers, the State regulators have moved in a slow and complicated manner, which only served to frustrate our efforts, increase our expenditures and advance NYT's obvious attempts to ultimately thwart the competitor," Kahn said.

In addition to the legal red-tape, Kahn's plans were dealt a blow earlier this year when NYT Cable was sold to a consortium of cable operators who are open to the idea of installing fiber optics in the system. Kahn has previously said he's satisfied the new operators will do a better job running the system than the previous owners did.

Kahn now will reportedly turn his attentions to fiber hardware; he's said he plans to research and develop a new fiber optic switch that will alter the way business is done in CATV. You can bet the industry hasn't heard the last of Mr. Kahn. ■

—Roger Brown

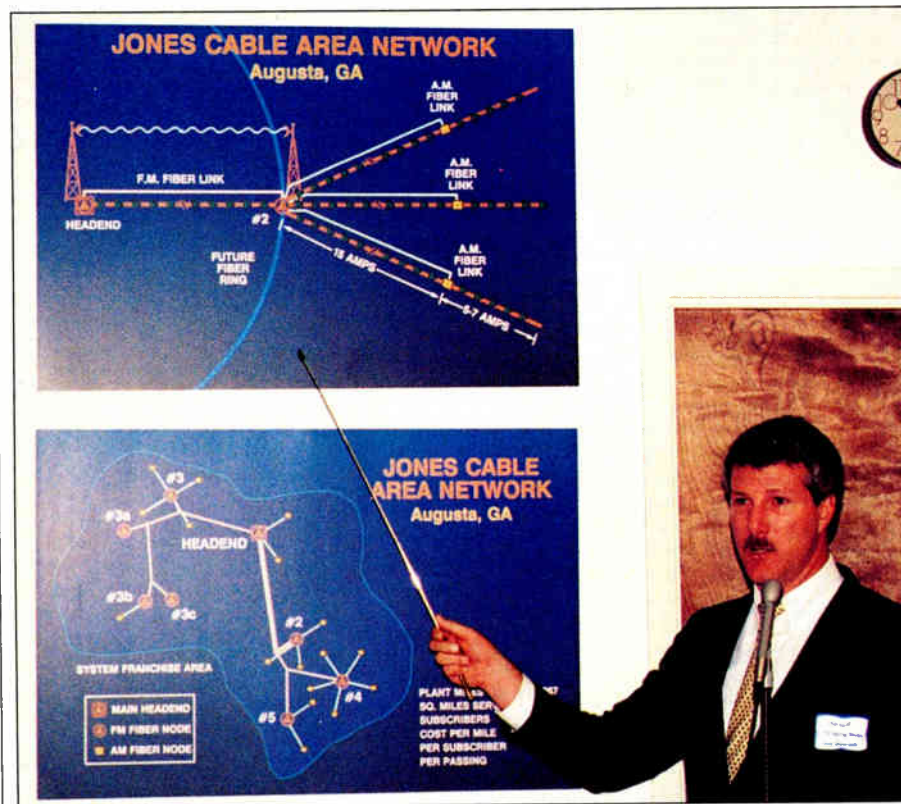

Jones Intercable's Bob Luff explains the Augusta system architecture.

# WE DON'T BITE THE HAND THAT INSTALLS US.

Specify Times T6 coax for the most rugged trunk and feeder

cable in the business. Also the most flexible and trouble-free.

With up to half the bend radius of the competition.

That's because only Times T6 is triple bonded.

The center conductor, dielectric, outer conductor,

and jacket operate as one mechanical unit. And

if the cable is somehow damaged, the dents

are clearly visible. So your installer

won't put up cable with unseen

defects inside. It also helps

prevent center conductor pull-outs during cold snaps. T6 also

offers full 600 MHz bandwidth. And the price won't break you

either. Costs are competitive with cable that gives less — and risks

more. For more information, call 1-800-TFC-CATV. Or write

us at 358 Hall Avenue, Wallingford, CT 06492.

We'll bend over backwards to help you.

Or frontwards. Or whichever way you need.



**TFC**  
TIMES FIBER COMMUNICATIONS, INC.®  
an LPL company

Where technology meets the bottom line

Reader Service Number 7

Distributors:

The Drop Shop  
800-526-4100

Hudson Supply  
Company Inc.  
800-441-0666

Midwest CATV  
317-448-1611

Power and Telephone  
Supply Company  
800-238-7514

TVC Supply Company Inc.  
800-233-2147

Deskin Sales (Canada)  
800-268-9832



Jack Trower

## Nurturing customer satisfaction

Cultivating a garden is often seen as hard work. For Jack Trower, newly elected president of the Society of Cable Television Engineers (SCTE) and corporate engineer for WEHCO Video Inc., gardening is seen as a relaxing, back-to-nature type of endeavor. But the underlying principles of gardening actually apply to Trower's personality in everyday life—the willingness to start a project, diligence in putting in the necessary time and the determination to work long and hard, if necessary, to ensure the end product is worth the effort.

With the cable industry, Trower's end product is customer satisfaction. And the nurturing hand that feeds that content is technical operations. "The most important responsibility I have as corporate engineer for WEHCO," says Trower, "is to make sure that the customer is getting the best quality product from a service viewpoint that we can give him. If I do that, everything else I do goes toward that objective."

To Trower, that means personnel who are: better trained, able to interact with customers better, able to do technical marketing, presenting the best image possible within the community and still maintaining good signal levels to the customer's home (without leakage). Although it may seem a formidable task, Trower sees it as

possible—and necessary. "If we don't pay attention to our technical operations from a customer viewpoint, rather than the bottom line," says Trower, "we're going to find ourselves with less bottom line to play with."

### Air Force was good background

Trower credits much of his outlook on life and work to his 21.5 years in the Air Force. Joining the service in 1956, Trower had ambitions of getting a commission and becoming a pilot. Instead, he spent most of his service career supervising, operating, managing and maintaining more than 30 complex communications systems. These included broadband systems, air-to-ground voice and data systems, navigational aide systems and speciality systems. Although this formed the basis for his engineering days in cable, Trower felt the most significant attribute of his service days was "the self-discipline I learned."

After ending his tour of duty in 1977, Trower spent some time adjusting to the civilian world by attending college and working briefly for Gemini Explorations. It was a football game, though, that opened the door for Trower's entry into cable television.

While attending his older son's game, Trower met and had a conversation with Len Harrison, who at that time was general manager for United Cable Television of Bossier City, La. Although Harrison felt Trower's background in communications was right for an engineering position, there were no openings and the subject was dropped.

However, Trower was later contacted by Harrison as he was leaving for a final interview with a steel company in Louisiana, and asked if he could drop by before his appointment. During their discussion, Harrison "convinced Trower he wanted to be in the cable industry" and Trower left the meeting as the newly hired system engineer for Bossier Cable. "It was very fortunate for me," says Trower, "because I've really enjoyed cable. I can't believe I wasn't in it for 100 years."

Although Trower originally felt he had no experience for cable television, he soon found the technology and the technician's abilities in the industry quite primitive compared to the Air Force. Broadband amplification was very simple in the service and Trower expressed surprise at the techniques

used by those in CATV. "Of course, after I'd been around for a while and saw the problems in the environment, I understood why it hadn't gone further than it had," states Trower. And early on, Trower saw the necessity for training. "One of the things we've seen in the last 10 years has been the fact that we train people better," says Trower. "But I still think we have a long way to go."

In the latter part of '79, Harrison was hired by B-Con Construction Company and Trower took over as temporary general manager for the Bossier system. Although Trower's goal was to become the permanent manager of the system, the new vice president for United "was of the MBA mentality that you couldn't have a general manager unless he had a business background and degree," says Trower. Since Trower didn't fit that bill and wasn't happy about United's plans for his career, he resigned.

### What? You again?

Later that same day, Trower dropped by the neighborhood bar and ran into his former employer, Len Harrison. When Harrison heard Trower had quit, he told Trower he wanted to start an engineering department for B-Con and asked if he'd be interested in the position.

"So I built an engineering department," laughs Trower. The department immediately got into strand mapping, design, quality control inspections and balancing some systems. But it was a different kind of job for Trower.

"With a cable system, it's easy to sit and listen to the sales pitches and decide who you're going to buy from," says Trower. "You didn't have to worry about making a payroll as much because you had a built-in revenue stream." Once the department got up and running, Trower was put into sales—something he'd never done before. "Now, I had to sell myself, the company and make payroll," he muses. "Everybody tells me I'm a salesman anyway but I've never seen myself as one. I like the one-on-one interaction with people. I enjoy that very much," Trower continues. "But I don't know if I could ever survive from a sales commission."

After two years with B-Con, Trower, Harrison and Sam Shirley left the company out of mutual consent and formed SJL Communications Inc. (The

# the **SOURCE**

The new Saturn 3.1 meter antenna.  
Exclusively from Midwest Communications.  
The premier antenna for C- or Ku-Band  
reception.

Dish and mount pedestal are precision-  
formed of high-grade steel. For durability.  
And years of consistent, low-maintenance  
performance.

This compact, affordable antenna from  
Midwest comes packed in one box, ready  
for easy ground or rooftop installation.

Save time, money and maintenance.  
With the Saturn all-steel 3.1 meter antenna.  
With a 10 year limited warranty –  
Exclusively from The Source.  
Midwest Communications.



**MIDWEST**  
Communications Corp.

One Sperti Drive • Edgewood, KY USA 41017 • (606) 331-8990

Reader Service Number 8

'S' was for Sam, the 'J' for Jack and the 'L' for Len.) The company was structured as essentially a competitor to B-Con: construction and engineering was its focus. Shortly after starting the company, Shirley left to work for WEHCO Video and Trower and Harrison continued the day-to-day operations of SJL. "It was then that I worked myself into health problems," says Trower.

"I was trying to do too much, working 18 to 20 hours a day, when my heart knocked me on my knees and said 'look here.'" After laying in intensive care for two weeks, Trower decided to get into a more relaxed atmosphere and sold his share of SJL to his partners. "I'm a workaholic. I love to work," states Trower. "And I had to take a new look at the way I do things. I still work, I still get up early, but I've learned to walk away from work when I need to," he adds.

Because Trower still wanted something to do, he started his own business, Trower CATV Services, in August, 1983. He immediately became involved with WEHCO Video as an outside consultant for an upgrade in Longview, Texas. After completing the 400 mile upgrade, Trower did additional design work and put together an audit team for WEHCO. It was during a discussion of audit teams with Jim Wilbanks, executive vice president of operations for WEHCO, that the topic of permanent employment with WEHCO, a mid-sized independent cable operator, came up.

"I agreed to move to Little Rock, Ark. as the corporate engineer for WEHCO," says Trower. "It was one of the smartest things I've ever done, both for the job and the city." So, in March, 1985, Trower made what he considers his final move in the cable industry. "I plan to be with WEHCO as long as I'm in the cable industry. I don't think there's a better job in the industry to be honest," Trower remarks.

#### Time to grow

Now that Trower had his feet planted firmly in one spot, he began to look at what his job entailed and how he could improve technical operations. Since training was uppermost in his mind as an integral part of operations, Trower began looking around for ways to help train his technical personnel. Although Trower had been a member of the SCTE since 1979, he had not been actively involved because of the lack of meeting or chapter groups in the

Arkansas/Louisiana area. "There wasn't any SCTE in the southcentral part of the U.S.," he recalls. "If you wanted to be in the SCTE, or get involved, you had to be on the East coast."

However, while attending a technical seminar put on by a regional distributor, Trower became involved in a discussion about starting a meeting group in Arkansas. Before he knew what was happening, an election was held during the seminar and Trower found himself the second vice president of the proposed meeting group. Think-

**'If a company is not out there doing its job right, and servicing its customers the way it should be, someone else will come in and do it for them.'**

ing this would be a good way to get some training for his personnel, Trower was pleased at the thought of the group forming. Unfortunately, both the newly elected president and first vice president were not SCTE members, did not join as they promised, and nothing happened.

Tired of waiting, Trower called Ron Boyer, who had been elected secretary, and the two decided to forge ahead with the meeting group. "We sent out a notice about a meeting group on such and such a day, said if you want to be a part of it, show up, if not—that's your problem," chuckles Trower. "We had about 18 to 20 people show up. Well, I opened my mouth and started pushing things around and got elected as president of what was then called the Razorback meeting group.

"I was still looking at it from the viewpoint that I was going to be able to train my people," says Trower. Regardless of the reason, things started rolling from there. Trower was eventually asked to run for the national board and was elected as the Region 8 director for the 1988 to 1990 term.

Once on the board, Trower started looking at things that could be done for the Society and decided the only way

to affect Society decisions was to run for president. After doing a little research and finding he had the support for the campaign, Trower ran and was elected president of the SCTE for the 1990 term.

"It was very gratifying," reflects Trower. "I was quite honored." During his presidency, Trower wants to influence the Society and the industry in different ways. "We've really moved forward in the last 5 years—giant leap after giant leap and put on some good programs," Trower says. "This next year I'd like to see us, I don't want to say stop or not keep progressing, but I want us to take a deep breath and look at those programs that we've put in during the last 5 years. We need to shore them up and make them strong.

"If we look seriously at strengthening all our programs, we won't lose the good things we have when we try and take another giant leap. I think there's more leaps out there, but we need to get off on a solid footing and a solid foundation."

Some of those future "leaps" Trower mentions includes an improved dialogue with the National Association of Broadcasters (NAB) on technical issues; more rapport with the Canadian association; and more standardization stemming from the recommended practices committee of the SCTE. "I think we'll see those kinds of things occur and it will be beneficial to the Society and the industry as a whole," he adds.

As for the future of the industry, Trower looks at it as exciting and at the same time, very competitive. Because he sees the possibility of competition from the telcos, Trower goes back to his underlying principle of customer service. "We have to prove that we can produce and deliver the product in the best manner for customer satisfaction," says Trower. "If a company is not out there doing its job right, and servicing its customers the way it should be, someone else will come in and do it for them."

With Trower's "green thumb" digging in, this may mean the difference between talk and action. For Trower, the SCTE presidency is a means to influence the Society and the industry. "I'm new to this and only plan on being president one year," Trower says. "Most of the things I'm going to affect will come from a procedural matter of shoring things up. That's my goal." Hopefully, as with Trower's very successful garden, the end product will definitely be worth the effort. ■

—Kathy Berlin



# BIG THINGS COME IN SMALL PACKAGES



## *Pioneer Sets the Industry Standard: Introducing the BC-4600 Standard Wireless Remote Converter with Volume Control*

- Volume Control/Mute
- Volume Level Display
- Parental Control With "Couch Potato" Remote Override
- Volume, Mute And Parental Control Indicator Lights
- Sleep Timer For 30, 60, Or 90 Minutes With Indicator Light
- Large And Clearly-Labeled Remote Control
- Parental Control Channel Skip
- Muted Sound On Channel Change
- Favorite Channel Memory/Last Channel Recall
- 550 MHz-HRC, IRC/STD — Programmable
- Output Channel — Programmable
- Frequency Offsets And Channel Remapping — Programmable
- Upper Channel Scroll Limit — Programmable
- Enable/Disable Volume And Parental Control
- Enable/Disable IR Remote And Sleep Timer
- Convenient Switched AC Outlet
- To Guard Against Surge Protection-Capristors

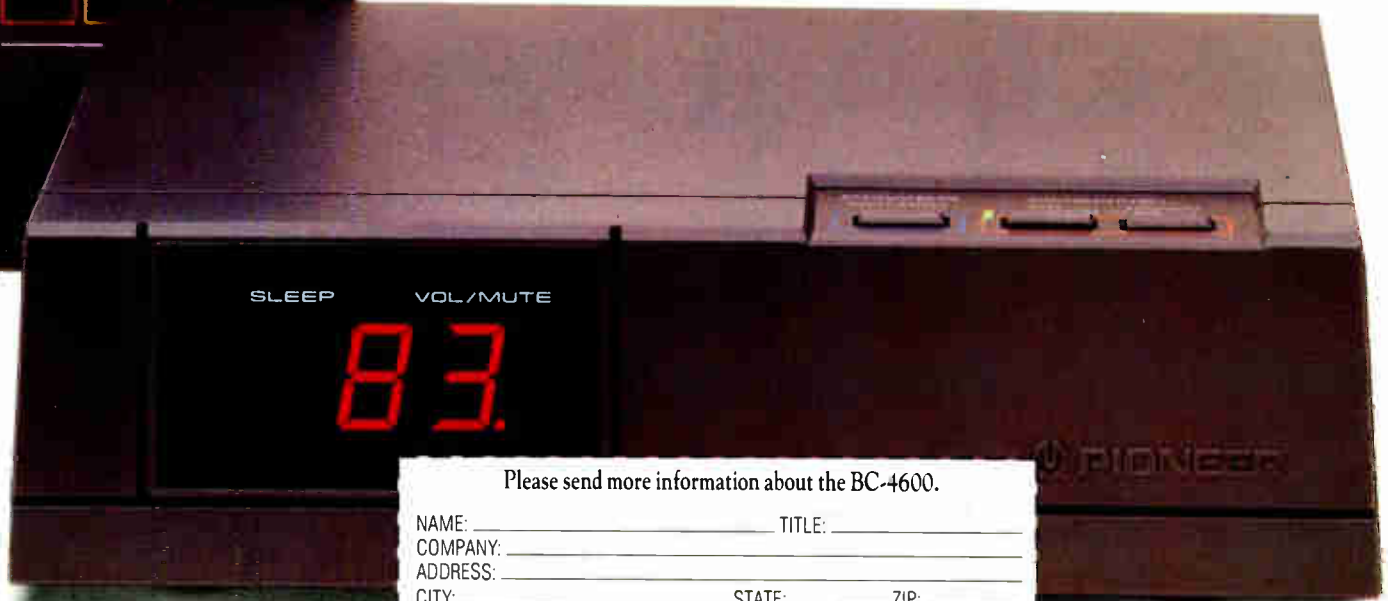

Please send more information about the BC-4600.

NAME: \_\_\_\_\_ TITLE: \_\_\_\_\_  
 COMPANY: \_\_\_\_\_  
 ADDRESS: \_\_\_\_\_  
 CITY: \_\_\_\_\_ STATE: \_\_\_\_\_ ZIP: \_\_\_\_\_  
 PHONE: \_\_\_\_\_  
 ATTENTION: BC-4600 Marketing

**ACTUAL SIZE**



PIONEER COMMUNICATIONS OF AMERICA, INC.

600 East Crescent Ave. • Upper Saddle River, NJ 07458 • (201) 327-6400  
 Outside New Jersey (800) 421-6450

© 1988, Pioneer Communications of America, Inc.

Send this coupon in today to receive a free "World of Pioneer" Poster. \*Poster offer for a limited time only.

- Stereo TV Compatibility — BTSC Transparent
- For Easy Inventory Tracking — Individually Bar-Coded
- For Accurate Tuning — Phase Lock Loop (PLL) Circuit
- To Maintain Stable Output Frequency — Saw Resonator
- Compatible With Pioneer SmartRemote™
- Non-Volatile Memory

Reader Service Number 9



## Information age already here

With increasing public awareness of high definition television (HDTV), it's not surprising that I was recently asked to speak about this and other new technologies to a large, well organized consumer group. This group was composed of 25 or so members, each of whom purported to represent consumers and their interests in one way or another.

As often happens when the topic is HDTV and EDTV (extended definition), the questions and discussions were expanded to include fiber optics. This also prompted questions of the possibility of the telephone companies (telcos) providing "true" HDTV via fiber optics better, sooner, easier and cheaper than cable television.

Readers of this magazine generally know the way to answer these questions and the difference between possibility and wishful thinking. However, one question (or statement of desires) made me pause. The speaker stated that he wasn't so sure the telco/cable differences mattered that much. Instead, he thought what was needed for the future emancipation of the average consumer was the development of informational data bases. Not only to have the data bases, but the ability for every consumer to easily use and benefit from their use.

*By Wendell Bailey, Vice President  
Science and Technology, NCTA*

### Information is available

What gave me pause was the realization that so few intelligent, well-read civic leaders are aware of the wealth of information available from electronic data bases today. On reflection, it appears that there is a large segment of the population that does not realize how much information and help is already available. Most are also unaware that this information is available to any citizen from his telephone and/or home computer, the VCR and tape rental outlet, a cable television system, the local post office and/or the public library.

Someone has convinced those who influence public opinion that the cornucopia of easy, cheap and vast information access must wait for technology changes in the future. The tone of the question strongly suggested that the required changes were related to the wiring of homes with fiber optics, along with the freeing of the regional bell operating companies (RBOC) to provide informational data bases.

What I find dangerous in this attitude is the fact that there is a second group (not quite as large as the first)

Guess who provides  
full motion video for  
pay? As Pogo said  
'it's us.'

who take for granted the same information and helpful material. The use of a home computer or even a touch tone telephone can yield an incredible abundance of data for any facet of daily life: airline schedules, crop reports, weather maps, statistical summaries, bank statements, movie times. The list of such items is truly endless. I would go so far as to say that the net number and usefulness of existing data bases will not be materially different 10 to 15 years from now—regardless of who optically wires the world or is allowed to produce and own the contents of data bases.

The essential difference between the larger group that looks longingly to the future for this bounty and the smaller group that knows and uses it today is

in the training and exposure to the access tools. The tools, I submit, may get easier to use, but the amount of information available is already enormous and accessible to anyone who knows how to ask for it.

### Telcos did their homework

The problem with this difference is that the telephone companies have done a masterful job of convincing people that only by telco intervention in the information marketplace will such things as bank-at-home, shop-at-home and informational data base access, via gateways, be possible. Telcos have others convinced that this intervention will only be possible if they are freed from regulations that prevent the installation of fiber optics in place of its existing copper based plant.

The truth is, there are *no* regulations that prevent RBOCs from replacing twisted pair copper plant with fiber optics on coaxial cable. The telco problem is that the change out has to be paid for by someone and that someone is the rate payer. In order to justify the cost difference, the telcos are touting the "new enhanced" services that bring their view of the future to the American public.

The unstated fact is this information is *all* available today, with the exception of full motion video. And guess who provides full motion video for pay? As Pogo said "it's us."

### Sending the right message

One of the attendees at the consumer leader seminar was asked to comment on the issue of telcos providing information (content based) services via their plant. His response was worth repeating. He said, "If the telcos are allowed to have it their way, all consumers should place a hand firmly over their wallets." This message, and the existence and capability of the information infrastructure already in place, should be a story the cable television industry goes out of its way to make wildly known.

We should also take pains to learn all we can about what is available and how subscribers could benefit from this knowledge. The industry that helps the consumer move into the information world of today will be well positioned to provide the services that are demanded by consumers in the future. ■

# Can You Tell the Difference?

---

## PROBABLY NOT! THE QUALITY OF PYRAMID PEDESTALS MAKES THEM SECOND TO NONE

---

Yes, Pyramid pedestals are now better than ever with some differences. For example, paint is electrostatically applied with computer-controlled equipment. This results in a long-lasting—average 25-years in use—finish that successfully meets stringent REA specifications and ASTM testing.

With Pyramid it's easy for installers to open the lid without paint-damaging tools. Convenient hand-holds are part of the pedestal's lid.

Your active equipment will stay cooler. You'll find that Pyramid pedestals provide more ventilation louvers than the competition which allows for maximum heat dissipation.

Next time you need pedestals choose Pyramid and call Hudson for a quote. Pyramid's approved by the major MSOs and is in stock at each of our nationwide warehouses.

So try Pyramid by calling Hudson. We get your order right the first time or we pay the freight!

**HUDSON**  
SUPPLY COMPANY, INC.

*Experience that Cares.*



**Los Angeles**

1-800-441-0666

FAX (818) 964-3664

**Chicago**

1-800-331-2258

FAX (312) 640-0568

**Atlanta**

1-800-343-9919

FAX (404) 979-9622

# Ask for the



## ***You did, and we delivered. . .***

### **Free Modulators.**

When you buy a 550 MHz output converter from ISS Engineering, you receive our modulator free. For about the price you'd pay other manufacturers for an output converter alone, you receive our output converter plus our Series II modulator, all in one space-saving unit—a savings of over \$700.00. We also give you HRC, IRC and T subchannel at no extra cost,\* all user-selectable via convenient, front-panel adjustments. More importantly, our modulator offers you expanded output capabilities from 54 to 550 MHz without the need for comb generators or special output modifications to comply with FCC stability requirements.

### **Equipment That Stays "Legal" Over Time.**

Others may claim to conform to current FCC regulations, but over time, dependent on ambient temperature, their components age and drift. Our components stay legal because we use temperature-controlled oscillators, each with its own oven and FCC-required offsets in both positive and negative

directions. So, frequent adjustments and maintenance are unnecessary and you can feel confident that your ISS equipment will stay stable over the long term.

### **Practical, Reliable Agility, Because You Really Do Need It.**

We at ISS were the first to make agility practical, reliable and compact. Before we introduced our line of agile modulators and demodulators, agility was expensive, cumbersome and often inaccurate. Our decision to specialize in agility, coupled with the manufacturing experience we've developed over the years, has now made us the market leader.

Other companies have fought to catch up with ISS by saying they now offer agile components, but their components are in reality quick, knock-off products, manufactured by an outside source, to which they have attached their labels. One claims that agility is not necessary all the time so it is provided for you only when you need it. If this is true, why has a whole market sprung up devoted to selling "used" modulators?

# Moon.



So when you're looking for agility, look to the leader the other leaders have been following—ISS Engineering. ISS' agile components were chosen by:

- Major cable television and broadcast operations.
- Two of the nation's largest, billion-dollar linear accelerators.
- Numerous federal agencies.
- Networks covering the papal visit and the Reagan/Gorbachev summit.
- The Seoul Olympics.
- U.S. armed forces' shipboard operational and video services.

And we "added life" to one of the largest soft drink manufacturers in the world.

**When you ask for the moon, don't be surprised when ISS delivers.**

For more information, please call or write:  
ISS Engineering, Inc.  
1047 Elwell Court, Palo Alto, CA 94303  
West: Toll-free (800) 227-6288 or (415) 967-0833  
East: Toll-free (800) 351-4477 or (205) 853-6919  
FAX (415) 967-0772

## **ISS** **Engineering, Inc.**

**We Simply Bring Communications Down to Earth.**

Reader Service Number 11

\*Series II Plus

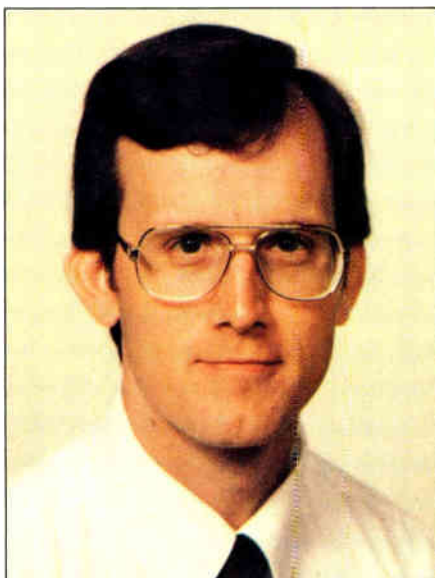

## G/T calculation

Last month we learned that the G/T of an earthstation can be considered as a figure-of-merit for its performance. This month, we'll dig a little deeper into the subject and present a set of equations that can be used to calculate the G/T of a typical system.

The G/T of an earthstation is the ratio of the gain, at a specified reference point in the system, to the system's noise temperature referred to that same reference point. In Figure 1, for example, we could choose the reference point to be either at the output of the antenna, at the input to the LNB, or at the output of the LNB, etc. The interesting thing is, no matter which reference point you choose, the calculation for G/T will always yield the same answer. So think of the reference point as nothing more than a convenient place to perform the calculation. For purposes of this discussion, I have chosen the reference point to be at the input to the LNB.

In order to calculate G/T, we need to know the various power gains (or losses) of each device in the system, as well as the effective input noise temperature of each device. Unfortunately, it's not often that all of the information we need is given to us—we usually have to work for it. This work is usually in the form of some intermediate calcu-

lations that must be made to translate the data we are "given" into a form that we can use.

So, what are we usually given? As shown in Figure 1, at the input of our "typical" system we have an antenna with a gain of 50 dB and a noise temperature of 25 Kelvin. The antenna is followed by a waveguide adapter (maybe an OMT) for the LNB which has a loss of 0.3 dB. The LNB itself has a noise temperature of 70 Kelvin and a gain of 50 dB. The LNB is followed by 17 dB of coaxial cable and splitting losses before finally reaching our satellite receiver which has a noise figure of 12 dB.

Note that the specifications outlined above for each component in the system are typically specified by the manufacturer. The only parameter we're missing in order to perform the G/T calculation (except for the standard transformations between dB and ratio) is the noise temperature of each of the "lossy" components in the system.

### Easily calculated

The effective input noise temperature of a lossy passive device can be calculated easily from its specified loss. Simply think of the loss of the device as being its noise figure. Our waveguide loss of 0.3 dB would translate into a noise figure (NF) of 0.3 dB, or a noise factor (f) of  $10^{(0.3/10)}$  or 1.07. Its effective input noise temperature can then be calculated using the standard equation for translation between noise factor and noise temperature:

$$T_e = (f - 1) * 290$$

where  $T_e$  is the effective input noise temperature and f is the noise factor of the device. You can then perform this same calculation to determine the effective input noise temperature of the coaxial cable and splitter, as shown in the diagram. You now have everything you need to perform the G/T calculation.

The 'G' in G/T is simply equal to

the sum of all of the power gains (or losses) in the system up to the reference point you have chosen for the calculation. For our purposes, the reference point gain (G) is equal to the sum of the antenna gain and the waveguide loss for a total of 49.7 dB, or a power ratio (g) of  $10^{(49.7/10)}$  or 93,325.43.

The system noise temperature at the specified reference point is not so easily described. In words, it is equal to the sum of the noise contribution from each component in front of the reference point with the effective input noise temperature of the components following the reference point. The noise temperature contribution of the antenna and waveguide is equal to:

$$(T_A + T_W) * g_W$$

To this we must add the effective input noise temperature of the rest of the system. You will recall that the effective input noise temperature of any series of cascaded devices can be derived by the general formula:

$$T_e = T_1 + T_2/g_1 + T_3/g_1 * g_2 + \dots$$

where  $T_n$  and  $g_n$  are the effective input noise temperatures in Kelvin and the power gains in ratio form of each cascaded device, respectively. For our purposes, as shown in Figure 1, we can simply substitute the LNB, coax/splitter, and receiver parameters as devices 1, 2 and 3, respectively.

Once the gain (g) and system noise temperature (T) at our chosen reference point are known, we simply take 10 times the log of their ratio to find the G/T of the system. ■

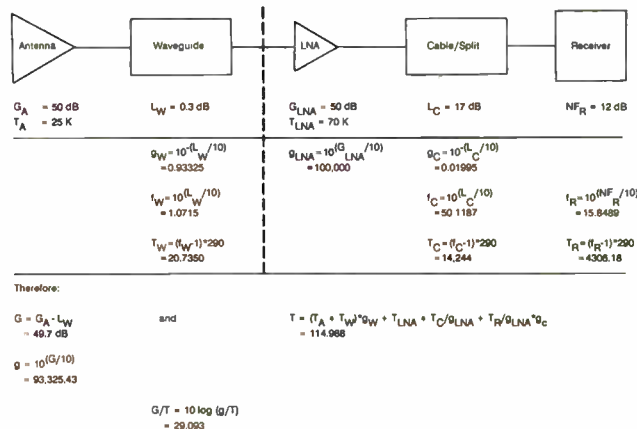

where:  
G = Gain in dB  
g = Gain in numeric ratio  
NF = Noise Figure in dB  
f = Noise Factor in numeric ratio  
T = Effective Noise Temperature  
L = Loss in dB

By Chris Bowick, Director of Engineering, Headend and Earth Station Products, Scientific-Atlanta





### Cable, sports and politics

Almost five years after enactment of the Cable Communications Policy Act of 1984, and two years after the rate deregulation provisions of that law took effect, there are rumblings of dissatisfaction among consumers and in Congress that, perhaps, the Act went too far in deregulating the cable industry. Much of the dissatisfaction, as we've discussed before, focuses on recent rate increases and on what is perceived as poor customer service.

But rates, customer service and quality of programming aren't the only factors that affect consumers' and legislators' views on cable television. There is, in addition, an uneasiness about how cable television will ultimately affect the availability of sporting events to the public. If it were to appear that cable television were somehow diminishing access to sporting events, public reaction would be severe.

#### That will be \$5 please

There's nothing new about this concern. Historically, broadcasters, movie studios, theatre owners and others who have sought to thwart competition from cable have understood that nothing could strike fear in the hearts of Americans more effectively than the

*By Michael Schooler, Deputy General Counsel, NCTA*

prediction that someday they'd have to pay to watch the World Series on cable television.

In 1975, the FCC adopted rules that actually prohibited cable systems from showing, on a per-channel or per-program basis, any specific sports event (like the World Series or Super Bowl) that had been shown on broadcast television within the previous five years. The FCC's ostensible concern was that shifting the World Series to cable would deprive the vast majority of viewers of the opportunity to watch the World Series, even if they were willing to pay for it. The FCC's anti-siphoning rules were, however, ultimately struck down by the United States Court of Appeals as unreasonable and outside the FCC's jurisdiction.

Soon thereafter, the siphoning issue died down. With the advent of satellite-delivered cable programming, which began at about the same time that the FCC's anti-siphoning rules were adopted, the effect of cable has been not to siphon off sports programming from broadcast stations but to supplement broadcast sports with much more sports programming than was ever before available. Broadcast networks continued to carry their football and baseball games of the week, and local stations in major markets continued to carry local and regional teams' games. Cable networks and superstations, meanwhile, provided a wide array of games and events that would not have been available over the air.

#### Sunday night football causes concern

Several recent occurrences have, however, begun to raise the old siphoning concerns again. First, ESPN's acquisition of the rights to show a weekly Sunday night NFL game, for example, did not diminish the number of NFL games available over the air to non-cable households but provided an extra game each week to cable viewers. Still, the fact that one or two games of a local team might not be available on over-the-air television in that team's community each season might have created political problems if ESPN had not agreed to allow each of its games to be broadcast over the air in the competing teams' communities.

Second, in some major league cities in which local broadcast stations showed most of the home team's games, there has been some migration of those games to cable—and, in some cases, to

premium rather than basic service. For television viewers in these cities, the prospect of having to pay for the very same thing that they became accustomed to watching free has been cause for alarm—even though for viewers in most cities (including those of us in Washington, D.C. who don't even have a baseball team), cable sports channels have vastly increased the number of games available.

Finally, even those who were willing to pay for Yankee games on cable were outraged when a now settled contract dispute between Cablevision and Madison Square Garden Network kept MSG (and, thus, all nonbroadcast Yankee games) off Cablevision's New York systems. Few sports fans may have understood or cared about the underlying dispute as to whether MSG should be carried as a basic or premium service. All they saw was that the cable system looked like a gatekeeper who was preventing them from even choosing to purchase the Yankee games that used to be free.

One result of the recent occurrences is that anti-siphoning legislation has been introduced that would limit the ability of baseball teams to shift television rights from broadcast stations to cable networks. Specifically, the bill introduced by Rep. Schumer of New York would prevent a team from giving a cable system exclusive local rights to more than 25 percent of its televised games in any year.

The prohibition would not apply, however, if (1) at least half of the team's televised games are broadcast by local television stations; (2) none of the games shown on cable are carried on a pay-per-view basis; and (3) the games shown on cable are carried on cable systems available to at least 75 percent of the cabled homes in the local community. Finally, the prohibition only applies to teams that have, in at least one of the last three years, televised at least 65 percent of its games on over-the-air broadcast stations.

But whether or not this legislation is ultimately enacted, the recent furor demonstrates the unique sensitivity of viewers (and legislators) to sports on television. Cable's demonstrated ability to vastly increase the amount of available sports programming ought to be a political and public relations plus. But if cable is ever seen as a gatekeeper that limits access to sports programming, trouble could ensue. ■





**IN THE NEAR FUTURE UL COMPLIANCE  
WILL BE THE REQUIRED STANDARD FOR  
UPGRADES & NEW BUILDS.**

Augat/Broadband is ready for tomorrow *today*. We're the first to introduce a complete line of UL approved indoor distribution amplifiers.

This means, in many cases, only Augat/Broadband *automatically complies* to building and fire codes.

At Augat/Broadband we know the importance of UL approval. So be ready for tomorrow *today* with Augat/Broadband. Innovation and foresight mark the qualities that make Augat/Broadband a leader in the CATV and LAN industries.

For more information call Augat Communications Group at 206-932-8428 or write to P.O. Box 1110, Seattle, Washington 98111.



WE'RE AUGAT COMMUNICATIONS GROUP WE TIE IT ALL TOGETHER...WITH EASE

## Syndex deadline getting closer

The first NCTA Engineering Committee meeting of the new committee year was held in Orlando, Florida just before the SCTE Engineering Conference and Expo, with Dr. Walter Ciciora chairing the committee. The first item of business was an update of issues in Washington delivered by Wendell Bailey.

### Syndicated exclusivity

The requirement to drop programs for which local channels have syndicated exclusivity comes into effect on January 1, 1990, unless court challenges are successful. NCTA is not appealing the regulations in court but a number of operators are challenging the rules. Operators should now be reviewing the requirements for equipment and manpower to implement the program deletions. Considering the number of systems and channels affected there will probably be long lead times for equipment as the deadline approaches. NCTA has prepared an information package on the implications of the rules.

The FCC has reviewed the need for the compulsory license and concluded that it should be abolished. It will recommend to Congress that the license be abolished. The broadcasters believe that compulsory license and must-carry issues should be tied together. If must-carry is not re-implemented, then the compulsory license should go, they say.

The Commission is now unable to act on a number of issues pending appointment of new commissioners. Commissioner Dennis has secluded herself on 17 items and this leaves only two commissioners while at least three are necessary to vote on an issue.

The number of meetings taking place on advanced TV continues at a very high level. Little progress is being made on the selection of a transmission standard as there is no equipment to test. It will be close to a year before a sufficient number of proponents are ready to begin testing. At least 18 months will be necessary to complete the tests and recommend a standard.

*By Brian James, Director of Engineering, NCTA*

Cable Labs and the Advanced Television Test Center are working toward developing joint tests and cooperation.

### Cerritos

The FCC granted a waiver of the cross ownership rules for a 5 year experimental system. There is presently no fiber in the ground, however, conduits are empty and waiting for the fiber. Fiber installation is expected to begin if the CCTA appeal is denied.

Rate increases and service quality have resulted in numerous complaints to Congressional representatives. Recent hearings have produced a lot of cable bashing and sensitized members to cable problems. While no immediate Congressional action is expected to occur, the long-range outlook is poor. The industry must change the present impression or risk a re-imposition of rate regulation.

The stay of the implementation of the requirement to provide information regarding A/B switch use and availability has been lifted. Operators must begin educating subscribers on the possible need and use of A/B switches.

The FCC is reviewing the need for a satellite scrambling standard. NCTA is filing comments opposing the implementation of a standard as there is a *de facto* standard and it is working well at this time.

### Subcommittee reports

Walt Ciciora reported that Cable Labs and ATTC are working toward an agreement on funding for advanced TV tests. The exact details of the amount and manner of funding has not been worked out, however, it is expected that the two groups will perform tests in the same location with Cable Labs funding the cable portion of the tests.

Tom Jokerst reported that MultiPort is now a full EIA standard called EIA 563. The final document will be available from EIA shortly. This removes one argument from the introduction of MultiPort TVs, VCRs and decoders. Two decoder manufacturers now have units available for shipment and a third manufacturer has indicated it is working on the development of a production unit. Field acceptance of decoders has proved to be good so far and consumers are very happy with the picture quality and return of their remote control functions. Cable Labs is studying the

financial impact of MultiPort decoders.

The EIA/NCTA joint committee announced that the TV RF interface standard development has been reactivated. With the introduction of MultiPort TV sets it is imperative that these sets operate in high field strength areas. To date, set manufacturers have been unconvinced that there is a significant problem with off-air pickup. In most instances the cable operator fixes the problem with a converter, unfortunately, this is not a good solution with MultiPort TV sets and the manufacturers must start addressing this problem.

### Program Identifiers

The committee is also beginning to look into program identifiers to ease in the programming of VCRs. With a program identifier the VCR would tune to the specified channel but not begin recording until the desired program starts. If adopted, this identifier could possibly be used for syndex deletions.

The 1990 edition of the National Electric Code is now available.

Ned Mountain of Wegener Communications reported that Wegener is continuing the development of a language set for a 9.6 kbit channel to be used for signalling commercial insertion equipment. The subcommittee needs the input from all potential users of the equipment and hopes to complete the task by December.

The Consumer Electronics Bus was demonstrated at the spring Consumer Electronics show. Signals were passed between power line, twisted pair and co-ax busses. The standard is due to be released in January. Major concerns of the CX working group is the lack of cable industry input and the need for reliable, easy to install connectors.

The FCC is reviewing the filing information for compliance reports. The current trend is toward a reporting form to be developed by the FCC and sent to all cable system managers with the 325 form. Reports would have to be filed by community identifier code to allow easy input by FCC staff and to help build a comprehensive data base. A draft form was distributed with the request that comments be sent to the FCC. The FCC will commence rulemaking shortly on the proposed form and filing requirements.

The next meeting is scheduled for August 9 and 10 in Boulder, Colorado. ■

# IN ORDER TO SHOW YOU EVERY PRODUCT WE HAVE AT CABLE SERVICES - WE'D HAVE TO FILL EVERY PAGE OF THIS MAGAZINE. SO, HERE ARE JUST A FEW EXAMPLES.

■ Head-end

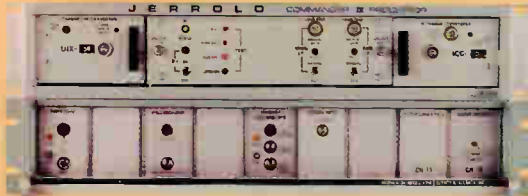

■ Distribution

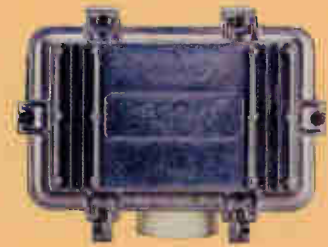

■ Test equipment



■ Cable & Connectors



■ Aerial



■ Underground



■ Tools & Equipment



■ Housedrops



Serving The Future Of The Cable Industry



Cable Services Company/Inc.



# Security and outdoor addressability

*The following article has been derived from numerous local SCTE Chapter meetings.*

**S**ecurity. In the context of cable television, security is the means whereby the cable operator allows subscribers to get some, all, or none of the cable company's signals, usually on the basis of how much money the subscriber pays.

In a system where security fails, many things happen: leakage problems from home-brew equipment and bad wiring techniques; lower penetration for both pay and basic subs; and damage to converters and other cable company property.

How do such security problems happen? That's the easy question. No

*By Mike Phebus, Sales Representative, Midwest CATV*

engineer can design a security system which cannot be defeated, at least not in the price range cable operators are able to pay. The difficult question is how a cable company responds to it.

Many companies have fought a security "arms race" with pirates—investing ever more dollars in hardware that appeared more sophisticated, was usually more expensive and presumably more difficult to defeat. All this investment was made only to find that, over time, a method to cheat the system was discovered.

As more and more people gain access to the "trick" involved, the cable operator's penetration of paying customers decreases.

Piracy is not the main cause of loss of security. Much of the loss can be traced to improper paperwork, lazy disconnect procedures, hardware failure and even outright employee fraud.

## Auditing to reduce theft

The only effective method of securing cable systems over time is by visual inspection and maintenance—auditing. Is the subscriber getting signals that the subscriber shouldn't? The best way, of course, is to check—at the site.

Resistance to auditing comes for two reasons. One is the subscriber's privacy. With security systems dependent wholly or in part upon devices located inside the subscriber's home, auditing may be seen by many, if not most, subscribers as an unwarranted intrusion on their privacy. Even if privacy wasn't an issue, indoor security raises difficult problems of access; many subscribers simply aren't home when the auditors stop by.

In security systems where the devices are located outdoors, access and privacy issues are eliminated, but an-

# Our Line Of Distri

Today the challenges of taking your delivery system further are enormous. Higher signal quality. More channels. Better reliability. Flexibility. That's why Scientific-Atlanta has developed the Total Systems Architecture™ approach to provide you with the tools to advance your delivery system and protect your investment.

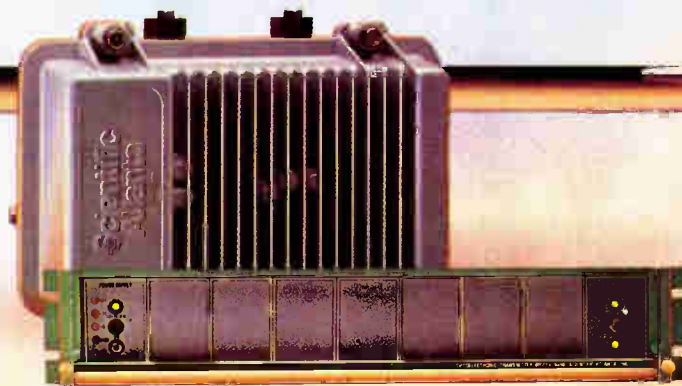

## FIBER OPTICS.

The ultimate in signal quality, with built in optical isolator and RF switch. Capability for up to four laser transmitters and three receivers. It's compatible with all coax systems. You can depend on Scientific-Atlanta's design experience and support.

other one—cost—is raised. Traditionally, outdoor devices, such as traps, are pole mounted and auditing pole mounted traps is difficult and expensive.

There are basically four security systems currently in use by cable systems—traps, scrambling, set-top addressability, and outdoor addressability. Virtually all cable systems use one of these methods and some systems use a hybrid of two or more of these methods. Each method has its advantages and disadvantages. Since non-addressable scrambling essentially places a security device inside a set-top converter, rather than outside the subscriber's home, the focus here will be on two security systems—traps and set-top addressability.

**To trap or not to trap**

Traps vs. set-top addressability (STA) is a classic "good news/bad news" situation. The good news about traps is they're user friendly and inexpensive. Traps are compatible with the subscriber's cable-ready set and VCR. Traps are also friendly with multiple set households, because the signal entering the home is "clean" and does not require further processing.

The bad news is that traps freeze the operator out of revenues, by denying the operator access to pay-per-view (PPV) and by making same day fulfillment of customer demand much more difficult (because a truck roll is re-

**Worst of all, trapped systems are expensive to audit (since the traps are pole mounted), leading to a loss in revenue over time.**

quired to change any service level). This expense in truck rolls make traps operationally expensive.

Trapped systems make it difficult and expensive to realign channels, at least those channels which are trapped. Furthermore, the pole mounting of traps means they are subject to the full fury of rain, snow, salt and wind. Mounting more than several traps on

any one pole poses nearly prohibitive mechanical stress on the taps, making multiple pay channels difficult and giving rise to hybrid systems, with an inevitable decrease in user-friendliness and pay penetration. (In security systems that require set-top converters for some channels but not for others, channels which require converters invariably suffer in penetration).

Worst of all, trapped systems are expensive to audit (since the traps are pole mounted), leading to a loss in revenue over time for those operators with an inadequate auditing program.

Despite all these powerful disadvantages, traps have more than held their own in recent years and have even staged something of a comeback. Why? The user interface problem of set-top addressability and scrambling has been the driving factor in the resurgence of traps. Their ease of use with cable-ready TVs and VCRs, and their equal ease with multiple set households make it clearly preferable to cable subscribers; no small advantage to an industry dedicated to customer satisfaction. In addition, auditing, while difficult and expensive, is at least possible, whereas with set-top addressability it is extremely difficult.

# Scientific Atlanta Products Will

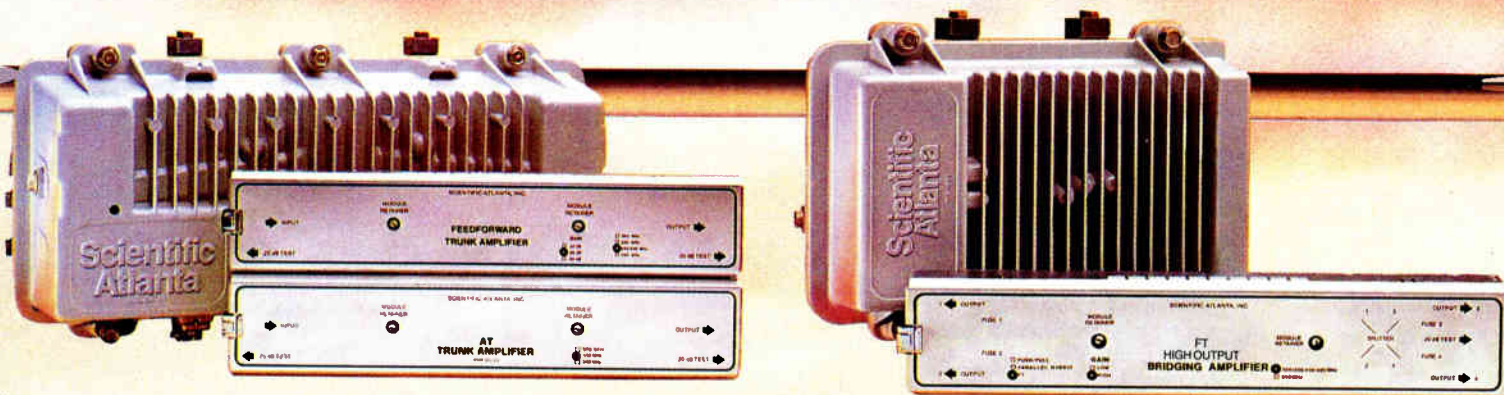

**FEEDFORWARD AND AT AMPLIFIERS.**

Get a full line of "drop-in" upgrades. Mix and match to grow capacity more economically. AT outdistances conventional power doubling, stretches spacing and maintains high picture quality. Feedforward amplifiers have over 99% reliability, earning us the industry's largest installed base.

**FT BRIDGER AND LINE EXTENDER.**

Super trunk performance out to the feeder, with output needed to deliver up to 27 more channels without respacing. FT takes high quality AT, feedforward, or fiber signals to the home. With twice the output of power doubling, half the distortion and 27% less power consumption, FT runs cooler and more reliable.

**Mirror Image**

Set-top addressability is almost a feature-for-feature mirror image to traps in their advantages and disadvantages. The good news is that cable operators have access to pay-per-view revenues. In addition, STA systems are dandy at quick customer order fulfillment. The system allows for fewer truck rolls, easier channel realignment, adaptability to multiple pay schemes, and non-exposure to weather conditions and salt.

The bad news is that STA is a disaster as a customer interface, negating some of the best features of the customers' new TVs and VCRs. Almost as bad, STA forces yet another remote control on the subscriber. STA is dreadful in multi-set households, since each set requires a separate (expensive) converter. STA is high-priced, with converters (which are easy to steal) costing up to \$100 or more. The repair, handling and retrieval of STA converters is also expensive.

Since the converters are inside, they are subject to the full fury of subscriber abuse, including theft, spills, damage from pets, children and adults, pulled cords, and so on. Perhaps worst of all,

since the converters are inside the sanctity of the subscriber's castle, auditing is practically impossible, resulting in a long-term loss of revenues (while pirating schemes for the most recent STA security systems receive wide

Outdoor addressability can be essentially a 'good news/good news' story, especially when combined with traps and placed on the customer's home.

circulation).

Outdoor addressability can be essentially a "good news/good news" story, especially when combined with traps and placed on the customer's home. Several outdoor addressable products accomplish this by placing traps in a box and "turning those traps on and

off" from a remote site. Electronically, the unit has switches which bring traps in or out of series with the cable signal.

For example, let's say that a pay service is on channel 15. If a channel-15 trap is installed in this box, and the switch corresponding to the channel-15 trap is closed, then the trap is in series, and the subscriber doesn't get the pay channel (the trap is turned "on"). If the switch is open, the cable doesn't "see" the trap (the trap is bypassed) and the customer receives the pay service.

Such security systems then, are user friendly, since the output of the cable is "clean" and does not require further processing. Therefore, these systems are compatible with cable-ready sets, cable-ready VCRs and multiple set households. The customer interface problem of set-top addressability goes away.

In a random survey, where 102 interviews were conducted by an independent survey group for Midwest CATV, the respondents selected, by 54 to 46 percent, "off-premise technology" when asked, "Does your company believe that off-premise or on-premise technology best serves your subscribers' needs?" Also, operators of such

# Take You Further Th

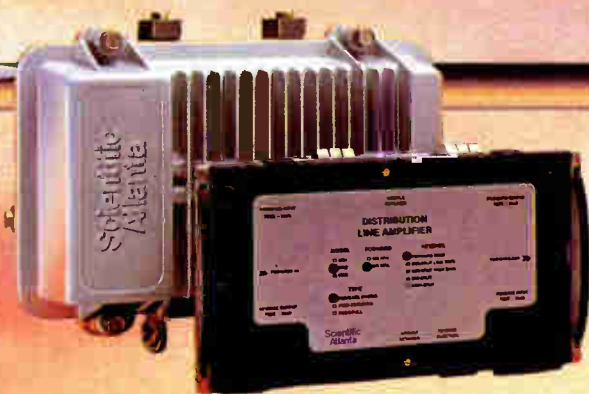

## 4-PORT DISTRIBUTION AMPLIFIERS.

Total flexibility is the key. Use a distribution amplifier for the trunk or feeder. Choose: push/pull, parallel hybrid or feedforward with bandwidth options that range to 550 MHz and beyond. Amplifier housings add flexibility, with internal splitters and AGC options.

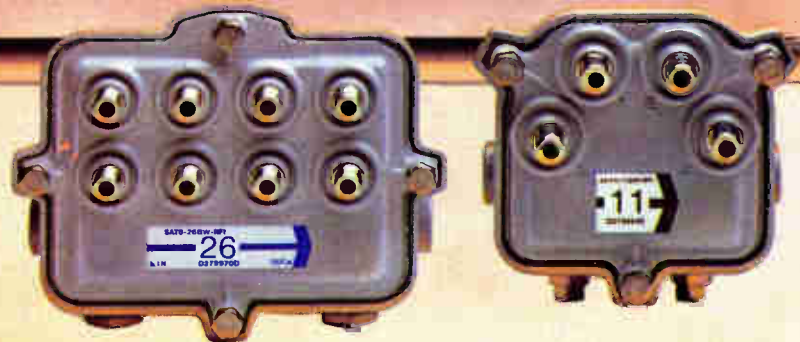

## TAPS AND PASSIVES.

Easy to install and almost impossible to break. Solid brass ports and powder based coating protect against corrosion. Ports are lengthened to accommodate locking terminators, security shields or weather boots. Modular design allows for easy upgrades and backward compatibility.

systems enjoy access to PPV revenues and quick customer order fulfillment. Off-premise technology eliminates truck rolls for service level changes including disconnects and reconnects, and can handle most multiple pay configurations easily. The traps inside the boxes are subject to temperature changes, but are not subjected to direct contact with rain, snow and salt—or to indoor abuse meted out by pets, children and adults.

The repair, handling and retrieval of STA converters is eliminated, and can be replaced where needed for non-cable ready sets (which are quickly becoming less and less common) by "plain vanilla" inexpensive converters.

**One disadvantage**

There is one minor disadvantage that trap-based outdoor addressability maintains over traditional traps. It remains difficult and expensive to change channel lineups for premium and pay-per-view channels since they are trapped, although it is easier to change out the traps (compared to a non-addressable trapped system), since traps are located at ground level and pole climbing is not necessary.

The big advantage that such outdoor addressable systems have over both STA and pole-mounted trapped systems is that it is *easy* to audit. An untrained person can walk down the street and do it, since no access to the inside of the customer's home or pole climbing is required.

Let's take a look at auditing and the success it brought to a Chicago area cable company. Centel had an audit recently, according to a Women in Cable presentation made by Mike Lovett of Centel, in which 465 homes of the 1,600 audited were illegal. Centel enjoyed a 26 percent sell rate within 30 days on the illegals and reaped a payback of a mere 2.5 months in single family homes and 3.2 months in the more difficult to audit multiple dwellings.

This audit didn't affect pay channels, since pay channels in the Centel system are controlled inside the customer's home, and this audit was strictly outdoors.

Since the audit had such a rapid payback on illegal hook-ups, consider the potential payback when pays are audited also. Going one step further, consider the payback once pole-climbing isn't necessary.

**No such thing as secure**

The ease of audit advantage is critical, since *any* security system can and will be defeated, and expensive audits tend to be quick candidates for budget cut-backs. *Repeat*, any security system can, and will, be defeated.

The longer a system goes unaudited, not only will the operator lose more revenues, but the chances of finding additional "amateur" wiring will increase.

Pole-mounted security systems are messy and expensive to audit. Converter-based systems, whether scrambled or addressable, are next to impossible to audit. The only thing standing between an operator and loss of revenues over time is an adequate auditing system, and outdoor addressable systems are much easier to audit than either conventional trapping or converter based security, whether addressable or scrambled.

Given the importance of security to a cable company's revenues, a system's technical integrity, and the importance of auditing to security, cable companies should look into the outdoor addressable systems that are now on the market. ■

# an Anyone Else.

Our Total Systems Architecture™ approach to CATV means we can take you further than anyone else. And we'll get you there more efficiently, reliably and, in the long run, more economically.

At Scientific-Atlanta — we do it right.  
 Call or write Scientific-Atlanta  
 Dept. AR, P.O. Box 105027  
 Atlanta, GA 30348 1-800-722-2009.

**Scientific  
 Atlanta**

Our customers are the winners.

Technologically speaking, a lot has changed over the past 12 months: AM fiber optics has become a reality; manufacturers are talking of 750 MHz and 1 GHz amplifiers; HDTV has

# Survey: dissension

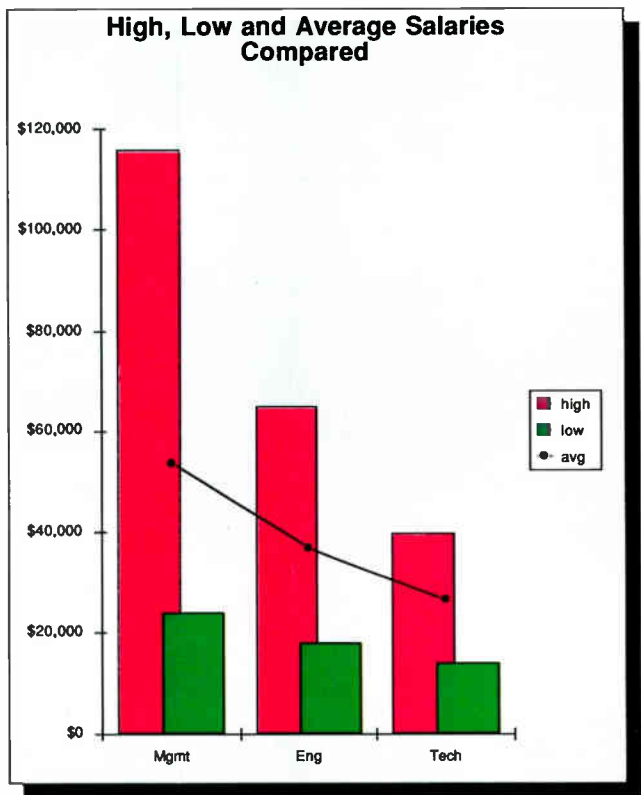

moved from a concept to a source of debate and almost to hardware manufacture; and Cable Labs is now up and running. But when it comes to the industry's cornerstone—its technical personnel—little has changed for the better.

According to *CED* magazine's second annual national salary and job satisfaction survey, low wages, lack of training and competition remain the three largest concerns expressed by technical personnel across the CATV industry, regardless of title or job function.

This year's survey, sent directly to 360 randomly selected *CED* readers categorized into management, engineering and technical titles, enjoyed a 44 percent response rate. In all, information about salaries, job longevity, financial and training satisfaction, and industry fears and concerns was returned from 58 managers (including system managers, vice presidents of engineering, system managers, etc.), 42 engineers (chief engineers, staff engineers, district engineers, etc.) and

58 technical persons (installers, technicians, technical managers, etc.).

Although the results were similar to those received last year, some interesting highlights came shining through. Among key observations include:

- Almost twice as many respondents expressed a desire to leave the industry, compared to last year. Managers and techs dominate those who say they plan to leave within the next three years; managers because of job pressures and/or retirement, techs because they want better wages.

- A very high percentage of engineers expressed dissatisfaction with the training they've received, while managers are highly satisfied with their training.

- Despite their differences in salaries, engineers actually directly supervise more people than managers do.

- Technicians complain bitterly about their wages and perhaps rightly so—salaries for technicians do not grow

When it comes to...technical personnel—little has changed for the better.

with experience at the same rate engineers' and managers' wages do.

- None of the 158 respondents had fewer than four years of CATV industry experience.

- The threat of competition, especially from the telephone companies, rated very high on everyone's list of industry concerns. Management concerns focus on "big picture" items like regulation, customer service, etc.

- Technician concerns are closer to

## Top 5 concerns of industry technical

Managers	Engineers
Competition	Training
Regulations	Competition
Budget orientation	Signal Leakage
Industry consolidation	Low pay
Customer relations/satisfaction	Regulations



# among the ranks

going all out to keep good employees and spend money for employee training and morale to enhance service. They also expect the vendors to foot the bill for new technology."

home: money, training and signal leakage compliance. Also industry consolidation worries techs because they wonder if they'll be forced out of their present jobs.

- Engineers express a mix of concerns, from low wages to regulatory trouble. They typically aren't concerned about job security but they're concerned that bottom-line pressures affect cable company efforts to provide quality product and customer service.

### The managers

According to this year's results, the "typical" manager is paid \$52,500, is 46 years old and boasts more than 10 years of industry experience. He's been a manager for more than six years and has had the same employer for more than six years. He works in a system of about 12,000 subscribers and personally supervises, on average, about a dozen people.

The survey shows managers are satisfied with their wages, and overall training, while only moderately satisfied with their opportunity for advancement, safety training and management training. Interestingly, nearly 16 percent of all managers surveyed say they expect to be out of the CATV industry within the next three years; typically because of retirement or job-related pressures.

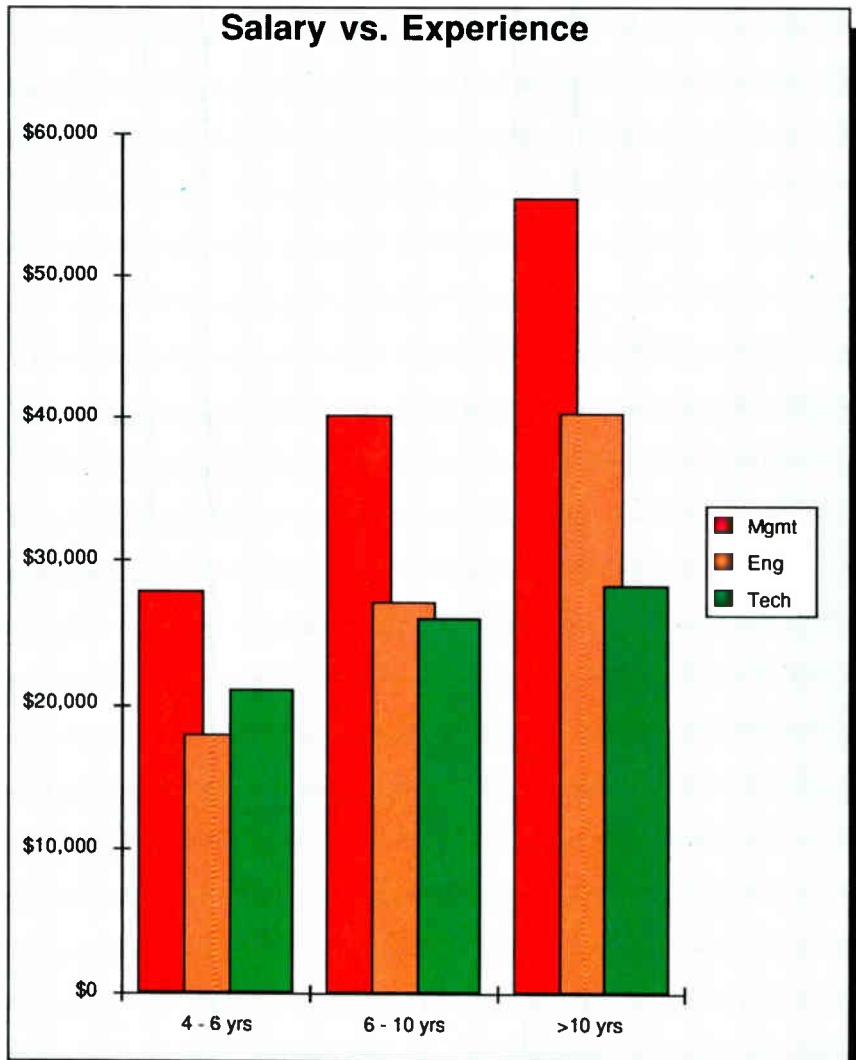

## personnel

### Technicians

Competition

Low pay

Training

Signal leakage

Job security

By far the issue posing the most concern to the industry in management's eyes is the threat of impending competition, especially from the telephone companies. A second concern is over an ever-changing regulatory environment, followed by concerns over too much "bottom-line" orientation by systems and MSOs, industry consolidation and customer relations and satisfaction.

For example, a management consultant who works in Wisconsin and New Jersey and makes more than \$100,000 per year, writes, "CATV companies are milking the 'cash cow.' They all talk of service but don't follow up by

The issue posing the most concern... is the threat of impending competition...

## SALARY SURVEY

A well-compensated, 37-year-old Pennsylvania manager with more than 10 years of CATV experience wrote that he was especially bitter about regulatory hassles, programming changes and buyouts in the industry and expressed his desire to get out.

"I used to feel this was an industry to be proud of and enjoyed providing quality. Now each day seems to be a battle...." he writes. "I had strong pride and desire in cable but lately

with all the industry problems, it sucks and I would like to get out."

Another seasoned veteran lambastes the industry for taking on too much debt and forcing the systems to adhere to strict bottom-line pressures instead of spending on technology and personnel. "Nearly all companies are not developing adequate technical staffs," he writes. "Management is too bottom-line oriented to spend the necessary money."

### Engineers

Looking at the surveys returned by the engineers, one gets the impression this person is both an enigma and the life-blood of a CATV system. He supervises more people than managers or techs, has headaches related to both industry developments and his local system, yet is optimistic about his future in CATV and is essentially satisfied with his basic technical training and knowledge.

Who is this engineer? He's about 42 years old, makes \$37,500 a year and is remarkably stable—having typically

...this person  
(engineer)  
is both an enigma  
and the life-blood  
of a CATV system.

been employed by the same company for more than 6 years. He's had his present job for more than 5 years and has been in the industry more than 10 years.

From there, though, things go downhill. Our engineer, on average, supervises 19 people in a system of between 10,000 and 20,000 subs; he's dissatisfied with his overall training (which includes safety, management of others, business management, etc.) but very satisfied with the technical training he's received.

As for engineers' industry concerns, it's clear that both "big picture" items like competition and regulations are on their minds as well as more system-level concerns like signal leakage and budget pressures. The engineers are truly the ones being pulled in two different directions.

Engineers also worry about finding competent employees but see the financial constraints they're put under. "CATV is a high-tech industry and it's time management starts paying higher wages and hiring electronics technicians instead of installers and people off the street who have no idea what electronics is and using them for techs," writes an engineer in Virginia.

# \$25,000\*

## FACTORY DIRECT PRICING DELIVERS!

Telsta's "Sweet Deal" Package can put a new 1989 A-28 van-mounted Telsta on the road for you with no hassle or headaches and at the lowest factory direct prices.

You'll get the most wanted lift in the CATV industry—fully equipped and ready-to-go.

You'll get fast delivery because we have chassis in stock at five locations across the country.

You'll get the strongest warranty in the industry backed by the strength of Telsta's nationwide network of parts centers and fleet of mobile service technicians.

And you'll get your Telsta direct from the factory with no third-party markup, no dealers, no aggravation. Pick up the phone and call our toll free direct sales line now. Then relax because it's that easy.

**CALL TOLL-FREE: 1-800-521-5351**



Utility version also available. Call for your special price.

\*Prices slightly higher in California. Prices good for 1989 chassis only. All prices FOB Telsta plant excluding taxes and registration.

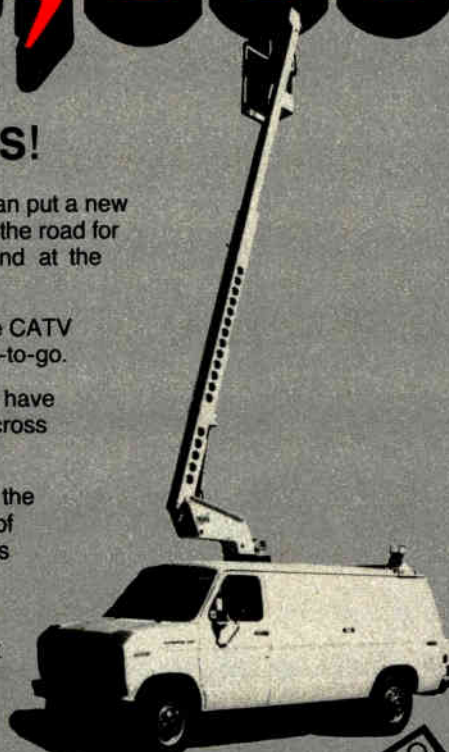

# TELSTA®

**A LIFT ABOVE THE REST**

General Cable Company

P.O. Box 666, 5600 West 88th Ave.  
Westminster, Colorado 80030  
Phone: 303/427-3700

Facilities in Hayward, CA; Frederick, MD; Lithonia, GA; Muncie, IN

**A Unit of Penn Central Industries**

Reader Service Number 16



# Jackson Tool Systems, Inc.

We Offer a Complete Line and Stocking  
of Aerial Tools for:

- **CATV**
- **TELEPHONE**
- **FIBER OPTICS**

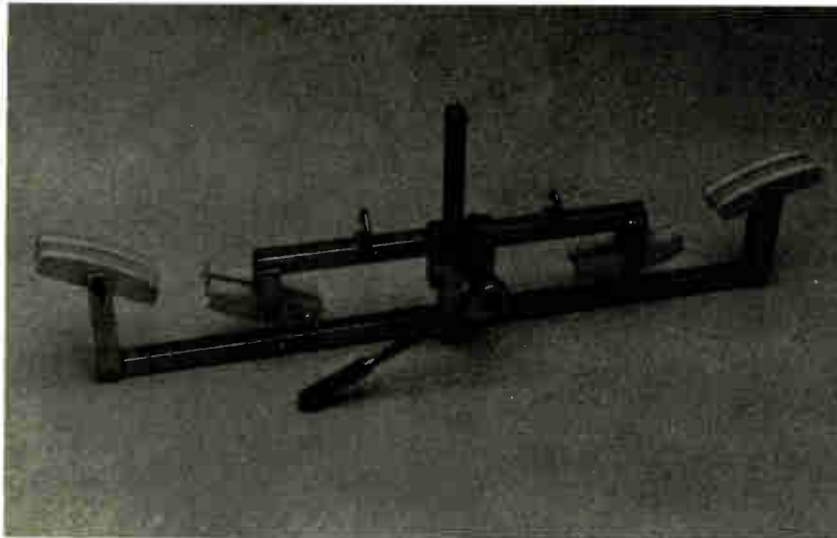

**Bender**



**Cable Block**



**Corner Block**

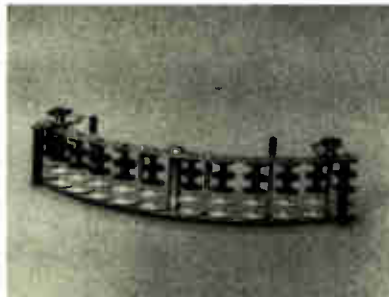

**Corner Block**



**Strand Brake and Roller**

- Jackson Tools are available thru the industry's leading distributors!
- Call us today for a FREE catalog and the name of distributor(s) in your area!
- **ASK US ABOUT OUR 3-YEAR TOOL WARRANTY!**



**Jackson Tool Systems, Inc.**  
P.O. Box 6, Clayton, Ohio 45315  
Phone (513) 836-2641  
FAX (513) 836-0396  
Reader Service Number 17

See us at the Eastern Cable Show, Booth #1404 & 1507.

Financial Compensation Satisfaction

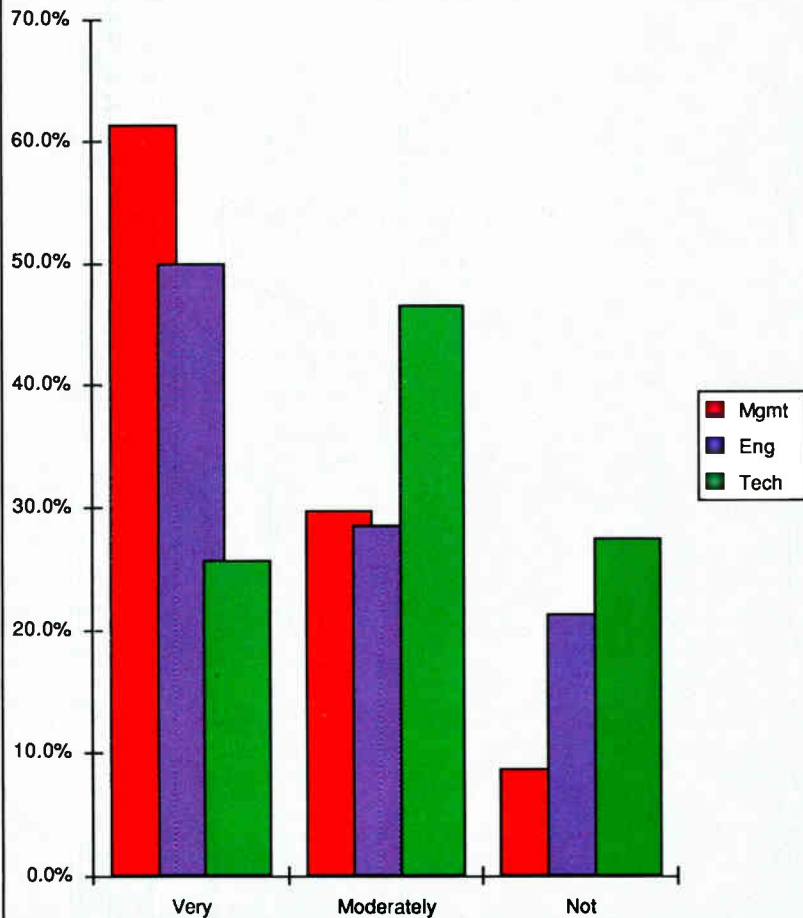

Most engineers find it extremely frustrating that management doesn't spend money to provide quality service. "The companies worry about dollars instead of 'sense,'" writes one from North Carolina. "For example, CLI (compliance) will reduce service calls, improve system performance, etc. but all the company sees is the added expense."

Others become irked over lack of wages, writing such comments as, "Financial compensation is low for work volume handled," and "Wage increases haven't even been close to cost-of-living increases—

we're losing more each year."

Finally, others get angry over what they see as interference from the Federal and local governments. "Congress and the cities and especially the FCC should leave us alone," writes a 63-year-old engineer from California who says he's otherwise happy. "After all, we're trying to give the customers what they want, not what the government, legislators or the broadcasters want."

Technicians

Rounding out the survey results is the information returned by the technical forces of the

Financial compensation is low for work volume handled.

industry. With this group, competition and low wages were the two most important concerns expressed, followed closely by training woes and CLI.

The survey's typical technician makes just under \$27,000 per annum, is 36.5 years old and yet has nearly 10 years of industry experience under his utility belt. He's held his present job for about 5 years and been employed by the same employer for just about as long.

However, when it comes to supervision, just 41 percent of the techs say they personally supervise others; and

Overall Training

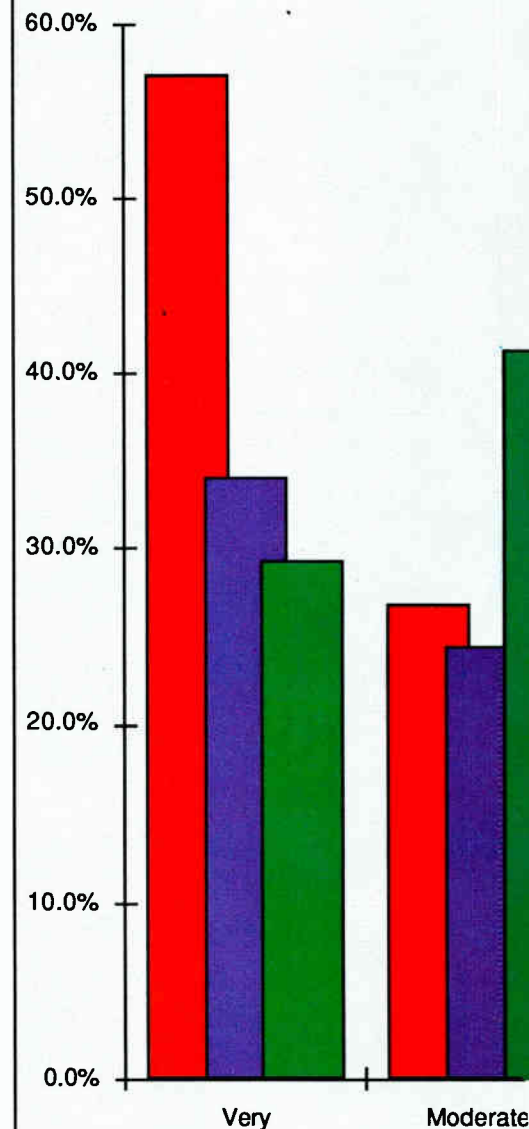

## SALARY SURVEY

those who have supervisory duties oversee an average of just seven people in a system with just over 10,000 subscribers.

In general, those who make up the technical category give poor marks to financial satisfaction, opportunity for advancement, the management and business management training skills they've received. Moderate marks were given for basic technical and on-the-job safety training. Concerns over money and industry consolidation led a full

### Satisfaction

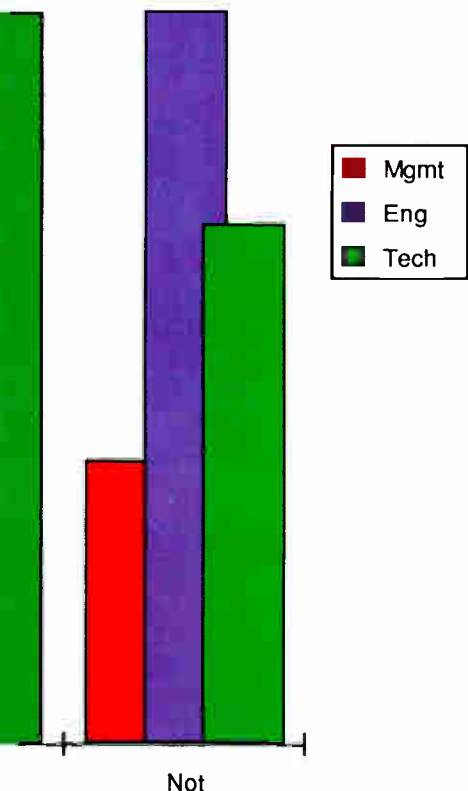

# GAIN MORE SIDE REACH AND BETTER LINE ACCESS WITH THE NEW TEL-29EA

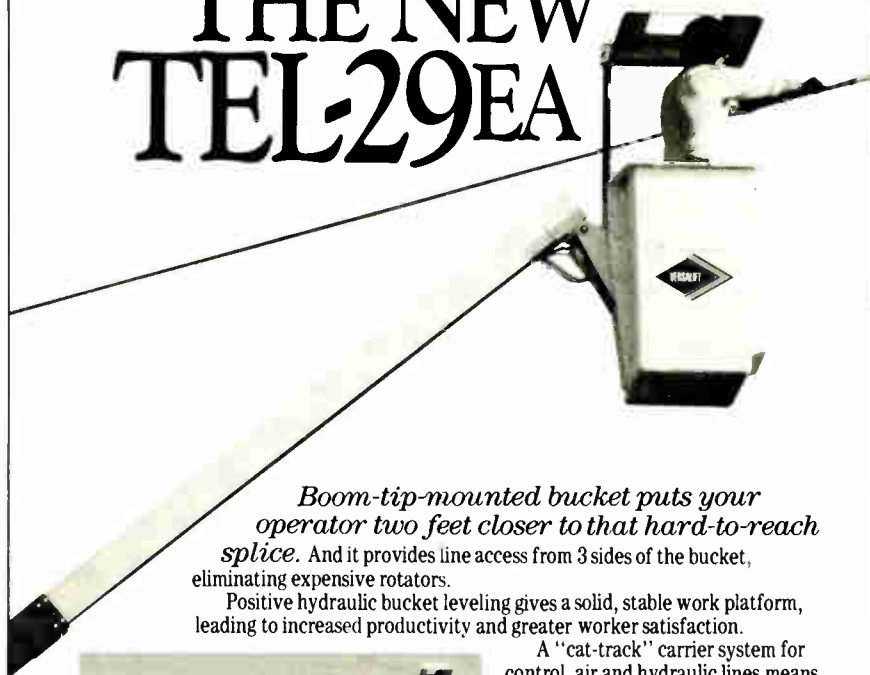

*Boom-tip-mounted bucket puts your operator two feet closer to that hard-to-reach splice.* And it provides line access from 3 sides of the bucket, eliminating expensive rotators.

Positive hydraulic bucket leveling gives a solid, stable work platform, leading to increased productivity and greater worker satisfaction.

A "cat-track" carrier system for control, air and hydraulic lines means less maintenance, more "up-time."

The VERSALIFT TEL-29EA can be mounted on any 10,500 dual rear wheel chassis with 60" C.A. and can be tailored to meet any aerial work requirement.

See your VERSALIFT Distributor for complete specifications, pricing and a demonstration!

It's TIME to check out VERSALIFT!

**TIME**  
MANUFACTURING COMPANY



TEL - 29EA  
Reader Service Number 18

P.O. Box 20368 Waco, Texas 76702-0368  
(817) 776-0900 TELEX (910) 894-5218 FAX (817) 776-7531

# VERSALIFT

## SALARY SURVEY

Percent with Supervisory Duties

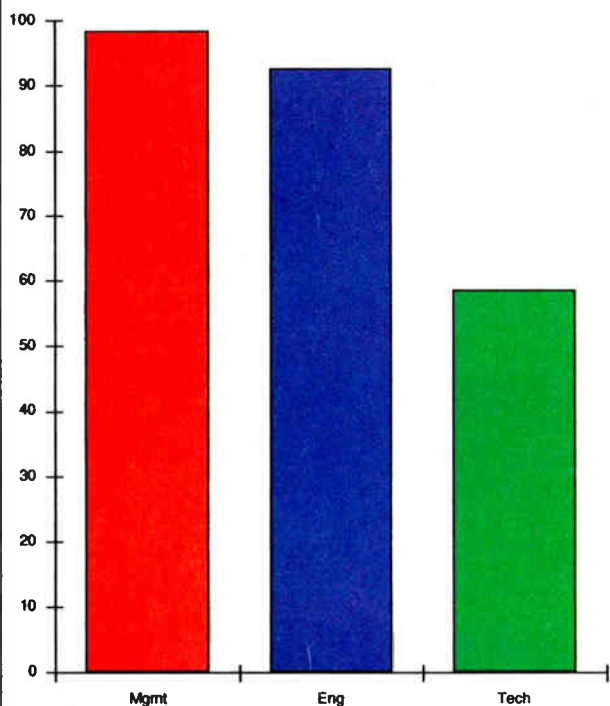

16 percent of all technicians to say they plan to leave the industry within the next three years.

"I'm overworked and underpaid," grouses a technician from Oklahoma. "I have 125 miles of plant in one system plus a second system of 15 miles and only one field person besides myself. When am I to find time for the management part of the job?"

Another technician from Nebraska makes this observation about system hiring practices: "When it comes to hiring, they don't want too much experience, or experience per se—the company might have to pay a good salary. So they hire people with little or no experience and give low pay."

Still others are wedged between the choice of making more money at the expense of advancement opportunities or assuring themselves of job security instead of higher wages. "Financial compensation (for me) is good because I belong to a union, but because I belong to a union, there is no place for advancement in Austin," writes a 37-year-old Texas technician." On the other hand, a tech in Kentucky says: "Advancement (opportunities) are good; in CATV you can go as far as you want and are able but compared to other closely related fields, pay is low."

In addition to wages, technicians give a lot of thought about the future of CATV and where they'll be in a few years. "I think in the next five years that the government will let the telephone companies back into the CATV field," writes a 49-year-old Missouri technician. "They have put a lot of

In addition to wages, technicians give a lot of thought about the future of CATV and where they'll be in a few years.

resources into R&D on fiber optics and that is what will be needed for HDTV and RFI will no longer be a problem.... (Fiber) will also make possible the routing of data in such a manner as to make electronic mail a real possibility. It also means less depends on satellite communications...."

And finally, there is a growing groundswell of friction between technicians and managers. Techs increasingly disbelieve what managers tell them and lack respect for managers who they see as incompetent or uncaring.

For example, a tech in Oregon sums up his possibilities for advancement this way: "Written promises by management have been kept, but verbal promises have not even though they keep reassuring us over the years." ■

—Roger Brown

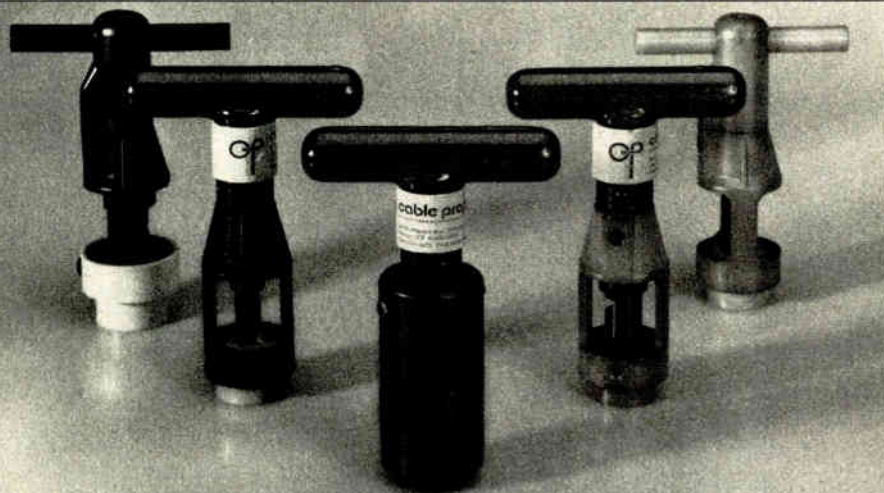

# OUTSTANDING IN STRENGTH AND PERFORMANCE

Cable Prep's RTH-4500 Ratchet T Handle for ease of operation

- Easy to install on any coring or stripping/coring tool with a 3/8" shaft with 3 flats.
- Can be purchased separately or at a discounted price with a new CABLE PREP SCT or DCT tool.
- Self contained unit — maintenance free.
- Fully backed by Cable Prep.
- Competitively priced. • Made in the U.S.A.
- Service-oriented manufacturer.

So user friendly it can be used with our competitor's tools!



**cable prep**

BEN HUGHES COMMUNICATION PRODUCTS CO.  
207 Middlesex Avenue, P.O. Box 373  
Chester, Connecticut, 06412-0373  
(203) 526-4337 FAX: (203) 526-2291

**We make your job easier!**

Copyright 1989 Ben Hughes Communication Products Co.

# Innovation Leads the Way

Protect and Secure  
your Traps Against  
Tampering by  
Unauthorized Persons

SC 70  
Top Shield



Construction and Subscriber Hardware Specialist



## SACHS®

Sachs Communications Inc.  
30 West Service Road, Champlain, N.Y. 12919-9703  
CALL TOLL FREE 1-800-361-3685

## SALARY SURVEY

**Average Number of Personnel Supervised**

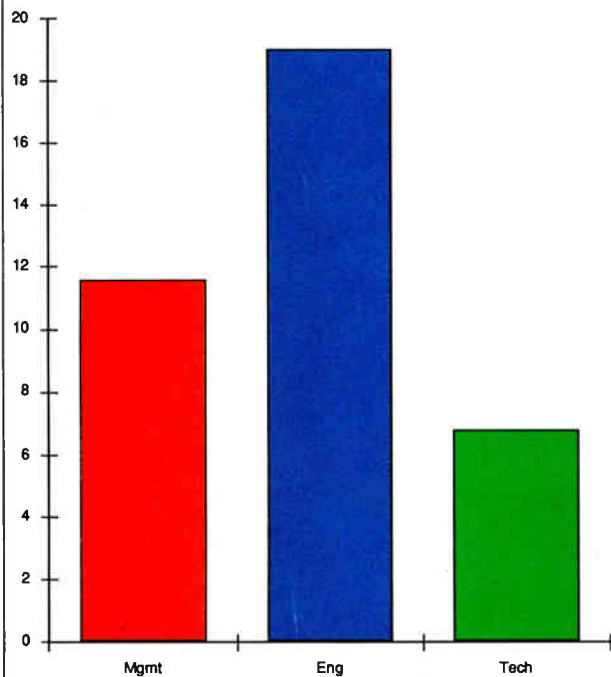

**Planning on Leaving CATV within 3 Years  
(% of total respondents)**

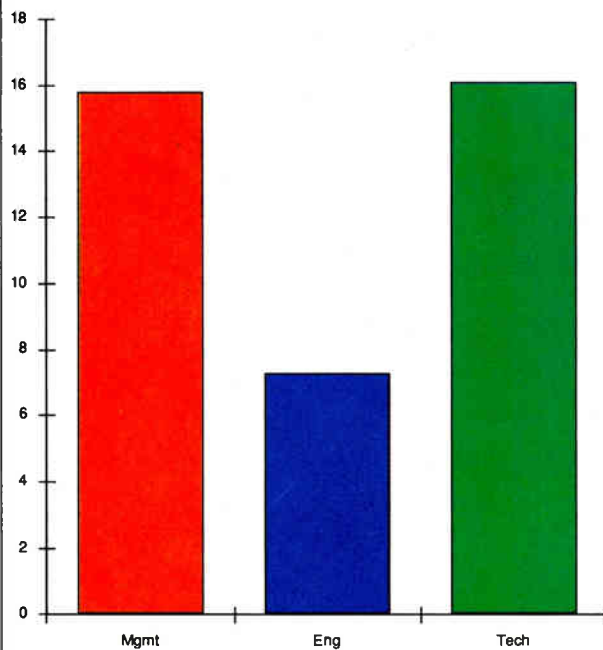

## Lakeshore Cable Contractors

Is proud to announce  
expansion in its  
Engineering Department:

- Linex CAD
- Strand Mapping
- Design
- As-built/New-build
- BOM
- Power Flow
- Trunk Tree
- Permitting

2524 Park Street  
Muskegon, MI 49444  
(616)733-2852

*A distributor with a difference . . .*

**HOLLAND**  
ELECTRONICS CORP.

We do more than just move product. We bring you the newest technology with the technical expertise to back it up.

So whether you're looking for the best price on connectors or the latest in head-end equipment, call us . . . and see the difference.

5308 Derry Avenue, Suite W Agoura Hills, California 91301  
(800) 628-6688 (818) 597-0015



IMPORTANT NEWS FOR CATV SYSTEM OPERATORS.

# WESFLEX. HORIZON CABLE.

## Your Number One CIC Connection In The Western States.

Wesflex and Horizon Cable/TVC Supply companies are teamed up to deliver affordable and reliable CIC materials on time—when and where you want them. From trunk to distribution to drop cable protection conduit, we have it all.

Better protection for your buried cable plant translates into better signal quality, better reliability, better subscriber service and better return on your investment.



That's why CATV Systems Operators in the West rely on FLEX-CON™ Conduit to protect their buried cable plants. Friendly to fiber and coax, FLEX-CON™ can be your strongest link from headend to hub to home.

Get the facts about prices and delivery on our FLEX-CON™ Conduit with cable installed, drop-in or empty with pull cords. Call Wesflex, Inc. or Horizon Cable/TVC Supply—Your Number One Cable Connection.



1716 E. Chocolate Avenue  
Hershey, PA 17033  
Telephone: 717/533-4982  
Facsimile: 717/533-6592



934-E Calle Negocio  
San Clemente, CA 92672  
Telephone: 714/361-2011  
Facsimile: 714/361-2106

**WESFLEX**  
INCORPORATED

A UNIT OF UTILITECH SERVICES CORPORATION

1880 Garden Tract Road  
Richmond, CA 94801  
Telephone: 415/233-6670  
Facsimile: 415/237-7322

# Strategies for a *de facto* cable/HDTV standard

If the cable industry was to hold an election today to decide whether it should jump right into high definition television, versus proceeding more cautiously by introducing enhanced NTSC while waiting for the terrestrial broadcast standard to be determined (primarily by forces outside the industry), the vote would not be fair.

While enhanced NTSC, what is often called the Faroudja-type approach, has been widely discussed in the trade press, at national conventions and at technical workshops, the bolder "strong alternative" of immediately proceeding into high definition optimized for cable television transmission has not.

Should the industry opt for its own *de facto* HDTV standard and perhaps suffer the consequences of not waiting for the FCC to make its rulings?

With national broadcast television network market share rapidly eroding, and the telephone industry's hands presently tied by regulatory concerns, the cable industry stands poised to eclipse all actual and potential competitors as early as the beginning of the 21st century (only 10 years away).

Is the American broadcast television industry, as it is currently configured, soon to be a dinosaur? Are the terrestrial broadcast HDTV standards being determined by the FCC actually irrelevant to the cable industry? Will national program providers, broadcast networks, cable premium services and local broadcast stations, see the writing on the wall and accept that cable television will be the high definition transmission media for all comers?

A survey of several key decision makers and strategic thinkers representing major MSOs, equipment manufacturers, programmers, and technologists within the cable industry revealed there is no clear consensus on a *de facto* HDTV standard for cable. But the sentiment is that it is technically feasible and could be the course of action quickly if television industry-wide cooperation proves not to take into account cable's needs.

A consensus also exists that broadcast will be with us for the foreseeable

future but its configuration and its competitive relationship with cable will change. What that change will look like is debatable. According to most of those surveyed, HDTV will not play a key role in the continued growth of the cable industry, that that growth will continue its dramatic climb predicated on other factors.

Most key thinkers now scoff at competition in video from the telephone industry. Many think the real competition for cable in the video domain will be at closed circuit baseband, and that competition will focus on quality of picture. The real question for cable is, "What does the consumer really want and when will he want it?" No one knows for sure.

## A CATV *de facto* standard

If the cable industry was to seek its own high definition standard, there would be no regulatory restrictions against doing so. The FCC has indicated it intends not to set a standard for cable or for any of the alternative media. "So, in principle, if it makes good business sense, cable would be free to set its own standards," says Walt Ciciora, vice president of technology for American Television and Communications, the second largest cable MSO, "and then try to negotiate with set manufacturers to manufacture sets so the standard could be utilized."

Ciciora is chairman of the joint EIA/NCTA Engineering Committee and is on loan to Cable Television Labs as director of advanced television projects, where he will oversee cable's testing of advanced systems. Ciciora is quick to add that it is doubtful that going for HDTV independently makes good business sense for cable.

Tony Wechselberger, vice president of engineering for Oak Communications says, "The advantage that we enjoy in the cable industry obviously is not being forced to be in a broadcast scenario. We can do whatever we want, whether it is experimental or otherwise, anytime we want with respect to paying attention to adjacent channels and bandwidth utilizations and so on. And, if the cable industry, Cable

Labs for example, wants to develop a *de facto* standard which would allow us to leapfrog or at least take a step ahead of everybody else, that would certainly be something that we would be free to do."

If cable were to opt for a *de facto* standard for HDTV over cable, what would it look like? "My key assumption is that the initial implementation of high definition would not be to upgrade every channel," says Hal Krisbergh, president of the Jerrold Division of General Instrument. "You would upgrade the premium channels." In most cable systems this would mean between two and five channels. "We have the bandwidth to do that with some relatively minor upgrades in the system today."

The bandwidth issue depends on who you are talking with. Some believe to really compete, cable will need to somehow get a 20 MHz or 30 MHz signal coming into the HDTV set at baseband. "That will set the standard," says Ciciora. "That will be near-studio quality."

Although being able to deliver a full 30 MHz signal to the home is possible, "it's probably not prudent," says Richard Green, president and CEO of Cable Labs. "I don't mean to prejudge that issue, but it seems to me that we need to face the spectrum efficiency issues and figure out how to get a very high quality signal in the minimum bandwidth."

Green points out that cable is the only medium so far that's delivered high definition pictures to homes. He cites the most recent experiment in Anne Arundel County, Maryland near Washington, D.C. in which a 8 MHz compressed MUSE signal was downlinked from the K-1 satellite to a cable headend and transported through the entire distribution loop including a long cascade of amplifiers.

While the 30 MHz MUSE signal compressed to 8 MHz suffers from motion artifacts, the demonstration pointed out what can be done. "That technology (MUSE) was developed for satellite transmission and not for cable transmission," Green points out. "When we look specifically for cable transmis-

By George Sell, Contributing Editor

# Perhaps our most important contribution to CATV powering is restoring meaning to the word reliability.

In the past fifteen years we've made some very significant contributions to the CATV industry. We've developed the most efficient standby power concepts. We've developed the powering technology that delivers the cable signal with unprecedented reliability. In fact, every major standby power innovation has come from Alpha, including complete status monitoring, automatic performance monitoring, uninterrupted power output, and more. But what makes us proudest is to hear people in the industry say we've brought respectability to the standby power business.

Standby power systems were introduced to make CATV signal delivery more reliable.

Ironically, many of the standby systems were notoriously unreliable. They gave the entire industry a black eye.

We've worked very hard to design and build products that keep working under the most demanding environmental conditions. The fact that we're continuing to grow at an increasing pace while others have faded or disappeared shows that our concern for quality is right. And when our customers tell us we've restored confidence in standby power systems, that's the payoff.

Alpha Technologies. We're here to back you up.



3767 Alpha Way, Bellingham, WA 98226-8302  
TELEPHONE 206-647-2360 FAX 206-671-4936

5700 Sidley St., Burnaby, B.C. V5J 5E5  
TELEPHONE 604-430-1476 FAX 604-430-8908

Reader Service Number 24

sion, we could come up with a pretty efficient signal."

Tele-Communications Inc. has publicly articulated its policy regarding HDTV. This includes adopting, in the near term, the Yves Faroudja system known as SuperNTSC while developing for the next century a non-compatible processed digital advanced definition system operating within 6 MHz. According to John Sie, senior vice president of TCI, "We think Faroudja's SuperNTSC will carry us in the next 10 years very comfortably so that we can begin a national focus on the priority of developing something that is quite difficult at the present time."

Sie believes all analog approaches to the eventual higher definition system is "foolish" and would be based on "yesterday's technology." He wants to avoid "rearranging the deck of the Titanic."

But not all experts accept the interim approach while an unknown future system is developed. Wechselberger says, "Any approach that we develop which prevents us from taking advantage of our inherent strength would set us back. If we are not setting upon or experimenting with an approach that allows us to get there

quicker, then we are basically inviting a delay."

**HDTV provider for all?**

John Malone, CEO of TCI, believes that whatever is done in the area of advanced definition systems, it must accommodate broadcasters. "As far as high definition goes, I think what we've all got to sit down and decide is how do we make the pictures that we can deliver in the near term, and are receivable by the average TV set, as good as we can possibly make them without requiring a major reinvestment by the public. How do we stay compatible with that, and if that ain't good enough, then how do we go to stage two, which is some alternative scheme and either stay within 6 MHz, which we believe is achievable, and accommodate over-the-air, or if we can't, go to some closed circuit system on cable and SuperNTSC over-the-air?" Malone believes local broadcasters will participate and extract some form of subscription income stream from the cable industry and the public for the high definition conversion of their signal by cable operators.

Ciciora adds, "It's got to be cheaper

to have a low power feed to a cable headend or multiple cable headends than to operate a high power transmitter. If the FCC continues in its philosophy on free market approaches to spectrum use, I suspect there will be an economic demand for other uses of that spectrum."

Broadcasters, in such a scheme, would generate two feeds, one over-the-air using SuperNTSC and one to the local cable headend for conversion to high definition. "That's one possibility," says Malone, "in which case the cable industry has a good deal of flexibility in the definition of high definition. It can, in effect, deviate from 6 MHz if it has to. We don't believe it has to."

Limiting bandwidth expansion, according to Switzer, is TCI's objective. "They figure 30 channels is enough for everybody. They want to concentrate on excellence on a small number of channels so that they get these ratings so they can sell advertising. Their spreadsheets show them that they can make more money from fewer channels. They deliberately restrict cable spectrum."

"There are a lot of things that can be done, clearly, on cable," says Jer-

# COST EFFECTIVE AND VERSATILE

**WITHOUT A LINE-WARD LINE LAYING MACHINE YOU COULD BE MISSING THE BEST BUY ON THE MARKET!**

- 800 lb. Of Efficient Strength At Your Fingertips
- Solid, Handcrafted Construction Assures Rugged Performance
- Continuing to make a record number of drops in-service for more than 16 years
- Not just low maintenance and downtime, but with proper care the gear case may never have to be opened for repairs.
- Moves On Tracks, Not Wheels, For Superior Traction
- No Restoration
- Up To 16" Depths

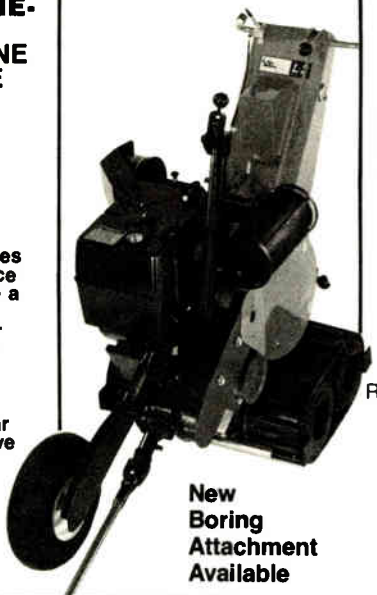

**New Boring Attachment Available**

**And, Our Machines Can Literally Turn On A Dime!**

The Unique, patented design of the L-2 positions the weight and the blade in the exact center of the machine.

**See For Yourself**

Call For A Free On-Site Demonstration Or, Write For Our Color Brochure

**Don't Settle For Less!**

Reader Service Number 25



Line-Ward Corp.  
157 Seneca Creek Road  
Buffalo, New York 14224  
(716) 675-7373

## MAP • a • bil • ity

from USGS data  
**DIGITAL MAPS**  
for AutoCAD® users

ideal for:

- cable system design
- detecting terrestrial interference
- marketing strategy

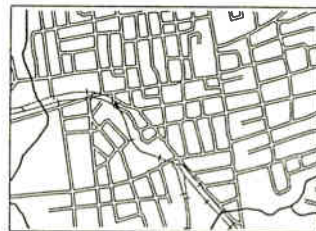

includes roads, highways, waterways, powerlines, railroads, landmarks, contours and terrain data.

Reader Service Number 26  
**AMERICAN DIGITAL CARTOGRAPHY™**

715 W. Parkway, Suite A • Appleton, WI • 54914  
414-733-6678

### **SIGNAL SENSITIVE**

The FCC has toughened their requirements regarding RF leakage. To meet the revised FCC codes, you need an RF leakage detection system that's sensitive. LRC's TR-1 can take equivalent readings of 10  $\mu\text{V}/\text{m}$  or less at a distance of 100 feet. That's sensitive.

### **BUDGET SENSITIVE**

Our TR-1 won't break your budget. We sell the TR-1 as a package — what you see is what you get. All of it — at a competitive price. That's sensible.

### **USER SENSITIVE**

The TR-1 is easy to use and easy

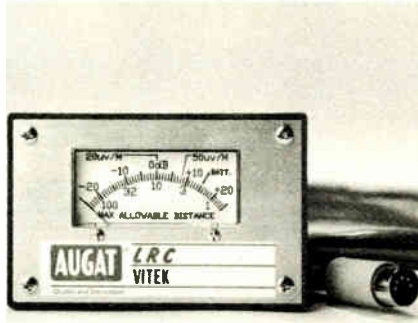

*The TR-1 Remote Meter\* — easy to read, easy to use. With velcro strips to mount unit in a variety of locations convenient to the driver.*

*\*Is not included in basic package.*

to read. The meter face highlights both 50  $\mu\text{V}/\text{m}$  for CLI reporting and 20  $\mu\text{V}/\text{m}$  to indicate leaks which need repair.

Our NEW remote meter makes it even easier. The remote plugs right into the TR-1 and uses the same meter/light combination. Velcro strips allow the driver to place the remote meter where he wants it. That's sensational.

**WHEN SENSITIVITY IS THE KEY — CALL AUGAT/LRC. 607-739-3844**

Or write: Augat Communications Group/LRC Electronics, P.O. Box 111, Horseheads, NY 14845.

# **WE'RE SENSITIVE TO YOUR NEEDS**

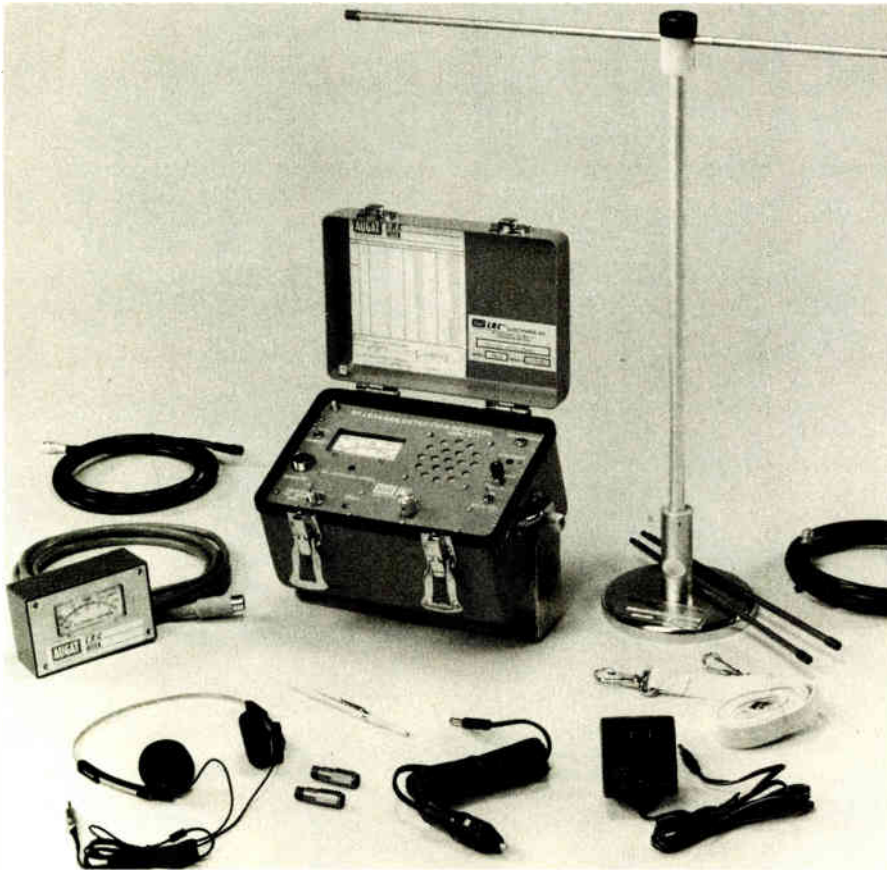

*LRC TR-1 tracer package includes; tracer unit, probe adapters, strap, wall mount charger, cigarette lighter plug, dipole antenna with 10ft of cable, headphones, 8 and 20 dB pads, tuning tool, and mounting bracket with hardware.*



WE'RE AUGAT COMMUNICATIONS GROUP. WE TIE IT ALL TOGETHER. WITH EASE.

# What do TBS and ESPN<sup>®</sup> say is as important as any of the 700 Wegener products?

## Clear Answers

world's Krisbergh. "The issue is really going to be in conjunction with the development of TV sets."

If the cable industry were to go it alone with its own HDTV standard, it could limit the inter-industry complexity by working with TV set manufacturers to develop receivers that are optimized for its own standard. Baseband sets that could handle the input of a raw 1,000-plus line, 30 MHz true HDTV signal from any source could be optimized if the cable standard in-

cluded a final signal width of 30 MHz. Such a signal could compete directly with the quality of HDTV videotapes and DBS signals.

It's certainly the concern of cable programmers. "From our perspective," says Paul Heimbach of HBO, "we don't see the broadcasters as competitors with respect to high definition television. We think that our competitors will be the VCR and laserdisc players and other media that will tend to take people's eyes away from our

programming."

"I don't think any industry can jump out in front until it becomes clear that there is going to be a receiver," says Green. "In a way, that's why I'm advocating we work through the system, we play a role in the development, we be part of the broadcast/cable/manufacturing consortium to develop the ideas. I think in the long run it is better to do that than it is to prejudge the market."

"The TV set guys are going to have to agree upon what kind of interface to the TV set, if indeed there is a baseband interface of some kind, is going to accept this kind of signal and what kind of format it's going to be in," says Wechselberger.

TV receivers essentially consist of two main components, explains Ciciora. "One is the display component and the other is the decoding component." Japan will have the tooling for a cost-effective method of production of HDTV displays for a variety of applications throughout the world. "It is almost certain that that display unit will have plugs on the back for baseband input which could be fed from the baseband VCR directly.

The complicating question now comes in as to what is the decoder that would be used in a situation where you don't have a full 30 MHz available to you." In the Japanese DBS plan, the MUSE system will require a MUSE decoder which by some estimates will cost roughly equivalent to the display unit, which itself could run as high as \$8,000 or \$9,000 when first introduced.

### Growth without HDTV

What role, if any, could a cable industry head start on true HDTV play in the competition with other video media? As cable penetration continues apace and broadcast network market share continues to erode, cable television stands poised to eclipse broadcast in the next two decades. Wouldn't a CATV/HDTV *de facto* standard ensure cable's preeminence by the turn of the century?

According to Israel "Sruki" Switzer of Cablecasting Ltd., "Preeminence will be assured by the variety, by the overwhelmingly huge amount of programming that can be dumped into a home relative to a broadcast. HDTV is not going to be a factor in that at all."

Krisbergh sees four major reasons why cable will soon have preeminence over broadcast, with or without high definition: New original programming

that segments pieces of network's market away; cable taking away traditional network fair; cable's market share increasing as penetration increases; and pay-per-view's ability to take away major sports and blockbuster telecasts from broadcasters.

#### Survival of broadcast

Why should broadcast networks continue to feed satellite transmissions to local affiliates for local transmission, when by the year 2000 up to 80 percent of viewers will receive that same signal over cable? Why not transmit all national programming, whether broadcast or cable, by satellite direct to cable headends for local transmission to the home?

"I think cable and broadcasters are really in it together, even by the year 2000," says TCI's Sie. "We'd be very happy with a 70 percent penetration, but that means 30 percent of the American public still has to watch television over-the-air. There is no other alternative in sight."

Local network affiliates' traditional role has been as providers of a transmitter for re-transmission of network feeds and local programming. Both functions may soon be irrelevant. Why shouldn't local broadcast stations abandon these functions and become local origination programmers supplying product to local cable operators for transmission, rather than commit themselves to the huge capital outlay required for high definition? A low power direct feed to the cable headend for high definition transmission and continued NTSC transmission over-the-air using existing equipment could solve their problems for the future.

"There is the tendency to think that if you eliminate the local affiliate," says Krisbergh, "somehow you are going to eliminate the local affiliate's contribution to local programming. The answer is that it is something that has to be separated out."

"Our success as an industry is not in any way, shape or form dependent on the demise of broadcasting," says Malone. "And we really view the world as a kind of long-term partnership. We regard broadcasters as programmers primarily. We think they should regard themselves that way."

Malone sees the local broadcaster continuing to play an important role in the configuration of the television industry. "The local advertising community supports a healthy percentage of the total creation of programming and it's distribution. Now, they could

become local programmers for cable, and I hope they will come to their senses, many of them, and will do so in order to hedge their bet and improve their long term economics."

#### Public policy

What about the telcos and their ability to deliver HDTV over fiber? Green feels it's a question of public policy. If the telephone industry is going to distribute video over fiber,

somebody, namely the consumer, is going to have to pay for it. "In all honesty, I've never heard from the telcos cost-effective proposals that deliver that kind of service. They may say they've got the fiber in, but if you really look at the elements of it there are a lot of pieces missing that are extremely expensive on a per-subscriber basis. The same kind of distribution can be made available through cable systems at a much lower cost."

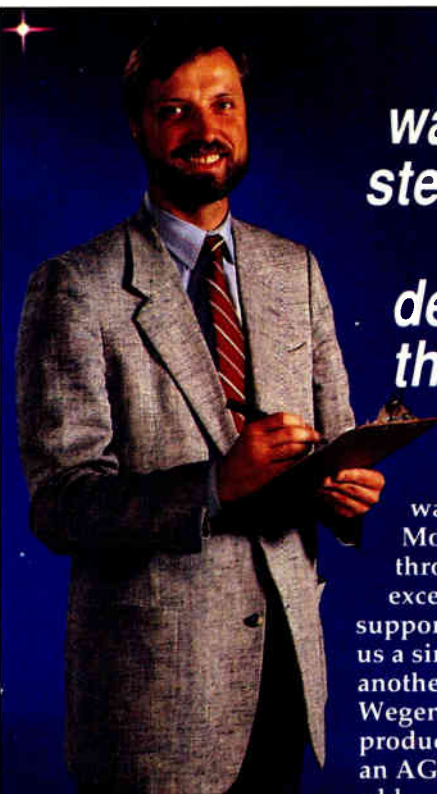

**"MY CHALLENGE was to find the best stereo encoder. Our California market demanded state-of-the-art equipment."**

**"THE CLEAR ANSWER,** after looking at 10 manufacturers, was Wegener. We now have about 170 Model 1602-95 stereo encoders spread throughout the region and they're excellent. While Wegener offers great support, to date, the product hasn't given us a single problem. We're already testing another Wegener product, an AGC add-on board to guarantee uniform output levels from variant input sources. The way Wegener designs and builds its products, I'm sure we'll add more Wegener equipment."



For a clear answer to your stereo encoder or other transmission challenges, call Steve Fox at Wegener Communications.

*"There is only one clear answer..."*

Reader Service Number 28

**WEGENER COMMUNICATIONS**  
TECHNOLOGY PARK/JOHNS CREEK  
11350 TECHNOLOGY CIRCLE  
DULUTH, GEORGIA 30136

Al Kuolas, Regional VP Engineering  
for Continental Cablevision, the  
nation's 3rd largest MSO.

(404) 623-0696 TELEX 54-3634 FAX (404) 623-0698

# PI SERIES\* CONNECTORS

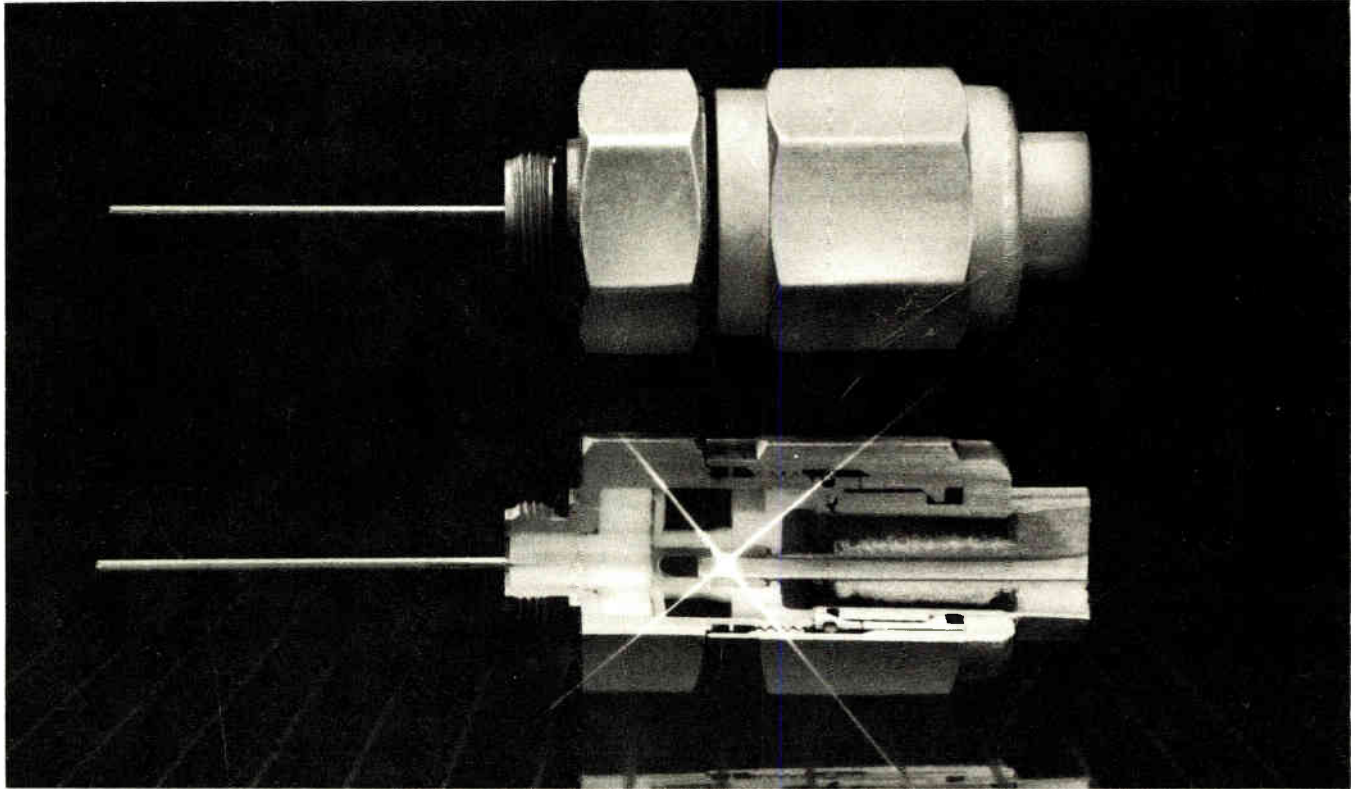

\*PATENT PENDING

## Interface Excellence From Pyramid.

Pyramid Industries offers a unique design in two-piece trunk and feeder connectors; the PI Series. The PI Series yields both a stainless steel sleeve and both cable seizing mechanisms together within the nut assembly.

### PI SERIES FEATURES:

- Two piece construction.
- 75 ohm impedance; 30 db return loss thru 600 mhz.
- Machined 6262-T6 aluminum body; Irridite finish for maximum weather resistance.
- Teflon and Delrin insulators; machined brass contact.
- Captive Stainless Steel Sleeve located and protected within nut sub-assembly; protects sleeve from damage or removal.
- Low-end torque required during wrenching operation; metal to metal positive stop.
- Cable jacket is sealed by means of an EP O-Ring located in nut sub-assembly; provides weather seal.
- Visual alignment of center conductor into seizing mechanism; insures connection.
- Captive sleeve and cable gripping mechanism "float" within restrictions of nut sub-assembly; eases cable insertion.
- Lightweight design reduces shipping costs; eases handling.
- Part number embossed on assembly; simplifies reordering and connector to cable match-ups.
- Rugged design considerations for maximum durability.
- High level of mechanical and electrical integrity; provides consistent performance, reliability and long life.

Call Pyramid Industries today for your free sample of PI Interface excellence.



**PYRAMID**  
INDUSTRIES, INC.

DISTRIBUTED BY: TONER CABLE 1 214 675 2013 SIGNAL VISION 1 714 586 896, POWER & TELEPHONE SUPPLY 1 800 288 2949, WESTERN CATV 1 800 531 2988, RYCOMM CORP 1 412 451 3328, DE COUNTRYMAN 1 800 328 6820, WILKS ENTERPRISES 1 404 963 2870

## 800-528-4529

3700 NORTH 36TH AVENUE  
P.O. BOX 23169  
PHOENIX, ARIZONA 85063  
(602) 269-6431 FAX (602) 272-7372

Reader Service Number 29



# 89-90 CAT

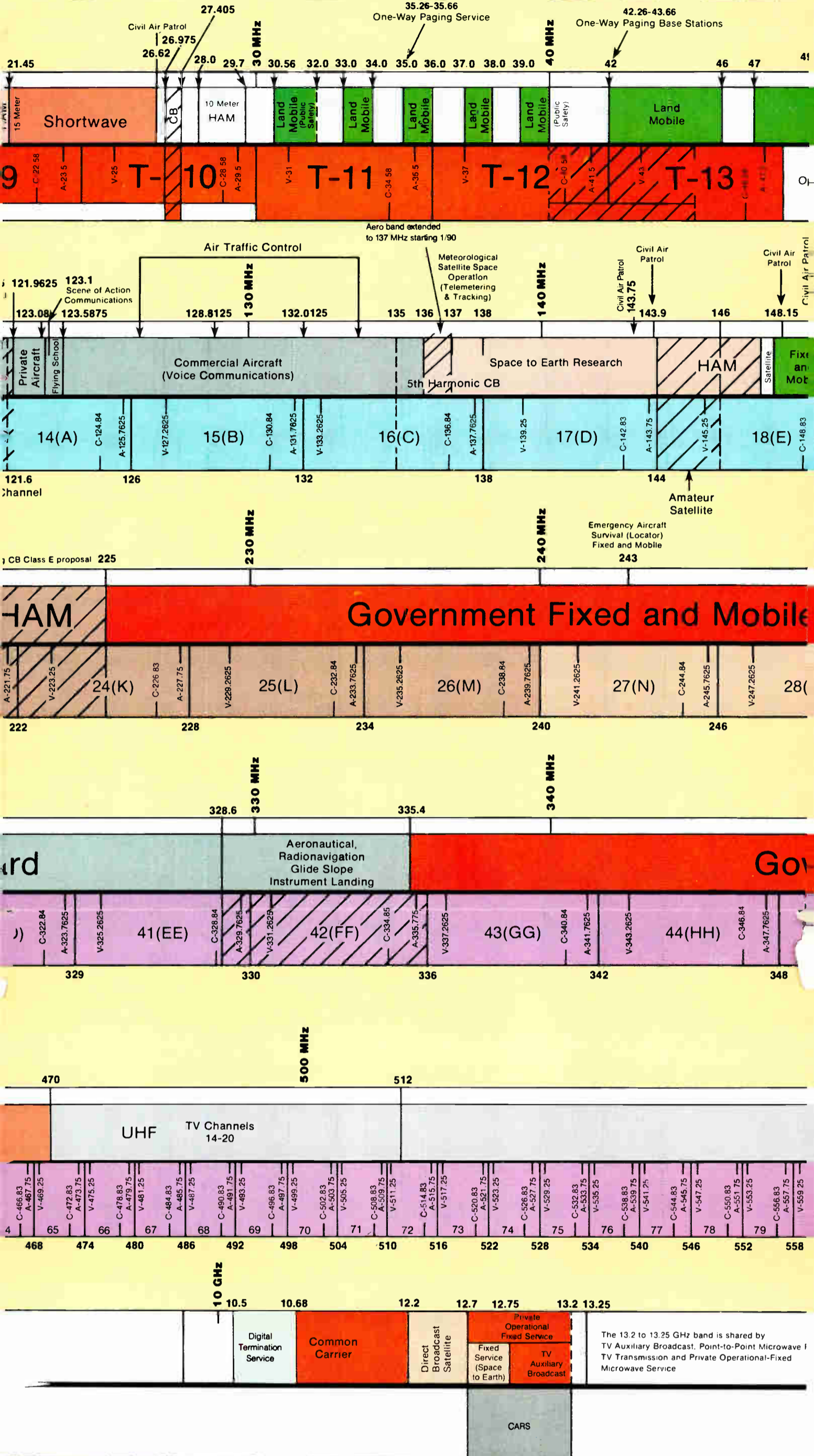

9.25 MHz and 85.25 MHz, channels with numbers other than 14-20 are not chosen to give these frequencies. Carrier frequencies in the 400 MHz are subject to

the frequency offset and notification requirements in Sections 76.610 through 76.619 of Part 76 of the Federal Communications Commission's Rules and Regulations. Positive offsets are displayed on this chart, but different offsets are employed where HRC systems are used or if the CATV operator elects to use negative offsets (see Section 76.612).

**GROUND/EARTH STATION**

Combines the leading CATV receiver and descrambler in one package. Agile Drawer backs up an entire system and eliminates costly inventory. Encoder integrates into existing system to provide superior performance.

**Scientific Atlanta**

Customers are the winners.

1-800-722-2009

105027, Atlanta, GA 30348

**ONE COMPANY FOR THE WHOLE**

- Construction
- Engine
- Equipment Supply
- Drafting

**Cable Services**

Reader Service Number 72

2113 Marydale Avenue • Williamsport, PA 17741

# Call Us With Your Next Order



Head-end

We'll compete with any distributor on price, selection, delivery, and service.



Test equipment

We stand solidly behind every piece of cable equipment we sell.



Distribution

Head-end through drop materials, it performs the way we say, or we'll correct it—immediately.



Taps & connectors

All items carry the manufacturer's full warranty.



Aerial

We stock all major brands, and can tailor packages to your needs.



Underground

Items arrive when you need them, not sooner or later.



Cable

And our engineers and technicians can answer any questions.

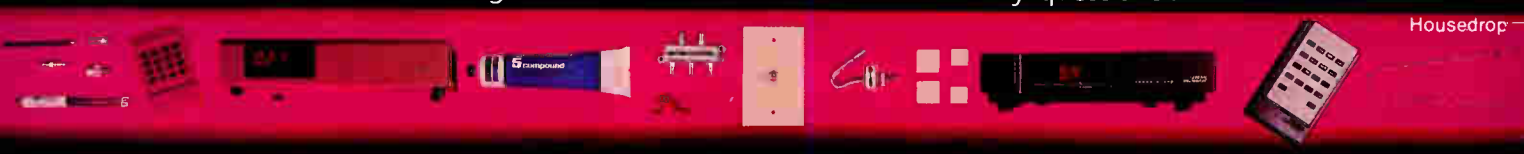

Housedrop

Call Cable Services with your next order, or for a free catalog.



Tools and safety

 Cable Services Company/Inc.

Reader Service Number 70

2113 Marydale Avenue, Williamsport, PA 17701 1-800-233-8452 • PA: 1-800-332-8545 • FAX: 1-717-322-5373



# V Frequencies

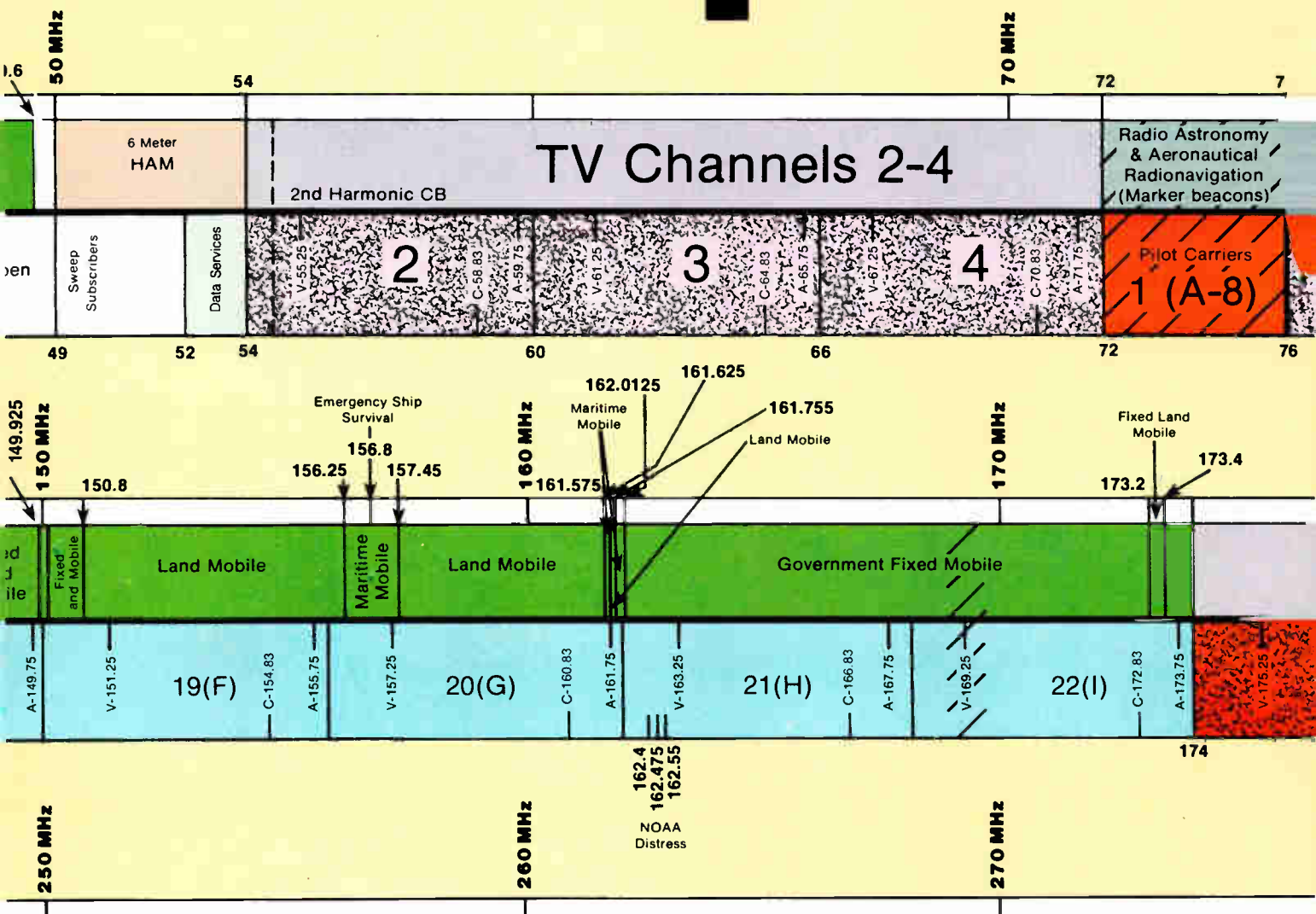

## Including Aero Communications

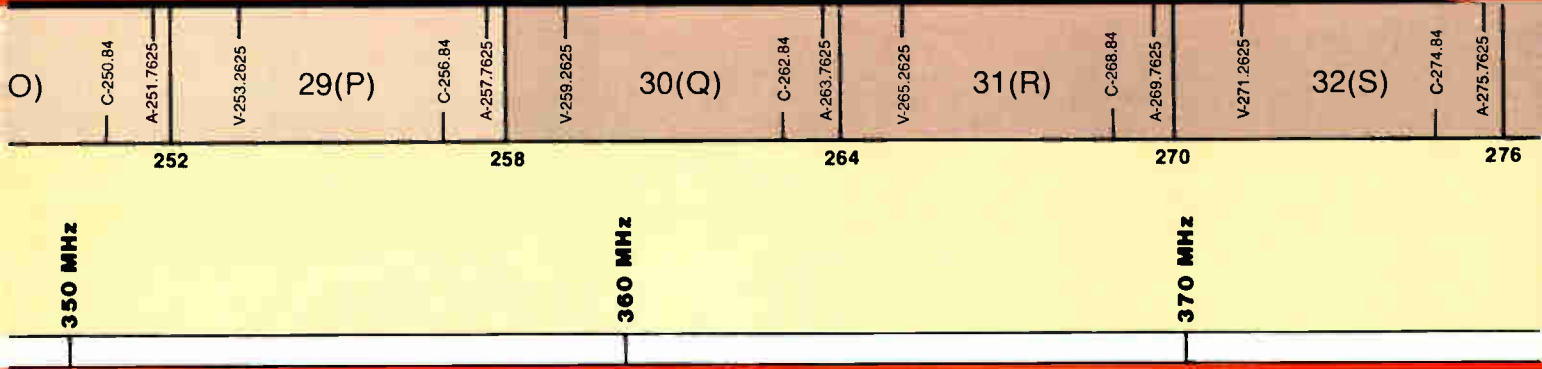

## Government Fixed and Mobile

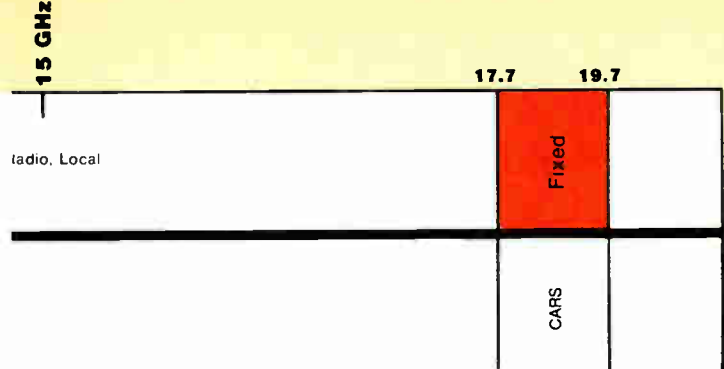
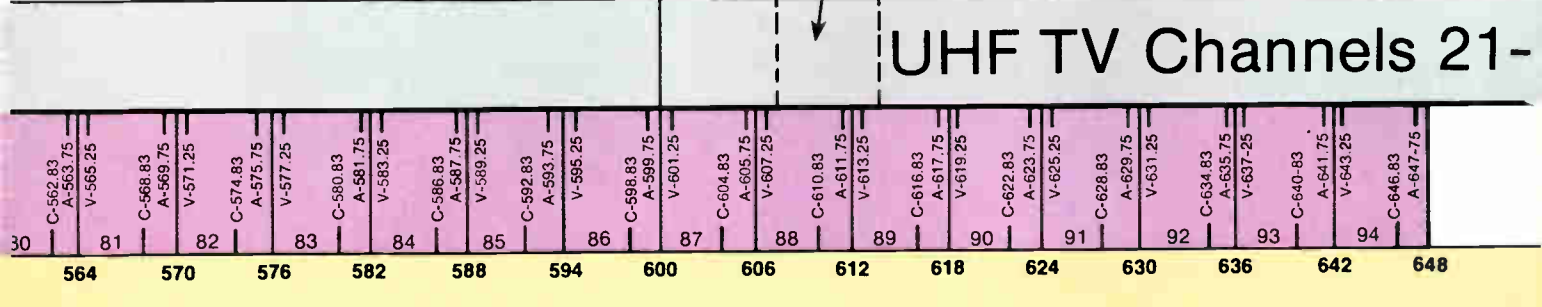
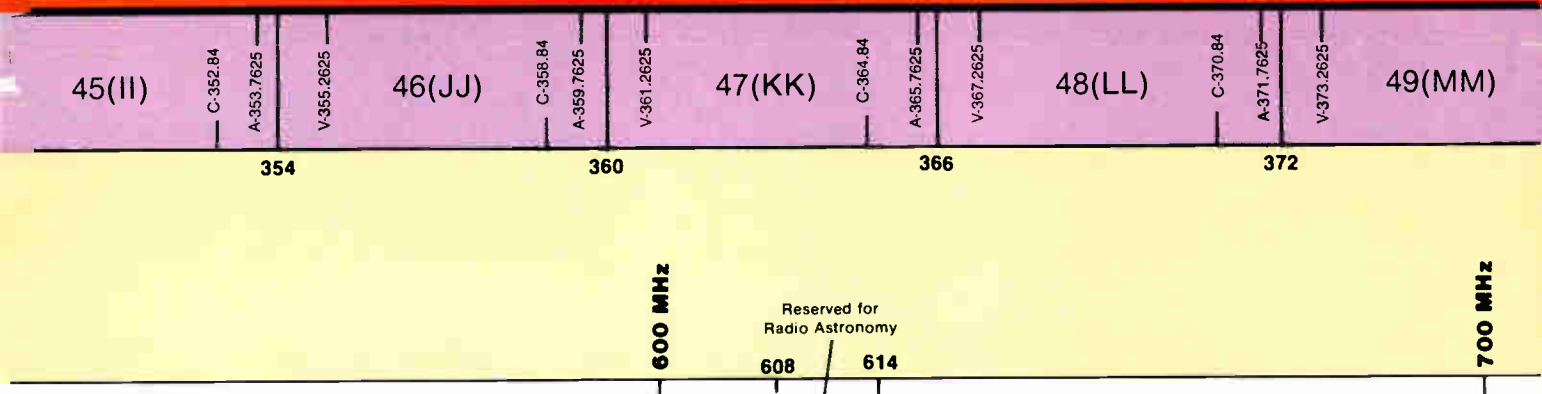

V-Video Carrier		A-Audio Carrier	
Sub Band	7-13	High Band	7-13
Low Band	2-6	Superband	2-6
Mid Band	98-22	Hyperband	98-22

## THE JOB FROM START TO FINISH

Engineering • Repair Service

Services Company/Inc.



701 • 800-233-8452 • In PA: 800-332-8545

**CABLE LEADER HEADEN**



# Frequency Chart

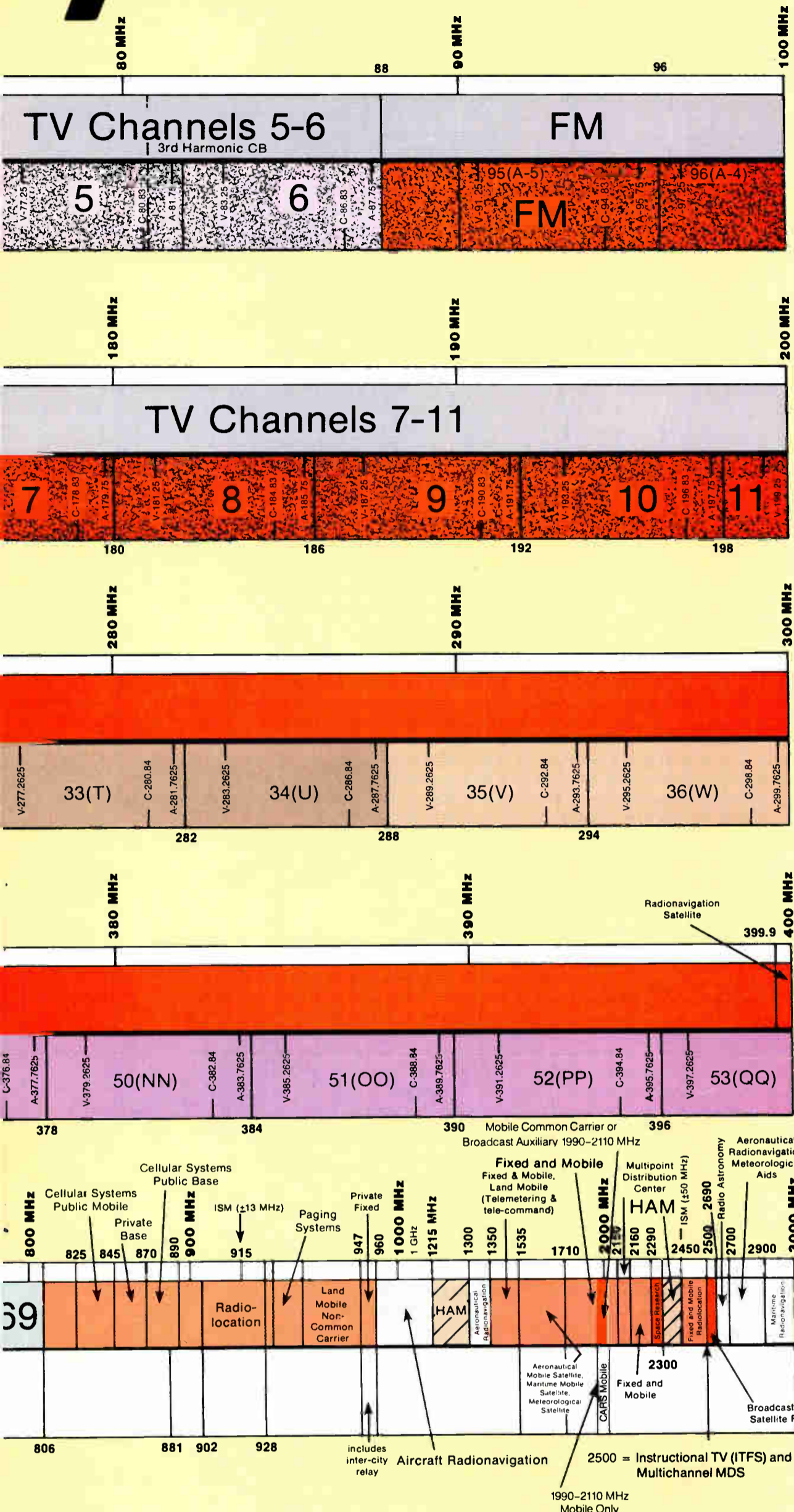

7-13	Same as Off-Air
23-36	Trouble Areas
37-94	

**Legend**

**CED Magazine**  
 600 South Cherry Street  
 Suite 400  
 Denver, CO 80222 (303) 393-7449  
 © CED Magazine, August 1989  
 All rights reserved. Reproduction in whole or in part without permission of the publisher is prohibited.

## TV SHIP FROM ID TO HOME

# JERROLD

GENERAL INSTRUMENT

2200 Byberry Road  
 Harboro, PA 19040  
 (215) 671-1800

Reader Service Number 73

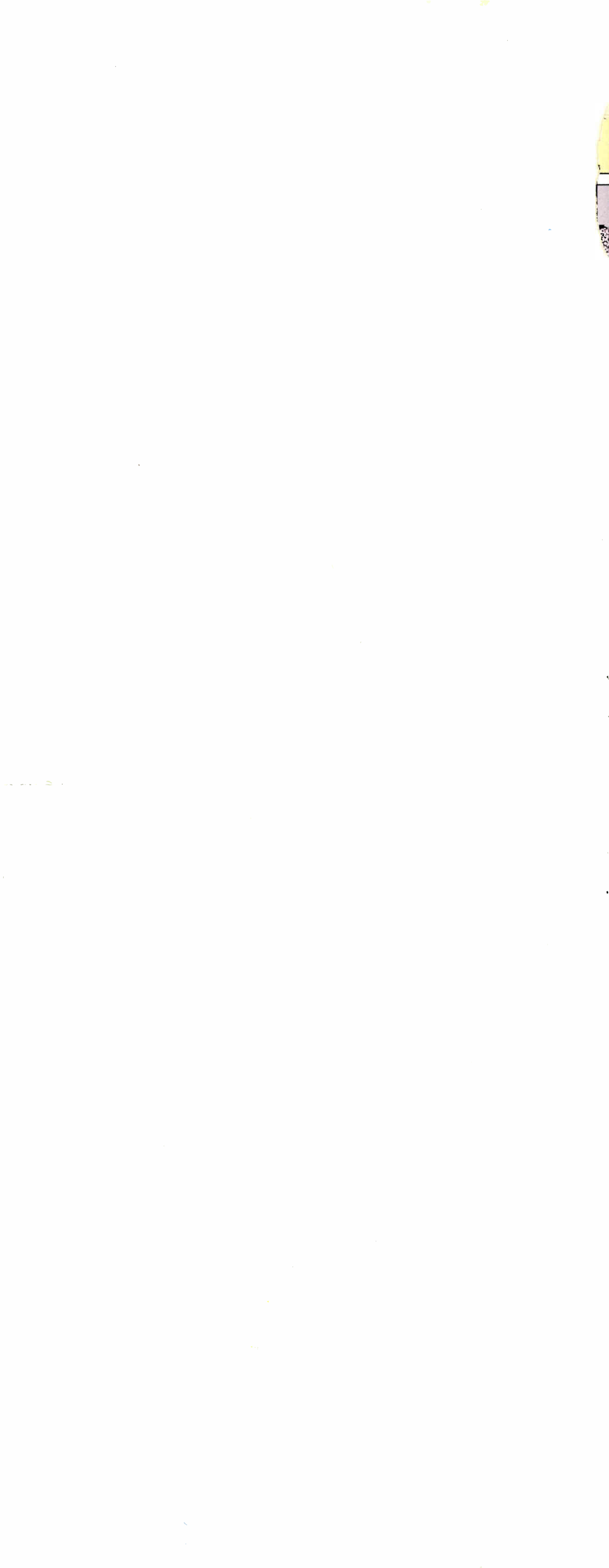

# CED 19

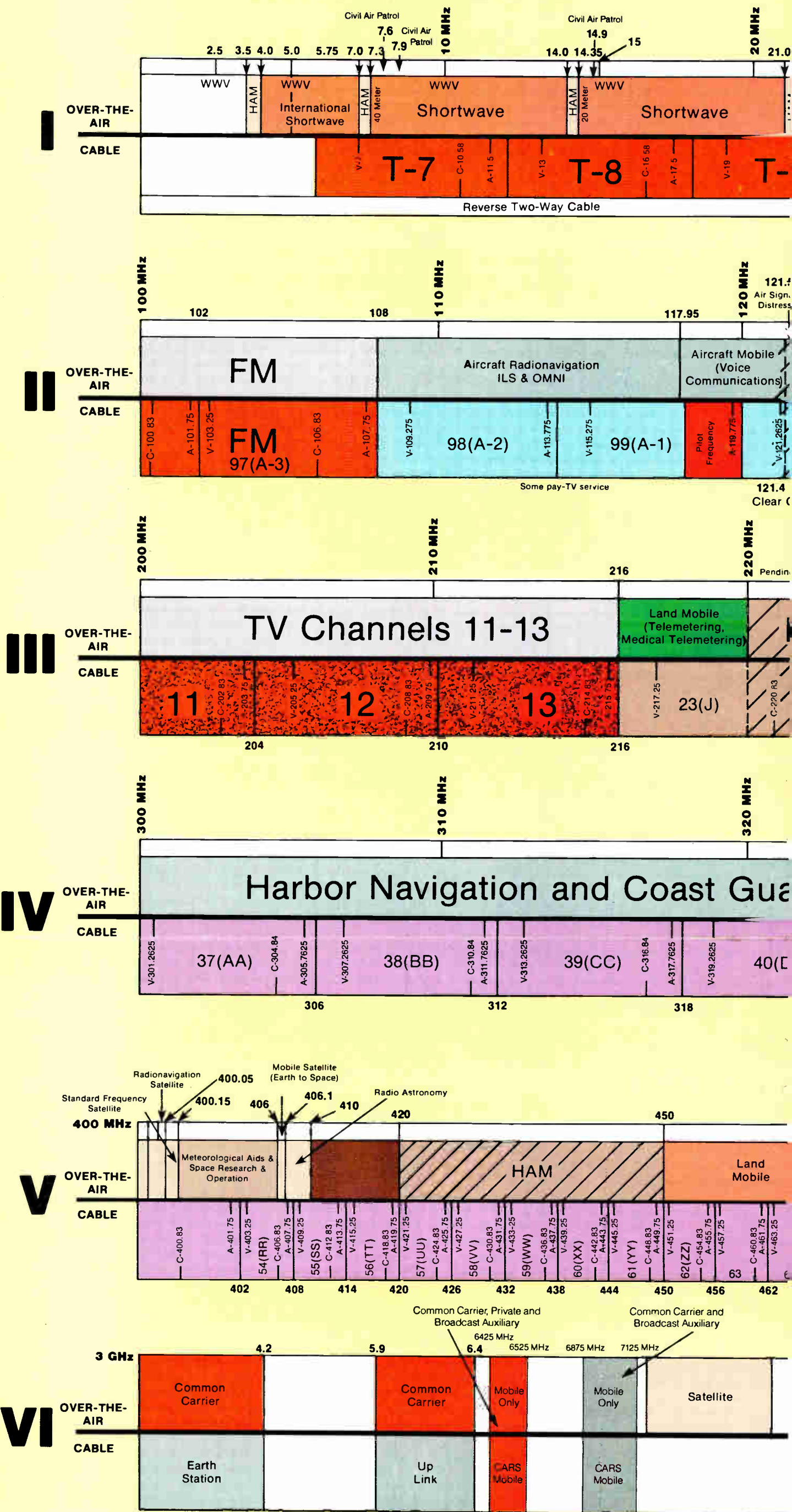

CATV channel designations reflect the Cable Television Channel Identification Plan recommended by a joint committee of the Electronic Industries Association and the National Cable Television Association. Former standard designations appear in parentheses. It should be noted that some manufacturers using phase-locked IRC channel spacing avoid using Channels 5 and 6 as designated on this chart. Instead, they set

the frequencies so the video carriers are at respectively, and usually designate those channels less than 5 or 6. The joint EIA/NCTA Committee has also changed channel spacings any numerical designations. Also note that CATV channels designated in the 108 MHz to 136 MHz and 225 MHz to

## THE WINNING TRADITION CONTINUES AT SCIENTIFIC-ATLANTA.

### DISTRIBUTION

- FOCUS. Fiber optics delivering superior, noise-free transmissions
- AT, PT and FT amplifiers take fiber and high quality trunk signals to the home
- All amplifiers have plug-in pads and equalizers to maintain engineering control
- Taps 2, 4 & 8-way-feature solid brass ports and protective coatings
- Multipoint Distribution Amp available in Feedforward, Parallel Hybrid and Push/Pull technologies

### HEADERS

- 9650 IRD and a satellite
- Frequency headend and
- 6380A Stereophonic systems to

*Orville And Wilbur Wright  
Showed That Commitment To A Goal  
Is No Flight Of Fancy...*

**Jerrold Cableoptics™ Proves History Repeats Itself!**

After nearly a decade of effort and experimentation – including over 200 wind tunnel tests – the Wright Brothers knew the reality of their vision was finally at hand. On a windy day in December, 1903, they seated their biplane on a rail embedded at the foot of Kill Devil Hill. The Wright Flyer was launched and 12 seconds later, the aviation age was born.

Wilbur and Orville knew all along that their plane would fly. But it took five years after Kitty Hawk to convince the skeptics of the practical value of what they had accomplished.

Today, there are scientists and inventors committed to a different kind of flight. The flight of television signals – not through the air or on wire – but as lightwave communication. These "Wilburs" and "Orvilles" are convinced that optical broadband signals will maximize clarity, increase the capacity and appropriately supplement current RF technology.

Jerrold's obligation is clear. Provide our scientists and technicians with substantial R & D investment. Bring products to market that totally integrate and enhance current RF transmission methods. And lead the cable industry into a new age of reliable, improved image quality and economic value.

Jerrold's commitment to the cable industry is over 40 years old. We launched the first successful cable TV system only through our determined effort to develop an amplifier that would deliver a clear signal. And time after time, we've been proven right as we helped bring cable television to homes throughout America.

At Jerrold, our vision of future cable television transmission through Cableoptics™ is as certain as powered flight was to the Wright brothers. And the future is just as bright.

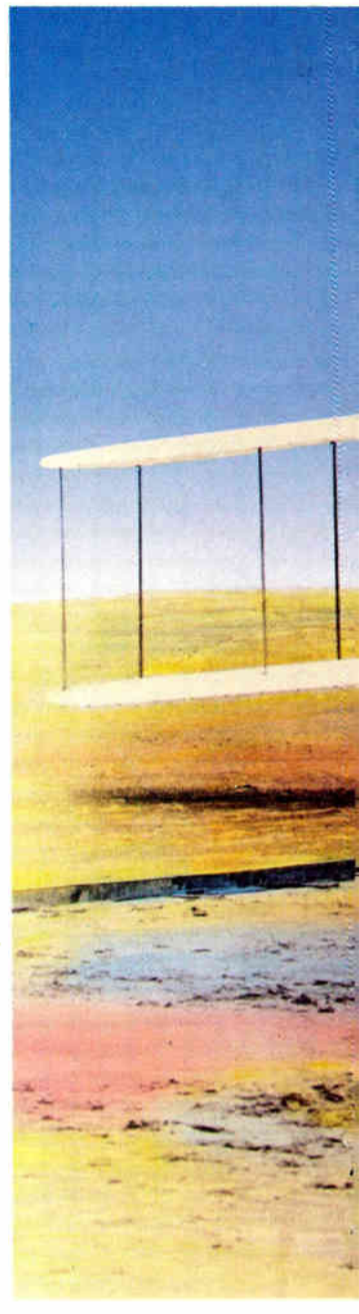

**CABLEOPTICS**  
**JERROLD**

Reader Service Number 69

2200 Byberry Road, Hatboro, PA 19040 215/674-4800

**GENERAL  
INSTRUMENT**

1-800-722-2009

P.O. Box 105027, Atlanta, GA 30348

Our customers are the winners.

**Scientific  
Atlanta**

- 9650 IRD combines the leading CATV receiver and a satellite descrambler in one package
- Frequency Agile Drawer backs up an entire headend and eliminates costly inventory
- 6380A Stereo Encoder integrates into existing systems to provide superior performance

- FOCUS. Fiber optics delivering superior, noise-free transmissions
- AT, PT and FT amplifiers take fiber and high quality trunk signals to the home
- All amplifiers have plug-in pads and equalizers to maintain engineering control
- Taps 2, 4 & 8-way-feature solid brass ports and protective coatings
- Multiport Distribution Amp available in Feedforward, Parallel Hybrid and Push/Pull technologies

HEADEND/EARTH STATION

DISTRIBUTION

**THE WINNING  
TRADITION CONTINUES  
AT SCIENTIFIC-ATLANTA.**

A SPECIAL PULL-OUT SECTION

Updated by the FCC

**Frequency  
Allocation  
Chart**

**1989-90 CATV**



"First of all, I don't think the telcos are going to move into the cable business," Malone says. "If they were to disassemble the regulatory, legislative, and judicial barriers that keep them out, the question is, 'What would they do?' Malone thinks they would either build or buy cable systems. He also questions the applicability of the telcos' switched star networks for cable. "It's very difficult to see how a tree-and-branch and a switched network shoved into the same concept ends up with anything but a Rube Goldberg device that's not economically viable."

Bringing video to the home is the only justification for the telco fiber installation. The twisted copper pair is capable of handling significant amounts of data. "They really haven't even dreamt up sufficient use for the bit rate capability of the twisted pair, let alone what the fiber is capable of," says Ciciora. "So, we have a situation where there already is an investment in quality twisted pair service that can do everything anybody wants except video, and there already is an investment in quality coaxial plant that can do video, and when upgraded can do really quality video and HDTV. Somebody is going to have to try and

understand why it's worth the really massive investment in thousands of dollars per subscriber to bring fiber directly to the home."

"I think fiber to the home is a joke," says Malone. Apart from the prohibitive economics, unless telco fiber is laid in conduits or concrete bunkers, Malone believes disruption of service will be common. "My vision of the world is the cable industry is protected by the backhoe from the telcos. There is no way of putting a bundle of optical fibers down the back alley. One cut and you've just destroyed your distribution system."

Ciciora subscribes to a theory he attributes to Jim Mooney, president of the NCTA. If the telephone companies become price cap regulated rather than rate of return regulated, so that they could keep all the profits that they can make by being more efficient, they will quickly lose interest in fiber to the home because existing plant can be extremely profitable doing voice and data.

The FCC has shifted to price cap regulation of AT&T's long distance service and is currently considering ruling telcos be regulated the same way. "The current regulatory situation

drives them to want to replace the copper with fiber. If they were price cap regulated, they would be driven in the opposite direction to become very efficient and profitable with the existing plant. And, that," says Ciciora, "would be the end of any drive to provide fiber to the home."

#### What consumers want

All this discussion eventually boils down to determining what the consumer wants and when he wants it. "I really think the biggest downside is making investments in things the consumer doesn't want," cautions Ciciora. "The consumer has a way of punishing companies that do that. The really important questions to ask are what are the benefits and what are the costs and do they balance, and what is the likelihood the consumer wants this particular format. At this point in the development of ATV, there are so many formats available to choose from that the likelihood that mistakes could be made by choosing the wrong one is high.

"Once it is determined what is wanted and when, the cable industry should do all it can to provide it." ■

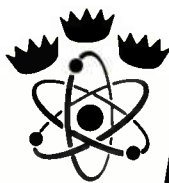

## Extended Value

Broad application Mini Trunk Line Extender Triple Crown Model: LA4229. Over two decades of innovative electronics experience is built into each and every Triple Crown amplifier. This assures you of dependable performance and excellent value.

- Selectable Bandwidth up to 450 MHz.
- Dual integrated circuit design.
- Automatic Level Control (LA4229ALC).
- 29dB Gain.
- Two way capability.
- Single "snap-in" module.
- 18-60 Volt switching mode high efficiency power supply.
- All input and interstage Controls built in.
- External test points.
- Corrosion resistant housing with stainless steel hardware.

4560 Fieldgate Drive  
Mississauga, Ont. L4W 3W6

(416) 629-1111  
800-387-3205 (U.S. Only)

Reader Service Number 30

## TRIPLE CROWN ELECTRONICS

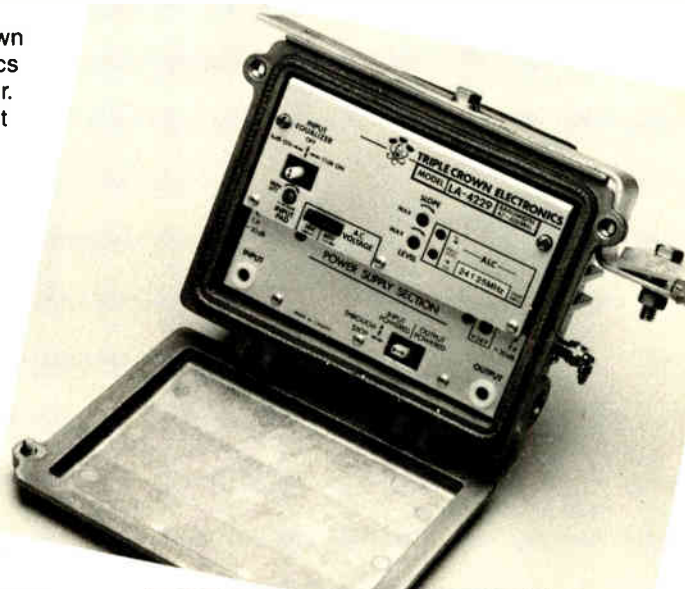

ONLY \$250.00  
\$275.00 with ALC

# How high will the bandwidth race go?

At the recent National Show in Dallas, nearly every manufacturer of CATV amplifiers was displaying "extended bandwidth" amps that passed 750 MHz, 860 MHz or even 870 MHz. There was even talk of the day when 1 GHz electronics would be readily available.

Upon hearing this, two immediate questions come to mind: Does the industry really need 150 channels of video and if so, when? The early cable pioneers would no doubt be shaking their heads today, wondering how subscribers could ever manage to find their way through a maze of 100 channels when five channels a couple decades ago was more than adequate.

But, as the cable industry has grown and penetration rates increased, new markets for niche programmers opened up. Narrowcasting has become the programming byword and promises to bring even more choices to cable viewers in the future.

## A channel loading issue

The market for extended bandwidth products will be driven by programming needs. Today, it's possible for amplifier hybrid chips to pass 750 MHz or more, but the real issue is channel loading. These devices haven't been designed to pass 100 or 120 channels; a lot more development is still needed until they are capable of delivering such numbers.

But that research is ongoing. Motorola and M/A-Com PHI (two hybrid manufacturers) are already examining new hybrid designs and determining what it will take to develop a hybrid that would allow cable operators to fully load a 1 GHz system.

"It'll take time and

money" to develop a high-performance 1 GHz product, says Charlie Hancock, PHI's RF module manager of sales and marketing. Hancock says that it may take a 10 GHz FT die to make such a hybrid (current hybrids are made using a 5 GHz or 6 GHz die) and that a development program to create such a die, including test equipment, could easily run into the millions of dollars.

Hank Pfizenmayer, CATV product manager at Motorola, says he sees the push to 1 GHz happening as part of a two-stage development. The first stage would be to improve today's hybrids and make them able to pass a fully loaded 750 MHz system. "That's quite achievable with the present generation of transistors," says Pfizenmayer.

## A generation away

However, to get to 1 GHz will require

one or perhaps two generations of transistor improvements, he says. At that level of loading, problems occur because of distortion. And there may have to be some tradeoffs. "Cable operators may have to give up some distortion (performance) to get to 1 GHz," Pfizenmayer says.

Other considerations that may effect the development of 1 GHz hybrids is test fixtures and packaging. "These are not trivial matters," says Pfizenmayer. Test equipment with 2 GHz or 3 GHz capabilities will be needed to test 1 GHz hybrids for gain and return loss.

Nevertheless, Motorola is committed to bringing the new product to market as soon as practically possible. When will that be? According to Pfizenmayer, Motorola's internal goal is to have product available by the end of 1991, "give or take a couple of quarters,"

says Pfizenmayer. "We've already identified our next generation transistor, but the generation beyond that hasn't been defined yet—and that's the one we'll need, I think," he says.

But all the research and development in the world won't bring such products to market if cable operators don't demand it. And there's the rub: Just when will cable operators see the need for electronics to deliver 150 channels?

## Need not immediate

The answer to that question is perhaps as elusive as the Fountain of Youth, but operators doubt the need will be shown anytime soon. But as more programming sources spring up, fiber optics becomes a way of life and HDTV comes on line, the need will eventually be demonstrated, insist the

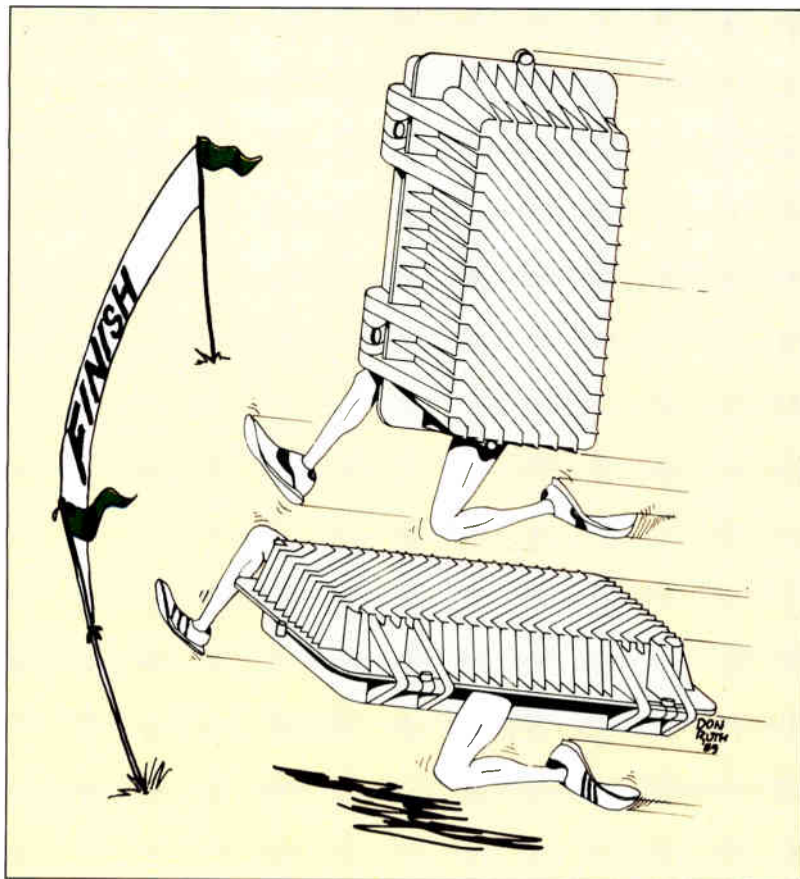

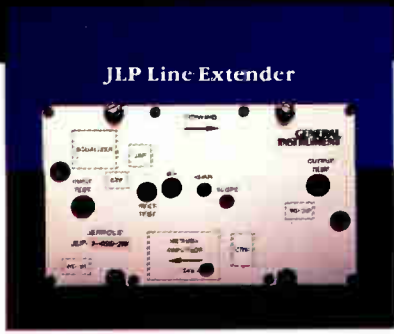
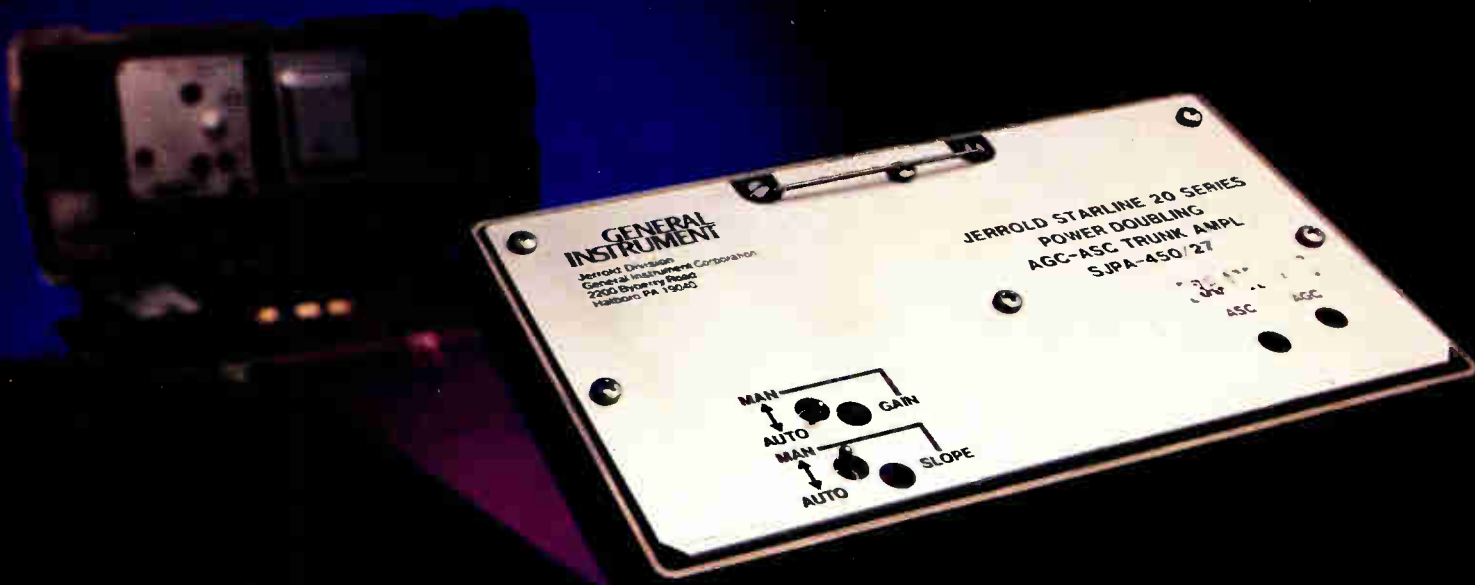

**Double The Performance At Less Than Half The Cost.**

**N**ow you can double the performance of your Jerrold STARLINE 20 amplifiers—and dramatically increase channel-carrying capacity—without major rebuild costs or service disruption.

The S.JPA upgrade module is designed for easy drop-in installation so you can take the labor savings, time savings and hardware savings all the way to the bank. But that's not all . . .

**You Can Bank On the S.JPA's:**

- ability to expand your present system's channel capacity.
- 5-sided die-cast shell for outstanding heat dissipation.
- exceptionally high picture quality.
- flat or tilted transmission capabilities.

Jerrold's modular approach to upgrades extends all the way down the line: from our high gain, power doubling, JLP line extender modules to our "J" series FFT brass port taps. And this modular design gives you the advantage of backward compatibility, underscoring Jerrold's commitment to long-term customer support.

**WHY BUY NEW HOUSINGS WHEN ALL YOU NEED IS MORE ROOM?**

So why throw away money on a new housing when all you really need is more headroom? For more information about these or any Jerrold product, contact your local Jerrold account representative. Or call

or write: Jerrold Division, General Instrument Corporation, 2200 Byberry Road, Hatboro, PA 19040. (215) 674-4800

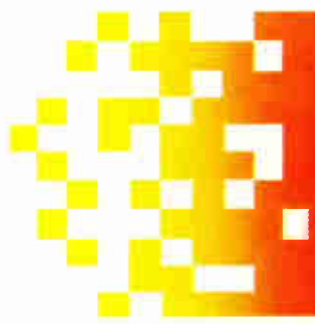

**GENERAL INSTRUMENT**

**JERROLD**

*A Division of General Instrument Corporation*

## BANDWIDTH RACE

MSOs.

"It's a question of when, not if," says Jim Chiddix, senior vice president of engineering and technology at American Television and Communications. Chiddix adds that it makes sense strategically to consider using extended bandwidth housings and passives when rebuilding plant so when the active electronics come along, it becomes a straightforward module upgrade. Of course, that strategy is predicated on the assumption that the housings and passives are available for a "small premium."

For instance, an operator who is upgrading his plant from 300 MHz to 450 MHz would be wise to buy 750 MHz housings and passives, perform a simple module upgrade to 450 MHz and perhaps add some fiber to reduce cascade lengths. At that stage, a couple of evolutionary steps remain before the operator has to fully load his system to 750 MHz and all the while he's had the hardware in place.

### Channel needs growing, though

Chiddix believes that the day will indeed come when operators will need that much bandwidth to satisfy view-

ers who demand different programming. And as long as new channels continue to be created (this year alone the industry has two new comedy channels, CNBC and the Sci Fi Channel so far), bandwidth will be chewed up. "Diversity of programming is important to keep the industry vital," says Chiddix.

But today there isn't room for everything. "Eighty percent of the (industry's channel capacity) is saturated," says Bob Luff, vice president of engineering and technology at Jones Intercable. Because there is no room, programmers with good ideas for product can't ever leave the starting gate, which causes market depression, says Luff. The industry needs more channel capacity in order to "keep the momentum going," he says.

Tom Elliot, director of research and development at Tele-Communications Inc., agrees that it's a good strategy to embrace the new extended bandwidth "platforms" being offered by the manufacturers because it's like buying insurance for the future. "It's probably an intelligent thing to do as long as it's not too expensive."

Those are welcome words to the amplifier manufacturers, but so far

only one MSO has demanded any product. Rogers Cablesystems of Canada, seeking to rebuild its Toronto system with fiber and fully redundant paths, needs increased bandwidth in order to offer what it calls near video-on-demand. The plan calls for the system to dedicate scores of channels to pay-per-view so viewers can watch movies almost anytime they want. It's a proposal that is bandwidth hungry and it may take 750 MHz or 1 GHz equipment to satisfy the appetite.

"The demand is latent," says Lemuel Tarshis, vice president and general manager of Jerrold's distribution product line. "People who recognize the potential of fiber and HDTV are saying we need to be prepared" to offer product.

To get active electronics to the 750 MHz level (and fully load them) will require a technology breakthrough, says Tarshis. "It will require an investment in R&D of millions of dollars" and CATV will have to drive that R&D program. It won't be easy to build high quality power-passing passives, either, but it won't require "massive R&D," says Tarshis.

Besides Rogers, Jones Intercable is also positioning itself to take advan-

# ChannelPlus®

INNOVATIONS IN VIDEO

Whether you are extending a CATV system, installing commercial private cable or residential custom video systems, ChannelPlus has the distribution components and FREE technical assistance that can maximize picture quality and make installations easier and less costly.

### FREQUENCY AGILE MODULATORS

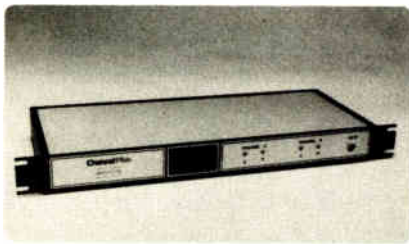

ChannelPlus modulators are the perfect way to "customize" a CATV system for an apartment house, condominium, hotel, hospital, etc. It is easy to add one or several "personalized" channels for a building or complex. Security cameras aimed at the lobby, parking area, or swimming pool are modulated to unused hyperband channels and combined onto the main cable feed. Front panel push-buttons are used to set up channel numbers — no test equipment is needed.

### GENLOCKS OVERLAY MESSAGES ON ANY VIDEO



Perfect for overlaying targeted advertising, customer information messages and public service announcements on any channel. The low cost of the ChannelPlus genlock message generators make them ideal for even the smallest CATV systems. The unit is installed in minutes and is easy to use! An optional multiplier device will allow the crawl line to overlay up to eight different channels.

### APARTMENT AMPLIFIERS — HIGH POWER & LOW NOISE

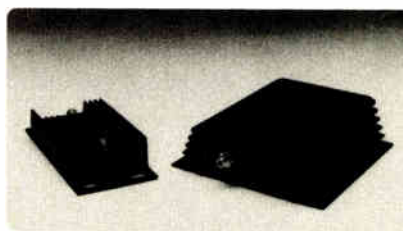

ChannelPlus RF distribution amplifiers combine high power, low noise and continuous coverage of all frequencies from 40 MHz to 1000 MHz. Perfect for apartment houses and other systems. A single amplifier will usually deliver superior picture quality to hundreds of TVs. ChannelPlus amplifiers are available in both local and line (through the cable) powered versions. ChannelPlus has an amplifier for any size or type of system.

multiplex®  
technology, inc.

251 Imperial Highway, Fullerton, CA 92635, U.S.A.  
714-680-5848 • 800-423-0584 (U.S.A.) • FAX 714-680-0645

© 1989 Multiplex Technology, Inc., Fullerton, CA 92635

Reader Service Number 32

# BY THE YEAR 2000, ALL AMPLIFIERS MAY BE THIS GOOD.

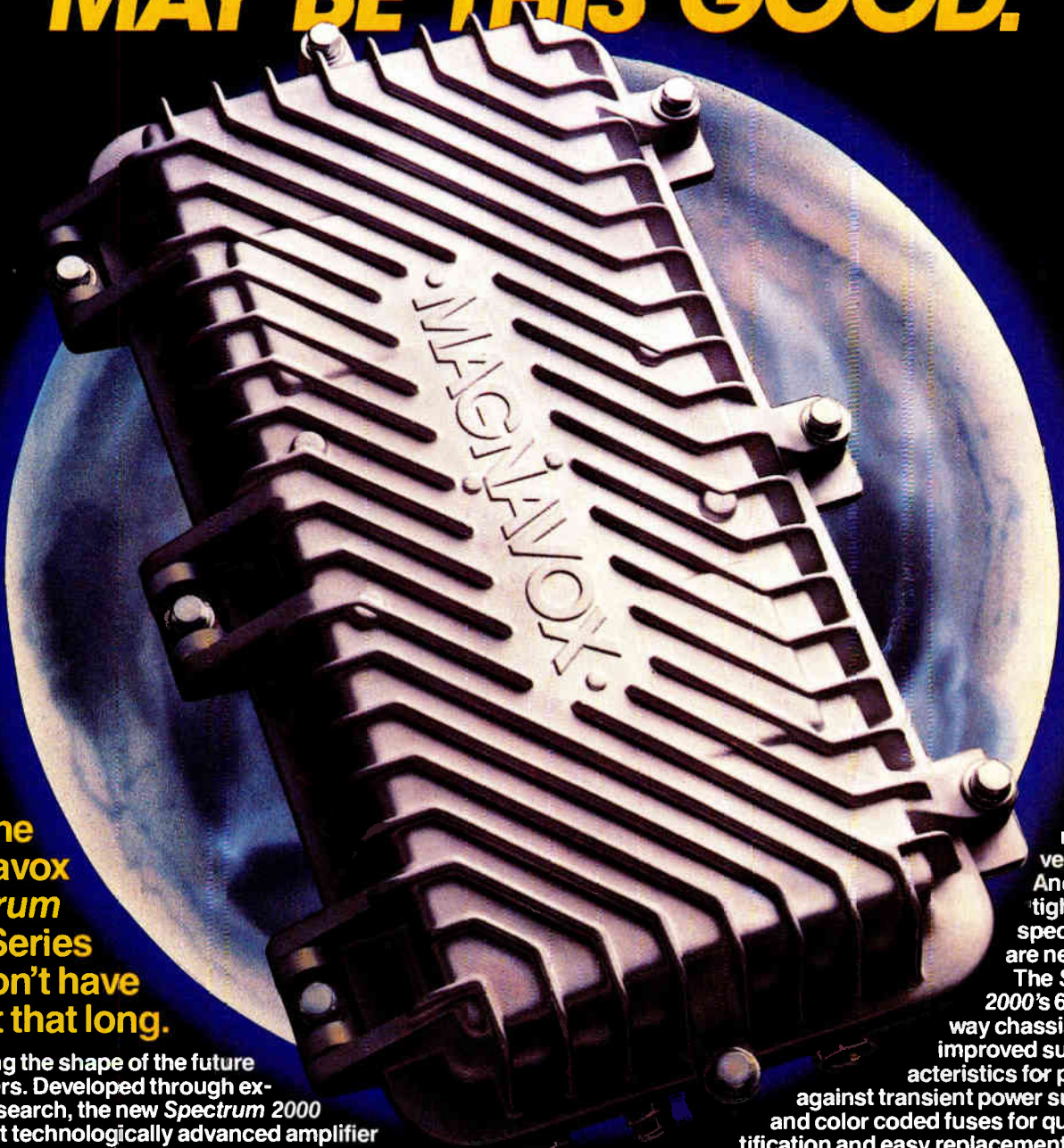

**With the  
Magnavox  
Spectrum  
2000 Series  
you don't have  
to wait that long.**

Introducing the shape of the future in amplifiers. Developed through extensive research, the new *Spectrum 2000* is the most technologically advanced amplifier series available. Inside and out.

Designed to shield your broadband electronics from the merciless elements, the *Spectrum 2000* housing\* is unlike any other. Computer designed convection fins provide superior heat dissipation in either vertical or horizontal installations—keeping internal modules cool. Plus, our improved weather and RF seals lock out external elements.

Our extended 5/8 inch ports are standard and are designed to accept a heat-shrink seal where the cable enters the housing. And our optional right angle ports even eliminate the need for 90° and 180° connectors making it a snap to mount in aerial, vault and pedestal installations. For ease of maintenance, the cover is reversible and always opens

\*Patent Pending

in the most convenient way. And it closes tight so no special tools are needed.

The *Spectrum 2000*'s 600 MHz 2-way chassis features improved surge characteristics for protection against transient power surges and color coded fuses for quick identification and easy replacement.

Available in a variety of bandwidths and bandsplits for worldwide usage, the *Spectrum 2000* amplifier is compatible with all Magnavox modules manufactured since 1972.

Bring your broadband system into the next century with the *Spectrum 2000* amplifier series. Call your Magnavox representative for more information.

## MAGNAVOX

**CATV SYSTEMS, INC.**

100 Fairgrounds Drive, Manlius, NY 13104  
(315) 682-9105 Fax: (315) 682-9006  
1-800-448-5171 (In New York 1-800-522-7464)

## BANDWIDTH RACE

tage of more bandwidth, says David Fellows, director of marketing, earth station/headend products at Scientific-Atlanta, who sees both MSOs deploying such electronics within the next two years. He said National Show attendees were more interested in knowing it is possible to add 70 channels on top of 450 MHz than in buying such equipment. Fellows also says the demand is coming from the European market, which already uses the 570 MHz to 870 MHz spectrum to deliver its UHF channels.

"I was delightfully surprised" at the interest shown at the National Show in extended bandwidth capabilities, says Jim Wonn, vice president of sales and marketing at C-Cor Electronics. But was there true interest, or just curiosity? It's probably impossible to tell, yet, Wonn says. "I have a hard time believing cable operators will put a lot of money in 1 GHz without there being an imminent need, and I don't get the feeling there's an imminent need."

Just when operators will want high-bandwidth active equipment is the \$64,000 question, but Luff is one who believes the time is coming sooner rather than later. He says demand for

new programs, CATV embracement of data carriage and creative service provision, along with HDTV, will provide the impetus—and soon.

### Cascades must be shortened

With such high frequencies, coax cable losses are much higher and distortions become so numerous that cascades have to be significantly reduced to make it all work. There is universal agreement that as bandwidth grows, amplifier cascades will have to be trimmed; at 1 GHz, cascades no longer than four or five amps could be tolerated.

Right now, using today's hybrids, at 750 MHz the maximum number of amps that could be cascaded is probably two or three, says Fellows. At 1 GHz, the cascade limit is "half an amplifier," he says. "We're just beginning to understand the limitations; we won't be selling 870 MHz amplifiers next month," Fellows adds.

Even if performance is improved dramatically at high levels, ultimate demand for such products may be limited for a long time to come. "Engineers have told me that 1 GHz products may end up accounting for no more

than 10 percent to 20 percent of the total hybrid demand," says Pfizenmayer. But that could change if HDTV demands it.

Frank Ragone, vice president of engineering at Comcast, a fiscally conservative MSO, perhaps puts it all in perspective. "We're just settling in on 550 MHz...we're not inclined to start designing our systems with 1 GHz in mind."

Ragone admits that amp spacings and housings may be considered in systems where upgrade work is occurring, but says too many other concerns remain unaddressed so far. "What's the ripple effect of 1 GHz on converters, cascadeability and headend equipment? What impact will it have on hubs and supertrunking?" he asks.

Ragone is even beginning to doubt that HDTV would drive a need for that many channels, now that the FCC has mandated that any transmission standard adopted must be NTSC compatible.

"I welcome the interest (in 1 GHz) and I think the development will enhance the current products, but I'm very cautious regarding implementation," Ragone adds. ■

—Roger Brown

# You Deserve Quality!

## Your Quality CAD system design maps come from Cable Link, Inc.



- strand mapping
- system design
- drafting services
- as-built mapping
- walkout
- make ready

(614) 221-3131

Cable Link, Inc. Buys, Sells, Repairs,  
converters, line amps, line extenders, headend, traps, parts

Over Thirty Years of  
**SERVICE,  
RELIABILITY**  
and  
**INNOVATION...**

- *the First 550MHz Apartment House Amplifier*
- *the First 700MHz Line Passives*

**NOW...** *the* **FIRST**  
**650MHz**  
**DROP AMPLIFIER**



---

Frequency	45-650MHz
Gain	10dB
Noise Figure	4.5dB
CTB	-65dB
SP and UL Approved	

---

*Lindsay...Your Full Line*  
CATV Manufacturer ...  
*Actives at 550MHz,  
Passives at 700MHz,  
Apartment House Amplifiers and  
Ganged Apartment Taps,  
with a full line of  
CATV Communication Antennas.*

*Lindsay*

PA: TONER CABLE EQUIPMENT  
FL: INTERSTATE CABLE ENTERPRISES  
PA: JIM MORTON & ASSOCIATES

215-675-2053  
800-245-4423  
717-243-4653

MN: GRUNWALD, BURNS & ASSOCIATES  
CO: MEGA HERTZ  
CA: WESTERN CATV DISTRIBUTORS INC.

218-739-3961  
303-779-1717  
213-539-8030

---

**LINDSAY SPECIALTY PRODUCTS** 1248 Clairmont Rd, Suite 3D-231, Decatur, Georgia, U.S.A. 30030  
Telephone: 404-633-2867 Fax: 404-634-1515 Head Office: 705-324-2196

---

# MultiPort testing begins

After waiting years for the introduction of the first MultiPort scrambling decoders, several cable system operators throughout the country are finally getting the opportunity to market test the boxes in real cable systems.

Both Zenith Cable Products and the Jerrold Division of General Instrument have shipped a small number of first-run decoders to cable systems in several different locations. As of press time, hundreds of units were scheduled to be placed in the field by Telecable, Cencom Cable Associates, Viacom

Cable and other MSOs. Other manufacturers have built and tested their versions of MultiPort, but to date, only Jerrold and Zenith have actually shipped product.

For the uninitiated, MultiPort is a descrambler that is attached to the back of a television, instead of on top of the TV, which has been designed to be "transparent" to the cable viewer and eliminate the incompatibilities between cable system descramblers and cable-ready TVs and VCRs. (However, the TV and/or VCR must have a MultiPort plug built into it for the system to work. So far, RCA, Panasonic, Quasar and General Electric have included the plug on their larger TVs; Bang and Olufsen is set to debut its MultiPort VCR later this year.) It is known as a baseband interface because it functions with unmodulated video and audio, however, systems that use RF scrambling schemes like Jerrold's can still use MultiPort.

## Features returned to remote unit

Because MultiPort doesn't include a tuner and doesn't process video signals, owners of cable-ready televisions can now use all the features on the remote control that comes with the television while at the same time enjoy better quality pictures.

Over the years, "MultiPort" has been referred to by a number of names,

including IS-15 (for Interim Standard number 15) and IS-15A (after changes were made to allow for impulse pay-per-view and Y/C video inputs). However, now the technical interim standard has become a true Electronic Industries Association recommended standard with

a new number—RS 563. To avoid confusion, the name MultiPort has been decided upon for future reference.

As for implementation, the bad news is that, so far, only small handfuls of MultiPorts have trickled into subscriber homes. Telecable has eight units operating, Viacom has one and

Cencom has just three working units. The good news is that those units are working flawlessly and subscribers are reportedly welcoming them in their homes.

One delay was caused by the unavailability of the umbilical cables that run from the decoder to the TV set. However, new shipments of the cables were expected as of presstime, making delivery of the decoders imminent.

Telecable, which has five Zenith units in its Overland Park, Kansas system and three more in Springfield,

Mo., has conducted regular telephone interviews with its MultiPort customers and the satisfaction level is high, according to Nick Worth, vice president of engineering at Telecable.

In fact, a third party study showed that existing basic-only subscribers have a slightly higher propensity to subscribe to premium services because of the convenience MultiPort brings. Worth wants to find out if that's true by enlarging his test in Overland Park, an upscale suburb of Kansas City with 67,000 subscribers. In all, Worth has ordered 400 units from Zenith and he expects to receive 200 of those units by the first week of July.

## Grassroots campaign

To increase early support for the product, Worth hosted a meeting of local television set dealers in and around Overland Park to educate them on MultiPort's benefits. In addition, Telecable will provide the dealers with point-of-sale informational brochures and a coupon for a free cable install, service upgrade or decoder swap-out to encourage consumer purchase of MultiPort-equipped TVs. "We're letting them (dealers) know we'll support them," said Worth.

The next step is to determine if the units are reliable by enlarging the test and adding them to more systems. If that is successful, Worth said he'll then

...basic-only subscribers have a slightly higher propensity to subscribe to premium services because of the convenience MultiPort brings.

## MultiPort: A user's perspective

Everyone is familiar with the problems cable causes when cable-ready TVs and addressable converter/descramblers are linked together. Subscriber ire is raised to intense levels when they find out they cannot connect the two, add a VCR and record pay services while watching something else.

Those scenarios are why MultiPort was designed. Cable operators, considered the "bad guy" in these cases, desperately needed to find a way to bow out of playing the villain's role. It's no wonder, then, that they've been frustrated while equipment manufacturers for years debated the viability of such a product.

So how does it feel to have remote

access to all the conveniences and features that were paid for with the new, expensive TV? Just fine, according to Tom Jokerst, director of engineering for Continental Cable's Illinois, Iowa and Missouri region, and long-time pro-MultiPort lobbyist.

Jokerst, a paying subscriber in Larry Lehman's Cencom system in St. Louis County, recently made his home a MultiPort test site by purchasing a 27-inch RCA color TV with a MultiPort plug built on its back. He reports that the box works well and is entirely transparent. "It's an effortless situation," he says. "Pay signals descramble quickly and the box is no longer on top of my TV." What's more, Jokerst



# Run with the LYNX!

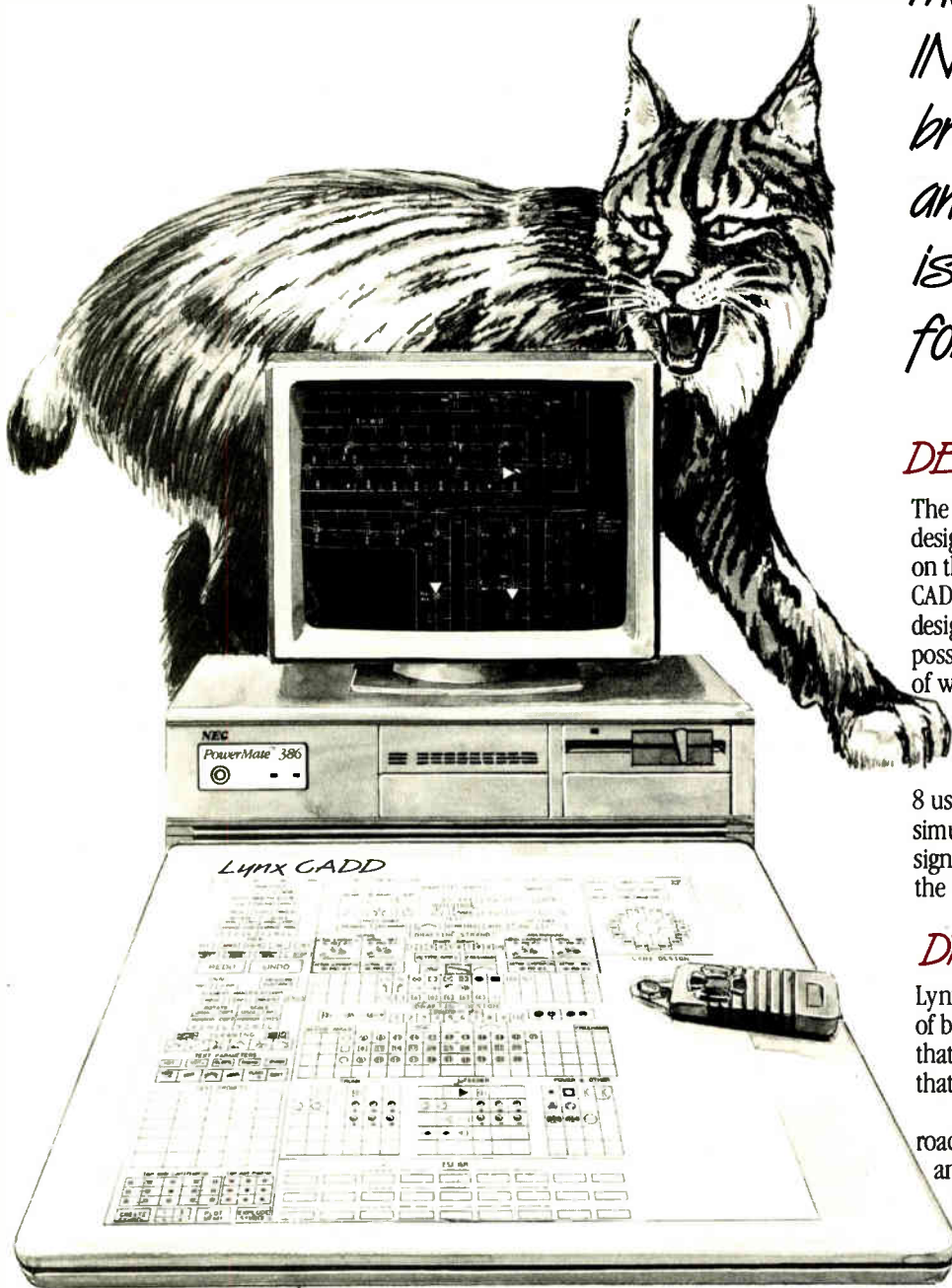

Featuring the NEC PowerMate 386.

## A.D.S.

Automated Drawing Systems, Inc.

Reader Service Number 36

The most powerful  
**INTEGRATED**  
broadband design  
and drafting package  
is now available  
for your PC . . .

### DESIGN . . .

The intelligence of Lynx CADD gives the designer the power to calculate design right on the map. Simply specify the area and Lynx CADD automatically calculates the optimum design for you. Or, explore alternate design possibilities simply and quickly for any type of what-if situation.

Detailed Bill of Materials are produced automatically.

With Lynx CADD, up to 8 user-specified frequencies are tracked simultaneously. And it is possible to monitor signal from a subscriber's house back to the headend.

### DRAFTING . . .

Lynx CADD has taken the basic functions of broadband drafting and created features that dramatically increase the number of miles that can be mapped in a day.

For **base** mapping, Lynx CADD has a road command with easy intersection cleaning and a MAP/CUT command which will automatically divide a topo, utility or tax map into the individually desired maps.

For posting **strand**, commands are available for automatic placement of text for footages, house counts, addresses and pole numbers.

If **design** is posted manually, the SCTE standard symbols are included for your use.

Call (404) 448-0977 or (800) 333-LCAD today for more information on this powerful PC-based system for broadband design and drafting.

3150 Gateway Drive, Suite 700  
Norcross, GA 30071

"go public" through video ads, bill stuffers, etc. However, any such public campaign will have to be done carefully—subscribers have to understand they need a MultiPort TV to get rid of their set-top converters.

When subscribers have MultiPort's benefits explained to them, they're anxious to get one. In Viacom's East Bay system, an existing multi-pay subscriber walked into the cable office and requested a MultiPort decoder because she had just purchased an RCA television with the MultiPort plug. She had been talking to the local TV dealer, who had been talking with Viacom about MultiPort, and was referred to the cable system's Pleasanton, Calif. office.

**Fortunate timing**

Viacom "just happened to have three prototype units" in that office and gave the subscriber one of them, said Del Heller, vice president of engineering at Viacom Cable. "Since mid-May she's been using it and she continues to be satisfied with its ease of use," he said.

Heller said he too is planning to host a meeting with TV dealers to explain MultiPort and its benefits. RCA has already provided Viacom with a list of people in its service area who have purchased new MultiPort sets (garnered from those who return TV warranty cards). Viacom has taken the names, compared them against its

subscriber list of premium services, and come up with a waiting list of 35 people so far. Those people will be contacted by telephone and offered the MultiPort box—as soon as Viacom's shipment of 175 units arrives.

Although Cencom doesn't yet have the decoders it needs to begin testing, Larry Lehman, vice president of engineering, has already planted the seed with his subscribers. Lehman contacted the St. Louis Post-Dispatch and discussed the consumer electronic interface and MultiPort with the writer. Although the resulting article focused on the interface issue and not MultiPort per se, Cencom became painfully aware of how many subscribers want to dump their converters.

Other operators are anxious to test the device, too. United Cable, which was scheduled to test MultiPort in its Denver systems, has apparently backed off until all the ramifications related to the merger with United Artists are known.

The lack of decoders has been the thorn of the side of cable operators who have wanted to address the consumer friendliness issue for some time now. Until recently, decoder manufacturers

have been reluctant to build and distribute MultiPort boxes until a larger market developed. But TV manufacturers threatened to discontinue offering the plug unless the cable industry showed some support for it. The operator was stuck in the middle.

Jerrold and Zenith were the first to

commit to small production runs (1,000 and 1,500 pieces, respectively). Jerrold, for one, has been pleasantly surprised at the operator reaction.

**Skepticism begets surprise**

"Frankly, we were a little skeptical (about MultiPort's chances for

When subscribers have MultiPort's benefits explained to them, they're anxious to get one.

product survival) going into the NCTA Show, but the response to it was overwhelming," said Dan Moloney, director of product management for Jerrold's subscriber products division. "We feel strongly that as they are put in the field and demand is great" MultiPort will be added to the Jerrold product line.

In fact, Jerrold took another step recently to encourage market acceptance of MultiPort by lowering its price from \$275 to \$140 each. As MultiPort boxes are produced in volume, the price is expected to drop well below addressable set-top unit prices because MultiPort is a simpler product to build. (Zenith, which recognized the consumer interface problems years ago and built a similar but different device called Redi-Plug, offers its MultiPort boxes at a price below \$100, according to industry sources.)

**S-A capitulates**

Intense industry pressure also forced Scientific-Atlanta to commit to building about 1,000 units sometime next year. S-A has steadfastly maintained that there is no market for MultiPort and has steered its R&D program toward off-premise addressability.

It's clear that MultiPort has a lot to offer cable operators by solving some of the consumer electronics interface problems. But even its proponents admit it isn't the only solution and that it will take time before it is significantly penetrated in the market. But finally, the process has begun. ■

can use the on-screen display and the built-in TV clock features.

While shopping for his MultiPort TV, Jokerst said he was struck by two things: the TV dealer's knowledge of MultiPort and his enthusiasm related to the prospect of working with the local cable operator to sell more TVs. "He (TV dealer) seemed real excited and interested" about MultiPort. "He's been helpful and anxious to cooperate because he wants to try to get himself out of the middle" of the consumer electronics incompatibility issue.

Because he was able to eliminate the set-top converter, Jokerst increased his cable programming menu to include multiple premium services and three pay-per-view services—becoming living proof of what many studies have seemed to indicate: that

basic-only customers will be more willing to take premium service if they don't need a converter.

Although Jokerst has his video system configured to allow him to record premium services using the timer feature on his TV, he admits that there is still a glaring need for MultiPort to be added to VCRs. But like an infant who needs to crawl before he can walk, the industry has to show support for MultiPort in this critical first stage before electronic equipment manufacturers commit to adding the feature to VCRs.

But if Jokerst can be considered to be an average cable subscriber, MultiPort could be the boon that cable operators, electronic dealers and premium service providers have been looking for.

—Roger Brown

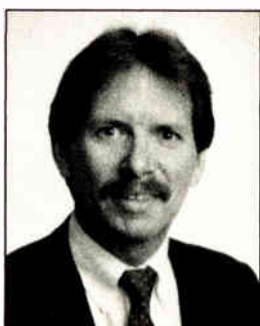

Tom Jokerst

—Roger Brown

# When yesterday isn't good enough.



## Anixter Cable TV stocks Belden drop cables

**SERVICE.** So many suppliers use that word. But only one lives up to it. Anixter Cable TV. Anixter stocks the complete line of Belden drop cables, ready for immediate delivery from a location near you. No minimum orders...and no minimum quantities. Just Belden quality. Every day.

**ANIXTER**  
CABLE TV

Reader Service Number 37

See us at the Eastern Cable Show, Booth # 527.

**WEST-ANAHEIM:** (714) 779-0500, (800) 854-0443; **DENVER:** (303) 740-8949, (800) 841-1531; **SEATTLE:** (206) 251-6760, (800) 426-7665; **MIDWEST-CHICAGO:** (312) 364-7000, (800) 544-5368; **CLEVELAND:** (216) 526-0919, (800) 321-8068; **DALLAS:** (214) 446-7337, (800) 231-5006; **IRON MOUNTAIN, MI:** (906) 774-4111, (800) 624-8358; **SKOKIE, IL HDQTRS:** (312) 677-2600; **EAST-ATLANTA:** (404) 995-5110, (800) 241-5790; **LONG ISLAND, NY:** (516) 293-7788, (800) 645-9510; **NEW JERSEY:** (201) 328-0980, (800) 631-9603; **TAMPA:** (813) 626-7115, (800) 282-9164; **CANADA-CALGARY:** (403) 250-9646; **MONTREAL:** (514) 636-3636; **TORONTO:** (416) 625-5110; **VANCOUVER:** (604) 321-5885.

In an emergency, weekends and holidays or after 5 P.M. call toll free 1 (800) 323-8166.  
CORPORATE OFFICES, ANIXTER CABLE TV, 4711 Golf Road, Skokie, IL 60076, (312) 677-2600

©1989 Anixter Cable TV

Ask anyone in the cable industry what syndex (syndicated exclusivity) means and you'll get such a smattering of grumbling and sour faces that you'll wonder why you asked in the first place. The issue of syndex isn't new; what is new, however, is that the first deadline for syndex notification (June 19) has come and passed, and the January 1990 deadline for implementation of the rule is just around the corner—without much hope for postponement.

Although simple in concept, syndex will create chaos for most cable system operators. Cable stations must delete, from distant signals, those syndicated programs for which the broadcast stations in their market have obtained exclusive rights. Although it seems clear-cut, there are exceptions, restrictions, and an awful lot of confusion about what will actually happen. What is the liability of cable? If a change in the blackout requirements happens within the 60-day period, do operators get another 60-day notice? What about programming delays because of sports program overruns? Who can request protection from whom?

Naturally, these questions, and others, have cable operators scrambling for answers. It's apparent in almost everyone's minds that some type of syndicated exclusivity will be imposed

# Syndex who? What? When? Why?

by January 1, 1990. That leaves an even more important question looming for the technical community: How will the actual switching be handled and how will the new source be inserted?

## More than a black box

As they join the syndex furor, many technical personnel see the technology as part of the problem, but not the central focus. Instead, some of their concerns rest with the fact that syndex is an unbudgeted expense, the rules will be cause for more equipment in an already overcrowded headend and, somehow, the syndication information will need to be tracked.

"The technical aspect of putting in a switch and making a transition is very minor," states Dominic D'Allesandro, president and CEO of ARVIS Corp. Inc. "Everybody has something that will do something like that. The

real problem we're looking at is the logistics of tracking the syndications." This tracking problem stems from the fact that broadcast stations are required only to notify a system of syndex rights—not with information pertaining to when and where the program is to be blacked out. That will be left up to the cable operator.

Another problem in tracking syndication is geographical determinations. Sammons Communications began a study early this year to determine the syndex impact on its budget year and is finding many of the answers difficult because of those logistics. (The study has focused on determining local markets and which are considered distant signals, and whether the distance is within the Grade B contour or significantly viewed.)

Sammon's Director of Engineering, Bob Saunders, says that "obviously, if you have a headend feeding two different municipalities and one's protected and the other is not, you're going to have to treat it as though both were (protected) because the trunk and feeder line gets so intermingled, it's pretty hard to separate one from the other."

Because of these considerations, the technical implications become fuzzy and undefined. Although in many cases the technical community is working rigorously with marketing departments

## What is syndex?

*With permission from the National Cable Television Association, following is a summarization of a primer developed by the NCTA Engineering Committee. The primer was originally compiled to aid cable systems in understanding and preparing for syndex. This excerpt is intended to provide a familiarization of syndex rules, its restrictions and exemptions. (Given the complexity of the syndex rules, the NCTA urges cable operators to consult with their regular communications counsel for additional information and advice concerning their syndex rights and obligations.)—Ed.*

The syndicated exclusivity rules are scheduled to take effect as of January 1, 1990 and require that cable systems in a broadcast station's market delete, from distant signals, any programming which that broadcast station has the

exclusive right to air. The rules apply to all cable systems that have 1,000 or more subscribers. Once a system reaches the 1,000 subscriber mark, it is required to send a notice to the FCC and each of the broadcast stations entitled to invoke syndex protections against the system.

- Only commercial broadcast systems that have expressly contracted for syndex rights can demand syndex blackouts. This does not include noncommercial educational stations, translators or low power television (LPTV) stations.

- In order to invoke syndex protection against a particular cable system, a broadcast station is required to notify the system operator *in writing*.

- For program contracts entered into after August 18, 1988, the syndex request must be furnished to the cable

operator within 60 days after the contract is signed and must be received by the operator at least 60 days before the requested period of syndex protection is to begin. The program contract must contain the appropriate syndex language in order to be valid.

- For program contracts entered into before August 18, 1988, the syndex requests must have been given by June 19, 1989, provided that the contract, as originally written, contains a clear grant of syndex rights. (Although it was not expected operators would receive many notices, several MSOs have already received notices in stacks two to three inches high.)

- Syndex protection is limited to a broadcast station's 35-mile zone, as measured from the FCC designated "reference point" for the station's city of license. Additionally, broadcast stations located in FCC-designated "hyphenated markets" are entitled to enforce syndex rights throughout the 35-mile zone of each of the communities

# We carry your size.

CSR-191  
controls one VCR  
for random  
sequential spot  
selection.



CSR-192  
controls two VCR's  
for random or  
semi-random  
access selection.

CSR-294  
controls four VCR's  
for random access  
selection during  
two minute breaks.  
It can insert spots  
on two satellite  
channels at  
mutually exclusive  
break times.

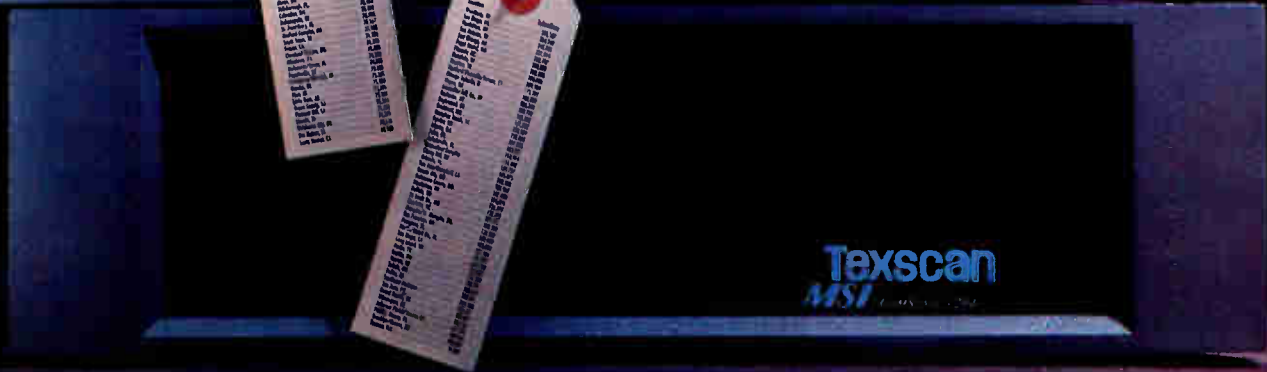

Advertising and engineering managers across the country demand the wide range of capabilities offered by ComSertex. Key benefits are random access spots, full stereo audio, direct spot search, automatic fail-safe modes, broadcast style switching, selectable end-of-break modes, video verification, advanced tape marking, simplified installation, automatic VCR timing adjustments, auxiliary inputs, external processor loop, preview outputs, multi-tasking operating system and modular design as well as thorough training and support. Our standards of quality and reliability have resulted in the selection of ComSertex being the commercial insertion equipment choice of 18 of the top 20 MSO's.

We're focusing on your future.

**Texscan MSI**

124 North Charles Lindbergh Drive, Salt Lake City, Utah 84116 / 800-367-6011 or 801-359-0077

to determine what can be done, the fundamental question of switching programs in and out still brings the problem back into the laps of the technical community.

**No simple solution**

Mike Watson, vice president of sales for Channelmatic, does not see a simple one-step, one-piece of equipment as the answer to syndex. "An all-encompassing, universal hardware approach is not going to satisfy 98 percent of the applications out there," says Watson, "because every cable system is different." In order for an operator to determine its specific needs, Watson sees the system as having to contemplate several items.

One of these considerations is the number of channels operators need to deal with on a headend-by-headend basis. Will it be local or remote control? Is the operator going to deal with single or multiple headends for switching hardware? Will there be regional or corporate control of the schedules for switching hardware? And what will an operator use to fill the blacked-out time?

As for source material to insert in

in a hyphenated market.

- Programs carried on distant broadcast stations (i.e., stations located more than 35 miles from a cable community) are subject to syndex blackouts. In fact, the rules require blackouts not only on national and regional superstations, but also on distant noncommercial, educational stations, translators and LPTV stations. *The rules do not require blackouts on cable services, such as USA, ESPN, TNT, etc.*

**Exceptions**

- Programs on stations which are more than 35 miles from the cable community, but which place a Grade B contour over any portion of a cable community unit are not subject to blackout by the community unit.

- A second exception are programs on stations which are more than 35 miles from the cable community but which are "significantly viewed" in the county in which the cable community is located. Significantly viewed refers to stations that have obtained a

place of a syndicated program, Watson also sees several considerations. One is to replace the program with a message for each channel that's blacked

three percent share and a 25 percent net weekly circulation (for network stations) or a two percent share and a five percent net weekly circulation (for independent stations).

**Responding to syndex**

- A cable operator is permitted to request a signed copy of the contract provision concerning the scope of the broadcaster's exclusivity protection.

- It is up to the cable operator to determine which distant signals are carrying programs covered by the blackout request and when those programs are scheduled for broadcast.

- The rules allow a cable operator to substitute other programming in place of the programs deleted pursuant to a blackout rule.

- The FCC's decision anticipates and approves of negotiations whereby the broadcaster agrees not to enforce its syndex rights in exchange for some valuable consideration from the cable operator. ■

out. This can be done using a common character generator feed for all the networks or a network-by-network specific character generator. Or perhaps

# SEE SPOT RUN.

Automatically. Seven days a week. With random or fixed positioning on all your network avails. SMPTE coding, automatic recovery and makegoods, unequalled broadcast quality. Automatic scheduling, confirmation and billing. See the best commercial insertion systems. See ARVIS today.

## ARVIS™

The Right Spot At The Right Time

300 Second Ave., Waltham, MA 02154  
1-800-272-7847 • In MA, (617) 890-5850

Reader Service Number 39

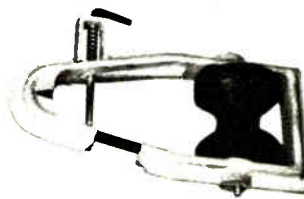

# Lemco

the  
tools  
of the  
trade

Call for your free  
catalogue.

**(800) 233-8713**

Reader Service Number 40

# MONROE ELECTRONICS SERIES 3000

## The Syndex Switching Solution

### PROGRAM TIMER SERIES 3000

MONROE ELECTRONICS, INC.



### SWITCHER PANEL SERIES 3000

MONROE ELECTRONICS, INC.



### CUE TONE RECEIVER SERIES 3000

MONROE ELECTRONICS, INC.



Monroe Electronics, recognized as the pioneer of Cue Tone Signaling, continues to set the standard in the changing world of cable programming.

The Series 3000 puts complete program switching control at your fingertips. You get automatic and unattended headend switching through the use of timed signals, network cue tones, and Touch Tones® at your remote location.

#### PROGRAM TIMER SERIES 3000

- 999 event capability
- 16 open collector outputs
- Expandable to control 20 dual 2X1 A/V switches
- RS232 port for up/downloading program data
- On-site logging of events for verification

#### SWITCHER PANEL SERIES 3000

- Vertical interval switching capabilities - 2 slots available for either one or both of the following:
  - Dual Form C 2X1 A/V Module
  - 4X1 Matrix A/V Module
- Front panel control
- Front panel module status indicators

#### CUE TONE RECEIVER SERIES 3000

- Four receiver inputs
- Telephone override of cue tones
- On-site cue tone programming by rotary switches
- Front panel control
- Front panel decoder status indicators

***Solutions for Program Switching and Syndicated Exclusivity***

Reader Service Number 65

**M** **MONROE ELECTRONICS, INC.**  
**E**

100 Housel Avenue, Lyndonville, NY 14098  
Phone: 716-765-2254 • FAX: 716-765-9330 • Telex: 75-6662

Authorized distributor for Telecommunications Products Corp. new Syndex control software.

the system will switch to an auxiliary satellite feed at the time the blackout has to occur. Another option is to roll a VCR and insert a half-hour program.

For Channelmatic, the equipment answers to these type of considerations depend on the operator. The program Channelmatic currently has under development is called X-Manager (the 'X' stands for program) which is a preliminary set of specifications that includes all the different choices and the hardware solutions to meet those considerations.

"Each of the six different hardware solutions have been tailored and matched to each different market," says Watson. "Some include matrix switching, some include a simple two-by-one switching on a per-channel basis and control software for frequency agile satellite receivers to enable choosing of the myriad of signals out there. Right now, there's not going to be one solution," he adds.

Gilbert Moreira, vice president of ARVIS Corp., agrees. "We have switching products and we have software," he says. "We have a number of solutions we're considering but haven't determined exactly which package is right. The key is, it really centers

around our customers and what they want to accomplish."

"What I foresee servicing the syndex market is a package that is flexible enough for the operator to lay out his requirements along with the one software package that will handle the

'The key is, it really centers around our customers and what they want to accomplish.'

different types of hardware approaches and connections," adds Terry Bush, vice president of the instrument division for Trilithic Inc.

Trilithic's basic proposal is a 7RSABM (75 ohm, remotely switched, A/B, manual) automated switch bank that can

switch RF and be controlled by an RS232 interface. The switch bank was developed to be definable per the headend, which allows the operator to create his own product. "We can define it by application, we can switch RF, IF or video and audio and the audio to include stereo," states Bush. "We're also coming up with some other utility products which are delayed closure, contact closure and encoder strips that allow operators to adjust the satellite control remotely if desired."

Bill Robertson, marketing manager for MSI Corp. is another advocate of the "more than a simple solution" approach for syndex. "Sure, if you want a switcher, we can provide one," says Robertson, "but there's too many ramifications of syndex to be able to provide one answer to fit everyone's needs. I think when the FCC originally voted for syndex, it was with the thought that the commercial insertion gear already in existence would solve any programming problems."

To Robertson, one solution for syndex is not a technical box, but a new program network. Robertson believes there's a need for someone to provide a network consisting of half-hour and one-hour "fillers" that a system could

# SEE SPOT CONFIRMED.

Automatically. Whether you insert one spot or dozens, advertise on one network or all networks. With ARVIS' SMPTE coding, random/fixed positioning, and automatic recovery and makegoods, you'll see your spots run. With our automatic scheduling, confirmation and billing, you'll also see a faster return on your investment.

Reader Service Number 39

## ARVIS™

The Right Spot At The Right Time

300 Second Ave., Waltham, MA 02154  
1-800-272-7847 • In MA, (617) 890-5850



## Scientific Atlanta

8500, 8550 & 8580

addressable  
converter  
repairs

- Repair cost \$16.95 plus parts
- Ninety day warranty on parts and labor
- Repaired with Scientific Atlanta parts only
- 10-15 working day turnaround time

Call for quotes on Distribution and Headend Equipment repairs.

800-346-3083



Midwest  
CATV Engineering

1818 Went Street Mishawaka, IN 46545



# The widest choice of power supplies made in the U.S.A.

## FERRO

Amps

2



4



6

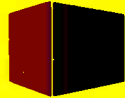

9

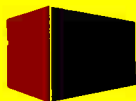

12



15



18



## STANDBY

Amps

4



6



9



12



15



## Now, you'll cut your power bill down to size.

Why buy 15 amps and run, inefficiently, at 9 amps?

Now, buy only the power you need! Lectro has 7 different power supplies, the widest range in the industry by far. Lectro's efficient, Sentry II, plug-in, modular standby power supplies are available in 5 different sizes, too. Nobody else comes close.

Less is more! The less power you waste, the more money you make. And if your capacity changes, just unplug one Lectro module...and plug in another!

Lectro is in the business to meet your needs today. When you need even more tomorrow, we'll be the first to respond. Again.

Call 1-800-551-3790.

In Georgia, (404) 543-1904

 **Lectro**

More power to you.

P.O. Box 567  
420 Athena Drive  
Athens, GA 30601

Reader Service Number 42

not ready to share the technical details of its new product. "Let's just say it's going to be the most user-friendly, efficient, easy-to-use program available for syndex," says Russell. "It won't require near the data input to create a switch as anything currently on the market. We will be taking program guide data and eliminating the need for key input or manually searching program guides to figure out where your switches have to occur," he adds.

#### Producing revenue, not chaos

Even though Russell may not want to exhort the virtues of the software product, he definitely has an opinion on syndex. "I think it's a blessing in disguise," states Russell. "Like anything else that comes along, if you look at it properly, you can always turn it into a positive." The positive in this case is using syndex to improve the quality of programming by eliminating duplication and make more revenue in ad sales.

"Everyone needs to remember that the basic premise of air-time, whether it's day or morning, is worth dollars," says Russell. "If that weren't the case,

there wouldn't be programs on TV all night long. That is revenue waiting to be generated."

Turning syndex into a positive, revenue producing action is an idea that is echoed by many. (Most opinions on syndex range from "pain-in-the-rear" to "mess" as opposed to a blessing, however.) Basically, the thought is to use that available air-time for several purposes. One would be to plug in local spots along with a local program. The space could also be used for cross-channel promotion, to instruct users on how to use specific services (i.e., pay-per-view) or even to give a free preview of pay channels. Obviously, the most popular thought is to turn an expense-laden, non-revenue producing issue into a paying item.

#### Running out of time

Even with the thought of syndex creating a new advertising market, no one is quite sure what the next step is. With an impending court date in October 1989 to delay, or even repeal the syndex ruling, operators are skeptical about taking that first step and ordering equipment. This delayed reaction will have its affect on the industry.

One, as already mentioned, syndex is going to be a large, unbudgeted expense. Two, the deadline is less than half a year away. How quickly can the manufacturers gear up and produce the equipment needed?

"Our problem is that a lot of operators will wait until November or December to order the equipment," says Ad System's Hall. "We're going to have a very high bubble on this thing. At this time we're trying to get out ahead of that and help with system's needs, and by the same token, measure the magnitude of the problem."

A few of the manufacturers see this as being an instrumental reason they delayed working on a syndex product. "One of the problems we had in coming up with a new product," says Ives, "is we weren't sure syndex was really going to happen. Now, we're sticking out our necks in terms of making some plans." Although Monroe has received several calls from major MSOs during the last couple of weeks, no one is placing firm orders.

"They're saying I need these fantastic numbers but guessing doesn't allow me to plan our production time," says Ives. Adding to the delay in ordering is the uncertainty in the courts as to whether syndex could still be repealed. To Russell, it's already too late. "If all the people capable of manufacturing equipment were to gear up full tilt, there's no way you'd make it in time," he estimates. "Unfortunately, in fighting this thing as long as we fought, it's going to work against the industry."

The most severe repercussion of syndex will be its affect on consumers. Once systems begin blacking out programs, it will be up to the operators to provide an explanation as to what is happening.

Obviously, the easiest solution is to let the public know it's the broadcasters and the FCC who are behind syndicated exclusivity. But as almost everyone knows, once the subscriber turns on his set and finds that programs are not being delivered, there's only one villain—cable. Brian James, director of engineering for the NCTA, says there's only one question a subscriber will ask: "Why did you do this?" Granted, cable operators are already bitter over the same thought. However, amidst all the confusion and uncertainty of syndicated exclusivity, the preeminent question seems to be, "How will we do this?" ■

—Kathy Berlin

# SEE ARVIS TODAY.

See the industry standard in automated video insertion systems. Whatever your size, your needs and your budget, there's an ARVIS system to give you more for your money. Call today. You'll see ARVIS. You'll see the light.

**1-800-272-7847**

Reader Service Number 39

## ARVIS™

The Right Spot At The Right Time

300 Second Ave., Waltham, MA 02154  
1-800-272-7847 • In MA, (617) 890-5850



When you leave  
the office, can  
you rest  
assured your  
"spots" ran?



If not, you can!

Telecommunication Products Corporation designs and manufactures ad sales automation systems (both hardware and software) with reliability and dependability in mind.

Call Tom Russell and ask about these products...

**NEXUS • MEDIUS • BASUS • ADMINISTRATOR • ADPOD**



**Telecommunication  
Products Corporation**  
**(717) 267-3939**  
Chambersburg, PA 17201

# Interpretation of airborne leakage data

**COMPLIANCE**

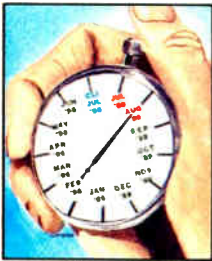

**Q**ualification of cable systems for leakage integrity is being performed by both ground and airborne procedures. A correlation of the airspace and ground measurements was established by the Advisory Committee on

Cable Signal Leakage in the late 1970s. This data was taken on a relatively few cable systems and is, therefore, subject to refinement as more data is collected.

Some initial observations of recent data provide certain insights into the leakage patterns observed in airborne observations and their sources on the ground. The effects of large single leaks on these patterns, some probable causes, and the implications on ground monitoring procedures are treated in this paper.

You would think that enough had been said about cable signal leakage to last a lifetime. Unfortunately, leakage control probably will last a lifetime and the discussion may never be done. When the FCC rules for qualification of cable systems to the leakage standards become effective in July 1990, we will only be at the "first hurdle in the race" since qualification must be done yearly and perhaps forever. Leakage is a relatively simple subject on the surface, however, there are many nu-

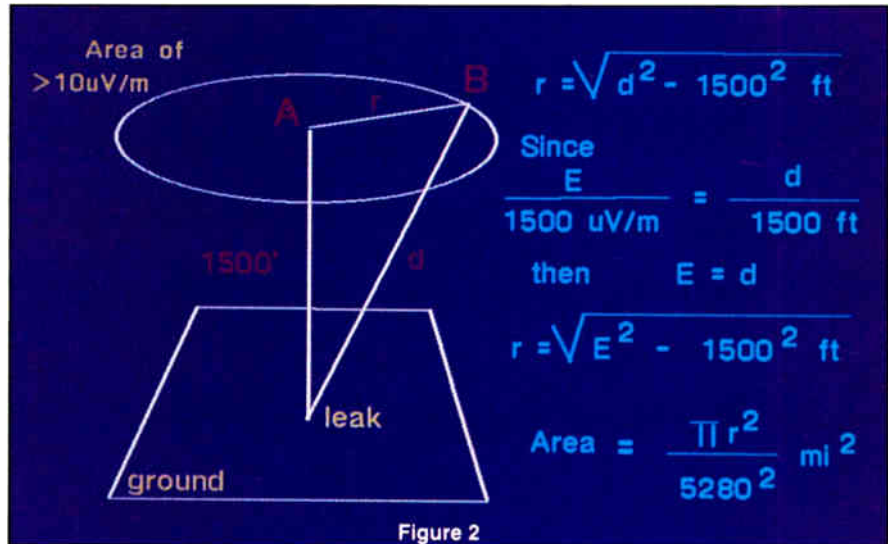

Magnitude of leak uV/m	Circle of excess signal at 1500' radius (ft)	area (sq.mi.)
1,500	0	0
2,000	1,323	.197
3,000	2,598	.761
4,000	3,708	1.55
5,000	4,770	2.56
10,000	9,887	11.0
20,000	19,944	44.8

Table 1

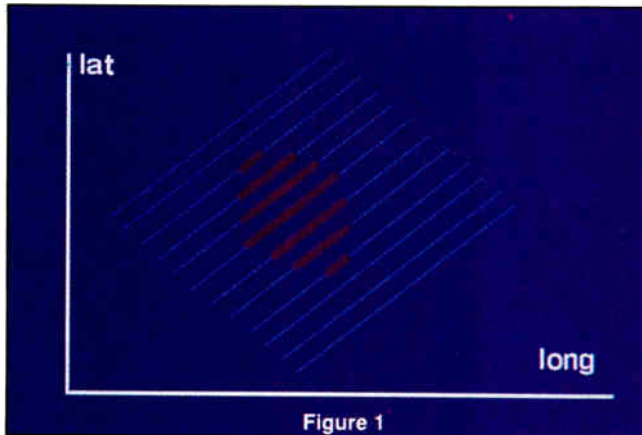

ances—some of which we have yet to learn.

The cable industry has gathered considerable data taken both from ground and airborne measurements. There is an pressing need to investigate correlation between ground and air results. To date, little work has been done toward investigating correlations because of a lack of concurrent ground/airborne data

plus the complexity of the situation. Analysis of data taken on a few systems has shown major disparities between ground and airborne results. In these cases the airborne data usually indicates more signal leakage in the airspace than predicted by the ground-based CLI.

As a matter of fact, flyover measurements of some systems look very bleak indeed, with large sections of the

*By Chris Duros, CableTrac Inc. and Edwin L. Dickinson, Dovetail*

©NCTA Reprinted with permission from the 1989 NCTA Technical Papers



# The new Wavetek SAM 2000. Push a button and your old world comes to an end.

After you try the new SAM 2000, anyone else's signal level meters will seem like a waste of time.

By comparison, they are.

Because Wavetek's SAM 2000 has just redefined what a signal level meter should do, and how fast it should do it. So the world of Cable TV testing as you've known it has just ended.

Direct LCD display with auto-ranging provides precise measurement with no interpretation required and indicates a comprehensive list of measurement parameters. All through quick, easy keyboard control.

FAV key allows fast checks on user programmed channels such as pay channels.

CAL feature permits instant field calibration for temperature variations and test probe, and it even shows when an error in calibration has occurred.

HI/LO pilot button quick-steps between system pilots.

Semi-automated C/N test prevents errors in measurement of this critical system parameter. The SAM 2000 easily locates power supply or filter problems through measurement of system hum modulation.

Two-button tilt function displays mathematical difference between the programmed hi and lo pilot, with realtime update.

Two-button Delta Video/Audio feature quickly displays video-audio level ratio.

The SAM 2000 comes packaged in a compact, lightweight, extremely durable weatherproof ABS plastic case, with built-on strand hooks. Even when open it can handle a sudden shower. And for night use an optional battery powered light illuminates the entire face of the unit.

The new Wavetek SAM 2000. In every way, it's designed to make the most of your time. So don't waste any in getting one.

For more information and the name of your nearest Wavetek sales rep, call us at 1-800-622-5515. In Indiana, 317-788-5965.

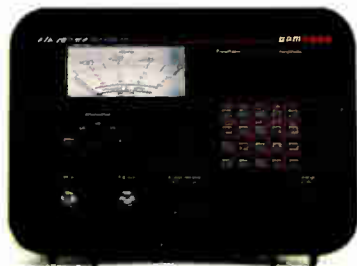

Reader Service Number 45

**WAVETEK®**

## CLI CALLBOOK

The following companies have paid a fee to have their listing appear in the CLI Callbook.

## Hardware

### (C) Comm/Scope, Inc. THE Cable in Cable TV.

**Comm/Scope, Inc.** . . . (704) 324-2200  
**WATS (National)** . . . (800) 982-1708  
**WATS (State)** . . . . (800) 222-6808  
 PO Box 1729  
 Hickory, NC 28603  
**PERSONNEL:** Chris Huffman, Marketing Manager; Elaine Jones, Customer Service Manager.  
**DESCRIPTION:** Manufacturers of CRD (Corrosion Resistant Drop) and APD (Amorphous Polypropylene Drop) extended life aerial drop cable products, including 67, 77, 95 percent braided, tri-shield, and Super-Shield constructions. Includes center conductor corrosion inhibitor treatment.



**ComSonics, Inc.** . . . (703) 434-5965  
**WATS (National)** . . . (800) 336-9684  
**FAX** . . . . . (703) 434-9847  
 1350 Port Republic Road  
 P.O. Box 1106  
 Harrisonburg, VA 22801  
**DESCRIPTION:** SNIFFER II—Signal leakage detector provides high selectivity, input preselector, squelch tone decoding and a tone coded variable squelch. Unit has internal calibration that provides a 20  $\mu$ V/m calibration source to the RF input port. Signal source and detector system design has a typical sensitivity level of -83 dBmV. SNIFFER III—Offers the same features as the SNIFFER II with logarithmic mode select which allows direct readings in  $\mu$ V/m from 2 to 2000. SNIFFER JR.—A pocket sized leakage detector

that allows for installers to check for leakage when they complete an install thus effectively increasing the size of your signal leakage detection team.



**Lindsay Specialty** . . . (705) 324-2196  
**Products Ltd.**  
**FAX** . . . . . (705) 324-5474  
**PERSONNEL:** Gordon Zimmerman, Sales; Mike Dowling, Sales USA; Koert Koster, Engineering.  
**DESCRIPTION:** Lindsay manufactures a full line of CLI measurement antennas.  
 1) Van Roof Mount CLI Radiation Measurement Antenna, Model CLVA-1.  
 2) Hand Held Field Strength Tuneable Survey Antenna, Models RTA-V&U.  
 3) Single Channel 3 Element Directional Hand Held Fold Up Antenna Model 3LTA-\*\*.  
 4) 20 dB 12 Volt Antenna Amplifier Model CLIA-20.  
 5) To complete the system a Fixed Calibration Antenna Model 5LMA-1.  
 Lindsay offers a custom antenna design & Engineering Service for CLI fly over applications.



**Multilink Inc.**  
**Communication Division**

**Multilink, Inc.** . . . . (216) 324-4941  
**FAX** . . . . . (216) 324-4947  
 P.O. Box 955  
 196 Morgan Avenue  
 Elyria, OH 44036  
**PERSONNEL:** Steve Kaplan  
**DESCRIPTION:** Manufacturer of the following CLI products: 1. tap port cleaner; 2. RF sealant—a rubber type material that is injected with carbon, that will shield the connectors if they start to leak. The product is called STEALTH SEAL.



**Pico Macom, Inc.** . . . (818) 897-0028  
**WATS** . . . . . (800) 421-6511  
**FAX** . . . . . (818) 899-1165  
 12500 Foothill Blvd.  
 Lakeview Terrace, CA 91342  
**PERSONNEL:** Frank Bailey, Sales Manager; Dave Lantz, Director of Engineering.  
**DESCRIPTION:** The patented Pico Macom AB-2 coaxial switch features an internal diecast case for excellent shielding. 75 ohm terminations are provided on the non selected input port. The 90 dB isolation and wide bandwidth (5 MHz to 900 MHz) make the switch desirable in the new FCC environment. Patent #3,940,584.



**Pico Products, Inc.** . . (315) 451-7700  
**WATS** . . . . . (800) 822-7420  
**FAX** . . . . . (315) 451-7904  
 103 Commerce Blvd.  
 Liverpool, NY 13088  
**PERSONNEL:** James Quigley, National Sales Manager; John Lockwood, Corporate Director of Engineering.  
**DESCRIPTION:** Pico's new mini "Perfect Trap" (PT), with the industry's only welded seams, guarantees that RF leakage is greater than 120 dB down, far exceeding the 1990 CLI requirements. In shielding effectiveness tests, the PT's welded seams were in excess of 127 dB down, at least 17 dB to 25 dB better than traps tested with rolled seams.



PRODUCTION PRODUCTS COMPANY  
 Div. of John Mezzalingua Assoc. Inc.

**Production Products Co. (PPC)** .(315) 682-2031

## CLI CALLBOOK

**WATS** . . . . .(800) 468-2288  
**FAX** . . . . .(315) 682-2386

One Mezzy Lane  
 Maulius, NY 13104

**PERSONNEL:** Daniel Hige, Dominick Maio

**DESCRIPTION:** PPC has introduced a unique three piece UNIVERSAL DROP CONNECTOR PACKAGE that assures consistency and virtually eliminates RF signal leakage. 1) A new cable prep tool, accurately prepares cable with consistent repeatability. 2) An improved crimp tool with one 0.360 crimp hex. 3) A torque wrench for proper connectorization. These tools matched to our UNIVERSAL and individually color coded (CFS 59 U—CFS 6 U) Brass "F" connectors solidify the perfect marriage.



**TRILITHIC**  
 Including  
**Texscan**  
**INSTRUMENTS**

**Trilithic, Inc./** . . . . .(317) 545-4196  
**Texscan Instruments**

**WATS** . . . . .(800) 344-2412  
**FAX** . . . . .(317) 547-2496

3169 N. Shadeland Ave.

Indianapolis, IN 46226-6233

**PERSONNEL:** Greg Marx, Director of Sales & Marketing/Instrument Products; Terry Bush, VP/Instrument Products.

**DESCRIPTION:** Trilithic, Inc. supplies the only complete line of CLI instrumentation available in the industry. TFC-450 and TFC-600 frequency counters for rapid frequency measurements. SEARCHER PLUSES for CLI measurements, SEARCHERS and FDM series for leakage monitoring plus a full line of antennas, accessories and software. Only Trilithic has it all!



**TFC** TIMES FIBER COMMUNICATIONS, INC.  
 an  
*LPL* company

**Times Fiber** . . . . .(800) TFC-CATV  
**Comm. Inc., An LPL Company**

**FAX** . . . . .(203) 265-8422

358 Hall Ave.

Wallingford, CT 06492

**PERSONNEL:** Jack Forde, President; Craig Scalzo, Director of Sales & Marketing

**DESCRIPTION:** Available exclusively from TFC, LifeTime is a corrosion resistant protectant designed to form a barrier against moisture ingress and retard corrosion. LifeTime drop cable is cost effective. Protecting against corrosion not only extends cable life, it also maintains performance. This means improved return on labor and material investment, while minimizing costs as the septem ages.

**Trilogy**  
**COMMUNICATIONS INC.**

**Trilogy** . . . . .(800) 874-5649  
**Communications**

**FAX** . . . . .(601) 939-6637

2910 Hwy. 80E

Pearl, MS 39208

**PERSONNEL:** William P. Kloss;

Michael Scrimshire.

**DESCRIPTION:** Manufacturer of a complete line of drop cables for CATV industry. Included are CATV, CATVX and corrosion proof cables available in all industry configurations.

**WAVETEK**

**Wavetek RF** . . . . .(317) 788-5965  
**Products, Inc.**

**WATS** . . . . .(800) 622-5515  
**FAX** . . . . .(317) 788-5999

5808 Churchman Bypass

Indianapolis, IN 46203

**PERSONNEL:** Mark Linton, Mike

Richardson.

**DESCRIPTION:** New line of cable leakage monitoring, measuring, and logging instrumentation. CLM-1000

Cable Leakage Meter monitors, measures, and logs leaks for print-out or computerized CLI calculation and control. SCOUT Leakage Detection Meter monitors two channels, detection alarm, level metered; vehicle mount and/or portable. CLR-4 Hand-held 4 channel scanning detector.

---

## Software

---



**COMSONICS** INC.  
 AN EMPLOYEE OWNED CORPORATION

**ComSonics, Inc.** . . . . .(703) 434-5965  
**WATS (National)** . . . . .(800) 336-9681

**FAX** . . . . .(703) 434-9847

1350 Port Republic Road

P.O. Box 1106

Harrisonburg, VA 22801

**DESCRIPTION:** SNIFFWARE—Allows for the logging of leakage locations, strength of leaks in dBmV or microvolts per meter and performs all calculations needed to obtain your Cumulative Leakage Index information. Included in the package is a leakage report form used for the routine leakage maintenance of a CATV plant. The report includes fields for location of leak, date, grid mapping, suspected cause of leak, action taken and other pertinent data.

---

## Long Systems, Inc.

---

**Long Systems, Inc.** . . . . .(619) 278-2700

8388 Vickers Street

Suite 201

San Diego, CA 92111

**PERSONNEL:** Harry E. Long, President; Warren Reihls, Western US Sales Rep.

**DESCRIPTION:** Cable industry specialty software program designers. Makers of the LES-Leakage Evaluation System, VIC-Vehicle Information

## CLI CALLBOOK

Center and other industry specific software. Long Systems also provides remote data entry terminals for collection of data in the field via hand-held computers. Software consulting services for individual MSOs or systems are available too.

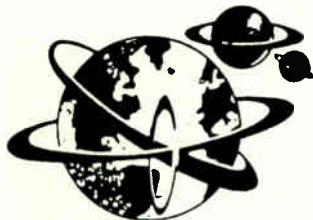

**Telecommunication Products Corp.** .(717) 237-3939

**FAX** . . . . .(717) 263-1547

1331 South Seventh Street  
Chambersburg, PA 17201

**PERSONNEL:** Tom Russell, Sales Manager; Leslie Miller, Marketing and Sales Representative.

**DESCRIPTION:** CLIDE software is a CLI management tool designed to be easy to use, with color displays, on-line help, and pop-up, user-friendly windows. Offering over 15 CLI management reports, CLIDE calculates the CLI Index, identifies individual leaks on a pass/fail basis, and performs statistical analysis on leak costs. CLIDE is compatible with the Wavetek CLM-1000 Leakage Detection Meter, the PSION hand-held computer, and the Tandy RS-102 laptop computer.



**TRILITHIC**  
Including  
**Texscan**  
**INSTRUMENTS**

**Trilithic, Inc./ Texscan Instruments** . . . . .(317) 545-4196

**WATS** . . . . .(800) 344-2412

**FAX** . . . . .(317) 547-2496

3169 N. Shadeland Ave.

Indianapolis, IN 46226-6233

**PERSONNEL:** Greg Marx, Director of Sales & Marketing, Instrument Products; Terry Bush, VP/Instrument Products.

**DESCRIPTION:** Trilithic's C.L.I.C.S. Software is a complete management

tool for CLI and leakage control. C.L.I.C.S. features on-screen displays updated with each entry for leaks per mile, CLI infinity, CLI 3000 leak level and "fix" categories, microvolts per meter, dB 20, dB 50 and dBmV entry modes plus valid FCC logs and other reports.

---

## Services

---

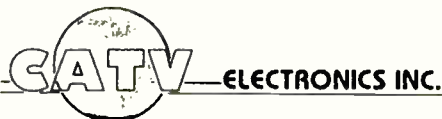

**CATV Electronics, Inc.** .(800) 284-4810

920 S. Wilcox Dr., Suite 12

Kingsport, TN 37660

**PERSONNEL:** Jeff L. Wiggs, Cathy Combs

**DESCRIPTION:** With July 1990 upon you, let us provide, without delay, the required frequency offsets or complete channel relocation on your headend equipment now. Let us make the necessary repairs and calibration of FSM's RF detectors, or instrumentation used for CLI measurements. We are your total repair facility, call today.



CATV Subscriber Services, Inc

**CATV Subscriber Services** . . .(919) 273-5553

**FAX** . . . . .(919) 274-9734

808 Summit Ave.

Greensboro, NC 27405

**PERSONNEL:** Raymond L. Galtelli

**DESCRIPTION:** If you're not sure how to meet the FCC standards on signal leakage, CATV Subscriber Services, Inc. has an answer. Our engineering staff will survey your system, detect leaks, correct them and then update your personnel in the proper preventive maintenance so that your system will continue to meet compliance.

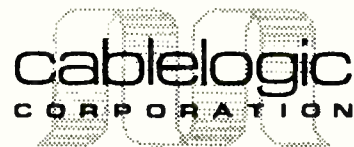

**Cablelogic Corp.** . . .(303) 730-8885

P.O. Box 2617 (80161)

#8 W. Dry Creek Cir., Ste. 203

Littleton, CO 80120

**PERSONNEL:** Thomas Moe, Michael McNeill

**DESCRIPTION:** CLI-MATE is a mobile signal leakage detection service. Provides fully equipped vans and qualified technicians who will generate documentation needed for FCC compliance in 1990. Included is a complete system driveout with reports of location and measurements of leaks as well as CLI calculations. Compatible with LES software.



**CableTrac, Inc.** . . .(206) 774-2100

**FAX** . . . . .(206) 771-2136

19011 36th Ave. W.

Suite A

Lynnwood, WA 98036

**PERSONNEL:** Chris Duros, Edwin L. Dickinson

**DESCRIPTION:** CableTrac is a supplier of nationally available aerial signal leakage testing services which provide fast and economical evaluation of CATV system signal leakage and annual certification for FCC Pt. 76.611.



**COMSONICS**  
INC.  
AN EMPLOYEE OWNED CORPORATION

**ComSonics, Inc.** . . .(703) 434-5965

**WATS (National)** . . .(800) 336-9681

**FAX** . . . . .(703) 434-9847

1350 Port Republic Road

P.O. Box 1106

Harrisonburg, VA 22801



## CLI CALLBOOK

**DESCRIPTION: CLI FLYOVER—** Offering system operators aerial signal leakage detection and CLI reporting. This service generates a statistical summary of test data as well as indicating hot spots from grid maps.

### Suppliers/Distributors

# ANIXTER CABLE TV

**Anixter Cable TV . . . (312) 677-2600**  
**FAX: . . . . . (312) 677-1097**

4711 Golf Rd.

Skokie, IL 60076

**PERSONNEL:** Tom Szumny, Chuck Krone

**DESCRIPTION:** Regal drop and installation passives with high RFI shielding, LRC, radiation leakage detection system and Raychem EZ-F connector system. All the products listed will help reduce and/or test for RFI leakage.



**CATV Services, Inc. . . (415) 651-4331**  
**FAX . . . . . (415) 651-8545**

2211 Warm Springs Ct.

Fremont, CA 94539

**PERSONNEL:** Steve Yerdon, Sylvia Murillo

**DESCRIPTION:** Full line distributor, representing: Wavetek leakage detection equipment and Telecommunications Product's Clyde leakage software to make FCC compliance easy. Call us today outside California (800) 227-1200 or inside California (800) 223-3152.



Cable Services Company Inc.

2113 Marydale Ave., Williamsport, PA 17701 • 717/323-8518  
1-800-233-8452 Nationwide

**Cable Services . . . (717) 323-8518**  
**Co. Inc.**

**FAX . . . . . (717) 322-5373**  
2113 Marydale Ave.

Williamsport, PA 17701-1498

**PERSONNEL:** Vic Carlson, Chief Engineer, Harry Wahl, VP/Turnkey Construction.

**DESCRIPTION:** Complete in-house turnkey construction services which guarantee FCC compliance to CLI regulations. Walkout, design, engineering, aerial and underground construction individually available. Full product distributor which includes test and spectrum analyzer equipment for CLI testing.

# THE DROP SHOP LTD.

**The Drop Shop Ltd. . . (201) 241-9300**

**WATS . . . . . (800) 526-4100**

**FAX . . . . . (201) 686-4657**

P.O. Box 284

Roselle, NJ 07203

**PERSONNEL:** David L. Wank, Harold Zoberg

**DESCRIPTION:** National Distributor specializing in the supply of all drop and installation materials. This includes the "SUPER-SPLITTER" series of passives; the highest RF shielding rating for passives in the industry (125 dB minimum—guaranteed!) Call any of our three locations for current stock and shipping information.

# HUDSON SUPPLY COMPANY, INC.

**Hudson Supply . . . (800) 441-0666**

**FAX: . . . . . (818) 964-3664**

17901 E. Ajax Cir.

City of Industry, CA 91748

**PERSONNEL:** Steve Egerer, Executive Vice President; Steve Brazil, Vice President, Sales.

**DESCRIPTION:** Providing the products you need to help keep your CLI from

becoming a problem. Choose Gilbert or LRC connectors, Times Fiber cable, Jerrold passive and active equipment. Use professional tools to do the job right with Cable Prep, Utility and Klein Tool.

# MIDWEST

# CATV

A division of Midwest Corporation

*More than supplies. Solutions.*

**Midwest CATV . . . . (304) 343-8874**

**A division of Midwest Corporation**

**WATS . . . . . (800) 532-2288**

**FAX . . . . . (304) 346-0624**

P.O. Box 271

Charleston, WV 25321

**PERSONNEL:** John Johnson, Purchasing Manager; Christopher Sophinos, Vice President/Chief Operating Officer.

**DESCRIPTION:** CLI questions? Call Midwest CATV. Our full line includes: the DA 30-450 indoor distribution amplifier with RFI gasket and filtered power cord; LRC snap-n-seal connectors, Gilbert USA connectors, Sachs SCO2M, SCO3E, and SC10 for drop installation integrity, plus our new Milenium house drop passives with die-cast housings and high RFI shielding. All Milenium ports, including the ground block, employ the CAM-port seizing mechanisms. More than supplies, solutions for CLI from Midwest CATV.

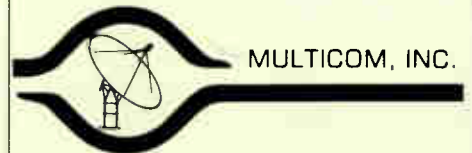

**Multicom, Inc. . . . (407) 331-7779**

776 Bennett Dr.

Longwood, FL 327

**PERSONNEL:** Jordan Miller, Toby Soileau

**DESCRIPTION:** Stocking distributor for Scientific-Atlanta, Jerrold, Blonder-Tongue, Pico Macom and many more—fast courteous service, same day shipments, technical assistance available.

**COMPLIANCE**



system showing leakage in excess of the limit of 10 microvolts per meter (10  $\mu\text{V}/\text{m}$ ) at 1,500 feet above the cable system.

In order to better understand the governing factors, let us review some of the Part 76 rules

and their implications.

Sections 76.605 and 76.611 of the FCC rules require limitation of leakage from any leak to 20  $\mu\text{V}/\text{m}$  at a distance of 3 meters (10 feet), while 76.613 prohibits harmful interference regardless of the magnitude of the leak. Calculation of CLI per 76.611(a)(1) requires only that leaks of 50  $\mu\text{V}/\text{m}$  or greater be included. Section 76.611(a)(2) prescribes a 10  $\mu\text{V}/\text{m}$  total leakage limit at 450 meters (1,500 feet) above

the cable system.

The implications of these sections relevant to this discussion are:

1. Leaks greater than 20  $\mu\text{V}/\text{m}$  at 3 meters are in violation. Smaller leaks are also in violation if they cause harmful interference.

2. In the calculation of CLI, leaks smaller than 50  $\mu\text{V}/\text{m}$  need not be included. The reason for this is that these smaller leaks are of minimal significance in the total field.

3. In a flyover measurement the limit of 10  $\mu\text{V}/\text{m}$  at 450 meters (1,500 feet) above the cable system, could be caused by a single leak. Such a leak measured on the ground at 10 feet, would have to be 150 times larger, (the ratio of 450 meters to 3 meters) or 1,500  $\mu\text{V}/\text{m}$  in order to equal this threshold.

It is interesting to note that the 1,500  $\mu\text{V}/\text{m}$  field strength at 10 feet is 75 times the permissible value of 20  $\mu\text{V}/\text{m}$ . This is equivalent to 5,625 times the power of 37.5 dB excess. You must admit that this is a very wide and generous margin, courtesy of the FCC.

**Flyover experience**

Getting back to actual flyover results, the data from most systems shows at least one area where the 10  $\mu\text{V}/\text{m}$  threshold is exceeded. This is in contrast to the ground monitoring and CLI data which usually indicates that the system complies. Although this may seem strange, several factors can contribute to the effect. Remember that the ground measurements for CLI probably required substantial elapsed time, so that it is likely that during the ride-out new leaks developed in the areas which were first measured. In fact, if the CLI was measured and computed and no further monitoring was done prior to a later flyover, the opportunity existed for many new leaks to develop in the interim.

Addressing the fact that most flyovers do show some areas where the leakage exceeds 10  $\mu\text{V}/\text{m}$ , the FCC rules have made still another provision in the cable operators favor. This is known as the "90th percentile" and requires that only 90 percent of the points taken where digital recording is used, show values equal to or less than 10  $\mu\text{V}/\text{m}$ .

As a result of this provision, a cable system showing a few areas of excessive leakage can still qualify. In review, it is fair to say that the FCC regulations are generous and allow for compounded problems without unduly penalizing the cable operator. Nevertheless, a flyover report showing sub-

# Prepare Now!

On July 1, 1990, the FCC's regulation on signal leakage goes into effect. Failure to comply with FCC standards may lead to stiff fines and a possible shutdown of your system. But that's nothing compared to the damage a major leak could cause if it interferes with air traffic control. If you're not sure how to meet



the FCC standards, CSS has an answer. Our engineering staff will survey your system, detect leaks, correct them and then update your personnel in the proper preventive maintenance so that your system will continue to meet compliance. July 1990 is right around the corner, so don't wait, give us a call today.

CATV Subscriber Services, Inc.  
808 Summit Ave.  
Greensboro, NC 27405  
(919) 273-5553

Reader Service Number 46



TFC-450 AND TFC-600



SEARCHER PLUS



FDM-4



C.L.I.C.S.



FDM-3



SEARCHER



FDM-5

## ARE YOU SEARCHING FOR CLI COMPLIANCE EQUIPMENT? ONLY TRILITHIC HAS IT ALL!

**TRILITHIC is the only source for all your CLI compliance needs.**

- The new **SEARCHER PLUS** provides vehicle mounted and handheld CLI measurement capability.
- The **TFC-450** and **TFC-600** frequency counters keep your carriers on frequency.
- The **SEARCHER** midband channel receiver and the **FDM Series** of dedicated carrier receivers offer affordable leakage monitoring.

- **C.L.I.C.S.** (Cumulative Leakage Index Computing Software) wraps it all up.

Search high and low — only TRILITHIC has everything you need for CLI compliance. You just supply the leaks.

For more information on TRILITHIC'S complete line of CLI instrumentation and accessories contact TRILITHIC or your authorized TRILITHIC representative.

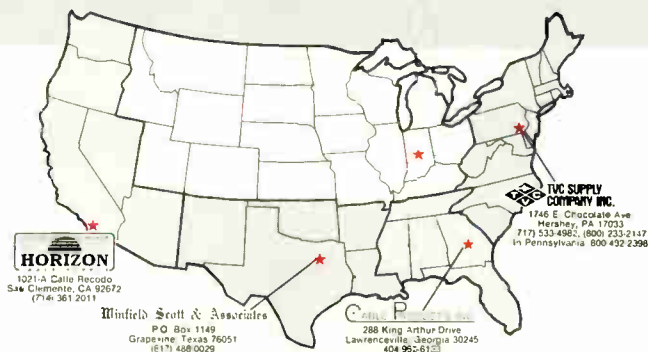

contact us at:

- ★ **TRILITHIC INC.**  
3169 N. Shadeland Ave.  
Indianapolis, Indiana 46226-6233  
(317) 545-4196  
Toll free outside Indiana: (800) 344-2412  
TLX: 244-334 (RCA) FAX: (317) 547-2496

## CLI DATA INTERPRETATION

### COMPLIANCE



stantial areas of excessive leakage can be very dis-comforting.

In some flyover reports areas of excessive leakage are seen as circular or elliptical patterns. Figure 1 illustrates this effect. The regularly spaced lines depict the path of the overflight to scale on a latitude/longitude plot. Areas of signal strengths greater than  $10 \mu\text{V}/\text{m}$  are shown by heavier lines. This plot is simulated because of the inability to reproduce the colors normally used to portray different signal strengths on the flight path.

#### Analysis of the effect

To investigate this effect we will consider the area of excessive leakage generated at 1,500 feet above the cable system by a single large leak. Assume that the leak radiates equally in all directions producing a hemispherical pattern (this assumption is unlikely but may be used for this simple exam-

ple). Figure 2 illustrates this model.

An airborne detector directly over the leak (point "A") would receive the maximum energy while in other locations the energy from the leak would have to travel further, thereby reducing its effect. For instance, a single leak measuring  $15 \mu\text{V}/\text{m}$  at 1,500 feet

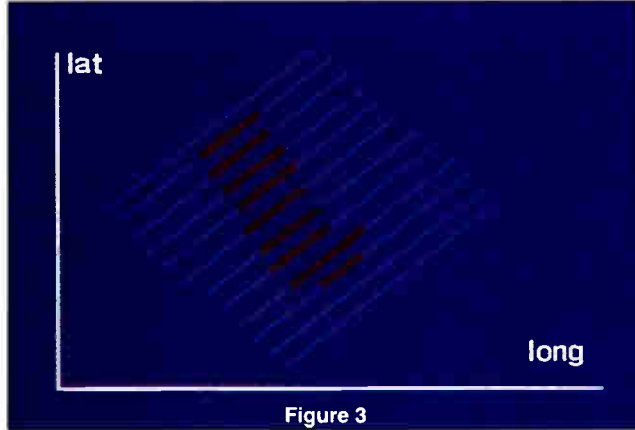

Figure 3

directly above (point "A"), would measure only about 71 percent of that (about  $10 \mu\text{V}/\text{m}$  if the observer were 1,500 feet away from the center (point "B"). This reduction in field strength is governed by the length of the hypotenuse of the triangle formed by the altitude and the

radius. The hypotenuse is, in this case, 1.414 times the length of either leg.

Signals traveling 1.414 times the distance will produce a received amplitude proportional to  $1/1.414$  or about 71 percent. Table 1 has been developed to illustrate the extent of this effect upon the signal strength at 1,500 feet from a single large leak. The table records the radii and areas of the circles bounding the region of excessive signal at 1,500 feet altitude.

As an example, a single leak of  $1,500 \mu\text{V}/\text{m}$  will cause only a single point of threshold level directly over the leak while a leak of  $3,000 \mu\text{V}/\text{m}$  generates a circle of excess single strength with a radius of 2,598 feet

and encompasses an area of about 0.76 square miles. The dimensions for larger leaks increase rapidly. From the table it can be seen that a single large leak can have a devastating effect on the overall survey results and, as a matter

*Continued on page 111*

## CLI Equipment

### FCC Compliance Made Easy

#### RD-1

Low noise, battery operated, pre-amplifier, tuneable Dipole, 16db gain, 50 to 250 MHz. \$450.00\*



#### CLR-4

High sensitivity, hand held leakage detector, scans 1-4 video carrier frequencies, locator tone varies with strength of signal detected. \$450.00\*



#### CLM-1000

Leakage field strength meter 50 to 550 MHz. Three meter equivalent measurements from 10 to 100 ft., audio alarm, non volatile storage (100 memories) & RS232 port. \$2,495.00\*

### WAVETEK

Authorized Sales & Service Representatives for CA, AZ, OR, WA, ID, MT, NV, AK

#### CLIDE - Control Leakage Index Data Easily

Software program for an easy & inexpensive way to record the levels & location of signal leakage in ground based inspections. Repair & FCC logs simplified. IBM PC Compatible. \$695.00\*



Inside California 800/223-3152 Outside California 800/227-1200

2211 Warm Springs Court, Fremont, CA 94538 • (415) 651-4331

\* Prices subject to change • Add tax & shipping.

Reader Service Number 48

# YES, *Cable Cares*

October 3-5, 1989

Call the Registration Supervisor

609-848-1000



Reader Service Number 49

# Z-VIEW. THE PAY-PER-VIEW SYSTEM THAT PROMISES MORE THAN JUST THE STARS.



It's true that with some PPV systems, subscribers can enjoy heavy star-gazing. But with the Zenith Z-View system, they can set their sights even higher. ★ That's because Z-View's two-way addressability provides a true, real-time link between you and your subscribers. A link that makes possible more than just simple, remote control PPV event access for your subscribers. ★

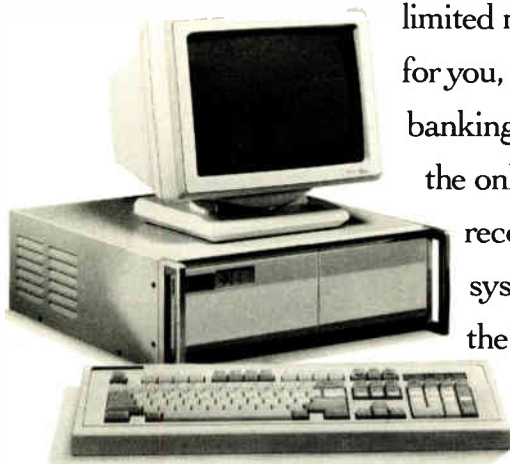

But also, unlimited marketing opportunities for you, such as channel monitoring, home shopping and banking, and opinion polling. ★ Zenith's Z-View is the only real-time PPV system that has a proven track record of over five years of reliable service in cable systems throughout the country. The Z-View signals are protected with SSAVI baseband scrambling for maximum security. Plus, rugged upstream data transmission allows for effective communication even in the most demanding cable plants. ★



So why settle for the stars when you can have the whole galaxy? Write or call for more information on the Z-View system and other Zenith cable products: Zenith CATV Sales, 1000 N. Milwaukee Avenue, Glenview, Illinois 60025. (312) 391-7702.

**ZENITH** | cable products

*ADDRESSING YOUR FUTURE TODAY*

# Loss budget considerations and contributions

The purpose of this paper is to review and explain optical loss budgets and considerations for the implementation of fiber optic technology into a CATV system. The optical loss budget must be established to enable the design engineer to correctly determine which fiber technology is best suited to the cable system under design.

## Basic considerations

The main reason for instituting fiber technology is to reduce the amount of active and passive components between the headend and the subscriber. This not only increases the reliability of the cable system but also improves the overall signal quality to subscribers. You will need to determine what your maximum amplifier cascade is to establish the best location(s) for the conversion of light back to the RF signal to serve your subscribers.

After you have established these basic criteria for design, you are now ready to begin the formulation of your optical loss budget.

## Contributing factors in loss budget

There are three main contributors to the overall loss in the fiber optic system. They are: 1) the fiber itself, 2) the splices and 3) the connectors utilized with your terminal equipment. Refer to Figure 1 for a loss budget worksheet typically used in calculating losses for each fiber optic link.

## Fiber loss

We will first look at the fiber loss associated in the path between the headend and hub/node site you have selected to maintain the maximum amp cascade required in your system design. It is not necessary for fiber to follow the existing coaxial route be-

cause it does not serve any customers between the headend and the remote hub/node site. This enables you to select the most direct path between the two points. This route also must take into consideration any and all future

use fiber with different loss specifications because of optical transmission equipment requirements or limitations.

Fiber is classified into two categories—MIFL or TPD. MIFL is the acronym for Maximum Individual Fiber Loss and TPD is Transmission Performance Designator. The difference between the two is that MIFL is a guaranteed loss per fiber, while TPD is the average of all fibers in the cable bundle. TPD packaging allows the manufacturer the ability to place different loss fibers in the bundle without maintaining the maximum loss on each fiber. A typical TPD rating of 0.4 dB/kilometer would not exceed a 0.45 MIFL rating on any individual fiber.

Fiber loss is calculated by multiplying the total length in kilometers times the selected fiber loss.

## BACK TO BASICS

*Fiber architectures, AM, FM and depressed or matched cladding are all issues that have been addressed time and time again as the industry delves even further into fiber optic technology. In this month's Back to Basics, Wesley Schick views fiber from another angle—optical loss budgets. What are some of the considerations? How is loss computed? These and other issues are the focus here.*

expansion plans. Be sure to check with all parties involved in the right-of-way for any changes.

There is usually a long term plan for any expansion to the area, whether it be road expansions or utility improvements. You will need this type of information to design for any change to the fiber route. You are now ready to calculate the associated loss for the fiber path.

The first step in calculating the path loss is to convert the distance from miles to kilometers. Fiber loss is specified in dB of loss per kilometer. The conversion is a simple calculation of multiplying the miles times 1.61. Fiber cable is available in various attenuations ranging from 0.5 to 0.35 dB/kilometer. The most commonly used fiber today is 0.4 dB/kilometer. You may be required to

## Loss Budget Worksheet

Phase # \_\_\_\_\_ of \_\_\_\_\_  
 Specification on \_\_\_\_\_ Mile FM AM Fiber Optic Link  
 \_\_\_\_\_ Miles  $\times$  1.61 = \_\_\_\_\_ km;  
 \_\_\_\_\_ Miles  $\times$  5280 = \_\_\_\_\_ ft

A. Specify Single Mode Fiber  
 Attenuation 0.5 dB/km @ 1300 nm  
 Fiber Loss = \_\_\_\_\_ km  $\times$  0.5 = \_\_\_\_\_ dB  
 Attenuation 0.4 dB/km @ 1300 nm  
 Fiber Loss = \_\_\_\_\_ km  $\times$  0.4 = \_\_\_\_\_ dB

B. Splice and Connector Losses  
 I. AM Outdoor Receiver  
 ( \_\_\_\_\_ ft/7500) + 2 = \_\_\_\_\_ splices/fiber  
 II. AM Indoor Receiver  
 ( \_\_\_\_\_ ft/7500) + 1 = \_\_\_\_\_ splices/fiber  
 III. ( \_\_\_\_\_ ft/7500) + 2 = \_\_\_\_\_ splices/fiber  
 \_\_\_\_\_ locations  $\times$  3 = \_\_\_\_\_ ST Conn/fiber  
 IV. Total Splice and ST Connector Losses  
 Active Alignment:  
 ( \_\_\_\_\_ splices/fbr  $\times$  0.10dB) + ( \_\_\_\_\_ ST's/fbr  $\times$  0.60 dB) = \_\_\_\_\_ dB  
 Passive Alignment:  
 ( \_\_\_\_\_ splices/fbr  $\times$  0.25dB) + ( \_\_\_\_\_ ST's/fbr  $\times$  0.60 dB) = \_\_\_\_\_ dB

C. Total Optical Loss  
 Fiber Loss + Splice & Connector Loss = Total Loss  
 \_\_\_\_\_ dB + \_\_\_\_\_ dB = \_\_\_\_\_ dB

rev 1/6/89

Figure 1

By Wesley J. Schick, Manager Fiber Optic Products and Services, Anxiter Cable TV

# THE PARTNERSHIP THAT WORKS

**RELIABILITY** Sumitomo Electric, a leader in communication cables for over 90 years, is a recognized manufacturer of quality optical fiber cables.

**SERVICE** We provide engineering services, contract splicing, training and project supervision. Additionally, we manufacture an integrated line of ancillary equipment including fusion splicing systems.

"Reliability for Today  
Creativity for Tomorrow"



Our dedicated people and state-of-the-art facilities assure the latest technological and best quality products.



Our construction group is capable of handling installation in any environment.



Fiber coating provides colors for easy identification.

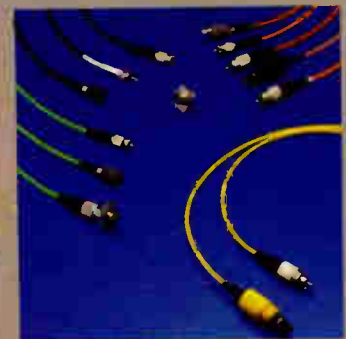

We manufacture a complete line of interconnection cables and connectors.



**Sumitomo Electric**  
Sumitomo Electric Fiber Optics Corp.

SEFOC is a Member of the  
Sumitomo Electric Industries, Ltd. Group

Reader Service Number 51

78 Alexander Dr.  
P.O. Box 13445  
Research Triangle Park, N.C. 27709  
(919) 541-8100  
800-358-7378

# YOUR SINGLE SOURCE FOR

CATV

Fiber Optics

Telecommunications

Aerial and

Underground

Construction

Services

There's  
just no  
substitute  
for  
experience!!!



Established 1972

Home Office: (912) 557-4751  
P.O. Box 760  
Reidsville, GA 30453

Regional Office:  
100 Adrienne Road  
Haines City, FL 33844

Reader Service Number 52

## OPTICAL LOSS BUDGET

### Splice loss

During the fiber route planning stage you will establish appropriate splice locations and calculate the number of splices to be used in your fiber optic loss budget. One distinct characteristic of utilizing fiber optic cable is that the reel lengths are much longer than the standard coaxial cable currently being used, which minimizes splice locations. Typical lengths between splices will vary from 10,000 feet to 14,000 feet.

Splice location selection should be given the same care you would use in selecting locations for your distribution electronics. The best way to determine the number of splices is to do an actual walk out of your fiber route. You will also need to take into account the future splices required in any expansion of the right-of-way. Now that you have the number of splices required to do your calculation, you must calculate the total insertion loss associated with these splices.

There are two methods of splicing available: mechanical or fusion. Mechanical splices have insertion losses varying from 0.2 dB to 0.02 dB per splice. Manufacturers' specifications will vary. The lower losses are attainable by active alignment of the splice.

Fusion splicing also has different losses associated with the different types of fusion splicers being used. You should check with the manufacturers to establish the typical loss that is exhibited with their equipment. Remember that splice loss improves as the splicer becomes more proficient. Our data shows the actual losses follow that of the mechanical splices 0.2 dB to 0.02 dB. It is advisable to add 0.05 dB to your calculations for each splice to compensate for any future splices associated with the repair of your fiber cable caused by the infamous "backhoe fades" or the moving of a pole line. To calculate the loss contributed by splicing add 0.05 dB to each splice insertion loss, and multiply the sum of all splices by the number of splice locations.

### Connector losses

The type of connector that you select will have a loss ranging from 0.5 dB to 0.25 dB depending on your application. If you have elected to use AM technology for the delivery of signals, it is common to avoid any connectors because of the limited loss budget associated with AM. In using other technolo-

gies you will need to check with the manufacturers for the specific loss associated with the connector. The calculation for connector loss is the same as a splice; multiply the number of connectors times the loss of the connector.

### Additional considerations

The other components which will affect your loss budget will be the use of optical splitters or couplers in your design. The major difference between the use of optical passives vs. coaxial passives is that for optical systems, you must include the connectorization of the passive device in your calculations.

It is advisable to add 0.05 dB to your calculations for each splice to compensate for any future splices associated with the repair of your fiber cable caused by the infamous 'backhoe fades' or the moving of a pole line.

Optical coupler manufacturers offer the flexibility of configuring any percentage of split to fit your system design. As an example, you may require that 90 percent of the power be on one fiber with only 10 percent required to feed another direction.

The total loss of the coupler is comprised of three components; 1) insertion or through loss, 2) connectorization and 3) the amount of power tapped off from the input. Figure 2 shows an example of different losses associated with optical couplers.

### Conclusion

The total optical loss budget will be the sum of fiber loss, splice loss, connector loss and any optical splitter loss.

Calculation of a fiber optic loss budget follows the normal criteria set forth in typical CATV design without



A pair of hands is shown from a top-down perspective, holding a magnifying glass. The magnifying glass is focused on a fiber optic cable connector, which has several colorful fibers (red, blue, green, yellow) protruding from it. The background is dark, and the lighting is dramatic, highlighting the hands and the cable.

# Cable Vision.

No one's been more farsighted in designing fiber optic cable than Siecor. As a result, our cable design is virtually the same today as it was nearly ten years ago. In the same time span, many of our competitors have redesigned their cables two and three times or more. And guess what? Their cables now look amazingly like ours.

One reason our design hasn't changed—and the reason it's so widely imitated—is simple. We anticipated the craftsman's most important needs.

In doing so, we introduced stranded loose tube design which groups fibers in tubes. This way, it provides the best protection during stripping and splicing. And makes fibers easy to identify and manage.

Furthermore, we designed a cable that's friendly to fiber—protecting it from environmental stress. And finally, we allowed for changing fiber optic technology. Our cable carries multimode or single mode signals at any transmission rate. It transmits at all wavelengths. And it accommodates the use of evolving splicing techniques.

The fact is, no better cable has come along in the last ten years. And no cable can prepare your system better for the future.

So talk to the company with the vision to see what's ahead in fiber optics. Call 704/327-5998. Or write Siecor Corporation, Literature Department (CO) TV-1, 489 Siecor Park, Hickory, NC 28603-0489. **SIECOR**

## OPTICAL LOSS BUDGET

the considerations of power losses through the cable or the necessary calculations to compensate for the tilt contributed by coax. It is important to review the fiber optic design in the larger context of the total system. The

The total optical loss budget will be the sum of fiber loss, splice loss, connector loss and any optical splitter loss.

project plan should encompass considerations for future expansion, as well as present day concerns for integration of fiber optics into an RF environment. Considerable expertise is available from equipment suppliers—don't be afraid to rely on them for assistance to make your project successful. ■

### Optical Coupler Loss Table

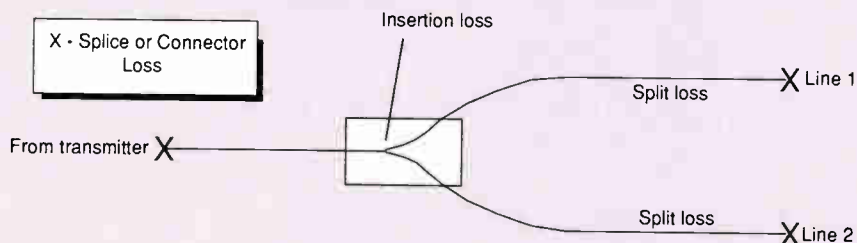

Losses are based on the Gould Series S Precision Splitter

Split		Split Loss			Total Line Loss	
Line 1	Line 2	Line 1	Line 2	Insertion Loss	Line 1	Line 2
50	50	3.0 dB	3.0 dB	0.3 dB	3.3 dB	3.3 dB
60	40	2.2 dB	4.0 dB	0.3 dB	2.5 dB	4.3 dB
70	30	1.6 dB	5.2 dB	0.3 dB	1.9 dB	5.5 dB
75	25	1.3 dB	6.0 dB	0.3 dB	1.6 dB	6.3 dB
80	20	1.0 dB	7.0 dB	0.3 dB	1.3 dB	7.3 dB
90	10	0.5 dB	10.0 dB	0.3 dB	0.8 dB	10.3 dB

Add Splice or Connector Losses  
Untuned Splices—0.4 dB.

Tuned Splices—0.2 dB.  
ST Connectors—1.0 dB.

Figure 2

**New Product**

## RISER-BOND INSTRUMENTS

### Model 1210

TIME DOMAIN REFLECTOMETER  
CABLE FAULT LOCATOR

- SUPERTWIST LIQUID CRYSTAL DISPLAY
- AUTOMATIC DISTANCE CALCULATION
- WAVEFORM/DATA PRINTER STANDARD
- RECHARGEABLE NICAD BATTERIES STANDARD
- TESTS ALL TYPES OF METALLIC PAIRED CABLE
- LIGHTWEIGHT, COMPACT AND RUGGED PACKAGING
- EASY TO OPERATE



**\$4,395**  
Complete

For more information or to place an order call or write:

**RISER-BOND  
INSTRUMENTS**

505 16th STREET P.O. BOX 188  
AURORA, NEBRASKA 68818  
402-694-5201

## \*VIDEOCIPHER II REPAIRS

*Fast Turnaround for Out of Warranty Repairs*

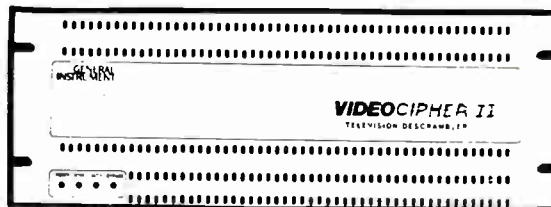

\* VIDEOCIPHER II DESCRAMBLER REPAIR

\*\*Fast Turnaround for Out of Warranty Repairs

\*\*Turnaround for most units 10 days or less. We do not repair units with loss of memory. Call Cindy for more information.



1575 N. 105th E. Ave./ Tulsa, Oklahoma 74116

(918) 836-8348

\*VideoCipher® is a Registered Trademark of General Instrument Corporation

Reader Service Number 66

Reader Service Number 67

# DISCOVER THE CLEAR CONNECTION

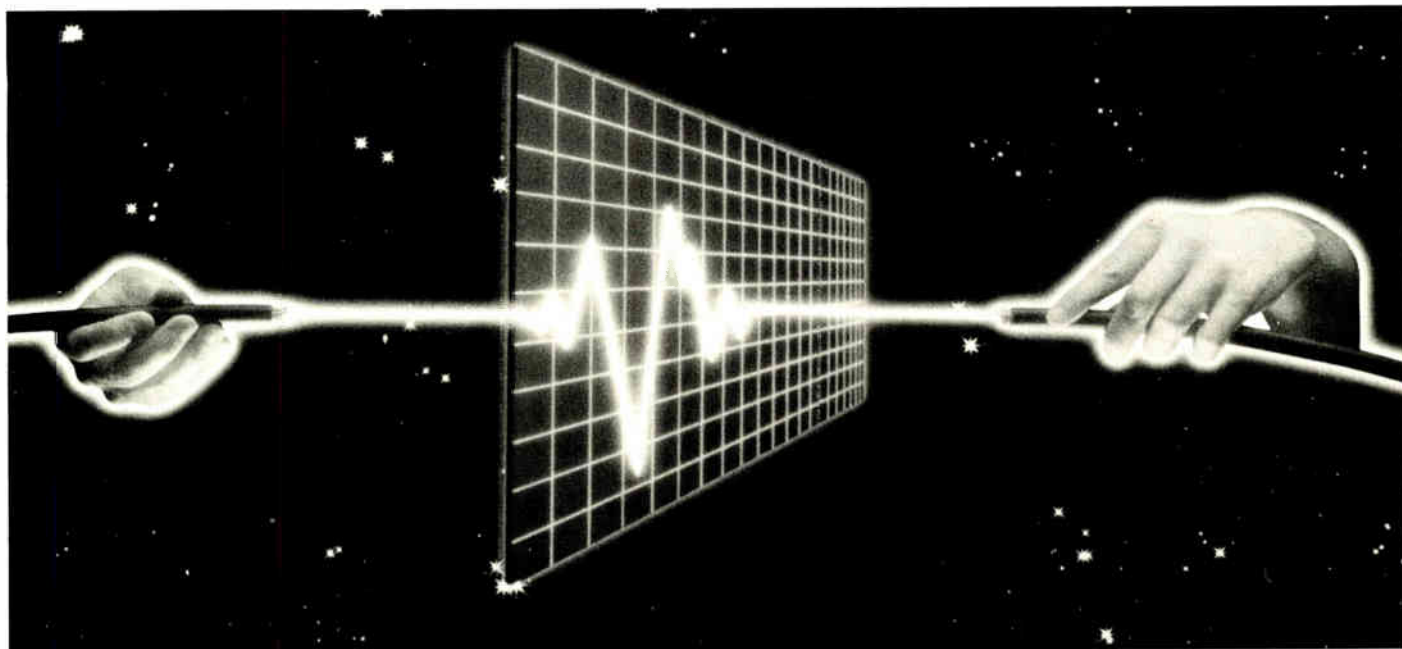

## U S WEST Communications Fiber Optic Technology

It's no secret that the wave of the future is fiber optic technology. With U S WEST Communications, you can capture your future today and stay on the leading edge of the cable television industry!

With our experience in fiber optic technology, we're ready to meet your transport needs now. Our 14-state region covers one third of the nation, from Canada to Mexico, including Arizona, Colorado, Idaho, Iowa, Minnesota, Montana, New Mexico, North Dakota, South Dakota, Nebraska, Oregon, Utah, Washington and Wyoming. Fiber optic facilities are available to cable television operators throughout much of our territory.

Our IntraLATA multi-channel video transport system provides you with:

- An advanced fiber optics network with underground cable.

- The replacement of AML microwave links with fiber optic trunk service, allowing for super-trunking of the cable TV signal.
- Broadcast quality signal strength, by inter-connecting your headends with broadcast TV studios.
- Optical systems designed to deliver up to 60 db SNR.
- Cost-effective and reliable maintenance with 24-hour staff and a built-in alarm system.
- An economical way to increase your channel capacity and reduce your amplifier cascade.

Let's discuss how we can help you design a multi-channel video transport system with crystal clear signals!

Call today! Justin Cislighi, (303) 896-4691.

**USWEST**  
COMMUNICATIONS 

## WHAT'S AHEAD

# SCTE

**August 10 Chesapeake Chapter** will present a technical seminar on "Terminal Devices" at the Holiday Inn, Columbia, Md. For more info call Tom Gorman, (301) 252-1012.

**August 16-17 Ohio Valley Chapter** will hold a technical seminar on "Fiber Optics" with representatives from Siacor Corp. and Catel Telecommunications. The August 16 seminar will be held in Cleveland, Ohio and the August 17 seminar will be in Cincinnati, Ohio. For more info call Bill Ricker, (614) 236-0523.

**August 16 The Golden Gate Chapter** will present a session on "CLI Update" at the Pleasanton Fairgrounds, Pleasanton, Calif. Four speakers will address such CLI issues as test methods, documentation and FCC requirements. For details call John Parker, (408) 437-7600.

**August 17 The New England Chapter** will hold a technical seminar at the Boxborough Sheraton, Boxborough, Mass. For topic info or details call Jeffrey Piotter, (508) 685-0258.

**August 18 Miss-Lou Chapter** will hold a technical seminar in Baton Rouge, La. For details call Charles Thibodeaux, (504) 641-9251.

**August 19 Razorback Chapter** will present a technical seminar on "Installer Seminar" at the Days Inn, Little Rock, Ark. Call Jim Dickerson, (501) 777-4684 for info.

**August 23 The Rocky Mountain Chapter** will host a technical seminar on "Transportation Systems" with Steve Dozier of Hughes and Steve Johnson of ATC. BCT/E exams will also be administered. Call Rikki Lee, (303) 792-0023 for details.

**August 23-24 Florida Chapter** will hold two

separate seminars: August 23 for the South Florida Group at the Holiday Inn, Ft. Lauderdale, Fla. and August 24 for the First Coast Group at the Holiday Inn Airport, Jax, Fla. For info on either seminar call Denise Turner, (813) 626-7115.

**August 24 Upstate New York Chapter** will host a technical seminar. Call Ed Pickett, (716) 325-1111 for further info.

**August 29 Satellite Tele-Seminar Program** will air "High-Definition Television Technology (Part II)" with Walt Ciciora of ATC, Donald Wilkinson of Fisher Broadcasting Co., Lawrence Lockwood of Contel, Paul Resch of The Disney Channel and William Thomas of Nielsen Media Research. Videotaped at Cable-Tec Expo '88 in San Francisco, the program will air from noon to 1 p.m. Eastern time on Satcom F3R, transponder 7.

# C-COR<sup>®</sup>

ELECTRONICS INC

C-COR Electronics "state of the art" seminars are three-day events designed to instruct relatively new technicians in basic theory, installation and maintenance of cable TV systems. Attendance is limited to a maximum of three persons from one system. The fee is \$195.

**September 19-21 C-COR Electronics Seminar** will be held in Dallas, Texas. Call Teresa Harshbarger, (800) 233-2267, ext. 326 to register.

**October 17-19 C-COR Electronics Seminar** will be held in Boston, Mass. Call Teresa Harshbarger, (800) 233-2267, ext. 326 to register or for info.

**November 14-16 C-COR Electronics Seminar** will be held in Phoenix, Ariz. Call Teresa Harshbarger, (800) 233-2267, ext. 326 to register or for additional info.

# MAGNAVOX

The Magnavox CATV Systems mobile training center is a fully-equipped laboratory on wheels for cable training. The three-day seminars combine instruction in theory and practical hands-on training, using gear and test equipment common throughout the industry. The fee is \$300.

**September 12-14 Mag-**

**navox Mobile Training** will be held in Columbus, Ohio. Call Amy Costello Haube, (800) 448-5171 (in NY state, (800) 522-7464) to register, or for additional info.

**September 18-20 Mag-navox Mobile Training** will be held in Detroit, Mich. Call Amy Costello Haube, (800) 522-7464) to register, or for additional info.

## Et cetera

**August 4 Brad PTS** will host its annual Cable Day at the Races at the Saratoga Race Track in Saratoga Springs, N.Y. Call Bob Price, (518) 382-8000 for more details.

**August 6-8 Cable Television Laboratories** will hold

a three-day seminar on "Fiber Optics" at the Clarion Harvest House Hotel, in Boulder, Colo. The seminar is free to Cable Lab members. For additional info call Karen Viesar, (303) 939-8500.

## New broadband photodiode

Ortel Corporation has introduced the 2605A, a broadband photodiode receiver for CATV applications. The 2605A uses a broadband RF output circuit (patent pending) to maximize delivered power and achieve 10 dB higher RF gain than an unmatched photodiode. Features of the 2605A include 10 MHz to 550 MHz frequency response, high responsivity >0.9 mA/mW, 14-pin DIP package, 10 dB gain over a standard photodiode, compatibility with 75 ohm CATV amplifier and 1300 nm singlemode fiber pigtail. For more details call (818) 281-3636.

Announced by Norland Products is the availability of a 0.5 mW helium-neon laser designed to detect light loss in optical fibers. With the injection of a red helium-neon light that travels down the core of the fiber, the Visualizer emits a visible red glow when detecting light loss in the system. The laser detects light loss up to one kilometer of fiber because of an optical adapter which pinpoints 75 percent of the laser beam into the fiber core. The Visualizer allows users to see the accuracy of a cleave and check for cleanliness of fibers during mechanical splices. The unit measures 9 by 2 by 2.5 inches and weighs 1.1 pounds. For more info call (201) 545-7828.

Available from BT&D Technologies (British Telecom & Dupont) is the TSL1000 tunable external cavity semiconductor laser. The laser, developed for use in the research and development laboratory, can substitute for distributed feedback lasers (DFB) in wavelength division multiplexing (WDM) topologies, but at a higher cost than DFBs. The TSL1000 offers a 100 kHz linewidth, mechanical tunability of 40 nanometers, electrical tunability of 25 GHz and power output from a single mode fiber pigtail of -3 dBm. Available in either 1300 or 1550 nm bands, the TSL1000 lasers are packaged with a self-contained heatsink and connectors for electrical drive. For more details call (800) 545-4306.

### New connector aids CLI compliance

Cable Connector Corp. of Amer-

ica has introduced the XLF™ series of premium drop cable connectors. The XLF™ is designed to improve drop connections thereby allowing CATV operators to meet CLI requirements by July, 1990. The XLF™ is mounted with a handtool, the T-XLF, which forces an internal ferrule to radially grip the RG-6 or RG-59 poly jacket. A lip on the XLF™ mandrel bonds with the cable's braided shield to achieve a grip commensurate with the tensile strength of the cable itself. Call (800) 343-8234 for more info.

General Instrument's VideoCipher division has introduced a new remote control for use with its home satellite TV integrated receiver/descramblers

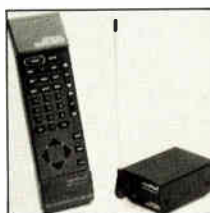

G.I.'s Any Where Remote

(IRDs), the AnyWhere™ UHF Remote Control. With the AnyWhere remote, all IRD functions can be controlled from up to 200 feet away from the IRD, regardless of physical barriers such as walls. In addition, the remote allows customers to view satellite TV on a second set without the purchase of a second satellite receiver. The AnyWhere remote is compatible with GI infrared remote controls, incorporating both infrared and UHF functions into the same system. For further info call (704) 327-4700.

Norsat International Inc. has introduced a BT-10A Block Translator to interface Scientific-Atlanta's model 6650 and 6680 satellite receivers with standard TVRO LNB's. When combined with a Norsat LNB, the BT-10A is capable of input temperatures of less than 50°K. The PLL controlled circuit converts C-band LNB output from 950 MHz through 1450 MHz to 270 MHz through 770 MHz. High side injection ensures compatibility with both the 6650 and 6680 series of receivers. The BT-10A will operate over a -20° centigrade to a +60° centigrade range and is covered under Norsat's two-year warranty program. Call (604) 597-6200 for more info.



Wavetek's 8500A

Wavetek Microwave, Inc. announced the availability of the Model 8500A Peak Power Meter. The 8500A combines peak power measurement accuracy with waveform analysis in a single instrument.

# How Reliable Are Your Repairs?

Scientific Atlanta

Panasonic

ZENITH

PIONEER

JERROLD

■ Qualified repair of Jerrold, Scientific Atlanta, Panasonic, Pioneer and Zenith converters

■ Bar coded WIP Tracking

■ Line equipment repair

■ National repair parts distribution center for Panasonic

Reader Service Number 56

CABLE BUSINESS ASSOCIATES, INC.

A COMPANY OF THE CBLX GROUP

2446 Palm Drive • Long Beach, CA 90806

213-424-9253

1944 N. Naragansett • Chicago, IL 60639

312-237-2400

The meter covers a frequency range from 30 MHz to 40 GHz with low speed (750 nanoseconds risetime) sensors and from 750 MHz to 40 GHz with high speed (15 nanoseconds risetime) sensors. A proprietary power sweep calibrator gives the meter a +20 dBm to -20 dBm power range along with  $\pm 3$  percent power linearity. A cursor is used to read out absolute power at any position on the pulse envelope. The 8500A is available in either a one channel model (designated 8501A) or a two channel model (8502A) for ratio measurements.

Also available from Wavetek Microwave is a family of 13 power sensors compatible with its Model 8002 Precision Scaler Analyzer. The sensors were designed to optimize power measurements on swept and continuous wave signals. The sensors cover a frequency range from 10 MHz to 40 GHz and a power range of 1 watt (+30 dBm) to 100 picowatts (-70 dBm) in four families. All sensors have a 90 dB dynamic range except the true RMS sensors, which have 50 dB dynamic range. For details call (408) 734-5780.

Introduced by Sadelco, Inc. are the Models SC-900 and SC-600 reference signal generators. Both models feature

an extremely flat white noise generator coupled to a Crystal Controlled CW generator. The generators check signal level meter calibration and can be used to sweep cable systems. The model SC-900 covers the frequency range from 4.5 MHz to 900 MHz with  $\pm 1/4$  dB accuracy. The model SC-600 has a frequency range of 4.5 MHz to 600 MHz with  $\pm 1/4$  dB accuracy. For more info call (201) 569-3323.

**Locating cable faults**

Clic Instruments Ltd. has announced the availability of the CCR-2 high-resolution cable fault locator. The portable locator is designed to simplify the location and identification of line impairments on communications cable with typically five inch resolution. The CCR-2 uses microcomputer technology to implement the Time Domain Reflectometry methodology. The unit measures 6 inches by 9 inches by



Clic Instrument's CCR-2

10 inches and weighs 7 pounds. It has a display resolution of 4.3 inches and a range up to 3,200 feet. The CCR-2 is priced at \$1,500. Call (613) 731-9030 for additional info.

Charles Machine Works, Inc. has introduced the Ditch Witch P40 and P80 directional rod pushers for guiding and tracking trenchless, long-range pipe and cable installations. Both rod pushers are compact and lightweight, producing equal force either pushing or pulling. The P80, with 81,350 pounds of thrust, is capable of pushing rods distances of 500 feet or more through compactible soils in normal conditions. The P40 delivers 39,150 pounds of thrust and is capable of boring lengths of 200 feet or more. Three directional heads are available for the rod pushers, each designed for boring in different soil conditions.



Charles Machine Work's Ditchwitch P-40

Charles Machine Works has also announced the addition of the True Trac extended-range guided boring sys-

**Channel Deletion Filters for:**

- TV or Data Channels
- Any Channel T5 to 62
- Deletes Entire Channel Spectrum
- Leaves Adjacents In-service
- Broadband - to 450 MHz

**Delivery: 1 week or sooner!**

**CCTV - Model** deletes incoming channel & provides new modulator input for:

- Pay-per-view
- Headend channel substitution
- Hospital nurse call channel
- School or training channel
- Hotel closed circuit channel
- Security camera

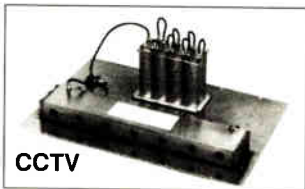

CCTV

Product details in **free catalog C/87**. The industry's most complete line of headend, security and interference filters for CATV/LAN/Private Cable & Institutional Broadband Networks.

At the same time, ask for **free catalog MTV/87** - a complete line of Terrestrial Interference filters for Private Cable, CATV, Institutional & other professional TVRO Installations.

Microwave Filter Co., Inc. 6743 Kinne St., E. Syracuse NY 13057  
Toll Free: 1-800-448-1666 • Collect: 315-437-3953 • Telex: 249-613 • Fax: 315-463-1467

Reader Service Number 57

**A date to remember.**  
(or one you'll never forget!)

This time next year, the FCC will be knocking on doors asking for documentation of Cumulative Leakage Index Logs.

Not prepared? **CLI-MATE** Mobile Signal Leakage Detection Service can help you. Our fully equipped vans and qualified technicians will generate the documentation needed for FCC compliance in 1990.



- CLI-MATE** can offer, for less than the cost of a days fine:
- A Complete System Drive Out
  - Exact measurement and location of leaks
  - Concise computer generated reports and documentation to satisfy FCC Rules 76, 611, (1)

■ Software compatible to your own computer system as well as a complete CLI report

Once your leaks have been located and repaired, service calls will decrease, picture quality will be enhanced, and you will have much happier customers.

For more information about **CLI-MATE's** service and a free cost analysis with no obligation, call today. 303/730-8885.

**cablelogic**  
CORPORATION

PO Box 2617  
Littleton, CO 80161

Reader Service Number 58

tem to its product line. The system was developed for trenchless installation of utility lines in various soil conditions, including solid rock. Three elements comprise the True Trac boring system: a drill frame, downhole tools and Ditch Witch tracking locators. The surface-launched downhole tools can bore four- to six-inch holes, to distances of 600 feet. Two steerable downhole tools are available, a pneumatic percussion tool based on the Pierce Arrow pneumatic piercing tool and a positive displacement, steerable air motor drill. For more info call (800) 654-6481.

EF Industries has added Jerrold addressable cable television converters to the products it services. Price per unit is \$16.50, including the replacement of minor parts, alignment to crystal controlled sources on all channels and environmentally controlled burn-in. Subassembly repairs are priced on a fixed schedule ranging from \$5 to \$16.50. Call (213) 777-4070 for details.

A series of new lessons covering installation troubleshooting has been announced by the National Cable Television Institute (NCTI). Several new installer course lessons and installer course lesson revisions will be the focus of its course enhancements

scheduled for the second half of 1989 and the first quarter of 1990. During that time, NCTI plans to produce 13 new lessons for its Installer and Installer Technician courses and will be enhancing five key areas of its current Installer lessons. The new additions are designed to keep NCTI's course up to date with changes in cable television technology and field practices along with adding information in areas of growing interest to the industry. For more info call (303) 761-8554.

A heavy-duty, ratchet-action cutter has been introduced by Klein Tools, Inc.. Designed to provide maximum leverage, the tool is capable of severe-service use in cutting ACSR, ACAR, common guy strand, steel-wire rope, steel rod (C.R.S. soft) and copper and aluminum cable. The cutter features drop-forged, heat-treated, shear-type blades and 36-inch steel handles for



Klein Tool's ratchet-action cutter

power-cutting leverage. Molded heavy-vinyl grips are an additional feature. For details call (312) 677-9500.

**'Blocking' signal leakage**

Available from Loctite Corp. is a system for blocking radio frequency signal leakage from and into cable television systems. Called Block Aid™ RFI Shield and Sealant, the system consists of a plastic boot which is snapped into position around the drop cable and "F" connector and injected with the Block Aid Shield and Sealant, a conductive rubberized sealant. The system provides a weathertight seal for protection against corrosion, loosening of the "F" connector and RF signal leakage. Cost of the Block Aid product and the plastic boot is approximately \$0.30 per application. Call (203) 278-1280 for further info.

Master Bond Inc. has announced the Master Bond AC83, a one component conductive adhesive coating specially designed for EMI/RFI shielding applications. Application methods include air or airless type spraying equipment, brushing, dipping and silkscreening. The AC83 cures promptly at ambient temperatures (tack free time 10 to 15 minutes, full cure overnight) or more quickly at elevated temperatures (45 minutes to one hour at 150° fahrenheit). The adhesive is

**CONSUMER CONTROL DEVICES**

SN-7 SN-1/2 SN-5 SN-PNL



QUALITY SNAP-ON CABLE TAGS

- Fits all 59 & RG-6 coax
- Recessed numbers for permanent I.D.
- Secure fit - no slip or slide

**CONVERTER SEALS**



**CS-L Converter Warden**  
**CS-S Screw Seal**  
Positive detection of converter tampering. If tampered with, reads VOID VOID VOID.

**CONTROL SEALS**

SS-1H SS-2H



Tamper Proof Screw(s)/Driver

- The best value for all seal needs.

**CABLETEK CENTER PRODUCTS, INC.**

850 TAYLOR STREET  
ELYRIA, OH 44035  
1-800-562-9378 • ELYRIA 216-365-3889



Reader Service Number 54

# TOWER CABLE CLIPS

for proven quality and economy.

**Tower-the world's largest supplier.**  
**22 different sized cable clips.**

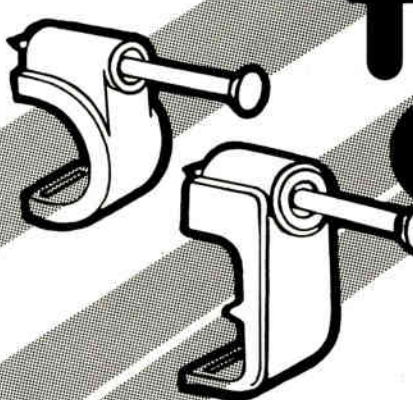

- Pre-assembled with plated, hardened, masonry nails for hardwood, masonry and cement block.
- Fits most cables from .10" to .63". Available in black, white and grey. For indoor and outdoor use.
- Sure-fit for quick simple installation.
- Tower cable clips distinctive design avoids damage to cable jacket.
- Stocked by leading distributors such as Anixter, Midwest, Graybar, Merit, Resco, The Drop Shop, Cable TV Supply, Signal Vision, TVC Supply, etc.
- Tower, Made in England — Major suppliers to the US CATV industry and the British Telephone Co. for many years.

Write today for free samples and literature.

**WELDONE TRADING CO. INC.**  
3285 Cavendish Blvd., Suite 360  
Montreal, Quebec, Canada H4B 2L9  
(514) 486-2714  
FAX (514) 486-3189

**EXCLUSIVE UNITED STATES IMPORTER**

Reader Service Number 59

## CLASSIFIEDS

### HELP WANTED

**Leader in the placement of Cable Television Professionals**  
**Call toll free 1-800/433-2160; In Texas call collect 817/599-7623.**

**REGIONAL ENGINEER**—dynamic growth position. East \$50K.  
**FIBER ENGINEER**—BSEE a must ground floor opportunity \$60K.  
**CHIEF ENGINEER**—Remote location \$40K.  
**SYSTEM ENGINEER**—Rocky Mountains addressability, AML \$40K.  
**REGIONAL ENGINEER**—Mountains \$40K.  
**CORPORATE STAFF ENGINEER**—East \$45K.  
**PLANT MANAGER**—S.E. high growth area \$30K.  
**R AND D ENGINEER**—Create own department. East \$50K.  
**FIELD ENGINEER**—AML a must, light travel East \$32K.  
**PLANT MANAGER**—rural S.W. \$30K.

**CONSTRUCTION MANAGER**—total rebuild fiber opt. East \$40K.  
**CONSTRUCTION MANAGER**—1,000 mile rebuild. East \$43K.  
**PROJECT ADMINISTRATOR**—West, high growth area \$38K.  
**C.A.D. DESIGN**—Nationwide. \$30-35K.  
**CHIEF TECHNICIAN**—Midwest \$26K.  
**CHIEF TECHNICIAN**—S.D., high growth ground floor opportunity. \$28K.  
**HEADEND MICROWAVE TECHNICIANS**—Nationwide \$28-35K.  
**ENGINEERING TRAINEES**—BSEE little experience required \$30K.  
**LINE TECHNICIANS**—All over U.S., companies will relocate—\$10/hr to \$25K.



### JIM YOUNG & ASSOCIATES

One Young Plaza 1235 Ranger Highway Weatherford, TX 76087  
 Call for information about these and many other opportunities nationwide.

### Baker Scott & Co. EXECUTIVE SEARCH

1259 Route 46 Parsippany, NJ 07054 201 263-3355  
**Specialists in the COMMUNICATIONS INDUSTRY**

CABLE TV/BROADCAST TELECOMMUNICATIONS  
 DIVISION DIVISION

POSITIONS AVAILABLE AT ALL LEVELS OF  
 MANAGEMENT. COAST TO COAST

Call or write in CONFIDENCE

FEE PAID

"WE DON'T TALK CABLE, WE KNOW CABLE"  
 PRINCIPALS DAVID ALLEN & JUDY BOUER

### CATV CHIEF TECHNICIAN

Wanted for 8000 Subscriber Cable TV System in Southwestern Michigan. Extensive technical knowledge of CATV plant operation and headend function required. Supervisory experience helpful, excellent wage and benefit package to the successful candidate. Please submit resume to:

**WESTMARC CABLE**  
 350 N. 22nd Street  
 Battle Creek, MI 49015  
 ATTN: Sam Towers  
 EOE/AA/M/F/H/V

### EQUIP. FOR SALE/RENT

**Anthony's** MANUFACTURING SERVICE

**PLOW BLADES**  
 Irrigation/Wire/Combination  
 For Any Machine—For Any Application

1-800-383-PLOW  
 (719) 475-PLOW P.O. Box 17701  
 Colorado Springs, CO 80935



### CHANNELCUE

Audio/video switching  
 equipment repair  
 Line equipment  
 and meter repair



**LEE ENTERPRISE**

623 4th STREET • P.O. BOX 560 • OESHLEER, NEBRASKA 68340  
 (402) 365-7520

### WANTED: SURPLUS CABLE EQUIPMENT

Jerrold, Oak, Hamlin & Scientific  
 Atlanta equipment.  
**Highest Prices Paid**  
 Cable Equipment Brokerage Co.

**(818) 709-3724**

### EMERGENCY ALERT SYSTEMS

by  
**Idea/onics**

69 channels 14 day delivery  
 compatible with all headends  
 —AFFORDABLE—  
**(701) 786-3904**

24 and 88 channel units  
 also available

### EQUIPMENT FOR SALE/RENT

### VIDEO SUPPLIES

CABLES • CONNECTORS • CANARE • BELDEN • SWITCHCRAFT • D.A.S. • TIES •  
 BATTERIES • NEUTRIK • 60 INTERFACE BOXES • TAPE • 500 DIFF. TAPE LABELS • GAFFERS  
 TAPE • CASES • PATCH BAYS • LIGHTS • ACOUSTIC FOAM  
 FORMS • MICROPHONES • SONEX • STANDS • MOUNTS  
 WIND SCREENS • ZEPPELINS • FIBRE OPTICS • RACKS  
 DUCT • REELS • TESTERS • FILTERS • CHEMICALS • TOOLS  
 ON-AIR LIGHTS • DEGAUSSERS • INTERFACE DEVICES  
 HEADPHONES • CLIPS • SWITCHES • CAM & S-VHS CABLE

**MARKERTEK VIDEO SUPPLY**  
 145 Ulster Ave. Saugerties, NY 12477 U.S.A.  
 TOLL FREE 1-800-522-2025  
 In NY: 914-246-3036



### AERIAL BUCKET TRUCKS

Large selection geared for CATV  
**STANDARD TRUCK &  
 EQUIPMENT CO.**  
 1155 Hill St. S.E.  
 Atlanta, GA 30315  
 Phone: 1-800-241-9357



BUCKET TRUCKS

### WANTED TO PURCHASE: SURPLUS CABLE INVENTORY

Zenith, Jerrold, Oak, Hamlin,  
 Scientific Atlanta, Pioneer

**S.C.I. Inc.**  
 718-262-0900  
 FAX: 718-657-4015

### Bucket Trucks—Used

Telsta, Versa-Lift, Digger Derricks—10 in  
 Stock. 30 other Utility Construction Trucks.  
 "We Buy and Sell"

**Opdyke, Inc.** (Philadelphia Area)  
 3123 Bethlehem Pike (215) 721-4444  
 Hatfield, Pa. 19440

### Let Classifieds work for you

For more information, call  
 Curt Stocker at (303) 393-  
 7449 or write: CableVision  
 magazine, 600 S. Cherry  
 Street, Suite 400, Denver,  
 CO 80222.



# CLASSIFIEDS

## BUSINESS DIRECTORY

### **CABLE CONSTRUCTORS, INC.**

IRON MOUNTAIN, MICHIGAN  
COAX - FIBER

QUALITY SERVICE PERFORMED ON A TIMELY BASIS  
- SINCE 1957 -

MAPPING · DESIGN · CONSTRUCTION · ENGINEERING

### **CABLE CONSTRUCTORS, INC.**

1-800-338-9292

**KLUNGNESS ELECTRONIC SUPPLY (KES)**

1-800-338-9299

## **NaCom**

BUILDING COMMUNICATION SYSTEMS THROUGHOUT AMERICA

- Installations (including fiber optics)
- Converter exchanges, PPV, audits, special projects
- MDU, SMATV, & LAN Pre/postwiring
- Strand mapping, engineering, signal leakage
- Design (AutoCAD)
- Aerial/underground construction

1900 E. Dublin-Granville Rd., Columbus, Ohio 43229  
614/895-1313 • 800/848-3998 • FAX 614/895-8942

## *White Sands*

### **Jumper Cables**

Custom connectors and cables for all aspects of CATV.  
Gilbert AHS All types of cable from Belden  
Magnavox Times  
Pyramid F59-81 Comm Scope  
LRC and others  
Quick delivery on all colors with lengths from 6" to 15

Write or call: (602) 581-0331  
335 West Melinda Drive, Phoenix, AZ 85027

## **Nationwide C.A.T.V. Auditing Services Inc.**

- Door-to-door verification of addresses and services being received.
- RF leakage indicators to comply with FCC Ruling Docket #21006, effective 7/1/90.
- Documentation and correction of G095 infractions (Drop Clearance).
- Termination of all open ports.
- The updating of Bridger Maps.
- Installation of Raychem fittings.

1-800-726-2405

John MacLean General Manager

## **ColorView Services, Inc.**

800-824-1943

SINCE 1953

### **CONVERTER REPAIR**

REALISTIC TURNAROUND

PROGRAMMABLE & ADDRESSABLE

JERROLD HAMLIN PANASONIC OAK SCIENTIFIC ATLANTA TEXSCAN

ASK ABOUT OUR PRICES! SIX MONTH WARRANTY!  
ALBUQUERQUE, NEW MEXICO

	Reader Service #	Page #
A.D.S. Inc	.36	.75
ATI Supply	.61	.110
Alpha Technologies	.24	.45
American Digital Cartography	.26	.46
Anixter Cable TV	37,64	77,116
ARVIS	.39	.80, 82, 84, 86
Atlantic Cable Show	.49	.96
Augat Broadband	.13	.27
Augat/LRC Electronics	.27	.47
Automation Techniques/Tulsat	.66	.102
C-COR Electronics	.12	.25
CATV Services Inc.	.48	.96
CATV Subscriber Services	.46	.94
Cable Exchange	.56	.105
Cable Link	.34	.72
Cable Prep/Ben Hughes Comm.	.19	.40
Cable Services	14, 70, 72	.29, Freq. Cht.
Cable Tek Center Products	.54	.109
Cablelogic Corp.	.58	.106
Channell Commercial	.4	6-7
Channematic	.43	.85
General Cable Apparatus Div.	.16	.36
General Inst./Jerrold	.31	.69
Holland Electronics Inc.	.22	.42
Hudson Supply	.10	.21
ISS Engineering	.11	22-23
Jackson Tools	.17	.37
Kennedy Cable Construction	.52	.100
Lakeshore	.21	.42
Lectro Products Inc.	.42	.83
Lemco Tool	.40	.80
Lindsay Specialty Prods.	.35	.73
Line-Ward	.25	.46
Magnavox CATV	.33	.71
Microwave Filter	.57	.106
Midwest CATV	.6	12-13
Midwest CATV Engineering	.41	.82
Midwest Communications	.8	.17
Monroe Electronics Inc.	.65	.81
Multiplex Technology	.32	.70
Nexus Engineering	.3	.5
Panasonic	.1	.2
Pioneer Communications	.9	.19
Pyramid Industries	.29	.50
Reliable Electric	.63	.115
Riser-Bond	.67	.102
Rite Cable Construction	.60	.110
Sachs Comm. Inc.	.20	.41
Scientific-Atlanta	15, 68, 71	.30-33, Freq. Cht.
SecaGraphics	.62	.111
Siecor Corp.	.53	.101
Standard Communications	.5	.11
Sumitomo Elec. Fiber Optics	.51	.99
TVC Inc.	.23	.43
Telecommunication Products Corp.	.44	.87
Texscan MSI	.38	.79
Time Manufacturing	.18	.39
Times Fiber	7, 73	.15, Freq. Cht.
Trilithic/Texscan Inst.	.47	.95
Trilogy Communications	.2	.3
Triple Crown Electronics	.30	.67
U.S. West Comm.	.55	.103
Wavetek	.45	.89
Wegener Comm.	.28	48-49
Weldone Trading Co.	.59	.109
Zenith	.50	.97

## ONE FINAL THOUGHT

# Global antenna television?

**G**o fiber" is today's rallying cry from almost everyone more or less entitled to counsel the cable television world. Why? Not only to cope with present needs, but to get some insurance for the future. With HDTV standards still being discussed and many regulatory issues still hanging, the best bet is to put in bandwidth...as much as is possible, i.e. affordable. Put in bandwidth to build the business.

Will fiber optics define the business? For an industry built on the careful engineering of aluminum tubes and their constraints in terms of channel capacity, signal quality and the need for constant regeneration and active powering, fiber optics represents nothing short of a revolution.

Perhaps it's really bandwidth that defines the business. Sort of like cars being defined by the engine. Early automobiles were literally horseless carriages. I'm not sure whether a Model A was cheaper than the competitor's buggy, but I do know that the horse population has virtually disappeared off the nation's roads. Fiber optic technology today is equivalent to the internal combustion engine at the horseless carriage stage. In 10 years will any of today's alternatives still exist?

## Fiber vs. coaxial cable

Looking around at the vendor community, the popular specification for an AM fiber system seems to be: 40 channels per fiber, 10 to 12 kilometers reach with a resultant signal-to-noise ratio (SNR) of 51 dB. The published ATC specification is 60 channels per fiber, 18 kilometers and 55 dB SNR.

While the current system specifications seem a long way off from the ATC

objectives, AM fiber optics can offer the system operator considerable advantage when looking at a channel upgrade or rebuild.

For example, we looked at a model system called Hometown Cablesystem and used a budgeting technique to designate various points in the system. We had one hub which we fed from the headend using an FM fiber optic supertrunk to get at least 60 dB SNR at that point.

From this 60 dB point, the 10 km typical AM system would yield around 51 dB SNR at its output. If instead we had chosen to build the link with coax, the 51 dB SNR point would very likely have been reached much sooner; after only about 4 or 5 km.

If part of the cable system's business strategy was to improve the signal quality delivered to the subscribers, then AM fiber optics clearly offers the opportunity to "push" the higher SNR signal deeper into the system. Since the "push" of fiber deeper into the system also reduces the average amplifier cascade per subscriber, the system reliability will also improve. With up to 30 percent of cable customers identifying signal quality and reliability as the most important issues in their cable service, the investment in fiber optics will pay back in fewer disconnects and more pay subscribers.

So even though the AM systems don't yet meet ATC's supertrunk specifications they can be competitive with coaxial cable in distribution applications, depending on the exact topology, density and business strategies. Horseless carriage?

## State of the art

The NCTA convention in Dallas this year brought out one startling thing: nothing startling. In contrast with the last year of announcements of all the latest in fiber optic fashions for cable television, the vendors in Dallas all seemed to be singing more or less the same tune (or at least marching to the same drummer...does the name Jim Chiddix ring any bells?).

On the basic system level, fiber optics for cable television is becoming somewhat more predictable. The AM systems now being presented by the

vendors all seem to have close to the same characteristics which probably indicates that that technology is approaching its limit in capability. Further improvements in AM transmission will likely take some fundamental device level breakthroughs.

What will come to differentiate the AM fiber systems (as well they should) are features such as system back-up, performance monitoring and other functionalities over and above basic point-to-point transmission. And these shouldn't be played down; most of the system operators we talk to cite improvements in reliability as their number one reason for looking at fiber optics.

As horseless carriage optics moves further along the evolution curve, there will be many new developments. However for the moment, some of the more advanced techniques seemed to have gone into hiding. For example, from one extreme to the other, exhibitors at the Dallas convention were showing neither systems based on external modulation (a la Dylor) nor systems based on digital signal processing.

## The move is on...

A recent poll published in *CableVision* magazine (4/24/89) indicated that 24 percent of cable system operators have installed fiber optic horseless carriages or are planning to do so soon. A similar poll done by DTI Telecom around the same time indicated that this figure is in fact much higher; approximately 65 percent of respondents identified plans to deploy fiber optics in a 1- to 3-year time frame. (DTI's poll was primarily of systems in California. As with surfboards, Mexican food and white zinfandel, one supposes California is also a leading indicator for fiber optics....)

Cable television is taking hold of the new horseless carriage. If the polls are even close to reality, the cable television industry will be an information age leader in bandwidth distribution. The "Community Antenna" system could take on a much broader role; a "Global Village Antenna" bringing not just television programming, but also electronic newspapers, magazines, advertising, movies and other information from all over the world. ■

*Rob Yates is Director of Studies*

*at DTI Telecom Inc., a Montreal-based consulting and engineering services company. Assistance in preparation of this article was provided by Robert Menard, DTI President.*

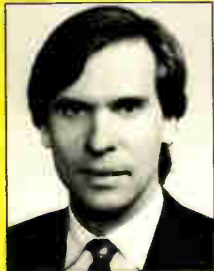

*Robert Yates*

# FAST FIELD SECURITY FOR YOUR CABLE TV PEDESTAL

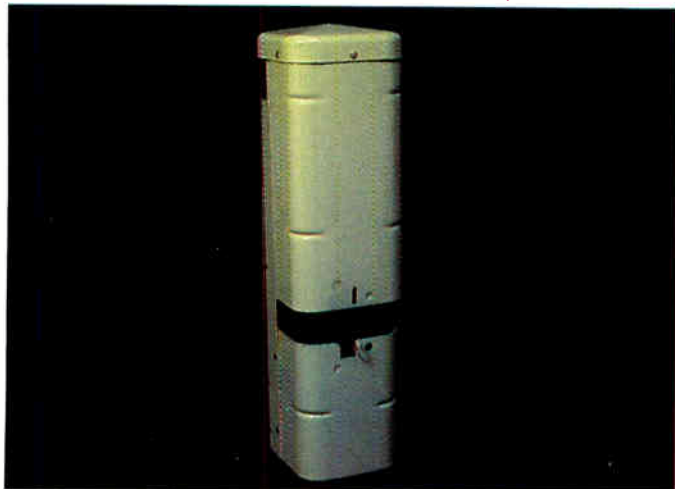

Pedestal cover with knock out in place.

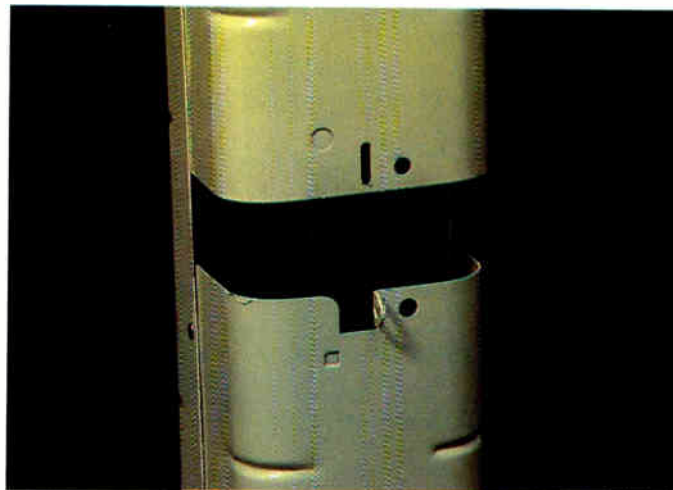

Knock out is easily removed with hammer and ordinary screwdriver.

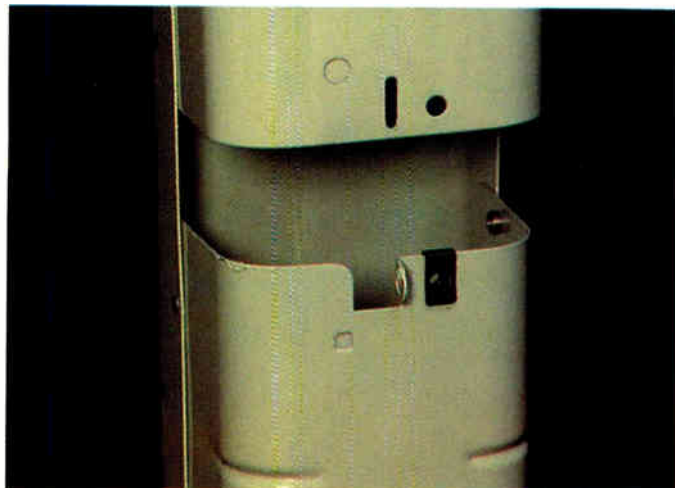

Locking clip fits over pedestal in seconds.



Star Lock is tightened and removed only with special screwdriver type key for maximum security.



Only Reliable pedestals come with factory-provided knock outs for installing **Diversified Control Systems Star Locks**.

A small but important feature...

because it provides maximum security for cable TV pedestals or apartment boxes

fast and easy right in the field.

Hasp broken or missing? No problem. Diversified's Star Locks are designed to deliver a secure closure without using the hasp.

It's a great combination: Star Locks and Reliable Electric, the best-selling pedestals in the industry. And you can get them both from one trusted source: Anixter Cable TV.

Reader Service Number 63

**RELIABLE**

RELIANCE COMM/TEC

**ANIXTER**  
CABLE TV

**WEST-ANAHEIM:** (714) 779-0500, (800) 854-0443; **DENVER:** (303) 740-8949, (800) 841-1531; **SEATTLE:** (206) 251-6760, (800) 426-7665; **MIDWEST-CHICAGO:** (312) 364-7000, (800) 544-5368; **CLEVELAND:** (216) 526-0919, (800) 321-8068; **DALLAS:** (214) 446-7337, (800) 231-5006; **IRON MOUNTAIN, MI:** (906) 774-4111, (800) 624-8358; **SKOKIE, IL HDQTRS:** (312) 677-2600; **EAST-ATLANTA:** (404) 995-5110, (800) 241-5790; **LONG ISLAND, NY:** (516) 293-7788, (800) 645-9510; **NEW JERSEY:** (201) 328-0980, (800) 631-9603; **TAMPA:** (813) 626-7115, (800) 282-9164; **CANADA-CALGARY:** (403) 250-9646; **MONTREAL:** (514) 636-3636; **TORONTO:** (416) 625-5110; **VANCOUVER:** (604) 321-5885

In an emergency, weekends and holidays or after 5 P.M. call toll free 1 (800) 323-8166.  
**CORPORATE OFFICES, ANIXTER CABLE TV, INC.,** 4711 Golf Road, Skokie, IL 60076, (312) 677-2600

© 1989 ANIXTER CABLE-TV

# The Future Is Here!



## The ANIXTER Fiber Optic Laser Link AM CATV System

AT&T and Anixter Cable-TV have joined forces to bring you — *today* — the most exciting technological advancement in the cable-TV industry. And, we're proud to say it's the *only* system that is truly "Made in U.S.A."

It's Anixter's Fiber Optic Laser Link AM CATV System — a major breakthrough for cable TV in the transmission of multiple AM analog television channels over long distances. Following extensive, highly successful field tests, initial installations of the Laser Link System will be made

*this year* by many MSO's. Major features and benefits include:

- Easy installation and maintenance
- Compatible with existing CATV networks
- Low start-up costs
- Reduced maintenance costs
- Easy network upgrades
- Improved signal quality and reliability



Call our Fiber Optic Information Center at: 1-800-FIBER-ME. (1-800-342-3763)

# ANIXTER CABLE TV

CORPORATE HEADQUARTERS: ANIXTER CABLE-TV, 4711 Golf Road, Skokie, IL 60076

Reader Service Number 64

See us at the Eastern Cable Show, Booth # 527.

©1989 Anixter Cable TV