

MAY 1987 \$3.00

BME

BROADCAST MANAGEMENT/ENGINEERING

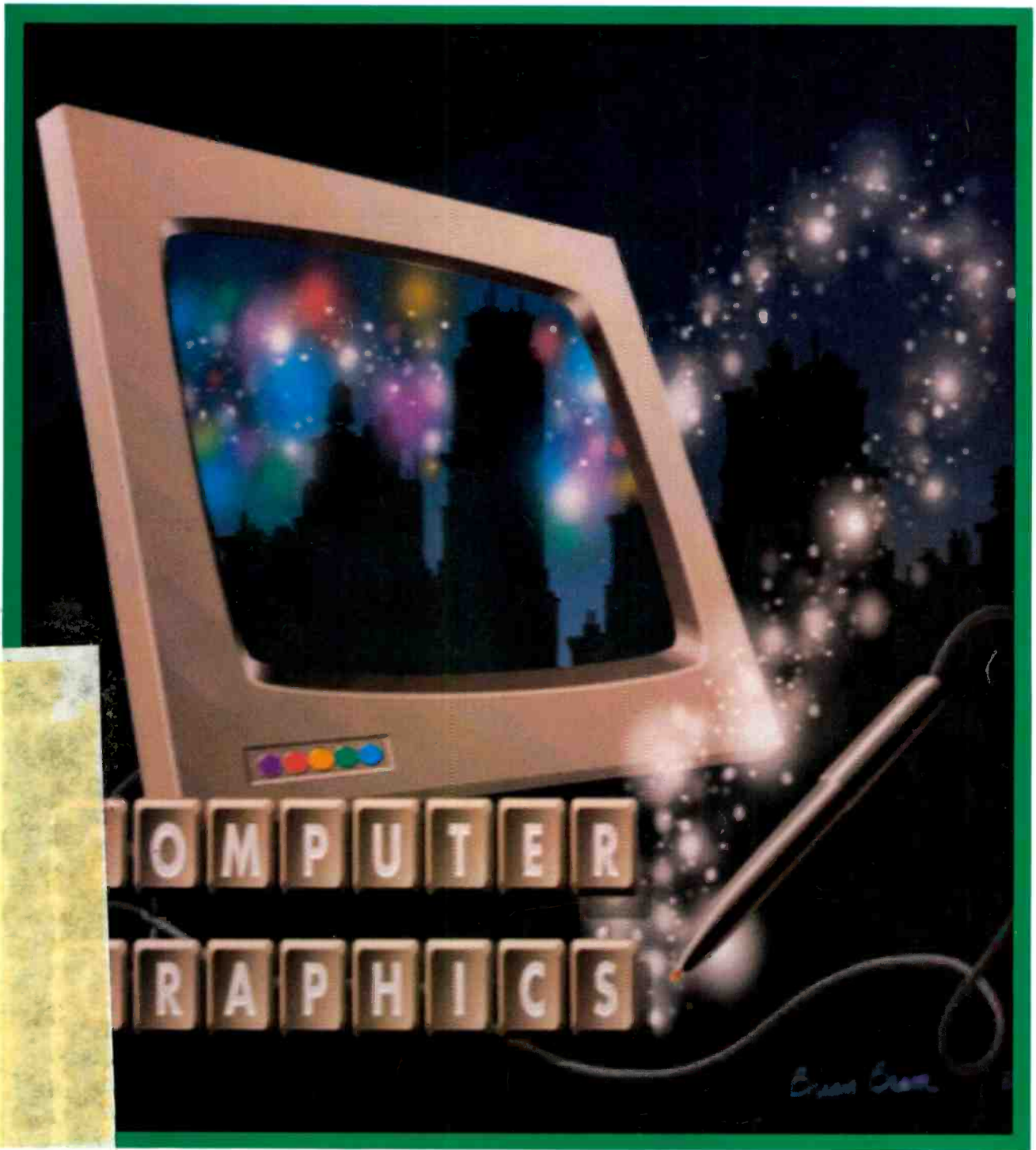

Also in this issue:

- Digital Audio EFX
- New RF Technologies
- 3D Animation
- BDA Preview

Tired of excuses from "third party" synchronizer companies? Studer, the world's premier tape transport maker, now offers two new intelligent SMPTE/EBU bus controllers.

SC 4008: Dedicated and Expandable - The basic SC 4008 system controls four audio, video or film machine transports via Studer TLS 4000 synchronizers. For more sophisticated applications, an optional expansion board extends SC 4008 control to as many as eight machines. The operating panel has a full array of dedicated keys logically grouped according to function.

Optional features include take count-down unit, VITC reader/translator, video character inserter, and event controller with outputs to trigger up to 10 additional non-synchronous sources.

SC 4016: Soft Alternative to Hard Production Tasks- The SC 4016 top panel shows a radical departure from the SC 4008 concept. Instead of dedicated keys, the SC 4016 employs eight "soft keys" with internal alphanumeric LED

displays. The software menu assigns functions to the keys according to selected system mode, and keys are automatically re-labelled to indicate currently assigned function.

The SC 4016 controls up to 16 synchronous transports, providing complete control (including shuttle and cue functions where applicable) as well as comprehensive machine status displays. Master and slave machine designations may be re-programmed at any time. And, for advance EDL preparation, the SC 4016 provides floppy disc data exchange with personal computers.

In Sync with Swiss Timing - Studer system controllers are made in Switzerland, the country famous for being in control and precisely on time. Every time. For more information on Studer system controllers, please contact your nearest Studer office.

Machine Control from a Machine Maker

STUDER REVOX

STUDER REVOX AMERICA, INC.
1425 Elm Hill Pike, Nashville, TN 37210, (615) 254-5651

Offices: Los Angeles (818) 780-4234/New York (212) 244-4462/
Chicago (312) 526-1660/Dallas (214) 943-2239
San Francisco (415) 930-9866

Circle 100 on Reader Service Card



SC 4008



SC 4016

STUDER SMPTE BUS CONTROLLERS



Synchronizing complex, Austrian Broadcasting Center, Vienna. Studer SC 4016 system controller, Studer mixing console, Studer tape machines



CTR124, CTR34 and CTR14 shown

The Dynamax® CTR30 Series

Our latest recorder has three decks

The DYNAMAX CTR30 Series of Three Deck Recorder/Reproducers is loaded with innovations. A built-in constant current recorder standard equipment on every unit. A unique trouble free motor that never needs adjustment. Proven CTR10 electronics. Audio switcher and mixer. Three cue tones. Independent removable decks, each equipped with a cleaning switch. And

serviceability so simple you'll never need our super service. Production studio, newsroom or on-air workhorse, the DYNAMAX family gives you the features you need at a price you can afford. Find out why DYNAMAX is fast becoming the world's leading name in cartridge machines. Call Fidelipac or your authorized DYNAMAX Distributor.



Fidelipac Corporation □ P.O. Box 808 □ Moorestown, NJ 08057 U.S.A. □ 609-235-3900 □ TELEX: 710-897-0254 □ Toll Free 800-HOT TAPE

DYNAMAX products are designed and manufactured in the U.S.A.

Circle 101 on Reader Service Card

Meet our b

Half-inch has just advanced a mile. Your suggestions and our experience were combined to create a superior form of Betacam.[®] Betacam SP.[™]

It delivers improved picture signal-to-noise. Four channels of high quality audio. And choices.

For great performance choose economical oxide tape. For superior performance choose metal particle tape.

Sony Communications Products Company, Broadcast Products Division, 1600 Queen Anne Rd., Teaneck NJ 07666 © 1987 Sony Corporation of America.



etter half.

And if you already own Betacam, you have the option of upgrading at your own speed. Because Betacam and Betacam SP are compatible. And that's a choice even your accountant will love.

For more information on the new line of Betacam products, contact your Sony Broadcast representative. Or call Sony at (201) 833-5231.

SONY
BROADCAST



Sony and Betacam are registered trademarks and Betacam SP a trademark of Sony Corporation.

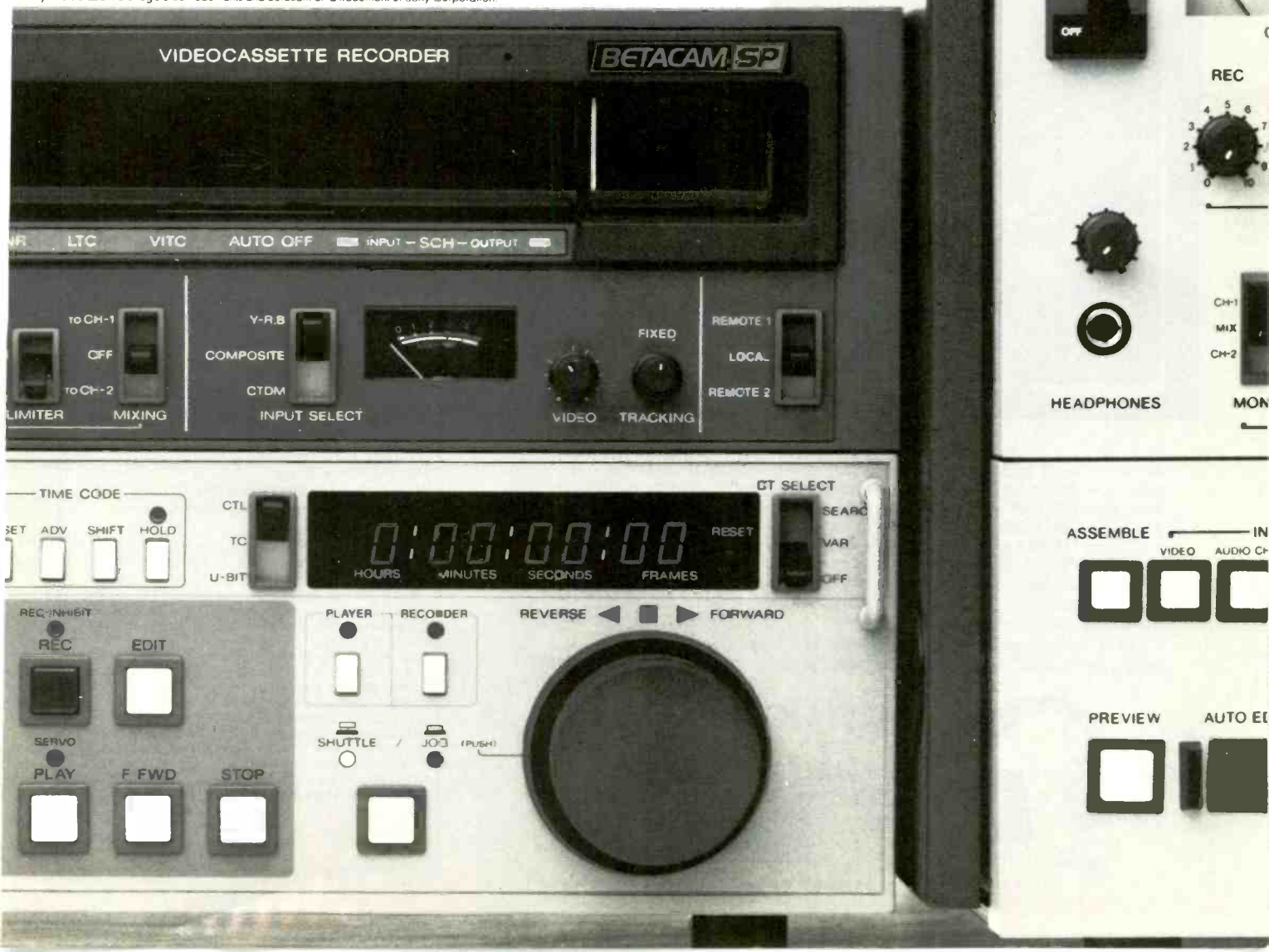

'A vital link'

Brian Sanderson, Sound Designer
Chanhassen Dinner Theatres

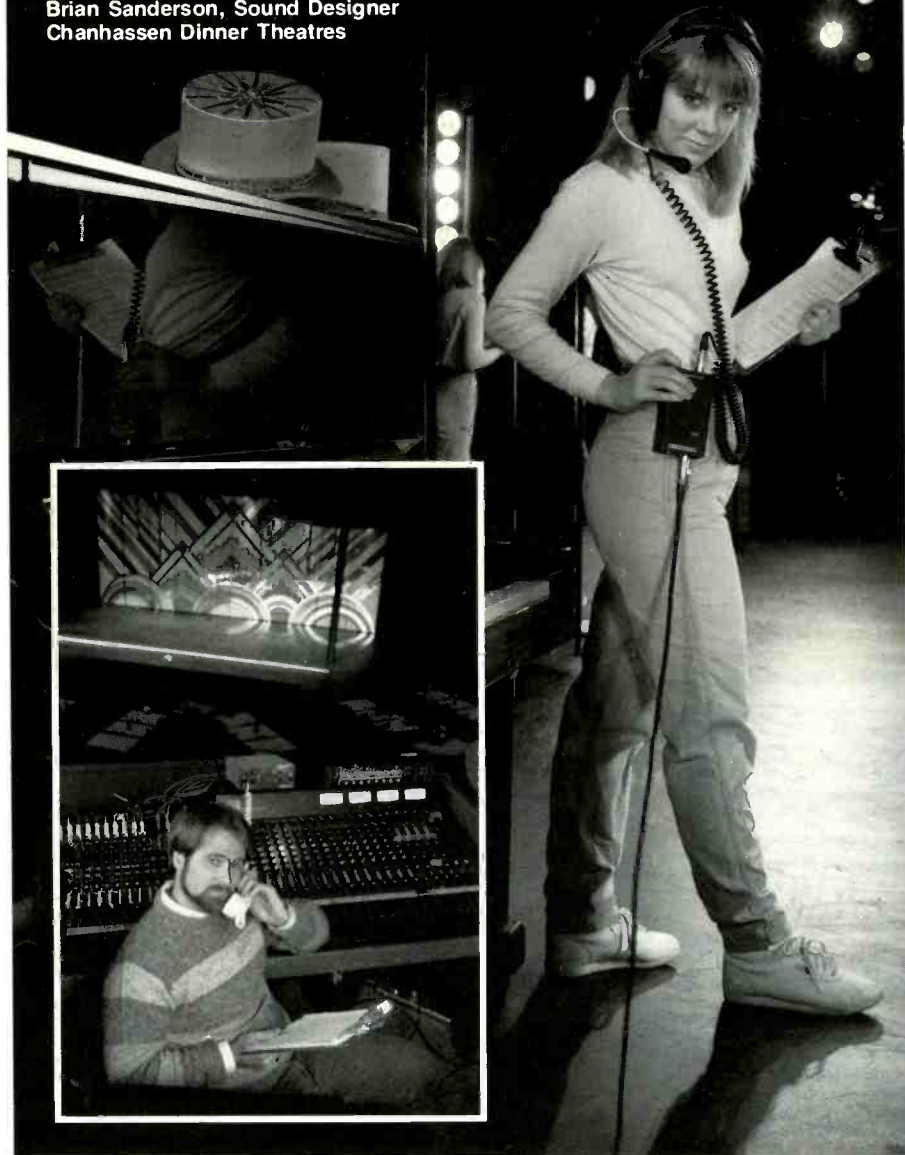

Brian Sanderson has been using Telex intercom equipment in each of the four theatres at the nationally acclaimed CHANHASSEN DINNER THEATRES complex for several years now. When "A Chorus Line", with hundreds of difficult stage and lighting cues, was recently added to its main theatre, Chanhassen upgraded the system to include a multi-channel master switchboard. "I can't imagine doing the show without the Telex Audiocom", Brian said, adding "I depend on it to provide a vital link between the house board and backstage".

The new Phase 2 Telex Intercom systems are uniquely flexible. You can start with the simplest two-party communication system and expand easily to a director controlled multi-channel network.

For complete details telephone or write to: Telex Communications, Inc.
9600 Aldrich Ave. So., Minneapolis, MN 55420 □ Telephone (612) 887-5550



AUDIOCOM

Phase 2

TELEX®

Circle 102 on Reader Service Card

BM/E

BROADCAST MANAGEMENT/ENGINEERING

PUBLISHING DIRECTOR

Charles C. Lenz, Jr.

EDITOR EMERITUS

James A. Lippke

EDITOR

Tim Wetmore

TELEVISION EDITOR

Brian McKernan

RADIO/AUDIO EDITOR

Steven Schwartz

RESEARCH EDITOR

Douglas Damoth

COPY EDITOR

Michael D. Espindle

FCC COUNSEL

Bechtel & Cole

BROADCAST FINANCIAL CONSULTANT

Mark E. Battersby

ART DIRECTOR

Andra Douglas

ASSOCIATE ART DIRECTOR

Raymond Wong

PUBLISHER

William G. McGorry

ASSISTANT TO PUBLISHER

Sharon Porges

PRODUCTION DIRECTOR

Nick Tartaglia

PRODUCTION ASSISTANT

Barbara Mendelsohn

MARKETING SERVICES DIRECTOR

Arlene M. Peters

MARKETING SERVICES ASSISTANT

Maria Cipollone

CONTROLLER

John Ailnovi

ASSISTANT TO CONTROLLER

Jesse Miloro

OFFICE MANAGER

Donald Cooke

SUBSCRIPTIONS/READER SERVICE

Helen C. Adams

Broadband Information Services Inc.

295 Madison Ave., New York, N.Y. 10017

(212) 685-5320, Telex: 64-4001

Also publishers of:

BM/E's **World Broadcast News**

E-ITV Educational-Industrial Television

ABP BM/E BROADCAST MANAGEMENT ENGINEERING (ISSN 0005-3201) is published monthly by Broadband Information Services Inc. BM/E is circulated without charge to those responsible for station operation and for specifying and authorizing the purchase of equipment used in broadcast facilities in the U.S. and Canada. These facilities include AM, FM and TV broadcast stations, CATV systems, ETV stations, networks and studios, audio and video recording studios, telecine facilities, consultants, etc. Subscription prices to others \$36.00 one year, \$50.00 two years. Foreign \$50.00 one year, \$75.00 two years. Air Mail rates on request. Copyright 1987 by Broadband Information Services, Inc., New York City. Second class postage paid New York, N.Y. and additional mailing offices. POSTMASTER: send address changes to BM/E Broadcast Management/Engineering, P.O. Box 6056, Duluth, MN 55806.

WHEN YOU KNOW EQUIPMENT BEST, YOU CAN BUILD SYSTEMS BEST.

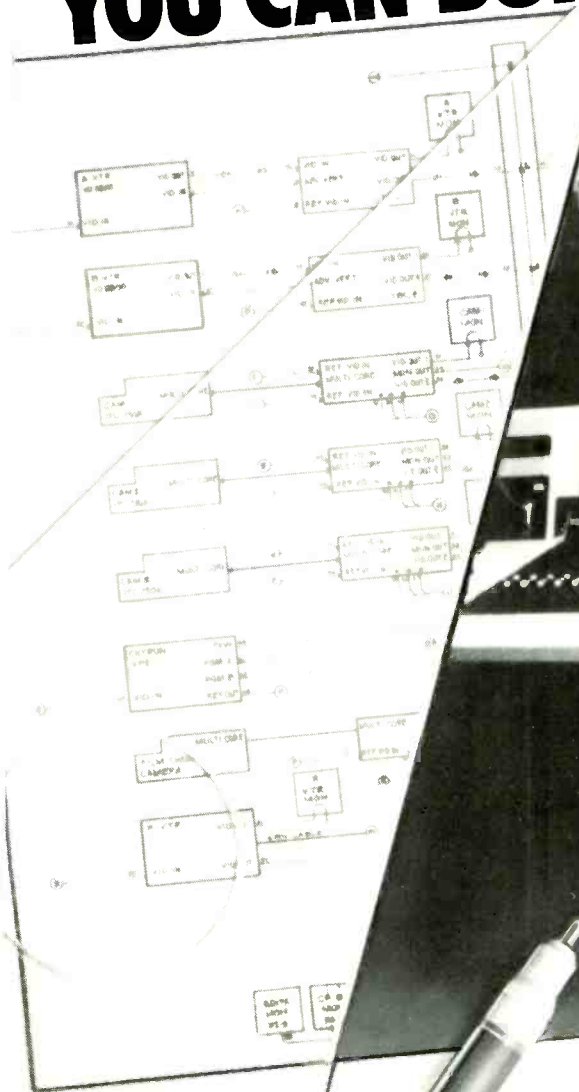

At Camera Mart, we get the latest state-of-the-science equipment first. Because we rent and sell them first.

So we get to know which components are best—so that we can design, engineer, build and install the video system that's best for you. Whether your system is a simple off-line unit or a complex broadcast studio, you get our total support and a complete "turn-key" operation.

What's more, since we're not compelled to "push" any particular manufacturer, we can recommend what equipment will work for you—within your budget.

Come, design a system with us. The best.

The Camera Mart, Inc.
SALES • SERVICE • RENTAL

Headquarters/New York
456 West 55th Street, New York 10019
(212) 757-5977
Telex: 275619/FAX (212) 582-2498

California
1900 W. Burbank Blvd., Burbank,
CA 91506 (818) 843-6644

Video Systems
designed, engineered,
serviced
by



Introducing the Model 200.

A powerful production switcher
that won't wipe you out.



The new Model 200 Production Switcher.

Two mix-effects, 20 inputs, five powerful keyers, an incredibly innovative wipe system,
nine color matte generators and an E-MEM[®] Effects Memory System.
More power than you ever thought possible for less than \$40,000.

Grass Valley Group[®]

THE GRASS VALLEY GROUP, INC. — P.O. Box 1114 - Grass Valley, CA 95945 USA - Telephone (916) 478-3000 - TRF 167832
OFFICES: New York (212) 486-7888; District of Columbia (301) 622-6313; Atlanta (404) 493-1255; Chicago (312) 264-0931; Minneapolis (612) 483-7590; Dallas/Fort Worth (214) 483-7447;
Los Angeles (818) 999-2303; San Francisco (415) 968-6680.

A TEKTRONIX COMPANY

Circle 104 on Reader Service Card



MAY 1987 VOLUME 23/NUMBER 5

Features

Cover:

The image was created by Brian Bram, design director at Boston Post Production, using an Ampex AVA-3 paint system. Bram notes, "The lighting effects were achieved with four-way gradations as well as airbrushing. The dimensional computer screen was created using the perspective features in the pasteup mode." The artwork was imaged by Ron Scott Photography in Houston.

BM/E

BROADCAST MANAGEMENT/ENGINEERING



30



43

- 20 TV Engineering & Production**
Seas of Color 20
 Computers are replacing traditional graphics tools in television stations, providing artists with both familiar and new ways . . . by *Brian McKernan, Television Editor*
- 2D, 2.5D, 3D: When Is Enough Enough?** 29
 Though there is a lot of interest in 3D graphics at TV stations, many are taking a wait-and-see attitude before rushing out to buy . . . by *Robert Rivlin*
- 43 Audio Engineering & Production**
Digital Audio: Production by the Byte
 Does the future of audio production reside in the digital domain? . . . by *Steven Schwartz, Radio/Audio Editor*
- 55 Broadcast Management**
Smart TV 55
 The BPME/BDA Seminar scheduled for Atlanta, June 10 to 14, will provide direction for broadcast managers . . . by *Tim Wetmore, Editor*
- Leasing Options** 59
 Creative answers to difficult questions. That's what is needed in the broadcast industry as it struggles to its feet. Leasing may be one of the creative answers . . . by *Tim Wetmore, Editor*
- Deregulation: FM Restrictions and Call Signs Go Under the Knife** 67
 Unusually heavy activity in Congress and at the FCC has prompted this expanded version of *BM/E's* regular FCC column . . . by *Harry Cole*
- 70 Transmission/Distribution Engineering**
New RF Techniques
 Both AM and UHF television are benefitting from fresh approaches to existing technology. Synchronized AM is gaining new impetus as is UHF . . . by *Robin Lanier*
- 8 Editorial**
 Financial Disclosure
- 10 Industry News**
 Computer graphics trends at NCGA
- 77 FCC Rules & Regulations**
 Minor Adjustments
- 79 New Equipment**
- 82 Advertisers Index**

Departments

Financial Disclosure

“The Commission now plans to implement a ‘random check’ of applicants who check the ‘yes’ box.”

As part of the discussion on station trading, the three-year rule, and other licensing considerations, financial disclosure has been hotly debated. Forcing applicants to prove financial stability is, on the surface, a good idea since it weeds out those who are not seriously in pursuit of the broadcast license, but rather some kind of buy-out fee. It also precludes unnecessary paper processing by the FCC since, in theory, financial disclosure was meant to cut down on the sheer number of applicants.

The operative term here is “in theory,” since it really hasn’t worked that way. There has been no shortage of applicants for any broadcast license, and the extra paperwork involved with examining credit statements and other financial data provided by applicants actually increased materials processing time at the FCC. The forms were then changed wherein the applicant could simply check a box—yes or no—as to whether or not he was qualified financially to undertake the broadcast licensee’s responsibilities.

The problem, of course, here is that anyone can check the “yes” box and hope for the money to come in later, or pray that the real players will buy out one’s interest in the license. The FCC has now come up with what they believe to be a solution for ridding the overburdened processing staff of such pretenders. The Commission now plans to implement a “random check” of applicants who check the “yes” box.

The FCC is doing the right thing now in trying to streamline its own operation and not requiring major proof of financial stability of broadcast license applicants. Instead the Commission is implementing a random checking of the certification applicants give as to their ability to undertake the financial burdens of obtaining and maintaining a broadcast facility. This accomplishes both goals: the elimination of paperwork, and the prevention of unqualified applicants.

This seems the only fair way to achieve the proper balance necessary between regulating a “deregulated” industry and permitting broadcasters to use a sensible form of license application. No legitimate contender should have problems with this method since, if he is qualified, he will pass the check. If the applicant does not have the necessary financial strength then, presumably, he will not file, or if he does he runs the risk of getting caught at a federal crime for which the punishment is fairly steep. If you want to know how steep, go ahead and try it.

Seems fair to me.



Tim Wetmore
Editor

Tough as Sony.



Pound for pound, Sony videotape is the toughest you can buy.

One word sums up everything we tried to achieve with VI-K one-inch videotape: durability.

It was perfected for the world where rugged dependability counts every bit as much as dazzling picture quality.

Its strength comes from a truly tough, cross-linked binder system, a very strong adhesive base film and our carbon black anti-static back coating.

This durable foundation protects an ultrafine Vivax™ magnetic particle

formulation, which delivers astonishing picture quality, higher stability and optimum S/N ratio.

Amazingly enough, VI-K also has the lowest headwear rate of any major one-inch videotape. Our efforts have benefited BCT Betacam® and the BRK U-matic® videocassettes, too, with trouble-free still frame editing, totally reliable repeated playback and worry-free long-term storage.

So, after all, Sony professional videotape is just like any other Sony: standard-setting video and audio with a "tough as nails" reputation. That's why it's the only videotape you can treat like a Sony.



SONY
THE ONE AND ONLY.

© 1986 Sony Corporation of America. Sony, Vivax, Betacam, U-matic and The One and Only are trademarks of Sony.

Circle 105 on Reader Service Card

26,000 View New Computer Graphics Trends at NCGA

Although the computer graphics and video industries have been trying to converge for years, there is no better proof that they are still on equal, but only parallel, tracks than the back-to-back scheduling of NAB and the National Computer Graphics Association (NCGA) shows this year. Only a very few manufacturers (the most notable were Cubicomp, Alias, Wavefront, and Symbolics) had the resources to do both shows so close together. And few attendees who were planning to visit Dallas beginning March 28 both-ered with the Philadelphia show that ended only one day earlier.

Ironically, the NCGA's annual video gala—presenting awards for the best computer animation in categories ranging from corporate communication to science and industry, and including theatrical—this year offered an award for the best broadcast computer animation. First place was taken by Robert Abel and Associates for an ABC logo and second place by Pacific Data Images for its *CBS Daytime Special*—though few broadcasters were on hand to witness the ceremony.

As usual, however, there were a number of developments at NCGA that may have an impact on TV graphics—if not immediately then certainly within the next few years. Most significant of these was the announcement of a new Silicon Graphics workstation, the IRIS 4D/60, that offers an enormous range of real-time computer animation capabilities (including mouse-driven control of light sources, object rotation, viewing angle, and so forth) in a hardware package priced at only \$74,900 (applications software from third-party vendors is not included). In frame-by-frame rendering applications the machine renders more than 40 benchmark frames per hour.

The heart of the new workstation technology is a 7 MIPS (million instructions per second) RISC CPU that operates



A proud quintet displays their awards at the BM/E Best Station and Facility Design Competition cocktail party on the evening of Sunday, March 29, in the grand ballroom of Dallas's Adolphus Hotel. The party is held during each NAB convention, and caps *BM/E*'s annual competition recognizing excellence in management, design, and engineering in radio, television, and teleproduction. Winning stations/facilities are selected by a *BM/E* readers' poll.

Receiving the awards for 1986 were (from left): Dennis Lowe, chief engineer, KMVT-TV, Twin Falls, ID; Ken Chambliss, president, Video Tape Associates, Atlanta; Roy Pressman, chief engineer, WLVE-FM, Miami; John Stuart, president, KVOO-AM, Tulsa; and Tom Bohannon, chief engineer, WDBO-AM/WWKA-FM, Orlando.

Your station or facility could be this year's winner. Watch for an announcement in an upcoming issue of *BM/E*, or send a postcard with your station's call letters/facility's name, address, and the name of the person to be contacted to: *BM/E* Magazine, Best Station Contest, 295 Madison Avenue, New York, NY 10017. Contest rules and entry information will be mailed out in August.

seven times faster than a VAX 11/780. This, coupled with the parallel processing graphics architecture, allows the real-time processing of 4,500 100-pixel polygons per second, including smooth shading and hidden surface removal. The system also incorporates full-color paint capability.

Silicon Graphics workstations are already well established in the computer animation market, forming the hardware platform for advanced 3D modeling and animation software from companies such as Alias and Wavefront, as well as Neo-Visuals (the 3D system now offered by 3M under the name Specter). Those wanting to improve on rendering speed,

however, were forced to invest in an additional high-speed graphics engine such as the Pixar Image Computer (an extra \$70,000 to \$80,000).

With the 4D/60's new real-time capabilities, however, large-market broadcasters as well as teleproduction facilities can now experience not only an interactive working environment for viewing the models and animation, but also a far more cost-effective process for turning out finished work: the new SGI workstation comes fully equipped to output NTSC video directly to a VTR.

Deliveries of the unit to third-party software vendors such as Alias and Wavefront are sched-

Performance and Portability



The S-1 Flyaway — Another Midwest Innovation

It's the world's first hi-performance, truly portable Ku-band satellite uplink. Each of the 13 A.T.A. approved cases weighs less than 100 pounds, and the complete system conforms to international baggage regulations. Checked as excess baggage, the S-1 arrives when you arrive. Economically.

The system utilizes a Vertex 1.8M offset-fed antenna with a transmit gain of 46.6 dbi. This precision, aluminum surfaced reflector antenna meets the 29-25 log Θ FCC 2° spacing curves.

Two STS phase combined power amplifiers provide fail-safe redundancy and plenty of reserve power. And an Intelsat-approved exciter

with half and full transponder transmit capabilities allows you to operate on any available satellite system. The S-1 can be set up fast, on-line in less than 30 minutes. And the S-1's modular electronics make system repair or replacement in the field easy.

Video and audio control and monitoring equipment are included in the standard S-1 package. Options include a 2-way communications channel, and an international receive configuration is available. The S-1 is also easily adaptable for data transmission. Contact Midwest for complete information.

The S-1 Flyaway from Midwest.

Built to perform. Packaged to go . . . anywhere.



MIDWEST

Communications Corp.

One Sperti Drive
Edgewood, KY 41017
606-331-8990

uled to begin shortly.

Ranging from the grandeur of a real-time 3D graphics processor to the more practical reality of PC-based graphics, the show also saw the introduction of the Vista board from AT&T—a high-resolution (1024 x 1024 x 32 bits to 2048 x 2048 x 16 bits) “big brother” of the Targa.

Fully NTSC and PAL compatible, the 32-bit graphics processor board also incorporates four mega-

bytes of video RAM (this is expandable to 12 MB with an additional board) and four 8-bit channels for instant, full-color video capture. Working at typical video resolution of 512 x 512 with 32 bits/pixel, the memory can thus be divided into four pages, suitable for limited animation effects. The AT&T Vista board, which can be plugged into either the AT&T PC 6310 or IBM AT and compatibles, is list priced at \$5,995.

New Owner for Ampex

Allied-Signal Inc., in a move to reorganize and focus on its aerospace and advanced engineering divisions, has sold its Ampex subsidiary to the Lanesborough Corp. The transaction, which cost \$479 million plus the assumption of certain liabilities, was announced April 6.

Under the agreement, Ampex will be acquired by a newly formed subsidiary of Lanesborough, which plans to operate Ampex with its present management and organizational structure intact.

“We are extremely pleased to be affiliated with Lanesborough,” said Charles A. Steinberg, Ampex president and CEO. “We’re especially excited that Ampex will again be operated as a standalone corporation.”

Edward J. Bramson, president and chief executive officer of Lanesborough, said, “We intend to make sure that Ampex has the financial and other resources to continue investing in the future. Ampex is a strong company with outstanding capabilities. We think the company’s prospects for growth are excellent.”

Videotape recording was invented by Ampex 30 years ago, and the company had sales last year in excess of \$500 million. It is one of seven electronics businesses Allied-Signal is selling. Ampex was acquired by Allied in 1985.

Lanesborough, a privately held chemical manufacturing concern, intends to finance the transaction through a combination of its own equity and an offering of debt or equity securities. In the interim, Lanesborough has arranged for credit facilities with commitments of up to \$475 million from a major New York bank.

The transaction is expected to be completed by the end of May, pending regulatory approval.

SMPTE Call for Papers

The Society of Motion Picture and Television Engineers (SMPTE) has issued a call for papers for its 129th Technical Conference and Equipment Exhibit, to be held October 30 to November 4, at the Los



Timesaver

telcom research

TCR 680

The TCR 680 SMPTE Time Code Reader/Insertor

Here's the perfect time and worksaving way to make a copy of your master tape — with time code displayed in the picture for efficient off-line edit decision-making.

Its highly portable design

makes the TCR 680 ideal for all location work, and an invaluable tool for precise editing.

Don't waste time! Call us for the name of your local dealer. The TCR 680. It's about time.

telcom research

1163 King Road, Burlington, Ontario. L7R 3X5 (416)681-2450

3D Digital Video Effects RP-1 From Microtime

Imagine... fluid smooth motion, superb transparency, and simplicity of operation. Unlimited resources at your fingertips, letting your imagination run wild.

Create... with variable axis rotation, perspective, continuous expansion and compression, border, crop, and other exciting effects.

Admire... the creative capabilities of **RP-1**.

Powerful, easy to use, and cost-effective. You couldn't ask for more in a **3D** digital video effects system:

- True **3D** movement with fluid smoothness
- Matte channel for flying keys
- Linear keyer for the ultimate realism in foreground or background compositing
- Two-channel option with plug-in digital compositor cards to float two variable transparency foregrounds over a background
- Microfloppy disk stores 256 sequences for loading into 20 run registers
- Built-in signature analysis diagnostics to evaluate circuit performance

So call Microtime today and see what **RP-1** can do for you.

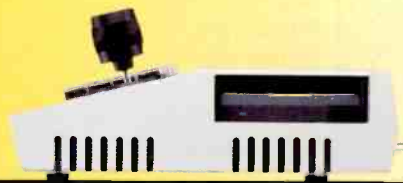

 **MICROTIME**

A Subsidiary of ANDERSEN GROUP

Angeles Convention Center.

The theme of the 129th SMPTE is "Imaging and Sound: Today and Tomorrow," which will cover most areas of film, television, and video technology. Topic headings have yet to be finalized, but sessions on laboratory practices, film and video post-production, computer applications for television, and enhanced television are expected to be on the conference's agenda. Any paper dealing with these or

other areas of motion-picture or television technology will be considered by SMPTE for inclusion in the program.

Persons interested in presenting papers should send their name, address, title of the proposed paper, and a 100-word abstract describing it to: Dollie Hamlin, SMPTE Program Coordinator, 595 West Hartsdale Ave., White Plains, NY 10607. The deadline is June 15.

AM Stereo, SNVs Subjects of NAB Surveys

Recent surveys commissioned by the NAB have served to highlight the continued growth of new broadcast technologies.

One survey, on technical advances at radio stations, reveals that the number of AMs broadcasting in stereo increased by more than 40 percent in the last eight months. The NAB cites figures of from approximately 446 AM stereo stations last August to more than 700 by the end of March 1987. The survey did not seek information on which AM stereo system stations used. The survey was conducted by telephone on a random national sample of 445 commercial stations on March 23 and 24.

There will be more satellite news vehicles (SNVs) on the road in the future according to another NAB phone survey, done between March 2 and 10. Seventy-one network affiliates with SNVs, and 253 other commercial stations without the trucks, were polled. Of the 253 stations, 23 percent said they plan to buy, lease, rent, or share an SNV within the next three years.

Of those stations with an SNV, 85 percent reported owning it. Stations said that they used their trucks an average of 12 days a month, with breaking news, emergencies, disasters, sports, and special events ranking as the types of stories usually involved. Eighty percent of the stations described their SNVs as "very valuable."

FMer Goes All-CD

WXCR-FM in Tampa, FL, has become the first classical radio station in the U.S. to feature full-time music programming on compact disc (CD). The station has been experimenting with the format for the last nine months, following a survey in April 1986 that revealed that 95 percent of the selections listeners prefer most are available on CD.

"Our reasoning was simple," says station manager Tom Shealy. "The audio quality is outstanding, and the audience was not interested in classic perfor-



Shure's SM83 Lavalier Mic makes everyone look good.

On-camera talent likes the omnidirectional SM83 condenser mic's mid-range dip, because it gives male and female voices a smoother, more natural sound.

Sound engineers appreciate the SM83's tailored frequency response because it requires less equalization, and its low-frequency rolloff quiets on-air rumble and clothing noise.

Set directors are impressed with the SM83's neat appearance and side-entry cord because it disappears behind clothing. *Production assistants* enjoy the SM83's mounting versatility. A single clip works vertically or horizontally. A double clip holds two mics. A universal mount can be sewed, pinned or taped to clothing.

Repair technicians love the SM83's easily accessible cartridge (just unscrew the cap), and that cable replacement requires only a screwdriver and needle nose pliers. (No soldering).

Field crews appreciate that the SM83's electronic pack is powered by a standard 9-volt battery or a mixer's phantom supply.

For more information on Shure's entire line of professional microphone products, call or write Shure Brothers Inc., 222 Hartrey Ave., Evanston, IL 60202-3696 (312) 866-2553. Available under G.S.A.

SHURE®

Breaking Sound Barriers for over 60 years™

The Outperformer!

IKEGAMI'S HL-79E IS MORE VERSATILE THAN EVER

Ikegami's HL-79E has lived up to its billing as the greatest achievement in hand-held camera technology, a claim supported by an increasing number of 79 series purchasers, presently in excess of 5000.

And yet, today, the engineers at Ikegami have found a way to improve the camera. Now, when equipped with the new VBA-1 adapter, the HL-79E is totally compatible with the Sony Beta recorder.

On your shoulder, the HL-79E is still unmatched in performance with features that include Dynamic Detail Correction, Chroma Aperture Correction, Highlight Aperture Correction and Auto Contrast Compression. Plus the HL-79E offers superior contrast range, S/N ratio, registration accuracy, resolution and more.

On a tripod, the HL-79E becomes the premier EFP camera which can be used in various systems configurations and controlled remotely by the MA-79 Multicore Adapter, through multicore cable (up to 300 meters) or by the TA-79E triax adapter through triax cable (up to 2000 meters).

The camera can be set up using conventional manual techniques or an optional microprocessor assist.

For a complete demonstration of the HL-79E and other Ikegami cameras and monitors, contact us or visit your local Ikegami dealer.



Circle 110 on Reader Service Card

Ikegami[®]

Ikegami Electronics (USA), Inc. 37 Brook Avenue Maywood, NJ 07607

West Coast: (213) 534-0050 Southeast: (813) 884-2046 Southwest: (214) 233-2844 Midwest: (312) 834-9774 Hawaii: (808) 945-5955

mances, but rather the overall sound of the station." If a classic performance is not available on CD the station strives to find an alternate version that is.

Shealy adds that the switch from analog LP and tape sources to CDs required extensive equipment modifications to accommodate the change in format. These included the addition of a CRL FM-4 multiprocessor system, reworking the RIAA equalization curve to add a boost in the mid-range frequencies, and dropping the console input and output reference levels to zero.

"In essence, we refined and upgraded the entire broadcast chain to mellow the full sonic and dynamic range of CDs to be passed on to the listener," explains Shealy.

After carefully evaluating a number of professional CD players, the station selected the Studer Revox B225 for its on-air applications. There are currently

six B225 players (with 1:1 redundancy) at WXCR, although six of the newer Studer B226 players are currently on order.

News and liners are still kept on analog tape and played back on Revox B77 two-track machines. Shealy hopes, however, to incorporate a PCM digital processor (used with any standard half-inch VCR) in the near future to compensate for the slight dip in audio quality that occurs when switching from digital to analog sources.

"The CRL processor eliminates most tape noise, but the PCM system will keep it all in a digital format," Shealy says.

He also points out that CDs that are digitally recorded and mastered offer significantly better sound than those that were simply digitally mastered. "You really can hear the difference—even on the air," he states.

In Memoriam

Jack Bush, a pioneer in television

journalism, died March 27, at his home in Doylestown, PA. He was sixty-eight.

Bush was director of electronic newsgathering at ABC News when he retired last year, having joined the network in 1963. His management positions at ABC included the supervision of worldwide camera crews, and the implementation of new technologies for newsgathering.

Prior to joining ABC, Bush was a newsfilm editing and production executive at CBS News, and the chief film editor for *March of Time* newsreels.

"Jack Bush walked amongst the likes of Stanton, Paley, Murrow, and Friendly," states Marc B. Wiskoff, Motorola district sales manager for special markets. "The ABC News organization benefitted greatly from his experience . . . his absence leaves a void that will never be filled."

Bush is survived by his wife Henrietta, and son Ethan.

Broaden Your Horizons

QUALITY MANUFACTURING & PERFORMANCE



Dielectric can broaden your FM broadcasting capabilities with quality-manufactured, reliable products. Dielectric components have provided years of continuous performance with very little maintenance for FM stations around the world. That's reliability you can't ignore.

Dielectric is the single source for all your equipment needs:

- Coaxial Transmission Line, Switches and Patch Panels for maximum isolation and low VSWR
- Panel Antennas for single and multiple frequencies
- Economical, high performance DCR Series of circularly polarized FM Ring Antennas
- Rigid Coaxial Transmission Line of welded, high conductivity copper that meets critical performance criteria
- Line Hangers and Accessories
- FM Multi-Station Combiners and Switching Systems for switching any transmitter to an antenna or station dummy load

Our complete line of FM broadcasting components is also backed by reliable customer services, including quality control, installation, start-up and servicing. So, for all your broadcast needs, there's only one number to call: (800) 341-9678.

DIELECTRIC

GS

Raymond, Maine 04071
(207) 655-4555 • (800) 341-9678
TWX: 710-229-6890

VERT POL
HORIZ POL



Best Show on Wheels. The New Video 20 Pedestal System.

When you and your EFP camera are on the go, get maximum portability plus studio comfort with the Video 20 Pedestal System from Sachtler. A pneumatically supported center column with its pressurized balance system provides multiple load capabilities for smooth and precise on air movement. The steerable dolly assures equally smooth and precise tracking. Also, the Video 20 Pedestal can be combined with the Sachtler Semi-Dolly or used as a stable, stationary unit. For lightweight portability and professional results, the Video 20 Pedestal System proves itself a champion in action. Everywhere. Every time. Of course all Video 20 Pedestal System combinations come with Sachtler's guaranteed leakproof fluid heads for the ultimate in smooth, precise shooting.

That's what we are known for. World-wide. For detailed information, please contact us.

Sachtler. The System.



Sachtler Corp.
55 North Main Street
Freeport, N.Y. 11520
Phone (516) 867-4900

3316 W. Victory Blvd.
Burbank, CA 91505
Phone (818) 845-4446

Sachtler GmbH Dieselstr. 16,
D-8046 Garching/München,
West Germany.

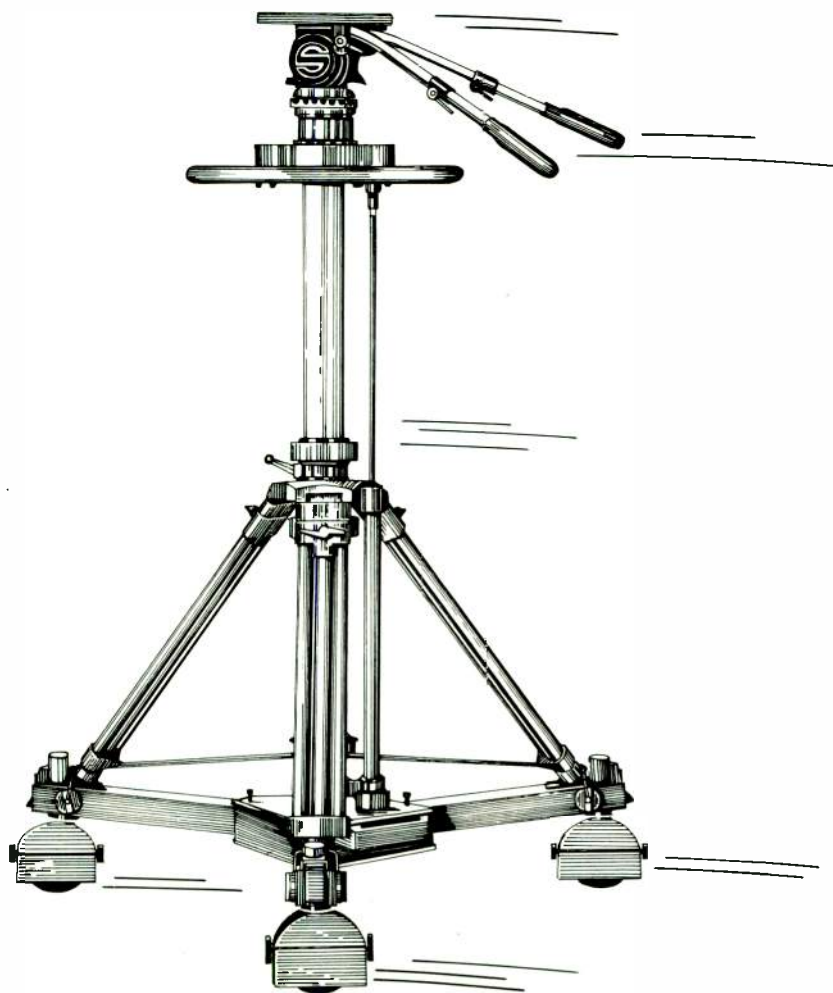

Circle 117 on Reader Service Card

"Digital has final



Sony Communications Products Company, Professional Audio Division,
1600 Queen Anne Rd., Teaneck NJ 07666. © 1987 Sony Corporation of America.
Sony is a registered trademark of Sony Corporation.

y adapted to me."

Sit down at a Sony PCM-3202 2-channel digital recorder and you'll notice something strange.

Mainly, that it's *not* strange.

You can rock its reels, splice the tape, in fact, you can do everything you're used to doing with a studio-quality analog recorder. But still get great digital sound.

And since it's Sony digital, you'll find that it's not only easier to work with, it's also easier to master with. Because the 3202 makes *direct* digital transfers to the world standard PCM-1630 CD mastering system.

So if you've been waiting for a great tape machine that happens to be digital; don't wait. Contact your Sony Pro-Audio representative for a demonstration.

For more information on the PCM-3202 and the PCM-3102 (7½ ips version) call the Leader in Digital Audio at (201) 833-5231.

SONY
PRO AUDIO

Circle 123 on Reader Service Card

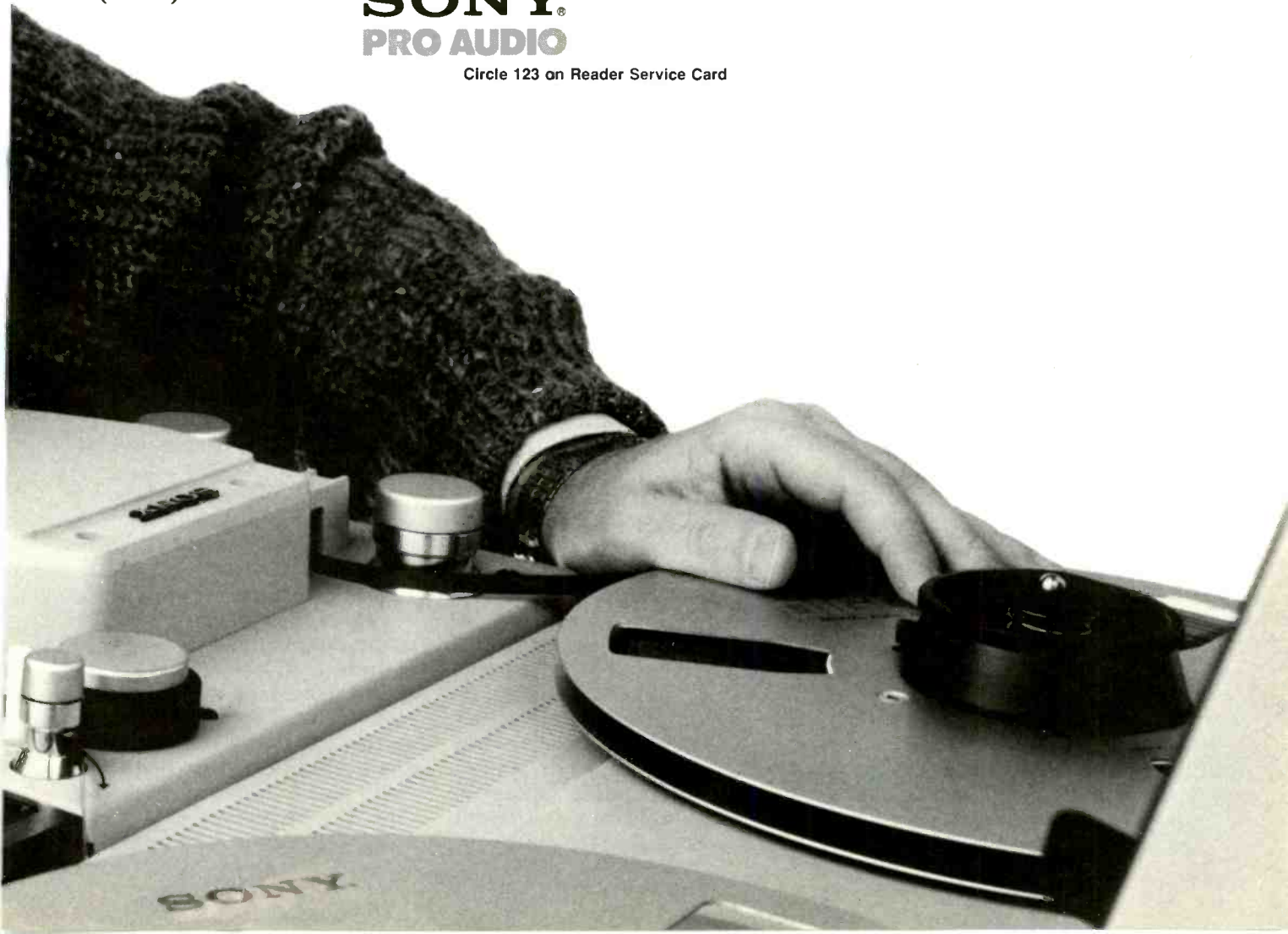

SEAS of COLOR

By Brian McKernan

Computers are replacing traditional graphics tools in television stations, providing artists with both familiar and new ways to work, and enough colors to rival a tropical reef.



The old saying that the first virtue of a painting is to be a feast for the eyes was never truer than today, as an increasing number of television stations add electronic paint systems to their complement of videographics equipment. The visual feast offered by paint does much to enhance a station's look, enabling it to present colorful, dynamic pictures whenever still images are called for. News is one of the major beneficiaries of this technology, which is rapidly making slides, razors, and airbrushes that require cleaning up anachronisms at many stations.

Still stores and character generators are, of course, also vital to a station's overall graphics operation, and are valuable adjuncts to using a paint system, even though today's paint systems often include elements of both. At the

other end of video's computer graphics spectrum, 3D animation systems usually include paint software. But regardless of how extensively a station may be equipped, for its day-to-day graphics needs, paint is fast becoming essential for creating images that grab viewers.

Getting started

"Just a few years ago, we basically did nothing in terms of over-the-shoulder news graphics," recalls Bob Rankin, director of broadcast design at WHAS-TV, in Louisville, KY. "Then in 1984 we got our Ampex ESS [electronic still store], and that started the ball rolling. The over-the-shoulder graphic became part of our news function. We got an Ampex AVA-3 video painting system in 1985, and since then we've used it almost constantly. We did a sur-

vey and found our production of compressions—over-the-shoulder graphics—had gone up 200 percent. The AVA-3 is an integral part of our news presentation now, and makes it look infinitely better."

(Editor's note: the aqua at the beginning of this article was created on an AVA-3.)

"Paint is indispensable when you're trying to report on technical topics," explains John Shumway, WHAS-TV general assignment reporter. "I did a series of stories on groundwater contamination, and wanted to illustrate a situation where water from a septic tank was polluting a well. We used the AVA-3 to show a cross section of the earth 150 feet deep, illustrating the house, well, septic tank, and sewage flow. There's just no other way to do it. No matter how much you



explain something like that, you can't get the point across without a picture."

Art parts

Paint comes in two basic configurations, as standalone units specifically made for that purpose, or as a software function included within a 3D video computer graphics animation system. Manufacturers vary in their design of both kinds of paint system, but the basic parts are usually the same.

First and foremost there is what is called the architecture, which refers to the computer driving the system, and—by extension—the logic behind the user interface. This can be defined as the layout of steps or the process you have to follow to achieve what you want out of a paint system.

Different paint systems incor-

porate different computers, but the rule is the more sophisticated the processor, the more capable the system. Bit-level graphics is one consequence of processing power, the greater it is the more colors you have to work with. A 24-bit system can give the user over 16 million colors to work with, with over 300,000 displayable at any one time. Magnetic disk-based image storage is usually included in paint systems, and is often expandable for additional disk storage.

Into the architecture enters the video signal, usually in analog form. After conversion to digital, the image is held in a frame buffer for modification and display. A keyboard is often included in a paint system for entering commands and for titling, storage, and retrieval of finished pages. The stylus and digitizing tablet,

however, are the major means of control and execution. A monitor displays the image being worked on. Edit menus may appear beneath it as pictures and/or text, or be displayed on a separate monitor. Menus using pictures—icons—feature touch-sensitive screens that activate desired functions when tapped by the stylus.

When the artist is finished, his images can be sent on to a still store, tape, or other media. What can be done to an image while it resides within a frame buffer is the essence of a paint system, and basically that includes anything that artists have been able to do with traditional tools.

Images can be created from scratch, or existing pictures can be grabbed—in real time—from any moving or still video image, and then be modified. Pictures can be enhanced or altered by means of cutting and pasting, painting or tinting in a selection of colors that depend on the bit-level graphics of the system. The stylus can act as practically any kind of drawing instrument, from airbrush to chalk, and stencils can be created to make rules or outlines in any shape.

Most systems offer real-time antialiasing, and although features vary from system to system, they often include the ability to practice and mix colors and brushes on "scratchpad areas" of the screen, create user-defined brushes, blow up any picture area for pixel-by-pixel retouching, retouch by using any color present in the image, tilt and change perspective, and insert and manipulate type from built-in font generators.

Moving paint

"Making a better paint system means not only making it work faster and easier, but also giving it more features," comments Dimitri Chernyshov, product specialist at the Quanta Corp.

Additional features are always valued by the user, even on basic systems. The two-year-old Quantapaint 2500 is an 8-bit sys-

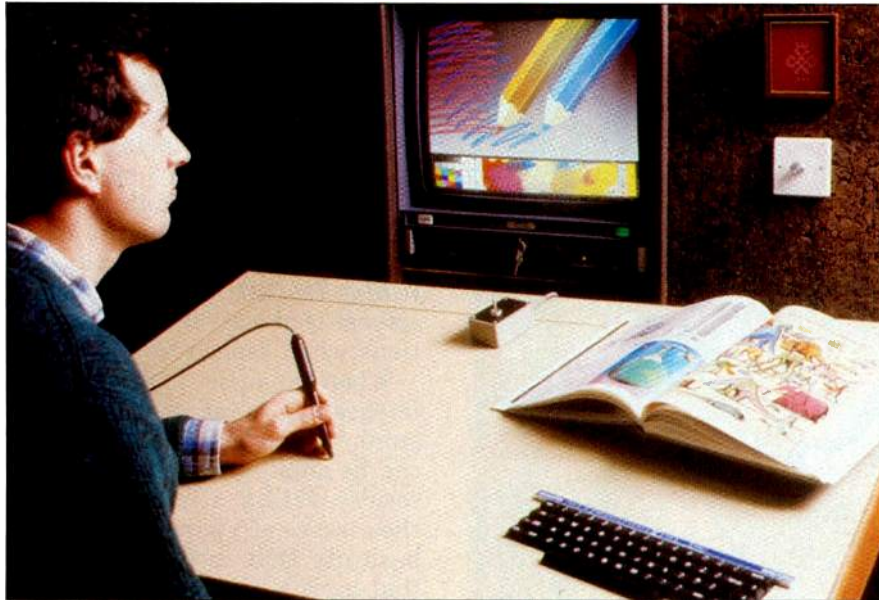

Paint systems—such as the Quantel Paintbox seen here—are designed for transparency and flexibility to allow the artist maximum freedom to create images.

tem, and for Tom Werner, chief engineer of KNPB-TV, in Reno, NV, its four-color color cycling enables him to do simple animation for a weekly newsmagazine show, *Silver State*.

“We’ve used the color cycling to make the grass appear to grow in a graphic on investments that compared money to a healthy lawn,” Werner explains. “And for a story on prison overcrowding we multiplied hand-drawn inmates. It’s a nice visual reinforcement.”

Combining a character generator with paint is a logical next step in video graphics, and for WYCC, in Chicago, this means using their Chyron Chameleon with an RGU-2. “We use the camera capture feature a lot, and combine freehand art with text to do graphics for just about every holiday,” says Don Rhodes, chief engineer. The station combines the output of the Chameleon and the RGU-2 in a switcher, and sends it to an Abekas A42 still store.

Moving up the product line, Chyron combines comprehensive character-generation effects and paint in one unit by adding a multimode graphics module (MGM) to their Chyron 4200 titling and graphics system. And at an even higher end, Chyron has recently introduced the

Shimatronic graphic image system, a full-featured paint system that can be expanded to do 3D animation.

“We started with paint but are growing into animation, which is a natural for paint systems,” explains Mick Ghazey, a vice president at Dubner Computer Systems, makers of the DPS-1 paint system. “Animation requires only a processor, frame buffer, and a tape recorder control, and that’s already part of paint hardware.”

In addition to comprehensive paint system features, the Dubner DPS-1 features real-time trajectory animation along spline paths. With this, the user can assemble single-frame animation sequences by specifying key frames, and then having the DPS-1 computer spline (draw the “in-between” pictures) according to the image’s size, rotation, and perspective. Each frame is then recorded on a VTR. The key to this animation feature is software, which, in the view of many, is the key to all significant future developments in paint systems.

Tug of ware

“Software is of course a major part of systems nowadays,” says Ghazey. “But the industry must make use of advances in both

hardware and software, although software takes longer to improve because of the thousands of lines of code necessary in writing it. I feel that parallel processing will help hardware continue to improve, especially where video is concerned because the large number of pixels involved allow for computation tasks to be spread among available processors.

“I disagree that hardware has reached a plateau. The fundamental limit on the size of the computer chip has yet to be reached, and speed increases as chips are made smaller. Every two years the price performance of memory quadruples, and there’s no end in sight,” Ghazey says.

“Hardware and software are always leapfrogging each other,” observes Wade Howie, marketing support manager of Alias Research. “When 32-bit processors first came out it took some time for programmers to catch up and write software that took advantage of that power. Now we’re at a stage where hardware will have to take a major step again. But this does give the software people a chance to consolidate the products they’re working on.

“The key to hardware and software updates is speed. If you can run things faster you can simplify what are really complex tasks for the user. Creative people need access to this power, and the more speed a system has the more transparent it is,” Howie says, touching on a crucial aspect of all paint systems.

Transparency improves with the speed of the computer driving the system, the quicker it responds to the artist using it, the better. The goal is for the artist to feel that he is using traditional methods, and not a computer. The more user-friendly a system’s architecture, the more the artist’s influence—as opposed to the machine’s—will be seen in the finished product.

“I’ve used other systems, and I feel that the Quantel Paintbox is just about the best one for an artist,” says graphic artist Deanna Provencher, of KTLA, in Los Angeles. “You don’t have to be an en-



ARTSTAR
presents ...

... a new workstation and high-speed local area network system ... the incredibly fast ARTSTAR is now even faster!



ARTSTAR 3D now features a new workstation designed to provide outstanding video graphics production and the ability to transfer multiple images via the popular Ethernet local area network system.

The possibilities are amazing: a cost-effective, high-speed, error-free method of accommodating multiple users on-line.

- Share data and images with other ARTSTAR systems
- Render images off-line, then send them to other workstations
- Paint images simultaneously and interactively
- Transfer finished graphics to laser disk—digital storage of 1,200 24-bit images on a single disk

And, ARTSTAR is the *only* combination 8, 24, and 32-bit high-resolution paint and 3D animation system available. This unique flexibility means you can actually merge 8 and 24-bit graphics into 32-bit images! Plus, an optional Motorola 68020 processor and array co-processor can *triple* system speed.

ARTSTAR has always been fast—it's always been powerful—it has become the price/performance system of choice among professional video graphics users. Now we've made the best even better—with *flash graphics* capability.

Circle 113 on Reader Service Card



actual raster photos

ARTSTAR
COLORGRAPHICS SYSTEMS INC.

DYNATECH Broadcast Group

6400 Enterprise Lane • Madison, Wisconsin 53719 • (608) 274-5786

Paint Systems

gineer to operate it. When you're airbrushing with the Paintbox, it feels like airbrushing. And there's no mess or fumes."

All quality paint systems should perform better and become easier to use proportionate to the amount of time spent with the system. As Provencher recalls, "Also, I do on-air promotions for the station's movies, programs, and sports, and I find that the more you work with Paintbox, the more things you discover you can do with it."

A changing picture

New features, such as animation, are expanding the range of what paint systems can do. But when integrated with other special effects devices, paint can do even more.

"We are the flagship station for the Pirates network, and we feed five other stations," explains Larry Komar, art director at KDKA-TV, in Pittsburgh. "We used our Aurora 220 videographics system to create all the ingredients of the opening graphics for Pirates baseball. It gives us a smooth, photographic look that is every bit as good as any network production, but for a fraction of the cost.

"This is the centennial year for the Pirates, and we've taken their logo and redone it with a woodgrain background. We did all the ingredients on the Aurora, and then we combined them in our one-inch room with ADO [Ampex Digital Optics] to tie it all together. We're still learning how to use the 220's optional 3D animation package, which we just received. It and the ADO will complement each other; production is always a challenge of finding the right machine to do the job.

"Other full-screen graphics for the show were also created on the Aurora, including the starting lineup, scouting report, and centennial trivia," Komar says. But KDKA's use of its paint system doesn't end with sports.

"In one case we've used the Aurora paint system to create a slick, video storyboard for a serious client who had never been on televi-

sion before. It showed him exactly what his ad would look like. We shot our own people in the station with a video camera, and then cut and pasted them into an imaginary office with the client logo displayed. When the storyboard was done it was dubbed onto VHS for the salesman to take to



Mitch Caster, KUSA-TV news artist, created this graphic to show how a disabled Air Force jet managed to land safely. Caster drew the picture with 3D Illustrator paint software on the station's BTS FGS 4000 animation system.

the client's office," Komar explains.

System approaches

Paint users can choose between standalone units, and those that are part of an integrated video computer graphic system. Quanta is developing its Dimension 32 graphics computer, which will offer software packages not only for paint, but also for 3D construction and animation and for character generation. That company is not alone in taking a systems-oriented approach.

"We're not primarily paint people," states Alias Research's Wade Howie. "Paint is integrated into our 3D modeler, and it rounds out the set of tools we provide the designer. We prefer the single-box solution for video computer graphics, instead of stringing several boxes together." The Alias/1 graphic design system is designed to accept future software upgrades, and is one of a new generation of machines that have been dubbed video workstations.

"I believe that the video graphics industry is at the same technological evolutionary point that the computer industry was at eight or

nine years ago," states Mark Gray, executive vice president of Pinnacle Systems. "Back then, if you went to buy a computer you'd either buy an accounting computer, or an engineering computer, or some other type. But then along came the PC, and it was revolutionary because now you could do more than one function in the same box, and people could program it themselves. That's what we're doing with our workstation concept."

Pinnacle's Video WorkStation is a multifunction, general-purpose video computer that starts with a model 2010 for digital effects. It becomes the 2020 with the addition of a still store via hardware and software upgrades. "The software is what gives the system its capabilities," Gray explains. "The technology exists to do more than one function in the same box. We can change a digital effects unit into a paint system by adding one board and a floppy disk." This—and a tablet and pen—turns the 2020 into the 2030, with 32-bit full-color paint system.

The Pinnacle Video WorkStation software-based architecture allows for on-site software upgrades. Modular design provides for future expansion via plug-in hardware upgrades and enhancements.

One very popular software-based paint system is BTS's 3D Illustrator, which can be added to their FGS 4000 animation system. Three-dimensional models of objects can be taken from the animation side of the system and placed into the 3D Illustrator, where paint functions can then be applied.

Television station KUSA, in Denver, recently took delivery on an FGS 4000. "I can't say enough good things about the system," says KUSA artist Eric Warp. "We're just setting it up. Over-the-shoulder is its main use now, but I plan to use it to revamp the station's entire look. We've all seen plenty of embossed backgrounds that stations have created with their paint systems, but I'm anxious to experiment with new techniques."

Only Canon Gives You

this...



and this...

and this!

J8 x 6 BIE: 6mm Wide, 96mm Telephoto, 11" M.O.D.!

Once again, superior Canon optical technology gives you greater flexibility and capability than ever before. The incredible Canon J8 x 6 BIE lens provides the wide-angle coverage you need in tight situations and its built-in 2X extender gives you 96mm—when you need to get closer.

Better still, even with the 2X extender, you can get as close as you want, since your M.O.D. is an amazing eleven inches, even at 96mm! The Canon J8 x 6BIE, it gives you more.

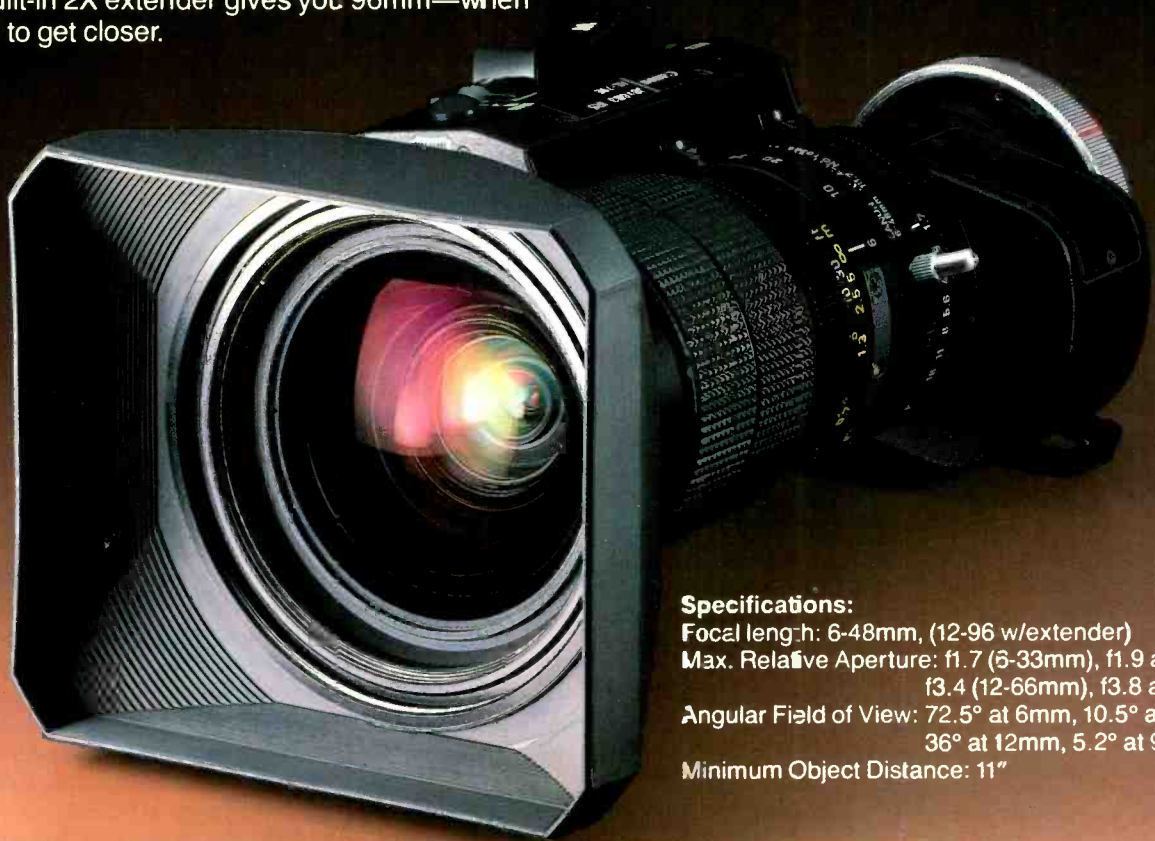

Specifications:

Focal length: 6-48mm, (12-96 w/extender)

Max. Relative Aperture: f1.7 (6-33mm), f1.9 at 48mm
f3.4 (12-66mm), f3.8 at 96mm

Angular Field of View: 72.5° at 6mm, 10.5° at 48mm
36° at 12mm, 5.2° at 96mm

Minimum Object Distance: 11"

Canon

Optics Division
Canon USA, Inc., Head Office: One Canon Plaza, Lake Success, NY 11042 (516) 488-6700
Dallas Office: 3200 Regent Blvd., Irving, TX 75063 (214) 830-9600
Chicago Office: 100 Park Blvd., Itasca, IL 60143 (312) 250-6200
West Coast Office: 123 Paularino Avenue East, Costa Mesa, CA 92626 (714) 979-6000
Canon Canada, Inc., 6390 Dixie Road, Mississauga, Ontario L5T 1P7, Canada (416) 678-2730
© 1986 Canon U.S.A., Inc.



Enjoy easy extended payments with the Canon Credit Card. Ask for details at participating Canon dealers and retailers.

Circle 114 on Reader Service Card

Paint Systems

"There should be a machine for every pocketbook and every desire," observes Jerry Tapley, sales manager of distributor sales at 3M Broadcast. "Larger facilities may not want multiple functions in one box because they run it all day, but other paint users may feel differently."

Tapley goes on to explain the importance of system configura-



KDKA's Komar scanned-in each picture element for this lineup card with an Aurora 220. Pirate player names and positions are generated on a Chyron IV; player pictures are inserted in the slate from an Abekas still store.

tion. "We took six different computers and made co-processors of them, with function cartridges for each capability that can all be plugged in at once. We call the unit the 3M Silver. The functions include font and logo generation, animation, still storage, a special effect generator, paint, and business graphics for charts and graphs. It's software-based and we feel that gives the unit a good lifespan. When feature improvements are on software you don't have to make capital investments every few years."

The painted set

Paint systems are being applied toward a variety of innovative uses, but perhaps one of the most interesting is happening at KMGH, in Denver. There, a new news set is being "built" not with wood and nails, but electronically with a Colorgraphics ArtStar 3D paint and animation system. Over 30 pictures of the set—one for every preset camera angle—are be-

ing drawn on the ArtStar 3D, and stored on a Quantel still store.

Talent, meanwhile, is positioned in designated areas in front of a seamless blue wall. The appropriate set backgrounds are then called up from the still store as they are needed, and integrated with live video of the newscasters through the use of the Newsmatte system.

The ArtStar 3D combines full paint and animation functions in one unit, and features both 8- and 24-bit graphics, which can be merged into 32-bit images. Like most other systems-oriented paint/animation products, ArtStar can be upgraded via software changes.

"Our ArtStar-drawn electronic set was conceived by Andrew Welsh, now with ABC/Capital Cities," explains Joe Negri, KMGH assistant advertising and promotions director. "It gives us a crisper, cleaner, high-tech, electronic, upbeat look. The set shows the Denver cityscape trimmed out as if you're looking out a window. It's framed in wood on all sides, with a gray felt material on the walls. All of the actual video frames are trimmed out in wood with a chrome-like polished insert of the station logo on the bottom. And because Newsmatte is a source feeding a camera—instead of a switcher—it allows you to do more effects, too."

Effects with the painted set include the ability for the anchor to intrude on an over-the-shoulder graphic without being cut out of the picture; in minidocumentaries this enables talent to actually "walk into" graphics. Floating boxes can be spontaneously inserted in the picture, allowing a newscaster to converse with a remote reporter. And flying letters playing on one-inch tape can be zoomed in behind the talent for various bumpers. Over-the-shoulder graphics are composited in the still store in advance.

"The set gives you more flexibility," Negri says. "It can be changed on a whim. If we want to create an election set, I merely take those backgrounds and make any adaptations I need to: put new signage on it, add stripes, and



DPS-185 Test Signal Generator

The DPS-185 meets the requirement of providing 32 selectable test signals on two independent channels at a reasonable price. Seven-segment digital displays permit easy recognition of the signals generated.

The DPS-185 is a price/performance breakthrough in a single, space-saving rack unit. This rugged, compact test generator simplifies maintenance, alignment and service procedures.

- Thirty-two test signals
- Two independent outputs per channel
- Seven auxiliary outputs
- Genlockable
- RS-170A specs
- Dedicated color black outputs

**Scientific
Atlanta**

Digital Video Systems Division

120 Middlefield Road, Scarborough, Ontario
Canada M1S 4M6 (416) 299-6888 Telex 065-25344

Circle 115 on Reader Service Card

then put it back in the still store. "The planning involved in the show is double the norm," Negri says, adding that the way the show is blocked has to be consistent from night to night because of the special format. Cameras are locked down, zooms are not possible, and the set images are backed up with tape and slides.

Print and praise

New uses continue to be discovered for paint systems, as more stations take delivery on these units. One use that further extends paint's applications even goes as far as the printing press. Paint-generated images and logos can be transferred to hard copy and be printed in newspapers and magazines, thereby rounding out station promotional campaigns.

"We're big on correlating print with on-air promotion, and getting a consistency there," says Lou Bortone, art director of WBZ, in Boston. A Quantel Paintbox user, Bortone feels that achieving the perfect print copy of a painted image is still an elusive task. "I haven't seen a really super system yet for capturing a print version of a videographic," he says, but feels that solving that problem is just a matter of time. Already, paint manufacturers are addressing this challenge. Quantel's high-resolution Graphic Paintbox, designed for the print industry, is one of several products that can solve the paint-to-print question. Chyron's Shimatronic graphic image system offers three different print options with increasing degrees of resolution and color.

"New equipment is coming down in cost, making it an exciting time for a local station," admits KDKA's Larry Komar, an Aurora and Colorgraphics user. "Paint has opened up a whole new world for our art department. Things that once went out of house aren't anymore, and we have better control over them.

"Paint allows your imagination to roam freely, but it's just a tool. The important thing is still the designer and his ideas. Executing them on a paint system is all part of the fun of broadcasting." BM/E

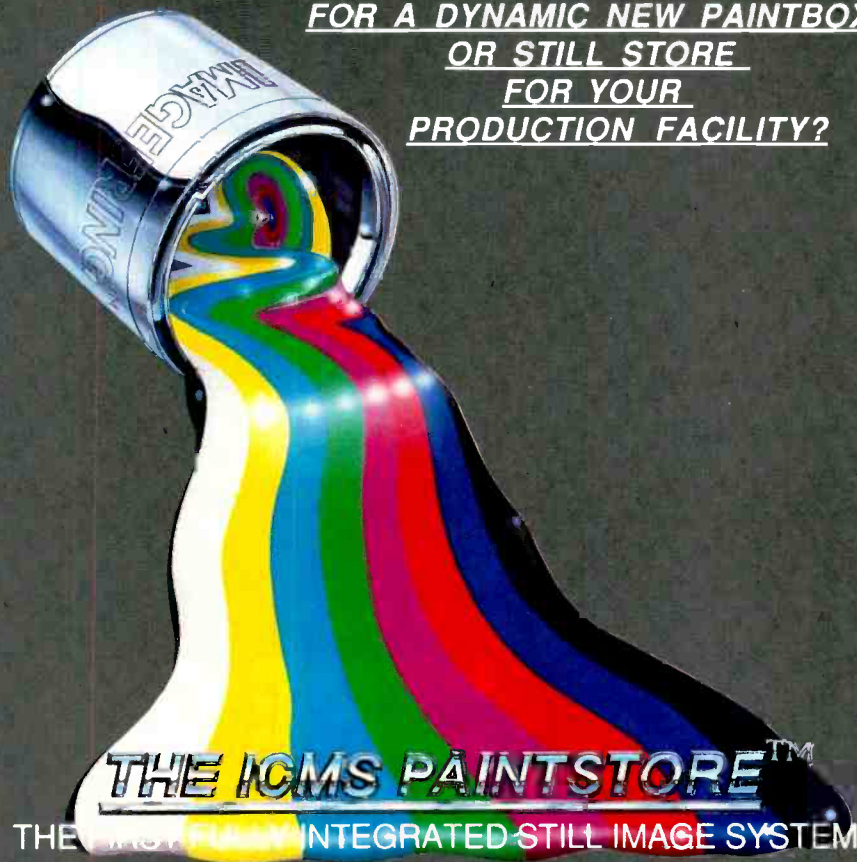

LOOKING
FOR A DYNAMIC NEW PAINTBOX
OR STILL STORE
FOR YOUR
PRODUCTION FACILITY?

THE ICMS PAINTSTORE™
THE FIRST FULLY INTEGRATED STILL IMAGE SYSTEM
THAT
LETS YOU CAPTURE, PAINT, COMPOSE AND DATABASE
THOUSANDS OF HIGH RESOLUTION DIGITAL
COLOR IMAGES

- Broadcast Quality, 600 line (6Mhz) performance
- Non-Volatile Sony Optical Disc Drive(s)
- Highest Capacity with 8000 Full Frames per removeable 12" Disc
- Flexible Dubner™ Paint, Cut/Paste, Forced perspective, Fonts Geometric primitives and many other Special effects.
- Practical, Plain English ImaMaster™ Software for single or Multi-user Image library management and access control
- Clear, expandable growth to millions of on-line color image
- Lowest cost system in a class by itself!

SEE
TOMORROW'S TECHNOLOGY MADE AFFORDABLE TODAY
AT THE PRO VIDEO EXPO
Los Angeles - May 20-22
Booth 118,120

IMAGEERING™



LASER DISK SYSTEMS, INC.
P.O. BOX 34755
MEMPHIS, TN 38134
1-(800) 922-4267
IN TN (901) 323-4762

Paint Store™, Image Master™ and ICMS™ are registered trademarks of Imageering Laser Disk Systems, Inc. USA
Dubner™ is a registered trademark of Dubner Computer Systems, Inc.

Circle 116 on Reader Service Card

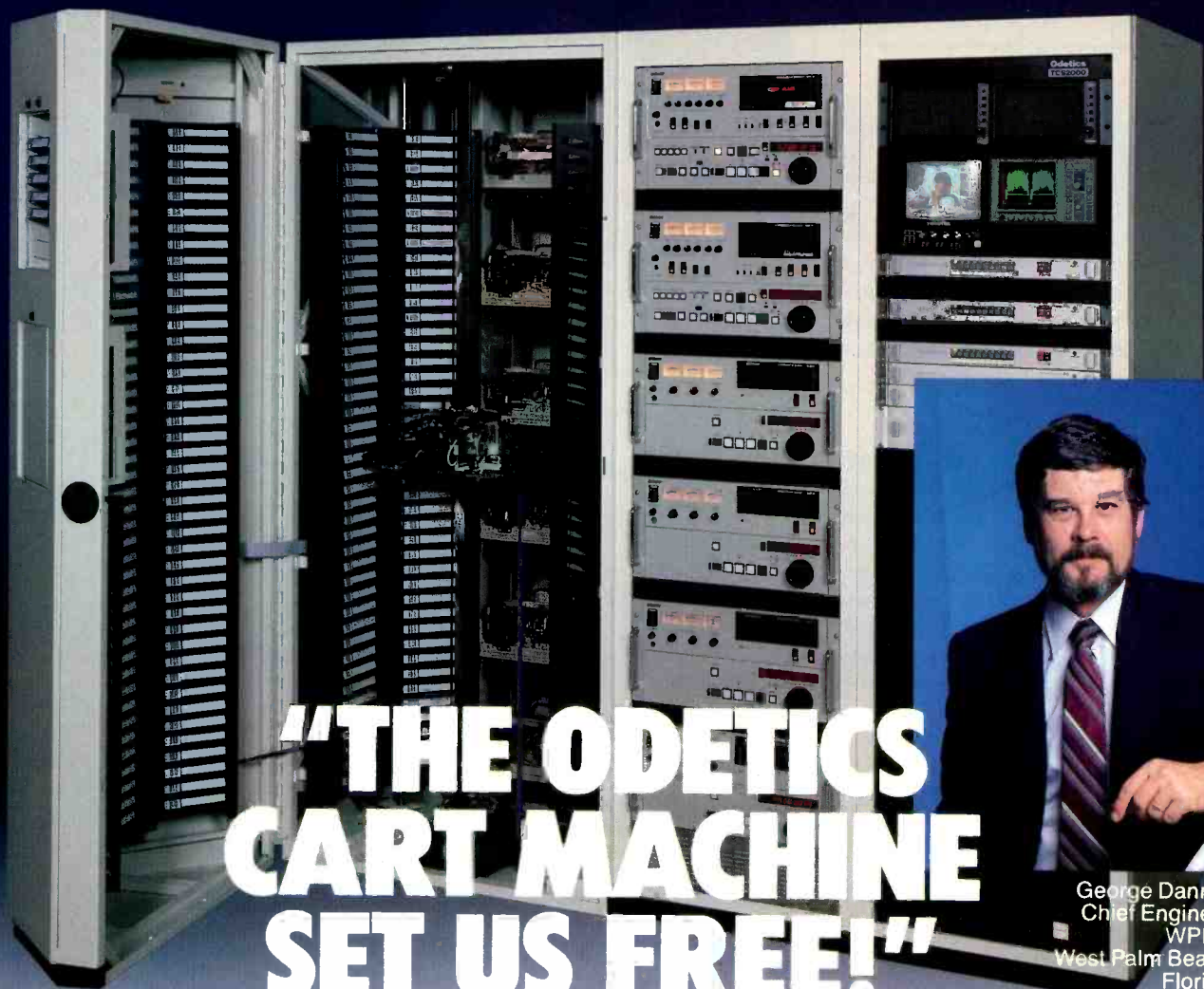

"THE ODETICS CART MACHINE SET US FREE!"

George Danner
Chief Engineer
WPEC
West Palm Beach
Florida

Now that the engineers at WPEC are free from the routine of continually handling carts, they have more time to be engineers.

As George explains:

"We air about 300 to 450 carts per 24 hour period. Before we installed the Odetics Cart Machine, our engineers had to devote a better part of their shift to filing carts and monitoring the programming system. With the Cart Machine working for us, we spend a lot less time handling carts. It means that for the first time we're free to keep a closer watch on station operations and attend to other responsibilities."

The Cart Machine can automatically manage, record and play-to-air all forms of spots and programs. Besides reducing cart handling time at WPEC, The Cart Machine's reliability allows the station to operate without dub reels. The Cart Machine even makes it simple to air the new 10 and 15 second spots.

Transfer of the daily program schedules from the traffic department is smoother because the Cart Machine interfaces with traffic computers and automatically downloads the schedules. Armed with a 65,000 cart database and 1,600 event look-ahead feature, The Cart Machine can automatically preplan spot play lists hours or even days in advance of airing.

The Cart Machine is available in your choice of small formats.

Call now and start streamlining your station operations with The Cart Machine.

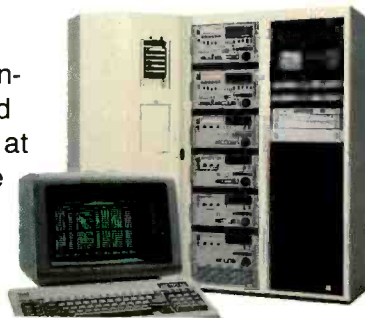

The Cart Machine from Odetics

1515 S. Manchester Ave.
Anaheim, CA 92802-2907

Call toll free 800-243-2001
In California call 800-238-4422
or 714-774-2200

2D, 2.5D,

3D: WHEN IS ENOUGH ENOUGH

?

Though there is a lot of interest in 3D graphics at TV stations, plenty of systems to choose from, and excellent reports from stations that have installed 3D, many are taking a wait-and-see attitude before rushing out to buy.

by Robert Rivlin

When you go to a show such as NAB and see all the interest in 3D graphics products, there's a tendency to get caught up in the excitement. "Every TV station in the country is going to have 3D soon" becomes the assumption. "I'd better get one right away."

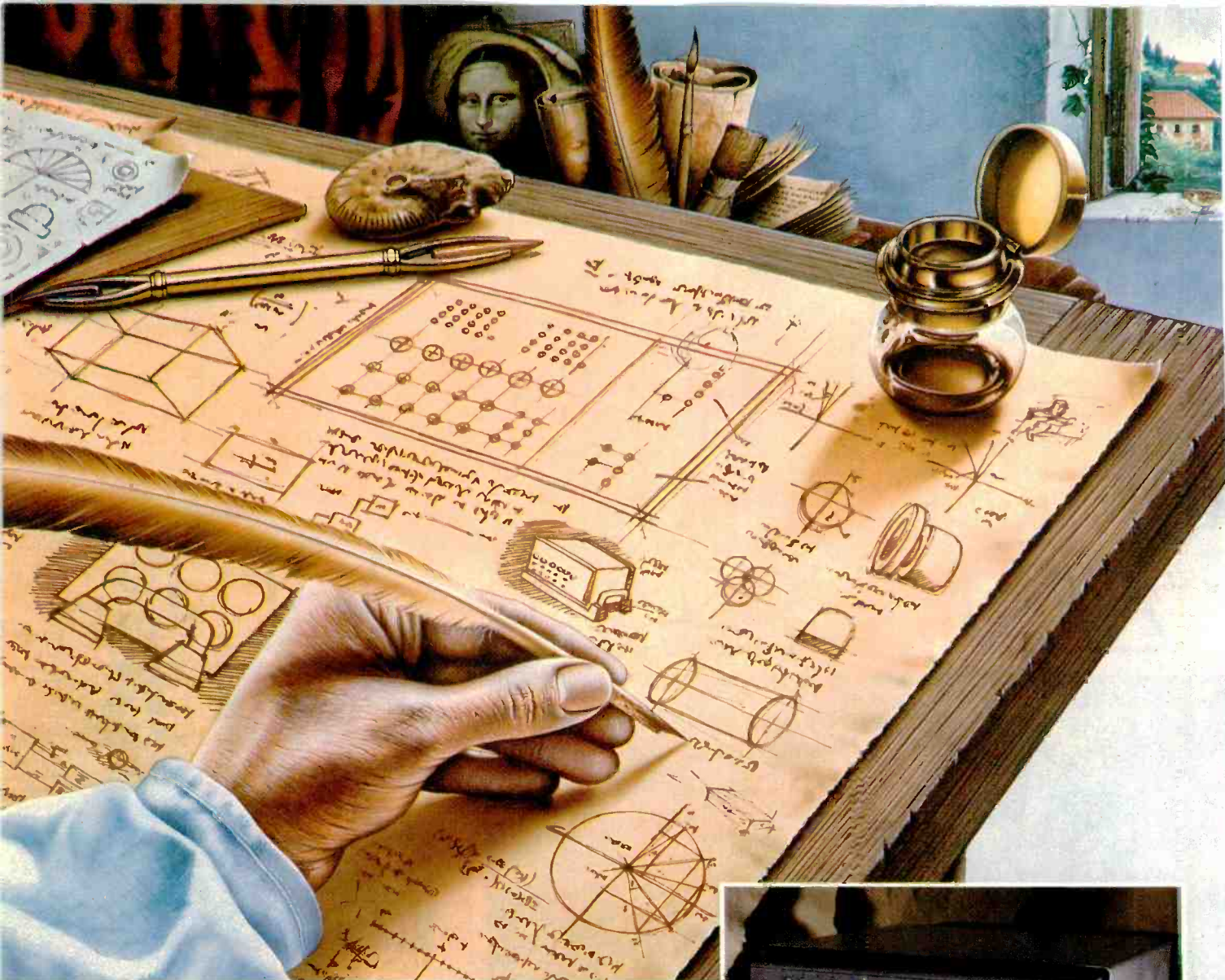

A NEW MASTERPIECE IN STANDARDS CONVERTERS IS OFF THE DRAWING BOARD AND READY FOR ACTION.

It's the revolutionary AVS ADAC—the new criteria against which all standard converters will now be measured.

It's a completely integrated design concept—a combination of advanced circuit design and the very latest component technology.

It's the only converter in existence with dynamic motion interpolation—constantly analyzing and adjusting every picture point to optimize quality of motion and provide transparent conversion.

The result is a true masterpiece of engineering innovation.



- Produces full broadcast quality
- Operates for all broadcast standards— including RGB, YUV (YIQ) and 4:2:2 digital— and all video formats
- The most sophisticated motion adaptive interpolation system ever devised
- Adaptive digital comb filter decoder
- Remarkably only 10½" high
- Exclusive sales and service in the U.S.A. by AFA



A.F. ASSOCIATES INC.

ADVANCED SYSTEMS AND PRODUCTS FOR THE VIDEO INDUSTRY

100 STONEHURST COURT NORTHVALE NJ 07647 (201) 767-1000

IN THE WEST: 10650 SCRIPPS RANCH BLVD. SUITE 200 SAN DIEGO, CA (619) 530-2970

Circle 118 on Reader Service Card



KVVU, Las Vegas TV5's logo is seen here created in 3D on an Aurora Systems AU/220.

When you look at the actual installed base of systems in the marketplace, however, and examine "plan-to-buy" figures, sobering reality sets in. According to the figures published by Sheer/DC&A Research as part of its most recent Broadcast Equipment Marketplace (BEM-2) study, only 21 commercial TV stations in the U.S. currently own 3D modeling and animation systems (ranging from the lower-end Ampex/Cubicomp product to the higher-end Bosch FGS-4000). And in 1987, only 26 more stations say they want to buy this kind of equipment.

Thus, while the rest of the market for graphics products—including paint, production switchers and digital effects—continues to be one of the hot growth areas in broadcast, 3D systems are still lagging behind. And while 3D is one of the major equipment trends at post-production facilities, local TV stations aren't that anxious to get involved yet.

Why? Industry analysts point to several factors. Perhaps the most fundamental reason is that 3D systems capable of doing the kind of work required by a television station have only been on the market for a very short time, and station graphics and engineering people are just becoming aware of their existence. Until two years ago, three-dimensional modeling

and animation were almost exclusively the domain of specialized computer graphics production companies, which did work such as image campaigns on a project-by-project basis.

That 3D systems have not yet caught hold of the popular imagination, or the budget lines, of local stations may simply be a matter of time. After all, in the early days of paint programs, when they were first starting to become affordable, few would have predicted that they would one day become a "must have" item.

Still another factor contributing to stations' "wait-and-see" attitude is the question "when is enough enough?" Many have only just recently made the commitment to 2D electronic paint. Indeed, at last year's Broadcast Designers Association conference in Dallas, out of an audience of hundreds of TV station art directors and promotion people asked if they had a paint system, only a few raised their hands. Stations are just beginning to realize the potential of their systems, including the ability of some of them to do "2 1/2D" or "pseudo-3D"—achieving the look of three-dimensionality by extruding two-dimensional objects (they cannot, of course, be rotated in 3-space, nor texture mapped or illuminated with imaginary light sources).

Learning new skills

Then, too, there is a potential "artist problem." Working with a 3D system demands a whole lot more of the station artist than simply learning a new piece of hardware: thinking in 3D means a complete reorientation of artistic sensibility. "You're taking a graphics artist, used to working in flat planes, and suddenly putting a piece of marble in front of him and saying 'sculpt'," explains one art director. "Not only does he suddenly have to think in three dimensions, but he then has to move the object around the screen—choreograph it. Some people are comfortable working in 3D animation . . . but some just aren't. And finding the right person to make the system do what the demo tapes say it can may be harder than you think."

Finally there's the question of "Is it worth it?" In one story, an art director working in media created a gorgeous, copper-metallic logo for a new high-tech magazine. It appeared to have been done with computer graphics, using reflection mapping, perhaps a fractal surface program, and certainly some advanced modeling techniques. How was the logo actually created? He had bought a piece of copper, taken it out into his back yard, and photographed it. He then took the color print and cut out the shapes of the letters in the logo.

Cost factors

As many arguments as there are against widespread use of 3D in broadcast television, however,



WNYC in New York uses this 3D logo created on the Bosch FGS 4500.

TWICE THE PERFORMANCE. HALF THE COST.

Mycro-Tek's Supra Star I and Supra Edit, Now Just

\$5995

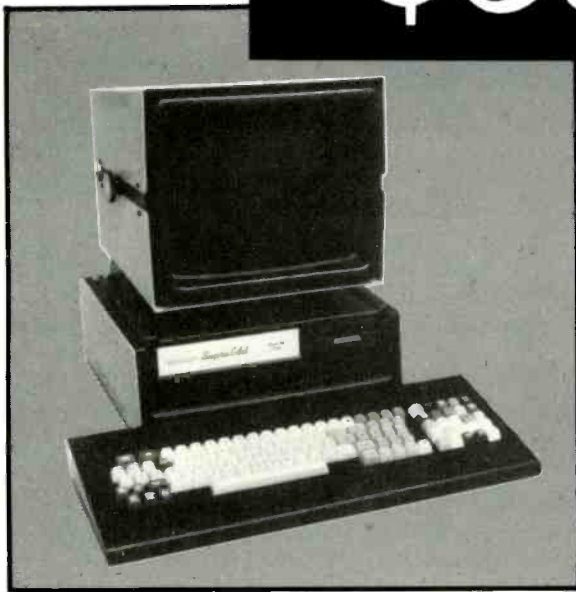

Supra Edit

- **MEMORY**-3½" micro drive with 720K (12,000 • pages) accessible memory storage
- **EDITING**-Complete off-line text editing
- **MONITOR AND KEYBOARD**
- **REMOTE CAPABILITY**-with modem

Now for a limited time, double your character generator capabilities at half the cost ... Buy two units for less than the price of one — only **\$5995**. Call Mycro-Tek today.

For extra channel add \$1000. Fonts may be limited by memory capacity of dual channel unit.

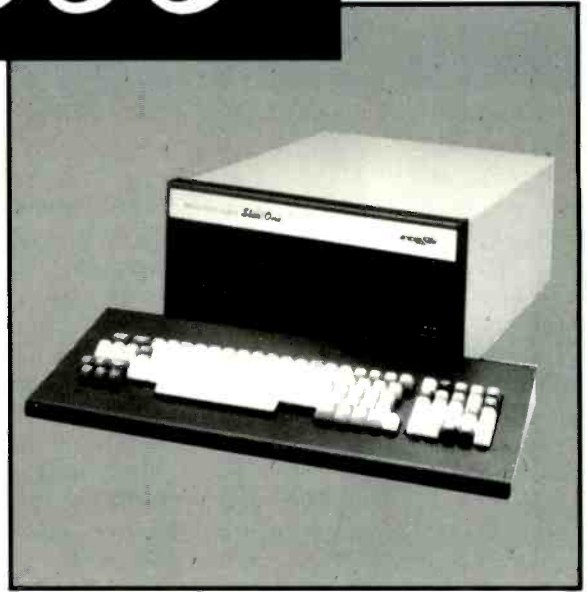

Supra Star I

- **10 FONTS**-8 regular plus 2 graphic • Upper and lower case • Double height and double width • PLUS a production font that's 33% larger
- **13 COLORS**-Line by line • Page by page • Character by character • Foreground and background
- **REAL TIME**-Random Access • Programming with 64K storage (500 pages)
- **GENLOCK**
- **WIRE SERVICE**-Weather and communication in/out option
- **KEYBOARD**

Magnificent Machines from

MYCROTEK

9229 East 37th St. North • Wichita, KS 67226 • Call Toll Free 800-835-2055 • In Kansas (316) 681-0550

Circle 119 on Reader Service Card

ATTENTION USERS OF GRAPHICS AND SPECIAL EFFECTS EQUIPMENT

Please take a moment to fill out the form below so we can plan even better coverage of graphics and special effects in the future.

1. Indicate your status on the following pieces of graphics/effects equipment; use the boxes to indicate the type of equipment you have now or intend to buy.

	Have now/ on order	Intend to buy		
		within 6 mos.	within 9 mos.	within 12 mos.
Art/Paint system under \$30,000	<input type="checkbox"/>	<input type="checkbox"/>	<input type="checkbox"/>	<input type="checkbox"/>
Art/Paint system over \$30,000	<input type="checkbox"/>	<input type="checkbox"/>	<input type="checkbox"/>	<input type="checkbox"/>
3D modeling system under \$30,000	<input type="checkbox"/>	<input type="checkbox"/>	<input type="checkbox"/>	<input type="checkbox"/>
3D modeling system over \$30,000	<input type="checkbox"/>	<input type="checkbox"/>	<input type="checkbox"/>	<input type="checkbox"/>
Digital effects—1 channel	<input type="checkbox"/>	<input type="checkbox"/>	<input type="checkbox"/>	<input type="checkbox"/>
2 channels	<input type="checkbox"/>	<input type="checkbox"/>	<input type="checkbox"/>	<input type="checkbox"/>
3+ channels	<input type="checkbox"/>	<input type="checkbox"/>	<input type="checkbox"/>	<input type="checkbox"/>
Effects rotation and perspective	<input type="checkbox"/>	<input type="checkbox"/>	<input type="checkbox"/>	<input type="checkbox"/>
3D image manipulator	<input type="checkbox"/>	<input type="checkbox"/>	<input type="checkbox"/>	<input type="checkbox"/>
Digital still store	<input type="checkbox"/>	<input type="checkbox"/>	<input type="checkbox"/>	<input type="checkbox"/>
Digital animation recorder	<input type="checkbox"/>	<input type="checkbox"/>	<input type="checkbox"/>	<input type="checkbox"/>
VTR animation recorder	<input type="checkbox"/>	<input type="checkbox"/>	<input type="checkbox"/>	<input type="checkbox"/>
Analog effects package	<input type="checkbox"/>	<input type="checkbox"/>	<input type="checkbox"/>	<input type="checkbox"/>
Character generator w/graphics	<input type="checkbox"/>	<input type="checkbox"/>	<input type="checkbox"/>	<input type="checkbox"/>
Text-only character generator	<input type="checkbox"/>	<input type="checkbox"/>	<input type="checkbox"/>	<input type="checkbox"/>
Weather graphics system	<input type="checkbox"/>	<input type="checkbox"/>	<input type="checkbox"/>	<input type="checkbox"/>
Typography-grade graphics system	<input type="checkbox"/>	<input type="checkbox"/>	<input type="checkbox"/>	<input type="checkbox"/>
Election package	<input type="checkbox"/>	<input type="checkbox"/>	<input type="checkbox"/>	<input type="checkbox"/>

2a. Do you have a separate graphics production department? Yes No

b. If yes, does this department serve all graphics needs within the station?
 Yes No

3. What departments have individual graphics capabilities?

- News Programming Creative Services/Sales
 Weather Promotion

4. Do you anticipate a need for a graphics system which produces:

- hard copy slides color prints

5. Where do you work?

- TV station Radio network
 TV network Production company
 Radio station Post-production facility
 Other (specify) _____

6. What is your job function?

- Chief Engineer Operations Manager Other (specify) _____
 Production Manager Graphics Director _____
 Engineer General Manager _____

7. What is your responsibility?

- Use the equipment? Make buying suggestions?
 Make buying decisions? Evaluate equipment?

NAME AND TITLE _____

STATION OR COMPANY _____

ADDRESS _____

CITY, STATE, ZIP _____

PHONE () _____

MAIL BEFORE JUNE 15, 1987

Fold here and staple closed. Thank you for your cooperation.

GRAPHICS AND SPECIAL EFFECTS SURVEY



GRAPHICS AND SPECIAL EFFECTS SURVEY

MAIL BEFORE JUNE 15, 1987

Fold here and staple bottom.



NO POSTAGE
NECESSARY
IF MAILED
IN THE
UNITED STATES

BUSINESS REPLY MAIL
FIRST CLASS PERMIT NO. 6377 NEW YORK, N.Y.

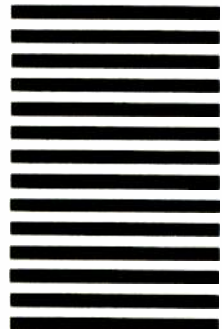

BROADCAST MANAGEMENT/ENGINEERING
295 Madison Avenue
New York, New York 10164-0008



there is a growing sense among station graphics people that, despite the excuses and the research projections, 3D is about to take off. Among the stations that already do have 3D, there are nothing but rave reviews for what the extra dimension can do to a station's graphics image.

"I'm no expert," says Brent Garrett, art director at WTVX, Ft. Pierce, Florida. "But I think that in a year or two we're going to see a 50 percent increase in the number of these systems around. Artists are going to begin demanding them, and stations are going to have to buy 3D in order to stay competitive within the market."

Another factor Garrett sees as critical to the widespread adoption of these systems is their continually decreasing cost. "In a market this size [WTVX's ADI is in the mid-50s]", Garrett explains, "there's a rule of thumb that a station can take a gamble with a piece of equipment that costs \$30,000 to \$40,000. That means that if it doesn't get used enough or doesn't add much or doesn't get noticed by anyone, the station still isn't going to lose its shirt. Right now 3D systems begin around \$40,000—that's what we spent for our ITI Ani-Maker. But when that price drops a bit, below the \$30,000 level, then you'll see stations jumping in."

Joe Negri, art director and assistant promotion manager at KMGH, Denver, agrees about the all-important factor of cost: "When electronic paint systems first came out, you couldn't touch one for under \$100,000, and that locked out just about everyone below the 40th market. But that's beginning to change now. You can get a good paint system for \$75,000. And then next year, when you want to add 3D, you only have to cost-justify a \$20,000 software upgrade rather than having to add a completely new hardware and software system. That makes a big difference in selling 3D capability to management. They can get so much more for so little these days."

Negri is convinced that because of this, 3D is going to catch on

even faster than paint—despite what the research says. "You can simulate 3D," he says, "but when you've really got 3D capability it opens up a whole new world—especially for opens and closes and packages for promotions. It adds a new facet to production."

Different applications

Each station in each market is probably going to have a slightly different set of applications for a 3D system. And, depending on its needs, the resource will be allocated differently among news, production (including news and local program work), and promotion.

At KUSA in Denver, a BTS FGS-4000 was purchased recently primarily for illustrating news stories, both with 3D stills and 3D animation. According to Don Perez, the real-time capabilities of the 4000 will enable the station to turn around animated news graphics with almost the same speed as still images. In addition, however, the production department will also be able to make use of the machine for designing opens, bumps, IDs, and the like, permitting the station to achieve a unified graphics look between the news and promotion efforts. When time is available, the system will also be made available to the production department where painting and 3D services will be offered to outside clients.

At WOWT, Omaha, art director Craig Brehm heads up a one-person graphics department based around an Ampex/Cubicomp PictureMaker. The system was originally purchased two years ago for news applications, an effort spearheaded by art director Judy Rosenfeld at KRON in San Francisco, Chronicle Broadcasting's flagship. Since WOWT's news department wasn't using one-inch machines, however, and to get the best quality results, the PictureMaker was tied into a one-inch machine in the production department. From a work-flow standpoint, this did not create problems, since the machine could be left to render frames unattended at night or in the early

morning when production had no need for the machine.

A more severe problem, however, rested in the demands made by the production department on the PictureMaker itself. "I used to do some work for station promotion and local commercial production as well as news," Brehm explains. "I'm still a one-man department, and my primary responsibility is the news. When you work for news, you have to get involved—you have to be available every minute of every working day. Production projects can take a week to put together, and you have to drop them in favor of news if you have to."

Perhaps this is why the station appears to sell commercial clients on PictureMaker animation, and why Brehm's art department is finally getting a one-inch VTR of its own. At the same time, the PictureMaker's capabilities have been expanded considerably with the addition of a full-color paint package, plus the new flash digitizer allowing fonts and logos to be captured and treated as three-dimensional objects.

How is Brehm using the PictureMaker for news? "It has to be for material we know about a day or two in advance—such as for special series, documentaries, and the like. Or for generic backgrounds and objects."

Brehm cites as an example a recent documentary about drugs in the schools. The anchor is portrayed in various dramatic situations, such as walking over to a brick wall where the show's title appears as if painted from a three-dimensional spray can. In another segment, a marijuana leaf is shown growing, then rolling itself into a joint; this is followed by a three-dimensional chart showing the various constituents of pot.

"Right now," explains Brehm, "I spend an average of five hours a day doing modeling and animation. It may only take me 30 minutes to an hour to design the piece. But rendering it may take one to six hours. I try to limit designs to make them more simple, and it's perfectly possible to turn out a 3D animation on a next-day basis."

3D Graphics

We could even do something in eight hours if we had to. But we don't see using it as a tool for the daily crunch of news graphics."

Not for day-to-day news

Lewin Humphrey, graphics and design director at WTVE, Nashville, agrees that in most cases, 3D animation for day-to-day graphics just isn't practical. "The low-end animation systems aren't fast enough," he notes. "They're fine for a logo to be used in newscast, or for a news series where we have a week's deadline, or for formatted news report such as 'Nashville Business' where we can just drop the latest figures into animation material that has already been designed and figured out. But these systems really can't do the work within the time frame demanded by day-to-day news operations. It's just not cost-effective to run the system for doing quickie graphics."

On the other hand, Humphrey is convinced that TV graphics are becoming very commonplace, and could use a little animation. That's why at the recent NAB he purchased a Colorgraphics Artstar and an Artstar 3D, and will incorporate it as part of a graphics suite that will also include a Chyron 4200 and may include an Ampex ADO as well as a small production switcher.

"First and foremost we were shopping for 2D paint systems," Humphrey notes. "But during the search period, we had two 3D animation projects that were being worked on by outside production companies that just didn't work out. That was when we began to look at ways of doing the projects in-house with our own equipment—so we could experiment and make changes without paying a fortune."

Humphrey calculates that the department's work is evenly split between news and promotion—and that they are often using the same material, such as an opening for a news series that can also be used to promote the series. The department also provides a wealth of other station graphics, including holiday messages, four-

Manufacturer	System	Workstation	Base price
Alias Research	Alias/1	3130	\$99,500
Ampex/Cubicomp	PictureMaker	AT	50,000
Aurora	AU/220	AT	68,000
	AU/280	Sun 3	160,000
BTS (Bosch)	FGS-4500	Sun 3	150,000
Chyron (Shima Seiki)	SDS-480	prop	170,000
ColorGraphics	Artstar 3D	Cromemco	115,000
Digital Arts	DGS-1 0	AT	35,000
Dubner	CBG-2LX	prop	115,000
Texta	500	prop	79,000
Integrated Technologies (ITI)	Ani-Maker	AT	40,000
3M	Specter	3130	150,000
Pinnacle Systems	3000 Series	prop.	39,500
Quanta	Dimension 32	prop	69,995
Symbolics		Symbolics	144,000
Vertigo	V-2000 Series	vanes	128,000
Wavefront Technologies		3130	145,000

3D Systems Abound

Whatever the reason that 3D is not taking off quite as fast as many had hoped it would, it is certainly not because of a lack of modeling and animation systems to choose from. Here is a brief summary of currently available 3D systems with an indication of the type of workstation and general price range involved. Some systems, it should be noted, come already equipped with a paint package as part of the basic configuration while others require the addition of a separate module.

second image IDs, show opens, and bumps for the station's extensive local programming efforts, as well as day-to-day news graphics.

Brent Garrett at WTVX is of a like mind: the majority of the station's 3D work, done with a recently purchased ITI AniMaker—will be for outside commercial clients, then promotion, then news—for opens and closes, generic art and backgrounds, and perhaps eventually series work, but not for day-to-day graphics.

"We've been going outside for station logos until now," he notes, "but I expect we'll be able to do most of that work in-house now. But the majority of our news

graphics will be done with a paint program, and fed to our ADDA still store through a Microtime Genesis 1 digital effects system and a production switcher." Animation, of course, is recorded on tape and rolled to air through the switcher.

Faster speeds

Stations that have bought more expensive 3D workstation systems might disagree with Brehm's assessment of whether graphics can be turned around quickly enough for the evening news. This is because the more costly systems produce rendered frames at greater speeds.

Another solution is that used by Joe Negri at KMGH: use the 3D system to create highly refined three-dimensional stills; or else produce animations by using short 16-frame loops in which the action is repeated, rather than rendering each frame of a sequence separately.

"We had a particular problem," explains Negri, who was initially called in to beef up KMGH's graphics to help overcome a sagging ratings problem. "We wanted to be able to create realistic-looking objects for reporting on stories such as the space shuttle, aircraft hijackings, and the like. And we wanted to be able to do three-dimensional logos. Plus we wanted a system that would also allow us to provide the three-dimensional shapes with the kind of variety that can be achieved through texture mapping—projecting a two-dimensional image onto the three-dimensional surface.

"For example, we had a story about a school-bus falling off a bridge. We wanted to actually show it happening—in 3D—not just a pretty painted picture. Three-dimensional graphics really helps the public understand what you're trying to portray."

Negri estimates that 80 percent of his department's work is for news, and that 30 to 40 percent of the work is currently devoted to 3D. Typical creation time for a "quick" graphic—the kind designed to be squeezed into a box



The only Painter that can display these kinds of graphics.

Dubner's DPS-1 Painter can store, paint and manipulate a frame of real video. All this and more for \$20,000.

Designed to meet the needs of broadcast, teleproduction, corporate and industrial users, the Painter also features: anti-aliased brushes, fonts and stencils; color and contrast correction; air,

solid, wash, fuzz, averaging, chalk, chrome, pattern and correcting brushes in 32 sizes with 100 transparency levels; millions of colors; X, Y, Z perspective mapping; 4-way color ramping; keying; posterizing; embossing; mosaic, magnify.

For more information on the DPS-1 Painter, call your authorized dealer.



DUBNER

DUBNER COMPUTER SYSTEMS, 6 Forest Avenue, Paramus, NJ 07652 USA (201) 845-8900 TWX 133-184 OFFICES: District of Columbia (301) 622-6313; Atlanta (404) 493-1255; Chicago (219) 264-0931; Minneapolis (612) 483-2594; Dallas/Fort Worth (817) 921-9411; Los Angeles (818) 999-2303; San Francisco (415) 968-6680. A Grass Valley Group Company.

(Top row, bottom left graphics) Courtesy of Advanced Video Services. Artist: Martin Pisano. (Bottom right graphic) Courtesy of TSC Video Post and Transfer. Artist: Randy Tede.

Circle 122 on Reader Service Card

and only used for one news story—is 30 to 40 minutes per still 3D graphic. For more polished graphics, designed to be used repeatedly or seen full-screen, Negri likes his artists to spend 1 to 1.5 hours per graphic. Located in the station's electronic design center (EDS), the ArtStar keeps two full-time artists busy on split shifts, and is running almost 24 hours a day between design work and rendering.

"Our main goal is to take care of news," Negri explains. But right behind that comes promotion and public affairs and special projects. The station produces 10 one-hour specials a year, and most of them require 3D animation. Plus we do extensive election coverage graphics on the system."

How does Negri decide which pieces will get the 3D treatment? "You design a product to be what you want it to look like not because you have a 3D system and want to put it to use. There has to

be a reason for using the 3D—something in the material that warrants it—if nothing more than simply giving the story extra depth or a different feel."

Selling a system to management

Given these reviews from stations beginning to experience the realities of 3D, is it likely they will catch on in the same way as paint? In some cases, the systems sell themselves—as was the case for Garrett at WTVX: "When we started looking it was for a weather graphics system—that had priority over the needs of the art department. But our news director went to the RTNDA show and saw that for the same amount of money we were going to spend on weather graphics alone we could get a full-blown graphics system. Our management people went to see the AniMaker and they were impressed—particularly with what it might do for our

commercial clients. So, without expecting it, I was presented with the ITI system."

In most instances, of course, management has to be sold on the idea of 3D. For some it will be a matter of increased station visibility and hopefully better ratings. "3D animation within news stories gets noticed and gets good response," notes WOWT's Brehm. "Animation in bumps gets seen, but it's the material in a reporter's package that gets noticed. Computer animation is still a mystery to the news department; but reporters are getting to know more about it and how to use it effectively."

Most often, however, a station is going to buy 3D because of bottom-line considerations. And here the reasons to rush out and buy a system are as plentiful as excuses to hold off. KMGH's Negri cites just one example: "We just created a brand-new open for our new four o'clock news show, and we did it in-house. It didn't happen overnight, and it wasn't without problems. But we did it—a job that would have cost \$10,000 to \$12,000 outside.

"It all comes down to a question of productivity. Using the electronic system we can produce twice as many graphics with the same people, and can make them look more and more sophisticated, more and more polished. Plus, we can redo things very quickly if they need changing or updating.

"Finally, there's the pure economics of the thing. In a couple of hours we can model and animate a client's logo so it never looked so good—\$5,000 to \$10,000 in outside production work that we can do right here, in front of his eyes. We look like heroes—who can argue with that?" **BM/E**

About the Author:

Robert Rivlin is president of Rivlin Communications, a Millwood, NY-based consulting firm specializing in video and computer graphics. He has been the editor of *BM/E* and *VideoPro* and technical editor of *Millimeter*.



Videotek's new "no-frills" waveform monitor keeps value-minded engineers happy.

Get back to basics with the new TSM 50, the most affordable 5" waveform monitor you're likely to find anywhere.

Right from the box, this economical, "no-frills" unit is ready to go to work. With two selectable inputs; switchable FLAT, IRE or CHROMA filtering and bandwidths up to 6 MHz for almost every application. It's built to be reliable and designed to get the job done right.

Don't pay for bells and whistles you don't need. See your Videotek dealer for the happy details today.

VIDEOTEK INC.
Designed for real needs.
Priced for real budgets.

243 Shoemaker Road, Pottstown, Pennsylvania 19464
(215) 327-2292 TWX 710-653-0125 FAX (215) 327-9295

Circle 121 on Reader Service Card

NEW The Standard Of The Industry...Townsend

Townsend Broadcast Systems stunned TV broadcasters with the unveiling of a totally new line of products at the 1987 NAB.

Not only new looks . . . but technology with a purpose . . . to improve the on-air performance of your station. Transmitters with on-board digital control with status panels to check overall operation at a glance. Video cart automation with foolproof controls for non-technical operators. All new products built with American technology and backed by 24 years of proven support.



TB-30TL 30 KW VHF Low Band Transmitter

Single tube type.
Triode simplicity.
Quick look status.
Memory of last 16 faults.
Redundancy throughout.
On-air reliability.



DC-80 Video Cart Automation System

Up to 24 transports.
Anti head-clog system.
Software controlled, with host computer.
Eliminates operator errors.
Improves on-air video and audio.
Stereo audio standard.

TOWNSEND

BROADCAST SYSTEMS INC.

79 Mainline Drive, Westfield, MA 01085
Tel. 413-568-9581 TELEX #710-356-1521

8222 Jamestown Dr., Suite C-131, Austin, TX 78758
Tel. 512-836-6011 or 800-252-9792
in Texas or 800-531-5232

There's a new gun in town. A highly automated, cutting edge studio camera called the Sony BVP-360. In shootouts, it's fast earning a reputation as a giant killer. Because it makes razor-sharp pictures that other cameras can't seem to beat.

For ammunition, it uses the remarkable Sony 2/3" Mixed Field tube. A result of Sony's industry-leading research in High Definition



Video Systems. A tube that delivers superior resolution, registration, and signal-to-noise ratios for the best picture quality in history.

For a look at the BVP-360, or better, a thorough evaluation, or better yet, an all-out shootout, contact your Sony Broadcast representative. Or call Sony at (201) 833-5231.



SONY
BROADCAST

Bang.



**NOW!
25 Inputs**

25 x 1 Video/Stereo Audio Switcher



DATATEK

Datatek's new D-4325 Video/Stereo Audio Switcher Features:

- Program line quality video and audio performance
- Two Video and two full performance audio outputs per channel
- Wide Video bandwidth; high audio output level capability
- Video cable equalizing and vertical interval video switching
- Only two rack units utilize optimum space
- Local or remote control panels provide unsurpassed flexibility—remote control over coax line
- RS-232/422 control standard
- Wire per crosspoint and binary parallel port control available
- All control arrangements are fully operable in parallel
- Expansion provisions are included

*For a descriptive
brochure and
further information
call or write:*

DATATEK
CORP.

1121 Bristol Road, Mountainside, NJ 07092
1-800-882-9100 • 201-654-8100 • TELEX 833-541

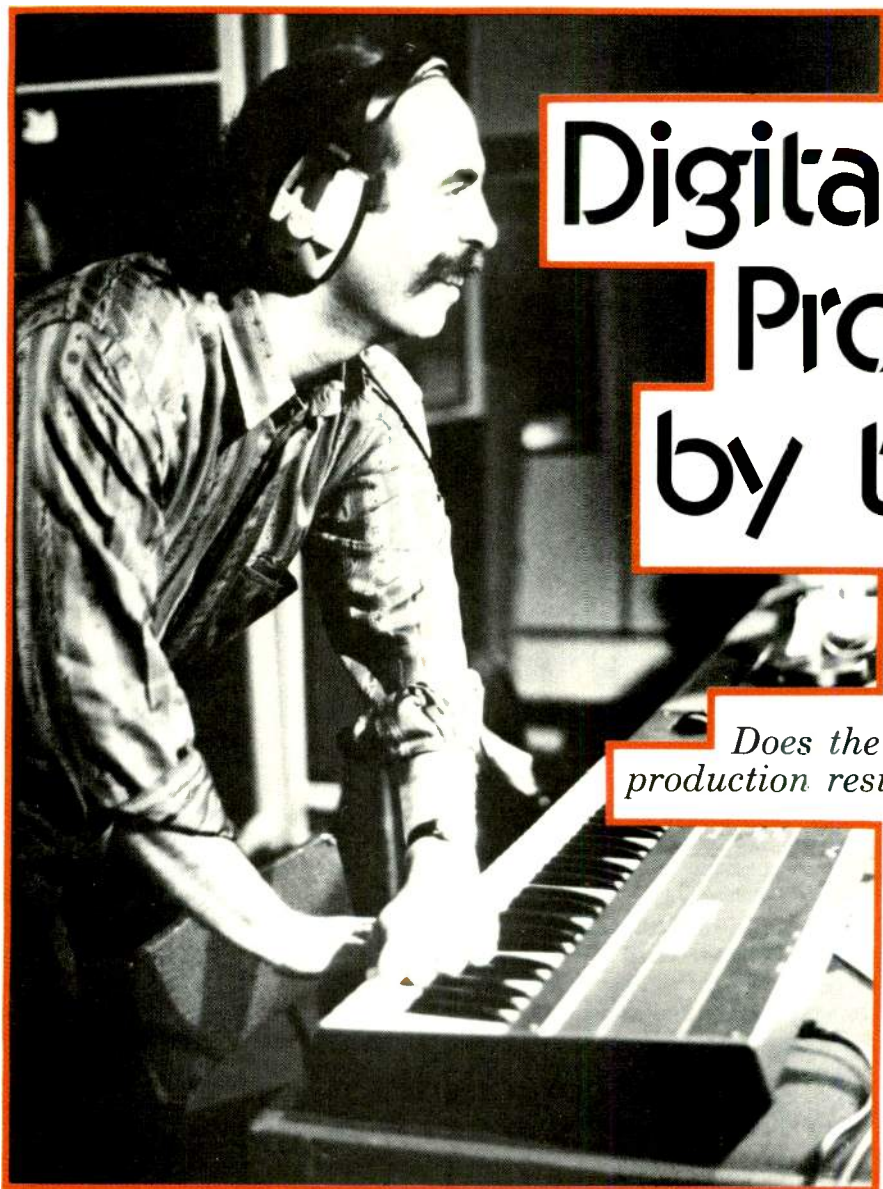

Digital Audio: Production by the Byte

Does the future of broadcast audio production reside in the digital domain?

By Steven Schwartz

WMMR zookeeper John DeBella triggering sound effects from his Mirage-DSK during a recent broadcast from London.

It's becoming increasingly clear that digital audio is more popular than ever in broadcasting. At last month's NAB show in Dallas, attendees gathered en masse for live demonstrations at the Fairlight and New England Digital (NED) booths. In simultaneous events, Jan Hammer displayed his audio-for-video compositional skills for *Miami Vice* on Fairlight's CMI (Computer Musical Instrument) Series III sound production system, while NED orchestrated a complete voiceover session with on-the-spot editing using the Direct-to-Disk recording option for its Synclavier digi-

tal audio system. At the same time, crowds filed into the Eventide, Lexicon, and Aphex booths to examine the latest digital effects processors.

Obviously, broadcasters—and radio personnel in particular—are beginning to realize the potential benefits of digital technology in audio production. In addition to providing the cleanest possible signals to work with, digital information affords unsurpassed flexibility and control throughout the production process.

Not surprisingly, recent interviews have indicated a sharp increase in the use of digital effects

processors, synthesizers, and CD libraries over the past year at radio production facilities. The trend is expected to continue, with several stations' production directors predicting a rise in future applications of MIDI (musical instrument digital interface), a standard for interfacing one or more electronic instruments with a personal computer or with each other.

"MIDI is the future of production in music, in radio—in everything," says James Rosenthal, production director at KKBQ-AM/FM in Houston. "It allows you to chain everything together. So,



Jon Taylor, production director at New York's KISS-FM, relaxing behind his Casio CZ-101 and Korg SQD-1 sequencer.

if you have five MIDI keyboards, you can run them off of separate channels and control everything with the computer. It lets you get things done faster and the way you want to get them done."

The use of digital instruments and effects processors in the broadcast environment also coincides with the recent emphasis on sophistication in the in-house production suite. It wasn't all that long ago that such installations were used exclusively for editing prerecorded material and simple commercial assignments from local advertisers; the majority of ads were placed by national advertisers and agencies that worked out of large recording studios. With the economic slump of the late seventies and early eighties, the ratio of radio advertising shifted from the national to the local market. Thus, a reliable production department became a valuable asset for stations looking to attract new business.

Moreover, the radio production suite is currently playing an increasingly active role in on-air programming, particularly with regard to promotional spots and "morning zoo" shows now featured on several stations around

the country.

Mirage at the zoo

Song parodies, skits, and humorous banter make up the basic ingredients of the morning zoo format. In Philadelphia, WMMR's morning zoo with "zookeeper" John DeBella is one of the city's most popular radio shows. A former production director, DeBella uses a Mirage-DSK (digital sampling keyboard) to reproduce a variety of sound effects live on the air. The instrument was presented to him about a year ago by his fans at the Ensoniq Corporation in nearby Malvern, PA, and is now his constant companion in the studio.

The Mirage-DSK uses digitally recorded waveforms of acoustic instruments and other sounds, which are stored on 3.5-inch diskettes; the disks can then be loaded into the keyboard via its built-in disk drive. The company currently offers more than 300 sounds, which are available in two 10-disk sets that sell for less than \$60 per set.

"I haven't even started to develop the extent to which I want to use it," says DeBella. "There's a way to program it to hold 18 dif-

ferent sounds. What I'd ultimately like to do is to put in a disc and have it eliminate 18 carts. I walk into the studio every morning with about 350 to 400 carts, so any way that I could cut down that load would make me very happy." He further notes that the station recently purchased a new sound effects library on CD, replacing an older library on analog LPs. "It was a smart move," DeBella remarks. "There ain't nothing worse than a phone ringing with a scratch on it."

In addition to the Mirage, WMMR's production director, Steve Lushbaugh, uses a Roland JX-10 digital synthesizer to create music beds for station promos and commercials. The JX-10 is a 12-voice polyphonic keyboard with 50 preset tones and 50 programmable settings. It combines digital and analog technologies by controlling the analog sound output with digital DCOs and envelope generators.

Lushbaugh uses the instrument with the optional Roland PG-800 programmer, which enables him to adjust the JX-10's parameters via the accessory's slide controls. "It brings all the parameter controls out to analog sliders and switchers," he explains. "So, I can sit here and look for a sound without having to know that putting such and such a number in on this parameter will cause this to change. It allows me to work really quickly. I can change three or four things with one hand that would have otherwise taken 30 or 40 keystrokes to change by pushing the buttons on the JX-10's front panel."

Meanwhile, DeBella points out that using digital instruments to create sound effects beds can be more economical than purchasing prerecorded packages that may cost as much as \$3000 per year for licensing. "It doesn't make a lot of sense to pay someone that kind of money for something that you can only use for a year, when, if you have someone with a little bit of musical talent, you can make your own for the same price and own them forever," he says.

The station has two four-track

production studios. Each is equipped with an Eventide H949 Harmonizer, an Otari MTR-12 four-track recorder, and two MTR-12 two-track machines. The newer room, which is used for most post-production assignments and creating all the music and special effects beds, features an Audiotronics 341 console with 16 inputs and six outputs; the older room, which is employed for less demanding tasks, employs a 12-channel McCurdy console with four independent outputs.

Although Lushbaugh has not yet employed MIDI in any production applications, he expects to start experimenting with it by the end of the year (he is in the process of shopping for a personal computer and drum machine). "Between the two synthesizers, a MIDI controller, and the multitracking capabilities we have here, we will be able to record some pretty sophisticated-sounding commercials and music beds," he says. "Unfortunately, it's getting to the point where four tracks is becoming inadequate. I can do most of what I want like that, but it's difficult on some things. I guess I shouldn't complain, though. After all, they did *Sgt. Pepper* on a four-track—and without SMPTE."

Making it with MIDI

In some cases, even eight tracks isn't enough. At Houston's KKBQ-AM/FM, production director James Rosenthal is getting ready to install MIDI patch cables through the walls of his studio that will enable him to use the station's Atari 520ST computer as a MIDI sequencer (with Music Studio software from Activision) for digital instruments that can be set up in another room.

Rosenthal has only recently started using MIDI on promo spots and sound effects beds, and claims that it will be at least another four months before everything is set up for full-scale production. Nevertheless, he has discovered that in addition to being able to compose, play, and edit



The ENG-4 Receiver is supplied with a small monitor earphone and a 1/4 wave antenna that mounts vertically or at a right angle.

It's a small wonder!

Big FOUR CHANNEL receiver and TWO CHANNEL transmitter packed into the smallest packages ever.

The system is designed for ENG broadcast and remote video production and operates in the VHF band between 165-216 MHz. There are 14 standard computer selected frequencies available from Telex. The receiver's simple rotary dial allows quick channel changes in the field. Spring-loaded battery compartment pops up so battery "sled" can be taken out and replaced instantly with a spare—reducing battery change downtime to just seconds. For more information on this "small wonder" write or call today.



ENG-4
Antenna can be mounted at a right angle

WT-400
is supplied with belt-pack carrying case not shown here

ENG-4

WT-400

TELEX®

TELEX COMMUNICATIONS, INC.
9600 Aldrich Ave. So., Minneapolis, MN 55420 □ (612) 887-5550

Audio Engineering & Production

Digital Audio

passages via computer, MIDI offers many other inherent advantages—including the ability to conserve tracks on a multitrack recorder.

"A lot of times I would MIDI through several tracks to play onto two tracks in stereo on our eight-track recorder," he says. "That way, what normally might have taken up six tracks, now only uses up two, and I still have six more tracks to use for effects or other instruments if I need them. It helps me push the equipment to its limits.

Rosenthal currently employs MIDI with two digital synthesizers, a Korg Poly 800B and Casio CZ-101. The Poly 800B is an 8-voice polyphonic keyboard with a built-in sequencer and variable tempo control, while the Casio features full programmability in a downsized package (see "Getting in synth" section below for product description). He also has another mini-key Casio SK-1 synthesizer that is not equipped for MIDI but does feature low-resolution, 1.4-second sampling at 9.3 kHz via an onboard mic, as well as 8 preset sounds, four-note polyphonic performance, and 11 synthetic drum rhythms.

For outboard effects processing, he uses an Eventide H969 Harmonizer, an Alesis digital reverb unit, and an Aphex Compellor limiter/compression device—which is used during the mixdown to two-track to keep everything at a consistent level. An Akai/IMC sampler is currently on order,

while a choice has yet to be made between the Roland TR-505 and Yamaha RX-15 MIDI-compatible drum machines. "It's going to be great," Rosenthal exclaims. "I'll be able to do all the cool effects—reversing, interpolation, flanging, comb filtering, rescaling, set sustain points. It's all available right now."

The majority of Rosenthal's production work is composed of song parodies and comedy routines for KKQB's morning zoo show (which is simulcast on AM and FM) and two nationally syndicated shows—*John Landers Hit Music U.S.A.* and *The National Comedy Network* with Dr. Dave Colin. The rest of the time is usually dedicated to creating promos and other station-related material.

KKQB has two production studios, one designed for eight-track recording and another for four-track assignments. The newer eight-track room—which Rosenthal uses for most of his work—features an Otari MX 70 eight-track recorder and a 24-channel Wheatstone SP-5 console with eight outputs, seven stereo inputs, and a selectable feature that allows the eight track returns to the board to double as instrument inputs.

Meanwhile, the four-track room has a 14-channel Ward-Beck console and an Otari MX 50-50 four-track recorder.

"I could do everything I do here on four-track," Rosenthal comments. "In fact, the four-track room is even better for things like

dubbing because everything is within reach and all the cart machines are right there. Having eight tracks to work with just makes things more convenient. But that's about as much as you'll ever need for standard radio production."

He has also recently begun using the digital audio capabilities of his Sony 8mm VCR from home for dumping audio tracks taken from television programs onto two-track for use on the station's Q-Zoo. "The sound quality is just so good that it would be ridiculous not to take advantage of it," he notes.

Another new addition at the studio is Firstcom's production music library on CD; Rosenthal also recommends the "Digital Director" series from Media General.

Still, Rosenthal's strongest endorsement of digital technology comes as a bit of a surprise. "I'm not a musician; I can't even sing," he confides. "But I listen and I know production. Mastering the equipment is the trick, once you've got that down you're set. And, with digital equipment, it's even harder to screw up. My rule of thumb for being a production director is to just be creative. If it sounds cool and hip—that's what's right. Follow your instincts."

Keys to the city

In addition to their application in "zoo" production, digital effects seem to go hand-in-hand with the high-tech sound of today's urban contemporary formats. At New York's KISS-FM, production director Jon Taylor uses an array of synthesizers and digital processors for a variety of tasks, from generating sound effects to creating original remixes of records (usually handled with a couple of turntables).

Taylor's digital arsenal—which was compiled within the past year—consists of two synthesizers, a Casio CZ-101 and a Roland Juno 106, which features a five-octave range, 128 memory settings, and sequencing capability; a Korg SQD-1 MIDI sequencer; two Eventide H969 Harmonizers; a Yamaha SPX90



Z100's J.R. Nelson in the station's production studio with his Roland Juno 106 above the console.

AL never met a tape he didn't like.

AL'S is an Automated Library System where all tapes are welcome. Beta, Beta SP, M, M2, U-matic or Digital 19mm formats -- you name it. AL'S can handle it. And in numbers enough to make even a station manager smile. 500, 1000, 1500. How big is your library? AL'S can handle it.

You want to mix formats? AL makes it up with the best of them. Any combination of tape formats is a piece of cake for AL. Full length programming or commercials -- you mix them up any way you want to. AL'S never been one to play favorites. AL'S will even play news tapes quickly along with all your others. *

AL is top drawer, high tech digital technology -- but he's no snob. Plain and simple, cut of the box, stock VTRs suit AL just fine. Why take a chance on prima donna machinery?

Why take a chance, period? Your tape library couldn't be in hands more capable than AL's.

For more information -- or, for an audience with AL himself, call us at (617) 244-6881. * Optional

**Automated
Library
System**
LaKart Division
287 Grove Street
Newton, MA 02116

LAKE
The Systems Company

Finally, day-long comfort and...

NEW

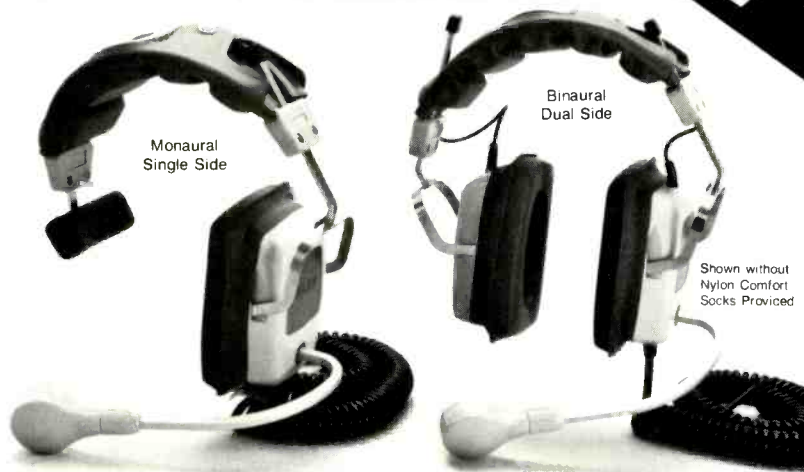

clear, two-way communications between camera and director.

This headset series is specifically designed to provide high quality communication through camera intercoms in television studios or remote locations. Telex camera headsets have sensitive carbon microphones with a smooth voice frequency range of 300 to 4500 Hz. They offer compatibility with Western Electric type intercom circuits and are available with or without push-to-talk switch for compatibility with most existing systems. The earphones contain high sensitivity magnetic receivers that can be easily removed and replaced in the field for convenience and economy.

Designed for comfort

All units are designed for long lasting durability and lightweight comfort that lasts throughout a long camera session. The headband and earphones have removable, soft foam filled pads covered in supple polyurethane that resists cracking even after years of constant use under hot studio lights or sunlight. The mike is housed on a boom that rotates on a swivel ball for full flexibility in positioning the mike to the mouth, while giving the user the option of wearing the headset with the mike on the right or left side of the head. Washable nylon earphone socks provide further comfort.



TELEX®

TELEX COMMUNICATIONS, INC.

9600 Aldrich Ave. So., Minneapolis, MN 55420 U.S.A., Telephone: 612-887-5550, 884-4051, telex 29-7053

Audio Engineering &

Digital Audio

digital multi-effects box; a Lexicon PCM-60 digital reverb; and an Aphex Compellor.

Unlike his contemporaries at WMMR and KKBQ, Taylor does not do a lot of straight music production, and hence, does not foresee MIDI playing a major role in his activities. "I use the synthesizers primarily to create sound effects," he says. "The Casio, in particular, is great for laser gun-type effects that are sort of in vogue now in hit radio. Occasionally, I might use the Korg sequencer for a repetitive pattern on simple electronic music beds for promos. But overall, the application of having to do something with music here is very, very limited. If I were creating 15- or 30-second music beds of original music that were fully orchestrated, I would probably want to get into some kind of MIDI recorder. But there really isn't any demand for it in this studio."

One of his recent projects involved spicing up an old promo for the station that featured a couple of people shouting "98.7 KISS-FM." After finding one of the station's DJs whose voice closely matched those on the recording, Taylor inserted the word "jammin'" in the beginning of the spot using the two Harmonizers to make the single voice sound like a chorus. "You run one of the Harmonizers up in pitch and the other one down," he explains, "and you get a sort of instant trio as soon as someone speaks or sings into it. Then you just overdub that a couple of times to make it sound like a whole crowd."

The station has two identical studios; one is used primarily for promo work, the other handles the more routine production assignments. Both rooms are equipped with 26-channel ABX-26 consoles from Pacific Recorders and Engineering, while all recording is done on MCI recorders (the station has a total of five quarter-inch two-track machines and two half-inch four-track decks). Taylor adds that most material is dubbed directly from four-track to cart using no noise reduction. However, to ensure maximum audio qual-

ity, the carts are run at 15 ips.

Taylor, too, now keeps an entire sound effects library on CD, compiled by the Toronto-based company Sound Ideas. Although he notes that CDs offer unparalleled convenience and sound quality, he complains that digitally mastered effects can sometimes sound "too realistic."

"That can really be a problem when you're trying to bring out an effect that can be instantly recognized," he says. "I'm frequently at a loss for finding things that are exaggerations of real sound effects, almost a comical sound. There isn't enough of that on some of the CDs I've heard."

In general, Taylor believes that the trend toward digital effects will continue to gain momentum among radio production directors. "I'm definitely hearing more of it on the air—and not just in the major markets," he observes. "I think it's because the equipment has become more plentiful and somewhat cheaper. I don't know the history of digital processing, but it seems like there's more of it going around. In fact, in the last year, I've seen a couple of companies spring up with people who just have big voices making a business on the side of putting out digitally reprocessed station IDs, which are really hot now. I think we're hearing fewer jingles on the air—which used to be all over the place—and a lot more of the dry voice-type promo with all kinds of fancy effects."

Meanwhile, J.R. Nelson, production director at New York's WHTZ-FM (Z100), sees the situation in a similar vein. "It's just a matter of coming into the eighties," he says, "although it's sometimes difficult to convince people that these aren't just little things that Howard Jones uses to accompany himself. These are actual tools that can make your life a lot easier."

In addition to his duties at the station (which include working on Z100's successful morning zoo show with DJ Scott Shannon and the nationally syndicated "Rock-in' America" series), Nelson operates his own syndication com-

pany as well as a small MIDI-controlled studio in St. Petersburg, FL, that creates IDs, sweepers, and promos for about 20 radio stations and serves as a showcase facility for Roland digital equipment. The Florida studio is equipped with several Roland synthesizers as well as Roland 707 and 737 drum machines, the new MKS-100 digital sampler, and an MX-50 interface box,

which acts as a central computer for changes in tempo, keys, and pitch.

Nelson also uses a Juno 106 keyboard at Z100, with processing supplied by an Eventide H949 Harmonizer and a Yamaha SPX90. "Most people use the Yamaha presets just as they are," Nelson says, "but I go in there and change everything around so they don't even sound like the original

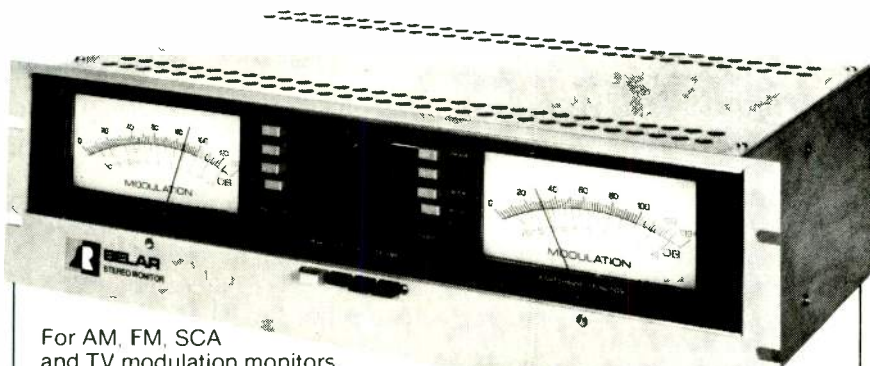

For AM, FM, SCA and TV modulation monitors.

WHEN ACCURACY COUNTS...COUNT ON...

Call (215) 687-5550 or write for more information on Belar AM, FM, Stereo, SCA and TV monitors.



Circle 128 on Reader Service Card

BRYSTON

BROADCAST PHONO PREAMPLIFIER

REQUIREMENTS

- Musicality
- Serviceability
- Low Distortion
- Balanced XLR Outputs
- 27dBm RMS 600 ohms balanced
- Cartridge load adjustment
- High Overload Threshold
- Linear Frequency Response
- Reliability
- Low Noise
- 1 Space Rack Mountable
- Accurate RIAA ($\pm .05$ dB)
- 21dBm RMS 600 ohms unbalanced
- Non-reactive Phono Stage
- Fully Discrete Gain Blocks
- Drive Loads as low as 300 ohms

SOLUTION



BRYSTON BP-1

(BP-5 also available with 3 switchable high level inputs)

In the United States:

BRYSTON VERMONT

RFD #4, Berlin, Montpelier, Vermont 05602
(802) 223-6159

In Canada:

BRYSTON MARKETING LTD.

57 Westmore Dr., Rexdale, Ontario, Canada M9V 3Y6
(416) 746-0300

Circle 129 on Reader Service Card

Audio Engineering & Production

Digital Audio

settings." The main studio at WHTZ is further equipped with an MCI eight-track recorder and an 18-channel Audiotronics console with four outputs.

Although MIDI is used extensively at the Florida facility, Nelson doesn't see a great need for it at WHTZ, noting: "In radio you do so much volume that, at this point, it really doesn't make any sense for me to have a computer in here for MIDI because I know what I want, and it's easier for me to punch it up and do it in the mix than it is to preprogram all that stuff. When you come right down to it, all you're really dealing with is voice and music tracks, so it's not all that complicated."

Likewise, although he is generally enthusiastic about the introduction of digital equipment in radio production, he cautions his contemporaries against going overboard with it. "Everybody has this new technology now, but the problem is that—just like any



WMMR's production director Steve Lushbaugh sitting behind his Roland JX-10 (and in front of a life-size cutout of John DeBella).

other new toy—after you play with it a while you get bored with it. And, when all is said and done, the production director's job is to be a producer. That's what you're supposed to be. You still have to stick to the basics of what radio is all about, which is the theater of the mind. That's probably the

most overused phrase in the world, but it's so true. You always come back to what your job really is, which, essentially, is being creative and producing."

Digital redoux

Unlike earlier digital audio equipment that provided high

AT LAST! STEREO FIELD MIXING COMES OF AGE!



Until you try the new AT4462, you'll never fully realize what other mixers put you through, just to get a stereo signal on tape, on film, or on the air. Because simply adding pan pots or another output to a mono mixer is not enough for today's stereo.

Field Tested and Refined

We went to network and independent broadcast engineers, and leading film and A/V audio people to learn your problems and needs first-hand. And we returned again and again to test our solutions. These tough critics agree that the new AT4462 sets up far faster, provides better signal control, and results in better audio...even in the hands of inexperienced personnel.

NEW AT4462 STEREO FIELD MIXER WITH EXCLUSIVE MODU-COMM™

Introducing Modu-Comm™

The AT4462 is designed for the real world. For instance, let's assume you're doing a simple sports remote. You set up microphones for the sportscaster and the color announcer, plus a stereo mike for the ambient crowd noise. Normally you would also have to run a

For literature and
name of A-T Sound Specialist
CALL 1-800-992-ATUS (2887)

performance at equally high prices, today's digital instruments and effects processors accommodate a wide range of applications and budgets.

The multitude of digital effects processors currently on the market runs the gamut from straightforward preprogrammed reverb units to ultrasophisticated, multi-effects systems. Lexicon's new 480L digital effects system, for instance, is the product of two year's research and development. Designed to meet audiophile specifications, it features an expandable architecture incorporating high-speed processors that perform 16 million operations per second for creating "reality-based" reverberation as well as Doppler flyby effects and reverse sampling. Other features include time-based effects, 18-bit equivalent analog-to-digital conversion, analog and digital I/Os, and multitasking capability that permits users to run two different

programs simultaneously.

The 480L allows up to 50 user setup programs to be stored on a removable cartridge with additional nonvolatile storage for 50 more inside the box. Furthermore, it can be fully automated via the Lexicon Dynamic MIDI ports or accessed with the optional Lexicon Alphanumeric Remote Control (LARC).

At the same time, Yamaha's MIDI-compatible SPX90 digital multi-effects processor provides a healthy assortment of signal processing capabilities at a suggested list price of \$775. It features 16-bit linear digital-to-analog (D/A) conversion and 30 ROM preset effects, each with up to nine controllable parameters. At the same time, the unit's RAM memory allows users to store 60 customized settings with English-language tags (as opposed to numeric codes). Effects include: reverb, delay, modulation (for stereo flanging, chorus, tremolo, and phasing

effects), gating, compression, programmable automatic panning, vibrato, parametric EQ, and a "Freeze" mode for 500-millisecond sound sampling.

Digital reverb units comprise the majority of digital effects processors on the market today; most are MIDI compatible and use high-resolution, 16-bit D/A conversion. The PRO-Verb from the Rochester, NY-based Applied Research & Technology fits that description. Although it is not programmable, it provides 100 stereo presets (50 natural reverb and 10 each for gated, reverse, chorus, echo, and delay effects) in a software-based system that will be compatible with future upgrades. The Midiverb II from Alesis similarly features 99 presets, any of which can be assigned to 32 MIDI patch points for custom control in MIDI applications, as well as input, mix, and output control knobs.

Meanwhile the Eventide Har-

wired or wireless feed to the sportscaster for his cue phone.

But with the AT4462 and Modu-Comm, cue is fed through the announcer's mike cable already in place. Add a small accessory decoder to the end and plug both the cue phone and the microphone into the same cable. Cue can be program, an outside line, or "talk over" from the mixer. No extra wires, no crosstalk, and no change in audio quality! Nothing could be simpler or more efficient.

Now, No-Fuss Stereo

Actual stereo mixing is equally straightforward. The sportscaster and the color announcer in our example appear on separate pannable inputs so they can be centered as desired in the sound field. The stereo crowd pickup goes to a stereo input, with clutch-ganged controls for one-hand level control. And there's a second stereo input for another mike or line level source

(a second field mike perhaps, or for pre-show interviews on tape).

True Stereo Limiting Plus LEV-ALERT™

Adjustable limiters can operate in tandem, or individually as you prefer. And our Lev-Alert system can give you peak level audible tone warnings in your headphones when you can't watch the VU meters. Trust Lev-Alert to keep your standards high... even when it isn't easy!

Take A Close Look

When you examine the new AT4462

you'll see a host of other features to help you do your job: Cue on every channel...Separate headphone amplifier...Phantom power for all types of mikes...Three-frequency tone oscillators...Slate mike...Supplied carrying strap and protective case...Powered either by internal 9-volt batteries or any external 12-18 VDC supply, any polarity.

A New Era in Stereo Begins

We've made the new AT4462 a working tool that helps you and your staff take full advantage of the production values stereo has to offer. And a hands-on test will quickly prove it. To learn how the AT4462 can help you create better audio every day, call or write us now.



audio-technica®
1221 Commerce Drive, Stow, OH 44224 • (216) 686-2600

Circle 130 on Reader Service Card

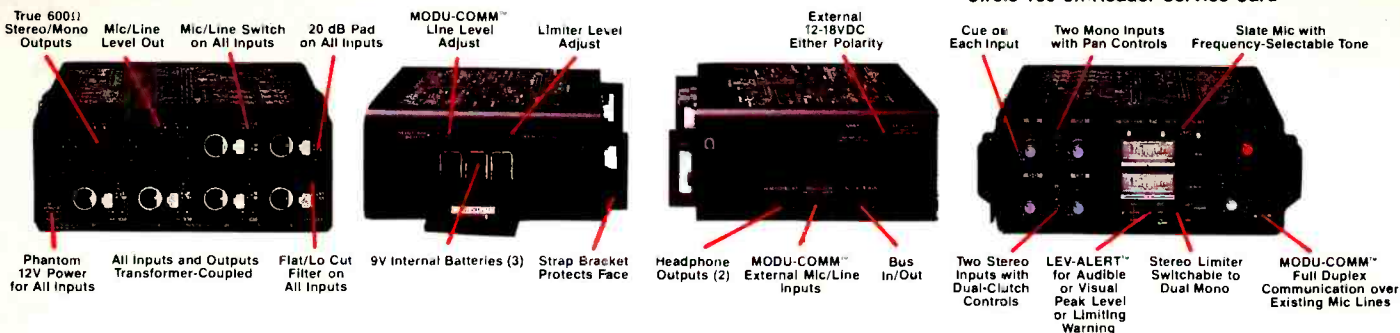

Audio Engineering & Production

Digital Audio

Otari's compact EC-201 SMPTE/EBU time-code reader is a natural for field or studio operation, and it costs only \$495. It offers 1/20 to 60X playspeed reading, 40 hour continuous use on battery power, and re-shaping circuitry on the loop output.

This advanced reader features a full hexadecimal user bits display (with a hold-button for edit logging), a -10 to +10 dBV input range, balanced XLR inputs/outputs, and includes an AC adapter, belt clip and batteries. It measures 1.5" x 4.2" x 5" and weighs 18 oz.

Contact Otari at (415) 592-8311 for your nearest dealer. From Otari: Technology You Can Trust. Otari Corporation, 2 Davis Drive, Belmont, CA 94002.

OTARI

TIME OUT!

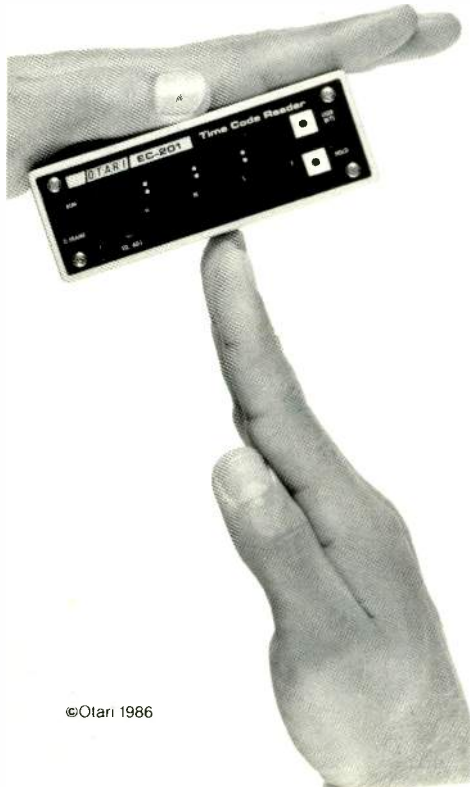

©Otari 1986

monizer is probably found in more radio stations than any other effects processor. There are currently two models available: the H949 and H969 with 16-bit linear PCM (pulse code modulation) circuitry. Features common to both units include: pitch change (one octave up, two down), time compression and expansion, variable delay and reverb effects, electronic flanging, time reversal (i.e., backward read out), and a repeat mode that plays back a 400-millisecond segment indefinitely. The H969 further adds 12 instant pitch change presets (as well as the added ability to pitch down more than three octaves), independent pitch and delay read-outs, dual concentric coarse and fine adjust control pots for pitch and delay, five delay presets, and a preamplified front panel input and headphone jack.

Eventide's marketing manager, Beth Babich, attributes the use of digital processors in radio as a sign of maturity in the marketplace, and points out that such equipment gives stations a distinctive, identifiable sound that also provides a competitive edge. "Stations are definitely making an effort to sound different from one another," she explains. "And these processors are helping them accomplish that. They're also very useful at smaller stations that have a limited number of DJs, in that they can alter voices in promos and ads to add variety to the programming. Generally speaking, radio is just becoming more sophisticated."

Getting in synth

The primary function of electronic instruments in radio production is to create music and sound effects beds—although they may also be used for song parodies and commercials. Programmable synthesizers that allow users to store settings on disks or RAM cartridges are extremely popular, while keyboards employing digital sampling of natural sounds are coming into vogue as well.

On the high end, instruments such as Fairlight's CMI Series III and NED's Synclavier are actu-

ally self-contained digital audio production systems. Like much of today's digital gear, both systems feature modular, software-driven designs that allow for compatibility with future upgrades. The Fairlight combines 14 megabytes of waveform RAM for more than 2.5 minutes of sampling at 44.1 kHz with SMPTE-based timecode synchronization, 16 internal voicings that can be accessed simultaneously, and a graphics pen for quick operation and menu access. Upcoming options will include two hours of sound storage on hard disks and up to 80 channels of digital audio provided by additional expansion racks.

The Synclavier similarly features stereo and polyphonic sampling of up to 100 kHz per channel with 16-bit resolution, digital synthesis, SMPTE synchronization, as well as optional Direct-to-Disk multitrack recording and engraving-quality music printing.

Although the capabilities of such systems exceed most broadcast production—and budgetary—requirements, they provide some indication of the future direction of audio technology. The concept of "tapeless" recording (i.e., the recording and manipulation of digital audio signals on hard disk), in particular, is already a subject of considerable speculation and controversy among broadcast engineers.

Meanwhile, new digital sampling keyboards such as Roland's S-50 and the Emax from E-mu Systems (both priced at under \$3000) incorporate many of the successful design parameters and specifications of earlier, more expensive models. The S-50 is a software-based, 16-voice polyphonic keyboard that offers 14.4 seconds of sampling at 30 kHz (28.8 seconds at 15 kHz). It features a 61-note (five octave) range, two 256K word memory banks, wave data and tone parameter edit functions, and a built-in 3.5-inch disk drive for sample storage.

Following in the footsteps of its predecessor, the popular Emulator II, the Emax offers six different sampling rates from 10 kHz to 42 kHz (19 seconds at the stan-

dard 28 kHz rate) with 12-bit linear resolution. It further allows up to 122 individual samples to be assigned to the keyboard at any one time and permits users to combine whole samples or parts of different samples to create new sounds. Other features include a five-octave range, multitrack MIDI sequencer, arpeggiator, and an RS-422 port for high-speed data transfer.

For general production applications, digital synthesizers offer a variety of options, including programmability, key size, number of octaves, MIDI capability, polyphonic or monophonic performance, and effect range—to name just a few. One digital keyboard that seems to have carved out a niche for itself with in-house production departments is the Casio CZ-101.

This mini-sized, portable MIDI synthesizer features 49 keys, eight-note polyphonic performance, and 32 built-in sounds (16

factory presets, 16 internal RAM settings). Voices are created via the Casio-developed PD (phase distortion) sound source system, which distorts the phase angles of sine and cosine waves for more realistic effects. Eight-step envelope generators provide total user control over timbre, volume, and pitch, while program data may be stored on RAM cartridges or placed into any of the 16 internal RAM settings. The unit accepts both AC and DC power supplies using six D-cell batteries (required for memory backup) or an AC adapter.

Another major electronic keyboard manufacturer, Yamaha, has recently introduced two new digital synthesizers that feature upgrades on the basic architecture of its popular DX7. The DX7IID and DX7IIFD both employ dual six operator, 32 algorithm FM tone generators (as found in the company's DX1 and DX5 keyboards); the DX7IIFD

further comes equipped with a 3.5-inch floppy disk drive for storing program data as well as MIDI data from sequencers and other instruments.

Both DX7II keyboards feature random pitch shift, in which the pitch of each note is slightly and randomly detuned to simulate the sound of several acoustic instruments playing the same note at different pitches. Furthermore, voice storage in the new keyboards is double that of the DX7, with 64 voices stored internally and another 64 on each external RAM cartridge. Other features of the DX7II series include expanded performance memory, which, in addition to storing the necessary program data, allows storage of all pedal, mod and pitch wheel, pitch bend, and other function data for each voice; 11 preset tunings; left and right outputs with panning capability; extensive MIDI implementation; and two foot pedals. **BM/E**



NEW!! SATELLITE EQUIPMENT

The PSA-35A Portable Spectrum Analyzer accurately measures wideband signals commonly used in the United States and European satellite communications industry. The PSA-35A frequency coverage is from less than 10 to over 1750 MHz, and from 3.7 to 4.2 GHz. The PSA-35A features switch selectable sensitivity of either 2 dB/div or 10 dB/div. The portable, battery or line operated PSA-35A Spectrum Analyzer is the perfect instrument for the critical dish alignment and tracking requirements necessary for maximum signal reception. **\$1965**



AVCOM's Single Channel Per Carrier Receiver, model SCPC-2000E, has been developed for the reception of FM SCPC signals from satellites operating in the 3.7 to 4.2 GHz band. The SCPC-2000E is a complete receiver that can tune up to 4 specific crystal controlled audio or data channels from a given transponder and is available in either wide or narrow band models. Optional circuitry is available to allow up to 8 crystals for channel selection. The SCPC-2000E may be used with the SS-1000 Slave for simultaneous reception of additional channels. **\$1875**



The AVCOM COM-96T Professional Receiver is compatible with all C and Ku band LNB's and BDC's that operate in the 950 to 1450 MHz range. The COM-96T provides complete 4 and 12 GHz performance in one system.

The COM-96T is a high performance, fully agile, dual conversion satellite receiving system for demanding commercial applications. Modular circuit packaging results in a compact and highly reliable Ku and C band receiver in a standard 19" rack mount configuration. Highly stable oscillators eliminate frequency drift and allow operation over wide temperature ranges. Special threshold extension circuitry offers superior video quality. The COM-96T may be ordered with optional threshold peaking and dual IF filters for receiving international type transponders. **\$939**

AVCOM 500 SOUTHLAKE BOULEVARD
RICHMOND, VIRGINIA 23236
TELEPHONE 804-794-2500 TELEX 701-545 FAX 804-794-8284

Circle 147 on Reader Service Card

A SIGHT FOR SORE EARS.

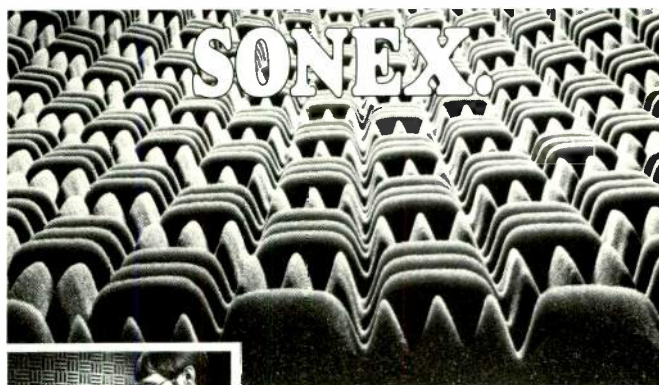

If ears could talk, they'd scream for SONEX.

The only patented acoustic foam with a specially sculptured anechoic design can replace traditional studio materials for a fraction of the cost. SONEX absorbs sound, controls reverb, eliminates stray reflections, and kills standing waves. What's left is true sound. Your ears know. Listen to them. Simple to apply and economical to buy, SONEX blends with almost any decor and looks clean, sharp, professional. Call or write us for all the facts and prices.

SONEX is manufactured by Illbruck and distributed exclusively to the pro sound industry by Alpha Audio.

Alpha Audio

2049 West Broad Street
Richmond, Virginia 23220 (804) 358-3852

Acoustic Products for the Audio Industry

Circle 146 on Reader Service Card

Dependable VHF Transmitters from a Dependable Source. NEC.

The PCN-1400 Series transmitters feature high performance exciters, high power transmitter amplifiers, superior reliability, excellent stability with power ranges of 1 to 35kW, in band I to band III. 100% solid state to 10kW; only one tube to 35kW. A 30% reduction in exciter parts means you get a 50% increase in MTBF—30,000 hours. It's ready for stereo without modification. NEC is a leader in today's transmitter industry, with over 1400 installations worldwide. Each one carries NEC's commitment to excellence. For today, and tomorrow.

NEC

IMAGINE WHAT WE'LL DO FOR YOU

NEC AMERICA, INC., Broadcast Equipment Division
1255 Michael Drive, Wood Dale, IL 60191
Phone 312-860-7600

Circle 133 on Reader Service Card

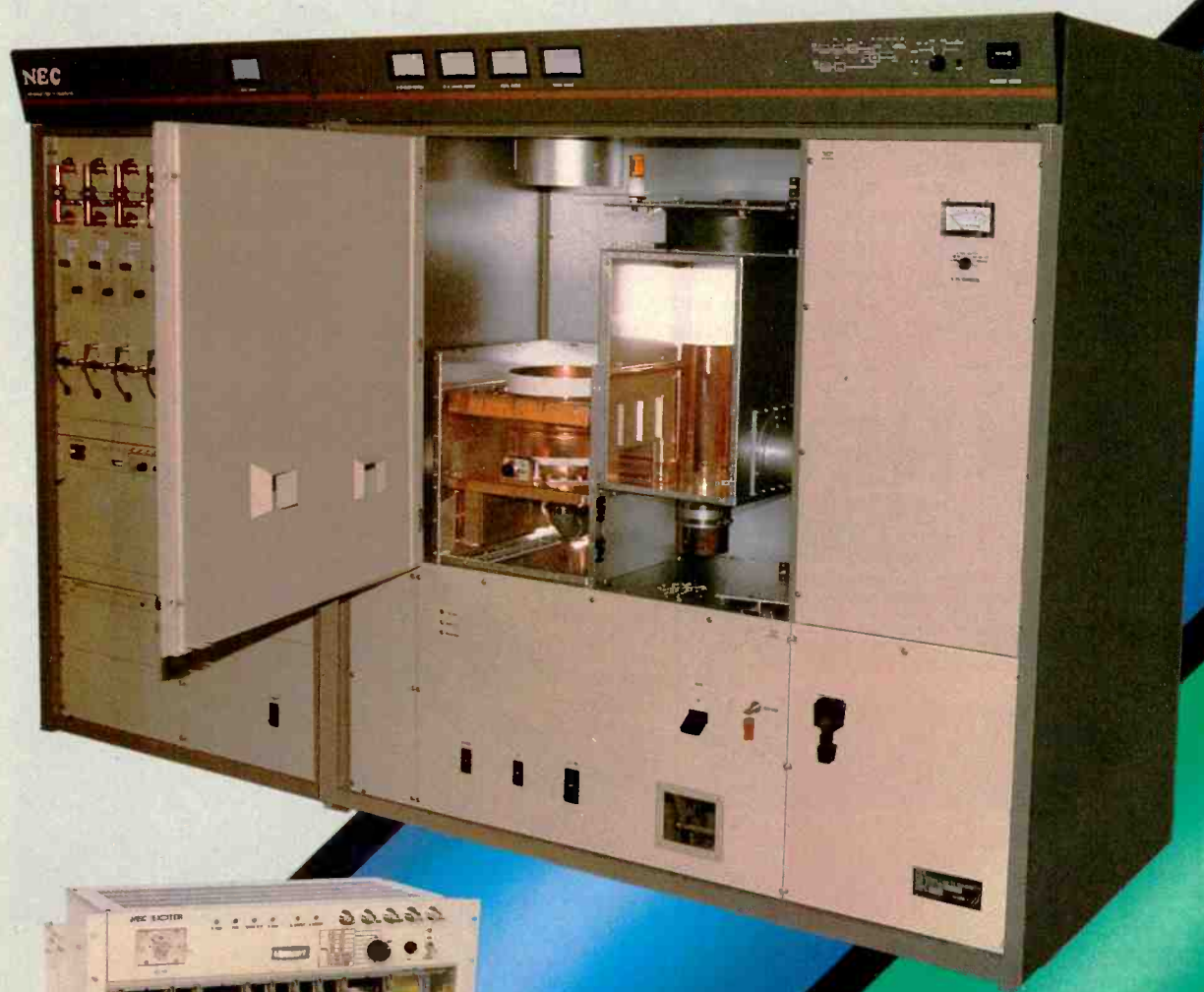

C&C

Computers and Communications

Smart TV



The BPME/BDA Seminar scheduled for Atlanta, June 10 to 14, will provide direction for broadcast managers and others pursuing the smart way to implement promotion and design into an intelligent operation.

By Tim Wetmore

The important considerations in broadcast design and promotion are often very difficult to target effectively. Especially when the sights keep moving. Addressing the questions raised in the various aspects of the broadcast design world, as it speeds so merrily on its ballistic path, is the essential *raison d'être* for the BPME/BDA Seminar.

Learning the techniques and strategies employed by colleagues is an essential function of these

conventions, as is keeping up to date on the latest hardware and software developments. This year's confab, held in the Atlanta Market Center and connected to the Peachtree Plaza Hotel via a skybridge, will not dissappoint. There are more booths (possibly up to twice last year's number of 70) and of a larger size than ever before. In addition, there will be sessions aimed at solving the many problems encountered by broadcast designers on a daily ba-

sis (see accompanying program).

Specifically, the BPME/BDA workshops will elucidate the various ways to approach promotional concepts and how to execute those concepts. There will be 40 workshops, some running continuously, and simultaneously, a number of which are hands-on sessions.

In addition to the workshops and seminars, there will be no dearth of distinguished speakers in Atlanta. These include Chuck

Jones, famed animator of Bugs Bunny, Road Runner, and many other famous cartoons. Also on hand will be Martin Holbrook, formerly with Quantel and now on his own, showing footage depicting the history of European broadcast design titled, "The Changing Image, Then and Now." Adding his name to the list of luminaries will be David Banel, editor of *Publisher Magazine*.

Banel will be speaking on Desktop Publishing, a discipline whose meteoric rise in capabilities in recent years has drawn great attention. It is this three-session topic, sure to be of interest

to both BPME and BDA attendees, that will demonstrate to broadcast designers the future of computers interfacing with other equipment in the plant. This new opportunity is expected to provide dynamic tools for internal communication involving multitask-kinds of computer systems for the television station of the future. BDA Seminar Chairman, Paul Sidlo, indicates strongly, "This may be the major theme for the coming years."

Attendees will also see at the conference many new exhibitors offering quality, low-cost paint systems. Recognized as another

strong current in the future of design, more quality at lower cost is on everyone's mind. Sidlo sees this occurring because "there is a hardware revolution going on, not necessarily in new technology, but in new economy. As the cost of equipment comes down, it allows small-market stations to buy the high-end paint systems permitting a growth in sophistication throughout the station market spectrum." In regard to the advancing of technology, there will be a number of workshops on the digital design studio, taking advantage of multilayering effects without loss of quality. **BM/E**

Seminar Agenda

Wednesday, June 10

10:00 a.m. to 6:00 p.m.

Registration

3:00 to 4:30 p.m.

Teaching and Evaluating Design

(Russ Smith, BDA)

4:45 to 5:15 p.m.

BDA Members Welcome Meeting

6:00 to 7:30 p.m.

Opening Reception, Exhibit Hall

Thursday, June 11

9:30 to 10:45 a.m.

What's New in Technology?

(Rodney Stock, Computer Arts Institute)

Illustration for Storyboarding

(John Townley, CCP)

2:00 to 3:15 p.m.

Desktop Publishing, Part I: What's It All About?

(Noel Travers)

Cable In-House Design

(Paul Sidlo)

3:30 to 5:00 p.m.

Desktop Publishing, Part II: The Software

Psst! How's Your Portfolio?

(Elaine Sorel)

5:15 to 6:30 p.m.

Designing a Sound Image

(Crit Harmon, Soundtrack Studio)

Desktop Publishing, Part III: User Groups

Friday, June 12

8:30 to 9:45 a.m.

Claymation

(Mark Gustafson, Will Vinton Studios)

Weather Graphics

(Eddie Terrell, Weather Channel)

10:00 to 11:00 a.m.

The Changing Image: A History of European Design

(Martin Holbrook)

11:15 to 12:30 p.m.

The Digital Design Studio

(Tony Redhead)

Small Budget Set Design

(Dave Joeris and Wiley Schmidt)

2:00 to 3:30 p.m.

Atlanta in Print

(Jackie Goldstein, Turner Broadcasting)

Using a Multimedia Approach

(Broadcast Arts, Olive Jar, Colossal Pictures, Will Vinton Studios)

3:45 to 4:45 p.m.

The Tire Kicker's Guide to Computer Graphics

(Glenn Entis, Pacific Data Images)

Creating a Winning Promotion & Design Team

(Elaine Sorel and Mike Berry)

5:30 to 7:00 p.m.

BDA Awards Reception

7:00 to 9:00 p.m.

BDA Awards Program

Saturday, June 13

10:00 to 11:15 a.m.

The Do's and Don'ts of Post Production

(Billy Pittard, Post Group)

Union Relationships

(Paul Sidlo)

12:30 to 2:30 p.m.

BDA Honors Luncheon

(Speaker: Chuck Jones, Warner Brothers)

3:30 to 4:30 p.m.

Design

(Randy Roberts)

Sunday, June 14

8:00 am to 1:00 p.m.

Everything You Need to Know About Post Production

(Richard Thorn, Post Group)

AFC GAMES

CINCINNATI	21
NEW ENGLAND	17
HOUSTON	10
SAN DIEGO	8
KANSAS CITY	17
MIAMI	6
DENVER	35
CLEVELAND	14



Now you don't have to be rich to get sophisticated.

With most character generators, the possibilities start at point A and end abruptly at point B. Increasing your equipment's level of sophistication with add-on graphics or paint capabilities can cost a bundle. So can upgrading to a whole new system. Until now.

Introducing the D-6000 Panther, from 3M. It's a character generator, graphics generator and paint system, all rolled into one. Yet it's priced to compete with a mid-line character generator.

Quite simply, it expands the realm of the possible. With the Panther, you can grab and digitize any image using a black & white copy camera. Paint in a little color. Roll or crawl over video, or roll the entire

screen. Create and animate a logo or fonts. And you can control all this from either keyboard or digitizer pad and stylus. Or both.

Best of all, the Panther increases in sophistication as you do. And it does much, much more. Find out about it.

Send for a free brochure. Mail in the Reader Service Card, or call 1-800-328-1008. Because with 3M's D-6000 Panther, you get more than just a character generator.

You get a whole new animal.

Logos shown are not meant to imply endorsement.



Broadcast and Related Products Division/3M

3M

Circle 134 on Reader Service Card



LEASING'S GREATEST HITS

Like music, equipment leasing and radio were made for each other. The fact is over 80% of American businesses lease the equipment they need — radio stations included.

There are a number of important reasons why leasing works to your advantage — from no down payment to

improvement of cash flow. There are also a number of reasons why you should consider leasing through LeaseAmerica — including knowledge of and a commitment to the radio industry.

Call LeaseAmerica next time you need equipment. We'll structure a program that'll be music to your ears!

**FOR A FREE BROADCAST INDUSTRY LEASING BROCHURE
CALL TOLL-FREE 1-800-553-7287. IN IOWA CALL 1-800-332-5342.**



LEASEAMERICA
A Life Investors Company

Leasing Options

Creative answers to difficult questions. That's what is needed in the broadcast industry as it struggles to its feet. Leasing may be one of the creative answers to the question of how best to update broadcast hardware.

By Tim Wetmore

When an industry slows down, both vendors and purchasers suffer. When solutions to the slow-down are discovered, both parties benefit. Given the lethargic state of recovery the broadcast industry is now experiencing, leasing equipment could be the way for both television and radio broadcasters to stay competitive and for equipment manufacturers to build their businesses. Although it is true that leasing high-ticket equipment items has long been a management practice, in today's broadcast reality the leasing option takes on new dimensions.

Competition in broadcasting markets continues to get more in-

tense as the years pass, bringing a greater number of entertainment variables into the industry, forcing the broadcaster to stay ahead of, if not at least in step with, those other entities that demand the time of the viewer/listener. After all, it is time that is sold by broadcasters, and a station can't sell time at a premium if it doesn't possess a significant audience share. How to maintain one's audience, while at the same time contending with an industry squeeze, becomes the broadcaster's overriding concern.

Addressing the industry's concerns while staying competitive means that station management must aspire to the purest equilib-

Broadcast Management

Equipment Leasing

rium between programming and talent costs, labor and equipment expenses. Perhaps the most critical decisions in maintaining the complex balance are delivered on the subject of equipment acquisition.

Reasons for this abound, but most acutely encompass the details of keeping the station's news and production on a par with the best in the industry, requiring the management of cash flow in the most meticulous manner. In the face of such challenges, all financing options must be considered. Arguably, equipment costs can be handled in a much more flexible manner than can those expenses associated with talent and programming. And this, from station management's perspective, is what leasing is all about: managing cash. As the saying goes, "You don't lease to save dollars, you lease to save cash."

ing to the buyers' needs. In addition, in some cases, and with certain leases, the payments may be treated as a pretax operating expense. In other situations, the lease may work, in effect, more like a loan. Perhaps of most value, though, in leasing is the ability of the manager to see exactly what expenses will be over the term of the lease, allowing accurate projection of cost and profitability. This includes the benefits to cash flow and keeping bank lines of credit intact to meet short-term needs and emergencies.

The leasing relationship

Many broadcast hardware manufacturers are very active in the leasing of their equipment. Of note in this regard, due to their size and longevity in the marketplace, is Harris Corp. Harris, which handles its television and radio sales forces separately,

official to the station as well.

The question then arises: in what situation is the best opportunity for a station to lease rather than to buy its equipment? Are there types of equipment for which leasing is the most viable solution, and is there a dollar amount beyond which leasing becomes most attractive? The answer to these questions can be found in the triangular relationship of vendor/leasing company/broadcast facility. In other words, the answer depends on the parties involved.

One of the companies Harris deals with, on the radio side, is LeaseAmerica Corp., of Cedar Rapids, IA. A typical radio deal for Harris may range from \$20,000 to \$150,000 with terms of three to five years. It is in this financial atmosphere where LeaseAmerica operates best, where it has found its business niche. Due to the internal structure, the amount of service provided to an account, and the set of rates determined by LeaseAmerica, the company has found that it can specialize in the radio market and price its programs accordingly. The important elements in a lease deal include, of course, the reputation of the vendor and the leasing company. Part of the reputation should be based on flexibility of terms in a lease.

It may be useful to examine how the leasing company operates and its motives for operating that way. Dave Harvey, vice president of marketing for LeaseAmerica on how and why: "Harris did a lot to introduce us to the broadcast market. When the satellite division in Melbourne, FL, got us involved in installing dishes at radio stations, we investigated the possibilities of expanding our base into the broadcast industry. Broadcasters looked good on financial statements regarding payments, so we got involved."

The company works with other vendors as well as with Harris, and has been involved with broadcasters for six years, maintaining 16 sales offices throughout the country.

Primarily, the company keeps

"Most fundamentally, leasing must be viewed as an alternate means of financing, often requiring no money down and offering 100 percent financing."

Leasing, it must be kept in mind, is not a panacea. It works in certain financial situations at certain times. Also, not all equipment manufacturers have agreements with leasing companies, and not all leasing companies will handle broadcast gear due to its high cost and early obsolescence. In other circumstances, it may be more expensive to lease than to purchase. Of course if short-term solutions provide answers to hardware questions then the excellent equipment rental houses, such as Camera Mart, Leaseametric, and others, will surely be considered. Still, leasing offers enough valuable options to bear looking into by station managers.

Most fundamentally, leasing must be viewed as an alternate means of financing, often requiring no money down and offering 100 percent financing. Other advantages include flexibility with the tailoring of size and frequency of payments manipulated accord-

works with a few different leasing companies. Brian McCorry, manager of sales finance at Harris, maintains that the association with leasing companies "allows us to offer to customers extended terms, making it easier for broadcasters to afford equipment. Vendors typically can't offer the extended terms or lower rates like the leasing company. It creates a good situation where everybody wins. The broadcaster gets equipment he might not have been able to afford otherwise and we get a sale we might have lost."

Some manufacturers find that a close association with one leasing company or with several does not serve them well and does not fit into the organization's sales approach very easily. Others, however, find that it is an asset to have an organized leasing relationship when approaching a sale at a facility. Harris assumes this approach, and the company has demonstrated that it can be bene-

UPGRADE YOUR ENG SYSTEM WITH MII

its broadcast leasing in radio because of the size of transactions. The company tends to be most competitive in rate structures up to about \$250,000.

For LeaseAmerica, as with all leasing companies, these areas of specialization become a function of how the financing company operates in terms of time. Also important are the number of people involved in the credit checks and the ability to analyze all gathered data. The way LeaseAmerica is structured, it is more efficient for the company to do a greater number of mid-size transactions than it is to do fewer, high-dollar deals, though they do not shy away from million-dollar opportunities if presented with the proper perspective.

Leasing companies are not the only game in town, naturally. Banks offer loans, and there are some companies that will service the financing of their own equipment.

Harris has, in the past, handled leasing and other financing completely in-house. The manufacturer found, however, that holding the paper was not using the company's resources efficiently. Harris is a manufacturing and sales/marketing organization, not a leasing company. The Harris financial people realized that it was less efficient for them to carry the financing than it was for a leasing organization. It became obvious that a relationship with a leasing company or companies would better serve both themselves and the broadcast customer by making the financial transaction more streamlined. When a deal can be consummated with efficiency, everyone benefits. Harris has used leasing companies for years, and its arrangement with LeaseAmerica for radio equipment is three years old now.

It should be noted that the company has exchanges with other leasing people, and that the essential purpose of any Lagreement is to arrange the deal so that all sides come out ahead. Harris' McCorry states the benefits of leasing thus: "Releasing the financial reins also allows the ven-



**If you use 1/2", 3/4" or any combination,
switch to MII and get high performance
and overall cost reductions.**

The MII Broadcast System is designed to enhance your ENG operations. With product like the AU-400 Camera Recorder that offers a combination of performance and capabilities never before available on 1/2".

Like multi-generation capability, playback through the view-finder, 4-channel audio, on-board time code generator/reader with selectable user bits and over 20 minutes of recording time on a compatible compact cassette. Even 90 minutes of operation with the MII Field Recorder, Field Editing and Studio VTR's. Plus performance of such high quality it can be used as an alternative to 1" C.

And with MII you have low maintenance and training costs. Tape consumption is dramatically reduced. Units are small and lightweight. Cassettes and parts inventory are interchangeable. And MII equipment is 100 percent compatible, so you can interface MII with your present system.

What's more, product is available now.

Find out how you can improve your production quality and cut your overall costs with the Panasonic MII Broadcast System.

*For more information call
(201) 348-7671.*



**Panasonic
Broadcast Systems**

Circle 136 on Reader Service Card

dor to provide greater flexibility to the buyer in that the buyer can step in and say, 'Yes, I'll take this equipment, but here is the leasing company or financial institution with whom I would like to complete the transaction.'"

Still, the solid relationship and comfort that can be achieved when working with fairly large dollars makes close arrangements with certain leasing companies valuable. At this year's NAB convention, Harris announced a newly formed association with another leasing company, U.S. Concord, to handle the equipment manufacturer's television financing. The reason for using a different company for television equipment than for radio is that each of the two broadcast sectors have different operations and, thus, different needs. Therefore, different financing programs are required to service the accounts properly. In light of this, broadcasters should be aware of the leasing option always, and the varieties of leasing programs, because radio and television not only have different equipment needs but disparate financial needs as well.

The distinctions between the two broadcast sectors is evident in Harris' use of two different companies and in the dollar amounts typical of transaction in the respective businesses. In television, a Harris deal may range from \$400,000 to approximately one million dollars, with a five-year term representing the typical deal. Other companies, like Sony and Grass Valley, which commonly conduct business in such dollar amounts, have employed the services of U.S. Concord in the past. This is due, in part, to U.S. Concord's abilities to operate most efficiently in this realm, offering finance leases that work much like a loan, whereas other structures may operate as a true lease with different tax advantages.

A broadcaster must, obviously, determine with the financial people if leasing will be advantageous to the station's fiscal health and, if so, what types of lease provide the most possibilities. The advantages of true leasing have to

do with the accounting of payments and obligations in capitalization and depreciation. All details must be reviewed before deciding which program is best for the station. This is where flexibility in a leasing company comes in. Obviously, if the leasing company has only one way of doing things, and it doesn't suit the broadcast operation, then using that leasing company may prove to be a disadvantage.

"Radio and television not only have different equipment needs but disparate financial needs as well."

The leasing structure

Bob Burtiss, formerly with Sony and now with U.S. Concord of Oak Brook, IL, explains his company's experience in broadcast and its philosophy of business. "We are a wholly owned subsidiary of Hong Kong Shanghai Bank, active in broadcasting for several years. As a service company we stay flexible regarding those with whom we deal, but prefer to use the vendor base as a source of referrals."

Although Concord has four areas of specialization, telecommunications (including broadcast and teleproduction), medical, print graphics group, and aircraft, the company has been involved in broadcast equipment financing for eight years now. With four sales persons throughout the country dedicated strictly to broadcast-related financing, the company has handled everything from new facility startups to individual equipment deals ranging from \$100,000 to approximately seven million dollars. Officially, the financing is stated as a financed lease with a dollar purchase option having depreciation going to the end user with fixed and floating rates available.

As previously mentioned, there

are various ways to structure leases, depending on the leasing company and the needs of the station. The foundation on which the lease deal is built is essentially the same from company to company; the type of structure you build on top of the foundation is where the "personalized approach" comes into play. In most leases, the vendor sells the equipment to the leasing organization, which then, in turn, leases the equipment to the station. This makes the leasing company responsible for carrying the paper, collecting, and generally executing the transaction, though responsible equipment vendors play a central role.

Epitomizing a flexible business approach to this area is Charter Financial, located in New York, NY. Charles Drucker, director of marketing for broadcast and motion picture markets states that, "we work both with the vendor and the end user. We like to tailor a lease program so that the vendor can go in and present the system and be able to say, 'Here it is, and this is what it will cost you per month.'"

Charter concentrates on what it considers the middle market: \$100,000 to five million dollars. Typically, they will purchase from the vendor and hold title until it's paid off. Also, in rare cases, Charter Financial will allow the client to put up collateral.

When asked about the attraction of leasing over buying Drucker quickly answers, "You earn income from equipment because you use it, not because you own it. This is especially true in an industry in which obsolescence occurs so quickly."

Charter also likes to have close associations with hardware manufacturers and has worked out programs with many companies, Wavefront Technologies among them. Such relationships become particularly relevant in the modern broadcast plant due to the onslaught of software-oriented developments as opposed to hardware. Will these developments cloud the clear waters of finance leasing since there is no actual

STANDARDIZE YOUR EFP SYSTEM WITH MII

piece of equipment on which to base the deal? This doesn't pose a problem, Drucker claims, because there has to be hardware tied to it somehow and, currently, when software only is involved, the dollars aren't high enough for Charter, or other large financing groups, to react to it. If and when the numbers grow, expect these types of companies to be involved.

Harris Rogers of Abekas echoes this sentiment about leasing in general. "As the dollar value of the item goes up, the possibility of leasing goes up. As a sales organization, you have to be sensitive to the buyers' needs. So if the subject of financing comes up, then leasing enters the conversation." Abekas has worked with U.S. Concord, Signal Capital, Charter Financial, Leasing Concepts in Radner, PA, and Phoenix Financial in New York City.

It must be remembered that financing, and terms of financing, are integral parts of any sale. How to structure a sale or a lease can make or break the deal. And, according to Abekas' Rogers, "It can be tricky if you are carrying your own paper. Leasing companies provide a service in that regard, making it a viable alternative if outright purchase is not possible."

For a vendor to carry the paper, he is risking a great deal on two fronts. One is that he tends to take on a lot more than he should just to make the sale, the other is that he gets stuck with uncollectables. What happens is that the sales figures begin to look rather impressive, but the amount of bad paper ends up destroying the profit and this is not good for the buyer or the seller. Thus the niche for the leasing companies.

There are many options besides leasing, of course. Cash purchase is one option. Bank loans are another. Still a third possibility that presents itself is a unique twist on equipment purchase that has been undertaken by Chyron. In a hybrid approach to financing, Chyron has come up with a plan that combines features of renting, leasing, and purchasing.

The company sells equipment



**If you use 1/2", 1" or any combination,
switch to MII and get high performance
and overall cost reductions.**

The MII Broadcast System was designed to enhance your EFP operations. With product like the AU-500 Field Recorder that offers a combination of performance and capabilities never before available on 1/2".

Like over 90 minutes of recording time even in the field, multi-generation capability, field color playback, 4-channel audio, on-board time code generator/reader with selectable user bits and TBC connection. The Field Recorder also accepts compact cassettes from the MII Camera Recorder. Plus MII's performance is of such high quality it can be used as an alternative to 1" C.

And with MII you have low maintenance and training costs. Tape consumption is dramatically reduced. Units are small and lightweight. Cassettes and parts inventory are interchangeable. And MII equipment is 100 percent compatible, so you can interface MII with your present system.

What's more, product is available now.

Find out how you can improve your production quality and cut your overall costs with the Panasonic MII Broadcast System.

*For more information call
(201) 348-7671.*



**Panasonic
Broadcast Systems**

Circle 137 on Reader Service Card

ALL OUR SATELLITE NETWORKS COME WITH THIS USER-FRIENDLY SUPPORT SYSTEM.



NOTHING WORKS HARDER THAN SCIENTIFIC-ATLANTA EQUIPMENT. EXCEPT SCIENTIFIC-ATLANTA PEOPLE.

One of the most important parts of a satellite network is the support team. And after over 30 years of experience in satellite communications, we've assembled one of the best. Highly-skilled professionals ready to help you get the most from your system. Whether you need that help ten days after purchase or ten years.

TURNKEY SYSTEMS.

As a turnkey supplier, we don't just sell equipment, we design, manufacture, integrate, and install it. And before you purchase anything, you

can consult with our project engineers to make sure you get the equipment that best suits your needs. So nothing is left to chance.

SINGLE-SOURCE SUPPLIER.

From specific components to complete systems, we have a full line of both C and Ku-Band products that meet broadcast-quality specifications. And for total security, we offer addressability and signal encryption through our proprietary B-MAC transmission system. Everything's available from one reliable source.

DEPENDABLE PERFORMANCE.

At Scientific-Atlanta, we not only build a better network, we help you

get the most out of it once it's built. With responsive after-sale support whenever you need it. From comprehensive training programs to the fastest possible turnaround on maintenance, replacement parts and repairs. We're not satisfied with our satellite networks until you are. For more information, call (404) 449-2314 or write to Scientific-Atlanta, P.O. Box 105027, Dept. AR, Atlanta, GA 30348.

Scientific Atlanta

Broadcast Management

Equipment Leasing

on extended terms employing three different plans. The plans are applicable to all three companies in the Chyron group—Chyron, DSC, and CMX—and can even include equipment purchased from two or three of the different companies. For example, a station may buy a Chyron IV, graphics equipment from DSC, and editing gear from CMX, and put it all on one purchase order and finance it under one plan.

The plans are based on one basic structure, explained by Chyron chairman and CEO, Al Leubert. "All plans require 10 percent down payment. The amount of payment and the duration is what varies. For example, on the 10-2-57 plan, if there is a purchase for \$50,000, the down payment is five thousand, two percent per month is one thousand per month for 57 months. Two other plans offered are the 10-3-35 and the 10-4-26 for lower-level purchases."

What this amounts to is an interest rate of a little over 10 percent. The plans, started in August 1986, were designed to allow salesmen to calculate on the scene what payments would be for any given purchase, based on the total equipment cost. It also permits salesmen to employ effective wraparound financing for the three companies in the group.

As a unique alternative to both purchasing and leasing, the plan seems to have been successful. Put succinctly by Leubert, "We have sold over 10 million dollars worth of equipment for all three companies with this plan since last August."

If a financing plan, any type of plan, is successful that means the smart broadcast manager has also been successful by taking advantage of it. As leasing programs become more versatile and customized to the industry, and the individual stations within the industry, look for the recovery to speed up as equipment manufacturers, leasing companies, and best of all, the stations themselves benefit from the flexibility of modern financing options. **BM/E**

SUBSTITUTE YOUR STUDIO VTR'S WITH MII

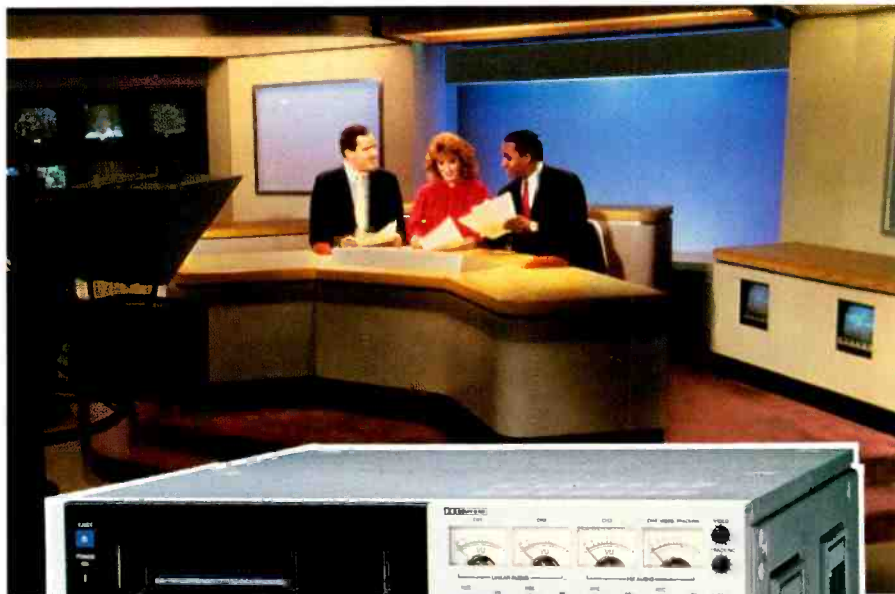

If you use 1", switch to MII and get high performance and overall cost reductions.

The MII Broadcast System was designed to enhance your studio production. With product like the MII AU-650 Studio VTR that offers a combination of performance and capabilities never before available on 1/2".

Like over 90 minutes of recording time, multi-generation capability, on-board TBC and time code generator/reader with selectable user bits, editing functions, variable speed playback including slow and still, Dolby-C noise reduction, and 4-channel audio. The Studio VTR also accepts compact cassettes from the MII Camera Recorder. Plus MII's performance is of such high quality it can be used as an alternative to 1" C.*

And with MII you have low maintenance and training costs. Tape consumption is dramatically reduced. Units are small and lightweight. Cassettes and parts inventory are interchangeable. And MII equipment is 100 percent compatible, so you can interface MII with your present system.

What's more, product is available now.

Find out how you can improve your production quality and cut your overall costs with the Panasonic MII Broadcast System.

For more information call (201) 348-7671.



Panasonic
Broadcast Systems

*Dolby is a trademark of Dolby Laboratories, Inc.

Circle 139 on Reader Service Card

COMPARED TO OUR NEW APOCHROMATIC ZOOM, OTHER LENSES ARE A LITTLE ROUGH AROUND THE EDGES.



Chromatic aberrations. They can cause loss of picture detail. Color fringing. Poor color registration.

The introduction of broadcast CCD and high quality tube cameras means compromises like these are no longer acceptable in zoom lenses. To meet these new and demanding camera specifications, Schneider introduces the TV-56 APO-VARON 14X ENG/EFP Zoom.

The TV-56 is a major leap forward in TV zoom technology. Its true apochromatic design focuses the image formed in the three primary color channels in precisely the same image plane.

The result is rather eye-catching. Both longitudinal and lateral chromatic aberrations are significantly reduced. MTF is increased, and picture quality is greatly enhanced.

Lightweight and compact with a sturdy weather-proof housing, the TV-56 is the type of rugged performer you'll value for other reasons, too.

It has a 2X extender, macro focus, and a unique servo iris control built into the zoom pistol grip. The TV-56 is available with positional servo focus. And the lens accepts a wide range of EFP accessories, including an aspheric attachment for superwide fixed focal length.

So if you're concerned about your image, do something about it. Get Schneider's new TV-56 APO-VARON Zoom.

For more information or a demo, contact: Schneider Corporation of America, 400 Crossways Park Drive, Woodbury, NY 11797, (516) 496-8500.

Western U.S.A. Service: 861 Production Place, Newport Beach, CA 92663, (714) 631-7430.



 **Schneider**
KREUZNACH
SHOOT FOR THE BEST.

Circle 140 on Reader Service Card

Deregulation: FM Restrictions and Call Signs Go Under the Knife

Editor's Note:

Due to the unusually heavy activity in Congress and at the FCC in the early stages of this new political term, we have decided to provide additional information beyond our normal FCC column regarding changes in Washington.

By Harry Cole, Bechtel & Cole, FCC Counsel

The dramatic face-lifting of broadcast regulation is continuing its phenomenal advance virtually unabated. This month, reports on the elimination of certain restrictions on the use of Class A FM channels is addressed, as well as a proposed change, which, if adopted, will certainly be more immediately noticeable to the listening and viewing public than just about any of the sweeping changes already effected in this decade of deregulation.

Class A FM restrictions

As most broadcasters are probably aware, for more than 20 years the Commission has designated 20 of the 80 commercial FM channels as Class A channels. That has meant that stations operating on those channels were limited to three kilowatts of effective radiated power and antenna height of 100 meters (328 feet); it also meant that the remaining 60 channels were reserved for higher powered Class B or C use. In other words, there was a real distinction

"The new rules are also almost certain to enhance the desirability of Class A stations."

between the Class A and Classes B/C, and imposed restrictions kept them far apart.

While the more limited Class A facilities were in many situations adequate to permit the Class A broadcaster to serve its community of license, they often proved inadequate to meet the competition from nearby Class B or C stations. Further, the better the station's facilities, the better its ability to serve a wider area than merely its community of license. Thus, Class A licensees have occasionally pressed for relaxation or elimination of the limitations on their potential facilities.

In connection with Docket No. 80-90 the Commission had taken

an initial step in the direction of breaking down the distinctions between FM channels with respect to the classes of station that could be operated on them. As part of the deliberations, the FCC had decided that applicants could use Class B or C channels for Class A use. In other words, even if a full Class B or C station could not be authorized on a particular channel in a particular community because of minimum mileage separation considerations, a Class A station could be established on that channel as long as it satisfied the less-stringent separation limits applicable to Class A stations.

Having thus opened all commercial FM channels to potential Class A operation, the Commission then moved to the next logical step: why not open all commercial FM channels to operation by any class of station? That is, why not permit Class B (including B1) or C (similarly including C1 and C2) stations to operate on channels previously restricted to Class A stations, as long as the more-stringent mileage separations can

be met. And, in February, that's precisely what the Commission did.

As a result, a variety of possible options are now available in the FM service. First, existing class A licensees may be able to upgrade to a higher class of service on their present channels. This will, in most instances, permit them to increase significantly their service areas, bringing service to audiences beyond the reach of their Class A signal. Such upgrading might require a change of transmitter site, in order to satisfy minimum mileage requirements.

Still, the advantages in increased coverage could be worth

channel classification and orders the petitioner to modify its operation accordingly; the NPRM will also invite interested parties to comment on the proposal. While some opposition might be submitted by, say, competitors in the market who would prefer not to face an upgraded operation, as a general matter there are few available grounds on which to oppose this kind of proposal successfully. (One such ground does exist where upgrading on Channel 221 is proposed and where there exists a nearby Channel 6 television operation. In such instances, the Commission intends to scrutinize the proposal closely to make sure

though.

The new rules were to become effective on March 23. If you wish to explore upgrading possibilities, you should contact your consulting engineer.

New call sign rules proposed

One area of FCC activity that many observers thought would not get simpler was the area of call sign regulation. After all, almost four years ago the Commission had substantially streamlined the call sign process, and things appear to have been working smoothly since then. But ever vigilant for more deregulatory possibilities—and also possibly because there are fewer and fewer areas left to deregulate—the Commission has again turned to call signs.

Basically, the Commission is looking to provide licensees with "greater flexibility in choice of call letters" and also to expedite processing of call sign requests. To those ends it has proposed to eliminate the requirement that "conforming call signs" be assigned only to a single licensee in a single market. Historically, the Commission has held that, where a licensee has a particular call sign (let's say, for example, WAAA), that licensee has an exclusive claim both to that call sign, and also to identical conforming call signs in different services.

An even more dramatic aspect of the Commission's overall proposal would be the elimination of the geographic restriction on the use of "K" and "W" prefixes in call signs. Since the earliest days of regulation the Commission has used the "K" prefix for stations west of the Mississippi and the "W" prefix for stations east of the Mississippi. Whatever basis that distinction may once have had, the FCC has concluded now that there is no longer any public interest justification for it. As a result, if the proposal is adopted, many listeners and viewers are likely to experience a whole new call sign sound, as the Ks travel east and the Ws travel west.

"The Commission is looking to provide licensees with greater flexibility in choice of call letters."

the difficulties encountered. The new rules are also almost certain to enhance the desirability of Class A stations that are subject to upgrade possibilities, a factor that could prolong what is largely a seller's market in FM licenses. And finally, vacant Class A channels that might previously have been written off as unattractive are sure to be scrutinized closely for upgrade possibilities.

In order to take advantage of the new rules, Class A licensees need not file an application. Rather, a licensee looking to upgrade will have to file a petition for rulemaking in which it demonstrates that a higher class of station could be operated on that channel at that location consistent with the mileage separation rules and other related allocation criteria. Your consulting engineer should be able to assist you in determining whether a particular situation is ripe for upgrading. A petition for rulemaking is usually a relatively simple document that should not take too much time (or money) to prepare and file.

If it is acceptable, the Commission's staff will issue a Notice of Proposed Rule Making (NPRM) in which it proposes to upgrade the

that the availability of existing and potential noncommercial educational FM service will not be adversely affected.)

Once the comments and reply comments have been submitted and considered, the staff will normally issue a Report and Order that (absent any effective opposition) adopts the proposed upgrade and orders the licensee to improve its facilities.

In revising its rules, though, the Commission did not change a couple of related rules. In particular, it chose to maintain the geographic zone designations, which determine whether non-Class A stations will be either Class B (or B1) or Class C (or C1 or C2). Also, it decided to maintain the Class A power and antenna height specifications of three kilowatts and 100 meters. Some parties had suggested that, to improve the lot of Class A operators, the Commission should simply grant across-the-board power and height increases. The Commission, however, concluded that it did not have enough information before it to make that decision at this time; in so doing, it left the door open to the possibility of making this type of change sometime down the line,

The final element of the proposal involves call sign swaps. These usually occur when an existing licensee in a given market sells its station(s) to trade up by buying a better station in the same market. In such situations, the licensee would obviously like to retain its original call sign for use at the newly acquired station. However, the FCC's existing procedures call for the licensee instead to turn in the old call signs and then apply for them again when the license assignment goes through. This process exposes the licensee to the risk that, before it can refile for the sign, another licensee will request it and, under the "first come, first served" rule, will be entitled to it. The Commission sees no reason not to give the licensees in such swap situations the assurance that they can retain their existing call signs. Accordingly, it is proposing to include this as an exception to the first come, first served approach.

The FCC's continuing march away from anything but absolutely minimal call sign regulation may cause some legitimate worries among broadcasters. After all, a station's call sign is its name, its public image. The notion of someone else using that call sign in a way that might confuse the public is a valid source of concern. The Commission's 1983 decision not to involve itself any longer in call sign disputes was bad enough; its proposal to eliminate just about any exclusive claims to conforming call signs creates even more potential problems in this area.

There is, however, a way in which a broadcaster can secure some measure of protection against the unfair use of its call signs (or confusingly similar call signs) by other unauthorized parties. The United States Patent and Trademark Office will accept applications for registration of a station's call sign as a registered

service mark. Separate registration can also be obtained for any fanciful logos or other designs that you may have developed in connection with the call sign itself. The registration application process generally costs in the range of several hundred dollars and can take more than a year to complete. Yet, if registration is obtained, it is much easier to halt an infringing use of your mark and to obtain damages for such infringement. Of course, if you are inclined to change call signs regularly, without building up any goodwill in any given call sign, registration is probably an unnecessary expense.

However, service mark registration is certainly an option to be seriously considered if you feel that your call signs are a valuable asset you want to protect as much as possible. You should contact your communications counsel for more information about the registration process. **BM/E**

With our Automatic Remote Control System your transmitter – and your personnel – will operate with increased efficiency

Have you ever wondered if your night operator will remember . . . to switch patterns at sunrise? . . . to periodically check critical levels? . . . the correct transmitter restart sequence? You'll never have to worry if Potomac Instruments' RC16+ is on the job. Because it'll do all these tasks for you. Plus a lot more. Automatically.

With its microprocessor based control logic, the basic RC16+ provides 16 telemetry channels with automatic out-of-tolerance alarms and remote raise/lower controls;

plus 16 status channels. The automatic functions — pattern shift, transmitter restart, power control — are pre-programmed in accordance with station license requirements and controlled with an accurate master clock.

The RC16+ is also expandable. In 16 channel increments, up to a total of 64 channels. With the remote video display option your chief engineer can get a detailed readout of all measured parameters. It's updated every 30 seconds and connects to any standard telephone. The optional plug-in automatic logger provides a permanent record of all transmitter activity. Log intervals, sequence, and alarm flags are user-selectable.

And, best of all, the RC16+ is cost effective. No other unit on the market offers these features and capabilities at this low price.

Basic System	\$4,995.00
Additional 16 Channels	1,865.00
Plug-In Automatic Logger	2,499.00
Remote Video Display Unit	650.00



POTOMAC INSTRUMENTS
 932 PHILADELPHIA AVE. SILVER SPRING, MD 20910
 (301) 589-2662

New RF Techniques

Both AM radio and UHF television are benefitting from fresh approaches to existing technology. Synchronized AM is gaining new impetus as is UHF with Klystron developments.

By Robin Lanier

The backbone of broadcasting, terrestrial RF, has been less glamorous technically in recent years than satellite networking, fiberoptics, advanced automation, digital modulation, and the various other exciting developments that are crowding the industry's stages. It is, therefore, important to take note of two developments in RF technology that promise substantial benefits for both AM broadcasters and UHF television.

The one area of technical development with, perhaps, the broadest impact is "Synchronized AM," which should be capable of improving coverage for many AM stations that have reception holes in parts of their assigned areas.

The other revamped technique is the Depressed Collector Kly-

stron, in the works for a number of years at NASA and Varian, which is aimed at achieving a reduction of at least 50 percent in power consumption by UHF transmitters.

Synchronized AM

Understandably, AM broad-

casters are looking for any lift they can get. Some will soon be able to get assistance from an old transmission technique, Synchronized AM, to help solidify audience coverage.

The technique involves the addition of one or more auxiliary transmitters, fairly close to the main transmitter, operating on the same frequency, and carrying the same programs (see Figure 1). The auxiliary unit is typically of much lower power than the main transmitter and is

within the station's assigned coverage area. It is important to note that, given the crowded state of the AM band, the auxiliary is not designed to extend coverage outside the station's assigned area. The purpose of the auxiliary is to improve reception in sections of the station's assigned area where

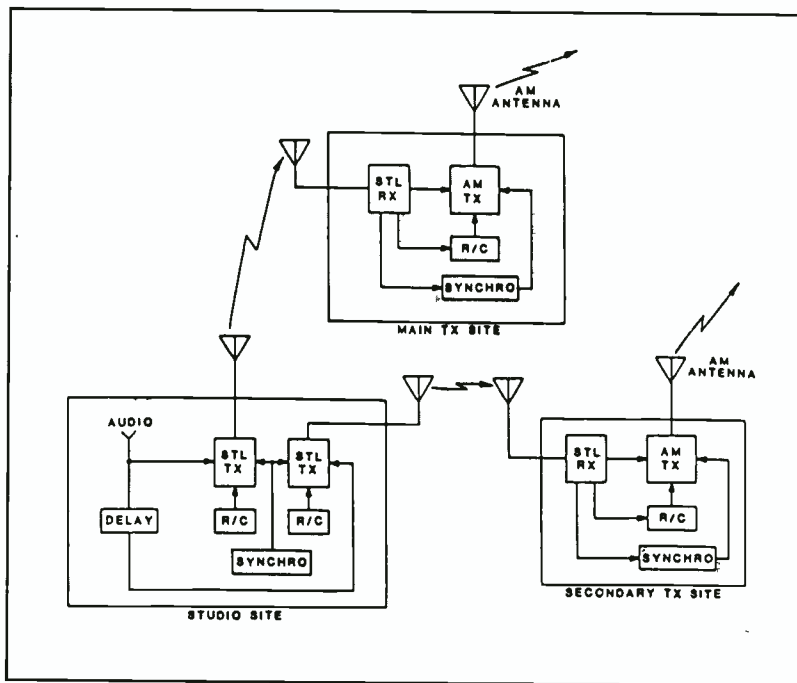

Figure 1: Typical block diagram for synchronous operation.

the signal is below standard.

In Europe, stations have been using synchronized AM for many years in their much less crowded "middle wave" bands, allowing the use of high-power auxiliaries to extend coverage over large distances. Of the half-dozen stations in the U.S. that have occasionally attempted to use the technology, WLLH in Lawrence, MA, has had an experimental license for synchronized AM since 1937, almost 50 years. The station was originally licensed to Lowell, MA, but later switched to Lawrence, maintaining both cities for its coverage area. In fact, the two synchronized transmitters are located one in each city and the station on-air ID must read "WLLH Lowell and Lawrence."

Yet, in spite of the fact that the FCC has not authorized synchronized AM on a regular basis, it has issued a Notice of Inquiry (MM Docket No. 87-6). In asking for comments toward a rulemaking for synchronized AM, the dates set for final comments was May 4, 1987, and, for reply comments, June 3, 1987.

The main impetus for recent action on synchronous AM came, in large part, from the Mass Media Bureau's "Report on the Status of the AM Broadcast Rules," issued in April, 1986. Positive reaction to the discussion led to the FCC's work on the Notice of Inquiry.

In the meantime, the Commission has publicly encouraged AM broadcasters to apply for experimental licenses, with the aim of developing technical experience that will be useful in the rulemaking. Four such licenses were issued in 1986.

Having received such encouragement from the FCC, broadcasters now await support from the hardware side. At least one manufacturer has shown a willingness to advance the cause, that being the Harris Corp., which has set up a program to develop equipment and systems for synchronized AM. Under the direction of Robert Weirather, the Harris program has given aid to several of the stations adopting experimental synchronized AM.

In a paper recently delivered at the NAB convention in Dallas,

Weirather detailed the main technical requirements and problems. The major obstacle is interference between the signal from the main transmitter and that from the auxiliary. Weirather stated that, "the two signals will coexist in an area surrounding the two transmitters, while interference is most likely to be troublesome in areas in which the two signals are of roughly equal strength."

To find the area most at risk, the broadcaster can draw signal contours for the two transmitters, or survey the area with field strength meters. The accompanying drawings from Weirather's NAB paper (Figures 2 and 3) suggest how this might be accomplished in typical cases.

A close synchronization of the carriers from the two transmitters, with the frequency difference brought as low as 0.1 Hz, will minimize interference effects. Moreover, there are a number of ways to find frequency references for the synchronization. According to Weirather, "These include, among others, satellite signals, WWV signals, and FM

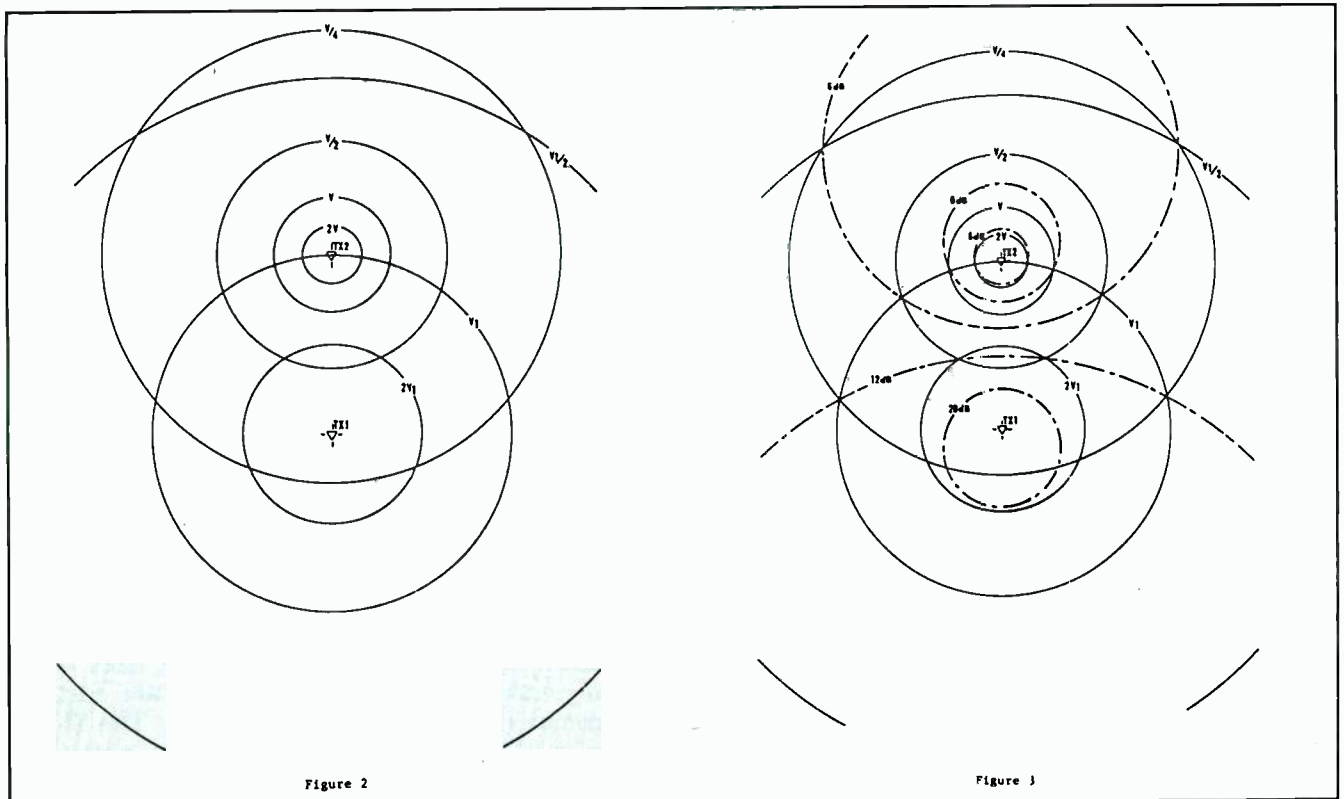

Figure 2 & 3: Signal contours for main and auxiliary transmitters in synchronized AM operation.

transmitters."

For more reliability, however, most stations are incorporating ultra-stable oscillators or phase-locked loop circuits into sync channels in the STL to the auxiliary transmitter. Either frequency or phase synchronization can be used to get the frequency offset to the 0.1 Hz parameter, giving the operation the best chances for escaping troublesome interference effects.

Even with such frequency control there may be a gray area in which the signal is noticeably degraded by interference. The broadcaster setting up the system must, in any case, survey reception conditions throughout the area reached by the two transmitters, carrying portable receivers and field strength meters to a number of locations. If there is a bad area, but with little or no present or potential audience, adjustment of the system, fortunately, is simplified.

On the other hand, if an important segment of the audience is due to get poor reception, the broadcaster must try to adjust the system to minimize the bad effects. Mark Durenberger of Durenberger Technologies in Minneapolis, MN, has been working with several stations around the country on the adjustment of synchronized AM systems. "One approach," claims Durenberger, "has been to set the frequency difference with ultra-stable oscillators so that the signal rise and fall can be absorbed by receiver AGC circuits."

An unknown result in the operation of synchronized AM is how it will mesh with a stereo signal. This will not presently affect any considerable number of potential users, with a total of about 300 AM stations transmitting in stereo. If AM stereo began to reach a substantial percentage of the industry, its relationship to synchronized AM could become more important.

These facts underscore the experimental nature of synchronized AM. Yet, the potential is so appealing to many AM broadcasters that the problems in the tech-

nique will gladly be addressed by the industry.

Synchronized in Vegas

At KROL in Laughlin, NV, the need arose to experiment with synchronized AM because the signal from the main transmitter did not reach Las Vegas, 90 miles away, adequately. Coverage of the city was assigned to the station, and preliminary study indicated that ground conductivity would be strong enough to help get a good signal into town. This analysis proved to be in error, and the station was faced with the prospect of poor service to a main part of its coverage area, an area from which was projected a significant influx of revenue.

The idea of a low-power auxiliary in Las Vegas was, therefore, attractive. The distance from Laughlin to Las Vegas made an elaborate STL necessary, especially since programs originated in Las Vegas, which was a fair proportion of programs aired, would have to go to the main studio in Laughlin and back again to the auxiliary transmitter in Las Vegas.

Given this situation, KROL was forced to install a microwave system with three hops for each one-way trip. General Manager Joe Reynolds reports that, "the adjustment of this system is still in process but hopefully will be completed during the spring." He adds that, "interference effects have been quite noticeable in some parts of the coverage area, especially at sunrise and sunset."

Reynolds is purchasing equipment to provide very close syncing, with the expectation that interference effects will be substantially reduced. The main transmitter has just gone to 10 kW, and the auxiliary puts out 300 watts by day and 500 watts at night. In addition, the KROL GM has applied for permission to increase the auxiliary power and believes that when the various changes have been accomplished he will finally put an excellent signal into Las Vegas.

A second example in which synchronized AM offered the alterna-

tive to transmission problems occurred in Albuquerque, NM. The need for the technique at KOB was the result of the longest-running contest over an AM channel in broadcasting history. Hearing after hearing, lawsuit after lawsuit, 50 kW station KOB and WABC in New York fought for more than 40 years over clear-channel use of the 770 MHz frequency. Finally giving up, KOB was forced to change its directional pattern to create a null in the direction of WABC. This action required moving one of the towers in the directional array.

The null met the regulatory requirement, but it also dropped a blanket over Santa Fe, the state capitol and a vital part of the KOB audience. A low-power auxiliary seemed an obvious solution. Chief engineer Gary Diamond set up a two-hop microwave STL, the first stage going eight miles to the top of Sandia Crest Mountain, the second stage going the final 42 miles into Santa Fe. The auxiliary contributes just 230 watts, with diplexing from an existing antenna tower in the center of town. This power augmentation supplies a good signal in Santa Fe and meets the legal restrictions now imposed on KOB.

Surveys of the areas between the two transmitters are currently underway. Mark Durenberger has been working with CE Diamond on final adjustment of the system. And, fortunately for KOB, there is almost no potential audience in the worst interference zones.

As opposed to the two previous examples WJNO, in West Palm Beach, FL, has employed synchronized AM as a positive expansion step rather than rectifying a "fault" in coverage. Population growth in the area is phenomenal, with estimates coming in at 900 new people every week. Areas on the fringes of the station's existing coverage, which used to be sparsely inhabited, are fast becoming metropolitan. The WJNO management would naturally gain something by adding these new listeners.

Chief engineer Dick Lucas is

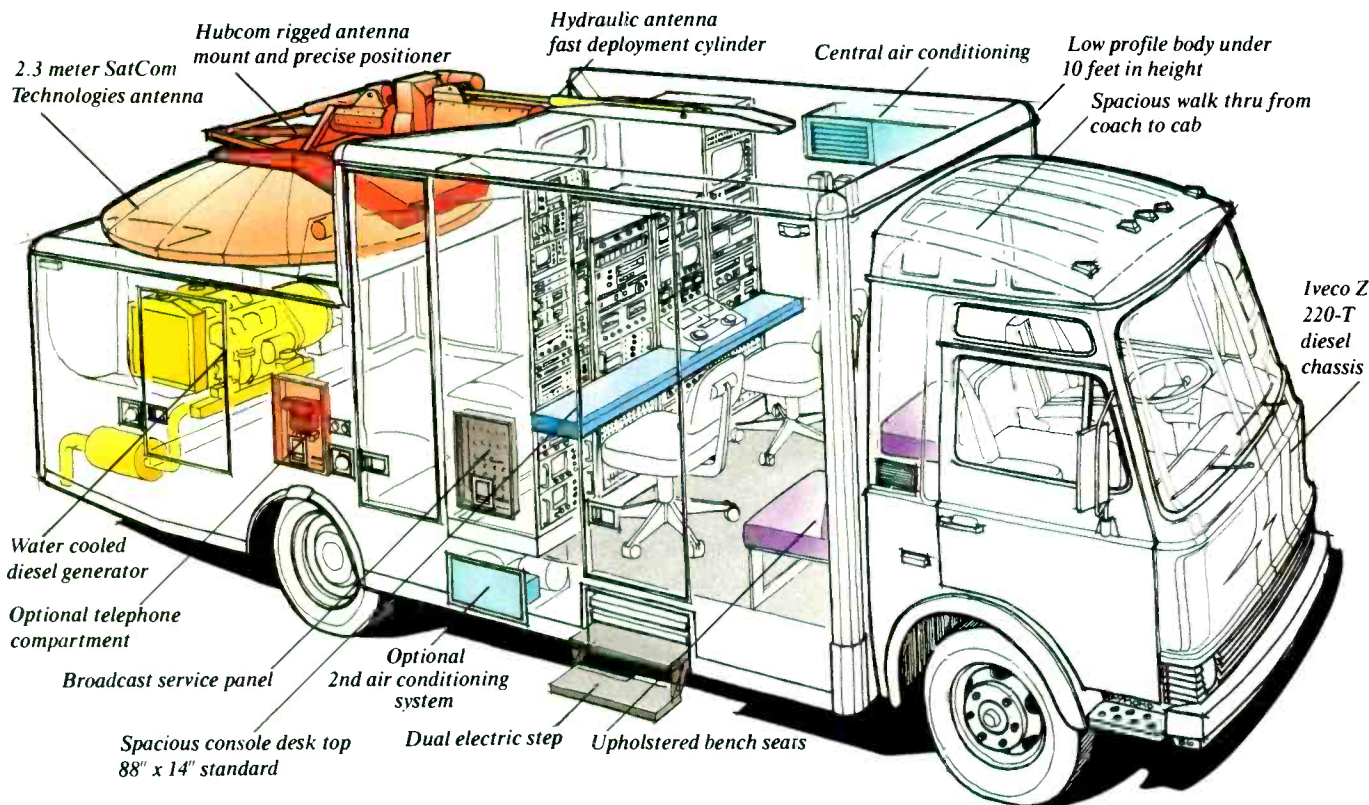

The Latest SNG[®] Innovations... From The Inventor Of SNG[®] Vehicles.

HUBCOM. Builder of the first SNG[®] vehicle in the U.S. HUBCOM. Builder of more SNG[®] trucks at work in the field than everyone else combined. HUBCOM. Introducing its second generation while others play "catch-up."

Lighter and better balanced. More compact for easier access to tight locations. Lower profiles. Improved antenna systems. And every HUBCOM SNG[®] vehicle comes equipped with a one year warranty and our 24-hour hotline.

Choose gasoline or diesel power. Choose a low profile or conventional vehicle. But whatever you choose, you'll get the latest SNG[®] innovations — from the inventor of SNG[®] vehicles...HUBCOM.

HUBCOM

HUBBARD COMMUNICATIONS, INC.

The last word in technology from the first name in the industry.

A subsidiary of Hubbard Broadcasting Inc.
12495 34th Street North, St. Petersburg, FL 33702
813/577-7759 TWX: 810-863-0417



Circle 142 on Reader Service Card



**WHEN LOOKING FOR THE LATEST TECHNOLOGY
IN UHF AND VHF TRANSMITTERS...**

Comark's recent track record of technological innovations is unmatched by any other US manufacturer. This impressive history of recognized advancements demonstrates our commitment to the future. A commitment backed by continuing substantial investments in research and product development activities.

Incorporating new technology into today's products is your assurance that the Comark transmitter purchased now will still be current in the year 2000.

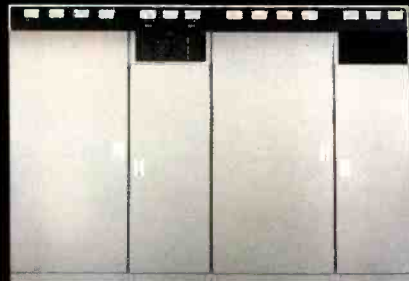

COMARK COMMUNICATIONS, INC.
A Thomson-CSF Company

Circle 143 on Reader Service Card

Route 309 & Advance Lane • Colmar, PA 18915
(215) 822-0777 • Telex: 846075

Transmission/Distribution Engineering

New RF Technology

BROADCASTING

Aug. 18, 1986

"Both COMARK and Thomson-LGT made news at the NAB..."
"COMARK introduced a 60 kw UHF transmitter with a KLYSTRODE..."

"...Thomson-LGT introduced a 30 kw SOLID-STATE VHF Transmitter..."

"Comark...first domestic source for BCD/ABC beam current pulsing systems."

 **COMARK**

**LEADING THE INDUSTRY
IN TECHNICAL
INNOVATIONS**

BM/E June 1986
NAB Show-In-Print

"...the principal advance reported at this NAB was the long-awaited commercial realization of the KLYSTRODE TUBE design in a production transmitter from COMARK."

"COMARK is first US manufacturer to build production transmitters specifically designed for and featuring wide band external cavity KLYSTRON amplifiers."

BROADCAST ENGINEERING—
May 1986 Transmission
Systems Special Issue

"High-performance Klystrons, Klystrodes and solid-state RF amplifiers are reducing operating costs and improving broadcast transmitter quality."

"COMARK was the 1st domestic manufacturer to design and produce no-tuning solid-state exciter/driver for use with Klystron transmitting systems."

putting in a synchronized AM system with an auxiliary transmitter 28 miles to the south. Lucas hopes to have it installed and running sometime in May of 1987. He is, of course, aware of the interference problem and regards the southward orientation as a trial venture, a way of finding out how the technique works in WJNO's setting. If it is successful, he will seek authorization for additional auxiliaries to the west and north to cover population growth; to the east lies the Atlantic Ocean.

Efficient Klystrons for UHF-TV

Every owner of a UHF television transmitter would like to reduce the amount of electrical power the final amplifier (most often a klystron) draws down from the power supply. A considerable number of methods and devices for raising the efficiency of klystrons have been developed over the years, and some have been effective, within fairly narrow limits. New, high-efficiency klystrons are currently promised by several manufacturers, and they will no doubt further cut the power load.

A technology that will provide major reductions in power consumption, and in a form that has been brewing in various laboratories since the early 1980s, now appears to be fairly close to a useable klystron form. At the NASA Lewis Research Center in Cleveland, OH, H.G. Kosmahl and his associates worked out the very difficult analytical problems of adapting the depressed collector technique, long used in travelling wave tubes, to high-power klystrons.

The fundamental idea behind the depressed collector is this: As the spent stream of electrons moves toward the output, it carries a considerable quantity of kinetic energy. This energy was, in the standard klystron, lost in heat at the collector. The multistage depressed collector is a series of concentric electrodes at gradu-

ated voltages "depressed" below the body voltage (hence the name). By proper geometrical configuration of the electrodes and assignment of voltages, the series of "rings" will pick up the electron stream, converting the kinetic energy to potential energy, and returning power to the supply.

A major problem of the design is to avoid "backstreaming"—sending some of the electrons back up the line—an occurrence that is obviously counterproductive. Beyond such considerations, the highest efficiency requires the smoothest possible collection of the electrons of various energies by the appropriate electrodes. Thus the problem is, to a large extent, one of trajectories. This poses the question: How do you configure the electric fields so that the electrons are guided effectively straight forward to the proper rings in the collector?

Kosmahl's work, reported by him in detail in the IEEE Proceedings in November, 1982, indicated that a depressed collector could be made to work. Earlier thought in the industry had been that the backstreaming and trajectory problems would be too difficult to handle and still bring about a net gain in efficiency. The NASA researchers used computer-aided analysis on a large scale and came up with convincing figures on the potential of depressed collector rings.

Such analytical success led to a large-scale development program jointly sponsored by NASA, the NAB, PBS, several transmitter manufacturers, and Varian. The latter began development under contract to the group. The stated objective was a high-power klystron for UHF television that cut the power load by 50 percent. The program got underway in June, 1984, at Varian.

E.W. McCune, of Varian, has reported each year at the NAB on the progress of the program. He has also presented papers on the program at various IEEE meetings; the super-efficient klystron is not going to spring upon the industry unheralded. In fact, industry observers agree that one, al-

ready evident, effect is the stimulation of work under other auspices toward higher efficiency.

A prototype based on the 60 kW VKP-7555, for 700 to 900 MHz, is now ready for actual operating tests at Varian, according to McCune.

The NAB, under the direction of chief of engineering Tom Keller, is now aiding in several engineering programs with broad interest for the industry. (One example is FMX, developed by Keller and Emil Torick of CBS, which is reported to enlarge the coverage area of FM stereo stations to get back the listeners stereo eliminates [see "FMX," *BM/E*, Sept. 1986, p. 47])

Similarly, PBS has a definite interest in the new klystron. As Mark Richer of PBS in Washington pointed out, "This organization has several television stations operating with UHF on very restricted operating funds. Cutting the consumption of power in the output by 50 percent will be of

obvious benefit to them."

It is important to note that the tube will be generally available throughout the industry, as manufactured by Varian or under Varian license.

The development work has several interesting aspects, though this article by constraint of form can only briefly touch on them. Shaping the electrodes so that they produce the right electric fields, for the right trajectories of particles, might have taken years of trial and error without very advanced computer programming assistance. To get the particles to the electrodes smoothly, Varian used a computer program designed in-house called HGUN. The software could "draw" the paths of the electrons with various selected electrode geometries (see Figure 4).

Researchers involved in the project also had to develop a special technique for coating the electrodes with a thin layer of carbon. A new sputtering device did the

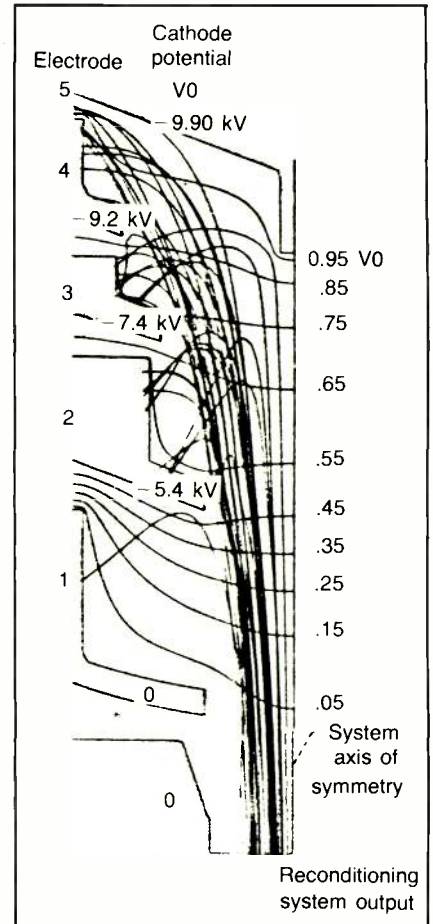

Figure 4: Electron trajectories in four-stage 2.4 cm-diameter depressed collector with TWT operating at saturation.

job successfully. The objective was to reduce the effects of secondary electrons, knocked out of the metal surface by the impact of arriving electrons.

As the entire industry begins its recovery from a severe slowdown, it seems that the backbone, terrestrial RF, is leading the way in strengthening existing technology, developing new strategies, and incorporating advanced design systems as a way of finding the right solutions. If the accomplishments in synchronized AM and UHF television are any indication, these contributions will help to straighten broadcasting's sagging posture. **BM/E**

About the Author:

Robin Lanier, formerly *BM/E*'s senior editor, is now an independent writer and consultant living in New York City.

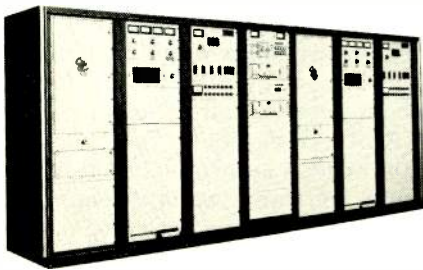

**A First
For The
Industry**

70,000 watts FM

Continental's new 817R-5 combines two proven 816R-5 35 kW transmitters to offer broadcasters many operating advantages. The 817R-5 uses husky components and is built to give many years of dependable service. The first 817R-5 has been shipped to KABL, San Francisco. For product data, call your local Continental Sales Manager.

- SCR power control
- Automatic RF power output control
- Automatic SWR circuit protection
- SWR output power foldback
- Remote control interface
- AC power failure recycle
- Grounded screen amplifier
- 802A exciter

Transmitters: 1 to 50 kW AM and to 70 kW FM, antennas, studio & RF equipment © 1986 Continental Electronics/6322



Minor Adjustments

By Harry Cole, Bechtel & Cole, FCC Counsel

With most of its substantive deregulatory measures already in place, you might think that the FCC would have little to do anymore. Think again. One of the problems with designing a major overhaul of longstanding rules, policies, and guidelines is that the results have to be monitored fairly closely for undesirable consequences.

Obviously, where such consequences arise, adjustments have to be made. And sometimes the problem is not so much in the monitoring of results as it is in the implementation of the policies in the first place: while the Commission may be clear as to what it wants to accomplish, it occasionally is not so clear as to how its goal can or should be accomplished. A clear example of this phenomenon popped up recently.

Financial disclosure

First, as anyone who has filed an application for, say, a new station within the last several years knows, you don't have to submit an exhaustive showing relative to your financial wherewithal as part of your application. In fact, you don't have to submit *any* showing. Instead, you merely have to put a checkmark in the "yes" box in response to two questions on the application form which ask, in effect, whether you are financially qualified to do the deal you are proposing in the application.

In the old days, things weren't so simple. Applicants used to have to provide a detailed listing of their anticipated expenses together with documentation demonstrating that they had sufficient funds available from committed sources to meet those expenses. This "documentation" could be a loan commitment letter from a bank, stock subscription agreements from shareholders, credit agreements with equipment suppliers, or other similar materials. They all had to be submitted with the application, which meant that they had to be negotiated, reduced to writing, and signed *before* the application could be finally assembled. Everything that was contained in the application had to be reviewed by the Commission's processing staff. That alone added to the time required to process applications.

Moreover, an applicant's financial documentation was available to competing applicants and petitioners to deny to review and criticize, which made the staff's job even more difficult—even if the staff might have been willing to overlook minor deficiencies in a financial showing, rest assured that competing applicants would not be so charitable. Thus, the requirement that documentation of financial qualification be submitted with the application tended to cause problems and slow

down the processing of applications. Accordingly, as part of its initial deregulatory approach, the Commission eliminated the documentation requirement and substituted, therefore, the "certification" approach.

Now, when the Commission adopted this approach, it did not intend that applicants would simply answer "yes" to the financial questions without having first done all the homework that would previously have been required of them. That is, applicants were still expected to generate their own list of projected expenses, and they were also still expected to arrange for sufficient financing, and they were also still expected to obtain and maintain documentation of these efforts in their own files. The only difference was that they were no longer required to file this documentation as part of the application.

That, however, is not how a number of applicants apparently have interpreted the new certification approach. Rather, the Commission has now determined that "a number of ... applicants have certified their financial qualifications without any basis or justification." Of course, the certification process certainly does not discourage that type of behavior. After all, if the FCC's form asks, in effect, "are you financially qualified," it should not be surprising if applicants are reluctant to answer "no." Further, the form itself was less than clear as to the assumptions that the Commission would attach to an affirmative answer. (Indeed, as we will discuss below, the Commission continues to be somewhat unclear on this.) But, in any event, the Commission is not pleased that it is uncovering so many instances of applicants who, despite affirmative certifications of financial qualifications, are turning out not to be qualified.

To adjust for this troublesome glitch in the deregulatory program, the Commission announced in March that it is instituting procedures "designed to detect and deter" false financial certifications. Those procedures call for the processing staff to "initiate a program of random checks" of applicants for construction permits for new broadcast facilities. The Commission has given no indication of how it will implement this random spot check system, although it did say that "where an applicant has a large number of pending broadcast applications, the staff may question the validity" of that applicant's certifications. Applicants who are selected for spot checking will be required to "submit documentation and information supporting its certification that it has available the financial resources to construct and operate the facility for three months without reliance on advertising or other station revenues."

Abuse of process

The real kicker is that failure to make an adequate showing in this regard will raise questions about whether the applicant has made misrepresentations to the Commission and whether it has abused the Commission's processes. These would present heavy-duty problems to an applicant because even in this deregulatory, non-enforcement-minded day and age, misrepresentation and abuse of the Commission's processes remain among the most serious charges that can be leveled against an applicant or licensee. Further, if the Commission concludes that misrepresentation or abuse of process has occurred, the guilty applicant could be rendered unqualified to own *any* broadcast facility. Also, intentional false certification is a federal criminal offense, the punishment for which is a \$10,000 fine and/or five years' imprisonment. This is, therefore, something which should not be fooled around with.

If you have any applications on file in which you have made a financial certification, you should be sure to review that certification (and the basis for it) with your communications counsel, to ensure that adequate justification for the certification exists. If it does not, you may have to take appropriate corrective steps immediately in order to avoid any adverse conclusion in the event your application is selected for a spot check.

In this last respect the Commission is less than clear relative to what, if any, steps can be taken now to correct a financial certification that, at the time it was made, lacked adequate justification. As a theoretical matter, an applicant who certified on the basis of inadequate justification could never correct the potential misrepresentation problem because, even if the applicant did manage to shore up its finances after the fact, it still technically filed a false certification. The Commission has made clear that false certifications are, in its view, misrepresentations.

The trouble is that, in its announcement of the random spot check procedures, the Commission states that, under the certification process, "applicants are spared the time and effort necessary to prepare and submit the documentation previously required to demonstrate their qualifications." This in effect says that the Commission may not have expected its applicants to "prepare ... the documentation" in order to justify a financial certification. If that is what the Commission actually believes, then it would theoretically be possible for an applicant to obtain documentation now in order to shore up a previously filed, inadequately justified certification.

While it remains to be seen how the Commission and its processing staff will deal with this question, it is reasonable to assume that a central focus of their review will be the applicant's actual efforts—independent of the availability (or lack thereof) of documentation—to establish its financial qualifications at the time it prepared its application. In other words, if the applicant sim-

ply checked "yes" in the financial certification boxes without giving any thought to how to finance its proposal, that applicant will likely have substantial difficulty if its application is randomly selected for checking, even if it can now secure some adequate form of documentation. On the other hand, if an applicant can prove that it did in fact meet with financial backers and did in fact make arrangements for funding when it first applied, the Commission may be willing to accept the certification even if the applicant did not have documentation of its efforts prepared at the time that its application was filed.

The new random spot checking approach is clearly a departure from the deregulated streamlined processes which the Commission has been working to develop. It is, however, a necessary approach if the Commission intends to continue to require that its applicants be financially qualified.

Revised licensing

On a marginally related note, the Commission also announced in March that it is now prepared to issue its revised Ownership Report form for commercial licensees. If you are a commercial licensee, you should have received your copy of the form by now; if you have not, you should contact your communications counsel. The Commission has long required broadcasters to provide it with information concerning their ownership structure. This information was generally submitted on formal Ownership Reports (FCC Form 323). Each time the information already on file changed at all, an updated report had to be filed. This was, in the Commission's deregulatory view, unnecessary and accordingly, a couple of years ago, it reduced the filing requirement substantially. Under the modified requirement, ownership reports need only be filed once annually (on the anniversary of the filing of the station's license renewal application). Licensees that are sole proprietorships or partnerships composed entirely of natural persons are exempted from even the annual filing requirement.

The modified Ownership Report filing requirement has not previously been implemented, though, because at the time that it was adopted the Commission also decided to revise the Ownership Report form to include various changes in Commission rules and policies. The revised version of the form required approval of the Office of Management and Budget, and that approval was a long time in coming.

In order to bring the Commission up to date on ownership changes that have occurred since the last reports were filed several years ago, all non-exempt commercial licensees are being required to file a Revised Ownership Report form on or before August 3, 1987. Then, starting next February 1, the annual reporting system will kick in, with each nonexempt licensee filing a revised report on the anniversary of its application. **BM/E**

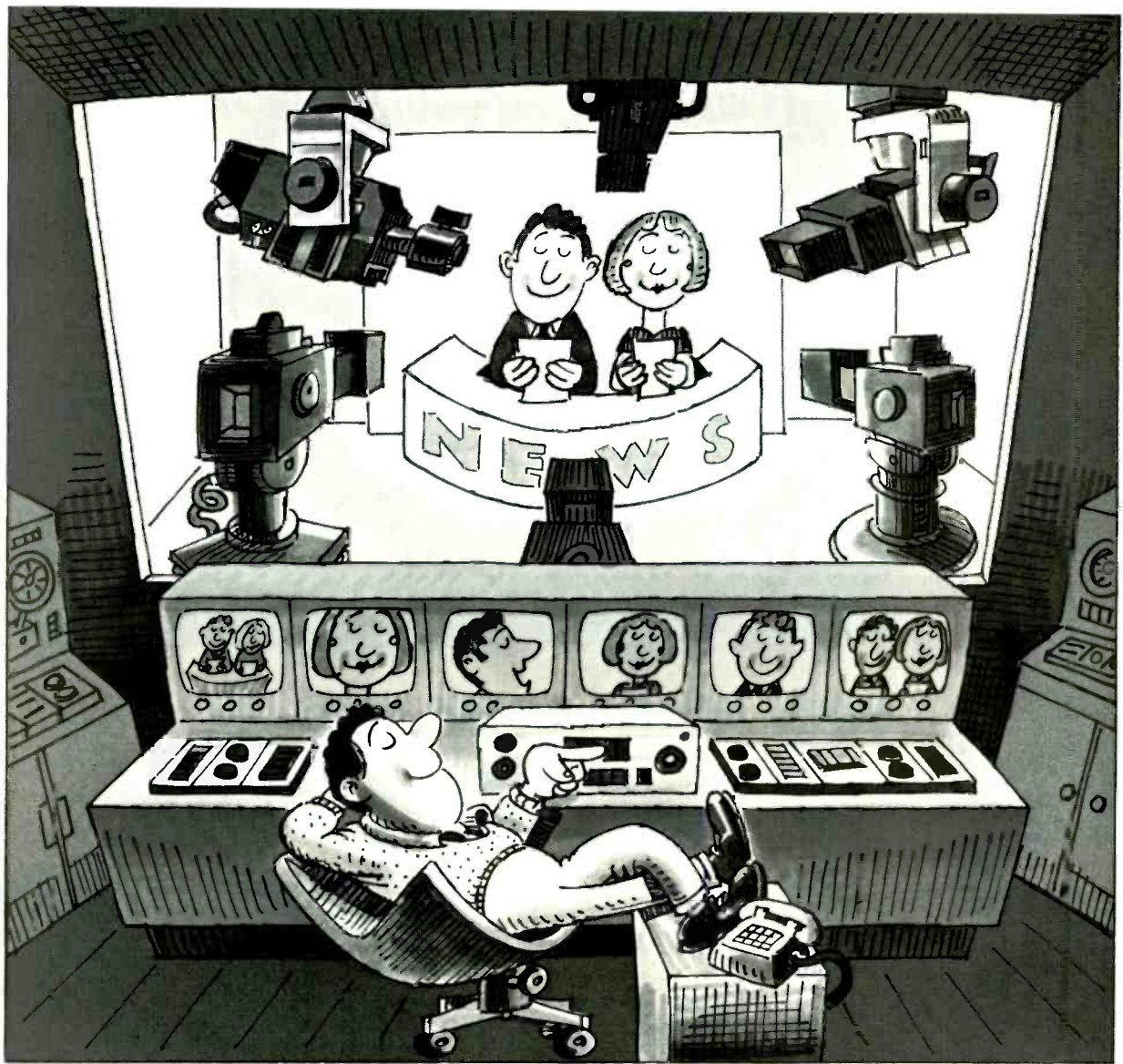

MULTIPLE CAMERAS. ONE OPERATOR.

Impossible? Not if your cameras are mounted on EPO Servo-Controlled pan and tilt heads. These extraordinary, labor-saving devices, which first found favor in legislatures where remote-controlled, unobtrusive coverage was a key factor, are now the basis for complete remote-controlled news studios.

Just look at these outstanding features:

- Up to 500 preprogrammed positions per camera, including control of iris and black levels
- Programmable fade modes that provide smooth transition from preprogrammed shots

- Ability to zoom and focus
- Unobtrusive
- Can be operated via telephone lines or microwave in a remote studio away from the main studio location
- Wide range of pan and tilt heads, for full studio cameras with teleprompters to ENG type cameras
- Wide range of control options, from panels with multiple-shot memories to simple joy stick remote controls.

It's flexible, affordable—and it's sold and serviced exclusively in the U.S.A. by A.F. Associates.

THE RADAMEC EPO REMOTE CAMERA CONTROL SYSTEMS

Your news show's bottom line will never look so good.



A.F. ASSOCIATES INC.

ADVANCED SYSTEMS AND PRODUCTS FOR THE VIDEO INDUSTRY
100 STONEHURST COURT NORTHVALE NJ 07647 (201) 767-1000
10650 SCRIPPS RANCH BLVD SUITE 200 SAN DIEGO CA (619) 530-2970

THOMSON-CSF

POLARIS 5576

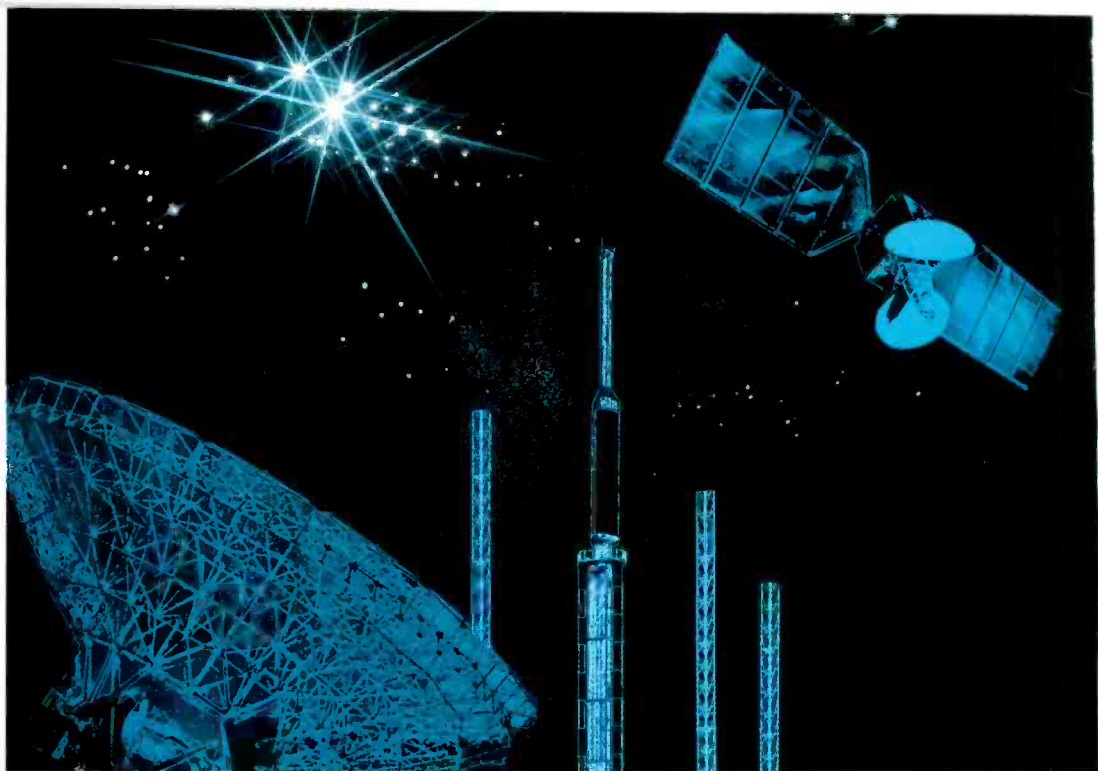

THE FURTHER WE GO, THE FURTHER YOU GO.

At Thomson-CSF we've been pioneers in developing the use of high-power tetrodes in transmitters for more than 70 years.

Over the years we've stayed ahead with such developments as Pyrobloc® grids and the Hypervapotron® cooling system.

We offer: A complete line of tubes for radio broadcasting applications from FM to the most powerful SW and LW transmitters - the quality of our 500-600 kW tubes has been amply demonstrated in 15 years of service in over forty transmitters worldwide.

A complete line of power grid tubes and their associated cavities for UHF/VHF TV transmitters. Thanks to their efficiency, reliability and tight tolerances, systems makers can offer their customers substantially more cost-effective products.



High power radio broadcasting tetrodes up to 1.2 MW.

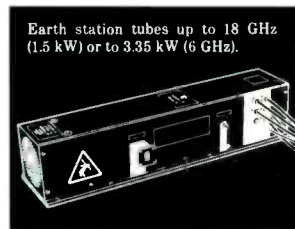

Earth station tubes up to 18 GHz (1.5 kW) or to 3.35 kW (6 GHz).

High efficiency space TWTs (including 50 W and 100 W Ku-band for next generation DBS Satellites).



A complete line of klystrons and TWTs for ground stations and space TWTs for direct broadcasting satellites (DBS) designed to last for at least a decade.

And we also produce high-resolution image pick-up tubes and devices (CCDs), and high-luminosity CRTs for top range professional applications.

In radio and television, telecommunications, military and civil aviation, as well as in a wide range of scientific and medical applications, Thomson-CSF know-how gets your systems moving. Fast.

The world's most powerful tubes for radio and TV broadcasting.

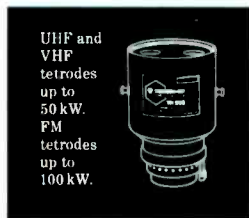

UHF and VHF tetrodes up to 50 kW. FM tetrodes up to 100 kW.



Matched cavities for best results.



THOMSON-CSF
ELECTRON TUBES

THOMSON ELECTRON TUBES
AND DEVICES CORPORATION
550 Mount Pleasant Avenue
P.O. Box 6500
DOVER, NEW JERSEY 07801.
Tel.: (201) 328-1400. TWX: 710987 7901.

Belgique : BRUXELLES
Tel. (32-2) 648 84 85
Tx 23113 THBXL B

Brazil : SAO PAULO
Tel. (55-11) 542 4122
Tx (011) 24-226 TCSF BR

Canada : MONTREAL-QUEBEC
Tel. (1-514) 288 41 48
Tx 5560 248 TESAFI MTL

Deutschland : MUNCHEN
Tel. (49 89) 78 79 0
Tx 522 916 CSF D

España : MADRID
Tel. (34-1) 405 16 15
Tx 46 033 TCCE E

France : BOULOGNE-BILLANCOURT
Tel. (33 1) 46 04 81 75
Tx THDMTUB 200 772 F

Italia : ROMA
Tel. (39-6) 639 02 48
Tx 620 683 THOMTE I

Japan : TOKYO
Tel. (81-3) 264 63 46
Tx 2324 241 THCSF J

Sverige : TYRESÖ
Tel. (46-8) 742 0210

United-Kingdom : BASINGSTOKE
Tel. (44 256) 29 155
Tx 858 865 TESAFI G

U.S.A. : DOVER
Tel. (1 201) 328 1400
TWX 710987 7901

Circle 151 on Reader Service Card

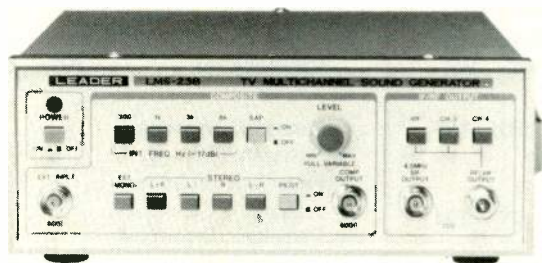

Leader Generates MTS Gear

Leader Instruments Corp. has introduced a new low-cost high-performance MTS signal generator, the LMS-238, that is designed to complement the firm's laboratory-grade LMS-237 MTS generator.

On-screen displays (L+R, L, R, L-R) indicate the selected mode of stereo or mono operation. Composite stereo and SAP outputs at baseband, SIF (4.5 MHz), VIF (45.75 MHz), Channel 3, and Channel 4 allow the technician to pinpoint the area of malfunction. Four selectable internal modulation frequencies (300 Hz, and 1, 3, and 8 kHz) at 14 percent modulation are provided as well.

The LMS-238 provides the necessary signals for test and alignment of both stereo and SAP decoders.

Circle #200 on Reader Service Card.



Shure Headset Mic Debuts

A new head-worn condenser mic, the SM15, has been announced by Shure Bros. Inc. Designed to incorporate the performance characteristics of a handheld mic with the convenience of a head-worn format, the SM15 features a brand-new uni-directional electret condenser cartridge.

The mic delivers a smooth frequency response (50 to 15,000 Hz) with a full "fat" low end. Sound pressure capacity is 141 dB, eliminating overloads in even the most extreme performance

conditions.

The headset chassis features a new double-braced headband with special grip pads to adjust the fit without dislodging the mic itself. In addition, the unit can be adapted to the Shure Wireless Microphone System. List price is \$275.

Circle #201 on Reader Service Card.

Vicon Intros Pan and Tilt

Vicon Industries Inc. has introduced the LV3530BPT broadcast-quality high-velocity servo positioner. The unit's features include a 60-pound load rating, infinitely variable pan and tilt speeds over a 12:1 range, continuously variable 1.2- to 15-degrees/second pan speed, and a 2.0- to 24-degrees/second tilt speed.

A newly developed zero-backlash differential planetary gear output positions the load across three independent precision gears (as opposed to a single gear), which cuts down on drive wear and tear.

The V3530BPT drive system, designed for studio-silent operation, features a totally enclosed housing assembly, which captures air-borne noise; sound-dampened azimuth and elevation motors; and hum-free gears and motors.

Circle #203 on Reader Service Card.

L I G H T I N G

Call **ESV** now
for the
brightest ideas
and the
lowest prices

Lamps up to **55% off** list,
lighting supplies and
fixtures at discount prices

Studio • Stage • Projection

GE • Sylvania • USHIO • Phillips

Osram • Thorn • Wiko

Phone or mail in business card for **FREE** quarterly
newsletter with money-saving tips on lighting.

ESV

ESV, Inc.
525 Court Street
Pekin, IL 61554

800-432-6411 (Illinois, 309/347-6685)

Circle 150 on Reader Service Card

Advertisers Index

Manufacturer	Page Circle	
	No.	No.
AF Associates Products	31	118
AF Associates Products	79	145
Alpha Audio	53	146
Audio Technica, U.S.	50-51	130
Avcom of Virginia	53	147
Belar Electronics	49	128
Bryston Vermont Ltd.	49	129
Camera Mart, Inc., The	5	103
Canon USA, Inc.	25	114
Chyron Corp.	Cov. 3	148
Colorgraphics Systems Inc.	23	113
Comark Communications, Inc.	74-75	143
Continental Electronics, a Division of Varian Associates, Inc.	76	144
Datatek Corp.	42	124
Dielectric	16	111
Digital Video Systems	26	115
Dubner Computer Systems	37	120

Manufacturer	Page Circle	
	No.	No.
ESV, Inc.	80	147
Fidelipac Corp.	1	101
Grass Valley Group, Inc., The	6	104
Hubbard Communications	73	142
Ikegami Electronics (U.S.A.)	15	110
Imageering Laser Disk Systems, Inc.	27	116
Lake Systems Corp.	47	126
LeaseAmerica	58	135
3M/Broadcast Products Div.	57	134
Microtime	13	108
Midwest Corp.	11	106
Mycro-Tek	32	119
NEC America, Inc.	54	133
Odetics	28	112
Otari Corp.	52	131

Manufacturer	Page Circle	
	No.	No.
Panasonic Broadcast Systems Co.	61	136
Panasonic Broadcast Systems Co.	63	137
Panasonic Broadcast Systems Co.	65	139
Potomac Instruments	69	141
Sachtler Corp.	17	117
Schneider Corp. of America	66	140
Scientific-Atlanta	64	138
Shure Brothers Inc.	14	109
Solid State Logic	82	—
Sony Broadcast Products Co.	2-3	—
Sony Broadcast Products Co.	18-19	—
Sony Pro Audio	40-41	123
Sony Tape Sales Co.	9	105
Studer Revox America, Inc.	Cov. 2	100
Telecom Research	12	107
Telex Communications	4	102
Telex Communications	45	125
Telex Communications	48	127
Thomson-CSF	80	150
Townsend Broadcast Systems	39	122
Videotek	38	121
Ward-Beck Systems	Cov. IV	—

Solid State Logic

is seeking an experienced

BROADCAST SALESPERSON

to join our growing West Coast operation

With the introduction of the SL5000M Series Audio Production System Solid State Logic requires an additional salesperson to cover the West Coast Broadcast Market.

This position involves direct sales and working with prospective broadcast clients to help translate their audio system requirements into specifications for production.

Applicants should have in-depth knowledge of broadcast audio practices and should have had technical or operational experience. Applicants with previous sales experience are preferred.

Please apply in writing, detailing your career experience to:

Andy Wild, **Solid State Logic**, 6255 Sunset Blvd., Los Angeles, CA 90028.

All enquiries will be handled confidentially.

SALES OFFICES

295 Madison Avenue New York, NY 10017 Telex: 64-4001 William McGorry, Publisher

Eastern States

295 Madison Avenue
New York, New York 10017
212-685-5320
Telex: 64-4001
Michael Dahle
Denise Lalonde

Central States

33 East Cedar St.
Suite 12F
Chicago, IL 60611
(312) 664-0572
Gene Kinsella

Western States

12333 South Saratoga-
Sunnyvale Rd.
Suite C
Saratoga, CA 95070
(408) 996-7300
William H. Sleight

Europe/United Kingdom

33A Station Road
North Harrow
Middlesex HA2 7SU England
(01) 427 9000
Telex: 21289
Ric Bessford

Japan/Far East

2-14-20, Minami-Aoyama.
Minato-Ku, Tokyo 107 Japan
(03) 405 5118
Telex: 2427388
Fax: (03) 401-5864
K. Yamamoto
Y. Yozaki

CHYRON IV and CHYRON's SCRIBE

Today's Graphics and Text Generators for the Next Generation!

In our fast-paced technology, helping professionals project the ultimate video image is CHYRON's constant goal...and CHYRON's repeated achievement. This requires the advanced expertise to innovate in systems and products—plus the resources to innovate continuously, to deliver the best in equipment today, and to enhance it with the breakthroughs of tomorrow, next year, and the next generation. That's why, in a world of studios, the name CHYRON is a "household" word.



The photographs shown are unretouched.

CHYRON IV. The First Graphics Generator with Motion. Electronic magic enhances CHYRON IV again! Now, with this industry pacesetter, you can create and screen sparkling animation, multi-color characters, independent background graphics, special effects and more—all with ultra-high resolution. First from CHYRON of course.

SCRIBE. The Ultimate Text Generator. Another "first!" CHYRON's SCRIBE unites the operating/ chromatic capabilities of the character generator with the high resolution of a virtually unlimited range of typographic images and styles formerly confined to print media. SCRIBE text generates new potentials in creativity and performance.

For all the facts on CHYRON IV, CHYRON's SCRIBE, or both—call CHYRON today.

The Breakthroughs of Tomorrow...Today.

CHYRON TELESYSTEMS
A MEMBER OF THE CHYRON GROUP

265 Spagnoli Road, Melville, NY 11747 • 516-845-2020 • Telex: 144522 CHYRON MELV

West Coast: 20469 E. Valley Blvd., City of Walnut, CA 91789 • 818-842-3244

Chyron (U.K.) Limited, Dancon House North Circular Road, Stonebridge Park, London NW10 7SS • Tel: (44-1) 965-6599

Circle 148 on Reader Service Card

The ST Series by Ward-Beck. Television's first true Stereo Console!

Ward-Beck proudly introduces the first purebred
Stereo Television Console.

This is no ordinary mixing board modified and adapted for stereo TV. The ST Series has been designed, without compromise, from the ground up to give television broadcasters full stereo facilities.

The ST evolved from extensive consultation with end-users, resulting in a microprocessor controlled system incorporating totally new circuitry, new module designs, and a unique console profile for enhanced operational simplicity.

The ST3642 has ample capacity for major production facilities, while the ST2442 is ideal for on-air and smaller production applications.

The ST Series... Legendary Ward-Beck quality, competitively priced, for every television market!

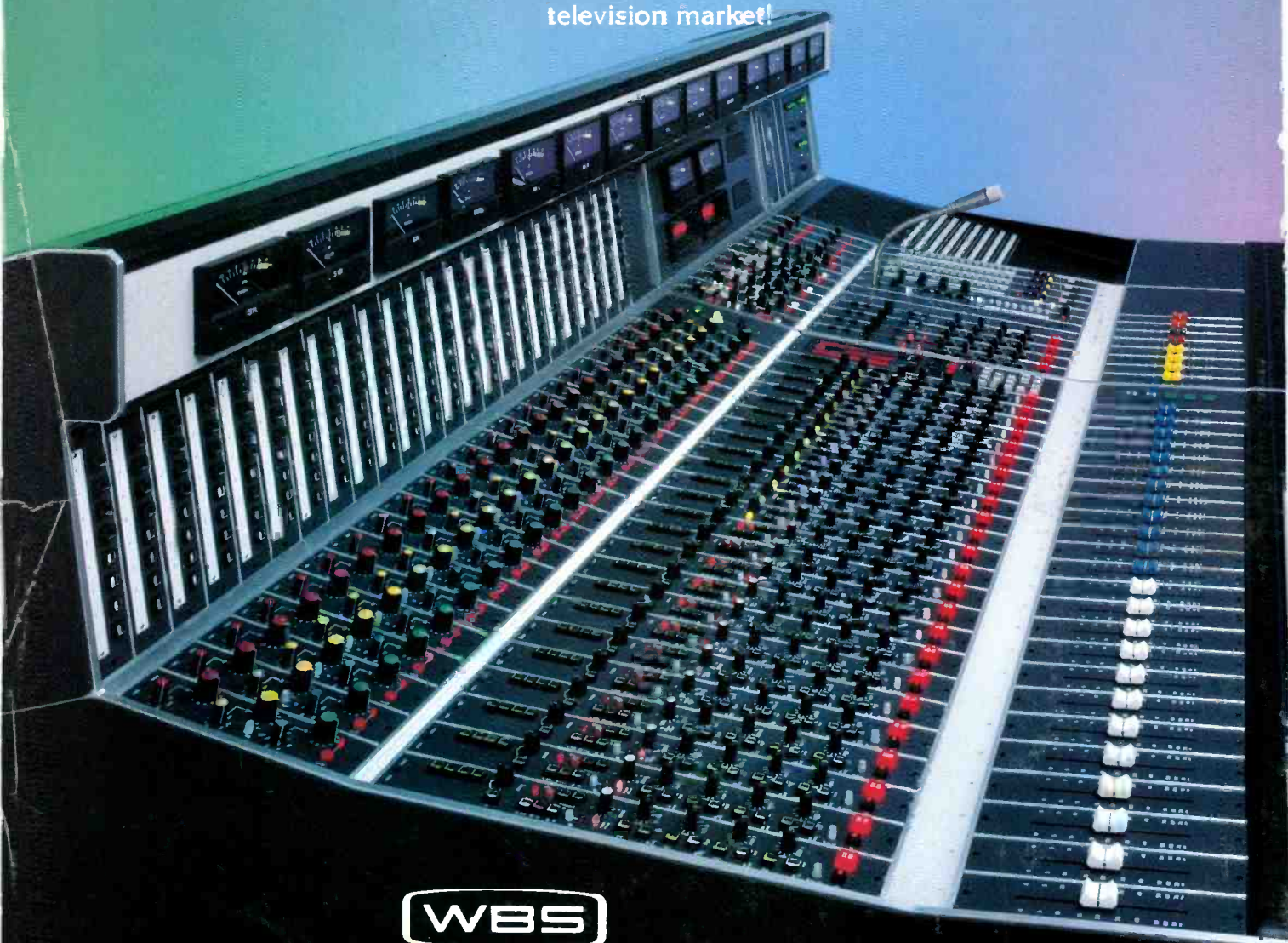

First by Design.

Ward-Beck Systems Ltd.,
841 Progress Avenue, Scarborough, Ontario, Canada M1H 2K4.
Tel: (416) 438-6550 Tlx: 065-2539E.