

B1072 R AT 3-5 575 1  
TERRY W DENBROOK, PROG M  
K P L U FM-PACIFIC LUTHER  
4617 N FRACE / AN UNIV  
TACOMA WASH 98407

# BROADCAST engineering®

*the technical journal of the broadcast-communications industry*



**Color camera  
review** page 18

Community Survey Tips  
Digital Logic Basics  
Phase Monitor Update

# How do you pick up sound without noise?

## Pick up the new RE50 and the new RE85 quiet microphones.



Model RE50 omnidirectional dynamic \$77.10. Model RE85 lavalier dynamic \$85.50. Suggested professional net prices.

ⓔ Introducing two microphones that aren't "microphonic". That are unexcelled for hearing air-borne sounds, but shrug off contact noises. The new hand or stand RE50 and the lavalier RE85 dynamics.

Small, light, and just barely larger than the smallest microphones of their type. Yet both use a unique double-wall construction that is more effective in reducing microphone noise than any other we have tested.



Let's look into the RE50 first. A cutaway shows that inside each RE50 nestles the familiar 635A, case and all. It's shock-mounted at top and bottom to the outer case. Even the connector is isolated from the actual microphone. And the problems

of mass and resonance have been worked out (with the aid of our computer) so that contact noises and cable rustling never reach the Acoustalloy\* diaphragm.

The result is remarkable isolation from all but air-borne sound, even in hand-held applications where microphone movement is uncontrolled. And when you add the extra protection of the built-in Acoustifoam\* blast and pop filter, this is one of the quietest omnidirectional microphones you can find. Yet response, output level, and polar pattern are essentially the same as the 635A (one of the most popular professional microphones of all time).

But if noise can be a problem with hand-held and stand microphones, it is a plague to lavalier types. Clothing rustle, cord noise, and accidental contact with hard surfaces are common troubles. Ex-

cept with the new RE85. Again, we have created a microphone within a microphone. But we've gone even farther. A special low-noise grille, for instance. And even the hard, smooth paint finish was chosen to reduce small rubbing noises.

The result is virtually noise-free operation even with inexperienced performers. And at no expense to sound quality. Like all E-V lavaliers, output of the RE85 is peak-free and natural. Each RE85 comes complete with neck cord, tie clip, and a belt clip to help control the cable. The RE50 is supplied with a Model 300 stand clamp.

Both the RE50 and the RE85 are now available at your E-V microphone headquarters. In this noisy world, it's a relief to know that help has quietly arrived.

\*E-V Trade Mark

a **Gulton**  
COMPANY

ELECTRO-VOICE, INC., Dept. 731V, 638 Cecil St., Buchanan, Michigan 49107  
In Europe: Electro-Voice, S.A., Römerstrasse 49, 2560 Nidau, Switzerland  
For More Details Circle (1) on Reply Card

**Electro-Voice**®

a GULTON subsidiary



## NEW ANTENNA FOR CARS BAND

Andrew has developed a new series of economical and versatile antenna systems for use in CARS band local distribution systems. An optional rear mounted enclosure allows mounting of radio equipment directly on the antenna or on the tower. When mounted on the back side of the reflector, the complete RF assembly, including feed can be readily removed for maintenance without disturbing antenna path align-

ment. These LDS antennas offer the best value available for reliable local distribution of CATV by microwave.

For further information write for Bulletin 1051A or contact your Andrew Sales Engineer.



**ANDREW**

ANDREW CORPORATION 10500 W. 153rd St., Orland Park, IL, U.S.A. 60462

ANDREW ANTENNA SYSTEMS Lochgelly, Fife, Great Britain KY5 9HG

ANDREW ANTENNA COMPANY LTD. 606 beech St., Whitby, Ontario, Canada

ANDREW ANTENNAS 171 Henty St., Reservoir, Victoria, Australia 3073

*For More Details Circle (4) on Reply Card*

[www.americanradiohistory.com](http://www.americanradiohistory.com)

# BROADCAST engineering

The technical journal of the broadcast-communications industry <sup>®</sup>

## in this issue...

- 18 **Color Camera Basics, part 1 of a series.** First of a two-part series that discusses color cameras from one to four tubes. Includes facts on design and operational aspects of cameras. **Joe Roizen.**

---

- 26 **Let's get going on that community survey.** Guidelines for making the survey less painful. Includes tips on how to get the survey going and how to conduct the interview. **Pat Finnegan.**

---

- 32 **Basic digital logic review.** First part of a series designed to fill the gaps in currently available information on the basics of digital logic circuits. **John M. Lee.**

---

- 40 **An update on phase monitors.** Last part of a series on interpretations of the FCC's dockets and rulings on phase monitors. **Bob Jones.**

---

- 44 **A report from Montreux.** Report from the scene of the recent international television symposium.

### ABOUT THE COVER

Pickup tubes are just a part of the meat for a special review of state-of-the-art color cameras and their systems. See article on page 18. Photo courtesy of Joe Roizen, Telegen.

### DEPARTMENTS

Direct Current	4
Letters to the editor	8
Industry News	11
SBE	14
Cable Engineering	CE-1
Engineer's Exchange	39
Book Reviews	47
People in the News	48
New Products	50
Tech Data	59
Classified Ads	63
Ad Index	63

Copyright, 1973, Howard W. Sams & Co., Inc. All Rights Reserved: Material may not be reproduced or photocopied in any form without written permission of publisher.

**EDITORIAL**  
 RONALD N. MERRELL, Director  
 CARL BABCOKE, Technical  
 PAT FINNEGAN, Maintenance  
 HOWARD T. HEAD, FCC Rules  
 ROBERT A. JONES, Facilities  
 WALTER JUNG, Solid State  
 ANDRA BOYLE, Editorial Assistant  
 H. G. ROESLER, Cartoonist  
 WEBB G. STREIT, Graphic Designer  
 JOE ROIZEN, Video  
 ARCHER TAYLOR, CATV

**EDITORIAL ADVISORY BOARD**  
 LES NELSON, Chairman  
 Howard W. Sams & Co., Indianapolis

**CIRCULATION**  
 EVELYN ROGERS, Manager

**ADVERTISING**  
 E. P. LANGAN, Director  
 R. JACK HANCOCK, Manager  
 FRANCES SIGMAN, Production  
 JAKE STOCKWELL, Sales

**REGIONAL ADVERTISING SALES OFFICES**  
 MICHAEL KREITER  
 1014 Wyandotte St.  
 Kansas City, Mo. 64105

**Indianapolis, Indiana 46206**  
 ROY HENRY  
 2469 E. 98th St.  
 Tele: 317/846-7026

**New York, New York 10017**  
 STAN OSBORN  
 60 East 42nd Street  
 Room 1227  
 New York, N. Y. 10017  
 212/687-7240

**Los Angeles, California**  
 RICHARD BOHEN  
 3600 Wilshire Blvd., Suite 1510  
 Los Angeles, California 90005  
 Tele: 213/383-1552

**London W. C. 2, England**  
 JOHN ASHCRAFT & CO.  
 12 Bear Street  
 Leicester Square  
 Tele: 930-0525

**Amsterdam C. Holland**  
 JOHN ASHCRAFT & CO.  
 W. J. M. Sanders, Mgr.  
 for Beneluxe & Germany  
 Herengracht 365  
 Tele: 020-240908

**Tokyo, Japan**  
 INTERNATIONAL MEDIA  
 REPRESENTATIVES, LTD.  
 Shiba-Kotohiracho, Minato-ku  
 Tele: 502-0656



**BROADCAST ENGINEERING** is published monthly by Intertec Publishing Corp., 1014 Wyandotte Street, Kansas City, Missouri 64105. Telephone: 913 888-4664.

**BROADCAST ENGINEERING** is mailed free to qualified persons engaged in commercial and educational radio and television broadcasting. Non-qualified subscriptions in the U.S. are \$6.00 one year, \$10.00 two years, \$13.00 three years. Outside the USA add \$1.00 per year to cover postage. Single copy rate 75 cents. Back issue rate \$1.00. Adjustments necessitated by subscription termination at single copy rate.

Controlled Circulation postage paid at Indianapolis, Indiana.



Robert E. Hertel, Publisher

INTERTEC PUBLISHING CORP.  
 Subsidiary of HOWARD W. SAMS & CO., INC.

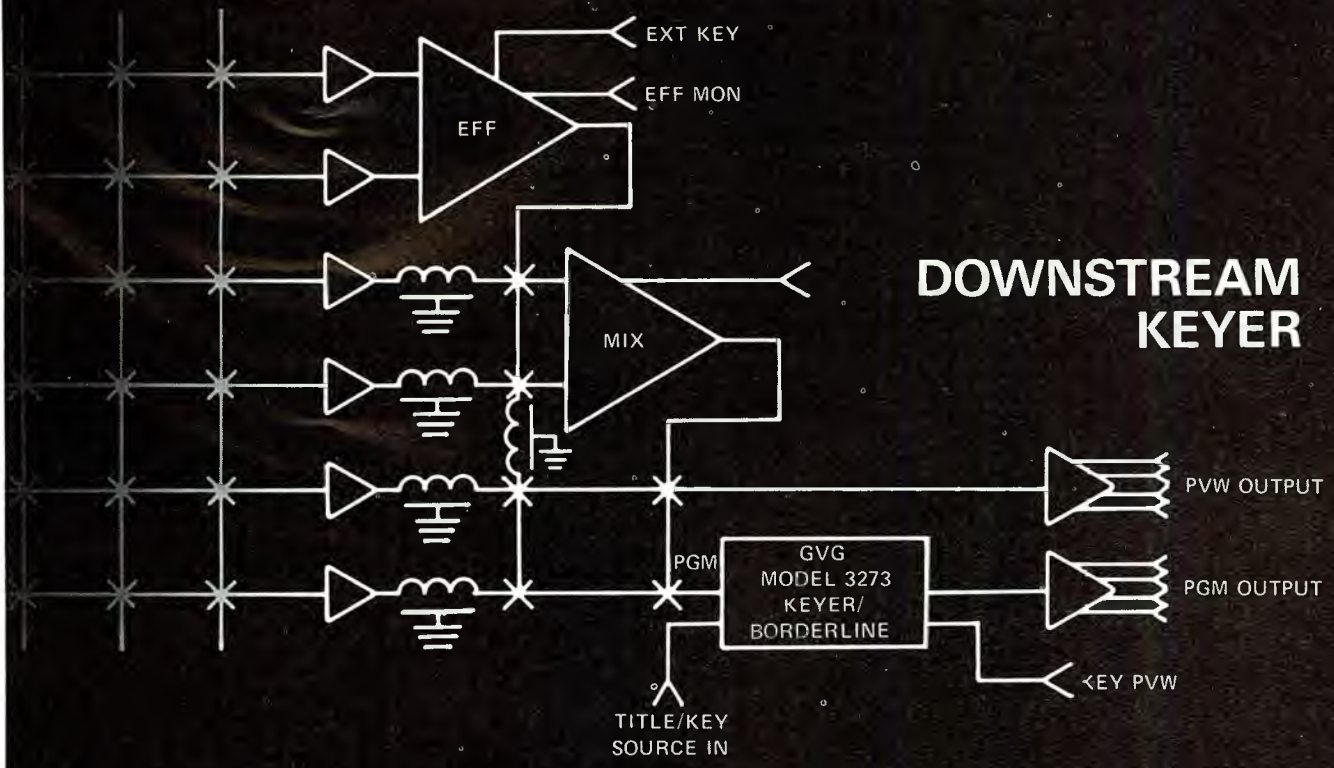

## DOWNSTREAM KEYSER



3273 REMOTE CONTROL

GVG's Model 3273 is a complete insert keying unit capable of producing electronically bordered titles over any synchronous source. It may be placed in the program line downstream from switching and effects equipment so that matted inserts can be accomplished very simply without the use of a special effects generator. The insert may be previewed and switched, during vertical interval, in and out of the program line. The matte may be colored\* and bordered in one of three modes: *BORDER* - bordered symmetrically, *SHADOW* - on right and bottom edges only, *OUTLINE* - only the border signal inserted. The Model 3273 offers the keying facility of a second special effects system but without any operational complication. It is an ideal means of interfacing an electronic character generator with a studio or master control switcher.

\*Optional accessories include a colorizer and a non-synchronous inhibit for key input.

### THE GRASS VALLEY GROUP, INC.

SOLD EXCLUSIVELY IN USA BY GRAVGO SALES, INC.

6515 Sunset Blvd. LOS ANGELES, CALIF. (213) 462-6618	Station Plaza East GREAT NECK, N.Y. (516) 487-1311	125 South Wilke Road ARLINGTON HEIGHTS, ILL. (312) 394-1344	Redbird Airport DALLAS, TEXAS (214) 330-1245	1644 Tullie Circle, N.E. ATLANTA, GEORGIA (404) 634-0521
--	--	---	--	--

OVERSEAS - GRASS VALLEY INTERNATIONAL, BOX 1114, GRASS VALLEY, CA 95945, USA

For More Details Circle (5) on Reply Card

# DIRECT CURRENT FROM D. C.

July, 1973

by Howard T. Head

## Private Funding Authorized for Cable Advisory Committee

In an action believed to be the first of its kind, the Commission has authorized the Cable Television Technical Advisory Committee (CTAC) to solicit private funds to be used for administering certain Committee activities. CTAC was established by the Commission in the Spring of 1972 to provide advice with respect to the formulation of technical standards governing the operation of CATV systems.

CTAC is made up of nine panels, representing various aspects of cable technical standards. These panels are staffed by volunteers from the cable and broadcasting industries. The funds to be solicited publicly will permit the establishment of a Washington Headquarters which will include a fulltime Executive Secretary and administrative staff.

## Land Mobile Activity in UHF TV Spectrum Space

Both the Bell System and Motorola have unveiled ambitious plans for the use of portions of the newly-assigned spectrum space near 900 MHz for a mobile telephone service. The Commission in Docket #18262 reassigned TV channels 70-83 inclusive, together with additional spectrum above 890 MHz, to the land mobile service (see 7/70 D.C.). The Bell and Motorola plans are similar in that large metropolitan areas are to be broken down into small cellular structures, permitting reuse of land mobile channel pairs at relatively close spacings. Computer techniques are to be employed for switching and hand-offs between cells. Both companies have concluded that the 900 MHz region is suitable for land mobile service, and that reasonably priced equipment can be mass-produced within a suitable time period.

Actual use of this portion of the spectrum for land mobile operations must await a Commission choice among competing plans. In the meantime, UHF TV translators operating on channels 70-83 will be permitted to continue on a non-interference basis with the land mobile service, although no new translator assignments are being made above Ch. 69. Considering that most TV translators are in remote areas, and that initial land mobile operation will be concentrated in the large cities, it seems likely that translators on these channels will enjoy a substantial grace period before their re-assignment to lower channels becomes necessary.

In another land mobile action, the Commission has proposed some readjustments in the allocations to the various land mobile

# Ain't nobody else can give you an S/N ratio up to 72 dB. Nobody.

We call it the Scully 280-B Professional Recorder/Reproducer. Not a very fancy name. But it's so new, we haven't had time for anything else but a number.

Briefly, here are the high points, new electronics for up to 72 dB S/N ratio on full track .25" tapes. And a greater dynamic range than you've ever been used to.

Two-track quarter-inch and four track half-inch 280-B lays on a crisp, clean 69 dB on an NAB weighted basis.

We've built in some other choice features, too. Like an OPTAC™ optical motion sensing system that gets rid of deck plate sensor mechanisms. Plus a new mother-daughter board architecture for super easy maintenance.

The spec sheet has all the details.

*For more information contact your Scully Distributor or write direct to Scully/Metrotech.*



For More Details Circle (6) on Reply Card

services in the 470-512 MHz band shared with UHF TV broadcasting (see 8/71 D.C.). Available assignments have essentially all been snapped up in the New York City area, and requirements for protecting television broadcast reception have proved to impose fairly substantial restrictions on the land mobile sharing.

#### NCTA Proposes Uniform CATV Technical Standards

The National Cable Television Association (NCTA) has filed a petition with the Commission asking the Commission in effect to be preempt technical regulation of cable television systems. Many municipal cable franchises impose technical standards on the systems which go beyond the requirements of the present FCC CATV Technical Standards, and in some instances are in conflict with FCC requirements.

#### Waiver of TV Remote Control Requirements Authorized

The Commission has authorized the Nebraska Educational Television Commission to operate certain of its television transmitters by remote control without the insertion of the required VIT signal at the remote control point. Three of the stations cannot meet the requirements for the VIT signal insertion and in the case of these three stations, the Commission has waved the requirement to permit remote control operation.

#### Deletion of TV Boosters Proposed by Commission

In the early days of TV, large numbers of unlicensed "booster" stations sprang up in remote and mountainous areas to receive, amplify, and re-transmit signals received from distant TV stations. Isolating the receiving transmitting antennas was often quite a trick to keep the feedback below the point of oscillation, and often the two sides of a mountain were used to accomplish just that purpose.

By the time the Commission finally got around to authorizing boosters and translators, the vogue for straight "boosters" was waning, with frequency translation becoming standard practice. Nevertheless, the Commission adopted Rules permitting the use of on-channel boosters. Only two booster stations were ever authorized, neither was ever licensed, and there have been no new applications filed within the last 12 years. Consequently, the Commission is proposing to discontinue any provision for this service.





## ***BUSY BEAUTY SPOT FOR SPARTA***

The sunny, oak-clad Vaca Hills surround this transmitter site, but there's nothing else sleepy about this bustling area between San Francisco and Sacramento. Within view of the Sparta 602A FM Transmitter lies Travis AFB, where our returning Vietnam POWs first touched their native soil. The Sierra Nevada brings heavy San Francisco Bay Area traffic to I-80, below, both summer and winter. This area is growing, and builder Don Reeves (left) is planning for the future.

Don has been associated with construction of ten stations in his nearly 30 years in radio, and was given the huge Broadcast Coordinator's job for the 1960 Winter Olympics. Consulting Engineer Cecil Lynch has worked with Don on many of those projects, including the mammoth Squaw Valley one.

Yes, these men know radio, and its future in busy Northern California. After five years exper-

ience with Sparta equipment at KPOP-KPIP in Roseville, Don and Cecil picked Sparta again for this new venture ... complete Showcase studio outfitting and the 602A Transmitter with the all new 680 Exciter and 682 Stereo Generator.

To their listeners they're KUIC. To us they're Don and Cecil.

SPARTA, the 'just right' company. Small enough to be first name friends ... big enough to offer EVERYTHING. Call us. Collect.



**SPARTA**  
**ELECTRONIC CORPORATION**

5851 Florin-Perkins Road, Sacramento, Ca. 95828  
916 383-5353 TELEX 377-488 CABLE SPARTA  
A DIVISION OF COMPUTER EQUIPMENT CORPORATION



# PROTECT your broadcast equipment against lightning surges with WILKINSON AC LINE SURGE PROTECTORS



Excessive voltage surges caused by lightning, transformer arcing and induced transients are everyday occurrences that cause heavy damage to valuable broadcast equipment.

Now through the use of WILKINSON voltage sensitive Line Surge Protectors you can protect your equipment from line surges that may exceed even twenty times the normal line voltage.

A WILKINSON pulse compensated Line Surge Varistor, is placed across a line of its rated voltage. Should a surge or increase of voltage occur, the resistance of the varistor decreases at log scale as the voltage increases, thus acting as a momentary load or short circuit to the surge. WILKINSON Line Surge Protectors draw little or no current and are capacitor compensated for microsecond surges, thus damping all line disturbances as well as excessive voltage increase.

A small investment in WILKINSON Line Surge Protectors is your assurance that your valuable broadcast equipment will not be damaged due to line surges.

Model SIA-1 110 V. Single phase \$175.00

Model SIA-2 220 V. Single phase \$275.00

Model SIA-3 220 V. Three phase \$375.00

Model SIA-4 440 V. Three phase \$475.00

For complete details write to:

## WILKINSON ELECTRONICS, INC.

1937 MacDADE BLVD. • WOODLYN, PA. 19094  
• TELEPHONE (215) 874-5236 874-5237

## LETTERS TO THE EDITOR

### Las Vegas Station Sends Call For Help

Dear Editor:

I have had some experience in soliciting donations of equipment for several 10-Watt FM stations. The most fruitful method I came across was to make phone calls to the CE's of stations in the area (including TV). Most CE's I talked to were very friendly and anxious to help locate the equipment we needed. The only items I found very difficult to locate were any kind of transmitter over 10 Watts, an antenna system, and monitors that work!

I'm currently in the process of trying to equip a non-commercial Educational FM station to serve Las Vegas, Nevada; the first one in Nevada (except two 10-Watters). We still need everything but especially a transmitter (at least 1K), antenna, and monitors. Donations are tax deductible, but if necessary, we can't pass up a good buy. All help and advice will really be appreciated. Also, if you are with a non-com station, write to us and anything we don't really need, we'll pass on.

**Bill Motley, Tech. Dir.**  
**Nevada State Public  
Radio Assoc.**  
**P.O. Box 1425**  
**Alhambra, Cal. 91802**

so hard pressed to keep current on new developments and their impact upon the operations of individual AM, FM, TV, CCTV, CATV, and recording facilities.

True to its mission as the industry's technical journal, **Broadcast Engineering** has endeavored to report and interpret these changes. To accomplish that objective we rely upon a cadre of specialists who monitor for our readers the changing technologies that now and in the future will influence broadcasters in the selection, operation, installation and maintenance of equipment, components and accessories. The objective of the contributing editors and the full-time staff is to demonstrate precisely how signal quality can be attained and maintained.

The readers of **Broadcast Engineering** comprise the buying team of the broadcast facility. Some exercise full authority in specifying while others exert direct influence upon the buying and specifying process by which stations and systems are modified or constructed. Some of these readers operate in

### Decision-Making Perspectives

Creativity in electronics has sparked a veritable revolution in broadcast technology. The past several years have witnessed a level of product innovation that has touched just about every aspect of the broadcast/communications industry. Never before have professionals in this field—even those with well rounded technical expertise—been



"OUR AUTOMATIC SOUND SYSTEM ISN'T WORKING. THIS IS A PERSON SPEAKING...."

technical capacities. Others hold corporate or management responsibilities. All, however, share the obligation to generate a quality signal and to employ techniques and equipment by which this goal is implemented. But all must have an eye to efficiency and eventual profitability of the overall broadcast operation. To this extent every reader shares a management responsibility. Since the new and emerging technologies affect the whole spectrum of operating economy, **Management Highlights** are underscored for most feature articles published.

The Editor

## Emergency Warning Systems

Dear Editor:

We are Americans living and working in Japan and we are very much concerned, in our respective jobs, with news of new products and technologies. We are quite interested in the February, October and November 1972 articles on automatic home warning in **Broadcast Engineering** magazine. In addition, we believe the matter to be socially very significant. Living outside America has given us a special insight.

America's proposed systems must be the first ever developed in any country for home warning. Your magazine has carried the first authoritative information we have ever seen anywhere on this life or death subject.

As citizens we believe the U.S. Government must be prudent not to make a wrong decision about such a vital matter. We agree with the author, Stephen A. Russell, that the general public must get

(Continued on page 10)

# REQUIRE ACCURACY? ...THEN BUY BELAR

## MONITORS

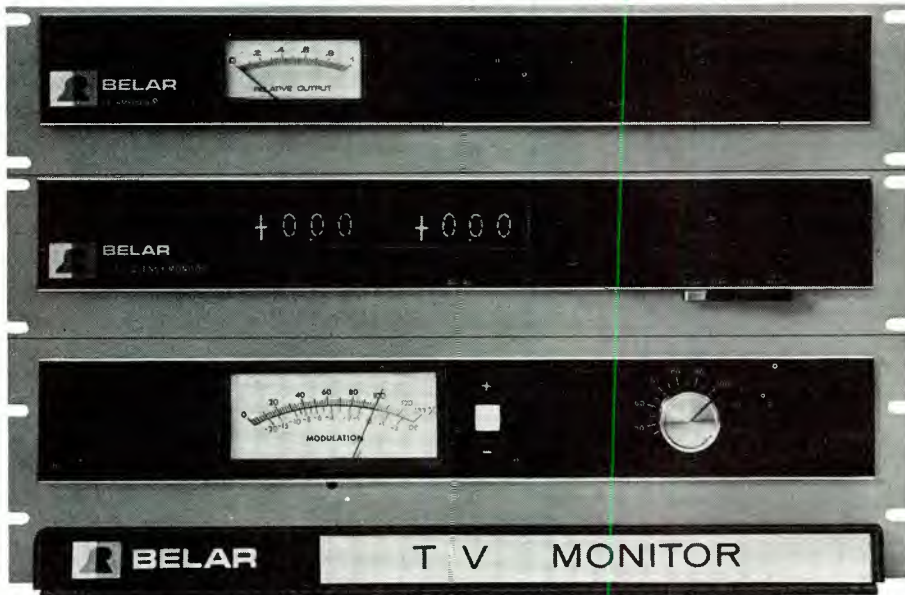

The least you can afford is the best possible monitoring of your program material. The Belar TV Monitoring System (VHF or UHF) guarantees your getting what you need . . . accurately.

The Belar TVM-1 Modulation Monitor is the most accurate monitor available. Our advanced design starts where others leave off. TVM-1 Monitors both positive and negative modulation simultaneously and registers the higher of the two. Yes, it even tells you whether the modulation is positive or negative and calibration accuracy can be checked from the front panel modulation calibrator at any time.

The TVM-2 and TVM-3 Digital Frequency Monitors will measure TV visual carrier

and aural carrier independently or aural intercarrier. These monitors provide continuous monitoring with inhibited off-frequency alarm drivers, switch settable to either  $\pm 500$  or 1000 Hertz. It requires three successive errors to produce an alarm. This means *no* false alarms for you.

For remote control operations add the RFA-3 for off-air monitoring.

If your TV monitoring requirements include ease of operation, functional checks and ACCURACY, call or write today for more information. We know you'll make the right decision and BUY BELAR.



**Plastic Reels**  
FOR MAG TAPE

Shipped from Inventory

Mfrs. of Amerline reels

**POLYLINE CORP.** (312) 489-1757  
2449 N. Western, Chgo. 60647



**BELAR**  
**ELECTRONICS LABORATORY, INC.**

LANCASTER AVENUE AT DORSET, DEVON, PA. 19333  
BOX 826 • (215) 687-5550

Where Accuracy Counts . . . Count On Belar

For More Details Circle (9) on Reply Card

For More Details Circle (58) on Reply Card

# AEL transmitter features: ...five-year warranty ...twenty-year parts availability.

The new AEL FM-25/25KD was designed to provide exceptionally high power FM broadcasting service with a high degree of redundancy and reliability to meet power level requirements of up to 50KW TPO.

To get it, we combined two AEL FM-25KD 25KW FM transmitters, whose combined outputs are connected to the antenna through a true 90° hybrid combiner.

If you're impressed so far, just wait until you see the specs and hear the whole story.

## THE NEW AEL FM-25/25KD BROADCAST TRANSMITTER Packs a 50KW TPO Wallop!

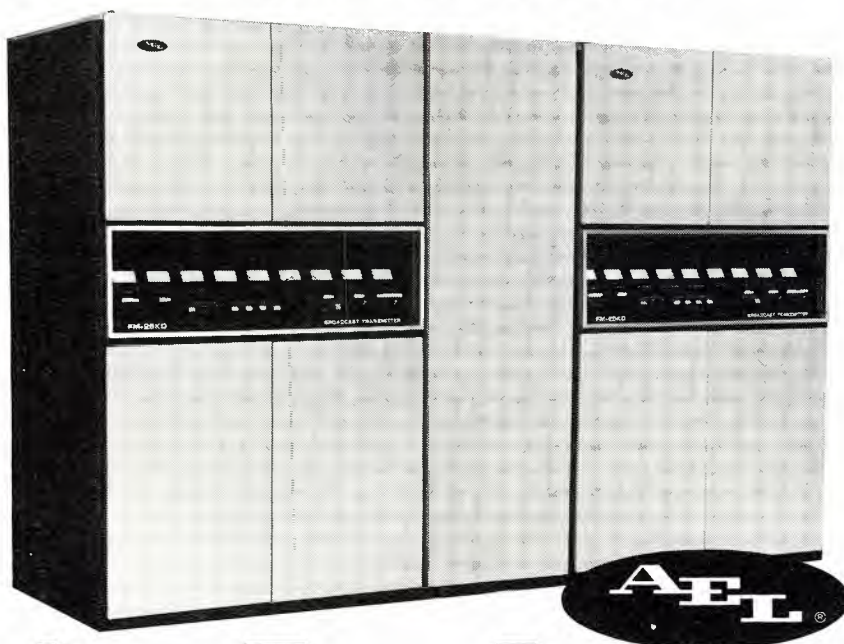

**A**merican **E**lectronic **L**aboratories, Inc.  
P. O. Box 552, Lansdale, Pa. 19446 • (215) 822-2929 • TWX: 510-661-4976 • Cable: AMERLAB

For More Details Circle (10) on Reply Card

## LETTERS TO THE EDITOR

(Continued from page 9)

their home warning from the commercial broadcasters (EBS) from the standpoint of national security, the public's economy and technical feasibility.

When we saw your story in Tokyo we were attracted by the fact that the technology for the proposed Unified Public Alerting System was invented by a Japanese engineer. It was very beautiful for us that a Japanese had gone to the trouble of offering Americans a means for saving lives during a nuclear attack, when his very own countrymen were twice victims of a U.S. nuclear attack. We hope his diligence will not go unappreciated. The limited ABM, home warning, and civil defense, are now the only purely defensive protection we can rely on.

There is too much emphasis on purely offensive means and weapons, for both defense and deterrence. A convincing, purely defensive deterrent, such as a perfect, low cost warning system for every home, is needed. In that sense, U.S. cities and people are now vulnerable to any sudden attack, just like defenseless hostages.

**Edwin C. Merner**  
**Stephen J. Baxter**  
*Kanagawa-ken, Japan*



"I'm the tenant from downstairs, and....."

**SEND YOUR  
LETTERS TO THE EDITOR  
to  
Broadcast Engineering  
1014 Wyandotte  
Kansas City, Mo. 64105**

manager, KIII, Corpus Christi, Tex., and William F. Turner, executive vice president and general manager, KCAU, Sioux City, Iowa. Turner continues as chairman.

## Radio, TV Committees Named

Four radio broadcasting executives have been named to two-year terms on the Small Market Radio Committee of the National Association of Broadcasters.

The appointments were made by NAB Joint Board Chairman Richard W. Chapin, president, Stuart Broadcasting Co., Lincoln, Neb., and NAB President Vincent T. Wasilewski.

Named to the seven-man Committee were Edward D. Allen, Jr., president and general manager, WDOR, Sturgeon Bay, Wis.; George Allen, president and general manager, KLGA, Algona, Iowa; Jim Ballas, general manager, KOWB, Laramie, Wyo., and Paul Reid, president and general manager, WBHB, Fitzgerald, Ga.

Continuing members are Arch Harrison, Jr., president and general manager, WJMA, Orange, Va.; Al Rock, general manager, WSMN, Nashua, N.H., and William J. Ryan, general manager, WNOG, Naples, Fla.

Rock was named chairman.

### Secondary Market TV Committee

Three television broadcasting executives have been named to two-year terms on the Secondary Markets Television Committee of the National Association of Broadcasters.

The appointments were made by NAB Joint Board Chairman Richard W. Chapin, president, Stuart Broadcasting Co., Lincoln, Neb., and NAB President Vincent T. Wasilewski.

Named to the seven-man Committee were William F. Duhamel, executive vice president, KOTA, Rapid City, S.D.; Robert E. Krueger, president and general manager, KTVB, Boise, Idaho, and John Shott, general manager, WHIS, Bluefield, W.Va.

Continuing members are Frank Harden, president, WCBF, Charleston, S.C.; Ray Johnson, executive

vice president and general manager, KMED, Medford, Ore.; Michael D. McKinnon, president and general

## Business Trends

A number of broadcast equipment manufacturers managed and sold their way into the black last year. There's no denying that business is good and growing. If the



## The duplicator that runs ahead of competition...

This one stands alone.

PRO-Series 2800 high speed EIGHT-TRACK tape duplicating systems by Pentagon.

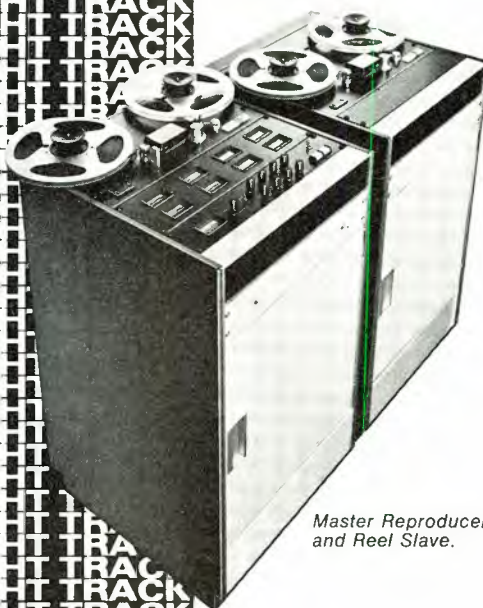

Master Reproducer and Reel Slave.

The only professional 8-track duplicating systems built in America at a surprisingly modest price. The only one.

Here is a duplicator system unique unto itself. It has a superb combination of features.

- Broadcast quality of duplicates
- Completely solid state
- Virtually maintenance free
- Full control facilities
- Excellent frequency response
- Fully automated operation for reel to reel duplication
- Modular plug-in solid state electronics

And what flexibility. Reel to open reel; Reel to direct cartridge hub (eliminates loading procedure); choice of 1/4 inch or 1 inch reel masters; automatic rewind and restart of your reel master, just to name a few.

Recognized as the leader in the manufacture of professional high speed in-cassette and open reel tape duplicators, Pentagon's entry into the 8-track duplicating equipment field fulfills a long awaited need for a truly versatile and professional system.

Write or call Pentagon direct for full information on the PRO-Series 2800 line of 8-track duplicating systems. You'll be glad you did.

**Pentagon**  
Industries, Inc.

4751 N. Olcott Ave.  
Chicago, Illinois 60656  
(312) 867-9200

Creators of quality in cassette duplicators

(Continued from page 11)

business at the NAB convention is any indication, the broadcasters are in much better shape. And that means the manufacturers will have a fast, busy year.

As an indication of how much improvement was possible, TelePro Industries reported that 1971 sales and earnings of \$4.6 million rose to just over \$7.3 million for 1972. TelePro is the manufacturer of Fidelipac tape cartridges.

According to Dennis W. Boardman, president of TelePro, sales and earnings for the year ended December 31, 1972 reached their highest level since the company was formed in 1963.

TelePro is a 58.1 per cent owned subsidiary of El-Tronics, Inc.

**For Latest News  
See  
Direct Current page 4**

## SMPTE Gearing Up For Oct.

The program chairman, arrangements chairman, and the exhibit chairman, have been appointed for SMPTE's 114th Technical Conference, by SMPTE editorial vice-president Gerald G. Graham, and conference vice-president Harry Teitelbaum.

The Conference is scheduled for New York's Americana Hotel, October 14-19.

R. L. Pointer, director, broadcast engineering, American Broadcasting Co., appointed program chairman, will have the basic responsibility of putting together a five-day technical papers program. He will appoint a program committee made up of topic chairmen, each representing a different discipline within the motion picture and TV areas. Topic chairmen will participate strongly in the acquisition of papers.

Charles Ahto, MPO/Tape Films,

arrangements chairman, will be responsible for all the non-program activities and arrangements. He will appoint a comprehensive committee to assist him in providing the many services required at an SMPTE Conference.

### Free Alignment Booklet

Fidelipac, a division of TelePro Industries Incorporated, announces publication of their booklet, **Aligning Your Cartridge System, A Practical Approach**. This 12-page booklet discusses machine alignment; head height, azimuth and insertion adjustments; tape guide and pinch roller adjustment; cartridge positioning and other subjects necessary for automatic tape cartridge recorder/reproducer maintenance. It is available, free of charge, from Fidelipac, 3 Olney Avenue, Cherry Hill, New Jersey 08034 or from Fidelipac distributors.



## INCREASE FM LISTENERS WITHOUT CHANGING FORMAT.

Reach into those difficult areas, car receivers and small portables. These hard-to-reach groups can represent a large audience. With our FM "Penetrator" antenna, you no longer give this audience to your competitors.

The patented "Penetrator" gives your signal more punch, even in the fringe areas, because it's circularly polarized

and features variable horizontal-to-vertical gain ratios.

Your stereo performance will also improve, because of the "Penetrator's" exclusive field trimming. They allow you to adjust your VSWR values, after installation, to 1.08 to 1. Unless you're willing to settle for ordinary audience ratings, don't settle for an ordinary antenna. Write us today.

### JAMPRO ANTENNA COMPANY

A DIVISION OF COMPUTER EQUIPMENT CORPORATION

Phone (916) 383-1177 • 6939 Power Inn Road, Sacramento, California 95828

J  
A  
M  
P  
R  
O

For More Details Circle (12) on Reply Card

## NAEB Sees Increases In Hours And Services

What are the program plans, the operational costs, and the over-all needs of public television stations in the years to come? A study conducted by NAEB's television division, Educational Television Stations, asked those questions of stations across the country—with a particular focus on the year 1976. Here are some of the projected answers:

- A full-service operation of 48 weeks per year, seven days per week, 16 hours per day (contrasted to 40 weeks, six days and 13 hours in 1972);

- A program source mix of local production, 26 1/2 hours/week; tape/film, 50 hours/week; and "real time" interconnection, 49 hours/week;

- Local production needs of classroom instruction, 8.7 hours/week; public affairs, 4.2 hours/week; non-classroom instruction, 3.5 hours/week; cultural, 3.0 hours/week; newscasts, 1.4 hours/week; and other, 1.3 hours/week.

- Local production costs of remote coverage-current events, \$3,700/hour; 32-program school course, \$1,800/program; social issue documentary, \$12,000/program; and in studio-public access, \$1,000/hour.

Licenses responding to the ETS questionnaire (62, representing 113 transmitters) indicated that an "optimal funding mix" for their regular production and broadcast operations would be: Federal, 32.5 percent; state/local, 44.0 percent,

and private, 25.5 percent.

Questionnaire responses pointed to a fiscal year 1976 program mix of approximately 20 percent local production, 40 percent tape and film use, and 40 percent from real time interconnection.

Different kinds of licensees will emphasize different kinds of programming:

- University stations will place heavy emphasis on public affairs and cultural, locally produced programming.

- State stations will focus on classroom and non-classroom instruction.

- School system stations will place their emphasis on child-directed instructional programming.

- Community stations will seek a programming mix with broader audience appeal.

The study also shows that stations related to academic institutions are less likely to provide year-round, seven-days-per-week, full-service operation, either currently or in their projections for the future.

"Ironically," the report suggests, "the diversity of public television, which is truly a boon to its many publics, is an impediment to its full development. It is an impediment because diverse purposes are often perceived as competitive purposes. This perception often results in the management of information for specific activities and creates sporadic areas of growth, rather than integrated, planned overall development."

Data from the ETS questionnaire was analyzed and interpreted by the Ohio University Broadcast Research Center, under the direction of OUBRC director James A. Anderson. Copies of "Operations and Costs: A Study of Educational Public Television Stations" may be obtained from NAEB/ETS.

## Commissioner Wiley in the field



FCC's Dick Wiley tours WTIM, Springfield, Ill. during trip to Illinois Broadcasters Association meeting. Wiley (at left) is shown here with President Don Jones and CE Roy Fritcher.

**Want A Free  
Subscription?  
Send Requests To  
Broadcast Engineering  
1014 Wyandotte Street  
Kansas City, Mo. 64105**



## SBE Members On The Move

### New SBE Chapters Forming

The following areas represent locations for possible future chapters. Information on any planned organizational or technical meetings may be obtained from the individual listed as the "contact" in each case. Anyone interested in chapter activities in other locations may contact Virginia Doss, Assistant Secretary-Treasurer, SBE, P.O. Box 88123, Indianapolis, Ind. 46208, or at WRTV, 1330 N. Meridian, Indianapolis.

In some cases, assistance from SBE national officers and directors may be available. Contact any officer or director, or SBE President James C. Wulliman, at WTMJ, 720 East Capitol Drive, Milwaukee, Wisc. Those involved in the development of new chapters should also keep the SBE Journal Editor posted so that this work can be aided by promotion in the Journal.

Location	Contact
Tucson, Ariz.:	H. J. Bart Paint, telephone 882-6644, or Chuck Deen, KOOL TV, 511 West Adams, Phoenix, Ariz., telephone 271-2345.
Miami, Fla.:	John Blattner, 11001 N. Kendall Dr., Apt. A107, Miami 33156.
St. Louis, Mo.:	Arthur H. Rounds, 1321 Aspen Drive, Florissant, Mo. 63031.
Puerto Rico:	Bob Beurket, Asst. Chief Engineer, WRIK TV, Ponce/San Juan, Puerto Rico. Telephone 809-724-7575.
San Francisco, Calif.:	Robert Daines, CBS Laboratories, One Embarcadero Center, San Francisco, Calif. 94111.

### SBE Insurance Plan Booms

The new SBE Directory is expected to be out in two to three months, perhaps by the time the next issue of our **Journal** reaches you....The rate of increase in SBE membership has increased since **Broadcast Engineering** started to include the SBE Journal as a supplement....The SBE insurance program is turning out to be even a greater bargain than at first expected. A 25 percent dividend was returned to members the first year, and a 40 percent dividend the second year.

Another new chapter within the next few weeks may be Louisville, KY.... Former SBE President and outgoing Director Lew Wetzel urges members to apply for Senior Member grade as soon as qualified. Advanced in grade conceivably may be a step toward promotion in your job. To upgrade your SBE membership, merely fill out an application blank (there is probably an application printed in this issue of **BE**), and check off the appropriate notation (x) Change in Grade, or (x) To Sr. Member.

Klaus Binder has accepted the position of Director of Engineering, United Broadcasting, Washington, D.C. Klaus is a former chapter chairman.

Michael D'Amore has been promoted by TeleMation to District Manager for the Kansas City office.

Ralph Thompson, former director of engineering WGBI AM FM and WDAU TV, Scranton, Pa., has moved to Las Vegas, Nevada, where he is Staff Engineering Consultant for Donrey Broadcasting, P.O. Box 2927, Las Vegas, 89104. Ralph had been active as chairman and in other positions in Chapter 2, North-eastern Pennsylvania.

By the middle of July, SBE members will have received a copy by mail of the new SBE Directory listing members alphabetically and geographically, regional chapters and chairmen, and society objectives. Also included is a list of officers, directors, and honorary and fellow members up to November, 1972.

Paul Evanosky, WVIA FM TV, and chairman of chapter 2, recently returned from the Bahamas where he and his new bride were honeymooning.

Charles Hallinan, former chief engineer of WKOP-AM-FM, Binghamton, N. Y., and former president and executive director of the SBE, is now a field sales engineer with CCA Electronics and has been guest speaker at meetings of several chapters in the northeastern U. S. Hallinan also brings along CCA's latest gear.

### Society Notes From The Editor

Through these pages, provided by special arrangement with the publisher of **Broadcast Engineering** magazine, members of the Society of Broadcast Engineers may now communicate with each other; SBE headquarters can pass along information to the general membership; SBE chapters can report and an-



nounce information concerning their meetings or other activities; and we can air issues of vital concern to all of us who are employed one way or another in the field of broadcast engineering.

A means of communication is vital to any organization. Let's utilize this unusual opportunity which is now available.

Here are some reminders from SBE Headquarters: Chapters: Be sure to apply for annual rebates from SBE headquarters. A rebate of up to \$100 annually is possible based on membership attendance for the preceding year. To obtain this rebate it is necessary to complete the Annual Attendance Report Form which may be obtained from Virginia Doss, SBE, P.O. Box 88123, Indianapolis, Ind. 46208. Virginia would also like chapters to remind members that attractive SBE tie tacks are available from her for \$3.50 (members only).

When corresponding with SBE about your membership include your membership number. Submit change of address promptly. If you are not receiving **Broadcast Engineering** magazine, provided as a courtesy by the publisher to SBE members at no cost, notify Virginia Doss. Letters to the Editor, Chapter News, articles, and other information for publication should be sent to SBE editor, Joe Risse, P.O. Box 131, Dunmore, Pa. 18512. Articles need not be professionally written but they should be technical informative—diagrams can be hand drawn, but legible and accurate.

## Chapter News

**Chapter 1 - Binghamton, N. Y.**  
**Chairman: Larry Taylor,**  
**WENY AM FM**  
**Mark Twain Hotel,**  
**Elmira, N. Y. 14902**

The annual joint meeting hosted by chapter 1 was held on May 8th at the Owego Treadway Inn, Owego, N.Y. The advance preparation and promotion efforts of chairman Larry Taylor and his associates paid off in good attendance by members of his chapter as well as by members of chapter 2 and 22. A smorgasbord dinner pre-

ceded the technical and business sessions. Angelo Domino, field sales engineer for Tektronix, provided an equipment exhibit, and a 4-minute description of their VIT Inserter and the Automatic Video Corrector. Bob Mahoney provided equipment demonstrations before and after the meeting.

The feature of the joint meeting was guest speaker Otis Hanson, chief of existing facilities of the Federal Communications Commis-

sion, Washington, D.C. Hanson is one of those involved with the drafting of new broadcast regulations, and confined his talk mainly to that topic. A high degree of interest was evidenced from the lengthy question-and-answer session that followed. Audience appreciation was also evident from the sustained applause.

(Continued on page 16)

Spotmaster®

# Space Setter

## \$469



5 3/8" height  
5 5/8" width

### Three/70™ Cartridge Playback Deck

Meet our midget. And don't be fooled by its modest exterior. The new Spotmaster® Three/70 packs the performance of its big brother—the incomparable Ten/70—into a pint-sized package at a pint-sized price.

Standard features include the Ten/70's direct drive synchronous motor, all silicon solid state circuitry, high output (+8 dbm) and plug-in modular construction. Deck operation is pushbutton-quick, with instantaneous response.

Now look what happens when you put a trio of Three/70s together. They fit side by side in a single rack mount. The whole thing takes up just 7" of rack space.

Three/70s accept all Type A cartridges, playing up to 10½ minutes at 7½ ips. Options include 3¾ ips operation, as well as 150 Hz and 8 kHz secondary and tertiary cue tones (to augment the 1,000 Hz primary stop/re-cue tone).

Good things do come in small packages. Learn more about the Three/70—contact us today.



## BROADCAST ELECTRONICS, INC.

— A Filmways Company —

8810 Brookville Road, Silver Spring, Maryland 20910 • (301) 588-4983  
 TWX 710-825-0432



**Chapter 2 - Northeastern Pa.**  
**Chairman: Paul Evanosky,**  
**WVIA AM FM**  
**Old Boston Rd., Jenkins Twp.**  
**Avoca, Pa. 18640**

The regular monthly meeting of chapter 2 was a joint meeting held with chapters 1 and 22, as described in the preceding report. The chapter's annual Ladies Night was also held on May 8th at Irem Temple Country Club, Dallas, Pa.; a refreshment hour and dinner were followed by dancing until early morning hours. Corsages were provided for the ladies plus special favors donated by Shelborne Electronics of Wilkes Barre and Pursell Electronics of Scranton. The event was planned by Milan Krupa of WPTS and Paul Evanosky, Jr., of WBRE TV. Krupa also served capably as Master of Ceremonies.

**Chapter 15 - New York, N. Y.**  
**Chairman: John M. Lyons,**  
**WWRL AM**  
**41-30 58th St., Woodside, N.Y.**

The May 10th meeting featured a dual program as has become the usual practice for the New York Chapter. One program is planned to appear to radio engineers and the other to television engineers. Held at the WQXR Presentation Theater, 2 blocks from the Port Authority bus terminal, at 229 West 43rd St., between 7th and 8th Avenues, many availed themselves of the opportunity to join in a social hour and dinner in the New York Times Cafeteria, 11th Floor of the Times Bldg. The program designed for audio people was "Stereo-Mono Compatibility in Broadcast Audio Equipment" with Eric Small, a broadcast audio consultant and chairman of the Broadcast Papers Committee of the Audio Engineering Society, the guest speaker. Small discussed the problems of left/right mixing for the composite mono signal as it applies to audio as well as to FM stereo equipment. The TV program was "Time Base Correction from Video Tape to Quad". Alan Nichols

of the Harvey Group was the guest speaker. He reviewed and demonstrated time base correction needed for transference from 1/2" videotape to quadruplex, with the emphasis on how to use low-cost videotape equipment in this process. Those interested in attending N. Y. chapter meetings may contact Bob Woerner, secretary, at 212-535-1000 or Art Silver, Gates Radio, 212-889-0790.

**Chapter 16 - Seattle, Wash.**  
**Chairman: John Maxson,**  
**KETO FM**  
**17425 63rd Place. S.E.,**  
**Issaquah, Wash. 98027**

The May 9th meeting, held at the Norseland Restaurant, Seattle, at noon, featured Howard Haskett, vice president, sales, and Elmer Wilson, technical lead man, both of Mann-Russel Electronics, Tacoma, who spoke on "Novem Applications of RF Energy". The topic was related to the use of dielectric heating in the manufacture of wood products ranging from laminated beams to tennis rackets and moisture detectors.

Bob Dietsch, of the local FCC office, provided his monthly report on Commission activities.

Annual election results, held also at this meeting are as follows: Chairman: John Maxson, KETO FM, Issaquah, Wash.; Vice Chairman: G. Lewis Rambo, KCTS Channel 9, Seattle, Wash.; Secretary/Treasurer: Bill Pickering, KOMO AM TV, Seattle, Wash.; Editor, NEWSLETTER: Nick Foster, 1124 N.E. 147th St., Seattle, Wash.

**Chapter 18 - Philadelphia, Pa.**  
**Chairman: Jack Jones,**  
**Asst. Dir., Engrg.,**  
**WCAU TV,**  
**City and Monument Aves.,**  
**Philadelphia, Pa. 19131**

On May 22, social hour and dinner preceded a talk by guest speaker Richard Smith, engineer in charge, Federal Communications Commission, Philadelphia. Smith's talk on the activities of the Field Engineering Offices, was supported by slides. A spirited question-and-answer session followed. There was a good turnout of members and guests.

**Chapter 20 - Pittsburgh, Pa.**  
**Chairman: Henry R. Kaiser,**  
**WWSW,**  
**1 Allegheny Square,**  
**Pittsburgh, Pa. 15212**

On May 17th, a noon luncheon at Buddies Restaurant was followed by an open discussion concerned mainly with "Antenna Monitors in Directional Antenna Systems." Members were provided an advance copy of FCC Docket No. 19622, which is an FCC Inquiry on this topic, so were well prepared to contribute opinions.

**Chapter 22 - Central New York**  
**Chairman: Hugh Cleland,**  
**WCNY TV FM**  
**506 Old Liverpool Rd.,**  
**Liverpool, N. Y. 13088**

The May 8th meeting was held jointly with chapter 1 of Binghamton and chapter 2 of Scranton-Wilkes Barre, and featured a talk by Otis Hanson, chief of existing facilities, FCC., as is described in the chapter 1 meeting report. The next meeting, scheduled for June 21st, was to be an inspection of WSYR's new on-air and production switching system.

**Chapter 28 - Milwaukee, Wisc.**  
**Chairman: Ed Wille,**  
**KENCOM**  
**7835 W. Caldwell St.,**  
**Milwaukee, Wisc. 53218**

The May 21st meeting, held at WTMJ, Inc., Radio City Auditorium, featured guests Jan Pritzl of WMVS, Ray Hernday of WTMJ-TV, and Todd Boettcher of WTMJ. The meeting included tours of the very fine color mobile units of WTMJ TV and WMVS. Among the equipment observed and discussed were TR-60 and TR-4 video tape recorders, and Norelco PC-70 and RCA TK-44 color cameras.

Ed Wille, chairman, appointed an Election Committee consisting of Guy Morrison, John Lafferty, and Jim Wulliman, who were to come up with a suggested slate of nominees. The committee recommended that the present officers be retained for another year, but that nominations should also be accepted from the floor. Results of the election will be reported in the next SBE Journal section of Broadcast Engineering.

## Translator Convention Held In Utah

The 1972 national meeting of the National Translator Association was held recently in Utah. Although it drew well, it might even have been higher if it had been held in a more highly populated area....but then, Utah is a good example of where translators are so often needed.

Bruno Zucconi, of Scala Radio Corporation, presented a paper on the Modern Antenna. He pointed out that good transmitting antennas are now available, as well as good transmission lines, but the real problem, he stated, lies in the home TV antennas. This is the weak link in the TV-to-translator-to-home service.

Bill Loveless, Assistant Director of Engineering, summarized the experience Bonneville International Company had had in applying for some 20 FM translators. He stated the need to select sites that were

outside other FM stations 1.0 MV/M plus watching  $\pm$  three channels and the need for new permission from the Forestry Bureau.

Marshall Smith of Acrodyne presented a paper on the basic features of the new "Modern Translators". Most new translators, both TV and FM are of the solid state variety, especially in VHF. Some UHF employ one or two tubes. One lesson the operators have learned is that, **unlike tubes, transistors are not very forgiving.** In this respect solid state is a new ball game.

Ed Craney, talked on the "necessity of making translators self sustaining". In addition to relating the beginnings of the NTA, he humorously referred to some of the early illegal translators. **The real reason there has not been a healthy growth of translators is due to the need for a profit motive.** The fact that KSL showed their translator film to the FCC has been one factor in getting the FCC to increase the length of local announcements from 20 to 30 seconds. He further pointed out a weakness of the FCC Rules in restricting FM

translators to just the 20 Class "A" channels. The Rules should be changed to permit all channels to be available. For example, in Japan, a country the size of Montana, there are 3000 translators. Yet in the United States we have the same number in the whole country. In fact, by proper use of spectrum, Ed Craney states we could accommodate 100,000 translators.

In the afternoon there were talks by industry and consulting engineers. Nat Ostroff of Acrodyne read a paper on the latest concept of envelope delay in TV translators. Robert A. Jones, consulting engineer from La Grange, Illinois, talked about FM translators. This talk included a slide presentation outlining the FCC Rules as well as showing examples of some of his clients' FM installations, and the unique features of the Model J-316/J-317 translators made by the Versa-Count Company. G. Johnson of ECW, Inc., spoke about the need for translator operators to resist the further encroachment into the TV bands.

**a new am & fm broadcast console**

# The Mod One

**modular for economy now,  
flexible for the future!**

Start with the format you need now, and expand later to meet new requirements. The Mod One console motherboard design accepts a wide selection of input modules and plug-in amplifier cards. 10 mixing positions, with up to 30 inputs. Modern vertical faders; silent operating switches; state-of-the-art circuitry.

Custom features and options with off-the-shelf availability. Monaural, stereo, or quadrasonic. Meets all FCC AM and FM standards.

Write for complete specifications. Available through better dealers throughout the USA.



a **URC** company

11922 Valerio Street, No. Hollywood, California 91605 (213) 764-1500

For More Details Circle (16) on Reply Card

was large enough to be subjectively discernable. Such highly specialized color cameras built for NASA with seemingly limitless public funds do not present immediately practical solutions for terrestrial color television problems. The more common single tube color camera operates on a much different sequential principle.

The faceplate of the pickup tube invariably a vidicon at this time-has in front of it a series of vertical (or diagonal) color strips (Figure 2) which are applied by electro deposition in a vacuum chamber. These finely spaced alternate color strips which act as filters in the selected primary colors break up the image focussed on the camera tube face plate by the optical system. The alternate color filter strips are of carefully selected widths and at precisely calculated spacings. This permits the image scanning action of the pickup tube electron beam to generate video signals which have discrete center frequencies for the primary color components. Band pass filters centered at these discrete frequencies are then used to separate out the RGB information in the video output signal of the pickup tube preamplifiers. The synthesized primary color (RGB) signals so obtained can then be used to drive the matrix circuitry of an encoder and produce a fully compatible composite output signal in the television standard desired.

A great deal of development effort has gone into improving the results that can be obtained with striped filter single tube cameras. However, they suffer from certain inherent defects that make them relatively unsuitable for any exacting color television applications. Among the disadvantages in resolution where there is fall-off toward the corners, interference patterns due to the color filter structure with "picket fencing" effect under rapid movement conditions and low sensitivity (requiring a high ambient light level) due to the losses in the optical path. Also a problem, are areas of color desaturation in the picture associated with scanning beam velocity errors arising from slight non-linearities of the horizontal sweep waveform. Registration problems are exchanged for sweep linearity problems.

For applications where adequate lighting is easily available, the subject matter requires little depth of field and no great resolution is required, (scanning color caption cards, fixed closeup of an announcer, etc.) the better versions of this type of camera may very well serve the non-broadcast purpose at a modest outlay in capital equipment cost.

### The Two Tube Camera

There are several versions of two tube cameras all of which take advantage of a unique character-

istic of human vision. Visual acuity is greatest in the green region and falls off in the red and blue areas. Since the luminance matrix of a color television signal is 59 percent green (and this contributes greatly to the resolution of the overall image), the two tube camera assigns one tube to handle the "wideband" green channel and uses the second pick-up tube to take care of the red and blue signals either sequentially or simultaneously.

An optical splitter behind the taking lens produces separate images that impinge on the pickup tubes as follows: The direct path to the "green" tube which also doubles as the luminance channel is the high resolution image which carries the bulk of the video information. The secondary image produced by the splitter is focussed on a pick-up tube with a color strip filter with only cyan (negative red) and yellow (negative blue) elements.

By the process described for the one tube camera, but now applied only to the narrower band width requirements of the limited acuity channels, a red and blue video signal (by inverting cyan and yellow) is derived from this second pick-up tube. After preamplification of both camera tube outputs and appropriate extraction through band filtering of the red and blue video signals, the RB and Y signals can be matrixed and encoded into a composite color signal.

Another approach in the two-tube camera is to further split the image in the red/blue channel into two side by side or one over the other images that appear on the face plate of the pick up tube. While the images are smaller, the limited resolution requirements for red and blue make it possible to produce adequate results by this method.

Still another technique that was used on portable color cameras developed for ABC sports coverage used a small synchronous color filter wheel with alternate red/blue optical filters in the red/blue channel. While the two-tube camera out-performs the single tube version in size and weight, it

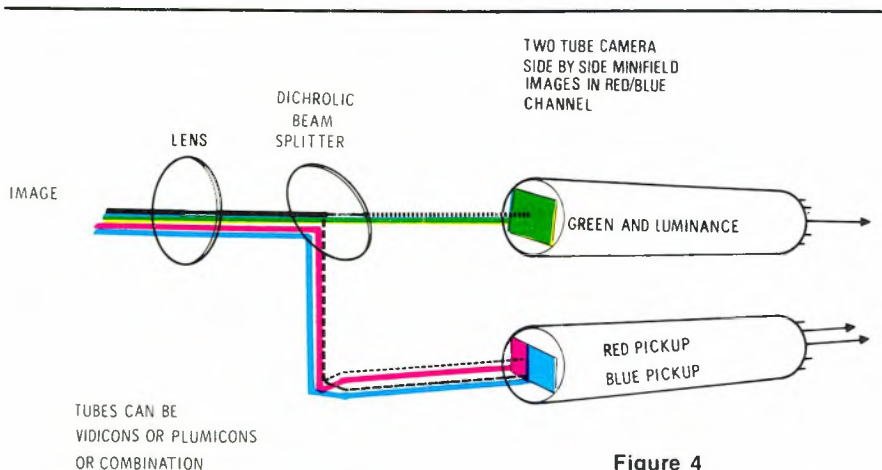
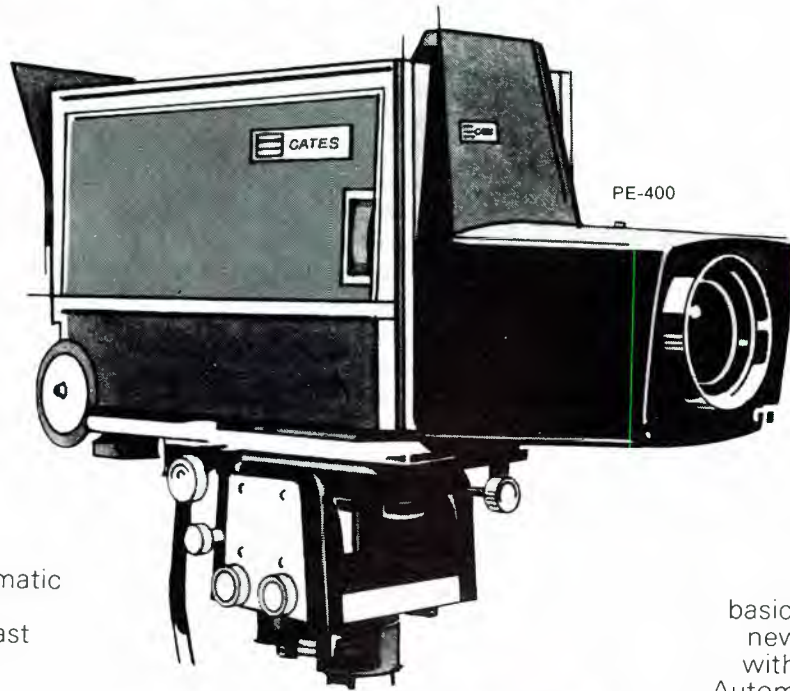

Figure 4

# Color TV cameras from Gates



*PE-400 live color TV camera.*  
Outstanding color fidelity. Excellent pick-up tube life. Automatic contrast gain control reproduces high contrast areas. Simplified setup and registration.

*TE-201 live color TV camera.*  
Economical long-term operating stability and excellent color fidelity in an extremely versatile, lightweight (40 lb.) camera. Superior low-light-level lag performance. Operating controls located at camera control unit. Simple setup.

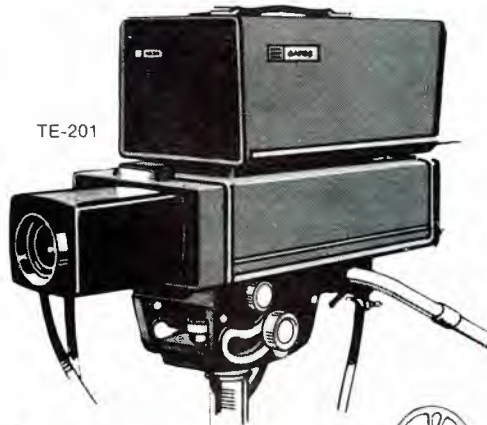

*PE-245 color TV film camera.*  
Praised for excellent performance and reliability. Proven basic design enhanced by new solid-state preamps with S/N ratio of 50 db. Automatic contrast control compensates for film variations.

*TE-202 color TV film island.*  
Integrated film island offering highly stable, reliable performance at low cost. Easy setup, hands-off operation.

**HARRIS**  
**GATES DIVISION**  
Quincy, Illinois 62301, U.S.A.

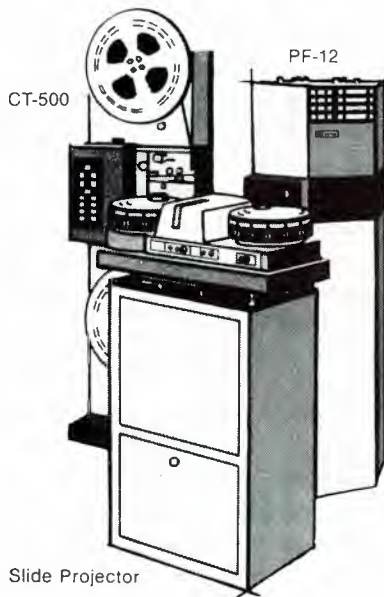

Slide Projector

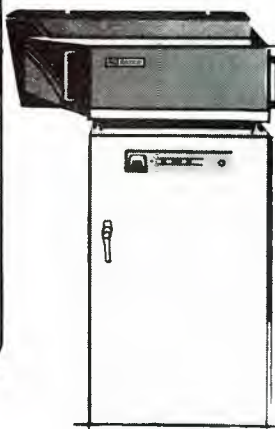

PE-245

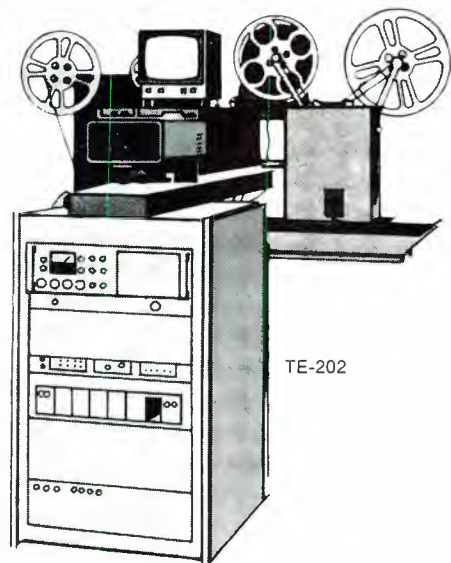

TE-202

For More Details Circle (17) on Reply Card

does so at a cost and complexity that sometimes exceeds the three tube version while still exhibiting some of the restrictions of the one tuber. Where cost, size and weight are imperative factors and some color picture degradation is acceptable, the two tube camera can fill the bill.

### The Three-and Four-Tube Cameras

Almost all color television cameras over the ten thousand dollar price bracket that are being produced today are of the three tube variety. There are, however, enough four-tube cameras still around to be worthy of mention.

Early high quality studio color cameras using three image orthicons were rather heavy and monstrous devices. Since most of the resolution information is conveyed in the luminance channel, camera designers were quick to come up with the approach that a color camera could be built with a high resolution luminance path with a large orthicon pick up tube and three low resolution color channels using vidicons to supply RGB signals that could be matrixed with the Y output of the orthicon. These were called separate luminance cameras and were widely used as studio and telecine cameras. Because four-tube cameras were relatively immune to the effects of registration drift, they were produced widely in two configurations, an I.O. with three vidicons or four plumbicons.

The switch to three tubes was occasioned by two significant developments, stable solid state electronics and a new family of more sensitive pick up tubes including the plumbicon, the SEC tube and the silicon diode. It was now possible to design new color cameras using only three tubes with characteristics equal to or better than the previous four tube type.

The three-tube camera is a straight forward approach to the optical separation of the RGB elements in the image by prisms and/or dichroic mirrors. The red, green and blue optical paths pro-

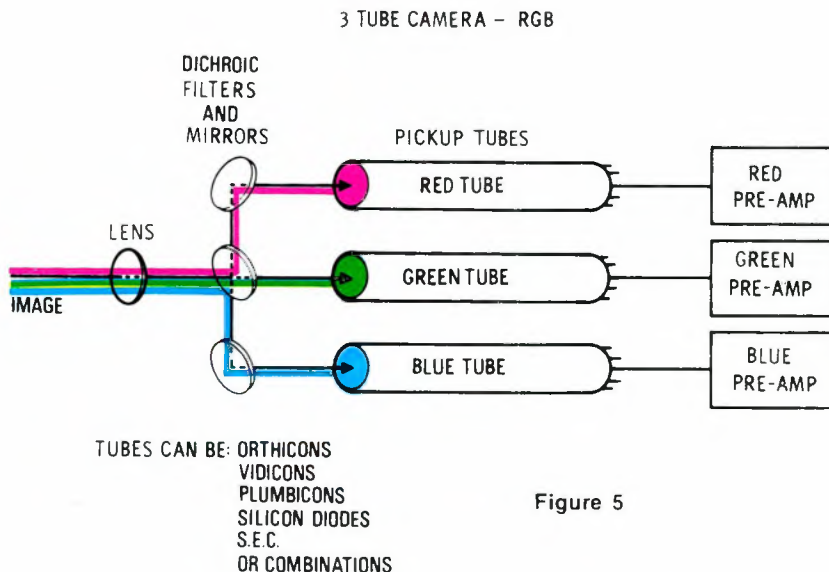

duce a focussed image on the faceplate of the appropriate pick up tubes, each of which produces a video signal relative to its selected primary color. The output signals from the camera are RGB non-composite video at a nominal 75 Ohm impedance and are delivered to the camera control unit for monitoring, further processing and encoding into a composite color signal output.

Three-tube color cameras are well suited for most studio applications since they provide a good base from which a proper composite signal can be generated. These cameras also lend themselves easily to external image enhancement, better signal monitoring and manipulation and full broadcast quality encoding techniques.

Three-tube cameras do vary greatly in price, performance and peripherals and the selection of a basic camera and its options must be tied to budgetary allowances in relation to the desired results. Here are some of the factors that should be considered in selecting a three-tube color camera.

### Optical Systems

The first element which controls the quality of the picture appearing at the photosensitive surface of the pick-up tubes is the combination of taking lens, relay lenses, and

dichroic filters or beam splitting prisms that combine to form the optical path of the color camera.

While the manufacturer of the camera usually provides no option to the internal optical system of a given camera model, most of them do offer a variety of lenses which can be specified by the user. Lenses have become sufficiently standardized that the major lens manufacturers have interchangeable models covering a wide range of applications. Lenses also come in very different price brackets which usually relate directly to the maximum aperture, the ratio of variable focal lengths and the method of control.

A color camera set up as part of a telecine chain requires a simple fixed focal length lens with a reasonable aperture since it is looking at a projected image with adequate ambient light level and in a constant focal plane. Some film cameras dispense entirely with a focussing lens and use a simple single element field lens into which the projector image is projected. This results in sharper pictures because several optical elements are eliminated.

Most studio cameras are required to cope with a variety of conditions that encompass extreme changes in camera to subject distances and in the variability of the light level and



**It's no big thing!**

**It's only a broadcast quality, portable  
COLOR camera that's priced under \$4000  
and weighs less than 6 lbs.!**

AKAI'S new CCS-150S Portable Color Camera weighs only 5.8 lbs. yet offers professional studio quality costing thousands more in any other camera.

The specifications tell the story:

- Completely compatible with any U.S. TV system.
- Two vidicon system with separate Luminance and Chrominance channels.
- S/N ratio: Luminance—Better than 40dB  
Chrominance—Better than 30dB
- 525 line scanning, 2 to 1 interlaced, locked chroma.
- Better than 300 line resolution.
- Built-in 6 to 1 zoom lens.
- Viewfinder—1.5" picture tube.
- Built-in directional microphone
- Servo controlled Iris.
- Sensitivity control: 80 to 2,000 ft. candles (without filters)
- AC or battery operated.
- Dimensions: 3 1/2" (W) x 10" (H) x 12" (D) including lens and grip.

The performance of AKAI's new CCS-150S color camera will amaze you! Whether you use it as the perfect tool for on-location shooting or as an alternate studio camera...

But see for yourself... It's really no big thing!

For More Details Circle (18) on Reply Card

From

**AKAI**<sup>TM</sup>

**The Innovators**

AKAI America, Ltd./P.O. Box 55055,  
Los Angeles, California 90055

contrast ratios of the scene. In addition to this the speed at which the change may have to take place imposes a need for automatic controls that maintain proper lens tracking between the extremities of the optical limits of the lens.

It would obviously be the easiest solution to purchase a lens with the maximum "F" stop, the greatest zoom ratio and the best electrically operated control system. Unfortunately, such an approach is impractical from both a budget or an adaptability viewpoint. Top of the line zoom lenses with an 18:1 ratio may be larger physically than the low cost camera it would attach to, and certainly more expensive. Small aperture, low ratio lenses may not suffice for a particular use. The selection of the lenses should be made on the following basis:

1. The maximum aperture should be adequate to provide suf-

2. The lens should have a zoom ratio that accommodates the scale of minimum to maximum image distances for the type of program production envisaged. Any unique requirements can usually be met with lens extenders that are added when necessary. Some lenses have built-in snap-in extenders.
3. The lens should exhibit good focal tracking between its minimum and maximum zoom positions. This feature cannot be over emphasized especially where less than the most proficient cameraman is to be used.
4. The quality of the lens should be carefully evaluated for chromatic aberrations, shading, flare suppression, image resolution, light transmission and

edge focus at wide openings.

5. The mechanical side of the lens is also important, check for smooth operation of the iris, zoom mechanism and ease of mounting and demounting. If there are electrical servo controls on the lens make sure the motor drives function freely and that they reset well from both directions.
6. If the lens uses extenders to increase focal range, find out if they are bolt-on, screw-in, or built-in. The former take a little time to attach, the latter can be inserted in seconds but cost more.

**In making a comparison between different color cameras, particularly with regard to optimum performance, it is important to make sure that the differences are not generated by the lens rather than the internal camera optics or electronics. Any valid comparison between two cameras should require the same or nearly identical lenses.**

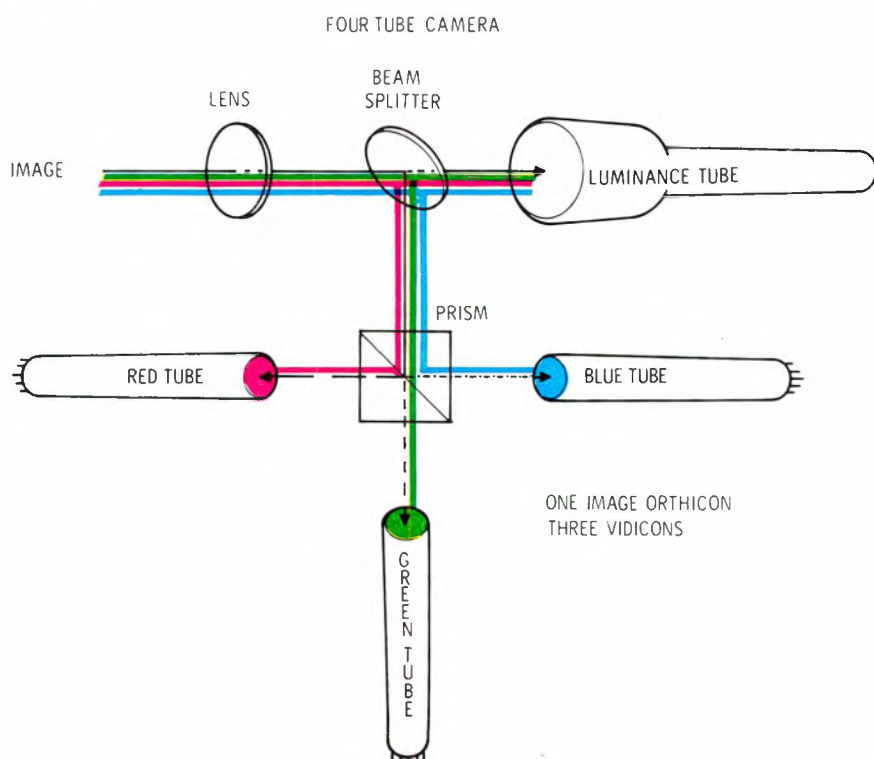

Figure 6

### Internal Optics

While the internal optics do not generally allow latitude of any different choice to the user, they do represent a variability in the quality of different cameras. The lenses, mirror and/or prisms that form the imaging system should be mounted on a firm base and be protected from the outside environment as much as possible.

The relay lenses and mirrors should introduce no significant geometric or chromatic distortions. The dichroic mirrors or prisms should have suitable optical spectra which provide precise colorimetric separation of the primary signals. A rigid optical path will eliminate the need for frequent mechanical readjustments of the glass elements. Adequate protection from the environment will keep out dust, dirt, moisture and other image deteriorating factors like sticky fingers that leave hard to remove oily deposits. Some cameras have fixed optical elements which require



no adjustment for the life of the camera.

Last but certainly not least, the internal optics of a camera sometimes limit the variety and focal length of the applicable available lenses by requiring unusual back focal distances from the rear exit pupil. **It is important to be sure that the desired camera will mate with the selected lens.**

### **Tube Selection**

Camera tubes not only come in a variety of photo conductive surfaces, diameter sizes and physical lengths, but also in increments of quality that determines their price. Much in the manner that solid state devices are manufactured then graded according to quality/cost categories, image pickup tubes are also graded by the manufacturer. The user is given the choice of paying a premium price for broadcast quality or a bargain price for industrial grade tubes with certain deficiencies. Where optimum color quality is desired, the three tubes are supplied as a matched set with carefully selected conjugate color response curves.

The most noticeable type of deficiency is the surface blemish which causes a spot in the image that cannot be eliminated. The number and position of such blemishes is the criterion by which the tubes are graded upward or downward. Blemishes are less noticeable in the low acuity red and blue channels than in the wide band green channel, making tube juggling a way of sometimes getting by with industrial grade units, which often exhibit more lag than the top grade tubes. Only the user can decide if his application demands the matched marvels or the cheapie.

When making a comparison between different color cameras, one should ascertain that both are using similar grade tubes from a performance standpoint or are being quoted with the same tubes with regard to cost.

The vidicon, plumbicon and silicon diode have similar enough

physical and electrical characteristics, that many cameras offer the customer the same model with tubes of his choosing. Only the SEC and image orthicon tubes are sufficiently different to require special camera structures to house them.

There are some basic ground rules to selecting the best tube or tubes for a given utilization, they are:

1. Vidicons may be used where there is a high ambient light level on the scene to be televised and where the lag produced by image movement is not objectionable. Telecines, caption scanners, outdoor scenes and brightly lit studios qualify.
2. Plumicons, which seem to be the most popular these days, make good pictures in lower light levels and exhibit little or no lag characteristics. Plumbicons which cost more than vidicons may be a good investment if they save you from needing extra lights (in your old monochrome studio) which is usually followed by additional air conditioning to keep the talent cool.
3. Where extended red sensitivity is required, the plumbicon in the red channel is replaced by a silicon diode tube. This not only extends the colorimetric range but improves the noise characteristics in that part of the spectrum where it is usually most objectionable.
4. SEC tubes are used only where the ambient light levels are very low. While they make good color pictures in just a few foot candles, the inherent noise level is higher than in any of the other pick up devices except image orthicon. Unfortunately, even when the light level increases the signal to noise ratio does not improve significantly. Applications that require SEC tubes are usually very specialized and are willing to sacrifice S/N ratio for sensitivity.
5. The image orthicon has been virtually displaced by the

plumbicon in new color camera design. the I/O has high sensitivity and good resolution with little lag, but its large mechanical size, set up complexity, and high price have phased it out of modern cameras. It also suffers from some of the noise problems inherent in the SEC tube. Most of the color cameras built prior to 1965 used one or more image orthicons.

### **Tube Selection**

Complex, expensive, high technology products like image pick-up tubes always confront the individual recipient with the dilemma of accepting what comes out of the suppliers shipping carton on good faith or to go through vigorous incoming inspection procedure that is time consuming and intricate. Large television networks have routine methods of detecting sub-standard tubes and, since they are volume buyers, they usually end up with the pick of the litter. Manufacturers being what they are, it is not unlikely that the network runt is repackaged in a new box and sent out to a less meticulous customer.

To avoid being a recipient of "hand me down" tubes a studio should have some minimal targets of performance that can be checked when the tubes are installed in the camera. With the lens cap on, the image in the view-finder is the state of the target. Check for blemishes and pin holes, especially as to where they are in relation to the image. The same defect may be perfectly acceptable at the edges of the image and totally unacceptable in the action areas. Check for shading effects in dark current, then remove the lens cap and set up camera normally to check for shading, colorimetry, noise, lag, halos, etc.

Another alternative is to know your supplier. Some camera manufacturers or distributors do their own screening of pick up tubes before shipping them. A conscientious supplier can save you a lot of camera tube problems. □

# WHO?...ME?

## Let's get going on that community survey

By Pat Finnegan  
BE Maintenance Editor

Who, me? Yes, you, the engineer, may find yourself conducting personal interviews with community leaders. The survey mandated by the FCC at license renewal time must be conducted by **management level** station personnel through personal interviews. Management level means management in its broader sense, and is not limited to titles.

Depending upon station size, many engineering people are in management level positions and are thus eligible to participate in this survey.

The license renewal date will determine the period of this survey, so this will vary from state to state. The survey creates a heavy additional workload, but if the time falls within a period of intensive community activity, such as the year end holiday season, the workload is greater yet. During such a period, many of the people you need to interview will be very busy and setting interview times will be difficult. Besides all the additional legwork and paperwork the survey creates, the greatest casualty of all will be time. This project consumes a tremendous amount of time.

### ***On The Bright Side***

Be optimistic and look at the

benefits...and there are benefits to be gained. Aside from the information gained on community needs and problems, there is a tremendous potential for station public relations work.

Many of those interviewed, and especially those in smaller communities outside your main community, will be quite impressed that you will personally seek their opinions. This makes them feel important, and in doing so, makes friends for the station.

Station engineering people are generally immersed in technical problems and "things" and are not often in contact with the public. Making these personal interviews can be a very satisfying experience that will broaden the engineer's viewpoint both as to the public and the station's responsibilities in the community.

### ***Planning The Campaign***

Prepare your campaign so that it can be conducted in a methodical manner. Your particular efforts will be a part of the total station effort. While you may have little to do with selecting the "panel" of Community Leaders, you may have a choice in selecting the particular names that you will interview. As a suggestion here, select the names of those you do not know personally. This will provide you an opportunity of getting to meet new people, and it will keep the survey

objective.

So that the interviews will be both fruitful and efficient, prepare those to be interviewed ahead of time. This can be done through a simple form letter sent to each one on your list. The station should provide you with such a letter and also one of the forms that will be used for the interview. Although it's a form letter, add a personal touch by addressing each letter to the individual and sign your own signature at the end. This letter will start the recipient thinking about the community problems and needs, and the interview form will show its outline.

You may have been assigned many people to interview so it will take some time. It is best to send out only enough letters at a time to cover one week of interviews. Allow the letters to be in their hands about one day and then call them on the phone to set up an interview date. Set this date for a day or so later or within a week. This quick follow up will continue their thoughts in this area and setting the interview a few days later will continue the process.

In case there are misunderstandings about the interview, you can clear it up on the phone. Some words convey different meanings than intended. The word "interview", for example, in the minds of many people means microphones, tape recorders, cameras and exposure over the air. Clear up misunderstandings, but don't get into the interview itself on the phone. This must be done personally. You can suggest that they jot down—on the form that was sent—their main opinions and some of the personal profile data, such as organizations they represent. During the interview itself, you can add to these main points with additional points they

### **Management Highlights**

The required community survey will make demands upon your time, even if you take the advice of the author. But his view, some pre-planning and time organization will make the effort a lot easier. And, yes, all members of the decision making team can participate.

# Electronic editing so precise you might kiss tape splicing goodbye!



The new Tape-Athon 1001 Recorder/Reproducer has everything the professional studio demands in a precision instrument, plus some exciting innovations we've added to make the 1001 a must-see-it-before-you-invest. Here are the basics: dual capstan, closed loop tape drive for clean, even tape travel with minimum wow and flutter; tach-controlled motion sensing to eliminate tape breakage, stretching or spillage; newly designed tape head section for easy threading, fast lifting; illuminated push button controls, flush mounted.

Now for the innovations, take a look at this control panel.



With the Tape-Athon 1001 you can initiate a "balanced torque mode" on the tape drive by activating the PLAY (or FAST FORWARD) controls simultaneously with the REWIND control. Both drive motors are balancing against one another, allowing the user to manually move the reels in either direction without drag, skipping or tape stretching. You can actually move the tape so precisely for editing purposes that splicing is virtually eliminated.

Call for complete details and specifications on the professional's professional 1001 Recorder/Reproducer (also now available in Reproduce-Only, 14 Inch Reel, and Logger versions for the broadcast industry) or write to:

**Tape-Athon Corp.**

502 S. Isis, Inglewood, CA 90301 • Tel: (213) 776-6933

For More Details Circle (2) on Reply Card

names of others interviewed, call them "other community leaders."

A straight question and answer type interview should be avoided also. Such an interview will tend to direct the discussion into areas you consider important. Sometimes people in sensitive positions may give you "standard positions" of the national organization, or they may give you opinions that appeared in a recently published national poll. If you sense this happening, ask a few probing questions so as to determine in what manner these apply to the local community. While these are valid in themselves, they may not be necessarily valid as applied to your particular community.

To sum up the interview itself: place the individual on stage in the spotlight. You are the audience. The program matter is free-wheeling and determined solely by that individual. This is his opportunity to freely express his own

opinions and in the order he considers them important and in what relationship to the community.

You should have an additional short form with you so that you can obtain some personal profile information on the individual, such as age, marital status, race, etc. For the age question, have this in 5 or 10 year brackets. You should be able to guess reasonably close on age. Most of the other information you can note without asking also. Another thing you need to know is length of time the person has been in the community. With women, it is best to pose the question this way: "Are you a lifelong resident, or have you lived here only a short while?" If you ask a woman how many years she has lived in the community and she is a lifelong resident, she may balk. To tell you the years will give away her age.

#### How About Length?

How long should the interview

last? Very busy people will be prepared but won't be able to give you too much time, while others may desire to talk a long time. But consider 15 to 30 minutes as average length of time for the interview. Don't allow the interview to run too long as you have scheduled others to follow. Once it is apparent you have obtained the main opinions and talk now begins to ramble off into very minor things, start asking some of your profile questions. This will effectively close off the interview. As any good salesman knows, once you have made the sale, don't dally too long but graciously take your leave.

It may come as a surprise to you, but you will meet many, many pleasant, thoughtful people who are deeply interested in and concerned for their community. And this is understandable, for it is these very attributes that made them community leaders in the first place. □

# Solve YOUR Cleaning Problems...

electronic components - tape heads - contacts

Economical MILLER-STEPHENSON aerosols take the headaches (and a lot of expense) out of what used to be a nuisance.



**MS-180 "FREON"® TF DEGREASER**—No need to disassemble components. Spray MS-180 onto relays, circuit boards, motor parts. Eliminate grease, prevent recontamination. Non-conductive, non-flammable. Reduces maintenance costs. "Freon"® DuPont Trademark

**MS-200 MAGNETIC TAPE HEAD CLEANER**—Spray away oxide dust before it ruins heads and tapes. MS-200 flushes it away. Manufacturers recommend it; communications experts prescribe it; EDP operators wouldn't be without it. U.S. & FOREIGN PATS.

**MS-230 CONTACT RE-NU**—Renew your contacts. Re-Nu does it. Flush away dirt, carbon, and other "interferences." Will not harm insulation; leaves no residue. Switch to MS-230 for your switches — and other points.

For **FREE** aerosol sample of any one of the above, write (on your company letterhead, please), or use coupon for free data.

**miller-stephenson chemical co., inc.**  
Danbury, Connecticut 06810 (203) 743-4447

Please send me data and prices on: **BE**  
 MS-180 DEGREASER  MS-200 HEAD CLEANER  
 MS-230 "CONTACT RE-NU"

INTENDED USE \_\_\_\_\_

NAME \_\_\_\_\_ TITLE \_\_\_\_\_

DEPT. \_\_\_\_\_

COMPANY \_\_\_\_\_

ADDRESS \_\_\_\_\_

CITY \_\_\_\_\_ STATE \_\_\_\_\_ ZIP \_\_\_\_\_

CHICAGO • LOS ANGELES • TORONTO  DIST. IN MILAN  
HAMBURG • PARIS • LONDON • BEIRUT

## Sept. Date For Video Expo

Video Expo IV, the fourth annual international exposition of private, closed circuit and cassette video delivery systems and programming, will be held September 18 through September 20 at New York's Commodore Hotel.

In making the announcement, Eliot A. Minsker, president of Knowledge Industry Publications, the sponsor of the exhibition stated, "Video Expo has established itself as the largest exposition of private video systems and programming in the country. This year's event promises to be bigger and better than ever.

"Over 3,000 industrial television system operators, instructional TV administrators, programmers, dealers and other executives active in the industrial, institutional and educational markets are expected at Video Expo IV," Minsker said.

He explained that the major video industry manufacturers will again be displaying film and tape cassette systems, cameras, tape recorders, time-base correctors, lights and other engineering and studio equipment. This year's show will have a large display of programming.

A unique feature of Video Expo is that two major video workshops and the second annual Video Publishing Conference, will be held simultaneously with the exhibition.

Media & Methods Magazine will sponsor a workshop aimed at the educational media specialists. Smith Mattingly Production of Washington, D.C. will coordinate the workshops which will emphasize subjects such as the Operation of a Single Camera VTR System, VTR Feedback and several "hand-on" sessions.

The International Industrial Television Association's eastern Region will sponsor the other workshop, which will be aimed at video users who have passed the beginner stage and use multicamera systems. Signal Analysis, Audio Procedures, Video & Software Distribution Systems and Remove Shows will be among the subjects discussed.

For further information contact Eliot Minsker, Knowledge Industry Publications, Tiffany Towers, White

Plains, New York 10602, (912) 428-5400.

## FCC Revision On Form 723

The April 1973 revision of FCC Form 723 may be used by applicants for type acceptance of equipment. Use of this form is en-

couraged although, presently, its use is optional. Future amendment of the rules is planned to require that this form be submitted with each type acceptance application. A separate copy of Form 723, together with one copy of the information and data required for type acceptance, should be submitted for each equipment type number.

On and after July 1, 1973, earlier issues of FCC Form 723 will be obsolete and only the April 1973 or later issues will be acceptable for use.

# Can Three Attractive Singles Share A Unit With No Cross Talk?

If they are attractive 6-inch monochrome monitors from Setchell Carlson they can!

These uniquely designed monitors give you three, 16 sq. inch screens, while occupying only 7 inches of vertical rack panel space. Yet there is no crosstalk between adjacent units due to effective inter-compartment shielding.

Professional quality and American made, the monitors have a horizontal resolution of 600 lines... plus 100% solid state circuitry,

and the most advanced single module circuit board currently available.

This unique SINGLE MODULE is a one-piece, easily removable chassis which permits rapid, on-the-spot maintenance for reduced maintenance costs and the elimination of valuable downtime. ALL components are readily accessible for ease of maintenance and testing.

For broadcast preview, security and surveillance, education, industry, medical monitoring, VTR and data display... the Setchell Carlson Single & Triple-6 monochrome monitors... are the finest you can buy.



Single-6  
also available.



**SC ELECTRONICS, INC.**  
A SUBSIDIARY OF AUDIOTRONICS CORPORATION  
530 5th AVE. N.W. ST. PAUL, MINNESOTA 55112  
PHONE (612) 633-3131

For More Details Circle (55) on Reply Card

# Basic Digital Logic Review

By John Lee

Engineer, Hewlett Packard Co.

From nearly every corner today you hear that digital circuits are the key circuits. And it was obvious at the recent national NAB convention that these circuits truly are popular with R&D engineers.

Last year this magazine published a series of four articles on digital logic, written by Stan Busby of Ampex. From the response we had to that series, we became acutely aware that there is — and will continue to be — a great need for more information on digital circuits.

When the industry was faced with accepting the solid state trend in equipment design, there were those who resisted. The vacuum tubes were such old, familiar friends that it was difficult to part company. Then too, there was so much new terminology to be learned. And in many cases, the terminology was more difficult to understand than the new components.

So it was, then, that we were settling down to the next step—integrated circuits—when along came logic circuits. Taking a hint from industry history, the editors decided to start at a very basic level in digital circuits in order that they once and for all could be understood and handled. Once more we found a new set of terms. If we could make the transition from tubes to transistors, it followed that we could understand the extension of transistors into IC's and the not-so-new circuits they would build into.

What it came down to was realizing that digital circuits displayed in their most basic form certainly are not difficult to understand. Perhaps the understanding of digital logic is at first perplexing, but this shouldn't hold true when we have a firm grasp of the basics. Of course,

as you saw in the Busby series and as you'll see in this series, there are some new symbols that go along with the new circuits. But here again, you will find that logic circuit symbols are simply a replacement for block diagrams. Once you become familiar with their meanings, many prejudicial problems will resolve themselves.

We feel that, combined with the Busby series, BE's new approach to digital logic circuits will be "must" reading for all engineers.

The world of electronics is becoming increasingly digital. This fact accounts for circuits today which are more complex, compact, and powerful than ever before. Calculators now perform functions that previously required a computer, communication systems are capable of carrying as many as 230,000 conversations simultaneously, and computers affect, if not control, many of our daily transactions.

But even the most complex digital system is based upon a

relatively small set of simple concepts. By repeated applications of these concepts and through today's integrated circuit technologies, designs which before challenged the imagination now become realities.

Because of this revolution, it is important that anyone involved in the design, testing, producing, or servicing of electronic equipment have a knowledge of the fundamental concepts of digital electronics. This series of articles is meant to provide an introduction to digital logic and circuitry. With this background, the reader will be able to study more complex circuits and subjects.

## Logic Conventions

The most common form of digital system in use today is the binary system. The information contained in a binary digital signal is quantized to two states. The basic information unit, the bit, represents the state of the digital signal at any fixed point in time. The two possible states of a bit are



Logic circuits are springing up everywhere. Here you see one of our employees setting the type for this article on a machine loaded with digital circuits.

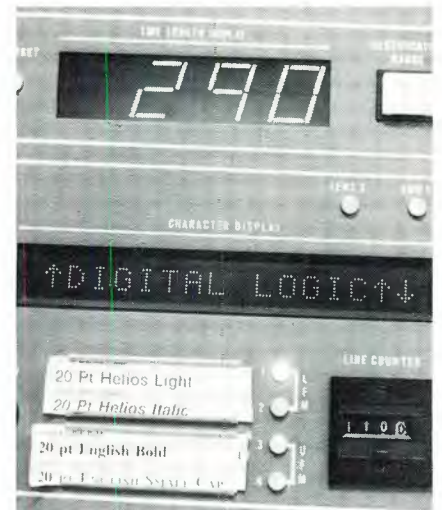

Here is a closeup of the left side of one of our typesetting machines. Notice that there are no less than three different types of readouts in use.

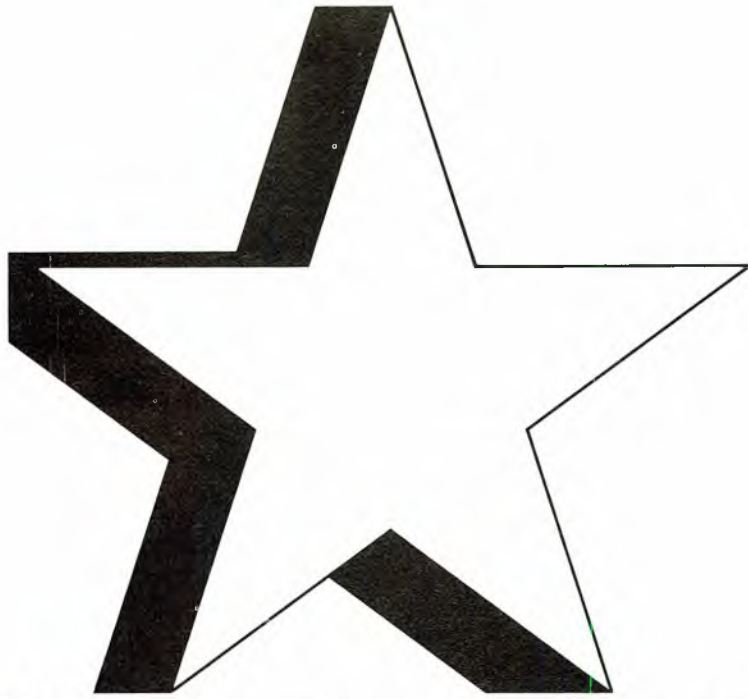

# Why we've started wearing the star.

You may have noticed a new symbol on our cover or index page: the star of the American Business Press.

This star means we've been elected to join a select group of business and professional journals in a special association. And it means something special to you.

## **How we earned our star.**

As a member of the American Business Press, we have pledged to uphold the highest ethical standards of journalism. Which means we are dedicated first and foremost to your interests as a professional reader by (1) striving constantly for honest and effective presentation of all news and articles, (2) maintaining absolute editorial independence and (3) refusing to accept any advertising we know to be false, misleading or unfair.

## **Let our symbol be your guide.**

Of the 2,335 business magazines published today, only 30 percent meet the stringent qualifications for ABP membership. So look for the star in selecting your professional reading. It's your guide to the finest magazines in nearly every business and professional field.

We're proud to have earned our star and proud to recommend any publication that wears it.



commonly associated with the "1", yes, assertion, or true condition and the "0", no, negative or false condition. Other associations are possible but these are the most widely used. In the electronics world, the "1" and "0" are generally used to denote the two possible states.

In reality, the state of a bit is determined by the relation of the digital signal to a predetermined condition. Most commonly this relationship is the voltage amplitude of the digital signal to a given voltage threshold (Figure 1). Due to inaccuracies in determining exact voltage levels and in order to increase the digital circuits immunity to noise, two threshold voltages are often used.

If the digital signal amplitude is greater than the high voltage threshold, the bit is said to be in the high state. If it is below the low threshold voltage, the bit is said to be in the low state. At points between the high and low threshold voltages, the bit's state is undefined.

Two conventions exist for logically interpreting a bit's state. The most widely used is the "positive true logic" convention. This states that a bit in the high state will be interpreted as a "1" and a bit in the low state will be interpreted as a "0".

Not so widely used is the "negative true logic" convention which states that a bit in the high state will be interpreted as a "0" and a bit in the low state will be interpreted as a "1". It is important to remember that regardless of which convention is used to interpret a bit, the actual signal levels are unaffected. A positive true logic "1" is the same as a negative true logic "0". Both represent a bit in the high state.

Because of the wide acceptance of positive true logic, this convention will be used throughout the remainder of these articles. By remembering that a positive true logic "1" equals a negative true logic "0", one can easily adjust to negative logic whenever it is encountered.

### Truth Tables

To describe the operation of a

digital device, a truth table is used (Figure 2). Since each input can exist in only one of two states, it is possible to record all input combinations. For an N input device there are  $2^N$  possible input combinations. A truth table lists the resulting output state for each of the input combinations. The truth table may be expressed in either bit states (highs and lows) or as positive true or negative true logic interpretations (1's and 0's). In practice the bit state is most often given by the device manufacturers and the positive true logic interpretation used by designers and service technicians. The truth table provides a complete and concise description of a digital device's operation.

### Fundamental Devices

The fundamental digital device is the gate. There are five basic types of gates from which all other digital devices are built. These are the AND, OR, INVERTER, NAND, and NOR. In general, a gate can be described as a single or multiple input device that produces a single high or a single low state output for a given combination of input states.

The symbols used to represent the basic gates are varied and many. The symbols used in this material represent those most widely accepted in practice. The actual symbol encountered is unimportant, for once a symbol is defined, the interpretation and use of that symbol to represent a well defined digital device is simple.

The AND gate is a multiple input device. It produces a low state output only when all inputs are in the low state. Another way of an N input AND gate will produce a high state output only when input 1 and input 2 and...and input N are in the high state, hence the term AND gate.

The OR gate is also a multiple

input device. It produces a low state output only when all inputs are in the low state. Another way of saying this is that the output is high whenever input 1 or input 2 or ...or input N is high, hence the term OR gate.

The INVERTER is a single input device that produces a high state output when the input is low and a low state output when the input is high. From these three gates, the AND, OR and INVERTER, all other digital devices can be implemented. But for flexibility and to be consistent with actual devices in use today it is important to add the NAND and NOR gates to our list of fundamental devices.

The NAND gate is an AND gate with its output inverted. That is, the NAND gate produces a low state output whenever all inputs are high and produces a high state output otherwise.

Similarly, the NOR gate is an OR gate with its output inverted. It produces a high state output whenever all inputs are low and a low state output whenever any input is high.

### Demorgan's Theorem

When analyzing digital circuits and observing the symbols used to represent these gates, it is important to know certain rules of equivalence. As is inferred in the symbol for the NAND and NOR gates, a small circle on a gate's input or output indicates that that signal is inverted. For example, the following symbols are equivalent:

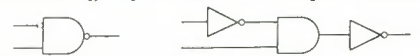

Figure 3 illustrates another set of important symbol equivalences. From the bit state truth table, we see that an inverted input OR gate is the same as a NAND gate and that an inverted input AND gate is the same as a NOR gate. This is known as DEMORGAN'S theorem.

### Management Highlights

Digital circuits are finding their way into countless broadcast equipments. There is no need to avoid the basics. You can start here and be as up to date on the state of the art as anyone.



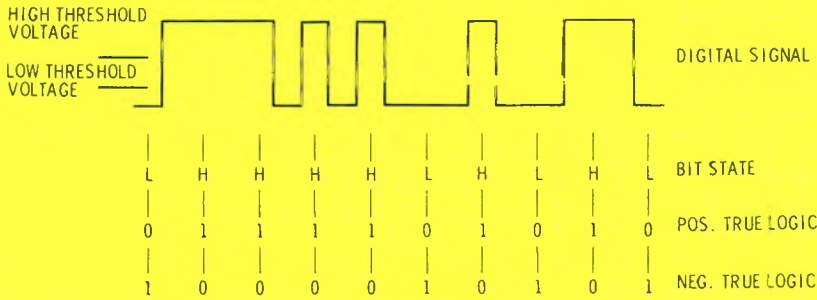

Fig. 1 The relationship of the digital signal to the bit state and the positive true logic interpretation of the Bit state.

INPUTS		OUTPUTS	
L	L	H	H
L	H	L	L
H	L	L	H
H	H	H	L

BIT STATE TRUHTTABLE

INPUTS		OUTPUTS	
0	0	1	1
0	1	0	0
1	0	0	1
1	1	1	0

POSITIVE TRUE LOGIC INTERPRETATION TRUHTTABLE

INPUTS		OUTPUTS	
1	1	0	0
1	0	1	1
0	1	1	0
0	0	0	1

NEGATIVE TRUE LOGIC INTERPRETATION TRUHTTABLE

Fig. 2 Truth table representation of the logical transfer characteristics of digital devices.

By remembering these equivalences it should not be confusing when an inverted input OR symbol is used in a circuit schematic while the data sheet of the actual component shows a NAND gate symbol. It is common practice today to use equivalent symbols on schematics when they simplify understanding of the circuit's operation rather than the data sheet logic symbol which, if used, may cause confusion or misunderstanding.

### Combinatorial Logic

The fundamental gates discussed thus far are part of a class of

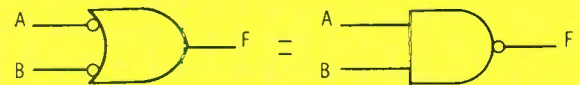

A	B	F
0	0	1
0	1	1
1	0	1
1	1	0

A	B	F
0	0	1
0	1	1
1	0	1
1	1	0

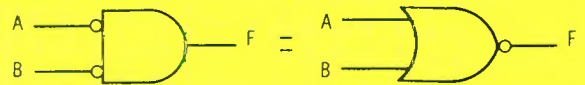

A	B	F
0	0	1
0	1	0
1	0	0
1	1	0

A	B	F
0	0	1
0	1	0
1	0	0
1	1	0

Fig. 3 Demorgan's theorem. From the truth tables below each symbol you can see that an inverted input OR is the same as a NAND, and an inverted input AND is the same as a NOR.

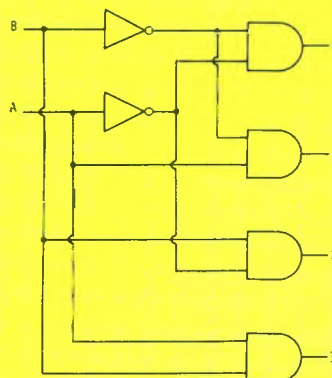

3	A	0	1	2	3
0	0	1	0	0	0
1	1	0	1	0	0
2	0	0	0	1	0
3	1	0	0	0	1

Fig. 4 Binary to decimal decoder. The line corresponding to the decimal equivalent of the inputs BA goes high and all other inputs remain low.

digital logic known as combinatorial logic. Combinatorial logic is the set of devices or circuits whose current output state depends only upon the current state of its inputs. Combinatorial logic has no storage and no memory. Combinatorial devices are easily characterized by truth tables and logic diagrams. A logic diagram is a functionally equivalent circuit composed of fundamental gates. Through study of a device's truth table and logic diagram, any combinatorial device can be analyzed and understood.

### Gates

Combinatorial devices can be classified into four main categories—gates, decoders, line driver/receivers, and MSI/LSI\* devices. An important combinatorial gate not yet discussed but which often appears in logic dia-

grams is the exclusive-OR gate (XOR).

Under the strictist definition, this device is not a true gate but rather a more complex circuit. In practice though it is usually referred to as a gate. The XOR gate is a two input device that produces a high state output when its inputs are different. An XOR is thus a digital bit comparator.

The AOI (AND-OR-INVERT) gate is another complex gate in the combinatorial logic family. The logic diagram and truth table shown illustrate that the output is high only when at least one input to each AND gate is low. The AOI gate is very useful in binary adders, subtractors and other computer circuits.

Buffer gates provide extraordinary output drive capability in addition to performing the same

logical function as the AND or INVERTER gates. These devices are used to interface digital logic families of different voltage levels or to provide increased drive capability within the same logic family. Quite often the outputs of these devices are tied in parallel to provide this extra drive capability. The 7406 Hex Inverter Buffer is an example of a TTL buffer gate. It allows TTL devices to be interfaced to MOS and extends the maximum current sinking capability to 40 mA, more than 20 times the ability of a normal TTL gate.

Some logic families also include expander gates in their product line. In general, these devices are not gates but rather analog circuits used to increase the effective number of inputs to another gate. Often the outputs do not meet the defined output threshold levels.

## Fundamental Logic Devices

### AND gate

A	B	F
L	L	L
L	H	L
H	L	L
H	H	H

BIT STATE TRUTHTABLE

A	B	F
0	0	0
0	1	0
1	0	0
1	1	1

POSITIVE TRUE LOGIC TRUTHTABLE

SYMBOL

### NOR gate

A	B	F
L	L	H
L	H	L
H	L	L
H	H	L

BIT STATE TRUTHTABLE

A	B	F
0	0	1
0	1	0
1	0	0
1	1	0

POSITIVE TRUE LOGIC TRUTHTABLE

SYMBOL

### OR gate

A	B	F
L	L	L
L	H	H
H	L	H
H	H	H

BIT STATE TRUTHTABLE

A	B	F
0	0	0
0	1	1
1	0	1
1	1	1

POSITIVE TRUE LOGIC TRUTHTABLE

SYMBOL

### XOR (Exclusive OR gate)

INPUTS		
1	2	OUTPUT
L	L	L
L	H	H
H	L	H
H	H	L

INPUTS		
1	2	OUTPUT
0	0	0
0	1	1
1	0	1
1	1	0

SYMBOL

### INVERTER

F	$\bar{F}$
L	H
H	L

F	$\bar{F}$
0	1
1	0

SYMBOL

### AOI (AND-OR-INVERT)

A	B	C	D	F
0	0	0	0	1
0	0	0	1	1
0	0	1	0	1
0	0	1	1	0
0	1	0	0	1
0	1	0	1	1
0	1	1	0	1
0	1	1	1	0
1	0	0	0	1
1	0	0	1	1
1	0	1	0	1
1	0	1	1	0
1	1	0	0	0
1	1	0	1	0
1	1	1	0	0
1	1	1	1	0

### NAND gate

A	B	F
L	L	H
L	H	H
H	L	H
H	H	L

BIT STATE TRUTHTABLE

A	B	F
0	0	1
0	1	1
1	0	1
1	1	0

POSITIVE TRUE LOGIC TRUTHTABLE

SYMBOL

They are sufficient, though, to drive the inputs of certain other gates known as expandable gates.

The 7460 is an example of a TTL expander gate. This device is merely a TTL input transistor followed by a transistor with open emitter and collector. Its output swings between .4 and .8 Volts. This is not a defined TTL signal.

### Decoders

Decoders are multiple input,

multiple output devices which accept a predefined set of inputs and produces a predefined set of outputs. Figure 4 shows a simple binary to decimal decoder. The inputs BA represent BCD number with A the least significant bit. The outputs 0 through 3 correspond to the decimal equivalent of the BCD input. For example, 10 is the binary equivalent of 2 and thus output 2 will go high when this input is present and all other outputs will

TRUTH TABLE

INPUT				OUTPUT					
A <sub>1</sub>	B <sub>1</sub>	A <sub>2</sub>	B <sub>2</sub>	WHEN C <sub>IN</sub> = 0			WHEN C <sub>IN</sub> = 1		
				E <sub>1</sub>	E <sub>2</sub>	C <sub>2</sub>	E <sub>1</sub>	E <sub>2</sub>	C <sub>2</sub>
L	L	L	L	L	L	L	H	L	L
H	L	L	L	H	L	L	L	H	L
L	H	L	L	H	L	L	L	H	L
H	H	L	L	L	H	L	H	H	L
L	L	H	L	L	H	L	H	H	L
H	L	H	L	H	H	L	L	L	H
L	H	H	L	H	H	L	L	L	H
H	H	H	L	L	L	H	H	L	H
L	L	L	H	L	H	L	H	H	L
H	L	L	H	H	H	L	L	L	H
L	H	L	H	H	H	L	L	L	H
H	H	L	H	L	L	H	H	L	H
L	L	H	H	L	L	H	H	L	H
H	L	H	H	H	L	H	L	H	H
L	H	H	H	H	L	H	L	H	H
H	H	H	H	L	H	H	H	H	H

LOGIC DIAGRAM

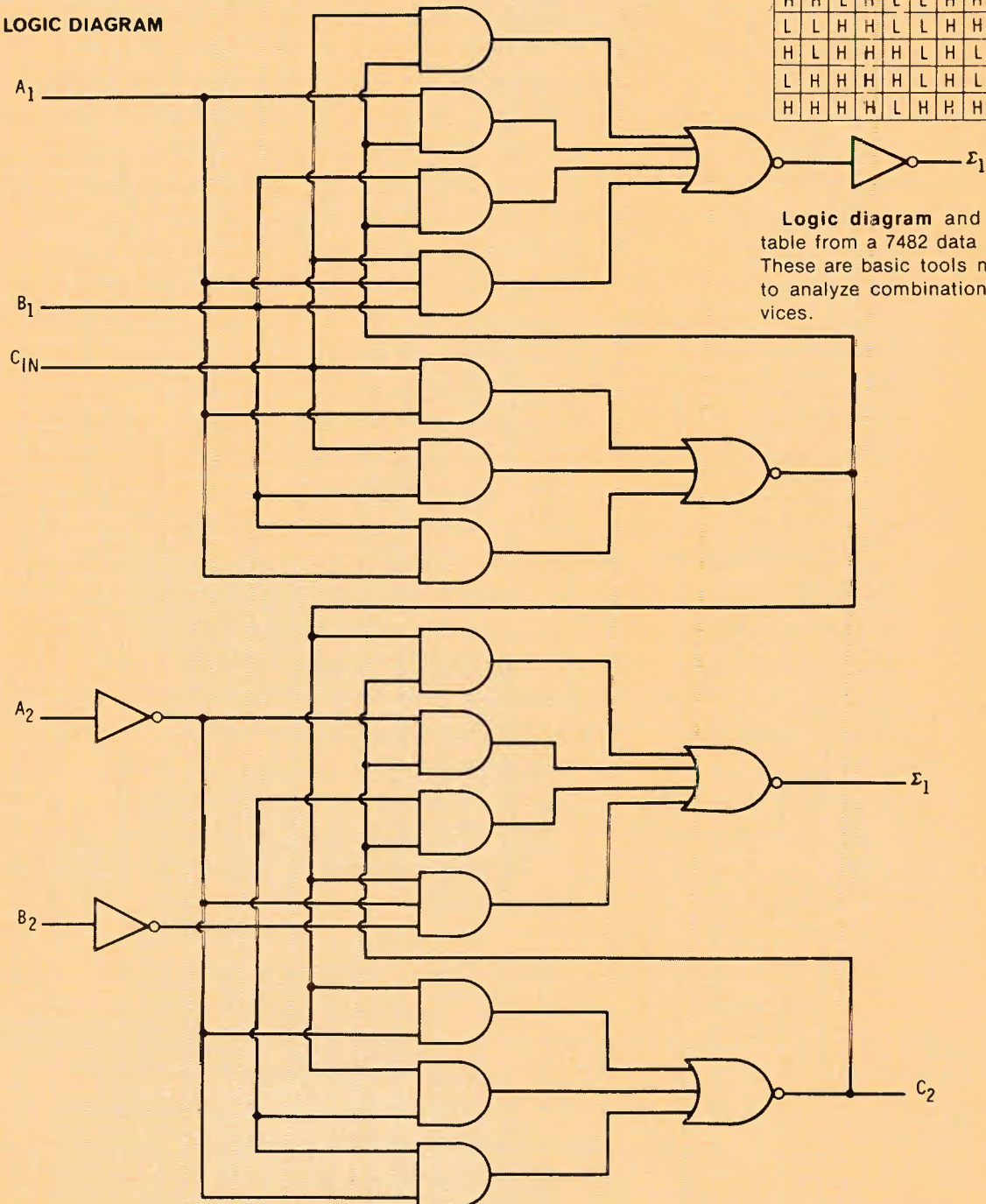

Logic diagram and truth table from a 7482 data sheet. These are basic tools needed to analyze combinational devices.



# RECYCLE YOUR USED TRANSMITTING TUBES

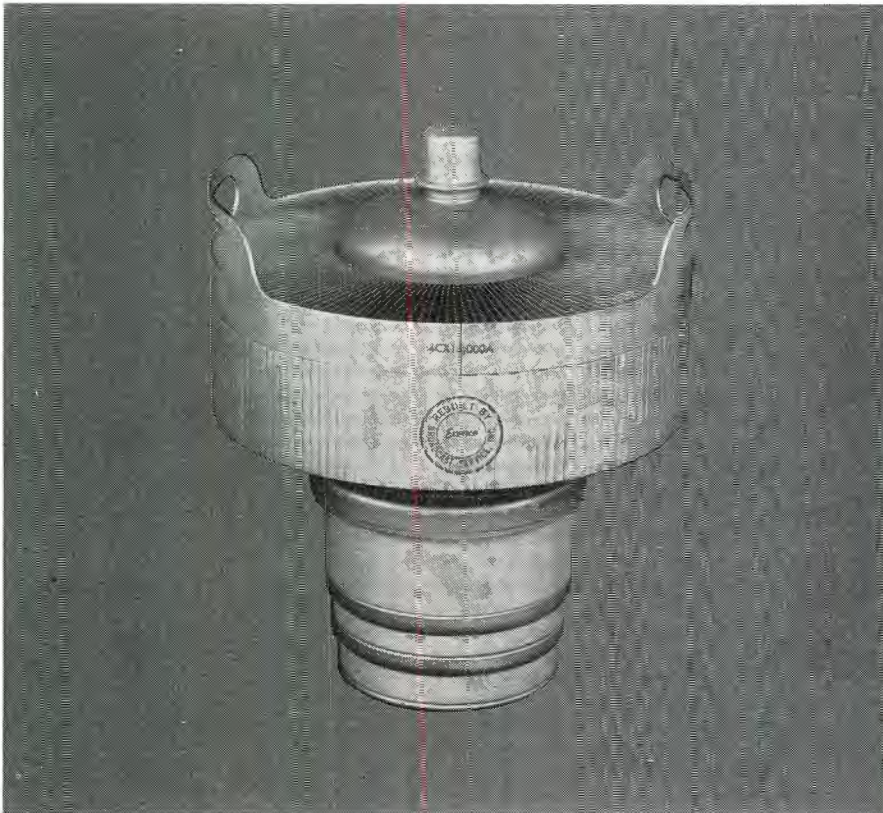

## 3000 HOUR WARRANTY EMERGENCY SERVICE

By having your used power tubes rebuilt, you can get a second, third or fourth life from them. In making new tubes a manufacturer must use many metals such as iron, nickel, cobalt, copper, tungsten, molybdenum, zirconium and precious metals such as gold, silver and platinum. Since Econco reuses most of the original parts in a tube, you help conserve these limited resources by sending your used tubes in for rebuilding. We will rebuild your used tubes for a price approximately half that of a new tube or we will buy your used tubes outright.

Here is a recycling program that saves you money and conserves valuable resources. Send us your tubes today!

For more information write or phone:

**ECONCO BROADCAST SERVICE, INC.**  
200 College Street  
Rt. 2, Box 188  
1302 Commerce Ave.  
Woodland, Calif. 95695  
(916) 662-6031

For More Details Circle (25) on Reply Card

remain low. Other decoders include EXCESS 3 to DECIMAL, BCD to SEVEN SEGMENTS, and BCD to DECIMAL.

### **Line Driver/Receivers**

Line drivers are semi-analog devices which generally perform some gating function on the input and provide the result on differential outputs to drive a twisted pair line. The outputs are current mode and do not swing between the defined threshold levels. Line receivers are high input impedance, high sensitivity devices used to detect the differential signal and to convert it to a signal compatible with the logic family being used.

### **MSI/LSI**

There are many other combinatorial devices of a much more complex nature. These are usually referred to as MSI (medium scale integration) or LSI (large scale integration), depending upon the degree of complexity of the device. Some such devices are MAGNITUDE COMPARATORS, PARITY GENERATOR/CHECKERS, ARITHMETIC LOGIC UNITS, LOOK AHEAD CARRY GENERATORS, DATA SELECTORS/MULTIPLEXERS, FULL ADDERS and many more.

Since it is impossible to discuss each and every one of these devices, we will analyze in detail one circuit, the 7482 2 BIT BINARY FULL ADDER and state that the techniques used can be applied equally well to the other devices.

The basic tools used to analyze any combinatorial device are the truth table and the logic diagram. On the data sheet for the 7482, the bit state truth table is given. This gives a complete and concise statement of the device's operation. From this table one can see that there are 5 inputs A<sub>1</sub>, B<sub>1</sub>, A<sub>2</sub>, B<sub>2</sub>, and C<sub>in</sub>. The arrangement of this table is slightly different from that described before. The state of the C<sub>in</sub> input determines which row of output states are to be used. This is equivalent to including the C<sub>in</sub> in the input column as done pre-

(Continued on page 62)

# ENGINEER'S EXCHANGE

## Phasing For Stereo PB

With emphasis on better quality these days the following procedure for proper phasing of stereo playback units should be helpful.

Normally a test tape is placed on the machine in question and the azimuth rotated for maximum out at say 10 kHz or so. This is fine for single track recorders, but with two tracks even after this adjustment the phasing can be off enough to cause a drop of several dB. With of course the same information on both tracks.

I suggest you make a test tape on your master machine by the following method. Connect your audio oscillator to your recorder with one channel 180 degrees out of phase with the other. This can be done with a 500-500 Ohm transformer with the secondary reversed. Record both channels simultaneously, for a 1000 Hz tone for two minutes, then 5000 Hz for two minutes. This completes the test tape.

Place the recorded tape on your PB machine to be adjusted. Now here you will need a method of monitoring both channels in a

mono condition. The level of the playback amplifiers should be equal.

Play the 1 kHz portion of the test tape and adjust the PB head for a null on the test VU meter or in the phones.

The audio in channel A will be equal and opposite to that in channel B, causing them to cancel. Figure 2 shows the output which results with mis-alignment.

Move to the 5 kHz portion of the test tape and adjust for further null. With a good quality recorded tape (and good heads) you should be able to adjust for zero output with proper alignment.

Perhaps the people who record the various music tapes will come up with a test tape for your PB machine in your automated systems.

**Thomas J. Arledge**  
Asst. Chief Engineer  
Birmingham Area ETV Studio

**Send Your  
Exchange Ideas  
to Broadcast Engineering  
Yes - We Pay**

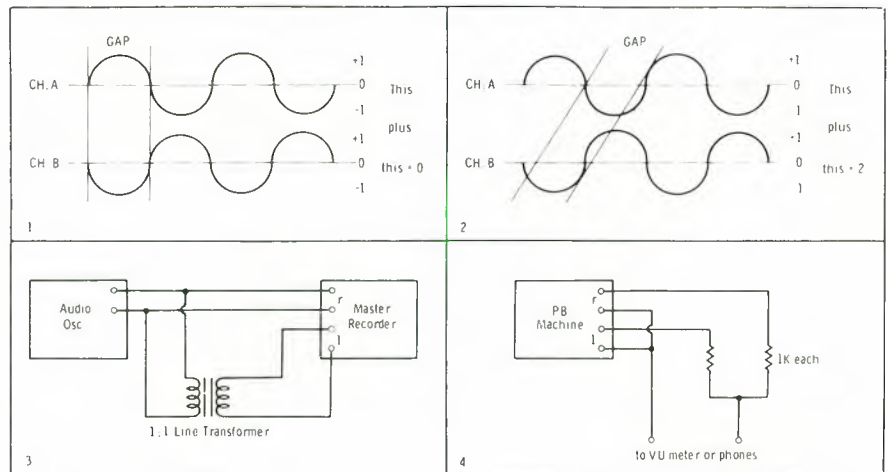

## GENERATORS or BATTERIES?

THERE'S REALLY NO NEED  
TO MONKEY AROUND

TELAN thermoelectric generators can work *with* your battery system—charging for those peak loads. Power from 10 to several hundred watts. 12-24-48 VDC standard. Operates on natural gas or propane.



**TELAN**  
thermoelectric generators

ARE THE ANSWER

**TELEDYNE ISOTOPES**

110 WEST TIMONIUM ROAD TIMONIUM, MARYLAND 21093  
TELEPHONE (301) 252-8220 TELEEX 87-780

For More Details Circle (26) on Reply Card



# An update on phase monitors

By Bob Jones\*

*BE's Facilities Editor brings you up to date on the directions the FCC is taking on antenna phase monitors.*

This article concludes my three-part story of the FCC's changes in the antenna monitor rules and regulations. The following comments relate to Docket #19692. It should be noted that the FCC has not concluded this Docket yet.

As a result of all the comments filed in reply to Dockets #18471 and #18455 the FCC has finally recognized that some standards should be set for the design and installation of sampling systems for antenna monitors used by standard broadcast stations employing directional antennas. The FCC asked by Notice of Inquiry dated February 21, 1973 for comments by interested parties on the standards set forth in the Appendix attached to the Docket. But first let me give a little history on this third Docket.

## **Docket Perspective**

The antenna monitor is an instrument utilized to provide indications of the relative phases and amplitudes of the currents in the elements of a directional array of a standard broadcast station. Such a monitor can furnish much of the information necessary to insure the proper maintenance of the station's radiation pattern, which is essential if a station is to stay where it belongs and prevent interference to other stations.

In the two previous Commission dockets and accompanying filings, the FCC amended its Rules and Regulations to establish type approval of antenna monitors and a schedule for their installation by all standard broadcast stations utilizing directional antennas. The implementation of these new rules means that all stations eventually will substitute accurate, stable and easily manipulated monitors, for the present equipment, much of

which is obsolete, of doubtful accuracy and stability. Also, some of these older types of monitors are comparatively complicated to operate. This is a special problem now that the FCC has permitted lesser grade duty operators at stations with directional antennas. These new antenna monitors are intended to give not only more accurate indications, but also to permit—in the case of remotely controlled stations with a directional antenna—a lessening of transmitter inspection requirements.

## **Coupling Complication**

While the FCC has provided a solution to improved instrumentation at all stations, one further step is necessary . . . or, so the FCC states, if we are to realize the full potential of the modern antenna monitors.

The signals which activate the antenna monitor are samples of the currents flowing in each tower of the array. These samples are obtained from coupling elements, usually mounted on each individual tower. The individual signals are delivered, by transmission lines (usually coaxial cable), to the antenna monitor located in the transmitter house. Each line may be up to several hundred feet in length. If the antenna monitor is to be relied upon for accurate and stable indications of relative phase and amplitude, it is essential that any sampling system be so designed that errors in indication, due to inadequacies in the system be minimized.

Many of the comments filed on Docket 18471, particularly from experienced consultants and technical personnel of broadcast stations, emphasized that the sampling systems presently employed in many stations are clearly of poor design, or have deteriorated through lack of adequate maintenance. And such poor systems can often introduce large and variable errors in monitor indications. These can be due to changes in temperature, wind velocity, humidity and other factors. Many of these engineers urged the FCC to establish at least minimum

standards for the installation and maintenance of sampling systems.

This of course the FCC admits to, and as they stated in Docket #19692, was the reason for this latest Notice of Inquiry. In setting forth possible sampling system standards, the FCC drew extensively from the information and suggestions submitted in Docket #18471. The FCC hopes by this only to establish minimum and essential requirements for a properly designed sampling system. They hope at the same time to avoid the imposition of unnecessary restriction on the prerogatives of consulting engineers who design the systems . . . or to place undue and costly burdens upon station licensees.

## **Getting The Job Done**

A number of questions immediately present themselves. For instance, should temperature stabilized cable be specified for all sampling systems? Also should all lines be required to be of equal length? Should only rotatable and/or shielded loops be installed in all instances? Should only loops be required, even for quarter-wave height towers? Should all sampling lines be required to match their impedance?

Undoubtedly engineers who have had extensive experience with installation, maintenance and use of such sampling systems will have strong opinions on these points.

In addition to these basic questions, the FCC is also looking for suggestions on comparatively simple and practical test procedures which might be employed periodically, perhaps at the time of the equipment performance measurements (Section 73.47) to ascertain that no deterioration has occurred in the sampling system.

The effort initiated by the FCC in this last Docket on antenna monitors and sampling system standards may be viewed as an action at variance with the Commission's avowed purpose, as expressed in its Public Notice of April 6, 1972. This Notice, you may

\*Broadcast Consultant, LaGrange, Ill., and Facilities Editor of Broadcast Engineering magazine.

recall, states that the FCC was going to simplify and—where possible—relax the regulations governing the broadcasting services. In the long run, the FCC points out, this tightening of sampling systems standards is aimed toward that end. The FCC's logic is that by using these new tighter standards, it may be feasible to relax certain existing operating requirements.

Since the general use of stable and accurate antenna monitoring systems by stations with directional antennas will substantially reduce the incidence of out-of-adjustment systems. Re-adjustment is a source of considerable trouble and expense to many stations.

The FCC suggests that one of the results possible in the future will be less frequent intervals at which monitor points have to be measured. In fact, it might be possible to rely completely on antenna ratios, with the elimination of the requirement for reading base currents. Many consultants have realized that with half-wave towers, remote ratios are more accurate than base currents.

The FCC broke down their Appendix in Docket #19692 into two general areas. These are Sampling Lines and Sampling Elements. Let me now go over each of these points along with my thoughts pro and con.

The first standard proposed under Sampling Lines is that all lines shall be of equal total lengths with equal portions of the lines subject to the same environmental conditions. This would make the cable people happy since they would sell more cable. But it has been my experience that most consultants now prefer equal length lines. There are two very good reasons.

By having equal length lines, the measured phase angles will work out in practice very close, if not identical with the theoretical phase angles. This is useful, since it gives you a better idea of how close you are to the true pattern. Another reason is that equal length lines will cause the same error to be introduced into all lines when the temperature of the cable changes. All prudent engineers have recognized

for years that coaxial cables expand and contract and that the electrical lengths change as the temperature of the cable changes. (In some cases I've seen a cable change by 15-20 degrees.)

What are the disadvantages to this standard? Obviously, it costs more money to the operator who wants to use direct, unequal length cables. And it must be recognized

that some systems with unequal lengths **do not** show wide changes due to environmental conditions. A second point against equal length is that it prevents the design engineer from adjusting the normal position on the monitor where a reading is logged. What often happens is, when, during a tuneup, the phase angle turns out to be close to zero or 180 degrees, the engineer will

Paragraph 73.69 of the FCC's Rules and Regulations states:  
**... every standard broadcast station employing a directional antenna must use a type-approved phase monitor.**



FCC Approval No. 3-204

## OUR AM-19 (204) IS THE ANTENNA MONITOR THAT MEETS ALL FCC REQUIREMENTS!

### WHAT THIS MEANS TO YOU

1. If you're a new station or if you're making significant changes—you must have a type-approved antenna monitor by June 1, 1973.
2. If you operate your station with less than a first class radiotelephone licensed engineer, you must have a type-approved antenna monitor by June 1, 1974.
3. If you are presently operating your station by "remote control", you must have a type-approved antenna monitor Now! Or—you can use a monitor "properly configured", if such a monitor was manufactured after 1965.
4. Every other directional station must have a type-approved antenna monitor no later than June 1, 1977.

### YOUR BEST CHOICE?

The AM-19 Antenna Monitor from POTOMAC INSTRUMENTS. The proven instrument for measuring phase and loop current ratio, the AM-19 can monitor up to 12 towers and accommodate DA-1,

DA-2 and DA-3 patterns. Phase meter resolution is 0.5 degrees. Loop current accuracy is  $\pm 1.0\%$  with a 0.5% resolution.

AND—the AM-19 (204) is the only type-approved antenna monitor that meets all FCC requirements NOW!

**YOU MUST HAVE A TYPE-APPROVED ANTENNA MONITOR — CHOOSE THE AM-19 (204) TODAY!**

For complete information, please write or call:



Producers of  
**NEMO CLARKE**  
 Broadcast Equipment

**POTOMAC INSTRUMENTS, inc.**  
 932 Philadelphia Avenue  
 Silver Spring, Maryland 20910  
 Phone: (301) 589-3125

For More Details Circle (27) on Reply Card

add or shorten that sampling line so that the phase can be read more easily so that minor changes in value are easily detected.

### A Line On Sampling Lines

The second standard suggested by the FCC is that all sampling lines shall have solid outer conductors with either air or polyethylene-dielectric, so proportioned as to produce a minimum phase temperature coefficient. Here again the rule seems to favor the cable manufacturer. Price-wise a typical solid dielectric type Heliac (5/8") cable sells for about 74 cents per foot. Their same (5/8") air dielectric, model Heliac sells for \$1.22 per foot. When you realize that most stations now employ either RG-11U or RG-8U cable, at \$ .16 per foot; the reason is obvious. Cost!

You have to look further into the FCC's reasoning on this suggested standard. One positive reason is that solid outer conductors provide a higher degree of shielding. And second, these solid conductor type

cables have less of a temperature coefficient than RG-8U or RG-11U type cables.

Most broadcasters have found that the difference in shielding effect between braided and solid outer conductors is nil. But even if it weren't, the fact that most operators now bury their sampling cables several feet below ground completely eliminates the question of whether any stray signals get into the braided type cables. Also, the fact that most operators now bury their cables stabilizes temperature effects and makes their RG-8U and RG-11U lines just as good as the solid type cables.

The third standard proposed is that all sampling lines shall have identical electrical characteristics. This is generally the practice followed today by most stations. When a new station is built, usually all the sampling cable is purchased at the same time from the same source. If so, then it would meet this proposed standard. The only place where one might get into trouble on this score is where he has had older cable that is no longer manufactured. Now let's say one of his lines is damaged by ice or fire and it needs to be replaced. It certainly is unfair for him to have to replace all his sampling lines, just because one cable became defective and that type of line is no longer manufactured. A more reasonable approach would be to permit the licensee to install a substitute cable of approximately the same characteristics and of the same electrical length.

### Laying the Line

The fourth proposed standard under sampling lines states that the portion of lines between the towers and the transmitter house should preferably be buried. Or, if run above ground, the lines shall be rigidly supported and positioned. What's more, the outer conductors shall be grounded at points necessary to insure that field from the array will not induce error currents in the lines.

Of the four standards proposed under Sampling Lines, this is the easiest for station owners to comply with. Most stations are already burying their cables to protect them, to stabilize their temperature

variations, and to eliminate the above ground maintenance problems.

In the case of stations where direct burial is not possible, it is just common sense to securely tie these sampling lines to a messenger line or other rigid device. Likewise, good engineering practice for years has been to ground these lines at short intervals to prevent induced RF errors. Some engineers have used a bundling ground wire instead of periodic grounds, since it serves the same purpose.

### Sampling Elements

In the area of Sampling Elements, the FCC has proposed four specific standards. These, as the reader will see, generate a lot more controversy.

The first suggested standard says that all sampling elements shall be a single turn, untuned, unshielded loop of rigid construction, with ample gaps at the terminals solidly supported by nonhygroscopic insulators. In effect this says all you operators who use the Gates or Collins shielded loops will have to change!

It's been my experience that the majority of stations who use loops use shielded loops. The primary advantage to such loops is that they pick up only the magnetic signal. Also, restricting a loop to a single turn will arouse objections from those low power stations who found it necessary to use two or even three turns within the supporting loops in order to achieve sufficient sensitivity to calibrate their monitor.

Such things as rigid construction, ample gaps and the use of good insulators are only good engineering practice and now meet the standards of most manufacturers.

The question of "untuned" may seem like it would cause no howls from licensees. But it will. I concede that very few stations have resorted to this technique. I presume the FCC's worry here is that untuned loops are more stable than tuned. I disagree, especially if the tuned loops were all tuned identically and if their condition is periodically checked.

WERK in Muncie, Indiana has employed tuned loops for many, many years with no instability. Certainly, if a station is required to

**BE Spotmaster**

## Program/Line Amplifier



## AND Monitor Amplifier

Stack the new Spotmaster amplifier twins in just 7" of rack space for troublefree wideband performance.

Model PLA-20 (shown here) serves as either a program or line amplifier. Input and output level are adjustable; gain is 60 dB, and maximum output is +20 dBm RMS.

Model MA-10 is a 10 watt (RMS) monitor amplifier designed to meet the most critical studio requirements. Gain is adjustable, frequency response is 30-20,000 Hz ( $\pm 1$  dB) and distortion is less than 1% at the rated output.

More details? Contact us today.

**BROADCAST ELECTRONICS, INC.**  
— A Filmways Company —  
8810 Brookville Rd., Silver Spring, Md. 20910  
(301) 588-4983 • TWX 710-825-0432



conduct a yearly recalibration of its sampling system, tuned loops can be reverified as simply as untuned.

The second standard proposed is that each sampling loop shall be oriented with the plane of the loop including the vertical centerline of the tower, and it shall be rigidly mounted on the tower in this orientation. The center conductor of the transmission line shall be connected to the side of the loop nearest the tower.

Here too, I expect howls from station operators. One of the reasons many owners purchased rotatable loops is so they can be used to help control the remote amplitude readings. Requiring all loops to be rigid and always oriented to the centerline of the tower will eliminate the "ease of adjustment" now enjoyed by such stations. Why the FCC has stated the inner conductor has to be connected to the side next to the tower, does not follow with accepted practice. If this becomes one of the standards, all those using the unshielded loops will have to change loops. Also all unshielded loops that are grounded to the tower can not comply, since if we connect the inner connector to the tower side of the loop, it will short out the signal. Thus to comply, nobody can use a grounded loop, which in the past has been the standard method of installing unshielded loops.

When one employs just a single turn loop, it really makes no difference at all which side connects to the tower. Until the loop is closed no current will flow, and once it does, it is a constant value in an untuned loop.

The third standard proposed for Sampling Elements is that all loops shall be of the same size and shape and be of identical construction, and shall be located at the same height on each tower (if the towers are of equal height) at a point close to the current maximum in the tower, but in no case less than 10 feet above ground level.

Probably the least controversial point here is the minimum height above ground of 10 feet. Almost all loops are at least that high off the ground. Of course the logic here is to get the loop high enough to be unaffected by vegetation, snow cover, etc. Some consultants have

insisted on their clients mounting loops a minimum of 50 feet up the tower. Good engineering practice has always dictated that loops be installed at or near the current nodes.

The real howl over this standard will result because of all loops being required to be equal size. Many engineers have found that when their tower currents are low, they have had to go to oversized loops in order to obtain sufficient signals to calibrate the monitor. In fact, some engineers vary the size of their tower loops to achieve equal signal magnitudes back at the monitor. One special case where loops have to be of differing sizes is when a directional array is composed of unequal height of towers or where one tower is guyed and one is a self supporting tower.

#### Current Transformer

The last point proposed as a standard for Sampling Elements states that for a tower of less than  $\frac{1}{4}$  wavelength in height, current sampling may be obtained from the transmission line, as close to the base of the tower as possible, by a current transformer or other coupling element.

The basic convenience of the use of current transformers is that they can be installed in the "dog house" out of the weather. When trouble occurs, or is suspected, they are easier to service. The FCC's logic in restricting these to only those stations who employ towers of  $90^\circ$  or less is not too clear. Many stations have used current sampling transformers on towers up to  $120^\circ$ .

Obviously with a  $180^\circ$  tower the readings of base sampling will result in a different set of conditions than a sampling up at the current node.

Well, this brings to a conclusion this three part series on the FCC's new phase monitor rules as they apply to the type approved monitors, how soon each of us will have to install one, how they affect those stations operating by remote control, as well as the proposed standards for sampling systems. If and when the FCC does issue a final ruling on Docket #19692 count on **BE** to keep you informed. Keep an eye on our Direct Current column. □

## UNLIMITED VARIETY

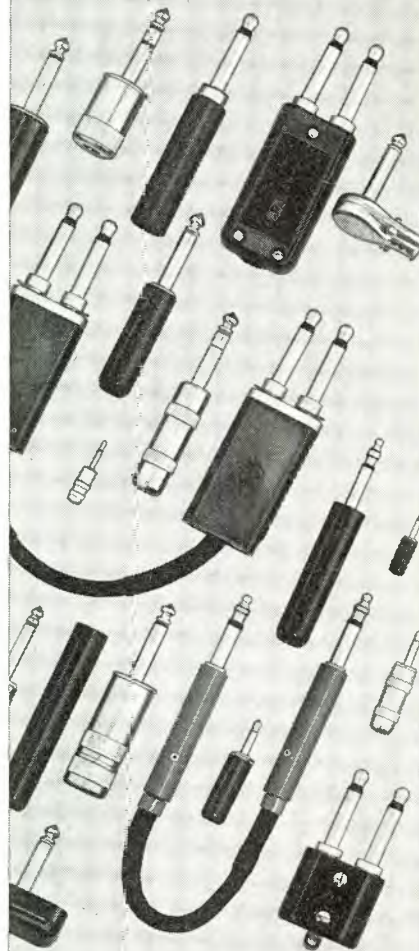

## INCOMPARABLE QUALITY

### SWITCHCRAFT PHONE PLUGS

Why waste time "shopping around" . . . whatever your plug requirement—regardless of size or type, Switchcraft makes it, and makes it better! The one piece tip rod, for instance, is staked into the terminal to assure tightness . . . the tip rod can't fall out! Switchcraft offers you the world's largest selection of phone plugs . . . with solder terminals, screw terminals, cable clamps; .250", .206", .140", .097" finger diameters; shielded handles, or tough plastic handles; single plugs, twin-plugs; 2-conductor or 3-conductor—you name it! Chances are it's a thoroughly proved, field-tested STOCK plug from the incomparable Switchcraft line of plugs.

SEND FOR NEW CATALOG P-202 or see your Switchcraft Authorized Industrial Distributor for immediate delivery at factory prices.

**SWITCHCRAFT**  
INC.

5535 No. Elston Ave.  
Chicago, Illinois 60630

For More Details Circle (28) on Reply Card

# A report from montreux

By Joe Roizen

Telegen, Mountain View, Calif.

The biannual symposium held this year in Montreux (May 18-24) has become the NAB of Europe. It attracts as delegates members from the TV broadcast industry from all over the world, including the USA. It is also the show place for the most producers of TV originating and distribution equipment and European representatives.

Since its inception in 1960, it has steadily expanded in scope and attendance so that it is now the foremost international platform for technical presentations and the largest exhibition of broadcast industry products.

Paradoxically, this small Swiss lakeside resort would seem to have nothing to attract a global conference of this caliber. Montreux cannot boast central commercial location like Chicago, national capitol status of Washington, D.C. or the program production facilities of Los Angeles. Instead it offers funny funiculars that run up and down the nearly perpendicular mountains, quaint chateaus that date back to the middle ages and all the fondue and dole the delegates can consume. Except for a few new high-rise hotels that plagerize the Hilton or Sheraton chains, most of the accommodations carry names like Grand Palace or Suisse Majestic and ensconce their patrons in the faded opulence

of late 19th century luxury. This includes exposed plumbing and grill work balconies overlooking Lac Lemman (Geneva) with its splendid backdrop of snow capped French mountains on the other side.

The emergence of Montreux as the cultural and technical watering hole for such renowned events as the International Jazz Festival, Rose D'Or TV Festival and other is the result of a clever decision on the part of the city management back in 1960. The highly seasonal tourist trade was extended into the months proceeding and following the mid-summer migrations of masses of English tourists. In this way the duty cycle of the available facilities would be expanded into more profitable utilization.

The first Montreux TV Symposium combined both the program contest and product exhibits and was held in 1960. It was scheduled to become an annual event. The technical conference and equipment display portion immediately ran into conflict problems with existant electronic conventions, which made it appear that not enough momentum could be gained to keep the show on the road.

In subsequent years it was alternately boycotted by the United Kingdom or Continental manufacturers who wanted to avoid two



Philips mounted one of their cameras on a pleasure boat and beam their signal back to shore in a unique demonstration. Gates, RCA, and Marconi located cameras on a fire escape landing in order to provide live pictures to the exhibit areas of the picturesque scenery.

full blown TV conventions in a given twelve month period. This situation was not unlike that which is now being experienced by the U.S. TV manufacturers in having to marshal their forces for NAB and NAEB that are approximately six months apart.

The International Broadcasting Conference in London was beginning to grow as were some of the regional TV expositions and annual technical fairs in Paris and Berlin. In evaluating the situation the Montreux Chamber of Commerce must have decided that half a loaf was better than none and come up with the logical compromise which has served to enhance the desirability to the broadcast industry of participating in this convention. The symposium was scheduled every second year, alternating with IBC in London.

This year's technical exhibition is enhanced by four separate occurrences. First, the general economic well being, particularly in Europe, is creating a good market for color TV studio equipment. Second, the United Kingdom's



Or did you know that Bosch was into CATV and MATV systems?

entry into the common market makes British products more competitive in a number of new areas. Third, the old Montreux Casino which housed the exhibit equipment was destroyed by fire and a public subscription raised by local residents produced a modern new exhibit hall which is now the site of the equipment display. Finally, the diminishing trade barrier between East and West is creating a significant television product flow into Eastern Europe and the Soviet Union. Large color mobile vans destined for delivery at the close of this exposition carry logos such as Telewizja Polska Kolor, Televiziunea Romana etc.

### Equipment Exhibits

The new Montreux Maison des Congres is a four floor low profile building with a unique internal design. It has areas of multi-level openings for the larger exhibits and sections of single level cubicles for the smaller one's. Outside, the canny Swiss have used a metal covering that has been allowed to rust, thus providing a warm brown color to the whole building: Paint (as everything else) is exorbitantly expensive!!

The only significantly new piece of major television originating equipment being displayed was the IVC built 9000 helical scan broad-

cast recorder. This machine is a joint venture between IVC, Thomson CSF and Rank Cintel and represents major competition for the quadruplex video tape recorders that now dominate the broadcast market. There were two 9000 machines operating in PAL and Secam, permitting demonstrations of full interchange, even on 100 percent saturated color bars.

Gates demonstrated their TE-201 cameras, their BT-1300H 1 kW transmitter, their program automation system. Gates' equipment and facilities expansion program has brought them into position as a major full line contender as a TV equipment manufacturer.

Fernseh was featuring the KCR portable color camera and RCA was emphasizing the cartridge recorder as was Ampex. Thomson had a very elaborate stand, complete with a night club revue imported from Paris, multiple camera coverage, control room with switching and special effects.

The Philips display was the most elaborate, in terms of set design, including multiple story structures, carefully planned shows with complex chroma keying and peripheral displays of non-broadcast equipment (CATV, Cassette, etc.)

Mobile units were having a big year. Multi-camera units made by the major supplier were parked



Dynair, along with a number of other American manufacturers are shown in these pictures preparing for the opening of the exhibits. There are a number of others not shown in these pictures, among them, Gates, IVC, RCA. Gates demonstrated their new TE-201 camera, their TV transmitters, and their "touch control" digital program automation system. Gates presented a technical paper on TV IF modulation, and other manufacturers as well played a major role in presenting the US TV state of the art. Unfortunately, pictures of more exhibits were not available at press time.

# We just made our first million.

# Now comes the hard part.

In the past four years, we've managed to get a million disadvantaged persons hired. It was a tough job, but there's an even tougher job. Giving the disadvantaged the hope, training and encouragement they need to stay on the job and move up within the system.

Working as a catalyst between government and the business sector, the National Alliance of Businessmen has learned a great deal about how to get the disadvantaged working and keep them working. We've expanded and refined our programs for the disadvantaged, Viet Nam-era veterans and disadvantaged youth.

Business has responded admirably. 56,000 companies have participated in helping with employment and training. Many corporations have loaned us top caliber executives. And on a city by city basis, local businessmen have helped us build a network of offices in 164 cities.

But the job is far from over. There are millions more who need to be hired and trained. In the months ahead, the National Alliance of Businessmen will be seeking the participation in our JOBS programs of many smaller companies, as well as the continued sponsorship of the largest corporations.

The problems of the disadvantaged are great, but we believe that working together, we can get everyone who wants to, working.

## National Alliance of Businessmen

"The JOBS People"

1730 K Street, N.W., Washington, D.C. 20006

cheek by jowl next to the building and provided continuous coverage of the passing scene. There was even one mobile van produced in Poland and displayed by UNITRA, the Polish export agency.

New lenses with ever increasing zoom ranges were everywhere supplied by Canon, Angenieux, Rank Taylor Hobson, Schnieder and others. The technical symposium included a wide array of papers covering general revues of the progress of television in various countries and very specific details on new technological features of the equipment on display. The lecture hall was not the best for this purpose but it was equipped with audio visual aids which included an Eidophor large screen projector and an AVR1 for tape playback. Major lectures were well attended by up to 300 delegates.

Aside from the normal technical talk that goes on at a symposium of this type, the major topic of conversation was the seemingly sudden skyrocketing of prices for almost everything a company or participant needed at this show. Montreux hotels were choked with American Express busses disgorging endless groups of tourists. As a result, room rates and meal prices just spiralled out of sight. It was not unusual to pay \$30 or over for a single room (with bath) or \$6 to \$10 for a mediocre meal poorly served. This is a far cry from the attractions that once made going to Montreux a high point in television activities. □



"That's one thing about helicopters, folks—people never lose their curiosity about them."

## Four-Channel Sound

If you are thinking about purchasing a four-channel system, converting to one, or interested in learning about it, **Four-Channel Sound** written by Leonard Feldman gives you the information you need.

The author covers four-channel sound from the reasons for it to the selection of the equipment. Matrix techniques and discrete four-channel discs are discussed at length.

Complete chapters are devoted to four-channel FM broadcasting, four-channel sound on tape, discrete records, and matrixing techniques. An appendix is included to acquaint the reader with new terms associated with this new and growing field of four-channel sound.

This book is available through Howard W. Sams & Co., Inc., Indianapolis, Ind.

*For More Details Circle (80) on Reply Card*

## Light Emitting Diodes

As early as 1907, emission of light from a semiconductor was produced by application of a low voltage potential to two points on a crystal of carborundum (silicon carbide). This discovery has only recently attained commercial application in the form of the light emitting diode (LED). The advantages of the LED over the conventional light sources (incandescent and fluorescent lamps) are solid-state reliability, speed of response, and compact size. Some of the applications for which the LED is particularly suited are miniature panel indicators, digital readouts, light-beam communication, optical radar, and logic status indicators.

Light emitting diodes have been developed to emit light in several different colors, mainly reds, oranges, and yellows, with others in the development stage. The color wavelengths are quite narrow; thus, the need for filters is kept at a minimum. LED's have also been constructed that emit in the infrared portion of the spectrum.

**Light Emitting Diodes**, written by Forest M. Mims, III, covers the topic of light emitting diodes thoroughly, starting with the theory of semiconductor emission and details of physical construction, then chapters are devoted to the infrared-emitting LED and the visible-light-emitting LED.

Chapter 4 discusses the use of the LED as a display device, with such applications as digital display, alphanumeric display, polarity and overflow displays, logic displays, and others. Chapters 5 and 6 deal with accessory devices necessary to make full use of the light provided by the LED; detectors, receivers, and viewing devices, and lenses and fiber optics.

This book is available through Howard W. Sams & Co., Inc., Indianapolis, Ind.,

*For More Details Circle (81) on Reply Card*

# LOW COST DIGITAL CLOCKS, TIMERS AND COUNTERS

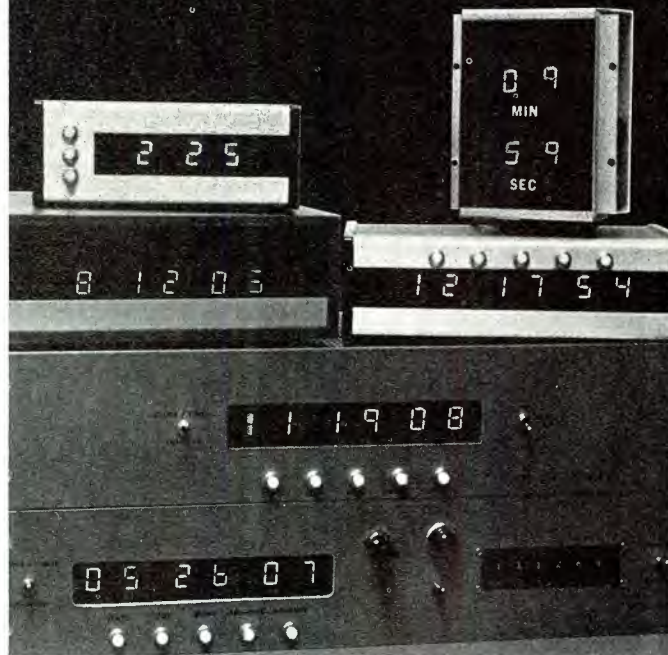

All ESE digitals are designed and constructed using the latest solid state electronic components and circuitry. This equipment is perhaps the most economical line of digital clocks, timers and counters available. Circuit efficiency and lasting quality are designed into every ESE digital product. Constructed with the built-in ruggedness necessary for studio use. No moving parts.

Special custom items, like the video tape/counter editor, a monitoring system with unique display configuration, 12 and 24 hour clocks or timers, 10 minute timers, 3 digit, 4 digit, 6 digit, record seconds in tenths, hundredths or thousandths . . . All available from ESE. Options include: Thumbwheel switch or patchboard programming, BCD outputs, relay closure outputs, and solid state buffered outputs. Many products available in kit form.

### MOST EFFICIENT DIGITAL CLOCKS/TIMERS AVAILABLE ANYWHERE:

**ES-112/124, 12 hour or 24 hour clock:** 6 digit — Records hours, minutes, seconds . . . . . \$ 90.00

**ES-300, 100 minute up/down counter:** Displays up to 99:59 — Easy pushbutton: Reset — Count up — Count down — Advance seconds — Advance minutes — Stop . . . . . 135.00

**ES-400, 10 minute timer:** Displays up to 9:59 — Pushbutton: Start — Stop — Reset . . . . . 75.00

**ES-500, 12 hour clock/timer:** 6 digit — Records hours, minutes, seconds. Start — Stop — Reset — Slow and Fast Advance buttons. Displays up to 12:59:59 . . . . . 120.00

**ES-510, 60 minute timer:** Displays up to 59:59 — Pushbutton: Start — Stop — Reset, Only 3 3/4" deep for flush mounting into walls or std. alum. case . . . . . 100.00



Inquire about our new thumbwheel or patchboard programmers.

WRITE, WIRE OR CALL TODAY:

506 MAIN ST. • EL SEGUNDO, CA. 90245 / (213) 772-6176

# PEOPLE IN THE NEWS

## Broadcast

**Charles Michel** has joined Dyma Engineering, Inc., broadcast equipment manufacture and sales organization to be based at the Los Angeles office....TeleMation, Inc. has announced the appointment of **Dennis Fraser** as Regional Broadcast Sales Manager and will be based at the company's Chicago office....**Harold Sobol**, of the research and engineering corporate staff at RCA's David Sarnoff Research Center in Princeton, N.J., has been elected general chairman of the 1974 Electronic Components Conference sponsored by the Electronic Industries Association and the Institute of Electrical and Electronics Engineers....

**John D. Jackson** has been named General Counsel for American Satellite Corp....**Milton F. Fleming** was elected Vice President of Prodelin Inc. at the May Board of Directors' Meeting....Brand-Rex Co. has announced the appointments of two salesmen for the company's telephone wire and cable product lines. **Duncan J. Wilson** will cover customers in North and South Carolina and western Tennessee. **Michael G. McGuire** will cover Minnesota, North and South Carolina, Nebraska, Wisconsin and Iowa....

**Andrew P. McClure** has been named Vice President, Manager of Sales for Schafer Electronics Corp....**Robert W. Selvage** has been named Sales Engineer and Modification Center Coordinator, for the Triplett Corp....**Elmer J. Stymiest** has been promoted to a newly created position, Director of Marketing....**Charles E. Hinds** has been appointed as Executive Director of the Chicago Archdiocesan Multimedia Communications Center and Network (OAMCAN)....**Dennis T. Goddard** is now Vice President-Marketing and **Robert F. Friedman** is Vice President-Operations for American Satellite Corp....

At the Annual Meeting of shareholders of Penril Data Communications, Inc., the shareholders elected **Merrill Solomon**, **Alva T. Bonda**, **Howard M. Metzbaum**, **Howard Andrews** and **Kenneth M. Miller** as its directors....**Remi Nadeau** has joined Collins Radio Co. as Director of Advertising and Public Relations....**Glen Page** has been appointed Manager, Eastern Region, for Technology Inc., HF Photo Systems Division....

After a 3-year absence, **Ivan Ryman** has returned to HF Photo Systems as Director of Engineering....Electro Sound has announced the appointment of **Ted W. Wuerthner** to the newly created position of vice president, marketing....**Myron F. (Mike) Wilson**, director of operations at the Collins Radio Company's plant in Cedar Rapids, has been promoted to vice president of manufacturing....**James Wulliman**, Manager of Engineering, Broadcast Division, at WTMJ, Inc., was recently elected President of the Society of Broadcast Engineers....

**Benjamin D. Wood** has recently been named manager of emitter-coupled logic (ECL) product engineering for Signetics Corp....**Eric King** has joined Vital Industries, Inc. as Northeastern Sales Manager....**C.E. "Cliff" Miller**, vice president and director of engineering, Fisher's Blend Station, Inc., owner and operator KOMO Radio & TV, Seattle, and KATU Television, Portland, Or., announced his retirement from active day-to-day responsibilities after 31 years of service. Miller will continue as Consulting Engineer, exclusively for Fisher's Blend Station. **Ralph Mifflin** will become Director of Engineering....

**George Nicholas Simcoe**, Chief of the Reference Room Branch of the FCC Broadcast Bureau, retired April 13, after 27 years' service....**Rosemary T. Fruehling** has been appointed to a four-year term as Commissioner on the New Jersey Public Broadcasting Authority....**Dr. Melvin G. Holland** has been named to the newly created position of manager of marketing and program development for Raytheon Company's Research Div....**Philip A. Phalon** has been elected vice president, international affairs for Raytheon Co....

Sonderling Broadcasting Corp. has named **Michael J. Corken** division vice president and general manager of WAST-TV, (Channel 13), Albany, and **Robert Burns Taylor Jr.** to the newly created position of division vice president for administration and operations....**Reb Foster** has resigned his position as program director at KRLA Radio, Los Angeles....**Lad F. Hlavaty**, director of engineering for WNAC-TV in Boston, has been

**ADD THIS POSITIVE  
PEAK FLASHER TO  
YOUR MOD MONITOR  
AND MEET FCC RULES  
FOR 125% PEAK  
MODULATION  
INDICATION**



WILKINSON PPF-1A

**WILKINSON  
ELECTRONICS, INC.**

1937 MacDADE BOULEVARD  
WOODLYN, PA. 19094  
TELEPHONE (215) 874-5236 874-5237

For More Details Circle (31) on Reply Card

appointed vice president and director of engineering for the RKO General Television Division....**Herbert S. Reeves** has been appointed Regional Representative for Communications Technology Corp....

**Richard R. Fried** has been named to the new position of director of marketing for Western Magnetics, Inc....**Stephen E. Wickstrom** has been appointed Field Sales Representative, Phelps Dodge Comm. Co....**Robert W. Coombs** has been named local sales manager for KRUX, Phoenix....The Belden Corp. Board of Directors elected **Everett W. Blome** and **Fred O. Weirich** group vice presidents....**Lynd John Carter** has joined Lenco Electronics as Sales Manager....**L. D. Altman** has been named president of Fabri-Tek Inc....**Robert Cizik** was elected President and Chief Operating Officer of Cooper Industries....**Mark W. Bullock** rejoins Continental Electronics Mfg. Co. as Vice President of Marketing....

### Cable

**Irwin S. Sylvan**, manager of national accounts and operations manager for Anixter Bros., Inc., has been appointed executive vice president of Anixter-Pruzan....**Les J. Lomax** has been appointed CATV sales representative, Anixter-Pruzan....**John Greenberger** was named Director of Programming of TeatreVision, Inc....**Barrie W. Braden** has been named Contracts Administrator for the CATV Equipment & Installation Operation of GTE Sylvania Inc....**E. Thayer Bigelow** is now vice president and treasurer of Sterling Manhattan

Cable Television....

**Herbert C. Granger** has been named to the new position of Vice President-Operation for United Video, Inc., Northeastern region....**Paul D. Askos** has been named Manager-National Product Sales for Ameco, Inc....**Stuart E. Yeaton**, vice president of General Cable Corp. has been elected Chairman of the Wire and Cable Div. of the National Electrical Manufacturers Assoc. (NEMA)....**Phil Glade** has joined Anixter-Pruzan as a CATV sales representative....General Cable Corp. (NYSE) announced that **Donald L. Nivling** has been appointment general manager of Bare Wire Operations....



**Desmond A. Garrity** has been appointed vice president and director of corporate planning for General Cable Corp....TeleVision Comm. Corp. (TVC) has named **Jay H. Kaplan** as vice president-assistant controller, and Herbert S. Ornstein vice president-business administration....**Marcus L. Winchester**, southern regional manager for Blonder-Tongue Laboratories, Inc., has won his company's third annual Key Man Award for outstanding sales achievement....**Larry Fry** has been promoted to the position of Customer of Customer Service Supervisor and **Phil D. Cook** has been appointed Sales Promotion Specialist for Anaconda....Continental Cablevision has elected **Patrick J. Conley** to the position of Assistant Vice President....**Edward J. Taylor** has been named Controller for Big Valley Cablevision, a subsidiary of Continental Cablevision, Inc.

**ERASE  
RECORD  
REPRODUCE**

**MONO - STEREO**

Professional Direct Replacement Heads with complete written and pictorial instructions

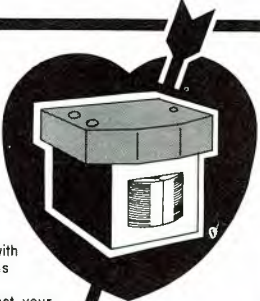
Our factory will clean, rebuild, adjust and test your head ASSEMBLY...install new MMI heads...replace minor hardware and modify your gate to accept our "NON-POPPING" springs

**AMPEX - SCULLY**

36 HOUR SERVICE - LOANERS AVAILABLE  
(612) 884-7393

**MINNEAPOLIS MAGNETICS, INC.**  
8125 PLEASANT AVE. SO., MINNEAPOLIS, MINN. 55420



**chroma key  
from encoded sources**

Chroma key with any composite NTSC signal including remotes, video tapes, network feeds and single line cameras.

We've developed an in-line chroma keyer that is not only inexpensive but really works. Using a unique chroma discriminator, noise problems and cross color effects are greatly minimized. You might say we've developed an 'intelligent demodulator'. Both normal and invert keying are possible and the remote control panel may be located up to 500' away.

We'd like to tell you more and demonstrate this remarkable device. Write for details.

**danscoll Ltd**  
9721 cote de liesse  
montréal 760 canada  
(514) 631 9884

**danscoll**

For More Details Circle (32) on Reply Card

For More Details Circle (33) on Reply Card

# NEW PRODUCTS

## Professional Tape Recorder

The availability of a new high-performance tape recorder for studio and broadcast application has been announced by **Tape-Athon Corp.** of Inglewood, California. The new recorder/reproducer has several innovative features, of which the most impressive has been designated "electronic editing" by the manufacturer.

Electronic editing allows the operator to move the tape across the recording heads so precisely that he may actually "split" musical notes and phrases and avoid the tedious practice of physically splicing tape. This precision control is accomplished by putting the recorder in a balanced torque mode which activates the drive motors of both tape reels simultaneously and



in opposite directions. In this mode, either reel may be moved manually, in minute increments, without the

creeping effect usually experienced in conventional machines.

For More Details Circle (60) on Reply Card

## Sound System Power Amplifier

A 100-watt solid-state power amplifier, designated the Model 810, is now being made available for professional sound applications, it was announced by **Electro Sound**, Sunnyvale, California. This amplifier joins with other sound components in Electro Sound's complete line for professional sound systems. The Model 810 is now in wide use in theatre systems at such installations as Burbank Studios, American Film Institute, Walt Disney Productions, ABC Theatres, United Artists Theatre Circuit, American Multi-Cinema, and Cooper Theatre Enterprises.

Of all-solid-state design, the Model 810 is intended for continuous non-attended service in installations where trouble free operation over long periods of time is required.

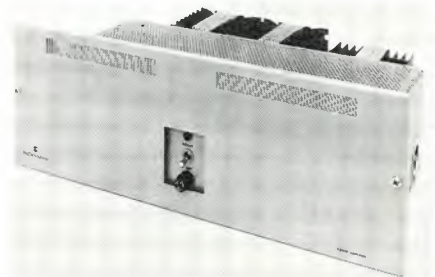

According to Mort Fujii, general manager of Electro Sound, "The Model 810 has several design features that make it especially useful for applications requiring long term reliability. For example, the unit has an internal current sensing circuit which protects the unit from overloads and holds its output within safe operating ranges even if an accidental short should occur. This design feature, along with massive oversized heat sinks for the output transistors, assures maximum protection and reliability."

For More Details Circle (61) on Reply Card

## the MCMARTIN 10 watt FM exciter



B-910 exciter \$1995.00

B-910T transmitter \$2355.00

**ULTRA STABLE** with automatic phase-lock sensing  
**EASILY MAINTAINED** with plug-in modular design  
**CRISP, CLEAN SOUND** from latest DCFM design

... a brilliant new addition to the "full choice line". The solid state B-910 is perfect for your new station, your 10 watt educational application or for updating your existing transmitter. This new exciter/transmitter brings you all the professional "know how" that McMartin has pioneered in SCA/Stereo.

Accessories: B-110 Stereo Generator \$1250. B-113 SCA Generator \$450.

For complete information, please contact: Director of Sales (402) 342-2753

### McMartin

4500 south seventy sixth street • omaha, nebraska 68127 • telex 048-485

For More Details Circle (34) on Reply Card

# transmitter

**Send your Engineer's  
Exchange Ideas To:  
BE, 1014 Wyandotte  
Kansas City, Mo. 64105**



### Motorized Zoom Lens

A new Neutral Density series of motorized zoom lenses designed for LLL television cameras is now available from **Canon USA, Inc.**, Lake Success, N.Y.

The lenses come with gradient density ND filters built right in, virtually eliminating the defraction limiting effect. They are available in four models: V6 x 16RND 16.5-95mm f/2.0; V8 x 15RND 15-120mm f/1.3; V10 x 15RND 15-150mm f/2.8; and V10 x 15-2 ND 15-150mm f/2.0.

Canon's Auto Iris Lens Control CC21A regulates zoom, focus and iris. The latter, activated by the video signal, can close down to f/360 or even f/500, depending on the lens. In addition, the iris may be controlled automatically or manually.

A dynamic braking system minimizes overshoot of lens operation.  
For More Details Circle (62) on Reply Card

### Low Cost 12-Inch Monitor

**SC Electronics**, a wholly owned subsidiary of Audiotronics Corporation and manufacturer of Setchell Carlson video monitors and monitor/receivers, recently introduced a new compactly-designed 12-inch monochrome monitor.

Model 12M918 is a broadcast quality monitor which features Setchell Carlson UTIT-IZED® Plug-In Circuit Modules for rapid, on-the-spot maintenance; 100 percent solid-state circuitry; horizontal resolution of 640 lines; and an amplifier bandwidth in excess of 8 MHz.

Applications include Broadcast, Data Terminal Display, Educational CCTV, Industrial CCTV, Medical, Security & Surveillance, Studio, Remote Installation, and VTR Display.

For More Details Circle (63) on Reply Card

### Field Strength Meter

The FSM-1 from **Delta Electronics** simplifies antenna strength measurements for any AM station. The field strength, from 100<sup>μ</sup> V/m to 1 V/m, is read directly from the

logarithmic front panel meter. The crystal controlled calibration and local oscillators are packaged as plug-in modules, eliminating all frequency adjustments. Operation at other frequencies is accomplished simply by replacing the modules. Calibrated and certified modules are available for any AM broadcast band frequency.

Extensive use of field effect transistors and a ceramic lattice band-pass filter assures excellent per-

formance characteristics. The flat, sharp skirt response provides at least 50 dB rejection of harmonic, adjacent channel, and other spurious signals.

The unit has an operating weight of 4½ pounds, measures approximately 5 x 5 x 8 inches, and will operate for 50 hours on 6 standard D-type batteries.

For More Details Circle (64) on Reply Card

(Continued on page 52)

# MEET THE "mini-MAXI" ✓ CHECK WITH AMERICAN DATA! MEET THE ALL NEW "MAXI 556" PRODUCTION SYSTEM.

"MAXI" CAPABILITIES - "MINI" PRICE AND SIZE

Ten Inputs - Composite - Non-Composite Loop-through (Expandable to 16) • 4 Buses-Program/Key, Preview/Mix A, Effects A, Effects B • Vertical Interval • 12 Pattern Effects Including Circle, Joy-stick positioner and Spotlight • 3 Input Downstream Keyer for internal-external-Matte and Chroma Keys • Cutbar • Black-Color Background Gen. • Effects behind Chroma Key • Effects into Mix or Effects or Mix on Program reentries • Program and Preview Output Switching • Program and Preview Tally • Split handle supers or fade to black • Processing Amplifier on Program Channel • Fully Color-timed.

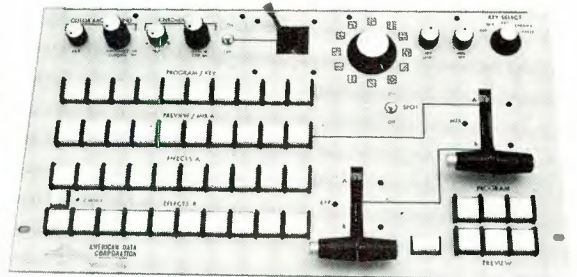

Control Panel 10.5 x 19.0 x 4.5 • Electronics package requires only 10.5 inches of vertical rack space.

Options RGB Chroma Keyer • AFV on Program Bus • Processing Amp on Preview Channel • Control cables up to 200' (25' furnished) • Second Color Matte Generator

CALL or WRITE TODAY

## AMERICAN DATA CORPORATION

Video and Communication Products



315 WYNN DRIVE, N.W. P.O. BOX 5191 HUNTSVILLE, ALABAMA 35806 TEL. 205-837-5180

For More Details Circle (35) on Reply Card

# IT KEEPS MANNIX FROM SHOOTING MARCUS WELBY.

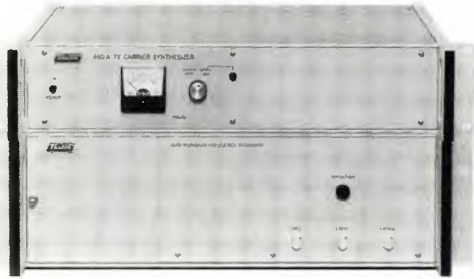

**Tracor Model 6500 Visual Carrier Generator. Reduces co-channel interference. Increases TV coverage area.**

It's 100 times more stable than any crystal oscillator system. Ends routine monitoring, standardization procedures, adjustments. Eliminates much external test equipment. Combines the 304D Rubidium Frequency Standard with the 650A TV Carrier Synthesizer. Just plug the 6500 system into the transmitter socket previously occupied by the quartz crystal. Without further attention, unaffected by environmental conditions, it will keep your station's carrier frequency stable within .05Hz per year. The 6500 is FCC approved and already in wide use. Write or call for full technical and application information.

**Tracor, Inc.** Industrial Instruments  
6500 Tracor Lane • Austin, Texas 78721 • AC 512/926-2800

For More Details Circle (36) on Reply Card

## NEW PRODUCTS

(Continued from page 51)

### Dynamic Cardioid Microphone

**Beyer** announces an addition to their range of professional microphones, the new M201. This has been developed to meet a demand from the TV and Film industries for a moving coil microphone with the same performance and physical dimensions as the omni directional **Beyer** M101, but with super cardioid characteristics.

The M201 incorporates one of the world's smallest professional super cardioid moving coil transducers. Overall microphone dimensions are 0.945 inches diameter by 6.3 inches long. The transducer utilizes a high energy magnetic circuit that gives an EIA sensitivity rating of -149 dBm from a very small diameter diaphragm. A special transducer mounting has also been developed to greatly reduce handling noise.

A super cardioid microphone, by the very nature of its sensitivity to popping and breath noise, requires careful windshield design. To help overcome these problems the M201 has a special sintered bronze breath shield with chromium finish.

The microphone also includes a hum buck coil giving hum rejection of approximately 20 dB. It has an overall frequency response of 40 - 18,000 Hz. ( $\pm 2.5$  dB) with side attenuation at 120 degrees between 18 and 22 dB depending on frequency.

For More Details Circle (65) on Reply Card

## The V11/21 Automatic Digital Logging System



from the industry's Creative Product Innovators.

The V11/21 Automatic Digital Logger records and prints out all necessary meter readings, saves valuable engineering time and assures total accuracy.

Here's a complete, self-contained system, including a printer which can display and print-date identification, time, channel number and meter readings in volts, amps, watts, etc. The system is capable of sampling, measuring, displaying and

recording analog inputs from single or multiple sources, and is equipped with a real-time, solid state, 24-hour digital clock. Precise time can be displayed visually and also printed out.

This compact unit is only 7" high. Virtually maintenance free, it utilizes plug-in printed circuit cards for quick and easy replacement. Optional elements and equipment can be added for even greater versatility.

### Magnetic Recording Films

A new line of acetate-base magnetic recording films, featuring an improved high-output, low-noise oxide coating, has been introduced by **3M Company**, St. Paul, Minn.

The unveiling of Scotch brand 337, 338 and 339 Magnetic Recording Films came at the annual meeting of the National Association of Broadcasters.

According to 3M, the improved

**McBEE LABORATORIES**

Special Electronic Equipment—for Broadcasting

5151 WISCONSIN AVENUE, N.W.  
WASHINGTON, D.C. 20016  
(202)244-2345 (202)244-5535

oxide coating gives the film a wide dynamic range with the same high-output and low noise characteristics of the polyester-based Scotch types 340 and 341. The new line also features better resistance to wear and scratching than acetate-based films previously available from 3M. The acetate backing facilitates edge numbering and editorial markings.

The new films are available in full coat, stripe coat and clear edge configurations for 35mm and full coat for 16mm.

Scotch brand 337 full-coat magnetic film is intended for the most critical original recording and mixing applications.

*For More Details Circle (66) on Reply Card*

### Audio Console

Designed for broadcast master control and production studios. The

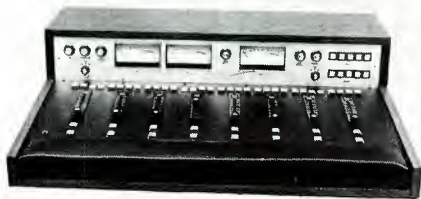

consoles are available in mono, stereo, and Stereo/Mono models with 5, 8, or 10 mixing inputs. Features include long life conductive plastic faders, silent momentary pushbutton audio on/off controls and machine control circuitry for each mixer. Power supply rack mounts separately from main console. Available in several attractive woodgrain exteriors from **Systems Engineering Co.**

*For More Details Circle (67) on Reply Card*

### Feedback Cure

Feedback, one of the most worrisome problems common to sound amplification, now may be drastically reduced through the use of a new dramatically effective component announced by **Shure Brothers, Inc.**, Evanston, Illinois.

Called the M610 Feedback Controller, the new unit can be easily added to any sound system for relatively little cost. Operation of the M610 requires no special skills—making it immediately applicable to existing sound systems in schools, churches, clubs, hotel and motel meeting rooms, paging systems and wherever else a sound reinforcement system is presently in use.

In a typical application, the M610 is inserted in the sound system between the preamplifier-

mixer and the power amplifier, or between the microphone and the preamplifier-mixer in a single microphone system. Once the M610 is part of the system, its special set of variable depth filters and roll-off switches can be used to smooth out the peaks in the total system's frequency response, so that the system gain may be increased to significantly higher levels before the feedback threshold is reached. The user is able to "tune" the total sound system to correct for the acoustic irregularities of the room, to gain maximum output—without danger of generating feedback. The M610 provides the basic advantages of room-system equalization, but without the very high cost involved in elaborate, complex equalization equipment.

*For More Details Circle (68) on Reply Card*

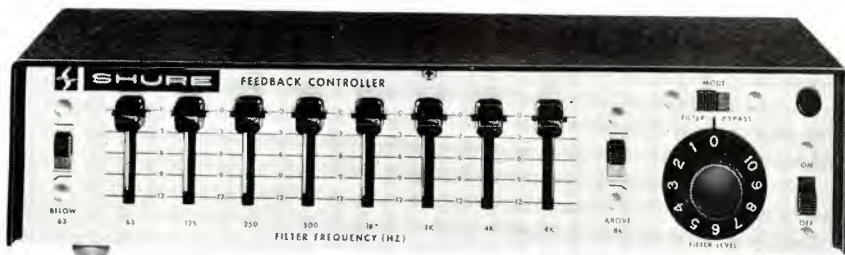

# Get a better Bang for your buck! Colortran® Pro-kit IV



a  
complete  
4 light kit  
for  
\$398.

**Berkey Colortran** division of **Berkey Photo Inc.**

1015 Chestnut St. Burbank, Ca. 91502 • 213 843-1200

*For More Details Circle (38) on Reply Card*

## NEW PRODUCTS

(Continued from page 53)

### Four Channel Production Board

LPB Inc., Frazer, Pennsylvania, announces the availability of their new S-9B 4 channel mono production board. This light weight (12 pounds) unit is constructed of heavy-gauge sheet aluminum for durability. The S-9B measures 16½" wide by 11½" deep by 5½" high. It can be used in a permanent installation, i.e.: newsroom, production studio or mobile unit; as well as for high quality remote applications. Features include:

- 8 inputs, 2 per channel.
- User made adjustments for mic or high-level inputs on all channels.
- Solid-State circuitry and PC board construction throughout.
- High quality Allen Bradley pots.
- Internal cue and monitor amplifiers.



- Cue speaker on front panel.
  - Front panel headphone jack.
  - Full spectrum frequency response.
- For More Details Circle (69) on Reply Card

### Alignment Tape

The Recorder Care Division of Nortronics Company, Inc., manufacturer of magnetic heads and professional recording accessories, has introduced a new broadcast alignment cartridge for use with NAB type endless-loop mono and stereo cartridge recorders and players.

A product of Nortronics' fast-

growing QM-SERIES™ of maintenance accessories, the new AT-320 alignment tape is a first generation master recording recorded full track at 7.5 IPS. It is engineered for routine maintenance of equipment and permits rapid testing and adjustment of Head Azimuth, Program Frequency Response, Program Record Level, Stereo Head Phasing, Cue Tone Sensitivity and Tape Speed. Detailed, easy-to-follow instructions for use are provided with the tape.

Test tones recorded on the AT-320 include: 1. 400 Hz., -10 dB Frequency Response; 2. 5 kHz., -10 dB Azimuth & Response; 3. 10 kHz., -10 dB Azimuth & Response; 4. 100 kHz., -10 dB Frequency Response; 5. 400 Hz., 0 dB NAB Standard Reference Level; 6. 100 - 10,000 Hz. - Sweep, Stereo Phasing; 7. 150 Hz. - Cue Adjust; 8. 8 kHz. - Cue Adjust; 9. 1kHz. - Cue Adjust; and 10. 1 kHz. - "Cue Up".

For More Details Circle (70) on Reply Card

## We don't give a toot!

That's right—we don't give a toot what goes over your horn . . . but we do care that what goes . . . gets there.

## Stainless MICROWAVE TOWERS

- Designed and built to meet every requirement.
- No off-the-shelf designs that end up as compromises or trade-offs. Not less tower than you need nor more tower. They're your towers . . .

We'd like to discuss your next tower requirements. Then you'll see how much we care.

# Stainless, inc.



North Wales, Pennsylvania 19454  
Telephone (215) 699-4871  
In Canada: Walcan Ltd., Toronto 12, Ontario.



For More Details Circle (39) on Reply Card

**Broadcast  
Audio consoles**

Collins Radio Company has added eight new broadcast audio consoles to its broadcast products line.

Designated the IC-10 (10 channel) and IC-6 (6 channel) series, the new audio consoles provide a wide range of features: all-solid-state construction, integrated circuit preamplifiers, plug-in modules, 15-Watt RMS monitor output, rear or bottom cable entrance, remote control function, stereo and mono headphone jacks, stereo audition, three separate stereo monitor outputs, a minijack input for cassette players.

The new consoles have been designed to provide versatility of application and custom configuration for most AM and FM broadcast needs.

All consoles in the new series are wired for stereo and monaural capability. Stereo capability can be added to a monaural console simply by adding plug-in amplifiers and VU meters. Preamplifiers are interchangeable.

Models in Collins' new series are the IC-10SM (ten-channel stereo plus monaural output), IC-10S (ten-channel stereo), IC-10D (ten-channel monaural with dual channel output), IC-10M (ten-channel monaural), IC-6SM (six-channel stereo plus monaural output), IC-6S (six-channel stereo), IC-6D (six-channel monaural with dual channel output), and IC-6M (six-channel monaural).

The new units are housed in aluminum cabinets measuring 10"x44"x20" for the IC-10 series and 10"x36"x20" for the IC-6 models.

The top cover and front panel of the units are hinged to provide easy access to plug-in modules and components. Connecting cables may be used either at the rear or the bottom of the chassis.

All consoles have balanced transformer isolated inputs, two program channel outputs, two audition channel outputs, and one monaural output.

Both the IC-10 and IC-6 (stereo or mono) come equipped with stereo input attenuators that control the left and right channels

*(Continued on page 56)*

# Stanton. Benchmark for an Industry.



## Stanton's 681 Series is the Calibration Standard to recording engineers such as Robert Ludwig.

Whatever the requirements for recording and playback, Stanton's Series 681 cartridges are the Calibration Standard. And there is a 681 model engineered specifically for each of these critical applications. That's why Stanton is truly the Benchmark for the industry.

**The Stanton 681A—For Cutting Head Calibration.** With Stanton's Model 681A, cutting heads can be accurately calibrated with the cartridge, for it has been primarily designed as a calibration standard in recording system checkouts. Frequency response is factory calibrated to the most rigid tolerances and the flattest possible response is assured for precise alignment of recording channels.

**The Stanton 681EE—for Critical Listening.** Stanton's Model 681EE is designed for low-distortion tracking with minimum stylus force, regardless of the recorded velocity or the distance of the groove from the disc center. High compliance, low mass and low pressure assure perfect safety even on irreplaceable records.

All Stanton Calibration Standard cartridges are guaranteed to meet the specifications with exacting limits. Their warranty comes packed with each unit—the calibration test results for that individual cartridge.

For complete information and specifications write Stanton Magnetics, Inc., Terminal Drive, Plainview, L.I., New York 11803.

All Stanton cartridges are designed for use with all two- and four-channel matrix derived compatible systems.

For More Details Circle (40) on Reply Card



## Send only the best.

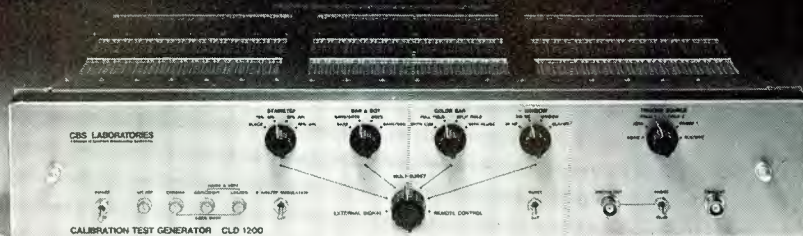

CBS Laboratories' new Calibration Test Generator puts color to the test. Providing an extremely stable signal, the CLD-1200 permits accurate testing, evaluating and calibrating of color television equipment. Digital circuitry insures precision pulse timing.

The CLD-1200's wide range of test signals far exceed industry standards. All test signals are available simultaneously!

The CLD-1200 can even be used as a standard sync generator. From CBS Laboratories, of course.

## CBS LABORATORIES

A Division of Columbia Broadcasting System, Inc.  
227 High Ridge Road, Stamford, Connecticut 06905

For More Details Circle (41) on Reply Card

15 day free trial shows you why ITC tape cartridge equipment is an industry leader.



SP SERIES REPRODUCER

A two week test in your own broadcast facilities is the only fair way for you to evaluate the performance of ITC's premium line cartridge equipment. Advertising statements are no longer simply claims, but become actual facts proven first hand. Find out for yourself how ITC has built in all the features demanded by broadcasters since tape cartridge equipment was invented. If ITC equipment fails to measure up, you're under no obligation. You'll find that ITC dependability is something on which you can rely completely.

RP SERIES RECORDER/REPRODUCER



Call us collect to arrange a 15 day free trial 309-828-1381

**ITC** INTERNATIONAL TAPETRONICS CORPORATION

2425 South Main Street, Bloomington, Illinois 61701

## NEW PRODUCTS

(Continued from page 55)

simultaneously.

The inputs to channels 1 through 8 (IC-10) or 1 through 5 (IC-6) are connected through two-position selector switches. Inputs for channels 9 and 10 (channel 6 for the IC-6) are connected through multi-position selector switches. These inputs are intended for remote lines, although any type of input including microphone may be accommodated.

A total of six stereo lines may be selected by each of these channels. Optional XL connectors are available for console inputs.

Each channel position consists of the two-position input selector, a dual rotary attenuator (stereo) with cue position, and a program key. Speaker muting is provided through the program keys. Pushbuttons for remote control of starting functions' etc., are conveniently located below gain control.

Monitor circuits allow monitoring of signals processed by the console. Signals on the cue bus are amplified by the plug-in cue amplifier and applied to the internal cue speaker. Signals on program, audition, and external monitor buses can be selected by the monitor selector switch, adjusted by the monitor level control, and amplified by the plug-in monitor amplifiers.

For More Details Circle (71) on Reply Card

### Solid-State Scope

With the new Heathkit IO-104, the **Heath Company** introduces a service bench oscilloscope designed to meet the needs of contemporary electronics.

The vertical bandwidth of DC to 15 MHz satisfies the requirements of most laboratory, quality control or trouble-shooting applications. Vertical sensitivity of 10 mV/cm, and 12 calibrated vertical attenuator positions up to 50 V/cm accommodate a broad range of input signals.

Any one of 22 calibrated time bases from 2 s/cm to 0.2 us/cm (X5 magnifier for maximum sweep of

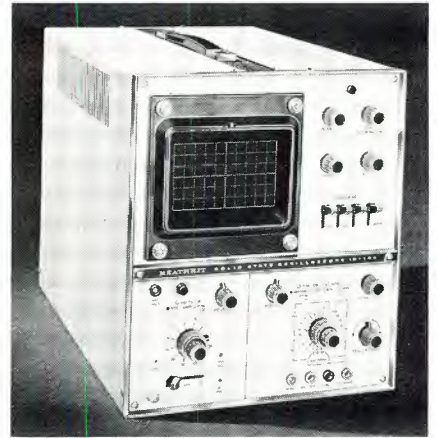

40 ns/cm) can be selected to provide accurate frequency measurements. The horizontal amplifier accepts external inputs from DC to 1 MHz.

A stable triggering circuit provides solid waveform displays. Trigger controls include selection of either normal or automatic modes; switch-controlled AC-DC coupling; provision for external triggering signals. The sweep may be triggered at any point along the positive or negative slope of the input signal.

For More Details Circle (72) on Reply Card

### Automatic Logging

**McBee Laboratories** will introduce their Automatic Digital Logging System. Digital systems offer the advantage of absolute readings, not subject to visual interpretation and with accuracies up to 10 times that of comparable analog data. An automatic digital logging system can therefore perform this necessary function faster and with a higher degree of accuracy than previously thought possible.

The V11/21 Automatic Digital Logging System was designed for this purpose and is a complete, self contained system, including the printer. The V11/21 Automatic Digital Logging System displays and prints, date identification, time Channel number and data, such as volts, amps, watts, etc. The date is entered initially by pushbutton switches on the front panel. Basically, a digital logging system will sample, measure, digitize, display and record (in digital form) the analog inputs from single or multiple sources. In addition, the V11/21 Automatic Digital Logging System

incorporates a real time solid state, 24 hour digital clock, the time of which can be both visually displayed and printed out.

Utilization of reliable, solid-state integrated circuit logic resulted in a compact design. Only 7 inches high. Maintenance requirements are at a minimum by using easily accessible plug-in printed circuit cards which promote modern servicing techniques. In addition to the benefits of low maintenance requirements, wider and more versatile applications are made possible through plug-in complementary optional elements and equipment.

For More Details Circle (73) on Reply Card

### Magnetic Film

A new line of acetate-base magnetic recording films, featuring an improved high-output, low-noise oxide coating, has been introduced by 3M Company, St. Paul, Minn.

According to 3M, the improved oxide coating gives the film a wide

dynamic range with the same high-output and low noise characteristics of the polyester-based Scotch types 340 and 341. The new line also features better resistance to wear and scratching than acetate-based films previously available from 3M. The acetate backing facilitates edge numbering and editorial markings.

The new films are available in full coat, stripe coat and clear edge configurations for 35mm and full coat for 16mm.

Scotch brand 337 full-coat magnetic film is intended for the most critical original recording and mixing applications.

Scotch 338 stripe-coat film features a 300-mil wide coating just inside the sprocket holes on one side and a "balance stripe" just inside the opposite sprockets. Both edges and the center of the film are clear to simplify synchronization with pictures or writing or editing directions.

Scotch 339 clear-edge magnetic  
(Continued on page 58)



We just feel like singing about RUSSCO's New STUDIO/MASTER 505 Audio-Mixer — LOOK! 5 mixing channels, 4 channels with built-in Preamps! Each adjustable for mic, phono or hi-level! Channel 5 has 5 hi-level push-button balanced inputs! Built-in Monitor Amp, cue-speaker, head-set amplifier! Push-button key switching with LED indicators! Allen-Bradley Mod Pots! FET monitor muting and much more! Available in attractive cabinet or as a rack mount (in 5 1/2" space) model. Mod colors — maroon & black face, blue-grey cabinet!! PRICES THAT START AT UNDER \$500!!!

For More Details Circle (78) on Reply Card



You get the most "headroom" for the money (+18 DBM) with RUSSCO's New "FIDELITY-PRO" and "FIDELITY-MASTER" phono preamps. 8 models stereo or mono to fit your needs, self-powered and featuring a unique "easy-service" case. Years ahead in engineering with economical prices starting at \$92.00

For More Details Circle (79) on Reply Card



**ELECTRONICS INCORPORATED**  
1070 Brookhaven, Clovis, Calif. 93612  
Phone (209) 299-2167

# 60 TO 30 IPS

THE MDA-1B IS A SELF-CONTAINED RACK MOUNT, OR TABLE TOP UNIT, INTENDED TO SUPPLY DRIVE MOTOR POWER TO PROFESSIONAL TAPE DECKS FOR THE PURPOSE OF VARYING TAPE SPEED UNDER PRECISE CONTROL.

**MULTISYNC MDA-1B**

**FEATURES**

- WIDE FREQUENCY RANGE 48 - 144 Hz
- VERNIER CONTROL FOR FINE PITCH ADJUSTMENT
- NO MODIFICATIONS OF RECORDER REQUIRED
- FIXED 120 Hz. FOR 30 IPS OPERATION
- FAIL-SAFE AMPLIFIER PROTECTION CIRCUITRY
- EASILY PATCHED FROM RECORDER TO RECORDER
- QUADRATURE DRIVE FROM DUAL AMPLIFIERS AND 90 DEGREE OSCILLATORS

**APPLICATIONS**

- "PHASING-DELAY" EFFECTS
- TUNE TRACKS FOR RECORDING NON-TUNEABLE INSTRUMENTS
- 30 IPS DRIVE FOR 7.5 15 IPS RECORDERS
- COMPENSATE FOR OFF-SPEED TAPES
- VARIABLE-DELAY FOR DOUBLE-TRACKING
- LENGTHEN-SHORTEN RUNNING TIME OF BROADCAST TAPES

THE MDA-1B CONTAINS ITS OWN POWER SUPPLIES, OSCILLATORS, AND POWER AMPLIFIERS. THE CONNECTIONS TO AND FROM A DECK ARE MADE BY TWO CONTROL CABLES THESE CAN BE INSERTED INTO EXISTING CONNECTORS WITHOUT ANY MODIFICATION TO THE TAPE DECK.

**PACIFIC RECORDERS AND ENGINEERING CORPORATION**  
11760 SORRENTO VALLEY RD., SAN DIEGO, CALIFORNIA 92121  
TELEPHONE (714) 453-3255

For More Details Circle (44) on Reply Card

UP TO

# 65% SAVINGS

Plus performance that is creating excitement in Engineers around the country! "Fantastic sound" . . . "Very Clean" . . . "Superb! . . . Send two more . . ."

Proof? Our standard 10 day evaluation period lets you see and hear the performance and the full service, 2 year warranty demonstrates the reliability.

Place your order today. Then prepare yourself for a very satisfying experience!



TURNTABLE  
PREAMPLIFIERS

MP-8 (Mono) \$60  
SP-8 (Stereo) \$90

Outstanding sensitivity and near perfect reproduction. RIAA/NAB equalized -0.5 mv sensitivity @ 1 KHz for +4 dbm out - Balanced 600 ohm out - minus 65 db S/N ratio - +20 dbm out max - =1 db freq. response - Internal power supply - Table top/bracket mount. Shipping weight, 3 1/2 lbs.



MIC/LINE AMPS

MLA-1 (Mono) \$68  
MLA-2 (Dual) \$96

Dual function utility amp. Inputs for mic and/or line - 600 ohm balanced outputs - mic input, -65 db for +4 dbm out - +20 dbm out max. - =0.5 db response, 10 Hz-20 KHz - 0.1% or less dist. - Internal power supply - Tabletop/bracket mount. MLA-2, Stereo/Dual Mono. MLA-1, Mono. Shipping weight, 4 lbs.



DISTRIBUTION AMP  
6 BALANCED OUT

DA-6 \$95

One third the cost of comparable units. Six 600 ohm balanced outputs - Balanced bridging input - 26 db gain - +20 dbm out max. - Input level control - 0.1% or less dist. - =0.5 db response, 10 Hz-20 KHz - Internal power supply - Tabletop/bracket mount - Shipping weight, 4 lbs.



TAPE CARTRIDGE  
LOADER (AUTOMATIC)

ACL-25 \$159

Precision winding without guesswork. Dial in the minute and/or seconds desired, throw switch to run. That's it! The exact amount of tape is fed onto the cartridge hub to the second, and shuts off automatically. No waiting around, no guesswork and 1 sec. accuracy. Also has exclusive torsion control for proper tape pack and winding of various cart hub sizes. TTL digital control circuitry. Shipping weight, 30 lbs.



RAMKO RESEARCH

2552 "E" Albatross / P.O. Box 6031  
Sacramento, Calif. 95860 (916) 489-6695

## NEW PRODUCTS

(Continued from page 57)

film specifically is intended for multiple track re-recording. It is fully coated except for each edge for easier viewing of edge numbers.

For More Details Circle (74) on Reply Card

### Automatic Counter

Monsanto has developed a new 32MHz Automatic Counter, the model 150A, to add to its extensive line of digital counter-timers, frequency generators, voltmeters,

data acquisition components and data acquisition systems. The new model 150A features a counting range from 5Hz to 32MHz, a crystal controlled clock, 5 digit long-life LED display, and automatic ranging for full resolution. Decimal points are automatically positioned as is the display of units of measurement and non-significant zeros are automatically blanked.

Able to operate on standard line AC or from an optional battery pack, the model 150A has a built-in test position and an overrange indicator in the manual mode.

For More Details Circle (75) on Reply Card

### Stereo and SCA Monitors

McMartin Industries, Inc., offers two new FCC type approved units for monitoring all parameters relating to stereo and SCA multiplex operating modes; the TBM-2200A Stereo Modulation/Pilot Frequency and the TBM-2000B SCA Modulation/Frequency Monitors. The newest generation models incorporate the latest in electronic, packaging, and function designs.

The TBM-2200A stereo unit may be driven by the new McMartin TBM-3700 FM Frequency/Modulation Monitor or by the previously available, TBM-3500A or TBM-4000A models. In addition to simultaneous metering of left and right channel modulation, the TBM-2200A features continuous monitoring of the 19 kHz pilot frequency deviation. The modulation meters serve a secondary function of measuring channel separation, crosstalk, 38 kHz suppression and individual channel stereo signal-to-noise ratios. Internal calibration of

pilot injection level and frequency is featured.

The TBM-2000B SCA modulation and frequency model may be used with the new TBM-3700 baseband monitor or with the previous McMartin TBM-3500A, TBM-4000A or TBM-4500 A models. The TBM-2000B monitors all SCA transmission characteristics; injection level, modulation, SCA carrier frequency, and SCA FM signal-to-noise and crosstalk. Internal push-button calibration of the frequency meter, injection level and modulation meter insure rapid and precise maintenance of the monitoring functions.

Crosstalk levels between main and subchannels or between subchannels as well as the inherent FM signal-to-noise level of the monitor can be measured. The TBM-2000B is available for standard 41 or 67 kHz operation and for other subchannel frequencies by special order.

For More Details Circle (76) on Reply Card

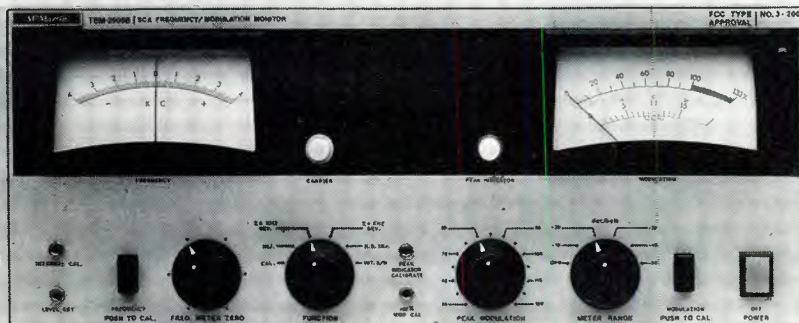

For More Details Circle (46) on Reply Card

BROADCAST ENGINEERING



# TECHNICAL DATA

For further information, circle data identification number on reader service card.

**112. HEATH/SCHLUMBERGER SCIENTIFIC INST.**—This 52-page catalog provides detailed descriptions and specifications for the complete Heath/Schlumberger line of design and lab instrumentation. Included in the catalog is a new series of VHF counters that can provide capability to 600 MHz for as little as \$795 . . . a complete line

**114. INTERNAT'L GOOD MUSIC, INC.**—New illustrated literature on the complete line of IGM audio control systems is now avail-

## USE OUR CASH FOR YOUR NEW EQUIPMENT

You choose the equipment; we will lease it to you—3-4 or 5 years with option to buy.

### Broadcast Equipment Leasing Co.

DIVISION OF ANCHOR LEASING CORP.

Grant Building  
Pittsburgh, Pa. 15219  
Area Code 412-281-3768

For More Details Circle (53) on Reply Card

## FREE ALARM CATALOG

Full line of professional burglar and fire alarm systems and supplies. 80 pages, 400 items. Off-the shelf delivery, quantity prices.

 **mountain west alarm**  
4215 n. 16th st., phoenix, az. 85016

For More Details Circle (51) on Reply Card

## FREE CATALOG TOOLS

### HARD-TO-FIND PRECISION TOOLS

Lists more than 1700 items—pliers, tweezers, wire strippers, vacuum systems, relay tools, optical equipment, tool kits and cases. Also includes four pages of useful "Tool Tips" to aid in tool selection.

 **JENSEN TOOLS**  
4117 N. 44th Street, Phoenix, Ariz. 85018

For More Details Circle (52) on Reply Card

July, 1973

able. A four-page brochure describes the IGM 400, an economical, prepackaged six-channel audio control unit, which schedules all talk features on a real-time basis with music automatically filling in the balance of the time. IGM's 500 system, detailed in a six-page brochure, is also of time-insertion type, but can handle any number of inputs and is expandable to include peg clock, music sequencer, real-time switcher, random select memory and automatic program logger. An eight-page brochure describes IGM's computerized 700 control systems. Seven models, each with built-in software, provide a wide range of memory capacity and operating features. All are sequentially programmable, with real time capability, are readily expandable and are compatible with automated traffic, accounting and billing systems.

**115. INTERNAT'L. RECTIFIER CORP.**—Three new series of 1.6 amp SCRs in TO-5 cans are described in a data sheet from the Semiconductor Division of Internat'l. Rectifier. The types, which provide an additional source for units previously on the market, further expand IR's line of low power SCRs. The series, IR5, 2N2322, and 2N4212, are available in versions with rated voltages of 25 to 400 Volts. The new units have sensitive gates and require only 200 microamps maximum gate current to trigger at 25°C. Included in the literature are eight graphs, a dimensioned outline drawing and a photograph of the devices. Complete ratings and specifications are provided. Applications include control of fractional horsepower motors, drivers for computer readouts, timers for industrial process control, shift registers, and switches for such devices as burglar alarms.

## HERE'S REAL VERSATILITY

**unique ballpoint drives hex socket screws from any angle**

Ever try to drive hex socket screws from an odd angle? Want an easier, faster way to drive 'em under any conditions?

**HERE'S YOUR ANSWER:** With unique "ball-point", you can slip these Xcelite screwdrivers into hex sockets . . . slick as a whistle and secure as a vise . . . straight-on or from any angle . . . to drive 'em home in a flash! 9 sizes: .050" - 3/16". With fixed handles, singly or complete set in roll up kit, and as interchangeable Series 99 blades, singly or with handle and extension in compact case.

REQUEST BULLETIN 273L

*nationwide availability through local distributors*



**XCELITE, INC.**

118 Bank Street, Orchard Park, N.Y. 14127  
In Canada contact Charles W. Pointon, Ltd.

For More Details Circle (48) on Reply Card

## NOW WHEN YOU THINK SMALL...THINK

# Xcelite Mini driver sets



Smaller than a matchstick, Xcelite's "Mini-Screwdrivers" put product precision in your hands for fine work. Technicians, servicemen, assemblers, model-makers, hobbyists welcome these color-coded little screwdriving gems.

Instruments, apparatus, machinery, optics, cameras, watches, clocks . . . useful wherever screws as tiny as 0000 are involved.

Two handy kits in see-thru plastic cases: M50—five drivers for slotted screws, tips from .040" to .100". M60—same plus 00 Phillips driver and piggyback torque-amplifier handle.

REQUEST GENERAL CATALOG 171

*nationwide availability through local distributors*



**XCELITE, INC.**

118 Bank Street, Orchard Park, N.Y. 14127  
In Canada contact Charles W. Pointon, Ltd.

For More Details Circle (48) on Reply Card

# ROH right from the start

Modular Audio Series 200

Roh has a quality line you can start with . . . and stay with. Buy a single module or several now. Then build an equity in fine audio equipment: modules, enclosures and accessories. Write for '73 catalog.

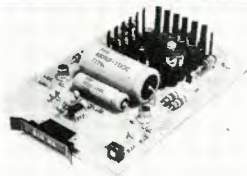

210 10 Watt Power Amplifier \$60.00

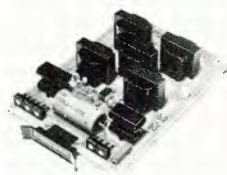

212 1x5 DA with Transformer Outputs \$110.00



214 Microphone/Line Preamplifier \$75.00



216 4 Channel LDR Attenuator/Switch \$60.00



218 Dual Channel Phono/Tape Preamplifier \$75.00

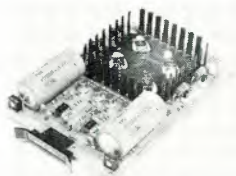

220 Dual 10 Watt/Single 30 Watt Power Amplifier \$110.00

## Roh Corporation

150 Technology Park/Atlanta Suite 15  
Norcross, Georgia 30071 Ph: 404/449-0873

For More Details Circle (49) on Reply Card

60

## TECHNICAL DATA

(Continued from page 59)

### 117. KAPPA NETWORKS, INC.

—A new brochure provides basic specifications on their standard and custom design LC filters. Full specifications are given for the dual in-line (DIP) filter series which offers cutoff frequencies up to 20 MHz. Additionally, photos and basic specifications are shown for these filter products: low pass, band pass, high pass, band reject, matched phase and attenuation, maximum flat delay, linear group delay, and group delay and attenuation equalizer networks. Specifications and a series of curves describing Kappa's constant group delay filters are included.

**118. K-TECH, INC.**—Burn-in and electrical test sockets and carrier/contact systems for semiconductor devices are described by this six-page two-color brochure. Parts are divided by type of package to be socketed. Information and specifications for insulating and contact materials are included. Instructions for estimating socket and tooling costs for custom racks are also featured.

**119. MAGNAVOX CO.**—New literature by Magnavox includes two revised catalog pages; one on indoor directional couplers and one on indoor splitters. Both revisions spell out improvements in performance specifications with particular respect to tap-to-output isolation and maximum insertion losses. Products described on the indoor directional coupler page are Series 1800M, Broadband Corner-Molding Couplers; Series 600B, Broadband Sub-Miniature Couplers; and Series 765B, Broadband Wallplate Couplers. Described within the indoor splitter page are Model ML-2, Miniature Two-Output Splitter; Model 4022, Sub-Miniature Two-Output Splitter; and Series 90, Hybrid Splitters in two, three, four and eight output versions.

**120. PHILIPS**—A four-page full

color brochure describing the Philips PM3400 1.7 GHz dual trace sampling oscilloscope is now available. The brochure describes the features and applications of the PM3400, which offers calibrated sensitivity of 1 mV/cm at 1.7 GHz, 30 nanoseconds delay in both channels, and stable triggering on amplitude-modulated carriers to 1.7 GHz. It also points out how the P39 long-persistence phosphor and the instrument's capability for continuously variable sampling rate combine to eliminate flicker even at extremely low signal frequencies. The PM3400 is available through Test & Measuring Instruments Inc., of Hicksville, New York.

**121. RAYTHEON CO.**—New literature offered by Raytheon Company's Special Microwave Devices Operation describes the company's line of Micro State low noise, high efficiency gallium arsenide avalanche diodes. Ranging from 4 to 40 gigahertz and from 20 milliwatts to more than 4 Watts, the line of 39 impact transit time (IMPATT) diodes is offered in six different package configurations.

**122. RCA**—Performance and operating details on the TK-630 are covered in a new, amply illustrated 16-page brochure. As a broadcast color camera for studio or field use, or for educational and closed circuit applications, the TK-630 Camera provides quality performance at moderate cost. A two-piece unit with detachable, plug-in viewfinder, the camera is readily portable, easy to set up and operate. Picture fidelity is excellent. The camera uses three 1-inch lead oxide pickup tubes, and incorporates many of the quality features of premium priced cameras, including a sealed prism optical system mounted on a rigid metal bedplate.

**123. RHG ELECTRONICS LABS., INC.**—A new one-page catalog sheet describing their Hybrid IC Preamplifiers for use in microwave receiving systems and monopulse and phased array radars, is now available. The company designs and builds microwave, RF, and IF components,

BROADCAST ENGINEERING

receivers and transmitters. The sheet describes and illustrates fixed gain, variable gain and high power models featuring low noise and small size. Price reductions from \$125 to \$95 on two specific fixed gain models are also noted. General information on size, weight, and special options are included.

**124. ROHDE & SCHWARZ**—The 1973 Rohde & Schwarz measuring instruments catalog is now available. The 232 information-packed pages provide a complete technical guide of the comprehensive Rohde & Schwarz production program. The instrumentation covered includes, power, sweep, noise, AM/FM-synthesized and programmable signal generators; precision terminations, fixed-variable and programmable attenuators; wave analyzers and selective microvoltmeters; field strength meters; spectrum analyzers; wide-band microvoltmeters and power meters; impedance and reflection measuring equipment; R, L, C and Q meters; diode, transistor and IC testers; TV measuring equipment; sound level meters.

**125. ROUNDTABLE, INC.**—A new catalog covering over 50 films and dozens of training aids is now available. The 1973 catalog will be useful to trainers and teachers in business, manufacturing, government, and public education organizations. Roundtable produces and distributes films on Business Management, Communications, Sales, Vocational Education, Supervision, and Business Skills Development.

**126. HOWARD W. SAMS & CO., INC.**—A new 1973 Sams Books catalog is now available. The 84-page book gives an alphabetical index and numerical index. Some of the topics covered are amateur radio; appliances; motors; power mechanics; audio & hi-fi; basic & hobbyist; cb & communications; circuits & components; data processing; and many others. Also included is information on Sams Photofact.

**127. SCOTT BUTTNER**—Two four-page bulletins are now available. Bulletin Number 400-1 describes the SBC-400 Voice-Over-

Video Subcarrier Multiplex. It is illustrated and gives specifications. Bulletin Number 502-1 describes the SBC 502 Wide Band Multiplex. It is fully illustrated and also gives specifications.

**128. TABER MFG. AND ENGINEERING CO.**—A new bulletin describes Taber's new audio heads for direct replacement in Ampex and Scully equipment. It also describes precision lapping of Ampex and Scully audio heads and custom audio heads.

**129. TELEDYNE PHILBRICK**—The Linear Short Form Catalog, a guide to all of Philbrick's latest developments in analog technology is now available. Specially featured is Philbrick's 1421 series of economy FET microcircuit op-amps, the 1421, 1422, 1424, 1425, 1426, 1428 and 1429. They offer a broad range of electrical specifications to meet the exact requirements of specific applications with standard, off-the-shelf products. Another exciting new microcircuit

(Continued on page 62)

**IF YOU NEED ATTENUATORS YOU NEED THIS CATALOG!**



**AUDIO AND RF ATTENUATORS TO MEET ANY REQUIREMENT**

Here in one compact and informative 24 page booklet is all the data you need to select a Precision Audio and RF Attenuator for your application.

Reference Charts, Circuit Diagrams, Types and Uses, Current and Voltage Ratio Tables, Ratings, Etc., make this a handy and invaluable reference.

**SEND FOR YOUR FREE COPY TODAY.**

**TECH LABS, INC.**

Bergen & Edsall Blvds.  
Palisades Park, N.J. 07650  
Tel.: (201) 944-2221

For More Details Circle (57) on Reply Card

## ATTENTION ENGINEERS: EQUIP YOUR STATION WITH A Complete Remote Package

Package includes:

- ★ Model 289 AC/DC Microphone Line Driver w/Built-in Voice Coupler by PDMC
- ★ The New Sportscaster Headset — Combination of finest professional microphone and high-performance headphone by Telex.

Only  
**\$174<sup>95</sup>**  
Complete



Complete  
Specs  
Available  
On Request

- ★ Fully warranted for one year against defects in Parts, Materials and Workmanship.
- ★ Satisfaction guaranteed. Money back if not satisfied with units after 15 day trial.

ENCLOSE CHECK WITH ORDER OR PHONE:

**PULSE DYNAMICS MANUFACTURING CORP.**  
Colchester, Illinois 62326  
Ph.: AC 309/776-4544  
ATTN: SALES MANAGER



For More Details Circle (43) on Reply Card

# TECHNICAL DATA

(Continued from page 61)

is our new Model 1324 fast-settling monolithic op-amp which offers guaranteed specification to accurately resolve high-speed data. Completing the list of new products are the 1028, 1029, 1030, 1702 and 1703 discrete op-amps and the 1423 and 1427 microcircuit units. A

section on nonlinear function modules and low-cost modular power supplies completes the product descriptions.

**130. TERRACOM DIVISION—**Conic Corp. A new four-page brochure describing the series TCM-6 Microwave radio has just been published. The TCM-6 is a frequency agile radio operating in the 1.7 to 15.25 GHz range and may be either fixed tuned or knob tuned across each band with frequency referenced to plug-in crystals for 0.005 percent stability. Both the transmitter and receiver are portable and may be tripod or fixed rack mounted. The brochure contains complete specifications and applications information.

**131. TRIPLETT CORP.—**A new 28-page catalog featuring many standard type panel meters and accessories plus a customized panel meter service, all for use in industrial process control, electronic instrumentation, communications equipment, military ground support equipment, computer and data processing systems, laboratory and educational applications, is now available. Many new panel instrument additions are contained in the comprehensive, two-color catalog which is three-hole punched for ring binder reference usage. To make it easy and quick to order, user net prices are provided for all panel instruments listed in the new catalog. Also, complete electrical specifications and dimensional drawings of the panel instruments and their mountings are given.

**132. WESTINGHOUSE ELECTRIC CORP.—**A new brochure describes most of the many different phosphors which can be supplied in the cathode-ray tubes made by the Westinghouse Electronic Tube Division. The 32-page publication helps buyers select a CRT with the optimum phosphor to meet any of a wide variety of application requirements. Spectral and persistence characteristics and typical applications are given for over 50 standard and special phosphors. A brief explanation of the use of phosphors in CRT screens and glossaries of terms and symbols are included.

## Digital Logic

(Continued from page 38)

viously. For the first state, one sees that with all inputs low and  $C_{in}$  high, the  $\Sigma 1$  output is high. Realizing that a carry bit is added to the least significant bit, this indicates that  $A_1$ ,  $B_1$  and  $\Sigma 1$  are the least significant bits of the numbers added and the resulting output. This then implies that  $A_2$ ,  $B_2$  and  $\Sigma 2$  are the most significant bits of this 2 bit full adder.

Consider now Row 6 of the table with  $C_{in} = 1$ . We are adding the two numbers 11 and 00 with a carry input of 1. The expected output would then be 00 with a carry output. This agrees with the entries for the output in the truth table. Similarly any state of input conditions can be analyzed to determine the expected output state.

Studying manufacturers' data sheets is a very good way to learn about digital IC's. All of the concepts discussed in this article can be studied in detail in any manufacturers' data book and at the same time a knowledge of real world device numbers, pin arrangements, and switching parameters such as rise, fall, and delay times can be obtained.

As supplemental reading in this area, the book **HANDBOOK OF LOGIC CIRCUITS\*** BY John D. Lenk presents a practical and easy to read study of many of the circuits in use today. □

\*Reston Publishing Company, Inc. 1972

**Spotmaster**

**Broadcasters' Choice:**



**Spotmaster/Revox  
A77 Mark III-B**

- Lifetime guarantee
- Takes 10½" reels & NAB hubs
- Standard & Dolby versions
- Superb specs & performance

Spotmaster and Revox have joined forces to develop this ruggedized, rack-mounted version of the A77 stereo recorder specifically for broadcast use. Choose the standard version, or the Dolby model with its incredible 70 dB S/N ratio. All basic parts except heads, capstan and pressure roller are guaranteed for life. Your choice of 2- or 4-track stereo operation at 7-1/2 and 3-3/4 ips. Other speeds, full-track heads, accessories optional. Call or write:

**BROADCAST ELECTRONICS, INC.**  
A Filmways Company  
8810 Brookville Rd., Silver Spring, Md. 20910  
(301) 588-4983 • TWX 710-825-0432

## MONAURAL STEREO SCA receivers

### TBM-1000B series

plug-in stereo, sca• and narrow band options

single channel for FM broadcast, 150MHz, VHF-TV aural

five channel for FM broadcast

prices from \$250•



**McMartin**

McMartin Industries Inc., 4500 South Seventy-sixth Street  
Omaha, Nebraska 68127 Phone (402) 331-2000 Telex 048-485  
For More Details Circle (50) on Reply Card

# PROFESSIONAL SERVICES

# CLASSIFIED

## WANTED

**WANTED:** All surplus broadcast equipment especially clean A.M. & F.M. transmitters, contractors, capacitors. Surpluss Equipment Sales, 2 Thorncliffe Pk. Dr. Unit 28 Toronto 17, Ont; Canada. 1-73-tf

**TUBES WANTED**—All types—CeCo 2115 Avenue X, Brooklyn, N.Y. 11235, 212-646-6300-Anytime. 7-73-12X

## EQUIPMENT FOR SALE

**SURPLUS AUDIO PATCH PANELS.** All Standard Configurations. Gulf Telephone & Electronics, Inc., P.O. Box 42130, Houston, Texas 77042. 7-72-tf

## MOTORS FOR SPOTMASTERS

**NEW** Paps hysteresis synchronous motor HSZ 20.50-4-470D as used in series 400 and 500 machines. Price \$39.00 each prepaid, while they last. 90 day warranty. Terms check with order only, no COD's. Not recommended for Tapecaster series 600 or 700.

TAPECASTER TCM, INC., Box 662, Rockville, Maryland 20851

1-72-TF

**"NEW & USED TOWERS, Buy, Sell or Trade.** Erect. Ground wire 85c lb. Bill Angle, 919-752-3040, Box 55, Greenville, N.C. 27834." 2-71-tf

**ONE STOP** for all your professional audio requirements. Bottom line oriented. F. T. C. Brewer Company, P.O. Box 8057, Pensacola, Florida 32505. 7-71-tf

**QUALITY AUDIO CONSOLES** are our specialty. Modern styling with slide potentiometers and "soft" audio switching. We manufacture 8 standard consoles at very competitive prices. However, we'll manufacture a custom system to your specifications if you prefer. Also plug-in audio modules including distribution amplifiers, pre-amplifiers, monitor amplifiers, etc. Write or phone for pricing and specifications. **SYSTEMS ENGINEERING COMPANY**, P.O. Box 49224, Atlanta, Ga. 30329. 404-482-2446. 2-73-12x

**HELIX-STYROFLEX.** Large stock—bargain prices—tested and certified. Write for price and stock lists. Sierra Western Electric, Box 23872, Oakland, Calif. 94623. Telephone (415) 832-3527. 1-73-tf

**PORTABLE B&W PRODUCTION UNIT** with 2-Ampex 327 Studio viewfinder cameras with tripods and heads, 1-Sylvania camera for effects. 3-11" monitors. 5 channel audio mixer, video switcher/fader, special effects unit, 2-1 sync, intercom (all equipment mounted in portable console). 1-EIAJ-1 V.T.R. with 19" receiver, mikes, cables, lens, etc. \$3350. Thomas Gilchrist 316-722-5116. 7-71-tf

## RECORDING STUDIO CONSOLE

Ideal for sophisticated TV audio. 18 microphone or high-level inputs with EQ & echo on each. EQ on each of the 4 output channels. Built-in multi-freq. oscillator. Group sub-mastering; channel masters; grand master. 4 reverb devices. 4 dual-60 watt amps. Intercom while recording; talkback (mic's. included). Audition any input while recording. "Silence" button prevents performer ruining audio by disturbance during echo "overhang" at end of "take". Producer's desk; all audio in accompanying rack. Very compact! Slightly used, guaranteed. Sacrifice for half of new value.

**SoundDesign**  
Box 291, Beverly Hills, Calif. 90213

Advertising rates in Classified Section are 15c per word, each insertion, and must be accompanied by cash to insure publication.

Each initial or abbreviation counts a full word. Upper case words, 30c each. Minimum classified charge, \$2.00.

For ads on which replies are sent to us for forwarding, there is an additional charge of \$2.00 to cover department number, etc., which is printed in advertising copy, and processing of replies.

Classified columns are not open to advertising of any products regularly produced by manufacturers unless used and no longer owned by the manufacturer or a distributor.

## TRAINING

**PASS FCC EXAMS** with Ameco books. Each book contains FCC questions plus simplified answers plus FCC-type exams and answers. 3rd class 75c, 2nd class \$2.25, 1st class \$1.50. Free catalog. Ameco Publishing, 314G Hillside Ave., Williston Park, N.Y. 11596. 8-72-tf

**FIRST PHONE** through tape recorded lessons at home plus one week personal instruction in Washington, DC, Atlanta, Boston, Detroit, New Orleans, Minneapolis, Seattle, Denver, Portland, Los Angeles. Proven results. Our 17th year teaching FCC license courses. Bob Johnson Radio License Preparation, 1060D Duncan, Manhattan Beach, Calif. 80266. Phone 213-379-4461. 1-69-tf

**PASS FCC** first and second class exams with new 21 lesson, 450-page course. Starts with basic electricity. Over 600 FCC-type, multiple-choice questions and sample exams included. No previous technical knowledge required. Commercial Radio Operator Theory Course, #15-01. Only \$5.95. Ameco Publishing, 314G Hillside Ave., Williston Park, N.Y. 11596. 8-72-tf

**EARN ELECTRONICS DEGREE**, mainly by correspondence. F.C.C. license preparation included at your option. Accredited by Accrediting Commission of NHSC. G.I. Bill approved. Free brochure. Write: Dean, Grantham School of Engineering, 1505 N. Western, Hollywood, California 90027. 8-72-tf

**FCC RADIO TELEPHONE OPERATORS LICENSE** in six weeks. Classes (day & evening) in Atlanta, Dallas, Denver, Ft. Worth, Hartford, Houston, Memphis, Nashville, New Orleans, Oklahoma City, and San Antonio. For information contact Elkins Institute, 2727 Inwood Road, Dallas, Texas 75235. 214-357-4001. 5-73-tf

## SERVICES

**CRYSTAL & MONITOR SERVICE.** Frequency change, repair or replacement of oven type broadcast crystals. Also frequency change and recalibration or repair of AM frequency monitors, and H-P FM monitors. Fast service at reasonable prices. 30 years experience! Call or write: Eidson Electronic Co. Box 96, Temple, Tx. 76501. Pho. 817 773-3901. 9-70-tf

**CARTRIDGES SPOTLESSLY CLEANED, REBUILT AND RELOADED** with Scotch 157. Like new at approximately half price. Also, BEST PRICES anywhere on new FIDELIPAC carts, 3M professional tape and other studio supplies. **YOUR ORDER IS YOUR CHARGE ACCOUNT!** Full guarantee. FREE CATALOGUE. Lauderdale Electronic Labs, 16 S.W. 13th Street, Ft. Lauderdale, Fla. 33315 (305) 525-0478. 4-73-61

**VIR JAMES**  
CONSULTING RADIO ENGINEERS  
Applications and Field Engineering  
345 Colorado Blvd.  
Phone: (Area Code 303) 333-5562  
**DENVER, COLORADO 80206**  
Member AFCCE

**SMITH and POWSTENKO**  
Broadcasting and Telecommunications  
Consultants  
2000 N Street, N.W.  
Washington, D.C. 20036  
(202) 293-7742

**CAMBRIDGE CRYSTALS**  
PRECISION FREQUENCY  
MEASURING SERVICE  
SPECIALISTS FOR AM-FM-TV  
445 Concord Ave. Phone 876-2810  
Cambridge, Mass. 02138

**RALPH E. EVANS ASSOCIATES**  
Consulting Radio Engineers  
AM - FM - TV - CATV - ITFS  
3500 North Sherman Blvd.  
**MILWAUKEE, WISCONSIN 53216**  
Phone: 414-442-4210

**CHU ASSOCIATES, INC.**  
Telecommunications Division  
AM - FM - TV - CATV  
Applications - Facilities Planning  
Field Surveys and Proofs  
Appraisals  
800 Fesler St., El Cajon, Ca. 92020  
(714) 442-9459  
TWX 910 331 1178

# SESCO, Inc.

47 NICHOLS AVENUE  
P. O. BOX 518

(206) 378-2137

FRIDAY HARBOR,  
WASHINGTON, 98250

Moving?  
Send Your Change  
Of Address To:  
Broadcast Engineering  
1014 Wyandotte  
Kansas City, Mo. 64105

**EQUIPMENT FOR SALE CONT.**

**SURPLUS MICA AND VACUUM TRANSMITTING CAPACITORS.** Large stock; immediate delivery. Price lists on request. **SURCOM ASSOCIATES**, 1147 Venice Blvd., Los Angeles, Ca. 90015 (213) 382-6985. 5-73-12t

**STEREO CONSOLE**, stereo limiter, stereo cart rec./pb. turntables w/arms and carts, misc. items. 1-817-723-6688. **KNT0**, 3700 Onaway Trail, Wichita Falls, Texas 76309. 6-73-2t

**PARTS** — for SPOTMASTER & TAPECASTER cartridge units. **IN STOCK** — IMMEDIATE DELIVERY over night to Pennsylvania, New York, & New Jersey. Pressure rollers for all machines. **LOW PRICES**, some used parts in stock. **COMMUNICATION MEDIAS**, Box 54, Allentown, PA. 18105 215-437-0607 or 437-9447. 6-73-2t

**BUILD YOUR OWN TV AND RADIO PRODUCTION EQUIPMENT.** Easy, inexpensive, (mostly IC). Plans or kits: Special Effects Generator, Automatic Logger, Vertical Interval Video Switcher, Solid State Lighting Board, Preset Audio-Video Board, Preset Lighting Board, Crystal Controlled Wireless Mikes with matching receivers. Subsonic Tone Control for audio tapes. 8MM SOF Cameras and Projectors. Distribution Amplifiers (Sync, Video, Audio), Audio Control Boards (Studio & Remote) Proc-Amp with compensation and regeneration for adapting Helical Scan VTR's to broadcast standards. **PLUS** specialized correspondence courses in Telephone Engineering (\$39.50), and Integrated Circuit Engineering (\$49.50). Plans from \$5.95 to \$15. **SUPER CATALOG** plus years updating of new devices Air Mailed \$1.00. Don Britton Enterprises, PO Drawer G, Waikiki, Ha. 96815. 4-73-12t

**FIDELIPAC CARTRIDGES**, Type A, used, assorted lengths. Over 700 in all. Open to offers, cash or equipment. Okanagan Broadcasters Ltd., P.O. Box 100, Kelowna, B.C. Ph. 604-762-3331. 7-73-2t

**CARTRIDGES-65 cents** each. Used Fidelipacs in various lengths and excellent condition. Minimum order-25. Send check or money order to Kartco, Box 291, Route #1, Stone Ridge, N.Y. 12484. Telephone (914) 687-9355. 7-73-3t

**SITUATIONS WANTED**

**ENGINEERING STUDENT**, 1st phone, maintenance background, production experience, seeks summer position possibly permanent. Bill Motley, 1212 S. Charlotte Ave., San Gabriel, California 91776 7-73-1t

**HELP WANTED**

**AN OPENING** exists for a mobile technician in the Detroit area. Experience in maintaining and operating VR 3000 and color cameras in the field is a prime requisite. Extensive travel may be necessary. Resumes and inquiries should be made to Editel Productions Incorporated, 24151 Telegraph Road, Southfield, Michigan 48075 or call: 313-353-1660. 4-73-4t

**CONSIDER THE MERITS** of using a respected employment service; both employer and employees have successfully used our service over the past 8 years. We fill all engineering openings at radio, television stations and cable systems. People are the real competitive difference. Employers, secure the finest people in broadcasting and cable. Employees, move up with AMPS. Send us your resume **now**. The AMPS Agency, 11661 San Vicente Blvd. Suite 300, Los Angeles, California 90049. (213) 820-2678. 5-73-tf

**EDUCATIONAL NETWORK** seeks experienced transmitter supervisor for transmitter site. Send resume, salary requirements and availability to: Director of Engineering, Iowa Educational Broadcasting Network, P.O. Box 1758, Des Moines, Iowa 50306 7-73-1t

**HELP WANTED CONT.**

**CHIEF ENGINEER** for like new non-directional AM and automated FM. Southwest resort area. Full maintenance. Light air watch. Excellent working conditions. Medium-small market. Local Ownership. \$800.00 per month start. Successful operation. Write Box: 284 Broadcast Engineering, 1014 Wyandotte St., Kansas City, Mo. 64105. 6-73-3t

**TELECOMMUNICATIONS CONSULTING FIRM** located in the South has an opening for an engineer with experience in broadcast and communications system designs, preparation of specifications, feasibility studies, and preparation of engineering reports. Qualifications include a thorough knowledge of communications and broadcast engineering fundamentals, FCC rules and procedures, and an ability to write technical reports. Include complete description of background, technical training, experience, and starting salary required, in application. Reply to: Broadcast Engineering, Box 285, 1014 Wyandotte St., Kansas City, Mo. 64105 7-73-1t

**REGIONAL SALES MANAGER:** with experience in selling of high quality television equipment to broadcaster and other users territory open in midwest. Liberal salary. Incentive and benefit program. Send Resume of qualification to the marketing manager, American Data Corporation, and Airpax Co., P.O. Box 5191 Huntsville Al 35806 7-73-1t

**MANUFACTURERS REPRESENTATIVE:** Needed in several critical U.S. areas. Must be involved in broadcast equipment sales and carry non conflicting switching and terminal equipment lines. Send Resume of qualification to marketing manager, American Data Corporation, and Airpax Co., P.O. Box 5191 Huntsville, Al 35806 7-73-1t

**CHIEF ENGINEER** full power, class "B" FM stereo with SCA. Must have prior experience and engineering supervisor and full knowledge FCC rules and regs. Send resume to Gen. Mgr., WRVR, 85 Claremont Avenue, New York, N.Y. 10027. 7-73-1t

**This may be your last chance to get up off your big fat complacency.**

Try this. Pick out one of our United Way agencies. Go out into the field with its workers. See for yourself the very real needs of the people it serves. The new and growing urgency of their problems.

Take a good hard look at the new things that the agency is doing to solve these problems. The new approaches. The new programs. The new money they take.

Then, when you pledge your Fair Share, you're bound to make it bigger. You will remember the faces and voices of those you are helping.

If you don't do it, it won't get done.

advertising contributed for the public good



**ADVERTISERS' INDEX**

Akai America, Ltd. ....23  
 American Data Corp. ....51  
 American Electronic Laboratories, Inc. ....10  
 Andrew Corp. ....1  
 Audio-Video Engineering Co. ....CE-8  
 Belar Electronics Laboratory, Inc. ....9  
 Berkey Colortran ....53  
 Broadcast Electronics, Inc. ....15,42,62  
 Broadcast Equipment Leasing Co. ....59  
 CBS Laboratories ....55  
 Danscoll Ltd. ....49  
 Dynair Electronics, Inc. ....29  
 EIE - Electronic Industrial Engineering, a Div. of RCA ....CE-3  
 ES Enterprises ....47  
 Econco Broadcast Service, Inc. ....38  
 Electro-Voice, Inc. ....IFC  
 Gates Div. Harris-Intertype Corp. ....21  
 The Grass Valley Group, Inc. ....3  
 International Affiliates Inc. ....64  
 International Tapetronics Corp. ....56  
 Jampro Antenna Co. ....12  
 Jensen Tools & Alloys ....59  
 McBee Laboratories ....52  
 McMartin Industries, Inc. ....50,62  
 Miller-Stephenson Chemical Co., Inc. ....30  
 Mincom Div., 3-M Co. ....CE-5  
 Minneapolis Magnetics Inc. ....49  
 Mountain West Alarm Supply Co. ....59  
 Pacific Recorders & Engineering Corp. ....57  
 Pentagon Industries, Inc. ....11  
 Polyline Corp. ....9  
 Potomac Instruments, Inc. ....41  
 Pulse Dynamics Mfg. Corp. ....61  
 RCA Electronic Components ....CE-7  
 Ramko Research ....58  
 Roh Corp. ....60  
 Russco Electronics Inc. ....57  
 SC Electronics ....31  
 Scully/Metrotech (Div. of Dictaphone) ....5  
 SoundDesign ....63  
 Sparta Electronic Corp. ....7  
 Spotmaster ....15,42,62  
 Stainless, Inc. ....54  
 Stanton Magnetics, Inc. ....55  
 Switchcraft, Inc. ....43  
 Tape-Athon Corp. ....27  
 Tech Labs, Inc. ....61  
 Teledyne Isotopes ....39  
 Time & Frequency Technology, Inc. ....IBC  
 Tracor Industrial Instruments Div. ....52  
 UREI ....17  
 Vital Industries, Inc. ....BC  
 Wilkinson Electronics, Inc. ....8,48  
 Xcelite Inc. ....59

**WANTED TO BUY USED/RECONDITIONED EQUIPMENT**

Complete color transmission package required. Also portable microwave links, TVM-1 or equal. Any type of color or black and white studio equipment—Camera's, VTR's, video switchers, sync generators, wireless microphones, sound consoles, remote control boards plus any other studio/broadcast equipment. Interested in CATV distribution amplifiers, line extenders and 2-way radio mobile equipment. Please write or call stating condition, model numbers, price wanted, etc.

**INTERNATIONAL AFFILIATES INC.**  
 147 West 35th Street, New York, N.Y. 10001, Tele: 212/695-8060

# The New Standards

for frequency and  
modulation monitors

Since TFT introduced its first instrument in 1971, TFT monitors have become the broadcast industry standards for reliability, accuracy and convenience. For example, in the past two years, more than 25 percent of the TV stations in the U.S. have installed TFT monitors. Plus many stations in foreign countries. What's more, TFT's new AM and FM monitors are meeting with the same kind of sales success.

And for good reasons: innovative design techniques . . . remote monitoring without an RF amplifier . . . less interference from unwanted

signals . . . digital readouts . . . proportional, oven-controlled master oscillator for exceptional frequency stability . . . far fewer calibrations . . . digitally settable plus and minus peak flashers to prevent ambiguity . . . built-in, 10MHz general purpose counter . . . and many more features you won't find in traditional monitors.

But prove it to yourself. Just ask anyone who owns one (a complete customer list is available on request). Then, let us demonstrate on your frequency. Contact your local TFT representative, or call us collect.

## TV (UHF & VHF)



FCC Type Approval 3-187

## AM

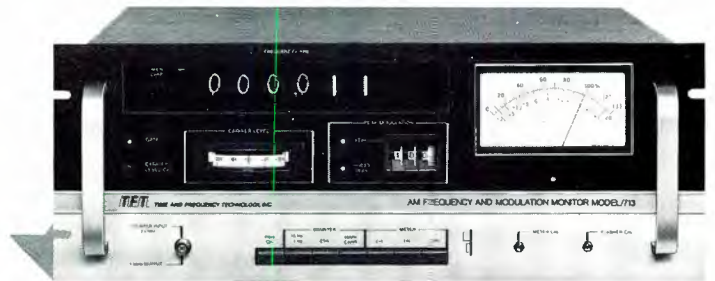

FCC Type Approval 3-195

## FM

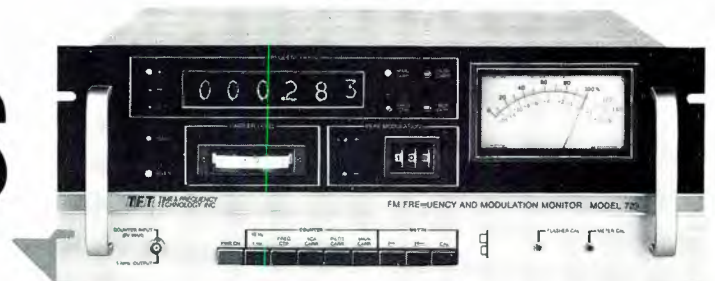

FCC Type Approval 3-202

**TFT** TIME AND FREQUENCY TECHNOLOGY, INC.  
3000 OLCOTT STREET, SANTA CLARA, CA 95050 (408) 246-6365

For More Details Circle (22) on Reply Card



**VIMAX  
27**

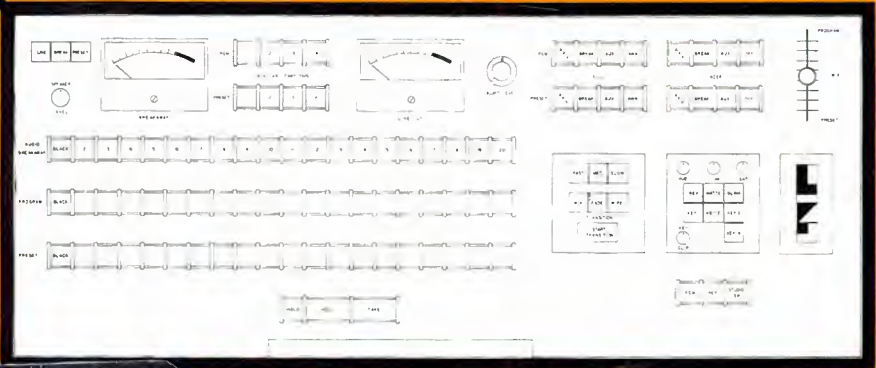

# the Vital way to tv automation

- New modular computer concept
- Extremely versatile, fast and reliable
- Easy operation with no computer training
- Standard and custom formats available
- 64 characters per line
- 27 events displayed at one time
- Full editing capabilities
- Multiple pre-rolls without time restrictions
- Full transition capability including fades, dissolves, pattern wipes and inserts
- Complete logging facilities for management and FCC purposes
- Manual override always "hot"
- Power failure protection
- Complete plant communications with auxiliary monitors
- Full spectrum of equipment can be controlled in any configuration and quantity
- Events on-air — by real, elapse, duration or cue time, plus manual
- Two automation systems in one: on-air plus 8 programmable selections for microwave switching, VTR's into record, etc.
- Optional mass data storage available for advanced scheduling from 27 events to one year

Several stations in America now enjoy daily use of the Vital Automation System. Write for your brochure describing our VIMAX-27 system.

Make Vital Industries, Inc. your single responsible source for your total system needs.

Fox Hill Rd., Lynchburg, Va. 24503  
703/384-7001

3620 Ridgewood Rd., N.W., Atlanta, Ga. 30327  
404/233-9459

7960 W. Beverly Blvd., Los Angeles, Cal f. 90048  
213/653-9438

2644 N. Seventh St., Terre Haute, Ind. 47804  
812/466-3212

GOOD ENGINEERING IS VITAL



**VITAL INDUSTRIES, INC.**

MAIN OFFICE: 3614 S.W. Archer Road, Gainesville, Fla. 32601 — Phone 904/378-1581

For More Details Circle (3) on Reply Card