

MAY 24 REC'D

AMERICAN RADIO HISTORY SOCIETY
K P L U - FI
R May 1972 75 cents

BROADCAST **engineering**

the technical journal of the broadcast-communications industry



A HOWARD W. SAMS PUBLICATION



**Telephone
interface basics**
page 14

**Cable Engineering Inside
Logic Tape Cue Circuit
Tape Recorder Maintenance**

BROADCAST engineering

The technical journal of the broadcast-communications industry

in this issue...

14 Telephone Interface Basics. Part 2 of a 2-part series on the basics of phone connections within the station. This part includes an "auto-patch" arrangement for sports remotes. **Clint Tinsley.**

19 Logic Controlled Cue Tones For Video Tape. KOMO-TV's project supervisor unveils a staff designed IC logic unit for controlling cue tones automatically. Includes construction details. **Fred Fowler.**

23 Burglars Visit KSST. A report on how burglars nearly cleaned out KSST. Includes request for information on how other stations protect themselves. **Dave Walvoord.**

26 Audio Tape Recorder Maintenance. BE's Maintenance Editor takes two approaches to tape machines. One, covering basic theory, is directed to newcomers. The major piece includes specific maintenance details. **Pat Finnegan.**

32 Automating The Mark II Image Enhancer. A TV engineer tells how his staff modified the Mark II to eliminate manual operation. **Miguel Triay.**

34 NAB Convention Recap. Notes from the recent NAB convention held in Chicago. **Ron Merrell.**

EDITORIAL

GEO. H. SEFEROVICH, Director
RONALD N. MERRILL, Editor
CARL BABCOKE, Technical
MORRIS COURTRIGHT, Automation
PAT FINNEGAN, Maintenance
HOWARD T. HEAD, FCC Rules
ROBERT A. JONES, Facilities
WALTER JUNG, Solid State
ANDRA BOYLE, Editorial Assistant
H. G. ROESLER, Cartoonist
DUDLEY ROSE, Art Director
LEO G. SANDS, CATV

EDITORIAL ADVISORY BOARD

LES NELSON, Chairman
Howard W. Sams & Co., Indianapolis

CIRCULATION

EVELYN ROGERS, Manager

ADVERTISING

E. P. LANGAN, Director
R. JACK HANCOCK, Manager
TERRY TEMPLE, Production
JAKE STOCKWELL, Sales

REGIONAL ADVERTISING SALES OFFICES

MICHAEL KREITER
1014 Wyandotte St.
Kansas City, Mo. 64105

Indianapolis, Indiana 46206
ROY HENRY
HOWARD W. SAMS & CO., INC.
2469 E. 98th St.
Tele: 317/846-7026

New York, New York 10019
CHARLES C. HORNER
3 W. 57th St.
Tele: 212/688-6350

Los Angeles, California
JOHN D. GILLIES
3600 Wilshire Blvd., Suite 1510
Los Angeles, California 90005
Tele: 213/383-1552

London W. C. 2, England
JOHN ASHCRAFT & CO.
12 Bear Street
Leicester Square
Tele: 930-0525

Amsterdam C, Holland
JOHN ASHCRAFT & CO.
W.J.M. Sancers, Mgr.
for Benelux & Germany
Herengracht 365
Tele: 020-240908

Tokyo, Japan
INTERNATIONAL MEDIA
REPRESENTATIVES, LTD.
Shiba-Kotohiracho, Minato-ku
Tele: 502-0656



ABOUT THE COVER

If you've long had questions on how your station's telephone interface system could be improved for talk shows and sports remotes, see page 14 in this issue for the second part of a special series. (Photo by Clint Tinsley)

DEPARTMENTS

Direct Current.....	4
Letters to the Editor.....	8
Industry News.....	10
CABLE	
ENGINEERING... CE-1	
Engineer's Exchange.....	38
New Products.....	40
Book Reviews.....	53
Tech Data.....	50
Ad Index.....	55
Classified Ads.....	55

BROADCAST ENGINEERING is published monthly by Intertec Publishing Corp., 1014 Wyandotte Street, Kansas City, Missouri 64105. Telephone: 913/888-4664.

BROADCAST ENGINEERING is mailed free to qualified persons engaged in commercial and educational radio and television broadcasting. Non-qualified subscriptions in the U.S. are \$6.00 one year, \$10.00 two years, \$13.00 three years. Outside the USA add \$1.00 per year to cover postage. Single copy rate 75 cents. Back issue rate \$1.00. Adjustments necessitated by subscription termination at single copy rate.

Controlled Circulation postage paid at Indianapolis, Indiana.



Robert E. Nertel, Publisher
INTERTEC PUBLISHING CORP.
Subsidiary of HOWARD W. SAMS & CO., INC.

Copyright, 1972, Howard W. Sams & Co., Inc. All Rights Reserved: Material may not be reproduced or photocopied in any form without written permission of publisher.

NEW! BORDERLINE GENERATORS

BORDER

BORDER

BORDER

BORDER

STARTING WITH A NORMAL KEY SIGNAL, THE GVG BORDERLINE WILL-----

PROVIDE A BLACK BORDER AROUND A MATTED TITLE OR-----

PRODUCE A DROPSHADOW EFFECT ON LETTERING OR TITLING OR-----

PRODUCE OUTLINE LETTERING FROM A SOLID TITLE SOURCE



DESCRIPTION

Grass Valley Group Borderline generators can be used to outline captions from camera video signals or character generators. The bordered inserts have excellent visibility and are particularly effective in situations requiring a white insert into a scene which is predominantly white.

Model 3273 is a complete system which provides bordered inserts into a composite video signal, such as at the output of a switching system. The unit is entirely self-contained and requires no horizontal or vertical driving signals.

Model 3271 is designed for use with GVG switching systems and special effects equipment. The keying circuitry in the special effects amplifier is utilized for the inserting function, and effects such as wipe key between bordered inserts are possible. The 3271 does not introduce system timing errors when installed in GVG switching systems.

Model 3272 is designed for use with special effects equipment of other manufacturers. It provides a widened key signal output which can be connected to the external key input of most special effects systems. The widened key output, together with a slightly delayed (H and V) title video signal, is used to achieve the border effect.

Borderline will be available for both NTSC and PAL/CCIR standards.

THE GRASS VALLEY GROUP, INC. 

SOLD EXCLUSIVELY BY GRAVCO SALES, INC.

6515 Sunset Blvd.
LOS ANGELES, CALIF.
(213) 462-6618

Station Plaza East
GREAT NECK, N.Y.
(516) 487-1311

125 South Wilke Road
ARLINGTON HEIGHTS, ILL.
(214) 330-1245

Redbird Airport
DALLAS, TEXAS
(214) 330-1245

1644 Tullie Circle, N.E.
ATLANTA, GEORGIA
(404) 634-0521

DIRECT CURRENT FROM D. C.

MAY, 1972

by Howard T. Head

EBS To Be Overhauled

A joint announcement from the Commission and from the White House Office of Telecommunications Policy (OTP) has given notice of the long-expected overhaul of the Emergency Broadcast System (EBS) (See March, 1972 Pompous Predictions). This overhaul comes in the wake of a series of incidents such as that of last year, in which an actual emergency alert message was transmitted by mistake to all participating broadcast stations.

The principal effect of the new changes is to separate the emergency warning system from a system intended to provide actual emergency information to the public. The warning system will be under the control of the Office of Emergency Preparedness (OEP) and will eventually rely on a system of low and medium frequency transmitters under that office's control (See February, 1972 BE).

Detailed instructions initiating the new changes are being distributed to all broadcast stations involved in EBS. The revised system will continue to rely on the voluntary support of the broadcasting industry,

New AM Modulation Rules Adopted

Also as predicted (See March, 1972 Pompous Predictions), the Commission has reimposed an upper limit on positive modulation for AM broadcast stations. Under the new rules, positive modulation may not exceed 125 percent under any circumstances.

The Commission's Order notes that such a limit is necessary to control interference to co-channel and adjacent-channel stations, and to maintain audio distortion and carrier shift within acceptable levels. At the same time, the Commission felt it necessary to provide some "head room" to take into account the fact that most modulating audio waveforms are asymmetrical, thus making inevitable some difference in negative and positive modulation levels.

The new requirement, established in terms of an absolute modulation level, cannot be measured with ordinary indicating instruments. The choice of methods employed to assure that the 125 percent value is not exceeded is left to the discretion of the individual licensee.

1 kW Nighttime Power Proposed for Class IV Local Channel Stations

The Community Broadcasters Association (CBA) has asked the Commission to modify the rules governing Class IV AM stations on the local channels so as to permit all Class IV stations to operate with nighttime power of 1 kW. The present Commission rules provide for daytime power of

Longer Life for an Old Timer

Introduced in 1947, the EIMAC 4-400A quickly became the mainstay for the majority of broadcast, shortwave and FM transmitters. Still popular today, this power tetrode design is now available as the improved long-life 4-400C.

Get an EIMAC 4-400C — the new generation tetrode specifically designed for long-life, high-performance broadcast and FM service. This premium quality tetrode is directly interchangeable with the 4-400A in existing equipment and is recommended for new equipment design.

The EIMAC 4-400C features a low temperature filament structure which retains its initial high level of electron emission for an extended period of time, greatly reducing frequency of tube replacement. This improved filament structure, plus strict processing and quality control, combines with improved current division and low drive requirements to provide a high-quality, long-life product.

Reduce down-time and replacement cost with the EIMAC 4-400C when you re-tube. And use this improved tetrode in your new equipment design. With a maximum plate dissipation of 400 watts, the EIMAC 4-400C provides long-life and consistent performance as an amplifier, oscillator or modulator. Another example of EIMAC's continuing program of quality, reliability and service.

For further information, contact EIMAC, Division of Varian, 301 Industrial Way, San Carlos, Calif. 94070. Or any of the more than 30 Varian/EIMAC Electron Tube and Device Group Sales Offices throughout the world.



Circle Number 6 on Reader Reply Card

1 kW but require that the power be reduced to 250 Watts at night.

CBA points out to the Commission that of the more than 1000 Class IV stations on the local channels, all but a handful have either increased daytime power to 1 kW or have plans for doing so. The new radio treaty with Mexico removed the last major international barrier to daytime power increases, and solutions to the remaining international problems appear to be in sight.

The principal advantage in the increased power is the improved ability to overcome man-made electrical noise, which continues to increase at a steady rate. Mutual interference among co-channel Class IV stations at night would remain unchanged if all stations should increase nighttime power simultaneously.

Operator Requirements Under Active Scrutiny

The Commission is giving careful study to an NAB proposal to permit radio broadcast operation employing lesser grade operators for many tasks such as AM directional operation, which now require the employment of an operator holding a first-class license. In the meantime, the Commission has proposed to permit the operation of aural remote pickup transmitters, aural STL transmitters, and TV translators by unlicensed persons under the direct control of the station licensee.

The new rules permitting a reduction in operator grade for various types of operation are one of four "priority" items on the NAB list, which also includes changes in the rules (Part 74) governing all broadcast auxiliaries, relaxation of the rule requiring operator visibility of transmitters operated by remote control, and a relaxation of the two-hour inspection requirement for AM directional antennas.

Short Circuits

The Commission has granted a Pre-Sunrise Service Authorization (PSA) for a daytime-only station operating on a Canadian clear channel . . . The Commission has adopted proposed rules permitting the removal of loss resistors now employed by several hundred AM stations (See July, 1970 D.C.) . . . The Commission has permitted a large city AM station to duplicate its FM programming during the entire broadcast day so as to retain a classical music program format on the AM. There were two immediate consequences: the station promptly cut back its daily schedule from 24 hours to 18 hours, and a public group protested the separation of a Midwest AM-FM combination which would have shut down a "progressive rock" format . . . The Department of Housing and Urban Development (HUD) has authorized a CATV experiment to test two-way cable communications in a Minnesota town . . . The Commission's staff has reduced its backlog of remote control applications and is now acting promptly on new applications.

Call Visual first for Quality Television Systems Video and Audio

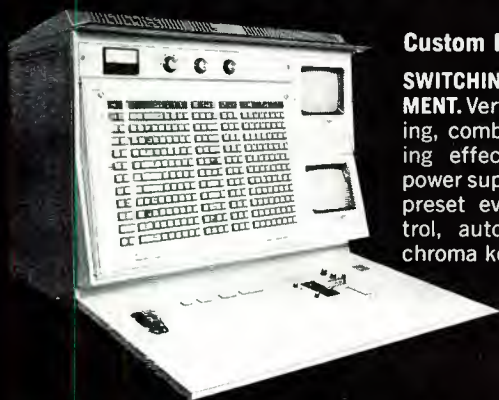

Custom Preset Switcher

SWITCHING & TERMINAL EQUIPMENT. Vertical Interval, sync sensing, combined mix-effects, rotating effects, quad split, matrix power supplies, pre-roll/take bars, preset event display, BCD control, automatic comp-noncomp, chroma key, AFV.



**20 Mixer TV
Production Console**

CONSOLES. Balanced circuitry, dual supplies, illuminated buttons, self-contained or remote amplifiers, DA's, wired patch panels.

+PLUS



Electronic Titling



**Programmable
Intercom Patch Panel**



Rapid-Q

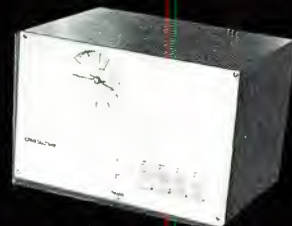

FAVAG Quartz Clocks

+PLUS A CONTINUING TRACK RECORD WITH TOP BROADCASTERS.

Recent large systems installed or in process for: Cox, Griffin, Gross, Meridith, Metromedia, Mullins, Nat onwide, RKO General, Scripps-Howard, Storer, Triangle, Westinghouse.

ALSO: KARD-TV, KROD-TV, KSLA-TV, KTEW, KTTS, WCCO-TV, WCPB, WDCA-TV, WFMY-TV, WKY-TV, WLTV, WTTW, WTVT.

VISUAL ELECTRONICS CORP.

356 West 40 St.
NYC. N.Y. 10018
(212) 736-5840

E. Clammer
5940 Avon Dr.
Bethesda, Md. 20014
301-530-1767

P. D. Thompson
2550 Weymouth Rd.
Winston-Salem,
N.C. 27103
919-765-3157

F. Bonvouloif
337 N. Dover Ave.
Chicago, Ill. 60525
312-482-7886

A. W. Greeson
219 Homewood Ave.
Greensboro, N.C. 27403
919-292-1791

Video Division
10 Robert St.
Clifton, N.J.
201-677-5100

Audio Division
40 North Daisy Ave.
Pasadena, Ca.
213-449-6176

Rapid-Q
1208A Kifer Rd.
Sunnyvale, Ca. 94086
408-738-0670

A New Slant...

Let's Pull Together

Dear Editor:

If those that complain the most (about engineering titles) would only remember that they were not born with the knowledge they now have, but only obtained it through the many efforts of those who trained or helped them, they might consider helping others in the same manner. It would help the broadcasting business a great deal and it could sure use it.

I started with the telephone company in 1916, in New York as a budding communications engineer. There was no other place to learn this business except with the telephone company. After five years of apprenticeship and several courses in their schools, I became a telephone engineer. (Honorary title of course—the telephone company did not give degrees with their training.)

I entered the engineering phase of radio broadcasting in 1925 (on loan from the telephone company) to help build some of the studio and control room equipment for the new radio stations just coming into existence. (WEAF-WJZ and WABC now WNBC-WABC and WCBS all in New York City.)

Although I sometimes worked with my hands with such tools as pliers, flats, screwdrivers and a soldering iron, my employers referred to me as an engineer... probably because I read blueprints and was rather adept at designing circuits, etc. As time went on I became a control engineer, recording engineer (acetate that is), design engineer and even chief engineer. All were honorary titles, of course, bestowed upon me by my employers. I think I have been everything except Vice President.

During my 56 years in the business, I was more interested in becoming an expert in my field and being able to prove it, than having

a title. So far I have had no complaints. Have any of you? By the way, I'm still a pretty good technician, also. So, what do you say, let's cut out all the bickering and get down to business and give the other fellow a chance. You might be working for him someday. Why not try to make radio broadcasting as good as it used to be. It needs the help of everyone, so watch the gain and 73's for now.

Warren T. Abbott, CE
San Diego, Calif.

Anyone For Women In Broadcasting?

Dear Editor:

It is sad indeed when broadcasters must be forced into equal opportunity employment. In reading the section "Equal Opportunities in Broadcasting for Women," in the February issue of **BE**, I felt a twinge of pain in my side.

I was in broadcasting for eight years, and have held an FCC ticket for seven years. In that time, I've had more offers to be a secretary than you would care to count. But when it came to employment as an announcer or audio engineer, as I am qualified, the answer was "you don't fit into our format" or an honest—"We can't hire another woman. We have one on our staff now." The only place for a female engineer is in a kitchen.

There are "all girl" FM'ers in this world just as there are all Black, all Spanish-American, and all Polish stations—but this is hardly the answer. These formats remind me of going to the zoo to see animals—separated from one another and on display rather than in a natural, inter-acting environment.

If a broadcaster can do the job, hiring should be regardless of who

IF YOU NEED ATTENUATORS YOU NEED THIS CATALOG!



AUDIO AND RF ATTENUATORS TO MEET ANY REQUIREMENT

Here in one compact and informative 24 page booklet is all the data you need to select a Precision Audio and RF Attenuator for your application.

Reference Charts, Circuit Diagrams, Types and Uses, Current and Voltage Ratio Tables, Ratings, Etc., make this a handy and invaluable reference.

SEND FOR YOUR FREE COPY TODAY.

TECH LABS, INC.

Drawer "B"
Palisades Park, N. J. 07650
Tel.: (201) 944-2221
TWX: (201) 947-0825

Circle Number 8 on Reader Reply Card

LEASE YOUR EQUIPMENT

broadcasting, CATV, background music. And,

RE-LEASE YOUR DOLLARS

We will purchase, the equipment—your choice—and lease it to you on a long-term basis.

Dealer inquiries invited.
Call or write for details.

Broadcast Equipment Leasing Co.

Division of Anchor Leasing Corp.
Grant Bldg., Pgh., Pa. 15219
Area Code 412-281-3768

Circle Number 9 on Reader Reply Card

he or she is. There shouldn't be an attitude of "one woman who is Black to fill the two categories at once."

While working as an engineer/announcer at a Chicago FM'er, I was treated as an equal of the male announcers; however, the station changed hands and a meeting with the new management was arranged. There was one Black male announcer, three or four white males, and myself, a white female. At that meeting I was told that their "sound" did not permit the use of a female voice or a Black man. They gave me a sales job and our Black announcer went on to bigger things in New York City. I dislike sales, so after three months I went to work for an audio-visual company as a production and mastering engineer for educational programs.

Women need not only do commercials for feminine deodorant sprays—they (we) can do plain old fashioned news, weather, sports, and our own programs. Women

don't have to offend other women either. Sure, the soft sexy voiced women would catch only the male ear, but a natural delivery with a sincere tone, will catch male and female ears.

I never went into broadcasting wanting to become a "star", nor did I expect super security, but I did go into the field expecting to work hard, learn a lot and be duly rewarded for my efforts. Instead, I worked hard, made little, and was released whenever my talents threatened a male's position on the staff. But I did learn a lot—and became bitter.

Now I'm employed with a company as a technician and engineer for VTR and audio—non broadcast, but educational. I gave up on trying to get jobs in the industry and have begun working for employers who appreciate good employees—white or Black, male or female—that's the way it's supposed to be.

**Pam Eberhardt
Chicago, Ill.**

Just send your worn cartridges to us
Our individual professional reconditioning
Assures you of properly serviced cartridges



**FOR BETTER
... LONGER
PERFORMANCE**

—JOA will inspect, service and reload your cartridges with ANY LENGTH tape

NO MINIMUM—NO EXTRA CHARGE FOR—

- (a) FOAM TEFLON-FACED PRESSURE PADS
- (b) replacement of minor parts
- (c) VISIBLE SPLICE

All cartridges PRETESTED under actual broadcast conditions—48-hour Processing
20 or more cartridges SHIPPED PRE-PAID

Need NEW CARTRIDGES fast? JOA will ship immediately . . . from stock . . . any size Fidelipac, precision manufactured NAB cartridge.

JOA—the cartridge service of authority—serving the broadcast industry.
Authorized distributor for NORTRONIC HEADS
phone or write



Cartridge Service
P. O. Box 3087
Philadelphia, Pa. 19150
Area Code 215, TUrner 6-7993

Circle Number 35 on Reader Reply Card

Fidelipac gives you phase control

... the Fidelipac 350 Cartridge has an adjustable guide corner post to solve your inter-track phasing problems. It's the new development from Fidelipac, of course, the people who are determined to make the best better, through research.

Available in all standard lengths. Compatible with all standard broadcast cartridge machines.

Don't wait! Call your Fidelipac Distributor or

FIDELIPAC



FIDELIPAC a division of TelePro Industries, Incorporated • 3 Olney Avenue, Cherry Hill, New Jersey 08034 • (609) 424-1234
Circle Number 10 on Reader Reply Card

your
NORTRONICS
 distributor is
 the best source
 for professional
 tape heads!



Nortronics . . . world's leading designer and manufacturer of magnetic heads . . . offers the precise replacement head for virtually every professional recorder . . . heads that provide outstanding performance, longest life and easy replacement with minimum downtime.

Nortronics' distributors stock the 'right' replacement head for *your* professional recorder—be it **Ampex, Magnequad, Scully, Concertone, Gates, Crown, RCA, ATC, Collins, KRS, Macarta, MCI, Tape-A-Thon, Sparta, Tapecaster**—or any other!

See your Nortronics distributor today for professional reel-to-reel or cartridge head requirements. He also carries a complete line of Nortronics accessories and offers head relapping services.



world's leader in magnetic heads

NORTRONICS

COMPANY, INC.

6140 Wayzata Blvd.
 Minneapolis, Minn. 55416
 (612) 544-0381

In Canada
 Len Finkler, Ltd.
 25 Toro Road, Downsview, Ontario
 (416) 630-9103

Circle Number 11 on Reader Reply Card

NAB Committee Asks For Simplified Radio Rules

A National Association of Broadcasters Committee set up to simplify radio requirements of the Federal Communications Commission, will ask the FCC for immediate action on pending NAB requests in four technical areas.

NAB Board Chairman Richard W. Chapin, who also serves as chairman of the Ad Hoc Committee on Radio Regulation, said the committee "agreed that the technical area deserved first priority on the basis of need and also because early action is possible."

Mr. Chapin, president of Stuart Enterprises, Lincoln, Neb., said "several technical matters are ripe for decision."

In each of the four areas, NAB has petitioned the FCC for rule making, but as yet no action has been taken. The areas are:

1. The visibility of the transmitter and metering system from the operator's position.

Present rules require that the transmitter and associated metering system be clearly visible and accessible from the operator's position. NAB seeks to amend that requirement to permit the use of extension metering where the transmitting equipment is not clearly visible. This would negate the need for remote control authorization for such situations.

2. First-Class Operator relief.

Present rules require a first-class operator to be on duty at all times at directional and higher powered AM & FM stations. The NAB petition asks that this requirement be relaxed so that the employment of one full-time first-class operator will fulfill the requirement. A third-class license with broadcast endorsement would be required for all other operating personnel (such as announcers).

3. Relief from the two-hour inspection rule for directional antennas.

Present rules require the inspection of the transmitter and antenna within two hours of activation of any directional antenna. NAB is petitioning the Commission to bring the inspection requirement for directional stations in line with those presently required for non-directional.

4. Modification of the rules governing the use of out-of-studio broadcast equipment.

NAB has requested that the archaic rules which apply to auxiliary broadcast services (radio remote pickup; studio transmitter links, inter-city relays and TV remote facilities) be brought into line with those which govern the use of similar equipment in safety and special services.

The Committee also began work on additional areas where modification and simplification of rules might be accomplished but Mr. Chapin pointed out "we regard early FCC action on these long-pending petitions as evidence of the Commission's interest in the overall effort to simplify radio rules and regulations."



Reid

"I TOLD YOU IT WOULD FALL DOWN IF I DID A REMOTE IN THERE!"

Present at the meeting were: Sam W. Anderson, general manager, KFFA, Helena, Ark.; Harold R. Krelstein, Plough Broadcasting Co., Memphis, Tenn.; Stanley W. McKenzie, general manager, KWED, Seguin, Tex.; Dick Painter, general manager, KYSM, Mankato, Minn.; Lee Allan Smith, station manager, WKY, Oklahoma City, Okla., and Joseph F. Tennesen, president, KFKA, Greeley, Colo.

Mr. Abe Voron, representing the National Association of FM Broadcasters also attended the meeting as an observer.

**For Current News
On FCC Activities
Read Direct Current
Page 4**

Broadcasters Are Not Common Carriers

The National Association of Broadcasters told the Federal Communications Commission that broadcasting is not a common carrier and the FCC should not develop policies on what individuals and groups demand should be aired by radio and television stations.

In the filing, NAB supported its stand by citing Congressional and court actions that leave programming decisions in the hands of the broadcast licensee.

Commenting on current FCC procedures and court reviews based on the request for air time by the Business Executives' Move for Vietnam Peace, NAB said the Supreme Court's pending review of the case "could well result in total elimination or at least redefinition of the directives contained in the Court of Appeals opinion."

At the very least, NAB said, "the Supreme Court's decision upon review will offer some precise guidance to the Commission which is requisite to any intelligent development of regulatory provisions

applicable to editorial advertisements.

In case after case, NAB said, "the federal courts have reaffirmed the necessity for honoring broadcasting's non-common carrier status and have done so expressly in the face of unequivocal demands for access by groups or individuals."

The Association also noted that "in spite of all the uproar and protest which is brought to the public's attention about access, no one has any idea of whether there actually is an access problem.

"For every individual or group who fails to receive access for his views or ideas on his terms, how many other views or ideas are being received by the public?"

NAB said no one really knows the answer, "and yet the Commission may be on the verge of dashing headlong into developing a solution to a problem it hasn't even properly defined."

NAB said Storer Broadcasting is in the process of preparing material for the FCC which will provide the first quantitative review of the

10 inch Giant

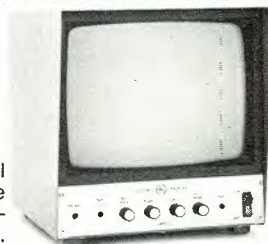

This is the new, unique Setchell Carlson 10-inch monochrome video monitor...the *only* professional-quality 10-inch monitor.

It gives you **13% more viewing area than standard 9-inch monitors, 26% more** when used in a dual rackmount configuration.

It is small and handy, but able to do giant duty. Use it for broadcast studios, industrial monitoring, surveillance, remote installations, medical, VTR display, educational, and many other applications.

You'll find the picture quality always superb (horizontal resolution 640 lines or better), the reliability factor amazing, the weight practically nothing (15 pounds), and the cost modest.

One hundred percent solid-state circuitry

assures you maximum performance and stability, low power drain, and a minimal heat factor. Setchell Carlson UNIT-IZED®

plug-in circuit modules make maintenance a breeze.

At \$199, it is the lowest-priced American-made monitor of comparable size, and is available in single or dual rackmounts.

Take a giant step forward...ask your Setchell Carlson dealer for more information, or write to us. Remember SETCHELL CARLSON, where quality is a tradition.



SC ELECTRONICS, INC.
A SUBSIDIARY OF AUDIOTRONICS CORPORATION
530 5th AVE. N.W. ST. PAUL, MINNESOTA 55112
PHONE (612) 633-3131

Circle Number 12 on Reader Reply Card

The Top Turntable



... is Spotmaster's new Studio Pro B, offering instant start and the tightest cue potential in the industry. Heavy duty hysteresis motor drives a 6½ lb. machined aluminum platter in a solid-cast aluminum chassis for inaudible rumble, lowest wow and flutter. Indicator lights tell speed (33 or 45) at a glance, and speeds can be changed with platter in motion. Detachable mounting plate (accepts any tonearm), integral 45 spindle and neutral cue position are other features ... all for just \$198.00.

And an Outstanding New Tonearm

... is the Spotmaster stereo BE-402 (mounted on Studio Pro B above), which combines reasonable cost, rugged design and professional specs. Features include high compliance for modern stereo cartridges, minimum tracking error, anti-skating, low mass, quick-change head, easy single-hole mounting ... for only \$54.95.

Complete line of Gray professional arms and all broadcast quality phono cartridges also available at competitive prices.

And the Best Turntable Preamp



... is our new Model TT-22, all solid state, modular, stereo equalized and completely self-contained. Features separate balance/level controls, high output (+8dbm), phone jack ... plus switchable and remountable rumble and scratch filters. Both stereo and mono models are available, starting at \$121.50. Our time-tested TT-20B mono preamp and PR-4C power supply (will power up to 4 preamps) are also available, providing top performance at economy prices.

... all from Spotmaster

PLUS a complete range of accessories for both turntable and cartridge tape operation. Write for details.

BROADCAST ELECTRONICS, INC.

A Filmways Company

8810 Brookville Rd., Silver Spring, Md. 20910
(301) 588-4983

actual access which the public is receiving, and other parties may be assembling similar data.

"In any event," NAB said, "the

Commission will for the first time have material before it which will make possible a balanced approach to the entire access question."

Wasilewski Reveals Copyright Compromise Package

President Vincent T. Wasilewski has pledged to Congress support of the National Association of Broadcasters in enacting copyright legislation that embraces all applicable provisions of the so-called cable television compromise.

Wasilewski said in a letter to Thomas C. Brennan, chief counsel of the Senate Judiciary Subcommittee on Patents, Trademarks and Copyrights that NAB agreed to accept four major principles in providing copyright liability on broadcast signals carried by CATV systems.

He said NAB agreed with other parties to seek legislation encompassing the four principles and "we pledge our support toward achieving enactment of those provisions."

The NAB president noted that Sen. John L. McClellan (D-Ark.) has described the agreement as "reasonable" and "in the public interest" and said NAB has deduced from this that Senator McClellan approves of "all of the copyright provisions" included in the compromise.

While feeling that the compromise did not "comport with our views as to the proper equities between cable operator and broadcaster," Wasilewski said, NAB nevertheless accepted it and agreed with all other parties to support copyright legislation "embodying all applicable provisions of the compromise."

He told Brennan that NAB is "actively engaged in the drafting of such legislation" and hopes language acceptable to all parties to the compromise will be forthcoming soon.

If the cooperation envisioned in the compromise fails to carry through on draft legislation, he said, NAB will either submit legis-

lation "representing the views of less than all the parties" or revert to its earlier position that CATV systems have full copyright liability on all broadcast transmissions.

The four provisions contained in the compromise agreement which NAB is willing to accept are:

1. "Liability to copyright, including the obligation to respect valid exclusivity agreements, will be established for all CATV carriage of all radio and television broadcast signals except carriage by independently owned systems now in existence with fewer than 3500 subscribers. As against distant signals importable under the FCC's initial package, no greater exclusivity may be contracted for than the Commission may allow."

(Wasilewski emphasized that NAB fully supports the exemption for independently-owned CATVs with fewer than 3,500 subscribers.)

2. "Compulsory licenses would be granted for all local signals as defined by the FCC, and additionally for those distant signals defined and authorized under the FCC's initial package and those signals grandfathered when the initial pack-



"I DEMAND EQUAL DIME."

age goes into effect. The FCC would retain the power to authorize additional distant signals for CATV carriage; there would, however, be no compulsory license granted with respect to such signals, nor would the FCC be able to limit the scope of exclusivity agreements as applied to such signals beyond the limits applicable to over-the-air showings."

(Wasilewski said it is imperative that any copyright legislation state clearly that full copyright liability pertains to any distant signals not defined in the FCC package or to those that are "grandfathered.")

3. "Unless a schedule of fees covering the compulsory licenses or some other payment mechanism can be agreed upon between the copyright owners and the CATV owners in time for inclusion in the new copyright statute, the legislation would simply provide for compulsory arbitration failing private agreement on copyright fees."

(Wasilewski said such a provision is necessary since CATV operators and copyright owners have been unable to agree on fees since the compromise was adopted.)

4. "Broadcasters, as well as copyright owners, would have the right to enforce exclusivity rules through court actions for injunction and monetary relief."

(Wasilewski said such a provision is needed to clarify the rights of broadcasters and copyright owners to seek relief in the courts.)

Brennan had asked Wasilewski to comment specifically on whether the compromise covered certain program material such as music and sports or whether such programming would require special copyright treatment.

Wasilewski said the compromise does not change a section of proposed copyright legislation dealing with "secondary transmissions by cable systems of professional sporting events." NAB, he said, supports the section but suggests that it be expanded to cover collegiate as well as professional sports.

another
brand
new



member

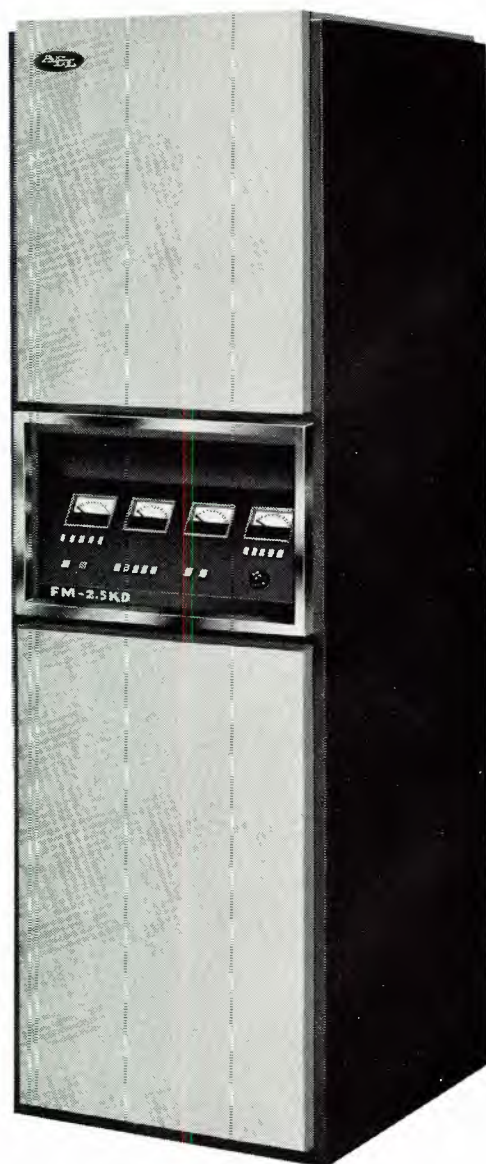

... meet the AEL FM-2500 watt and FM-1000 watt transmitters.

Here are the newest members of the AEL Advanced Equipment Line with the answer to efficient, economic Class A operation (up to 3kw ERP).

High transmitter power, low antenna gain or low transmitter power, high antenna gain (you name it) AEL offers solid state reliability, easy accessibility and high quality standards of production.

FEATURING:

- full 2500 or 1000 watt power output
- automatic recycling
- mid-cabinet metering
- circuit breaker protection
- remote control provisions
- single phase power supply

The FM-2.5KD and FM-1KD Transmitters have the built-in capabilities to give you true Sound Fidelity for the Seventies.



ADVANCED EQUIPMENT LINE

AMERICAN ELECTRONIC LABORATORIES, INC.:

P. O. Box 552 • Lansdale, Pa. 19446 • (215) 822-2929

Circle Number 13 on Reader Reply Card

Station telephone interface basics

Part 2 of a 2-part series. This part deals with basic telephony from the transmission end. Includes auto-patch system for sportscasting.

By Clint Tinsley*

In Part I of this article, the emphasis was on the terminating/receiving end of the line. Since the time that the article was written, we have gone into the sportscasting business on our FM station with the addition of a very sport-minded sales staff member. In Part II we will undertake a further discussion of basic telephony, from the transmission end, and a further modification to the auto-patch system to aid in sportscasting.

Back to Basics

Figure 1 is a schematic of the

*Chief Engineer, KATN, Boise, Idaho.

WE 425 network as I know it and verified it to be at one time. Figure 2 is a reprint from Part I of the original article, with a slight correction, if the network is used without a dial, F and RR are to be strapped together with F/RR and C being the input to the network. The dial is a normally closed switch across F and RR.

I noted a method of connection which had been used by our sports-minded salesman; however, a couple weeks later when called upon to repair a remote amp of another radio station, I noted the same arrangement. This method required removing the carbon microphone from the handset and clipping on to the two exposed contactors. The method does work, obviously. But let me note two things: The feed is into a normal DC circuit usually necessitating DC isolation and secondly, to open this circuit

raises the network resistance (DC) to a measured 1.5-2 K raising the possibility of an accidental disconnect.

Returning to Figure 1, the carbon microphone is in series with the primary DC path through the primary halves of the induction coil, but due to the placement of section A of the secondary, side-tone is reduced at the receiver but not eliminated. V₁, V₂ and V₃ are varistors which compensate for telephone loop length.

Some Constants, Maybe

Fairly standard with AT&T Bell affiliates is the use of a three or four conductor house cable which used to come in about a #20 and now comes in about a #24 gauge wire (with the author approximating). The colors of the conductor insulation within were red/green/yellow for the three conductor cable and red/green/yellow/black for the four conductor. Probable assignments are shown in Table 1.

The AC voltage will run 6-8 Volts for lamping purposes, usually.

The Remote Broadcast, Simplex

Early in the sports season, it was the practice of this station to do the home games via our Marti mobile unit. This necessitated someone, which turned out to be the author, going to the game and running 150' of audio and power line to the van and checking everything out. Thus, having the support of the sports department, we convinced management to put in a phone line, engineering time being more valuable, spent elsewhere.

We have the standard four prong jack installed at the remote location. We had initially modified a standard "home type" 500D set in the manner prescribed by Figure 3. We are now using another phone which was provided for the purpose by

Table 1.

	Red	Green	Yellow	Black
3 Cond., 1 Sta.	T	R	Ground	-
4 Cond., 1 Sta.	T	R	Ground, AC ret.	AC
4 Cond., 2 Sta.	T-line	1-R	T-line	2-R

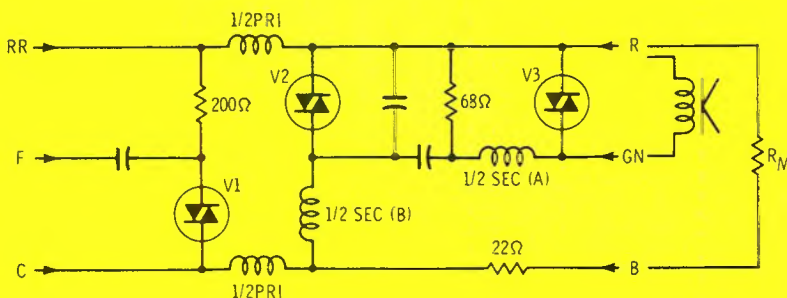

Fig. 1 Schematic of the WE 425 network.

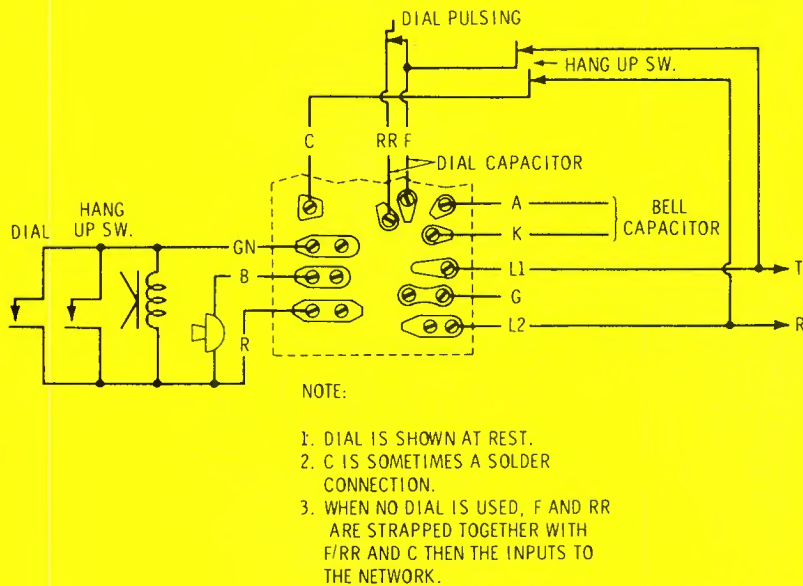

Fig. 2 The WE 425E network.

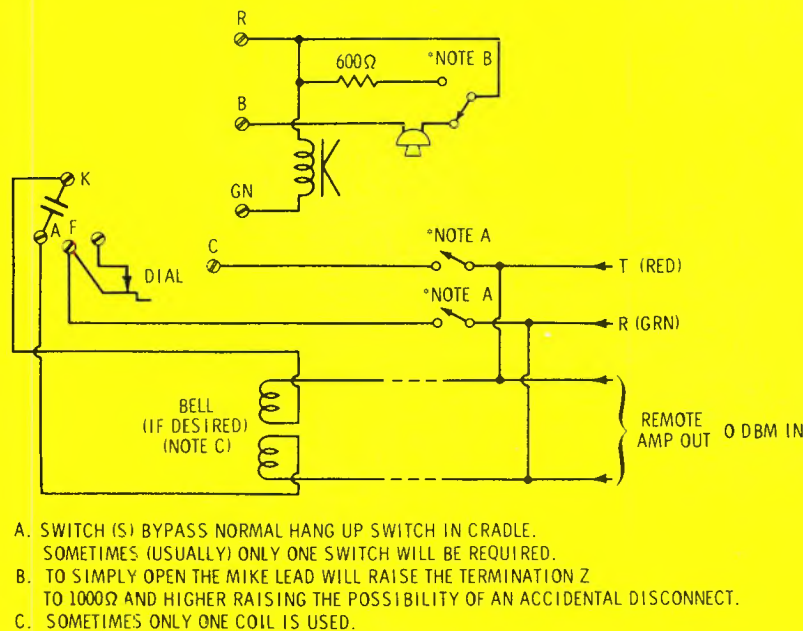

Fig. 3 Modified home type 500D set.

the phone company and it has a few extra frills which are beyond the scope of this article, but it is basically as shown in Figure 3.

Note B deals with the fact that the opening of the microphone lead raises the DC resistance value of the phone set. The DC value can be limited to 600 Ohms by switching in a 600 Ohm resistor in place of the microphone as shown. I should also mention that in the 302 sets and older, opening the microphone lead opens the DC path through the telephone set completely. If you use one of these sets, experiment until you find a 600 Ohm terminating value.

0 dBm into the phone line will normally result in a clean broadcast.

Remote Equipment

This subject is as varied as telephones. There are many reasonably priced units on the market for this purpose and then again, sometimes the engineer prefers to build his own.

My primary duty as chief engineer at KATN/KBBK is that of chief background music installer of Valley FM Background Music Co., a subsidiary. I borrowed one of our inexpensive PA amplifiers which is rated at 20 Watts and has two microphone inputs. I used the 70 Volt line output which gave me a little better isolation from the amplifier proper. Figure 4 is the build out circuit which at 70 Volts will load out approximately 20 Watts.

The metering circuit is not important, I used an inexpensive meter and this resistor system allowed a calibration in the vicinity of 0 dBm. What is important is the output switching, in that you can directly terminate the phone line, if desired or necessary. S2 is normally left open, since I firmly believe in utilizing the phone itself as the proper terminating element. The normal ratio of a 70 Volt line transformer tapped at 2.5 Watts is

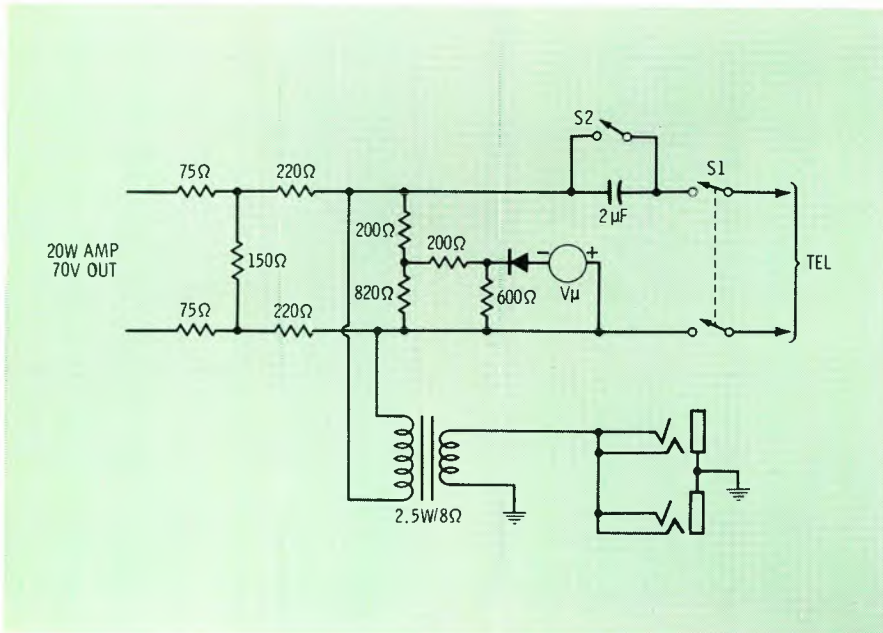

Fig. 4

2K on the line side to 8 Ohms on the speaker side. We use the inexpensive variety of stereo headphone with the padded earmuffs for monitoring, which are generally 8 Ohms per unit, thus presenting a 2 Ohm load to the speaker side of the line transformer and a 500 Ohm load to the source. One additional note, unless individual volume controls are provided, use a matched pair of headphones, the reason being that they vary greatly in efficiency.

AUTO-PATCHcasting

In this modification of the auto-patch system, the conference mode switch was changed to a three position switch. Figure 5 shows the updated wiring of the auto-patch. In the sports-cast position, the switch removes power from the mike booster amp and leaves the mike changeover relay in the console feed position but locks up K4 as it did in the hold position. This switch should be of the make-before-break type or shorting to prevent pops when going from hold to normal.

K6, called the system status control relay, has an additional service. In the hold (rest) position, AM program is fed into the phone lines thus we can feed another station when called to do so. This has other advantages. When the remote feed is out of our coverage area, by flipping the switch during the commercials, a direct cue is provided for the sportscaster. If the need arises to take a feed via the telephone and send at the same time, the conference facility will take care of that need, or the source can be broadcast through the back-up system. The receiving station then takes it's feed from the AM program feed facility in the conference facility.

Etcetera

At KATN the present system was installed in September 1971. It is backed up by the original system of the 2 mfd capacitor and repeat coil, but it has not been called

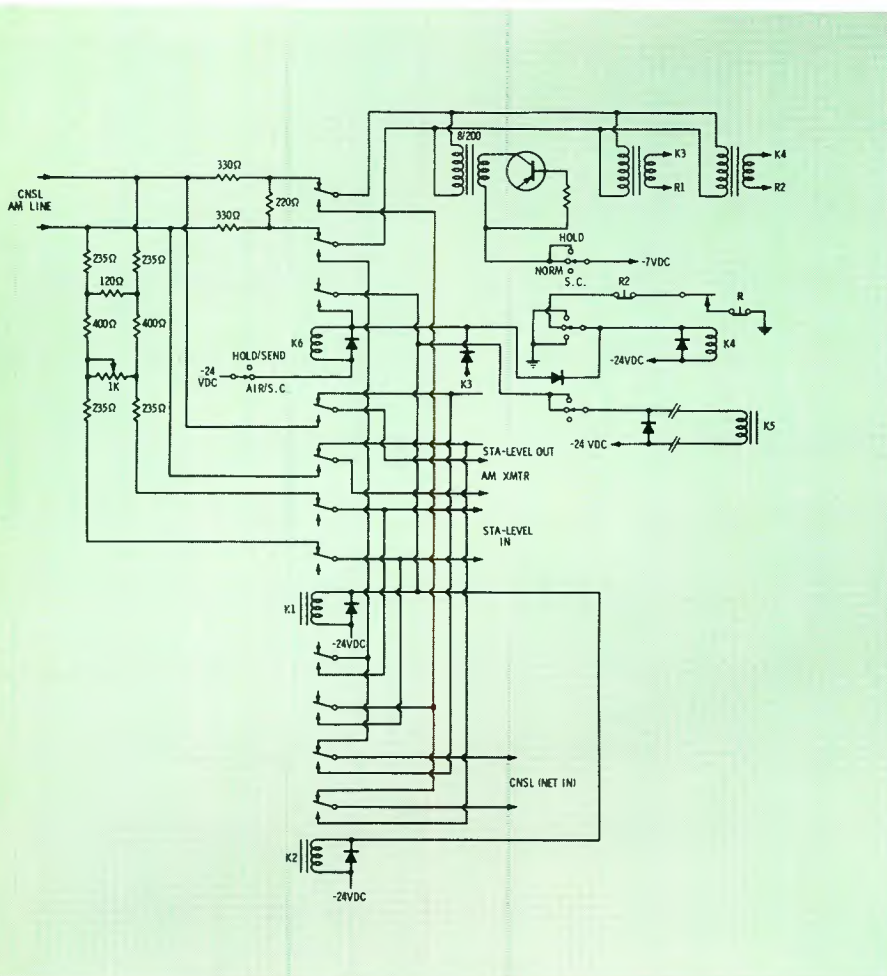

Fig. 5 Updated wiring of the auto-patch.

on since the installation of new system.

This new system was the result or culmination of developments in the old system which rather evolved over an eighteen month period of changes and improvements. The old system was a tube prototype and had two relays including the present K5. It used a low pass filter to reduce sideband splatter (or rather, eliminate sideband splatter) on the main carrier. I didn't have that problem with the new system. The only real changes were the changes to the transistorized mike booster amp, Stancor transformers instead of repeat coils, and automatic changeover to the AGC amplifier.

With the prototype, we would patch the AGC amp physically into the phone system at the start of the talk show where it would stay for the entire program. The basic key control system described in Part I of this article was used in every version of the Auto-Patch without modification. During the evolution days, many times we went back to the original system due to birdies that kept creeping in, particularly on rainy days (or at least it seemed that way).

I did have some discussion with the phone company when a couple of telco engineers came out to visit

with me about my system, received a copy of the schematic, and left saying that they would get back to me in a couple days. That was two years ago.

If I was to start to build a patch tomorrow with the knowledge I have now, I believe the result would be the same. The conference facility did not pay off in the talk show, but it did pay off in the sports-casting department. The moderators like the conference facility, but would rather have the guest in the studios for control of the program. The facility had been requested by a moderator which isn't with us but the feature was discussed with the present staff before construction started on the present system. We do not use any equalization on the phone lines since it would change the announcers voice — which now remains consistent with the present system.

Meanwhile we will be improving my mini-mation system and the particulars on that will be appearing in another issue of BE.

**SEND YOUR
LETTERS TO THE EDITOR
to
Broadcast Engineering
1014 Wyandotte
Kansas City, Mo. 64105**



The KATN auto-patch on the board for easy access.

precise timing for precision programming at very low cost...



the quartzmatic clock by WESTCLOX

- ▶ Precision accuracy of plus or minus only 1 minute in 525,600 minutes (1 year) . . . that's reliability.
- ▶ Perfect for radio and TV stations, recording studios, news bureaus, ham radio operators, weather stations.
- ▶ Completely portable, move it anywhere . . . accuracy unimpaired.
- ▶ Easy to read at a glance, large 12" diameter face with 1 1/2" numbers, red sweep second hand.

and only \$55⁰⁰

- ▶ Powered by two "C" size batteries, over 1 full year battery life.
- ▶ Choice of colors — white or tan face with charcoal numbers, both have woodhue case.
- ▶ One year Factory Guarantee from Westclox, a division of General Time, the world's foremost maker of precision clocks and watches.

For precise timing, order the latest advance in timekeeping technology, the WESTCLOX QUARTZMATIC CLOCK . . . only \$55.00

Send check or money order and we'll pay shipping charges. Please include all applicable taxes. If preferred, we'll send C.O.D. Please indicate color; white or tan. Batteries not included. Allow two weeks for delivery.

ORDER FROM: GENERAL TIME SERVICE
NEW YORK 150 E. 47th St., N.Y. 10017
CHICAGO 206 N. Michigan Ave., Ill. 60601
LOS ANGELES 5404 Wilshire Blvd., Cal. 90036
SAN FRANCISCO 540 Mission St., Cal. 94105
DALLAS 400 S. Ervay St., Tex. 75201

Quartzmatic movements available separately, write for details.

 **GENERAL TIME SERVICE**
A TALLEY INDUSTRIES COMPANY

Circle Number 14 on Reader Reply Card

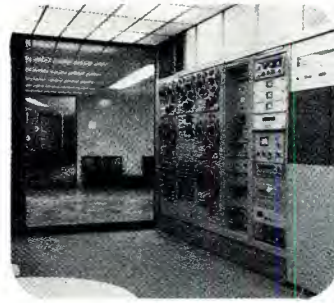
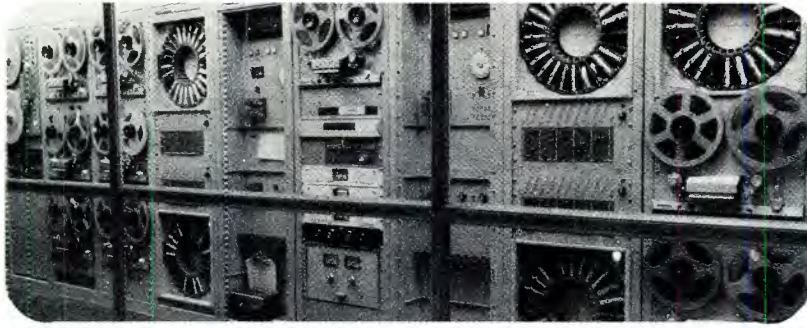

Photos of Radio Comerciales S.A., Guadalajara, Jal., Mexico

How to get your share of the Latin American broadcast market.

Right now, there are close to 6,000 radio and television stations in Spanish-speaking areas of the world. Competition among stations is keen. To remain competitive - and keep pace with Latin America's rapidly growing economy - their equipment must be kept in top condition. Clearly, a substantial market exists for all kinds of broadcast equipment and components. New and used.

One publication — RADIO y TELEVISION — serves this vast purchasing potential. It provides saturation coverage among buyers and those who influence purchasing at broadcast facilities throughout Latin America and Spain. Owners, managers, engineers and technicians at commercial and educational radio and TV stations, recording studios, electronic equipment manufacturers and related businesses.

As the Spanish-language counterpart of Broadcast Engineering, RADIO y TELEVISION delivers technically-oriented editorial aimed at helping readers to select, operate and maintain equipment and components for maximum **signal quality**. This unique content provides the precise environment that induces buyer receptivity. It enables advertisers to "sell the broadcaster when his mind is on signal quality."

There's a lot more to the story. And we'd be happy to give you more information about this unique medium and the dynamic market it serves. Just circle the Reader Service number or write directly to:



Radio y Televisión

The technical journal of the Latin American broadcasting industry.

1014 WYANDOTTE STREET



KANSAS CITY, MISSOURI 64105

will inhibit FF2 from any further influence from its clock input. This zero output from FF2 appears at the AND Gate input and inhibits it from passing pulse train B.

The count continues inhibited until the 4th output of the decade counter goes low and is inverted to a high through NOR Gate 2, then into OR Gate 1, and again a high appears at the AND Gate enabling it to pass pulse train B. Only two will get through to the relay as pulse train C will step the decade counter along to the next count, reversing the process and inhibiting the AND Gate.

Pulse train B is no longer used through the gates, but continues to operate FF1, which keeps the decade counter counting. When the decade counter output 7 drops to low it is translated to a high by NOR Gate 3. This high goes through OR Gate 2 and closes the output relay for one second until the count goes on to 8 and opens the relay.

At this point the tones are finished, but pulse train C continues to run the decade counter until the count of ten goes low. This low appears at an input of OR Gate 3, which is already seeing a low at its other input from OR Gate 1. (Pulse train H.)

OR Gate 3 reacts to two low inputs by applying a low to the J and K inputs of FF1, inhibiting this flip flop from following its clock input.

This is the end of the entire program and the clock remains free running through the only open gate (NOR Gate 1), but these pulses are being ignored by a closed AND Gate, and an inhibited FF1.

The system is re-set, ready for another push of the start button.

Construction Briefs

This unit is a pre-programmed, self-synchronizing device which will apply seven precisely spaced cue tones on video tape with one push of the start button, then reset

itself to zero.

Each clock pulse will be .258 seconds in width so the entire time of coding will be 8 seconds.

Flip flops and counters used here are all triggered by the negative excursion of the counting pulse.

A PNP germanium transistor and a tunnel diode furnish square wave pulses .258 seconds wide. These trigger a buffer transistor used to isolate the clock from the load. The 1 K pot is a frequency control for the clock.

Pulse trains are depicted on a relative time basis and designated by a letter of the alphabet in the order of their generation on the logic diagram.

NOR gates are used as inverters wherever necessary to match the logic to the gates.

Jumper wires were used in lieu of a double sided PC board. Our board plugs into an Elco Jack and the 250 mfd. capacitor is wired to the jack.

The rather unusual start circuit serves the functions of instantly synchronizing the clock and clearing the flip flops.

Shielded pairs are needed from the power supply and the VTR machine to the counter. Until the shields were grounded the counter made a number of ad lib contributions when transients caused it to start.

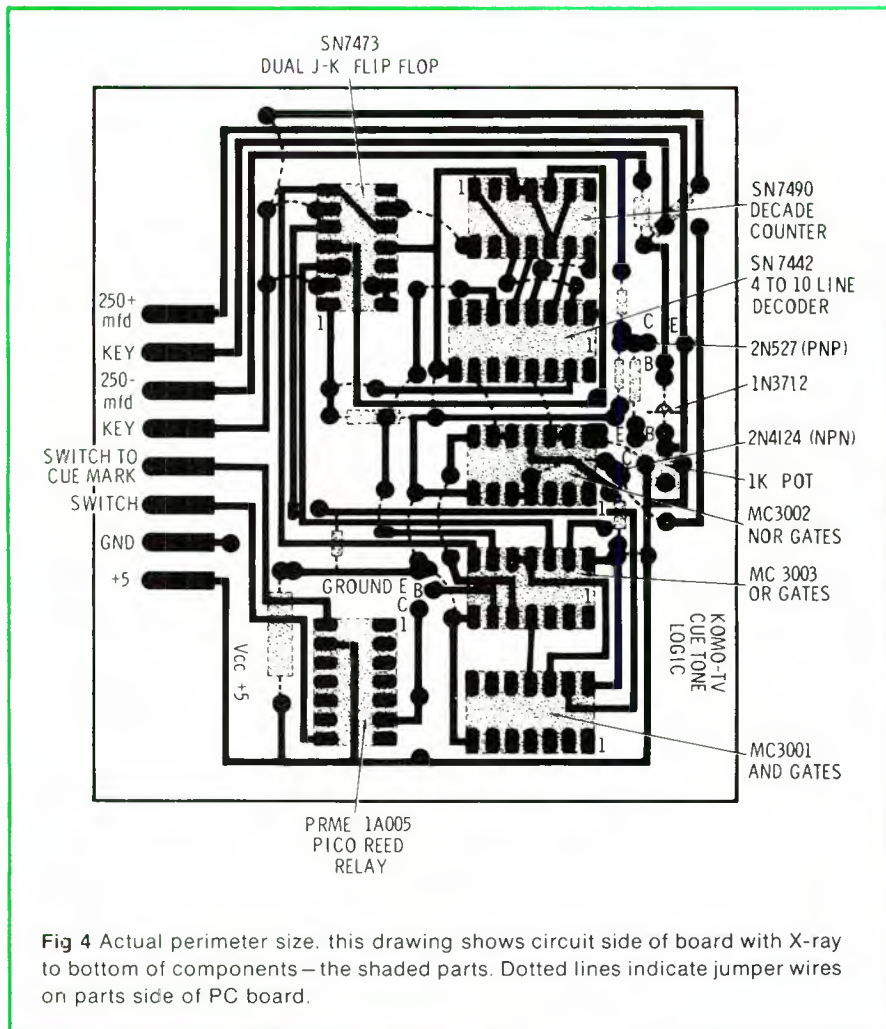

Fig 4 Actual perimeter size. this drawing shows circuit side of board with X-ray to bottom of components – the shaded parts. Dotted lines indicate jumper wires on parts side of PC board.

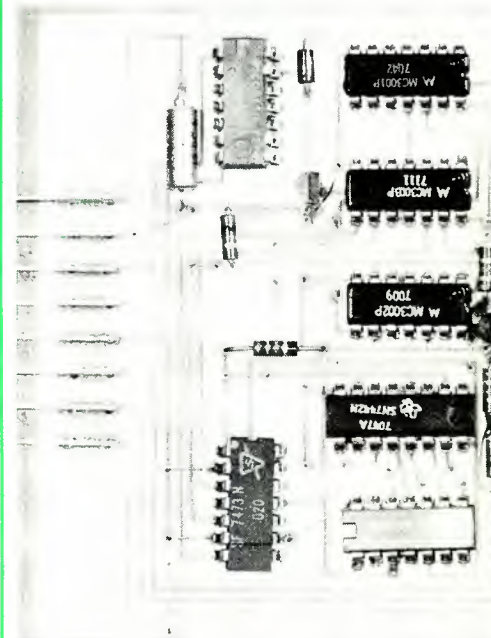
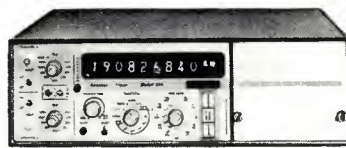

Fig. 5 Photo showing finished unit, a credit to the engineering staff of KOMO.

COUNTERS... TIMERS... PRINTERS... PULSE GENERATORS!

MEASURE FREQUENCIES FROM MEGAHERTZ TO GIGAHERTZ...RESOLVE NANOSECOND TIME INTERVALS...COUNT, TOTALIZE, AND CONTROL...AND READ IT OUT OR PRINT IT OUT.



Model 901 ~~\$2475.00~~ \$1249.00
Model 904 ~~\$1975.00~~ \$899.00

UNIVERSAL COUNTER-TIMERS

The Model 901 is a state-of-the-art instrument. It is the industry's first, true, 200-MHz, universal counter-timer capable of achieving its range without prescaling, heterodyning, or using plug-ins... while also offering as part of its main-frame capability the measurement of frequency, period, multiple period average, time interval, ratio, multiple ratio averaging, totalizing, scaling, and the measurement of time interval from an external standard... plus a heterodyning capability for gigahertz operation.

The readout has nine decades with automatically positioned decimal point, large readout tube with units symbols, and an overflow lamp. Printer output in the form of BCD in the 1-2-4-8 code is a standard feature. Remote programming of the entire front panel controls, except trigger levels and attenuators, is an optional feature. Time Interval mode offers resolution to 10 nanoseconds. Gate output, useful in determination of the amplifier trigger points in the Time Interval mode, is a standard feature of the 901.

The 200-MHz Model 904 is identical to the Model 901 except that it offers an eight-digit readout instead of nine, and BCD output is not provided.



Model 616
~~\$1975.00~~
\$649.00

Model 616 provides low-cost direct frequency measurement from 10 Hz to 225 MHz by means of a unique prescaler built into the instrument. It can be rack-mounted. All-silicon semiconductor circuitry assures dependable operation over wide temperature ranges. 1 MHz crystal time base; stability ± 2 parts in 10^7 per month. Seven decade in-line display is standard -- eighth decade optional. Standard automatic decimal and display storage.

Model 631 ~~\$775.00~~ \$395.00

Model 631, turret-type, positive switching 100 MHz to 1.3 GHz Heterodyne Converter.

Model 633 ~~\$300.00~~ \$89.00

Model 633, 1 μ sec resolution Time Interval Plug-in with range from 1 μ sec to 10 sec.

Model 635 ~~\$825.00~~ \$695.00

Model 635, continuous tuning, 200 MHz to 3.3 GHz Heterodyne Converter.

VARIABLE TIME-BASE COUNTER

Model 614 ~~\$1300.00~~ \$595.00

50%* DISCOUNT

*The total sale inventory has been discounted an average of more than 50% off regular price.

ON BRAND NEW INSTRUMENTS!

TAKE ADVANTAGE OF THE GREATEST INSTRUMENT SALE OF THE YEAR! BUT HURRY! THE SALE ENDS WHEN THE EXCESS INVENTORY IS GONE. GET YOURS NOW WHILE THERE ARE STILL SOME LEFT!

MAIL THIS COUPON NOW — OR CALL US COLLECT: (213) 341-0800!

901/904 FREQUENCY EXTENDER PLUG-INS



Model 931
~~\$825.00~~ \$645.00

Turret type, positive switching 100 MHz to 1.3 GHz Heterodyne Converter. Sensitivity is 50 mV across its entire range.



Model 933
~~\$325.00~~ \$149.00

Video Amplifier increases gain of Model 901 and 904 thirty times.



Model 415
~~\$1650.00~~
\$749.00
11 columns

LOW-COST, DATA LOGGING PRINTER FEATURES IC DESIGN AND SUPERB MECHANISM

The new Model 415 Digital Printer employs IC design and utilizes IC sockets for accurate reliable performance and easy maintenance.



Model B-7B ~~\$675.00~~ \$449.00
HIGH-AMPLITUDE PULSE GENERATOR

B-7B is a general purpose instrument with repetition rate to 2 MHz and 50V into 50 ohms. Variable rise/fall time control.

PORTABLE PULSE GENERATORS

Model B-14 ~~\$475.00~~ \$249.00

Model B-15 ~~\$525.00~~ \$299.00

Model B-14 is a low-cost, portable unit with repetition rate of 20 Hz to 2 MHz. Delay is 0 to 10 msec. Amplitude is 15V into 1K, 8V into 50 ohms. Variable pulse width. Rise and fall time is less than 10 nsec fixed. B-15 has a repetition rate of 5 Hz to 5 MHz.

CHECK THESE QUANTITY DISCOUNTS AND PACKAGE DEALS!

If you are buying more than one instrument, you may choose between a quantity discount schedule or combination package deals. Any 2 instruments — 5%; 3 to 5 — 7%; 6 to 10 — 10%. And if you purchase a combination package of many of the compatibles on sale, you will earn even better discounts. Example: 904 on sale for \$899, 931 on sale for \$645. Buy them as a package for only \$1419. Ask for details.

DYNASCIENCES

9601 CANOGA AVE., CHATSWORTH, CALIF. 91311

TELEPHONE: (213) 341-0800 • TWX 910-494-1951 • TELEX 67-3382

- Okay, I know a bargain when I see one. Deliver (Model(s)) _____ to me ASAP.
 My Check # _____ is enclosed.
 My P.O. # _____ enclosed will follow.
- I'm from Missouri. Please reserve (Model(s)) _____ for me at the sale price for 15 days to give me time to check the data sheets you're going to send me before I buy.

ORDER COUPON

Name _____ Title _____
Company Name _____
Address _____
City _____ State _____ Zip _____

I understand that there is a full 90-day warranty on all instruments.

Circle Number 16 on Reader Reply Card

“They’ve Cleaned Us Out” Burglars Visit KSST

By David Walvoord
Commerce, Texas

At 12:45 a.m., January 8, radio station KSST in Sulphur Springs, Texas, ended its broadcast day. When the morning DJ arrived at the station shortly before 4:30 the next day, he discovered that thieves had removed the station’s main transmitter, the console which controls all the station’s operations, its power supply, cable TV cameras, a video tape recorder, microphones and typewriters.

The station’s general manager and engineer, W. E. (Bill) Bradford, was notified immediately and work was begun to get the station back on the air.

The transmitter was removed during the early morning hours to the rear of the station where two pick-up trucks and a rented trailer had been parked.

There the burglars good luck ended and their bad luck started. The trucks and trailer became bogged down in the station’s water-logged yard. Faced with this obstacle, the thieves abandoned the project and equipment.

“My initial reaction was forget the main control room,” Bradford recalled, “It would have been impossible to re-cable that in anything like a reasonable length of time.

“The first priority, we thought, was that we had to get something going. Fortunately, we have been programming Channel 2 on the cable system which covers about 90 per cent of the homes in the city.”

Bradford, who installed most of the equipment in the station when it was moved to its present location five years ago, grabbed a soldering iron and a roll of shielded cable and ran a line from the console in the booth where newscasts are made and hooked it into a transformer that feeds the audio on Channel 2.

The station was broadcasting on

the cable one hour after the burglary was discovered.

Later, the programming operation was moved upstairs to the cable television studio. That studio did not have a turntable, so a stereo unit received as a Christmas present by Bradford’s 13-year-old daughter was pressed into operation. Later in the morning, the one untouched camera in the studio was turned on so that cable viewers could also see the DJ, farm editor and basketball coach giving their regular Saturday morning shows.

Bradford next moved to restore

the main transmitter to operation.

“I knew that the RCA transmitter contains some massive inductor transformers that are not bolted down but are placed in position,” he noted. “These were bound to have shifted when the transmitter was turned on its side.”

When Bradford inspected the transmitter in the trailer, he found that one of the cables had been pulled loose and the transformers were in a heap.

He used some numbered adhesive labels and disconnected the transformers. Each wire was num-

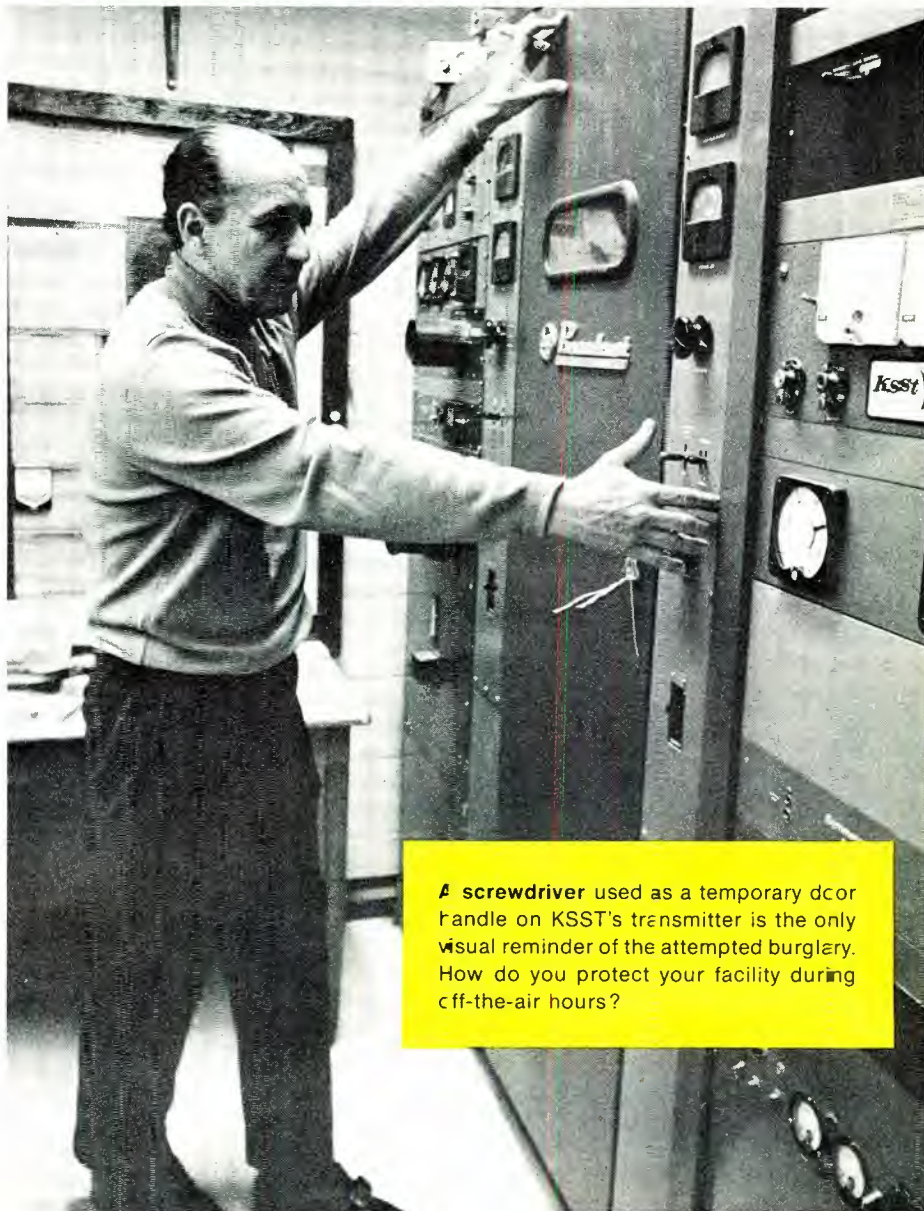

A screwdriver used as a temporary door handle on KSST’s transmitter is the only visual reminder of the attempted burglary. How do you protect your facility during off-the-air hours?

bered to make the re-installation easier. With the transformers removed, five people carefully moved the transmitter back into the station.

The re-installation began with only necessary circuits being reconnected. "We reconnected frequency and modulation monitor because this was important," Bradford recalls, "We made no effort to reconnect the trapezoid scope lead, either RF or modulation transformer audio, because it's a luxury item."

By 1:30 p.m., the transmitter was back in operation.

"We were extremely lucky that none of the transformers that were dislodged punctured windings on other transformers. It could have made hash out of some of the other interior components," Bradford said. The only damage to the transmitter was the cabinet door handle which was knocked off during the burglary.

Once the transmitter was back in operation, programming moved to the EBS center which normally is

used for production.

At first Bradford estimated that it would take a month to put everything back into working order, but he was able to complete the job in two weeks.

Bradford is quick to admit that he does not know what the answer to station security is. "Many radio stations have experienced the loss of tape recorders and microphones in a quick burglary," Bradford recalled. "I know of no one who has lost their main transmitter."

Bradford does not know where the well equipped burglars were taking the transmitter, but he speculates that "there is a possibility that it could have been taken to a foreign country." The thieves took only commercially built equipment. They avoided equipment built by Bradford.

The door of the station was not damaged in the burglary. Officers theorized that the thieves may have had a key. Bradford said that the locks on the station had not been

changed since it was built five years ago and during that time any number of people have had keys. He plans to install bar type latches on the back and side doors of the station and use only the front door at night. He worries, however, that if thieves return they may break the plate glass window to enter.

Before Saturday ended, police in the East Texas dairy community had arrested one man and issued warrants for two more.

As for Bradford, he hopes he won't get another early morning call with the voice on the other end of the line saying, "They've cleaned us out."

Editor's Note:

We've had other reports of thieves breaking in and vandals destroying station property or equipment. We'd like to hear from BE readers on how these losses can be avoided. Send your comments to: The Editor, Broadcast Engineering, 1014 Wyandotte, Kansas City, Mo. 64105.

Broadcast-quality CATV pictures

Easy to Achieve with
DYN AIR Solid-State Equipment



RX-4B DYNA-TUNE

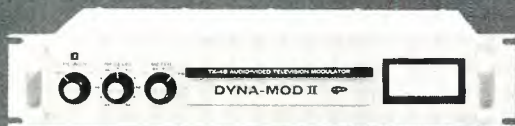

TX-4B DYNA-MOD II



TS-100B SIDEBAND ANALYZER

Look to DYN AIR's field-proven, solid-state equipment to solve CATV head-end problems and assure broadcast-quality pictures. From the company with years of experience in TV transmission equipment and CATV head-end systems, here are three tried-and-proven units to guarantee that every picture you supply will be truly first-class . . . truly broadcast-quality.

HIGH-FIDELITY OFF-AIR COLOR—RX-4B DYNA-TUNE uses completely new filtering and signal-restoration concepts to provide superior adjacent-channel color performance in either microwave-fed or demod-mod systems. Actually improves the color signal in many critical areas over that produced by the broadcast RF transmission system.

BROADCAST-QUALITY TRANSMISSION—TX-4B DYNA-MOD II supplies signals approximating FCC specifications. Provides interference-free pictures in a full 12-channel system—with clean, crisp color. Available for operation on any standard VHF channel.

BROADCAST-PRECISION TESTING—TS-100B Sideband Analyzer quickly checks overall alignment of video amplifiers, modulated stage and RF amplifiers of modulators—in normal operation—without even removing covers! Provides the same test techniques used by broadcasters and eliminates tedious point-to-point checking. Tunes to all channels for system flexibility.

The EXPERIENCED manufacturer of solid-state head-end equipment

DYN AIR

6360 FEDERAL BLVD., SAN DIEGO, CALIF. 92114, PHONE (714) 582-9211

Circle Number 17 on Reader Reply Card

WREK And WGKA
Work Out Quad Sound

WREK and WGKA-FM have broadcast the first discrete quadrophonic sound in the Atlanta area. This was after many months of searching for an adequate source of discrete quad material. With only a few exceptions, the large majority of the programming came from the RCA quad eight track cartridges.

The cartridges were dubbed using the Toyo four-channel eight track cart player and a Scully 280 four-channel 1/4-inch tape recorder. The original quad library, consisting of about eighteen hours of discrete quad material, was stored on 14" reels until the programs were prepared.

Each three-hour program was put together from the library of tapes by splicing the various selections together onto a 14" reel for airing. For the actual broadcast, the Scully was used to play the music, while a Teac TCA40 four-channel recorder was used to play the announcements. Four announcers were used, two from each station. The voice tracks were cut in advance and then spliced together along with the music beds for the spots onto a 7 inch reel for playback on the Teac. Voice tracks for the spots were played from cartridge over the front channels (WGKA-FM) only, since WREK is a non-commercial station.

An Ampex mixer was used for the front channels. This was used to feed a line amp which then fed the phone lines to WGKA-FM. All four channels of programming originated from WREK's studios. Both stations had four-channel studio monitoring facilities.

The material that was not from the eight track cartridges consisted mainly of four-channel pre-recorded open reel tapes (primarily Project III) and studio dubs (such as *Gandharva* from Orban Studios, Menlo Park, Calif.). An electronic piece by Dick Robinson of the Atlanta Symphony was also included. The facilities for dubbing the half-inch tape to quarter-inch tape were provided by Bob Richardson of Mastersound Studios in Atlanta.

DISCOVER *the* SUPERIOR
ALL SOLID STATE
AM FREQUENCY MONITOR

Naturally **FROM WILKINSON!**



MODEL TAMF-1A
FCC No. 158

- ★ Triac Controlled Crystal Oven
- ★ Instantaneous Operat on — No Warm-up Time
- ★ Requires only 5¼ inches of Rack Space
- ★ I. C. Regulated Solid State Power Supply
- ★ Self Testing from Front Panel

For complete details write:

WILKINSON
ELECTRONICS, INC.

1937 MacDADE BLVD.
WOODLYN, PA. 19094
PHONE (215) 874-5236 874-5237

DISCOVER *the* SUPERIOR
ALL SOLID STATE
AM MODULATION MONITOR

Naturally **FROM WILKINSON!**



MODEL TAMM-1A

- FCC Type Approval No. 156
- Wideband 500 KHz to 26.1 MHz
- Uses Latest IC Innovations
- New as Tommorrow . . . Reliable as Forever

For complete details write:

WILKINSON
ELECTRONICS, INC.

1937 MacDADE BLVD.
WOODLYN, PA. 19094
PHONE (215) 874-5236 874-5237

Circle Number 90 on Reader Reply Card

Audio tape recorder maintenance review

By Pat Finnegan*

The tape recorder is one of the most basic equipment items in any broadcast station today. And unfortunately to say, when the tape equipment is inoperative, a severe bottleneck is placed in the normal daily operations. Thus, it is important that these machines be kept in top operating condition at all times.

There are many electro-mechanical functions in a recorder and these can cause many problems during operation. The most critical section of any recorder, however, is the tape-head function. All the other functions of the recorder are supporting functions to the tape-head function. Many problems occur in the tape-head section which are not always recognized as such, but are often blamed on other sections of the recorder. This area may deteriorate and go unnoticed for some time because such deteriorations are usually not abrupt—for example, response fall-off. This article will concentrate on this most critical area in both cartridge and reel-to-reel recorders.

Maintenance

Head alignment is most important if tapes are to be
*BE Maintenance Editor

compatible on all station machines, and if output levels and response are to be maintained. The face of the head and the tape must be aligned in proper relationship with each other, so there are at least five requirements that must be met for good alignment. These alignment positions are shown in Figure 4A, B, C, D, E. All these alignment requirements may not be totally accurate and the results still may be passable, but the more accurate the settings, the greater the consistency of quality.

Head alignment is always necessary when a head has been replaced. How easy or difficult the job will be depends much on the particular recorder and the mechanical arrangement of the machine. Whenever possible, take the machine to the workbench to make the change and alignment tests.

Before a head replacement, make a note of all the pertinent physical positions. That is, the markings on the head (top or bottom), its protrusions in front of the clamps, the guides positions, etc. Make as little change in all these things as possible. Do only that which is necessary to physically replace the head. When treated this way, you'll find that alignment of the new head may only take a minimum of adjustment

Reviewing the basics

Since the recording medium is tape, a brief review of tape is in order. Audio tape is constructed of a plastic base material, coated on one side with a fine iron oxide. There are several base materials which may be acetate, mylar, or polyester. A bonder holds the iron oxide to the plastic base, and a silicone lubricant is worked into the tape to prevent mechanical squeeks as the tape is pulled across the head.

The grade of iron oxide, its evenness in distribution along the tape, and its even density will directly affect the quality of the reproduced program material and output levels. The oxide should be smooth, without either lumps or pits, and the density along the tape should be even. The binder should hold all the iron particles to the base so that they do not flake off, leaving holes or pits in the coating.

Any of the better quality tapes have these characteristics well controlled during manufacture. Lesser grade tapes may not do so well in these areas. Buying the lesser quality tape may cost less initially, but it is

a poor bargain for broadcast stations.

Along with the standard tape, there is a special lubricated tape which is used in tape cartridges. This tape has a special graphite base lubricant applied to the side of the tape base material opposite the iron oxide. Standard tapes will not give satisfactory results nor hold up in tape cartridges.

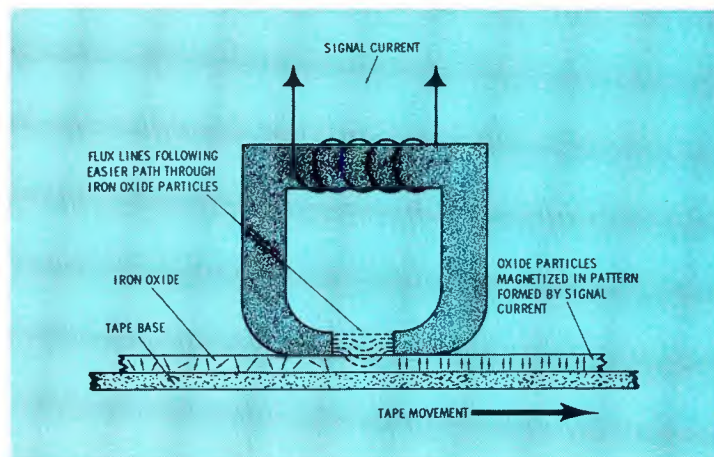

to prevent stretching by fast winding and sudden stops. Once the playback head of the machine is properly aligned, the playback will serve as the standard for the record section and head.

Head Adjustment

Single tones are applied to the amplifier input while adjusting the Record head. You must be certain to get the alignment tape off the machine or it will be ruined if the machine is turned into record mode. Another caution is the level of the input signal to the recorder. These should be set at least 10 dB below standard program recording level, and 15 dB if noise is low. This must be done because the equalizer boosts the high audio frequencies into the head. The boost could saturate the tape so that the output readings would appear as a flat response. That may be far from the truth.

The reference level should be a lower frequency, in the range of 200 Hz to 1 kHz. To be consistent, align the Record head using the same frequencies as were on the standard alignment tape. Less confusion will result when this is done.

High input levels on tone can cause another condition that may give false results. These high levels can "ring" the equalizers, giving rise to spurious frequencies from the equalizers. The output meter may be indicating the level of these tones rather than the fundamental tone.

Cartridge Head Alignment

Head alignment in cartridge machines must consider cartridge alignment at the same time. This is so because the tape, guides, and pressure pads are in the cartridge itself. In cartridge alignment, check these areas: 1. The pads should press the tape directly against the head; 2. The tape should fall easily and

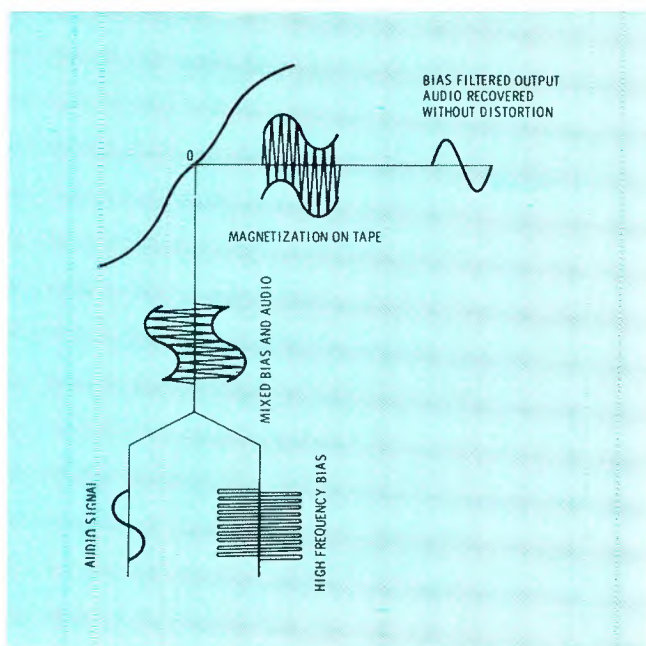

High frequency bias (about 75 kHz and several times the amplitude of the signal) is mixed with the audio signal. On playback, the bias is filtered out, leaving an undistorted audio signal. The bias has the effect of "lifting" the audio into the linear region.

to bring it into full alignment. Some manufacturers have gauges and plates to assist in correct positioning. This is particularly true of cartridge equipment. These gauges can put the head almost in correct position. There is always a need for final "tweaking" to bring the head into full alignment.

The Playback head should always be aligned first while playing a standard alignment tape that conforms to NAB standards. (There is a standard NAB cartridge alignment tape available, also.) These standard tapes should be carefully preserved and handled. Try

The signal current flowing through the head and iron oxide on the tape will be distorted near the zero current line. This is caused by residual magnetism in the tape and head and the reluctance of an inductive circuit to change directions rapidly.

Simplified view of the action of the tape head on the tape. The flux lines will take the easier path through iron oxide, magnetizing the oxide into a pattern following the signal current.

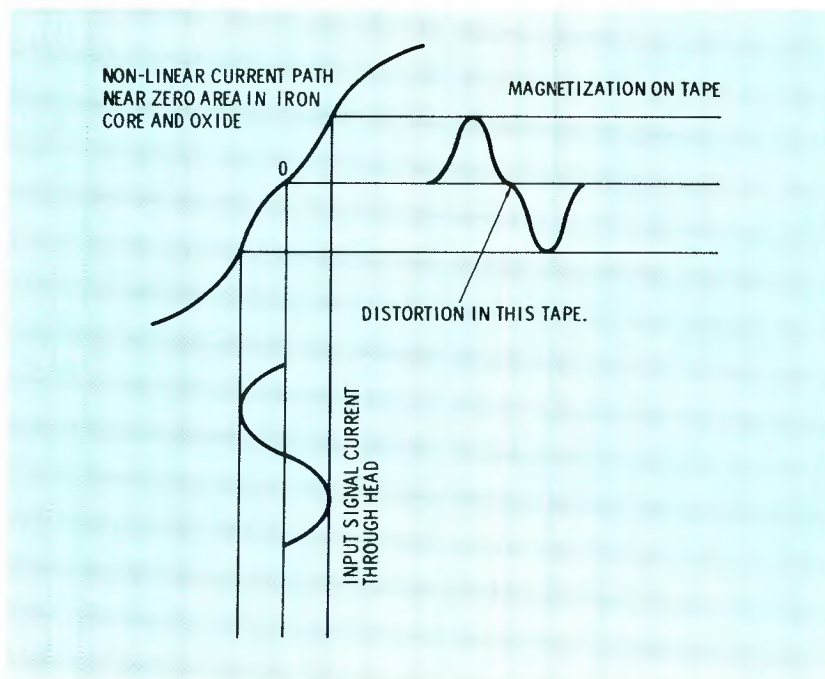

MULTRONICS®

Your No. 1 source for Antenna Systems & Components

CUSTOM-DESIGNED PHASOR SYSTEMS

Full phasing systems, couplers and AC control circuits are custom designed to meet your exact station requirements. We can also offer full financing if required. For any phasing needs, Multronics will be pleased to quote the optimum system required for your pattern.

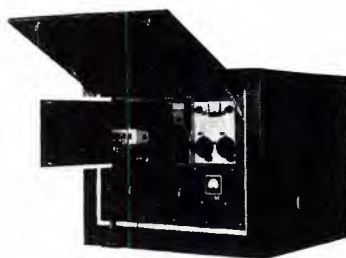
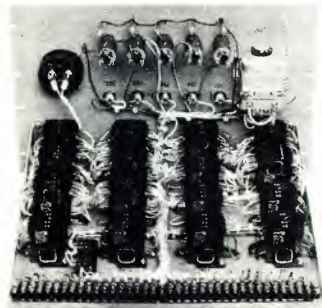

HI-Q RF INDUCTORS Our RF Inductors provide unmatched stability for systems requiring impedance matching, phase shifting, power dividing and filtering. Typical inductors range from 15 to 100 ampere current handling capability, inductance values from 6 to 620 microhenries, and special units built to meet specific requirements. Our expansive line of MULTIFILAR RF inductors provide higher inductance and current handling capacities in minimum size configurations. All are suited for motor-driven applications in remote-controlled systems.

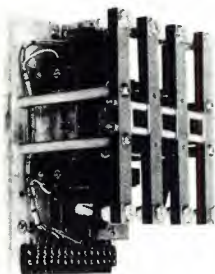

RF CONTACTORS A wide choice of rugged, recoil- and corona-free multi-pole contactors are available for high voltage RF switching. All feature strong Melamine construction for extra ruggedness and ease-of-maintenance. Ideally suited for RF applications in the VLF, LF, MF and HF ranges, they are rated from 208 to 240 VAC capability (24KV and 40KV models available).

In addition to: Folded Unipole Kits Meter Switch Assemblies Phase Sampling Loops J-Plugs (test jacks) Plug-in Meter Boards Isolation Inductors Limit Switch Assemblies for controlling motor-driven variable inductors and vacuum capacitors.

For complete information, please write or call:

MULTRONICS® INC.

12307 Washington Avenue • Rockville, Maryland 20852
Phone: (301) 881-5774

Circle Number 18 on Reader Reply Card

Tape recorder maintenance (continued)

directly into any guides that may be on the head assembly; 3. The cartridge should allow the tape to be pressed deep enough by the head, so check any depth adjustment if available; 4. The "keyhole" in the base of the cartridge should allow the shaft of the pinch roller to pop through without pulling the cartridge to one side or rubbing to prevent the pinch roller going its full swing; 5. The front lip of the cartridge base should not touch the capstan motor shaft; 6. The side guides should be set so that they permit the cartridge to make this entry directly into the head assembly. All of these conditions can be seen by careful observation, and adjustments made accordingly.

Back To The Bench

It is more convenient to take a machine to the workbench for head alignment. It is convenient from the standpoint of the operating position and programming going on around the maintenance. But it can be very inconvenient on the workbench if you use a "haywire" setup. In order that the workbench location can be truly convenient, make up input and out cables with the appropriate connectors to quickly connect the machine to test equipment. These cables should be preserved as maintenance items for the next time the machine is on the bench.

Proper terminations are necessary once the equipment is away from its normal input and output circuits of the system. Thus, the test cables which have been made up can include provision for attaching proper terminating resistors. Ingenuity will come up with a setup that suits your particular equipment. One thing to consider is a quick disconnect type arrangement.

Worn Heads

The iron oxide on the tape is very abrasive and will

The basics (continued)

Tape is available in three thicknesses, 0.5 mil, 1 mil, and 1.5 mil, for audio machines. The thickness of the base material is generally reduced to produce these thicknesses, and the quality of the program on any of them will be about the same. The length of time a given reel of tape will play is affected, since more footage of the thinner tape can be wound onto a given reel, but the thinner tapes require more delicate handling both by the operator and by the machine.

The Head

The head is the most important part of the recorder. It is nothing more than a specially designed, properly shielded electromagnet. A coil of wire is wound on a magnetic core, so shaped that the pole pieces are separated from each other by a very fine gap. The signal current flows through the coil, producing magnetic lines of flux that are basically confined to the iron core. These lines of flux are continuous loops and will cross the gap between the pole pieces even though the gap provides a greater resistance to their movement. These flux lines will follow the signal cur-

wear down the head. After much usage, a groove or rut will be worn in the head. These create ridges at the edge of the groove. Tape may sometimes fall so that its edge is riding on top of the ridge and out of contact with the pole pieces of the head. The result is a pressure problem and the output from that side of the tape can be low or non-existent. On a full-track machine, this may not show up as a serious problem, but in a multi-track head, it can produce many problems. For example, in a two track stereo plus cue track, the cue track is at the bottom edge of the tape. If this edge is riding on top of the groove and has very low output, the events that make use of the cue tones are in trouble. This can cause an automation system to "go wild" or grind to a halt.

Aside from the erratic behavior of output signals, a worn head can be detected by observing the head and shining a light across it at an angle. Another method: Run your fingernail lightly over the face of the head. If there is a groove, you can feel it. When a head is this bad, replace it as soon as possible.

Head wear may include a widening of the gap between the pole pieces. This will cause the high frequency response to drop off. What's more, loose oxide from the tape may fill the gap until the head becomes "clogged." This oxide will provide a short circuit away from the tape for the flux lines and the output will drop.

Worn Or Weak Pressure Pads

A steady pressure of the tape against the head is required and the pads are supposed to do this. If they are bent or the springs weak, they will hold the tape at varying distances from the head and problems result. If weak so that they are not doing their job at all, the tape may vibrate intermittently against the head and

rent in the coil both in direction and in intensity.

The audio tape with its iron oxide side held tightly across the pole pieces of the head, is pulled along at a constant speed. The iron oxide on the tape bridges the gap between the pole pieces, and this iron will have less resistance than the air in the gap. Consequently, the flux lines will flow through the iron on the tape, and will magnetize these iron particles in a pattern that conforms with the direction and strength of the flux at any given instant. Thus, the iron particles on the tape are magnetized in a pattern that is a replica of the signal current flowing in the head. The pattern will be laid down upon the tape in a track as the tape is pulled along.

For a given input signal level, low frequencies will magnetize particles more deeply in the tape than will high frequencies. Also, increasing or decreasing the signal level to the head will cause the flux to increase or decrease. This will cause greater or lesser penetration of the flux into the tape. All these factors will affect the level of playback, because the greater the penetration of the flux the stronger will be magnetization of the iron particles.

LOW COST DIGITAL CLOCKS, TIMERS AND COUNTERS

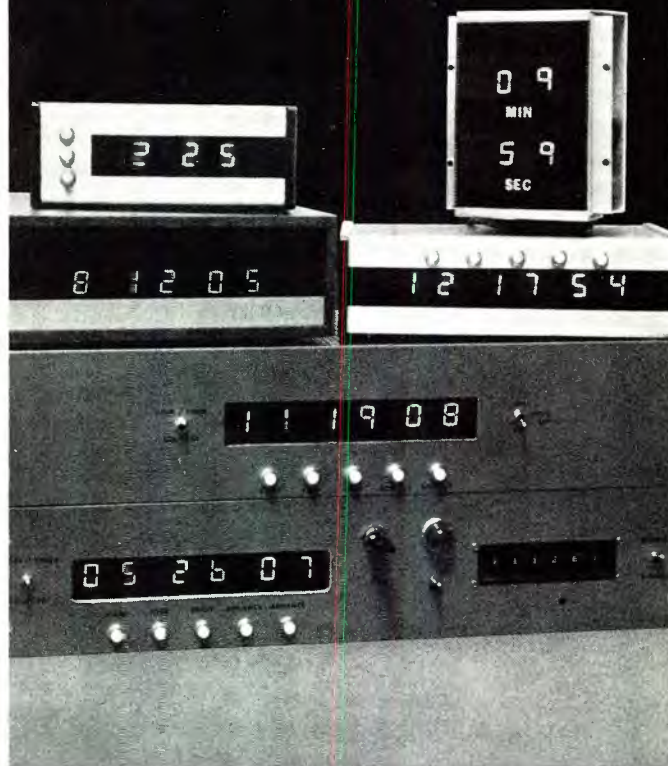

All ESE digitals are designed and constructed using the latest solid state electronic components and circuitry. This equipment is perhaps the most economical line of digital clocks, timers and counters available. Circuit efficiency and lasting quality are designed into every ESE digital product. Constructed with the built-in ruggedness necessary for studio use. No moving parts.

Special custom items, like the video tape/counter editor, a monitoring system with unique display configuration, 12 and 24 hour clocks or timers, 10 minute timers, 3 digit, 4 digit, 6 digit, record seconds in tenths, hundredths or thousandths... Even a station ID reminder, all available from ESE. Options include: Thumbwheel switch programming, BCD outputs, relay closure outputs, and solid state buffered outputs. Many ESE products are also available in kit form.

WRITE, WIRE OR CALL TODAY FOR DETAILS:

DEPT. 572

ESE ENTERPRISES

506 MAIN ST. • EL SEGUNDO, CA. 90245 / (213) 772-6176
Circle Number 19 on Reader Reply Card

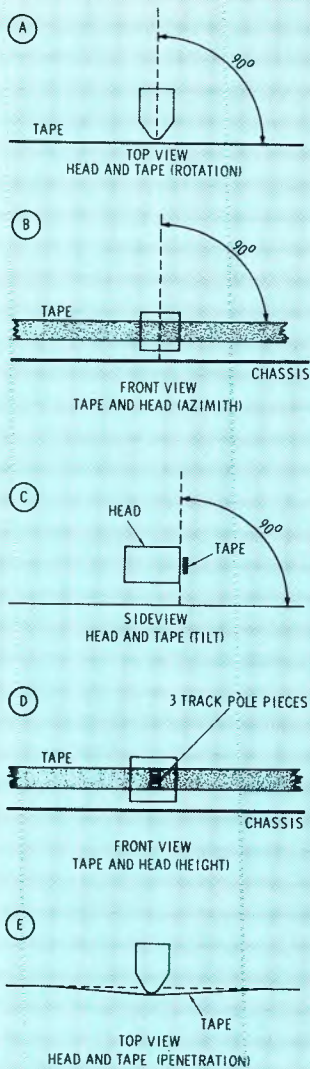

Five conditions required for correct head alignment.

Tape recorder maintenance (continued)

away from the head. This will cause the output level to flutter. If they are bent, both levels and high frequency response can suffer.

Cartridges are especially critical in the pressure pad area. If the pads are made with bronze springs and felt pads, the springs should be fairly firm but springy and the felt needs to be on the end of the spring. The springs need to be in place, facing the front of the cartridge. These can easily be pushed back into the cartridge so that they are ineffective. The sponge type pads should have the metal backing straight across and parallel to the cartridge front, positioned vertically so that they just cover the tape as viewed from the front. These can get tilted so that they press the tape at an angle. Cartridges require constant inspection.

Other cartridge problems may include: 1. Wrinkled tape due to improper winding causing the output to be "bubbly" or distorted; 2. Tape wearing quickly with unpredictable output results (only special lubricated tape should be used); 3. Lubricant or teflon washer under turntable dried up or missing will cause a drag on tape so that there may be "wows" in the output.

Capstan and Pinch Rollers

The tape speed across the head is determined by the capstan speed and pressure of the pinch roller. The rubber in these rollers can become glazed from lubricant, or hardened with age. If so, the roller can slip and cause speed variations. These will show up as "wows" in the program. The rubber roller can be cleaned with alcohol or other cleaner. If it becomes hardened or glazed, it should be replaced.

The capstan motor itself may develop dry or bad bearings, or defects in the windings. With the power

The basics (continued)

Tape Playback

During playback of a recorded tape, the reverse process takes place. As the tape passes across the pole pieces of the head, the magnetic fields on the tape track will induce a current into the coil and an output voltage that is a replica of the previous signal recorded on the tape will be provided out of the head. The stronger the magnetic track put onto the tape, the greater will be the output voltage of the head and thus the level.

Heads for Playback and Record are somewhat different. The Record head must carry higher current and will be lower in impedance than Playback heads which must work into a higher impedance load. You must be careful when changing heads so as not to install them in the wrong circuits. The results will prove very disappointing, because a Record head used for playback will give very low output.

As mentioned earlier, the low frequencies will record deeper into the tape than high frequencies. From this, it follows that the output level of the playback will vary in intensity. To say it another way, the

high frequency response will fall off. To correct this situation, it is necessary to pre-equalize the signal going into the Record head. Standard curves are used for these equalizers, as are standard curves used in the equalizers of the playback amplifiers.

Tape Erasing

A tape that has been recorded can be re-used by erasing the recorded information. This is done by applying a strong AC field across the tape which will rearrange the iron particles in random formation on the tape. This field may be applied either by an Erase head (used on some reel machines) or by a bulk eraser.

An Erase head will erase the information as it passes over the head, while a bulk eraser will erase the whole tape at one time. How well the erasure is done will depend upon how strongly the particles are magnetized and upon the erase field. Tapes that have been severely overloaded, that is, very strongly magnetized, will require many passes over the erase head to completely erase the tape. What is not erased will sound like crosstalk in the background or will cause a high noise level.

shut off, the motor or flywheel can be spun by hand. It should spin freely and continue to coast easily for several seconds after the hand is removed. If it is stiff or stops almost immediately, it needs to be taken out and cleaned and reoiled, or the bearings should be replaced. If none of these are possible, the motor should be replaced. Many manufacturers have an exchange arrangement for capstan motors.

Bias Adjustment

The bias will affect the output level and high frequency response. The best way to adjust when metering is not available, is by recording a high frequency tone and then adjust bias for highest output. Improper bias can produce some curious results. If it is failing and at some critical point, it can show up irregularities

in tape, even new tape.

A tape head meter is a handy instrument for running down problems at the head, especially with cartridge equipment. The meter plugs into the chassis immediately behind the head. It contains a transistor amplifier that will amplify the output of the head directly up to earphone level, and it has a meter that will read relative levels. When questions arise, it is easy to isolate the problem to head, tape or elsewhere, by simply listening to the program from the tape and comparing its level with a standard tape or what you normally expect to read off a good tape. As a routine maintenance technique, you should make level checks from a good tape, or an alignment tape when the head is new, so you will have something for comparison when a fault occurs.

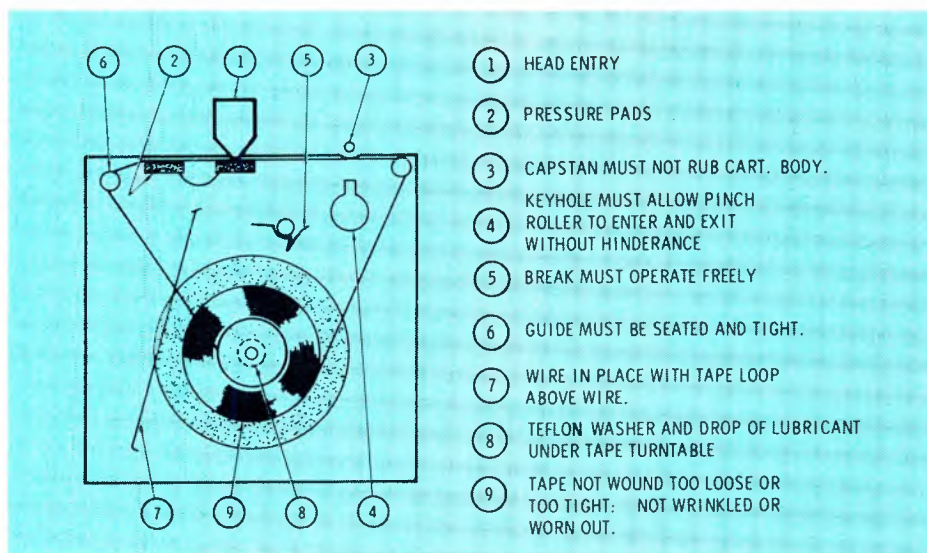

Nine points where trouble can occur in a tape cartridge. Most of these should be inspected visually regularly.

Care should be taken in the use of bulk erasers. These develop strong magnetic fields. The tape should not be in its field when it is turned on or off, because the collapsing field can cause a strong magnetizing of the tape that can be difficult to erase. The eraser should be turned on, the tape brought into the field and erased. Then, with the eraser still turned on, the tape should be moved out of the eraser field.

There is another important feature of the recording head that must be met. The head is an inductive device and will not allow the signal currents to flow through it in a linear manner. This is due to residual magnetism and the fact that magnetic fields are reluctant to change direction. Thus, as the current begins to flow into the head until it reaches its maximum in one polarity, the magnetic field will also be established. Now the current will reverse itself and go to the opposite maximum polarity, but the reluctance of the magnetic field to change, along with the residual magnetism in the iron core and the iron oxide of the tape will force the current into a path other than through the zero line. When plotted, this produces the familiar

magnetic curve. The signal current will be distorted near the zero line.

This distorting effect by the head and tape are overcome by the use of high frequency bias. The frequency of this bias is about 75 kHz and several times the amplitude of the signal. The bias and signal are mixed together before being sent to the head. The audio signal will appear as twin curves, in phase, riding the peaks of the bias signal. During playback, the bias is filtered out, leaving the audio curve undistorted, since the audio was "lifted" into the linear part of the magnetic curve.

Another important feature of the head is its gap and relationship to high frequency response. The absolute upper limit of frequency response occurs when the gap distance equals one wavelength of the head current frequency. This is so because the flux will change polarity across the gap and cancel all that was recorded, so the net result will be zero output. In audio work, the maximum limit is no concern, but the gap width does effect high frequency response. Present day heads have a very narrow gap so that frequency response to 15 kHz is easily obtained.

Automating the Mark II Image Enhancer

By Miguel Triay/WKAQ-TV, San Juan, Puerto Rico

About a year ago, our station bought a CBS Mark II Model 502, Image Enhancer. Our intention was to install it on the line continuously to improve the apparent resolution of our video, but we ran into trouble and had to take it out. When we adjusted it to suit the Film Chain TK-27, the live cameras TK42 and TK43 had too much enhancement, and in the shows, the star appeared with facial blemishes.

Conclusion: We needed a "Variable Enhancer". We started to design a system which ties up the quantity of the enhancement with the source; maximum enhancement with the film chain, and with old black and white films, less with videotape, and almost none with live shows.

It was a big task to tie up all these sources because we have four

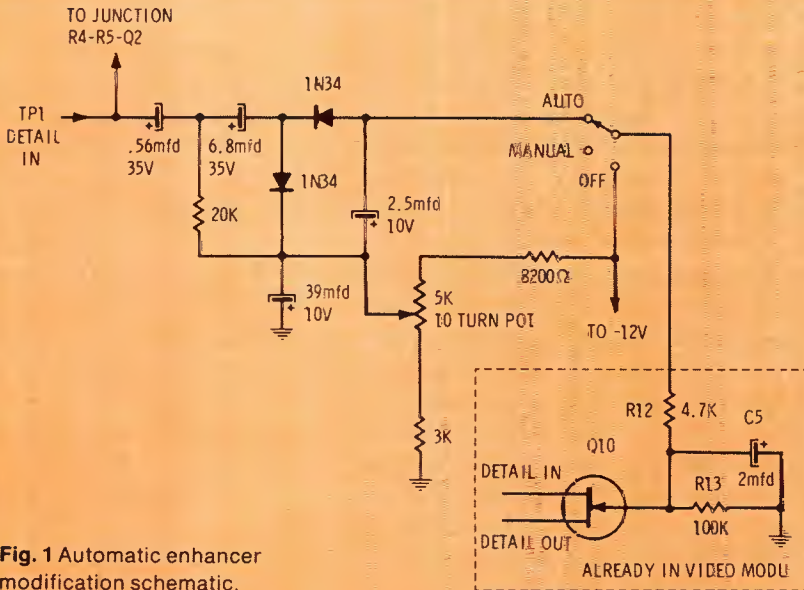

Fig. 1 Automatic enhancer modification schematic.

Fig. 2 Blocked off area shows positioning of the PC board for enhancer modification.

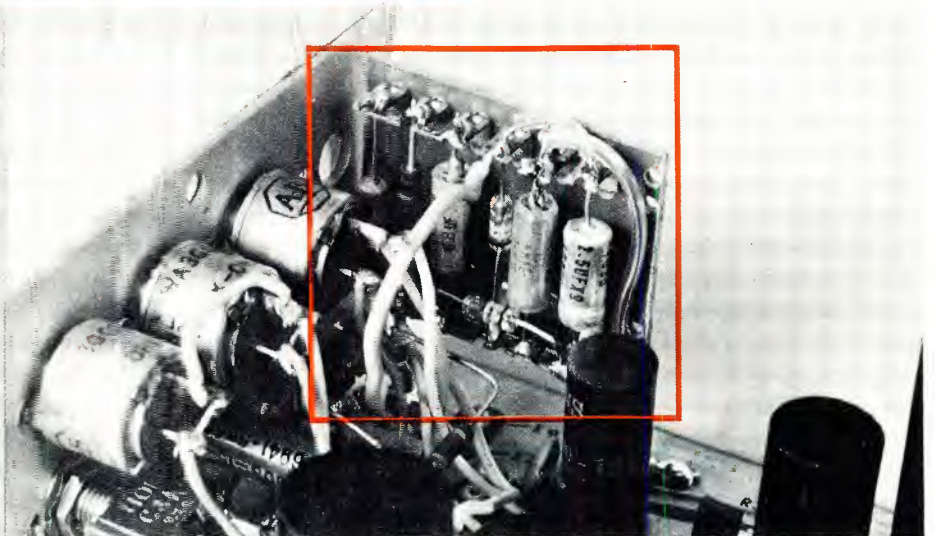

Fig. 3 View of the completed modification on the video module.



switches and to route the signals and select them was a mess...So we began to wonder, why not take the control signal from the unit, the Image Enhancer? We devised a very simple circuit to do this.

In the Video Module there is a test point (TP-1 Detail) where the signal tells about the quantity of sharpness of the picture. Basically, the detail is rectified by a doubler, filtered and a variable bias added to it. The sum of the two DC signals is applied to the gate of Q10 in the Video Module, which works as a variable resistance for the detail signal. Q10 is already in the Video Module and was used to switch the detail ON or OFF.

We mounted the two diodes, four capacitors and three resistors in a small board and installed it in the Video Module and removed the

two toggle switches labeled Local-Remote and DETAIL ON-OFF. We substituted them with one three position switch and a 5K 10 turn Helipot. That's all!

The new toggle switch has three positions labeled AUTO., MAN. and OFF. In the MAN. and OFF positions, the enhancer works as in the original design. In the AUTO., the quantity of enhancement is determined by the detail already in the picture and the position of the new pot. In other words, the system tries to maintain a constant quantity of detail in the video going out of the unit.

To adjust it, turn the 5K pot all the way counterclockwise, put the new switch on MAN. and adjust the unit by the Instruction Book. And using a video signal of poor resolution, adjust the quantity of

enhancement to your choice, then put the switch on AUTO and feed a signal that has very good detail (the output will look overenhanced) and move forward the 5K Helipot until the enhancement is reduced to a level similar to your previous choice. When switching back to a signal poor in detail, the enhancer automatically increases the sharpness of the picture.

Our unit with this modification has been continuously on the air for the past nine months, with very good results. It has helped us by improving the old black and white movies and not so sharp news films, without overenhancing our live and taped shows.

We appreciate the help given by Mr. Armando Menendez, our maintenance supervisor, during the construction and testing of the unit.

TELAN

gas fueled thermoelectric generators

Nestled under the ice covered eaves of an equipment shed on a 11,000 foot mountain peak in Utah, this TELAN generator provides power for a TV translator. The propane tanks supplying fuel to TELAN require service only once a year. TELAN is available in from 10 to several hundred watts. 12-24-48 VDC standard.

 **TELEDYNE ISOTOPES**

110 W. TIMONIUM ROAD — TIMONIUM, MD. 21093
PHONE: 301-252-8220 — TELEX: 87-780

Circle Number 20 on Reader Reply Card

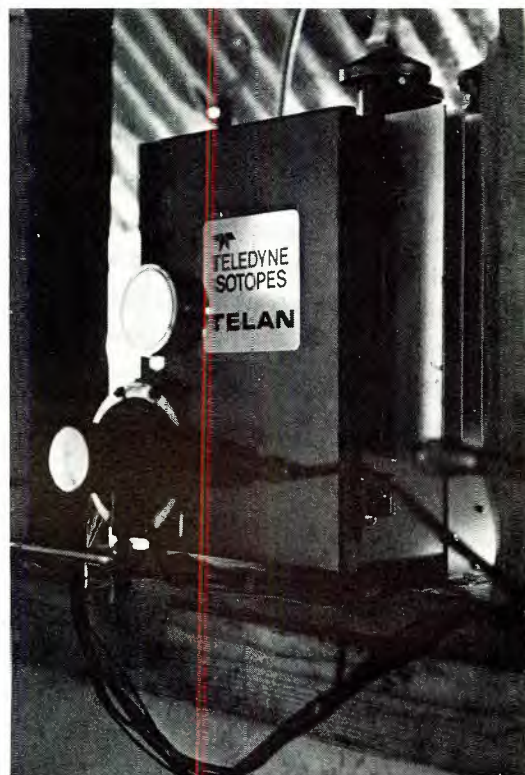

NAB Convention Notes

The NAB convention in Chicago last month opened...and closed on a note of optimism. Owners, managers, engineers, and manufacturers set the stage early for a serious approach to the convention that hasn't been seen in a long time, and it may pay off. Even on the first day, when the exhibit areas are flooded with lookers, contracts were being signed on the floor.

And as the convention progressed, there were signs of the good old days, even though there was little of the old show biz approach to attracting people out of the aisles and into the exhibit booths. But that's the main subject of our new products approach for May and June. (See *New Products*.)

The Business At Hand

Despite the specific values of various papers delivered at the convention, three speakers took on the task of calming and clearing the muddied waters of the broadcast industry. Broadcast Engineering feels that anyone connected with broadcasting should weigh and consider the ideas they discussed. Generally, they said that broadcasting is not simply a business adventure, and perhaps a great many of the problems today stem from the fact that there are those in the business who are motivated solely by profits. On the other hand, broadcasters realize that the preponderance of rules today (1) recognize the influence of broadcasting on its audience, (2) seek to increase broadcastings commitment to its audience, but they (3) overlook the fact that broadcasting cannot remain at the same level or climb without profits. And because of the issues involved in (2), profits could greatly decrease.

In the June issue of Broadcast Engineering, we will return to NAB coverage and bring you both management and engineering actions.

FCC Chairman Dean Burch got his discussion of Fairness Week underway when he said that broadcast critics are saying that the industry serves the lowest common denominator in behalf of profits... "that you avoid the hot issues before American society...that you act as if the dissident and the alienated don't even exist."

Burch went on to say, then, that with extremes taken by all sides, the Commission does not simply take the middle ground hoping for the average. Then he added, "I have no doubt that 'good intentions' are involved. That goes for both broadcasters and their severest critics, both of whom quite understandably want certainty and predictability rather than a succession of cliff-hangers.

"But, at the same time, I have no doubt that great risks are involved. And there are pragmatic obstacles as well. The entire concept of a perfect, all-purpose formula implies that every dispute would have to fit or be fitted into a pre-determined mold...and, candidly, that smacks of either a dream-world or a straightjacket."

(From the editor's viewpoint, you may well bore your neighbors with such a discourse, because they want bulk entertainment. The intellectual community, on the other hand, may be looking for something quite different. Or...have we learned anything from the ratings?)

But as Burch continued, it was certain that he was asking for greater commitments in equal opportunity, controversial issue

programming and children's programming.

Finally, Burch reminded his audience of a statement he made to the NAB two years ago: "That our obligation, by sharp contrast, is to cultivate the **freedom** in which broadcasters will be able to serve their local publics in a flexible way. This has particular pertinence to some aspects of radio, and you may have my personal commitment that we will intensify our study of this question...and stand ready to rewrite as much of the books as necessary, or urge that it be rewritten." So much for freedom.

Wasilewski's NAB Viewpoint

In his address to the NAB general assembly, Vince Wasilewski said, "It is no answer to stand by criticizing and wringing our hands and yearning for the good old days. If we do that, things will come out very badly for us and very badly for the industry we believe to be so important to American life.

"What does this mean to broadcasters?" he continued. "It means that we must modify some of our old beliefs and make some adjustments in our traditional ways of doing things.

"It does not mean that we throw in the towel; that we abandon beliefs and values which we hold as both essential and true.

"How do we do this? First, we sort out the things that are important...the really basic concepts which make the American system of broadcasting unique. Then we set some priorities; otherwise, our efforts will be shattered into ineffectiveness.

"And finally, we must fight; and, at the same time, we must educate."

helical vtr processor



- Regenerate sync pulses to EIA standards when using video equipment with non-standard sync.
- Produce special effects and mixes with a helical scan VTR by locking the pulse feeds required by the special effects generator or mixing amplifier into synchronism with the VTR output.
- Insert titling into existing videotapes by feeding sync outputs to camera locked to the VTR playback.
- Clean up and stabilize the signal from half inch portable VTR
- Widest locking and tracking range available.
- Basic model price of TSP 101 is only \$1,145.00

For complete details on Helical Scan VTR Processors and other terminal equipment, write DANSCOLL LTD, 9721 Cote de Liesse, Montreal 760, Canada or telephone (514)-631-9884.

DANSCOLL

Circle Number 21 on Reader Reply Card

Use this unique, complete test facility free for 30 days!

Versatile all-in-one precision test unit

- Sine wave generator
- Millivoltmeter
- Wow & Flutter bridge
- Harmonic distortion analyzer

Simple to operate

- Learn to use in minutes
- Minimum set up time
- Only two leads necessary
- Pushbutton activation

Use it anywhere

- Recording & broadcasting studios
- Testing laboratories
- Service shops
- Compact, portable, lightweight

All this for only \$1200.

Sturdy carrying case optional

FERROGRAPH RTS-1

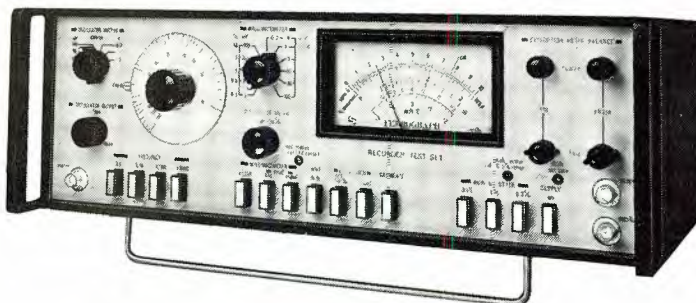

RETURN COUPON BELOW FOR FREE TRIAL OFFER

BE-5

Yes I'm interested in the Ferrograph RTS-1 test facility. Send details and qualification form.

I am interested in a distributorship. Please send details.

ELPA MARKETING INDUSTRIES, INC., New Hyde Park, N.Y. 11040

NAME _____

TITLE _____

COMPANY _____

ADDRESS _____ CITY/STATE _____ ZIP _____

Circle Number 22 on Reader Reply Card

Pointing to current pressures, Wasilewski commented, "We must recognize that the station operation of the future is going to involve more citizen participation. Rather than treating that as a bad development, we should regard it as an opportunity. We should approach the idea of citizen participation positively. We should be searching for creative solutions, ways in which those impulses can be accommodated and channeled to the good of the community and the station. Raising the battle flags of tradition and crying "never" can only lead to imposition of odious and restrictive terms on us.

Summing up, the NAB president said, "Various proposals to require a broadcaster to put on this kind of program or that kind of program, or to require him to put this person or that on the air... all these would convert the most and popular democratic instrument in our society to a system of delivering a splintering cacophony of propaganda serving special interests. Against that, we must draw the line; against that, we must fight.

"There is only one way we will win that fight. First, we must educate people to the original concept of the law: it is ideas that are entitled to be heard, not specific individuals. If we take the responsibility to see that ideas important to our communities are heard, then we draw the teeth of our critics and vitiate their arguments. To do this is going to require... as I have said about all our other problems... positive and creative approaches... a willingness to open our minds to doing things differently."

Billy Graham Gives Thanks

In an imperfect world, American radio and television "have performed with great honor and credibility," according to Evangelist Billy Graham. "I say this," he added, despite the brickbats which broadcasting draws from some self-styled critics who chastise it for falling short of perfection."

Mr. Graham spoke during the opening General Assembly after receiving the association's Dis-

SAT+BE=ADC

SPACE AGE
TECHNOLOGY
+
BROADCAST
EXPERIENCE
=
AMERICAN DATA
QUALITY

WRITE OR CALL
FOR CATALOG AND
CURRENT PRICES
CONCERNING

SWITCHING SYSTEMS
DIGITAL CLOCK SYSTEMS
DISTRIBUTION SYSTEMS
PROCESSING SYSTEMS
PULSE SYSTEMS
TEST SYSTEMS

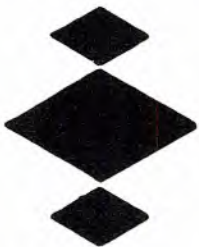

AMERICAN DATA
CORPORATION



4306 Governors Drive, S.W.
Huntsville, Alabama 35805
Phone (205) 837-5180

Circle Number 42 on Reader Reply Card

tinguished Service Award for significant and lasting contributions to broadcasting.

"Actually it is I who should be honoring you," the noted evangelist said, "for—next to the Lord himself—it is radio and television, along with the press, which have been primarily responsible for any success my ministry has had."

Mr. Graham challenged broadcasters to solve the moral and spiritual crisis that, he said, was at the root of all other problems we face today.

"You and your industry are remarkably qualified to do this," he added, "for you have the brains, the know-how, the research capacity, the writers and the talent to set in motion the kind of programming that can reawaken moral sensitivities."

"You can arrest America's deterioration," he concluded, "by providing the kind of moral leadership America is crying for."

Secondary Markets

Ask Full Representation

General problems of the small market broadcaster were discussed in a panel program planned to provide feedback from the secondary markets operators.

Panelists were, Richard D. Dudley, Forward Communications, Wausau, Wis., chairman of the special committee on NAB Goals and Direction; William Turner, KCAV-TV, Sioux City, Ia., Thomas C. Bostic, Cascade Broadcasting Co., Yakima, Wash., Jack Rosenthal, Harriscope Broadcast-

ing Corp., Casper, Wyo., Joe Bonansinga, WGEM, Quincy, Ill., and William A. Patton, KATC-TV, Lafayette, La.

Patton is chairman of NAB's Secondary Markets Television Committee. Turner, Bostic, Rosenthal and Bonansinga are committee members.

Primary thrust of the panel was toward full-time representation of secondary market broadcasters both in NAB and in appearances before the FCC.

Pointing out that slightly under 40 per cent as NAB's TV membership are secondary market (i.e. under the top 100 markets) operators, the panelists expressed the view that their particular and specialized needs were not being fully represented. As an example, they pointed out that none of the members of Dudley's Special Committee are from the Rocky Mountain States, nor had there been any small market broadcasters on the committee that agreed to the recent TV-CATV rules.

Dudley agreed that such problems exist, and said the panel's purpose was to pinpoint them with the purpose of correcting them in the future.

"No single individual can tell you what all the problems are nor how to solve them," he said. "That's why we are in need of input like this."

Six Elected To NAB Television Board

Six television executives were elected to the Television Board of Directors of the National Association of Broadcasters.

Each will serve a two-year term beginning with the close of NAB's Golden Anniversary Convention.

Those elected were:

Leslie G. Arries, Jr., vice president and general manager, WBEN-TV, Buffalo, N.Y.

Walter E. Bartlett, Sr., senior vice president, television, AVCO Broadcasting Corp., Cincinnati, Ohio.

George Comte, general manager, WTMJ-TV, Milwaukee, Wisc.

Mark Evans, vice president and



director of public affairs, Metro-media, Washington, D.C.

Ray Johnson, executive vice president and general manager, KMED-TV, Medford, Ore.

Dale G. Moore, president, KGVO-TV, Missoula, Mont.

NAFMB Plans To Double Seminar Schedule

The annual membership meeting of the National Association of FM Broadcasters, which concluded the organization's convention Sunday (April 9), announced plans for increased activities and services for stations.

Abe Voron, Executive Director of the NAFMB, said that in addition to increased flow of information to member stations concerning FM, the number of regional seminars would be doubled in 1972. John Richer, NAFMB President, assured members that the Association would continue its efforts to encourage the production of automobile FM receivers. Richer also announced that a coalition of non-commercial and commercial broadcasters is being developed to promote all-channel legislation.

FCC Commissioner Robert T. Bartley was presented the first FM Pioneer Certificate during the Third Annual Pioneer Breakfast at which he spoke.

The NAFMB sessions Saturday (April 8) ended with the liveliest and most heated meeting of the convention. A confrontation of three proponents of matrixed four-channel broadcasting (CBS Labs, Electro-Voice, and Sansui), and supporters of the discrete four-channel as developed by Quadra-cast, Inc. and tested on K-101, San Francisco.

**For Late News
Read
Direct Current
Page 4**

Remote Telephone Line Coupler

Microphone Line Driver with Built-In Voice Coupler



MODEL 285

900 OHM Output with DC isolation for Direct coupling to Telephone Lines.

LO-Z Microphone and Bridging Inputs — Also 600 OHM Audio Loop Output — VU Meter.

\$74⁹⁵ Complete

For Additional Specifications on Above Units and Other Amplifier Products Write:

Send Check or Money Order to:

Telephone
309/776-4544

PULSE DYNAMICS MANUFACTURING CORP.
Fulton Street Colchester, Illinois 62326

Warranted for 1 year against defects in Parts, Materials and Workmanship.

Circle Number 24 on Reader Reply Card

another new **mcmartin console** *"FIVE" channel mixer*



B-501 Mono Console \$750.00

B-502 Stereo Console \$1,050.00

McMartin has designed a series of 5-mixer consoles for production or subcontrol room application . . . with enough flexibility to serve as the main control console in smaller station operations.

Two models are available: The B-501 mono and the B-502 stereo version.

Plug-in card design for all program circuits permits full latitude in assignment of ten input sources to the five mixing channels.

Professional performance . . . human engineering . . . attractive design . . . combine to offer the user the ultimate in monaural and stereo five-mixer consoles.

For complete information, contact: Director of Sales (402) 342-2753

McMartin

• 605 north thirteenth street • omaha, nebraska • 68102 •

EVALUATE VIDEO TAPES

Off-line

using the field-proven

RECORTEC

VIDEO TAPE EVALUATOR



- Display total number of edge damages.
- Display total number of surface defects.
- Display total tape time.
- Tape fully cleaned, uniformly packed and degaussed.

Longitudinal testing of video tapes at high speed makes it possible to evaluate and re-wind a one-hour reel in 10 minutes. Tape edge damage which can cause control signal variations and audio dropouts is readily identified. Detected video dropouts exhibit excellent correlation with results obtained by evaluating the same tape on a VTR.

If your operation requires testing of tapes, this equipment will quickly pay for itself by keeping your valuable VTR for more productive applications. Additional savings can be obtained by rehabilitating tapes and reducing VTR head wear.

Incidentally, it can also be used as a cleaner/winder for tapes with recorded program.

Write or call us for details. Ph. (415) 961-8821

RECORTEC, INC.

160 East Dana St., Mountain View, California 94040

Circle Number 26 on Reader Reply Card

ENGINEER'S EXCHANGE

Remote Start For Projectors

The WCCO-TV News Department requires the use of several multireels of film in the editing of a story. Sound on film, interviews and background sound requires a synchronous start of all selected projectors used for the story. In the past, this was quite a difficult accomplishment as our remote start buttons for the individual projectors were not conveniently grouped together.

WCCO-TV uses five Eastman 285 and four RCA TP-8 film projectors all equipped for magnetic or optical sound. The engineering department developed the following fail-safe multi-start circuit for precise control of all projectors, without affecting our normal mode of operation. The individual projectors may be started

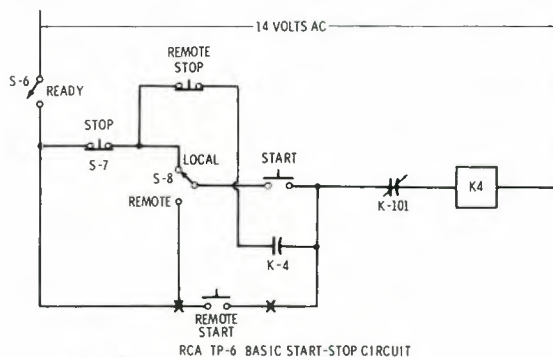
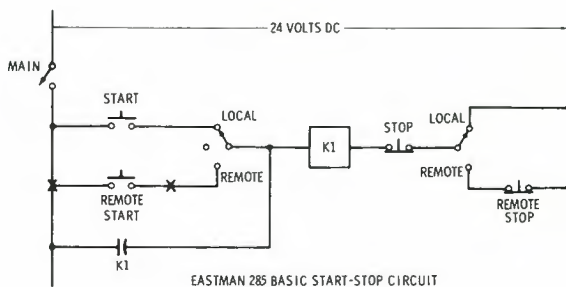
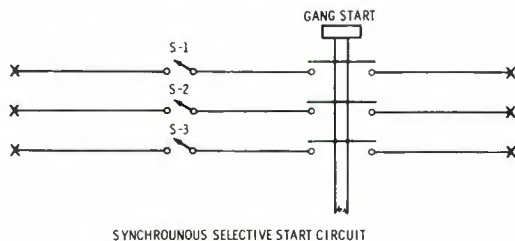

Fig. 1



EASTMAN 285 BASIC START-STOP CIRCUIT



SYNCHRONOUS SELECTIVE START CIRCUIT

Fig. 2

regardless of what position the select switches are in. A synchronous stop was not necessary for our operations.

Figure 1 shows the basic start-stop circuit for the

two different projectors. The basic difference between the starting of the projectors is the voltage used in the control circuit. The RCA uses an internal AC voltage, while the Eastman requires an external 24 Volt DC supply.

Figure 2, in conjunction with Figure 1, shows the simple parallel circuit of the synchronous start. Using single-pole/single-throw switches to select the desired projector and a "T" Bar multi-pole single-throw switch, up to eight projectors may be started with one button simultaneous.

The modification has resulted in improved operations.

William A. Baeten
WCCO-TV
Minneapolis, Minn.

Tape, Turntable Speed Adjustments

Tape deck and turntable speed adjustment is an excellent application for the frequency counter. However, there is a more precise method which utilizes more conventional broadcast equipment.

If a good quality audio signal generator and distortion analyzer (null type) is available the speed of tape decks and turntables can be checked using standard alignment tapes and records. First, check the accuracy of the signal generator against WWV using a scope (of almost any type) and the standard Lissajous pattern. The null type distortion analyzer should be then connected to the output of the generator and adjusted for a null at the frequency of interest. Then connect the analyzer to the audio console and run the alignment tape or disc. Adjust the speed for minimum null.

As a quick check, records can be established and the systems compared to original on a quarterly basis. This is usually adequate, although it can be done on a more frequent basis for exacting standards. Since the reference of this method is the 500, 600, 1k, and 1.2k cps tones transmitted by WWV, any error resulting from carefully executed work will be small.

Many engineers use the obsolete strobe method which used the public power frequency as a reference. However, since the advent of "automation" we find that the frequency of the power isn't accurate for most applications. Accumulative errors resulting from using synchronous motors and speed adjustment based on power line frequency could be as high as 2.0 RPM on turntables.

Michael D. Lee
WFUN Radio
Miami, Fla.

CLEAN AND WIND TAPES

Off-line

using the field-proven

RECORTEC

VIDEO TAPE CONDITIONER

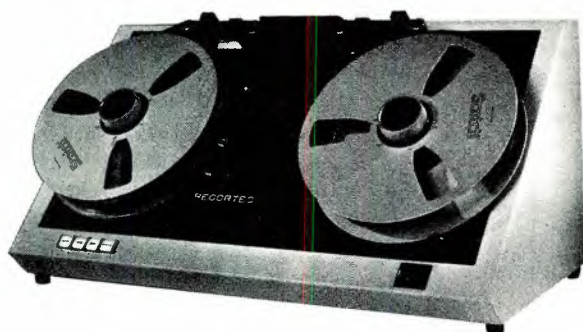

Our transport uses a vacuum chamber for gentle tape handling, combined with vacuum grid cleaners to avoid scratching or cutting valuable tapes.

- Extends tape and head life by removing loose oxide and debris from tape surfaces.
- Improves quality of video recording due to reduced dropouts.
- Minimizes tape damage by improving the tape pack.
- Increases VTR utilization.
- Options such as erase, splice count, audio playback, etc., are also available.

If you take your car in for preventative maintenance regularly, why not do the same for your valuable tapes to extend their useful life?

There are many users here and abroad. This equipment pays for itself in less than one year. Let us show you how much you can save in your tape operations.

Write or call us for details. Ph. (415) 961-8821

RECORTEC, INC.

160 East Dana St., Mountain View, California 94040

Circle Number 27 on Reader Reply Card

SPIN

WITH



A
PRO!



GO Russco!

The RUSSCO CUE-MASTER features No Slip Starting, a Precision machined steel copstan and the reliable Bodine synchronous motor all in a beautifully engineered turntable with only 3 rotating parts! Plays 33, 45 and 78 with a built-in adapter for 45. Great Dependability and Performance priced amazingly low at only

\$178.00



RUSSCO is also your Top-Quality manufacturer for Monitor Amplifiers and fully transistorized Mono and Stereo Pre-amplifiers. Send for Free Brochure.

RUSSCO
ELECTRONICS

1070 BROOKHAVEN, CLOVIS, CALIF.
PHONE (209) 299-2167

Circle Number 28 on Reader Reply Card

NEW PRODUCTS

(Use circle number on reader service card for further information)

Most of the new products featured in this month's New Product section were introduced for the first time at the NAB convention. This is, of course, that convention time of the year. We will continue to show the new goods of the communications industry heaped up during the convention season. If you want more information on any of the products we describe (or on products advertised), fill in the Reader Service card in this issue and send it in.

Low Cost Color Film Chain System

Marco Video Systems, Inc., Phila., Pa. announces a new TOTAL NTSC Color Film Chain System.

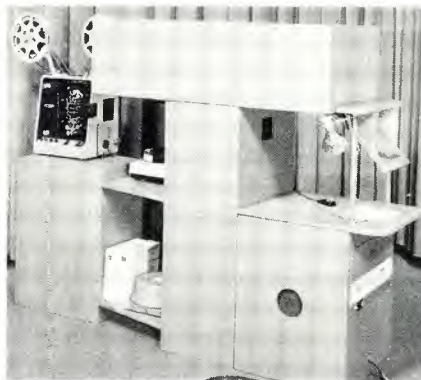

The system includes three tube color pick-up, multiplexer, 16 mm projector, 35 mm slide projector. The system has the ability to accept opaque art work, overhead transparencies and small three dimensional objects in a 7" x 9" horizontal field.

It has the built-in capability to split screen and wipe between the motion picture film and the 35 mm slides.

Circle Number 65 on Reader Reply Card

Audio Control Console

A solid-state four-channel mon-

aural audio control console, the Studioette 80, has recently been introduced by the Gates Division of Harris-Intertype Corporation.

Successor to Gates' famous Studioette, this compact new con-

angeneux service corporation of california
13381 BEACH AVE., VENICE, CALIF. 90291 • (213) 821-5080

Now Two
**FACTORY SERVICE
CENTERS**

angeneux corporation of america
440 MERRICK RD., OCEANSIDE, N.Y. 11572 • (516) 678-3520

Circle Number 29 on Reader Reply Card

GET SECOND LIFE FROM YOUR POWER TUBES

... at about 50% of
original cost!

Emission life of a thoriated tungsten filament depends on carbon evaporation. When the carbon is depleted, emission drops. Until now, you were in for an expensive replacement!

Now Freeland Products offers expert reprocessing of certain types of thoriated filament tubes. Our service is backed by a warranty and over 30 years experience.

Send today for descriptive brochure and price list. Freeland reprocessing assures FULL AVERAGE EMISSION LIFE of new tubes—yet you'll save up to 50% of original cost!

Scores of Satisfied Customers

WAOK	KHOF	KPQ
KBCL	KHOM	WPLO
KBHS	KHOU	KXXX
WBKH	WHAL	WQAM
KCIJ	WHAS	WQMV
KCIM	WHB	WRUF
WCCO	WIRK	WSMB
WCMI	WJCV	WTAE
WDAE	WJDX	WTIX
WDAK	WJLS	KVAL
KELI	WKIZ	KVOL
WEEB	KLCN	KWHI
KFDA	KLIV	WWST
WFOR	WMRI	WYES-TV
KGBC	KOKE	WPRS
KGUD	KOMA	WVHI
WGRY		

And Many More!

Freeland Products Co.
3233 Conti St. • New Orleans, La. 70119
504/822-9223

Circle Number 30 on Reader Reply Card

BROADCAST ENGINEERING



sole provides a high degree of flexibility through the use of 13 input selector switches. These inputs include: four microphones, three turntables, two reel-to-reel recorders and one cartridge machine —plus two remote lines, and network. For future expansion and controlling auxiliary equipment, the Studioette 80 was designed with three utility keys for specialized station needs.

Silicon transistors are used throughout the console. Dual muting relays handle speaker and warning-light functions. These relays are shock mounted on a sub-chassis to prevent mechanical noise during switching.

The Studioette 80 is only 24 inches wide, yet offers adequate facilities for use as a main console

in medium and smaller size stations. In larger stations it may be used as a production console or for independent programming from a second studio. The console is equally well suited for mobile units and remote locations.

Circle Number 66 on Reader Reply Card

Air Cooled 5 kW Load

The new **BIRD** model 8785 air-cooled **TERMALINE®** Load Resistor dissipates 5,000 watts continuously in ambient air **without** blowers or circulating water. This is almost indispensable for both remote and automated operation of broadcast transmitters.

In such installations, the outputs from two identical transmitters are added in a combiner for increased power to the antenna. A reject load is connected to a fourth port of the combiner, and in normal operation (when both phase and level are matched) there is little power directed into it. However if one transmitter fails, the remaining transmitter splits its output equally between this load and the antenna



so that signal transmission continues with reduced power.

This emergency condition requires a reject load capable of absorbing 25% of the installation's total average visual power, and another one for 25% of the total aural power. The loads must be continually ready without requiring

(Continued on page 42)

TIRED

OF PAYING SHOCKING PRICES FOR ELABORATE WAVEFORM MONITORS OFFERING COSTLY SELDOM-USED FEATURES?

TRY THE NEW VW-0 WaveForMonitor™
especially for CCTV, Educational, Cable-TV . . .
at the lowest cost in the broadcast industry



And take a view of our incredible new low cost PULSE CROSS Picture Monitor incorporating *underscan, variable bandwidth, internal or external sync.* and audio!

request bulletin no.

BE 572

Ultra Audio Products

Post Office Box 921 • Beverly Hills
California 90213 U.S.A.

Circle Number 31 on Reader Reply Card

Stepping Stones to a Better Job in Broadcasting

8 new and recently revised texts from Sams.

WORKSHOP IN SOLID STATE

By Harold E. Ennes
An outstanding training text, complete with exercises at the end of each section (answers in back of book). Provides the engineer-technician trained in vacuum-tube circuitry with a rapid, practical and effective transition to the mastery of solid-state circuitry in all broadcast applications. 384 pages, hard cover. No. 20735—\$9.95.

TELEVISION BROADCASTING: Equipment, Systems, and Operating Fundamentals

By Harold E. Ennes
This comprehensive, new reference volume for practicing technical personnel and student tv technicians and operators covers the NTSC color system, camera chains, sync generators, signal distribution, recording systems, studio lighting, studio equipment operation, microwave relay systems, antennas, transmitters, and operating procedures. 656 pages, hard cover. No. 20786—\$14.95.

TELEVISION BROADCASTING: Camera Chains

By Harold E. Ennes
Authoritatively provides the fundamentals necessary for more efficient assimilation of modern instructional books. The overall "system" concept is used to discuss studio lighting, camera mounting, interconnection facilities, power supplies, video amplifiers, video processing, camera control, setup circuitry, and more. 464 pages, hard cover. No. 20833—\$12.95.

FIRST-CLASS RADIOTELEPHONE LICENSE HANDBOOK, 3rd Edition

By Edward M. Noll
More than a question and answer book, it is also an excellent reference text on broadcast communications with a thorough coverage of theory and basic principles. It

supplies all information needed to progress from a 2nd to a 1st class radiotelephone license. 416 pages, softbound. No. 20804—\$6.50.

SECOND-CLASS RADIOTELEPHONE LICENSE HANDBOOK, 4th Edition

By Edward M. Noll
Covers all information needed to pass the 2nd class FCC radiotelephone exam, covering FCC Rules and Regulations, communications theory and practices, solid-state two-way equipment, etc. Questions and answers based on the FCC exam. 360 pages, softbound. No. 20824—\$6.50.

RADIO SPECTRUM HANDBOOK

By James M. Moore
This highly informative book covers the entire usable frequency spectrum. Allocations, types of transmissions, and examples of transmitting and receiving equipment used in each band are included. 192 pages, hard cover. No. 20772—\$7.95.

NORTH AMERICAN RADIO-TV STATION GUIDE, 7th Edition

By Vane A. Jones
This updated and expanded edition provides a comprehensive one-source reference to all commercial broadcast stations in North America. Lists frequencies, call letters, and locations for a-m, fm, and tv stations. 160 pages, softbound. No. 20843—\$3.95.

COMMERCIAL RADIOTELEPHONE LICENSE Q AND A STUDY GUIDE

By Woodrow Smith and Robert Welborn
Contains questions taken from the first four elements of past and present government publications of "Study Guide and Reference Material for Commercial Radio Operator Examinations," and thus presents questions used in FCC examinations. 272 pages, softbound. No. 24027—\$5.95.

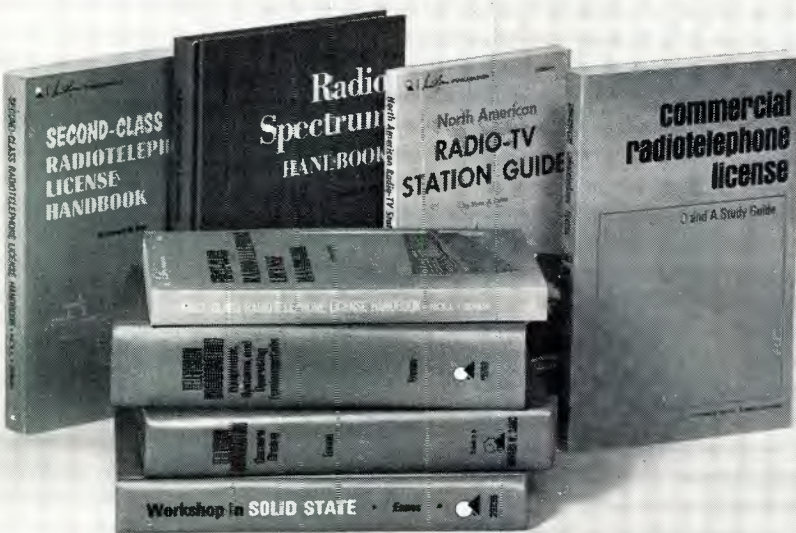

(Continued from page 41)

attention or service to moving parts.

The new BIRD 5,000 watt termination is designed for paralleled TV transmitters of 33 kW peak power and for 20 kW FM and aural systems. This can be doubled to 66 kW peak TV and 40 kW FM or aural systems by using two Model 8785 Load Resistors with a power divider/impedance transformer.

Model 8785 has a low VSWR of 1.1 from DC to 1,000 MHz and is available with 50 ohm or 51.5 ohm 3/8" dia. input connectors. It is compact (17" dia. x 35" high) and easily movable on its integral dolly.

Circle Number 67 on Reader Reply Card

Ring-Focus Fresnel

Berkey Colortran, Inc., a division of Berkey Photo, Inc., has announced the introduction of its new 12' 5000 watt Ring-Focus Fresnel. The unique focus ring permits rapid focusing from any position. A new lens design provides greatly increased performance.



This new 5000 watt Fresnel features the Colortran four-point contact socket (patent pending) for positive mounting and improved lamp life. Lamp life is further enhanced by the Fresnel's unique cooling design. Focusing is done by moving the lens rather than moving the lamp. Filament vibration and shock is eliminated further increasing lamp life by as much as 50%. Thrust out relamping permits lamp changes without moving the fixture or disturbing barndoor adjustment. The unit accepts 5kW 3200° and 3400° tungsten-halogen lamps. The Bi-post lamp socket remains sta-

 **HOWARD W. SAMS & CO., INC.**
4300 W. 62nd Street, Indianapolis, Indiana 46268

Order from your Electronics Parts Distributor, or mail to Howard W. Sams & Co., Inc.

Send books checked at right. \$_____ enclosed. Please include sales tax where applicable. Canadian prices slightly higher.

Send FREE 1972 Sams Book Catalog.

BE 052

<input type="checkbox"/> 20735	<input type="checkbox"/> 20824
<input type="checkbox"/> 20786	<input type="checkbox"/> 20772
<input type="checkbox"/> 20833	<input type="checkbox"/> 20843
<input type="checkbox"/> 20804	<input type="checkbox"/> 24027

Name _____

Address _____

City _____ State _____ Zip _____

Circle Number 32 on Reader Reply Card

tionary; thus, no flexing of the input wiring. It is available in both hanging models for grid use or stand models for floor operation.

Circle Number 68 on Reader Reply Card

Variable Type Font TV Titling System

Chinese characters and any other foreign letters or symbols are now easily stored and reproduced on television screens with a new electronic titling system developed by **Systems Resources Corporation**. This new variable-font character generator could ultimately have applications in foreign countries as well as in the United States for educational purposes, and closed circuit TV and in TV broadcasting.



This new device, known as the **CHIRON II**, was first introduced publicly at the National Association of Broadcasters Convention in Chicago on April 9th.

Operating from a typewriter-like keyboard, as many as six different font styles, in different sizes, shapes or languages can be selected from keys and "typed" on the TV screen. An unlimited library of different type fonts can be stored on **VIDI-LOOP** magnetic tape cartridges and then pre-selected for use in the **CHIRON II** Titling System.

A unique feature of this new system is its ability to create new type fonts directly from graphic art work as picked up by a standard TV camera. This "do-it-yourself" capability means that any station or system can create its own individual distinctive type fonts for its own programs easily and quickly.

The **CHIRON II** permits flexibility in title composition, including positioning of individual characters or lines, up or down, right or left, for esthetic reasons.

Circle Number 69 on Reader Reply Card

Mini-Programmer

Cole Instrument Corp. has developed a mini-programmer that will actuate any number of switches

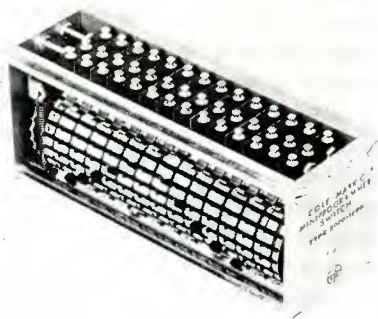

in any or all of 24 positions per revolution of its drum.

Called the **Mark C**, the unit can be changed in its settings quickly

and as often as needed, or it can be left as originally set up to repeat in cycles.

Thumb nail switches are rated at 5 amps, 250 VAC.

Available with homing, remote indexing, or relay activation designed for positive tab location.

Circle Number 70 on Reader Reply Card

100 Watt Translator

Introduction of a solid state 100 watt UHF translator featuring modular construction has been an-

(Continued on page 44)



Multi-Cartridge Decks Grow with Your Needs!



1 x 303C = 3 decks



2 x 303C = 6 decks



3 x 303C = 9 decks



1 x 305C = 5 decks



2 x 305C = 10 decks



3 x 305C = 15 decks

Mix and match these new **SPOTMASTER** multi-cart decks. They're designed to meet your needs today, and grow with them tomorrow.

Look at our 303C and 305C Mini-Decks. Space-saving combinations of 3, 5, 6, 9, 10 and 15 decks accept type A carts. Slightly wider is our Mini-603C (not shown), accepting both type A and B carts, three decks to a unit, six decks to a compact rack.

All these mini-giants feature plug-in, modular, solid state construction with separate audio amplifiers, selectable output level (-10, 0, +8), logic switching, and many more features. They're ideal for manual operation or programmed automation systems.

Save still more money with our time-tested Five-Spot and Ten-Spot multi-cart players. You can even get plug-in record modules. Write or call for complete information:

BROADCAST ELECTRONICS, INC.

— A Filmways Company —

8810 Brookville Road, Silver Spring, Maryland 20910 • (301) 588-4983

DO COLLEGES HELP BUSINESS AS MUCH AS BUSINESS HELPS COLLEGES?

Yes, they do. But not in the same proportion.

Business contributes about 15% of the total voluntary support received by colleges.

But today, business gets half the college-trained people who are employed. Tomorrow, it will need even more.

As a result, businessmen should think seriously about increasing the level of corporate giving to education. Can you, as a businessman, think of a better investment?

For the latest national figures on corporate giving to higher education, write on your letterhead for "CFAE Survey of Corporation Support of Higher Education," and enclose \$2.00 to help cover costs. Mail to: Council for Financial Aid to Education, 6 East 45th Street, New York, N.Y. 10017.

Give to the college of your choice. Now.



Advertising contributed for the public good.

nounced by Emcee Broadcast Products.

According to the company, the new Emcee TU-100U unit is completely solid state with the exception of the final amplifier, and is specifically designed to provide quality performance, long-term reliability, and simplified maintenance. The same modular design is being made available in 1 watt and 10 watt completely solid state UHF translators.

The solid state translator features interchangeable broadband modules to simplify maintenance. It is designed to cover channels 14-83 and CCIR bands IV and V.

Front panel metering is provided, including a true peak output power meter. Other metering includes: final plate current, plate voltage, and filament voltage.

Circle Number 71 on Reader Reply Card

Program Control System

IGM's new model 700 control system, was introduced at 1972 NAB in Chicago. It features built-in circuitry for memory control of reel-to-reel transports as well as talk or music on cartridges. Its solid-state memory of up to 3,000 program events permits a station to preprogram as many as 24 hours at a time, with each hour having up to 125 separate audio events. Each hour can be different from every other as necessary, and last-minute changes made without reprogramming the basic format. The system also permits a station to produce DJ shows from a DJ talk tape.

TV Election Reporting System

TeleMation, Inc. unveiled the TED-1 Television Election Display System. Company officials said that the system was developed to offer broadcast television stations a flexible, easy-to-use and relatively inexpensive system for coverage of elections and other major events. The TED-1 uses electronic character generators, mini-computers, teletypewriters and other associated equipment to automatically display alphanumeric information on a television screen.

A major advantage of the system from a broadcaster's point of view is that such a system could save a

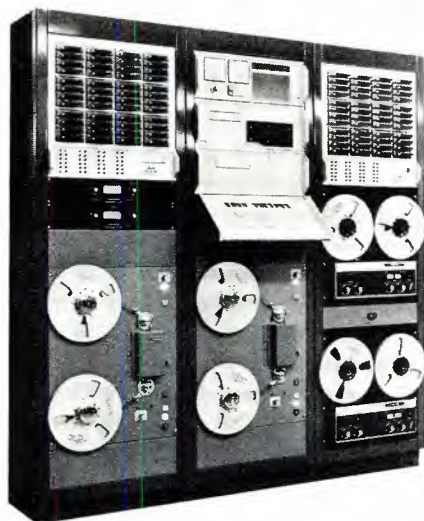

Available in two models (1,000-event and 3,000-event memories), the Series 700 systems standardize a combination of programming capabilities formerly available only through customized manufacture.

Circle Number 72 on Reader Reply Card

ask about our new am | fm | tv monitors



Call or Write ARNO MEYER

BELAR ELECTRONICS LABORATORY, INC.

Delaware & Montrose Avenues, Upper Darby, Pa. 19084 Box 83
(215) 789-0550

Circle Number 59 on Reader Reply Card

TV station the cost and inconvenience of building and rebuilding tote boards and sets for elections.

An important part of the system is a simplified computer which receives, processes and stores voting information, and displays selected election races on command. Anyone can use the computer since it is set up to use conversational language. A significant feature of the system is the simultaneous entry and display from different positions in a station. After elections are over, the various equipment components can be used for sports coverage, automatic news and weather reporting or other events.

Circle Number 74 on Reader Reply Card

Color Television Monitors

A new solid-state color television monitor using a 12-inch single-gun, three-beam, cathode ray tube was introduced by **Conrac Corporation**.

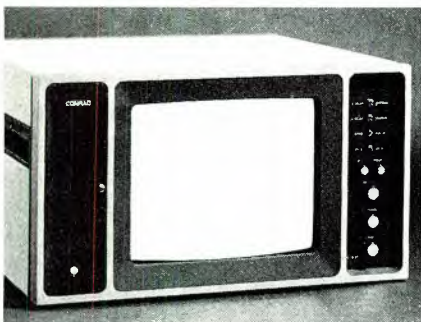

The new Conrac 5000 Series monitors have several option packages that permit the units to meet a range of professional and industrial requirements at optimum cost. They feature exceptionally bright and sharp picture presentations, excellent colorimetry and stability, and modern styling. All controls and switches are on recessed front panels, with all setup controls behind a lockable door.

A basic option package includes preset controls for contrast, brightness and chroma, two switch-selectable video input channels, and a continuously variable aperture correction. A professional option package adds to these a color/monochrome switch, under-scan switch, horizontal and vertical delay switches, a tally light and a blue signal output jack.

FM Frequency, Modulation Monitor

The new **McMartin TBM-3700** combines the FM frequency deviation and modulation percentage monitoring functions in a single, 7-inch rack mount unit.

The two functions are independ-

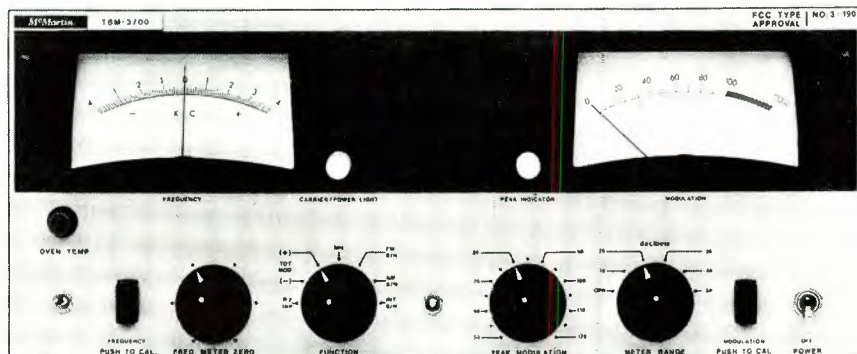

100% modulation) as well as system AM and FM signal-to-noise ratios can be measured directly.

The absence of an input RF signal automatically mutes the audio output. Auxiliary alarm contacts are provided for interconnection of an external carrier failure alarm.

dent of each other. Frequency measurement and calibration adjustments may be made without interruption of modulation monitoring.

A precise, internal reference signal permits calibration of the 100% modulation point at any time. The inherent internal FM noise of the TBM-3700 (typically -75 dB below

All critical circuitry is placed on plug-in, glass epoxy printed circuit boards accessible from the rear.

A kit is available for remote monitoring of frequency deviation and modulation percentage, as well as the peak flasher.

Circle Number 73 on Reader Reply Card

These options permit industrial, educational and CATV applications to use a high quality color monitor at a price compatible with most budgets, to move up slightly if additional signal control is required, yet permits stringent broadcast requirements to be met with the professional features. The 5000 Series also is an ideal component in any color VTR installation.

Linearity in the 5000 Series is within 2% of raster height, con-

vergence is 0.75% of picture height, interlace is better than 90%, stability within 1%. Luminance channel response is ± 1 dB, luminance and chrominance differential gains are less than 5%. Color decoder error is less than 2.5°.

The Conrac 5000 Series color monitors are available in cabinet, rack, bail mount and chassis versions. In its rack mount version, the 5000 takes up 10.5 inches (26.7 cm) of vertical space in a

(Continued on page 46)



VCA-2 with its differential input is designed to accept a 1 volt, ± 3 db composite video signal. Its back porch clamp removes unwanted low frequency signals, such as hum and bounce which may be contained within the input video signal. Call us, we'll answer all your questions.

RICHMOND HILL LABORATORIES INCORPORATED
142 Central Ave., Clark, New Jersey 07066
(201) 381-5955 Telex 01-38245

Circle Number 36 on Reader Reply Card



bring joy to your
little corner
of the world...



**Plant a Tree
for tomorrow!**

For details, write:
The National Arbor Day Foundation
Box 100 Arbor Lodge
Nebraska City, Nebraska 68401

(Continued from page 45)

standard 19-inch (48.3 cm) rack. The monitors are available with various standard color decoders—RGB, NTSC, PAL B and M, SECAM 50 and 60. Weight is 40 pounds (18 kg) net.

Circle Number 75 on Reader Reply Card

Parametric Equalizer

The Parametric Equalizer ME-230 from ITI Audio Products is an active stereo equalizer utilizing new signal processing techniques to replace the functions of several conventional equalizers, while increasing flexibility and performance.

Each channel provides both hi and low frequency shelving equalizers as well as 3-section parametric control group. Each section includes the following infinitely variable controls: frequency, level ± 12 dB, and shape (Q). The frequency ranges of the three sections are 10-800 Hz, 100-800 Hz, and 400-25,600 Hz, each accurately calibrated. Shape is variable from 4 to 14 dB/octave and does

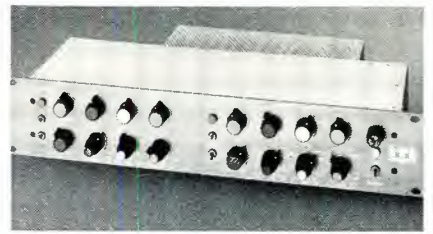

not affect amount of equalization. No inductors are used in the parametric sections, and ringing on transients is virtually non-existent.

Since the system has unity gain, it may be inserted in a line without program quality degradation—transient-free switching permits use as needed.

Typical uses include remix and transfer rooms, wave shaping in electronic labs, removal of room resonances, environmental compensation, and all forms of audio spectrum controls.

Circle Number 76 on Reader Reply Card

Computer Controlled Lighting System

Skirpan Lighting Control Corporation of New York City an-



MULTIPLE TIME PROGRAMMER

- Precision crystal controlled digital clock.
- 16 events may be programmed to the exact second.
- Each of the 16 outputs appear as isolated relay contacts.
- Any of the events may be re-programmed at will.
- Automatic battery change over in case of power failure.
- Net Price \$995.00.

TAPECASTER TCM, INC.
AUTOMATION AND DIGITAL PRODUCTS DIVISION
Box 662, 12326 Wilkins Avenue, Rockville, Maryland 20851

Circle Number 60 on Reader Reply Card

nounced that it has acquired the manufacturing and patent rights to a new computer memory lighting control system which will be marketed under the trademark 'AutoCue'.

The system, which was invented by Adrian B. Ettlinger, uses a combination of computer and television technology to memorize complete sequences of lighting effects for theatrical or television productions, and is currently in use at the CBS Television Studios in Hollywood.

Circle Number 77 on Reader Reply Card

Modular Tape Cart Equipment

SPARTA Electronic Corporation introduced the Century Series, a completely new modular line of ultra-compact tape cartridge equipment. Record and playback modules are the same size: three will mount side by side in standard racks. Single and multiple desk models are also available.

Features include "touchbar"

operation, built-in audio switcher, electronics on a single plug-in printed circuit board, three audio inputs to record amplifier, and optional secondary tone. Mono playback can be field-converted to stereo. Replacement circuit boards are available at a nominal exchange price after the one-year warranty period.

Circle Number 78 on Reader Reply Card

Helical Scan Time Base Corrector

Television Microtime, Inc., a subsidiary of Andersen Laboratories, Inc., announces the introduction of their new Time-Base-Corrector. The unit will be sold as an accessory to the newest types of Helical VTR's, as offered by AMPEX and International Video Corporation.

Time-Base errors in Helical VTR's are of such magnitude as to render the output signal incompatible with other sources of video (cameras, film chain, other

(Continued on page 48)

McMartin SCA Multiplex Receivers

"State of the art" design. Exclusive **UNI-STRUCTION™** provides high quality reception, minimum maintenance, field-proven reliability. Meet FCC Rules, Part 15.

TR-66B

Most advanced SCA receiver on the market. Accommodates plug-in amplifier modules plus balanced mike input.



TR-55

McMartin's unequalled combination of high performance and economy. Available with matching 10, 25 and 75 watt (RMS) amplifiers.



For complete information including details on new TR-E1 educational receiver write:

McMartin industries, inc.
605 North 13th Street
Omaha, Nebraska 68102

- Broadcast
- Background Music
- Commercial Sound

Circle Number 40 on Reader Reply Card

Make YOUR COMMUNICATIONS "Whisper-Clean"

Economical MILLER-STEPHENSON aerosols take the headaches (and a lot of expense) out of what used to be a nuisance.



MS-180 FREON TF DEGREASER—No need to disassemble components. Spray MS-180 onto relays, circuit boards, motor parts. Eliminate grease, prevent recontamination. Non-conductive, non-flammable. Reduces maintenance costs. MS-180 available in quarts, gallons, and 5 gallons.

MS-200 MAGNETIC TAPE HEAD CLEANER—Spray away oxide dust before it ruins heads and tapes. MS-200 whisks it away. Manufacturers recommend it; communications experts prescribe it; EDP operators wouldn't be without it. U.S. & FOREIGN PATS.

MS-230 CONTACT RE-NU—Renew your contacts. Contact Re-Nu does it. Knock out dirt, carbon, and other contaminants. Will not harm insulation; leaves no residue. Switch to MS-230 for your switches—and other points.

For FREE 16-oz. aerosol sample of any one of the above, write (on your company letterhead, please), or use coupon for free data.

**ms miller-stephenson
chemical co., inc.**
ROUTE 7, DANBURY, CONN. 06810

Please send me Data on:

- MS-180 DEGREASER MS-200 HEAD CLEANER
 MS-230 CONTACT RE-NU

INTENDED USE _____

NAME _____ TITLE _____

DEPT. _____

COMPANY _____

ADDRESS _____

CITY _____ STATE _____ ZIP _____

- CHICAGO • LOS ANGELES • TORONTO
 DIST. IN: MILAN • HAMBURG • PARIS • LONDON

Circle Number 49 on Reader Reply Card



...your "sound"
out of date?

for best performance

STL TEST TAPES

STANDARD TAPE LABORATORY

Most Accurate STL tapes are tops for accurate Azimuth Reference.

Produced Independently by Standard Tape Laboratory with its own precision equipment.

Internationally Acclaimed by major equipment manufacturers, broadcasters and recording studios throughout the world.

All Audio Widths 150 mil. to 2-inch. Catalog-listed tapes of 1/4" priced at \$24.00 each.

Prompt Delivery (by return mail) to insure freshness.

For the distributor
in your area

Call or
write: **TABER**

**MANUFACTURING &
ENGINEERING CO.**

2081 EDISON AVE. • SAN LEANDRO, CALIF. 94577 • PHONE: (415) 635-3832

Circle Number 41 on Reader Reply Card

IT'S A MONEY-MAKING MEMORY

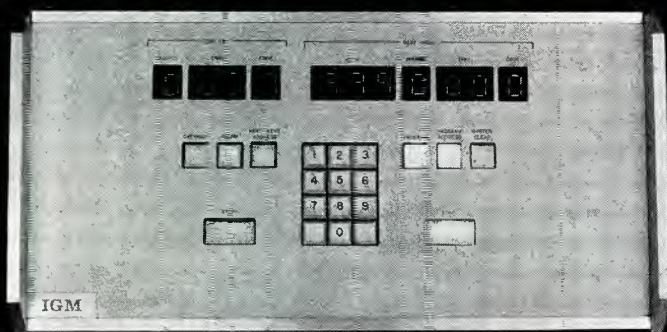

IGM's MOS memory minds the store for you, all day, all week, and never misses a sale. It has such a wide range of capability that it's mind-blowing. Write or phone for complete information.

3950 Home Road
Bellingham, Wash. 98225
(206) 733-4567

IGM

Circle Number 46 on Reader Reply Card

(Continued from page 47)

VTR's) and this has limited their use to closed-circuit.

TMI's new TBC operates on the output of the recorder as the automatic delay line. Using station timing as a reference, the TBC corrects the time errors down to a stability suitable for broadcast standards. Its range of correction is ± 2.2 microseconds, with a final resolution of ± 3 nanoseconds. It is housed in a standard 19" rack-drawer, 7" in height.

Circle Number 79 on Reader Reply Card

Super 8 Film Chain Projector

A new super 8 television film chain projector offering a variety of convenience features at a low price was shown by **Eastman Kodak Company**.

The Eastman super 8 videofilm projector, model TV-M100A, provides television stations, CATV systems, and closed-circuit television systems with a low-cost means for projecting super 8 movies with magnetic sound tracks into a television system.

Among the projector's features is a magnetic recording section with inputs for microphone and phonograph or tape recorder, high-precision sound head using ultrahard Alfenol material for long life, safety lock on the record-play switch to help prevent accidental sound erasing, solid-state amplifier, and a red signal light indicating record mode.

Circle Number 80 on Reader Reply Card

Random Access Select TV Titling

A new generation of electronic titling equipment—called Vidifont X—was introduced at the convention by **CBS Laboratories**. The new machine uses a random access memory that permits the use of changeable typographic font styles in any size to be stored and retrieved on command.

Because CBS designed the unit with compatibility in mind, any Vidifont user who wants the latest innovations, including random access memory, will be able to have it pin-for-pin compatible without his Vidifont becoming obsolete.



The Vidifont X can be set up by viewing a monitor, then storing for later recall. Unit capability includes color letters and words in combination, flash, crawl or roll, upper and lower case, serif or sans serif. Font change takes about 10 seconds.

A nixie readout gives logging numbers for later recall.

When baseball scores are put in the roll mode, they can be momentarily stopped in order to keep pace with the on-air sports announcer.

Circle Number 81 on Reader Reply Card

One-Inch Video Production Recorder

A console version of the VPR-7900 1-inch video production recorder with time base corrector has been placed on the market by **Ampex Corporation**. It contains a 12-inch picture monitor and video waveform monitor for convenient checkout of recorder functions.

The new VPR-7950 is designed for use in sophisticated closed circuit teleproduction centers in education, business, industry, and medicine for origination and editing of color or monochrome television program material.

The VPR-7950, when used with the color version of the TBC-790 time base corrector, produces color pictures stable enough to meet all government and industry standards, according to A. A. Sroka, marketing manager, audio-video systems division.

It was demonstrated for the first time at the National Association of Broadcasters' convention in Chicago.

"The VPR-7950 is designed to contain many of the features of standard quadruplex broadcast recorders while greatly simplifying service and maintenance compared with other one-inch recorders used in closed circuit teleproduction applications," Sroka said.

The VPR-7950 contains a time base corrector and processing amplifier which correct errors introduced into a tape recording by the electro-mechanical portions of the recorder.

Color versions also contain a direct NTSC color module which corrects color phase errors. Optional accessories include a color dropout compensator which senses dropouts and replaces them with video and chroma information from the previous line, and an automatic velocity compensator which eliminates line-by-line color errors caused by minute mechanical disturbances occurring within each line.

The VPR-7950 is available in color or monochrome configurations. It is 42 inches wide, 71 inches high, 26 inches deep.

Circle Number 82 on Reader Reply Card

Quad-Eight Mixer

Quad-Eight is introducing a new mixing tool. This device is all that is required to add full Quadra-sonic Mixdown Capability to any well designed 16 Track Console.

The 16 inputs are positioned in 4 quadrants by concentric pan pots. These new concentric quad pan pots are exclusive with **Quad-Eight** and they are also part of the **Quad** features and options in our new consoles.

These new pots are identical circuits to the Joystick variety. However, they offer compactness, low cost and the concentric knobs can be calibrated to allow easy return to logged positions.

Four echo return pots are provided, plus four balance pots and master gain control.

Circle Number 83 on Reader Reply Card

FREE CATALOG
HARD-TO-FIND PRECISION TOOLS

Lists more than 1700 items—pliers, tweezers, wire strippers, vacuum systems, relay tools, optical equipment, tool kits and cases. Also includes four pages of useful "Tool Tips" to aid in tool selection.



JENSEN TOOLS and ALLOYS
4117 N. 44th Street, Phoenix, Arizona 85018

Circle Number 45 on Reader Reply Card

Spotmaster

Tape Cartridge Racks

- Free standing
- Table top
- Wall mounting



Enjoy real fingertip convenience with these Spotmaster tape cartridge racks. Three styles, holding up to 200 cartridges, meet every need. RM-100 wood rack stores 100 cartridges in minimum space, for wall or table top mounting, \$47.50. LS-100 lazy susan rack holds 100 cartridges on table top rotating stand, \$79.50. RS-200 revolving rack is on casters for floor storage and mobility, accepts 200 cartridges, \$145.50. RS-25 rack sections, used in rotating racks, hold 25 cartridges, may be wall mounted individually; rugged steel construction, \$13.00.

Order direct or write for details.

BROADCAST ELECTRONICS, INC.
A Filmways Company
8810 Brookville Rd., Silver Spring, Md. 20910

SPARTA

everything in AM transmitters

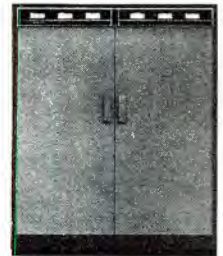

Throughout SPARTA's Fritz Bauer designed AM Transmitters you'll find quality components such as oil-filled modulation transformers, vacuum capacitor final tank tuning, and a tally-light fault finding system. AM Transmitter reliability is yours with SPARTA equipment. Call or write your SPARTAMAN today!

SPARTA ELECTRONIC CORPORATION
5801 FLORENZ-BERKINS ROAD SACRAMENTO CALIFORNIA 95820 (916) 383-5100

A DIVISION OF COMPUTER EQUIPMENT CORPORATION

Circle Number 44 on Reader Reply Card

PASS FCC EXAMS FOR FIRST & SECOND CLASS LICENSES

New 21 lesson, 450 page course. Includes over 600 multiple-choice, FCC-type questions. Easy-to-understand. No previous technical knowledge required. Starts with basic electricity. Covers both First and Second classes. Cat. #15-01.

Ameco Publishing Corp. Complete Only **\$5.95**
314G Hillside Avenue
Williston Park, N.Y. 11596

Circle Number 58 on Reader Reply Card

ROH INC.

200 Series

BROADCAST AUDIO EQUIPMENT

10 Popular Audio Processing Modules

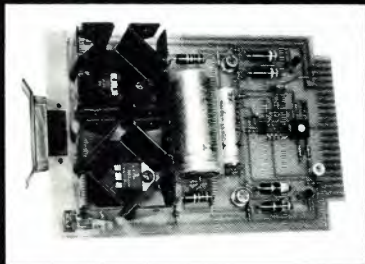

Model 210 10 Watt Amplifier

And 4 Multiple Module Enclosures



Model 201/202 10 Module Enclosure

Plus Accessories



Models 206-209 Power Supplies

Model	MODULES	Price
210	10 Watt Monitor Amplifier	76.00
211	1x5 DA Unbalanced Output	70.00
212	1x5 DA Balanced Output	120.00
213	12x1 Active Combining Network	55.00
214	Line Microphone Pre-amplifier	70.00
215	Program Amplifier Balanced Output	65.00
216	4 Channel Variable Attenuator	55.00
217	4x1 Solid State Crosspoint Switch	80.00
218	Dual Channel Photo/Tape Pre-amplifier	65.00
219	Audic Processing Amplifier	100.00

ROH CORPORATION

3161 Maple Drive, N.E., Atlanta, Georgia 30305

Circle Number 34 on Reader Reply Card

TECHNICAL DATA

For further information, circle data identification number on reader service card.

100. ALLEN AVIONICS, INC.— General catalog #16 covers a wide range of precision delay lines, laboratory decade delay lines, L-C filters, variable and fixed attenuators and video equalizers. Featured in the delay lines section is "Spiradel", the most complete group of stocked high ratio compact distributed delay lines available. Also specified are low silhouette units designed for dual-in-line packaging, including "LC Dip", the smallest 14 pin tapped lumped constant delay line. The 16-page catalog contains complete specifications, drawings, and applications.

101. BURWEN LABORATORIES— A new six-page brochure on the company's Noise Eliminator Model 2000 is now available. The Model 2000 Noise Eliminator is a record-play signal processor which extends the dynamic range of a studio tape machine or transmission link to as much as 110 dB. The brochure lists features, specifications and is illustrated.

102. CHRONO-LOG CORP.— A new bulletin describing the Series 40,000 Video Digital Clocks which generate video characters for the remote display of digital time on inexpensive video monitors is now available. These clocks are useful in digital time systems which require several remote displays. The Series 40,000 Video Clock overcomes three major problem areas previously encountered in remote digital time display systems; (1) No need for high cost remote digital displays— inexpensive video monitors can be used; (2) Only a single conductor cable need be run to each remote— and these cables may be daisy-chained from one display to the next; (3) Large numerical displays several inches high are easily achieved on video monitors, with no parallax reading errors, and

high readability even in high ambient light. Specifications are also included in the bulletin.

103. COMPUTER LABS— A new data sheet on the LAB 210 Transverter contains both specifications and application notes. The LAB 210 Transverter is a measuring device which provides the functions of five precision instruments in one: A/D Converter, AC Digital Voltmeter, 100-word Memory, Transient Max/Min Detector and D/A Converter. The data sheet also contains photograph and drawings.

104. EDITEL PRODUCTIONS LTD.— Editel is offering an Information Kit on their Super Truck Studio which carries a whole TV studio on its back. The 57 foot long tractor trailer has more television equipment than most TV stations have. It contains six color TV cameras and facilities to satisfy all the technical requirements of any broadcaster.

105. EMR COMPUTER— A new 30-page 'Communications General Information Manual' prepared expressly for those faced with the task of implementing a modern data communications system is now available. Designated EMR Publication No. PP-1200-001, the new manual begins with an introduction to data communications terms and techniques and then thoroughly discusses methods of integrating computer hardware and software into a total communications system. Discussion centers around EMR's 6100 Series systems, including the 6135 computer—a field-proven system now operating in numerous data communications installations—and the new 6145 computer—which represents a combination of high-performance hardware and efficient, multi-use software. Numerous charts and block diagrams illustrate the text.

106. GENERAL AUTOMATION, INC.—A new 16-page pocket size Product Handbook providing descriptions of its new SPC-16 and SPC-12 minicomputers, System 18/30 Supervisory Computer—a replacement for IBM-1130 and IBM-1800 computers, software, Disk Monitor System, interface modules (minicontrollers) for OEM and systems users, and its Automotive Industries Division is now available.

107. GENERAL ELECTRIC CO.—Three General Electric lighting reference publications used by the television, motion picture, and theater lighting industries have been completely revised. "Quartz-line™ and Incandescent List" (SS-1) catalogs the lamps most frequently used in lighting theater stages, television and motion picture production, and professional still photography. "Fixture Relamping Guide" (SS-3) lists more than 1,200 lighting fixtures made by 29 firms. In addition to the maker's catalog or model number, each listing describes the unit, recommends maximum allowable wattage, and tells where suitable lamps for the unit are listed in publication SS-1. The third booklet, "ANSI Cross-Reference List" matches the ANSI code with the equivalent GE lamp or replacement.

109. GRAY RESEARCH—Gray Research is now offering Product Specification Sheets on their new products. Each specification sheet contains photographs, drawings and prices. Some of the products included are: Professional Turntable Preamplifier, Automatic Antenna Heater Control System, Modular Studio Furniture, Broadcast Equalizer, and Professional Stereo Tone Arm.

110. HEWLETT PACKARD—Testing RF transmission line runs (coax and waveguide) is the subject of a new 16-page Data Sheet. Test arrays covering 0.01 to 18 GHz are detailed for swept measurements of Insertion and Return Loss vs. Frequency. In addition, these test systems can perform frequency-selective location of faults (discontinuities) in the transmission line.

These are shown by displaying Return Loss vs. Distance for carrier frequencies to be used in the line. This capability is especially useful in evaluating performance of transmission lines associated with RF/microwave communications systems. The test methods described will yield more than 60 dB of dynamic range, will read out distances digitally to 1% and will function in coax or waveguide (or combinations of the two) with a single, portable "interface" unit. Equipment used in the measurements is general-purpose instrumentation (e.g., sweep oscillator, spectrum analyzer, frequency counter), therefore usable separately for all usual purposes.

111. PACE WIRE & CABLE CORP.—A new 4-page brochure gives applications on their line of wire and cables. It includes hookup wire; internal hookup cables; special purpose multiconductor cable; electrical shielded pair cable; paired intercom cable; audio cable, unshielded; audio cable, shielded; communication cable, shielded pairs; communication cable to REA Spec. PE-20; and shielded microphone cable.

112. PHELPS DODGE COMM. CO.—A recently introduced series of collinear roof top vehicular antennas is described in a new catalog sheet. The literature fully describes the new 5.2 dB gain antennas and their operation as end fed collinear arrays with the greatest possible two element aperture size yielding the stated gain over the quarter wave whip they were designed to replace. Individual model numbers are provided for each style of antenna offered.

113. PHONPLEX CORP.—Phonplex Corporation's DVM 1300, the first modem for the simultaneous transmission of quality voice and significant quantities of data over a single voice grade telephone line, is detailed in a new technical brochure. The brochure describes applications of the modem in various configurations as well as equipment specifications, features and principles of operation. DVM 1300

(Continued on page 52)

LPB

**is definitely
not
fattening...**

LPB is a manufacturer and distributor of Studio and Broadcast equipment at low, low prices. It's worth your time to find out more, so call Dick Crompton or Ted Davey or write



LPB Inc.
520 Lincoln Highway
Frazer, Pa. 19355
(215) 644-1123

117

Circle Number 47 on Reader Reply Card

SPARTA

**everything
in
audio consoles**



Five channels with 14 inputs or 8 mixing channels with 22 inputs, take your choice! SPARTA has the monaural console for your broadcast needs. SPARTA consoles are in a class by themselves in versatility and mixing. Add a SPARTA Extender Panel and the capability of your console is expanded! Quality equipment at a realistic price is yours with SPARTA. Contact your SPARTAMAN today.



SPARTA ELECTRONIC CORPORATION
5851 FLORIN-BERKINS ROAD SACRAMENTO, CALIFORNIA 95828 (916) 283-5353

A DIVISION OF COMPUTER EQUIPMENT CORPORATION

Circle Number 48 on Reader Reply Card

versatile new 14-Piece, 1/4" Sq. Drive socket wrench set drives fasteners 7 different ways



REVERSIBLE RATCHET — Precision made, long life, fully enclosed mechanism. Short handle swing for close quarter work.

UNIQUE SPINNER/EXTENSION — 5-3/4" overall. Plastic (UL) handle with 1/4" sq. drive socket insert for ratchet. Use also as regular nutdriver.

2" DRIVE EXTENSION — Fits on ratchet or either end of spinner/extension.

RUGGED, HEAT TREATED, ALLOY STEEL SOCKETS — Nine for hex sizes 3/16" thru 1/2". Two dual purpose for hex and square sizes 1/4" and 5/16".

FREE STICK-ON INITIALS personalize the sturdy plastic case and help prevent loss or mix-up.



No. 1001 SET

Made
in U.S.A.

nationwide availability through
local distributors

REQUEST BULLETIN N770

XCELITE®

XCELITE, INC., 118 Bank St., Orchard Park, N. Y. 14127
In Canada contact Charles W. Pointon, Ltd.

Circle Number 50 on Reader Reply Card

Tech Data

(Continued from page 51)

enables simultaneous transmission of digital and voice information by notching out a part of the available telephone line bandwidth and utilizing the open frequency to transmit digital data at up to 1300 bits per second.

114. INTERNATL. RECTIFIER CORP.— A low cost 20 amp general purpose rectifier, featuring a diffused junction and a high surge current rating (400 amps), is described in a new brochure. The 20F series replaces all known DO-4 package devices through 400 Volts. It is available with repetitive reverse voltage ratings from 100 through 400 Volts. Applications include battery chargers, motor controls, power supplies, transmitters and transceivers. The brochure includes complete electrical, thermal and mechanical specifications. Five graphs provide complete information on both steady state and transient operating characteristics. The combination of DO-4 package and 20 amp forward current gives the rectifiers an unusually high size to current: 1 ma average at a junction temperature of 175° C.

115. RAYTHEON CO.— Micro-wave ferrite switches are described in a new six-page bulletin. The theory of operation of ferrite switches is presented along with information on applications in radiometry, attenuators, and real time delays. Fifteen devices for operation at L, S, C, X, and Ku bands are described with their principal specifications.

116. RCA-ICAN-6724, "A Flexible Integrated Circuit Color Demodulator for Color Television" is now available. This Application Note details the use of the RCA-CA3067 in a color television receiver. A complete block diagram of a color receiver is shown, and schematics are given detailing the interconnections of the CA3067 to peripheral components and drive circuitry. Graphs showing the performance of the color demodulator circuitry using the CA3067 are also included.

117. REVOX CORP.— Micro-phones and headphones are described in a new brochure. The brochure also contains accessories, photographs, prices and descriptions of the equipment.

118. RHG ELECTRONICS LAB., INC.— A new four-page technical information bulletin describing their multi-octave double balanced imageless mixers is now available. Known as Bulletin M-172, it contains general information, applications and operating theory for the unique mixers which offer frequency coverage from 1-12 GHz in a single assembly. A block diagram and figures showing comparative frequency spectrums and performance characteristics are included along with a listing of available standard models.

119. RUSTRAK INST. DIV.— A new eight-page catalog covers Rustrak's Series 400 Potentiometric strip chart recorder line. The catalog describes the Model 400 miniature single channel recorder, the Model 3400 dual channel recorder and the single channel Model 1400 for EIA rack mounting. A number of features and options for each model is also shown. More than 70 ADD-A-FUNCTION plug-in Signal Conditioners are included for converting the basic 0-100 mV recorders into DC voltage and current, AC voltage and current, temperature, and special application recorders.

120. SOS PHOTO-CINE-OPTICS, INC.— A new 40-page catalog, "Editing And Film Handling Equipment", is now available. It contains over 1,000 items fully described, priced and liberally illustrated. Included are separate categories covering the latest in film editing machines, viewers, sound readers, synchronizers, rewinds, splicers, editing tables, film cleaners, racks and cabinets, plus the complete range of sundry items covering film punches, scissors, gloves, leader, labels; reels, cans and cases, etc.

**Send Your Industry News
To Broadcast Engineering
For Better Coverage**

bookreview

The **Guide to Professional Radio & TV Newscasting** is a practical self-study guide especially written for those who want to get started in the field of broadcast journalism. The author, Robert C. Siller, is an experienced network journalist. He discusses all the basic elements needed, then goes on to show how the pros on both local and network levels prepare for a newscast—the ritual they follow to keep informed, and how they plan and produce a newscast in conjunction with other staff members. Some of the more detailed content encompasses how a newsman writes his copy, how he “plays” a story, how writing style is developed. Based on first-hand knowledge, the author tells how the pros mark and time a script, how they “road map” for easy delivery on the air, stopwatch and back-time, with actual samples. The book also explains the various ways audio tape is used to advantage in broadcast journalism.

Also revealed are the “fine points” of TV news, beginning with an examination of the services provided by the visual medium. Here, the reader is acquainted with the typical TV newscast “line up”; how news stories, commercials, promos, film and tape inserts are blended into a workable script; and how last minute revisions are handled. Next the author presents the elements of the TV newscast—the script format, production problems and techniques, film and slide projection, plus the use of video tape.

Clearly outlined are the duties and requirements of the anchorman at various levels—local station, medium-sized station, and network—including what’s expected at each stage of professionalism. Finally the author describes the opportunities available to the new man, how to get that elusive first job, serving the apprenticeship, climbing the ladder to the top, plus some notes on wages and working conditions.

This book is available through Tab Books, Blue Ridge Summit, Pa.

Circle Number 85 on Reader Reply Card

Television Broadcasting Camera Chains, written by Harold E. Ennes, provides the fundamental and advanced training that is necessary if full benefit is to be obtained from the information in modern instruction books. To do this most effectively, where possible, complete, detailed schematics have been avoided, and, instead, use has been made of block diagrams with simplified diagrams of individual blocks under discussion. The overall system concept is stressed so that the reader can more readily grasp the meaning of a specific circuit adjustment in terms of its effect on system performance.

The 464-page book contains 11 chapters.

This book is available through the Howard W. Sams Co., Indianapolis, Ind.

Circle Number 86 on Reader Reply Card

Increase Head Life with ISOLAIR New Clean Air Unit by LIBERTY

This unit provides a laminar down flow of the cleanest possible air at the critical video head area. Excessive wear and damage by airborne contaminants are virtually eliminated, extending head life by 100% or more and insuring better overall VTR performance, as well as saving time and money. The unit is suspended from the ceiling thus requiring no additional floor space. It is easily installed and maintained and meets Federal Standard 209a, Class 100.



An additional positive effect is the cumulative result of the constant filtering of air from the entire room, so that during an extended period of use, the level of contaminants in the surrounding environment is progressively reduced.

Liberty Industries has the capability for providing complete clean air environments for any size or type of operation. Our sales engineers are ready to help you.

Call or write.



LIBERTY INDUSTRIES, INC.

598 Deming Road, Berlin, Conn. 06037
Telephone (203) 828-6361

Circle Number 38 on Reader Reply Card

**ERASE
RECORD
REPRODUCE**
MONO - STEREO

Professional Direct Replacement Heads with complete written and pictorial instructions

Our factory will clean, rebuild, adjust and test your head ASSEMBLY...install new MMI heads...replace minor hardware and modify your gate to accept our “NON-POPPING” springs



36 HOUR SERVICE - LOANERS AVAILABLE
(612) 884-7393



MINNEAPOLIS MAGNETICS, INC.
8125 PLEASANT AVE. SO., MINNEAPOLIS, MINN. 55420

Circle Number 39 on Reader Reply Card

**can your
fm
antenna
do this...**



and this..



**if not,
let's
trade.**

Trade in your weak signal for one that reaches into those difficult fringe areas, car receivers, small portables. "Trade-in" your old PULSE and ARB ratings for better ones.

Trade your old antenna for our "Penetrator." It's the only patented circularized FM antenna. The "Penetrator" features will meet your exact horizontal-to-vertical ratio requirements and save you money, too!

Built to last with marine brass and thick-wall copper, the "Penetrator" features low wind resistance, lightweight, high power capabilities, and wide VSWR band widths of 1.08 to 1 + 200 KC.

Your antenna does have **trade-in** values. Write us today for prices, catalog and trade-in details.

J

A

M

P

R

O

**ANTENNA
COMPANY**

A DIVISION OF
COMPUTER EQUIPMENT
CORPORATION
(916) 383-1177
6939 POWER INN ROAD
SACRAMENTO, CALIF.
95828

Wiring The World—The Explosion In Communications was written by the editors of the Book Division, U.S. News & World Report, Inc., with the assistance of Richard Doan, columnist and staff writer for TV Guide.

The book presents a history of the growth of cable television; a description of how cable TV works; analysis of the programming of cable TV, and the advantages and disadvantages as compared to broadcast TV; and a history of the growth of government regulation of cable TV. The book also informs the reader about picture telephones, videocassettes, and the development, present and potential uses of communications satellites.

This book is available through the Book Division, U.S. News & World Report, Washington, D.C.

NAB Announces Management Seminar

The National Association of Broadcasters has announced that its eighth Management Development Seminar for radio and television executives will be held July 16-28 at the Harvard Business School.

The two-week seminar, conducted by Business School faculty members, will utilize the case-study method.

The major objective of the seminar, which is limited to 60 broadcast executives, is the development of managerial skills used in the analysis and solution of broadcast management problems.

Almost 500 broadcasters from the U.S. and abroad have graduated from the seminar program since its inception in 1959.

Industrial TV Set For Video Tape Meet

The Industrial Television Society will hold its Fourth annual Video Tape Competition and annual meeting in Chicago, June 18-21, meeting at the O'Hare Field Marriott Inn.

Five cities will hold regional judging events prior to the June Chicago meeting. These regional video tape judging cities include, Tulsa, Toronto, San Francisco, Atlanta and Philadelphia. Winners in the regional competitions will be judged nationally for awards by the Society in Chicago. Deadline for regional judging entries has been set for May 1st.

Entrants will be able to submit video tape productions in the following categories: Instructional, Promotional, Informational programs, Sales/Marketing shows and Social Documentaries. Technical achievement winners will also be judged in addition to the five general categories.

This years competition centers on a design to honor the efforts of practitioners in the field of video tape instruction and training via tape media, and those who promote the use of video tape in industry, education sales/marketing and like fields of everyday use.

Persons interested in further details and necessary entry forms may obtain same by writing: Mr. Joseph Gormen, Box 542, Niagara Falls, N.Y. 14302 or Mr. Pat McGowan, Box 11219, Palo Alto, Calif. 94306

VIR JAMES
CONSULTING RADIO ENGINEERS
Applications and Field Engineering
345 Colorado Blvd.
Phone: (Area Code 303) 333-5562
DENVER, COLORADO 80206
Member AFCCE
TWX 910-931-0514

**COURTRIGHT
ENGINEERING**
MORRIS COURTRIGHT, Jr., P.E.
Automation - Applications Field Engineering
ELECTRICAL AND BROADCASTING
Route No. 1, Box 854A, Flagstaff, Ariz. 86001
Phone (602) 774-8206

**CAMBRIDGE CRYSTALS
PRECISION FREQUENCY
MEASURING SERVICE**
SPECIALISTS FOR AM-FM-TV
445 Concord Ave. Phone 876-2810
Cambridge, Mass. 02138

TODD ASSOCIATES
CONSULTING RADIO ENGINEERS
Alva C. Todd, Ph.D., P.E., Principal
827 S. Summit Avenue, Ph: (312) 832-4104
VILLA PARK, ILLINOIS 60181

B. F. GOLDBERG & ASSOCIATES
Consulting Radio Engineers, Architects-Engineers
since 1961 . . .
AM, FM and TV Applications
Facilities Planning & Architectural Service
Acoustical Expertise
Field Engineering
Antenna Measurements & Proofs
2100 Beltline Blvd.
(803) 782-5302 Columbia, S. C. 29204

SESCO, Inc.

47 NICHOLS AVENUE
P. O. BOX 518

(206) 378-2137

FRIDAY HARBOR,
WASHINGTON, 98250

CLASSIFIED

Advertising rates in Classified Section are 15¢ per word, each insertion, and must be accompanied by cash to insure publication.

Each initial or abbreviation counts a full word. Upper case words, 30¢ each.

Minimum classified charge, \$2.00.

For ads on which replies are sent to us for forwarding, there is an additional charge of \$2.00 to cover department number, etc., which is printed in advertising copy, and processing of replies.

Classified columns are not open to advertising of any products regularly produced by manufacturers unless used and no longer owned by the manufacturer or a distributor.

Ameco Publishing Corporation.....	50
American Data Corporation.....	48
American Electronic Laboratories.....	13
Angenieux Corporation of America.....	40
Audio Video Engineering Co.	CE-12
Belar Electronic Laboratories, Inc.	44
Berliner Uitar Audio Products.....	41
Broadcast Electronics	12, 43, 49
Broadcast Equipment Leasing Co.	8
Canon Inc.	Cover 3
Cohu Electronics, Inc.	1
Danscoll LTD.	35
Dynair Electronics, Inc.	24
Dynasciences Corp., Instrument Syst. Div.	22
Eastman Kodak Company.....	CE-9
Eimac Div., Varian.....	5
Electro Voice, Inc.	Cover 2
Elpa Marketing Industries.....	35
ES Enterprises	29
Fidelipac, A Div. of Telepro Industries, Inc.	9
Freeland Products	40
General Time Service.....	17
The Grass Valley Group, Inc.	3
International Good Music.....	48
Jampro Antenna Co.	54
Jensen Tools and Alloys.....	49
Joa Cartridge Service.....	9
Liberty Industries, Inc.	53
Low Power Broadcast Co.	51
Marco Video Systems.....	18
McMartin Industries, Inc.	37, 47
Miller-Stephenson Chemical Co., Inc.	47
Minneapolis Magnetics, Inc.	53
Multronics, Inc.	28
Nortronics Company, Inc.	10
Panduit Corp.	CE-6
Philips Broadcast Equipment Corp.	CE-11
Pulse Dynamics Mfg. Corp.	37
Recortec, Inc.	38-39
Richmond Hill Laboratories.....	45
Roh Corp.	50
Russco Electronics Mfg. Co.	40
SC Electronics, Inc.	11
Howard W. Sams & Co., Inc.	42
Sparta Electronic Corp.	49, 51
Spotmaster	12, 43, 49
Taber Manufacturing & Engineering.....	48
Tapecaster TCM., Inc.	46
Tech Laboratories, Inc.	8
Teledyne Isotopes	33
Varian Associates EIMAC.....	5
Visual Educom Incorporated.....	CE-5
Visual Electronics, Inc.	7
Vital Industries, Inc.	Cover 4
Xcelite, Inc.	53

Training

To advance in electronics, knowledge and ability are required. Grantham offers correspondence and resident instruction, in depth, leading to the degree of Associate in Science in Electronics Engineering. G. I. Bill approved. Credit for previous training and experience allowed. Free Catalog Write: Dept. E-2, Grantham School of Electronics 1505 N. Western Ave., Hollywood, California 90027. 6-67-tf

First phone through tape recorded lessons at home plus one week personal instruction in Washington, DC. Atlanta, Boston, Detroit, New Orleans, Minneapolis, Seattle, Denver, Portland, Los Angeles. Proven results. Our 17th year teaching FCC license courses. Bob Johnson Radio License Preparation, 1060D Duncan, Manhattan Beach, Calif. 80266. Phone 213-379-4461. 1-69-tf

PASS FCC EXAMS with Ameco books. Each book contains FCC questions plus simplified answers plus FCC-type exams and answers. 3rd class 75¢, 2nd class \$2.25, 1st class \$1.50. Free catalog. Ameco Publishing, 314G Hillside Ave., Williston Park, N.Y. 11596. 5-72-1t

Services

CRYSTAL & MONITOR SERVICE. Frequency change, repair or replacement of oven type broadcast crystals. Also free frequency change and recalibration or repair of AM frequency monitors, and H-P FM monitors. Fast service at reasonable prices. 30 years experience! Call or write: Eidson Electronic Co, Box 96, Temple, Tx. 76501. Pho. 817 773-3901. 9-70-tf

DID YOU KNOW that we can repair and recalibrate to original accuracy G.R. 1181-A and Gates MO-2890 frequency monitors at very reasonable prices? Also broadcast crystals; 30 years experience. Eidson Electronic Co, Box 96, Temple Texas 76501. (817) 773-3901. 3-72-e.o.m. 4-72-4t

MISCELLANEOUS FOR SALE

DICTIONARIES, WEBSTER. Library size, 1971 edition, brand new, still in box. Cost new: \$45.00. Will sell for \$15. Deduct 10% on orders of 6 or more. Mail to North American Liquidators, 1450 Niagara Falls Blvd., Dept. TT-1809, Tonawanda, New York 14150. C.O.D. orders enclose \$1.00 good will deposit. Pay balance plus C.O.D. shipping on delivery. Be satisfied on inspection or return within 10 days for full refund. No dealers, each volume specifically stamped not for resale. Please add \$1.25 postage and handling. New York State residents add applicable sales tax. 4-72-4t

Equipment for Sale

"New & Used Towers, Buy, Sell or Trade, Erect. Ground wire 85¢ lb. Bill Angle, 919-752-3040, Box 55, Greenville, N.C. 27834." 2-71-tf

HELIX-STYROFLEX. Large stocks—bargain price — tested and certified. Write/call for price and stock list. Sierra-Western Electric, Box 23872, Oakland, Calif. 94623. Tele: (415) 832-3527. 1-71-tf

BROADCAST TAPE CARTRIDGES. New empties; load yourself and save. Sold in lots of 25 only, 25/\$1.20 each; 50 or 75/\$1.10 each; 100/\$1.00 each. Enclose payment with order, shipping collect. Redding Radio, Box 344, Fairfield, Connecticut 06430. 3-72-4t

RCA AVQ-10 Weather Radar system complete with Raydome, Heater, 400 cycle power supply, VJ-B monitors, cabling and spare parts—excellent condition, ready to use. Priced at 2/3 original cost. Some installation assistance included. Dept. 261, Broadcast Engineering, 1014 Wyandotte Street, Kansas City, Missouri 64105. 3-72-4t

EQUIPMENT FOR SALE CONT.

MOTORS FOR SPOTMASTERS

NEW Paps hysteresis synchronous motor HSZ 20.50-4-470D as used in series 400 and 500 machines. Price \$39.00 each pre-paid, while they last. 90 day warranty. Terms check with order only, no COD's. Not recommended for Tapecaster series 600 or 700.

TAPECASTER TCM, INC. Box 662,
Rockville, Maryland 20851.

1-72-TF

TAPE SPECIAL

SCOTCH 150 AMPEX 600 SERIES REEVES SOUNDCRAFT
1 mil mylar 3600' on 10 1/2" Fiberglass reel. No boxes, Bulk packed. 30 reels to a carton, slightly used in Government application but in excellent condition. Original 1/4" width, not re-split: \$2.50 per reel. Quantity price breaks on request. Will wind to 3", 5" or 7" reels. Accurate Sound Corp., Box 2159, Garland, Texas 75041.

3-72-3t

AMPEX PARTS AND HEAD REPLACEMENTS

Complete inventory of replacement parts for Ampex 300 and AG 440 equipment. New and used Recording Equipment. Write for catalog, Accurate Sound Corp., Box 2159, Garland, Texas 75041.

3-72-3t

CARTRIDGE TAPE EQUIPMENT—Completely rebuilt and reconditioned. Tape-caster and Spotmaster Record/Playbacks \$375.00. Playbacks \$250. 30-day money-back guarantee. AUTODYNE, P. O. Box 1004, Rockville, Maryland 20850 (301/762-7626).

11-71-tf

FOR SALE, 7 HIGH VOLTAGE RECTIFIER TUBES, TYPE 8-7-B, MOST WITH LESS THAN 5,000 HOURS. CONTACT R. B. NIEKAMP, CHIEF ENGINEER RADIO STATION KXEN, P.O. BOX 28, ST. LOUIS, MO. 63166 OR CALL 314-436-6550.

4-72-2t

ONE STOP for all your professional audio requirements. Bottom line oriented. F. T. C. Brewer Company, P. O. Box 8057, Pensacola, Florida 32505.

7-71-tf

FOR SALE: McMartin TBM 4000 fm Modulation Monitor with SCA Multiplex. REL Studio transmitter Link Model 707. Fairchild Conax recording equalizer Model 602 Stereo. Three Symmetra-Peak Units Model SP 58-1A. Gates Level Devil M 5546. All equipment in good working condition. Swanco Broadcasting, Inc., 1502 South Boulder, Tulsa, Oklahoma, 74119. (918) 582-6195.

5-72-1t

FOR SALE: FM antenna used, RCA BFA-4A, 4 bay horizontal with deicers, tuned to 104.1 mc., 515-274-2551. Mastertone Company, 8101 University Blvd., Des Moines, Iowa 50311.

5-72-1t

FOR SALE. Spartamate record and play deck good condition with extra heads just 350 dollars. Flood Production, 705 Grace La Junta, Colorado 81050. Jerry Westerberg 303-384-2267.

5-72-1t

FOR SALE Ampex 350 with carrying case, Box 12811, Pittsburgh, Penna. 15241. 412-833-7524.

5-72-1t

FOR SALE. Complete B&W portable production studio with 3 vidicon cameras (2-viewfinders), switcher fader, audio mixer, rack monitors, sync generator, 1/2 V.T.R. and tape, mikes, and caples. In portable rack cases in A-1 condition. Thomas Gilchrist 316-722-5116, early evening.

5-72-1t

100 WATT UHF TRANSLATOR: Emcee U-HTU-100-D. Presently Channel 24 in, 18 out. Never used, still in original factory cartons. Save 50%. (201) 233-6200.

5-72-1t

FOR IMMEDIATE DELIVERY: New AMPEX AG-440B, AG-500B, AG-600B, AM-10, AA-620, CBS Volumax & Audimax, RUSSCO turntables, GRAY tonearms, E-V & AKG microphones, CONTEL Tape Cartridge Equipment and many other broadcast products. **SPECIAL PACKAGE DEALS. CONTINENTAL ELECTRONIC WHOLESALE CORPORATION, P.O. Box 205, Hiialeah, Fla. 33012. Phone (305) 822-1421.**

5-72-3t

Beckman 6023 2MHz Solid State EPUT Meter, NEW \$475.00. Beckman 6122 100MHz Solid State Frequency Meter, NEW \$875.00. Tektronix 526 Vectorscope NEW \$1200.00. All in original cartons. Also new Varian Klystrons, 609-541-4203. 5-72-1t

AMPEX 351 full track, completely rebuilt, \$1,175.00; AMPEX 350, rebuilt, \$975.00; AMPEX 601, rebuilt, \$400.00; PR-10 full track, excellent; \$400.00; MX-10, \$200.00. All rebuilt equipment carries a 90 day parts and labor warranty. Accurate Sound Corp., Box 2159, Garland, Texas 75041. Phone: 214-278-0553. 5-72-1t

Wanted

Small non-profit private college needs television equipment to expand present facilities. All donations tax deductible. Rev. Herman Huttinger, St. Fidelis College, Herman, Pa. 16039.

5-72-1t

WANTED TO BUY: A good used 5 or 10 kilowatt FM transmitter. Contact KOLY Radio, Mobridge, South Dakota.

5-72-1t

Help Wanted

Job Headquarters for all Radio and Television Engineers. Immediate openings exist in 9 western states and elsewhere for qualified engineer and technical personnel. All categories from trainees to experienced transmitter maintenance, chief, assistant chief, live color video maintenance and technical operations. Send us your complete resume now. The AMPS Agency, 11661 San Vicente Blvd., Suite 300, Los Angeles, Calif. 90049. Telephone: 213-820-2678. By Broadcasters — For Broadcasters.

11-68-tf

SALES ENGINEER wanted for East Coast U.S.A. Custom switching and terminal equipment, video and audio. Vital Industries, Inc., 3614 S.W. Archer Rd., Gainesville, Fla. 32601, (904) 378-1581.

4-72-tf

TV TECHNICIAN with First Class License for operation of transmitter and studio equipment. Equal opportunity employer. Send resume to Assistant Chief Engineer, WJKS-TV, P.O. Box 17000, Jacksonville, Florida 32216.

5-72-1t

SYSTEMS ENGINEER

Teleproduction Products

TIP OF SYNC opportunity for practicing EE with TV broadcast background. You will help develop product plans for time base correctors and other precision timing products for color TV systems used in broadcasting, CATV, CCTV.

This is a small new engineering organization offering rapid promotion to the engineer with current knowledge of market needs, and up-to-date skills in circuit and product design. Recent experience with quad and heliscan VTR's will filter you out of the competitive noise level.

Attractive starting salary and benefits package. Stimulating suburban Hartford, Connecticut location, plus full opportunity for professional recognition.

For Immediate Consideration And Interview

Call Collect Or Send Resume To:

MR. DAVE WILKINSON

(203) 242-0761

Television Microtime, Inc.

A Subsidiary Of Andersen Laboratories, Inc.
1280 Blue Hills Ave. / Bloomfield, Conn. 06002

An Equal Opportunity Employer

This may be your last chance to get up off your big fat complacency.

Try this. Pick out one of our United Way agencies. Go out into the field with its workers. See for yourself the very real needs of the people it serves. The new and growing urgency of their problems.

Take a good hard look at the new things that the agency is doing to solve these problems. The new approaches. The new programs. The new money they take.

Then, when you pledge your Fair Share, you're bound to make it bigger. You will remember the faces and voices of those you are helping.

If you don't do it, it won't get done.

advertising contributed for the public good



For more details about products in this issue use free readers service card in the back of this issue.

Shopping for lenses? Compare Canon!

Draw up a checklist that includes price, specifications and image brilliance, then start comparing catalogues. You'll probably come up with the Canon answer, like so many major camera producers—for broadcast 1" or 1 1/4" Plumbicon® or CCTV 1", 2/3" vidicon.

Stack these two Canon popularity favorites against anything else on the market and see what we mean.

The Canon TV Zoom Lens P17X30B2 has an impressive 1:2.5 relative aperture at focal length range (440-500mm), in spite of its 17X zoom ratio. At 30—440mm it's a remarkable 1:2.2, offering the same performance as our P10X20B, specially designed for maximum versatility with three different range extenders.

Both are ideal for a variety of situation, including dim lighting and open areas like field events.

Here are some other examples of the wide Canon line:

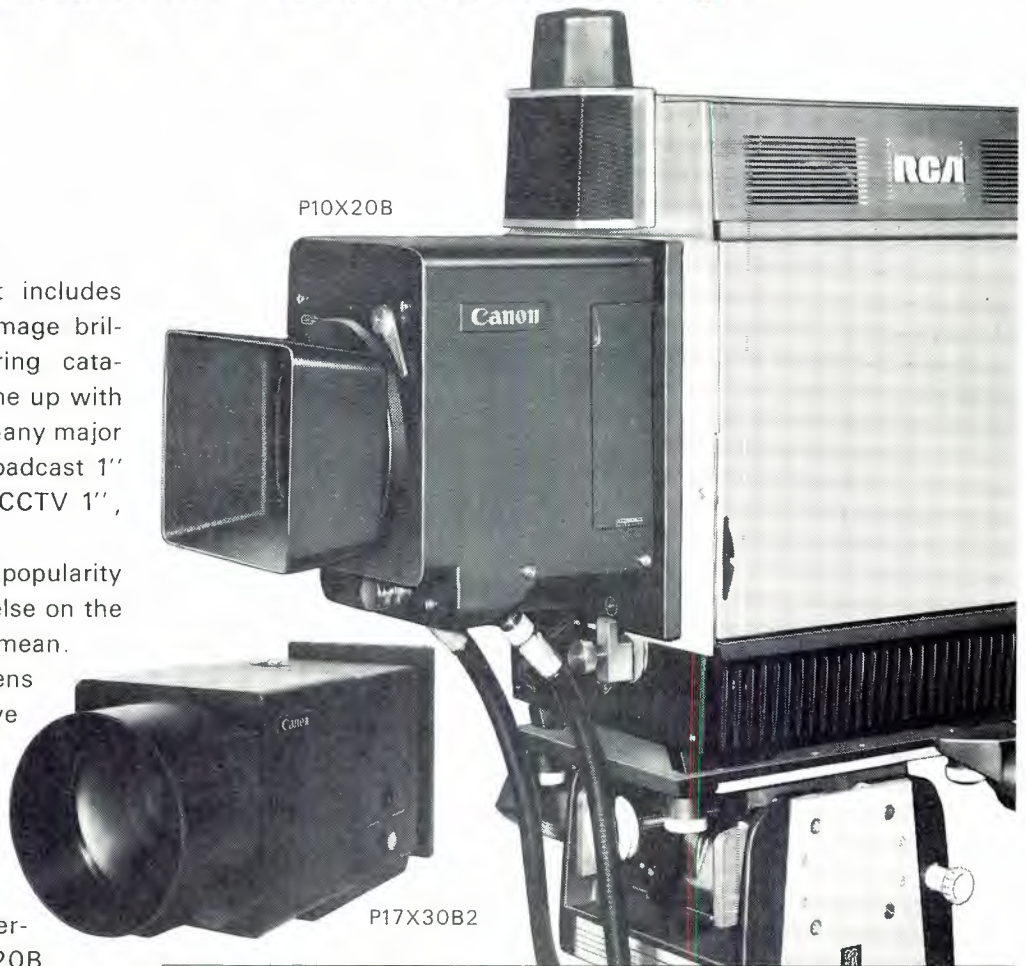

Manual				
	Name	Range of Focal Length	Zoom Ratio	Maximum Relative Aperture
1 1/4" Plumbicon	P17 x 30B2	30—500mm	1 : 17	F 2.2
	P10 x 20	20—200mm	1 : 10	F 2.2
1" Plumbicon	PV17 x 24B	24—400mm	1 : 17	F 1.8
	PV10 x 16	16—160mm	1 : 10	F 1.6
	PV10 x 15B	15—150mm	1 : 10	F 2.0
1" Vidicon	V10 x 15	15—150mm	1 : 10	F 2.8
	V6 x 16	16.9— 95mm	1 : 6	F 2.0
	V5 x 20	20—100mm	1 : 5	F 2.5
	V4 x 25	25—100mm	1 : 4	F 1.8
2/3" Vidicon	J10 x 13	13—130mm	1 : 10	F 2.8
	J 6 x 13	13— 76mm	1 : 6	F 1.9
	J 5 x 15	15— 75mm	1 : 5	F 2.1
	J 4 x 12	12.5— 50mm	1 : 4	F 1.8
Servorized/Motorized				
	Name	Range of Focal Length	Zoom Ratio	Maximum Relative Aperture
1 1/4" Plumbicon	P10 x 20B4	20—200mm	1 : 10	F 2.2
1" Vidicon	V10 x 15R (DC)	15—150mm	1 : 10	F 2.8
	V6 x 16R (AC/DC)	16.9—95mm	1 : 6	F 2.0
	V4 x 25R (AC/DC,EE)	25—100mm	1 : 4	F 2.5

● CANON U.S.A., INC. - 10 Nevada Drive, Lake Success, Long Island, New York 11040, U.S.A. (Phone) 516-488-6700 ● CANON U.S.A., INC. - 457 Fullerton Ave., Elmhurst, Illinois 60126, U.S.A. (Phone) 312-833-3070 ● CANON OPTICS & BUSINESS MACHINES CO., INC. - 3113 Wilshire Blvd., Los Angeles, California 90005, U.S.A. ● CANON AMSTERDAM N.V.: Gebouw 70, Schiphol Oost, Holland ● CANON LATIN AMERICA, INC.: Apartado 7022, Panama 5, Panama ● CANON INC.: 9-9, Ginza 5-chome Chuo-ku, Tokyo 104, Japan

Canon

Circle Number 2 on Reader Reply Card

www.americanradiohistory.com



a better
switching
system
is **Vital**
for better pictures



Vital's specialized experience in the field of video, audio switching and automation can benefit your operation.

Discover the advantages Vital has to offer you in ...

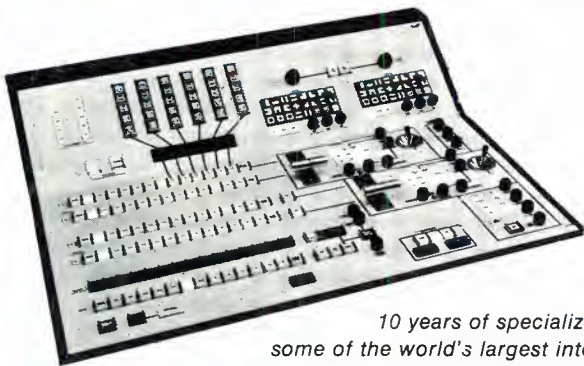

- Production Switchers
- Master Control and Automation Systems
- Audio, Video Routing Switchers
- One Line Machine Controls
- One Line Pulse Distribution Systems
- Video and Audio Distribution Amplifiers
- Video Processing Equipment

10 years of specialization. Designed, manufactured and delivered some of the world's largest integrated telecommunication systems.

3620 Ridgewood Rd., N.W.
Atlanta, Ga. 30327
404-233-9459

7960 W. Beverly Blvd.
Los Angeles, Calif. 90048
213-653-9438

2644 N. Seventh Street
Terre Haute, Ind. 47804
812-466-3212

GOOD ENGINEERING IS VITAL



VITAL INDUSTRIES, INC.

MAIN OFFICE: 3614 S.W. Archer Road, Gainesville, Fla. 32601—Phone 904-378-1581
Circle Number 3 on Reader Reply Card