

Broadcast Engineering®

the technical journal of the broadcast-communications industry



A HOWARD W. SAMS PUBLICATION



Basics of Digital Logic
see page 24

**FM Overmodulation
Automatic Enhancer
Cart Quality Control**

BB-69

DNC

CHESTER A. SIEGRIST
1107 CATHEDRAL STREET
LEBANON PA 17042

**Free loan-for-trial.
Free repairs for the first two years,
no matter what happens.
Plus a lifetime guarantee.**



We're very confident. But then we've been offering all this for years!

E.V. A careful study of guarantees can tell you quite a bit about a company. And that's why we're so proud of ours. For instance, every E-V Professional-line microphone has a 2-year UNCONDITIONAL warranty against malfunction; regardless of cause. Even accidental damage is covered, no questions asked. All absolutely free—except one-way postage. And for a modest charge we'll even hide the scars!

But that's just part of the story. Every

Electro-Voice microphone is also guaranteed for the life of the unit to be free from factory defects in workmanship and materials. To show you we're really serious, we've printed the entire guarantee below. There's no finer in the industry.

How can we afford such liberal guarantees? By making products that have served for decades as the yardstick of reliability in studios throughout the world. And by creating designs that really solve your sound problems, day after day.

Which brings us to our other unusual offer.

Did you know that most Electro-Voice distributors will loan any E-V Professional product to responsible firms for trial without cost or obligation? You can make every test you want under actual working conditions. And in the rare event that you aren't satisfied, just return the unit. Your distributor then exchanges it for fresh stock from us. No cost to either him or you. We've found this simple system helps you choose the products that really solve your problems. And we're happy to help.

A great guarantee and a time-tested loan-for-trial program. Plus a broad line of professional products that fit almost every studio need. We wouldn't want to do business any other way.

ELECTRO-VOICE, INC., Dept. 911V,
638 Cecil Street, Buchanan, Michigan 49107

In Europe: Electro-Voice, S.A., Lyss-Strasse 55,
2560 Nidau, Switzerland

WARRANTY

Electro-Voice Professional Broadcast and Recording Microphones are guaranteed unconditionally against malfunction for two years from date of purchase. Within this period Electro-Voice will, at its option, repair or replace any E-V Professional microphone exhibiting any malfunction regardless of cause, including accidental abuse. This warranty does not cover finish or appearance. Also, every Electro-Voice microphone is guaranteed for the life of the microphone to be free of factory defects in materials and workmanship, and will be repaired or replaced (at our option) at no charge if exhibiting malfunction from this cause. Microphones for warranty repair must be shipped prepaid to Electro-Voice, Inc. or its authorized service agency, and will be returned prepaid.

high fidelity systems and speakers • tuners, amplifiers, receivers • public address loudspeakers
• microphones • phono cartridges and styli • aerospace and defense electronics
Circle Number 1 on Reader Reply Card

Electro-Voice®

a GULTON subsidiary

sync logic

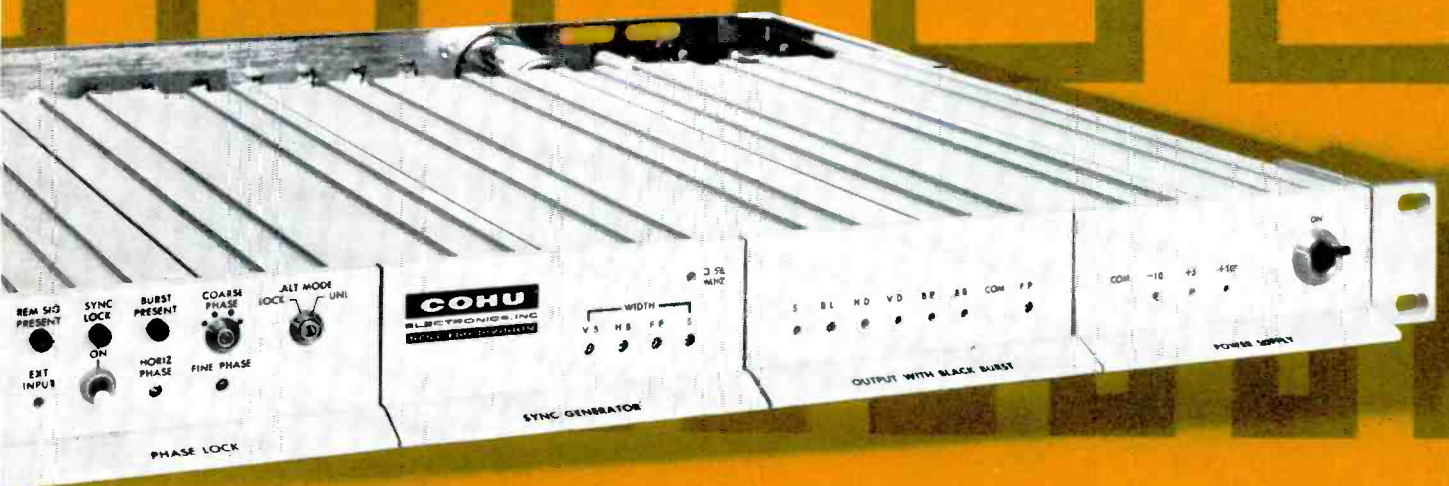

logic will bring you to the best Cohu's 2617 Sync Generator

STABILITY - Pulse to pulse, hour to hour, no other sync generator offers greater stability. **JITTER-FREE** - Between subcarrier and sync, and leading edge to trailing edge. **MODULAR DESIGN** - Precision fitting front plug-in modules for ease of maintenance. **LOCKS TO EXTERNAL CW SUBCARRIER** - As well as standard broadcast signals.

For details on the logical sync generator, contact Cohu's TV Sales Department, Box 623, San Diego, California 92112, Telephone 714-277-6700, TWX 910-335-1244.

COHU
ELECTRONICS, INC.
SAN DIEGO DIVISION

Circle Number 4 on Reader Reply Card

Broadcast Engineering

The technical journal of the broadcast-communications industry

in this issue...

24 Basics of Digital Logic. Part 1 of four part series designed to acquaint broadcast engineers with digital basics and how they apply to broadcast equipment. **E. Stanley Busby, Jr.**

32 Film In Local Origination. Part 2 of two parts. Showing how and when film can be used to advantage in cable and closed circuit systems. **A. L. Williams.**

37 Preventing FM Overmodulation. Eliminating overmodulation and associated distortion and enhancing the FM signal with properly installed and operating corrective equipment. **W. J. Kabrick.**

44 The Automatic Image Enhancer. Illustrations and description of the operation of the CBS automatic image enhancer. **Bob Burns.**

48 Cartridge Quality Control. A Miami station explains how it cut costs and improved its air sound with a special emphasis on cartridge control. **Gene Rider.**

ABOUT THE COVER

This month's cover serves as the kickoff for a special series on digital circuits in broadcast equipment that will run through December. Cover was shot by Ampex's photographer Hudson Edwards. (Series begins on page 24.)

DEPARTMENTS

Direct Current	4
Letters to the Editor	8
Industry News	12
CATV Scope	16
Industry Calendar	43
New Products	52
Ad Index	55
Classified Ads	56

Copyright, 1971, Howard W. Sams & Co., Inc. All Rights Reserved: Material may not be reproduced or photocopied in any form without written permission of publisher.

EDITORIAL

GEO. H. SEFEROVICH, Director
RONALD N. MERRELL, Editor
CARL BABCOKE, Technical
MORRIS COURTRIGHT, Automation
PAT FINNEGAN, Maintenance
HOWARD T. HEAD, FCC Rules
ROBERT A. JONES, Facilities
WALTER JUNG, Solid State
ANDRA BOYLE, Editorial Assistant
H. G. ROESLER, Cartoonist
DUDLEY ROSE, Art Director
LEO G. SANDS, CATV

EDITORIAL ADVISORY BOARD

LES NELSON, Chairman
Howard W. Sams & Co., Indianapolis

CIRCULATION

EVELYN ROGERS, Manager

ADVERTISING

E. P. LANGAN, Director
R. JACK HANCOCK, Manager
JOAN HIRES, Production
JAKE STOCKWELL, Sales

REGIONAL ADVERTISING SALES OFFICES

Indianapolis, Indiana 46206
ROY HENRY
HOWARD W. SAMS & CO., INC.
2469 E. 98th St.
Tele: 317/846-7026

New York, New York 10019
CHARLES C. HORNER
3 W 57th St.
Tele: 212/688-6350

Los Angeles, California
JOHN D. GILLIES
3600 Wilshire Blvd., Suite 1510
Los Angeles, California 90005
Tele: 213/383-1552

London W. C. 2, England
JOHN ASHCRAFT & CO.
12 Bear Street
Leicester Square
Tele: 930-0525

Amsterdam C, Holland
JOHN ASHCRAFT & CO.
W.J.M. Sanders, Mgr.
for Benelux & Germany
Herengracht 365
Tele: 020-240908

Tokyo, Japan
INTERNATIONAL MEDIA
REPRESENTATIVES, LTD.
1, Shiba-Kotohiracho, Minato-ku
Tele: 502-0656



BROADCAST ENGINEERING is published monthly by Intertec Publishing Corp., 1014 Wyandotte Street, Kansas City, Missouri 64105. Telephone: 913/888-4664.

BROADCAST ENGINEERING is mailed free to qualified persons engaged in commercial and educational radio and television broadcasting. Non-qualified subscriptions in the U.S. are \$6.00 one year, \$10.00 two years, \$13.00 three years. Outside the USA add \$1.00 per year to cover postage. Single copy rate 75 cents. Back issue rate \$1.00. Adjustments necessitated by subscription termination at single copy rate.

Controlled Circulation postage paid at Indianapolis, Indiana.



Robert E. Hertel, Publisher

Intertec Publishing Corp.
Subsidiary of Howard W. Sams & Co., Inc.

BROADCAST ENGINEERING

DIGITAL MACHINE CONTROL SYSTEMS

(FOR FILM CHAINS, VTR'S, ETC.)

With the new GVG machine control system, pushbutton commands from the studio are encoded into digital form and transmitted serially on a single audio pair. The information is decoded at film or VTR locations to provide contact closures. The status of the control relays is then transmitted back to the studios for confirmation of proper operation. Each controlled machine has a unique address, so that only desired equipment will be operated.

The delegation of control functions is accomplished by connecting the machine receiving terminal to the proper studio control bus. These control buses are routed to all film and tape machines in a loop-through fashion. The machine receiving terminals are merely bridged onto the desired control bus. There is no practical limit to the number of machines the system can handle, still using the same single audio pair per studio.

Studio control panels can be arranged in any desired fashion. A particularly compact and versatile arrangement is illustrated in the photo.



ACTUAL SIZE

BLOCK DIAGRAM

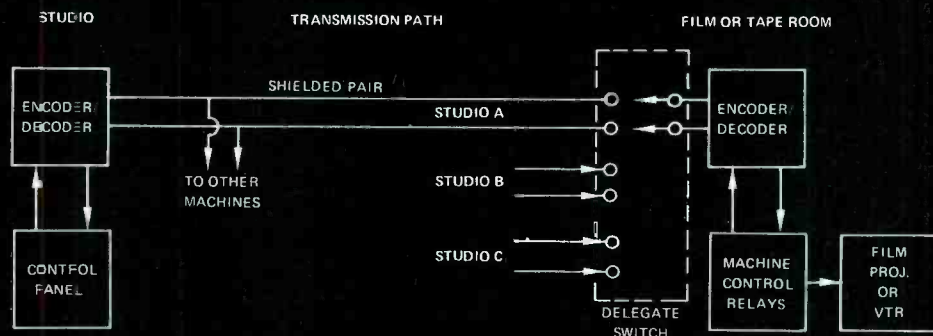

THE GRASS VALLEY GROUP, INC. 

FOR ADDITIONAL INFORMATION, CONTACT GRAVCO SALES, INC.

6515 Sunset Blvd.
LOS ANGELES, CALIF.
(213) 462-6618

Station Plaza East
GREAT NECK, N.Y.
(515) 487-1311

125 South Wilke Road
ARLINGTON HEIGHTS, ILL.
(312) 394-1344

2626 Mockingbird Lane
DALLAS, TEXAS
(214) 352-2475

1644 Tullie Circle, N.E.
ATLANTA, GEORGIA
(404) 634-0521

DIRECT CURRENT FROM D. C.

September, 1971

Howard T. Head

Commission Reaches Tentative CATV Policy Decision

The Commission has reached a tentative decision as to future plans for CATV regulation. In a precedent-setting "letter of intent" to Congress, the Commission has outlined rules which it proposes to adopt by the end of 1971 to become effective March 1, 1972. The obvious purpose of the letter, well in advance of the proposed effective date, is to give Congress an opportunity to make its own voice heard in the matter.

The heart of the matter, insofar as cable system operators and broadcasters are concerned, is the carriage by cable systems of distant broadcast signals. Distant signal carriage would be pegged at two distant signals in the top 100 markets, although provision is made for carriage of additional signals in situations such as overlapping markets, provided that there is "significant viewing" of the signals over the air.

To the cable systems, however, the provision for carriage of additional broadcast signals is not without its price. The Commission emphasizes that this price is the "obligation to provide for substantial non-broadcast bandwidth" and proposes to require that for each broadcast signal carried by the cable system provide equivalent bandwidth for non-broadcast uses. This approach appears to be the Commission's answer to the rejection by the Court (see July, 1971 D.C.) of the Commission's authority to require local originations by CATV systems.

The Commission intends to adopt CATV technical standards in essentially the form originally proposed. These would apply, however, only to what the Commission designates "Class I" cable channels to carry broadcast television signals. A technical Task Force is to be formed, to advise the Commission in other technical areas. For the time being, however, no technical standards are to be applied to local originations for non-broadcast services, although the Commission expresses the hope that inexpensive equipment such as half-inch video tape players may some day approach acceptable technical quality.

The Commission also intends to require that cable systems incorporate the capacity for two-way communication. This requirement appears to stem from the claims of the cable systems of their utility for two-way non-broadcast service, notwithstanding the almost complete absence of any visible public demand for such services.

In Canada, in the meantime, the Canadian Radio-Television Commission (CRTC) has adopted a cable policy, which, while acknowledging the need to avoid undermining the Canadian television broadcasting system, points in an entirely different direction. Basically, the CRTC policy provides that cable television systems pay for Canadian television programs

(Continued on page 6)

A new number one from number one.



RCA's TT-50 FH. The latest from the company that's been number one in TV transmitters since TV began. It's the most solid state VHF color television transmitter ever made. It uses the latest technology.

Performance specs are 100 percent better than any previous generation transmitter.

For example, visual amplitude vs. frequency response went from ± 1.5 dB to $+0.75$ dB. Modulation capability (visual) from 10% to 3%. Subcarrier phase vs. brightness from $\pm 7^\circ$ to $\pm 2^\circ$. Differential gain from 1.5 dB to 0.5 dB maximum. And harmonic radiation from -60 dB to -80 dB.

The TT-50FH has solid state diode modulation at carrier frequency and sideband shaping at the output, so you get greater assurance of spectral purity than from any other transmitter. With only two tuned visual amplifier stages, the TT-50FH is easy to maintain. The fewer stages, the less adjusting, the less chance for trouble.

You make an adjustment and it lasts. Because the design is reliability itself. Circuits are solid state design up to the IPA. Only three tubes in each transmitter. Only two tube types. And solid state control logic. That's more solid state than any other transmitter. Planning unattended operation? The TT-50FH is designed for it, with provisions for automatic logging and remote control. It's the only VHF transmitter specifically designed as a twin system, which fulfills the FCC's requirements for remote operation with once-a-week inspection. Because it has built-in redundancy.

That's what superior performance is all about. That's what the TT-50FH is all about. The number one transmitter from the number one company.

RCA

Circle Number 6 on Reader Reply Card

taken from broadcast stations. Distant signal carriage will be authorized using microwave relaying where necessary, and cable systems which fulfill basic Canadian services to their community will be permitted to provide other channels, including up to three channels from stations not licensed in Canada (ordinarily U.S. stations).

OCD Going Own Way on Civil Defense Warnings

Radio and television broadcasters participating in the Emergency Broadcast System (EBS) have become increasingly aware of the inadequacy of coordination between EBS and Civil Defense warning systems provided by the Office of Civil Defense (OCD). Shortcomings in EBS were emphasized by the NORAD incident on the morning of February 20, 1971, when an actual emergency alert was transmitted by mistake over the EBS system (see April, 1971 D.C.).

OCD has announced the awarding of a contract for a transmitter at Edgewood Arsenal, Maryland, to operate with 50 kW power on 179 kHz, transmitting voice, teletype, or tone signals over voice-grade channels. These signals will be received on special receivers in those portions of the eastern United States within range of the transmitter. These is some speculation that the OCD system might ultimately take the place of EBS.

These problems have come to the notice of the White House, and are already under study by the newly-formed Office of Telecommunications Policy (OTP).

". . . Who Your True Friends Really Are"

In one of the season's more interesting surprises, industry filings in connection with the Commission's proposals for the establishment of a prototype Regional Frequency Spectrum Management Center at Chicago, and for the allocation of land mobile frequencies in those portions of the 475-512 MHz band shared with television broadcasting, found the television broadcast industry solidly supporting the Commission with almost equally solid opposition from land mobile interests. FCC Chief Engineer Ray Spence had really expected it to come out the other way.

Television broadcasters have insisted throughout the land mobile proceedings that apparent land mobile frequency shortages stem from careless and haphazard use of existing frequency assignments. Although broadcasters would have preferred no sharing at all of television bands, they have applauded the Commission's attempts to use the new spectrum assignments in an orderly manner. The land mobile people on the other hand would have preferred "business as usual", and have taken exception to the Commission's new policies calling for firm management of land mobile assignments.

Short Circuits

Long-time Commission engineer Wallace E. Johnson has been named Chief of the Commission's Broadcast Bureau . . . Representative Charlotte Reid of Illinois has been confirmed to be the FCC's second woman Commissioner in history . . . Canadian studies have indicated that even complete elimination of the 20-mile UHF "taboos" would permit few additional UHF channel assignments . . . New FCC Form 301-A, required to be filed for the remote control of television transmitters, is now available from the Commission . . . The Commission has terminated its proceeding which would have required licensees to provide more control over telephone interview programs.

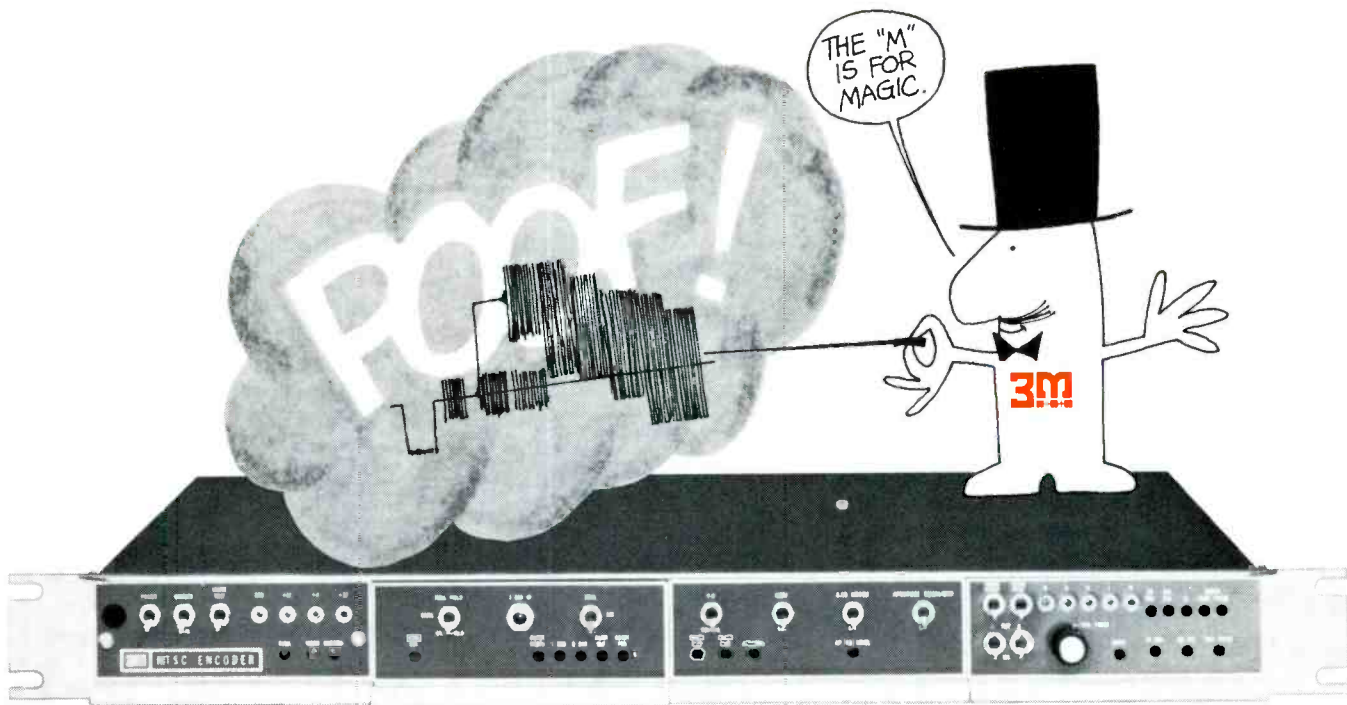

Presto! Change-o!

Before your very eyes, the flick of a switch converts the output of any 3- or 4-channel camera, no matter what its price, into an encoded signal that meets all applicable EIA and NTSC specs!

The switch is on the 3M color video encoder, and it's loaded with features and performance like nothing you've ever seen before:

Its all-digital color bar generator, accurate to within $\pm 1/2\%$, requires no adjustments and has already earned a

reputation for being rock solid with temperature variations.

Its video input clamping circuits eliminate low frequency hum and noise, and prevent APL changes and ground loops from causing color errors.

Its amplitude-dependent aperture equalizer provides noise-free picture crispening.

Its luminance-enhancement circuits increase the resolution of 3-channel cameras, improve the color fidelity of 4-channel cameras, and provide automatic green channel luminance when switching to monochrome.

And maybe best of all, its price is lower than you'd expect.

As we said, like nothing you've ever seen before, so why not let us show you? Ask for a demonstration. There'll be no hocus-pocus, no mumbo jumbo — we let the 3M color video encoder speak for itself.

We've made more believers that way. Mincom Division, 3M Company, 300 South Lewis Road, Camarillo, California 93010. Telephone (805) 482-1911.

VIDEO PRODUCTS
Mincom Division **3M**
 COMPANY

Circle Number 7 on Reader Reply Card

**This is
the
world's
finest
and
largest
selling
turntable.**



**Gates
CB-77**

For complete details on the CB-77 12-inch turntable, write Gates, 123 Hampshire St., Quincy, Illinois 62301.

**HARRIS
INTERTYPE
CORPORATION** **GATES**
A DIVISION OF HARRIS-INTERTYPE

Circle Number 8 on Reader Reply Card

LETTERS TO THE EDITOR

When Is An Operator A . . .

Technician Or Engineer?

Dear Editor:

Concerning the continuing controversy over the job titles "Broadcast Engineer" and "Broadcast Technician," may I call your attention to my recent correspondence with our State Board of Registration for Professional Engineers. The title "Engineer" is protected by law in most states, and is apparently only available to those who have obtained a professional engineering license.

It is unfortunate that most of these laws were passed **after** the term "Broadcast Engineer" had become widely accepted in the broadcast industry, but the term is not protected by Federal law since the FCC refers to technical people as "operators" (Part 73.113). The term "Broadcast Technician" is most accurate, but even this may soon be restricted by legislation.

T. Frank Ritter

KBAT

San Antonio, Texas

Yes, current licensing procedures do pinpoint the use of the words "Engineer" and "Operator", and these definitions spell out legal meanings.

In commercial broadcasting the term "operator" was once as popular as the handle "Sparks". The man on duty was riding gain, tweaking knobs, and other chores more commonly associated operator duties. The after effects of this period can still be seen in test questions. In fact, you can see the history of maritime radio in the terms used and in the test questions.

Within the broadcast-communications industry there are people listed as engineers who, in reality, are communications repairmen. There are those whose daily routine involves applying engineering principles and interpreting engineering data, and they may happen to be called technicians. The terms applied reflect the trends within the industry. CE is now as familiar as

PE. But other than PE, the title often depends upon geographic location.

The problem of titles is magnified today by the glorification of jobs—not by services rendered so much as pseudo job upgrading. Garbage collector=sanitation engineer. In other words, the title changes but not the work type. But in broadcasting and closed circuit communications the evolution of the technology has caused changes in the work accomplished. Thus, only in the broadest sense does the term Operator still apply for AM and FM.

The job requirements of the First Class Operator are usually such that, depending upon the time of day, one could be considered an electrical engineer, audio engineer, maintenance technician, civil engineer, broadcast operator. And how about Engineering Vice President? Director of Engineering? (And now from the manufacturing side we see the sales engineer on the scene.)

If you want really different views of engineering, ask MIT, the US Corps of Army Engineers, Federal bodies, State bodies, and the unions. For my money, the station electronic maintenance and overall electronic operation is accomplished by a broadcast engineer. Because of the work done, you might give him this or some similar title . . . unless you want to work up a whole new title. Is there a title that really fits the total responsibility implied or practiced in the field?

I'm not certain why state licensing boards choose to use the title Professional Engineer. What engineer isn't being paid to be professional? The whole problem gets to be an exercise in semantics. Old words are constantly being used in new and different ways. You can get comfortable with a word such as "nice", until you find that it meant "stupid" in Old French and "Ignorant" in Latin.

The Editor

Change In Management Can Mean Changes In Engineering Duties

Dear Editor:

First of all, I'm glad to know there is a publication like **Broadcast Engineering** for us engineer's to call "our own."

I'd like to discuss a few things in this letter and as some engineer reads this, he'll probably say "amen" or "isn't that a kick in the head."

Recently, we underwent a change of management and he called us in his office, one by one, and asked us what our job at the station consisted of, etc. Then after, he called a general staff meeting and made the usual comments. The interview and the meeting was to be expected. About two weeks later, the "Master" summoned me into his office—"I'd like to know why you were late for work this morning—you are the highest paid employee here (the rest are school boys at \$1.65 per hour) and I expect you to be here on time. And something else, from now on, get my permission before you leave the station during business hours—you come and go as you please and I don't like it. And while we're discussing this, from now on, wear a tie. And too, here is a list of other duties, in addition to the ones you have now. Remember, no more being late!"

As I left his office, I was silent, but foaming at the mouth. The only reason I didn't give my notice was, my kids were still in school. As for being late, he didn't know that I was at the station from midnight until 4 AM working on and testing equipment which was in use before the "Master" was born. As for leaving the station from time-to-time, it would be to another station to beg for some bailing wire to hold this junk together. The other duties I inherited; emptying the trash baskets each day, vacuuming the floors twice a week, clean and polish all desks, and keep the toilet clean. There were still five weeks of school left at the time. Grin and bear it I thought, than leave.

**Name Withheld
by Request**

(Continued on page 10)



Telex headphones and headsets give you that comfortable feeling of assurance when you monitor broadcasts or communications. Signals come through loud and clear — intelligibly and reliably.

Telex professional monaural or stereo headphones incorporate audiometric-type transducers that are impervious to temperature or humidity changes and provide you with absolute performance consistency day in, day out. These sensitive dynamic transducers produce high output levels with minimum consumption of transmission power. Available in single or dual muff configuration and with noise cancelling dynamic or carbon boom microphones.

And you'll never miss a cue or program buss with a Telex Anouncers Earset®. Inconspicuous for 'on camera' work, it has practically become standard in the industry.

Or you can select a Teleset®, Twinset® or Earset® for lightweight, comfortable and inexpensive private monitoring. And for special applications in business or home, industry or institution, Telex makes a listening device to fit your requirements. Available at better sound dealers or write for free information. You'll hear more from Telex.

PRODUCTS OF SOUND RESEARCH
TELEX®
COMMUNICATIONS DIVISION

9600 ALDRICH AVENUE SOUTH
MINNEAPOLIS, MINNESOTA 55420



CANADA: DOUBLE DIAMOND ELECTRONICS, LTD., 34 Progress Ave., Scarborough 4, Ontario
EXPORT: ROYAL SOUND COMPANY, INC., 409 North Main Street, Freeport, N.Y. 11520 U.S.A.

Circle Number 9 on Reader Reply Card

(Continued from page 9)

Information Wanted On AM Tower Guys

Dear Editor:

About five years ago, perhaps in an effort to squeeze some more life out of our AM tower guys, white lead and an animal fat mixture was used to dress the wires. This treatment apparently is used sometimes on flexible cable that is to be immersed in salt water. However, this is done two or more times a year and **only** on flexible cable.

Where animal fat was used as mix, it had an acid effect. The interaction between the head compound, animal fat and our guys had disastrous effects. The guys are now rusty and pitted and must be replaced.

I'd like to see more views on the upkeep of towers, guy tensions, and guy wires.

Gordon E. Miller
Technical Director
CFBC Radio AM-FM
St. John, N. B.

Editor's Note: BE is an open forum where needs and desires are aired

each month. We'd like to hear more from the field on this subject, too.

Diode Characteristics

Dear Editor:

The article by Pat Finnegan in your June issue of **Broadcast Engineering** about Automatic Assistance circuits is wrong in its treatment of the diode as a transient suppressor.

Figure 2 on page 51 shows the transient voltage as being of opposite polarity to the applied DC and the text on page 52 under the heading "Diode as Transient Suppressor" follows this reasoning stating that a diode across the coil will short circuit the transient. Actually, the transient voltage is of the same polarity as the applied DC and it is the Zener breakdown characteristic of the diode that limits the voltage of the transient.

Harold L. Thompson
Chief Engineer
WLWD
Dayton, Ohio

July BE IC Article Makes Comeback

In the July issue of **BE** we ran an article by Walt Jung on IC's in power supplies ("Power Up With IC's", page 38). Since then, Walt has advised us that we should have used current generator symbols instead of the signal generator symbols that appeared.

In checking this over, we found that some texts do not distinguish between these two generators. In power supply circuits, however, you cannot dispute the symbol required—the current generator. The signal generator strictly defined is different.

If you read through enough texts, you will find notations beside the symbol, and scope waveforms of the signal inside the symbol of some generators.

(Continued on page 50)

Spotmaster

Multiple Cartridge Playback Units

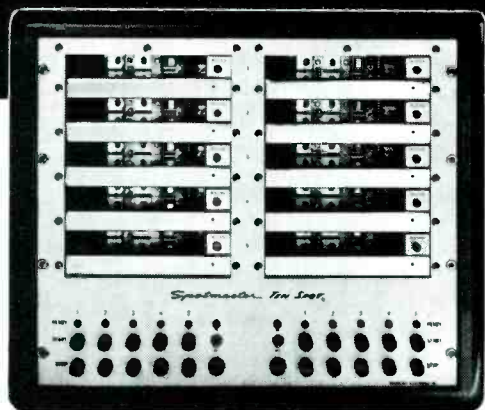

Ten • Spot Model 610B

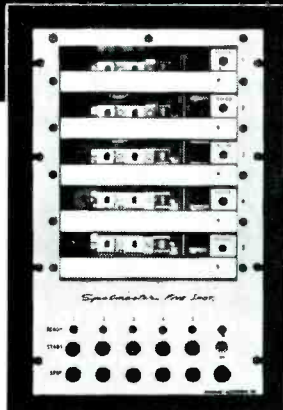

Five • Spot Model 605B

... bringing a new dimension to pushbutton broadcasting

Spotmaster Ten • Spot (holding 10 cartridges) and Five • Spot (holding five) will reproduce any NAB Type A or B cartridge instantly at the push of a button . . . at random or in sequence. They may be operated manually or incorporated into programmed automation systems, using one, two or three NAB standard electronic cueing tones.

The Ten • Spot is designed for 19" rack mounting while the Five • Spot is available either in an attractive walnut-finished case or with a 19" front panel containing a cartridge storage cubicle. Both are backed by Spotmaster's iron-clad full-year guarantee.

For further information about these and other Spotmaster cartridge tape units, call or write today. Remember, Broadcast Electronics is the No. 1 designer/producer of broadcast quality cartridge tape equipment . . . worldwide!

BROADCAST ELECTRONICS, INC.

8810 Brookville Road, Silver Spring, Maryland 20910; Area Code 301, 588-4983



**Send Your
Letters To The
Editor**

**To: 1014 Wyandotte
Kansas City, Mo. 64105**

You can do more

with Collins new stereo consoles

Increase your station's capability and programming flexibility by selecting Collins 4-channel 212K-1 or 8-channel 212L-1. Both are all new, all solid-state. And packed with features such as reverse cue and stereo headphone output jacks.

The 212L-1 has dual stereo monitor outputs and a monaural program output.

Both consoles have fresh new styling—easy to look at, comfortable to use.

And under this new look . . . Collins design and manufacturing quality.

For more information, see your Collins representative or contact
Collins Radio Company, Dept. 400, Dallas, Texas 75207.

Phone: (214) 235-7863 (direct line).



COMMUNICATION / COMPUTATION / CONTROL

Circle Number 10 on Reader Reply Card

UNLIMITED
VARIETY

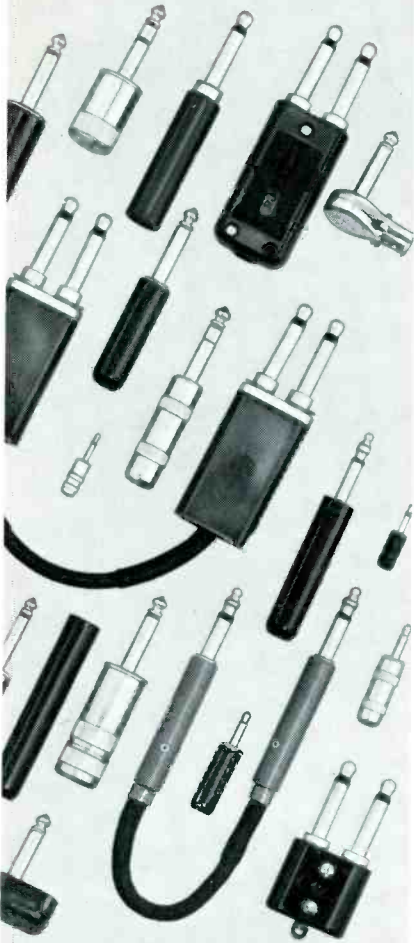

INCOMPARABLE
QUALITY

SWITCHCRAFT PHONE PLUGS

Why waste time "shopping around" . . . whatever your plug requirement—regardless of size or type, Switchcraft makes it, and makes it better! The one piece tip rod, for instance, is staked into the terminal to assure tightness . . . the tip rod can't fall out! Switchcraft offers you the world's largest selection of phone plugs . . . with solder terminals, screw terminals, cable clamps; .250", .206", .140", .097" finger diameters; shielded handles, or tough plastic handles; single plugs, twin-plugs; 2-conductor or 3-conductor—you name it! Chances are it's a thoroughly proved, field-tested SWITCHCRAFT plug from the incomparable SWITCHCRAFT line of plugs.

SEND FOR NEW CATALOG P-202 or see your Switchcraft Authorized Industrial Distributor for immediate delivery at factory prices.

SWITCHCRAFT[®]
INC.

5535 No. Elston Ave.
Chicago, Illinois 60630

Canada: Atlas Radio Corp., LTD.
50 Wingold Ave., Toronto, Canada

Circle Number 11 on Reader Reply Card

INDUSTRY NEWS

FCC: Open Cable Potential Without Hurting Broadcasters

Proposals for regulation of cable television, including importation of distant signals, use of nonbroadcast cable channels, technical standards, and federal, state and local government jurisdictional responsibilities has been sent by the FCC to the Congress.

The FCC said its objective in preparing the cable proposals was "to find a way of opening up cable's potential to serve the public without at the same time undermining the foundation of the existing over-the-air broadcast structure."

Final documents on the proposals will not be released until the "latter part of the year," the Commission said, in order to give Congress an opportunity to consider them. The Commission projected an effective date of March 1, 1972 for the new rules.

The "fundamental question" in meeting its objective of providing cable benefits without jeopardizing over-the-air television is the number of signals that cable should be permitted to carry, the Commission said.

The Commission proposed a formula which would allow all cable viewers to receive all television signals significantly viewed in the community, provide cable viewers with a minimum level of service, and permit cable systems to carry a limited number of additional signals in markets where this would not have an "undue impact" on TV stations in the area.

Market Formula

Specifically, a 35-mile radius would be set for each market. All cable systems would have to carry the signals of all stations within 35 miles of the cable community. Where markets overlap, a signal would have to be carried in an adjacent market if there is "significant" over-the-air viewing of the signal in the cable community.

The Commission said that consistent with other public interest considerations, cable viewers should have "at least a minimum number and choice of signals." Distant signals could be imported to meet minimum standards if sufficient signals were not available within the 35-mile radius including signals meeting the "significant viewing" test.

In the top 50 television markets, the minimum standard for cable systems would be three full network stations and three independent stations. In markets 51 to 100, the minimum requirements would be for three network stations and two independents. Systems in these markets would, in any event, be permitted to carry two distant signals. In markets below 100, the minimum requirements would be for three network signals and one independent.

Cable systems in the top 100 markets carrying distant independent station signals would have to carry, as a first priority, any independent UHF-TV station within 200 miles. If no UHF station were available, they could carry any VHF station within 200 miles. There would be no restrictions if no such signals were available within 200 miles, and also the second signal could be free from restrictions as to point of origin. In those few markets where a third independent may be brought in, that signal would have to be in-state or within 200 miles.

ETV Signals

CATV systems would be permitted to carry any number of educational signals, local or distant, if there were no objection from local educational TV interests. They would also be permitted to import non-English language stations without having them counted against distant signal limits.

The Commission proposed that

cable systems provide a channel for non-broadcast use for each broadcast signal carried and that new systems in the top 100 markets have a potential capacity for at least 20 channels. It would require, in addition, a public access channel to be made available, at no cost, to non-commercial users. A channel also would have to be available for five years at no cost, for State and local government use, and a similar channel for local educational groups. "Excess" channels would have to be available for lease to all potential users, systems would ensure that channels were available for use in response to demand, and two-way capacity would be required.

Public Access

Regulation of public access and channels presenting non-broadcast programming is "properly the concern of this Commission," the letter states, pointing out that the channels "are designed to fulfill Communications Act purposes and are integrally bound up with the broadcast signals being carried over the system." It said that dual regulation, involving local areas of responsibility would be "confusing and impracticable." The Commission stated, however, that it did not think detailed regulations should be advanced at this time.

Outlining general guidelines for experimentation, the Commission called for "nondiscriminatory access on a first-come, first-served basis." It would also prohibit any censorship or control of program content, by the cable operator, of material presented on the public access channel. Advertising, lottery announcements and broadcast of obscene or indecent material would be prohibited.

Access rules would apply to all new systems in the top 100 markets. Presently operating systems in the top 100 markets would have five years to comply.

Technical Standards

The Commission said it would set technical standards to "assure the subscriber at least a minimum standard of reception quality, while at the same time permitting the continuation of technical experimentation." While at present, the standards would apply only to television signals, the Commission said that

it would expect to apply other requirements to various cable services as they develop.

The Commission stated that it did not propose to proceed with federal licensing of systems at this time because it would result in an "unmanageable administrative burden." While leaving a number of areas to local regulation, the Commission said it would "take steps to insure efficient nationwide communications service with adequate facilities at reasonable charges."

Franchise Rules

Cable systems would be required, before being permitted to begin carrying broadcast signals, to file with the FCC copies of their franchises, and proof that the franchising authority has considered the cable operators legal, financial and construction qualifications. Local franchising authorities would be required to set "reasonable deadlines" for construction and operation of cable systems to prevent franchises from remaining inoperative or subject to trafficking.

The Commission said that the local franchising authority also

(Continued on page 51)

WE HAVE ALL THE RIGHT CONNECTIONS.

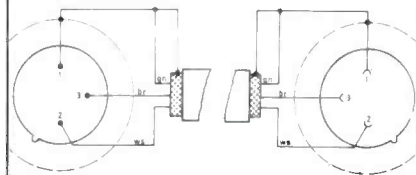

A "simple" microphone extension cable isn't so simple. Not if it's going to match today's phase accuracy and continuity requirements!

At Gotham, we start with double RF shielded, 3-conductor cables made to Neumann's tight specifications. And we attach Switchcraft "Q-G" (XLR compatible) connectors with a special technique, so the connector shell is grounded.

Our price? Practically what you'd pay for cable and plugs alone. Ten feet, \$7.50. Twenty-five feet, \$10.50. Fifty feet, \$16. One hundred feet, \$27.

Order through your Neumann Microphone Dealer. Or from Gotham directly.

GOTHAM
AUDIO CORPORATION

2 West 46th Street, New York, N Y 10036
(212) 265-4111
1710 N. LaBrea Ave., Hollywood, CA 90046
(213) 874-4444

the new mcmartin consoles



The new 8-mixer McMartin consoles feature outstanding flexibility, ease of operation and clean-cut styling. All modules are plug-in. Up to 27 inputs may be accommodated. Highest quality components, including maintainable step-type attenuators, are used.

Typical program circuit program specifications are: ± 0.5 dB frequency response; distortion of 0.5%, 20 to 20,000 Hz; and signal-to-noise ratio of 74 dB for all models. Full cue, intercom and monitor facilities are standard.

Mono stereo or dual channel models are available. The new McMartin B-800 series consoles deliver performance, operating flexibility and are priced right.

MONAURAL	
B-801.....	\$2,350.
STEREO	
B-802.....	\$3,200.
DUAL CHANNEL	
B-803.....	\$2,650.

For details, contact:
Broadcast Product Manager

McMartin
mc martin industries, inc.
605 north thirteenth street
omaha, nebraska 68102

Circle Number 12 on Reader Reply Card

Station Identification At Start-Up, Shutdown No Longer Needed

Section 73.1201(a) of the Rules (station identification requirements) has been amended by the Commission to delete the requirement that TV stations make both visual and aural identification at the beginning and ending of each broadcast day. The action becomes effective August 6, 1971.

Section 73.1201(a) requires broadcast stations to identify themselves at the beginning and end of each overall operating period and within 2 minutes of each hour when on the air. TV stations were also required to make announcements both visually and aurally at the open and close of operation.

Noting that the requirement for both visual and aural identification was initially imposed to aid its enforcement activities, the Commission said that the requirement for two visual identifications in addition to a number of aural identifications in the entire day's transmissions did not appreciably aid the

Commission's enforcement program. (Action by the Commission July 28, 1971, by Order. Commissioners Burch (Chairman), Bartley, Robert E. Lee, H. Rex Lee, Wells and Houser.)

Network Programs More Available For Non-Affils

The rule designed to make television network programs more readily available to unaffiliated stations in three-station markets has been affirmed by the FCC with modifications to take into account certain geographical and market situations (Docket 18927).

On March 24, 1971, the Commission amended Section 73.658 of the rules to provide that where an unaffiliated third station has reasonably comparable facilities, the network, which is without a primary affiliate in the market must offer its evening programs, and weekend and holiday sports programs (up to 15 hours) to the third station (usually a UHF) before it can present

them over one of the two stations (usually VHF) regularly affiliated with other networks. The rule applies to such markets as Raleigh-Durham, N.C., Augusta, Ga., and Traverse City-Cadillac, Mich.

The rule covers programs on and after October 1, 1971 but networks were permitted to offer programs to unaffiliated stations by July 15, 1971 where possible.

On July 14, 1971, the Commission extended the effective date to August 2, 1971, in order to consider petitions for reconsideration and stay filed by the three networks (ABC, CBS, NBC) and various licensees. The effective date for the Augusta, Ga., market however was extended until at least April 1, 1972, because of the uncertainty as to whether that city's UHF station, WATU-TV, would go back on the air.

As adopted in March, the rule applied to all-VHF as well as VHF-UHF markets. The Commission has now modified the rule in the Idaho Falls-Pocatello situation (three VHF stations) because one of the stations does not put a predicted Grade A signal over Idaho Falls, one of the two large population centers of the market, and "all-VHF" situations like this were not part of the basic reason for the proceeding—which was furtherance of UHF in 'intermixed' situations." As modified, the rule will apply only where the unaffiliated station puts a Grade A signal over the cities of license of the other regular (not satellite) affiliated stations.

Where one of the regular affiliates puts only a Grade B signal over the nearby city, the unaffiliated station will also be required only to provide a Grade B signal to qualify under the modified rule. The Commission said the rule change provides some guarantee that the coverage area of the unaffiliated station is in the same general location, as well as comparable in size to, that of the affiliated stations.

new production techniques

ROTEC

Rotating quad split

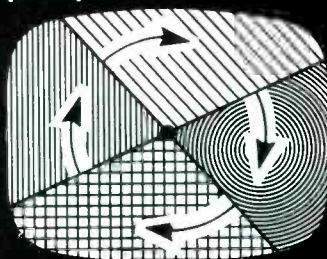

Rotating split

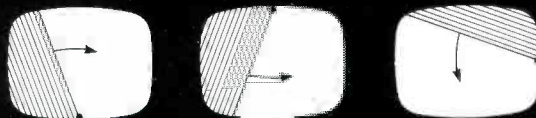
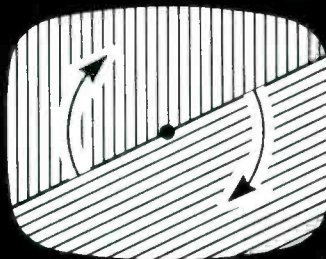

A family of windshield wipes (8)

Enjoy the competitive edge in your market with these exclusive production techniques.

Write or call: 812/332-7251



SARKES TARZIAN, INC.
Broadcast Equipment Division
Bloomington, Indiana 47401

Circle Number 13 on Reader Reply Card

Send your Engineer's
Exchange Ideas To:
BE, 1014 Wyandotte
Kansas City, Mo. 64105

Equipment Radiation Limited

Rules have been proposed by the FCC to limit the amount of radio frequency radiation permissible from restricted radiation devices (Class I TV devices) that produce a radio frequency carrier modulated by a television signal, including inexpensive television cameras and TV cartridge and video-player systems. It was also proposed that these devices be type approved by the Commission.

The action would amend Part 15 of the rules and is in response to a petition from Motorola, Inc., asking for rules to govern the operation of its Electronic Video Recorder (EVR), developed by CBS Laboratories, which Motorola has been

licensed to manufacture. There are many similar devices in this field, the Commission noted.

Upper Limits

The proposed rules would place an upper limit on permissible radio frequency radiation from Class I TV devices. The limit is intended to permit the reproduction of a picture of good quality when the device is directly connected to a television receiver of average characteristics, but the limit is intended to be sufficiently low that the interference potential of the device, coupled with a TV receiver, would be confined to an area within a few feet of either unit.

Remote Control Gets New Rules

On March 17, 1971, the Commission amended Part 73 of the rules concerning operation of television broadcast stations by remote control (Docket 18425, FCC 71-285). Included in the new rules is the requirement that applications for television remote control be filed on FCC Form 301-A (Section 73.677(a)). The use of this form has previously been limited to applications for remote control of AM and FM broadcast stations. The form is now revised to also elicit the information required by the Commission to properly process and consider applications for remote control of both VHF and UHF television stations.

Copies of the revised Form 201-A, Application for Authority to Operate a Broadcast Station by Remote Control or to Make Changes in a Remote Control Authorization (July, 1971), are available upon request at either the Commission's Washington or Field offices. The revised form (July, 1971) should also be used for future remote control applications for AM and FM stations.

A limited number of applications for television remote control authorization under the amended television rules have been tendered by applicants using the superseded Form 301-A. Before Commission acceptance and consideration of such applications, it will be necessary that they be resubmitted on the revised Form 301-A and the supporting data amended, as may be necessary, to reflect all the information required by the new form. Pertinent information already filed need not be resubmitted when appropriately referenced.

A filing fee of \$50.00 is required for all broadcast remote control applications. Additional filing fees will not be required when amendments are filed to applications already tendered and for which the necessary fee has been paid.

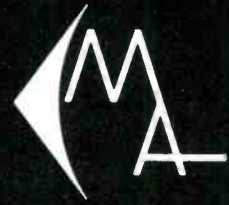

PROFESSIONAL PRODUCTS FOR PROFITABLE BROADCASTING

AUTOMATIC DIGITAL TRANSMITTER LOGGER



MODEL ADP-220

- 0.1% ACCURACY
- 20 CHANNEL CAPABILITY
- CLEAR LOG FORMAT
- CIRCLE 14 ON READER REPLY CARD

REMOTE CONTROL SYSTEMS FOR AM - FM - TV



MODEL PBR-30A

- 30 CHANNELS
- WIRE OR WIRELESS OPERATION
- MODULAR CONSTRUCTION
- CIRCLE 190 ON READER REPLY CARD



MODEL PBR-15A

- 15 CHANNELS
- DC WIRE, AC WIRE AND WIRELESS OPERATION
- FIELD CONVERTABLE
- CIRCLE 191 ON READER REPLY CARD

MOSELEY

ASSOCIATES, INC.

111 CASTILIAN DRIVE
GOLETA, CALIF. 93017
(805) 968-9621

Circle Number 14, 190, 191 on Reader Reply Card

SCANNING THE CATV SCOPE

By Leo G. Sands

Simplified System Test Procedure

Exotic test equipment is great. But, the proof of CATV performance is "picture quality". So why not use a television receiver as a test instrument? There are portable television receivers light enough for a technician to take up a ladder or pole, and many are operable from self-contained batteries.

A VOM (volt-ohm-milliammeter) is a most useful device, but a technician hanging by a safety belt may find it difficult to operate its range-function selector switch and to reverse lead polarity. So why not build a simple tester which will provide all of the required information and which is almost idiot-proof?

Figure 1 is a schematic diagram of such a tester. It consists of a 50-0-50 DC microammeter, two resistors, a diode, a capacitor, an SPST and an SPDT switch. With switch S1 set to "DC" and S2 set to "50", the meter will indicate 0 to 50 volts regardless of polarity. When S2 is set to "5", the full-scale range is 5 volts, again regardless of polarity. When S1 is set to "AC", the meter will have an AC range of 5 or 50 volts full scale, depending upon the setting of S2. (The values of R1 and R2 depend on the internal resistance of the meter.)

Of course, it's not accurate unless precision resistors are used and DC to AC compensation is provided. But, it's accurate enough for servicing.

Using The Tester

This tester can be used for checking AC voltage across a CATV cable and DC voltage at the output of the power supply of a line amplifier. In addition, it can be used for in-circuit checking of transistors and DC operating voltages. Because its meter won't go off scale in the reverse direction, since it's a zero-center meter, the technician can immediately note polarity and voltage.

In the field, the technician will seldom try to determine what is wrong within a line amplifier assembly. If it isn't functioning, he will simply replace it or one of its modules. The tester will tell him if AC power is present and if the amplifier power supply is functioning. But, at the bench, the tester will enable him to make a stage-by-stage analysis of operating voltages and transistor conditions. Of course he could use a VOM on the bench, but this tester will let him do his job faster.

A portable television receiver can be used for checking the picture quality of up to 12 channels at the input and output of a line amplifier and at subscriber drops. Its input can be connected to the -20 dB test points of an amplifier to one of the 300-ohm receiver antenna terminals and the receiver chassis. The signal voltage at the receiver input will be one-tenth (-20 dB) the actual amplifier input and output signal voltages

which should be adequate. If excessive, an adjustable 75-ohm attenuator can be inserted in series with the receiver antenna input.

In addition, the field technician should of course have an FS (field strength) meter for measuring the level of each channel so he can make a quantitative analysis. But for a "qualitative" analysis, a television receiver will reveal conditions other than signal levels.

Testing Amplifiers On The Bench

On the bench, it is customary to have a sweep generator, an oscilloscope and various other devices for checking line and distribution amplifiers. And those who can afford it will also have a spectrum analyzer. They are essential for professional-quality work. How to use these instruments is spelled out in amplifier service manuals and instrument operating manuals.

When these instruments are not available or in use because of a heavy workload, garden-variety instruments can be used for making go-no/go checks. For example, as shown in Figure 2, a tunable RF signal generator can be used to feed a signal into the input of a line amplifier and the output level of the amplifier can be monitored with a VTVM (vacuum tube voltmeter) equipped with an RF probe, or with a field strength meter.

The approximate gain of the am-

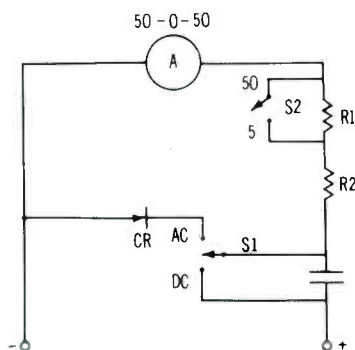

Figure 1

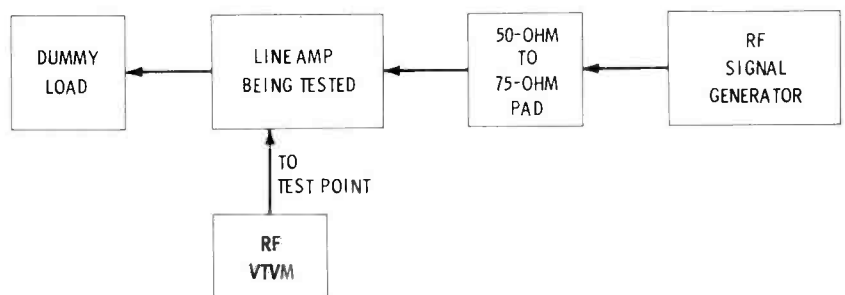
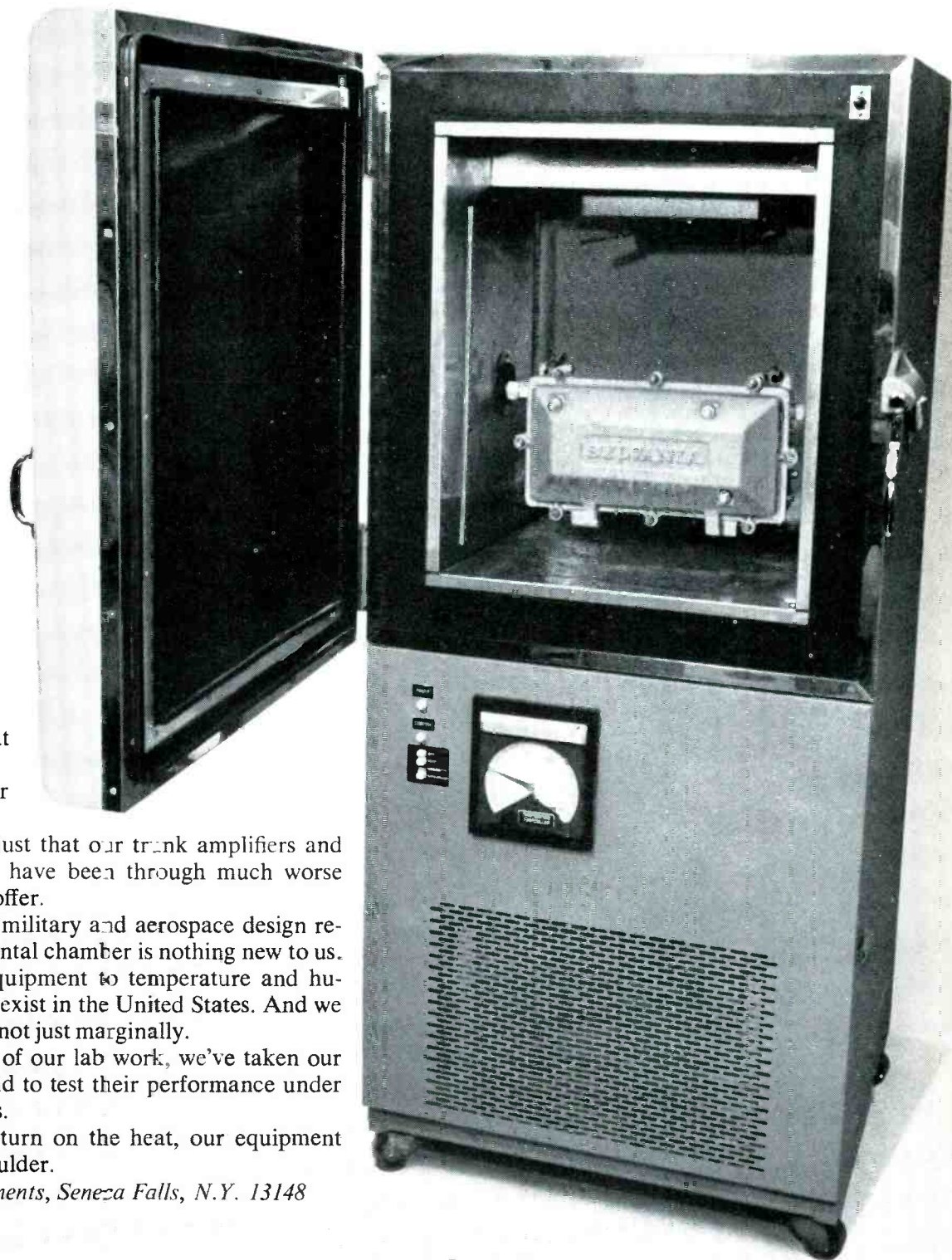

Figure 2

We send our amplifiers to Siberia before we send them to you.



We really don't care what the climate is in your area.

And neither does our equipment.

It's not disinterest, it's just that our trunk amplifiers and other CATV components have been through much worse than anything you have to offer.

With our experience in military and aerospace design requirements, the environmental chamber is nothing new to us.

We take our CATV equipment to temperature and humidity extremes that don't exist in the United States. And we make sure they work. And not just marginally.

And then to make sure of our lab work, we've taken our CATV units out in the field to test their performance under actual operating conditions.

As a result, when you turn on the heat, our equipment won't give you the cold shoulder.

Sylvania Electronic Components, Seneca Falls, N.Y. 13148

the oldest new company in CATV.

GTE SYLVANIA

Circle Number 15 on Reader Reply Card

plifier can be ascertained by noting signal generator output level, subtracting the insertion loss of the impedance matching devices, and measuring output signal level. The frequency response of the amplifier can be determined by tuning the signal generator through the 50-220 MHz range and adjusting its output level to maintain amplifier output at the same level at all frequencies. The frequency response can be plotted by noting what signal levels are required at various frequencies to maintain output signal level constant.

Of course, the amplifier sees a simple signal, not a complex one as when fed by a sweep generator or a multiplicity of television signals. Nevertheless, meaningful measurements can be made and amplifier defects can be detected.

The use of conventional signal generators for testing line amplifiers for cross-modulation are recommended in the "RCA Power Circuits" manual. In this book, it is stated that such a test conducted with a number of modulated television channels applied "is not really conclusive, because TV windshield wiper effects can be seen more read-

ily on some pictures than on others".

The RCA book says that "the accuracy of the test is greatly increased if an unmodulated signal is substituted for the picture signal on the viewing channel" and that "this technique provides a white screen which does not change during the test, and allows more consistent and critical observations."

Cross-Modulation

The recommended test set-up for determining the cross-modulation of an amplifier on a relative basis is shown in Figure 3 and the procedure is as follows: (1) Tune the field strength meter and signal generator A to 150 MHz; set signal generator modulation to 30 percent at 1000 Hz, and the RF level to the rated output of the amplifier; adjust the potentiometer and AC voltmeter for a convenient level which then corresponds to 100 percent cross-modulation; then turn off the modulation; (2) Tune signal generator B (modulated 30 percent at 1000 Hz) and the field strength meter to 210 MHz and adjust RF level to the rated output of the amplifier. (3) Set the field strength meter to 150 MHz and note the indication of the

AC voltmeter; then calculate the percentage of cross-modulation based on the previously determined 100 percent level.

To operate a line amplifier on the bench, it is necessary to provide an AC operating voltage at either its input or output. While the AC can be applied through an RF choke, it is usually better to apply it through a power inserter as is done in the CATV system.

The AC power source should be adjustable so that the input to the power supply of the amplifier can be set to any level from 20 to 40 volts so that actual field conditions can be simulated. It can be a metered power supply, as shown in Figure 4, consisting of a step-down transformer, an AC voltmeter and a variable auto-transformer (Variac, etc.) which is used for setting input voltage to the step-down transformer primary.

Figure 4 also shows an alternative way to monitor amplifier output for gain and frequency response tests using a field strength meter for single-signal tests and also a TV receiver for tests made with a TV signal.

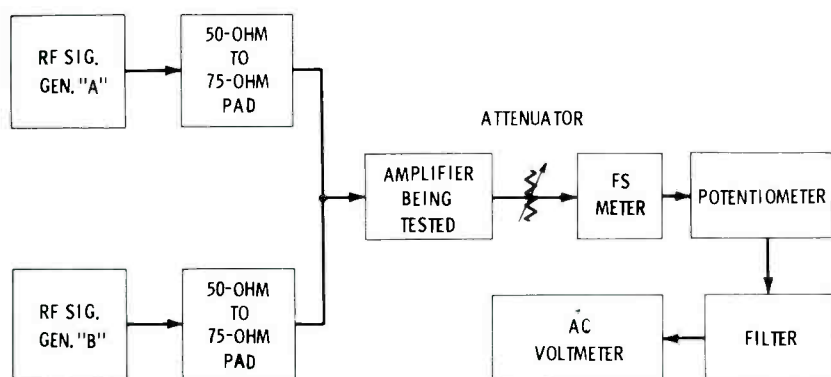

Figure 3

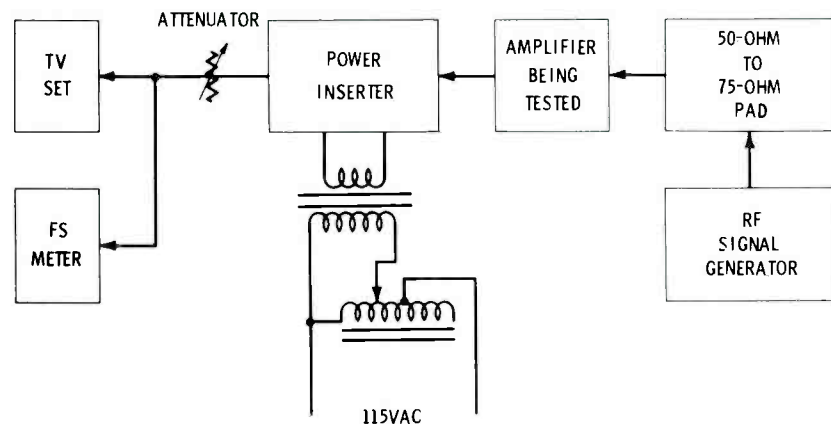
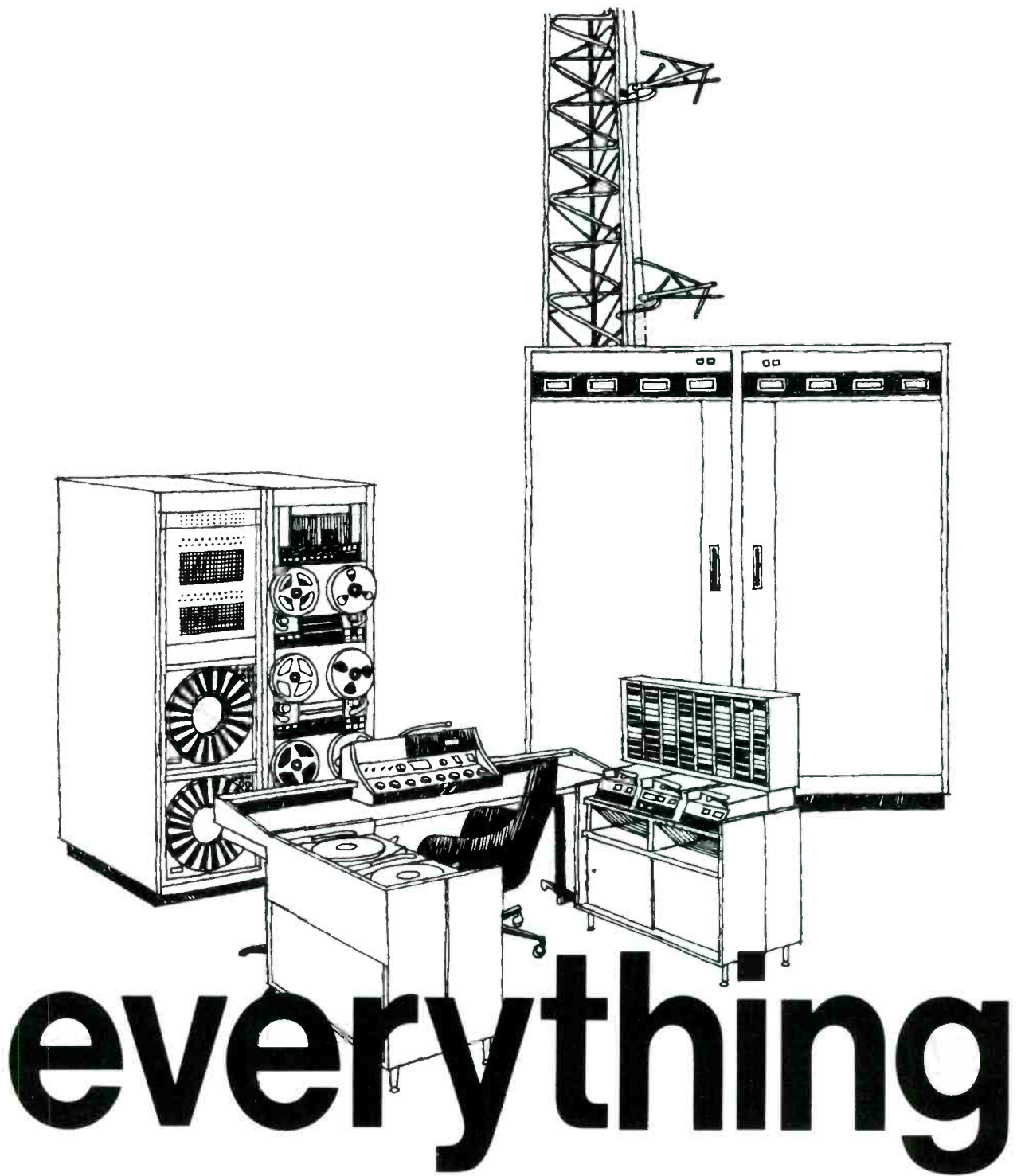

Figure 4

Magnavox Exhibits New Cable TV Set

The first home television terminal (receiver) designed exclusively for cable television was introduced by Magnavox at the National Cable Television Association Convention, Washington, D.C. Called the Magnavox "TV 101" Cable TV Terminal, the console unit is designed to take full advantage of the high quality reception available through CATV systems. The new receiver is engineered to assure that the picture reception quality will be fully comparable to the signal transmitted.

The Magnavox terminal offers a total of 31 channels for cable reception, as well as the standard UHF channels demanded by FCC regulations for all TV receivers. Fine tuning is automatic and ensures maximum channel stability. This feature combined with improved selectivity assures excellent



everything

... for your every broadcasting need, and with 100% financing!! It's faster, easier, and less costly for you to let SPARTA service your needs.

A telephone call right now will put you in touch with people familiar with the entire spectrum of broadcasting, including audio consoles, tape cartridge systems, automation, transmitters and antennas. Plus a wide selection of accessory products!

A smooth and profitable operation is yours with SPARTA equipment because value is built in, in such a

way that dollar for dollar you can't find a better buy in quality broadcast products. From a complete station-transmitter package to a microphone for your production studio, SPARTA can fill your requirements faster, easier, and less costly than ever before!!

Call, write, or wire us today and we'll send you colorful brochures showing our complete line of transmitters and antennas, automation, and studio equipment. Let us help you plan your next equipment purchase using our 100% financing plan. SPARTA HAS EVERYTHING!!!



SPARTA ELECTRONIC CORPORATION

5851 FLORIN PERKINS ROAD SACRAMENTO, CALIFORNIA 95828 (916) 383-5353

14616 SOUTHLAWN LANE, ROCKVILLE, MARYLAND 20850 (301) 424-2920

A DIVISION OF COMPUTER EQUIPMENT CORPORATION

Circle Number 16 on Reader Reply Card

adjacent channel performance.

The receiver is equipped with Magnavox's new Deluxe Total Automatic Color System which includes an improved Matrix picture tube and a redesigned high-performance hybrid Magna-Power chassis.

The set, which will be available in early 1972, is also designed to operate efficiently with standard antenna in non-CATV situations.

"The need for a special terminal for CATV subscribers has long been apparent", says Magnavox President R. H. Platt. He said that the

introduction of the terminal also reinforces Magnavox's entry into the cable television systems market which now serves about 6,000,000 subscribers through 2,573 systems.

Platt stated that "Recognizing the need for a CATV receiver, the National Cable Television Association has petitioned the FCC to institute proceedings to define the specifications necessary to a cable television receiver.

"In 1970, 120 CATV systems were added in the U.S.," he said, "and in 1971, 40 new systems were

started, making a total of 2,573 systems operating today, serving about 6,000,000 subscribers."

"In addition, 2400 more systems are franchised but not yet operating and 2600 franchise operations are pending," according to Platt. "The new Magnavox CATV terminal will enable these systems to help fulfill their potential to their subscribers."

The 31 channel capacity of the CATV receiver is accomplished by inserting 8 channels in the frequency gap between standard channels 6 and 7, and by adding 11 channels above channel 13. The "TV 101" has detented electronic tuning, as specified in the NCTA request to the FCC, and is double-shielded with coaxial integrity to prevent interferences from the off-the-air TV transmissions.

Political Broadcast Survey Now Available

The Survey of Political Broadcasting in the Primary and General Elections Campaigns of 1970 will be available for sale by the National Technical Information Service (NTIS) of the Department of Commerce.

Price of the 320-page report is \$6.00 per copy Microfiche copies are 90 cents each.

Orders should be addressed to U.S. Department of Commerce, National Technical Information Service, Springfield, Va., 22151. All orders should include the accession number: PB 200-434.

The report was submitted to Congress on June 16 by FCC Chairman Dean Burch in his testimony on political broadcast bills. It contains complete summaries of political broadcasting expenditures in the 1970 elections with breakdowns of spending in individual Senatorial, Gubernatorial and Congressional races. It reveals that political broadcasting expenditures totalling over \$50 million in 1970 were 85 percent higher than in 1966, the previous non-Presidential election year.

Film In
Local Origination
Page 32

Spotmaster

The incomparable new **Ten/70**



World's finest cartridge tape equipment

Here is the bold new standard in cartridge tape performance, versatility and ruggedness—the equipment that has *everything!* Five models of the magnificent Ten/70 are offered to meet every recording and playback application. All have identical dimensions. Any combination of two will fit in our sleek 19-inch roll-out rack panel, just 7 inches high.

Control features and options include manual high-speed advance, exclusive Auto-Cue with automatic fast-forward, automatic self-cancelling record pre-set, front panel test of cue and bias levels, built in mike and line level mixer, color-coded design for easiest possible operation.

Inside is a massive U.S.-made hysteresis synchronous "Direct Drive" motor, solid state logic switching, modular construction and premium components throughout, separate heads for A-B monitoring, full bias cue recording, transformer input and output, flip-top access to heads and capstan.

THE CLASSIC 500 C SERIES. Long the industry standard, SPOTMASTER'S 500 C series is still offered. Performance and specifications are second only to the Ten/70.

For complete details about SPOTMASTER cartridge units (stereo, delayed programming and multiple cartridge models, too), write or call today. Remember, Broadcast Electronics is the No. 1 designer/producer of broadcast quality cartridge tape equipment . . . worldwide!



BROADCAST ELECTRONICS, INC.

A Filmways Company

8810 Brookville Road, Silver Spring, Maryland 20910 • (301) 588-4983

now . . .
 a company
 that has AM, FM
 and TV frequency
 and modulation
 monitoring
 systems.

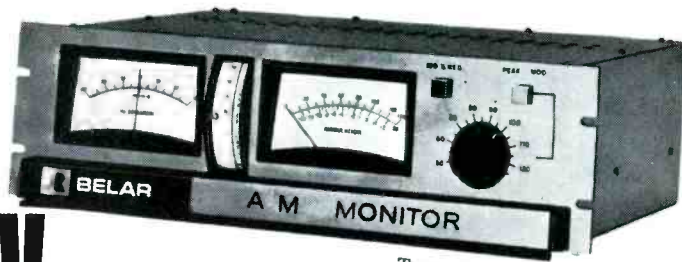

Type Approval #3-176

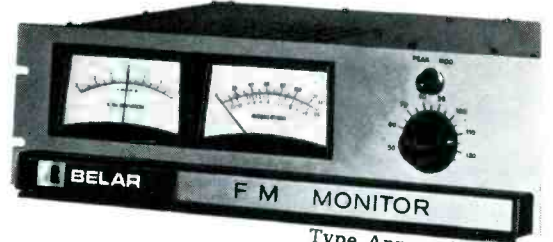

Type Approval #3-129

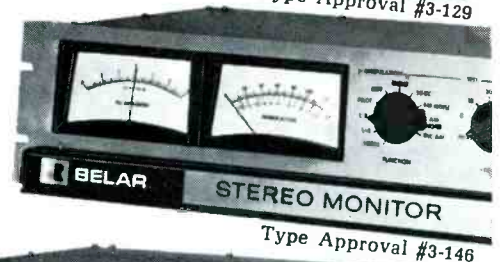

Type Approval #3-146



Type Approval #3-162



Type Approval #3-181



Type Approval Not Required

Now . . . Belar. Belar is the only company that has the necessary type approvals on all three monitoring systems. Belar accuracy permits use of the maximum power allowable and maximum power means maximum profit. Add to this that all Belar equipment is immediately available.

Isn't it time you stopped running around and finally settled for a company that can handle *all* your frequency and modulation monitoring needs? Contact Arno Meyer . . . he'll show you the way.



BELAR ELECTRONICS LABORATORY, INC., DEPT. BE-91
 BOX 83, UPPER DARBY, PA. 19084 • (215) 789-0550

Circle Number 17 on Reader Reply Card

Plug into \$63,000 savings...

with a Norelco
color camera that uses
triaxial cable.



Savings with the new Norelco triax cable cameras are immediate and substantial. Our \$63,000 figure is a *conservative* estimate, calculated by determining such normal (and inevitable) costs as initial outlay for cable, set-up and strike, cable repair and storage, and depreciation, and extending the good news over a five year period. We repeat, \$63,000 is conservatively estimated. In checking our cost figures against your own, it is almost a certainty that you will arrive at an even greater saving. For the down-to-earth facts, send for our paper, "The Economics of Triaxial Cable Color Television Cameras." It will allow you to define *your* savings in detail.



Norelco PC-100A...the only camera with A.C.T. Plumbicon* tubes ... solve high-contrast problems at the source.

Here's the camera that introduced two revolutions in color television. A cable revolution—using light, low-cost triaxial cable. And a tube revolution with the new Anti-Comet-Tail "A.C.T." Plumbicon.

A new gun design gives the A.C.T. Plumbicon tube an unprecedented dynamic range (inherent overbeaming capability equivalent to five or more f-stops overexposure) with no washout or loss of detail even in action scenes with brilliant highlights and deep shadows. It's standard in the PC-100A, and the contrast problem is defeated at the source . . . not partially offset through complicated, costly, extra-option hardware. As a bonus, the A.C.T. tube handles low-light situations with matchless fidelity.

This is the camera that stunned every audience at NAB with its remarkable reliability . . . with quick, easy assembly . . . three and one-half minute cable butting . . . and sparkling color pictures that were called "the best color television picture ever achieved."

Norelco PCP-90B...the only broadcast-quality portable. It operates RF fully system-integrated Triax system-integrated Backpack-to-VTR fully N.T.S.C.

This is the tried and proven hand-held color camera that is enabling broadcasters and production firms to go where they never went before, get pictures never before attainable.

Part and parcel of the Norelco camera revolution, the PCP-90B is adding daily to its illustrious record of getting the action—anywhere and anytime—and getting it in faithful, crisp Norelco color.

Best of all, the PCP-90B operates on triaxial cable to afford the same kind of day-in and day-out savings now possible with the PC-100A. When it isn't on a remote, the three-Plumbicon PCP-90B doubles as a studio camera. Truly far-out mobility comes with the camera's optional microwave link; great examples are the widely acclaimed helicopter applications of this unique broadcast-quality camera. It is the most versatile camera available, and can be fielded as a self-contained battery-operated camera with a portable video tape recorder to record the action. And remember, you get all these revolutionary advantages on top of tremendous operational dollar savings.



†Write on your letterhead for our detailed report, "The Economics of Triaxial Cable Color Television Cameras." Plug in your figures and compute your short- and long-term savings.

One Philips Parkway, Montvale, New Jersey 07645 (201) 391-1000

*Reg. TM N. V. Philips of the Netherlands

Circle Number 18 on Reader Reply Card

Digital Logic Basics

Part 1 of a four-part series *By E. S. Busby, Jr.**

Competition and automated manufacture have drastically reduced the cost of integrated circuits. With this inducement the makers of broadcast equipment embraced the IC with the same fervor and suddenness as they adopted the transistor a few years ago. The especially low cost of digital IC's coupled with the spread of computer technology is reflected in a drift toward digital solutions to cir-

*Engineer, Ampex Corp., Redwood City, Calif.

cuit design problems rather than analog ones.

IC's are simply ready-made, conveniently packaged circuits made up of transistors, resistors, very few capacitors and no inductors. "Linear" IC's are amplifiers whose output voltage is proportional to the input voltage. "Digital" IC's are circuits in which the transistors either conduct fully or not at all. The term "digital" is actually a misnomer; "digital" implies "ten" since we humans have ten "digits"

or fingers. The name stems from the first computers which were structured around base ten arithmetic. A more proper term would be "binary", since the terminals of digital IC's, like relays and switches have only two defined states.

Except for the following mention, this and the succeeding articles of this series deal only with digital devices and techniques.

The Linear

Generally, any IC that isn't a

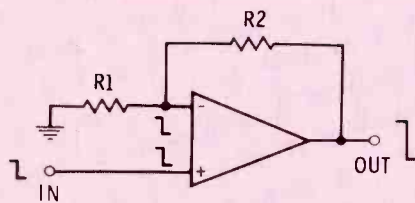

NON-INVERTING AMPLIFIER

$$\text{GAIN} = 1 + \frac{R2}{R1}$$

INPUT IMP. IS HIGH

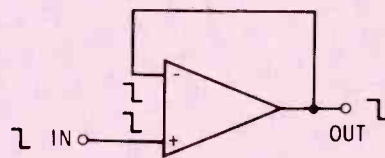

SPECIAL CASE:
VOLTAGE FOLLOWER

GAIN = 1
HI Z IN, LOW Z OUT

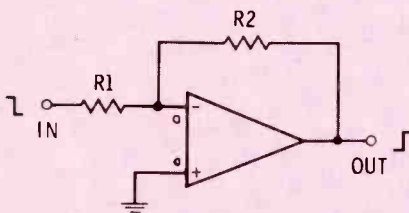

INVERTING AMPLIFIER

$$\text{GAIN} = \frac{R2}{R1}$$

INPUT IMP. = R1

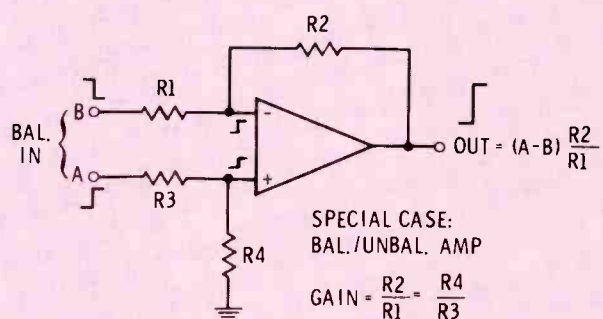

SPECIAL CASE:
BAL./UNBAL. AMP

$$\text{GAIN} = \frac{R2}{R1} = \frac{R4}{R3}$$

WITH RATIOS SHOWN,
IN-PHASE INPUTS CANCEL.
TO TERMINATE A BALANCED
LINE IN IMPEDANCE Z,

$$R3 = \frac{Z}{2(1 + \text{GAIN})}$$

$$R4 = R3 \times \text{GAIN}$$

$$R1 = \frac{Z}{2} + R4$$

$$R2 = R1 \times \text{GAIN}$$

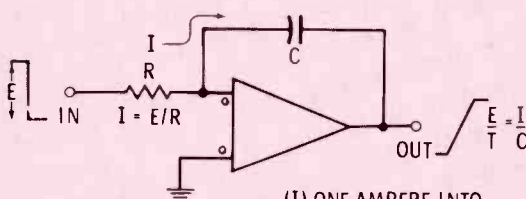

INTEGRATOR
(I) ONE AMPERE INTO
(C) ONE FARAD YIELDS:
(E) ONE VOLT RISE IN
(T) ONE SECOND

Fig. 1 Example linear amplifier circuits.

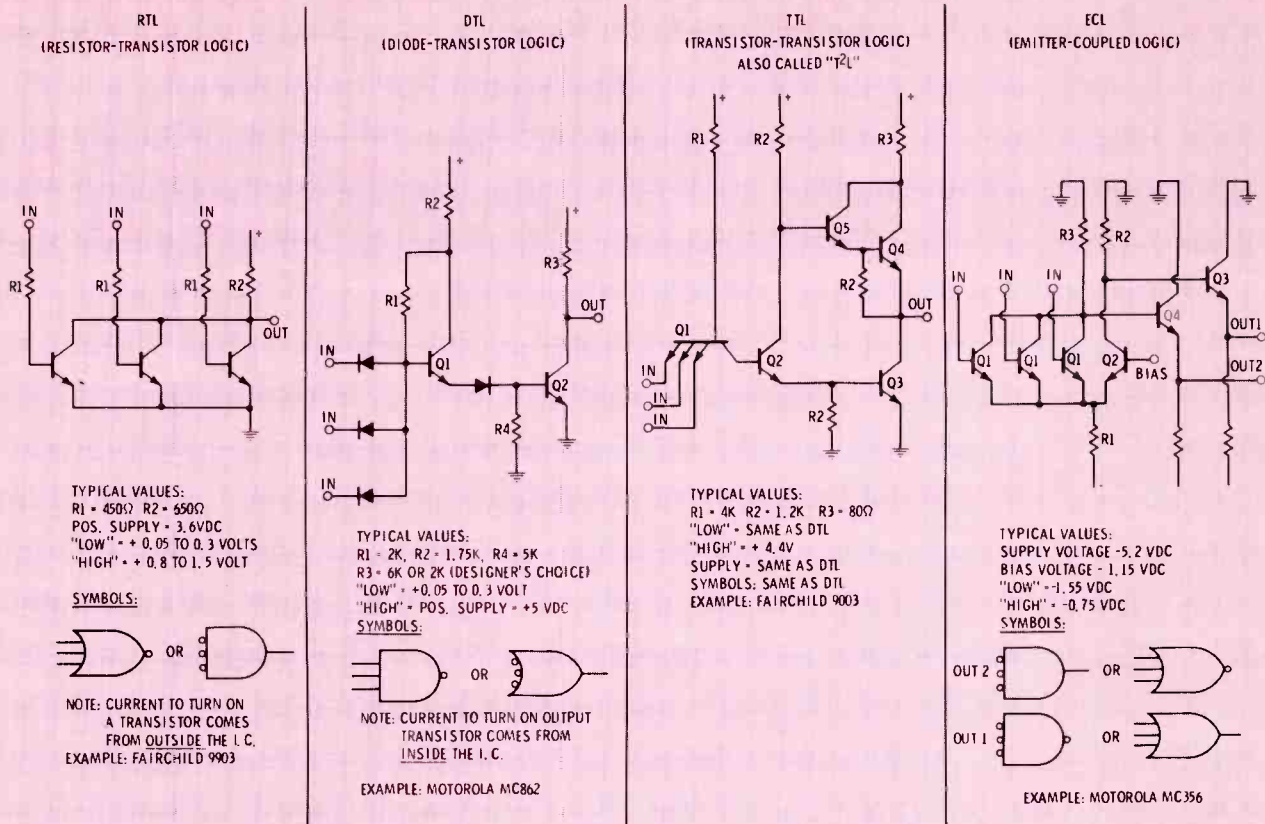

Fig. 2 Four kinds of three-input gates. Note: **For RTL:** taking any input positive furnishes base current to its transistor and turns it on, shorting $R2$ to ground. If no input is positive, $R2$ is not shorted and other inputs connected to this output will be taken positive via $R2$. **For DTL:** taking any input to ground lowers emitter voltage of $Q1$, turning off $Q2$. The output voltage rises to + supply. If all inputs are high, all diodes are back-biased and $Q1$'s emitter furnishes base current to $Q2$, turning it on and shorting $R3$ to ground. The output then serves to ground any inputs or other outputs tied to it. $Q1$'s emitter current is limited by feedback from collector to base via $R1$. It doesn't saturate.

Note For TTL: Same logic and supply voltage as DTL. Grounding any emitter of $Q1$ pulls down base of $Q2$, turning off $Q3$ and $Q2$. Base of $Q5$ rises, pulling $Q4$ emitter and

the output with it. Short circuit current is limited by $R3$. Output has low source impedance in both states because of "active pull-up" action of $Q4$ & $Q5$. Good for driving capacitive loads, but prevents outputs being connected together.

Note For ECL: $R1$ furnishes current to emitters of $Q1$ & $Q2$. A bias voltage is supplied to base of $Q2$. If any input is made more positive than the bias, current is steered through its $Q1$ into $R3$, and $Q2$ is cut off. If all inputs are more negative than bias, all current goes through $Q2$ and $R2$, and all $Q1$'s are cut off. $Q3$ and $Q4$ are emitter-follower outputs. Since outputs are opposing, circuit is good for driving twisted pair lines. Output impedance is low. Bias voltage is supplied by special IC which controls bias to compensate for temperature.

strictly logic device is lumped under the title "linear". Many, such as FM limiters, though anything but linear, are so classed. The linear amplifier found in broadcast equipment is typically a high gain (80-120 dB) DC amplifier, having balanced inputs (called "inverting" and "non-inverting") and a single ended output. Useful bandwidths extend to a megahertz or so, though some units are useful to 10-20 MHz, but exhibit less gain. The full gain is rarely used as inverse feedback from the output to the inverting input is almost always applied.

Most IC amplifiers require from one to three "stabilizing" components externally attached. Their values depend on the nature of the feedback path. They roll off the response to prevent oscillation.

For analysis and diagnosis of trouble, it is adequate to presume that a linear amplifier with negative feedback applied (also called an "operational amplifier") will always act so as to maintain the voltage between its input terminals at zero. From this and Ohm's law, all else follows. See Figure 1 for some typical examples.

By The Numbers

Broadcast equipment makes heavy use of digital circuits in the performance of simple two-state control logic, pulse shaping and frequency division (as in counting to 525 in a sync generator). In these uses the parameters are fixed, i.e. it's **always** 525 lines and **always** six equalizing pulses. The ability to economically expand the use of digital circuits has resulted in their application to variables.

Frequencies and time periods can be easily converted to a digital form by simply counting cycles of the

SYMBOL	NAME	MEANING	EXAMPLE	BOOLEAN EXPRESSION	REMARKS
	INVERTER	IF A IS LOW, THEN B IS HIGH	MOT. MC836	$B = \bar{A}$	- MEANS "IF"
	"	IF A IS HIGH, THEN B IS LOW	"	$\bar{B} = A$	\bar{B} MEANS B NOT HIGH B " " IS "
	TWO-INPUT "NAND" GATE	IF A IS HIGH AND B IS HIGH, THEN C IS LOW.	MOT. MC846	$\bar{C} = A \times B$ ALSO $\bar{C} = \bar{A} B$	X Means "AND" AB MEANS A AND B
	"	IF A IS LOW OR B IS LOW, THEN C IS HIGH	"	$C = \bar{A} + \bar{B}$	+ MEANS "OR"
	TWO-INPUT "NOR" GATE	IF A IS LOW AND B IS LOW, THEN C IS HIGH	MOT. MC1810	$C = \bar{A} \times \bar{B}$	"N" IN "NOR" AND "NAND" INDICATES INVERSION
	"	IF A IS LOW OR B IS HIGH, THEN C IS LOW.	"	$\bar{C} = \bar{A} + B$	IS "AND" SHAPE
	TWO-INPUT "AND" GATE	IF A IS HIGH AND B IS HIGH, THEN C IS HIGH.	MOT. MC1806	$C = A \times B$	IS "OR" SHAPE
	"	IF A IS LOW OR IF B IS LOW, THEN C IS LOW.	"	$\bar{C} = \bar{A} + \bar{B}$	BUBBLE INDICATES "LOWNESS"
	TWO-INPUT "OR" GATE	IF A IS LOW AND B IS LOW, THEN C IS LOW	MOT. MC1808	$\bar{C} = \bar{A} \times \bar{B}$	NO BUBBLE INDICATES "HIGHNESS"
	"	IF A IS HIGH OR IF B IS HIGH, THEN C IS HIGH	"	$C = A + B$	
	EXCLUSIVE "OR" GATE	IF A IS HIGH OR IF B IS HIGH, BUT NOT BOTH, THEN C IS HIGH, IN OTHER WORDS, IF A AND B ARE DIFFERENT, C IS HIGH	MOT. MC1812	$C = A \oplus B$	\oplus IS SPECIAL SYMBOL FOR EXCLUSIVE OR
	VARIOUS OTHER DEVICES	IF "MR" MEANS "MASTER RESET", BUBBLE INDICATES THAT A "LOW" CAUSES RESET IF C MEANS "COUNT" (EDGE-TRIGGERED) BUBBLE MEANS COUNT OCCURS ON A LOW-TO-HIGH TRANSITION. LACK OF BUBBLE INDICATES HIGH-TO-LOW CAUSES THE ACTION.	FOR FULL INFORMATION ON COMPLEX DEVICES, COUNTERS, ETC. CONSULT MFG'S DATA SHEET OR CATALOG.		

Figure 3

input frequency for a known period of time, or counting a known frequency over an input time period. Note that in each case the variable is converted into a **number** (of counts). Today's VTR servo systems and time-base correction accessories employ these techniques.^{1,2}

A variable amplitude can also be converted to numeric form, or "digitized". In this form, the variable can have the same operations performed upon it as before: it can be

added to, subtracted from, multiplied, divided, compared with other variables, encoded and decoded, transmitted and received, maxima, minima and zero crossings detected . . . with one important difference: **the exact result of any operation can be predicted.** All the binary elements which constitute and define the number are clearly either on or off. No calibrating, no balancing, no drift . . . the only way to distort a digitized quantity is for one or

more of the digits to be totally wrong. To process a variable through a digital computer, it **must first** be digitized.

Except for satellite transmissions,³ it is not yet customary to digitize program video and audio signals. When the advantage of doing so justifies the cost, it will be done.

A kind of digitized video is widely used, however. Circuits using "read-only" digital memories (a "look-up" table) are used in char-

acter generators to produce synthetic video that displays numerals, punctuation marks, and letters of the alphabet on a standard TV monitor.

In some studio cameras, control voltages are digitized, then "serialized" (sent one binary element at a time), so that many controls may time-share one wire in the cable. In the camera, these signals are re-converted to DC voltages and routed to the proper pick-up tube electrodes or circuits. One video switcher uses a similar technique in that each button, when pressed, emits a serial "code" which is recognized at the switch point and initiates the desired action.⁶ The savings in weight, copper and installation time are appreciable.

Complex digital circuits are becoming more so, are being used more often, and employ an ever-widening spectrum of prepackaged circuit functions. From the maintenance point of view this is a mixed blessing. On one hand, the behavior of a digital circuit can be predicted **exactly**, usually mentally, sometimes with pencil and paper. To do this quickly, however, requires knowledge of digital techniques. Digital circuits rarely have any adjustments and failure to work cannot be corrected by "tweaking". Rapid diagnosis and isolation requires a new and more complicated reasoning process... and when the culprit is found, it is more difficult to replace than a transistor. The first and most important tool you will need is knowledge.

The "Families"

Let's first divide all digital IC's into two classes: those which employ ordinary transistors, and those which use field effect transistors (usually MOSFET types). The FET types are called "MOS devices" and little more will be said about them beyond this:

1. Like ordinary transistors, they turn on and off.
2. They use less power and therefore more circuit func-

tions can be fitted into a given package.

3. They operate more slowly.

Devices using ordinary transistors (mostly NPN) are called "bipolar". In this category are four families likely to be found in broadcast equipment. Please refer to Figure 2 and study it carefully before continuing.

Of the four circuits you have just examined, one (ECL) is unique in that none of its transistors ever saturate. (The collector voltage does not closely approach the emitter voltage.) Since it takes extra time to drive a transistor out of saturation when turning it off, ECL circuits are particularly fast, and are used when high frequencies (15 MHz to 100 MHz) are to be handled. All families offer a "buffer" unit, which is simply a logic element with a high-current output stage capable of driving three or four times as many inputs as an ordinary gate.

DTL and TTL devices are compatible and can often be directly interchanged. Special units are available which act as an interface between otherwise incompatible families.

King-Size or Regular? Filter or Non-Filter? Flip-Top or Soft Pack?

The digital designer is faced with a bewildering choice.

- A. He will choose a "family", based on economics and the system's requirements. But within each family there is a choice of:
 - B. Operating temperature ranges. -55°C to +125°C—full military range 0°C to 75°C—industrial range.

Some plastic packages are limited to 15°C to 50°C, but are otherwise the same as their "industrial" counterpart. Just as 5% resistors are of no better quality than 10% ones, the temperature range does not necessarily reflect on quality, but rather on testing, marking and, of course,

price. Besides the temperature range he will choose a:

- C. Package. There are round, hermetically sealed metal cans (about the size of a TO-5 transistor), having 8, 10 or 12 leads, or a round molded plastic equivalent. The "Dual in-line package", comes in 8, 14, 16, 24 and 36 pin versions, often available in either plastic or ceramic. For high circuit board density, there is a "flat pack", usually ceramic, whose leads solder to the top of a circuit board rather than protrude through holes. There are still other packages, too numerous to mention. Besides the package, the designer may elect to choose:
 - D. Low power units. These units operate at a somewhat slower speed, but consume about 1/8 the power of normal devices. Using the same supply voltage, they may be intermixed with normal power units if certain rules are followed. Circumstances may dictate that the designer choose:
 - E. High level logic. These units use a higher supply voltage (typically +12V), and offer a greater immunity to extraneous noise signals. They may

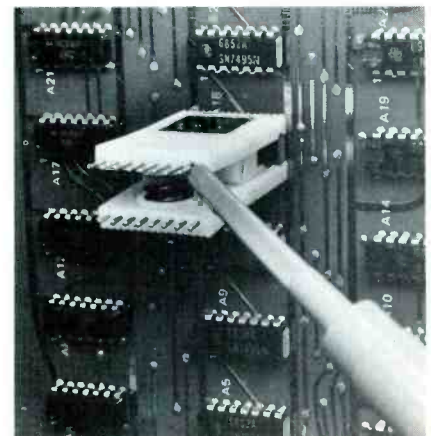

Fig. 4 Clamp-on "clothespin" for DIP's attached.

be used when an existing design must be modified, and only +12V is available. Some industrial equipments use it to provide greater immunity from the transients generated by motors, welders, etc.

Not all combinations of these choices are available. The most popular devices used in new broadcast equipment designs are of the DTL and TTL family, in the dual in-line 14 or 16 pin package, normal power level and supply voltage, and temperature-rated for 0°C to 75°C. Some earlier designs made wide use of RTL; some newer ones employ ECL.

Most IC's Fail On Weekends

It is reassuring to have on hand an exact replacement, bearing all the same numbers. Often, however, one must improvise. Here are some suggestions:

A. Manufacturers license others to make and sell their designs, but not all makers use the original numbering system. Sometimes it is identical, sometimes vaguely similar,

sometimes completely different. The NAME of the device and its pin configuration are much more standardized than its number.

B. Except for DTL and TTL, stay within the family. Many TTL and DTL units are pin-compatible, and may be substituted. If replacing a DTL with a TTL device, be sure to check that no output is connected to another output. This is not normally permitted with TTL circuits. DTL, being slower than TTL, might not work in high-speed circuits.

C. Devices with a wide temperature range may be substituted for ones with a narrower range. The opposite will usually work as it is seldom that any broadcast equipment exceeds 75°C. The worst that can happen is failure to operate properly when it gets hot, in which case, open the door and plug in a fan.

New Hieroglyphics

The old schematic diagram with its maze of Q's and R's, and to a degree the block diagram, have been

supplanted by the logic diagram, which, equipped with package numbers and pin numbers, serves as a schematic. Over the years a number of logic symbol sets have been devised and used, but one survives: ANSI Y32.14.⁷ In this scheme, the shape of the symbol tells what purpose a device serves in the circuit, and the presence or absence of a small circle or "bubble" at the input and output terminals defines the voltage level at that terminal when the device is doing what the shape suggests. Study Figure 3 before going further.

Beware: there are old diagrams around which use obsolete symbols, and ones which employ the right shapes, but wrongly use the bubbles. Unless you like the idea of indulging in symbolic translation 10 minutes before sign-on, you would do well to examine and correct your schematics.

Or In Other Words

The terms "positive logic" and "negative logic" refer only to explanatory notes and do not affect the schematic otherwise. A statement (such as RECORD BUS) in "positive logic" means the bus is high when active; in "negative logic" it would be low when active. A negated statement (such as RECORD BUS, in positive logic, means the line, when active (recording), is NOT high (therefore is low).

Many instruction books fail to state which notation is being used and are inconsistent as well. Negative notation is often used with RTL designs and positive notation for others. "Purify" the notations on your schematics. It is good practice and a worthwhile exercise.

ECL devices typically use a negative power supply with collectors returned to ground. An ECL "high" is a less negative voltage than a "low", therefore for the families mentioned, a "high" is further up on the scope than a "low".

Tricks and Tools Of The Trade

Plan to use a scope. Use low-capacity probes. For VTR's with



Fig. 5 Pneumatic device for removing solder.

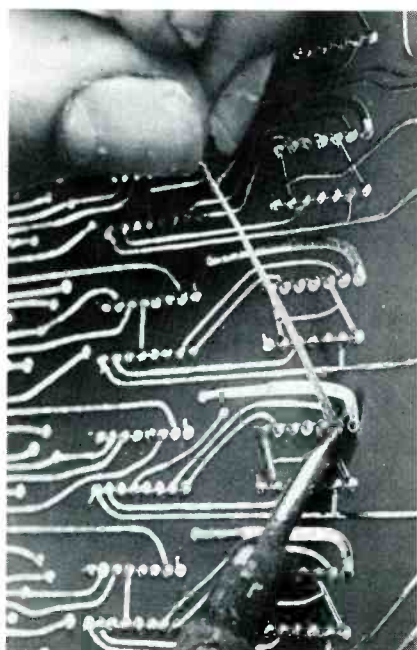

Fig. 6 Flux-impregnated braid can be used to "wick up" solder by capillary action.

All-digital circuitry.
All-digital genlock.
Programmable pulse widths.
Mono and color lock.
Bar/dot and black burst.
Front-panel test points.
Best time-base stability.
Two rates of genlock.
Full maintenance access
during operation.
Built to network specs.



Anything less isn't
the world's most advanced
color sync generator.

Write today for complete technical and price
information on the Telemation TSG-3000.

TELEMATION

P.O. Box 15068, Salt Lake City, Utah 84115
Phone: 801-487-5399

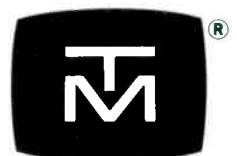

Circle Number 19 on Reader Reply Card

editing equipment, cassette tape transports, or anything with a slow cycle time, a memory scope is needed. Have access to a dual-trace preamp, and for memory scopes, four traces can be useful. The preamp sensitivity should be such that 0.1 V is easily discernable. A clamp-on "clothespin" connector for DIP's is available. See Figure 4. Get as many as you have preamp inputs plus one for the trigger probe. When not using the clothespin, use a sharp probe to avoid slipping. Many an IC has become silicon vapor from an accidental short from the positive supply to an output.

Ultimately reason, logic, observation and (as a last resort) consulting the instruction book lead to an illogical IC. If the IC isn't in a socket it pays to search for external causes of malfunction before performing surgery.

A. If an output is stuck at the

power supply voltage, touch a 3.3K resistor between output and ground. If the output voltage fails to lower at all, chances are it is shorted to the supply somewhere.

B. If the output is exactly at ground, touch the resistor from output to supply voltage. Failure to change indicates a short to ground.

C. If the output remains logically "low", but exhibits the typical 50 to 300 millivolts above ground of a saturated collector, it is possibly shorted to another output which is "low". Outputs are sometimes deliberately connected together in what is called a "wired-or connection." First try an ohmmeter check to other outputs on the circuit board. Then isolate the output from all loads by clipping the pin or cutting a circuit board trace. (These are quicker to repair than a full replacement.)

D. If a DTL or TTL input never gets more positive than about 1.5 to

2 volts, check for an open circuit on the board. Plated through holes on double sided boards are notorious offenders.

Unless it is a very expensive IC, don't try to save it intact. It isn't worth the time. The author has found it most convenient with DIP's to nibble the thing off at the ankles with a pair of end-cutting offset nippers so that each lead may be worried out of its hole individually. A spring-operated pneumatic piston device" is available for getting out solder. (Figure 5). Another popular method is flux-impregnated tinned braid." Pressed next to a solder filled hole with a hot iron, it picks up the solder by capillary action. (Figure 6). When most of the solder around a lead has been extracted, grip the lead with a pair of long-nosed pliers and vigorously wiggle it laterally until it is free in the hole.

Before removing an IC, carefully note its position. There are nine wrong ways to install a round 10-pin IC. Mark the position of the tab or other reference mark on the package. Use only a wax-type colored pencil . . . never a graphite pencil. When free, remove it gently. Forcing or prying an IC often results in peeling a trace from the top of the board.

When installing a round IC, clip off a tiny bit of each lead except one, such that all are different lengths. This way you must guide only one lead at a time into its hole. Solder first, then clip off excess length.

With DIP's it is considered prudent to solder pins on top the board as well as on the bottom wherever a top trace joins a pin. This uses the IC pin as a guaranteed connection between top and bottom. . . just in case the plated through hole was damaged during removal.

Finally, let the IC cool a few tens of seconds before applying power.

Handyman's Special

In many dynamic circuits, i.e. counters, data modulators, etc.,

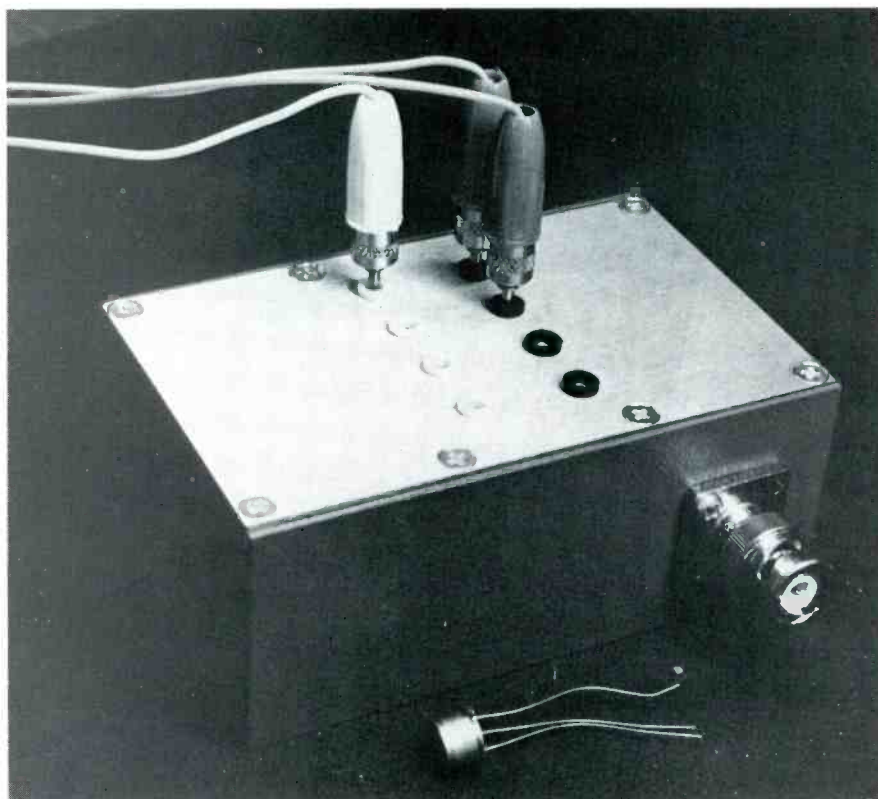

Fig. 7 "And-Gate" trigger with multiple inputs for triggering a scope one count before something is supposed to happen.

there is a frenzy of logic being performed. Decisions can be made, verified, used and forgotten in a microsecond. To observe the inputs and resulting outputs of a complex dynamic circuit calls for close attention to scope triggering and sweep rates.

One feature the author has often wanted on his scope is an "and-gate" trigger with multiple inputs. With it one can, for example, trigger a scope one count **before** something is supposed to happen by "anding" appropriate counter stages. Such a device was built and tested. (Figure 7). It is adequate for moderate speeds and for DTL or TTL devices. With all inputs open it doesn't consume power (three pen-light cells), and with an input active draws about 3 ma. Enclosed in a minibox with the right connector on the rear, it can plug directly into a scope's external trigger input. See Figure 8 for schematic.

Footnotes

1. R. Oldershaw, "The Servo and Transport Design for a Fast Response Television Tape Recorder"; Paper presented at the SMPTE Winter Television Conference, Jan. 22-23, 1971.
2. R. P. MacKenzie, "The Logical Design of the AVR-1 Buffer"; Paper presented at the SMPTE Winter Television Conference, Jan. 22-23, 1971.
3. L. S. Golden, "Digital Television Transmission Systems for Satellite Communications Links"; Paper presented at International Broadcasting Convention (London), 1968. See IEEE Conference Pub. #46.
4. Anthony C. Cuomo, "A Digitally Controlled Color Television Camera"; Journal, SMPTE, Nov. 1970.
5. Ampex VS600 Studio Switcher.
6. Harper, *Handbook of Electronic Packaging*, Chapter 9; McGraw-Hill, 1969.
7. *Logic Graphic Symbols for Logic Diagrams*, American National Standards Institute, Y32.14.
8. Integrated Circuit test clip, Mfg. by AP Inc, 72 Corwin Dr., Painesville, Ohio.
9. "Soldapullit", Mfg. by Edsyn, Inc., 15954 Arminta St. Van Nuys, Calif.

10. "Wick-it", Cat. #1005, Mfg. by Wick-it Electronics Corp., 2573 Spring Street, Redwood City, Calif. 94063.

11. *Digital Integrated Circuit D.A.T.A. Book*, Pub. by D.A.T.A., 32 Lincoln Ave. Orange, N.J. (Book plus up-dating service).

Suggested Reading

- ABC's of Boolean Algebra*, Allan Lytel, pub. by Howard W. Sams.
 "Meet the Operational Amplifier"; Walter Jung, *Broadcast Engineering*, Dec. 1970.
 "TV applications for IC Differential Amplifiers", Walter Jung, *Broadcast Engineering*, Sept. 1969.
 "A Survey of I.C. Application Ideas", Walter Jung, *Broadcast Engineering*, Oct. 1969.
 "IC Application Ideas", Walter Jung, *Broadcast Engineering*, Dec. 1969.
 "Digital Circuits for Broadcasting", J. L. Smith, *Broadcast Engineering* March 1968.
 "Transistor-Transistor Micrologic® Integrated Circuits", John Nichols, Fairchild Application bulletin #APP-131.
 "HLLDT_μL Integrated Circuits, R. Repass and O. Lykins, Fairchild Application bulletin, APP 166.
 "Let's Clarify I.C. Noise Margins", R. Cleve Ghest, Fairchild Publication TP-44. ▲

Intelligence Is Knowing Where To Look It Up

You should have ready access to IC data for use in troubleshooting, design of accessories and modifications, and for study. A substitution guide is handy.¹¹ It has pin numbers and descriptions. The most complete info can be obtained by writing the manufacturer for data sheets on the devices you use. They are free. The manufacturers catalogs have become so extensive that they often must be purchased, but two or three from the larger firms will be useful for their background and application data.

Some makers have published application notes in pamphlet form. These are free and make useful reading. Write for lists. Keep abreast of new IC's. Read the ads. Circle the numbers. Get on the manufacturers mailing list. When corresponding directly, it helps to use your company's letterhead.

Lastly, save this article and the others to come.

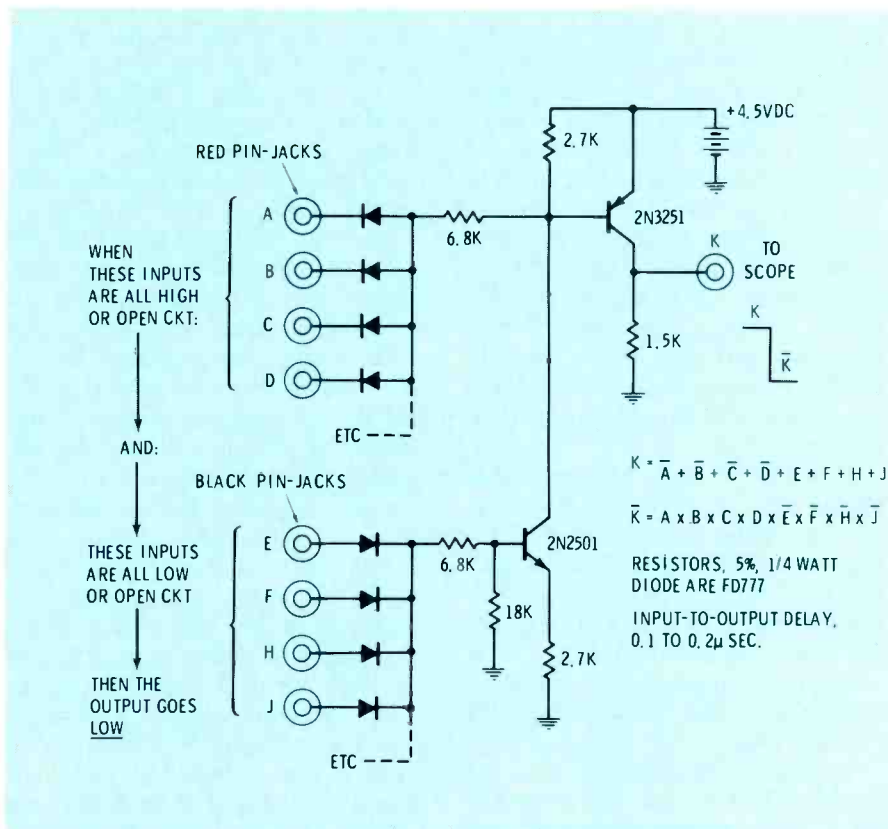

Fig. 8 "And-Gate" trigger box schematic.

Film In Local Origination

Part 2 of a 4-part series By A. L. Williams*

In recent months, you've probably heard or seen a dozen "sales pitches" for 16mm film in CATV. You've been told about film's flexibility; low cost; rugged, nontemperamental equipment; fast, nearby processing services (or in-house processing systems); and easy-to-use editing techniques.

During this same time, cablecasters have also been hearing a lot from the promoters of videotape and its attendant features.

At the outset, then, let me suggest a couple of guidelines for the so-called film-tape controversy. First, it seems to me that motion pictures **and** video tape are here to stay, at least in the foreseeable future. Neither medium will replace the other for CATV, but rather—as has already happened in commercial and public television—cablecasters will enjoy the flexibility of choosing the medium that does the best job within specific project parameters of time, money, manpower, and the objectives of the project.

It seems to me that any cable system that is really serious about developing the potential of the market—a potential that "Newsweek" described recently (5/31/71) as dependent on CATV's "ability to offer something new and different on a regular programming basis"—will build in the facilities for both film and tape.

During the course of a series of seminars that Kodak has presented for CATV managers around the

U.S. this year, we've developed recommendations for "mini-" and "midi-" size film production units. Most cable systems, we've found, are not yet ready for the "maxi" shopping list.

A CATV operator can actually begin local origination with a 35mm still camera for shooting color slides, which can then be transmitted directly over the cable. Another dimension for the 35mm still camera: Combine it with a copystand and shoot close-ups of artwork for station logos, or special promotions.

The next step, of course, is into motion pictures in the "mini" style. There are many kinds of 16mm hand cameras available today ranging in cost from \$750-\$1,000:

One is the Cine-Kodak K-100 turret camera. It features a bright viewfinder that is designed for use in low-light conditions, plus a 40-foot wind. Other cameras include the Bell & Howell, model 70DR; the Bolex, 3-lens turret camera; and the ultra-modern Beaulieu and Canon Scopic cameras.

Our suggestion for an all-round lens: a wide-angle (15mm focal length) with moderately high speed (f/2.5 or larger). The experience of hundreds of TV stations has shown that the cameraman seldom has all the light or all the space he needs. The wide-angle, "fast" lens offers maximum flexibility. If the CATV budget can incorporate additional lenses, we suggest a "normal" lens (25mm, f/1.9 or faster) and perhaps a moderate telephoto (50, 63,

or 75mm focal length). A zoom lens is a useful addition—it's versatile, convenient, and contributes to fast shooting.

A handy accessory with the 16mm silent film camera is a cassette tape recorder to capture background sound or even interviews while covering an event. By combining sound and visuals, with no attempt at synchronization, the CATV operator can turn out a professional-looking news story.

Leave a little room in the CATV film production budget for a good, solid tripod. It will do wonders for helping the cameraman achieve sharp, steady pictures. In addition, an exposure meter pays for itself many times over in film and effort saved. Look for a sensitive meter, usable in low-light levels.

And speaking of low-light levels, it's handy to have a basic lighting package: 2 or 3 small clamp-on halogen lamps of 650-1000 watts will soon prove their worth. Some of these come with batteries so that your camera crew (whether it's a crew of one or more) can be truly self-contained, day or night, indoors or out. It's also helpful to have a lightweight fiber case to hold all the gear in one, easy-to-carry packet . . . camera, exposure meter, extra rolls of film, and a set of filters (we'll describe their use in Part III).

Sound On Film

The key feature of the "midi" film production unit is the addition of sound on film. There are three

*Eastman Kodak.



HUNT CINE COLOR CHEMISTRY

**gaining big footage in the pro league
for the reversal processing of
Ektachrome motion picture films.***

If you're among the "pros" involved in processing TV news, sports, commercial or industrial films, you'll find that Hunt Cine Color Chemistry offers you advantages over the chemistry you're now using, including significant savings in material costs and operating costs.

The most important advantage of using Hunt Cine Color Chemistry is that both the color developer and the color developer replenisher come in liquid form. These liquid concentrates assure you of

- exceptional pH stability—which means stable color balance in your daily production
- elimination of noxious, irritating dust in the processing area
- savings in mixing time.

All Hunt Cine Color Chemistry replenisher steps offer complete "on top" compatibility with the chemistry you are now using. There is no need to dump your present processor or replenisher tanks when you start to use Hunt Cine Color Chemistry. In addition, you can continue with your present quality control methods.

Hunt Cine Color Chemistry is the economical, quality chemistry for use in all of the industry's leading machines for processing Ektachrome films.

The complete system, packaged in 100 liter sizes includes:
HUNT CINE COLOR • Prehardener & Replenisher • Neutralizer & Replenisher • First Developer • First Developer Replenisher • Stop Bath & Replenisher • Color Developer • Color Developer Replenisher • Bleach & Replenisher • Fixer & Replenisher • Stabilizer & Replenisher.

Hunt Cine Color Chemistry is available to you direct from 22 Hunt sales and service offices throughout the country. For prompt "pro league" service contact your nearest Hunt office today.



* EF Film, Types 7241 and 7242 • ER Film, Types 7257 and 7258 • MS Film, Type 7256 • R Print Film, Type 7388 • Reversal Print Film, Type 7386 • and any other Ektachrome films, regardless of size, using the ME-4 process.

PHILIP A. HUNT CHEMICAL CORPORATION
PALISADES PARK, NEW JERSEY • PHILIP A. HUNT COMPANY (CANADA) LTD TORONTO

Are you on this spot?

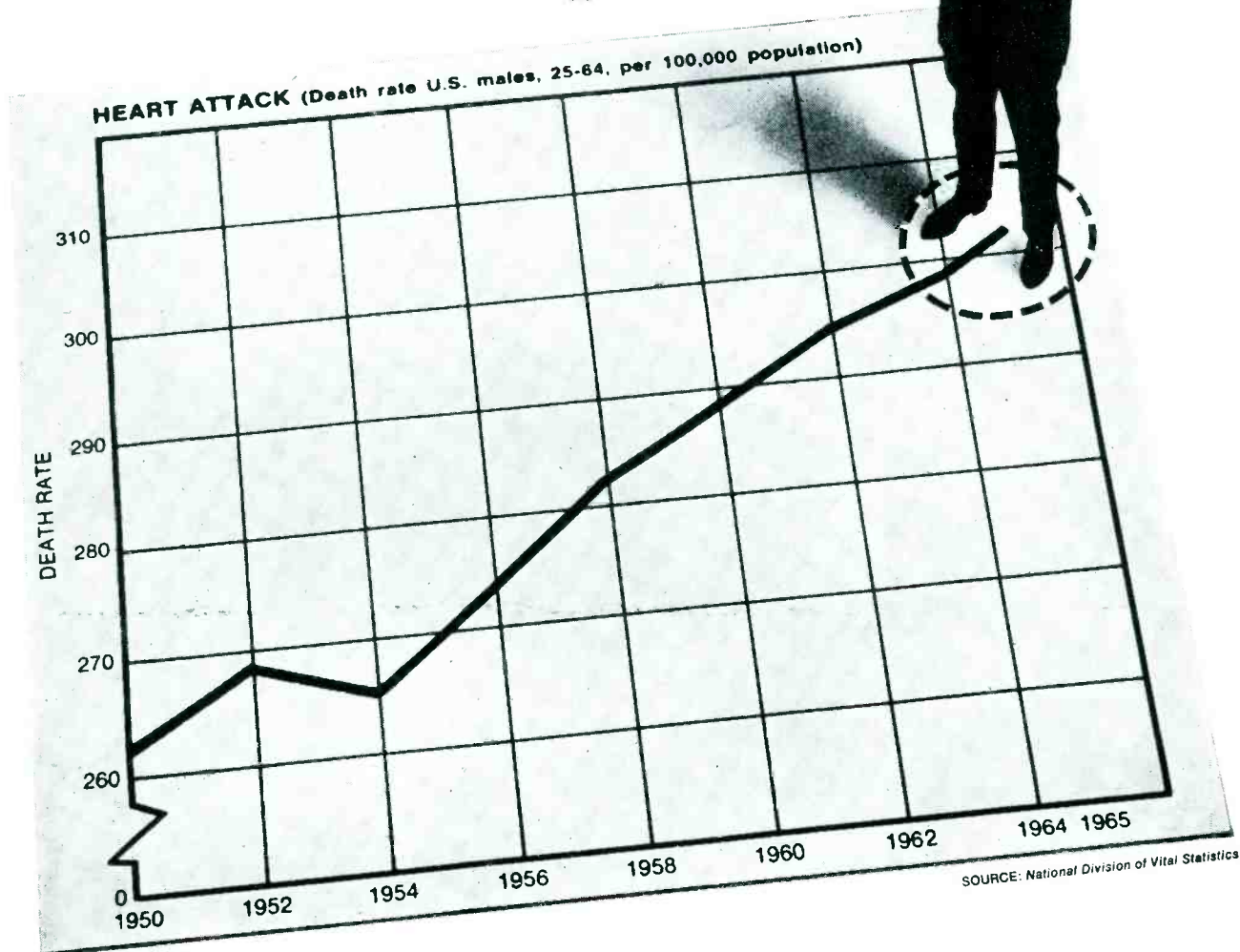

You are if you are a man 25 to 64

You are the #1 target for heart attack.

Medical scientists have sharply cut the death rates from stroke and from heart disease caused by high blood pressure in your age group. But the heart-attack death rate continues to climb, as this chart shows.

While researchers are seeking more and better controls, you can reduce your risk of heart attack

by taking these simple steps:

- Eat foods low in saturated fats and cholesterol
- Stop smoking cigarettes
- Reduce if overweight
- Exercise moderately, regularly
- Control high blood pressure
- See your doctor periodically

GIVE... so more
will live



HEART FUND

Contributed by the Publisher



Fig. 1 A color film commercial can be set up on location, such as this hair-dressing shop in California, and often with a minimum of lighting.

possible approaches—the simplest being the “voice over” approach. In this case, the cameraman shoots the picture without sound but using prestriped film in the camera. After processing, the footage is edited, then run through a 16mm projector that has a built-in recording head. At this point, the narration can be recorded “voice-over” to match the visual coverage of the event—with the added option of erasing and rerecording the audio with no possibility of harming the film image.

Double-System Sound

Once the basics have been acquired, a cable system can easily expand to the next level: “double-system sound, lip sync.” With this approach, for example, a 16mm film interview is still exposed as silent footage, but a complete recording of the sound is made on the spot. After editing, then, it is possible to synchronize the desired portion of the audio with the visual image of the subject as he speaks. This technique, while relatively easy, requires some experience on the part of the editor, but the end product appears more professional than the simple “voice-over” narration **without lip sync**.

The third step in sound on film is the “single system” in which picture and sound are recorded simultaneously onto prestriped film in the camera. This is the “maxi” approach, and it entails more elaborate cameras and editing equipment than the “double-system” technique

—plus the need for a skilled editor. Our experience has shown that, in the initial phases, most CATV operators should consider double-system sound for their 16mm film origination.

So far, then, we have examined the “mini” and “midi” film production units, including the following list of equipment:

- 35mm still camera Under \$500
- 16mm silent film camera \$750-\$1,000
- cassette recorder . . Under \$100
- wide-angle lens . . . Under \$150
- accessory package (tripod, light meter, lights, extra lenses) . . \$300 (approx. cost)
- 16mm projector with optical/magnetic recording

capability Under \$1,300

The Film Chain

Essential for any film origination is the film chain: The means by which the television system transforms the finished motion-picture footage into a video signal. The key to the film chain is the TV projector.

Once again, the building-block approach with film equipment applies to the film chain: You can interchange most of the parts without obsoleting the other components. For example, your basic 16mm TV projector will do a fine job with black-and-white film. It can project its image directly onto the face of a one-inch Vidicon tube to provide quality black-and-white



Fig. 2 A television staff photographer shoots a sequence on 16 mm film that will be used for a promotional spot.

pictures at the other end of the cable. The same projector will continue to serve you when you add a multiplexer, color, or additional film-chain equipment.

One further suggestion: We recommend that the cable operator consider, at the outset, buying the capability to originate in color. The extra initial cash outlay will not be much greater and the color equipment will not become obsolete. More and more CATV systems are finding that to compete with commercial and public television programming, they, too, must offer the excitement of color to their subscribers. Of course, the film equipment described here—cameras, projectors, editing equipment, etc.—will handle color or black-and-white film without modifications.

The Projector

A highly sophisticated TV projector is a good-size investment but a CATV film production unit of any consequence will find that the projector is a real workhorse. It operates hour after hour, day after day, handling not only the cable system's origination on film, but also the myriad motion pictures available on loan or for modest rental from thousands of library titles. If given minimum care, this TV projector will go on for decades.

Experts advise that, if your plans include two to three hours of film cablecasting each day, your best buy is a heavy-duty TV projector. One more tip: A professional-quality used projector may be available from a broadcast station in your area at a fair price. **Good** used equipment isn't cheap, but if a modest service charge will correct any worn parts, it may be a better initial investment for the small CATV operator than new equipment.

As part of the complete film-chain system, cable operators should also be ready to show slides . . . and there are a number of TV slide projectors available. Incidentally, one often-overlooked method for getting slides on the air is by live camera pickup of an image projected onto a high-reflectance surface. This approach enables the

CATV operator to light the studio set—an on-camera newscaster, for instance—without washing out the image projected onto the screen, and thus display them simultaneously.

The minimum film-editing equipment list for a CATV system includes a set of rewinds, some film reels and containers, and a splicer. As production expands and becomes more sophisticated, you'll probably want to add an action viewer, a sound reader, and a synchronizer. Power-driven rewinds make editing and film handling a bit easier, too.

Editors who do a great deal of film handling and assembly prefer cement splices. A so-called "hot splicer"—which actually only gets warm from a small heating element that speeds drying time—may pay for itself in time saved when working with film cement. The CATV film production unit will also need a shelf or table in a relatively dust-free area, with the editing gear attached, and, perhaps, an opal glass panel with a light beneath to make inspection easier. There should also be some means for cleaning film. To start with, some soft cloth moistened with movie film cleaner (with lubricant) that can be held against the film as it turns through the rewinds. Or, the cleaner can be semiautomatic by means of applicator equipment through which the operator runs the film. And, as mentioned earlier, you'll want a regular 16mm sound projector in the editing area for screening your

production in progress, as well as for previewing available commercial footage, and for recording sound on the film, if that is your program.

Super 8

So far, we have limited our discussion of film for CATV local origination to 16mm films. What does Super 8 have to offer?

At the present time, Super 8 is "in the wings", primarily due to the lack of high-quality professional equipment that would enable cablecasters and broadcasters to produce a home video image that meets today's standards. Several companies are working on developing high-quality Super 8 equipment; however, all the equipment components are not here yet, and it will undoubtedly be some time before complete Super 8 systems, especially designed for television use, become available.

In the meantime—16mm film is an accepted standard throughout the world, and thousands of programs are available on 16mm film, cleared and ready for television use.

The average cablecaster should consider whether he can afford to wait until the full Super 8 technology is developed . . . until a complete system is available. The demand for local origination is here now, and so are the profit opportunities from it.

To meet **today's** demands for high-quality locally originated programming, we feel that 16mm film is the ideal tool to meet the cablecaster's needs. ▲



Fig. 3 A student employee at a cable system in North Carolina loads commercial slides into a slide projector used in the film chain.

The History Savers at work.



David Hall and Sam Sanders discuss a fine point.

Deep inside a building at New York's Lincoln Center for the Performing Arts, recorded history is being recorded again. At the Rodgers and Hammerstein Archives of Recorded Sound, technician Sam Sanders is busy continually transcribing all sorts of old recordings, transcriptions and acetates. Not only will there then be a more permanent record of this valuable material, but access to it is made easy through a sophisticated catalogue system, by which interested persons can hear material that was otherwise unavailable.

The Rodgers and Hammerstein Archives of Recorded Sound are part of the New York Public Library, Research Library of the Performing Arts, and encompass virtually the entire history of recorded sound. But to get these early (and often irreplaceable) discs onto tape wasn't easy. Because until the recording industry established its own standards, playing speeds, groove widths and depths were widely varied.

Stanton engineers worked closely with Archive Head David Hall and engineer Sam Sanders



when the Archive Preservation Laboratory was being set up. Standard Stanton 681 cartridge bodies were chosen for their superior reproduction characteristics. However, some 30 different stylus types had to be prepared to give the tape transfer operation the variety needed to match the various old groove specifications. Each was hand-made by Stanton engineers to fit a particular disc's requirements. So when Sam Sanders begins the careful disc-to-tape transfer, he must first match the stylus to the record. Both microscope and trial-and-error techniques must be often used together. But one of the special styli will enable every last bit of material to be extracted from these recorded rarities.

It goes without saying that a company willing to take such care in helping to preserve recorded history must also be interested in superior reproduction of today's high fidelity pressings. Which is one reason why Stanton cartridges remain the choice of professionals the world over.

For an informative brochure about our professional-quality cartridges, write to Stanton Magnetics, Inc., Terminal Drive, Plainview, N.Y. 11803.



Circle Number 21 on Reader Reply Card

COLOR MONITORING FOR UNDER \$400 ...AND THE QUALITY SPEAKS FOR ITSELF!

Listen to what Otto Claus, Chief Engineer, WBAL-TV, Baltimore, says about general purpose monitoring with RCA'S low-cost commercial color receiver:

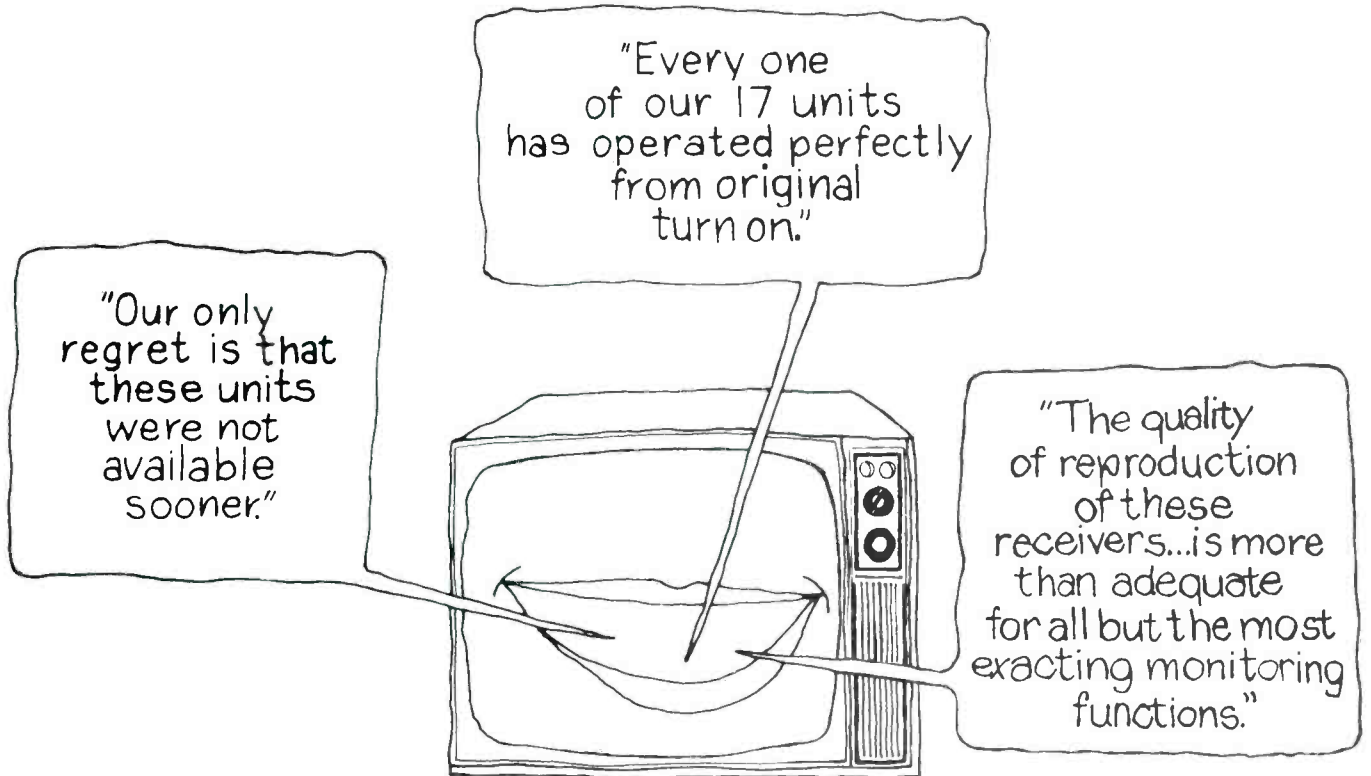

Unlike color sets intended for home use, this receiver is equipped to accept RF or bridged direct video and audio line feed without the need for costly adaptors. For under \$400, you get every non-critical monitoring function you can ask for — picture, sound, live or tape, color or monochrome. It's especially suitable for monitoring needs backstage, for the band, for the audience, and similar applications.

For complete details, send the coupon. We'll show you cold cash reasons why RCA's commercial color TV is your best answer.

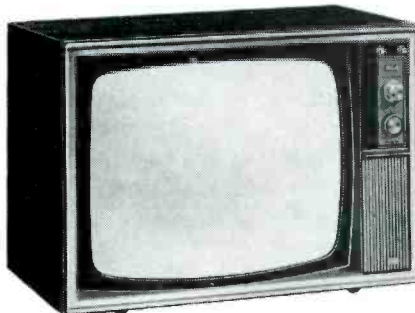

RCA AccuColor 

Circle Number 22 on Reader Reply Card

RCA Service Company W-141
A Division of RCA
Commercial Products Sales, Bldg. 203-3
Camden, N. J. 08101

Please furnish further information about RCA commercial color sets for broadcast monitoring purposes.

Name _____

Title _____

Station _____ Phone _____

Address _____

City _____

State _____ Zip _____

Preventing FM Overmodulation

By W. J. Kabrick*

With the advent of better broadcasting and recording systems, and the liberty enjoyed by today's recording artists, the high frequency signals programmed into the FM transmitter are often of sufficient amplitude (after pre-emphasis) to cause gross overmodulation. The optimum placement of the peak limiting amplifier and the use of auxiliary protective devices are important.

Through the years there has been considerable controversy about the wisdom of pre-emphasizing the signal fed into the FM transmitter. The reason for the pre-emphasis was that the signal-to-noise figure was enhanced by the attenuation of the high frequency part of the audio spectrum in the receiver. Since there was appreciably less energy in the upper section of the 30 to 15,000 cps region than in the part below 1,000 cps, a 75 microsecond pre-emphasis curve was adopted to take advantage of this distribution.

The standard 75 microsecond curve, shown in Figure 1, is flat below 200 cps, rises to +0.9 dB @ 1 kHz, +8.3 dB @ 5 kHz, +13.8 dB @ 10 kHz and +17 dB @ 15 kHz. As the graph shows, this is quite a severe curve. When it was adopted, there must have been very little anticipation of the kind of effects that are programmed today. Also, the broadcaster was expected to operate his FM transmitter with rather low values of average modulation to allow transmission of the full dynamic range of even classical music.

Competition in FM Broadcasting was not too keen and programming was not stressed too highly in most areas. So, the low average modulation concept was generally prac-

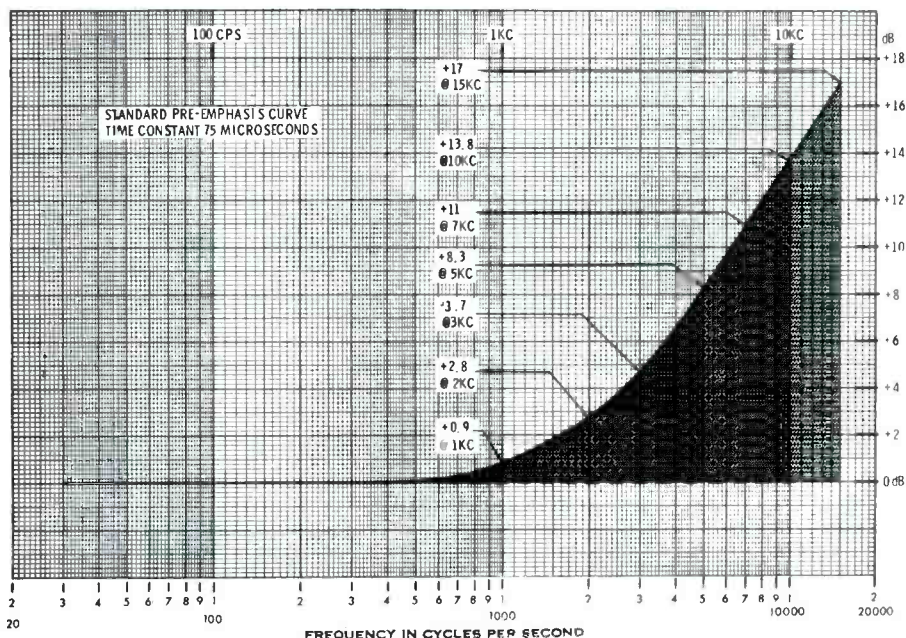

Figure 1

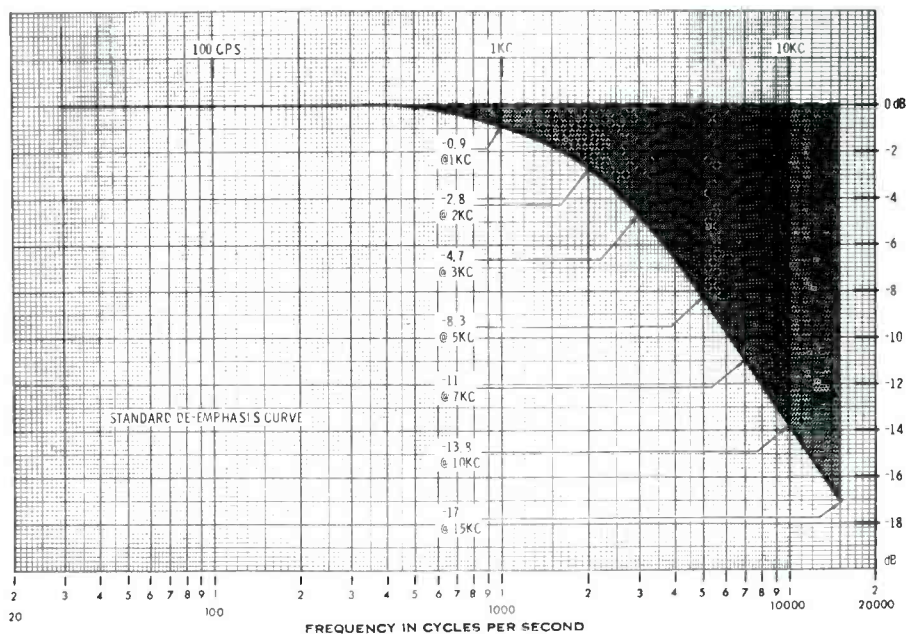

Figure 2

ticed. In fact, many FM stations did not employ a peak limiting amplifier, or any type of automatic levelling amplifier.

FM broadcasting is competitive now. Programming is becoming commercial, and FM stations are showing a profit. This is healthy for the general public and broadcaster alike, because it will permit

better coverage of many areas and a wider choice of programs in every area.

Nearly all of the practices that helped prevent FM overmodulation in the past are being modified, in a direction that contributes to overmodulation, today. Peak limiting amplifiers are being used extensively, yet more and more FM

*Advance Development Engineer, Gates Radio Company.

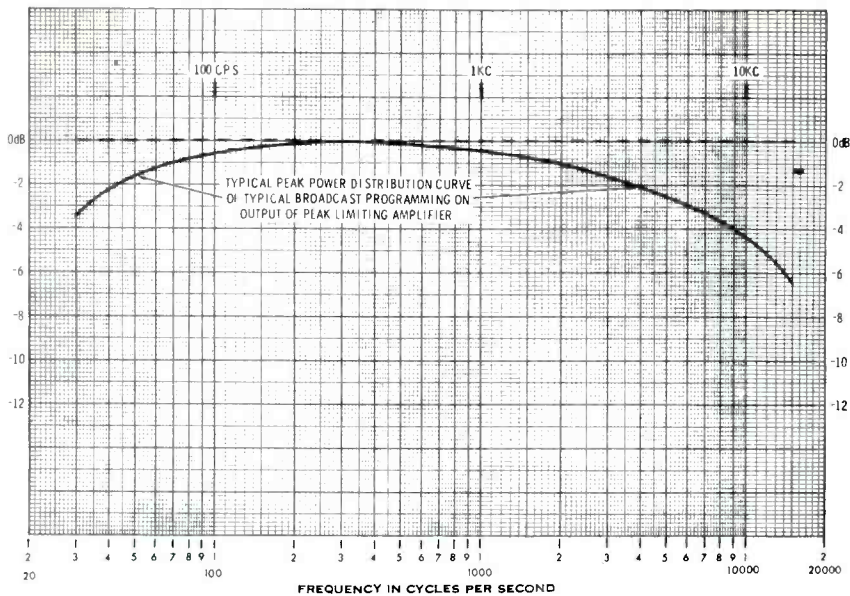

Figure 3

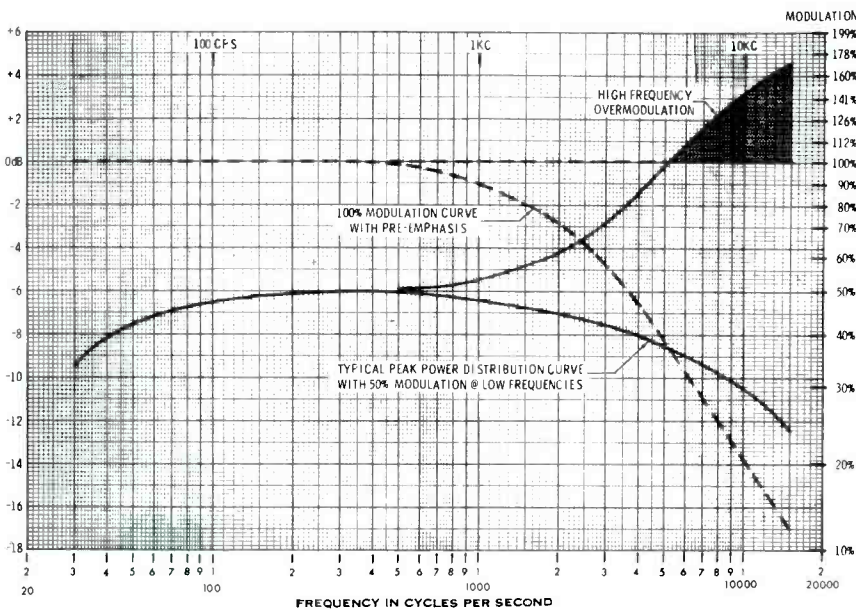

Figure 4

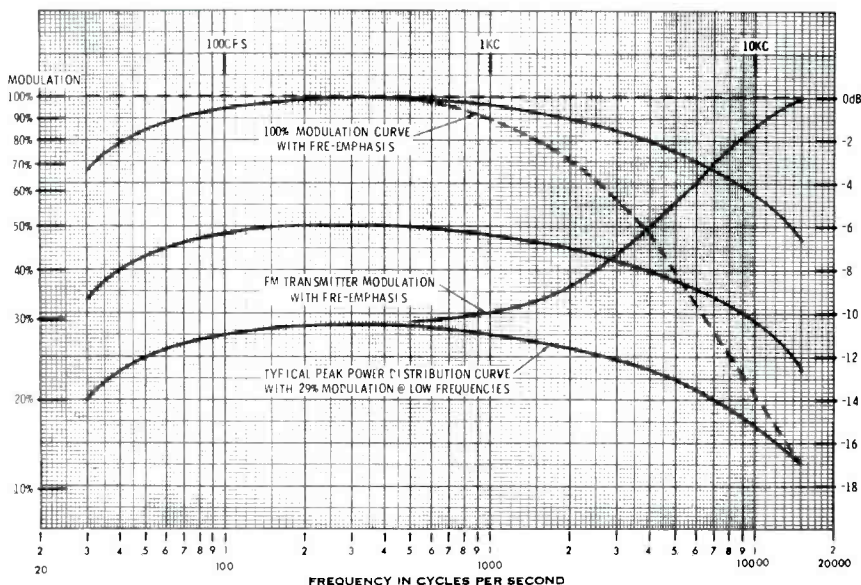

Figure 5

stations are being cited for overmodulation. This has caused many station engineers to believe that their limiting amplifiers are defective, or that the attack time is much too slow. However, their limiting amplifiers limited on a flat response curve, where the high frequencies did fall below the threshold of limiting, and the amplifiers were operating correctly. The problem was caused by pre-emphasis of the signal after it was processed through the limiting amplifier. It was typical FM overmodulation.

Analysis Of Problem

If the high frequency content of any part of the day's programming never exceeds the curve shown in Figure 2, the peak limiting amplifier could feed into the FM transmitter pre-emphasis filter (assuming a fast limiter attack time) and no overmodulation would occur. Good microphones, tape machines, phono cartridges and recordings make this very unlikely, however.

This curve is complementary to the standard pre-emphasis curve, and is the one that should be used in the receiver to de-emphasize the signal to restore the original frequency response. However, if any of the high frequencies do exceed the limits of the curve shown in Figure 2, and go into the shaded area, overmodulation will result.

A good FM transmitter can tolerate extensive overmodulation without excessive distortion. The carrier swing is extended very rapidly from the maximum allowable ± 75 kHz, however. A program peak of only 6 dB will amplify the carrier swing to a very illegal ± 150 kHz. He have reports of FCC citations with relatively low percentages of overmodulation.

Many receivers and tuners cannot tolerate excessive overmodulation without serious distortion because of bandwidth and/or discriminator curve linearity restrictions. They frequently suffer from a type of base line shift that can cause perceptible distortion in the

audible frequency range. Thus, the broadcaster has a two-fold reason to stop overmodulating his FM transmitter.

An extensive search of current publications failed to reveal the distribution of spectral energy of modern recordings or of broadcast programs. After some reflection, this was readily understood. The extensive use of program equalizers, graphic equalizers and other frequency response shaping units (in not only the original programming—but in subsequent reproduction as well) eliminate any chance of two stations (or even one on a regular basis) having a typical curve. The limitations of recording media are even circumvented to a large extent by a judicious use of levels.

However, this study requires at least an arbitrary curve for an illustration. Various spectrum analyzers and wave analyzers were employed in approximating the typical peak power distribution curve shown here. This is a composite curve of the peaks observed in many types of programming over an appreciable portion of the broadcast day in a typical FM station.

A conventional limiting amplifier maintained a constant mid-range level. The very high and very low frequency peaks occurred much less frequently than the intermediate high and low frequency peaks. Yet, they were frequent enough to fully understand why stations are being cited for overmodulation. It is safe to assume that nearly every FM station will have a peak power distribution curve that will approach or exceed that shown, unless drastic preventive steps have been instituted.

Lowering The Modulation Level

Perhaps the first step taken by many stations was to simply reduce the level of modulation to an average of 50 percent, effectively reducing the average program power to 1/4th the maximum allowable station power. Figure 4 shows the

result of 50 percent modulation of the low and mid frequencies. No overmodulation occurs below 5 kHz on the typical peak power distribution curve. It is possible, however, to overmodulate as much as 70 percent at 15 kHz—which constitutes an engraved invitation for a citation. The 10 kHz point shows up to 150 percent modulation under the conditions described.

Obviously, an even lower level of mid-frequency modulation is necessary to prevent high frequency overmodulation. This is true, in spite of the fact that the mid-frequencies are controlled with a limiting amplifier.

After this part of the study was completed and the levels shown in Figure 5 were established, the manager of our engineering section responsible for FM transmitters was asked what mid-frequency modulation level was required to prevent high frequency overmodulation with average programming. His prompt reply was, "Around 30 percent". Figure 5 shows that this study was in full agreement, as it resulted in a figure between 29 percent and 30 percent modulation. However, certain types of programming could still cause more than 100 percent modulation at high frequencies,

even with 29 percent mid-frequency modulation. Thus, even lower levels of modulation are required to be sure that no overmodulation will occur.

With 30 percent average modulation, the program power output of the station is approximately 1/10th of the maximum allowable power. Many of the program peaks that are causing the reduction in modulation are so high that some receivers will not even pass them, and some listeners are incapable of hearing them. Also, they are relatively scarce in most programming, so the wisdom of using very low modulating levels is questionable.

Pre-Emphasis Ahead Of Limiting Amplifier

The second step considered by many stations is to place the pre-emphasis before the limiting amplifier, so it can limit the high frequencies as well as the mid and low. If the program level is maintained carefully at a point that is generally well below the threshold of limiting, this method will produce fairly acceptable results. However, certain types of programming still will cause quite unnatural effects, as shown in Figure 6.

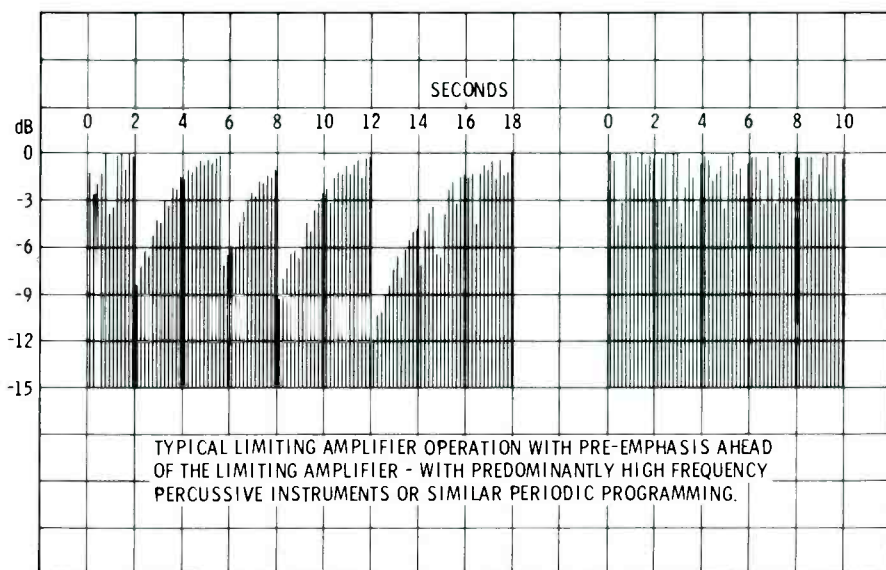

Figure 6

A conventional peak limiting amplifier with an attack time of approximately one millisecond and a 90 percent recovery time of around two seconds will have an output similar to that shown in Figure 6, with certain types of programming. This is a result of high pre-emphasized high-frequency peaks exceeding the threshold of limiting, causing the attendant gain reduction of mid-frequencies.

When the resultant signal is de-emphasized, it sounds like the limiting amplifier could be undergoing a blocking type of oscillation, where the gain suddenly drops for no audible reason, then recovers on the normal R-C slope. This is an excellent way to gain a large group of irate listeners, which will soon degenerate into a much smaller group of irate listeners.

The right hand portion of Figure

6 shows the same type of programming without pre-emphasis ahead of the limiting amplifier. Only the upper half of the waveforms are represented in both portions, since this is a sketched representation of the scope display observed under the two conditions covered.

Methods Of Correction

If the typical peak power distribution curve shown in Figure 3 were never exceeded, the problem could be eliminated by the installation of a low pass filter, such as shown in Figure 7. A listening test of quite a few FM stations indicate that some must be using this method. Unfortunately, this performance is easily surpassed by the majority of the AM stations with modern transmitting and programming equipment.

A low pass filter indiscriminately curtails all signals that fall on the filter slope, degrading all programming just to protect the station from a relatively few overmodulation peaks.

One corrective method that does merit serious consideration is to simply repeal the decision to pre-emphasize FM signals in the transmitter. There have been many advances in the state of the art since the original decision and the original noise reduction requirement could probably be solved with modern components. With stereophonic operation becoming more prominent, with the usually severe phase balance requirements from L+R to L-R, the injection of pre-emphasis and de-emphasis is a big handicap. It is the opinion of many that a better overall system would result with the elimination of pre-emphasis.

Since so many existing receivers are involved in the proposed elimination of pre-emphasis, perhaps it would be best to consider a graduated reduction of pre-emphasis. For example, after July 1 of this year, the pre-emphasis could be reduced from +17 dB @ 15 kHz to +12 dB @ 15 kHz. Nearly all of the decent existing FM systems have

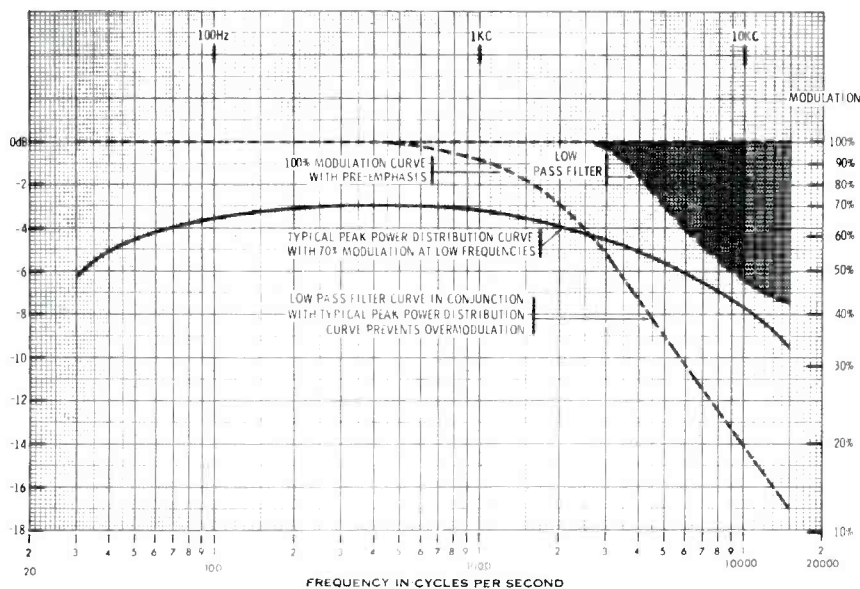

Figure 7

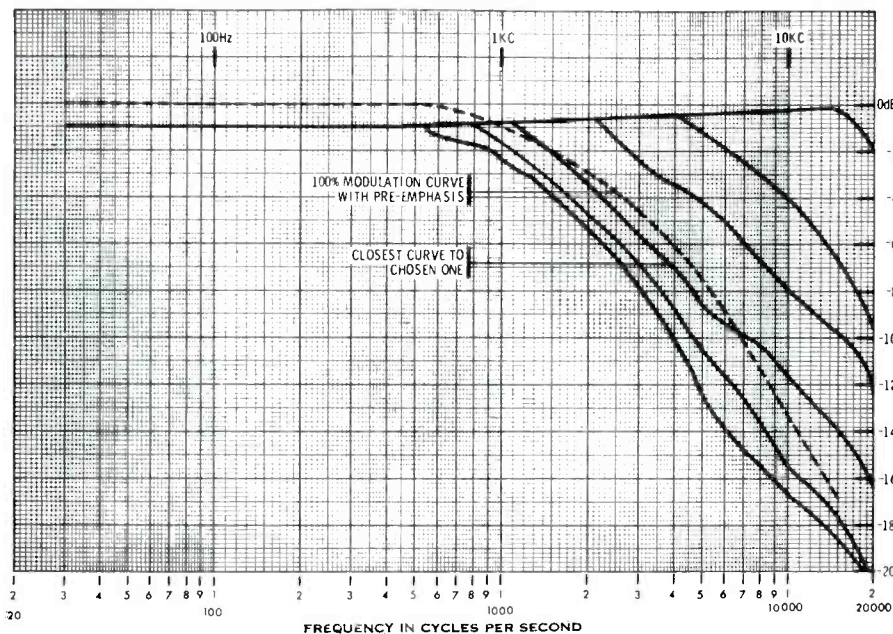

Figure 8

tone controls that could effectively compensate for the reduction of high frequency pre-emphasis.

In 1970 the 15 kHz peak could be reduced from +12 dB to +6 dB. The systems sold in the five year interim could compensate with their tone controls. Older systems (the majority of them would be more than ten years old) could have a simple and economical change in the de-emphasis circuit to make them compatible with the 6 dB standard.

In 1975 the pre-emphasis could be completely eliminated. All of the FM systems sold in the preceding five years, and all of the older systems that had been modified to the 6 dB standard, could again compensate their tone controls. Only the sets manufactured to the 12 dB standard would need a simple change to make them fully compatible with the new 0 dB standard. Thus, in a controlled program the pre-emphasis problem can be wiped out without causing anyone a great hardship. The broadcaster should have no real objection to buying a new pre-emphasis filter every five years. In fact, the old one could probably be modified by simply installing a factory specified shunt resistor.

There surely must be a method of controlling the high frequency peaks, yet permitting decent levels of modulation with full quality. This problem is not unique in the FM broadcasting industry. Disc recorders have been faced with an almost identical problem, and a product has been marketed that certainly has the correct approach to the problem. Essentially, it pre-emphasizes the signal along a slope that corresponds to the problem area of the device that it eventually feeds, wipes out any peak that exceeds this slope, de-emphasizes in a complementary slope to give an overall flat response.

Figure 8 shows the advertised curves in solid lines, plotted in the same scale as all of the previous figures in this study. This graph is advertised for use with a 75 micro-

second pre-emphasis curve in FM transmitters. The standard 75 microsecond pre-emphasis curve is shown in the dotted line on the graph. One of the curves falls remarkably close to the standard 75 microsecond curve and would eliminate FM overmodulation with much of the standard programming. Selecting one of the two more severe curves would surely eliminate the problem. However, they would

cause unnecessary reduction of all frequencies above 600 to 900 cps with some resultant degradation of signal.

Figure 9 shows the amount of overmodulation possible with the curve that falls closest to the 75 microsecond curve. With the low frequencies held to approximately 90 percent modulation by the peak limiting amplifier (which should precede this unit for best control),

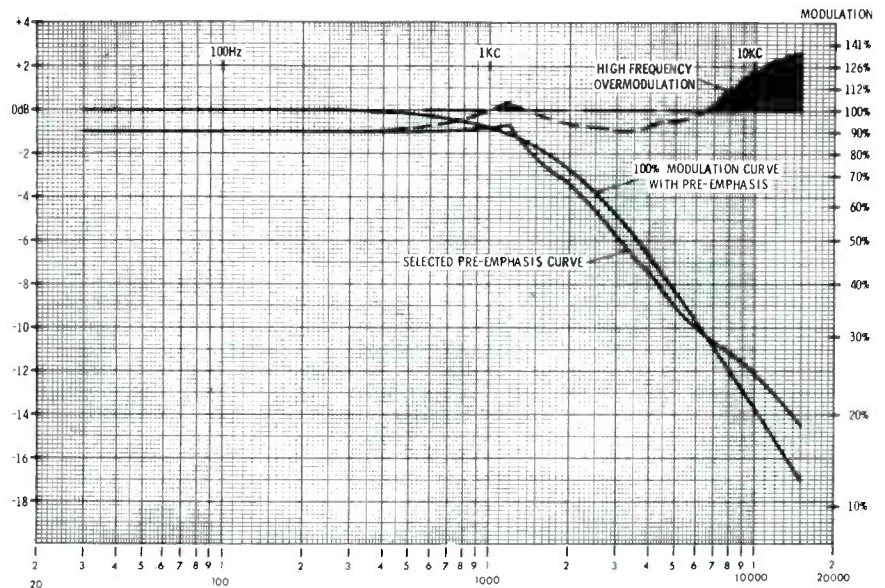

Figure 9

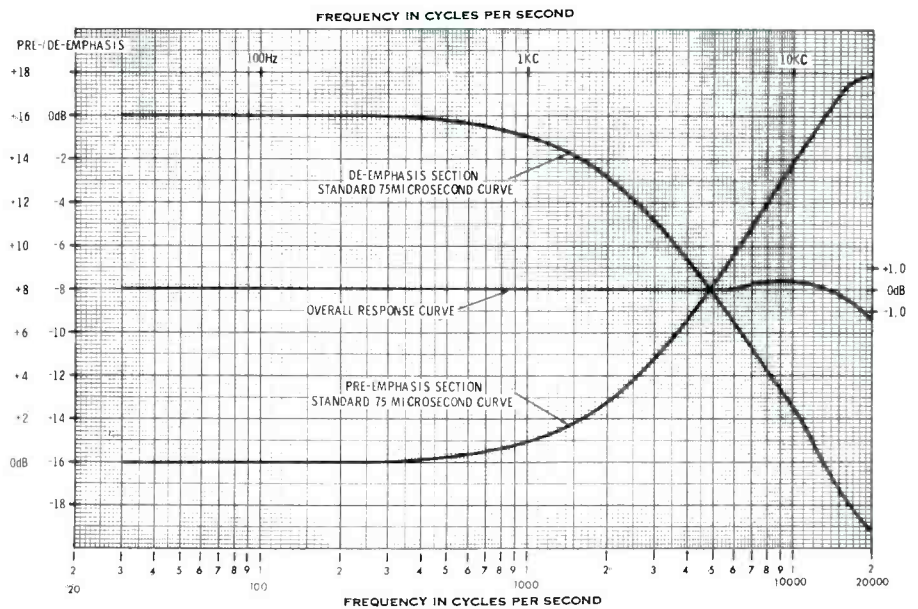

Figure 10

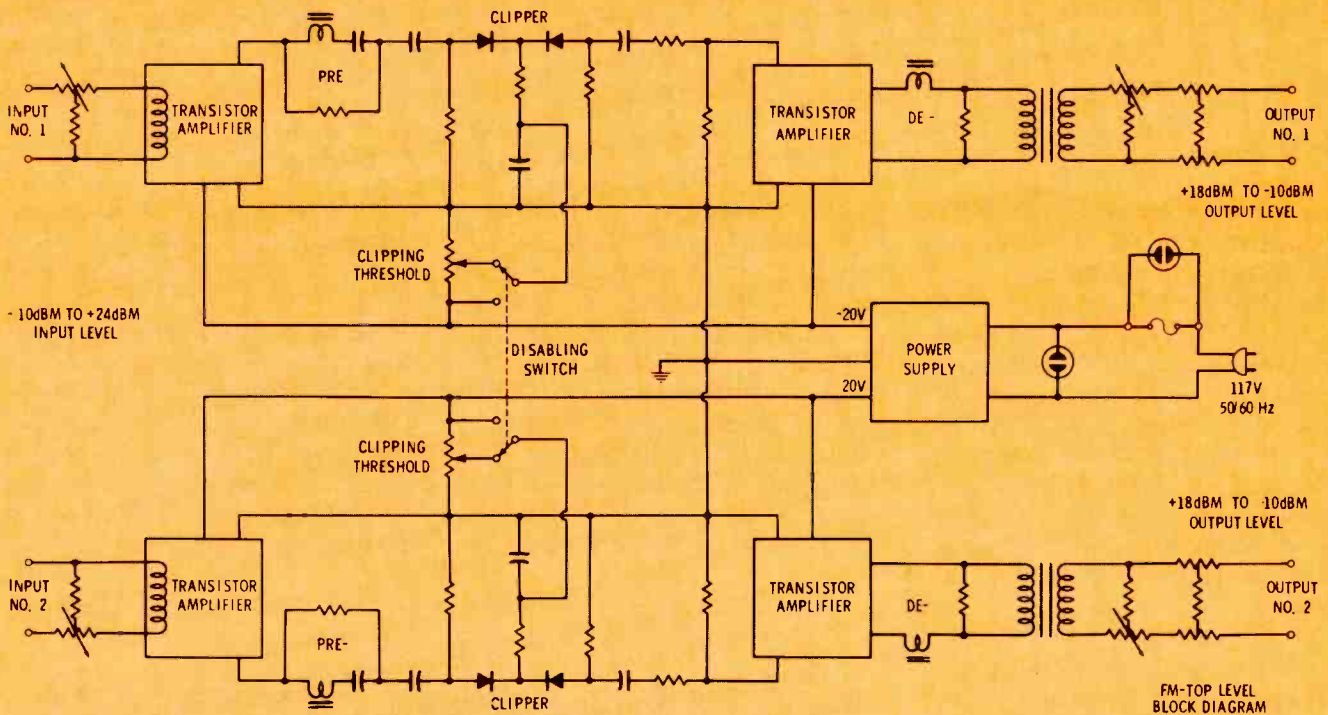

Figure 11

it is possible to get a small amount of overmodulation in the 1100 to 1200 cps area. Then, it is possible to get a serious amount above 6500 cps, with up to 130 percent @ 15 kHz.

Another apparent deficiency occurs in the 2 kHz to 5 kHz region, where the networks and larger stations generally install circuitry to give the system a gentle hump for "presence effect". The curves shown will give an almost opposite effect.

The system that apparently would give the least degradation of signal, but yield full protection against FM overmodulation is shown in Figure 10. The signal is pre-emphasized with a standard 75 microsecond curve, and any random program peak that exceeds this curve is clipped off. Then, the signal is fed through a standard 75 microsecond de-emphasis curve to give an overall flat response.

Top Level Unit

Actually, the three curves shown are carefully plotted from the test data on the new FM Top-Level Unit that was developed specifically to eliminate FM overmodulation. The pre-emphasis filter measured within 0.1 dB of the standard curve.

The overall response measured $+0.2$ dB @ 10 kHz and -0.2 dB @ 15 kHz, it was essentially flat below these frequencies. The FM Top-Level has two identical sections with essentially complete separation. Thus, it may be used for FM in one channel and TV on the other.

The same problem that has been discussed for FM does exist on the aural portion of TV stations. It needs the same method of correction.

Figure 11 shows the block diagram of the FM Top-Level. After the variable input gain control a transistor amplifier boosts the gain to the proper processing level. This is followed by a precision pre-emphasis filter, a balanced series clipper with its output matching section. This feeds into another transistor amplifier to recover the circuit losses of the preceding components; then into a precision de-emphasis filter, isolation transformer, variable output gain control, and finally into a 6 dB isolation pad.

The unit has 28 dB gain, ± 1 dB

frequency response, 0.5 percent maximum distortion (below the clipping point), 75 dB or better noise, instantaneous attack and release time, an input level range from -10 dBm to $+24$ dBm, and an output level range from $+18$ dBm to -10 dBm after the 6 dB line isolation pad.

The unit does not cause deterioration of the programming when properly used because it does not act until the offending program peak tries to exceed 100 percent modulation. Then it instantly clips the excessive portion of the peak only, without affecting any of the associated signal. The harmonics generated by this clipping are greatly attenuated by the following de-emphasis filter so the action of the unit is extremely difficult to detect by critical listening tests.

In Summary

Pre-emphasized FM overmodulation presents a very complex problem that requires custom designed equipment to correct. With properly installed and operating corrective equipment, the FM system is actually enhanced since gross overmodulation and associated distortion are completely eliminated. ▲

INDUSTRY CALENDAR

September

- 23-25 The fall Broadcast Technical Symposium will be held at the Washington Hilton hotel Washington, D.C.
- 23-25 Meeting, Minnesota Association of Broadcasters. Location to be announced.
- 23-25 The annual broadcast symposium sponsored by Group of Broadcasting, Institute of Electrical and Electronic Engineers will be held at the Washington Hilton hotel, Washington.
- 26-28 The Nebraska Association of Broadcasters will hold their meeting at the Village motel in Lincoln.
- 27-29 The 11th annual conference sponsored by the Institute of Broadcasting Financial Management will be at the Regency Hyatt House, Atlanta.
- 28- Oct. 2 The Radio-Television News Directors Association will hold their annual national conference and workshops at the Statler Hilton hotel, Boston.

October

- 3-5 The New Jersey Broadcasters Association will hold their fall convention at the Hotel Dennis, Atlantic City.
- 3-8 The 110th Technical Conference and Equipment Exhibit of the SMPTE will be held at the Queen Elizabeth hotel in Montreal, Canada.

- 6-8 The Tennessee Association of Broadcasters will hold their meeting at the Sheraton hotel in Nashville.
- 7-9 The Massachusetts Association of Broadcasters meeting will be held at the Sheraton-Hyannis hotel in Hyannis.
- 8 The fourth annual management seminar sponsored by the Kansas Association of Broadcasters will be held at the Ramada Inn, in Manhattan, Kansas.
- 10-12 The Mississippi Cable Television Assoc. will hold their meeting at the Broadwater Beach hotel in Biloxi.
- 12-14 The Illinois Broadcasters Association will hold their fall convention at O'Hare Marriott hotel in Chicago.
- 14-15 The National Association of Broadcasters first fall conference will be held at the Regency Hyatt House in Atlanta.
- 17-19 The North Carolina Association of Broadcasters meeting will be held at Grove Park Inn in Asheville.
- 17-20 The National Association of Educational Broadcasters will hold their annual convention at the Fontainebleau hotel in Miami Beach.
- 18-19 The National Association of Broadcasters regional meeting will be held at the Pick Congress hotel in Chicago.
- 20-22 The Indiana Broadcasters Association will hold their annual election of officers at the Ramada Inn in Nashville, Ind.

Increase Head Life with ISOLAIR New Clean Air Unit by LIBERTY

This unit provides a laminar down flow of the cleanest possible air at the critical video head area. Excessive wear and damage by airborne contaminants are virtually eliminated, extending head life by 100% or more and insuring better overall VTR performance, as well as saving time and money. The unit is suspended from the ceiling thus requiring no additional floor space. It is easily installed and maintained and meets Federal Standard 209a, Class 100.

An additional positive effect is the cumulative result of the constant filtering of air from the entire room, so that during an extended period of use, the level of contaminants in the surrounding environment is progressively reduced.

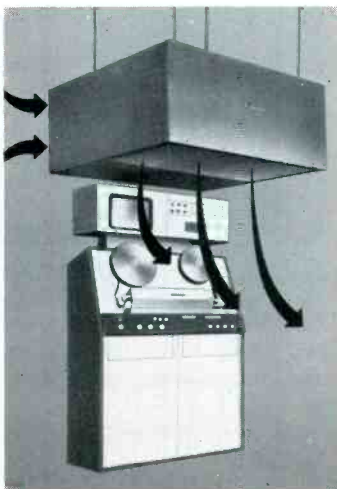

Liberty Industries has the capability for providing complete clean air environments for any size or type of operation. Our sales engineers are ready to help you.

Call or write.



LIBERTY INDUSTRIES, INC.

598 Deming Road, Berlin, Conn. 06037
Telephone (203) 828-6361

GBC CUTS VIDICON PRICES IN HALF!

If you're not buying your replacement vidicons from GBC, you're wasting money. These are brand new, first quality, fully guaranteed tubes in factory sealed cartons. Made by Hitachi. How do we do it? The answer is volume. GBC sells more than 90% of the replacement vidicons used in this country.

Model 7735A Very high sensitivity. Provides sharp clear pictures even at low light levels, with minimum lag . . . \$34.50

Model 8507 Similar to 7735A, but separate mesh design allows overall beaming without loss of detail. Improves resolution and high amplitude response. \$74.50

Model 7038 Used in many live cameras and film chains . . . \$34.50

Model 7262A Exact replacement for Sony and Panasonic . . . \$34.50

Model 20 PE11 2/3" vidicon. Used in many low priced cameras . . . \$34.50

Model 8823 2/3" vidicon. Used in Sony battery operated portable . . . \$34.50

1" Tivicon Silicon diode faceplate \$695.00

2/3" Tivicon Silicon diode faceplate \$695.00
Prices shown are in lots of 5. Add 10% for lesser quantities.



EXTRA! We also carry a full line of GE broadcast and industrial vidicons. Name your own poison. Whatever you need, we can supply . . . at incredibly low prices.

GBC **GBC Closed Circuit TV Corp.**
74 FIFTH AVE., N.Y., N.Y. 10011/(212) 989-4433

Circle Number 23 on Reader Reply Card

Circle Number 24 on Reader Reply Card

Automatic Image Enhancement

By Robert Burns

Leo G. Sands & Associates



Fig. 1 Photograph of the image on a video monitor of an unenhanced slide.



Fig. 2 Note the change in the image after processing through a manually-controlled single enhancer.



Fig. 3 Over-enhancement is apparent here after the image has been processed by two manually controlled-enhancers.

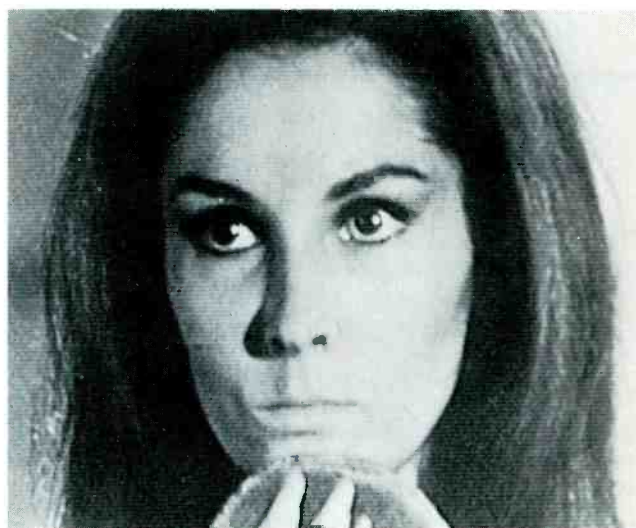

Fig. 4 Photograph of same image after processing by one manual controlled and one automatic enhancer.

A new automatic television image enhancer improves the quality of both monochrome and color pictures. It is connected in series with the video line. Once its three front panel operating controls have been adjusted, it can be set to operate in the automatic mode for hands-off operation.

Ordinarily, one of the new image enhancers would be used at the studio to improve the quality of

locally-originated programs. In addition, it enhances the network feed. But, most important, it automatically disables itself when sensing images that have already been enhanced and thus prevents over-enhancement.

The new Mark III series of image enhancers were developed at CBS Laboratories, Inc. by R. H. McMann, Jr., vice president-engineering and Clyde Smith group leader of

the TV engineering staff.

These new image enhancers were recently demonstrated to this **Broadcast Engineering** reporter at CBS Laboratories in Stamford, Connecticut. Since no known practical printing process has the same color range as color television, the proof of image enhancement is shown here in a series of monochrome half-tones.

These pictures show operation of

the Mark III used in a standard program line. They were taken with two image enhancers in the line. The first picture (Figure 1) is with both units by-passed and it shows the lack of detail in the model's features. The second picture (Figure 2) has standard enhancement added and the added details can be noted around the eyes, nose and mouth.

The third picture (Figure 3) shows the result of too much enhancement that can occur when using manually controlled units. This could occur when the picture is enhanced at the source and then enhanced again before transmission.

The last picture (Figure 4) shows the result when the second unit is placed in the automatic mode. It has sampled the video signal and found it to be enhanced and an AGC circuit has reduced the detail gain to provide the correct picture.

Enhancer Operation

In these new image enhancers, a crisped comb filter is used to prevent color signal distortion during enhancement of the luminance signal. This filter separates the color signals from the luminance signals and allows image enhancement of only the luminance signal. Figure 5 shows two oscillograms. At the top is the horizontal detail frequency response when the crisped comb filter is not used. At the bottom is shown how the horizontal detail frequency response is improved when the crisped comb filter is used.

Crisping eliminates noise or graininess while allowing the important picture transitions to sharpen. Crisping removes low amplitude equalizing signals such as facial blemishes or background wall texture but picture lines such as eyes, teeth, lips and hair highlights are enhanced.

This is particularly important when using Super-8 film. Detail is improved but film graininess is not seriously increased.

The basic function of the image enhancer is to take a single line of video and compare it element-by-element with the lines preceding and following it.

Figure 6 is a block diagram of the new enhancer. The video signal is applied to the input buffer amplifier and then to the self clamp which eliminates the need for external pulses. The signal is then modulated and sent through a delay line of approximately 63.55 microseconds, or one horizontal line. This signal is then sent through a post amplifier. A portion of the signal is sent through a driver amplifier to a second delay line of 63.55 microseconds which becomes a twice delayed horizontal line.

Both of the delayed signals are detected and fed to the horizontal and vertical detail generators along with a signal that has no delay. The vertical signal is fed through a 2 MHz limiter at this point. The 2 MHz limiting is used to improve the SNR since the noise voltage in Plumbicons or vidicons is triangular and largely lies above 2 MHz.

The horizontal signal is applied to a comb filter which separates the color signals from the luminance signals. This precludes any distor-

tion of the color signals during the enhancement of the luminance signal. This is then applied to the horizontal aperture correction network. This circuit generates the horizontal detail signal which is then added to the vertical detail signal to give a resultant contour detail signal.

At this point the signal is fed through a blanking circuit and into the black and white clipper circuit. The clipper prevents excessive black or white detail signals. Thus, whiter-than-white and blacker-than-black peaks are eliminated by selective clipping and the main chroma signal is not affected.

The signal is then fed through a variable gain amplifier and back to the main program line to a mixer where it is added to the signal and then through a final driver amplifier to the output.

In Case Of Trouble . . .

The automatic gain control circuit samples the signal and, if enhancement has already been added, cuts down the signal being fed back into the program line to prevent over-enhancement. This automatic feature may be defeated by a front panel switch.

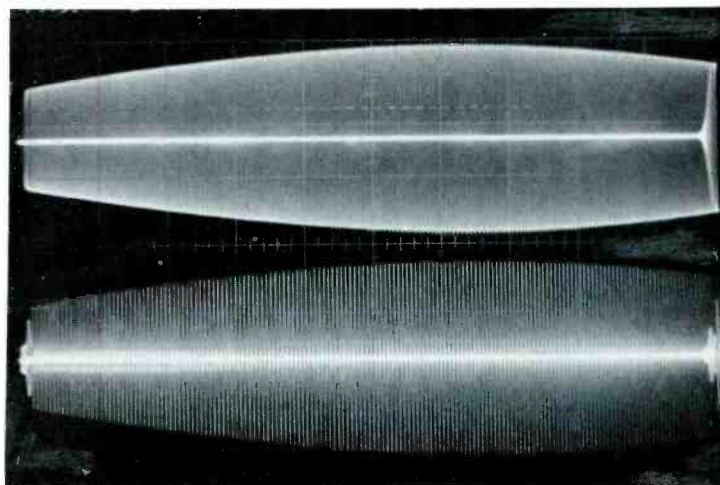

Fig. 5 At top, horizontal detail frequency response without "crisped" comb filter. Below, horizontal detail frequency response with "crisped" comb filter.

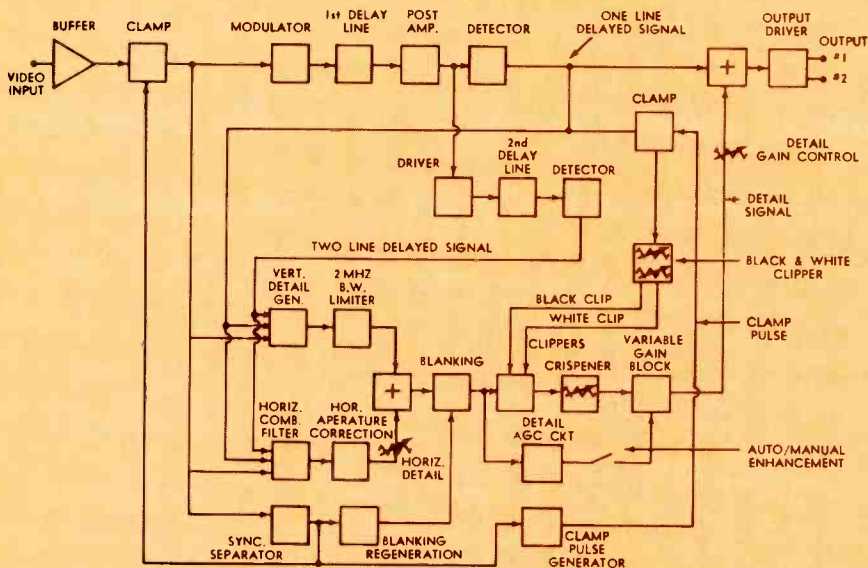

Fig. 6 Block diagram of the Mark III image enhancer.

The two video outputs allow the program line to be used without looping while a video monitor line can be run from the second output. In case of a failure in the unit, a by-pass circuit is hard-wired through so that the video program signals will not be lost. This by-pass has a relay which will drop out and directly connect the input to the output in case of unit failure.

The new image enhancers require only 1¾ inches of rack space and, as shown in Figure 7, the number of controls has been kept to a minimum.

The photograph shows the front-panel controls. The three-position switch at the left is the correction on-off switch that can be set to the "remote position" to enable cutting-

Make YOUR COMMUNICATIONS "Whisper-Clean"

Economical MILLER-STEPHENSON aerosols take the headaches (and a lot of expense) out of what used to be a nuisance.



MS-180 FREON TF DEGREASER—No need to disassemble components. Spray MS-180 onto relays, circuit boards, motor parts. Eliminate grease, prevent re-contamination. Non-conductive, non-flammable. Reduces maintenance costs.

MS-200 MAGNETIC TAPE HEAD CLEANER—Spray away oxide dust before it ruins heads and tapes. MS-200 whisks it away. Manufacturers recommend it; communications experts prescribe it; EDP operators wouldn't be without it.

MS-230 CONTACT RE-NU—Renew your contacts. Contact Re-Nu does it. Knock out dirt, carbon, and other contaminants. Will not harm insulation; leaves no residue. Switch to MS-230 for your switches—and other points.

For FREE 16-oz. aerosol sample of any one of the above, write (on your company letterhead, please), or use coupon for free data.

 **miller-stephenson chemical co., inc.**

ROUTE 7, DANBURY, CONNECTICUT 06810

Please send me Data
 MS-180 DEGREASER sample MS-200 HEAD CLEANER sample MS-230 CONTACT RE-NU sample

INTENDED USE _____

NAME _____ TITLE _____

DEPT. _____

COMPANY _____

ADDRESS _____

CITY _____ STATE _____ ZIP _____

Circle Number 25 on Reader Reply Card

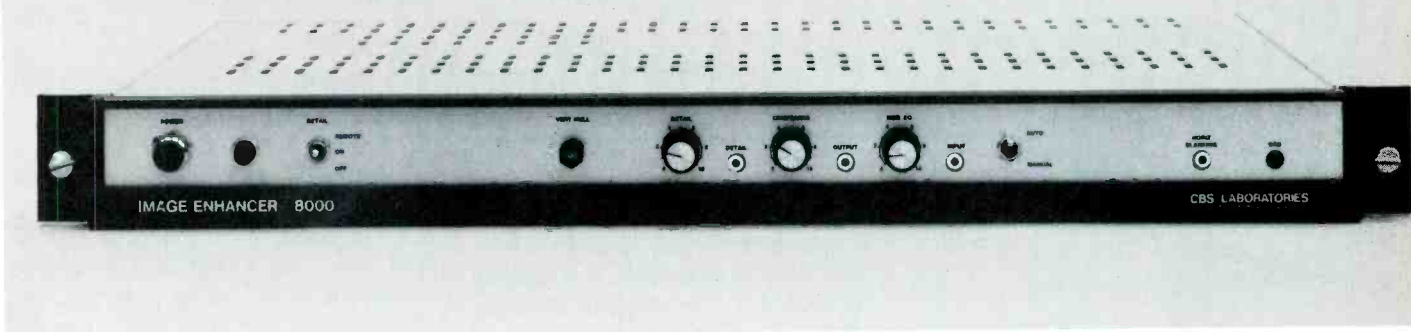

Fig. 7 Front panel controls of the Mark III.

in or cutting-out the enhancer from the control room or other location. The three knobs from left to right are for controlling the composite levels of both vertical and horizontal enhancement (detail), controlling "crispening" to reduce noise and

graininess of the background of images which contain no detail, and for controlling "horizontal equalization" by varying the amount of horizontal aperture correction. The only routine maintenance control is at the left of the detail control knob

and is adjusted with a screwdriver to null the vertical detail.

CBS Laboratories engineers say that the new image enhancers are much more stable than earlier models and, therefore, are suited for "hands-off" and remote operation.

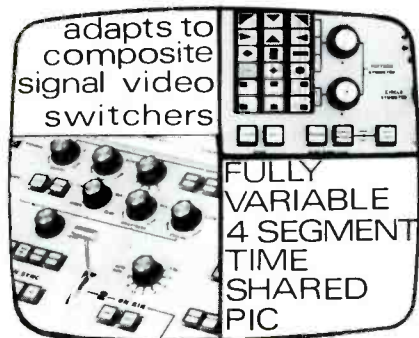

IF EACH PICTURE IS WORTH A THOUSAND WORDS JUST THINK WHAT 4 PICTURES WILL DO

RICHMOND HILL LABORATORIES' NEW QS-I, QUAD SPLIT GENERATOR CAN ANSWER SOME OF YOUR FALL PROGRAM PRODUCTION PROBLEMS.

This new unit can be readily added by your own staff to existing switcher systems. Call our Engineering Services Group for any custom video equipment installation.

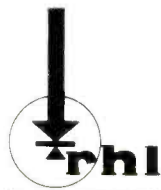

RICHMOND HILL LABORATORIES INCORPORATED

142 CENTRAL AVE., CLARK, NEW JERSEY 07066

(201) 381 - 5955

Telex 01-38245

Circle Number 26 on Reader Reply Card

Cartridge Tape Supermarket!

Here's a one-stop shopping center for the most and best in broadcast quality cartridge tape equipment—a SPOTMASTER supermarket of variety and value.

Just check the boxes and send us this advertisement with your letterhead. We'll speed complete information to you by return mail.



Ten/70
Record-Play

Single-Cartridge Equipment

Record-play & playback models, compact & rack-mounted

- The incomparable Ten/70
- The classic 500C
- The economical 400 (from \$415)
- Stereo models
- Delayed programming models

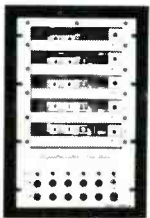

Multiple-Cartridge Equipment

- Five•Spot (5-cartridge deck)
 - Ten•Spot (10-cartridge deck)
- Versatile Five•Spot

Cartridge Tape Accessories

- Tape cartridge winder
- Calibrated tape timer



Tape Cartridge Racks

- Remote controllers
- Cartridge racks (wall, floor & table top models)
- Degaussers (head demagnetizers & cartridge erasers)

- Telephone answering accessory
- Replacement tape heads
- Adjustable head brackets
- Head cleaning fluid
- Alignment tape
- Bulk tape (lubricated, heavy duty)

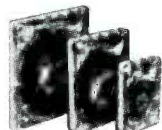

Cartridges: All Sizes

- Tape tags
- Cartridges, all sizes, any length tape (or empty), no minimum order, lowest prices

The nation's leader in cartridge tape technology can fill your every need, quickly and economically. That's how we became the leader. Write:

BROADCAST ELECTRONICS, INC.

A Filmways Company

8810 Brookville Rd., Silver Spring, Md. 20910
(301) 588-4983

Cartridge Quality Control

By Gene Rider*

Quality sound from cartridges doesn't just happen. It has to be worked on seven days a week. Here are some practices that can aid in establishing a better sound through realistic cartridge control.

Our cart machine heads are cleaned daily. Azimuth on every recorder and playback is checked weekly, and frequency response is checked quarterly. Most of the major manufacturers and the NAB have excellent azimuth and frequency response cartridges available. Another useful device is a collimeter. It permits visual head alignment problems, such as restoring azimuth after a head change.

Distortion is checked monthly by recording a 400 Hz tone at minus 5 on the recorder VU meter (allowing 5 dB headroom for complex waveform overshoot) and measuring the playback distortion. A 2% overall distortion at this level is acceptable for this station. A figure in excess is possibly attributable to poor tape, a VU meter in error, or bias problems. (Adjust the bias trimmer for maximum playback while recording a 1 KHz tone at minus 5 level).

Pinch rollers are carefully inspected on a regular basis and changed at the first sign of excessive wear.

Speed problems are usually discernible immediately by ear. These problems are few and far between, generally. When it does happen a speed check tape is helpful. A timing tape is easily made up by winding a cartridge with a carefully measured 150 feet of one mil lubricated tape on a cartridge. This loop should cue out in 4 minutes to meet NAB specs with a tolerance of plus or minus 0.4% or .96 of a

second (A good frequency counter also could be used.)

A head penetration check is made occasionally and is a definite requirement after a head change. Proper penetration is marked off in red on a blank cartridge loaded in a new machine just in from the factory—after checking the measurement against NAB specs. A copy of these specs is referred to as necessary. It is a gold mine when it comes to precise measurement of all operating dimensions such as guide, penetration and tension.

NAB's 45 dB monophonic noise level specification seldom has to be measured out on the recorders because experienced broadcast technicians can accurately gauge noise level with a quick listen. This spec is usually met with new tape on a properly maintained recorder.

When a cartridge is returned to stock by your program people, the first step is a thorough cleaning (cartridge rebuilding is done by station engineers). Label adhesive and a laboring DJ's sweat are sometimes stubborn. A mixture of one third isopropyl alcohol and two thirds mineral spirits and a clean, soft cloth are helpful. If the tape has been in jingle service or shows signs of wear, it is dumped. If tape wear is minimal it is erased for re-use.

It's difficult to get an erasure without spokes with a hand held eraser. A modified Ampex AE 100 automatic degausser (probably no longer in production) does a good job. This was originally a reel to reel tape eraser. The traverse arm, with magnets underneath, had to be raised to clear the flat cartridges and their holding jig. The eraser's spindle was threaded to take a wing nut. One paper-based recording disc is attached to the eraser turntable, four cartridges laid out pie shaped on it, and another paper based disc placed atop the cartridges and the thumb nut screwed down to form

*WIOD, Miami, Florida.

a holding jig. The unit delivers a 65 dB erase, without any start-stop clunks in a 50 second automatic cycle. By removing the holding jig, the eraser is restored to operation for reel use.

Next step: 100 Hz and 10 KHz tones are recorded on the cartridge and if they show a playback level within plus or minus 2 dB of each other, the cartridge is ready to be put into the splice finder.

But more than likely the playback level will be down at 10 KHz if the cartridge has had rough handling. Since the recorder has had regular azimuth and frequency response checks, this points to a cartridge problem. Most of the time the guide post within the cartridge can be repositioned vertically to restore the 10 KHz playback to an acceptable level. Use a touch of lacquer thinner on a Q tip to melt a bit of the post's plastic seating and meld it to the post for drying out to a sturdy bond in its newly seated position. Various glues and adhesives are available that would do equally well.

If frequency response is not improved by guide post positioning, pressure pad adjustment or alignment, a whole set of pads may be needed. Occasionally, a change of tape is required.

Cartridge rebuilding and reloading are done by station personnel because frequency response has to be taken. It has been found that a great many new cartridges need minor work to achieve good response. If reloading is necessary, the cartridge is wound on the station's timing-winder. Besides building your own special lengths, it adds flexibility to an operation.

Then the cartridge is put into the splice seeker for cue up. Once cued, a marking tape tab with date of check out is put on the cartridge and it is placed in stock for either mono or stereo use.

These procedures may seem drastic and time consuming to the point of requiring many technical people, but this station has five engineers for a 24-hour a day 5 kW AM operation and a 24-hour a day stereo operation in a major market. Engi-

neers do all mono cartridge make-up, logging for two transmitters, keep the FM automation going, check in several remotes, and make many NBC delays and remote delays. They also run control on FM splits and studio control on 8 hours of delayed talk and telephone shows nightly. A great many pro football, basketball and spring training baseball remotes are overtimed for out of town stations. On weekends and after coffee the engineer on duty hacks away at rebuilding cartridges and checking them for audio quality. Everyone should be involved in achieving a clean sound.

With such a routine established, the cartridge situation stabilizes and the routine checks begin to move very quickly. Once the machines are well adjusted, fewer and fewer problems turn up. A couple of thousand cartridges were gradually worked through our station and fewer and fewer had to be reworked when returned to stock. This kind of quality control can make you sound better and sell easier.

FM ... **ICE**

FM ... **ICE**

FM ... **ICE**

* ... **ICE**

GRAY'S 2570 ANTENNA HEATER CONTROL SYSTEM WON'T LET THIS HAPPEN TO YOU. WRITE FOR DETAILS

*** OFF THE AIR !!!**

GRAY RESEARCH
ONE FIFTY PARK AVENUE
EAST HARTFORD, CONN. 06108

Circle Number 27 on Reader Reply Card

**ERASE
RECORD
REPRODUCE**

MONO - STEREO

Professional Direct Replacement Heads with complete written and pictorial instructions

Our factory will clean, rebuild, adjust and test your head ASSEMBLY...install new MMI heads...replace minor hardware and modify your gate to accept our "NON-POPPING" springs

MMI

36 HOUR SERVICE - LOANERS AVAILABLE
(612) 884-7393

MINNEAPOLIS MAGNETICS, INC.
8125 PLEASANT AVE. SO., MINNEAPOLIS, MINN. 55420

Circle Number 28 on Reader Reply Card

What FM transmitter power do you need?

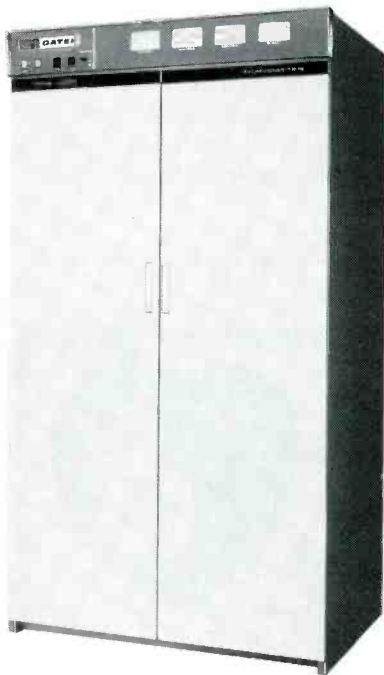

Gates has the most complete line of FM transmitters in the industry. From 10 to 40,000 watts. All with a 100% solid-state exciter employing DCFM (direct carrier frequency modulation) and DAFC (digital automatic frequency control).

The TE-3 exciter is the heart of all H3 series transmitters—one tube (1kW), two tube (2, 3, 5 and 10kW), and three tube (20kW). All FCC-type accepted, ready for prompt shipment.

Tell us the power you need and ask for data on our FM antennas. Write Gates, 123 Hampshire St., Quincy, Illinois 62301, or phone (217) 222-8200 today.

**HARRIS
INTERTYPE
CORPORATION** **GATES**
A DIVISION OF HARRIS-INTERTYPE

Circle Number 29 on Reader Reply Card

Letters (Continued from page 10)

In this same article, we were running short on space. The table that appears here was originally a part of that article. The table was dropped as planned, but we didn't

Parameter	LM300	723C	MC14690.R	
Input Voltage (volts)	Min	8.0	9.5	9.0
	Max	30	40	35
Output Voltage (volts)	Min	2	2	2.5
	Max	20	37	32
Output Current (ma)	Max	40	150	200(G), 500(R)
	Line (input) Regulation (%/volt)	typ	.05	.01
	Max	.1	.1	.03
Load Regulation (%)	typ	.1%	.03%	
	Max	.5%	2%	
		I _L < 12 ma	I _L 1-50 ma	
Output Impedance (milliohms)				35 min, 120 max I _L = 25 ma
	Reference Voltage (volts)	1.8	7.15	3.5
Temperature Coefficient of Output Voltage (%)	Min	-.3%	.003%/°C	
	Max	1%	.01%/°C	± .002%/°C

remove the reference to it on page 43. If you've ever had one of those days when things just seem to go wrong, you know how we feel.

The Editor

Looking For More Sense In Hiring

Dear Editor:

I would like to take some issue with the letter in your July issue by Mr. Ridgeway. Specifically to the statement, and I quote: "A man leaving this course with his FCC license is, as an operator, as well qualified on the job as a BS in Electronic Engineering." In my experience, this is simply not true. I have, in the course of the last several years, been responsible for hiring, and worked with many graduates of these so called 'ticket mills.' Of these I can recall one who was, in my opinion, a qualified operator. I am confronted with individuals who cannot tune a transmitter, who have no idea how to tune for efficiency, ("out of the fast rising side of the dip, quoth I. Dawk? quoth they), who do not know how to read a base current ratio graph, do not know what is legal variation, etc. A station I once worked for lost 45 minutes of air time once after a two-minute power failure. The operator on duty was not sure how the transmitter was to be turned on. The outage would have been longer but the manager's 12-year-old boy came in on his bicycle,

read the posted instructions, and then turned the transmitter back on.

Quite frankly, I am wholeheartedly in favor of the current proposal that the operation of directional radio systems be permitted the holder of an endorsed Third Class, with the power cut and tuning being done by a First Class licensee, most likely the Chief Engineer. I believe the Commission should be in favor of this, as in reality, they are already permitting it, since the graduate of a ticket school is nothing more than a Third Class license holder who has paid several hundred dollars to the school. This would be a boon to the announcing fraternity as well, as once again the premium would be on an announcer's talent and not on whether or not he had his "meal ticket."

Perhaps some sort of apprentice system would be a good proposal, however, it would never be accepted by the Broadcasting Industry. The famous shortsightedness of the Broadcast Industry is what created the situation anyway, and I see no likelihood of change in the near future. It is a point of interest that myself, and many other competent engineers I know, are currently called by other area radio stations almost daily, in an attempt to press us into service as cheap consultants, on everything from simple console repair to correction of parameters in a directional system. All of the stations have "Chief Engineers" but the managers always will say (he's a ticket school grad—don't know anything, works cheap though) and then smile at the money they are saving by not paying a competent engineer and just taking the chance they can get someone if they have trouble. (I always try to charge as much as possible in these cases, it seems somehow fitting.)

If the above mentioned proposal were adopted I, like Mr. Ridgeway, would rely on my experience and educational background, and not be too worried about holding my job.

Floyd S. Phillips
Chief Engineer
Geyer Broadcasting Co.
Evansville, Ind.

CATV Rules

(Continued from page 13)

would be required to place a "reasonable limit" on the length of a franchise. Pointing out that a "franchise in perpetuity" would be an "invitation to obsolescence," the Commission suggested 15 years as a maximum franchise term.

Subscriber rates would have to be specified or approved by the franchising authority the Commission said, with provisions for review and adjustment and public notice of rate changes.

Commenting on franchise fees, the Commission said that its goal was to strike a balance between federal aims and adequate revenue for the local regulatory program. While suggesting that franchise fees should run between three and five percent as a maximum, the Commission said it would specify only that the fee be reasonable and not interfere with federal goals. However, where fees are in excess of three percent, the franchising authority would be required to show how it related to the local regulatory program.

Sports Squeeze

Discussing the matter of sports telecasts, the Commission noted that there are Congressional policies in this area (PL 87-331) and that cable systems will not be permitted "circumvent" them. The Commission said "we intend to issue very shortly a notice of proposed rule making directed to this area, in order to ascertain the full thrust and purpose of 87-331 and how best we can formulate a rule to implement these purposes."

FCC Closes Proposal On Interview Ruling: May Approve Speakerphones

A rule making proceeding, which proposed amending Part 73 to provide for licensee control of matters broadcast during telephone interview programs on AM, FM and TV stations, has been terminated by the Commission (Docket 18928).

The Commission pointed out that while the proceeding was of value by alerting licensees to their responsibilities with respect to matters broadcast on telephone interview programs, particularly those neces-

sitating Fairness Doctrine and personal attack rules and policies, it has decided that the rules are not clearly warranted at this time, and therefore should not be adopted.

FCC Hearing Examiners may approve the use of a speakerphone by parties to a hearing as a way of attending a prehearing conference "if such use is found to conduce to the proper dispatch of business and to the ends of justice," the Commission has ruled. A speakerphone is an attachment to a telephone that permits users to speak and to hear without holding a receiver. It may be used by a group in conference seated near the telephone.

The Commission action amends Section 1.248(f) of the rules and is in response to a request for rule making by "The Telephone Company" of Nevada.

In appropriate cases, the Commission said, this procedure may help parties who are required to appear at prehearing conferences (and who have previously been inconvenienced by long distance travel for short appearances) without interfering with the efficient handling of FCC business.

Spotmaster

Tape Cartridges



All lengths and sizes stocked — fast service — highest quality

Series	Time at 7½ ips	Unit Price
300	20 sec. (13')	\$ 2.00
300	40 sec. (25')	2.05
300	70 sec. (44')	2.10
300	100 sec. (63')	2.25
300	140 sec. (88')	2.35
300	3½ min. (132')	2.50
300	5½ min. (207')	2.90
300	8½ min. (320')	3.70
300	10½ min. (394')	3.90
300	empty cart.	1.60
600	16 min. (600')	6.25
600	empty cart.	2.80
1200	31 min. (1163')	10.45

Also: DL cartridges (for Spotmaster delay machines), bulk tape, tape-tags and other accessories.

ANY ASSORTMENT—NO MINIMUM ORDER

BROADCAST ELECTRONICS, INC.

A Filmways Company
8810 Brookville Rd., Silver Spring, Md. 20910

the Tracor 6500 Carrier Generator System

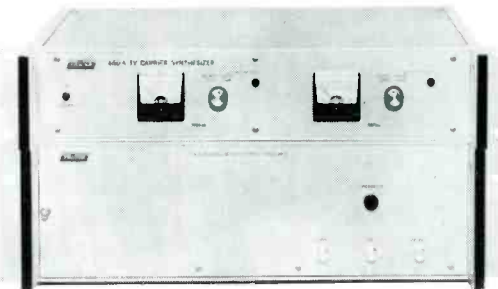

stops "grade B" coverage loss

Co-channel interference is essentially eliminated adding solid audience to your coverage.

With a TRACOR 6500 Carrier Generator System driving each transmitter, co-channel carriers are held so constant (within 0.05 Hz) that visibility of the beat pattern is reduced 16 db. The inherent stability of atomic frequency standards also eliminates the need

for constant adjustment . . . making the 6500 ideal for remote-site operations.

For more information, contact TRACOR, manufacturers of the 6500, Carrier stabilization systems, sub carrier sync systems, and video failure alarms.



Industrial Instruments Division

6500 Tracor Lane, Austin, Texas 78721, AC 512/926-2800

Circle Number 30 on Reader Reply Card

take it off neat and quick



NEW WIRE STRIPPER-CUTTERS

3 MODELS TO CHOOSE FROM. Made in USA to highest quality standards, these tools cleanly strip and cut all commonly used solid and stranded insulated wire.

Features include adjustable screw stop or unique, patented cam for adaptation to different wire sizes. Self-opening handles have slip ring or thumb-operated catch to keep them closed in tool box. Blades are hardened and ground, cut with a smooth shearing action. Handles have comfortable Cushion Grips.

WRITE FOR DESCRIPTIVE LITERATURE.

nationwide availability through local distributors



XCELITE, INC., 118 Bank St., Orchard Park, N. Y. 14127
In Canada contact Charles W. Pointon, Ltd.
Circle Number 31 on Reader Reply Card

NEW PRODUCTS

(Use circle number on reader service card for further information)

More Monitor Competition

Triple 5-Inch Monochrome Monitors

SC Electronics, Inc. recently introduced the new Setchell Carlson Triple Five, the smallest American-made 5-inch monochrome monitors on the market. Designed for monitoring of three video sources in the minimum possible space, these professional quality monitors, mounted side by side in a 3-unit configuration, occupy only 5 1/4" of vertical rack space with a depth of only 14".

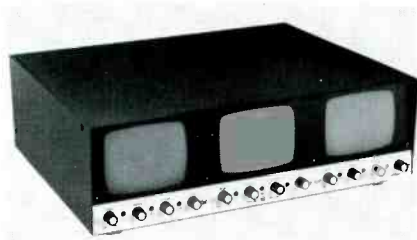

Model 5M916RM3 is supplied with a steel cabinet with light blue

finish for desktop use, and includes all necessary hardware for standard 19" rack-mounted applications. Ideal for broadcast, educational, VTR display, and industrial use, these monitors feature 540-line horizontal resolution; UNITIZED® plug-in circuit modules for rapid on-the-spot maintenance; front-located operating controls for ease of operation; and a regulated power supply that prevents raster size or brightness deviations due to line voltage fluctuations.

Other features include a fast AFC circuit which ensures excellent display for helical scan video tape recorders; 100% solid-state circuitry for outside performance and reliability; front-panel screwdriver adjustments for Vertical Linearity, Height, and Focus to prevent accidental misadjustment; and a plexiglass reflection shield to reduce picture-tube glare.

Circle Number 60 on Reader Reply Card

Low Cost Switcher

DYNAIR Electronics, Inc., has developed a new low-cost vertical-interval two-buss video switcher-fader for use in CATV, broadcast, educational, and remote television studio applications.

The new VS-150A is completely solid-state and has all controls functions necessary for professional studio programming, including instantaneous switching and split-arm controls for fade-in, fade-out, lap-dissolve and superimposition, with

any degree of signal mixing.

The unit accepts three non-composite and two composite video inputs. Only the non-composite busses are connected to the fader mechanism, preventing inadvertent fading of composite signals which would result in sync difficulties. The non-composite signals are switched by solid-state switch junctions, with switching occurring during the vertical interval to assure a glitch-free transfer of signals.

The composite inputs, located on

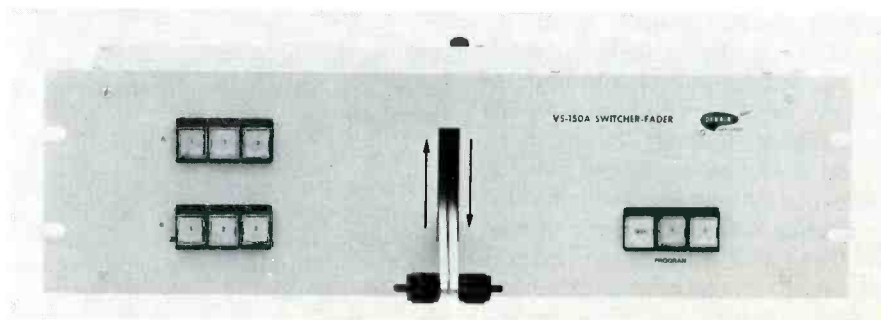

a separate three-pushbutton buss, provide a selection between the mixer output and either of the two composite video sources. All push-buttons are of the illuminating variety, providing a positive indication of program conditions.

The switcher-fader is designed to mount in a standard 19-inch console arm. It has a front panel height of 5¼ inches and an overall depth of 4¼ inches.

Circle Number 61 on Reader Reply Card

Quad Splitter

OMNIX announces a new generation of quad splitters. Model 910B Quad Splitter has the following unique features: It can be used as a 4X1 vertical interval switcher; It can generate an exact preset 4 quadrant split; It can be used to wipe to any of the four inputs with a joystick control which operates over the full screen.

It contains a variable border control which allows the user to adjust the horizontal or vertical border separately. The adjustment range is from 0 to 30 picture elements. The border luminance is adjustable or can be colorized with an external colorizer.

It is supplied complete with a remote control panel and fifty feet of cable.

Circle Number 62 on Reader Reply Card

27 Input Audio Consoles

The new **McMartin** console series offers a choice of monaural, stereo or dual channel in their models B-801, 802, and 803.

All modules in these consoles are plug-in. And overall, they allow 27 inputs along with step-type attenuators. Typical program specs are: ±0.5 dB frequency response; distortion of 0.5%, 20 to 20,000 Hz; and a signal-to-noise ratio of 74 dB for all models.

These console models include full cue, intercom, and monitor facilities as standard features.

Circle Number 63 on Reader Reply Card

Multicartridge Tape Playback

Two new multicartridge tape playback systems, the FT-16 and FT-26, are now available from **RCA** for broadcast and professional audio applications. Offered in both monaural and stereo versions, these systems meet or exceed all NAB

specifications, and provide an economical approach for sequential or random accessing up to twelve cartridge decks.

The RT-16 contains six playback decks; the RT-26 is a twelve-deck unit. Both systems feature the latest advances in electronic switching, using solid state logic circuitry instead of mechanical relays. A heavy-duty synchronous motor and redundant, solid state plug-in circuit boards assure reliable operation. Tape decks are simple to remove and replace.

Circle Number 64 on Reader Reply Card

Cue Board

Laird Telemedia Inc. has developed an Electronic Q Board for use in VTR production work to record tape identification and cue timing. Provides both aural and visual cue marks for a full 10 second count down. Large, center-located, seven-bar readout permits a zoom to full screen numeral, following ID. A local speaker will alert talent and studio personnel. Separate laminated message surfaces protect permanent format but permit ready changes in title information. It is housed in two-tone shock resistant plastic case.

LAIRD TELEMEDIA INC			
PROGRAM		Q BOARD	
REC. DATE	10	AIR DATE	
26 JUN 71		TBA	
LENGTH	10 SEC	TAKE	2
CODE NO.	1121	DIRECTOR	ALLEN

The unit has no moving parts and features solid state IC circuit design. The time base is accurately derived from 50 or 60 Hz power line frequency. Local controls include speaker volume and a local reset switch. A low Z "Beep Tone" audio output at a fixed mike level is provided. The AC power cord and remote reset cord are easily detached.

Circle Number 65 on Reader Reply Card

(Continued on page 54)

For more details about products in this issue use free readers service card in the back of this issue.

You can name the four leading antenna manufacturers

1. _____ 3. _____
2. _____ 4. _____

Only one of them has the ASTROSCAT

and the MINISCAT



and the ZIG-ZAG

Plus HIGH PERFORMANCE LOGS
Plus BUDGET-PRICED YAGIS
Plus ALL-ENVIRONMENT YAGIS
Plus RUGGED CORNER REFLECTORS

Rely on RF engineering competence. Write or call our commercial division.

RF SYSTEMS, INC.

155 King Street
Cohasset, Mass. 02025
Telephone: (617) 383-1200
Circle Number 32 on Reader Reply Card

(Continued from page 53)

Zoom Lens

Wollensak, Inc., Rochester, New York announces the new Ultrafast f/1.8 TV Zoom Lens. The line includes a 10:1 and 6:1 version in both manual and motorized models. The manufacturer claims that the new lenses feature exceptional resolution and extreme wide angle coverage. The line also includes a wide selection of accessories and controls for use with the new lenses.

Circle Number 66 on Reader Reply Card

TOOL KITS

FIELD ENGINEER TOOL KIT JTK-17

More than 100 fine tools required for servicing in the field. Used on communications equipment, business machines, computers, all kinds of electronic systems. All tools and VOM tester are furnished in deluxe attache' case. Write for details.

JTK-17.....\$222.50

Free Catalog →

ELECTRONIC ASSEMBLY TOOLS

JENSEN TOOLS and ALLOYS
4117 N. 44th Street, Phoenix, Arizona 85018

Circle Number 33 on Reader Reply Card

New COMPACT REVERBERTRON from FAIRCHILD



MODEL 659A

Another exciting edition of the world-famous FAIRCHILD Reverbertron systems is the new Model 659A FAIRCHILD COMPACT REVERBERTRON.

Identical in performance characteristics to the preceding studio model—the Model 659—the new compact Model 659A also supersedes all other artificial reverberators within its price range by providing the same natural, real-life reverberation effects as the world's finest acoustic chambers.

Including lock mechanism for portability the rack mount Fairchild Compact Reverbertron is 19" wide x 9" deep x 7" high—truly the finest compact reverberation system available today.

*U. S. Patent #34336674

For complete details contact your Fairchild Distributor or write:

FAIRCHILD

Sound Equipment Corporation
SUBSIDIARY OF ROBINS INDUSTRIES CORP
10-40 45th Ave., L.I.C., N.Y. 11101

Circle Number 34 on Reader Reply Card

Grass Valley Group, Inc. has introduced their master control/automation switcher for the broadcast market.

The model 1400 features all switching and transition functions that are operable from an automatic source. The 20 video inputs includes takes, dissolves, keys, fades, inserts and wipes that are made by either electrical or manual control.

The 1400 also will handle 30 audio inputs electrically or manually controlled, and they include takes dissolves, fades, and AFV or break-away (over or under PGM).

Designed for the most demanding roles, this model a preview/bypass bus that permits selection of any input to an on air output, allowing the mix and effects busses and equipment to be used for both studio production and/or rehearsal. Here is a likely candidate for the National Association of Educational Broadcasters equipment exhibit during their national convention in October.

Circle Number 67 on Reader Reply Card

Color Studio Package System

A new color studio system package for use in cable and closed-circuit television program production has been introduced by **International Video Corporation.**

The Colorcaster IV is the latest in a series of studio packages offered by IVC, according to Michael A. Moscarello, president, and is designed for origination of broadcast quality color from film, slides, and recorded video tapes as well as live monochrome production at low cost.

IVC performs the complete studio installation, relieving the user of all design and planning details. The user need only provide the space and operating personnel. IVC also trains the user's personnel in the operation of the system as part of each complete package.

Included in the Colorcaster IV is the newest IVC equipment incorporating the IVC-40M monochrome camera and the IVC-700 color videotape recorder as well as the IVC-870 color videotape recorder with assemble and insert electronic editing.

The full color IVC film chain in the Colorcaster IVC package features the IVC-92 color camera with a three-input multiplexer plus 16mm film projector and 35mm slide pro-

jector, remotely controlled.

All the equipment in the system can be interconnected and operated through a single, versatile control console, offering a wide range of production capabilities such as remote pickups, superimposition of graphics, and live and videotaped local program origination. Most of the equipment can be operated independently permitting, for instance, separate and simultaneous remote and studio operation.

Other equipment includes: waveform monitor, portable lighting system, control console desk and matching VTR cabinets, and master color monitor.

Circle Number 68 on Reader Reply Card

Monitor Module

The **Singer Company** has introduced an AM module for its FM-10 and FM-10C service monitors. With this module, Model OAM-1, the FM-10 and the FM-10C become the only monitors in existence with both FM and AM servicing capability.

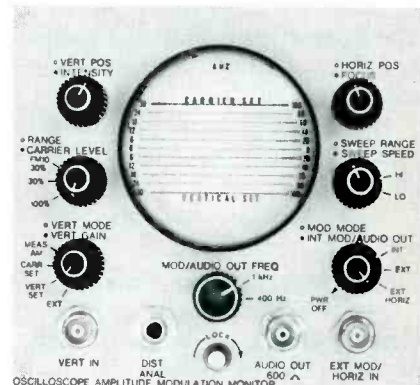

The OAM-1 provides oscilloscope display of recovered audio for visual checking of transmitter problems and measurement of percentage modulation. It measures AM modulation up to 95% with 10% accuracy and generates AM from 0% to 30% with 3% distortion. The plug-in supplies audio test tones of 400 Hz and 1KHz and provides general purpose oscilloscope functions with external or internal inputs for both vertical and horizontal axes.

Circle Number 69 on Reader Reply Card

Variable Heat Soldering Iron

The new ORYX Model 50 soldering iron from **Telvac Instrument Co.** features close control of soldering temperature, from 400 to 750°

F. It is designed for soldering delicate components, including semi-conductors, that can be damaged by high temperatures . . . as well as for any use where it is desirable to maintain close control over temperature.



A thermostat built into the handle of the iron keeps the temperature constant, regardless of the size of the joint, amount of solder applied, speed of soldering, fluctuations in line voltage, or other variables. The 50-watt element provides fast initial heating and almost instantaneous recovery from heavy joint loads. Variations in temperature during soldering are negligible, even when soldering heavy lugs or terminals.

Circle Number 70 on Reader Reply Card

Video Switcher

International Nuclear Corp. has introduced a new broadcast video switcher that is designed primarily for smaller broadcast production studios and remote mobile operations.

The switcher, Model VBS-250-M/E, contains features normally included only in more sophisticated and expensive production switchers. The VBS-250-M/E switcher accepts 15 non-composite or composite signals (synchronous), and all video signals are switched by solid-state, "plug-in" switch crosspoints. It is designed for full broadcast color.

The video switching matrix design, featuring "plug-in" input/output amplifiers, video switching modules, and SCR electronic control circuits offers the option of imple-

menting any number of inputs from one to 15. Inputs not implemented immediately can be made operational at any time with the addition of the required number of amplifiers, switch modules, SCR control circuits and switches.

The VBS-250-M/E switcher contains several features not usually found in switchers of this size, including: Bounce-free switching, with no input clamping or DC restoration required; four operating busses for preview, program, mix/eff A and mix/eff B; 11 effects with mixes and wipes, external and internal keying; momentary closure buttons; tally control; and a remote control panel.

Several optional features are available, including color mating non-additive mixing, sync add, and three to 12 additional effects patterns.

Circle Number 71 on Reader Reply Card

ADVERTISERS' INDEX

Belar Electronic Laboratory Inc.	21
Canon	IBC
Cohu Electronics, Inc.	1
Collins Radio Co.	11
Eastman Kodak Co.	16A
Electro-Voice, Inc.	1FC
Fairchild Sound Equipment Corp.	54
Gates Radio Co., Div. Harris Intertype Corp.	8, 50
GBC Closed Circuit TV Corp.	43
Gotham Audio Corp.	13
The Grass Valley Group, Inc.	3
Gray Research Div.	49
Hunt Chemical	32A
Jensen Tools and Alloys	54
Liberty Industries, Inc.	43
3M Co., Mincom Div.	7
McMartin Industries, Inc.	13
Miller-Stephenson Chemical Co., Inc.	46
Minneapolis Magnetics, Inc.	49
Mosely Associates, Inc.	15
North American Philips Corp.	BC
Philips Broadcast Equipment Corp.	22-23
RCA Commercial Electronic Systems Div.	5
RCA Service Co.	36
RF Systems, Inc.	53
Richmond Hill Laboratories Limited	47
Russo Electronics Manufacturing Co.	55
Sarkes Tarzian, Inc.	14
Sparta Electronics	19
Spotmaster	10, 20, 48, 51
Stanton Magnetics, Inc.	35
Switchcraft, Inc.	12
GTE Sylvania, Electric Components	17
Telemation, Inc.	29
Telex Communications Div.	9
Tracor Industrial Instruments Div.	51
Xcelite, Inc.	52



NEW RUSSCO STUDIO-PRO

CUSTOM MODEL TURNTABLE

Single lever controls 33 & 45 Speeds. Plays 45's without adapter. Illuminated speed indicators. Has detachable tone arm mounting plate. Comes with syn. motor only.

INTRODUCTORY PRICE \$198

SOLD DIRECT OR TO DEALERS



NEW RUSSCO CUE-MASTER

STANDARD MODEL TURNTABLE

Single lever controls 33, 45 & 78 speeds. Plays 45's without adapter. Simple rugged construction, only 3 rotating parts.

PRICE WITH 4 POLE IND. MOTOR \$145
PRICE WITH SYN. MOTOR \$169.50

Call or write for folder



'52 MONAURAL MODEL 1-M

RUSSCO BROADCAST PHONO Preamplifiers MONAURAL & STEREO MODELS

STEREO MODEL 1-S \$104



RUSSCO POWER SUPPLY UNITS model 1-P \$42

RUSSCO Electronics Mfg.
6879 N. SUNNYSIDE, CLOVIS, CALIF.
PH. 299-4692

Circle Number 35 on Reader Reply Card

PROFESSIONAL SERVICES

VIR JAMES

CONSULTING RADIO ENGINEERS
Applications and Field Engineering
345 Colorado Blvd.
Phone: (Area Code 303) 333-5562

DENVER, COLORADO 80206

Member AFCCE
TWX 910-931-0514

WALTER F. KEAN CONSULTING RADIO ENGINEERS

P.O. Box 4201
Santa Fe, New Mexico 87501

Phone: 505-983-5175

Member AFCCE

CAMBRIDGE CRYSTALS PRECISION FREQUENCY MEASURING SERVICE

SPECIALISTS FOR AM-FM-TV

445 Concord Ave. Phone 876-2810
Cambridge, Mass. 02138

COURTRIGHT ENGINEERING

MORRIS COURTRIGHT, Jr., P.E.
Automation - Applications Field Engineering
ELECTRICAL AND BROADCASTING
Route No. 1, Box 854A, Flagstaff, Ariz. 86001
Phone (602) 774-8206

RALPH E. EVANS ASSOCIATES

Consulting Radio Engineers
AM - FM - TV - CATV - ITFS
3500 North Sherman Blvd.

MILWAUKEE, WISCONSIN 53216

Phone: 414-442-4210

CLASSIFIED

Advertising rates in Classified Section are 15¢ per word, each insertion, and must be accompanied by cash to insure publication.

Each initial or abbreviation counts a full word. Upper case words, 30¢ each.

Minimum classified charge, \$2.00.

For ads on which replies are sent to us for forwarding, there is an additional charge of \$2.00 to cover department number, etc., which is printed in advertising copy, and processing of replies.

Classified columns are not open to advertising of any products regularly produced by manufacturers unless used and no longer owned by the manufacturer or a distributor.

Equipment for Sale

HELIAX—STYROFLEX. Large stocks — bargain price — tested and certified. Write/call for price and stock list. Sierra-Western Electric, Box 23872, Oakland, Calif. 94623. Tele: (415) 832-3527. 1-71-tf

"New & Used Towers, Buy, Sell or Trade, Erect, Ground wire 85¢ lb. Bill Angle, 919-752-3040, Box 55, Greenville, N.C. 27834." 2-71-tf

ONE STOP for all your professional audio requirements. Bottom line oriented. F. T. C. Brewer Company, P. O. Box 8057, Pensacola, Florida 32505. 7-71-tf

Equipment for Sale (Contd.)

CLOSE OUTS of cable equipment of any kind from Distributors, Manufacturers or Wholesalers, as well as used workable equipment from cable system operator. Call or write. Cablevision, Inc., Box 113, Phone 608-624-3232, Soldiers Grove, Wis. 54655. 9-71-1t

A wide assortment of Electronic Equipment housed in a twenty foot Wells Cargo trailer with dual tandem wheels. For indoor and outdoor events such as County Fairs, etc. Contains control panel for switching from monaural to stereo loudspeaker work. WLC University bull horns, numerous other horns with drivers, amplifiers, microphones, mike inputs, equipment tester and many more items. You name them I have it. For complete list of equipment and picture of trailer please send 50¢ to cover cost of handling to Post Office Box 142, Mantua, N.J. 08051. 9-71-1t

Grass Valley Routing Switcher. Audio Follow Video. 12 x 10. 10 Control Panels with cable. Presently used Network Operations. New 15. 5K sell for 9K. Call KCET (213) 466-4212 Ext. 307. 9-71-2t

Electronic Research type 425 25KW iso-coupler for feeding FM antenna on your AM tower. Frank Carman, KLUW, Salt Lake City. 801 359-7794. 9-71-3t

300 reels 2" broadcast Video Tape, good for color. B/W, mostly 3M type 379, used: \$25/hr., \$30/1½ hr. 200 empty aluminum NAB reels for 2" video tape: \$5/hr., \$6/1½ hr. Comquip, Box 12, Ridgewood, N.J. 07451 (201) 444-0196. 9-71-2t

GE COLOR FILM CAMERA model 4PC16A, with multiplexer, 2 Eastman 285 projectors and slide projector. Also 3 Marconi Mark IV 4½ inch image orth cameras and 35 ft. semi TV van. Lobos Teleproductions, 3620 South 27th St., Arlington, Va. 703 671-1300. 9-71-1t

NEW FILM CAMERA FOR TV NEWS. 16mm CP-16, extremely lightweight, crystal-control camera specifically designed for the TV news cameraman and documentary filmmaker. Incorporates Auricon centerplate mechanism, single system sound, magnesium body, maximum portability and comfortable hand-holding balance. Write for specs and price. Orders now being taken by Alan Gordon Enterprises, 1430 Cahuenga, Hollywood, Calif. 90028. (213) 985-5500. 9-71-1t

Position Wanted

ATTENTION STATIONS!! Currently working as summer relief technician. Will be available for permanent employment after September 27th. Charles Rohr — 1022 Taylor—Topeka, Kansas 66612. Phone 913-232-2765. 8-71-2t

BROADCAST or INDUSTRIAL electronic engineering position wanted by male, 27, married, good health, Purdue University Associate degree. First Phone with Radar endorsement (9 Yrs.) Experience includes Broadcast Field Service Engineering, Solid state electronic and electrical development lab work. Military completed—will relocate, send reply to 2414 North Purdum, Kokomo, Indiana 46901 Phone 317 457-3657. 8-71-1t

Help Wanted

Job Headquarters for all Radio and Television Engineers. Immediate openings exist in 9 western states and elsewhere for qualified engineer and technical personnel. All categories from trainees to experienced transmitter maintenance, chief, assistant chief, live color video maintenance and technical operations. Send us your complete resume now. The AMPS Agency, 11661 San Vicente Blvd., Suite 300, Los Angeles, Calif. 90049. Telephone: 213-820-2678. By Broadcasters — For Broadcasters. 11-68-tf

Help Wanted (Contd.)

Video Engineer wanted for large CATV local origination department. Reply Dept. 256, 1014 Wyandotte, Kansas City, Mo. 64105. 9-71-1t

WANTED: Experienced video technician. NORELCO PC-70 cameras, for Washington D.C. area commercial production center. 9-71-1t

Services

CRYSTAL & MONITOR SERVICE. Frequency change, repair or replacement of oven type broadcast crystals. Also frequency change and recalibration or repair of AM frequency monitors, and H-P FM monitors. Fast service at reasonable prices. 30 years experience! Call or write: Eidson Electronic Co. Box 96, Temple, Tx. 76501. Ph. 817 773-3901. 9-70-12t

VIDEO TAPE CLEANING SERVICE for 1" and 2" Video Tape. The Magnetek Video Tape Cleaner removes up to 70% of video dropout and winds tape with constant tension and a flat pack. Will not harm or deteriorate recording—preserves masters—extends tape life—head life—improves general operation. Rates and information from Television Equipment Associates, P. O. Box 1391, Bayview, New York 11709 (telephone: 516 628-8068). 8-71-2t

Training

To advance in electronics, knowledge and ability are required. Grantham offers correspondence and resident instruction, in depth, leading to the degree of Associate in Science in Electronics Engineering. G. I. Bill approved. Credit for previous training and experience allowed. Free Catalog Write: Dept. E-2, Grantham School of Electronics, 1505 N. Western Ave., Hollywood, California 90027. 6-67-tf

First phone through tape recorded lessons at home plus one week personal instruction in Washington, DC, Atlanta, Boston, Detroit, New Orleans, Minneapolis, Seattle, Denver, Portland, Los Angeles. Proven results. Our 17th year teaching FCC license courses. Bob Johnson Radio License Preparation, 1060D Duncan, Manhattan Beach, Calif. 90266. Phone 213-379-4461. 1-69-tf

IMMEDIATE OPENINGS: Qualify for any of the following positions: RCA CCTV Equipment, monochrome or color. Salesmen — TV Systems Engineers — Project Engineers — Supervisors — Managers — Maintenance Technicians — Video Engineers — to work either New York, Pennsylvania, New Jersey or California area. Write: RCA Rep. P. O. Box 268, New Hyde Park, New York 11040. 4-70-tf

Television Chief Engineer—23 years all phases—experienced 2500 MHz systems—Can train your staff. R. Willard, 21206 St. Francis, Farmington, Michigan 48024. 313-476-3863. 8-71-2t

GET COMPLETE DETAILS

about the products
advertised or described
in this issue.

●
Use Free Inquiry Card.

Be sure to include your
name and address

Shopping for lenses? Compare Canon!

Draw up a checklist that includes price, specifications and image brilliance, then start comparing catalogues. You'll probably come up with the Canon answer, like so many major camera producers—for broadcast 1" or 1 1/4" Plumbicon® or CCTV 1", 2/3" vidicon.

Stack these two Canon popularity favorites against anything else on the market and see what we mean.

The Canon TV Zoom Lens P17X30B2 has an impressive 1:2.5 relative aperture at focal length range (440-500mm), in spite of its 17X zoom ratio. At 30—440mm it's a remarkable 1:2.2, offering the same performance as our P10X20B, specially designed for maximum versatility with three different range extenders.

Both are ideal for a variety of situation, including dim lighting and open areas like field events.

Here are some other examples of the wide Canon line:

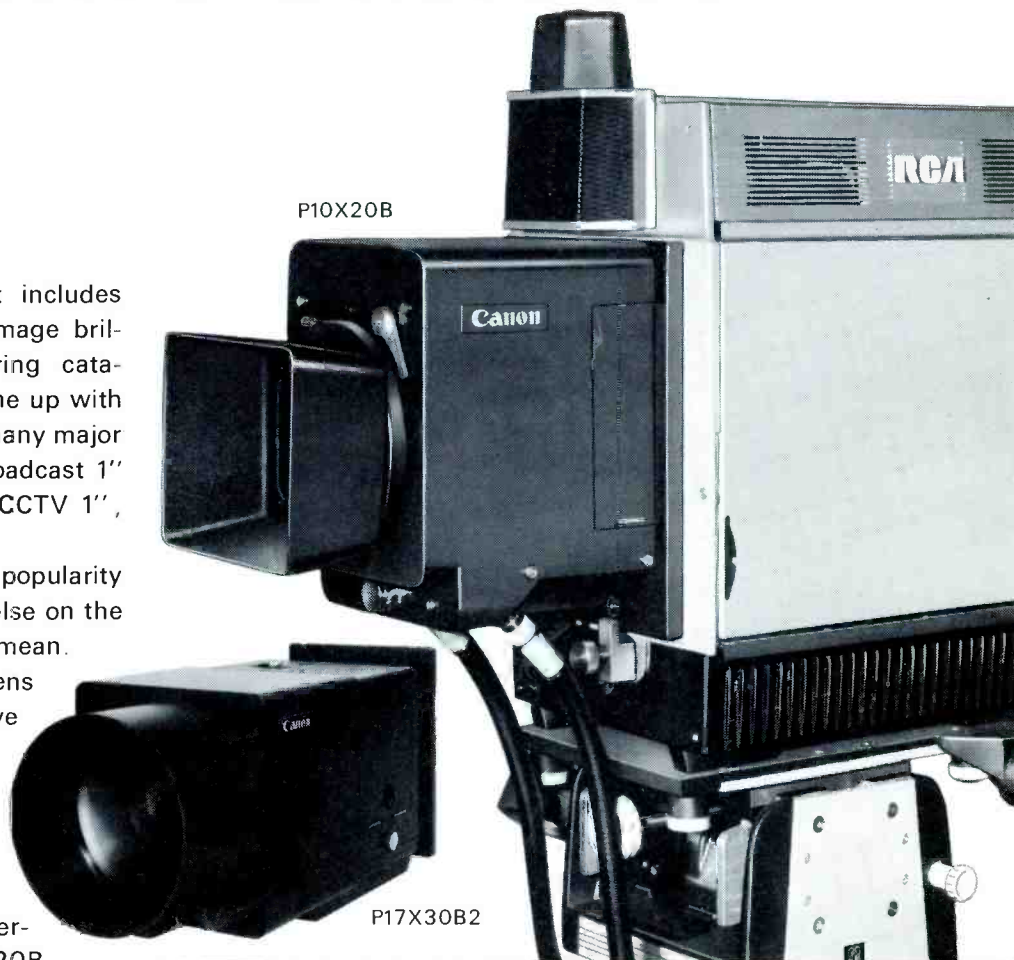

Manual				
	Name	Range of Focal Length	Zoom Ratio	Maximum Relative Aperture
1 1/4" Plumbicon	P17 x 30B2	30—500mm	1 : 17	F 2.2
	P10 x 20	20—200mm	1 : 10	F 2.2
1" Plumbicon	PV17 x 24B	24—400mm	1 : 17	F 1.8
	PV10 x 16	16—160mm	1 : 10	F 1.6
	PV10 x 15B	15—150mm	1 : 10	F 2.0
1" Vidicon	V10 x 15	15—150mm	1 : 10	F 2.8
	V6 x 16	16.9—95mm	1 : 6	F 2.0
	V5 x 20	20—100mm	1 : 5	F 2.5
	V4 x 25	25—100mm	1 : 4	F 1.8
2/3" Vidicon	J10 x 13	13—130mm	1 : 10	F 2.8
	J 6 x 13	13—76mm	1 : 6	F 1.9
	J 5 x 15	15—75mm	1 : 5	F 2.1
	J 4 x 12	12.5—50mm	1 : 4	F 1.8
Servorized/Motorized				
	Name	Range of Focal Length	Zoom Ratio	Maximum Relative Aperture
1 1/4" Plumbicon	P10 x 20B4	20—200mm	1 : 10	F 2.2
1" Vidicon	V10 x 15R (DC)	15—150mm	1 : 10	F 2.8
	V6 x 16R (AC/DC)	16.9—95mm	1 : 6	F 2.0
	V4 x 25R (AC/DC,EE)	25—100mm	1 : 4	F 2.5

® N. V. Philips Holland

CANON U.S.A., INC.: 64-10 Queens Blvd., Woodside, New York 11377, U.S.A. (Phone) 212-478-5600
 CANON U.S.A., INC.: 457 Fullerton Ave., Elmhurst, Illinois 60126, U.S.A. (Phone) 312-833-3070
 CANON OPTICS & BUSINESS MACHINES CO., INC.: 3113 Wilshire Blvd., Los Angeles, California 90005, U.S.A. (Phone) 213-384-3113
 CANON AMSTERDAM N.V.: Gebouw 70, Schiphol Oost, Holland
 CANON LATIN AMERICA, INC.: Apartado 7022, Panama 5, Panama
 CANON INC.: 9-9, Ginza 5-chome, Chuo-ku, Tokyo 104, Japan

Circle Number 2 on Reader Reply Card

Canon

Reach! We've got you covered.

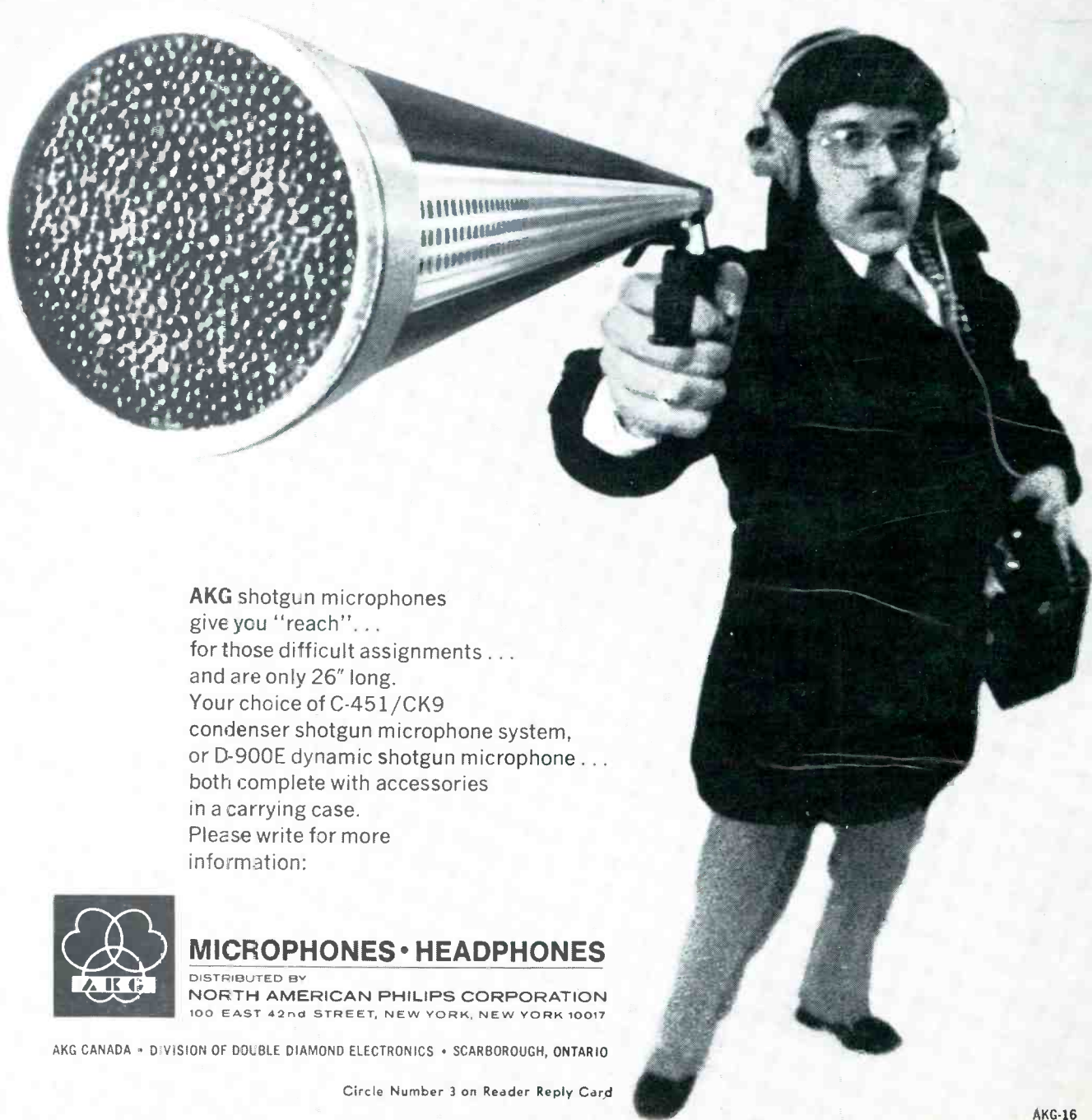

AKG shotgun microphones
give you "reach" . . .
for those difficult assignments . . .
and are only 26" long.
Your choice of C-451/CK9
condenser shotgun microphone system,
or D-900E dynamic shotgun microphone . . .
both complete with accessories
in a carrying case.
Please write for more
information:



MICROPHONES • HEADPHONES

DISTRIBUTED BY
NORTH AMERICAN PHILIPS CORPORATION
100 EAST 42nd STREET, NEW YORK, NEW YORK 10017

AKG CANADA • DIVISION OF DOUBLE DIAMOND ELECTRONICS • SCARBOROUGH, ONTARIO

Circle Number 3 on Reader Reply Card