



A HOWARD W. SAMS PUBLICATION



August, 1969/75 cents

# Broadcast Engineering

*the technical journal  
of the broadcast-  
communications industry*



LIVE FROM APOLLO 10



*The challenge  
of Apollo...*  
**REMOTES IN  
SPACE** Page 12



# ONE COMPANY

in the  
television industry  
offers a complete  
line of solid-state  
instrumentation for  
video analysis,  
simulation, processing  
and control.

## **RIKER VIDEO**

100 PARKWAY DRIVE SOUTH, HAUPPAUGE, L. I. NEW YORK 11787

A subsidiary of The RIKER MAXSON Corporation

Circle Number 1 on Reader Reply Card

# the Cohu compacts

TV accessories in the  
small, economy size

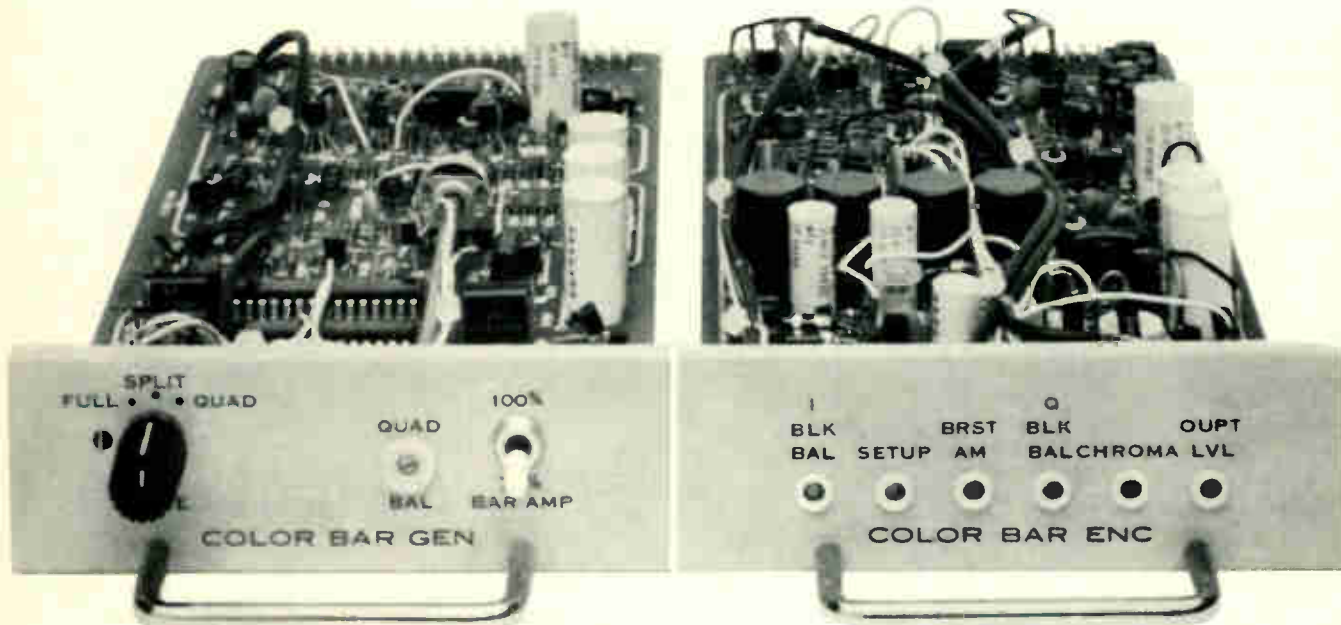

Cohu's Color Bar Generator facilitates adjustment of color monitors, encoders and other studio equipment requiring RGB I-Y-Q signals which meet EIA specifications. Video bar outputs are switchable from 100 to 75%. Special test pulses allow adjustment of quadrature without use of a vectorscope.

Cohu's Color Bar Encoder expands the basic usefulness of the color bar generator by adding an accurate and stable matrix and phasing circuit to provide encoded color bars which meet EIA RS-189 specifications. Television transmission characteristics can be checked with the encoded bar signals.

Compact, modular design of Cohu's 2610/2620 Accessory Series results from the use of integrated and solid-state circuits and provides reliable and versatile operation. Each compact is 1½" high by 4¾" wide and plugs into a frame which occupies only 1¾" of a standard 19" rack. In addition to the color bar generator and color bar encoder, other accessories include a drive generator, colorlock, black burst generator, dot • bar • crosshatch generator and background generator.

For specific data on each accessory, contact your local Cohu representative, or call Bob Boulio direct at 714-277-6700 in San Diego. Box 623. San Diego, California 92112. TWX 910-335-1244.

**COHU**  
ELECTRONICS, INC  
SAN DIEGO DIVISION

Circle Number 4 on Reader Reply Card



# Broadcast Engineering

The technical journal of the broadcast-communications industry

## *in this issue...*

- 
- 26 Remotes In Space.** Showing how space broadcasts are handled and how space may become the ultimate testing area for new products of the broadcast industry. **Ron Merrill.**
- 
- 32 Selecting Standby Generators.** A discussion of the factors involved in selecting a generator for specific uses. Includes a comparison of generator engine types. **Loren Mages.**
- 
- 39 An Emergency Power Changeover System.** Author gives details of a changeover system designed for operator convenience and to save loss of air time. **Fred Moore, John Morris**
- 
- 44 Building A Solid-State Chroma Keyer.** Covers operation and construction details for building a low-cost chroma keyer. **Robert Blauvelt.**
- 
- 48 A Portable Console For Booth And Studio Operations.** The story of how WBCO put together a portable console from used parts and scrap lumber. **Fred Clinger.**
- 
- 50 NCTA Convention Report.** Covering the 18th national convention of the National Cable Television Association in San Francisco.
- 
- 54 Building A Low Cost Failure Alarm.** Construction details of an amplifier that can be used as a carrier failure alarm. **Richard Hogsbro.**
- 

### ABOUT THE COVER

Cover pictures were shot from monitors at Houston Control during the Apollo 10 mission. For details on complex broadcasts from space, see article on page 26. Photos courtesy of CBS News and CBS Labs.

### DEPARTMENTS

Direct Current .....	4
Letters to the Editor .....	8
Industry News .....	12
Scanning the CATV	
Scope .....	18
Educational Broadcasting .....	24
Engineer's Exchange .....	56
New Products .....	58
Tech Data .....	60
People in the News .....	62
Advertisers Index .....	67
Classified Ads .....	68

### EDITORIAL

GEO. H. SEFEROVICH, Director  
 RONALD N. MERRELL, Editor  
 WENDALL BURNS, Field Editor  
 ROBERT A. JONES, Field Editor  
 HARRY A. ETKIN, CATV Editor  
 HOWARD T. HEAD, FCC Rules Editor  
 MIKE SMITH, Educational Editor  
 C. ANDREWS, Editorial Assistant  
 CARL BABCOKE, Technical Editor  
 DUDLEY ROSE, Art Director  
 LEE JOHNSON, Assistant Artist

### EDITORIAL ADVISORY BOARD

LES NELSON, Chairman  
 Howard W. Sams & Co., Indianapolis

### CIRCULATION

R. VINCENT WARD, Director  
 EVELYN ROGERS, Manager

### ADVERTISING

E. P. LANGAN, Director  
 R. JACK HANCOCK, Manager  
 S. F. WILSON, Production

### REGIONAL ADVERTISING SALES OFFICES

Indianapolis, Indiana 46208

ROY HENRY  
 HOWARD W. SAMS & CO., INC.  
 2469 E. 98th St.  
 Tele: 317/846-8561

New York, New York 10019

CHARLES C. HORNER  
 3 W. 57th St.  
 Tele: 212/688-6350

Los Angeles, California

JOHN D. GILLIES  
 3600 Wilshire Blvd., Suite 1510  
 Los Angeles, California 90005  
 Tele: 213/383-1552

Mission, Kansas 66208

JAKE STOCKWELL  
 C.H. Stockwell Co.  
 4916 W. 64th St.  
 Tele: 913/722-4417

London W. C. 2, England

JOHN ASHCRAFT & CO.  
 12 Bear Street  
 Leicester Square  
 Tele: 930-0525

Amsterdam C, Holland

JOHN ASHCRAFT & CO.  
 W.J.M. Sanders, Mgr.  
 for Benelux & Germany  
 Herengracht 365  
 Tele: 020-240908

Paris 5, France

JOHN ASHCRAFT & CO.  
 9 Rue Lagrange  
 ODEon 033-2087

Tokyo, Japan

INTERNATIONAL MEDIA  
 REPRESENTATIVES, LTD.  
 1, Shiba-Kotohiracho, Minato-ku  
 Tele: 502-0656



BROADCAST ENGINEERING is published monthly by Intertec Publishing Corp., 1014 Wyandotte Street, Kansas City, Missouri 64105. Telephone: 913/888-4664.

Subscription Prices: U.S.A. \$6.00, one year; \$10.00 two years; \$13.00 three years. Outside the U.S.A., add \$1.00 per year for postage. Single copies are 75 cents, back issues are \$1.00.

Controlled Circulation postage paid at Indianapolis, Indiana.



Robert E. Hertel, Publisher  
 Intertec Publishing Corp.  
 Subsidiary of Howard W. Sams & Co., Inc.





## Color it red, green or blue but above all— color it true!

The rhyme may be pretty corny, but take our word for it, the results you can expect with our new Model 538 Chromax Masking Processor aren't. Whether it's Campbell Soup Red, Oasis Blue, or even Lucky Strike Green, Chromax delivers true color fidelity from your telecine chain.

The new CBS Laboratories development electronically corrects color distortion caused by optical color filter overlap and the response characteristics of camera pick-up tubes. You get true color fidelity — automatically — without adding noise to the picture.

Come to think of it, you really don't have to take our word for anything. You can call us collect anytime (203) 327-2000 for details on how you can try one in your PE-240 chain. If you're not in too much of a hurry for a better color picture, then write the Professional Products Department at CBS Laboratories for more details on this Masking Processor and others now being designed.

PROFESSIONAL  
PRODUCTS  
**CBS LABORATORIES**  
Stamford, Connecticut 06905  
A Division of Columbia Broadcasting System, Inc.

Circle Number 5 on Reader Reply Card

# DIRECT CURRENT FROM D. C.

August, 1969

By Howard T. Head

## CATV Technical Standards Under Study

The Institute of Electrical and Electronics Engineers has established a Cable TV Task Force to develop proposed technical standards in the areas of measurement techniques, and mechanical and electrical requirements for cable TV systems. Items under study include frequency allocations, definitions of terms, noise in cable systems, and cable characteristics. Study groups have been established in these areas and are drafting proposals which will be considered by the Task Force at its next meeting in September, scheduled to coincide with the IEEE Broadcast Symposium in Washington.

The FCC has also formulated plans for the establishment of an industry-government group to study CATV technical standards to be applicable to systems subject to FCC regulations. This group is expected to include representatives of both the broadcasting and cable TV industries. Hopefully, meaningful standards will be agreed upon which will lessen the controversy concerning picture degradation when broadcast signals are carried on cable TV systems.

## FM Channel Assignment Proposals Must Be Specific

The Commission continues to receive and grant numerous petitions for the assignment of new FM broadcast channels and the reassignment of existing channels. Except in the simplest case where an unused channel may be simply "dropped in" without requiring any other changes, a showing must be made as to the overall effect on existing channel assignments provided by the Commission's table.

Continued on page 6

- + video
- + audio
- + cutbar
- + non-additive mixing
- + breakaway audio

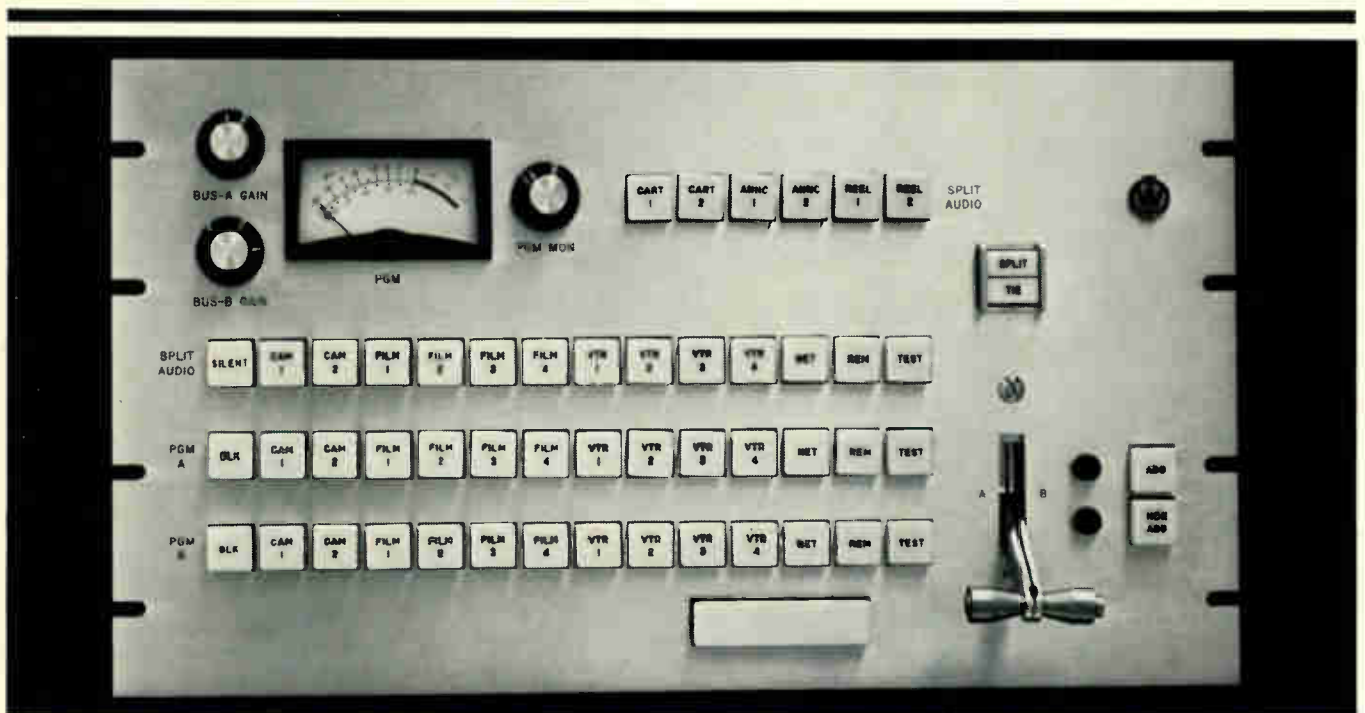

... add up to make the TS-211 Master Control Switcher one of the most versatile and economical, high quality switchers, ever!

- Ideal for master control and small studio applications.
- Vertical Interval — Solid State design.
- 14x2 video matrix.
- Automatically switched cutbar/mix mode.
- Video inputs may be all composite or all non-composite.
- Audio-follow-video, and split audio for 14 inputs.
- 6 auxiliary audio inputs for cartridge tape, announce, etc.
- DC remote audio level controls on panel.
- Compact rack space, only 14" high.
- Control panel, 19" x 10½", brushed aluminum finish, with illuminated pendar push button switches.
- Camera tallies on terminal block.



## WARD ELECTRONIC INDUSTRIES

142 CENTRAL AVE., CLARK, N. J. 07066 • (201) 382-3700

Circle Number 6 on Reader Reply Card

The Commission will consider whether making the proposed changes will have an adverse effect on future changes, both on the channels affected and the adjacent channels. In addition, a detailed study is required as to the creation or elimination of "white area", areas with no FM broadcast service. These studies must take into account not only operating stations, but the assumed future use of assignments provided by the Commission's table.

#### NAB Studying Proposals for Relaxed Operator Requirements

The National Association of Broadcasters plan to ask the Commission to relax the present operator requirements for television STL and remote pickup transmitters. The present rules require a first or second class operator at the control point of any TV STL or remote pickup transmitters. Plans being studied by the NAB include a proposal to permit operation by a third class operator.

In a recent case, the Commission permitted a VHF television station to be operated by holders of third-class radio-telephone licenses. This permission, granted for six months for a TV station in Gaum, took into account the fact that the licensee was having difficulty obtaining qualified personnel.

#### FM Stations Must Have Approved Stereo and SCA Monitors

The Commission's engineers are disturbed by an increasing number of reports which indicate that FM stations broadcasting in stereo or under an SCA are not employing modulation monitors meeting the requirements of the Technical Standards set forth in Section 73-253(a) of the Commission's Regulations.

All FM stations broadcasting in stereo or under an SCA are required to have type approved modulation monitors. An exception is provided in the case of a relatively small number of monitors in service prior to July 5, 1966, which do not fully meet the type approval requirements.

#### Short Circuits

The Commission has ordered hearings on a proposal by the TV stations in Charleston, S.C. to move to tall towers in an "antenna farm area", solely on the grounds of impact on UHF stations in the area . . . The Commission has waived the AM "freeze" to accept applications from six Class IV local channel stations proposing daytime power increases from 250 watts to 1 kw . . . The Commission has proposed numerous relaxations in the requirements for television translator identification, including the substitution of frequency shift keying for code wheels . . . A Chicago firm has proposed an identifying code on lines 21 through 23 and 260 through 262 at the beginning and ending of video tape and film transmissions for the purpose of verifying commercial carriage and establishing rights to residuals.

Howard T. Head





# *no credibility gap*

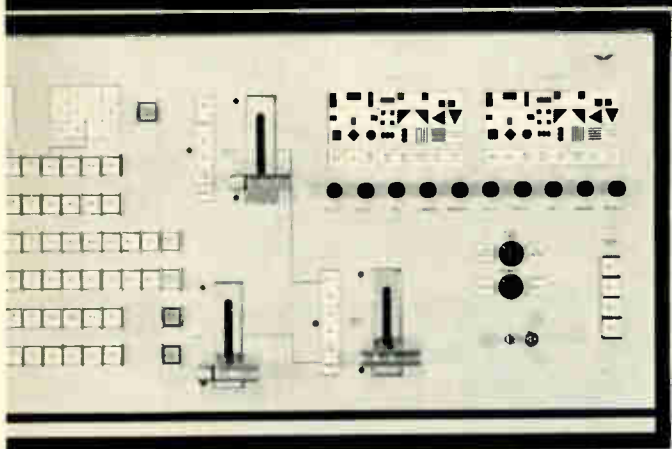

FIRST VIDEO SWITCHER  
TO USE DIGITAL  
COMPUTER TECHNIQUES

in a Vital

## **VERTICAL INTERVAL SWITCHER**

*it keeps performing and outperforming*

The Vital VIX-108 vertical interval switching system uses the latest state of the art electronics and is production-oriented in design. All electronic components such as effects, mixers, delays, proc. amps., etc. are designed and manufactured by Vital Industries, Inc. for total system responsibility. We custom-build a switching system to reflect your station's personality rather than govern your production expressions by the limitation of the equipment.

### FEATURES:

- Extensive use of integrated circuits with solid state cross points for long term stable performance.
- Unique electronic packaging uses minimum coax interconnections for any size system. Typical system cross-talk 60 DB down at 3.58 MHz.
- Production oriented design with automatic sync and clamping on all inputs for bounce-free switching of video with varying luminance levels.
- True composite additive/non-additive mixer with automatic inhibit of non-synchronous dissolves.
- Fade network color to network black burst with automatic inhibit.
- Fade to monochrome, maintain color burst or choose to drop color burst. Only one reshaped burst and constant level sync during all dissolves.
- Custom built production or routing switching with the latest state of the art accessories designed as an integrated system are all furnished by Vital Industries, Inc.

### OTHER VITAL PRODUCTS:

- VSE-2000 Special Effects
- VI-750 — VI-1000 Video Proc. Amp. with automated features.
- VI-500 Stab. Amp. with AGC.
- VSG-100 Digital Sync. Generator.
- Video and pulse distribution equipment.

Selecting the right switcher is Vital

GOOD ENGINEERING IS VITAL



*Call or write for systems engineering ideas and services*

**VITAL INDUSTRIES, INC.**

3614 SOUTHWEST ARCHER ROAD  
GAINESVILLE, FLORIDA 32601 - PHONE (904) 378-1581

Circle Number 7 on Reader Reply Card

# Stay up- tight!



AUTOMATE  
... WITH  
MINI-MATE

Station profit-ability depends on tight programming.

MINI-MATE lets your station stay "up-tight" while it takes the pressure off your personnel . . . allowing for smoother, more efficient programming. The new "mini-mate" automation system by Ampro lets you mix-and-match men to machines to meet your own specific station needs, thereby eliminating loss of even one second of precious air time.

The automated MINI-MATE multicartridge tape player provides you with programmed automatic sequencing. And, at the same time, it permits FULL MANUAL OPERATOR CONTROL . . . another new product from the innovators.



## Insta-tape

A DIVISION OF AMPRO CORP.  
ONE LIMEKILN PIKE, GLENSIDE, PA.  
(215) 886-1414

ASK ABOUT OUR LINE OF: Single and Multicartridge Equipment • Logger Printer System • Automation Systems • Cartridge Duplicator • Sound Effects System • Audio/Slide Projector

Circle Number 42 on Reader Reply Card

# LETTERS

## TO THE EDITOR

### New Column, Editor

Mike Smith has joined the **Broadcast Engineering** editorial staff as editor of our newly instituted column on non-commercial broadcasting.

Smith brings to BE readers a broadcast background that includes jobs with WTMJ-TV and the Delaware ETV Network. He has had specific assignments as VTR operator, camera operator, video switcher, audio engineer, studio technician, operations manager, assistant traffic manager and producer/director.



Mike Smith

A graduate of the Marquette University broadcasting sequence, Smith is employed by National Instructional Television in Bloomington, Indiana.

With this issue, Smith's column on Educational Broadcasting will become a permanent fixture. For more complete coverage in this area, we suggest that you send your news to: Mike Smith, 1442 Winfield Road, Bloomington, Indiana 47401.

### Keep It Clean

Dear Editor:

While of interest to the engineering staff, this letter is probably of most value to station management.

A flash of blue flame, a puff of smoke, and about four hours lost revenue has again emphasized the need for, and the value of, good engineering practice. As so often happens in small AM station operation, in the case above, the immediate operating problems had taken priority over engineering and its attendant cost. Then, as frequently is the course, the immediate savings were offset by lost revenue and strained customer relations.

Two lessons are to be learned from such occurrences. First, the employ of "short course" First Phones as the only source of engineering may seem cheaper, but eventually leads to major problems. Second, good engineering and cleanliness go hand in hand.

The first point has been covered by Mr. King and Mr. Tcimpidis in previous letters, so I will comment on the second—cleanliness.

The failure mentioned at the beginning involved a capacitor in the current dividing section of a directional phasor and occurred in an area of heavy dirt and dust buildup. While true that it cannot be proved dirt was the sole cause of the failure, no more than spotless gear can be guaranteed 100 percent breakdown free, and it is also true that well-kept equipment has a significantly lower failure rate.

So, station managers, seriously consider budgeting a salary adequate to hire a qualified engineer. And, when you perform your weekly major inspection, don't just look—clean!

**Morris Courtright, Jr.**  
Consulting Engineer  
San Jose, Calif.

### Impedance Mismatch

Dear Editor:

Here is a hint you may want to pass along to your readers.

If you have a number of police monitors in your news room connected to a single antenna, as we do at WQUA, you may have problems with reduced sensitivity due to antenna impedance mismatch. We solved our problem with a CATV type amplifier-splitter.

The Jerrold TAC-4 fit our needs. It provided a matching circuit from one antenna to four receivers, and has a 3db gain amplifier to boot. It greatly improved reception of police dispatchers as well as cars. This unit will work on the 150 or 450 MHz bands only.

**David L. Barquist, Engineer**  
WOUA Radio  
Moline, Illinois

(Continued on page 10)

IT ALWAYS SEEMS THAT 3M PROVIDES  
A COUPLE OF FEATURES  
THAT OTHER PRODUCTS DON'T

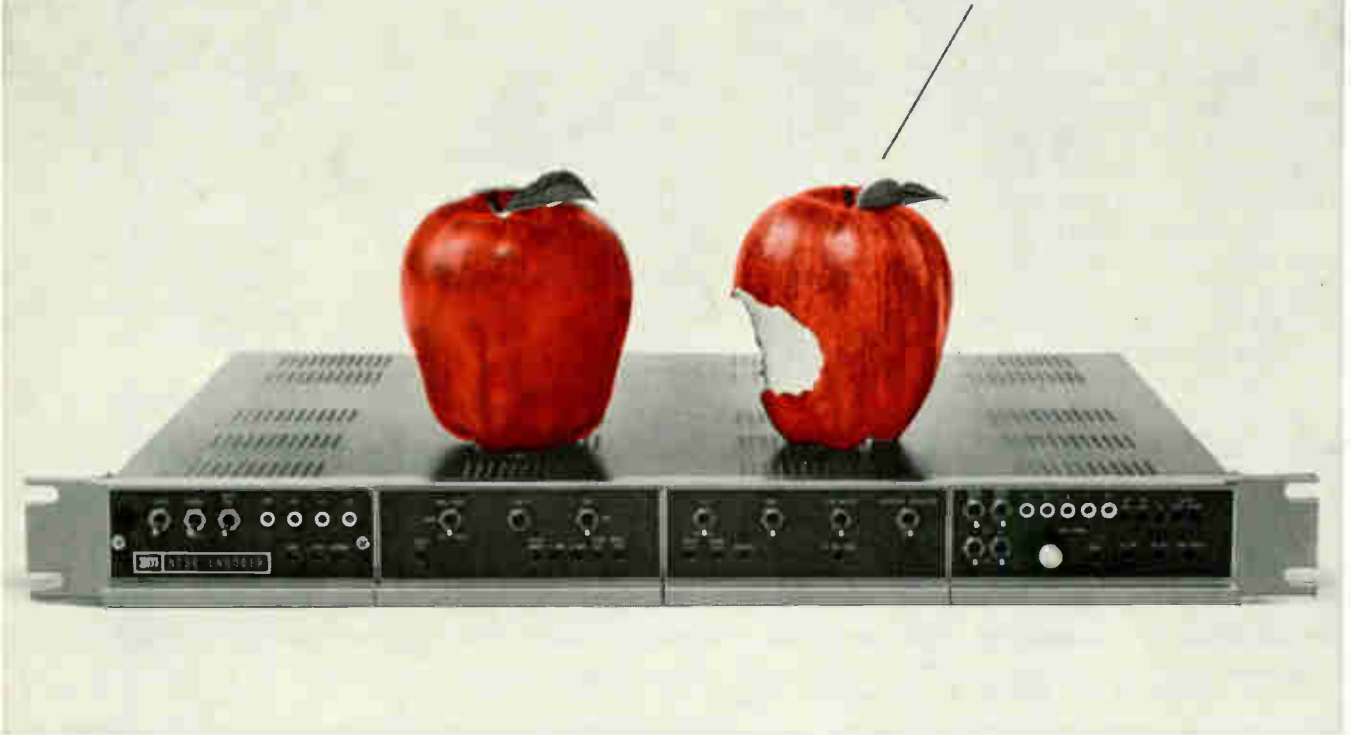

## TAKE THIS 3M COLOR VIDEO ENCODER, FOR EXAMPLE...

The 3M Brand Color Encoder has two unique features not obtainable elsewhere. The color bar generator is one. It is **completely** digital, not partially digital. Simplifies setting up procedures, and maintains accuracy between encoders. Affords precision without adjustments. With digital you **know** it is accurate.

Another unique fact is that the 3M Color Encoder considers smaller, lower cost cameras as well as the big expensive ones. A method of input clamping is used on video signals that eliminates low frequency hum and noise and other unwanted effects on the matrix. If you have access to an SMPTE color test film (hand test over colored bolts of cloth) you can determine whether your camera needs clamping. If it does, you're in clover with this 3M Encoder.

The 3M Color Encoder is compatible with all 3-tube and 4-tube cameras, meets all applicable FCC and EIA specs. There's also a 2F notch filter in the horizontal aperture equalizer to prevent noise beyond camera frequency response.

Luminance enhancement at the flick of a switch assures a sharp picture even if registration is not perfect. With a 4-tube camera, enhancement is from the luminance tube. The green channel is used for enhancement in 3-tube cameras. Switching is on the front panel, as are all operation and setup controls, including notch filter.

Overall, you'll find that the 3M Brand Color Encoder is equal or superior to anything on the market yet costs somewhat less. Could we send a brochure?

Mincom Division **3M**  
COMPANY

300 SOUTH LEWIS ROAD • CAMARILLO, CALIFORNIA 93010

Circle Number 8 on Reader Reply Card



## Signal Quality

Dear Editor:

The article by Patrick Finnegan on FM Proof of Performance Measurements in the May issue of **BROADCAST ENGINEERING** brought to mind a serious deficiency common to many stations.

Although in 1946, the concept of measurement of performance from microphone input terminals to transmitter output was the only practical method of evaluating the performance of a station, the definite advances in music reproduction clearly indicate the need for additional measurements. It seems absurd that a station operating a full-time automated schedule will activate a piece of equipment (dust covered, no doubt) once a year to provide a microphone input for system performance measurements.

What about the quality of the system used on the air? There are entirely too many stations polluting the air with hum-filled, muffled, wow-infested automation systems. I suspect that in some cases no one on the staff of the station is listen-

ing to the output of the machine for days at a time; yet such performance is not disclosed by required "Proof of Performance" measurements.

We at WIGS feel it is the moral obligation of a broadcaster to offer top quality reproduction of all program material. An investment of ten dollars in a test record can expose many problems. Do not assume that because your station sounds good on a particular radio that there is nothing wrong. Many stations are operating with improper RIAA compensation that gives extreme bass and treble response. This may sound better on a portable than the competition that is within 1 dB from 30 to 15,000 Hz, but it isn't right.

Modern solid-state equipment has eliminated much of the tedious routine maintenance that engineers used to perform. Rather than sitting back and relaxing, it pays to take the time to make performance checks more frequently. Once a month is hardly too often to make a complete series of measurements. Once the characteristics of the console VU meters are known, checking the frequency response of the en-

tire studio facilities from stylus to console output can be done in about one minute per turntable, with no test equipment required.

Noise level measurements are difficult to make accurately without additional equipment, but as a rough check, try listening to your air monitor. Noise that is more than 60db below 100 percent modulation should be virtually inaudible. A further check can be made by listening to the air monitor with all pots on the board closed. Under these conditions, advance the monitor level control until you hear some noise. Now open each pot on the board, one at a time, noting the change in the noise level. You should hear a slight increase in noise when a turntable or tape machine pot is opened; a defective preamp will make its presence known very quickly.

Although these checks can be performed in less than five minutes by a top-40 jock, they can bring about a continuing improvement in transmission quality.

**Roy W. Krause**  
**WIGS AM-FM**  
**Gouverneur, N.Y. 13642**

# TAPECASTER®

# T C M

**If you buy a tape cartridge machine without a SUPER-TORQUE hysteresis synchronous motor, you may be purchasing built-in obsolescence.**

The new SUPER-TORQUE hysteresis synchronous motor found in Tapecaster is the first significant improvement to be introduced to tape cartridge machines. Because of increased performance, Tapecaster obsolesces all other machines. That's why Tapecaster is the leader in professional tape cartridge equipment.



Box 662 — 12326 Wilkins Avenue  
Rockville, Maryland 20851  
Phone: 942-6666 Area code 301



Tapecaster  
now has  
**SUPER-TORQUE.**  
Why settle  
for less?

Circle Number 9 on Reader Reply Card



# Ben Levesque automated coffee breaks, lunch hours and vacations.

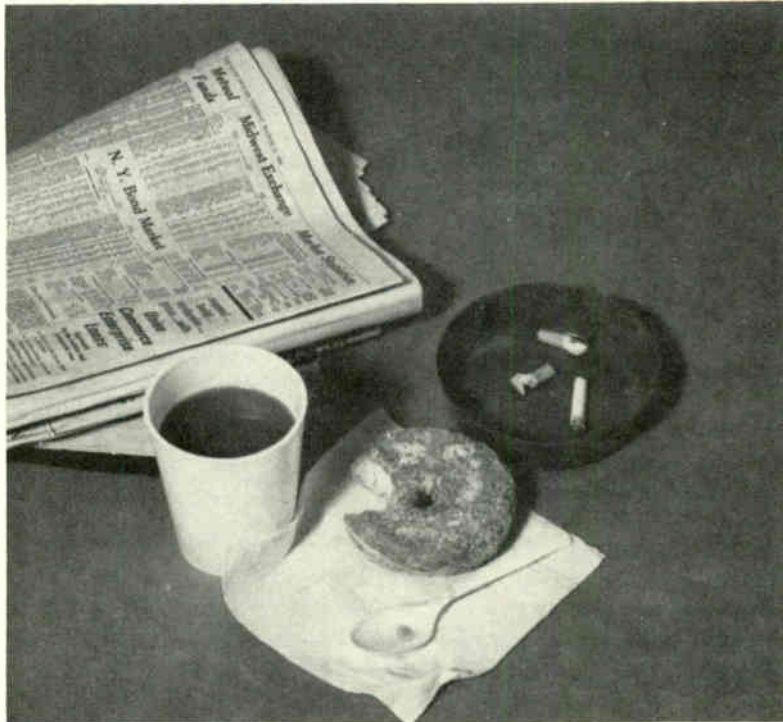

## He bought a Gates automatic tape control system.

"Our Gates Automatic Tape Control System does the work of two people. We just tell it what to do and when. It automates programs for 4, 8, 12 hours or more and joins the CBC Network," says Ben Levesque, President, CHRL-AM, Roberval, Quebec, Canada.

A Gates Automatic Tape Control System does the work of two people because it handles all commercial announcements. Switches from tape reels to live announcers to tape cartridges. Even logs time.

"And because it never takes a break, we get continuous programming, automatically," adds Ben, "and this saves us time and money."

Want details and costs for your particular programming?  
Write Gates, Automatic Tape Control Division, 1107 East Croxton Ave.,  
Bloomington, Illinois 61701, U.S.A. Or call (309) 829-7006.  
Ben Levesque did!

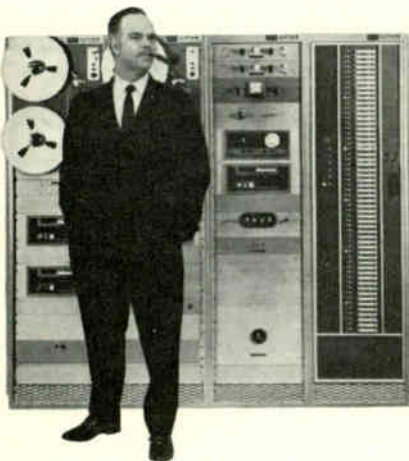

HARRIS  
INTERTYPE  
CORPORATION

# GATES

Automatic Tape Control Division

Circle Number 10 on Reader Reply Card

## Program Ready For SMPTE Meet

In an experimental program format designed to present topics of current interest and of applicability corresponding with recent developments in the motion-picture industry, a special Symposium on Super 8mm Production Techniques will be held during the last two days of the 106th Technical Conference and Equipment Exhibit of the Society of Motion Picture and Television Engineers, Sept. 28-Oct. 3, at the Century Plaza Hotel, Los Angeles.

SMPTE Vice-President for Motion-Picture Affairs and program chairman for the Symposium, Dr. Richard J. Goldberg, Houston Fearless Corp., Los Angeles, has announced that the program will consist mainly of tutorial papers specially invited for the two-day event. "We will attempt to define where we are, where we've been and where we are going," Dr. Goldberg said, "and in particular we want to thor-

oughly explore optical vs. magnetic track recording and loop vs. reel-to-reel concepts of presentation as well as other pertinent topics." Ten papers will be scheduled, some of which will be from abroad. Each paper will deal with a different aspect of super 8 production.

The traditional portion of the Conference program, Sept. 29-Oct. 1, will follow the usual format. Papers will be presented in six topic areas with over 50 papers expected for presentation in the areas of Laboratory Practices, Theater Presentation and Projection, Photo Sensitive Material for Motion Pictures and Television, Instrumentation and High-Speed Photography, Applications and Technology and Television. Program Chairman for this part of the Conference is Dr. Roderrick T. Ryan, Eastman Kodak Co., Hollywood.

## Pennsylvania Public TV Moves To Color Programs

The new seven-city Pennsylvania Public TV Network is leasing color studio equipment in a move to make color broadcasts available to viewers of all its stations.

The arrangement covers 12 TR-70 color video tape recorders and four TK-27 color TV film systems which, when added to existing equipment, will give each station the ability to originate color programs from either TV tape or film.

The broadcast equipment is being made available for a five-year period under a leasing program recently established by the RCA Commercial Electronic Systems Division.

David H. Leonard, the network's General Manager, said the colorization step was part of an interconnection plan which will link the stations by microwave on a permanent

basis. Currently, telephone company facilities are used to feed programs to the stations from WHYY-TV in Philadelphia.

## New FCC Hours

On June 30, 1969, the official hours of the Federal Communications Commission main offices at 1919 M Street, N.W., Washington, D.C., were changed to 8 a.m. to 4:30 p.m. Former hours were 8:30 to 5 daily.

The immediate Office of the Secretary and the Mail and Files branch are continuing to remain open until 5 p.m. to receive documents filed with the Commission. The Office of Information is also maintaining its 5 p.m. closing time.

District #24 Field Office at 1919 M Street and the Laboratory Division in Laurel, Maryland, are conforming to the new hours. Office hours of all other FCC field offices are determined by local requirements and are remaining unchanged.

## NAB To Celebrate Broadcasting's Golden Anniversary

The Public Relations Committee of the National Association of Broadcasters has approved a comprehensive program for celebrating the broadcasting industry's golden anniversary next year.

The 50th anniversary program, submitted to the NAB's Board of Directors at its June 16-20 meeting at NAB headquarters in Washington would be conducted on national, state and local levels.

Features would include on-air presentations by radio and television stations on the industry's past and future which emphasized its unmatched service to the public. Other highlights include participation by community and public service organizations.

The committee also decided to canvass the NAB membership for additional ideas. Chairman Don C. Dailey, vice-president of KGBX, Springfield, Mo., said the committee is anxious to see that widespread industry participation is reflected in the celebration.

During a day-long meeting at NAB headquarters, the committee also previewed a Careers in Broadcasting presentation featuring stereo sounds on tape. The tape-talk is designed for use by members in encouraging high school and college students to pursue careers in radio and TV. It is expected to be ready for distribution soon.

John M. Couric, NAB vice-president for public relations, outlined for the committee plans to record radio's own march—"Radio . . . the All-American Sound"—which would be based on a martial air first used during celebration of last year's National Radio Month.

In addition to Dailey, committee members present were John L. Vath, Sr., general manager of WSMB, New Orleans, La.; J. R. Livesay, president, WLBH, Mattoon, Ill.; Harold Essex, president, the WSJS Stations, Winston-Salem, N.C.; Al Ross, president, KNAB, Burlington, Colo.; A. Louis Read, president, WDSU (AM-FM-TV) New Orleans, La.

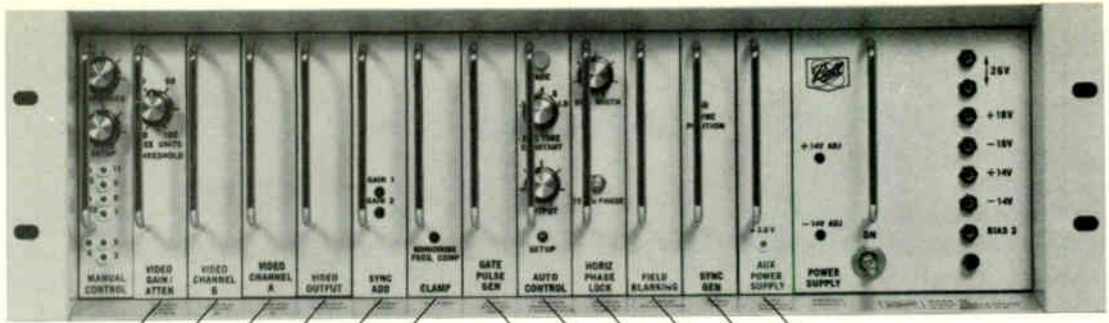

VIDEO GAIN/ATTEN  
 VIDEO CHAN B  
 VIDEO CHAN A  
 VIDEO OUTPUT  
 SYNC ADD  
 CLAMP

AUX POWER SUPPLY  
 SYNC GEN  
 FIELD BLANKING  
 HORIZ PHASE LOCK  
 CONTROL FUNCTION  
 GATE PULSE GEN

**now**  
**you can**  
**put your video**  
**system on automatic**  
**gain control for 30 days-**  
**FREE!**



The Mark 10-B Video Processing and AGC Amplifier corrects or minimizes "a baker's dozen" of common video disorders — color or black and white program signals—all in one reliable, easy-to-operate, all-solid-state package.

The Mark 10-B automatically corrects input video level variations of  $\pm 6$  dB. It also automatically adjusts to maintain constant set-up for input set-up variations of up to  $\pm 25$  IEEE units.

It suppresses up to 3 V p-p 60 Hz hum by 40 dB. It minimizes undershoots and overshoots without affecting chroma. It removes front and back porch noise. It corrects distorted timing information in the horizontal blanking interval.

The Mark 10-B continues to generate composite sync when input video signal is lost.

It replaces lost or distorted vertical sync and equalizing pulses. It reshapes distorted color burst to EIA standards. It permits independent chroma amplitude adjustment of  $\pm 3$  dB. It allows adjustment of  $\pm 12$  degrees of burst phase adjustment. And, that's saying a lot!

**We know that manufacturers' claims are often misleading. We also know that evaluations must be made in your system, by you, to be effective. So, we would like to loan you a Mark 10-B Amplifier for 30 days —FREE! Then you can check the amplifier's utility value and technical performance against your special problems.**

**For FREE use of a Mark 10-B Amplifier for 30 days, send your request — on your company letterhead — to Ball Brothers Research Corporation, Boulder, Colorado 80302.**

**Ball Brothers Research Corporation, Boulder, Colorado 80302**

Circle Number 11 on Reader Reply Card

BB9/5



# Anti Discrimination Rules Adopted By Commission

Rules to prohibit discrimination in employment practices by broadcast licensees (Docket 18244), have been adopted by the Federal Communications Commission. Based on the equal opportunity program requirements adopted by the Civil Service Commission for Government agencies, the new rules provide that "Equal opportunity in employment shall be afforded by all licensees or permittees of commercially or non-commercially operated standard, FM, television or international broadcast stations . . . to all qualified persons, and no person shall be discriminated against in employment because of race, color, religion, or national origin."

The new rules require each station to "establish, maintain and carry out a positive continuing program of specific practices designed to assure equal opportunity in every aspect of station employment policy and practice." The licensee will also be expected to review job structure and employment practices and "adopt positive recruitment, training, job design and other measures needed in order to insure genuine equality of opportunity . . ."

In an associated item, the Commission asked for comments on proposals which would require broadcasters with five or more full time employees to submit equal employment opportunity programs they are adopting for employment of Negroes, Orientals, American Indians and Americans with Spanish surnames. These programs would be filed with applications for new licenses and transfers. At renewal time, reports on the working of the programs would be submitted. Licensees would also be required to make annual statistical reports on minority group job participation. In this connection, the Commission submitted a proposed new form to be used for reporting purposes and asked for advice and suggestions on its makeup. It said the form would "permit inter-industry comparisons and should minimize industry burdens."

The action prohibiting discrimi-

nation in broadcast employment originated in an order issued on July 5, 1968. At that time, in response to a petition by the United Church of Christ, the Commission ruled that racial discrimination in broadcast employment was not consistent with operation in the public interest. The Commission decided at the time, in consideration of its limited resources, to carry out its anti-discrimination policy on the basis of individual complaints. It also instituted a rule-making proceeding to examine the question of whether the non-discrimination requirement should be made part of the Rules, whether licensees should be required to demonstrate compliance and whether notices of equal employment rights should be posted and included on employment applications.

Comments received from broadcasters generally opposed Commission action as unnecessary, beyond FCC authority or duplicative of the work of other agencies. Comments by civil rights groups, churches and similar organizations opposed the complaint-oriented procedure and urged adoption of a rule and requirements for affirmative compliance showings.

The Commission, responding to the broadcasters' comments, stated that "a substantial case has been made that because of the relationship of the Government of the United States to broadcast stations, the Commission has a constitutional duty to assure equal employment opportunity." It said that the "importance and urgency" of the situation required implementation of non-discrimination practices wherever possible and that its actions would complement the activities of other government agencies. The Commission stressed that it had "an independent responsibility to effectuate such a strong national policy in broadcasting," and that it did not need to wait for action by "some other forum or tribunal."

In response to comments that "spurious" or "inconsequential" discrimination complaints could be

used to delay consideration of applications, the Commission referred to its earlier opinion, which stated that only "substantial issues of discrimination" would be referred to other agencies and that it might make its own investigations instead of referring complaints. It emphasized that "no licensee need fear undue delay arising out of the referral procedure," but also stated that it did not believe an application should be granted "where a serious qualification question remains unresolved." It said renewal would not be "appropriate where there is a pattern of substantial failure to accord equal employment opportunities."

## Antenna Designer Loses Two Stations In Huge Blaze

Clarence C. Moore, originator of the Cubical Quad Antenna, announced the loss by fire of two of his commercial radio stations the night of May 12th in Elkhart, Indiana. All broadcasting equipment for both WCMR—AM and WXAX-FM was totally destroyed, and the beautiful three-year-old structure was extensively damaged by smoke and severe heat. Cause of the blaze is unknown.

With loaned equipment, WCMR set up a temporary studio at Crown International, a manufacturing plant of which Moore is the president, and was back on the air the next morning. Both stations are now broadcasting from interim mobile home facilities at the transmitting site, where rebuilding is expected to be completed in three months.

The 5KW AM station was established in 1956 by Moore, and the 20KW FM in 1963. Since then, numerous improvements in power, coverage and programming have been achieved. In addition, WFWR, a new 1KW AM station, was established two years ago in Fort Wayne, Indiana, soon to be joined by a sister FM station.

Moore is presently working with missionary radio station HCJB of Quito, Ecuador, and Trans World Radio of Bonaire, consulting on the construction of high-gain rotary Quad antennas of his own design, to increase their world-wide radio service.



# RCA Vidicons ...

## First in broadcasting, CCTV, space

RCA invented the Vidicon. So it's only natural that more TV cameras use RCA Vidicons than any other kind. More broadcast cameras. More CCTV units. Now they take off in NASA and ESSA project satellites where there's no margin for error.

Think of that when you replace Vidicons next time. Ask your RCA Industrial Tube Distributor how you can step up with RCA. Step up resolution with separately-connected mesh electrode types. Step up sensitivity by selecting Type II photoconductor types. And step up over-all performance with RCA Vidicons—made in the same plant, with the techniques, controls, and quality assurance checks used to make the Vidicons that gave us our first close-up look at the moon.

RCA Electronic Components | Harrison, N. J. | 07029



### Use This Short Form Step-Up Selector

For Color Film Pick-up	For B&W Film Pick-up	For Live Color In RCA TK42 Cameras
RCA-7038 RCA-7735B* RCA-8134/V *† } in RCA RCA-8480/V † } TK27 RCA-8507A*† RCA-8572A†	RCA-7038 RCA-7735B* RCA-8480† RCA-8507A*† RCA-8572A†	RCA-4493*† RCA-4494*† RCA-4495*†

NOTES: †types feature separate mesh electrode construction  
\*indicates Type II photoconductor

And, RCA has many other types for industrial, commercial, and educational closed circuit TV—such as 4478, 7262A, 7735, 7735A, 8134, and 8573A.



Join the Big Phone-In. Call your RCA Industrial Tube Distributor. He supplies dependable RCA Vidicons—plus technical data on the newly revised catalog CAM-700A.



## Lee Sees Need For Flexibility In Spectrum Allocations

FCC Commissioner Robert E. Lee called for flexibility on spectrum allocations and cautioned against attempts to "attach dollar values" to broadcast stations, in an address on "Spectrum Utilization" delivered before the Federal Communications Bar Second Annual Seminar in Williamsburg, Virginia.

Commissioner Lee said, "I suspect that there are those who represent the broadcast industry and members of the industry itself, who think reallocations of TV broadcast space can't happen and, even if it does happen, they as individual licensees will not be adversely affected. I wouldn't be too sure."

"The proposed rulemaking," he continued, "in Docket 18261 and 18262 looks toward allocating a sizeable portion of UHF spectrum to the land mobile service. While we proposed sharing channels 14-20, the proponents of land mobile expansion have requested exclusive use of these bands. Whether or not

I, or any other defender of the UHF-TV band is unsympathetic to such claims on the spectrum, is immaterial to the threat to preempt a sizeable portion of the spectrum and is appealing to those who are intrigued with the police requirements and oblivious to the mismanagement that has caused our current crisis."

## NAB Agrees With FCC On Monitors

The National Association of Broadcasters agrees with the Federal Communications Commission's proposal to require type-approved phase monitors at AM radio stations operating with directional antennas, but has asked that they not be mandatory for existing stations before 1975.

The Association said it is "concerned over the impact premature implementation of such a requirement would have upon existing stations" which now have phase monitors which are not type-approved.

In a June filing, Douglas A. Anello, NAB general counsel, said "any rule which would require the immediate replacement of all existing monitors would have a serious economic impact upon the industry

which may not be justified at this time."

Therefore, Anello said, "all monitors presently being used to determine the phase relationship of the various currents in a directional antenna system be 'grandfathered' and that the continued use of such instruments be authorized until 1975, at which time all stations would be required to comply with the type-approval standards of the new rule."

The NAB general counsel also said it is difficult to envision the FCC's establishment of a blanket tolerance figure because of the varying design conditions of directional antennas.

Therefore, he said, the two degree tolerance specified by the Commission in its proposal should be deleted, and if any tolerance figure is adopted, it should be established "on a case-by-case basis and made a part of the instrument of authorization."

Anello said that if the Commission does adopt the proposed two degree blanket tolerance figure, it should merely be a yardstick.

---

**Send Your Industry News  
To Broadcast Engineering  
For Better Coverage**

---

## New Style Background Gives TV Studio Acoustical Effect

Management of Station KFVS-TV, Cape Girardeau, Mo., is the innovator of a new style studio background which combines an interestingly textured, colorful appearance and at the same time has a sound-absorbing, acoustical effect. Adjoining triangles, outlined by the framing lumber at back, were painted in different colors, and the backs of the openwork Masonite Filigree panels are covered with fiberglass insulation.

The acoustical screen, one of which is shown here, is duplicated in floor-to-ceiling coverage of the studio back wall for its acoustical effect. The backgrounds were designed and built by KFVS-Television. The announcer's desk was custom-built using sides and front of Masonite Royalcote panels in a woodgrained finish.



# DUAL CHANNEL PERFORMANCE...

## at single channel price

Collins' new 212V-1 Audio Console, with its 8 mixers and 2 metered program channels, increases a station's capability for high fidelity AM and FM, TV broadcasting, and program control.

Though priced at only \$2600, the new unit carries Collins' reputation for quality, design, performance and styling. Also, the 212V-1 is easily maintained. A ringed front panel tilts forward, allowing easy visual inspection or removal of all components.

Find out how Collins' 212V-1 Audio Console lets you combine economy with solid-state reliability. Contact a Collins representative or write Broadcast Communication Division Collins Radio Company, Dallas, Texas 75207.

COMMUNICATION / COMPUTATION / CONTROL





# SCANNING THE CATV SCOPE

By Harry Etkin

## Task Force Report Released

The Task Telecommunications Force report has been released without endorsement by President Nixon. Although the report studied the entire telecommunications complex, it specifically recommended a relaxation of the FCC's restrictive CATV policies and described CATV as the "most promising" means of promoting "localism and diversity."

NCTA president Frederick W. Ford praised the White House for making the report public. "This unbiased report," he said, "clearly shows that the American people are being short-changed in television programming because of excess regulation by the Federal Communications Commission."

Future policy problems, and basic regulatory patterns, relating to CATV would continue to be set by the FCC, although under Congressional guidance local franchising authorities also have a continuing role to play. The Task Force Report also saw a need for an executive branch agency to share the responsibility of the regulatory process. Its role would be allocation of the spectrum, making policy recommendations and studies, and intervening in proceedings.

The Report was prepared under the Johnson administration but had been under wraps since its submission to the President last December.

### Rostow's Comments

Eugene V. Rostow, Chairman of the Task Force, in a speech before the American Management Association, said, "While I realize that copies of the Report, in plain wrappers, are hawked at the corner of Wall and Broad Streets for 50 cents apiece or less, this famous—or notorious—document, which, according to law at least, is still shielded

from profane view by the doctrine of Executive Privilege."

The unregulated development of CATV could, in theory, threaten the viability of some over-the-air broadcasting, especially in the UHF class. While this fear is exaggerated, the possibility raises a legitimate question for Congress and for the FCC to keep under careful review.

Rostow stated that the FCC has taken action which seems inconsistent with its professed goal in instituting its Proposed Inquiry into CATV Rules. Expressing a positive interest in the future development of CATV, it has ordered what is for all practical purposes a standstill in the industry for an indefinite period while Congress considers new legislation in the copyright field and the Commission studies the situation in the light of the Supreme Court decisions.

## CATV Editor Knows Industry Inside-Out

For those of you who do not know our CATV editor, Harry Etkin, here is an abbreviated biography. (His full background story would take up several pages.)

Everyone around the field, even those at some distance from it, recognize names like Westinghouse and RCA. Harry Etkin has worked for them. But it takes oldtimers to accurately recall Atwater Kent and the Brooklyn Edison Company. Harry worked with them, too.

For more than 25 years Etkin was affiliated with the Department of the Navy in such positions as Inspector of Engineering material, Senior Inspector of Radio, and Technical Director. In 1965, he was designated as chief of the RCA Moorestown Section under the cognizance of the Department of Defense.

## Experts Discuss CATV Before Subcommittee

The role of CATV in the political arena, in the economy, and in education was discussed before the Subcommittee.

The important role of CATV in Congressional elections was the theme of Rep. Edgar F. Foreman's (R-N.M.) testimony to his fellow congressmen.

Dr. Harold Barnett, Professor of Economics at Washington University, St. Louis, Mo., and co-author of "A Proposal for Wired City Television," gave the Subcommittee an economist's view of CATV. He told them that an increase in low-cost TV channels would eventually insure a significant increase in program numbers and diversity. He stated that CATV will provide channels to public bodies at no cost, originate low-cost programs, and show local people and activities in order to increase and maintain at a high level the number of subscribers.

Dr. Harold Wigren, educational television consultant for the National Educational Association, and president of the Joint Council on Educational Telecommunications, made clear to the Congressmen that educational interests were determined to reserve 20% of present and future CATV systems.

And beyond working as a consultant and writer, Etkin has worked for radio stations WIP and WCAM. His life has spanned electronic generations from monster "bottles" to solid-state components and from early radio to CATV.

In 1924 he was engaged in the design of the peanut tube diode detector, the replaceable 110 volt AC filament receiving vacuum tube, and an attempt to build a gas discharge vacuum tube. Staying on top of the times, Etkin converted radio station WQAL-FM to full time stereo and changed over their high voltage plate supply to solid-state rectifiers. That was about five years ago.

Because his tenure in electronics includes innovations in design and interest in progress, Harry Etkin is well suited to the task of bringing CATV into focus in **Broadcast Engineering**.





STANTON 681EE CAL. BRATION STANDARD

**"The tracking was excellent and distinctly better in this respect than any other cartridge we have tested....The frequency response of the Stanton 681EE was the flattest of the cartridges tested, within  $\pm 1$  dB over most of the audio range."**

From the laboratory tests of eleven cartridges, conducted by Julian D. Hirsch and Gladden B. Houck, as reported in *HiFi/Stereo Review*, July, 1968.

To anyone not familiar with the Stanton 681, this might seem to be an extraordinary statement. But to anyone else, such as professional engineers, these results simply confirm what they already know.

Your own 681 will perform exactly the same as the one tested by Hirsch-Houck. That is a guarantee. Every 681 is tested and measured against the laboratory standard for frequency response, channel separation, output, etc. The results are written by hand on the specifications enclosed with every 681.

You don't have to be a professional to hear the difference a Stanton 681 will make in your system, especially with the "Longhair" brush that provides the clean grooves so essential for flawless tracking and clear reproduction.

The 681EE, with elliptical stylus, is \$60.00. The 681T, at \$75.00, includes both an elliptical stylus (for your records) and an interchangeable conical stylus (for anyone else's records). For free literature, write to Stanton Magnetics, Inc., Plainview, L.I., N.Y.



Circle Number 13 on Reader Reply Card

You never heard it So good

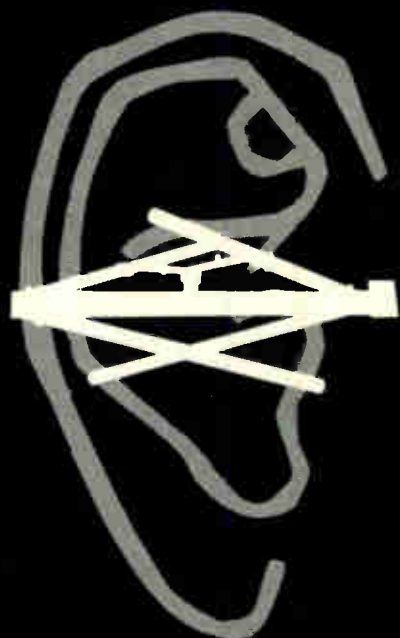

SO SAYS  
**KCTC**  
STEREO 96

SACRAMENTO'S  
LEADING FM STATION

"Before, we had signal, now, we have signal and *sok!* Jampro's new circular polarized FM antenna has given us terrific listenership increases. Formerly weak signal areas have become good and solid. The best part of all is the entire change-over to Jampro circular polarization was relatively inexpensive. In fact, it's already paying for itself. Our performance surveys proves it, and so does the last PULSE."

Dean Cull, Station Manager

**PROVE IT TO YOURSELF**

Call or write Jampro for complete information and details.

**JAMPRO**

ANTENNA COMPANY

A DIVISION OF COMPUTER EQUIPMENT CORP.

6939 Power Int. Road

Sacramento, California 95828

Circle Number 14 on Reader Reply Card

## FCC Adopts New CATV Procedures

Interim procedures have been adopted by the Federal Communications Commission to simplify and expedite CATV processing while the CATV rule making and inquiry in Docket 18397 is pending. The Commission also issued a Further Notice of Proposed Rule Making revising its original proposals in several areas. It asked for comments on zone protection for construction permits for a limited time, changes in listings in five markets and methods for determining the radius of a zone, among other issues.

The Commission action was in response to petitions for reconsideration and other relief filed by trade associations, CATV operators and broadcasters. The interim procedures, incorporated in a public notice, state that in proceedings involving CATV service which would be consistent with the proposed rules, the Commission will endeavor to act on the merits of a case within 60 days after reply findings have been filed. The Commission will also afford parties an opportunity to file supplementary pleadings on the merits where processing is deferred while the rule making is pending. Broadcasters challenging CATV service as inconsistent with the proposed rules need not address the full merits, unless the only issue is "leap-frogging" (by-passing a closer signal of the same type) or consistency is claimed by another party. Broadcasters failing to treat the merits in a close case, do so at their own risk, the Commission said.

The Commission also clarified the nature of the interim processing procedures. It declined to consider at this time, before consideration of comments, requests for substantive modification of the proposed rules, and denied petitions in this respect.

In its rule making notice, the Commission proposed to accord limited zone protection to a station not on the air but authorized by construction permit. The protection extends for a period of eighteen months from the CP grant on February 15, 1970—whichever is later.

The Commission also proposed to change the listings in five markets,

and to attribute additional communities to the listed community and 12 other markets for purposes of proposed Section 74.1107(c) only. Oakland, for example, would then be included in the listing of San Francisco market signals that could not be carried in another major market. The San Francisco market, however, would have only one 35 mile zone, measured from San Francisco. Comments were requested on remedial action in some unusual situations.

To clear up confusion about zones, the Commission proposed to modify definitions to make clear that every TV station would have a specified zone, whether "major television market" (the communities named in the top 100 listing in proposed Section 74.1107(a) or "smaller television market" (all others). As originally proposed, zones were to be measured from central post office locations. The National Cable Television Association pointed out, however, that there is no readily available list in terms of geographic coordinates to compute distances. It suggested using U. S. Department of Commerce Special Publication No. 238, **Air-Line Distances Between Cities in the United States**, which lists 492 cities, and it prepared a list based on post office locations for cities not included. The Commission proposed to include this reference list as a new section 74.1108 of the Rules, adopting the calculation methods of NCTA. Communities with authorized stations not on the air would be added. The Commission also proposed that the zone would extend from the community of license, rather than the committees of assignment in Section 73.606.

The Commission also proposed a revision in the original proposals for smaller TV markets (below the top 100 but within 35 miles of a TV station). It suggested that for a system located within 35 miles only of an educational TV station and outside the 35 mile zone of any commercial station, the zone restriction on distant signals apply only to distant educational signals.

## NAB Says CATV May Complement Industry

At a recent hearing of the House Commerce Subcommittee on Communications, the National Association of Broadcasters said that the unregulated growth of cable television would lead inevitably to "a system of CATV-PAY TV which will cause a significant decline in the amount and quality of free radio and television broadcasting available to the American public."

The NAB definitely supports regulatory controls over CATV by the FCC, but in testimony before the Subcommittee, stated that the NAB is not interested in abandonment of CATV, but rather in its incorporation "as a complement to the finest system of mass communications media ever developed." The chief concerns are the importation of distant television signals, CATV program originations, and the leasing of CATV channels on a carrier basis.

## Recent Action On CATV Requests

The Federal Communications Commission recently denied CATV operators the specific requested waivers pertaining to the following sections:

1. Section 74.1103 (a)—Carriage requirements.  
Section 74.1103 (d)—Single channel requirements.  
Section 74.1103 (e)—Program Exclusivity—14 denied waiver requests for the foregoing sections.
2. Section 74.1107—Distant Signal authorization—three denied waiver requests.

## Ford Accuses FCC Of 'Harassing' Cable

Frederick W. Ford, president of the NCTA accused the FCC of harassing the industry and asked Congress to transfer regulation to the Commerce Department.

Ford said that the FCC had made one proposal after another and one ruling after another to restrict, harass and contain cable television. Ford testified before a House Interstate and Foreign Commerce Subcommittee studying legislation on regulating cable television.

# DISCOVER *the* SUPERIOR ALL SOLID STATE AM FREQUENCY MONITOR

*Naturally* FROM WILKINSON!



- ★ Triac Controlled Crystal Oven
- ★ Instantaneous Operation — No Warm-up Time
- ★ Requires only 5 1/4 inches of Rack Space
- ★ I. C. Regulated Solid State Power Supply
- ★ Self Testing from Front Panel

**MODEL TAMF-1A**  
FCC No. 158

For complete details write:

**WILKINSON**  
**ELECTRONICS, INC.**

1937 MacDADE BLVD.  
WOODLYN, PA. 19094

PHONE (215) 874-5236 874-5237

Circle Number 15 on Reader Reply Card

# DISCOVER *the* SUPERIOR ALL SOLID STATE AM MODULATION MONITOR

*Naturally* FROM WILKINSON!



- FCC Type Approval No. 156
- Wideband 500 KHz to 26.1 MHz
- Uses Latest IC Innovations
- New as Tomorrow . . . Reliable as Forever

**MODEL TAMM-1A**

For complete details write:

**WILKINSON**  
**ELECTRONICS, INC.**

1937 MacDADE BLVD.  
WOODLYN, PA. 19094

PHONE (215) 874-5236 874-5237

Circle Number 16 on Reader Reply Card



**we've uncovered  
two conrac  
color  
monitors**

**with  
a lot**

**in common.**

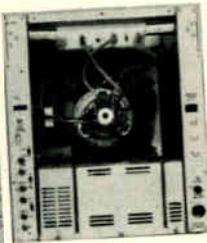
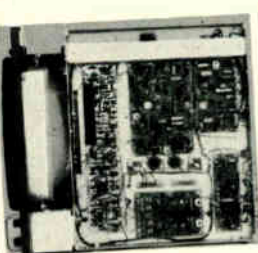
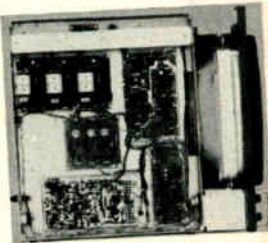

Conrac Model  
RHA 19 - \$2700

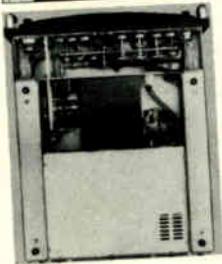

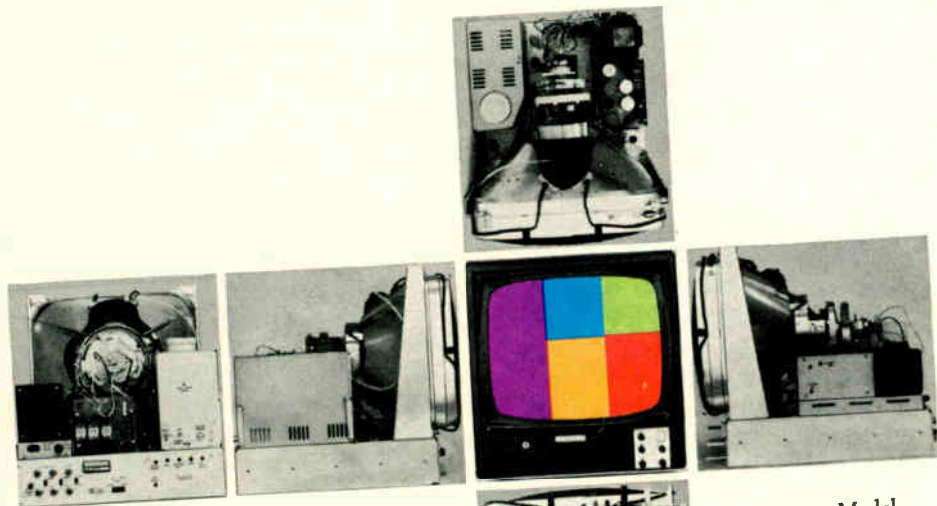

Conrac Model  
KHA 19 - \$1200  
(\$75 more for 25")

Both are solid state units with characteristic Conrac quality. Both are ideal for their respective applications. Both are designed for the professional broadcast engineer. Yet one sells for \$1200 and the other \$2700. With their covers off you can see why at a glance. Inside, where it counts, there is a difference between them of 25 diodes, 113 transistors and 10 circuit boards. That difference is design refinement which makes one a high-quality professional unit well suited for rigid broadcast-studio requirements, and the other an excellent utility monitor for less stringent audience or client-room use. The two complement each other. It all depends upon what you want to do. Compare the photos above. You'll see what we mean.

**CONRAC**

600 No. Rimsdale Ave. • Covina, California 91722 • (213) 966-3511

Circle Number 17 on Reader Reply Card

# EDUCATIONAL BROADCASTING

Looking Inside Non-Commercial Broadcasting

By Mike Smith

## Kentucky ETV Network Dedicated

The Kentucky ETV Network (KET) was formally dedicated in May and is now finalizing preparations for the coming school year.

Twelve RCA transmitters with interconnection facilities leased from South Central Bell Telephone Company blanket the state with instructional and public television programs daily. The 12 transmitters are scattered throughout the state along five major legs.

The western leg serves Louisville, Owensboro, Bowling Green and Paducah with four of the transmitters. The northern leg serves the area between Lexington and Covington with three transmitters. Two additional legs provide signals to

the northeastern and southeastern portions of the state.

A key feature of the network plan is the fifth leg that will connect all of the higher education centers by closed circuit. There will be regional production studios at each of the state college and university facilities, and output from these studios can be fed via the closed circuit to the network control center for network distribution. Completion of the return connections from all six regional production studios is scheduled for fall 1970.

The network nerve center is a \$3 million, 35,000 square foot plant which houses two production

studios, an art department, conference and screening rooms and offices. The center is color capable for both production and distribution, with one studio set up exclusively for color and the other for monochrome. The network nerves are designed to permit as many as four open circuit and four closed circuit transmissions and three incoming signals to be handled at once.

## NAB Will Support Educational Bill

The National Association of Broadcasters will support proposed legislation which would aid the construction of educational radio and television stations and the Corporation for Public Broadcasting.

NAB president Vincent T. Wasilewski, in a statement for the record filed with the House Subcommittee on Communications, said non-commercial educational broadcasting "has a great potential for service through development of a broad range of cultural, informational programs for the most varied needs and interests of the public."

## WHERE WILL THE "PHANTOM" PROVE ITS AMAZING POWER NEXT?



In your studio, perhaps?

The "Phantom" can't resist the challenge of a multi-microphone power supply problem. It may look like a simple plug-in printed circuit card and frame. But it's actually the most unique compatible central powering unit in the world.

Why is it called the "Phantom"? Because you install it in one place, anywhere at all, and it simultaneously powers up to 40 Neumann FET-80 microphones wherever they may be—miraculously, *without* changing existing microphone outlets or wiring.

Plug any other kind or make of microphone into the same outlets and—the "Phantom" vanishes.

Why buy a new \$84 power supply each time you add two microphones? Buy the \$84 "Phantom" just *once*, and don't buy another until you buy your 41st Neumann!

Write to Dept. BE-8  
for free brochure with  
complete information.

**GOTHAM**  
AUDIO CORPORATION  
2 West 46th Street, New York, N.Y. 10036 (212) CO 5-4111  
1710 N. LaBrea Ave., Hollywood, Ca 90046 (213) 874-4444  
In Canada: J-Mar Electronics Ltd.



Circle Number 30 on Reader Reply Card

## SPOTMASTER Solid-State Portable REMOTE AMPLIFIER



The RA-4CA is a lightweight, four-channel portable mixer amplifier specifically designed for remote broadcast or auxiliary studio use. It is completely self-contained and operates from either AC or batteries (switching automatically to battery operation if AC power fails); runs as long as 200 hours on low-cost "D" cells. It offers four microphone channels with master gain and P.A. feed, all controlled from the front panel. Lightweight construction (just 11 pounds with batteries), a convenient carrying handle and a snap-on front cover mean the RA-4CA can be easily set up to operate anywhere. For further information, please write or call today:

*Spotmaster*  
**BROADCAST ELECTRONICS, INC.**  
8810 Brookville Road  
Silver Spring, Maryland 20910  
Area Code 301 • 588-4983

BROADCAST ENGINEERING



## Programs Selected For National ETS/PS

The Program Selection Committee of the Educational Television Stations Program Service recently selected 72 new public TV programs for its national ETS/PS distribution. The Committee also created a new sub-committee to handle program selection matters requiring immediate action for national interconnection.

The ETS Program Service is the national public TV library and exchange service. It is headquartered at Indiana University, here. Its programs are distributed to the nation's 180 ETV stations by video tape, film, and national interconnection. Current usage averages several ETS/PS programs weekly per station.

The 72 new programs selected were chosen from 33 program series reviewed, representing 222 programs, and submitted by 24 stations. The addition of these new programs will bring to approxi-

mately 1,370, the total number of different programs available from ETS/PS.

The Program Selection Committee is appointed by the ETS Board of Directors. The committee consists of chairman Bruce Beale, program director, WHY-Y-WUHY, Philadelphia-Wilmington; Wayne Bundy, program manager, KNME-TV, Albuquerque; John Felton, program director, WTHS, Miami; Zoel Parenteau, general manager, KCSD,

Kansas City; Jack Schlaefle program director, KRMA-TV, Denver; Sam Silberman, program director, WOED, Pittsburgh; C. P. Zimmerman, program director, KUHT, Houston; Duane Straub, director of programming, ETS/PS, and Holt Riddleberger, associate director, ETS, Washington, D. C. Also attending this meeting was David Stuart, director of special projects, Corporation for Public Broadcasting, Washington, D. C.

## National Convention Set For November

The 45th annual convention of the National Association of Educational Broadcasters, which will focus on educational broadcasting and social responsibility, has been set for November 9-12 at the Sheraton Park Hotel, Washington, D.C. The meeting is expected to draw more than 5000 delegates from the non-commercial broadcasting industry as well as representatives from allied fields.

The Sheraton Park's Exhibition Hall has been sold out to broadcasting equipment manufacturers,

according to Frank Masters, president of Trade Associates, Inc., who manages the exhibit area for the NAEB. The Hall is the largest hotel facility of its kind in the country.

A comprehensive series of meetings is in the planning stage at the NAEB. On Sunday, November 9, the NAEB Board will hold its semi-annual meeting. A number of committee meetings, regional network meetings and related association meetings have also been scheduled for that day. The opening reception will be held that evening.

## 2x2 slide projectors for the television film chain

by **SELECTROSLIDE**

Spindler & Sauppe offers the broadest line of slide projectors for the television industry . . . seven models in all. There's one to fit your requirements exactly: color or monochrome; uniplex or multiplex; forward or reverse actuation; sequential or random access operation; 16-slide to 96-slide capacity. All built to the highest professional standards. Write for complete information.



spindler & sauppe inc.  
1329 grand central  
avenue / glendale  
california / 91201



**SPECTRUM 32:** The most advanced slide projector available. 32 slide, for color or monochrome chains. Many exclusive features.



**MODEL 332:** Workhorse of the industry, now improved. 32 slide, for monochrome chains. Model 322: single turret for 16 slides, monochrome or color.



**MODEL SLX-TV:** 96 slide, random access. **SLS-TV:** 48 slide, random access. **SLD-TV:** 96 slide, sequential. **SL-TV:** 48 slide, sequential. **SLR-TV:** 48 slide, sequential forward/reverse. All for monochrome or color chains.

Circle Number 19 on Reader Reply Card

# Remotes in space

## THE CHALLENGE OF APOLLO

By Ron Merrell

■ There was a time when portable cameras met their initial test on the floor of a convention hall or in coverage of football games and other special events. But now that the Apollo series has about reached its apex, space remotes have provided another challenging setting. And it is this setting that might well provide even greater progress in television remote broadcasting.

In the beginning, television remotes from space were not very well accepted by the astronauts. Prior to the Apollo 7 mission, Commander Walter Schirra indicated that he didn't like the idea of flight controllers looking over his shoulder. Then too, there was some dispute as to the picture quality of the RCA camera they were asked to use. The crew insisted that the picture wasn't good, and that they didn't want to take anything along that was not perfect.

During the Apollo 7 mission, it was obvious to ground controllers and the viewing public that the picture quality was good. In fact, the crew hammed it up during broadcasts as have other crews since.

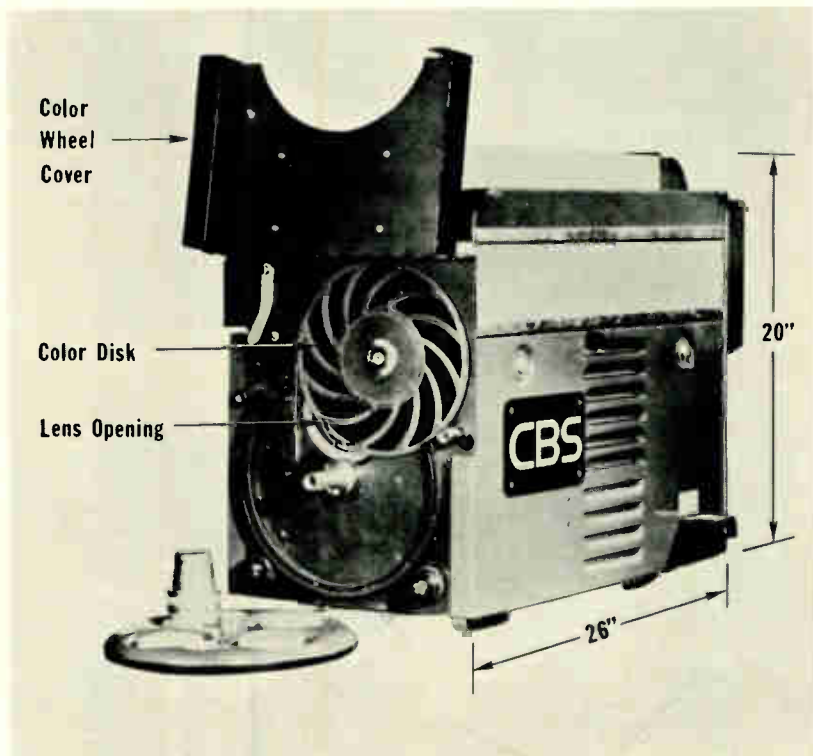

Fig. 1 Weighing more than 100 pounds, the 1950 field sequential system camera used a 7.5-inch rotating disc.



Fig. 2 Color camera used in the capsule during the Apollo 10 mission.



Fig. 3 Camera designed by Westinghouse for use on the surface of the moon.



That particular camera consumed little more than six watts and used a 500 Hz bandwidth. It operated at 10 frames a second using 325 scan lines. It weighed about 4½ pounds.

### The Camera

The Apollo 10 mission hauled a color camera into space that represented the past, present and future. The system which beamed the world's first successful color television 28 years ago was used to relay man's first color telecast from near the moon's surface to a global television audience.

The tiny field sequential camera, built by Westinghouse, uses a 3.5-inch disk with the primary colors red, green and blue, which rotates in a sequential motion to produce images in their original hues. This system was first developed by Dr. Peter C. Goldmark, president of CBS Labs.

This camera is about 17 inches long, including a variable focus lens. The lens' focal length is capable of ranging from 12.5 mm to 75 mm and can provide a diagonal field of view that can vary from 9 to 54 de-

grees. There is a range of aperture stops from f2.2 to f22. The focus range is from 20 inches to infinity.

A small television monitor was also in use. It weighed less than four pounds and had a viewing screen that measured 2 x 2 inches. The use of the zoom lens and the television monitor were space firsts.

Unfortunately, this color camera was not designed for use in the vacuum of space. It works only in the space capsule. The black and white lunar camera could be used with an outboard color disk rotated by hand in front of the lens. However, the camera would need to be mounted on a tripod and rotation would likely be clumsy at best.

Backing up the spacecraft cameras is an electronic system that "peps up" signals to improve pictures on home sets. Known as the image enhancer, the unit employs techniques used in high resolution space photography, examines color signals as they are transmitted and adjusts the details of the picture.

### The Lunar Camera

The primary objective of the

Apollo lunar television camera is to provide real-time, or live, television pictures of the moon mission that can be viewed by scientists and the public on standard television receivers. Excellent resolution and motion rendition of the pictures in both lunar day and lunar night are necessary so that the moon's surface can be observed in detail and with sufficient clarity to enable differentiation of objectives and textures.

Another objective is the observation of the astronauts. This will enable Mission Control to obtain operational information for the mission and future missions.

The Westinghouse-designed lunar television camera was designed for use on the first lunar exploration mission. The camera should continue to transmit during the entire mission including the lunar exploration and round trip moon flights.

At launch, the camera is mounted in the Apollo command module in a position to view the astronauts. Once the spacecraft is in earth orbit, the camera will be relocated to observe both the instruments and the activities of the astronauts. If all systems are working, the portable camera will view the earth and moon through the spacecraft ports.

The camera's primary scanning rate is 10 frames per second with 320 scan lines. It has a second mode of operation in which the scanning rate is 0.625 frame per second. This extremely slow scanning rate enables more detailed observation of the moon's features by scientists on earth. A tripod must be used to support the camera for use in this mode since even minute movement would cause smear in the picture.

During the mission, signals produced by the camera in the 10-frame-rate mode are transmitted to an earth station, converted to the standard television frame rate and then supplied to earthbound scientists and the television networks.

When the spacecraft reaches its lunar orbit, the camera is transferred to the LEM (Lunar Excursion Module) and stored during the LEM's descent to the lunar surface.

The essentials of portability, and consequently light weight and compactness, and reliability dictated certain design constraints. These were: low power requirement, limited

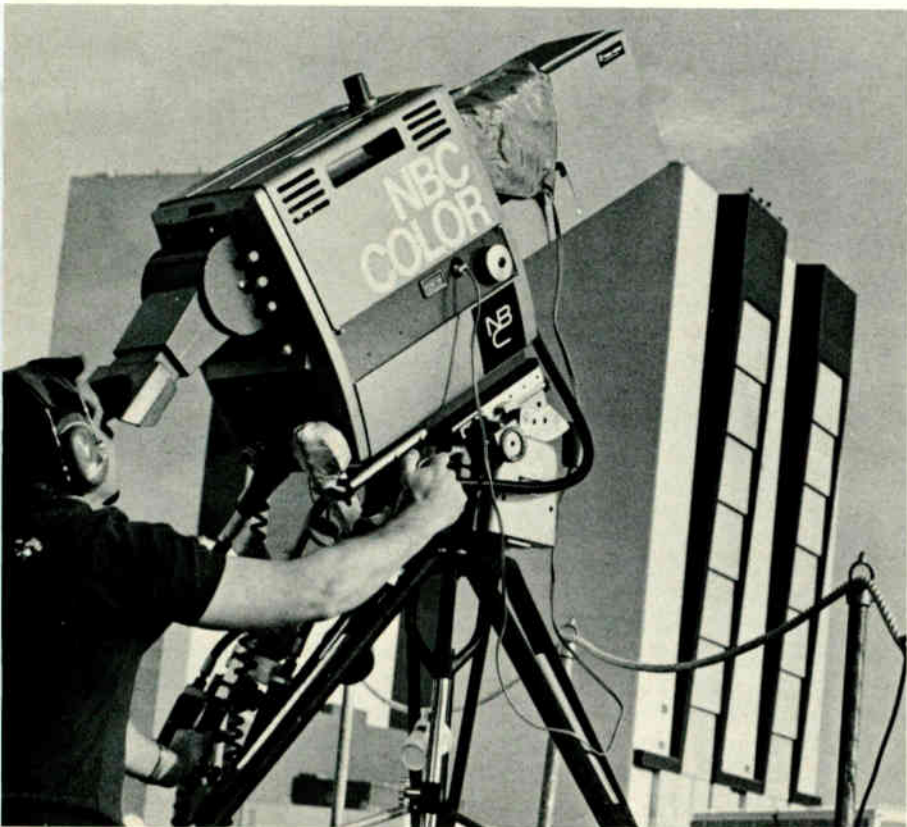

Fig. 4 NBC camera tracks Apollo mission during blastoff.



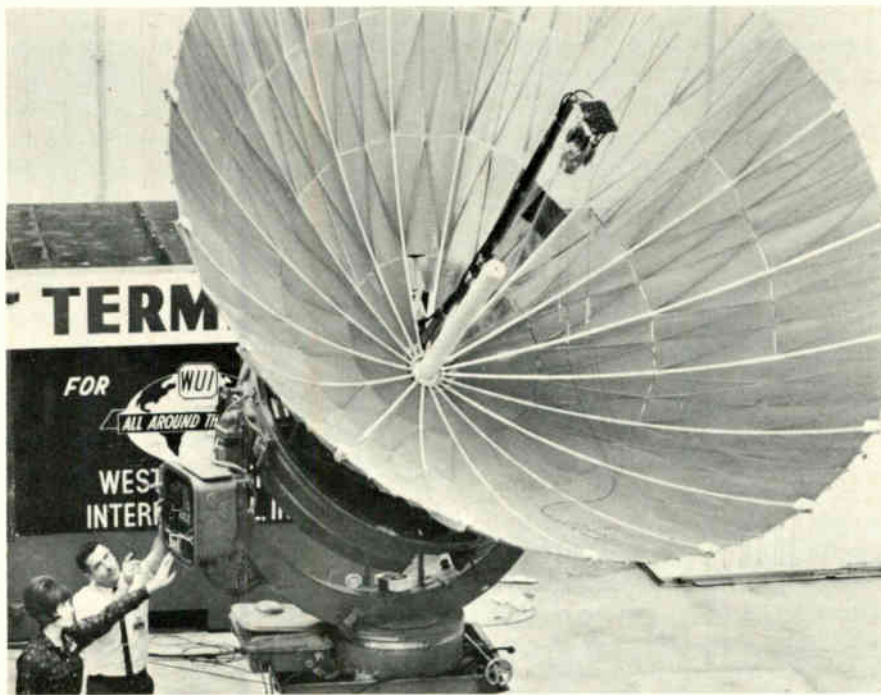

Fig. 5 Electronic sharpshooter portable antenna tracks Apollo during splashdown.

bandwidth, simplicity of operation and a 35-year mean-time-between-failures (MTBF) requirement. Other strict requirements were necessitated by the design environmental conditions such as +250 degrees F ambient lunar temperature; 10-14 millimeters of mercury pressure (a hard vacuum); micrometeoroid and radiation bombardment; the possibility of lunar dust; conditions in the LEM and the command module such as vibration, shock, 100 percent salt-contaminated humidity, and 100 percent oxygen; and operation in both lunar day and lunar night.

The heart of the camera is the secondary electron conduction (SEC) image sensor. This type of tube was invented and developed by the Westinghouse Research Laboratories. It has the wide dynamic range needed to obtain good pictures at the very low light levels of earthshine during lunar night. The tube, in addition, has a good storage capability, particularly important because of the slow scan rate.

#### Apollo Transmission

Looking down from Apollo missions to the home TV sets is a complicated process. One route that could be used to bring in Apollo space broadcasts begins with a COMSAT earth station located near Perth, Australia.

The earth station there can relay the Apollo broadcasts to the U.S. via the new Intelsat III satellite stationed over the Pacific. In this country, it could be received by the newly operational earth station near Jamesburg, California. The Jamesburg station would send it on to NASA headquarters in Houston.

A much more simple route would be to send the signals from Apollo to the Goldstone NASA earth station in California on down to Houston, but there are many factors involved in the decision to use a particular route.

Once in Houston, the signal is sent to New York via land microwave for distribution. Sending the signal to countries in the Pacific area would mean sending it by phone lines back to the station in Jamesburg. From there, it would be sent to an Intelsat satellite over the Pacific and back down where it could be received by stations in Hawaii, Japan, Australia, Thailand and the Philippines.

Distribution to Europe and South America is accomplished by piping the signal from New York to an earth station in Etam, West Virginia. From there it is relayed to an Intelsat III satellite over the Atlantic. Stations in South America that could receive the signal include Argentina, Brazil, Chile, Panama,

Peru and Puerto Rico.

In Europe, the signal will be received by a single station representing the European Broadcasting Union (EBU). The EBU will then distribute the signal to stations throughout Europe via land lines.

#### TV Museum

With each Apollo flight goes a list of space firsts. But seldom are the "firsts" on the ground achievements mentioned. One of the last places you'd expect to see a "first" would be around a museum, but it happened.

As launch crews went through their countdown for Apollo 10 and 11, NBC network crews had their own countdown in the Planetarium of the Denver Museum of Natural History. NBC was preparing to cover Apollo flights by televising them from earth as a backup for their crews at the launch site.

When not viewing the voyage into space, the telescope-television system focused on other astronomical phenomena including flares and other activity on the sun. Complementing broadcasts from the Apollo spacecraft, the planetarium system offered close-ups of the moon's surface before the astronauts reached it. The system can magnify craters and convolutions and pinpoint possible landing areas.

The planetarium's system was designed by curator Donald Lunetta and by Robert Bacon, an official of Telemation, Inc. The original equipment was supplied and installed by Telemation Colorado, Inc.

#### Covering Splashdowns

Before the Apollo program, earlier splashdowns and recoveries were limited to black-and-white television coverage using a giant, 30-foot wide, rigid paraboloid antenna mounted on a massive pedestal bolted to the ship's deck.

The size of such installations on aircraft carrier flight decks emphasized the need to employ a smaller, highly portable antenna which would accommodate itself more easily to the operational requirements of a Navy recovery force vessel.

For the first Apollo mission, Western Union International, Inc.,—working with General Electric—accepted a challenge from the major

U.S. television networks to provide the world's first, live color TV coverage from an aircraft carrier. Available time called for the design, development and installation of a complete, compact shipborne earth terminal system within a deadline of only 16 days. Such a system would normally require about three months to complete.

GE's space systems organization assigned a team of 25 engineers, technicians and other support personnel to create the unique, first-of-its kind system. It involved building a six-kilowatt traveling wave tube TV transmitter, video processing equipment, power supplies, two-way audio transmission equipment with related control, monitoring and test equipment, a 15-foot diameter paraboloid antenna of a space-related folding design, a newly-designed gyro-stabilized pedestal and monopulse tracking antenna system, and an air-inflated protective antenna "bubble" 20 feet high and 22 feet in diameter.

Western Union International's communications requirements were received on September 20th, 1968.

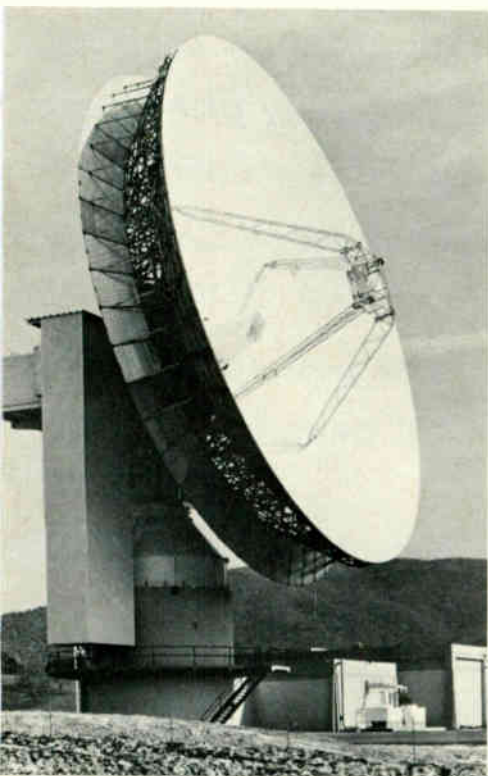

Fig. 6 Giant parabolic dish antenna located near Jamesburg designed to handle space communications.

By October 7th, 1968, the hardware for the satellite telecommunication terminal system was installed on the aircraft carrier USS ESSEX before it departed for the Apollo 7 primary recovery area.

The successful color TV coverage of the Apollo 7 splashdown and recovery on October 22nd was repeated on December 27th, 1968 when Apollo 8 returned from its historic orbital flight around the moon. Live color television pictures of Apollo 9's return from space were transmitted from the recovery ship, using an electronic system developed for TV network coverage of the Apollo program by General Electric for Western Union International, Inc.

WUI and GE aimed a color TV signal beam, 8/10ths of a degree wide, toward a pinpoint in space where a communications satellite ATS-3 hovers in synchronous orbit 22,500 miles above the equator. A 15-foot diameter, parabolic antenna directed the pencil-thin beam toward the satellite while the recovery ship maneuvered, pitched and rolled on station at the splashdown area.

Color television signals from the shipboard system were transmitted skyward with an average of 6 kilowatts or as much as 14,000 kilowatts of power as required by the satellite. The satellite's transponders relayed the signals back to a permanent earth station.

Shipboard color TV coverage involves an average of five color cameras, each linked by cable to an enclosed van housing a conventional network-type television studio. The down-range producer operating this equipment is either CBS, NBC or ABC, with each TV network taking the assignment on a rotation basis. Color TV signals produced by the shipboard crew are supplied to all three networks on a pool basis.

The conventional color TV signals from the down-range network studio van located on the hanger deck are carried by coaxial cable up to the nearby portable terminal van on the flight deck. The van, about 11 feet long, 7 feet wide and 7 feet high, houses the necessary equipment for transmission of the color TV signal via FM modulation of the nominal 6 GHz uplink transmitter signal to the satellite.

For the Apollo 9 splashdown, NASA's station at Rosman, North Carolina, was used. A microwave link carried the signals to a TV network pool studio in New York City. Recovery of Apollo missions can be viewed simultaneously on the three major U.S. television networks, as well as Western Europe's TV stations, those of the Far East and other parts of the world with a second satellite transmission. The re-transmission to overseas points goes, with Comsat's cooperation, to U.S. earth stations and satellites of the Intelsat global network.

The time lag between actual event happenings and display on U.S. television screens is an estimated  $\frac{1}{4}$  of a second with an additional  $\frac{1}{4}$  of a second for re-transmission abroad.

Permanent earth stations in the world's existing earth-to-satellite-to-earth system rely on huge 85-foot diameter parabolic "dish" antennas mounted on 10-story high pedestals. Some 22 of these stations are now in operation around the world, furnishing intercontinental television capabilities to key population areas. But many other areas are without such live TV service, limiting television news coverage to tape and film recordings.

Western Union International is identified as the "uplink" carrier on all Apollo splashdown and recovery missions. The "downlink" carrier may be any one of the five international carriers using the satellite, since each carrier in rotation is assigned all satellite "downlink" transmissions for one week at a time.

### Conclusion

The old field sequential system lives on . . . but only for a while. Other systems will be used in space. And once we better understand the confines of space broadcasting, so will the heavens offer what may prove to be the ultimate testing area. Trouble is, when marveling over craters and moon rubble, we forget the space remote support system of the ATS-III satellites, COMSAT, the NASA network and the antenna that tracks the capsule while rolling in heavy seas.

Between missions someday, we may come to understand that we have inadvertently developed the format for future earth remotes. □



# We just widened the generation gap.

It's the significant lag between "our own things" and the also rans.

The first time we did it (a couple of years ago) we came up with the first all-digital sync generator with a near perfect time base stability (4 nsec typical) and pulse jitter spec. Nobody else can touch it.

Now we've added a color encoder with all plug-in boards and built-in color bars. It has balanced modulators using linear IC's. Provisions for contours out of green. The works.

And still another first. A television programmer with magnetic disc memory. Whether used for CATV non-duplication or station automation, it gives maximum capacity and flexibility at minimum cost. Like 200 events on 26 output channels with one second resolution. Repeats to 7 days. (So you could say 1400 event capability.) Greatest reliability. Simplest operation.

Then we have a broadcast electronic character generator. Format is 14 lines of 40 characters each. Raster (not dot) generation assures



TSG-2000 series  
All-digital sync generator



TCE-1600 video color encoder

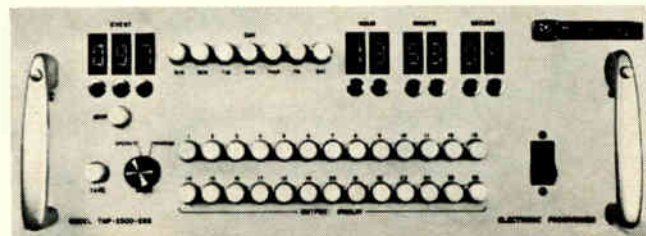

TMP-2500 programmer



# (again)

maximum readability even on poorest home receivers.

And EIA video test generators. Multiburst. Stairstep.  $\text{Sin}^2$ —Window. Modulated 20T pulse. Color bar. All EIA/NTSC/VIT compatible. Can be used singly or with new electronic sequential switcher to provide single continuously switched output. Has it all.

Now for the sleeper. A Vertical Interval Data Transmission system. Transmits data from news wires or character generator over existing video channels. Provides VIT keying pulse and adds test signals. Works with any video, local or remote. Encodes. Decodes. Erases. 8 line selection. So many applications it boggles the mind.

These are just some of our new ideas. If you take time to check the parameters of the products we've mentioned, you'll find no one else is half as close in concept. Let alone delivery.

So when you want some real help with your ideas, talk to TeleMation.



TELEMATION, INC.  
*The Total System Supplier*  
2275 South West Temple  
Salt Lake City, Utah 84115  
(801) 486-7564



TCG-1440 Character generator

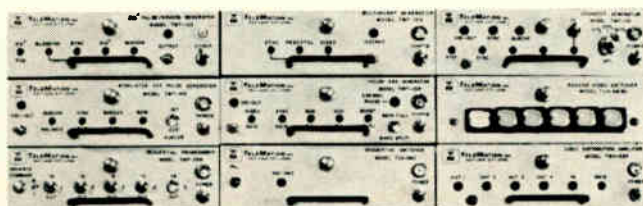

TMT-100 series video test generators

Circle Number 20 on Reader Reply Card

# Selecting standby generators

By Loren Mages  
Forces, Inc., Northlake, Ill.

Have you lost your power lately? Power outages do not respect territorial rights. Despite the fact that you are in an area normally free of disturbances, you cannot be assured that your station will not go off the air because of a power failure. In some areas, power failures are a certainty. Providing a suitable standby power source may prove profitable (continuing advertising revenue even during emergencies)

and at the same time afford an excellent opportunity to perform public service by keeping the public informed during a power failure. Yet surprisingly, a large number of stations are not equipped for such an emergency.

## Power Failure

There are numerous reasons why power outages occur. The wide area power failure of November 9, 1965, which hit the northeastern states was caused by a misadjusted relay. A utility company tower carrying power to the University of Califor-

nia was dynamited in March of 1968. Not only was the University cut off, but the interruption also cut power to the Lawrence Radiation Labs and to several surrounding counties. Then a blizzard dealt the Boston area a severe blow (winds to 80 miles per hour) that left more than two feet of wet snow and 80,000 customers without electric power. A recent survey of 675 interruptions reported in major metropolitan newspapers over a six month period disclosed a pattern as follows: 60% of all outages will last more than one hour; that almost half the interruptions will be caused by damage to the distribution systems because of storms or accidents; that most outages will occur between 3:PM and 9:PM; and that no state is immune. Power failures occurred in all the states during the period surveyed.

## The Standby Source

A broadcaster can provide for a second source of electric power by several means. In some areas the local electric utility can offer a second line: that is power supplied from a second generating station or substation. This method is attractive from a cost standpoint, but the second line method may not offer the desired protection. For example, the second incoming line offers no protection in the case of wide area outages. Further, when there is a power interruption, and loads are transferred to the other power station, overloads may occur which trip the breakers and cause loss of power even on the alternate source. The modern engine generator system provides a completely independent standby emergency electric power capability.

## Standby Installation

The first consideration when planning the installation of a standby electrical generating system is to determine the size of power

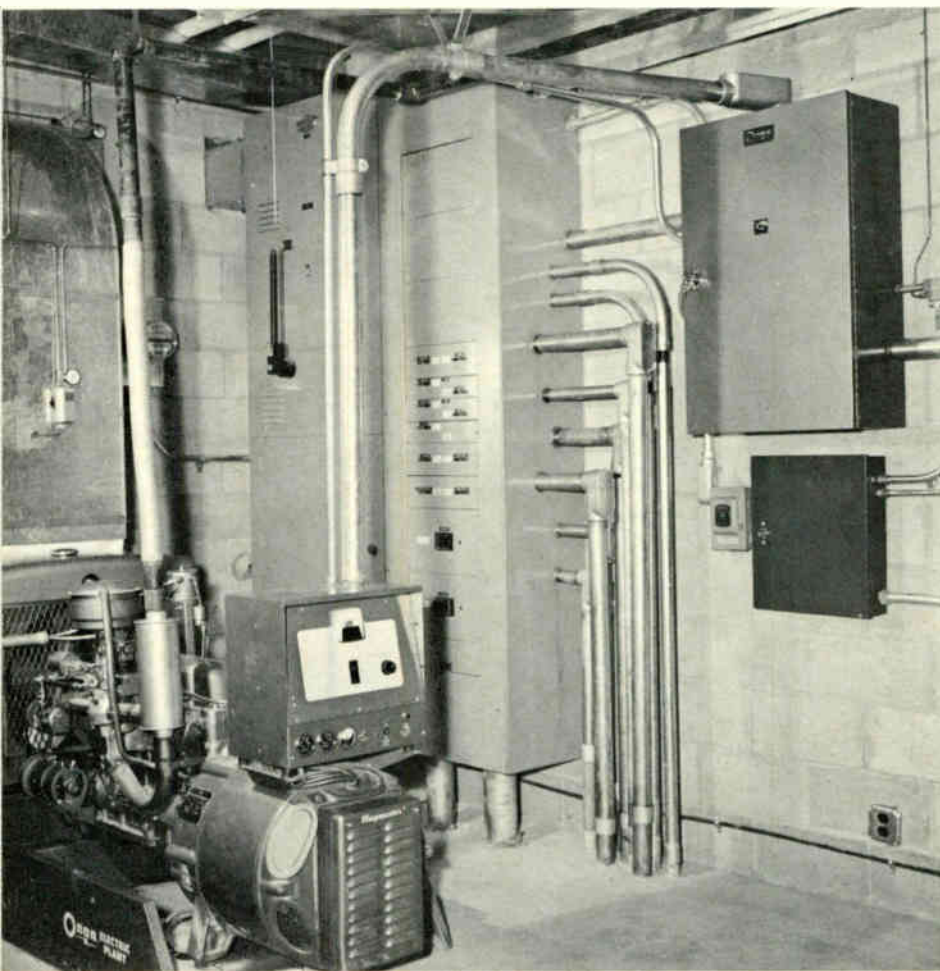

Standby generator mounted in a basement. Note that a flexible line removes exhaust, but a rigid line connects the control head to the box on the wall. Vibration of the unit could cause control box problems. All cables, piping and ducts must be free to flex.

generator needed. This requires a decision to assume only so-called essential loads, tower lights, transmitter and audio consoles, heat, sump pumps, and lights, or to assume the total normal building operating load. You may be surprised to learn that the first choice is not necessarily the least expensive selection.

If a new building is being planned, it will be relatively easy to put "essential" loads through a separate panel board. Sizing the generator to these loads simply requires totaling the individual circuit loads from nameplate data. Be certain to consider momentary starting loads on motor driven devices. Instantaneous requirements for motor driven machinery may be three to eight times their normal running load.

If the standby equipment is being provided for an existing facility, expensive rewiring may be necessary to split off essential loads from the total connected load. You may find it less expensive in the long run to purchase a larger machine and not bother to rewire. Check your electric bills for the past 12 months. Note the peak demand for any month. The largest demand will tell the size generating plant needed to assume the total building load. Do you notice a peak during the months air conditioning is used? It might be possible to greatly reduce the size of the generator needed if you could forego the convenience of air conditioning during emergency operation.

### Engine Selection

One can purchase engine generator sets which operate from gasoline, diesel oil, natural gas, liquid petroleum (LPG) or other gaseous fuels. Since we are considering generators for standby service, fuel operating economy is not of prime importance. More serious considerations are the availability of a particular fuel at the installation site, local fuel storage code requirements, initial equipment cost and long term engine generator maintenance costs.

Except for minor differences in fuel line accessories and carburetion, gasoline, natural gas, LPG and other gaseous fueled engines are very similar to the standard automot-

ive engine. Qualified servicemen for such engines are available most everywhere. Generator sets up to the 100 KW level will usually have a lower first cost if furnished with a gasoline or gaseous fueled driving engine. Once over the 100 KW size, the first cost advantages swing towards diesel-fueled engine generating equipment.

In municipalities, local fire codes may prohibit the storage of ample gasoline supplies on the site—be certain to check local building codes on this point. Also, gasoline does not store well for extended periods. Points in favor of gasoline as the system fuel are quicker starting, ready availability, and good operation over wide ranges in ambient temperature.

Gaseous fuels promote long engine life and lower maintenance costs. There is no wash down of cylinder walls with resulting crankcase oil dilution. Also, there will be no deposits of tetraethyl lead on the spark plugs. Here again, check local codes if bottled gas is to be used.

Natural gas piped in from the local gas utility solves the fuel storage problem. On the other hand, a point can be made for the desirability of a completely independent standby generating capability with ample capacity and fuel storage on the site.

Diesel engines offer long life, unsurpassed dependability and low long-term maintenance costs. High initial equipment cost, especially for smaller size machines are a disadvantage. But diesel fuel storage requirements are at a minimum, and diesel generating systems can often be installed at sites where others cannot be used because of code and insurance needs. Special cold weather starting considerations may be needed if the equipment must operate at low ambient temperatures. Allow only fully qualified diesel mechanics with proper test equipment to service a diesel engine.

The most popular engine speed used today for standby applications is 1800 RPM. Higher RPM machines may not stand up during prolonged outages. Slower machines are considerably larger, heavier and more costly. The best compromise for lowest initial cost with depend-

ability for commercial standby applications seems to hit at about 1800 RPM.

### Heat Dissipation

An operating engine generator system uses only 25% of the BTU's available from the fuel consumed to make electricity. The balance is converted into heat energy and must be suitably dissipated. Generator sets up to 15 KW ratings most frequently utilize air cooled engines. Special flywheel mounted blowers keep the air circulating, and assuming the room or engine compartment has sufficient openings, the air movement will adequately cool the engine and generator. Larger sized generating systems use liquid cooled engines. Even liquid cooled engines require some cooling air, and of course, ample combustion air is needed for both air and liquid cooled machines.

Radiator cooled engines sometimes have the radiator mounted on a common base with the engine and generator. At other times, it may be more convenient to remotely mount the radiator on the lawn, the roof or elsewhere. The radiator is normally filled with water, or in colder regions, a mixture of water and permanent type antifreeze.

Another form of liquid cooled engine uses water from the city water mains for cooling. This is known as city water cooling, and there are several versions of these systems. Unless your community is served by an overhead water storage tank, the pumping station is protected against loss of electrical power, or you have your own well, don't use a city water cooling system. Obviously, with a city water cooled machine you must be assured of a continuous water supply if your system is to function during an emergency.

### Matching The Source

The electrical output of the generating system must match the incoming power source with respect to voltage, frequency and phase. There seems to be a tendency for radio engineers to go overboard when it comes to frequency and voltage regulation specifications. Most modern engine generator sets incorporate voltage regulation of

*(Continued on page 36)*



**The finest color camera  
ever made for sales managers  
is the finest ever made for  
sponsors, engineers and cameramen.**

## **The New 3-Tube RCA TK-44A.**

The TK-44A can improve your station's color image and help increase sales.

It outperforms any other color camera in the world today. Once you see and try the TK-44A, you'll agree. You'll discover features found in no other camera. Features that mean better color and faster set-up. Features that mean more time for your engineers and camera-men to spend in program production instead of tinkering, to assure less tension and greater efficiency—indoors and out!

The TK-44A. The maximum-performance studio camera that can double as your most dependable remote camera. The camera with the innovations you need today . . . and tomorrow!





A



B



C



D



E



**You get more for your money in color control and fidelity.**

**A** The TK-44A can deliver the kind of color you like. No more old-fashioned painting which always unbalances grey scale. Reason: the "Chromacomp."

**B** The TK-44A can bring your sponsors' products to the home TV screen in truer-to-life color than any other lead-oxide camera. Reason: "Chromacomp."

**C** The TK-44A can give you the highest degree of color-match with any color camera you own. No other camera can offer you this important operating advantage. Reason: the unique "Chromacomp" Color Masker.

**D** The TK-44A can increase picture sharpness without causing a corresponding increase in noise. Reason: the unique comb filter Contour Enhancer.

**E** The TK-44A can produce life-like color at all light levels. Even at 15 foot candles, it can still deliver full video levels. Reason: optics 30% more efficient than the No. 2 camera.

In the months ahead, we will tell you why the new TK-44A offers you more for your money in operating flexibility. But if you want complete details now, call your RCA Broadcast Representative or write: RCA Broadcast Equipment, Bldg. 15-5, Camden, N. J. 08102.

**RCA...Totally Responsive**



±5% or better and frequency control of three cycles. Bear in mind that these ratings are based from "no load" to "full load". Actually, the load of an operating station varies very little and voltage and frequency can be closely regulated without resorting to special and expensive controls and accessories. But do watch those tower lights, they can really cause grief on a small generator system.

### System Transfer

A means must be provided to transfer the electrical load from the normal source to the emergency generator. Manual and automatic double throw transfer switches are available. Most modern installations use fully automatic engine starting and load transfer controls. When the power interruption is sensed, the engine is started, and once up to rated voltage and frequency, the load is disconnected from the dead line and transferred to the generator output. When the normal power service is restored, the load is transferred to the commercial power line and the engine is shut down. Engine starting and transfer of the load

is normally accomplished within 5 to 10 seconds. Fully automatic operation is essential at unattended facilities. Manual load transfer can be used at attended stations where economy is a prime consideration.

Numerous accessories are available to make the automatic load transfer control more valuable. This control should incorporate provision for proper charging of the engine starting battery, cranking, limiting, and testing. In addition, the purchaser can select various under or over voltage protective relays, full protection against loss of a phase, time delay relays for many purposes, signal alarms or trouble lights, and instrumentation as desired.

### Engine Starting

No single element of the standby system requires more attention than the engine starting battery. An investigation was made to determine why many emergency lighting systems did not function at the time of the big power outage in November of 1965. The State of Pennsylvania, which requires emergency lighting systems in most public buildings, found that in over 90%

of the "failed to operate" investigations, the problem was traced to defective batteries or battery cabling. Battery cases were found cracked, batteries were sulphated, dry, cells shorted, terminals eaten away, and similar problems. Be sure you get the proper size battery for your machine, the proper charger, and see that it is properly maintained.

The manufacturers of engine generator sets and their agents can offer special guidance in the planning of a standby installation and the selection of the needed equipment and accessories. The local distributor will usually know all the building codes applicable to your location. Seek his assistance, and above all, follow the installation instructions furnished with equipment to the letter. Establish a program for routine preventative maintenance. A properly installed and maintained standby generating system should have an economic life well in excess of 15 years. In areas where power outages represent a continuing problem, a standby generator backed by a routine maintenance program can be the answer. In other areas it represents a good insurance program.

## SERVOPAK SYSTEMS

... offer unique flexibility and performance in Servo Controlled lens systems

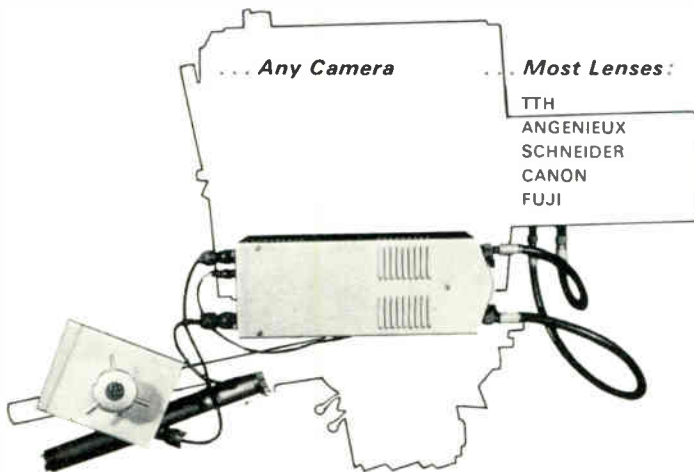

FROM SERVO TO MECHANICAL IN MINUTES

As an alternative to the integrated system design, the Servopak Control System provides precisely the same facilities with very significant advantages. Even if your lenses outnumber your cameras, only the cameras need to be equipped with Servopak. The zoom lens and servo system can be serviced separately. Servopak units may be easily and quickly substituted with mechanical controls.

Servopak zoom and focus control drive unit is a complete package containing all power supplies, AC amplifiers, control circuitry and high powered AC Servo motor/generators with integral gear boxes and resetting potentiometers. Command signals are initiated by the operation of separate operator's hand controls, either camera mounted or remote. The drive output is from splined gears which are coupled through specially silenced cables to the mechanical drive outlets of any standard zoom lens.

Servopak has a simplified system for setting the maximum and minimum zoom and focus positions. The stops are controlled electrically by a simple screw-driven adjustment and prevent the stresses encountered in normal mechanical stop arrangement. Built-in indicator lamps in the unit enable adjustment to be made by unskilled operators.

Write for Servopak bulletins.

### POWER-OPTICS, INC.

P.O. BOX 226, FAIRVIEW VILLAGE, PA. 19409  
(215) 272-5300 • Telex—846411

Western inquiries contact:  
Television Products, Inc. (213) 678-2388

Circle Number 22 on Reader Reply Card



**FAIRCHILD**

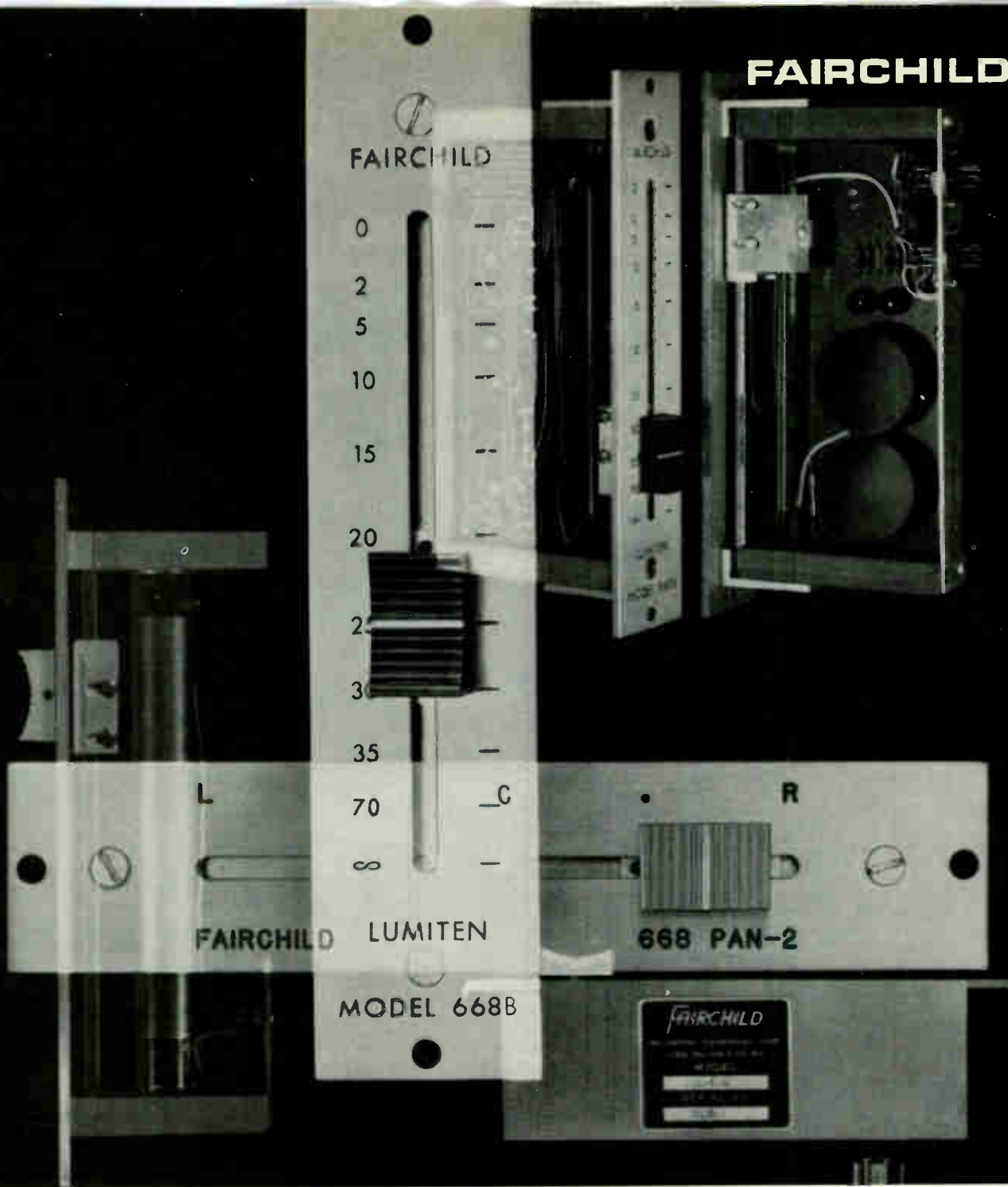

## THE NEW FAIRCHILD LUMITENS

Fairchild introduces a complete new line of noiseless attenuators with 7 new advantages: 1. Transistorized drives require only minute current to actuate circuit.

2. Multi-channel operation with common light sources to all channels guarantees tracking to within ½ db between channels. 3. 4 channels or more can be driven by a single actuator. 4. Infinite resolution from 0-∞

5. Plug-in light source allows instantaneous replacement. 6. Improved mechanical construction of slide faders' precious metal sliding contacts gives long trouble free life, offers adjustable feel. 7. Plug-in, remote, and slide-wire models range from one to four channels and are designed with ultimate versatility in packaging;

compact cards range in size from 1¾" x 4" to 5¼" x 6¼"; housings from 7" x 1½" x 1¾" to 7" x 1½" x 3".

All Fairchild Lumiten attenuators use the same light principle. As light intensity is made to vary, cadmium sulphide cells within the circuitry effect identical and simultaneous variations of the audio signal. The Fairchild Lumiten is, in fact, as noiseless as a beam of light.

Fairchild Lumitens (available in 600 and 150 ohms) include: 668II Attenuator, 668 PAN-2 Pan Pot Attenuator, 658 ACT Remote Cell Actuator, 668 STII Stereo Attenuator, 668 RSB Remote Stereo Attenuator, 668 MC 4-channel Master Control Attenuator card, 668 RAB Remote Attenuator packaged on compact PC card, 692 D1 Single Remote Attenuator, 692 D2 Two independent Attenuators. Slide Wire Fader: SWL 600 (600 ohm L pad).

Contact your Fairchild Recording Distributor or write **FAIRCHILD RECORDING EQUIPMENT CORPORATION**, Dept. 8E-8, 10-40 45th Avenue, Long Island City, New York 11101.

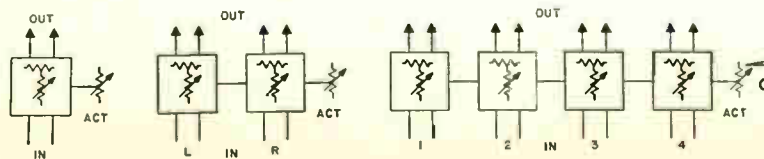

Circle Number 23 on Reader Reply Card

**“Many businesses are contributing generously to higher education. Have you looked recently to see if you’re giving enough?”**

**Roger M. Blough\***

In addressing business leaders, Roger Blough backed up this question with the alarming estimate of rising costs for higher education. “By the mid-seventies, annual expenditures will reach \$30 billion, about double the 1965 figure.”

It’s vitally important that every business evaluate investment in higher education—and do so in light of rising costs. Corporate contributions that are geared to yesterday’s expenditures aren’t keeping pace with changing needs. If your company has not yet started an aid-to-education program, it’s time to get involved.

Business needs educated people to produce money. Colleges need money to produce educated people. With tuitions covering only about 1/3 of the soaring costs, colleges and universities must have more help, now.

Write for: “How to Aid Education.” It’s a booklet for management—of particular interest, if your company has not yet established an aid-to-education program. Address: Council for Financial Aid to Education, 6 East 45th Street, New York, N.Y. 10017.

\*Former Chairman, United States Steel Corporation

Give to the college of your choice.



advertising contributed for the public good.



# An emergency power changeover system

By Fred Moore, John Morris, WQAM, Miami Beach, Fla.

■ When a broadcast studio building loses electrical service, things should happen fast. And automatically, if possible. For without the ability to feed audio down the program line to the transmitter, everything might just as well be turned off. The system described here automatically supplies emergency power just after our studio building loses public power from incoming lines.

## Air Conditioning Load

The service supplied to our building is three phase, 240 volt power. The only equipment actually requiring three phase power are two 7½-ton air-conditioning units on the roof of the building. They supply most of the cooling air for the building, to offset the tropical Florida heat. The rest of the cooling is done by a separate 5-ton unit which requires only single phase 230 volt power. The changeover relay described here is a single phase unit and does not switch the large air-conditioners, only the small one to keep the studio temperature down to a livable level during an outage.

The large units are left across the public power line at all times.

When the power fails, an AC relay connected in the five-ton unit supply line drops out, removing its own "seal-in" voltage (Fig. 1). This relay must be reset by pushing a button on the relay chassis located near the main changeover control panel. The purpose of this relay is twofold. First, it prevents damage to the compressor in event of a short outage by not allowing power to be removed and then reapplied quickly. Several minutes must be allowed between the time power is removed and the time it comes back on the compressors. This time lapse allows coolant pressures to equalize throughout the system. The second function of the relay is to assure that the heavy starting current required for the five-ton unit is not drawn from the emergency generator until the generator speed has stabilized and all the other equipment necessary for studio operation is functioning.

## Functions And Circuitry

Public power must be interrupted

for at least two seconds before the relay unit reacts. The unit ignores outages of shorter duration because K5 is kept closed by the charged time delay capacitor C1. This capacitor charging voltage is supplied off the public power line by a simple half-wave DC supply consisting of R1, D1 and C1. For an outage lasting longer than two seconds, K5 drops out, its upper contacts completing the generator start terminals circuit and starting the generator.

As the generator starts, its output feeds TD1, an Amperite 115NO5 time delay relay. After five seconds of output from the generator, the frequency has stabilized and the unit is ready for a load. TD1 closes, its contacts completing the circuit to K3 and closing it with power being supplied from the generator. The contacts of K3 connect generator AC to the coil of power relay K1 through latching relay K2. This action transfers the building load to the generator output.

The power relay is a momentary type, with the same coil serving to latch the relay in either mode. Volt-

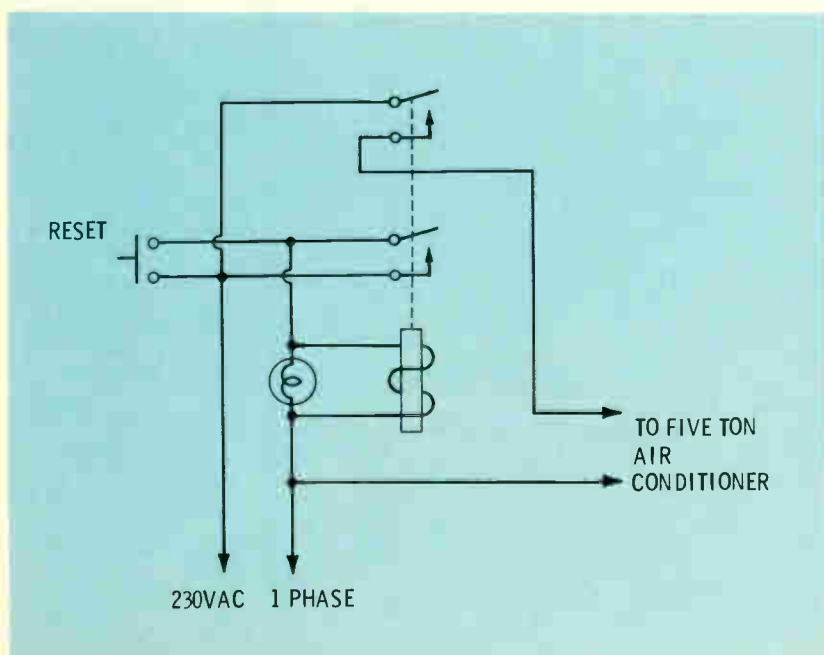
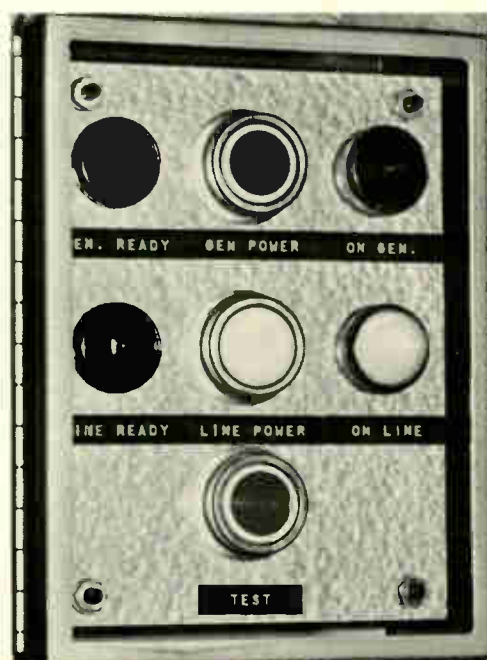

Fig. 1 Air-conditioner relay wiring.



Control panel shows all power conditions.



age, therefore, cannot remain across the coil after the changeover is completed. The voltage is only momentary because of the following action. When K1 switches to emergency position, its auxiliary contacts cause latching relay K2 to also change position, thus removing power from the K1 coil being supplied through arm #2 of latcher K2. The latcher is a 24 volt DC 6p.d.t. unit supplied from the generator batteries.

This relay is used for circuit connect and disconnect to the K1 power relay coil and for mode indication through type 10S6 lamps on the control panel. The latcher coils are wired to simply follow the position of the power relay, K1. When the power relay is switched to the emergency position, it changes the latcher to that position, etc.

Now we have the studio building on emergency power, with AC be-

ing supplied from the 30 kw generator. After a few minutes of emergency power operation, the announcer comes into the power room and pushes the button to reset the five-ton air conditioner relay described earlier. This restores cooling to the studio area. The building will now stay in the emergency power mode until manually changed back to the public power line by the operator on duty. To do this, he operates pushbutton PB1, labeled "REGULAR POWER" on the control panel. The change back to public power was left to manual control purposely to prevent an automatic circuit from actuating the power relay during a commercial, thus causing a "pop" on the air during a client's message.

The circuit is fully interlocked to prevent switching to a dead line in either mode. Once on emergency

mode, the unit cannot be forced to change back to the public power line until normal voltage has existed on that line for at least three minutes. When this condition is met, TD2 closes because it is connected directly on the public power line. TD2 closing seals in K4 which, in turn, lights L1, the "REGULAR POWER GREEN" lamp. This indicates to the operator that public power has been restored and that the building will transfer back to these lines if the "REGULAR MODE" pushbutton is now operated. If this button is pushed when the "REGULAR POWER GREEN" lamp is not lit, nothing happens, preventing an erroneous changeover to a dead or intermittent public power line.

As the building load is transferred back to the public power line, the emergency generator is shut

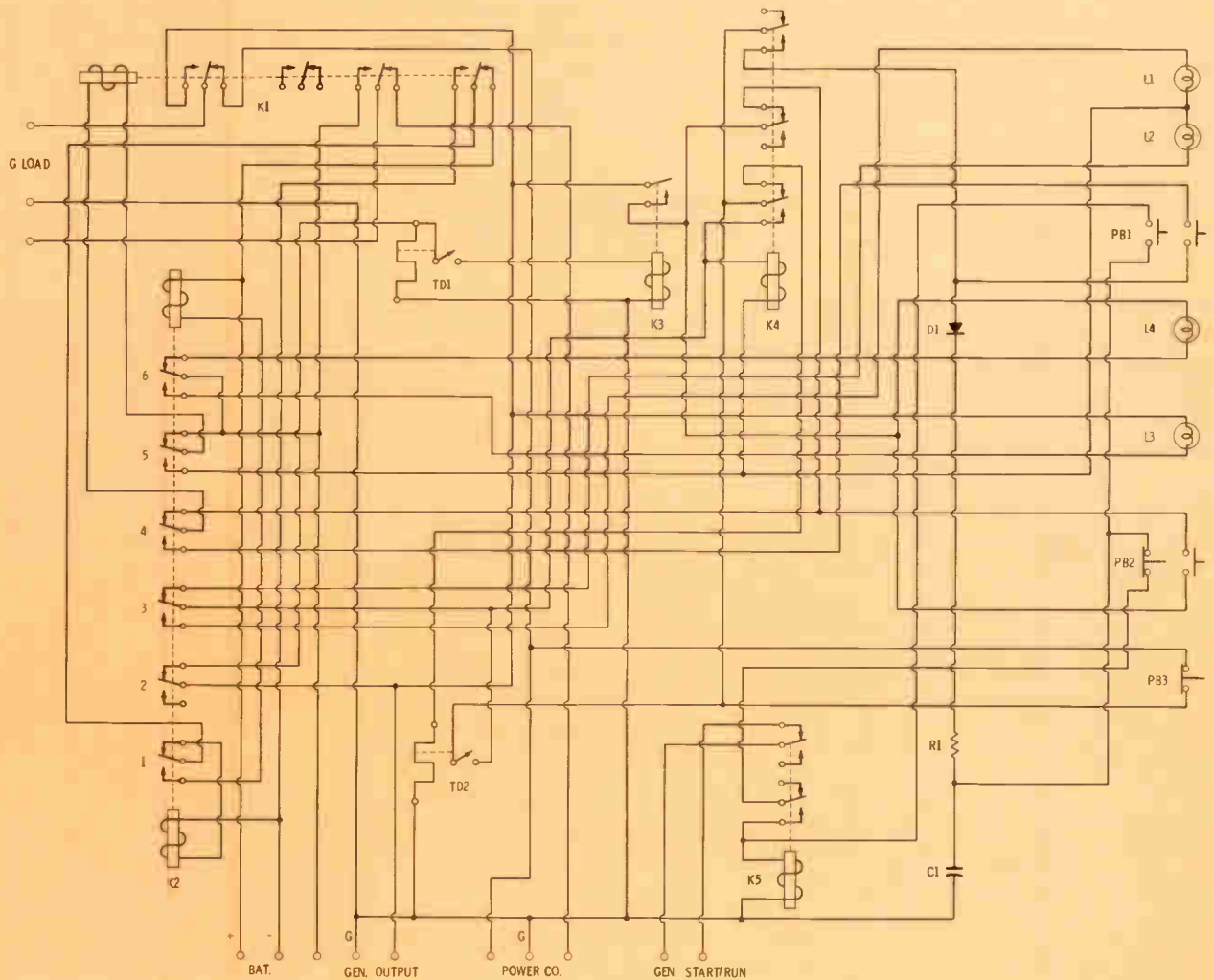

down because K5 is resealed by the appropriate contacts on PB1, the "REGULAR POWER" pushbutton. The generator stops only if the "REGULAR POWER GREEN" lamp is lit, however, preventing shutdown of the generator while the building load is on it! This function is taken care of because the half-wave charging supply is fed from the topmost "down" contact of K4, making reseat voltage available only when TD2 is closed.

Another safety feature prevents a mistaken changeover to the generator output when it is either off or not quite ready for load yet. Since K1 voltage is supplied from the generator output through K3, in the "regular power" mode, there is no changeover when the "EMERGENCY POWER" button is pushed if the "EMERGENCY POWER GREEN" lamp is not on.

The generator will start now, however, to ready the panel for a changeover. since "seal-in" voltage for K5 was removed by normally closed contacts on the emergency power pushbutton. After the generator has come up to speed, the emergency power green lamp comes on as TD1 closes. Pushing the emergency power pushbutton now, of course, will transfer the building load to the generator. In the event of severe weather, the generator is started manually as described above and left running through the peak of the storm. In this way, if an outage occurs, changeover to the generator is instant upon failure of public power. This changeover is so fast it will not stop our reel-to-reel or cartridge machines while they are running on the air.

Also incorporated into the circuitry is PB3, the test pushbutton.

Holding this button in until the building load is transferred to the generator output, tests all the switching circuitry. It is wired simply to fool the relays into thinking that public power has failed. It is a normally closed switch in series with all connections to one side of the public power line. This button is used only by station engineers during the maintenance period on Monday mornings.

As the pictures show, all connections to the relay subpanel are by spade lugs. If maintenance becomes necessary, all voltages can be removed from the circuitry in the subpanel by removing the appropriate lugs from their barrier strip terminals. All relays and time delays are plug-in.

This system is a considerable improvement over the old manual switch method of emergency power operation. Previously, the announcer had to grope through total darkness following a public power failure to the power room where he had to operate disconnect switches to remove the air conditioning load, start the generator manually, wait for it to run up to full speed and then push the handle of a 200 amp transfer switch to get back in business.

The large power relay used is made by Automatic Electric Company and was left over from an earlier transmitter installation. As manufactured, the unit contained its own control relays mounted with the power relay on a bakelite panel inside a metal enclosure. The old unit was cleaned of everything inside except the power relay and the bakelite panel on which it was mounted. The subpanel shown in the photo was built from scratch using an eighth-inch aluminum rack panel. Fanning strips were used on the barrier strips wherever possible. The original metal enclosure was used to house the newly rebuilt unit. Having the large power relay on hand was admittedly a cost windfall, but the remainder of the unit cost less than \$75, using available parts from replacement stocks. Installation by a licensed electrician ran about \$200.

We had the usual bugs to work out after construction, but the unit has been in operation now for six months and has worked flawlessly.



#### Parts list

##### for changeover panel

- K1** Automatic Electric Co. 3PDT 200 amp relay
- K2** 6PDT Latching Relay, 24 volt d.c. coils. Magnecraft W88 LX-7
- K3** Magnecraft ACPX-8 SPST 110 volt a.c. relay
- K4** Potter Brumfield 3-PDT 240 volt a.c. relay KRP-14AG
- K5** Magnecraft DPDT 10,000 ohm plate relay
- TD1** Amperite 115 NO5
- TD2** Amperite 115NO180
- PB1-PB3** Square D brand modular pushbuttons
- L1-L4** 10S6 220 volt, 10 watt bulbs.

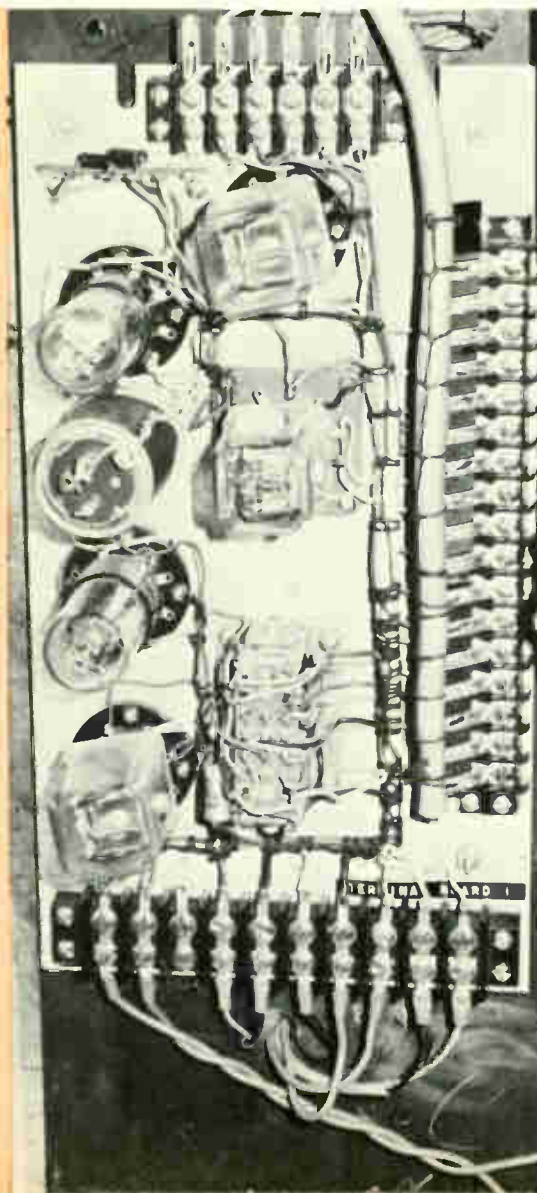

**Fig. 2**  
Emergency changeover schematic.

Subpanel layout detail.





# The switch- hitters

**THE PHILIPS PC-70** ... the prime time king of color cameras ... serves on more live and taped studio color shows, by far, than any other camera.

And it's a fantastic switch-hitter. If the PC-70 is a winner in studio work, in the field it's no contest. For major outdoor news and sports events, the PC-70 consistently takes the most valuable player award.

Why? Its unsurpassed color picture, faithful and sharp. There are over 700 Philips 3-Plumbicon® cameras in use worldwide. A videoman's dream. The cameraman's camera. Management's assurance of the best, most reliable, and most economical performance.

When a better camera is built, Philips will build it.\*  
In the meantime, the PC-70 is the ticket.

\*The Philips PC-100, announced at NAB '69, will be available early in 1970.

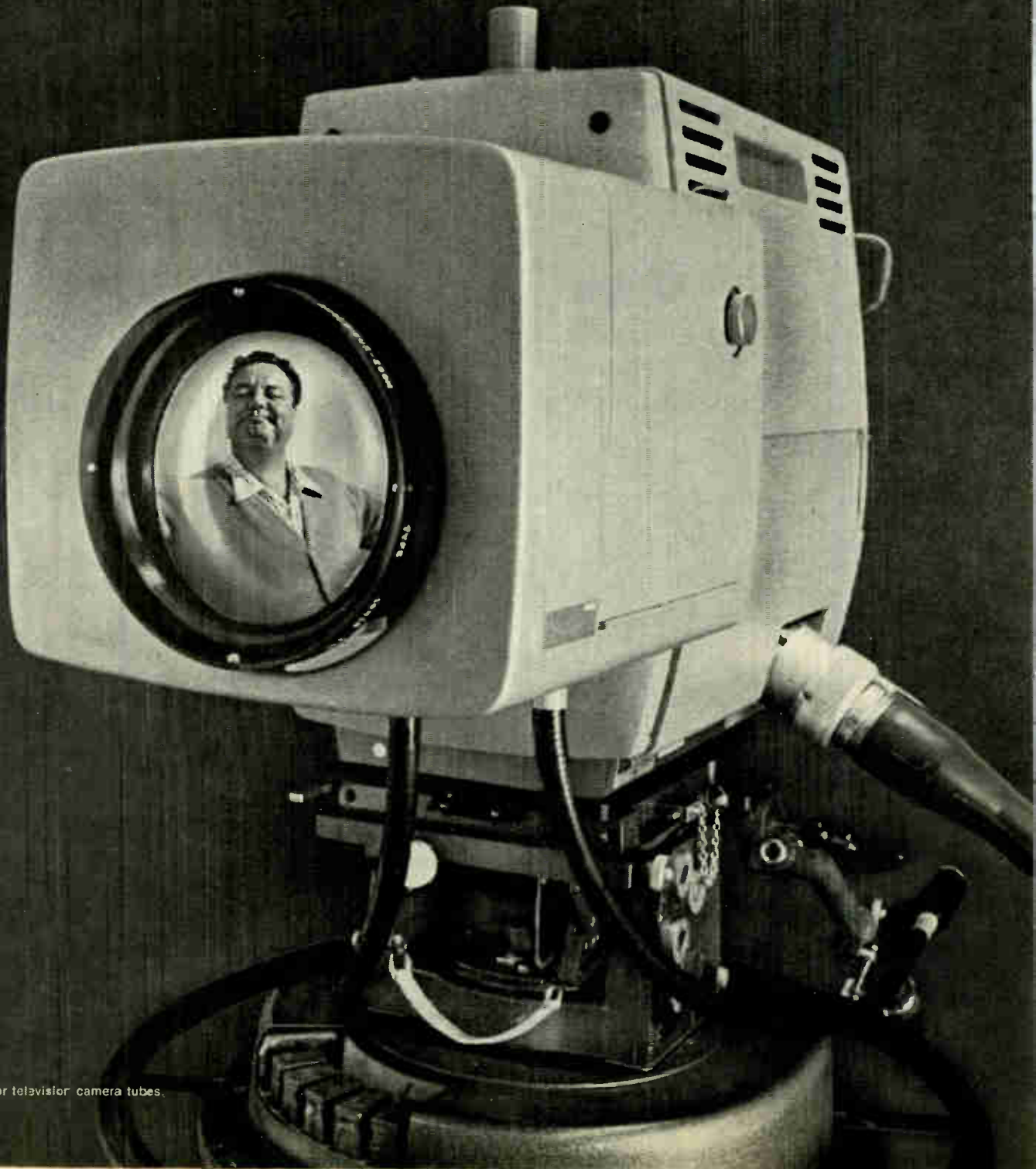



**THE PHILIPS PCP-90** digitally controlled "Minicam" takes the field alongside the PC-70 as the most mobile and versatile of portables. Operating wireless or on small, cost-reducing triax, the 3-Plumbicon Minicam brings total flexibility to broadcast-quality telecasting.

The PCP-90 is designed basically as a field camera. Controls may be beamed from as far away as 30 miles. Signal processing is done in the backpack. The Minicam produces a real-time color-composite signal for direct broadcast. Or it can go into the field with a portable recorder to tape interviews or other action—totally unencumbered.

And here again, you have a star switch-hitter. Three new one-inch Philips Plumbicon tubes perform to broadcast standards, bringing the Minicam right into the studio.

Training camps for Minicam prototypes included crowded conventions, major sports, the inauguration and other events. Now it's ready to sign with you.

**PHILIPS**

**PHILIPS BROADCAST  
EQUIPMENT CORP.**

One Philips Parkway, Montvale, N.J. 07645 • 201/391-1000

A NORTH AMERICAN PHILIPS COMPANY



# Building a solid-state chroma keyer

By Robert Blauvelt\*

■ One of the most useful and least understood color production accessories is the chroma keyer. Its uses are unlimited. This article describes a chroma keyer that was designed and built by the author at KRDO-TV shortly after the purchase of live color cameras. The unit described equals or exceeds the quality of the average network chroma keyer. If all new components are used, this unit may be duplicated for approximately \$150.00.

Chroma keyers are basically quite simple. Fig. 1 shows a block dia-

\*Engineering staff, KRDO, Colorado Springs at time of writing.

gram of the one built at KRDO-TV. This unit consists of Darlington pair input amplifiers driving a three input, two output matrix. Here the colors are added and subtracted to derive a keying waveform corresponding to any given color. This keying signal is then further processed in a high gain differential amplifier, clamped, black clipped, and delayed with a variable delay line. The delay line is used to compensate for encoder and cable delays in the studio system.

A common base amplifier is used to provide the necessary gain to overcome circuit losses and to drive

the totem pole output state to 0.7 volt pp. Sync is applied to the unit for clamping purposes. The sync enters via a Darlington pair and is amplified and inverted to drive the clamp transistor.

The purpose of all this circuitry is to develop a positive-going signal, coincident in time with the camera's scan of the particular color area to be keyed. This positive signal (normally 0.7 V pp.) is applied to the station's special effects system via an external key input. Thus a particular color tells the special effects system when to switch.

Although blue is normally used

Fig. 2 Coarse hue control is at left, fine hue is second control from left. Balance adjust is between fine hue and gain controls.



Fig. 3 Top view of keyer with panels removed.

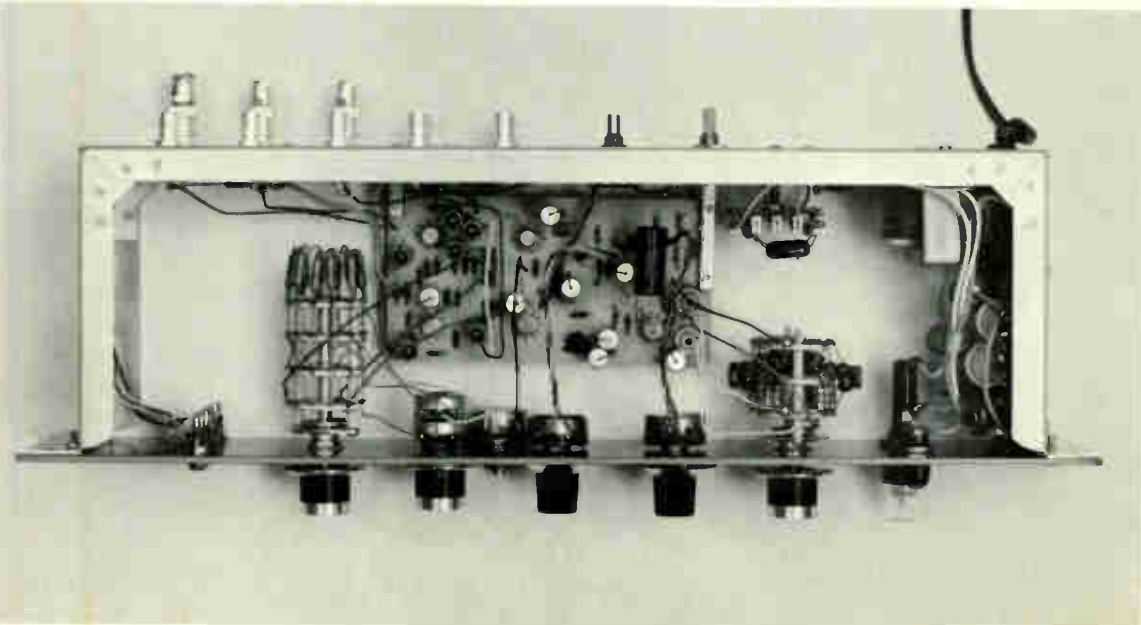

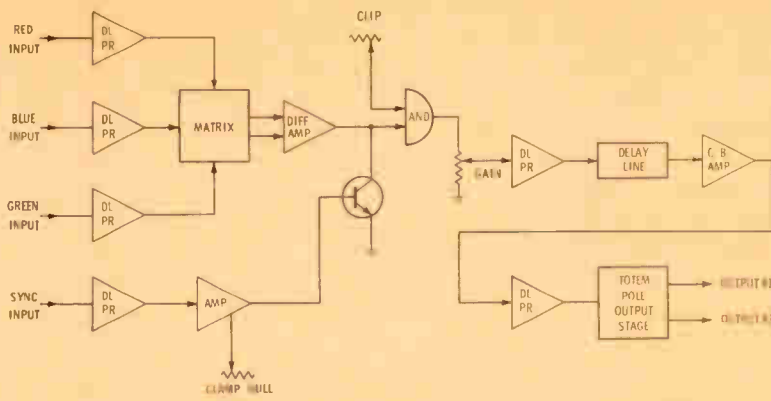

Fig. 1 Chroma keyer block diagram.

as the keying color because it is the least prevalent in flesh tones, any color may be used. The primary colors, (red, blue, and green) tend to work the best, however.

### Construction

The actual unit is assembled on a 3½ inch rack panel and bathtub chassis (see Fig. 2). The matrix and delay line should be preassembled

before mounting to the front panel. The matrix, with the exception of the dual 200 ohm pot, is wired on the switch. The delay line is assembled on the switch, except for the termination resistors which are mounted on the printed circuit board.

The lettering on the author's front panel is letter press, which should be available in your local art store.

After the lettering is applied, a few coats of lacquer should be sprayed over the panel to prevent the letters from rubbing off. Once the front panel is assembled, it should be set aside until the main chassis is finished.

The major portion of the circuit is on a printed circuit (see Fig. 3). Fig. 4 is the schematic of the keyer less matrix, power supply, and delay line. The omitted circuits are Figs. 5, 6, and 7). There are six IC's and six transistors used in the active circuits. IC's one and two are RCA CA 3036 dual Darlington. These are used as matching and isolation between the high impedance loop through inputs and the low impedance matrix. The second half of IC 2 is biased a little differently from the other Darlington Pairs so that it will pass negative-going sync instead of positive-going video. The outputs of these are fed to the matrix via voltage dividers. The outputs via voltage dividers, which will be used to provide an effective return path to ground for IC 3.

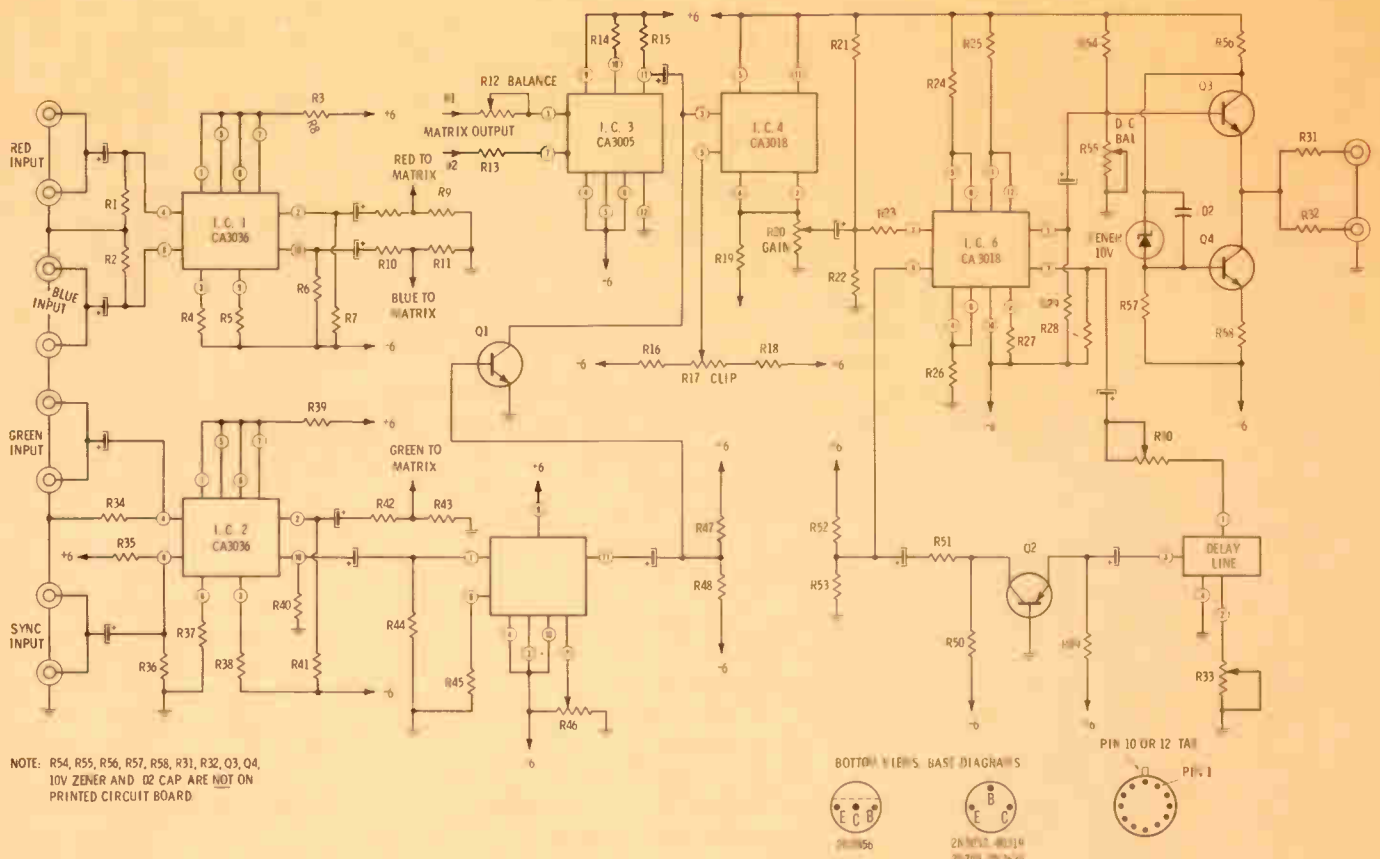

Fig. 4 Chroma keyer main schematic.



The output of the matrix is fed to IC 3 (RCA CA 3005- high gain differential amplifier), via R-12 and R-13 which are used to balance out circuit tolerances. The output of the differential amplifier contains positive-going video corresponding to the selected color. It also contains negative-going video corresponding to unwanted colors. The output of IC 3 is clamped to ground by Q-1 during the horizontal sync period. This allows IC 4 to clip off all of the undesired portions of the signal without DC drift. R-17, the clip pot, is mounted on the front panel for this purpose. After the video is clipped, the remainder is amplitude controlled by the front panel gain control (R-20).

IC 6 is used as a delay line driver and as an output driver. The IC is an RCA CA 3018, a four transistor array in which two of the transistors are internally wired as a Darlington pair. One half of this IC feeds the delay line via R-30, the sending end termination. The other delay line termination is R-33. The output of the delay line is amplified by Q-2, a common base amplifier which provides high gain with no signal inversion.

After amplification, the signal passes through the second half of IC 6. This is wired as a Darlington pair and served as the original output stage. It proved unsatisfactory, so it is now used as a driver for the totem pole output stage. This is the reason the output stage is not mounted on the printed circuit board.

IC 5 (RCA CA3001) is used as a variable gain, sync inverting amplifier to drive Q1, the clamp transistor. It was planned to also take the negative output of this IC and, by resistive mixing, make one output composite. This caused some problems in the output circuits and was later deleted. The gain of IC 5 is controlled by the pot labeled "Clamp Null."

The totem pole output stage consists of a pair of series connected 2N708 transistors biased so that the common emitter-collector point is at 0.00 volts DC—thus no output capacitor is required.

The power supply, input and output BNC connectors, clamp null pot, and DC balance pot are all mounted on the bathtub chassis. The power supply is all "hard wired." It could be assembled on a PC board if desired.

The power supply is actually two supplies derived from one transformer. The regulators are a simple zener diode reference series circuit that seem to do an excellent job of removing all ripple. It is strongly recommended that the supply voltages not be varied from a nominal plus and minus 6 volts ( $\pm 1/2$  volt) because of IC limitations. The voltage will vary a little, however, due to zener tolerances.

The matrix schematic shows a switch with three wipers. This is actually a three deck switch interwired so that the wipers are 120 degrees apart. The photographs of the keyer that show the matrix show a four section switch. This was an older design and since has been replaced.

The printed circuit board may be duplicated if desired, however, the keyer works just as well built upon Vectorboard as did the prototype. The printed circuit board is set up for  $1/4$  watt resistors and normal small size transistor capacitors mounted on end. The ultra sub-miniature tantalum capacitors were not used due to excessive cost. It should be noted that three resistors were mounted on the foil side of the board due to wiring complications. These are R-27, R-28, and R-29. They may be seen in the lower left corner of the bottom view in Fig. 3.

nect the plus and minus 6-volt lines from the power supply. Load each regulator with a 2.7 K ohm resistor and apply power. The regulator outputs should be plus 6.2 volts and minus 6.2 volts  $\pm 1/2$  volt and should show little, if any, ripple on an oscilloscope. When the power supplies are operating correctly, they may be reconnected to the rest of the circuits. Apply standard staircase to the red, blue, and green inputs. These should be looped from one feed and terminated at the last input. With the oscilloscope attached to the hot end of the gain pot, adjust the balance pot (R-12) for video cancellation of the entire staircase. This pot is then locked in place. R 55 is now adjusted for 0.00 volts DC at the keyer output with the gain control set a minimum. The only remaining adjustments are for the delay line.

With the oscilloscope connected to the output of the keyer, the staircase applied to only one input (red, blue or green), and sync applied to the sync input, adjust the gain and clip controls so that only the last step remains which is 0.7 volt pp. The matrix switch may have to be rotated to achieve positive-going video under these conditions. R-30 and R-33 are alternately adjusted for the flattest top and sharpest fall on the trailing edge of the observed pulse. The delay line should be set to maximum delay for this adjustment. It should be possible to adjust the terminations so that the delay line will pass the signal with only slight distortion, if any.

### Keyer Checkout

The final checkout is subjective. Apply the red, blue and green color bar drives to the appropriate inputs and terminate the looping connections. One of the keyer outputs is applied to the external key input of the station effects unit. With encoded color bars applied to one of the effects' inputs, adjust the coarse hue, fine hue, gain, and clip controls for a clean keying-out of the desired hue or bar. The delay line is now adjusted to exactly position the key-out area under the replaced video.

If everything is working to complete satisfaction, the keyer is now ready to be mounted in one of the live cameras. The red, blue and

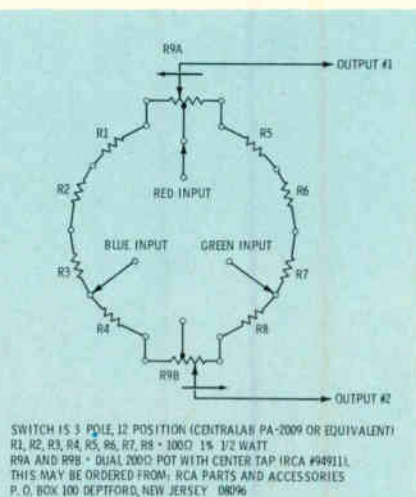

Fig. 5 Chroma Keyer matrix.

### Keyer Setup

After the keyer is built and all obvious errors are removed, discon-

green inputs should be supplied with processed video of approximately 0.7 volts pp. If the second keyer output is applied to a video monitor, the keying signal will be viewable as a white-on-black picture, with the white areas corresponding

to the keying color. This is very useful in initial setup and any later color changes. This chroma keyer has proven reliable and should run for weeks without any adjusting.

Having only one chroma keyer is almost the same as having only

one VTR machine. With this in mind, you might want to build one for each color camera or even install an input transfer switch so that one keyer may be used with more than one camera. The possibilities for modifications are endless. ▲

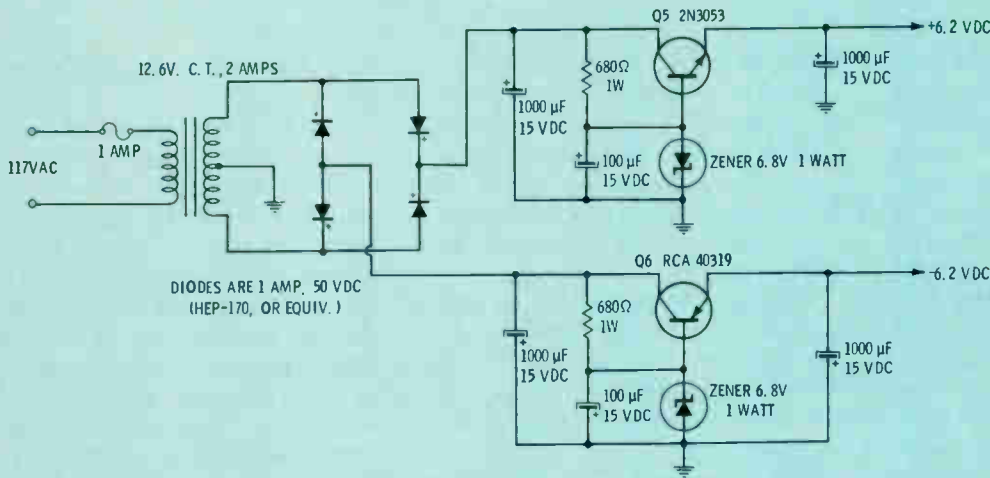

Fig. 6 Power supply

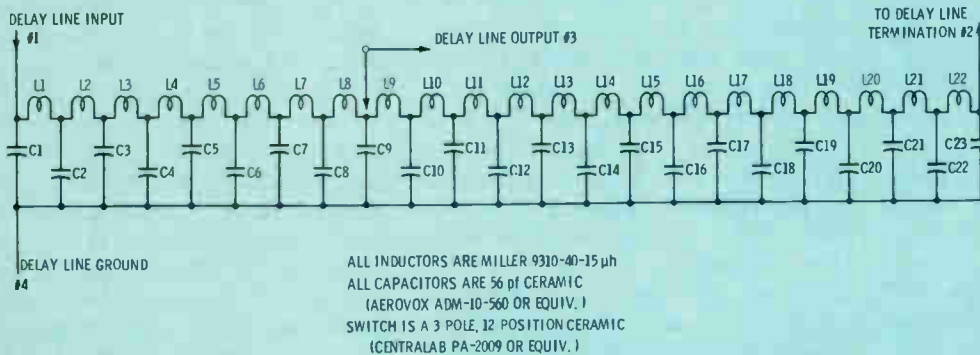

Fig. 7 Keyer delay line

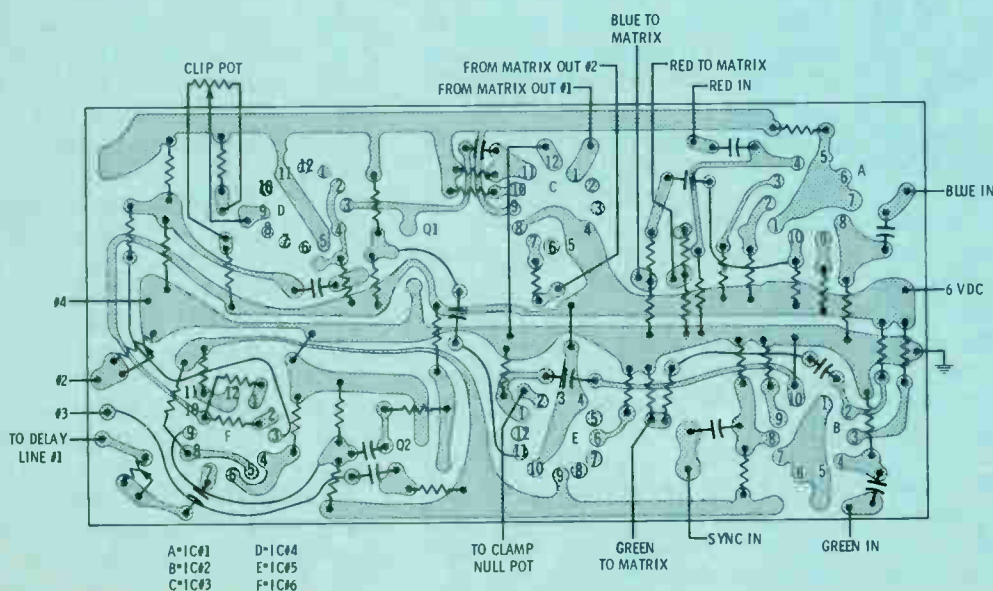

Fig. 8 Bottom view of printed circuit board parts layout. Top view shown in Fig. 3



# A portable console for booth and studio operations / By Fred Clinger\*

■ The WBCO engineering department had a unique problem which had been growing over the past several years. Each year at county fair time, the production studio was torn down and moved to the Fair for its five to six day run. The station broadcasts about ten hours a day from a booth on the fair grounds. The effort usually netted a myriad of engineering headaches.

All production had to be done at least a week in advance, last minute spots could not be produced, the wiring became frayed, connections were questionable, and a considerable amount of crossfeed was taking place in the board. Not to mention the fact that the chief engineer had to work the Sunday before the fair setting up equipment, and the Sunday after, tearing it down.

With the coming of the new year, the author decided not to go through another county fair with these nagging problems.

One of the problems of the old production setup was the fact that the components were scattered over a large area, and rather unwieldy for efficient production. The Gates Yard Board was sitting on a 3 x 8-foot table, with a 30-inch rack at one end which contained the board power supply, connecting strips, an ATC cartridge playback-record unit, and the record amplifier, plus an outdated patchpanel. At one end of the table was an Ampex 300 console tape recorder. Another smaller portable Ampex was on the table. The entire setup worked okay, if you had arms like a gorilla.

Taking inventory of a rather large junk box for a small station, we found two old console turntables in 24 x 24 inch square cabinets, 30 inches high. The tables were solid mechanically, and had the huge gear-boxes not seen on the market today. We also had the good fortune to have two almost new Gray

Research arms, complete with turn-around cartridges. Further scrounging produced two small, one-tube, turntable pre-amps which could be used. Also sitting at the other end of the table was a Collins 808 portable board, which was used for turntables.

After convincing the station manager that engineering could build a new efficient unit for about 30 or 40 dollars, and free the Collins portable board for other uses, we started on the project.

We determined that the entire unit would have to be set up and checked out at another location, and then moved into Studio "B", which serves as the production studio. The new unit could not be built in studio "B", as there was not room for two units, and the first could not be torn down until the second was nearly completed.

The author then took over Studio "A", which is large and little used. The first item on the agenda was to clean up and sand down the two turntable cabinets. Then part of our 30 dollar budget was spent on a can of light brown paint (this was after we made the mistake of discussing the color matching problem with our Women's Director, who insisted on doing everything in coral). Two coats of paint were applied to the cabinets.

Shopping around for a top to fit over the two turntables, the author discovered three heavy, hollow core doors at the local lumber yard, which had been returned by a contractor after completing a job. All three were in excellent condition, but they had a hole for a doorknob and holes on the edge for hinges. A door was purchased for ten dollars.

The lumber company persuaded us to make 24-inch square cutouts on each end for the turntables (see diagram). The door was received a couple of days later, after wooden inserts were glued into place where

the cutouts were, to strengthen the top.

The door was walnut prefinished on one side, and had a blond prefinish on the other. We elected to use the dark side. We also purchased four seven-foot 2 x 4's, to hold the cabinets together. I determined that a seven-foot overall length would be suitable for the job. This would allow the needed three foot between the turntables for the Gates Yard. The cabinets were leveled, spaced, then bolted together, and the 2 x 4's painted. The top was then fastened to the cabinets and 2 x 4's with a number of three-inch wood screws.

The engineering department then asked a local welder to make up a small rack, which would run the entire length of the assembly (see Fig. 1). The rack was given one coat of rust-colored primer. While this was drying, the new arms were attached to the turntables, and checked. The one-tube pre-amps were also installed in the cabinets, and this was followed by a pot for level adjustment and a matching transformer for each unit. The metal rack was then attached to the top of the console.

After everything was checked again, the production department was warned that the production studio would be torn down for one day. I came in the next day at six a.m. and, with the assistance of the duty engineer, took apart the new console, (it would not go through the two doors), moved it into the production studio, took apart the old console, and transferred the board to the new console. The 30-inch rack was then placed on top of the metal rack in the center. The rack was measured beforehand and made to fit the metal top exactly. Next came the rewiring.

Several hours were spent removing a lot of old non-shielded wiring from the console and recording rack. This was replaced with shielded cables which eliminated the crossfeed

\*WBCO, Bucyrus, Ohio



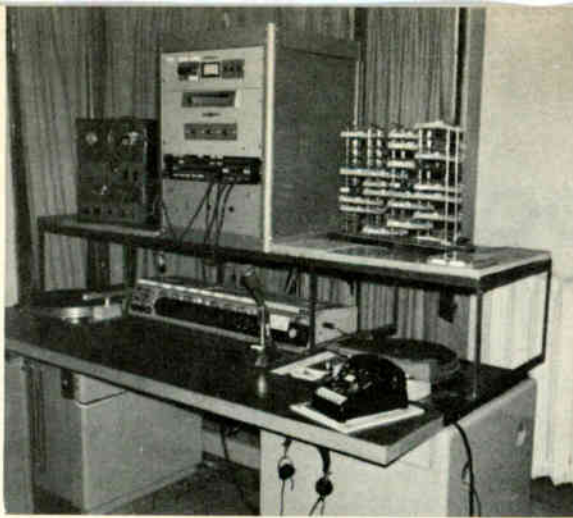

**Fig. 1** Operator position showing door table, the special rack and new location of equipment.



**Fig. 2** Console tape recorder is positioned at operator's left side.

problems mentioned earlier. The mike was removed from a temporary, banquet arm-stand setup, and put on a small desk stand. A number of patches were removed from the patch panel, and some new ones were added.

The two 24-inch cutouts from the door were cut down slightly, and used as shelves on each side of the recording rack. Electrical wiring was the next order of business, with a fifteen plug multiple outlet being attached behind the left turntable. This was wired through a master switch under the console at the operator's left knee. On the left shelf the small reel tape machine was positioned, and on the right we placed the empty cartridge rack.

The board was wired so that any switch thrown to the left, or audition, will automatically route the signal into the main input of the console tape machine. Any switch thrown to the right will route the program into the tape cartridge machine and onto the patch panel to "console out." Other patches on the panel include, "console in," "channel four input," "channel five in-

put," "telephone," "studio line," "cartridge machine in," "network," and "Ampex auxiliary input." The pots on the board include, mike 1, mike 2, telephone, console tape machine playback, turntable one, turntable two, cartridge machine playback, and network.

I ended the problem of a dangling headphone cord across the console by adding a headphone extension cord which plugged into the headphone jack on the right side of the board, and terminated the cord in a small aluminum box at the operator's right knee (Fig. 1). The headphones are then hung up on a small hook, keeping them off the console when not in use.

Also included in the Board are facilities for monitoring network on cue, and monitoring FM off-air signal, also on cue position. Each pot was also identified with stick-on labels.

The large console tape recorder was positioned at the left and in front of the new console, which puts it right at the operator's elbow (Fig. 2). Cartridges can be played back over the telephone for sponsor ap-

proval by patching from "console out" to "telephone," then simply playing back the cartridge.

Many network programs are recorded for later playback. Our system was designed so that the network could be recorded on the console tape recorder without disturbing production. We simply patch the "network" to an auxiliary input. The level is then controlled by the input pot on the tape machine, thus freeing the board for other duties. The console tape recorder is equipped with remote controls which are located in the control room. The controls include, stop, start, and record. This allows the machine to be started and stopped by the control room operator. The tape also can be played back in the control room and aired while the production studio is tied up.

The "console out" jack is patched to "studio line," which again bypasses the production facility. Audio, either off-air or from one of the remote receivers, can be routed over the studio line to the console tape machine for recording.

The small portable reel-type tape machine is used mostly for dubbing incoming commercial and public service spots onto cartridge. Its output feeds a "black box" which contains a pad and matching transformer. A lead from the black box then terminates in a patch panel plug, and the machine can be patched into either "channel four input" or "channel five input."

Since the photos in Figs. 1 and 2 were taken, a remote control panel has been added to the system. The panel is movable, satisfying both right and left handers, and is attached to the equipment by an eight-foot cord. Five switches on the panel control turntable one, turntable two, record set, stop, and start on the recording cartridge machine, placing all the necessary controls at the operator's fingertips.

The new setup answers the need for portability and ease of operation. And it proves once more that the engineers and technicians can be of more than maintenance value to the station. A little ingenuity and a good junk box were all that was needed. ▲

# NCTA convention report

## Progress and Promise Set Stage For Future

As the date drew near for the 1969 NCTA national convention in San Francisco, cable owners, operators and technicians stood in the midst of a freeze. They were very much aware of the FCC proposals and they were hopeful that a working agreement would emerge from the recent NAB-NCTA negotiations.

Equally important, the delegates were looking for long-range plans that would give the industry targets beyond wiring up a given number of homes per year. In order to do this, the NCTA brass needed to produce a plan that would transcend decades realistically, yet in such a manner as to challenge the imagination and give incentive to those in the industry. This kind of forward planning could add to the stature of the NCTA.

### The First Step

It was appropriate that NCTA president Frederick Ford led the charge as the first speaker on a panel considering CATV via satellites. Ford asked, "How does the satellite communications technology relate to the CATV industry? And is there a future for CATV in this exploding communications technology?"

He answered these questions by saying, "We are proposing today that the CATV industry take immediate advantage of the satellite technology by participating within the existing framework of organizations. The Communications Satellite Corporation is presently authorized to be a carrier's carrier. In other words, it is authorized to receive and deliver signals from other authorized carriers. We are proposing that the CATV industry become one of the prime users of the satellite capability in order to bring more program options and a diversity of services

to the television homes of the United States."

"We are proposing," Ford continued, "that we contract for part of the domestic satellite service to the extent that it would provide the backbone of a trunking system that would eventually interconnect several million CATV subscribers to provide a selection of program options that only CATV is designed to fulfill."

According to Ford, the concept would be to provide subscribers all local signals and a special "extra" package. The package would include six channels of programming. Two of these channels would be available to the Corporation for Public Broadcasting. A third channel would be a full-time, 24-hour weather service. This channel would be backed by a professional group of meteorologists who would devote 10 to 15 minutes per time zone.

A fourth channel would cover medical and health information as



NCTA President Frederick Ford . . . Six channels via satellite.



Beisswenger . . . Nobody in Washington is taking care of you.



well as special programming for medical and hospital professionals. The other two channels would provide continuous Capitol Hill reports and a special selection of program reruns.

"This, then, is a proposal," said Ford, "that will make major markets a viable CATV enterprise, and the technology exists today to put the programming package and the interconnect system together."

#### Beisswenger Urges Action

NCTA national chairman Bob Beisswenger told cable delegates, "Nobody in Washington is taking care of you, and you must fight the battle yourselves in your own area with your own congressmen."

Speaking before an early morning session, Beisswenger recounted the progress of the cable industry in the past year and commented at length on the recent NAB-NCTA meetings that at first surprised broadcasters and cable operators, then irritated them. He went on to insist that cable operators need to bear a major portion of the effort required to overcome the stall and move forward. Beisswenger made it clear that the NCTA cannot by it-

self dissolve all current industry problems.

Beisswenger pointed out that if the NAB and the NCTA do not settle their differences soon, Congress would have to intervene. Al-

though he urged further contact with the NAB, he said that if future meetings appeared to be designed to delay an agreement they should be immediately rejected by the NCTA.

## Mayor Speaks On Campus Unrest



Mayor Alioto

San Francisco's mayor, Joseph L. Alioto, addressed convention delegates on the subject of past, present and future methods of handling unrest on the nation's college campuses.

The chief of police and the mayor can handle the situation, Alioto said, if they move swiftly. He added that such problems can be handled best by professionals, not by college presidents.

"We ought to encourage dissent and be inordinately liberal on the side of dissent and reform," the mayor said, "but we must also say 'if you resort to violence, we will not hesitate to use police force'."

Mayor Alioto was speaking from personal experience. He also has addressed college audiences on more than 20 campuses in California and other states.

# NOW....the digital master clock you asked for.

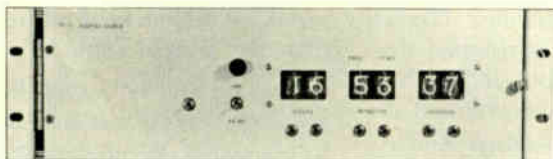

#### MASTER CLOCK DTI-701

Accuracy of 50 PPM. Readout of day, hour, minute, second. Internal or external sync. Fail-safe power supply. External reset. 1 second pip outputs at 4 audio frequencies.

#### ACCESSORY INSTRUMENTS SYNCHRONIZED TO DTI-701

##### RACK-MOUNTED SLAVE DTI-702

Cabinet and bracket available for wall mounting.

##### EXECUTIVE DESK MODEL DTI-703

Walnut cabinet. Attractive blue read-outs.

##### STUDIO MODEL DTI-704

Large read-outs for camera pick-up.

#### ELECTRONIC STOP-WATCH DTI-705

Reads out in hours, minutes, seconds, tenth's of second. Pause control. Zero Reset. Walnut cabinet or custom panel for installation into studio production control panel. Audio pips cue output.

#### RACK-MOUNTED SLAVE WITH STOP-WATCH DTI-706

Combines features of DTI-702 and DTI-705. Remote control stop-watch.

#### ELAPSED TIME CLOCK DTI-707

Presets to any time up to 9 hours in minutes, seconds. Internal or external preset input. Manual or external start. Pulse output in 1 second intervals, 10 seconds to zero, with synchronized audio pips.

For more details write or call:



**TELCOMP**  
MANUFACTURING

A DIVISION OF TELEVISION AND COMPUTER CORPORATION

2056 U. S. HIGHWAY 22, SCOTCH PLAINS, NEW JERSEY 07076 • (201) 233-6200



# NCTA shaping a future

## Technical Sessions Give Needed Lift

Along with a workable plan for reaching distant goals, the cable industry needed the backing of an industry that would produce the necessary hardware and accessories.

COMSAT representatives said they have the technology and the hardware to provide the industry with a satellite interconnect. And, they added, satellites are not toys. They are a dependable means of communications, with a versatility unmatched by present conventional means.

Meanwhile, J. Walter Johnson of Microwave Associates, Inc., told his session audience that the Community Antenna Relay Service (CARS) is now capable of handling CATV signals. Johnson said that microwave relay has not been popular because of technical problems in achieving system stability and the necessary transmitter power. Recent



advances have overcome these problems, he insisted, making quality multi-hop systems feasible for CATV applications.

Dr. Joseph Vogelman of Chromalloy American Corp. and Hubert Schlafly of TPT discussed recent microwave system developments and their possible applications.

There were also several session speakers detailing progress made in systems other than microwave. The session on demodulators was in-

tended to provide a broad background. It did just that, but one could not miss the importance of tests and new units covered in a speech by B.W. Osborne of Telemate and George Stoeppel of Rhode and Schwartz.

Moving from VTR's to antennas, the technical sessions were well attended and were aptly comprehensive. However, it did prove difficult for some delegates to make the 8 a.m. "Eye Opener" sessions as the days of the convention wore on.

## Congress watching NCTA-NAB negotiations

U.S. Congressman Torbert H. Macdonald, chairman of the House Subcommittee on Communications and Power, told members of the NCTA that the recent decision of the National Association of Broadcasters to seek extended re-negotiations of NCTA-NAB staff proposals for cooperation "must bear the closest examination."

Addressing a general luncheon meeting during the 18th annual national convention, the Massachusetts Democrat declared: "Subsequent developments will be watched closely by my committee and the Congress in general to see that the momentum gained thus far will not be dissipated." Reviewing the processes through which Congress deals with the problems of regulatory legislation, Macdonald told the convention delegates: "It is clear to me that legislation is needed to define your status in the communications complex."

Macdonald noted that there are two areas of jurisdiction which concern the cable television industry and that this has presented Congress with considerable difficulty: "Basic to your operation is legislation defining regulatory responsibility, but essential to orderly construction of such a bill is a resolution of the copyright questions that confront you." "It would seem," he said, "that one cannot be expeditiously resolved without the others."

Noting that the complexities of the cable television industry defy simplistic treatment, Congressman Macdonald borrowed from Newton and proclaimed "Macdonald's law": "For every regulatory action in communications there is violently adverse reaction."

Macdonald expressed concern that the public should not be deprived of service they now receive by whatever means of transmission

distribution, and declared: "I don't want to see any broadcast stations go dark; nor do I want to see CATV service diminished in areas it now serves or discouraged in those areas that may benefit from it."

He said that he hoped that, in an industry as volatile and as subject to technological advance as communications, "we should not be forever wed to concepts that inhibit rather than encourage innovation."

With regard to NCTA's recent efforts to reach an accord with the broadcasters, Macdonald said: "You must assume the burden of pursuing your present discussions and bring them to a satisfactory or at least realistic conclusion." "And then," he added, "you must support that conclusion in Congress." Macdonald warned that some members of Congress would not be particularly tolerant of sharp divisions between CATV and broadcast interests once accord has been reached by the two.

## Association Elections Held During Convention

Delegates to this 18th annual national convention were warned by session speakers that continued progress could only be made by excellence of leadership. With this in mind, they cast their votes and singled out M. William Adler as their new president.

Adler, the head of Television Communication Consultants of New York City, was a NCTA director in 1959 and 1960 and has been association treasurer. He has also served on the association's Community Services and Legislative committees.

Newly-elected NCTA vice chairman, Ralph L. Weir, Jr., of Junction City, Kan., is currently on the board of directors of Mid-America Cable TV Association and previously served as its president and vice president.

Monroe M. Rifkin, president of the American Television and Communications Corporation of Denver, Colo., was chosen national secretary and W. Randolph Tucker, Chairman of the Cypress Communications Corporation in New York City, was elected treasurer.

The newly-elected members of the NCTA board of directors are George J. Barco, president, Meadville Master Antenna, Inc., Mead-



ville, Pa.; William R. Brazeal, general manager of Community Television, Inc., Denver, Colo.; G. R. Gamble, president of National Trans-Video, Inc. of Dallas, Texas; Abram E. Patlove, president of Athena Communications Corp., a subsidiary of Gulf & Western Corp.; Robert G. Scallorn, general manager of three of Communications, Inc.'s operations.

Other directors are Gene W. Schneider, president of the GenCoE Corporation in Tulsa, Oklahoma; George L. Sisson, Jr., president and manager of Westerly Cable Television, Inc., of Westerly, Rhode Island, and Joel P. Smith, executive

vice president of Nation Wide Cablevision, Inc., Los Angeles. With the exception of Richard Gamble, the newly-elected NCTA directors will serve three-year terms. Gamble, who has already served one year as a director, will serve for a two-year term.

### Convention Notes

With the loss of NCTA president Fredrick Ford through a recently announced resignation, the cable industry is hard pressed to find continued excellence at the top. But the problem of finding quality people does not end there.

Throughout the communications industry there is a real need for technical people to keep a quality signal on the air and on the cable. Perhaps in future, conventions of national organizations will deal with this problem in panel sessions.

Of equal importance is the setting of and adherence to practical standards. Proof of performance standards and records, so much a part of broadcast life, could be used in cablecasting. But along with this must come some cooperation with future home TV set designs.

There were comments that the next NCTA convention should have improved booths and fewer sessions. A larger booth area would have aided the interchange of ideas between manufacturers and cable operators. However, in a young and growing industry, there must be a multiplicity of sessions available, even if they need to begin at 8 a.m. And it would be just as well to carry this thought over into regional and state associations



Converted cable cars were used as shuttle busses during the convention. While they were a convention convenience they will never replace the San Francisco originals.







# failure alarm

arranged in a voltage doubler configuration. A single diode in series with the grid supplies enough voltage to operate the tube to cut-off, but the time required to charge the delay capacitor approximately equals the release time. Therefore, with the voltage on the grid raised, the charge time was reduced to one second, and the bias bleed-off time was almost doubled at the maximum setting.

If a start pulse is required to operate in an automated system, the additional circuit shown will work satisfactorily. The duration of the pulse will be determined by the size of the charging capacitor. Any standard 24 VDC relay would suffice.

To set the unit up for operation, first set the threshold control, with no audio applied, until the alarm light operates. Advance the control

just a hair beyond this point. Then advance the audio sensitivity control until the light goes out. Setting the time control to midpoint will produce approximately a 15 second delay. Determining the time delay setting is largely a matter of trial and error. Kill the audio in the circuit being monitored, and wait a sufficient length of time so as to be sure the bias on the 6C4 grid has been completely bled off. Then reset the threshold control until the alarm comes on. Reapply the audio, and go through the procedure again. After several tries, consistent operation will be attained.

A certain amount of interaction between the audio sense control and the time control will be experienced, as increasing the sense control increases the negative charge on the time capacitor. Therefore, it will re-

quire a different setting of the time control to maintain the same release time.

Construction should follow standard practices, such as twisting all leads carrying alternating currents, and isolation of inputs and outputs as much as possible. The unit was constructed on a standard 3½ inch rack panel, using a chassis 3" x 4" x 17" mounted with the chassis opening downward to prevent dust collection. Components are mounted on terminal strips as much as possible.

It is hoped that construction articles, such as this one, will cause many engineers to try their hand at constructing their own equipment, thereby increasing their own ability and worth . . . and saving management much money in commercial equipment. ▲

## OPERATING LOG

## MODEL ADP-120

# DIGITAL AUTOMATIC TRANSMITTER LOGGER

DATE

STANDARD  
 DAYLIGHT

TIME	CAL.	1	2	3	4	5	6	7	8	9	10	11	12	13	14	15	16	17	18	19	20
------	------	---	---	---	---	---	---	---	---	---	----	----	----	----	----	----	----	----	----	----	----

0525	1000	0400	0300	2000	4000	2440	1300	0100	1500	0100	6800	0300	4000	3200	1010	2120	0200	4800	2000	1010	2120
0530	1000	0400	0900	2000	4000	2440	1320	0710	1500	0100	6800	0300	4000	3200	1010	2120	0200	4800	2000	1000	2120
0540	1000	0400	0900	2000	4000	2440	1320	0700	1500	0100	6800	0300	4000	3200	1010	2120	0200	4800	2000	1000	2120
0550	1000	0400	0300	2000	4000	2440	1320	0700	1500	0100	6800	0300	4000	3200	1010	2120	0200	4800	2000	1000	2120
0600	1000	0400	0300	2000	4000	2440	1320	0700	1520	0100	6800	0300	4000	3200	1010	2120	0200	4800	2000	1000	2120
0610	1000	0400	0300	2000	4000	2440	1320	0700	1520	0100	6800	0300	4000	3200	1010	2120	0200	4800	2000	1010	2120
0620	1000	0400	0300	2000	4000	2440	1320	0700	1520	0100	6800	0300	4000	3200	1010	2120	0200	4800	2000	1010	2120
0630	1000	0400	0300	2000	4000	2440	1320	0700	1520	0100	6800	0300	4000	3200	1010	2120	0200	4800	2000	1010	2120
0640	1000	0400	0300	2000	4000	2440	1320	0700	1520	0100	6800	0300	4000	3200	1010	2120	0200	4800	2000	1010	2120
0650	1000	0400	0300	2000	4000	2440	1320	0700	1520	0100	6800	0300	4000	3200	1010	2120	0200	4800	2000	1010	2120
0700	1000	0400	0300	2000	4000	2440	1320	0700	1520	0100	6800	0300	4000	3200	1010	2120	0200	4800	2000	1010	2120
0710	1000	0400	0300	2000	4000	2440	1320	0700	1520	0100	6800	0300	4000	3200	1010	2120	0200	4800	2000	1010	2120
0720	1000	0400	0300	2000	4000	2440	1320	0700	1520	0100	6800	0300	4000	3200	1010	2120	0200	4800	2000	1010	2120
0730	1000	0400	0300	2000	4000	2440	1320	0700	1520	0100	6800	0300	4000	3200	1010	2120	0200	4800	2000	1010	2120
0740	1000	0400	0300	2000	4000	2440	1320	0700	1520	0100	6800	0300	4000	3200	1010	2120	0200	4800	2000	1010	2120
0750	1000	0400	0300	2000	4000	2440	1320	0700	1520	0100	6800	0300	4000	3200	1010	2120	0200	4800	2000	1010	2120
0800	1000	0400	0300	2000	4000	2440	1320	0700	1520	0100	6800	0300	4000	3200	1010	2120	0200	4800	2000	1010	2120
0810	1000	0400	0300	2000	4000	2440	1320	0700	1520	0100	6800	0300	4000	3200	1010	2120	0200	4800	2000	1010	2120
0820	1000	0400	0300	2000	4000	2440	1320	0700	1520	0100	6800	0300	4000	3200	1010	2120	0200	4800	2000	1010	2120
0830	1000	0400	0300	2000	4000	2440	1320	0700	1520	0100	6800	0300	4000	3200	1010	2120	0200	4800	2000	1010	2120
0840	1000	0400	0300	2000	4000	2440	1320	0700	1520	0100	6800	0300	4000	3200	1010	2120	0200	4800	2000	1010	2120
0850	1000	0400	0300	2000	4000	2440	1320	0700	1520	0100	6800	0300	4000	3200	1010	2120	0200	4800	2000	1010	2120
0900	1000	0400	0300	2000	4000	2440	1320	0700	1520	0100	6800	0300	4000	3200	1010	2120	0200	4800	2000	1010	2120
0910	1000	0400	0300	2000	4000	2440	1320	0700	1520	0100	6800	0300	4000	3200	1010	2120	0200	4800	2000	1010	2120
0920	1000	0400	0300	2000	4000	2440	1320	0700	1520	0100	6800	0300	4000	3200	1010	2120	0200	4800	2000	1010	2120
0930	1000	0400	0300	2000	4000	2440	1320	0700	1520	0100	6800	0300	4000	3200	1010	2120	0200	4800	2000	1010	2120
0940	1000	0400	0300	2000	4000	2440	1320	0700	1520	0100	6800	0300	4000	3200	1010	2120	0200	4800	2000	1010	2120
0950	1000	0400	0300	2000	4000	2440	1320	0700	1520	0100	6800	0300	4000	3200	1010	2120	0200	4800	2000	1010	2120
1000	1000	0400	0300	2000	4000	2440	1320	0700	1520	0100	6800	0300	4000	3200	1010	2120	0200	4800	2000	1010	2120
1010	1000	0400	0300	2000	4000	2440	1320	0700	1520	0100	6800	0300	4000	3200	1010	2120	0200	4800	2000	1010	2120
1020	1000	0400	0300	2000	4000	2440	1320	0700	1520	0100	6800	0300	4000	3200	1010	2120	0200	4800	2000	1010	2120
1030	1000	0400	0300	2000	4000	2440	1320	0700	1520	0100	6800	0300	4000	3200	1010	2120	0200	4800	2000	1010	2120
1040	1000	0400	0300	2000	4000	2440	1320	0700	1520	0100	6800	0300	4000	3200	1010	2120	0200	4800	2000	1010	2120
1050	1000	0400	0300	2000	4000	2440	1320	0700	1520	0100	6800	0300	4000	3200	1010	2120	0200	4800	2000	1010	2120
1100	1000	0400	0300	2000	4000	2440	1320	0700	1520	0100	6800	0300	4000	3200	1010	2120	0200	4800	2000	1010	2120
1110	1000	0400	0300	2000	4000	2440	1320	0700	1520	0100	6800	0300	4000	3200	1010	2120	0200	4800	2000	1010	2120



Designed specifically for the broadcaster, the **ADP-120 Digital Automatic Transmitter Logger** provides a typed log in a clear and familiar vertical columnar format. A true data printer, an IBM Output Writer, types the log. Utilizing the field proven features of our ADP-101 Logger, the ADP-120 will log up to 20 parameters automatically every 10 minutes. All active circuitry is silicon solid-state and of plug-in modular construction for easy access. Out-of-tolerance parameters can be printed in red and an aural alarm sounded to alert personnel. Contact our Marketing Manager for Bulletin 221A describing the **ADP-120 Digital Automatic Transmitter Logger**.

**MOSELEY ASSOCIATES, INC.**  
SANTA BARBARA RESEARCH PARK

111 CASTILIAN DRIVE  
GOLETA, CALIFORNIA 93017  
(805) 968-9621

Circle Number 26 on Reader Reply Card

**COMPARE...  
YOU'LL BUY a  
CCA "ULTIMATE"  
10 FADER STEREO or  
DUAL CHANNEL MONO  
CONSOLE**

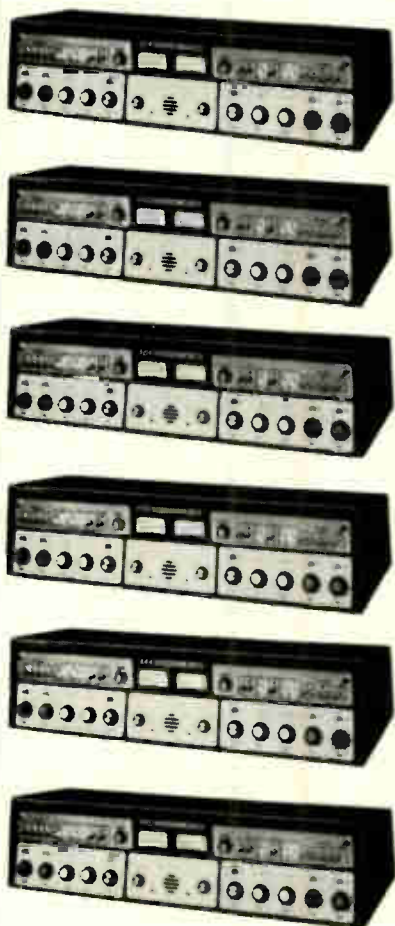

We've not spared any expense in offering our completely transistorized, full capacity, ten fader stereo and dual channel mono consoles. We're using Altec faders, Altec pre-amplifiers and Altec transformers!! Substantial switchcraft switches!! A completely enclosed RF shielded metal cabinet dressed with mahogany wood and covered with handsome formica!! Switching facilities beyond your expectations!! You will understand why we call these consoles — the "ULTIMATE". Detailed literature upon request.



**CCA ELECTRONICS CORP.**  
716 Jersey Ave., Gloucester City,  
New Jersey 08030 • (609) 456-1716

## Cartridge Tape Tips

Dear Editor:

Here are a couple of solutions to some of my problems with tape cartridges.

The small station with a limited budget must get the utmost from each equipment dollar. A few cents here and a few more cents there often makes the difference when it comes time to hit the boss up for a new microphone or some other item. Here are a few tips that have saved a lot of money by extending the useful life of our tape cartridges to two or three times the usual life span.

A major cause of premature failure of our Fidelipac 300 cartridges is the tendency of the cartridge top to give out in the area around the screw-hole. I mentioned this to our cartridge supplier, and he said he would be most happy to sell me some new cartridge tops for only 65¢ each. Rather than pay out the better part of a dollar for a new top that would probably break down in less than a year, I set out to find a more economical solution. Every cartridge I have seen has a flat-head screw in a hole that is not counter-sunk. In regular use, the flexing of the top places undue stress sideways and downwards, causing the flimsy plastic boss to eventually tear out. Tear-out can be furthered by over-zealous use of the screwdriver. By substituting a pan-head screw with flat shoulders for the original flat-head screw with sloping shoulders, the stress is distributed properly over a much larger area, and the sideways stress is completely eliminated. After instituting this change over a year ago, I haven't encountered a single case of "shattered screw-hole syndrome." This amounts to quite a savings when you consider that screws cost only a few cents apiece, and replacement cartridge tops cost 65¢.

Another cause for concern is "cauliflower cartridge." This becomes evident after a year or so of

hard use, and is characterized by scratched sides and ragged edges, particularly around the openings for the record and playback heads. The first step is to select an especially sad cartridge, insert it into the machine and note which sharp projections cause corresponding burrs on the cartridge. File these projections away or pad them with pieces of adhesive plastic label tape such as that used in Dymo label makers. Be sure to check out each recording and playback machine in turn. Finally, place strips of tape on the deck near the outsides of the cartridge slot and line all guides and pad all stops with tape. By lining and padding all wear points, you will prevent wear, permit easier insertion and reduce damaging shock.

Embarrassing on-air tape drag and costly loss of valuable recorded material can be drastically reduced by periodically checking pressure pads, wires, corner posts and Teflon washers. Replace worn parts whenever they are observed, and be sure to lube the washer and center post everytime the cartridge is rewound. I have found that Lubriplate works very well. Keep a stock of repair parts on hand for emergency repairs. If you have trouble obtaining parts, they are available from Sparta Electronic Corp., 5851 Florin-Perkins Road, Sacramento, Calif. 95828.

With proper preventive maintenance measures, I am sure that you can extract the full measure of service from those expensive tape cartridges.

**Steven G. Damewood**  
KRNO Radio  
Roseburg, Oregon

**Moving?  
Send Your Change  
Of Address To:**

**Broadcast Engineering**  
**1014 Wyandotte**  
**Kansas City, Mo. 64105**



Dear Editor:

George Jennings of WCMB provided some excellent angles in the May 1969 issue on repairing cartridge lids with broken-out screw holes, which are a common problem at many stations.

Here are a couple of additional comments on this problem. George complained of not having been able to locate a supplier of replacement parts for cartridges. We have purchased tops and other parts from JOA Cartridge Service, Box 3087, Wadsworth Station, Philadelphia, Pa. 19150.

Another hint related to tape cartridges: a fairly simple method of winding small quantities. We wind the new tape onto a small tape reel on our Ampex recorder, timing the tape length. Then this small reel is put on a turntable, with a Teflon washer under it to allow it to run freely. We wind it across onto the cartridge hub on the other turntable. This system winds the tape loosely and has given us no trouble with tight cartridges. While winding, the cart hub rim is held down on the turntable with a piece of masking tape. This is a fairly simple system and probably already in use at many stations. For those who haven't already discovered it, we suggest you give it a try.

In replacing the old-style felt pressure pads with the new Teflon-coated pads, there are two problems. First, the old slot in the cartridge base is too thin to accept the thicker unit; and second, the new unit must be glued or otherwise fastened in place. We have found one simple solution to both these problems. After removing the old pressure pad assembly, place the new unit in the slot, pressing it down as far as it will go. Then press down lightly on it, at its center with a clean, hot soldering iron until it has imbedded itself with the metal strip flush with the top edge of the plastic. Remove the soldering iron and quickly make any final adjustments needed for alignment.

When the assembly has cooled, it is ready to go.

**Paul Martin**  
Chief Engineer  
WNOG/WNFM  
Naples On The Gulf  
Florida

# The Perfect Log

## STANCIL-HOFFMAN R-70

### 24 HR. 4 TRACK RECORDER



Here's a full 24 hour, 4 track logger that's so compact and versatile you can take it anywhere to handle any assignment with 100% dependability or rack mount it in the studio. A remarkable new series of silicon transistor plug-in amplifiers makes the R-70 the most versatile ever—AGC, recall, full remote or automatic control, stereo, fail-safe, synchronous time injection, etc. 4 channels round the clock, complete on just one 7" reel of 1/4" tape.

WRITE NOW FOR SPECIFICATIONS AND PRICES.

**STANCIL-HOFFMAN CORP.**

921 NORTH HIGHLAND, HOLLYWOOD, CALIFORNIA 90038

Circle Number 27 on Reader Reply Card

## LDA SERIES LAP-DISSOLVE AMPLIFIERS



- No Tracking Adjustments Required
- No Clamp Drive Pulses Required
- No Color Shift During Transition

LDA Series Lap-Dissolve Amplifiers assure a velvety transition between two signal inputs. All solid state, the units provide the signal handling characteristics of a high performance distribution amplifier. Photoelectric cells, remotely controlled by DC circuits, eliminate the possibility of color shifts and level changes; and differential phase and gain do not change even during the lap interval. For convenience, a Fader Arm control is optionally available.



**APPLIED ELECTRO  
MECHANICS, INC.**  
2350 Duke Street  
Alexandria, Virginia 22314  
Phone: (703) 548-2166

Circle Number 28 on Reader Reply Card

## The Sound Buy: STL TAPES

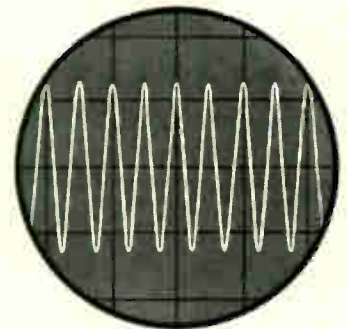

Taber handles a complete line of STL professional test tapes, including full-track 1/4" test tapes at speeds of:

3.75 ips 7.5 ips 15 ips

Dealing directly with us—factory to user—allows low price of \$21.00 each. Orders received today are shipped today!

**STRETCH** your budget!

Make Taber your tape headquarters!

Call or write: **TABER** MANUFACTURING AND EQUIPMENT COMPANY

OAKLAND INTERNATIONAL AIRPORT, BLDG., L-821  
P. O. BOX 2365 • OAKLAND, CALIFORNIA 94614  
Telephone (415) 635-3832

Circle Number 29 on Reader Reply Card



# NEW PRODUCTS

## Recording Tape

A new CCTV magnetic recording tape that offers the same professional performance as broadcast tape is announced by **Memorex Corporation**, producers of a wide range of precision magnetic media.

Called Chroma, the new tape is a high-sensitivity tape made for CCTV recording. It can be used in color or black and white, and was designed for the new slower speed recorders, whether 1 inch or 1/2 inch.

The manufacturer claims the high sensitivity of Chroma gives better pictures and sound, a significantly lower noise level than tapes previously used on slow-speed recorders, and tests reveal that initial drop-out activity is 1/3 less than those of the best competitive CCTV tapes.

Chroma's coating not only gives unusually long wear lift but also minimizes the possibility of clogged heads, thus reducing the frequency of recording failure or playback interruption due to loss of head-to-tape contact.

Circle Number 55 on Reader Reply Card

## Program Automation

A new advancement in radio automation has been announced by William J. Overhauser, president of **Sparta Electronic Corporation**. The first product in a new line called SPARTAMATION is an Automatic Program Controller Model 726.

Overhauser said that the Model 726 is a low cost device that will control any combination of broadcast quality audio sources to provide an automated program service, limited only by the imagination of the user. Applications include radio and television, CATV and background music."

It can be used with existing time announcers, network joining systems, random selecting spot players, etc. Both cartridge and reel-to-reel equipment can be intermixed, and it is not necessary to use only one

manufacturer's transports. This makes it possible to use existing equipment rather than having to purchase a complete automation system from the ground up. The SPARTAMATION Model 726 provides for seven audio sources and twenty six events.

Circle Number 56 on Reader Reply Card

## Voltmeter

The new Model 2006 Frequency Selective Voltmeter from **B & K Instruments, Inc.**, Cleveland, Ohio, is a completely self-contained, precision instrument designed to directly measure voltages in AM-FM, single sideband, and television frequency ranges.

The battery-powered voltmeter features seven overlapping frequency ranges from 100 kHz to 230 MHz. It will perform a number of selective RF voltage measurements within a 2-millivolts to 50-volts range. Voltage level and audible characteristics, as well as modulation percentages of an input signal, can be determined.

A versatile readout system is employed, with four major output indicators provided—dual range meter for modulation index and voltage sensitivity levels, frequency indicator dial, and built-in loud speaker to permit the operator to listen to incoming signal characteristics.

Self-calibration is established from a built-in, stabilized 2.5 mV, 30 MHz reference voltage oscillator. Further adjustments while sweeping the frequency range are not required. A high impedance probe and dual inputs for impedance probe and dual inputs for impedance matching provide maximum versatility for voltage measurements.

Circle Number 57 on Reader Reply Card

## Remote Control System

Ten metering positions plus calibration and 20 individual control functions are the capacity of a new remote control system introduced recently by **Moseley Associates, Inc.** of Santa Barbara, California.

Designed exclusively for radio (STL) service, this system, Model RRC-10T, utilizes modular, plug-in PC card construction. Control sub-carrier generator and detector are included for interfacing with the firm's aural STL's. Unique slide-out drawer construction is employed.

Routine maintenance or servicing is accomplished by simply sliding out a drawer.

Metering is returned via a sub-audible signal, 22-36 Hz, sinusoidal. This subaudible metering is used by many FM stations to allow metering return on an SCA channel while simultaneously programming this SCA channel. Metering return signals of this type are also proposed for use by AM stations in Docket #17873, RM-320 submitted by the Santa Barbara firm and now pending before the FCC. An audible metering output is available on special order.

Circle Number 58 on Reader Reply Card

## Impedance Adapter

The complex impedance (magnitude and phase) of antennas and cable networks, of filter and amplifier inputs and outputs, or of any two-terminal device can now be determined on a sweep-frequency basis in a range between 10 kHz and 32 MHz. This is made possible by a new accessory, the **Hewlett-Packard Model 11138A Impedance Adapter**, for the Hewlett-Packard 675A/676A Network Analyzer.

Measurement results are displayed as plots of impedance magnitude and phase vs frequency on an oscilloscope or X-Y recorder. The device to be measured is connected to the Impedance Adapter, which in turn connects through attached cables to the input and output connectors of the Model 676A Tracking Detector. The Model 675A Sweeping Signal Generator supplies RF power to the Impedance Adapter by way of the Tracking Detector.

The measurement range of the Impedance Adapter is from 0.3  $\Omega$  to 3 k $\Omega$ , wide enough to accommodate most RF devices. Impedance magnitude is displayed on a logarithmic scale in units of dB, enabling the user to observe a 10,000:1 impedance variation on one scale with simultaneous display of phase over a  $\pm 90^\circ$  range. Accuracy is specified to be within 15% but accuracies of 1% are possible by using the ability of the system to compare an unknown to a standard impedance, or by calibrating the system with a known impedance of about the same magnitude as the unknown.

Circle Number 59 on Reader Reply Card

## Microwave System

Collins has a new MW-318 all solid-state microwave radio relay system designed to provide improved performance and reliability in the long haul transmission of voice and data in the 6.425- to 6.875-GHz range. Increased fade margins result from full one-watt transmitters and low-noise receivers providing system gains as high as 115 db from antenna to antenna.

With low-noise receiver and transmitter basic oscillators operating higher than 1 GHz in frequency, the noise performance of the MW-318 is typically 10 dba0/path 300 channel loading or 12 dba0/path/600 channel loading.

Reliability is reportedly improved with the use of all-solid state construction, extensive use of integrated circuits, high speed waveguide and base-band switching.

The MW-318 is available in a number of non-standby, hot-standby, and diversity configurations and operates from either -24 vDC or -48 vDC battery power sources. Power requirements are low: 90 watts per transmitter/receiver.

Circle Number 60 on Reader Reply Card

## CATV Demodulator

Availability for the first off-the-air demodulator designed specifically for cable TV head-end systems has just been announced by **DYN-AIR Electronics, Inc.**

Called the RX-4B Dyna-Tune, the demodulator is completely solid-state and features a field-effect transistor front end with liberal use of the latest integrated circuits. The standard unit is supplied with a plug-in variable tuner which will receive any standard VHF or UHF television channel. An optional tuner model is available for crystal-controlled operation on a single pre-selected channel.

Utilizing completely new filtering and signal-restoration techniques, the Dyna-Tune provides adjacent-channel color performance in either microwave-fed or demod-mod cable television systems. DYN-AIR claims these developments allow the Dyna-Tune to improve the color signal in many critical areas over that produced by the broadcast RF transmission system.

Circle Item 61 on Tech Data Card

# Safe Driver

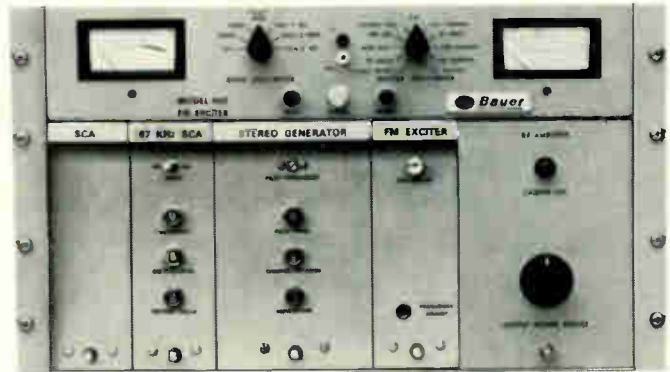

## NEW SOLID-STATE FM "DRIVER" PUTS STEREO, MONO AND SCA CONTROL AT YOUR FINGERTIPS

Even old amplifiers get a fresh, clean start with the Granger Model 660 FM Exciter. The 5 to 12 watts output offers plenty of driving power to give FM'ers a new sound.

The G/A Exciter's direct-FM system assures the cleanest possible signal, and stereo separation is 35 db or better from 50 Hz to 15 kHz. Compact plug-in modules for mono, stereo and SCA use reliable integrated circuits and are completely solid state. Built-in meters and test probe let you make on-the-air checks for easy, routine maintenance. A built-in load fault protection system keeps the RF amplifiers safe from short or open circuits.

There's more to tell. Write for information. . . and drive safely with the Granger (Bauer) 660 FM Exciter.



**BAUER**  
BROADCAST PRODUCTS

1601 California Ave., Palo Alto, California 94306

Circle Number 32 on Reader Reply Card



For  
any Vidicon  
camera you  
put here...

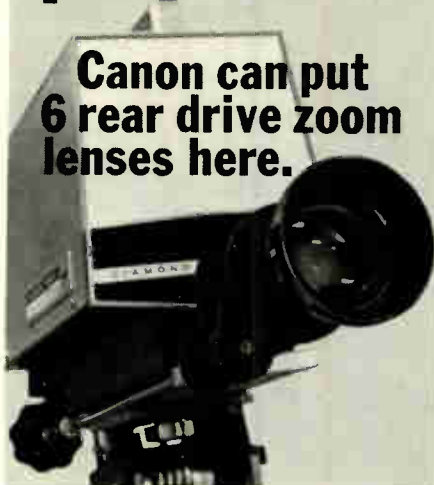

And they're all interchangeable . . . without changing the rear drive controls. So you can swap the 4:1 Canon zoom on your Ampex camera with the 12:1 Canon on your GBC. Or, if you need a faster lens, add our 15-120mm f/1.3 (the fastest zoom around) without having to replace your control drive.

Canon gives you the biggest zoom selection, too, in 4X, 5X, 6X, 8X, 10X and 12X ratios. All available manually operated, with interchangeable rear rod or cable drive, or with powered remote control of focus, zoom and iris. (There's even an automatic iris version of our 25-100mm remote lens.)

Need zooms for Plumbicons or Image Orthicons? We have them, too. Plus fixed focal length lenses for every "C" mount application. All with the optical precision for which Canon is famous. Write for full information.

The lens you need is made by

**Canon**

Canon U.S.A., Inc. 64-10 Queens Boulevard  
Woodside, N. Y. 11377

Please send information on  manual zooms,  remote-control zooms,  fixed focal length lenses for  Vidicon,  Image Orthicon,  Plumbicon TV cameras.

Name \_\_\_\_\_  
Title \_\_\_\_\_  
Company \_\_\_\_\_  
Address \_\_\_\_\_  
City \_\_\_\_\_ State \_\_\_\_\_ Zip \_\_\_\_\_

Circle Number 33 on Reader Reply Card

# TECHNICAL DATA

100. **ALCO ELECTRONIC PRODUCTS, INC.**—A detailed 4-page catalog lists a new line of ALCOLITE miniature lamps and panel assemblies. Neon T-1 $\frac{3}{8}$ " sub-miniature lamps with a choice of short bare leads or 10" insulated leads are described for individual lamp or as part of a panel assembly. Alco BFK-1 replaceable lamp assemblies are shown, and a detailed listing of 110V neon light indicators using NE2H high intensity lamps are included.
101. **AMERICAN ELECTRONIC LABORATORIES, INC.**—The company announces the publication of a new brochure on its series of solid-state switches. The AEL single pole single throw solid-state coaxial switches make frequency ranges available from .005 through 8.0 GHz. The single pole double throw solid-state coaxial switches offer frequency ranges from .02 through 4.0 GHz. Single pole single throw solid-state waveguide switches range from 5.4 through 11.2 GHz.
102. **AMERICAN MICA INSULATION CO.**—A new 4-page brochure describes the products and processes used in fabricating insulation materials. The brochure updates the company's participation in the fabrication of phenolics, mylar, mica and glass base materials, as well as illustrating its expanded facilities for handling contract assemblies.
103. **BIRD ELECTRONIC CORP.**—The new 4-page Short Form Catalog SF-69 lists nearly all the coaxial load resistors, absorption wattmeters and directional wattmeters stocked by Bird. Feature product is a new series of miniature insertion wattmeters for maintenance of communications systems.

One of a series of brief discussions  
by Electro-Voice engineers



Upgrading a successful product to take full advantage of present technology is always an interesting challenge to the design engineer. Any alterations must provide clear benefits to the user and/or advantages in production efficiency in order to offset the costs of the changes.

A case in point is the new Electro-Voice Musicaster 1A\*. This indoor/outdoor wide-range PA speaker has found wide application where extended response is required for both voice and music at high efficiency in a modest size.

In this redesign effort, only the basic concept remained untouched. New advances in molding glass-filled polyester permitted uniform thin-wall construction that saved over 2 lbs. compared with the original aluminum die-cast enclosure. Strength and rigidity were undiminished by the change. The new material possesses much higher internal damping than the original aluminum casting, thus improving system transient and frequency response.

Speaker size has been increased from 8" to 12" with a notable improvement in low frequency range and response uniformity. To further smooth overall response, the Musicaster 1A interior is filled with fiberglass and the peripheral ducted ports from the original design have been retained.

Silicone treatment of the cone aids in resisting the effects of moisture. In addition, the speaker is now protected by a  $\frac{1}{4}$ " thick Acoustifoam\* weather barrier behind the grille screen. This unusual open-cell foam plastic sheeting is virtually transparent to sound, yet its small cell construction effectively bars water droplets from entering, even when driven by relatively high winds.

In addition to the functional changes to improve performance and reliability, appearance changes were made to create a contemporary style more in tune with today's architectural trends.

The result of these changes has been to create an entirely new speaker system that retains the basic advantages of the original Musicaster while providing better performance and easier installation at lower cost to the user.

\*Electro-Voice trademark

For reprints of other discussions in this series,  
or technical data on any E-V product, write:  
ELECTRO-VOICE, INC., Dept. 893V  
638 Cecil St., Buchanan, Michigan 49107



Circle Number 34 on Reader Reply Card

BROADCAST ENGINEERING



104. **HEWLETT-PACKARD** — A new edition of the Electronic Counter Selection Guide is available. It compares all H-P counters, giving model numbers, descriptions, frequency ranges, numbers of digits, measurement functions, input characteristics, time base stabilities, gate times, digital outputs, remotely controllable functions and prices.
105. **MARYLAND TELECOMMUNICATIONS** — An illustrated 4-page catalog sheet SC-269-1 describes flexible, pre-packaged Video Explorer CCTV systems including the variety of special optics for instrumentation, inspection and training applications.
106. **MONSANTO ELECTRONICS**—Monsanto Co. announces the latest issue of Monsanto Metricist. This sixth issue contains articles on the selection and use of a plug-in counter, programming the Monsanto Model 3100A-016 frequency synthesizer, as well as the second in a 3-part series by Robert Sinusas, senior engineer specialist, Monsanto, on the true nature and behaviour of the capacitor.
107. **NATIONAL SEMICONDUCTOR CORP.** — A reliability report on transfer mold encapsulation of integrated circuits is available upon request from National Semiconductor. The report describes the results of various combinations of possible materials under environmental and life testing conditions. Complete description and step-by-step flow chart of molded encapsulation process is given. Also—a report describing the company's reliability program on selected linear integrated circuits is available.
108. **NORELCO**—Product sheets are now available on Philips leakage-breakdown voltage meters, generation counter-timers and digital multimeters, Philips Model PM 6509 voltage meter, Model PM 6630 counter-timer, and the new Philips multimeter, PM 2421.

109. **PHOTO RESEARCH**—Technical literature is available describing the "SPECTRA" line of photometers, illumination meters and related photometric equipment. The literature is well illustrated and includes complete price sheets.
110. **SAN FERNANDO ELECTRIC**—General characteristics and complete ordering data by series for the complete West-Cap line of Monoceram Ceramic Capacitors, type 1200 or NPO are highlighted in a 24 page brochure. Bro-

chure contains detailed information on sizes and configurations in each series, also temperature ranges and coefficients, capacitances, tolerances, types of leads and electrical parameters. A set of charts is included.

111. **TRAIID CORP.**—Just published is a 14 page booklet illustrating the 16mm and 35mm data cameras, lenses, projectors, film movements and automatic film readers in the company's 1969 line.

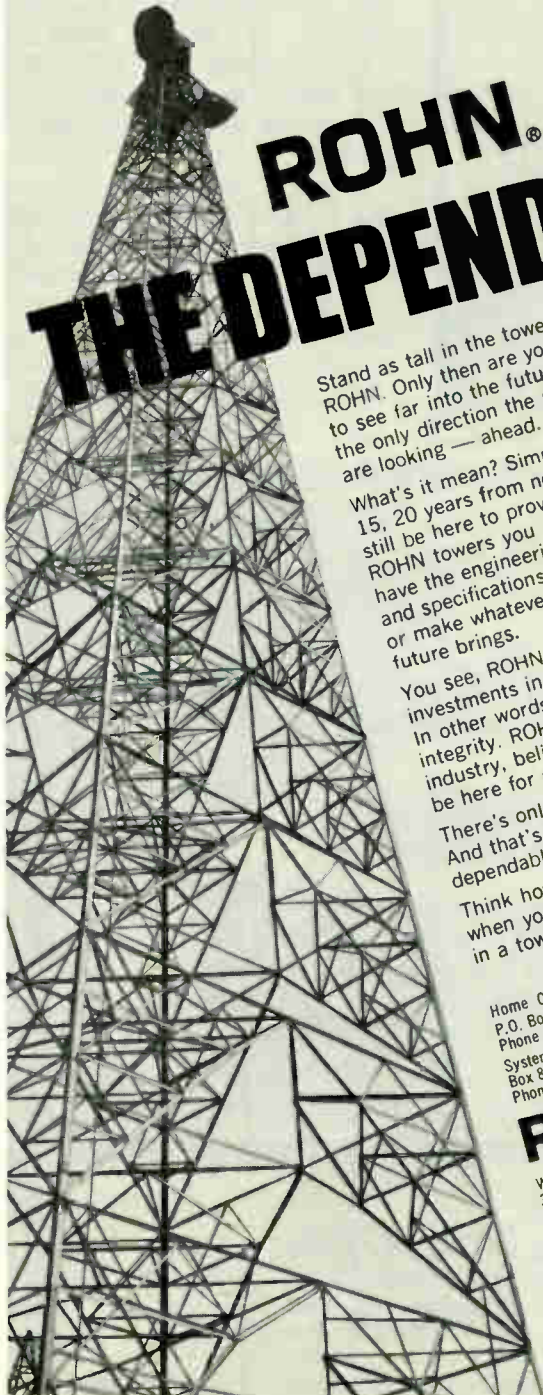

# ROHN® THE DEPENDABLES

Stand as tall in the tower field as ROHN. Only then are you high enough to see far into the future. That's the only direction the men at ROHN are looking — ahead.

What's it mean? Simply that in 10, 15, 20 years from now, ROHN will still be here to provide service for the ROHN towers you erect today. Still have the engineering files, drawings, and specifications to update, upgrade, or make whatever changes the future brings.

You see, ROHN has tremendous investments in plant and equipment. In other words, financial and personal integrity. ROHN supports this industry, believes in it, and plans to be here for a long, long time to come.

There's only one way to do that. And that's to be absolutely dependable.

Think how important this is when you make an investment in a tower!

Home Office — Factory  
P.O. Box 2000, Peoria, Illinois, U.S.A. 61601  
Phone 309-637-8416 TWX 309-697-1488

Systems Office —  
Box 877, Richardson, Texas 75080  
Phone 214-AD1-3481

## ROHN®

Western Office —  
310 Quincy Street, Reno, Nevada 89502  
Phone 702-322-9300

Eastern Office —  
P.O. Box 2101  
Hanover, Mass. 02339  
Phone 617-826-2511

Southern Office —  
P.O. Box 6537, Birmingham, Ala., 35217  
Phone 205-841-1789

For further information, circle the product identification number on the reader reply card.

Circle Number 35 on Reader Reply Card

## DAR SERIES VIDEO DISTRIBUTION AMPLIFIERS



- All Solid State
- Distribution to Six Isolated Outputs
- Exceed All NTSC Specs

AEM Video Distribution Amplifiers are designed to be **INSTALLED** and **FORGOTTEN**. All solid-state, they provide distribution to six isolated outputs while exceeding all NTSC color and monochrome specifications. Units contain front panel input and output test jacks for each line, and have their own regulated AC to DC power supply. Available in rack mount or portable configurations, the units offer "Sync Add" and Remote Gain Control options.



**APPLIED ELECTRO  
MECHANICS, INC.**

2350 Duke Street  
Alexandria, Virginia 22314  
Phone: (703) 548-2136

Circle Number 36 on Reader Reply Card

## PEOPLE IN THE NEWS

### EIA Honors FCC Chairman

**Rosel H. Hyde**, chairman of the Federal Communications Commission, was honored by the Electronic Industries Association for his service to the communications industry.

In a presentation made at a luncheon meeting during the EIA 45th Annual Convention in Chicago, Association President Mark Shepherd, Jr., recalled Hyde's 23 years of service with FCC, which was known as the Federal Radio Commission when he first joined it in 1928.

"We are convinced," Shepherd said in making the presentation, "that no government official in Washington's executive departments and agencies has won greater respect from the public he serves and the industry the FCC regulates than has Commissioner Hyde." Hyde, a

Republican, was appointed FCC Commissioner in 1953 by President Eisenhower and in 1966 by President Johnson. His past term on the Commission expired June 30.

**George Hall**, associate director, National Association of Educational Broadcaster's Office of Research and Development, has been invited by UNESCO to join a twelve man study team to evaluate the possibilities of establishing a center for educational innovation in Indonesia. The mission, headed by Robert Lecerf, UNESCO economist, left June 9 for UNESCO headquarters in Paris for a week's briefing. Their tour in Indonesia is expected to take about a month.



**SPARTA-MATION**  
MODEL 726 AUTOMATIC PROGRAM CONTROLLER



**ELECTRONIC CORPORATION**

5851 FLORIN-PERKINS ROAD  
SACRAMENTO, CALIFORNIA 95828 (916) 383-5353

A DIVISION OF COMPUTER EQUIPMENT CORPORATION

*Meet our  
Simple Minded*

## PROGRAM DIRECTOR

Works for pennies 24 hours a day, 365 days a year, without a complaint, a vacation or a raise!! It does not drink, smoke, gamble or have babies! It DOES give you a simple low cost Automation System.

The new, Model 726 Program Controller can be used with your existing reel-to-reel and cartridge equipment! It gives you absolute sound and format control automatically without buying a mass of expensive equipment.

Circle Number 37 on Reader Reply Card



**Ralph E. Green** has been appointed Director of Engineering for CBS Radio effective July 14, it has been announced by **Maurie Webster**, vice-president, CBS Radio Division, for Division Services.



**Ralph E. Green**

Green has been Director of Operations for WCBS and WCBS-FM, New York, since 1965. He began his broadcasting career as a staff engineer at WCAU-AM, FM and TV, Philadelphia, in 1950. From 1962-65, Green was Director of Engineering at WCAU and WCAU-FM.

## Indiana ETS/PS Director Named

**Robert M. Reed**, Director of the Hawaii ETV Network has been named Director of the Educational Television Stations Program Service (ETS PS) in Bloomington, Indiana. Reed was also Associate Professor of Education and Director of Educational Television at the University of Hawaii. He succeeds David H. Leonard, now Director of the Pennsylvania Public Television

Network, and will assume his new post on August 15.

## IEEE Appointment

The Institute of Electrical and Electronics Engineers has appointed **H. James Carter** to the newly created post of managing editor of IEEE Transactions.

As Managing Editor, Carter will have responsibility for the copy editing, styling and production of thirty-three technical journals serving the members of IEEE Groups.

## Rapid-Q Tape Cartridge Equipment



- Automatic fast-forward rapid cue — minimizes wait between messages
- Exceeds all NAB standards
- Full logic switching — without relays
- Stereo or monaural

- Latest integrated circuitry — most compact recorder-reproducer available
- Proven servo-controlled drive
- Desk-top or rack-mount

**VISUAL ELECTRONICS CORPORATION**  
356 W. 40th St., New York, N. Y. 10018 ■ (212) 736-5840

Circle Number 38 on Reader Reply Card

# Scala PARASLOT

Model SL8 for Channels 14-83  
UHF low power TV transmitters  
and translators

- The patented Paraslot Antenna is made of anodized, extra heavy wall precision machined aluminum tubing.
- Radiation elements are precision machined slots.
- No exterior projections; radiating elements are not exposed to weather.
- Maximum gain over isotropic source: 13.63 db.
- Maximum gain over dipole: 11.49 db.
- Minimum gain over isotropic source: 9.33 db.
- Minimum gain over dipole: 7.18 db.
- Total vertical beam width at half power point: 5.8
- 1.75 down tilt standard. Combined down tilt and null fill available.

Write for detailed specifications—and complete catalog on corner reflectors, color logs, UHF-VHF yagis, ground plane antennas, and Paraflector antennas by Scala.

**SCALA RADIO CORPORATION**  
1970 Republic Ave., San Leandro, California 94577  
(415) 351-3792

Circle Number 39 on Reader Reply Card

## ERASE RECORD REPRODUCE

MONO - STEREO

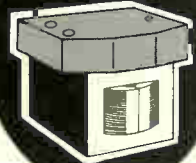

Professional Direct Replacement Heads with complete written and pictorial instructions

Our factory will clean, rebuild, adjust and test your head ASSEMBLY...install new MMI heads...replace minor hardware and modify your gate to accept our "NON-POPPING" springs

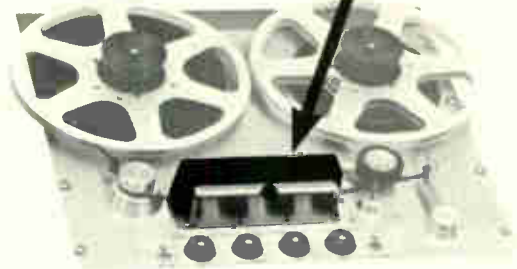

36 HOUR SERVICE — LOANERS AVAILABLE  
(612) 884-7393



**MINNEAPOLIS MAGNETICS, INC.**

8125 PLEASANT AVE. SO., MINNEAPOLIS, MINN. 55420

Circle Number 40 on Reader Reply Card



**Dr. George Bair**, chairman of the Executive Board of Directors of the National Association of Educational Broadcasters, on June 10 announced the appointment of three new public members of the NAEB Executive Board. They are **Laymond Robinson**, public relations director of the National Urban League, N.Y.; **Elvis Stahr**, president of the National Audubon Society, New York, N.Y., and **Edmund F. Ball**, president and chairman of the board, Ball Brothers Co., Inc., Muncie, Ind.

## NAB Elects Board Chairmen

**Willard E. Walbridge**, vice-president and general manager of KTRK-TV, Houston, Tex., was unanimously elected as chairman of the 44-member Board of Directors of the National Association of Broadcasters.

He succeeds Grover C. Cobb, vice-president and general manager of KVGB, Great Bend, Kans.

The Radio Board of Directors of the National Association of Broadcasters June 19 elected **Richard W. Chapin**, executive vice-president, KFOR, Lincoln, Nebr., as its chairman.

**James M. Caldwell**, vice-president and station manager, WAVE, Louisville, Ky., was elected vice-chairman.

The Television Board of Directors of the National Association of Broadcasters on June 18 elected **Harold Essex**, president of the WSJS Stations, Winston-Salem, N.C., as its chairman.

**Hamilton Shea**, executive vice-president, Gilmore Broadcasting Corp., Harrisonburg, Va., was elected vice chairman.

The Spotlight Is on

# Spotmaster

## Superior Tape Cartridge Recording and Playback Equipment



Model 500 C



Model 400 A

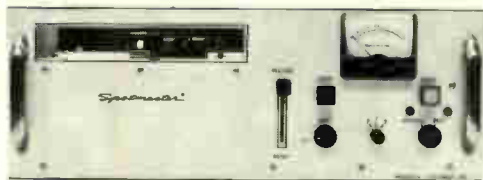

Model 500 CR

**COMPACT 500 C SERIES**—Completely solid state, handsome 500 C equipment features functional styling and ease of operation, modular design, choice of 1, 2, or 3 automatic electronic cueing tones, automatic record pre-set, separate record and play heads, A-B monitoring, biased cue recording, triple zener controlled power supply, transformer output . . . adding up to pushbutton broadcasting at its finest. Specs and performance equal or exceed NAB standards. Record-play and playback-only models are available.

**RACK-MOUNTED 500 C MODELS**—The 500 CR rack models offer the same Model C design and performance features and are equipped with chassis slides ready to mount in your rack. Each unit slides out for easy head and capstan cleaning and other routine maintenance.

All 500 C models carry iron-clad full-year guarantees.

**ECONOMICAL 400 A SERIES**—Now even the smallest stations can enjoy Spotmaster dependability with the low-cost, all solid state 400 A series, available in compact record-play and playback-only models. Performance and specifications are second only to the 500 C series.

For complete details about these and other Spotmaster cartridge units (stereo, delayed-programming and multiple-cartridge models, too), write, wire or call today. Remember, Broadcast Electronics is the No. 1 designer/producer of broadcast quality cartridge tape equipment . . . worldwide!

### BROADCAST ELECTRONICS, INC.

8810 Brookville Road, Silver Spring, Maryland 20910; Area Code 301, 588-4983



## Wasilewski Appoints 10 To NAB Committee

Vincent T. Wasilewski, president of the National Association of Broadcasters, has appointed 10 broadcast engineers to NAB's 1969-71 Engineering Advisory Committee.

Named were **Albert H. Chismark**, director of engineering, Meredith Broadcasting Co., Syracuse, N.Y., chairman; **Eugene R. Hill**, director of engineering, Kaiser Broadcasting Corp., San Francisco, Calif.; **George Hixenbaugh**, chief engineer, WMT (AM-TV), Cedar Rapids, Iowa; **William B. Honeycutt**, director of engineering, KRLD (AM-FM-TV), Dallas, Tex.; **Leslie S. Learned**, vice-president for engineering, Mutual, New York, N.Y.; **James D. Parker**, staff consultant, telecommunications, CBS Television Network, New York, N.Y.; **Royce LaVerne Pointer**, director, broadcast engineering, ABC, New York, N.Y.; **L. Keith Townsden**, technical director, KAYS, Inc., Hays, Kans.; **William H. Trevarthen**, vice-president, operations and engineering, NBC, New York, N.Y., and **Benjamin Wolfe**, vice-president for engineering, Post-Newsweek Stations, Washington, D. C.

## FCC Commissioner Lee Addresses OAB Meeting

Freedom brings with it responsibilities, and broadcasters have a commitment to maintain freedom by assuring high broadcast standards FCC Commissioner Robert E. Lee told the Ohio Association of Broadcasters in an address before their Spring Convention in Dayton, Ohio (May 16). Commissioner Lee told the broadcasters that "It is the obligation of the broadcaster to bring his positive responsibility affirmatively to bear upon all who have a hand in providing broadcast matter for transmission through his facilities so as to assure the discharge of his duty to provide acceptable program schedules consistent with the public interest in his service area."

Highlights of Commissioner Lee's address:

"The public and Congressional reaction today to an overkill of sex and violence can be traced to many of the productions of several years ago and now, for the first time, available to television. What will happen 4 or 5 years hence when the television rights to current controversial movies become available? We have the very best television and communications network in the world, which was not brought about by government regulation but by the broadcaster's responsible use of freedom of speech and expression, and I might add, a large measure of his perspiration and common sense.

"I can say that personally I rely heavily on the standards set by the industry itself in the Code of the National Association of Broadcasters and the commitment of each individual broadcaster, as far as the judgments I am called upon to make in the field of programming. It is my belief that if all broadcasters lived up to the Code and observed their programming commitment as updated to a true cross section of the public interest, it seems, my job as a Commissioner would be much easier and the growing number of skeptics would be obliged to concede that ours is the best broadcast system in the world. But as you know, all broadcasters do not live up to the Code and I am afraid some new ones treat the public with an 'I know what is best for you attitude,' or simply do not care.

"I question whether a broadcaster is actually exercising his right of freedom when an off-color program is permitted on the air only to be cancelled after one night due to the vociferous outcry of an overweary public. This is your responsibility. I question the individual network affiliate's right to accept the judgment of a review board in New York. This is your duty as a broadcaster and you cannot delegate such obligation. Here the local licensee cannot look to the network to perform this duty for him. It is not the answer to say that the local broadcaster has no control over network programming or is obliged to take whatever comes over the 'line.' Unlike the network, the local broadcaster is a censor of programming with the exception of political broadcasting."

## "Want a Good Job in Broadcasting?"



## You'll Need a First Class FCC License."

Matt Stuczynski knows. He's the Senior Transmitter Operator of Radio Station WBOE. His story is typical of hundreds of men who have used Cleveland Institute Training as a springboard to success in Broadcasting. Here's what Matt says about Cleveland Institute:

"I give Cleveland Institute credit for my First Class FCC License. Even though I had only 6 weeks of high school algebra, CIE's AUTO-PROGRAMMED™ lessons really made electronics theory and fundamentals easy. After completing the CIE course, I took and passed the First Class Exam. I now have a good job in studio operation, transmitting, proof of performance, equipment servicing. Believe me, a Commercial FCC License is a 'must' for a career in Broadcasting."

If you want rapid advancement in broadcasting, the first step is a First Class FCC ticket with *your* name on it. And Cleveland Institute Home Study is a fast, economical way to get one. What's more, CIE backs their licensing programs with this money-back warranty:

"A CIE License Course will quickly prepare you for a First Class FCC License. If you complete the course but fail to pass the exam on *your first attempt*, CIE will refund all tuition."

With Cleveland Institute you get your First Class FCC License or your money back! Send coupon today for FREE book or write to Cleveland Institute of Electronics, 1776 E. 17th St., Dept. BE-59 Cleveland, Ohio 44114.

### ENROLL UNDER NEW G.I. BILL

All CIE courses are available under the new G.I. Bill. If you served on active duty since January 31, 1955, or are in service now, check box in coupon for G.I. Bill information.

### MAIL COUPON TODAY FOR FREE BOOK



## CIE Cleveland Institute of Electronics

1776 East 17th Street, Cleveland, Ohio 44114

Please send me your FREE book, "How To Get A Commercial FCC License."

Name \_\_\_\_\_ (please print)

Address \_\_\_\_\_

City \_\_\_\_\_ State \_\_\_\_\_ Zip \_\_\_\_\_

Occupation \_\_\_\_\_ Age \_\_\_\_\_

**Veterans check here for GI Bill information**

Accredited Member National Home Study Council  
A Leader in Electronics Training . . . Since 1934

BE-59

Circle Number 41 on Reader Reply Card



# TELCOMP'S NEW IC...OP AMP AUDIO D. A. BREAKS THE COST BARRIER...

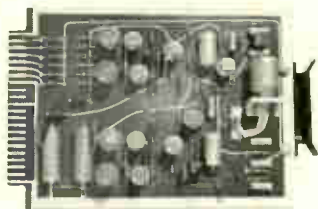

Model A-100

- 6 OUTPUTS
- +20 DBM EACH
- 60 DB ISOLATION BETWEEN OUTPUTS
- 20 DB GAIN FOR UNITY ADJUSTMENT
- MEETS OR EXCEEDS EVERY PROFESSIONALLY RECOGNIZED AUDIO STANDARD
- 12 UNITS REQUIRE ONLY 5¼" RACK SPACE

**PRICE under \$175.00**

RACK FRAME  
Model CF-300  
(accepts 12 Model A-100's)

POWER SUPPLY  
Model PS-600

ADA-7 PACKAGE  
consisting of  
12 Model A-100  
1 POWER SUPPLY P-600  
1 RACK FRAME CF-300

For more details write or call:



A DIVISION OF TELEVISION AND COMPUTER CORPORATION

2166 S. HIGHWAY 20, SCOTCH PLAINS, NEW JERSEY 07076 • (201) 233-6200

Circle Number 47 on Reader Reply Card

## Hyde - FCC Should Promote Diversity

In his address before the 45th annual convention of the EIA in Chicago, FCC Commissioner Rosel Hyde said the FCC has a mission to encourage and foster new services and promote diversity.

"One recent aspect of our search for diversity that has captured some of the headlines for the moment," Hyde said, "is subscription television." He added that despite what some opponents of the new service have claimed, the Commission was very careful to see to it that subscription television will supplement rather than supplant free television.

Because of the regulatory measures set down by the FCC, Hyde said the Commission is "confident that the new service will bring valuable diversity and a challenge to free television which may well result in improvements in that service."

The Commissioner said that certain regulatory measures had also been taken by the FCC in regard to CATV. In order to deal with any unfair competition and protect the local stations, he said the Commission had adopted rules relating to non-duplication and also placed certain restrictions on importation of distant signals.

Hyde added that broadcast and CATV interests should continue to resolve their own differences and to develop a regulatory plan which would be acceptable to both industries.

In a reference to the technological advances in the communications field involving satellites and computers, Hyde said, "the Commission is faced with the challenge of keeping its regulatory philosophy abreast of technological advances."

Hyde told the delegates, "these are indeed challenging times . . . the rapid advance in communications technology has brought us to a crossroad in the history of communications."

Send Your News  
of  
**Non-Commercial Stations  
and Organizations  
to Broadcast Engineering**

## TELEVISION SYSTEMS ENGINEER

The Broadcast Equipment Division of Sarkes Tarzian, Inc., announces an immediate opening for an experienced Television Systems Engineer. This challenging position encompasses the following responsibilities:

Functional design of complete video/audio systems.

Physical layout planning of complete television broadcast facilities including integral equipment groups.

Development of operational performance specifications.

Development of systems proposals.

For further information, contact:



Ron Adamson  
Sarkes Tarzian, Inc.  
Bloomington, Indiana  
AC 812/332-7251

## SPOTMASTER

The all solid state AD1A

## AUDIO DISTRIBUTION AMPLIFIER



Meet the AD1A, a solid state audio distribution amplifier specifically designed for AM, FM and TV broadcast stations and recording studios. The AD1A distributes audio signals via five separate output channels (up to 25 with the addition of AD1A-X extenders), and incorporates a front-panel VU meter and monitor jack to permit visual and aural monitoring of the incoming signal at the output of the line amplifier. Response is essentially flat from 40 to 20,000 Hz, with low distortion and noise, 60 db channel isolation and 12 db peak factor. For further information, write or call today:

*Spotmaster*

**BROADCAST ELECTRONICS, INC.**

8810 Brookville Road  
Silver Spring, Maryland 20910  
Area Code 301 • 588-4983



# Advertisers' Index

American Pamcor Inc. ....	67	Mincom Div., 3M Co. ....	9
Ampro Corp. ....	8	Minneapolis Magnetics, Inc. ....	63
Applied Electro Mechanics, Inc. ....	57, 62	Moseley Associates, Inc. ....	55
Ball Brothers Research Corp. ....	13	Philips Broadcast Equip. Corp. ....	42-43
Broadcast Electronics, Inc. ....	24, 64, 66	Power Optics, Inc. ....	36
CBS Laboratories ....	3	RCA Commercial Electronic Systems ....	34-35
CCA Electronics Corp. ....	56	RCA Electronic Components ....	15
Canon U.S.A., Inc. ....	60	Riker Video Industries ....	Cover 2
Cleveland Institute of Electronics ....	65	Rohn Manufacturing Co. ....	61
Cohu Electronics, Inc. ....	1	Sarkes Tarzian, Inc. ....	66
Collins Radio Company ....	17	Scala Radio Corp. ....	63
Conrac Div., Conrac Corp. ....	22-23	Sparta Electronic Corp. ....	62
Electro-Voice, Inc. ....	60	Spindler & Sautpe ....	25
Fairchild Recording Equip. Corp. ....	37	Spotmaster ....	24, 64, 66
Gates Radio Company ....	11	Stancil-Hoffman Corp. ....	57
Gotham Audio Corp. ....	24	Stanton Magnetics, Inc. ....	19
Granger Associates, Bauer Broadcast Products ....	59	Taber Mfg. & Eng. Co. ....	57
International Nuclear Corp. ....	Cover 3	Tapecaster (TCM) ....	10
Jampro Antenna Co. ....	20	TeleMation, Inc. ....	30-31
		Telemet Company ....	Cover 4
		Television and Computer Corp. ....	51, 66
		Visual Electronics Corp. ....	63
		Vital Industries ....	7
		Ward Electronic Industries ....	5
		Wilkinson Electronics, Inc. ....	21, 67



## PROTECT your broadcast equipment against lightning surges with WILKINSON AC LINE SURGE PROTECTORS

Excessive voltage surges caused by lightning, transformer arcing and induced transients are everyday occurrences that cause heavy damage to valuable broadcast equipment.

Now through the use of WILKINSON voltage sensitive Line Surge Protectors you can protect your equipment from line surges that may exceed even twenty times the normal line voltage.

A WILKINSON pulse compensated Line Surge Varistor, is placed across a line of its rated voltage. Should a surge or increase of voltage occur, the resistance of the varistor decreases at log scale as the voltage increases, thus acting as a momentary load or short circuit to the surge. WILKINSON Line Surge Protectors draw little or no current and are capacitor compensated for microsecond surges, thus damping all line disturbances as well as excessive voltage increase.

A small investment in WILKINSON Line Surge Protectors is your assurance that your valuable broadcast equipment will not be damaged due to line surges.

### AVAILABLE IN 3 MODELS!

Model S1A-2 220 V. single phase	\$200.00
Model S1A-3 220/240 V. 3 phase	\$300.00
Model S1A-4 480 V. 3 phase	\$389.50

For complete details write to:

# WILKINSON

## ELECTRONICS, INC.

1937 MacDADE BLVD. • WOODLYN, PA. 19094  
• TELEPHONE (215) 874-5236 874-5237 •

## ANY WIRE, ANYWHERE.

Electrical crimp-type terminals and connectors for any place you connect a wire . . . and direct sales and assistance anywhere in the U.S.A. Group shown covers #26 to 12 AWG and coaxial—over 30,000 others available up to 1000 MCM. Talk to us about your connecting problem or write for free Terminal and Connector Handbook. American Pamcor, Inc., Valley Forge, Pa. 19481

**AMERICAN PAMCOR**

A SUBSIDIARY OF  
**AMP**  
INCORPORATED



Circle Number 45 on Reader Reply Card

Circle Number 46 on Reader Reply Card

## Professional Services

### FRANK A. ZOELLER

TELEVISION SYSTEMS  
CONSULTANT

20 Years Experience

Box 366 • San Carlos, Cal. 94070  
(415) 593.1751

### VIR JAMES

CONSULTING RADIO ENGINEERS  
Applications and Field Engineering  
345 Colorado Blvd.

Phone: (Area Code 303) 333-5562

**DENVER, COLORADO 80206**

Member AFCCE  
TWX 910.931-0514

### CAMBRIDGE CRYSTALS PRECISION FREQUENCY MEASURING SERVICE

SPECIALISTS FOR AM-FM-TV

445 Concord Ave. Phone 876-2810  
Cambridge, Mass. 02138

### JAMES C. McNARY

Consulting Engineer  
National Press Bldg.

Washington 4, D.C.  
Telephone District 7-1205

Member AFCCE

### JOHN H. MULLANEY and ASSOCIATES

Suite 71,  
1150 Connecticut Ave., N.W.  
Washington, D. C. 20036  
Phone 202-223-1180

Member AFCCE

### ROSNER TELEVISION SYSTEMS

ENGINEERS — CONTRACTORS

29 South Mall  
Plainview, N.Y. 11803  
(516) 694-1903

## Classified

Advertising rates in Classified Section are 15¢ per word, each insertion, and must be accompanied by cash to insure publication.

Each initial or abbreviation counts a full word. Upper case words, 30¢ each.

Minimum classified charge, \$2.00.

For ads on which replies are sent to us for forwarding, there is an additional charge of \$2.00 to cover department number, etc., which is printed in advertising copy, and processing of replies.

Classified columns are not open to advertising of any products regularly produced by manufacturers unless used and no longer owned by the manufacturer or a distributor.

## Help Wanted

# SENIOR SALES ENGINEERS

### Video Products

These important positions require demonstrated sales success with sophisticated video equipment.

To qualify, you must have 3-8 years experience in selling to the broadcast industry, and a BSEE or equivalent. Positions are located in Washington D.C. and New York.

Ampex offers you superior growth opportunities and an outstanding benefit package that includes all company-paid benefits and an exceptional profit sharing program.

Please send your resume to Mr. R. V. Gilliland, 2655 Bay Road, Redwood City, California 94063. Ampex is an equal opportunity employer.

# AMPEX

**IMMEDIATE OPENINGS:** Qualify for any of the following positions: RCA CCTV Equipment, monochrome or color, TV Systems Engineers - Maintenance Technicians - Video Engineers - to work in either New York, New Jersey or California area. Write: RCA Rep., 1559 Jericho Tpke., New Hyde Park, New York 11040. tf

### Sound Maintenance Engineer

Required for large 5-studio complex in N. Y. Experienced in motion picture recording equipment, Selsyn systems, re-recording consoles, optical recorders, installations, etc. Contact: Ron Brown, Recording Studios, Inc., 212 W. 48 St., NYC, 212-757-8855.

Job Headquarters for all Radio and Television Engineers. Immediate openings exist in 9 western states and elsewhere for qualified engineer and technical personnel. All categories from trainees to experienced transmitter maintenance, chief, assistant chief, live color video maintenance and technical operations. Send us your complete resume now. The AMPS Agency, 3924 Wilshire Blvd., Los Angeles, California 90005. Telephone DU 8-3116. By Broadcasters—For Broadcasters, 11-68-tf

**FIRST-CLASS TICKET,** capable of maintenance and short announcing shift. Will later become chief. Lowell Jack, KMAN, Manhattan, Kansas. 913-776-4851. 7-69-2f

## Equipment for Sale

AM or FM Audio P.O.P. form kit \$1.50 postpaid. Broadcast Service Co., Box 2605, Corpus Christi, Tex. 78403. 2-69-tf

CoAx TRANSFER SWITCHES—3½" Andrews 6720 50 ohm—Unused. \$500.00 each. Sierra-Western Elect. Co., Oakland, Cal. 94607. Phone 415-832-3527. 3-69-tf

Surplus audio and video patch panels and patch cords, 500 to 500 ohm repeat coils flat to 20,000 cycles. Send for list, Gulf Electro-Sales, Inc., 6325 Beverly Hill, Houston, Texas 77027. 4-69-12f

**NEW COLLINS TT 400/200 TURN-TABLES**—Due to the acquisition of QRK by CCA Electronics, it has been mutually agreed, QRK will no longer manufacture these turntables for Collins. QRK has available a limited number of these turntables at 10% discount with full warranty. QRK will maintain a complete inventory of parts for Collins TT 400/200 Turntables. Contact QRK (209) 251-4213 or your CCA Area Representative: CCA Electronics Corporation, 716 Jersey Avenue, Gloucester City, New Jersey, (609) 456-1716. 7-69-2f

For Sale: 30,000 feet #10 soft drawn, non-insulated new copper wire for antenna ground system, \$1,000 F.O.B. Mobile, S.D. KOLY Radio. 8-69-6f

**FOR SALE—EQUIPMENT—UHF.** Television transmitter, RCA TTU 12.5 KW, modified for color, complete with accessories, now operating on Ch. 27. Synch Generator, 2 X 2 slide projectors, TA9 stabilizing amplifiers, Collins audio console, video distribution amplifiers, side band analyzer and UHF converter, power supplies, TRT-1B video tape recorder (color), TK-31-C (2) Field camera chains, TS-11 Studio Switcher, 35 ft. mobile unit, 500 ft. Tower, Contact Hal Schumacher, Ph. 606-254-2727, P. O. Box 655, Lexington, Ky. 40501. 8-69-1f

G.E. BT11B 10 watt FM Transmitter Tuned 89.3 MHz with spare exciter, \$750.00. Ampex 403C Console and portable case, \$450.00. WHHS 215. Hilltop 6-3578. 8-69-1f

## Training

To advance in electronics, knowledge and ability are required. Grantham offers correspondence and resident instruction, in depth, leading to the degree or Associate in Science in Electronics Engineering. G. I. Bill approved. Credit for previous training and experience allowed. Free Catalog. Write: Dept. E-2, Grantham School of Electronics, 1505 N. Western Ave., Hollywood, California. 90027. 6-67-tf

First phone through tape recorded lessons at home plus one week personal instruction in Washington, DC, Atlanta, Boston, Detroit, New Orleans, Minneapolis, Seattle, Denver, Portland, Los Angeles. Proven results. Our 17th year teaching FCC license courses. Bob Johnson Radio License Preparation, 1060D Duncan, Manhattan Beach, Calif. 90266. Phone 213-379-4461. 1-69-tf

# JITTER BUG?

The New TCS2 Color Oscillator Standard is free of jitter.



The color standards which are now available to the industry show, in some cases, a certain degree of jitter which has proved to be intolerable when second and third generation tapes are made. Our TCS2 is free of jitter and has been thoroughly tested for several months under a variety of conditions. The stability of the 3.58 MHz oscillator is better than one part per million.

Complete technical data sent on request.  
Price \$975.00 each F.O.B. Nashville, Tenn.



**INTERNATIONAL  
NUCLEAR CORPORATION**

608 Norris Avenue  
Nashville, Tennessee 37204  
(615) 254-3355



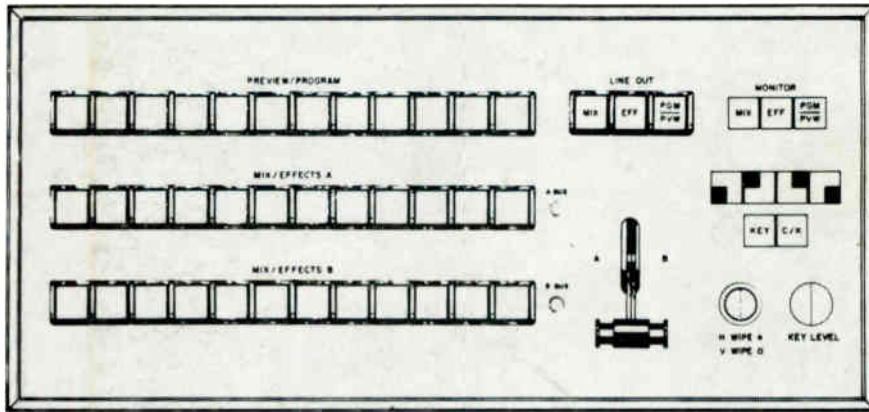

2 R 1-5 572 2  
 CHARLES RETI  
 15303 LINNHURST  
 DETROIT MICH 48205

# We're offering a brand new vertical interval switcher—with effects—for only \$6500.

**We figure that's a good way for us to get clipped.**



Our SS-36 vertical interval switcher is brand new ■ color or monochrome ■ 12 inputs and 8 special effects ■ perfect for broadcast, educational and CCTV transmission ■ mobile or remote operation, too.

Choose your system:

- SS-36.** Vertical Interval Switcher with three outputs, special effects, mixer and internal power supply . . . . . **\$6500.**
- SS-36R.** SS-36 with remote control . . **\$7600.**
- SS-48.** SS-36 with four outputs, mix effects A & B, preview and program included **\$7500.**
- SS-48R.** SS-48 with remote control . . **\$8600.**

I'm all choked up. Give me a demonstration.

Cool it. Let's see a spec sheet first.

Name \_\_\_\_\_ Title \_\_\_\_\_

Company \_\_\_\_\_

Address \_\_\_\_\_

City \_\_\_\_\_ State/Zip \_\_\_\_\_

**T E L E M E T**

a division of **GEOTEL, INC.**

185 DIXON AVENUE, AMITYVILLE, NEW YORK 11701

TELEPHONE: (516) 541-3600

**Better ideas for  
the broadcast industry**