

POST-NAB
ISSUE

A HOWARD W. SAMS PUBLICATION



MAY 1964/75 cents

Broadcast Engineering

*the technical journal
of the broadcast-
communications industry*

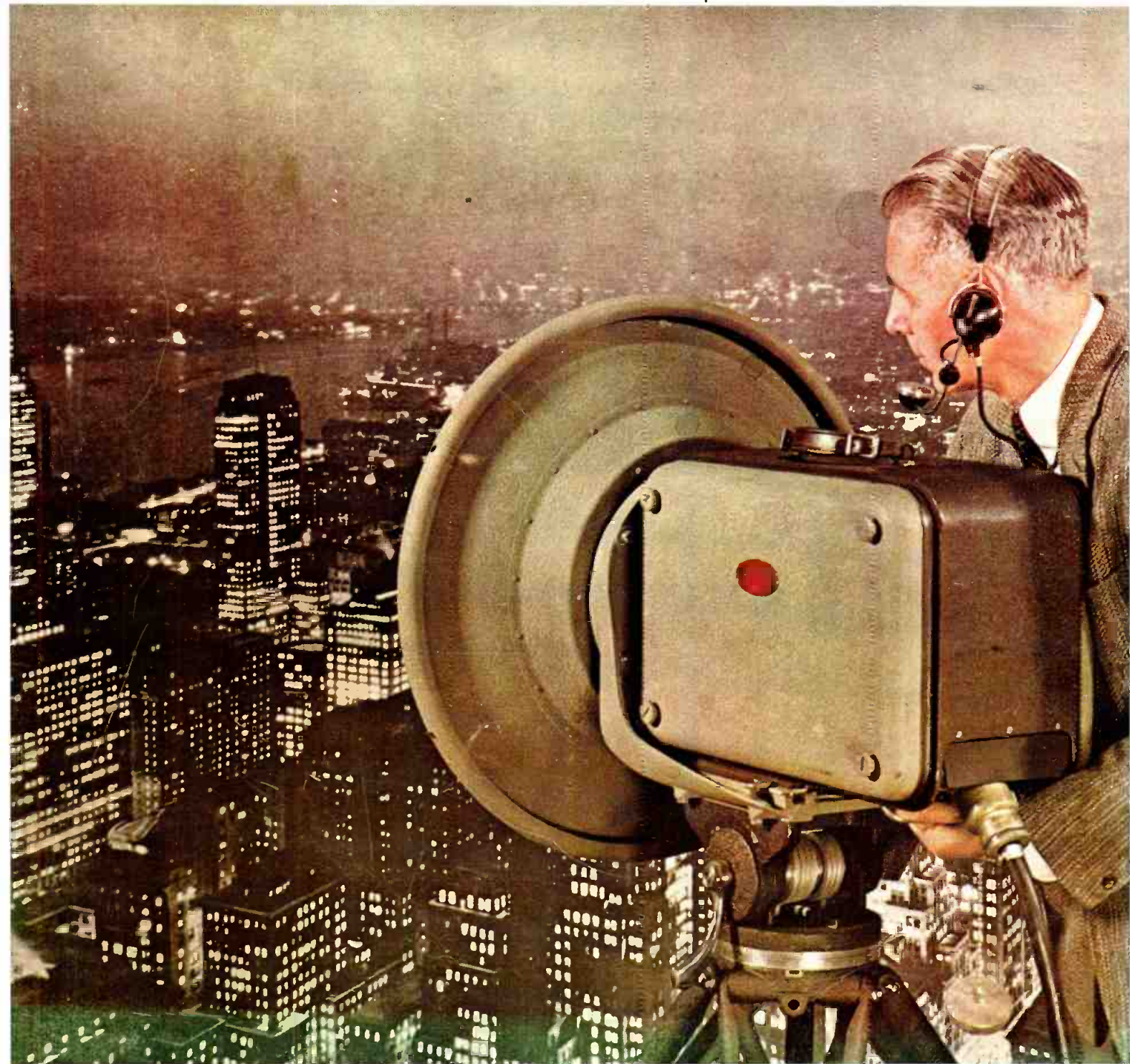

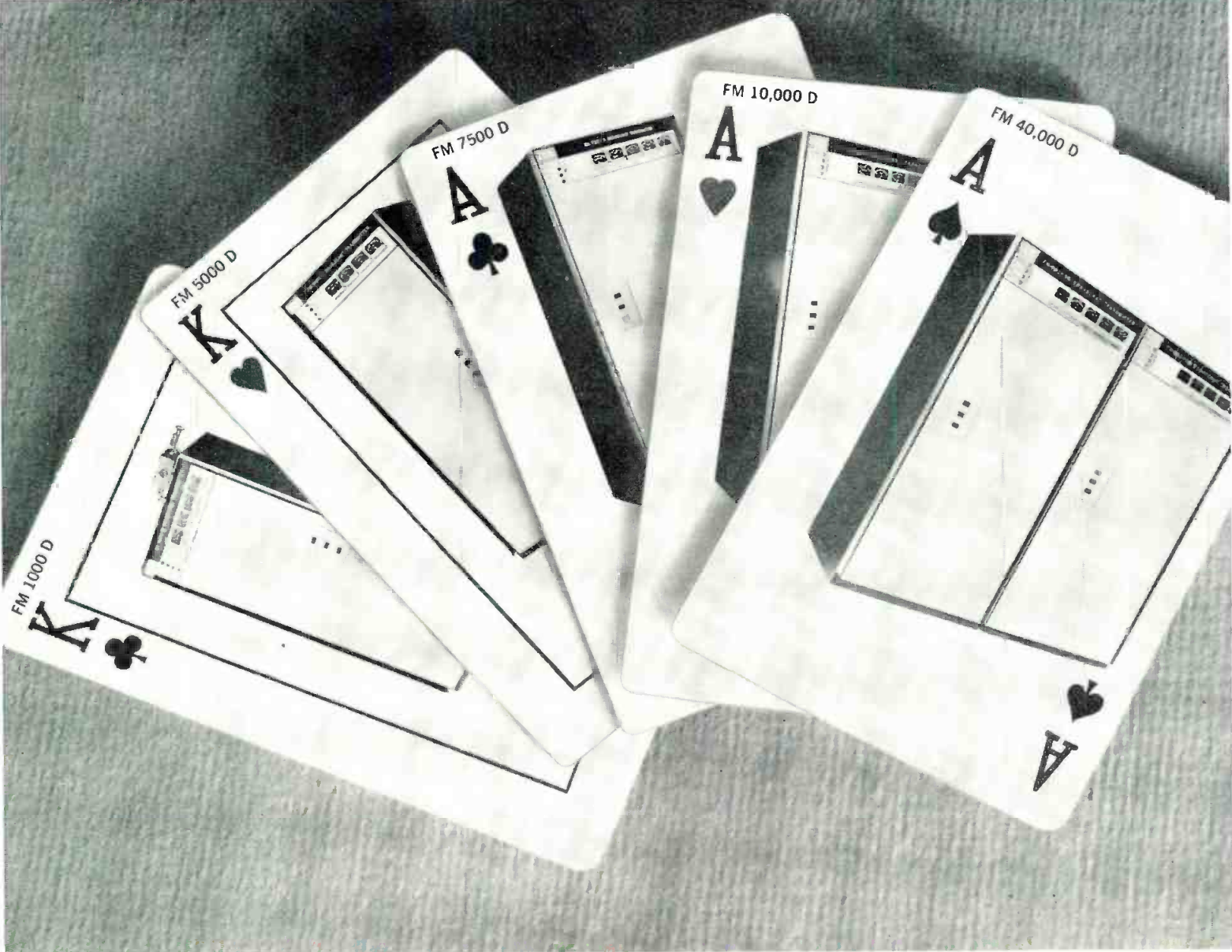

FULL HOUSE OF FM POWER

From 10 to 40,000 watts Featuring the New PERFECT EXCITER For Stereo or Monaural

Every new ITA transmitter is equipped with the ITA 10D FM Exciter. Proven in the field, the 10D has been consistently **distortion free!** All transmitters delivered to date equipped with the 10D have registered performance equal to that shown on the charts at right.

For immediate particulars write, wire or phone ITA today.

FCC Type Acceptance Performance

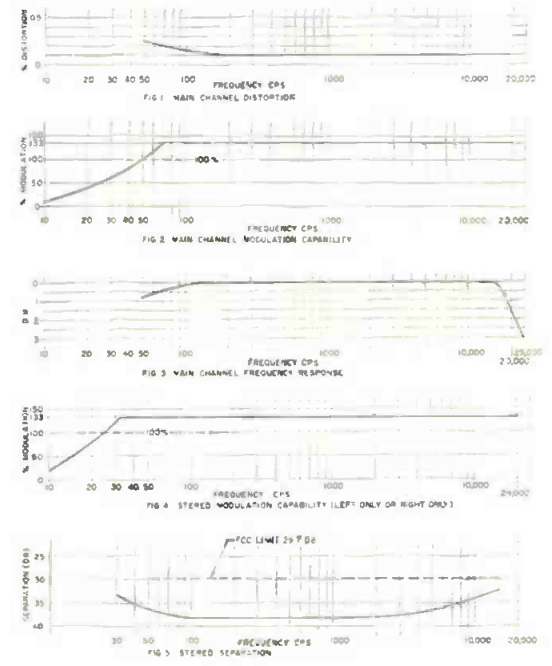

ELECTRONICS
DIVISION OF TRIANGLE PUBLICATIONS, INC.

130 EAST BALTIMORE AVENUE, LANSDOWNE, PENNSYLVANIA
Circle Item 1 on Tech Data Card

www.americanradiohistory.com

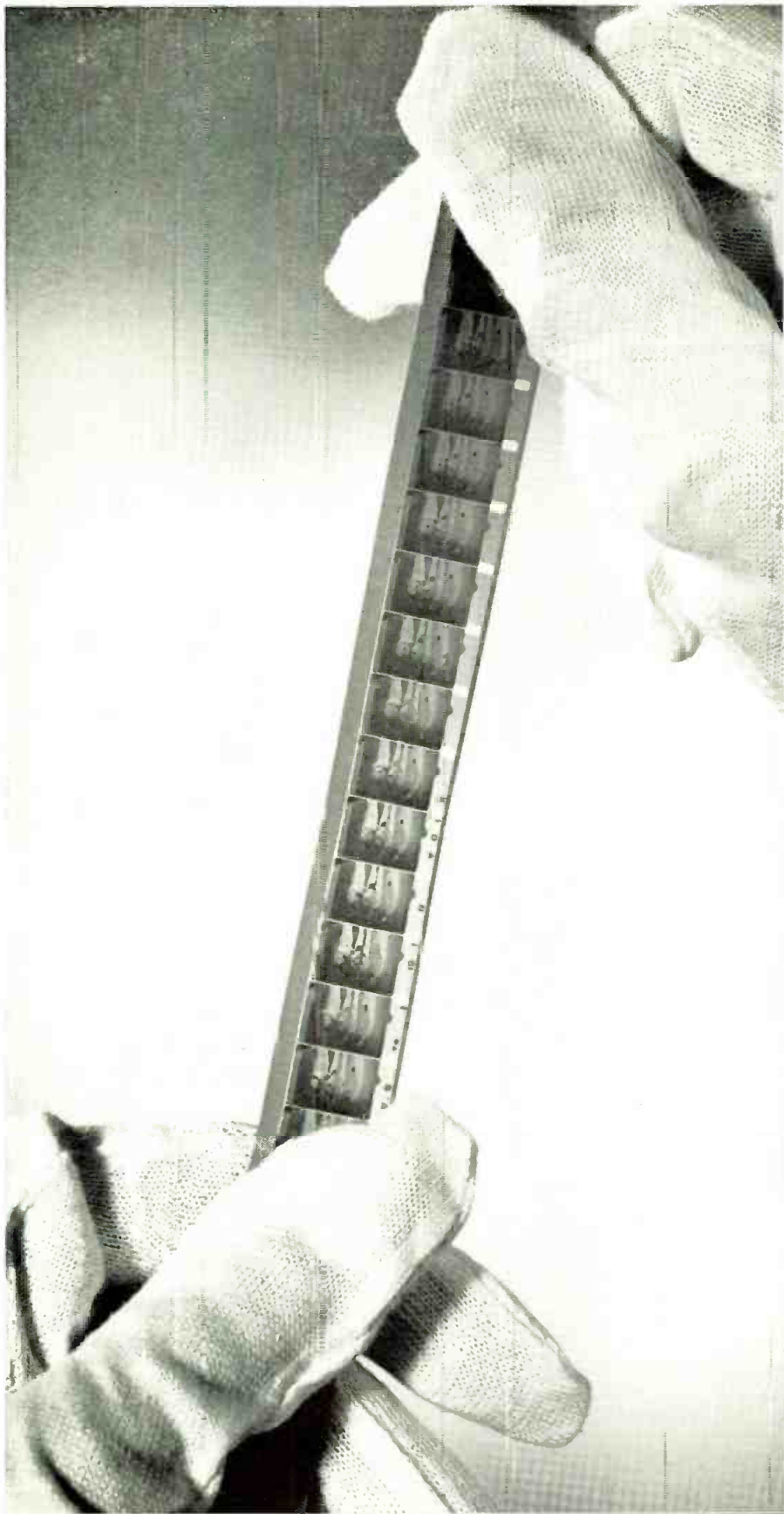

**Unmatched convenience
for single-system
sound recording: new
prestriped negative film
from EASTMAN***

Here's a film designed to meet today's demands for *deadline* performance—EASTMAN RP Panchromatic Negative Film, Type 7229. Greater production efficiency is yours because this film is available with magnetic prestripping. It's ideal for news, sportscasting, documentation!

This new camera-negative film is sharp, fine-grained, and has a speed rating of 250 . . . just 1/3 of a stop less than Eastman Tri-X negative film.

While it is prehardened specifically for high-speed, high-temperature Viscomat processing, this film can be handled by any commercial laboratory.

Eastman Type 7229 film is part of the new Eastman 16mm sound-film system, designed especially to speed and simplify film handling from exposure to playback. Other elements in this versatile system include the KODAK Reflex Special Camera, EASTMAN VISCOMAT Processor, and EASTMAN 16mm Television Projector, Model 275.

For further information write or phone for special descriptive brochure S1-4:

*A unit in the new EASTMAN 16mm Sound-Film System . . . Prestriped Film + 16mm Reflex Camera + Processor + TV Projector

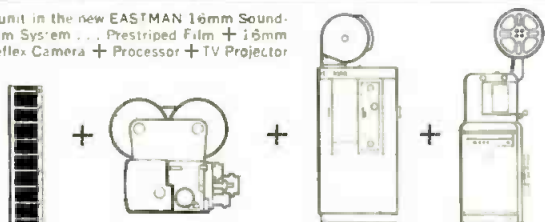

Motion Picture Products Sales Department

**EASTMAN KODAK
COMPANY**

Rochester, N.Y. 14650

Circle Item 2 on Tech Data Card



Broadcast Engineering

Volume 6, No. 5

May, 1964

CONTENTS

FEATURES

Design of Directional Antennas	10
by Bryce W. Tharp — Procedures involved in the design of an actual operating array.	
Matching and Isolating Pads	12
by Joseph H. Dessen — Part I. Introduction to resistance networks used in audio systems for recording and broadcasting.	
Converting Transmitters for Remote Pickup	14
by Phil Whitney — Steps in the modification of a surplus mobile transmitter for remote pickup applications.	
Touring the Convention Booths	16
by the Editors — A brief review of the exhibits at the 1964 NAB Convention and Engineering Conference.	
Emergency Operation on Flea Power	20
by Patrick S. Finnegan — A method of providing emergency facilities at a minimum cost.	
Maintenance of Mountain Top Translators	30
by George M. Frese — Techniques employed in servicing remote installations to keep efficiency high.	
Use of Audio Level Devices	40
by Bruce L. Mackey — Suggestion on making effective use of audio-level control equipment.	
Television STL Antenna Alignment	44
by Harry A. Etkin — These steps can be employed to obtain optimum performance from studio-to-transmitter links.	

DEPARTMENTS

Letters to the Editor	6	Engineers' Tech Data	66
Bulletin from Washington	27	Advertisers' Index	68
News of the Industry	60	Professional Service	68
New Products	63	Classified Ads	68

PUBLISHER: Howard W. Sams

EDITORIAL: Editor, Forest H. Belt; Managing Editor, Stuart N. Soll; Associate Editors, George F. Corne, Jr., and James M. Moore; Washington Correspondent, Howard T. Head.

CIRCULATION: Manager, J. A. Vitt; Fulfillment: Manager, Pat Tidd; Assistants, Katherine Krise and Cora LaVon Willard.

PRODUCTION: Manager, Robert N. Rippy; Art, Robert W. Poole; Photography, Paul A. Cornelius, Jr.

ADVERTISING: Sales Manager, Dave L. Milling; EAST—Gregory C. Masefield, Howard W. Sams & Company, Incorporated, 3 West 57th Street, New York, N. Y., Phone MU 8-6350; MIDWEST—Hugh Wallace, Howard W. Sams & Co., Inc., 4300 West 62nd Street, Indianapolis 6, Ind., Phone AX 1-3100; SOUTHWEST—C. H. Stockwell Co., 4916 West 64th Street, Mission, Kansas, Phone RA 2-4417; LOS ANGELES 57, CALIF., Maurice A. Kimball Co., Inc., 2550 Beverly Blvd., Phone DU-8-6178; SAN FRANCISCO, Maurice A. Kimball Co., Inc., 580 Market Street, Phone EX 2-3365; PARIS 5, FRANCE, John Ashcraft, 9 Rue Lagrange, Phone ODeon 20-87; LONDON W.C. 2, ENGLAND, John Ashcraft, 12 Bear Street, Leicester Square, Phone Whitehall 0525; TOKYO, JAPAN, International Media Representatives, Ltd., Kisha Kurabu 14, 2-chome Marunouchi, Phone (502) 0656.

SUBSCRIPTION PRICE: U.S. \$6.00, one year; \$10.00, two years; \$13.00, three years. Outside U.S.A. add \$1.00 per year for postage. Single copies, 75 cents, Back issues, \$1.00.

BROADCAST ENGINEERING is published monthly by Technical Publications, Inc., an affiliate of Howard W. Sams & Company, Inc. Editorial, Circulation, and Advertising headquarters: 4300 West 62nd Street, Indianapolis 6, Ind. Copyright © 1964 by Howard W. Sams & Co., Inc.

 **A HOWARD W. SAMS PUBLICATION**



BROADCAST ENGINEERING



**SAF-T-CLIMB
SAVES A LIFE!**

Saf-T-Climb — the only 100% positive safe climbing device — prevents falls from any vertical structure, above or below ground.

And, Saf-T-Climb is simplest to install, simplest to use — even on convex and concave structures. Galvanized, aluminum or stainless Saf-T-Notch Rail attaches rigidly to structure.

Worker wears belt snapped to manganese bronze Saf-T-Lok Sleeve with patented locking pawl that limits falls to 6-inch maximum. Widely approved; proven in use for over 12 years.



For informative brochure write:

AIR SPACE DEVICES, INC. 

Safety Tower Ladder Division
Dept. 4L, 5428 Vineland Ave. BY SAMS DEVICES, INC.
N. Hollywood, Calif. 91603/TR 7-0314

Circle Item 3 on Tech Data Card

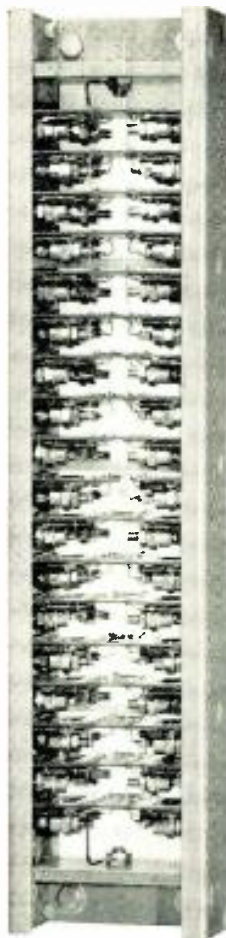

STATIONS WITH STACKS* STAY ON THE AIR

* Westinghouse high-voltage silicon rectifier stacks, 250 watts to 50 kw

Why tolerate transmitter outages from rectifier arc-back? Mercury vapor tubes, the principal contributors to lost air time, are just plain old fashioned. Westinghouse solid-state rectifier stacks will give you 100% power-supply dependability—*no matter what the make or power level of your transmitter.*

Modernize your high-voltage cubicle. Join the growing group of key network and independent stations (AM, FM and TV) whose chief engineers have switched to Westinghouse silicon rectifiers. These men based their choice on the knowledge that Westinghouse high-voltage assemblies have racked up over 20,000,000 hours of failure-free operation. Delay just doesn't pay, especially if you are running

unattended or plan to do so in the near future. The cost of a silicon rectifier assembly for your transmitter can be less than *one* set of mercury replacement tubes. Take this important step toward trouble-free operation today. Call or write Ozzie Jaeger, Code 412, WA 5-7272. Westinghouse Semiconductor Division, Youngwood, Pennsylvania. SC 2002

P.S. Our megawatt rectifier assemblies are helping to carry the message of hope behind the Iron and Bamboo Curtains.

You can be sure if it's Westinghouse



NEW IMPROVED ATC 55

FROM AUTOMATIC TAPE CONTROL

See this newly engineered multiple cartridge handler at the NAB show, April 5-8. Built into a standard Cabtron rack cabinet, the improved ATC-55 may be made a part of your existing automatic broadcasting equipment or may be used as a cartridge library for live broadcasting.

Check these features:

- New positive indexing direct current braking system.
- New gravity lock cartridge loading stops.
- New element guided floating cartridge storage rack.
- New quieter operation.
- New ease of maintenance.
- Adaptable to existing automatic systems.
- Can be used with ATC Automatic Program Logging.
- Automatic Electric dual contact relays used throughout.
- Available in stereo.

Make it a point to stop in and see this new and improved cartridge handler at Booth 24-W at the 1964 NAB. Or, write ATC for literature and more information.

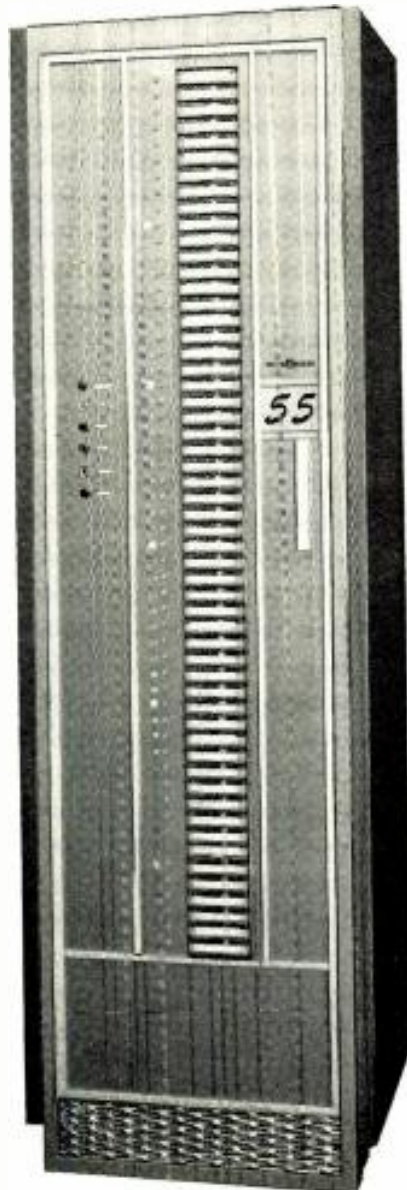

AUTOMATIC  **TAPE CONTROL**
1107 E. Croxton Ave. Bloomington, Illinois

Circle Item 5 on Tech Data Card

LETTERS to the editor

DEAR EDITOR:

I feel that I must take exception to a statement made in the article "Minimizing Problems in SCA Service" by Donald L. Coleman, Jr., in the March 1964 issue.

In the first paragraph under "The Transmitter," Mr. Coleman makes a broad, sweeping statement to the effect that involved circuitry is best left alone by the station engineer; the circuitry was lined up by the manufacturer and hence all adjustments are optimized when the equipment is received. While in 99% of the cases the equipment may have been lined up properly at the factory, there is absolutely no assurance that the equipment has not become misadjusted during shipment, or that changes in component values haven't occurred due to age.

A station engineer owes it to himself and his employer to be sure that the equipment meets or exceeds the specifications guaranteed by the manufacturer. Any person employed as a chief engineer or technical supervisor should be intimate with all circuits of all equipments in the station, from the simplest amplifier or power supply circuit to the most sophisticated AFC or modulation circuit under his care. By this I do not condone indiscriminate diddling or modification, but rather a solid understanding of the adjustments, and symptoms.

As a consultant, I have many times been called in to a situation where the station engineer has been told by a factory engineer or his predecessor as chief not to touch this or that, that it is now operating properly (?), and in all probability will continue doing so if he doesn't touch it. By sitting down with the instruction manuals and determining the action of the circuits, effects of adjustments, and symptoms of troubles, valuable time could be saved.

In addition to making emergency action easier, routine preventative maintenance should include performance measurement and adjustment or repair of all circuits that have degenerated since the last check.

In his opening statement of the article, Mr. Coleman indicates that much of the information in the article was learned the "hard way," no doubt while the background music operation was in trouble. I heartily agree with Mr. Coleman when he states that we should not consider ourselves "know-it-alls." I do feel, however, that every new piece of equipment should be approached with the idea of "what can I learn from this piece of equipment" to the station's and the engineer's own betterment. Anytime an engineer is afraid of a piece of equipment and he knows that he is not as much familiar with it as he could be, he is only doing himself and his employer a disservice.

DON LARSEN

Chief Engineer, KRFM,
Phoenix, Arizona

BROADCAST ENGINEERING

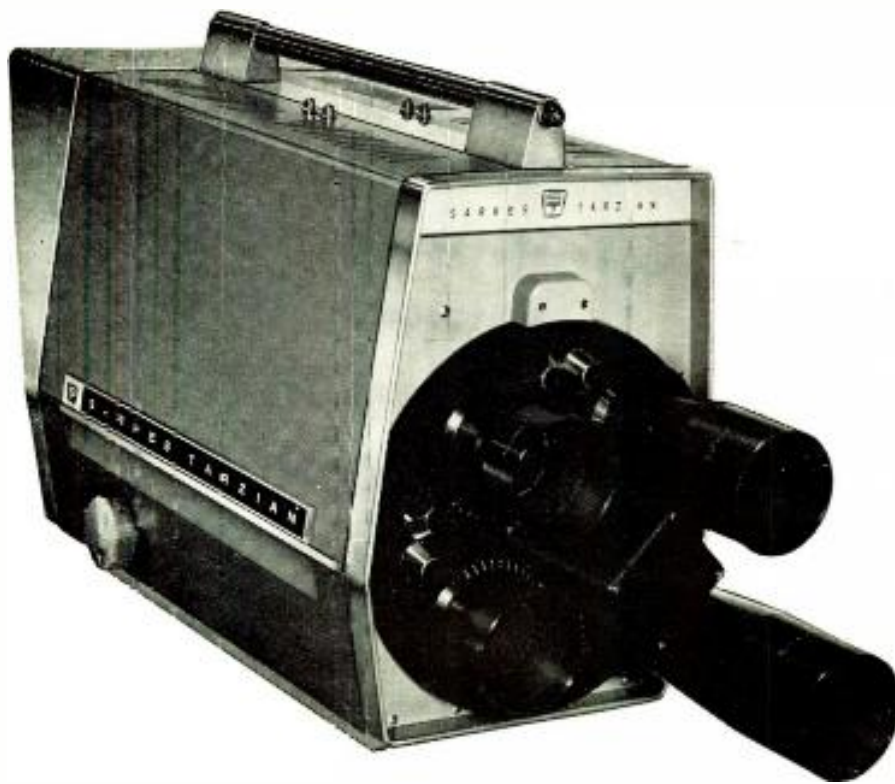

Now—Go Fully Solid State—All Cameras

● For the first time, you can update your camera gear—all of it—to solid state equipment.

Tarzian set the standards for solid state television with the first studio camera to have all camera circuits completely transistorized. Now, Tarzian is first again with a complete line of fully transistorized studio and remote cameras to meet all your programming needs—including the outstanding new Image Orthicon studio camera (see it—try it at NAB) and the 1-inch vidicon, or 1.5" image pick-up camera.

Common to this select line of cameras is a versatile processing unit, thoroughly field-tested and in operation more than a year—a full year longer than any other available—and presently in use in major market stations with unqualified broadcast quality performance.

All Tarzian cameras bring you the maintenance-free, economical operation of completely solid state circuitry—readily accessible on plug-in printed circuit cards. All feature the same dependable performance and striking design that broadcasters have come to expect—and rely upon—from Tarzian.

SARKES  **TARZIAN**

BROADCAST EQUIPMENT DIVISION • BLOOMINGTON, INDIANA

Circle Item 6 on Tech Data Card

PREDICTION FOR 1964:

This will be the local TV station's most popular program!



3M announces the first comprehensive program to help TV stations, advertisers, agencies create new profits with video tape!

Now, for the first time, local tv stations, tape producers, advertisers and agencies can receive real assistance in creating and producing better-selling commercials on video tape.

Here is a complete program that includes both professional demonstration and reference materials from 3M, maker of SCOTCH® BRAND Video Tape. Local tv stations and tape producers will be able to offer expanded production counsel and services. They can provide practical materials to help advertisers take full advantage of video tape's production convenience and versatility, "live" picture quality, and the speed, certainty, flexibility that only tape can provide.

A few of the new materials: A 25-minute demonstration tape shows production techniques, actual commercials, explains tape's

benefits. The "Comparator," a pocket-size quick reference guide to the relative advantages of tape, live and film production for tv commercials. "The Television Producer," a deluxe 50-page encyclopedic workbook of how-to tape production information. The program includes industry achievement recognition, many additional pieces of helpful literature.

If you operate a tv station with video tape recording equipment, and haven't received full details on this program, please contact us. Call or write 3M Magnetic Products Division, Dept. MDV-54, St. Paul 19, Minn.

SCOTCH® IS A REG. TM OF 3M CO., ST. PAUL 19, MINN. © 1964, 3M CO.

Magnetic Products Division



Circle Item 7 on Tech Data Card

DESIGN OF DIRECTIONAL ANTENNA SYSTEMS

by Bryce W. Tharp, Staff Engineer, WXLW, Indianapolis, Ind. — The step-by-step procedures employed in the design of a directional antenna system.

The design of the conventional three-tower in-line directional antenna pattern is based considerably upon patterns having two towers. This is due to the three-tower patterns being the result of the multiplication of two two-tower patterns. Therefore, the mathematical equations and functioning of a two-tower system will now be studied.

The equation for a two-tower system is:

$$E = E_1 f_1 \alpha \sqrt{2F_2 \left[\frac{1+F_2^2}{2F_2} + \cos(S_2 \cos \alpha \cos \gamma + \sigma_2) \right]} \quad (1)$$

E is field strength at any designated azimuth angle.

E₁ is the unattended magnitude of the field intensity at unit distance in the

horizontal plane produced by antenna #1 acting alone, with the total power of the array in this antenna. This is obtained by charts.

$$f_1 \alpha = \frac{\cos(G \sin \alpha) - \cos G}{(1 - \cos G) \cos \alpha} \quad (2)$$

F₂ is the current ratio of towers = $\frac{I_2}{I_1}$

S₂ is the spacing in degrees between antennas,

reference point measured in degrees.

α is the elevation angle from the space reference point measured in degrees.

γ is the azimuth angle (the amount the space reference point being considered is off a line going through the towers).

σ₂ is the phase of antenna #2 in reference to antenna #1.

Equation 1 is for the pattern shape

only, and does not take into consideration the mutual impedance between the antennas. This will be considered later.

If only the horizontal radiation pattern is required (which is generally the case), the vertical radiation components can be eliminated and equation 1 can be simplified to:

$$E = E_1 \sqrt{2F_2 \left[\frac{1+F_2^2}{2F_2} + \cos(S_2 \cos \alpha + \sigma_2) \right]} \quad (3)$$

The important terms in this equation are the terms:

$$\frac{1 + F_2^2}{2F_2}$$

and (S₂ Cos γ + α₂). The first determines if the nulls are either complete or partly filled; the second term determines the direction of the null points. If the first term is made unity, complete nulls are obtained since the equation under the large square root sign will equal 1 + (-1) = 0 in the direction of the nulls. As the ratio is increased, the nulls are filled more and more until, finally, a nondirectional circular pattern is obtained.

Since the second term determines the direction of null points, it is now convenient to examine this term. What is required is to make this term equal to the number -1, with a predetermined S₂ and direction of required null. Since plus or minus 180° = -1, this can be shown in Equation 4:

$$S_2 \cos \gamma + \sigma_2 = \pm 180^\circ \quad (4)$$

Since we are solving for σ₂, this reduces to σ₂ = 180° - S₂ Cos γ. The angle α is the azimuth angle from the line of the towers.

An examination of Equation 4 will show that for spacing up to 90°, one null will result. Up to 180°, two nulls will result, and for spacing up to 360° four nulls will result. Of course, in a two-tower

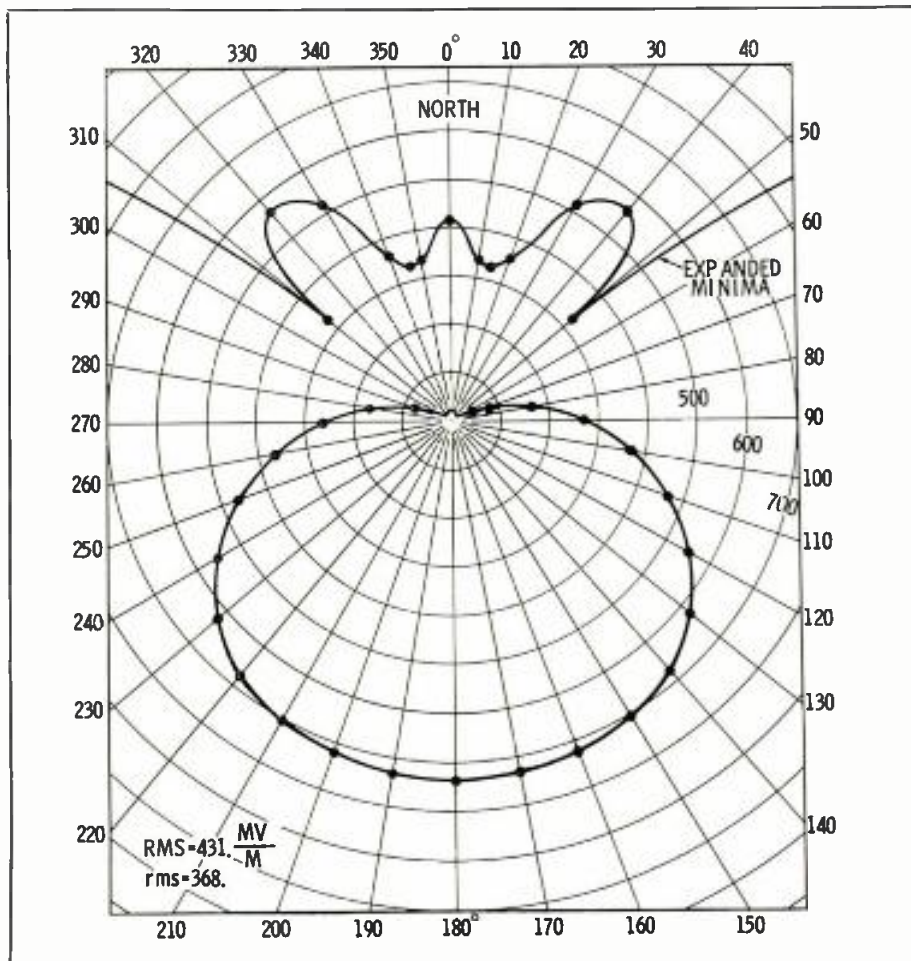

Fig. 1. Directional radiation pattern of the three-tower array.

$$E = ZE_1 \sqrt{2F_2 E_3 \left[\frac{1+F_2^2}{2F_2} + \cos(S_2 \cos \gamma + \sigma_2) \right] \left[\frac{1+F_3^2}{2F_3} + \cos(S_3 \cos \gamma + \sigma_3) \right]}$$

(EQUATION 5)

system, the pattern is symmetrical on either side of a line drawn through the two towers. With two nulls, it is also possible to have one or two other minimums. By inspecting charts for two-tower directional systems, an approximation of the correct pattern may be chosen.

Since three-tower directional systems consist of two basic two-tower systems multiplied together, the equation for a three-tower system is now as shown in Equation 5. The vertical radiation components are not shown, neither is the mutual impedance factor.

Design Example

Equation 5 can best be demonstrated by considering the design of an actual three-tower directional antenna system. The requirements are nulls to be at 310° and 14.7°, and these are allowed to be filled to the extent of 8.2 mv/m. Since the three-tower pattern is symmetrical on either side of a line drawn through the three towers, null points will also occur at 50° and 345.3°. With only one null per set of towers being required, a tower spacing of 90° is selected, with the line of towers being in a true north-to-south bearing.

With σ_2 considered the phase for the first set of towers and σ_3 the phase for the second set, each set of tower phases can now be shown:

$$\begin{aligned} \sigma_2 &= 180^\circ - 90^\circ \cos 14.7^\circ \\ &= 180^\circ - 87^\circ = 93.0^\circ \\ \sigma_2 &= 180^\circ - 90^\circ \cos 50^\circ \\ &= 180^\circ - 57.8^\circ = 122.2^\circ \end{aligned}$$

If the field magnitudes of the three towers are changed so that the center tower can have a unit field intensity magnitude, Equation 5 can be simplified to the following:

$$E = 2FE_1 \left[\frac{1}{2F} + \cos(S \cos \gamma + \sigma) \right] \quad (6)$$

This is for the horizontal plane and assumes towers of equal height. The values of F and σ are found by:

$$F = \frac{1}{2 \cos \left(\frac{\gamma_2 - \gamma_1}{2} \right)}$$

and,

$$\sigma = \frac{\sigma_3 - \sigma_2}{2}$$

In the the directional tower design being considered:

$$F = \frac{1}{2 \cos \left(\frac{122.2^\circ - 93^\circ}{2} \right)} = .516$$

and

$$\sigma = \frac{122.2^\circ + 93^\circ}{2} = 107.6^\circ$$

The mutual impedance factor of the towers needs to be determined now, in order to find the true field intensities of the three towers. This is figured from the formula:

$$K = \sqrt{\begin{aligned} &1 + F_2^2 + F_3^2 \\ &+ 2F_2 \cos \sigma_{12} J_0(S_{12}) \\ &+ 2F_3 \cos \sigma_{13} J_0(S_{13}) \\ &+ 2F_2 F_3 \cos \sigma_{23} J_0(S_{23}) \end{aligned}}$$

where, J_0 is the Bessel function of tower spacing.

In this example, K is 1.171. The unattenuated RMS field intensity at one mile over a perfectly conducting earth is found from charts to be 431 mv/m. This is for an antenna height of G which has been chosen to be 83.5°. It has been found that, as G is decreased from 90°, the field intensity decreases very little. The center tower field intensity, therefore, is:

$$\frac{431}{1.171} = 368. \text{ mv/m}$$

and this is the rms value.

The center tower phase is now to be determined, in order to fill the nulls to the required 8.2 mv/m. This phase α is equal to:

$$\sin \alpha = \frac{8.2}{368} = .0223 = 1.25^\circ$$

At such a small angle and large magnitude, this is practically equivalent to adding a J 8.2 vertical component to the center tower current.

At this time, it probably is best to summarize all the tower parameters calculated in this example; these are shown in table 1.

Table 1 — Summary of tower parameters.

#3	O	.516/+107.6	S = 90°
	S		G = 83.5°
#1	O	1/1.25	RMS radiation = 431. mv/m
	S		rms = 368. mv/m = E _i
#2	O	.516/-107.6	Required nulls at 310° and 14.7°
			Magnitude of nulls = 8.2 mv/m

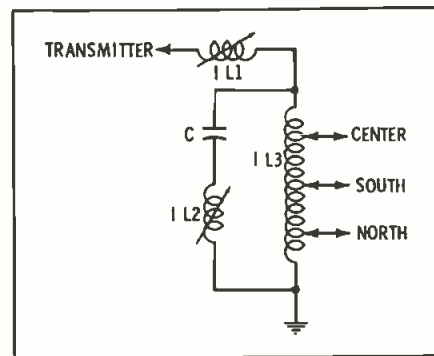

Fig. 2. Power divider for three towers.

The field strength for all azimuth angles can now be calculated by Equation 6, and this will now be done for an azimuth angle of 0°:

$$E = 2(.516)(368.) \left[\frac{1}{2(.516)} + \cos(90^\circ \cos 0^\circ + 107.6^\circ) + J 8.2 \right] = 10.7 \text{ mv/m}$$

For 50° or 14.7°:

$$E = 381. [.967 + \cos(90^\circ \cos 50^\circ) + 107.6] + J 8.2 = 8.2 \text{ mv/m}$$

For 180°:

$$E = 381. [.967 + \cos(90^\circ \cos 180^\circ) + 107.6] + J 8.2 = 742. \text{ mv/m}$$

Chart 1 shows all the values tabulated for every 10° azimuth. The pattern is plotted on the polar coordinate graph in Fig. 2.

It is interesting to note that with only 8.2 mv/m in the nulls, and with a 5-kw nondirectional value of 431. mv/m, this is a reduction ratio of 52.6. Since power varies as the square of the voltage, this is equivalent to sending only about 1.8 watts in these directions. In the 180° direction, the signal strength increases by a ratio of 1.72; so the power increases to about 15,000 watts.

Driving Impedance

In order to calculate the antenna current, power, and the network for matching the antenna to the transmission line, each antenna driving point impedance must be known.

• Please turn to page 56

MATCHING AND ISOLATING PADS

by Joseph H. Dessen, Chief Engineer, Audio Research Products Co., Blackwood Terrace, N. J. — Part I. Introduction to the many types of resistance networks employed in audio systems for broadcasting and recording.

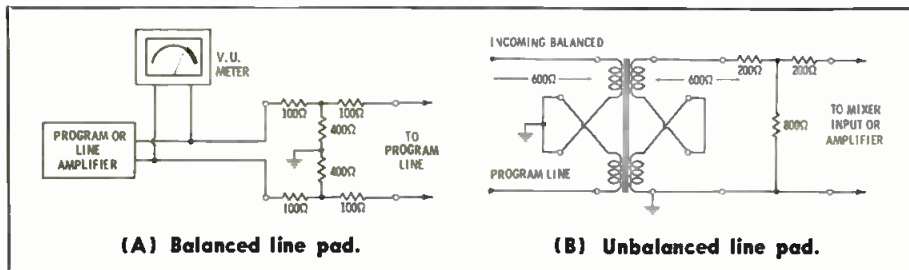

Fig. 1. Balanced and unbalanced six-decibel loss resistance networks for isolation.

The subject of transmission networks covers a great number of types and classes of networks, filters, and circuits used in electrical and electronic communication. It is the purpose of this article to discuss only the simpler resistance networks commonly employed in broadcast and recording facilities.

There are many applications for networks in audio installations. Fixed attenuators, or pads, perform essential functions such as providing impedance stabilization when inserted between the program amplifier and program line of a console (Fig. 1A). The pad isolates the output of the amplifier from the impedance variations of the line and provides for correct vu-meter readings. These networks are known as line pads and have a standard loss of 6 db.

Networks are also used at the receiving end of a program or remote line. When employed with a balanced-line transformer (repeat coil) they provide solid resistance termination (Fig. 1B).

Line pads may be the balanced-H type or unbalanced T, depending on the position of the line transformer. This transformer is used to provide impedance matching from a balanced line to an unbalanced line, to an unbalanced-line pad, or to the mixer input circuit. Generally designed for 600-ohm circuits, line pads may in special cases be designed for 150 ohms; an example is the application in a short unequalized program loop.

Another type of network, known as the taper pad can be designed to provide match between two circuits of different impedances. At the same time, the taper pad will introduce any desired amount of loss into the circuit. Each network does, however, have a certain minimum-loss limit. For example, as the insertion loss of a T network is decreased, one of the series arms eventually reaches zero resistance and reduces the circuit to a minimum-loss L network.

Definition of Terms

Before proceeding with the analysis and design of matching pads

it is necessary to define the terms, image-impedance and image transfer constant.

The image impedance of a network will simultaneously terminate each pair of terminals so that the impedances in both directions are equal; therefore, the network is matched at each end. Under these conditions the network is said to be terminated on an "image basis."

The image transfer constant is a measure of the power ratio of the network from input to output. It represents a loss for a resistance pad, and a gain for an amplifier.

In general, two units are used in measurements and calculations. The first is the neper, now often used in theoretical discussions. The second unit is the decibel, widely employed in many phases of practical audio work.

The neper (N_n) is defined as one-half the natural logarithm of the ratio of output power to input power:

$$\text{Nepers } (N_n) = 1/2 \log_e \frac{P_2}{P_1}$$

The decibel is defined as ten times the common logarithm of the ratio of output power to input power:

$$\text{db} = 10 \log_{10} \frac{P_2}{P_1}$$

The neper is equal to 8.686 decibels and one decibel is equal to 0.1151 nepers. Nepers are still used in some parts of Europe for measuring the characteristics of transmission systems.

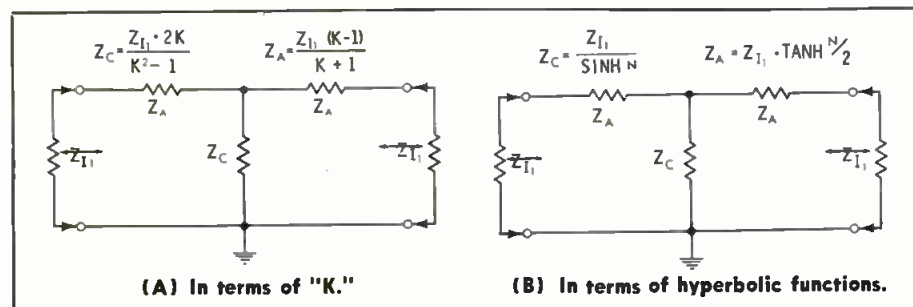

Fig. 2. Two techniques for designing a symmetrical unbalanced-T resistance network.

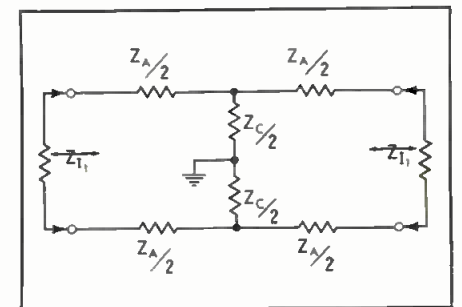

Fig. 3. A symmetrical balanced-H pad.

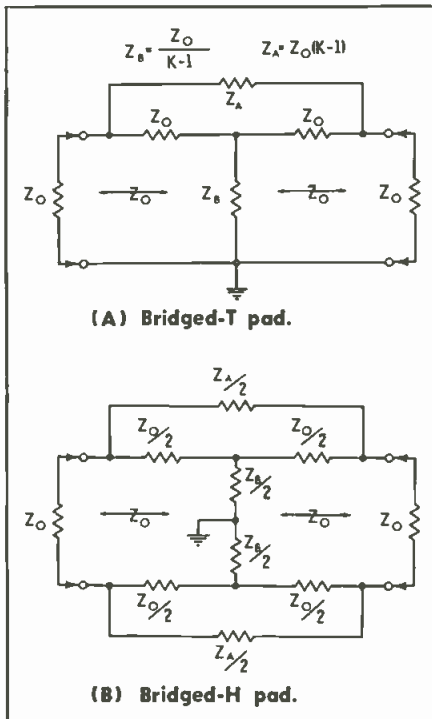

Fig. 4. Two symmetrical bridged networks.

Symmetrical Networks

We shall consider first the symmetrical T pad, which has equal image impedances at both input and output. Two basic unbalanced T pads in this group are shown in Figs. 2A and 2B, complete with equations for both "K" and hyperbolic function design. The arrows in the illustrations denote impedance matching.

The "K" term in Fig. 2A is the voltage or current ratio. The loss is calculated as follows:

$$\text{Loss (db)} = 20 \log_{10} K$$

$$\text{Loss (N}_n) = .01151 \text{ Loss (db)}$$

The unbalanced T network is employed in unbalanced-to-ground circuits, while the balanced H pad (derived by use of the same formulas) finds wide use in balanced-to-ground configurations. The balanced H is shown in Fig. 3.

A symmetrical network which finds a great application in program transmission circuits is the bridged T pad. It is commonly employed as a variable attenuator in mixer circuits. The unbalanced version is shown in Fig. 4A, while in Fig. 4B the bridged H pad is seen. In both cases, "Z_o" is image impedance.

Dissymmetrical Networks

Having considered symmetrical networks with equal image impedances at input and output, we now

turn to the more general case of dissymmetrical configurations. Dissymmetrical networks have different image impedances at input and output, Z_{t1} and Z_{t2}.

At the beginning of the article, taper pads were mentioned. These networks make use of the two different image impedances to provide a match between circuits of dissimilar impedances. A taper pad derived in terms of K, the voltage or current ratio, is shown in Fig. 5A. The T-type taper pad is shown once again in Fig. 5B, but this time derived in terms of hyperbolic functions. In Fig. 5C, on the other hand, is the balanced H version of the taper pad, with conversion factors.

One form of taper pad is employed in the source, or sending end, of a transmission measuring set (gain set) as shown in Fig. 6. This is the rotary impedance matching network which offers a constant impedance of 600 ohms at the input. It also provides series steps of 30, 50, 125, 150, 200, 250, 500, and 600 ohms at the output side. It is not necessary to correct for loss due to different source impedances at each setting of the range control.

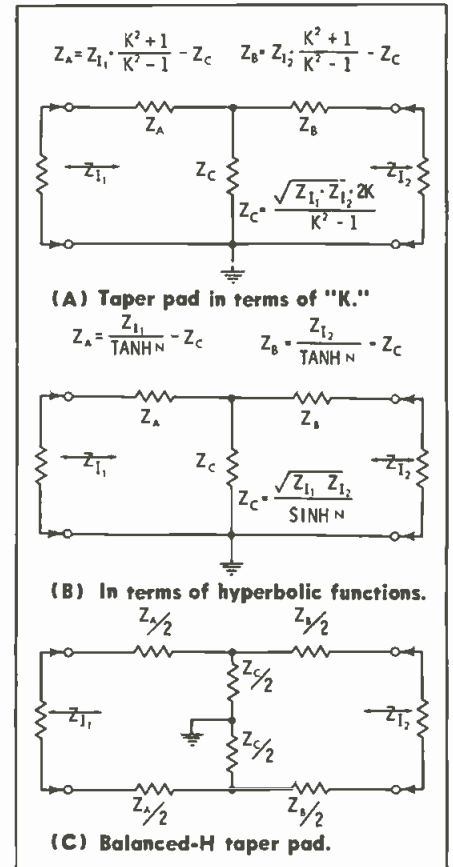

Fig. 5. Two dissymmetrical taper networks.

Now when one of the series arms of the T-type taper pad becomes zero (as the insertion loss is decreased), the network is reduced to

● Please turn to page 58

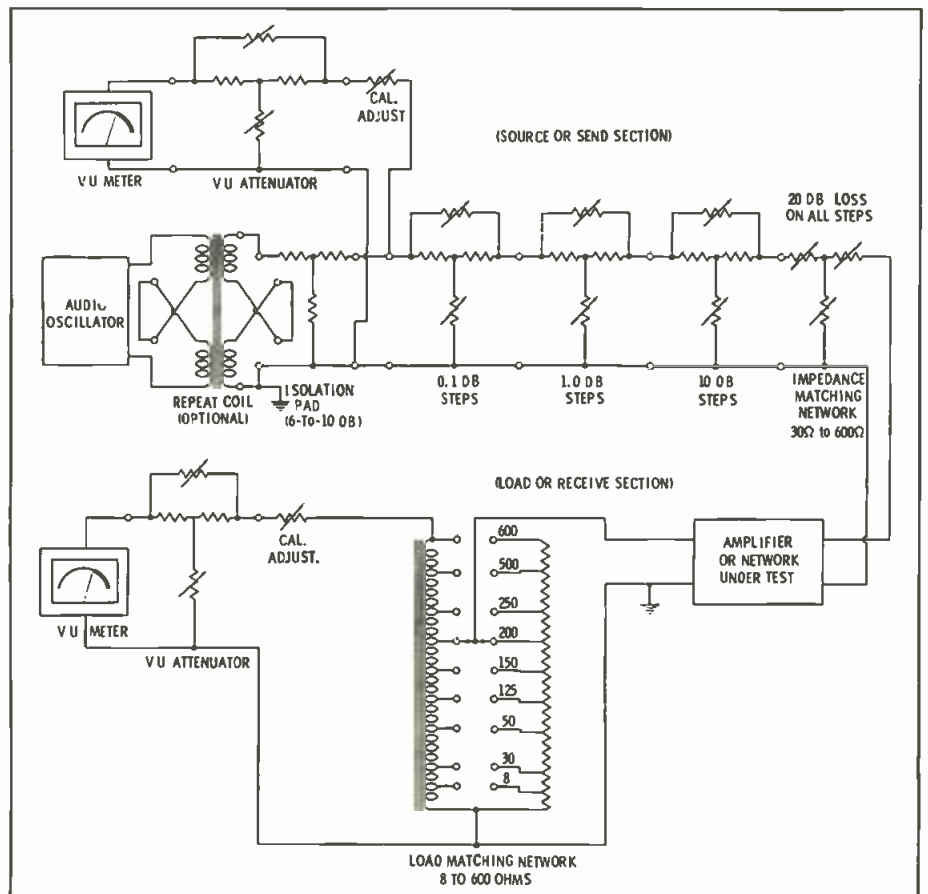

Fig. 6. Unbalanced transmission set employing rotary impedance matching network.

A REMOTE PICKUP TRANSMITTER CONVERSION

by Phillip Whitney, Director of Engineering, WINC, Winchester, Va. — Step-by-step procedures for modifying a surplus transmitter for remote pickup applications.

Ask any station manager if he could get along without his remote pickup radio gear after using it a year, and nine times out of ten he'll answer with an emphatic NO!

Operating this type of equipment in the 150- to 170-mc band, a station can set up for an unexpected broadcast within the hour; the resulting feed attains fidelity usually not possible even with class-A telephone lines. The list of programs is almost endless. Everything from a sports event to a symphony concert can be neatly handled by a readily available surplus unit, which can be obtained for as little as \$15. Conversion costs vary, of course, but the parts can usually be obtained for less than \$75.

Frequencies

In the 150- to 170-mc region, the FCC licenses remote pickup broadcast transmitters in three groups. Frequencies in group K include 152.87, 152.93, 152.99, 153.05, 153.11, 153.17, 153.23, 153.29, 153.35, 161.64, 161.67, 161.70, 161.73, and 161.76 mc. In group L there is one frequency, 166.25 mc, and in group M, 170.15 mc. Frequencies from 152.87

through 153.35 mc are licensed only subject to the condition that no harmful interference to the Industrial Radio Service be caused. The frequencies between 161.64 and 161.76 mc may not be used in Puerto Rico or the Virgin Islands, although these territories have a special group of nine frequencies assigned. The frequencies in groups L and M will not be assigned in certain parts of the continental United States.

Bandwidths vary with frequencies. For example, 60 kc is assigned for the frequencies between 152.87 and 153.35 mc inclusive, 160.89 to 161.37 mc inclusive, and 170.15 mc. Bandwidths of 30 kc are assigned to frequencies between 161.64 and 161.76 mc inclusive.

Modification

The transmitters discussed here can be purchased with either a genemotor (dynamotor) or a 115-volt AC supply. The latter are, naturally, more difficult to find, since there are so many more mobile units than base stations. Because conversion of base stations involves no more than insertion of a pre-emphasis network in the modulator

grid circuit and the substitution of a broadcast-quality audio input transformer, this article will concentrate on the conversion of the mobile model.

For remote applications, one of the 6-volt models is more desirable than the 12-volt models; however, either can be used. To convert a 12-volt unit, the filament dropping resistors must be removed, and the filaments rewired for straight 6-volt operation. (Of course, a 12-volt filament supply could be used, but the required type of transformer is often somewhat more difficult to track down.)

The sets we are considering here are often called "turkey roasters" because of the manufacturer's designation, or "coffin sets" because of the appearance of the large chassis cover. Some stations may want to discard the cover and sides, mount the chassis on a standard 19" panel, and have a ventilated cover made at the local sheetmetal shop.

A good starting point for the conversion is to remove the cover and sides, and clean away the carbon deposits which accumulate on mobile units; use "Varsol" or some similar cleaning fluid (exercise the normal care necessary to prevent

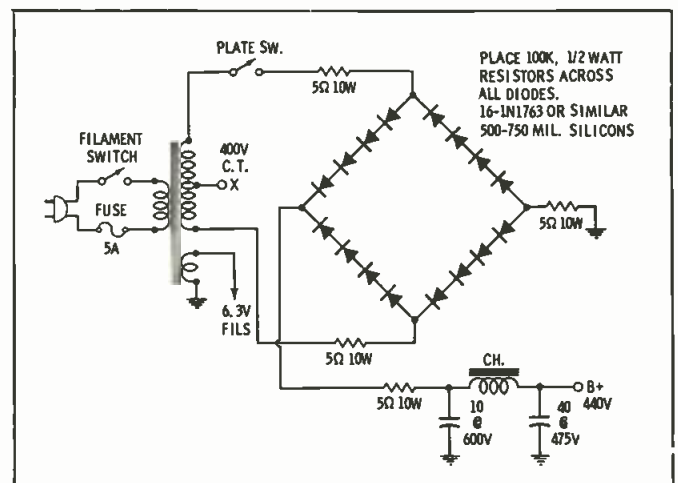
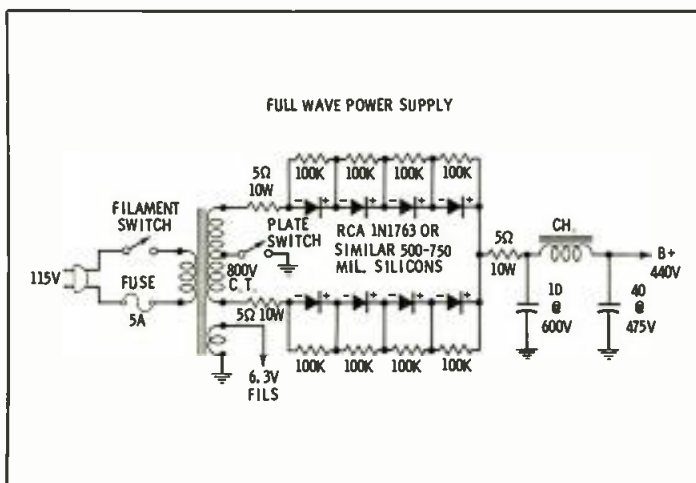

Fig. 1(A). Full-wave power supply for converted transmitter.

Fig. 1(B). Bridge power supply for converted remote transmitter.

igniting the volatile fumes). A standard cotton swab is a "best friend" when cleaning grime from tube sockets and small, inaccessible areas.

Now, remove the genemotor, filament relay, B+ relay, and genemotor starting relay. Next, take the "control," "receiver," and "power" sockets from the front panel. If a simple phone jack microphone connector is preferred to the four-prong receptacle provided, the latter can be removed.

Temporarily pull all tubes, marking their locations on the chassis. Now remove the long terminal board extending from the front of the chassis to the rear, which is used to change the unit from AC to DC operation. Cut the leads as close to the terminals as possible. Next remove the automatic deviation control assembly board (with numerous resistors and diodes), which is usually located near the microphone transformer. Remove microphone input transformer T-1, leaving intact the two wires which go to the modulator grids. Label them for future use.

Now slit the cabling ties on all below-chassis wiring and extract all wires which have both ends disconnected. Remove the transmit-receive coaxial switch from the front panel, being careful to leave the output-coupling hairpin intact for later connection to a type 83-1R output connector.

Next, using a tube manual and ohmmeter, locate the filament supply lines to the tubes and label them. Do the same with the B+ to the 225-volt line, then mark the B+ lines to the driver and finals. Clean away any dirt from the chassis or components.

Cut a piece of stiff sheet alumi-

Transformers

power: 800 volts c.t. @ 340 ma. (approx.):

Triad R25A, 400 volts @ 500 ma,
Thordarson 22R35, 400 volts @ 340 ma.
Thordarson 26R57, 344 volts @ 390 ma.

(for bridge circuit, 400 volts c.t. @ 340 ma. may be used).

audio input: 500 ohms to 50,000-ohm grid (Stancor WF20, or equivalent).

filter choke: 2 to 5 henries @ 340 to 400 ma.

Rectifiers

8, RCA 1N1763, or equivalent (16 if bridge circuit is used).

Quan. Description

3	5-ohm, 10-watt resistor
8	100K, 1/2-watt resistor.
4	33K, 1/2-watt resistor.
2	2.7K, 1/2-watt resistor.
2	1 meg, 1-watt resistor.
1	10-mfd @ 600 volts electrolytic capacitor.
1	40-mfd @ 475 volts electrolytic capacitor.
4	.001-mfd ceramic capacitor.
2	.05-mfd ceramic capacitor.
2	.0022-mfd ceramic capacitor.
8	terminal strips.
1	A1 jack and insulating washers.
1	pilot light assembly.
2	spst toggle switches.
1	line cord and plug.
3	2E26 tubes (if needed).
1	crystal.

small pieces of aluminum or copper, 10 feet of No. 28 enameled wire, mounting screws and nuts, tube-cooling fan, 115-volt.

num or copper to fit behind the front chassis apron; this should cover all holes on the right half of the chassis. Drill six mounting holes in both the chassis apron and this metal plate. Temporarily holding the plate behind the apron, mark the three large holes ("control," "receiver," and power) and the small one (microphone). Remove the plate and drill 1/2" holes exactly

in the center of all four circles. Mount the filament switch (spst bathandle) in the "control" socket hole. In the center of the "receiver" socket hole, mount the "plate" switch (similar to filament switch). Insert a grommet for the 115-volt power cord in the "power" socket hole. Mount a phone jack—positioned with insulated washers—in the microphone connector hole, being sure that it does not touch the chassis. Bolt the new panel in place behind the front apron.

Mount the coaxial connector in the antenna connector hole at the left end of the front chassis apron. Solder the end of the coupling hairpin into the back of the connector. If necessary, extend hairpin lead 1/2" or so with a piece of number 10 or 12 solid wire. Mount a pilot light in the old "receiver" coax hole.

Using a plastic-tape type or other labelling device, place new designations on the front of the chassis: "Filament" over the old "Control" sign, "Plate" over the old "Receiver" label, and a new "Power" sign over the old. Place a "Pilot" label over the old "Receiver" sign on the left side of the chassis. The original fuse retainer will be used to hold the fuse for the 115-volt line, which enters the chassis through a grommet in the farthest right hole.

It is suggested that a silicon-diode supply be substituted for the old vacuum-tube rectifier circuit. This eliminates a serious heat problem and the possibility of broken rectifier filaments with transportation of the unit. Mount the diodes on a terminal strip fastened to the right underside of the chassis, near the filter capacitors. The power transformer and choke can be mounted where they fit the best, atop the

● Please turn to page 54

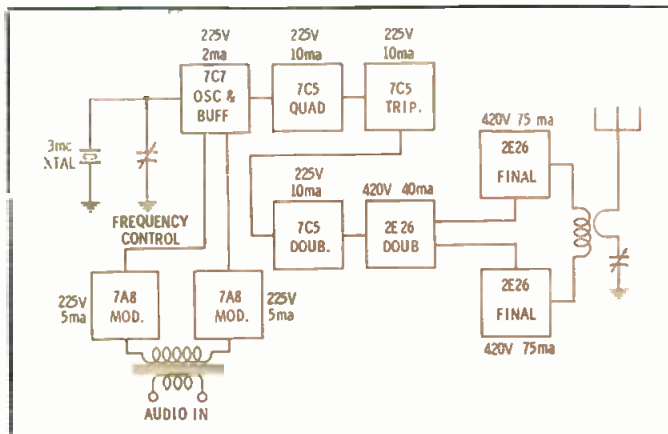

Fig. 2. Block diagram of converted surplus remote transmitter.

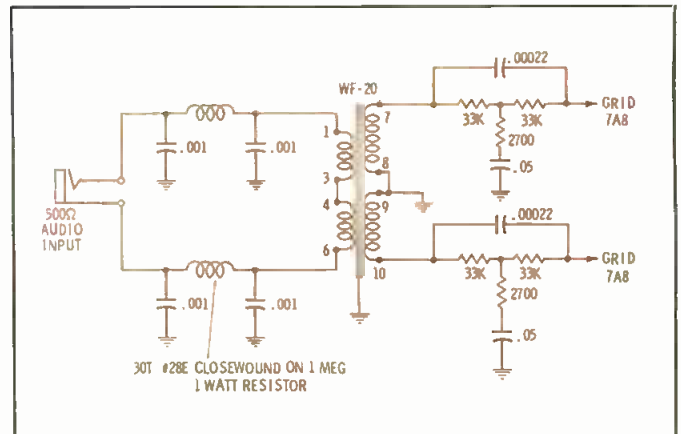

Fig. 3. Audio input equalizing network to correct response.



BROADCAST ENGINEERING Tours the 1964 NAB Convention Exhibits

A B-E Staff Report — by *Stuart N. Soll,
Forest H. Belt, and John J. Walsh*

The scene at the exhibition hall of the Conrad Hilton Hotel, in Chicago, over the weekend of April 4 was one of "organized chaos." It marked the beginning of the 42nd Annual Convention & Broadcast Engineering Conference of the National Association of Broadcasters.

Trucks arrived and departed in almost endless lines; crews were at work furiously assembling and arranging some 91 exhibits right up to the time the hall doors opened to admit the first conventioner.

After registering and accepting the cordial welcome of a hard working and patient NAB staff member, the visitor proceeded through the double doors to the exhibition area. From this vantage point, several steps above the main floor, he could gaze out upon row after row of booths comprising the largest display of the world's finest broadcast equipment ever to be gathered under one roof.

Many a visitor asked himself, "Where do I start?" Most attempts at planning a route through the mass of chrome and enamel equipment ended in failure before many steps were taken; no sooner did one lay out his course when he would be sidetracked to some display which caught his eye.

More than 3800 persons were on hand to tour the exhibits. Many had special interests and went first to see the most appropriate displays. Most conventioners, however, just let their eyes serve as guide and let their feet carry them from booth to booth. They saw much time-proven equipment and a host of new innovations, many of which are sure to make a mark on the broadcast industry and be a part of station systems for some time to come.

Instead of only discussing specific equipment, let's look at some of the categories and their respective ranks by number of displays.

As you might guess, audio equipment ranked first, with 15 companies displaying such gear as consoles, remote amplifiers, preamps, amplifiers, monitors, tape recorders, phono devices, equalizers, filters, and other studio equipment.

The trend here was to transistorization, as was the case with most equipment on display. Examples range from rather simple audio amplifiers for background music service to complex solid-state audio mastering recorders for studio use, such as the new Ampex MR-70 two-speed machine which uses industrial/military grade nuvisitors to achieve its 70-db signal-to-noise ratio.

In the field of audio-level control devices is a new automatic peak-level controller which was demonstrated by CBS Labs. Designed to do the job previously filled by peak limiters, the Volumax Peak Controller 400, was explained by company representatives to eliminate pumping effects and distortion caused by high levels. The automatic controller analyzes program material and then automatically selects the proper limiting speed. By using the instrument with an automatic level unit, complete audio control from studio to transmitter can be provided.

Also on hand in the exhibit hall was a new line of audio components shown by the new Audio Controls division of Altec. Included in the line are low-pass and high-pass filters, a microphone equalizer, a sound-effects filter, solid-state preamps and power supplies, a program equalizer, and a graphic equalizer.

The latter item, the graphic equalizer, permits control in 1-db steps on a panel laid out in the form of a frequency-response grid. Seven individual vertical slider controls permit 8 db of boost or 8 db of attenuation at 50, 130, 320, 800, 2000, 5000, and 12,500 cps.

In second place by number were the displays of transmitters including those for AM, TV, VHF, UHF, ETV, and FM in mono and stereo. Fourteen companies had various combinations of these on display at their booths. The equipment encompassed units from a low-power TV transmitter for educational applications to a new 50-kw UHF transmitter by G-E and 30-kw UHF transmitter by RCA, both for high-power television stations. Among these were a 2-kw VHF television transmitter which employs but five tubes and a one-tube transistorized kilowatt AM transmitter that made a big hit at the show.

Complete with its "sold" sign (which appeared shortly after the show opened) the "one-tube" transmitter, Gates Radio's Vanguard I,





takes up little more space than a home clothes dryer. Seven controls on the sloping front panels permit all operational adjustments to be made from the outside and from one position. The controls are: PA Load, PA Tune, two multimeter selectors, an oscillator selector switch (the exciter accommodates two solid-state oscillators), plus the filament and plate on-and-off switches. Two large meters, positioned just below eye level, monitor plate current and voltage; a third serves as the multimeter providing thirteen separate current and voltage readings in the driver, modulator, and final amplifier sections.

Other features that make this transistorized transmitter quite interesting include a built-in dummy antenna rated at 1 kw; complete front accessibility by means of lift-up-and-off panels; the use of one 4CX3000A final tube. In all, this transmitter received good acceptance at the show and should find popularity among many AM radio operations.

Another transmitter of small physical size (smaller than many 500-watt units) is a 2-kw VHF television unit, Model TL-623, which employs only five tubes; it uses transistors in the video amplifier, sync stretcher, audio amplifier, and FM frequency multiplier. The Standard Electronics transmitter provides 2-kw peak visual output and either 200 or 1000 watts of aural power. This complete television transmitter can also be used without modification to drive a 10-kw, 25-kw, or 50-kw linear amplifier.

Thirteen companies displayed antennas, towers, and/or accessories. These included AM, FM, TV, VHF, UHF, CATV, and relay. Fourth on the list of items by number of

displays were television cameras and accessories. In this category were a wide range of units in such a variety of sizes and configurations that the broadcaster found a choice never before available. In almost every case, fully or partially transistorized cameras were included in the booths. Many companies showed cameras with zoom lenses built in or mounted externally, with provisions for remote control. Two new color cameras were on hand, and several compact vidicon studio cameras were demonstrated. A number of 3" and 4½" I-O cameras as well as an ultraminiature pickup unit complimented the exhibits.

Ranking fifth in number, with ten firms displaying, was film equipment and services. Recorders, processors, cameras, and complete services were represented.

A device which rates mention here is a new automatic-threading film inspection machine—the Mark IV-B Auto-Thread by Harwald. The equipment simplifies inspection by automatically stopping when it detects cellophane tape splices, pins, broken film, weak splices, sprocket hole damage, and sound-track defects. In addition, the inspection machine can be set to stop automatically at all splices for editing purposes. In normal use, good splices are counted, dirt is removed, and defects are detected automatically.

Next in number were stereo transmitters and equipment, video equipment, cartridge recording equipment, and test instruments. Nine firms displayed the former two items, while eight companies were on hand with the latter two.

A field that received great attention during the exhibit was that of program automation — there were

seven booths displaying such gear. The devices ranged from relatively simple cartridge cuing units to complete automatic logging, programming, switching, and accounting systems for an entire station.

Two complete systems that can be used individually or together for complete station control were exhibited by Continental Electronics. One system, called "Trafficcounting", handles all traffic control, accounting control, schedules, programs, and all functions normally performed by the traffic and accounting departments. Requiring one or a maximum of two operators, the system employs IBM tabulating machines and may be used with computers. Following development by broadcasters at a radio station about two years ago, the system was field-proven and now is available to the industry.

Also offered by the same company is the Prolog automatic programming system which may be used with the above system or separately. A fan-folded paper log is typed on a continuous sheet in 15-minute segments with each program notation inserted by a special key affixed to the standard typewriter. As the log is scanned in the programmer, the codes are sensed to completely control music tapes, announcements, cartridge machines, and other sources. The system is available with various combinations of these devices, a typical setup consisting of: programmer/logger unit, manual control panel, five music-source tape transports, three 24-cartridge units, three single-cartridge units, cartridge recording equipment, 25-cps tone generator, and four racks.

Seven booths had on display television automation and switching

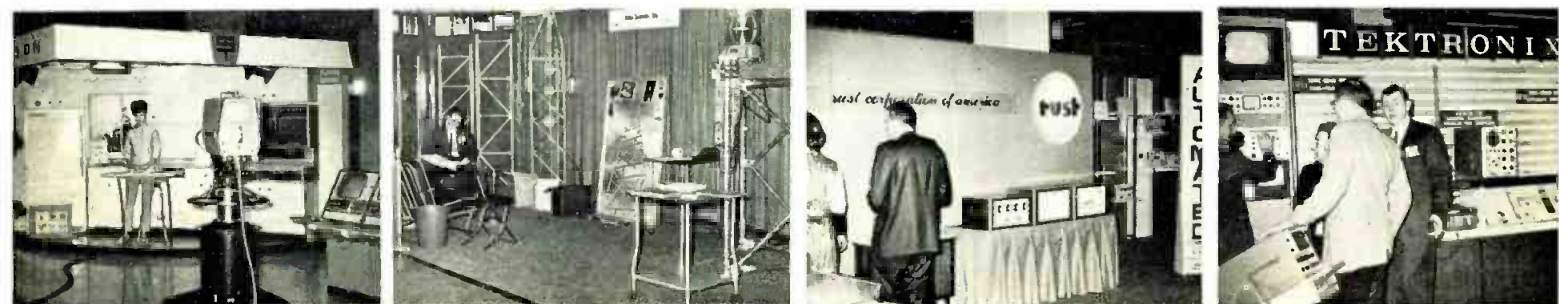



apparatus. They ranged from the low-cost STEP preset switching system of Chronolog Corp., which employs pinboard-type cards to accurately control entire break sequences while permitting changes up to the very last minute, to a complex solid-state computer programmer which is set up in advance to control an entire day of television station operation.

The APT computer system by Sarkes Tarzian can be programmed from an operator keyboard (an integral part of the equipment), punched cards, punched tape, or paper tape readers. At any time the operator may take over control and then return to automatic operation; all events are displayed on numerical readout devices and video monitors. The basic system consists of a special-purpose digital computer, a digital input/output switching unit, visual displays, and a complete operator keyboard for control and computer loading.

Six manufacturers displayed STL and microwave equipment; five firms each were on hand with lighting equipment, remote control equipment, and video monitors.

Although further down the list by number of displays (and, by that same token, competing companies), television tape recording equipment and video tape attracted a great deal of attention. Of five companies, all displayed accessory equipment, four showed television recorders, and four showed video tape.

A product that attracted much attention in this area was a new long-life slick-surface video tape that has tested to permit more than 700 passes. According to Reeves Soundcraft, head wheels used with their type 302 Microplate tape will

have a life of 1000 hours. With orders coming in on the spot, representatives of the tape firm were kept so busy writing they hardly had time to demonstrate their product.

Nearby was the exhibit of another video tape and a broadcast-type helical-scan television recorder, complete with signal stabilizer for

The company's 2" V-21T tape, designed for transverse machines, is claimed to have a wear life in excess of 300 passes, and has properties to lengthen head life.

Among the five firms exhibiting microphones, we noticed several condenser units. All are of high quality and intended for use in broadcast stations and recording studios. Two companies showed noise-cancelling microphones for mobile-unit applications.

On display at the Shure booth was the new SM-3 ribbon microphone which employs internal rubber-spider suspension within the main housing. A newly introduced unit, designed for boom use exclusively, is the SM5-U cardioid microphone which has a completely internal shock mounting and an outer wind screen of special foam material. The combination is said to reduce mechanical noise to a minimum.

Rounding out the exhibits were several other categories of equipment. Representative items include: automatic logging equipment, SCA gear, TV prompters, office copying devices, lenses, wire, cable, transmission line, standby power and regulation equipment, components, towers, translators, CATV equipment, camera mounting devices, and remote pickup equipment. Because of space limitations, we have discussed only a few of the items which were on hand at the convention — to list all companies and products would require an entire issue. We hope this brief discussion and the accompanying photos have helped the reader gain some idea of the vast range and selection of broadcast equipment that contributed toward making the 1964 NAB Convention so successful. ▲

B-E's Editorial and Consulting Author Staff Meets

On April 6 several members of the BROADCAST ENGINEERING staff met for their first annual Consulting Author Dinner. Attending the successful get-together, hosted by editor Forest H. Belt, were Mr. and Mrs. Howard T. Head (Washington Correspondent), Dave L. Milling (advertising sales manager), Stuart N. Soll (managing editor), Mr. and Mrs. Len Spencer, Phil Whitney, Bill Kessel, Mr. and Mrs. Bob Kastigar, Melvon Hart, J. Gordon Elder, Robert A. Jones, Patrick S. Finnegan, Elton Chick and John J. Walsh. Guests of honor were James A. Milling, president of Howard W. Sams and Co., Inc., and Robert G. Weston, executive secretary of the Committee for the Full Development of All-Channel Broadcasting. Speaking briefly before dinner, Mr. Milling acknowledged the important contribution of the Consulting Authors to the broadcast field; he pointed out how the consumer electronics industry depends on proper station operation. Then, in an informative after dinner talk, Mr. Weston discussed the FCC's efforts for UHF television; he described the field tests, and answered many pertinent questions.

meeting all FCC requirements. The Sony BV-100 portable machine may easily be taken on location — it weighs approximately 100 pounds. The signal stabilizer remains at the studio and is used only during playback.

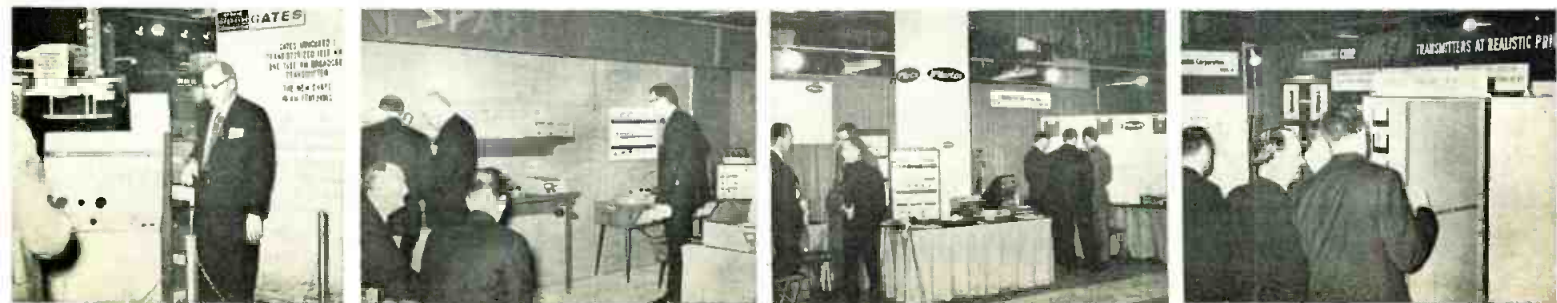



Introducing a New Era in Television Tape Production: The Ampex VR-2000

More than a new look! More than a new name! The Ampex VR-2000 Videotape* television recorder offers a completely new concept in television tape recording. With the introduction of this all-new machine, the ability to achieve full production capability . . . on tape . . . becomes a reality. True "tele-production" becomes an accomplished fact instead of a glowing promise. From its Mark IV heads with rotary transformers and integral preamps, to its highly sophisticated control and monitoring system, the VR-2000 has been designed to entirely new parameters of quality and performance without regard for limitations of previous technology. The result is a recorder offering unparalleled results on current "low-band" standards . . . and opening the door to an entirely new "high-band" standard as an optional operating mode, providing a new performance level presently unattainable on any other recorder. For networks, television

*T. M. Ampex Corp.



production companies, and quality-conscious stations, this "high-band" standard means vast improvements in band width and signal-to-noise ratio . . . permits tape copies to the third generation with picture quality equal to "master" tapes made on today's recorders . . . gives color performance that outstrips anything ever demonstrated. Yet, for all its sophistication, the VR-2000 achieves a new degree of simplicity, dependability, and ease of maintenance. Only Ampex could build the VR-2000 . . . and only Ampex offers a complete family of VTR production accessories: Intersync* (standard equipment on the VR-2000), Amtec*, Colortec*, Electronic Editor, Editec* . . . all proven products . . . not promises . . . ready now to increase your VTR profits and capabilities. So it's little wonder that a major European network is now installing the VR-2000. Ampex Corporation, Redwood City, California. Worldwide sales, service. Term leasing, financing.

Circle Item 8 on Tech Data Card

EMERGENCY OPERATION ON FLEA POWER

by *Patrick S. Finnegan*, Consulting
Author, Chief Engineer, WLBC AM-TV,
WMUN(FM) — One solution to the
problem of providing emergency
power at minimum cost.

Severe weather warnings are out, howling winds and driving rain are in progress, and listeners are depending on your station to keep them posted on the progress of the storm. There is a flash of lightning, a clap of thunder, and—blackout, the power fails. You are off the air. Most broadcasters have experienced this feeling of helplessness at one time or another. While commercial power is generally reliable, power failures do occur and often do so at the most inopportune times.

The desirability of having standby power generators is recognized by most broadcasters. However, as the power demand of the station increases, the cost of auxiliary power equipment also increases. Hence, cost considerations keep many stations from acquiring a standby power source.

The Generators

The power requirements of our stations have kept increasing as we provide more services to our community, and, as with other smaller-market stations, money is not the most plentiful of our commodities. We found that a minimum of 125 kw would be needed to operate our technical and building equipment from our auxiliary power source. The cost of a new generating plant capable of supplying this amount of power was found to be prohibitive. The used-equipment market did not look any more promising. Carrying the investigation further, we discovered that, since we were a part of the old Conelrad system and our FM station was a relay link in the Indiana FM network, we were eligible to secure generators through the local Civil Defense—if any were available.

While some were on hand, they were of the 5- and 10-kw, war-surplus variety. Three-phase units



Fig. 1. The emergency operation booth.

were even more scarce. Resigning ourselves to make the best of it, we were able to secure one 10-kw single-phase generator and one 10-kw three-phase generator. The cost involved was on the order of \$100 each. Ownership of the generators remains with the Civil Defense, although the station may use them in any desired way so long as they are available for use during a national emergency.

Setting Up the System

Securing the generators turned out to be the easy part. When we became committed to their use, numerous other problems presented themselves. For example, with only 20 kw of power available and a

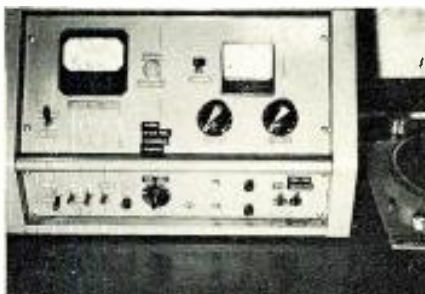
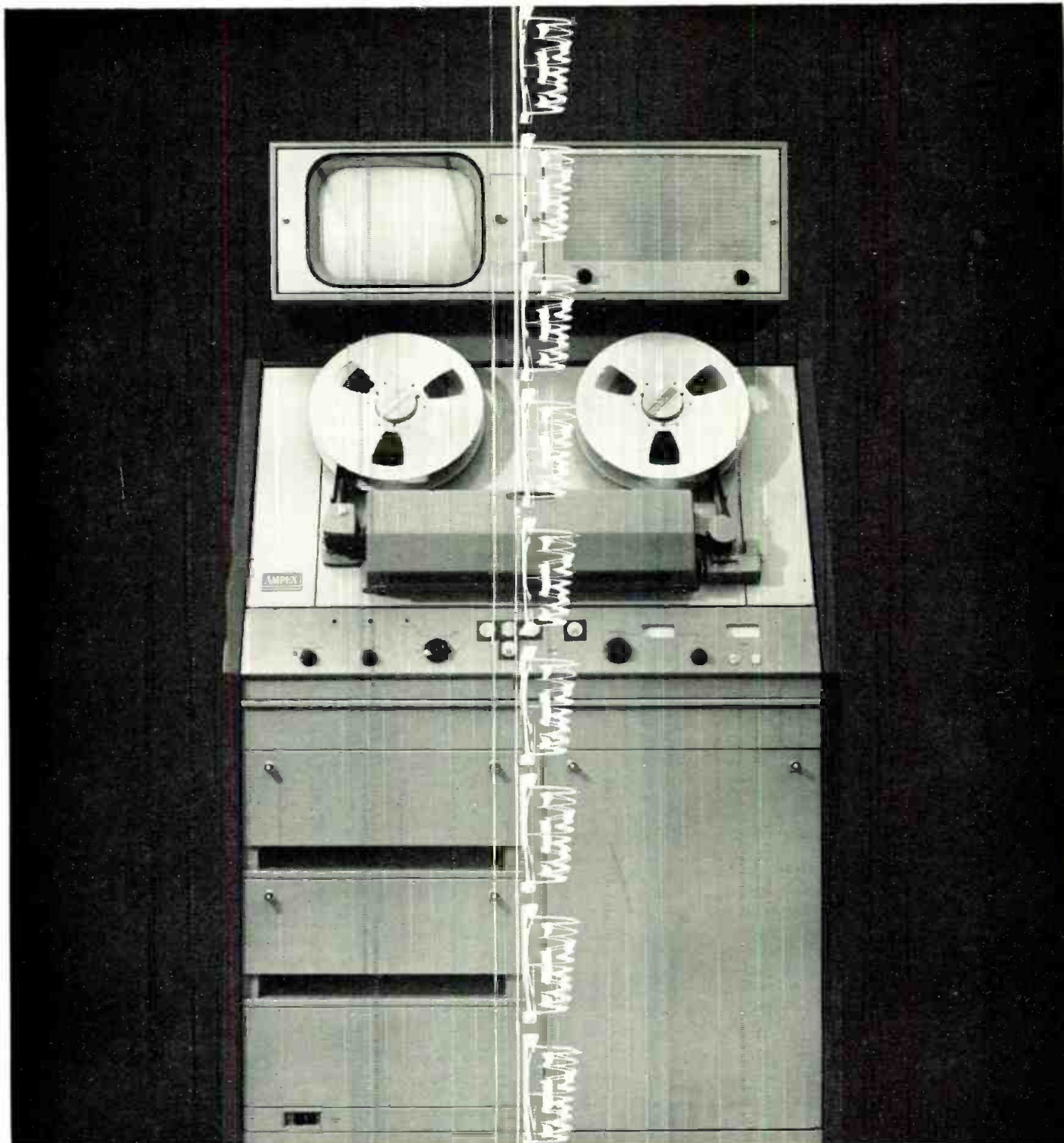

Fig. 2. Station-built console and switcher.

total demand of 125 kw, what equipment is essential to operation during a power failure? When you have a very complex control room, how do you sort out a few items to operate and interconnect them in a manner that doesn't require a complicated patching arrangement? After these items of equipment have been earmarked for emergency use, do you run dual power circuits to each of them, and how do you simplify power switching?

It was necessary to provide a shelter to protect the generators from tampering and the weather, since they must be ready to run on instant notice. Our solution to this was a single-car garage. Since we intended to heat it, the walls and ceiling were insulated. No windows were used, but to provide ventilation screened louvered openings were provided near the generator radiators. A piece of insulating board is used to seal the openings when the units are not in operation. To carry the fumes outside the building, flexible steel pipe was purchased in bulk length and attached to the exhaust pipe of each generator. Since these pipes get hot, a sheet of rigid asbestos was used to insulate the pipe from the frame siding. A baseboard type electric heater, with its own thermostat, was installed along one wall. The heater is normally used only to keep the temperature above freezing.

Equipment selection and power routing required some serious thought. Keeping in mind our obligations under the National Defense Emergency Authorizations held by both AM and FM stations, these two services had to operate. Television was ruled out because it would be impossible to maintain even a minimum operation of this service. The FM transmitter requires three-phase power, so the three-phase generator was assigned



One more good reason for buying the VR-1100: **Color**

Ampex has added color to the world's fastest selling VTR, and you can order it now. What kind of color? Ampex Colortec, the color tape system nobody's been able to duplicate. And this new color accessory is every bit as advanced as the other features of the VR-1100. Characteristics? A fully-transistorized, modular unit that takes up only 5½ inches of rack space. It can be factory-installed when you purchase your VR-1100. Or it can be ordered separately whenever you're ready to go color. That's the whole idea behind



the VR-1100: buy the most advanced basic VTR now, add the accessories you want when you want them. And that's why the VR-1100 is the greatest value and the fastest-selling VTR in the world today. Ask your Ampex representative for more detailed information. Or write the only company providing recorders, tape and core memory devices for every application. Ampex Corporation, 401 Broadway, Redwood City, California. Term leasing and financing are available. Sales and service offices throughout the world.

Professional reel-to-reel quality
with tape cartridge convenience



KRS 1-Stack ELECTRONICS

REVERSIBLE - HIGH SPEED FORWARD TAPE UNIT

- A BROADCAST CARTRIDGE — provides the superior quality of professional reel-to-reel. Full length programs.
- REVERSIBLE — HIGH SPEED FORWARD — all functions pushbutton operated, full editing capability in a continuous loop cartridge.
- COMPATIBLE WITH STACT Broadcaster — for program make up, automation, and provision for three cue tones.

VISUAL, the leader...
first to offer a complete
solid-state broadcast facility

VISUAL ELECTRONICS CORPORATION

356 west 40th street • new york, n. y. 10018 • (212) 736-5840

Circle Item 10 on Tech Data Card



to FM. The transmitter, the frequency/modulation monitor, and the off-air receiver consume almost the complete output of this generator. Only 10 kw of single-phase power remains to operate everything else that must run. This presented a real headache until we came up with a solution that we considered very satisfactory and that also alleviated some of our regular day-to-day operation bottlenecks.

The Emergency Booth

At one time most of our programming on AM radio consisted of live disc jockey and network shows. Left over from that operation was an announce booth located adjacent to the main control room. After we changed over to the almost exclusive use of cartridge tape for our radio programming, a recording booth had been set up to make up all our programs on tape. Traffic and scheduling programs in the use of the recording booth were creating severe bottlenecks in our operation, while the old announce booth remained idle except for a few live newscasts and some special live announcements.

We decided to equip this booth as a second recording facility, even though it was very small. Once the decision had been made, the way was clear for an easy solution to our emergency-system problems. It would be far simpler to supply our emergency power to only this booth rather than trying to route it to individual pieces of equipment scattered about the control room. Our first recording booth could not easily be adapted for emergency use because it is an integral part of the control room, being interconnected by many patch lines and relay-operated circuits.

The emergency booth (Fig. 1) was now equipped with one of each of our program equipment units—cartridge tape record/playback machine, conventional reel-to-reel tape recorder, turntable, AGC amplifier of the gated type, microphone, and monitor amplifier. We decided to build our own switcher console (Fig. 2) so that all these pieces of equipment could be operated conveniently. Connections of the booth equipment are shown in Figs. 3 and 4. With the exception of the cartridge tape recorder, no equipment was purchased to equip this booth;

BROADCAST ENGINEERING

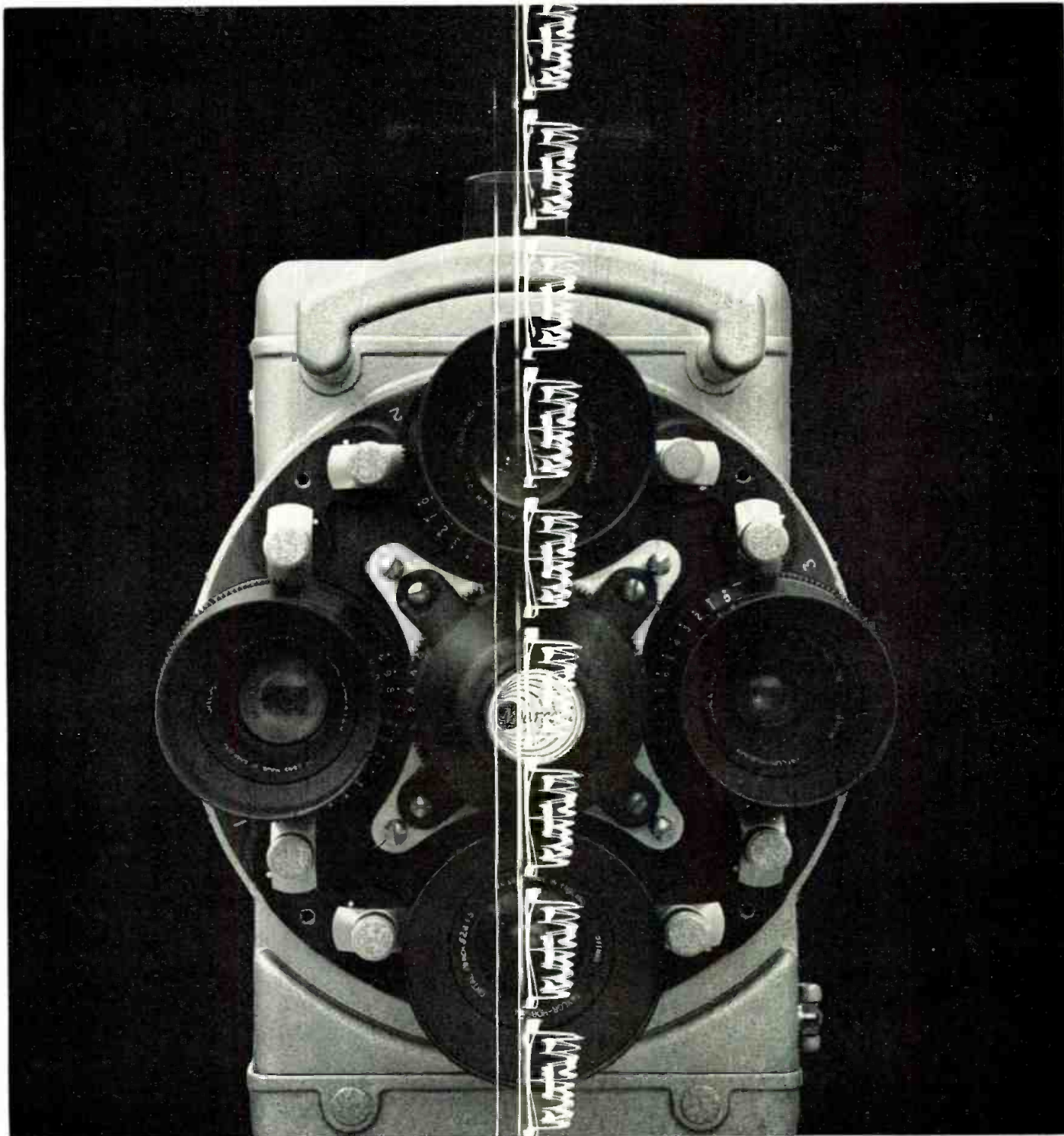

Funny that nobody's been able to duplicate the Mark IV

It's certainly not for want of trying. Since Marconi introduced the first 4½ inch Image Orthicon camera, everybody and his brother have been trying to catch up. A thousand Marconi 4½" cameras have gone into service in 38 countries. The Mark IV has literally become the world's standard television camera. And for good reason. It's the camera that improved picture quality 50%. It was the first camera to make it possible for the cameraman to concentrate entirely on composition and focus—and leave all other functions to the control room. Another first: once you set it up it stays set up. Little wonder that a lot of people have been trying to duplicate it. But there's one hitch. While the others have been trying to build a camera as good as the Mark IV,

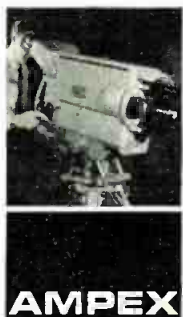

AMPEX

Marconi has been radically improving it. Long-lived silicon rectifiers have replaced selenium units in the power supply. The iris system is virtually jam-proof. A shielded yoke keeps the camera in focus even if there's magnetic interference. A solid-state head amplifier has been added. And the Mark IV is now instantly switchable from one world standard to another. In short: by the time somebody makes a camera as good as the 1959 model Mark IV, they'll have the 1964 model to contend with. And that goes for the whole line of Marconi specialties: vidicon telecine equipment, switchers, color cameras, and closed circuit vidicon cameras, accessories. Distributed by Ampex Corp., Redwood City, California. Worldwide sales and service. Term leasing and financing.

Circle Item 11 on Tech Data Card

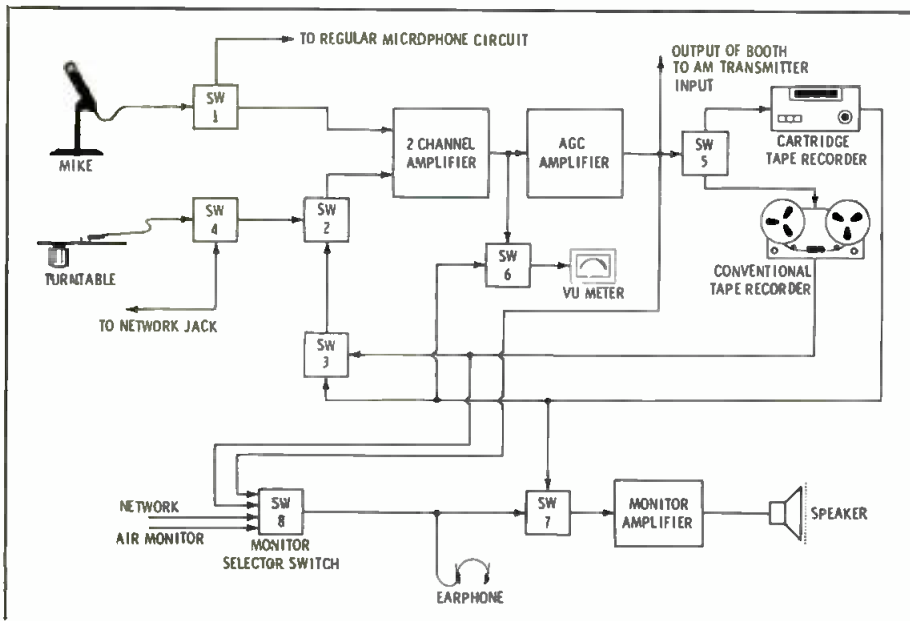

Fig. 3. Block diagram of equipment arrangement in the emergency operation booth.

all items used were those that either were idle or saw little use previously.

In the design of our console, we avoided anything that would use power. Consequently, there are no pilot lamps or relays. All switching is done by lever-type switches. The only power-consuming unit is a small tube-type, two-channel remote amplifier. This unit has two microphone inputs, individual faders, a master fader, and a VU

meter. It is capable of an output of +8 VU into 600 ohms.

The mixers and the VU meter were taken out of the amplifier and mounted on the front panel of the console; the chassis remained inside. A switch is provided to shift the meter to the output of either the console or the cartridge tape machine. This is a convenience for checking recorded tapes for level. Since the booth is still used for live

newscasts, the original microphone circuit is now routed through the console so that it may be used as before with the control-room equipment or switched to the emergency console. Since no relays are used, there is no speaker muting. When the microphone is to be used, the speaker is switched off and earphones are used for monitoring.

Patching has been simplified when converting to emergency operation. Only two patch cords are required; one is used to patch the network to the console and the other is used to patch the output of the booth to the AM transmitter input. These jacks are color-coded to facilitate quick identification.

Operation of the booth, although not as convenient as in the regular control room, permits programming of network material, live announcements, and recorded material (from cartridge tapes, conventional tapes, and records). Also included in this booth are a wind speed and direction indicator, barometer, recording thermometer, and clock.

Power Distribution

Power distribution takes the form shown in Fig. 5. The FM transmitter, its frequency/modulation monitor, and the off-air receiver are fed from the three-phase box. The single-phase box feeds the AM transmitter, its frequency modulation monitor, and the AM remote-control unit. Single-phase power also goes to the telephone-company equipment, news and weather teletypes, Conclrad receiver, the emergency booth, and an outlet in the basement to operate the water pump and furnace electrical controls. No lighting is provided except one lamp in the emergency booth. In other parts of the building, battery-operated lights are installed. These come on automatically if the regular power fails.

Operation and Maintenance

Experience gained through use has led to many small refinements in the system, including replacement of some of the original equipment with newer and better units. The first emergency operational problem appeared as a lack of antenna current reading on the remote antenna meter. We had overlooked the fact that the diode used for the remote antenna meter was a tube type which required AC power. In



— 1 KW AM — BROADCAST TRANSMITTER

FCC TYPE APPROVED

Outstanding

BEAUTY •
RELIABILITY •
PERFORMANCE •

**INTRODUCTORY
PRICE**

\$4,495.00

INQUIRIES INVITED

OTHER **CCA** AM &
FM TRANSMITTERS

10W, 100W, 250W,
500W, 1KW, 3KW,
5KW, 10KW, 20KW, 50KW.

CCA

CCA ELECTRONICS CORPORATION

542 INDUSTRIAL DRIVE • P.O. BOX 121
YEADON INDUSTRIAL PARK • YEADON, PA.

TELEPHONE: MADISON 6-1427

Circle Item 12 on Tech Data Card

ANNOUNCING...

A most significant advance in transmitter design: Continental's 317C 50 kw AM broadcast transmitter with High Efficiency Screen Modulated Power Amplifier.*

It provides higher efficiency at lower operating cost as compared to any other 50 kw transmitter.

It has the highest overall efficiency of any 50 kw transmitter known to be in existence today.

Both power amplifier tubes operate as conventional class "C" amplifier, requiring low RF drive and no neutralization. High level screen modulation system eliminates high power modulation transformer and reactor. Separate low power modulator tubes supply alternate half cycles of audio, with peak tube modulated by positive half cycles and carrier tube by negative half cycles. This novel arrangement allows modulator to operate similar to a push-pull class "B" amplifier with resulting high efficiencies.

Advancement of the state of the art has been made possible by use of newly developed high power tetrodes, and this unique modulating technique.

Compact design requires only 54 square feet of floor space. All components are self-contained within cabinets, including switch gear, power distribution and blowers. Only external component is the plate transformer which is in a self-contained enclosure that occupies 8 square feet of space. No transformer vaults are required.

*Patents applied for

For additional information and specifications, write:



LTV

Continental Electronics DIVISION
CONTINENTAL ELECTRONICS MANUFACTURING CO.

MAILING ADDRESS: BOX 5024 / DALLAS, TEXAS 75222 / TELEX CEPSCO
THE SPECIALISTS IN SUPER POWER RADAR & RADIO TRANSMITTERS



the beginning we used the indirect method of computing power during emergency operation, but later we replaced the tube-type diode with a solid-state device. The second problem was fuel supply. We had no idea how many "miles per gallon" we would get on these gasoline engines, and almost did not have enough fuel on hand. Fortunately, the regular power was restored just before we ran out of gas. We have now provided several 5-gallon cans of gas in the shed. One thought has occurred to us, although we have never investigated it—if the power is off in our section of town, could service stations pump gas if they were also without power?

Taking care of the generators could have been a problem, since none of our people are well acquainted with this type of equipment. Fortunately the Civil Defense, which has a number of generators placed throughout the county, had located a man who knew these generators quite well. He agreed to handle our service problems, and his fees have been quite reasonable. To insure that the generators will start and be in working condition

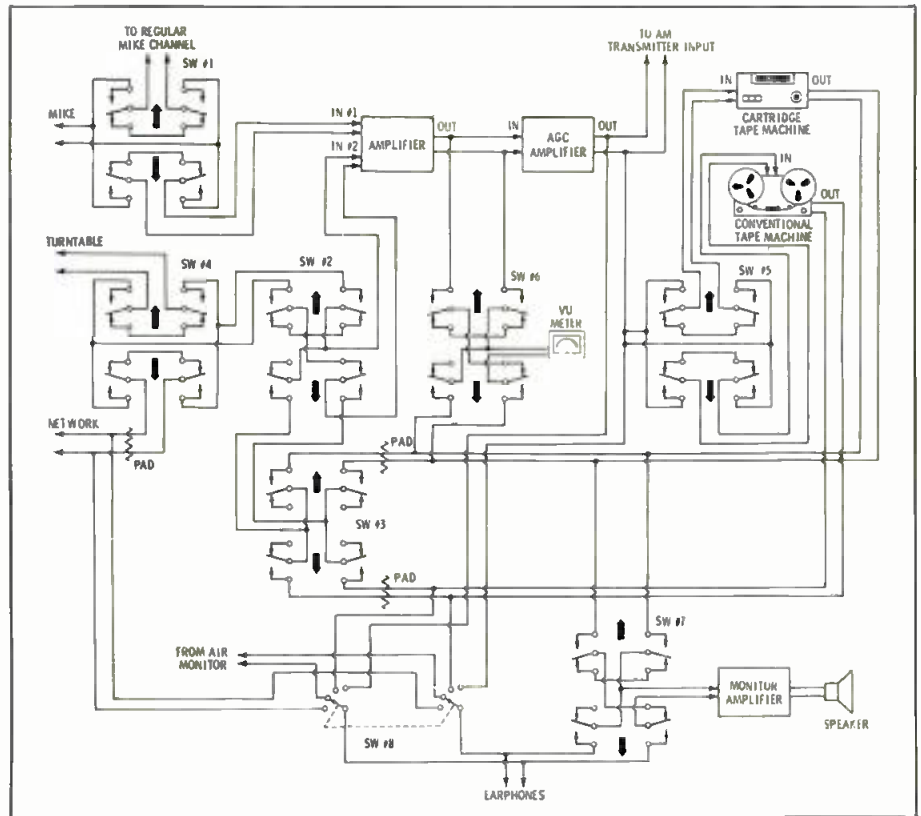
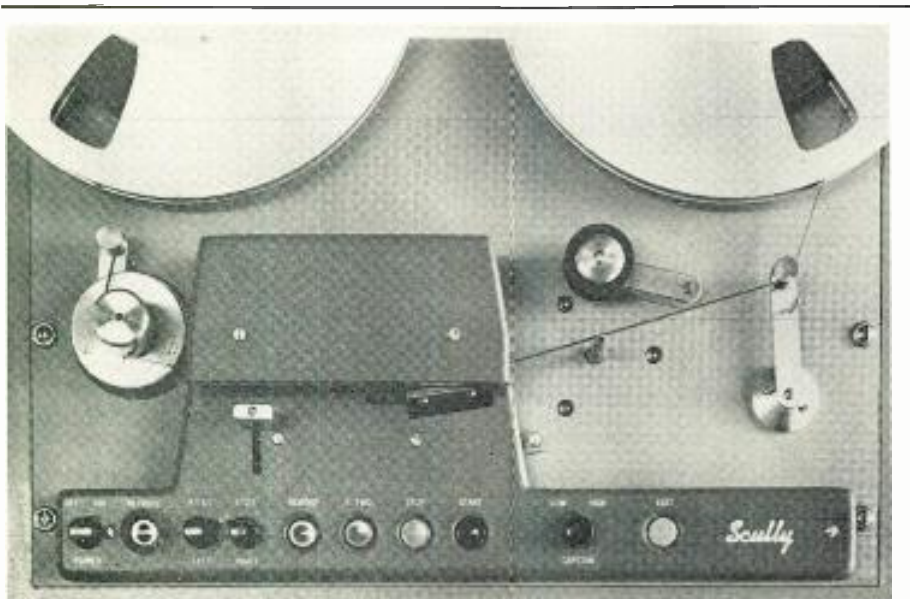

Fig. 4. Schematic diagram of the switching arrangement used with the booth equipment.

when they are needed, our building maintenance man runs both generators a half hour daily. He keeps the supply of fuel replenished and

fills the tanks each day. He also checks on the oil level and keeps water in the batteries and radiators.

Our emergency system has been in operation for the past year, and during this time we have had to use it at least three times. One of these periods lasted for about two hours. A two-hour loss of air time can be a heavy revenue loss, especially if the power failure should occur in a strong commercial time segment. Another important advantage of the emergency system is the sustained contact with our listeners, who in many cases did not realize we were using emergency power. A big bonus is the extra facility which permits more efficient recording.



SCULLY MODEL 280 SOLID STATE PROFESSIONAL TAPE RECORDER

A new solid state professional tape recorder/reproducer with plug-in amplifiers, modular construction, plug-in relays, disc brakes, interchangeable heads . . . designed and constructed in the Scully manner for reliable performance in critical broadcast applications. Write for descriptive literature and price information.

Makers of the renowned Scully Lathe . . . since 1919 the symbol of precision in the audio industry.

Scully Recording Instruments Corp.
480 Bunnell Street, Bridgeport, Conn. 06607

Circle Item 14 on Tech Data Card

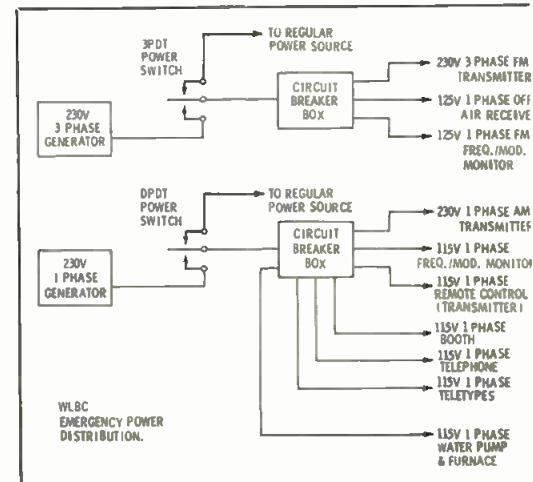

Fig. 5. Diagram of power routing system.

May, 1964

We interrupt this magazine to bring you ...

Late Bulletin from Washington

by Howard T. Head

Aural-Visual Ratios

As predicted in last month's Bulletin, the FCC has brought the VHF television aural-visual power ratio in line with the UHF ratios; the change will become effective May 11. Aural power at VHF may now be anywhere between 10% and 70% of visual power, the same as at UHF. At the same time, the Commission invited comments on proposals to narrow the range, possibly stipulating 10% to 20% at both VHF and UHF.

Pre-Sunrise Operation

The FCC has made another interim revision in its policy governing the operation of daytime-only AM stations prior to local sunrise. For many years, the Commission's Rules (Section 73.87) have permitted daytime-only stations on regional channels (the clear channels excepted) to sign on as early as 4:00 AM local standard time. In instances where actual interference was caused to a full-time station on the channel, and the full-time station was able to demonstrate by actual listening tests that interference was being received within their normally protected contour, the Commission would order the daytime-only station to refrain from operation prior to the local sunrise established by the daytimer's license.

About a year and a half ago, the Commission issued a proposal which would permit daytime-only stations to operate prior to sunrise, with reduced power, in communities where no other radio service was available; this proposal disregarded interference which might be caused to unlimited-time stations during the pre-sunrise period.

After this latest proposal was issued, the Commission made substantial changes in the procedure required for full-time stations to protest interference received from daytime-only stations. The requirement for listening tests was abandoned, and interference could be demonstrated by calculations based on the propagation curves and interference ratios contained in the Commission's Technical Standards. Coupled with an engineering showing of interference on this basis, the complaining station was required to establish that it (the full-time station) was operating with its nighttime directional antenna prior to sunrise, and that the daytime-only station actually was operating during the pre-sunrise hours.

The Commission has now given its blessing to a new procedure which would permit daytime-only stations to continue pre-sunrise operation, but with reduced power; however, agreement must have been reached between the full-time station and the daytime-only station that the former will be satisfied with the lesser interference caused by reduced power. The Commission sanctioned this procedure in a recent case involving daytime-only station

WEEE, Rensselaer, New York, and gave notice that favorable consideration would be given to similar agreements in the future.

Filing Fees

The Commission has reminded all applicants for licenses and renewals that the new schedule of filing fees has become effective. The fees have been protested in court, but the Commission is permitted to continue collecting fees until the Court decides the case; the fees will be refunded if the Court should rule them to be invalid. Of particular interest to the readers of BROADCAST ENGINEERING are the fees for operator examinations. Application fee for examination for a First Class License is \$5; for a Second Class, \$4; and Third Class, \$3. Applications for renewals, endorsements, and duplicates must be accompanied by a fee of \$2. Applications for Restricted Radiotelephone Permits must be accompanied by a \$2 fee. Under the new system, fees are charged for all classes of applications in all the radio services under the FCC's jurisdiction.

CATV

The FCC and the community-antenna television industry (working through the National Community Television Association -- NCTA) have been endeavoring to reach agreement on Commission Rules and possible legislation governing the operation of CATV systems in areas served by both broadcast stations and CATV systems. Under existing law, the Commission can control CATV systems only indirectly, and this only in those CATV systems that employ microwave for television program relay. These systems make up approximately 20% of the total CATV systems now in operation.

The Commission has proposed that CATV systems subject to FCC jurisdiction be required to carry, on request, the programs of any station showing calculated Grade-A service to the city where the CATV system is located. CATV systems will be expected to refrain from carrying network program material not carried by local stations and to maintain specified standards of technical quality in relaying program material. In conferences between the FCC and NCTA, agreement has been reported on these three points, as well as on legislative proposals for Congress to extend the Commission's jurisdiction to all CATV systems rather than only those employing microwave.

UHF

The Commission is analyzing comments received in connection with its proposal to add a substantial number of UHF television channel assignments, both commercial and educational, to the assignment table now provided by the Commission's Rules. Adoption of the new assignments, which is expected in the near future, will represent another step in the Commission's effort to provide for the maximum ordinary growth of UHF television broadcasting in the United States.

Erratum

The third paragraph of the April Bulletin contains an editorial mistake. The second sentence of that paragraph should read: "The recent adoption of fixed mileage separations between new FM stations found numerous existing stations operating closer together than the separations established under the new Rules."

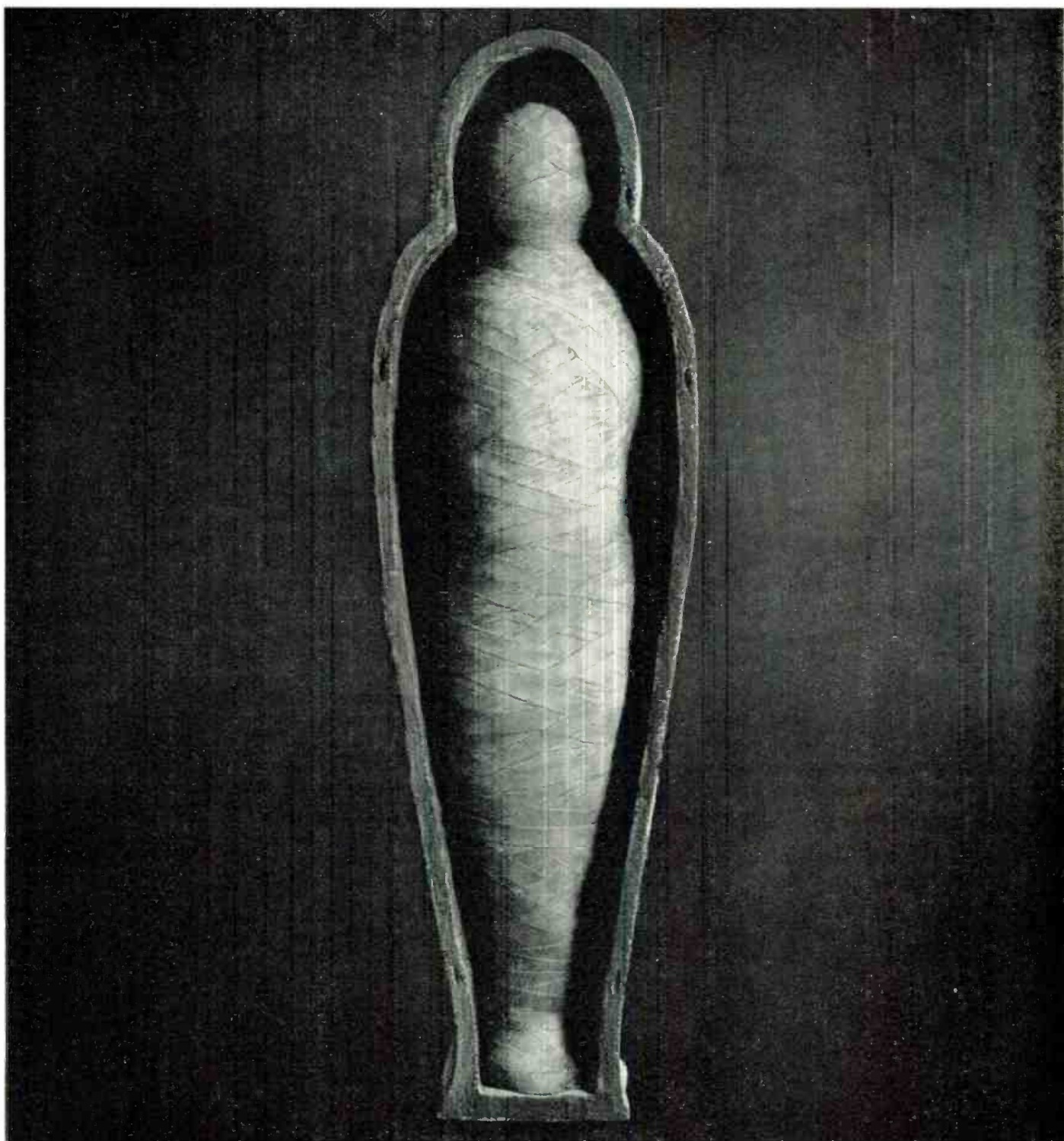

The Egyptians had a way with tape, too!

To this day, no one has learned the Egyptian's secret with mummy tape! Everyday, however, more and more recording engineers learn about RCA's Red Seal tape and use it exclusively. What's the secret? Originally, RCA developed Red Seal tape strictly for its own recording purposes. In doing so, chemical engineers and physicists were brought together with sound engineers in the country's most modern tape plant. Quite naturally,



they developed the finest tape ever. To maintain this superb Red Seal quality, RCA exercises relentless quality control. 101 tests in all. Magnetic tests for frequency response, distortion, drop-out, noise and print-through. Physical tests for coating thickness, anchorage, layer-to-layer adhesion, aging, cupping and slitting. So, why not preserve the purity of your sound with Red Seal Recording tape! Remember, the best is made by RCA.

RED SEAL RECORDING TAPE



The Most Trusted Name in Sound
Circle Item 15 on Tech Data Card

MAINTENANCE OF MOUNTAIN TOP TELEVISION TRANSLATORS

by **George M. Frese**, Consulting
Author, Professional Engineer, East
Wenatchee, Wash. — Procedures for
efficient maintenance and servicing
of remotely located installations.

The maintenance of a television translator station on an isolated mountain top can require more exacting techniques than are normally expected for an easily accessible broadcast facility. The quality of service that a translator station can provide is, of course, dependent on the quality of the original design and construction, but service also depends on a continuing program of maintenance. This article is written for the man who finds that at the moment his lot in life is the maintenance of a television translator station. If the re-transmitted picture quality is good, he will go almost unnoticed. His reward does not come from popularity among the viewers, but in part from monetary compensation and in part from a feeling of satisfaction from a difficult job well done.

Maintenance Requirements

The author is of the belief that it is not practical to perform an overall maintenance of the system (especially if there are three or

more translators at the same location) on one field trip, nor is it even desirable to do so. A field trip once every three months seems pretty necessary, but you should not decide in advance what maintenance you are going to do. More will be said about determining what maintenance is to be done on a specific field trip later in this article.

Tubes

When you take on the maintenance of any type of broadcast facility, a good place to start is with the tube stock. A list of all the tube types used in the system should be made in a vertical column in numerical order. A second, corresponding column should show the number of spares you intend to keep on hand for each type. Every time you leave the translator building, make sure you list the tubes you have used, then be sure to bring up the needed replacements on the next trip. If you carry your spare tubes in a tube caddy or have still another system, **make sure** you are not left without a spare tube when it is needed.

Instruction Manuals

Make sure you have in your possession all available instruction manuals for the equipment to be maintained, particularly all schematic diagrams. Some schematics are very poor, especially in the area of power-control circuits. If you have such diagrams it is suggested that you break them down into a simpler form on separate sheets of paper; include your simplified circuits as part of the instruction manual. It is wise to break down your translator system into maintenance blocks. Fig. 1 shows a typical translator system divided into sections for maintenance purposes.

Logging

A good, workable system of logging events, readings, observations, and corrections is very important. To the inexperienced this may sound simple, but the more experienced technical person will probably agree that keeping logs can become a frustrating problem. What to log and what not to log, how to log it, what forms to make up, where to keep the logs—these are some of the questions to be answered. It is often very valuable to know some past history of the apparatus, but one should not go to the extreme of logging reams of useless material. This practice is a waste of time, and the needed material probably could not be sifted from the chaff. The system presented here is not claimed to be a final answer to this problem, but it seems to work pretty well.

For each piece of equipment being maintained, we tape a blank log sheet to the closest vertical, flat surface. This gives two or three log sheets for each translator; one is taped on the inside of the front door, one on the inside of the back door, and one on the wall nearest the preamplifier. The date, all

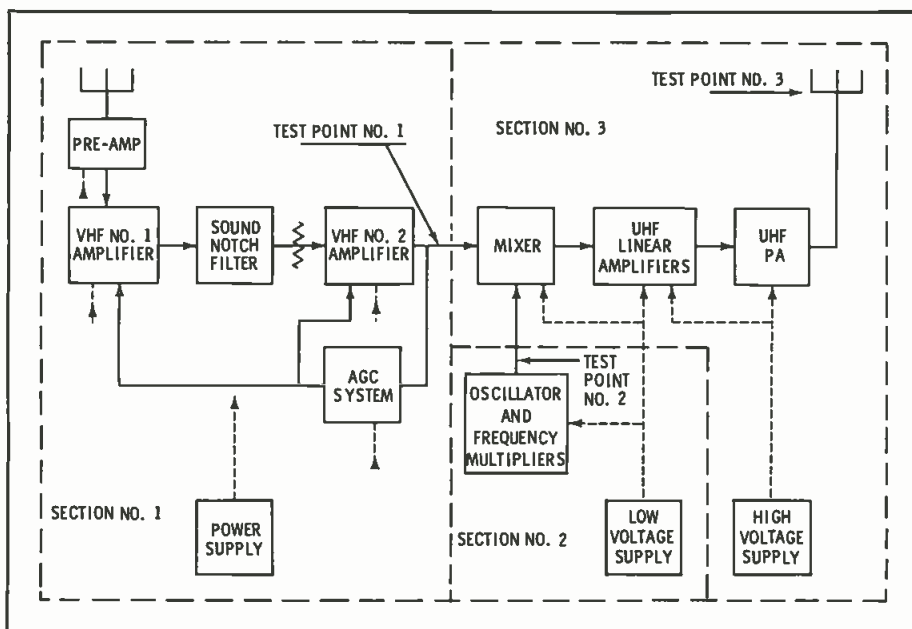

Fig. 1. Block diagram for maintenance of a typical television translator installation.

FOR PROFESSIONALS ONLY! SOUND RECORDING PRODUCTS by REEVES SOUNDCRAFT

Here are some of the facts that make SOUNDCRAFT the preferred name in every professional sound recording application.

MASTERING



SOUNDCRAFT LOW PRINT MASTERING TAPES assure recordings of unprecedented dynamic range and minimum layer-to-layer signal transfer. Print-through is 8 db better than ordinary tapes—high-frequency output is 5 db greater than other low print tapes. In ¼" and ½" widths, 1½ mil Acetate and Mylar.*

*DuPont TM

DISC RECORDING



SOUNDCRAFT MICROLAC[†] RECORDING DISCS fill every professional need—Masters for matchless fidelity; Playbacks for high quality volume production; Auditions for the professional and amateur recordist.

†TM

FILM RECORDING



SOUNDCRAFT FULL-COATED FILMS are the accepted professional standard for all original film recording. Supplied with clear edges or coated edge to edge. Available in 35mm, 17½mm and 16mm. SOUNDCRAFT ACADEMY AWARD WINNING MAGNA-STRIPE for editing and release prints.

VIDEO RECORDING



SOUNDCRAFT'S NEW MICRO-PLATE** HEAVY-DUTY VIDEO TAPE insures longer tape life, longer head life and better picture. "Micro-Plate," an exclusive Soundcraft process, produces a tape surface so smooth you cannot visually tell which side has the oxide. The result: a tape that has provided up to 700 passes without appreciable tape or head wear.

**TM

DUPLICATING



SOUNDCRAFT DUPLICATING TAPE is engineered for greater fidelity in high-speed copying. It has 25% greater high-frequency output and 7 db better signal-to-noise ratio than conventional duplicating tapes. In ¼" width on either 1 mil or ½ mil Acetate and on 1 mil "Mylar."

BACKGROUND MUSIC AND BROADCASTING



SOUNDCRAFT UNI-LUBE 75T CARTRIDGE TAPE offers greatly improved tape life over other cartridge tapes. The Perma-Graph †† lubricating layer minimizes friction; the ultra-thin oxide layer provides maximum short wavelength signal-to-noise characteristics for superior reproduction.

††TM

SOUNDCRAFT Professional products are the result of research, imagination and considerable specialized experience in the manufacture of magnetic recording products. The products listed here are acknowledged top performers by professionals in broadcast, sound recording and film studios. For complete data on these and many other Soundcraft products, write:

REEVES SOUNDCRAFT
DIVISION OF REEVES INDUSTRIES INC.

Main Office: Danbury, Conn. • New York • Chicago • Los Angeles | Export: C.B.S. International, N.Y.C. • Canadian Reps: Vancouver • Toronto U.K. Reps: Soundcraft Magnetic Ltd.
Circle Item 16 on Tech Data Card

measurements taken, tubes changed, circuits retuned, and other fault observations and corrections are legibly recorded. We also have a visitation log on the wall, on which all persons entering are invited to sign. Specific log entries will be discussed later in connection with maintenance of specific sections.

Test Equipment

There are certain pieces of test equipment that are essential for the maintenance of a television translator system. There is very little actual maintenance that can be done with just a tool box and a multimeter. Table 1 shows a list of test equipment that I consider the minimum necessary equipment needed to do a complete job.

Determining Needed Maintenance

The first step in determining what maintenance to perform is to set up the test equipment needed to read test point 3 for each of the translators. Usually one position of the pickup dipole can be found in front of the transmitting antennas

which will perform quite well for measuring all the translator systems. Fig. 2 shows the test setup. Read and log the following data for each translator station:

1. Date and condition,
2. Power output (usually read with a crystal probe and vom.)
3. Sound - to - picture power ratio (the sound carrier power related to the picture peak sync power and recorded in db below picture peak sync power, or dbp),
4. Linearity, in terms of sync-pulse amplitude units (full sync pulse is 40, half-amplitude pulse 20, etc.),
5. Picture-quality comments.

After reading test point No. 3 for all the translators, the technician can determine which translators are in need of service. If performance is excellent for all translators, he might oil some blower motors, sweep the floor, and go home; but this will seldom happen.

Assume that one translator shows some defects in the output. The next step is to take readings at test points 1 and 2 in the defec-

Table 1. Test Equipment Needed for Maintenance of Television Translators

A. Equipment Used to Read Test Point 3	
1.	UHF sample-pickup dipole
2.	UHF-to-VHF converter
3.	VHF two-way splitter
4.	TV receiver (small portable)
5.	VHF field meter
6.	Oscilloscope
7.	Variety of RF connecting cords (type F fitting)
8.	Multimeter
B. Equipment Used to Read Test Point 2	
1.	Vacuum-tube voltmeter
2.	Demodulator, 52-ohm UHF (use depends on whether or not the equipment comes with suitable crystal test points).
C. Equipment Used to Read Test Point 1	
1.	VHF field meter
2.	TV set (sometimes)
3.	Oscilloscope (sometimes)
D. Equipment Used for Maintenance of Section 1	
1.	Equipment used to read test point 1 under "C"
2.	VHF sweep generator
3.	VHF marker generator
4.	VHF demodulator and oscilloscope
5.	Multimeter
6.	VTVM
7.	Tube tester
8.	Variety of 75-ohm RG-59 U cords
E. Equipment Used for Maintenance of Section 2	
1.	Equipment used to read test point 2 under "B"
2.	Multimeter
3.	Tube tester
4.	When real trouble develops, special test equipment may be needed such as: (1) grid-dip oscillator, (2) wide frequency range of field meters
F. Equipment Used for Maintenance of Section 3	
1.	Equipment used to read test point 3 under "A"
2.	UHF sweep generator
3.	100 feet of high-loss RG-29 U 52-ohm coax
4.	Marker mixer
5.	UHF 52-ohm demodulator and scope
6.	Tube tester

SWITCHCRAFT PATCH CORDS

New! Quality Nylon Covered Patch Cords



How Much Better Are Switchcraft's Patch Cords? PLUG ONE IN AND TRY IT!

Built-in Switchcraft quality assures dependable, reliable connections in broadcast studio applications. A complete line of cords featuring bronze tinsel conductors insulated with thermoplastic, over which a braided shield and black Nylon braid are woven, is available in 3 series. Lengths from 6 inches to 10 feet. Cords are assembled with Switchcraft's Mil-Type 2 and 3 conductor phone plugs and 2 conductor twin-plug.

For complete details write for Bulletin No. 121 or see your local Switchcraft Authorized Industrial Distributor for immediate delivery at factory prices.

SWITCHCRAFT®

5535 N. Elston Ave., Chicago, Ill.
Canadian Rep.: Atlas Radio Corp., LTD.
50 Wingold Ave. Toronto, Ontario, Canada



tive systems and record the measured data. From this data you can conclude which sections are in need of attention. For example: test point 1 reads good, but test point 2 reads considerably below the last recorded normal test value. This indicates that maintenance should be performed on section 2. If sections

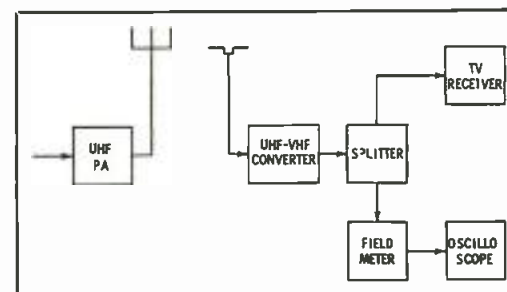
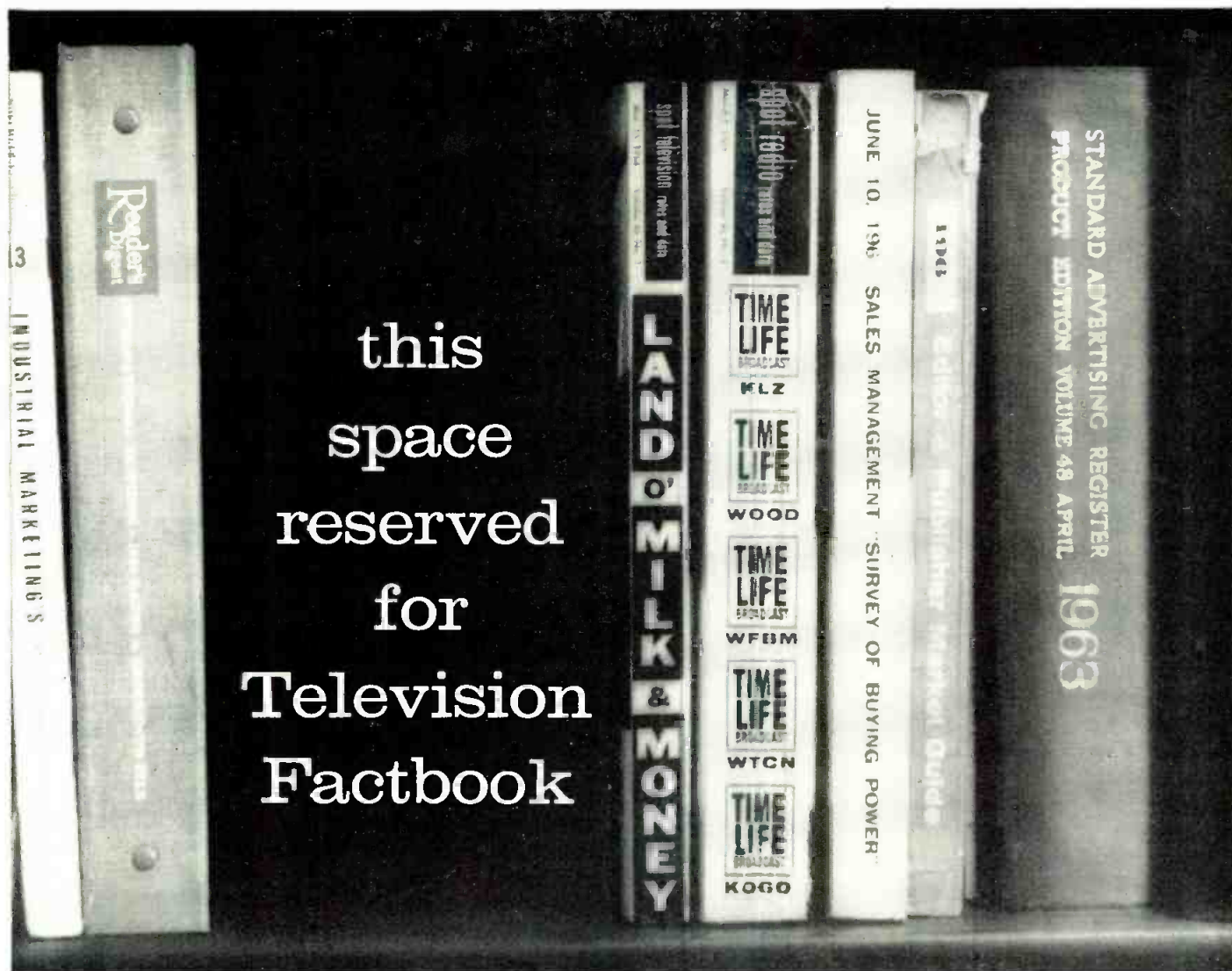

Fig. 2. Test setup for test point three.



this
space
reserved
for
**Television
Factbook**

Broadcast-Communications engineers find **TELEVISION FACTBOOK**, the basic industry reference since 1945, to be one of their most valuable tools. Its detailed and comprehensive coverage of all facets of the Television and Electronics industries make it the most authoritative reference work in the field. Its 1220 pages contain over 100 directories and a full page of data, with a current coverage map, for each television station in the United States, its possessions, and major cities in Canada. Here is a partial list of major features:

- A full page devoted to each TV Station, complete with coverage map, ARB circulation data, Grade A & B coverage contours, personnel, engineering data and other features.
- Most comprehensive International TV Directory available anywhere in the world, greatly expanded from preceding editions of the Factbook.
- Detailed data on all Community Antenna TV Systems (CATV), including ownership, personnel, number of subscribers, rates, stations, etc.
- Full data on all Educational TV Stations; covering

ownership, personnel, technical facilities, legal and engineering representatives, etc.

- Directories of Network Executives, Basic Time Rates and Affiliates.
- Directories of Attorneys, Engineers, Brokers, Consultants, FCC Personnel and Congressional Committees.
- Directories of Station Equipment Manufacturers, TV Set Makers, Tube Manufacturers and comprehensive TV-Radio-Phono Production Tables for 1922-1963.
- Complete and up-to-date list of VHF and UHF Transmitters.
- Subscription Television organizations.

With your **TELEVISION FACTBOOK** you also receive a 23" x 35" wall map of the United States and its possessions and Canada, showing all cities with operating stations, all AT&T and privately owned inter-city network routes and a complete log of U.S. and Canadian stations.

The price is only \$19.50 per copy (\$17.00 if you buy five or more), and we pay the postage if you send payment with your order.

A Service of **TELEVISION DIGEST**, the Weekly Industry Newsletter. Write to:

Television Factbook

SUITE 210-B, 2025 EYE ST. N.W., WASHINGTON, D. C. 20006
Circle Item 18 on Tech Data Card

DYNAMIC NEWS FROM ALTEC

2 New Microphones Expressly for Professional Use

Two new studio dynamics—Altec 688A Omnidirectional; Altec 689A Cardioid—have been developed by Altec specifically for broadcast, recording, and TV use. Part of the famed Altec Series 680, these microphones offer maximal characteristics to meet and exceed the strictest professional recording and broadcast standards. Each is equipped with the exclusive Altec "Golden Diaphragm" which is not only extremely rugged in use but which also contributes inherent low resonance qualities and peak-free response. These two new microphones plus Altec's famed M20 Omnidirectional Condenser Microphone System and M30 Cardioid Condenser Microphone System now offer the industry superb qualities and characteristics to meet any and all requirements that can be imagined.

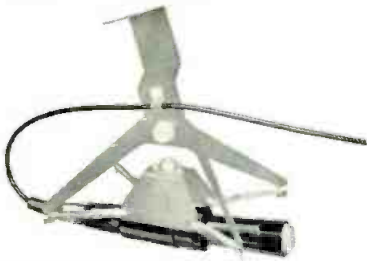

ALTEC 688A OMNIDIRECTIONAL DYNAMIC MICROPHONE—\$90 net. Extremely uniform response from below 35 to over 20,000 cycles. Highly efficient. Low hum pickup. Shown in an Altec 181A Boom Mount. Output Impedance: 30/50, 150/250 and 20,000 ohms (selection by connections in microphone cable plug). Output Level: -55 dbm/10 dynes/cm². Hum: -120 db (Ref.: 10⁻³ Gauss). Dimensions: 1½" diameter at top (1½" largest diameter), 7½" long not including plug. Weight: 8 ozs. (not including cable and plug).

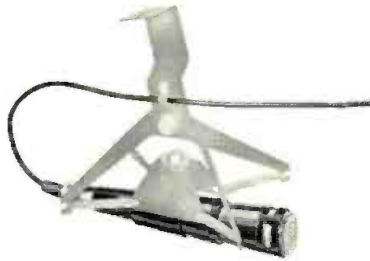

ALTEC 689A CARDIOID DYNAMIC MICROPHONE—\$108 net. High front-to-back discrimination for an average of over 20 db from 40 to over 16,000 cycles. Virtually flat response throughout this frequency range. Output Impedance: 30/50, 150/250 and 20,000 ohms (selection by connections in microphone cable plug). Output Level: -54 dbm/10 dynes/cm². Hum: -120 db (Ref.: 10⁻³ Gauss). Dimensions: 1½" diameter at top, 7½" long not including plug. Weight: 11 ozs. (not including cable and plug).

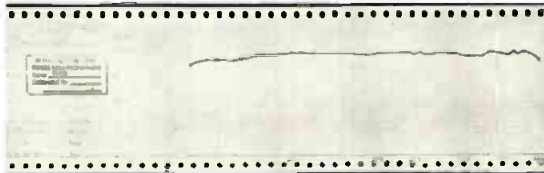

Each 688A and 689A microphone comes with its own individual response curve made by a Bruel & Kjaer servo-driven recorder in conjunction with an Altec anechoic chamber. The curve serves as a permanent record of the unit's response characteristics for immediate reference at any time required.



ALTEC M20 OMNIDIRECTIONAL CONDENSER MICROPHONE SYSTEM—\$233 complete with base, stand attachment, and power supply. This is the famous "Lipstik"—so named for its miniature size—the only American-made condenser on the market. The M20 provides the wide, uniform frequency response of a laboratory standard—an exceptional microphone for broadcast and recording of highest quality.

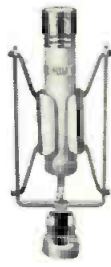

ALTEC M30 CARDIOID CONDENSER MICROPHONE SYSTEM—\$280 complete. This directional microphone offers the superb response characteristics of the condenser with the ruggedness and small size available only from Altec. 20 to 20,000 cycle range with better than 10 db front-to-back discrimination at the extremes, better than 20 db in the mid-range.

ANNOUNCING AN IMPORTANT NEW DIVISION AT ALTEC

The Audio Controls Division was recently organized at Altec Lansing Corp. The new division specializes in design and manufacture of precision attenuators, equalizers, filters, networks and switches, as well as custom consoles and associated products specifically for the recording and broadcast industries. It is headed by Arthur C. Davis, a Fellow of the AES and well-known in this field as a leading design engineer and manufacturer.

For specific engineering details and free demonstration, call your nearest Altec Distributor (see Yellow Pages) or write Dept. BE5



ALTEC
LANSING CORPORATION

ALTEC LANSING CORPORATION
A Subsidiary of Ling-Temco-Vought, Inc.
ANAHEIM, CALIFORNIA

© 1964 ALTEC LANSING CORPORATION

1 and 2 both test good, section 3 is in need of maintenance.

For the remainder of this article I will discuss some of the main points of the actual maintenance procedures for specific sections in the translator system. Caution: do not go into a section looking for one specific trouble, find that trouble, make the correction, and call it good. When it is determined that a specific section is in need of maintenance, the maintenance of that section should be complete.

Maintenance of Section One

Assume the decision has been reached to perform maintenance on section 1. Connect the sweep generator (and associated marker generator) to the preamplifier input, and adjust the sweep-generator output power to approximately the level normally supplied by the receiving antenna. Connect the demodulator-scope unit to the output of the preamplifier. Observe the bandwidth presentation and amplifier gain on the oscilloscope. It will help to mark the bandpass curve on the face of the scope with a grease pencil or ink pen.

You are now ready to test the tubes and tube-circuit performance. Remove the first tube and place it in the tube tester. Observe all tube characteristics: mutual conductance, element shorts, gas, grid leakage. If the tube is obviously defective, discard it, but if it is only slightly low in mutual conductance, investigate further. Place a new tube in the tester and compare it to the old tube. Then place the same new tube in the preamplifier. Compare the new-tube performance of the preamplifier with the old-tube performance by observation of bandpass and gain on the scope.

With all the tube data and performance data before you, you should now be able to conclude whether to continue using the old tube or to replace it with the new tube. Do not throw away a tube just because it has seen a lot of service. It may still last longer and perform as well as or better than a new one. Go through the same test procedure with all of the tubes in the preamplifier. After you have placed in the preamplifier the tubes you intend to use, observe the RF bandpass characteristic. If the characteristic is not exactly as desired,

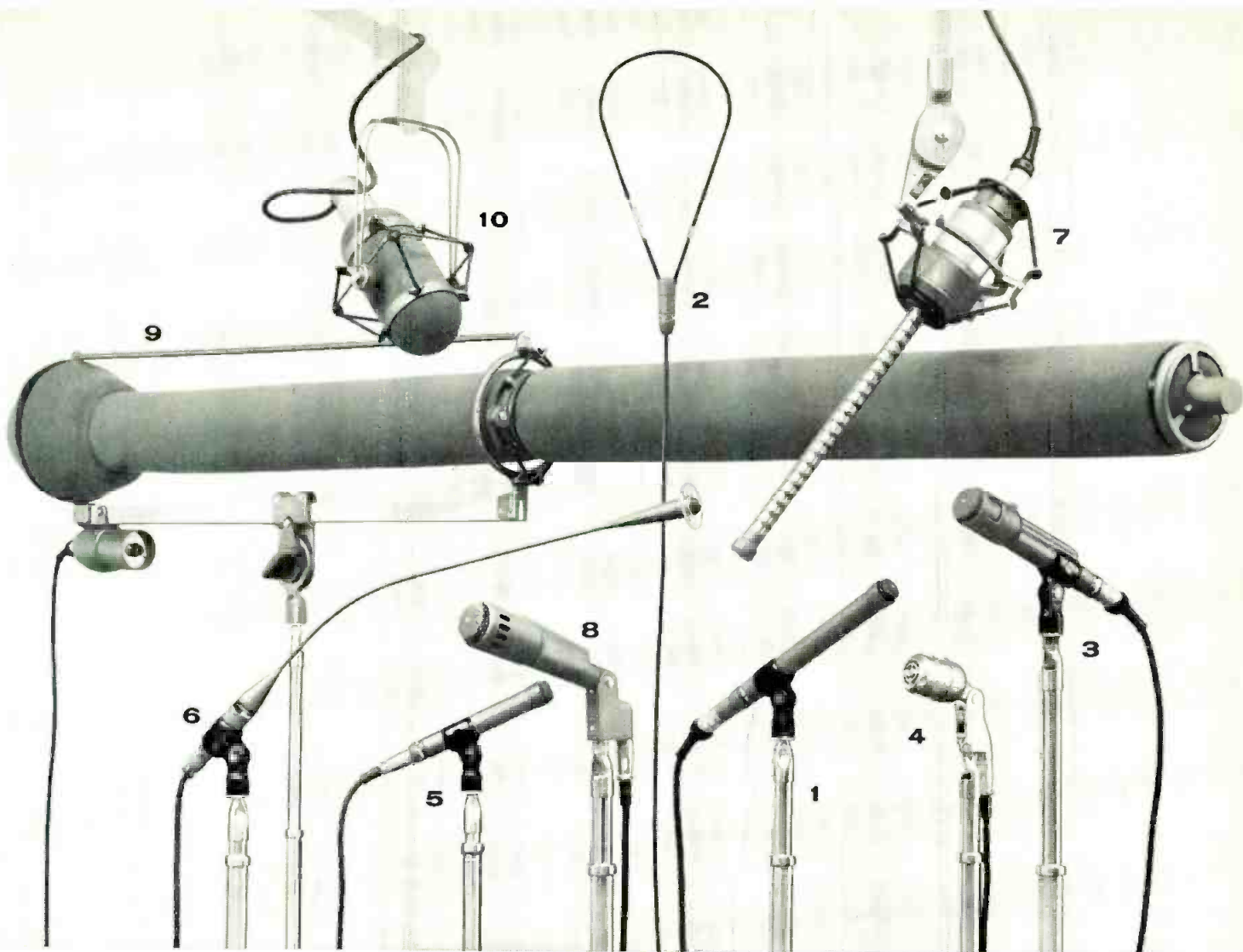

Ten Good Reasons Why Leading Audio Engineers (Who'll Stop at Nothing to Improve Quality) Choose E-V Professional Microphones!

1. High FIDELITY is your stock in trade. And the peak-free 40-20,000 cps response of the E-V 655C provides it simply and directly, with no complex added equipment to burden you.

2. It's quite easy to maintain complete COMPATIBILITY between the sound of lavalier microphones and stand units. Simply use the tiny E-V 649B with your larger E-V microphone. Voice quality mixes perfectly.

3. The reputation for RELIABILITY enjoyed by the E-V 666 comes from its ability to deliver superb cardioid response even after accidental abuse that would destroy many a lesser microphone.

4. The ready AVAILABILITY of E-V professional microphones at leading radio parts distributors everywhere is an E-V pioneered policy begun back when the "workhorse of the industry", the E-V 635, was introduced.

5. Outstanding in its FLEXIBILITY is the new E-V 654A. This versatile micro-

phone slips easily into floor or desk stands, or can be hand held or used as a lavalier.

6. Ten E-V professional models give you unusual VARIETY. For instance, if you require close-up sound pickup, yet mustn't hide the performer, the ultra-thin E-V 652 solves both problems handsomely.

7. The CREATIVITY of E-V engineers comes from intimate knowledge of field problems. It earned them an Academy Award for their unique solution to film and TV sound problems with the E-V 642 microphone.

8. ECONOMY is vital in every studio operation, yet quality must be upheld. And the E-V 665 is ideal where superb cardioid performance is needed, but the utmost in mounting flexibility is not required.

9. Even the 7-foot long E-V 643 ultra-directional microphone is protected by this unique E-V GUARANTEE: except for refinishing, all repairs are free no

matter what happens to the unit during the first two years!

10. The VITALITY of E-V design comes from constant improvement of existing models, plus fresh new ideas that solve your problems. Newest is the E-V 668, specifically created for boom microphone applications.

Put all ten good reasons to work for you in your studio or in the field by choosing the E-V Professional microphone that's right for your sound pickup requirements. Your E-V distributor can offer up to 15 years of experience in assisting studios to better sound. See him today, or write for a complete distributor list and free microphone catalog.

ELECTRO-VOICE, INC.

Dept. 541V, Buchanan, Michigan





**3 PLANTS TO SERVE YOU BETTER
HERMETICALLY SEALED
PRECISION GROUND
CUSTOM-MADE
NON-OVEN CRYSTALS**

Gold or silver plated, spring mounted, vacuum sealed or inert gas, high freq. stability, 10 milliwatt max. current cap. Meet mil. specs.

Frequency Range	Fund. Freq.	Price
1000KC to 1600KC	(Fund. Freq.)	Prices on Request
1601KC to 2000KC	(Fund. Freq.)	\$5.00 ea.
2001KC to 2500KC	(Fund. Freq.)	4.00 ea.
2501KC to 5000KC	(Fund. Freq.)	3.50 ea.
5001KC to 7000KC	(Fund. Freq.)	3.90 ea.
7001KC to 10,000KC	(Fund. Freq.)	3.25 ea.
10,001KC to 15,000KC	(Fund. Freq.)	3.75 ea.
15MC to 20MC	(Fund. Freq.)	5.00 ea.

OVERTONE CRYSTALS

15MC to 30MC Third Overtone	\$3.85 ea.
30MC to 40MC Third Overtone	4.10 ea.
40MC to 65MC Third or Fifth Overtone	4.50 ea.
65MC to 100MC Fifth Overtone	6.00 ea.

DRAKE 2-B Receiver Crystals\$4.00
(All Channels—Order by Freq.)

OVEN-TYPE CRYSTALS

For Motorola, GE, Gonset, Bendix, etc.

Add \$2.00 per crystal to above prices

SUB-MINIATURE PRICES slightly higher

**ORDER FROM CLOSER PLANT
TEXAS CRYSTALS**

DEPT. BE
1000 Crystal Drive
FORT MYERS, FLORIDA
Phone 813 WE 6-2109
TWX 813-334-2830

Division of



AND
4117 W. Jefferson Blvd.
LOS ANGELES, CALIF.
Phone 213-731-2258
TWX 213-737-1315

Circle Item 21 on Tech Data Card

**BEHIND
THIS
DOOR**



—IN THIS CABINET JUST 42" HIGH IS A DUAL STL THAT MEETS AND SURPASSES THE DEMANDS OF FM STEREO, TV AURAL, INTER-CITY RELAY AND OTHER AM OR FM STEREO OR MONAURAL REQUIREMENTS.

—FOR FURTHER INFORMATION ON WHAT'S BEHIND THE DOOR WRITE

MOSELEY ASSOCIATES INC.

P.O. BOX 3192, SANTA BARBARA, CALIF.
TELEPHONE--AREA CODE 805
967-1469 OR 967-8119

Circle Item 22 on Tech Data Card

retouch the proper tuning slugs or capacitors to obtain the correct bandpass. When you have completed the preamplifier service, note all changes, corrections, and findings in the closest log.

Move the sweep generator and demodulator-scope unit to VHF amplifier 1, and go through the same procedure as just described for the preamplifier. Then move the sweep generator and demodulator-scope unit to VHF amplifier 2 and proceed again. Be sure to clamp all AGC points with a fixed DC voltage equal to the normal operating AGC voltage. Also read all power-supply voltages before doing tube and sweep maintenance if these have not been checked for the last two recording periods.

Peak the AGC system on a VTVM in accordance with the instruction manual or known procedures, and test the associated tube in a process similar to the one described for the preamplifier. Leave the demodulator on the output of VHF amplifier 2. Connect the sweep generator back to the preamplifier input, and observe the overall bandpass of section 1. If it is not just right, touch up the input and output tuning circuits, which may have been slightly disrupted by the insertion of test equipment.

Read the picture-carrier strength and sound-to-picture ratio directly off the antenna coax and make a notation. Connect the antenna into the preamplifier and adjust the pads and AGC gain controls to produce the proper level at each respective amplifier and mixer input. Check the AGC voltage to make sure it is the correct value and record it. The sound-to-picture ratio should be -3 dbp. Now set the sound notch filter to produce a sound-to-picture ratio of -10 dbp. Make sure you know what to do here, so that you do not impair the picture color bandpass. For the first few times you do this, you will need to recheck the overall bandpass to make sure some of your sound notch did not get into the picture bandpass.

Finally, read the output at test point 1 to be sure section 1 is up to past logged performance.

Maintenance of Section Two

Read all of the oscillator and multiplier test points with the

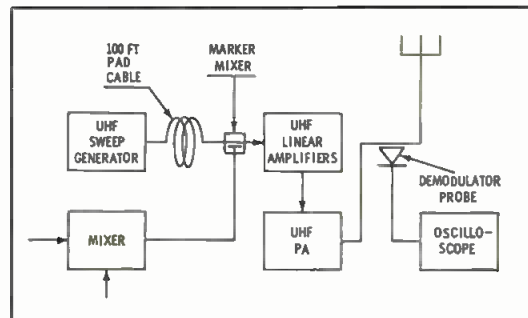

Fig. 3. The test setup for section three.

VTVM; record and compare the values to the old log readings. From the meter reading comparisons it can be determined which stages are in need of attention. Start with the first stage that reads low. Try to retune this stage and the stage before it. If the reading still does not come up to full value, replace the tube, using somewhat the same tube-tester techniques as described under "Maintenance of Section One." Make other repairs needed to bring readings to normal.

Maintenance of Section Three

Connect a UHF sweep generator, through 100' of 52-ohm RG-29 U pad cable and a UHF marker mixer, into the input of the first UHF linear amplifier (Fig. 3). Connect the output of the first UHF linear amplifier to the UHF 52-ohm RF demodulator-oscilloscope unit. The 100' of high-loss cable serves as an input-connecting pad so that an amplifier input tuning circuit, although it may not reflect exactly 52 ohms, will not distort the RF bandpass presentation due to standing waves in the input connecting cable. The marker mixer is a very workable system of using the converted carrier signals for markers.

Another method of connection is to use a VHF sweep generator through the VHF-UHF mixer and into the UHF linear amplifier. This method is satisfactory if done correctly and has to be used in the absence of a UHF sweep generator. It is preferable, however, to use a good UHF sweep generator if one is available. With a grease pencil, mark the bandpass curve on the oscilloscope. Go through a tube-testing procedure as described in the discussion of section one. Realign tuning where necessary.

Move the demodulator to the output of the second linear amplifier and reconnect the test input between the first and second linear

*New from Telechrome**

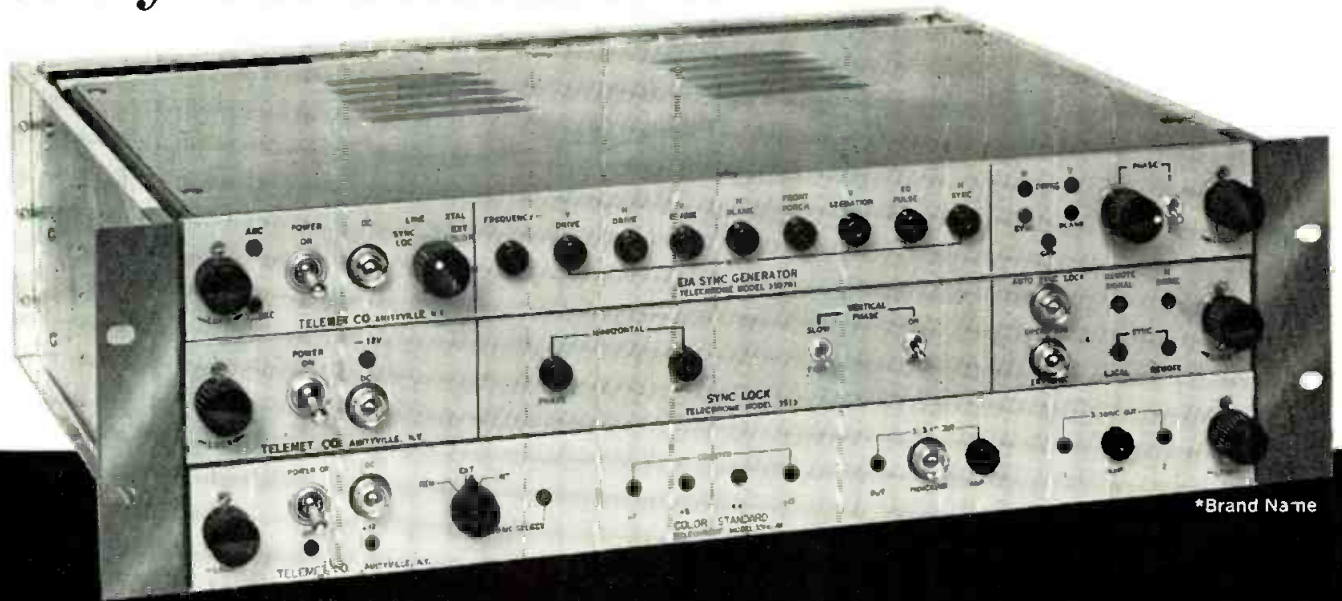

*Brand Name

"ADD-ON" STUDIO SYNC GENERATING EQUIPMENT

**COMPACT / FLEXIBLE / STABLE / SOLID STATE
MEETS ALL RS-170 REQUIREMENTS**

in any combination of:

**3507C1 SYNCHRONIZING WAVEFORM GENERATOR
3513A1 SYNC LOCK • 3514A1 COLOR STANDARD
3509A1 SYNC CHANGEOVER • COMING-COLOR SYNC LOCK**

Pictured above is new multi-unit frame with internal blower cooling—available in various heights to hold any combination of 2 or more Telechrome 1 3/4" modules.

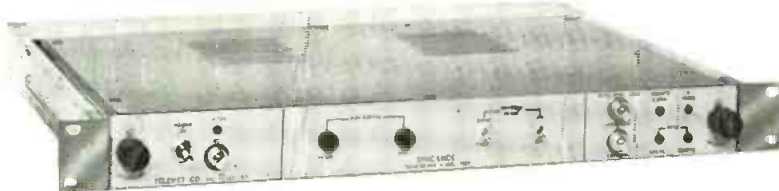

Units also available in individual mounting frames.

For Multiple Studio Distribution: Model 3202A1 Regenerative Pulse Distribution Amplifier.

TELEMET COMPANY

a division of

GIANNINI SCIENTIFIC CORPORATION

AMITYVILLE, N.Y.: 185 DIXON AVENUE • PHONE (516) 541-3600
SANTA ANA, CAL.: 3841 S. MAIN STREET • PHONE (714) 545-7171



Circle Item 23 on Tech Data Card

FEATURES

SYNC GENERATOR

Internal Crystal, Line, Color or Sync Lock. ■ Auto-changeover to internal lock when remote sync fails.

SYNC LOCK

Advance counter reduces lock-in time. Composite or non-composite remote sync input.

COLOR STANDARD

Temperature controlled crystal oven. Binary Dividers.

amplifiers. The scope display now shows the gain and bandpass of the second amplifier. If the linear-amplifier tubes are of a type that cannot be tested in a standard tube tester, circuit performance is the only method of testing the tube. If you suspect the performance of the second amplifier is poor due to the tube, change the tube and see. It is a good idea to exercise the finger stock anyway, so don't be afraid to remove the tube. When replacing the tube, put a thin coating of petroleum jelly on the electrode

terminals (if it is of the cavity, finger-stock socket type).

Reconnect the second to the third linear amplifier, and connect the oscilloscope to the antenna-line demodulator probe. From experience you will know whether or not the PA-stage gain is near normal.

The adjustment of the final PA plate tuning and loading circuits is one of the most important tuning techniques in the system. Here you are interested in maximum power output capability along with satisfactory linearity. The bandpass

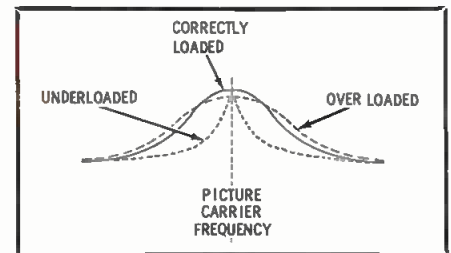

Fig. 4. Curves for three amplifier loads.

characteristic is of secondary importance because deviation from desired bandpass will be compensated for in lower-level stages.

Plate tuning should always be adjusted so that maximum amplification is at the video carrier frequency. Loading should be adjusted to produce maximum power output from the amplifier. Fig. 4 shows curves for underloaded, correctly loaded, and overloaded amplifiers. After adjusting the power amplifier, go back and carefully stagger tune the driver linear amplifiers to obtain the correct bandpass for the UHF linear amplifier system.

Final Adjustments

Sometimes the VHF generator is connected into the preamplifier, the AGC is clamped with fixed bias, and the overall bandpass is observed on the output demodulator. If the bandpass is not just right, by now you may have a good idea where to touch up the alignment.

Connect the antenna television signal back into the preamplifier. Remove the AGC clamp and increase the gain control setting until sync compression is just observed on the output video waveform. At this point the power output meter should be reading rated power, or more. If this happens, all has gone well, and the power output should be set to its proper operating value.

Observe the antenna reflectometer readings as a check on the transmitting antenna, and record the readings. You are about finished, but before you leave check for the following:

1. All logs are complete.
2. You have the list of tubes and parts needed for the next trip.
3. All test equipment is packed for the return trip.
4. All output meters are reading normally.
5. Heaters, lights, cooking plates, and other electrical devices are turned off.
6. The ventilator is properly set.
7. The building door is locked. ▲



HOW DO YOU



MEASURE QUALITY



IN FILM TRANSFERS?

Clarity. Definition. Truest grey scale. All are measures of quality demanded by the most critical buyers we know—our customers! Companies like MGM-TELESTUDIOS, MCA-TV, HEATH De ROCHEMONT, AMERICAN MOTORS, even AMPEX. We've been perfecting quality for 18 years. To insure quality control all of our work is done under one roof. AND...we offer "in by 9—out by 5" processing—with your transfer jetting back the same night. But, *don't* take our word. Try us and see. Optimum quality guaranteed. Acme Film Laboratories, Inc. 1161 N. Highland, Hollywood 38, Calif./Hollywood 4-7471

ACME FILM TRANSFERS



Circle Item 24 on Tech Data Card

Why fully automated WTEV, Providence, chose a Raytheon Dual Link STL



WTEV

TELEVISION, INC.



TELEVISION CENTER, NEW BEDFORD, MASSACHUSETTS ● 617-993
SHERATON-BILTMORE HOTEL, PROVIDENCE, RHODE ISLAND ● 401-42

February 10, 1964



Mr. Hugh Bannon, General Products Manager
Raytheon Company
Communications And Data Processing Operation
1415 Providence Turnpike
Norwood, Massachusetts

Dear Hugh:

As the first television station in the nation to use a fully automated punch card programming system, we were determined to avoid program interruption due to equipment failure.

After careful evaluation of available STL systems we chose a Raytheon Dual Link STL for three basic reasons:

1. It offered us the same continuous monitoring and automatic switching as our network back-up service.
2. It cut our anticipated costs for this service in half.
3. It provided full 1-watt output at substantially lower cost than competitive systems.

Apparently, our choice was a good one. The equipment has been in constant use for over a year now without a failure and is one of the most reliable and stable systems I have ever seen.

Thanks again for helping us put automation to work where it counts the most -- in delivering the completed product to the transmitter for broadcast.

Sincerely,

Maurice P. Wynne
Maurice P. Wynne
Chief Engineer

P.S.

May we do the same for you? Write:
Dept. BE-564, Raytheon Company,
CADPO, 1415 Providence Turnpike,
Norwood, Mass.

RAYTHEON

USE OF AUDIO LEVEL DEVICES

by Bruce L. Mackey, Chief Engineer, WKRT AM-FM, Cortland, N. Y.—Some suggestions on making the most effective use of audio-level control equipment.

Now that an excellent series of articles¹ has been completed on the subject of various audio-level devices which are currently available, perhaps it might be desirable to discuss how these devices can best be employed by the engineer. The suggestions offered here are based on experience gained at WKRT from extensive experimentation in this field, and are geared to programming that includes everything from jazz to the classics. Fig. 1 shows the audio chain at WKRT.

There are several undesirable results caused by misuse of these devices—namely high distortion, lack of adequate dynamic range, pumping, and overmodulation.

Distortion is produced by almost all limiters and compressors currently in use except those units employing optically actuated compression. The more limiting or compression employed, the greater the distortion becomes.

Lack of adequate dynamic range and pumping usually result from overcompression and/or the use of fast attack and recovery times.

Insufficient overmodulation protection results from an attempt to use a limiting amplifier as a compressor rather than as a peak limiter. This causes sharp peaks to fall outside the control range.

In order to avoid these pitfalls, we at WKRT have formulated some ideas regarding the use of audio level devices. The following suggestions have proved helpful to us, and we hope they will prove equally helpful to others.

Compressors

Most compressors have a specified range over which they will operate most satisfactorily to produce the desired gain control consistent

1. Audio Level Devices, Thomas R. Haskett. BROADCAST ENGINEERING, June, July, August, November, 1963.

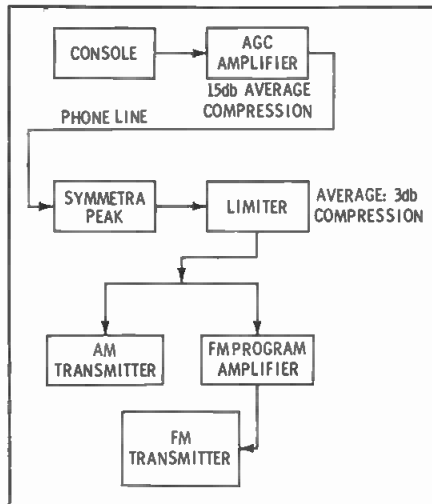

Fig. 1. Broadcast station audio arrangement—compression is less than 20 db.

with minimum distortion. We have found that the most desirable results can be obtained by operating a compressor in the middle of its compression range, or as a program-averaging device. For example, the General Electric BA-9-B Unilevel amplifier employed at WKRT has a 30-db range over which it will operate satisfactorily. It has been set up so that normal program material at a console output level of +8 dbm produced 15 db of compression. Everything above this level is compressed; everything below this level is expanded. The unit has been adjusted for an attack time of 50 milliseconds and a release time of 15 seconds. We have found that 50 milliseconds is a good average attack time because it prevents serious holes in the program which would result from a very fast attack time

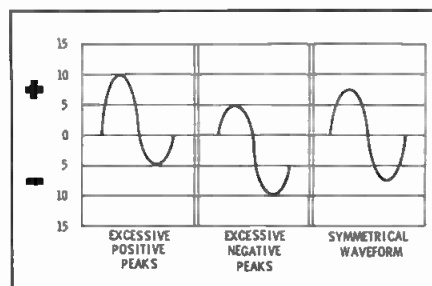

Fig. 2. Peak distribution device converts either of first two waveforms into the last.

and a slow release time. We have also found that it is desirable to allow a release time of one second for each decibel of compression. This prevents the rapid buildup of background noise during pauses and allows retention of short-term dynamic range in musical selections.

Limiters

A peak limiter should be employed for only the purpose its name implies. All too often this piece of equipment is used to increase average modulation by employing the full limiting range under normal program conditions. Sudden peaks exceeding this average program range fall outside the limiting range and produce overmodulation as well as distortion in both the limiter and the transmitter.

Our experience has shown that 3 db of peak limiting on average program peaks is desirable. With most limiters this allows ample limiting margin for peaks which exceed the normal program level. The General Electric BA-5-A limiter employed at WKRT has a limiting range of 12 db over which the output remains constant. This means that 9 db of compression is available to handle sudden peaks that exceed the normal program level.

Attack time for an ideal limiter should be instantaneous. Release time should also be as rapid as possible in order to prevent holes in the program, but not so rapid as to result in pumping. We have found a variable release time—one that is controlled by the program material—to be most satisfactory.

Special Accessories

Most audio-level devices are designed to operate best when the input waveform is symmetrical. However, many audio sources do not provide a symmetrical waveform. Some microphones produce positive and negative peaks which differ in amplitude by as much as 10 db.

One device which corrects this situation is the Kahn Laboratories Symmetra - Peak which equalizes positive and negative peak excursions within $\frac{1}{2}$ db. The action of this device is illustrated in Fig. 2. Such equalization enables higher compression levels (and greater efficiency) in the use of compressors and limiters. It also enables the engineer to obtain the greatest modulation efficiency from his transmitter because both positive and negative modulation peaks will be identical. Program material such as music, which is basically symmetrical in waveform, will not benefit greatly from this device, but most speech signals (the most common source of unsymmetrical waveforms) will be markedly improved.

Conclusions

While many seasoned engineers may raise their eyebrows a bit at some of the thoughts presented here, the proof is in the trying. The results to be obtained by employing these suggestions are: minimum distortion, excellent short-term dynamic range, and an overall compression ratio of approximately 6:1. For console audio output levels

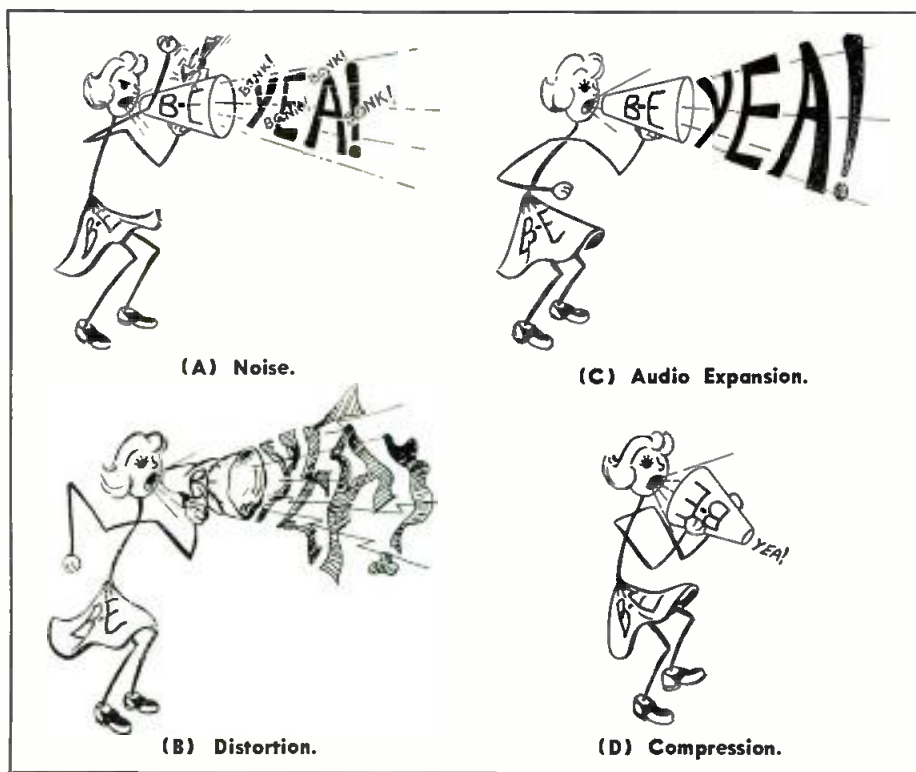

Fig. 3. Cartoon renditions of four common audio characteristics and conditions.

varying ± 20 db from the normal average program level, there is only a ± 3 -db variation at the input to the transmitting equipment.

If you should still be skeptical, try running a proof of performance

with your audio-level devices set up as they are currently being employed and without disabling the compression. This will demonstrate more vividly why misuse of these devices doesn't pay. ▲

"Our ANGENIEUX-ZOOMAR LENS... one of our most useful production devices"

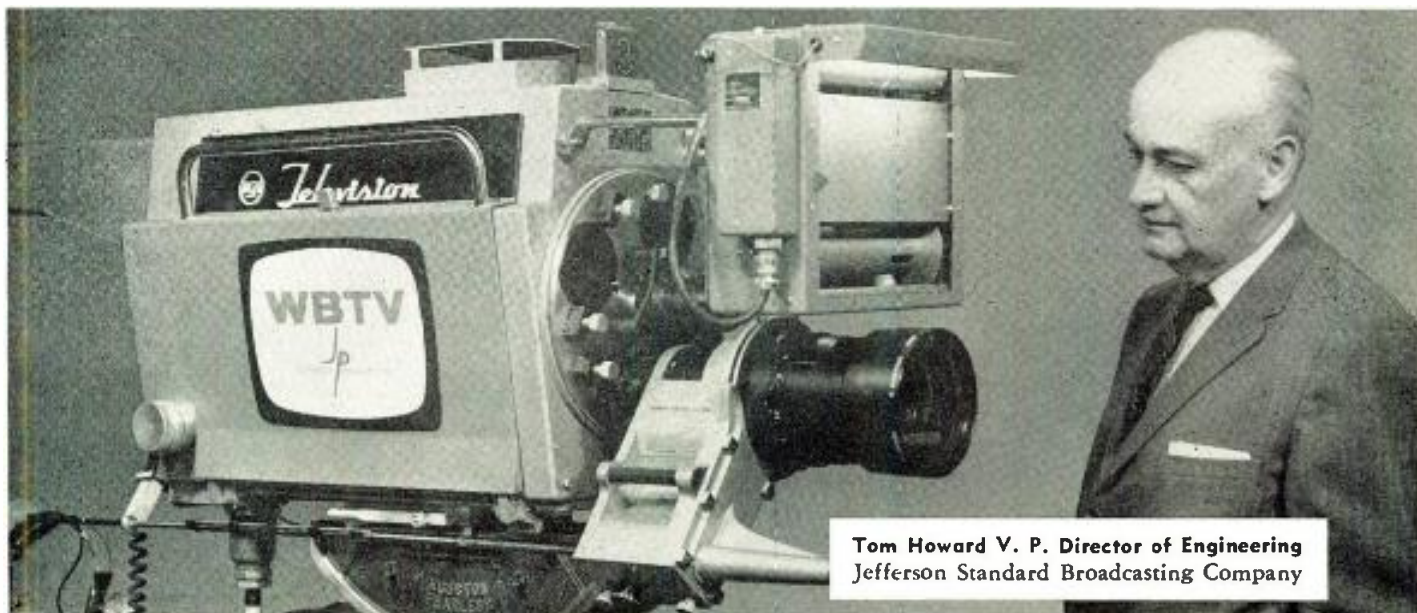

Tom Howard V. P. Director of Engineering
Jefferson Standard Broadcasting Company

"One of our most useful production devices is our Angenieux-Zoomar lens. This lens, when used in conjunction with our new $4\frac{1}{2}$ inch I.O. cameras, has brought us numerous compliments from our clients on the quality of our product. Optical performance of our Angenieux-Zoomar is outstanding and the 35 mm. wide angle view and the three foot minimum focusing distance make this the finest and most versatile lens you have yet produced."

For a demonstration
on your camera... call

JACK A. PEGLER • BILL PEGLER

TELEVISION ZOOMAR COMPANY

500 FIFTH AVENUE, ROOM 5520 • NEW YORK 36, NEW YORK
BRyant 9-5835

Circle Item 27 on Tech Data Card

VIDEO PROCESSOR SWITCH PANEL

by James P. Rodgers,
Senior Engineer, WVAN-TV,
Pembroke, Georgia

Here are construction details of a processor switch panel we constructed for our Ampex VR1000C.

Since our machine uses the transistorized processor, the rack contains a 5" recessed blank panel immediately above this unit. We mounted a four-pole, double-throw switch in the center of this panel. Using a piece of sheet metal, we fashioned a channel-shaped chassis 15" long and 4" deep. This open-ended chassis was bolted to the back of the 5" Ampex panel after the necessary wiring and connectors were installed in the chassis.

Six Amphenol SO-239 flush-mount coax connectors were mounted on the back of the chassis with straight runs of solid copper wire from the inner conductor connections to the appropriate points on the wafer switch. All coax connectors were tied together with a common ground bus.

A panel-light assembly using a No. 1819 lamp was mounted on either side of the wafer switch. The lights (one red and one green) were also wired to the wafer switch and the leads brought out by two-pair shielded cable. The indicating lights are connected to terminal board D, terminals 13 and 14, in the same rack as the transistorized processor.

Facing the switch panel from the back, we have labeled the coax connectors from left to right as follows: 1-Proc out, 2-VTR line out, 3-VTR in, 4-Line in, 5-Demod out, 6-Proc in.

The processor amplifier output from J1 is connected through a short length of RG-59/U to 1-Proc out on our panel. Output J2 remains connected to the monitor bridge. The output cable removed from the processor

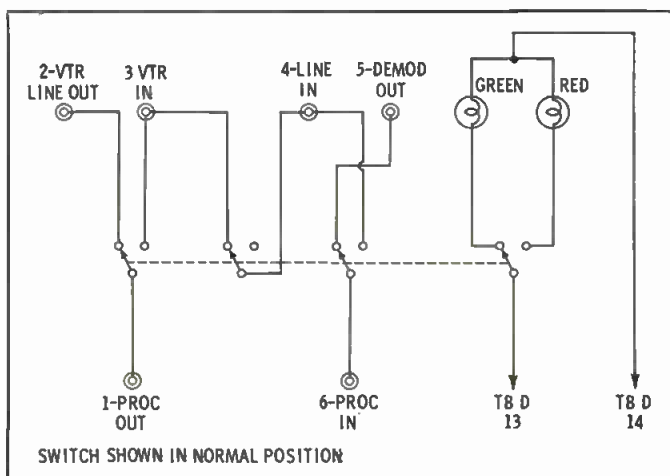

Fig. 1. Diagram of completed video processor switch panel.

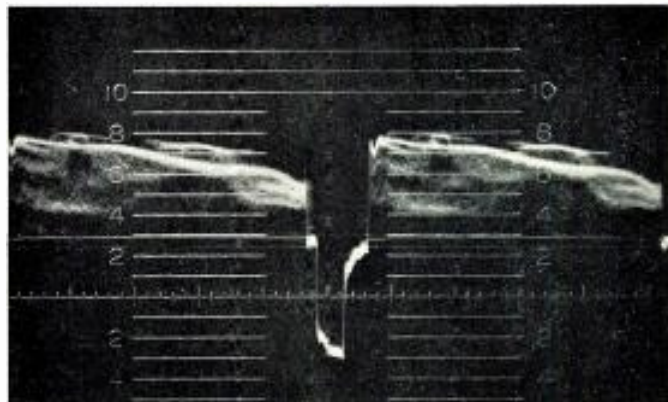

Fig. 2. Video at test point 5; selector switch in "Normal."

amplifier is connected to a short RG-59/U extension cable and then to 2-Line out on our panel.

The incoming video line to the machine, which was originally connected to terminal board J, connector 1, was removed, and a length of RG-59/U was connected between this point (TB J-1) and connector 3-VTR in on our panel. The incoming video line which was connected to 4-Line in on our panel.

The cable from the demodulator, which was connected to J8, the processor input, was removed and connected through an RG-59/U extension to 5-Demod out on our panel. Another cable was then connected between J8 and 6-Proc in on our panel.

These were the only connections necessary, since none of the other signals produced by the processor were needed in our installation. Our use of the VTR is primarily for playback of classroom lessons, but occasionally we record a program off the air from a commercial station about 35 miles distant. This switch panel permits us to clean up the video considerably and correct sync-to-video ratios before the signal enters the Modulator.

The switch is labeled Normal-Record. In the Normal position the green lamp is lit, and the incoming video line is normaled through to the input of the machine. The demodulator feeds the input of the processing amplifier and the processor output feeds the VTR video output line. Throwing the switch to Record lights the red lamp, switches the incoming video line to the input of the processor amplifier, opens the normal through line, and connects the output of the processor amplifier to the modulator. ▲

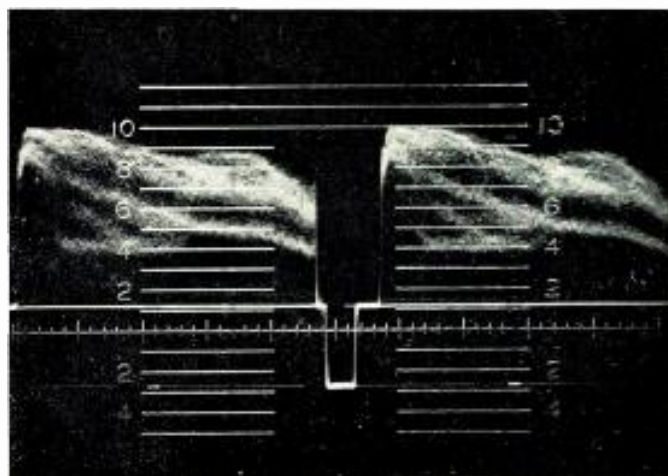

Fig. 3. Video at test point 6; selector switch in "Record."

new camera

for Tektronix Oscilloscopes

Type C-27

pictures full 8-cm x 10-cm graticule
on Polaroid* 3 1/4" x 4 1/4" film

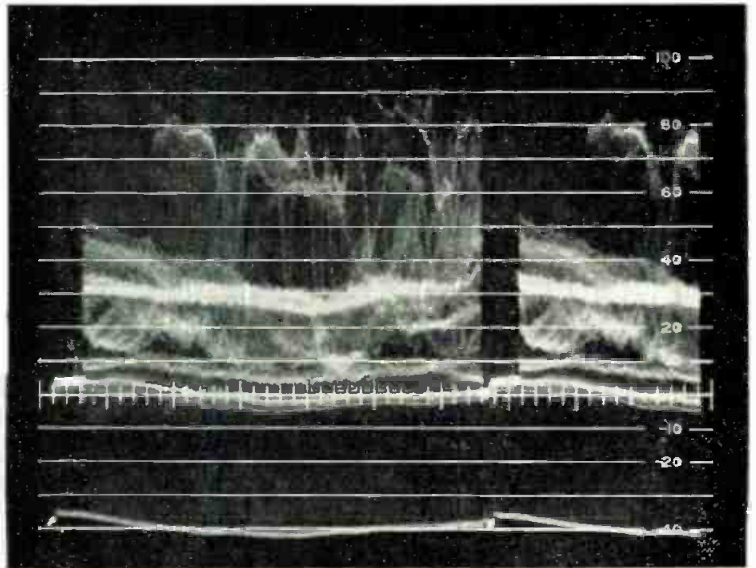

Full-size reproduction of composite video signal—as displayed on Tektronix Type RM527 Waveform Monitor. Note that image is not reversed, right to left.

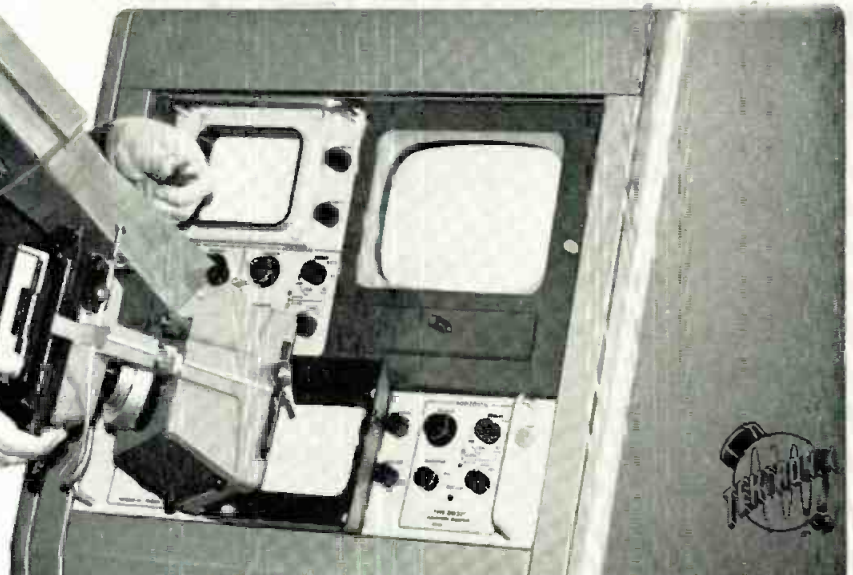

- BINOCULAR VIEWING
- DIRECT RECORDING
- ACCESSIBLE CONTROLS
- ONE-HAND PORTABILITY
- LIFT-ON MOUNTING
- SWING-AWAY HINGING

Plus

- COMPONENT INTERCHANGEABILITY . . . with C-27 Camera able to accept other lenses, film backs, shutter actuator, 35-mm film attachment, other accessories.

- CALL YOUR TEKTRONIX FIELD ENGINEER FOR A DEMONSTRATION OF THE C-27 CAMERA.

Includes f/1.9 lens with 1:0.85 object-to-image ratio, cable release, direct binocular viewing system with removable viewing tunnel, and Polaroid* Land Pack Film Back using Type 107 black and white film or Type 108 color film.

One mounting bezel adapts C-27 Camera to Type RM527 Waveform Monitor. Another mounting bezel adapts C-27 Camera to most other oscilloscopes. Bezels available separately \$15.

C-27 CAMERA \$420
U. S. Sales Prices f.o.b. Beaverton, Oregon

* ©by Polaroid Corporation

Tektronix, Inc.

P.O. BOX 500 · BEAVERTON, OREGON 97005 · Phone: (Area Code 503) Mitchell 4-0161 · Telex: 036-691
TWX: 503-291-6805 · Cable: TEKTRONIX · OVERSEAS DISTRIBUTORS IN 25 COUNTRIES
TEKTRONIX FIELD OFFICES in principal cities in United States. Consult Telephone Directory

Tektronix Australia Pty., Ltd., Melbourne; Sydney · Tektronix Canada Ltd., Montreal; Toronto
Tektronix International A.G., Zug, Switzerland · Tektronix Ltd., Guernsey, C. I. · Tektronix U. K. Ltd., Harpenden, Herts

Circle Item 28 on Tech Data Card

TELEVISION STL ANTENNA ALIGNMENT

by Harry A. Etkin, Consulting Author,
Engineer, WQAL-FM, Philadelphia,
Penna.—Techniques for deriving optimum
performance from Studio-to-transmitter
link antennas.

The Electronic Industries Association standard defines a studio-to-transmitter relay system as: “. . . a television relay system of one or more hops providing service from a television studio to its associated transmitter.” Therefore, the TV microwave system is a direct link between the program source and the transmitter.

To provide a high degree of reliability and realize the full capabilities of a TV broadcast microwave system, the most significant procedure is accurate alignment and orientation of the studio-to-transmitter link transmitting and receiving antennas.

Microwave Unit Locations

In securing good STL performance, the broadcast engineer should locate the relay transmitter and receiver so there will exist an unobstructed line-of-sight transmission path between the microwave antennas.

Many approaches to the problem of microwave unit location have been developed, and each has its own merits and difficulties. Maps are convenient to use but give erroneous results due to revisions. Balloons, lights, and other optical devices may show line of sight but do not provide clearance measurements.¹

No one technique is the complete answer to STL microwave location problems. Maps lack accuracy but are suitable for planning. The rod and transit technique is the most accurate but slow to perform. Aerial surveys are rapid and practical for large systems but give no indication of site suitability.

Choice of equipment location is usually limited by the studio and transmitter locations, length of signal path, type of terrain, meteorological conditions, and presence of high buildings or other obstacles along the proposed transmission path.

The TV-station engineering staff, having tentatively selected a site, should perform a series of seven measurements. The results will usually be affected by the distance from the studio to the transmitter and the diameter of the parabolas. In any case, the factors to be calculated are:

1. Total free-space loss (attenuation)
2. Antenna gain at the microwave transmitter and receiver
3. Net path clearance
4. Transmitter power output
5. Video signal-to-noise ratio (P-P/rms) and audio signal-to-noise ratio
6. Fading margin
7. Propagational reliability

After installation and test of the TV microwave equipment, excellent performance may be obtained if the suggested antenna alignment procedures are carried out. Fig. 1 shows an excellent TV microwave transmitter installation.

Antenna Alignment Techniques

In television relay practice each antenna assembly consists of a parabolic reflector from two to ten feet in diameter and/or a passive reflector. It operates in conjunction with its associated transmitter, receiver, waveguide, and feedhorn assembly. The antenna gain will vary with the diameter and area of the parabola and the microwave band used. The present frequencies allocated by the FCC for TV microwave links are in the 2000-, 7000- and 13,000-mc bands.

In TV microwave systems the radiated energy is concentrated in a very narrow angle, or pencil-like beam, much the same way that light is focused into a beam by a searchlight. The narrow beam widths are

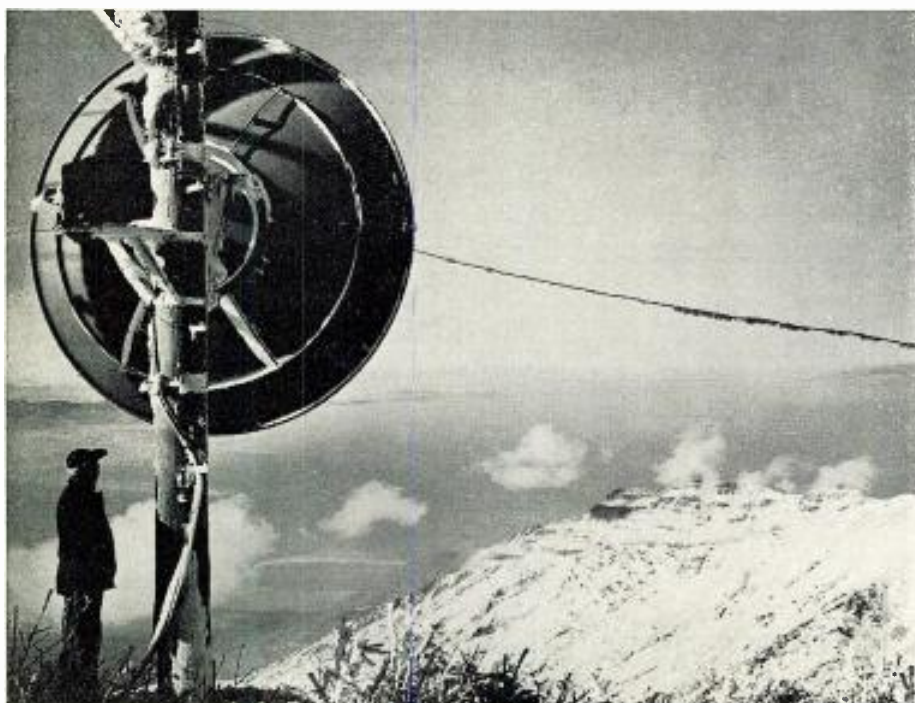

Fig. 1. Television microwave transmitted antenna installation.



**INTRODUCING THE WORLD'S NEWEST MICROPHONES...
GUARANTEED FOR FIVE YEARS!**

ALL NEW DESIGN...ALL NEW PERFORMANCE—Today... from the laboratories of University... an advanced technology has produced a great new breed of microphones for broadcasting, TV, professional and home recording, P.A., ham and CB applications. Each one represents a clean and dramatic break with tradition...with outmoded notions. Each one is far superior to any other microphone in its class. Let other microphone manufacturers offer the usual two to three-year warranty. Every University microphone—whether designed for the professional studio or the home recordist—is sold with a five-year warranty. For complete specifications, write: Desk BE-5, LTV/University, 9500 West Reno, Oklahoma City, Oklahoma.

EXAMPLES OF THIS GREAT NEW LINE!

MODEL 8000—A high performance dynamic cardioid for only \$29.95 net! Response: 70-13,000 cps. Sensitivity: -156 db (EIA). Output Level: -59 db/1mw. 10 dynes/cm². Includes 15 ft. cable with Cannon plug and receptacle, and desk stand adaptor.

MODEL 2040—VOICE REALISM AT ITS BEST! Near omnidirectional dynamic microphone that has astounded hams in initial trials! Modulation free of the harshness and muddy effect common to most microphones in this class. Ideal for upgrading P.A. and home tape recording performance as well.

MODEL 1000—CARDIOID DYNAMIC. Unique directional characteristics provide unexcelled discrimination against unwanted sounds—assure superior results even in noisy or reverberant locations. Internally shock-mounted—sensitive elements float, vibration-free, on polystyrene ribs! For any application requiring a truly discrete sound source.



**LTV
UNIVERSITY**

A DIVISION OF LING-TEMCO-VOUGHT, INC.

Circle Item 29 on Tech Data Card

AUTOLOG



like
having
an extra
pair of hands

AM, FM or TV—or all three. Accurate parameter logging in complete accord with FCC rules. A proven record in the nation's largest stations. Write:

RUST
corporation of america
195 Massachusetts Avenue
Cambridge, Mass.
GEL FM STEREO TRANSMITTERS
RUST REMOTE CONTROL AUTOLOG

Mr. John Wymann
Sales Manager
Rust Corporation of America
195 Massachusetts Avenue
Cambridge 39, Massachusetts

Yes! I'm interested in automatic chart recording using the proven AUTOLOG system. Send me more information.

Name..... Title.....
Station..... For AM FM TV ALL
Street Address.....
City..... State.....

important in efficient transmission of energy by point-to-point microwave systems. Controlling this beam is somewhat difficult; proper alignment requires accurate control in aiming the signals from the transmitting antenna toward the receiving antenna to obtain highest power gain.

Initially, both the transmitting and receiving antennas are set for horizontally polarized directional patterns and pointed toward each other. Passive reflectors should initially be adjusted to a 45° angle (to the vertical) with the antennas optically pointed at the passive reflectors. With the antennas and reflectors installed to previously calculated angles, and when the exact azimuths and elevations between antenna sites have been determined, the transmitting and receiving antennas (and/or reflectors) should be traversed horizontally and vertically. The adjustments will become finer until maximum signal is indicated at the receiver site. The STL antennas will be accurately aligned when the signal-to-noise ratio is within 2 db of the predetermined value. Fig. 2 illustrates calculated signal-to-noise ratio figures.

A word of caution—high winds, snow coverage, and ice loading may shift and deform antenna elements to the point of loss in signal during a program.

Measuring Video Signal-To-Noise Ratio

The following procedure should be used to measure signal-to-noise ratio:

1. Turn on the TV microwave transmitter and receiver.
2. Set all controls for normal levels and apply a video signal, preferably the EIA test pattern, to the STL equipment input.
3. Measure the amplitude of the video signal at the terminated output of the receiver.
4. Without changing the controls which were set for normal levels, remove the video signal and terminate the video modulator input. Noise signal may now be measured accurately at the terminated output of the receiver by a peak-to-peak device, such as a wideband oscilloscope which is flat to at least 6 or 10 mc.
5. Set the oscilloscope sweep for

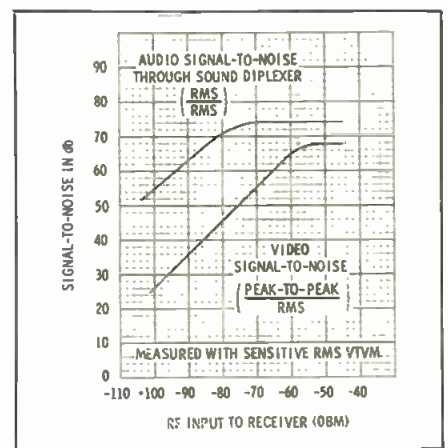

Fig. 2. Graph of STL microwave s/n ratio.

60 cps and an amplitude of 1/4". By phasing the sweep properly, the noise signal may be discerned from the 60- or 120-cps hum in the equipment. Peak-to-peak noise values can now be read on the oscilloscope.

6. The peak-to-peak noise value to peak-to-peak video signal value may now be converted into the signal-to-noise ratio by the formula:

$$S/N(\text{db}) = 20 \log \frac{\text{P-P video volts}}{\text{P-P noise volts}}$$

The resulting peak-to-peak signal-to-noise ratio should now be converted into rms values. This can be accomplished by the addition of a conversion factor of 20 db to the signal-to-noise ratio which has been measured on the wideband oscilloscope.

The rms noise voltage can be measured directly by using a sensitive rms vacuum-tube voltmeter (VTVM) with a flat bandwidth response of at least 6 mc. The rms signal-to-noise ratio is determined by the formula:

$$S/N(\text{db}) = 20 \log \frac{\text{Peak Video Voltage}}{\text{rms Noise Voltage}}$$

Test instruments which may be used to measure rms values are the Ballentine 314 VTVM and the General Radio Type 1932-A Noise and Distortion Meter, or their equivalents. A sensitive rms VTVM provides better accuracy in measuring S/N ratios than the oscilloscope method.

7. Compare the measured S/N figures with the predetermined values shown in Fig. 2. If the measured S/N ratio is within 2 db, the antennas, which have been previously oriented in azimuth and elevation for maximum signal, are properly aligned.

This is WBAL-TV's new building in Baltimore. The exclusive use of Belden Audio, Camera, and Control Cables in this \$2,000,000 studio building helps maintain their high level of broadcasting efficiency.

Looking over part of this 125,000-foot Belden wire and cable installation are John Wilner, Vice President, Engineering, Hearst Corporation, operators of WBAL-TV (left), Mary Kann, Belden Distributor (center), and Hank Hine, Belden Territory Salesman. All of the wire and cable for WBAL-TV was purchased from Kean-Electronics, Inc., Belden Warehouse distributor.



WBAL-TV Turns to Belden Exclusively for Audio, Camera, and Control Cables

Belden manufactures a complete line of application-engineered wire and cable for TV and radio broadcasting, recording studios, remote control circuits, and similar applications. Call your Belden electronic distributor for complete specifications.

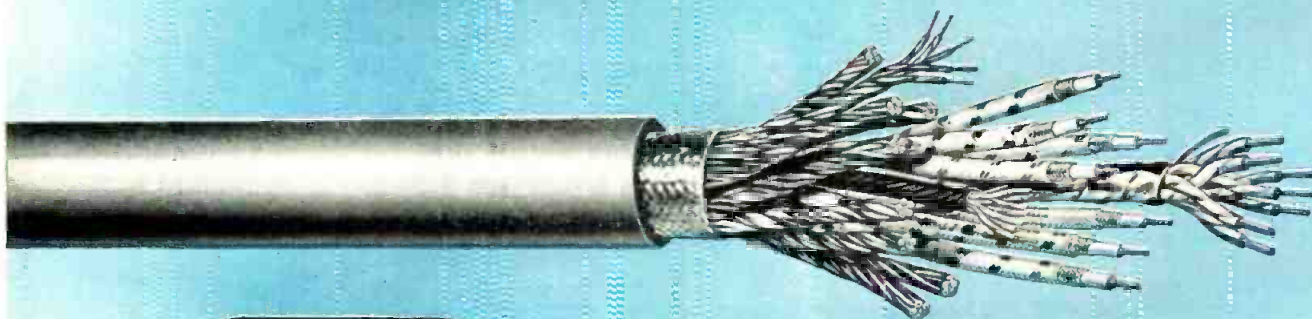

power supply cords • cord sets and portable cordage • electrical household cords • magnet wire • lead wire • automotive wire and cable • aircraft wires • welding cable

3-7-2

Circle Item 38 on Tech Data Card

Enjoy Dynamic Programming with Spotmaster ... the International Standard of Excellence in Cartridge Tape Systems

Check SPOTMASTER

- ✓ Compact and rack-mount models
- ✓ Recorder-playback and playback-only models
- ✓ Monophonic and stereo units
- ✓ Delayed programming option
- ✓ Superior quality



500A
Compact
Recorder-
Playback



500A-R
Rack-Mount
Recorder-
Playback



SPOTMASTER tape cartridge equipment is the preferred choice on five continents. These quality-engineered machines permit snap-in cartridge loading and split-second, one-hand operation ... plus all the other time-tested and field-proven SPOTMASTER features.

Write or phone today for full details about the wide range of rugged, dependable SPOTMASTER equipment ... their outstanding features and options ... modular construction ... easy maintenance ... complete line of accessories ... competitive prices ... lease/purchase plans. Remember, all SPOTMASTER models are backed up by an ironclad, full-year guarantee.

NEW DELAYED PROGRAMMING OPTION

The optional SPOTMASTER 500 A-DL (Delayed Programmer) provides a 5-second to 16-minute delay in the broadcast of program material. Permits instant censoring and deletion of objectionable material from interviews and other live originations while the program is on the air ... also meets many other delayed programming requirements. With the DL function switched off, the unit operates as a standard 500A recorder-playback. Available in rack or compact models.



BROADCAST ELECTRONICS, INC.

8800 Brookville Road, Silver Spring, Maryland
Telephone: Area Code 301 • JUniper 8-4983

Sold nationally by:
VISUAL ELECTRONICS
356 W. 40th St., New York, N. Y.

Canada:
Northern Electric
COMPANY LIMITED
Branches from coast-to-coast in Canada

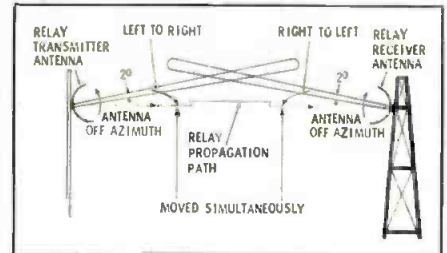

Fig. 3. Maximum signal orientation plan.

8. To minimize any 60- or 120-cps hum, the noise-voltage measurements should be taken through a hum filter. After taking the noise reading, the hum filter should be removed when the video signal voltage is measured.

Alignment Procedures and Pointers

In STL practice the radiated energy is concentrated into a narrow beam. Exact control in aiming the signal toward the receiver requires careful simultaneous horizontal and vertical movements of both the transmitter and receiver antennas until the signal beams virtually intercept each other. Fig. 3 illustrates adjustment for maximum signal.

Unless the pickup point is in the line of sight, the broadcast engineer should have available a private line between the ends of the STL system so that optimum orientation of all elements in the system may be attained.

Additional facilities, such as a surveying transit and compass, should be available to obtain the proper on-path azimuth and elevation orientation for both antennas or passive reflectors. The use of maps, lights, altimeters, and other devices will not be discussed in this article.

Before the STL system can provide a maximum signal at the receiver, the polarization of the transmitter and receiver antenna systems must be the same. Antennas may have their polarization adjusted by rotation of the feed at either end of the relay link.

Azimuth Orientation

When using a transit, it is help-

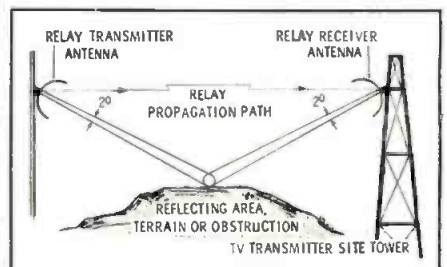

Fig. 4. Antennas off in same direction.

NEW

FOR THE BROADCASTER WHO WANTS:

- FULL FIDELITY SOUND
- SIMPLICITY OF OPERATION & MAINTENANCE
- COMPACT SIZE & SMART, MODERN STYLING
- FAMOUS SPARTA QUALITY & DEPENDABILITY
- AND - A CHOICE OF LEASE OR PURCHASE!



BP-11 BATTERY POWERED TAPE CARTRIDGE PLAYBACK

The sensation of the 1964 National Association of Broadcasters convention! Plays 40 minutes on rechargeable Nickel-Cadmium battery. Weighs only 11½ pounds. Fully transistorized . . . completely self-contained, including battery and charging unit. Plays all size cartridges. Comes with protective slip-cover with cartridge pocket and battery charger cord. Now available with audible cuing as optional extra.

BP-11 . . . \$179.50 Optional Audible Cue . . . 17.50

SPARTA-MATIC 400 SERIES

400RP (Record/Playback) and 400P (Playback only) New, improved design permits faster, effortless cartridge insertion and release. All-transistorized circuitry. Amplifier modules constructed on individual epoxy-glass printed circuit boards. Heavy gauge steel cabinets with anodized brushed aluminum control panel. Large, illuminated stop-start buttons. Each unit requires only 10½" X 14" space. Both units conform to the proposed NAB standards.

400RP . . . \$625 400P . . . \$450

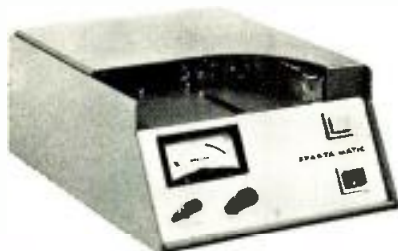

CD-15 TIME DELAY AND "SPECIAL EFFECTS"

All transistorized tape cartridge unit with separate record, playback, and erase heads makes possible program time delays from 3 seconds to 30 minutes (for on-the-air telephone conversations, etc.) Length of time delay adjusted simply by changing length of cartridge used. May also be used to create "echo chamber" and reverberating echo effects.

CD-15 . . . \$395

AS-100 STEREO AUDIO CONSOLE

All transistorized with stereo inputs for microphone, two turntables, and auxiliary.

Unit has plus 4 dbm 600 ohm balanced output. Contains plug-in program amplifiers, plug-in microphone preamplifiers, and line-balancing input transformers for all channels. Microphone muting, turntable cue, and program monitor contact terminals are provided. Individual controls for monitor headphone and cue gain, as well as master gain controls for program, right and left channels.

Unique, three position lever-switching for maximum flexibility of operation.

AS-100 . . . \$525



OUR PRODUCTS ARE OUR BEST SALESMEN!

For immediate delivery . . . or further details,
Call, Write, or Wire Today:

SPARTA ELECTRONIC CORPORATION

6450 FREEPORT BOULEVARD • SACRAMENTO 22, CALIFORNIA • GA 1-2070



Circle Item 32 on Tech Data Card



Audio Controls Division
Altec Lansing Corporation

Art Davis, leading studio equipment design engineer and manufacturer, recently joined Altec to head the newly created Audio Controls Division. A Fellow of the Audio Engineering Society, Davis holds many audio equipment patents and last year received the John Potts medal for his contributions. This column on broadcast and recording is his first in a series.

To my friends in the industry, the move to Altec will come as no surprise. Personally, I know of no other firm which so deserves its place of honor as a trusted supplier to the recording and broadcast industries. Already we are busy designing and building what we hope will be superior attenuators, equalizers, filters, networks, switches, all-transistor limiter, monitor and preamplifiers, and power supplies. We are making these devices (and others) expressly for your industry, with our combined know-how and ability behind them.

NEW SOLID STATE PREAMP ONE OF FIRST ITEMS

For example, we've just finished designing a new solid state preamplifier, the 470A. Use it as a preamp or line, booster, and program amp; no internal changes needed! Here's the way it came about: First we decided to find out what you really wanted. So we took a survey among hundreds of recording and broadcast engineers. Guided by the results, we built the 470A to provide the size and capabilities for which most of you asked.

DESIGNED TO YOUR REQUIREMENTS

For instance, most of you felt that miniaturization had gone 100 far. So the 470A is a little larger than some "subminiature" models; however, you'll still get 8 in a 19" panel and occupy only 3 1/2" height. That size difference will help with the age-old heat problem and all the attendant damages. Another thing, the 470A has larger "plug-in" connectors to simplify wiring and circuit tracing; easier to solder and cement. Sensible size also makes it easier to maintain and service the 470A.

It's important to note the 470A has a lower noise level than any tube amplifier designed for this function and is free of characteristics, or personality of its own. It excels in patching applications because it's unaffected by length of transmission lines (over 100 feet fore and aft!)

Specs? We think you'll like them, too: gain, 44 db; power output (max.), 29dbm, 20-20,000 cps; frequency response, -0.25 db, 20-20,000 cps; less than 1% THD, 20-20,000 cps; less than .2% THD, 50-20,000 cps (both at rated output).

Perhaps you see what we mean when we say the 470A solid state preamplifier is designed for you. It's just what we mean. And that applies to everything we're going to make. That's why we would like to hear from you. To find out what you need and perhaps come up with something for you. So give me a call, or drop me a line. I'll be happy to hear from you and send you the latest on our products.

Art Davis

Art Davis
Audio Controls Division • Altec Lansing Corporation • Anaheim, California

© ALC 1984

Circle Item 33 on Tech Data Card

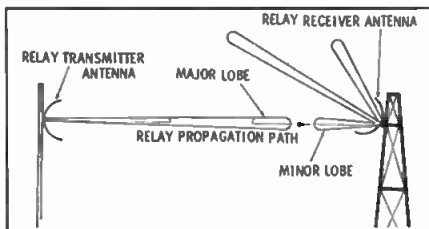

Fig. 5. Transmitting antenna major lobe aligned with receiving antenna minor lobe.

ful to drive a stake a few hundred feet along the line of the signal path. This stake will provide a guide line to permit aiming the transmitting antenna or reflector in the desired direction. After placing the transit over the stake, adjust the top and bottom edges of the reflector (or the plane of the feed horn if an antenna is used) so they are parallel to the horizontal cross hair of the transit telescope. This sighting assures the engineer that the antenna or reflector is properly aimed toward the stake.

If the antennas at each end of the path are oriented in azimuth, one at a time, for a maximum signal, it is possible to have both beams off on the same side of the relay propagation path. For illustrative purposes Fig. 4 shows both beams off on the same side with an

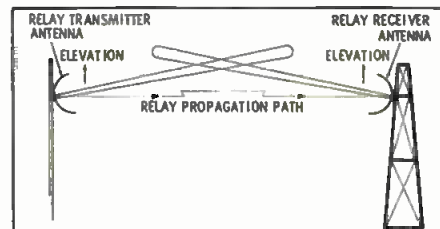

Fig. 6. Both beams aimed above signal.

apparent maximum signal. This will produce an S/N ratio approximately 10 db lower than required. The signal produced will be a false maximum signal. To remedy this situation, the engineer should simultaneously move one antenna or reflector to the left while the other is moved to the right (Fig. 3) to obtain the desired maximum signal.

A similar situation could prevail in which the major lobe of one antenna is aligned with a minor lobe of the other. (See Fig. 5.) This type of orientation will also produce a false maximum signal with an approximate 10-db loss in the final S/N ratio. Any movement of the parabola in a high wind would produce severe degradation of the signal at the microwave receiver.

Elevation Orientation

When the received signal strength

Set your VIDEO TAPE MACHINE FREE during Editing, Assembly, Timing, Rewinding



Let the Moviola Video Tape Sound Reader with Video Tape Power Rewinder relieve your video tape machine from the many editing chores which do not require picture reproduction.

After your tape recording has been marked or cued for editing at the tape machine console, the rest can be done away from the machine with a Sound Reader—Power Rewinder setup. Your video tape splicer completes the ideal table editing arrangement pictured above.

- Increases productive time of tape machine
- Reduces "log jams" at the tape machine
- Saves costly tape machine head wear
- Sound Reader prevents tape wear by reading from base side
- Built-in program timer eliminates tape machine timing reruns
- Sound Reader is battery powered and transistorized with individual program and cue track pre-amps
- Power Rewinder is variable speed foot controlled

moviola
manufacturing co.
motion picture television equipment

Write or call for brochures which give detailed information:

5539 Riverton Avenue, North Hollywood, California 91601
Telephone: 877-2173 (area code 213)
Cable Address: Moviola, North Hollywood, California, U.S.A.

Circle Item 53 on Tech Data Card

BROADCAST ENGINEERING

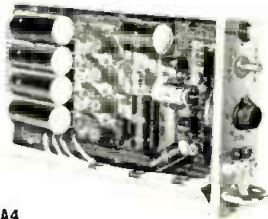

TDA4
Plug-in Video/Pulse
Distribution Amplifier



TDA2 Video/Pulse Distribution Amplifier

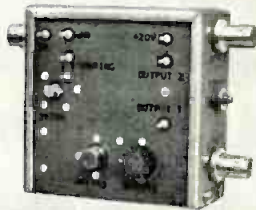

TCA3
Camera Amplifier



TCA7 Color Camera Amplifier



TDA26
High Gain Video Amplifier



TDA5 Balanced/Unbalanced, Video/Pulse Distribution Amplifier

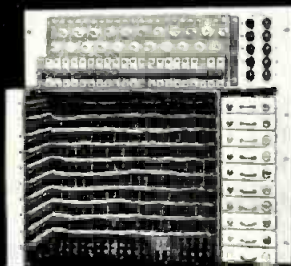

VS22-10 Video
Crossbar Switcher

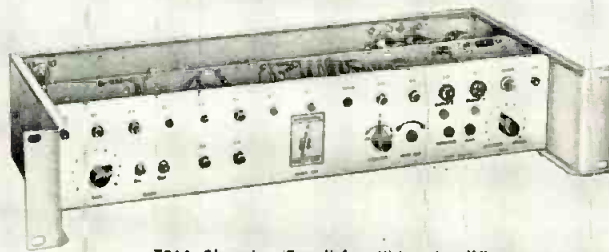

TSA1 Clamping/Equalizing Video Amplifier

Leading the Industry in Transistorization

Our goal is to make available reliable, modern instruments built to last virtually forever.

Our design criteria are precision, versatility, flexibility, simplicity, compactness and ease of maintenance in every piece of television equipment bearing the International Nuclear trademark.



Write for complete specifications and details to Department C.

INTERNATIONAL NUCLEAR CORPORATION

608 NORRIS AVENUE

NASHVILLE 4, TENN.

is found to be adequate in azimuth, the next consideration is obtaining the correct elevation adjustment. The same techniques used for azimuth adjustment should be applied for exploring in elevation. Some practical factors in elevation alignment are:

1. When the antenna parabola is in a vertical position the signal will be at maximum.
2. With a passive reflector and antenna setup it is advisable to have the reflector at an angle of 45° with the vertical for maximum signal.
3. A false maximum signal produced by ground reflections should be avoided.

Figs. 6 and 7 illustrate two possible results of orienting one dish at a time. Both conditions will lead to loss of signal at the receiver.

Passive Reflector Setup

The advisability of using a curved or bowed surface as a passive reflector depends on several factors. Therefore, curvature adjustment of the reflector should not be directly below the reflector and on

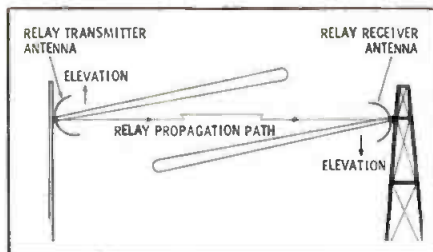

Fig. 7. Beams above and below path. the line of the signal path properly illuminates the flat surface to produce the predicted gain and signal-to-noise ratio. An increase in signal strength of a few db may be obtained by judiciously adjusting the reflector curvature. When the reflector surfaces have been properly aligned, the driving antenna should be moved in both azimuth and elevation to establish the proper maximum signal at the STL receiver site. Fig. 8 illustrates a passive reflector and antenna illustration.

Reflections from tall steel towers, buildings, or other structures may cause an error in reflector illumination with a consequent degradation in the predicted gain and signal-to-noise ratio. A loss in signal as illustrated in Fig. 6 could result when aligning passive reflectors in eleva-

tion and azimuth. The predicted antenna system gain may usually be obtained from the parabola and reflector performance curves given for various diameter parabolas in the manufacturer's microwave relay equipment instruction book.

Open-Waveguide Orientation

Proper alignment of microwave STL antennas is difficult due to the concentration of radiated energy into a narrow beam. A practical approach to the problem is the application of the open waveguide horn for use as a radiating element. By this method azimuth and elevation alignment is not critical due to the broad beam radiated from the open waveguide horn. It is also possible to adjust one end of the system at a time.

In a parabola installation the antenna feed horn is removed at either end of the STL. At a passive-reflector site the open waveguide horn should be installed between the driving antenna and reflector so as to bypass the passive reflector.

Although this procedure has the advantage of noncritical azimuth and elevation alignment, it presents

PRODUCTS WITH A FUTURE

GATES TRANSISTORIZED CARTRIDGE II MONAURAL/STEREO PROFESSIONAL CARTRIDGE TAPE SYSTEM 1, 2 OR 3 CUE TONE

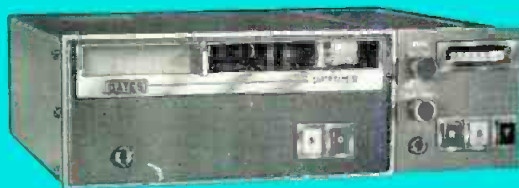

■ Plug-in modular construction

■ Exclusive positive insert opening

■ Separate record/play heads

■ Small—5½" high

Buy only the system you need now. Gates "second generation" design, with modular construction and plug-in transistor amplifiers allows immediate, economical expansion. Reliable? Positively!

A six-page brochure tells the whole story, No. A113. So does Gates new Broadcast Equipment Catalog, No. A95.

GATES

GATES RADIO COMPANY

A Subsidiary of Harris-Intertype Corporation

QUINCY, ILLINOIS

Offices in: Houston, New York, Los Angeles, Washington, D.C.

In Canada: Canadian Marconi Company, Montreal Export Sales: Rocke International Corporation, New York City

**HARRIS
INTERTYPE
CORPORATION**

Circle Item 35 on Tech Data Card

SPOTMASTER Tape Cartridge Winder



The new Model TP-1A is a rugged, dependable and field tested unit. It is easy to operate and fills a need in every station using cartridge equipment. Will handle all reel sizes. High speed winding at 22½" per second. Worn tape in old cartridges is easy to replace. New or old cartridges may be wound to any length. Tape Timer with minute and second calibration optional and extra. Installed on winder or available as accessory. TP-1A is \$94.50, with Tape Timer \$119.50.

Write or wire for complete details.

Spotmaster
BROADCAST ELECTRONICS, INC.
8800 Brookville Road
Silver Spring, Maryland

Circle Item 36 on Tech Data Card

BROADCAST ENGINEERING

NEXT MONTH

Solid-State Features:

TRANSISTORIZED CAMERA AMPLIFIER

Solid-state video preamp and bias supply

SOLID-STATE VIDEO CHOPPER

Permits video modulation checks without tearing

A CUSTOM AUDIO CONSOLE

Transistorized board has built-in compressor

Other Features include: MICROWAVE EQUIPMENT MAINTENANCE

WINTER TO SUMMER CONDUCTIVITY EFFECTS

MATCHING AND ISOLATED PADS

... PLUS, Engineers' Exchange, Technical Talks, Washington Bulletin, and many other timely items you'll want to read!

Don't wait—reserve your issues now! Fill out and send in the handy card bound in this issue to enter or renew your subscription. Remember, the new subscribers' bonus—Broadcast Engineers' Maintenance Guide—absolutely FREE!

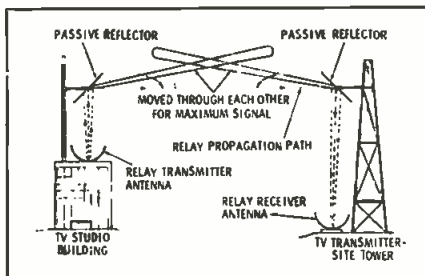

Fig. 8. Antenna and a passive reflector.

the following technical problems:

1. It may be difficult to obtain proper height location and horn orientation to provide Fresnel-zone clearance for preventing obstruction losses.²
2. Loss of signal in coax, waveguide, and clearance losses may render this technique useless.
3. Low values of gain and S/N.

There are some advantages to the use of the open waveguide end (low-gain horn) method, provided all conditions such as obstruction losses, weather conditions, waveguide horn location, and coax and waveguide losses are favorable. The waveguide horn could be off the signal path and still provide maximum signal to the receiver, and a reflected signal in the path of the pattern would be barely perceptible.

Conclusion

The STL system has gained considerable acceptance in the transmission of television programming. The wide variation of conditions which must be met by the broadcast engineer in the alignment and orientation of the antennas in the link system has been discussed. Microwave relay peculiarities and major differences between high-gain antenna and low-gain horn alignment methods have also been mentioned. It is hoped this general review of the alignment techniques will assist the broadcast engineer in selecting the proper procedure. ▲

1. When the clearance provided between the proposed path, the earth, and other obstructive objects in or near the line of sight equals or exceeds the calculated value, satisfactory propagation will be assured.

2. Although the subject of path clearance is very important and should be considered carefully, the calculation of path clearance is beyond the scope of this article. Full information on the subject may be obtained from:

- A. Microwave relay equipment instruction books.
- B. NAB Engineering Handbook (Fifth Edition), pages 4-101 and 4-102.
- C. Air Force Handbook T.O. 31R5-1-9 "Microwave Radio Relay Systems—44 mc to 13,000 mc."

INTRODUCING!

1 KW AM TRANSMITTER

Automatic Power Control and New Cabinet Styling. Exclusively offered as a "kit" or factory assembled.

1 KW FM TRANSMITTER

Featuring Automatic Power Control and the lowest tube investment in the industry.

5 KW AM TRANSMITTER

Offering *Increased Reliability* with a new twelve-phase high voltage Power Supply.

"LOG ALARM"

New ... simple method to log transmitter readings with complete "remote control" features.

WRITE TODAY FOR COMPLETE INFORMATION

Bauer
ELECTRONICS CORPORATION
1663 Industrial Road, San Carlos, California
Area Code 415 591-9466

Circle Item 57 on Tech Data Card

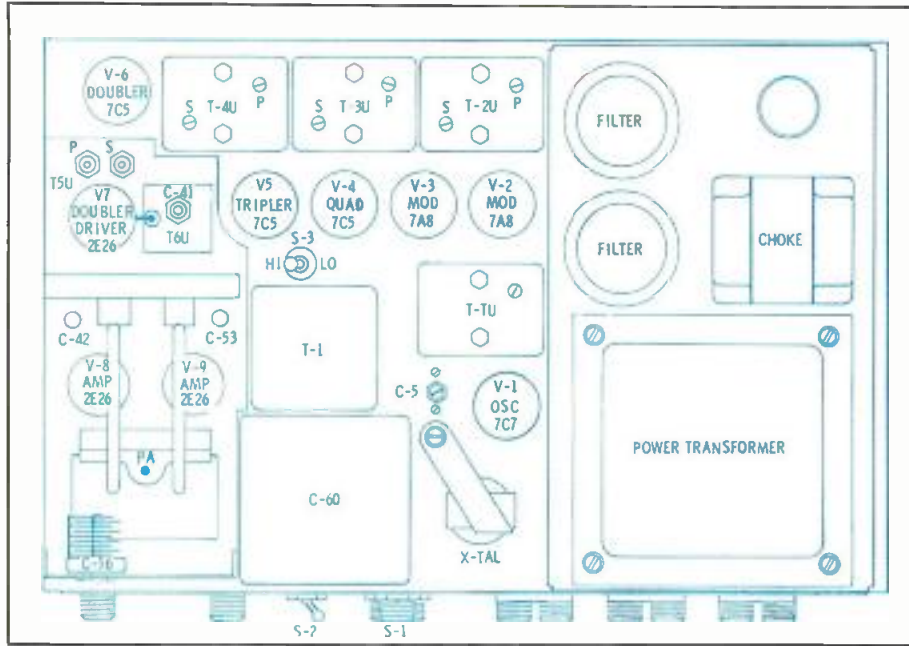

Fig. 4(A). Top view of FMTRU and FSTRU FM communication transmitter units.

chassis on the right side.

The power supply will be called upon to furnish up to 440 volts at 300 to 400 ma. Standard 500- or 750-ma silicon diodes may be used in either a full-wave or bridge circuit, depending on the power transformer available. Some TV transformers will fill the bill. Only a plate winding and a 6.3-volt filament winding are needed. When the 5-volt winding is not used, a 340-ma transformer will usually do the job without overheating. Of course, a 420-ma transformer provides an added safety factor. With a center tapped 800-volt secondary, a regular full-wave rectifier configuration can be used. If your transformer has a 400-volt center-tapped secondary, the center tap lead can be cut off and a full-wave

bridge rectifier circuit (similar to that shown in Fig. 1A) employed. In the simple full-wave circuit, the plate switch can be used to connect the secondary center tap to ground. In the bridge circuit, the plate switch connects one side of the secondary to the bridge. Mount the power supply components securely, since moving the unit frequently causes heavy components to loosen. For maximum reliability, the capacitor box (C-60) should be removed, and high-voltage filters substituted.

In older mobile models, 2E24 tubes are used in the PA stage. The fixed-station AC models employ 2E26 tubes. If the unit to be converted has 2E24's, they should be replaced by 2E26's. Checking the tube manual will show that one minor socket wiring change is nec-

essary. This change should be made in the wiring of all three sockets.

Fig. 2 is a block diagram of a typical set, indicating the function, voltage, and approximate current drain of each stage. As shown, the crystal frequency is 1/48th of the final operating frequency. When ordering your crystal, specify the model number of the transmitter in which it is to be used and the crystal type. The frequency tolerance necessary is .005%, but many companies can supply a .0025% crystal for the same price.

Cut a 2 1/4" square piece of aluminum or copper. This will be the mounting plate for the high fidelity input transformer. Cut a 1 1/8" hole in the center and mount the transformer. Now drill the plate to match the old mounting screw holes of the original microphone input transformer. Place two five-terminal tie-point strips under the mounting screws. On these terminals, assemble the equalization networks diagrammed in Fig. 3. Connect the two modulator grid wires to terminals 7 and 10 of the transformer (previously labelled). Run the lines from the RF filter network to the phone jack mounted on the front chassis apron. This is the 500-ohm audio input to the transmitter. In operation, the remote amplifier should apply a 0-VU signal at this point.

Wire all tube filaments and the pilot light to the 6.3-volt winding; ground one side. Attach the driver-doubler (2E26) and final amplifier (2E26's) B+ lines to the 400-volt B+ supply. The B+ lines to all other tubes can then be connected at the 220-volt end of the large dropping resistor (red-blue, 3,000 ohms, R45). Connect the power transformer primary to the 115-volt line cord through the fuse retainer and filament switch.

Flip the "Hi-Lo" switch to the "Lo" position for the tuneup to follow (return to "Hi" after tuneup). Replace all tubes. With the "Plate" switch off, turn the filament supply and check all tubes for lighted heaters. Attach a voltmeter, set on its 600-volt scale, to the high B+ line. Momentarily switch the plate supply on and off, noting the reading. It should be around or above 400 volts. Install the crystal, and the transmitter will be ready for alignment.

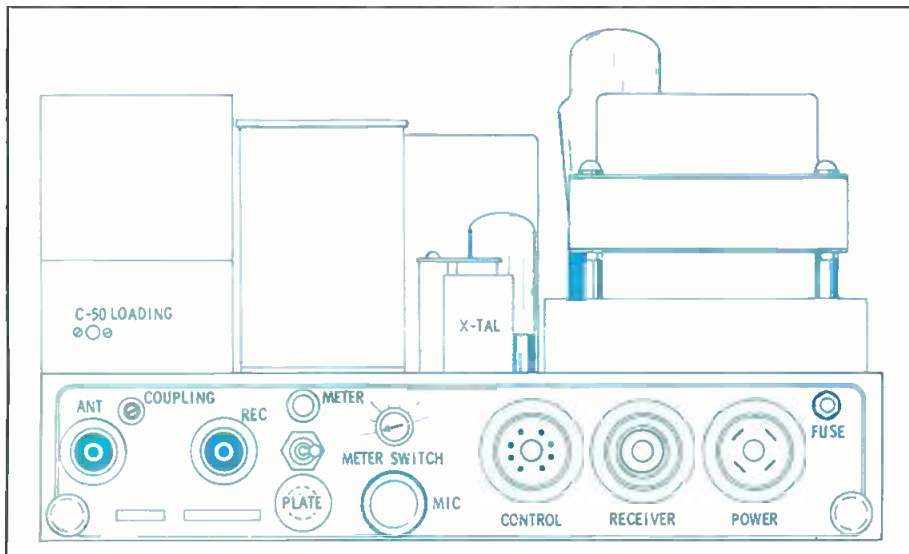

Fig. 4(B). Front view of FMTRU and FSTRU FM communication transmitter units.

Alignment

A "Micromatch," or similar power output indicator, and a dummy load should be employed in aligning the transmitter. The dummy load can be made of twenty 1000-ohm, 2-watt carbon resistors, soldered between a pair of 2" copper plates. This assembly should be attached to a coaxial plug, type 83-1SP. (Motorola recommends using a 32-volt, 25-watt, electric lamp as a dummy load. When using such a lamp, output is adjusted for maximum brilliance. The lamp is fed through a 4-mmf ceramic capacitor mounted within the coaxial plug, which replaces the base.)

For tuneup of low-level stages, use a 50- μ a meter with shunt resistors, or a multimeter set on the lowest current range. Attach the indicating device by means of a standard phone plug inserted in the meter jack. The shunts are necessary for higher power stages which may indicate greater currents. The transmitter manual, if one can be obtained, should be followed for the tuneup procedure. Merely adjust each stage for maximum grid

current in the stage following. Set the meter switch in position 1, while adjusting the capacitor in the top of T-1U for maximum meter reading. Proceed to position two and vary the two screws in the top of can T-2U, continuing the alignment. Shut down the plate supply between adjustments.

Proceed through the adjustments numbered T-5U and T-6U. Then, through the top of the PA cage, adjust the screw that slides the shorting bar up or down on the final plate tank. Adjust C42 and C63, in the same cage, for maximum output. (These may also be used to balance currents in the output tubes.) Finally, adjust the coupling capacitor in the front of the PA compartment and the loading screw on the front chassis apron for barely maximum transmitter output, as indicated by the output meter (or lamp). The output should be approximately 30 watts when the "Lo-Hi" switch is placed in "Hi" position. Now go back and retouch all adjustments. **Note**—Adjust the small capacitor beside the 7C7 crystal oscillator only when

monitoring the transmitter frequency on an approved meter.

Allow the transmitter to operate into the dummy load for an hour or more to test for possible component breakdown. Carefully watch for plate overheating in any of the 2E26's. If this is apparent, back off on the loading control and retune the final for minimum current. Be careful; the plate current jack is at high voltage! It may be wise to install a small tube-cooling fan directed toward the 2E26's.

Now, using your 150- to 170-mc remote pickup receiver, run a frequency-response proof of the converted transmitter. A slight adjustment of the four capacitors in the audio equalizing network will improve any peaks or nulls in the response. Be sure the receiver has the standard 75-microsecond de-emphasis circuit, rather than one which produces the narrow response necessary for communication purposes. Even a rough adjustment should render a frequency response better than a class-A telephone line, but the unit is entirely capable of ± 2 db from 50 to 20,000 cps. ▲

ANOTHER EXAMPLE OF "TOTAL VALUE" ASSURANCE...

COMPLETE LINE

AUDIO PLUGS

FOR

AUDIO/ELECTRONIC APPLICATIONS

FROM AUTHORIZED

CANNON DISTRIBUTORS

On a moment's notice... Cannon quality and service from the most efficient distributor network in the electronics industry.



Cannon's complete line of audio plugs is readily available to you through local sources. Featuring the most advanced audio/electronic design concepts, these plugs exceed all specifications for reliability and performance in low level circuit applications. CANNON® Audio Plugs are available to you in a wide selection of shell sizes, contact layouts and connector types and meet all requirements for use with: radio, television, microphones, amplifiers, tape recorders, computers, control devices, and other audio and instrumentation applications. For more information on audio plugs, contact the Cannon Authorized Distributor in your area. For Cannon's Distributor Directory, containing complete purchasing information, write to:



Our 50th Year

CANNON ELECTRIC INC.

3208 Humboldt St., Los Angeles 31, California



A SUBSIDIARY OF INTERNATIONAL TELEPHONE & TELEGRAPH CORP.

© "CANNON" IS A TRADEMARK REGISTERED IN U.S. PAT. OFF. AND IN FOREIGN COUNTRIES BY ITT CANNON ELECTRIC INC. © 1964 ITT CANNON ELECTRIC INC.

Circle Item 38 on Tech Data Card

Mike Reel



115 Volt AC single phase motor driven microphone cable reel for raising and lowering multi-microphone installations. Available with 2 to 8 conductor slip rings. Remote operation.

Port-O-Reel



Port-O-Reel, hand wound for use with shielded microphone cable for public address systems, radio stations, etc. Also can be furnished with power cord for lighting.

All sizes and types of reels are available. Write for catalogue 61A

INDUSTRIAL ELECTRIC REELS, INC.

1509 Chicago Street Omaha, Nebraska

Circle Item 39 on Tech Data Card

SPOTMASTER

RS-25



Tape Cartridge Racks

RM-100



... from industry's most comprehensive line of cartridge tape equipment.

Enjoy finger-tip convenience with RM-100 wall-mount wood racks. Store 100 cartridges in minimum space (modular construction permits table-top mounting as well); \$40.00 per rack. SPOTMASTER Lazy Susan revolving cartridge wire rack holds 200 cartridges. Price \$145.50. Extra rack sections available at \$12.90.

Write or wire for complete details.

Spotmaster

BROADCAST ELECTRONICS, INC.
8800 Brookville Road
Silver Spring, Maryland

Circle Item 40 on Tech Data Card

Directional Antenna

(Continued from page 11)

This is determined from the antenna self impedance and mutual impedance of the towers. Since finding these two quantities by means of equations is somewhat of an empirical process, this is usually found from graphs of self and mutual impedance curves.

In the example under consideration having equal tower heights, the following equations are used for determining driving point impedance:

$$Z_1 = Z_{11} + F_2 Z_{21} + F_3 Z_{31}$$

$$= 22.54 + j 32.8$$

$$Z_2 = \frac{Z_{12}}{F_1} + Z_{22} + \frac{F_3}{F_2} Z_{32}$$

$$= 36.17 + j 78.7$$

$$Z_3 = \frac{Z_{13}}{F_1} + \frac{F_2}{F_3} Z_{23} + Z_{33}$$

$$= 8.4 + j 12.16$$

The self impedance is Z_{11} and is equal to Z_{22} and Z_{33} ; also, the mutual impedance equals Z_{12} and Z_{23} , and Z_{13} equals Z_{31} .

Using the tower ratios as currents, the approximate tower current and power can now be found:

$$P = I_1^2 R_1 + I_2^2 R_2 + I_3^2 R_3$$

$$= 34.4 \text{ watts}$$

Since this is a 5,000 watt station, each tower power can be found by multiplying the above tower powers by the ratio of:

$$\frac{5000}{34.4} = 145.1$$

This makes the center tower have a power of 3285 watts; so its current is

$$I = \frac{3285}{22.54} = 12.1 \text{ amps.}$$

Since the end towers have a ratio of .516, this means they will each have a current of 6.25 amperes. Tower No. 2 has a power of 1395 watts, and Tower No. 3 has a power of 320 watts.

In actual practice, the above tower currents and powers would be slightly higher, to allow for losses in the ground system, etc.

Chart 1 — Field strength for each 10°.

Azimuth Angle	mv/m	Azimuth Angle	mv/m
0°	= 10.7	90°	= 257.8
10°	= 8.95	100°	= 361.
14.7°	= 8.2	110°	= 462.
20°	= 8.7	120°	= 552.
30°	= 12.8	130°	= 624.
40°	= 13.7	140°	= 675.
50°	= 8.2	150°	= 709.
60°	= 32.5	160°	= 730.
70°	= 85.9	170°	= 739.
80°	= 162.9	180°	= 742.

Plant Layout

Before considering the aspects of impedance-matching networks between the antennas and transmission lines, the general layout of the transmitter site must be considered. This is due to the fact that the placement of the transmitter building determines the different lengths of transmission lines going to the towers. This, in turn, determines the required phase lead or lag of the impedance-matching networks.

The placement of the transmitter building conveniently works out in this example if placed north of the towers. Therefore, the signal from the transmitter has a longer distance to travel to the south tower, in relation to the center tower, and the signal to the north tower a shorter distance than the center tower. With all three transmission lines the same type and make, the propagation constant will cancel and the phase difference of these lines can be measured directly from their difference in length. With the center tower considered reference or zero degrees, the signal arriving at the south tower will have a -95° lag and the north tower signal a $+95^\circ$ lead, for this installation.

Matching Networks

The purpose of this section is to show how the matching networks, with their phase-shifting properties, are coordinated in the entire plant layout, in order to end up with the desired phases at the antennas. The actual design of these networks is

Table 2 — Phase delays for each leg of system.

Output of Transmission Line	Output of Matching Network			
-95.0	-189.60	=	-108.85	or -107.6 south
0	-80.75	=	0°	or 1.25 center
+95.0	+25.60	=	+106.35	or 107.6 north

dealt with quite adequately in engineering text books and need not be covered here.

The center tower network is designed first, and is found to have a phase delay of -80.75° . With the required south tower phase at -108.85° and the center tower phase now at -80.75° , a phase difference of $(-108.85^\circ) + (-80.75^\circ)$ or -189.60° is now required going into the south tower. A phase delay of $-189.6^\circ - 95.0^\circ = -94.6^\circ$ is required for this line.

For the north tower, a phase is now required of $+106.35^\circ + (-80.75^\circ) = +25.60^\circ$. For this antenna delay of $95.0^\circ - 25.6^\circ = -69.4^\circ$. All this is shown in Table 2.

Phase Shifters

In order to have control in the transmitter building of the tower phases, a phase shifter network is needed in the building. This will go after the power divider unit and will be in the input to the North and South transmission lines. A variable inductance and capacity can be used for this purpose. This series circuit is designed to resonate at the operating frequency, with some adjustment left in the coil at resonance. Therefore, a $+J$ or $-J$ factor with a corresponding phase lead or lag can be introduced into the line. The line can be artificially lengthened or shortened. The transmission line impedance in series with this circuit tends to dampen down the "Q" of such a low loss circuit.

Power Divider

The power divider chosen is shown in Fig. 2. The theory of operation is that $1L3$ in parallel with C and $1L2$ acts as a parallel circuit. The purpose of $1L2$ is merely to control the value of C ; therefore, the C and $1L2$ leg form the capacity part of the parallel circuit.

In the adjustment of this power divider unit, $1L2$ is adjusted to the correct value of resistance as read on a bridge, in order to get the correct power input to this circuit. For a 5-kw station, the correct power is about 5400 watts, to allow for losses in the directional system. The value of $1L1$ is then adjusted to balance out the reactive component and get a pure resistance for the transmitter to work into. ▲

Professional Performance ...at your fingertips

... with VIKING tape components proven in countless broadcast installations year after year.



VIKING 95 or 96 TRANSPORTS
10 1/2" reel capacity. Relay rack mounting. Remote control. Automatic sequence breaking. Hysteresis capstan motor. Two reel drive motors. Photo cell controlled. Elective head configurations. Hyperbolic heads on Model 96 only.



Retro-Matic 220 Professional Tape Recorder. Two directional playback, quarter track stereo at two speeds. "Feather-touch" pushbuttons, remote control, 12 watt amplifier, simultaneous record / playback with 20-25,000 cps frequency response. Independent channel controls, "Luma-Touch" record buttons and illuminated VU meters. Photo electric run-out sensor, hyperbolic heads, hysteresis capstan motor plus two reel drive motors and digital counter. Stainless steel face plate. Operates vertically or horizontally.

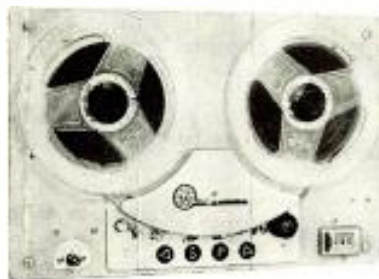

VIKING 230 TRANSPORT SERIES
Electric pushbutton controls. Remote control. Relay rack mounting. Interchangeable, unitized head blocks with various, hyperbolic head configurations.

MATCHING RECORD/PLAY AMPLIFIERS



Stereo SA90.



Monaural RP62 VU.

For Information Write to Customer Service Dept.

IF IT'S USED WITH TAPE IT'S MADE BY VIKING



VIKING OF MINNEAPOLIS, INC.

9600 Aldrich Avenue South, Minneapolis, Minnesota, 55420

Your assurance
of Quality in
Tape Components

Circle Item 41 on Tech Data Card

**"The greatest contribution
we've made
towards upgrading WKFM"**

Frank Kovas

FRANK KOVAS, PRESIDENT
WKFM, CHICAGO

(DEMONSTRATION STATION FOR FM
STEREO AT 1982 NAB CONVENTION)

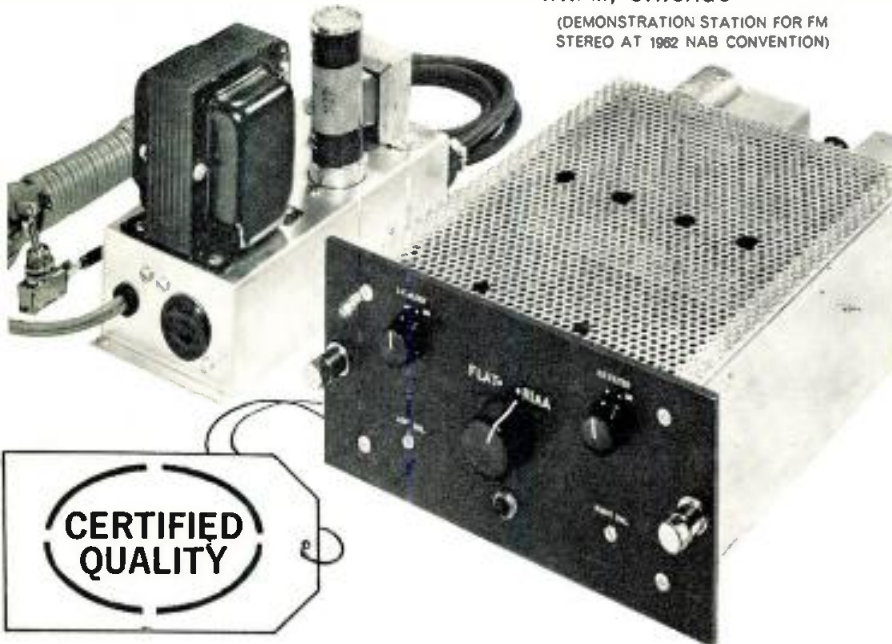

**SHURE
STUDIO
SE-1**

**STEREO
TRANSCRIPTION
PREAMPLIFIER**

Certified quality because every characteristic on every unit is checked to make sure it passes specifications. That's why Mr. Kovas says "It is unfortunate that we (WKFM) wasted so much time in experimenting with hi fi type stereo preamps which looked good on specifications . . .

"I'll have to admit that nothing equals the performance of the Shure SE-1 for stereo multiplexing."

What are the certified specifications? The SE-1 has plenty of gain to feed a 600 ohm line at +4 or +8 dbm from a magnetic stereo phono cartridge and still provide for peak power. (1.2 mv input gives at least +4 dbm output.) Balance is provided with separate gain controls for each channel. *True* RIAA equalization with ± 1 db 30 to 15,000 c.p.s. of RIAA curve. Optional flat position for measurement and calibration in the studio. Separate high and low response trimmers for each channel with NO interaction between channels, or between high and low end. Hum and noise level at least 64 db below output level. Channel separation better than 37 db between 50 and 10,000 c.p.s. Distortion is under 1% at +15 dbm 150 or 600 ohms output impedance. Compact size (7" x 3 3/8" x 11" deep) . . . Convenient slip-in mounting for easy installation. Separate power supply reduces panel space requirements.

Priced at only \$295 net. Write for technical data sheet: Professional Products Division, Shure Brothers, Inc., 222 Hartrey Avenue, Evanston, Illinois.

Circle Item 34 on Tech Data Card

Isolating Pads

(Continued from page 13)

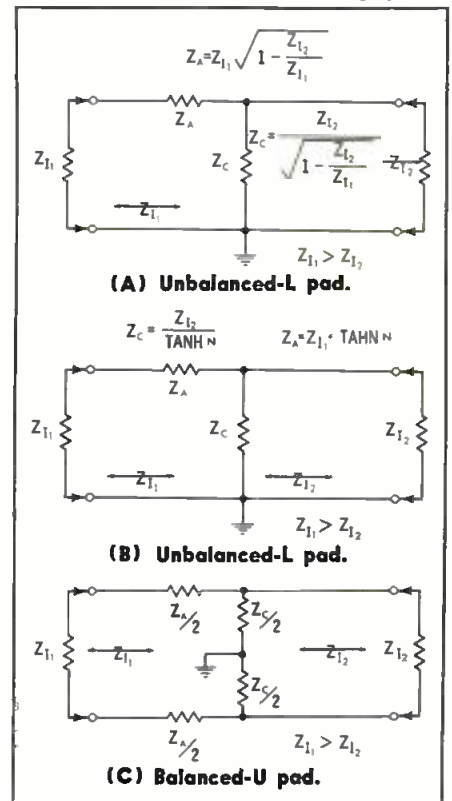

Fig. 7. Minimum-loss resistance networks.

a minimum-loss L pad. In the case of the balanced H version, the result is a minimum-loss U pad. If Zb becomes zero, we have:

$$\text{Minimum Loss (db)} = 20 \log_{10} \sqrt{\frac{Z_{11}}{Z_{12}} + \sqrt{\frac{Z_{11}}{Z_{12}} - 1}}$$

This value is the minimum loss that can be obtained with a resistive network between two different image impedances. Minimum loss pads of the unbalanced-L network type are shown in Figs. 7A and 7B, while the balanced U appears in Fig. 8.

Minimum-loss taper pads find important applications where impedance matching transformers might add hum, noise, distortion, or frequency loss.

Conclusion

In part 1 we have introduced some networks which are popularly used for attenuation and impedance matching in broadcast and recording applications. Part 2 will give the design details of various pads and will discuss impedance stabilizing, or isolating, properties.

While space does not permit the derivation of many equations, we shall apply formulas to specific examples, and use hyperbolic functions to simplify calculations. ▲

ENGINEERS' EXCHANGE

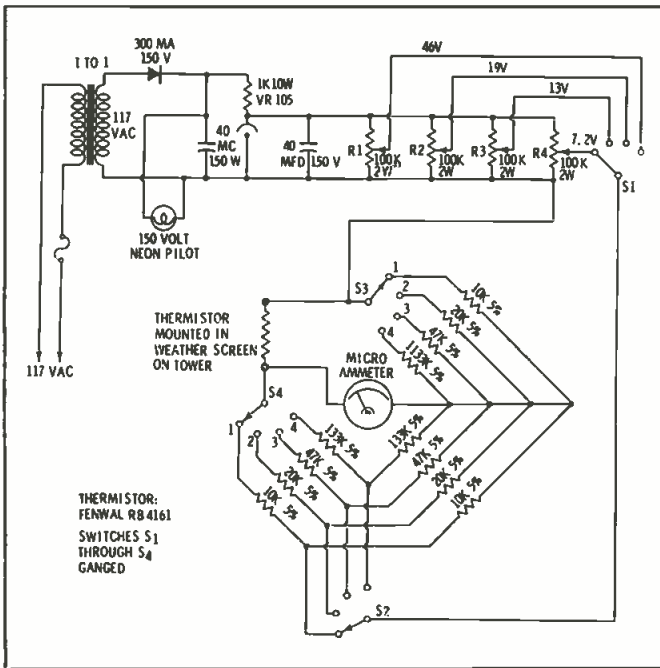

Electronic Temperature Gauge

by Phil Moore, WMER, Celina, Ohio.

This temperature gauge is simple to construct and easily adjusted. It has proved to be quite accurate and reliable.

The RB 41L1 was first coated several times with a commercial product known as Instant Tempo Spray No. 20, manufactured by Tempo Products Co., Cleveland 3, Ohio. It is important only to keep the thermistor dry and out of direct sunlight while at the same time allowing free air flow around it. It should also be protected from bugs and birds. We constructed a small weather screen measuring about one foot in each direction and mounted it on the transmitting tower above surrounding buildings.

The 2-watt controls shown in the power supply are used to adjust the high end of the scale in order to get proper overlapping. The fixed resistors of the bridge determine the low-scale reading. For calibration we simply compared a few gauge readings with readings taken from the local bank's time and temperature gauge. This information was recorded in a chart. It could also be converted to a direct-reading scale under the hand of the meter.

The gauge could be made with one bridge to read the entire temperature range, but we have found that the use of four separate scales to cover the entire range from -20° to 120° is desirable. This arrangement makes the instrument easier to read and calibrate.

Any 0 to 100- μ A meter will do, but a large instrument is preferable, especially when the meter is calibrated directly in degrees. The voltages shown are approximate and will vary slightly with the thermistor used. ▲

G.E. FIRST

ON THE MARKET...

WSM-TV

NASHVILLE, TENN.

FIRST

ON THE AIR...

WITH TV'S FIRST 4-VIDICON COLOR FILM CAMERA SYSTEM

This transistorized 4-V camera overcomes the two greatest problems existing in color film today: registration and monochrome resolution. Some of the other stations who are first in their own markets with the G-E 4-V include: KMSP-TV, Minneapolis; WAST, Albany; WJXT, Jacksonville; WGEM-TV, Quincy, Ill.; WRGB, Schenectady; WRAL-TV, Raleigh; WESH-TV, Daytona Beach; WFIL-TV, Philadelphia; WNBK-TV, Binghamton; WAGA-TV, Atlanta; WWJ-TV, Detroit; WFBG-TV, Altoona; WJW-TV, Cleveland; KTVT, Fort Worth.



PE-24-A/B

For further information, contact your G-E Broadcast Equipment Representative, or General Electric Company, Visual Communication Products, 212 W. Division St., Syracuse, New York 13204.

GENERAL ELECTRIC

Circle Item 42 on Tech Data Card

**CUT HOLES
FAST**



GREENLEE CHASSIS PUNCHES

Make accurate, finished holes in 1½ minutes or less in metal, hard rubber and plastics. No tedious sawing or filing — a few turns of the wrench does the job. All standard sizes . . . round, square, key, or "D" shapes for sockets, switches, meters, etc. At your electronic parts dealer. Literature on request.

GREENLEE TOOL CO. 
2028 Columbia Ave., Rockford, Illinois

Circle Item 43 on Tech Data Card

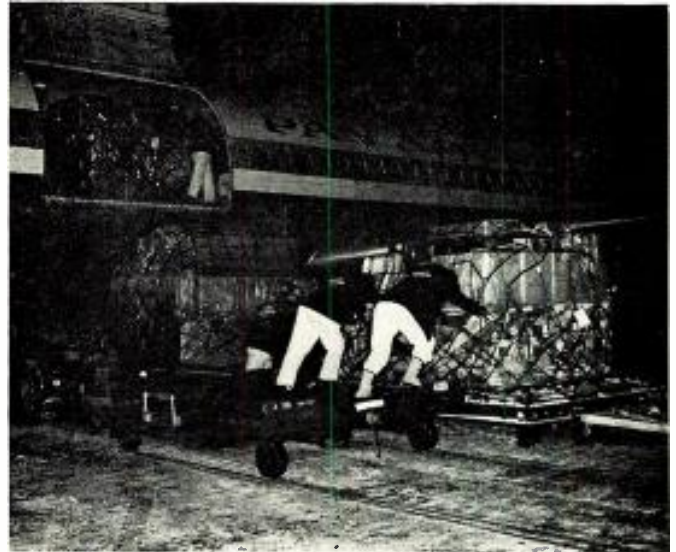

Solarbronze Plate Glass for Spain

Over six tons of Pittsburgh Plate Glass have been shipped to Barcelona, Spain, to be used as TV safety windows in receivers made by Inter-Electronica, S. A. The bronze tinted safety windows, fabricated by the Chicago Dial Co. from PPG's 13/64" Solarbronze tempered plate glass, are used in many European countries.

Radio Station Earns Award

Chicago Radio Station WAIT and Maurice Rosenfield, executive director, were the unanimous choice of the judges in the 1964 National Headliner contest as the best of all the entries for Public Service by a local radio station. WAIT Radio is one of three stations in the nation to receive a 1964 National Headliner award and the only one to receive the public service award. The award was given to WAIT for the outstanding work performed by the station in the Lloyd Miller murder case. As a result of the crusading spirit of Maurice Rosenfield, WAIT's executive director, an impartial hearing was obtained for Miller after a long legal battle.

NAB Objects to FCC Licensing Fee

The National Association of Broadcasters has advised the U.S. Court of Appeals for the Seventh Circuit that it intends to intervene against the FCC order requiring payment of fees for certain broadcast licensing activities. NAB's general counsel Douglas A. Anello said in filing the notice that radio and television stations would be "adversely affected" by the requirement. The FCC order states applications, most of which are filed on a continuing basis, must be accompanied by a fee. Mr. Anello said the reason for intervening in the court case is NAB's conviction that the Commission should have specific authority from Congress before it establishes filing fees. Fees required for a new station, a major change in an existing station, assignment of a license, and for renewals at least every three years, would be \$50 for radio and \$100 for television. All other types of applications would require a \$30 payment.

UHF-TV Tubes to be Made in England

Jack A. McCullough, board chairman of Eitel-McCullough, Inc., announced what he termed the "two most significant" international licensing agreements in the history of the 29-year-old electronic manufacturing firm. McCullough said that the non-exclusive licensing agreements have been granted by Eitel-McCullough, S.A., to two major British electronic firms to manufacture its family of high-performance UHF-TV kly-



About the Cover

The use of microwave equipment for the relay of television and radio programs from location to studio, and from studio to transmitter site, is growing rapidly throughout the world. A typical example of the application is the portable microwave television relay unit shown on this month's cover. The scene is at night in the heart of New York City, where a broadcast engineer adjusts antenna alignment in preparation for covering a news event. The receiver pictured will pick up the signal from a transmitter at the location of the event, and relay the program to the studio.

Cover photo through courtesy of Raytheon Company.

stron tubes in England. These advanced Eimac klystrons are currently being used in new U.S. UHF-TV stations and in older stations to provide increased power output and signal strength. The licenses are English Electric Valve Co., Ltd., and I.T.T.'S British subsidiary, Standard Telephones & Cables, Ltd.

Engineer Appointed

Gates Radio Co., a subsidiary of Harris-Intertype Corp., announces the appointment of Howard Dempsey as broadcast sales engineer covering the territories of Colorado, New Mexico, Utah, Wyoming, and Nebraska. Mr. Dempsey was formerly with the engineering staff of WIRE, Indianapolis, and more recently was chief engineer of KFML in Denver.

The International Scene

India—The Indian Parliament recently awarded a multi-million dollar contract to instigate a program for expanding the country's telephone system. Automatic switching equipment including six local exchanges totaling 48,000 lines and four trunk exchanges will be installed. The second part of the two-part proposal calls for the establishment jointly with the Indian government and the Belgian firm of a factory capable of turning out 100,000 lines a year of automatic switching equipment.

Nigeria—Nigerian External Telecommunications Limited has ordered equipment for a major expansion of Nigeria's international communications. Equipment includes a new transmitting station at Ikorodu and additional equipment and expansion of facilities at the existing radio station at Ikoyi, which will become the new receiving station. The British firm supplying the equipment will be responsible for coordinating the project and training Nigerian technical personnel.

London, U.K.—The BBC 2 has awarded contracts for three more UHF television antennas. The new antennas are for the masts at Rowridge on the Isle of Wight, Pontop Pike in North-East England, and Black Hill in Scotland.

International General Electric (IGE) has been awarded a contract to supply a 250,000-watt HF shortwave broadcast transmitter to the American Committee for Liberation for use by its Radio Liberty network station in Spain. Headed by Howland H. Sargeant, former Assistant Secretary of State for Public Affairs, the American Committee for Liberation provides support on a private basis for the freedom network broadcasting in 18 languages to peoples of the Soviet Union.

Exhibitions and Fairs

London will become the center of the electronics industry in May when 600 firms from all parts of the world show the latest developments and equipment at the largest exhibition of its kind ever to be held. The International Instruments, Electronics and Automation Exhibition will be held at Olympia from May 25 to 30, 1964. It is the fifth of a highly successful series of exhibitions which is attracting an increasing worldwide interest.

Other international trade meetings coming up during the next few months include:

The 6th Swiss Import Fair, Zurich, Switzerland, June 5-14. A wide range of control and automation equipment will be shown. Categories covering measuring, indicating, recording, control systems, and instrumentation—electric, electronic, pneumatic, and hydraulic types.

Tel Aviv International Trade Fair, Tel Aviv, Israel, June 16-July 7. To be shown are electronics instruments and components, testing equipment, computers, scientific and laboratory research equipment, and communications apparatus.

ABC-TV Purchases Film Center

The ABC Television Network and G.E. announced the signing of a contract for the purchase of a contract for the purchase of the first major network universal film center. The Universal film center was given its first air-test in April, 1963, with the ABC-TV telecast of "The Vatican" using four-vidicon film cameras. The system was developed by G.E. with the cooperation of ABC Engineers. The new four-vidicon transistorized film camera channel employs a "coloring book" principle which results in steadier and sharper TV transmission of motion picture film, both for black-and-white and color.

G.E. FIRST

ON THE MARKET...

KERO-TV

BAKERSFIELD, CALIF

FIRST

ON THE AIR...

WITH TV'S ONLY 2nd GENERATION UHF KLYSTRON TRANSMITTER AND UHF ZIG-ZAG ANTENNA

In the early 1950's G.E. pioneered UHF television Klystron Transmitters. Now—14 years later—others are catching up. G.E.'s second generation units are setting new standards for performance, stability, economy and compactness. Today, the transmitter and G.E.'s new high-gain, directional Zig-Zag Panel Antenna enable KERO-TV to increase overall market coverage beyond its previous VHF pattern. Four other stations will be first in their markets with G-E second-generation Klystron Transmitters by June.

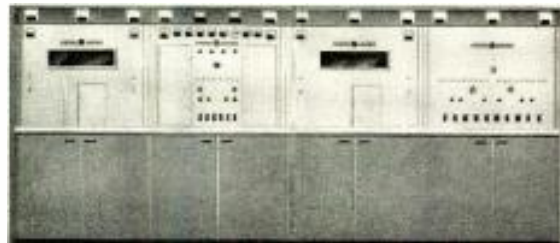

TT-57-A



Zig-Zag Antenna

For further information, contact your G-E Broadcast Equipment Representative, or General Electric Company, Visual Communication Products, 212 W. Division St., Syracuse, New York 13204.

GENERAL  ELECTRIC

Circle Item 44 on Tech Data Card

new

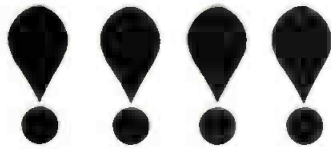

RECORDER REPRODUCER

for two-track stereo or
half-track monaural operation

FOR MULTIPLEX BROADCASTERS

TAPE SPEEDS: 7.5 and 15 inches per second
REEL SIZE: 5-, 7- and 8-inch E.I.A. hubs
HEADS: Selectable 2-channel Erase, 2-channel Record, 2-channel play and 1/4-track play.
DIMENSIONS: 19" wide, 15 3/4" high, 12" deep

A big, important number in the new Magnecord 1000 Series, the Model 1022 has been developed to meet the most exacting requirements for the Multiplex field. Here is performance reliability insured by the name Magnecord — yet at the lowest conceivable price. The 1022 requires no accessories!

ONLY \$739



magnecord 1022

(fully transistorized)

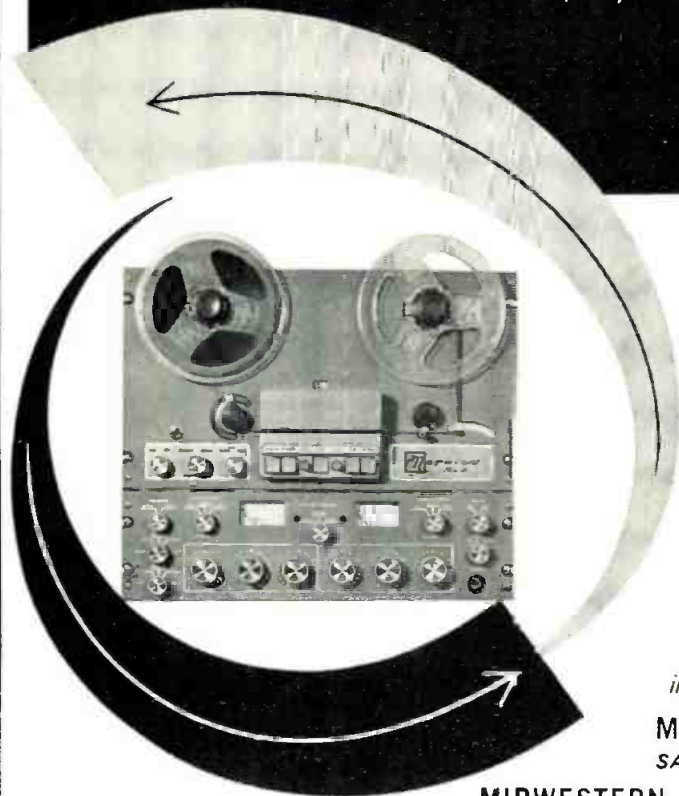

for more
information write:

**MAGNECORD
SALES DEPARTMENT**

MIDWESTERN INSTRUMENTS

P. O. BOX 7509 / TULSA, OKLAHOMA / 74105

Spot Recording Research

In response to requests from advertising agencies and the radio broadcasting industry, Ampex Corp. has undertaken engineering studies of several new approaches to recording and playback of spot announcements, it has been announced by **C. Gus Grant**, vice president of operations. Grant said Ampex had been approached as a result of industry controversy over professional cartridge tape recording systems, and methods of using them. He said the company was looking at several approaches to the spot announcement problem, including cartridge and non-cartridge methods, and hopes to report on its findings by April.

Radio Stations Sold

Metromedia, Inc., has officially acquired radio station **WCBM (AM-FM)** in Baltimore from the **Baltimore Broadcasting Corp.** WCBM first went on the air in 1924 and is the second-oldest radio station in Maryland. The sale has been approved by the FCC.

The assets of radio station **KRIB**, owned by the **Western Broadcasting Co., Inc.**, of Mason City, Iowa, have been sold—subject to approval by the FCC—to **William H. Sandberg** and **D. Bryce Ekberg** of Minneapolis, Minn.

Sarkes Tarzian, Inc., has purchased the stock of Radio Station **WIGO**, Indianapolis, Ind., from **Stokes Gresham** and **Luke Walton**, subject to the approval of the FCC.

The sale of Radio Station **WJIL**, Jacksonville, Ill., has been announced by **Mr. Donald E. Udey** owner of the station. The purchasing group is headed by **Mr. Everett G. Wenrick**, Oskaloosa, Iowa, who has interests in Station **KBOE**, Oskaloosa, and **KTTT**, Columbus, Neb.

WLAC Radio, one of the South's leading 50,000-watt AM stations, plans to enter the field of FM broadcasting through the acquisition of station **WFMB**, Nashville, **WLAC, Inc.**, wholly-owned subsidiary of **Life and Casualty Insurance Co.**, will purchase the 35,000-watt FM facility from **Great Southern Broadcasting Company, Inc.**, subject to FCC approval. **WFMB** is the oldest FM station in Tennessee and the oldest independent FM radio station in the South; it operates on 105.9 mc.

Distribution Set Up

AKG of Vienna, manufacturers of condenser and dynamic microphones, are being represented in this country by **AKG of America**, a division of **North American Philips Company, Inc.** The new division has become the sole authorized distributor of **AKG** products in the United States, according to **Fritz Sippel**, director of international marketing for **AKG**. Repairs and service, as well as a complete inventory of **AKG** products, will be available at the Long Island City service center.

BROADCAST ENGINEERING

NEW PRODUCTS



150-Foot Microwave Test Tower

Near the 8,000-foot Echo Summit, Lake Tahoe, Calif., a special lightweight aluminum tower transported in individual 6-foot folding sections compacted to 6-foot flat packages was delivered by helicopter. Erected in 3 hours to a height of 150 feet, the aluminum tower was used by Pacific Telephone Co. to pinpoint the best possible location for a permanent microwave tower on a transcontinental microwave route. The high-capacity tower supports test antennas mounted on a carriage which rolls up and down special tracks. Called a Stairway Tower, it is manufactured by Up-Right Scaffolds.

Circle Item 57 on Tech Data Card

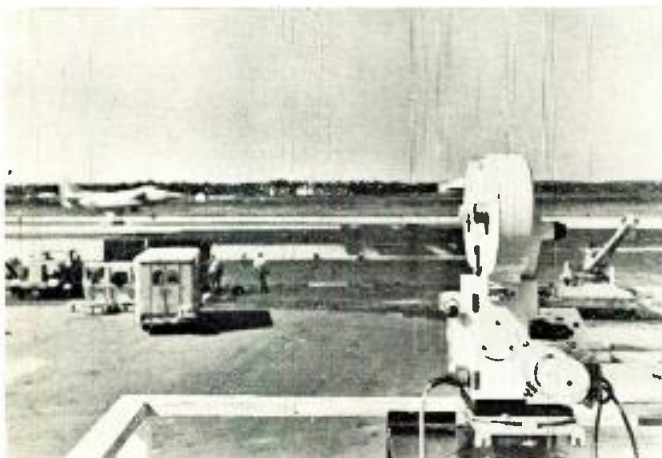

Photographic Recorder

The Cinerama Camera Corp. series HS-35 photographic recorder with PUPPET (Precise Universal Photographic Presentation of Elapsed Time) is shown on a test stand at the Flight Test Division, U. S. Naval Air Station, Patuxent River, Md. The advanced intermittent pin-registered 300-frame-per-second rate camera provides data acquisition to military users. The PUPPET timing system speeds test data reduction by recording elapsed time directly onto film.

Circle Item 58 on Tech Data Card

G.E. FIRST

ON THE MARKET...

ABC-TV

WASHINGTON, D. C.

FIRST

ON THE AIR...

**WITH TV's
FIRST PROFESSIONAL
TRANSISTORIZED STUDIO
VIDICON CAMERA**

First on the air—first in network operation. The PE-23-A/B/C system can do 80% of network or station studio programs—at operating cost as much as 90% less than a comparable image orthicon camera system and 50% less initial cost. Transistorized... eliminates day-to-day drift, reduces set-up time, saves up to 14 cubic feet of rack space.

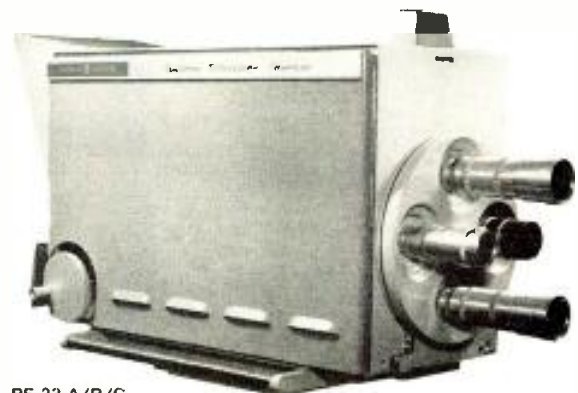

PE-23-A/B/C

For further information, contact your G-E Broadcast Equipment Representative, or General Electric Company, Visual Communication Products, 212 W. Division St., Syracuse, New York 13204.

GENERAL  ELECTRIC

Circle Item 46 on Tech Data Card

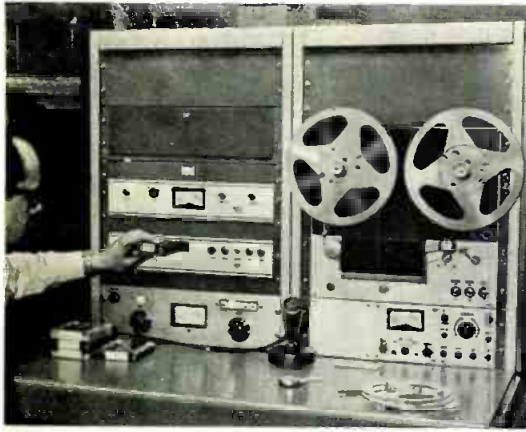

Audio Recording and Editing System

A new custom-designed system for recording, editing, or rerecording audio tape in broadcast studios was developed recently by the RCA Broadcast and Communications Products Div. The first two systems are in use at KSTP, Minneapolis, Minn.; in the photo. John Kalbrenner, assistant product manager for radio, can be seen loading a cartridge into the equipment. The system is capable of accepting program information from a variety of inputs—network, live, disc, or tape—and mixing it into a prerecorded, broadcast-ready show. Independent from the studio control center, the system permits station personnel to prepare or edit tapes without interfering with on-the-air programming. Other uses include sequential recording

of spot announcements for automation systems, and auditioning of records and tapes by nontechnical personnel. The system also may be used as an originating point for broadcasts.

Circle Item 59 on Tech Data Card

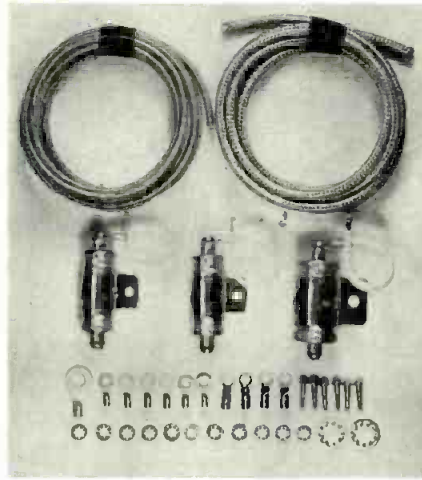

Noise Suppression Kit

Two-way radio noise interference caused by automobile generators or voltage regulators can be controlled with a noise suppression kit from Webster Manufacturing. The Band Spanner 6400-AG1 alternator-regulator/generator suppression kit controls whine associated with worn generator brushes and popping caused by the making and breaking of voltage regulator contacts. Generator whine varies directly with engine rpm.

while voltage regulator interference resembles spark plug noise except that it is not proportional to engine speed. Suggested list price is \$11.50.

Circle Item 60 on Tech Data Card

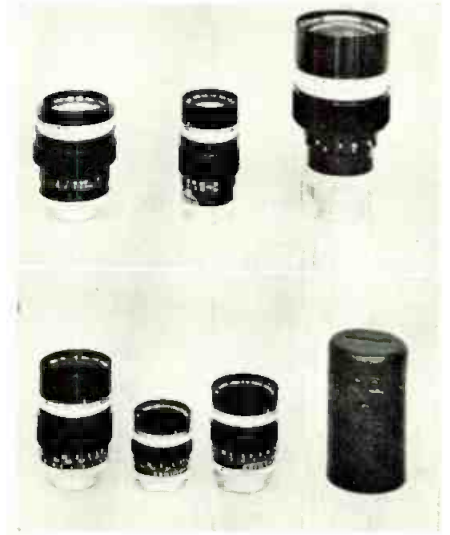

Vidicon Camera Lenses

A series of Canon C-16 lenses have been designed for use on vidicon cameras. This includes the following lenses: 13 mm f 1.5, 25 mm f 1.4, 50 mm f 1.4, 50 mm f 1.8, 75 mm f 3.2, and 100 mm f 2. The lenses are all equipped with click stops and a focusing ring. All lenses are individually packaged in leather cases.

Circle Item 61 on Tech Data Card

FAST DELIVERY for

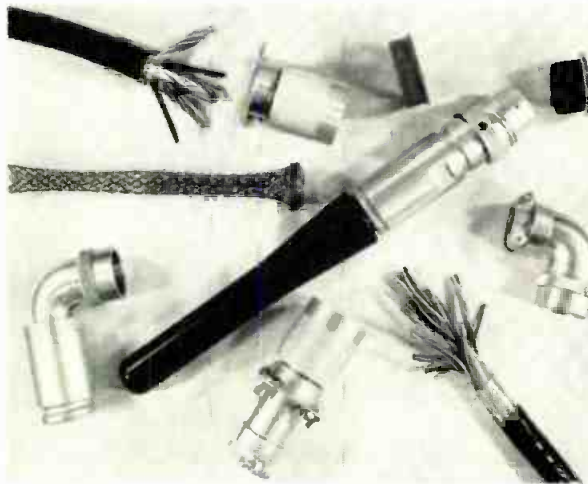

BRITISH and AMERICAN TV CABLES

We offer speedy delivery of cables, connectors and complete cable assemblies for all cameras.

BIW cables are unusually flexible for smooth, easy camera movement, yet are rugged and tough to resist blows and rolling stock damage.

Let us know your requirements. We'll be glad to send complete information and quotations.



"Designers and makers of Specialty Cables since 1905"

BOSTON INSULATED WIRE & CABLE COMPANY

Main Office and Factory
80 Bay St., Boston 25, Mass.
Tel. COlumbia 5-2104

Canadian Factory
Boston Insulated Wire & Cable Co., Ltd.
118 Shaw St., Hamilton, Ontario
Tel. JACKSON 9-7151

Circle Item 47 on Tech Data Card

WOLLENSAK Tape Recorders
 deliver a wallop bigger than many twice the size.
ATTN: SCHOOLS & GOVERNMENT PURCHASING AGENTS. We have the most complete selection anywhere. New models include: 524, 1400, 1440, 1500, 1515-4, 1570, 1780, 1580, 1980, 1981 and 422, & SA-421 speaker/amplifiers. Whether you order 1 or 1000 units, your order receives prompt attention.
REQUEST COMPLETE TAPE RECORDER DISCOUNT SHEET

EICO new Transistor Stereo/Mono 4-track Tape Deck

Model RP 100W
 Completely assembled, wired and tested with 3 heads, and stereo record and stereo playback preamplifiers.
 Model RP 100K
 Semi-Kit includes transistor completely assembled and tested with 3 heads; and control electronics, stereo record, and stereo playback pre-amplifiers in easy-to-assemble kit form.

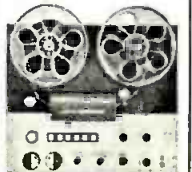

We now have the EICO 2100 series, 3 motor decks in both factory and kit form. Write SAXITONE for low quotes on EICO decks.

TAPE STORAGE OR CARRYING CASE

reg. 9.95, now 5.95
 Heavy wood construction, waterproof vinyl covering. Holds up to 24 tapes.)
 reg. 2.75, now 1.79
 (Pressed cardboard, holds 10 tapes or 60 45 rpm records.)



SAXITONE RECORDING TAPE

275' Plastic, 3" reel	.35
600' acetate (plastic), 5 inch	.70
600' MYLAR 5 inch reel	.75
900' MYLAR (Polyester), 5 inch	.89
1200' MYLAR, 1/2 mil, 5 inch reel	1.18
1200' acetate (plastic), 7 inch	.99
1200' MYLAR, 1 1/2 mil, (strong)	.98
1800' acetate (plastic) 7 inch	1.19
1800' MYLAR 1 mil, thick, 7 inch	1.59
2400' MYLAR, tensilized, 7 inch	2.25
2400' MYLAR, tensilized, 7 inch	2.79
3600' MYLAR, tensilized, 7 inch	3.89
Revere M-2 blank cartridge tapes	3.33
30% off Revere automatic music tapes	

PLUS Postage (greater discounts to quantity buyers.)



SAVE 30-60%
 4-track stereo music on tape
 FREE 50-PAGE CATALOG



1776 Columbia Road, N. W., Washington 9, D. C.

Circle Item 48 on Tech Data Card



Aerovox Heavy Duty Degausser

The Aerovox type 710 degausser is designed for clean, noise-free erasures of magnetic tape without rewinding. The professional heavy duty instrument improves quality of new tapes and erases tapes up to 1-inch wide. It handles up to 7 and 10-inch spools. Made of heavy gauge steel construction, it comes complete with rubber feet, screw-in fuse, and 6 feet of rubber-covered line cord. \$49.95.

Circle Item 62 on Tech Data Card

Portable Video Recorder

A transistorized studio-type television camera with 8" view finder and a portable video tape recorder, said to operate as easily as a home sound tape machine, were displayed by Dage Television Co. at the recent Western Radio and TV Conference in San Francisco. The 420 camera series is designed primarily for use in educational television, but with its 700-line resolution, is capable of handling studio, field, tape, and kinescope applications for both broadcast and closed circuit work. The new video tape recorder has a provision for viewing the tape as it is being rewound. This editing advantage is said to be extremely useful at high speeds. The DV-200 permits slow motion and multi-speed motion in forward and reverse directions. According to Dage, its stop frame action offers many potential benefits such as the review of split second decisions in sports events, detailed examination of x-ray and fluoroscope pictures without danger of exposure and the pinpointing of possible defects in recorded programs. The recorder may be stopped for periods in excess of one hour, the company says. The recorder uses 1" tape and has a recording time of 63 minutes on a 7" reel. The completely transistorized recorder is \$12,450 with built-in picture monitor.

Circle Item 63 on Tech Data Card

TIGHT BUDGET? RENT CAMERA LENSES

Now! If you are working on a tight budget, but want to make a tremendous showing at a small outlay . . . your T.V. station can RENT the World's finest Lenses from B & J. Extensive selection! Off-the-Shelf Delivery! Pioneers in T.V. Optics—since 1936!

FREE! Lens List and Equipment Catalog!

Write BURKE & JAMES, INC.
321 So. Wabash Ave. Chicago 4, Ill.

Circle Item 55 on Tech Data Card

G.E. FIRST

ON THE MARKET...

WGR-TV

BUFFALO, N.Y.

FIRST

ON THE AIR...

WITH G-E 2nd GENERATION TRANSISTORIZED AUDIO EQUIPMENT

In 1958, G.E. was the first to introduce transistorized Studio Audio Equipment, now used by hundreds of stations. Today, the BC-31-B Stereo Console, part of the second generation of G.E.'s complete transistorized line, offers broadcasters the widest range of inputs, controls and functions available today—for either stereo or monaural, single or dual channel, in AM, FM, TV studios or master control audio systems.



BC-31-B

For further information, contact your G-E Broadcast Equipment Representative, or General Electric Company, Visual Communication Products, 212 W. Division St., Syracuse, New York 13204.

GENERAL  ELECTRIC

Circle Item 49 on Tech Data Card

Get a top job in broadcasting . . .

A First Class FCC License

...or Your Money Back!



Your key to future success in electronics is a First-Class FCC License. It will permit you to operate and maintain transmitting equipment used in aviation, broadcasting, marine, microwave, mobile communications, or Citizens-Band. Cleveland Institute home study is the ideal way to get your FCC License. Here's why:

Our training programs will *quickly* prepare you for a First-Class Commercial Radio Telephone License with a Radar Endorsement. Should you fail to pass the FCC examination after completing your course, you will get a *full refund* of all tuition payments. You get an FCC License . . . or your money back!

You owe it to yourself, your family, your future to get the complete details on our "proven effective" Cleveland Institute home study. Just send the coupon below TODAY. There's no obligation.

MAIL COUPON TODAY FOR FREE CATALOG

Cleveland Institute of Electronics

1776 E. 17th St., Dept. BE-15
Cleveland 14, Ohio

Please send FREE Career Information prepared to help me get ahead in Electronics, without further obligation.

CHECK AREA OF MOST INTEREST -

- | | |
|-------------------------------------------------|----------------------------------------------------|
| <input type="checkbox"/> Electronics Technology | <input type="checkbox"/> First-Class FCC License |
| <input type="checkbox"/> Industrial Electronics | <input type="checkbox"/> Electronic Communications |
| <input type="checkbox"/> Broadcast Engineering | <input type="checkbox"/> _____ other _____ |

Your present occupation _____

Name _____ Age _____
(please print)

Address _____

City _____ Zone _____ State _____

Accredited Member National Home Study Council

How to Succeed in Electronics



ENGINEERS' TECH DATA SECTION

AUDIO & RECORDING EQUIPMENT

64. AKG—Product sheets list prices and specifications of condenser and dynamic microphones.
65. ALTEC—Brochures cover playback and speech-input equipment for recording and broadcast studios.
66. ATLAS—Catalog contains specs for line of PA speakers and microphone stands.
67. BROADCAST ELECTRONICS—Packet has specs and price information on cartridge tape equipment.
68. CINE SONIC SOUND—Data sheet describes background music rental service which supplies 7", 10", and 14" reels for all playback machines.
69. FERRODYNAMICS—Brochure shows 3" and 3¼" tape reels containing 150 to 600 feet of tape for portable and miniature recorders.
70. GIBBS—Folders describe reverberations units for audio systems and mobile use.
71. 3M—Sample cards have specs and swatches of audio and video tape.
72. QUAM-NICHOLS—General catalog lists speakers for general replacement, high fidelity, background music, and mobile use.
73. RCA VICTOR—Bulletin lists physical and magnetic properties of magnetic recording tape.
74. SCULLY—Brochure describes professional solid-state tape recorder.

COMPONENTS & MATERIALS

75. ALPHA WIRE—Wire and cable catalog details more than 7,000 items available from stock.
76. AMPEREX—Catalog lists tubes for broadcast transmitting and receiving applications.
77. BRADY—Self-sticking markers for electronics wires, cables, leads, terminals, and connectors are described in brochure.
78. BOSTON INSULATED WIRE—Brochure on TV camera cables for U. S. and British equipment has curve of coax cable length versus attenuation.
79. LAMTEX KOPPERS—Brochure, "Tomorrow's Materials Today" discusses plastics for electronic applications.
80. SPRAUGE—Transistors, transformers, test equipment, resistors, capacitors, and other components are listed in 72-page catalog.
81. SWITCHCRAFT—Lighting stacks and stack switches for company's "Multiswitches" are presented in data bulletin.
82. VERNAY LABORATORIES—Booklet describes components and engineering devices based on elastomeric materials.

MICROWAVE DEVICES

83. MICRO-LINK—Data sheets detail fixed and portable business links, and 2500-mc instructional TV systems.

MOBILE RADIO & COMMUNICATIONS

84. FINNEY—Bulletins describe line of beam antennas for 6, 2, and 1¼ meters.
85. OUTERCOM—FM two-way radio for broadcast news and remote pickup uses is detailed in illustrated brochure.
86. WATERS—Radio communications equipment for commercial service is shown in four-page pamphlet.

POWER DEVICES

87. ONAN—Unusual brochure uses transparent acetate overlays and cutaway illustrations to describe gasoline and diesel electric plants.

- 88. TERADO—Product circular shows portable power pack for operating motion picture cameras away from AC source.
- 89. WORKMAN—Informative brochure describes transistorized power converter for 12-volt input and 117-volt output at 125 watts continuous.

RADIO & CONTROL ROOM EQUIPMENT

- 90. CROWN—An automatic self-reversing tape player for continuous playback with remote control for broadcast automation is shown in bulletin.
- 91. FAIRCHILD—Technical bulletin discusses dynamic reverberation system that employs electronic circuitry for variation of delay time.
- 92. McMARTIN—Pamphlet describes selective programmer for operation of SCA storecast and background music while FM Stereo is transmitted.
- 93. SPARTA—Product sheet covers transistorized stereo audio console for production studio and remote use.
- 94. CLEVELAND INSTITUTE—Booklet outlines courses in electronics including those for broadcast engineering and FCC license.
- 95. H. W. SAMS—Latest booklet covers technical books for all phases of electronics and the related fields.

STUDIO & CAMERA EQUIPMENT

- 96. DAGE—Brochure covers high-resolution television camera system and helical-scan video recorder.
- 97. TV ZOOMAR—Illustrated brochures list lenses for image orthicon cameras.

TELEVISION EQUIPMENT

- 98. DIAMOND—Data sheets provide information and prices on television system test materials and a complete line of CCTV equipment.
- 99. ENTRON—Low-high band extender amplifier for feeding low and high VHF and FM band signals into a transmission line.
- 100. INTERNATIONAL NUCLEAR—Spec sheet describes transistorized clamping video amplifier.
- 101. JERROLD—Case history of closed-circuit TV and communications system for Southern California Edison is detailed in pamphlet.
- 102. REEVES SOUNDCRAFT—Technical spec sheet lists characteristics of video tape.
- 103. TELEMET CO.—In three bulletins, these transistorized units are described—sync lock, color standard, vertical interval signal keyer.

TEST EQUIPMENT & INSTRUMENTS

- 104. SECO—Eight-page tube tester brochure gives details of three compact models.
- 105. TEKTRONIX—Illustrated 36-page booklet covers family of accessories for oscilloscopes.

TRANSMITTER & ANTENNA DEVICES

- 106. ALL PRODUCTS—Technical data summary details VHF corner reflector antenna.
- 107. BARNSTEAD STILL & STERILIZER CO.—Bulletin is devoted to compact cooling water repurification loops for transmitting tubes.
- 108. CCA—Catalog sheets cover 1, 5, and 10 kw AM transmitters; 1 and 5 kw FM transmitters.
- 109. DYNAIR—Bulletins describe 500- and 5000-watt VHF broadcast television transmitters.
- 110. RUST—Data sheet covers 1-kw FM transmitter which occupies a single 24" x 28" cabinet.
- 111. STANDARD ELECTRONICS—Illustrated catalog showing line of radio and television transmitters includes those for commercial broadcast, military, and industrial applications.

May, 1964

G.E. FIRST

ON THE MARKET...

WCTV

TALLAHASSEE, FLA.

FIRST

ON THE AIR...

WITH TV'S FIRST TRANSISTORIZED STUDIO VIDEO EQUIPMENT

In 1958, G.E. introduced television's first transistorized Studio Video Equipment, the Sync Generator, a unit which was 50% smaller and used less than one-half the power of previous models. To provide greater performance, economy and reliability, G. E. has continued to pioneer the design, development and improvement of transistorized broadcast equipment such as cameras, video distribution amplifiers, processing amplifiers, and power supplies.

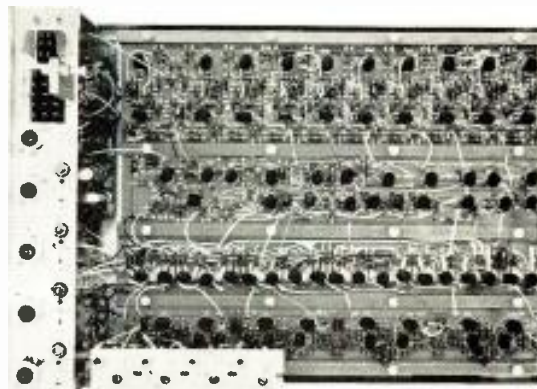

PG-5-B Second Generation Sync Generator

For further information, contact your G-E Broadcast Equipment Representative, or General Electric Company, Visual Communication Products, 212 W. Division St., Syracuse, New York 13204.

GENERAL  ELECTRIC

Circle Item 50 on Tech Data Card

Professional Services

VIR JAMES
CONSULTING RADIO ENGINEERS
Applications and Field Engineering
345 Colorado Blvd.
Phone: (Area Code 303) 333-5562
DENVER, COLORADO 80206
Member AFCE

JOHN H. BATTISON & ASSOCIATES
CONSULTING RADIO ENGINEERS
TV-AM-FM & Microwave Applications and
Installations
Specializing in all forms of communications
engineering.
422 Washington Bldg. Washington 5, D. C.
Phone ST 3-3484
Established 1954

RUSSCO SUPPLIERS of
QUALITY
OR
PROFESSIONAL TURNTABLES



- Quality
- Continuous Performance
- Simplicity

Priced from \$115.00 to \$235.00

REK-O-CUT pick-up arms



12 inch \$34.95
18 inch \$36.95



Model 607

CONCERTONE tape recorders

Full track -or Stereo
Width 19" for rack mounting -also portable
Professional broadcast quality

Send for prices and literature.

STANDFORD-OMEGA
Condenser Microphones

\$130.00 to \$150.00



Viking Tape Recorders Superex Headphones
Kwikheat Soldering irons

Send for literature.

FAST FAST FAST Service

Shipped by Motor Freight, Air Freight or Parcel Post

RUSSCO Electronics Mfg.

6879 No. Sunnyside Clovis, California
Ph. 299-4692 Area code 209

Circle Item 51 on Tech Data Card

Classified

Advertising rates in the Classified Section are ten cents per word. Minimum charge is \$2.00. Blind box number is 50 cents extra. Check or money order must be enclosed with ad.

The classified columns are not open to the advertising of any broadcast equipment or supplies regularly produced by manufacturers unless the equipment is used and no longer owned by the manufacturer. Display advertising must be purchased in such cases.

EQUIPMENT FOR SALE

COMMERCIAL CRYSTALS and new or replacement crystals for RCA, Gates, W. E. Bliley and J-K holders; regrinding, repair, etc. BC-604 crystals; also service on AM monitors and H-P 335B FM monitors. Nationwide unsolicited testimonials praise our products and fast service. Eidson Electronic Company, Box 96, Temple, Texas. 5-64 1f

Leeds Northrup Galvanometer shunt. New. Leeds Northrup Pointer Galvanometer. NEW. Daven Resistance Decade Box. Four dials. Slide wire 0-1.3 ohms. In case. National NPW-0 dial. New. F. D. Fallain, 224 E. Court St., Flint Mich. 48503 4-64 1t

Will buy or trade used tape and disc recording equipment—Ampex, Concertone, Magnecord, Presto, etc. Audio equipment for sale. Boynton Studio, 295 Main St., Tuckahoe, N. Y. 1-64 1f

Ampex Head Assemblies for 300 and 400 series recorders reconditioned. Service includes lapping and polishing all three head stacks, cleaning entire assembly, readjusting and replacement of guides and realignment of stacks as to azimuth and zenith. Full track assemblies—\$60.00. Taber Manufacturing & Engineering Co., 2619 Lincoln Ave., Alameda, California. 5-64 1f

Trim 504 Audio Patch Cords \$4.00—Audio Jack Panels for 19" racks, 12 pair \$9.95—10 pair \$8.95. Repeat coils 500-500 ohm flat to 20 kc, \$4.00—relay racks and equipment cabinets—write for list. Gulf Electro Sales, Inc., 7031 Burkett, Houston, Texas. 4-64 3t

Two Motorola mobile remote pick-up units for 12 volts; one base unit for 115 V-AC. Rebuilt by Communications Service Inc. of Dallas. Broadcast quality frequency response. Make offer or inquire by mail. KOLS, Pryor, Okla. 4-64 2t

GOVERNMENT SURPLUS, NEW 10 CM WEATHER RADAR SYSTEM—Raytheon, 275 KW peak output S band. Rotating yoke P.P.I. Weather Band 4, 20 and 80 mi. range. Price \$975 complete. Has picked up clouds at 50 mi. Wt. 488 lbs. Radio Research Inst. Co., 550 5th Ave., New York, New York. 5-64 1f

Audio Equipment bought, sold, traded. Ampex, Fairchild, Crown, McIntosh, Viking. F. T. C. Brewer Company, 2400 West Mayes St., Pensacola, Fla. 3-64 1f

Ampex Videotape Recorder, Type 1000C, only run 195 hours, in first class condition. Monitor bridge, monochrome, two spare videohead assemblies, splicer kit, 4 RCA TK11 camera chains less cameras. 12" and 17" monitors, sync generators, distribution amplifiers. 2 motor pedestals, 3 color cradle heads. Full list on request. RAM Productions, Cedar Point, Mackinac Island, Mich. 49757. 5-64 1t

TRANSMITTING TUBE SALE—All tubes are new with a 1,000 hour Pro Rata Warranty. 3X2500A3—\$125, 4-400A—\$36, 4-1000A—\$85, 4X150A—\$14, 892R—\$275. Write for complete price list **THOR ELECTRONICS CORP.**, 287 Morris Ave., Elizabeth, N. J. 07207. 5-64 2t

Television and Video Tape Recording Studio (3 years old only only 15 months of use), must dispose of all equipment as soon as possible, including RCA Tk31A orthicon cameras, 3 Ampex recorders, zoom and fixed lenses, 77 DX microphones plus many other types, tape and film editing equipment, racks of terminal and test equipment, etc. Will send equipment list—contact Al Ajar, Video Projects Company 163 Atlantic Avenue, Brooklyn 1, N.Y., Tele. UL 2-4864. 5-64 1f

GOVERNMENT SURPLUS. New 6 foot diameter aluminum parabolic reflectors solid surface. \$175.00 ea. Radio Research Inst. Co., 550 5th Ave., New York 36, N. Y. 3-64 1f

PERSONNEL

Chief Engr. AM-Directional audio proofs and installation looking for more experience now in AM-FM and/or TV. Good electronics background and voice. Phone 813-639-3862. Wayne Davis, 128 Central, Charlotte Harbor, Fla. 5-64 1t

REMOTE THERMOMETER (Electronic)

Outside temperature from mike position. Installed in less than 1 hour. Ask about our other weather equipment. Send for Brochure. P. O. Box 6111. 1246 Shafter St., San Diego 6, Calif. 2-64 1t

- **SYNCHRONOUS MAGNETIC FILM RECORDER/REPRODUCER**
- **MAGNETIC TAPE RECORDERS**
- **NEW—THE portable MINTAPE** synchronous 13 lb., battery operated magnetic tape recorder for field recording.

THE STANCIL-HOFFMAN CORP.
921 N. Highland, Hollywood 38, Calif.
Dept. B HO 4-7461

Advertisers' Index

Acme Films Labs.....	38
Air Space Devices	4
Altec Lansing Corp.	34
Audio Control Div.	50
Ampex Corp.	19, 21, 23
Automatic Tape Control, Inc.	6
Bauer	53
Belden Mfg. Co.	47
Boston Insulated Wire & Cable Co.	64
Broadcast Electronics	48, 52, 56
Burke & James	65
CCA Electronics Corp.....	24
Cleveland Institute of Electronics... ..	66
Continental Electronics	25
Eastman Kodak Co.....	3
Electro-Voice, Inc.	35
Gates Radio Co.	52
General Electric Co....	59, 61, 63, 65, 67
Greenlee Tools	60
ITA	Cover 2
ITT-Cannon	55
Industrial Electronic Reels, Inc.	56
International Nuclear Corp.....	51
Magnecord Div., Midwestern Instruments	62
McMartin Industries	Cover 3
Minnesota Mining & Mfg. Co.....	8, 9
Moseley Associates	36
Moviola Mfg. Co.	50
RCA Broadcast and Television Equipment	Cover 4
RCA Victor Record Div.....	29
Reeves Industries	31
Russco Electronics Mfg.	68
Rust Corp. of America.....	46
Sarkes Tarzian, Inc.	7
Saxitone Tape Sales.....	64
Scully Recording Instruments Corp.. ..	26
Shure Brothers	58
Sparta Electronics Corp.....	49
Switchcraft, Inc.	32
TV Factbook	33
Tektronix, Inc.	43
Telemet Corp.	37
Television Zoomar Co.....	42
Texas Crystals	36
University Loudspeakers, Inc.	45
Viking of Minneapolis, Inc.....	57
Visual Electronics Corp.....	22
Westinghouse Electric Corp.....	5

McMartin

No other FM MONITORS can do so much!



McMartin TBM-4000

**FM/SCA MULTIPLEX MONITOR
FCC TYPE APPROVED #3-116**

This is the most versatile instrument available for monitoring all main channel modulation and SCA Multiplex operating characteristics. Compatible with FM stereo.

Direct meter readings of:

- Total Modulation
- SCA Modulation
- SCA Frequencies
- Crosstalk
- SCA Injection



McMartin
TBM-3000

**FREQUENCY & MODULATION MONITORS
FCC TYPE APPROVED #3-113, #3-119**

- The TBM-3000 is a completely self-contained frequency monitor and the TBM-3500 is a self-contained modulation monitor.
- The 3000 used in conjunction with either the 3500 or 4000 fulfills the FCC requirement for a station monitor.
- The TBM-3500 is completely compatible with FM stereo.

McMartin
TBM-3500



McMartin TBM-2500

**RF AMPLIFIER FOR
REMOTE MONITOR OPERATION**

The TBM-2500 will drive any combination of two monitors including other brands.

- Isolated high and low level outputs.
- Excellent stability and long tube life.
- 2 watt output with 1000 μ v input.
- Complete with yagi antenna and coaxial cable.

McMartin

Originality by

McMartin Industries, Inc.

605 North 13th Street

Omaha, Nebraska

Code 402 — 342-2753

In Canada Sold By: Canadian Marconi Company, Montreal 16, P. Q.

Check Item 52 on Tech Data Card

Created by the hand of experience

RCA-4415 AND 4416 IMAGE ORTHICONS

Living color with only black-and-white studio lighting

With this 3-tube set in the TV camera, the studio lighting you now use for B&W pickup is all you need to transmit superior color pictures. At the same time, you air high resolution pictures having normal tone rendition for B&W receivers. You avoid many of the lighting costs normally associated with high-quality studio color pickup...as well as the high scene-lighting temperatures and need for extra air-conditioning.

Precision construction, field mesh, and closely matched tube characteristics assure excellent registration and color uniformity over the entire scanned area.

RCA ELECTRONIC COMPONENTS AND DEVICES, HARRISON, N.J.



The Most Trusted Name in Electronics

High signal-to-noise ratio and signal output, and excellent life expectancy are additional features of the RCA-4415 and -4416.

This factory-matched set consists of two RCA-4415's and one RCA-4416 with a high blue sensitivity which increases over-all camera sensitivity by as much as a factor of two. For quick identification, each image orthicon is marked for its particular color channel.

Write or call your local distributor of RCA broadcast tubes for information on these orthicons that enable you to air living color with only B&W studio lighting.

AVAILABLE THROUGH YOUR LOCAL RCA BROADCAST TUBE DISTRIBUTOR

FOR NAME AND ADDRESS OF YOUR LOCAL DISTRIBUTOR WRITE OR CALL YOUR NEAREST RCA DISTRIBUTOR PRODUCTS SALES OFFICE—NEW YORK, NEW YORK: 36 W. 49th St., [212] MU 9-7200; NEEDHAM HEIGHTS 94, MASSACHUSETTS: 80 "A" St., [617] HL 4-8450; WASHINGTON 6, D. C.: 1725 "K" St., N.W., [202] FE 7-3500; ATLANTA, GA.: 134 Peachtree St., N.W., [404] JA 4-7703; CLEVELAND, OHIO: 1621 Euclid Ave., [216] CH 1-3450; CHICAGO, ILL.: Merchandise Mart, [312] 467-5903; DALLAS 7, TEXAS: 7901 Carpenter Freeway, [214] ME 1-3050; KANSAS CITY 14, MO.: 7711 State Line, [816] EM 1-6462; HOLLYWOOD, CALIFORNIA: 6363 Sunset Boulevard, [213] 461-9171; SAN FRANCISCO 2, CALIFORNIA: 420 Taylor St., [415] PR 5-5135-6-7.