



**SPECIAL NAB CONVENTION ISSUE**

Extensive coverage of the 41st annual NAB Convention and Engineering Conference, including previews of products, show news, exhibitors floor plans, and Conference agenda.

- Interpreting FCC Interference Rules 13  
A New System for Automatic Program Logging 20  
High Power UHF Television 28  
... plus, IEEE Show News and Product Previews 48

# Broadcast Engineering

*the technical journal of the broadcast-communications industry*



# 30-30

30 cycles

30 minutes

# at 105

105% modulation

**WILL YOUR 1KW AM TRANSMITTER MEET THIS TEST ?**

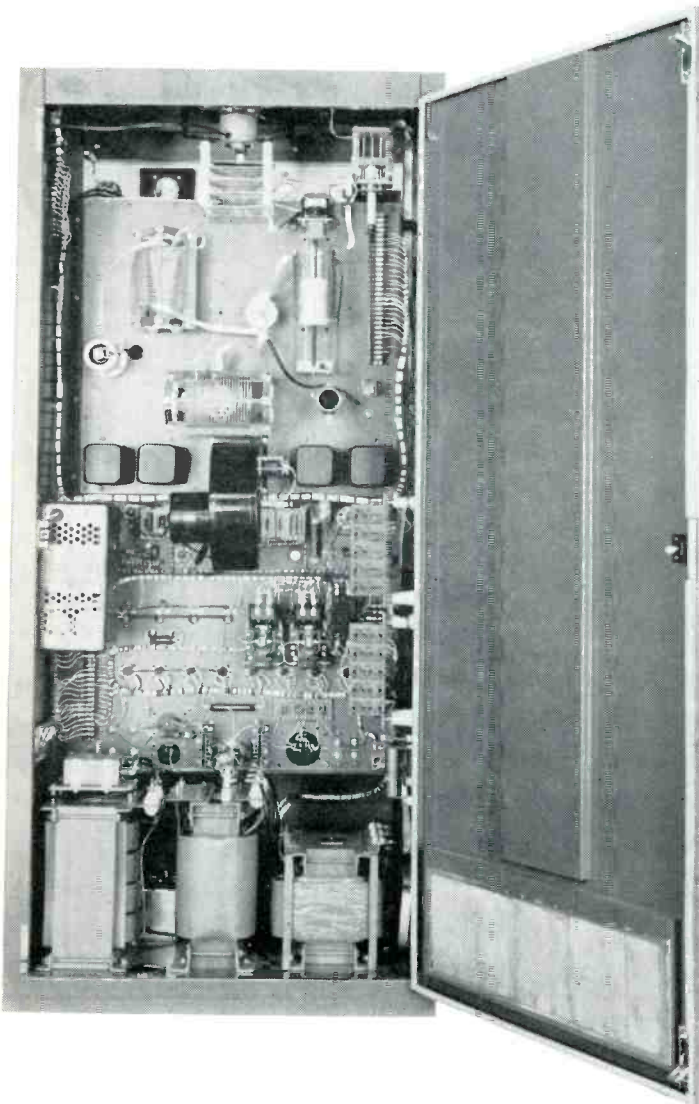

It will if it's the **ITA AM-1000-A**... the only 1 kw AM with all these features

- Sola Regulation
- Built-in Dummy Load
- Vacuum Capacitor Tuning
- Extra Heavy Duty Modulation Components
- Silicon Power Supplies
- Built-in Transfer Switch for Dummy Load
- Automatic Recycling
- Extra Large Blower
- Motor Driven RF Output Control

Circle Item 1 on Tech Data Card

No other transmitter compares with this ITA unit for long-life and dependable operation at lowest cost. With regulated filament and low voltage power supplies the AM-1000-A features single control operation and requires only three tube types for easy maintenance. It's your best buy in 1 kw AM transmitters! For complete information contact ITA today.

**ITA ELECTRONICS CORPORATION**  
BROADCAST DIVISION • LANSDOWNE, PENNSYLVANIA



# Do you want a \$10 test instrument for adjusting all audio equipment—and ballistic calibration of VU meters?



## Try BTR 150!\*

\*A new record especially for AM, FM, MX broadcasting; frequency response checks; ballistic calibration of VU meters; AGC-limiter adjustments, phasing tests, and many other tests never before available.

**CBS LABORATORIES**  
High Ridge Road, Stamford, Connecticut  
A Division of Columbia Broadcasting System, Inc.

Please send me \_\_\_\_\_ copies of BTR 150 @ \$10.00 each. My remittance is enclosed.

NAME: \_\_\_\_\_  
TITLE: \_\_\_\_\_  
STATION: \_\_\_\_\_ ADDRESS: \_\_\_\_\_  
CITY: \_\_\_\_\_ ZONE: \_\_\_\_\_ STATE: \_\_\_\_\_

If you're going to be at NAB, Chicago, March 31-April 3, bring this ad to Booth 72W, and get your BTR 150 at half-price.

Circle Item 2 on Tech Data Card

March, 1963



# Broadcast Engineering

Volume 5, No. 3

March, 1963

## CONTENTS

### FEATURES

<b>The Practical Application of FCC Engineering Rules</b> . . . . .	<b>13</b>
by John H. Battison — Part 2. More on filling out Form 301, Section V-A.	
<b>A Transistorized Television Monitor</b> . . . . .	<b>16</b>
by Peter Vogelgesange — A technical description of solid-state video monitor design.	
<b>Mechanical Aspects of Antenna Towers</b> . . . . .	<b>18</b>
Technical Talks — Nonelectronic factors concerning antenna structures.	
<b>A New System for Automatic Program Logging</b> . . . . .	<b>20</b>
by Joseph A. Risse — This equipment automatically records programming on discs to eliminate hand-writing logs.	
<b>Interpreting FCC Interference Rules</b> . . . . .	<b>24</b>
by Dean George Hill — This discussion promotes understanding of the regulations which set limits on tolerable interference.	
<b>High-Powered UHF Television</b> . . . . .	<b>28</b>
by Donald Quaranta — Here's how one UHF television station employs high-power tubes and techniques.	
<b>A Profile of the NAB Engineering Department</b> . . . . .	<b>32</b>
by George W. Bartlett — What this technical division of the NAB does, including services and cooperating functions.	
<b>SPECIAL NAB SHOW SECTION</b> . . . . .	<b>35</b>
A Welcome From the President . . . . .	35
A Message from the FCC Chairman . . . . .	36
Looking at the Future . . . . .	37
Floor Plans For Exhibiting Booths, and Participating Manufacturers List . . . . .	38
NAB Convention News . . . . .	40
NAB Conference Agenda . . . . .	40
Product Previews . . . . .	41
<b>IEEE SHOW SECTION</b> . . . . .	<b>48</b>
Technical Sessions Schedule . . . . .	48
Product Highlights . . . . .	50

### DEPARTMENTS

Letters to the Editor . . . . .	6	Engineers' Tech	
Engineer's Exchange . . . . .	44	Data Section . . . . .	72
News of the Industry . . . . .	56	Advertisers' Index . . . . .	74
About the Cover . . . . .	60	Classified Ads . . . . .	74
New Products . . . . .	66	Professional Services . . . . .	74

**PUBLISHER:** Howard W. Sams  
**EDITORIAL:** Executive Editor, Verne M. Ray; Editor, Forest H. Belt; Managing Editor, Stuart N. Soll; Consulting Editor, John H. Battison.  
**CIRCULATION:** Manager, Pat Tidd; Assistants, Katherine Krise, LaVon Willard.  
**PRODUCTION:** Manager, Robert N. Rippey.  
**ADVERTISING:** Sales Manager, John W. Groce; EAST: Charles Horner, Howard W. Sams & Co., Inc., 3 West 57th Street, New York, N. Y., Phone—MU 8-6350; MIDWEST—Hugh Wallace, Howard W. Sams & Co., Inc., 4300 West 62nd Street, Indianapolis 6, Ind., Phone AX 1-3100; SOUTHWEST—C. H. Stockwell Co., 4916 West 64th Street, Mission, Kansas, Phone—RA 2-4417; LOS ANGELES 57. CALIF., Maurice A. Kimball Co., Inc., 2550 Beverly Blvd., Phone—DU-8-6178; SAN FRANCISCO, Maurice A. Kimball Co., Inc., 580 Market Street, Phone—EX 2-3365; PARIS 5, FRANCE, John Ashcraft, 9 Rue Lagrange, Phone—ODEON 20-87; LONDON W.C. 2, ENGLAND, John Ashcraft, 12 Bear Street, Leicester Square, Phone—WHITEHALL 0525; TOKYO, JAPAN, International Media Representatives, Ltd., Kisha Kurabu 14, 2-chome Marunouchi, Phone—(502) 0656.  
**SUBSCRIPTION PRICE:** U.S. \$6.00, one year; \$10.00, two years; \$13.00, three years. Outside U.S.A. add \$1.00 per year for postage. Single copies, 75 cents.  
**BROADCAST ENGINEERING** is published monthly by Technical Publications, Inc., an affiliate of Howard W. Sams & Company, Inc. Editorial, Circulation, and Advertising headquarters: 4300 West 62nd Street, Indianapolis 6, Ind. Copyright (c) 1963 by Howard W. Sams & Co., Inc.

## TELEQUIP

*is proud  
to  
announce  
its  
appointment  
as*

**U. S. Distributor  
for all**

## PYE TV BROADCAST EQUIPMENT

*See the*

**Fabulous PYE 4 1/2"  
I.O. Camera at Booth 3E,  
N.A.B., Chicago  
or Write**

## TELEQUIP Corp.

319 East 48th St., N. Y. C. 17, N. Y.

PL 2-8885 - PL 2-9037



# Sound Control with Sony



PROFESSIONAL COMMAND OF SOUND FOR EVERY RECORDING AND BROADCAST SITUATION

**Sony CR-4 Wireless Microphone**—The perfect transistorized microphone and pocket-size transmitter for active singer/dancers and TV performers to give complete freedom from entangling cables and obstructing mike stands. Mike and transmitter together weigh only 13½ ounces. *Complete with transmitter, receiver and carrying case:* \$250.

**Sony EM-1 Newscaster Portable**—A full track, all transistorized portable recorder designed for rugged service and dependable performance in remote locations. Meeting NARTB specifications, the EM-1 is ideal for on-the-spot interviews and sound recording. • Governor controlled, constant speed spring wound motor • Rewind while recording • 13¼ pound weight. *Complete with microphone and accessories:* \$495.

**Sony MX-777 Stereo Mixer**—A six chan-

nel all transistorized self powered stereo/monophonic mixer featuring: 4 balanced microphone inputs, 2 balanced hi-level inputs and 2 balanced recorder outputs. Other features include individual level controls and channel 1 or 2 selector switches, cannon XL receptacles and switch for bridging of center staging solo mike. *Complete with carrying case:* \$175.

**Sony C-37A Condenser Microphone**—Remarkably smooth and uncolored natural response through the full range of recorded frequencies has earned the C-37A the title of "world's most perfect microphone." • Adjustable for omni-directional or uni-directional • Frequency response ±2 db 20-18,000 cps • Signal to noise—more than 55 db for signal of 1 micro-bar at 1000 cps. *Complete with CP-3 Power Supply, carrying case and 30 feet of cable:* \$295.

**Sony C-17B Condenser Microphone**—A miniaturized, uni-directional companion to the famous Sony C-37A Microphone. With outstanding background isolation characteristics, the uni-directional cardioid pattern is ideal for TV, night club and solo voice stereo recording application. The slim 1¼" diameter size minimizes visual problems. *Complete with CP-3 Power Supply, carrying case and 30 feet of cable:* \$350.

**Sony CP-3 Power Supply**—For the C-37A and the C-17B microphones, the CP-3 features: Switch for 3 positions of low frequency attenuation; special high cut filter switch for all frequencies above 10,000 cps.

For more complete specifications and name of nearest dealer, write Superscope, Inc., Dept. B, Sun Valley, California.

In New York, visit the Sony Fifth Avenue Salon, 585 Fifth Avenue.

All Sony Stereorecorders are Multiplex Ready!

**SUPERSCOPE** The Tapeway to Stereo

Circle Item 3 on Tech Data Card

# Tarzian stays ahead in **SOLID STATE SWITCHERS**



Tarzian's new "C" model, fully solid state Vertical Interval Switcher, incorporates all the desirable features of the highly successful VIS-88 plus recent engineering refinements adding even greater performance.

This switcher does more—in less space—than any other available. All the advantages of transistorized switching are yours in a compact, low-cost package.

See the new  
*Tarzian Solid State Switcher*  
at NAB—Space 17E



Broadcast Equipment Division  
**SARKES TARZIAN, INC.**  
Bloomington, Indiana

Circle Item 5 on Tech Data Card

## LETTERS to the editor

DEAR EDITOR:

In the December, 1962 issue of *BROADCAST ENGINEERING*, you published an article entitled "Camera Tube Alignment Using 30 Cycles." In this article, author Bill Kessel describes a generator for rocking the focus voltage on a vidicon camera as an aid to proper beam alignment. Unfortunately, there is a mistake in the diagram, and the circuit will not operate as shown. The cathode of V2a is shown returned to B+ instead of to ground. The wire from the cathode of V2b is shown crossing the wire from the cathode of V2a, it should be connected, not jumped.

With this correction, we find that the circuit works very well. The only problem we had was bypassing a filter network on the beam line of our RCA TK-15 cameras. It was necessary to send the 30-cps signal to the camera head on a spare wire in the camera cable, and connect it to the local focus control, which is unfiltered.

DICK ALLMAN

Chief Engineer  
Brooklyn College TV

Yep, looks like we got our wires crossed alright, that should be a connection, not a jump. Thanks for pointing out the missing dot, Dick.—Ed.

DEAR EDITOR:

While reading "Letters to the Editor" in the December, 1962 issue, I came

across a note stating that back issues containing the articles "Audio Studio Maintenance" and "Radio Transmitter Maintenance" are still available for 75¢ each.

Enclosed please find a check to cover the cost of the issues containing the articles cited.

I am a recent subscriber to *BROADCAST ENGINEERING*, find the content of the publication most informative, and look forward to each new issue with much interest. Keep up the good articles concerning the development of audio recording studios.

D. F. EMMETT

Recording Technician  
Radio Productions  
Norfolk, Va.

Your compliment is encouraging. We already have several features planned on audio studios.—Ed.

DEAR EDITOR:

You list in the "Book Review," the *NAB Engineering Handbook*: I have been trying for some time to purchase this book but could never get the address of the publisher.

Can you supply me with the book, or the address and publisher?

W. A. SCHOFIELD

Chief Engineer  
CKEN-CFAB  
Kentville, N.S.  
Canada

Yours is one of several letters concerning this publication. We cannot supply this book, but it can be obtained from the National Association of Broadcasters, 1771 N. St., NW, Washington 6, D. C. Price is \$27.50—Ed.

### NOTES ON THIS ISSUE

#### From The Editor

We hope you are favorably impressed with this **Special NAB Convention Issue**. Within the expanded 76-page content you'll find, in addition to the usual monthly technical features, a special 8-page **NAB Section** plus a preview of the **New York IEEE International Convention**. For those of you who attend either of the shows, this issue will serve as an excellent directory and guide to things you'll want to see and hear. Floor plans direct you to NAB exhibitors' booths, an outline provides you with details on the Engineering Conference, and IEEE technical sessions are listed with subject, time, and location.

If you can't make the NAB Convention, you will be missing one of the very best meetings ever held by and for Broadcasters. However, you still won't miss out — because between this issue and the coverage next month, we'll provide you with all the highlights.

During the IEEE Show, look us up at Booth 4035. You might also run across us at the NAB Convention, where we'll be, roaming through the exhibits and gathering last-minute news and information for our April issue. We'll be seeing you!

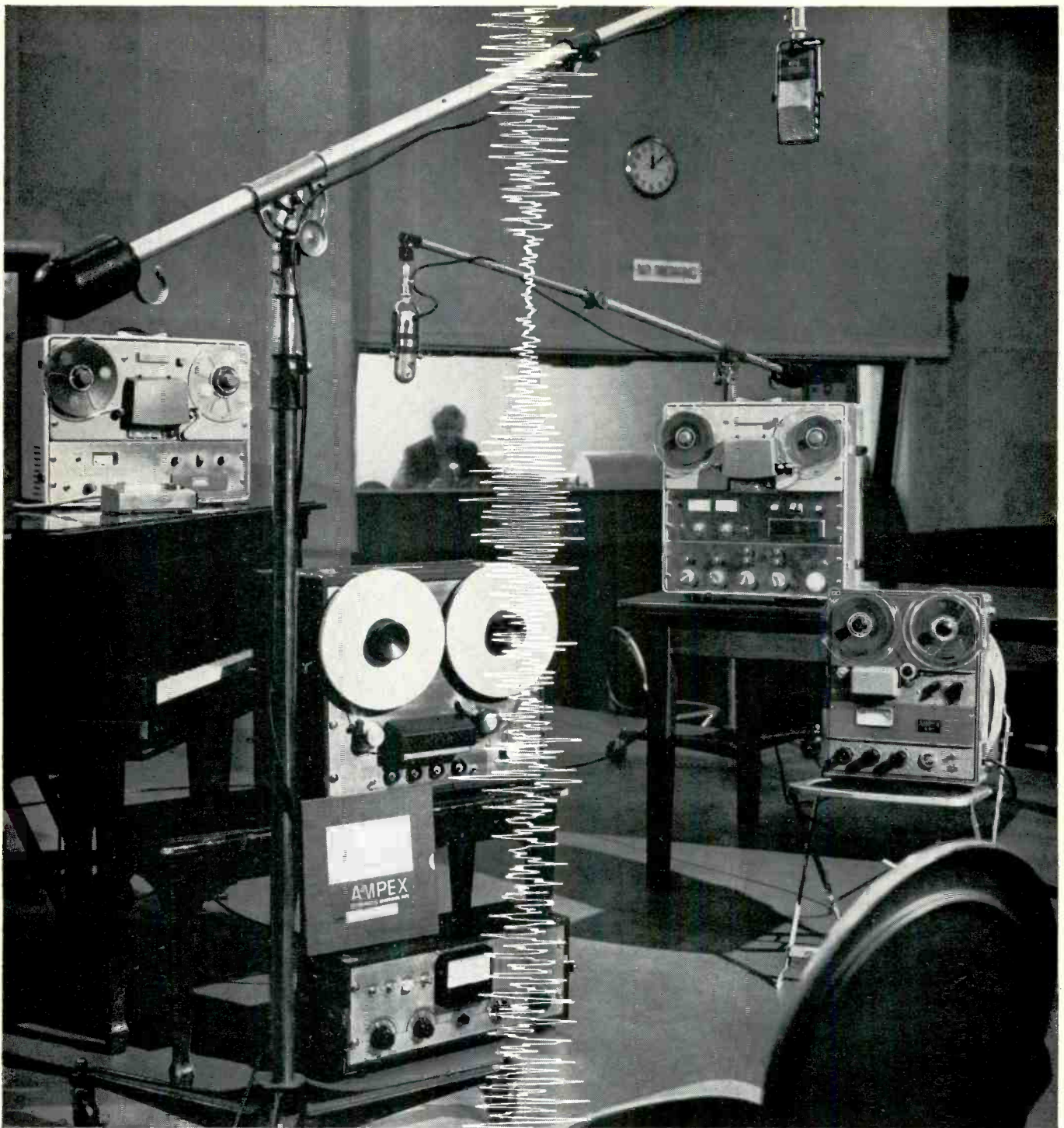

**Who has a recorder to fill every broadcast need?**

**AMPEX**

Ampex offers the widest selection of professional broadcast recorders today. Each providing superior performance. Each providing maximum reliability. There's the Ampex 351, standard of the broadcast industry. The Ampex 352, reproducer for monophonic or stereophonic sound. The Ampex 354, recorder/reproducer designed for stereophonic sound. The Ampex 601, professional quality portable recorder/reproducer. The Ampex PR-10, suitcase-size recorder/reproducer with capabilities of a studio console. And the Ampex 3200 duplicator, master/slave combination for high qual-



ity tape duplicating at low cost. Most Ampex recorders have stereophonic versions. The 350 and PR-10 Series offer 4-track playback. All are dependable, flexible, easy to operate. And all carry the Ampex "Four Star" one-year warranty. Ampex also makes 600 series professional tape noted for long life and constant performance. For more details write the only company providing recorders, tapes and memory devices for every application: Ampex Corporation, 934 Charter St., Redwood City, California. Sales and service engineers throughout the world.

**AMPEX**

Circle Item 6 on Tech Data Card

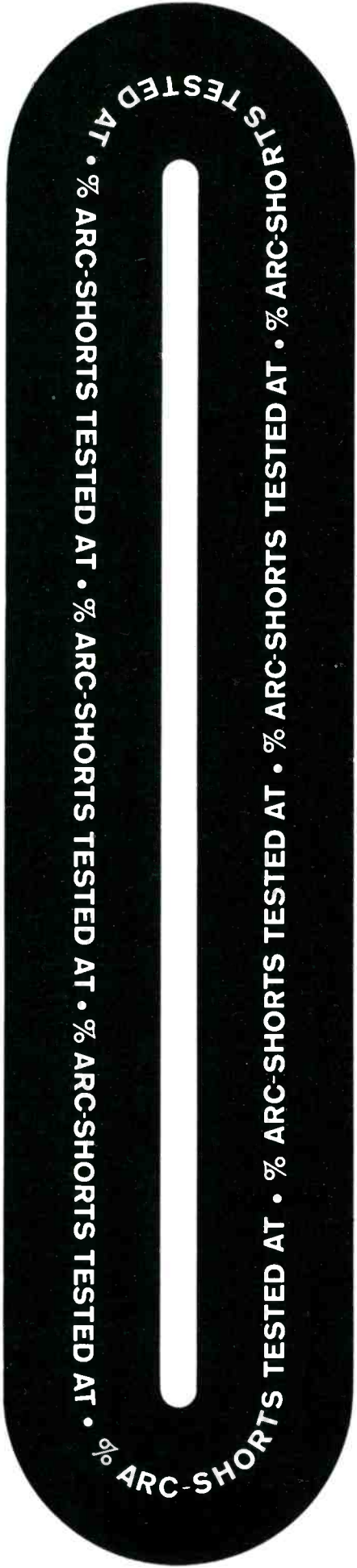
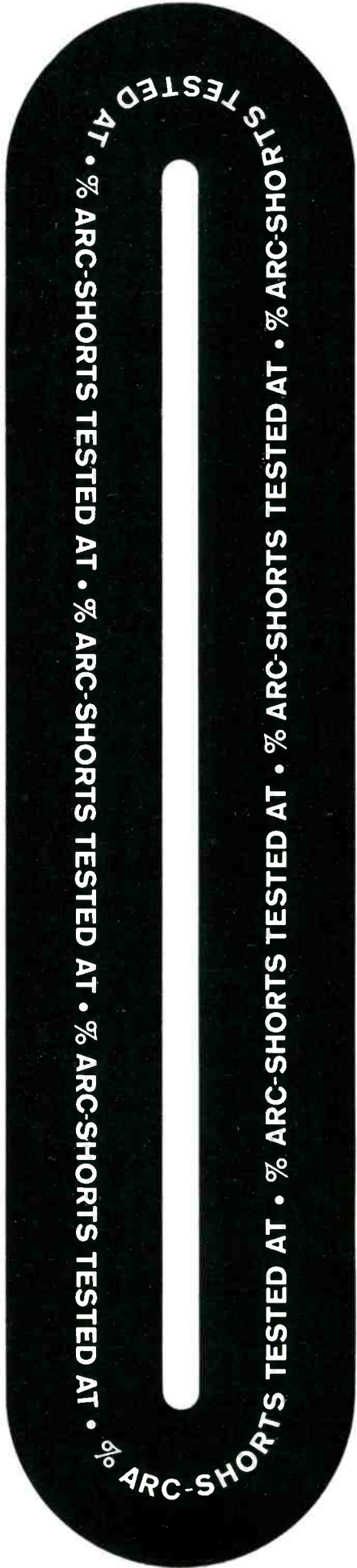



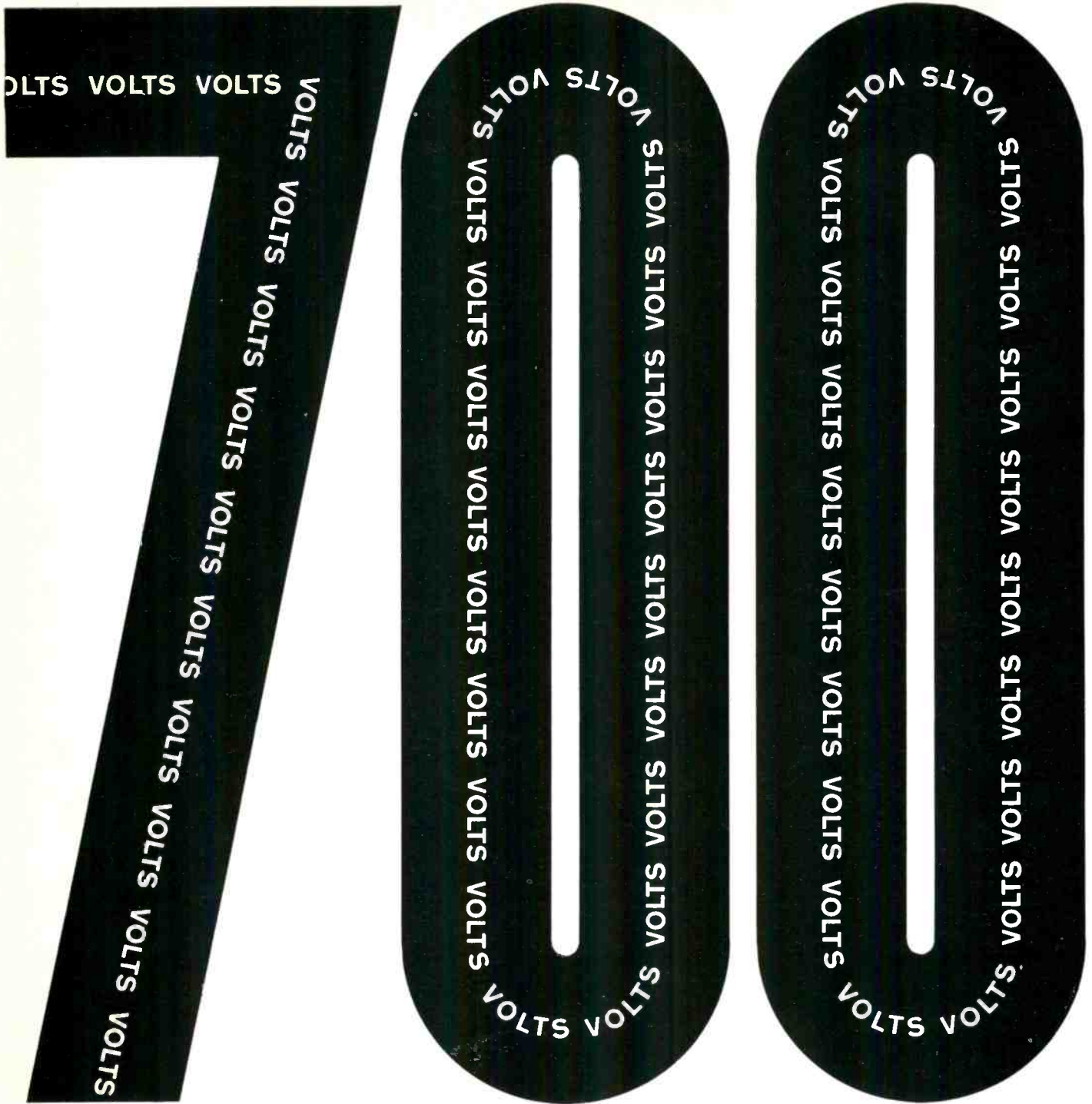

**100% arc-shorts testing at 700 volts...that's your assurance of no arcs.**

If you are bothered with arcing in standard 6336's then you will want to use the Raytheon CK6336A, a ruggedized and reliable power triode, specifically designed for broadcast applications in regulated power supply service. ■ In addition to assurance testing before shipment, the Raytheon CK6336A is constructed better. Raytheon's construction features large cathodes for good emission and ceramic insulators supporting zirconium-coated graphite anodes. This is your assurance of no warping. ■ You can also reduce your operating cost by specifying the Raytheon CK6336A. It will replace standard 6336's with no circuit change and it will give you longer life. Contact your Raytheon Distributor, or write to Raytheon, Distributor Products Division, Westwood, Massachusetts.



Circle Item 7 on Tech Data Card



# TRANSLATORS BRINGS

# KLAS-TV TO 7,000 MORE VIEWERS

*Says Bob McKenzie, Chief Engineer, KLAS-TV, Las Vegas, Nevada.*

In Las Vegas and throughout the U.S., more and more knowledgeable people are turning to EMCEE Translators as the logical means of extending TV coverage . . . efficiently and economically. These unattended, rebroadcast transmitters reach more people at lower installation cost and maintenance than any other system. Community service organizations seeking to improve TV or bring TV to their area and broadcasters wanting to fill in shadow areas . . . all should investigate the EMCEE Translator System. These systems are available for VHF or UHF . . . from 1 watt to 100 watts . . . from individual area service to multi-hop regional systems . . . as an equipment package or installed by one of EMCEE's many franchised dealers. Whatever is needed, the logical choice is EMCEE . . . the world's largest manufacturer of VHF and UHF translators and accessories.

*Write for information on . . .*

- VHF and UHF Translators • Multiple Output Amplifiers • Legalizing Equipment
- Low Noise Pre-Amplifiers • Filters
- Power Splitters • Transmitting Antennas
- UHF Transmitters

**Electronics, Missiles & Communications, Inc.**  
 262 East Third Street • Mount Vernon, New York • Dept. BE

Gentlemen: Please rush

Free planning package including data sheet, complete installation check list, coverage calculation form.

Detailed Specifications of UHF Translators.

Detailed Specifications of VHF Translators.

NAME \_\_\_\_\_

ADDRESS \_\_\_\_\_

CITY \_\_\_\_\_ STATE \_\_\_\_\_

**ELECTRONICS, MISSILES AND COMMUNICATIONS, INC.**  
 262 East Third Street • Mount Vernon, New York • 914 MO 8-3012  
 See us at the NAB Convention, Booth No. 53 West.  
 Circle Item 8 on Tech Data Card

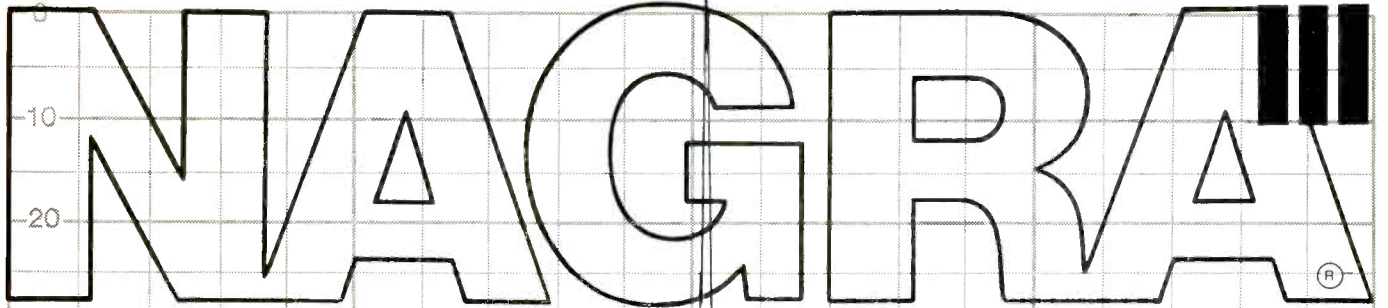

## FOR TOP QUALITY TAPE RECORDING

The NAGRA III is a self contained professional tape recorder, assuring an excellent reliability factor, and the best recording quality available outside your studio. The frequency response, signal to noise ratio and wow & flutter characteristics of the NAGRA III, are similar to those of the

best studio console recorders, but modulation noise is even better. This spectrogram measurement of the NAGRA III, was taken by the Electro-Acoustical laboratory of the Royal Institute of Technology, Stockholm.



Battery operated, truly portable

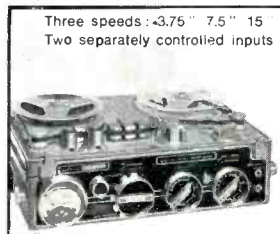

Three speeds: 3.75" 7.5" 15" Two separately controlled inputs

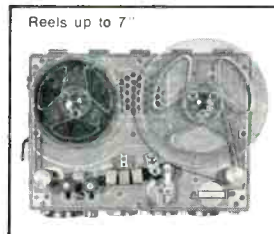

Reels up to 7"

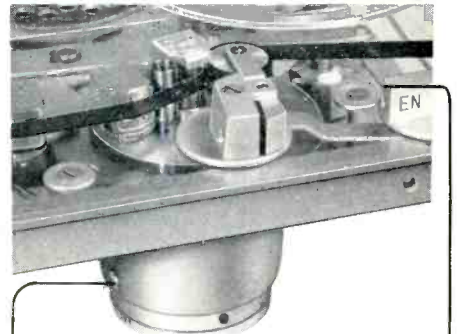

Servo loop speed control



### SPECIFICATIONS

Frequency response	30 - 18 000 c/s ± 1 db (15")
	40 - 15 000 c/s ± 1 db (7.5")
Play back circuit signal/noise ratio:	72 db ASA A
Erase :	- 80 db
Wow & flutter:	at 15" : 0.04 % RMS 2-200 c/s
	at 7.5" : 0.06 % RMS 2-200 c/s
Recording power consumption :	205 ma (12-25 V)
Weight with 12 flash light batteries :	15 lb.
Dimensions :	14.2 x 9.5 x 4.3"

SUGGESTED NET USER PRICES IN THE UNITED STATES

NAGRA III B **\$ 1045.-**

NAGRA III NP FOR LIP SYNC IN MOTION PICTURES PRODUCTION **\$ 1095.-**

SLP SOUND TRANSFER SYNCHRONIZER **\$ 295.-**

ASK YOUR NAGRA DEALER FOR NEW ILLUSTRATED BROCHURE, OR WRITE TO:

# KUDELSKI

6, CH. DE L'ÉTANG PADEX LAUSANNE SWITZERLAND

NAGRA AGENCIES FOR SALES AND SERVICE

#### NEW YORK

Magna Tech Electronic Co. Inc.  
630 ninth avenue  
Film Center Bldg.  
New York 36 N. Y.  
Phone : JU 6-7242

Harvey Radio Inc.  
103 West 43rd Street  
New York 36 N. Y.  
Phone : JU 2-1500

#### CHICAGO

Behrend Cine Corp.  
161 East Grand Avenue  
Chicago 11 ILL.  
Phone : MI 2-2281

#### DALLAS

Audio Acoustic Equipment Corp.  
208 South East Street  
Arlington Texas  
Dallas Phone : AN 2-3136  
Arlington Phone : CR 6-2259

#### LOS ANGELES

Ryder Sound Services Co.  
1161 North Vine Street  
Hollywood 38 Calif.  
Phone : HO 9-3511

Magnetic Recorders Co.  
7120 Melrose Avenue  
Hollywood 46 Calif.  
Phone : 933-5545

Circle Item 9 on Tech Data Card

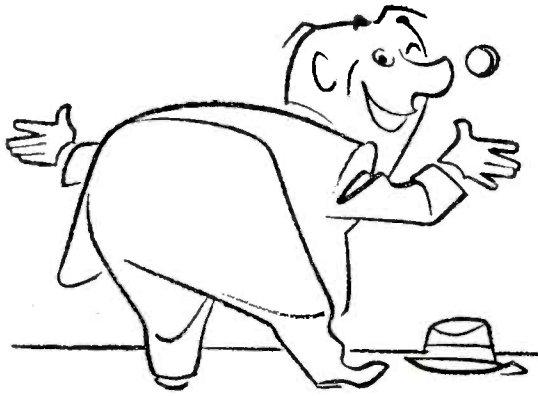

# SEE...

## MOSELEY ASSOCIATES NEWEST UNITS

Low Cost • Advanced Design  
Economical Operation

### Booth 48W N.A.B. Convention, Chicago

## **NEW** COMPACT 10 WATT FM MAIN CHANNEL EXCITER

### Model LPE-10

Designed as retrofit exciter for older style FM transmitters and complete 10 watt educational FM transmitter. Accepts monaural input directly with provision for two SCA inputs. For FM stereo use Model SCG-3 Stereo Generator.

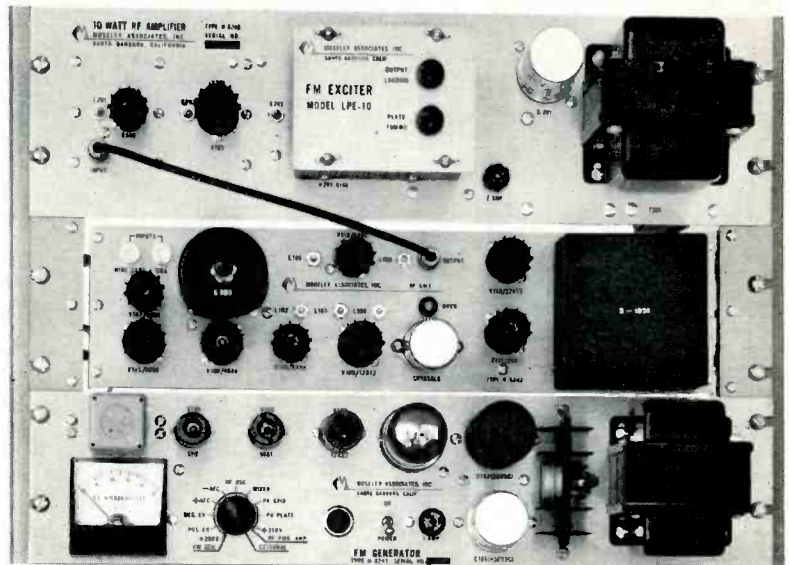

### FM STEREO GENERATOR

**Model SCG-3.** Complete with power supply, this unit delivers a composite output signal in full accordance with FCC Rule 3.322. Use with Model LPE-10 FM Exciter. Can be adapted to most direct FM exciters.

### SCA SUBCARRIER GENERATOR

**Model SCG-4.** Designed for multiplex operation. Includes modulation indicator and automatic subcarrier muting. Use with Model LPE-10 FM Exciter or any exciter unit designed for multiplex operation.

### STUDIO-TRANSMITTER LINK

**Model PCL-2B.** For AM, FM, and TV aural broadcast service. Operates in the 942mc to 952mc band. Two inputs are available for SCA multiplex subcarriers. Includes two 18db gain antennas.

### RADIO REMOTE CONTROL SYSTEM

**Model RRC-10S.** Compatible with FM stereo and SCA multiplex transmission. Ideally suited for mountain top transmitting sites.

### WIRE REMOTE CONTROL SYSTEMS

**Model WRC-10/25.** Ten and twenty-five channel systems designed for operation over one d.c. telephone pair.

**SEE THEM  
BOOTH 48W  
N.A.B. CONVENTION  
or WRITE**

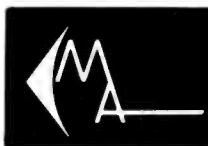

**MOSELEY ASSOCIATES INC.**

P. O. BOX 3192 • 4416 HOLLISTER AVE. • SANTA BARBARA, CALIFORNIA

PHONE  
Area Code 805  
967-1469

Circle Item 15 on Tech Data Card

BROADCAST ENGINEERING

# THE PRACTICAL APPLICATION OF FCC ENGINEERING RULES

by John H. Battison\* — Part 2.

Further information on completing Form 301, Section V-A, explaining some pitfalls, and where special maps may be obtained.

## Contours

On page 2 of FCC Form 301, Section V-A, (Fig. 1) we encounter the first request for technical information that the chief engineer must calculate. Paragraph 12A calls for a map, preferably a Sectional Aeronautical Chart so that the scale is sufficiently large to give the Commission's engineers a clear impression of the situation. On the map the applicant plots the 1,000 mv/m (1 v/m), 25 mv/m, 5 mv/m, 2 mv/m, and the normally protected contour which in the case of daytime operation is 0.5 mv/m.

Also required on page 2 is the

\*Consulting Editor, Washington, D. C.

interference-free contour for the proposed operation with all possible interfering stations taken into account. If for any reason the 2 mv/m contour is not served, it need not be shown on this map. However, any daytime application that does not propose to serve the 2 mv/m contour would have a very poor chance of being granted. On the other hand, at night it is quite unlikely that service to the 2 mv/m contour would be provided unless the station were in a very remote part of the country.

It should be noted in the interests of saving time and labor that there is no need to show the 0.025 mv/m

contour in this exhibit; it will be shown later in the application.

If the proposed operation calls for night contours they should be shown on a separate map. In this case the calculated night-limit contour must be shown in exactly the same way as the daytime interference-free contour; for this is what the night limit contour is.

The 25 mv/m and 1 v/m contours normally cannot be drawn on the SAC because they are too small. A satisfactory solution is to obtain a US Quadrangel (topographical map) for plotting these two contours. The essential 25 mv/m city contour will thereby show; if the

## 12. Allocation Studies:

A. Attach as Exhibit No. \_\_\_\_\_ map or maps, having reasonable scales, showing the 1000, 25, 5, 2, normally protected and interference-free contours in mv/m for both day and night operation both existing and as proposed by the application. (NOTE: the 2 mv/m night contour need not be supplied if service is not rendered thereto.)

B. (1) For daytime operation, attach as Exhibit No. \_\_\_\_\_ an allocation study, utilizing Figure M-3 of the Rules or an accurate full scale reproduction thereof and using pertinent field strength measurement data where available, a full scale exhibit of the entire pertinent area to show the following:

- (a) Normally protected, the interference-free, and the interfering contours for the proposed operation along all azimuths.
- (b) Complete normally protected and interference-free contours of all other proposals and existing stations to which objectionable interference would be caused.
- (c) Interfering contours over pertinent arcs of all other proposals and existing stations from which objectionable interference would be received.
- (d) Normally protected and interfering contours over pertinent arcs of all other proposals and existing stations which require study to show the absence of objectionable interference.
- (e) Plot of the transmitter location of each station or proposal requiring investigation, with identifying call letters, file numbers, and operating or proposed facilities.
- (f) Properly labeled longitude and latitude degree lines, shown across entire exhibit.

(2) For daytime operation, when necessary to show more detail, attach as Exhibit No. \_\_\_\_\_ an additional allocation study, utilizing World or Sectional Aeronautical charts to clearly show interference or absence thereof.

(3) For daytime operation, attach as Exhibit No. \_\_\_\_\_ a tabulation of the following:

- (a) Azimuths along which the groundwave contours were calculated for all stations or proposals shown on allocation study exhibits required by Paragraph 12B above.
- (b) Inverse distance field strength used along each azimuth.
- (c) Basis for ground conductivity utilized along azimuths specified in (3) (a). If field strength measurements are used, the measurements must be either submitted or be properly identified as to location in Commission files.

Fig. 1. A portion of paragraph 12, section V-A, FCC form 301.

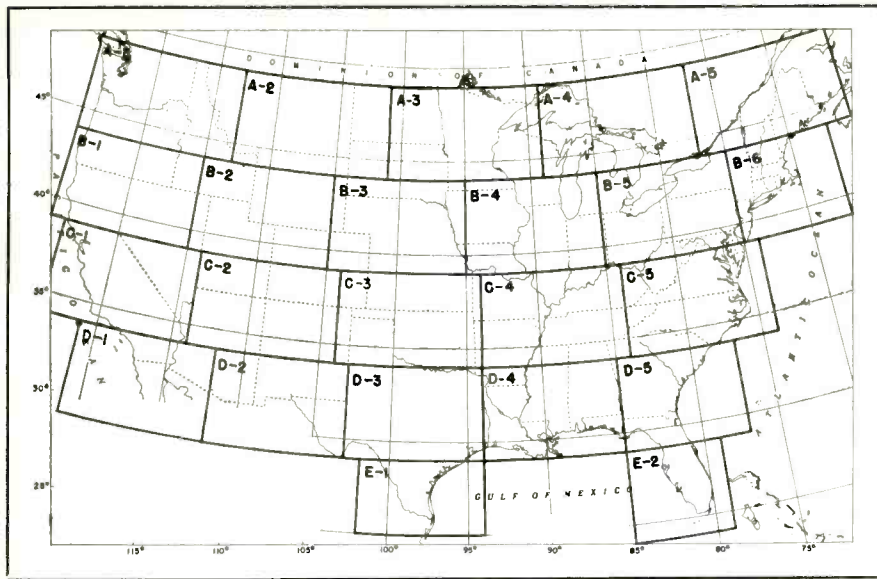

Fig. 2. An index of ground conductivity maps.

proposed site does not give this coverage the fact will become readily apparent. If there are fewer than 300 people residing within the 1 v/m contour, the fact need only be stated in the table of populations and areas. If there are more than 300 people within this contour they will have to be counted, and shown as a percentage of the normally protected contour population. Generally the Commission frowns on more than 1%.

### Conductivity Maps

Paragraph 12 B (1) (a), which calls for an M-3 exhibit, is the one that generally causes the most headaches to the uninitiated. First of all, the Commission calls for an "accurate full-scale reproduction" of Figure M-3. This means just what it says — and most photostats will not be accepted because of distortion in processing; there are also other forms of copying which will not be accepted. Reproductions of the type produced by the Goetz Company of Washington, D.C. are acceptable.

A direct approach makes use of

the full size M-3 put out by the Government Printing Office; the only problem is that they cost \$3.50 each, making it rather expensive to cut up several for the average application. Probably the best solution, and one that is used by many consulting engineers is to have the exhibit reproduced by the Xerox process, or else offset printed.

The original contour plotting work can be done on one of the sectional M-3's put out by the Seabrooke Printing Company of Washington, D.C. They cost 25¢ each and are listed in an index which shows the regions of the country covered (Fig. 2).

After the required contours are plotted, the map can be reproduced by one of the methods mentioned earlier. One probable reason for the insistence of the FCC on maintaining the map copies accurate is to insure that individual maps can be superimposed over each other and the overall situation seen at a glance.

### Sources of Data

It is most important to note that

if field intensity measurements are available on the stations involved in the application, they must be used. However, if the only measurements available are from a station to the proposed site they cannot be used backwards; that is, from the proposed site to the measured station, or vice versa. Use in this manner will only result in the work being returned.

If field intensity measurements are used, the source must be clearly specified in the application, giving the call letters, date of measurements, file number, and all identifying data so that the FCC can duplicate your calculations. The latest measurements must always be used.

Failure to provide full information on the M-3 exhibit called for in the last two sub-paragraphs will probably result in rejection of the application. The other sub-paragraphs are self-explanatory. However, one requirement often is missed by inexperienced engineers.

When the FCC says "complete contours" it means just that — not half-circles or arcs, but the entire contour in the case of 0.025 mv/m, 0.5 mv/m, normally protected, and interference-free contour. Unless these instructions are followed to the letter there is every chance that the application will be returned.

As will have been observed, Figure M-3 is too small in scale to permit great detail in furnishing the allocations data. For this reason the FCC asks in 12 B (2) for another map showing the entire allocation picture similar to that shown on the M-3, but in larger scale so that areas can be measured and details of interference and essential coverage checked.

### Field Intensity Measurement

Item 12 B (3) calls for full information on the azimuths, or radials, along which the contours

13. Attach as Exhibit No. \_\_\_\_\_ tables of the areas and populations within the contours included in Paragraph 12 (A) above, as well as within the normally protected and interference-free contours of each station or proposed operation to which interference would be caused according to the Commission Rules.

(NOTE: See the Standard Broadcast Technical Standards. All towns and cities having populations in excess of those given in Section 3.182(g) are not to be included in the tabulation of populations within the service contours. The 1950 or later Census Minor Civil Division maps are to be used in making population counts, subtracting any towns or cities not receiving adequate service, and where contours cut a minor division assuming a uniform distribution of population within the division, to determine the population included in the contours unless a more accurate count is made.)

Fig. 3. Paragraph 13, of Section V-A, FCC Form 301.

were calculated, as well as the radiated field in mv/m (e.g. 185 mv/m for 1 kw) at one mile. Or, in the case of a directional station the actual radiation in mv/m along the azimuth in question should be noted. Finally, the basis for ground conductivity is required. If it is taken from the M-3 map it is only necessary to say so. On the other hand if the conductivity is derived from any other source, this reference must be clearly identified and submitted (if based on field intensity measurements made by the applicant) or identified in the FCC's files by number and call letters.

If the ground conductivity employed in the application is derived from the results of measurements made by the applicant, an entire report on the measurements must be included in the application. Unless the engineer making the measurements is skilled and experienced in doing so, he would be wise to seek the assistance of a consulting engineer. This is particularly so in the case of measurements that are intended for use in hearing, because in this situation the going gets very rough, and an inexperienced "measurer" can experience a very uncomfortable half hour at the hands of the opposition when the proceedings begin.

Contrary to the opinion of many people it is not essential to submit in this portion (or any other) of Form 301, the actual ground conductivities used; question 12 does not actually ask for it. However, it is a good idea to include this information in the application, for two reasons — to enable the FCC engineers to work from the same data as the applicant did (and there is thus a greater chance for agreement), and secondly it is immediately available if it is later desired to recheck or change the work.

There is an easy method for showing the variations in conductivity. Assume that on a particular radial, say 200°, the conductivity is 4 for 8 miles, 2 for 5 miles, 8 for 18 miles, and then 4 for the remainder of the distance. This can be shown as follows:

Az. 200° 4 F 8: 2 F 5 : 8 F 18 : 4 out (means all the way out).

### Populations and Areas

Paragraph 13 (Fig. 3) calls for a table of the proposed (or existing,

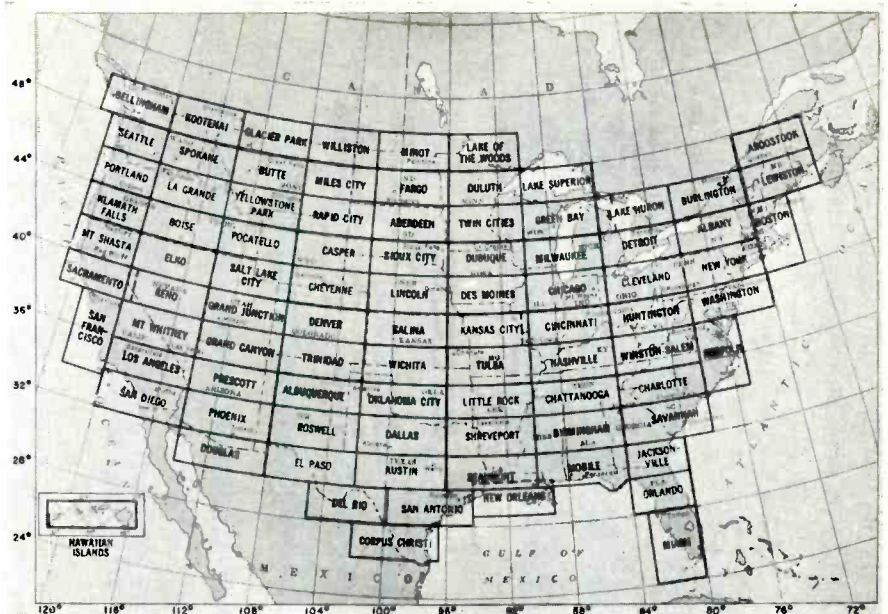

Fig. 4. An index of Sectional Aeronautical Charts published by the Dept. of Commerce.

such as in the case of a power increase) populations and areas. However, measuring the areas is simple, by use of a Polar Planimeter, which measures the area of the contour on four dials. The actual area in square miles is obtained through multiplying by a constant derived from the map used. Because Planimeters are expensive and rather seldom used, most engineers who do not require them often employ another very accurate method involving the use of coordinated paper.

The area to be measured is traced very carefully onto the paper which should have the smallest scale possible, (e.g., millimeters). The next part calls for a very careful eye, as every square must be counted and the total noted.

Because the contour tracing is from the SAC figure, or should be, the coordinate paper carries an exact copy of the contour in the same scale. It is easy to find how many squares there are in one, or ten square miles, and then divide this figure into the total number of squares to find the area of the contour in square miles.

A word of warning is in order regarding two aspects of the signature paragraph. First, the date must be on or before the day that the main body of the application is signed — it cannot be later. If it is later, the FCC will return the application, because the person signing Section 1 must have been able to read the engineering part before signing.

The second concerns the practice

of unlicensed engineering. Most states have licensing laws governing professional engineering. It is perfectly all right for an **employee** or an owner to do his own engineering, or for the employee to do the engineering and sign it as "Technical Director" or "Chief Engineer." But if an unlicensed engineer makes a practice of completing these forms for people other than his employer or his own operation, he may find himself, in trouble with the local licensing authority, for practicing engineering without a license.

### Section V-G

Section V-G goes to the FAA for the purpose of checking airplane height clearance. For this reason every question must be answered; it will not suffice to say, "On file — no change".

Most items on page V-G are self explanatory, but be sure to give the correct address, and the same name as on V-A. The request for aeronautical data can be filled by using a SAC (Fig. 4) with the red aeronautical overlay if an instrument landing chart is not available.

Section V-G is to be submitted with two extra copies plus the exhibits included in it. Generally these are the sectional aeronautical chart showing the local details around the site, and the vertical sketch showing the tower height(s). These two extra sets of V-G and exhibits should be stapled together and then attached to the back of the complete engineering report bearing the sworn affidavit. ▲

# A TRANSISTORIZED TELEVISION MONITOR

by Peter Vogelgesange\*—

Problems and solutions in the development of a transistorized video monitor.

Development of a fully transistorized monitor which equals or exceeds the performance of a vacuum-tube monitor is no small task. The principal difficulty is that the transistor circuits must be adapted to the same CRT used in vacuum-tube monitors. The considerable reduction in power consumption that

usually results with a change from vacuum tubes to transistors cannot be fully realized in a television monitor because of the basic CRT requirements. However, a power saving of approximately 50% can be accomplished.

The development of a transistorized monitor was undertaken at

Miratel with the intention of equaling or exceeding the performance characteristics of a corresponding vacuum tube device. It is the purpose of this article to describe some of the problems encountered, and how they were solved.

A block diagram of the monitor is shown in Fig. 1. The monitor is divided physically and electrically into six major parts (Fig. 2): a synchronization module, a video module, a horizontal-deflection module, a high-voltage module, and a regulated power-supply which is part of the monitor chassis. The modules are plug-in units (Fig. 3) which connect to the chassis through Blue Ribbon connectors. Identical modules and similar construction are used in the 8", 14", 17" and 21" monitors (Fig. 4).

## Video Amplifier

The video amplifier presented the difficult problem of having to deliver the required 100-volts peak-to-peak video signal to the kinescope grid, while maintaining good bandwidth and good differential-gain characteristics. This was accomplished by using two stages of power amplification followed by an output voltage-amplifier employing an NPN silicon transistor which operates at a collector voltage of 120 volts.

One of the major difficulties was preventing "glitch", or ringing currents, from getting into the circuit. The horizontal-deflection amplifier delivers peak currents of 8 amperes into the yoke, and even husky ground busses cannot be relied upon to remove the unwanted voltages that result. Also, contrary to the usual problem of capacitance be-

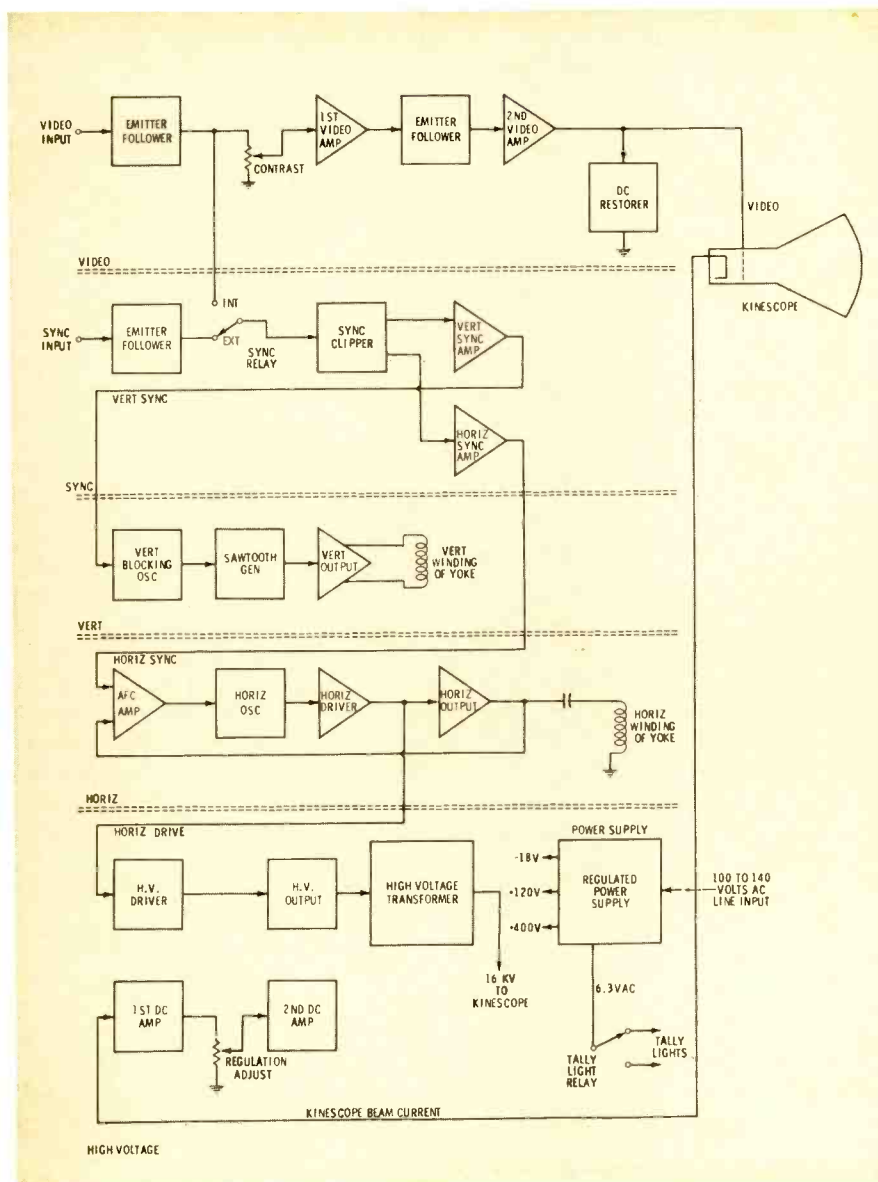

Fig. 1. Block diagram of transistorized television monitor.

\*Chief Engineer, Miratel Electronics, Inc., New Brighton, Minnesota



tween adjacent wires, the high currents in the monitor posed the problem of inductive coupling. Shielding sensitive wires was not sufficiently effective, and the isolation had to be achieved by judicious routing of wires and careful selection of ground points. The end result is wiring which closely resembles VHF circuitry, and a raster completely free of ringing even at maximum contrast.

With an input of 0.75 volts, the video amplifier delivers 100 volts peak-to-peak to the CRT grid. Bandwidth of the amplifier exceeds 10 mc and differential gain is better than 2% up to 70 volts. An emitter follower provides an amplifier input impedance of approximately 20,000 ohms, making it suitable for bridging inputs.

### Horizontal Deflection

Compared to vacuum tubes, transistors are generally low-voltage devices. In order to deliver comparable power to the horizontal-deflection coil, transistors must supply considerably greater current than vacuum tubes, and the reactance of the yoke must be substantially lower. The monitor described here uses a 60-mh horizontal winding which is driven with peak currents of 8 amps. Average DC current in the winding is about 1 amp. Horizontal flyback-time is approximately 6 msec, at 200 volts. Since this flyback voltage exceeds the rating of any single transistor which possesses the necessary switching characteristics, two series-connected transistors are used to drive the yoke. A capacitive divider insures that the flyback voltage is equally divided across the transistors, and individually-adjustable drive resistors provide balance adjustment. The output circuit uses type GC46 transistors, (the high-performance counterpart of the type 2N1908).

The horizontal winding of the yoke is composed of many turns of wire as in a vacuum-tube circuit, but they are connected in parallel to produce the effect of only a few turns. This permits fabrication of the yoke by standard methods, and allows the magnetic field to be distributed as though it were being generated by many individual turns.

The yoke is not driven through a flyback transformer, but rather is

impedance coupled (choke and capacitor) to the transistors. Capacitive coupling of the yoke eliminates a centering bias which would exist if the direct-current component of the driving waveform were allowed to pass through the winding. The capacitor is a 10-mfd Mylar — a type which can handle the power without being destroyed by internal heating.

The horizontal-driving transistors are used simply as switches to minimize power dissipation; that is, they are alternately saturated and cut off. For this reason, horizontal linearity cannot be controlled dynamically. The horizontal scan tends to be stretched on the left and compressed on the right, necessitating compensation by two means. The horizontal coupling capacitor introduces parabolic correction which compresses the center to match the right side of the raster. Then, by using an adjustable loss circuit to compress the left side of the raster, an overall linearity of better than 1% is achieved.

The horizontal deflection module uses an L-C stabilized oscillator and an AFC circuit which is comparable to the vacuum-tube counterpart. The time coincidence of the horizontal sync and flyback pulses are compared in a diode detector, and the error voltage developed corrects the oscillator frequency (pull-in range is over 2 kc).

### High Voltage

The transistorized monitor employs a kinescope accelerating-voltage of 16 kv. To develop this from a primary source of only 18 volts requires a high transformer turns-ratio, indeed. And, even with an input impedance of only several ohms, the output impedance of such a transformer must necessarily be very high. High output impedance implies poor regulation — a characteristic which cannot be tolerated when the load current can vary from zero to 400-mamps with picture brightness. Furthermore, if high voltage is derived from the same transformer that drives the horizontal winding of the deflection yoke, load changes will be reflected as changes in raster width. For this reason it was decided to divorce the high-voltage circuit from the horizontal-output amplifier completely,

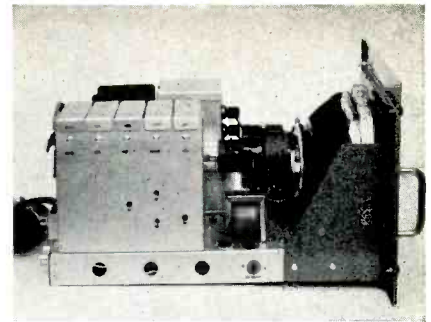

Fig. 2. Side view of 8" monitor showing major sections including plug-in modules.

in spite of the additional power consumption.

The high-voltage circuit consists of a two-stage amplifier which drives a flyback transformer, and a two-stage DC amplifier which regulates the high voltage. The driving amplifier is fed by the horizontal oscillator so that the high-voltage flyback pulses developed in the transformer occur during horizontal blanking, thus eliminating the possibility of ringing getting into video during the picture interval. The cathode circuit of the CRT is connected to the input of the DC amplifier. The output is proportional to the CRT current, or the load. This current boosts the input power to the flyback transformer and keeps the output voltage constant. The gain of the DC amplifier is variable, and can actually be adjusted to produce negative regulation — increased output voltage with increased load. When properly adjusted, the regulation is better than 1% from zero to 400-mamps kinescope current.

The flyback transformer contains two secondary windings which are used in a voltage-doubler configuration with 1X2B rectifiers. The high-voltage rectifiers are the only vacuum tubes in the monitor, and are employed for the sake of economy. Available solid-state rectifiers which are capable of handling the high

• Please turn to page 64



Fig. 3. High-voltage plug-in module of the transistorized television monitor.

# MECHANICAL CONSIDERATIONS FOR AM, FM & TV TOWERS

by John H. Battison — Variables which affect the mechanical and electrical stability of antenna towers must be considered in planning and maintenance.

The antenna tower is a prime link in the chain connecting the broadcast program with the listener. Much has been written about these structures, and a lot said in discussion, yet it often appears that the tower is somewhat misunderstood! The lack of information on the part of users may result from the tower being basically a passive object permitting little opportunity for electronic maneuvering.

Fundamentally, the AM tower is a tall metal structure required to have certain physical dimensions of length (height), shape, and location. The most important, from a broadcast engineer's point of view, is length—because it directly affects the electrical performance.

Only in the case of AM towers is the type of base affected by the electronic considerations. A series-fed tower will call for a base insulator strong enough to support the total weight of the tower, plus any extra attachments such as communication, FM, and TV antennas that may be added—often after the original installation.

On the other hand, a shunt-fed tower will be secured directly to the ground on a concrete pier. Although there is no insulator in this case, the forces acting on the base are important, and can be increased beyond safe limits by the haphazard addition of extra antennas, etc.

## AM Antennas

The only function of an AM antenna is to radiate, and to this end it is important that there be no resistance losses in the tower. For this reason galvanizing is always advisable, even though the tower will be painted in the approved FAA colors later. Some time ago RCA conducted some very interesting experimental work on this subject

under the direction of Dr. G. H. Brown. The net impression gained from the released information was that galvanizing is advisable because it reduces variation of resistance.

Theoretically, the electrical characteristics of an AM tower are calculated on the basis of uniform cross section, while in practice the tower may be triangular guyed or tapered self-supporting. There are no reasons why a self-supporting tower cannot be built in a uniform cross section, or a guyed tower in a tapered form—except that of cost. A circular cross section tower is very efficient electrically, but may be difficult and expensive to build.

One of a broadcaster's main interests is price. He reasons, quite rightly, that if the metal in the tower is normal he will get adequate radiation. In most towers structural carbon steel which is strong and inexpensive, is used. Another popular material is pipe. It can be as strong as structural steel, and cheaper; however, pipe is not always available in all diameters. Alloys of steel and aluminum are also available, and used on occasion.

Discussion of tower materials and configurations would not be complete without mention of weight. A

very important factor in design, total tower weight determines the requirements for the base insulator (if used), the base pier, and the steel in the base section.

A base insulator at the tower pivot will lessen the load on the foundation, saving steel in construction. All the forces acting on the base are in one direction—down—and less concrete is needed in the base pier as a result. On the other hand, a rigid base tower can be erected more easily because temporary guys are not needed, but problems are encountered in leveling the base legs and insulators.

Of the many types of structural forms used in antenna tower construction, X-Type braced trusses, which are generally of bolted construction with the joints acting as hinges, and rigid trusses are popular. Rigid trusses which are welded allow no moment because the individual members are susceptible to bending as well as axial stresses. In general, for short towers, rigid frame trusses have proved to be very acceptable.

## Guy Insulators

The base insulator of a series-fed tower is a much neglected item; the same is often the case for guy insulators. For short towers on the order of 300' high or less, power-line type insulators are used. Originally designed as strain insulators to guy power lines, they take the stress by being compressed in the middle. This type of insulator is inexpensive, and easy to obtain, even in the more remote parts of the country. It is not very likely that one of these insulators will fail, but should this happen the tower's structural stability will not be affected. When properly inserted, the two loops of guy wire will be inter-

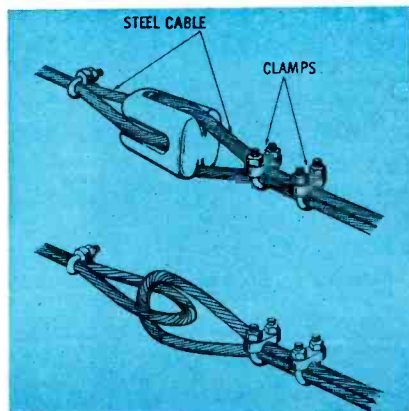

Fig. 1. Antenna tower guy insulator.

laced (Fig. 1) if the insulator disintegrates. There have been cases where the assembly was incorrect, so when the insulator broke under the pull the two guys merely fell apart.

In many instances the guy wire may be up  $\frac{1}{2}$ " in diameter—this is quite stiff and hard to form. However, regardless of the stiffness, it is essential that the guy be formed tightly around the insulator, and then clamped to itself close to the insulator. If the guys are not thus inserted and clamped, there may be a tendency for the insulator to twist and take the guy strain at an odd angle, resulting in failure.

### Base Insulators

Although a few newer base insulator materials are making their appearance, porcelain, in general, holds first place and probably will for a long time to come. Strangely enough, porcelain is not a particularly suitable material for supporting heavy towers which produce very large moments. In the case of self-supporting towers, in fact, the problem becomes quite severe. The design is such that the base insulator is alternately fighting either compression or strain (pull) from the tower sides, as the structure moves with the wind.

The problem of base insulators is compounded when the terrain is such that the tower base has to be raised to avoid short circuiting due to flood waters. It is not unusual for a tower base to be as high as 20' above ground, supported by a steel pier. This provides another possible source of relative movement, since this 20' extension may move in a different direction from the main tower it is supporting. So we expect to, and almost always do, find an installation of this type employing a pivot insulator. However, individual insulators may be used if the base is firm and level.

A popular base insulator is the pivot or ball type, in which the load-weight compression is transmitted down to the porcelain, which can handle it successfully. But should an unexpected strain or bending moment be encountered, there is every possibility of the insulator cracking.

One of the greatest problems encountered in tower work is keeping

the insulators insulating! In many cases a high voltage is developed across an insulator, depending on the electrical height and method of feed. Dirt on the insulator, combined with sooty carbon and moisture, provides an excellent path to ground for those hard-to-come-by watts. Sometimes poor performance can be traced to an unnoticed, moist, dirt-filled crack in a base insulator which is secreting carbon produced by hours of operation. It is also possible for water to accumulate in the insulator and cause cracking during freezing weather.

### Bonding and Grounding

The exact opposite of insulation is bonding, which in an AM antenna is of enormous importance since resistance losses can greatly reduce radiation efficiency.

If the tower is galvanized, surface contact will generally be quite satisfactory. However, if the tower section has been laying around for some time prior to being erected, it will pay to brighten the galvanized areas that will be in contact prior to bolting and securing. If the tower is second hand, and has been previously painted, it is essential to remove every trace of paint at these joints prior to erection—tower paint is quite an efficient insulator.

There are two ways to ensure

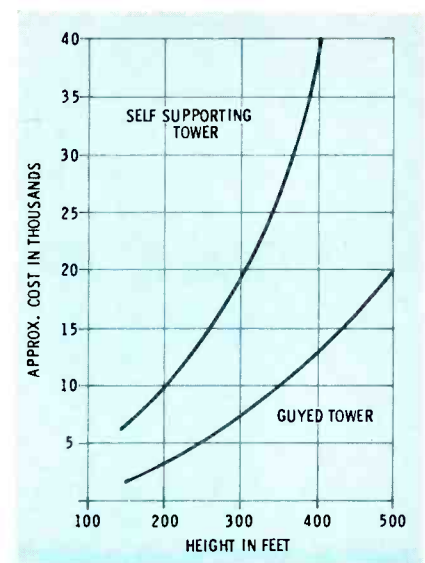

Fig. 2. Approximate costs of towers.

good electrical conductivity. Welding is positive, and when properly done results in a tower which is effectively one long piece of steel with a very low resistance. However, if there is any likelihood that the tower may ever be dismantled, another bonding method should be employed. Welding also requires the use of electricity or gas, which can cause damage to guy installations. The other acceptable method is copper-jumper bonding. Holes are drilled adjacent to each other in the tower sections, and copper plugs joined by copper cable, are

● Please turn to page 62

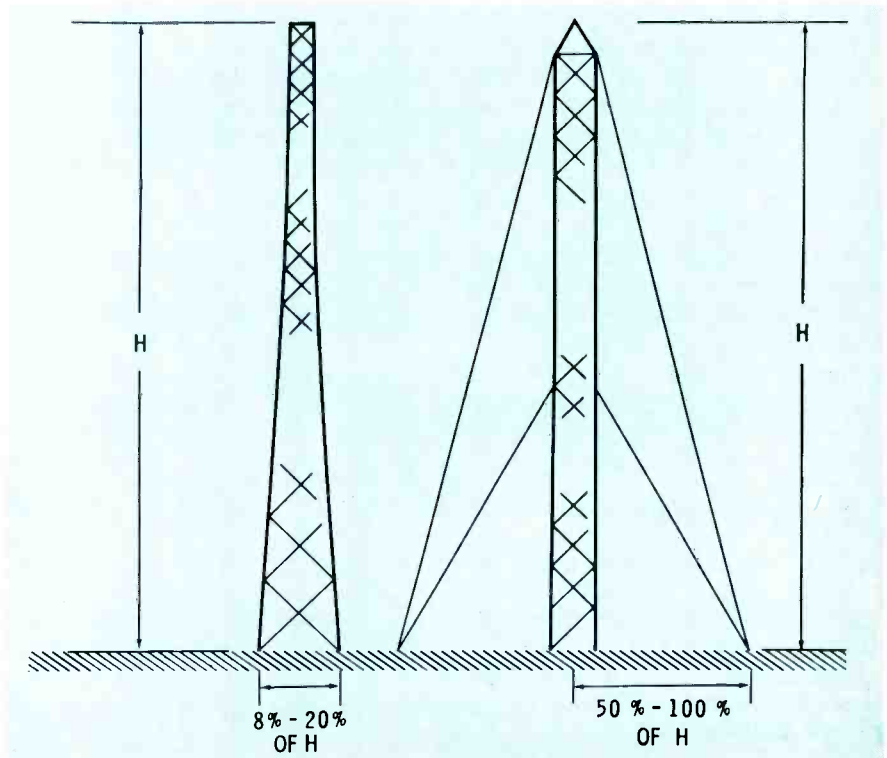

Fig. 3. Ground space required for guys.

# A NEW SYSTEM FOR AUTOMATIC PROGRAM LOGGING

by Joseph A. Risse\*—Description of a device which automatically records programming on discs for logging purposes.

One of the important FCC requirements of broadcast station owners is that they maintain a daily program log showing certain details concerning each program, commercial, or announcement. Required, for example, is the time each program begins and ends, identification of the sponsor, notations of interruptions in the program (such as from technical difficulties), spot or public-service announcements, etc. These logs must be kept on file for examination on request by the commission, for a period of at least two years. The application for renewal of a station license must be accompanied by regular program logs for a particular composite week specified by the Commission.

At most radio and TV stations, recording the details on this daily operating log is the duty of the studio control operator or the announcer/operator. Keeping the log accurate and current requires considerable time and attention which could be put to other profitable use (e.g., rehearsal of an upcoming spot, performance of certain preventive maintenance, or preparation of a new program).

Early in October, 1962, in response to petitions of station owners and interested manufacturers, the FCC took appropriate action. The Commission granted approval for the recording of the details required in a conventional operating log, by reliable automatic means.

## Automatic Logging Methods

The main requirement of any automatic logging device is that it provide a means to retain complete program transcripts. It should be practicable to later obtain from

these transcripts any information that might be desired; for example, the week long log now required for license renewals. Also, since the information, whether handwritten, typed, or automatically recorded, must be kept on file for a considerable time, a serious storage-space problem would soon be created unless the logging device was a high-density recording type.

One device already available for automatic logging is the **Documenter** (Fig. 1), manufactured by ITA Electronics Corp., Lansdowne, Penn. It was recently developed for use in broadcasting, military, and commercial applications.

The **Documenter** is a disc recorder which furnishes 12 hours of recording on each side of a 9-inch vinyl disc. A 1-year supply of these discs stacks slightly less than four inches high and costs about \$150.00. The 12 hours of recording time per side results from the 2-rpm turntable speed and a recording density of 750 lines per inch. After a 12-hour period of recording, it is necessary to either turn the disc over, or by means of an automatic changeover provision, switch instantaneously to a second recorder.



Fig. 1. The Documenter logging device.

The basic operation of the equipment is similar to that of a conventional turntable. With the required controls and adjustments properly set, the recording arm is placed in position and any one of six inputs is selected. A built-in compression amplifier limits the dynamic recorded range. The frequency response at this slow recording speed is 300 to 3000 cps, entirely adequate for all intended uses. The required audio input level across the 600-ohm balanced circuit is  $-30$  dbm for 0 db of compression. The output level is 5 watts from 500-, 16-, 8-, or 4-ohm taps with rated distortion less than 7.5%, and signal-to-noise ratio  $-30$  db. Turntable wow and flutter are less than 2%.

## Circuit Features

The device consists basically of two major units — the transport system and the electronics system. The transport includes the turntable, motor, arms, etc., and the electronics system includes the vacuum-tube amplifier stages, controls, switches, meters, etc. A schematic of the Documenter is shown in Fig. 2, and a block diagram in Fig. 3.

It is possible to switch between two machines at the end of each 12-hour period of recording. To accomplish this, the Mode switch on the recorder being controlled is set to Auto. It will then automatically be energized by the interconnected machine at the proper time. To use this second machine independently, the Mode switch is thrown to Manual.

## Monitor Amplifier

The monitor consists of two main sections: a preamplifier and a power amplifier. The first two stages, con-

\*Director, School of Electronics, International Correspondence Schools, Scranton, Penn.

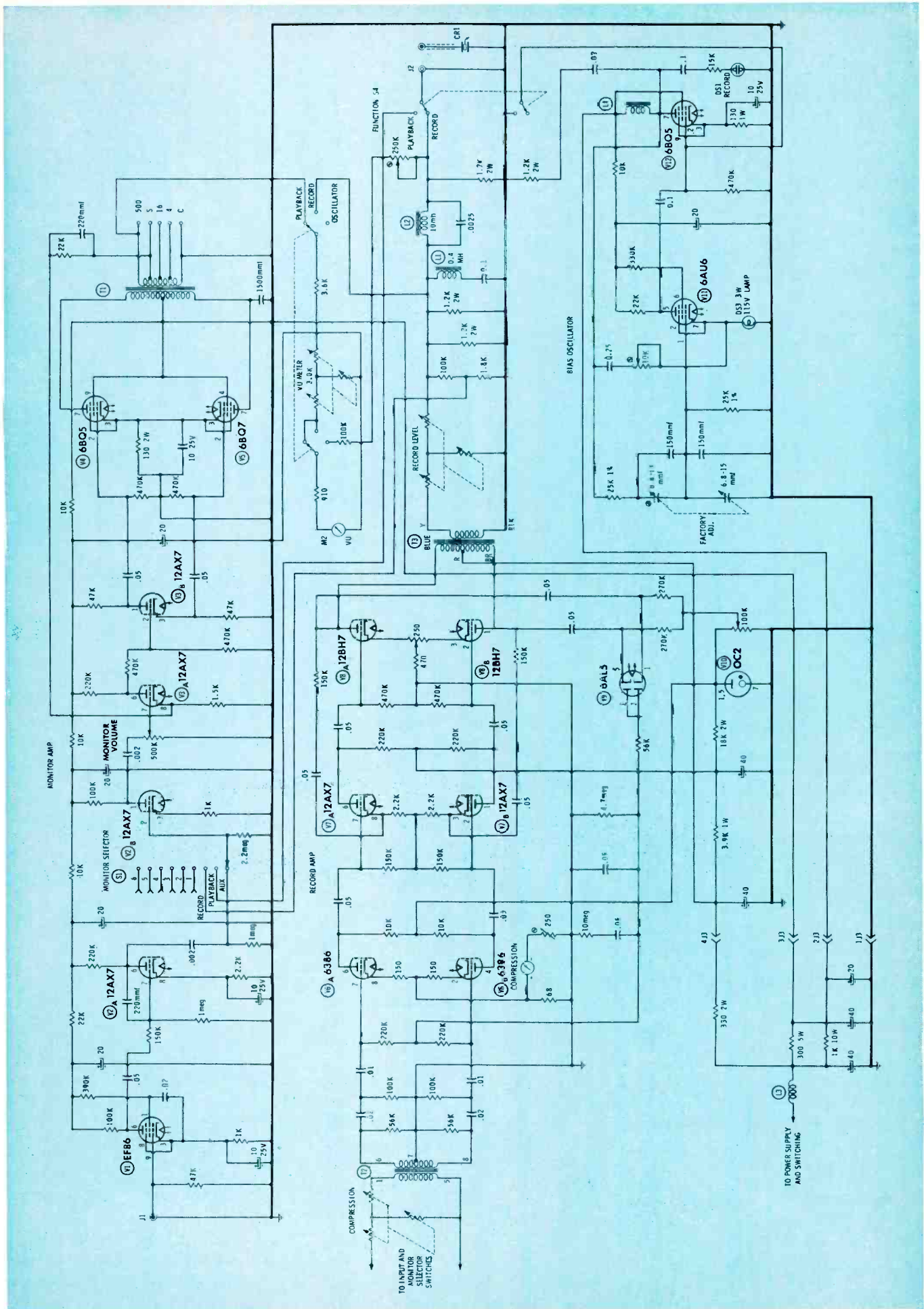
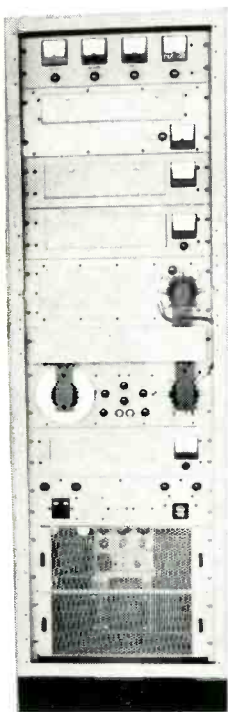

Fig. 2. Circuit of the Documotor automatic program-logging recorder.

# The Sarkes Tarzian HETERODYNE MICROWAVE RELAY



See it at NAB  
Space 17E

## PROVEN PERFORMANCE Where It Counts

Over three years actual in-field use has proven Tarzian's multi-hop microwave delivers exceptional quality color transmission, simultaneously with broadcast quality sound—at lowest possible cost. And, Tarzian's renowned microwave systems engineering department is at your disposal for assistance with planning and installation.



Broadcast Equipment Division  
**SARKES TARZIAN, INC.**  
Bloomington, Indiana

Circle Item 16 on Tech Data Card

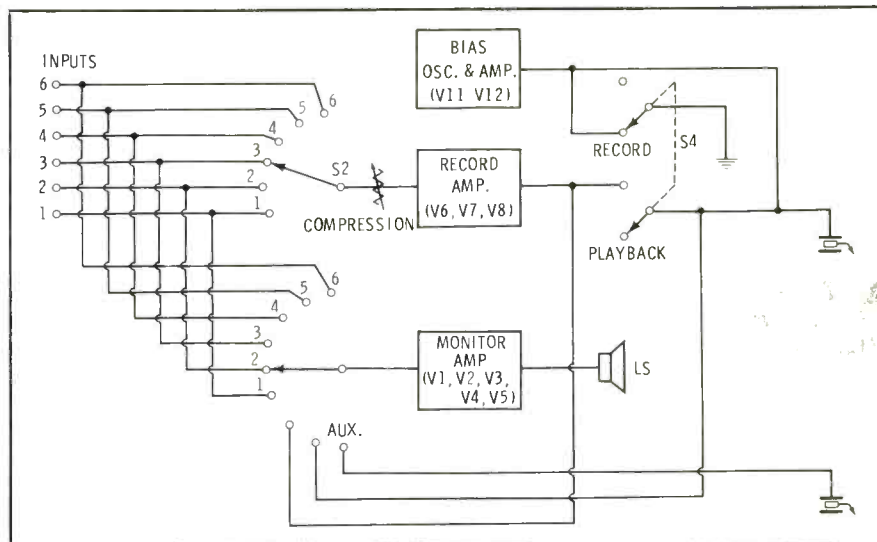

Fig. 3. Block diagram of the program logging device showing input switching.

sisting of V1 and V2, comprise the preamplifier. The second section consists of voltage amplifier stage V2-B, driver V3-A, phase splitter V3-B, and the output amplifier stage made up of V4-A and -B with associated components. The output of the monitor amplifier may be read on the vu meter by setting S3 (the vu-meter function switch) to the playback position.

To improve the frequency response of the monitor amplifier, a feedback network consisting of C9 and R17 is connected from the secondary of output transformer T1 to the cathode, pin 8, of V3.

### Record Amplifier

The record amplifier consists of three push-pull stages balanced for minimum distortion. The compression, adjustable by means of R28 at the input of T2, can be read continuously on compression meter M1. The compression control, R28, is usually set between 8 and 10 db. The controlled stage in the compression circuit employs a remote-cutoff dual triode tube, type 6386 (V6), designed especially for gain-control applications.

The action of the compression circuit is fairly simple. The output of V6 is amplified by V7 and V8. The output of each of the V8 triodes is applied to dual-diode V9 cathodes. Negative half cycles of the audio voltage, above a predetermined value, cause V9 to conduct. This predetermined value (threshold) is set by R79, a voltage divider across regulator V10, which biases the V9 cathodes with a positive voltage. At the plates of V9, a

negative voltage, which varies with the output of V8, is applied through R52, R33, and R34, to the grids (7 and 3) of V6. The RC network consisting of R52 and C21 provides a fast "attack" time (rapid application of bias for a sudden increase in audio level); R46, C21, R41, and C20 provide a release or recovery time which depends on how long this sudden level increase lasts. The longer it lasts, the greater will be the charge on C20, and thus the longer it will take to discharge through R41. The positive voltage across R35, which is common to both cathodes of V6, is proportional to the compression and is indicated on meter M1.

The output of the record amplifier is delivered through output transformer T3 and Record Level control R62, to Function switch S4. In the Record position of S4, the audio is applied, along with the bias amplifier V12, to the recording head CR1.

### Bias Oscillator

The bias oscillator, consisting of a 2-stage amplifier in a wien-bridge circuit (V11 and V12), produces a high-frequency bias for the recording head. The frequency determining components are C32, C33, C34, R80, and R82. Capacitor C35, resistor R81, and lamp DS3 (acting as a continually varying resistor) make up the negative-feedback circuit for the oscillator. With the Function switch in Record, the VU meter in the Bias position should read 100, within 5%. If outside this limit, adjustment of R81 is required. ▲

SAN FRANCISCO

KFAX

50,000 WATTS AM

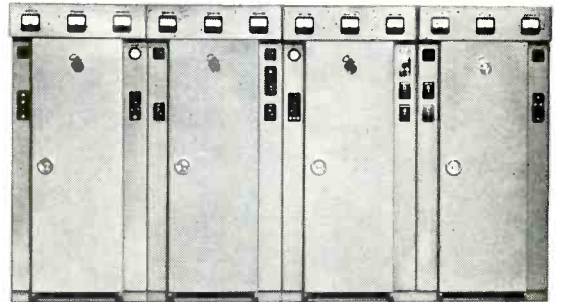

GOES CONTINENTAL



Left to right: Roger L. Roberts, Chief Engineer, A. J. Krisik, President, Argonaut Broadcasting Co., inspecting new Continental Type 317B 50 kw transmitter.

"KFAX purchased its complete 50 kw transmitting plant on a turn-key contract from Continental Electronics. The Type 317B Transmitter has been in service just over a year now, and we are more than pleased with its performance. Frequency response is excellent, and overall distortion including San Francisco studio equipment averages less than 2%. Much of our programming originates at the transmitter, so the actual sound we get on the air is even better than reflected in the overall performance curves. The transmitter operates into a four-element directional antenna with excellent stability. We like the reasonable size of the transmitter, and the accessibility for servicing. Continental personnel have been thoroughly cooperative; and this meant a great deal to us during the construction phase."

*Roger L. Roberts*

Roger L. Roberts, Chief Engineer, Argonaut Broadcasting Co.

For more information on putting the sound of quality to work in your market, write or call:

**Continental Electronics**

PRODUCTS COMPANY • MAILING ADDRESS: BOX 5024 • DALLAS 22, TEXAS  
AD 5-1251 • TELEX CEPCO *LTV* SUBSIDIARY OF LING-TEMCO-VOUGHT, INC.

*Designers and Builders of the World's Most Powerful Radio Transmitters*

See Continental Electronics Exhibit, Booth 25W, NAB Show

Circle Item 12 on Tech Data Card



# INTERPRETING FCC INTERFERENCE RULES

by Dean George Hill\*—An explanation  
of the FCC Rules and Regulations  
limiting the permissible interference a  
proposed station may tolerate.

Within recent months attention has been paid to Sections 3.24(b) and 3.28(d) (3) of the Federal Communications Commission's Rules and Regulations. In his address before the Federal Communications Bar Association on December 13, 1962, E. William Henry, the newest and youngest commissioner, referred to the need for clarification of Section 3.24(b) to eliminate ambiguities which arise when one attempts to apply it in conjunction with Section 3.28(d). Both of these sections, in part, are concerned with the exception if the interference received standard broadcast station is permitted to receive. Section 3.24(b) requires the applicant to show that the proposed station will not suffer interference to such an extent that its service would be reduced to an unsatisfactory degree. Section 3.28(d)(3) prohibits the assignment of a channel to a standard broadcast station if the interference received would affect more than 10% of the population within the normally protected primary service area. This provision is commonly referred to as the "10% Rule."

The normally protected primary service area depends upon the class of the station. For Class III stations which operate on regional channels, normal protection extends to the 0.5 mv/m daytime groundwave contour and either the 2.5 mv/m or the 4.0 mv/m nighttime contour. As can be expected, the existence of two sections concerning permissible interference which a proposal for a new AM station or for an improvement of an existing station may include requires determination as to which section applies. The Commission held in *Suburbanaire Inc.*, 29 FCC 953, 19 RR 1227 (1960), that the

standard in 3.24(b) is given precise meaning in Section 3.28(d)(3). This means that received interference is to be judged on the basis of population affected rather than the area affected. So long as the proposal will not suffer interference affecting more than 10% of the population within its normally protected contour, the amount of the area affected is unimportant; it can be in excess of 10% for the total area within the normally protected contour.

Contained within Section 3.28(d) (3) are two provisions granting exceptions to the 10% Rule. Excepted are nighttime proposals which would give a community its first licensed nighttime station, and nighttime proposals which would provide the first interference-free service to 25% or more of its protected service area.

The Commission viewed the exceptions as a means for furthering two of the three overall objectives of the standard broadcast service—provision of a service with satisfactory signal strength to all areas of the country, and service of local origin to as many communities as possible. This meant, however, a compromise with the FCC policy of favoring only so-called "efficient operations" if the real purpose of the allocation system, the overall objectives, was to be obtained. In effect this was a slight admission of the fact that there is a big difference between an efficient operation under any definition of the term, and an efficient utilization of the channel; and further, it recognizes that the former might best be defined by the latter. There is no doubt that the existence in the Rules of the exception provisions has resulted in what the Commission considers to be a serious problem. However, as will be shown, the problem is not so much the existence of the exceptions, but rather

the choice of language used therein. The provisions provide a blanket exception to any amount of interference suffered, whether this be 30, 40, or 80%. The result has been that while the Commission has seized upon Section 3.24(b) as a means to question some of the nighttime proposals which qualify as exceptions to the 10% Rule, this practice has not been effective in controlling the granting thereof.

It is quite common for a proposed nighttime facility to suffer interference affecting from 30 to 90% of the population within its normally protected nighttime contour. The Commission for several years watched the steady increase in the value of the Nighttime RSS Limitations (interference-free contours) for proposals which qualified as exceptions to the 10% Rule. In time applicants were receiving grants without a hearing where their proposals would barely provide interference-free service beyond, and in some cases not quite to, the 25 mv/m contour. The majority of Class IV stations operating on the local channels usually provide interference-free service to the 15-20 mv/m nighttime groundwave contour. The Commission also witnessed during this period the movement in some cases of an existing daytime only station, licensed for a large city which already had a licensed nighttime facility, to a suburban community which was without a licensed nighttime operation. The purpose of this was to qualify the nighttime proposal as an exception to the 10% Rule; thereby the licensee avoided having to seek a waiver which meant almost certain denial. In addition the FCC was beginning to doubt the effectiveness of one of the exceptions in furthering one of the two overall objectives of the AM allocation system, and was

\*Communications Attorney, Washington, D. C. and Sioux City, Iowa. Member of Iowa bar.



# INDUSTRY'S MOST COMPLETE LINE OF CARTRIDGE TAPE EQUIPMENT



1.

monophonic units

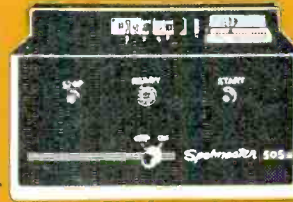

2.



3.

stereophonic units

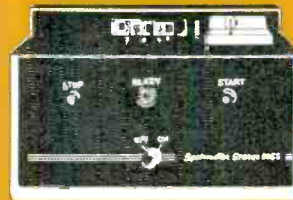

4.



8.

lazy susan



5.



6.

rack mounted units



9.

wall mount cartridge rack



7.

tape cartridge winder



10.

cartridges

This is Spotmaster—the most complete line of quality cartridge tape equipment in the World. Pioneered by Broadcast Electronics, Inc.—Spotmaster equipment is now being used in over 500 radio and television stations in the U.S.A. and in over 100 stations in Canada, Mexico, Europe and Australia.

1. 500—Compact combination cartridge tape recorder/playback unit; 2. 505—Compact cartridge tape playback unit; 3. 500S—Compact combination stereo cartridge tape recorder/playback unit; 4. 505S—Compact stereo cartridge playback unit (also available in rack mount); 5. 500R—7" rack mount combination cartridge tape recorder/playback unit; 6. 505R—7" rack mount cartridge tape playback unit; 7. TP1—Tape cartridge winder; 8. RS200—Lazy susan revolving cartridge rack; 9. RM100—Wall mount cartridge rack; 10. 300, 600, 1200—Tape cartridges.

SOLD NATIONALLY BY: Visual Electronics Corp., 356 W. 46th St., N.Y., N.Y. CANADA — Northern Electric Co., Ltd., 250 Sidney St., Belleville, Ontario. AUSTRALIA—Simon Gray Pty., Ltd., 28 Elizabeth St., Melbourne, C.I.

*Spotmaster*

BROADCAST ELECTRONICS, INC., 6300 BROOKVILLE RD., SILVER SPRING, MD.

questioning the relative importance in another of the overall objectives. The Commission discovered that the substantial increase in the number of nighttime operations had failed to materially decrease the size and extent of the area in the country still without any nighttime primary service. Furthermore, due to the population trends, the Commission began to wonder whether its original concept of separate communities and their individual need for an outlet for local expression was realistic and justified. All these factors led to an impression that the exceptions to the 10% Rule were amounting to a wholesale giveaway of frequencies to marginal operations.

As a result, Section 3.24(b) was seized upon in order to question the extent of interference that a nighttime proposal which qualified as an exception could receive. The Commission regarded the section as a balance in those cases where a proposed station would receive interference affecting more than 10% of the population within the nighttime normally protected contour. But since the "escape provisions" (the exception provisions had fallen into disfavor) of Section 3.28(d) (3) were met, compliance with the latter was not in issue.

The first nighttime proposal challenged by the Commission under its newly discovered authority was that for Station WLAT at Conway, South Carolina, which at the time was operating on 1330 kc, daytime only, with a power of 5 kw. In many respects the WLAT proposal was not the one to be challenged. This proposal seemed to be in harmony with the original intent and purpose of the exceptions. Conway is removed from other large cities. The proposal qualified under not one but both of the exceptions, and also proposed to provide the first nighttime primary service to approximately 10,000 persons — a sizeable population. But because interference-free service would be provided to just the 24.8 mv/m nighttime groundwave contour, resulting in a population loss of 33.5% and an area loss of 88.4% (plus possibly the impatience of the Commission), caused the application for a construction permit to be designated for hearing in 1960 on the issue of whether the proposal was in compliance with Section 3.24(b) of the Rules.

Station WLAT submitted, among other exhibits, an engineering study designed to show the effect that a grant of the WLAT nighttime proposal would have upon the future nighttime utilization of the channel. The study supported the conclusion that the nighttime proposal would have no adverse effect on future utilization of the channel by other assignments, nor would it have any effect in the way of causing interference to future assignments over and above what they would receive in the absence of the WLAT proposal. Existing daytime-only stations, as well as future daytime-only stations which might be assigned in areas under the present standards of allocation, were considered to be sources of future utilization of the channel at night. No reason could be found to justify a denial of the application. Thus the reason given as the basis for the grant was the "complete inutility" of denying the proposed operation. Since the two exceptions to the 10% Rule are the embodiments of two of the three overall objectives of the AM allocation system, a denial of

• Please turn to page 65

## AUTHORIZED IOM Tube DISTRIBUTORS



- |  |   |  |
|--|---|--|
| <p><b>ALABAMA</b><br/>BIRMINGHAM<br/>M G Elect. &amp; Eq't Co.<br/>312 Sixth Ave. South</p> <p><b>ARKANSAS</b><br/>LITTLE ROCK<br/>Carlton-Bates Co.<br/>1210 East 6th St.</p> <p><b>CALIFORNIA</b><br/>ANAHEIM<br/>Federated Purchaser, Inc.<br/>266 N. Manchester</p> <p>HOLLYWOOD<br/>Hollywood Radio &amp; Elect.<br/>5250 Hollywood Blvd.</p> <p>INGLEWOOD<br/>Newark Elect. Co., Inc.<br/>4747 Century Blvd.</p> <p>LOS ANGELES<br/>Federated Purchaser, Inc.<br/>11920 W. Olympic Blvd.<br/>Radio Product Sales<br/>1501 South Hill St.</p> <p>OAKLAND<br/>Brill Electronics<br/>610 E. 10th St.</p> <p>PALO ALTO<br/>Zack Electronics<br/>654 High Street</p> <p>PASADENA<br/>Dow Radio, Inc.<br/>1759-67 E. Colorado Blvd.</p> <p>SACRAMENTO<br/>Beitelman's Elect. Supp.<br/>2616 Marconi Avenue<br/>Sacramento Elect. Supp. Co.<br/>1219 S. Street</p> <p>SAN DIEGO<br/>Radio Parts Company<br/>2060 India St.</p> <p>SAN FRANCISCO<br/>Eber Electronic Supply<br/>2355 Market St.</p> <p>STOCKTON<br/>B. J. DeJarnatt Wh'ise Co., Inc.<br/>715 E. Washington St.</p> <p>SUNNYVALE<br/>Sunnyvale Electronics<br/>534 So. Murphy Ave.</p> <p>VALEJO<br/>Electronics Best Buys<br/>1219 Monterey St.</p> <p><b>COLORADO</b><br/>DENVER<br/>Rapsco-B.A.<br/>1237 16th Street</p> <p><b>CONNECTICUT</b><br/>BRIDGEPORT<br/>Hatty of Bridgeport<br/>2465 Main Street</p> <p>HARTFORD<br/>Hatty of Hartford<br/>100 High Street</p> <p>NEW HAVEN<br/>Radio Shack<br/>230-234 Crown Street</p> <p>WATERBURY<br/>Bond Radio Supp. Co., Inc.<br/>439 W. Main St.</p> <p><b>FLORIDA</b><br/>MIAMI<br/>East Coast Elect., Inc.<br/>1900 N. W. Miami Court</p> <p>TAMPA<br/>Leader Distributors, Inc.<br/>3411 S. Dale Mabry Hgwy.</p> <p><b>ILLINOIS</b><br/>CHICAGO<br/>Allied Radio Corp.<br/>111 N. Campbell Avenue<br/>Newark Electronics Corp.<br/>223 West Madison Street</p> <p><b>INDIANA</b><br/>INDIANAPOLIS<br/>Graham Elect. Supp. Inc.<br/>122 S. Senate Avenue</p> <p><b>IOWA</b><br/>BURLINGTON<br/>Tri-City Radio Supply, Inc.<br/>877 Jefferson St.</p> <p>CEDAR RAPIDS<br/>Iowa Radio Supply<br/>719 Center Point Road N.E.</p> <p>DAVENPORT<br/>Tri-City Radio Supply, Inc.<br/>1205 E. River Rd.</p> <p>DUBUQUE<br/>Tri-City Radio Supply, Inc.<br/>1696 Central Avenue</p> <p><b>KANSAS</b><br/>SALINA<br/>Radio Supply Co., Inc.<br/>1809 S. Broadway</p> <p>WICHITA<br/>Radio Supply Co., Inc.<br/>115 Laura St.</p> <p><b>KENTUCKY</b><br/>COVINGTON<br/>United Radio, Inc.<br/>313 Bakewell St.</p> <p><b>LOUISIANA</b><br/>NEW ORLEANS<br/>Epcor<br/>3622 Toulouse St.</p> | <p><b>MAINE</b><br/>PORTLAND<br/>Maine Elect. Supp. Corp.<br/>148 Anderson St.</p> <p><b>MARYLAND</b><br/>BETHESDA<br/>Empire Elect. Supp. Co.<br/>4907 Rugby Avenue</p> <p>SILVER SPRING<br/>Federated Electronics<br/>1310 Apple Ave.</p> <p><b>MASSACHUSETTS</b><br/>BOSTON<br/>Lafayette Elect. Corp.<br/>110 Federal Street</p> <p>A. W. Mayer Co.<br/>893 Boylston St.<br/>Radio Shack<br/>730 Commonwealth Ave.</p> <p>SPRINGFIELD<br/>Del Padre Elect. Supp.<br/>999 Worthington St.</p> <p><b>MICHIGAN</b><br/>DETROIT<br/>Newark-Ferguson Elect., Inc.<br/>20700 Hubbell Avenue</p> <p>GRAND RAPIDS<br/>Industrial Elect. Supp.<br/>704 Jefferson, S. E.</p> <p><b>MINNESOTA</b><br/>MINNEAPOLIS<br/>Electronic Center, Inc.<br/>107 Third Avenue North</p> <p>ST. PAUL<br/>Electronic Center, Inc.<br/>312 University Ave.</p> <p><b>MISSOURI</b><br/>KANSAS CITY<br/>Burststein-Applebee Co.<br/>1012 McGee Street</p> <p>Walters Radio Supply Co.<br/>3635 Main St.<br/>McGee Radio Co.<br/>1901-07 McGee St.</p> <p>ST. LOUIS<br/>Olive Elect. Supp. Corp.<br/>6662 Olive Street</p> <p><b>NEBRASKA</b><br/>OMAHA<br/>J. B. Distributors Co.<br/>1616 Cass Street</p> <p><b>NEW JERSEY</b><br/>CAMDEN<br/>General Radio Supp. Co., Inc.<br/>600 Penn Street</p> <p>NEWARK<br/>Lafayette Elect. Corp.<br/>24 Central Avenue</p> <p>PARAMUS<br/>Lafayette Elect. Corp.<br/>182 Route 17</p> <p>PLAINFIELD<br/>Lafayette Elect. Corp.<br/>139 W. 2nd Street</p> <p>SPRINGFIELD<br/>Federated Purchaser, Inc.<br/>155 U.S. Rt. 22</p> <p><b>NEW YORK</b><br/>BINGHAMTON<br/>Stack Electronics, Inc.<br/>45-49 Washington St.</p> <p>BUFFALO<br/>Radio Equipment Corp.<br/>147-151 Genesee Street</p> <p>Summit Distributors, Inc.<br/>916 Main St.</p> <p>ELMIRA<br/>ICECO, Inc.<br/>649 Madison Avenue</p> <p>JAMAICA<br/>Lafayette Elect. Corp.<br/>165-08 Liberty Avenue</p> <p>MINEOLA<br/>Arrow Radio<br/>525 Jericho Turnpike</p> <p><b>NEW YORK CITY</b><br/>Arrow Radio<br/>65 Cortlandt Street</p> <p>Bruno-New York<br/>460 West 34th St.<br/>Lafayette Elect. Corp.<br/>100 Sixth Avenue</p> <p>ROCHESTER<br/>Simcona Elect. Corp.<br/>101 Ridgeroad W.</p> <p>SYOSSET<br/>Lafayette Radio<br/>111 Jericho Turnpike</p> <p>VESTAL<br/>Federal Electronics<br/>Vestal Parkway</p> <p>WESTBURY<br/>Adelphi Electronics, Inc.<br/>Jericho Turnpike</p> <p><b>NORTH CAROLINA</b><br/>DURHAM<br/>Womack Elect. Supp.<br/>601-603 Ramseur St.</p> <p>GREENSBORO<br/>Carolina Radio Supp.<br/>838 Huffman St.</p> | <p><b>NORTH DAKOTA</b><br/>MINOT<br/>John Iverson Co.<br/>214 W. 2nd St.</p> <p>WILLISTON<br/>John Iverson Co.</p> <p><b>OHIO</b><br/>CINCINNATI<br/>United Radio, Inc.<br/>1314 Vine St.</p> <p>CLEVELAND<br/>Radio Electronics Parts<br/>3235 Prospect Ave.</p> <p>COLUMBUS<br/>Hughes-Peters<br/>481 E. 11th Ave.</p> <p>DAYTON<br/>Stotts-Friedman<br/>108 N. Jefferson St.</p> <p>YOUNGSTOWN<br/>Ross Radio Co.<br/>325 W. Federal St.</p> <p><b>OKLAHOMA</b><br/>OKLAHOMA CITY<br/>Johnson Wholesale<br/>927 N. W. 1st St.</p> <p>Radio, Inc.<br/>903 North Hudson</p> <p>TULSA<br/>Radio, Inc.<br/>1000 S. Main St.</p> <p><b>PENNSYLVANIA</b><br/>ALLENTOWN<br/>Federated Purchaser, Inc.<br/>1115 Hamilton St.</p> <p>LEWISTOWN<br/>Telo<br/>130 W. Market St.</p> <p>PHILADELPHIA<br/>Herback &amp; Rademan, Inc.<br/>1204 Arch Street</p> <p>PITTSBURGH<br/>Cameradio Co.<br/>1121 Penn Ave.</p> <p><b>RHODE ISLAND</b><br/>CRANSTON<br/>Radio Shack<br/>1301 Reservoir Ave.</p> <p>PROVIDENCE<br/>Electronic Distributors<br/>41 Broadway</p> <p><b>SOUTH CAROLINA</b><br/>GREENVILLE<br/>Carolina Radio Supply<br/>221 W. Washington St.</p> <p><b>TENNESSEE</b><br/>KNOXVILLE<br/>Bonduant<br/>9106 Sevier Ave.</p> <p>NASHVILLE<br/>Electra Distributing Co.<br/>1914 West End Ave.</p> <p><b>TEXAS</b><br/>ABILENE<br/>R &amp; R Elect. Supp. Co.<br/>1010 Pine St.</p> <p>DALLAS<br/>All State Electronics, Inc.<br/>2411 Ross Avenue</p> <p>EL PASO<br/>Midland Specialty Co.<br/>500 W. Paisano Dr.</p> <p>HOUSTON<br/>Angie Electronics Supply Co.<br/>2300 Chenevert St.</p> <p>Busacker Elect. Eq't Co., Inc.<br/>1216 W. Clay St.</p> <p>ODESSA<br/>Midland Specialty Co.<br/>2101 Andrews Highway</p> <p>SAN ANTONIO<br/>Busacker Elect. Eq't Co., Inc.<br/>1216 W. Clay</p> <p>Modern Electronics Co.<br/>910 W. Laurel</p> <p><b>UTAH</b><br/>OGDEN<br/>Ballard Supply Co.<br/>3109 Washington Blvd.</p> <p>SALT LAKE CITY<br/>Ballard Supply Co.<br/>44 East 6th South</p> <p><b>WASHINGTON</b><br/>BREMERTON<br/>C &amp; G Electronics Co.<br/>1301 Pacific</p> <p>CENTRALIA<br/>C &amp; G Electronics Co.<br/>217 So. Tower</p> <p>SEATTLE<br/>C &amp; G Electronics Co.<br/>2221 3rd Avenue</p> <p>TACOMA<br/>C &amp; G Electronics Co.<br/>2502-06 Jefferson Ave.</p> <p><b>WISCONSIN</b><br/>MILWAUKEE<br/>Allied Radio Corp.<br/>2461 W. Center St.</p> <p>Marsh Radio<br/>838 N. 4th St.</p> |
|--|---|--|

**The New Concept**  
 .....  
**in Receiving Tube Reliability and Performance!**

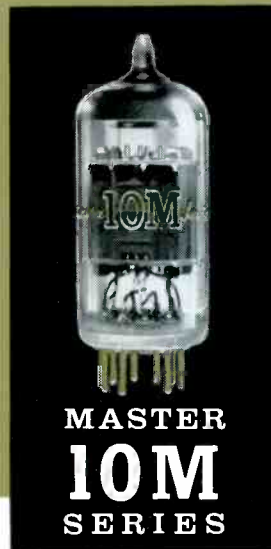

The quality of Mullard electron tubes can be attributed to their design and manufacture...for built into each tube, at the very outset, are basic components and features which will insure long life and performance...engineering achievements such as coiled heaters, unique grid designs and special cathode materials. Each tube reflects advanced techniques in glass-to-metal sealing, evacuation control and precise electrode spacing.

But today, quality cannot be measured by performance or long life alone. New exacting circuits require a new concept of receiving tube reliability, for they

demand more from a tube. The 10M tube has been engineered to satisfy this new concept.

Each 10M tube is subjected, *individually*, to a comprehensive laboratory test procedure based on *extremely tight and stringent parameters* for contact potential, cathode stability, grid cut-off, grid emission, heater current, transconductance, interelectrode leakage...to insure tube-to-tube uniformity...to insure that all electrical specifications are met...to insure section-to-section uniformity...to insure that each tube will operate in a circuit *exactly* as it was designed to perform

and at levels kept within the closest possible tolerances. Each 10M tube is *guaranteed* to provide this exact performance...is *guaranteed* for 10,000 hours within a two-year period...is *guaranteed* for uniformity.

The 10M tube *IS* the new concept of receiving tube reliability and performance.

10M tubes are available *today* to satisfy your tube requirements...and are now in stock at your local 10M distributor (see list alongside). *For further information and technical assistance, write to:*

*International Electronics Corporation*  
 81 Spring Street, New York 12, N. Y.



# HIGH-POWERED UHF TELEVISION

by Donald Quaranta\* — How high-power transmitting tubes and techniques are employed at UHF-television Channel 31 in New York City.



Fig. 1. 6181 beam-power transmitting tube, used as driver amplifier.

NYC-TV, Channel 31 in New York, is unique in many ways. It is not only the first UHF broadcast station in that city, but at present is one of the largest UHF installations in the country.

Channel 31 has already served in many ways. It has given the Federal Communication Commission important technical data about the feasibility of UHF-TV in a large metropolitan area, and has familiarized technical personnel at the station, with major developments in high-powered UHF transmission.

\*Chief Supervisor, Maintenance, WNYC-TV, Municipal Broadcasting System, New York, N. Y.

This article will explain in simple terms some advances in tube design and special techniques which are being used at the Channel 31 transmitter and which have helped to further the art of UHF television.

For years, the biggest problem in transmitting ultra-high frequencies has been due to the limitations of the negative-grid tube, one major factor being instability. At ultra-high frequencies, feedback through the interelectrode capacitances of the tube becomes troublesome. Also the inductance effect of the cathode lead-in causes a loss in tube amplification through input-circuit loading. Finally, as the operating frequency is increased, the problem of transit-time loading becomes apparent. This electronic action hampers both input loading and phasing. It occurs in a vacuum tube because of the finite time required for electrons to travel from the cathode to the control grid and on to the plate.

The high-frequency instability problem of tubes has been combated in several ways, one being special redesign for UHF operation. One well designed negative-grid device employed in the Channel-31 transmitter which has been in television service for years is the RCA 6181 beam-powered tetrode. This ceramic-metal tube is capable of

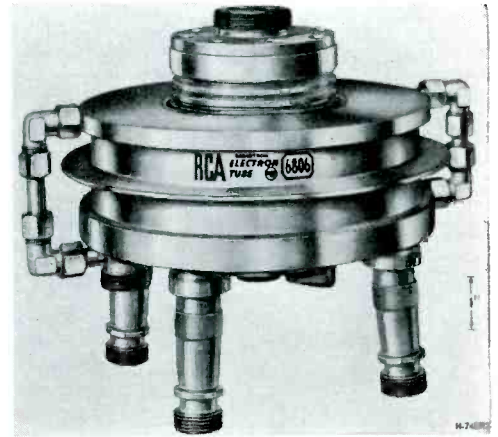

Fig. 2. 6806 high-power beam tetrode tube, used as second driver amplifier.

1200 watts of TV output up to 900 mc. Fig. 1 illustrates the construction used to cure instability in this tube. The elements are arranged in layers; the input and output circuits are thus physically separated, minimizing feedback. Interelectrode capacitance and lead induction effects of the cathode were reduced both in physical design and in circuitry. This tube is of the unipotential cathode type, indirectly heated by a filament. Transit-time effects were minimized by placing the control grid close to the cathode and by using higher plate voltages to increase electron acceleration. The screen grid is aligned with the con-

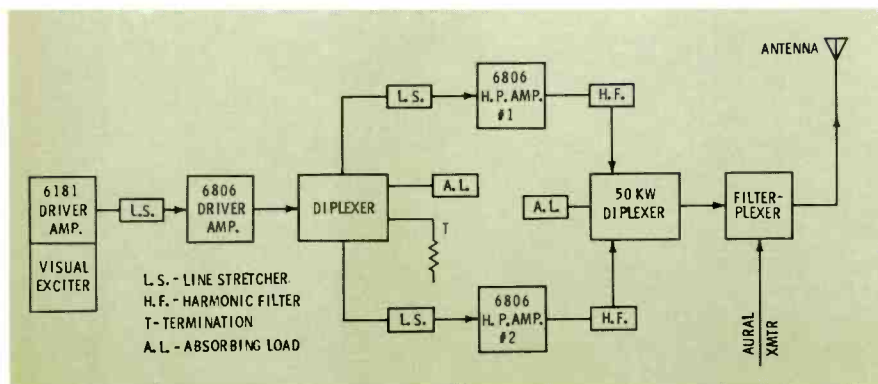

Fig. 3. Block diagram of UHF-television transmitter visual section.

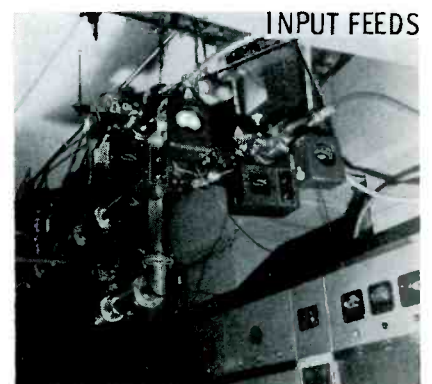
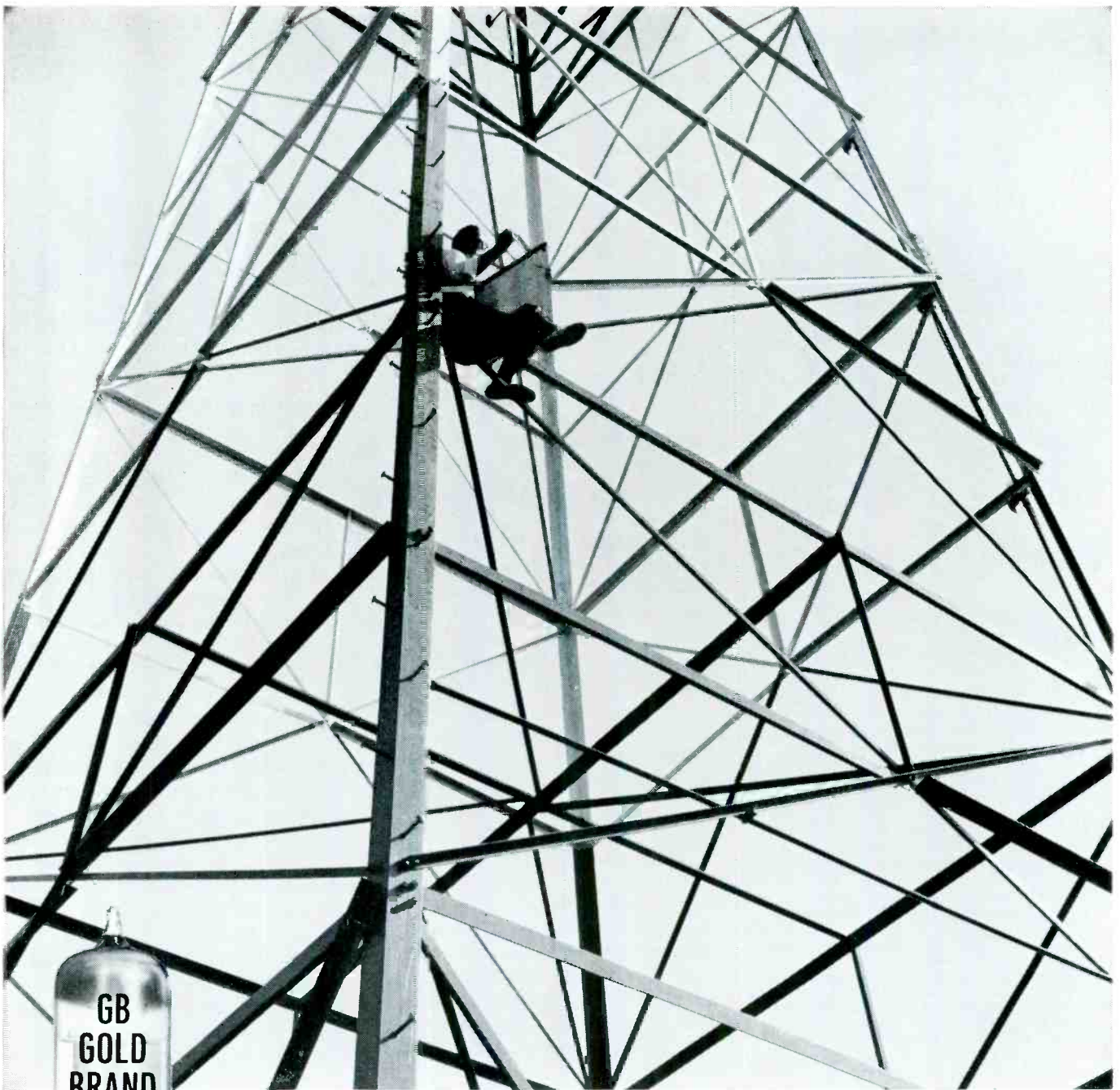

Fig. 4. Input diplexer with meters.



## Tubes designed from the user's viewpoint

...use them wherever reliability is essential

When reliability really counts—as it does in broadcasting—be sure with tubes custom-designed and tested for the job.

Sylvania engineers traveled the country—met with engineers and maintenance groups in broadcasting, public service radio, industry, the airlines—listened to their problems and studied them. From this came GB Gold Brand, a superior line of new and upgraded tubes,

each tailor-made to a specific job. A given tube may have, for example, low noise, exceptional stability or vibration resistance. Or a critical parameter may be as much as three times the usual value. In each case, performance and reliability have been verified by actual user experience as well as laboratory testing.

This extra effort has paid off. "Excellent results," says an airline official. "No failures,"

reports a highway patrol department. "Hundreds of dollars saved in program interruptions," reports a TV station. "Less costly in the long run," discovered a county government. Similar results can be yours with a truly reliable, genuinely interchangeable GB Gold Brand Tube.

Electronic Tubes Division, Sylvania Electric Products Inc., 1100 Main St., Buffalo 9, N. Y.

AVAILABLE FROM YOUR SYLVANIA INDUSTRIAL TUBE DISTRIBUTOR

# SYLVANIA

SUBSIDIARY OF

**GENERAL TELEPHONE & ELECTRONICS**



Circle Item 14 on Tech Data Card

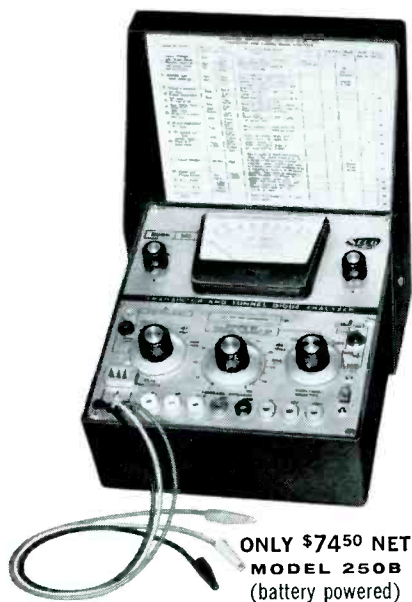

ONLY \$74<sup>50</sup> NET  
MODEL 250B  
(battery powered)

## Complete Transistor Lab

### NEW TRANSISTOR AND TUNNEL DIODE ANALYZER

Look at this "SECO PLUS" — a complete transistor lab for transistors and diodes used in broadcasting equipment! All these functions and advantages in one compact unit.

- Requires no set-up data
- Identifies NPN and PNP transistors immediately
- Provides dynamic GO-No Go test without removing transistors from circuit
- Provides accurate DC analysis of transistors out of circuit
- Indicates transistor leakage and gain
- Matches transistors of similar types by AC dynamic test or DC analysis
- Tests signal and power transistors, also tunnel and zener diodes
- Indicates tunnel diode negative resistance characteristics
- Indicates diode forward conductance and reverse leakage current
- Includes VOM meter with appropriate ranges

Here's the most rapid, complete and accurate semi-conductor test set in the medium priced field. You'd expect to pay much more for a set that—needs no setup data—includes a "speed test socket"—reads BOTH  $I_{cbo}$  and  $I_{ceo}$  leakage currents—subtracts  $I_{ceo}$  leakage for TRUE gain readings. Available in two models: (1) the AC powered 250A at \$86.50; and (2) the "B" battery powered 250B at \$74.50. Choice of metal or wood case. Both include 24" test leads with slim line test prods.

See the new Model 250 Transistor and Tunnel Diode Analyzer at your electronics supply dealer or send in the coupon below for complete information.



SECO ELECTRONICS, INC.  
1219 South Clover Drive, Minneapolis 20, Minn.  
Please rush information on the Model 250 Transistor and Tunnel Diode Analyzer plus full line folder describing complete range of Seco test equipment.

NAME \_\_\_\_\_  
COMPANY \_\_\_\_\_  
ADDRESS \_\_\_\_\_  
CITY \_\_\_\_\_ STATE \_\_\_\_\_

Circle Item 13 on Tech Data Card

control grid so that electron beams pass through instead of striking them. The result is higher tube efficiency and lower screen current. This tube is usually cathode-modulated and employed as a driver for a high-powered amplifier.

As the art of UHF progressed toward higher power, additional problems arose. One such difficulty was the dissipation of heat. There had to be continuous compromises in design of both tube elements and envelopes. This is because large elements are needed to handle the higher currents, while small elements are required for reduced interelectrode capacitance.

A tube that fits these needs, and which is used in the Channel 31 operation, is the RCA 6806 beam powered tetrode (Fig. 2). It is capable of 28-kw TV output at 550 mc. The electrodes are closely spaced to reduce transit-time effects, and are made as small as possible since water cooling is employed.

To operate up to 50 kw of visual power, as in the case of Channel 31, special diplexer techniques are employed. Fig. 3 shows a block diagram of the transmitter visual section.

The 1-kw 6181 amplifier is used to drive a 6806 amplifier. Normally, in the case of a 25-kw transmitter this would be the final high-powered output stage going into the filterplexer and antenna. But in order to attain the power required in this transmitter, the output of the single 6806 is used as a second driver stage feeding a special input diplexer. This device divides the power output of the 6806 driver and feeds two additional 6806 amplifiers in parallel to develop the final 50 kw.

Fig. 4 shows the input diplexer suspended above the driver stage. The output of the 6806 driver feeds a tee network where the driving power is evenly split to feed each input probe of the parallel 6806 final amplifiers. To minimize tuning interaction of the final amplifiers and to provide good stability, an absorbing load is also inserted as part of the diplexer. The output loading of the driver is tuned exceptionally broad, thus reducing the gain of the stage, and limiting driving power into the final high-power amplifiers. Metering and monitoring circuits are placed at input and out-

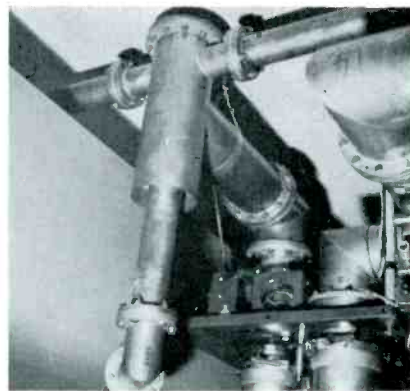

Fig. 5. 50-kw output diplexer fed by parallel 6806 final amplifiers.

put points to simplify the complete tuning operation. The outputs of the parallel 6806 final amplifiers feed an output diplexer which acts in reverse to the input diplexer; it has two output lines terminating into one.

Fig. 5 shows the output transmission lines of the 6806 final amplifiers combining into the 50-kw output diplexer, cut for Channel 31 operating frequency. These techniques are possible in UHF circuits because of the small operating wavelengths which make practical the construction of compact diplexers.

The combined high-powered visual output goes into a special waveguide filterplexer (Fig. 6) which has constant input impedance, and is constructed of heavy gauge metals to eliminate the need of extra cooling or pressurizing gear. Here the lower sideband from the visual transmitter is attenuated, the resulting signal is diplexed with the output of the aural transmitter, and the combined power is fed into a single output transmission line to the antenna.

As UHF broadcasting becomes more popular in the coming years, we can look forward to newer techniques and higher power tubes with special cooling features. ▲

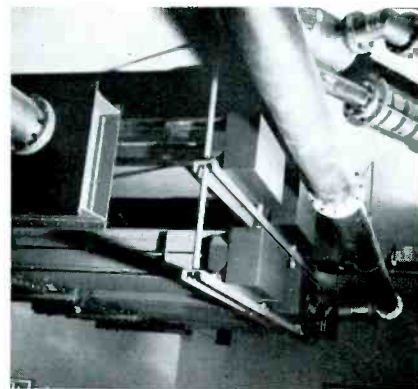
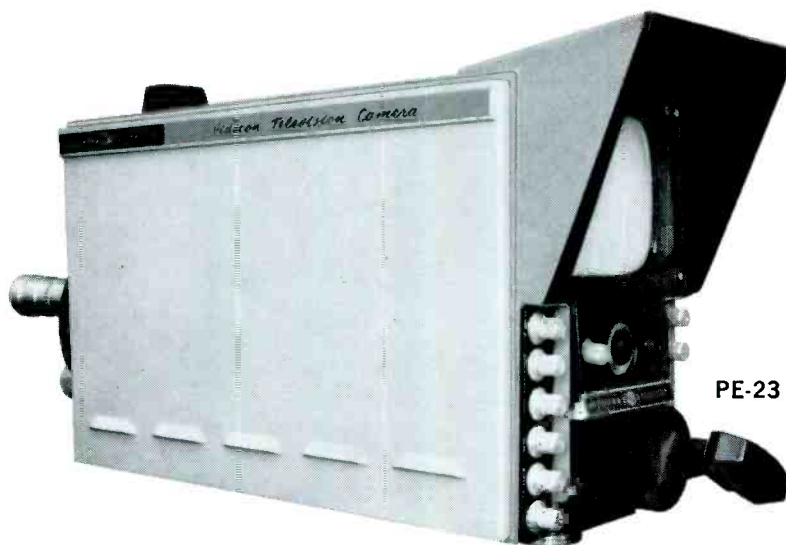

Fig. 6. Constant impedance filterplexer.



**This reliable camera is best for 20% of your live shows**



**This new one handles all the rest at one-tenth the cost/hour**

The top camera is General Electric's 3"/4½" image orthicon TV camera, Type PE-20. Over a year of field experience has proved its unmatched reliability for "action" shows requiring I-O performance (probably about 20% of your shows).

The new one below is the first truly professional transistorized studio vidicon camera—General Electric's Type PE-23. It offers outstanding performance for such studio productions as news, panel, and quiz shows (which constitute up to 80% of today's live studio programming). The

PE-23's initial cost is 50% less and its operating cost is 90% less than its I-O counterpart. For more data, contact your General Electric Broadcast Equipment Representative, or write Technical Products Operation, 212 W. Division St., Syracuse 8, N.Y.

*Progress Is Our Most Important Product*

**GENERAL  ELECTRIC**

# A PROFILE OF THE NAB ENGINEERING DEPARTMENT

by George W. Bartlett\* — The functions, services, and activities of the National Association of Broadcasters' Engineering Department.

The NAB Engineering Department deals with all aspects of radio and television. Primarily, its activities relate to domestic problems of member stations; but occasionally, the Association participates in international work such as the International Radio Consultative Committee (CCIR) Study Group X, which is concerned with broadcasting.

Close liaison is maintained with the engineering departments of various other broadcasting organizations such as the European Broadcasting Union (EBU), the European counterpart of the NAB, the Canadian Association of Broadcasters (CAB), and the British Broadcasting Corporation (BBC). Liaison is accomplished through exchange of basic information, publications, engineering aims, and goals, as well as periodic visits on the part of EBU, CAB, and BBC engineering divisions to Washington. Such topics as standards, automation, frequency allocations, satellite communications, operational techniques, developmental programs, and special projects are freely discussed. These meetings assure the technical interchangeability of international programming.

Domestically, the Department participates in many governmental/industrial panels and organizations whose activities have a direct bearing on broadcasting and its ability to provide efficient service. Until recently, for example, one day a week was usually spent by Engineering Department Staff attending meetings of the Washington Airspace Panel which recommended to the FCC whether or not a proposed tower, or tower height modification, was an unwarranted hazard to aeronautical navigation. The NAB, as an association member of the Panel, represented the broadcasting industry on an overall basis providing technical information when re-

quested. Another example was participation on the Joint Industry/Government Tall Structures Committee (JIGTSC) which was established to review and ultimately recommend a new tall-tower lighting and marking criteria for inclusion in Part 17 of the FCC Rules. Proposals of the committee in the area of lighting and marking are now being evaluated and field-tested by the Federal Aviation Agency (FAA).

Other recent undertakings pertained to the Television Allocations Study Organization (TASO) charged



\*Manager of Engineering, National Assn. of Broadcasters, Washington, D. C.

with studying and evaluating VHF/UHF TV propagation and transmission. The Department also participated in the FCC UHF-TV experimental television project which has just been concluded in New York City. The project was designed to determine the feasibility of assigning UHF-TV channels to a large metropolitan area. There are, of course, many other examples of Engineering Department participation.

The Department cooperates with other technical societies and organizations and is currently taking part in various efforts with such groups as the Institute of Radio Engineers (IRE), The Society of Motion Picture & Television Engineers

(SMPTE), American Standards Association (ASA), American Institute of Electrical Engineers (AIEE), and the Electronic Industries Association (EIA). All of these efforts directly involve broadcasting, and the NAB Engineering Department represents the industry. This representation involves participation on IRE committees including Video Techniques, Audio Recording Characteristics, Video Tape Measurements; SMPTE committees such as Video Tape Standardization, and the Advisory Committee to the President on Television Matters; ASA Aural Tape and Disc Standards committees; and AIEE committees covering TV and Aural Broadcasting Systems, and Power Line Interference to Radio and Television Reception. The Department also serves as the industry representative on the Federal Communications Commission's National Industry Advisory Committee (NIAC) which concerns itself with AM, FM, and TV broadcasting in time of emergency, and the Commission's Radio Propagation Advisory Committee (RPAC).

There are two standing committees of the NAB pertaining to the work of the Engineering Department: the Engineering Advisory Committee and the Broadcast Engineering Conference Committee. These groups function on overall matters relating to the industry and in preparation for the annual Broadcast Engineering Conference held concurrently with the NAB Convention (which this year will be held at the Conrad-Hilton Hotel in Chicago, March 31 through April 3).

This year the Engineering Conference Committee is under the chairmanship of Mr. Orrin Towner, WHAS, Louisville, Kentucky. Other members are William S. Duttera, NBC; James D. Parker, CBS Television Network; Frank Marx, ABC;



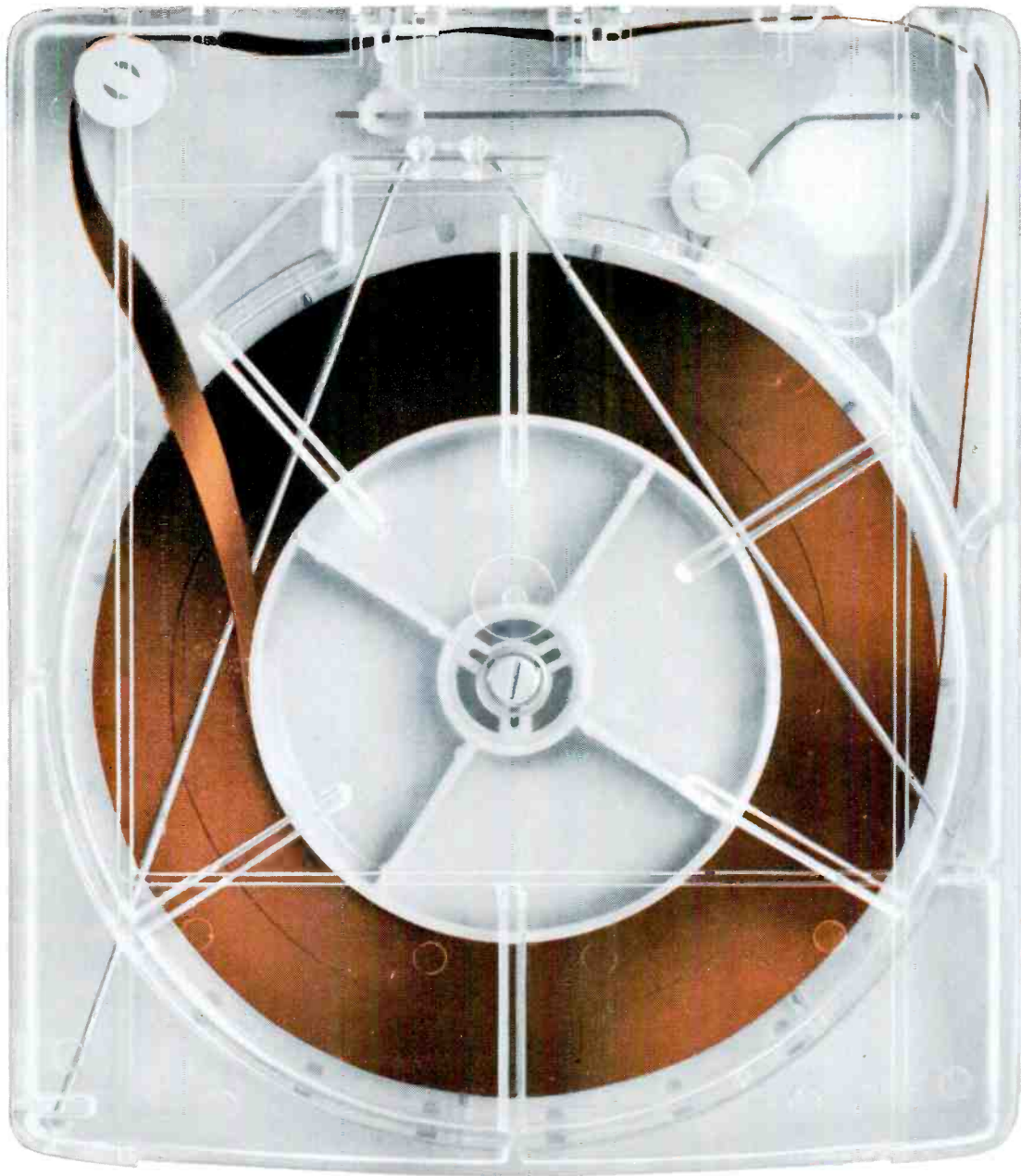

## Glutton for punishment

*(Soundcraft's new Uni-Lube cartridge tape)*

Soundcraft Uni-Lube is the new longer-wearing cartridge tape that plays and plays and play and plays. It meets the punishing conditions of endless loop cartridge applications head on—and comes back for more!

Uni-Lube is a Mylar<sup>®</sup> base tape, oxide-coated on one side, lubricated on the other. The base is coated with PERMA-GRAPH, a new permanent anti-static lubricant that keeps the tape free of friction during playback, eliminating the problems of heat and tape deterioration and assuring uniform tape motion.

The other side of Uni-Lube is coated with Soundcraft's new, durable, *ultra-thin oxide formulation* that produces maximum short wave length signal-to-noise characteristics

for low speed systems. Short wave sensitivity is *3 to 5 db higher* than standard tapes. This remarkable oxide coating records the widest dynamic range ever achieved on a cartridge tape.

The combination of the physical properties of the "Mylar" base, the PERMA-GRAPH lubricant and the new oxide formulation result in the longest-wearing cartridge tape available today—a tape free from friction—free from shedding and head fouling—free from breakage and the effects of heat, cold and humidity. *This is the cartridge tape you've been waiting for.* Available in 1 mil "Mylar" and the new  $\frac{3}{4}$  mil Tensitized "Mylar" for extra strength and longer play. Write for complete details. \*DuPont T.M.

### REEVES **SOUNDCRAFT** CORP.

Main Office: Great Pasture Rd., Danbury, Conn. • New York: 10 E. 52nd St. • Chicago: 28 E. Jackson Blvd. • Los Angeles: 342 N. LaBrea • Canadian Reps: Toronto • Vancouver

Circle Item 18 on Tech Data Card

# SPRAGUE®

## MODEL 500

### INTERFERENCE LOCATOR

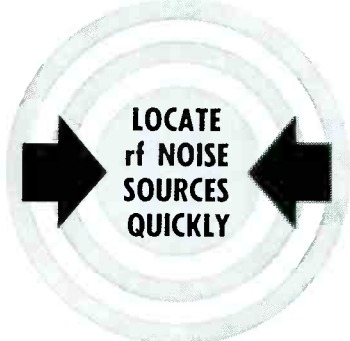

This versatile instrument is a highly sensitive interference locator—with the widest frequency range of any standard available unit! Model 500 tunes across the entire standard and FM broadcast, shortwave, and UHF-TV spectrums from 550 kc. to 220 mc. in 6 bands.

It's a compact, portable, rugged, versatile instrument—engineered and designed for most efficient operation in practical field use. It features a transistorized power supply, meter indications proportional to carrier strength as well as sensitivity of 5 microvolts minimum for 5% meter deflection over entire tuning range.

For full details, send for brochure IL-106.

**SPRAGUE ELECTRIC COMPANY**  
475 Marshall Street, North Adams, Mass.



GET THE FULL STORY AT IEEE BOOTH 2424  
Circle Item 19 on Tech Data Card

Leslie Learned, Mutual Broadcasting System; Joe Epperson, Scripps-Howard Stations; James Gray, WYDE; Albin Hillstrom, KOOL; Clyde Hunt, Post-Newsweek stations; and Jack Petrik, KETV. Other committees are established from time to time on an ad hoc basis dealing with specialized problems. Recently such ad hoc committees have dealt with AM/FM allocations and changes in the technical rules pertaining to these two services.

On behalf of the broadcasting industry, the Department works toward simplification of certain FCC rules and regulations which would benefit from updating in consonance with the state of the art. Participation is required in many rule making proceedings of the FCC, such as remote pickup allocations for TV and radio, FM allocations, AM development, microwave frequencies, and numerous others. In many of these matters, cooperation is requested of manufacturers and stations in supplying information which can best be presented to the FCC by an overall industry spokesman.

One question perhaps needs a little elaboration — how can member stations of the NAB use the Engineering Department? First, it should be explained that the constitution and by-laws of the Association preclude the Department from engaging in a consulting practice competing with established firms. The Department is not permitted to undertake frequency searches, directional antenna design, proof-of-performance measurements, the equipment adjustment, or other services normally performed by consulting engineers. The Department, however, serves in the capacity of a third hand for the station engineer. In looking over the approximately 1000 letters per year which are answered, several examples represent the ways the Department serves member stations.

The diverse subjects covered in the correspondence pertain to such matters as: remote pickup frequencies, cost and services of common-carrier facilities, hours of station operation, stereo broadcasting, the obtaining of used equipment, station layouts and floor plans, labor problems, automation, remote control, etc.

During the past ten months, the Department has been engaged in three projects worthy of special note. One is a series of field experiments and tests, in cooperation with several stations and manufacturers, for studying the development of a system to remotely control television transmitters. A second project concerns itself with the development and field-testing of a remotely controlled phase monitor, and the third is the updating of the NAB Recording and Reproducing Standards. This last undertaking is monumental in scope—approximately 50 industry engineers are participating. The project involves the revision of the 1953 Disc and Magnetic Tape Recording and Reproducing Standards, which are considered an industry "Bible," and the inclusion of standards pertaining to cartridge tapes and systems. These standards are designed to assure the interchangeability of recorded programs for use in the broadcasting industry.

Over the past few years various technical publications of the Engineering Department have been made available to member stations. Most stations are familiar with the 5th edition of the NAB Engineering Handbook, a technical manual of over 1700 pages dealing with the subjects of radio and television.

The Department also publishes a monthly technical bulletin entitled, "Engineer's Corner." It is mailed to the Association membership and contains timely information on matters of general interest. Recent bulletins pertain to FCC technical violations, stereo broadcasting, their allocation and usage of microwave frequencies, video tape, remote pickup equipment, etc.

Another Engineering Departmental function is industry surveys to determine electronic health, utilization of auxiliary broadcast frequencies, equipment, practices, etc. Data from these surveys are extremely helpful when formulating basic departmental policy and often serve as guide lines in Commission filings. Surveys also provide the Association with industry information considered pertinent and timely.

These then, are the activities, functions, and goals of the NAB Engineering Department . . . an organization dedicated to maintaining one of the world's finest broadcasting systems. ▲



## THE 41st ANNUAL NAB CONVENTION AND ENGINEERING CONFERENCE A Welcome From the President

This year will mark the 41st anniversary of the National Association of Broadcasters Annual Convention. This Convention is steeped in a proud history of broadcasting progress and technological advancements.

For the past 17 of these 41 years, our Annual Broadcast Engineering Conference has been operated concurrently with the Convention. The Engineering Conference is designed, programmed and directed toward the engineering phase of our industry, and is of prime interest to all our technical people.

Although this aspect of our Convention is but 17 years young, it represents more than four decades of technical progress—progress which began with the advent of the crystal detector and catwhisker, the Quaker Oats coil form and the traditional headset. During the ensuing years we have watched our technical fraternity accomplish such wondrous developments as the vacuum tube, the loudspeaker, ganged tuning, and the superheterodyne that brought about the state of the art as we know it today.

You will find evidence of these great achievements in the Exhibit Halls this year—displays dealing with stereophonic broadcasting, automatic programming, automation devices and new AM/FM/TV transmitters. In addition, there will be countless other pieces of broadcast equipment and systems which attest to our continuing efforts to improve the end product and provide the public with the best possible service.

The National Association of Broadcasters is extremely proud of its role in these developments and of its part in making available the opportunity for this fascinating display. The 1962 Exhibit required nearly 28,000 square feet of floor space, and was the largest ever assembled, but the 1963 Exhibit will surpass this in size.

The 1963 Convention will undoubtedly be our finest, and it is a fitting tribute to a strong and vigorous association that we are able to offer such an excellent technical program in addition to the Exhibit.

Let me take this opportunity to welcome you to the 41st Annual NAB Convention.

LeRoy Collins  
President,  
National Association of  
Broadcasters



## CHALLENGE—UHF TV

### A Message From the Chairman of the FCC

*Newton S. Minow*

In the last few years I've become acquainted with the engineering side of the broadcasting industry. Although I can't yet speak all the language, parts of it come through loud and clear.

One basic point I've learned is about engineers in general — the minute one of these admirable fellows finds out that a particular problem can't be solved, he proceeds to solve it. It may take awhile, but sooner or later, up comes the answer.

And I have learned something else. While engineers are professionals, they seem not to exhibit that so-called "professional jealousy" that one hears about in other endeavors. In fact, when one engineer can't seem to find an answer to a problem, he doesn't hesitate to call on one of his friends for help, and if the problem is big enough, the whole fraternity joins in the search for the answer. I suppose there are some engineering problems that are insoluble, but in my two years with the Commission, every problem I have heard about either has been solved or is on its way toward solution — no failures.

This brings me to the subject of this message.

As you are well aware, the Commission has been trying for years to come up with a way to encourage UHF television. Finally, last year a legislative step was taken to breathe vitality into UHF. Of course, I am talking about the all-channel TV receiver legislation.

We know that the establishment of an adequate educational TV network depends on effective use of the UHF TV channels. And the expanded use of UHF TV will unlock new competitive opportunities for our commercial television system. Many communities will be able to have their own local TV stations where none now exist.

Engineers are especially knowledgeable about the importance of education — educational TV will help solve many of our national problems, and extend the range of gifted teachers to countless youngsters.

Engineers also know the value of competition. Our television system is based on choice to the public — the wider the choice, the better. Added services will

help ensure that the great public benefits obtainable through a national competitive TV system will be available to all of us.

The passage of the all-channel TV receiver legislation will not automatically bring all of these good things about. The reason is that there are one or two engineering problems still to be solved.

First, but not necessarily the most important, the public will expect the same type of channel tuning used on present VHF TV sets. I know this problem has already been recognized by engineers in the receiver industry, and that manufacturers are now studying the problem — but this problem is of equal concern to the broadcast engineers working in the TV industry. We are confident that the tuning mechanism on a UHF TV set two or three years from now will be much improved through imagination and talent.

Second, I am told that one of the reasons that UHF TV doesn't give the same kind of coverage as VHF is due to the greater sensitivity of the "front end" in the VHF tuner with its RF amplifier stage. Engineers will lick this problem too. It is utterly amazing to me that a few db increase in signal to noise ratio in a receiver is equivalent to raising the TV transmitter power by several times.

A third question is UHF propagation problems — I guess everyone is willing to admit that one of the reasons it is more difficult to cover a given area with UHF than with VHF is due to differences in propagation losses. I have heard it said that UHF can never compete with VHF due to this factor. I don't believe it! If it were true, Channel 13 could not compete with Channel 2, but it does! Sure, a couple of tricks serve to help this — for example, a station on Channel 13 can use about three times the power authorized for Channel 2. I understand there are plenty of engineering problems involved in obtaining really high power, in the order of megawatts, on UHF. But it will be done. And when it is, I predict that discussions of differences in VHF and UHF TV propagation will become about as obsolete as a scanning disc.



**Robert W. Flanders,**  
Dir. of Eng., WFBM Stations,  
Indianapolis, Ind.

A short time ago we were blithely saying that intercontinental TV would be a certainty; how quickly and successfully this step has been accomplished. Many other "exotic" communication developments — lasers, masers, micromodules—will soon become working realities. However, the "processing line" in the realm of everyday broadcasting has high on its list the exciting advance in color, the rewarding economy of solid-state devices, and the stringent requirements of picture performance demanded by today's sophisticated audiences.

The operating engineer must be freed from routine functions (which can be performed by mechanical and/or electronic methods) and allowed to concentrate his energies toward a constant vigil over picture quality. Maintenance and supervision will become the passwords!

As the operating engineer expands into the more complex technical regions, his need for greater knowledge requires an expanded, more intense educational program on a continuous basis. Encouragement of and participation in such a program is the responsibility of all forward thinking broadcasters.



**Frank Marx,**  
President, ABC Engineers,  
New York, N. Y.

The techniques and equipment being used in broadcasting today are considerably more refined and more efficient than those used in the earlier days of radio and television.

# LOOKING AT THE FUTURE

The introduction of such advances as solid-state and automated equipment calls for a new breed of engineer. As the broadcasting industry makes more widespread use of such improvements, the education and skill of the technical people in the industry must, by necessity, be greater.

Still more important breakthroughs are on the way. Television will find its young history repeating itself. In the early days there was low VHF television and high VHF television. Today, there is no difference to the viewer. At some point in the future, the viewer will not know he is watching VHF or UHF television. He will not have to fiddle with the set to select a high or low channel.

The same applies to radio. Someday the listener will be able to choose from the full range of program sources without differentiating between AM and FM.

In both cases, the customer (viewer or listener) will be able to pick what he wishes from a greater number of program choices.

History will repeat itself in one other form. Just as radio turned from communal entertainment to a very personal companion with the advent of the transistor radio, so too will television. Miniature television receivers are already finding impressive acceptance. Television, the world's most personal and effective means of communication, is going to become even more personal.



**Lawrence J. Cervone,**  
Vice President - Sales,  
Gates Radio Co., Quincy, Ill.

Broadcasting in 1963 can reach higher standards of excellence if signal quality and reliability are made key objectives in equipment planning. Transistorized broadcast equipment provides a step forward in the continued advances of broadcast engineering. Performance of this equipment exceeds that of vacuum-tube devices. The advantages of solid-state equipment include lower power consumption, reduced heat with a corresponding reduction in air conditioning needs, improved electrical stability and reliability, increased life of all components due to lower heat, greater personal safety due to lower operating voltages, and less

stringent space requirements due to smaller size.

Designing with transistors provides the broadcaster with unsurpassed performance characteristics, such as amplifiers of high output levels with distortion of less than .25% over the entire dynamic range. Even more astounding things are yet to come as we approach the reality of solid-state transmitters.

It is in the area of solid-state products that industrial engineering advances will continue for the benefit of broadcasting. The station engineer has a responsibility to keep abreast of current engineering developments and to maintain the highest engineering standards in his station.



**D. Ridgely Bolgiano,**  
General Manager, WDHA-FM  
Dover, N. J.

FM automobile radios will be the next mass consumer step. To serve this audience many stations will install vertically polarizing antennas in addition to their present horizontal radiators. Several stations on each coast are now transmitting equal power in both planes and achieving excellent results in reduction of multipath flutter and increased signal strength for their small mobile listening public. My experience with vertical polarization at WDHA-FM indicates that the installation is not difficult.

Stereophonic broadcasting will become standard for at least part of the broadcast day for almost all FM stations which do not simulcast AM or operate with an SCA subchannel. Along with this development, measurement standards for FM-stereo transmissions will be achieved with the introduction of at least two competing monitors; however, the FCC will not approve standards for type acceptance before 1965. Station operators will learn that FM stereo is a promotion tool (and an excellent one if handled properly), and not a sales tool. Sponsors will still buy airtime on the basis of total or demographic audience and not on the basis of an FM-stereo audience alone. Hi-fidelity manufacturers will not greatly increase their spending with FM-stereo stations, except in very isolated instances; even then, they will be more interested in reaching the monophonic audience.

Special NAB section

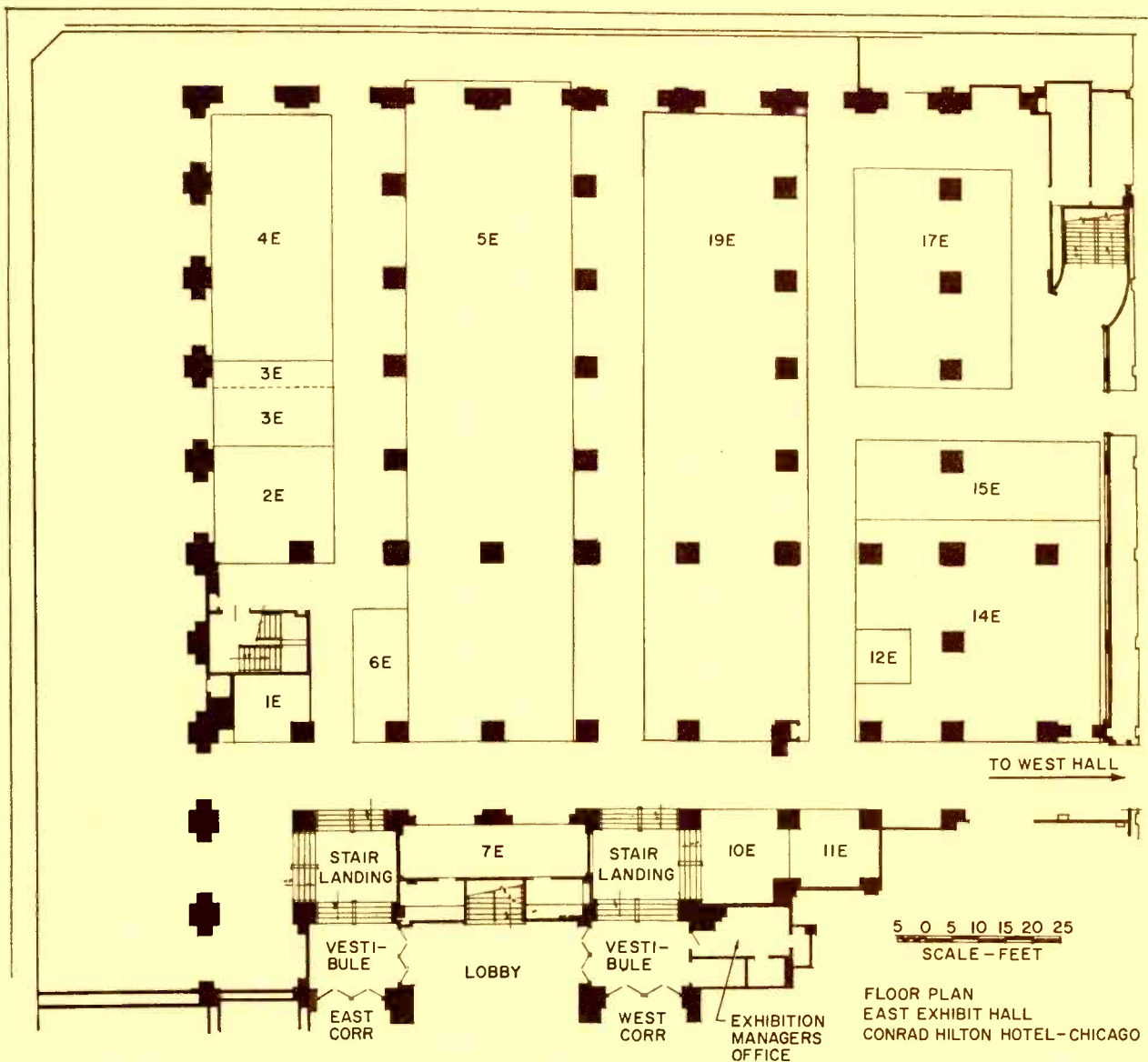

## NAB ASSOCIATE MEMBER EQUIPMENT MANUFACTURERS EXHIBITING AT NAB CONVENTION

Conrad Hilton Hotel, Chicago, Illinois, March 31 - April 3, 1963

**Aitken Communications, Inc.**  
305 Harrison St., Taft, Calif., 64W

**Alford Manufacturing Co.**  
299 Atlantic Ave., Boston 10, Mass., 21W

**Ampex Corp.**  
934 Charter St., Redwood City, Calif., 28W

**Andrew Corp.**  
P.O. Box 807, Chicago 42, Ill., 70W

**Automatic Tape Control, Inc.**  
209 E. Washington St., Bloomington, Ill., 22W

**Bauer Electronics Corp.**  
1663 Industrial Rd., San Carlos, Calif., 56W

**Boston Insulated Wire & Cable Co.**  
65 Bay St., Boston 25, Mass., —

**CBS Laboratories Div.**  
227 High Ridge Rd., Stamford, Conn., 72W

**Chrono-Log Corp.**  
2583 W. Chester Pike, Broomall, Pa., 47W

**Collins Radio Co.**  
5200 C Ave. N.E., Cedar Rapids, Ia., 27W

**Conrac Division**  
**Giannini Controls Corp.**  
19217 E. Foothill Blvd., Glendora, Calif., 7E

**Continental Electronics Mfg. Co.**  
4212 S. Buckner Blvd., P.O. Box 17040,  
Dallas 17, Tex., 25W

**Dresser-Ideco Co.**  
875 Michigan Ave., Columbus, O., 61W

**Dynair Electronics, Inc.**  
7564 Broadway, Lemon Grove (San Diego),  
Calif., 49W

**Electronics Applications, Inc.**  
80 Danbury Rd., Route No. 7, Wilton,  
Conn., 20W

**Electronics, Missiles & Communications**  
262 E. Third St., Mount Vernon, N.Y., 53W

**EMI/US**  
1750 N. Vine St., Los Angeles 28, Calif., 4E

**Federal Manufacturing &  
Engineering Corp.**  
Television Specialty Co. Div.  
1055 Stewart Ave., Garden City,  
L. I., N. Y., 55W

**Gates Radio Co.**  
123 Hampshire St., Quincy, Ill., 44W

**General Aniline & Film Corp.**  
Ozalid Div., Binghamton, N. Y., 63W

**General Electric Co.**  
212 W. Division St., Syracuse, N. Y., 19E

**General Electronic Labs., Inc.**  
195 Massachusetts Ave., Cambridge 29,  
Mass., 41W

**GPL Div. — General Precision, Inc.**  
63 Bedford Rd., Pleasantville, N.Y., 12E

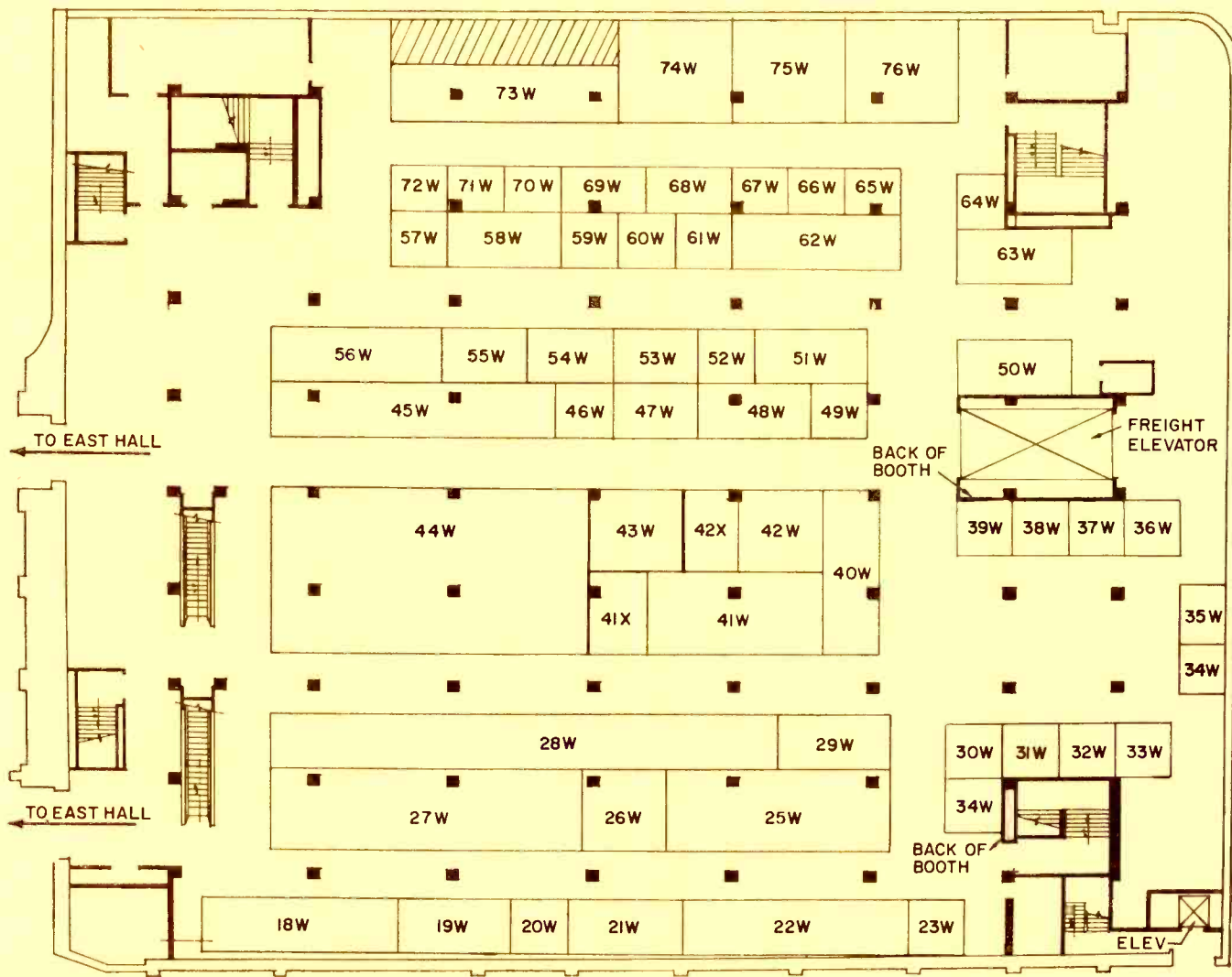

5 0 5 10 15 20 25  
SCALE - FEET

FLOOR PLAN  
WEST EXHIBIT HALL  
CONRAD HILTON HOTEL-CHICAGO

- Harwald Co., Inc.**  
1245 Chicago Ave., Evanston, Ill., 68W
- International Business Machines Corp.**  
618 S. Michigan Ave., Chicago 5, Ill., 18W
- International Good Music, Inc.**  
1610 Home Rd., Bellingham, Wash., 65W
- International Nuclear Corp.**  
608 Norris Ave., Nashville 4, Tenn., 3E
- ITA Electronics Corp.**  
130 E. Baltimore Ave., Lansdowne, Pa., 15E
- Jampro Antenna Co.**  
7500 - 14th Ave., Sacramento 22, Calif., 39W
- Johnson Electronics, Inc.**  
P.O. Box 7, Casselberry, Fla., 52W
- Kliegl Bros. Universal Electric Stage Lighting Co., Inc.**  
321 W. 50th St., New York 19, N.Y., 1E
- Lighting & Electronics, Inc.**  
81 Prospect St., Brooklyn 1, N.Y., 69W
- MaCarta, Inc.**  
709 Railroad Ave., W. Des Moines, Ia., 42W
- Magne-Tronics, Inc.**  
850 Third Ave., New York 22, N.Y., 46W
- McMartin Industries, Inc.**  
605 N. 13th, Omaha 2, Neb., 43W

- Minnesota Mining & Mfg. Co.**  
2501 Hudson Rd., St. Paul 19, Minn., 19W
- Miratel, Inc.**  
1st St., S.E. & Richardson, New Brighton 12, Minn., 34W
- Mitchell Vinten, Inc.**  
666 W. Harvard St., Glendale 4, Calif., 62W
- Moseley Associates, Inc.**  
P.O. Box 3192-4416 Hollister Ave., Santa Barbara, Calif., 48W
- Radio Corp. of America**  
Building 15-6, Camden 2, N. J., 5E & 6E
- Raytheon Co.**  
1415 Providence Turnpike, Norwood, Mass., 11E
- Riker Industries, Inc.**  
52 Cove Rd., Huntington, N.Y., 58W
- Rohn Systems Inc.**  
P.O. Box 2000, Peoria, Ill., 50W
- Schafer Electronics**  
235 S. Third St., Burbank, Calif., 73W
- SoundScriber Corp.**  
6 Middletown Ave., North Haven, Conn., 54W
- Sparta Electronic Corp.**  
6450 Freeport Blvd., Sacramento, Calif., 56W

- Surrounding Sound, Inc.**  
5757 Santa Monica Blvd., Hollywood 38, Calif., 76W
- Sarkes Tarzian, Inc.**  
Broadcast Equip. Div., E. Hillside Dr., Bloomington, Ind., 17E
- Tektronix, Inc.**  
P.O. Box 500, Beaverton, Ore., 29W
- Telemet Corp.**  
185 Dixon Ave., Amityville, L. I., N. Y., 2E
- Telequip Co.**  
319 E. 48th St., New York 17, N.Y., 3E
- Television Zoomar Corp.**  
500 Fifth Ave.—Rm. 2223, New York 36, N. Y., 59W
- Tower Communications Co.**  
2700 Hawkeye Dr., Sioux City 2, Ia., 24W
- Utility Tower Co.**  
3140 N.W. 38th St.—P.O. Box 7022, Oklahoma City, Okla., 40
- Visual Electronics Corp.**  
356 W. 40th St., New York 18, N.Y., 14E
- Vitro Electronics, Div. of Vitro Corp. of America**  
919 Jesup-Blair Drive., Silver Spring, Md.,

# NAB CONVENTION NEWS



## Engineering Achievement Award to George R. Town of Iowa State University

Dr. George R. Town, dean of engineering at Iowa State University, has been selected by the NAB to receive its 1963 Engineering Achievement Award. It will be presented April 3 at a luncheon during the Annual Broadcast Engineering Conference.

Dr. Town, who headed the monumental TASO study of television channel allocations in 1957, was chosen because of his valuable contributions to technical knowledge and literature, his development of new engineering techniques, and his leadership in broadcast engineering activities.

TASO's objectives were to develop full, detailed, and reliable technical information,

and engineering principles based thereon, concerning present and potential UHF and VHF television service. These principles and data were made available to the FCC so that a determination could be made concerning the soundest approach to television channel allocations.

A native of Poultney, Vt., Dr. Town is a graduate of Rensselaer Polytechnic Institute, Troy, N.Y., from which he holds two degrees: electrical engineering, 1926, and doctor of engineering, 1929. He has been a faculty member at Iowa State since 1949 and was professor of engineering and associate director of Engineering Experiment Station before his appointment as Dean of Engineering in 1960. Before joining the Iowa State faculty, Dr. Town was associated with the Stromberg-Carlson Co., University of Rochester, Rensselaer, Leeds and Northrup Co., and Arma Engineering Co.

## NAB Announces 1963 National Radio Month Plans

The National Association of Broadcasters announced recently that the May 1963 observance of National Radio Month will emphasize radio's mobility and ability to serve a nation on the go. The theme—"Radio . . . the Mobile Medium"—stresses not only radio's facility in covering rocket shoots, symphony concerts, and other important events but its unique ability as well to accompany listeners wherever they may go.

John M. Couric, manager of public relations, said special Radio Month kits are being prepared by the NAB Public Relations Service to help stations and networks tell the "mobility" story to the public. They

will contain live spot announcements, program and promotion ideas and suggestions, a speech text, filler facts and other material useful to the radio industry, including a special blank proclamation, ready for signing, so a member station can have the governor, mayor, or other official proclaim May as Radio Month in his area.

Scott-Textor Productions, Inc., New York City, has been retained by NAB for the second straight year to produce jingles for the annual observance. The jingles will be recorded in various tempos and styles to fit the wide range of American musical tastes.

## Canham to Moderate Panel

Erwin D. Canham, editor of the Christian Science Monitor and network radio commentator, will moderate a special afternoon session on "Broadcasting in a Free Society" during the 41st Annual NAB Convention.

This session, a new feature at the Convention, is designed to crystallize two opposing viewpoints — one favoring greater freedom from government control, the other favoring an increased role for government in regulations. Theodore Pierson, noted Washington, D.C., communications attorney, will speak for freedom. Dean Roscoe Barrow, of the University of Cincinnati Law School, will talk in support of increased government regulation. They will be joined by four additional panelists who will be selected from academic and business fields.

The Committee also announced that the FCC has agreed to hold its traditional panel session again this year, on the afternoon of April 3.

The exhibition of broadcast equipment and services will open Sunday, March 31,

## 17th NAB BROADCAST ENGINEERING CONFERENCE

Conrad Hilton Hotel Chicago, Illinois

March 31 - April 3, 1963

### AGENDA

#### Monday Morning, April 1

10:30 AM Joint Session with Management for opening of Convention.

12:30 PM Engineering Conference Luncheon.

Presiding: William S. Duttera, Director, Allocations Engineering, NBC.

Speaker: Dr. Edward E. David, Bell Telephone Labs.

#### Monday Afternoon

Presiding Officer: J. B. Epperson, Engineering Vice President, Scripps-Howard Broadcasting Co.

Session Coordinator: Leslie S. Learned, Dir. of Engineering, Mutual Broadcasting System.

2:30-2:40 PM Opening of the 17th Broadcast Engineering Conference—Governor LeRoy Collins, President, NAB.

2:45-3:10 PM The Use of Spectrum Display in Broadcast Monitoring—Granville Klink, WTOP, Washington, D. C.

3:15-3:30 PM. Status Report Concerning NAB Recording and Reproducing Standards — Warren Braun, WSVA, Harrisonburg, Pa. (Chairman, NAB Recording and Reproducing Tape Standards Com.)

3:35-3:55 PM Sound Reinforcement in TV Theaters —CBS Television Network.

4:00-4:25 PM Broadcast Engineering Activities in Canada—Dr. Maurice Levy, Canadian Association of Broadcasters.

4:30-5:00 PM A VLF Standard Frequency Transmission—American Broadcasting Co.

#### Tuesday Morning, April 2

##### RADIO

Presiding Officer: Jack Petrik, Chief Engineer, KETV. Session Coordinator: Clyde M. Hunt, Vice President for Engineering, Post-Newsweek Stations.

9:00-9:25 AM Radio Automation.

9:30-9:55 AM Considerations for a New FM Multi-channel Modulation Monitor—Collins Radio Co.

10:00-10:25 AM The Effects of Climatic Conditions on Soil Conductivity—Pete Johnson, Consulting Engineer, Charleston, W. Va.

10:30-10:55 AM On the Go With Radio—Vincent P. Marlin, Chief Engineer, WFBL, Syracuse, N. Y.

11:00-11:25 AM A Precision Phase Monitor for Critical Directional Arrays—John K. Birch,



but the opening assembly will not be held until Monday, April 1. At that time, **Bob Hope** will receive the NAB's Distinguished Service Award from NAB President **LeRoy Collins** who will deliver the Convention keynote address at the Monday luncheon. FCC Chairman **Newton M. Minow** will speak at the Tuesday luncheon.

### Bob Hope to Receive Distinguished Service Award

The National Association of Broadcasters will present its Distinguished Service Award for 1963 to **Bob Hope**. Mr. Hope will become the first entertainer to receive the tribute; previous recipients include network and station executives, former President **Herbert Hoover**, and USIA Director **Edward R. Murrow**. The presentation will be made by NAB President **LeRoy Collins**.

When notified that he will receive the award, Mr. Hope told the NAB President: "I'm very pleased and flattered . . . I don't know how you picked on me, and I don't want to change your mind. However, I think there must be greater fellows in the broadcast field who deserve this award. But let's not go into this. I will just take it and run. This is what happens if you hang around the business as long as I have. It's got to fall your way. But I really appreciate it, and I will be there and act like a regular recipient. I will study up on it."

### Communications Expert to Address Engineering Conference

**Sidney Metzger**, space-age communications expert charged with developing the communications system and equipment for Project Relay, will address the April 1st luncheon of the Broadcast Engineering Conference in Chicago. Mr. Metzger, employed by RCA's Astro-Electronics Division in Heights-town, N. J., was in charge of the group

### NAB Asks Tighter Engineering, Standards for Applicants

The **National Association of Broadcasters** called on the FCC recently to beef up engineering standards and financial qualifications for AM license applicants. The NAB said this would provide "the necessary climate for a sound and orderly development of AM radio . . . without making any basic changes in the competitive free enterprise system." The association stated that it "could not subscribe to any proposal which would arbitrarily place a limit on the number of radio stations in a given market." They added, however, that the FCC should institute a policy permitting one or more stations not in compliance with engineering standards to merge, thereby withdrawing the substandard assignment.

Introduced by NAB President **LeRoy Collins**, **George C. Hatch**, president of **KAAL**, Salt Lake City, Utah, and chairman of the NAB radio development committee said that with an expanding economy and an increasing population, he believed that if greater reliance is placed on sound engineering and financial qualifications in AM allocations, the radio industry will prosper and continue outstanding service to the American people.

**Mr. Carl E. Lee**, chairman of the NAB Engineering Subcommittee, suggested that the Commission should require an applicant whose proposal involves more than insignificant interference to prove that his is the most efficient possible. Also, first service should be provided bona fide communities not part of a metropolitan area already served with multiple signals. In addition, Mr. Lee urged that the Commission consider reviewing its directional standards and methods of calculating skywave interference, as well as requiring licensees to file a skeleton proof of a directional antenna system at the time of license renewal.

which developed satellite and ground-based radio equipment for Project Score (the "Talking Atlas") in 1958, and the communications systems for Tiros, the weather satellite. As manager of communications systems for Project Relay, he is responsible for supplying the equipment for a sophisticated version of Telestar that beams radio signals and TV pictures across oceans and continents.

### NAB Membership/Subscriber Totals Reach All-Time High

The **National Association of Broadcasters** claims that 1962 was its most successful year for membership. **William Carlisle**, NAB

vice-president for station services, said that record totals were reached during the 12-month period in every category of active and associate membership. Membership totals include: 1,851 AM radio stations, an increase of 95 during 1962; 660 FM radio stations, an increase of 58; 396 television stations, an increase of 16; and 138 associate members (equipment manufacturers, film distributors, etc.), an increase of 18. **Robert D. Swezey**, director of the NAB's Code Authority, said that at the year's end the number of Radio Code subscribers had climbed to an all-time high of 1,685 and the total of Television Code subscribers had hit the 400 mark for the first time.

Vitro Electronics, Silver Spring, Md.

11:30-12:00 N A New Method of Broadcasting Three Dimensional Stereophonic Sound—**Kenneth R. Hamann**, Chief Audio Engineer, Transcontinent station **WDOK**, Cleveland, Ohio.

#### TELEVISION

Presiding Officer: **Albin R. Hillstrom**, Dir. of Engineering, **KOOL**.

Session Coordinator: **James D. Parker**, Dir., Television RF Engineering, **CBS Television Network**.

9:00-9:25 AM Design and Installation of a TV Antenna for Simultaneous Operation on Two VHF Channels—**Richard K. Blackburn**, Technical Dir., **Gannett Radio & TV Group**, Rochester.

9:30-9:55 AM Simplified Operating Practices for 4½" Image Orthicon Cameras—**Joseph A. Flaherty**, **CBS Television Network**.

10:00-10:55 AM Remote Control of TV Transmitters (Symposium)—**NAB**, **RCA**, **GEL**, **GE**, **Gates**, and **Moseley**.

11:00-11:25 AM Plant Installation and Timing Considerations in Color Systems—**NBC**.

11:30-11:45 AM **VIDIAC**—**Long Lines Div.**, **American Telephone and Telegraph Co.**, New York.

12:30 PM Engineering Conference Luncheon.

Presiding: **Leslie S. Learned**, Dir. of Engineering, **Mutual Broadcasting System**.

Speaker: **Mr. Sidney Metzger**, Manager, Communications System, Project Relay, **RCA Astro-Electronics Division**.

#### Tuesday Afternoon, April 2

No sessions scheduled to permit delegates to visit exhibits and hospitality quarters.

#### Wednesday Morning, April 3

Presiding Officer: **Frank Marx**, President, **ABC Engineers**, **American Broadcasting Co.**

Session Coordinator: **James E. Gray**, Chief Engineer, **WYDE**.

9:00-9:25 AM A Review of Latest Developments of Video Tape Recording—**Grant Smith**, Video Engineering, **Ampex Corp.**, Redwood City.

9:30-9:55 AM What to Look for in New Designs Using Transistors—**R. N. Hurst**, **RCA**.

10:00-10:25 AM An Automated Audio Console—**ITA**.

10:30-10:55 AM Color Standards—**ABC**.

11:00-11:25 AM A New Approach to a Color Film Channel—**GE**.

11:30-12:00 N RF Interference Elimination in TV Pickups—**NBC**.

12:30 PM Engineering Conference Luncheon.

Presiding: **Orrin W. Towner**, Chairman, **Broadcast Engineering Conference Committee**.

Presentation of Engineering Achievement Award: **George W. Bartlett**, **NAB**.

Acceptance of Award: **Dr. George R. Town**, Dean of Engineering, **Iowa State University**, Ames, Iowa.

Speaker: **Dr. Simon Ramo**, Vice Chairman, **Thompson Ramo Wooldridge Company**.

# PRODUCT PREVIEWS



## FM Multiplex, Frequency, and Modulation Monitors

A complete line of FM monitors and audio amplifiers will be displayed by **McMartin Industries** at booth 43-W. Among the equipment shown will be an SCA multiplex monitor, frequency and modulation monitors, and transistorized audio amplifiers for broadcast and commercial sound applications. In addition to this equipment, other devices will be on display—for the first time, an RF amplifier for remote monitor operation; rebroadcast receivers for FM network and relay transmissions. **McMartin** engineers will be on hand to discuss multiplex plans and demonstrate equipment.

## Broadcast Equipment Line

On hand at **Visual Electronics Corp.**, booth 14-E, will be a wide range of radio and video studio and control room equipment. A few of the devices to be shown are automation systems, TV master-control equipment, vidicon film system, image orthicon tubes, clock system, monitors, projectors, transmission line, power supplies, tape cartridge machines, and audio equipment. In addition, **Visual** will be unveiling a completely new product which should be of interest (according to **Visual's** John P. Gallagher) to everyone in the television field. **Visual** will also present a seminar after the convention on April 4 and 5.



## STL and Intercity Microwave

The Communications and Data Processing Operation of the **Raytheon Company** will feature the **Dual-Link Automatic Hot-Standby STL** and intercity television microwave equipment at booth 11-E. Also on dis-

play will be portable TV microwave equipment. Product data describing the complete complement of rack-mounted and portable 7-gc and 12-gc devices and accessories will be available. A demonstration of the **Dual-Link STL** will highlight the exhibit.

## Transmitter and Studio Devices

Booth 27-W will be filled with a line of transmission and audio equipment from **Collins Radio Co.**, Audio devices to be shown include a tape cartridge system; speech input consoles for mixing 9 of 22 inputs (dual channel), 9 of 13 inputs, and 6 of 17 inputs, respectively; a transistorized remote amplifier which will mix 4 inputs, switch automatically between power sources in the event of power failure, and which has a built-in tone oscillator; a three-channel remote amplifier which is fully transistorized with roller-type gain controls, tone oscillator, and simple uncluttered panel; and a remote turntable-console, a transistorized combination mixer/amplifier/two-turntable combination for portable and fixed use. Transmission equipment includes an FM stereo multiplex generator which feeds monaural audio and subchannel on a single, composite signal; a 1000/500/250-watt AM transmitter; a 250-watt FM transmitter/exciter; a 1-kw FM transmitter/exciter; and a 5-kw FM transmitter.

## Tape Products Under Security

A new plastic video-tape case, a video spot-announcement 6½" reel, an 8" heavy-duty precision video reel, and a modulator tape-storage rack for audio-range tapes are the items that will be featured at **3M Company's** booth 19-W. Information has been withheld until the show, at which time technical service engineers will be available for consultation.

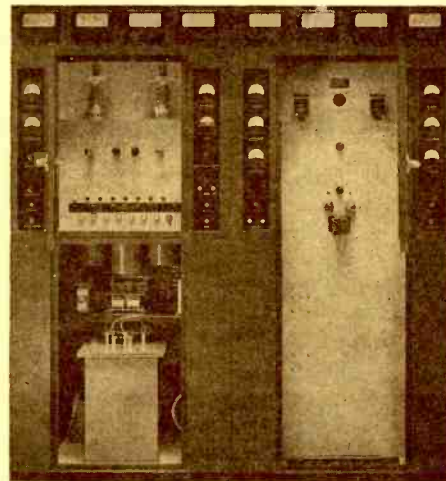

## Transmitters and Logging Equipment

Three pieces of equipment will be shown for the first time by **Bauer Electronics**, booth 56-W, as will one device introduced previously. The new equipment includes a 5/1-kw AM transmitter, a 50-watt carrier current transmitter, and automatic logging devices. A 1-kw/250-watt transmitter will also be on display. The new 5-kw high-level plate-modulated transmitter is for use in the

standard AM broadcast band. As seen in the photo, the cabinet is of two-bay construction, requiring 68 by 30 inches in floor space. An external plate transformer, completely enclosed, requires an additional 12 by 24 inches. The transmitter has built-in remote control facilities; silicon rectifiers and power cut-back to 1-kw are standard equipment.



## Condenser and Dynamic Microphones

**Electronic Applications, Inc.**, will feature its line of **AKG** microphones and accessories at booth 20-W. Included will be the C-24 and C-60 (shown in photo) condenser microphones, D-19C broad-band dynamic microphones, and the special CKS-4 probe microphone with response up to 80 kc. In addition to displays and demonstrations of this equipment, complete literature and data sheets will be available.

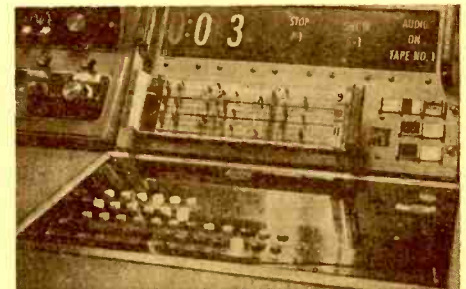

## Television Programmer

**Chrono-Log Corp.** will show their Step—sequential television equipment programmer and digital clocks at booth 47-W. The **STEP**, shown in use at **WTVR**, Richmond, Va., is designed to help TV stations handle complex station and commercial breaks by automatically pulsing equipment on in accordance with a variable pre-determined sequence. A complete 16-step sequence can be set up by inserting pins in a programming board which is interchangeable with boards set up for different sequences. The system controls film projectors, television tape recorders, slide projectors, microphones, turntables, and audio tape units. It can also return video and audio to remotes, network, or one of three studios. A complete operating **STEP** system will be demonstrated at the booth.

• Please turn to page 70



Around the world  
the most valued microphones are

# NEUMANN

## CONDENSER MICROPHONES

— the standard against which  
all others are compared.



**NEUMANN  
SM-2**  
Compatible  
"M-S" Stereo  
Microphone.



**NEUMANN  
KM-54a**  
Miniature  
Ultra-Cardioid  
Microphone.



**NEUMANN  
KM-56**  
Miniature  
3-Pattern  
Switchable  
Microphone.



**NEUMANN  
U-67**  
All-purpose  
Studio Microphone.



**NEUMANN  
M-269**  
Remote Controlled  
Pattern Version  
of the  
U-67  
Condenser  
Microphone.

**NEUMANN  
M-49b**  
Remotely Controlled  
Pattern Concert  
Microphone.



Write today, indicating company affiliation, for complete data on  
Neumann Condenser Microphones

**GOTHAM AUDIO CORPORATION**

2 WEST 46 STREET, NEW YORK 36, N. Y. • 212-CO 5-4111

In Canada:

J-MAR ELECTRONICS LTD., P.O. BOX 158, DON MILLS, ONTARIO



Circle Item 20 on Tech Data Card

# ENGINEERS' EXCHANGE

## Winding Reels for Tape Cartridges

by Terence King, Chief Eng., WILL, Willimantic, Connecticut

Due to the increasing use of automatic tape-cartridge units, many stations are now winding their own cartridges. In a small station the number of cartridges respooled to replace worn tapes or to make up special lengths may not warrant buying a commercial tape winder. At WILL, we recently made up over fifty cartridges with tape lengths in multiples of 75 seconds (1X, 2X, 3X, etc.), using our conventional tape machines for winding.

Place a reel of bulk lubricated tape on the tape machine and wind it onto a regular empty reel in the normal manner. Time the correct length of tape by running it through the machine at 15 ips. Cut the tape, remove the bulk reel, and invert the takeup reel with the timed tape on the right spindle. Next, place the blank cartridge reel on the supply side of the machine and thread the tape directly from the **top** of the right-hand reel to the **bottom** of the cartridge reel.

With the automatic shut-off arm defeated, start the machine in the rewind model and hold a pencil or similar object against the edge of the tape to assure correct winding on the flangeless cartridge reel. This procedure winds the tape without holdback tension and with the

oxide side out, as required.

The manufacturer's instructions should be followed for splicing the tape and placing the reel in the cartridge. The first 12 inches or so of tape pulled from the center of the reel will wrinkle. So just yank away until you have about a foot of tape, then pull the rest off smoothly. We have found that the initial tape slack, at the time of splicing, should be 10 inches for a 1-minute tape and 16 to 18 inches for longer tapes.

Our system of employing tape lengths in 75-second multiples allows us to automatically rotate two or more different commercials for a single sponsor while eliminating logging of cut numbers. We record 30-second commercials **twice** on a 75-second cartridge so that the cuing time is less than 10 seconds at all times.

## Rain Shields for Bowl Insulators

by Robert A. Jones, Consulting Engineer, LaGrange, Ill.

One of the disturbing problems in maintaining base currents at the FCC prescribed values is encountered during weather conditions of rain and mist; the reading will often exceed allowable limits.

At WRSW, Warsaw, Indiana, we noticed this effect occasionally over a period of several years, when the readings would increase in all three

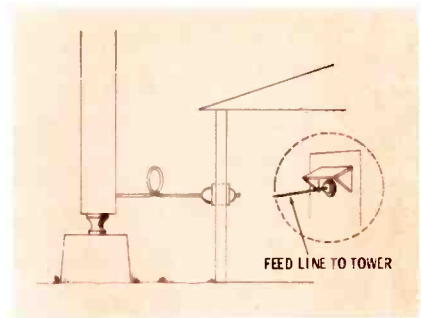

base meters. Moisture on the towers and guy wires—over which we had no control—was believed to be the cause of the problem. The setup of the feedthrough insulators at WRSW is typical of most stations. The thought occurred to us one day that rain on the tuning-house walls, particularly in the vicinity of the bowl insulator, might be causing the change. This dampness apparently affects the capacity from the feed line to ground, thereby altering the antenna current.

During the next rain storm, we tested our theory by vigorously wiping the walls near the insulators with dry towels. With the moisture thus checked, no noticeable change was observed in the base current readings. For a permanent solution, small hoods were constructed as shown. The dimensions are not critical as long as the insulators are covered.

## Reducing Delay Time in Thermal Relays

by Elton B. Chick, Rounsaville Radio Stations, Cincinnati, Ohio

While testing a new phaser, we discovered the manufacturer had provided a two-second switching relay. The purpose is to allow the transmitter output to die out, thus preventing "hot switching" and RF contactor damage. Transmitter tests showed that the output decayed in less than one-half second after the plate-off switch was thrown—meaning a two-second delay was unnecessary. Although this is a short interval of time, it is a noticeable program interruption by the standards of many stations.

A quick check of relay manufacturers' literature revealed that two seconds is the minimum delay available in the type of relay employed. Some brief experimentation, however, resulted in a very simple modification to reduce delay time. The arrangement decreases delay from two seconds to just over one-

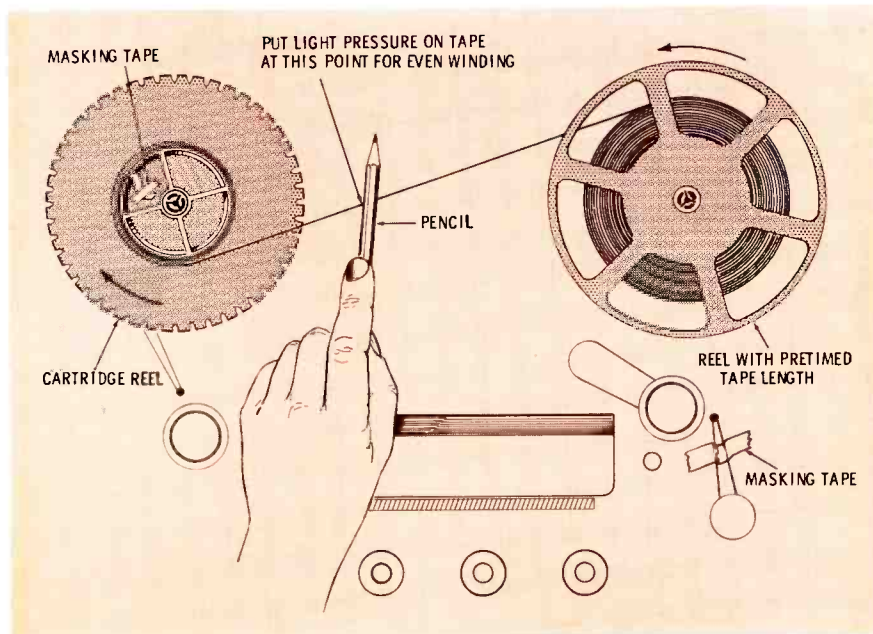

# BURGESS *Magnetic* Recording Tape a SUPERIOR TAPE at NO EXTRA COST!

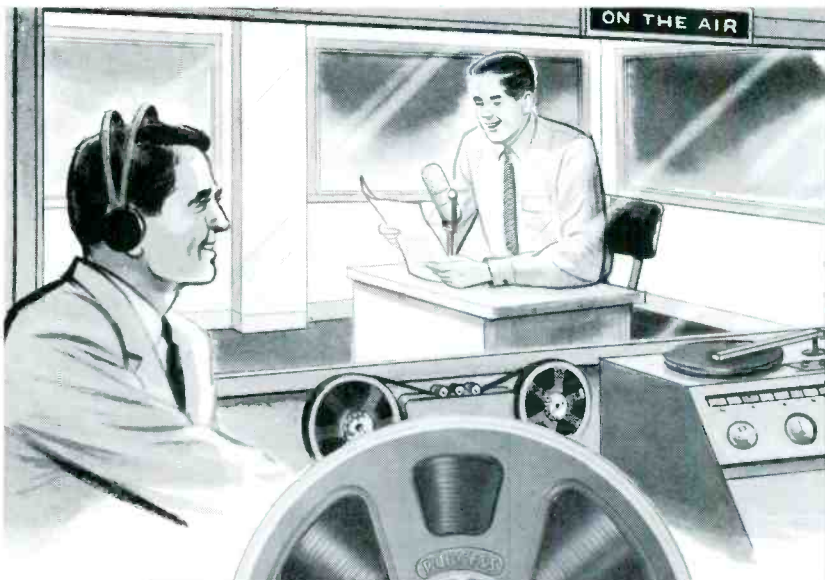

Burgess Magnetic Recording Tape is made to *save you money!* The strength of Burgess tape enables it to withstand rough handling... no need to worry about fraying, breaking, rippled edges and other problems accompanying heavy tape use. Every reel of Burgess Magnetic Tape produces consistent high quality reproductions without changing bias. And, you get *all these extras* in Burgess Magnetic Recording Tape at *no increase in price.* Try Burgess. Call your Burgess tape distributor today.

## 8 REASONS WHY IT PAYS TO BUY BURGESS

1. **UNIFORM QUALITY** — reel after reel. Same high reproduction quality today, tomorrow or next month.
2. **SUPERIOR BUILT-IN LUBRICANT** — enables tape to glide friction free on smooth, mirror-like surface. Prolongs head life.
3. **GREATER DYNAMIC RANGE** — top frequency response. Burgess wide bias latitude gives professional results on all recorders.
4. **LOWER PRINT-THROUGH** — after months of storage. Special processes greatly reduce magnetic transfer.
5. **GREATER TENSILE STRENGTH** — a "tough" tape. Special processes and formulas enable Burgess tape to take rough handling.
6. **LOWER NOISE LEVEL** — new dispersion techniques eliminate "hissing" or "popping."
7. **NO FLAKE-OFF** — Burgess precoat formula eliminates flake-off, reduces frequency of head cleaning.
8. **ERASES CLEAN** — Burgess tape erases clean and evenly.

## BURGESS BATTERY COMPANY

DIVISION OF SERVEL, INC.



### MAGNETIC TAPE DIVISION FREEPORT, ILLINOIS

1.

"JAN" shields kill tubes faster than ordinary bulb heat

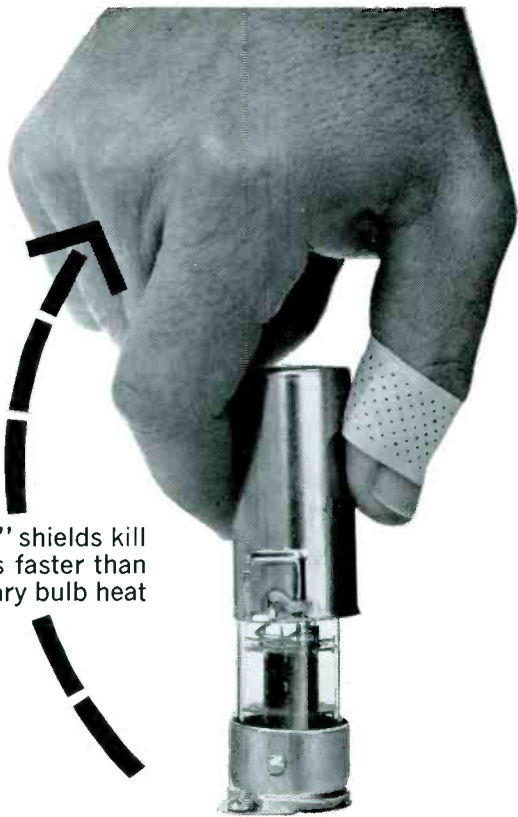

## HERE'S THE WAY TO SAVE MAINTENANCE DOLLARS!

Electron tube failures account for 70% of electronic equipment failures. Extending tube life two to twelve times with **IERC heat-dissipating shields** can greatly reduce equipment maintenance and downtime costs.

TR series shields install as quickly as shown into your present equipment, giving failure-free performance proved in new military and industrial equipment using IERC shields.

WRITE FOR LITERATURE to help you order TRs—and reliability, **TODAY!**



2.

Heat-dissipating shields extend tube life 2 to 12 times



Patented

**INTERNATIONAL ELECTRONIC RESEARCH CORPORATION**  
 135 West Magnolia Boulevard, Burbank, California • Victoria 9-2481  
 Foreign Manufacturers: Europelec, Paris, France. Garrard Mfg. & Eng. Co., Ltd., Swindon, England

Circle Item 27 on Tech Data Card

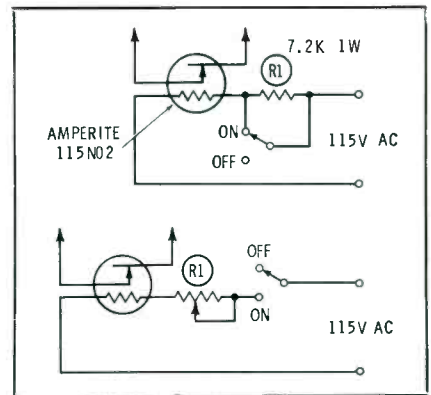

half second. A trickle current is passed through R1 to keep the heater slightly warm, thereby accelerating its operation. (During the investigation we also discovered that the delay time could be increased if necessary, by wiring a resistor in series with the heater.)

## Cueing Protection for VU Meters

by Terrance O'Rourke, Chief Engineer, KBAT, San Antonio, Texas

When tape recorders are run in the rewind or fast-forward functions by remote control (with the gate closed), a very large signal is developed in the playback amplifier. Since our machines are operated by announcers and DJ's, remote control is used a good part of the time.

To prevent damage to the vu meters in our tape machines—which would result from the high amplitude signal—we installed a simple filter in each unit. The circuit has proven quite satisfactory in reducing the level to a safe value, while still permitting cues to be heard.

At the same time, the system attenuates the high amplitude, high frequency signals that might otherwise be coupled into other circuits through crosstalk.

Note in the schematic that the filter relay will be energized in the play function, and de-energized in the fast-forward, rewind, and stop modes.

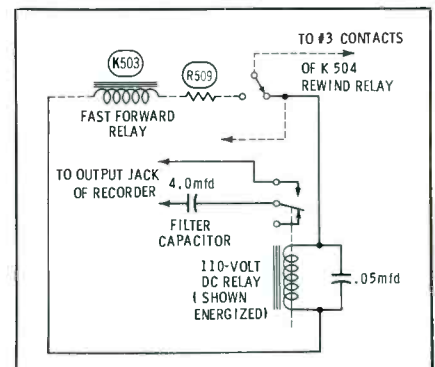

# TEKTRONIX WAVEFORM MONITORS

## ...NOW with illuminated "zero-parallax" graticules—for greater accuracy



In a rack or console, this Tektronix Waveform Monitor *adapts* easily to control applications. For example, in addition to conventional two LINE and two FIELD displays, you can choose from three calibrated time-base rates—at 0.125 H/CM, at 0.025 H/CM with 5X Magnifier, and at 0.005 H/CM with 25X Magnifier—which eliminates the need for time markers.

You can use the dual inputs differentially.

And you can observe bright displays accurately and dependably over a full 7-centimeter by 10-centimeter viewing area.

*Adaptable and versatile, this Waveform Monitor features:* amplitude linearity within 1% over full 7-cm of vertical deflection • sensitivity from 0.25 volt minimum to 1.6 volts maximum for 140 IRE units • response flat within 1% from 60 cps to 5 Mc or new IRE rolloff • internal calibrator for 1.0 and 1.4 volt peak-to-peak signals • backporch dc restoration, *with no color-burst distortion.*

### SPECIAL MODEL TYPE RM527 MOD132

This special model of the rack-mount waveform monitor has all capabilities of the Type RM527 plus two additional features—a Line Selector and a Video Distribution Amplifier.

The Line Selector permits detailed analyses of single television lines (particularly useful with 4½ inch cameras), and the Video-Distribution Amplifier permits slaving a picture monitor to the oscilloscope display.

Type RM527 MOD132 . . . . . \$1230

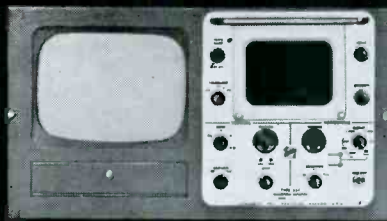

8" monitor

Type 527

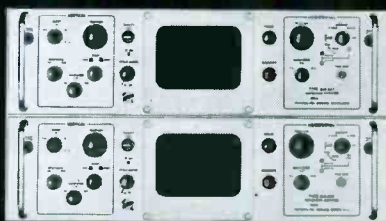

2-RM527's slide mounted

Type RM527 . . . . . \$1000  
5¼" high, 16¼" wide, 16" deep



2-527's cradle mounted

Type 527 . . . . . \$925  
9¼" high, 8¼" wide, 16¼" deep



10½"

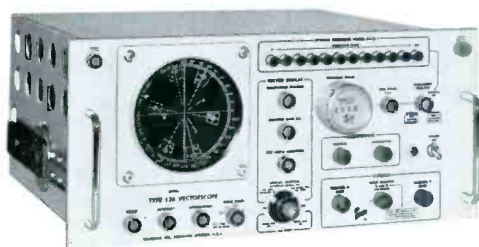

### TYPE 526 COLOR-TELEVISION VECTORSCOPE

The Vectorscope enables quick and accurate relative phase and amplitude measurements (of chrominance information in the N.T.S.C. Color Signal). Dual inputs facilitate equipment matching. Also, in addition to vector display, the Vectorscope can present the chroma signal demodulated along any phase-angle axis with respect to time.

Type 526 Vectorscope . . . . . \$1665

U.S. Sales Prices f.o.b. Beaverton, Oregon

**Tektronix, Inc.** / P. O. BOX 500 · BEAVERTON, OREGON / Mitchell 4-0161 · TWX-503-291-6805 · Cable: TEKTRONIX.  
OVERSEAS DISTRIBUTORS IN 27 COUNTRIES AND HONOLULU, HAWAII.

Tektronix Field Offices are located in principal cities throughout the United States. Please consult your Telephone Directory.

Tektronix Canada Ltd: Montreal, Quebec · Toronto (Willowdale) Ontario · Tektronix International A. G., Terrassenweg 1A, Zug, Switzerland.

## VISIT TEKTRONIX BOOTH 29W AT THE NAB SHOW

Circle Item 23 on Tech Data Card

March, 1963

47

# IEEE INTERNATIONAL CONVENTION

A preview of products  
and points of interest to  
Broadcast Engineers.

During March 25-28, the first International Convention of the Institute of Electrical and Electronic Engineers will take place in New York City. To be held at the New York Coliseum and the Waldorf-Astoria Hotel, the convention will consist of 850 exhibits and 54 technical sessions as well as a cocktail party, banquet, and activities for members' wives.

The exhibits, with key personnel from participating companies on hand, will demonstrate and display the

advanced developments in electricity and electronics represented by their products and systems.

All four floors of the Coliseum will be taken: components on the first and second, instruments and systems on the third, and production on the fourth. Technical sessions will be held both locations, with 33 at the Waldorf-Astoria, and 21 at the Coliseum. A highlight of the convention will be a special symposium on optical masers, Tuesday evening, March 26.

## 1963 IEEE INTERNATIONAL CONVENTION TECHNICAL PROGRAM

Waldorf-Astoria and  
New York Coliseum

### MONDAY, MARCH 25,

2:30 - 5:00 P.M.

Sessions at the Waldorf-Astoria:

1. Data Processing and Acquisition, Starlight Roof.
2. Engineering Writing and Speech, Astor Gallery.
3. Geoscience Electronics, Jade Room.
4. Point and Counterpoint of Engineering and Education, Sert Room.
5. Computer Components, Empire Room.

Sessions at the New York Coliseum:

6. Human Factors in Electronics—A Technical Status Report, Faraday Hall.
7. Analytical and Statistical Techniques in Reliability Analysis, Marconi Hall.
8. Vehicular Communications, Morse Hall.

### TUESDAY, MARCH 26,

10:00 A.M. - 12:30 A.M.

Sessions at the Waldorf-Astoria:

9. Information Processing and Telemeter Systems, Starlight Room.
10. Circuitry Theory I, Astor Gallery.
11. Ultrasonics Engineering I, Jade Room.
12. Components for Miniaturized Electronic Assemblies, Sert Room.
13. Modern Applications of Computers, Grand Ballroom (terminates at 12:00 noon).

Sessions at the New York Coliseum:

14. Semiconductor Devices, Faraday Hall.
15. Reliability Techniques in Components Application and Evaluation, Marconi Hall.
16. Aerospace Electronics I, Morse Hall.

### TUESDAY, MARCH 26,

2:30 - 5:00 P.M.

Sessions at the Waldorf-Astoria:

17. Antennas and Propagation, Starlight Roof.
18. Circuit Theory II, Astor Gallery.
19. Ultrasonics Engineering II, Jade Room.
20. Electron Devices, Sert Room.

Sessions at the New York Coliseum:

21. Military Electronics, Faraday Hall.
22. Fabrication Techniques, Theory and Application of Electronic component Parts, Marconi Hall.
23. Aerospace Electronics II, Morse Hall.

### TUESDAY, MARCH 26,

8:00 - 10:30 P.M.

Sessions at the Waldorf-Astoria:

24. Panel: Lasers-Workhorse or Play-boy, Grand Ballroom.

### WEDNESDAY, MARCH 27,

10:00 A.M. - 12:30 P.M.

Sessions at the Waldorf-Astoria:

25. Array Antennas, Starlight Roof.
26. Measurement Devices and Techniques, Astor Gallery.
27. Communication Networks, Jade Room.
28. Broadening Device Horizons, Sert Room.
29. Information Processing Tech-

niques, Grand Ballroom. (terminates at 12:00 noon).

Sessions at the New York Coliseum:

30. Radio Frequency Interference, Faraday Hall.
31. Engineering Management I, Marconi Hall.
32. Communications System, Morse Hall.

### WEDNESDAY, MARCH 27,

2:30 - 5:00 P.M.

Sessions at the Waldorf-Astoria:

33. Antennas and Electromagnetic Waves, Starlight Roof.
34. Space and Propulsion Instrumentation, Astor Gallery.
35. Transmission in Processing of Information, Jade Room.
36. Microwave Devices and Techniques, Sert Room.

Sessions at the New York Coliseum:

37. Broadcasting, Faraday Hall.
38. Engineering Management II, Marconi Hall.
39. Communications Transmission, Morse Hall.

### THURSDAY, MARCH 28,

10:00 A.M. - 12:30 P.M.

Sessions at the Waldorf-Astoria:

40. Biomedical Electronics — The Scope of Life Science Engineering, Starlight Roof.
41. Space Phenomena and Measurements, Astor Gallery.
42. Status Session on Theory and Application of Optimal Control, Jade Room.
43. Microwave High Power, Sert Room.
44. Industrial Electronics Around the World, Empire Room.



# Presenting...BETTER PRODUCTS FOR BETTER BROADCASTING!

SEE OUR DISPLAY,  
BOOTH #56W,  
NAB CHICAGO SHOW,  
APRIL 1-3



**300 PLAYBACK** The absolute ultimate and most advanced design in a tape cartridge playback. All transistorized, plug-in modular construction. Continuous duty rated with proven reliability ..... **\$495.00**

**300 RECORD** Just 3½ inches high the all-transistor record unit compliments the new compact, modern and functional design of the 300P. Both units allow table-top, custom, or, (illustrated) rack mounting ..... **\$230.00**



**200 RECORD/PLAYBACK** Economy with outstanding rugged reliability. Now every broadcaster can afford the up-to-date, modern benefits of cartridge equipment. Transistorized control circuitry for improved toneburst cueing. Compare with others priced 20% to 40% higher..... **\$545.00**



**200 STEREO RECORD/PLAYBACK** Record and playback in stereo with full fidelity broadcast quality and positive performance. Enjoy the benefits of cartridge tape, producing all announcements, themes and production sound aids in wondrous stereo..... **\$750.00**  
(Playback only ..... **\$510.00**)



**200 PLAYBACK** The work horse of the industry! Offering simplicity with proven reliability. Compatible with all other cartridge equipment. Add another playback to your present system at only..... **\$385.00**



**CP-5 PORTABLE PLAYBACK** An invaluable new sales and production aid for all cartridge equipped stations. Light weight with convenient carrying handle to audition spot/presentations anywhere in the station or clients office..... **\$149.50**

## OUR PRODUCTS ARE OUR BEST SALESMEN!



**SPARTA A-50 PORTABLE STUDIO** Production studio, Remote Facility, Main Studio. A triple-threat, rugged and solidly built unit designed for many years of continuous duty. Legs unscrew and clip inside the bench which then becomes the lid for transporting. Complete with turntables, equalizers, pre-amps and A-10 Audio Console..... **\$845.00**

**SPARTA A-10 AUDIO CONSOLE** Provides a total of eight inputs selected through four mixing channels with completely transistorized circuitry and plug-in modular construction throughout..... **\$375.00**  
(Carrying case with monitor speaker..... **\$49.50**)



Call, Write or Wire Today

**SPARTA ELECTRONIC CORPORATION**

6450 FREEPORT BOULEVARD • SACRAMENTO 22, CALIFORNIA • GA 1-2070

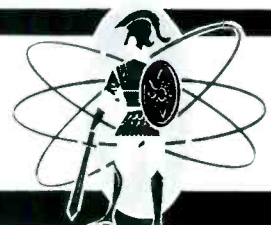

Plan now to attend  
**IEEE's special  
 TV  
 Symposium**

Wednesday, March 27,  
 2:30-5:30 p.m.  
 Morse Hall, at the  
 Coliseum, New York

Hear these 5 technical  
 papers:

**The South Carolina ETV  
 Story**

Part I: R. Lynn Kalmback,  
 General Manager, South Carolina  
 ETV Center

Part II: W. R. Knight, Jr.,  
 Chief Engineer, Bell Telephone &  
 Telegraph Co.

You will view Educational TV  
 on a wide screen via closed-  
 circuit direct from Columbia,  
 S.C. Both studio and class room  
 will be seen in actual operation.

**Compensation for Dropouts  
 in TV Magnetic Tape  
 Recording**

I. Moskovitz, Mincom Division,  
 Minnesota Mining &  
 Manufacturing Co.

**New York City's UHF TV  
 Project Reports**

Mobile Field Strength  
 Measurements: Daniel Hutton,  
 FCC, Washington, D. C.

Analysis of Measurements &  
 Observations: George Waldo,  
 FCC, Washington, D. C.

Chairman: Arnold B. Covey,  
 AT&T, New York

Organizer: Clure Owen, Ameri-  
 can Broadcasting Company,  
 New York

Just one of 54 worthwhile  
 technical sessions at IEEE's  
 International Convention &  
 Exhibition in New York.

March 25, 26, 27 &  
 28, at the  
 Coliseum & the Waldorf  
 Astoria Hotel.

Admission: Members \$1.00;  
 non-members \$3.00. Minimum  
 age: 18.

Circle Item 25 on Tech Data Card

Sessions at the New York Coliseum:

- 45. Broadcast and Television Re-  
 ceivers, Faraday Hall.
- 46. Audio, Marconi Hall.
- 47. Digital Modulation, Morse Hall.

**THURSDAY, MARCH 28,**

2:30 - 5:00 P.M.

Sessions at the Waldorf-Astoria:

- 48. Biomedical Electronics, Starlight  
 Roof.

49. Nuclear Instrumentation and  
 Measurements, Astor Gallery.

- 50. Automatic Control, Jade Room.
- 51. Microwaves, Sert Room.

Sessions at the New York Coliseum:

52. Symposium on the Impact of Mi-  
 croelectronics on Circuit Theory,  
 Faraday Hall.

53. Machine Processing and Genera-  
 tion of Sound, Marconi Hall.

54. Advanced Techniques in Product  
 Engineering, Morse Hall.

**IEEE PRODUCT HIGHLIGHTS**



**UHF Octave Amplifier**

Two new UHF octave amplifiers, which  
 together cover frequencies from 250-  
 1,000 mc, will be shown at booth 1915,  
 by Community Engineering Corp., State  
 College, Pa. The Model 1033, 250-500  
 mc, has a noise figure of 7 db max.  
 The model 1035, 490-1,000 mc, has a  
 noise figure of 10 db max. Each is made  
 up of two identical amplifiers supplied  
 with its own solid-state power supply.  
 Each modular has a gain of 18 db nomi-  
 nal, band flatness of  $\pm .5$  db for the  
 1033, and  $\pm 1$  db for the 1035. Imped-  
 ance in and out is 50 ohms with a VSWR  
 of 1.75:1 max. The standard 19" panels  
 are 3 1/2" high.

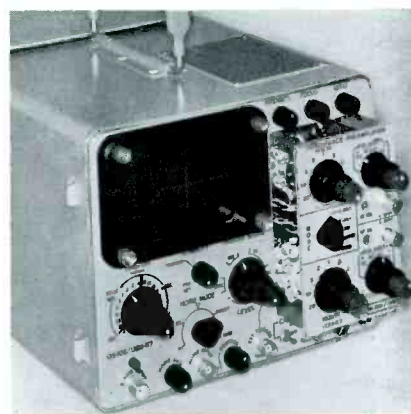

**Transistorized Oscilloscope**

Dual-trace capability in a portable all-  
 transistorized, all-militarized oscilloscope  
 will be introduced by the Electronic Tube  
 and Instrument Div. of General Atronics  
 Corp. (booths 3315-17). The dual trace  
 is achieved by a newly designed plug-in  
 unit for ET&I's popular tote-size model  
 K-106. The DT-106 transistorized dual-  
 trace vertical amplifier is interchangeable  
 with the high-gain, single-channel ampli-  
 fier which is standard equipment. The  
 bandwidth of the dual trace plug-in gives  
 the 18-pound, mil-rugged K-106 presen-  
 tation of all signals. Features of the DT-  
 106 include 6-mc bandwidth, single or  
 differential presentation, and chopped or  
 alternate presentation of two phenomena

simultaneously through high-frequency  
 (approx. 100-kc) switching.



**Indicator Lights**

Drake Manufacturing Co. (booth 2212)

will be displaying a wide variety of their  
 indicator lights including several new  
 ones, as well as their new modern logo  
 after discarding the duck which they used  
 for 30 years. The new logo contains a  
 design of their main produce — an indi-  
 cator light — to the left of the name.  
 Among the new products being featured  
 is Glo-Lite, a one-piece, nylon body and  
 lens. Recent requests for an indicator  
 light with a rectangular lens for midget-  
 flange base lamps prompted Drake engi-  
 neers to design their new MF unit. Fea-  
 tured on Drake's animated display are  
 Bi-Pin cartridge lamps and lampholders,  
 which are replaceable from the front of  
 panel and available in many-colored fil-  
 ters. The Deluxe Molded indicator light  
 is a refined version of the Drake 101N.  
 The laminated fibre socket housing has  
 been replaced by a molded Glaskyd  
 housing giving the unit a much improved  
 appearance, and better electrical and me-  
 chanical properties.

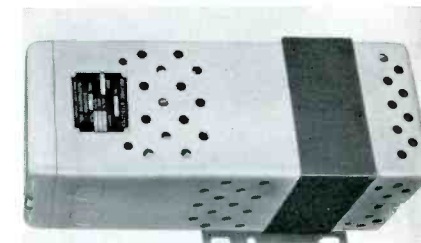

**Power Regulation Equipment**

An extensive line of power regulation  
 devices, to be marketed under the trade  
 name "Powerguard," will be introduced  
 by Stancor Electronics, Inc., Chicago,  
 Ill., (booth 1216). The first of these  
 products to be available are a group of  
 automatic voltage stabilizers. Initially,  
 30, 60, 250, 500, 1,000 and 3,000 VA  
 units are being produced, but additional  
 ratings will be available soon.

**BROADCAST ENGINEERING**

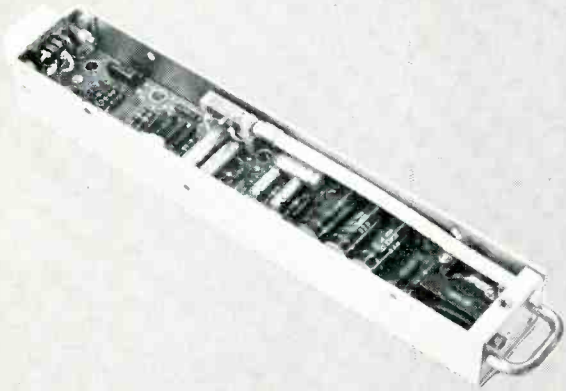

# NEW FROM



# GENCOM\*

## VIDEO DISTRIBUTION AMPLIFIER



**4 OUTPUTS • LESS THAN \$70 PER OUTPUT • COMPLETELY SOLID STATE • SELF  
CONTAINED REGULATED POWER SUPPLY • PLUG-IN MODULAR CONSTRUCTION**

Now, a solid-state video distribution amplifier with four outputs at less than the price previously paid for two outputs. The new  VDA4-S is a compact plug-in module that is completely solid state — with resulting long life, high reliability and low power consumption. Drawing only 3½ watts of power, the VDA4-S features less than 1° differential phase and less than 1% differential gain. Frequency response is within ±0.5 db to 10 mc. Each unit has an adjustable gain control on the front panel. Yet, eight of these amplifiers, **each with its own built-in power supply** and supplied with their own mounting frame, require only 3½" of standard 19" rack space.

With all these features the new VDA4-S saves you money — in original price and in maintenance and operating costs. Compared to most tube type amplifiers the multiple savings of the  VDA4-S enables it to actually pay for itself within a year.

Also available is the new PAT-4, a four output **pulse regenerating distribution amplifier** with the same basic features as the VDA4-S.

Find out for yourself — write now for complete details.

 <p><b>ELECTRA MEGADYNE INC.</b> also suppliers of television equipment manufactured by</p>  <p><b>EMI ELECTRONICS LTD</b></p>	<p>1750 N. Vine St., Los Angeles 28, California Phone: 213-462-4909</p> <hr/> <p>Hayes, Middlesex, England</p>
--	--

\* TM, General Communications Div., Electra Megadyne Inc.

Circle Item 28 on Tech Data Card

**Solid  
State**

*Video and Pulse*  
**DISTRIBUTION  
EQUIPMENT**

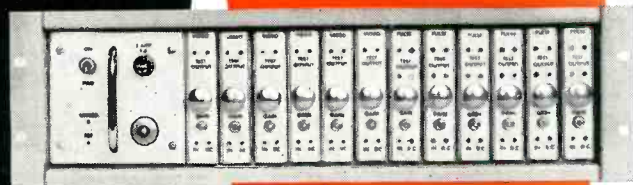

A complete transistorized video and pulse distribution system in convenient plug-in Module construction.

This basic 5¼" rack mount frame containing its own Plug-in power supply can provide 48 pulse outputs or 36 video outputs. If desired, pulse and video distribution amplifiers can be put in the same frame utilizing the same power supply.

- Modular Plug-in Construction
- High Input Impedance
- Identical Multiple Outputs
- Maximum Output to Input Isolation
- Plug-in Power Supply with individual voltage regulator on each amplifier
- Simple Stable Circuitry
- Designed For Reliability
- Minimum Cost per Output

For the best and most modern broadcast systems and supplies, look to **VISUAL**—your **SOURCE** for Superior Equipment from Specialist Manufacturers.

Write today for complete technical specifications.

**VISUAL ELECTRONICS**  
CORPORATION

**Keeps You in View!**

356 west 40th street • new york 18, n. y. • pennsylvania 6-5840

Circle Item 22 on Tech Data Card

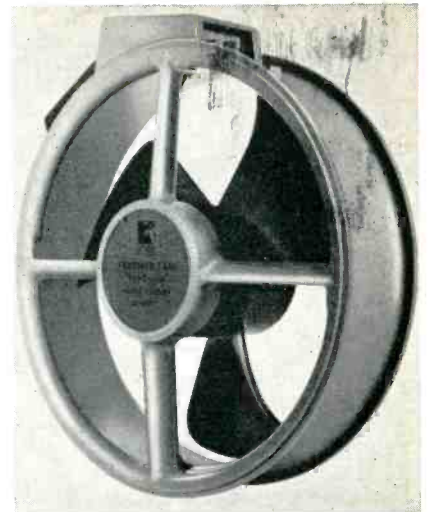

**Lightweight Heavy-Duty Fan**

The lightweight, high-performance "Feather Fan" by **Rotron Manufacturing Co.**, Woodstock, N. Y., for cooling electronic packages in broadcast consoles, relay racks, power supplies, instruments and hundreds of other applications will be on display in **booth 2427-2429**. The fan is a commercial-quality unit, although it incorporates many of the features found in military types. It delivers 270 cu ft of air per minute, is equipped with precision miniature stainless steel ball-bearings, and prelubricated to provide years of maintenance-free operation. Weighing only 1.5 pounds, its compact design (7" in diameter and only 2-7/16" thick) permits simple and easy mounting on any equipment panel.

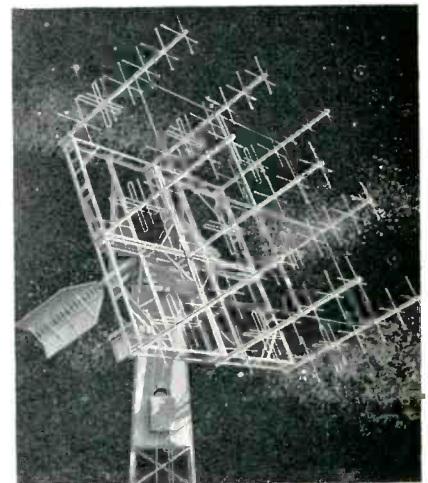

**Antenna Products Line**

Highlighting the **Technical Appliance Corp.**, Sherburne, N. Y., **booth 3912** will be a working model of a variable speed telemetry antenna. There will also be examples or literature for products such as: automatic satellite-tracking systems, an increasing line of remote- and servo-controlled antenna positioners, yagi arrays, phased arrays, helical antennas and arrays, special application antennas, and high-performance feed systems. Also to be exhibited will be examples of rigid coaxial transmission line. Particular attention will be paid to the overall systems capabilities of TACO.

**BROADCAST ENGINEERING**



## THE HOUSE THAT TAPE BUILT!

**Complete facilities to manufacture the tape you can depend on completely!**

Out of sheer necessity, RCA Red Seal Magnetic Tape was born! When recording the world's greatest artists, RCA Victor recording engineers had to be positive beyond a doubt that every inch of master recording tape would deliver the ultimate in quality performance. Working with RCA Sound Engineers, they developed RCA Red Seal Tape with the

exacting specifications required for their own use. Today it is available to you.

At 6800 East 30th St., Indianapolis, Ind., one of the most modern tape plants in the country houses complete facilities for the manufacture of Red Seal tape. From the time raw materials reach the factory until they emerge as finished tape, every step is minutely checked.

Quality control tests are rigid. Every inch of tape must live up to tough mechanical tests—have the same magnetic properties and the same recording-bias characteristic. Here's tape you can depend on completely — try RCA Red Seal Tape once—you'll never use any other tape!



**THE MOST TRUSTED NAME IN SOUND**  
RADIO CORPORATION OF AMERICA

Circle Item 26 on Tech Data Card

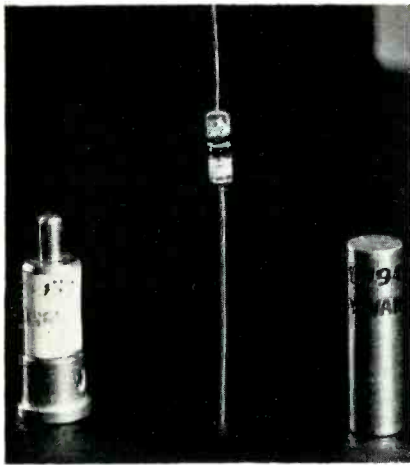

### Microwave Diodes

A series of 100% verified microwave diodes for ultra-reliability requirements covering the frequency range from 1 gc through 35 gc will be displayed by the Semiconductor Division of **Sylvania Electric Products, Inc.** in booths 2322-2332 and 2415-2425. Each unit is processed through 14 separate tests. They are individually serialized, tested for electrical parameters, and subjected to operational tests, including temperature cycling and storage through  $-65^{\circ}\text{C}$  to  $+150^{\circ}$ ; radio leak-rate testing to  $1 \times 10^{-11}$  cc/sec;  $150^{\circ}\text{C}$  operational test, and shock at 1,500 G for 0.5 milliseconds.

### Portable Test Set

A compact, portable instrument for aligning and maintaining transmission lines

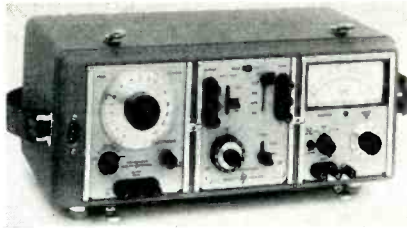

will be shown for the first time by **Hewlett-Packard Co.**, Palo Alto, Calif. (booths 3402-3412). Model 3550A contains a wide-range oscillator, a voltmeter, and an attenuator with impedance-matching networks to match both oscillator and voltmeter to 135-, 600- and 900-ohm lines. Both oscillator and voltmeter are transistorized and operate from internal rechargeable batteries or from the AC line. The batteries provide 40 hours of operation between chargings and are recharged automatically during AC-line operation. The oscillator response is  $\pm 3\%$  from 50 cps to 560 kc; the voltmeter has a 0.001- to 300-volt range from 5 cps to 2 mc; the attenuator provides 110 db of attenuation in 1-db steps. The  $30\frac{1}{2}$ -pound test set is priced at \$990.00.

### Wide-Range Voltmeter

Among 12 new instruments to be introduced by **General Radio Co.**, West Concord, Mass. (Booth 3201-8) is the Type 1806-A electronic Voltmeter, with accuracy of  $\pm 2\%$  of indicated value, frequency range to 1500 mc. AC and DC voltage ranges to 1500 volts, and ohmmeter, ranges from 0.2 ohm to 1,000 megohms. DC input impedance is 100



megohms, AC is 25 megohms in parallel with 2 pf, except 25 megohms in parallel with 15 pf on the highest (1500-volt) range. The type 1806-A is priced at \$490.00. Other instruments to be displayed at the GR booth are: a sweep-frequency generator covering 700 kc to 230 MC; a digital time and frequency meter; a precision coaxial connector; a VSWR recording system; and a microphone reciprocity calibrator. Also to be shown are impedance bridges and standards, oscillators, power supplies, stroboscopic equipment, sound- and vibration-measuring instruments, a general-purpose pulse generator; and autotransformers.

## Looking for the Finest TV Antennas?



24 CAROL ROAD, WESTFIELD, N. J. / AD 2-0250 / Cable: COELTENNA WESTFIELD

Specialists in Advanced Antenna Systems

Circle Item 29 on Tech Data Card



## *For distinguished service*

If distinguished service in the field of video tape—for inventing it in the first place, for producing it in commercial quantities in 1957 to meet the scheduling demands of Daylight Savings Time, or for carrying the first taped pictures transmitted via Telstar—would deserve a medal, it might look something like the above.

But much more meaningful than any medal is the overwhelming preference engineers every day vote "SCOTCH" Brand Live-Action Video Tape.

This tape began its career nearly 7 years ago; and not a day has gone by since that 3M research in video recording and tape making hasn't been at work improving on this "seven-league-boots" head start. And in the audible range recording field as well, 3M is constantly developing refinements and improvements that set the standards in tape technology. "SCOTCH" Video Tape as well as "SCOTCH" Sound Recording Tapes put this experience and lead time at your service.

"SCOTCH" IS A REGISTERED TM OF 3M CO., ST. PAUL 19, MINN.

*See us at the NAB Show, Booth 19W*

**Magnetic Products Division** **3M**  
COMPANY

Circle Item 30 on Tech Data Card



## A Preview of Next Month's Issue

### SPECIAL NAB SHOW COVERAGE

A rundown of what was seen and heard at the 41st annual NAB Convention and Engineering Conference.

### LIGHTING FOR YOUR TV STUDIO

How to plan lighting systems for television studios.

### HARMONIC SUPPRESSIONS FOR STANDARD BROADCAST STATIONS

Procedures for controlling RF harmonic radiation to comply with FCC regulations.

### WHAT TO DO WHEN THE PROOF OF PERFORMANCE FAILS

Detailed instructions on how to check out a broadcast system and make repairs to keep it within specs.

### CARTRIDGE TAPE AT WORK

Solving the problems in changing from reels to a cartridge tape system.

### ROUTINE FOR MAKING ANTENNA PROOFS

Technical Talks — How to make the measurements and adjustments necessary to bring a directional antenna pattern back to normal.

AND . . . The ever popular Engineers' Exchange, as well as other timely items you won't want to miss!

Why Not Sign Up For Your Own Subscription Today? Just Fill Out and Mail the Handy Card at the Front of This Issue.

# NEWS OF THE INDUSTRY

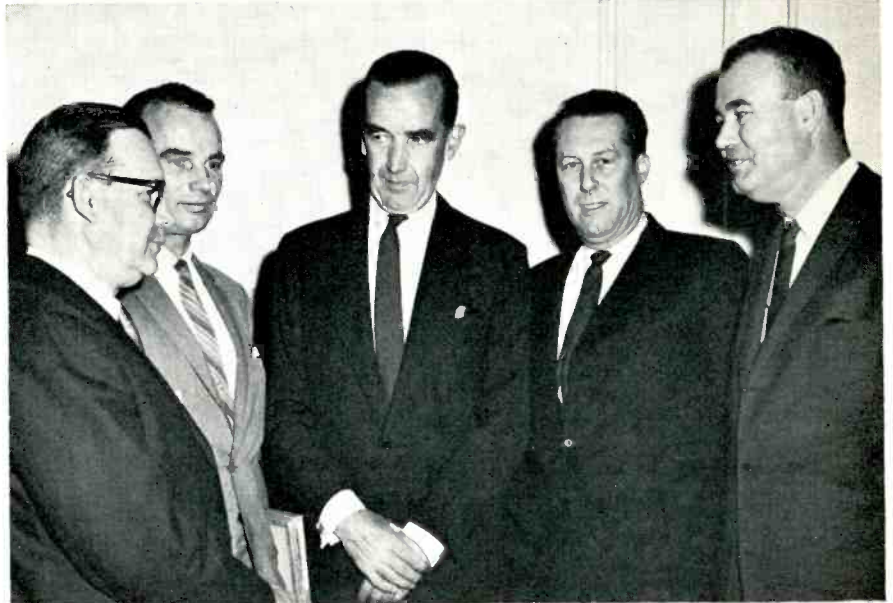

**Voice of America Dedication** — Edward R. Murrow, director of the U.S. Information Agency and principal speaker at the dedication of the world's most powerful short-wave broadcasting facility in Greenville, N. C., discusses the potential of the new setup with (left to right) Allan S. Austin, president of the **Austin Co.**; Henry Loomis, director of **Voice of America**; Mr. Murrow; Fred Blackburn, project manager responsible for operation of the new VOA center; and Richard F. Wittenmyer, Austin Company VOA project manager and manager of engineering and research.

### Musictapes Releases Pre- recorded Tape Cartridges

**Minnesota Mining and Manufacturing Co.**, St. Paul, Minn., has announced that **Musictapes, Inc.**, of Chicago, is releasing a repertoire of 12 jazz, popular, and classical music selections for playing on the Revere stereo tape-cartridge recorder-playback system. Musictapes, which has exclusive manufacturing and marketing rights for music recorded by United Artists, also markets pre-recorded taped music under the following labels: Elektra, GNP-Crescendo, Prestige, Starday, Seafair, Veejay, Caedmon, Monitor, Mahalo, and Stereophonic Musictapes.

### Rhenium Tungsten Heaters

A rhenium tungsten alloy, which enhances strength and reliability, is being used in the heaters for 14 types of re-

ceiving tubes produced by the Electronic Tube Division of **Sylvania Electric Products, Inc.**, Emporium, Pa. Other types of receiving tubes incorporating the alloy will be added to the line in the future. Although tungsten is basic in the construction of tube heaters, the use of rhenium is new to this technology. Due to its high recrystallization temperature, the rhenium tungsten alloy has an improved hot strength when compared with conventional heaters. This reduces brittleness during the heating and cooling that occurs during off-on cycling of electronic tubes.

### Dynamics Corp. to Acquire IERC Assets

The **Dynamics Corp. of America**, New York, N. Y., will acquire the assets of **International Electronic Research Corp.**,

## NEW FM ANTENNAS WITH DIGITAL TUNING\*

JAMPRO now offers its wideband FM antennas with digital tuning.\* Vee element end caps may be field tuned for extremely low VSWR—so necessary for finest stereo. Check literature card for details.

VISIT NAB BOOTH 39-W  
**JAMPRO ANTENNA CO.**

7500 - 14th Avenue  
Sacramento 20, California

Circle Item 51 on Tech Data Card

BROADCAST ENGINEERING



# KEEP STATION PERFORMANCE UP MAINTENANCE COSTS DOWN...



Model 3508A1 Video Transmission Test Set pictured with optional Model 3507A1 EIA Sync Generator

## with Telechrome\* Transistorized Video Broadcast and Test Equipment

\*Brand name

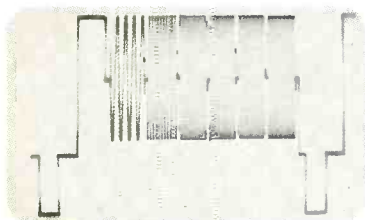

Multiburst Signal-Line Rate-Internal Sync

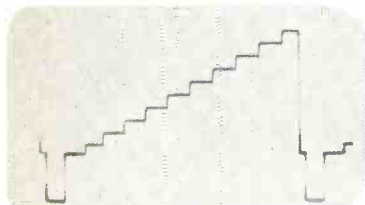

10-Step Signal-Line Rate-Internal Sync

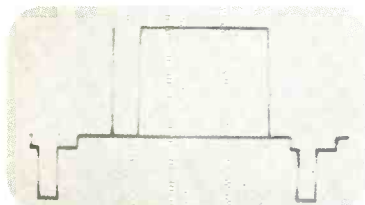

Sin<sup>2</sup> & Window Signal-Line Rate-Internal Sync

**NOW** — condensed into one small light-weight portable unit — fully transistorized

- Multiburst ■ Stairstep
- Sine Squared Pulse & Window
- Optional EIA Sync Generator

### FEATURES:

- Rack mount or portable
- Carrying case contains 1 3/4" utility drawer which can be removed for installation of an EIA Sync Generator (Model 3507A1). Case pre-wired for sync generator.
- All operating controls conveniently located on front panel.

■ Operates from self contained non-interlaced sync, plug-in EIA Sync Generator, or external EIA Sync and Blanking.

■ VIT Operation — when used with external VIT Keyer, provides vertical interval test signals through a high impedance (line bridging) output.

■ Low distortion multiburst — plug-in oscillators permit selection of frequencies to 4.2 MC. 10 MC optional.

■ Preset 3, 5 and 10-step stairsteps with variable APL and 3.58 MC sub-carrier on all modes.

■ T and 2T (.125  $\mu$ sec and .250  $\mu$ sec) Sine squared pulses. Window signal also sine-square filtered.

NAB VISITORS: See the new Telechrome Transistorized Special Effects Generator at the TELEMET BOOTH NO. 2E • CONRAD HILTON, CHICAGO • MARCH 31-APRIL 3.

# TELEMET

C O M P A N Y



A Giannini  
Scientific Co.

AMITYVILLE, NEW YORK: 185 DIXON AVENUE, (516) 541-3600 • SANTA ANA, CALIF.: 2509 SOUTH BROADWAY, (714) 546-2881

Circle Item 31 on Tech Data Card

March, 1963

57

Burbank, Calif., through a proposed exchange for 100,000 shares of DCA preferred stock and approximately 340,000 shares of DCA common stock. The announcement was made jointly by R. F. Kelly, DCA president, and Harvey Riggs, IERC president. IERC, manufacturers of electronic instruments and components, will join the other subsidiaries of DCA in the production of specialized aerospace systems and equipment, communications equipment, and a wide range of industrial and consumer products.

#### Radio Stations Sold

Radio Station **WPDX**, Clarksburg, W. Va., has been sold to Mr. George L. Kallam of Charleston. The station, which operates 750 kc at 1 kw, was sold by Messrs. Raymond C. Warden and Robert D. Hough. Radio Station **WBBR-AM & FM**, East St. Louis, Ill., has been sold to Mr. Paul Adams by a group headed by Messrs. Larry R. Picus and Robert L. Walker. Mr. Adams is chief engineer at Television Station **WCPO** in Cincinnati, Ohio. **WBBR** is a 500-watt day, 250-watt night, fulltimer on 1490 kc. Radio Station **KTWN-AM**, St. Paul, Minn., (formerly **WMIN**) has been sold to Gene Posner, owner of **WMIL-AM & FM**, Milwaukee, Wisc. **KTWN**, which operates on 1400kc, was sold by the Franklin Broadcasting Corp.

#### Sparta Moves to New Plant

**Sparta Electronic Corp.**, Sacramento, Calif., has moved to a modern new plant, according to William J. Overhauser, President. The new location, which more

than triples previous plant capacity, houses the general offices, complete laboratories for engineering, research, development, and product design, as well as extensive production facilities. Since the company was founded in 1958 it has introduced many new products to the broadcasting industry including tape cartidge systems, transistorized audio consoles, and portable studios.

## PERSONALITIES

**Benjamin P. Ransom** has been appointed supervisor of audio-video requisition engineering in **General Electric's Technical Products Operation**, Syracuse, N.Y.,. In his new position Mr. Ransom will head a new engineering sub-unit responsible for all requisition engineering activities to adapt the company's standard for broadcast and closed-circuit television products to highly specialized customer requirements.

**Mrs. Ruth H. Musser**, vice-president of Radio Station **WMCA**, New York, N.Y., announced the appointment of **Michael Peshkur** as studio supervisor. Mr. Peshkur's new duties entail the hiring and training of new engineering personnel, daily work assignments, and staff job performances. Also announced was the appointment of **Robert Kanner** to the post of maintenance supervisor.

**J. Harry Frankfort** has been named area manager for the **Projects Development**

**Department of Vitro Engineering Co.**, New York, N. Y. The announcement was made by **Lal'rance A. Mitchell**, vice-president of **Vitro Corporation of America**.

**General Electronics Laboratories, Inc.**, (GEL) of Cambridge, Mass., has announced the appointment of **B. T. (Ben) Newman** to the newly created post of broadcast administrative manager. **Sal Fulchino**, broadcast sales manager, said that the need for this position has arisen out of the greatly increased sales of broadcast equipment by GEL. Mr. Fulchino also announced the appointment of **Milan Leggett** of Dallas, Texas, as broadcast sales engineering representative in the states of Texas, Louisiana, and Mississippi.

The appointment of **Charles R. Denny** as vice-president and managing director of the **RCA International Div.** was announced recently by **Charles M. Odorizzi**, group executive vice-president. Mr. Denny succeeds **Douglas C. Lynch**. An active executive in various divisions of RCA and NBC for the past 15 years, Mr. Taylor is a former chairman of the FCC.

**Joseph E. Baker** has been appointed manager of distributor sales in the Industrial Products Div. of **Adler Electronics, Inc.**, New Rochelle, N. Y. Mr. Baker was formerly a field sales engineer in this division, which markets UHF TV broadcasting systems and educational TV systems.

# NEW!

## MODEL TCA3

### CAMERA AMPLIFIER

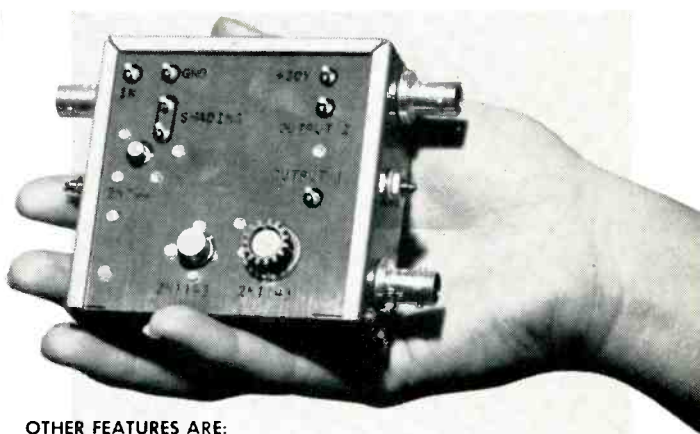

#### OTHER FEATURES ARE:

- STREAKING CONTROL
- HIGH FREQUENCY PEAKING CONTROL
- 600-LINE DEFINITION
- NON-MICROPHONIC NO HUM
- PROVISION FOR HORIZONTAL SHADING THRU PRESENT CAMERA SHADING CONTROL
- SIGNAL TO NOISE BETTER THAN VACUUM TUBE AMPLIFIERS
- GAIN AND FREQUENCY RESPONSE EQUAL TO PRESENT VACUUM TUBE MODELS
- SECOND OUTPUT TO FEED CAMERA VIEW-FINDER
- OUTPUTS TERMINATED TO MATCH 51 OHM CAMERA CABLE, WITH 0.4 VOLTS PEAK-TO-PEAK INTO CABLE AND 0.8 VOLTS PEAK-TO-PEAK INTO VIEW-FINDER FROM 51 OHM SOURCE

Model TCA3 is a compact, completely transistorized camera amplifier that replaces vacuum tube preamplifiers now used in all image orthicon cameras. The TCA3 quickly mounts within available space in camera... vacuum tube amplifier need not be permanently disabled.

Operating voltage is obtained from 285-volt source within camera and is regulated within the TCA3. A built-in protective device protects unit if high-voltage blocking capacitor at the image orthicon anode short circuits. Signal connectors are BNC type, as well as solder-terminals. Dimensions: 3 1/4 x 3 1/4 x 1 1/4 inches.

The TCA3 has been fully on-the-air tested for over a year. It is factory guaranteed to give years of completely trouble-free service and is priced below all present vacuum tube models.

Your inquiries for additional information will receive our prompt attention.



NOTE: SEE THE TCA3 AT BOOTH 3E AT THE NAB CONVENTION

INTERNATIONAL NUCLEAR CORPORATION

608 NORRIS AVE. • NASHVILLE 4, TENNESSEE

Circle Item 32 on Tech Data Card

Authoritative reference data from the industry's leading wire, cable and tubing manufacturer

# ALPHA ENGINEERING CATALOGS TELL YOU

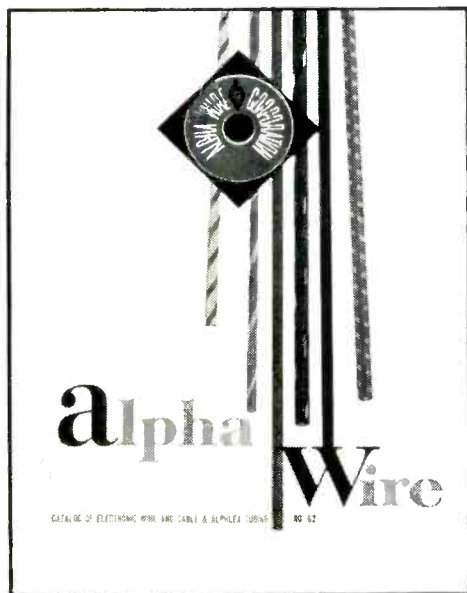

## HOW TO SPECIFY ELECTRONIC WIRE, CABLE & INSULATING MATERIALS

### COMPREHENSIVE 52-PAGE WIRE AND CABLE CATALOG

### ALL-NEW 24-PAGE 1963 TUBING GUIDE

Complete with all specifications, this descriptive and illustrative catalog details over 6000 electronic wire, cable and tubing products. A wealth of valuable and helpful data featuring...

Complete engineering information, featuring the most exciting innovation in tubing insulation today... irradiated heat shrinkable tubing — the versatile insulation that shrinks skin-tight to a predetermined size... then stops!

- a 6-page complete selection of MIL-W-76B Plastic Wire
- a 5-page complete selection of MIL-W-16878C Plastic Wire
- 13 pages on audio and hook-up wire and cable
- Teflon wire, cable and tubing
- Retractable coil cords and extension cord sets
- Shielding and braiding
- a complete section describes Alpha's complete prime manufacturing capabilities plus the special facilities for custom services such as stripping, cutting, stripping, tinning, coloring of cable jackets, and short run cables.

- A complete 11-page "how to" section on FIT™ shrinkable tubing, replete with descriptions, engineering data and applications — featuring:
- Shrinkable PVC tubing, ideal for cable jacketing • all-purpose polyolefin tubing in colors and clear • semi-rigid polyolefin tubing in colors and clear • wire termination caps for splices and cables • 4-way markers for wire and cable identification

Also included in this comprehensive book are sections on...

- PVC plastic tubing
- Teflon extruded tubing
- Zipper tubing
- Plastic impregnated fiberglass tubing
- Lacing cords and tapes
- RF shielding tape

Whatever your needs in wire, cable and tubing, you can depend on Alpha for...

- the most extensive manufacturing and custom facilities
- the fullest "in-depth" engineering assistance
- the latest engineering reference data

So — whether your requirements are for

- mass production
- prototypes
- short runs
- or anything in the unusual

we suggest you do as hundreds of leading OEM manufacturers do — lean on Alpha for *thorough reliability... from original concept to final production.*

All 6,000 Alpha Wire products in these guidebooks are IN STOCK and available from Alpha or your local electronic parts distributor. Write today for your free copy of these 2 guidebooks.

See our complete product listing in

**The Radio-Electronic MASTER**



Manufacturers of electronic wire, cable, and tubing.

### ALPHA WIRE CORPORATION

Subsidiary of LORAL Electronics Corporation

200 Varick Street, New York 14, N. Y.

Pacific Division: 11844 Mississippi Avenue, Los Angeles 25, California

**41 YEARS OF APPLIED ENGINEERING KNOW-HOW AT YOUR SERVICE!**

Communications, mobile radio...

# A First Class FCC License

...or Your Money Back!



Your key to future success in electronics is a First-Class FCC License. It will permit you to operate and maintain transmitting equipment used in aviation, broadcasting, marine, microwave, mobile communications, or Citizens-Band. Cleveland Institute home study is the ideal way to get your FCC License. Here's why:

Our training programs will *quickly* prepare you for a First-Class Commercial Radio Telephone License with a Radar Endorsement. Should you fail to pass the FCC examination after completing your course, you will get a *full refund* of all tuition payments. You get an FCC License . . . or your money back!

You owe it to yourself, your family, your future to get the complete details on our "proven effective" Cleveland Institute home study. Just send the coupon below TODAY. There's no obligation.

**MAIL COUPON TODAY FOR FREE CATALOG**

**Cleveland Institute of Electronics**

1776 E. 17th St., Dept. BE-8  
Cleveland 14, Ohio

Please send FREE Career Information prepared to help me get ahead in Electronics, without further obligation.

**CHECK AREA OF MOST INTEREST -**

- |   |  |
|---|--|
| <input type="checkbox"/> Electronics Technology | <input type="checkbox"/> First-Class FCC License   |
| <input type="checkbox"/> Industrial Electronics | <input type="checkbox"/> Electronic Communications |
| <input type="checkbox"/> Broadcast Engineering  | <input type="checkbox"/> _____ other _____         |

Your present occupation \_\_\_\_\_

Name \_\_\_\_\_ Age \_\_\_\_\_  
(please print)

Address \_\_\_\_\_

City \_\_\_\_\_ Zone \_\_\_\_\_ State \_\_\_\_\_

Accredited Member National Home Study Council

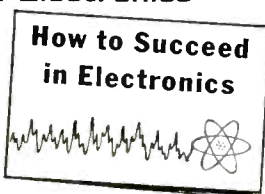

Circle Item 34 on Tech Data Card

## ABOUT THE COVER

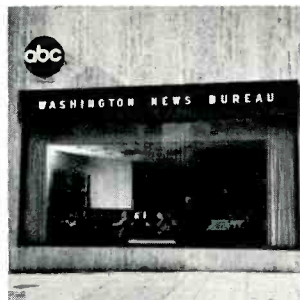

The latest advances in broadcast-equipment transistorization have been incorporated in the new ABC Washington, D.C. News Bureau, pictured on the cover and in the accompanying photos. The first completely solid-state television and radio broadcasting plant in the United States, the news headquarters houses complete facilities for radio and television broadcasting of live, filmed, and taped programming. Practically the only vacuum tubes used are the camera tubes and the cathode-ray tubes in the monitors. The ground-level studios and control rooms can be seen from the street through the huge plate glass window. (Video control on the left, radio control on the right). Cameras, moni-



tors, scopes, recorders, amplifiers, switchers, mixers, ccu's, and all other equipment are transistorized. The new solid-state vidicon cameras provide smoother pictures than do standard image-orthicon units. All are equipped with wide-range zoom lenses, providing 10-to-1 focal length ratio instead of the usual 6-to-1. In addition to complete television tape-recording facilities, the new plant is equipped with automatic film-chain units built to ABC Engineers' specifications. A unique lighting system in the studios employs small quartz-iodine lamps which provide high-intensity illumination with long life, and control units designed with silicon controlled rectifiers.

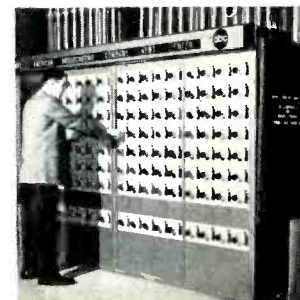

**BROADCAST ENGINEERING**

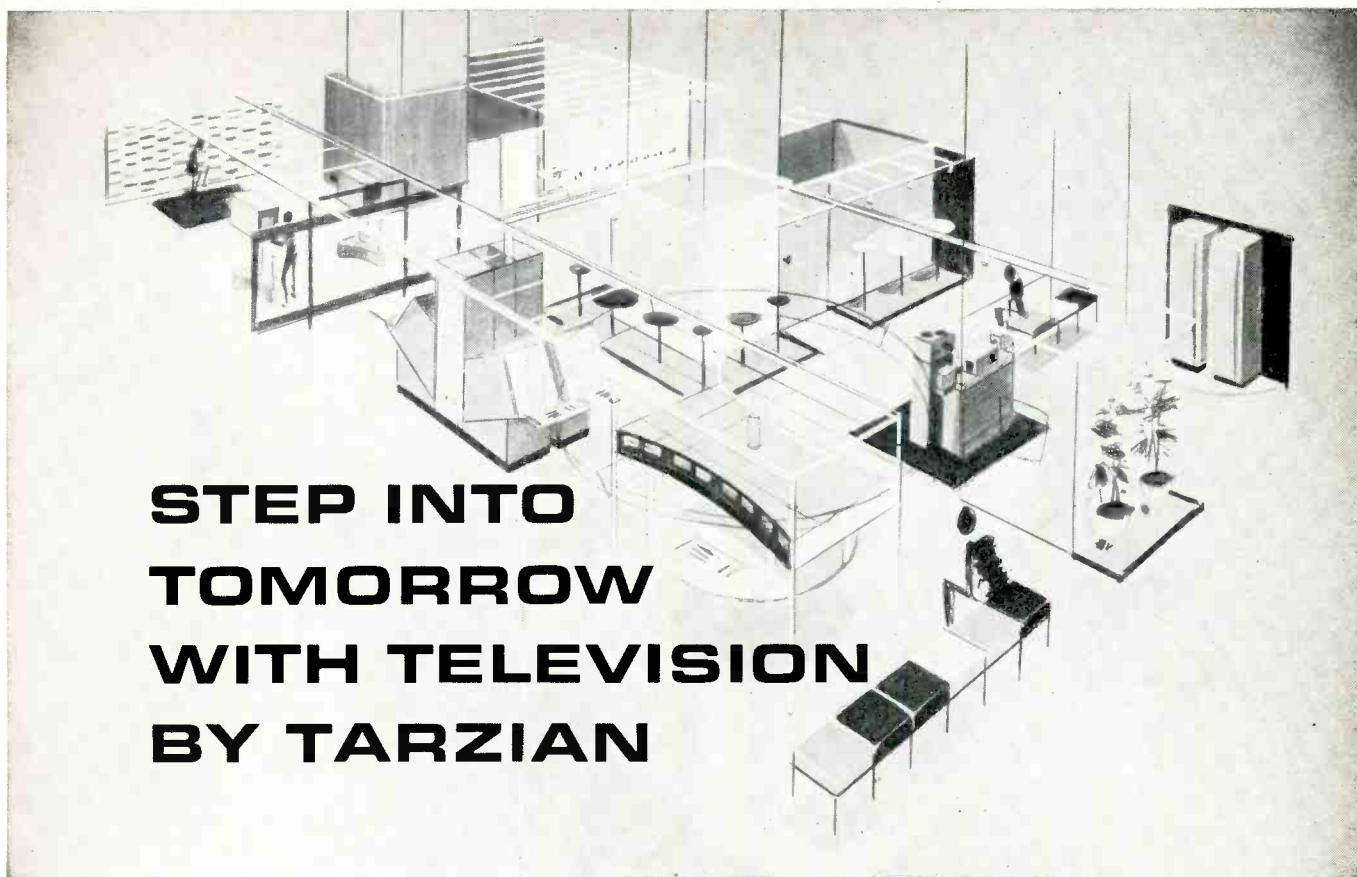

## **STEP INTO TOMORROW WITH TELEVISION BY TARZIAN**

*See it at  
NAB—Space 17E*

A complete line of Solid State television broadcast equipment will be unveiled by Sarkes Tarzian, Inc. at the National Association of Broadcasters Show in Chicago, March 31.

Reflecting an outstanding capability in the engineering and manufacturing of sophisticated broadcast equipment, the entire Tarzian line will introduce a new concept in the design of television equipment. From the exciting, functional exteriors by Schory-Steinbach Associates—Industrial Designers—to the incomparable transistorized engineering, the new Tarzian look is a look of quality—quality in performance matched by quality in appearance.

These solid state electronic products come to you in the longtime Tarzian tradition of uncompromising quality at reasonable cost.

*Broadcast Equipment Division*



# **SARKES TARZIAN, INC.**

*Bloomington, Indiana*

Circle Item 35 on Tech Data Card

"King Mike I" Tells All! Or...

## HOW TO SUCCEED IN THE "KING" BUSINESS WHEN ALL THE CARDS ARE STACKED IN YOUR FAVOR



Altec Regional Sales Manager, Milt Thomas, after coronation as "King Mike the First" receives congrats of Altec President A. A. Ward (l.) and H. S. Morris, V.P. for Marketing. Thomas won crown and scepter when customers in the Southeast decided to up their purchases of Altec microphones by 235%.

"A funny thing happened to me on the way to the office the first day of the 'King Mike' Contest. I kept repeating the first principle of Salesmanship: Know Your Product—then tell the people the *facts* about it in terms of benefits. Well, I know my Altec mikes, and I knew the *facts* that made them preferred by many of those canny broadcast and recording engineers.

"On all my sales calls during the Contest, I laid it on the line to prospects about Altec's exclusive *Sintered Bronze Filter* and how it positively bars entry of iron dust, metal particles, or any foreign matter to make it the most perfect acoustical filter ever made... I waxed enthusiastic about Altec's *Microphone Exchange Plan* whereby customers return to Altec a microphone in need of repair and receive a brand new, factory-sealed mike in exchange for a nominal charge.

"I showed my prospects individual certified calibration curves that are supplied with each Altec 684, 685, 688 and 689 Dynamic, *free of charge*, as proof of their superior performance. I almost bought a couple myself as I showed them *documented comparisons* of Altec microphone curves vs. other famous-name competitive equipment (there was no comparison!).

"Next, I followed-up with *comparative A-B tests* that naturally proved Altec best in sensitivity, smoothest in response, best in overall performance.

"Finally, just to clinch the sale, I'd pull out all stops on Altec's 15 different models of professional mikes—from \$42.00 dynamics to \$275.00 condenser systems—for over fifty different applications in every area of broadcasting and recording. And, I bore down hard on the fact that *Altec competes on the basis of price and quality with any line of microphones offered by any manufacturer!*

"In conclusion, I'd like to offer a few words of advice to "King Mike II," whoever he may be: You gotta tell the customer about the many superiorities of Altec microphones that no other make of microphone can touch. So to get better results, *give 'em the facts* about Altec. The facts are enough..."

Here are two impressive examples:



**PROOF OF SUPERIOR PERFORMANCE!** In the entire broadcast and recording industry, only Altec provides concrete visual proof of superior performance by supplying individual, certified calibration curves with each of four models of professional dynamics.

For complete specifications, please call your nearest Altec Distributor (Yellow Pages) or write Dept. BE-3



# ALTEC LANSING CORPORATION

LTV A subsidiary of Ling-Temco-Vought, Inc.  
ANAHEIM, CALIFORNIA

© 1963 ALTEC LANSING CORPORATION

Circle Item 36 on Tech Data Card

## AM, FM-TV Towers

(Continued from page 19)

driven into them. Thus, a copper strap connects each tower section and forms a continuous electrical path. However, great care must be used to see that the holes are clean and completely filled by the copper plugs. Otherwise, water can get into the holes and deteriorate the connections.

A natural follower of bonding is grounding. Due to the height of the tower, above nearby objects, it is an effective lightning conductor, **if properly grounded.** Most radio towers are struck by lightning all year round, without consequence. On the other hand, lightning can do damage to some parts of the tower assembly. Records exist of cables being burnt through by direct hits, as well as of beacons being damaged and tower lights failing. The fact remains that a series-fed tower is not directly grounded, so the lightning horns across the base insulators must be properly adjusted, and adequate precautions taken to protect other equipment that could receive discharges due to lightning jumping gaps.

It is important to ground guy wires at the ground stakes since long lengths of guy can, and do, accumulate heavy charges. This can be accomplished by tying the guys together at each stake and grounding them to a copper rod in the ground. Anyone who has been in the vicinity of a 200 or 300 foot tower during periods of lightning conditions will recall the crackle of discharges across the guy insulators. Even a grounded tower will accumulate a charge strong enough to arc over guy insulators in dry weather. During static conditions, there have been cases in which an observer's hair stood on end when he stood under the umbrella of guys around a tower.

### Galvanizing and Painting

The question of painting or galvanizing for tower protection is one that does not have to be decided by station engineers. Nevertheless, one should be aware of the pros and cons. If your tower is one which has been exempted from painting requirements, it should definitely be galvanized. The major purpose of galvanizing is protection

BROADCAST ENGINEERING

of iron and steel from rust and deterioration. Galvanizing is performed by dipping the tower members into a bath of molten zinc. The yardstick for describing the resulting zinc coat is so many ounces of zinc for one square foot of steel or iron.

Guy wires are always galvanized before being woven. The small diameters of the strands render them particularly susceptible to attack by acids in the air. When tubular tower members are used, they must be galvanized inside and out, unless precautions are taken to prevent moisture from entering and causing rust on the inner surfaces.

Even the apparently simple job of painting a tower presents problems. Paint will not adhere to newly galvanized surfaces; it is therefore necessary to rough up the smooth metal. A suitable solution for this, such as that containing sulphuric acid, copper nitrate, and a few other ingredients, is applied and allowed to dry. In about ten hours the surface is ready to paint and will not need a primer coat. If an older surface is greyish or black, a primer will probably not be needed because weathering has done the etching for you! In any case, be sure the surface is free from grease, oil, or any other dirt, and use good paint with a primer, if necessary.

#### Cost and Space

The question of cost can be answered only when the full details are known, and the tower company has been given time to produce an adequate estimate. In any event, prices (Fig. 2) vary a great deal from one part of the country to another. It might suffice to say that guyed towers are less expensive than self-supporting types, by about 2½ times. As the height goes up so does the ratio, to about 4:1 for a 600-foot tower.

There is a rough rule of thumb for estimating the ground space required for the two types of towers. For guyed towers between 50 and 100 per cent of the height should be allowed out from the base for guys (Fig. 3)—the closer in the guys are, the heavier the load on the tower, and the heavier the cables must be. In the case of self-supporting towers, the area required for the base will be about 8 to 20% of the tower height. ▲

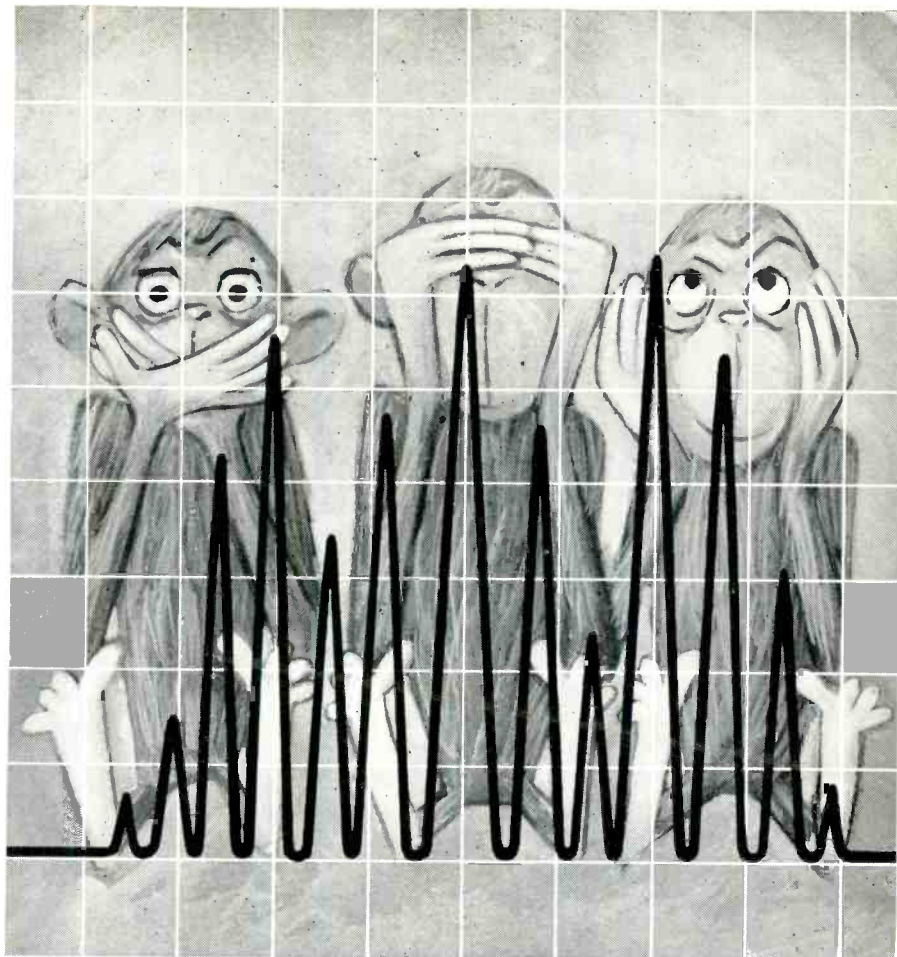

## Speak—See—Hear No Evil with NEMS-CLARKE® Spectrum Display Unit

Here is a new kind of station monitor that gives the broadcaster a complete picture of the frequency spectrum in which he operates. It measures TV and FM frequency deviation by both the bandwidth and Bessel null methods and it determines amount of sideband or subcarrier attenuation, locating spurious radiations and identifying sources of interference.

The SDU-520 is a receiver and a spectrum display unit in one chassis. A plug-in RF unit continuously tunable from 54-260 mc, covers the FM and VHF television channels. The FM spectrum is displayed in segments of from 50 kc to 2 mc on a five inch screen calibrated horizontally in frequency deviation and vertically in decibels. Crystal controlled marker pips at  $\pm 25$  kc and  $\pm 75$  kc provide precise horizontal scale alignment. The SDU-520 also takes an optional plug-in AM tuner covering 540 kc to 1600 kc.



For further information write:  
Vitro Electronics, 919 Jesup-Blair Drive,  
Silver Spring, Maryland.  
Sales Offices: Houston and Los Angeles  
A Division of Vitro Corporation of America

**Vitro** ELECTRONICS

#### Specifications:

1. Tuning Range . . . 54-260 mc plug-in RF tuner
2. Sweep Width . . . (a) variable . . . 0-2 mc  
(b) fixed . . . 50, 150, 300 kc and 2 mc
3. Resolution . . . . . 3 kc
4. Markers . . . . .  $\pm 25$  kc . . . . .  $\pm 75$  kc
5. Sensitivity for full defl. . . . 30 micro volts
6. Audio . . . . . FM or AM selectable
7. Size . . . . . 8¾" x 19" x 16"

Circle Item 37 on Tech Data Card

## Transistorized Monitor

(Continued from page 17)  
voltage while maintaining low leakage are too costly for most applications of the monitor.

### Vertical Deflection

Aside from the video amplifier, the vertical deflection amplifier is the only linear amplifying-circuit in the monitor. A blocking oscillator drives a discharge circuit which develops a sawtooth waveform at the vertical scan rate. This waveform is amplified by two power transistors which are direct-coupled to the yoke; no coupling transformer is used. Linearity is achieved by negative feedback from the output amplifier to the sawtooth generator.

### Synchronizing Circuits

Transistors are ideally suited to pulse applications because of their saturation characteristics. When properly driven they behave much like switches, producing output waveforms of uniform amplitude and excellent rise time.

The synchronizing circuits, there-

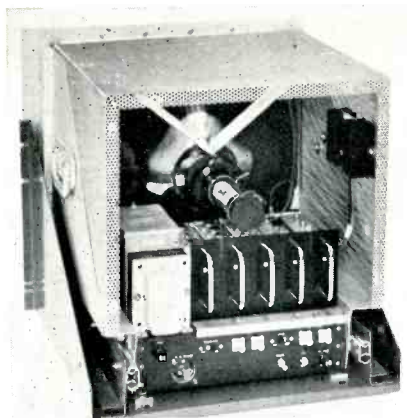

Fig. 4. Rear view of 14" video monitor.

fore, presented little difficulty. Even the classic transistor problem of temperature stability is eliminated because all circuits are overdriven, and a shift in operating point has little effect upon circuit performance. The monitor has been operated for extended periods in a temperature environment of 195° with no adverse effects. For example, vertical interlace, which is essentially a function of the synchronizing circuits, is excellent at all operating temperatures. In fact, the vertical-hold control cannot be adjusted to destroy interlace — if the

picture locks, it is interlaced.

### Power Supply

The power supply delivers —18-volts DC to all modules. This voltage, regulated by an amplifier and series regulator, is constant with a line-voltage variation from 100 to 130 volts (no effect on the picture can be detected). The power transformer also supplies 120-volts DC to the output stage of the video amplifier, and 400-volts DC for the brightness and focus circuits of the kinescope.

### Conclusion

It can be said with assurance that transistorized video monitors are now practical. Performance which equals, and in many instances surpasses, the performance of vacuum-tube monitors can be achieved with transistors. The increased reliability of transistors demonstrated by the maintenance schedules of studios which have converted to transistorized equipment, should make solid-state devices the choice in applications where high reliability and low maintenance costs are demanded. ▲

# FREE HOME DEMONSTRATION!

Enjoy a free demonstration of the remarkable Electro-Voice Model 643 in the comfort of your own living room. No cost or obligation. No fuss or muss, no coupons to fill out, and no salesman will call! All you do is flick a switch!

Turn on your TV set during the next presidential news conference. Any channel. Look closely and you may see what appears to be a "bazooka" on stage next to each TV camera covering the reporters. This is the E-V Model 643 dynamic Cardiline microphone, the most directional broadcast microphone on the market!

The 643's are up to 50 feet away from the reporters, yet the sound is clear and natural in quality... you can hear as well at home and sometimes better than the President himself! Compare this unobtrusive pickup with the conventional hand-held microphones or "cornfields" of microphones used in the past. A dramatic demonstration that the 643 reaches farther than any other broadcast microphone available!

And there are plenty of other demonstrations. At football games and parades, 643's pick up marching bands with recording fidelity up to two city blocks away! In TV and film studios and on remotes the 643 delivers clean dialogue despite wind and noise that would spoil the "takes" from an ordinary microphone.

The E-V Model 643 is another example of the many positive contributions by Electro-Voice to professional sound pickup techniques. If your sound problems can be solved by a 7-foot microphone that "reaches" farther than any other, arrange now for a studio demonstration of the unique new 643. Ask your E-V professional microphone distributor for details today!

*New 7-Foot Long  
Electro-Voice  
Microphone*



**Electro-Voice**®

**ELECTRO-VOICE, INC.**  
Commercial Products Division, Dept. 331V  
Buchanan, Michigan

Circle Item 38 on Tech Data Card



## FCC Interference

(Continued from page 26)

the WLAT would have meant a repudiation of these objectives. This can best and possibly only be done through rule making.

The pattern since the WLAT Case has been constant—a hearing on Section 3.24(b), formidable engineering studies regarding the effect of the proposal upon future utilization of the channel, and a subsequent grant. Through the process, the engineering studies have been refined to include such points as whether the presence of the proposed operation would unduly restrict the permissible radiation of future facilities. It also appears that a hearing can be avoided if the engineering study concerning the proposal's effect upon future utilization of the channel is provided to be considered at the time the application is processed. It should be pointed out that during preparation of the application, no consideration is given by the consulting radio engineer to affording protection to future possible assignments. Whatever protection exists is purely ac-

cidental. But with surprising regularity, the engineering studies have disclosed that this unintentional protection tends to be the case rather than the exception. There has been one case where the engineering study revealed the nighttime proposal would slightly raise the interference level of an area where under the present rules a new assignment might be possible. This was found to be the case in the nighttime proposal for Station KRSI, St. Louis Park, Minnesota. An attempt was made to ascertain the extent of the effect even to providing population and area data concerning a hypothetical loss zone. The KRSI situation was most unusual in view of the fact that the application for a construction permit was granted without a hearing even though the population and area loss amounted to 81% and 77.6% respectively.

The important point to remember is that even by the use of Section 3.24(b) the FCC has not been able to curb the granting of nighttime proposals which have extremely limited interference-free service areas. The Commission at the present time finds itself denying night-

time proposals which would involve interference from 20 to 30% because they are by definition "inefficient operations," while granting proposals which would suffer interference in the order of 85% because they supposedly make for an efficient utilization of the channel, although by definition they too are "inefficient operations." As a result the Commission has announced that it intends to re-examine the exceptions to the 10% Rule. It is possible that the exceptions will be eliminated. More probably, however, the FCC will restrict the exceptions by placing a ceiling on the extent of interference above 10% which a proposal can suffer and still qualify as an exception to the 10% Rule. At present not all the proposals which qualify are challenged. One estimate is that the interference-free contour must be greater than 10 mv/m, the population affected in excess of 50%, or a combination of both in order for the Commission to raise a 3.24(b) issue. Thus, the exception provisions could be revised to include a ceiling of 50% of the population and/or area. ▲



*More E-V microphones are  
seen at major news events  
than any other brand.*

# NEW PRODUCTS

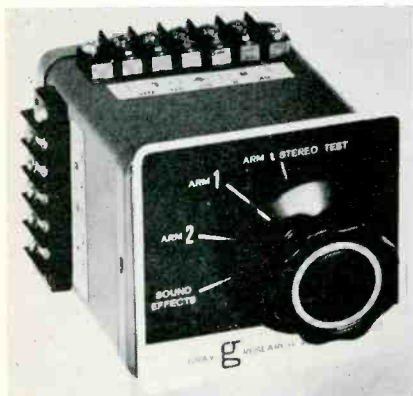

## Low-Level Audio Control

A new low-level audio control designed for the broadcast industry is available from **Gray Research and Development Co., Inc.**, Elmwood, Conn. Permitting smooth switching between two monaural or stereo tone arms, the 404 tone arm switch enables untrained personnel to check out a stereo system. It also offers a wide range of features to station engineers. The new switch connects two tone arms to either a monaural or stereo equalizer and permits the operator to shift from one arm to the other as needed in playing various types of records. In record-cutting operations the 404 provides groove noise information for adjusting and controlling heat on the

stylus. It permits the production of continuous sound effects, provides vertical output for cartridges used on hill and dale transcriptions, and can be connected to the majority of the equalizers on the market. The 404 is priced at \$37.05.

Check Item 54 on Tech Data Card

## Colored Film Leader

A new film leader material which does not require scraping to produce a splice since there is no emulsion is available from **Neumade Industries, Inc.**, New York, N. Y. The 16-mm leader, both sound and silent, comes in black, white, red, blue, grey, and yellow—all fade-proof. The colors are impregnated in the film base itself. With this product it is possible to color code all prints, not only identifying head and tail, but by type and subject matter as well. Limited color choices are available for 8-mm and 35-mm leader.

Check Item 55 on Tech Data Card

## Illuminated Push-button Switches

A new series of illuminated push-button switches for use on control panels and in "press-to-test" applications have been introduced by **Switchcraft, Inc.**, Chicago, Ill. The "NF-Lite" switches, Series 4100 and 4200, are flat-frame, leaf-type, momentary-action switches. A wide range of multiple-pole switching is available as

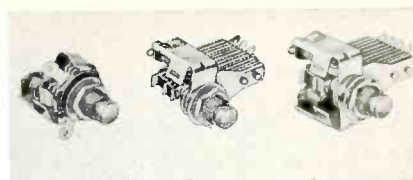

standard, from a single 1-A circuit (spst-no) to a 3-C circuit (3 pdt). Contacts are fine silver, rated at 3 amp., 120 volts, AC, noninductive load. The 6-volt and 28-volt lamps are housed in a snap-out assembly for easy replacement. Colors (red, amber, yellow, and white) can be changed in the field at any time.

Check Item 56 on Tech Data Card



## TO-18 Size Heat Dissipator

The **IERC Div. of International Electronic Research Corp.**, Burbank, Calif., has recently made available a "Fan-Top" heat dissipator for TO-18 transistors. Effective thermal control is achieved with the "Fan-Top" to reduce  $T_j$  up to

**Bauer**  
BROADCASTER

## 50 WATT CARRIER CURRENT TRANSMITTER

The Bauer Broadcaster is ideal for Test Site, College & University, Military and other Low Power Applications because it utilizes AC Power Lines for the Antenna. VACUUM CRYSTAL CONTROLLED • WIDE OUTPUT TUNING RANGE • MEETS FCC SPECS • MIKE & TAPE LEVEL INPUTS • ONLY 10½" RACK SPACE. Write for complete story.

# Bauer

**ELECTRONICS CORPORATION**  
1663 Industrial Road, San Carlos, California  
Area Code 415 591-9466

Circle Item 39 on Tech Data Card

BROADCAST ENGINEERING

25% and prevent degradation of temperature-sensitive electrical characteristics. A large surface area and thin cross section attain a high heat-transfer rate. Angled "fan" segments induce turbulence and increase convection efficiency in forced air. A spring finger design of beryllium copper allows one size to fit all TO-18 packages, or other packages with diameters between .178" and .196". They are priced from \$0.09 to \$0.20.

Check Item 57 on Tech Data Card

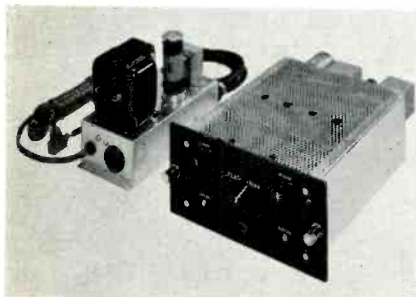

### Stereo Transcription Preamplifier

A professional stereo equalizer-preamplifier for use with magnetic stereo phonograph cartridges in recording and film studios and TV and radio broadcast stations has been announced by **Shure Brothers, Inc.**, Evanston, Ill. Prototypes of the Model SE1 were tested for several months in typical broadcast and recording studios to make certain production units would meet all requirements of professional use, including insensitivity to high RF signals. Each production unit is assembled when ordered and individually inspected under rigid quality-control procedures and processes. Specifications include: RIAA equalization,  $\pm 1$  db 30 to 15,000 cps; gain to feed a 600-ohm line at +4 or +8 dbm from a magnetic stereo phono cartridge and still provide for peak power (1.2-mv input gives at least +4 dbm output); hum and noise level at least 64 db below the output level; channel separation is better than 37 db between 50 and 10,000 cps; and distortion is under 1% at +15 dbm 150 or 600 ohms output impedance. Other features include separate gain controls for each channel, a switch-selected flat response, and separate high and low response trimmers for each channel with no interaction between channels or high and low end. Compact in size (7" wide x 3 3/8" high x 11" deep) it has a separate power supply and allows maximum flexibility in location. Price of the SE1 is \$295.00.

Check Item 58 on Tech Data Card

### Gray Base TV Recording Film

The **Eastman Kodak Co.**, Rochester, New York, now offers Type 5374 (35mm) and Type 7374 (16mm) television recording film on a gray base. The safety gray cine negative support provides improved recording quality and simplifies handling of the film in processing laboratories. Because the gray base has the same density as other negative materials, it can be used at the same printer light levels. The film, designed for photographing television picture-tube images, is useful for delayed broadcast or syndication, sponsor's records, program rec-



## TURNER'S 401 makes frequency response adjustment elegantly easy

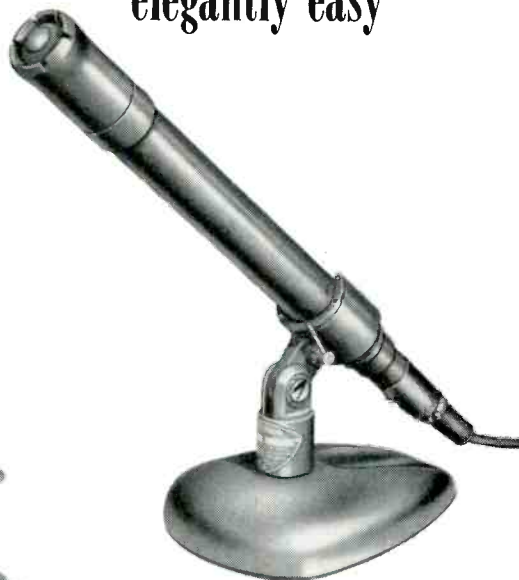

The top microphone in Turner's famous Magnifique 400 Series — the model 401 — combines singular versatility, high style and quality sound reproduction for studio use in radio or TV. Features combination impedance — frequency response conveniently adjusts with a screwdriver at the mike. And Turner's exclusive Positive Grip Cam Lock means complete mounting versatility — locks anywhere, in any position — allows instant insertion or removal without disconnecting. Sound reproduction is elegant, too — from crashing crescendo to polite pianissimo. Write today for complete specifications on the Turner 401. Get exclusive versatility . . . exacting reproduction . . . elegance.



### THE TURNER MICROPHONE COMPANY

907 17th St. N.E.,  
Cedar Rapids, Iowa

IN CANADA: Tri-Tel Associates, Ltd.  
81 Sheppard Ave. West, Willowdale, Ont.  
EXPORT: Ad Auriema, Inc.  
85 Broad Street, New York 4, N.Y.

ords for legal protection, future production planning, and many other purposes. In the future types 5374 and 7374 will be available with the former clear base on a special order basis only.

Check Item 59 on Tech Data Card



### Voltage Adjusters

The **Terado Corp.**, St. Paul, Minn., recently released two voltage adjusters (the Planet No. 50-203 handles electrical equipment up to 300 watts; the Polaris, No. 50-204 has a capacity to 500 watts). Both of these adjusters change abnormally high or low AC voltage to normal. The manufacturer points out that TV

and radio broadcasting and other electrical equipment operate best at the 115 volts for which they were designed. Useful in low-voltage remote locations to restore normal operation to preamps, amplifiers, and monitors, the adjusters also bring out full fidelity in hi-fi and stereo equipment. They are particularly useful for increasing the speed of small motorized equipment, such as cameras, recorders, turntables, and tools.

Check Item 60 on Tech Data Card

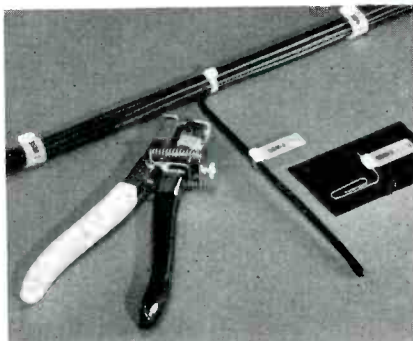

### Identification Strap for Bundles or Single Wires

An identification marker for wiring harnesses and cables (Sta-Strap) that may be hand or tool installed is now available from the **Panduit Corp.**, Tinley Park, Ill. The all-nylon marker comes in two sizes—SSM-2, range 0-1-3/4", and SSM-4, range 0-4". The marker strap can be removed for wiring revisions and the marked portion reused. The strap can

be hot stamped or marked with any commercially available nylon marking ink.

Circle Item 61 on Tech Data Card

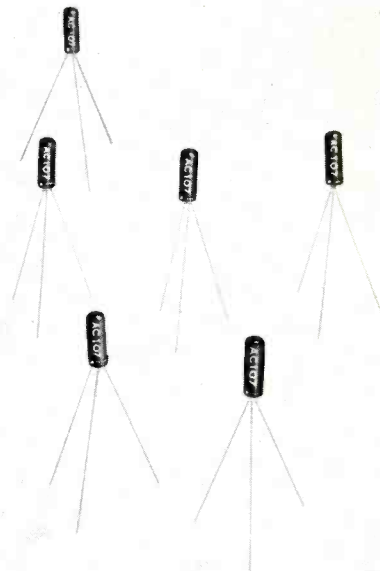

### Transistor for Magnetic Tape Head Inputs

**Amperex Electronic Corp.**, Hicksville, L.I., N.Y., has announced the availability of their new transistor designed specifically for magnetic tape head inputs and other applications characterized by low signal level and stringent noise requirements. The AC107, a germanium PNP transistor, is available in a hermetically-

## Travels the Signal Further...

Microwave remote links and mobile transmitters cover more distance with less fading... thanks to Micro Link's new WA-5 TWT amplifiers. The self contained, weather-proofed units deliver 10 watts of power from inputs of 0.1 to 1 watt and operate in the 5.9 to 7.2 Gc range.

Designed for easy mounting on new or existing equipment, the WA-5 features front panel controls, solid-state power supply and quality construction throughout.

Micro Link Corp also designs and manufactures Microwave Systems for STL, remote or CATV applications.

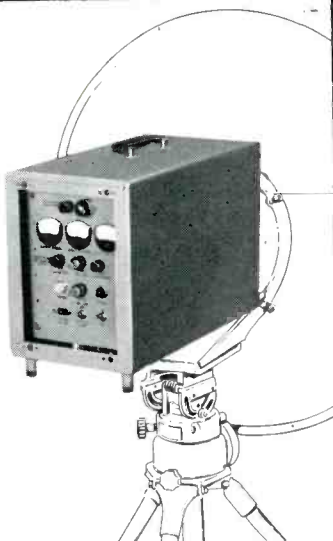

Send for full information or call now—

SEND LITERATURE  PLEASE CALL

Name \_\_\_\_\_ Title \_\_\_\_\_

Company \_\_\_\_\_

Address \_\_\_\_\_

City \_\_\_\_\_ State \_\_\_\_\_ Phone \_\_\_\_\_

**micro link corp.**

1355 MARCONI BLVD., COPIAGUE, NEW YORK (516) LI 1-5656

Check Item 53 on Tech Data Card

## SONOCRAFT MOST COMPLETE SOURCE FOR THE PROFESSIONAL TRADE!

New Modified

**PR 10**

Unconditionally Guaranteed

PROFESSIONAL STEREO

OR

MONOPHONIC RECORDER



Portable or to fit rack. 19" wide by 14" high.



Large Stock of All

Recorders, Duplicators, Slaves, Accessories and Parts.

**PULTEC**

Professional Program Equalizers Sound Effects Filters



**FAIRCHILD**

Conax Series — Power Amplifiers — Compressors — Automatic Attenuators — Transcription Tables — Limiters — Recording Lathe — Compact Compressors.

Courteous Consultation, Engineering Service, Complete Parts Supply, Accessories, TRADE-INS ACCEPTED, New professional catalog, B-3 on request.

**SONOCRAFT CORP.** 115 West 45th St., New York 36, N.Y. Third Floor • JUdson 2-1750

Circle Item 42 on Tech Data Card

**BROADCAST ENGINEERING**

sealed all-glass case fitting a TO-1 outline. The noise figure for this type is based on measurements over the entire audio bandwidth, which duplicates the actual operating conditions.

Circle Item 62 on Tech Data Card

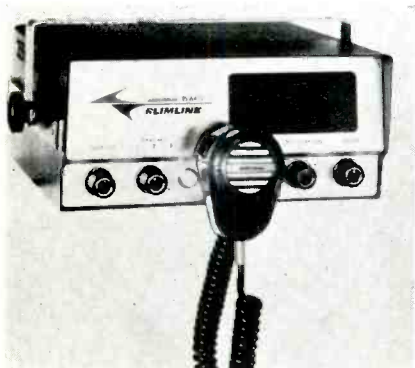

### 35-Watt Slimline Two-Way VHF-FM Radio

A 35-watt, VHF-FM, two-way mobile radio set that is designed for up-front mounting in any vehicle has been announced by **Aeronautical Electronics, Inc.**, Raleigh, N. C. The set may also be mounted in a truck or other convenient location and operated by a remote control unit mounted under the dashboard. The Aerotron Slimline '35 is supplied with transmit and receive crystals for one channel, transistor-powered microphone, mobile antenna, connecting cables, and installation accessories. The unit comes with one channel as standard equipment and three others switch-selected are available at extra cost. The Slimline '35 is priced at \$395.00.

Circle Item 63 on Tech Data Card



### Microphone Shock Mount

**Atlas Sound Div.**, American Trading and Production Corp., Brooklyn, N. Y., announces the Model VM-1 microphone shock mount. The device eliminates or greatly reduces microphone pick-up of external mechanical shock and stand vibration. It is equipped with male and female  $\frac{5}{8}$ "-27 threads permitting insertion between microphone and stand. The VM-1 is constructed of die castings and brass turnings finished in bright polished chrome. The compact unit,  $4\frac{3}{4}$ " long by 1" in diameter, is priced at \$7.50.

Circle Item 64 on Tech Data Card

## "The greatest contribution we've made towards upgrading WKFM"

*Frank Kovas*

FRANK KOVAS, PRESIDENT  
WKFM, CHICAGO

(DEMONSTRATION STATION FOR FM  
STEREO AT 1962 NAB CONVENTION)



**SHURE**  
**STUDIO**  
**SE-1**

### STEREO TRANSCRIPTION PREAMPLIFIER

*Certified quality* because every characteristic on every unit is checked to make sure it passes specifications. That's why Mr. Kovas says "It is unfortunate that we (WKFM) wasted so much time in experimenting with hi fi type stereo preamps which looked good on specifications . . .

I'll have to admit that nothing equals the performance of the Shure SE-1 for stereo multiplexing."

What are the certified specifications? The SE-1 has plenty of gain to feed a 600 ohm line at +4 or +8 dbm from a magnetic stereo phono cartridge and still provide for peak power. (1.2 mv input gives at least +4 dbm output.) Balance is provided with separate gain controls for each channel. *True* RIAA equalization with  $\pm 1$  db 30 to 15,000 c.p.s. of RIAA curve. Optional flat position for measurement and calibration in the studio. Separate high and low response trimmers for each channel with NO interaction between channels, or between high and low end. Hum and noise level at least 64 db below output level. Channel separation better than 37 db between 50 and 10,000 c.p.s. Distortion is under 1% at +15 dbm 150 or 600 ohms output impedance. Compact size (7" x 3 $\frac{3}{8}$ " x 11" deep) . . . Convenient slip-in mounting for easy installation. Separate power supply reduces panel space requirements.

Priced at only \$295 net. Write for technical data sheet: Professional Products Division, Shure Brothers, Inc., 222 Hartrey Avenue, Evanston, Illinois.

Circle Item 43 on Tech Data Card

## NAB Product Previews

(Continued from page 42)

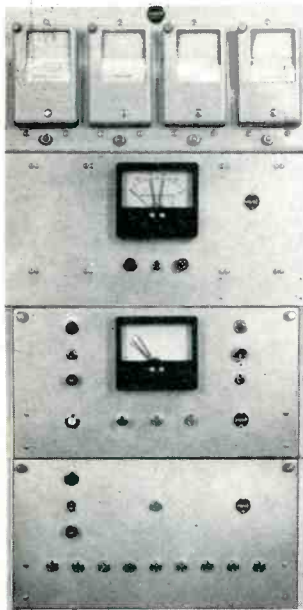

### Transmitters, Logging Equipment, and Consoles

Transmitter and audio equipment will be featured by **General Electronic Labs**, booth 41-W. 1-kw and 15-kw transmitters will be displayed along with a stereo console. Highlighting the exhibit will be a demonstration of the Autolog chart-recording logging system. This system can be used with the remote-control equipment of any current

manufacture without modification. The Autolog (pictured) employs sequential sampling and records nine parameters on dry pressure-sensitive paper. In addition to the logging demonstration, there will be a demonstration of the company's transistorized stereo equipment.

### Antennas and Filters

At booth 21-W, **Alford Manufacturing Co.** will display UHF and VHF television broadcasting antennas, directional antennas, diplexing filters, and vestigial sideband filters. Full technical data and sales information will be available from company representatives at the booth.

### Lenses and Equipment

**Television Zoomar Company** is to have a display of their complete line of television camera lenses. To be shown at booth 59-W are zoom lenses for image orthicon cameras, including F:3.9 lenses in ranges from 2½ to 72 inches, a lens which zooms from 35 to 350mm at 3 feet to infinity, one for 35 to 140mm, and lenses with 10-to-1 zoom ratio. Remote lens controls will also be on hand. Full information will be available at the booth regarding a wide variety of lenses of all ranges and speeds. All the lenses are serviced and guaranteed by Zoomar.

### Remote Control and Multiplex Equipment

At booth 48-W **Moseley Associates** will display their line of remote-control and multiplex equipment, including STL, radio remote control, wire remote control, FM and SCA generators, 10-watt FM exciter and

transmitter. Of special interest will be the operational display of the LPE-10 FM exciter with stereo and SCA generators.

### Lighting Equipment

**Kliegel Bros.** will feature a new line of quartz-iodine lamps and silicon-controlled rectifier dimmers at booth 1-E. Most information has been kept under wraps up to now, but full data will be available at the show.



### Audio Equipment Line

A line of tape-cartridge equipment will be displayed by **Sparta Electronic Corp.** at booth 56-W. This includes a stereo system, a playback and spot-timer, a compact record/play unit, and an automatic transistorized modular playback machine. Also demonstrated will be a transistorized port-

**Crown**  
INTERNATIONAL



**B X 8 0 0**  
PROFESSIONAL  
TAPE RECORDER

The BX800 Series is a maximum-versatility instrument engineered to meet or exceed the highest professional standards. It is available in six models with three tape speeds: 3¾, 7½, and 15 ips (1⅞ and 1⅝ available). Each model features 3 heads: (1) erasing (2) recording (3) reproducing or monitoring; three motors (one synchronous drive type with 99.8 timing accuracy—two shaded-pole type); 10½ inch reel capacity for ¼ inch tape; hub adapters for NAB reel hubs; accommodation of 6 types of input; and .06% wow/flutter @ 15 ips with 30 cps—28 KC response ±2 db, full track. Standard operational features in this series include 3-speed equalization, remote control facility, front panel monitor jack and VU meter, cue control, automatic stop, micro-touch electric control system and extremely fast start/stop time—plus multi-speed performance and frequency response that meet all broadcast and laboratory requirements.

For additional information write: Dept. 20

CROWN INTERNATIONAL, 1718 MISHAWAKA ROAD,  
ELKHART, INDIANA

Patented magnetic braking (never needs adjusting)  
Hardened stainless steel flywheel shaft  
Non-magnetic capstan  
Micro-sync timing  
Individual "Proof of Performance" record  
(furnished with each specific recorder)  
Performance that exceeds professional standards



Circle Item 44 on Tech Data Card

Professional Line  
Stereo Magnetic  
Tape Heads by  
**NORTON**



Send now for technical literature with specifications on the complete Norton line of magnetic heads.

**NORTON**  
ASSOCIATES, INC.

240 Old Country Road, Hicksville, N. Y.

Circle Item 45 on Tech Data Card

able studio with two turntables, and transistorized remote amplifier with eight inputs and four mixing channels (pictured).

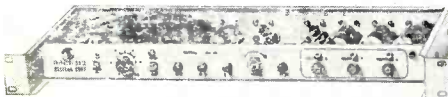
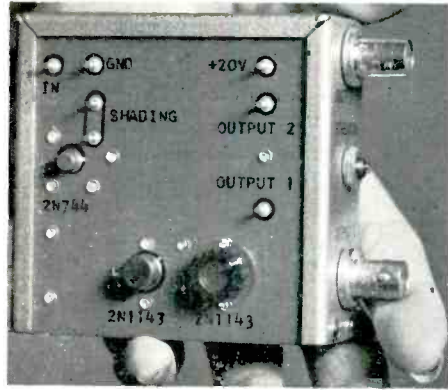

### Video Amplifiers and Equipment

A line of transistorized amplifiers will be shown at **booth 3-E** by **International Nuclear Corp.** The model TCA 3 (pictured being held) will replace the vacuum-tube preamplifier in all image orthicon cameras now used in television studios. The device picks up its power from within the camera and provides an output of 0.4 volts peak-to-peak into a 51-ohm cable and an output of 0.8 volts peak-to-peak to the view finder from a 51-ohm source. Also shown will be a video/pulse distribution amplifier, a high-gain amplifier, and a balance/unbalanced video amplifier. The amplifiers have socket-mounted transistors, built-in regulated power supplies, 75-ohm inputs, and 75-ohm outputs.

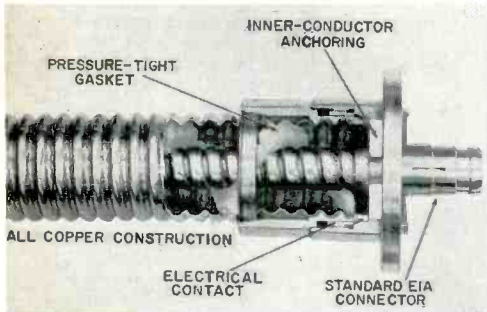

### Antenna Devices

Heliax flexible coaxial cable will be shown by **Andrew Corp.** at **booth 70-W**. There will also be coaxial transfer switches and FM antennas. Pictured is a longitudinal cutaway view of Heliax and a connector. This is a flexible, air dielectric cable that can be handled with standard tools in the field. It has a 50-ohm characteristic impedance, 1600-mc maximum frequency, and 315-kw peak power rating. Heliax is available in continuous lengths to serve long and complex installations.

March, 1963

De Forest and his wireless phone, 1908 (Culver Pictures, Inc.)



## BROADCASTING HAS MOVED TO A NEW TIME SPOT



Modern FM-stereo studio (WTFM, New York, N. Y.)

Television, color, stereo, multiplex, UHF, FM, AM — all are a part of broadcasting today, 55 years after De Forest developed his wireless phone. Broadcast engineering today is a complex of advanced technologies. In this maze of progress, there is a critical need for fast, dependable delivery of electronic equipment and components. To meet this need, there is an outstandingly reliable source: MILO, double decade pioneer of industrial electronic distribution.

Whatever your requirements, you can depend on MILO's vast inventory of more than 100,000 different products representing 145 brand name manufacturers to satisfy your needs. Just one call to MILO does the job of many calls to scattered sources. Delivery? Immediate. Cost? Never more than buying from the manufacturers. Isn't it time you put MILO to work for you?

*America's Leading  
Industrial Electronics Distributor*

# MILO

**MILO ELECTRONICS CORP.**

530 CANAL ST., N. Y. 13, N. Y. (212) BE 3-2980 • "ENTERPRISE" phone service in all industrial areas  
REGIONAL SALES & STOCKING WAREHOUSES: Orlando, Fla.; CY 5-1710 • Temple City, Calif.; AT 7-9777  
REGIONAL SALES OFFICES: Wilmington, Mass.; CO 6-7400 • Westport, Conn.; CA 7-5354

Circle Item 46 on Tech Data Card

# There's a FAIRCHILD CONAX



## on top of the Empire State Building!

WNEW-TV Channel 5 in New York uses the FAIRCHILD CONAX to maintain high average audio levels despite pre-emphasis problems. The CONAX is silently at work minimizing problems created by sibilants, finger snapping, the shrill sounds of children, the rattling of dishes, muted trumpets and cymbals, which are all part of WNEW-TV's program schedule. No more reduction of apparent loudness because of these high frequency problems.

Why not let the FAIRCHILD CONAX help you maintain high average audio levels.

**FAIRCHILD RECORDING EQUIP. CORP.**  
10-40 45th Avenue, Long Island City 1, N. Y.

Circle Item 47 on Tech Data Card

### DO YOU HAVE AN OBSTRUCTION LIGHTING PROBLEM?

Your Best Answer is  
**HUGHEY & PHILLIPS, INC.**  
—the most dependable source of  
Obstruction Lighting Equipment.  
—the widest selection of Control &  
Alarm Apparatus in the industry.

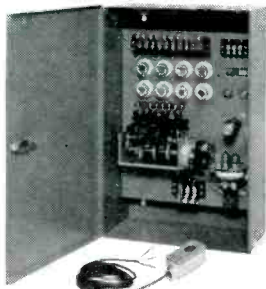

Model LC 2076

For 4 towers with "A-2" or "A-3" lighting, **FOUR CIRCUIT FLASHER, PHOTO CONTROL** with 20 ft. remote photo-tube cable. 115/230 V (indoor housing).

MANY OTHER MODELS AVAILABLE  
Visit us at the NAB Exhibit Hall

Write for literature on your specific problem  
**HUGHEY & PHILLIPS, INC.**

Manufacturers of

300MM Beacons, Obstruction Lights, Photo-Electric Controls, Beacon Flashers, Special Junction Boxes, Microwave Tower Light Control and alarm Systems, Tower Isolation Transformers, and Complete Kits for: Tower Lighting, Sleetmelter Power and Control.

3200 N. San Fernando Blvd. Burbank, Calif.

Circle Item 48 on Tech Data Card

## ENGINEERS' TECH DATA SECTION

### AUDIO & RECORDING EQUIPMENT

71. AMERICAN ELITE — Booklet covers condenser microphones, and leaflet shows straight-line attenuator.
72. AUDIO INSTRUMENT CO. — Special instruments for audio and acoustical measurements covered in catalog.
73. AUTOMATIC TAPE CONTROL—Booklet entitled "Planning for Automated Radio Programming."
74. BROADCAST ELECTRONICS — Spec sheets on cartridge tape equipment.
75. COUSINO ELECTRONICS CORP. — Brochure describes miniature cartridge tape deck.
76. CROWN INTERNATIONAL— Brochure describes professional series of tape recorder/reproducers.
77. GOTHAM AUDIO—Catalog and price list of studio condenser microphones.
78. KUDELSKI — Brochure presents portable tape recorder.
79. MACARTA — Data sheets and price bulletins explain tape cartridges and cartridge equipment services.
80. McMARTIN INDUSTRIES — Equipment catalog includes data and pricing for frequency, SCA, and multiplex monitors; preamps; and audio amplifiers.
82. RCA VICTOR RECORD DIV. — Brochure lists properties of company's magnetic recording tape.
83. SPARTA ELECTRONICS — Price and data sheet for tape cartridges.

### COMPONENTS & MATERIALS

85. ALPHA WIRE — Heat shrinkable tubing selection chart and catalog on complete line of insulating tubing.
86. ALLIED ELECTRONICS — Catalog of components, equipment, and supplies.
88. ENGLISH ELECTRIC VALVE — Booklets on special-purpose tubes, and image orthicons.
91. RAYTHEON — Brochure introduces line of filters and delay lines.
92. SWITCHCRAFT — 8-page catalog present stack switch components.

### RADIO & CONTROL ROOM EQUIPMENT

93. BOGEN-PRESTO — Spec sheets on a broadcast automation system.
94. FAIRCHILD— Bulletins describe automatic limiting amplifiers.
95. GATES—Brochure on stereo/monaural cartridge tape system.
96. JENSEN MFG. — Catalogs list stereo headphones and high fidelity speakers for monitoring.
97. MOSELEY ASSOCIATES — Description of 10-watt FM exciter for monaural or stereo broadcasting with SCA sub-carrier.

98. RUSSO ELECTRONICS — Data on line of broadcast turntables.

### STUDIO & CAMERA EQUIPMENT

100. DENSON ELECTRONICS—Video components catalog includes a section on how to build a low cost TV camera.
101. GENERAL ELECTRIC — Brochure discusses line of compact vidicon cameras.
102. S.O.S. PHOTO-CINE OPTICS—Product sheets list camera, tape, film, audio, and lab equipment.

### TELEVISION EQUIPMENT

104. CBS LABORATORIES — Bulletins on video distribution amplifiers and automatic level controls.
105. ELECTRO PRODUCTS LABS. — Catalog lists proximity switches for automatically stopping and cueing television films.
107. INTERNATIONAL NUCLEAR — Data sheets describe video distribution amplifiers and camera amplifiers.
109. VISUAL ELECTRONICS — Brochure shows television program automation system, and includes glossary, specs, and a description of applications.

### TEST EQUIPMENT & INSTRUMENTS

111. SECO—Data sheet covers transistor and tunnel diode analyzer.
112. SEMCO—Illustrated bulletin on constant-voltage transformers.
113. TRIPLETT ELECTRICAL INSTRUMENT —Catalog lists panel instruments giving prices, and specs.

### TRANSMITTER & ANTENNA DEVICES

114. ALFORD MFG. — Catalogs describe television broadcasting equipment including antenna systems, components, and transmission devices.
115. ANDREW CORP. — Catalogs list broadcast antennas and equipment, transmission lines, and two-way antennas for mobile radio applications.
116. CO. EL. — Catalogs describe broadband dipole antennas, FM antennas, UHF slot antenna, filters, and diplexers.
117. FINNEY CO. — Bulletin presents line of FM antennas for monophonic and stereo reception.
118. ITA ELECTRONICS — AM, FM, and TV transmitters; audio consoles, monitors, and logging equipment are covered in bulletins.
120. STANDARD ELECTRONICS — Data sheets cover TV and FM transmitters and amplifiers, and single-sideband equipment.

## QRK PROFESSIONAL TURNTABLES

offer you more...

- QUALITY
- CONTINUOUS PERFORMANCE
- SIMPLICITY

Quality all the way with QRK. Full speed range—33, 45, 78. Built rugged with jewel precision. Plays 45's without adapters. Rocket acceleration — EZ queuing. Single idler maintains constant speed regardless of normal wear.



Priced from \$110. to \$235.

Send for detailed folder!

Western Distributor

**RUSSCO Electronics Mfg.** 1406 Clovis Ave. — Clovis, Calif.

Phone CY 9-4692

Circle Item 49 on Tech Data Card

BROADCAST ENGINEERING



# AUTOLOG™

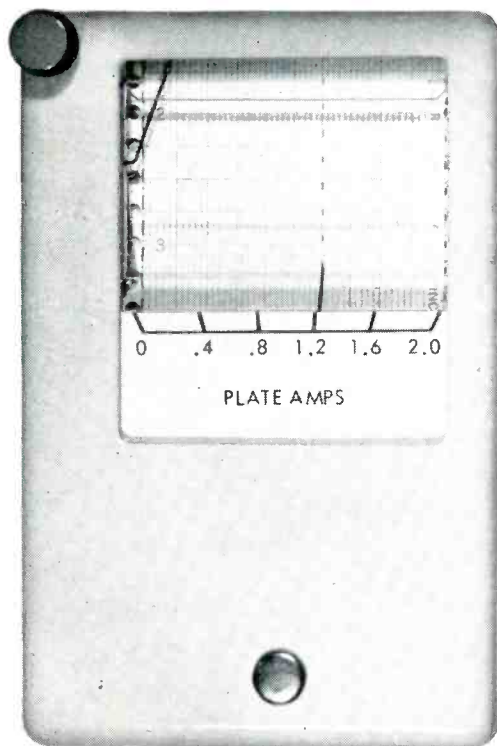

## TAKE ADVANTAGE OF NEW FCC RULING ON REQUIRED READINGS WITH A LOW-COST MODULAR SYSTEM

AUTOLOG features the lowest cost modular system with four to nine channels available for local or remote use. Why spend extra money on an elaborate system when AUTOLOG maintains legally and technically correct logs?

Ready for delivery.

### YOU HAVE SEEN AUTOLOG IN ACTION

- First demonstrated at 1962 NAB Show, Chicago, Ill., April, 1962
- Florida Association of Broadcasters, Tampa, Fla., June, 1962
- Georgia & So. Carolina Joint Meeting, Jekyll Is., Ga., Aug., 1962
- IRE Annual Broadcast Symposium, Washington, D.C., Sept., 1962
- Seven NAB Regional Conferences Oct.-Nov., 1962



**GENERAL ELECTRONIC  
LABORATORIES, INC.**

195 MASSACHUSETTS AVE., CAMBRIDGE 39, MASS.

Please send me AUTOLOG information for my station.

Transmitter Make and Model \_\_\_\_\_

Present Remote Control Make and Model \_\_\_\_\_

Number of Towers \_\_\_\_\_ Frequency Monitor Make \_\_\_\_\_

Name \_\_\_\_\_ Title \_\_\_\_\_

Station \_\_\_\_\_ Address \_\_\_\_\_

City \_\_\_\_\_ State \_\_\_\_\_

## Professional Services

**VIR N. JAMES**  
CONSULTING RADIO ENGINEERS  
Applications and Field Engineering  
232 S. Jasmine St.  
Phone: (Area Code 303) 333-5562  
**DENVER 22, COLORADO**  
Member AFCCE

- SYNCHRONOUS MAGNETIC FILM RECORDER/REPRODUCER
- MAGNETIC TAPE RECORDERS
- NEW—THE portable MINITAPE synchronous 13 lb., battery operated magnetic tape recorder for field recording.

**THE STANCIL-HOFFMAN CORP.**  
845 N. Highland, Hollywood 38, Calif.  
Dept. B HO 4-7461

**JOHN H. BATTISON & ASSOCIATES**  
CONSULTING RADIO ENGINEERS  
Specializing in AM-FM-TV Applications and measurements.  
4103 Bradley Lane Washington 15, D. C.  
OL 4-2565  
Established 1954

## Classified

Advertising rates in the Classified Section are ten cents per word. Minimum charge is \$2.00. Blind box number is 50 cents extra. Check or money order must be enclosed with ad.

The classified columns are not open to the advertising of any broadcast equipment or supplies regularly produced by manufacturers unless the equipment is

used and no longer owned by the manufacturer. Display advertising must be purchased in such cases.

## EQUIPMENT FOR SALE

**Acme Kinescope Recorder**, double system. 16 mm professional broadcast quality. Will record half hour programs. Used less than 150 hours film running time. Equipment is contained in three standard racks plus camera and pedestal. Also includes Conrac tuner, three 1,200-ft. Mitchell magazines, ten 1,200-ft. reels of 7374 double perf raw stock, miscellaneous spare parts, reels, cans and magnetic film. Further details and photograph on request. KRMA-TV, 1261 Glenarm Place, Denver 4, Colorado. 3-63 11

**GOVERNMENT SURPLUS, NEW 10 CM. WEATHER RADAR SYSTEM**—Raytheon, 275 KW peak output S band. Rotating yoke P.P.I. Weather Band 4, 20 and 80 mi. range. Price \$975 complete. Has picked up clouds at 50 mi. Wt. 488 lbs. Radio Research Inst. Co., 550 5th Ave., New York, New York. 1-63 6t

**USED TV EQUIPMENT FOR SALE**—Specialists in RCA Types. Many bargains in stock. TK-30's, TK-11's, Power Supplies, Monitors, etc. Our exclusive refurbishing process. Guarantees Satisfaction. Write, Wire or call for prices.  
**TELEQUIP CORPORATION**, 319 East 48th St., New York 17, N. Y., PLaza 2-8885—PLaza 2-9037. 2-63-6t

**Ampex Head Assemblies** for 300 and 400 series recorders reconditioned. Service includes lapping and polishing all three head stacks, cleaning entire assembly, readjusting and replacement of guides, and realignment of stacks as to azimuth and zenith. Full track assemblies—\$60.00. Taber Manufacturing & Engineering Co., 2619 Lincoln Ave., Alameda, California. 1-63 2t

**Transmission line**, styroflex, heliax, rigid with hardware and fittings. New at surplus prices. Write for stock list. Sierra Western Electric Cable Co., 1401 Middle Harbor Road, Oakland 20, California. 6-61 tf

**Commercial Crystals** and new or replacement crystals for RCA Gates, W. E., Bliley and J-K holders; regrinding, repair, etc. BC-604 crystals. Also A. M. monitor service. Nationwide unsolicited testimonials praise our products and fast service. Eidson Electronic Company, Box 96, Temple, Texas. 9-61 tf

**Late model Progress Line GE 2-way equipment**. 6-12 V. mobile, 110 V. base, 55 watts output on 153.23 Mc. remote pickup frequency. Excellent condition—all cables, mikes, speakers, but less antennae. \$800 FOB. WILL, Willimantic, Conn. 3-63 1t

**AM FREQUENCY MONITOR GR1181A**. Used, good. \$165. Stamp appreciated for free 8 pages of surplus. Richard Wilder, Syracuse, N. Y. 3-63 1t

**WE BUY USED TV AND RADIO EQUIPMENT. LET US KNOW WHAT YOU HAVE TO DISPOSE OF. WRITE TELEQUIP CORPORATION**, 319 East 48th St., New York 17, N. Y. 2-63-6t

Will buy or trade used tape and disc recording equipment—Ampex, Concertone, Magnecord, Presto, etc. Audio equipment for sale. Boynton Studio, 295 Main St., Tuckahoe, N. Y. 10-62 6t

**SPECIAL: 3/8 inch rigid coax 38 inches long**, flanged on both ends, \$2,500. Microwave test equipment 50% off. Jericho Electronic Supply, 80 Jericho Tpke., Syosset, N. Y. WA 1-7580. Communications Servo Microwave. 3-63 1t

## Advertisers' Index

Alpha Wire Corp.	59
Atec Lansing Corp.	62
Ampex Corp.	7
Bauer Electronics Corp.	66
Broadcast Electronics, Inc.	25
Burgess Battery Co.	45
CBS Laboratories	3
Cleveland Institute of Electronics	60
CO EL	54
Continental Electronics Mfg. Co.	23
Crown International	70
Electra Megadyne Inc.	51
Electronics Missiles & Communications, Inc.	10
Electro-Voice, Inc.	64, 65
Fairchild Recording Co.	72
General Electric Co.	31
General Electronic Laboratories	73
Gotham Audio Corp.	43
Holiday Motor Motel	74
Hughey & Phillips	72
IERC Div., International Electronic Research Corp.	46
The Institute of Electrical and Electronics Engineers, Inc.	50
International Electronic Sales Corp.	26-27
International Nuclear Corp.	58
ITA Electronics Corp.	C2
Jampro Antenna	56
Kudelski	11
McMartin Industries, Inc.	C3
Micro Link Corp.	68
Milo Electronics Corp.	71
Minnesota Mining & Manufacturing Co.	55
Moseley Associates	12
Norton Associates, Inc.	70
Radio Corp. of America, Electron Tube Div.	C4
Raytheon Co., Equipment Div.	8-9
RCA Victor Record Div.	53
Reeves Soundcraft Corp.	33
Russco Electronics Mfg.	72
Sarkes Tarzian, Inc.	6, 22, 61
Seco Electronics, Inc.	30
Shure Brothers, Inc.	69
Sonocraft Corp.	68
Sparta Electronics Corp.	49
Sprague Electric Co.	34
Superscope, Inc.	5
Sylvania Electric Products, Inc.	29
Tektronix, Inc.	47
Telemet Corp.	57
Telequip Corp.	4
Turner Co., The	67
Visual Electronics Corp.	52
Vitro Electronics Div., Vitro Corp.	63

# YOUR *Holiday* IN MINNEAPOLIS

... Where every luxury and convenience awaits you, including • Superbly comfortable guest rooms • Suites with real fireplace in living room • Air-conditioning • King-size beds • TV and phones in all rooms • 24-hour switchboard service • Holiday Coffee Shop • Redwood Dining Room

(recent winner of American Restaurant Magazine feature award)

- COCKTAIL LOUNGE
- HEATED SWIMMING POOL
- Ideal location . . . just 5 minutes from downtown Minneapolis on Highway 100 (the Belt Line) . . .

in beautiful **GOLDEN VALLEY**

Write, Wire or Phone for Reservations

Phone: JUNiper 8-4665  
812 Lilac Dr. N.

**MINNEAPOLIS, MINN.**

Circle Item 41 on Tech Data Card





Memo To:  
**FM:** *Station Managers*  
*Station Owners*  
*Chief Engineers*



**LOOK TO**  
**FOR LEADERSHIP IN**  
**MONITORS, MULTIPLEX AND RELAY**  
**RECEIVERS AND AUDIO**

By outstanding performance, dependability and economy, McMartin built FM multiplex and audio products have earned a reputation for leadership. McMartin experience and engineering are continually at work developing new products and improving present ones to be of greater service to the industry.



TBM-4000  
**McMartin**  
**FM/SCA**  
**MULTIPLEX**  
**MONITOR**

The most versatile instrument of its kind for monitoring all main channel modulation and SCA Multiplex operating characteristics. The only Monitor which directly reads crosstalk.



TBM-3000 and TBM-3500



TBM-3000 is a completely self-contained frequency monitor, and the TBM-3500 a self-contained modulation monitor. The 3000 used in conjunction with either the 3500 or 4000 fulfills the FCC requirements for station monitors.



**MULTIPLEX**  
**RECEIVERS**

Proven performance and reliability . . .  
 More than 9,000 in use throughout the world.



**TBM-1000/2000**  
**FM/SCA Multiplex**  
**Re-Broadcast Receivers**

Ideal for area network relays . . . defense networks and off-air monitoring.



**8 & 32 watt**  
**TRANSISTOR AMPLIFIERS**  
**LT 80A & LT 300**

McMartin is the world's largest producer of amplifiers for the commercial background music industry.



originality by

**McMartin Industries, Inc.**

605 North 13th Street Omaha, Nebraska  
 Code 402 — 342-2753

In Canada Sold By: Canadian Marconi Company, Montreal 16, P. Q.

Check Item 52 on Tech Data Card



## BTA-IR1

1 KW AM Transmitter

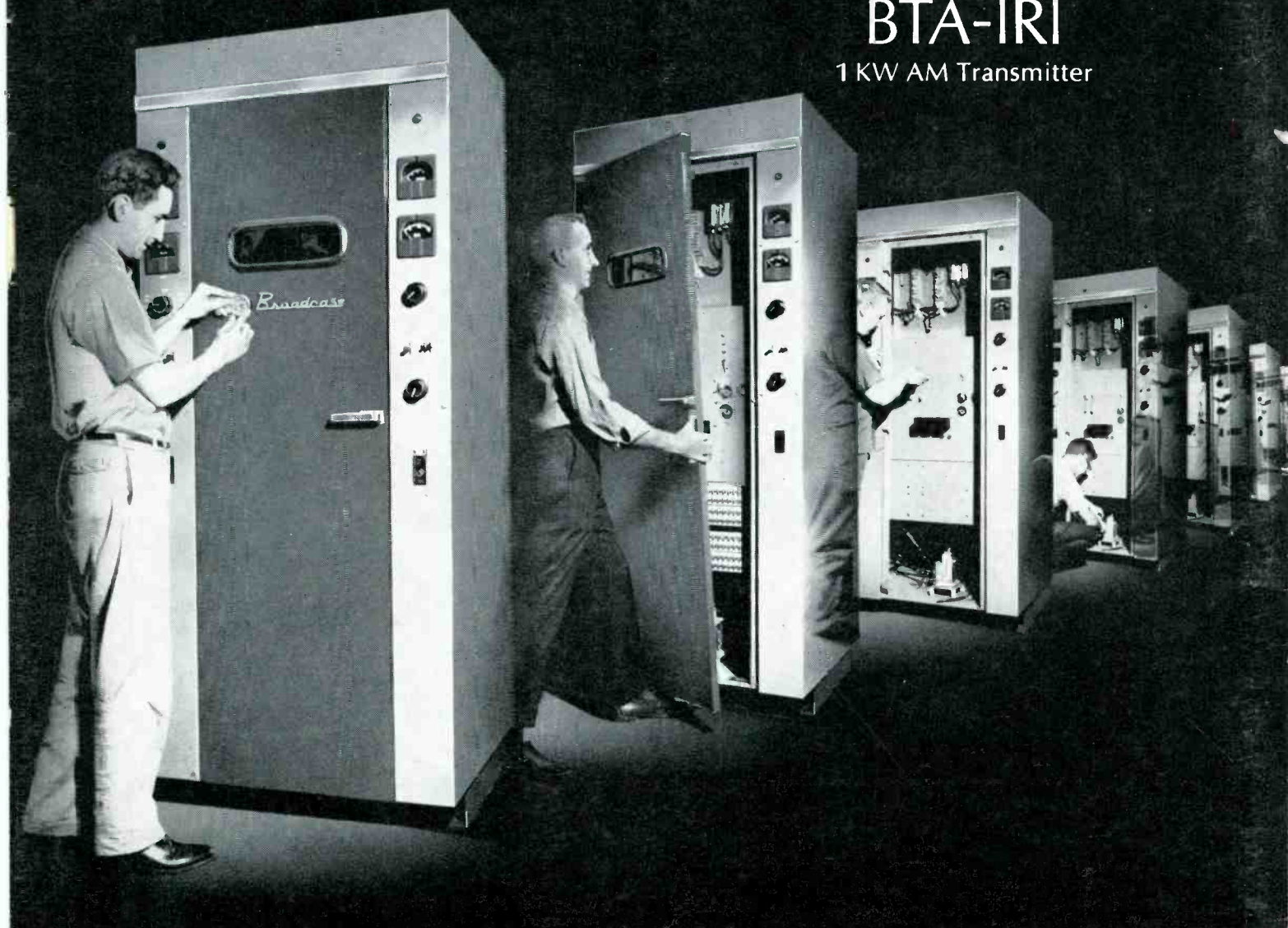

## RCA's most popular AM transmitter

This 1 KW AM Transmitter is one of the finest RCA has ever offered. More have been installed than any other type RCA 1 KW Transmitter—because it ideally meets requirements of local stations.

For the listeners, the best sound and the loudest sound. For the owners, highest assurance of fine performance, with a long list of operating advantages: Accessibility full front and rear for easy maintenance... low operating costs with few tube types... unrestricted remote control without need

for building heat, thanks to reliable silicon rectifiers and temperature controlled crystals... simplified operation and single tuning procedures, with all operating controls mounted on the front panel.

If you want the finest 1 KW, you'll want to know more about the BTA-IR1. Call your RCA Broadcast Representative. Whatever your broadcast requirements, you'll find him exceedingly helpful. Or write to RCA Broadcast and Television Equipment, Building 15-5, Camden, N.J.



The Most Trusted Name in Radio