

NOVEMBER, 1961

BROADCAST ENGINEERING

®



THE TECHNICAL JOURNAL OF THE BROADCAST INDUSTRY



**WORLD'S
LARGEST
SPACE
RADOME**

NOW

COLOR TV

From FOTO-VIDEO

NEWS FLASH!

United States Air Force, Pentagon, Orders \$550,000 Closed-Circuit Color TV System, Designed and Manufactured by FOTO-VIDEO To Meet Requirements of Speed and Security of Vital Information for National Defense.



V-298
21" Color TV
Monitor
All Modular
Construction

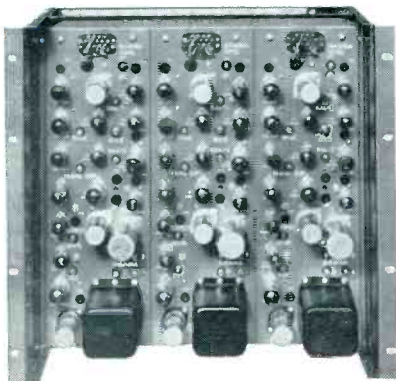
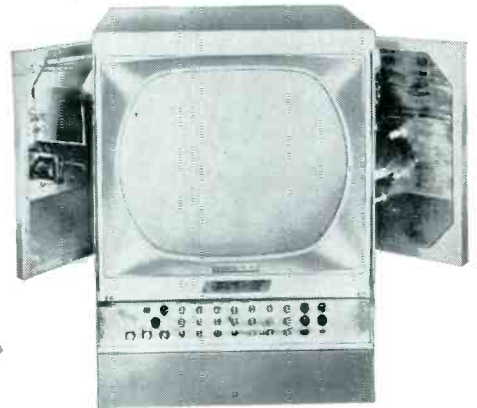

V-225 Color Gamma
Correctors



V-229 Color Matrix
Delay



V-230 Encoder

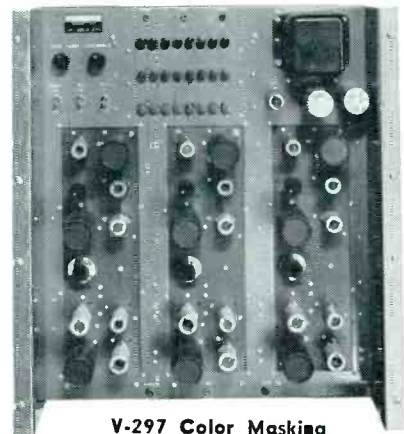

V-297 Color Masking
Unit



V-8 Color Sub-Carrier
Generator



V-516 Automatic Level
Control



V-139 Color Sync
Change Over



V-17 Color Burst Keying
Unit

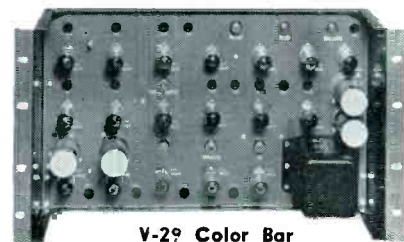

V-29 Color Bar
Generator

ALSO V-525 — 3-V Color Film Camera Chain • F-602 Color Film Slide Multiplexer • V-184 — 12 — 4 Color TV Diode Switcher • V-243 Color Stabilizing Amplifier • V-292 Color Special Effects Generator and Amplifier • F-107 — 1 Light Box and Test Chart Kit for Color • V-700 Transistorized Sync Generator • V-128 Transistorized Sync Slave

FOTO-VIDEO Electronics, Inc. Cedar Grove, N. J. Center 9-6100

William E. Endres, National Sales

(Write or Phone for Information)

Langevin

MODEL AM-5301 LEVELINE AMPLIFIER

+ 37 dbm OUTPUT (6 WATTS)

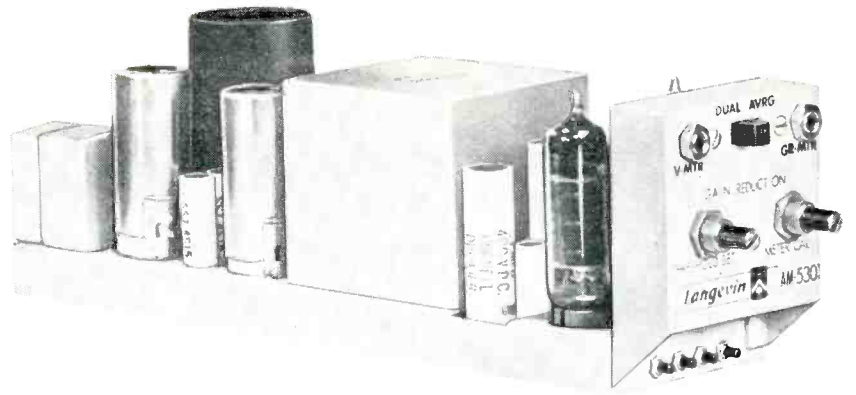

INTRODUCTION

This new limiter amplifier is a miniature plug-in unit which acts as an automatic averaging or as a peak level amplifier in TV-Broadcast, Microwave, Recording and Industrial Sound applications. It operates with a push-pull variable gain input stage driving a 2 stage push-pull program amplifier. Silicon rectifiers provide bias to regulate gain of the input stage.

Maximum program variations up to 30 db can be controlled, thus relieving studio personnel of many exacting level adjustments. In recording, this unit allows higher signal-to-noise ratios by loading the tape or disc; thus, the engineer is not required to anticipate overloads. This anticipation results in lower signal to noise and lower maximum levels than those otherwise possible.

APPLICATIONS

EXPANDER-COMPRESSOR—With an average program material level sufficient to produce 15 db of gain reduction, the output signal will be compressed for incoming signals exceeding 15 db, and expanded for incoming signals below 15 db.

AUTOMATIC MASTER GAIN CONTROL—Simply replace the program amplifier by plugging in the Leveline Amplifier; the AM-5301 Leveline Unit replaces directly a program amplifier and can be used as a monitor amplifier of 6 watts.

AUTOMATIC LEVEL CONTROL FOR A REMOTE LINE—The Leveline units permit unattended operation of the remote line.

AUTOMATIC CONTROL OF LEVEL DIFFERENCES BETWEEN 2 OR MORE PROGRAM SOURCES—Controls differences between turntables, projectors, network program and microphone preamplifier sources.

USE AS A "DUCKER"—A program can be automatically lowered the recommended 8 db (one-half loudness) to allow an announcer to override without apparent program interruption.

USE AS A NORMAL PROGRAM AMPLIFIER—Turning off the integral chassis bias limiting control allows operation as a conventional program amplifier.

ELECTRICAL CHARACTERISTICS

Gain: 53 db with 600 ohm input source; **Input Source:** 125 to 600 ohms balanced or unbalanced; **Output Impedance:** 150 - 600 ohms; **Output Power:** +37 dbm when strapped for monitor, +26 dbm strapped for Leveline operation; **Output Noise:** Unweighted, equivalent to an input signal of -110 dbm or less over the band 20 - 20,000 cps; **Frequency Response:** ±5 db 20 - 20,000 cps; **Distortion:** Less than 1% at +36 dbm operating levels including compression. Less than .5% at +26 dbm; **Compression Ratio:** Adjustable from 1.6:1 to 5:1 over a 30 db range at input with 4:1 being optimum; **Attack Time:** 11 milliseconds, adjustable to 100 microseconds; **Release Time:** For 63% recovery, .5 seconds in "dual" position; 3 seconds in "average" position; **Tube Complement:** 1-12AY7-select (Langevin Model TUS-12AY7), 1-6ES8 Variable Gain Input Amplifier (Langevin Model TUS-6ES8), 2-6005-5 Star Output Amplifiers (Langevin Model TUS-6005); **Bias Rectifier:** 2-Silicon Bias Rectifiers; **Power Requirements:** 6.3 Volts ac or dc at 1.5 amperes; 300 vdc at 90 ma strapped for monitor; 50 ma strapped for Leveline operation.

MECHANICAL SPECIFICATIONS

Mounting Tray: Langevin Model TRY-5017; **Finish:** Light gray baked enamel over 18 gauge bonderized (rustproofed) steel; **Weight:** 4 lbs. net, shipping 5 lbs.; **Size:** Length 10¼ in., width 2¾ in., height 3 in.

RECOMMENDED ACCESSORIES

Model MTR-507 Bias Voltmeter
Model TRY-5017 Mounting Tray
Model VR-112 100K Extension Bias Control
Model TK-5301 Tube Kit

ORDERING INFORMATION

MODEL AM-5301 LEVELINE AMPLIFIER, Complete with tubes, weight 4 lbs. net, shpg. 5 lbs. Price, Net, \$158.80.

MODEL AM-5301 LEVELINE AMPLIFIER LESS TUBES, same as above but less tubes. Price, Net, \$145.00.

MODEL TK-5301 TUBE KIT for above, consisting of 1 each (Langevin Model TUS-6ES8) 2 each 6005 5 star (Langevin Model TUS-6005) and 1 each 12AY7, select, (Langevin Model TUS-12AY7). Weight, net ¼ lb. shipping ½ lb. Price, Net, \$13.80

MODEL MTR-507 BIAS VOLTMETER, special scale marked for optimum operating point of AM-5301 Leveline Amplifier. Panel size is 1-13/16 in. round opening for rear panel mount, 1 7/8 in. square overall, depth is 1 5/8 in.; reading is 0-70 vdc, weight 3 oz. net, shipping 10 ozs. Price, Net, \$15.00

MODEL VR-112 100K continuously variable moulded composition resistor for panel mount bias limiting control of AM-5301, includes knob but no dial, weight 4 oz. net, shipping ½ lb. Price, Net, \$5.00.

MODEL TRY-5017 MOUNTING TRAY for above, with plug socket complete. Price, Net, \$8.25.

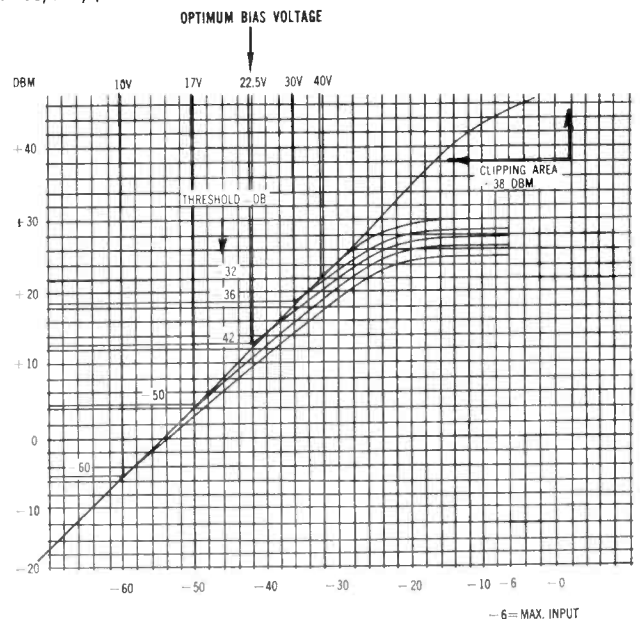

"Over thirty-five years of audio progress"



A Division of Sonotec Incorporated

503 SOUTH GRAND AVENUE • SANTA ANA, CALIFORNIA



BROADCAST ENGINEERING

THE TECHNICAL JOURNAL OF THE BROADCAST INDUSTRY [®]

VOLUME 3

NOVEMBER, 1961

NUMBER 11

Contents

Experience in Remote Control Operation of AM Plants	4
A group changeover proves reliable.	
Time Base Compensation in Wideband Magnetic Recording	8
The analysis of time base error and the corrections used in VTR operation.	
Super Dome Shelters Newest Antenna	14
The FCC and the Clear Channels	22
The Commission resolves 16-year-old rule-making.	

Departments

F.C.C. Regulations	32
Industry News	38
Product News	39
Index to Advertisers	40
Classified Ads	40
Professional Services	40

Cover Story

A total of 15 tons of nuts, bolts and washers, 930 fiberglass triangles covering an acre and a half in area form the world's largest radome to protect this nation's newest space communication antenna.

EDITORIAL

ROBERT E. HERTEL, Editorial Director
 JOHN L. HUMPHREYS, Associate Editor
 D. F. BOICOURT, Managing Editor
 DUDLEY ROSE, Presentation Editor
 E. P. LANGAN, Advertising Director
 S. F. WILSON, Production Manager

ADVERTISING SALES OFFICES

Great Neck, New York
 PAUL AND DON WEIL
 260 Northern Boulevard
 Telephone HN. 6-0212

Chicago 1, Illinois
 WILLIAM L. MILLER, JR.
 E. F. LUKENS
 C. E. PARKER
 307 N. Michigan Ave.
 Telephone FRanklin 2-5944

Cleveland 16, Ohio
 DAVID H. HERTEL
 3100 Wooster Road
 Telephone EDison 1-2370

Southwest
 C. H. STOCKWELL CO.
 4916 W. 64th Street
 Mission, Kansas
 Telephone RAndolph 2-4417

Los Angeles 57, California
 MAURICE A. KIMBALL CO., INC.
 2550 Beverly Boulevard
 Telephone DUUnkirk 8-6178

San Francisco 5, California
 MAURICE A. KIMBALL CO., INC.
 681 Market Street
 Telephone EXbrook 2-3365

Paris 5, France
 JOHN ASHCRAFT
 9 Rue Lagrange
 ODeon 20-87.

London W. C. 2, England
 JOHN ASHCRAFT
 12 Bear Street
 Leicester Square
 WHitehall 0525

Tokyo, Japan
 INTERNATIONAL MEDIA
 REPRESENTATIVES, LTD.
 Shadan Hojin, 14, 2-chome Marunouchi
 Telephone 571-4450

Editorial, Circulation and Advertising head-
 quarters, 1014 Wyandotte St., Kansas City 5,
 Missouri; Telephone VICTor 2-5955.



**Subscription Price: U. S. \$6, one year; Out-
 side U. S. A., \$7. Single copies, 75 cents.
 Adjustments necessitated by subscription
 termination at single copy price.**

Broadcast Engineering is published monthly by
 Technical Publications, Inc., 1014 Wyandotte St.,
 Kansas City 5, Missouri, U. S. A.

Corporate Personnel: Robert E. Hertel, Presi-
 dent; Frank D. Smalley, Executive Vice-Presi-
 dent; E. P. Langan, Vice-President; Kenneth
 Long, Vice-President.

PERFECT FOR MULTIPLEX STEREO BROADCASTING

**NOW!
FROM
GRAY**



A STEREO
**TONE
ARM**
FOR THE
PROFESSIONAL

The most versatile ever developed—

The ultimate in simplicity, ruggedness and reliability. Virtually maintenance free. Unexcelled audio performance. Sets a new low in tracking distortion. Response ± 1 DB from 5 cycles to cartridge limit.—This is the finest tone arm Gray has ever made and it is already setting new industry standards.— Here's why:

Plug in all cartridges including the G.E. Broadcast turn-around. **Dual balanced line output.**

New modular weight system allows mounting almost any cartridge with hardware supplied.

Individual slide "memory" of the physical and electrical arm adjustments for each cartridge.

Built-in calibration to allow instantaneous exchange of cartridges between arms.

Set up in seconds for monophonic or stereophonic operation as your Broadcast schedule dictates.

Eliminate forever special equipment or "lash ups".

Available from stock now for immediate delivery.

Write today on your company letterhead for complete technical information, specifications, and application data.

GRAY SPECIAL PRODUCTS DIVISION 17 ARBOR ST., HARTFORD 1, CONN.

EXPERIENCE IN REMOTE CONTROL OPERATION OF AM PLANTS

Group change over proves reliable

By Ogden L. Prestholdt, Director of Engineering,
CBS Radio Network, New York City

THE EXCELLENT reliability record of high power AM transmitters over the past decade in combination with decreasing revenue from the operation of radio stations has convinced station management that the economies to be effected by remote control of radio transmitters are in order. CBS owns seven radio stations: Table I lists these stations. Six of them operate with a power of 50 Kw; one of these, KCBS, utilizes a directional antenna with different patterns day and night; WEEI is a 5 Kw station with a single direc-

tional pattern day and night. A little over two years ago a project was initiated to remote control these seven transmitting plants. Since the operation of radio and television stations are in separate divisions of the CBS corporate structure, the remote control points were chosen to be the main studio control area for each radio station. Detailed study of the seven plants demonstrated that five of these plants could be quickly adapted for remote control but that major modifications would be required at the other two plants before

initiating remote control. Those five stations that could be quickly adapted for remote control were so modified and have been remotely controlled for from 5 to 13 months. The major modifications have been completed at KNX and it has been remotely controlled for one month. Construction is in progress at WCBS.

I. Design Philosophy

The seven CBS transmitting plants had been in 24 hour operation for many years and were manned by operators who were

TABLE I
CBS RADIO STATIONS

WBBM	CHICAGO, ILL.	50 KW	780 KC
WCAU	PHILADELPHIA, PA.	50 KW	1210 KC
WEEI	BOSTON, MASS.	5 KW	590 KC DA
KCBS	SAN FRANCISCO, CALIF.	50 KW	740 KC DA-2
KMOX	ST. LOUIS, MO.	50 KW	1120 KC
KNX	LOS ANGELES, CALIF.	50 KW	1070 KC
WCBS	NEW YORK, N.Y.	50 KW	880 KC

TABLE II
STATION OUTAGE RECORD WITH OPERATORS

	WBBM	WCAU	WEEI	KCBS	KMOX	AVG.
TOTAL OUTAGE						
NUMBER	3	2	11	40	25	17.6
TIME HOURS	0.023	5.015	1.618	0.447	2.065	1.83
PERCENT OF AIR TIME	0.0003	0.059	0.019	0.005	0.024	0.022
OUTAGES REQUIRING REPAIRS						
NUMBER	1	2	11	6	7	5.4
TIME HOURS	0.021	0.181	1.618	0.082	2.002	0.74
PERCENT OF AIR TIME	0.0003	0.002	0.019	0.001	0.024	0.0092

very familiar with the plants—many of these operators had seen the current plants go in and had spent many years there. Therefore, these operators knew the equipment intimately and could almost anticipate trouble. Our objective was to approach the past reliability record as closely as possible.

An analysis was made of past performance of these plants: this performance must be transformed into an equivalent performance under remote control. Momentary outages due to overloads, power dips, lightning and similar disturbances, after which operation is restored automatically or by reapplication of plate voltage, are not affected by remote control. Failures requiring some corrective action by the operators at the transmitter plant take on an entirely different aspect under remote control. An outage such as a small tube failure that can be diagnosed and remedial action taken in one to five minutes in a manned plant can become a major failure in a remotely controlled plant. The minimum time to find an available operator and have him travel to the transmitter at most of our stations is about one hour; it is doubtful that many trips will be made in that minimum time.

Table II is a tabulation of the outage record of the first five CBS AM stations to be remotely controlled during the year prior to their conversion to remote control operations. Note that the average number of outages requiring corrective action by an operator at the plant is 5.4 per station per year and that the average outage time per failure was 0.74 hours. Assuming the minimum time of one hour required to get an operator to the plant and that the average time to effect repairs and restore normal operation is 0.74 hours, it is seen that a loss of 9.4 hours per year could be expected. Assuming an operating time of 8500 hours per year, this represents outages of 0.11 per cent of the operating time. This is many times the actual average outage rate of 0.022 per cent for these stations during the last year of manned operation, and would be considered intolerable by our management.

Consider now two transmission systems each with a probable outage of 0.11 per cent of the time and

that the causes for such outages are all totally unrelated. Then the probability of failure of both systems at the same time is the product of the probability of failure for each. This factor, 0.00012 per cent, is the probability of failure of these two systems at the same time. This represents a significantly lesser outage time than our past average and is the key to safe design for remote control.

It is impractical to carry the transmission system duplication to the ultimate. However, a practical approach that very materially increases the reliability can be made. Before detailing this system duplication one more factor must be considered. That is, can the second system have some degraded performance such as operation at reduced power. At CBS it was established that some degradation could be accepted in this second transmission system and that it would be acceptable to operate with the second system for substantial segments of time when necessary.

II. Plant Construction

Table III is a listing of the major areas into which the transmission system may be divided for analysis. Six of the CBS stations had no auxiliary antenna system. Therefore, an antenna failure at any of these stations would be an extended failure under manned operation; in fact, the outage would most likely be many times the one hour transportation delay introduced by remote control. Therefore, no justification was found for the duplication of CBS antenna systems as a result of remote control. Further support for this decision may be found in the fact that CBS has, to my knowledge, had only one tower failure in thirty odd years. Transmission line and tuning system failures have been rare, less than one per plant per 20 years.

For the 50 Kw plants it was decided that a 10 Kw auxiliary transmitter would maintain adequate emergency service and provide 5 or 10 Kw for Conelrad operation as required. The 5 Kw plant already had an old 5 Kw transmitter that was serving as an auxiliary. RF switching was arranged so that the actuation of the remote control plate-on switch for a transmitter, connected that transmitter to a

TABLE III

MAJOR SYSTEM DIVISIONS

ANTENNA SYSTEM

TRANSMITTER

AUDIO INPUT FACILITIES

STUDIO-TRANSMITTER AUDIO CIRCUIT

PRIMARY POWER

REMOTE CONTROL SYSTEM

FIRE PROTECTION

GENERAL PLANT SECURITY

properly tuned antenna and then applied the plate voltage. The unused transmitter is always connected to a dummy load but with plate power off. A test switch is provided at the transmitter to bypass this control arrangement so as to permit the testing of the unused transmitter into the dummy. This arrangement prevents any confusion in the remote control operator's mind as to which transmitter is on the air and which is in the dummy. Although this prevents testing of the auxiliary transmitter by remote control, this should not be a hardship. The transmitter is tested weekly during the maintenance period.

Audio input facilities were revamped so that one channel would feed both transmitters and a second identical local channel could be switched into its place if the first one failed. Two studio-transmitter audio circuits were maintained, one by regular telephone facilities, the second by a differently routed telephone facility or by utilization of the station's FM adjunct when necessary.

Primary power was found to be the most variable item in the existing systems. The existing equipment and service ranged from a minimum of one utility service and an auxiliary generator that was too small to carry the new 10 Kw auxiliary transmitter, to a plant with two utility services with automatic switching and with better than average reliability and an auxiliary generator capable of carrying the main transmitter at reduced power. All plants were equipped so that at least two sources of power were available: either two separately routed utility services with automatic transfer in case of failure of the preferred service or, one utility service and a local

TABLE IV
PRESENT MAINTENANCE SCHEDULE

	WBBM	WCAU	WEEI	KCBS	KMOX	KNX
MAINTENANCE						
TWO MAN MAINTENANCE 8 HRS MONDAY MORNING	X	X	X	X	X	X
SUPPLEMENTARY INSPECTIONS						
TWO INSPECTIONS DAILY				X		
ONE INSPECTION DAILY			X			X
ONE INSPECTION PER WEEK	X	X		X		

auxiliary generator capable of carrying the 10 Kw transmitter, tower lights, and building services, and arranged to automatically start upon failure of the utility service for more than 5 seconds, and then to take the designated load.

All of the foregoing equipment duplication would be of no use unless a suitable control system is available to control it with similar reliability. Two systems were utilized, one for each transmitter. Different cable routings were provided by the telephone companies where possible, so that a cable failure would not be common to the two systems.

As was noted in Table III, the design of the plant can't stop with the electronic equipment but consideration must be given to security. The equipment was protected against damage from fire by the installation of automatic CO₂ fire extinguishing systems. These systems are arranged to shut down the transmitter and blower systems immediately upon receipt of fire signal, then insert about a 30 second delay to permit blowers to stop, and then to release the CO₂ into the transmitter cubicles. The transmitter buildings were modified so that all

windows were bricked up or barred, and doors were secured so that the danger of unauthorized entrance was minimized. Suitable fencing was added to prevent access to the tower bases, coupling houses, guy anchors, transmission line, power mat and building.

To aid in reporting such events as the operation of the fire protection systems, attempts at unauthorized entry, building under or over temperature, water in the basement, and many other functions not associated with the day to day operation of the transmitter, an automatic alarm system was developed. This system transmits a signal advising the operator of such an occurrence and utilizes the regular remote control lines for this service. The first five CBS stations were modified in accordance with these concepts and, as stated before, have been in operation for some time. The sixth plant, KNX, was designed from the ground up in accordance with these principles (Fig. 1). In addition to the following brief description of the plant, it may be of interest to mention that this building was constructed around the tower while KNX maintained a 24 hour a day 50 KW operation. Fig. 2 shows the

TABLE V
STATION OUTAGE RECORD WITH REMOTE CONTROL

	WBBM	WCAU	WEEI	KCBS	KMOX	AVERAGE PER STA. PER YEAR
OPERATING TIME HOURS	7800	7600	6900	5800	1400	8500
NUMBER OF OUTAGES	47	55	18	36	4	46
TIME LOST HOURS	0.231	0.655	1.179	2.470	0.083	1.33
PERCENT OF AIR TIME	0.003	0.008	0.017	0.042	0.059	0.0156

interior as viewed from the front door.

Since this plant was designed for unattended operation, a minimum of the normal creature comforts were included. Space is held to a minimum to discourage the storage of unnecessary items; the building location and layout were chosen so as to provide maximum security and minimum cost. Figure 3 is a floor plan of the building; note that a minimum of interior partitions are provided. There are only four rooms; the main transmitter room, the transformer vault, the auxiliary generator room and the lavatory. An open antenna court is also included. It should be noted there are no windows in the building, one outside door and the outlets for generator cooling air are the only openings in the walls. All intake air is provided through the antenna court, thus, protecting the air supply from tampering; all air exhaust is through the roof and hence equally protected. Figure 4 is a close up from the Northeast showing the building, power company transformer area, and the tower as it is protected by the building.

Figures 2, 5 and 6, show the pertinent areas within the plant includ-

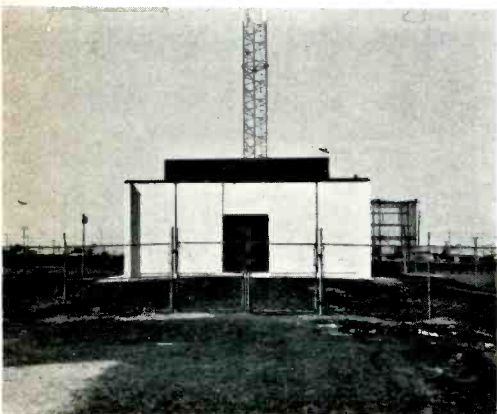

Fig. 1
The KNX Transmitter Building.

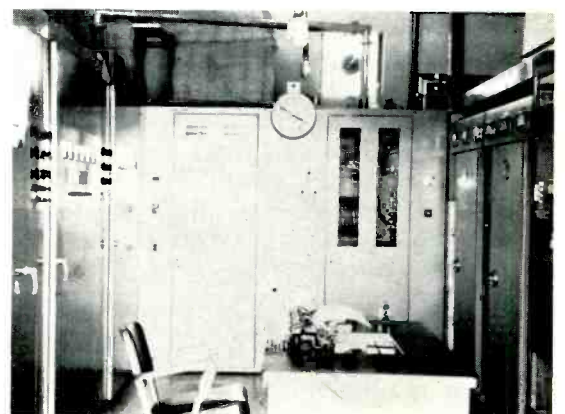

Fig. 2
The main and standby transmitters and antenna coupling and dummy load units.

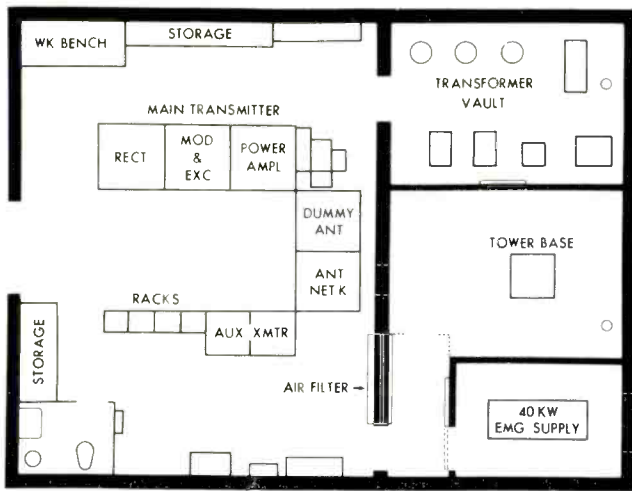

Fig. 3
KNX floor
plan.

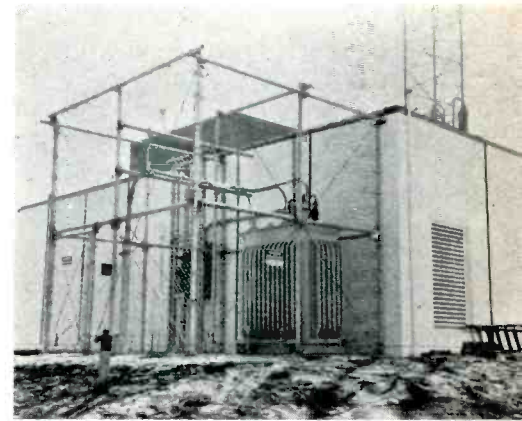

Fig. 4
The power line trans-
formers are protected
by fence.

ing the main transmitter, dummy antenna, antenna network, auxiliary transmitter, transformer vault, and auxiliary generator. Note the equipment layout is functional; no effort has been made to dress up the plant or isolate the control area from the equipment. This plant joined our remote control family on April 12, 1961.

III. Operating Experience

CBS's operational experience to date with these six remotely controlled plants has been rewarding. At present the maintenance and inspection schedules have been reduced to about the minimum at most of these plants. Table IV lists this present schedule. Note that KCBS has two inspections daily. This is not required from an equipment operation standpoint but is required by the FCC for surveillance of the antenna system. The same is true for the daily inspection at WEEI. The daily inspection at KNX reflects the newness of their remote control operation. This accumulation of over three years of experience has developed an operating record that is consistent with the expectations and design criteria.

Table V is a brief summary of outages under remote control. It should be noted that there is more uniformity in station reliability than existed before remote control and that the average outage time is down.

Two major problems have been uncovered as a result of this remote control operation. These are, personnel training and reliability of control lines. The personnel training required is in the operation of the transmitter by remote control. Detailed operation procedures must be set up in terms of actions to be taken when various failures occur, as well as thorough training in the proper use of the remote control equipment. This training must also include instructions in keeping the necessary logs.

The main operational complaint was the reliability of the telephone lines used for remote control. The grade of circuit that we are using, and I believe that most other stations are using the same type, is a signal grade circuit, probably the cheapest class of circuit available. Apparently, the reliability of these circuits is given minimum considera-

tion by the phone companies. It seems to us that an industry wide review of this problem would be in order. The solution might provide another grade of circuit for this function and have reliability, or at least freedom from telephone company tampering, its main feature.

One other comment that may be in order, the operator who is now in control of an AM transmitter has other duties which occupy his mind a large portion of the time. As a result of this preoccupation, the operator is not interested in following any complicated procedure in controlling the transmitter. He is deserv-ing of a system designed for ease operation, not one designed for simplicity of manufacture—in short a system with some human engineering in it.

I would like to give credits to some of the CBS personnel who have helped to make this entire project possible. Without the conscientious cooperation of such men as Bill Fligel, WBBM; Jack Leitch, WCAU; Warren Stevens, WEEI; Alan Cormack, KCBS; Larry Burrows, KMOX; and Harold Peery and Ted Denton, KNX, this project could not have been completed.



Fig. 5
The speech equip-
ment racks.

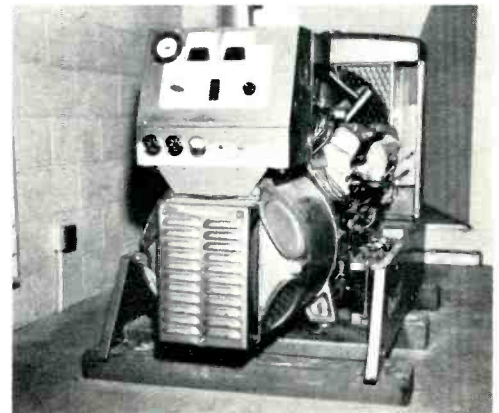

Fig. 6
The auxiliary power
generator with auto-
matic switch-over.

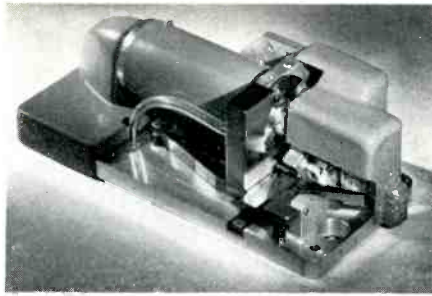

Fig. 1—The longer life 340 Ferrite Video Head to fit Videotape recorders.

By *L. W. Weiland*
 Manager, Engineering Div.
 Ampex Corp.

SINCE the inception of the video recorder, designers have had to overcome two cardinal problems. The first and the most obvious problem is that of recording high frequency signals on the tape and retrieving these on playback with some degree of fidelity. The problem was solved by going to a very high writing speed, 1500 ips, and by using a suppressed carrier vestigial sideband FM modulation system. The high writing speeds were obtained by a method, which I am sure you are familiar with and that is, rotating a four-headed drum at 14,400 rpm in a transverse scan across the tape as seen in Figure 1. Having recorded the high frequency signals and achieved the necessary high writing speeds, the next problem of time base stability on playback becomes evident.

The transverse four-headed scan configuration was the obvious choice for achieving a time base stability that would be commensurate with the FCC's specifications for the rate of change of horizontal frequency for a transmitted television signal. With such a scanning assembly we achieve the best possible immunity from tape flutter since the flutter component is a longitudinal one and the head, in effect, is writing perpendicular to the direction of flutter.

I would like to trace for you the evolution of this art of time base control in the four-headed transverse scan wideband recorder. The first bench mark in the growth of the

Time Base Compensation In Wideband Magnetic Recording

The analysis of time base error and the corrections used in VTR operation

sophistication of time base control occurred in 1956 with the introduction of the first basic video head servo system which permitted the playback of a television signal within the FCC specified rate of change of horizontal frequency of .15 per cent per second per second. The next step came with the ability to tie the playback signal to a station synchronizing generator or another video signal. This was done with a commercial unit which was called Inter-

Sync*. Further improvement in time base compensation and elimination of timing error was made through the use of an open loop, all-electronic, variable delay system accurate enough to eliminate all geometric errors in the television signal. Finally we came to the ultimate in time base compensation with an additional open loop electronic delay system which we call Colortec*, which permits us to playback color from a video tape without the use of

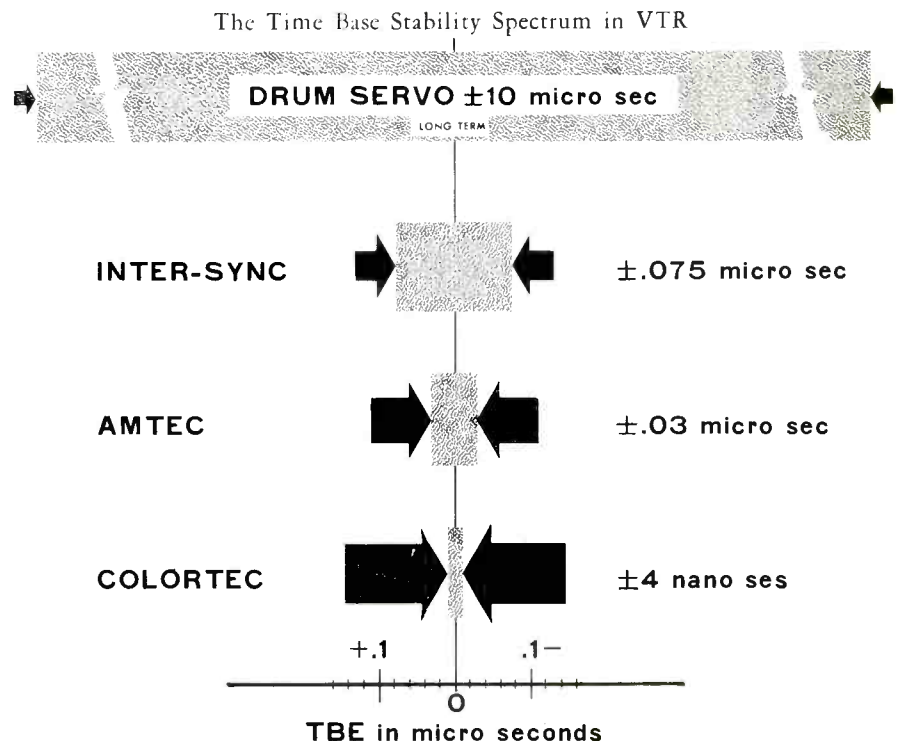

Fig. 2

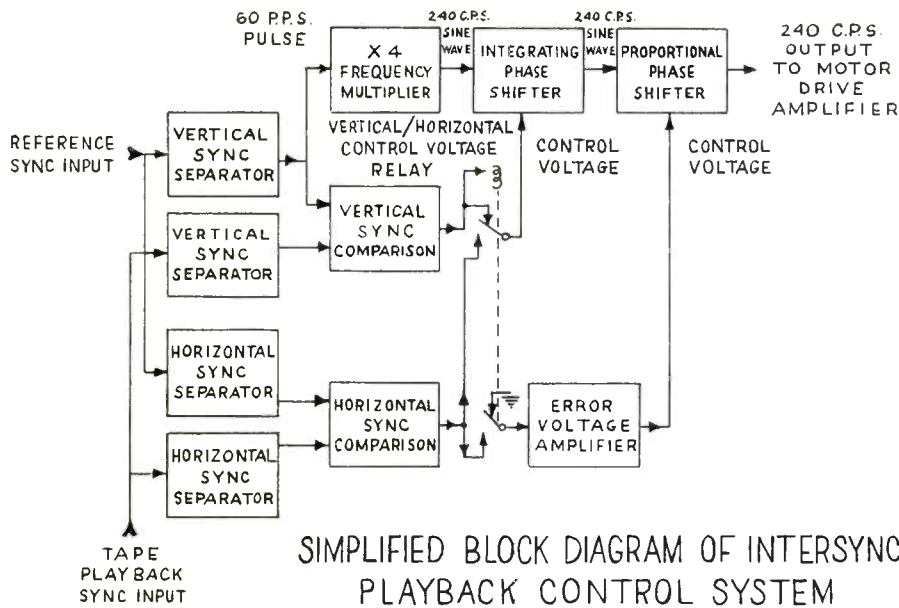

Fig. 3

such debilitating methods as heterodyning. From Fig. 2 we see we have a time base stability which starts off in the basic servo with a long term accuracy of about 10 microseconds, progresses to the Inter-Sync servo stability where we have time base errors less than .15 of a microsecond line to line, to the voltage variable delay line time base corrector called Amtec* which as a time base correction to ± 30 millimicroseconds line to line, and finally to the Colortec, or a direct color system, in which we achieve a time base stability of ± 4.0 millimicroseconds either line to line or over a long term period. Now these efforts in time base stability correction have two general classes — closed loop electro-mechanical and open loop all electronic. In the coarser efforts, the electro-mechanical system is operated via servos with varying degrees of complexity to achieve up to .15 of a microsecond in time base stability between lines. Extensive analytical work led our engineering staff to the conclusion that the Inter-Sync with this degree of control was as far as one could practically go in the design and manufacture of an electro-mechanical closed loop system. Thus, the next step was obviously one in which we have an open loop system, in which we control the time base stability via all electronic means, which implies a voltage variable delay line whose signals to control it are derived from an average

of the interval between the leading edges of successive playback horizontal sync pulses.

The Electro-Mechanical Closed Loop System

A quick look at the geometry of the video tape recorder top plate would indicate the necessity for two types of time base control. Admittedly these are both coarse, but obviously both are necessary. One would be the capstan servo control to govern the longitudinal position of the tape, and the other to control the rotational position of the video heads. Both must be inter-related and identical in playback as they were in record mode. Further, if we are to achieve interchangeability of tapes, these two parameters must be the same on all machines at all times. The tape positioning control, or the capstan servo system, does its work by locking the rotation of the capstan motor to that of the head drum motor during the recording

process. The 240-cycle output of the photoelectric cell on the head drum is divided down to 60 cycles and serves as the source to drive the capstan synchronous motor. This same signal is also recorded longitudinally on the bottom of the tape and serves, in effect, as magnetic sprocket holes. During the reproduce mode, the capstan servo system compares the signal from the reproduced control track with the signal from the photoelectric cell which is an instantaneous tachometer. The capstan motor speed is then governed by a servo which makes this comparison in order to maintain the exact relationship between the angular head position and the longitudinal tape position that existed during the record mode. Now, the head drum motor, which is rotating at 14,400 rps, is controlled through a two-servo loop system. One is a fast servo which provides the proper frequency to the head drum synchronous motor. This serves both servo systems and insures that the vertical sync is recorded at the same position on the tape at all times. The fast servo loop stabilizes the drum motor and suppresses hunting and corrects for the physical and mechanical variations that might tend to affect the rotational speed. In the servo loop, the phase position of the drum motor is determined by 240-cycle output of the photoelectric cell. The fast servo loop in this system uses the photoelectric cell output to control the phase of the voltage that is fed to the head drum motor. Now a combination of these two servo systems in the drum servo control unit results in a timing error of about 1 microsecond short term and 10 microseconds on long term, and rate of change less than .15 per cent per second over 2.5 to 6.5

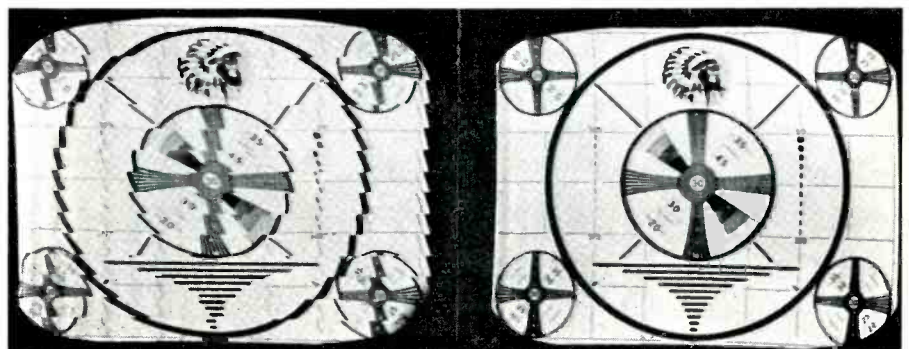

Fig. 4

*Trademark, Ampex Corp.

milliseconds. In practical terms this accuracy was sufficient to meet FCC requirements, but would not permit the inter-synchronization that the many broadcast operations require.

Inter-Synchronization

Let us now look at the next step in sophistication of servo control which achieved inter-synchronization. Since the drum is rotating at 240 revolutions per second we know that it will rotate .0864 degrees in one microsecond and further, if we are to achieve an accuracy of control to .10 of a microsecond, it becomes obvious that the drum rotation must be held to within .00864 degrees of error. This is cumulative in both record and playback. A number of years ago it was felt that to achieve this degree of stability in a tape machine would be quite impractical. In an attempt to verify the feasibility of this type of electro-mechanical control, the Stanford Research Institute carried on a development program for Ampex to prove or disprove such a possibility. Needless to say the results of the experiment indicated that such control was possible. It is interesting to note that these experiments at S.R.I. made use of a microscope, a high sampling rate tachometer disk, and phase detector whose frequency was 126 kilocycles per second or eight times the horizontal sync pulse repetition rate. In the final practical machine which has now been on the market for over a year, Harold Clark, Ampex Corp., devised a method in which the sync pulse in-

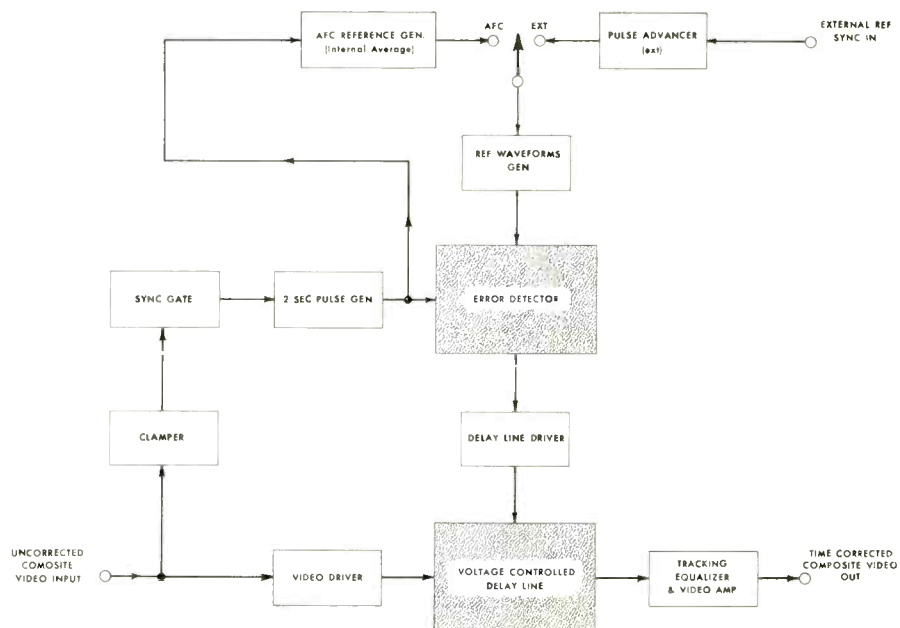

Fig. 5—Functional diagram of the Amtec.

formation could be used as a measure to accomplish this type of super servo control. The key to the operation involved accomplishing all the high accuracy servo control during the playback mode. Of course, while it is desirable to make as stable a recording as possible since an accurate recording would mean less servo correction on playback, it was found that sufficient control of torque applied to the video head drum in playback could be achieved by controlling the three-phase driving signal to the hysteresis synchronous drum motor. The torque developed by a three-phase synchronous motor is proportional over

a considerable range to the angle between the magnetic pole of the motor and the rotating magnetic field of the stator. Then, to control the instantaneous torque developed by the motor, it is only necessary to control the instantaneous phases of the three-phase current driving the motor. This block diagram (Figure 3) shows the operation of the Inter-Sync. Here we see on the upper left that the vertical sync component of the reference signal, that is, the one to which we are synchronizing the tape playback, is applied to a frequency multiplying circuit. From this circuit we obtain a 240-cycles-per-second sine-wave voltage locked to the reference sync signal. This is then coupled to a block labelled integrating phase shifter. The output voltage phase of this circuit is shifted with respect to the input phase by an amount proportional to the time interval of the control voltage applied to the circuit. Stated in non-mathematical terms, this indicates that if a small, constant, positive control voltage is applied to the circuit, the output phase will continue to advance from the input phase at a constant rate as long as the control voltage is maintained. When the control voltage is removed the output frequency will revert to the input frequency, but the output phase will remain shifted from the input by the total amount accumulated during the application of the control voltage. The signal is next

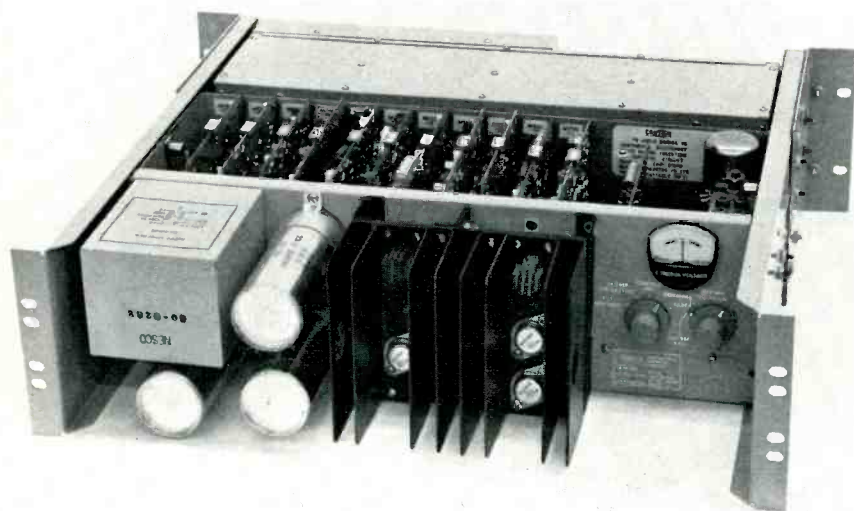
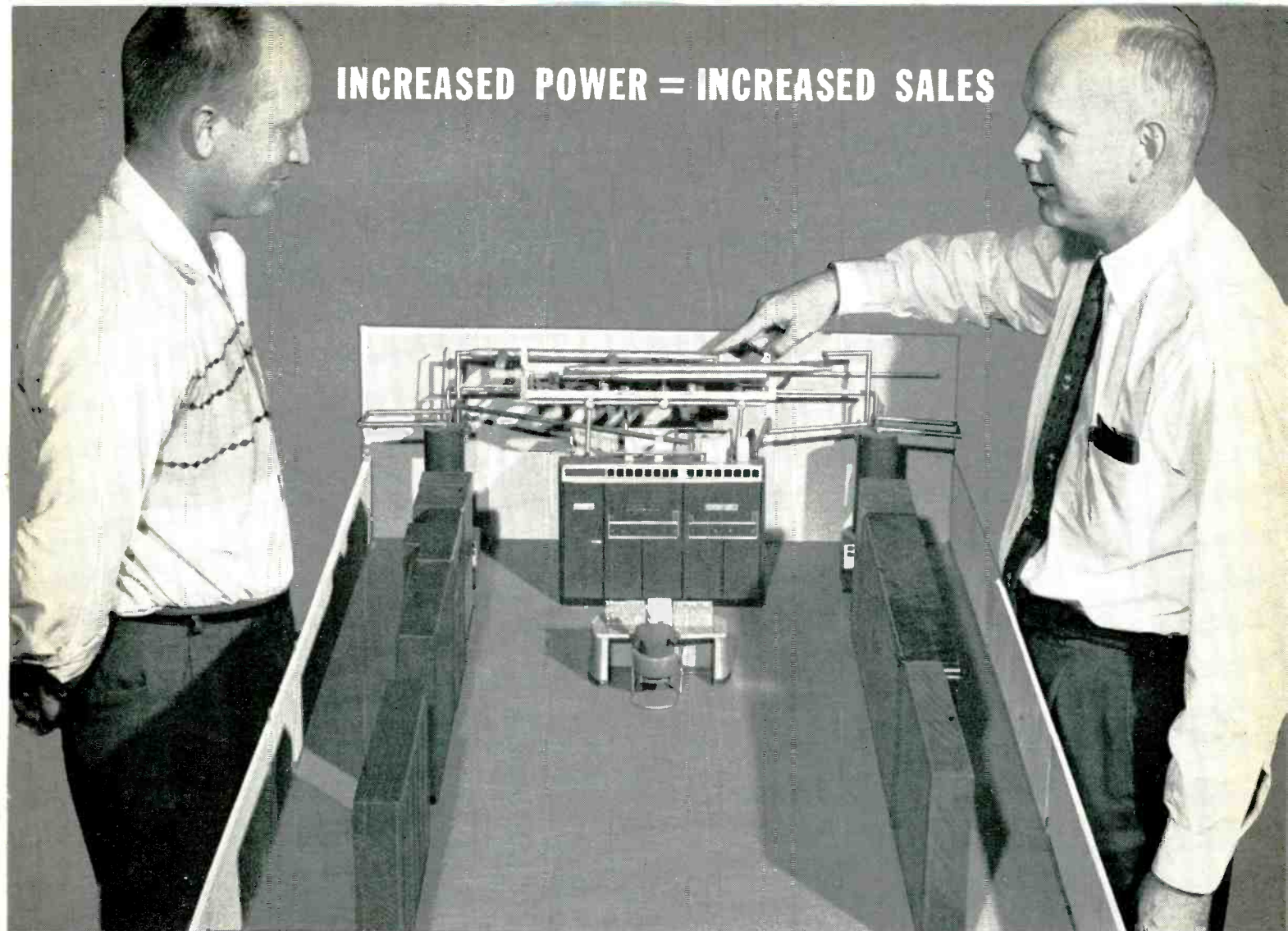

Fig. 6—The commercial unit, the AMTEC, time element compensator acts as an automatic watchman in the playback of TV tape.

INCREASED POWER = INCREASED SALES



KPHO-TV and KPHO radio director of engineering, George McClanathan (right), points to a section of the "model" used to construct KPHO-TV's new transmitter building as Engineering Supervisor, Glenn Thompson, looks on

RCA High-Power Transmitter-Antenna Combination — Extends Coverage — Improves Picture Quality

... says George McClanathan, Director of Engineering, KPHO-TV

"We've completely modernized our transmitter plant and stepped up KPHO-TV's sales power with a new high-power RCA transmitter. The improved facilities started paying for themselves at once—by increasing sales. And even though operating at maximum power, we are obtaining very low operating costs, because of the way we did it."

The new power amplifier is capable of 25,000 watts output. However, the new RCA six-bay superturnstile antenna needs less than 20,000 watts of this power to get full 100 kilowatts of ERP. This puts a very light load on the transmitter, which results in low operating costs, long life, and very reliable performance.

All reports on extended coverage show that KPHO-TV's

signal is extremely good. KPHO-TV's programs originating in Phoenix, Arizona, are now being enjoyed as far west as Blythe, California; as far north as Page, Arizona; as far south as Nogales, Arizona; and as far east as Silver City, New Mexico. And 90 per cent or more of the reports show far superior picture quality.

Learn how an RCA modernization program can increase your station's sales while providing reduced maintenance and increased reliability. Your RCA Broadcast Representative will be glad to give you additional information about new transmitters and antennas that can bring your station up to date. There's a complete RCA line to choose from. Get the facts before you buy. RCA Broadcast and Television Equipment, Dept. B-367, Building 15-5, Camden, N. J.

*Television station modernization
starts at the Transmitter Plant*



The Most Trusted Name in Television
RADIO CORPORATION OF AMERICA

coupled to the input of a circuit labelled proportional phase shifter. The output 240-cycle voltage from this circuit is shifted in phase with respect to the input by an amount directly proportional to the control voltage. That is, if a small, constant, positive control voltage is applied to the circuit, the output signal voltage will be shifted in phase with respect to the input by a small, constant, positive amount. This phase shift will remain fixed as long as the control voltage is maintained constant. When the control voltage is removed, the output signal will revert to its original phase relation with the input signal. The output 240-cycle voltage is now ready to be amplified by the motor drive amplifiers and applied to the drum motor. So much for the electro-mechanical servo system.

The Time Element Compensator

Once the gross errors have been corrected by the Inter-Sync, we can turn our attention to the smaller errors, such as skewing, scalloping, quadrature, geometric distortion of tape, random recorded noise, bearing runout, and tape thickness variations such as due to passage of a splice. The correction of this next class of errors must necessarily be done electrically through variable delay techniques. This is done in Amtec, as the results may be seen in Figure 4, which measures the interval between successive sync pulses in order to measure the extent of these errors. Having thus established the size of the error, the video is passed through an amount of delay sufficient to cancel the error (1 microsecond maximum). The automatic time error correction with Amtec may be used by itself as a picture straightener, or it may be used with Inter-Sync to compensate for the final .1 usec. residual error left by the electro-mechanical servo. This results in a long term stability error of about 30 millimicroseconds. In practical terms, this

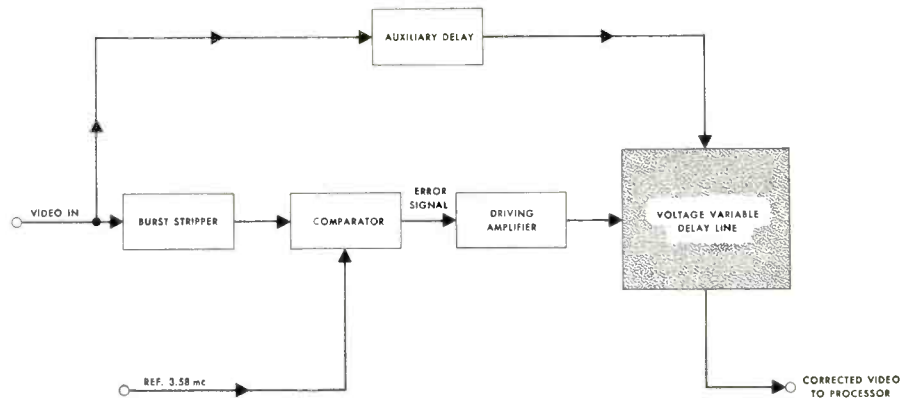

Fig. 7—Colortec simplified diagram.

means that one could superimpose test pattern from tape playback, and station monoscope, and see no differential jitter even at the bottom of the test pattern wedge. Thus it is now possible for VTRs and cameras to be held in dissolves, split screens or inserts, that are absolutely perfect from a timing viewpoint.

Now let us turn to a functional diagram of the Amtec which will a little more fully describe its operation, seen in Figure 5.

The error detector is primarily concerned with the timing (or leading) edge of the horizontal sync pulses contained in the incoming composite video signal. For this reason the horizontal sync pulses are clamped to a reference voltage, while en route to the error detector. The gate allows approximately the last 0.75 microsecond of the front porch, and approximately 4.25 microseconds of the sync pulse to pass to the two-microseconds pulse generator.

As its name implies, this pulse generator produces a rectangular pulse of two microseconds duration. It is formed by the leading edge of the sync pulse, and its output is therefore timed by sync. This is the signal that the error detector compares with a stable timing reference, for the derivation of the error (or bias) voltage. The error voltage is

developed during the five-microsecond interval following the leading edge of horizontal sync pulse, and is the bias proportional to the fourth power of the timing error, that is ultimately applied to the voltage-controlled delay line. During the interval between sampling pulses, the bias voltage is held constant. In this way the line of picture information following each sync pulse is held at the corrected time until the next sampling pulse occurs. No additional sampling or correction takes place during the visible portion of the picture.

During the "picture straightening mode" the error signal contains only "ac" or high rate-of-change timing error information. The "dc" or low rate-of-change components are not required for the mere correction of picture geometry.

Because the reproduced picture elements must remain stable with respect to the corresponding picture elements of another video signal during the "Inter-Sync" mode, the "dc" and low rate-of-change components of the error signal must be detected and delivered to the delay line. Under this requirement, the reproduced signal is time compared with an external timing reference, instead of an average of the horizontal sync contained in the uncorrected composite video. The exter-

(Continued on page 16)

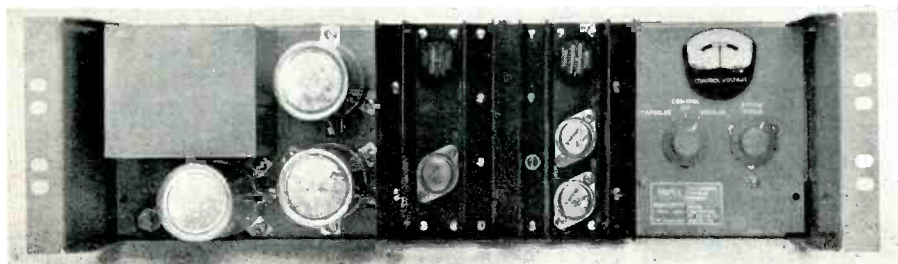

Fig. 8—The rack view of the Colortec, the direct color recovery system.

This is WGN's new Mid-America Broadcast Center . . . one of the world's largest and most modern studios for radio and TV transmission. Dedicated in June, 1961, it has more than 100,000 square feet of floor space, including three 72' x 48' TV sound stages, and two 30' x 18' radio studios.

Carl J. Meyers, center, Vice President and Manager of Operations and Engineering; and Woody Crane, left, Chief Engineer of Television, discuss WGN's wire and cable needs with Belden sales engineers, who, on behalf of Belden distributors, have just toured the new facilities.



90% of WGN TV-camera, Microphone, and Audio Cables made by Belden

Belden manufactures a complete line of wire and cable for TV and radio broadcasting, recording studios, remote control circuits and similar applications. Call your Belden electronic distributor.

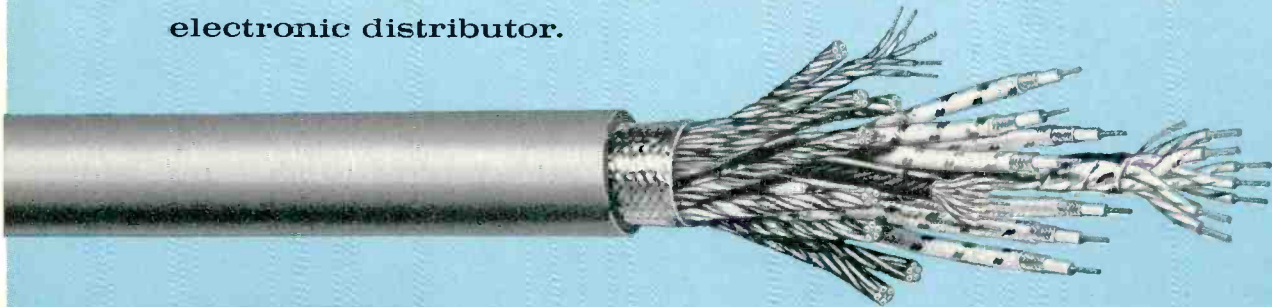

Belden

WIREMAKER FOR INDUSTRY
SINCE 1902 — CHICAGO

power supply cords • cord sets and portable cordage • electrical household cords • magnet wire • lead wire • automotive wire and cable • aircraft wires • welding cable

8-12-1

SUPER DOME

Shelters Newest Antenna

THE WORLD'S largest radome, a 134-foot high gleaming white sphere, was completed this September atop a Tyngsboro, Mass., hill for the U. S. Air Force.

It will be used to shelter one of the most sensitive research antennas ever built, a "dish" 120 feet in diameter designed for global communications and space studies. The facility is scheduled to go on the air by the end of 1962.

Constructed under direction of Electronic Systems Division (AFSC) Hanscom Field, Mass., the radome contains more than a million and a half cubic feet of space, and is designed to withstand winds up to 130 miles an hour. Completed after four months of construction, the dome is 150 feet across at its widest point and 90 across its base.

It is the first of its kind to be built, in accordance with a new design by MIT's Lincoln Laboratory for the Air Force. The frame of the radome is composed of hollow aluminum beams up to 15 feet long. The beams would stretch for three miles if placed end to end. The thin "skin" of the dome is made of glass-fiber-reinforced plastic triangles, measuring up to 15 feet on a side. The panels are only 30 thousandths of an inch thick or about the thickness of six of these printed pages. Completion of the radome for the \$5,000,000 project will enable engineers to begin on the foundations for the massive antenna under cover from the weather.

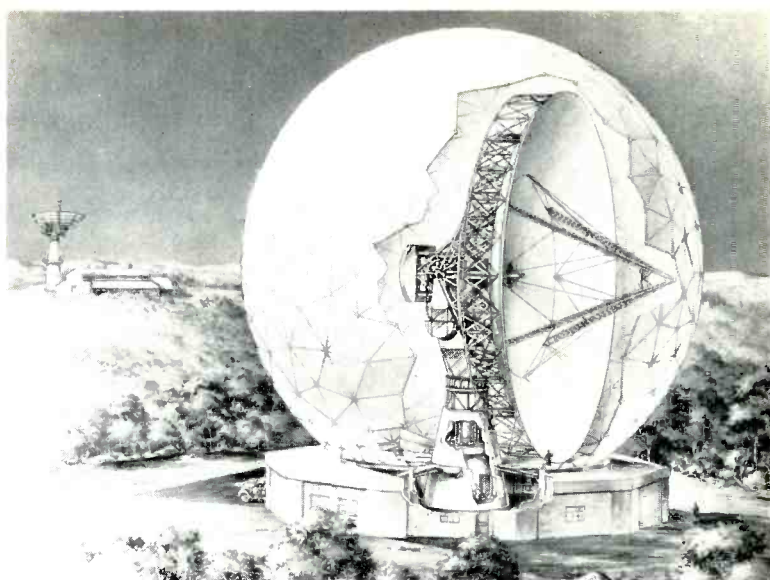

The research instrument will be located a short distance from Lincoln Laboratory's famed Millstone Hill radar in Westford, forerunner of today's high-power, long-range radars and one of the free world's prime sources of satellite tracking information.

The radio facility to be built inside the radome is designed to serve as a test-bed for development of the large ground-based transmitting and receiving equipment that will be needed to operate high-capacity satellite-relay systems for round-the-world communications.

This new Air Force research antenna will be the most precise structure of its kind ever attempted in this size. The high precision is necessary to concentrate the transmitter power into a needle-sharp beam of very high intensity, and to provide an equally sharp receiving beamwidth to discriminate weak, distant sources of radio signals.

As an instrument for radio communications research, the Haystack system will be used to probe the troposphere and the ionosphere, and to study atmospheric irregularities that may limit radio antenna performance. It will also be used to measure electrical noise generated in the atmosphere, and to study the diffraction and scattering of radio waves at the super high frequencies that will be used for global satellite-relay communication systems now under development by various agencies.

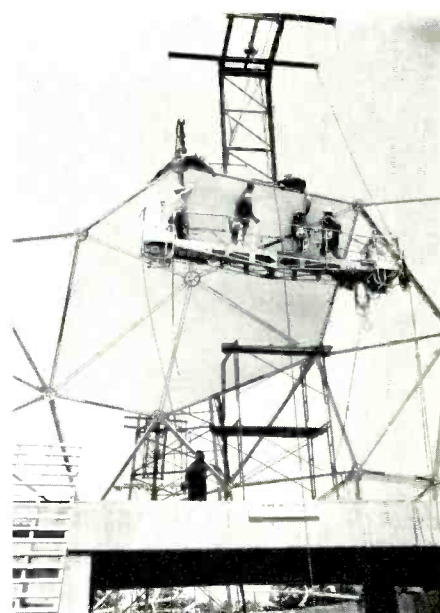



quality

ITA 5 kw AM Transmitter

No other 5 kw AM transmitter matches ITA for quality features that are basic to the unit. It's the most compact 5 kw AM transmitter ever designed . . . yet, it remains fully accessible. Your best choice for efficiency and economy—check this line-up of features—AM's best 5 kw buy!

QUALITY FEATURES

- High Efficiency PA Circuit
- Solid State Rectifiers
- Only 5 Tube Types
- Remote Control Provisions
- Power Cutback to 1 KW
- Conventional High Level Modulation
- Automatic Recycling

ITA

ITA ELECTRONICS CORPORATION
BROADCAST DIVISION • LANSLOWNE, PENNSYLVANIA

ITA

ITA Sales Offices: Chicago, Ill. AN 3-3797
Cincinnati, Ohio CH 1-6386
Dallas, Texas FL 7-9607

Jacksonville, Fla. EL 6-0121
Kansas City, Mo. GR 1-2838
Lansdowne, Pa. CL 9-8200
Los Angeles, Cal. MA 2-8552

New York City, N.Y. CH 2-1999
Portland, Ore. CA 2-2651
Washington, D.C. 337-2884

Time Base Compensation

(Continued from page 12)

nal timing reference is the local station sync generator.

Note the tracking equalizer in the lower right corner of Figure 5. As you might suspect, the video band pass characteristics of the voltage-controlled delay line vary with changes in delay and, therefore, must be compensated. This is done via a tracking equalizer which has a balanced input and is connected to the

push-pull voltage output of the isolation amplifier and as such receives the output of the voltage control delay lines. This tracking equalizer exhibits a variable band pass characteristic that is the conjugate of the band pass characteristic of the delay line. The result then is to maintain the Amtec band pass flat to 4.2 mc throughout its entire range of delay.

The commercial version of the Amtec is fully transistorized with a self-contained power supply. It takes 5¼ inches of rack space and,

as you will see from the photograph of Figure 6, it employs plug-in cards.

Direct Color Recovery

We come now to the ultimate in open-loop electronic servo systems called Colortec. This is the final step by which we may take a signal that has been corrected by Amtec to an accuracy of ± 30 nsecs. through an additional correction stage to bring our time base stability error down to ± 4.0 nsecs. In terms of color television, this is equivalent to ± 5 deg. of 3.58 subcarrier. In effect, this degree of correction is sufficient to eliminate any perceptible hue changes due to time base instability.

Once having accomplished the geometrical correction with Amtec, the next stage to a direct color playback, through Colortec, is a natural extension of the voltage variable delay line technique. Figure 7 shows a simplified block diagram of Colortec. As in the case of Amtec, the heart of the system once again is the voltage variable delay line and the error generator. In this instance, instead of comparing the time interval between the leading edges of sync, as in Amtec, we measure the variation in phase of the color burst retrieved from the tape compared to a reference 3.58 signal. You will notice the inputs on the left of this diagram are video, from the playback of the tape, and plant reference 3.58. In the comparator, a dc error signal is generated through the comparison of the reference 3.58 and the burst stripped from playback video. The error signal feeds through a driving amplifier to a control bus of the voltage-controlled delay line. You will notice that the video path goes through an auxiliary delay to make the video delay equal to the delay of the error signal. Finally, the corrected video signal from the voltage variable delay line is fed to the processing amplifier.

Of necessity, the range in the voltage variable delay line in Colortec is considerably shorter than that in Amtec. However, its resolution is significantly higher, since we are correcting our signal to within ± 5 deg. of the 3.58 color subcarrier. It should be pointed out that the Colortec unit must operate in conjunction with the two coarser time-base corrective devices, namely Inter-Sync and Amtec.

The value of this type of direct-

Concertone

Proudly Presents the New SERIES 90

Concertone's new Series 90 represents the first breakthrough in the commercial/professional recording equipment field at a medium price. Designed for rugged reliability under continuous performance conditions, the Series 90 meets the most exacting broadcast requirements.

Note These Outstanding Features

EDIT-O-MATIC—provides the countless advantages of high speed search, cueing and editing.

AUTOMATIC TAPE LIFTERS—eliminate the annoyance of "squeal" in fast mode.

FOUR HEADS—allow reproduction of monaural, 2-track or qtr. track tapes with the flick of a switch. The fourth head position can also be used for special heads.

ELECTRIC RELAYS—provide instant, positive action for stop, start, fast forward and rewind modes.

REMOTE CONTROL—record, stop, start, fast forward and rewind.

NEW TAPE TRANSPORT—precision design and construction. 3 motor drive system, including the heavy duty hysteresis synchronous capstan motor.

These exciting features mark the Series 90 as the ultimate in professional recorders. From

THE NEW 508—AT A MODEST PRICE

Advanced recorder design with professional reliability, extreme fidelity and tape-handling ease. The 508 has no equal for broadcast performance or custom installation. Available as a precision tape player or with separate electronics for mono or stereo recording. In half or full track at \$520.



See Concertone at better professional dealers everywhere. Write for name of nearest dealer and complete information. Dealer inquiries invited.



AMERICAN CONCERTONE, INC.
A DIVISION OF ASTRO-SCIENCE CORPORATION
9449 WEST JEFFERSON BOULEVARD • CULVER CITY, CALIF. 90230

EXPORT: Telesco International Corp., 171 Madison Ave., New York, N.Y.





S-5018—replaces 5AU4, 5AW4, 5AZ4, 5T4, 5U4, 5V4, 5W4, 5Y3, 5Z4, 5931, 6087, 6106



S-5207
replaces 6X4



S-5130—replaces 866, 866A, 3B28



S-5367—replaces 8020



S-5343—replaces 816, 836, or 3B28 and 866 at reduced voltage



S-5033—replaces 6AU4, 6AX4, 6BL4, 6W4, 12AX4, 17AX4, 25W4, 6U4
S-5019—replaces 5R4



S-5011A—replaces 80, 82, 83, 83V, 5Z3
S-5017—replaces 0Z4, 5X4, 5Y4, 6AX5, 6X5



S-5251—replaces 5U4, 5AU4, 5AW4, 5AZ4, 5T4, 5V4, 5W4, 5Y3, 5Z4

*Illustrations
approximately 1/2 size*



S-5347
replaces
12BW4, 6BW4



S-5344
replaces 872A



S-5373
replaces 8008

Sarkes Tarzian Tube Replacement Silicon Rectifiers improve circuit performance

These standard Tarzian tube replacement rectifiers are directly interchangeable with over 95% of all popular vacuum tube rectifiers. Although they are generally smaller and more compact than the tubes they replace, their dc current ratings are as much as three times as high.

In addition, they offer the inherent advantages of solid state rectification:

1. Greater electrical stability
2. Compact, rugged construction
3. Instant operation; no warmup; no filament supply

4. Cooler operation

For applications requiring high efficiency, wide temperature range, and long-period, maintenance-free operation, these compact units are unmatched. They are available in production quantities, at realistic prices. Special designs and modifications engineered on request. Special tube replacement units designed by Tarzian engineers include rectifiers with peak inverse voltages to 19,000.

Write for specifications and prices of tube replacement silicon rectifiers. Application engineering service is available on request.

Quality in volume



SARKES TARZIAN, INC.

World's Leading Manufacturers of TV and FM Tuners • Closed Circuit TV Systems • Broadcast Equipment • Air Trimmers • FM Radios • Magnetic Recording Tape • Semiconductor Devices

SEMICONDUCTOR DIVISION • BLOOMINGTON, INDIANA
In Canada: 700 Weston Rd., Toronto 9 • Export: Ad Auriema, Inc., New York



announcing

A NEW 20 KILOWATT FM TRANSMITTER IN THE STANDARD ELECTRONICS CONCEPT...

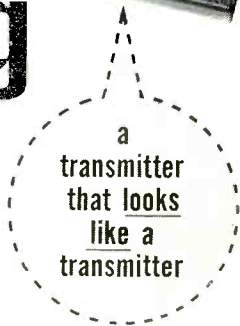

Frankly, we don't subscribe to the theory that "modern" transmitters must resemble oversized refrigerators. Nor do we agree with the idea that the Broadcast Engineer or Station Manager is overwhelmed with exotic exterior design.

STANDARD ELECTRONICS ENGINEERS AND DESIGNERS LIVE BY THE CREED THAT PERFORMANCE, ACCESSIBILITY OF COMPONENTS, AND RELIABILITY ARE THE PRIMARY CONSIDERATIONS.

The Standard Electronics 20 KW FM Transmitter Type 2012 has been developed to this concept.

intensely-modern INTERNAL design includes:

Proved 8000-hour-plus power tubes

Performance-proved tubes that have met the test of time in TV transmitter application.

"Patchover" protection

Another TV-tested feature that keeps you "On-air" by routing the rf signal around a temporarily inoperative amplifier.

Simplified operation and maintenance

Front-end controls, switches and dials, along with multiple metering points, facilitate circuit monitoring and provide optimum ease of operation.

For more information on the Standard Electronics 20 KW FM transmitter, simply send in the attached coupon. We will be happy to fulfill your every technical wish.



standard electronics

PRODUCT LINE BY REEVES INSTRUMENT CORP.
SUBSIDIARY/DYNAMICS CORPORATION OF AMERICA
FARMINGDALE NEW JERSEY

send more information on the Standard Electronics 20 KW FM transmitter,

NAME _____

STATION _____

ADDRESS _____

color playback lies in the rendition of full band-width black and white as well as high quality color. In all previous color systems, the integrity of the 3.58 phase was re-established through some sort of heterodyne technique. This could be heterodyning up to the 20-Mc region or down to almost dc. In either case, it was necessary to process the luminance and chrominance through different paths. The technique used to separate the luminance from the chrominance involved a bandpass device which inevitably resulted in very narrow band luminance and chrominance signals, since the luminance and chrominance bandpasses overlapped. With the direct-color system, the debilitating effects of heterodyning are eliminated. The viewer sees full band-width monochrome reproduction of the color as well as freedom from the "working of the sharp edges" that result in rapid transitions from high to low brightness. Indeed, from the purist's standpoint the playback signal from direct color can be considered the only legal taped color signal on the air, since the older color systems achieve a mere average interlace between horizontal sync and burst frequency, since the Colortec playback provides absolute lock. This absolute lock has a subjective value as well, since the critical observer will no longer see objectionable "dot crawl" in his color tape playbacks from Colortec.

The commercial unit Colortec, like Amtec, is fully transistorized, contains its own power supply, and takes 5½ inches of rack space (Figure 8).

I would like to mention an additional development that has been an outgrowth of these various time base correction techniques in video recording. Using modified broadcast equipment, we now have engineering models of general purpose instrumentation recorders available for scientific applications which are continuous (no transient), wide-band, and have time base stabilities of ±30 nsecs. over a long range.

I would like to thank Harold Clark, inventor of the Inter-Sync; Charles Coleman, the designer of Amtec; and Peter Jensen, design engineer on Colortec, for their assistance in the preparation of this article.

3 NEW WAYS TO AUTOMATE YOUR STUDIO



PD-9
MOTOR
DRIVEN



PD-7 ELK
ELECTRO-LIFT
KIT

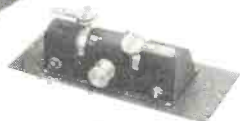

MCH-6
REMOTE
CONTROL

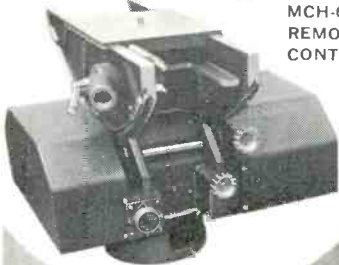

PD-9 Silent maneuverability... up, down and dolly shots... with the cameraman in complete control every instant. Raise or lower (19" travel) electrically while dollying and without stooping. Lets the cameraman concentrate on the big picture. For color or monochrome cameras.

PD-7 ELK Transform your easy-glide PD-7 pedestal to full automatic up-down control with the new Electro-Lift Kit. Installs as quickly as you can tighten four bolts, with no machining or drilling. A real low-budget improvement to every studio's operation.

MCH-6 This fully automatic remote-control camera head operates pan and tilt. Control panel is planned for remote operation of lift, diaphragm setting, zoom-lens and focus... all done as if you were behind the camera! Three years in development under commercial studio conditions. Adds a new dimension to closed-circuit TV.

Westwood Division / Houston Fearless Corp.
11851 West Olympic Blvd., Los Angeles 64, California

Give me a fast dissolve to the commercial.

PD-9 PD-ELK MCH-6 FILM PROCESSORS

Name _____ Position _____

Company _____

Address _____

City _____ Zone _____ State _____

WESTWOOD DIVISION **HF** HOUSTON FEARLESS CORPORATION, LOS ANGELES 64, CALIFORNIA

November, 1961

19

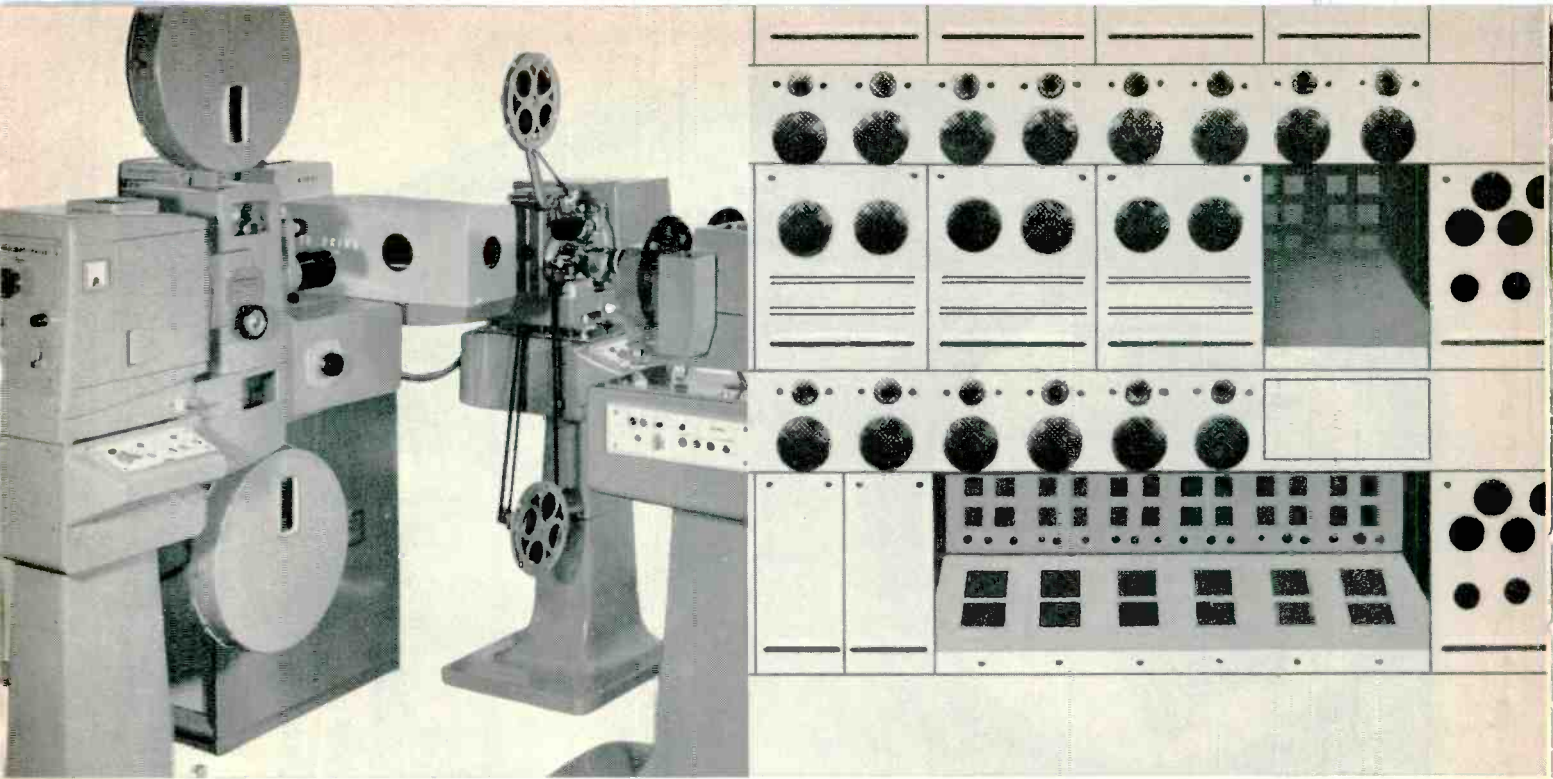

From both England and America, here is the new,

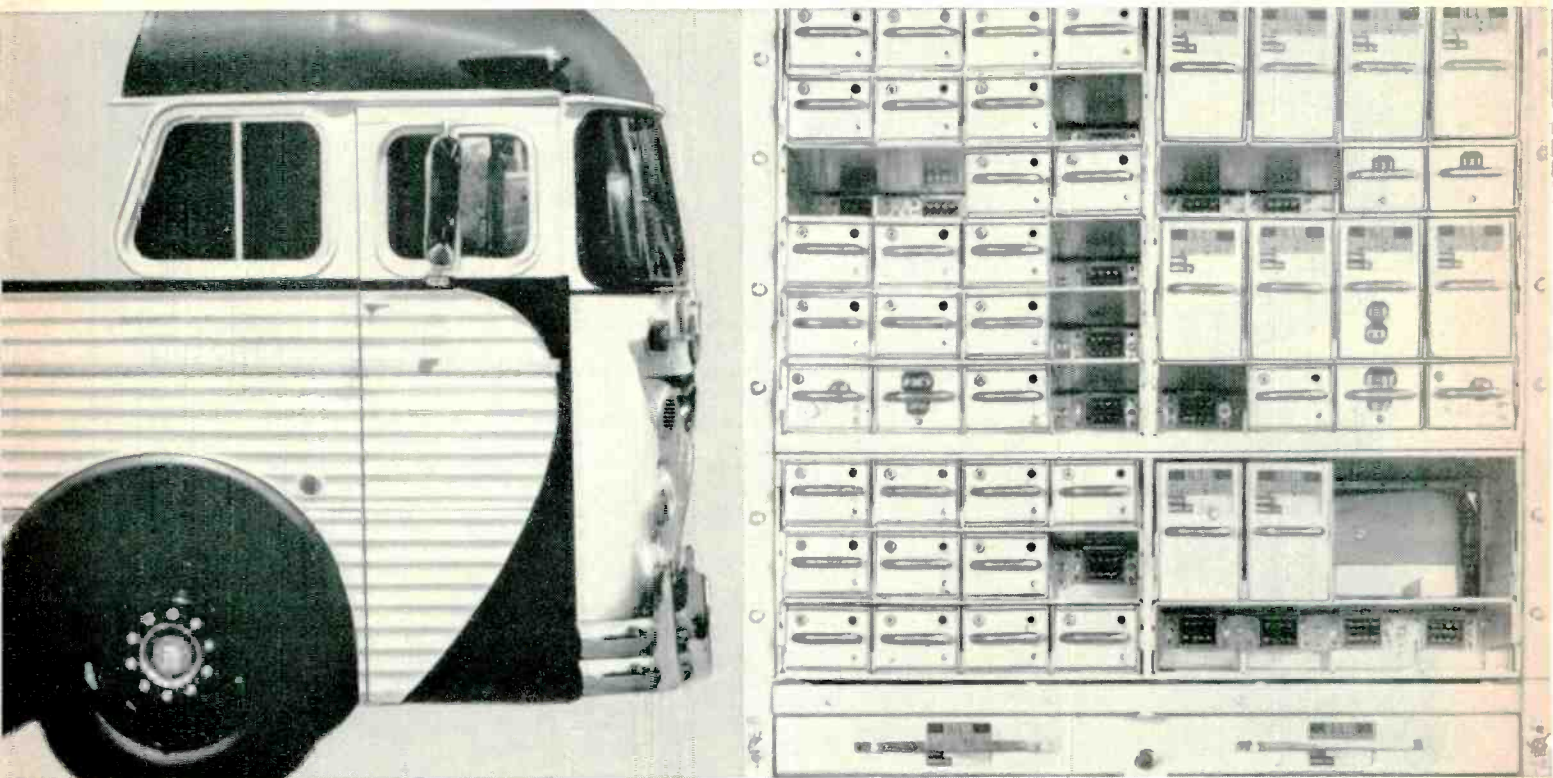

systems and equipment—much of it solid-state.

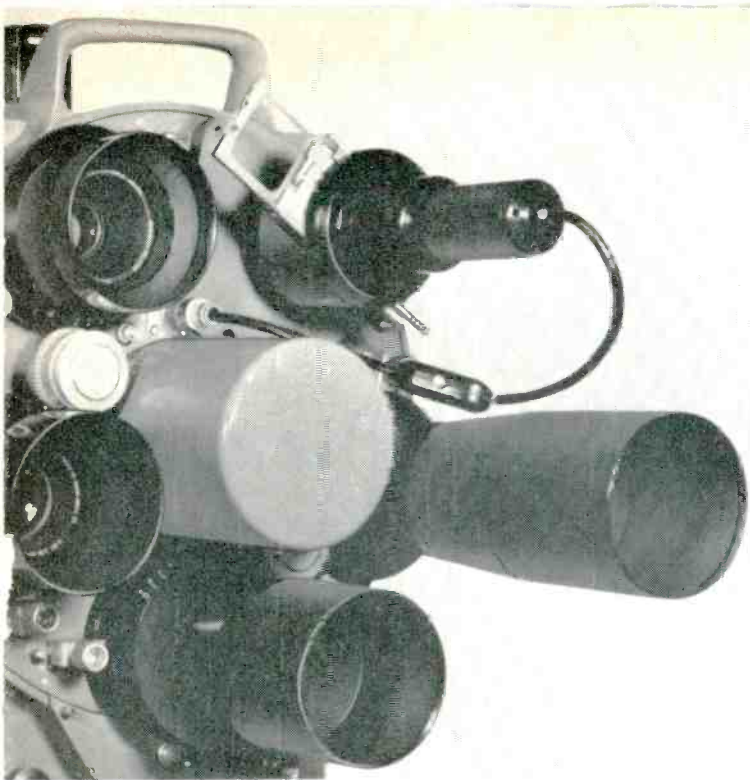

integrated line of EMI/US telecommunications

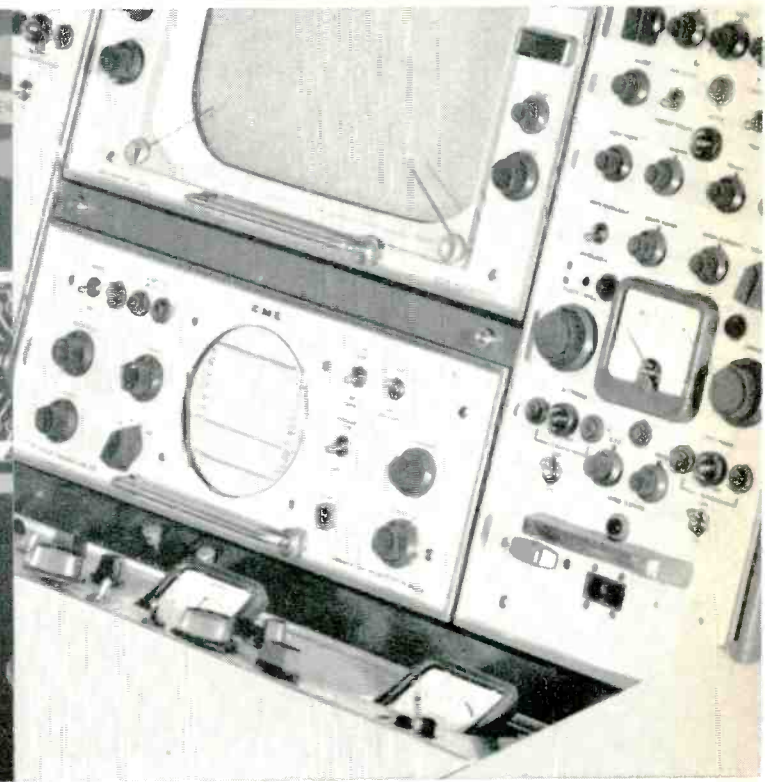
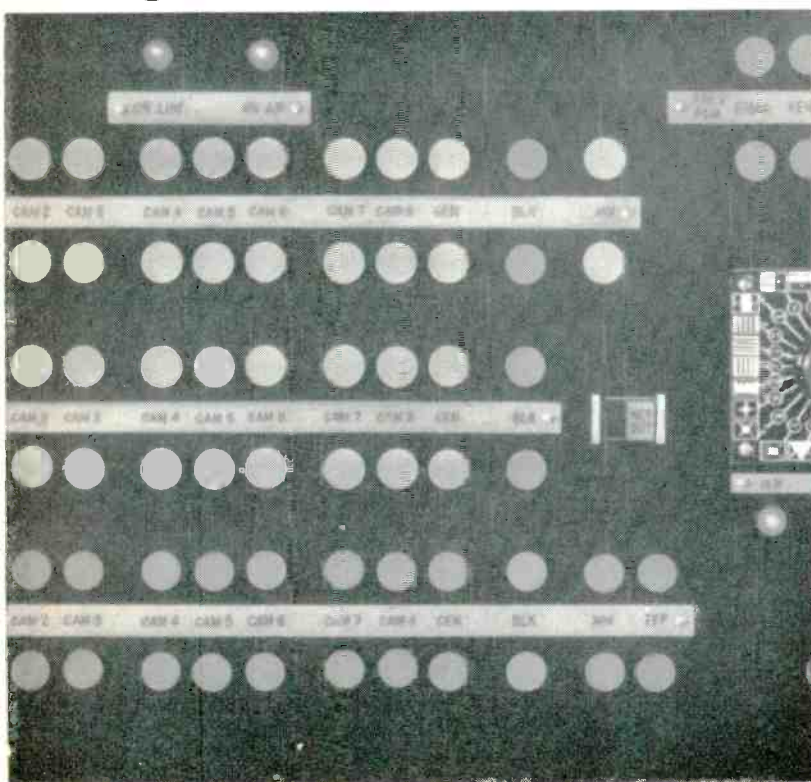

Now in one integrated line: everything in the video-audio spectrum from cameras and monitors through solid-state terminal equipment, switching, distribution and studio intercom systems to mobile vans and video recording tape—including just about all the components in between. And, all of highest quality. Some from England's EMI Electronics, Ltd., one of the world's largest electronics companies and developer of the first public TV system. More from our own manufacturing plant, the recently acquired General Communications facility of Fort Atkinson, Wis., a highly regarded developer of solid-state systems. We offer planning and design service, too, as well as 24-hour availability of parts and service. For details, write, phone or wire. Los Angeles 28, California: 1750 No. Vine Street, HO 2-4909. New York 36, New York: 315 W. 44th Street, CI 5-1216.

EMI / US General Communications Division

THE FCC and THE CLEAR

The Commission resolves sixteen-year-

EDITOR'S NOTE:

This report presents some of the views of the Federal Communications Commission as released by the Acting Secretary on the long standing clear channel proceedings.

This action, far from being settled, is most certain to be challenged through litigation and by Congress, causing further delay and obstruction.

The complete rule making as amended may be found in Broadcast Engineering's regular FCC department, "Amendments and Proposed Changes of FCC Regulations."

THE BASIC question in this proceeding is whether and in what manner it would serve the public interest to amend the rules governing the use of the standard broadcast frequencies designated as "clear channels." The proceeding was instituted by the Commission on February 20, 1945, largely as a result of insistent claims that the clear channel concept of permitting only one station to operate at night on 24 of the 107 channels available for standard broadcasting is wasteful of valuable spectrum space and otherwise not in the best interests of efficient utilization of the frequencies involved. Resolution of the matter has been complicated during the intervening years by changing treaty obligations, the necessity for disposing of precedent collateral problems, themselves difficult of settlement, and by marked changes in the socio-economic climate for a standard broadcast medium beset by the emergence of television as a vigorous competitor for audience, program material, and advertiser support. Proposals for settlement have been narrowed by the Commission's "Further Notice" of April 15, 1958, and a "Third Notice" adopted September 18, 1959. The course we take today marks our best judgment of the most practicable manner in which the clear channels can, at this stage, be better utilized to improve service in the standard broadcast band.

The Basic Conflict

Two basically divergent views have persisted as to the measures best calculated to make more efficient use of the clear channel frequencies. On one side, it has been urged that the principal objective of providing satisfactory night-

CHANNELS

old rule-making



time service to areas lacking such service is most likely to be attained by improvement in the capacity of the clear channel stations, particularly the Class I-A stations, to provide a good skywave signal to wide areas, this is to be accomplished by permitting those stations to operate at substantially increased power and by limiting, and at night excluding, co-channel stations. The conflicting view has contended for an increase in the number of unlimited time stations on the clear channels. The clear channel inquiry was instituted against this background of conflict between the basic alternatives or higher power versus duplication.

Shortcomings of Present Clear Channel Allocations

As noted in our opening paragraph, we are concerned with whether and in what manner to amend the rules governing clear channels. Whether to amend them is comparatively simple to resolve. The proceeding was instituted because of insistent demands that present utilization is not adequate. That assumption underlies the entire proceeding. However, we must now look to the validity of that assumption and in doing so we conclude it has not only stood the test of time but that the situation has, if anything, become worse. We have noted that a great increase in the number of stations has only insubstantially reduced night-time white area. Moreover, with our population growth, the number of people in white areas is growing. There is substantial support in the comments for a conclusion that the exclusive night-time use of a channel by a single station limited to 50 kw is less justifiable now than it was when clear channels

were first allocated in this way. Since that time techniques have been established and highly developed for directional transmission of signals, with a high degree of suppression now possible to protect the service areas of co-channel stations. In addition, heterodyne interference resulting from uncontrolled deviations from the assigned frequency has been substantially eliminated. Thus it is now possible, particularly in the case of Class I-A stations located in or near the northeast portion of the country, to assign additional co-channel unlimited time stations to provide needed service at distant locations; while preserving the capacity of the present station to provide a usable signal over wide primary and secondary service areas. In these circumstances there is serious question whether the most efficient use of the Class I-A clear channels can be achieved under the long-standing rules which, on the one hand, preclude power above 50 kw, and on the other hand, bar co-channel unlimited time assignments in distant areas which the present station cannot effectively serve, and where a new station could be operated so as to afford reasonable protection to the areas the present station does effectively serve at 50 kw. Almost without exception the commenting parties either note the need for additional service or at least do not attack the underlying assumption of such need. There were, however, a few comments to the effect that maintenance of the status quo would be preferable to adopting the alternative which the commenting party opposed.

Resolution of the Issues

Our review of the record and our analysis of the numerous substantive,

procedural, and administrative questions which it raises make it convincingly clear that it would be undesirable to set in motion the simultaneous reallocation of all the Class I-A clear channels. The enormity of the consequent administrative burden alone would further glut our license processing and hearing resources and delay not only the achievement of improved service on the clear channels, but additionally delay our strenuous efforts to reduce the excessive and persistent backlog of pending standard broadcast applications.

Quite apart from these considerations, which in our considered judgment would alone warrant progressive rather than simultaneous approaches to reallocating the Class I-A clear channels, we find compelling reasons for avoiding a course which would precipitate changed modes of utilizing the Class I-A clear channels without opportunity to review and evaluate, as we go along, the effectiveness of such reallocations as we herein adopt for some of the channels.

Both in the Further Notice of April 15, 1958, and in the Third Notice of September 18, 1959, the Commission invited comments on proposals to remove the heretofore total exclusivity of night-time use of the Class I-A channels by a single station. The Third Notice contemplated additional unlimited time station assignments on substantially all of the Class I-A channels. The earlier Further Notice had looked toward this step on half of them. The underlying justification, in each case, was the compelling need to go as far as possible toward reducing the vast areas which lack any nighttime primary service. The record is replete with data demonstrating that, to

why ATC is the most widely used tape magazine system in broadcasting

If price was the only factor involved in the manufacture of an Automatic Tape Control system, most of our problems would be solved. But because ATC magazine-loaded tape units must produce high fidelity playback in conjunction with the finest broadcast equipment made, we have refused to make any concessions in materials and components just to meet a price. The ATC is an engineer's delight. High quality, heavy-duty construction is evident throughout. All electrical components are conservatively rated for long life and marked for easy identification. All components and wiring are easily accessible for efficient preventative maintenance. Modular construction eliminates costly downtime. High performance vacuum tube circuitry assures reliable operation to $+65^{\circ}$ C. ATC delivers a frequency response of ± 2 db from 70 to 12,000 cps; ± 4 db from 50 to 15,000 cps. Signal-to-noise ratio is 55 db, and wow and flutter is under 0.2% rms. AUTOMATIC TAPE CONTROL, INC., introduced the original Automatic Tape Control system in 1958. Formerly distributed exclusively by Collins Radio Company, the ATC system is now in use in over 600 radio and TV stations. More than 4,000 units have been manufactured, installed and proved under actual "on-the-air" conditions. For complete information and illustrated brochure, write, wire or phone collect today.



Playback Unit

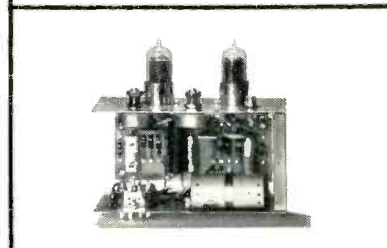

Program Amplifier Module

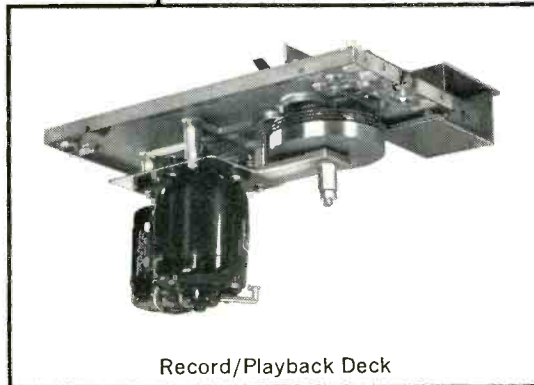

Record/Playback Deck



Record Amplifier

an extent, this can be done with resultant increments of nighttime primary service to persons now lacking it without undue interference to the wide area service rendered by the Class I-A stations. This possibility derives from a combination of factors including directionalization of new unlimited time stations on these channels, the long distances between their prescribed locations and the transmitter sites of the existing co-channel I-A stations and the numbers of other services available in limited areas where interference from the new station may to a limited extent interfere with present reception of skywave service from the existing Class I-A station. Moreover, the limited amount of skywave service which would be so subjected to interference is of a low order since new unlimited time stations will be required to protect the 0.5 mv/m 50 per cent skywave contour of the Class I-A station—generally located approximately 700 miles from its transmitter.

These basic considerations, in our considered view, strongly underscore the desirability of permitting the establishment of new unlimited time stations on at least some of the Class I-A channels, and, we make appropriate provision therefore, in the rule amendments, on 13 of the Class I-A channels: i.e. 670, 720, 750, 760, 780, 880, 890, 1020, 1030, 1100, 1120, 1180, and 1210 kc.

There is support, recognized in our Third Notice in this proceeding, for the similar treatment of additional Class I-A clear channels. To pursue that course at this time would, however, be subject to the grave objections already noted. It would, moreover, in one stroke crystallize a particular pattern of clear channel usage which would at least limit and at worst frustrate the future possibilities for employing other techniques of clear channel utilization. One of these is the use of higher power to improve the nighttime range of and, within existing service areas, the quality of skywave service reaching into the vast land areas where this is the only available technique for improving service since much of those areas lie beyond the foreseeable range of the primary service of any new stations which could be fitted into the crowded standard broadcast spectrum. Whether the public interest would be served by the authorization of higher power, whether, on the channels at this time left in status quo, duplication in the manner here adopted for 13 channels would serve the public interest, or whether any other alternatives including possible combinations of these techniques would best serve to improve service on these channels, we do not now decide.

We now have the benefit of updated comments directed to the two approaches of the Further Notice and the

made by broadcasters for broadcasters

AUTOMATIC  **TAPE CONTROL**

209 E. Washington St. • Room 124 • Bloomington, Illinois

Entirely New GATES FM-5C 5KW FM Transmitter...

With Tomorrow's Engineering Exclusives Today!

Here is an *advanced* five kilowatt FM transmitter, designed and built for the FM broadcaster who wants the best and expects to get it.

Compare these exceptional features:

■ *New, Advanced "Shadow Box" Styling.* A picture of conservative simplicity, with clean vertical lines accented by an array of controls protectively enclosed in a horizontal three-dimensional setting. The basic cabinet is medium dark gloss gray, outlining the soft tones of the recessed twin doors and meter panel. The FM-5C is further distinguished by the contrasting brushed aluminum door handles and the narrow aluminum bars outlining the new control panel housing. The smartly styled FM-5C identification adds individuality to this remarkable transmitter.

■ *New low-noise cooling system.* This new air-cooling technique reduces blower noise to an extremely low level. A low, whispering hum is the sound of the FM-5C at work.

■ *Longer tube life.* One type 4CX5000 power tetrode tube, conservatively rated for long tube life, is used in the final amplifier.

■ *Built-in remote control.* All remote control accessories are included as part of the transmitter. You merely connect remote control unit to terminals already provided in the transmitter.

■ *Silicon Rectifiers* used in all power supplies.

■ Plus many more that tell an exciting story of engineering excellence.

Gates now offers a completely new FM line—including transmitters for 5000, 7500, 10,000, 15,000 and 20,000 watts—all with advanced shadow box styling and the industry's finest engineering features.

Write today for complete technical information — yours for the asking.

GATES

GATES RADIO COMPANY

Subsidiary of Harris-Intertype Corporation

QUINCY, ILLINOIS

Offices in: HOUSTON, WASHINGTON, D.C. In Canada: CANADIAN MARCONI COMPANY
Export Sales: ROCKE INTERNATIONAL CORP., 13 EAST 40th STREET, NEW YORK 16, N.Y., U.S.A., Cables: ARLAB

HARRIS
INTERTYPE
CORPORATION

LEADING BROADCASTERS ENDORSE

Bauer Kit

1 Kw TRANSMITTER

★ "It is, without a doubt, the nicest looking transmitter on the market, and it has a most desirable arrangement of parts."
—CONSULTANT

★ "Again I want to say that I think that our selection of the Bauer transmitter was a wise decision and already other people in the broadcasting industry in this area have shown an interest in the transmitter and we are glad and proud to show it to them."—KTOC, JONESBORO, La.

★ "It was a real pleasure for me to test out the Type 707 transmitter in Tacoma, and your organization is to be congratulated on the excellent design of this unit."—CONSULTANT

★ "56 spare time hours to build—45 minutes to check out—it's terrific!"—KXRX—San Jose, California

★ "The transmitter checked right out. We were all pleasantly surprised with the performance."
—WDIG—DOTHAN, ALA.

★ AND MANY MORE.

They are all talking about the Bauer Model 707 1000/250 watt AM transmitter available either factory assembled or in KIT form.

**WRITE FOR THE COMPLETE
ENGINEERING STORY TODAY!**

 **Bauer**
ELECTRONICS
CORPORATION
1663 Industrial Rd. • San Carlos, Calif.

PROFESSIONAL PRODUCTS IN KIT FORM

Third Notice. The course we take is consistent with both of these proposals in the basic sense that both proposals envisage the nighttime sharing of at least 12 of the Class I-A clear channels by more than one station. In addition, the Further Notice would reserve for future determination the use to be made of the remaining I-A channels. The method of duplication we adopt is that proposed in the Third Notice for 23 channels and proposed in the Further Notice for 7 channels. As noted, we have (except on 770 kc) removed the directionalization requirement for Class I stations. Since the two approaches do contemplate duplication of up to 12 frequencies, we have re-examined each of the 24 Class I-A channels, plus 1030 kc which is reclassified here as a I-A clear channel. The conditions projected in the Third Notice for the operation of additional stations afford a high degree of protection to the 50 kilowatt Class I-A stations now occupying these channels, i.e., to their 0.5 mv/m 50 per cent skywave contour. Such interference as our action would permit to minor, fringe reception beyond the 0.5 mv/m 50 per cent skywave contour of those stations is, in our judgment, acceptable in view of the additional services which are made possible from new stations in underserved areas.

While we do not now reach a decision either for or against the use of higher power, and while we thus leave entirely open the question of what station assignment plans would best serve the public interest on the 12 Class I-A clear channels left in status quo at this time, we recognize the critical importance of so tailoring the partial reallocation as to avoid undue prejudice to practical latitude for future decision. Our review of the comments persuades us that such undue restriction would have resulted from adoption of the proposal in the Third Notice to place additional unlimited-time stations on virtually all of the Class I-A clear channels.

Implementation of our judgment that we should at this time refrain from permitting shared nighttime use of all the Class I-A channels poses the problem of selecting, on a suitable basis, those channels on which we open the way to additional unlimited-time stations and those reserved for future decision. Numerous considerations bear on such a selection. The basic determinant is the question of whether, taking into account the numerous circumstances affecting each channel and the resultant overall pattern of service, it is best suited to shared use or to the preservation of possibilities of wider service from the existing Class I-A station through utilization of higher power. Key factors having a bearing on this judgment include:

a. Location of needful white areas.

b. The possibilities for providing a primary nighttime service in those white areas at sufficient distance from the Class I-A station to permit requisite protection of the generally usable portion of the existing station's skywave service, i.e., the service area within its 0.5 mv/m 50 per cent skywave contour.

c. Due protection to existing co-channel U. S. daytime stations and to U. S. stations on adjacent channels.

d. Consideration of adjacent channel interference to stations located in neighboring countries, and to foreign co-channel stations to which the United States is committed, under international agreements, to afford a stated degree of protection.

e. Avoidance of adjacent channel interference among new unlimited-time stations assigned to the Class I-A clear channels.

f. The location of white areas apparently beyond the reach of foreseeable new stations which could provide a nighttime primary service.

g. Existing skywave services in the foregoing areas and the consequent benefits from improved additional skywave services.

h. The location of Class I-A stations so situated—with reference to geographic relationships to the needful areas and co-channel and adjacent channel domestic and foreign interference considerations—as to indicate that they would be best adapted to the provision of additional and improved skywave services to the needful areas.

In the case of no single channel would all of the foregoing determinants uniformly indicate that it be earmarked for additional unlimited time assignment or that it be held in status quo for future consideration of alternative action. In each case we have arrived at our judgment by the painstaking process of determining and evaluating all the pertinent factors and deciding, on net balance, which course would best serve the public interest both in usage of the individual channel and in terms of the resultant assembled pattern of additional nighttime primary services on the one hand, and the potential for additional and improved skywave services in needful areas on the other hand. In weighing our choices of channels to be left at this time in status quo we have taken into account the desirability of endeavoring to preserve the potential of at least four reasonably reliable and satisfactory skywave services throughout all white areas.

In arriving at the selection of Class I-A clear channels for duplication and for status quo, we have scrutinized with great care the entire record of this proceeding, including testimony, exhibits,

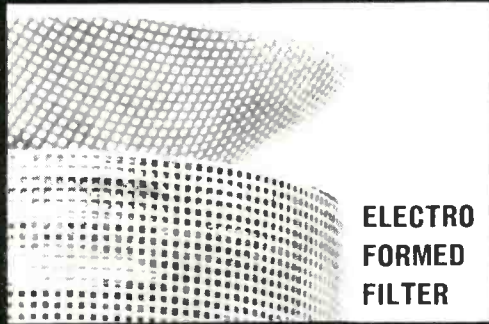

**ELECTRO
FORMED
FILTER**

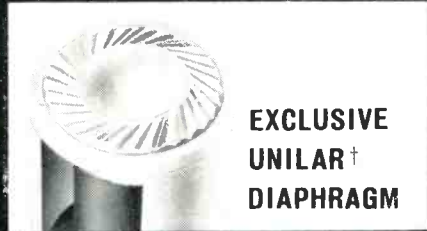

**EXCLUSIVE
UNILAR†
DIAPHRAGM**

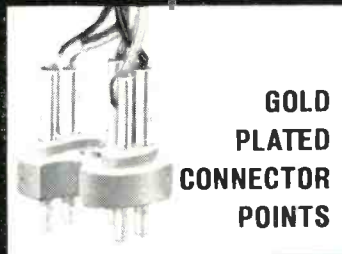

**GOLD
PLATED
CONNECTOR
POINTS**



INTEGRAL SHOCK MOUNTING

EXCLUSIVE FEATURES

Found only on University MODULAR MICROPHONES†

Features that make a University microphone better than most. Better in quality and utility for applications requiring the ultimate in pickup. Better to answer every exacting need with unswerving performance, flexibility and durability.

Let's see why.

Electro-formed Filter: Actually, **two** screens are used, one of silk, the other of electromesh—a type of metal screening so fine that it can be formed only by a selective plating process—ensuring positive deterrence against airborne particles. The unique mating of the two screens is also most effective in preventing annoying wind noise and breath pops.

Exclusive Unilar† Diaphragm: Why Unilar? Because it possesses conflicting properties—lightness **and** great rigidity—which permit the microphone diaphragm to mirror perfectly every subtlety of the original performance. And Unilar has astonishing immunity to both high and low temperature extremes, humidity and many corrosive elements. Beyond this, Unilar can withstand extreme physical stress. For example, if deformed by extreme high intensity sound pressures, it springs right back to its original shape! Thus Unilar is your assurance of constancy of performance.

†TRADEMARK

Gold Plated Connector Points: University has made certain—to the nth degree—that no obscure malfunctions shall be permitted to mar the final performance of any microphone. To this end, gold plated push-on connectors and pins are employed on all modules and adapters. The mechanical integrity of the push-on connectors is such as to assure **perfect** electrical contact without annoying crackle noises due to corrosion.

Shock Mounting: University's unique integral shock mounting gives more widespread benefits than ordinary shock mountings, which are limited to the isolation of the microphone from vibrations transmitted through the stand. University actually 'floats' the cartridge element in a specially-designed foam rubber bed, thus isolating it not only from floor vibrations, but **also** from spurious sounds **originating at the microphone case itself**—such as when a performer handles the microphone or when it is being passed around.

For **more** exclusive features, and descriptions of the entire line of University modular microphones, write: Desk N-11, University Loudspeakers, Inc., White Plains, N.Y.



A Division of Ling-Temco-Vought, Inc.

briefs, oral argument, comments and other pleadings which have included diverse alternatives and counter proposals.

Considering all pertinent factors and taking into account the skywave services presently received, we have determined that the public interest will be served by deferring action at this time on the following frequencies: 640, 650, 660, 700, 770, 820, 830, 840, 870, 1040, 1160, and 1200 kc. The potential for widespread improvement in skywave service is thus preserved for future evaluation.

In selecting 640, 820, 1160, and 1200 kc for inclusion in this group, we have noted that these are the only I-A channels (other than 1040 and 1120 kc discussed below) serving the West; that the West is characterized by vast regions of low population density, where skywave signals afford the only nighttime broadcast service; that a choice among skywave signals is not generally available to a substantial part of the West; and that acceptable locations for assignment of new unlimited time stations on these channels would, in general, be limited to eastern areas already receiving abundant service. Accordingly, at this stage, we preserve the potential for improving skywave service which these channels afford.

On 660 and 770 kc, unlimited time

assignments, in addition to the Class I-A stations, are already operating. For this reason, as we state in the Third Notice, no additional assignments on these channels is deemed warranted at this time. Similarly, we do not at this time take any action with respect to 830 kc because of the pendency of an adjudicatory proceeding involving WNYC's use of that frequency during nighttime hours.

The potential for improved skywave service which arises from the location of 650 kc at Nashville, 700 kc at Cincinnati, 840 kc at Louisville, and 870 kc at New Orleans warrants inclusion of these channels in the group as to which no action is to be taken at this time. We have examined the feasibility of duplication on these channels and, while we recognize that duplication on these channels is possible, we are reluctant to take any action at this time which would limit the potential of these stations for providing improved skywave service in underserved areas of the Southeast.

Of the group on which action is deferred, there remains only 1040 kc to be discussed. The Class I-A station on 1040 kc is located at Des Moines, Iowa. Both 1040 kc and 1120 kc, on which KMOX, St. Louis, Missouri, is the Class I-A station, are somewhat centrally located and those channels could be used either to provide nighttime groundwave service

to white areas in the west or to provide some improved skywave service. We have concluded that, in attempting to achieve a proper balance between the immediate benefits of duplication and retaining a potential for improved skywave service, it is preferable to defer action on 1040 kc but to permit an additional station on 1120 kc. An important factor in making this choice was a realization that the potential of 1120 kc for providing improved skywave service is considerably limited in all directions by adjacent channel operations at Omaha, Nebraska, Charlotte, North Carolina, Shreveport, Louisiana, Minneapolis, Minnesota, and New York, New York.

Turning now to the remaining Class I-A channels, we have determined that they can best be utilized by permitting operation of an unlimited time Class II station on each, thereby serving the important and immediate objective of providing nighttime primary service to white areas. This is not to indicate that other channels, among the group not presently duplicated, could not be duplicated and provide valuable service to white areas. As we have indicated, our action here leaves to future determination, in the light of future developments, the decision as to what use should be made of those channels on which the status quo is presently retained.

We conclude that the proper balance between immediate objectives and possible future goals is best achieved by deferring action on the channels noted above and by permitting one new unlimited time operation on the following: 670, 720, 780, 880, 1020, 1030, 1100, 1120, 1180, and 1210 kc. In addition 750 and 760 kc will be duplicated but in a way designed to meet special situations arising out of the entry into force of the United States/Mexican Broadcasting Agreement.

Class I-A stations on 880, 1020, 1030, 1100, 1180, and 1210 kc are located at or near the northern or eastern boundaries of the country thereby affording maximum opportunity for assignment of unlimited time stations in the West where serious deficiencies in present service exist and the corresponding need for improvement is great. Such location permits flexibility in meeting the required spacing between co-channel Class I-A and unlimited time Class II stations. Moreover, the impact of the new unlimited time Class II stations on the present skywave service of these Class I-A stations will be at a minimum because the useful skywave service these stations render is generally confined to the extreme northeastern portion of the country.

The Class I-A stations on 670, 720, 780, and 890 kc are located in Chicago

**QUIET THOSE
BACKGROUND NOISES**

\$290

with the new
RON Gate Amplifier 40A

Broadcast • Communications • Recording • TV Film

Truly a sound gated amplifier. First sound keys to full level instantaneously (attack time 8 milliseconds). In the absence of signal above threshold, the Gate Amplifier fades smoothly down to whisper quiet: 14 db down.

Eliminates annoying TV studio background sounds • Reduces errors and maintains security in communication systems by eliminating background voices • Suppresses TV film noise. Response, 30 to 15,000 cps ± 1 db; distortion 1% or less.

RON ELECTRONICS CORP.
150 Pine Street, Montclair, New Jersey • PI 4-8330

and, while they are, of course, west of the group just discussed, they still offer useful opportunity for assignment of unlimited time stations in the far West. Several western states will meet spacing requirements and, additionally, the useful skywave service provided by the Chicago I-A stations is confined to the region of the Great Lakes which insures a minimum impact by the new co-channel unlimited time Class II stations to their skywave service. An added consideration in selecting the Chicago I-A frequencies for duplication is the limited potential which they have for improving skywave service in areas which need it. Adjacent channel Class I operations in New York would limit radiation to the east and requirements of protection to stations in Cuba and Mexico would limit radiation to the south. Their potential for improving skywave service to the west, moreover, is not so great as that of the Class I-A channels on which we are presently retaining the status quo.

We have already discussed 1120 kc. The special considerations concerning 750 and 760 kc are treated separately in subsequent paragraphs of this Report and Order.

Our decision to permit nighttime sharing of 13 of the Class I-A clear channels could be implemented in several ways. If we were to follow the practice heretofore established in assigning new standard broadcast stations, applications meeting announced interference criteria and other technical standards would be accepted and processed without confining such applications to designated areas. This would not be practicable here. The acceptability of any location proposed for new unlimited stations on clear channels depends not only upon requisite protection to existing stations but also upon avoidance of undue interference among the new stations so assigned. This means that if we followed the general basis for standard broadcast station assignments we could expect to receive considerable numbers of mutually exclusive applications which conflict either because they propose mutually inconsistent uses of the same frequency or because they propose conflicts as to acceptable locations of new adjacent channel assignments on Channels 10, 20, and 30 kilocycles removed from the channel applied for. For these reasons the hitherto customary approach to new station assignments could be expected to require numerous complicated and inter-related hearings which would be vastly and unnecessarily time consuming.

Much of this impediment and delay can be avoided by the system we adopt—of designating the particular state or states within which each of the I-A channels to be duplicated will be available for an additional unlimited time station. The states so designated have

AVAILABLE FROM BLONDER-TONGUE

NEW BENCO (MODEL T-6)

VHF

TRANSLATOR ^{U.S. USER PRICE} \$834 (FCC TYPE ACCEPTED)

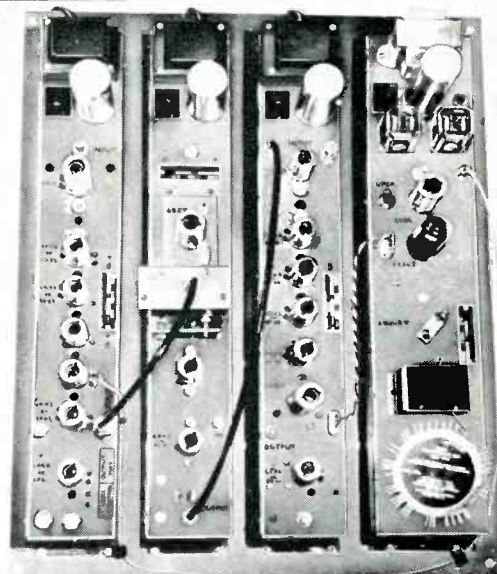

THE ECONOMICAL APPROACH TO TRANSLATOR INSTALLATIONS

The Benco T-6 VHF Translator is a straightforward unit—it is business-like with no frills, yet it provides all the capabilities necessary for top performance in a translator installation at an economical price. It is a high quality translator, meeting all FCC requirements.

The T-6 provides one watt of undistorted power. It will cover distances from 8 to 30 miles. Its low noise preamp includes AGC to maintain satisfactory picture quality with input signals as low as 50 microvolts. The T-6 is equipped with an identification unit which meets FCC specifications. It sends out identifying signals and provides automatic shutoff when the master station goes off the air. If the T-6 is installed in a remote or inaccessible area, it can easily be equipped with the RC-1 remote control unit to turn the translator power on or off from a distance of 5 miles or more.

TECHNICAL SPECIFICATIONS

Primary Power Source	117 v ± 10% 60 c/s
Power Consumption 120 W
Temperature Ambient	—30°C to + 50°C
Overall Noise Figure	
Low Band4 db ± 1 db
High Band6 db ± 1 db
Recommended Input	50—4000 microvolts
Max. Permissible Power	1 Watt (Peak Power)
Frequency Stability02%
Gain (maximum)105 db
Band Width6 Mc (3 db points)
Dimensions (metal base)18"x22½"
Weight27 lbs.

BENCO VHF AND UHF TRANSLATORS FOR EVERY TYPE OF INSTALLATION

MODEL T-1 VHF TRANSLATOR *FCC type-accepted.* 1 watt output for U. S. use. There is no finer translator available today. It not only meets but exceeds FCC specifications. Some of its features include a noise proof automatic shutoff; regulated power supply for stable operation even at the end of poor quality power lines; and under-rated output section for continuous service; a weatherproof housing; quick easy coding of identification unit; built-in direct reading power meter.

MODEL T-14 VHF-TO-UHF TRANSLATOR *FCC type-accepted.* 2.5 watts output. For United States use. Includes identification units with automatic "on/off," power indicator and voltage regulator. VHF input, channels 7-13.

MODEL T-13 VHF-TO-UHF. Same as T-14 except: VHF input, channels 2-6; not yet FCC type accepted.

If you're planning a translator installation, contact Blonder-Tongue. Free layout service; field engineering assistance at nominal cost are available.

engineered and manufactured by

BLONDER-TONGUE

9 Alling St., Newark, N. J.

BE-11

Canadian Div.: Benco Television Assoc., Toronto, Ont. Export: Morhan Export Corp., N. Y. 13, N. Y.
home TV accessories • UHF converters • master TV systems • closed circuit TV systems

FAIRCHILD CONAX
 MAKES THE
Big Difference
 IN STEREO BROADCASTING
 FOR WDHA/FM

WDHA/FM in New Jersey, one of the first FM stations to go stereo, recommends FAIRCHILD CONAX. Here is what WDHA has to say about the FAIRCHILD CONAX Model 602:

"After installation of the CONAX our average modulation level was found to be up 6 db from that without the CONAX, and there was no over-modulation in the stereophonic broadcasts.

It has subsequently been the conclusion of our Program Department that the use of the CONAX will in no way offend our serious music listeners.

I certainly recommend installation of the FAIRCHILD CONAX 602 to other FM stations planning stereophonic broadcasts."

For details write to
FAIRCHILD RECORDING EQUIPMENT CORP.
 10-40 45th Ave., Long Island City 1, N. Y.

**PROOF OF SUPERIORITY
 NO OTHER MICROPHONE
 CAN MATCH!**

**LEADING NEWSWEEKLY
 MAGAZINES PICTURE E-V
 MORE OFTEN THAN THE NEXT
 FOUR BRANDS COMBINED!**

Write now for catalog of
 microphones preferred by top radio, TV,
 newsreel and sound engineers!

Electro-Voice
 ELECTRO-VOICE, INC.
 Commercial Products
 Div., Dept. 1111V
 Buchanan, Michigan

been selected with a view to making the most fair, equitable and efficient use of the frequency taking into account limitations imposed by the need to protect existing co-channel and adjacent channel stations, the areas of greatest need for additional nighttime primary service and the avoidance of undue mutual interference among the new stations themselves. Due regard has additionally been given requisite protection to stations in neighboring countries.

In the interests of fulfilling to the greatest possible extent the prime objective of the new unlimited time stations on the Class I-A clear channels, i.e., to create new primary services in white areas—we propose to give preference to those applications which most fully serve this objective; and we will not consider any application for a new unlimited time station on one of the Class I-A channels unless it meets a specified minimum criterion for new primary service to white areas.

For the foregoing reasons we reject proposals that we fix by rule the specific communities in which these frequencies may be so used. It would not be possible to anticipate, in advance of the filing of specific station assignments, the finite circumstances of principal city and radiation pattern which could best serve the objective of clear channel duplication. We leave this for decision on the basis of applications to be submitted in accordance with the rules adopted.

As to the suggestion that more than one unlimited time Class II station be authorized on the same Class I-A channel, we deem it preferable at this time to permit only one unlimited time Class II station on the channels selected for such use. After we have the benefit of the manner in which the new unlimited time Class II stations are utilized, and details of actual performance, interference, etc., become available, we will be in a position to determine whether the public interest warrants assignment of additional unlimited time facilities on these channels, and, if so, to determine under what conditions they should be permitted. We are convinced, however, that such a decision should await further developments and that extension of the plan adopted herein to include such multiple use is not warranted at this time.

The record also reveals that many of the comments requesting Class II facilities come from parties seeking to improve their existing service—which is all too often in the areas of concentrated population where little "white area" would be served. We have emphasized our aim of securing standard broadcast radio service to those areas which lack nighttime primary service. The standards we adopt herein are directed toward the achievement of that end and

represent our considered judgment of the best way to fill these gaps in service at this time. In considering applications for Class II facilities on these clear channels we shall look closely at the applicants' plans for serving such "white area." The extent to which the facilities thus made available are ultimately utilized is, and necessarily so under our free competitive system, dependent upon the business judgment of prospective applicants and licensees. The fact that the theoretical optimum of service is unlikely of practical attainment due to such considerations as population distribution does not preclude our adopting a solution which more nearly achieves the objectives of broadcasting in the standard band than does the present utilization of Class I-A clear channels at night by only one station. The net result of the action we take today is to open the way for additional nighttime primary service to the public, especially in those areas where such service is needed, while at the same time holding to a minimum any loss of existing service to the listening public.

Moreover, it is expected that, upon final resolution of this proceeding, applications may be forthcoming from parties who have not commented in this proceeding and that additional sites within the states selected will be proposed. We can in a comparative hearing consider, inter alia, the white area population expected to be served under the various proposals. Indeed, prospective applicants should be aware that we intend, absent decisive countervailing circumstances, that as between fully qualified applicants complying with all our rules, the one who will serve the largest white area population will receive the grant. Parties are forewarned that white area population served rather than total population served is of prime importance here. We can foresee at this time only one kind of circumstance in which it may be anticipated that the grant should not necessarily go to the qualified competing applicant proposing the first primary service to the largest number of people. Under § 3.182 (g) of the rules, primary service is not considered to exist in towns with a population from 2,500 to 10,000 if available groundwave service has a field intensity of less than 2 mv/m. It is possible that one applicant for an unlimited time Class II station may be in a position to show that he would provide a first nighttime primary service to more people than a competing applicant, in reliance upon his provision of groundwave service with a field intensity of 2 mv/m or better to persons living near enough to an existing unlimited time station, so that they now receive service of 0.5 mv/m or better, although less than 2 mv/m. Some usable groundwave signals, although not

of the standard contemplated in § 3.182 (g), are thus available to persons so situated. A competing applicant, on the other hand, may be in a position to demonstrate that he proposes a first groundwave service to a larger number of people who do not now have an 0.5 mv/m groundwave signal or better available to them. Considering the objectives of our rule changes herein, it would be appropriate, in reaching our decision in such case, to take this circumstance into account and not necessarily to grant perfunctorily an application which reflects a first primary service to the largest number of people by virtue of including in the count persons who, although they do not receive the 2 mv/m signal prescribed in § 3.182 (g), are nevertheless able to receive a signal of at least 0.5 mv/m.

Concluding Observations

This proceeding, which was initiated in 1945 on eleven issues of wide scope and pursued further under subsequent Notices issued in 1958 and 1959, has embraced an encyclopedic variety of approaches and proposals going to the basic question of how best to utilize almost half the spectrum space devoted to standard broadcasting. While the sheer volume of the record and the fact that it has spanned a period of consequential change in standard broadcasting have added difficulty to the task of deciding upon the most desirable course, the Commission has been vastly assisted by numerous helpful contributions made in submissions on the record through testimony, exhibits, briefs, oral arguments, comments and other pleadings.

In the hard fought, head-on conflict between the two basic approaches of extending the reach of major stations on clear channels or increasing the numbers of stations permitted on these channels, much valuable data and analysis have been placed before us by the proponents of both approaches. Recognition is due to the fact that some merit attaches to very many of the proposals which have been urged upon us, including some of those which we herein reject. Our essential task in this proceeding has been to select among the myriad solutions offered those which, on net balance, taking into account the many pertinent considerations, would best serve the public interest. The opposed factors bearing upon our judgments in some instances are closely balanced. While recognizing that much can be said for numerous alternative approaches, we now conclude that the course laid out herein, both as reflected in the rule changes now adopted and in the preservation for the time being of the status quo on 12 Class I-A clear channels, represents the best solution available at this time.

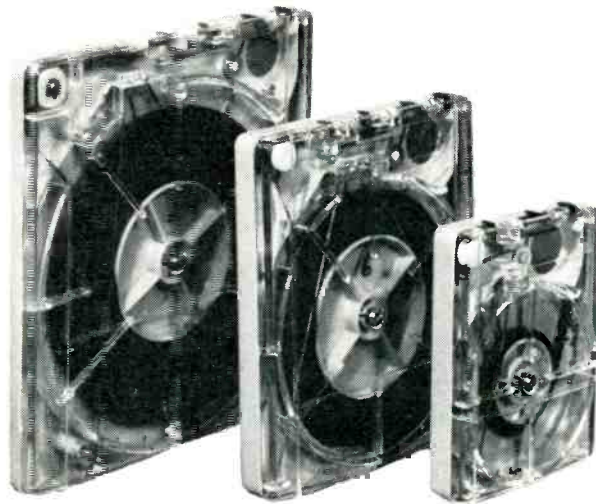

“We at WRTA feel that SPOTMASTER is the most versatile instrument introduced to broadcasting since the advent of tape.”

Louis Murray, WRTA, Altoona

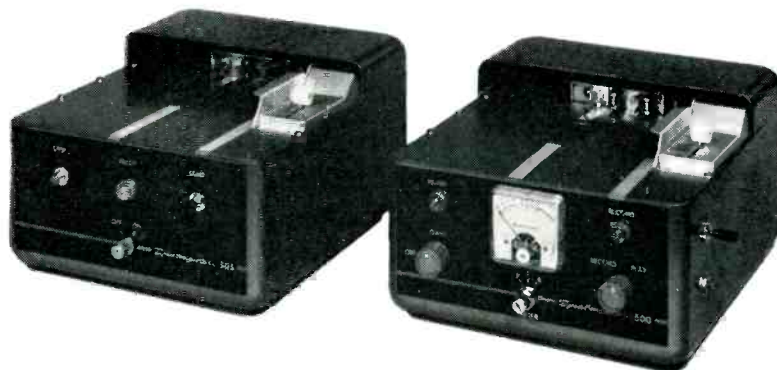

Wherever you find a SPOTMASTER unit in use—the opinions of broadcasters are the same: “Tighter cueing and better sound . . . we are very pleased.” (KOGO, San Diego) “No more noisy playbacks or jumping grooves. We have not bought a single acetate blank disc since installing your machines in July, 1960.” (WFBR, Baltimore) “We have improved our production immensely,” (KING, Seattle) “. . . frankly, I don’t know how we ever got along without this equipment.” (WGTC, Greenville, N. C.) SPOTMASTER, is engineered for compactness, efficiency, reliability and low maintenance. It is the most field-tested and field-proven cartridge equipment manufactured anywhere. We would like to tell you more about the SPOTMASTER Cartridge Recorders. Call, write or wire today.

Your Key to Pushbutton Broadcasting

Spotmaster

BROADCAST ELECTRONICS INC.

8800 Brookville Road, Silver Spring, Maryland, Dial JU8-4983

SOLD NATIONALLY BY: *Visual Electronics Corp., 356 West 40th Street, N.Y., N.Y., Richard H. Ullman, Inc., 1271 Ave. of the Americas, N.Y., N.Y., CANADA—Northern Electric Co., Ltd., 250 Sidney St., Belleville, Ontario, AUSTRALIA—Simon Gray Pty., Ltd., 28 Elizabeth St., Melbourne, C.I*

AMENDMENTS AND PROPOSED CHANGES OF F.C.C. REGULATIONS

EDITOR'S NOTE:

For the basic background of this proceeding, see the editorial feature, "The FCC And The Clear Channels" in this issue of Broadcast Engineering.

PART 1—PRACTICE AND PROCEDURE PART 3—RADIO BROADCAST SERVICES

Clear Channel Broadcasting in the Standard Broadcast Band

It is ordered, That, effective October 30, 1961, the Commission's rules are amended as set forth below; and

It is further ordered, That all pleadings, petitions, comments and reply comments, requesting other changes in our rules relating to clear channels; requesting that no changes be made; requesting further hearing, oral argument, or evidentiary hearing; or requesting other relief not adopted herein are denied; and

It is further ordered, That this proceeding, Docket No. 6741, is terminated.

(Sec. 4, 48 Stat. 1066, as amended; 47 U.S.C. 154. Interpret or apply secs. 303, 307, 48 Stat. 1082, 1083; 47 U.S.C. 303, 307.)

Adopted: September 13, 1961.

Released: September 14, 1961.

FEDERAL COMMUNICATIONS
COMMISSION¹⁵

[SEAL] BEN F. WAPLE,
Acting Secretary

¹⁵ Commissioner Lee dissenting; Commissioner Cross dissenting in part.

1. Section 1.351 is amended to read as follows:

§ 1.351 Applications for frequencies adjacent to Class I—A channels.

Notwithstanding the provisions of any other rules of the Commission, all applications (regardless of when they were or may be filed) for frequencies located within 30 kc of a Class I-A channel listed in § 3.25 (a) of this chapter will be subject to the provisions of this section. The provisions of paragraph (a) of this section apply to the frequencies listed therein, which are within 30 kc of a Class I-A channel on which an unlimited time Class II assignment is specifically provided for in § 3.22 or § 3.25 (a) of this chapter. The provisions of paragraphs (b) and (c) of this section apply to the frequencies listed in paragraph (b) of this section, which are within 30 kc of the remaining Class I-A channels. Where a frequency is listed both in paragraphs (a) and (b) of this section, applications for facilities on such

frequency are subject to the provisions and restrictions contained in both of said paragraphs.

(a) (1) The provisions of this paragraph apply to the following frequencies: 680, 690, 710, 730, 740, 790, 800, 810, 850, 860, 900, 910, 920, 990, 1000, 1010, 1050, 1060, 1070, 1080, 1090, 1110, 1130, 1140, 1150, 1170, 1190, 1220, 1230, and 1240 kc.

(2) Where it appears that the facilities requested in any application for one of the designated frequencies (other than an application by an existing Class IV station to increase daytime power on 1230 or 1240 kc) involves undue risk of objectionable interference to, prohibitive interference from, or prohibited overlap with, a possible new Class II-A assignment specified in § 3.22 of this chapter or a new unlimited time Class II assignment at Anchorage, Alaska, or San Diego, California, specified in § 3.25 (a) of this chapter, such application will not be granted until the location and operating facilities of such new Class II stations are established. Assignments of such new Class II stations will be made without regard to the pendency of applications on adjacent frequencies. Any hearing which may be held on such an application for an adjacent frequency will not be comparative with respect to the Class II facility, and any issues pertaining to the mutual impact of the Class II and adjacent channel operations concerned will be confined to the question of whether, with a Class II station operating as proposed, the public interest would be served by a grant of the adjacent channel application.

(b) (1) Until Sept. 1, 1964, or such earlier date as may be announced, the provisions of this paragraph and of paragraph (c) of this section will apply to all applications for the following frequencies:

610, 620, 630, 680, 690, 710, 730, 790, 800, 810, 850, 860, 900, 1010, 1050, 1060, 1070, 1130, 1140, 1150, 1170, 1190, and 1220 kc.

(2) Applications for new stations on, or for change of existing stations to, one of the designated frequencies will not be granted, and, except as provided in paragraph (c) of this section, will be placed in the pending file without further processing or consideration. Where before October 30, 1961, such applications had attained protected status

under § 1.354 or by designation for hearing, they will retain such status to the extent so established. Additionally, such applications will be protected, as provided elsewhere in the rules, through designation for hearing. They will not be otherwise protected.

(3) Applications for increase in power or operation during nighttime hours not previously authorized will be processed in normal course, but will be considered in the light of the effect that grant thereof might have upon possible future uses of the Class I-A channel or channels located within 30 kc of the frequency involved (e.g., authorization of power greater than 50 kw for Class I-A stations, or additional unlimited time co-channel assignments). Such applications will not be granted if it appears that they risk prejudice to such possible future uses of the Class I-A channels concerned. Because of interference caused or received, or prohibited overlap. In these situations the application involved, if otherwise ready for grant (after hearing or otherwise) will be placed in the pending file. Where it appears that because of these considerations an application cannot be granted in due course, the applicant will be so notified and, notwithstanding the provisions of §§ 1.311 and 1.354, will be permitted to amend his application within 45 days of such notice, without change in position in hearing or on the processing line, in order to remove the circumstances which stand in the way of a grant. Applications will acquire and retain protected status as they would in normal course.

(4) Applications for other changes in facilities on the designated frequencies will be processed and acted upon in normal course.

(5) Action will not be withheld under this paragraph on applications for facilities in Alaska, Hawaii, Puerto Rico, or the Virgin Islands.

(c) (1) After October 30, 1961, hearings will not be designated on applications falling under paragraph (b) (2) of this section unless they conflict with applications not falling under paragraph (b) (2) of this section.

(2) If the decision in a hearing looks toward grant of an application which under paragraph (b) (2) or (3) of this section, cannot be made immediately, such application and all applications

conflicting with it will be placed in the pending file, and will retain protected status.

2. In § 1.354, paragraphs (a) and (c) are amended, paragraphs (d) through (j), inclusive, are redesignated paragraphs (f) through (l), inclusive, and new paragraphs (d) and (e) are added, as follows:

§ 1.354 Processing of standard broadcast applications.

(a) Applications for standard broadcast facilities are divided into three groups.

(1) In the first group are applications for new stations (except applications for new Class II-A stations) or for major changes in the facilities of authorized stations, i.e., any change in frequency power, hours of operation, or station location: *Provided, however,* That the Commission may, within 15 days after the tender for filing of any application for other modification of facilities, advise the applicant that such application is considered to be one for a major change and therefore is subject to the provisions of § 1.359.

(2) The second group consists of applications for licenses and all other changes in the facilities of authorized stations.

(3) The third group consists of applications for new Class II-A stations.

* * * * *

(c) Applications for new stations (except new Class II-A stations) or for major changes in the facilities of authorized stations are processed as nearly as possible in the order in which they are filed. Such applications will be placed in the processing line in numerical sequence, and are drawn by the staff for study, the lowest file number first. Thus, the file number determines the order in which the staff's work is begun on a particular application. There are two exceptions thereto: the Broadcast Bureau is authorized to (1) group together for processing applications which involve interference conflicts where it appears that the applications must be designated for hearing in a consolidated proceeding; and (2) to group together for processing and simultaneous consideration, without designation for hearing, all applications filed by existing Class IV stations requesting an increase in daytime power which involve interlinking interference problems only, regardless of their respective dates of filing. In order that those application which are entitled to be grouped for processing may be fixed prior to the time processing of the earliest filed application is begun, the Commission will periodically publish in the **FEDERAL REGISTER** a Public Notice listing applications which are near the top of the processing line and announcing a date (not less than 30 days after publication) on which the listed applications will be considered

available and ready for processing and by which all applications excepting those specified in exception (2) in this paragraph must be filed if they are to be grouped with any of the listed applications.

(d) Applications for new Class II-A stations are placed at the head of the processing line and processed as quickly as possible. Action on such applications may be at any time: (1) More than 30 days after public notice is given of acceptance of the application for filing, or (2) after January 30, 1962, whichever is later.

(e) The processing and consideration of applications for new stations or major

changes on those frequencies specified in § 1.351 are subject to certain restrictions, as set forth therein.

3. Section 3.21 is amended to read as follows:

§ 3.21 Classes of standard broadcast channels and stations.

(a) *Clear channel.* A clear channel is one on which the dominant station or stations render service over wide areas, and which are cleared of objectionable interference within their primary service areas and over all or a substantial portion of their secondary service areas. Stations operating on these channels are classified as follows:

(1) *Class I station.* A class I station

KODA Houston	Paul Taft
KQUE Houston	Dave Morris
KFMK Houston	James R. Corry
KEEZ San Antonio	Charles Balthrope
KTBC Austin	Foley Broadus
KEFC Waco	R. E. Lee Glasgow
KGAF Gainesville	Joe M. Leonard, Jr.
KNTD Wichita Falls	Bill Ritchie

TEXAS IS MULTIPLEXING WITH McMARTIN

The experts . . . the decision makers in Texas, are building this dynamic new industry.

Their selection of McMartin monitors and receivers assures them of the very finest in performance and reliability — surpassing all others.

We salute our long-time friends and continuing partners!

CONTINENTAL MANUFACTURING, INC.
1612 California St., Omaha, Nebraska



is a dominant station operating on a clear channel and designed to render primary and secondary service over an extended area and at relatively long distances. Its primary service area is free from objectionable interference from other stations on the same and adjacent channels, and its secondary service area free from interference except from stations on adjacent channels, and from stations on the same channel in accordance with the channel designation in §§ 3.25 or 3.182. The operating power shall not be less than 10 kilowatts nor more than 50 kilowatts. (Also see § 3.25 (a) for further power limitation.)

(2) *Class II station.* A Class II station is a secondary station which operates on a clear channel (see § 3.25) and is designed to render service over a primary service area which is limited by and subject to such interference as may be received from Class I stations. Whenever necessary a Class II station shall use a directional antenna or other means to avoid interference with Class I stations and with other Class II stations, in accordance with § 3.182 (and § 3.22 in the case of Class II-A stations). Class II stations are divided into three groups:

(i) *Class II-A station.* A Class II-A station is an unlimited time Class II station operating on one of the clear channels listed in § 3.22 and assigned to a community within a state specified in the Table contained in that section. A Class II-A station shall operate with power of not less than 10 kilowatts nighttime nor more than 50 kilowatts at any time.

(ii) *Class II-B station.* A Class II-B station is an unlimited time Class II station other than those included in Class II-A. A Class II-B station shall operate with power not less than 0.25 kilowatts nor more than 50 kilowatts.

NOTE: The Class II station operating unlimited time on 760 kc at San Diego, Calif., shall be limited to a power of 5 kw and the Class II station operating unlimited time on 750 kc at Anchorage, Alaska, shall be limited to a power of 10 kw. Both stations shall protect the I-A station on the same frequency to its 0.5 mv/m 50 per cent skywave contour.

(iii) *Class II-D station.* A Class II-D

station is a Class II station operating daytime or limited time. A Class II-D station shall operate with power not less than 0.25 kilowatts nor more than 50 kilowatts.

(b) *Regional channel.* A regional channel is one on which several stations may operate with powers not in excess of 5 kilowatts. The primary service area of a station operating on any such channel may be limited to a given field intensity contour as a consequence of interference.

(1) *Class III station.* A Class III station is a station which operates on a regional channel and is designed to render service primarily to a principal center of population and the rural area contiguous thereto. Class III stations are subdivided into two classes.

(i) *Class III-A station.* A Class III-A station is a Class III station which operates with power not less than 1 kilowatt nor more than 5 kilowatts and the service area of which is subject to interference in accordance with § 3.182.

(ii) *Class III-B station.* A Class III-B station is a Class III station which operates with power not less than 0.5 kilowatt, nor more than 1 kilowatt night and 5 kilowatts daytime, and the service area of which is subject to interference in accordance with § 3.182.

(c) *Local channel.* A local channel is one on which several stations operate with powers no greater than provided in this paragraph. The primary service area of a station operating on any such channel may be limited to a given field intensity contour as a consequence of interference. Such stations operate with power no greater than 250 watts nighttime, and power daytime no greater than:

(1) 250 watts if the station is located 100 kilometers (62 miles) or closer to the Mexican border, or in the area of the state of Florida south of 28 degrees north latitude and between 80 and 82 degrees west longitude; or

(2) 1 kilowatt if the station is located elsewhere.

(3) *Class IV station.* A Class IV sta-

tion is a station operating on a local channel and designed to render service primarily to a city or town and the suburban and rural areas contiguous thereto. The power of a station of this class shall not be less than 0.1 kilowatt, and not more than 0.25 kilowatt nighttime and 1 kilowatt daytime, and its service areas is subject to interference in accordance with § 3.182.

NOTE 1: Under NARBA, the power ceiling for Class IV stations is 250 watts daytime as well as nighttime. The U. S.-Mexican Agreement permits such stations to operate with up to 1 kilowatt power daytime if they are located further than 100 kilometers (62 miles) the Mexican border. Pursuant to the U. S.-Mexican Agreement and informal coordination with the other NARBA signatories, the Commission will consider applications for Class IV stations on local channels with daytime powers more than 250 watts, up to 1 kilowatt, if such station is to be located outside of the areas specified in subparagraph (1) of this paragraph, and if no objectionable interference would be caused (under the standards set forth in the pertinent international agreement) to a duly notified station in Mexico, Haiti, or any foreign country signatory to NARBA.

NOTE 2: All authorizations of new or changed Class I-B, Class II-B, Class II-D, Class III or Class IV facilities after October 30, 1961, are subject to whatever interference may be received from, or whatever overlap of 2.0 mv/m and 25 mv/m groundwave contours or overlap of 25 mv/m groundwave contours may be involved with, previously or subsequently authorized Class II-A facilities.

4. Section 3.22 is amended to read as follows:

§ 3.22 Assignment of Class II—A stations.

(a) *Table of assignments.* One Class II-A station may be assigned on each channel listed in the following table within the designated State or States:

Channel (kc)	Existing Class I station	State(s) in which Class II-A assignment may be applied for—
670.....	WMAQ	Chicago..... Idaho
720.....	WGN	Chicago..... Nev. or Idaho
780.....	WBPM	Chicago..... Nevada
880.....	WCBS	New York..... No. Dakota, So. Dakota or Nebr.
890.....	WLS	Chicago..... Utah
1020.....	KDKA	Pittsburgh..... New Mexico
1030.....	WBZ	Boston..... Wyoming
1100.....	KYW	Cleveland..... Colorado
1120.....	KMOX	St. Louis..... Calif. or Ore.
1180.....	WHAM	Rochester..... Montana
1210.....	WCAU	Philadel- Kan., Nebr. phia..... or Okla.

(b) *Minimum service to "White" areas.* No Class II-A station shall be assigned unless at least 25 percent of

Spot-O-Matic

SE-II custom playback

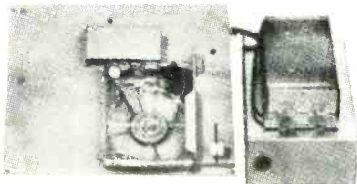

for the first time a cartridge unit that allows complete freedom for custom installation. Available in tone cue (SE-IIT custom) or cue strips (SEII custom)

Write **SIERRA ELECTRONIC ENTERPRISES**

6430 Freeport Boulevard

Sacramento, California

Whatever your transformer needs, Peerless engineers can design to any military or commercial specification and manufacture in any quantity. See REM for complete catalogue of standard units or write for information to Dept. B-11-PE

PEERLESS

ELECTRICAL PRODUCTS

A DIVISION OF ALTEC LANSING CORPORATION

6920 McKinley Avenue, Los Angeles 1, California

its nighttime interference-free service area or at least 25 percent of the population residing therein receives no other interference-free nighttime primary service.

(c) *Power.* Class II-A stations shall operate with not less than 10 kw power nighttime.

(d) *Protection—(1) Protection by Class II-A stations to other stations.* The co-channel Class I-A station shall be protected by the Class II-A station to its 0.1 mv/m contour daytime and its 0.5 mv/m 50 percent skywave contour nighttime. All other stations of any class authorized on or before October 30, 1961, shall normally receive protection from objectionable interference from Class II-A stations as provided in § 3.182.

(2) *Protection to Class II-A stations.* A Class II-A station shall normally receive daytime protection to its 0.5 mv/m groundwave contour and nighttime protection to the contour to which it is limited by the co-channel Class I-A station.

(c) *Applications not complying with this section.* Applications for Class II-A stations which do not meet the requirements of paragraphs (b) and (c) of this section will be returned without further consideration.

5. In § 3.24, paragraph (b) is amended; present paragraph (i) is redesignated paragraph (j); and new paragraph (i) is added; as follows:

§ 3.24 Broadcast facilities; showing required.

(b) That objectionable interference will not be caused to existing stations or that, if interference will be caused, the need for the proposed service outweighs the need for the service which will be lost by reason of such interference. (For special provisions concerning interference from Class II-A stations to stations of other classes authorized after October 30, 1961, see Note 2 to § 3.21 and § 3.22(d).) That the proposed station will not suffer interference to such an extent that its service would be reduced to an unsatisfactory degree. (For determining objectionable interference, see §§ 3.182 and 3.186.)

* * * * *

(i) That, in the case of an application for a Class II-A station (see § 3.22), 25 percent or more of the area or population within the nighttime interference-free service contour of the proposed station receives no nighttime interfer-

ence-free primary service from another station.

6. In § 3.25, paragraphs (a) and (b) are amended to read as follows:

§ 3.25 Clear channels; Classes I and II stations.

* * * * *

(a) On each of the following channels, one Class I station will be assigned, operating with power of 50 kw: 640, 650, 660, 670, 700, 720, 750, 760, 780, 820, 830, 840, 870, 880, 890, 1020, 1030, 1040, 1100, 1120, 1160, 1180, 1200, and 1210 kc. In addition, on the channels listed in this paragraph, Class II stations may be assigned as follows:

(1) On 670, 720, 780, 880, 890, 1020, 1030, 1100, 1120, 1180, and 1210 kc, one Class II-A unlimited time station, assigned and located pursuant to the provisions of § 3.22.

(2) On the channel 750 kc, an unlimited time Class II station located at Anchorage, Alaska.

(3) On the channel 760 kc, an unlimited time Class II station located at San Diego, California.

(4) On any of the channels listed in this paragraph (to the extent consistent with the assignments provided in subparagraphs (1), (2), and (3) of this paragraph), unlimited time Class II stations located in Alaska, Hawaii, Virgin Islands, or Puerto Rico, which will not

deliver more than 5 microvolts per meter groundwave day or night or 25 microvolts per meter 10 percent time skywave at night at any point within the continental limits of the United States excluding Alaska.

(5) On any of the channels listed in this paragraph (to the extent consistent with the Class I, Class II-A, and Anchorage and San Diego Class II assignments provided in this paragraph, and, in the case of limited time stations, subject to the restrictions contained in § 3.38), limited time and daytime only stations, as follows:

(i) In Alaska, Hawaii, Puerto Rico, and Virgin Islands.

(ii) Within the continental United States excluding Alaska, where the station would operate with facilities authorized as of October 30, 1961.

NOTE 1: In view of special circumstances arising from the provision of pre-sunrise broadcast service on 640 kc at Ames, Iowa, applications will be accepted for broadcast operations on 640 kc between 6:00 a.m., central standard time and local sunrise at Ames, Iowa, with not to exceed 1 kw power: Provided, That such applications will be acted upon only after and in light of the decision reached in Docket No. 11290.

NOTE 2: In view of special circumstances arising from the provision of a service during some nighttime hours by a Class II station operating on 830 kc at New York, N. Y. (i.e., from 6:00 a.m., to local sunrise and from sunset at Minneapolis to 10:00 p.m., e.s.t.), applications will be accepted for such operation: Provided, That they will be acted upon only after and in light of the decision reached in Docket No. 11227.

NOTE 3: On the frequency 770 kc, two Class I stations may be assigned.

This H-F Crossbar Switches 300 Video-Pulse Circuits with Negligible Crosstalk and Less Than 0.1 DB Distortion From DC - 10MC.

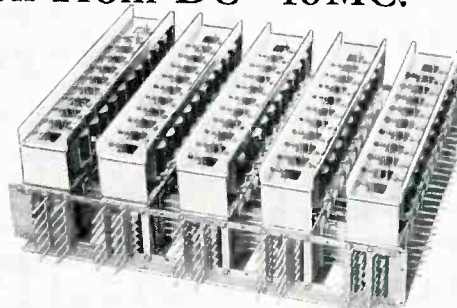

This unique* switch behaves electrically like a matched coaxial line . . . from DC-10MC. You need no longer accept compromise performance in audio/video or high-frequency switches. 20 million operations/circuit are guaranteed — 100 million are common.

The inherent versatility of the matrix format poses a real intellectual challenge. Care to accept it? Ask for Bulletin 60-115.

*Cunningham designs are protected by U.S. and Foreign Patents.

Cunningham

ESTABLISHED 1838

SOPHISTICATED SWITCHING SYSTEMS
BOX 516, ROCHESTER 2, NEW YORK

- Plant & Offices:
- Honeoye Falls, N. Y.
- Phone: Honeoye Falls 485
- TWX RO 572-U

LOOKING FOR RACKS?

Turn to section 1400



eem — ELECTRONIC ENGINEERS MASTER

Continental's

ANTENNA COUPLING EQUIPMENT

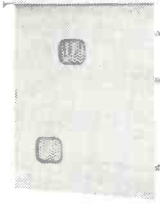

FRONT CLOSED

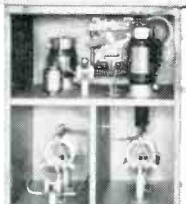

FRONT OPEN

Custom designed and manufactured to meet customer requirements.

write for details today!

Continental
Electronics

MANUFACTURING COMPANY

4212 South Buckner Blvd. Dallas 27, Texas

☐ SUBSIDIARY OF LING-TEMCO ELECTRONICS, INC.

for your tower requirements check **ROHN SYSTEMS**

A complete tower erection service that has these special advantages:

- ✓ DEPENDABILITY
- ✓ RELIABILITY
- ✓ COMPLETE ENGINEERING
- ✓ COAST TO COAST SERVICE

Be sure to obtain price quotations and engineering assistance for your complete tower needs from America's foremost tower erection service.

ROHN SYSTEMS, INC.

6718 W. Plank Road

Peoria, Illinois

NOTE 4: See NARBA concerning priority for Canadian Class I-B and Cuban Class I-C assignments on 640 kc.

NOTE 5: See NARBA concerning Cuban Class II-E assignments on 660, 670, 760, 780, 830, 1020, 1030, and 1120 kc.

NOTE 6: See U. S.-Mexican Agreement concerning Mexican use of 660, 760, and 830 kc.

(b) To each of the following channels there may be assigned Class I and Class II stations: 680, 710, 810, 850, 940, 1000, 1060, 1070, 1080, 1090, 1110, 1130, 1140, 1170, 1190, 1500, 1510, 1520, 1530, 1540, 1550, and 1560 kilocycles.

NOTE 1: See NARBA and the U. S.-Mexican Agreement concerning a Cuban Class II-E assignment on, and Mexican use of, 1030 kc.

NOTE 2: Class I and Class II stations on 1540 kc shall deliver not over 5 microvolts per meter groundwave or 25 microvolts per meter 10 per cent time skywave at any point of land in the Bahama Islands, and such stations operating nighttime (i.e., sunset to sunrise at the location of the Class II station) shall be located not less than 650 miles from the nearest point of land in the Bahama Islands.

7. Section 3.28 (a) is amended to read as follows:

§ 3.28 Assignment of stations to channels.

(a) The individual assignments of stations to channels which may cause interference to other United States stations only, shall be made in accordance with the provisions of this part for the respective classes of stations involved. (For determining objectionable interference, see §§ 3.22, 3.182, and 3.186).

8. In § 3.182, the introductory text and subparagraphs (1) (i) and (2) of paragraph (a) are amended; paragraph (c) is added; and paragraphs (s), (t), and (v) are amended, as follows:

§ 3.182 Engineering standards of allocation.

(a) Sections 3.21 to 3.34, inclusive, govern allocations of facilities in the standard broadcast band of 535 to 1605 kc. § 3.21 establishes three classes of channels in this band, namely, clear channels for the use of high-powered stations, regional channels for the use of medium-powered stations, and local channels for the use of low-powered stations. The classes and power of standard broadcast stations which will be assigned to the various channels are set forth in § 3.21. The classification of the standard broadcast stations are as follows:

(1) * * *

(i) The Class I stations in Group I-A are those assigned to the channels allocated by § 3.25 (a), on which, except to the extent provided by that section and by § 3.22, duplicate nighttime operation is not permitted. The power of these stations shall not be less than 50 kilowatts. The Class I stations in this group are afforded protection as follows:

Daytime: To the 0.1 mv/m groundwave contour from stations on the same chan-

nel, and to the 0.5 mv/m groundwave contour from stations on adjacent channels.

Nighttime: To the 0.5 mv/m, 50 per cent skywave contour from stations on the same channel, and to the 0.5 mv/m groundwave contour from stations on adjacent channels.

* * * * *

(2) Class II stations are secondary stations which operate on clear channels with powers not less than 0.25 kw nor more than 50 kw, except that Class II-A stations shall not operate nighttime with less than 10 kw. Class II stations are required to use a directional antenna or other means to avoid causing interference within the normally protected service areas of Class I stations or other Class II stations (for special rules and standards concerning Class II-A stations, see § 3.22). These stations normally render primary service only, the area of which depends on the geographical location, power, and frequency. This may be relatively large but is limited by and subject to such interference as may be received from Class I stations. However, it is recommended that Class II stations be so located that the interference received from other stations will not limit the service area to greater than the 2.5 mv/m groundwave contour nighttime and 0.5 mv/m groundwave contour daytime, which are the values for the mutual protection of this class of stations with other stations of the same class (except that Class II-A stations are normally protected to their 0.5 mv/m groundwave contour daytime, and nighttime to the limit imposed by the co-channel Class I-A station).

* * * * *

(s) The existence or absence of objectionable groundwave interference from stations on the same or adjacent channels shall be determined by actual measurements made according to the method hereinafter described, or, in the absence of such measurements, by reference to the propagation curves of § 3.184. The existence or absence of objectionable interference due to skywave propagation shall be determined by reference to the appropriate propagation curves in Figure 1 or Figure 1a or Figure 2 of § 3.190.

(t) In computing the fifty (50) percent and the ten (10) percent skywave field intensity values of a station operating on a clear channel specified in § 3.25 (a), use shall be made of the appropriate curve set forth in Figure 1a of § 3.190, "Skywave Signals for 10 percent and 50 percent of the Time." In computing the fifty (50) percent and ten (10) percent skywave field intensity values of a station operating on a clear channel specified in § 3.25 (b), use shall be made of the appropriate curve set forth in Figure 1 of § 3.190, entitled "Average Skywave Field Intensity (corresponding to the second hour after sunset at the recording station)." In computing the ten (10) percent skywave field intensity values of

LOOKING FOR TUBES?

Turn to section 5700



eem - ELECTRONIC ENGINEERS MASTER

a regional channel station, use shall be made of the appropriate curve in Figure 2 of § 3.190, entitled "10 percent Skywave Signal Range." The curves in Figure 1 of § 3.190 are drawn for a radiated field of 100 mv/m at one mile in the horizontal plane from a 0.311 wavelength antenna. The curves in Figure 1a and Figure 2 of § 3.190 are drawn for a radiated field of 100 mv/m at one mile at the vertical angle pertinent to transmission by one reflection. In computations based on Figure 1, the pertinent vertical angle shall be determined by use of Figure 6 of § 3.190. In computations based on Figures 1a or 2 of § 3.190, the pertinent vertical angle shall be determined by use of Figure 6a of § 3.190.

(v) Protected service contours and permissible interference signals for broadcast stations are as follows (for Class I and Class II-A stations, see paragraph (a) of this section):

Class of station	Class of channel used	Permissible power	Signal intensity contour of area protected from objectionable interference ¹		Permissible interfering signal on same channel ²	
			Day ³	Night	Day ³	Night ⁴
I-A	Clear	50 kw	{ 8C 100 uv/m AC 500 uv/m SC 100 uv/m	{ SC 500 uv/m (50% skywave) ⁷ AC 500 uv/m ³ SC 500 uv/m (50% skywave)	{ 5 uv/m 5 uv/m	{ 25 uv/m ⁷ 25 uv/m
I-B	do	10 kw to 50 kw (daytime)	{ AC 500 uv/m 500 uv/m	{ AC 500 uv/m ³ 500 uv/m ³	{ 5 uv/m 25 uv/m	{ 25 uv/m Do.
II-A	do	10 kw to 50 kw (nighttime)	{ 500 uv/m 500 uv/m	{ 500 uv/m ³ 2500 uv/m ^{3 5}	{ 25 uv/m do	{ Do. 125 uv/m
II-B and II-D	do	0.25 kw to 50 kw	do	2500 uv/m ^{3 5}	do	125 uv/m
III-A	Regional	1 kw to 5 kw	do	2500 uv/m ³	do	Do.
III-B	do	0.5 to 1 kw (night), and 5 kw (day)	do	4000 uv/m ³	do	200 uv/m
IV	Local	0.1 to 0.25 kw (night), and 0.1 to 1 kw (day)	do	Not prescribed ⁶	do	Not prescribed ⁶

¹ When a station is already limited by interference from other stations to a contour of higher value than that normally protected for its class, this contour shall be the established standard for such station with respect to interference from all other stations.

² For adjacent channel, see paragraph (w) of this section.

³ Groundwave.

⁴ Skywave field intensity for 10 per cent or more of the time.

⁵ These values are with respect to interference from all stations except Class I-B, which stations may cause interference to a field intensity contour of higher value. However, it is recommended that Class II stations be so located that the interference received from Class I-B stations will not exceed these values. If the Class II stations are limited by Class I-B stations to higher values, then such values shall be the established standard with respect to protection from all other stations.

⁶ See paragraph (a)(4) of this section.

⁷ Class I-A stations on channels reserved for the exclusive use of one station during nighttime hours are protected from co-channel interference on that basis. On the frequency 770 kc, two Class I stations may be assigned.

SC—Same channel. AC—Adjacent channel.

9. In § 3.185, paragraph (b), and the introductory text of paragraph (d) are amended, and new paragraph (k) is added, as follows:

§ 3.185 Computation of interfering signal from a directional antenna.

(b) For signals from stations operating on Class I-B clear channels (those specified in § 3.25 (b)), in case of determining skywave interference from an antenna with a vertical pattern different from that on which Figure 1 of § 3.190 is predicated (the basis of the night mileage separation tables), it is necessary to compare the appropriate vectors in the vertical plane.

* * * * *

(d) Examples of the use of skywave curves on Class I-B clear channels:

* * * * *

(k) For signals from stations operating on Class I-A clear channels (those specified in § 3.25 (a)), skywave interference is determined by using the 10 percent curve of Figure 1a of § 3.190, entitled "Skywave Signals for 10 percent and 50 percent of the Time." The pertinent angle of departure is to be determined by use of Figure 6a of § 3.190, in a manner similar to that described in paragraph (g) of this section for regional stations. An example of the determination of skywave interference in this situation is as follows: Assume a Class I-A station and a proposed Class II-A station, operating on the same channel, are separated 1450 miles and that the 0.5 mv/m—50 percent skywave contour of the Class I-A station is located 740 miles from the station. The distance from the Class II-A station to the protected contour of the Class I-A station is 710 miles and from Figure 6a

the critical angles of radiation are 5° to 9°. If the vertical pattern of the antenna of the proposed Class II-A station is such that between these angles the maximum radiation is 34 mv/m at one mile, the value of the 10 percent field as read from Figure 1a is multiplied by 34/100 to determine the interfering 10 percent field intensity at the 0.5 mv/m—50 percent skywave contour of the I-A station, which would be 0.025 mv/m.

10. Section 3.190 is revised by adding new Figure 1a, and modifying the legend to the title on Figure 6a, and amending the text to read as follows:

§ 3.190 Engineering charts.

This section consists of the following figures: 1, 1a, 2, R3, 5, 6, 6a, 7, 8, 9, 10, and 11.

WLDM

Detroit's finest FM station chooses FM's finest TRANSMITTER GEL'S HIGH POWER 15KW FM TRANSMITTER

You, too, can take advantage of the same dependable service, negligible maintenance, and rock-steady stability enjoyed by WLDM and other GEL Transmitter owners.

SELECT FIELD-PROVEN, HIGH QUALITY GEL EQUIPMENT:

- 30 KW FM Broadcast Transmitter
- 15 KW FM Broadcast Transmitter
- 1 KW FM Broadcast Transmitter
- FM Multiplex Systems
- Rust Remote Control Systems
- FM Stereo Equipment

Write to Broadcast Sales, Dept. 8 for GEL FM Technical Bulletins



GENERAL ELECTRONIC

LABORATORIES, INC.

195 Massachusetts Avenue, Cambridge 39, Mass.

Industry News

EMI/US, Ltd., Announces Major Operations Expansion

A. Bruce Rozet, vice-president and general manager of EMI/US, Ltd., has announced a major expansion of operations with the purchase of assets of General Communications, Inc., which becomes the General Communications Div. of EMI/US, and will incorporate the products and personnel of the former Broadcast Div. of EMI/US.

General Communications' products to be integrated into the EMI/US communication equipment line include: fully-transistorized television switching equipment, mechanical and electro-mechanical switching devices, solid-state video and pulse distribution equipment, special effects generators, dial monitor systems, picture monitors, custom studio consoles, solid-state power supplies and automation systems.

The Broadcast Div. has been marketing a complete line of television cameras and other associated broadcast equipment.

RCA Ships First Units of FM Stereo Generators

The first units of Radio Corp. of America's new FM stereo generators were shipped recently to five radio stations preparing to enter the stereo broadcasting service.

Shipments of the pre-production unit, a model of which was displayed at the National Assn. of Broadcasters' convention, went to stations WQXR-FM, New York; WDTM, Detroit; KLSN, Seattle; KIXL, Dallas; and WUPY, in the Boston suburb of Lynn, Mass.

New U.S.A. Distributors of Television Camera Tubes

Roy H. Deighton, commercial manager, English Electric Valve Co., Ltd., Chelmsford, Essex, England, has announced the appointment of Visual Electronics Corp., New York

City, as distributor for television camera tubes in the Customs Union of the United States.

The distributorship, states Visual's president, James B. Tharpe, has been established to provide the United States broadcast industry with prompt delivery of all English electric camera tubes and to offer full engineering and sales services from coast to coast.

Gift of TV Equipment for Closed Circuit System

Through the generosity of Dr. John E. Fetzer and WKZO-TV, the educational television program at Western Michigan University has been given substantial assistance. Valued in excess of \$40,000, the equipment has materially aided in the production of video tapes for classroom use and in the development of TV on the campus, says Robert P. Dye, director of television.

Included are two complete camera chains, from the cameras themselves to the control room monitors and all intermediate linkage and lines; a 16-mm film projector; and a 2 x 2 slide projector.

**LOOKING FOR
DIALS?**

Turn to section 2400



eeem — ELECTRONIC ENGINEERS MASTER

JAMPRO

ONLY FM ANTENNA
designed specifically for
MULTIPLEX STEREO

Write for full details.

JAMPRO ANTENNA CO.

7500 14th Ave.
Sacramento 20, California



Save 30% on 4-Track
Stereo Music on Tape!

Empty 3 in. Plastic Reels 7c ea.

BARGAIN PRICES! Send for our **FREE** Tape Recorder/Blank/Prerecorded Tape Catalog #B-3

SAXITONE RECORDING TAPE

* Oxide guaranteed not to rub off or squeak—or money back. Compare ours with other "Bargain" tape. You'll find it's more than just "price" when you deal with us. We are original pioneers in the tape recorder business and our reputation means everything to us.

600' Acetate (plastic), 5".....	.75
600' MYLAR 5" reel.....	.95
900' MYLAR (Polyester), 5".....	.99
1200' MYLAR, 1/2 mil. 5" reel.....	1.18
1200' Acetate (plastic), 7".....	1.19
1200' MYLAR, 1 1/2 mil. (Strong).....	1.68
1800' Acetate (plastic), 7".....	1.79
1800' MYLAR, 1 mil. thick, 7".....	1.99
2400' MYLAR, unsensitized, 7".....	2.69
2400' MYLAR, sensitized, 7".....	2.99

Studios, Large Users Even Lower. **PLUS POSTAGE.** Also—Scotch, Irish, Audio, Reeves, Ampex and Sarkis-Tarzan magnetic tapes, mikes, audiocassettes, needles, etc. We'll surprise you with our quotations!

SAXITONE TAPE SALES

(Division of Commissioned Electronics Company, Inc.)
1776 COLUMBIA ROAD WASHINGTON 9. D. C.



NORELCO SPEAKER

Famous AD3800M, twin cone 8" (75-19,000 cycles) discontinued model, former list 16.00, usual net 9.90 going at 3.73 plus postage. (8 for 27.85). Other Norelco speaker sizes at bargain prices. Send for **SPEAKER SPECIFICATION SHEET.**

AM - FM - TV - INTERCITY

STUDIO TRANSMITTER LINK

(942-952MC BAND)

MODEL PCL-2A

IMMEDIATE DELIVERY

MODERN LEASING PLANS AVAILABLE



MOSELEY ASSOCIATES, Inc.

P. O. Box 3192 4416 Hollister

Telephone: 967-1469

SANTA BARBARA, CALIFORNIA

ADDRESS CHANGE???

We can give you faster, more complete service on your

CHANGE OF ADDRESS

if you will advise us of your OLD address as well as the NEW.

Write to:

CIRCULATION DEPARTMENT

BROADCAST ENGINEERING

1014 WYANDOTTE

KANSAS CITY 5, MO

Product News



SWEEP FREQUENCY TEST RECORD FOR STEREOGRAPHIC SYSTEMS

Pacific Transducer Corp., 11836 W. Pico Blvd., Los Angeles 64, Calif., has announced a new stereophonic sweep frequency test record, which is said to offer an instantaneous method of checking frequency responses on all types of stereophonic equipment.

With the new unit, the manufacturer states, all that is needed is a cathode ray oscilloscope for instantaneous response measurements; only a few quick adjustments on the equalizer or change of components, and the work is completed.

The new test record has the recording of the left side of the groove on one side of the

record, and the right side of the groove on the other side of the record. The record is designed with all necessary correction factors included in it, and requires no charts or graphs. Standard 33 1/3 rpm speed; .001-inch stylus. Stereophonic reproducing head required. For Monaural systems, the 102M audio sweep frequency record is available.

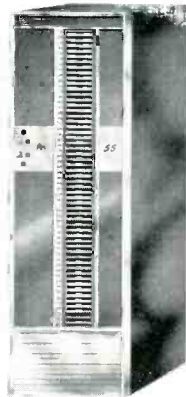

MULTIPLE TAPE PLAYBACK UNIT

Automatic Tape Control, Inc., Dept. 55, 209 E. Washington St., Bloomington, Ill., has developed a new unit designed to play back 55 tape-in-magazine messages in sequence without threading, reloading or manual cueing.

The ATC 55 is a multiple tape reproducing device utilizing a model PB-2, two-tone automatic tape control playback unit which is on an elevator that is positioned behind a tier of 55 ATC tape magazines on the vertical plane of the front of the cabinet. The magazines are automatically inserted

into the playback unit. The basic ATC 55 is designed to operate sequentially from top to bottom. As the elevator moves the playback unit from position to position, a tape magazine is automatically inserted. After the magazine has been played, the unit automatically rejects the magazine, returning it to its proper place in the front of the panel.

The tape magazine may be started either manually or automatically. In the manual mode, the operator presses the start button. The tape reproduces the recorded information and the 1,000-cycle cue tone on the tape cues up the cartridge, stops the mechanism and actuates the movement of the elevator to the next magazine position. In automatic operation, a second tone of 3,200 cps is placed on the tape immediately following the recorded information. The auxiliary control tone may then start additional equipment, including other ATC units, other tape machines, television slide projectors, record changers, etc.

Two or more ATC 55's operated together are said to provide a full automatic program service. The dual-tone cueing principle is designed to assure that there will be no dead air between program sources.

U. S. LEASING OFFERS NEW EQUIPMENT LEASING BROCHURE

A new illustrated brochure, "The Engineered Equipment Lease," is being offered by United States Leasing Corp., 580 California St., San Francisco 4, Calif.

The brochure explains how any type or amount of equipment can be obtained on lease. Subjects include: conservation of capital and credit; tax-timing benefits; balance sheet effect; cash flow improvement; recovery of capital through sale and lease-back; and other advantages.

IMMEDIATE DELIVERY from Stock!



Professional Transistorized Portable Field Recorders

Exceed NAB Broadcast Standards

Assure studio quality performance with complete independence from AC power.

Over 25 models available in two series:

TransFlyweight® Series 312: 8 lbs.; electric motor, battery-operated. Size: 5 1/2 x 9 x 12 inches.

TransMagnetite® Series 612: 15 lbs.; spring motor. Operates 125 hours from rechargeable batteries. Choice of single or multiple tape speeds, one or two tracks. All models equipped with multi-purpose VU meter. Full unconditional 2-year Guarantee.

Write for Literature

AMPLIFIER CORP. of AMERICA

An Affiliate of the Keystone Camera Co., Inc.
398 Broadway, New York 13, N. Y. • WO 6-2929

THE TELE-COMMUNICATIONS

PORTA-CASTER

Model 675

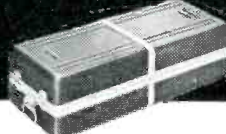

Size: 15" x 19" x 4 1/2"

Weight: 90 lbs.

Console only 13 lbs.

Cabinet: Grey unbreakable fiberglass and aluminum with removable legs and cover.



Console completely self-contained (including monitor amplifier) and may be removed for remote broadcasts.

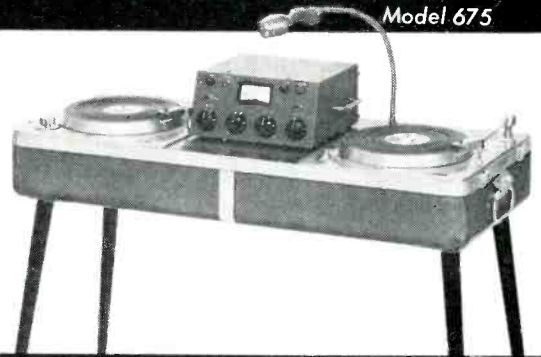

A COMPLETE, COMPACT TRANSISTORIZED PORTABLE UNIT FOR STUDIO OR REMOTE USE

INPUT CONTROLS:

2 Turntables with cue position, 1 Microphone Control with two inputs, 1 Remote Control with high level inputs.

OUTPUT CONNECTIONS:

1 Line Output, 1 P.A. Output with control, 1 External Speaker Output, 1 Phone Output.

EQUIPMENT:

Includes 2 Rek-O-Kut, Rondine B-12 Turntables, 2 Presto PA-1 Tone Arms (with snaplock), 2 G.E. Type 4G-050 Triple Play Cartridges.

FOR INFORMATION CONTACT

TELE-COMMUNICATIONS CORP.

AN AFFILIATE OF TELEBROADCASTERS, INC.

50 DRUMM STREET, SAN FRANCISCO, CALIFORNIA • YUkon 2-4314

Product News

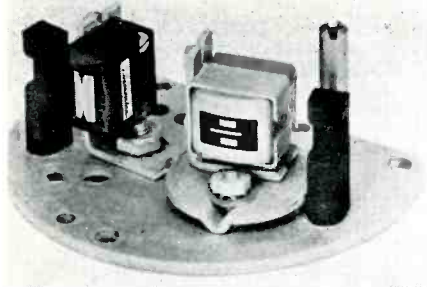

STEREO CONVERSION KIT FOR ROBERTS TAPE RECORDERS

Nortronics Co., Inc., 1015 S. 6th St., Minneapolis 4, Minn., has introduced the R-67 conversion kit designed to convert Roberts, Metzner, Akai and Terracorder tape recorders to four-track stereo playback, while retaining existing monophonic record/play capabilities.

The four-track stereo recording may be performed by using the original two recording amplifiers, or one amplifier plus the Nortronics RA-100 recording amplifier.

The record/play head in the R-67 kit is

the model TLB-2 laminated core head, which is said to have a fine 100 micro-inch gap for superior high frequency response. The erase head is the model SEQ-1 stereo erase head.

Complete instructions and accessory parts are furnished with the kit.



TRANSISTORIZED VIDEO/PULSE DISTRIBUTION AMPLIFIER (TV)

A completely transistorized video/pulse distribution amplifier, TDA2, featuring light weight, compact size, low heat factor and four signal outputs, has been introduced by International Nuclear Corp., 501 Elysian Fields, Nashville 11, Tenn. The unit is interchangeable with tube-type amplifiers without alteration of existing cables.

The TDA2 mounts in standard 19-inch racks, and requires only 1 3/4 inches of panel space. Overall dimensions are 1 3/4 x 19 x 7 inches, and weight is under 4 lb. The unit contains its own regulated power supply and

draws only four watts at 115 volts. Input impedance (bridging or terminated) is 75 ohms, and the four independent outputs are also terminated at 75 ohms. The TDA2 is non-microphonic, and cross-talk between outputs is down better than 40 db, the manufacturer states.

All transistors are socket-mounted and available at front panel, as are the color coded test jacks for the most important voltages and signals. A chart of individual measurements for voltages, frequency response, noise level, gain and pulse outputs is also furnished.

PAR-METAL PRODUCTS CATALOG 61

Par-Metal Products Corp., 32-62 49th St., Long Island City 3, N. Y., has announced a new 36-page, two-color Catalog 61, containing illustrations, descriptions, complete specifications and prices of Universal cabinet racks and deluxe console assemblies.

Also included are several innovations designed to assist engineers in planning electronic housings; for example, the component group check list on page 15, which breaks down all basic units needed to make single, double or triple console assemblies; this applies to consoles with or without desk panel cabinets on table tops, and also covers table tops, or extension desk tables for use with these units.

Advertisers' Index

Altec Lansing Corp.	34
American Concertone, Inc.	16
Amplifier Corp. of America	39
Automatic Tape Control, Inc.	24
Bauer Electronics Corp.	26
Belden Mfg. Co.	13
Blonder-Tongue Laboratories	29
Brennan, Charles E.	40
Broadcast Electronics, Inc.	31
Commercial Radio Monitoring Co.	40
Continental Electronics Mfg. Co.	35
Continental Mfg. Co.	33
Cunningham Son & Co., Inc.	35
EMI/US Magnetic Tape Div.	20-21
Electronic Engineers Master Catalog	35, 36, 38
Electro-Voice, Inc.	30
Fairchild Recording Equipment Corp.	30
Foto-Video Electronics, Inc.	IFC
Gates Radio Co.	25
General Electronic Laboratories, Inc.	37
Gray Mfg. Co.	3
Houston Fearless Corp., Westwood Div.	19
ITA Electronics Corp.	15
James, Vir N.	40
Jampro Antenna Co.	38
Langevin, A. Div. of Sonotec, Inc.	1
Moseley Associates	38
Peerless Electrical Product Div.	34
Radio Corp. of America	11, BC
Rohn Systems, Inc.	36
Ron Electronics Corp.	28
Sarkes Tarzian, Inc.	17
Saxitone Tape Sales Div.	38
Sierra Electronic Enterprises	34
Stancil Hoffman Corp.	40
Standard Electronics Div.	18
Telechrome Mfg. Corp.	IBC
Tele-Communications Corp.	39
University Loudspeakers, Inc.	27
Weller, Donald A.	40

Classified

Advertising rates in the Classified Section are ten cents per word. Minimum charge is \$2.00. Blind box number is 50 cents extra. Check or money order must be enclosed with ad.

EQUIPMENT FOR SALE

Transmission line, styroflex, heliax, rigid with hardware and fittings. New at surplus prices. Write for stock list. Sierra Western Electric Cable Co., 1401 Middle Harbor Road, Oakland 20, California. 6-61 tf

Commercial Crystals and new or replacement crystals for RCA, Gates, W. E. Bliley and J-K holders; regrinding, repair, etc. BC-604 crystals. Also A. M. monitor service. Nationwide unsolicited testimonials praise our products and fast service. Eidson Electronic Company, Box 31, Temple, Texas. 9-61 tf

Used 50 KW Transmitter. Western Electric 407A-4 in good condition with spares. Priced at one-fourth less than a new transmitter. Can be handled with as little as 10% down. Broadcast Engineering, Dept. BE-4, Kansas City 5, Mo. 8-61 4t

Two Ampex PR-10-2 Stereo Recorders, perfect condition, less than 200 hours use. 15-7 1/2 & 7 1/2-3 3/4 \$695 each FOB. Box 126, Oakland 4, California. 11-61 1t

WANTED

Wanted: New or used FM receivers with audio amplifiers, incorporating relays with 15,000 and 20,000 mute and boost system, or information about where this might be secured. Write stating condition of equipment and asking price. Broadcast Engineering, Dept. BE 5, Kansas City 5, Mo. 11-61 1t

Distortion Meter Wanted: Hewlett-Packard 330B or 330C or General Radio 1932-A. J. E. Thompson, 908 Burns Ave., Flossmoor, Ill. 11-61 1t

BUY, SELL OR TRADE

Will buy or trade used tape and disc recording equipment — Ampex, Concertone, Magnecord, Fresto, etc. Audio equipment for sale. Boynton Studio, 10 BE Pennsylvania, Tuckahoe, N. Y. 10-61 6t

Professional Services

VIR N. JAMES

Specialty

Directional Antennas

232 S. JASMINE DEXter 3-5562

DENVER 22, COLORADO

Member AFCCE

CHARLES E. BRENNAN

(Member AFCCE)

DONALD A. WELLER

Consulting Radio Engineers

405 E. Lincoln Ave. • Milwaukee 7, Wis.
Humboldt 3-3370 Humboldt 3-3371

Precision Frequency Measurements

AM-FM-TV

COMMERCIAL RADIO MONITORING CO.

103 S. MARKET ST. LEE'S SUMMIT, MO.
Phone Kansas City, LA. 4-3777

- SYNCHRONOUS MAGNETIC FILM RECORDER/REPRODUCER
- MAGNETIC TAPE RECORDERS
- NEW—THE portable MINITAPE synchronous 13 lb., battery operated magnetic tape recorder for field recording.

THE STANCIL-HOFFMAN CORP.
845 N. Highland, Hollywood 38, Calif.
Dept. B HO 4-7461

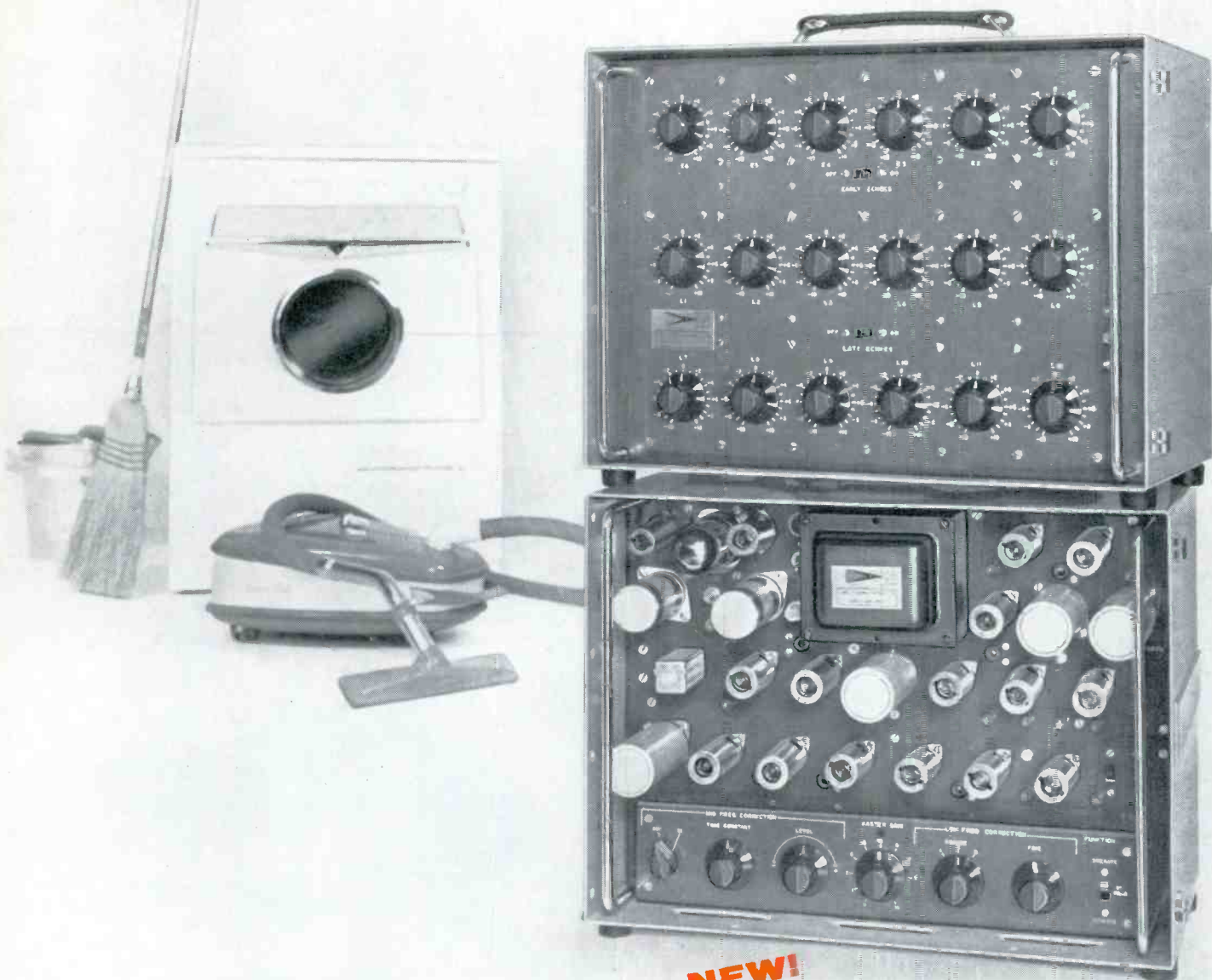

NEW!

...clean-up video distortions easily



Photos, taken a few seconds apart, show how the Model 20/20 cleans up smears, overshoots, ringing and other waveform defects.

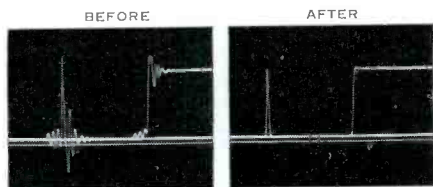

Waveform correction is illustrated by before-and-after photos of an expanded portion of Sine²-test signal. The Model 20/20 can be used with any desired test signal for pre-broadcast, or on-the-air correction.

At the recent NAB show, Telechrome demonstrated a remarkable new device, the Model 20/20 Time Domain Equalizer. If you saw it in operation at the show, you were, no doubt, amazed at the ease with which it corrected tilt, smear and rings. If you have antenna icing problems, transmitter ring, video tape degradation, reflections on remotes, or, in short, almost any video distortion problem, let us demonstrate the 20/20 to you and your staff.

Prove the value of the 20/20 at your own facilities for on-the-air or pre-broadcast signal corrections.

The 20/20 requires no special signals or set up, so a few minutes of your time is all that is necessary to produce the picture that is worth the proverbial thousand words. For your demonstration contact H. Charles Riker, Vice President Marketing. No obligation of course.

TELECHROME

AT THE FRONTIERS OF ELECTRONICS

ELECTRONICS



DIVISION

TELECHROME MANUFACTURING CORP., AMITYVILLE, L.I., NEW YORK
Division Offices: Lombard, Illinois • Van Nuys, California • Dallas, Texas • Washington, D.C.



AN IMPROVED VERSION OF A PROVEN FAVORITE

For years telecasters have known and relied on the RCA-5762. Now the 5762A combines the rugged dependability of the original with important improvements.

The 5762A is unilaterally interchangeable with the 5762/7C24. Its entirely new grid design and grid characteristics make it ideal for both TV and FM. Its maximum plate dissipation is 4 Kw and it can be used at the highest VHF channel. The synchronizing-level power output is 6.35 Kw with less than 1 Kw of driving signal.

The new type retains the highly efficient radiator of its predecessor; the thoriated tungsten filament for economical power consumption; the complete shielding between filament leads and plate; the low grid-to-plate capacitance; and the high perveance. It is a worthy successor to one of the most respected tubes in broadcasting.

Also from RCA...

A NEW GENERATION OF BROADCAST VETERANS

Every familiar RCA broadcast tube has been steadily improved over the years. Each of the types below, manufactured for years, are in service in hundreds of transmitters. Today's *improved* versions represent the best transmitting tube investment the broadcaster has ever been able to make.

No.	Type	Typical Broadcast Application	Service	Plate Dissipation Watts	Power Output Watts
813	Beam Power Pentode	TV	AF Power Amplifier and Modulator	100 (CCS)	380 (two tubes)
833A	Power Triode	TV Radio	AF Power Amplifier and Modulator	300 (CCS)	1650 (two tubes)
6166A/7007	Beam Power Tube	TV	RF Power Amplifier	12,000 (CCS)	14,000
575A	Half-Wave Mercury-Vapor Rectifier	TV Radio	Half-Wave Rectifier		
673	Half-Wave Mercury-Vapor Rectifier	TV Radio	Half-Wave Rectifier		
866A	Half-Wave Mercury-Vapor Rectifier	TV Radio	Half-Wave Rectifier		
872A	Half-Wave Mercury-Vapor Rectifier	TV Radio	Half-Wave Rectifier		
8008	Half-Wave Mercury-Vapor Rectifier	TV Radio	Half-Wave Rectifier		

Be sure you have the latest ratings and technical data on these important tube types. Check with your Authorized RCA Broadcast Tube Distributor this week—or write directly to Commercial Engineering, Section K-115-0, RCA Electron Tube Division, Harrison, N. J.



The Most Trusted Name in Electronics

