

A supplement to **BroadcastEngineering** magazine - June 2009

# Special Report

Hot new products from **NAB2009**





# Ki Pro Worldwide Roadshow

## From Lens to Post.



# KiPRO

# ProRes

AJA Video just announced the revolutionary Ki Pro at NAB 2009, and now we're taking it on the road so you can see it for yourself!

Finally, shoot on the same codec as you edit with, full raster 10-bit Apple ProRes 422, built natively into Ki Pro's stand-alone, portable hardware.

Experience Ki Pro for yourself at one of our US roadshows

Chicago - June 10th

Toronto - June 16th

Los Angeles - June 17th

New York - June 18th

Atlanta - June 23rd

Miami - June 25th

Vancouver - July 14th

Dallas - July 16th

Mexico City - July 21st

Sao Paulo - July 23rd



Find a city near you,  
and register today!

Register at:  
[www.aja.com/kiprotour](http://www.aja.com/kiprotour)

Ki Pro. Because it matters.

# AJA

VIDEO SYSTEMS



Imagination to Creation

[www.for-a.com](http://www.for-a.com)

- Head Office (Japan)  
Tel: +81 (0)3-3446-3936
- USA Western (CA)  
Tel: +1 714-894-3311
- USA Eastern & Midwest (NJ)  
Tel: +1 201-944-1120
- USA Southern (FL)  
Tel: +1 352-371-1505
- Latin America & Caribbean (FL)  
Tel: +1 305-931-1700
- Canada (Toronto)  
Tel: +1 416-977-0343
- UK (London)  
Tel: +44 (0)20-8391-7979
- Italy (Milan)  
Tel: +39 02-254-3635/6
- Korea (Seoul)  
Tel: +82 (0)2-2637-0761
- China (Beijing)  
Tel: +86 (0)10-5170-9870

**FOR.A**<sup>®</sup>  
INNOVATIONS IN VIDEO  
and AUDIO TECHNOLOGY



## HVS-300HS: The New Standard in Small HD/SD Switchers!

Unrivalled Features, Unequalled Cost Performance

- Very compact main unit (1RU high)
- 4 types of control panels: standard panel, front panel, remote panel, and control GUI
- HD/SD-SDI 4 input/4 output standard, Max. 12 input/8 output
- Frame sync, re-sizing engine, and Proc Amp on each input
- Variety of I/O options: HD/SD-SDI, DVI-D, VGA, HD/SD analog component, and analog composite
- Built-in 16-split multiviewer, supporting 4, 10 or 16-split view with tally and title display
- Up-stream Keyer (with Chroma Key) and DSK both with 2D DVE
- Dual Picture-in-Picture function
- Various 2D and 3D DVE transitions
- Over 100 wipe patterns
- Two channels of still stores
- ANC data pass through
- Aux remote control (option)



Main Unit with HVS-30RU Remote Panel



Main Unit with HVS-30FP Front Panel



Main Unit with HVS-300U Operation Unit

Now FOR-A offers a complete line of switchers from our affordable 1M/E up to our new 3Gbps ready 4M/E model



# SPECIALREPORT

## COVERAGE YOU CAN DEPEND ON

For four days, 83,000 attendees and more than 1600 exhibitors made for an exciting 2009 NAB Show. To help capture all the products and technology, the editors and writers at *Broadcast Engineering* canvassed the entire 900,000sq ft of Las Vegas Convention Center space looking for the latest broadcast/production products, technology and solutions.

Even if you attended the show, it was impossible to see everything. So, to help you discover what you might have missed, read on. Each product highlight includes a brief description and full company contact information.

So, sit back, relax, and enjoy! There's lots to cover, and we're just getting started.

*Brad Dick*

Brad Dick, editorial director

A supplement to *BroadcastEngineering* magazine - June 2009

# Special Report

Hot new products from NAB2009

1. Audio-Technica BP4025  
2. EVS XS Studio  
3. Harris 3Gb/s distribution amplifiers  
4. Nucomm ProQ  
5. OConnor Ultimate 2575D  
6. Rohde & Schwarz R&S ETL  
7. RTW Remote Display 30010  
8. Snell Alchemist Ph.C-HD  
9. Wheatstone D-8

## ON THE COVER

1. Audio-Technica BP4025
2. EVS XS Studio
3. Harris 3Gb/s distribution amplifiers
4. Nucomm ProQ
5. OConnor Ultimate 2575D
6. Rohde & Schwarz R&S ETL
7. RTW Remote Display 30010
8. Snell Alchemist Ph.C-HD
9. Wheatstone D-8

### Editorial Director:

Brad Dick, brad.dick@penton.com

### Editor: World Edition:

David Austerberry, editor@broadcastengineeringworld.com

### Managing Editor:

Susan Anderson, susan.anderson@penton.com

### Production Editor:

Collin LaJoie, collin.lajoie@penton.com

### Production Editor:

Angela Snell, angela.snell@penton.com

### Production Editor:

Erin Shipps, erin.shipps@penton.com

### Art Director:

Robin Metheny, robin.metheny@penton.com

### Technical Consultants:

Computers & Networking – Brad Gilmer

Antennas/Radiation – Don Markley

Digital Video – Aldo Cugini

Transmission Facilities – Donald L. Markley

Legal – Harry C. Martin

New Technology – John Luff

Industry Watcher – Anthony Gargano

New Media – Craig Birkmaier

### Group Publisher:

Wayne Madden, wayne.madden@penton.com

### Marketing Dir.:

Kirby Asplund, kirby.asplund@penton.com

### Dir., Online Product Development:

Dean Muscio, dean.muscio@penton.com

### Vice President of Production:

Lisa Parks, lisa.parks@penton.com

### Production Manager:

Kathy Daniels, kathy.daniels@penton.com

### Classified Ad Coord.:

Sarah Maxey, sarah.maxey@penton.com

### Dir., Audience Marketing:

Barbara Kummer, barbara.kummer@penton.com

### Group Show Director/LDI:

Sharon Morabito, sharon.morabito@penton.com

## Penton Media

Penton Media, Inc.

249 West 17th Street,

New York, NY 10011

### Chief Executive Officer:

Sharon Rowlands, sharon.rowlands@penton.com

## SALES OFFICES

### US/CANADA WEST

George Watts III  
(360) 546-0379; Fax: (360) 546-0388  
georgeww3@aol.com

### EAST

Josh Gordon  
(718) 802-0488; Fax: (718) 522-4751  
Jgordon5@verizon.net

### MIDWEST

Emily Kalmus  
(312) 840-8473; Fax: (913) 514-6301  
emily.kalmus@penton.com

### MEMBER ORGANIZATIONS

Sustaining Member of:

• Society of Broadcast Engineers

Member, American Business Media; Member, BPA

International,

The Missouri Association of Publications



**BE US/Canada SUBSCRIPTION RATES:** Free and controlled circulation to qualified subscribers. Non-qualified persons may subscribe at the following rates (Prices subject to change): USA and Canada, 1 year, \$99.00, 2 years, \$171.00, 3 years, \$242.00; Outside USA and Canada, 1 year, \$116, 2 years, \$204.00, 3 years, \$292.00 surface mail (1 year, \$193.00, 2 years, \$347.00, 3 years, \$506.00 airmail delivery).

**BE World SUBSCRIPTION RATES:** Free and controlled circulation to qualified subscribers. Non-qualified persons may subscribe at the following rates (Prices subject to change): USA, 1 year, \$94.00, 2 years, \$160.00, 3 years, \$226.00; Outside USA, 1 year, \$110, 2 years, \$193.00, 3 years, \$275.00 surface mail (1 year, \$182.00, 2 years, \$336.00, 3 years, \$490.00 airmail delivery).

**ARCHIVES AND MICROFORM:** This magazine is available for research and retrieval of selected archived articles from leading electronic databases and online search services, including Factiva, LexisNexis and Proquest. For microform availability, contact National Archive Publishing Company at 800-521-0600 or 734-761-4700, or search the Serials in Microform listings at napubco.com.

**REPRINTS:** Contact Penton Reprints to purchase quality custom reprints or e-reprints of articles appearing in this publication at 888-858-8851. Website: www.pentonreprints.com. Email: reprints@pentonreprints.com

**PHOTOCOPIES:** Authorization to photocopy articles for internal corporate, personal, or instructional use may be obtained from the Copyright Clearance Center (CCC) at 978-750-8400. Obtain further information at copyright.com.

**PRIVACY POLICY:** Your privacy is a priority to us. For a detailed policy statement about privacy and information dissemination practices related to Penton Media products, please visit our Web site at www.penton.com.

**EDITORIAL and BUSINESS OFFICE:** Penton Media, 9800 Metcalf, Overland Park, Kansas 66212 • 913-341-1300 • penton.com

Copyright 2009, Penton Media, Inc. All rights reserved.

### INTERNATIONAL EUROPE

Richard Woolley  
+44-1295-278-407  
Fax: +44-1295-278-408  
richardwoolley@btclick.com

### Israel

Asa Talbar  
Talbar Media  
+972-3-5629565; Fax: +972-3-5629567  
talbar@talbar.co.il

### JAPAN

Mashy Yoshikawa  
Orient Echo, Inc.  
+81-3-3235-5961; Fax: +81-3-3235-5852  
mashy@fa2.so-net.ne.jp

### CLASSIFIED ADVERTISING

Julie Dahlstrom  
(312) 840-8436  
Fax: (913) 514-3684  
julie.dahlstrom@penton.com

### LIST RENTAL SERVICES

Marie Briganti, Walter Karl  
(845) 620-0700  
(845) 620-1885  
marie.briganti@walterkarl.infousa.com

### REPRINTS

Penton Reprints  
888-858-8851  
www.pentonreprints.com

### Customer Service: 913-967-1707 or 800-441-0294

Broadcast Engineering, June 2009, Vol. 51, No. 6 (ISSN 0007-1994) is published monthly and mailed free to qualified persons by Penton Media, Inc. 9800 Metcalf Ave., Overland Park, KS 66212-2216. Periodicals postage paid at Shawnee Mission, KS, and additional mailing offices. Canadian Post Publications Mail Agreement No. 40612608. Canada return address: Bleuchip International, P.O. Box 25542, London, ON N6C 6B2. POSTMASTER: Send address changes to Broadcast Engineering, P.O. Box 2100, Skokie, IL 60076-7800 USA. CORRESPONDENCE: Editorial and Advertising: 9800 Metcalf, Overland Park, KS 66212-2216 Phone: 913-341-1300; Edit. fax: 913-967-1905. Advert. fax: 913-967-1904. © 2009 by Penton Media, Inc. All rights reserved.



# INGENIOUS



Intelligence is relative. Except when it comes to broadcast tools. Consider the **Dolby® DP600 Program Optimizer**, a flexible file-based platform for cable, satellite, IPTV, terrestrial TV, and postproduction environments. With capabilities to rival a full rack's worth of gear, the DP600 can encode, decode, convert, and

transcode between a multitude of broadcast audio formats, and supports the next-generation technologies Dolby Digital Plus and Dolby Pulse. Add automated loudness analysis and correction with Dialogue Intelligence™, adaptive upmixing, and other innovations, and it's easy to see why the Dolby DP600 is, quite simply, in a class by itself.

**DOLBY**

[dolby.com/dp600](http://dolby.com/dp600)



## SERVER

### 360 SYSTEMS MAXX-2400 HD

Plays up to four HD video streams at once, or can record two streams, while playing two others; also can be used as a graphics store, with linked key-and-fill capability; standard features include HD-SDI video I/O with frame synchronization for recording wild sources like tape and satellite feeds; audio formats include embedded audio, and your choice of AES/EBU digital or balanced plus four analog.

818-991-0360; [www.360systems.com](http://www.360systems.com)

## DIGITAL AUDIO ROUTER/ CONCENTRATOR

### AEQ TITAN BC 2000 D



Equipped with five bidirectional optical fiber ports that use non-blocking architecture; each port can connect up to 1024 channels; features control system based on TCP/IP architecture; allows 1024 x 1024 audio channel subrouters to be interconnected.

+34 916 861 300; [www.aeq.es](http://www.aeq.es)

## FRAME SYNCHRONIZER AND CONVERTER

### AJA VIDEO FS1



Universal SD/HD A/V frame synchronizer and converter; can simultaneously work with both HD and SD video — all in full 10-bit broadcast quality video and 24-bit audio; supports virtually any input or output, analog or digital, HD or SD; can up- or downconvert between SD and HD and provide simultaneous HD and SD outputs; crossconversions between HD formats are also supported, with simultaneous output of both formats.

530-274-2048; [www.aja.com](http://www.aja.com)

## FRAME SYNCHRONIZER FOR-A UFM-30FS

Available in single- or dual-channel with 3Gb/s upgradeability as well as with audio mux or demux with single HD/SD-SDI I/O; features automatic changeover switching function; can work in traditional frame sync or line sync mode; includes 16-channel embedded audio with sampling rate converter.

714-894-3311; [www.for-a.com](http://www.for-a.com)

## SWITCHER

### ANALOG WAY DI-VENTIX LE



A multilayer mixer, scaler and seamless switcher with universal analog and digital input/output and full high-resolution digital processing; offers numerous live effects including picture in picture, downstream keying and chroma key as well as a multilayer mixer operation mode; can display up to four layers: two live sources, one frame and one logo.

212-269-1902; [www.analogway.com](http://www.analogway.com)

## CAPTURE CARD

### BLACKMAGIC DESIGN DECKLINK STUDIO

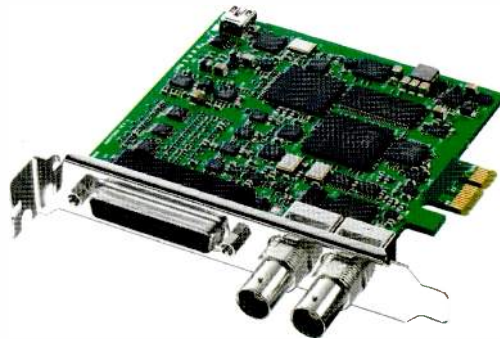

Features SDI and enhanced analog connections: SDI, analog component, S-video and composite video; has a built-in hardware downconverter and four channels of balanced analog audio, eight channels of SDI audio and two channels of AES/EBU digital with sample-rate converters; enables users to move seamlessly between SD and HD workflows; includes RS-422 deck control and blackburst and trisync reference input.

408-954-0500

[www.blackmagic-design.com](http://www.blackmagic-design.com)

## RED ONE HANDLE

### ANTON/BAUER QR-RH

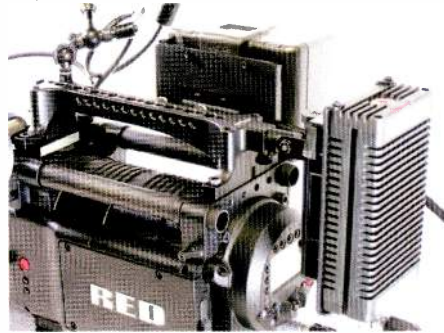

Enables multiple mounting and the ability to mount the RED drive in various locations; permits users to attach various accessories to the camera's handle via 1/4-20 and 3/8-16 tapped holes; tape hook provides tape measure attachment for camera focus.

203-929-1100; [www.antonbauer.com](http://www.antonbauer.com)

## REMOTE MONITORING SYSTEM

### ARG REMON



Allows non-SNMP equipment to be managed in an SNMP network; offers the control and monitoring of equipment via any Web browser; 1RU chassis comes complete with dual power supplies and connection for up to 40 GPIs and contact closures; front-panel control provides alarm control and system health status.

+44 1285 658 501; [www.arg.co.uk](http://www.arg.co.uk)

## CAMERA MONITOR

### AUTOSCRIPT MINISCRIP 5.6

A 1lb, 5.6in flat-screen portable on-camera monitor; includes connections for composite BNC and Hirose power inputs; has all of the standard functions of the company's larger displays; delivers a "live" feel that provides an intimacy between presenters and their audiences, increases creative options for producers and draws viewers into the action.

203-338 8356; [www.autoscript.tv](http://www.autoscript.tv)

## DISTRIBUTION AMPLIFIERS

### HARRIS 3GB/S DISTRIBUTION AMPLIFIERS

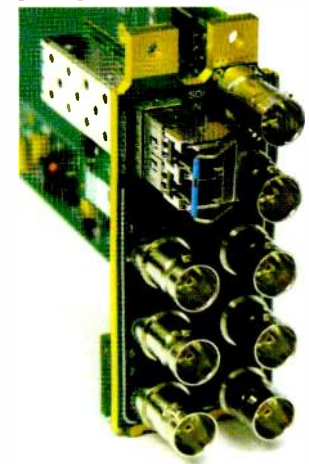

Provide broadcasters with a unique combination of configurations, including single-channel transceiver, dual-channel fiber transmitter, dual-channel fiber receiver, and dual-channel fiber receiver with dual fiber transmitters per channel; the DA-HRO6803+D is a single-channel 1x8 DA with O-to-E or E-to-O conversion; the DA-DHROE6803+D is a dual-channel 1x4 DA with E-to-O conversion; the DA-DHROE6803+D is a dual-channel 1x4 DA with O-to-E conversion; the DA-DHROOE6803+D is a dual-channel 1x4 DA with O-to-E conversion.

800-442-7747

[www.broadcast.harris.com](http://www.broadcast.harris.com)





## Rethink multi-viewer quietness

Our award-winning, ultra-quiet Kaleido-X16 multi-viewer is ideal for use within control rooms and mobile applications. Designed for 3Gbps/3D and HD/SD/Analog video, it delivers the highest level of image quality, extreme layout flexibility, and tight router integration. All this comes from a compact 1RU chassis, with 16 inputs, two multi-viewer outputs, and a 16 x 2 router. It's time to rethink what's possible.



Rethink what's possible



[www.miranda.com/kaleido-X16](http://www.miranda.com/kaleido-X16)

## HD WORKFLOW

### AVID HD NEWS



An end-to-end HD news system that enables broadcasters to cost-effectively produce HD programming; broadcasters can easily acquire, edit, network, manage assets, playback and control functionality of XDCAM HD (long GOP HD MPEG-2) content with a workflow designed to deliver significant time, storage and bandwidth savings; consists of the new AirSpeed Multi Stream production server version 1.0, NewsCutter software version 7.5, as well as the Interplay Production Asset Management and Unity shared storage systems.

978-640-6789; [www.avid.com](http://www.avid.com)

## MULTIVIEWERS

### AVITECH MCC-8004

Can display up to 120 inputs in a single display group; combine digital or analog video, audio and computer signals on one display; video can be composite, SD-SDI, HD-SDI or component; audio can be balanced or unbalanced; computer signals can be DVI or VGA; offers an integrated on-screen display, which includes on-screen labels, borders, alarms, optional audio meters as well as support for Asian and European symbols.

877-284-8324; [www.avitechvideo.com](http://www.avitechvideo.com)

## SD/HD/2K VIDEO CARD

### BLACKMAGIC DESIGN DECKLINK HD EXTREME

Features SDI, HDMI and analog component, NTSC, PAL and S-Video capture and playback, combined with dual-link 3Gb/s SDI technology and hardware downconversion; SDI, HDMI and analog video capture and playback, combined with both balanced analog and AES/EBU digital audio, lets users connect to all decks, cameras and monitors; instantly switches between SD and HD video.

408-954-0500

[www.blackmagic-design.com](http://www.blackmagic-design.com)

## EXTENDER

### AVOCENT LONGVIEW 1000P

Separates users up to 1000ft from computers; user PC experience unaffected over distance of 1000ft; extends audio and serial ports; single cable-to-user design simplifies installation and moves; with its dual transmitter, supports connectivity to a second user station.

866-277-1924; [www.avocent.com](http://www.avocent.com)

## TRANSMITTER

### AXCERA 6X SERIES

Liquid-cooled transmitter uses the company's frequency agile exciter and the latest LDMOS devices for broadband operation across the entire UHF band; power amplifier systems operate at the highest power density available, reducing floor space requirements; uses parallel amplifier and power supply modules, which can be removed and replaced while the transmitter is on the air.

800-215-2614; [www.axcera.com](http://www.axcera.com)

## WIRELESS

### MICROPHONE SYSTEMS

#### AZDEN 325ULT SERIES

Dual-channel UHF camera-mount wireless systems; feature 188 user-selectable frequencies displayed on an LCD screen so users can always find a free channel; consists of the 325UPR dual-channel on-camera receiver, the 35BT belt-pack transmitter, the 35HT handheld microphone/transmitter and the 35XT plug-in transmitter; the 325ULT comes with two 35BT/EX-503L body-pack mics along with the 325UPR receiver, packed in a carry case.

516-328-7500; [www.azdencorp.com](http://www.azdencorp.com)

## MULTIFORMAT

### FACILITY ROUTER

#### MIRANDA NVISION 5128

Designed to offer easy mixing and matching of up to eight different formats in the same frame, including 3Gb/s, HD, SD and analog video, as well as digital and analog audio; can be used for time code, sample rate conversion and machine control signals.

514-333-1772; [www.miranda.com](http://www.miranda.com)

## PRODUCTION SWITCHER

### BARCO FSN SERIES



Seamlessly integrates SD, HD and 3Gb/s video along with computer graphics formats; introduced with the FSN-150, a 1.5M/E control console, and the FSN-1400, a 14-slot video processing chassis; base configuration includes one eight-channel native input card and one two-channel universal input card that are capable of accepting any video or computer format; base system also includes the M/E output card that provides program, preset, clean-feed and six native aux outputs; in addition to the cards included in the base model, users can currently add up to five additional input cards for a maximum of 38 inputs.

678-475-8000; [www.barco.com](http://www.barco.com)

## DATABASE BROWSER

### FLORICAL INVENTORYBROWSER

Optional module within S.M.A.R.T. Central; allows user to browse the database and view low-res copies of the inventory; user can log in from any networked machine and view content that has been dubbed into the on-air servers.

352-372-8326; [www.florical.com](http://www.florical.com)

## PRODUCTION SERVER

### EVS XS STUDIO



A four-channel video production server specifically designed for studio applications; part of the new Silverline brand; optimized for the recording of multiple audio and video feeds, as well as instant control and multichannel playback operations; offers multiple SD and HD codec configurations with native support, such as IMX, Avid DNxHD and Apple ProRes 422 for faster and easier media exchange with post production.

973-575-7811; [www.evs.tv](http://www.evs.tv)





# Screen Service

## END-TO-END SOLUTIONS

now featuring ATSC-MH

DVB-T/H  
PAL  
NTSC  
ATSC  
FLO  
QPSK  
QAM  
ISDB-T



**HEAD END**



**DISTRIBUTION**

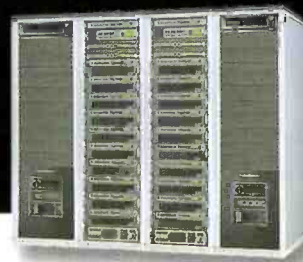

**BROADCASTING**



**IPTV and MMDS**

**SCREEN SERVICE BROADCASTING TECHNOLOGIES S.p.A.**  
Via G. Di Vittorio, 17, 25125, BRESCIA, ITALY  
tel. +39 030 358 2225 - fax +39 030 358 2226  
info@screen.it | www.screen.it

**SCREEN SERVICE AMERICA LLC**  
6095 NW 167th Street, Suite D-10 - Miami, FL 33015  
info@screenservice.net | Phone +1 305 826-2212  
Fax +1 305 826-2290 | USA Toll Free 1-888-522-0012

**SCREEN SERVICE DO BRASIL**  
Rua Tapajós, 90 | Boa Vista | CEP: 37.540-000  
Santa Rita do Sapucaí - MG | BRASIL | Tel: +55 35 3473- 3915

**RRD USA, Inc.**  
350 5th Avenue,  
Suite 3600  
New York, NY 10118 - USA  
Phone: +1 (212) 695 8378



## COAXIAL CABLE

BELDEN 7732LL

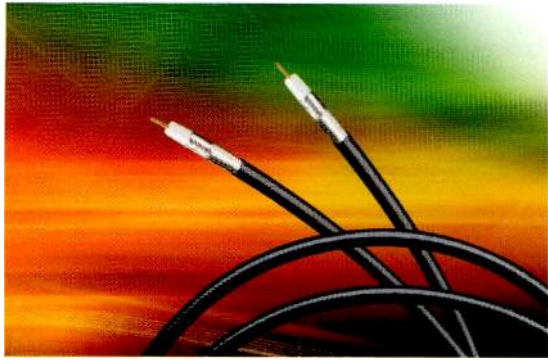

Plenum-rated RG-11 precision digital video coaxial cable; offers significant performance enhancements over Belden's previous plenum-rated version (Product No 7732A), especially when deployed in long cable runs for high-definition video (HD-SDI) or 1080p/60 applications; features a return loss of -23dB from 5MHz to 1.6MHz and -21dB from 1.6GHz to 4.5GHz.

800-245-3361; [www.belden.com](http://www.belden.com)

## STREAMING SOLUTION

BITCENTRAL AIRNOW!



Streams a live shot from the field without a laptop, software or special training; connects to a camera and streams content directly in real time; uses EvDO to deliver broadcast-quality video; provides a portable wireless hotspot that converts the broadband cellular network to standard WiFi.

949-253-9000; [www.bitcentral.com](http://www.bitcentral.com)

## TEST SIGNAL AND SYNC PULSE GENERATOR

ENSEMBLE DESIGNS  
BRIGHT EYE 57

A 3Gb/s, HD, SD and analog test signal and sync pulse generator; memory card allows users to create custom test patterns and audio clips; analog audio, AES, LTC, VTC and tri-level sync outputs are also provided; can be used as either a slave or master reference generator; can lock to house reference or to its own internal precision standard; suited for remote trucks, post, helicopters and flypacks.

530-478-1830

[www.ensembledesigns.com](http://www.ensembledesigns.com)

## ANTENNA

BROADCAST MICROWAVE SERVICES  
(BMS) DIVERSATRACKER

Directional/diversity receive antenna with built-in controller; when combined with the DR6000 receiver, creates a system that combines the benefits of six-way diversity reception with the extended range that a dedicated tracking antenna affords.

800-669-9667; [www.bms-inc.com](http://www.bms-inc.com)

## RAID SYSTEM

CALDIGIT VR



Advanced two-drive RAID system supports a quadruple interface for easy connectivity (FireWire 400/800, USB 2.0 and eSATA); there is no performance loss when daisy-chaining the unit using FireWire 800; modular design provides two hot-swappable drive modules and an easy-to-read front LCD; with support for RAID 0, 1 and JBOD, it can reach speeds of up to 220MB/s; includes an easy-to-use GUI for configuration and monitoring, which supports e-mail notification.

714-572-6668; [www.caldigit.com](http://www.caldigit.com)

## AUDIO CONSOLE

CALREC AUDIO

Audio console features Bluefin High Density Signal Processing technology; includes an innovative control interface offering expanded flexibility and enhanced visual feedback.

+44 1422 842159; [www.calrec.com](http://www.calrec.com)

## FINAL CUT PRO PLUG-IN

AJA VIDEO IO HD



A transportable plug-in solution that works with HD and SD in Final Cut Studio 2; with a single FireWire 800 connection, it supports the new Apple ProRes 422 Codec natively, in hardware, to bring production-quality HD editing to the Mac Pro desktop and the MacBook Pro laptop.

530-274-2048; [www.aja.com](http://www.aja.com)

## CABLE CHECKER

CANARE FCT-FCKIT

Features the company's exclusive HFO connector design for reliable transmission and easy cleaning; allows fast, easy confirmation of HFO cables in the field; no heavy, bulky equipment to drag around; the compact design features a backlit digital display to measure optic loss and electrical continuity; small size and light weight make mobile installs smooth, secure and constant.

973-837-0070; [www.canare.com](http://www.canare.com)

## HD/SD-SWITCHABLE GRAPHICS SERVER

CHYRON MICROCLYPSS

Provides instantaneous clip recall and playout; can be configured as either HD or SD with synchronized audio, video and key outputs as well as a built-in keyer for compositing clips on program video; features local and remote browse, media management and playback control.

631-845-2000; [www.chyron.com](http://www.chyron.com)

## ONLINE

COMMUNITY PLATFORM

CISCO EOS

A hosted software platform that enables media and entertainment companies to deliver community-driven Web sites, creating more personalized experiences around their content and brands while increasing overall end-user engagement and retention; unlocks unrealized value in media company Web sites by integrating social networking, content targeting, asset management, and site administration features into a robust backend system.

800-553-6387; [www.cisco.com](http://www.cisco.com)

## INTERCOM SYSTEM

CLEAR-COM ECLIPSE

VERSION 5.1

Includes Logic Maestro and Production Maestro modules within the Eclipse Configuration Software (ECS); with Logic Maestro, ECS users can access a graphical object-oriented tool for rapid programming customization and simulation; Production Maestro offers a flexible and fast conference routing tool that can preset and manage live external lines in and out of a master control room to remote users' panels and their keys.

510-337-6600; [www.clearcom.com](http://www.clearcom.com)



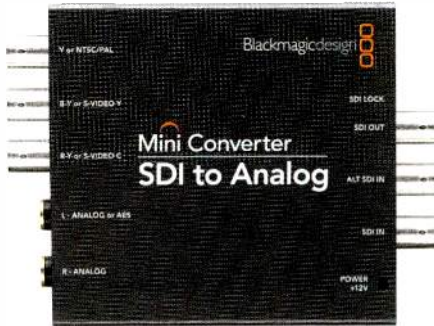

SDI to Analog  
**\$495**

New Down Converter!



Analog to SDI  
**\$495**



SDI to Audio  
**\$495**

New for 2009!

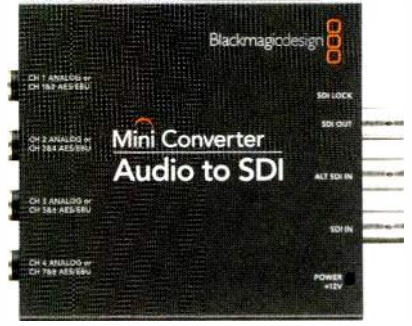

Audio to SDI  
**\$495**

New for 2009!



SDI to HDMI  
**\$495**



HDMI to SDI  
**\$495**



Optical Fiber  
**\$495**

New for 2009!



Sync Generator  
**\$295**

## The most advanced 3 Gb/s converters for SD and HD that include AES/EBU and analog audio!

Build your studio with the world's most advanced converters. Only Mini Converters include auto SD/HD switching, redundant input, AES/EBU and analog audio on 1/4 inch jack connections, plus advanced 3 Gb/s SDI! There are 8 great models to choose from depending on the conversion you need!



### Auto Switching SD and HD

Mini Converters instantly switch between all SD and HD formats, including NTSC, PAL, 1080i/59.94, 1080i/50, 1080PsF/23.98, 1080PsF/24, 720p/59.94, 720p/50. Updates can be loaded via USB.

### Redundant SDI Input

Most Mini Converters feature a redundant input and loop through SDI output. Connect a redundant SDI cable to the second input, and if the main SDI input is lost, Mini Converters will automatically switch over in an instant. That's great for mission critical tasks such as live events.

### Pro Analog and AES/EBU Audio

Standard 1/4 inch jacks are built in to most Mini Converters for professional balanced audio that switches between AES/EBU or analog. Unlike other converters you don't need expensive custom audio cables.



### 3 Gb/s SDI Technology

Mini Converters include the latest 3 Gb/s SDI technology, so you're always future proofed! 3 Gb/s SDI is also fully compatible with all your existing standard definition and high definition SDI equipment.

### Broadcast Quality

Mini Converters are built to the highest quality standards with low SDI jitter, so you get the longest SDI cable lengths combined with ultra low noise broadcast quality analog video and audio. Mini Converters are the world's first converters to include 3 Gb/s SDI on all models!

### Eight Exciting Models

Mini Converters include more new technologies than other converters, while every model is an affordable \$495. The Sync Generator model is only \$295!



Mini Converters  
**\$495**  
Sync Generator  
**\$295**

Learn more today at [www.blackmagic-design.com](http://www.blackmagic-design.com)



## GRAPHIC GENERATION AND OVERLAY

### COMPIX MEDIA CHANNEL BRANDER

Designed for channel branding, dedicated logo insertion, EAS message generation and automated template-based sports-score generation; accepts static graphic/logo import of TGA, BMP, JPEG, GIF, PNG, and TIF files, automatically converting images to and from different video resolutions as needed; uses Compix Media's GenCG software; offers 4000 True Type fonts and 300,000 premium quality images.

800-589-2555; [www.compixmedia.com](http://www.compixmedia.com)

## SATELLITE RECEIVER

### COMTECH EF DATA

#### CMR-8500

Encapsulates IP data into multiprotocol format for distribution over an asynchronous serial interface; designed for high-speed data applications; unit's 1RU rack-mountable platform is equipped with two GigE inputs and dual ASI outputs; capable of network throughput up to 155Mb/s and an aggregate packet processing of 140,000 packets per second.

480-333-2200; [comtechefdata.com](http://comtechefdata.com)

## REPLAY CONTROLLER

### GRASS VALLEY K2 DYN0

Coupled with K2 Summit; features intuitive user interface that includes the GV T-bar, switcher-quality buttons, a touch-screen LCD and high-speed GigE networking; can operate as a dedicated client within MediaFrame; users can import and export MXF, QuickTime and GXF files directly using a USB device.

530-478-3000; [www.grassvalley.com](http://www.grassvalley.com)

## CROSSPOINT ROUTING SWITCH

### CRYSTAL VISION SW803 3G

An eight by three crosspoint routing switch that works with 3G HD, HD and SDI and is ideal as a small or secondary matrix for multistandard environments; fits in standard frames, with up to six routing switches in 2RU; the double-decker 100mm by 266mm module saves valuable rack space; can send the eight inputs to any of the three outputs; timing information is provided by either black and burst or trilevel sync references, allowing the unit to switch in the vertical blanking interval to avoid picture disturbance.

+44 1223 497049; [www.crystalvision.tv](http://www.crystalvision.tv)

## VIDEO STREAMING APPLIANCE

### DIGITAL RAPIDS TOUCHSTREAM



Provides live streaming in a self-contained form factor; streamlined software controls are accessible through a touch-screen interface with integrated live video monitoring and VU meters for audio validation.

905-946-9666; [www.digital-rapids.com](http://www.digital-rapids.com)

## PROGRAM OPTIMIZER

### DOLBY DP600

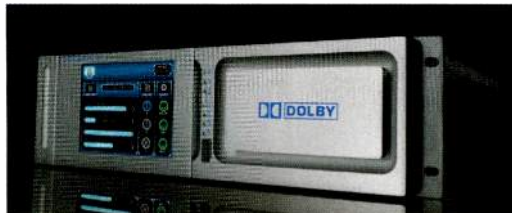

Program optimizer provides automatic analysis and intelligent correction of audio loudness and metadata (if applicable) for common broadcast media file and audio formats in use today; offers the option of faster-than-real-time file-based encoding and decoding of Dolby Digital, Dolby Digital Plus and Dolby E content, as well as efficient transcoding between the formats.

415-558-0200; [www.dolby.com](http://www.dolby.com)

## MD SWITCHER

### ECHOLAB OVERTURE1, OVERTURE2



Available with 1 or 2 M/Es; now features 3Gb/s (1080p60) format support to its existing range of SD, 720p and 1080i over a single SDI or HDMI input; offers internal conversion and synchronization with powerful key layering and special effects to put creative control at the user's fingertips; uses internal frame synchronization to help ensure the quality of effects.

978-715-1020; [www.echolab.com](http://www.echolab.com)

## DENG WIRELESS CAMERA SYSTEM

### ELBER WLCT-02SD

Wireless camera transmitter is ideal where portability and mobility is important; can be installed on the camera back without losing the optimum power dissipation; the integrated MPEG-2 4:2:2/4:2:0 digital encoder can accept digital SDI video as well as analog, and up to four mono audio channels or SDI embedded; provides a high-quality digital video and audio signal that can be used with others coming from wired cameras.

+39 0185 351 333; [www.elber.com](http://www.elber.com)

## TEST AND CHIP-LEVEL INTERFACE

### AUDIO PRECISION DIGITAL SERIAL I/O



Allows engineers to test audio devices at the level of individual ICs rather than being limited to evaluating only the external inputs and outputs of a device; enables all normal audio measurements to be carried out on A/D and D/A converters, codecs, DSPs and sample rate converters; interface can generate and measure up to eight audio channels simultaneously using TDM or multiple data lines.

503-627-0832; [www.ap.com](http://www.ap.com)

## X/Y STEREO FIELD RECORDING MIC

### AUDIO-TECHNICA BP4025



Designed for broadcast and professional recording; stereo condenser offers large-diaphragm capsules in an innovative coincident capsule configuration; allows for a smaller housing while producing an X/Y stereo image with the spatial impact and realism of a live sound field.

330-686-2600

[www.audio-technica.com](http://www.audio-technica.com)



# EVOLVING THE DIGITAL WORLD

Receiver Decoders · Digital Media Gateways · MPEG Monitoring & Analysis · Transcoders · Modulators · RF Analysis Equipment · IPTV Monitoring & Analysis  
ATSC Mobile DTV Signal Generators · ATSC Mobile DTV Signal Analyzers · Baseband Monitoring & Analysis · HD/SD SDI Monitoring & Analysis

The Sencore Modular Receiver Decoder (MRD) is installed by more broadcast, cable, satellite, and telco service providers, and across a wider range of applications than any other multi-format receiver decoder.

The Sencore MRD sets the standard for performance, scalable functionality and cost of ownership. It supports innumerable applications by combining dual-channel processing capability with MPEG-2, MPEG-4, 4:2:0, 4:2:2, SD, and HD video decoding.

With the wide range of interfaces, the Sencore MRD adapts to virtually any contribution, distribution, or backhaul environment while allowing easy upgrade paths to future technologies making it the only choice for operators seeking a truly future-proof solution.



MRD 3187B  
Modular Receiver Decoder

All Sencore products are backed by the absolute BEST customer service in the industry.



## DIGITAL TUNER AURORA MULTIMEDIA V-TUNE PRO HD



Designed for any integrated system, including for legacy NTSC tuning or ATSC/QAM capability; is LAN-addressable, IPTV-ready and capable of decoding MPEG-2, MPEG-4 and H.264; features intuitive RS-232 command sets for reliable two-way communication via traditional control systems, in addition to IP-based control for networked arrays.

732-591-5800

[www.auroramultimedia.com](http://www.auroramultimedia.com)

## VIDEO OVER IP ENCODER/DECODER ELECTROSONIC ES7100



Enables 3G-SDI, HD-SDI and SDI video transmission over IP networks at bit rates of 10Mb/s-150Mb/s; features PURE3 codec designed specifically for network transmission; provides resilience to network errors with real-time error concealment and constant latency of 70ms; can encode or decode.

818-333-3602; [www.electrosonic.com](http://www.electrosonic.com)

## TV ANALYZER ROHDE & SCHWARZ R&S ETL



Performs 8-VSB testing and optional MPEG-2 monitoring; analyzes and generates analog and digital test signals in a single box; allows new TV standards to be implemented on a software and hardware basis; uses real-time demodulation throughout.

410-910-7800; [www.rohde-schwarz.com](http://www.rohde-schwarz.com)

## CONVERTER ENSEMBLE DESIGNS AVENUE 5360

Converts four channels of analog video and audio to four streams of SD-SDI with embedded audio; the A-to-D converter and embedder is for broadcast and satellite applications; built-in TBC and frame sync allow users to bring in any analog signal with ease; expandable, modular, tray-based signal integration system is housed in a 1RU or 3RU frame; allows any combination of HD video, SD video, DVB-ASI and audio modules in the same frame.

530-478-1830

[www.ensembledesigns.com](http://www.ensembledesigns.com)

## HD TIME CODE READER/ GENERATOR/INSERTER ESE HD-488



Accepts multiple HD formats; generates/inserts time code; features dual LTC output, USB setup interface, time zone offset, LCD setup/status display and a universal power supply; enables as many as 30 characters of text to be superimposed onto the video.

310-322-2136; [www.ease-web.com](http://www.ease-web.com)

## VIDEO CONVERTER/FRAME SYNCHRONIZER EVERTZ HD2020 VIDEO PASSPORT

Integrates four independent up/down/crossconversion paths, each with a full frame synchronizer with a wide range of AV I/Os; can generate a multi-image display from eight select video clean switch I/Os; features embedded Web server and dual 10/100 Ethernet ports.

905-335-3700; [www.evertz.com](http://www.evertz.com)

## NEAR-LIVE EDITING TOOL EVS CLEANEDIT-XT[2]

Combines key features of CleanEdit timeline editor with XT[2] production server; supports program editing and highlights production for any near-live environment; covers all SD/HD workflow requirements from ingest to playout with advanced live editing tools.

973-575-7811; [www.evs.tv](http://www.evs.tv)

## UP/DOWN CONVERTER EYEHEIGHT UD-2



High-quality up/downconverter with three-field temporal processing and 3:2-pull-down frame rate conversion; compatible with the 18 video standards currently in use across 525/625, 720p, 1080p and 1080i; advanced video noise reduction features enable overall noise and artifacts associated with DCT compression to be minimized.

+44 20 82 552 015; [www.eyehight.com](http://www.eyehight.com)

## DVR AND PLAYER FAST FORWARD VIDEO ELITE HD



Camera-mounted DVR and player harnesses the J2K compression codec for recording HD-SDI video signals; accepts an incoming HD-SDI video signal with eight channels of embedded audio and records at data rates up to 100Mb/s with 4:2:2 sampling and 10-bit quantization at near-lossless compression; records video on commercially available, hot-swappable 2.5in SATA drives.

800-755-8463; [www.ffv.com](http://www.ffv.com)

## VIDEO CONNECTORS GEPSCO V-CON

Provide bandwidth and electrical performance necessary for multichannel HD interconnects in a durable, all-weather design; available in three- to six-channel versions as well as 10-, 12- or 14-channel versions; can be used for both component video and high-density, uncompressed HD video applications.

847-795-9555; [www.gepco.com](http://www.gepco.com)

## COLOR CORRECTOR FOR-A UFM-30DCC

Offers balanced, differential and sepia modes, as well as red, green and blue controls over white, black and gamma levels; available in single- or dual-channel configurations; upgradable to 3Gb/s capability.

714-894-3311; [www.for-a.com](http://www.for-a.com)



# Centralcasting Made Simple



Look what's  
**NEW!**

at Florical Systems

Contact us at: [sales@florical.com](mailto:sales@florical.com) | 352.372.8326 | [www.florical.com](http://www.florical.com)

## **S.M.A.R.T. Central** - Opens a whole new world of workflow opportunities

- ❖ Monitor or control channels through Supervisory Monitor.
- ❖ Control any individual channel through Remote AirBoss.
- ❖ View or Edit schedules through web based editor without on-air "control".
- ❖ Search, Browse, Edit the database remotely. Remotely view low-res copies of server inventory with Low-Res Viewer option.
- ❖ Traffic logs are "discovered" & converted to schedules without operator intervention (native file, BXF or LiveLog-BXF interfaces).
- ❖ Urgent Request Notifications and Deviation Reports are automatically emailed.
- ❖ Automated Dub and Purge List Processing.
- ❖ Easily update / replace workstations. Software is automatically installed when a user logs into S.M.A.R.T. Central. Simply add a new PC to the Florical Network then log into S.M.A.R.T. Central to access S.M.A.R.T. Central applications and reports

**RemoteEditor - NEW!** - a module within S.M.A.R.T. Central that allows access to current and future schedules for viewing or editing. As with all of S.M.A.R.T. Central products, RemoteEditor can be access from any networked machine so that last minute changes can be made from almost anywhere ... potentially eliminating make-goods.

**InventoryBrowser Low Res Viewer- NEW!** - a module within S.M.A.R.T. Central to browse the database and view low resolution copies of server inventory. With the power of smart client technology, the user can log in from any networked machine, whether from a Sales laptop in the field or Traffic desktop, and search view content that has been dubbed into the broadcast servers. The tool is perfect for Traffic or Sales to view spots from the convenience of their desktop.

**AssetDispatcher - NEW!** - streamlines central ingest systems. AssetDispatcher is a transfer agent that uses regional dub-lists and programming settings to push commercial and long-form from a centralized ingest location to regional sites after material has been approved. Timing and all metadata can be entered once and shared by all.

**Remote AirBoss - NEW!** - a module within S.M.A.R.T. Central for master control automation that allows access to monitor or control on-air from any workstation within the Florical Network. RemoteAirBoss can be used to control a single channel or can simplify centralization of master control, allowing dynamic selection of "hub" location based on your unique workflow needs or as your workload changes.

## Broadcasters who need the best, turn to Florical



## SWITCHER

### GEFEN 4X1 3G SDI SWITCHER



Allows four 3G SDI sources to be switched to one 3G SDI destination; offers access to any source by front-panel selector, IR remote or RS-232 connection; 1080p full-HD resolutions can be switched for each source, delivering 3G SDI video with no delays.

818-772-9100; [www.gefen.com](http://www.gefen.com)

## MONITORING SYSTEM

### GENELEC SE DSP

Small Environment DSP monitoring system is designed to solve acoustic problems associated with small recording and mixing environments; combines the SE7261A 10in DSP subwoofer with 8130A digital input active monitors, configurable as a subassisted stereo or multichannel reference system.

508-652-0900; [www.genelecusa.com](http://www.genelecusa.com)

## TRANSFER AGENT

### FLORICAL ASSETDISPATCHER

Option in S.M.A.R.T. Central; streamlines central ingest systems; uses spoke dub lists and programming settings to push commercial and program from a centralized ingest location to spoke sites after material has been approved; timing and metadata can be entered once and shared by all.

352-372-8326; [www.florical.com](http://www.florical.com)

## MODULAR RECEIVER/DECODER

### SENCORE ATLAS MRD 3187B

Combines dual-channel processing with MPEG-2, MPEG-4, 4:2:0, 4:2:2, SD and HD video decoding; adapts to virtually any contribution, distribution or backhaul environment while allowing upgrade paths to future technologies; features DVB-CI and SCTE35/104 messaging support.

605-339-0100; [www.sencore.com](http://www.sencore.com)

## MODULAR I/O RACK

### SOLID STATE LOGIC B-RIO

Features 7RU chassis with dual PSUs standard, integrated 24 GPI card, integrated MADI x 4, five audio card expansion slots for mic, line and AES card options, single-sided access and support for n+1 redundant MADI links.

+44 1865 842300

[www.solidstatellogic.com](http://www.solidstatellogic.com)

## HD PRODUCTION CLIENT

### GRASS VALLEY K2 SUMMIT

Supports SD/HD live event news production and live-to-tape/disk applications; supports four bidirectional channels of DVCPRO HD, DVCPRO 50 and DVCPRO 25; features responsive performance, a small form factor, instant playback of recorded material and built-in transition effects that only take one playback channel.

530-478-3000; [www.grassvalley.com](http://www.grassvalley.com)

## MULTISCREEN TRANSCODER

### HARMONIC PROSTREAM 4000

Offers real-time transcoding of MPEG-2 and MPEG-4 AVC content for Internet, 3G/4G mobile and broadcast mobile TV services; can transcode up to 16 channels simultaneously; features an all-IP infrastructure and flexible software.

408-542-2500; [www.harmonicinc.com](http://www.harmonicinc.com)

## HD CAMCORDER

### PANASONIC AG-HPX300

P2 HD camcorder with 10-bit, 4:2:2, individual frame recording and native 2.2-megapixel imagers; offers the flexibility of interchangeable lens but comes standard with a 17x HD Fujinon lens; incorporates advanced 1/3in 2.2-megapixel 3-MOS technology to acquire full native resolution HD images.

201-392-4127

[www.panasonic.com/broadcast](http://www.panasonic.com/broadcast)

## DTV TRANSMITTERS

### HARRIS MAXIVA

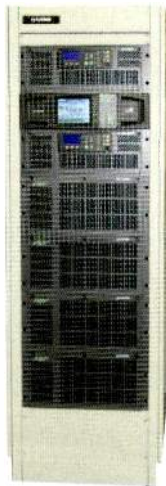

A range of compact, efficient liquid-cooled (high-power) and air-cooled (low-power) UHF transmitters; the company's MPH platform can be installed inside Maxiva and other DTV transmitters to create a compact, multiplatform transmission solution, delivering DTV, HDTV and mobile DTV services together in the same slice of bandwidth.

800-442-7747

[www.broadcast.harris.com](http://www.broadcast.harris.com)

## HDTV STUDIO/FIELD

### PRODUCTION CAMERA

#### HITACHI KOKUSAI ELECTRIC SK-HD1000

Offered with hybrid fiber-optic cable or digital triax cable transmission; converts into a solid-state field recorder and wireless configuration; features two-piece body design, F10 sensitivity with 60dB signal-to-noise ratio, 14-bit analog-to-digital conversion and CCU outputs of 1080i, 720p or switchable between the two.

516-921-7200; [www.hitachikokusai.us](http://www.hitachikokusai.us)

## WIRELESS HEADSET SYSTEM

### HME DX300ES



Supports hands-free, two-way digital conversations for up to 15 system operators with interfacing for two channels of external radio or intercom communications; features a compact design for portability and quick setup; uses digital spread spectrum system that requires no frequency coordination or license for operation.

800-848-4468; [www.hme.com](http://www.hme.com)

## STORAGE/PLAYBACK SYSTEM

### ALCORN MCBRIDE DIGITAL

#### BINLOOP HD



Provides playback of up to eight HD video channels in 3RU; stores video on CompactFlash; handles resolutions of 1080i, 720p, 480p/576p or 480i/576i; outputs video via HDMI or HD-SDI with embedded audio; can offer simultaneous SD/HD monitor outputs; supports stereo audio and Dolby or DTS bit streams.

407-296-5800; [www.alcorn.com](http://www.alcorn.com)



# Complete ATSC Mobile DTV Transmission Solutions



Upgrade any ATSC fixed transmission system to support ATSC Mobile DTV transmission (also known as ATSC-M/H (Mobile/Handheld)).

Axcera's complete ATSC Mobile DTV Transmission System includes:

- ▶ Axcera's ATSC Mobile DTV Preprocessor/Multiplexer combines ATSC fixed and mobile content into a single transport stream to feed an ATSC broadcast transmitter or Distributed Transmission System (DTS).
- ▶ Paired with Axcera's Axciter™ digital modulator, any digital transmitter can be made ATSC Mobile DTV capable.
- ▶ Working with best-of-breed technology partners, Axcera offers a complete integrated solution including mobile content encoders and an electronic service guide.

For improved in-building coverage Axcera offers the only commercially deployed DTS systems available.

To learn more about the most comprehensive ATSC Mobile DTV transmission solutions, visit: [www.axcera.com/atsc-mh-solutions](http://www.axcera.com/atsc-mh-solutions).



Call Us Today at 1-800-215-2614 or Email [info@axcera.com](mailto:info@axcera.com) to Learn More!  
[www.axcera.com](http://www.axcera.com)





## IMAGE PROCESSING SOLUTIONS

### ALGOLITH ALGOGEAR

Flexible, future-proof, modular solution can maximize bandwidth and clean, synchronize and scale media; comprised of image processing and enhancement solutions that harness the technology of the company's core Intellectual Property (IP); series includes noise reduction (VNR-1000-SD and VNR-1000-HD), upconversion (XVC-1001-UC), downconversion (XVC-1001-DC), frame synchronization (FRS-1002-MD), and line delay (VLD-1002-MD).

514-335-9867; [www.algolith.com](http://www.algolith.com)

## TRANSCODING SOFTWARE

### AMBERFIN ICR VERSION 4.5



Content mastering and transcoding software; now offers native support for Avid DNxHD and Final Cut Pro, offering instant interoperability with Avid and Apple editing systems; strengthens the link between content creation and distribution to expedite editing and versioning; extended MXF support of native Panasonic P2, Sony XDCAM and Avid Op Atom MXF further increases interoperability with a wide range of tapeless cameras, VTRs, editing and server systems.

866-939-3167; [www.amberfin.com](http://www.amberfin.com)

## DIGITAL AUDIO ROUTING AND INTERCONNECT SYSTEM

### SALZBRENNER STAGETEC

### MEDIAGROUP NEXUS

Audio network and routing system for controlling studio or mixing console resources, routing areas, OB trucks and sound reinforcement; offers audio format conversion, A/D and D/A converter systems, audio processing, data forwarding, routing interfaces, multichannel metering, power-amplifier control and intercom.

888-782-4391; [www.stagetec.com](http://www.stagetec.com)

## SD/HD PRODUCTION SWITCHERS

### ROSS VIDEO VISION QMD/X V9.0



Enhancements include up to eight channels of DVE in a single MLE, WhiteFlash transition type, expanded still-store functionality with thumbnails, animation trimming, new warps, MLE auto follow and memory attributes; also offers an expanded complement of device controls, including serial or Ethernet control of VTRs, video services, audio servers and audio mixers.

613-652-4886; [www.rossvideo.com](http://www.rossvideo.com)

## VIDEO ANALYSIS SOFTWARE

### INEOQUEST VERIFRAME

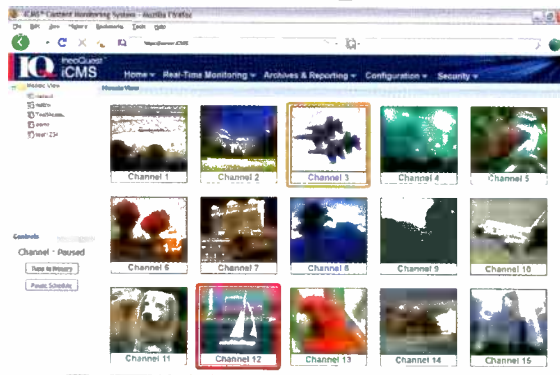

Offers baseband content monitoring and auditing; delivers both real-time and historical metrics; designed for use with a variety of solutions, including ad insertion (e.g., splice performance and ad auditing) and distributed video verification where generic remote consumer video viewing products are typically used; enables users to automatically verify video and audio content frame by frame, detect black screen, luminance levels and freeze frame, and monitor audio levels.

866-464-4636; [www.ineoquest.com](http://www.ineoquest.com)

## TAPELESS ENG SYSTEM

### IKEGAMI GF SERIES

Developed in cooperation with Toshiba; includes the GFCAM HDS-V10 tapeless camcorder, the GFSTATION GFS-V10 studio deck and the GFPK high-capacity flash media to record more than two hours of HD video; features an open-codec HD/SD architecture, proxy video and metadata convenience.

201-368-9171; [www.ikegami.com](http://www.ikegami.com)

## MASK/FILTER COMBINER

### JAMPRO ANTENNAS UHF RWED-516-U



Incorporates four-port directional filter/combining that can be used either as a mask filter or as a constant impedance-combining module for high-power UHF TV broadcasts; cross-coupled design accommodates adjacent channels, meets stringent filtering standards and provides constant impedance performance in adjacent channel applications as well as channel separations greater than 15 channels.

916-383-1177; [www.jampro.com](http://www.jampro.com)

## LEGALIZER

### EYEHEIGHT LE-2MD



A small, powerful legalizer that is compatible with all commonly-used signal standards from 525- and 625-line SD up to 720p and 1080i HD; structured as two internal independent legalizers in series; can be configured to operate in composite and RGB domains simultaneously, including conformity to the 75 percent chroma settings commonly used in the United States, Japan and Australia.

+44 20 82 552 015; [www.eyehight.com](http://www.eyehight.com)

## MPEG ANALYZER

### JDSU DTS-330

A video test solution that supports emerging technologies like MPEG-4 AVC, video over IP and broadband; helps with monitoring and troubleshooting digital video in networks of many varieties, including cable, broadcast, IP and terrestrial; supports the following: IGMPv3, GigE and QAM Channel Scanning, SNMP and MS-RTP.

408-546-5000; [www.jdsu.com](http://www.jdsu.com)



Are you looking for a way to **correct mismatched audio levels between program sources** in broadcast? LevelTrack adjusts the overall audio level of the signal, correcting inconsistencies based on channel history, maintaining the internal dynamics of the audio.

Could we come visit you at your facility and bring some demo gear? We'll bring easy-to-use equipment that will make your move to HD and 3G easier.

From our new **automatic gain control** for audio to **HD** and 3G test signal generators, and 3G capable frames - try Avenue from Ensemble Designs. Equipment that makes your **daily business more efficient, more reliable.**

Call us and we'll come visit you.

www.ensembledesigns.com  
+1 (530) 478-1830

**ENSEMBLE**  
DESIGNS

## New, Reliable Products for You For Broadcast and Post

20 + New Products

Ask for a hands-on demo, try these for yourself:

- Closed Caption Compliance/Detection
- Audio Automatic Gain Control Simplified
- Analog Video & Audio to Digital Converter
- 310M/ASI Converter
- 3G Test Signal Generator
- 3G/HD/SD Frame and more...



Purveyors of Fine Video Gear - Loved By Engineers Worldwide • [www.ensembledesigns.com](http://www.ensembledesigns.com)

**ENSEMBLE**  
DESIGNS



## PORTABLE HEADPHONE AMPLIFIER

JK AUDIO REMOTEAMP THREE



Provides a listen-only connection for IFB or full-bandwidth audio monitoring; XLR line-level input accepts either a balanced mono signal or a one- or two-channel party-line intercom feed (listen only); the XLR source switch selects between balanced input and intercom monitoring; an integrated speaker is disabled when headphones or earphones are connected.

815-786-2929; [www.jkaudio.com](http://www.jkaudio.com)

## SDI INSERTER CARD

JÜNGER AUDIO C8486

Controls loudness with Level Magic functionality; features four-channel audio processing and SD-SDI interface as well as HD-SDI interfacing and eight-channel Level Magic Surround as an option or upgrade.

+49 30 677 7210; [www.junger-audio.com](http://www.junger-audio.com)

## PROHD CAMCORDER

JVC GY-HM700



Shoulder-supported camcorder records directly to SDHC memory card in the QuickTime format for Final Cut Pro, and optionally to SxS media compatible with Sony's XDCAM EX format; includes several key technology innovations that result in improved resolution in the camera's CCD/optional block, lens and viewfinder.

973-317-5000; [www.jvc.com/pro](http://www.jvc.com/pro)

## LIGHTING SYSTEM

KINO FLO BARFLY 400

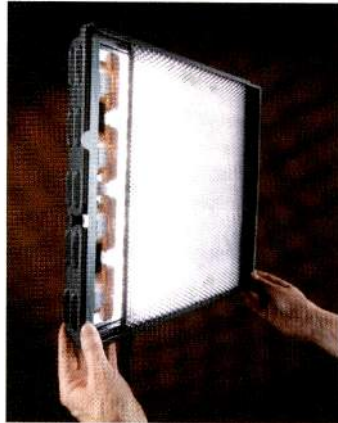

Uses True Match 55W QFL daylight and tungsten lamps; draws 4A of power on 120VAC; features four-lamp remote fixture and removable center mount; mounts to stand; includes 90-degree honeycomb louver, gel frame and built-in harness; runs up to 75ft from ballast.

818-767-6528; [www.kinoflo.com](http://www.kinoflo.com)

## SOFTWARE FOR PRODUCTION CONSOLES

LAWO V4.4 SOFTWARE



For the mc<sup>2</sup> series production consoles, which includes the mc<sup>2</sup>90, mc<sup>2</sup>66 and mc<sup>2</sup>56; with the Lawo Router MKII, the new software provides a redundant control system that initiates an automatic takeover if an error on the router module/control system occurs; control system redundancy activates if the standby system notices a loss of the connection between both control systems; this can occur as a result of either a software failure or a hardware error in the active control system.

888-810-4468; [www.lawo.de](http://www.lawo.de)

## ENG RECEIVER

LECTROSONICS DIGITAL HYBRID WIRELESS

Features two independent channels that can feed separate inputs or can be mixed internally to feed a single input; offers two diversity modes: SmartDiversity reception is employed by independently combining antenna phase for each receiver channel, while the two channels can be used together in True Diversity Ratio mode as a single receiver.

505-892-4501; [www.lectrosonics.com](http://www.lectrosonics.com)

## CONNECTORS AND CABLES

LEMO

The company has partnered with 3SAE Technologies to offer fusion splicing technology for its fiber-optic HDTV connectors and cables; the technology allows for both factory and on-site termination by replacing the fiber-optic connector polish process with a spliced fiber contact connector; reduces the time and level of expertise required for terminating the LEMO fiber-optic hybrid connectors.

707-206-3776; [www.lemo.com](http://www.lemo.com)

## HD WIRELESS CAMERA TRANSMITTER

LINK RESEARCH L1500

Supports a wide selection of RF modules that can be swapped over to operate in bands of 1.4GHz to 7.5GHz; uses the company's encoding and modulation methods to cut transmission delays to about one frame, making the transmitter suitable for live sports productions; includes options for camera control for Sony and Thomson Grass Valley cameras.

+44 1923 474060; [www.linkres.co.uk](http://www.linkres.co.uk)

## SIGNAL PROCESSING

LYNX TECHNIK YELLOBRICK

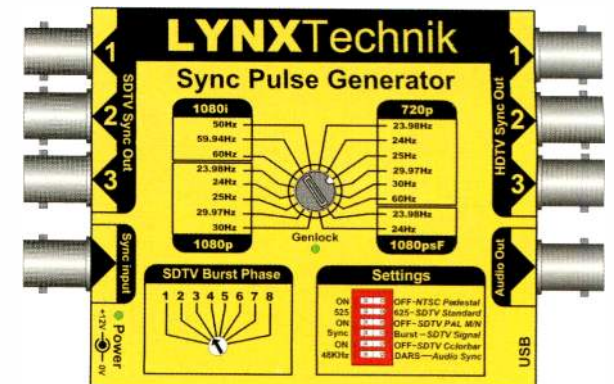

Modular interface products offer an array of cost-effective SD/HD standalone solutions for signal processing; provide straightforward user controls and instructions directly on the unit; available modules include an SD/HD sync pulse generator, SD/HD sync pulse generator with genlock, 3GHz SDI distribution amplifier, 3GHz SDI to fiber-optic transmitter, 3GHz fiber optic to SDI receiver, and 3GHz fiber-optic/SDI transceiver.

661-251-8600; [www.lynx-usa.com](http://www.lynx-usa.com)



# ELBER PRODUCT LINE

To satisfy the needs of the always growing number of clients and to be competitive in different applications, Elber has a wide range of products in continuous evolution. The products can be distinguished: fixed radio links (STL systems), mobile radio links, DENG systems and FM links for radio broadcasters.

The fixed radio links product line have always been Elber's selling force. Superior performance and the simplicity of installation are the main characteristics of these products that bring Elber to the world leadership in this market segment.

However, to respond to the constant evolutions of the market, it is necessary to develop equipment that require fast installation and have small dimensions. Such characteristics are met by the mobile radio links, a sector where Elber has made many investments in the past years.

The latest challenge for Elber is the DENG market. Aware of the ever increasing need of portable and fast set-



up systems, Elber presents a new highly technological range of products, maintaining the Company's idea of offering high performance equipment at competitive prices.

The R&D department offers an innovative and highly performing solution for Radio Broadcasters: apart from the renowned NBFM-01 microwave link, using an innovative digital signal processing of the modulated FM signal, Elber has developed new and alternative solutions for audio transport on digital networks. A new product line, called SRS, has been developed based on the Radio Software technology, obtaining excellent results and flexibility unique on the world market.

Fig. 1 gives a general view of the 4 main product categories offered by Elber for the transport of audio and video signals on large scale.

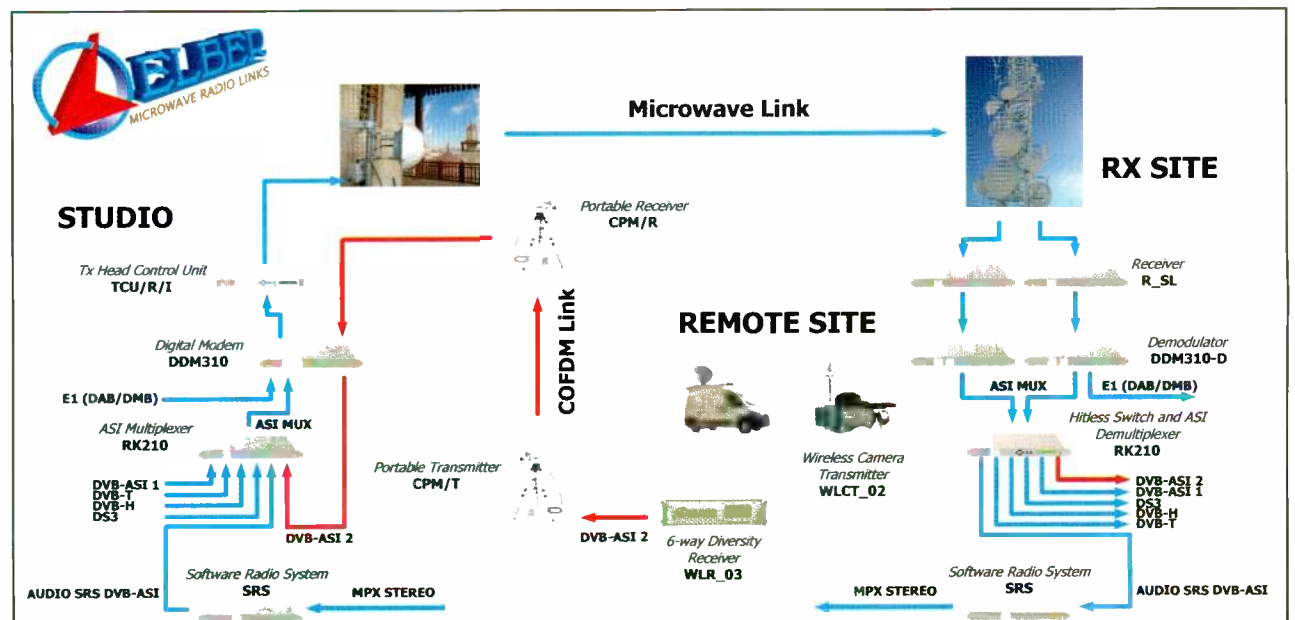

Fig. 1 Elber's Products

For a television broadcaster it is extremely important to have equipment which is quick and easy to install, suited for mobile applications. This is the typical configuration for live transmissions for both news, and entertainment programs, where the use of a wireless camera system (WLCT-02) is ideal to guarantee portability and mobility. The video signal of the wireless camera is transmitted to the mobile site (OB-VAN) where a digital COFDM receiver and decoder (WLR-03) are installed. The DVB-ASI output signal from the receiver is subsequently transferred to the studio through a portable microwave link (CPM).

The studio applications vary from the transport of the DVB-ASI signal coming from a remote site, to the transport of a DVB-ASI signal generated by the Software Radio System (SRS)- able to process digitally and transport audio signals (MUX STEREO) on DVB-ASI streams.

The multiplexed composite signal ASI-MUX is modulated by the highly reconfigurable DDM310 digital modem. The modulated signal is then transmitted (T\_SL) on the desired frequency band. The output signal of the transmitter can be divided and sent to two separate antennas placed at different

heights, to protect the system from multipath fading.

The reception of both signals is independent but with the use of a Hitless Switch, the two composite ASI-MUX streams are aligned and packet by packet, the error-free stream is sent to the output. The ASI demultiplexer separates and gives back the original signals.

## CPM Digital Portable microwave system

The digital portable multi-channel microwave radio system CPM is Elber's R&D latest product. The working frequency can be any 500 MHz band between 6 GHz and 15 GHz and the modulation can be either analogue (FM), digital (COFDM) or both. An external IF input for back-up signals is also available. These features make the CPM the ideal equipment for fast and reliable mobile links, even in hard weather conditions.

The COFDM section includes an SD 4:2:0/4:2:2 encoder. In addition, an FM modulator and demodulator implemented with Software Radio techniques are also available.

The control unit can be either indoor or outdoor. The latter is housed in a weatherproof box, while the indoor control unit is lodged in a 1U 19" standard rack.

we'll bring the world  
to you

**ELBER**  
MICROWAVE RADIO LINKS

**YOUR BROADCASTING PARTNER**

ELBER Srl. Via Pontevecchio, 42W - 16042 Carasco (GE) Italy • Tel: +39 0185 351333 Fax: +39 0185 351300  
www.elber.com - elber@elber.it



## PLAYOUT AND AUTOMATION SYSTEM

### OMNIBUS ITX NEWS

Offers the ability to take edits to air without prior rendering; generates graphics, audio and video effects, stills and captions in real time; allows users to ingest and edit together SD and HD sources and combine them in the same playlist with non-broadcast material, such as user-generated content, with real-time format conversion and effects rendering.

303-237-4868; [www.omnibus.tv](http://www.omnibus.tv)

## SD/HD/3GB/S ROUTERS

### MIRANDA NVISION 8288

Available in sizes up to 576 x 576; are half the size and weight of comparable routers and consume half the power normally required; ideal for flypack and truck applications.

514-333-1772; [www.miranda.com](http://www.miranda.com)

## SINGLE/DUAL-LINK FIBER-OPTIC TRANSPORT SOLUTION

### MULTIDYNE DVI-6000

Designed for RGB-HV and DVI-D with DVI-I interface; supports WQXGA, 2560 x 1600 resolution with dual link over a single fiber; provides optional stereo audio and bidirectional data for monitor control; transports image with no frame dropping up to WUXGA, 1920 x 1200; enables 24 bits for all scan rates.

516-671-7278; [www.multidyne.com](http://www.multidyne.com)

## SINGLE-MODE HYBRID CABLE

### NEUTRIK

Newest addition to the opticalCON line is a low-voltage camera/single-mode hybrid cable; optimized for camera link systems (ENG/SNG), camera adapter systems, camera cranes and powered down converter boxes for broadcast applications where only ELV (Extra Low Voltage, <50 VAC) is required.

732-901-9488; [www.neutrikusa.com](http://www.neutrikusa.com)

## NEWSROOM COMPUTER SYSTEM

### OCTOPUS NEWSROOM OCTOPUS6

Cross-platform system enables using Windows, Mac and Linux platforms simultaneously, reaching free operating systems as well as working with Apple Final Cut Pro; a new FCP plug-in gives users access to stories and scripts while editing their video footage.

+420 221 181 511

[www.octopus-news.com](http://www.octopus-news.com)

## LCD MONITOR

### SONY BVM-L170

The 17in LCD monitor incorporates a 10-bit 120Hz LCD panel, nonlinear cubic conversion imaging technologies, 12-bit signal processing engine, optical feedback stability systems and automatic calibration operation; delivers high levels of color accuracy and color reproduction, imaging quality and picture consistency; features full 1920 x 1080 HD resolution, a wide viewing angle, 10-bit driver and LED backlight system.

201-930-7330

[www.sony.com/professiona](http://www.sony.com/professiona)

## STANDARDS CONVERTER

### SNELL ALCHEMIST PH.C - HD



Offers simultaneous SD and HD conversion; new features include a FilmTools option, which delivers results with film-like quality quickly and affordably, and a new option for integrated Dolby E audio handling, which simplifies broadcast and post-production workflows and eliminates the need for outboard Dolby decoders and encoders; provides SNMP support.

212-481-2416; [www.snellgroup.com](http://www.snellgroup.com)

## SMART ANTENNA SYSTEM

### NSI QUICK SHOT



An advanced transmit system for mobile operations; reduces setup time by automatically aligning the transmit antenna with the receive location; can be remotely controlled by the NSI MC5; takes the microwave setup activities out of the truck and allows a single operator at the studio to control both ends of the microwave link; incorporates an NSI Silhouette or Stiletto directional antenna and a pan/tilt positioned; existing antennas can be used in some cases.

410-964-8400; [www.nsystems.com](http://www.nsystems.com)

## INTERCOM CONTROL PANELS

### RIEDEL ARTIST 4000

Provide the full functionality of Riedel's digital matrix intercom solutions at an entry-price level; eight-key control panel is housed in a universal enclosure, which allows both rack-mount and desktop operation; available in two versions either with marker strips or an eight-digit, high-contrast, full graphic LCD display.

914-819-0495; [www.riedel.net](http://www.riedel.net)

## DTV IFB RECEIVER

### NUCOMM PROQ



IFB solution for ENG users during DTV transmission, monitoring of DTV signals through a DVB-ASI output and streaming video over an IP connection to a laptop or other IP-enabled device; measures 5in x 1.75in x 8.5in; features dual UHF/VHF antennas, two advanced silicon tuners and sixth-generation VSB demodulators; contains an MPEG Layer 1/Layer 2 audio decoder that is capable of decoding two independent sound programs, providing up to four audio channels and using bit rates as low as 32kb/s for each.

908-852-3700; [www.nucomm.com](http://www.nucomm.com)

## FLUID HEAD

### OCONNOR ULTIMATE 2575D



Improvements include ergonomic changes to controls and more pan bar mounting points; features dual platform scales, one on each side, and four handle rosettes to allow operation from either side of the head as well as front or back handle mounting; weighs 22.9lb (10.4kg); carries 0-87lb (39.5kg) payload.

818-847-8666; [www.ocon.com](http://www.ocon.com)



## CHANNEL LAYOUT OMNEON MEDIADECK GX



Combines video server playout, graphics and advanced audio processing, all of which operate under the control of the user's preferred automation system; offers rich branding and master control functionality; designed to make it easier and more affordable for broadcasters to launch new services or to make incremental additions to their existing channel line-up.

408-585-5000; [www.omneon.com](http://www.omneon.com)

## MONITOR WALL PROCESSING VIDEOFRAME TALLY SERVER VNODE

Solves interface and equipment control issues for monitor wall processing; interfaces to Ethernet and serial tally streams, as well as GPI/GPO ports, with full logic capability; includes a time code input for timed events.

530-477-2000

[www.videoframesystems.com](http://www.videoframesystems.com)

## HD CAMERA

### TOSHIBA IK-HD1

One-piece, single-chip CMOS camera is in an ultra-sized housing measuring just 1-3/4in x 1-3/4in x 4 1/16in and weighs 4.3 ounces; outputs a full 1920 x 1080 resolution (12-bit) switchable between 1080i and 1080p at 60fps via DVI-I; DVI-I output affords users more flexibility by interfacing with less expensive HD monitors and recorders; can easily be converted to HDMI via adapter.

713-466-0277; [www.toshiba.com](http://www.toshiba.com)

## LI-ION BATTERY

### PAG L95E

14.8V 6.5A/h, 95W/h battery is available in V-Mount and PAGlok formats; V-Mount model can be charged on Sony chargers; incorporates a new 5 LED capacity indicator; displays charge status in terms of percentage; each LED represents approximately 20 percent of available capacity.

818-760-8265; [www.paguk.com](http://www.paguk.com)

## MASTER CONTROL

### HARRIS MASTER CONTROL SOLUTION

Consists of the company's NEXIO AMP media platform providing broadcast video feeds to the IconMaster master control switcher, CENTRIO multi-image processor, Platinum routing switcher and ADC automation; the five systems work seamlessly together, simplifying workflow in multichannel situations and for automated and manual control.

800-442-7747

[www.broadcast.harris.com](http://www.broadcast.harris.com)

## CONDENSED INTERCOM SYSTEM

### RTS ZEUS III

Features a compact size, 32 channels in/out and two configurable party-line interface channels; with the addition of Ethernet, the system can be configured from virtually anywhere on the network using AZedit Intercom software; can be directly connected to AZedit through the use of the USB connector on the front panel.

877-863-4169; [www.rtsintercoms.com](http://www.rtsintercoms.com)

# GOOD THINGS COME IN ALL SIZES

Marshall Electronics offers the widest selection of professional rack-mount and standalone LCD monitors in the industry. Marshall's video offerings range from 10-screen rack monitors and Quad Viewers to Super Transflective Outdoor monitors and a full series of displays with integrated In-Monitor Display (IMD) capability. We also offer a variety of DigitalAudio Monitors, professional microphones and pro audio cable.

- Quality • Innovation • Experience
- Customer Service
- Designed, Engineered, and Assembled in the USA

**Marshall Electronics / LCDracks.com** Tel.: 310-333-0606 / Toll Free: 800-800-6608



## HD LCD MONITOR PANASONIC BT-LH1710



Features a 1280 x 768 in-plane switching panel; incorporates the latest panel and image-processing technology to deliver higher contrast, improved black level performance and more functionality; uses a newly designed 10-bit image-processing circuit that reproduces color with increased accuracy and detail; has a 3-D look-up table that calibrates the panel to reproduce accurate images according to the specific color standard selected.

201-392-4127

[www.panasonic.com/broadcast](http://www.panasonic.com/broadcast)

## AUTOMATION SYSTEM

### PEBBLE BEACH SYSTEMS NEPTUNE

Features floating lists, global timers and multi-time zone support, as well as further expansion of Anchor, the company's integrated media management tool; floating lists allow any channel to be played from any physical playlist, which is then automatically routed to the right output; the system is aware of the available hardware and can determine whether the broadcast equipment can support SD, HD or both.

+44 1932 333790; [www.pebble.tv](http://www.pebble.tv)

## GRAPHICS TEMPLATE

### PHAROS EVENT TEMPLATES



Tie the graphics preparation workflow to playout and delivery when using Pharos Mediator and Playtime; simplify the creation and delivery of complex secondary events such as "coming up next" graphics, credit squeezes and promotions; frame-accurate markers can be added at any stage in the Mediator workflow to assist graphics design and trigger promotions during playout.

+44 118 950 2323; [www.pharos.tv](http://www.pharos.tv)

## PORTABLE FIELD/CAMERA-TOP MONITOR MARSHALL ELECTRONICS V-LCD70P-HDA

Features digital TFT-megapixel high-res LCD screen with 1.2 million pixels, four-pin XLR power jack and optical-grade polycarbonate screen protection; digitizes analog signals using 10-bit processing with 4x oversampling and adaptive five-line comb filter; available in 3G-SDI and HDMI configurations.

310-333-0606; [www.lcdracks.com](http://www.lcdracks.com)

## ROUTING SWITCHER QUSTREAM TIGER PRO



Compact and modular 144 x 144 fiber-optic routing system for 3G-SDI, HD-SDI or as a dual-link DVI switcher when used with the QFX series of video extender modules; starts at 36 x 36 and expands to 144 x 144 within the same frame; frame supports redundant power and redundant control; crosspoint switching is based on a single front-loaded 144 x 144 hot-pluggable matrix card; each input or output card supports up to 36 fiber-optic connections using standard LC-type SFP modules; I/O fiber cards are based on 1310nm single-mode lasers but can be used in multimode applications with reduced performance.

416-385-2323; [www.qustream.com](http://www.qustream.com)

## SIX-WAY COFDM DIVERSITY RECEIVER RF CENTRAL RFX-RMR-X6-II-D



Features an internal SD/HD decoder, on-screen display of stream data, Ethernet monitoring for remote-control access and IP encapsulation for Internet broadcast; available as a standalone COFDM receiver with ASI output or with an integral SD/HD encoder.

717-249-4900; [www.rfcentral.com](http://www.rfcentral.com)

## DIGITAL WIRELESS INTERCOM RIEDEL ACROBAT



License-free, full-duplex, wireless communications intercom; allows the operation of an unlimited number of wireless belt packs; features both partyline and point-to-point communications, digital audio quality and no interference with radio microphones or in-ear monitoring.

914-819-0495; [www.riedel.net](http://www.riedel.net)

## MULTIPLEXER ROHDE & SCHWARZ R&S AEM100



Enables network operators to completely upgrade their ATSC networks to ATSC Mobile DTV standard; can be integrated in the existing infrastructure.

410-910-7800; [www.rohde-schwarz.com](http://www.rohde-schwarz.com)

## DIGITAL PRODUCTION SWITCHERS

### ROSS VIDEO CROSSOVER SERIES



Designed for small studios, small mobile trucks, flight packs and linear editing; comes in both multidefinition and SD versions and with either six or 12 inputs; available in four configurations; features a patented UltraChrome chroma keyer, dual animation stores, two channels of 2-D DVE and four up/downconverters..

613-652-4886; [www.rossvideo.com](http://www.rossvideo.com)

## VIDEO TRANSPORT ENCODER STREAMBOX SBT3-9500

Enables broadcasters to get more HD/SD video back to the studio over networks including 3G, WiFi, WiMAX, the Internet and satellite; facilitates multiplexing/demultiplexing of a single video stream over two IP networks; based on ACT-L3 codec; encodes full-frame 1080i/720p HD video and NTSC/PAL SD video and audio.

206-956-0570; [www.streambox.com](http://www.streambox.com)



## LOUDNESS MONITORING DEVICES

### RTW LOUDNESS FAMILY

Includes SurroundControl, SurroundMonitor, DigitalMonitor, and an integrated loudness display conforming to the ITU BS.1771 guideline as a standard feature; help with monitoring the loudness of stereo, multichannel and surround signals in a wide range of applications, as a complement or an alternative to conventional peak meters; users can select integrated loudness measurement, as per ITU BS.1771 for stereo signals, as an alternative to the usual peak meter bar graphs.

+49 221 709130; www.rtw.de

## ARCHIVE SYSTEM

### SGL FLASHBOX

Based on SGL's FlashNet content archive and storage management software and hardware; provides scalable disk and tape storage, whilst providing from 1000 to 5250 hours of DV25 storage in a single appliance; when combined with FlashBrowse II, can serve as entry-level storage and content management.

+44 1489 88 99 30; www.sgluk.com

## DIGITAL MIXING CONSOLE

### SALZBRENNER STAGETEC

### MEDIAGROUP AURATUS

Developed as a small production, broadcasting and live console; has 54 input channels and a fixed bus layout; modular structure supports versions featuring eight, 16 or 24 channel strips; available as desktop or fitted versions without legs; designed for 5.1 and stereo formats; a stereo-only version is available on request.

888-782-4391; www.stagetec.com

## MULTIPLEX SIGNAL

### GENERATOR

### SENCORE ATX2000

Developed for ATSC-M/H standard; provides a variable broadcasting simulation test environment; can be tailored to specific situations using a comprehensive set of parameter and multiplexing function controls; offers easy-to-use interface and high-quality RF and ASI outputs in a portable platform.

605-339-0100; www.sencore.com

## DENSE DECODER AND DESCRAMBLER

### SCOPUS VIDEO NETWORKS

### INTEGRATED RECEIVER PROCESSOR



Combines a dense receiver that uses a variety of front ends, a dual decoder, a transport stream descrambler and a remultiplexer; features multiple DVB-s/S2, ASI and GigE inputs, a variety of TS outputs, two integrated DVB common interface modules that allow descrambling of two complete transport streams, and regeneration of MPTS to multi-MPTS/SPTS.

609-987-8090; www.scopus.net

## SATELLITE NEWSGATHERING

### STRATOS BGAN

Provides an SNG solution in a small, portable satellite terminal; offers broadcast-quality IP streaming and store-and-forward capabilities; simultaneous voice and data lines allow field reporters to maintain voice contact with the studio for cueing without compromising data.

709-748-4226; www.stratosglobal.com

## The ESE HD-488/SD Time Code Reader, Generator and Inserter

ESE introduces a new world of flexibility and features for time code with the HD-488/SD Time Code Reader, Generator and Inserter for HD and SD Serial Digital Interface video.

- Generates/Inserts Time Code • USB Setup Interface • User Friendly Control
- Universal Power Supply (90-264 VAC) • Accepts Multiple HD Formats
- Time Zone Offset • LCD Setup/Status Display • Dual LTC Output



142 Sierra Street  
El Segundo, CA 90245 USA  
Tel: (310) 322-2136

[www.es-web.com](http://www.es-web.com)



## DIGITAL TV TRANSMITTERS SCREEN SERVICE BROADCASTING MAGNUM SERIES

Digital TV transmitters for SFN and MFN networks; feature a built-in SFN adapter and advanced technology, which allows implementation of all modulation patterns for either digital or analog in the same hardware; firmware allows zero-error signal processing thanks to an internal 32-bit architecture; the SDT ARK-1 is an all-in-one transposer and transmitter for all modulation, including the ISDB-Tb.

+39 030 358 2225; [www.screen.it](http://www.screen.it)

## ROUTER CONTROL SOFTWARE SIERRA VIDEO TYLIXX PRO

Designed for the company's entire line of video and audio routing switchers; provides unique profiles for each user; adds additional security features for the control system; has a Windows-based GUI that allows users to virtually recreate their routing system on their computer desktops, defining sources and destinations, signal formats and cabling.

530-478-1000; [www.sierravideo.com](http://www.sierravideo.com)

## SHARED STORAGE

### SMALL TREE GRANITESTOR ABCSAN

iSCSI-based shared storage solution designed for audio/video and graphic artists to manage shared and direct attached storage solutions; provides robust (greater than 600MB/s), consistent performance over Ethernet networks, while offering optimal cost-efficiency; features an intuitive GUI with single pane class management for users who wish to manage RAID sets, volumes, targets and shares from one screen.

866-782-4622; [www.small-tree.com](http://www.small-tree.com)

## CAMERA RF AUDIO SYSTEM

### ZAXCOM QRX100



Receives four channels of audio from up to two stereo or mono digital transmitters; outputs these received audio channels as both analog and AES digital formats; a unique interface allows broadcasters to record all channels from four-channel ENG cameras quickly and easily.

973-835-5000 ; [www.zaxcom.com](http://www.zaxcom.com)

## SD/HD PRODUCTION SWITCHER

### SNELL KAHUNA



New features include the K-Watch software application, which allows file content and graphics to be converted and uploaded to one or multiple networked Kahuna systems, and the K-Mirror software application, which facilitates the rapid backup and sharing of Kahuna projects; also features 3-D stereoscopic functionality.

212-481-2416; [www.snellgroup.com](http://www.snellgroup.com)

## HD POV CAMERA

### SONY HXR-MC1



HD compact point-of-view camera and solid-state recorder combination; has a unique design that separates the camera head from the control unit/recorder, giving professional users more flexibility to capture shots in video applications where increased mobility is required beyond the use of traditional handheld or shoulder-mount cameras; records onto Memory Stick PRO Duo media using AVCHD compression; can record up to six hours of HD content onto a 16GB Memory Stick media.

201-930-7330

[www.sony.com/professional](http://www.sony.com/professional)

## DVI SCALER

### TV ONE 1T-C2-750

Converts between digital DVI-D and analog DVI-A signals including RGBHV, RGBS, RGsB and YPbPr formats; supports DVI-D resolutions up to 1920 x 1200/60Hz with DVI-A resolutions up to 2048 x 2048 and HDTV resolutions up to 1080p/60Hz; can be used as a seamless switcher device.

859-282-7303; [www.tvone.com](http://www.tvone.com)

## UPS

### STACO ENERGY

### UNISTAR P SERIES



A single-phase online UPS; available in 6-, 8- and 10-kVA models to protect from outages and irregularities in incoming line voltages from 160VA to 280VA at 45Hz to 65 Hz; up to four modules can be installed in parallel for redundancy or additional capacity; features a near unity input power factor and AC to AC efficiency greater than 90 percent that meets industry standards for energy savings and less than 5 percent reflected harmonics.

866-261-1191; [www.stacoenergy.com](http://www.stacoenergy.com)

## TRANSCODER

### TANDBERG TELEVISION RX8250

Part of an end-to-end cable HD distribution system that allows content providers to carry six to eight MPEG-4 AVC HDTV channels on a satellite transponder; helps operators with networks that have a large installed base of MPEG-2 HDTV set-top boxes by enabling efficient transcoding of MPEG-4 AVC/DVB-S2 distributed content into high-quality MPEG-2 HD.

678-812-6300; [www.tandbergtv.com](http://www.tandbergtv.com)

## VGA MONITOR

### RTW REMOTE DISPLAY 30010

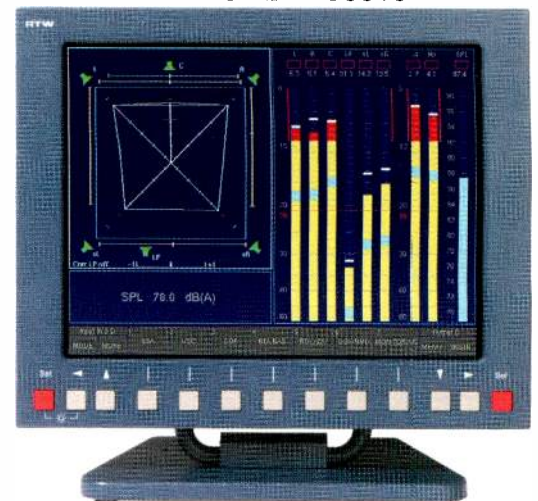

An 8.4in VGA monitor featuring function keys situated below the display screen; further enhances the ergonomics of the SurroundMonitor 11900; controls the instrument functions of the SurroundControl 31900; connected to the VGA connectors; allows the user to remotely visualize all instruments, options and measurement values of the units.

+49 221 709130; [www.rtw.de](http://www.rtw.de)



## ENG/SNG FIELD CAMERA INTERFACE STUDIO TECHNOLOGIES LIVE-LINK



Features full status LEDs, support for all video formats, two mic/line connections with selectable gain and phantom on/off, two line-level paths for IFB, two-channel auto-nulling intercom, 10/100 Ethernet transport and Anton/Bauer battery adapter.

847-676-9177; [www.studio-tech.com](http://www.studio-tech.com)

## AUDIO AND VIDEO MONITOR TSL AVMU2-3G

3G audio and video monitoring unit with integral loudspeakers and a 4.5in, 16:9 high-resolution LCD TFT display, combined with four 53-segment bar graphs for simultaneous monitoring of four audio channels and comprehensive loudspeaker monitoring.

+44 1628 676 200; [www.tsl.co.uk](http://www.tsl.co.uk)

## MONITORS

### TAMUZ BROADCAST IMPERIAL EAGLE/ RLM HD CLASS-1

Class 1 32in monitor; meets SMPTE, ITU and EBU recommended specifications; HD-capable and use customized LCD panels; conform to the EBU t3320 Grade-1 and EBU t3325 measurement and exceed the recommended specifications values for brightness, contrast and black level.

908-879-0010; [www.tamuz-usa.com](http://www.tamuz-usa.com)

## ENGINEERING SERVICES AND DESIGN

### TV MAGIC

Offers complete design, renovation and build-out of facilities, including television stations, post-production and production studios; follows a rigorous five-phase system, which is a complete, extensive process consisting of initial design, system drawings, and line-item equipment lists that follow on to system installation, proof of performance, and end-user system training.

858-650-3155; [www.tvmagic.tv](http://www.tvmagic.tv)

## CONTROL PANELS

### VIDEOFRAME LCD24PL/24PR

Machine control and router-master control panels feature 24 programmable LCD switches; the four menu buttons are located either to the left of the LCD switches (24PL) or to the right of the LCD switches (24PR); use Power over Ethernet technology, eliminating the need for an external power supply.

530-477-2000

[www.videoframesystems.com](http://www.videoframesystems.com)

## TS MONITOR AND ANALYZER

### TRIVENI DIGITAL STREAMSCOPE MT-40

Provides real-time analysis and verification of DTV transport streams; facilitates end-to-end MPEG-2/MPEG-4 transport stream monitoring and analysis for DTV signals carried by broadcast, cable, satellite, IPTV, or mobile networks; features two PCI card slots; supports RF (VSB), SMPTE310, ASI, QPSK, 64/256 QAM GigE, and file inputs, and broadcasters can select the two inputs best suited for their operations.

609-716-3500; [www.trivenidigital.com](http://www.trivenidigital.com)

**GET THE  
STORY.  
OR WATCH  
SOMEONE  
ELSE  
REPORT IT.**

## NOTE TO SELF: VIDEO OVER IP.

Competition fuels the news business. It's get or get out. So give your team an unfair advantage: Streambox. Instead of rolling ENG/SNG trucks, broadcasters can deploy a scalable IP-based solution that helps you get more news faster and at a lower cost. Go live-to-air, edit the story for later broadcast, or feed video to websites and affiliates. Call us to schedule a demo.

 **Streambox**  
Innovation is in the box™

Learn more at [www.streambox.com](http://www.streambox.com)  
or call +1.206.956.0544 ext 222.



## REAL-TIME INTERNET BROADCASTING SOLUTION HARRIS DYNACAST



Provides a two-screen, interactive viewing experience for TV audiences; allows broadcasters to synchronize Web content with live and prerecorded programming; connects the broadcaster's channel and brand to the Internet, creates a compelling new way to engage audiences through an enhanced viewing experience and generates revenue through cross-promotion of on-air and online media.

800-442-7747

[www.broadcast.harris.com](http://www.broadcast.harris.com)

## ENCODER VIEWCAST NIAGARA PRO II



Captures, encodes and streams video and audio over the Internet and mobile networks for live viewing and video-on-demand applications; comes with Simul-Stream and Niagara SCX Pro control and management software, which allow users to manage the streaming workflow from a single user-friendly Web interface and enable a single video source to be streamed simultaneously at multiple resolutions, at multiple data rates, and in a variety of streaming formats, including H.264, MPEG-4, Adobe Flash, Windows Media (Silverlight compatible), and 3GPP/3GPP2 for mobile applications.

800-540-4119; [www.viewcast.com](http://www.viewcast.com)

## HDTV ENCODER NTT ELECTRONICS

Encodes 4:2:2 chroma AVC/H.264 HDTV/SDTV real-time, ultra-high quality video; supports MPEG-2 format to enable smooth migration from current MPEG-2 technology to future AVC/H.264.

+81 42 796 2496; [www.nel-world.com](http://www.nel-world.com)

## LCD VIDEO MONITOR WOHLER RM-4290W-2HD



Measures 4RU in height; incorporates two 9in widescreen LCDs with 800 x 480 resolution and 16.2 million colors.

510-870-0810; [www.wohler.com](http://www.wohler.com)

## TECHNICAL FURNITURE TBC CONSOLES TRAC SERIES



Series includes the IntelliTrac, TracWall and SmartTrac consoles; provide modular designs for control room consoles, edit desks and flat-panel monitor walls; integrate perfectly with each other; offer highly adaptable furniture solutions.

888-266-7653; [www.tbconsoles.com](http://www.tbconsoles.com)

## HYBRID ELIMINATION DEVICE TELECAST FIBER SYSTEMS HDX-3D

Accommodates stereoscopic camera systems from Ikegami and Sony; using local power, the device provides power and optical connectivity to camera heads, making 3-D acquisition easy; also supports HD cameras from Panasonic and Thomson.

508-754-4858; [www.telecast-fiber.com](http://www.telecast-fiber.com)

## ELEVATOR PEDESTALS TELEMETRICS EP-PT-S2 AND EP-PT-S2-2

Remotely controlled, motorized telescoping tripods are designed to add pedestal height control to the Telemetrics Robotic Pan/Tilt product line; available in two versions: 1-stage (EP-PT-S2) and 2-stage (EP-PT-S2-2) for additional height.

201-848-9818; [www.telemetryinc.com](http://www.telemetryinc.com)

## ANCILLARY DATA MONITORING

### TEKTRONIX ANC DATA INSPECTOR

Enhances the ancillary (ANC) data monitoring capabilities of the WFM7120 and WFM6120 waveform monitors; ensures that all required ANC data is present and correctly configured through an intuitive data display.

800-835-9433; [www.tektronix.com](http://www.tektronix.com)

## ROUTER

### SNELL 3GB/S ROUTER

The new 1080p router offers a mix of video and audio routing modularity with optional SFP 3Gb/s fiber; the large-scale, multiformat router is easily expanded up to 1152 x 1152 simply by linking two frames via multiway cables without the need for any external splitters or combiners; further capacity is added by linking further frames, even when the system is in use.

212-481-2416; [www.snellgroup.com](http://www.snellgroup.com)

## ADJUSTABLE-BEAM FLUORESCENT LUMINAIRES VIDESSENCE POWER KEY

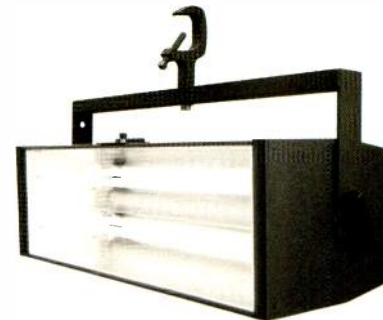

Feature adjustable mounting yoke and lever at the back fixture to adjust each lamp cell; allows adjustments from 60 degrees to 90 degrees beam spread; reflector refocuses the light without the need for additional accessories; use 55W Biax lamps; P055-155BX is 55W, P110-255BX is 110W and P220-455BX is 220W.

626-579-0943; [www.videssence.tv](http://www.videssence.tv)

## MULTICHANNEL LEVEL CONTROL WARD-BECK SYSTEMS MLC8

Handles AES, Dolby E, Dolby AC3, analog audio or HD/SD embedded signals; equipped with eight LED bar graph level displays, individual channel and master level control with mute function, level status LED indicators, presets and toggling between 5.1 and stereo listening, and 7.1 and 5.1 to stereo mix-down capability.

416-335-5999; [www.ward-beck.com](http://www.ward-beck.com)

## ROUTER AND DA SERIES UTAH SCIENTIFIC PROPRODUCTS

Series includes fixed frame and modular routers, as well as distribution amplifiers, for all signal types, including the 3G format; also includes a full-featured sync and test signal generator with options designed for all professional video applications.

801-575-8801; [www.utahscientific.com](http://www.utahscientific.com)



## ROBOTIC AND MANUAL PEDESTAL

VINTEN RADAMEC FUSION FP188



Recognizes new, compact L-shaped floor targets that offer more precise reference positioning across a wider range of floor finishes; features smoother on-shot transition sequencing and collision avoidance protection; 187lb payload supports an expanded camera/prompter package, including the talent-facing vanity monitor often attached to the head during HD production.

845-268-0100; [www.vinten.com](http://www.vinten.com)

## DVCAM TAPE FOR HDV

SONY  
Offers the convenience of one familiar format for SD or HD shoots; allows standard DV cameras to be fully compatible with the HDV format, so video professionals can shoot in SD or HD without the cost of moving to a completely new format; first-time HD users can take advantage of 720p HD recording at a video bit rate of 19Mb/s or 1080i HD recording at a video bit rate of 25Mb/s; improved RF output using HPE IV magnetic layer technology provides a high error-rate margin for fewer dropouts and better picture stability.

201-930-7330

[www.sony.com/professional](http://www.sony.com/professional)

## VARI-FOCAL LENSES

FUJINON DV SERIES  
Three-megapixel, vari-focal lenses are designed for half-inch camera formats; the DV3.4x3.8SA-1 is a manual iris version and has a focal length range of 3.8mm-13mm, an aperture range of F1.4 to T360, and a 97-degree horizontal angle of view at 3.8mm; the lens is also available as DV3.4x3.8SA-SA1, an auto iris DC Type model; the DV10x8SA-1 offers a focal length range of 8mm-80mm without compromising an aperture range of F1.4 to T360 and is a manual iris version; the lens is also available as DV10x8SA-SA1, an auto iris DC Type model.

973-633-5600; [www.fujinon.com](http://www.fujinon.com)

## CABLE ASSEMBLIES

WIREWOKS BG CABLE ASSEMBLIES

Can be used in both microphone and line level applications; feature MusiLUX microphone cable or AES/EBU digital cable teamed with Neutrik's convertCON connector; available in four configurations: XLR male to convertCON, XLR female to convertCON, convertCON to convertCON and quarter-inch TRS to convertCON.

908-686-7400; [www.wireworks.com](http://www.wireworks.com)

## PRODUCTION/ARCHIVE SOLUTION

VIZRT VIZ VIDEO HUB V1.2.1

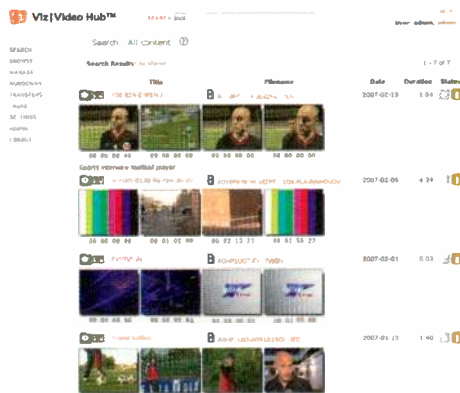

Enables broadcasters to archive video assets directly within the system as well as quickly retrieve and repurpose them; allows graphics solutions to search for video clips on the MAM storage, retrieve and edit them and add them to graphics and templates; assets can be directly accessed through the Escenic Content Studio software.

212-560-0708; [www.vizrt.com](http://www.vizrt.com)

## NEWS PRODUCTION SYSTEM

VSN VSNNEWS

Allows text/video editing in the same application; covers all issues in a uniform environment, including rundown planning and creation, resource management, word processing, video feed recording, and archive storage, organization and cataloging.

305-629-3201; [www.vsn-tv.com](http://www.vsn-tv.com)

## AUDIO CONSOLE

WHEATSTONE D-8



Surround-sound audio console for medium and smaller market stations, remote trucks, or secondary on-air/production rooms in larger facilities; features 24 motorized input faders, surround, four submasters, two main buses, two aux sends, and extensive processing (four-band parametric EQ, filters, compressor/limiter, de-esser).

252-638-7000; [www.wheatstone.com](http://www.wheatstone.com)

## PORTABLE RECORDER/PLAYER

PANASONIC AG-HPG20



A solid-state P2 portable recorder/player with AVC-Intra, DVCPRO HD/50/25 and DV compatibility; the 10-bit, 4:2:2 deck can be used for fast, file-based recording; removable solid-state cards offer recording times that exceed those of tape or optical disc-based products.

201-392-4127

[www.panasonic.com/broadcast](http://www.panasonic.com/broadcast)

Curious? See you at infocomm Orlando, booth 6833

**RIEDEL**  
The Communications People

**ARTIST DIGITAL MATRIX INTERCOM**  
The Solution for World Class Events.

Riedel Communications Inc. • 1721 Victory Blvd • Glendale, CA 91201 • USA • [www.riedel.net](http://www.riedel.net)



## SIGNAL SWITCHER

### WHIRLWIND AB-8

Eight-channel, balanced bidirectional switcher auto-senses loss of input on its eight primary inputs; automatically switches to secondary inputs for backup in live tracking applications; can also be used manually to switch between inputs and outputs when multitracking in a studio; channels can be switched individually or globally; AB-8 units can be master/slaved for switching large numbers of channels.

585-663-8820; [www.whirlwindusa.com](http://www.whirlwindusa.com)

## CONNECTOR

### WHITE SANDS ENGINEERING AIRBNC

Combines the high performance needed for broadcast applications with the ease of termination and reliability of a one-piece design; meets and exceeds the requirements of SMPTE 292M and provides headroom out to 4.5GHz.

623-581-033

[www.whitesandsengineering.com](http://www.whitesandsengineering.com)

## HD BROADCAST SERIAL DIGITAL INTERFACE CARD

### YAMAHA MY8-SDI-D

Enables the input of HD-SDI embedded audio signals directly to the host Yamaha digital console or digital mix engine; features one HD-SDI input with one HD-SDI-through output, replacing the need for conventional converters to feed Yamaha digital consoles; of the 16 audio channels of audio in HD-SDI, eight are selectable (two groups of four); can synchronize to either video or audio signals; is installed via I/O slots in Yamaha's digital mixers and mix engines; I/O options allow direct interface to EtherSound, CobraNet, AES/EBU, MADI, ADAT, mLAN and other formats.

714-522-9011; [www.yamahaca.com](http://www.yamahaca.com)

## VERIFICATION NETWORK

### XORBIT PROOFPOSITIVE



Improvements to the watermark-free delivery verification network include a new 3RU video signal monitor (VSM) chassis, new motherboard and CPU, new video capture technologies, and version 2.0 software; provides engineering with audio-level alerts and video-overlay alerts automatically; features a single interface to monitor alerts and play back clips, new full-search capability, auto-filing alerts by location for tracking and archival purposes, and a "watch list" capability, so specific locations can be tagged as high priority.

301-362-9500; [www.xorbit.com](http://www.xorbit.com)

## CONFIGURABLE CONTROL PANELS

### HI TECH SYSTEMS ASIGN



Allow Mac and Windows application controls to be allocated to LCD key switches or a control wheel, giving operators a clear and quick interface to a computer application without the need for keyboard and mouse; allows for multiple applications on multiple computers to be allocated to just one panel; LCD keys can be configured for color, brightness, text or icon, and other operational functions, such as grouping, GPI triggering, a string of keyboard shortcuts or the launch of Java scripts.

+44 1256 780880; [www.hitechsys.co.uk](http://www.hitechsys.co.uk)

## WIRELESS RECORDING SYSTEM

### ZAXCOM TRX992



Environmentally friendly wireless audio transceiver designed specifically for boom pole and sports applications; performs the functions of an audio transmitter, monitor return receiver, backup recorder and phantom power supply in a single unit; a 100 percent digital transmission system optimized for boom mic operators working on motion picture and TV production; transceiver features internal recording, which backs up all transmissions to guard against lost audio files.

973-835-5000; [www.zaxcom.com](http://www.zaxcom.com)

## MANAGEMENT SYSTEM

### ZEUS BROADCAST

Software solution manages the service department; provides help desk communications; tracks all asset activities, changes and configurations; handles multi-organizational, multi-locations or multi-group topologies; provides fully searchable and sharable information while at the same time maintaining the separation and control that each organization, location or group requires.

407-352-6501

[www.zeusbroadcast.com](http://www.zeusbroadcast.com)

## SHARING/STORAGE SYSTEM

### BITCENTRAL OASIS MEDIA MARKETPLACE



Enables local TV stations to share and sell media over existing bandwidth without paying for satellite transmissions; stations can share within their own groups while selling content to other stations.

949-253-9000; [www.bitcentral.com](http://www.bitcentral.com)

**HD DIGITAL**  
**CANARE**  
digital interconnect technology

**COU-\*\*\***  
Connector Unit

**COU-BP\***  
Blank Panel

**COP\*-\*\*\***  
Connector Panel

**COP-FM3**  
1 Unit Terminal Panel

**COF-\*\***  
Frame

Hybrid Fiber-Optic Camera Connector Panels

**Features**

- SMPT 311 Standard
- Integrated splice enclosure
- Easy maintenance & Installation
- Patent Design modular system
- Available in 2RU, 3RU and a variety of Configurations

canare.com | [lcano@canare.com](mailto:lcano@canare.com) | 973.837.0070 | hybrid fiber-optics & EO/OE | snake systems | connectors | cable reels | patchbays | cables



## STORAGE

### BYCAST STORAGEGRID 8

Virtualizes information retention and access over a range of storage devices from high-performance disk to archival media, distributed over multiple sites; features the new Distributed File System Gateway (DFSG), a high-performance clustered file system front-end; provides a unified solution to manage the storage of digital data and images from primary storage to deep archive.

866-217-6813; [www.bycast.com](http://www.bycast.com)

## PAN-TILT CAMERA SYSTEM

### CANON BU-50H

Remote-control robotic indoor pan-tilt HD camera system; provides exceptional HD video imagery and versatile performance in such locations as houses of worship, legislative chambers, studio POV camera positions, indoor security areas, and many other environments; an extremely quiet P/T system and features a maximum noise level of NC30.

800-321-4388

[www.canonbroadcast.com](http://www.canonbroadcast.com)

## INTERCOM SYSTEM

### CLEAR-COM CONCERT 2.0

Connects to the Eclipse matrix system via the IVC-32 high-density card, establishing a single communication environment for traditional and IP intercom users; customizable user interface is now available in a soft-panel that emulates a traditional intercom station, offering functionalities such as push-to-talk, monitor and latch-to-talk keys for communication with other Concert users, as well as connection to predefined conferences.

510-337-6600; [www.clearcom.com](http://www.clearcom.com)

## DOLBY DIGITAL ENCODER

### DOLBY CAT. NO. 561 DOLBY DIGITAL PLUS ENCODER MODULE

Designed for integration into third-party AV products featuring the new generation of video codecs such as H.264; offers broadcast equipment manufacturers the ability to add real-time multistream and multi-channel encoding of Dolby Digital and Dolby Digital Plus audio bit streams to their products.

415-558-0200; [www.dolby.com](http://www.dolby.com)

## CONTENT MANAGEMENT

### FRONT PORCH DIGITAL DIVADIRECTOR V4.0

Features key frame and thumbnail support, enabling the addition of visual markers in query results and to better identify segments in shot lists; collaborative shot list support allows users to share viewing and editing of shot lists; virtual asset support enables an asset and its metadata to be added to the system in anticipation of the clip's later arrival in the archive.

303-440-7930; [www.fpdigital.com](http://www.fpdigital.com)

## AVC SD/HD ENCODER

### FUJITSU IP-9500



Supports HD satellite newsgathering applications that require high picture quality at SD bit rates with low delay; features advanced H.264 compression technology; produces high-quality bit rates of 4Mb/s to 27Mb/s; other features include 300ms low latency, low bit rates, DVB-ASI or IP transports for network flexibility, and full compatibility with industry-standard decoders.

800-626-4686; <http://us.fujitsu.com>

## ROUTER

### GRASS VALLEY TRINIX NXT

Switches any signal from analog and SD to 3Gb/s 1080p HD; available in configurations of 128 x 128 in 8RU, 256 x 256 in 15RU and 512 x 512 in 32RU; integrated with CleanFlow architecture to minimize number of connector contacts; provides redundancy options including redundant matrix switching on the 128 and 256 input frames.

530-478-3000

[www.grassvalley.com](http://www.grassvalley.com)

## DWDM 1550NM

### TRANSMISSION SYSTEM HARMONIC SUPRALINK

Enables cable service providers to reuse their existing optical fiber network to deliver increased bandwidth to subscribers; supports up to eight wavelengths per single fiber over link distances of 40km with optical amplification and 25km without optical amplification for up to 1GHz of digital/analog content per wavelength.

408-542-2500

[www.harmonicinc.com](http://www.harmonicinc.com)

## SDTV STUDIO/FIELD PRODUCTION CAMERA

### HITACHI KOKUSAI ELECTRIC Z-4500W

Offered with configurations for digital/analog triax, OFDM wireless, multicore and ENG-HDR; features 520,000-pixel IT CCDs, 16:9/4:3 switchable aspect ratio, -130dB vertical smear specification; 14-bit A/D converters; 67dB signal-to-noise ratio, digital NTSC encoder and gunlock system and digital SMPTE color bar generator.

516-921-7200

[www.hitachikokusai.us](http://www.hitachikokusai.us)

## ETHERNET AND TRIPLE-PLAY TEST PROBE

### JDSU QT-600

Carrier-grade, scalable, multiservice probe that is a component of the company's NetComplete Service Assurance Solution; through proactive traffic monitoring, it detects patterns of QoS degradation and, from a centralized location, quickly segments the network to identify the source of the problem; provides a detailed view of network and service performance through distributed data gathering and consolidated reporting capabilities.

408-546-5000; [www.jdsu.com](http://www.jdsu.com)

**openGear** SOLUTIONS FROM WARD-BECK

- + Analog Audio / Video Distribution
- + AES/EBU Distribution
- + Analog to Digital Audio Converter
- + Digital to Analog Audio Converter
- + Muxing / Demuxing
- + DOLBY E/AC3 Decoding
- + Embedded Audio Processing
- + 3 Gb/s HD Distribution

**M6205C** Embedded Audio Processor

Ward-Beck Systems Ltd. // 10-455 Milner Avenue • Toronto, Ontario // M1B 2K4 // North America // 800.771.2556 // International // 416.335.5999 // [www.ward-beck.com](http://www.ward-beck.com)



# SPECIALREPORT

## SERVER

### 360 SYSTEMS MAXX-1200 HD

Plays three HD video streams at once, while ingesting another via Ethernet; serves as a graphics store, with linked key-and-fill capabilities; standard features include SDI video I/O (with frame synchronization) for recording wild sources like tape, camera or satellite feeds; eight channels of embedded audio and two channels of plus four analog audio are provided for each video stream; for surround, audio is easily expanded to a total of 24 channels.

818-991-0360; [www.360systems.com](http://www.360systems.com)

## DSP CARD

### JÜNGER AUDIO C8086-8

Features eight channels; incorporates Dolby Metadata Generator option; allows users to verify, modify or generate metadata, including dialnorm, according to Dolby specifications; with Level Magic system, can transport metadata from point of origin to point of Dolby Digital encoding.

+49 30 677 7210; [www.junger-audio.com](http://www.junger-audio.com)

## HANDHELD CAMCORDER

### JVC GY-HM100

Records files directly to solid-state media in the native format of Apple's Final Cut Pro; recorded material can be edited directly from the solid-state memory card, reducing the amount of time required to edit programs together; delivers high-bandwidth recordings at 1080p, 720p and 1080i on SDHC Class 6 memory cards.

973-317-5000; [www.jvc.com/pro](http://www.jvc.com/pro)

## SD WIRELESS CAMERA TRANSMITTER

### LINK RESEARCH L1360

Operates in various frequencies including 2.05-2.45GHz, 2.4-2.7GHz and 1.85-2.15GHz, among others; supports PAL, NTSC and SDI video as well as one stereo pair of line/mic level audio; powered by 12V; features DVB-T QPSK, 16QAM and 64QAM support.

+44 1923 474060; [www.linkres.co.uk](http://www.linkres.co.uk)

## SIGNAL PROCESSING

### LYNX TECHNIK P IE 5610 FLEXCARD



The latest edition to the FLEXCARD Series 5000 line of configurable HD/SD signal processing solutions; allows users to define their own toolset from a menu of firmware options including aspect ratio conversion, up/down/crossconversion, noise reduction and video delay; enables users to build a feature set of any combination of options specific to their application.

661-251-8600; [www.lynx-usa.com](http://www.lynx-usa.com)

## SERIAL DIGITAL VIDEO FIBER-OPTIC TRANSPORT LINK

### MULTIDYNE HD-3000

Supports 1080p progressive 3Gb/s HD-SDI SMPTE424M format; provides fiber-optic transport and distribution of virtually any digital signal from 5Mb/s to 3Gb/s.

516-671-7278; [www.multidyne.com](http://www.multidyne.com)

## RECEIVER

### NUCOMM NEWSCASTER DR 2



The diversity receiver offers new features including a split box and the ability to receive UHF digital signals in the 150MHz to 850MHz band; works with external block downconverters that receive a wide range of frequencies from 1.99GHz to 7.1GHz.

908-852-3700; [www.nucomm.com](http://www.nucomm.com)

## CONTENT DISTRIBUTION PLATFORM

### OMNEON PROCAST CDN

Manages and distributes content between two discrete locations as well as between any number of disparate sites worldwide; provides content exchange, disaster recovery and remote file access; enables the user to schedule transfers, manage bandwidth of each individual transfer and prioritize rules-based transfers.

408-585-5000; [www.omneon.com](http://www.omneon.com)

## TRANSMISSION SYSTEM

### OMNIBUS ITX ON-DEMAND

Allows broadcasters to transmit conventional channels and save VOD-ready content from the same iTX workflow and hardware, without having to reingest or reformat material explicitly for VOD use; can be used to create everything from low-resolution files for Web download or mobile phones to HD MPEG-4 files with Dolby surround sound for broadband IPTV applications.

303-237-4868; [www.omnibus.tv](http://www.omnibus.tv)

**Wish you could predict the future?  
You can with Zeus.**

Don't be caught off guard with unnecessary equipment issues. Get Zeus...the most trusted web-based equipment management and trouble-ticket system.

**zeus**  
BROADCAST  
[zeusbroadcast.com](http://zeusbroadcast.com)

Anytime, anywhere. That's the beauty of our 100% web-based equipment and service management system. Made by broadcasters for broadcasters, Zeus allows an infinite number of users to access the site from any Internet connection at anytime. Isn't that simple?



## BATTERY CHARGER

### PAG CUBE

Four-channel unit features PAG's Intelligent Parallel Charging software, which uses current efficiently for fast, fully automatic charging; capable of supplying approximately 100W (6A at 16.8V); designed for parallel charging of PAG and Sony V-Mount Li-Ion batteries.

818-760-8265; [www.paguk.com](http://www.paguk.com)

## HD CONVERTIBLE CAMERA

### PANASONIC AW-HE870



A 2/3in HD/SD convertible camera that supports 1080i/720p/480i image acquisition; compatible with most 2/3in motor drive zoom lenses, all current Panasonic Broadcast pan/tilts and controllers and many third-party systems; 38-bit digital signal processor and 14-bit A/D converter deliver sharp images even in difficult lighting; spatial offset and image-processing technologies provide high-quality, HD imaging; 12-axis color correction allows for precise control and matching of HD video.

201-392-4127

[www.panasonic.com/broadcast](http://www.panasonic.com/broadcast)

## SERVICE ASSURANCE TOOL

### PIXELMETRIX ELECTRONIC

#### COUCH POTATO

Measures and reports end users' experience for delivered video services; integral elements include telemetry and fault information from multiple points along the transmission chain, as well as consolidation of that information to one or more points of central control and observation; features telepresence, which allows remote monitoring of the audio and video output of the STB.

954-472-5445; [www.pixelmetrix.com](http://www.pixelmetrix.com)

## LCD VIDEO MONITOR

### WOHLER RM-2443W-2HD



Monitor is 2RU in height; incorporates four widescreen LCDs that measure 4.3in in size; features 480 x 270 resolution with 16.7 million colors.

510-870-0810; [www.wohler.com](http://www.wohler.com)

## AUTOMATION

### SNELL MORPHEUS

Includes a new scripting capability that allows users to automate repetitive tasks, improving productivity and consistency; anything users do via the user interface is captured within macro code and can then be mapped onto LCD panels; new fast commercial break feature tracks all commercials within a schedule, allows an operator to instantly swap or move them and also provides detailed information on what has been aired.

212-481-2416; [www.snellgroup.com](http://www.snellgroup.com)

## VIDEO OPTION CARDS

### QUSTREAM CHEETAH

#### MUX AND DE-MUX

Provide fully integrated routing of embedded audio signals from the Cheetah video router; support seamless intermixing of a wide variety of signal formats, including embedded audio, MADI, balanced and unbalanced AES and analog signal formats in both synchronous and asynchronous formats; feature 16 video channels per card; Cheetah DE-MUX video input card can de-embed 128 separate audio changes from any of 16 video channels on a single card and provide discrete audio signals to other distributed routing audio system elements; Cheetah MUX video output card can seamlessly embed 128 individual, external distributed audio routing system audio from MADI, AES and analog sources into any of 16 video outputs.

416-385-2323; [www.qustream.com](http://www.qustream.com)

## MULTIFORMAT VIDEO SIGNAL GENERATOR

### TEKTRONIX TG700

Upgrades include the addition of the 1080p SDI signal generation on a single link; this capability is added through the new 3Gb/s HD3G7 module that supports both Level A and Level B 1080p SMPTE formats; GPS7 module allows the unit to act as a master clock and synchronization system, including video reference and time code.

800-835-9433; [www.tektronix.com](http://www.tektronix.com)

## TRANSMITTER

### ROHDE & SCHWARZ R&S SCX8000



Features integrated cooling, integrated splitter and coupler station and new redundancy concept for the exciter and amplifier; can be switched from analog to digital transmission as required; power output stage comes ready with broadband precorrection for user's preferred digital standard.

410-910-7800

[www.rohde-schwarz.com](http://www.rohde-schwarz.com)

## COLOR DISPLAY DESKTOP PANEL

### RTS DKP 16 CLD



Controlled using a full-color graphic interface; features a USB port, two user-programmable buttons, one-touch listen volume adjustment and a backlit keypad.

877-863-4169; [www.rtsintercoms.com](http://www.rtsintercoms.com)

## MEDIORNET

Re-Defining Fiber-Optic Networks

- Fiber Signal Transport for Multi-Channel HD/SD Video, Audio, Intercom & Data
- Supports any Combination of Network Topologies
- Integrated CWDM Multiplexing
- Uncompressed Real-Time Signal Distribution and Routing
- Supports 3rd Party Router Control
- Software-based Signal Processing and Conversion
- Future-proof Hardware Platform

[www.mediornet.com](http://www.mediornet.com)

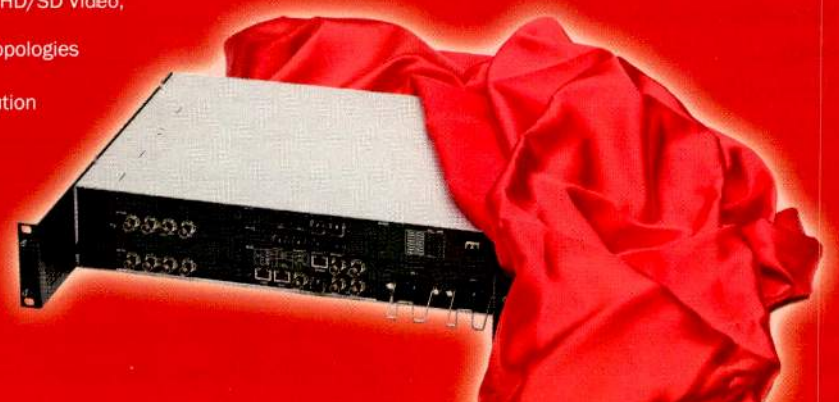

**RIEDEL**  
The Communications People



## ON-CAMERA LED LIGHT FIXTURE

SACHTLER REPORTER 8LEDIM



Offers a full range of dimming from 100 percent to zero; can be powered off input voltage from 6V to 24V; can be used as a small location light by placing it on a mounting base or on a mini croco clamp; available in a daylight or tungsten version.

845-268-0100; [www.sachtler.us](http://www.sachtler.us)

## SCHEDULING COMPONENT SCHEDULE ALL PROCESS MANAGER

Provides granularity of task-based scheduling, faster work order/process creation via drag-and-drop templates and enhanced forecasting, budgeting and reporting within the project workflow spectrum; enables a greater degree of visibility across the enterprise.

954-334-5406; [www.scheduall.com](http://www.scheduall.com)

## STANDARDS CONVERTER SNELL MACHHD

Offers cost-effective, high-quality motion-compensated HD and SD standards and format conversion with synchronization capability; offers multirate HD/SD inputs and outputs; provides up/down/crossconversion, along with aspect ratio conversion and colorspace conversion; supports embedded AES and analog audio.

212-481-2416; [www.snellgroup.com](http://www.snellgroup.com)

## DENSE DECODER AND DESCRAMBLER

SCOPUS VIDEO NETWORKS INTEGRATED RECEIVER PROCESSOR



Combines a dense receiver that uses a variety of front ends, a dual decoder, a transport stream descrambler and a re-multiplexer; features multiple DVB-s/S2, ASI and GigE inputs, a variety of TS outputs, two integrated DVB common interface modules that allow descrambling of two complete transport streams, and regeneration of MPTS to multi-MPTS/SPTS.

609-987-8090; [www.scopus.net](http://www.scopus.net)

## ARCHIVE TOOL

SGL FLASHBROWSE II

A client-based Web tool that allows FlashNet users to capture simple metadata and archive and restore media from many different forms of archive; can be used on any platform — Mac, PC or Linux; users can search for content held in the archive as well as view low-res proxy versions without restoring the original material from the archive; supports both simple and advanced searches.

+44 1489 88 99 30; [www.sgluk.com](http://www.sgluk.com)

## IP-BASED VIDEO SERVER STREAMBOX STORE AND FORWARD SERVER

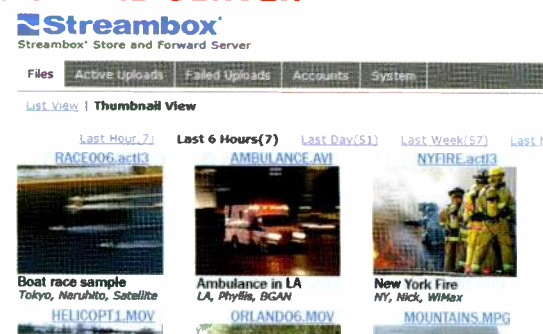

Supports hundreds of simultaneous video file uploads from field crews, stringers and citizen reporters; provides searchable metadata via a Web-based interface; can be customized to facilitate rule-based transcoding to and from a variety of file formats.

206-956-0570; [www.streambox.com](http://www.streambox.com)

## RAID STORAGE SYSTEM

SONNET TECHNOLOGIES FUSION F3



Encloses a pair of high-performance 3.5in SATA drives to create 1TB, 2TB or 3TB configurations; each of the drives is mounted side-by-side on its own multipoint shock isolation sled to virtually eliminate vibration-related problems such as crosscoupled vibration; measures 1RU high, a half-rack wide and 14.25in deep.

949-587-3500; [www.sonnettech.com](http://www.sonnettech.com)

ADVERTISERS MARKED IN RED

## ADVERTISERINDEX

	Page #	Advertiser Hotline	Website Address
AJA Video .....	IFC	800-251-4224	<a href="http://aja.com/kiprotour">aja.com/kiprotour</a>
Axcera.....	17	800-215-2614	<a href="http://axcera.com/atsc-mh-solutions">axcera.com/atsc-mh-solutions</a>
Blackmagic Design.....	11	408-954-0500	<a href="http://blackmagic-design.com">blackmagic-design.com</a>
Canare Cable Inc. ....	30	973-837-0070	<a href="http://canare.com">canare.com</a>
Dolby Laboratories Inc. ....	5		<a href="http://dolby.com/dp600">dolby.com/dp600</a>
Elber S R L.....	21	+39 0185 351333	<a href="http://elber.it">elber.it</a>
Ensemble Designs .....	19	530-478-1830	<a href="http://ensembledesigns.com">ensembledesigns.com</a>
ESE.....	25	310-322-2136	<a href="http://ese-web.com">ese-web.com</a>
Evertz Microsystems Ltd. ....	IBC	877-995-3700	<a href="http://evertz.com">evertz.com</a>
Floral Systems Inc.....	15	352-372-8326	<a href="http://floral.com">floral.com</a>
For. A Corporation of America .....	3	714-894-3311	<a href="http://for-a.com">for-a.com</a>
Harris .....	BC	800-231-9673	<a href="http://broadcast.harris.com">broadcast.harris.com</a>
Marshall Electronics Inc. ....	23	800-800-6608	<a href="http://lcdracks.com">lcdracks.com</a>
Miranda Technologies Inc.....	7	514-333-1772	<a href="http://miranda.com/kaleido-x16">miranda.com/kaleido-x16</a>
Riedel Communications .....	29	914-592-0220	<a href="http://riedel.net">riedel.net</a>
Riedel Communications .....	33	914-592-0220	<a href="http://mediornet.com">mediornet.com</a>
Screen Service Broadcasting Technologies .....	9	888-522-0012	<a href="http://screen.it">screen.it</a>
Sencore.....	13	800-SENCORE	<a href="http://sencore.com">sencore.com</a>
Streambox.....	27	206-956-0544	<a href="http://streambox.com">streambox.com</a>
Ward-Beck Systems Ltd.....	31	800-771-2556	<a href="http://ward-beck.com">ward-beck.com</a>
Zeus Broadcast .....	32	407-352-6501	<a href="http://zeusbroadcast.com">zeusbroadcast.com</a>



# IntelliTrak™ Program Video & Audio Lip Sync Analyzer

**IntelliTrak™** measures the lip sync error between the audio and video with precise accuracy. It is unique as it does not introduce any type of watermarking or flag insertion into the stream, operating in a completely non-intrusive manner.

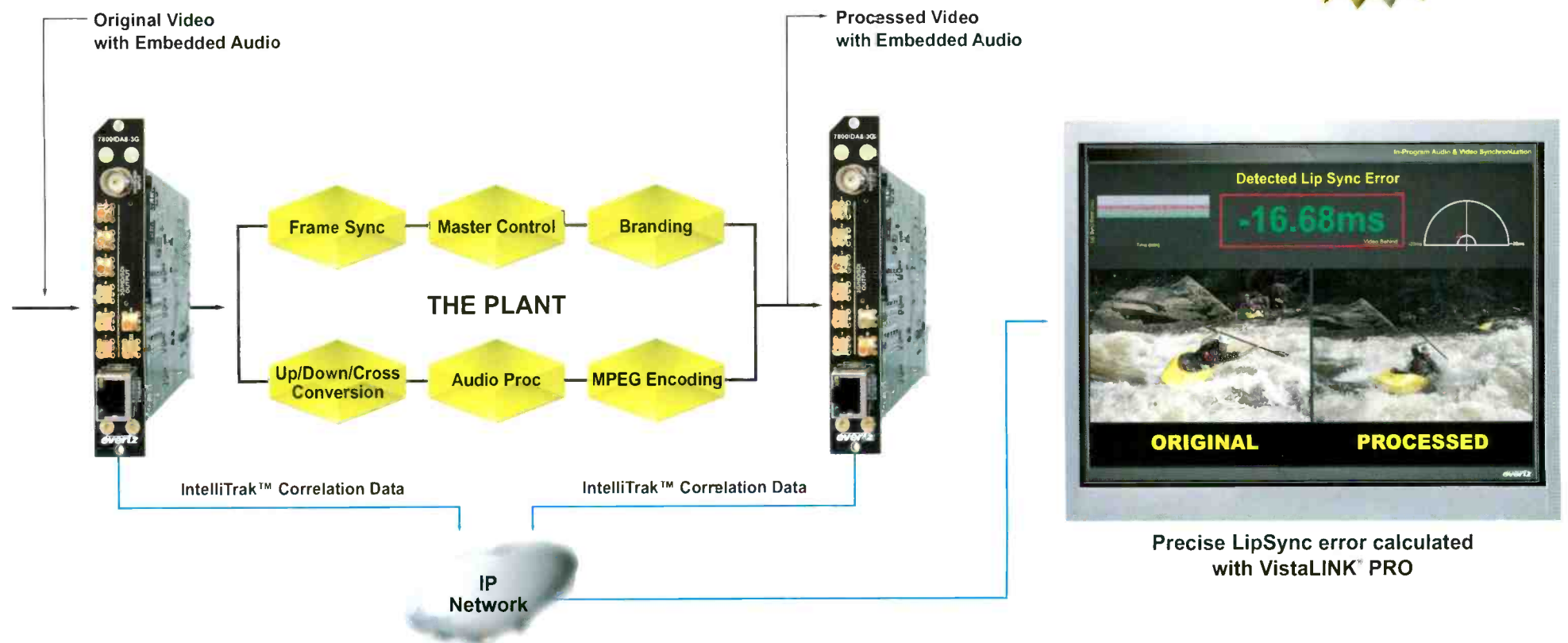

## IntelliTrak™ • Features and Applications



### Features:

- Non-intrusive, in-service lip sync error measurement (no watermarking)
- Precise sub-millisecond accuracy
- Works with all types of audio and video signals
- For use within the plant or external with outdoor broadcasting units
- An advanced ordering option for many Evertz® products
- Designed to provide precise measurements through all sorts of facility signal processing such as up/down/cross conversion, mpeg encoding/decoding, dolby processing and more

### Applications:

- Inter-Facility Lip Synchronization
- LipSync Validation through MPEG Encoding/Decoding
- Mobile Applications

See Us At InfoCOMM - Booth #4879



1-877-995-3700 • sales@evertz.com • www.evertz.com

US West Coast Sales  
818.558.3910  
LASales@evertz.com

New York Sales  
newyorksales@evertz.com

Washington DC Sales  
703.330.8600  
dcsales@evertz.com

UK Sales  
+44 116 935 0200  
uksales@evertz.com

Scuth-East Europe Sales  
+385-1-2059-325  
SEuropesales@evertz.com

Dubai Sales Office  
011-971-50693-0204  
middleeastsales@evertz.com

Asia Pacific Sales  
+852 2850-7989  
asiapacificsales@evertz.com



# POWERING

## ADVANCED MEDIA WORKFLOWS

To compete in an industry speeding toward total media convergence, you need interoperable solutions that fuel today's advanced media workflows — and provide a solid return on your investment.

Only Harris merges traditional broadcast and IT systems with tight software control to improve efficiency, reduce operating expenses and enable all-new revenue streams.

Now more than ever, you need a partner that can deliver the future today. Power up with Harris.

For more information, please visit [www.broadcast.harris.com](http://www.broadcast.harris.com).

North America +1 800 231 9673 • Caribbean and Latin America +1 786 437 1960

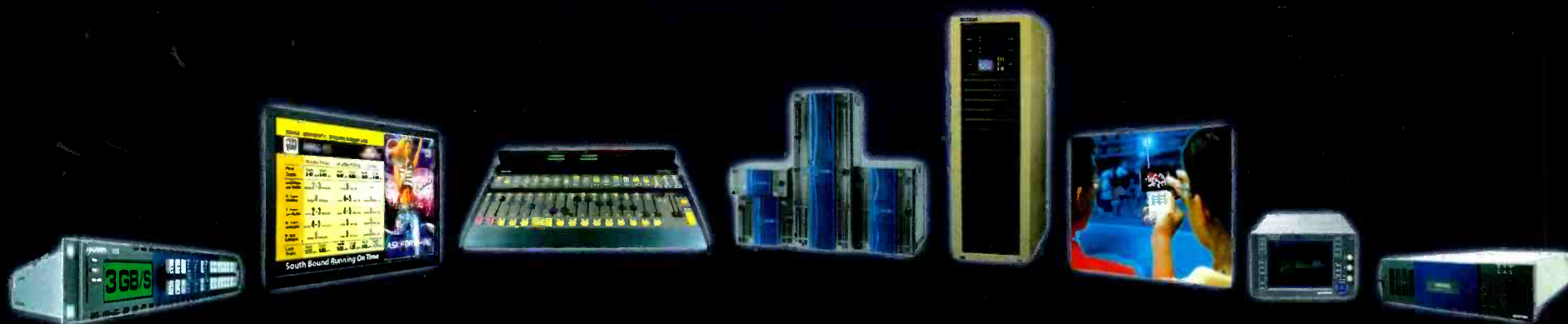

ONE Company. ONE Direction. The Future.

**HARRIS**

assuredcommunications®

Broadcast Communications • RF Communications • Government Communications Systems

[www.harris.com](http://www.harris.com)