

# THE BELL SYSTEM TECHNICAL JOURNAL

VOLUME XXXII

SEPTEMBER 1953

NUMBER 5

*Copyright, 1953, American Telephone and Telegraph Company*

## Transmission Design of Intertoll Telephone Trunks

By H. R. HUNTLEY

(Manuscript received June 12, 1953)

*At the 1952 Minneapolis summer meeting of the A.I.E.E. a symposium\* on the nationwide toll switching plan went into such features as the fundamental plant layout, numbering plan, toll switching and automatic accounting equipments. The present paper is intended to round out this coverage of the plan with a further discussion of the transmission features.*

### THE PROBLEM

In the new nationwide toll switching plan using switching machines the layouts of toll circuits and the routings of traffic will be quite different from that of the earlier plans which were based on manual switching. Individual calls can be switched so fast and cheaply that switching is no longer a limiting factor and circuits can be laid out and used in such a way as to obtain maximum economy with few, if any, limitations from the switching standpoint.

An example of these changes is given in Fig. 1 which shows in (a) the circuit groups which would be used to handle a given (assumed) flow of traffic on a manual basis and in (b) the groups which would be used to handle the same traffic on a dial basis. In (a) there are 44 different

\* Trans. A.I.E.E., 71, Part I, Sept., 1952.

(a) RINGDOWN OPERATION

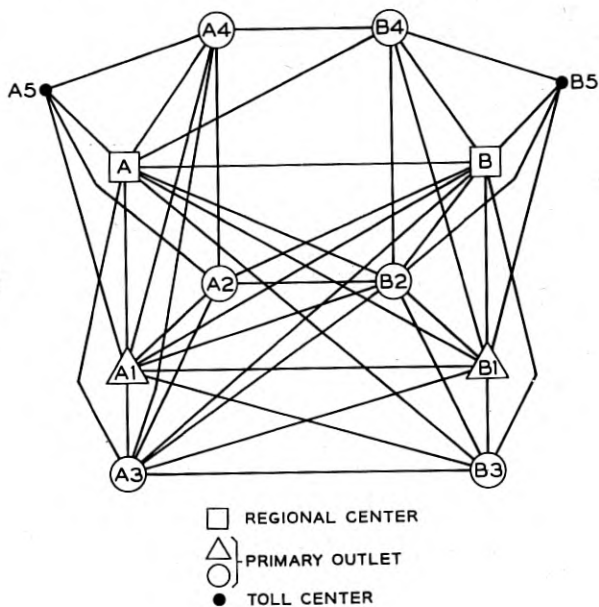

(b) NATIONWIDE TOLL DIALING

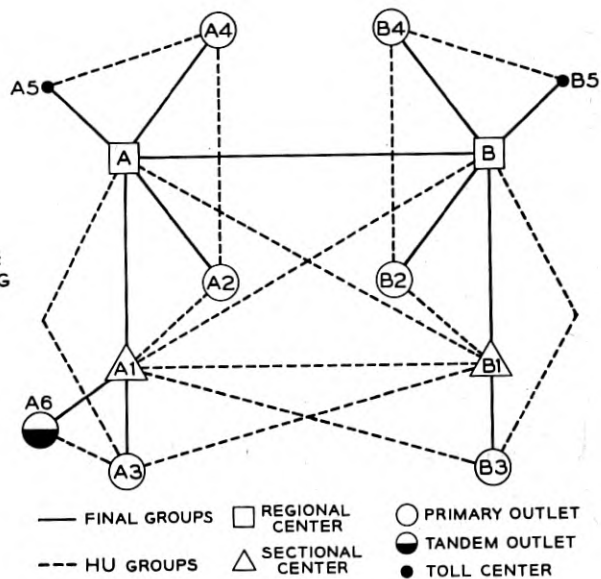

Fig. 1 — Typical intertoll trunk networks.

circuit groups and in (b) there are 26 circuit groups. More specific ideas regarding the effects of these differences can be obtained by considering how calls between specific centers (for example, A1 to B1) would be routed in the two plans.

From the transmission standpoint the principal impact of the new plan is that the situation will be changed from one in which as much of the traffic as practicable was handled over direct circuits with a minimum of switched traffic (circuits in tandem) to one in which two or more (up to a maximum of eight) circuits will be used in tandem on many calls and in which different numbers and make-ups of circuits may be encountered on successive calls between the same two telephones, as a result of the alternate routings employed with machine switching. This means that the losses of circuits must be low in order to provide adequate transmission on all calls and to avoid large differences in transmission on successive calls between the same two places.

The ideal method in such a situation would be to operate all circuits at zero loss since this would make the results independent of the number of circuits in tandem. However, the distances involved in the Bell System are so great that the propagation times, which affect echo, and the crosstalk between circuits require that even carrier circuits be operated at finite losses. Also, the plan must accommodate many voice frequency circuits on which the noise and singing conditions, as well as echo and crosstalk, may be more severe than on carrier circuits. The practical plan, therefore, is to:

1. Operate every circuit at the lowest loss practicable considering its length and the type of facilities used.
2. Assign circuits with different transmission capabilities in accordance with the parts they have to play in the operation of the over-all network.

The principal problem is to determine how low circuit losses can be made without getting into trouble due to one or more of the limitations mentioned above. This problem is complicated by the fact that the effects of these limitations are not directly proportional to circuit length or to the number of circuits in tandem. For example, if circuit (a) can be operated by itself at a loss of  $X$  db and circuit (b) can be operated by itself at a loss of  $Y$  db, the loss permissible when circuits (a) and (b) are switched together is less than  $X + Y$ . Ideally, therefore, each circuit should have a different loss in each different connection in which it is used. However, this is not practicable and a compromise must be adopted. This compromise provides that in some connections a particular circuit will operate at its lowest practical loss while in other connections higher losses will be employed to give over-all figures that will be ade-

quate from the standpoint of echo, crosstalk, etc. The general procedure is as follows:

1. When a toll circuit is switched to another toll circuit at both ends work it at a loss which is called "via net loss" (VNL).

2. When the circuit is switched to another at one end only (the other end being at the point of origin or destination of the call) work it at a loss higher than VNL by an amount which we shall call " $S$ " (" $S$ " being a generic term derived from the fact that it may be associated with switching pads — usually called " $S$ " pads).

3. When the circuit is used by itself (i.e., the origin and destination of the calls are at the ends of the circuit) increase its loss by " $S$ " again — that is, work it at VNL plus  $2S$ . This is known as "terminal net loss" (TNL).

Via net loss is, of course, to be the "lowest loss practicable" referred to above, and the next step is to establish methods of deriving VNL and of selecting the best value for " $S$ ".

Since it would be a very complicated process to work simultaneously with all four of the limiting factors mentioned above, (echo, crosstalk, singing, and noise), the practical approach has been to select one of them as the basis of design and then check the results against the other three, modifying the final solution as necessary so that all four are kept under control. Since long experience indicates that echo is likely to be the most difficult and complex factor to control, it has been used as the starting point in the solution of the problem. As will be evident later, there are a large number of solutions possible from the echo standpoint and the one which has been selected has been affected to a considerable extent by the other factors.

The next part of the material in this paper is, therefore, devoted to an analysis of circuit design from the echo standpoint.

#### DETERMINING LOWEST PRACTICABLE CIRCUIT LOSS FROM ECHO STAND- POINT

The over-all objective is to have practically no cases in which objectionable echo will be observed by customers.

If circuits could be precisely adjusted to the requirements in each different connection the probability of echo would be the same on all connections and the computations would have been carried out on the basis of a very small probability — say, 1 in 10,000. However, losses can be changed only in discrete steps ( $S$ ) so that in a very large proportion of cases the losses will be higher than are theoretically necessary.

Hence it seems sensible to compute the theoretical losses on the more liberal basis of 1 in 100, relying on the excess loss in most connections to reduce the over-all probability to the very small value desired.

The echo problem with which we are concerned is illustrated in Fig. 2. As shown there, part of the speech power which is being transmitted to the listener "leaks" across the hybrid (or four-wire terminating set) at the listener's end and returns to the talker. This is known as "talker echo." Actually, of course, some of the echo which returns to the talker can leak across the hybrid there and go back to the listener. This is known as "listener echo." However, with modern plant listener echo will not be important if talker echo is adequately controlled.

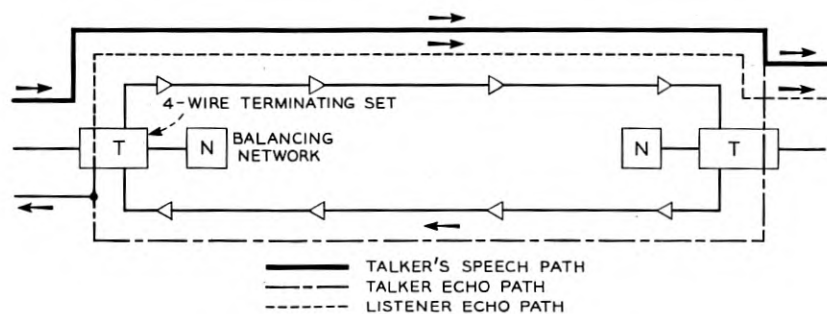

Fig. 2 — Echo paths.

Considering the effect of echo on the talker, if the elapsed time before the echo gets back to him is very short it is just like hearing his own voice through the sidetone in his own set, and unless it is very loud he doesn't notice it. If on the other hand, the elapsed time is long it sounds to him very much like the familiar acoustical echoes arising from physical obstacles. In extreme cases he may get the impression that the distant party is trying to interrupt him. The over-all effect of echo then depends on the following:

1. How loud it is — which in turn depends on how much loss there is in the echo path.

2. How long it is delayed before it gets back to him.

3. How easily he is annoyed by it (i.e., his "tolerance" to echo).

The factors involved are discussed in more detail in the following. For simplification four-wire circuits and four-wire switching are assumed; two-wire circuits and two-wire switching are treated as variations and are discussed later.

*Tolerance to Echo*

People vary greatly in their reaction to echo of given magnitude and delay and it is therefore necessary to treat them statistically, that is, what we need are the two statistical terms which are usually used to describe a mass of data, i.e., "average" and "standard deviation."

"Average" is simply the familiar algebraic average of the data — no talker is average but it is possible to obtain the average of a lot of talkers.

"Standard deviation" is a *number* which tells in general terms how the individuals spread out on both sides of the average. Usually: 30 to 35 per cent will be between the average and one standard deviation below the average; 30 to 35 per cent will be between the average and 1 standard deviation above it. At least 45 per cent will be between the average and two standard deviations below it and at least 45 per cent will be between

TABLE I

Round-Trip Delay (Milliseconds)	Loss in Echo Path Just Satisfactory to Average Observer
0	1.4 db
20	11.1 db
40	17.7 db
60	22.7 db
80	27.2 db
100	30.9 db

the average and two standard deviations above it. Very few, if any, will be outside of plus or minus three standard deviations.

Judgment tests under controlled conditions and with a number of observers (talkers), under conditions simulating connections to subscribers near the toll office, have given the basic data on these effects in Table I. (These data are slightly different from some published earlier because of recent reevaluations. Further studies are now under way and may indicate some further changes.)

An analysis of all the test data indicated that the observer judgments conformed fairly well with a normal law curve having a standard deviation ( $D_0$ ) of 2.5. This means, for example, taking the 40 millisecond delay condition, that while on the average a 17.7 db loss was required in the echo path to make the echo just tolerable, some 30 to 35 per cent of observers could tolerate 2.5 db less loss. Another 30 to 35 per cent were sensitive enough to need 2.5 more loss for satisfactory echo condition. Practically no observer was so sensitive as to require  $3 \times 2.5 = 7.5$  db more than 17.7 db, and practically none was so tolerant that he could permit 7.5 db less.

### *Terminal Return Loss*

As shown in Fig. 2, with four-wire switching and four-wire type circuits the only source of echo is lack of perfect balance between the balancing network of the four-wire terminating set (hybrid coil or its equivalent) and the trunk, loop, and subscriber station connected at the customer side of the set at the distant terminal. The ratio of the amount of power reflected back into the hybrid coil to the amount which goes on toward the listener can be expressed as a loss in db. This "terminal return loss" in the echo range (approximately 500 to 2,500 cycles) has been found by tests and computations to have an average value of 11 db and a standard deviation,  $D_t = 3$ .

### *Round-Trip Circuit Loss*

The round-trip circuit loss plus the terminal return loss is the total loss in the echo path. The round-trip circuit loss, i.e., the over-all loss which the intertoll trunk (or trunks) inserts in the echo path, is the sum of the losses in the east-to-west and west-to-east directions. If the circuit regulation were perfect, this loss would simply be twice the nominal one-way loss of the trunks — which is the thing we are looking for.

However, regulation is not perfect, and in order to determine what the nominal loss should be we must take into account the deviations from it which are certain to occur in practice. A considerable amount of experience indicates that these deviations can be treated statistically and considering some improvement in maintenance methods and procedures and a wider use of carrier systems with improved regulation, a standard deviation of  $D_v = 2$  db for round-trip losses seems a not unreasonable assumption for the next few years.

### *Relationship Between Working Echo Net Loss and Round-Trip Delay*

We now have all of the data we need to solve our problem — which as stated before is to find what VNL to assign to a circuit of given length and on a given type of facility.

Our first step mathematically is to combine the three statistical distributions we have been talking about — i.e., tolerance to echo, terminal return loss and the variations in round-trip circuit loss.

The combined standard deviation ( $D_e$ ) of the three sets of distributions is the square root of the sum of the squares of the standard deviations of the individual distributions. The first two distributions are independent of the number of links,  $N$ , (assuming four-wire switching) but the distribution of circuit loss variations is a function of the number

of links. The mathematical expression for the combination of these three standard deviations is:

$$\begin{aligned} D_c^2 &= D_o^2 + D_i^2 + ND_v^2 \\ &= 2.5^2 + 3^2 + N2^2 \end{aligned}$$

From this equation Table II can be constructed.

In line with the principles stated at the outset, the mathematics will be worked out on the basis that 99 calls out of 100 will be free from echo; then margins will be added. The mathematics are as follows: (1) In order to meet 99 per cent of the cases, 2.33 standard deviations must be used, or: Avg. Rd. Trip Loss = Avg. Echo Tol. - Avg. Ret. Loss + 2.33 Std. Dev. (2) The average one-way loss is the loss to be assigned and is one-half the average round-trip loss.

TABLE II

No. of Links	Standard Deviation
1	4.4 db
2	4.8 db
3	5.2 db
4	5.6 db
5	5.9 db
6	6.3 db
7	6.6 db
8	6.9 db

Permissible average losses with several different numbers of links, based on this equation, are given in Table III. These data are for four-wire circuits and four-wire switching. It will be noted from Table III that for a given total round-trip delay the necessary increase in over-all loss for increasing numbers of links varies somewhat for different conditions but for the more severe cases it is about 0.4 db per link.

Because, as stated at the outset, the relationship between round-trip delay and permissible circuit loss is not linear, Table III can not be used directly in selecting the working net loss of a circuit to be used in switched connections. An example will make this clear:

(a) From Table III, the permissible loss of a circuit with 20 ms round-trip delay is 5.0 db.

(b) If this were used as the basis for designing the circuit, the loss of four such circuits in tandem would be 20.0 db whereas the table shows that four links with a total round-trip delay of 80 ms could be operated at 14.6 db.



The problem then is to find the best method of determining "VNL" and "S". As indicated earlier, this problem has a wide variety of solutions among which the best can be selected on a judgment basis. The process is as follows:

(a) In Fig. 3 a solid curve is shown giving the relation between working loss and round-trip delay for a single link, the information being taken from Table III.

(b) With the plant as it will be in the reasonably near future the round-trip delay on any connection without an echo suppressor will not exceed about 45 ms. This figure is based on a survey of geographical lengths, with some adjustment for the expected more extensive use of carrier and taking into account the "rules" (discussed later) for the use of echo suppressors.

TABLE III

Total Round-Trip Delay (Milliseconds)	Permissible Working Over-all One-way Loss (db)			
	1 Link	2 Links	4 Links	6 Links*
0	0.3	0.8	1.7	2.5
20	5.0	5.6	6.5	7.4
40	8.5	9.0	9.8	10.6
60	10.9	11.4	12.3	13.1
80	13.2	13.7	14.6	15.4
100	15.1	15.6	16.5	17.2

\* With the switching arrangements which will be used, not more than 6 inter-toll trunks will be used in tandem without an echo suppressor.

(c) Then starting at any arbitrarily selected value of  $S$ , a straight line can be drawn from  $2S$  (since there is  $S$  at each end) plus 0.4 (required to be added per link for variations) and intersecting the curve at 45 ms.

(d) In Fig. 3, three such straight lines are drawn, for  $S = 1$ ,  $S = 2$  and  $S = 4$ , which have slopes (in db per millisecond) about as follows:

$S$	Slope (db/ms)
1	0.15
2	0.10
4	0.016

(e) From these data, equations for VNL and TNL for four-wire circuits can be worked out in terms of round-trip delay, "d," thus:

$S$	VNL	TNL = VNL + 2S
1	0.15d + 0.4	0.15d + 2.4
2	0.10d + 0.4	0.10d + 4.4
4	0.016d + 0.4	0.016d + 8.4

The slopes of the lines can be converted into factors (called "via net loss" factors — VNLF) in terms of db per mile by dividing twice the slope by the velocity of propagation in miles per millisecond. The product of VNLF and circuit length in miles plus 0.4 gives VNL. As an example, for  $K$  carrier circuits with a velocity of propagation of 105,000 miles per second, the via net loss factor for  $S = 2$  would be  $(2 \times 0.10) \div 105 = 0.0019$ .

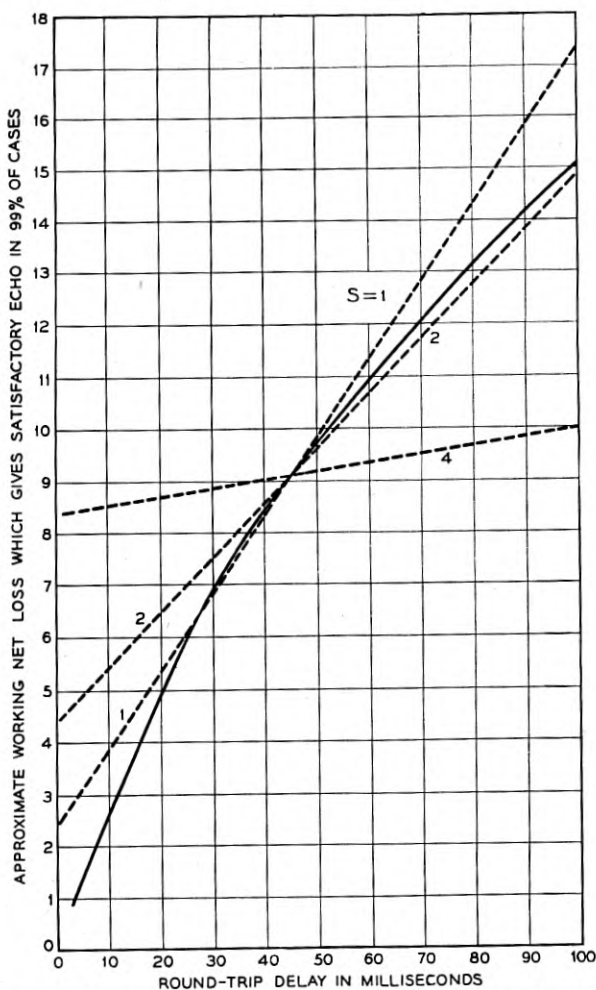

Fig. 3 — Approximate relationships between round-trip delay and permissible working one-way loss for an intertoll trunk from echo standpoint for four-wire circuits and four-wire switching.

For two-wire circuits the local echo paths at the repeaters make it impracticable to establish a straightforward relationship between over-all delay and echo performance. The via net loss factors for such circuits are approximations based on judgment and experience.

#### SELECTION OF VIA NET LOSS FACTORS AND $S$

From the foregoing, it is evident that the values of  $S$  and VNLF are interrelated and that there is a wide variety of possible relationships.

Fig. 3 shows that, up to fairly long delays, the lower the value of  $S$ , the lower the over-all losses at which the circuits can be worked from the echo standpoint.

Since the lower delay calls are much more numerous than longer delay calls, it is desirable to use as low an  $S$  as is practicable. However, in selecting a value, the other factors which have been neglected to this point — crosstalk, singing and noise — must now be taken into account and we must be sure that echo margin is now added. Each of these factors is discussed separately in the following.

#### *Singing*

The more extensive use of carrier reduces the importance of singing because voice frequency circuits are becoming shorter, thus eliminating the difficult singing problems associated with multi-repeater-section two-wire circuits. On the other hand, some of the conditions at circuit terminals may become more severe from the singing standpoint.

Studies indicate that over-all losses obtained with  $S = 2$  are adequate to care for singing under most conditions but that if  $S = 1$  were adopted, singing would be more important. With  $S = 2$  the necessity for increasing circuit losses to avoid excessive danger of singing will probably be confined to a few open wire circuits having large discrete irregularities.

#### *Noise*

Noise is usually not a factor in the assignment of circuit losses. Carrier systems are designed so that under normal conditions the noise is low enough so that any desired loss can be used. If, in a specific case, noise in either carrier or voice frequency circuits is too high, the approach is to get rid of it by one or more of the means available.

#### *Echo Margin*

Reference to Fig. 3 will indicate that for  $S = 2$  there is 2 db or more round-trip echo margin in all cases with round-trip delays less than the

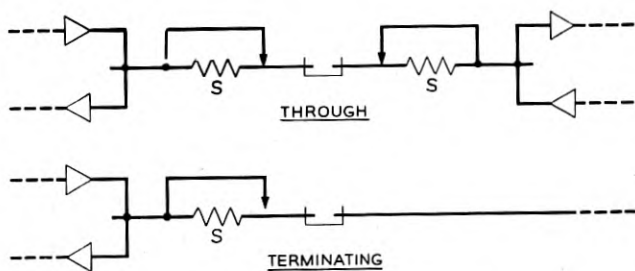

(a) PAD IN INTERTOLL TRUNKS

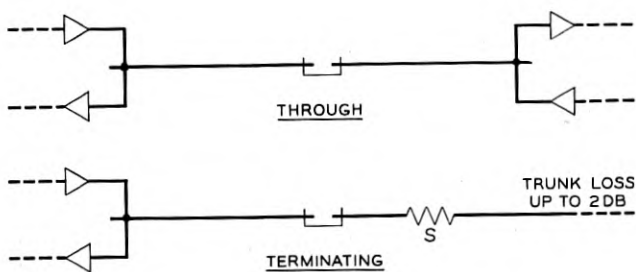

(b) PAD IN TOLL CONNECTING TRUNK

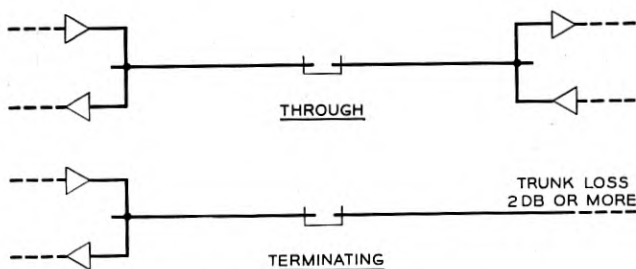

(c) USING LOSS OF TOLL CONNECTING TRUNK

Fig. 4 — Methods of providing "S".

order of 30 or so milliseconds. With  $S = 1$  there is little margin and with  $S = 4$  there is excessive margin.

There will be very few connections with delays greater than about 30 milliseconds — which is roughly 1,500 miles of carrier — without echo suppressors. While the effect of the margin on probability of observing echo is difficult to compute quantitatively, it is estimated that with  $S = 2$  this probability will be very small. Additional margin is also provided by the fact that on many connections the connecting trunk loss at the talker's end is greater than the loss used in the tests for establishing the echo tolerance curve.

### *Crosstalk*

Analysis of many situations indicates, again, that with  $S = 2$  the losses are about as low as are practicable in general from the crosstalk standpoint. With  $S = 1$ , they would be too low in many cases, and with  $S = 4$ , they would be unnecessarily high.

With  $S = 2$ , there may be a few cases where specific attention to crosstalk will be needed, particularly in open wire.

### *Final Selection*

From the consideration of factors like the foregoing the value of 2 db has been selected for  $S$  on a judgment basis.

### PROVISION OF $S$

The loss  $S$  can be provided in any of the following ways as appropriate. (See Fig. 4.)

1. As a switchable loss pad in the intertoll trunks.
2. As a fixed loss pad in the toll connecting trunk.
3. As part of the conductor loss of toll connecting trunks. This can be done only if the structural return loss of the connecting trunks against the balancing network is reasonably good.
4. If there is to be no switching to other intertoll trunks or to connecting trunks with more than 2 db loss,  $S$  may be provided simply by increasing the circuit loss by 2 db.

### VIA NET LOSS FACTORS

Table IV lists typical VNLF's of Bell System intertoll trunk facilities for the condition  $S = 2$ . Typical losses at which circuits would be worked with  $S = 2$  and with the via net loss factors tabulated in Table IV

TABLE IV—TYPICAL VIA NET LOSS FACTORS

Facility	VNLF (db per mile)	
	2-Wire Circuits	4-Wire Circuits
19H-88-50.....	0.03	0.014
19H-44-25.....	0.02	0.010
O. W. Voice.....	0.01	—
O. W. Carrier.....	—	0.0017
K or N Carrier.....	—	0.0019
L Carrier.....	—	0.0015
Radio.....	—	0.0014

are given in Table V. The advantages of high velocity, four-wire circuits (carrier and radio) are obvious from these tables.

#### ECHO SUPPRESSORS

Even if the intertoll trunk plant of the Bell System were all carrier, the length of some connections would be so great that some method of controlling echo other than simply increasing circuit loss is desirable. Lower losses can be obtained on such connections through the use of an "echo suppressor," an electronic device which under control of the talker's speech currents places a high loss in the return path at the right time to intercept the return echo currents.

Echo suppressors perform very well so long as not many circuits equipped with them are connected in tandem and there is not too much time delay between them. With manual operation the switching is so limited that the chances of connecting circuits with echo suppressors in tandem are small and it has been practicable to apply echo suppressors on the basis of round-trip delay of the individual circuits. However, with dial operation it will be possible to establish connections which are long enough to require an echo suppressor but which are composed of circuits each too short to require an echo suppressor based on its round-trip delay. For example, an echo suppressor would not normally be used on a 500-mile carrier circuit, but if eight such circuits were connected in tan-

TABLE V

Type and Length of Trunk	VNL (db)	TNL (db)
50-mile N1 Carrier.....	0.5	4.5
50-mile 2-W H-88.....	1.9	5.9
200-mile 4-W H-44.....	2.4	6.4
500-mile K Carrier.....	1.4	5.4

dem giving a total length of 4,000 miles, an echo suppressor would be imperative, if over-all loss is not to be excessive.

It is not practicable to take care of this problem merely by reducing the delay time at which an echo suppressor is applied, since if this were done it is conceivable that eight circuits each with an echo suppressor might be connected in tandem. It has been necessary, therefore, to establish more or less arbitrary rules to insure at least one echo suppressor on long connections and to make it very improbable that more than two will be encountered. In general, these rules specify that echo suppressors will be placed on:

- a. All RC-NC circuits.
- b. All RC-RC circuits.
- c. On high-usage group circuits when the desired losses can not be met without them.

Our ideas as to when suppressors of Item c will be required may change with the trend from voice-frequency towards high-velocity carrier circuits. Experience will be a valuable guide, for it is not likely that an intolerable situation will build up overnight and without casting some shadow of coming echo; and the echo suppressor, being a discrete equipment unit, can be installed after it is found to be needed without appreciable lost motion or additional cost.

#### ALLOCATION OF FACILITIES

If the intertoll plant were homogeneous the over-all problem would be solved at this point — each circuit would be designed in accordance with the preceding and that would be that.

But the plant is not homogeneous — it consists of everything from loaded voice frequency circuits to circuits on microwave radio with VNLF's ranging from 0.03 to 0.0014. It is, therefore, necessary to allocate these facilities among different circuit groups in such a way that as far as practicable the higher performance facilities are used in the more demanding parts of the network.

As an aid to allocating facilities, charts like Fig. 5 are used. This chart shows ranges of losses within which circuits in different parts of the network are expected to fall. The losses shown there are exclusive of  $S$  which must be added, as indicated before, at both ends of each connection. It should be emphasized that these losses are not "limits" in the usual sense, neither are they attempts to divide up over-all losses among circuits. They simply help in allocating facilities in the non-homogeneous plant among different circuit groups. As the use of carrier

is extended, the plant will become more homogeneous and the need for such charts will gradually disappear.

Fortunately, from the transmission standpoint, while the machines will set up a wide variety of connections, the routing patterns will be rigidly controlled. Thus, it is practicable to know for each circuit group the maximum number of other circuits with which it can be used in tandem. The lower velocity circuits, two-wire circuits, narrow band circuits, etc. can (within practical limits) be allocated to groups which have relatively easy requirements.

#### TWO-WIRE SWITCHING — OTHER CONSIDERATIONS

Present views are that even the ultimate plan will involve two-wire switching at many points, mainly at the smaller switching points where

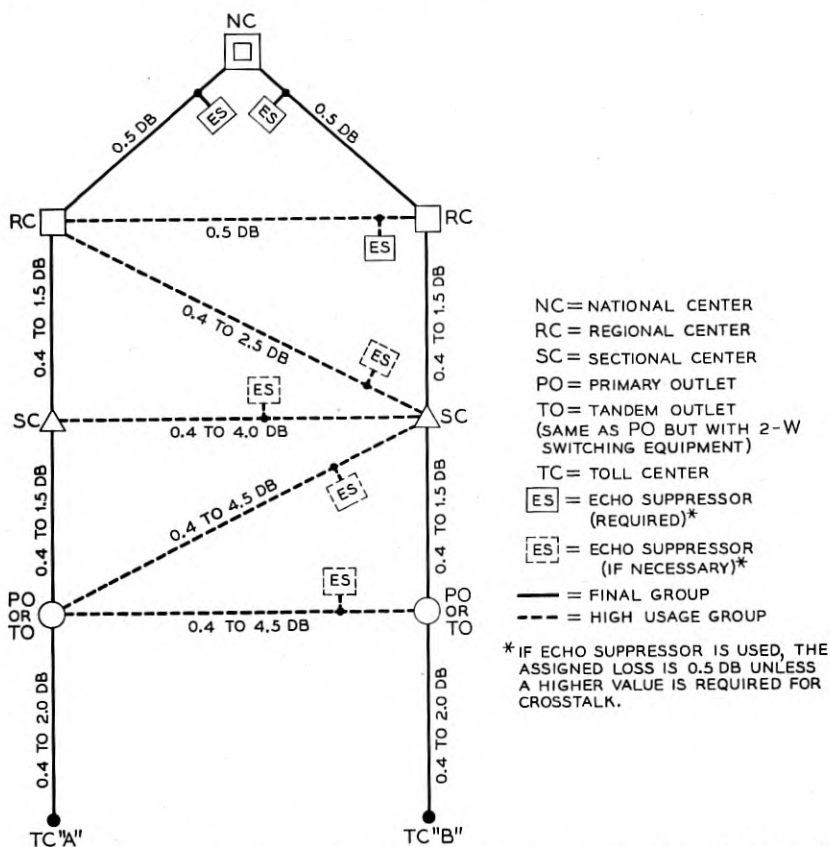

Fig. 5 — Intertoll routing pattern between two regions showing typical circuit groups.



the amount of traffic will not support the cost of complete automatic alternate routing features. This will cause some additional complication, for each such point introduces another source of echo due to the fact that the capacitance and resistance of the office cabling reduces the balance obtainable when two intertoll trunks are switched together. The effect of such switching on VNL's can be cared for by adding appropriate loss increments which will be small if a careful job of impedance matching is done and the distances from the toll terminal equipment to the switches is held within bounds.

No increment is added if the return loss for about 84 per cent of the circuits in the group is 24 db or more. These increments increase to about 0.2 db for a return loss of 20 db, 0.4 db for 18 db and so on. They are added to VNL of circuits between a two-wire switching point and a four-wire switching point and of circuits between two two-wire switching points. Impedance matching is usually accomplished by adding capacitance across the compromise network and in some cases across the shorter cable runs in an office.

All circuit losses referred to in this paper are 1000-cycle values, i.e., no allowance is made for the effects of noise and frequency distortion. Careful design, layout, and coordination of individual transmission systems are depended on to keep noise within proper bounds; and all new carrier systems going into the plant have transmitted bands wide enough to require no assignment of distortion transmission impairment (DTI). Circuits having excessive noise and those circuits with large DTI's are earmarked for improvement by any means that may come along. But beyond this, frequency distortion does not enter into VNL calculations since it can not be offset by reducing circuit losses without encountering trouble from the echo or other standpoint.

While we have considered only circuit design in this paper, it is evident that the success of the whole plan also depends on how closely circuit losses are maintained. This is important from two aspects.

1. The expected variations determine the allowance which must be made in the assigned loss. As indicated previously, it is expected that an allowance of 0.4 db per link will be adequate for the near future and it is hoped that as time goes on this figure can be reduced.

2. A more important factor is that unless circuit losses are maintained fairly precisely, large positive or negative excess losses can be accumulated on multi-switched connections. Avoidance of such large excesses is particularly important with dial operation since detection and avoidance of unsatisfactory transmission conditions by operators will be much less effective.

While the maintenance problem is at least as complex and difficult as the design problem, it is beyond the scope of this paper.

#### SUMMARY

To summarize the preceding discussion: For the particular conditions in the Bell System, a formula has been set up to give adequate approximations of the lowest practicable loss for practically all intertoll trunks as follows:

$VNL = VNLF \times L + A + B$ , where:

VNL = "Via Net Loss" (db) of the trunk.

VNLF = "Via Net Loss Factor;" i.e., a factor which depends on and is appropriate to the type of facilities used in the trunk.

$L$  = Length in miles.

$A$  = Design allowance for expected variations of circuit loss in service (0.4 db).

$B$  = Amount to be added if two-wire switching is used; the magnitude depends on the passive return loss obtainable on such connections at the two-wire switching office.

At each end of the connection a loss of 2 db ( $S = 2$ ) is added by appropriate means as discussed earlier.

#### CONCLUSION

Let it be emphasized that we have been talking largely of planning for the future in all that has preceded, for the switching plan as outlined is a growing thing and it will be a couple of years before much complex automatic alternate routing is done. And we would be very much surprised to escape growing pains and change of ideas as the plan develops. We are confident, however, that the plan is sound economically and transmission-wise; and flexible enough to adapt itself to further developments and experience.

#### ACKNOWLEDGMENT

As in most papers like this it would be prolix to mention all persons who took an active part in the preparation or in the development of the background data. But the author would be remiss if he did not call by name L. L. Bouton, who just prior to his recent retirement from Bell Telephone Laboratories, did much of the basic work on the mathematical concepts involved, on the simplification of these concepts for practical application, and on the re-evaluation of data that was required in these applications.

# The Card Translator for Nationwide Dialing

By L. N. Hampton and J. B. Newsom

(Manuscript received August 24, 1953)

*Nationwide operator and customer dialing requires the existence of a number of switching centers equipped with automatic systems having a much higher order of mechanical "Intelligence" than previous systems. One of the most important components of this new switching system is the Card Translator. Its function is to take the telephone address of a call and determine how to advance this call toward that address. This translator has to meet unique requirements in that it must accommodate a very large number of addresses; must provide a great amount of information for routing the calls; and must enable quick and convenient changes to be made in its stored information. It must also meet, of course, the normal basic requirements of reliability, economy, long life, etc. The fundamental principle of this translator is that of a card file, containing individual coded cards for each destination, with routing information recorded on each card. Whenever the routing information for a specific code is needed, the system selects the appropriate card, and reads the information by means of electronic circuits employing phototransistors and transistor amplifiers.*

## INTRODUCTION

The "Card Translator" was developed for the 4A toll crossbar system used at Control Switching Points (CSP) in the nationwide dialing network of offices. Although the many problems and conditions presented in the development and implementation of a nationwide dialing plan have been discussed in papers\* by A. B. Clark, J. J. Pilliod, H. S. Osborne, W. H. Nunn, F. F. Shipley and others, it is necessary to restate some of these because of their effect on the translation problem and the features the card translator had to have in order to meet the nationwide dialing requirements. Translation is the process of converting the called destination code into information that is needed for the proper routing of the call.

\* B.S.T.J., 31, pp. 823-882, Sept., 1952.

## NUMBERING PLAN

For nationwide dialing it is necessary that each customer have a distinctive universal number. This numbering system is accomplished by dividing the country and Canada into about ninety numbering areas. Each of these areas is assigned a distinctive three digit code which, in order not to conflict with local office three digit codes, has either the digit "1" or "0" as the second digit. Within these numbering areas each local office will have a distinctive non-conflicting, name and number code. Since each customer in an office has a distinctive number, a corresponding distinctive nationwide universal number is thus provided. To reach a customer outside the local numbering area will require the dialing of three digits for the area code, three digits for the office code and four or five digits for the line number. Thus by dialing ten or eleven digits a connection can be made to any customer anywhere within the country and Canada. Fig. 1 shows the present numbering area code assignments for the United States and Canada.

## TOLL LINE SWITCHING NETWORK

A second requirement for nationwide dialing is the provision of about 70 strategically placed automatic switching toll offices called control switch points (CSP) throughout the United States and Canada. The switching system used at each of these 70 or so CSP offices have several new features as follows:

1. Six digit translation.
2. Ease in changing and adding routings.
3. Automatic alternate routing.
4. Code conversion.
5. Storing and sending forward digits as needed.

## BASIC SWITCHING ARRANGEMENT

In the CSP offices the transmission paths are established through crossbar switches mounted on the incoming and outgoing link frames as shown in Fig. 2. The setting up of the connection through these switches and the linkages is controlled by equipment common to the office which is held in use only long enough to set up each connection.

The major items of common control equipment are the senders, decoders, markers and card translators.

The sender's function is to receive and register the digits of the called destination, to transmit the area and, if required, the office codes

to the decoder, and then, as directed subsequently by the marker, to send digits ahead as may be required.

The decoder's function is to receive the code digits, either 3, 4, 5 or 6, from the sender and to submit them to the translator for translation and to make selections of alternate routes as required to route the call to the destination. The decoder also gives instructions to the sender and marker to enable them to carry out their functions.

The marker gets access to an outgoing trunk group through the trunk block connector and selects an idle outgoing trunk in this group, then chooses an idle linkage between the incoming and outgoing trunks, operates the crossbar switches to close the transmission path, and gives the sender information for pulsing ahead as may be required.

The operation of these common control circuits is briefly as follows. On the arrival of a call the incoming trunk is connected to a sender through the sender link frame. When the code has been registered the sender makes connection to the decoder through the decoder connector circuit. The decoder passes the code to the translator for translation. There is a translator associated with each decoder which contains the three-digit cards for the local offices and area codes, also perhaps some six-digit code cards. However, most of the six-digit cards (there may be several thousands of them) will be in a group of foreign area translators used in common by all decoders. The decoders obtain information from the area code card for selecting the particular one of these translators. Connection to them is made through an appropriate translator connector. The translator gives information for the selection of an outgoing trunk and passes other information for routing the call both to the decoder as well as to the marker. The marker proceeds with trunk test and the operation of the switches to establish the connection. When the proper information has been given to the marker, then the decoder and translator release from that call. When the marker has given information to the sender for routing the call and has established the talking connection, the marker releases. The sender releases as soon as it has finished pulsing ahead. In this way these common control units handle many calls in rapid succession.

#### SIX DIGIT TRANSLATION

This feature is needed in nationwide dialing because from a particular CSP to points in another numbering area there may be several routes or trunk groups. To reach a point in such an area it is necessary that the office code as well as the area code be translated to select the route to



\* OKLAHOMA AND ONTARIO ARE TO BE DIVIDED INTO TWO AND THREE NUMBERING PLAN AREAS RESPECTIVELY. THE NEW AREA CODE NUMBERS HAVE NOT BEEN ASSIGNED

Fig. 1 — Nationwide toll dialing area



the United States and Canada.

the desired point in the area. To other areas there may be only one route and in this case the area code will suffice.

The provision of facilities for the translation of six digits greatly affected the design of the switching system for the nationwide dialing CSP offices. It led to the development of the basically new card translator. In previous toll common control systems translation is done by means of relays. The code digits, never more than three of them, resulted in the operation of groups of relays in certain combinations and led to the eventual operation of a route relay for the particular combination of code digits. This route relay with cross-connecting facilities from its contacts is used for the identification and selection of trunk groups and other information as might be required for the particular code routings. To change a routing with this system of translation required the removal and reconnection of many cross-connections.

With the nationwide dialing plan in operation, routing changes or opening of new offices in one part of the country will necessitate translator changes in many offices, some of them far removed from the scene of the event that forced them to be made. The changes in any one CSP may, therefore, be frequent under certain conditions, and to make them by running cross-connections would be cumbersome and expensive. The new translator uses punched cards instead of relays making it possible to effect changes by the simple process of removing old cards and insert-

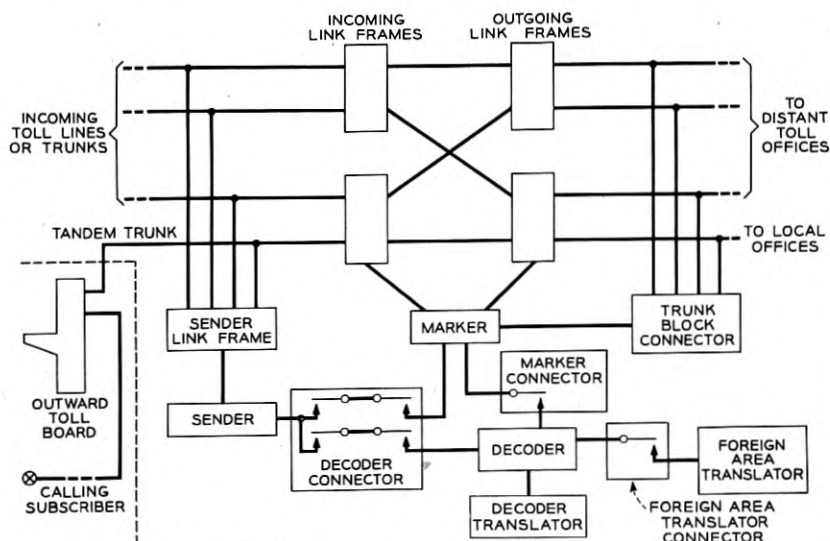

Fig. 2 — Schematic diagram of crossbar switching system for CSP's.



ing new ones in the machine. This can be done in a very short time and requires less out-of-service time for the equipment.

#### CARD FILE

A card is provided for each area code and also one for each office code that must be translated in a particular CSP, the cards representing destinations. The cards are lined up in a box as in a filing drawer with tabs along the bottom of the cards resting on select bars which run the length of the box. It is by operating the select bars in combinations, depending upon the code, that the particular card for the destination is selected. Each card, as shown in Fig. 3, has tabs, one for each select bar along the bottom edge. The information presented to the card translator for the selection of a card is in the form of code digits on a two-out-of-five basis. Each card is coded by removing all of the tabs except those that represent the particular combination of select bars for the particular code. When a code is presented to the translator, a combination of select bars corresponding to the code is lowered and the card having all tabs removed except those that were resting on the lowered select bars will be selected while all other cards will remain in their normal positions.

The groups of tabs labeled, A, B, C, D, E and F (Fig. 4) are for the six code digits. For each digit, two tabs remain, since the digits are

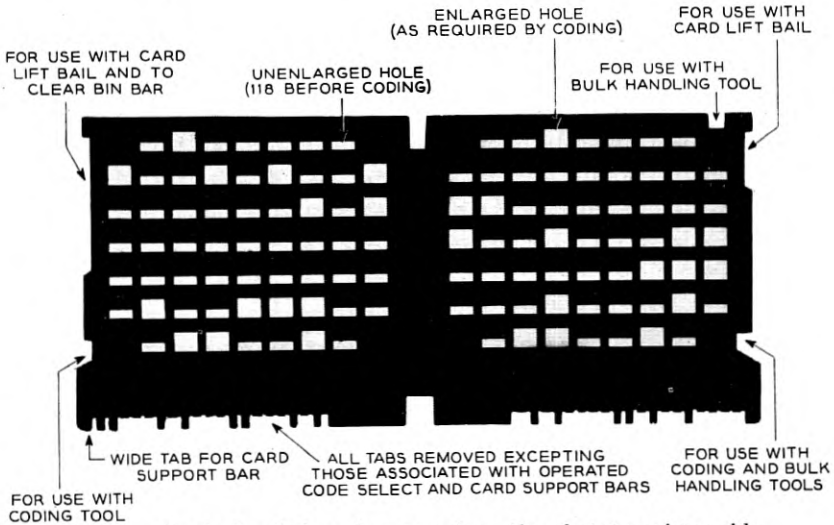

Fig. 3 — Typical coded card as seen from the phototransistor side.

registered in the sender on a two-out-of-five basis and the leads from the sender will cause the select bars to be operated. If the card represents an ordinary three digit code, all the tabs will be cut off except two each for the A, B, and C groups of tabs, and, for reasons that will be discussed later, two of the four CG tabs, card group, will also be removed. In addition, either the VO or NVO tab may be removed. The VO and NVO tabs are used when the group of toll lines over which the call will be routed is divided into one sub-group of a transmission grade suitable only for terminal traffic (NVO, meaning "not via only") and another subgroup for either terminal or switched-thru traffic (VO meaning "via only"). If the card represents a six-digit code, two tabs will be left in each of the six code digit positions and a different pair of card group tabs will be used.

The cards, then, are in different groups and are selected by combinations of code select bars together with the card group select bars. As noted there are four of these card group bars, CG0, CG1, CG2 and CG4. They are used in the six possible combinations, two at a time as follows: For the regular three-digit code cards CG1 and CG4, for the regular six-digit code cards CG2 and CG4; the other four combinations CG0 and CG1, CG0 and CG2, CG1 and CG2, and CG0 and CG4 are used for selecting the four groups of alternate route cards, which may be of the three-digit or six-digit variety.

#### CODE CAPACITY

The card translator by means of the code select bars and card tabs provides facilities for a great number of different codes and routings. There are 40 select bars provided, 36 of these are used in the combinations as has been described, two are reserved for possible future use and the remaining two are used for aligning the cards as will be discussed later. The total possible card code combinations is sufficient for growth in nation-wide dialing for the foreseeable future.

#### TRANSLATOR CARD CAPACITY

In some CSP offices there will be many thousands of cards for the destinations to be reached. It was not mechanically practicable to design a single translator capable of accommodating all these cards and moreover it would not have been economical, particularly for many of the smaller CSP offices. Also for service hazard reasons and to provide for the simultaneous translation of several calls, needed to handle traffic during heavy load periods, more than one translator is required in a

CSP. Considering these factors, it was found desirable to design the card translator to accommodate over a thousand cards.

#### TRANSLATORS

Since several translators are needed in a CSP, for further economy and consistent with service hazards, the translators are segregated according to the groups or kinds of cards they contain. These are as follows:

##### *Decoder Translators*

These translators contain the local three-digit office code, the three-digit area code, the alternate route code and, where space permits, some of the high usage six-digit foreign area code cards. Several of these translators are furnished, one for each decoder, depending upon the volume of traffic handled by the particular CSP.

##### *Foreign Area Translators*

These are furnished, one or two per office (maximum 19), for each 1000 or so foreign area code cards. These translators are in a common pool and the particular one is selected when needed for the six-digit code to be translated.

##### *Decoder Foreign Translators*

If there are sufficient high calling rate, six-digit, foreign area cards, to justify it, these translators may be provided, one per decoder.

##### *Emergency Translator*

Provisions are made so that the emergency translator can be substituted for any other translator by changing the cards of the translator in trouble to the emergency translator.

#### TRANSLATOR OUTPUT

The translator output information required for a CSP office for nationwide dialing must be very extensive to accommodate the many varieties of routes over which calls must be completed. The need for automatic alternate routing, code conversion and the storing and sending forward of digits also affects the need for increased translation output. The output is provided by means of the 118 holes in the face of each card.

PRETRANSLATION										OGT APPEARANCE										TRAF. SEP. PC										TRK. GRP. PC & OF																					
NCA		CA4	CA5	CA6	IT		TC	ITC		TS0		TS1	TS2		TPC	TPO		TP1	TP2		CLT0		CLT1	CLU0		CLU1	CLU2		CLU3	CLU4		CLU5	CLU6		CLU7	CDLC															
IND1		HB	BTO	BT1	BU0	BU1	BU2	BU3	BU4	BU7	CLT0		CLT1	CLU0		CLU1	CLU2		CLU3	CLU4		CLU5	CLU6		CLU7	CDLC		IND2		IND3		IND4		IND5																	
AREA CODE CONTROL										ALTERNATE ROUTE PATTERN NUMBER										CODE CONVERSION										TRUNK BLOCK CONNECTOR																					
NAC		AC	AHA	AFA	ART0	ART1	ART2	ART3	ART4	ART7	CDC0		CDC1	CDC2		CDC3	CDC4		CCT0		CCT1	CCT2		CCT3	CCT4		CCT5	CCT6		CCT7	CCT8		CCT9	CCT0		CCT1	CCT2		CCT3	CCT4		CCT5	CCT6		CCT7	CCT8		CCT9			
ROUTING INSTRUCTIONS										CONT & DIGIT CONTROL										CODE CONVERSION										TRUNK BLOCK CONNECTOR																					
RIO		R11	R12	R14	R17	GDC0		GDC1	GDC2		GDC3	GDC4		CCT0		CCT1	CCT2		CCT3	CCT4		CCT5	CCT6		CCT7	CCT8		CCT9	CCT0		CCT1	CCT2		CCT3	CCT4		CCT5	CCT6		CCT7	CCT8		CCT9								
VAR. SPILL CONTROL										GROUP START										TRUNK BLOCK CONNECTOR										GROUP END																					
NSK		SK3	SK6	TCT0		TCT1	TCT2		TCT3	TCT4		TCT5	TCT6		TCT7	TCT8		TCT9	GCU0		GCU1	GCU2		GCU3	GCU4		GCU5	GCU6		GCU7	GCU8		GCU9	GCU0		GCU1	GCU2		GCU3	GCU4		GCU5	GCU6		GCU7						
GST0		GST1	GSU0	GSU1	GSU2	GSU3	GSU4	GSU7	GCU0		GCU1	GCU2		GCU3	GCU4		GCU5	GCU6		GCU7	GCU8		GCU9	GCU0		GCU1	GCU2		GCU3	GCU4		GCU5	GCU6		GCU7	GCU8		GCU9	GCU0		GCU1	GCU2		GCU3	GCU4		GCU5	GCU6		GCU7	
A		B		C		D		E		F		G		H		I		J		K		L		M		N		O		P		Q		R		S		T		U		V		W		X		Y		Z	

Fig. 4 — Card layout as seen from the exciter lamp side.

By enlarging these holes in combinations the output information for the particular route is obtained.

As seen in Fig. 4 the top holes beginning at the left of the card are used for "pretranslation" purposes. The senders are not provided with facilities which enable them to predetermine when to present for translation the first three digits received or when to wait for more than this number as when six-digit translation is required. Therefore the sender always requests translation when the first three digits are received. So for six-digit calls, the sender must be informed to disconnect from the translator after three digits have been received and wait for six digits. The CA6, (come again six) hole in the card is used for this purpose. The CA4 and CA5 holes are used similarly for calls to certain four- or five-digit operator codes, informing the sender to apply again for translation with four or five digits. The NCA (No Come Again) hole is used for three-digit calls.

The "OGT" holes are used to inform the common control equipment on which train of switches the outgoing trunk appears to enable the associated circuits to select the proper switching train. The remaining holes on the top line are for controlling operation of traffic meters.

On the second line, the TRANSLATOR BOX NUMBER holes are used on area code cards to indicate which translator contains the particular cards for the called area when six-digit translation is required. The INDI hole on the second line and the IND2 hole on the fourth line which commonly are referred to as index holes are never enlarged. They serve as an indication that a card has dropped and that all is ready for translation output detection. These index holes also aid in trouble detection in case of light failure, for routing of certain calls where cards are deliberately omitted and for calls where a blank code was dialed in error.

The CLASS holes are used for indicating the type of outpulsing and the kind of signalling channels used on trunk groups out of the office.

The AREA CODE CONTROL holes on the third line are used for determining the number of digits to be transmitted forward to the next office and for supplying undialed code digits needed primarily in connection with automatic alternate routing. The ALTERNATE ROUTE PATTERN NUMBER holes are used for the selection of the series of alternate routes to be used.

The holes on the fourth line are for making proper disposition of calls when all trunks are busy and to inform the associated circuits how many digits should be received for the particular code.

The CODE CONVERSION holes on the fifth line are used to supply the sender with information as to the outpulsing of certain arbitrary digits

as may be required through step-by-step toll trains. Facilities are provided for the outpulsing of one, two or three digits as may be required.

The VARIABLE SPILL CONTROL holes on the sixth line inform the sender when to pulse forward all digits as received, or to omit sending the first three or six code digits.

The remaining holes on the card define the location on the switching frames having the desired outgoing trunk appearances. The notches around the outer edges of the card are for proper positioning of the card in the stack and for card removal purposes as will be discussed later.

#### CARD OUTPUT DETECTION

The enlargement of the holes in the face of the card to obtain the translation output as previously stated is recognized by means of modulated light beams falling on phototransistor detectors. With all of the

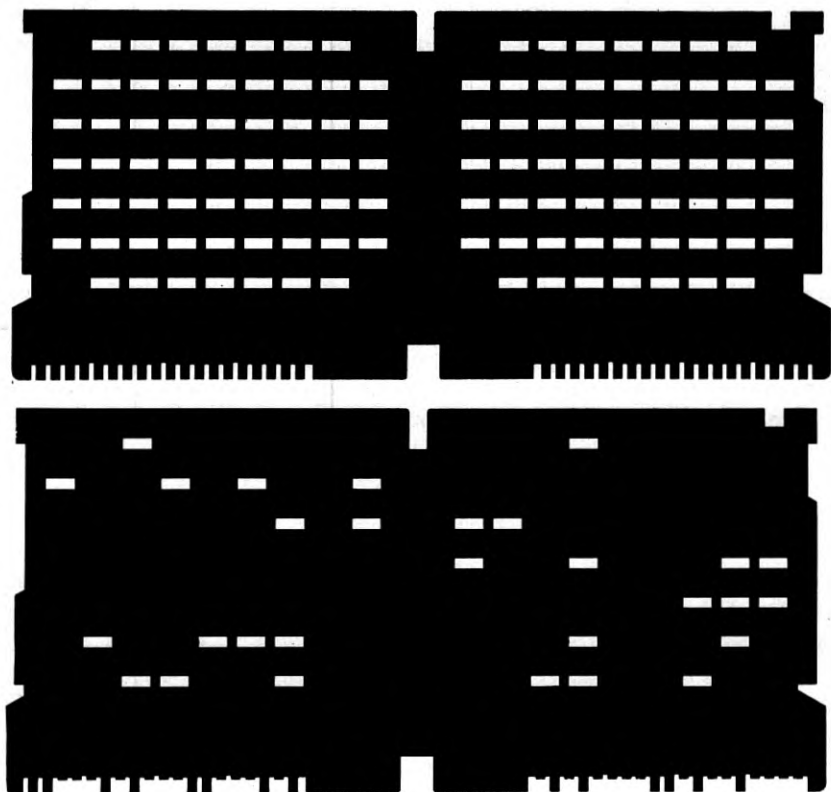

Fig. 5 — Normal (above) and dropped card views as seen from the phototransistor side.

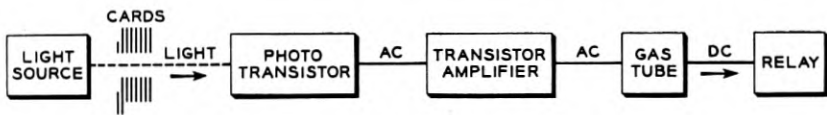

Fig. 6 — Block diagram of channel circuit.

cards in their normal positions they are aligned and the holes in the cards form unobstructed, horizontal tunnels called channels through the entire stack. When a particular card has been selected and dropped a distance slightly greater than the height of an unenlarged hole, these light beams through all of the channels are blocked by the dropped card except for those holes which have been enlarged. This results in a pattern of clear channels which represents the translator output information.

The change in the silhouette of the stack from the condition of all cards normal to that of one card dropped is shown in Fig. 5.

#### THE CHANNEL CIRCUIT

Fig. 6 is a block diagram of the circuit used to determine whether a particular channel is interrupted by a dropped card or not. Each block, with the exception of the light source, represents a piece of equipment provided individually for each channel. The light source is common to all channels. If the hole in the dropped card for a particular channel has been enlarged, the light will pass completely through the stack of cards and fall on the phototransistor. The phototransistor converts the light into an electrical signal which, after being increased by the transistor amplifier, is used to trigger a cold cathode gas tube. The gas tube in turn operates the channel relay. This relay is located in the associated equipment which uses the information supplied by the translator to process the call.

In making a detailed examination of the channel circuit, it is convenient to consider it in two parts: the optical section and the electrical. The optical section includes everything up to the point where the light falls upon the germanium of the phototransistor. This part of the channel is shown functionally as Fig. 7. The light source is a standard projection type lamp normally rated at 500 watts. To obtain long life it is operated in the translator at about half of its rated voltage at which level its input is approximately 170 watts. This type of lamp was chosen because of its high concentration of light in a small plane area.

The light from the lamp passes through a motor driven perforated disc which modulates it with an approximate square wave at a 400-cycle rate. Modulated light is used because it is more economical to use ac

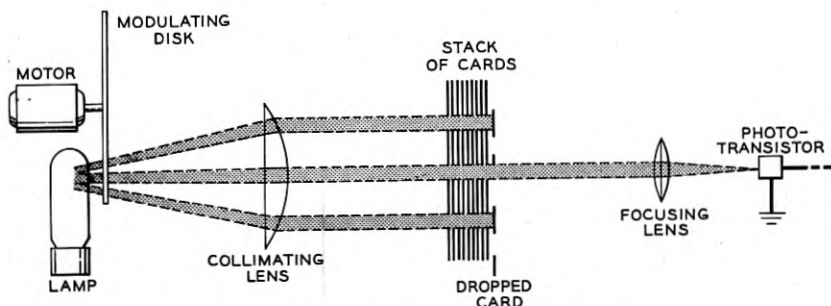

Fig. 7 — Optical section of channel circuit.

than dc amplifiers and also since the difference between the light and dark currents of the phototransistor is the important factor rather than the absolute value of either. The modulated light is collimated by a lens to minimize the loss as the beam passes through the holes in the card. Unless interrupted by a dropped card, this light beam will pass through all of the cards and fall on the lens which focuses the light on the sensitive area of the phototransistor. The light intensity at the lens of the phototransistor is 34-foot candles minimum. This is equivalent to about 12 millilumens at the phototransistor, a figure relatively small when compared to the light intensity that is required by conventional photoelectric cells.

The electrical part of the channel circuits starts with the phototransistor and is shown in Fig. 8. The light acts as the emitter of the phototransistor. The collector is of the conventional type for point contact transistors. As is normal in grounded base transistor circuits, the collector of the phototransistor is biased in the high impedance direction. A variation in the light intensity causes a variation in the collector impedance of the phototransistor. The type used has an impedance of about 10,000 ohms when dark which is reduced to approximately 3,000 ohms when illuminated. The output of an illuminated phototransistor when coupled to the amplifier ranges from 1.3 to 12 volts positive peak at 400 cycles depending upon the age and condition of the transistor.

Since the discrimination by the channel circuit between a clear or blocked light path depends upon the presence or absence of an ac output from the phototransistor, noise of sufficient magnitude, if present when the channel is dark, would cause a false indication. To guard against such false indications each phototransistor is checked during manufacture for dark noise. During a five minute interval the dark voltage must not exceed 75 millivolts.



The phototransistor is coupled to the amplifying transistor by transformer T1. This permits convenient matching of impedances and separation of the dc bias voltage. A voltage limiting varistor, V, is connected across the input of the transformer to limit surges which might otherwise damage the amplifying transistor. The circuit of the transistor amplifier is a conventional arrangement.

Voltage gain of the amplifier, including the input transformer to the gas tube, varies from 40 to 100. However, when operating in the translator, the phototransistors normally will drive the amplifier to saturation

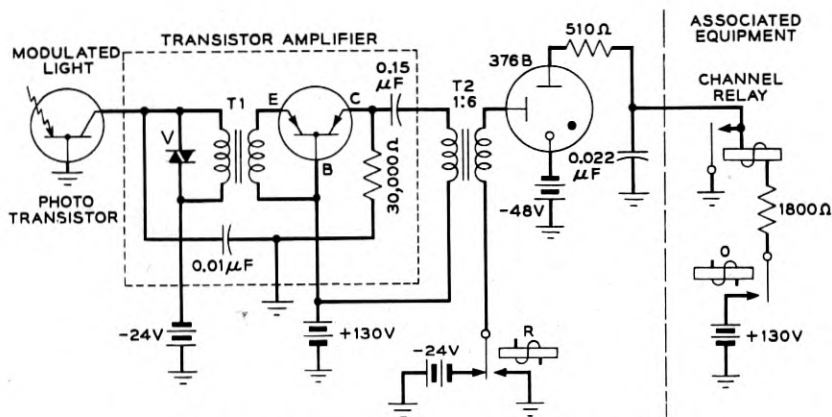

Fig. 8 — Electrical section of channel circuit.

which limits the output to 160 volts positive peak. For the purpose of guaranteeing operation, a minimum output voltage of 38.5 has been set as a rejection point for a phototransistor-amplifier combination.

The output of the transistor amplifier is normally sufficient to break down the control gap of the cold cathode gas tube. Sufficient current flows in this control gap to insure reliable transfer to the main gap when the output control relay O in the associated equipment operates. To aid deionization of the gas tubes, the bias of  $-24$  volts is removed from the control anode just before channel operation is required. The relay R, which replaces the bias voltage with ground, is operated by a circuit which checks that the card being dropped is completely down. This "down" check circuit utilizes the two index holes in the card which are never enlarged and employs two phototransistors to detect the presence or absence of light through these holes.

Fig. 9 shows the card down check circuit. It differs from the routing information channel circuits in that the operation of a relay is required

when the light is blocked. Therefore the transistor amplifier-gas tube circuit is not applicable. For the down check channels, the output of the phototransistors is amplified by the first section of a conventional double triode thermionic emission tube V1. The ac signal at the plate of V1 is rectified by a conventional full wave rectifier consisting of transformer T3 and tube V2. The rectifier voltage is negative with respect to ground and when it is impressed on the grid of the second section of tube V1, that section is driven beyond cutoff. Therefore, as long as light falls on the phototransistor, no current flows through the relay. When the

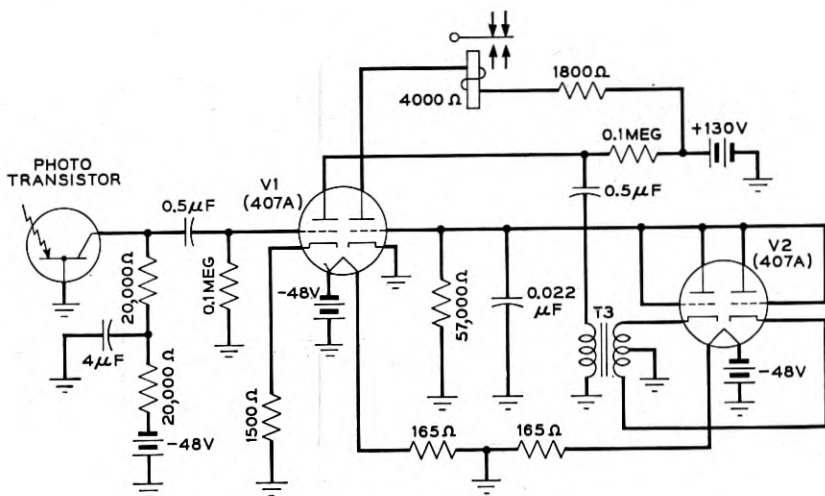

Fig. 9 — Card down check circuit.

dropped card blocks the light, the negative voltage on the grid disappears and the tube conducts, thus operating the associated relay. While the prime purpose of this down check is to signal the associated equipment that the card is in position for recording its output code, advantage is taken of this circuit's ability to distinguish between a light and dark phototransistor at any time to provide alarms in the event of a lamp or modulating disc failure.

After the card has been checked down and the associated equipment is ready to accept the output of the card, that equipment connects a positive 130-volt battery through its channel relays to the main anodes of the gas tubes. All gas tubes associated with illuminated channels will have their control gaps fired and will transfer to the main gaps. This operates the corresponding channel relays in the associated equip-

ment. The relays in operating lock to ground and thereby extinguish the main gap discharges thus increasing the life of the gas tubes. Those channels which have been blanked out will not have the control gaps of the gas tubes broken down. Therefore when the 130 volts is applied, the relays associated with the darkened channels will not operate. The operation or non-operation of the relays in the associated equipment completes the function of the channel circuits.

The capacitor and resistor network at the main anode of the tube is to prevent transients due to the operation of other channels from falsely firing the main gap of a dark channel.

#### CHANNEL PACKAGES

The phototransistor is mounted in a metal tube along with a lens that focuses the collimated light on the transistor. Fig. 10 is a cutaway

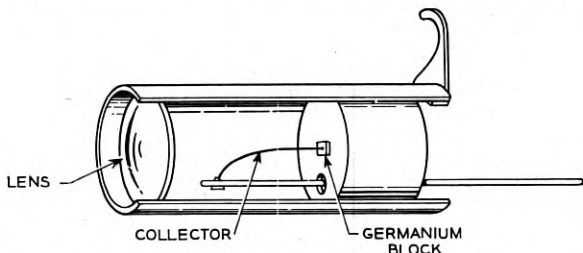

Fig. 10 — Cut away view of phototransistor.

view of the 3A phototransistor showing the relationship of the lens to the transistor. To mount in the translator, the tube is slipped into an accurately positioned hole and clamped in place using the slotted ear. This mechanical fastening is also the ground connection. The output lead from the collector is attached using a slip-on connector.

The amplifying transistor, transformer T1, varistor V, the resistor and two capacitors of the amplifier are packaged in a convenient "plug-in" unit. Fig. 11 is a photograph of these amplifiers. As shown, the transistor is mounted under a removable cap on the package so that it may be conveniently replaced if necessary.

The gas tube, transformer T2, and the associated resistor and capacitor are also assembled as a packaged unit.

#### TRANSLATOR CIRCUITRY

The card translator is mounted on an associated translator table as shown in Fig. 12. The translator table contains the transistor amplifiers

and the cold cathode tubes one for each of the channel circuits as previously discussed, and, in addition, the miscellaneous relays through which the operation of the translator is controlled. As already stated, the connection between a translator and the associated decoder is through suitable connector relays which are either a part of the decoder or on a separate connector frame.

The phototransistors may be adversely affected by temperatures greater than 130°F. Therefore, to provide satisfactory operation during sustained heavy traffic load periods and with high ambient room temperatures, an air circulating and filtering unit, as shown in Fig. 13, may be provided. This unit mounts on the translator in place of the regular end cover and otherwise requires no further apparatus change. For convenience in ordering, the "1B" translator is specified when the air cooling unit is desired. Otherwise the "1A" translator will be furnished.

The translator table contains relays for controlling the dropping, checking, and restoring of the cards in the translator. First are the relays that operate the card "pull-up" and "pull-down" magnets. Then there are select code bar control relays, one for each bar, operated from the sender or decoder, which in turn operate the associated select code bar solenoids. These relays are necessary since the lead resistance from the sender to the translator would adversely affect the operating time of the code bar solenoids. Finally, there are relays that check the code bars for proper operation on a "two-out-of-five" basis. Two, and only two code

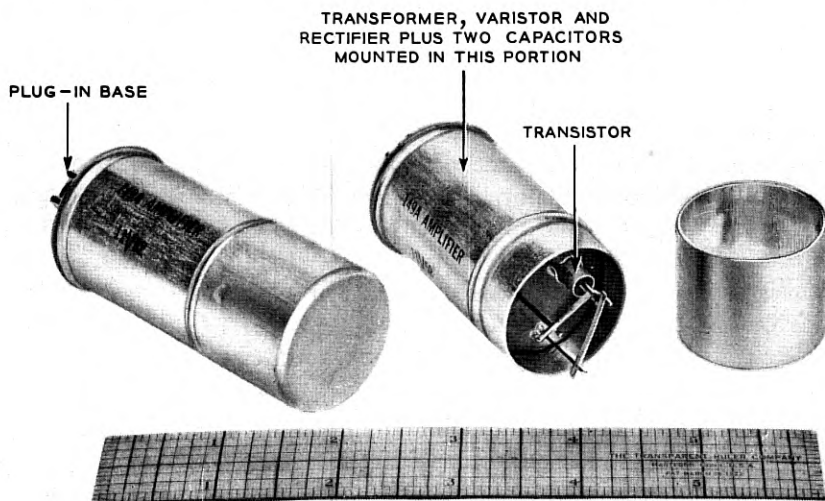

Fig. 11 Transistor amplifier.

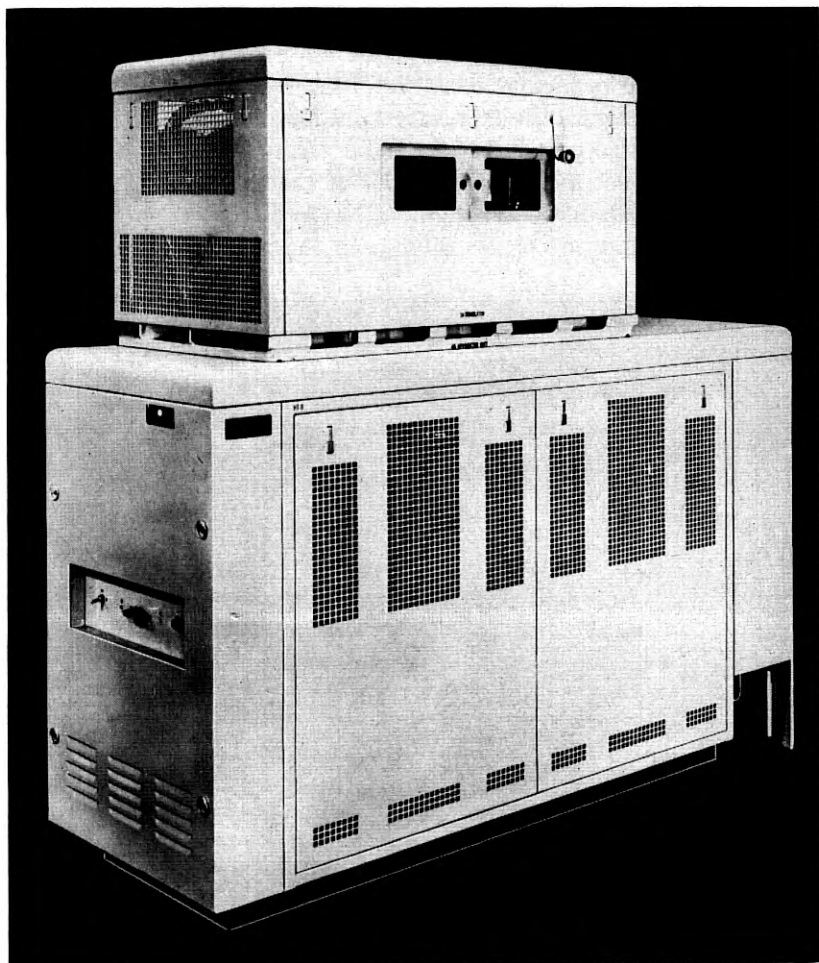

Fig. 12 — Card translator and table.

bars for each digit must be operated, before an attempt is made to drop a card.

The operating cycle of the relays and the translator in selecting a card and restoring it is then as follows:

When the translator is first seized the pull-up magnets are energized and when the cards are suspended the latches are operated. The decoder then closes the leads over which the code bar relays operate and they in turn operate the code bar solenoids. When the proper number of these are operated a check for this is made which releases the latch.

With the latch restored to normal the pull-up magnet is de-energized. All the cards then drop until they meet the code bars, about 0.016". The card for the particular code, however, continues 0.180" further, because the bars for all the tabs have been lowered until it rests on the pull-down magnetic pole face. The index channel relays then operate causing the decoder to read the output of the card.

When the decoder has checked that it has received proper information from the card, and on certain calls when the marker has selected an

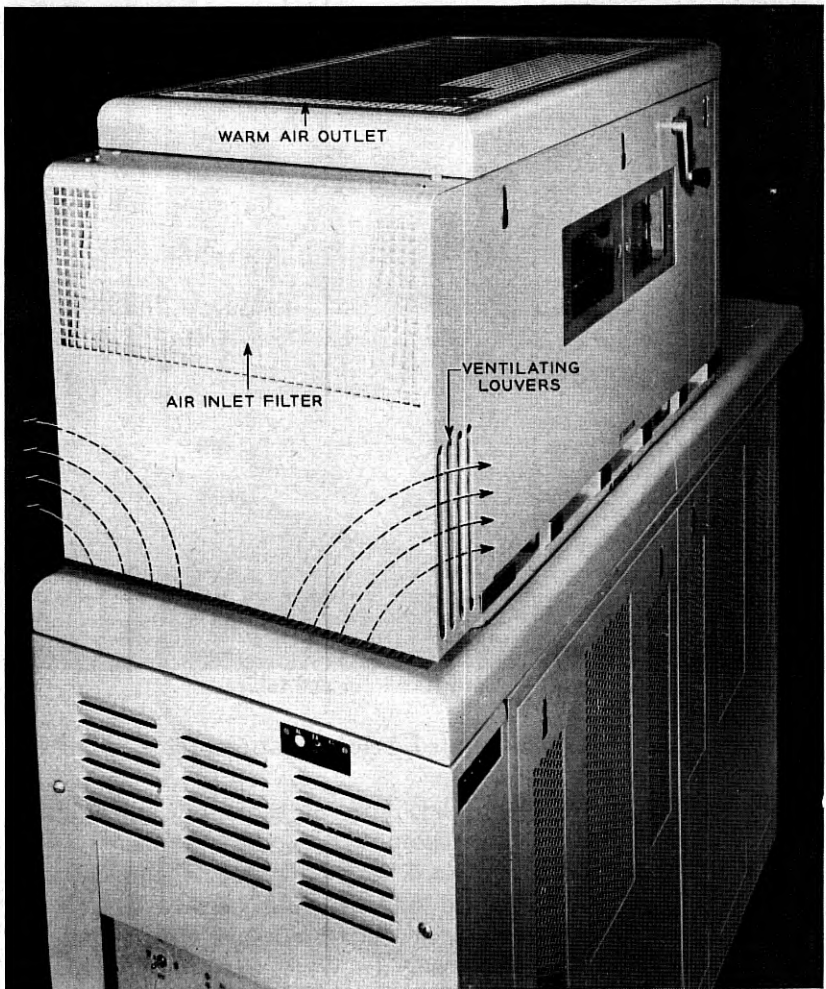

Fig. 13 — Card translator equipped with cooling unit.

outgoing trunk, the decoder releases the translator. Just prior to this, the decoder operates an automatic restoral relay in the translator, which causes the card to be restored to its normal position in the stack. This takes place by again energizing the pull-up magnet, and, when the cards are again suspended, the latches are operated and the code bars are released, restoring to their normal positions. The card that was down is restored by the code bars to its position in the stack. All the relays in the translator table then release except for a slow releasing relay which remains operated holding the pull-up and latch magnets energized so that a subsequent call does not have to wait for these magnets to operate and suspend the cards. This feature saves time under heavy traffic.

#### TRANSLATION TIME

The call carrying capacity of a translator and the number of translators for a particular CSP is directly related to the time required for translation, that is, the selection, reading and restoral of the translator cards. For this reason, particular attention to translation time was used in the design, not only of the translator, but throughout all the associated circuits of the switching system.

Since the translators in service are always controlled by the decoder circuits and since the number of decoder translators and decoder foreign area (DFA) translators are directly proportional to the number of decoders, the times for the various types of translation and alternate routing will be given in terms of the holding time of the decoder.

#### PRETRANSLATION

This requires approximately 235 milliseconds. On this type of call translation of three digits, when either four, five or six digits are needed for the routing, informs the sender to release the decoder and wait for the rest of the code.

#### THREE DIGIT TRANSLATION

The time for this type of call is approximately 330 milliseconds. This is when three digits are sufficient for a routing.

#### SIX DIGIT TRANSLATION

The time for this is approximately 550 milliseconds, assuming that the six-digit card is in the decoder translator. This does not include the

pretranslation time. Pretranslation does not occur if the office code as well as the area code is registered in the sender before the decoder is connected. This often occurs during periods of heavy traffic. On six-digit translation, two cards must be translated, the three-digit area code followed by the six-digit destination code card.

#### SIX DIGIT TRANSLATION IN FOREIGN AREA TRANSLATOR (FAT)

This type of call requires approximately 560 milliseconds. The area code card in the decoder translator gives the information for selecting the particular FAT in which the six-digit card is located. The translation time will be extended if there is a delay, due to another decoder using the FAT. Pretranslation time, as stated above is not included.

#### SIX-DIGIT TRANSLATION-PRINCIPAL CITY AND VACANT CODE ROUTING (FAT)

In this case translation requires approximately 615 milliseconds. This is for routings to areas where there is a principal city (PC), usually another CSP, through which all calls to that area can be completed, although in the area there are other destinations reached over direct high usage trunks. In this case, to save cards and perhaps translators, the six-digit cards for all destinations reached directly through the PC are deliberately omitted. The time given is for a call to such a destination. The three-digit card for the area has on it information for the proper routing of the call to the principal city. For those destinations where the six-digit cards are omitted, as well as for vacant codes in such areas, the call is routed to the principal city. Pretranslation and foreign area translator delay times, if any, are not included.

#### THREE-DIGIT CARD-TO-CARD TRANSLATION

This type of card-to-card operation is used where there are several sub-groups of trunks or routes to the destination and the decoders do not have facilities for determining which group of trunk has an idle trunk. The routing information for each trunk group must be presented successively to the marker in selecting an idle trunk.

The translation time, considering that an idle trunk is selected from information on the first card, is approximately 330 milliseconds, assuming no marker delays. When the trunks for the first card are found busy and routing is made from the second card, the total time is about 550 milliseconds. This increases to about 770 milliseconds for routings



from the third card and finally to 1060 milliseconds for the fourth card routing.

#### SIX-DIGIT CARD-TO-RELAY TRANSLATION

This type of operation is used where the first group of trunks to the destination is of the type that requires test by the marker for selecting an idle trunk. There are alternate routes, however, in which the decoder can determine which group has an idle trunk. In this case the area code card provides information for the selection of the first six-digit card. This card has information for routing the call over the first group of trunks. There are alternate route cards for each subgroup of alternate routes. There may be as many as five alternate routes, each of which may have as many as four sub-groups of 40 trunks each.

The translation time, assuming the routing is from the first card, is about 550 milliseconds. For routings from any one of the alternate route cards, the time increases to approximately 800 milliseconds. Pretranslation and FAT delay time, if any, are not included.

#### THREE-DIGIT CARD-TO-RELAY TRANSLATION

The time required is about 350 milliseconds for routings from the first card and about 580 milliseconds for routing from an alternate route card.

#### SIX-DIGIT RELAY-TO-RELAY TRANSLATION

This type of operation is used where all of the trunks including the alternate routes are tested by the decoder in determining in which group there is an idle trunk.

The translation time, assuming the routing is from the first six-digit card, is approximately 575 milliseconds. For routings to succeeding alternate routes the time is approximately 800 milliseconds.

#### MAINTENANCE FACILITIES

Although the card translator and all of its components are designed for relatively long and trouble-free life, adequate testing facilities and maintenance procedures are essential because of the importance of the individual CSP's in nationwide dialing. Adequate guards and methods of procedure have been made available in case of almost any catastrophe that would incapacitate any CSP office. Moreover the complete breakdown of a translator or even several of them in a CSP office would not completely stop calls through that office although the call carrying

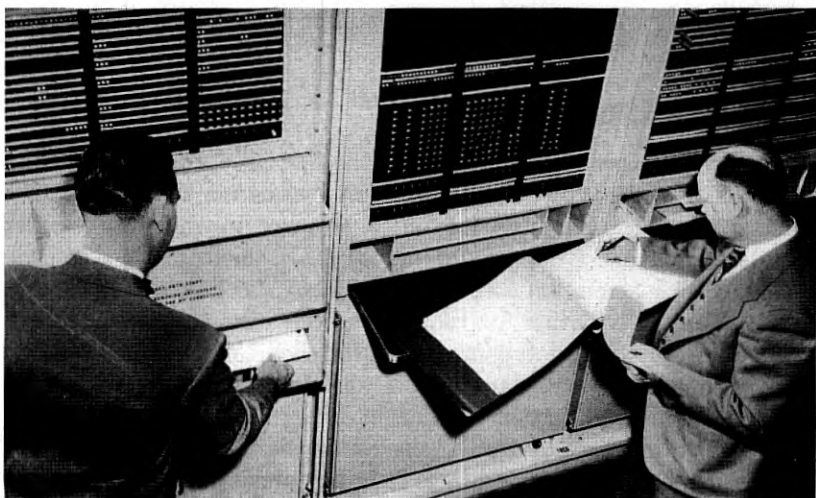

Fig. 14 — A trouble record card is being removed from the perforator and information from a punched card is being entered in the office records.

capacity of the CSP office or the switching system would be reduced. However, to insure satisfactory operation of the card translators automatic trouble recording, test circuits and maintenance methods are provided.

#### TROUBLE RECORDER

In CSP offices, where the card translators are used, the card punching type of trouble recorder will be provided as shown in Fig. 14. In the event of a failure of any translator, the associated decoder circuit will block and time out. This causes the connection of a multiplicity of leads between the trouble recorder and the decoder as well as to the translator. The trouble recorder will then automatically punch and drop a properly designated paper card (Fig. 15) that shows which translator and decoder are in trouble. The state of the various elements of the translator and decoder will also be recorded. In addition, a record is made showing which code bars, pull up and pull down magnets, latches and important relays are operated. Also the important key relays which are operated in the decoder will be shown. The associated sender will be identified as will also the marker if one is connected. Then too, the state of the marker will be recorded. From this trouble record the cause of the failure can, in most cases, be determined.

When the trouble recorder card has been punched, the associated

equipment is directed to make another trial. This usually will be with an alternate decoder and translator so that the call is usually completed with a delay of a little more than one second required for punching the trouble recorder card. The trouble recorder, once it has completed punching a card, is immediately available for recording another failure. The trouble recorder is also available for recording failures of other CSP equipment such as the controllers, senders and markers in a manner similar to that described for the decoder and translators.

#### TRANSLATOR TEST

There are facilities provided on the trouble recorder frame, through keys and connecting relays, for adding and removing cards from the translators. On adding a card, a check can be made to verify the card output to make sure that it is in agreement with the template from which the card was coded. Test calls using all decoders and markers can be made to verify the selection of a trunk in accordance with the routing information on the new card as well as on any card in any translator. These tests can be caused to recycle automatically and to drop a trouble recorder card in case of failure. This feature is useful in isolating infrequent failures in any of the associated translators, decoder or markers. Facilities are also provided for removing the translator selector unit for periodic inspection and adjustment as may be necessary. Also timing tests can be made from the trouble recorder frame to check the time required for the translator to drop and restore a card.

To determine if any of the output channel elements of the translator, which includes the photo-transistors, transistor amplifiers and cold cathode tubes, for all the channels, have satisfactory operating margin, means are provided for making a mass test of the channels. This test is made under a controlled voltage (36.5 volts) which is considerably below the worst service condition. In case of a failure of an element under this test, a trouble record card will be dropped which will show, by a punched hole, each element that is operating satisfactorily. This mass test is provided to detect any channel element that is approaching end of life and thereby assures that there is at all times ample operating margins of these important channel elements.

#### *Portable Test Set*

In addition to the test facilities provided on the trouble recorder frame, there is also a portable test set for the translators as shown in Fig. 16. This test set is connected to the translators by means of multicontact

2-3825 (1-52)

	0	5	10	15	20	25	29
58	SOURCE OF RECORD		0	MARKER-IT OR COMB		DECODER	
	D	M	C	D	T	M	T
57	TYPE OF RECORD		TRI	TR2	MARKER-TC		
	F	I	F	M	F	T	S
56	TYPE OF RECORD		DGT	SR FR UNIT		SR FR	
	R	O	P	R	O	S	R
55	TRANSLATOR ENGAGED		DECODER CONNECTOR		DECODER INPUT CODE		
	H	E	M	T	O	T	O
54	DECODER INPUT		LATCH MAGNETS		CARD GROUP		
	A	O	I	2	4	A	7
53	DECODER INPUT		LATCH MAGNETS		CARD GROUP		
	A	O	I	2	4	A	7
52	DECODER INPUT		LATCH MAGNETS		CARD GROUP		
	3	D	6	D	A	V	O
51	DECODER ROUTE ADVANCE		MARKER REGISTRATION-CODE CONVERSION		MARKER REGISTRATION		
	R	A	R	A	I	R	A
50	DECODER ROUTE ADVANCE		MARKER REGISTRATION-CODE CONVERSION		MARKER REGISTRATION		
	N	C	A	C	A	S	C
R7	ALTERNATE ROUTE		CODE CONVERSION		ROUTING INST.		
	C	D	C	N	A	C	A
R6	TRUNK BLOCK CONNECTOR		TRUNK BLOCK		GROUP START		
	D	I	M	R	D	T	O
R5	DECODER ROUTING INSTRUCTIONS		MARKER REGISTRATION-CODE CONVERSION		MARKER REGISTRATION		
	C	C	R	R	F	O	F
R4	MARKER REGISTRATION		MARKER REGISTRATION-CODE CONVERSION		MARKER REGISTRATION		
	M	B	R	O	P	R	O
R3	TRANSMITTED-MARKER TO SENDER		FRAME IDENTIFICATION		MARKER REGISTRATION		
	M	C	M	F	S	D	L
R2	DECODER PROGRESS		MARKER PROGRESS		MARKER PROGRESS		
	C	K	G	H	T	K	S
R1	DECODER PROGRESS		MARKER PROGRESS		MARKER PROGRESS		
	D	C	B	D	C	B	A
R0	MARKER PROGRESS		MARKER PROGRESS		MARKER PROGRESS		
	A	K	B	K	C	H	S

Fig. 15 — Trouble recorder card showing the multiple

plugs, cords and jacks. This set can be used for adding and removing cards and verifying that the new card will drop. Bins are provided for storing cards in the process of adding, removing, and transferring cards. Timing tests can be made not only of the over-all time of the translator, as from the trouble recorder frame, but also of the individual component parts of the translator. The test set can also be used for removing the translator selector unit and for bench testing this selector. In this connection, a re-cycling test can be made of the code bars, card support bars and latches to check that they operate smoothly and evenly. Current flow adjustments can be made of the code bar solenoids, latches, and pull up and pull down magnets.

DESIGN OBJECTIVES

When, in the course of the development, the controlling requirements that had to be met became apparent, the design objectives were considered. The reasoning applied is set forth in retrospect in the following paragraphs.

It will be apparent from the foregoing that administrative problems would be involved should it be necessary to arrange and maintain the individual cards in any particular order in the card stack and, therefore, indiscriminate loading became a design objective.

Since the cards will be changed from day-to-day and sometimes on

30	35	40	45	50	55	59
DECODER CROSS (X-)			DECODER TIME-OUT			MARKER TIME-OUT
CA REC	1X	CRN	BDT	TRB	CF	TRL
HARRIER CROSS (X-)			TR STR			MRL TIF TOF
X	15	1PS	10	ST	MS	K
O	1	2	4	7	0	1
JP	1LS	OLS	JS	SM	SMT	SMD
TL	RCK	TKS	TR	TRL	STR	MRL
TC	TC	FB	FB	MS	MS	MS
TO	1	T2	0	1	2	3
TC	TC	TC	TC	TC	TC	TC
UO	1	2	3	4	5	6
U9	20	21	22	23	24	25
INCOMING FRAME GROUP			INC SWITCH			
O	1	2	3	4	5	6
7	8	9	10	11	12	13
SELECT MAGNET						
O	1	2	3	4	5	6
7	8	9	10	11	12	13
SELECT MAGNET			INC. FR.			OUT FR.
30	31	32	33	34	35	36
37	38	39	E	O	E	O
OUTGOING FRAME GROUP			OUT SWITCH			
O	1	2	3	4	5	6
7	8	9	10	11	12	13
JUNCTION CONTROL			JUNCTION WALKING			
O	1	2	3	4	5	6
7	8	9	10	11	12	13
JUNCTION PATTERN			CHANNEL			
O	1	2	3	4	5	6
7	8	9	10	11	12	13
DECODER-MARKER TEST			CONN PREF CONTROL			
LPD	CL12	NCF		CHR	MSK	XPS
SMG		SMB				
CONF GROUP						
A	B	C	D	E	F	G
CONTROLLER			CONTROLLER CONNECTOR			LK FR-TENS
0	1	2	3	4	5	0
1	2	3	4	5	0	1
2	4	7	0	1	2	4
TRUNK GROUP			TRUNK LEVEL			SEC. SW.
0	1	2	3	4	5	6
7	8	9	0	1	2	3
REFERENCE			SEC. SW. LEVEL			SDR. TYPE
A	B	C	D	E		DP
CONTROLLER PROGRESS			CROSS			CONTROLLER TEST
TT	FR	GR	CL	OI	OT	PC
DTC	DTC	PA	PB	SA	SB	SC
HO	HM	GX	PX	SX	HX	CLX
A	B	C	SR	AR	NF	TR

OFFICE  
DATE

107

TIME

MADE IN U.S.A.

tems that may be recorded by punched holes.

short notice, the provision of cards capable of being readily coded in the field became another objective.

It was estimated that from five to ten per cent of the cards used in nationwide dialing would have to be replaced annually because of routing changes, that on the average a card would be selected for routing purposes about one million times before its replacement due to routing changes would be necessary and that the average routing change interval would be from five to ten years. It was recognized that in the course of this period, cards might have to be loaded and unloaded several times. These facts established ruggedness consistent with high-speed operation as still another objective.

Ruggedness indicated the use of metallic cards. The comparatively large number of input tabs and output holes required made for substantial size. These considerations together with the comparatively large number of cards that are to be stacked together made it obvious that considerable weight would have to be contended with. Yet it was known that highspeed operation is mandatory. These conditions suggested that the cards be made from magnetic material so that their manipulation might be assisted by suitably applied magnetic forces such as may be developed by the pull-up and pull-down magnets that already have been referred to and illustrated. Thus provision for the use of cards made from magnetic material became an added objective.

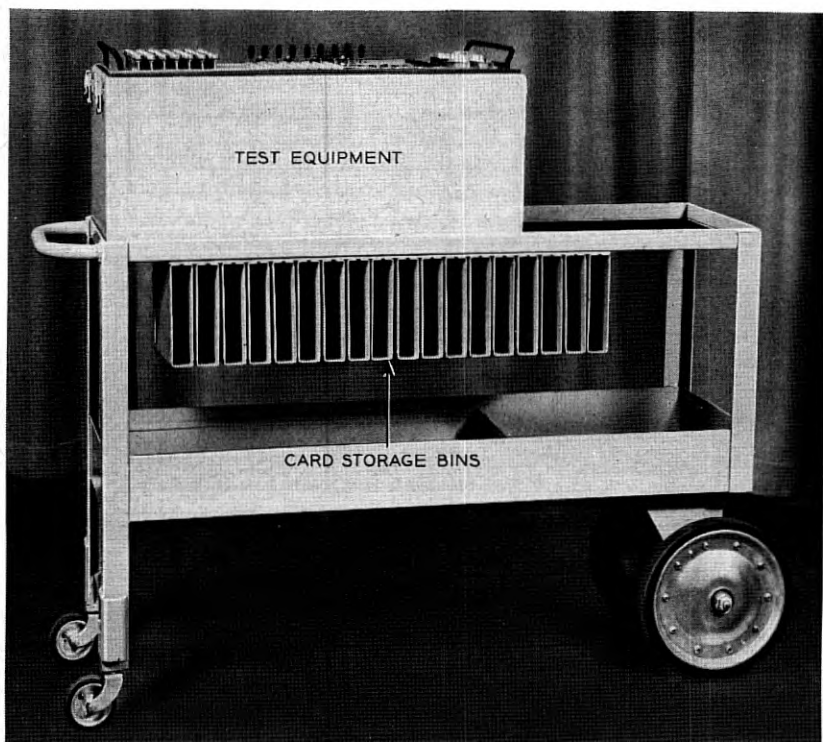

Fig. 16 — Portable test set.

It was estimated that a card translator, on the average, would be called upon to function from twenty to thirty million times a year. Accordingly, provision for direct-acting, high-speed, long-life and readily replaceable components became another objective.

A further objective was the provision of means for reading the routing information without mechanically contacting the cards, as for instance by utilizing photo-detection circuits, such as have been referred to, as it was reasoned that in this way reliability over an extended period could best be assured.

#### ELECTRO-MECHANICAL DESIGN

Phototransistors are utilized as the photo-sensitive elements, the light source is a standard projection lamp, the light beams are modulated and then directed through the card formed tunnels by dual collimating lenses and then upon emission from the card stack are focused on the phototransistors. (See Figs. 17 and 18.) To a large extent the card, which is

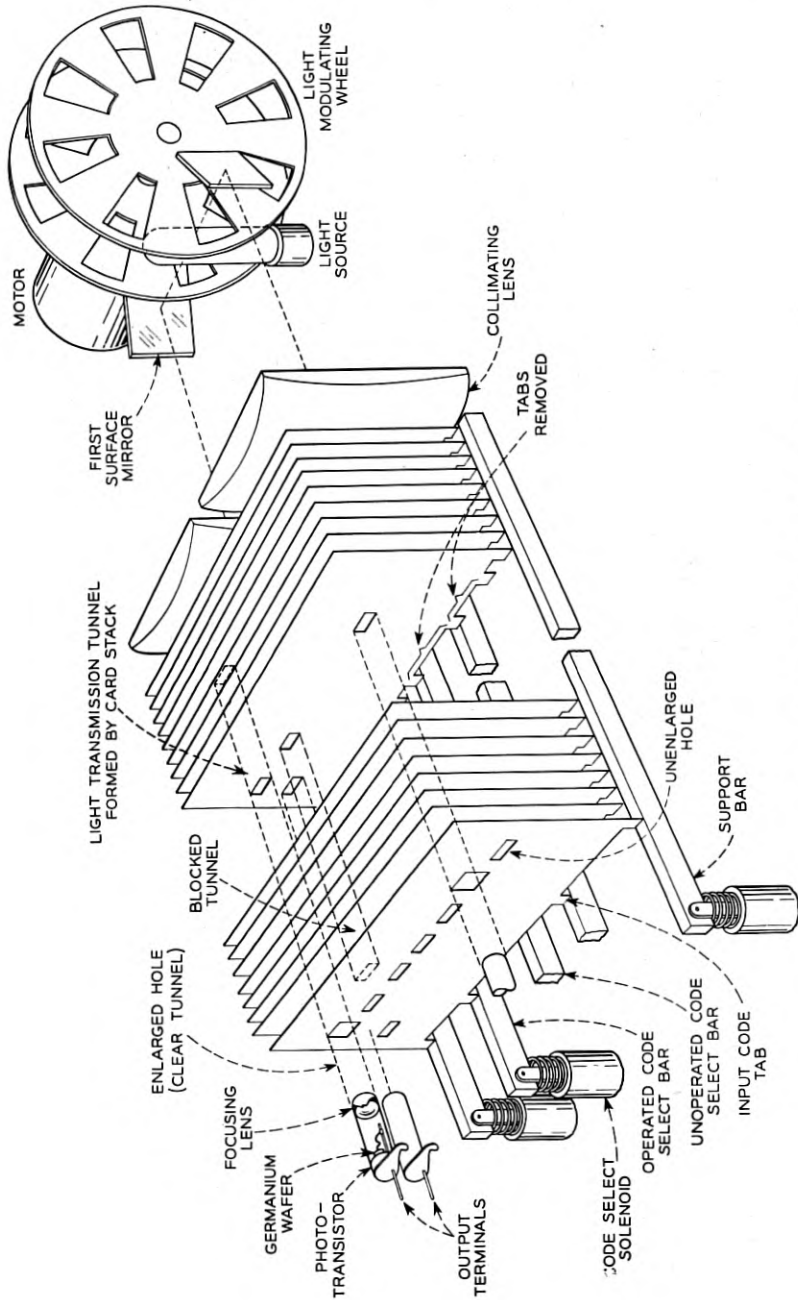

Fig. 17 — Functional mechanical schematic.

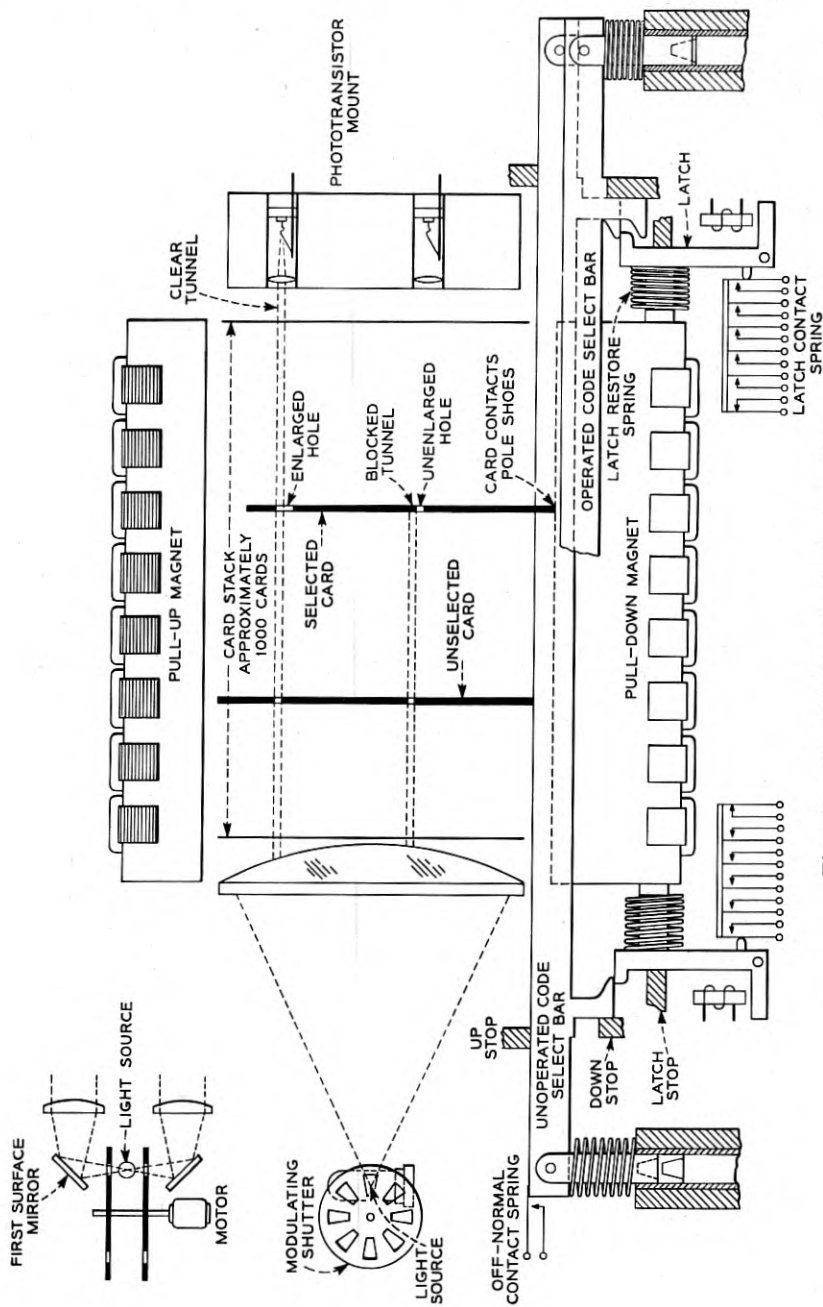

Fig. 18 — Simplified mechanical schematic.



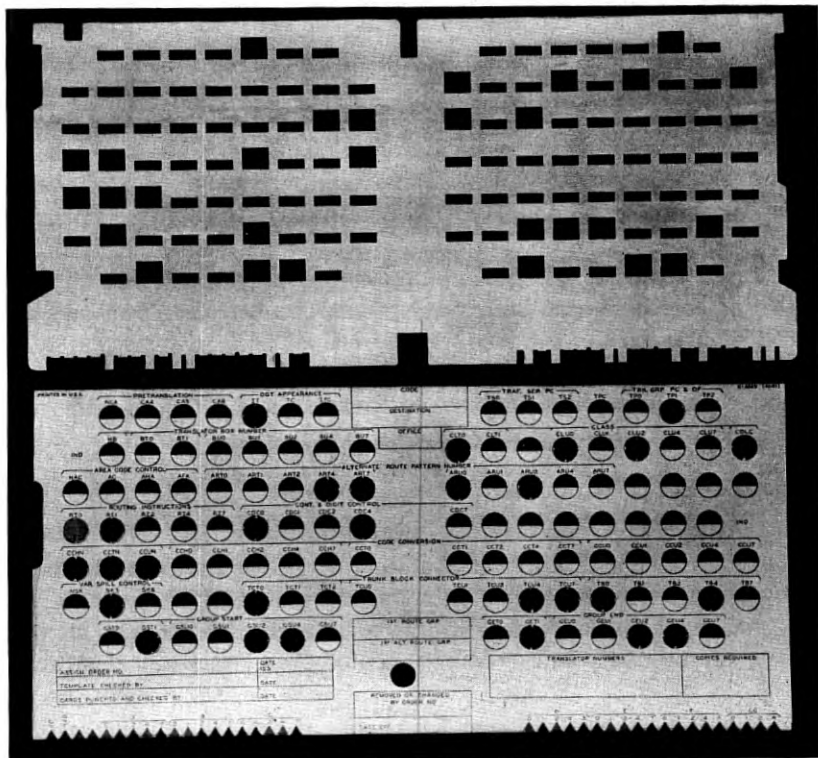

Fig. 19 — Coded template (below) and associated card.

manufactured as the 200A blank, was controlling and, therefore, it will be discussed in some detail.

#### CARD (200A BLANK)

The general form of the card is illustrated by Fig. 4. The working card, however, is unmarked as may be observed by reference to Fig. 3. Marking is not required because the cards are coded in accordance with information furnished on a paper template, such as is shown in Fig. 19 and this template is retained as part of the office records for ready reference. A card may readily be identified for reassociation with its template by reading its tab code. The template provides considerable administrative data. The dark half of the holes and the triangular representation of the tabs are printed in red as is a strip along a portion of the left-hand edge. After coding, the card is placed over the template. If the red edge portion is visible the card must be turned end-for-end. If, after

having done so, any red can be seen, more holes have been enlarged and/or more tabs have been removed than the template calls for. If, on the other hand, openings in the template are visible through holes in the card that have not been enlarged, the hole coding is not complete. If tab notches appear in the template other than in registration with the portion of the card from which tabs have been removed, the tab coding is not complete. Accordingly, the template also serves as a convenient means for checking the coded card for accuracy. As a convenience, the holes of the template were made round and its tabs triangular.

The holes of the card before being enlarged are of a form and size that simulates the filament face area of the light source. To accommodate the 118 holes, the optimum dimensions of the holes were determined to be  $\frac{3}{8}$ " wide, 0.140" high and the optimum vertical and horizontal spacing proved to be 0.535" and  $\frac{1}{2}$ ", respectively.

The tabs are of a form and size determined largely by the mounting space required for the solenoids that are used to operate the code select and card support bars, the vertical displacement required for shuttering the holes and ruggedness considerations. Thus, the nominal size of the tabs associated with the code select bars became  $\frac{1}{8}$ " wide  $\times$  0.205" long with a spacing of  $\frac{3}{16}$ ". The tabs associated with the card support bars — one at either end — being used for each translation instead of

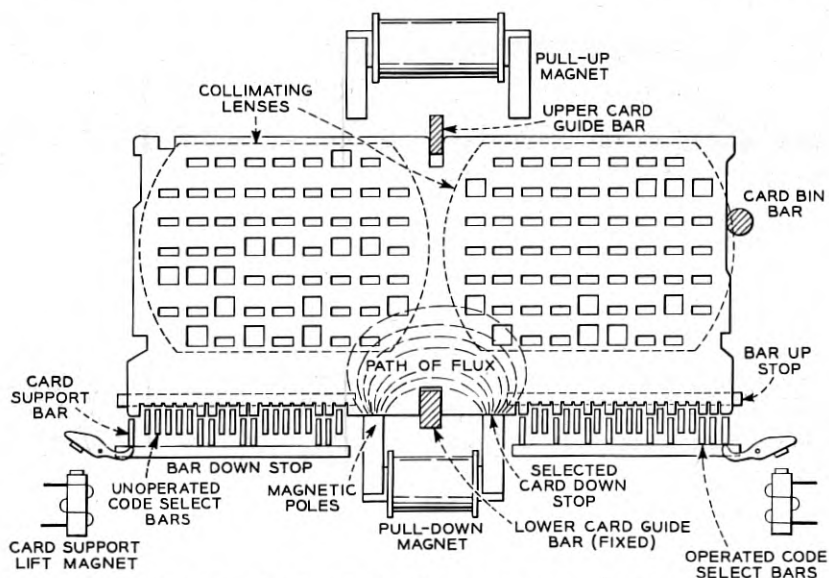

Fig. 20 — Card and directly associated components.

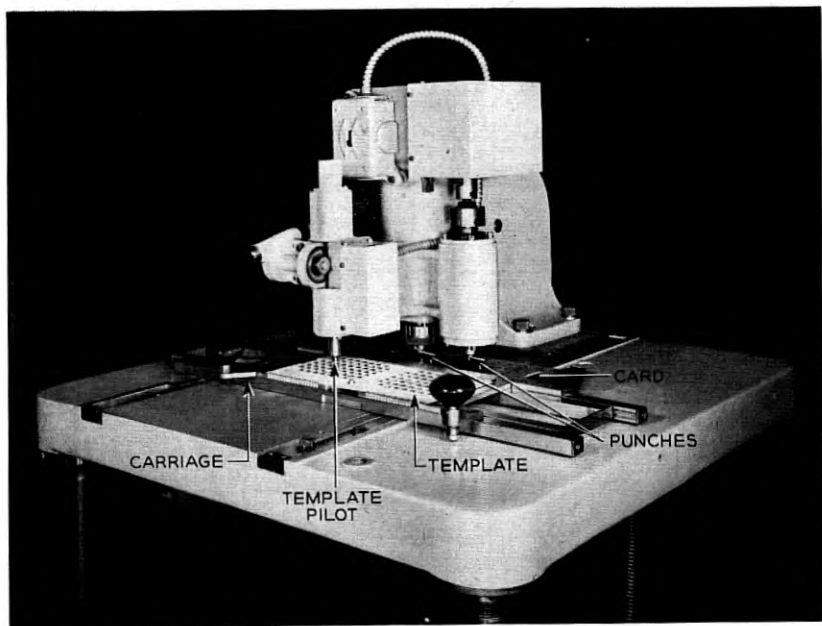

Fig. 21 — Card coding tool.

only selectively as in the case of the tabs associated with the code select bars were made  $\frac{1}{4}$ " instead of  $\frac{1}{8}$ " wide and their outer corners were rounded generously. The additional ruggedness thus provided is particularly beneficial because the end tabs are subject to more abuse than the others in handling.

Left and right-hand grouping of the holes and tabs was necessary for the dual lense system and to provide space in the central area for guide notches and for mounting the pull-up and pull-down magnets, as shown in Fig. 20.

Center, top and bottom notches are provided for engagement with card guide bars that position the cards for proper alignment of the holes and tabs. In addition, these notches guide the cards during their operative displacement.

Other marginal notches are provided for mass lifting of the cards, end-for-end positioning in the card cage, locating the cards properly in a tool for coding cards, and for another tool which facilitates handling the cards in bulk. The coding and bulk card handling tools are illustrated respectively by Figs. 21 and 22.

The over-all size to accommodate the various elements and to provide adequate strength is  $10\text{-}\frac{3}{4}$ " wide  $\times$  5" high.

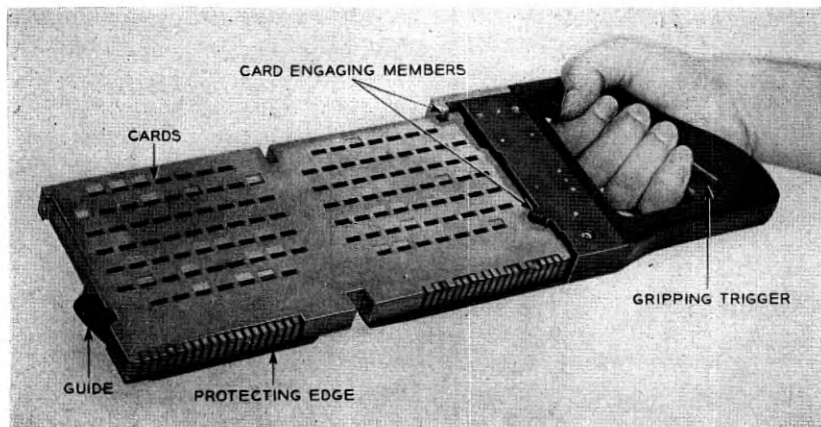

Fig. 22 — Bulk card handling tool. One side plate has been removed to show cards.

The card material had to be magnetic so that electromagnets could be used to assist in the manipulation required in the course of a translation. After giving due consideration to the use of permalloy, Armco iron and several other materials it was concluded that the most practicable compromise would be to use hard-rolled AISI-C1008 strip steel.

The protective finish selected was chromium flash over nickel-plate. The nickel provides reasonable protection against corrosion, while the chromium provides surface characteristics consistent with the need for maintaining interface friction and wear at low levels. The finishes are applied to the strip stock by a continuous plating process and it may be interesting to point out that the current value when applying the chromium is in the order of 1,000 amperes. It will be realized, therefore, that one of the problems in producing satisfactory material is maintenance of the rolls over which the material is fed and which also are circuit elements, free from foreign materials because otherwise high resistance points may develop and cause burning.

Flatness is important because any deviation from a plane, in effect, increases the thickness of the card and thus limits the card capacity of the translator. Manufacture is controlled so that the slight bowing that results from handling the material in rolls always is in the same direction as the material is fed to the perforating and blanking tools. Out-of-flatness is held to maximum 0.012" within 72 hours after fabrication. Bowing subsequently increases the out-of-flatness but not to an important extent. The out-of-flatness is checked by means of the gauge illustrated by Fig. 23, which was developed especially for the purpose.

It comprises a flat metallic plate upon which the card is laid, two rails which are insulated from the plate and project about it an amount equal to the thickness of the stock from which the cards are made plus the allowable amount of out-of-flatness and a metallic roller that is sufficiently long to span the rails. The rails and the flat plate are elements of a neon tube detection circuit which is arranged so that if the roller in passing over the card contacts it the tube will fire. If it does not fire, the card is within the flatness setting of the gauge.

To meet the 0.012" allowance consistently it was necessary to resort to special stress relief annealing. In developing the process it was found that the cards have to be degreased thoroughly and a clean condition has to be maintained at all times. The cards are clamped under heavy pressure between thick nickel plated plattens and are then heated and

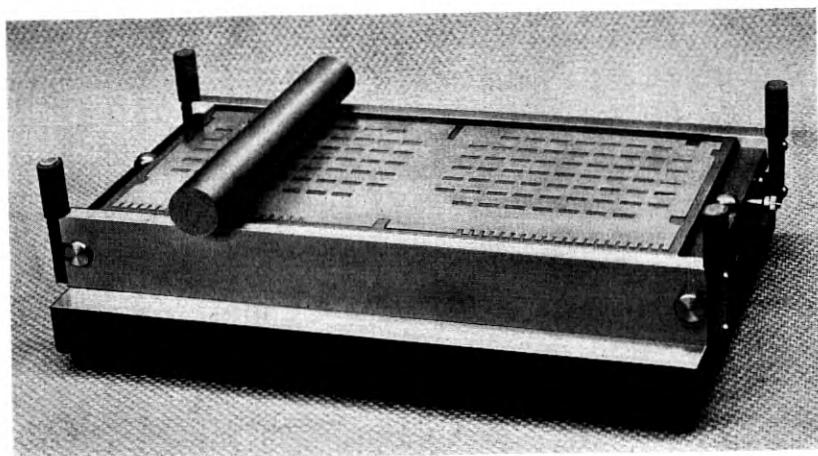

Fig. 23 — Card flatness gauge.

later cooled in a reducing atmosphere. Such a procedure would seem to be reasonably straightforward, but it was found that the heating cycle has to be controlled precisely as otherwise the surface is roughened.

Smoothness of the cards was found to be related to surface color. Improperly stress relief annealed cards usually assume hues of blue and brown which were traced to surface films of so little thickness — perhaps in the order of 500 to 1000 Angstrom units as to cause interference colors. It was found that when the surfaces are discolored excessively, there often is an appreciable increase in interface friction, sometimes amounting to 30 per cent. This is undesirable because free action of the cards is of paramount importance and of course, wear should be minimized. It

was found that roughness is caused by cannibalistic grain growth of the nickel after recrystallization; that is, some of the grains grow at the expense of others, thus causing surface roughness. In this connection it may be interesting to refer to the photomicrographs of Fig. 24. In each, the top, light and almost structureless portion depicts the basic material (steel). The adjacent layer characterizes the nickel plating, the columnar structure being typical of the electro-plating process. The next layer shows the chromium flash and the black portion, a block used to mount the specimen.

The top view of Fig. 24 is representative of the material as received from the supplier. The center view illustrates satisfactory stress relief annealing. The bottom view illustrates unsatisfactory annealing. It will be noted that after satisfactory annealing some recrystallization of the nickel has taken place and that grain growth has started but has

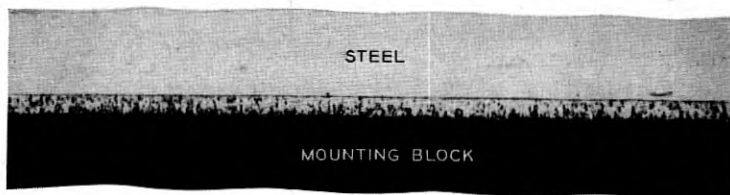

MATERIAL AS FURNISHED

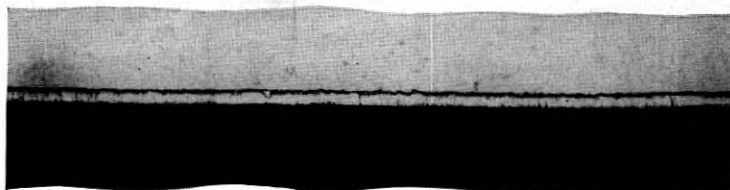

MATERIAL SATISFACTORILY STRESS-RELIEF ANNEALED

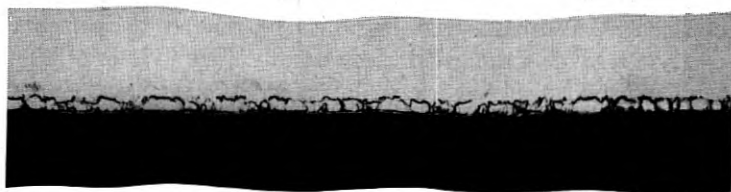

MATERIAL ANNEALED AT TOO HIGH A TEMPERATURE

Fig. 24 — Photomicrographs of sections of cards (1000X).

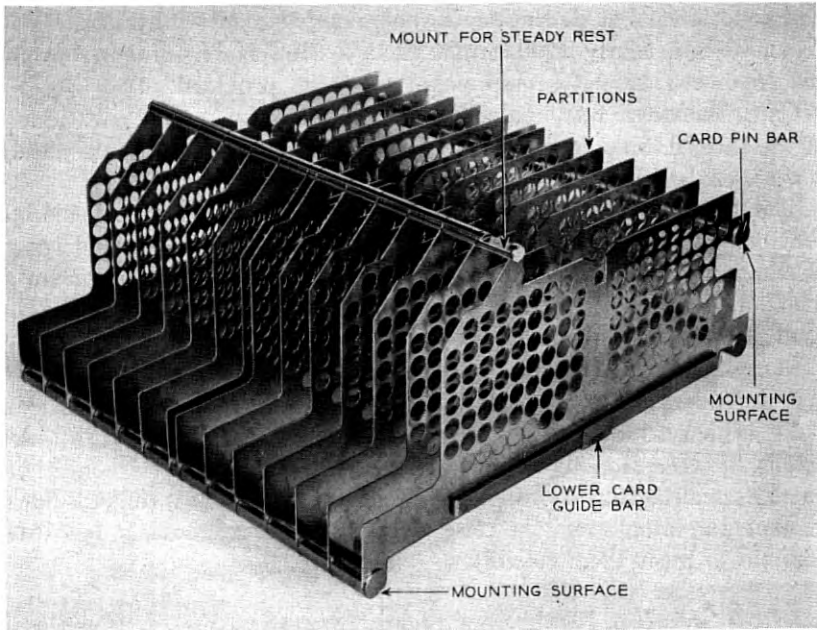

Fig. 25 — Card cage.

not progressed far enough to affect the surface sensibly. It will be observed that when the temperature is too high the grain growth is more pronounced and that as a result substantial protuberances appear on the chromium surface. Cards possessing such protuberances exhibited a marked increase in interface friction.

Distribution of the cards in the translator posed some important problems. Sufficient space had to be provided to accommodate a full complement of cards. Yet it was realized that there would be cases where the translator would not be fully equipped and under these conditions the cards, due to the surplus space available, might lean sufficiently to render them inoperable. To obviate such a possibility a partitioned cage — see Fig. 25 — is provided for the cards. The partitions are close enough to one another to assure that if but a single card is used in a compartment it will operate satisfactorily. This is illustrated by Fig. 26. The spacing thus arrived at is a little less than 1". This spacing provides sufficient room for reliably handling 98 coded cards and a blank card adjacent each partition making a total of 100 cards to a compartment. The blank cards improve the performance of the adjacent cards.

Twelve compartments were decided upon after due consideration of the many related problems such as light tunnel transmission losses,

and code select bar deflection. Twelve compartments fully loaded can accommodate nearly 1200 cards. Thus a comfortable margin beyond the 1000-card capacity requirement has been provided.

Card thickness was controlled by considerations such as stiffness of the tabs, flatness and overall length of the card stack. It ultimately was concluded that the optimum thickness is 0.007" nominal.

The weight of a card after coding averages 40 grams and, considering that nearly 1200 cards may be in translator the total card load is approximately 100 pounds. This is considered to be enormous from a telephone switching apparatus viewpoint and largely accounts for the need of the pull-up magnet.

Manipulation in effecting a translation has to be fast. The displacement of the selected card has to be comparatively large and the card stack, which also has to be moved for each translation but to a lesser extent, is exceptionally heavy. These are not compatible conditions but by advantageous coordination of the pull-up magnet, the pull-down magnet, the latches and the card support bar lift magnets, it has been possible to meet them reliably.

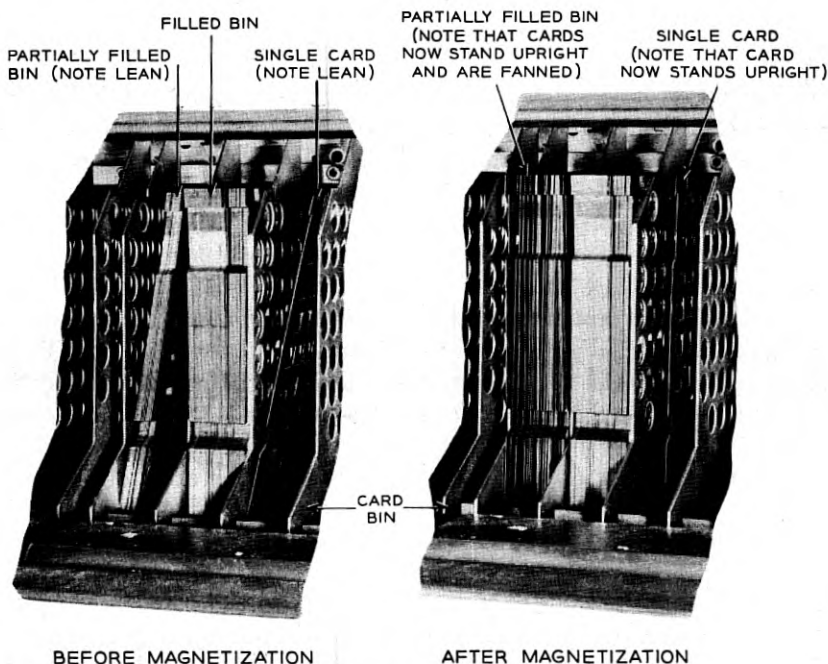

Fig. 26 — Card stack before and after magnetization.



The weight of the stack normally is borne by the latches via the code select bars, but as the time approaches for their operation the stack is elevated by energization of the pull-up magnet and the latches thereby are freed for fast operation.

Separation of the cards just prior to dropping a selected card is effected by the pull-up and pull-down magnets. These magnets induce like magnetic poles in corresponding portions of all the cards and the partitions of the card cage as may be deduced by reference to Fig. 20 and the resulting mutual repulsion causes the cards to separate as may be noted by reference to Fig. 26. This assures free action of the selected card. The pull-up magnet is deenergized when the required code select bars are checked down. The pull-down magnet is maintained energized to assist the dropping of the card.

The nominal initial jump of the card stack, or the separation between the top of the card stack and the pull-up magnet pole faces is nominally 0.016". When the magnet is energized the stack "jumps" to the pole faces in about 15 milliseconds which is fast considering that the load may be as much as 100 pounds.

The nominal drop of the selected card is 0.180". Accordingly, the theoretical free fall time is 33.2 milliseconds and the terminal velocity is 12.7" per second. However, under working conditions, the selected card does not fall freely and except for the added pull of the pull-down magnet, the drop time would average about 40 milliseconds. The pull-down magnet is capable of reducing the drop time in a working translator to as little as 16 milliseconds or approximately one-half the theoretical free fall time with a measured terminal velocity as high as 35" per second. Should this speed be permitted, the impact forces developed would be of sufficient magnitude to cause the tabs of the cards to mushroom to an unworkable degree and to cut through the nylon surfacing of the pole faces of the pull-down magnet in less than one million operations. Under the restraining influence of the card support bars, the drop time averages 33 milliseconds or a reduction of approximately 20 per cent with respect to the unaided operate time and the maximum terminal velocity measured has been 20" per second. Working at this speed, there is virtually no mushrooming during the normal life of the card and the nylon facing survives well over 100,000,000 operations, thus showing a gain attributable to the use of card support bars of more than 100 to 1.

Inadvertent dropping of all cards of the stack is possible although highly improbable. It can happen if the stack is released from its suspended position when the latches are not in a position to support the code select bars. The combined strength of retractile springs of the

solenoid operated bars is insufficient to support the load and, therefore, if this happens, the bars will yield until the load is taken up by the pole faces of the pull-down magnet. The total drop amounts to 0.180" which then will become the effective air gap at the pull-up magnet pole faces. This is more than ten times the normal gap (0.016") and the pull-up magnet is incapable of restoring the card stack to its normal level. This is despite the fact that when the gap is normal, the pull exerted is in the order of 400 lbs and the breakaway pull is approximately 1000 lbs. Accordingly, mechanical means had to be provided for restoring the stack to normal under this condition. Since this rarely occurs, it was concluded that manual restoration would suffice and a hand crank, together with sundry components, including card lift bails, that are illustrated by Figs. 27 and 28 are provided.

Coding of the cards involves many considerations. It has been mentioned that a template is used to indicate the holes that should be enlarged and the tabs that should be removed. Obviously, punch and die sets are required to do this. They are provided as components of a tool which is illustrated by Fig. 21. This tool provides a carriage upon which the card to be coded and the template that provides the coding information are mounted in fixed relationship. The carriage may be moved about to effect registration of the holes to be enlarged or the tabs to be removed, with respect to the punches and dies. When enlarging holes, the carriage is moved to a position where a foot treadle operated pilot registers with a hole in the template and then the treadle is depressed. The pilot enters the hole in the plate that supports the template. The hole is close fitting to effect approximate alignment. As the motion progresses a pilot that is part of the punch assembly effects precise alignment between the punch and the hole to be enlarged. This final alignment is made possible by providing for a small amount of float of a card on the carriage. As the foot treadle is depressed further, the punch enlarges the hole in the card. For coding the tabs, a second punch and die set is provided. It is brought into action by a microswitch controlled solenoid that actuates the punch. The carriage referred to is notched along one edge in registration with the tab positions of the template. Wherever the template is notched, the corresponding card tab is to be removed and the carriage is positioned so that these notches successively may be registered with a stylus associated with the solenoid control switch. The carriage then is moved against the stylus and in doing so the switch is operated which causes the solenoid to actuate the punch, thereby clipping off the corresponding tab of the card. In clipping off tabs the punch does not have to be aligned precisely with the tab

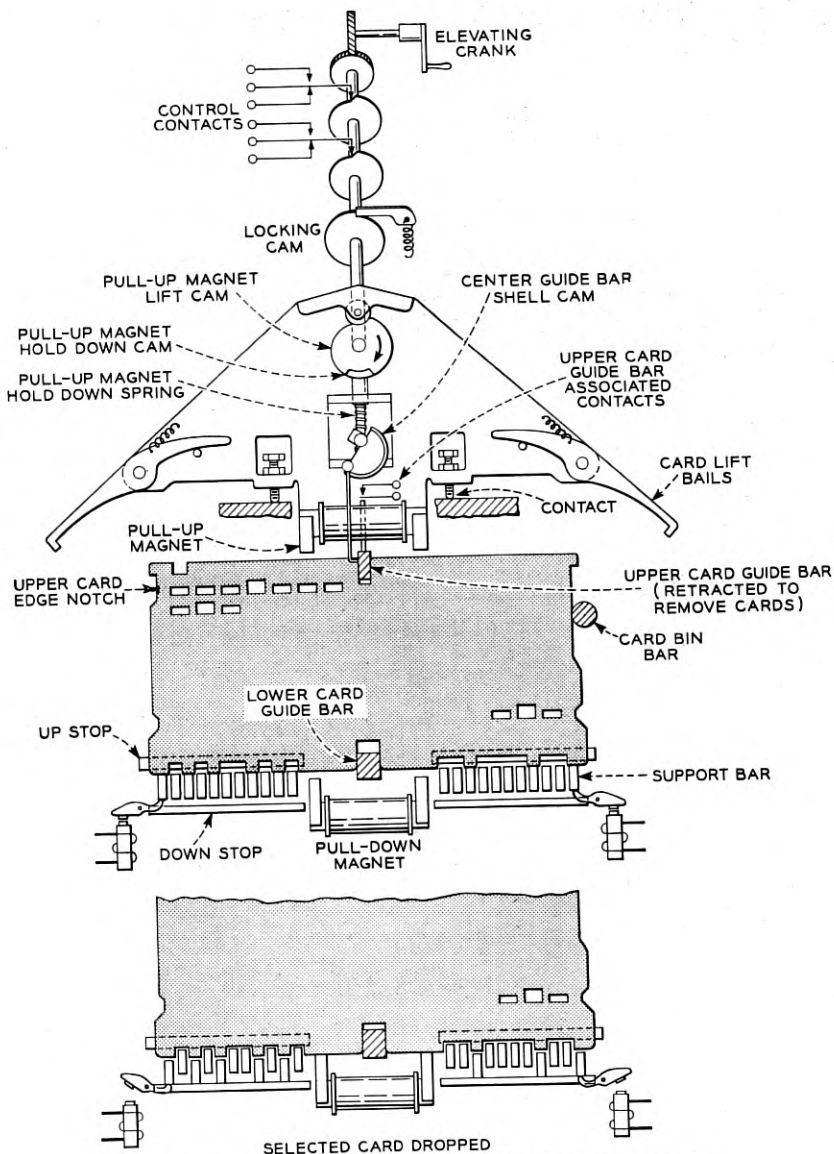

Fig. 27 — Interrelationship of card select components.

position and, therefore, the tab punch has not been provided with a positioning pilot.

Freedom from burrs after coding is assured by passing a sulphur-free abrasive bearing rubber pad over the card several times.

Care is required in handling the cards to avoid distortion of their

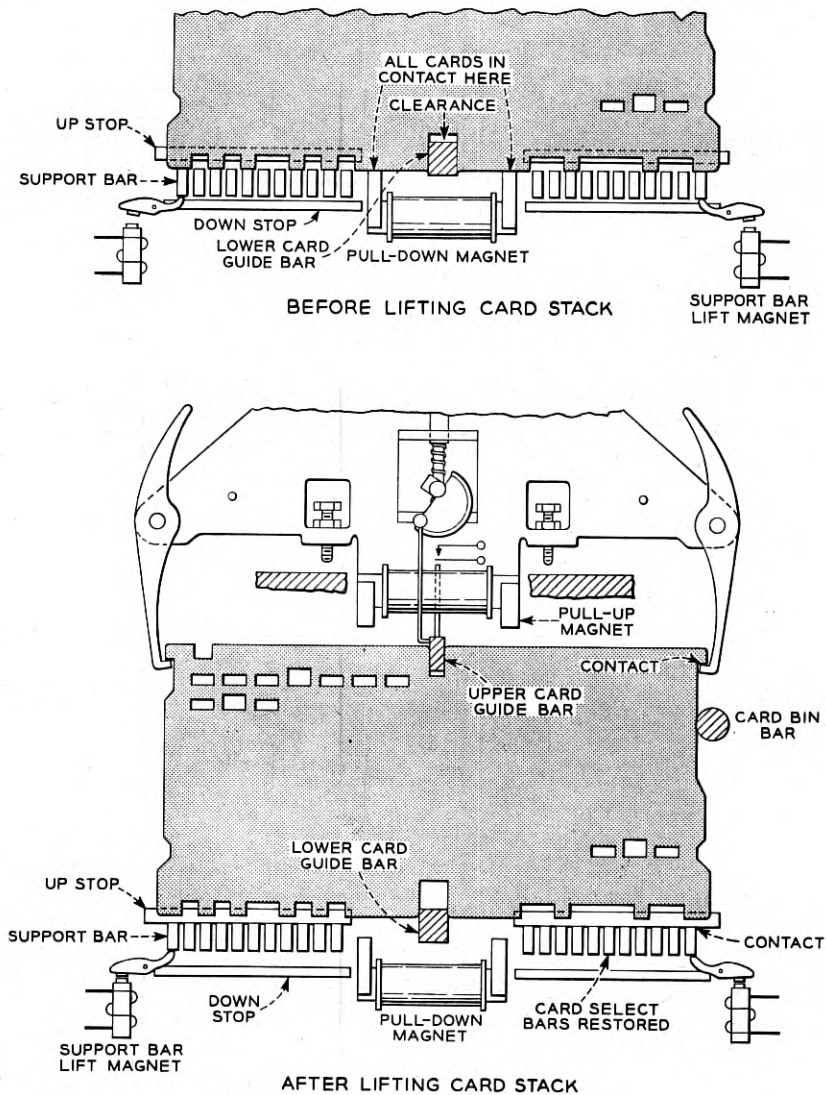

Fig. 28 — Mechanical lifting of cards.

tabs. As a precautionary measure, tools have been made available that afford adequate protection of the cards while they are being handled. One of these tools is for inserting one card at a time in the card stack. The other tool, which is illustrated by Fig. 22, is used when it is necessary to handle a number of cards at a time. It will be noted that it affords protection for the tabs. This tool may be used for loading and unloading all of the cards of a compartment of the card cage in a single operation. The cards, after bulk removal, may be conveniently stored in one of the card compartments of the test set illustrated by Fig. 16.

#### CODE SELECT AND CARD SUPPORT BARS

The load on a single bar may be as much as 24 pounds. Deflection due to loading has to be maintained at a minimum because any deflection reduces the effective height of the light tunnels through the card stack. However, the bars have to be light because high-speed operation is required. In addition, they have to be wear-resistant because of the many millions of operations to which they are subjected annually. These are difficult conditions to meet but a satisfactory solution was found by providing deep section die cast magnesium bars that are fitted with details made from suitable wear-resistant materials at the point of loading. Such bars, as components, are depicted by Fig. 29, in which the bottom bar is of the card support type. The other three bars shown are code select bars. They illustrate the different terminations that are required by the mounting arrangement employed.

The spacing is  $\frac{3}{16}$ " to affect alignment with the tabs of the cards. This close spacing makes it necessary to vary the amount of overhang beyond the up and down stops so that the associated solenoids may be mounted in staggered array and thus their diameter need not be unduly restricted. Despite the variations in conditions it was made possible to use but a single mould by casting the ends of the bars of uniform cross-section and long enough to accommodate the longest extension required. For those cases requiring lesser extension, the bars are cut off to suit. The bars are designed so that they may be used end-for-end and, therefore, although five mounting positions have to be taken care of, the three different end terminations illustrated suffice. It may be noted that the bars during fabrication are straightened if necessary by bumping. In this way, the necessity for side surface machining is obviated and in consequence the side skin of the bars is maintained intact which enhances stiffness.

The weight is only 115 grams each and yet their deflection under the heaviest working load that may be developed is but 0.003" which is

immaterial insofar as reduction in the effective height of the card stack light tunnels is concerned. The stresses developed are so low that fatigue failures should not be experienced.

Nylon is bonded to the top surface of the bars because of its proven ability to resist the cutting action of the cards. Details made from graphitized phenolic linen are secured to the bars at the lateral guide points because of the superior ability of this material to resist wear under the sliding action involved. This material also is well adapted to resist the heavy loading that is developed where (top of center slot) the card support bars are engaged by the tongues of the card support bar lift magnets and it is, therefore, used here also. Beryllium copper details are affixed to the ends of the bars where they are coupled to the associated solenoids. Beryllium copper is used here because of its wear-resistant and non-magnetic characteristics. For the same reasons it is used for details that are secured to the bottom edge of the bars where end guides are engaged and the bars cooperate with the latches.

The beryllium copper details affixed to the bottom of the code select bars are each provided with toe-like projections. The bottom of the toes

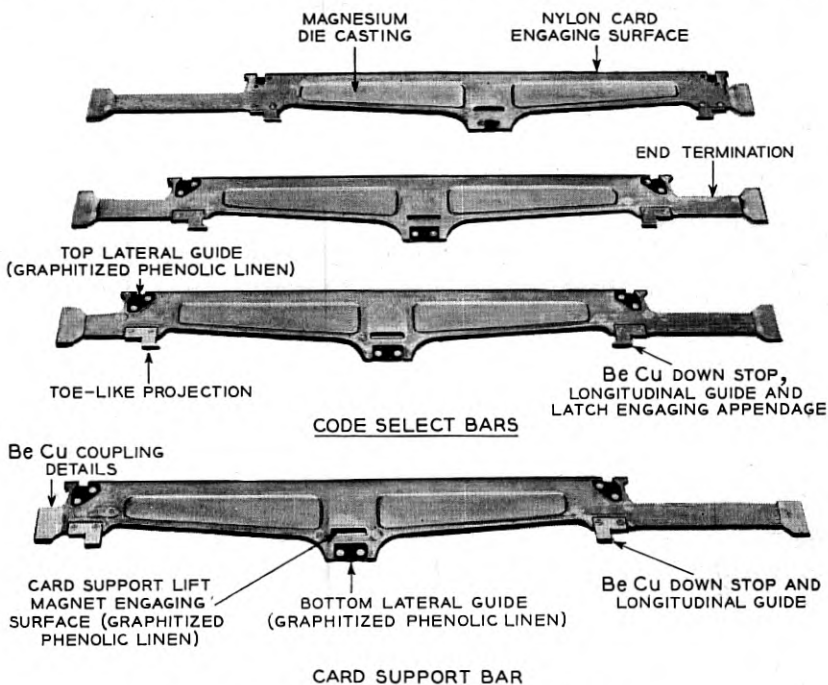

Fig. 29 — Code select and card support bars.

normally rests on the support blade of the latches. After the pull-up magnet is energized, support by the latches no longer is required and they are operated to move their support blades out from under the toes of the code select bars, so that the combination of bars called for by the code digits may be depressed. After the combination is checked down, the latches return to normal so that they are again in position to support the card stack. The toes of the depressed bars project under the support bars of the latches, thus tending to prevent any of the depressed bars from restoring prematurely. The card support bars are not provided with toe-like projections and therefore, may be depressed regardless of the position of the latch support blades. This is necessary because the card support bars have to operate after the depressed code select bar combination has been checked down and the latches restored. The selected card then rides the support bars down and controls the terminal card velocity within safe limits.

Transverse alignment of the code select and card support bars within close limits is important to proper coordination of the bars with the tabs of the cards and also to maintain transverse operating clearance between the bar coupling details and the blade like extension of the plungers of the associated solenoids. It also is necessary to control the up-stop level of the bars accurately so that the close vertical alignment of the holes in the cards that is required may be assured. These conditions are met by the provision of details that serve both as transverse guides and as up-stops for the bars in groups of twenty each which is consistent with their left and right-hand grouping. Since these combined stop and guide details are needed at both ends of each group, four are provided. They comprise details that are stepped to provide a horizontally disposed surface that serves as a common up-stop and a vertically disposed wall that is slotted to form a comblike transverse guide for the solenoid operated bars. The nylon surfaced top of the code select and card support bars engages the bottom surface of the combined up-stop and comb guide details under the action of the solenoid retractile springs. The comb portion engages the graphitized phenolic linen details that are set into the code select and card support bars near their top at both ends.

The lowermost position of the solenoid operated bars has to be controlled in order to establish their proper operated position with respect to the pole faces of the pulldown magnet and the bars have to be guided endwise so as to maintain a longitudinal operating clearance at the coupling details. This is accomplished by providing stop bars, the top and inside surfaces of which cooperate respectively with horizontally and vertically disposed surfaces of the beryllium copper details that are

fastened to the bottom of the bars. Both the top and the inside surfaces referred to are faced with nylon. The combination stop and guide details are located so that the top surface of the solenoid operated bars lies about  $\frac{1}{64}$ " below the pole faces of the pull-down magnet when the bars are fully depressed. This under flush condition is necessary to assure that the pole faces act as the down-stop for the selected card as is intended.

#### CENTER GUIDES

To maintain the intended vertical disposition of the solenoid operated bars, additional comb-like guides are provided that engage the bars at their center near the bottom edge. Actually they engage the graphitized phenolic linin details that are inserted at the center of the bars. This arrangement of the comb guides provides triangularly disposed guidance that affords both transverts and vertical stability with minimum working friction.

#### OFF-NORMAL CONTACTS

It is important that all of the code select bars necessary for selecting the required routing card be checked down before proceeding further with a translation and it is equally important that after translation they all be checked up before proceeding further towards restoration of the translator to normal. Off-normal contact springs that are operated by the bars are provided for this purpose. They are mounted at the light source end of the bars as indicated in Fig. 18. They also are illustrated by Fig. 30, and from this illustration it will be noted that off-normal contacts also are provided for the card support bars. These latter contacts close as the bars are operated to start timing of the "no card" timing circuit. When the card support bars are released, their off-normal contacts control the circuit of the card-support lift-bar magnets. This is a desirable arrangement because these magnets are required to supplement the solenoid retractile springs only as the card-support life-bars approach their upper stop position where they engage any cards that may be tilted. Late energization of these magnets prevents the development of high tab impact forces.

#### LATCHES

The latches are magnetically operated to free the solenoid operated bars and are spring returned to their bar engaging position. Four are provided: two at each end of the bar array, one for the left-hand grouping and the other for the right hand. Accordingly, each has to be capable



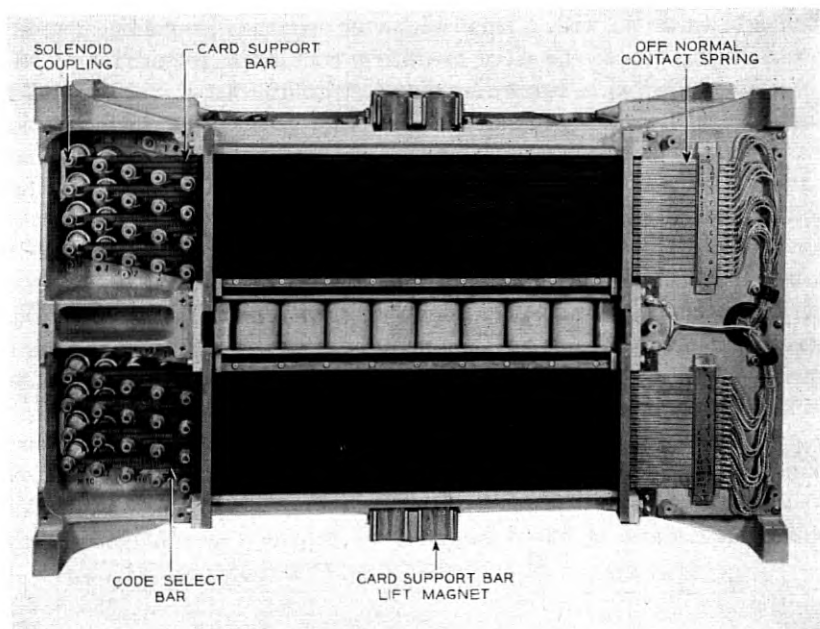

Fig. 30 — Top of dynamic unit illustrating off-normal contacts and solenoid arrangement.

of supporting one-quarter of the weight of a full complement of cards or 25 lb each. Yet the latches have to be fast. This is accomplished largely by providing for "on center" loading as may be discerned by reference to Fig. 31 keeping in mind that the beryllium copper appendages on the bottom of the code select bars engage the support blades of the latches virtually directly above the pivot center. Furthermore, a major portion of the moving member is made from magnesium. A spring pileup such as may be seen in Fig. 32, is associated with and is operated by each latch and the translator circuit is so arranged that a translation cannot progress beyond the latch operate point until all four latches have operated. The same is true when the latches are to be restored to normal, that is, the cycle cannot progress further until all four latches are restored.

The operate time of the latches averages 40 milliseconds, the restoral average being 15 milliseconds.

#### SOLENOIDS

The main problem here was to provide high-speed operation in the presence of a comparatively large non-operated gap and considerable

load and to do so with a small diameter solenoid. Magnetic cross-fire possibilities born of the close mounting conditions required also had to be contended with. Regarding diameter limitations, it will be recalled that the tabs of the cards are on  $\frac{3}{16}$ " centers and that five solenoids are grouped in stagger arrangement. Thus six positions or five spacings have to be considered and, therefore, the diameter of the solenoids has to be less than  $1\frac{5}{16}$ ". This is very small considering what the solenoids have to do, but satisfactory performance was achieved by the use of solenoids of which Fig. 33 is representative. The coil tube is made from beryllium copper because of its high resistivity, resistance to corrosion and its ability to resist wear. The main body of the operating plunger is surfaced with a heavy plating of chromium. The plunger then is ground to size, lapped and buffed to provide a very smooth surface. The blade-like extension that is secured to the main body of the plunger for coupling purposes is made from steel. It is hardened, ground and polished to assure long life. The fixed plunger is adjustable axially so that a small but definite operated gap may be provided as otherwise mush-

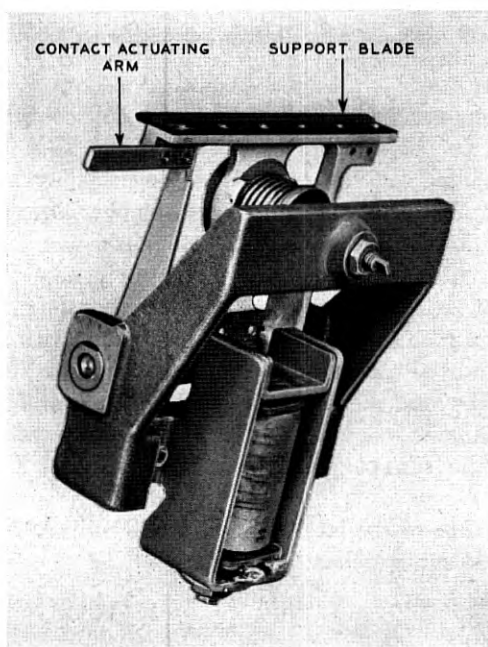

Fig. 31 — Code select bar latch.

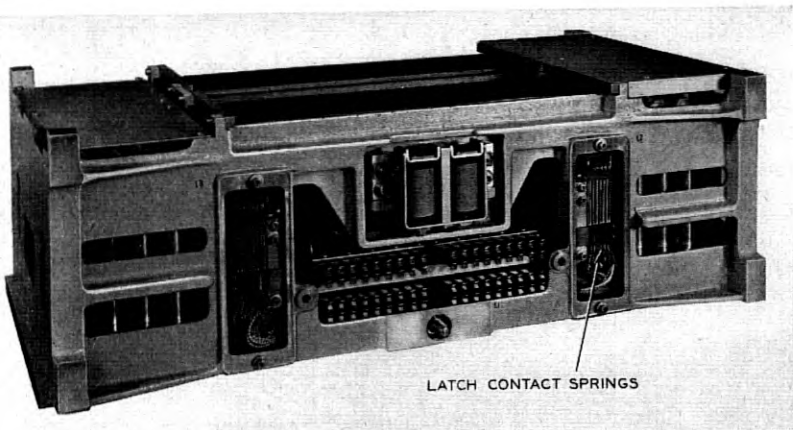

Fig. 32 — Jack side of dynamic unit showing latch contact springs.

rooming due to impact would be experienced. It is possible to maintain a small operated gap because the down-stop position of the solenoid operated bars is precisely controlled by common stop details that engage the solenoid operated bars and thus limit the motion of the solenoid plungers to which they are coupled. The solenoid is provided as a package including the necessary retractile spring and coupling details. One of the coupling details is a rubber buffer. This buffer cushions the impact developed when the bar that is coupled to the solenoid engages the up-stop. At the top of the bar coupling detail another rubber buffer is mounted. This second buffer cushions the impact when the downstop is engaged. A crowned washer is cemented to the first buffer and the assembly provides a slight vertical freedom of the plunger extension in the bar coupling detail. Combined, these features permit sufficient freedom of action to prevent binding in the event one solenoid of a bar acts faster than the other.

The average operate and restoral times of the solenoid are 32 and 28 milliseconds, respectively. The unoperate gap pull averages 325 grams, and the unoperated force of the retractile spring is 200 grams. The solenoids are operated dry to prevent gumming.

The beryllium copper coupling details secured to the ends of the solenoid operated bars provide a slot through which the flattened extension of the solenoid plunger passes. The position control of the solenoids and of the bars is such that side friction at the coupling is virtually non-existent. There is adequate end or longitudinal clearance to permit of unrestrained tilting of the bars such as may be experienced if one solenoid operates faster than the other.

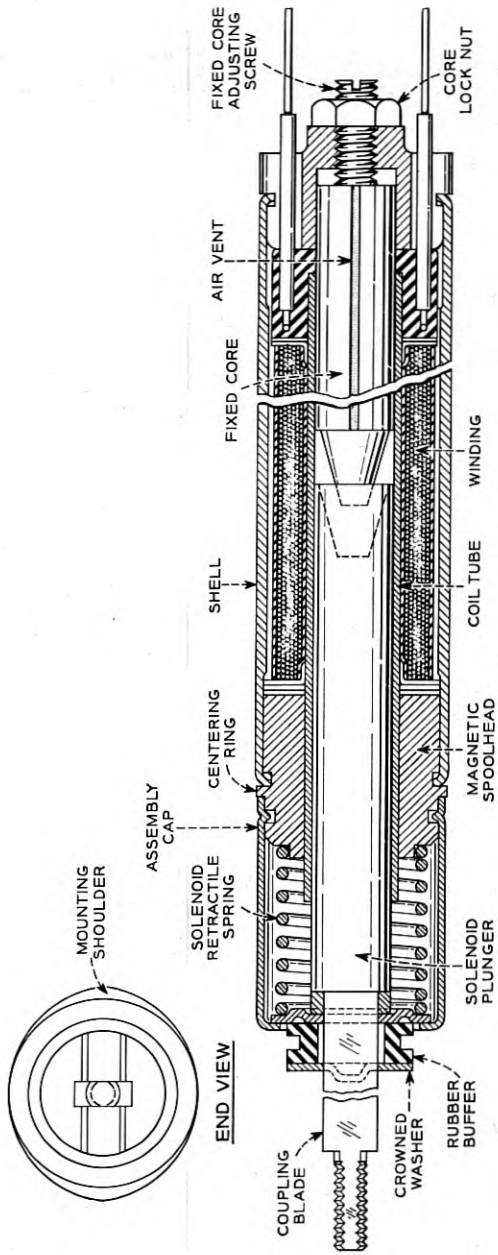

Fig. 33 — Solenoid.

## CARD SUPPORT BAR LIFT MAGNETS

It is possible that a translator may be equipped with a group of cards from which all tabs except a very small number common to the group have been removed from one side. To select any card of the group all of the code select bars associated with the remainder of the tabs on the side involved have to be operated. Under these conditions the unselected cards of the group would be unsupported on one side and would, therefore, tilt to the extent permitted by the card guide bar working clearances that prevail. The closest practicable clearances have been established and yet, insofar as the card guide bars are concerned, the lower corner of the cards would be free to drop approximately 0.015" below the nominal bottom surface of the card stack. The combined weight of the tilted cards could be more than the associated code select bars can support; therefore, these bars would be depressed slightly. Actually they could be depressed sufficiently to interfere with the intended free action of the latches when they are called upon to operate and release for restoral of the translator to normal. This could happen, despite the fact that the powerful pull-up magnet would be energized at this time, because the flux shunting action of the adjacent and higher cards reduces the pull on the tilted cards to a very small value. The high cards in rising decrease the chances of the tilted cards following. Therefore, supplementary magnets have been provided that assist the retractile springs of the card support bars in lifting the tilted cards. These magnets are powerful enough (6.6 lbs.) to straighten up the tilted cards.

The form of these magnets, which have been called card support bar lift magnets, is illustrated in Fig. 34. It will be noted that, like the latches, they are constructed as units to permit convenient servicing in the field. Two coils are used for each magnet because in this way standard comparatively small diameter coils can be used and thus the magnets may be mounted more readily in the space available.

## 214A SELECTOR

All of the dynamic components, that is, the code select and card support bars, the solenoids, the latches, the card support bar lift magnets and the off-normal contacts are combined in a subassembly that is arranged on a plug-in basis. This combination, which as a convenience includes the pull-down magnet and of necessity many supporting details, is illustrated by Figs. 30 and 32. It is manufactured as the 214A selector but commonly is called the dynamic unit. It may readily be removed from a translator and placed on a portable elevator table such

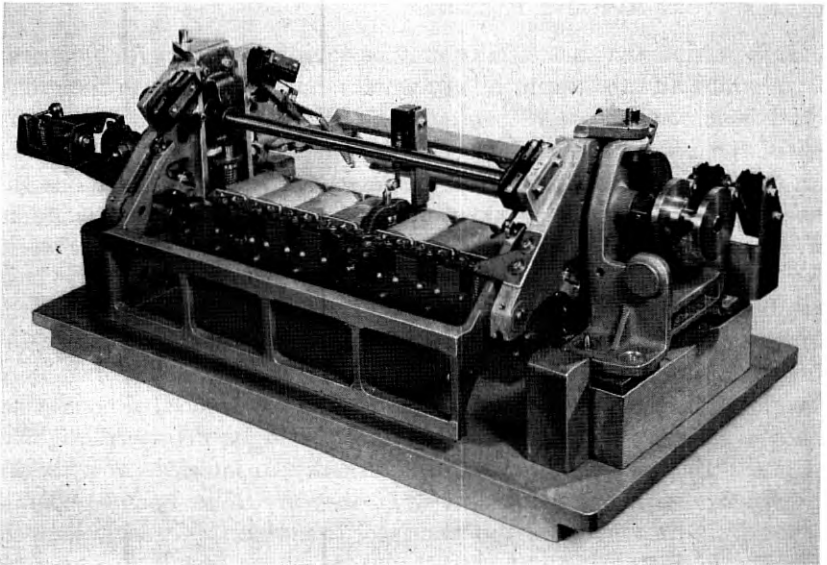

Fig. 34 — Pull-up magnet and lift superstructure.

as is depicted by Fig. 35. Accordingly, when the dynamic unit needs to be serviced, it may be taken to a location suitable for the purpose and meanwhile the translator may be continued in service by substituting a spare dynamic unit.

#### REMOVAL OF THE UNIT

To remove the dynamic unit, the cards first either have to be removed from a translator or in some way they have to be supported clear of the code select and card support bars. In some cases it will be possible to service the unit in a few minutes, and in such cases, should the cards have to be removed, their handling would constitute the major effort. The pull-up magnets could be energized in which event the cards would be suspended clear of the solenoid operated bars thus permitting the removal of the unit. However, conditions might be such that the pull-up magnet thus would have to be kept energized for a comparatively long time and this would be undesirable because the current drain is heavy. In any event, suspension of the cards by the pull-up magnet for this purpose would be hazardous because should the circuit be interrupted only momentarily, the cards would fall and considerable damage no doubt would result. Accordingly, mechanical means were provided whereby the cards may be elevated quickly and held suspended safely

for an indefinite period. This was accomplished by providing hooked end bails pivotally mounted on the pull-up magnet structure and so arranged that they may readily be swung into a position where their hooked ends enter the top notches in the end edges of the cards. A manually operated crank is provided whereby the bails and hence the cards may be elevated. The mechanism employed is shown in Figs. 27, 28 and 34. It will be noted that the bails are arranged to act much like ice tongs, that is, the heavier the load the more securely they grip.

#### CLEARING A "CARD CRASH"

It is possible, under certain conditions, involving double trouble, for the pull-up magnet circuit to be broken while the latches are operated clear of their code select bar supporting position. If this happens, the card stack will fall and unless the translator is very lightly loaded, the weight of the card stack will overcome the solenoid retractile springs and all of the cards will move down to the pull-down magnet pole face level. Such a condition has been dubbed a "card crash". If it occurs, the pull-up

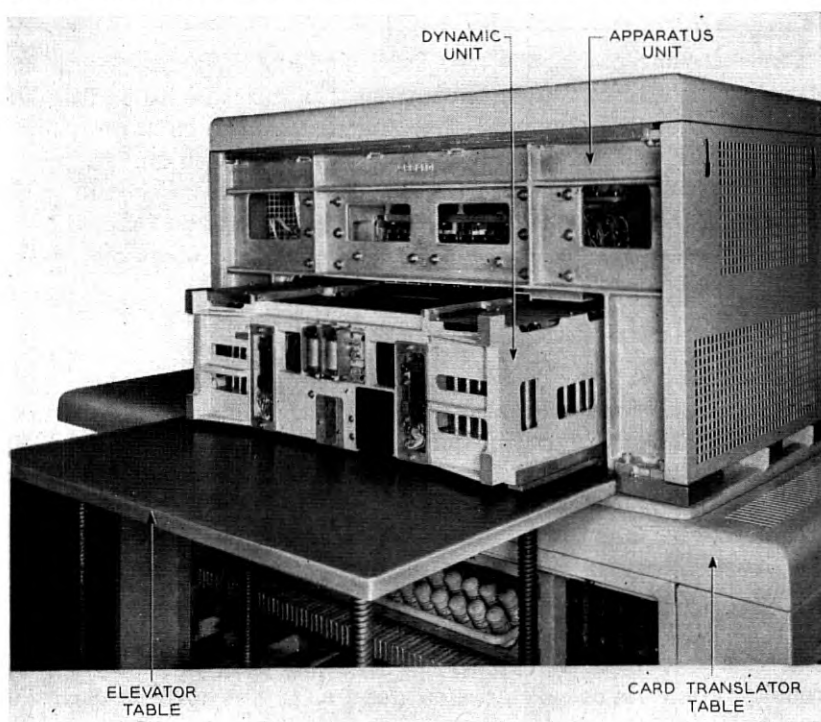

Fig. 35 — Portable elevator table.

magnet will be incapable of lifting the card stack because of the materially increased airgap and, therefore, the translator will be rendered inoperable. However, the bails provide a convenient means for clearing the trouble because the top notches in the cards are so located and are of such a size that they may be engaged by the bails even when the cards are at the pull-down magnet level and the lift motion is sufficient to permit the latches again to assume their card stack supporting role.

#### REMOVAL OF CARDS

To remove the cards, the pull-up magnet must be lifted sufficiently to permit of the cards being raised above the lower card guide bar. In addition, the upper card guide bar must be lifted clear of the stack. The crank referred to may be used to effect the required action. The upper card guide bar is raised by rotating the crank beyond the position required to raise the pull-up magnet whereupon a cam of the internal peripheral shell type engages mechanism adapted to lift the guide bar while the pull-up magnet dwells in the elevated position already effected. The mechanism referred to is illustrated schematically in the Figs. 27 and 28.

Cams, locking pawls, and associated circuitry cooperate to prevent operation of the crank while the translator is in service, to limit to the necessary extent the amount that the crank may be turned when removing the dynamic unit or alleviating a card crash and to permit of its being turned sufficiently further to elevate the upper card guide bar to clear the cards when they are to be removed or are being loaded. Study of related figures will make clear the mode of operation of the elevating mechanism.

#### PULL-UP AND PULL-DOWN MAGNETS

These magnets (see Fig. 18) are of the eight coil common pole type. They differ principally in that the cores for the coils of the pull-up magnet are laminated to provide for fast operation as is required. The operate and release timing of the pull-down magnet is such that its cores need not be laminated.

It is of vital importance that all of the coils of the magnets are effective as otherwise some of the cards may not be elevated when the latches are called upon to operate, or the cards may not fall reliably. Accordingly, a slave relay is used in series with each of the coils and if a relay fails to operate, thereby indicating possible magnet coil failure, the trouble recorder is called into action and steps are taken to clear the trouble.



The pull-up magnet is capable of exerting a pull of 350 lb when the airgap is 0.020" which is approximately 25 per cent more than the normal operate gap and since the cards weigh approximately 100 lb. it will be seen that a reliable operate margin has been provided. The performance capabilities of the pull-down magnet were developed in the discussion of its effect on the drop time of the cards. The breakaway pull of this magnet is approximately 1,000 lb.

#### LIGHT SOURCE

The light source comprises the projection lamp, the light beam modulating wheels, the wheel driving motor, and the two first surface mirrors, as illustrated by Fig. 18. The mirrors direct light from either side of the major plane of the lamp filament via the dual collimating lenses and the card stack formed light tunnels to the photo-transistors. Various adjustment and supporting details are combined in a subassembly illustrated by Fig. 36. The subassembly is shown mounted on a fixture that is used during manufacture.

The lamps usually can be interchanged without readjustment of the mount or the associated components. At the most, all that has to be done is to orient the lamp so as to obtain reasonable alignment of the major

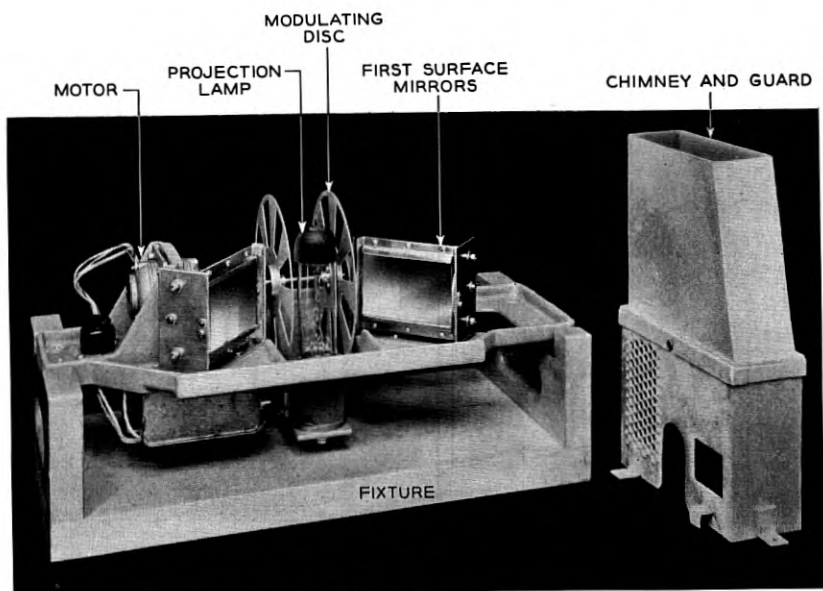

Fig. 36 — Exciter lamp assembly.

plane of its filament with the longitudinal center line of the translator. The combination chimney and guard that is provided as part of the subassembly includes a peep-hole to facilitate filament orientation.

The lamp, although operated at reduced voltage, generates considerable heat. Because of this, its guard and chimney are treated with a cotton flock finish which prevents direct contact with the metallic base and thus the guard may be touched without discomfort.

The first surface mirrors are mounted so that they are accessible for cleaning.

#### COLLIMATING LENSES

The light level at the photo-transistors may be lessened because of the accumulation of foreign material on the surfaces of the lenses. Because of this, the collimating lenses have been mounted in a frame (see Fig. 37) which makes it convenient to remove them simultaneously for cleaning and to replace them without readjustment. The photo-transistors are red sensitive and, therefore, the focal length had to be determined on this basis.

#### CARD CAGE

The cards are mounted in a cage, as illustrated by Fig. 25. The partitions are made from magnetic iron. They tend to repel the cards that are mounted adjacent to them when the pull-up and pull-down magnets are energized. This is beneficial when a card close to the partitions is selected, as it gives better assurance of the card dropping reliably. However, as has been mentioned, it is desirable to mount an uncoded card adjacent to the partitions because the first and last card in a com-

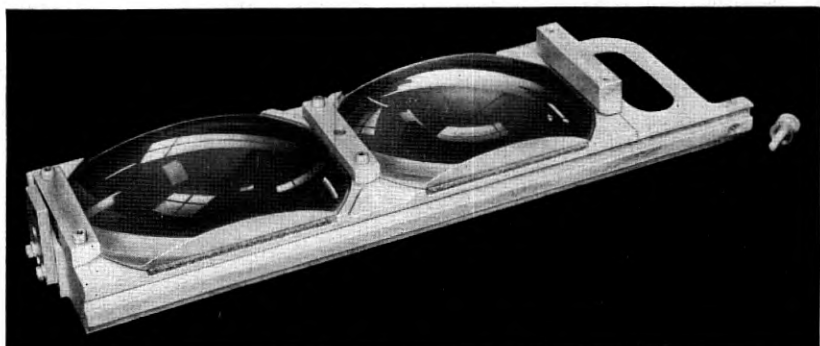

Fig. 37 — Collimating lenses.

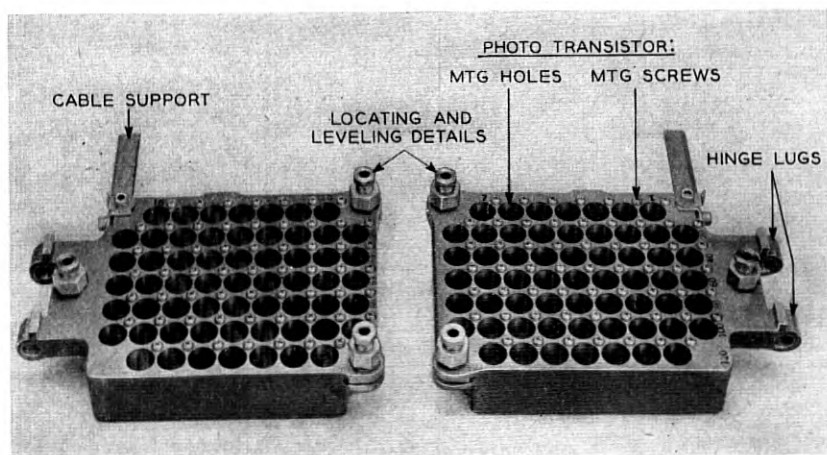
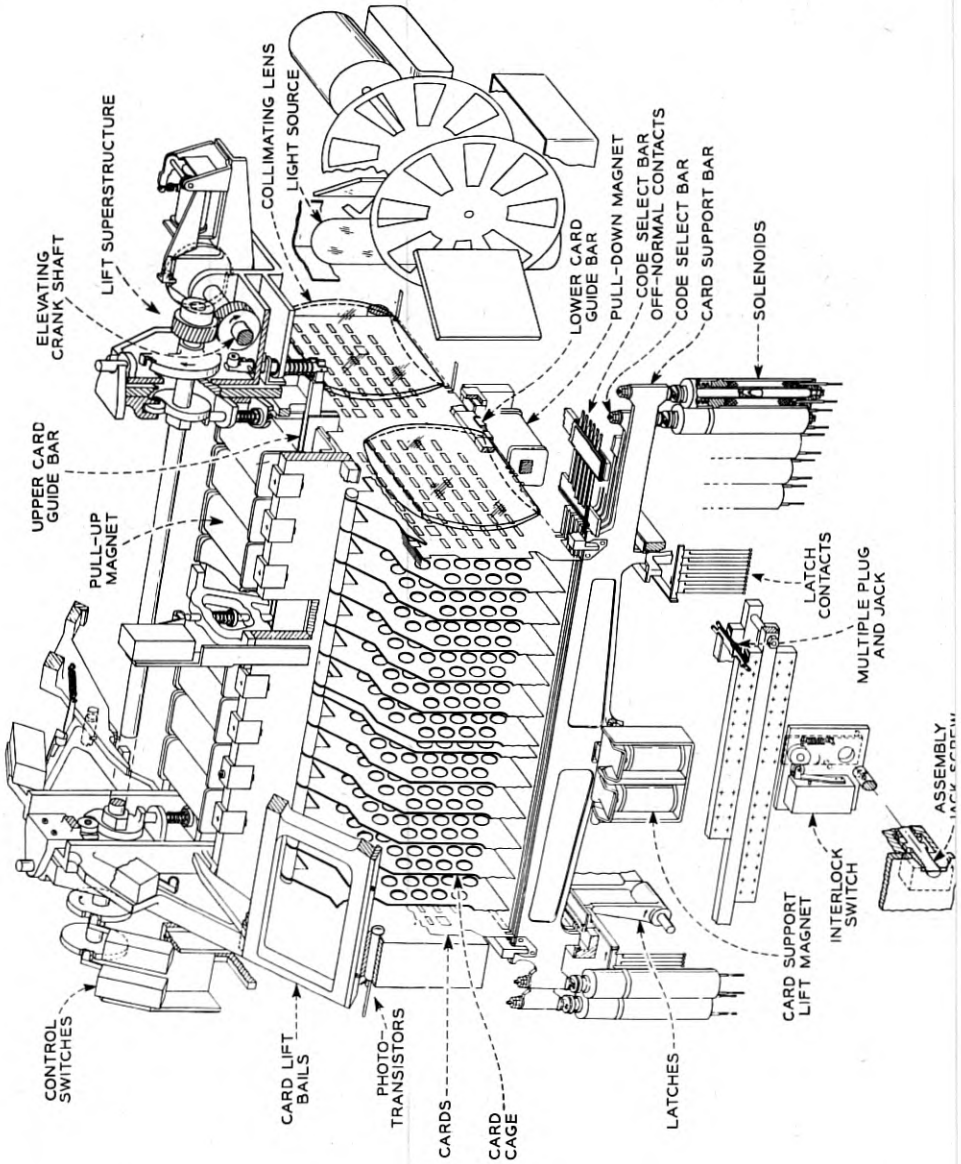

Fig. 38 — Phototransistor mounts.

partment are not as free acting as the others. The holes in the partitions, it will be noted, are round. Round holes were used merely as a convenience in manufacture. They are of sufficient size to clear the light beams that pass through the card formed tunnels.

#### PHOTO-TRANSISTOR MOUNT

The photo-transistors, consistent with the left and right-hand grouping of the holes in the cards, are mounted in left and right-hand groups of fifty-nine each. The mounts used comprise frames that are precisely machined, necessary because the activating light beams have to be concentrated on a very small piece of germanium and many variables are involved. These frames normally are secured to the translator framework by means of three special mounting screw subassemblies that provide means for positioning and leveling to obtain optimum light distribution over the whole field of fifty-nine photo-transistors. However, it was recognized that the focusing lenses of the photo-transistors should be readily accessible for cleaning and that it should be possible readily to view the light beams transmitted by the card formed tunnels as for instance by placing a piece of ground glass or translucent paper near the end of the card cage. In this way preliminary adjustment of the first surface mirrors, three dimensional adjustment of the light source, etc., can be effected quickly. Accordingly, the special subassemblies include screws that may readily be removed without affecting the position or leveling adjustments. As a convenience, loose hinges also are provided so that after the mounting screws have been removed, the



mounts may be swung aside as gates to gain access to the photo-transistor lenses for cleaning. The photo-transistor mounts are illustrated by Fig. 38.

#### COVERS

Covers are provided for the four sides of the translator and its top. These covers may be dismantled quickly when servicing is necessary. The base casting is cut away beneath the covers so as to form air passage ways to its interior. The covers are perforated near their top and in this way a chimney effect is created which is beneficial to cooling.

#### 4A AND B APPARATUS UNITS

All of the static elements, that is, the light source, the collimating lenses, the card cage, the pull-up magnet superstructure, the photo-transistor mounts, the terminal block, and the multi-terminal jack sub-assemblies, the framework, the covers and sundry details are combined in a subassembly known as the 4 type apparatus unit.

#### COMPREHENSIVE SCHEMATIC

The over-all appearance of the working translator is disclosed in Figs. 12, 13, 39 and 40. The principal component groupings entering the assembly have been discussed at some length and have been illus-

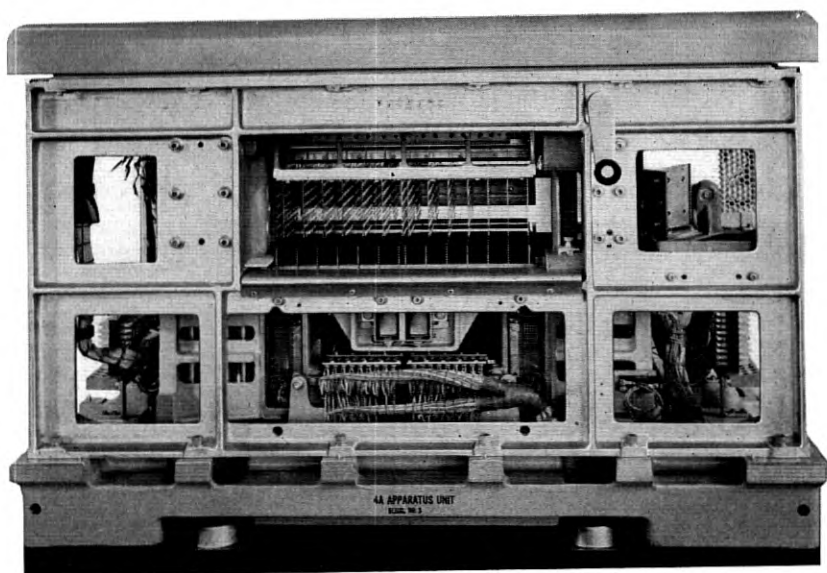

Fig. 40 — Translator (card access side).

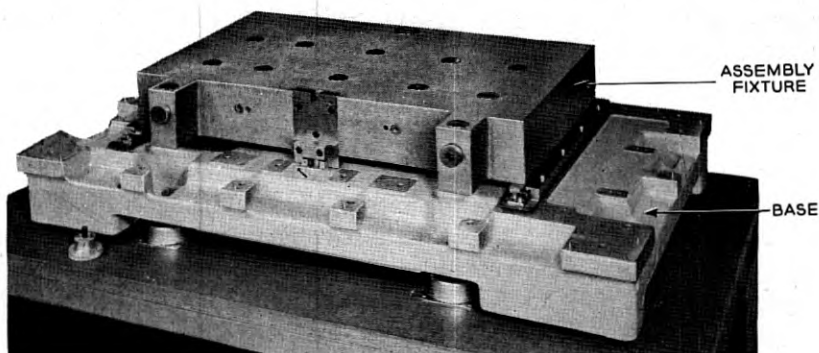

Fig. 41 — Base and assembly fixture.

trated in other figures. However, the combination of these principal components needs to be illustrated more specifically. Fig. 39 serves this purpose.

#### WORKING TRANSLATOR

Fig. 40 is a view of the working translator showing how the supporting structures knit together the principal components illustrated

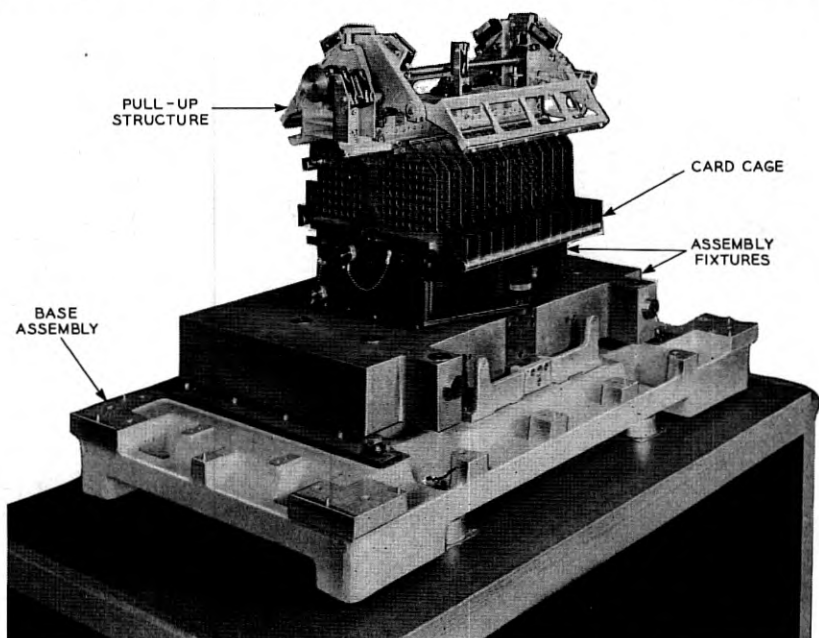

Fig. 42 — Base and assembly fixture together with card cage and pull-up superstructure.

in perspective by Fig. 39. It supplements Figs. 12 and 13, which depict the translator with its covers in place. The coded translator (1A) is 38" long by 21- $\frac{1}{2}$ " wide by 27" high. Its weight is approximately 410 lb. The weight of the dynamic unit is approximately 110 lb.

#### BASIC PLAN FOR CONSTRUCTION

As the development progressed, it became apparent that unusual and exacting manufacturing problems would be encountered which could be solved to best advantage by providing design features that would facilitate alignment of the light tunnels, the optical elements, the card select and card support bars with respect to the tabs of the cards, etc. Accordingly, the design was worked out so that the assembly could be built up around a base casting provided with reference surfaces and locating pins adapted to be used with a surface plate type of fixture that could be mounted in the space normally occupied by the dynamic unit and upon which supplementary fixtures could be mounted for

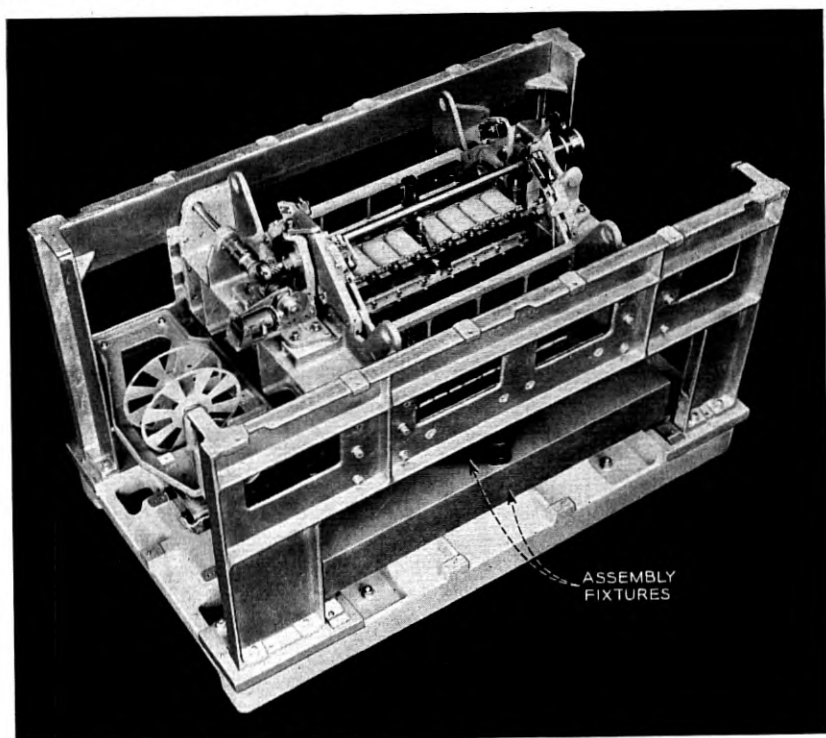

Fig. 43 — Base and plug assembly fixture, card cage and frames.

aligning the various components. With fixtures of this kind virtually all assembly can be made without resorting to measurements. The design of the translator and the fixtures were, therefore, carried forward concurrently.

An initial step in fabricating the card translator with the aid of these fixtures is illustrated in Fig. 41, in which the basic surface plate is shown mounted on the base casting. Fig. 42 shows another step in the fabrication of a translator. It will be noted that in this instance a supplementary fixture had been added which supports the card cage and the pull-up magnet superstructure. Later the side frames are added and these too are located by means of the fixtures as is indicated by Fig. 43. It will be understood that many additional fixtures are used in completing the job and that one of the most important of these is a fixture which locates the gates in which the phototransistors are mounted. However, by the time this fixture is used, the assembly has built up to a point where the fixture used is obscured by the side frames and other details. This method of construction has proved to be very effective as is evidenced by the fact that after assembly there have been no cases where the performance requirements could not be met readily because of misalignment of components.

The development of nationwide dialing is the result of close cooperation of many people in the American Telephone and Telegraph Company, the associated Telephone Companies and particularly for the card translator, the Western Electric Company, as well as of many people in Bell Telephone Laboratories. All who have had a part in this development, which may justifiably be considered a milestone in the development of the switching art, can view with pride their accomplishments. This development, serving as the means for connecting on a nationwide basis all the customers' lines into one vast automatic switching network, is truly a major contribution to the telephone art.



# Development and Manufacture of Electroformed Conductor for Telephone Drop Wire

By A. N. GRAY and G. E. MURRAY

(Manuscript received June 15, 1953)

*Telephone drop wire is that familiar black overhead wire which brings the telephone service to the home. It is a parallel pair of conductors separated and positioned in an extruded insulation, covered by a cotton serving and jacketed with a neoprene compound of tire tread-like qualities. In the past, a cast copper jacketed steel ingot, rolled and drawn to size, has been used to provide a wire that combines high strength and good conductivity. In order to assure more than a single source of supply and to provide improved mechanical and electrical characteristics, a completely new plant has been constructed for continuous plating of steel wire at completed size. This process provides a stronger, yet smaller and, therefore, less costly wire than was possible previously. Plating is done at 100 feet per minute on 25 wires simultaneously. The conductor is then processed as formerly to provide the neoprene jacketed drop wire.*

## HISTORICAL BACKGROUND

It has been customary in manufacture to apply a lead and a brass plate to drop wire conductor to secure good adhesion to the insulating compound. The brass provides the adhesion while the lead prevents attack on the copper by the sulfur in the rubber. In 1941, two tandem lead and brass plating machines were placed in service at the Point Breeze Works of the Western Electric Company to apply these coatings on a production basis. Their successful operation proved that electrolytic deposition of two metallic coatings in tandem at high speed was commercially practicable. It was not difficult to imagine the addition of a copper plating section to deposit copper, in addition to lead and brass, on a steel wire as a combined operation. The technical problems involved,

however, were of considerable magnitude, and their successful solution required a substantial amount of investigation and development.

Such a process appeared to offer a number of attractive features. The maximum strength of the steel core could be utilized since no compromise in physical properties would be required to permit rolling and drawing. A highly uniform cross section could be secured which would provide continuous copper protection for the steel core against corrosion. Since the steel core wire would be a standard commercial item available from a number of manufacturers, alternate sources would be available to assure continuity of supply.

There were also substantial economic inducements. The higher strength wire of uniform construction would reduce the cost of trouble calls to the Bell System. It appeared that a plant could be designed which would require no more labor to operate than was required for the existing lead-brass plating operation. By starting with a steel wire of uniform and circular cross section and applying a uniform copper jacket, the desired physical and electrical requirements could be met by a conductor  $2\frac{1}{2}$  thousandths smaller in diameter, which would, in turn, reduce the overall dimension of the finished product. Although this reduction might appear small, the very large footage of wire required indicated a saving of a half-million pounds of copper a year, and a combined saving of steel, copper, rubber, cotton and neoprene, all strategic materials, of a million pounds a year. Combined savings to the Bell System Operating Companies and Western Electric Company were estimated at better than one million dollars a year.

World War II prevented further work until 1946 when the project was reopened and methods of obtaining heavy copper deposits investigated on a laboratory scale. Initial developments showed promise and late in the year, a separate development laboratory was set up to investigate various electro-chemical problems and to develop information on which a pilot plant could be designed. The term "Electroforming" was first applied at this time because it was apparent that the process was not to be one of electroplating in the ordinary sense but rather was to substantially change the physical and electrical properties of the wire. In other words, the terminology was intended to differentiate between utility and what are usually decorative or protective functions.

A pilot plant was built and installed which operated successfully the first day it was placed in operation. The results obtained on the pilot machine exceeded expectations. The limiting current density for the acid copper plating solution determined in the laboratory was 1,000 amps./sq. ft., whereas 2,000 amps./sq. ft. was realized on this machine. This in-

crease in current density meant a rate of deposition double that which had been predicted.

On this pilot machine the operating limits of the various plating and cleaning solutions were established. Methods of control, materials of construction and design features were evaluated. A field trial lot of 200,000 linear feet of drop wire and numerous samples of wire were processed for examination and design approval.

Some time was spent in making the basic plant decisions, evaluating pilot plant experience and carrying through the numerous special investigations required to guide the engineering design. The detailed engineering and drafting were begun and firm orders placed for equipment.

#### DESIGN PREMISES

Certain design premises became apparent from experience with the pilot plant. The nature of the process dictated continuous operation on a three-shift, seven-day basis. To secure such operation, it was necessary to duplicate certain critical facilities, use the largest practical reel size for maximum wire run time and to employ great care in the design of the wire handling equipment to minimize wire breaks. The second premise was low maintenance. This required that the materials in contact with the various chemicals could be selected only on the basis of extensive corrosion tests. This involved the study of many of the grades of stainless steel as well as the rarer metals and the broad field of plastics and elastomers to select suitable materials for tank lining, machine parts, and piping.

Substantially automatic operation was set up as another design objective. This, of course, involved the isolation of the factors requiring control and selection of the most suitable means. The safeguarding from waste of valuable solutions was a fourth consideration. Spare tank capacity was provided in case any of the storage tanks developed leaks and had to be repaired. Facilities were required to recover electrolyte carried out from plating operations by the wires themselves. Means had to be provided for recharging and reconditioning the various electrolytes. Still another premise was the permanency of solution: no dumping and replacing of plating solution was contemplated. And, of course, safety to personnel was a must. In addition to the usual hazards from acids and alkalis in a chemical plant, accidental mixture of electrolytes could give rise to highly poisonous gases. This necessitated the selection of highly reliable piping materials and the provision of adequate employee protective devices and routines.

### BASIC PROCESS

The starting point in the process is commercial improved plow steel wire 0.0336" in diameter delivered on 450-pound reels. Twenty-five strands pass through the plating machine in parallel at 100 feet per minute. After suitable cleaning, approximately  $2\frac{1}{2}$  thousandths of copper plus a thin plate of lead and brass are electrolytically deposited on the wire. To apply this deposit requires nine different electrolytes, approximately 80,000 amperes at 5 volts, and a 600-ft machine with a wire span from supply to take-up of 850 feet.

The plating portion of the machine is a relatively simple structure consisting of a long trough containing plating cells alternating with contact rolls. The electrolytes are pumped into the plating cells through which the wire passes, cascade into return troughs, flow back to reservoirs and are continuously recirculated. The contact rolls position and propel the wires through the machine and serve as the means of making electrical contact.

The general structure of the machine is uniform throughout, only the material changing to fit the chemical requirements of the electrolyte in the particular section. The wire, in passing from one electrolyte to another, travels through washing and wiping facilities mounted in the troughs to prevent contamination of electrolytes and reduce dragout of valuable solutions. The finished wire, controlled to specified conductivity, is then taken up on reels ready for insulating.

### THE BUILDING

The building is 91 feet wide by 340 feet long, of brick and steel construction, in keeping with Point Breeze architecture. It was specifically designed to fit the process. The first floor is given over to wire supply and take-up, electrolyte mixing, pumping and conditioning and material storage. All plating operations take place on a mezzanine. The upper portion of the building is divided into three bays by a pair of lengthwise partitions. The center section contains the two plating machines, each machine being constructed in the form of the letter "C", the two "C" shaped machines being placed face to face. The outer bays contain the rectifiers, electrical controls and heating and ventilating equipment. The floor of these bays is steel grating. The partitions prevent the entrance of any vapors released by the heated plating solutions, and the ventilating equipment forces a steady stream of clean and tempered air downward over the electrical facilities and through the grating into the first floor area below.

The ventilating equipment draws in fresh air from the roof, heats it

if required, and distributes it down the electrical bays by means of overhead ducts. The system operates under modulating temperature control with 100 per cent fresh air make-up. After reaching the first floor, the air then flows upward through the center section of the building, past the plating machines and is exhausted through the roof by fans at the rate of 160,000 cubic feet per minute.

Power for the building is supplied from a substation located in the south electrical bay. A pair of underground cables bring in energy at 13,200 volts to high-voltage switches for distribution to two identical, 1500 kva, three-phase transformers where it is stepped down to 480 volts before entering low voltage switch gear for distribution about the building. The electrical system is designed so that the entire plant load can be supplied by either of the high-voltage cables and for a short period of time by either of the step-down transformers. Steam, city water and house water are furnished through an underground tunnel.

In addition to electric power, the building is furnished with 150 lb./sq. in. steam for process and heating, 90 lb./sq. in. compressed air for control instruments and various process functions, city water and house water. A sanitary sewer for the washrooms plus separate acid and alkali sewers of chemical resistant pipe have been provided from the pits where the electrolyte storage tanks are located. These latter sewers are for emergency use only. All solutions are reconditioned and recirculated in normal operation and as the plating solutions are permanent no disposal plant has been deemed necessary.

Lighting throughout the plant is furnished by incandescent lamps in simple porcelain reflectors, designed to give a minimum of 17 foot candles at all locations. This is supplemented by fluorescent fixtures at the take-up stands because experience has shown that appearance of the wire on the take-up reels is an important indication of the quality of the plate. The entire interior of the plant, as well as all machinery, is finished with vinyl base paint. Extensive tests were made of various types of chemical resistant finishes and the vinyls were found to be the outstanding performers.

For moderate service conditions, metal surfaces were wire brushed and washed down with cleaning solution before the wash type primer was applied. For severe service, the surfaces were cleaned by sand blasting before priming. The customary primer coat was then applied and several top coats, the number depending upon the severity of the service.

#### WIRE HANDLING EQUIPMENT

Tonnage-wise the steel core wire is the largest, if not also the most important, single item of raw material procurement. In searching the

market for a high-strength, bright finish steel wire which would be readily available from a number of supply sources, it was found that improved plow steel wire as regularly used in wire rope manufacture would meet the proposed requirements and could be purchased under the several wire mills' own control specifications and tolerances, giving Western the reliability of an established commercial supply without the price premiums for a specialty wire.

In only one important particular was it found expedient to deviate from the steel mills' standards as regards the steel core wire, and this specifically concerned the packaging of the wire to facilitate subsequent handling in our plant. It has been customary for the steel mills to ship this type of wire to customers in paper-wrapped bundles which are block-wound, catch-weight coils, shaken down and bound with soft iron tie wire. Because of the coil-forming action on the draw-blocks, the steel wire mills have found that bundles containing more than about 250 pounds of 33-mil wire cannot be made without greatly increasing the dangers of tangling and breaking when wire is payed out from the bundle.

An economic study of wire handling in both the electroforming plant and the subsequent insulating and jacketing departments showed that a 450-pound steel wire package free of splices to avoid excessive scrap, cut-over and reel handling losses was most desirable. It was found impractical to put this much core wire in a single bundle with any assurance that the wire could be payed out of the coil without too many breaks from snarling, tangling and fouling of the wire on the pay-off stands.

After extended negotiations with the suppliers, decisions were made to obtain the core wire on reels, in order to insure reliable pay off from supply units of the weights required. Agreements were reached to handle the wire on returnable reels which the mills provided to suit their own winding equipment. No unwinding problem exists at Western Electric because the supply reel is not rotated to unwind.

The nature of the electroforming and electroplating operations renders it impracticable to stop a running wire to replenish an exhausted supply. Consequently, it was necessary to provide for splicing the inner end of the supply wire paying off onto the outer end of a standby supply. Where the supply reels are revolved to unwind and remove the wire, such provision calls for compensator loops or accumulator towers to accumulate temporarily enough feed-out wire to keep the machine going while a splice to the new supply is being made.

Such accumulator devices require a large amount of space which was not economical to provide. They demand that an operator be precisely on the spot to make the splice before the limited feed-out accumulation

is exhausted, an impractical demand considering the small number of operators assigned to the plant. Furthermore, rotating supply reels of the size under consideration require special feed-off drives and controls to maintain a pay-out drag of an order to establish the range of operating tensions demanded in the plating lines. To circumvent the objectionable features of the rotating supply reels, provision has been made to take the wire off "over end" from a stationary reel, lying flat on one of its heads, so that the inner (or tail) end of the wire paying off can be spliced to the outer (or starting) end of a stand-by at any time before the pay-off length runs out. To this end arrangements were made with the steel core wire suppliers to bring the inner end of the wire to the outside within the reel heads, allowing enough free length for making the splice.

Each of the twenty-five wire channels on each of the electroforming machines is provided with a dual supply stand holding two reels in the immediate vicinity of each other, one the pay-off and the other a stand-by (Fig. 1). When placed in position on the supply stand, the upper heads of both reels are set up with flyers to guide and tension the off-coming wire, and facilitate automatic transfer from one reel to the next. The



Fig. 1 — Steel wire supply stands, two for each of the twenty-five channels on a machine, permit continuous operation. A 450-lb. spool of wire is being positioned by the nearest operator while behind him another operator is electric welding a wire joint.

flyer rotates about an extension of the reel axis and is lightly restrained with a friction drag-brake which prevents flyer overrun and puts just enough tension in the lead-off wire to keep it from flying wild and tangling. The nature of the over end pay-off causes too wide a change in tension as the supply reel is depleted so the flyer braking force is limited and an auxiliary brake sheave is used to supply most of the back-drag on the wire and create a more stable and uniform approach tension to the machine. From this sheave the wire passes through guide tubes to a fanning section which arranges the wires in proper order and guides them to the supply capstan on the mezzanine at the entrance to the plating line (Fig. 2). The supply capstan is of large diameter and strongly electromagnetic and the wire is snubbed to a 140-degree wrap on it to minimize wire slip and creep. The supply end capstan is the speed governor for the entire machine. It is positively driven with a shunt-wound dc motor regulated to hold capstan speed within  $\frac{1}{2}$  of 1 per cent over the adjustable wire speed range of 80 to 120 f.p.m. (Fig. 3).

The twenty-five wires of each machine are carried through the plating line in spaced relationship by passing alternately over and under a series

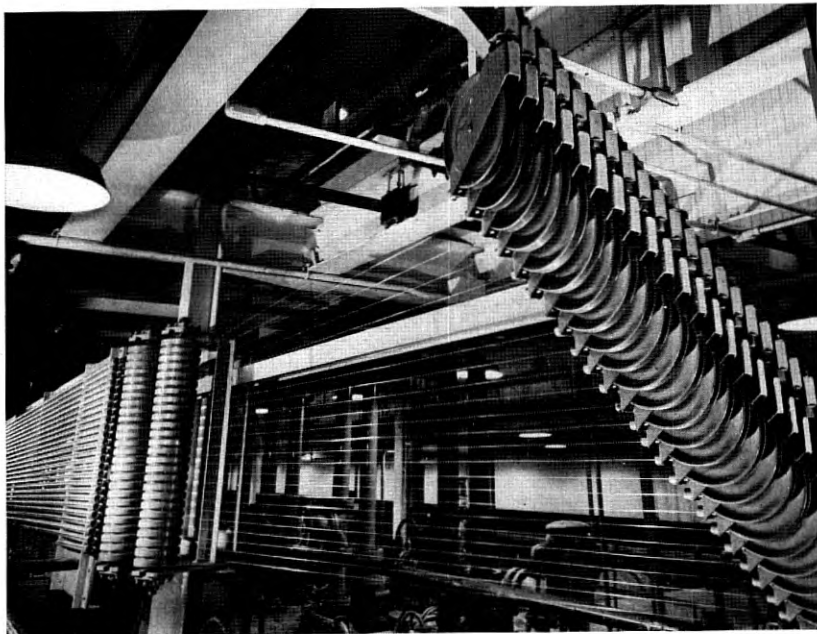

Fig. 2 — String-up of the twenty-five channels of wire carries them from supply spools, left, through guides and sheaves to the mezzanine location of plating operations.



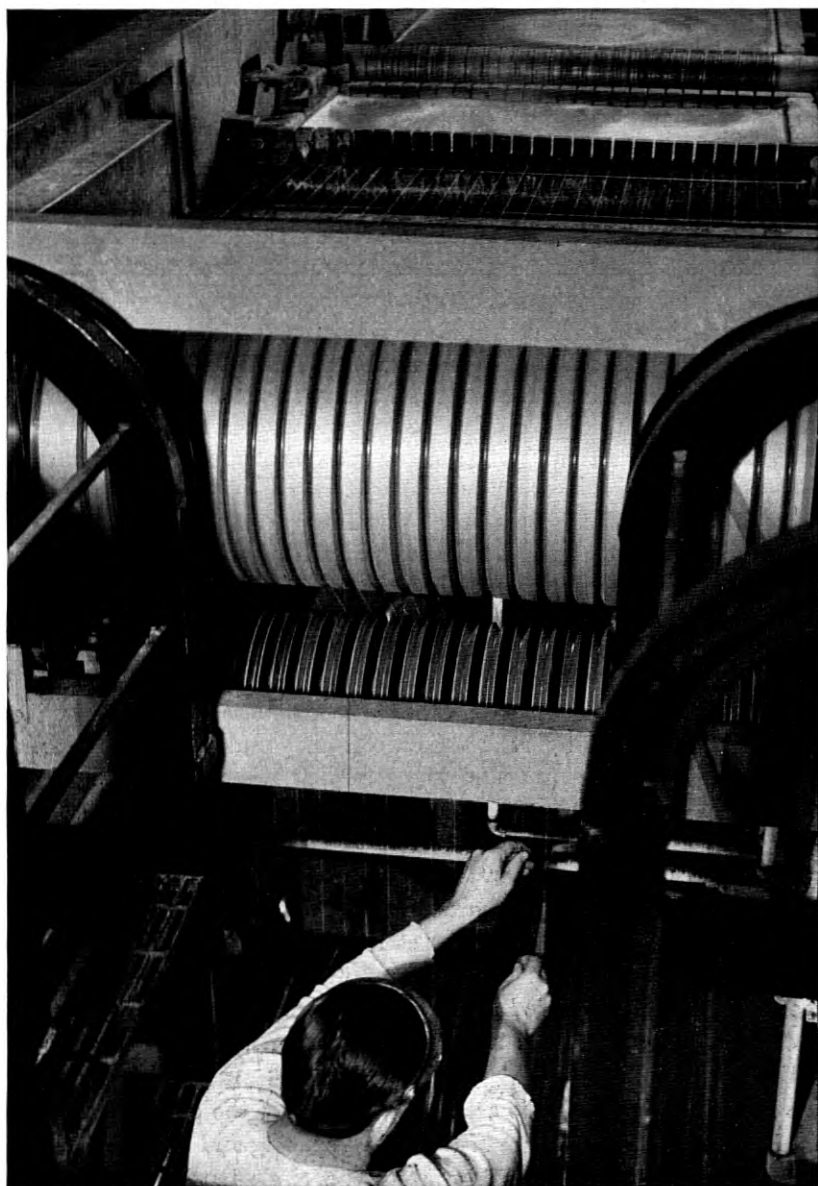

Fig. 3 — Up and over the capstan the steel wires are drawn from the supply position on the first floor to the initial wire preparation baths to begin the 600-ft. journey through the electroforming process.

of grooved rolls. There are a hundred of these rolls in each plating line and all but a very few of them are equipped with contact brushes to supply cathode potential to the wires in the cells. Because of bearing, roll seal, and brush friction, these rolls offer considerable resistance to turning; this frictional resistance is subject to rather wide variations under service conditions. To limit and control the rate of wear on the roll grooves, and to prevent a build-up of excessive wire tensions in the plating lines, all rolls are positively driven at constant speeds. The rolls are grouped on eight separate drive units, each powered by its own motor, so that each carries a definite portion of the total roll load. The motors are geared in and speed regulated by resistances in the motor control circuits to drive all the contact rolls a little faster than wire speed, each successive group of rolls being also driven slightly faster than the preceding one. This roll overdrive, as a result of wire-to-roll friction, produces a closely controllable pull on each individual wire since the only service factor affecting roll pull is the total wire tension (the consequent wire-to-roll pressure) prevailing in any given part of the plating line. The roll pull on the wire increases wire tensions toward the entry end of the plating line so that the point of highest wire tension is at the supply capstan recess, but the total increase is moderate because most of the roll pull is absorbed in overcoming wire drag through the cells.

Wire tensions on the approach side of the magnetic supply and capstan are held low in the interest of safety, efficiency and economy. Those on the recess side of the capstan are higher, which means that the capstan is actually pulled by the wire. So that the motor on the capstan does more than just a braking job, it is made to drive the first group of contact rolls, all those in the preparation leg. In this way the supply capstan motor is loaded about the same as other motors in line so that it operates at a comparable point on its characteristic curve, and performs in substantially the same way as the other motors. It is important that this motor be positively loaded so that it "motors" instead of "generates" because this motor drives a tachometer generator which controls the entire drive.

Most of the contact rolls are in the acid leg of the plating line. They are hardest to drive because of their close spacing and the large number of brushes they carry. To safely limit drive chain tensions and produce the desired roll overdrive gradients the acid leg rolls are grouped in six drive units each with its individual motor. These are matched motors with similar load characteristics and they are geared in at comparable

points on their characteristic curves so that they perform alike under speed and load fluctuations.

The finishing leg rolls and the take up capstan are driven with a single motor identical to the motor driving the supply capstan and the preparation leg. The take-up end capstan adds only slightly to the wire tension over and above that produced at the take-up spools. For that reason the take-up capstan alone does not load the drive motor enough to make it perform like the other motors under load and speed changes. To build up the load on this motor to where it performs at a point on its characteristic curve corresponding to the other motors and "follows" properly it is made to also drive all the contact rolls in the finishing leg.

The take-up end capstan at the exit of the plating line, in conjunction with the take-up spool is fundamentally the tension establishing means for the entire plating line.

From the take-up capstan, the plated wire is passed back to the main floor over another fanning section, and through guide tubes to the take-up spools. While the take-up capstan may be said to establish tensions for all of the plating line up to it, it is the take-up spool drive which basically originates and determines the order of wire tensions for the entire machine. Any tension increase or decrease originating at the take-up spool is reflected all the way back through the machine to the magnetic supply capstan (Fig. 4).

On the electroforming machines wire tension control is quite important. If tensions become too low, the wire may intermittently lose contact on the rolls, sag or weave in the plating cells enough to disturb the spacing between the wire cathode and the anode bed in the cell, or actually stall or hesitate long enough to be burned in two at a contact roll. On the other hand, if tensions are permitted to become too high, the tight wire produces excessive wear on the contact rolls, and bruises or scrapes the relatively soft thin lead and brass plate on the wire. For these reasons the wire tensions developed by the take-up spool drives must be controlled within narrow limits.

The power required to drive a take-up spool is practically constant from an empty to a full spool, but the rotary speed of the spool must decrease as the spool fills up, while the driving torque must increase to compensate for the increase in winding radius. The take-up spools are therefore individually driven with compound-wound dc motors which automatically slow down as the spool fills up, meanwhile holding wire tensions between 15 and 20 pounds from start to finish of a spool.

All the plated wire produced from a 450-pound core wire supply is taken up on one spool to eliminate intermediate wire cuts, and to produce

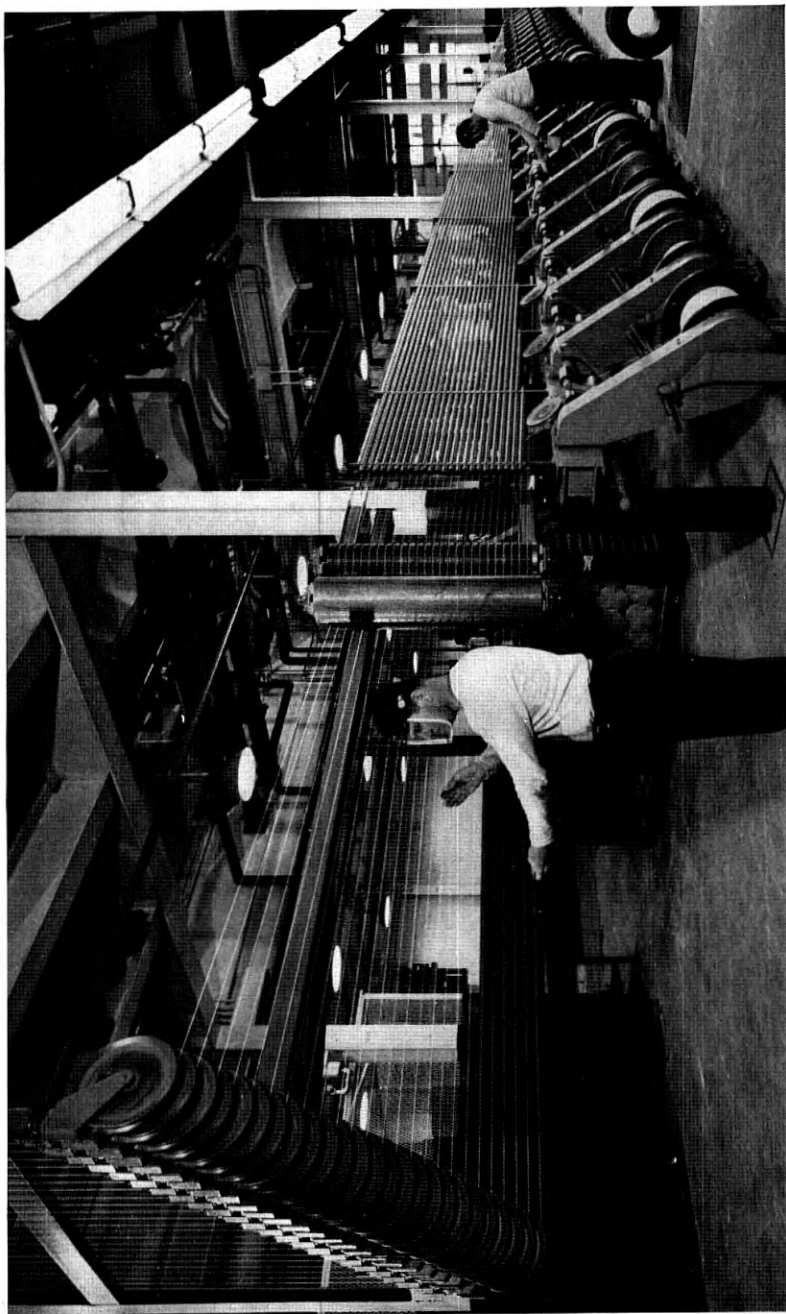

Fig. 4 — Finished wire, after a series of cleaning and plating operations in the electroforming process, is wound onto take-up reels for final inspection and shipment to the Wire Shop.

the longest lengths of plated wire that can be made from a single reel of core wire. This means that for each core wire reel that goes onto the pay off stands, one spool of plated wire comes off at the take ups. This practice reduces scrap operating losses and spool handling, and simplifies the keeping of production records. The take-up spools, which nominally hold 600 pounds of plated wire, were made large enough to take 750 pounds. This allows steel wire suppliers up to 50 pounds overrun above 450 pounds of core-wire per spool.

The spools are made with large arbor-holes which are slightly counter-sunk to provide seating surfaces for engaging cone plates which hold the spool in the take-up stand. The cone plates clamp the spool between them under the pressure of a direct-acting compressed air cylinder closure, which permits quick loading and ejection of the spools and greatly reduces the time required to make spool changes thus keeping scrap to a minimum. Driven pinch rolls are provided at each take-up stand to draw the wire from the take-up capstan while a spool change is being made. The pinch rolls do not contact the wire while it is being wound onto a spool. Operating linkages are provided whereby the pinch rolls are applied to engage the wire at the instant the take-up spool is stopped. In this way there is no pause and no interruption of the wire's motion from the take-up capstan. Wire passing through the pinch rolls is slightly flattened, so it must be scrapped. Spool changes can be made quickly enough so that no more than 10 feet of wire in 125,000 feet have to be scrapped from this cause.

The wires are laid evenly on the spools with a gang-distributor driven by a separate motor. The spool traverse is wide, the wire lay is close, and the distributor travel can be accurately set, both at the distributor traversing screw and at the individual take-up position, so that the wire will be distributed on the spools without camber or end pile-up. Every precaution is taken to insure good wire distribution on the take-up spools, because the wire is subsequently taken off them at high speed at the insulators where wire breaks resulting from faulty wire distribution cannot be tolerated.

#### PLATING MACHINE

The plating machine frame is a simple structure built up of regular structural steel sections and lined with sheet steel. The cross section of the machine resembles the letter "H" with the cross bar set low. The tops of the "H" are joined to lengthwise channels, which form a continuous rail. The bottoms of the "H" are welded to heavy longitudinal channels which transmit the weight of the machine through rollers to a

pair of heavy lengthwise "I" beams which form a part of the building structure. Supported within this framework is the "U" shape trough of stainless steel or low carbon sheet steel covered with Koroseal lining if required by the electrolyte utilized. A step is formed in the bottom corners of the "U" to support the plating cells leaving a trough-shaped channel in the center for the return of the electrolyte. The header from which the electrolyte is supplied to the individual plating cells is located between the legs of the "H," flanked on one side by the positive electrical bus and on the other by the negative bus. Partitions are provided as required in the length of the trough to separate sections in which different electrolytes are confined. The entire machine is sloped towards the central portion of the building so that the effluent electrolyte is directed to the low portion where a downspout to the solution storage tank on the floor below is provided.

The actual plating operations are carried out in a series of cells which are supported on the steps in the return trough by insulating blocks (Fig. 5). All cells are of the same basic design. A typical cell consists of a "U" shaped body of formed and welded sheet steel which may be low carbon steel, stainless steel or low carbon steel Koroseal lined and covered, depending on the particular electrolyte involved. Studs are mounted in both ends of the body for fastening the weir plates. These are of molded hard rubber and provided with twenty-five equally spaced slots on  $1\text{-}\frac{1}{2}$ " centers to pass the wires. The weir plates on the two ends of the cell body differ in thickness, the thick weir containing an interior manifold which serves to distribute electrolyte uniformly across the cell and which is connected to the electrolyte supply pipe by a flexible rubber ell. Molded rubber spill catchers are bolted to the outside of the weir plates to collect the electrolyte discharged from the weir slots and direct it through a rubber tube into the return trough with a minimum of splash.

In the case of unlined cells, the cell body serves as anode or cathode as the operation may require and the electrical connection from the bus bar is made directly to a tap on the cell body. For the lined cells, an anode plate of a suitable metal is provided in the bottom of the cell and covered with anode material in the form of cast shot. In this arrangement, all the electrolytic corrosion takes place on the shot bed, leaving the lead-in plate undisturbed.

The thick, or feed weir, is placed on the low end of the cell to take advantage of friction loss in the long weir slots to reduce the discharge of electrolyte from the cell. Maple wedges coated with vinyl paint placed between the cell bodies and the trough sides allow easy and accurate

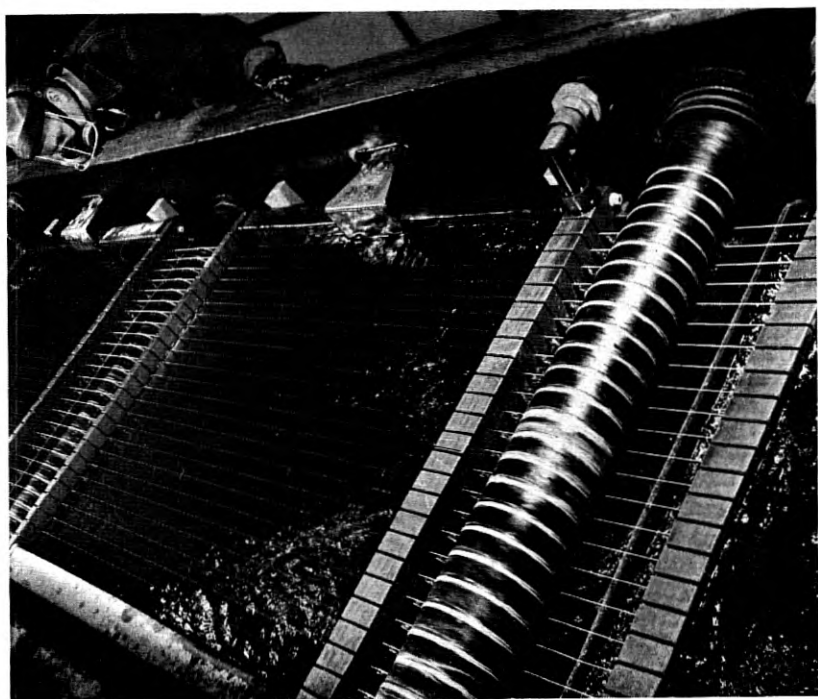

Fig. 5 — Typical cell of the many in each of the two 600-ft. long electroforming machines shows how the twenty-five channels of wire pass through a plating solution and are propelled and fed electric current by rolls like that seen in the foreground. An operator, wearing his protecting safety gear, checks over the operation.

alignment of the weir plates with the wires and maintain the cells rigidly positioned.

The electrical circuit for the plating current is completed through the contact rolls which position and make contact with the wires between plating cells. The rolls are heavy-walled tubes carried on axial shafts by internal ball bearings and insulated from the machine frame. The materials of construction are copper, steel, stainless steel, or monel metal, depending on the electrolyte involved. The ends of the tubes project through the trough walls and the shafts are carried on external brackets which bolt to the upper longitudinal frame channels. One of the brackets is cast iron and the tube on this end is furnished with an insulated sprocket for the driving chain. The other bracket is a copper casting, insulated from the machine frame and carrying brush holders for copper-graphite brushes which contact the opposite end of the tube. The plating

current is carried from the copper casting by a flexible connection to the bus bar. The surface of the tube is provided with shallow grooves on  $1\frac{1}{2}$ " centers to position the wires and the whole contact roll assembly consisting of tube, bearings and shaft can be shifted laterally to bring a new set of grooves into play when wear dictates.

Pilot plant experience had shown that electrolyte will be carried by the wires to the contact rolls and will spread out over their surface, eventually reaching the bearings and the brush contacting surfaces. Some type of seal had to be provided where the roll passed through the wall of the trough. Various types of commercial seals were tried, but all left much to be desired. The seal finally developed for the application is in two parts: a molded Neoprene double slinger ring on the roll, operating in a molded Neoprene housing inserted in the trough wall. The slinger ring successfully prevents the passage of electrolyte while the housing prevents splash from carrying past. This seal has the important further advantage that there is no contact between the fixed and moving parts so that there is no friction loss and no wear. Also, it is a simple molded rubber part which slips into place and requires no fastening.

The wires, in their travel through the plating machine, are acted upon by nine different electrolytes. An appreciable amount of electrolyte is carried with them and if means were not provided to remove the envelope of solution, the succeeding baths would be quickly contaminated, and in some cases dangerous gases would be generated. In general, the transition section between dissimilar electrolytes is made up of an air wiper, a water wash and a steam wiper, in order of wire travel. The wiping element at each wire is the convergent blast of steam or air from three small nozzles. Twenty-five sets of these nozzles, one set for each wire channel, are mounted in a manifold. In the case of an air wiper, the spent air and droplets of electrolyte wiped from the wire are directed into an eliminator where the droplets are caused to separate from the air stream by impinging on the metal baffle plates. The steam wiper is of similar construction except that a water-cooled condenser is substituted for the eliminator. The cooling water for the condenser is discharged into a typical cell, mounted between the two wipers where it washes the wire and discharges to waste.

While these washing facilities may appear somewhat elaborate, they are justified on the basis of reliability and safety. The failure of any one of the three services, air, water and steam, will not cause appreciable contamination before repairs can be made.

At the copper cyanide, brass cyanide and acid copper plating sections, the wipers are preceded by dragout recovery units. A dragout recovery



unit consists of a cell and a small, individual reservoir with a small pump which circulates the liquid in the reservoir through the cell, the overflow returning to the reservoir. Makeup water to replace that lost by evaporation in the associated plating section is added to the reservoir, serving to continuously dilute the electrolyte washed from the wire. The reservoir operates at constant level, the excess of dilute electrolyte passing on as makeup. The dragout recovery units act as an additional safeguard to limit the loss of valuable plating solution and to minimize the contamination of wash water going to sewer.

Last in the design of the machine are the precautions taken to protect against stray currents and to provide for expansion and contraction. Protection against stray currents is an important consideration in any equipment employing highly conductive liquids and heavy currents. All plating cells are insulated from the machine frame by their supporting blocks. Both positive and negative plating circuit buses are insulated. All electrolyte pipe lines contain neoprene flexible joints which serve both to sectionalize them electrically and to provide for expansion and contraction. Contact rolls are insulated at their mountings. These are the principal precautions taken.

The expansion and contraction problem was rather complex. The three trough sections of each machine are continuous units, the shortest 77 feet, the longest 300 feet in length. The plating cells in the trough are supplied with current and electrolyte from a number of different locations in the building and the building itself is provided with a single expansion joint in the center. To allow for relative motion between machine and building, the machine sections are mounted on rollers. Since these sections are required to operate at various temperatures, from room conditions to 195°F, and are required to be supplied at frequent intervals with current and electrolyte, all electrical connections to bus bars are made with flexible joints and electrolyte is supplied to each plating cell through a special flexible molded ell.

Each machine section is anchored to the building steel to prevent creep. An analysis was made of the several movements to be expected under various operating conditions and ambient temperatures and the anchor point was selected for each section so that the relative motions are minimized.

#### PLATING OPERATIONS

From the chemical point of view, the electroforming process consists of a series of unit processes in tandem, to clean the steel core wire and to successively deposit the several metallic coatings required to make

the completed conductor. In the course of the complete travel thru the machine the wire receives thirty-two separate treatments in nine different chemical solutions.

The first solution that the wire enters is the alkali cleaner which removes oil, drawing compound and dirt. The heated bath contains an alkaline solution with a small quantity of a wetting agent. This section of the machine contains eight stainless steel cells alternated with seven stainless steel contact rolls mounted in a stainless steel trough. The wire is anodic with the body of the cells acting as the cathode. A current density of 100 amps./sq. ft. is applied to the wires causing a heavy ebullition of gas which materially helps the cleaning operation. The alkali cleaner section is followed by a steam wiper.

Next the wire passes into a sulfuric acid pickle section where scale, rust and occlusions are removed and a slight etch is imparted to the surface of the steel to promote adhesion with the subsequent copper deposit. A small quantity of an inhibitor is added to prevent the dissolving of an excess amount of iron which would result in a heavy carbon smut on the surface of the conductor. There are six cells and three monel metal contact rolls. Following the pickle is an air wiper, a water wash cell and a steam wiper. This completes the cleaning and preparation of the wire surface prior to the first plating operation. The tank and cells in the sulfuric acid are constructed of Koroseal lined mild steel.

The initial coating is a thin layer of copper from a copper cyanide solution termed a "cyanide flash" and is designed to give a smooth deposit. There are five plating cells and four contact rolls of low carbon steel and the machine trough is likewise of low carbon steel. The wire is cathodic and the copper is deposited at a relatively low current density.

Following the copper cyanide flash the wire passes directly to the copper cyanide plate solution where a copper coating of not less than 0.0001" thickness is applied in a bath designed to operate at a high current density and, therefore, at a higher rate of deposition than is obtained in the flash bath. Seventeen plating cells alternated with sixteen contact rolls are needed to deposit the required thickness at the operating current density. Cells, rolls and troughs are made of low carbon steel, and copper shot resting directly on the steel cell bottoms forms the anode surface. The cyanide plate section is followed by a dragout recovery unit, a water wash cell and a steam wiper. This completes the preparation leg of the machine.

When the wire leaves the preparation leg, it passes through a turning section (Fig. 6) which reverses the direction of travel prior to entering the acid copper plate leg where the bulk of the copper is deposited.



Fig. 6 — Turning section of the machine where the twenty-five channels of wire, after having been cleaned and partially plated in the tanks on the left, reverse their direction and travel the full length of the building, receiving added copper coating in the series of plating cells.

The production plating machine has 58 plating cells alternating with 57 copper contact rolls. The plating solution is very corrosive so that all surfaces of containers are covered with Koroseal. Copper plates in the bottoms of the cells distribute current to a bed of copper shot which forms the active anode surface.

A relatively large number of cells is required because of the magnitudes of the total plating currents involved. Faraday's Law shows that several thousand amperes are required to deposit copper at the rate of 0.001" per minute.

Instantaneous fusion of a steel wire 0.033" in diameter would result if this current were forced through it at one time. The repeated passage of smaller currents which will not overheat the wire will, however, deposit the same amount of copper. The design of a plating section thus takes the form of a number of plating cells separated by contact rolls.

The contact rolls are designed to have a wall thickness of copper adequate to prevent more than a negligible voltage drop between the two outside wires in the machine. This insures that the same voltage is ap-

plied to all wires across the machine and permits a design in which the current collecting brushes are always located on the same side of the machine.

When the wires leave acid copper plate cell No. 58, the full deposit of copper has been applied. They pass into a dragout recovery cell where they are washed by the makeup water, through an air wiper, and a water wash cell before entering the heat treat section. The heat treatment has two functions: First is to change the grain structure of the deposited copper to an annealed form having small random crystals free of strain. Second is to strain relieve the hard drawn steel core wire sufficiently to increase its elongation to between 3 and 7 per cent. This is accomplished by passing current through each wire to heat it to the necessary temperature. The heat treated wire passes through a water wash cell which serves as a quench and through a steam wiper which dries it in preparation for entering another turning section where it again changes direction 180° to enter the finish leg of the machine.

The first solution that the wire enters at the finish leg is hydrofluosilicic acid which serves to remove any oxide which may have formed in the heat treatment. This cleaning operation is performed in a single koroseal covered cell.

Four koroseal covered cells, three copper contact rolls and a koroseal lined section of trough make up the lead plate section. The electrolyte is lead fluosilicate. Lead sheets in the bottom of the cells are covered with lead shot to form the active anode surface.

The brass plating section applies the final deposit to the wire. Its function is to provide a coating which will unite chemically with the insulating compound, giving good adhesion so that the load from the drop wire clamps used to support the wire in service will not cause the insulation to slip on the conductors. The composition of the deposited brass is controlled between very close limits to obtain the desired adhesion between conductor and insulating compound. The electrolyte contains copper and zinc cyanide. There are four steel plating cells, three steel contact rolls and a low carbon steel trough in the brass plate section. The anode material is a mixture of copper and brass punchings which rest directly on the steel cell bottoms. The finished wire is then wound onto 660-pound reels.

#### ELECTRICAL POWER

Electrical power is purchased from the local utility company at 13.2 kv and brought into the building by a pair of three-conductor, 300,000 circular mil, 15,000-volt, lead-covered cables running in underground

ducts. These are terminated in two 1500-kva metal-clad substations which consist of high-voltage switching units, transforming units, and low-voltage feeder units. Each unit substation has the self-cooled rating given in Table I.

On the incoming line side of each substation are two load interrupter disconnecting switches so that the building may be supplied by either of the two incoming high-voltage cables. The high-voltage switches feed the power into the two transformers, each of which is rated at 1500 kva, three-phase, 60-cycles, 55°C rise, and is self-cooled, filled with non-inflammable liquid. For a short time interval, with proper switching, either of these transformers can supply the total building load if fan cooling is provided.

The 480-volt power from each transformer is then fed into its respective low-voltage switchgear for distribution to various parts of the build-

TABLE I

Capacity (55°C.)	1500 kva
Normal voltage	13200/480-277 delta-wye volts
Frequency	60 cycles
Phases	Three
Circuits:	
Three-wire incoming, 12300 volts	Two
East unit, four-wire, outgoing 480/277	Six
West Unit, four-wire, outgoing 489/277	Five

ing. Lighting, heating and ventilation services are provided totally from one substation by way of a disconnecting bus tie switch which automatically throws over to the other substation in case of failure of one.

Other than the lighting, heating, ventilation and some plant services, each substation is designed to supply power for the operation of one machine.

From each substation one low-voltage ac feeder supplies on its machine a number of rectifiers which transform and rectify the 480-volt, three-phase, ac power to dc power at a low voltage. From this feeder is supplied all of the "auxiliary" plating power for that machine: alkali cleaner, acid pickle, cyanide copper flash and plate, electrocleaner, lead plate and brass plate. In addition the dc power for establishing the field in the magnetic capstan is supplied from a rectifier on this feeder at 55 volts.

Another low-voltage ac feeder from each substation feeds through an induction voltage regulator which in turn feeds sixteen rectifiers of one machine. From these rectifiers is taken the dc plating power for the acid copper plate section of the machine. The function of the induction voltage

regulator is to automatically control the dc plating current in the acid copper plate section through a control system which continuously measures the electrical resistance of the product and signals the need for variation in power in accordance with the variation in resistance.

All of the rectifiers associated with one machine (Fig. 7), including the "auxiliary" units and those on the regulated feeder, are located in the outer mezzanine bay nearby that machine. The two regulators, although each is associated with a different machine, are both located in the sub-station room on the south side of the building.

The induction voltage regulators are basically standard regulators of the type used in lighting service but modified slightly by the addition of a control slidewire for electrically indicating the position of the rotor. Each unit is three-phase, self-cooled by non-inflammable liquid, rated at

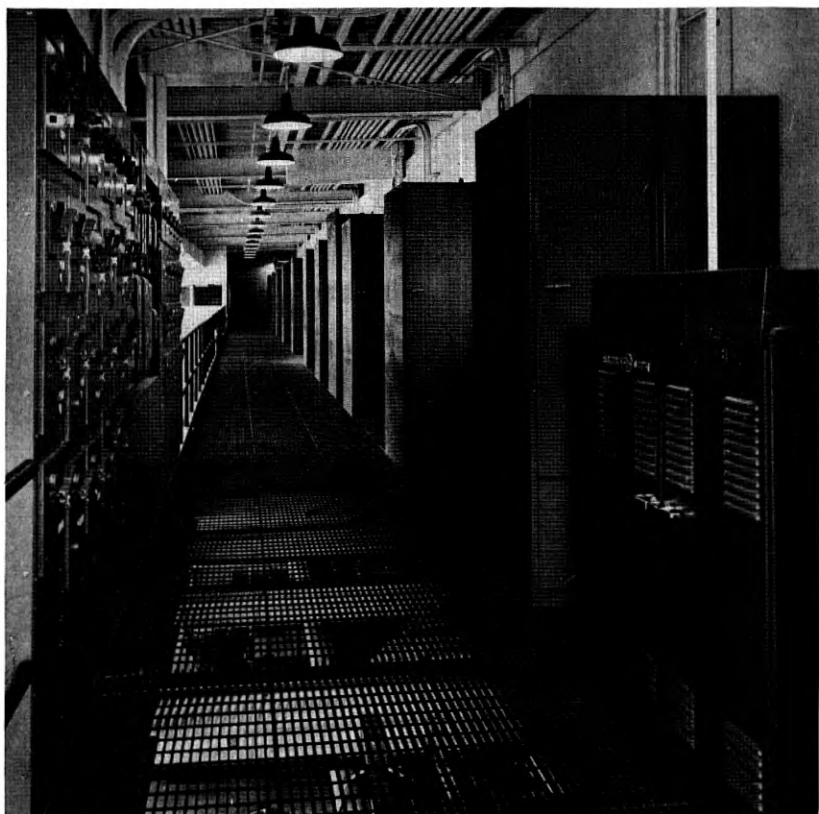

Fig. 7 — Electrical heart of the electroforming process are these rectifiers and controls where alternating current is converted to direct current.

480 volts ac and having at least 105-kva capacity according to NEMA standards. Each regulator is able to buck or boost line voltage by 20 per cent at maximum rectifier load.

The rectifiers used for converting three-phase, 60-cycle, 480-volt ac power to low voltage dc are all of the copper-oxide "dry-disc" type. A detailed investigation of various sources of dc power was made before this type of converting equipment was purchased. Because of the similarity between the continuous copper plating of wire and the continuous tin-plating of sheet steel, a tour of several steel plants which plated strip steel in a continuous process was made. Here were observed some of the best and some of the poorer installations of electrical converting equipment, including motor-generator sets, copper-oxide rectifiers and selenium rectifiers. This survey terminated in a decision to use totally enclosed, air cooled copper-oxide rectifiers, in which the enclosed air is recirculated past air-to-water heat exchangers for cooling purposes. This decision was based on a desire for low maintenance costs, efficiency, compactness of installation and flexibility. Choice of copper oxide over selenium rested on the fact that copper oxide rectifiers are less costly and better suited for low voltage output (less than 6 volts).

The actual design of the rectifiers was arrived at after a series of conferences between Western's engineers and those of the manufacturers. Accessibility of all parts for inspection and maintenance purposes, adequate protection of components through control circuits, limited occupancy of floor space and low cost were design criteria. These features are nicely combined in the final design and the manufacturer standardized the rectifier for sale to other purchasers.

Each rectifier is of the completely enclosed, air recirculating type. It is equipped with its own heat exchanger and is gasketed to minimize air leakage. The air-to-water heat exchanger is of a type especially designed for use with well water containing some fine sand. It features ease of cleaning and is a type suitable to these conditions. The fins and tubes are of copper and water connections are external to the rectifier housing.

All other components are readily accessible through gasketed doors in the housing. One or two fans, as required, circulate the air within the rectifier housing to transfer the heat generated in the rectifier cells and in the transformers to the water cooled heat exchanger. As protection both to equipment and to personnel, a rectifier can be automatically tripped off the line for any of the following reasons: Electrical overload and short circuit, dc over-voltage, failure of air circulation, overload of fan motor, water failure, momentary power interruption, over-temperature of the air, and by opening any of the doors on the rectifier.

Control of the output of the entire bank of rectifiers of the acid copper plate section is accomplished through the associated induction voltage regulator. Individual adjustment of load and compensation for aging of the rectifier stacks has been provided for by bringing out to terminal boards within the housing a number of leads from the primary windings of the rectifier transformers. For a given feeding voltage, the output of each rectifier can be adjusted over a considerable range by the positioning of jumpers at the terminal boards. Except for aging compensation, this adjustment, once made, need not be made again. Control of the output of the "auxiliary" rectifiers is accomplished by tap-switching, under load, between taps brought out from open-delta autotransformers on the primary side of the rectifier transformers.

The capacity of the bank of the sixteen rectifiers feeding the acid copper plate section of each machine is larger than is actually required to produce the wire. With this additional capacity distributed among the rectifiers, it is possible to continue plating operations in case of failure of one rectifier. The automatic control system will increase the output of the remaining fifteen units immediately after the one has dropped off the line.

The bay in which all rectifiers are located is separated from the operating bay by a plaster partition which serves the purpose of forcing the incoming fresh air flow past the rectifiers protecting them from any corrosive atmosphere which might be present in the operating bay. The rectifiers are placed against the wall and their bus terminals extend through small apertures into the operating bay. Because the operating bay floor level is about two feet higher than that of the rectifier bay, the rectifier terminals emerge from the plaster partition below the floor elevation of the machine. This permits the running of the busbars out to the machine by passing them under the operators' walkways.

These feeder busbars from the rectifiers terminate beneath the section of the machine which they are to feed. Flexible laminated connectors join the feeder buses with the buses running longitudinally under the machine: from the longitudinal buses additional flexible connectors carry the current up to the rigid terminals leading into the plating cells or up to the copper castings supporting the brushes and contact rolls.

The dc circuit, both inside and outside the rectifiers, has been completely insulated from ground excepting that grounding caused by electrical contact with the wire itself. Stray currents are thereby minimized and kept out of pipe lines or building steel.

All of the busbars used on the machine are of the square drawn copper tubing type. Aluminum was considered but rejected because of the seri-



ous danger of electrolytic corrosion at the joints (which necessarily had to be made to copper) from the warm, moist, corrosive atmosphere. The square copper tubing is ventilated by holes drilled in the upper and lower faces to give it comparatively high current carrying capacity with low temperature rise. The fact that the bus is in the form of tubing gives it an inherently high mechanical strength; the supports for the tubing, therefore, could be spaced much farther apart than for ordinary bus. All tubing bus joints are of the compression type made up by the use of standard clamps rather than by brazing or bolting. All of the tubing was purchased cut to size and coded. During installation, the preparation of the joining surfaces was carried out on benches in the area. Such planning resulted in an exceptionally easy and rapid installation.

A complete picture of the electrical operation of a given machine is provided to the operator through a control console located in the operating bay of the mezzanine (Fig. 8). On the control console are located the tapswitches for adjusting the output of the "auxiliary" rectifiers, an ammeter and a voltmeter for each rectifier (a total of forty-six such meters per machine), a meter which indicates wire speed, switches for

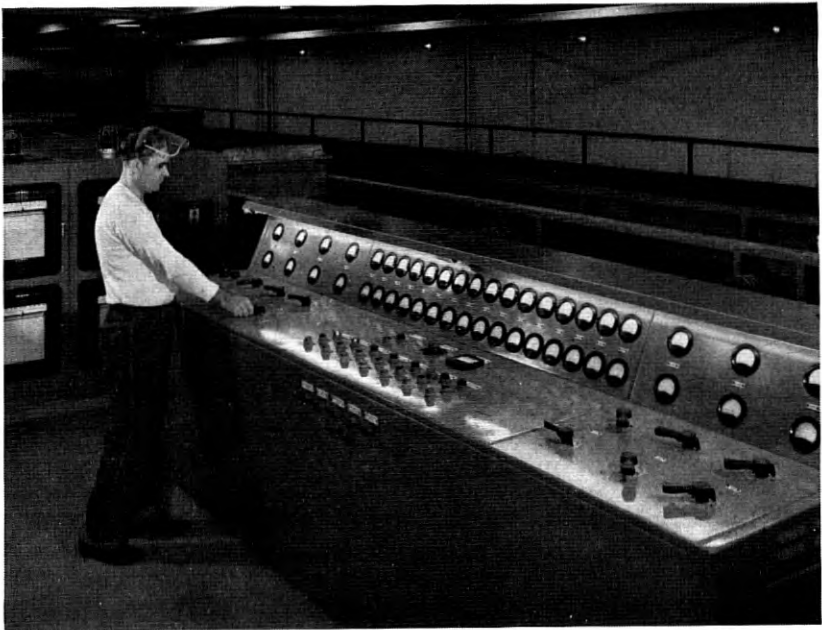

Fig. 8 — Control console for the entire process is readily available when necessary.

the ventilating roof fans, a switch for removing the magnetic field from the supply-end capstan, a selector switch for selecting the speed of wire passage through the machine, and seven push-button stations which give the operator individual control over various elements of the machine. The push buttons energize relays mounted in a bank within the control console and thus permit a large degree of interlocking. The interlocking is designed to prevent accidents from occurring in the process. For example, the operator cannot permit the pickling acid to flow over the wire while the wire is stationary; otherwise the acid would dissolve the wire in a short time. Time delay relays also are used to advantage. They insure, for example, that the full length of moving steel core wire has its flash coating of cyanide copper prior to the rise of the acid copper plate solution into the cells and around the wires which, without the copper envelope, would be eaten through in a short time.

The overall machine control system has been broken down into two parts because of the two-floor design. From his console, the second floor operator controls only those portions of the process which are visible to him on the second floor. He can, for example, permit solution to flow into the plating cells by electrically opening the valves in the circulating system. Actual control of the first-floor pumps which move the solution, however, is in the hands of the first-floor operator who has a control panel strategically located near each storage tank and pumping station. Here he can operate filters, pumps and level control systems.

#### WIRE RESISTANCE CONTROL

There has been provided for each machine in the electroforming plant a control system which automatically adjusts the dc plating current in the acid copper plate section to that value which, under all normal operating conditions, will produce a wire meeting the electrical resistance specification for the product.

Control is necessary because of the number of variable factors which, if uncontrolled, would interfere with the proper flow of plating current and, therefore, with the amount of copper deposited. These variable factors can occur in the physical and chemical properties of the raw materials entering the process, in the plant services feeding the process, and in the process itself. Some of the more important variables are as follows:

1. Incoming electrical line voltage fluctuations.
2. Failure of one of the sixteen rectifiers feeding the acid copper plate section.

3. Changes in the temperature or in the concentration of the electrolyte.

4. Changes in the distance between the anode bed and the wire because of the wasting away of the anode bed during plating operations.

5. Wire speed changes (by removal of the magnetic field from the supply-end capstan).

6. Operation of the machine at less than its capacity number of channels.

Control is justified by the savings in copper which accrue, by the relieving of the operating personnel of tasks which could become tedious, and by the resulting production of an exceptionally uniform product. In view of the size tolerances available on steel wire, it was decided that the most practicable approved way was to manufacture to uniform conductivity and to ignore wire size within reasonable limits.

Two systems produce the overall control function. A primary system senses the total value of the dc current in the acid copper plate section by means of a current transformer located in one phase of the common ac feeder servicing all sixteen rectifiers. Changes in that current are immediately detected and compensated for by adjustment of an induction voltage regulator located at the head of the feeder. This system therefore maintains the dc plating current essentially constant in value and corrects for such fluctuations as are listed from 1 to 4 above before they can seriously affect the product.

Changes in certain other variables, as exemplified by 5 and 6 of the above list, require that a new value of total current be established and maintained constant by the primary system. Otherwise the maintaining of the previous value of total plating current would result in a change in the resistance of the product. Such variables are cared for in a secondary control system which uses the resistance of one of the finished wires as the control parameter. The secondary system automatically positions the control point of the primary system, depending on the value of electrical resistance of the pilot wire which is measured continuously.

In addition to control equipment each machine has an inspection device which automatically measures the resistance of each of the twenty-five wires and records the values on a chart. A cycle of all twenty-five wires is completed each hour.

Both the control and inspection resistance measuring equipments use Kelvin Bridge circuits and measure approximately five feet of wire at one time. Continuous contact with the wire being measured is made through rotating sheaves and brushes. This avoids any scraping of the soft lead and brass surfaces of the product.

The inspection wire contacting device automatically moves from wire to wire across the machine, sampling the resistance of each wire for about fifteen seconds. The chart provides the observer with a complete picture of the behavior of the plating operations at a glance and enables the operator to properly select the controlling pilot wire in such manner that minimum energy and copper are expended. The control wire contacting device is manually set in position against one wire until conditions require selection of a new pilot wire.

Both contacting devices are located in the position just preceding the take-up capstan from which the wire moves down to the first floor to be taken up on reels. To avoid the by-passing of the bridge current through ground and the building steel, each channel has been completely insulated from ground and from other channels between the contacting devices and the end of the wire on the take-up spool. The take-up capstan, all sheaves, guide tubes, rollers, and the take-up stands themselves have been designed to provide the required insulation.

Aside from presenting to the operating personnel a complete chart showing the values of the electrical resistance for each channel, the sensitive resistance measuring equipment also gives indication of process difficulties long before they are evident from any other source. For example, an increase of organic contamination above certain concentrations in the acid type plating bath will produce wide variations in the structure and, hence, in the electrical resistance of the copper deposit. These fluctuations can occur in very short sections of the product. While the average value of the resistance may remain constant for long sections of the product, the resistance charts provided by the control and inspection equipment will record the individual wide fluctuations and thereby provide experienced operating personnel with a positive indication of imminent serious trouble.

#### SOLUTION HANDLING

In this plant, all unit processes are similar if not identical in arrangement and operation.

A typical handling system consists of a storage reservoir, mixing and filter station, circulating pumps, heat exchanger, solution supply, and return piping between storage tank and processing area, and a solution temperature and level control. (Fig. 9.) The chemicals of which the electrolyte is composed are placed in the mix tank and agitated. This mixture is then transferred through the filter into the storage tank. The filtered solution in the storage tank is first circulated through the heat exchanger and finally delivered to the processing area on the mezzanine

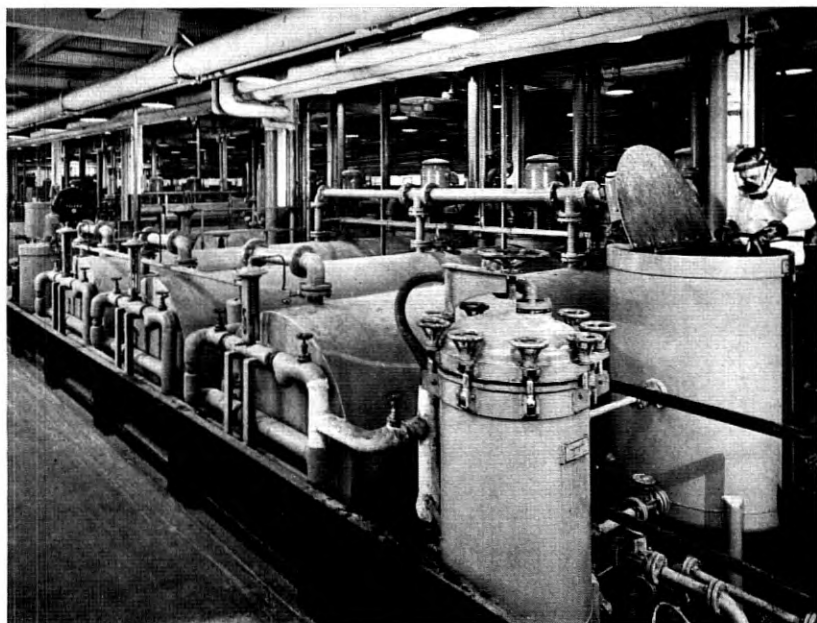

Fig. 9 — Solutions for the plating operations are stored in this battery of tanks. Full safety equipment is worn by the operator as he performs the job of tank-filling.

floor. It returns by gravity to the storage reservoir and the cycle is repeated.

The storage reservoirs are cylindrical horizontally mounted steel tanks. Those containing acid solutions are Koroseal lined, and many are covered externally with thermal insulation. All tanks have the same inside diameter, but vary in length depending on storage requirements for each electrolyte. Since the electrolyte used in similar unit processes of the two machines is the same, provision has been made for complete interchangeability of solution between the storage tanks of the two machines.

The purpose of the filtering operation is to permit the continuous removal of suspended solids and foreign material in the process solutions. The mixing and filter station provided for this purpose is an assembly of components all of which are mounted on a common base or platform. The basic assembly consists of a closed pressure type alluvial-leaf filter, centrifugal pump, mixing tank with agitator, various valves for directing and controlling the quantity of solution, water and air used in the filter operation, and a discharge to sewer for cleaning. Within the pressure tank a series of double faced screen assemblies or leaves comprise the

filtering elements which hold back the undesirable solids and discharge a clear product into the common filtrate manifold on which they are mounted. There are eight leaves in each pressure tank providing sixty square feet of filter area. The filter cycle is begun by filling the mix tank with unfiltered solution or electrolyte from the storage tank. Sufficient filteraid for precoat is rapidly mixed in by agitator. This mixture is forced through the filter leaving a deposit or coat of filteraid on the intake surface of the leaves. The purpose of the coating is to provide a filter medium which is dense enough to prevent the passage of suspended solids in the solution and yet is easily removed and replaced. The appearance of the liquid on returning to the mix tank gives an indication when an adequate precoat has been deposited on the leaves. Once the coat has been applied, the filter is put on the line and clear filtrate is discharged to the storage tank. The filtration stage terminates when the filter tank pressure approaches a maximum operating value, at which time the leaves are washed, a new coat is applied, and the cycle is repeated.

The storage reservoir is fitted with one or more heavy duty vertical sump type pumps to transfer the electrolyte in the processing area. All pump parts in contact with chemical solutions are constructed of either cast iron or a stainless steel alloy known in the industry as FA-20. All pumps are fitted with graphitar bearings. Each pump is connected directly to its electric motor and the entire assembly may be quickly removed from the storage tank.

All piping associated with solution handling is either steel or saran-lined steel. The Saran-lined pipe has flanged type joints and the unlined steel pipe has welded joints except where disassembly is provided for and here welded-on flanges with neoprene gaskets are installed. Flexible neoprene joints are provided in the solution riser and return pipe to insulate the plating machine from the circulating pumps. To control solution flow to the processing area, air operated diaphragm valves have been installed.

The two-pass heat exchanger selected for the process consists of a steel shell, but all parts in contact with corrosive solutions, including the tube bundle, are constructed of a chemically inert carbonaceous material. The heat transfer rate of this graphite base material is the highest of all non-metals and is higher than that of most metals. For example, the thermal conductivity of 18-8 stainless steel is approximately one-fifth that of the graphite base material.

Operating temperatures for all solutions are specified and equipment to control these temperatures has been provided. The temperature of each solution is measured with bulb type expansion thermometer. The

temperature is recorded by an instrument attached to the outer trough of each process on the mezzanine floor. In addition to recording temperatures, the instrument also operates a spring loaded valve, by air pressure, in the heat exchanger piping. The correct operating temperature can be chosen by setting the manually operated pointer on the recording chart.

Automatic, electrically operated, liquid level control devices have been provided for each solution. These controls are provided for the following reasons:

1. The evaporation of water from the solutions used in the process is of such magnitude that some means of maintaining solutions within their proper concentration range is necessary.

2. The solution level in the storage tank must not reach a specified lower limit, or the circulating pump suction head will fall below the minimum operating value.

3. When the electroforming machine is in operation, the total solution volume in any unit process is composed of the portion in storage and the portion in circulation. If the portion of solution in the storage tank exceeds a known value, the remaining volume of storage space will be insufficient to accommodate the circulating portion of solution which returns to storage when the machine is shut down.

The liquid level control device consists of four electrodes which dip into the contained solution. The four electrodes are arranged so that as the level varies, the solution closes different electric circuits. During normal operation at proper level, the electrical connection between the low electrode and a common electrode holds the solenoid operated water valve closed. When the level falls about  $\frac{1}{2}$ " below the prescribed level, the circuit opens and releases the solenoid water valve to the dragout recovery cell or the valve in the water line leading to the filling nozzle in the storage tank. When solution again rises to the prescribed operating level, another tripping circuit is activated which causes the water valves to close.

In order to show whether or not the level controls are operating satisfactorily, a red and a green light are mounted above and in line with each storage tank. When the green light is on, the levels are proper. The red light is a signal that the level is increasing beyond the point at which the tripping circuit should have been activated. In this case, the water valve is immediately turned off. When both lights are on, the solution level in the reservoir is low and make-up water is added automatically.

Due to the chemical action of fluoboric acid on the copper anode material in the acid copper plating bath, the copper concentration of the solution rises during operation of the electroforming machine. In order

to hold the concentration within the established operating range, copper removal equipment was developed.

The equipment consists of two Koroseal lined tanks installed in a concrete pit and fitted with graphite anodes and sheet copper cathodes. When the copper concentration of this solution exceeds the maximum operating value, the pump associated with the copper removal unit automatically cuts into the acid copper plate equalizer line and transfers solution to the removal unit. The excess copper in solution is electrolytically deposited onto copper cathodes, and the restored solution is returned by gravity to the equalizer line.

#### RAW MATERIALS HANDLING

Except for the anode material (shot), all materials handling is confined to the main floor. In this way the plating deck operators are fully relieved of all materials handling chores, other than the one job of replenishing anodes in the cells, and this job is purposely delegated to them because anode maintenance is a critical part of the plating deck operator's responsibility for product quality. All heavy, bulky units are handled on the main floor so that none of the untidiness and confusion always attending the opening of containers, truck movement, and receiving and shipping operations are present on the plating deck to interfere with the prime job done in that area.

All chemicals to be used in the various cleaning and plating solutions are stored along the north wall of the building, each in the area nearest the preparation and mixing equipment in which it will ultimately be used. Wherever chemicals are stored close to one another, which, if accidentally mixed, might create hazards, solid barrier walls are provided to keep them separate. Chemicals are stored in their shipping containers, all of which are fully identified as to contents and adequately marked with any warning labels which might be required. Chemicals, at the receiving dock at one end of the building, are removed from the motor truck, placed on wood pallets, and transported by electric truck to the storage area. The use of pallets for handling and storing the chemicals reduces the total electric truck haul-time and protects the containers from mechanical abuse while in storage. The wood pallets also permit flushing of the floors without soaking the containers, especially those of paper or wood. Facilities are provided for flushing out the emptied container as well as for washing down the floors after accidental spillage or breakage.

Wire is stored along the south wall of the building physically well



isolated from the chemical storage, handling and mixing operations along the north wall. This minimizes exposing the wires to the splash or vapors from the chemicals which would damage the wire. Core wire is the bulkiest and one of the heaviest items handled. It is stored in an area near both the core wire pay-off stands and the receiving dock, to shorten the truck-hauls and enable the pay-off stand operator to obtain his core wire supply direct from storage without leaving the operating area. The core wire supply reels are narrow and of large diameter so they can readily be handled upright, and rolled along on their head rims. From the upright position, the reels are picked up with a rotatable grapple on a monorail hoist, turned 90 degrees, and placed head down on a waiting transfer car to be moved to the supply or pay-off stands. The transfer car operates on steel rails flush with the floor so that the car can be spotted close alongside the pay-off stands, without danger of being bumped into them (Fig. 1) The bed of the transfer car as well as the beds of the pay-off stands are built up of gravity roller conveyor sections and in loading position both are at the same height. The reel is easily pushed off the car and onto any pay-off stand. Emptied core wire reels are removed with the same equipment and accumulated in the storage area for return to the supplier.

#### ANODES AND ANODE HANDLING

Soluble anodes for the plating cells are supplied in the form of random-cast shot or pellets and punchings varying in diameter from about  $\frac{1}{4}$ " down to  $\frac{1}{32}$ ", the percentage of fines being limited by raw material specifications to control the rate of dissolution in the plating electrolytes and to limit the formation of anode muds or sludge. The copper shot is cast from commercial wire-bar copper. The lead shot is made from commercially pure virgin lead, and the brass punchings are obtained from lead-free brass scrap. The brass anode usually contains too much zinc, so the brass bath composition is corrected by adding pure copper shot in with the brass, the proportions being determined by plating bath and plate composition analysis. The shot is laid evenly in a bed about 1" thick over a relatively thin plate electrode covering the entire bottom of the plating cell. Plating potential is supplied to the soluble anode bed through the electrode.

In the cyanide brass and cyanide copper plating cells the anode material is spread directly on the steel bottoms of the cells, steel not being soluble to any consequential extent in the cyanides. Lead electrodes are used in the lead plating cells. The lead and brass anode materials are

used in such small quantities that they are replenished by hand. Copper, however, is plated out of each machine at the rate of 900 pounds per eight-hour shift. Copper shot added to replenish this plate-out from the cells must be spread out evenly over a cell area of more than 500 sq.ft. extending 280 ft. along the machine. When this is done, the average depth of the material added is less than  $\frac{1}{10}$ ". As a quality control on the copper plate, the anode-to-cathode spacing in the cells (copper shot layer-to-wire spacing) is not permitted to vary from the specified spacing by more than 25 per cent at any spot on the cell surface and the average must not exceed 15 per cent. Shot must be added at least once every eight hours to meet this requirement, and the addition must obviously be made while the wires are running. It would be impracticable to do this job manually in any reasonable time and with any assurance that the quality of the electroformed copper deposit would not be impaired during the addition.

Copper shot is, therefore, added to the cells with a mechanical distributor which automatically sprinkles the shot into the cells uniformly while the machine is running. It is essentially a hopper mounted on a motor driven carriage which travels on the two upper rails of the acid leg of the machine, the bottom of the hopper being fitted with a rubber surfaced feeder roll and a stripper comb which releases from the hopper a controlled amount of material. The feeder roll is also motor driven and timed relative to the travel speed of the carriage. Both carriage and feeder roll are operated from rubber grips so that the machine operator may stop the distributor wherever he wishes or by-pass any cell if he so desires. To prevent the spillage of shot on the contact rolls between the cells, block-out cams are placed on one rail to operate a cut-out switch which stops the feeder roll while the distributor passes over the contact roll space between cells. The speed of the feeder roll can be varied, and the height of the stripper comb can be changed to vary the amount of shot released per foot of distributor travel. A feed run of the distributor requires an operator's attendance and takes about twelve minutes to discharge shot to the entire acid-copper plating line. The distributor returns to its starting point automatically when the feed-run has been completed. The feeder roll is inoperative while the distributor is returning. Power is supplied to the distributor through trolley operating in fully guarded feed rail running overhead and parallel to the plating line.

Copper shot is added to the distributor hopper with tilting bucket on a monorail hoist. The bucket is filled in the raw material storage area on the main floor, raised with an electric hoist to the plating deck and moved on monorail track to dumping position over the distributor hopper.

## FINISHED WIRE HANDLING

The spools of plated wire removed from the take-up stands are rolled onto a chock-strip in the operating aisle centrally between the two take-up stand lines. This strip serves as a temporary storage and spots the finished wire spools directly under and overhead monorail. The spools are picked up from this strip with a hair-pin hook on a trolley-mounted electric hoist and pushed to a pallet-loading area at the open end of the take-up line. Each pallet holds four spools of wire, and both spools and pallets are of such size that four spools may be placed with a single spotting of the pallet. The pallets are of special design, double-sided and made for stacking. Loaded pallets can be stacked four deep, the upper pallets resting on the heads of the spools on the lower pallets. The spool heads are made of cast steel and are of ample strength to sustain this load.

The loaded skids are picked up with an electric fork truck and moved to the loading dock at the far end of the building. Here the loaded pallet is moved directly into a motor-tractor drawn van parked at one of 2 loading doors. The van holds one day's (24 hours) output of electroformed wire.

## SAFETY FEATURES

The electroforming process involves the use of chemicals all of which are dangerous when taken internally. Many are corrosive to the skin and some form poisonous vapors and gases under abnormal conditions. Specifically, extensive use of acids and cyanides demanded that extreme care be exercised in the layout of chemical storage and handling areas associated with each unit process. To aid in preventing any accidental mixing of these compounds and the possible generation of lethal hydrocyanic acid gas, a number of safety features are embodied in the design of the machine. The more important of these features are the following:

1. Individual pits for isolating the storage, mixing and filtering equipment associated with each unit process have been installed. By this action any overflow from a storage reservoir or solution leak in the handling equipment of any unit process will be confined to its own pit and may be neutralized and flushed to sewer.

2. Whenever acid and cyanide compounds occupy adjacent locations in the chemical storage and handling area, chemically resistant protective barriers have been erected between them.

3. Air wipers, water wash cells, and steam wipers have been installed in the processing sections of the machine between each acid and cyanide

bath to effectively remove from the wire any dragout from one bath before it proceeds to the next.

The safety features thus far discussed are installed with a view toward preventing the accidental generation of hydrocyanic acid gas. Additional measures have been adopted to further protect the employee. Limited admission to the electroforming building is enforced and authorized identification cards are issued only to engineering, operating and maintenance personnel assigned to the process. By such action the possibility of injury to the unacquainted observer is eliminated. Protective face shields are required equipment, they are stored on racks at the main entrance to the building and are available to all personnel. Safety showers have been strategically located throughout the building. Gas masks have been provided and are readily available at three locations. These masks are the self generation type, they will provide oxygen regardless of the nature of the surrounding atmosphere. Emergency machine shut-down buttons have been installed at four positions in the building. Finally, an evacuation alarm system has been installed for use of personnel in the building in case of an accident or failure of equipment that would result in the generation of hydrocyanic acid gas. The system includes three push-buttons under glass, one at each entrance to the building and one on the machine control consoles. A siren is provided and is audible throughout the building. Operation of any one of these buttons will trip the 480-volt substation circuit breakers for all power feeders with the exception of the lighting and ventilation circuit breakers and completely shut down both machines including all associated auxiliary machinery. The siren will be sounded and annunciator drop will be operated together with a bell and indicating light in the Firehouse and Watch Service Organization.

#### PERSONNEL REQUIREMENTS

It may be of interest to note that in planning this installation careful attention has been given to the increasing shortage of labor and to the provisions of automatic control and mechanical aids to reduce the labor requirements.

No standard measuring stick being available to determine the result of the efforts to reduce labor, it can be said that in a building 340 feet by 91 feet containing two million dollars worth of equipment capable of manufacturing two million dollars worth of product a year on a 350-day 3-shift basis the total operating force is 21 (five men per shift plus a material handler on the day shift).

The project is essentially chemical requiring a considerable amount of both electrical and mechanical engineering and may be regarded as a

good example of what can be done by a team of interested and competent engineers. The entire project from conception thru development of process and design and construction of equipment was conducted by Western Electric engineers. The product was specified and checked as to properties and electrical and mechanical requirements by Bell Telephone Laboratories.

The process as developed and operated is probably applicable to a number of other Bell System requirements which will be investigated and will form the basis for future expansion.

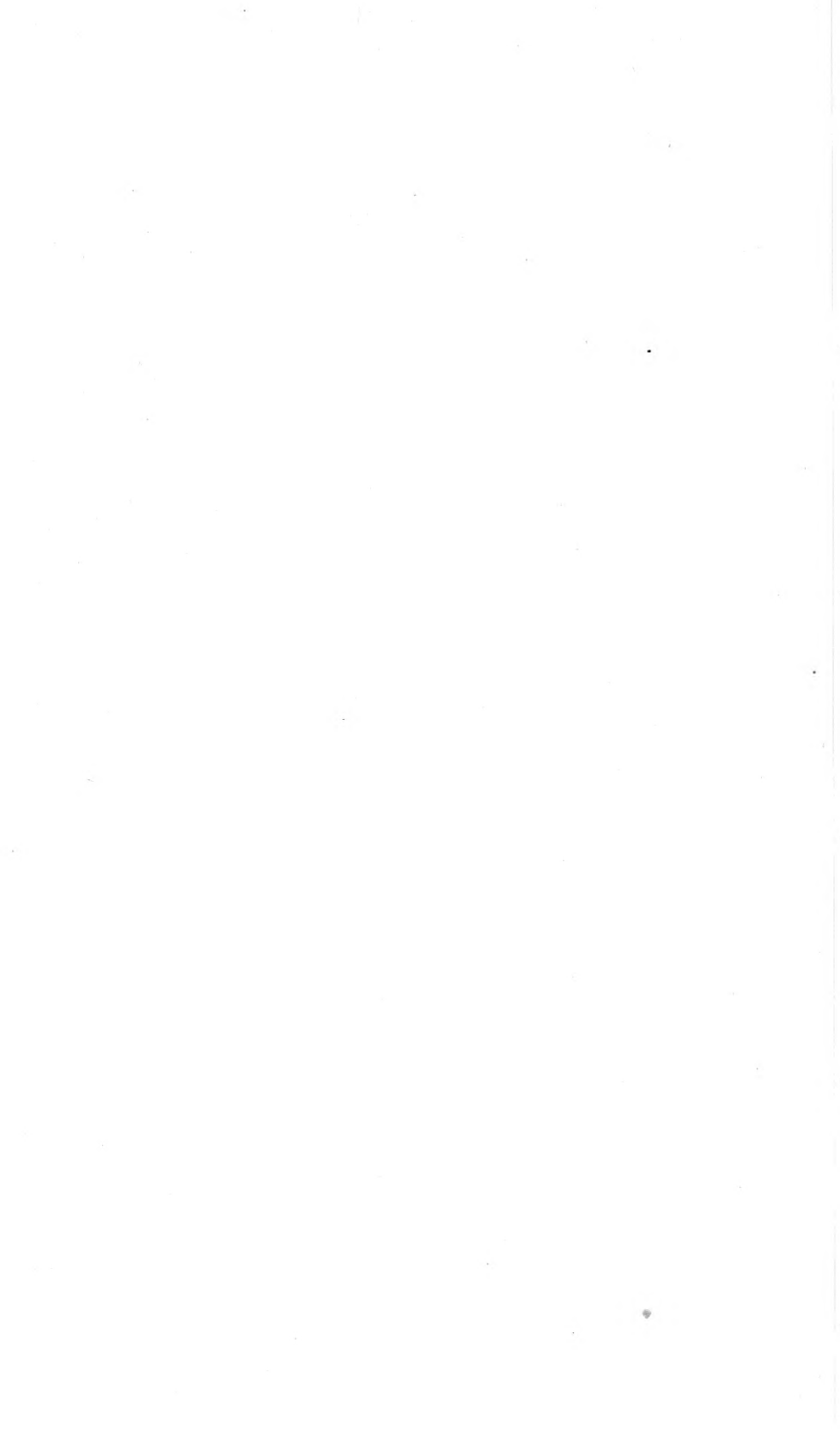

# Semiconductor Diode Gates

By LUTHER W. HUSSEY

(Manuscript received May 22, 1953)

*Diode gates, which are the body of modern pulse communication and computing devices, are discussed. Methods of analysis, by which practical first order design is possible, are given with experimental verification. The general properties of the gates, both virtues and defects, are noted and methods shown for minimizing the defects.*

## INTRODUCTION

Semiconductor diodes are old from the viewpoint of communication engineering. The crystal detector was a fundamental part of the early radio receiver. It was also a troublesome part. The crystals were highly variable and unreliable and there was little theoretical understanding of their physics which could be used as a basis for successfully exploring and controlling their characteristics. While the semiconductor continued to be useful in the field of power rectifiers and the copper oxide modulator later found extensive use in carrier telephone systems, the development of the vacuum tube into a relatively reliable device, with controlled characteristics, tended to eliminate the semiconductor from most of the communication field.

The copper oxide modulator, in a carrier telephone system, is an early example of the type of application which could bring the semiconductor back into competition with the tube rectifier. In a radio receiver, the difference in unit cost, power consumption, space requirements, and maintenance expense, between a tube detector and a crystal, may be small compared with the engineering advantages; but in a telephone plant, with its multiplicity of units, each of these small increments of cost may be integrated up to a major item, and may determine the economic feasibility of the whole system.

The need for better semiconductors than copper-oxide, when carrier frequencies moved up into the megacycle range, was a major stimulus to continue research in the semiconductor field. Within the last few years, physicists, using their recently acquired understanding of the structure

and mechanisms involved, have returned to other semiconductors — particularly to silicon and germanium to obtain great improvements.

The interest in diodes was undoubtedly a factor in the chain of investigations which culminated in the invention of the transistor and the development of the transistor has in turn accelerated the improvement of the diode. The development of the transistor also has greatly increased the demand for diodes. Replacing vacuum tubes by transistors, in modern pulse communication and computer system design can expand the potentialities of such systems since such systems, even more than the telephone carrier, use large numbers of elements and the increments of cost (initial unit cost, power consumption, space requirements, maintenance) all become vital. In a typical system there may be a dozen diodes to every transistor or vacuum tube. In a vacuum tube system the use of tube diodes is generally undesirable. In a transistor system is is absurd.

#### FIELD OF APPLICATION

These two new and rapidly expanding applications of diodes (pulse communication and computing) are amazingly simple in their basic ideas and circuit building blocks. Practically all they do is:

1. Generate pulses or accept them from another source and regenerate them.
2. Store pulses.
3. Route pulses to a desired output.

The complexity of the modern computer with its thousands of tubes or transistors and diodes lies in the number of operations, not in the individual operation itself. The modern computer is capable of solving complex mathematical problems involving any of the normal mathematical operations and may do it primarily with diode networks — aided by amplifiers to compensate for losses, and delay networks, or timing devices, to insure that processes take place in the proper sequence<sup>1</sup>. The diode networks, which are the body of a modern computer or pulse communication system, are “gates” and routing circuits which, by controlling and guiding the passage of pulses, are capable of performing all the logical processes required.

#### TYPES OF DIODE GATES

A “gate”, for our purposes, is an electrical device with an input, an output, and one or more control inputs. The control inputs and the other

<sup>1</sup> Felker, Regenerative Amplifier for Digital Computer Applications, Proc. I.R.E., 40, Nov., 1952. Chen, Diode Coincidence and Mixing circuits, Proc., 38, May, 1950.



input may be indistinguishable. When a certain combination of potentials is impressed on the controls an output appears at the output terminals. In the case of a "linear" gate the input signal has simply passed from input to output, so the output signal is approximately a replica of the input signal. In the case of a "switching" gate the output is a pulse which may have no resemblance, except in duration, to the pulses and potentials which are impressed on the controls.

There is essentially only one kind of linear gate. When a signal appears at its input, the potentials then present on the controls determine whether it shall pass to the output or be blocked. Switching gates, in spite of their apparent complexity in some particular applications, are constructed of two basic types — OR circuits and AND gates. A typical OR circuit is shown in Fig. 1. When a positive pulse is impressed on either of the input terminals (terminal 1 in the illustration) it drives the corresponding diode conducting and the pulse appears at the output (3).

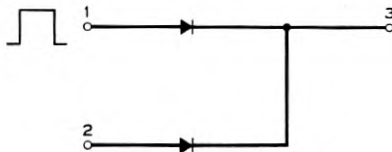

Fig. 1 — Diode or circuit.

The signal pulse drives the other diode non-conducting, blocking that path.

An AND gate is shown in Fig. 2. The biases are so adjusted that, in the rest condition, the output voltage is zero, the diodes are conducting and the bias current from the bias current source (B) flows through the diodes and the control terminal resistors. In this case, when a positive pulse is impressed at one of the control inputs the corresponding diode is cut off and bias current ceases to flow in it. However, there is very little resulting change at the output because the bias can still flow in the second, low impedance control diode and resistance. If a second pulse is simultaneously impressed on the second control input, the second diode is also cut off and the bias current is forced to flow in the load, producing an output pulse of magnitude determined by the magnitude of the bias current and the magnitude of the load resistance.

There is a third fundamental gating concept which must also be introduced. That is the INHIBITING control. Its purpose is to prohibit an output, whatever may be done to the other controls. It is illustrated in Fig. 3. As far as control 1 is concerned, this is like the AND gate. The output, in the rest condition, is zero and the diode is conducting. There

might, in fact be two or more such controls, forming a standard AND gate. The second control shown is the INHIBIT control. It is so biased that the diode is in the high impedance, cut off condition. If let alone, it has negligible influence on the behavior of the remainder of the system. If a large negative pulse is impressed on it, overcoming the bias ( $C_2$ ) the diode becomes conducting and the load remains shunted by the low control circuit impedance. Whatever the condition of the other control (or controls) very little current can get to the load and an output is inhibited.

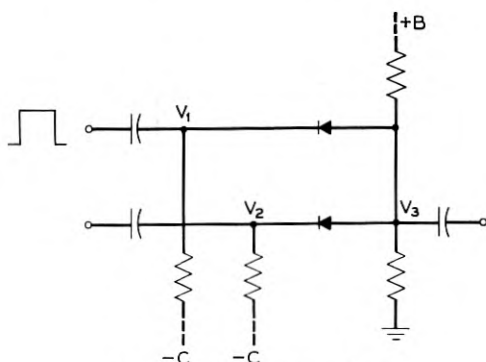

Fig. 2 — Diode AND gate.

There are several possible demands that might be put on a two control gate which can be shown in the following tabulation. In this tabulation a (1) means the presence of a pulse; a (0) means no pulse.

<i>Control 1</i>	<i>Control 2</i>	<i>Output*</i>
0	0	0
0	1	0
0	1	1
1	1	1
1	1	0

These, and the corresponding relations when the two controls are interchanged, are all the available combinations of input and output. The first two are trivial — satisfied by a lack of any connection between input and output. The third demands an OR circuit. The fourth demands an AND gate. The final case requires a new configuration but can be satisfied by a combination of gates by adding the inhibiting controls. Fig. 4 shows such a gate. The boxes show gates of the type of Fig. 3, with the functional symbolism which is commonly used. A line with an

arrow aimed at the box represents a control; an arrow on a line, aimed away, represents an output connection; a control input with a small semi-circle represents an inhibiting control. This combination satisfies what is called the AND NOT requirements. A pulse appearing at input (1) will pass gate (1) if there is no pulse simultaneously on gate (2). Similarly, a pulse on input (2) will pass gate (2). If pulses appear simultaneously on both inputs, each will inhibit the passage of the other and there will be no output.

In practice there are many complications encountered in using these

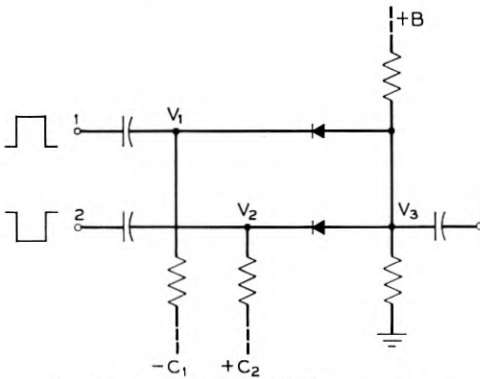

Fig. 3 — Gate with inhibiting control.

gates. In particular, networks using the INHIBITING control can, in the simple form show, get into difficulty due to the fact that pulses may not be exactly simultaneous. These difficulties are overcome in practical circuits by making part of the control voltages essentially dc potentials which set up the control conditions so that a final control pulse may produce an output, or be blocked, as the case requires. In a great many systems, this final pulse is an additional "clock pulse" from a master control or clock which synchronizes the sequence of operations of the entire computer. The details of how this is done and how the three types of gate may be combined is outside the scope of this paper. During the last few years there has been an extensive literature build up in the technical journals and a few books<sup>2</sup> published in this field.

#### TRANSMISSION GATE

Rather than analyze in detail the many forms a gate may take, only two forms will be discussed here. The methods (and in many cases the

<sup>2</sup> Keister, Ritchie and Washburn, *The Design of Switching Circuits*, Van Nostrand. Hartrie, *Calculating Instruments and Machines*, Univ. of Illinois Press.

results) can readily be applied to the numerous variants which may be encountered. The first is a form of "linear" or "transmission" gate. As previously stated, this gate has one or more control inputs, a signal input, and an output. When the control input enables the gate, a reasonably accurate replica of input signal should appear at the output. When the control input disables the gate, transmission of a signal should be effectively suppressed. Fig. 5 shows a form of this gate with a single control. This differs from the gates previously shown in that there is a diode in series with the output. Since this gate has superior discrimination and impedance characteristics, compared with the simpler forms it seemed desirable to analyze it as the typical transmission gate.

In this circuit,  $I_o$ ,  $G_o$  represent the signal generator as a current generator with internal conductance  $G_o$ . Since the transmission proper-

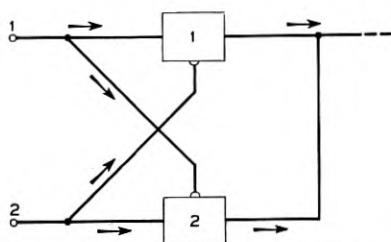

Fig. 4 — Combination of inhibited gates into AND NOT gate.

ties are of major interest, the load has been assumed to have the same conductance as the signal generator. A constant current bias  $I_b$  is impressed<sup>3</sup> at the midpoint of the gate. The control input voltage is represented by  $E_b$ . The internal control generator conductance, which should be large, is assumed to be included in the corresponding diode conductance, for computing purposes. The diodes are assumed to have a large conductance  $G$ , or a small conductance  $g$  depending on whether they are forward biased or reverse biased. Fig. 5 shows the gate enabled, with the series diodes in the conducting state and the control diode in the reverse bias, or non-conducting condition. If the  $G$  and  $g$  are interchanged the gate is in the disabled condition.

The relative magnitudes of  $V_o$ ,  $V_1$ ,  $V_2$  evidently determine whether the diodes are biased forward or backward. Their magnitudes are immediately obtainable. The equations for the case shown in Fig. 5 are:

<sup>3</sup> In case the internal conductance of an actual bias source is not sufficiently small to be neglected, its main effect will be on transmission loss. In computing the loss, the bias conductance may be added to the conductance of the control connection.

$$(G_0 + G)V - GV_1 = I_0 \quad (1)$$

$$-GV_0 + (g + 2G)V_1 - GV_2 = I_b + gE_b \quad (2)$$

$$-GV_1 + (G_0 + G)V_2 = 0 \quad (3)$$

Their solutions are:

$$V_0 = \frac{I_0 \left( g + G + \frac{G_0 G}{G_0 + G} \right) + (I_b + gE_b)G}{gG_0 + gG + 2G_0 G} \quad (4)$$

$$V_1 = \frac{I_0 G + (I_b + gE_b)(G_0 + G)}{gG_0 + gG + 2G_0 G} \quad (5)$$

$$V_2 = \frac{G}{G_0 + G} V_1 \quad (6)$$

The corresponding equations for the disabled gate are obtained by interchanging  $g$  and  $G$  in the above.

#### ENABLED GATE

Considering the enabled gate first, it should be evident from the figure that there are four requirements if the gate is to be properly enabled:

$$V_1 > V_0 \quad (7)$$

$$V_1 > V_2 \quad (8)$$

$$V_1 < E_b \quad (9)$$

$$V_1 > 0 \quad (10)$$

$V_1$  is a positive voltage, so equation (6) insures that (8) will always be satisfied.

Putting the values of  $V_1$  and  $V_0$  in (7) gives

$$(I_b + gE_b) > \left( \frac{g}{G_0} + \frac{G}{G + G_0} \right) I_0 \quad (11)$$

In the case that  $g$  is much smaller than  $G_0$  (which is normally true)  $gE_b$  is effectively the current from a constant current control generator and the above inequality has a simple interpretation:

In determining whether (7) is satisfied, and the input diode held conducting, the above inequality compares the total current which the bias and control generators put into midpoint ( $V_1$ ) of the gate with the

maximum current which the signal generator could put into the same point when that point is grounded. If the control and bias current sum is larger, the current in the input diode cannot reverse.

The inequality (10) is to insure that the output diode remains conducting. Substituting the value of  $V_1$  in it gives:

$$I_b + GE_b > \frac{-G}{G_0 + G} I_0 \quad (12)$$

The only way that the output diode could be cut off (with positive bias and control) is by a large negative signal current. The above inequality requires:

To hold the output diode conducting, the sum of bias and control generator currents must be greater in magnitude than the maximum negative signal current that the signal generator could put into the midpoint when the midpoint is grounded.

A zero potential on the midpoint is the boundary condition between the diodes being conducting or non-conducting. The two inequalities together compare the currents that the generators can put into the grounded midpoint. They require: The sum of bias and control generator currents should exceed in magnitude the maximum current of either polarity, that the signal generator can put into the grounded midpoint.

There remains the inequality (9) which is necessary if the control diode is to remain non-conducting. This gives:

$$\frac{GI_0}{G_0 + G} + I_b < 2 \frac{G_0G}{G_0 + G} E_b \quad (13)$$

This compares the same bias and signal generator currents with the current which would flow in the input and the output circuit if  $V_1$  were replaced by  $E_b$ . If the inequality is satisfied  $V_1$  can never get as large as  $E_b$  and the control input diode remains cut off.

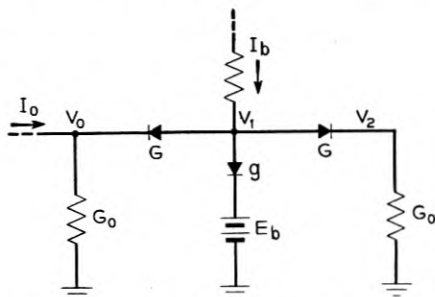

Fig. 5 — Transmission type diode gate.

## DISABLED GATE

The condition under which the gate is held disabled is much simpler than the enabling conditions. All that is necessary is that  $V_1$  be held more negative than the most negative signal generator voltage:

$$V_1 < V_0 < 0 \quad (14)$$

If equations (4), (5), and (6) are used in the disabled case (i.e., with the  $g$ 's and  $G$ 's interchanged), the condition can be obtained:

$$\frac{1}{G} I_b + E_b < \frac{1}{G_0} I_0 \left( 1 + \frac{gG_0}{(G_0 + g)G} \right) \quad (15)$$

When  $g$  is much smaller than  $G_0$ , so that the signal generator is effectively open circuited, this is a direct comparison of voltage components on the two sides of the input diode. The first term on the left, is the positive voltage at the midpoint ( $V_1$ ) due to the bias current  $I_b$ . The term on the right of the inequality is approximately the open circuit signal generator voltage. The inequality says that  $E_b$  must be sufficiently negative to overcome the positive bias and hold the midpoint more negative than the most negative signal voltage.

## OPTIMUM CONDITIONS

What constitutes optimum conditions depends on the particular requirements of the associated circuit. It is, however, always true that the diode conductance ratio should be as large as possible:

$$G/g \text{ as large as possible.}$$

For *minimum power loss* the gate, which is a resistive T network, to the approximation considered here, should be terminated in its characteristic conductance:

$$G_0 = \sqrt{\frac{gG}{2 + g/G}} \quad (16)$$

For *small voltage loss* the terminating conductance should be small:

$$G_0 \ll G$$

For good discrimination (large loss in the disabled state) the terminating conductance should be large:

$$G_0 \gg g$$

These all add up to the general requirement:

$$g \ll G_0 \ll G \quad (17)$$

and the particular choice of  $G_0$  is generally a compromise between good discrimination and low transmission loss.

#### PEDESTAL

A major defect of diode gates is an output voltage variation produced by control voltage changes. The output voltage is very small and negative when the gate is disabled, but when the control voltage switches the gate to the enabled condition a positive voltage, called the pedestal, appears at the output. From (5) and (6), with  $I_0 = 0$ , it is

$$V_2 = \frac{1}{G_0} \frac{I_b + gE_b}{2 + \frac{g}{G_0} + \frac{g}{G}} \quad (18)$$

Since  $g$  is small, this approximates the voltage due to half the bias and control currents flowing in the output. The signal output is superposed on this pedestal and may swing from zero to twice  $V_2$ . If the frequencies involved in the signal and the control voltages are widely different, this pedestal is not important since it can be filtered out from the transmitted signal but it is a serious output distortion in other cases where signal frequency components from the control pulse may be transmitted as a spurious signal.

#### EXPERIMENTAL CHECK

In the preceding discussion it was tacitly assumed that a diode switches between two constant conductance values. On a dc basis, the equations are still valid with a variable conductance, except for the signal loss relations. In computing the small signal loss, the conductances chosen should be the dynamic or differential conductances at the particular bias currents chosen.

The following is an example of the kind of experimental checks obtained in which, using 400B diodes, the actual behavior of a gate was tested on a dc basis. The particular units had approximately an impedance ratio (at about 5 volts) of 20,000/200. The load conductance was chosen (somewhat arbitrarily) as the geometric mean of the diode conductances, giving:

$$\begin{aligned} G &= 5 \cdot 10^{-3} \\ g &= 5 \cdot 10^{-5} \\ G_0 &= 5 \cdot 10^{-4} \end{aligned}$$



If the maximum signal generator current is chosen as

$$I_0 = 5 \cdot 10^{-3}$$

inequalities (11) and (13) take the form:

$$\begin{aligned} I_b + 5 \cdot 10^{-5} E_b &> 5.05 \cdot 10^{-3} \\ -1.1 I_b + 10^{-3} E_b &> 5.0 \cdot 10^{-3} \end{aligned}$$

No negative signal voltages were used, so inequality (12) is not involved. The above inequalities limit  $I_b$  and  $E_b$  as shown in Fig. 6.  $I_b$  and  $E_b$  must be chosen from the shaded area. The values chosen were  $I_b = 5ma$  and  $E_b = 15$  volts.

Comparing experimental results with analytic, gives:

Voltage loss 1.0 db (computed 1.6 db)

Pedestal 5.05 volts (computed 5.45 volts)

Further experimental results, which are all in reasonable agreement with expectations are given on Figs. 7, 8 and 9. Fig. 7 shows how the pedestal voltage varies with gate voltage ( $E_b$ ). This is also a measure of the load capacity, since the signal output can swing from zero to twice the pedestal. The useful range is above the point where the pedestal ceases to increase with gate voltage. In this range the control diode is cut off. Figure 8 shows the pedestal against bias current  $I_b$ . The limiting is not as sharp here because the forward conductance of the input and output

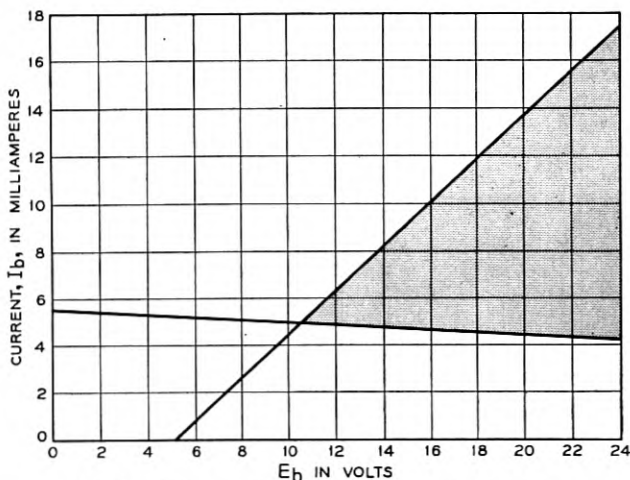

Fig. 6 — Bias restrictions on transmission gate.

diodes are involved and they do not change as rapidly with current in milliamperes as the reverse conductance does with volts. Fig. 9 shows the actual input output relation for the signal. It is linear over 80 to 90 per cent of the 5-volt range and then limits as expected.

The discrimination was not measured. It computes to better than 60-db voltage loss and discrimination of that order of magnitude has been measured in gates of this type.

#### SWITCHING GATE

A form of gate which is useful for pulse systems, since it lacks the pedestal, is shown on Fig. 10. This is, of course, basically the same configuration as that shown on Fig. 5, but it is operated quite differently, with pulses or dc potentials applied to the two control inputs and an output obtained by switching the bias current from flowing in a control path to flowing in the load. More specifically, if both  $E_1$  and  $E_2$  are sufficiently negative, diodes  $D_1$  and  $D_2$  are both conducting,  $V_b$  is negative, and  $D_3$  is non-conducting. Thus practically all the bias current  $I_b$  flows in  $D_1$  and  $D_2$ , and  $V_2$  is zero or slightly negative. If one of the control voltages is increased until its diode cuts off, the bias current can still flow in the other control path and the change in the output voltage is extremely small. If both the control voltages are increased until the two control diodes are cut off, then  $V_b$  becomes positive,  $D_3$  conducts and practically the entire bias current flows in the load, producing an output voltage

$$V_L = I_b R_L.$$

The above operation gives a two control AND gate with no pedestal

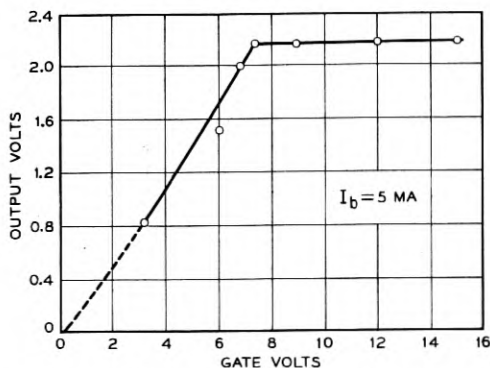

Fig. 7 — Transmission gate output (pedestal) potential versus gating control potential.

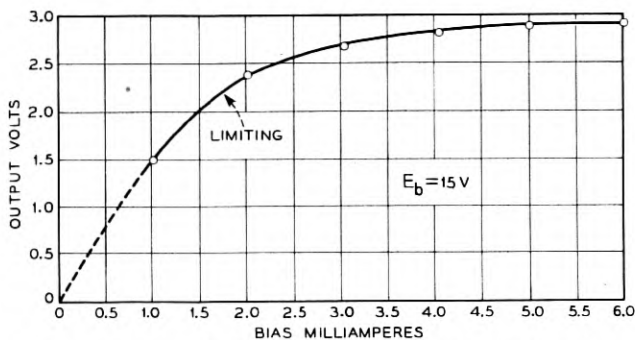

Fig. 8 — Transmission gate output (pedestal) potential versus bias current magnitude.

difficulty. One of the controls could instead be used as an inhibitor. For example, if  $E_2$  were normally biased sufficiently positive it would have no effect on the output, which would be controlled by  $E_1$  alone. However, a negative, or INHIBITING pulse, sufficient to make  $D_2$  conducting, would permit the bias current to flow in that path and prevent an output, whatever the state of  $D_1$ .

This circuit could be analyzed in exactly the same manner as was done with the transmission gate. However, after a value of  $R_L$  has been chosen, a simple first approximation to a design may be carried out by assuming that the diodes are ideal, switching between zero and infinite resistance. In choosing  $R_L$  there are three major considerations:

1.  $R_L$  must be small compared with the reverse resistance of the diode,  $D_3$ , or there may be an appreciable negative output when the gate is disabled.

2.  $R_L$  must be large compared with the forward resistance of  $D_3$  for efficient operation of the enabled gate,—preventing an appreciable voltage loss due to the voltage drop in  $D_3$ .

3. The peak amplitude of the output pulse is  $I_b R_L$ .

The value of  $R_L$ , which is chosen from the wide range of possibilities, is a matter of practical compromise, depending on the impedance levels in the system and the constant current generators which are available.

Having chosen  $R_L$  and  $I_b$  there remain only the control voltages,  $E_1$  and  $E_2$ . The voltages which are necessary to hold the gate enabled can be obtained by noting that (in the ideal diode case)

$$V_b = V_3 = R_L I_b \quad (19)$$

To hold the control diodes non-conducting the voltages  $E_1$  and  $E_2$  must be greater than  $V_b$ . This gives:

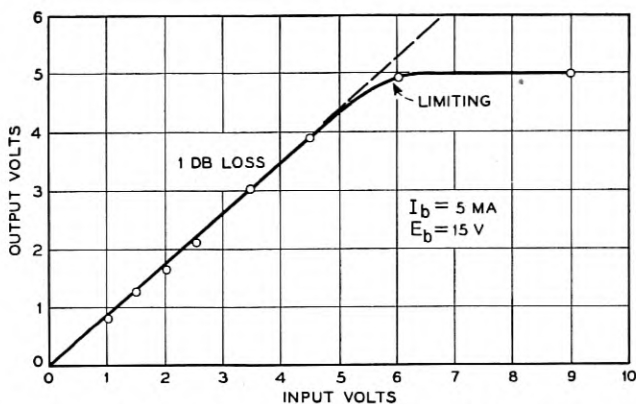

Fig. 9 — Transmission gate signal output potential versus input signal potential.

To *enable* the gate, voltages must be impressed such that

$$\begin{aligned} E_1 &> R_L I_b \\ E_2 &> R_L I_b \end{aligned} \quad (20)$$

In disabling the gate, either one of the control paths may have to carry the full bias current. If, for example, the bias current were flowing in  $D_2$  it would bias that control path positive by an amount  $R_2 I_b$ . To overcome this, and keep  $V_b$  negative, the requirement is:

To *disable* the gate, voltages must be impressed such that

$$\begin{aligned} E_1 &< -R_1 I_b \\ E_2 &< -R_2 I_b \end{aligned} \quad (21)$$

These sets of conditions give the magnitudes of the biases which are necessary to hold the gate either enabled or disabled, and the difference between them is the minimum magnitude of the necessary switching pulse.

#### EXPERIMENTAL GATE

An example may be given, using 400B diodes. The bias was chosen as 5 *ma* and the load resistance, 2,000 ohms. The control resistances were made small, as is desirable for reasons which will be discussed later. For this gate the output voltage is 10 volts. From (20) and (21) the gate could be enabled by 10 volt positive control pulses and disabled by very small negative control values. A larger than necessary control voltage was put on control 2,

$$E_2 = 15 \text{ volts}$$

and the output measured as a function of  $E_1$ . The results are shown on Fig. 11. Since the diodes are not ideal, there is a transition region, but, as predicted the output is very small at small negative control voltage and the output is the full 10 volts when  $E_1$  is 10 volts.

The curve also shows what happens if one of the enabling biases are too small. A case is shown in which  $E_2$  was only 5 volts. There is no significant difference until the output gets up to 5 volts. Above that voltage the diode,  $D_2$ , becomes conducting and the output is clamped at that voltage.

#### GATE CHARACTERISTICS

The main virtues of this type of gate is that there is no pedestal and a constant amplitude pulse is produced. It is also simple and has good discrimination. There are limitations:

1. Unless a very low control path resistance is used, there is a large loss — that is the output pulse is much smaller than the control pulse. For example, if the control resistance is equal to the output resistance there is a two to one loss.

2. A rather large load is put on the control generator, partly because it must produce the enabling voltage across a small resistance and also because, in some cases the total bias current flows in the control generator output.

3. A phenomenon called "hole storage", which is present to some extent in all semiconductor diodes can make trouble. When a diode has been resting in the conducting state with a current flowing in it and the voltage is reversed, the diode does not immediately change to high impedance. A reverse current flow for a short time — up to a few microseconds. This can result in very inconvenient, spurious, output pulses being produced by a gate which is supposed to be disabled.

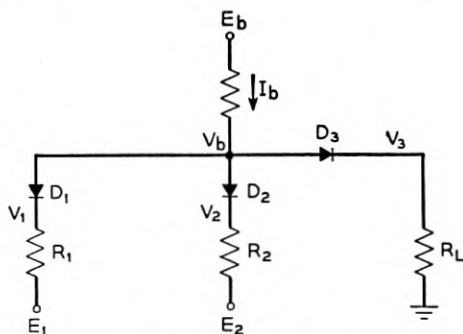

Fig. 10 — Switching type diode gate with two controls.

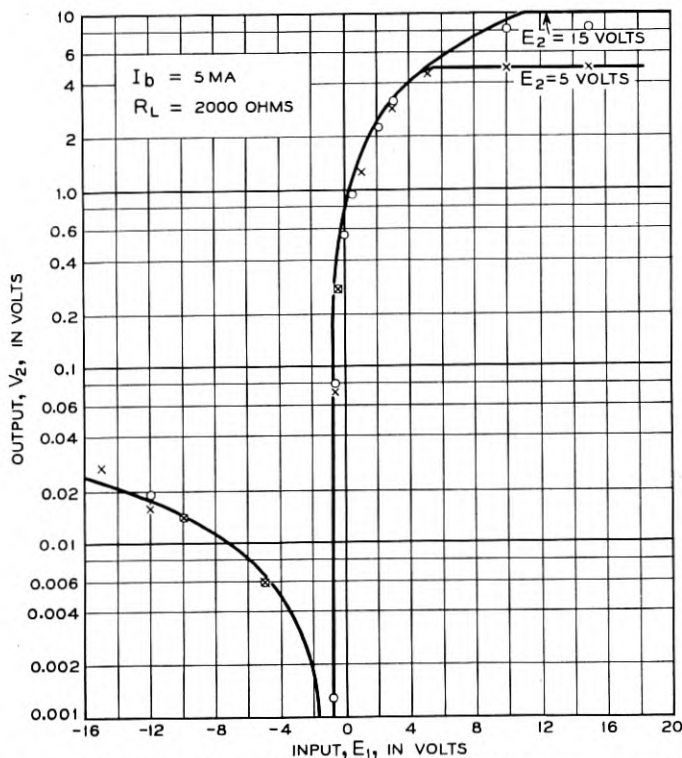

Fig. 11 — Switching type diode gate output potential versus control potential with a second control in the "enable" state.

#### SPECIAL CIRCUIT

It is not intended, in this paper, to attempt to list the numerous modifications which have been made of diode gates to overcome limitations and satisfy particular requirements, but it seems desirable to note an example of means to minimize the limitations.

One simple way of minimizing the difficulty, is to use point contact diodes in places where a spurious pulse could make trouble and use junction diodes elsewhere, since junction diodes have better impedance ratios but worse hole storage. For example, the output diodes in the switching gate could be a point contact unit, while the better discrimination of the junction unit made use of for control diodes.

A second means of avoiding hole storage effects is to avoid leaving diodes with large currents flowing in them, when they must be switched rapidly to the non-conducting state.

Fig. 12 illustrates both these design ideas. One of the control inputs has the control pulse impressed by means of a transformer and so has a very low dc impedance without making excessive demands on the control pulse generator. The biases are so adjusted that, in the disabled state, all the control diodes are just on the edge of conducting except the one in the transformer path. Because of the low DC impedance, practically all the bias current flows in this path. Thus there is no possibility of hole storage except in this one diode. If a positive control pulse is impressed while the potentials on the other controls are at their more negative value, the bias current just switches into those control paths; the output diode remains non-conducting and any spurious hole storage

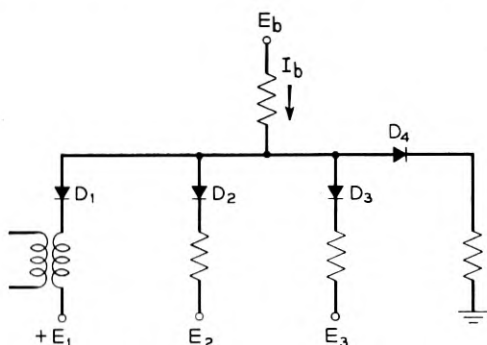

Fig. 12 — Switching type gate which minimizes "hole storage" effects.

current from the diode in the transformer control also goes into the other control paths. Since there is no storage in the other control paths, positive pulses may be simultaneously impressed on all the controls, the diodes in all but the transformer control path will immediately become high impedance and any hole storage current from the one diode will harmlessly add to the bias current flowing into the output.

Junction diodes are used in all the control inputs except the one with a transformer. A point contact unit is used here to minimize the hole storage. A point contact unit is also used in the output position. This is a critical location where good diode action is more important than a very high discrimination.

There is an additional advantage, in this configuration, that the relatively large bias current flows in the control generators only very briefly — while the disabled gate is being pulsed by the transformer control.

ACKNOWLEDGMENTS

It is impossible to give due credit to all the people who contributed to the development of the gates discussed here. Credit, however, should be given to W. D. Lewis, L. A. Meacham, and A. J. Rack who developed and explored the basic transmission gate analyzed here, and to J. R. Harris who made the modifications in the gate to avoid hole storage difficulties.

Acknowledgment is also due that part of the work reported on here was done in connection with a Joint Services contract.



# A Review of New Magnetic Phenomena

By R. E. ALLEY, Jr.

Manuscript received May 25, 1953

*As a result of new developments, the classical concepts of magnetic materials, characterized by hysteresis loss and eddy currents, are no longer adequate. Study of the ferrites has revealed new and important magnetic phenomena. These materials, because of their high resistivities and correspondingly low eddy currents, exhibit useful magnetic properties at frequencies well above those at which magnetic alloys are applicable. This paper reviews the new phenomena — domain wall motion and dimensional effects in the low megacycle region, and ferromagnetic resonance and the Faraday effect in the microwave region — and relates them to modern theory. Some possible microwave applications are discussed briefly.*

## I. INTRODUCTION

Up until a few years ago, the classical concept of magnetic materials, characterized by hysteresis and eddy current effects, was adequate for the communications engineer. Recent new and important developments, however, have made it necessary for him to have a broader knowledge of magnetic phenomena than is given by the old picture. Because of the low resistivities of existing magnetic materials, their properties at high frequencies have been dominated by eddy currents which in many cases have completely masked other magnetic effects. In contrast, the newly developed ferrites have resistivities from  $10^6$  to  $10^{12}$  times greater, and eddy currents are usually negligible. The ferrites are, therefore, useful at far higher frequencies than previously available materials. Furthermore they have revealed new and important magnetic phenomena.

It is the purpose of this paper to present the modern picture of magnetism from the standpoint of the engineer. It describes the new phenomena and relates the experimentally observed behavior of magnetic materials at high frequency to the present physical theory of magnetism. The new phenomena include dimensional and domain wall motion effects in the low megacycle region and ferromagnetic resonance and the recently observed Faraday effect in the microwave region.

Although we are concerned more with magnetic phenomena than with the properties of particular materials, we will relate our discussion to ferrites, since these are the materials in which high frequency phenomena have been explored. We begin, therefore, with a brief description of these materials.

## II. DESCRIPTION OF FERRITES

The term "ferrite" as used here refers to a class of ferromagnetic oxides that are structurally the same as magnetite (the naturally occurring magnetic mineral commonly known as lodestone) and as the mineral spinel from which the structure derives its name.<sup>1, 2, 3</sup> These compounds form extensive solid solutions of both the substitutional and the subtractional type. Nickel zinc and manganese zinc ferrites are important examples of the substitutional type. In these, the zinc and nickel or manganese are thought to be in solid solution in magnetite ( $\text{Fe}_3\text{O}_4$ ) where they have directly replaced equivalent amounts of iron in the lattice. An example of the subtractional type of solution is  $\gamma\text{-Fe}_2\text{O}_3$ . Here, oxygen is considered to be in solution in magnetite, not, however, having replaced iron, but having eliminated it, thus leaving vacant sites in the lattice. Magnetically, the ferrites are thought of as consisting of two interpenetrating lattices of metal ions whose magnetic moments point in opposite directions. Since, however, these moments are in general not equal, the material has a net magnetic moment.

Ferrites are manufactured by carefully mixing oxides of the constituent materials. The resulting powder is then pressed into desired shapes. These formed parts are fired at a temperature of  $1000^\circ\text{C}$  or more to produce the finished materials. The finished product is technically classed as a ceramic, and among its properties is extraordinarily high resistivity compared with magnetic alloys. Mechanically, ferrites have some of the characteristics of ceramics. They are extremely hard and brittle and cannot be machined by ordinary methods. They may be ground and lapped by use of abrasive cutting tools.

Experience has shown that the properties of the finished product depend upon composition (both what elements are present and in what proportions) and upon heat treating conditions (atmosphere, maximum firing temperature, and time of firing). It is apparent that, since there are so many possible variables in manufacturing procedure, one may expect a wide variety of electrical and magnetic characteristics.

Ferrites have been commercially available for several years. NiZn ferrite is being used extensively in deflection coils and flyback transformers in television sets. MnZn ferrite has found specialized but im-

portant use in inductors for networks and in transformers in telephone circuits. Magnetic recording tape makes use of  $\gamma\text{-Fe}_2\text{O}_3$ . An increasing amount of information of interest to the design engineer is becoming available in manufacturers' catalogs.

### III. DC CHARACTERISTICS

For convenience in the following discussion, the frequency range under consideration has been divided somewhat arbitrarily according to the magnetic phenomena which have been observed. We will begin by discussing dc behavior of magnetic materials.

As far dc magnetic properties are concerned, the modern picture is the same as the classical one. The study of ferrites has revealed no essentially new phenomena, at least so far.

Hysteresis loops for typical ferrites are shown in Fig. 1, together with loops for iron and for permalloy. It will be observed that some ferrites compare favorably with permalloy with regard to hysteresis loss (proportional to the area of the hysteresis loop). Their saturation flux density is considerably lower, the maximum so far obtained being between 4,000 and 5,000.

By applying pressure to a sample and thereby introducing strain, some investigators have found it possible to produce ferrite cores having practically rectangular hysteresis loops,<sup>4</sup> just as similar effects have previously been obtained with permalloy and other magnetic material.

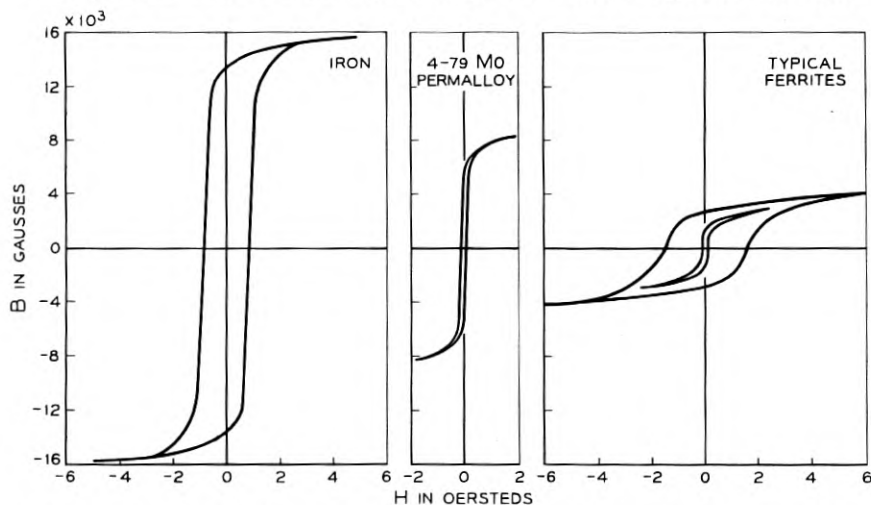

Fig. 1 — Hysteresis loops of iron, permalloy and typical ferrites. The thin ferrite loop is for a MnZn ferrite, while the larger loop represents a NiZn ferrite.

Such cores find an important application in memory circuits employed in connection with digital computers. Suitably cut ferrite single crystals also exhibit rectangular loops when properly annealed.<sup>5</sup>

Initial permeability of ferrites has a wide range of values depending upon the material under consideration. It may be as low as 4 for magnetite and as high as 3,000 for manganese-zinc ferrites. Curie temperature (the temperature above which the material no longer exhibits ferromagnetic properties) is around 80°C for the high permeability MnZn materials and is several hundred degrees C for the low permeability nickel ferrite. Resistivity also depends upon the composition of the material. Typical data gives values of 100 ohm-cm for a MnZn ferrite and 10<sup>6</sup> ohm-cm for a NiZn ferrite. The commonly used metallic magnetic materials have resistivities of the order of 10<sup>-5</sup> ohm-cm. As mentioned above, this much higher resistivity is the feature of ferrites which makes possible their application at frequencies where ordinary metallic materials are generally not usable. At dc the dielectric constant of ferrites is high. Determination of dielectric constant is rather difficult, but the best measurements to date indicate values of from 10 to 30.

#### IV. LOW FREQUENCY PHENOMENA (0 to 1 mc)

A convenient and commonly used method of determining low frequency characteristics of magnetic materials consists in making bridge measurements of inductance ( $L$ ) and effective series resistance ( $R$ ) of a uniform winding placed on a toroidal core of the material. Subtraction of the dc winding resistance gives a value of resistance ( $R_m$ ) which represents the core loss in the material. Permeability may be calculated from the inductance measurements. The method of analysis described by Legg<sup>6</sup> may be applied to powdered or laminated alloys. The method consists essentially in determining the coefficients in the equation

$$R_m = e\mu f^2 L + a\mu B_m f L + c\mu f L, \quad (1)$$

where  $B_m$  is maximum flux density,  $\mu$  is permeability,  $f$  is frequency, and  $e$ ,  $a$  and  $c$  are constants. For alloys in laminated or powder form these constants are associated respectively with eddy current, hysteresis, and residual losses. From measurements of  $L$  and  $R_m$  at two or more frequencies with a fixed flux density,  $B_m$ , and two or more values of flux density at a fixed frequency,  $f$ , the coefficients  $e$ ,  $a$  and  $c$  can be determined by solving the simultaneous equations obtained from equation (1).

Equation (1) is equally applicable to the ferrites at frequencies below that at which domain wall resonance and dimensional effects (discussed in Sections VI and VII) begin to appear. This frequency, which is some-

what below that indicated by  $f_1$  in Fig. 3, depends upon the particular ferrite. The range of applicability of equation (1), therefore, varies. Regardless of frequency, the eddy current and hysteresis terms in equation (1) are valid. However, additional terms are required to cover other losses which become quite high and in comparison with which the "residual" term in equation 1 may be negligible.

Frequently, the separation of losses indicated in equation (1) is not called for. The practice then is to lump all losses together and express them in terms of the material  $Q$ , which may be a function of frequency and flux density. Here  $Q$  is the ratio of the reactance of the winding on a toroidal ring to the core loss expressed as a series resistance,

$$Q = \frac{\omega L}{R_m}.$$

The product  $\mu Q$  is convenient in describing magnetic characteristics. Sometimes air gaps are introduced in ferrite magnetic cores in order to provide higher coil  $Q$ 's or greater stability of  $ac$  permeability with superposed  $dc$  magnetizing force. It can be shown that the product  $\mu Q$  remains constant even though the core is divided by one or more air gaps. Fig. 2 shows curves of  $\mu Q$  versus frequency for various ferrites and also for certain other materials. An extensive discussion of methods of measurement and of results of measurements at low frequencies is given in a recent paper by Owens.<sup>7</sup>

It should be pointed out that eddy currents in ferrites are so small that solid shapes are usually used whenever ferrites are applicable. This is a considerable advantage, eliminating the necessity for thin tapes or insulated fine particles which are required in many applications of metallic cores. However, so far, no ferrite has been developed which has permeability nearly as great as that of some of the permalloys.

## V. CHARACTERISTICS ABOVE 1 MC

So far, our discussion has covered the frequency range in which magnetic materials have traditionally found many important uses and in which the ferrites have properties generally like other magnetic materials, differing from them only in degree. We now come to the frequency range in which new magnetic phenomena have recently been observed — a range above that in which magnetic materials have heretofore been generally applicable.

In discussing the higher frequency characteristics, it is desirable to introduce a somewhat different set of parameters by which the properties

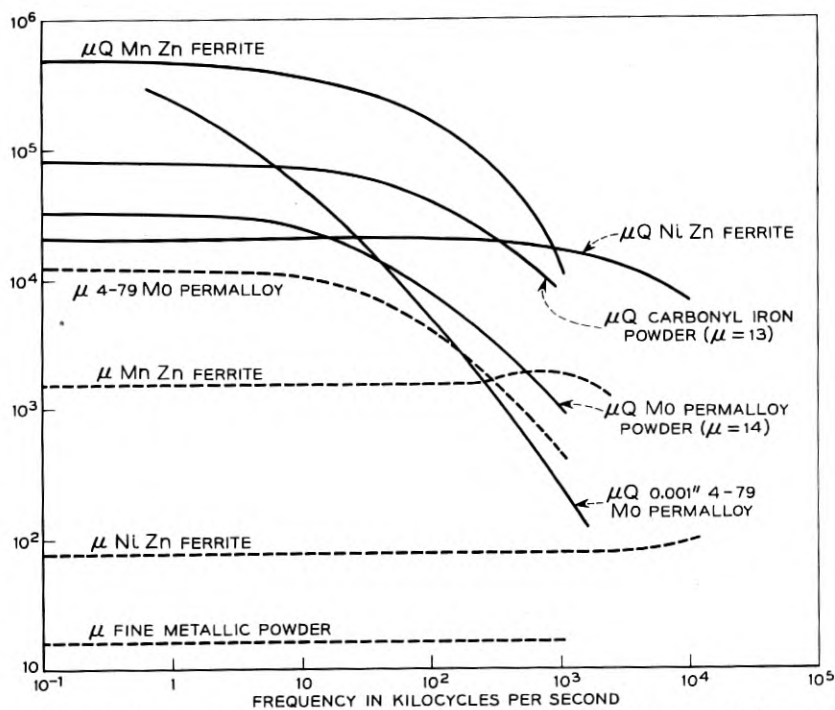

Fig. 2 — Comparison of the frequency variation of  $\mu$  and  $\mu Q$  for ferrites and other magnetic materials.

may be described. This comes about because the ferrites, in which the new effects are observed, have both dielectric and magnetic properties. The material is most conveniently described in terms of two complex quantities: the permeability,  $\mu = \mu' - j\mu''$ , and the dielectric constant,  $\epsilon = \epsilon' - j\epsilon''$ .  $\mu'$  corresponds to the usual low frequency permeability and  $Q = \mu'/\mu''$ . Similarly  $\epsilon'$  corresponds to the usual low frequency dielectric constant, while  $\epsilon''/\epsilon' = \tan \delta$ , the loss tangent of the material. Thus the quantities  $\mu''$  and  $\epsilon''$  are measures of the magnetic and dielectric losses per cycle respectively, in the material.<sup>8</sup> The fact that  $\mu''$  and  $\epsilon''$  represent loss *per cycle* means that much higher values of these quantities can be tolerated at low frequency than at microwave frequencies.

At frequencies above a few megacycles, it becomes very difficult to make meaningful observations on wound toroidal cores. Such difficulty may be overcome by making measurements on a toroidal sample placed in a coaxial line. Details of the experimental procedure may be found in references 9 through 12. The same procedure may be applied at microwave frequencies with waveguide used instead of coaxial line. In this case,

the sample is in the form of a slab, cut to fit snugly against the walls of the waveguide.

Fig. 3 shows in a qualitative way the behavior of a typical ferrite. In this figure we have plotted the real and imaginary parts of permeability as functions of frequency. Examination of the results obtained by various investigators for a number of different ferrites leads to the conclusion that they all behave in a fashion similar to that shown in Fig. 3. Frequency  $f_1$  usually lies in the region between 1 and 100 mc and  $f_2$  frequently lies in the neighborhood of 3000–4000 mc. Available data are not sufficient to provide similar curves for dielectric constant, but what there are indicate a decrease from the very high apparent value at low frequencies to a constant value of the order of 10. This decrease generally occurs somewhere around 10 mc, although it depends upon the material and also probably upon sample dimensions as will be discussed below.

The consensus is that the high experimental values of dielectric constant observed at low frequencies result from the peculiar structure of ferrites. They are considered to consist of grains of conduction material (of moderately high conductivity) separated by thin layers of dielectric material having a dielectric constant of the order of 20. Measurements on such a structure would give very high apparent dielectric constant and low  $Q$ . Such behavior was observed several years ago in samples of powdered permalloy, and has also been found in samples of plastic in which finely divided particles of copper have been dispersed.

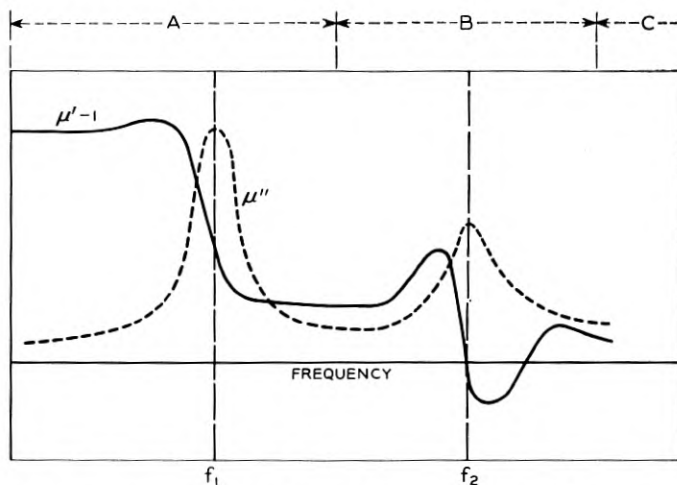

Fig. 3 — Frequency characteristics of a typical ferrite. The components of complex permeability ( $\mu = \mu' - j\mu''$ ) as functions of frequency. The behavior in the neighborhood of  $f_1$  is attributed to domain wall motion or to dimensional effects.  $f_2$  represents the frequency at which ferromagnetic resonance occurs.

For convenience in the following discussion, Fig. 3 has been divided into three regions as indicated. It will be observed that there are two peaks in the curve of  $\mu''$  versus frequency, one in Region A and the other in Region B. The frequencies at which these occur are those at which relatively large amounts of energy are absorbed by the material. These two absorption peaks are due to entirely different mechanisms within the ferrite and it is, therefore, of interest to consider them separately. We begin with Region A.

The behavior indicated in Region A is typical of polycrystalline samples of ferrite (as distinguished from single crystals which will not be considered here).  $\mu'$  rises somewhat above its constant low frequency value and then decreases rather suddenly. If  $f_1$  denotes the frequency at which the peak in  $\mu''$  occurs, we find that in general a high value of  $\mu'$  at low frequency is associated with a low value of  $f_1$ , and vice versa.

At the present time, we are not sure which of two experimentally observed effects in the ferrite is responsible for the behavior shown in Region A. It is quite likely that what one observes in a given sample is actually a combination of the two effects, domain wall motion and dimensional resonance, each of which will now be described.

## VI. DOMAIN WALL MOTION

The basic unit of magnetism is the spinning electron. In an atom of ferromagnetic material, there is an excess of electrons with spins in one particular direction. As a result, the atom has a net magnetic moment. Any ordinary sample of ferromagnetic material consists of many small, irregular volumes called domains, each of which may contain many atoms. Each domain is completely magnetized along some direction. Both the size of the domains and the directions of their magnetizations vary from point to point throughout a sample. In an unmagnetized material, the random orientation of individual domain magnetizations results in a mutual cancellation of their effects. However, if a magnetic field is applied, certain domains will be in a preferred orientation, having their magnetic moments more nearly in the direction of the applied field than others. These will grow at the expense of less favorably oriented domains by a process of motion of the walls separating adjacent domains. When an alternating field is applied, the walls will be subject to an alternating force which will tend to move them first in one direction and then in the opposite direction. Now it has been shown<sup>13</sup> that, under these conditions, the permeability of the material is proportional to the ease of displacement of the domain walls. Therefore, if we can predict how a wall will move as the frequency of the applied field changes, we can predict how the permeability will change with frequency.



The walls have been found to exhibit properties of mass and stiffness and to be subject to damping. Thus it is possible to write an equation which describes the motion of a wall under the influence of an alternating field.<sup>13, 14</sup> If  $x$  is the displacement of the wall from its equilibrium position, then

$$m \frac{d^2x}{dt^2} + \beta \frac{dx}{dt} + \alpha x = M_s H e^{j\omega t}, \quad (2)$$

where

$m$  = mass/unit length of wall,

$\beta$  = damping coefficient,

$\alpha$  = stiffness parameter,

$M_s$  = saturation moment of sample,

$H e^{j\omega t}$  = applied field,

This equation should look familiar to electrical engineers. It has the same form as that for an  $RLC$  circuit subject to a sinusoidal applied voltage.<sup>15</sup> If the damping constant is not too great, we would expect the wall motion to have a resonance at a frequency,  $f_0$ , for which

$$\omega = \sqrt{\alpha/m}.$$

Fig. 4 shows the expected variations of  $\mu'$  and  $\mu''$  in the vicinity of resonance under these conditions.

If, however, the mass of the wall is negligible, the situation is somewhat different. In this case,  $\mu''$  has a maximum at a frequency for which  $\omega = \alpha/\beta$ , while  $\mu'$  decreased monotonically from its low frequency value, reaching  $1/2$  this value at  $\omega = \alpha/\beta$ . It is apparent that this behavior is analogous to that of an  $RC$  circuit. It is commonly known by the term "relaxation". We see, therefore, that, depending upon wall mass, there are two possible ways in which wall motion may contribute to the behavior shown in Region A of Figure 3, namely, through domain wall resonance and through domain wall relaxation.

## VII. DIMENSIONAL RESONANCE

The second phenomenon which may aid in accounting for the behavior indicated in Region A is dimensional resonance. In 1950, Brockman, Dowling, and Steneck<sup>16</sup> reported the results of some experiments on a manganese-zinc ferrite known commercially as Ferroxcube III. Using blocks of this material, they built a closed rectangular core. Measurements on a winding placed on this core showed behavior like that of region A with  $f_1$  lying between 1 and 2 mc. When they decreased the

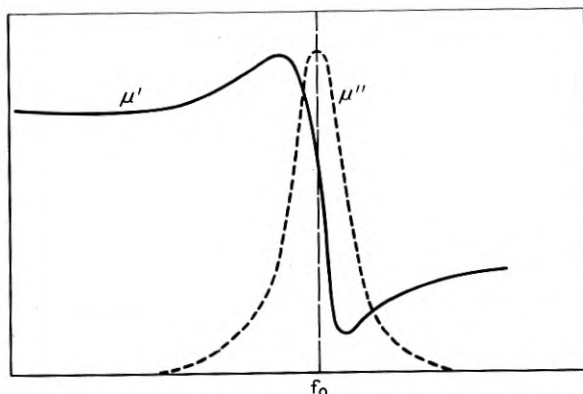

Fig. 4—Typical behavior of the components of complex permeability ( $\mu = \mu' - j\mu''$ ) in a ferrite in the neighborhood of domain wall resonance.

cross section area,  $f_1$  moved to a higher value. Brockman, Dowling and Steneck attributed this to a cavity type resonance effect resulting from a high dielectric constant which gave wavelengths in the material of the same order of magnitude as the dimensions of the sample under test. Another way<sup>17</sup> of looking at the phenomenon is to recognize that in the ferrites there are displacement eddy currents which correspond to the conduction eddy currents in magnetic alloys. Analysis based on this approach gives resonance frequencies which are the same as those calculated by Brockman, Dowling and Steneck.

In any sample it is possible that both mechanisms — domain wall motion and dimensional resonance — contribute to the behavior of the material in Region A. Furthermore, it is evident that considerable caution is required in interpreting results of experiments designed to measure  $\mu$  and  $\epsilon$  as functions of frequency. One must always bear in mind that what one obtains is the *effective*  $\mu$  and  $\epsilon$  of the sample under test, and the actual  $\mu$  and  $\epsilon$  for the material may be different from the observed values, depending upon the effect of sample dimensions.

It is clear that in a design problem the communications engineer must take into account the dimensions of the ferrite part as related to the permeability and dielectric constant of the material and to the frequency at which it is being used. This may impose a practical limitation on the size of a part for a particular application.

#### VIII. FERROMAGNETIC RESONANCE

The behavior indicated in Region B of Fig. 3 is attributed to ferromagnetic resonance. This phenomenon was first observed in magnetic metals by Griffiths<sup>18</sup> and has been studied intensively in ferrites.<sup>21</sup>

Consider a single electron. Because it is a spinning charge, it has a magnetic moment which lies along its axis of spin. Because it has mass, it has mechanical angular momentum. The ratio of these two quantities is the magnetomechanical ratio,  $\gamma$ . If a steady magnetic field,  $H_0$ , is applied, there will be a torque on the electron as a result of the interaction between  $H_0$  and the magnetic moment of the electron. The electron will, therefore, precess about the direction of  $H_0$  with a frequency which has been shown to be given by  $\omega_0 = \gamma H_0$ . This phenomenon is the well-known Larmor precession.<sup>19</sup> We may say then, that the electron has a resonance frequency  $\omega_0$ .

Now suppose a sample of ferrite to be placed in a magnetic field  $H_0$ . By virtue of the contributions of its many spinning electrons, the sample has a magnetic moment,  $M$ . If  $H_0$  is a strong field,  $M$  will be parallel to  $H_0$ . However, there will be, as in the case of the single electron, a frequency at which  $M$  will precess about the direction of  $H_0$ . This precession frequency is proportional to an effective field,  $H_e$ , and to  $M/J$ , where  $J$  is the vector sum of the individual angular momenta of the electrons.  $H_e$  is a function of  $H_0$  and also of the demagnetizing fields within the ferrite. If an alternating field of this frequency is supplied perpendicular to  $H_0$ , then absorption will occur. The amplitude of the precessional motion will become such that the energy supplied by the alternating field is equal to the energy transformed into heat in the sample. At the resonant frequency,  $\mu'$  is equal to 1 and  $\mu''$  reaches a maximum.

Although the above discussion postulates a strong external field, a more detailed analysis leads to the conclusion that resonance may be expected even with zero external field. This is attributed to the presence of internal fields which result from such things as crystal anisotropy, magnetostrictive strain, and internal demagnetizing fields in the material. These demagnetizing fields are generally the most important factor in determining the resonant frequency of a demagnetized ferrite.

A number of investigators have studied ferromagnetic resonance in ferrites. Some experimental methods and results are described in References 19 through 23. Much of the investigation has been carried out on single crystals of ferrite. In these cases, the experimental results depend upon the orientation of the crystal axis with respect to the external field. In the case of polycrystalline samples, the resonance is still present, but the resonance is not as sharp.

Most of the experiments in which ferromagnetic resonance has been studied have been with fixed frequency and varying magnetic field. Fig. 5 shows some typical results of such an experiment. From a practical experimental standpoint, this is preferable to varying frequency with a fixed magnetic field. However, it is apparent that if one holds the magnetic

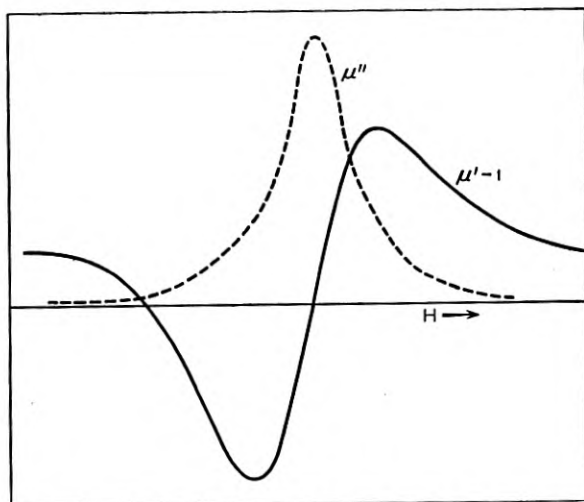

Fig. 5 — Behavior of a magnetic material in the neighborhood of ferromagnetic resonance. This represents the usual experimental situation, where frequency is kept constant and the external magnetic field is variable.

field constant at some value  $H_0$  and varies the frequency, one will obtain curves similar to those of Fig. 5. This is indicated in Region B of Fig. 3. Furthermore, for a given sample, as  $H_0$  increases, the frequency at which resonance occurs increases.

#### IX. MICROWAVE FARADAY EFFECT

If a linearly polarized wave of microwave frequency travels through a ferrite which is magnetized in the direction of propagation of the wave, the plane of polarization will be rotated. The sense of the rotation depends only upon the direction of magnetization of the ferrite and is independent of the direction of propagation of the wave. Thus the effect is anti-reciprocal.

This phenomenon, which derives its name from the analogous optical effect was demonstrated experimentally by Roberts<sup>24</sup> and has been extensively investigated by Hogan.<sup>25</sup> It occurs at frequencies above the ferromagnetic resonance frequency, that is, in Region C of Fig. 3. In principle, the effect might be expected in any ferromagnetic material but, so far, only the ferrites are sufficiently transparent to microwaves to allow the effect to be detected. The effect is illustrated in Fig. 6. The linearly polarized microwave in waveguide A passes through a transition section into the circular guide B. A tapered cylinder of ferrite is inserted in B. A solenoid, external to B, supplies a steady field parallel to the axis

of propagation. Upon emerging from the sample, the wave passes into C, a circular to rectangular waveguide transition which may be rotated for maximum transmission of energy down section C. The angle of displacement of C with respect to A is a measure of the rotation of the plane of polarization of the wave in its passage through the ferrite. The rotation per centimeter of material depends upon the longitudinal field in the sample, increasing with this field and reaching a constant value when the ferrite is saturated.

Hogan<sup>25</sup> has given a discussion of the theory of this ferromagnetic effect. The incident linearly polarized wave may be described as a combination of two oppositely rotating circularly polarized waves. The real part,  $\mu'$ , of the permeability of the ferrite varies with magnetic field in a different way for the two circular polarizations, as shown in Fig. 7. The velocity of propagation of the two polarizations is therefore different, and in passing through the ferrite they will fall out of phase by an amount proportional to sample length. Upon emerging they will combine to form a linearly polarized wave whose plane is rotated with respect to the incident wave. Reference to Fig. 7 shows that the most useful region for obtaining this effect lies below the field required to produce ferromagnetic resonance (i.e., at frequencies above the ferromagnetic resonance frequency) in the region where the two curves are practically parallel. In this region the device is relatively insensitive to small field changes and is somewhat "broadband" with respect to frequency.

For the practical application of the Faraday rotation, it is desirable that the attenuation per degree of rotation be small. Attenuation varies widely for different kinds of ferrites and is a function of frequency. For

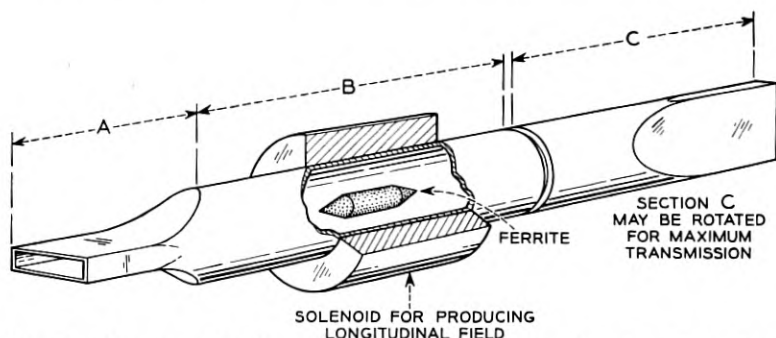

Fig. 6 — Apparatus for demonstrating the microwave Faraday effect. Energy is supplied to section A. Rotation of plane of polarization occurs in section B and is controlled by controlling the longitudinal field. Section C is rotated for maximum transmission. The angular displacement of C with respect to A is a measure of the rotation.

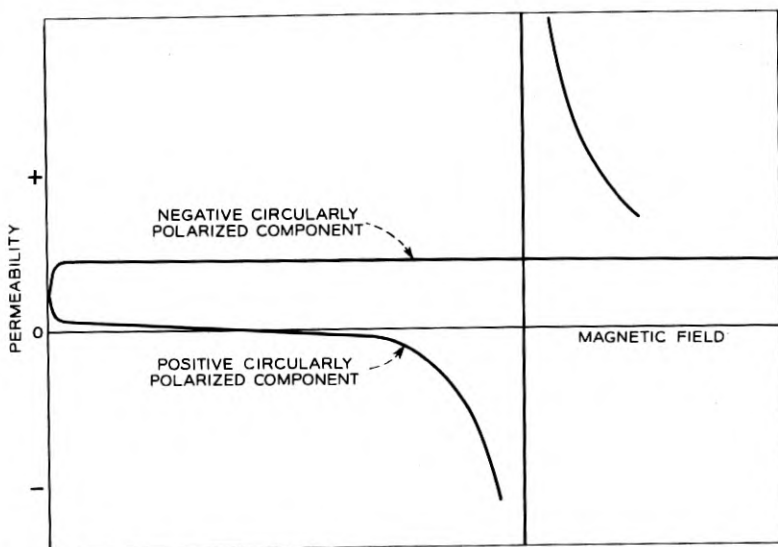

Fig. 7 — Real part ( $\mu'$ ) of permeability of a ferrite versus applied magnetic field for the two circularly polarized components into which an incident plane wave may be resolved. The useful region for the Faraday effect is that for low  $H$ , where the two curves are approximately parallel.

one sample at 9,000 mc, Hogan found a rotation of 60 degrees per cm of path and an attenuation of about 0.5 db per cm.

#### X. EFFECT OF CROSS FIELD

When a steady magnetic field is applied to a ferrite in a direction perpendicular to the path of transmission of electromagnetic waves through the material, the effective ac permeability of the material varies with the applied magnetic field. For a given frequency, the permeability starts out positive. As the magnetic field increases the permeability goes through zero and approaches a large negative value as ferromagnetic resonance is reached. Above resonance the permeability is positive and gradually decreases with increase in magnetic field.

Since the characteristic impedance of the ferrite relative to an empty waveguide is

$$Z = \sqrt{\frac{\mu}{\epsilon}},$$

it is apparent that  $Z$  may be varied by changing the applied field. When  $\mu$  is zero, the ferrite appears to be a perfect reflector, while when  $\mu = \epsilon$ , it provides a perfect match to the empty guide. Since it is possible to

vary the characteristic impedance over a wide range, this effect has possibilities of application in attenuators, modulators, and phase shifting devices.

#### XI. NEW MAGNETIC APPLICATIONS

The engineer is naturally interested in some of the uses to which the new magnetic phenomena may be put. Several applications will be described briefly.

1. The gyrator. This is a four pole element for which there is a  $180^\circ$  phase difference between the two directions of propagation. In other words, the transfer impedances in the two directions are equal in magnitude but opposite in sign. Thus the device violates the reciprocity theorem.

Hogan<sup>25</sup> built the first microwave gyrator using the arrangement shown in Fig. 8. In this device, a wave traveling from left to right has its polarization rotated  $90^\circ$  counter-clockwise in the twisted section and another  $90^\circ$  in the same direction by the ferrite — a total rotation of  $180^\circ$ . For a wave traveling from right to left the two rotations, that in the ferrite and that in the twisted section, cancel each other. Thus, if *A* and *B* represent points of the same phase for a left-to-right wave, they represent points of  $180^\circ$  phase difference for a right-to-left wave.

2. One way transmission system. If the input and output waveguides in Fig. 6 are oriented with their planes at  $45^\circ$  to each other and if the solenoid current is adjusted for  $45^\circ$  rotation in the ferrite, the result is a one-way transmission system.<sup>25</sup> Such a device is broadband. An arrangement of this sort may be employed in a microwave system to isolate the transmitter or receiver from the waveguide. It has the advantage that loss in the forward direction can be made quite small by proper choice of material.

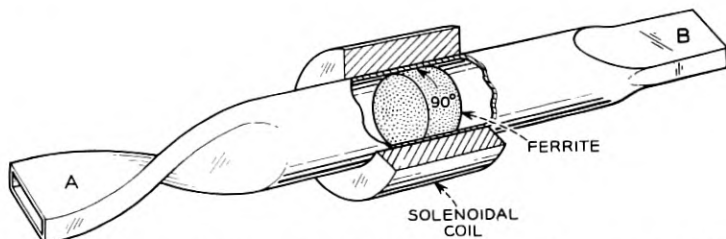

Fig. 8 — Schematic diagram of a microwave gyrator. From left to right, the plane of polarization is rotated  $180^\circ$ ; corresponding to a phase shift of  $\pi$ . From right to left, the plane of polarization is not rotated and the phase shift is therefore zero.

3. The polarization circulator. This is a modification of the one way transmission system in which there are two connections, with polarizations at  $90^\circ$  to each other, on either side of the ferrite rotating element. This is shown schematically in Fig. 9, along with a symbol which has been suggested for this element.<sup>25</sup> Energy sent into the device with polarization A emerges with polarization B, polarization B is rotated into C, polarization C is rotated into D, and polarization D emerges as *minus* A. One practical application of this device is as a TR box in a radar system. Another, recently suggested by A. G. Fox, is as a device for separating the various channels in a multichannel communication system. Referring to Fig. 10, the signal comes in at A. Branch B is terminated in a filter which accepts one channel but reflects the remainder of the signal which is passed on to C. Here another filter accepts the second channel but passes the remainder on to D. D in turn feeds a second circulator. This process can go on until all channels are taken care of.

4. Measurement of magnetic field strength. The phenomenon of ferromagnetic resonance suggests a means of making measurement of magnetic field strength by observing the resonance frequency for a ferrite when subjected to the unknown field.<sup>26</sup> Allen<sup>27</sup> has recently described a magnetometer in which an unknown field is measured by observing the Faraday rotation which it produces in a standard sample.

5. Other applications. There are several ways in which the interaction of the steady field with the microwave field may be utilized in designing switches, attenuators, and modulators. For example, one might set the two rectangular guides in Fig. 8 with their transmission planes at  $90^\circ$ . Then by varying the current in the solenoid and thereby varying the magnetic field applied to the ferrite, one may vary the amount of energy accepted by the second waveguide. This is then an electrically controlled attenuator. This same device offers the possibility of providing modulation of the microwave signal by modulating the current in the solenoid.

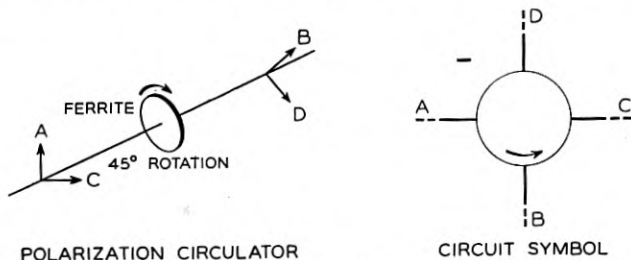

Fig. 9 — Schematic representation of polarization circulator. The ferrite is adjusted to  $45^\circ$  rotation by an external field, not shown. The circuit symbol for the circulator is shown at the right.



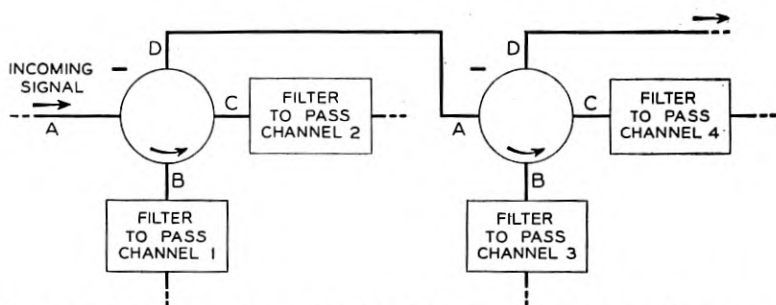

Fig. 10 — Schematic diagram showing the proposed use of circulators to separate the various channels in a multichannel communication system.

Reggia and Beatty<sup>28</sup> have recently described a coaxial line variable attenuator in which the transmission loss is controlled by variation in an external cross field.

## XII. CONCLUSION

From the discussion which has gone before, it should be apparent to the communications engineer that a whole new field of applications of magnetic materials has opened up. It is therefore essential that the engineer be acquainted with the modern picture of magnetism including the phenomena which have been described here — low frequency resonance, ferromagnetic resonance, and microwave Faraday effect. Some applications have already been made of the high frequency characteristics, particularly of the Faraday rotation. Knowledge of the general high frequency characteristics of magnetic materials will enable the engineer to interpret new experimental information as it becomes available and intelligently to utilize the new materials in a variety of engineering applications.

I wish to express my appreciation to J. K. Galt, A. G. Ganz, C. L. Hogan, and V. E. Legg for several discussions which aided in the clarification of certain points described herein and to Messrs. Ganz and Legg for their careful criticism of the overall presentation.

## REFERENCES

1. J. L. Snoek, Non-Metallic Magnetic Materials for High Frequencies, *Philips Technical Review*, **8**, p. 353, 1946.
2. A. Fairweather, F. F. Roberts and A. J. Welch, Ferrites, *Reports on Progress in Physics*, **15**, p. 142, London, The Physical Society, 1952.
3. R. L. Harvey, I. J. Hegyi, H. W. Levernz, Ferromagnetic Spinel for Radio Frequencies, *R.C.A. Review*, **11**, p. 321, 1950.
4. H. J. Williams, R. C. Sherwood, M. Goertz and F. J. Schnettler, Stressed

- Ferrites with Rectangular Hysteresis Loops, Scheduled for publication in A.I.E.E. Transactions.
5. J. K. Galt, Motion of a Ferromagnetic Domain Wall in  $\text{Fe}_3\text{O}_4$ , *Physical Review*, **85**, p. 664, 1952.
  6. V. E. Legg, Magnetic Measurements at Low Flux Densities using the A. C. Bridge, *Bell System Tech. J.*, **15**, p. 39, 1936.
  7. C. D. Owens, Analysis of Measurements on Magnetic Ferrites, *Proc. I.R.E.*, **41**, p. 359, 1953.
  8. C. Kittel, Theory of the Dispersion of Magnetic Permeability in Ferromagnetic Materials at Microwave Frequencies, *Phys. Rev.*, **70**, p. 281, 1946.
  9. J. B. Birks, Measurement of the Permeability of Low Conductivity Ferromagnetic Materials at Centimeter Wavelengths, *Proc. Phys. Soc. (London)*, **60**, p. 282, 1948.
  10. G. T. Rado, R. W. Wright and W. H. Emerson, Ferromagnetism at Very High Frequencies. III. Two Mechanisms of Dispersion in a Ferrite, *Phys. Rev.*, **80**, p. 273, 1950.
  11. *Techniques of Microwave Measurements*, (M.I.T. Radiation Laboratory Series, **11**), McGraw-Hill Book Co., N. Y., 1947.
  12. W. H. Surber, Jr. and G. E. Crouch, Jr., Dielectric Measurement Method for Solids at Microwave Frequencies, *J. Appl. Phys.*, **10**, p. 1130, 1948.
  13. J. K. Galt, Initial Permeability and Related Losses in Ferrites, *Ceramic Age*, p. 29, Aug., 1952.
  14. R. Becker and W. Doering, *Ferromagnetismus*, Julius Springer, Berlin, 1939.
  15. M.I.T. Staff, *Electric Circuits*, John Wiley & Sons, N. Y., p. 323, 1943.
  16. F. G. Brockman, P. H. Dowling and W. G. Steneck, Dimensional Effects Resulting from a High Dielectric Constant Found in a Ferromagnetic Ferrite, *Phys. Rev.*, **77**, p. 85, 1950.
  17. P. M. Prache and H. Billottet, "Magnétodynamique des Semi-Conducteurs", *Cables et Transmission*, **6A**, p. 317, 1952.
  18. Griffiths, *Nature*, **158**, p. 670, 1946.
  19. C. Kittel, Ferromagnetic Resonance, *Le Journal de Physique et le Radium*, **12**, p. 291, 1951.
  20. H. G. Beljers and J. L. Snoek, Gyromagnetic Phenomena Occuring with Ferrites, *Philips Tech. Rev.*, **11**, p. 313, 1950.
  21. W. A. Yager, J. K. Galt, F. R. Merritt and E. A. Wood, Ferromagnetic Resonance in Nickel Ferrite, *Phys. Rev.*, **80**, p. 744, 1950.
  22. R. M. Bozorth, *Ferromagnetism*, New York, D. Van Nostrans Co., p. 803, 1951.
  23. H. G. Beljers, Measurements on Gyromagnetic Resonance of a Ferrite Using Cavity Resonator, *Physica*, **14**, p. 629, 1949.
  24. F. F. Roberts, A Note on the Ferromagnetic Faraday Effect at Centimeter Wavelengths, *Le Journal de Physique et le Radium*, **12**, p. 156, 1951.
  25. C. L. Hogan, The Ferromagnetic Faraday Effect at Microwave Frequencies and its Applications, *Bell System Tech. J.*, **31**, p. 1, 1952.
  26. Theodore Kahan, Ultra-High Frequency Magnetometer, U. S. Patent 2597149.
  27. P. J. Allen, A Microwave Magnetometer, *Proc. I.R.E.*, **41**, p. 100, 1953.
  28. F. Reggia and R. W. Beatty, Characteristics of Magnetic Attenuators at UHF, *Proc. I.R.E.*, **41**, p. 93, 1953.

# The Correlatograph

## A Machine for Continuous Display of Short Term Correlation

By W. R. BENNETT

(Manuscript received April 24, 1953)

*An analog device has been constructed which displays short term correlation as a three-dimensional plot in which the rectangular coordinates are running time and lag time and the intensity of the pattern represents the correlation function. Preliminary tests on the properties of such a device are reported.*

The place of the electrical spectrograph<sup>1</sup> as a signal analyzer has become well established in laboratory technology. It has occurred to many investigators however that the spectrum is not the only property of a signal which may be worthy of study, and in recent years there has been a considerable interest in other features, notably the correlation functions. On the basis of the accepted mathematical definitions the auto correlation function is the Fourier cosine transform of the power spectrum and in this sense would contain equivalent information presented in a different form. However, the mathematical definitions apply to a very long time interval and in practice we often deal with short segments of non-stationary processes. The spectrograph does not evaluate the true spectrum in such cases but gives instead a spectrum-like function of frequency which changes with the observation time. We may regard the resolving filter as performing a weighted analysis in which the most recent parts of the signal contribute most heavily to the instantaneous response. The resulting "short term" spectrum depends on the characteristics of the resolving filter as well as the signal, but over a useful range of filtering selectivity the individual peculiarities of the signal are distinguishable even though the structural background may be characteristic of the filter.

"Short term" correlation functions, in which the averaging interval is finite, have also been investigated and show phenomena analogous to

the short term spectrum. Comparison of the two short term functions is a much more involved matter than when the time interval is large in both cases. The subject has been extensively treated in the literature,<sup>2</sup> but the conclusions are still somewhat obscure. In an investigation which was started by the present author and the late Liss C. Peterson in 1950, we noted that a complete correlation analogue of the audio spectrograph had apparently never been constructed even though suggestions had appeared concerning the possibility.<sup>3</sup> It seemed that some of the questions concerning the merits of the correlation method of analysis could not properly be answered without actually building and testing such a machine and it also appeared possible that we would thereby add another useful tool for the problems associated with speech and other signals of interest. We accordingly undertook the design and construction of a "correlatograph" following lines closely parallel to spectrographic experience in order to economize in new shop designs.

In a spectrograph, such as used in visible speech for example, a three-dimensional display is obtained in which time and frequency are two rectangular coordinates and the short term power spectrum is represented by the intensity of light or density of marking. The functional mechanism is illustrated in Fig. 1. The incoming signal is delivered to a bank of band pass filters with midband frequencies uniformly spaced throughout the frequency range of interest. The envelopes of the filter output waves are picked up in turn by a rotating switch arm to control the voltage impressed on a marking stylus. The stylus moves across the paper in synchronism with the collector arm and the paper advances after each stroke.

The analogous diagram for a correlatograph is shown in Fig. 2. We recall that the correlation of two functions is defined as the average of

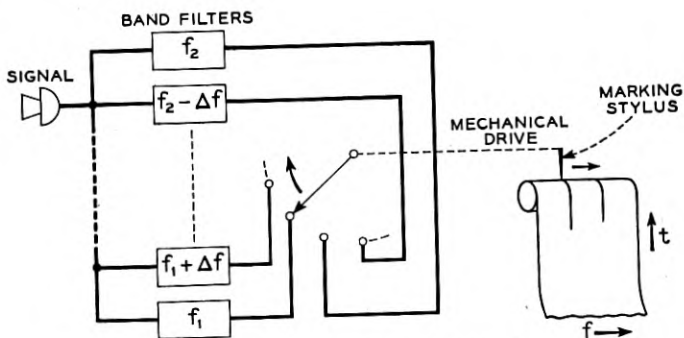

Fig. 1 — Mechanism of spectrograph.

their product with fixed time lag; i.e., when  $T$  is large, the expression

$$\psi_{12}(\tau) = \frac{1}{T} \int_0^T f_1(t)f_2(t - \tau) dt$$

gives the cross-correlation of  $f_1(t)$  and  $f_2(t)$ , and the expression

$$\psi_{11}(\tau) = \frac{1}{T} \int_0^T f_1(t)f_1(t - \tau) dt$$

gives the autocorrelation of  $f_1(t)$ . In short term correlation  $T$  is finite. In Fig. 2, the different lag times are obtained by a tapped delay line and each tap is followed by its own multiplier and integrator. The integrated values are picked up by a rotating switch arm to control the marking stylus voltage as in Fig. 1. The rectangular coordinates are now  $t$  and  $\tau$  instead of  $t$  and  $f$ . The marking intensity represents the correlation function.

In actual spectrographs it is usually found expedient to replace the bank of filters by a single filter and use a swept frequency oscillator and modulator to heterodyne the signal across the filter band. A rotating condenser plate tuning the oscillator thus takes the place of the rotating switch. The sweeping frequency must not change too rapidly for the analyzing filter to respond adequately, and also must not change so slowly that short signal bursts are imperfectly registered. A preliminary recording of the signal wave with a subsequent reproduction at a different

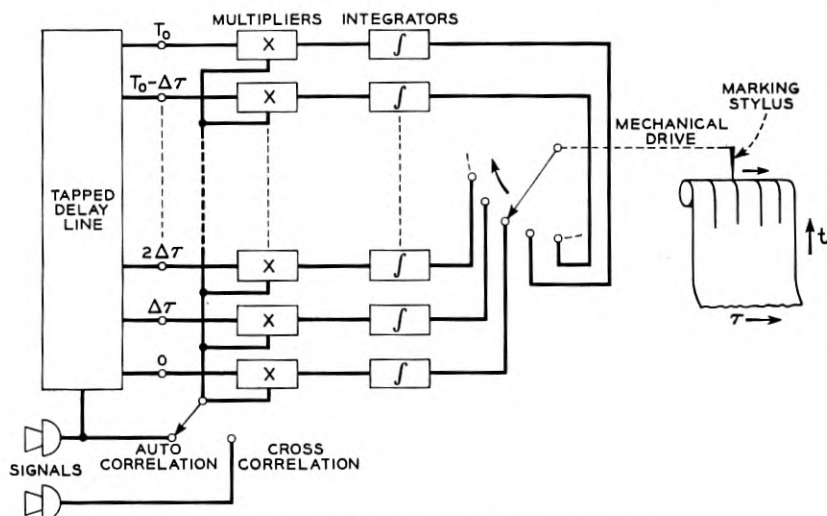

Fig. 2 — Mechanism of correlatograph.

speed forms a practical technique for securing the desired resolution in both frequency and time. Likewise in the correlatograph we can dispense with individual multipliers and integrators if we are willing to give up some of the otherwise available integration time for each  $\tau$  value. One multiplier and one integrator are then put in series with the switch arm and the contacts go directly to the delay line taps as shown in Fig. 3. A complete analogy with the simplified spectrograph would require a line of variable delay with a single output tap. This could be done with magnetic recording and moving heads, thereby eliminating the rotating switch. We felt however, that the fixed delay line would furnish the more stable and accurate component and chose the arrangement of Fig. 3. An auxiliary recording and reproducing process made it possible to accommodate a wide variety of signals with the one delay line.

#### DETAILS OF APPARATUS

Fig. 4 shows the arrangement of apparatus chosen. Our program was aimed at signals such as might occur in a nominal speech band extending from 200 to 4,000 cps recorded on magnetic tape at 15 inches per second. The reproducing element was a spinning double-ended pickup coil which successively scanned a one-inch loop of tape with one end beginning its scan just as the other end left the tape. The coil made 60 revolutions per second and hence the reproducing speed was 120 inches per second or eight times the recording rate. Our speech band was thus made to occupy the range from 1,600 to 32,000 cps, and this was therefore the range chosen for the delay line. A recording speed other than 15 inches

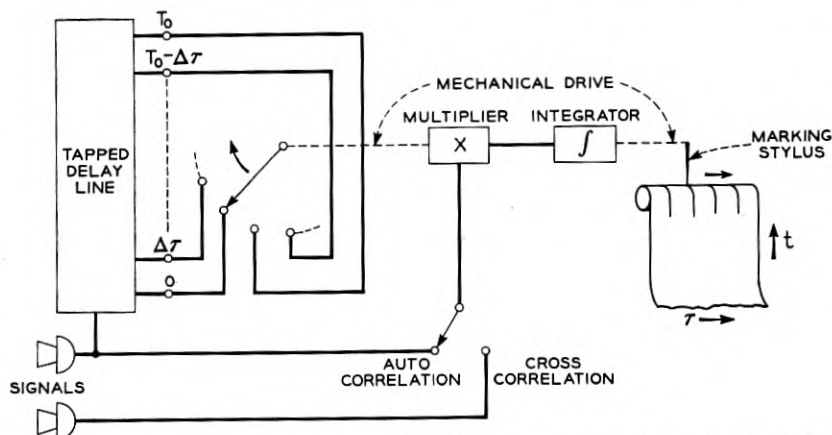

Fig. 3 — Mechanism of correlatograph with common multiplier and integrator.

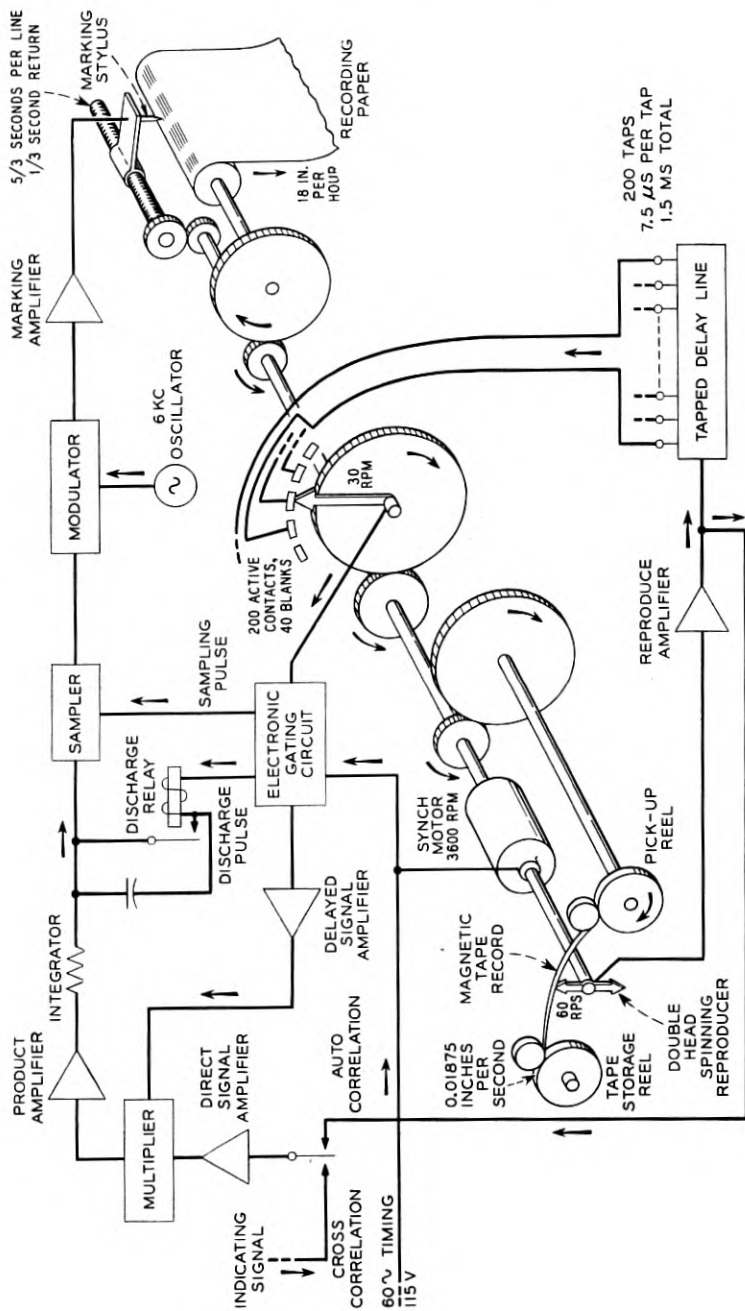

Fig. 4 — Arrangement of apparatus for correlatograph described.

per second brings a correspondingly different signal band into the range of the delay line. The magnetic tape advances relatively slowly during the scanning process and for any one scan of a one-inch section may be regarded as stationary. The revolving pick up thus delivers segments of signal  $1/120$  second (8.33 ms) long for the correlation analysis. Our delay line consists of 1.5 ms total delay with 200 taps spaced  $7.5 \mu\text{s}$  apart. During the first 1.5 ms of each scan, the delay line contains parts of the response from two successive scans and hence is not suitable for correlation measurement for lag times corresponding to all taps. We make provision therefore for excluding this interval from the analysis and use only the last 6.83 ms of each scan. The rotating switch advances one tap on the delay line for each one inch scan, so that the value of short term correlation corresponding to one value of lag time is computed every 8.33 ms. 200 values are computed in 1.67 sec after which a time of 0.33 sec is allowed for the return of the marking stylus to its initial position. The rotating switch thus makes one revolution in two seconds but the last sixty degrees of the revolution are not used for display of correlation. The recording paper advances 0.01 inch after each stroke of the stylus. The rate of advance of the signal tape is adjustable by means of a gear train. In terms of the original signal wave, one second of recorded time is represented by the distance the paper moves in one second (0.005 inch) multiplied by the ratio of recording speed to speed of tape advance past the scanning head.

The tape scanning mechanism with the synchronized motion of stylus and paper is due entirely to I. E. Cole, who designed this part of the system and supervised the necessary shop work. Mr. Cole also cooperated in the choice of a design plan for the rotating switch, which was manufactured to meet our special requirements by Applied Science Corporation of Princeton, N. J. The switch output is followed by an electronic gating circuit which removes the effect of time jitter in the beginnings and ends of the contact intervals and trims off the previously mentioned 1.5 ms interval during which the tail end of one scan of the tape loop remains in the delay line. The gating wave is generated from the common 60-cycle power supply which drives all the mechanical apparatus. The output of the electronic gating circuit consists of segments of signal 6.83 ms long with 1.5 ms separation and with the delay increasing in steps of 7.5 microseconds between one segment and the next. This constitutes one input to the multiplier; the other input is the undelayed signal in the case of autocorrelation or an independent signal for cross-correlation.

The multiplier consists of a bridge of germanium varistors with the two



inputs applied across the two diagonals and the output taken off one pair of input terminals through a low pass filter. Each varistor is operated in a substantially square law range. If  $A$  and  $B$  represent the two inputs, we try in effect to produce an output proportional to

$$(A + B)^2 - (A - B)^2 = 4AB.$$

The necessary conditions are conveniently expressed in terms of sine wave inputs in order that analyzer measurements may be used as a check on accuracy. Let  $P \cos pt$  represent a typical component of the signal impressed as one input to the multiplier and  $Q \cos qt$  a typical component simultaneously applied to the other input terminal. The product is

$$(P \cos pt)(Q \cos qt) = \frac{PQ}{2} \cos (p + q)t + \frac{PQ}{2} \cos (p - q)t.$$

Since our purpose is to integrate the output of the multiplier over a time interval relatively long compared to the periods of components within the signal band, we have no interest in the product component of frequency  $p + q$  and in fact filter out such components immediately along with the original signal components to prevent loading the product amplifier with unessential waves. A significant test on the accuracy of the multiplier is therefore the fidelity with which the amplitude of the difference frequency term  $\cos (p - q)t$  follows the product of the amplitudes of  $\cos pt$  and  $\cos qt$ . This is not sufficient in itself however because it does not give a check on the balancing out of the squares of the individual inputs. To test the latter we superimpose the two components  $P \cos pt$  and  $Q \cos qt$  on one input circuit with no signal applied to the other input and measure the output component of frequency  $p - q$ . We also repeat the measurement with the two sine waves impressed on the second input and nothing on the first input. Typical results are shown in Fig. 5. The varistors were selected by R. R. Blair from persistent screen cathode ray tube displays of the characteristics. The square law region is enlarged and the output increased by applying a direct current bias to the bridge through a series resistance. This form of multiplier copies a design worked out by R. R. Riesz for a different purpose.

The product output of the multiplier is weak at best because a relatively small range of varistor inputs fit the necessary law. A fairly high gain product amplifier is therefore provided. Fortunately we do not have to amplify a band which extends all the way down to zero frequency. The significant component when calculating the autocorrelation function of  $P \cos pt$  for lag time  $\tau$  is  $(P^2/2) \cos p\tau$ , which is constant only when  $p = 0$  or  $\tau$  is constant. Our lowest value of  $p$  corresponds to 1600 cps. The value

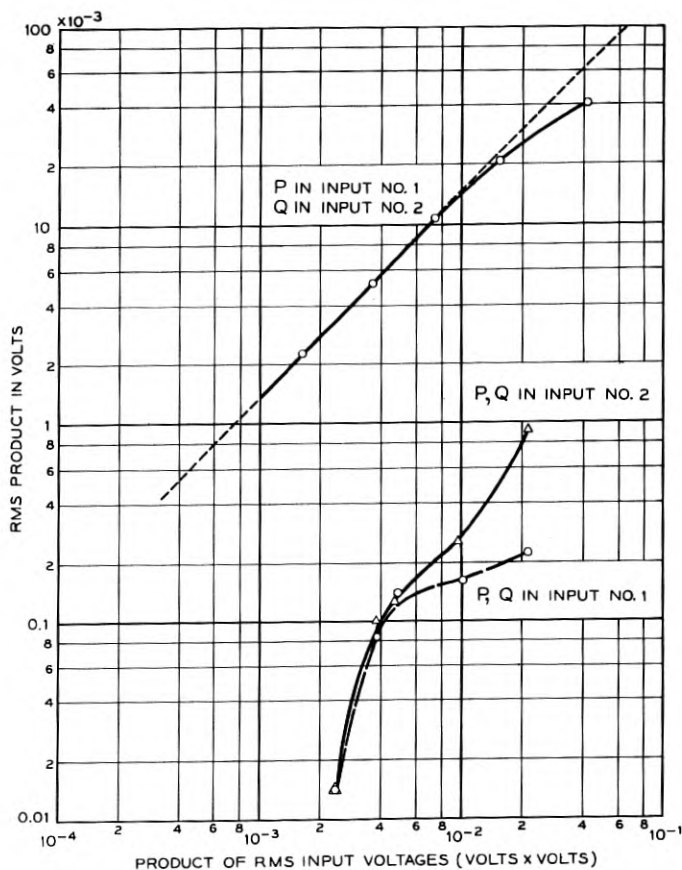

Fig. 5 — Performance curves of multiplier.

of  $\tau$  increases in small steps from 0 to 1.5 ms in  $5/3$  sec. and therefore can be approximated by  $\tau = bt$ , where  $b = .0015/(5/3) = 0.0009$ . Hence the lowest product frequency is roughly  $1600 \times 0.0009 = 1.44$  cps. The actual low frequency cutoff of the amplifier is made about 0.1 cps to allow for changes in the signal components and to preserve good transmission within the nominal band. The upper cutoff frequency is likewise made somewhat higher than the nominal value of  $32,000 \times 0.0009 = 28.8$  cps.

The integration is performed by a series condenser and shunt resistance at the amplifier output. A good approximation to integration is accomplished by a large time constant such that the indicial admittance

remains linear during the integrating interval. Such a long time constant would carry over too much charge from previous intervals if continuous integration were permitted so a shorting relay is provided to discharge the condenser quickly to ground after the integrated value is sampled. The sampling is done by a two-way clamp circuit with the timing pulse generated from the trailing edge of the pulses which gate the switch outputs. The shorting relay operates directly from the 60-cycle supply and is of a type specifically designed to give a brief closure of about one ms. every half period of the driving wave. The sampled outputs of the integrator are applied to a balanced modulator to which is also applied a 6-kc carrier. The resulting double sideband suppressed carrier wave is amplified to form the marking voltage applied to the stylus. Instantaneous compression is incorporated in the marking amplifier to extend the range of input magnitudes which are encompassed by the relatively narrow recording range of the paper. The stylus responds equally to positive and negative voltages and does not resolve the individual high frequency oscillations. The result is like full wave rectification of the correlation functions.

Grateful acknowledgement is given to A. J. Rack, A. E. Johanson and P. A. Reiling for suggested physical configurations and design information suitable for the circuits which generate the various control pulses, and which sample and hold the integrated outputs. G. W. Blake tested and adjusted these circuits after they had been constructed by the wiring shop. Performance runs were made by F. H. Tendick and N. K. Poole. Also at various stages of the project assistance was given by W. A. Klute, F. W. Kammerer and R. L. Carbrey. We have also received helpful advice from many other associates too numerous for explicit mention.

The 200-tap delay line was constructed by the transmission networks department. It consisted of one low pass filter section per tap with mutual inductance between sections to maximize the linearity of the phase curve. The taps were taken off high impedance shunts with the output fraction tapered down the line to give constant loss along the taps. C. E. Jakielski planned, assembled, tested, and adjusted the delay line. The intricate task of connecting the 200 output taps to the corresponding 200 contacts of the switch was performed by M. Biazzo. The delay line and switch appear in the photograph, Fig. 6. Additional electronic apparatus not shown in this photograph was placed on independent panels for experimental convenience but can be arranged in a chassis in the same cabinet with the other apparatus, now that the components have been determined.

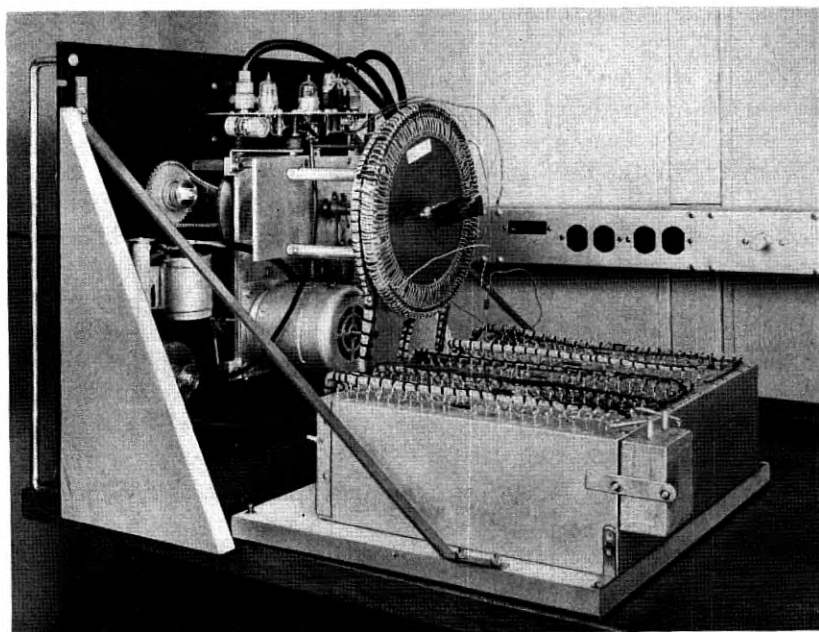

Fig. 6 — Rear view of correlatograph showing rotating switch and delay line.

#### PRELIMINARY RESULTS

Tests on the complete correlatograph have only been carried far enough to date to verify that the operation is as planned. Fig. 7 shows correlatograms obtained with purely sinusoidal inputs of frequencies 200, 400, 600, 800, 2,000, 3,000, and 4,000 cps recorded on the tape at 15 inches per second. In terms of the original signal the values of  $\tau$  extend from zero to 12 ms. The profiles represented by the light and dark bands should be rectified cosine waves starting with a peak at  $\tau = 0$  and repeating at intervals of one half the period of the wave. In the total range of  $\tau = 0.012$  sec, a frequency of 200 cps should show 4.8 periods, 4,000 cps would show 96 periods, and in general  $f$  cps would show  $0.024 f$  periods. The sudden changes in density parallel to the stripes were caused by manual adjustments of the marking amplifier gain.

Fig. 8 shows correlatograms of a 1,000-cps sine wave embedded in various amounts of flat thermal noise extending throughout the entire input band. The sequence from bottom to top is noise alone, signal and noise power equal, signal power down on noise power by 5 db, 10 db, 15 db, and 20 db. A long time correlation analysis would show zero correlations for the noise alone except for small values of  $\tau$ . Short

term correlation gives a mottled background level. The signal pattern shows through this background quite plainly when the two powers are equal. As the signal is reduced relative to the noise the signal pattern is obscured and seems entirely missing at 20 db below the noise level. This is a limitation based mainly on the integration time of this particular apparatus. It is possible to improve the resolution by using longer integration periods with corresponding sacrifice of ability to detect fast changes in the applied signal. As pointed out by C. B. Feldman, the autocorrelation type of analysis suffers the same sort of limitations in the low signal-to-noise ratio case as filtering after detection imposes in spectral analysis. That is, finite integration time in the autocorrelation case and finite filter band width in the postdetection filter both allow errors from interaction of noise with noise to swamp the relatively small desired effect of signal.\* Cross-correlation on the other hand is like filtering ahead of the detector in that the interaction of noise with noise is suppressed leaving as the dominant error the relatively small interaction of noise with signal. We cannot obtain this advantage of cross-correlation if we do not have available a noise-free signal to cross-correlate with, and analogously an accurate knowledge of the frequency to be selected is helpful in securing the best possible results from predetection filtering.

It will be noted that alternate stripes of the signal pattern fade at first as the signal is decreased relative to the noise. This effect appears to be associated with incomplete suppression by the multiplier of the components proportional to the squares of the individual noise inputs. If the noise inputs were steady, the squares would produce mainly direct current which is not transmitted by the product amplifier. Variation in

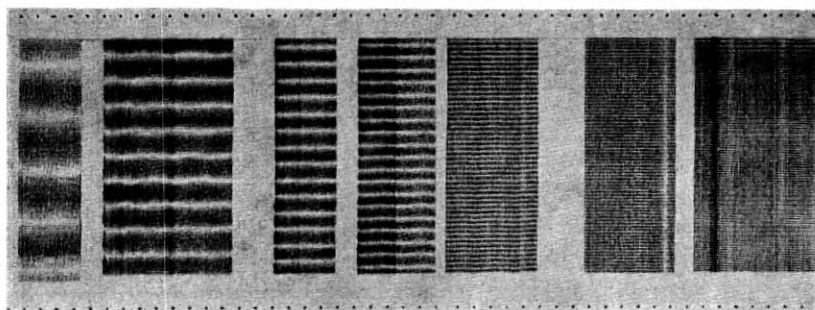

Fig. 7 — Correlatogram of single-frequency wave.

\* The autocorrelation method however has an advantage if the signal can be recognized at all in that it is capable of measuring the frequency of the original components, which the postdetection filter cannot do at best.

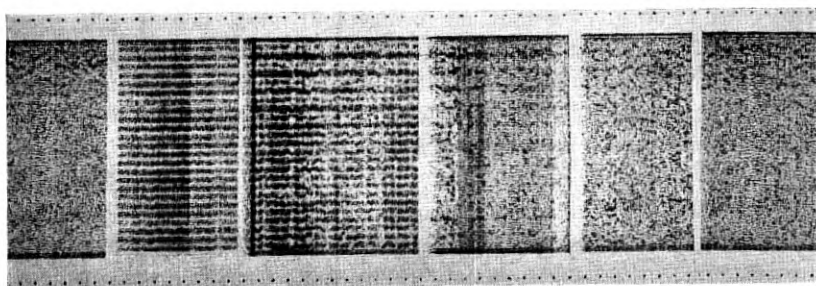

Fig. 8 — Correlatogram of single-frequency wave and random noise.

one noise input because of the idle interval during which no signal is supplied by the delay line is a source of change in the direct current which is partially transmitted through the product amplifier to give a biased integrated value and hence an unequal treatment of positive and negative correlation. Effects of this sort would be particularly noticeable when the noise is large relative to the sinusoidal component.

Fig. 9 shows a sample correlatogram of the sentence "He beats his head against the posts." spoken by G. E. Peterson. The locations of the sounds were marked on the tape by observation during an audio playback and from these marks the corresponding positions on the correlatogram were found. The lower legend gives the ordinary English letters and the upper the symbols of the international phonetic alphabet. The characteristic frequency indicated by the vowel sounds is of the order of 600 cps, which coincides very well with the first formant frequency of the speaker's voice. It is a characteristic of this method that the pattern is dominated by the largest component present. To show the higher formants, which have weaker amplitudes, it would be necessary

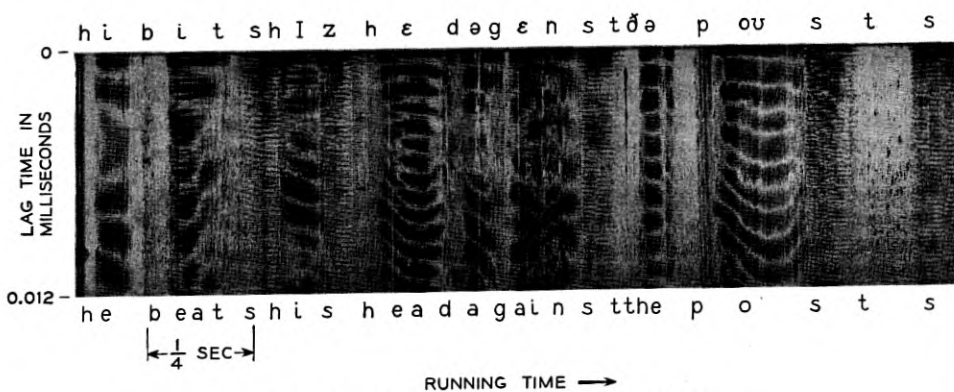

Fig. 9 — Correlatogram of speech sentence.

to filter out the strong low frequency components from the input. The "s" sounds show closely spaced stripes indicating a concentration of energy at the top of the band. Some of the consonants do not show much under the conditions of this test.

It is of interest to compare correlatograms with spectrograms of the same signal. For the single frequency input, the stripes on the correlatogram would be replaced by a single line on the spectrogram. It would be possible to construct signals such that these patterns are interchanged. For example, a rounded band of noise transmitted over two paths having different times of transmission would have a correlatogram with two stripes corresponding to lag times of zero and the delay difference while the spectrogram would show a periodic array of stripes corresponding to the interference pattern of the two paths. It appears that there may be complementary fields of usefulness for the two kinds of analysis and further study is planned.

Besides the many individuals previously named as contributing the various phases of the project, I would like to acknowledge the inspiration and guidance of R. K. Potter in initiating and carrying through the program. L. C. Peterson shared equal responsibility with the author in the project and but for his untimely death would have been a co-author of the present paper.

November 6, 1952

#### REFERENCES

1. W. Koenig, H. K. Dunn and L. Y. Lacy, The Sound Spectrograph, *J. Acoust. Soc. Am.*, **17**, pp. 19-29, 1946.
2. Y. W. Lee, T. P. Cheatham, Jr. and J. B. Wiesner, Applications of Correlation Analysis to the Detection of Periodic Signals in Noise, *Proc. I.R.E.*, **38**, pp. 1165-1171, 1950.
3. K. N. Stevens, Autocorrelation of Speech Sounds, *J. Acoust. Soc. Am.*, **22**, pp. 769-771, 1950.





# A Statistical Study of Selective Fading of Super-High Frequency Radio Signals

By R. L. KAYLOR

(Manuscript received May 7, 1953)

*The results of two months of comprehensive frequency-sweep measurements of selective fading in the band between 3750 and 4190 mc over a radio relay path in Iowa are reported. An abridgement of the data, general conclusions derived from the data and an example of the use of the data in connection with frequency diversity measures for radio relay systems are given.*

## INTRODUCTION

It is well known that, in the high-frequency range during fading conditions, radio signals on different frequencies may exhibit at any instant radically different behavior. This may be true even though they are in the same frequency band and exhibit the same statistical behavior, when observed over a longer period of time. It is also known that h-f fading may be frequency selective enough within the narrow limits of a single radio channel to cause severe distortion of modulated signals. It has been established that the cause of these phenomena is multipath transmission. This knowledge, which is of long standing in the high-frequency range, raised questions concerning the prevalence of similar phenomena in the super-high-frequency range about which relatively little has been known until recently.

During recent years studies of super-high-frequency propagation and fading have been made which have been previously reported.<sup>1</sup> In these tests a frequency-sweep method was used to determine how the loss of a particular radio path varied with frequency at a given instant; and short-pulse methods were used to determine the path length differences which were involved when multipath transmission occurred. These are

---

<sup>1</sup> A. B. Crawford and W. C. Jakes, Jr., Selective Fading of Microwaves, and O. E. DeLange, Propagation Studies at Microwave Frequencies by Means of Very Short Pulses, Bell System Tech J., **31**, Jan., 1952.

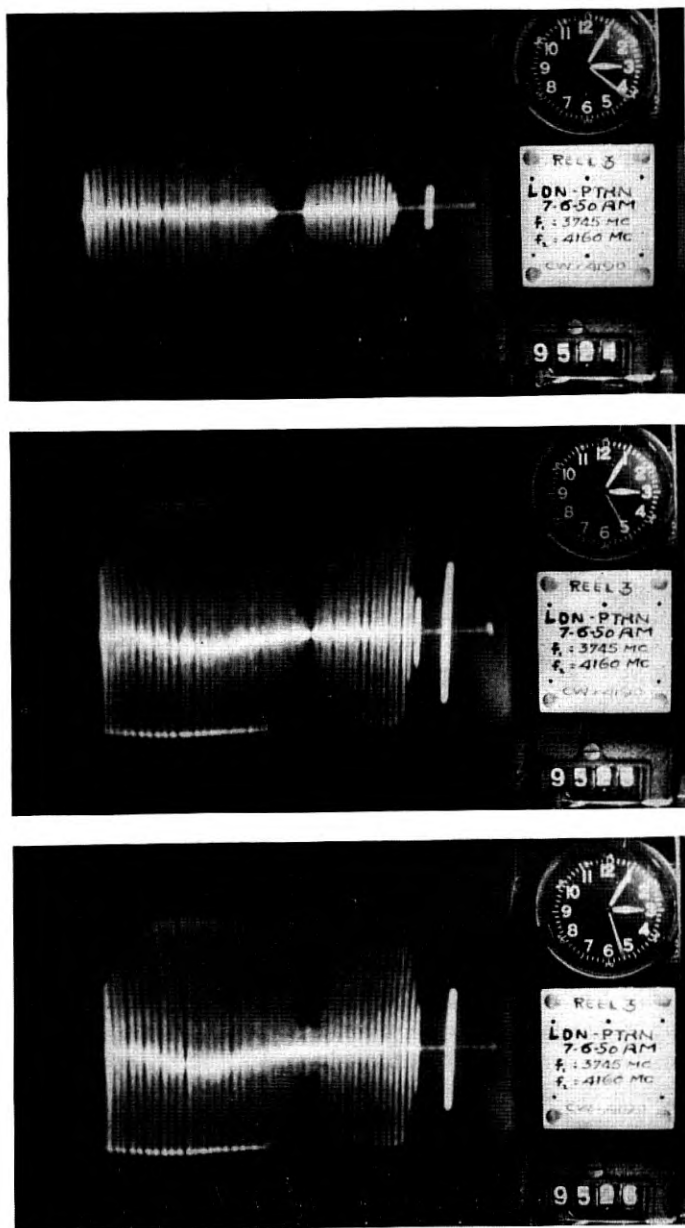

Fig. 1 — Typical records obtained during the Lowden-Princeton, Iowa, frequency-sweep transmission measurements. The horizontal scale is proportional to frequencies between 3,750 and 4,150 mc (the single spike on the right is at 4,190 mc); and the vertical scale is proportional to the amplitude of the received signal.

standard methods for studying multipath transmission (or selective fading) and the results obtained were in good agreement.

Some frequency-sweep transmission measurements were made during the summer of 1950 over a typical radio relay path in the mid-continent region of the United States for the purpose of obtaining additional data of a statistical nature which could be used in system engineering.

The objective of the tests was to determine what per cent of the fading was frequency selective and the degree of its frequency selectivity. Such data were needed to evaluate the advantages of using frequency diversity as a means of minimizing the effects of fading, and to provide quantitative data for designing frequency-diversity measures. Recordings were made throughout the months of July and August which serve as the basis for a statistical picture of the fading occurring during those months in the frequency band between 3,750 and 4,190 mc.

#### *Path Over Which Measurements Were Made*

The measurements were made over a 30.8-mile path between the Lowden and Princeton (Iowa) towers of the Chicago-Omaha Radio Relay System. This path was chosen as a typical radio relay path as to length, clearance above terrain, and climatic conditions. Height-loss runs made by the American Telephone and Telegraph Company (when originally selecting the path as part of their radio relay route) indicated that ground reflections on this path were unimportant. The reflection coefficient was less than 0.1

#### *Method of Tests*

The frequency-sweep equipment used in these tests was similar to that used in the previous studies.<sup>1</sup> With this equipment about 50,000 record photographs were obtained of a cathode-ray tube presentation of the path-loss vs frequency characteristic of the path between 3,750 and 4,150 mc. Fig. 1 shows three illustrations of these record photographs, which are more fully discussed below. The taking of these records was distributed throughout the months of July and August in such a manner as to give complete coverage of all the fading during that period. In addition the single-frequency path loss at 4,190 mc was continuously recorded throughout the two months.

The data from these records were analyzed on a statistical basis; and families of curves were obtained depicting several aspects of the nature of the selective fading encountered during the tests. These are described more fully below.

## GENERAL DISCUSSION OF FADING PHENOMENA

The variations in the strength of a received radio signal known as "fading" are caused by variable or temporary conditions in the transmission path. These conditions fall into two broad classes: those causing partial obstruction of the path, and those causing multipath transmission. The latter class is believed to be the principal source of frequency-selective fading.

Multipath transmission involves the reception of more than one signal ray, each of which travels over a different path between the transmitter and receiver. Generally each such path has a different length between the transmitter and receiver. Multipath transmission involves either or both reflection or refraction of at least one (and in some cases all) of the received rays. Since the conditions of the atmosphere are continuously varying, the paths of the received rays are variable with time. The received signal is the resultant of all the rays accepted by the receiving antenna. The relative phase of the different received rays depends on (1) the differences in the lengths of the paths over which they have travelled and (2) the signal frequency. If the rays arrive at the receiving antenna in nearly the same phase, they add and enhance the received signal; if they arrive in phase opposition they partially cancel each other and fading results. This fading is not only variable with time but also with signal frequency, and is called "(frequency) selective fading". Since the conditions which cause this kind of fading are substantially random, the variation of fading with time on a statistical basis might be expected to approach the Rayleigh distribution. There has been experimental confirmation of this.

A number of other factors are involved which will not be treated here, since the mechanism and effects of multipath transmission have been discussed quite thoroughly in the previously mentioned reports by Crawford and Jakes, DeLange and in an earlier paper.<sup>2</sup>

*Results of Tests*

Fig. 1 shows three illustrations of the type of records obtained. On each record the horizontal deflection of the cathode-ray-tube trace is proportional to the radio signal frequency. The vertical deflection is linearly proportional to the amplitude of the received signal, which because of constant transmitter power is inversely proportional to the

---

<sup>2</sup> H. T. Friis, *Microwave Repeater Research*, Bell System Tech. J., 27, Apr., 1948.

path loss.<sup>3</sup> In each record one second was required for the trace to travel through the entire frequency range covered.

The three records shown are consecutive, being taken at 3:05:21 AM, 3:05:25 AM and 3:05:27 AM. The first record (frame number 9524) was taken with 10 db more attenuation in the input to the measuring equipment than when the later two records were taken (frame numbers 9525 and 9526). There is obvious overloading in the left hand portions of the records on frames 9525 and 9526; but the accuracy of the right hand portions of these records (showing the deeper part of the fade) is unimpaired. The noticeable difference between the shapes of the curves near the deeper parts of the fade on frames 9525 and 9526 is typical. These changes occurred within two seconds. Generally, the deeper parts of the fades show more rapid changes than the less deep parts.

From the 50,000 record photographs all those pertaining to fading of 30 db or more were segregated and analyzed. The remaining records were analyzed on a sampling basis, except that every record showing unique effects was analyzed. About 1,800 path-loss versus frequency curves such as those illustrated in Figs. 2 and 3 were obtained. These curves were separately studied, and were also treated statistically.

Because the levels during the deeper part of the fade are too low to show on frame 9524, and because portions of frame 9525 showing the less severe part of the fade are affected by overloading, it was necessary to combine two records (shown on Fig. 1) to obtain the single path-loss versus frequency curve shown as Fig. 2(a).

Theoretically, it should be possible to synthesize by means of an addition-of-vectors method each of the path-loss versus frequency curves obtained from these tests. Each vector term of the equation would correspond to a component of the received signal and would be of the form  $R \cos \omega T$ , where:  $R$  is the magnitude of a particular component (normalized to the magnitude of the direct signal component),  $T$  is the delay (in seconds) between the time of arrival of the direct signal component and the particular interfering component, and  $\omega$  is  $2\pi$  times the frequency.

In practice, however, it has been found in the case of deep fades that components of relatively small magnitude and relatively long delay are of importance in determining the shapes of the curves near maxima of path loss. Also it has been found that in most such cases quite a few components are involved. These factors make accurate analysis of many

---

<sup>3</sup> A logarithmic amplitude characteristic (db scale) would have been preferable; but time did not permit modifications of the test equipment before the start of the 1950 fading season.

curves impractical without a computer capable of handling a relatively large number of components several of which may be relatively small.

However, experimentation with a trial and error method of solution on a few selected curves has shed considerable light on the nature of received signals which could produce the types of curves included in the data under consideration.

Curve (a) on Fig. 4 is one of those selected for analysis and was synthesized by using a direct signal component and six interfering components as shown in Table I. If components 5 and 6 had been omitted from the synthesis, curve (b) would have resulted; and, if components, 3, 4, 5 and 6 had been omitted curve (c) would have been obtained.

The difference between curves (a) and (b) illustrate the radical effect which can be produced on the shape of a curve near maxima of path loss

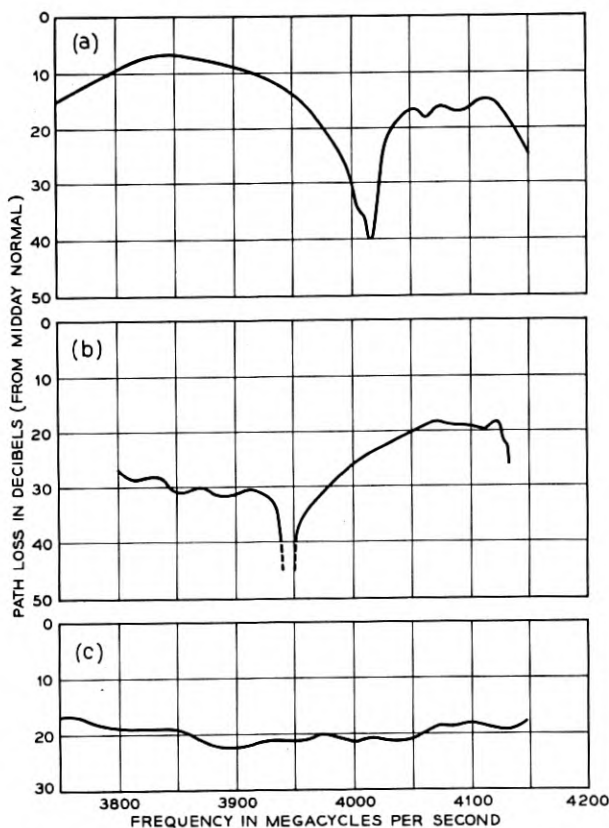

Fig. 2 — Typical path-loss versus frequency curves observed on the Lowden-Princeton, Iowa, path during July and August, 1950.

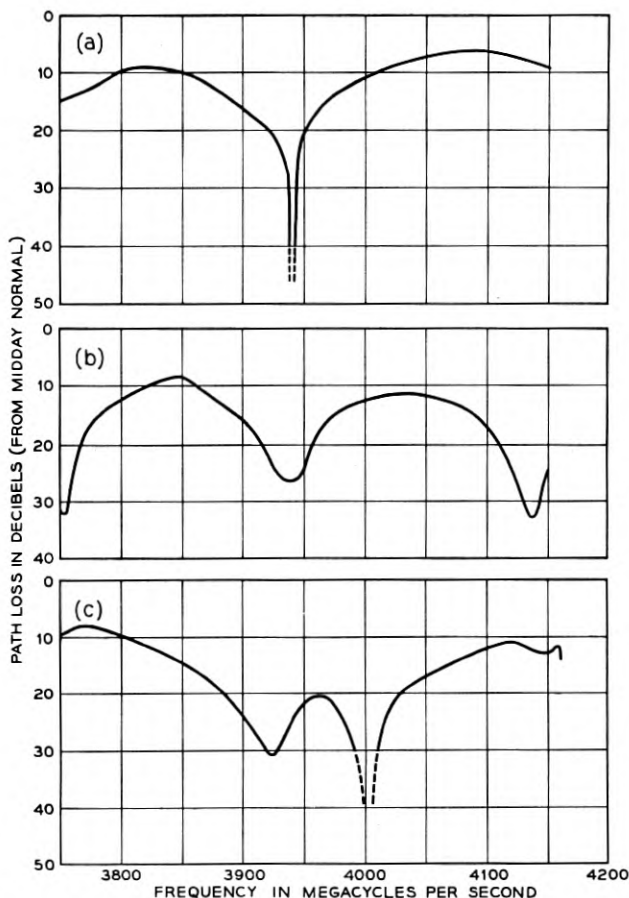

Fig. 3 — Typical path-loss versus frequency curves observed on the Princeton-Lowden, Iowa, path during July and August, 1950.

by relatively small components such as components 5 and 6. In the case of deeper fades much smaller components may be of importance in determining the shapes of the curves near maxima of path loss; hence the curves for deep fades are quite difficult to synthesize. The shape near the maximum of path-loss on the curve in Fig. 2(a) is quite typical of the shapes to be found in the data under discussion.

Based on the experience gained in attempting to synthesize some of the curves, it is possible to recognize the significance of certain features of other curves, and to generalize the nature of all the curves. The principal conclusions are:

1. No deep fades were found which did not show definite frequency

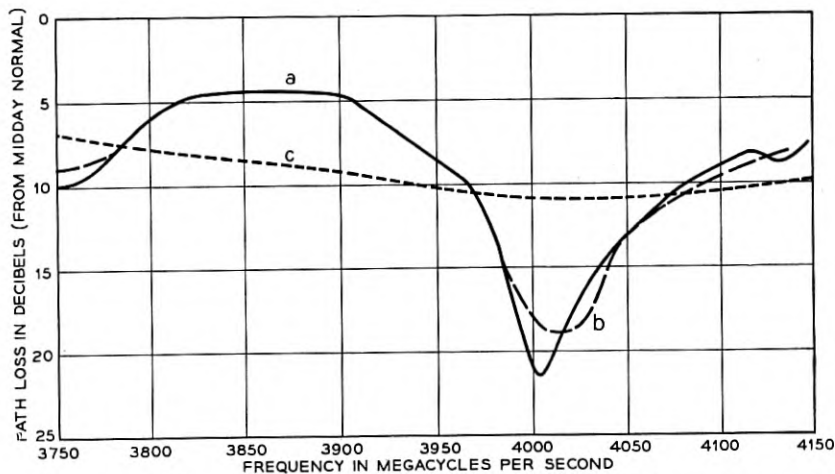

Fig. 4. — Path-loss versus frequency curves synthesized from components shown in Table I.

selectivity. (Statistical data are given later which bear out this conclusion).

2. No deep fades were found that did not include an appreciable component of loss with little appearance of frequency selectivity; that is, no deep fading occurred unless the signal was already depressed 10 or so db across the entire observed band. This could be caused either by (a) the presence of appreciable interfering signals of slight delay from the direct signal component, see curve (c) on Fig. 4, or (b) by non-frequency selective attenuation of the direct signal component. The former seems more likely; but the evidence is not conclusive in this regard.

3. No curves for deep fades were found which appeared as if they could be synthesized satisfactorily with fewer than four to six components.

TABLE I

Component	$R$ (Normalized to magnitude of direct received signal)	$T$ Milli-Microseconds	Phase Shift From Direct Signal Component	
			Half Wave Lengths	At Frequency
0	1.0	0	0	Any Freq.
1	0.45	0.122	1	4090 mc
2	0.26	0.370	3	4050 mc
3	0.10	2.86	23	4033 mc
4	0.115	3.14	25	3981 mc
5	0.025	3.9	31	3972 mc
6	0.02	12.1	97	3993 mc



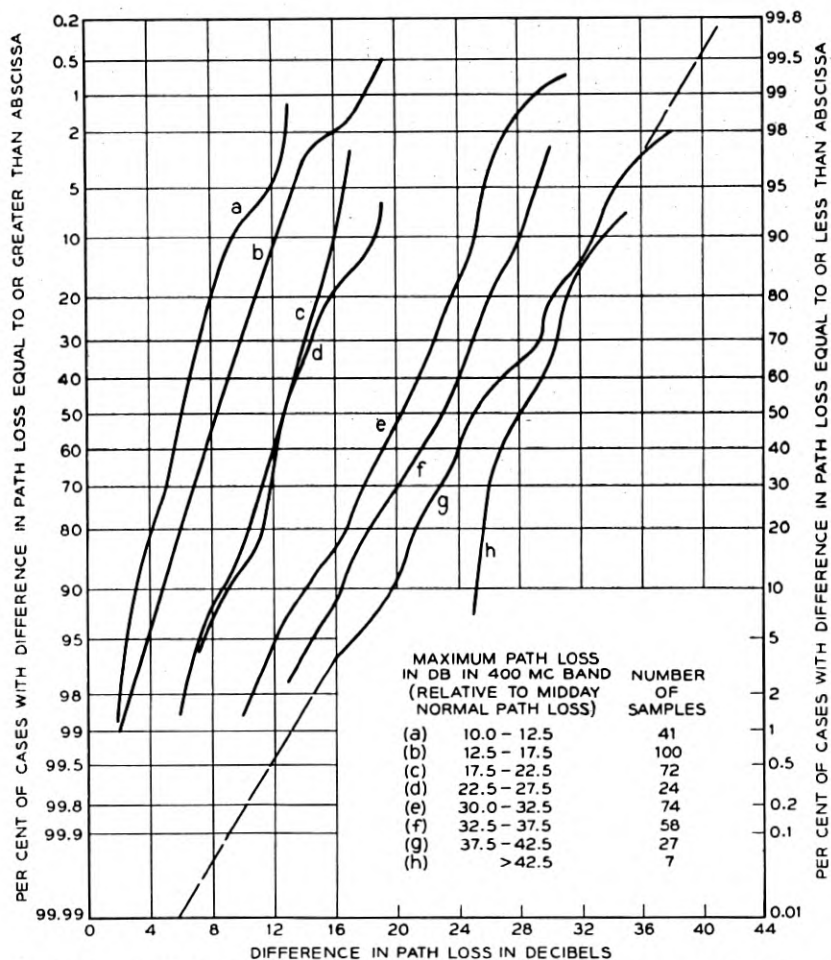

Fig. 5 — Statistical distribution of differences between maximum and minimum path loss in bands 400 mc wide. (Center frequency of 400-mc band random with respect to frequencies corresponding to maxima and minima of path loss).

4. It seemed to be the rule that components with relatively long delays were appreciably smaller in magnitude than those with shorter delays.

5. At the bottom of the deep fades some of the small signal components with relatively long delays were an important factor in determining the shape of the path-loss versus frequency curves.

Fig. 5 illustrates one type of statistical information which was derived from the 1,800 individual path-loss versus frequency curves. The family of curves on Fig. 5 shows the per cent of fades (of a given depth) which

were frequency selective to any given degree. For example, 95 per cent of fades which were 40 db deep showed a variation in path loss (frequency selectivity) across the observed band 400 mc wide of at least 17 db. By extrapolating the curve for 40 db fades (which appears to follow a normal distribution law) it can be estimated that 99 per cent of the 40 db fades had at least 13 db of frequency selectivity within the observed band 400 mc wide. Probably, observation of a wider band would have shown even greater evidence of frequency selectivity.

During periods when the received signal was materially stronger than mid-day normal there was practically no evidence of frequency selectivity. Several periods were observed when the path-loss across the entire

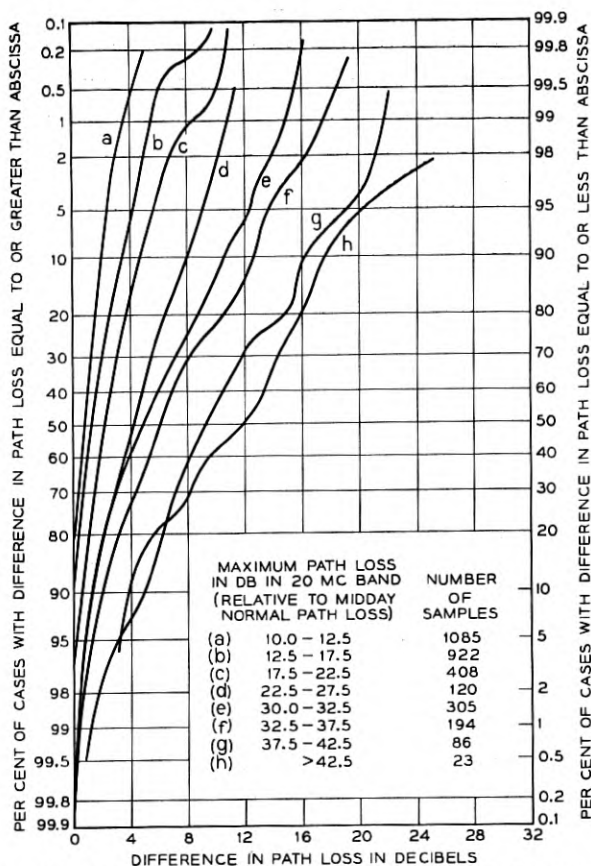

Fig. 6 — Statistical distribution of differences between maximum and minimum path loss in bands 20 mc wide. (Center frequency of 20-mc band random with respect to frequencies corresponding to maxima and minima of path loss).

400-mc observed band was 8 db less than mid-day normal; and in one case it was more than 10 db less than mid-day normal.

Another family of curves is shown by Fig. 6. These curves were obtained by dividing the 400-mc observed band into a number of 20-mc bands, chosen at random with regard to the shapes of the path-loss versus frequency curves. These data show the difference between the maximum and minimum losses within a single 20-mc broad-band channel which might accompany a fade of a given depth. Such data are of use in estimating possible distortions of a modulated signal occupying a band width of 20 mc.

### *Frequency Diversity*

The fact that the instantaneous fading may be different on different frequencies within the same frequency range offers a means for mitigating transmission impairments caused by fading. During periods when there is fading in excess of a specified value on the regular carrier frequency, the carrier can be shifted to an alternate frequency in the hope that the fading on the alternate frequency may be less severe. The merit of using this type of frequency diversity can be gauged from the statistical distribution of fading on the alternate frequency during periods when there is fading in excess of the specified value on the regular frequency.

The data obtained in these tests indicates that there was no correlation between the fading on frequencies separated by: (1) 40 mc or more during periods when there was fading of 10 db on one of the frequencies and (2) 160 mc or more during periods when there was fading of at least 20 db on one of the frequencies. However, during periods of severe fading, the data indicate considerable correlation between the fading on regular and alternate frequencies separated by 80 mc or less.

Fig. 7 shows the distributions of fading on alternate frequencies at specified frequency separations from the regular frequency, when there is fading of a specified depth on the regular frequency. Table II indicates which of the curves on Fig. 7 applies to a particular set of conditions.

Curves *G* and *H* on Fig. 8 show the distributions of depths of fade at 4190 mc during the entire months of July and August, respectively. Comparison of the 4,190-mc data with data from tests made over other paths indicates that the fading occurring during the Iowa tests was nearly as severe as during the "worst month" observed on any path to date.

Curve *B* on Fig. 7 shows the statistical distribution of fading on any frequency (within the range under consideration) during periods when important fading is prevalent. The fading shown by this curve is con-

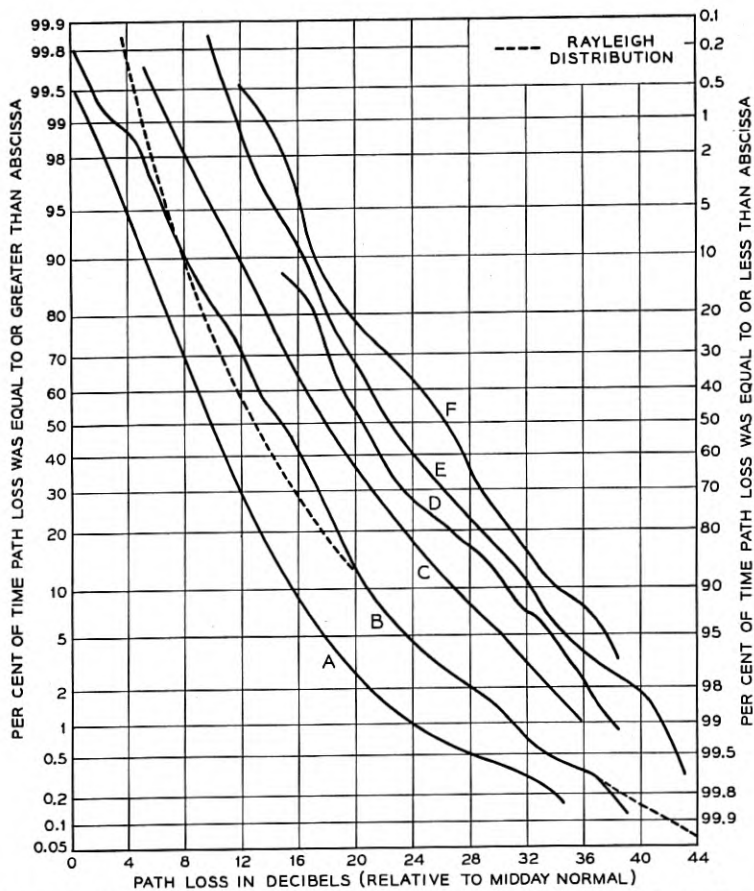

Fig. 7 — Statistical distributions of fading measured on Lowden-Princeton, Iowa, path during July and August, 1950. These curves are useful in predicting the efficacy of specific frequency-diversity systems as described in the text.

siderably more severe than is shown by the curves on Fig. 8. This is because the latter curves include all the time within the months under consideration. Therefore, they include much time when the fading mechanism was not present in the path, and the path loss remained steady near mid-day normal.

There is evident similarity between the shapes of Curves *A* through *F* (on Fig. 7) with the shape of the curve which is based upon the Rayleigh distribution. This is consistent with the theory that deep fading associated with multipath transmission is caused by random phasing of a large number of vectorial components.

These data have been applied practically to the design of frequency-diversity measures for minimizing circuit outages caused by fading in TD-2 radio relay systems.

Fig. 9 shows an illustration of the practical use of the data. Curve *H* (which is the same as Curve *H* on Fig. 8) shows the distribution with time of the fading on a typical radio relay path without frequency diversity measures. Curve *J* shows the distributions of fading if certain specific frequency diversity measures are used (based solely on fading considerations). The difference between Curves *H* and *J* shows the improvement gained by using that specific kind of frequency diversity. For example, Curve *H* shows that without frequency diversity fading in excess of 30 db will occur 0.075 per cent of the time and fading in excess of 40 db will occur 0.02 per cent of the time. But, if the kind of fre-

TABLE II

Depth of Fade on Regular Frequency	Separation Between Regular and Alternate Frequencies	Curve
10 db	40 mc or more	A
20	40 mc	C
20	80 mc or more	B
30	40 mc	E
30	80 mc	C
30	160 mc or more	B
40	40 mc	F
40	80	D
40	160 mc or more	B

quency diversity to which Curve *J* corresponds is used, fades deeper than 30 db will occur only 0.0012 per cent of the time, and fades deeper than 40 db will occur only 0.00008 per cent of the time. Thus the improvement resulting from this type of frequency diversity is a reduction of fades deeper than 30 db from 0.075 to 0.0012 per cent of the time, and fades deeper than 40 db from 0.02 to 0.00008 per cent of the time.

To explain how Curve *J* was derived, let us assume that during any time when there is a fade of 30 db or more on the operating frequency of a given channel the signal will be switched to another channel frequency. Let us further assume that the alternate frequency will be separated by 160, 240, 320, or 400 mc from the assumed operating frequency and that the choice of alternate frequency is random. If we also assume that the conditions of August, 1950, on the Iowa path prevail, we will find from Curve *H* on Fig. 8 that the assumed operating frequency will have a fade of 30 db or more 0.075 per cent of the time. Then a new distribution curve can be prepared, based on (1) Curve *B* (on Fig. 7) for

0.075 per cent of the time, and (2) that portion of Curve *H* (on Fig. 8) which corresponds to fades of less than 30 db for the remaining 99.925 per cent of the time. Curve *J* on Fig. 9 is such a curve.

If frequencies separated from the assumed operating frequency by 80 mc were used instead of those assumed above, Curve *C* instead of Curve *B* on Fig. 7 would have been used. This would have shown a somewhat smaller improvement because of some correlation between the fading on the assumed operating frequency and an alternate frequency separated from it by 80 mc. However, the improvement gained from the use of this system would be ample to prove-in its use.

The question is sometimes raised concerning the reason that the curves on Fig. 9 show an apparent improvement for fading of less than 30 db, since the circuit is switched only when fading deeper than 30 db occurs. This is because the curves are cumulative distribution curves;

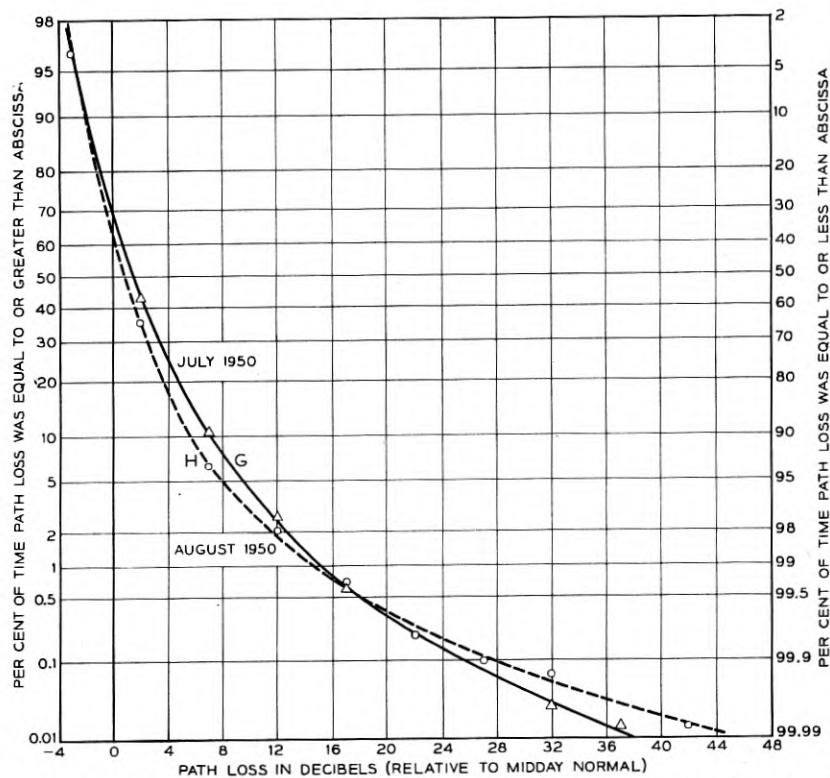

Fig. 8 — Statistical distribution of fading loss Princeton-Lowden, Iowa, path July and August, 1950.

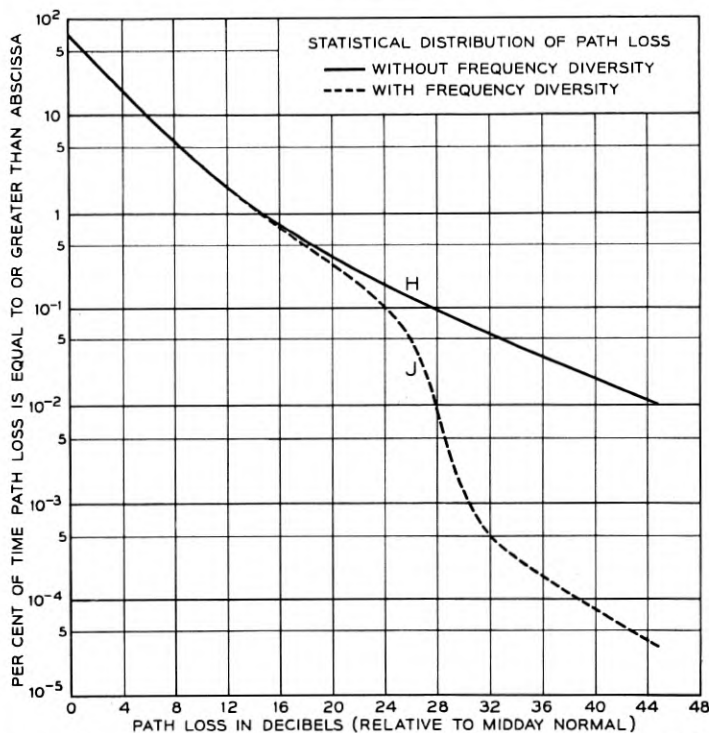

Fig. 9 — Effect on transmission of use of frequency diversity in 3,750–4,150 mc range.

and reduction of the per cent of time when there is fading deeper than 30 db also reduces the per cent of time when there is fading deeper than 25 db, etc.

#### CONCLUSIONS

Quantitative information on fading phenomena is essential in the engineering of super-high-frequency systems and in evaluation of frequency diversity arrangements. The data obtained from the field tests and the statistical analysis reported herein, while limited to a single path and particular season, fill a gap in previous knowledge. They have found practical application in the design of diversity systems for improving the reliability of radio relay systems.

The principal conclusions that can be drawn from the available data are: (1) all of the deep fading is definitely frequency selective, and is caused by a complex multi-path transmission; (2) deep selective fading

is ordinarily accompanied by a 6 to 10 db signal depression over a band of at least several hundred megacycles; (3) fading on frequencies separated by 160 or more megacycles shows little correlation, but fading on frequencies more closely spaced shows an increasing correlation as the frequency difference is diminished; and (4) frequency diversity offers a practical means of mitigating circuit impairment due to fading, if the transmission can be shifted to a frequency far enough away to minimize correlation with fading on the original frequency.

#### ACKNOWLEDGEMENTS

The author wishes to acknowledge the important contribution of J. Mallett, who conducted the field tests during which the data were obtained. The field tests and data analysis were under the supervision of R. P. Booth.



# Acceleration Effects on Electron Tubes

By F. W. STUBNER

(Manuscript received June 19, 1953)

*This paper discusses methods of measuring shock and vibratory accelerations to which electron tubes may be subjected in various equipments, and the influence of these disturbances on the performance of the tubes. An outline is given of the design problems connected with the elimination of tube damage or faulty operation of tubes under adverse shock or vibration conditions, and of the methods used for simulating these conditions by means of production test machines and test methods.*

## INTRODUCTION

The rapid expansion of the use of electronic equipment by industry and the armed services has created increasingly new demands on both the electrical and mechanical characteristics of electron tubes. Since these tubes are electronic devices, it is only natural that their structural designs are dictated to a large extent by electrical requirements. However, the experience gained with conventional tubes in some of the new equipment applications has revealed certain mechanical shortcomings which reflect on the proper functioning or life of the tubes. The realization of the increasing importance of mechanical design has resulted in an increased effort for structural improvements to assure more reliable tube performance. The term "reliable", as used here, denotes that a tube has a high degree of dependability when subjected to specific conditions, either electrical or mechanical. Thus, the requisites for reliability may differ for various applications. Although, in designing a tube, many requirements must be taken into consideration, only some of the problems connected with dependable tube performance under mechanical disturbances, i.e., shocks and vibrations, will be discussed here.

Since the performance of a tube depends on the geometry of its component parts, minute changes in element spacing may produce variations in its characteristics. Because of the necessarily delicate structure of some tube elements, permanent or transient dimensional changes may be produced by mechanical forces acting on the tube unless the tube is

specifically designed to minimize the effects of such disturbances. For a rational design, it is, therefore, necessary to have some knowledge of the nature of the disturbances likely to be encountered by tubes during their service life. If one considers the numerous conditions under which electronic equipment is required to function, it becomes clear that the mechanical requirements are manifold indeed. Equipment applications can be divided into three general groups, each one imposing in many cases special requirements on tubes. These groups are: (a) stationary equipment, such as central office telephone installations, home radio and television receivers, etc., (b) mobile equipment used in land vehicles, ships or airplanes, and (c) portable equipment. In many instances, military equipments straddle above subdivisions and superimpose additional requirements. It must be stressed, too, that pre-service conditions encountered through handling and shipping must be taken into consideration, since a tube is of no use to the customer until it is installed and operating.

A knowledge of expected service conditions is not only useful in the initial design stage but also aids the manufacturer in devising suitable test gear to check the quality of the product at the factory. Although a wealth of data has been collected on shocks and vibrations to which electronic equipments are subjected under actual service conditions, little is known how these disturbances are altered by the mechanical structures of the equipments before they reach the tubes. In general, the nature and magnitude of mechanical disturbances can be expressed in terms of acceleration, velocity, or displacement. Since electron tubes may respond to a wide frequency range of vibrations, the most sensitive measure is acceleration, which varies as the square of the frequency of the element displacement. Velocity or displacement instruments are usually not sufficiently sensitive to give a true record of disturbances in the higher modes of vibration due to the small velocity and displacement values involved.

The investigation of the nature of accelerations at tube sockets offers special problems. The accelerometers must approximate the weights of the tubes used in the respective sockets so that the disturbances are not modified by the substitution of acceleration pick-ups for the tubes. For the same reason, the method of fastening the accelerometers in the sockets must duplicate that of the tubes, and since the accelerating forces may act in several directions, the accelerometers must be capable of exploring these various directions. Lightweight accelerometers meeting the above requirements have been developed recently. These instruments are generally built to approximate the weight, weight distribution, and shape of vacuum tubes. A more detailed description of these accelerometers and associated recording circuits is given in the following chapter.

## ACCELEROMETERS AND ASSOCIATED INSTRUMENTATION

Instrumentation employed for measuring accelerations depends largely on the frequency range of the disturbances to be recorded, which, for vacuum tube applications, covers approximately the audio spectrum.

In practically all cases, electronic recording equipment is used because of its high degree of flexibility. Its basic components consist of (a) a mechanical-electrical transducer which translates mechanical disturbances into proportional electrical potentials, (b) an electronic amplifier to step up the voltage output of the transducer to desired levels, and (c) an indicating instrument, usually a cathode ray oscilloscope, for observations of the disturbances.

*Accelerometers*

Although several types of mechanical-electrical transducers or pickups are in existence,<sup>1</sup> it has been found that the self generating types employing materials such as quartz or ferro electric crystals, are most useful since they can be constructed so that their output is directly proportional to acceleration over a large frequency range. Velocity and displacement indicating instruments are sometimes used for low frequency work; by suitable differentiation their output signal will be proportional to acceleration.

An accelerometer must have the following fundamental properties:

(a) the signal produced must be proportional to the accelerations to be measured.

(b) its calibration must be stable and unaffected by humidity and temperature changes encountered.

(c) its mechanical strength has to be adequate to withstand the acceleration stresses to which it is subjected.

(d) its weight must be sufficiently low so that the disturbance patterns are not modified by loading.

(e) its sensitivity (voltage output/g) and useful frequency range must be sufficiently high to cover acceleration magnitudes and frequency components to be recorded.

A number of piezoelectric materials are available and have been employed in various electro-mechanical transducers. The development of practical light-weight transducers has been made possible by the use of some of the relatively new ferro-electric ceramics. By proper compounding, firing and poling, these materials can be made to have very high sensitivity and good life stability. Other advantages are their high dielectric values, good mechanical strength and relative insensitivity to usually

encountered humidity and temperature conditions. Accelerometers approximating the size and weight of electron tubes are now commercially available and used for measuring accelerations imparted to tubes through their sockets.

By proper construction the voltage output of these pick-ups is proportional to the stresses induced in the active elements within the desired frequency range. Depending on choice of material and construction, their active elements can be used in compression, shear, or torsion. Fig. 1(a) shows the simplified construction of a compression type pick-up. It consists of (1) a base which is rigidly fastened to the point at which accelerations are to be measured, (2) a sensitive element, (3) a weight, and (4) a retaining spring. The whole assembly is shown held together by a screw. The mechanical equivalent of this structure is shown in Fig. 1(b).

When this unit is subjected to sinusoidal motion its displacement is given by

$$X = X_0 \cdot \sin \omega \cdot t$$

Where  $X$  = instantaneous displacement of the base from equilibrium at time  $t$

$X_0$  = maximum displacement from equilibrium

$\omega$  = circular frequency of the motion

The instantaneous acceleration then becomes

$$a = \frac{d^2x}{dt^2} = -X_0\omega^2 \text{Sin } \omega t \quad (1)$$

The motion is transmitted to the mass  $M$  through the parallel spring

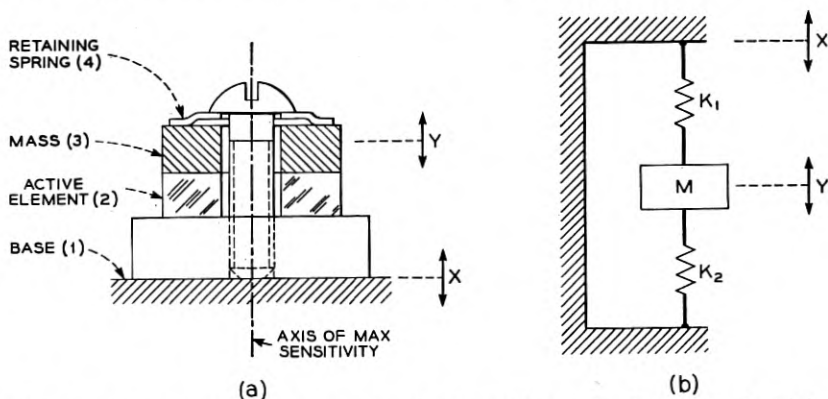

Fig. 1 — Compression type accelerometer (a) and its mechanical equivalent (b).

system formed by the stiff active element  $K_2$  and the retaining spring  $K_1$ . For negligible damping in these springs the motion of the mass relative to the base is:

$$y_1 = \frac{X_0 \left(\frac{\omega}{\omega_n}\right)^2}{1 - \left(\frac{\omega}{\omega_n}\right)^2} \cdot \text{Sin } \omega t \quad (2)$$

Here  $\omega_n$  = the natural circular frequency of the mass on the springs. The force  $F$  exerted by the springs on the mass is:

$$F = (K_1 + K_2)y_1 = \frac{(K_1 + K_2)X_0 \left(\frac{\omega}{\omega_n}\right)^2}{1 - \left(\frac{\omega}{\omega_n}\right)^2} \text{Sin } \omega t \quad (3)$$

The accelerometer is constructed so that the spring constant  $K_1$  of the retaining spring is considerably smaller than that of the active element  $K_2$ . Therefore, for vibration frequencies relatively low as compared to  $\omega_n$ , equation (3) becomes:

$$F = \frac{K_2}{\omega_n^2} X_0 \omega^2 \text{Sin } \omega t \quad (4)$$

Where

$$\frac{K_2}{\omega_n^2} = M, \quad \text{and} \quad X_0 \omega^2 \text{Sin } \omega t = a$$

The stress produced by this force  $F$  produces a charge on the active element which is proportional to the instantaneous value of the acceleration to which the unit is subjected. Properly calibrated therefore, the acceleration can be measured in gravitational units. When the disturbing force consists of a number of these components, the total instantaneous output is proportional to the sum of these components, within the frequency limitation of the pick-up.

In deriving the above expressions, a number of assumptions have been made. Equation (4) therefore holds only if:

(a)  $\omega_n$  is made large compared to the highest shock or vibration frequencies that are to be recorded.

(b)  $K_1$  is small compared to  $K_2$ . Since the function of the retaining spring is merely to hold the assembly together for peak accelerations encountered, a soft spring with a sufficiently large static deflection can be employed or the spring may be replaced by conducting cement to hold the parts together.

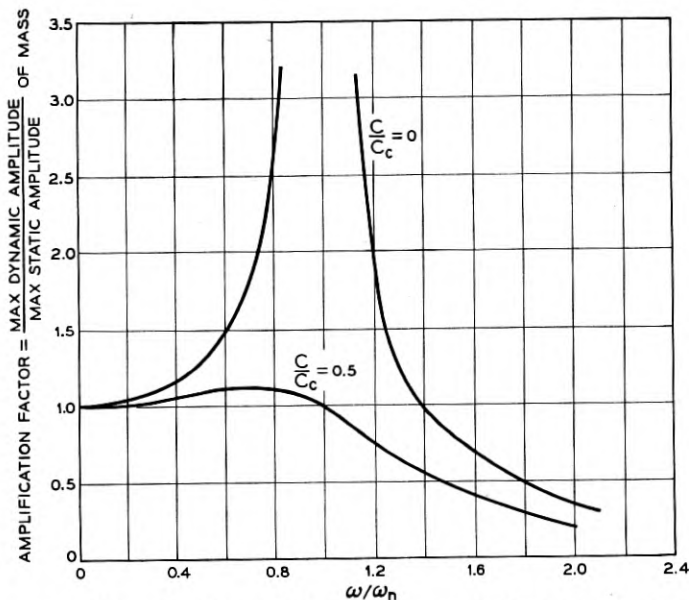

Fig. 2 — Amplification of forced vibration on mass for two degrees of damping.

(c) damping of the system is small. If damping is considerable, equation (2) becomes

$$y_1 = \frac{\left(\frac{\omega}{\omega_n}\right)^2 X_0 \sin \omega t}{\left(\left[1 - \left(\frac{\omega}{\omega_n}\right)^2\right]^2 + \left[2 \frac{c}{c_c} \frac{\omega}{\omega_n}\right]^2\right)^{1/2}} \quad (5)$$

In this expression  $c/c_c$  = fraction of critical damping. However, since by construction, the natural frequency of the system is large compared to the forcing frequencies, and damping of the active elements employed in these accelerometers is small, the term  $\left(2 \frac{c}{c_c} \cdot \frac{\omega}{\omega_n}\right)^2$  becomes negligible. Equation (5) therefore simplifies to equation (2).

The useful upper frequency limit is generally fixed at  $\frac{1}{4} \omega_n$ , because, as shown by Fig. 2\* amplification of the impressed signal results as  $\omega/\omega_n$  increases. If the disturbances contain frequencies beyond the useful limit, low pass electrical filters must be employed in the associated amplifier to suppress these frequencies. The fact that this type of pick-up has very low damping offers some disadvantage in recording complex waves be-

\* Figs. 2 and 3 were obtained from material given in Reference 2.

cause phase distortion between the impressed and recorded frequency components takes place. Fig. 3\* graphically illustrates this relation. This figure shows that  $\left(\frac{c}{c_c}\right)$  would have to be made approximately 0.5 in order to have a phase angle proportional to the impressed frequencies, i.e., to obtain a true recorded pattern of the disturbance. Damping is generally not employed in accelerometers built to duplicate the size and weight of electron tubes due to constructional difficulties. The useful frequency limit of these devices is often not governed by the resonant frequencies of the active elements but by the lowest resonant frequency of their housing structure.

As mentioned previously, the active elements of these light weight transducers can be employed in various ways. The first models which were developed a few years ago made use of the elements in compression, following the practice of their predecessors, or: the relatively heavy and large quartz crystal accelerometers. A working model of a compression unit is shown in Fig. 4(a). Although this type of unit can be constructed to have a very wide useful frequency range (high resonant frequencies), it possesses two disadvantages: its internal capacity is rather low, and it has poor directional sensitivity. Its sensitivity decreases to roughly

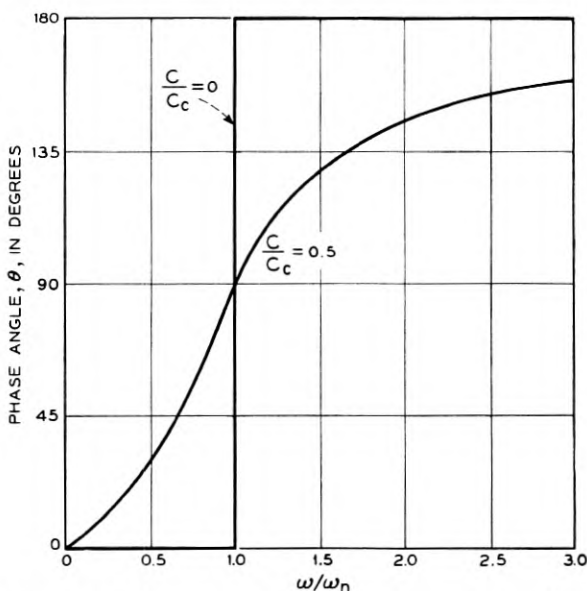

Fig. 3 — Phase angle between force and displacement as a function of the forcing frequency for two values of damping.

10 per cent of maximum in the direction perpendicular to the sensitive axis. Some improvements in directivity were obtained by utilizing the elements in shear. Fig. 4(b) illustrates a tandem shear type accelerometer. The construction of this unit is somewhat more complicated. The elements first have to be poled in the proper direction. The conducting layers used for poling in this direction then have to be removed and new conductive coatings have to be applied on the areas facing the base and mass  $M$ . The unit shown is sensitive to accelerations in the radial direction. The improved directivity of the shear elements over compression elements is shown in Fig. 5. Although shear elements are superior for detecting acceleration components along desired directions, it is difficult to make their internal capacity sufficiently high without increasing the over-all weight of the accelerometer for a given sensitivity. The use of cantilevers for these applications also suggested itself, for relatively high tensile and compressive stresses can be produced in such structures. Cantilever type elements have been constructed as shown schematically in Fig. 6(a). Here thin laminations of active material are cemented on opposite sides of a small metal cantilever. Under the action of external forces bending of the inner member subjects the outer laminations to

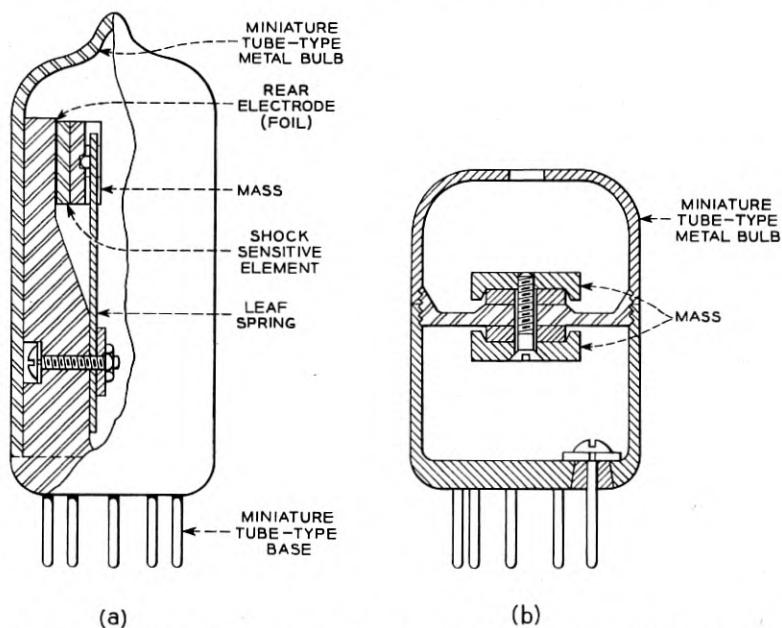

Fig. 4 — (a) Radial miniature tube compression type accelerometer and (b) radial miniature tube shear type accelerometer.



tension and compression stresses respectively, thereby producing the desired charges in these elements. The characteristics, i.e., the resonant frequency and sensitivity, of these elements are largely determined by the dimensions of the metal member. Relatively high internal capacities can be obtained by this construction. A recent variation of such a structure is shown in Fig. 6(b). In this design the inner metal component of the cantilever described above has been eliminated. The entire structure is made of the active material, in this case in cylindrical shape for ease of

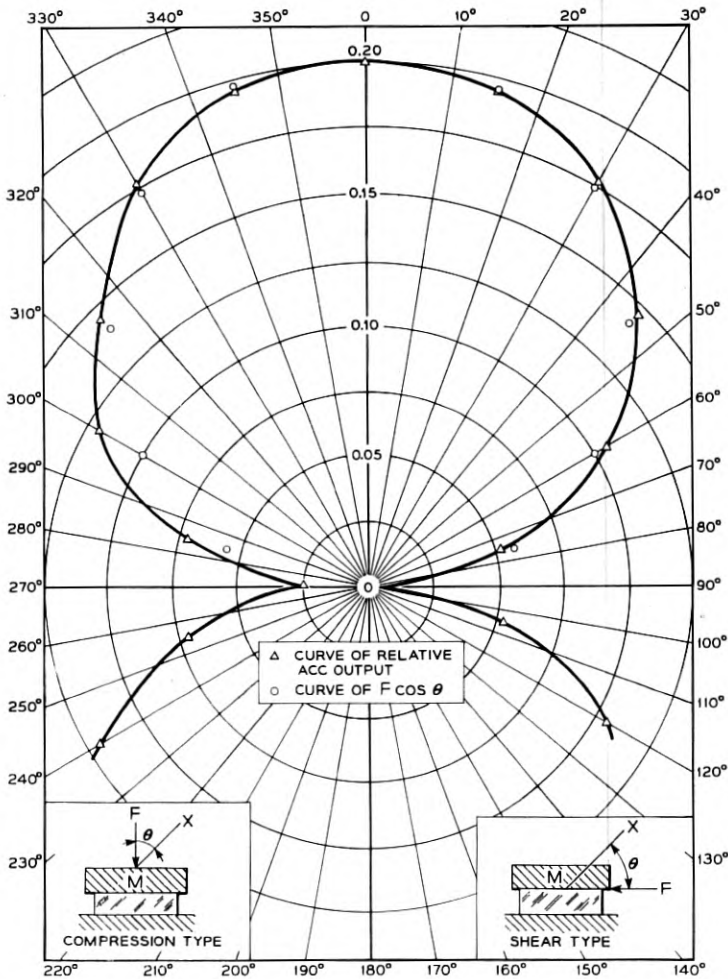

Fig. 5 — Relative angular response of compression and shear type ferro electric crystal accelerometers.

manufacture. Sections of conductive coating are deposited on this cylinder as shown. These are used to initially polarize the material, and, in use, to collect the charges produced by stressing the inner and outer fibers of the cylinder. It is interesting to note that these elements can be used to detect, by proper choice of connections, either radial or axial accelerations. Through suitable external instrumentation both directions can also be recorded simultaneously if desired.

The above illustrations show but a few applications of this material for detecting accelerating forces. Additional forms will suggest themselves, each of particular advantage for specific application.

The sensitivity of an accelerometer is generally given in coulombs/g or open circuit voltage. Its effective voltage output over a given frequency range is a function of the characteristics of the associated equipment including the connecting cable. Calibration in the lower frequency range up to a few hundred cycles may be performed by vibrating the accelerometer on variable frequency vibration machines or resonating spring

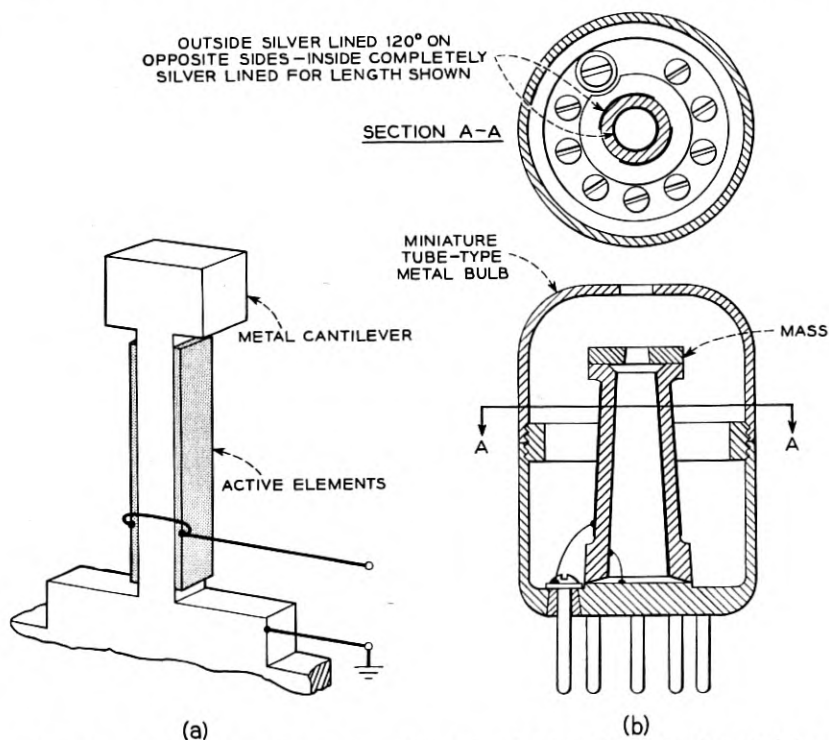

FIG. 6 — (a) Metal cantilever type element and (b) radial and axial miniature cantilever type accelerometer.

systems at amplitudes that are measurable with the help of a microscope. The peak acceleration in gravitational units for sinusoidal motion is given by:

$$g = .102 (\text{c.p.s.})^2 \times \text{amplitude (inches)}$$

At higher frequencies, this method of calibration becomes increasingly difficult due to the decrease in obtainable amplitudes. A calibration method for a wide frequency range is described in Reference 3. In general, the sensitivity of an accelerometer is a function of the active material, its size, and the weight  $M$  employed. The useful frequency range increases with decreasing sensitivity. For a given design, a compromise therefore has to be made between these quantities and the over-all permissible weight of the finished unit. To illustrate the approximate relations of weight, size and sensitivity, units have been constructed in the shape of miniature tubes weighing only 33 per cent more than their prototypes, with sensitivities in the order of 0.005V rms/g and a useful frequency range of 3,000 cycles.

Since these accelerometers are calibrated for rectilinear motion, the results obtained in measuring equipment vibrations or testing machines must be carefully interpreted. In many instances the disturbing forces impart a rocking motion to the units so that the position of the active elements in the housings will influence the acceleration magnitudes that are registered.

#### *Associated Instrumentation*

Since the voltage output of self generating accelerometers is small, electronic amplifiers have to be employed to bring the signal to desired levels. Fig. 7 illustrates a typical arrangement of the necessary equipment. A cathode ray oscilloscope is shown as the visual indicating means, although other recording instruments can be employed, depending on the nature of the disturbances to be measured and the type of record desired. The prime requirements of the equipment are:

(a) phase distortion must be low, so that the disturbance pattern is correctly presented.

(b) its transient and frequency response must be adequate for the frequencies to be recorded.

In the circuit shown in Fig. 7, the signal is fed into a cathode follower stage having a high input impedance in order to obtain good sensitivity and frequency response. The use of a cathode follower also offers more flexibility in the proper matching of the high impedance pick-ups to suitable low pass filters or to the following amplifying stage. The generated

signal is shunted by the capacity of the connecting cable. Since the voltage impressed on the grid of the first stage is approximately

$$V_2 = V_1 \frac{C_1}{C_1 + C_2}$$

it is desirable to have  $C_1$  large compared to  $C_2$ . In some types of investigations cable whip may result in the introduction of spurious voltages on the signal. These voltages are produced by capacitance changes and static charges on the cable dielectric. To minimize this effect, the cable may be shunted by a padding condenser at the expense of the voltage  $V_2$ . The National Bureau of Standards recently reported the development of a low noise cable<sup>4</sup> that is reported to overcome the shortcomings of the ordinary shielded cables. Cables with a sufficiently low noise figure have also become available commercially.

A timing and calibration voltage can be impressed across the low valued resistor  $R$  for comparison with the disturbance signal. If resonant frequency signals of the accelerometers are excited by the disturbances being investigated, or the recorded frequency range is to be limited, the signal is fed through low pass filters before being amplified. This prevents possible overloading of the amplifier by the unwanted frequencies, so that maximum gain can be realized for the desired signal.

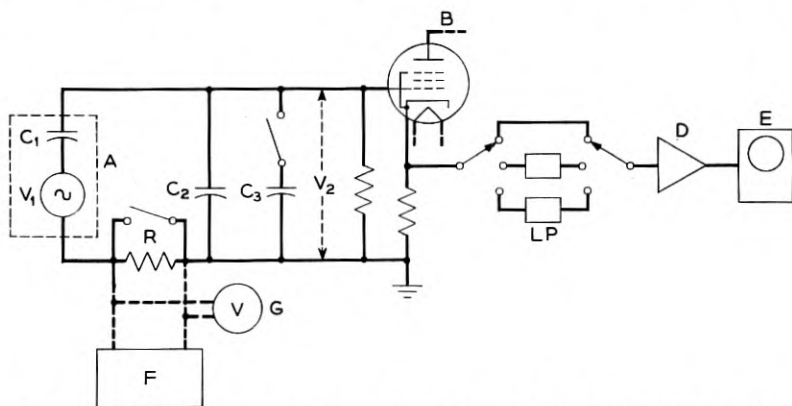

Fig. 7 — Schematic of accelerometer and associated recording circuit.

- |  |  |
|--|--|
| A — Equivalent circuit of accelerometer    | D — Voltage amplifier                    |
| B — Cathode follower stage                 | E — Recording instrument                 |
| LP — Low pass filters                      | F — Audio oscillator                     |
| $C_1$ — Internal capacity of accelerometer | G — Voltmeter                            |
| $C_2$ — Cable capacity                     | R — Calibrating resistor                 |
| $C_3$ — Padding condenser                  | $V_1$ — Voltage source                   |
|  | $V_2$ — Voltage impressed on first stage |

Particular attention must be paid to the design of the filters since these elements are apt to introduce excessive phase shift and oscillations. A variable frequency electronic filter has been found to be quite serviceable due to its flexibility in the choice of cut-off frequencies.

Additional information on shock and vibration instrumentation is given in Reference 5. Since the presentation of mechanical disturbances is, to some extent, limited by the transducers and their associated circuits, there is a trend towards a certain amount of standardization of these components so that results can be compared on an industry wide basis.

#### TUBE DESIGN PROBLEMS IMPOSED BY ENVIRONMENTAL CONDITIONS

It follows from the numerous acceleration measurements made at the installation points of equipment, that electron tubes, together with other components, have to withstand a large variety of conditions. Without over-simplifying the problems involved, it is perhaps permissible to divide these disturbances into two classes: ballistic shock, and transitory or sustained low  $g$  vibrations. Although, as a first approach, the effect of these disturbances on tube elements may be probed by mathematical analysis, the final design must be proven in by laboratory tests under controlled conditions. In discussing the influence of shock and vibration on tubes, their elements are frequently presented schematically as cantilevers, Fig. 8(a). While this assumption is a close approximation for some of the older tubes, such as the Western Electric No. 349B tube, Fig. 8(b), most tubes of later design, Fig. 8(c), do not lend themselves to such simple analysis due to their more complex structure. The response of elements to even simple shock pulses on tube envelopes are influenced by factors such as the clearances in micas, mica fits in the bulbs and tightness of mount assemblies.

It is obviously beyond the scope of this paper to analyze the destructive effects of shocks and vibrations on equipment. A few of the many excellent articles and publications on this subject are listed in Reference 6. It is equally impossible to present all of the many problems facing the electron tube engineer in designing tubes that will reliably serve their purpose under adverse conditions. Since tubes must be designed to withstand disturbances encountered in the field or be adequately protected, the following notes, highlighting some of these problems, will be of interest to equipment as well as tube engineers.

#### *Influence of High $g$ Shocks*

In certain applications, tubes are required to withstand occasional high shocks such as those produced in military applications by explosions

of some kind. It is generally permissible that, during very severe shocks, electronic equipment is non-operative; therefore, the response of tubes during these disturbances may fall outside of assigned limits. However, since it is highly important that operations resume immediately, the tubes must show no permanent change nor have caused damage to the circuits as a result of temporary faulty operation. Although protective shock mounts are usually employed on equipments exposed to these conditions, damped equipment vibrations excited by the attenuated shock wave are superimposed on the pulse felt by the tube.

Brittle or stiff tube components are most susceptible to shock because of their inability to absorb the shock energy by elastic deformations. Failures falling into this category are:

(a) glass breakage, which may be brought about by impact due to excessive movement of the tube or adjacent components during the impact.

(b) metal to glass seal fractures, produced by shock loads on the tube leads and seals.

(c) heater or filament failures and opening of welds.

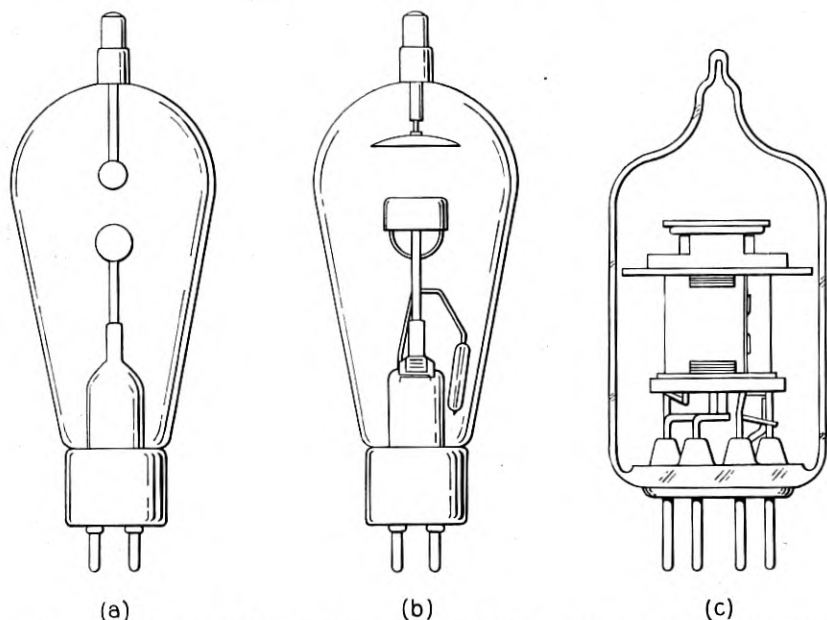

Fig. 8 — Electron tube structures: (a) Simplified anode and cathode structure of a Western Electric No. 349B tube, (b) Western Electric No. 349B tube, and (c) typical miniature tube.

(d) damage to mica serrations and enlarging of the mica holes which support and space tube elements. The deterioration of the mica is also known to liberate gas, which, in turn, results in a reduction of the vacuum.

Permanent damage is also caused by deformation of elements beyond their elastic limit. Bowing of grids and cathodes as a result of shock has been reported in some applications.

Although not always realized by design engineers, shocks and vibrations of surprising magnitudes may also occur in handling and shipping. If these conditions are not taken into consideration during the design stage, the over-all cost of the product may be adversely affected by the necessary protection that has to be built into the shipping container to assure safe arrival of the packaged article at its destination. While many factors enter into the proper design of shipping containers, such as moisture and corrosion protection, the selection of cushioning materials is perhaps the most important. Since it is desirable from a storage and shipping cost standpoint to keep the package bulk to a minimum, and protective packaging cannot always compensate for design weakness, adequate strength must be designed into the tube even though it will not be subjected to severe shocks once it is installed. A rather complete analysis of the dynamics of package cushioning is given in Reference 7. At present, military requirements specify that packaged tubes must safely withstand several three foot drops onto a hard surface.

#### *Influence of Low g Disturbances*

In contrast to the relatively infrequently occurring high peak shock and vibrations, we find that many equipments are often subjected to repetitive shocks and sustained vibrations at lower acceleration levels. These conditions are generally encountered in vehicle, ship and airplane applications. Although these shocks and steady state vibrations can be attenuated through the use of shock and vibration mounts, the effectiveness of these mounts may be reduced sharply by a change in disturbance frequencies from normal.

Tube failures resulting from these conditions are generally caused by fatigue of some tube elements. For instance, the continual hammering of micas against tube walls or chattering of cathodes and grids in the mica, may reduce the value of the micas as supporting and spacing elements, and since tubes are required to function under these conditions, the gradual degradation of the micas will bring about an increase in the tubes' microphonic output. Where microphonism is a factor, the useful

life of a tube is, therefore, terminated long before more apparent failures occur in the tube structure. Other points of weakness are heater and filament leads.

As may be deduced from the above, microphonism is a frequent cause of complaint when tubes are subjected to low but repetitive shocks or transient vibrations. To illustrate the influence of such disturbances on tube performances, the results of recent investigations of tube microphonism found in a certain equipment will be cited.

In this case, field reports indicated that certain tubes exhibited excessive microphonism in the equipment, although the tubes were found to be within limits when judged by standard factory tests. It was apparent, therefore, that these tests did not simulate actual conditions. Acceleration measurements made at the equipment base and at tube sockets revealed that the steep, short duration impact of a blow delivered to the outer case excited resonant vibrations of the chassis on which the tubes were mounted. The magnitudes of these vibrations were only in the order of 0.1g, but their lowest frequency (approximately 550 cps) was close to the mount resonances of some of the tubes. Further tests also showed that those tubes having pronounced response, i.e., low damping, to vibratory motion in this frequency range also proved to be microphonic in the equipment. (The vibration spectrum of one of the tubes is reproduced in Fig. 9.) It was found that the various modes of vibration of the tube mount produced the high peaks in the range between 500 and 1000 cps. Unfortunately, present factory tests do not include a complete evaluation of tube response over a wide enough frequency spectrum.

Observations made on several equipments indicate that structural changes in the chassis or re-positioning of tubes would, in some instances, reduce the effect of mechanical disturbances on tubes. An occasional source of trouble is introduced by equipment motor vibrations, especially after mechanical wear has increased play in the moving parts. The accelerations involved in these vibrations are usually very small, but if their frequencies coincide with structural resonances in the tubes, unsatisfactory operation of the equipment may result. The influence of such disturbances on tube operation is not always recognized by equipment designers.

Several programs are currently pursued by both military and commercial agencies to increase tube reliability. Since the necessary requisites that make a tube reliable depend on the type of service to be performed and environmental conditions, the requirements stressed in the various programs differ in many respects. Some of these requirements are still in a state of flux, as actual needs are as yet not clearly known.



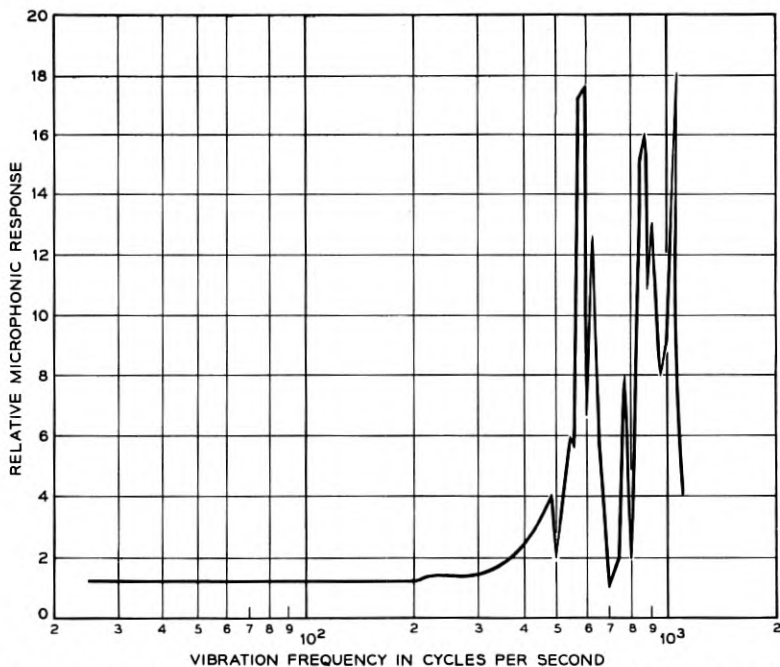

Fig. 9 — Frequency response of a tube that exhibited microphonism in equipment. The direction of vibration is perpendicular to the major diameter of grids and tube axis.

#### SHOCK AND VIBRATION REQUIREMENTS AND TEST EQUIPMENT

##### *General requirements*

Certain tests have been written into the MIL-E-1B<sup>9</sup> and other specifications to control the shock and vibration characteristics of tubes, and to check on their behaviour under given mechanical excitation. Long usage has given these specifications some validity in that they control the quality of the product even though actual field conditions may not necessarily be simulated in the tests.

At present, one or more of the following three types of tests are called for on tube specifications:

(a) *Shock tests.* These are high acceleration tests to insure that tube structures will withstand occasional shocks of given maximum magnitudes. Since, in general, tubes are not required to function during high peak shocks, no operating voltages are applied to the tubes for this test. The post shock requirements are that the tube characteristics must not have drifted out of their limits. In many cases, the type of shock tester to be used is specified, because it is difficult to define the shock output of

many of these machines in terms of acceleration and frequency content, etc. The response of tube structures may be vastly influenced by shocks of the same nominal acceleration but differing acceleration wave forms. Shock tests are also performed on tubes during their initial development to obtain the degree of cushioning required for safe shipping and handling purposes.

(b) *Vibration tests.* These are low acceleration, fixed frequency tests. They are made on machines with sinusoidal displacement output. Short time duration 25-cycle — 2.5g, or 50-cycle — 10g tests are specified for tubes that are generally not exposed to constant vibrations. Usually no voltages are applied to the tubes under test since their prime purpose is to check for sound tube structures. Electrical post vibration performances are the criteria of tube quality. In this category also fall the long time duration vibration tests made on tubes intended for use in equipment that is known to be subjected to continual vibration, such as shipboard or mobile equipment. Present specifications call for 96-hour tests at 2.5g — 25 cycles. This, therefore, is a fatigue test which determines the capability of tube structures, under prolonged cyclic stresses.

(c) *Microphonic vibration test.* A 25-cycle — 2.5 g test performed with specified voltages on the tubes under test to investigate the influence of low acceleration vibration on the output of tubes. This test is specified on certain tubes, especially those used for audio applications. The permissible magnitude of spurious signals excited by vibration is limited on the respective tube specifications.

(d) *Tap tests.* These tests are performed for two purposes. One is for the detection of defects such as foreign particles between close spaced adjacent elements, damaged elements, or poor welds. Open and short testers of given sensitivity are used to indicate these defects. The second purpose for tap testing is the investigation of microphonic response of tubes to mechanical disturbances. For these tests the tubes are made to work in Class A amplifier circuits. Acoustic feedback may be used, so that the tube is not only subjected to the mechanical tap, but also to the sound of the tap excited microphonic signal which is reproduced through a loud speaker spaced at a given distance from the tube. Sustained microphonism can be produced by these means under certain conditions. The purpose of this type of test is to simulate conditions to which tubes are subjected in some equipments, especially those closely coupled to audio output components.

### *Equipment*

The following is a brief description of the machines used for the performance of the above tests and their output characteristics.

*MIL-E-1B Bump Tester*

This is one of the earliest devices employed for shock testing of tubes under controlled conditions. In order to assure uniformity of results the MIL specifications give its physical dimensions. Fig. 10 illustrates the tester and its method of use. The magnitude of the shock and its duration is given by tube weight, shape of tube envelope contacted by the hammer, resilience of rubber pad on the hammer, and the angle ( $\theta$ ) through which the hammer is permitted to swing before striking the tube.

Although for the performance of the tests, only the angle ( $\theta$ ) is specified, the shock characteristics of this device have been investigated,<sup>10</sup> so that shock magnitudes and durations for any tube may be computed from the parameters given above. A typical acceleration time curve is shown in Fig. 11. The simple bell shaped outline of the accelerogram is given by the non-linear spring characteristic of the rubber pad and the generally cylindrical shape of the tube envelope.

*Shock Testing Mechanism per ASA-C39.3*

This mechanism is also used to check and compare the resistance of tubes to mechanical shocks of predetermined magnitude and duration. In this device the sample to be tested is rigidly fastened on a platform. A steel leaf spring supported at both ends is attached underneath this platform. The test on the sample is performed by raising the platform to a certain height, allowing it to fall on a steel anvil, and then catching it on the rebound.

The shock magnitude is given by

$$G \text{ max} = \sqrt{\frac{2hk}{W}}$$

and its duration by

$$J = \pi \sqrt{\frac{W}{12Kg}}$$

where  $W$  = tableweight (lbs.)

$h$  = height of fall (inches)

$K$  = spring constant of leaf spring.

A number of leaf springs are available to produce the desired shock characteristics. A full discussion of this mechanism and its performance are covered in Reference 11. A slightly modified version of the tester, used by the Laboratories, together with a typical shock pulse, is shown in Figs. 12 and 13. It can be seen that the pulse is essentially of sinusoidal shape with higher frequencies superimposed on it. The fundamental frequency is produced by flexing of the leaf spring during its contact

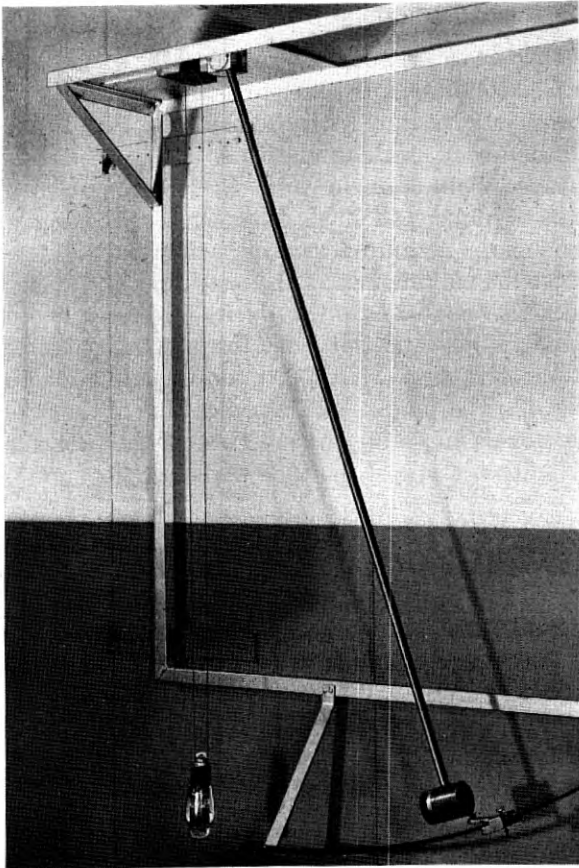

Fig. 10 — One of the early devices employed for shock testing of tubes under controlled conditions — the MIL-E-1B bump tester.

with the table anvil while the higher frequencies are due to table resonances which are excited by the metal-to-metal impact of spring and anvil.

#### *High Impact Machine for Electronic Devices*

This machine was originally intended to test the resistance of tubes to high peak-short duration shocks similar in nature to those encountered by equipment fastened to parts of ships that are likely to be exposed to direct explosion pressures.<sup>12</sup> The shock is produced by a steel hammer pendulum striking a movable steel table on which the tube under test is mounted. The shock magnitude is given by the angle through which the

pendulum is allowed to swing under the action of gravity before the hammer strikes the table. The forward motion of the table produced by the impact is arrested by two shock absorbers.

The impact of the hammer on the anvil of the table produces an abrupt velocity change of the table and excites table resonances, both horizontally and vertically. Because of the structure of the table a very complex acceleration wave form results. In general the accelerations for a given hammer swing vary over the table surface. It is for this reason that, in testing procedures, the position of the tubes on the table and their method of clamping are well defined; and since the acceleration wave shape is the sum of many vibratory frequencies rather than a single shock pulse, the severity of the test is expressed by the angle of hammer swing instead of a shock magnitude and duration. Although some uniformity in performance is attained by rigid standardization of the structure of the machines and the above mentioned positioning of the tubes, minute differences in these parameters may produce sufficient variations in shock output to reflect on test results. Acceleration-time traces of shocks measured in the shock direction by an accelerometer fastened near the anvil of the table and a second accelerometer clamped to the center of the table, are shown in Figs. 14 and 15. The records were simultaneously taken through 10,000-cycle low pass filters. Even though the recording of accelerations containing high frequencies of large amplitudes is, to some extent, a function of the measuring equipment, it is seen that significant differences in output exist between the two points of measurements.

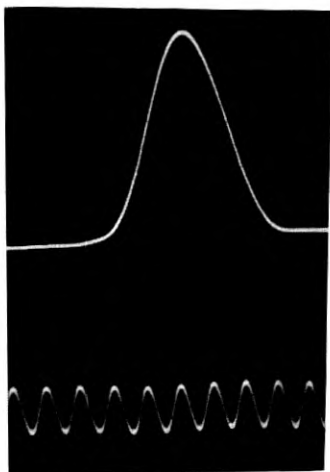

Fig. 11 — Acceleration-time pulse produced by MIL-E-1B bump tester.

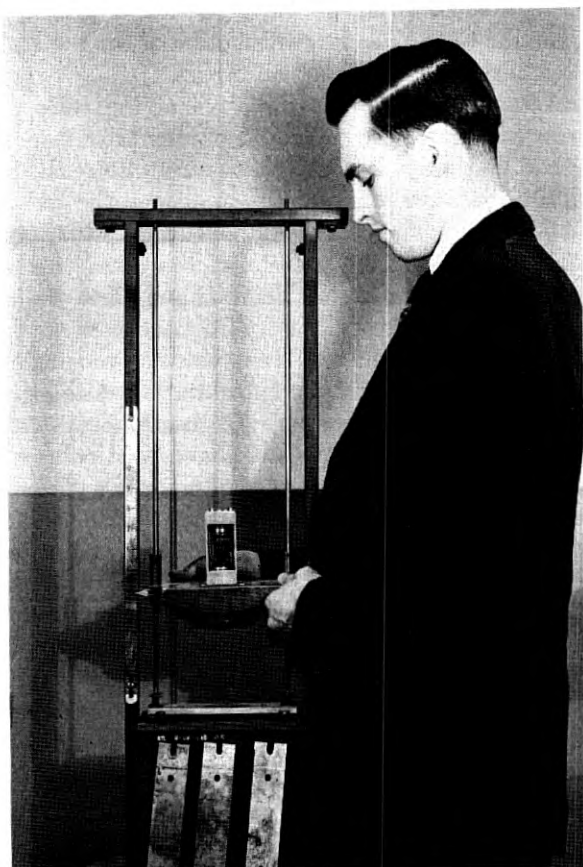

Fig. 12 — Shock testing mechanism per ASA-C39.3.

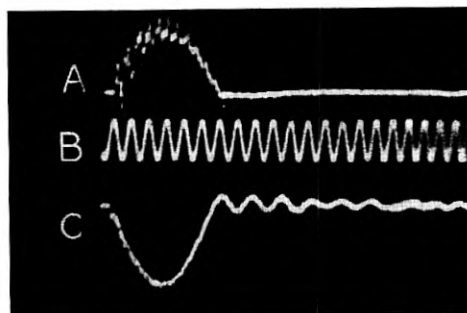

Fig. 13 — Typical shock pulse obtained with the tester shown in Fig. 12 (A) acceleration pulse, (B) timing trace, and (C) stress in leaf spring.

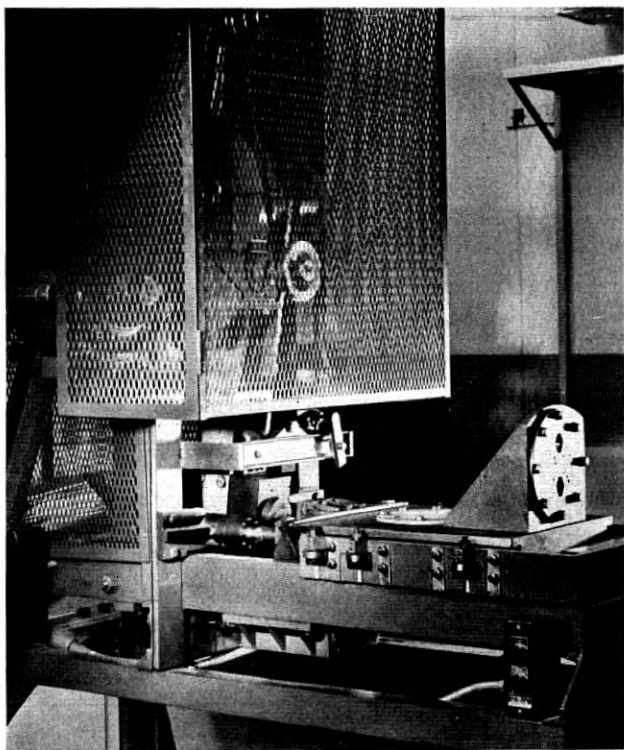

Fig. 14 — High-impact machine for testing electronic devices.

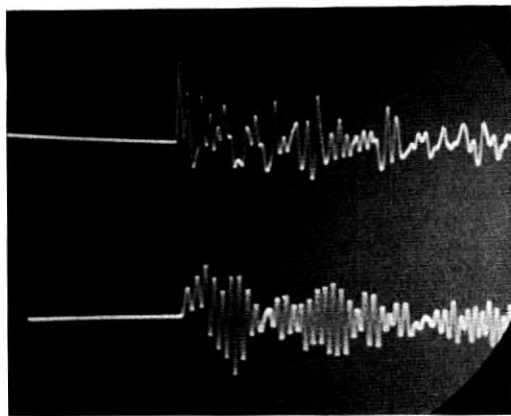

Fig. 15 — Acceleration-time pulses produced by machine shown in Fig. 14. Upper trace recorded near anvil, lower trace recorded in center of table.

This machine can also be used to produce lower G shocks of longer duration and simpler wave form by interposing a resilient rubber pad between the anvil and hammer. The resulting shock resembles the bell shaped output of the MIL-E-1B bump tester. Its magnitude and duration are given by the hammer swing, resilient characteristics of the pad, and the table and specimen weight. The capacity of the machine permits shock testing of heavier tubes (such as the larger magnetrons) by this method. Attainable shock levels are sufficiently high to cover the requirements placed on these tubes by conditions encountered during transit.

#### *The L.A.B. Package Tester*

Of particular interest to the packaging engineer, this machine is intended to duplicate the destructive vibrations and shocks experienced by a product during transit. It consists of a horizontal table that can be made to vibrate with a circular motion in the vertical plane. Adjustments permit variations of this motion to simulate freight car and motor truck movements. Tests performed on this machine, therefore, check on the mechanical strength of the outer shipping container as well as on the adequacy of cushioning materials employed to protect the product. The services are also considering this machine to test equipment designed for use in vehicles. Tests are now in progress by the Signal Corps to determine proper parameters for this application.<sup>8</sup>

#### *Vibration Machines*

A number of vibration machines, made by various manufacturers, are employed for vibration testing of tubes. Due to the high hash output of most mechanically driven machines, which contain gears and linkages, great care must be taken in the selection of these machines. Certain tests, especially the microphonic tests on receiving tubes, require machines with good sinusoidal output, in order to obtain comparable results. It is for this reason that the leaf spring vibration machine (Fig. 16), developed several years ago by Bell Telephone Laboratories, has been recommended as a standard for performing vibration tests. This is a fixed frequency, 25-cycle — 2.5 g machine which, due to its construction, has a relatively clean output as shown in Fig. 17.

Several types of electronically or motor-generator driven vibration machines are on the market. These are variable frequency and variable amplitude machines especially useful for determining resonance frequencies of structures and for performing cycling vibration tests. Accessory equipment has been made available lately to conduct these tests on an automatic basis at either constant acceleration or constant am-



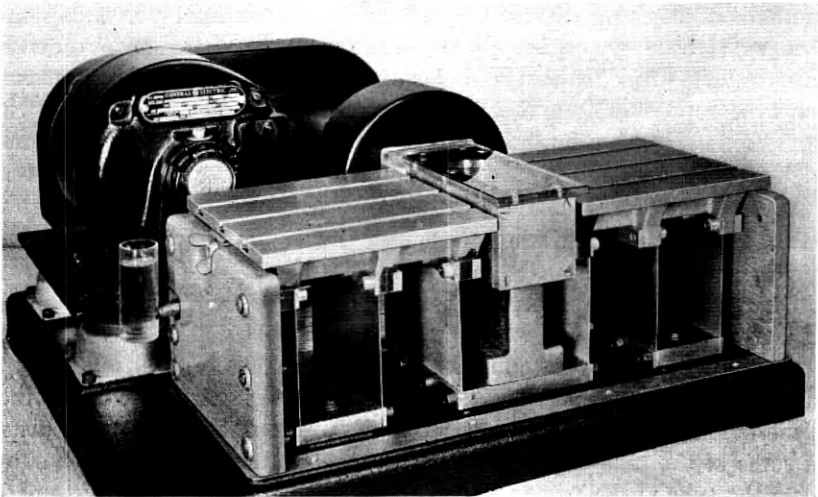

Fig. 16 — Leaf spring vibration machine developed several years ago by Bell Telephone Laboratories.

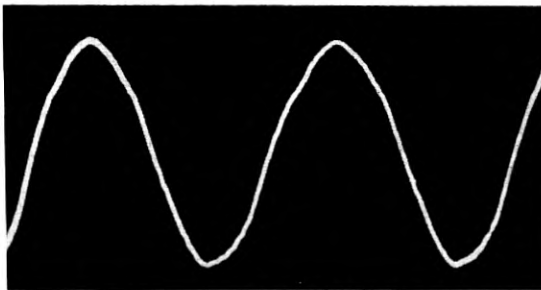

Fig. 17 — Acceleration output of the leaf spring vibration machine.

plitude over a given frequency range. Within the limitations of these machines and their power sources, it is also possible to subject specimens to complex disturbances. For instance, a projected use is the reproduction of recorded equipment vibrations so that the response of tubes to these conditions can be studied in the laboratory.

#### *Tube Tappers*

The physical construction of tube tappers used in the electron tube industry varies from the simple manually operated cork mallets to the more complicated automatic tappers. Since it has long been recognized that the reproducibility of manual tapping is rather poor, efforts have been made to replace these devices by automatic tappers or other

methods of checking microphonism in tubes. The industry, in collaboration with the Services, is now engaged in standardizing on automatic tappers. The prime requisites for such tappers are: (a) their shock output must be reproducible and must fall within definable limits, (b) their operation cycle must not adversely affect the time required for performing tap tests, and (c) the results obtained must have some relation to the environmental requirements for the tubes. This last condition is, perhaps, the most difficult to attain considering the diverse conditions encountered by tubes in various equipments.

Of the many tappers devised and employed by the industry, the use of only two are at present approved in the MIL-E-1B specifications. One is a manually operated cork mallet. This mallet is still retained in spite of its shortcoming, for lack of better devices. The second is the General Electric Automatic Tapper, specified for checking microphonism of some of the reliable tubes. This is a motor driven tapper which subjects the tube under test to damped low "g" vibrations at the rate of 2 taps per second. The tapper and associated circuits are fully described in the MIL specifications.

Space does not permit the discussion of other proposed tappers or test methods. Two rather interesting papers are listed in References 13 and 14, which illustrate the problems involved in the development of suitable devices for checking microphonism in tubes and describe some of the various methods of approach.

#### SUMMARY

The rapid growth of electronic equipment development during the late war has continued with the ever increasing new applications to both military and civilian purposes. It is realized that this growth has placed more stringent requirements on the mechanical characteristics of electron tubes. In order to define intelligently tube requirements, the nature of the disturbances to which tubes may be subjected must be known. It was pointed out that merely applying equipment requirements to the tubes, is not very realistic, since the shock and vibration patterns may be vastly modified by the equipment structures.

With the help of the recent development of light weight accelerometers, it is now possible to investigate the disturbances at the tube sockets. Both the Industry and the Services have begun to utilize these instruments to collect this information. The benefits derived from this work will enable the equipment and tube designers to formulate more accurate requirements and to devise test gear that will simulate more closely field conditions to check on tube quality.

Although, as a result of the trend to miniaturization, the strength of electron tubes has been increased, due to the smaller size and mass of elements employed, much has still to be done to increase tube resistance to ballistic shock. This would result in simplification of shipping containers and reduce the need for protection by shock absorbers in equipment. Equally important is the effort now made to reduce the microphonic response of the tubes. Here, too, the smaller size of the late tubes is of advantage because element resonant frequencies are increased. And since the higher frequency components of disturbances are largely attenuated by equipment structures, the tube responses have been lessened.

With a better understanding of the problems involved in tube protection, it is also quite possible that further improvements can be effected in some instances by structural changes of equipment members, or re-orientation of tubes in the equipment to reduce the effects of shock and vibrations on tubes.

#### BIBLIOGRAPHY

1. Shock and Vibration Instrumentation, NRL report #0-2645.
2. Mechanical vibrations, Den Hartog, McGraw-Hill Book Co.
3. The reciprocity calibration of piezo-electric accelerometers, M. Harrison, A. O. Sykes, and P. G. Marcotte, The David Taylor Model Basin, Report 811.
4. A Noise Free Instrument Cable, National Bureau of Standards, Technical News Bulletin, **36**, No. 3.
5. Research and Development Toward Construction of Accelerometers, Gulton Mfg. Co. report. New Techniques for Measuring Forces and Wear, W. P. Mason, B.S.T.J., **31**, May, 1952. Proceedings of symposium on Barium Titanate Accelerometers, National Bureau of Standards, Report No. 2654, Aug. 1953.
6. Bureau of Ships Publications, Nav. Ships 900,036, and Nav. Ships 900,052. The David W. Taylor Model Basin, Report 481. Vibration and Shock Isolation, C. E. Crede, John Wiley & Sons. Response of Damped Elastic Systems to Transient Disturbances, R. D. Mindlin, F. W. Stubner, H. L. Cooper, Experimental Stress Analysis, **5**, No. 2. Measured Aircraft Vibrations as a Guide to Laboratory Testing, D. C. Kennard, Jr., A. F. Technical Report No. 6429.
7. Dynamics of Package Cushioning, R. D. Mindlin, B.S.T.J., **24**, July — Oct., 1945.
8. Evaluation of Electron Tube Quality on the Tethered Weapons Carrier, Signal Corps Engineering Laboratories, Army Project No. 0302A.
9. MIL-E-1B, Military Specifications for Electron Tubes.
10. Characteristics of the JAN Bump Tester, R. D. Mindlin, F. W. Stubner and H. A. Lefkowitz, MM-45-2920-4.
11. Shock Testing Mechanism for Electrical Indicating Instruments, ASA-C 39.3
12. Mechanical Shock Characteristics of the High Impact Machines for Electronic Devices, I. Vigness, R. C. Novak and E. W. Kammer, NRL Report No. 0-2838.
13. Proposal for Revised Noise and Microphonic Evaluation for MIL-E-1B Specifications, NML Report, Dated July 30, 1951.
14. A Study of Microphonism, Philco Research Report No. 183.



# Arcing of Electrical Contacts in Telephone Switching Circuits

## Part I—Theory of the Initiation of the Short Arc

By M. M. ATALLA

(Manuscript received April 1, 1953)

*This is a presentation of a theory for the mechanism of the initiation of the short arc commonly observed on the closure and opening of electrical contacts. The theory is based on the experimental evidence that an established arc is generally preceded by a period of local high frequency discharges at the contacts. During this period the circuit current builds up. If and when this current reaches the arc initiation current of the contact a steady arc is established. It is shown that this initiation period of the arc is directly determinable from the circuit conditions and the contact condition. This mechanism furnishes rather simple explanations to some complex phenomena commonly observed before the establishment of the arc. The mechanism of the initiation of an individual discharge, however, still remains uncertain.*

### INTRODUCTION

In the course of study of arcing phenomena between electrical contacts, it has been long established that a condition for sustaining the short arc is to maintain a current through the arc greater than a minimum value called the minimum arcing current. This current is generally a characteristic of the contact material and is appreciably affected by surface contaminations. For clean metals the minimum arcing current is usually equal to a few tenths of an ampere. Before establishing the arc, therefore, there must exist a certain mechanism which accounts for a rapid current build-up from zero to a value as high as the minimum arcing current. For an inductive circuit, a higher inductance should result in a longer period of current build-up. With a sufficiently high circuit inductance this initiation period may be made long enough to be directly observed and to allow an examination of the mechanism involved. Such experiments have been made and observations have indicated that the initiation period consisted of a succession of rapid dis-

charges at the contacts from the open circuit voltage to a lower voltage. During this process the current in the circuit built up in a discontinuous fashion and the steady arc was established only when the circuit current reached the minimum arcing current of the contact.

In this paper is presented our study of this initiation period. The following are the main objectives: (1) to establish the analytic relations governing the performance of a few simple contact circuits during the arc initiation period; (2) to check the analysis by direct measurements; (3) to apply the theory to explain a few arcing phenomena and empirical relations previously reported; and (4) to shed some light on the nature of the rapid local discharges at the contacts and the characteristics of the influential circuitry at the immediate neighborhood of the contact.

## NOTATION

$C$	Main circuit capacitance
$I$	Circuit current
$I_i$	Arc initiation current
$I_m$	Arc termination current or minimum arcing current
$L$	Circuit inductance
$(L)_{Limit}$	Limiting or maximum inductance above which a steady arc cannot be established
$R$	Circuit resistance
$V$	Voltage
$V_0$	Initial voltage
$V_{CT}$	Main condenser terminal voltage
$c$	Local capacitance at the contacts
$\ell$	Local inductance at the contacts
$n$	Number of discharges at the contacts
$r$	Local resistance at the contacts
$t$	Time
$v$	Voltage across a steady short arc
$\bar{v}$	Voltage across the contacts at the termination of a single local discharge
$z$	Local impedance at the contacts $\left[ \frac{\ell}{c} \right]^{1/2}$
$\alpha$	Ratio of capacitances $c/C$
$\omega$	Angular frequency $(Lc)^{-1/2}$

## ANALYSIS

In this section a few simple contact circuits are considered. In each case relations are derived for the current and voltage changes in the

circuit during the period of rapid discharges at the contacts preceding the steady arc. The analysis is based on the following simplified model of the mechanism involved: (1) The first local discharge at the contact takes place when the proper separation corresponding to the initial voltage  $V_0$  is reached; (2) this discharge time is assumed to be short and negligible in comparison to the following charging time; (3) the local capacitances at the contact recharge from the main circuit until the same initial voltage  $V_0$  is reached when a second discharge takes place; (4) this process repeats until a steady arc is established provided that the circuit is capable of building up enough current, — otherwise, the local discharges will continue and finally stop when the main circuit becomes incapable of charging the local contact capacitances to  $V_0$ ; and (5) all the local discharges at the contact are terminated at a constant voltage  $\bar{v}$  for any one set of circuit conditions. The nature of  $\bar{v}$  is left to be determined and physically understood from our measurements.

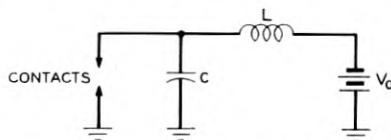

Fig. 1 — Typical battery-inductance-contacts circuit.

*Battery  $V_0$ ,  $L$  and Contacts, Fig. 1*

Following the first discharge at the contact from  $V_0$  to  $\bar{v}$  the local contact capacitances will recharge with a current

$$I = (V_0 - \bar{v}) \left(\frac{c}{L}\right)^{1/2} \sin \omega t,$$

where  $\omega = (Lc)^{-1/2}$ .

The voltage at the contact will reach  $V_0$  at  $t_1 = \pi/2\omega$  and the corresponding current is

$$I_1 = (V_0 - \bar{v}) \left(\frac{c}{L}\right)^{1/2}.$$

A second discharge will then take place and recharging will proceed with the new boundary conditions: at  $t = 0$ , the contact voltage is  $\bar{v}$  and the circuit current is  $I_1$ . By following this procedure, a general expression for the  $n$ th charging process is obtained:

$$I(n) = (V_0 - \bar{v}) \left(\frac{c}{L}\right)^{1/2} (n)^{1/2} \tag{a}$$

and

$$\omega \cdot t(n) = \cot^{-1} (n - 1)^{1/2} \quad (1)^*$$

The relation between the number of discharges  $n$  and time  $t$  is given by

$$t = \frac{1}{\omega} \sum_{n=1}^{n=n} \cot^{-1} (n - 1)^{1/2}.$$

Only an empirical expression for this summation was obtained with a maximum error less than 10 per cent:

$$t = \frac{\pi}{2\omega} (n)^{1/2}.$$

The current build-up in the circuit is, therefore, expressed as a function of time by the following relation:

$$I(t) = \frac{2}{\pi L} (V_0 - \bar{v})t \quad (2)$$

In other words, the current is independent of the contact capacitances and increases linearly with time at a rate inversely proportional to the circuit inductance.† As soon as the circuit current reaches the arc initiation current  $I_i$ , a steady arc is established. The initiation time of the steady arc is therefore given by:

$$t_i = \frac{\pi}{2} \cdot \frac{I_i L}{V_0 - \bar{v}} \quad (3)$$

For  $I_i = 0.5$  ampere,  $L = 10^{-6}$  henry and  $V_0 - \bar{v} = 30$  volts,  $t_i = 2.6 \times 10^{-8}$  second.

### *C, L and Contact, Fig. 2*

If the battery is replaced by a condenser  $C$  where the ratio  $\alpha = c/C$  is much less than 1.0 an analysis similar to the above can be made. In

\* The assumption that all discharges will take place from the same voltage  $V_0$  is only true if: the motion of the contact is negligibly small, the discharges do not change the contact geometry to the extent of materially changing the contact separation, and if the effect of the residual ions is negligible.

† This is only true if the circuit resistance is zero. For a finite circuit resistance  $R$ , and  $\frac{R}{2} \left(\frac{c}{L}\right)^{1/2}$  much less than 1.0, it can be shown that the current approaches the asymptotic value  $\frac{V_0 - \bar{v}}{2R}$ .

‡ It is shown later by measurement, that the initiation current  $I_i$  is essentially the same as the arc terminating current  $I_m$ .



this case, however, in setting the boundary conditions one must consider the drop in voltage across the main condenser during the previous charging processes. The following are the resulting expressions for the circuit current, main condenser voltage and the charging time, all as functions of  $n$ :

$$I(n) = \frac{V_0 - \bar{v}}{L\omega} \cdot \left[ n(1 - \alpha(n - 1 + \alpha n)) \right]^{1/2} \quad (4a)$$

$$V(n) = V_0 - \alpha n(V_0 - \bar{v}) \quad (4b)$$

$$\omega \cdot t(n) = \sin^{-1} \alpha \left[ \frac{n}{1 - \alpha(n - 1)} \right]^{1/2} + \tan^{-1} \left[ \frac{1 - \alpha(n - 1)}{(1 + \alpha)(n - 1)} \right]^{1/2} \quad (4c)$$

Only an empirical expression for the summation

$$\sum_{n=1}^{n=1} t(n)$$

was obtained with an error less than 10 per cent

$$\sum_{n=1}^{n=n} \omega \cdot t(n) = \frac{\pi}{2} (n)^{1/2} (1 + \alpha n).$$

The current relation indicates that the current increases from zero at  $n = 0$  to a maximum current

$$I_{\max} = \frac{V_0 - \bar{v}}{2} \left( \frac{C}{L} \right)^{1/2}$$

at  $\alpha n = 1/2$  then drops back to zero at  $n\alpha = 1.0$  when the discharges are terminated. The total discharge time is approximately  $\pi(LC)^{1/2}$  and the terminal voltage on the main condenser is  $V_{CT} = \bar{v}$ . If during the process of current build-up the current reaches a value equal to the arc initiation current a steady arc is established. It is evident that a steady arc cannot be established if the maximum current attainable during the discharges is less than the arc initiation current. This leads to the concepts of a limiting inductance and limiting voltage in a circuit that can allow the establishment of a steady arc.<sup>1</sup> The limiting inductance is

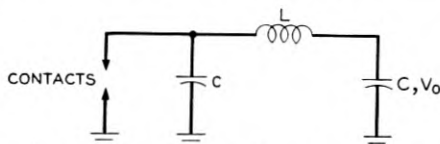

Fig. 2 — Typical condenser-inductance-contacts circuit.

<sup>1</sup> L. H. Germer, Arcing at Electrical Contacts on Closure, Part I, J. Appl. Phys. **22**, p. 955, 1951.

defined as the largest inductance for a given circuit above which a steady arc cannot be obtained and the limiting voltage is defined as the lowest voltage for a given circuit below which a steady arc cannot be obtained:

$$(L)_{\text{Limit}} = \frac{C}{4} \cdot \left( \frac{V_0 - \bar{v}}{I_i} \right)^2 \quad (5a)$$

$$(V_0 - \bar{v})_{\text{Limit}} = 2I_i \left( \frac{L}{C} \right)^{1/2} \quad (5b)$$

The assumption made that all charging processes are much longer in time than the discharging times, imposes a limitation on the applicability of the above relations. Equation 4c can show that the minimum charging time is  $(2/\omega)\alpha^{1/2}$ . The accuracy of the above relations is better the larger this time is compared to the discharge time of the local contact capacitance. Assuming distributed characteristics for the local and relatively small contact circuitry\* the discharge time is  $2(\ell c)^{1/2}$ . The limitation involved, therefore, is that  $(2/\omega)\alpha^{1/2}$  must be greater than  $2(\ell c)^{1/2}$  or  $L/C > \ell/c$ . In other words, the impedance of the main circuit must be greater than the impedance of the local circuit at the contact.

#### MEASUREMENTS

All the measurements presented were obtained from an inductive type circuit, *C-L-Contact*. The main circuit, Fig. 3, consisted of a condenser *C* in series with a honeycomb inductance which is connected by a short lead, about 2 cms, to a pair of clean palladium contacts operating in laboratory air. The contacts were mounted on a cantilever bar arrangement, described by Pearson<sup>2</sup>, which allows fine adjustments of the separation between the contacts as well as slow motion of the contacts to avoid physical closure before the end of a transient.

Three sets of measurements were made.

(1) Contacts voltage measurements: the transients obtained usually needed some correction to compensate for the effects of the measuring oscilloscope circuit. None of these measurements are presented in this paper. It may be mentioned, however, that they indicated the existence of rapid discharges at the contacts preceding the establishment of the steady arc.

(2) Circuit current measurements, Fig. 3 (a): these were made by

\* In a later section of this paper, measurements were shown to indicate the plausibility of this assumption.

<sup>2</sup> G. L. Pearson, Phys. Rev. **56**, p. 471, 1939.

measuring the voltage change across a 10-ohm non-inductive resistor inserted between the main circuit condenser and ground.

(3) Main condenser voltage measurements, Fig. 3(b): the oscilloscope plates were shunted by an  $1100 \times 10^{-12}$  farad capacitor and the combination was used as the main circuit condenser. The above sets of measurements 1 and 2 furnished the data necessary for a quantitative establishment of the theory. It is evident that the measuring scope circuits did not interfere with the normal behavior of the contact circuit.

#### *Development of Circuit Current During Arc Initiation Period*

The circuit in Fig. 3(a) was used. The contact separation was gradually decreased until the discharges started and the resulting current transients were recorded. The circuit parameters were chosen such that, according to Equation 3 of our analytical results, the initiation time was of the order of microseconds. Fig. 4(A) shows a typical current-time transient where a steady arc was established. The circuit had  $L = 1100 \times 10^{-6}$  henry and  $C = 10^{-6}$  farad. The current started from zero and increased during the multiple discharge period until point 1 where the current was 0.2 ampere and a sustained arc was established. The current then increased to a maximum of 1.7 amperes then dropped. At point 3 the arc stopped when the current was 0.24 ampere. In Fig. 4(B) the first

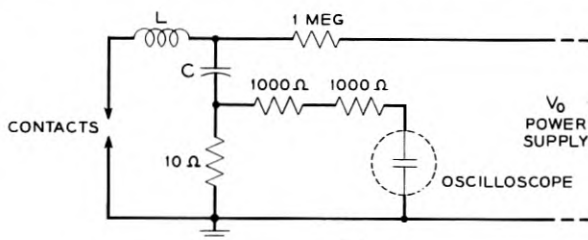

(a)

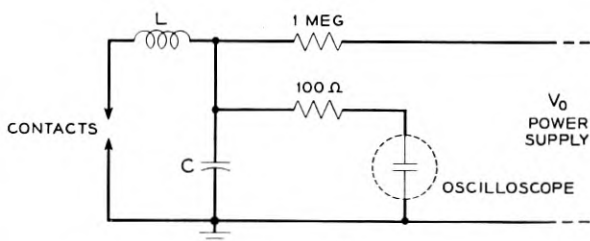

(b)

Fig. 3 — (a) Contacts circuit and circuit current measuring circuit. (b) Contacts circuit and main condenser voltage measuring circuit.

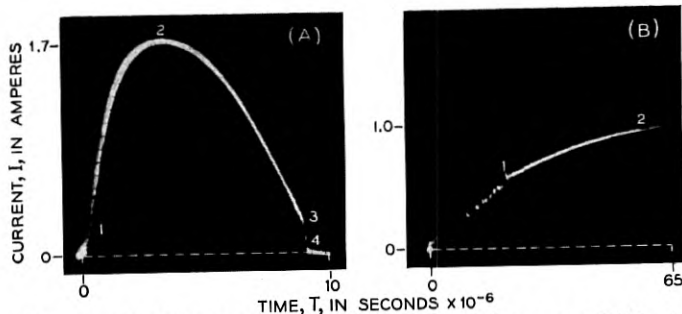

Fig. 4 — Circuit current transients with steady arc established.

portion of a similar transient is shown:  $L = 5100 \times 10^{-6}$  henry and  $C = 10^{-6}$  farad. The current build-up during the multiple discharge period is shown as an interrupted line 0-1. The steady arc was established at 0.57 ampere.

From a group of similar transients, pairs of measurements were made of the initiating current and terminating current of the steady arc. The results are given in Table I. It is concluded from the results that *the initiating current and terminating current of an arc are the same.*

The high-frequency discharges at the contact do not necessarily have to be followed by a sustained arc. *A sustained arc is only obtained if the maximum current established during the local discharges at the contact is equal to or greater than the arc initiation current.* Fig. 5 (A) shows a current-time transient without an initiation of the steady arc:  $V_0 = 400$  volts,  $L = 5100 \times 10^{-6}$  henry and  $C = 1100 \times 10^{-12}$  farad. The maximum current reached was only 0.13 ampere which was not sufficient for initiating a steady arc. It is of interest to notice that the oscillations superimposed on the zero current line following the transient can allow a calculation of the local capacitances at the contact. Such a calculation gave  $c = 7.8 \times 10^{-12}$  farad. Fig. 5 (B) shows a similar transient for the same circuit with  $V_0 = 500$  volts. Following the first current build-up and drop, 1-2-3, the main condenser had a residual negative voltage high enough to produce a reversed current build-up and drop, 3-4-5.

#### *Voltage Drop in Main Condenser During Arc Initiation Period*

During the period of rapid discharges the current build-up in the circuit is accompanied by a voltage drop at the main condenser. This drop may correspond to one of two phenomena at the contact: (1) multiple discharges leading to a steady arc, and (2) multiple discharges without steady arc, followed by an open circuit. Fig. 6 and 7 are re-

TABLE I — ARC INITIATION AND ARC TERMINATION CURRENTS  
 PALLADIUM CONTACTS IN AIR\*

Arc Initiation Current $I_i$ : Amps.	0.12	0.21	0.21	0.15	0.25	0.19	0.23	0.40	0.65	0.61	0.57	0.52	0.45
Arc Termination Current $I_m$ : Amps.	0.13	0.16	0.17	0.20	0.22	0.24	0.24	0.42	0.50	0.52	0.53	0.58	0.59

\* Both numbers given in one column were obtained from the same transient.

spective records of the voltage change at the main condenser. Fig. 6 (A) corresponds to the case where the multiple discharge period was short and lead to a steady arc. During this arc the main condenser voltage dropped from point 1 to point 2 when the arc was arrested. This was followed by striking a second arc in the opposite direction which lasted until point 3. Line 3-4 represented the recharging of the main condenser from the power supply circuit. Superimposed on the same figure is the trace 1-2-3-5 corresponding to a closure at the contact instead of an open circuit. While line 1-2-3 shows two consecutive arcs, it is generally possible to obtain any number of such arcs. An even number of arcs will result in a *positive* residual voltage at the main condenser, Fig. 6 (A) while an odd number of arcs will result in a *negative* residual voltage at the main condenser, Fig. 6 (B).

Figs. 7 (A) and 7 (B) correspond to the case when the multiple discharges did not lead to a steady arc due to insufficient current build-up. The multiple discharges caused a voltage drop 1-2 across the main condenser followed by an open circuit and recharging, 2-3.

#### Discharge of the Local Circuitry at the Contact

Fig. 8 (a) represents a plausible representation of the local circuitry at the contact. When the conditions between the contacts are favorable

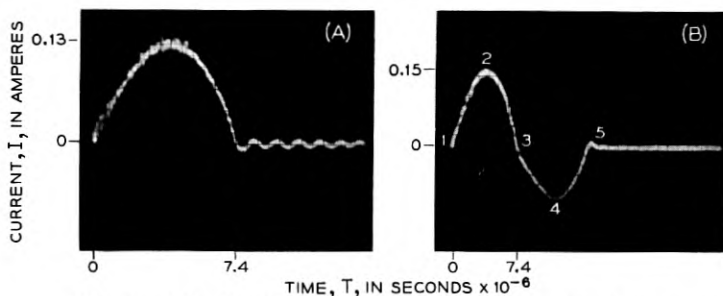

Fig. 5 — Circuit current transients without a steady arc.

for the initiation of the arc, a small local capacitance  $c'$  will furnish the necessary charge, through a small impedance  $z'$ , according to whatever mechanism that may be involved in the initiation process.\* The connection from the contact to the main circuit is represented by a short transmission line with the distributed characteristics,  $r$ ,  $\ell$  and  $c$ . The drop at the contact from the initial voltage  $V_0$  to the arc voltage  $v$  will cause a current surge  $(V_0 - v)(c/\ell)^{1/2}$ , if  $r$  is neglected, for a period  $2(\ell c)^{1/2}$  corresponding to the time required by the pulse to travel to the end of the line and return to the contact. At this time the arc is extinguished by the reflected pulse and the final voltage at the contact is  $-(V_0 - 2v)$ . Figs. 8(b) and 8(c) are diagrammatic representations of the process. For a purely inductive line, therefore, the contact voltage  $\bar{v}$  following one discharge is  $-(V_0 - 2v)$ . For a dissipative line, however,  $\bar{v}$  is algebraically greater. Equation 4 of Germer and Haworth<sup>3</sup> was derived to give the voltage following an arc for a similar circuit with lumped characteristics. For  $r/(\ell/c)^{1/2}$  less than 1.0 this equation can be

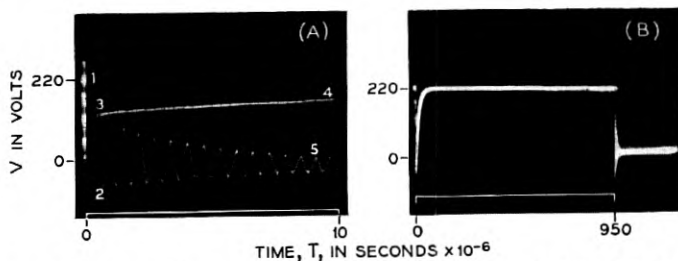

Fig. 6 — Voltage transients across main condenser with steady arc established.

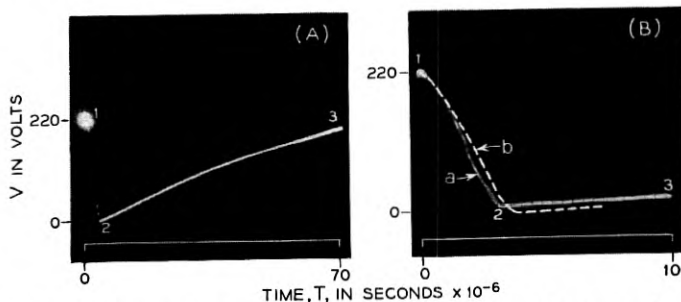

Fig. 7 — Voltage transients across main condenser without steady arc.

\* This mechanism is not clearly understood at the present time. It is the opinion of the writer, however, that the initiation time is only a few times the transit time of the metal ion under the prevailing conditions.

<sup>3</sup> L. H. Germer and F. E. Haworth, Erosion of Electrical Contacts on Make, Appl. Phys. **20**, p. 1085, 1948.

approximated by:

$$\bar{v} = 2v - V_0 + \frac{\pi}{2} \cdot \frac{r}{z} (V_0 - v) \quad (6)$$

where  $z = (\ell/c)^{1/2}$ .

Our measurements were then applied to demonstrate the plausibility of the above description of the local circuitry at the contact. This was done in the following fashion.  $\bar{v}$  was obtained by three methods. (1) Measurements were made of the multiple discharges preceding a steady arc, from records similar to Fig. 4(B), and  $\bar{v}$  was calculated from Equation 3, (2) measurements were made of the maximum current attainable during the multiple discharge period, from records similar to Fig. 5(A), and  $\bar{v}$  was calculated from the expression

$$I_{\max} = \frac{1}{2} (V_0 - \bar{v}) \left( \frac{C}{L} \right)^{1/2},$$

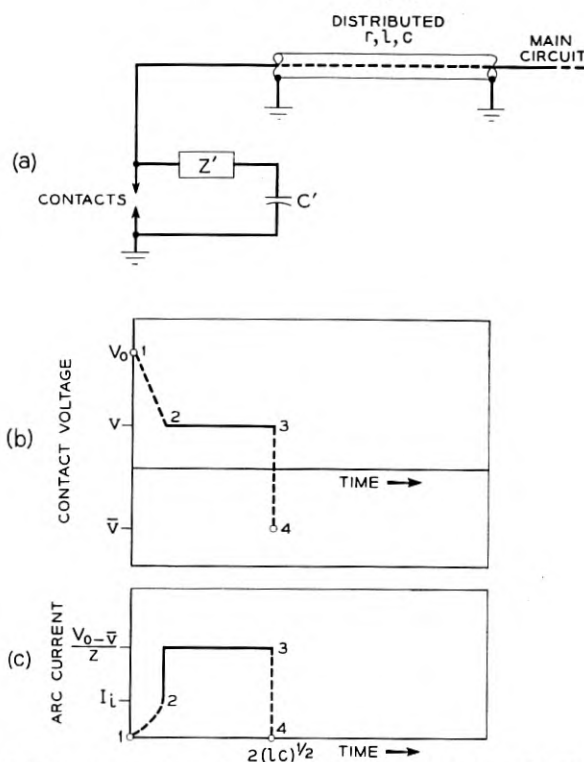

Fig. 8 — (a) Representation of local circuitry at contacts. (b) Voltage transient at contacts during one discharge of local circuitry. (c) Current transient at contacts during one discharge of local circuitry.

TABLE II — RATIO  $r/z$  FOR LOCAL CIRCUITRY AT CONTACTS

Initial Voltage $V_0$	100	150	200	230	250	300	360	400	460
$\frac{r}{z}$	0.56	0.65	0.55	0.41	0.55	0.30	0.40	0.40	0.48

and (3) measurements were made of the terminal voltage across the main condenser at the end of the multiple discharges, from records similar to Fig. 7, which, according to our analysis, is equal to  $\bar{v}$ . For these values of  $\bar{v}$  Equation 6 was used to compute  $r/z$ . The results are given in Table II. Each value of  $r/z$  in this table is the average of 3 to 6 values obtained by the different methods described above. In all cases  $r/z$  was between 0.4 and 0.7. This indicates that the local contact circuitry is oscillatory. For our circuit,  $c$  was measured at  $7.8 \times 10^{-12}$  farad and if  $\ell$  is assumed to be  $2 \times 10^{-8}$  henry, the computed resistance  $r$  is 20 to 35 ohms. This is about 500 times greater than the dc resistance of the same circuit. With this concept of the local contact circuitry  $\bar{v}$  was well defined and was then possible to perform some checks of the main analytical relations presented in this paper with new measurements and with measurements previously published.

#### *Comparison of Theory with Measurements:*

(1) Voltage drop across main condenser: In Fig. 7(B) is shown the voltage drop across the main circuit condenser as a function of time for  $L = 10^{-3}$  henry,  $C = 1100 \times 10^{-12}$  farad and  $V_0 = 220$  volts. Line (a) was measured and Line (b) was computed using Equation 4(b). The value of  $\bar{v}$  used was obtained from Equation 6. Good agreement is indicated.

(2) Limiting circuit conditions for obtaining a steady arc: It was pointed out in a previous section of this paper that a steady arc can be established only if the maximum current reached during the multiple discharge period is equal to or greater than the arc initiation current. Equations 5(a) and 5(b) are expressions for the limiting circuit inductance and the limiting initial voltage respectively. Equation 5(b) was used to compute the limiting voltage for a set of circuit conditions for which measurements were made and published, Reference 3. In Table IV Column 3 of this reference measured values of the limiting voltage  $V_0$  were presented. A comparison of measured and computed  $V_0$  are given here as Table III. It may be pointed out that the deviations between measurements and calculations are of the order of the measured



spread in the minimum arcing current as given in the same reference, Table V.

(3) Contact activation and limiting circuit conditions for arcing: In Reference 3, it was reported that the limiting inductance for active contacts was greater by more than 2 orders of magnitude than for clean contacts. By calculation, Equation 5(a),

$$[(L)_{\text{active}}/(L)_{\text{clean}}]_{\text{Limit}} = 600.$$

It was also reported that for  $C = 10^{-8}$  farad and  $V_0 = 50$  volts the limiting inductance observed for active silver was between  $10^{-3}$  and  $10^{-2}$  henry. By calculation, Equation 5(a), the limiting inductance for the same conditions is about  $4 \times 10^{-3}$  henry.

(4) Contact activation and arc initiation time: According to Equation 3 the initiation time of the steady arc is directly proportional to the arc initiation current. For the same circuit conditions, therefore, active contacts should have a shorter period of arc initiation. This result seems to contradict some published observations<sup>4</sup> where it was pointed out that the voltage drop into an arc was shorter for clean contacts than for activated contacts. A number of transients, furnished by the authors, were carefully examined. It was observed that in most cases

TABLE III — COMPUTED AND MEASURED LIMITING VOLTAGES FOR ESTABLISHING A STEADY ARC BETWEEN CLEAN SILVER CONTACTS\*

Observed ( $V_0$ ) Limit for first detectable arc	Computed ( $V_0$ ) Limit
50	49
66	102
220	211
38	38
85	75
206	153
31	28
64	52
200	102
24.5	23
60	40
30	20
13	16
11.5	14
13	13
25	17

\* A few observations were not included in this table. These correspond to the cases where the calculated initiation times of the arc were of the order or greater than the time of physical closure of the contacts. As expected, the observed voltages were consistently higher than the computed voltages.

<sup>4</sup> L. H. Germer and J. L. Smith, Arcing at Electrical Contacts on Closure, Part, III. J. Appl. Phys., **23**, p. 553, 1952.

for *both* active and clean contacts the transient started with a rapid drop. For clean contacts this drop was directly to the steady arc voltage of the contact metal. For active contacts the drop was to a higher voltage between 15 and 32 volts followed by a gradual and irregular drop in voltage. The time of the first rapid drop was invariably between  $2 \times 10^{-9}$  and  $4 \times 10^{-9}$  second for *both* clean and active contacts over a range of circuit inductances between  $0.1 \times 10^{-6}$  and  $48 \times 10^{-6}$  henry. This time was just about the time resolution of the scope used indicating that in all cases the initiation time was less than the time resolution of the scope. This was also borne out by our calculations, Equation 3, where the longest initiation time for the conditions studied was only  $1.2 \times 10^{-9}$  second. The higher arcing voltage of active contacts mentioned above has been previously reported in Reference 3. It was pointed out that active contacts have arc voltages comparable with those of carbon, 19 to 30 volts.\* The slow drop in voltage following the first rapid drop observed with active contacts is probably a burning off process of the activating substance on the contacts as indicated by a continuous approach of the arc voltage to that of the clean metal. It may be added that for cases where the initial circuit voltage is closer to the carbon arc voltage one should expect a smaller initial drop. This was confirmed by measurements made at 35 volts.

In connection with the experimental study of the initiation of the arc, the following concluding remark may be made. Unless the measuring apparatus has a response faster than the individual discharges at the contacts, the recorded transient will essentially be some particular average of a complex contacts transient. It should not, accordingly, be mistaken for the more fundamental and usually much faster formative transient of the arc.

The author is indebted to Dr. P. Kisliuk and Dr. L. H. Germer for much valuable discussion.

\* Recent measurements by the writer on arc lamp carbon have given arc voltages as high as 43 volts.

# Polyethylene Insulated Telephone Cable

By. A. S. Windeler

(Manuscript received August 25, 1953)

*The physical properties of polyethylene are such as to make it attractive for many wire insulating applications, particularly in multi-conductor communications cables. This article presents certain factual information relating to new types of multi-conductor cables having extruded polyethylene insulation, and describes briefly their initial installation in working telephone plant. The literature is replete with information on the physical and chemical properties and the behavior of polyethylene, so no attempt is made to explore the quality of the material per se. Polyethylene insulation extruded in the form of both solid material and foam to impart certain desired electrical properties is discussed. In a broad sense this article may be considered as announcing an important new insulating material for telephone cables which may be expected eventually to have very extensive applications in the Bell System plant.*

From almost the beginning of the art, multiconductor telephone cables have been insulated with paper, applied as a helical tape or laid down directly on the conductor in the form of pulp. Solid paper has a dielectric constant in the order of 2.5 to 3.0 but in the case of either ribbon or pulp insulation a considerable amount of air is included in the electric field surrounding the conductor so that the composite effective dielectric constant is of quite low value, usually about 1.5 to 1.6 in a typical design. In recent years, as various plastics and other polymeric materials have become available, these have been studied as competitors of paper, and polyethylene in particular now appears to have an important field of application. Polyethylene appears attractive because of its excellent electrical properties including low dielectric constant and power factor, compared with other useable plastics, and high dielectric strength. It is also highly impermeable to water or water vapor and is available in the desired quantities at a reasonable price. Additionally it is considered probable that the long term price trend will be downward.

The various electrical and mechanical characteristics<sup>1, 4</sup> of polyethylene are shown in Table I, along with some of the other materials considered. Among these other materials only polytetrafluoroethylene (Teflon) and polystyrene have power factors and dielectric constants in the same low range as polyethylene. There are basic objections to both of these materials. Polytetrafluoroethylene is so expensive as to be uneconomical for this application and polystyrene in thick sections is too stiff and brittle to handle in a satisfactory manner.

The use of polyethylene in telephone cables is not altogether new but it has heretofore been confined to special types of high-frequency cable. For example, the coaxial cable and video pair have polyethylene disc insulation and strip-and-string insulation respectively (see Fig. 1). These cables were designed for low attenuation in the megacycle range and the use of polyethylene or a similar low power factor material was a necessity. A low power factor is of lesser importance in the carrier systems for which the multipair cables are used and the polyethylene insulation on these cables must show other advantages in order to prove in.

Polyethylene insulation is applied to the wire by an extrusion process; the insulation may be either solid or expanded depending on the application. Generally the polyethylene is supplied as granules previously compounded with an antioxidant. In the case of solid polyethylene insulation the granules, in which the pigment has been incorporated, are fed into the extruder and formed on the conductor as a uniform close fitting tube of insulation.

TABLE I — CHARACTERISTICS OF INSULATING MATERIALS

	Polyethylene	Plasticized Polyvinyl-Chloride	Polystyrene	Polytetrafluoroethylene (Teflon)	Polyamide (Nylon)
Density—gms/cc.	0.92	1.2-1.4	1.06	2.2	1.09
Tensile strength—psi	1400-2000	1500-3000	500-9000	1500-2500	7000
Elongation %	600	200-450	2-5	100-200	100-200
Water absorption % in 24 hrs.	<0.01	0.4-0.65	<0.05	Nil	0.4-2.0
Diel. strength, RMS volts/mil 1/8" thickness*	400-500	300-700	500-700	400-500	400
Power factor, 1-300 kc.	0.0002	0.09-0.16	0.0002	0.0002	0.04-0.2
Diel. constant, 1-300 kc.	2.3	3.5-5.0	2.5-2.6	2.0	3.5-8

\* Dielectric strengths are greater for thinner sections—for example, in 14 mil thicknesses polyethylene has a dielectric strength of approximately 2500 RMS volts per mil.

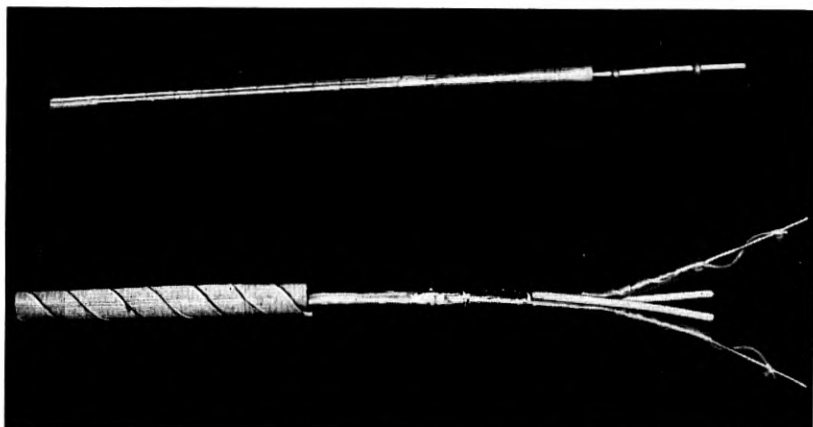

Fig. 1—(a) Polyethylene disc insulated coaxial. (b) Polyethylene ribbon and string insulated video pair. Note expanded polyethylene interstice fillers.

The idea of using spongy or foamed hydrocarbons as conductor insulation is not new. A British patent issued in 1930 contemplates such a structure and numerous United States patents of more recent dates cover various aspects of cellular hydrocarbon insulation. The problem is one of forming the cylinder of aerated plastic in an extrusion process operating at high speed and producing a closely controlled uniform covering having precise physical and electrical properties. The original development work was carried on by F. B. Lyons of the Western Electric Company in cooperation with the author. This early work demonstrated that material having the desired range of properties could be applied in a continuous extrusion process and subsequent work has shown that the necessary control of properties and speed of extrusion can be achieved.

The expansion of polyethylene is accomplished by methods similar to those employed in the making of many of the numerous polymer and rubber "foams". The process used to produce the cellular polyethylene involves the addition at the extruder of a chemical blowing agent which decomposes under heat and releases nitrogen gas. By proper mixing and process control this nitrogen gas can be entrapped in the polyethylene in the form of very small discrete bubbles, thus achieving the cellular structure shown in Fig. 2. It is interesting to note that the foamed plastic tends to form a desirable "skin" of solid material on the inner surface over the conductor, Fig. 2(a).

Various degrees of expansion can be achieved as required by varying the amount of blowing agent and by other means. The degree of expansion, or percent entrapped gas, can be determined readily by weigh-

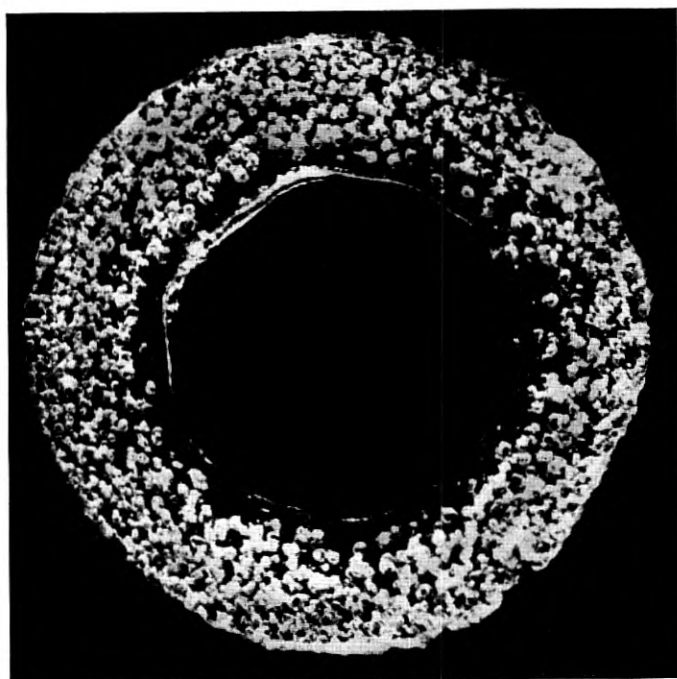

Fig. 2(a)—Cross section of expanded polyethylene insulation from 19 gauge conductor—35 per cent air. Magnified 75 times.

ing a sample of insulation, with the conductor removed, on an analytical balance. The inside and outside diameter of the cylinder of insulation and the density of solid polyethylene are required to complete the determination.

The composite dielectric constant obviously varies with the degree of expansion. In a coaxial configuration this effect is calculable from the formula for the dielectric constant of a mixture,<sup>6</sup> the relation being given by the following:

$$\frac{\epsilon - \epsilon_p}{3\epsilon} = V \frac{(\epsilon_a - \epsilon_p)}{(\epsilon_a + 2\epsilon)}$$

where  $\epsilon$  = composite dielectric constant

$\epsilon_p$  = dielectric constant of polyethylene = 2.26

$\epsilon_a$  = dielectric constant of added material, in this case 1 for air

$V$  = volume fraction =  $\frac{\text{percent air}}{100}$

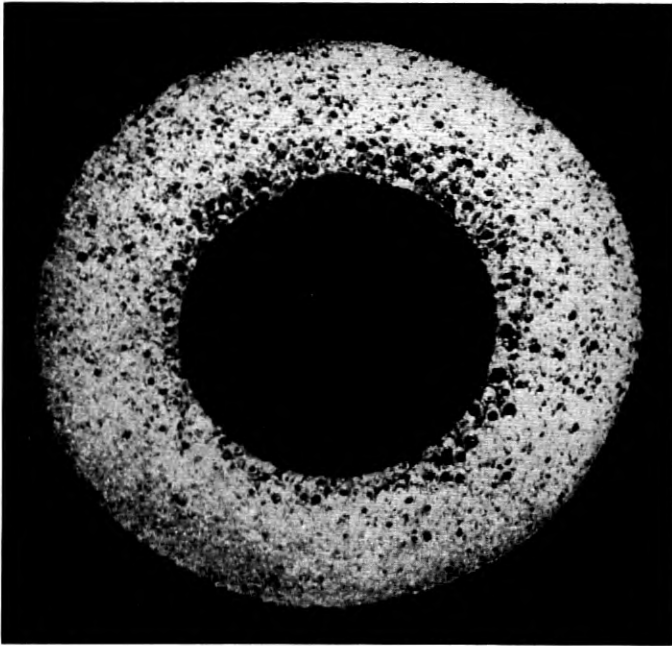

Fig. 2(b)—Cross section of expanded polyethylene insulation from 19 gauge conductor—55 per cent air. Magnified 75 times.

The upper curve in Fig. 3 was determined in this manner. However, in multipair cable the dielectric constant is not amenable to calculation and must be determined experimentally.<sup>2</sup> The empirical relation between the percent air in the insulation and the dielectric constant in the cable for a typical design is shown in the lower curve in Fig. 3. Effective dielectric constants as low as 1.40 have been achieved in expanded polyethylene cables.

Solid polyethylene insulated cables are more costly for given transmission characteristics than those insulated with paper or pulp and, therefore, are restricted to special uses where a system saving can be obtained in spite of the higher first cost. One such use is for small aerial toll cables in rural areas where, with paper-insulated cable, maintenance costs are likely to be high. There are several factors which tend to increase the maintenance costs in such cables. For instance, in small isolated cables lightning troubles are common because of the high sheath resistance.<sup>3</sup> While the incidence of sheath breaks from other causes is usually neither more nor less than in other aerial cables, maintenance is more difficult and costly because of inaccessibility. Maintaining gas pressure on these cables is expensive for the same reason.

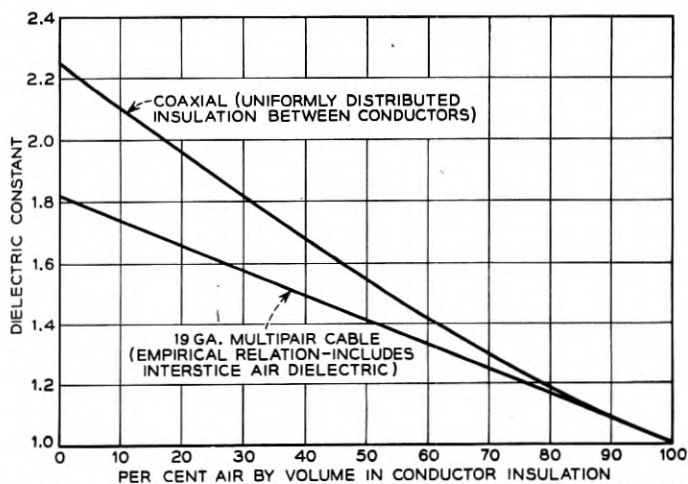

Fig. 3—Change in dielectric constant of coaxial cable and multipair cable with degree of expansion of polyethylene conductor insulation.

In the case of a sheath break with no insulation damage in polyethylene-insulated cables, there is no interruption in service due to entrance of moisture into the cable and repairs can be made on a routine maintenance basis. Gas pressure maintenance is unnecessary and its omission effects appreciable annual savings. Because these cables usually contain not more than 51 pairs the first cost penalty for the use of solid polyethylene, in terms of cents per foot, is small. Small aerial toll cables in rural areas, therefore, are the most promising candidates for solid polyethylene insulation.

The solid polyethylene insulation development has progressed to the point where several cables have been made for field trials. The first of these was at Cooperstown, New York, where approximately four miles of 26-pair 19-gauge cable was installed aerially. The sheath on this cable was a composite of aluminum and polyethylene commonly known as "alpeh" sheath. The Cooperstown cable (see Fig. 4) was one of the first to be installed by the pre-lashing method which has been developed as a means for effecting economies in placing aerial cable.

A second trial installation of solid polyethylene insulated cable was made between Trout Lake and St. Ignace, Michigan, a distance of twenty-eight miles. This cable contained 51 pairs of 19 gauge and was also covered with alpeh sheath. Since that time solid polyethylene cables have been installed in other locations where the anticipated maintenance savings were believed to justify the higher first cost.

Development of expanded polyethylene insulation has been carried



on concurrently with that of solid polyethylene. In expanded polyethylene insulation the cost, as would be expected, varies with the degree of expansion. There are two reasons for this: first, as the proportion of gas is increased, less polyethylene is used in the insulation, and second, because of the lower dielectric constant, the cable can be made smaller for the same attenuation, resulting in savings in sheathing materials. An initial trial installation of about nineteen miles of 51-pair 19-gauge expanded polyethylene insulated cable has been completed between Grandville and Zeeland, Michigan. This route is to be developed for N carrier, and since recent Systems' studies have indicated the lower overall costs will result if low attenuation cable is used, the Grandville-Zeeland cable was designed for a capacitance of 0.066 microfarad per mile rather than the 0.084 microfarad per mile capacitance for which earlier polyethylene-insulated cables were designed. The Cooperstown, Trout Lake and Grandville cables are illustrated in Fig. 5.

It is of interest to compare polyethylene-insulated cables with paper-insulated cables having the same voice frequency attenuation. Some of the more important characteristics are shown in Table II. It will be

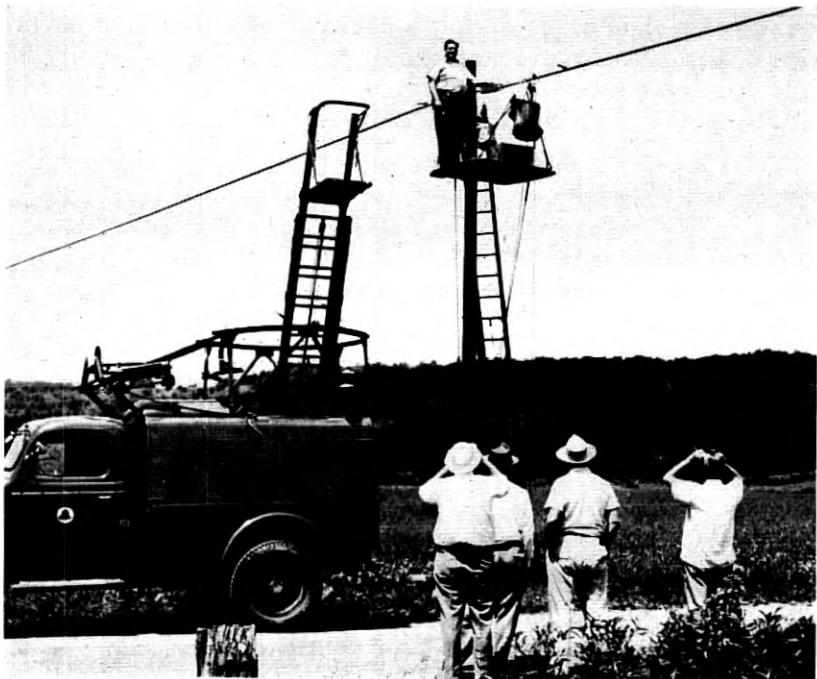

Fig. 4—Installation of Cooperstown-Cherry Valley (N. Y.) cable.

noted that the polyethylene-insulated cables excel in dielectric strength. The values shown in Table II are the test voltages that all the reels of cable were required to withstand between conductors and from core to sheath. These voltages are naturally made lower than the inherent dielectric strength of the insulation to allow for minor manufacturing irregularities and thus avoid excessive rejections. Some idea of the inherent dielectric strength of solid and expanded polyethylene insulation can be obtained from tests on short samples of insulated conductor immersed in water. In Fig. 6 the inherent dielectric strength obtained in this manner for conductors with a 14-mil wall is plotted against percent air in the insulation. It will be noted that the dielectric strength falls off rapidly as the polyethylene is expanded.

The capacitance unbalance to ground, or difference in direct capacitances of the wires of a pair to ground, is a rough indication of one important factor in the susceptibility of cable circuits to noise and interference. The electrical disturbances which cause noise in the cable may come from atmospheric static, radio stations, power lines, or from telephone plant sources. The former energize the cable circuits via the surface transfer impedance<sup>5</sup> of the sheath, or by way of an open wire tap, the latter via all of the conductors in the cable. For this reason the two wires of a pair should have nearly equal capacitance to the surrounding pairs and to the sheath. To achieve this condition the cylinders of insulation on the two wires of a pair must be alike in size and dielectric



GRANDVILLE-ZEELAND (MICH.) PROJECT  
51 PAIRS NO. 19 GAUGE - EXPANDED POLYETHYLENE INSULATION



COOPERSTOWN-CHERRY VALLEY (N.Y.) PROJECT  
26 PAIRS NO. 19 GAUGE - SOLID POLYETHYLENE INSULATION



TROUT LAKE-ST. IGNACE (MICH.) PROJECT  
51 PAIRS NO. 19 GAUGE - SOLID POLYETHYLENE INSULATION

Fig. 5—Polyethylene insulated multipair cables.

TABLE II — COMPARATIVE DATA ON 51-PAIR 19-GAUGE CABLES

Type of Insulation	Inside Diameter of Sheath	Mutual Cap. $\mu\text{f}$ per Mile	Attenuation* DB per Mile—70°F			Average Unbalanced to Ground $\mu\text{f}/1500'$	Minimum Dielectric Strength—KV	
			1 kc	60 kc	150 kc		Cond. to Cond.	Core to Sheath
Solid polyethylene (Trout Lake project) . . . . .	0.92"	0.082	1.24	4.51	6.86	104	10	10
Paper (std. CNB). . . . .	0.80"	0.084	1.26	4.94	7.79	310	0.7	1.4
Expanded polyethylene (Grandville project) . . . . .	0.97"	0.066	1.11	3.92	5.96	118	3	10
Paper (std. DNB). . . . .	0.94"	0.066	1.11	4.05	6.40	240	0.7	1.4

\* Computed from primary constants.

constant. The low value of capacitance unbalance obtained with solid polyethylene insulation is a result of the remarkable uniformity with which this insulation is extruded. The value of 104 micro-microfarads per 1500 feet for the capacitance unbalance to ground is on the average only 0.4 per cent of the direct capacitance of either wire to ground.

The other important factor in unbalance is the uniformity of the twisting, that is, the extent to which wire and mate form symmetrical helixes around the center line of the pair. Polyethylene-insulated pairs appear to be better in this respect for reasons which are not very obvious. The fact that the polyethylene forms firm tubes of insulation of equal size on both conductors of the pair probably is a factor in achieving this uniform twisting.

The precision or accuracy with which the length of pair twist is maintained is also better with the solid polyethylene insulated conductors. If an adequate number of different twist lengths is used in the cable precision twisting is an advantage since the cross talk between adjacent pairs is reduced over that which exists in the less precisely twisted paper insulated cables. The cross talk between pairs with like lengths of twist is kept to a low value by designing the cable so that such pairs are widely separated.

The carrier-frequency attenuation of polyethylene-insulated cable is substantially lower than that of paper-insulated cable which has approximately the same voice-frequency attenuation. In the case of solid polyethylene cable there are two reasons for this lower carrier-frequency attenuation — the inductance is higher and the conductance is lower than those in comparable paper-insulated cable. The higher inductance

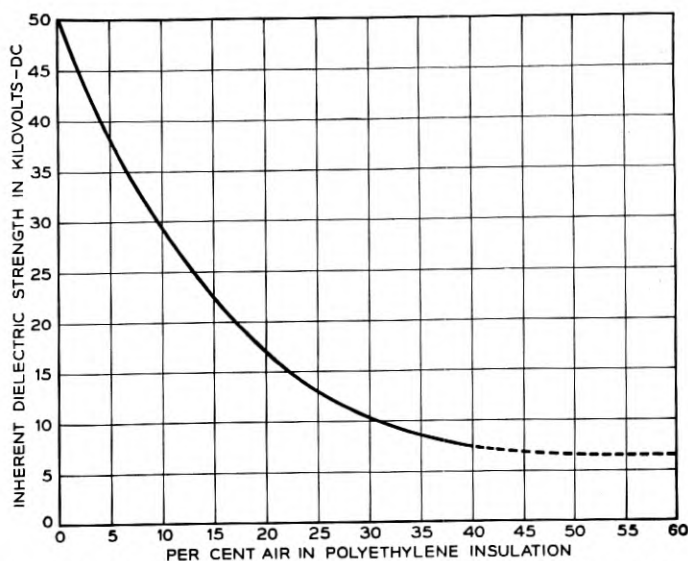

Fig. 6—Inherent dielectric strength of expanded polyethylene versus degree of expansion. 19-gauge 0.064-inch D.O.D. conductors. Short samples immersed in water.

is a result of the greater separation between the wires of a pair and the lower conductance is a result of the lower power factor of polyethylene compared to that of paper. The voice frequency attenuation is relatively independent of inductance and conductance.

While the electrical characteristics of polyethylene cables are superior to those of paper cables, the higher first cost of cables insulated with solid polyethylene has been a deterrent to their widespread use. This higher first cost is inherent in solid polyethylene because, in addition to the higher cost of polyethylene as compared to paper, the cables must be larger for the same voice frequency attenuation. It will be noted that the 51-pair Trout Lake-St. Ignace cable is 15 per cent larger in diameter than the comparable paper cable. The larger size is necessary because of the higher effective dielectric constant which is approximately 1.80 in solid polyethylene cable as compared to 1.60 in a typical paper cable. The effective dielectric constant is higher in the case of solid polyethylene insulation because of the lesser amount of air space which can be incorporated in the dielectric between wires.

As was illustrated in Fig. 3, the dielectric constant can be decreased by expanding the polyethylene. A value as low as 1.40 has been attained experimentally. The effective dielectric constant of the Grand-

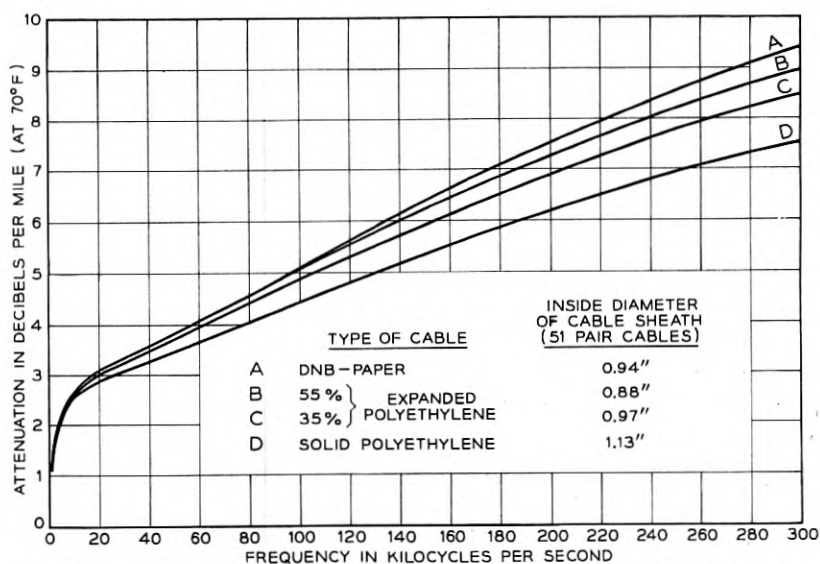

Fig. 7—Attenuation versus frequency. 19-gauge cables having  $0.066 \mu\text{f}$  per mile capacitance.

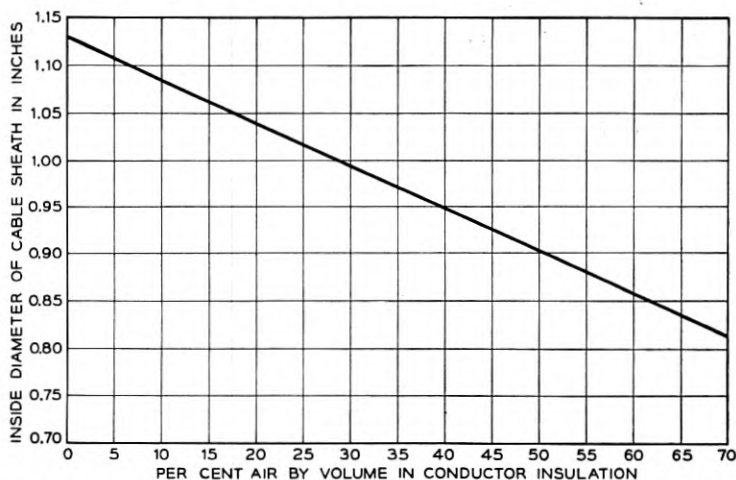

Fig. 8—Change in cable diameter with degree of expansion of polyethylene conductor insulation. 19-gauge 51-pair cable,  $0.066 \mu\text{f}$  per mile capacitance.

ville-Zeeland cable was 1.54, obtained by expanding the conductor insulation to the point that 35 per cent of the volume was gas.

The curves on Fig. 7 represent the attenuation over the N carrier-frequency range for a paper-insulated cable and three polyethylene-insulated cables all designed to have a capacitance of 0.066 microfarads per mile and a voice frequency attenuation of 1.1 db per mile. The lower carrier-frequency attenuation of the polyethylene cables is evident. The size of the polyethylene cables varies with the degree of expansion as illustrated in Fig. 8.

Since the dielectric strength decreases as the degree of expansion increases, the saving in first cost must be balanced against the value of the reduction in reliability. As mentioned before, the Grandville-Zeeland project was the first trial installation of expanded polyethylene cable. A very moderate degree of expansion was chosen for this project. However, as more experience with expanded polyethylene is gained, it should be possible, for a given application, to determine the degree of expansion which strikes the optimum balance between dielectric strength and dielectric constant, giving proper weight to the mechanical properties and to cost factors.

#### REFERENCES

1. Modern Plastics Encyclopedia.
2. Maupin, J. T., Measurements in Multipair Cables. Bell Sys. Tech. Jl., **30**, pp. 652-667, July, 1951.
3. Horn, F. W., and H. B. Ramsey, Bell System Sheath Problems and Designs. A.I.E.E., Trans., **70**, Part I, pp. 1811-1816, 1951.
4. Shockleton, W. J., General Characteristics of Polyethylene. A.I.E.E., Trans., **64**, pp. 912-916, Dec., 1945.
5. Schelkunoff, S. A., Electromagnetic Theory of Coaxial Transmission Lines and Cylindrical Shields. Bell Sys. Tech. Jl., **13**, p. 532, Oct., 1934.
6. Boettcher, C. J. F., Recueil des Travaux Chimiques des Pays Bas, **64**, p. 47, 1945.

# Abstracts of Bell System Technical Papers\* Not Published in this Journal

ANDERSON, P. W.,<sup>1</sup> AND P. R. WEISS<sup>6</sup>

**Exchange Narrowing in Paramagnetic Resonance**, *Revs. Mod. Phys.*, **25**, pp. 269-276, Jan., 1953.

In this paper the problem of the line shape in paramagnetic resonance when large exchange interaction is present is discussed from the standpoint of a simplified mathematical model. The mathematical model can be called the model of "random frequency modulation": It is assumed that the atom absorbs a single frequency, which varies over a distribution determined by the dipolar local fields, but that this frequency varies randomly in time at a rate determined by the exchange interactions. The predicted line shape in the case in which exchange is large is of resonance type in the observable center of the line, but falls off more rapidly in the wings. This line shape has been verified experimentally in a number of cases. This conclusion seems quite independent of any assumption about the type of random frequency modulation, etc.

The quantitative conclusions are reached in the following way: It is suspected, since the exchange motion is the superposition of the effects of a number of neighbors which is not particularly small, that a good approximation to the modulation function is Gaussian noise with a Gaussian spectrum. This, of course, is what would result from the superposition of a large number of rather small effects. Under this assumption both the second moment (which is independent of exchange) and the fourth moment of the line shape can be calculated. This kind of modulation is the simplest one which does give a finite fourth moment; a Markoffian, or "jump", type of modulation, which might seem more reasonable at first, does not. These moments are then compared with the moments computed by Van Vleck [*Phys. Rev.* 74, 1168 (1948)] to fix the two adjustable parameters, mean square frequency, and average rate of change of frequency, of the theory.

The result as to line breadth, which is essentially

$$\Delta \cong \frac{\langle (\Delta\omega^2) \rangle_{AV} \text{ dipole-dipole}}{J/h}$$

\* Certain of these papers are available as Bell System Monographs and may be obtained on request to the Publication Department, Bell Telephone Laboratories, Inc., 463 West Street, New York 14, N. Y. For papers available in this form, the monograph number is given in parentheses following the date of publication, and this number should be given in all requests.

<sup>1</sup> Bell Telephone Laboratories.

<sup>6</sup> Rutgers University, New Brunswick, N. J.

if  $J$  is the exchange integral, can be compared with observed line breadths by estimating  $J$  from Curie-Weiss constants for a number of materials. The results are quite satisfactory if the theory is extended in two ways: (a) When the exchange frequency is larger than the resonance frequency, it can be shown that the off-diagonal elements of the dipolar interaction must be included, leading to a line-width larger by a factor of roughly  $10/3$ ; (b) in a number of cases hyperfine and Stark splitting is contributing importantly to the width.

The good agreement with experiment in the cases we have investigated leads us to believe that a quantitative approach to the paramagnetic resonance line breadth problem, using only the already known concepts of dipolar interaction, exchange narrowing, and fine structure splitting, will probably explain all the observed phenomena.

ANDRUS, J., see J. K. GALT.

ARNOLD, S. M., see MISS S. E. KOONCE.

BENEDICT, T. S.,<sup>1</sup> AND W. SHOCKLEY<sup>1</sup>

**Microwave Observation of the Collision Frequency of Electrons in Germanium**, Letter to the Editor. *Phys. Rev.*, **89**, pp. 1152-1153, Mar. 1, 1953.

BIES, F. R.<sup>1</sup>

**Attenuation Equalizers**, *Audio Eng. Soc. J.*, **1**, pp. 125-136, Jan., 1953.

In all systems there are components which attenuate some frequencies to a greater extent than others, and attenuation equalizers are usually required to correct the overall gain-frequency characteristic. This paper will deal with the types of attenuation equalizer that are found most useful, the performance that they display, and a chart method of computing their insertion loss.

BOZORTH, R. M.<sup>1</sup>

**Permalloy Problem**, *Revs. Mod. Phys.*, **25**, pp. 42-48, Jan., 1953 (Monograph 2102).

In attempting to explain the unusual magnetic properties of the iron-nickel alloys, single crystals of alloys containing 35 to 100 per cent nickel were prepared, and measurements made of the magnetic crystal anisotropy and magnetostriction as dependent on cooling rate. It is confirmed that there is a large effect of cooling rate on the anisotropy in the region near  $\text{FeNi}_3$ , but the experiments show also a substantial effect between 50 and 85 per cent nickel. Two magnetostriction constants,  $\lambda_{100}$  and  $\lambda_{111}$ , were measured on the

<sup>1</sup> Bell Telephone Laboratories.



same crystals. The effect of cooling rate on magnetostriction was found to be substantial only in the composition range 70 to 80 per cent nickel. When the specimens are quenched,  $\lambda_{111}$  goes through zero for a nickel content just below 80 per cent nickel, a composition very close to that for highest permeability. This is understandable because the magnetostrictive strain caused by movement of the boundary between two domains, each magnetized spontaneously in a [111] direction, depends on  $\lambda_{111}$  alone. The same physical picture predicts that near 45 percent nickel, where [100] is the direction of easiest magnetization and  $\lambda_{100}$  goes through zero, the permeability versus composition curve should again have a maximum. Such a maximum is known to exist, and initial permeabilities as high as 15,000 have been observed. Although simple theory suggests that domain-rotation should occur in very weak fields when the crystal anisotropy is very small (75 per cent nickel in quenched alloys), nevertheless, rotation involves magnetostrictive strains which prevents  $\mu_0$  from becoming infinite. Internal poles are also likely to be formed. In slowly cooled alloys the anisotropy is zero at about 63 per cent nickel; here there are random strains caused by magnetostriction and possibly also by atomic ordering. The principal changes in magnetic properties with composition are explained in terms of the crystal anisotropy and magnetostriction, and their change with heat treatment.

BOZORTH, R. M.<sup>1</sup>

**Behavior of Magnetic Materials**, Am. J. Phys., **21**, pp. 260-266, Apr., 1953 (Monograph 2105).

This is a review of recent work in which the atomic theory of ferromagnetism and the domain theory of magnetization are applied to new materials.

BOZORTH, R. M., see H. J. WILLIAMS.

BURNS, R. M.<sup>1</sup>

**Science and Scientists in Telecommunications**, Electrochem. Soc. J., **100**, pp. 90C-94C, Apr., 1953.

COLLEY, R. H., see G. Q. LUMSDEN

COY, J. A.,<sup>1</sup> AND E. K. VAN TASSEL<sup>1</sup>

**Type-O Carrier Telephone**, Elec. Eng., **72**, pp. 418-423, May, 1953.

The Type-O carrier is an economical short-haul carrier system especially suitable for use under 150 miles. It fulfills the same purpose for open-wire lines as the Type-N carrier system does in cable routes. Numerous laboratory tests have indicated that good service standards have been maintained in spite of its low cost.

<sup>1</sup> Bell Telephone Laboratories.

FINE, M. E.<sup>1</sup>

**Magnetomechanical Effects in an Antiferromagnet, CoO**, *Revs. Mod. Phys.*, **25**, p. 158, Jan., 1953.

FINE, M. E.<sup>1</sup>

**Elasticity and Thermal Expansion of Germanium between -195 and 275°C**, *J. Appl. Phys.*, **24**, pp. 338-340, Mar., 1953 (Monograph 2069).

Young's moduli (E) of the directions (100) and (111) and the shear modulus (G) for (100) were determined in germanium from -195 to 255, 275, and 140°C, respectively. From these moduli, the elastic parameters, the compressibility, and Poisson's ratio were calculated. The thermal expansion was measured from -196 to 275°C.

GALT, J. K.,<sup>1</sup> ANDRUS<sup>1</sup>, J. AND H. G. HOPPER<sup>1</sup>

**Motion of Domain Walls in Ferrite Crystals**, *Revs. Mod. Phys.*, **25**, pp. 93-97, Jan., 1953.

GRAY, A. N.<sup>3</sup>

**Development of Electroformed Copper-steel Wire**, *Wire and Wire Products*, **28**, pp. 166-168, 218-219, Feb., 1953.

The author traces the development and the functioning of the apparatus in the successful efforts to produce a satisfactory copper coated steel wire used for telephone drop wire.

GROTH, W. B.<sup>1</sup>

**Principles of Tape-to-Card Conversion in the AMA System**, *A.I.E.E. Trans. Commun. and Electronics Sect.*, **5**, pp. 42-52, Mar., 1953.

HAYNES, J. R.,<sup>1</sup> AND J. A. HORNBECK<sup>1</sup>

**Temporary Traps in Silicon and Germanium**. Letter to the Editor. *Phys. Rev.*, **90**, pp. 152-153, Apr. 1, 1953.

HEIDENREICH, R. D., see E. A. NESBITT.

HOGAN, C. L.<sup>1</sup>

**Ferromagnetic Faraday Effect at Microwave Frequencies and Its Applications**, *Revs. Mod. Phys.*, **25**, pp. 253-262, Jan., 1953.

<sup>1</sup> Bell Telephone Laboratories.

<sup>3</sup> Western Electric Company, Inc.

HOPPER, H. G., see J. K. GALT.

HORNBECK, J. A., see J. R. HAYNES.

HUGHES, W. T.<sup>1</sup> AND J. J. LANDER<sup>1</sup>

**Vacuum Tube Electrometer Amplifier**, Rev. Sci. Instr. **24**, pp. 331-332, Apr., 1953.

KERSTA, L. G.<sup>1</sup>

**Interesting Property of Certain Conductive Rubbers**. Letter to the Editor. J. Polymer Sci., **10**, pp. 447-448, Apr., 1953.

KOCK, W. E.<sup>1</sup>

**Acoustic Gyrator**, J. Am., Acoust. Soc. **25**, p. 575, May, 1953.

KOCK, W. E.<sup>1</sup>

**Acoustic Gyrator**, Arch. Elektr. Übertragung, **7**, p. 106, Feb., 1953.

A gyrator for acoustic waves is described which is the analog of the ferrite gyrator for microwaves described by C. L. Hogan. The required non-reciprocal rotation of the plane of polarization of transverse acoustic waves propagating in a tube is accomplished by rotating the tube at high speed.

KOCK, W. E.<sup>1</sup>

**Ähnlichkeit zwischen Vokalformanten und Formanten von Musikinstrumenten (Similarity Between Vowel Formants and the Formants of Musical Instruments)**, (in German), E.T.Z., **74**, p. 166, Mar. 1, 1953.

KOHMAN, G. T., see M. C. WOOLEY.

KOONCE, MISS S. E.,<sup>1</sup> AND S. M. ARNOLD<sup>1</sup>

**Growth of Metal Whiskers**. Letter to the Editor, J. Appl. Phys., **24**, pp. 365-366, Mar., 1953.

LANDER, J. J., see W. T. HUGHES.

LUKE, C. L.<sup>1</sup>

**Photometric Determination of Antimony in Lead Using the Rhodamine B Method**, Anal. Chem., **25**, p. 674, Apr., 1953.

<sup>1</sup>Bell Telephone Laboratories.

LUMSDEN, G. Q.,<sup>1</sup> AND R. H. COLLEY<sup>1</sup>

**Review of American Standard Fiber Stresses of Wood Poles, Standardization, 24, pp. 114-117, Apr., 1953.**

McKAY, K. G.<sup>1</sup>

**Crystal Conduction Counter, Physics Today, 6, pp. 10-13, May, 1953.**

Development of the crystal counter (essentially an ionization chamber that is solid instead of being filled with gas) has progressed in the last few years, but is still delayed for lack of better understanding of crystals and their electrical behavior.

McMAHON, W., see M. C. WOOLEY.

MASON, W. P.<sup>1</sup>

**Rotational Relaxation in Nickel at High Frequencies, Revs. Mod. Phys., 25, pp. 136-139, Jan., 1953.**

Measurements of the  $\Delta E$  effect and the decrement made by Bozorth, Mason, and McSkimin and by Johnson and Rogers are compared with that expected from a calculation of domain wall relaxations for a distribution of domain sizes as determined by the optical measurements of Williams and Walker. At low frequencies the agreement is good but at high frequencies a second relaxation region is indicated. It is shown that this region is consistent with a domain rotation relaxation and introducing this effect, a good agreement is obtained between theory and experiment for the entire frequency range.

MATHY, P. T.<sup>3</sup>

**Clever Conveyorization Avoids Handling Headaches, Am. Mach., 97, pp. 140-143, May 11, 1953.**

MORRISON, J.<sup>1</sup>

**Controlled Gas Leak, Rev. Sci. Instr., 24, pp. 230-231, Mar., 1953.**

NESBITT, E. A.,<sup>1</sup> AND R. D. HEIDENREICH<sup>1</sup>

**Physical and Magnetic Structure of the Mishima Alloys, Rev. Mod. Phys., 25, pp. 322-323, Jan., 1953.**

---

<sup>1</sup> Bell Telephone Laboratories.  
<sup>3</sup> Western Electric Company, Inc.

PEARSON, G. L.,<sup>1</sup> AND M. TANENBAUM<sup>1</sup>

**Magnetoresistance Effect in InSb.** Letter to the Editor, Phys. Rev., **90**, p. 153, Apr. 1, 1953.

PUGH, S. G.<sup>5</sup>

**Southern Bell Switches to Chemical Brush Control,** Elec. World, **139**, pp. 122-123, Mar. 23, 1953.

If properly planned and executed, chemical control costs less in time and money and does a better job.

RALSTON, R. W.<sup>4</sup> AND B. D. WICKLINE<sup>4</sup>

**Television Coverage of the National Political Conventions,** A.I.E.E. Trans. Commun. and Electronics Sect. **5**, pp. 1-14, Mar., 1953, and Elec. Eng., **72**, pp. 383-389, May, 1953.

The first large-scale television coverage of both national political conventions occurred last year in Chicago and this presented many new problems to the telephone company of that city. Special video conductors and amplifiers were used in eight of the 19 channels to the amphitheatre and microwave facilities for the rest.

SHIVE, J. N.<sup>1</sup>

**Properties of Germanium Phototransistors,** J. Opt. Soc. Am., **43**, pp. 239-244, Apr., 1953 (Monograph 2103).

This paper describes, summarizes, and compares the properties of three photoelectric devices, namely: point contact phototransistors,  $p-n$  junction phototransistors, and  $n-p-n$  junction multiplier phototransistors, which have resulted from the prosecution of the transistor program at Bell Telephone Laboratories. The first of these devices is characterized by a comparatively high dark current and a quantum yield of 3 or 4 electrons per quantum. The second has a dark current in the microampere range and a quantum yield of approximately unity. The  $n-p-n$  device has a sensitivity corresponding at best to a quantum yield of several hundred electrons per quantum. All these devices have long-wave thresholds around 1.8 microns. The structures lend themselves readily to miniature encapsulation.

SHOCKLEY, W., see T. S. BENEDICT.

<sup>1</sup> Bell Telephone Laboratories.

<sup>4</sup> Illinois Bell Telephone Company.

<sup>5</sup> Southern Bell Telephone Company.

SLADE, F. D.<sup>2</sup>

**Mechanized Billing of AMA Toll Messages**, A.I.E.E., Trans. Commun. and Electronics, **6**, pp. 175-182, May, 1953.

SLEPIAN, D.<sup>1</sup>

**On the Number of Symmetry Types of Boolean Functions on  $n$  Variables**, Can. J. Math., **5**, pp. 185-193, 1953.

TANENBAUM, M., see G. L. PEARSON.

VAN SICLEN, H. E.<sup>3</sup>

**What We Did to Cut Costs of Finishing Telephone Woodwork**, Ind. Finishing, **29**, pp. 44-52, Apr., 1953.

VAN TASSEL, E. K., see J. A. COY.

WILLIAMS, H. J.,<sup>1</sup> AND R. M. BOZORTH<sup>1</sup>

**Magnetic Study of Low Temperature Transformation in Magnetite**, Rev. Mod. Phys., **25**, pp. 79-80, Jan., 1953.

WOOD, E. A.<sup>1</sup>

**Simple Attachment for Low Temperature Use of an X-Ray Diffraction Camera**, Rev. Sci. Instr., **24**, pp. 325-326, Apr., 1953.

WOOLEY, M. C.,<sup>1</sup> G. T. KOHMAN,<sup>1</sup> AND W. McMAHON,<sup>1</sup>

**Polyethylene Terephthalate — Its Use as a Capacitor Dielectric**, A.I.E.E. Trans. Commun. and Electronics Sect., **5**, pp. 33-37, Mar., 1953 (Monograph 2125).

The steady increase in the severity of operating conditions for capacitors and the need for more diverse characteristics has spurred the search for new and better capacitor dielectrics. The synthetic plastics industry, which is the source of a number of useful dielectric materials, has recently produced a new and promising dielectric in film form known as polyethylene terephthalate or "Mylar." This material is unusually strong, has a high softening point, and is available in very thin films which makes it especially suitable for capacitor insulation. The electrical characteristics of capacitors wound

<sup>1</sup> Bell Telephone Laboratories.

<sup>2</sup> American Telephone and Telegraph Company.

<sup>3</sup> Western Electric Company, Inc.

with Mylar film are likewise promising. As compared to mineral-oil-impregnated paper capacitors, unimpregnated Mylar capacitors exhibit higher dielectric strength, higher insulation resistance, and can be operated at higher ambient temperatures. Their loss characteristics are comparable with those of impregnated paper and the capacitance stability over the usual range of ambient temperatures approaches that of mica capacitors. Mylar is relatively nonhygroscopic and tests indicate that for moderate atmospheric conditions capacitors made from it do not require additional moisture protection. The film can be metallized readily by current techniques and, when used in metallized capacitors, appears to possess advantages over metallized paper in several respects.

WRIGHT, S. B.<sup>1</sup>

**Higher Frequencies for Ground-Air Communications**, Air Univ. Quart. Rev., **5**, No. 4, pp. 60-70, 1952-1953.

---

<sup>1</sup>Bell Telephone Laboratories.

Addendum to  
**Delay Curves for Calls Served at Random**

By JOHN RIORDAN

B. S. T. J.

January 1953

Pages 100 to 119

I owe the following remarks, which help to complete the record, to Emile Vaultot:

1. The Erlang formula for delay with order of arrival service, for the proof of which reference has been made to a paper by E. C. Molina, was proved earlier by E. Vaultot (*Application du Calcul des Probabilités à l'exploitation téléphonique. Revue Générale de l'Electricité, 16*, pp. 411-418, 1924). Indeed his seems to be the first proof.

Also, the associated Erlang C function  $C(c, a)$ , for which I said there was no extensive tabulation, is tabulated for  $n = 1$  (1) 139 and an extensive but irregular set of  $a$ 's by Arne Jensen (*Moe's Principle, Table III, Copenhagen Telephone Co. Copenhagen, 1950*). Also the recurrence relation for this function given in a footnote has previously been given by Conny Palm (*Väntetider Vid Slumpvis Avverkad Kö, Tekniska Meddelanden Fran. Kungl. Telegrafstyrelsen, Specialnummer för Teletrafikteknik, pp. 109. Stockholm, 1946, see p. 43*).

2. The extensive treatment of delay by Conny Palm, just mentioned, includes a section on random service (section 4); it may be noticed that this is dated May 15, 1946, which is only a few months after Vaultot's article on the same subject (Jan. 28, 1946), and of course is an independent development.

I owe the following to my colleague S. O. Rice. Pollaczek, in the *Comptes Rendus* paper mentioned, has given an integral effectively for what I have called  $F(u)$ . Rice has put this in a slightly different form adapted to numerical computation and has obtained the following results for  $F(u)$

$$v = u(1-\alpha)$$

$\alpha$	1	2	4	6	8	10	12	14
0.8					0.0079	0.0039	0.0020	0.0011
0.9	0.2866	0.1388	0.0471	0.0198	0.0094	0.0049	0.0026	0.0015

Comparison with the tables of the papers shows a satisfying agreement and substantiates the conjecture that approximation by a relatively small number of exponentials is sufficient.

JOHN RIORDAN



## Contributors to this Issue

REUBEN E. ALLEY, JR., B.A., University of Richmond, 1938; E.E., Princeton University, 1940; Ph.D., Princeton University, 1949. Massachusetts Institute of Technology, Radiation Laboratory, 1942 and 1943; University of Richmond, 1948-51; Bell Telephone Laboratories, 1952-53. While at Bell Laboratories, Mr. Alley was engaged in investigations of the magnetic properties of ferrites, with particular interest in frequencies above 20 megacycles. He recently accepted an appointment at the University of Richmond as an associate professor of physics. Member of the American Physical Society, A.I.E.E., I.R.E., Phi Beta Kappa and Sigma Xi.

M. M. ATALLA, B.S., Cairo University, 1945; M.S., Purdue University, 1947; Purdue University, Ph.D., 1949; Studies at Purdue undertaken as the result of a scholarship from Cairo University for four years of graduate work. Bell Telephone Laboratories, 1950-. For the past three years he has been a member of the Switching Apparatus Development Department, in which he is supervising a group doing fundamental research work on contact physics and engineering. Current projects include fundamental studies of gas discharge phenomena between contacts, their mechanisms, and their physical effects on contact behavior; also fundamental studies of contact opens and resistance. In 1950, an article by him was awarded first prize in the junior member category of the A.S.M.E. He is a member of Sigma Xi, Sigma Pi Sigma, and Pi Tau Sigma, and a junior member of the A.S.M.E.

WILLIAM R. BENNETT, B.S. in E.E., Oregon State College, 1925; M.A., Columbia University, 1928; Ph.D., Columbia, 1949. Bell Telephone Laboratories, 1925-. His early Laboratories projects included work on wire transmission problems, particularly the development of terminal apparatus in the voice and telegraph range, the design of circuits for television, and submarine cable telephony. Concerned with the coaxial cable in 1935, he spent several years working on the requirements and measuring techniques applicable to the load rating of multi-channel repeaters. His work during World War II was directed to a

number of military projects. Since then he has concentrated on pulse code modulation and general transmission problems. Member of the A.I.E.E., I.R.E., The American Physical Society, Tau Beta Pi, Eta Kappa Nu and Sigma Xi.

A. N. GRAY, Bell Telephone Laboratories, 1922-1929; Western Electric Company, 1930-. Mr. Gray, Assistant Superintendent, Development Engineering, Point Breeze since 1946, is engaged in the development of new equipment and processes. He was Manufacturing Engineer, Rubber Covered Wire, throughout the period of World War II when the Western was heavily loaded with the manufacture of communications items for the Armed Services. He is a member of the A.S.T.M., being Western's representative from Point Breeze, and is assigned to Committee D-11 on Rubber and Rubber Products.

L. N. HAMPTON, Cooper Institute of Technology; Experimental Department, Otis Elevator Company, Engineering Department; Western Electric Company and Bell Telephone Laboratories, 1917-. In the Western Electric Company's Apparatus Development Department, he designed Signal Corps apparatus for the detection of airplanes and submarines. Later, in Switching Apparatus Development, he was in charge of the development of apparatus for use in the telephone plant. After World War II and work on airborne radar and computing systems for military projects, he was engaged in the development of train-dispatching apparatus, cameras for photographing subscribers' message registers and the cam switching panels of the overseas radio privacy systems. He also was responsible for the development of the trouble recorder used in the 4 and 5 crossbar systems and the apparatus aspects of the card translator. More recently he has been active in the development of components for guided missiles. Member of the A.S.M.E. and the General Society of Mechanics and Tradesmen of New York; secretary, Foundation for Homeopathic Research.

H. R. HUNTLEY, B.S. in E.E., University of Wisconsin, 1921. Wisconsin Telephone Co. 1917-1930, except for a leave of absence to complete education begun earlier at Leland Stanford University and continued at the University of Wisconsin. Leaving The Wisconsin Telephone Company where he was Transmission Engineer, Mr. Huntley came to the Foreign Wire Relations Section of the Operating and Engineering Department of American Telephone and Telegraph Company in 1930. In 1942 he transferred to the Transmission Section and has been Transmission Engineer since 1951.

LUTHER W. HUSSEY, A.B., Dartmouth College, 1923; M.A., Harvard University, 1924. Union College, Instructor, 1924-30; Bell Telephone Laboratories, 1930-. Mr. Hussey was first engaged in research on non-linear resistive and reactive devices such as copper-oxide and germanium diodes. He worked on the development of a non-linear coil for the magnetic pulse generator and the harmonic generator in the megacycle range. He has been concerned with the development of modulating devices, negative impedance circuits, and switching and computer devices, and is currently associated with an electronic apparatus development group working on transistors and transistor circuits. He is a member of the I.R.E.

ROBERT L. KAYLOR, B.S. in E.E., University of Michigan, College of Engineering, 1927. Detroit Edison Company, 1922-27; American Telephone and Telegraph Company, Development and Research Department, 1927-34; Bell Telephone Laboratories, 1934-. At A. T. and T. he was engaged in field testing of new telephone apparatus and fundamental studies of noise and cross-induction in telephone circuits. He continued these and related studies after transferring to the Laboratories, his work including fundamental studies of methods of measuring radio noise. During World War II he was Signal Officer with several Army and Air Corps organizations, and is now a Lieutenant Colonel in the Air Force Reserve. Mr. Kaylor returned to the Laboratories in 1945 to do field trials of radio relay systems, and analysis and measurement studies in the 4,000-mc range. More recently he has been engaged in classified military projects. Member of the A.I.E.E., Associate of the I.R.E.

G. E. MURRAY, Western Electric Company, 1936-. Mr. Murray has been active in the development of equipment and processes for the electroforming project and is in charge of the electrochemical development group. During World War II, he was engaged in the manufacture of rubber covered wire and communications items for the Armed Services. He is a member of the American Chemical Society.

JAMES B. NEWSOM, Western Electric Company and Bell Telephone Laboratories, 1920-. After four years of military service in World War I, he joined Western Electric, directing his attention to the development of manual telephone systems and the panel telephone system. Since the incorporation of the Laboratories in 1925, he has been a member of what is now Switching Systems Development II and has devoted time

to the design of panel and crossbar systems, crossbar tandem and toll crossbar systems. During World War II he was a Lieutenant Commander in the U. S. Navy, assigned to the Naval Research Laboratory in Washington, D. C. Since 1946, Mr. Newsom has been in charge of a group concerned with the development of toll crossbar senders, decoders, translators and markers.

F. W. STUBNER, B.S., Cooper Union, 1930. Bell Telephone Laboratories, 1929-. Mr. Stubner joined the Laboratories' research drafting department and became a design engineer concerned with the design and building of apparatus and testing equipment for telephone instruments and submarine cable. Transferring to the Electronic Apparatus Development Department in 1940, he worked on the design of vacuum tubes, magnetic switches, and glasswork for the carbon deposited resistor. Since 1944 he has been associated with the applied mechanics laboratory, responsible for strength tests on vacuum tubes, shock and vibration studies, and associated design assignments. He transferred to Allentown, Pa., in 1948. Member of the Engineers Club of the Lehigh Valley and the Society for Experimental Stress Analysis.

A. S. WINDELER, B.S., Rutgers University, 1930; Bell Telephone Laboratories, 1930-. Mr. Windeler has been engaged in the design and development of toll cable, including coaxial, video pair, and microwave, types. He is currently in charge of a group concerned with the development of expanded polyethylene insulated conductors for multipair cable.