

# G.A.S.H.— A Ferroelectric Crystal

A. N. HOLDEN *Physical Research*

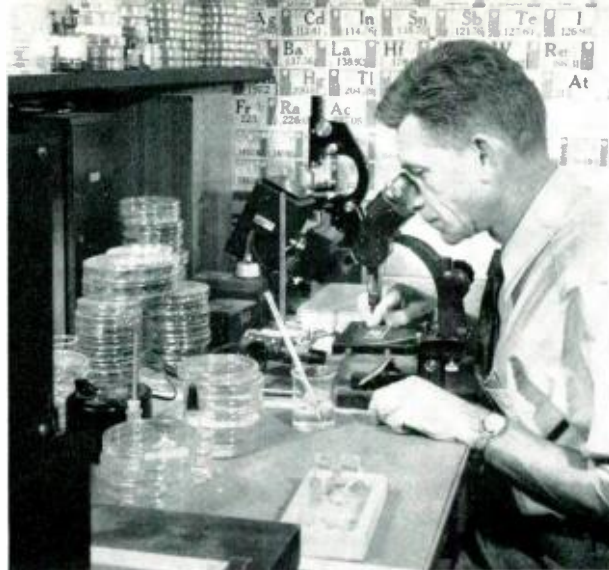

A year ago G.A.S.H. — Guanidinium Aluminum Sulphate Hexahydrate — was added to the select company of known ferroelectric materials. Barium titanate thus acquired its first companion for possible use as a “memory” crystal in telephone switching systems. A puzzling variation in properties is apparent in both of these ferroelectric materials, and a many-pronged attack on these puzzles is in progress.

B. T. Matthias was hunting a needle in a haystack. Picking a little crystal from one of an array of labeled bottles before him, he painted silver-paste electrodes on opposite faces of it, put an alternating voltage across it, and looked at the trace of the charging curve on an oscilloscope. In almost all known crystals, the displacement of charge which a voltage produces is proportional to that voltage. When Matthias' oscilloscope showed the usual straight line (Figure 1), he returned the crystal to its bottle and moved on to the next.

He sought a “ferroelectric” material. In those materials — so called because they exhibit the electrical analog of ferromagnetism — the voltage does *not* produce a proportional charge; Matthias' oscilloscope would display a hysteresis loop (Figure 2). In fact it did, when he reached the third bottle.

This is the more remarkable when you consider the composition of the haystack which yielded this needle. The bottles contained samples of some two hundred different crystals grown by the writer ten and more years ago in a search for new piezoelectric materials—the search which uncovered EDT<sup>o</sup> (ethylene diamine tartrate). The few ferroelectric materials already known are also strongly piezoelectric, and that fact suggested Matthias' choice of haystack. But the ferroelectric crystal which he found is only very feebly piezoelectric; it has even

been reported as not piezoelectric at all. And so, young scientist, if you would hunt needles in haystacks, by all means follow what clues you can, but be sure to perform the crucial experiment.

The substance which Matthias thus brought into prominence is guanidinium aluminum sulfate hexahydrate, promptly abbreviated to G.A.S.H. Before dealing with it in particular, recall some facts about ferroelectric materials in general.

There are both technological and scientific reasons for paying attention to ferroelectric crystals. Barium titanate, the best known of them, is used in the form of polycrystalline ceramics as a piezoelectric material, to interconvert electrical impulses and mechanical motions.<sup>o</sup> Its high dielectric constant provides small capacitors of high breakdown strength and high capacitance. But its most exciting application, still not quite developed to the point of use, involves single crystals of the substance rather than ceramic aggregates of little crystals. That application is the storage and later release of “bits” of information: a “memory,” one of whose uses might be in telephone switching systems.† It is here that G.A.S.H. may supplement barium titanate, offering another string to memory's bow.

The property of a ferroelectric crystal which equips it for this use is a curious one. Over large

<sup>o</sup> RECORD, December, 1947, page 458.

<sup>†</sup> RECORD, August, 1949, page 285. † RECORD, September, 1955, page 335.

regions of it, there is a "spontaneous" displacement of charge; the center of gravity of the negative charges in its atomic make-up does not coincide with that of the positive charges, Figure 3(a). That displacement has a definite direction relative to the structure of the crystal, and a voltage applied to the crystal along that direction will tend to change that displacement.

You can apply the voltage in two opposite senses along that direction. In one of those senses the voltage will increase the displacement, Figure 3(b), and when you remove the voltage the displacement

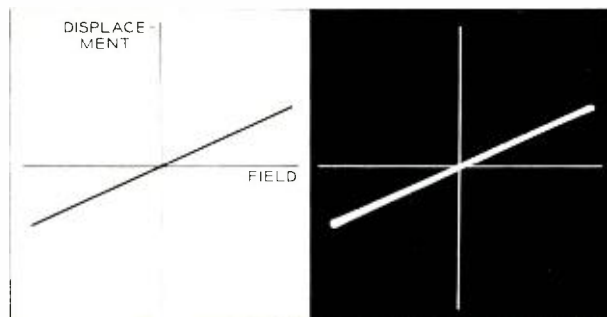

Fig. 1—A voltage applied to a crystal produces in it an electric field measured by the ratio of the voltage to the separation of the electrodes. In almost all crystals an electric field produces a proportional displacement of electric charge. The constant of proportionality is the dielectric permittivity. The dielectric constant is the ratio of that permittivity to the permittivity of empty space.

will return to its original value. A voltage in the other sense will decrease the displacement.

But there is a further characteristic difference between these two cases. When you increase the voltage in the displacement-decreasing direction you cannot reduce the displacement to zero. Suddenly the displacement "flops" over into the opposite direction: the charges move so that their centers of gravity are reversed. To the voltage, the crystal looks as if you had turned it upside down, and the voltage is now in the displacement-increasing direction for the new displacement. When you remove the voltage, the displacement has the original value but is in the opposite direction, Figure 3(c). Under an alternating voltage, the resulting behavior is the hysteresis loop of Figure 2.

Apply now not an alternating voltage but a single pulse of voltage. If the pulse is in the displacement-increasing direction, the small motions of the charges in the crystal will produce a small current pulse in the circuit which applies the volt-

age. If the voltage pulse is in the other direction, a large current pulse will flow as the displacement reverses its direction. A second pulse in that same direction will now cause only a small current pulse: the preceding voltage pulse "switched" the crystal.

Here you see both the memory and the method of reading it. The crystal remembers which way you pulsed it last. This is its only "information" — plus or minus, north or south, one or zero, call it what you will — one "bit". A later exploratory pulse can always reveal this information through the size of the current it evokes: big or small. The exploratory pulse gives a "destructive read-out," because after it the information in the crystal is the direction of that last pulse. But this need not be fatal, for the information read-out can be used at once to apply a pulse which restores the original information.

Some elementary requirements for a crystal in a memory device now emerge. Apart from the obvious demand that it should be stable, holding on to its information reliably for a long time, it should ask for no inconveniently high voltages, consume only comfortable amounts of power, operate reproducibly in repeated use, provide easy discrimination on read-out, and accept and discharge its information rapidly on request, or in other words exhibit a short "switching time."

It is interesting to compare barium titanate and G.A.S.II. in these respects. Both are adequately stable when they are not stressed; stresses, in assembly and in use, can be avoided with care. Since the electric field required to "flop" the displacement is about the same in the two materials — about 1,000 volts per centimeter — so, roughly speaking,

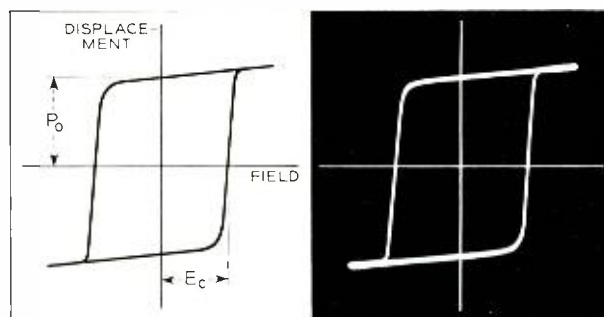
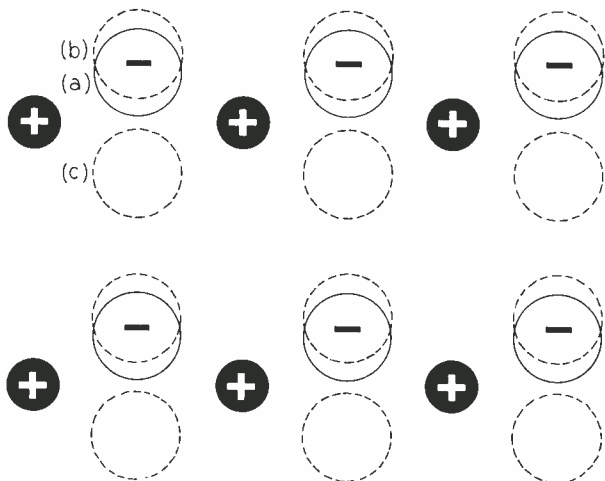

Fig. 2—In ferroelectric crystals, the displacement of charge is not a single-valued function of the applied electric field but depends on the voltage-history of the crystal. When no field is applied, the crystal has a "spontaneous" or "remanent" displacement  $P_0$ . A finite electric field  $E_c$ , the "coercive force," is required to switch the displacement from one direction to its opposite.

are their respective operating voltages. Twenty volts includes a sufficient factor of safety to operate crystal sections one thousandth of an inch thick, so long as the required speed of switching is not too high.

Consider next that speed requirement. You can always increase the switching speed by increasing the operating voltage. Under comparable conditions barium titanate switches about thirty times as fast as G.A.S.H. (whose time is 10 to 100 microseconds) and thus in certain fast-switching applications which barium titanate may handle, G.A.S.H. would require prohibitive voltages. But a fast-switching application is usually a frequent-switching application as well, and here barium titanate exhibits a defect of its own. Barium titanate sometimes ages with use; under severe operating requirements, a few million pulses seriously degrade the crispness and intensity of its response. G.A.S.H. has the converse idiosyncrasy: it profits from exer-



*Fig. 3 — Even when no voltage is applied, the center of gravity of the negative charges is displaced from that of the positive charges in a ferroelectric crystal. (a). When you apply a voltage producing the field  $E$  in one direction, (b), you increase that displacement, and when you remove that voltage, the displacement returns to its original value, (a). A large enough voltage in the other direction, however, “switches” the crystal, and when you remove that voltage, the displacement (c) looks like (a) upside down. Thus the crystal is what apparatus engineers term a “bi-stable device.”*

cise and shows a sluggishness after rest which another period of exercise will cure.

Look now at the discrimination you can achieve between the two directions of displacement. The discrimination is measured by the ratio of the cur-

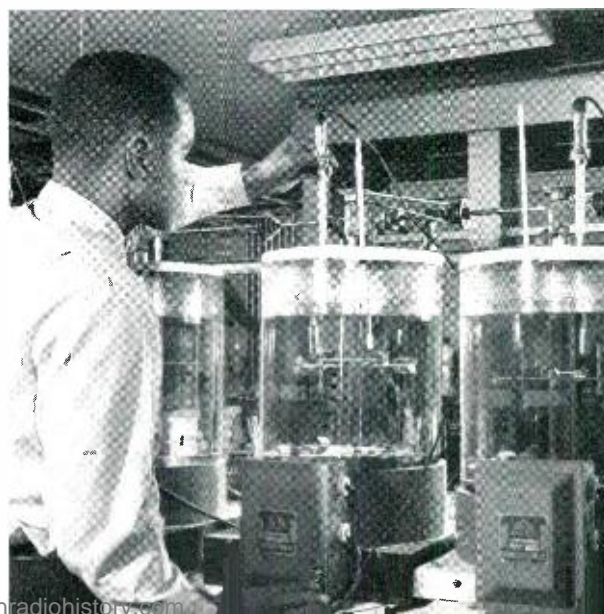

*Fig. 4 — B. T. Matthias puts silver paste electrodes on a crystal preparing to test it for ferroelectricity. In this way, he recently found that guanidinium aluminum sulphate hexahydrate, a substance discovered by Ferraboschi in 1908, was ferroelectric.*

rent pulses you get in the two cases. Each current pulse is proportional to the additional displacement which the exploring voltage produces. Figure 6 shows schematically what that additional displacement is for each of the two directions of the exploring pulse. In one direction it is the electric field times the slope of the line at the top of the hysteresis loop—in other words the field times the “small-signal dielectric constant.” In the other direction it is approximately the distance between the top and the bottom of the hysteresis loop—in other words twice the “spontaneous polarization.”

Since roughly the same voltages operate both barium titanate and G.A.S.H., the ratio of the spontaneous polarization to the dielectric constant for each material provides a number which can be used to compare their discriminating abilities. The spontaneous polarization of G.A.S.H. is 0.35 mi-

*Fig. 5 — C. E. Miller uses the reciprocating rotary crystallizer, developed by the author to grow ADP crystals during World War II, to grow crystals of G.A.S.H. from a water solution.*



cro coulombs per square centimeter, only about 1/70 that of barium titanate. But the small-signal dielectric constant of G.A.S.H. is only 6, which is about 1/30 that of barium titanate. The theoretical discrimination ratio for G.A.S.H. is thus about one half of that for barium titanate; it still leaves plenty of discrimination to spare.

What about power requirements? The figures in the last paragraph provide the answer. The principal power-consuming operation is the complete reversal of displacement. The power is the product of the voltage and the displacement and since the same voltage switches a displacement only 1/70 as large in G.A.S.H., the new crystal requires only 1/70 the power of barium titanate in slow switching if the electrodes have the same area.

There remain vexing problems associated with other properties of these materials. G.A.S.H. for example, does not have the same properties in different parts of the same single crystal, and thus arises a lack of reproducibility from sample to sample. The data cited come from the better samples.

J. P. Remeika has shown that "etch figures," produced on crystal surfaces by water, is one criterion for locating the better portions of the crystals.

Here technology interlaces with science. The straightforward solution to such a problem is first to answer the question "why are these things going on?" and then to act in some suitable way on that answer. But the "why?" is a scientific question.

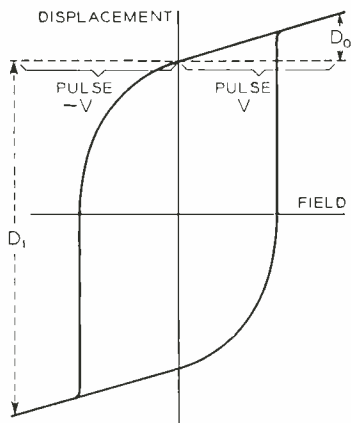

*Fig. 6—The change in electric displacement produced in a ferroelectric crystal by a voltage pulse in one direction is  $D_0$ , and in the other direction is  $D_1$ , if the voltage is large enough to provide a field exceeding the coercive force.*

For practical purposes, it is often worth while to try to find a less straightforward solution — some trick by which the reproducibility is improved. In the case of G.A.S.H., one trick which suggests itself is to apply the principles of crystal chemistry to produce other materials having the same structure. One of them may shed light on the problem.

The opportunities for making such "isomorphous" materials are unusually inviting in the case of



*Fig. 7—J. P. Remeika slices a crystal to examine etch figures produced by water on G.A.S.H.*

G.A.S.H. There are many other ions having, nearly enough, the same size and properties as aluminum to replace it in some crystal structures. The replacement of sulfur by selenium, to form the selenate ion, usually avails. Hydrogen, one would suppose, can be replaced by its heavy isotope, deuterium, both in the water of the "hexa-hydrate" and in the guanidinium, which is a complex ion containing carbon and nitrogen as well.

Indeed it turns out that such replacements can be made in this case also. The heavy hydrogen and the selenium compounds have been prepared and examined, as have the compounds in which aluminum is replaced by gallium, chromium and vanadium. Their crystals look for all the world like those of their parent, except that the chromium and vanadium compounds have the gorgeous violet and claret colors of those ions. They behave like their parent also: all are ferroelectric with similar coercive forces, spontaneous polarizations, dielectric constants, and switching times. And they all show the same variations from point to point. The virtues and vices of G.A.S.H. seem to be immutable by these means.

Return then to the straightforward, the scientific, solution. What we already know, and what we do not know, about the inner workings of ferroelectric materials are stories too long for this article. We know what are the physical principles which lead to the occurrence of ferroelectricity, and our knowledge on this point is in some part discouraging. We know that the phenomenon arises from an "accidental" balance of forces. The forces are of a type we understand, but the balance is so refined that we cannot design from first principles an atomic layout which will assuredly, or even probably, be ferroelectric.

This balance is usually sensitive to temperature: above a critical temperature, characteristic of the substance, the spontaneous polarization disappears. More often than not, that "Curie point" is below room temperature, and thus most of the few known ferroelectric materials are worthless to the engineer. For barium titanate that temperature is about 120° C. It is one of the puzzles of G.A.S.H. and all its isomorphs that we cannot find their Curie tem-



*Fig. 8 — A. G. Chynoweth measures Barkhausen jumps in G.A.S.H. with equipment affording high electrical resolution.*

peratures. They are ferroelectric right up to the temperature (about 200°C.) at which decomposition becomes too rapid to permit easy measurement.

We also know that ferroelectric crystals are usually compounded of "domains" polarized in different directions. The preceding discussion has treated the crystal as if it consisted of only a single domain, and indeed some crystals do. But domains are the clue to the mechanism by which even a single-domain crystal switches.

Studies of barium titanate<sup>o</sup> show that, when the voltage is increased to the switching point, new

little domains appear, polarized in the newly favored direction, and rapidly "shoot through the crystal" so to speak, growing at the expense of the unfavorably oriented remainder until all or almost all of the polarization has reversed. Assume, with suitable caution and subject to check, that the switching mechanism is similar in G.A.S.H. Then the explanation of switching times must come in part from the studies of these domains which have engaged W. J. Merz. One asks, among other questions, "Is the switching time determined by the readiness with which the new domains are formed, or by the velocity with which they shoot through the crystal *after* they are formed?" The new domains "nucleate" at the surface of the crystal. Hence, if nucleation is the rate-determining step in switching, our handle on the switching time must perhaps be applied at the surface of the crystal, not within its bulk.

When you look very closely at the behavior of the polarization during its reversal, as A. G. Chynoweth has, you find that it does not progress smoothly but by little jumps. Analogous jumps of the magnetization in ferromagnetic materials have long been known as "Barkhausen jumps." In the magnetic case, the jumps seem to be due to the temporary hanging up and sudden release of the "domain walls", in their effort to shoot through the crystal, by imperfections in the crystalline bulk. In the electric case, they might alternatively be due to the springing into being of the newly nucleated domains at the surfaces. Chynoweth's studies of the "distribution" of these jumps—how many are of what size—will help to decide.

Are there other ferroelectric materials at which we should be looking as intensively as we are looking at G.A.S.H. and barium titanate? Young scientist, grab your optimism and two hundred bottles.

<sup>o</sup> RECORD, September, 1955, page 335.

#### THE AUTHOR

A. N. HOLDEN received an S.B. degree from Harvard University in 1925 and became a member of Bell Telephone Laboratories that year. After five years in the staff organization of the General Methods Department, and six years in the Publication Department, he transferred to the Research Department. From 1936 to 1945 he was in the Chemical Department and, after 1945, in the Solid State Group of Physical Research. Mr. Holden worked on originating new piezoelectric materials and perfecting methods of growing crystals for research investigations, a project which led to the development of the reciprocating rotary crystallizer and to the use of EDT as a substitute for quartz in some applications. Recently he has been engaged in studies of spectroscopy in the microwave region, and the behavior of ferromagnetic materials.



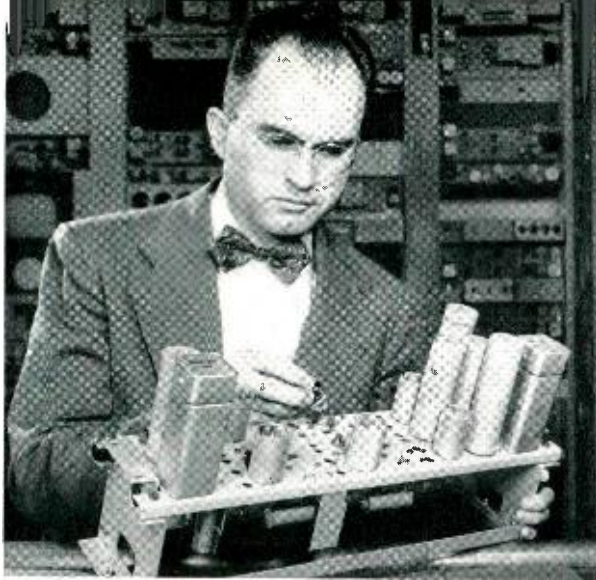

# *The A2A Video Transmission System*

**R. E. ANDERSON**

*Transmission Systems Development*

**Almost all television programs in the United States go through one or more Bell System local wire-line circuits before they are broadcast from a transmitter. These circuits are short compared with intercity routes, and are used, for example, between a broadcasting studio and a transmitting tower. The new A2A video system transmits either monochrome or color signals. It is more reliable, stable, and offers better transmission characteristics than equipment previously used for such short-haul service.**

Transmitting a television signal over wire or cable is in some respects like making a telephone call. A call to someone in our own local area involves only a relatively short connection to the telephone office and thence to the called party, and voice frequencies alone pass over the telephone wires during the conversation. On a long-distance call, voice frequencies pass through one or more offices, but then are frequently translated to some higher range of frequencies for transmission over a long-haul carrier system.

Television signals are also treated in this manner. Locally, they are usually transmitted in their original or natural frequency range over special shielded pairs of conductors. Typical circuits interconnect studios, master control locations, and transmitters, which may be separated by just a few blocks or by several miles. Other uses of local circuits include closed-loop transmission networks or non-broadcast service for theater television, medical demonstrations, and sales promotions. These conditions impose requirements for flexibility that place local television transmission in a different category from that of long-distance services, which translate the television signals to a higher frequency band and transmit them over coaxial cable or microwave radio systems.

The new A2A system is a part of an over-all improvement program in the Bell System's broadband transmission facilities for television network service. The first commercial television networks used the L1 coaxial system for the intercity circuits and the A2 video transmission system for the local or intracity connections. Improved long-distance transmission facilities have been provided by the TD-2 radio and L3 coaxial carrier systems,\* and now the A2A system furnishes the complementary improvement in the local connecting circuits. In comparison with the A2 system, the A2A provides improved transmission throughout the video-frequency band, increased service reliability of repeaters and terminals, improved stability, and increased spacing of the repeaters.

One of the basic problems encountered with this and other cable or wire transmission systems is that of equalization. Since higher frequencies are attenuated more than lower frequencies, the line must be equalized—that is, the high frequencies must receive additional amplification, or the lower frequencies must be further attenuated, to main-

\* For descriptions of these four systems, see RECORD, January, 1942, page 127 (L1); December, 1951, page 556 (A2); October, 1950, page 442 (TD-2); and January, 1954, page 1 (L3).

tain the original relative signal strengths throughout the band. Local video circuits are unlike most long-distance cable systems which have reasonably uniform or standard repeater spacings as far as the attenuation characteristics are concerned. A system for local television transmission must have considerable versatility to operate over the range of distances involved. Repeaters are needed in some cases but not in others, and a means must be provided to apply different amounts of amplification and equalization at the ends of circuits. When repeaters are required, their spacings usually are not equal because installations are made where possible in existing telephone company buildings, which frequently are not at optimum locations. The video amplifier equipment is also installed in customers' buildings and occasionally in special huts or rented quarters.

To meet this variety of conditions, considerable application flexibility — both electrical and mechanical — has been provided in the A2A system. The basic plan provides blocks of wide-band amplification and cable equalization that may be used in tandem as required for each particular circuit length. Transmission up to about 4.8 miles may be obtained with terminal equipment only. With these arrangements, some pre-equalization for the cable loss is applied to the signal at the sending end. The remaining equalization and amplification are provided in the receiving terminal, which consists of two to four amplifiers and associated equalizers. Figure 1 shows a block schematic diagram for a typical system of this type. For longer runs, one or more repeaters at spacings up to 4.6 miles may be required. Each repeater in this system has two

to four amplifiers and associated cable equalizers.

The cable<sup>o</sup> used with this system consists of 16-gauge pairs, insulated with polyethylene and shielded with two layers of copper tape. It is designed especially for video transmission, provides good shielding against crosstalk and noise, and has an attenuation of about 18 db per mile at 4.5 mc. The construction of the cable is shown in Figure 3 and

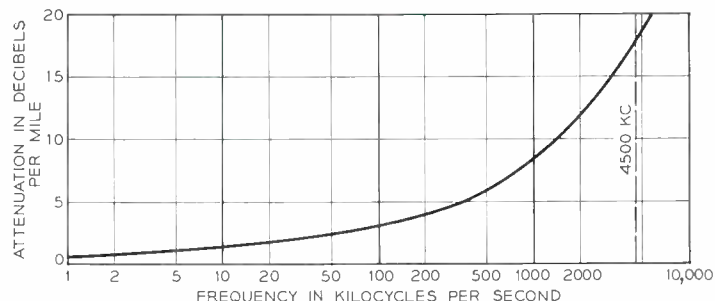

Fig. 2 — Attenuation characteristic of cable used.

its attenuation characteristic in Figure 2. Several of these shielded pairs are usually combined with telephone exchange pairs in the same lead-sheathed or composite-sheathed, pressurized cable, which is normally installed in an underground duct.

Most of the correction for the large cable attenuation slope is obtained from the plug-in fixed equalizers, whose loss-vs-frequency characteristic is inverse to that of the cable. These are available in several sizes, which furnish equalization for sections of cable ranging from about 0.14 to 1.8 miles.

The fixed cable equalizers permit equalization over the 4.5-mc band to about plus or minus 1 db of flatness. To obtain the required transmission per-

<sup>o</sup> RECORD, April, 1952, page 171.

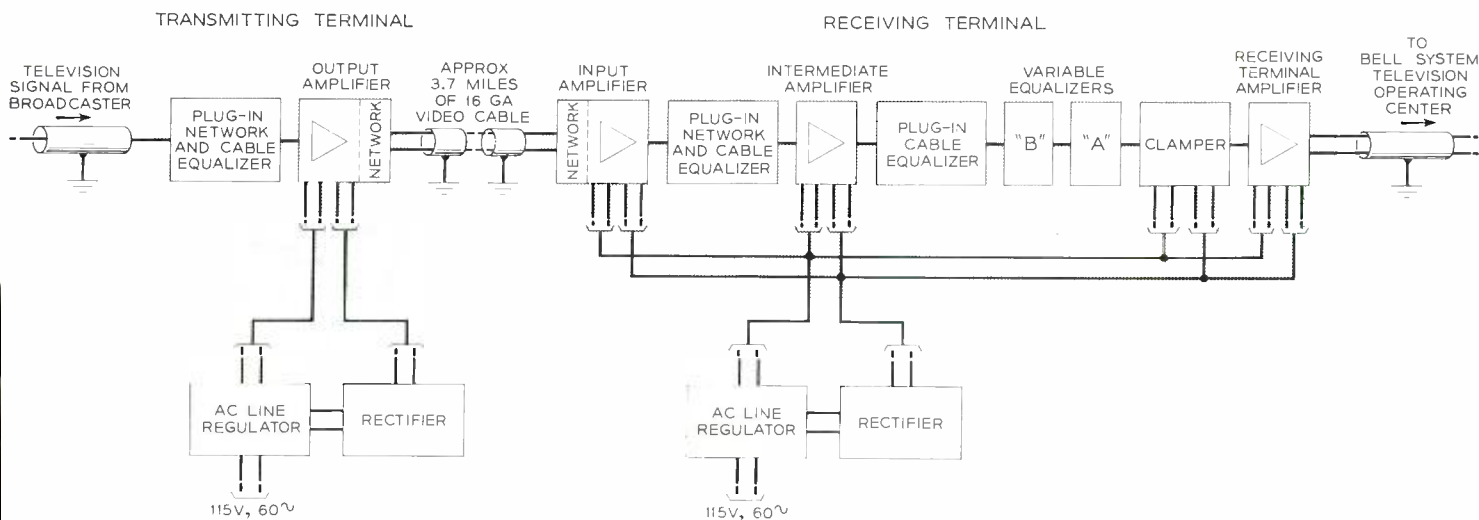

Fig. 1 — Block schematic diagram of the A2A video transmission system.

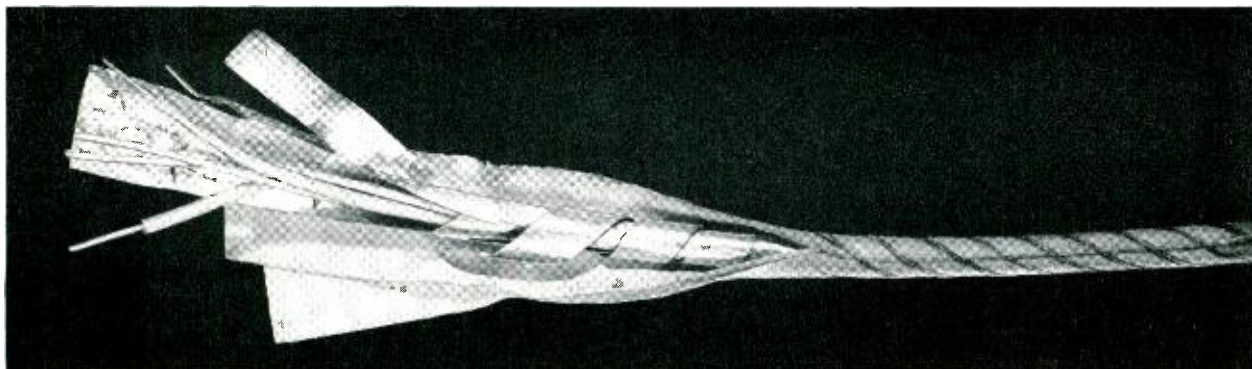

Fig. 3 — Sixteen-gauge cable used for A2A system: polyethylene-insulated copper pairs shielded with two layers of copper tape.

formance, this deviation must be further reduced by a factor of about 30. This is accomplished by means of a series of nine adjustable equalizers with loss-vs-frequency characteristics chosen to compensate for certain deviations in the cable attenuation. Each characteristic can be manually adjusted in small steps from a "slope" or "bump" in one direction down through zero to the same characteristic in the opposite direction. Figure 4 shows several typical loss characteristics of one of the adjustable equalizers. Five of these nine equalizers are assembled in one container as a unit, designated the "A" equalizer for convenience. The other four are grouped as another assembly called the "B" equalizer, which supplements the "A."

Six new video amplifiers have been developed for the large number of circuit conditions in the A2A system. Uses of four of these amplifiers, whose different gains range from about 8 to 24 db, are indicated in Figure 1. The "output amplifier," used in the transmitting terminals and repeaters, delivers the video signal to the outgoing line; the "input amplifier" receives the signal from the line in the receiving terminals and repeaters. The input and output amplifiers indicated in Figure 1 contain networks that contribute to cable equalization by providing greater gain at the high frequencies than at the low. The networks alone do not have the required gain-vs-frequency characteristic to equalize for cable attenuation. These amplifiers are therefore always used in combination with the "network equalizers," which provide the necessary correction to the network response and also furnish some fixed cable equalization. For use on shorter circuits, other input and output amplifiers are available without networks. The "receiving terminal amplifier" furnishes the last block of gain in a system. Its output circuit may be arranged to have either an unbal-

anced or balanced impedance to ground. The unbalanced output is used when the signal is delivered to a customer, and the balanced when the signal is delivered to a television operating center. When additional equalization is needed for long cable routes, one or two "intermediate amplifiers"<sup>o</sup> may be installed in each repeater or receiving terminal. The gain provided by this amplifier is enough to make up the losses of the largest fixed cable equalizer.

Each receiving terminal in an A2A system contains an electronic circuit called the clamper, which has the ability to reduce low-frequency distortion and interference. Large suppression is provided to low-frequency noise voltages such as 60-cycle interference, which may be coupled to the A2A system from power cables near the video cable. The clamper permits economies in the designs of the low-frequency responses of the amplifiers because

<sup>o</sup> The headpiece shows the author inserting a tube into an A2A intermediate amplifier.

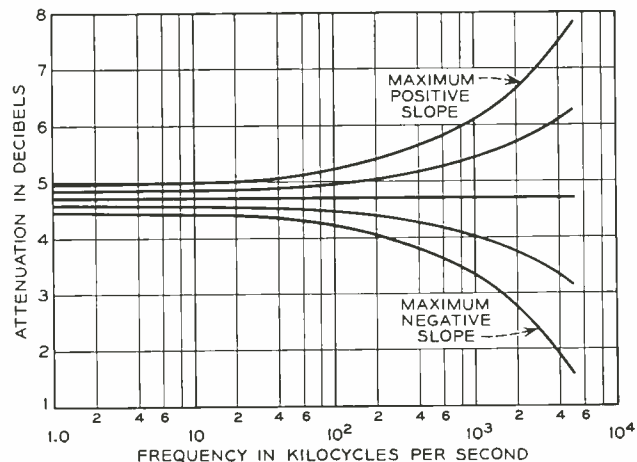

Fig. 4 — Several typical loss characteristics of one of the adjustable equalizers for A2A.



it reduces the resulting low-frequency distortion, which is cumulative from the several amplifiers in tandem in each system. The ability to identify and suppress noise and distortion in a television signal is possible because of the presence of the synchronizing pulses, which are used to trigger the sweep circuits in the television receivers. These pulses occur at regular time intervals and at a constant voltage. Distortion or interference that cause the synchronizing pulses to wander from this fixed value are suppressed by the clamper when it re-aligns these pulses.

The A2A amplifiers are operated from 115-volt, 60-cycle commercial power. DC voltage for the electron tubes is obtained from a metallic rectifier. Regulated ac power for operating the rectifier and the tube heater transformers is obtained from a magnetic ac line regulator. The regulator output voltages are maintained within close limits over the ranges of input voltages from most commercial power systems.

The basic frameworks and panels for the video equipment and power supplies are fabricated from sheet metal and designed for mounting on the standard cable-duct framework. Most of the video amplifiers are shock-mounted to reduce microphonic effects that might be caused by vibrations or accidental mechanical shocks on the bay framework. The maintenance controls are screwdriver adjustments that are accessible from the front of each amplifier. These include potentiometers for setting gain and bias, and a switch for dropping the heater voltage for in-socket tube tests.

A field trial over a five-mile circuit in New York City has shown that the A2A system meets the design objectives for transmission of monochrome and color video signals. Production equipment became available in October, 1954, and the system first saw commercial service in Los Angeles during November, 1954. Since then, A2A systems have been installed in other cities throughout the United States.

#### THE AUTHOR

---

R. E. ANDERSON received a B.S. degree in E.E. from the University of Wisconsin in 1940. He also studied electronics at Northwestern University in a training program for the Signal Corps during World War II and did some graduate study in evening classes at Columbia University. He was employed by E. I. du Pont de Nemours and Company and the Radio Research Laboratory of Harvard University before joining the Laboratories in 1945. As a member of the Transmission Systems Development Department, he has worked on the development and design of equipment for local video transmission systems, the Bell System Television Operating Center, and the television terminals for the L1 and L3 carrier systems. Mr. Anderson is a member of I.R.E. and Eta Kappa Nu.





# Answer-Only Machines in the Bell System

J. H. CRAIG

*Special Systems Engineering*

No matter how efficient a telephone system is, there are bound to be times when all circuits are busy, and calling customers must be informed as to the length of possible delays. Number changes often produce a need for operator assistance. These and other similar situations are now being met quickly and economically by the use of answer-only machines, their recorded announcements freeing intercept operators for other duties.

Operating Telephone Companies in the Bell System are finding more and more uses of "answer-only" machines for announcement purposes. Weather and time announcement services are two of the well-known old-timers. Several others are not yet in general use, but will be required at some fairly early date as Direct Distance Dialing expands throughout the country.

One typical application of answer-only machines is the 5A announcement system used for "circuit-busy" announcements formerly known as "delay quote." The demand for such an arrangement has been the result of the extension of nationwide dialing by both customers and operators. Normally, a tone is used to indicate a paths-busy condition. However, during periods of heavy traffic, such as on

Mother's Day and Christmas or during emergencies, it is desirable to indicate to the customer how long a circuit is expected to be busy. In the early arrangement used with the first No. 4 toll dialing systems, a supervisory patch panel and a toll switchboard permitted operators to quote delay times on trunk groups in accordance with delay estimates posted in front of them. The toll switchboard was used quite inefficiently and, because of its special design and different operation, required special operator training.

The 5A system is a relatively simple arrangement involving the substitution of a recorded announcement, Figure 2, for teams of operators. This system uses a heavy-duty announcement machine,\*

\* RECORD, September, 1952, page 365.

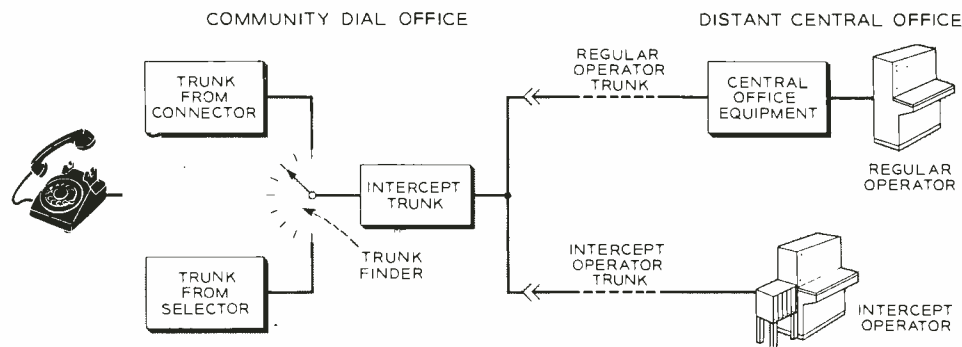

Fig. 1 — Manual intercept arrangements at an unattended community dial office.

Figure 3, capable of operating over relatively long periods of time and having a capacity of six different recorded messages. The six outputs are carried to a patch panel where the recorded announcements are patched to trunk groups requiring delay quotations. The 5A system has made it possible to free the delay quote operators for other duties and eliminate the many positions of toll switchboards formerly used for this purpose.

Another typical application is in the 7A announcement system, designed for intercept use in an unattended community dial office (CDO) to replace the present manual arrangement. In the manual arrangement, Figure 1, telephone calls reaching vacant selector levels or connector terminals are connected through a trunk finder and an intercept trunk to the regular "zero" operator at the distant attended office. This operator may handle the call herself or trunk it to an intercept operator. In either event, the customer is told the present status of the number he called. Another scheme, also shown in Figure 1, with separate in-

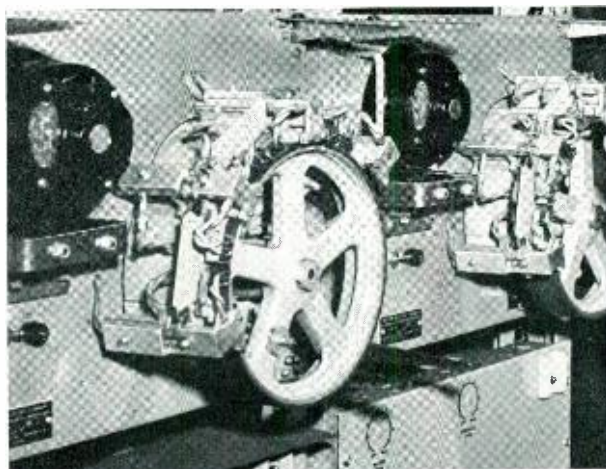

Fig. 3—The type of recorder used in a 5A announcement system.

signed for use by telephone customers who require recorded announcements for their own purposes.

The arrangement using a 2A machine, Figure 4, is considerably less costly than previous methods and has made it possible to justify intercept announcement service in many CDO's where economics prohibit the older, more expensive arrangements. Although naturally some expense is involved in the new method, part of it is offset by savings in the use of toll circuits by the elimination of unnecessary repeated attempts in Direct Distance Dialing.

There are, however, some differences. With either manual plan, each operator gives individual announcements whereas, with the mechanical system, one machine can serve a group of customers with a single "blanket" announcement. The 2A set is normally idle and starts up only when a call is intercepted. If more than one call needs to be intercepted at a time, the second call "barges in" and hears the remainder of the message being played back to the first call. The machine is capa-

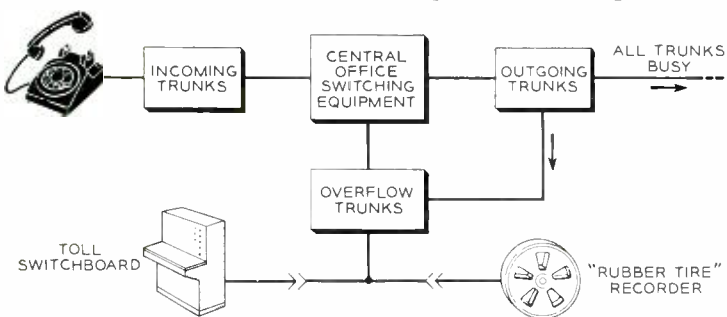

Fig. 2—A 5A announcement system uses a six-message "rubber tire" recorder.

cept trunks direct to an intercept operator at the remote office, is used where there is sufficient volume of traffic to justify it.

Both these manual arrangements are relatively expensive, and many CDO's do not use either one; calls to vacant numbers are simply not answered. With the advent of Direct Distance Dialing by customers as well as operators, it became imperative to review the possible intercept arrangements so that repeated attempts, by customers dialing long-distance to non-working numbers, could be eliminated. This review quickly established that no inexpensive way could be developed to handle these calls at the associated remote office; some new arrangement was required at the CDO itself. This suggested that a recorded announcement could be used and it was agreed to try an answer-only machine, such as the 2A telephone answering set de-

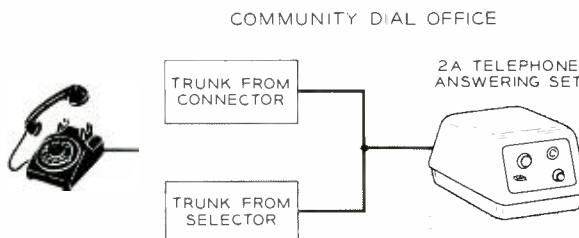

Fig. 4—A 7A announcement system uses a 2A answering machine as in the headpiece illustration.

ble of handling a maximum of 20 simultaneous calls — adequate for CDO use.

Three field trials of this arrangement have been made in New Hampshire, Texas, and Illinois. These trials are now in their final stages and all have been successful with no adverse comments. The 7A announcement system was recently standardized for the Bell System.

A third application is a new use of the 2A telephone answering set. Special problems in the handling of intercept traffic arise when the telephone number of a customer having a large volume of traffic is changed. Such an instance was brought to the Laboratories' attention by the New York Telephone Company. One of the airlines was planning to relocate its information service from LaGuardia Field, on Long Island, to New York City.

In such cases, so many calls will require interception to inform the calling customers of the change that normal intercept facilities may be overloaded unless preventive steps are taken ahead of time. Two methods of handling the expected intercept traffic were investigated. The first, using intercept operators, was estimated to cost about six times as much as the second method using 2A machines, for an operating period of 12 weeks. This project shows how the use of answer-only machines can effect substantial savings and at the same time give high-quality service.

These are but three representative samples of how answer-only devices are being used by the Bell System itself to help carry out its functions more efficiently and at less cost. Many other applications of such devices are expected in the future.

#### THE AUTHOR

---

JOHN H. CRAIG was first associated with the Laboratories as a student in the M.I.T. cooperative course during 1937 and 1938, and the next year joined the systems department's trial installation group. He was a member of the technical employment and training group in 1940 and 1941, and engages in recruiting of technical staff today. Following World War II work on airborne radar for the military, he turned his attention to the development of control terminals and associated equipment for mobile telephone service. In 1949, he became interested in toll switchboard problems, and in 1953 took charge of a group concerned with local dial systems. Mr. Craig is presently engaged in special systems engineering. He received the B.S. and M.S. degrees in Electrical Engineering from M.I.T. in 1939.



---

## *Ships Readied for Laying Alaska Cable*

Submarine cable, developed by the Laboratories and identical in design to the transatlantic cable, is scheduled to be laid in the near future between Port Angeles, Washington and Ketchikan, Alaska.\* The two telephone cables involved in this project will be laid by the cable ship *Albert J. Myer* with the *Arthur M. Huddell* serving as cable supply ship.

W. A. Klute of Transmission Systems Development II will represent the Laboratories aboard the *Myer*.

The *Huddell* is a Liberty ship that has been in the "mothball fleet" since the close of World War II. It has been chartered by the A.T.&T. Co. from the U. S. Maritime Administration and is now being refitted in Baltimore. The special design of the *Huddell* makes it especially well suited for use as a cable supply ship.

---

\* RECORD, September, 1954, page 357.



# *Ferrite Attenuators for Traveling-Wave Amplifiers*

**R. KOMPNER and J. S. COOK**  
*Electronics Research*

**Ferrite materials have found numerous important applications in communications equipment because they have a property exhibited by no other magnetic material — they can be arranged in a circuit to allow microwave energy to pass in one direction but not in the other. Devices for electrically isolating one circuit from another, for routing microwave energy over different waveguide paths, and for many other purposes have therefore been constructed with ferrites. In recent research investigations, this material has also been used experimentally in traveling-wave tubes to eliminate reflections that cause troublesome oscillations.**

Because of their high amplification over a great range of frequencies, traveling-wave tubes are now being used extensively in broadband microwave transmission systems. Like most important technological developments, however, the traveling-wave tube did not suddenly appear overnight in its most efficient form. A number of fundamental problems had to be solved first. One of the most important of the problems concerns the efficiency of traveling-wave tubes as amplifiers. The nature of these tubes is such that reflected signals may set up unwanted oscillations that greatly reduce their effectiveness.

The simplest form of traveling-wave tube,\* as shown in Figure 1, consists of a helical conductor through which a beam of electrons is passed. An electromagnetic wave to be amplified is launched on the helix at the end where the electrons enter (left in the illustration), and travels at about the velocity of light along the path of the helical conductor. Its effective velocity along the axis of the helix, how-

ever, will be considerably smaller, and will have a value depending somewhat on the frequency of the wave, but mostly on the pitch angle of the helix. Typically, the helix is wound with a pitch that reduces the effective axial velocity to about one-sixteenth the velocity of light. The beam of electrons is then adjusted to the same velocity (accelerating potential about 1,000 volts). Amplification results because the electron beam continuously "boosts" the electromagnetic wave over the helix length, so that a much more powerful signal is taken off the output end.

Unfortunately, it is practically impossible to extract all of the output signal without permitting some signal energy to reflect back along the helix. The reflected signal may travel to the input end and be reflected again, with the result that the helix itself becomes a feedback circuit and causes unwanted oscillation. This effect is particularly troublesome because of the tremendous gain of which most traveling-wave amplifiers are capable; a very small reflected signal can produce a very large

\* RECORD, December, 1946, page 439.

amount of re-transmitted energy. An integral part, then, of every high-gain traveling-wave amplifier is some means of preventing reflected signals from returning to the input end of the tube.

In the past, these oscillations have been overcome by introducing a certain amount of loss into the tube. This loss reduces somewhat the amplification of the signal traveling in the forward direction, but the weaker reflected signal is drastically reduced. For example, if we had a tube with an amplification of 45 db, we could insert a "cold" loss (loss with no signal present) of the same value. It is a significant feature of the helix-electron beam arrangement that this 45 db of loss would reduce the net gain by only about one-third, to about 30 db, while the reverse loss of 45 db would be sufficient to absorb the reflected energy. In other words, we sacrifice 15 db of gain to prevent oscillation. In practice, such attenuation has usually been provided by coating parts of the helix-supporting structure with a re-

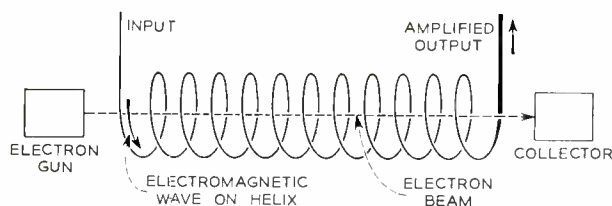

**Fig. 1** — Simplest form of traveling-wave tube; electron beam amplifies electromagnetic wave traveling along the path of the helical conductor.

sistive film. The resistance can be distributed over the entire length of the helix, or it can be "lumped" in a small section of this length.

More recently, an alternative solution to the problem of traveling-wave tube oscillations has been suggested. This is based on the unique property of the ceramic-like ferromagnetic material called "ferrite" to exhibit non-reciprocal attenuation;<sup>o</sup> that is, a properly magnetized ferrite can be arranged to pass an electromagnetic wave in one direction with very little loss, but to attenuate greatly any electromagnetic energy returning from the opposite direction. Such non-reciprocal attenuation may now be obtained in helix-type traveling-wave tubes through the use of ferrite materials.

Figures 2 and 3 can be used to illustrate an experimental method of using this non-reciprocal property of ferrite. In Figure 2 a "cut-away" of the helix is shown, and lines of magnetic flux are drawn around the conductor at several places to show their

<sup>o</sup> RECORD, October, 1955, page 385; December, 1955, page 419.

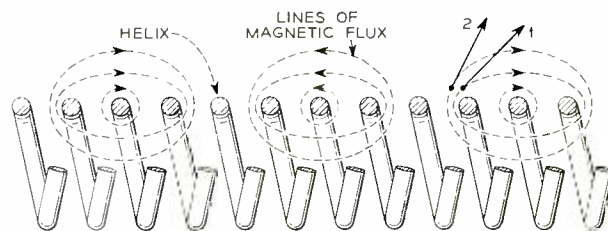

**Fig. 2** — Rotation in direction of lines of magnetic flux; when wave moves left to right, arrow appears to rotate in a counterclockwise direction.

pattern at a given instant of time. Arrows indicate the direction of the magnetic field at the points where the arrows are tangent to the lines. Now, if a hypothetical observer were standing beside the helix, and if he were able to watch one of the arrows as the wave went by, this arrow would appear to rotate. Assume, for instance, that the wave is passing from left to right in the illustration. The observer would first see the arrow in position number 1, then later would see it in position number 2, closer to the vertical. That is, the arrow would appear to be rotating counterclockwise. If the wave were passing from right to left, he would see the arrow first in position number 2 and later in position number 1, or clockwise rotation.

Let us now slip a hollow cylinder of ferrite over the helix, and with a dc field magnetize it in a cir-

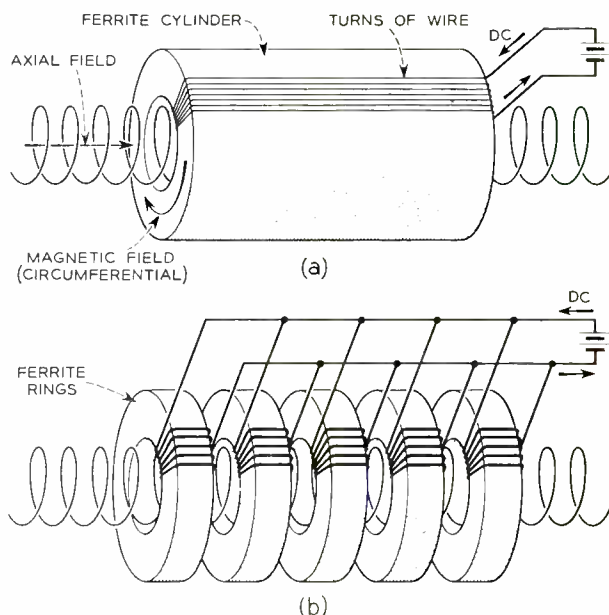

**Fig. 3** — (a) Ferrite cylinder over helix assembly of traveling wave tube; direct current in turns of wire magnetize ferrite in circumferential direction; (b) "Life-Saver" ferrite rings used to decrease distortion of beam-focusing magnetic field.



# The Mechanism of Plastic Deformation

W. T. READ, Jr.  
*Physical Research*

As part of the Laboratories' constant endeavor to improve the materials and techniques used in communications systems, a number of research programs are being carried out to investigate the fundamental make-up of matter. Such a program dealing with the internal structure of solids has resulted in important advances in "dislocation theory." One of these is a plausible answer to one of the most important questions in metallurgy: Why do metals deform so easily?

Two recent articles in the RECORD\* by F. L. Vogel, Jr., and C. Herring, respectively, have discussed what are known as dislocations—a type of imperfection, or irregularity, in the usually regular arrangement of atoms in crystalline solids. Dislocations are especially significant in the process of permanent, or plastic deformation, in which sufficiently large loads are applied that the material does not regain its original shape after the loads are removed. In fact the distribution of dislocations in a crystal largely determines its yield strength—that is, the applied stress necessary to make the material deform plastically.

Thus dislocations are of considerable interest from a practical viewpoint. Recently they have been intensively investigated by both physicists and metallurgists. This article presents another chapter in the progress that has been made in the effort to understand plastic deformation in terms of what the atoms do. In particular we will discuss (1) why plastic deformation not only begins but continues at unexpectedly low stresses and

\* RECORD, March, 1955, page 104, and August, 1955, page 285.

(2) why such deformation does not take place more or less homogeneously throughout the material but is confined to certain small areas known to metallurgists as "slip planes."

Crystalline solids—which include metals and semiconductors—are made up of atoms arranged in one of a number of simple repetitive patterns. For example, in zinc, the atoms are arranged in a simple pattern that one would choose to pack the maximum number of golf balls in a given space. Vogel and Herring have introduced dislocations in terms of slip—the process by which crystals deform plastically. In slip, planes of atoms slide over one another rather like playing cards in a deck. The result is the "block sliding" shown in Figure 1(a). However, since the atomic planes are not perfectly rigid, the amount of sliding, or slip, may not be the same over the whole plane. This is illustrated in Figure 1(b), where slip has occurred only over the right portion of the crystal. The boundary between areas on a slip plane that have slipped by different amounts is defined as a dislocation, represented on the drawing by the inverted "T" symbol.

an early stage in the process; CD has just started to rotate (in the plane ABCD) about the fixed point D. The line sweeps out a horizontal area shaded in the illustration. This represents the increase in the slipped area since the deformation began. The steady pressure of the expanding slipped area makes the dislocation continue to move, rotating about the fixed point D, and thus sweeping out a larger and larger horizontal area.

The next drawing in the sequence, at the upper right in Figure 3, shows a later stage after the dis-

erator were continually producing new dislocations.

In another variation of the mechanism, the original dislocations in the crystal grow and subdivide so as to produce closed circular loops of dislocations which expand and sweep over the whole slip plane, like the successive ripples after a stone has been dropped into a smooth body of water.

At present there is no direct experimental verification of the Frank-Read mechanism. It is widely accepted as a basis for theories of plastic deformation because during twenty years of speculation

*Fig. 3 — Progressive stages of one form of the Frank-Read mechanism: at upper left, portion of dislocation, CD, can rotate around fixed portion. DE, by application of pressure in horizontal plane. Line CD rotates, sweeping out horizontal area and forming step on rear face (upper right). Finally CD sweeps out entire area, forming step on front face, and begins to sweep out the slip plane again (lower right).*

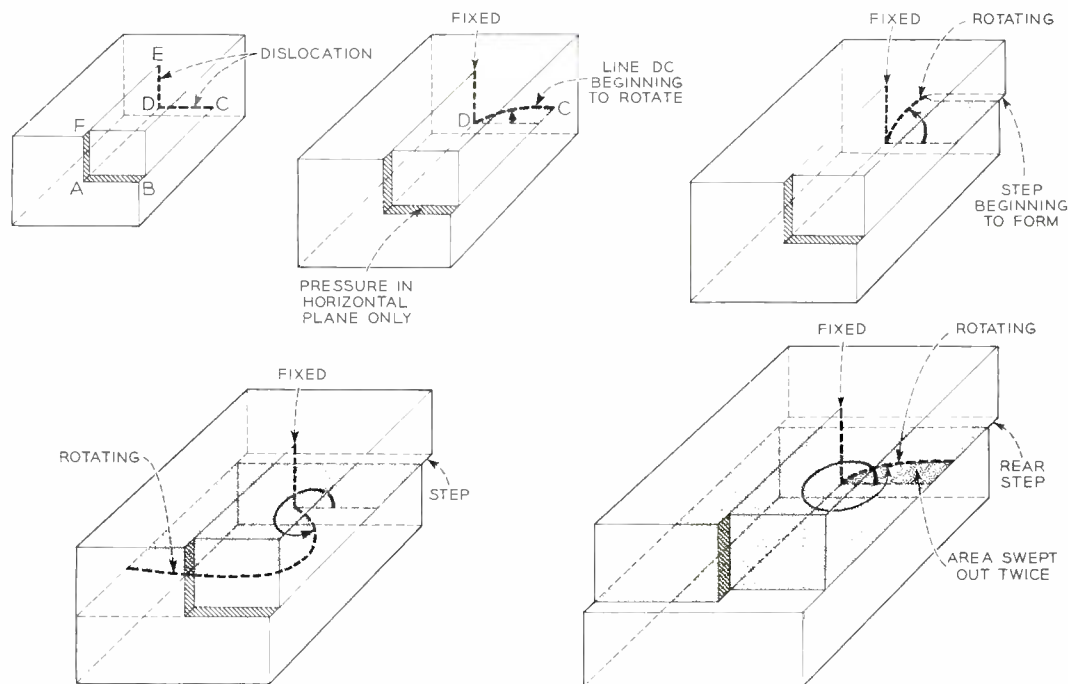

location has intersected the rear face of the crystal. A portion of the crystal has slipped over the bottom of the crystal to create a step. In the next drawing at the lower left, dislocation CD has made almost one complete revolution. A full step is left behind on the rear face, and the dislocation has swept out most of the slipped plane. The final drawing at the lower right shows a still later stage; here the rotating dislocation has made one complete revolution and has started another. Notice that the dislocation, in sweeping across the front face of the crystal, has left another step. In this drawing, the area with the darker shading represents an area that has slipped *twice* since the dislocation started to move. The dislocation can go on rotating and sweeping over the slip plane again and again—just as the hand of a clock sweeps over the face again and again. Thus a large amount of slip will occur on a single slip plane—as is actually observed. The effect of this is the same as if a gen-

erator were continually producing new dislocations. no other tenable theory has been advanced to account for the fact that a few initial dislocations can give rise to so much slip. It is now in the same state that the whole of dislocation theory was until recent techniques, such as the etch pits described by Vogel, made it possible to distinguish individual dislocations.

There remain a large number of unsolved problems in plastic deformation, but the basic ideas seem to be well established. A typical example is the problem of work hardening—that is, for instance, why a piece of iron increases in strength under the blows of a blacksmith's hammer. Why does the yield stress increase as deformation continues? What stops the Frank-Read mechanism, or why does the crystal not shear in two? The answers to these questions are not known in detail, but the basic principle seems to be this: Dislocations interact strongly with one another. They tend to get tangled up and lock into certain stable pat-



W. T. READ, JR., received a B.S. degree from Rutgers University in 1944 and an M.S. degree in Applied Mathematics from Brown University in 1948. During 1943 to 1946, he was with the National Defense Research Committee, and engaged in air-blast and earth-shock tests at the Princeton University Station, and in measurements of air blast at the atomic bomb tests at Bikini. Mr. Read joined the Mathematics Department at Bell Telephone Laboratories in 1947, where he worked on mechanical problems, especially stress analysis. He began working on dislocation theory and problems of plastic deformation in 1949, and is the author of *Dislocations in Crystals*, published by the McGraw-Hill Book Company in 1953. Mr. Read was with the Transistor Physics Department from 1950 to 1954, and is presently a member of the Solid State Physics Department, where he is concerned with the theory of flow and space charge of holes and electrons, and with the electrical and mechanical effects of dislocations and other imperfections in semiconductors.



---

terns, thus immobilizing one another. When they have difficulty in moving, the structure is stronger.

We may summarize the present view of plastic deformation as follows: Some dislocations exist in even the most carefully grown crystals. These dislocations move easily, and in moving allow the crystal to deform and yield to an applied stress (which furnishes the driving force for the deforma-

tion). The few original dislocations can, by the Frank-Read mechanism, produce a large amount of slip on a few slip planes. In a variation of the mechanism, the original dislocations can multiply. The dislocations moving inside the crystal get tangled up with one another, so that the applied stress must be increased in order for deformation to continue.

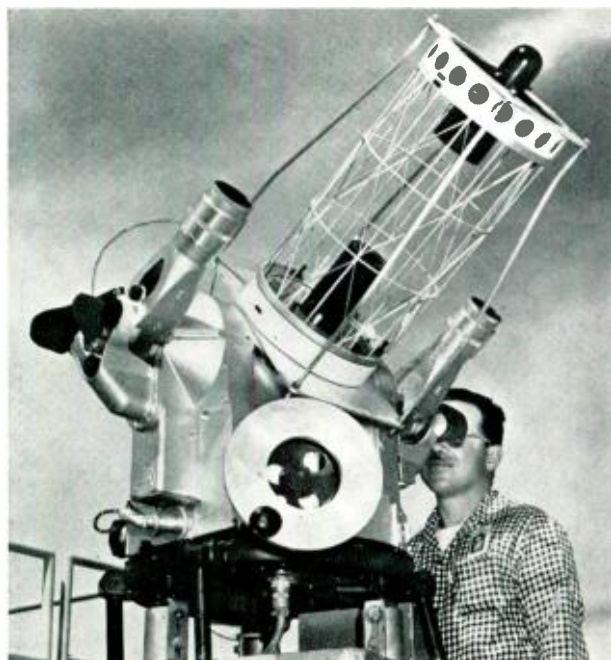

### *Special Tracking Camera*

The odd looking instrument shown at the left is not a prop from a science-fiction film, but a special tracking camera — one of several used to test the falling characteristics of experimental atom bomb “shapes” developed by Sandia Laboratory in New Mexico. It is used at the Salton Sea Base in south-east California, where such cameras obtain a complete photographic record of a dummy bomb’s behavior during its descent from a military plane to an offshore target. Both the base and the laboratory are operated for the Atomic Energy Commission by Sandia Corporation, a non-profit subsidiary of Western Electric.

# Electrical and Weather Seal for Microwave Antennas

The old proverb "A small leak will sink a great ship" can well be applied to microwave radio transmission. As microwave signals are transmitted across the country, great care must be taken to prevent them from becoming lost in a sea of noise and crosstalk. Highly directive antennas are used to guide them on their courses, and, like the proverbial ship, these antennas must be so constructed that small leaks will not harm their performance.

When the new broad-band horn-reflector antenna was designed for the TD-2, TH, and TJ microwave systems,<sup>\*</sup> plans were included for sealing the seams to minimize microwave leakage. Another requirement was an airtight weather seal that would permit pressurization of the antenna with a dry air

<sup>\*</sup> RECORD, November, 1955, page 401.



*Horn-reflector antenna that is used for making tests at the Holmdel Laboratory.*

supply. Both of these sealing requirements were met with a combination electrical and weather seal consisting of a woven metallic braid having an integral fin to which is applied a ribbon of conducting rubber compound.

The construction and installation of this seal are indicated in Figure 1. The insert at the left in this illustration shows that the metallic braid consists first of a core, woven of flat aluminum wire. This core, Figure 2, is shaped to a rectangular cross section approximately  $\frac{1}{8}$ th inch thick and  $\frac{3}{16}$ th inch wide. Over this core is woven a "sleeve" of round aluminum wire fabric. The sleeve has about twice the internal size necessary to accommodate the core, so that when it is gathered tightly about the core and stitched, excess sleeve material remains on the side. This excess material is flattened to form a side fin running the length of the strip. Onto this fin is applied a conducting rubber compound, which was developed by the Laboratories Chemistry Department and which is similar to the butyl rubber compound used for sealing cable splices.<sup>†</sup> Principal features of the new material are a high

<sup>†</sup> RECORD, November, 1954, page 405.

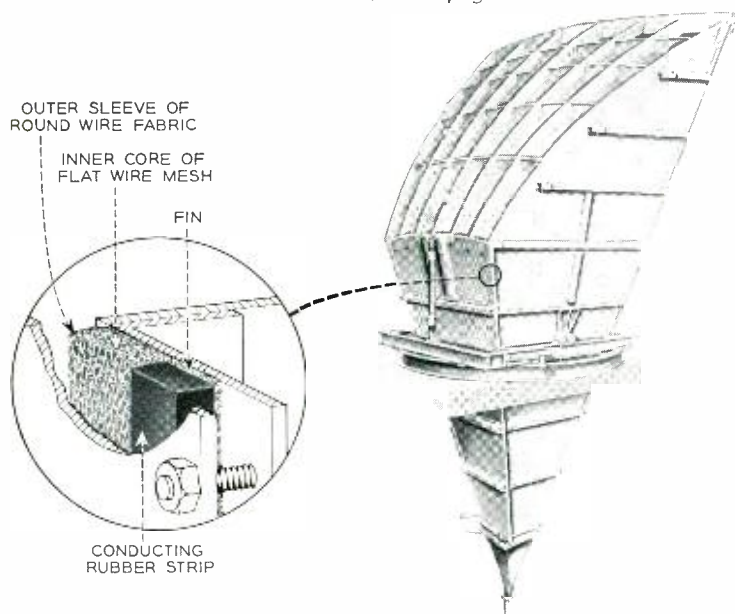

*Fig. 1—Horn-reflector antenna showing details of combination seal and installation in seam.*

electrical conductivity and a plasticity comparable with that of putty.

The insert in Figure 1 also shows how the complete sealing strip is inserted into one of the seams of the antenna structure. When the assembly bolt is tightened, the wire mesh compresses into an almost continuous metallic seal having about one-quarter the thickness of the original strip. At the same time, the rubber strip material is forced throughout the mesh of the side fin, filling all spaces and establishing an air-tight and weather-tight seal.

The electrical action of the seal can be explained by the fact that for any frequency there is a certain minimum-sized waveguide that will pass the transmitted energy. Microwave energy attempting to get through a smaller waveguide will be blocked or "cut off." The purpose of the wire mesh is therefore to provide a very large number of tiny "waveguides," much below the cut-off dimensions. The round-wire outer sleeve is under sufficient pressure to penetrate the surface oxide films on the aluminum flanges of the seam, and the large number of point contacts to the metal underneath has the effect of creating very small cross-sectional areas of the "waveguides." The flat wire mesh inside the sleeve has the effect of providing relatively long



*Fig. 2—The new wire-mesh and conducting rubber microwave seal.*

"leakage paths" in which the microwave energy is blocked out. In addition, the conducting properties of the rubber provide an important secondary barrier against leakage that might occur through flaws or porosities in the compressed wire mesh.

Thus every detail of the combination seal contributes to maximum effectiveness in minimizing microwave leakage. Laboratory tests indicate that the total attenuation through this combination seal exceeds 100 decibels at frequencies up to 11,000 mc per second.

E. J. HENLEY, *Western Electric Company, formerly Transmission Systems Development*

---

## *Trial of T-J Microwave System Planned*

The T-J microwave system, now being developed at Bell Telephone Laboratories, is scheduled for a trial installation over the 40-mile route between Mt. Clemens, Michigan and the Long Lines' Atlas tower on the Detroit-Saginaw TD-2 system. This route will include two terminals and an intermediate repeater with the installation of equipment scheduled to begin in the spring of this year. The necessary buildings and towers will be erected by the Michigan Bell Telephone Company.

The T-J system, developed specifically for short-haul toll and television service, will operate in the 10,700-11,700 megacycle band. Prototype T-J bays are now being assembled at the Laboratories.

Average repeater spacing for this system is expected to be from fifteen to twenty-five miles in

most of the country with routes including up to nine repeaters. The frequency plan calls for as many as six two-way radio channels per route and in common installations each channel will be capable of carrying as many as 96 telephone messages or one television signal in either color or black-and-white. It is expected that considerably more circuits per radio channel can be obtained by using a suppressed carrier system such as is used in the "L" carrier systems.

At 11,000-megacycle frequencies, rain attenuation, in addition to adequate path clearances, must be considered in engineering reliable repeater spacings. Propagation tests now underway at Mobile, Alabama will provide information for estimating rain attenuation in various localities.



# *The 1A1 Key Telephone System*

L. H. ALLEN *Station Apparatus Development*

**A significant portion of Bell System business consists of professional and business telephone installations. Frequently, customers with these installations require access to more than one telephone line. To provide this service without the need for having several telephones on each desk, the Bell System has had key telephone sets available for a number of years. Using such a set, a customer can gain access to any one of several lines by merely depressing a button. To improve this type of service and make it even more versatile, the Laboratories has developed the 1A1 key telephone system.**

It has become a common sight in recent years to see telephone sets equipped with four or six push buttons along the front edge. Such sets may be found in doctors' offices, garages, business houses and in executive offices of firms served by PBX's. In fact, they can be used in any situation where access to more than one telephone line is desired. Out of sight of each of these telephones is a cabinet equipped with apparatus similar to that found in a central office. This equipment provides for the necessary signaling, switching, and transmission; together with the telephone and its associated wiring, it constitutes a key telephone system. At the present time these systems are in such demand that about one out of ten telephone sets being manufactured is of the key type.

To provide the widest possible selection of service features for telephone customers, both the original 1A key telephone system and the newer 1A1 system are based on the building block, or feature, principle. In the earliest key telephone system,<sup>o</sup> each relay assembly, equipped with screw terminals, was a unit. By selecting the proper kind

and number of units, a station installer could provide service with features as desired, usually on from two to six lines.

As use of the 1A key telephone system became more widespread, a modification of the small building block principle resulted in the development of larger units. These larger units were intended to supplement the earlier designs, and reduce the installation time by exchanging shop assembly and wiring for similar field work. A variety of service features were also made available in package form; that is, certain models included the apparatus for two, three or four central office or PBX lines in an equipment cabinet. To the telephone user the service features were no different from those in the earlier design, so the system name remained unchanged.

There are five kinds of lines provided for in the 1A key telephone system, but by far the most commonly used is the central office or PBX type which uses five relays per line. A redesign of this circuit reduced the number of relays to three per line. This was the foundation upon which the 1A1 key telephone system was built. Many other improvements, however, were also incorporated in the de-

<sup>o</sup> RECORD, June, 1940, page 315.

sign of this newer arrangement. Among these are new service features, improved cabinet design with simpler mechanical details and reduced maintenance and greater economy. This new system replaces only the larger units referred to above. The original small unit designs are still being used for the smaller, simpler installations. A typical key telephone installation has three or four lines. However, there are frequent instances where the number is greater.

A much simplified schematic of the three relay line circuit is shown in Figure 2. Each of the relays has a simple function to perform. On an incoming ringing signal the R relay operates and causes lamps to flash at the key buttons of the telephone sets identifying the called line. At the same time an audible signal (ringer or buzzer) is operated. This audible signal may be common to a number of lines or individual to one. The line may be associated with one or a number of telephones.

Depressing the lighted push button and removing the handset from the mounting will operate the A relay, closing the talking conductors through to the telephone set. Ringing is stopped at the central office, and the flashing lamp is changed to steady under control of the A relay. This indicates to all stations that the line is busy.

If the called customer wishes to hold the line, perhaps to make a call on another line, he depresses the hold key. This causes the H relay to operate on current flowing through the telephone set. The H relay remains operated, and causes the line lamp at the telephone sets to wink as a hold signal. This signal serves to remind the user that the first calling customer is waiting to resume conversation. On the upstroke of the hold key the operated line or pick-up key is restored. The held line may be picked up again at any telephone at which the line appears.

*Fig. 1 — Joint-use line unit which permits mixing lines of 1A and 1A1 systems in either system.*

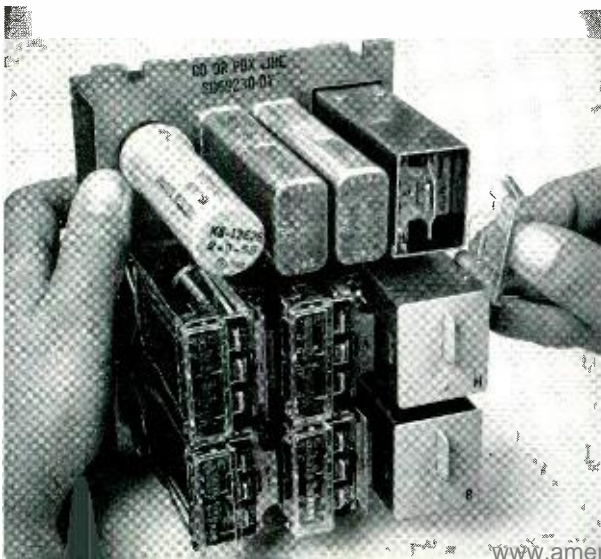

With the introduction of the 1A1 key telephone system, two new service features were made available on an optional basis. One is the winking hold signal referred to above. This simply removes current from the line lamp about one-fortieth part of each second. The other service feature is an in-

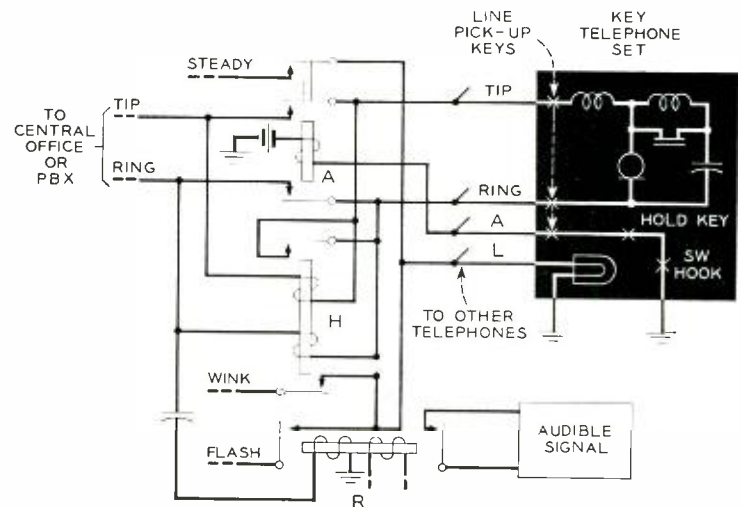

*Fig. 2 — Simplified diagram of 1A1 central office or PBX line circuit used in the key telephone system.*

tercommunicating line at a pickup button which provides for selective dialing any one of eight other stations. This provision for intercommunication fills a long felt need for a simple, inexpensive method that avoids a number of push buttons and their associated wiring. The telephone user makes such a call by first observing that the line is idle (the push button not lighted) and then depressing the button. When he selects the line, corresponding lamps at the other eight stations are lighted to indicate that the line is busy. One pull of the dial is all that is required to ring the desired station. That station lamp flashes until the call is answered; it then remains lighted, as do all other station lamps, to signify a busy line. Another feature, available on an optional basis, provides privacy. That is, when a connection has been established between two stations, no other station can hear the conversation.

To provide an adequate equipment cabinet to house the apparatus for many of the larger installations, the new design was made larger than its predecessor. To illustrate, the usual cabinet employed in the 1A system accommodates four central office lines (without extra optional features), whereas the newly designed cabinet, shown in the headpiece of this article, houses fourteen circuits of the type shown in Figure 1 along with the



*Fig. 3—The author connecting a test lead to a joint-use line key telephone system unit.*

equipment common to the key telephone system.

There are many new mechanical features provided in the cabinet. It may be screwed to a wall surface or bolted to two floor stands 10½ inches high, which keeps it out of range of wet floor mops. The ac operated power supply can be attached to the floor-supported stand above the equipment cabinet. The cover is molded of glass-reinforced plastic and includes a sound blanket to minimize noises of apparatus operation. As shown on page 140, the frame of the cabinet is attached to a wooden backboard. The apparatus is mounted on a hinged metal gate which permits access to the rear for wiring and maintenance.

As mentioned earlier, the building block principle has been followed in the 1A1 system. Each of

five types of line circuits—the common equipment unit, the wink feature unit, and the dial intercommunicating unit—is built on a unit basis. There is also one unit available for three central office or PBX lines including their associated common equipment. Much thought was given to the physical form each unit should take, and the arrangement adopted is shown in Figures 1 and 3.

The panel construction is common to the new units. Each panel has a vertical dimension of  $6\frac{15}{16}$  inches; in the horizontal direction, drilled and tapped holes accommodate apparatus mountings in any multiple of  $\frac{7}{16}$  inch. Two rows of panels may be mounted in the cabinet described above. On the rear of each unit is an insulated panel with screw terminals for the circuit connections. Thus, a screwdriver and cutting pliers are the principal tools for making connections.

It is possible to operate the 1A1 system on commercial ac power at 105-130 volts. The power plant provides dc power for the relays and switches, 60-cycle ac power for the lamps, and 20-cycle power for ringing. Where commercial ac power is not available or is subject to interruptions, dc power and 20 cycle ac power from the central office may be supplied over cable feeders.

There are a number of situations involving the use of the 1A1 system where larger installations require different equipment and telephone facilities than those described. However, the basic circuit and panel-type equipment designs lend themselves to a variety of small as well as large centralized installations on relay racks.

Constantly increasing shipments illustrate the popular acceptance of the 1A1 key telephone system. It is expected that the rate of growth will continue as the telephone business expands.

#### THE AUTHOR

---

L. H. ALLEN was graduated from the Massachusetts Institute of Technology in 1920. Shortly thereafter, he joined the Systems Development Department of the Western Electric Company and transferred with this department when it became part of Bell Laboratories. Mr. Allen was early engaged in the development of manual and dial systems, and from 1927 to 1936 was concerned with fundamental circuit studies of telephone systems. Subsequently, he engaged in work on crossbar dial, PBX, and stations systems. In 1942, Mr. Allen became supervisor of a PBX and Station group which was concerned with various Bell System and military projects. After World War II, he was for a time engaged in Systems Development studies, and in 1949 became a member of the Station Apparatus Department, where he is in charge of a group concerned with several different types of station systems.

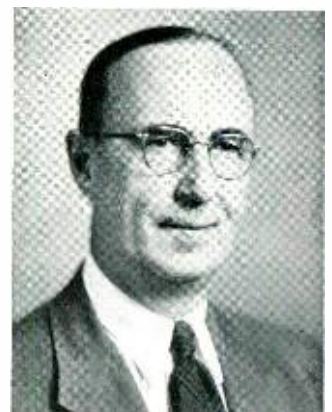

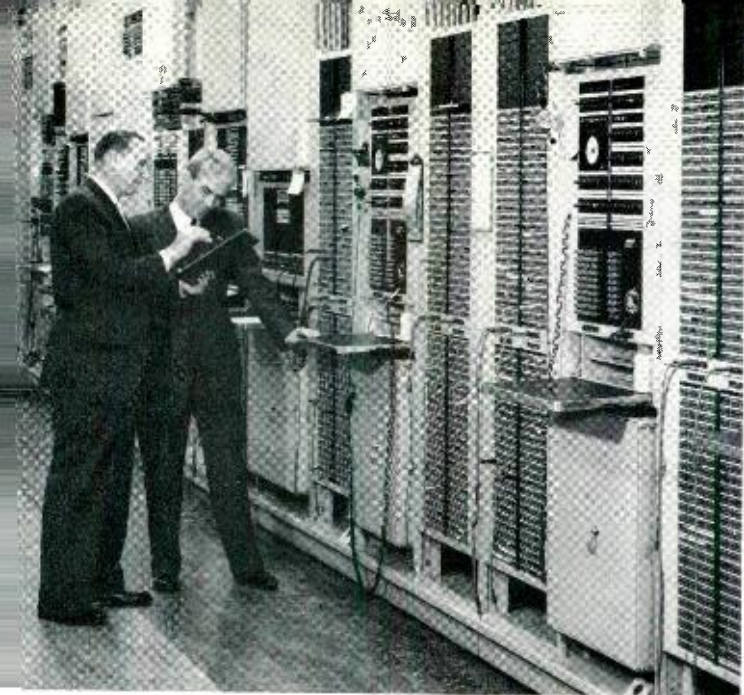

# *Versatility of Crossbar Tandem*

**M. E. MALONEY** *Switching Engineering*

**Just as many another idea has grown from seemingly limited usefulness to widespread application, so the crossbar tandem automatic switching system has grown from its original rather limited use to the point where it can take its place in the direct distance dialing plan. As various new telephone switching facilities have been needed, time after time crossbar tandem has answered the challenge with additional features. Impulsing and outpulsing arrangements now permit crossbar tandem to connect nearly all types of local and toll central offices. Centralized automatic message accounting was built around the crossbar tandem system. Future developments, such as automatic identification of a calling line, promise even greater versatility for this growing giant.**

One of the most cherished of American traditions is that of the hired man. He did anything — sharpened the lawn mower, sprayed the apple trees, removed water from the carburetor, varnished the go-cart — whatever he was asked to do. The Bell System has a pretty good “hired man” in crossbar tandem. It was not meant to be a “jack-of-all-trades” (in fact, some people thought it would be limited largely to New York City) but, as a factor in the growth of extended-area customer dialing and the implementation of direct distance dialing (DDD),<sup>\*</sup> it has had to take on one new job after another. New features added as the needs developed give it a versatility undreamed of in the 1930’s.

Tandem offices handle essentially trunk-to-trunk traffic, usually with fairly high calling rates because the trunk groups carry traffic that has been concentrated from low calling-rate customer lines in

the originating local office. Tandem systems are not suitable for the switching of traffic submitted directly from customer lines.

Before the advent of crossbar tandem, some cities were using panel-type office-selector tandems, sometimes called “two-wire offices,” to save outside plant. Figure 2 shows the application. The light lines represent direct trunk groups — many miles of conductors, usually working at low efficiency. The heavy lines show the same traffic routed through a tandem office, consolidating much of the traffic from an originating office onto a highly efficient trunk group to a tandem for local distribution to the terminating offices.

The panel selector used for tandem has certain limitations. For instance, it has no common-control functions and no memory; it cannot translate one type of pulsing into another, nor can it take alternative action if it encounters busy trunks or trouble. Noisy contacts sometimes develop and the maintenance cost is comparatively high. With the advent

<sup>\*</sup> RECORD, *October, 1953, page 369, January, 1954, page 11, and April, 1954, page 153.*



*Fig. 2 — G. Plaag of the New York Telephone Company adjusts one of a group of multi-frequency receivers associated with incoming senders.*

of the crossbar switch, engineering studies were made to see if a simple crossbar tandem could economically replace the panel-selector tandem; the results turned out favorably.

Originally, the crossbar tandem system accepted only incoming revertive pulsing because that satisfied the requirements at the time. The chief advantage was in the varieties of outpulsing, because the common-control circuits permitted outpulsing to panel, crossbar, or step-by-step local dial offices in addition to completion to manual offices, Figure 3. Shortly after the initial installation, a demand arose for an arrangement to permit dial pulsing into crossbar tandem by operators from switchboard positions in the same city. An incoming dial-pulse sender was developed to satisfy this need, and it later proved adaptable without change for dial pulsing from inward toll lines.

The next step in the evolution of crossbar tandem was forced by the enormous postwar growth in toll business that threatened to swamp both the No. 4 toll switching systems and the manual toll systems that had not yet been replaced by No. 4. The development of an incoming multi-frequency (MF) sender to permit crossbar tandem to accept MF signals was easily justified by the wide usage of MF pulsing, and quick relief was realized, par-

ticularly in the larger, more heavily overloaded cities.

For example, Gotham tandem, at 13th Street in New York City, has more than 3,000 incoming toll trunks. These represent calls that could not have been dialed at all because the New York No. 4 system was at full capacity. All these trunks would have had to stay on the manual inward toll switchboards with operating penalties. Another No. 4 could have been started but, at the time, production facilities were hard pressed and the No. 4 systems being manufactured were urgently needed in Chicago, Boston, Cleveland, and Oakland, California. Since the switching load was inward to New York City only, crossbar tandem could handle it with little modification and with certain economies.

In Washington, D.C., with no toll dial system available for 2 to 3 years, crossbar tandem was arranged to serve outward toll calls requiring dial pulses. The required features were already in the dial-pulse sender and no development was needed other than fitting existing building blocks together. However, the outward digit capacity was limited to 6 digits.

Multi-frequency outpulsing, of course, was under development and is now available. This expands the field of use of crossbar tandem for inward and outward switching and also for through switching where transmission considerations permit.

About 80 crossbar tandem systems are now in service. They are serving the original need for saving trunks on local-to-local business, they are handling remote-control zone registration, and they can carry tremendous double-tandem loads such as the San Francisco-Oakland cross-bay traffic. Gotham tandem in New York has relieved the New York No. 4 system of more than 2,000 toll lines; Chestnut, Shephard, and Hyattsville tandems around Washington, D.C., not only relieve the Washington 4A system but provide emergency service

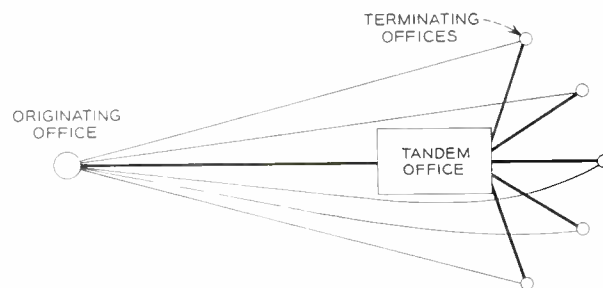

*Fig. 1 — A tandem office permits the use of a single high-usage trunk group instead of several low-usage groups operating at low efficiency.*



protection on account of their dispersed locations.

The versatility of crossbar tandem is well illustrated by the multiplicity of inpulsing and outpulsing "languages" now possible, Table I. PCI (panel call indicator — originally provided visual indications in manual offices, now a method of signaling) was designed to provide changes in both polarity and amplitude of signaling pulses. DP (dial pulsing) is a decimal counting scheme where each digit is represented by a number of identical pulses equal to the numerical value. RP (revertive pulsing) combines arbitrarily-chosen groups of pulses into the office code. The thousands and hundreds digits are sent in a manner referred to as "brush" and "group." After another brush selection, the tens and units digits are sent. MF (multi-frequency pulsing) is sent by two simultaneous pulses out of five possible frequencies. Start-pulsing and end-pulsing signals are also required. MF is the fastest,

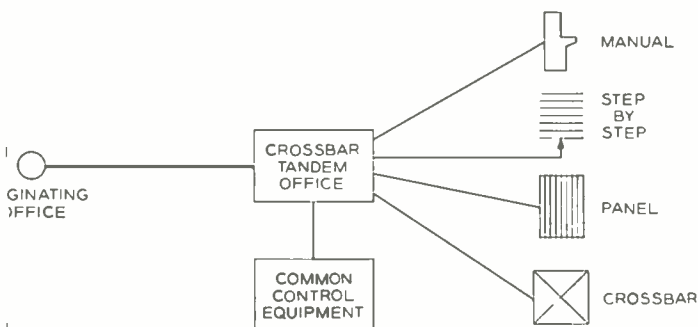

Fig. 3—Common-control equipment in crossbar tandem permits outpulsing to several types of offices.

about one second for seven digits; PCI is next, about three seconds; and the other two methods take about seven seconds each.

Coin zone dialing, which has limited use today, probably will be greatly expanded. This is a method of extended-area operation in which a customer at a coin telephone can dial his call. The call is completed except for sending the last digit and an operator, guided by lamp signals, intervenes and says, for instance, "Deposit twenty cents, please." After checking that the deposit is correct, she releases the call and allows it to complete.

An interesting application of crossbar tandem (which required no development at all) is its use as a "directional tandem." In New York City, all calls to Vesey tandem go to New Jersey, and all calls to Connecticut tandem go to Connecticut or a few up-state New York points. This eliminates the need for 6-digit translation in the tandem office since, in effect, the entire office handles only foreign-

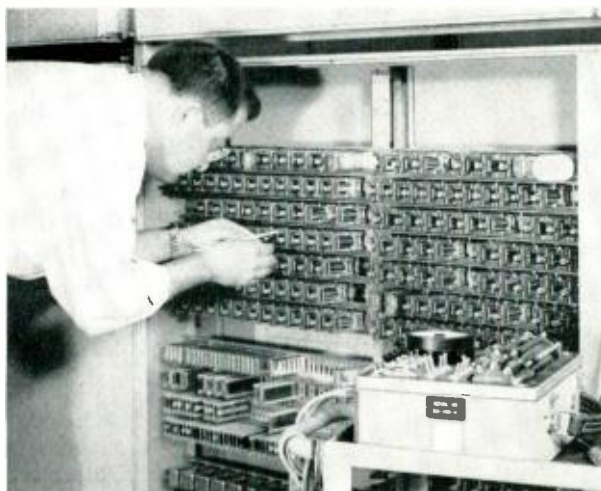

Fig. 4—J. Montepaone adjusts a relay in a multi-frequency incoming sender.

area traffic. Directional tandems will not have wide usage since obviously the traffic volume must be very large to justify them, but the cases cited (actually 4 offices — there are 3 Vesey's) proved quite useful.

Possibly the most important aspect of crossbar tandem is its use in centralized automatic message accounting (CAMA).<sup>†</sup> In this arrangement, the necessary equipment to record billing data for automatic message accounting (AMA),<sup>‡</sup> centrally located at a crossbar tandem office, serves up to 200 local offices. These local offices thus get the benefits of AMA without the need for a considerable

<sup>†</sup> RECORD, July, 1951, page 241. <sup>‡</sup> RECORD, September, 1951, page 401.

TABLE I—CHARACTERISTICS OF PULSING LANGUAGES

Type of Pulsing	Characteristics	Pulsing rate (Digits per Second)
Dial Pulsing	Decimal; counted by open and closed contacts in loop.	Average 1°
Revertive Pulsing	Coded non-decimal and decimal; open and closed contacts in terminating office; counted in originating office.	Average 1-2°
PCI Pulsing	Variations in voltage and polarity.	Invariable 2.9
MF Pulsing	Two out of five voice-frequency tones.	Maximum 7°

° Machine time. Humans (customer or operator) may be slower.

amount of additional equipment in each local office. Crossbar tandem offices permit such an arrangement. The latest development is an arrangement whereby step-by-step offices will be provided with CAMA service. This has been made possible by a new CAMA dial-pulse incoming sender for crossbar tandem, to work with the step-by-step equipment in local offices. The first arrangement of this type will be cut over in San Diego early this year, followed closely by another in Hartford, Connecticut and others as the equipment becomes available from the Western Electric Company.

Under development at present and expected to be installed in the near future is a new multi-frequency (MF) incoming sender to permit CAMA operation of offices that can outpulse MF signals. Closely allied with this development is the feature of automatic calling-line identification. This is expected to be developed within about two years. It will provide full automatic CAMA operation of panel and crossbar offices equipped to outpulse MF signals, so that an operator will no longer have to intervene on each call to determine verbally the calling telephone's number.

#### THE AUTHOR

---



MARTIN E. MALONEY joined the Laboratories in 1927 after receiving an E.E. degree from Cornell University. He had previously received a B.S. degree from Georgetown University in 1923. He contributed to the development of PBX, crossbar, and automatic ticketing systems until 1940, when he became engaged in switching engineering of the No. 4 toll crossbar system. During World War II, Mr. Maloney worked on communications for aircraft warning and fighter-plane control. After the war, he devoted his efforts to switching engineering and planning for nationwide dialing, and subsequently to expanding the field of application of crossbar tandem. Mr. Maloney is presently engaged in switching engineering problems relating to the transatlantic telephone cable.

---

### *Laboratories Activities Described in New Book*

The Laboratories has been described as "America's premier industrial research organization" in a book called *The Mighty Force of Research* compiled by the editors of *Fortune* Magazine and published recently by the McGraw-Hill Book Company, Inc. This book contains fifteen reprinted articles on various phases of research that originally appeared in *Fortune* Magazine between January, 1953 and August, 1955.

Among the articles, *The Information Theory* developed by Claude Shannon of the Laboratories and Norbert Wiener of M.I.T. is described as "one of the most brilliant theoretical concepts in modern

science"; *The Transistor* includes an account of the device's invention and development at the Laboratories; and *The Long-Range Planners* describes the work of the Laboratories systems engineers. In *The Strange State of American Research*, the A. T. & T. Co. is described as being "in the front rank" of industry in its support of basic research; *The Young Scientists* includes descriptions of W. O. Baker, Claude Shannon and Conyers Herring, all of the Laboratories, as three of the top young scientists in U. S. industry; and *The New Metals Age* describes how the Laboratories and others have developed "a whole new range of metals and alloys".

# Precision Current Adjuster

*At the right, E. C. Mener demonstrates the precision current adjuster for M. A. Logan.*



A specific current value seems an easy thing to set up. The applied voltage is simply adjusted until the current through a piece of apparatus is the value desired, as read on an accurate meter. Unfortunately, in certain applications this is not enough. Sometimes, as in determining relay pull curves, it is necessary to adjust a current more accurately than can be done with the best meters. For such purposes, the Laboratories has developed a current adjuster that provides currents of precise values.

One of the necessary requirements of relay design and development is that of providing reliable data on magnetic pull. When the Instron tensile tester\* is used for such measurements, pull curves are traced by the machine for several values of relay coil current. Pull varies with both the coil current (or the corresponding ampere-turn value) and the armature gap, and is defined by a family of curves. Each curve is taken with a constant current value. Since pull is proportional to the square of the current, an error of 2 per cent, for example, in adjusting the current would produce an error of 4 per cent in the pull measurement. The new current adjuster permits specific values between 2 and 500 milliamperes to be set with a precision of 0.25 per cent.

Essentially, the device is a null indicator, balancing a voltage produced by the desired current against a preset reference voltage, Figure 1. A 1.5-volt dry cell supplies the reference voltage, a portion

of its voltage being adjusted to equal that of a Weston standard cell in the CAL position of the test switch. When the switch is operated to the TEST position, the calibrated output from the dry cell produces exactly 20 millivolts across the galvanometer. When the relay test current is properly adjusted, this 20 millivolts is exactly balanced out and the galvanometer shows no deflection.

An external voltage source is used to energize the relay under test, and the relay current is adjusted by a motorized potentiometer across the source. One feature of the device is the inclusion of an Ayrton, or ring, shunt. This is a circuit designed to provide multiple ranges for current-indicating meters: in this application, it is connected in series with the relay under test. The Ayrton shunt circuit splits the relay test current into two parts in a predetermined way. For a specified relay current, the precision decade resistors are set to give an over-all value  $R = 1000/I$ ,  $I$  being the desired current in milliamperes. With this setting, the Ayrton shunt always provides the same current through the meter branch of the circuit. Instead of a meter, a precision resistor is used, and the voltage drop developed across it is compared to the calibrated portion of the voltage from the dry cell. When the relay current is adjusted so as to produce equality of the two voltages, as indicated by zero deflection of the sensitive galvanometer, then the magnitude of the test current has an accuracy as good as the precision resistors and standard cell.

\* RECORD, January, 1954, page 27.

The procedure is quite simple. The decade resistances, shown as simple potentiometers in Figure 1, are first set to the predetermined value, and the test switch is set to a demagnetizing position (not indicated), to eliminate any residual magnetism from the relay. Next, the switch is set to the CAL position, and the galvanometer is balanced. This fixes the reference voltage. The test switch is then set to TEST, and the motorized potentiometer is operated until the galvanometer balances. A sensitivity switch associated with the galvanometer (not shown) permits a rough adjustment to be made with the 0-500 milliamperemeter; the final adjustment is made by watching the galvanometer for a null indication.

Should the current through the relay vary, the output voltage from the Ayrton shunt will change. One problem in making pull curves is that the grad-

ually increasing current for the different curves produces heating in the coil and changes its resistance. This problem is overcome when using the current adjuster, because any change in resistance affects the current, and this in turn will be indicated by the galvanometer. By continuously monitoring the galvanometer, any necessary corrections for current changes can be readily made with the motorized potentiometer.

Additional features of the current adjuster include a preliminary "soak" circuit, to measure the relay pull from the desired test current plus the additional magnetization introduced by the "soak" current, and provisions for disconnecting or repoling the relay without removing it from the test fixture on the Instron machine.

E. C. MENER, *Switching Apparatus Development*

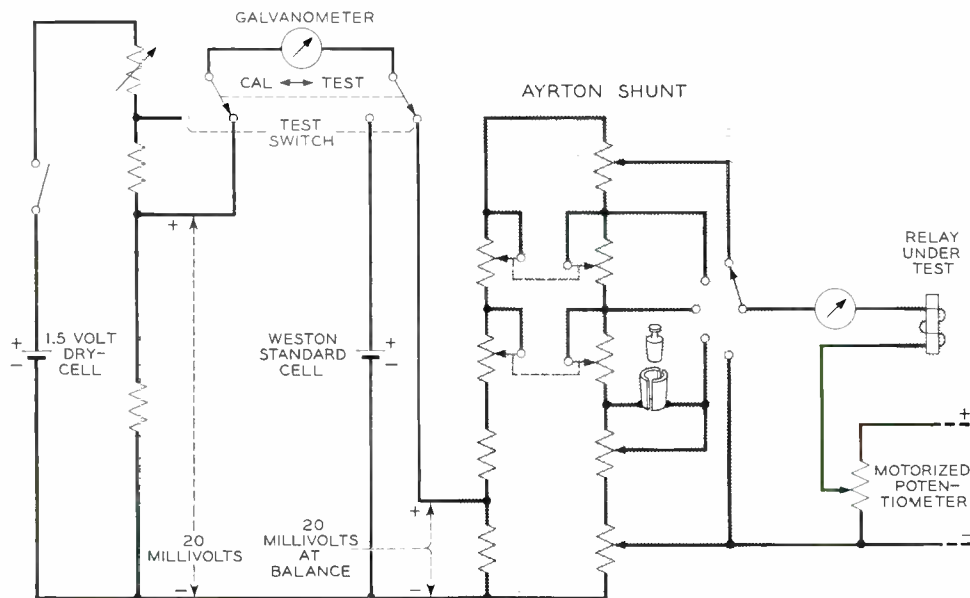

Fig. 1 — When the relay test current is of the desired value, there is no deflection of the galvanometer.



# *Development of Wire-Spring Relays*

**H. M. KNAPP**  
*Component Development*

**In the wire-spring relay development, several major objectives could only have been met through close cooperation between Laboratories and Western Electric engineers. Design engineers had to be kept advised as to what problems their designs might engender in the production process, while the manufacturing engineers had to be kept abreast of the development as it went along so as to foresee what production methods might be best for the various operations.**

Much has already been written about wire-spring relay designs, their expected performance, and some phases of their manufacture,<sup>o</sup> but very little has been said of the special need for cooperative effort by the designer and the manufacturer in certain phases of a project of this type. This need may seem obvious to anyone associated with apparatus design or manufacture. However, it is particularly important for apparatus such as wire-spring relays where much of the manufacture is accomplished by automatic machinery. This machinery represents a substantial investment and does not lend itself to relay design changes that might be indicated by field performance of the relays or by experience in manufacture. Also, many of the characteristics that determine satisfactory performance of the relays are dependent upon the accuracy of manufacture. Hence, it is vital that design engineers and manufacturing engineers work together closely during all phases of development, design, and initial manufacture, to assure a good product at low cost and one that will endure for a long period of time with a minimum of design changes.

Apparatus design and manufacture are essentially inseparable by their nature. A good design engineer necessarily envisions, at least in a general way, the process by which each of the parts of his design might be manufactured. This includes such details

as the magnitude of manufacturing tolerances on dimensions affecting the fit of parts in an assembly, and performance characteristics in service. Likewise, the manufacturing engineer should know, in addition to his direct responsibilities, the general performance requirements of the apparatus. Without this information, neither engineer can perform his part of the job as completely as desired for over-all Bell System economy. This overlapping of responsibilities calls for close cooperation and a free exchange of ideas and information between the Laboratories and the Western Electric Company.

Low over-all cost for switching systems was a major objective in the development of wire-spring relays. This naturally meant that the manufacturing cost should be as low as possible and, in addition, that equipment and maintenance costs should also be kept to a minimum. Both design and manufacturing engineers shared the responsibility in accomplishing this broad objective of low cost.

Principles of low-cost manufacture and optimum performance characteristics were agreed upon as a basis for the wire-spring relay development. For example, the use of wires instead of flat springs was

*The illustration at the top of the page shows automatic production machinery at a Western Electric manufacturing plant. Wire-and-plastic "combs" are fed into one end, wires are bent into the proper shape, contacts are welded, and finished combs emerge at the right.*

<sup>o</sup> RECORD, November, 1953, page 417, and September, 1954, page 351.

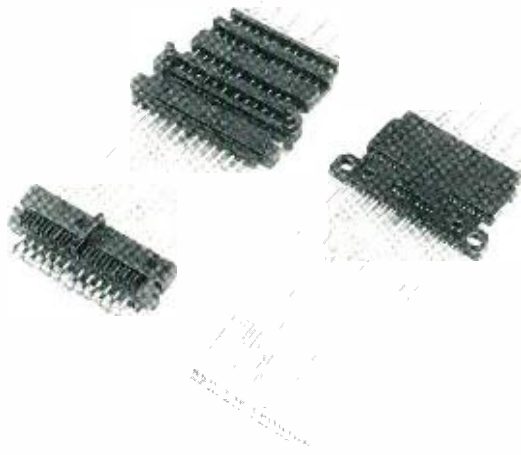

Fig. 1 — A stationary comb, above, and a twin-wire comb for the general-purpose relay.

more suited for low-cost automatic manufacture as well as for improved spring operating characteristics. These wires are automatically straightened by a method worked out at the Laboratories and made practical by Western Electric engineers. The straightened wires are molded into subassemblies, and equipped with contacts to become completed contact assemblies. Contact assemblies for general-purpose relays are shown in Figure 1. Assemblies of this type not only lend themselves to automatic manufacture but also permit greatly reduced relay assembly costs.

These assemblies also illustrate how some of the relay characteristics are "built-in" to the relay rather than obtained by adjustment. By so doing, the adjusting cost of a relay is greatly reduced and a better over-all product is obtained. To accomplish this, however, calls for recognition by both the design and manufacturing engineers of all the factors that are involved.

The most important, and the most difficult of all characteristics to build into a relay, is that of contact closure point. This is the position of the armature when the contacts close. In the case of a normally open or make contact, if the contact closes too late, there may be inadequate allowance for wear and contact erosion that will occur in normal usage. If it closes too early, the contact separation will be inadequate to insure opening of the circuit and to allow for spring vibration and possible bounce of the armature against its backstop. Consequently, there is an optimum point of closure around which limits must be established to allow for commercial variations in manu-

facture. Since the objective was to meet these limits without individual spring adjustments, realistic agreement had to be reached among the design and manufacturing engineers regarding the magnitude of the expected normal variations in dimensions affecting this characteristic.

It was the further objective to keep the manufacturing variations in closure point to an absolute minimum because the maximum amount of variation has a direct effect on the amount of armature travel required. Figure 2 shows that the expected variation in closure point of the contacts necessarily increases the total armature travel by a like amount, to guarantee the minimum allowances indicated. The situation is further complicated by the fact that more than one contact must operate within these limits. As many as 24 contacts on the general-purpose relay must be controlled within the same limits for all codes of relays. It would not be commercially feasible to have different limits for different codes of relays, depending on the number of contacts.

This relationship of closure point to armature travel is what makes its control so important. Good control means shorter travel, higher speeds, increased sensitivity, lower power drain, reduced chatter, reduced armature rebound, and less wear of the parts. Hence, all-around better performance results at reduced cost.

It is axiomatic that better control will be obtained in manufacture if the design can be arranged to reduce the number of dimensions affecting the desired characteristic. The single or stationary wire comb in Figure 1 is one example of how Laboratories and Western Electric engineers coordinated their efforts to accomplish this result. The location of the contact surfaces relative to the mounting areas on the front molded block, Figure 3, is one of several dimensions affecting the closure point of the contacts. This dimension might vary considerably, because of warping of the molded block during molding,

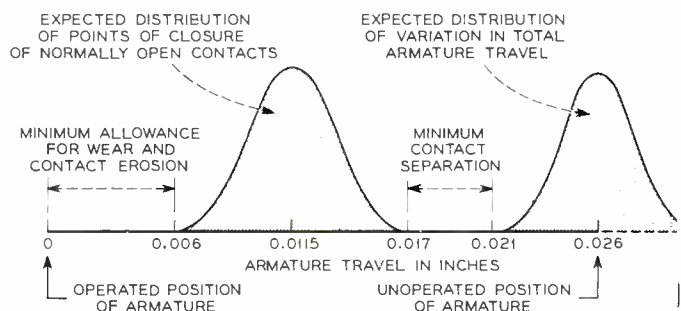

Fig. 2 — Expected variations in contact closure point increase the total armature travel by a like amount.

deflection of the block — which acts as a loaded beam in the assembled relay — variations in wire locations in the block, and variations in welding the contacts. The effect of these variations on contact location can readily be seen from the front view of the block, Figure 3(a), where the variations have been deliberately exaggerated. Actually, their total effect would be, possibly, plus or minus 0.010 inch. However, to achieve short armature travels and no individual adjustment of the contacts, contact location needed to be held to plus or minus 0.002 inch on all of the contacts on a block in a finished relay because there are necessarily several other major dimensions controlling closure of the contacts.

To accomplish this close control, the principle of

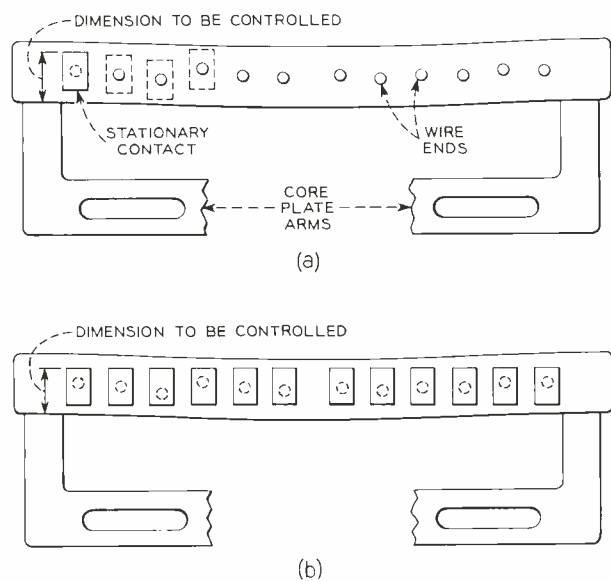

Fig. 3 — Several factors can affect the correct positioning of the contacts (a). With functional location of the contacts (b), the critical dimension is affected only by welding variations.

functional location of the contacts is being applied. During welding, the contacts are located relative to the mounting surfaces of the front block with the comb held and tensioned in the welding fixture as it would be in the assembled relay. In this way all but the welding variations are eliminated with the result shown in Figure 3(b).

The advantages of this were discussed with the Western Electric engineers, who then worked out the manufacturing technique; it consists of butt welding the contacts to the end of the wires by a process known as percussive welding. This form of arc welding is the only welding process that can be used in the present design to take advantage of the

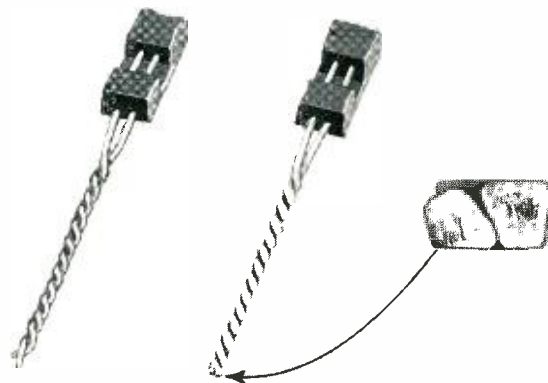

Fig. 4 — Twin wires: (left) twisted only; and (right) twisted, swaged, and trimmed.

principle of functional location. In this method, the welding electrodes that engage the wires can be applied to the terminal ends of the wires, well away from the weld zone, permitting the contact ends of the wires to be free of electrodes and to take the positions they would when mounted in a relay. With the usual resistance welding of contacts, the electrodes must be located adjacent to the areas to be welded.

Another important example of close cooperation between the design and manufacturing engineers is the design of terminals to make them suitable for solderless wrapped connections. While the ability to make satisfactory solderless wrapped connections had previously been demonstrated on punched terminals, the problem became more difficult with wire terminals. This was particularly the case with the "twin" wires where two wires had to be joined to act as one. Furthermore, the connections had to be low in resistance and stable, even when jarred or vibrated under conditions corresponding to the life of the equipment — about 40 years. To develop accelerated testing techniques to predict with confidence the performance of connections on a variety of terminal shapes is in itself a large undertaking.

The two associated twin wires were first joined by solder dipping but this was found to cause instability of the wrapped connection due to the residual torque of the connection causing cold flow of the solder. Joining the two wires of a twin terminal without the use of solder became a fundamental requirement in the design of the terminals.

A variety of twin-wire terminal designs were made up to illustrate methods of joining. These in-

cluded welding, adding an applique to provide the equivalent of a punched terminal, and twisting the two wires together. After discussions with Western Electric, it was agreed that twisted wires offered the most promise. Furthermore, the twisting operation could be added to their automatic wire-forming and contact-welding lines, thereby avoiding the added cost of handling.

Unfortunately, the electrical and mechanical requirements were not met by twisting alone. To produce corners that would imbed into the connecting wire it was found that swaging to the proper cross-sectional shape was needed. The amount of imbedding had to be closely controlled. Too little would result in a poor connection and too much introduced the hazard of possible breakage of the

connecting wire. Furthermore, the cross-sectional shape of the swaging die had to be such as to cause the two wires to engage more closely. Normal swaging techniques—squeezing between two parallel plates—tended to separate the twisted wires. A trapezoidal section held to close tolerances was found to be most suitable from design and manufacturing standpoints. The twin terminal now in production at the Hawthorne plant of the Western Electric Company is shown in Figure 4 (right).

These are only two of many examples of the close cooperation of Laboratories and Western Electric engineers. While wire-spring relays seem rather simple in construction, considerable design and manufacturing development was necessary to produce the best equipment at a low over-all cost.

---

#### THE AUTHOR

H. M. KNAPP joined the Laboratories in 1928 with an M.E. degree received that year from Stevens Institute of Technology. A member of Apparatus Development, he was first engaged in precious-metal contact studies, transferring during World War II to supervisory work on the mechanical design of magnetic fuses for the Bureau of Naval Ordnance. Since the war, he has been in charge of a group working on relay development, including the UB-type relay and more recently the development of all types of wire-spring relays. Mr. Knapp is a member of Tau Beta Pi, and holds several patents relating to relays.



---

### *J. R. Pierce Author of Book on Electronics*

John R. Pierce, Laboratories Director of Research—Electrical Communications, is the author of a book titled *Electrons, Waves and Messages* recently published by Hanover House.

Dr. Pierce discusses a wide variety of subjects in the seventeen chapters of his book. Among these are: electron dynamics, electric and magnetic fields, waves, radiation, microwave tubes, noise, microwave communication systems, television, relativity theory, quantum mechanics, and communication or information theory.

As F. E. Terman, provost of Stanford University,

said in a review, "this book is about the science of electronics, and the electronics of communication. It is not a text, but rather a philosophical discussion of electronics written in simple and interesting language. *Electrons, Waves and Messages* has something in it to appeal to everyone interested in electronics. Even the beginner will find much in it that he can understand, and that is of value to him. The book is recommended for anyone interested in electronics who, as a relief from books that must be painfully studied, would appreciate an electronics book that can be read just for pleasure."



# “Hard Tube” Pulsers for Radar

H. A. REISE *Military Systems Development*



High-vacuum electron tubes are again being considered for circuits that form the high-power pulses necessary to operate radar systems. Because of recent developments in electronic components, such “hard tube” pulsers can now be developed to be comparable in size, cost, weight and efficiency to the more commonly employed circuits using hydrogen thyratron tubes.

It is now well known that radar systems operate by transmitting short pulses of ultra-high and super-high frequency radio waves, which reflect from a target and thus indicate its position. Radar systems therefore need a source of this high frequency energy, and also need a device which causes this energy to be transmitted in very short pulses. The magnetron,<sup>o</sup> an oscillator tube whose cathode and plate function under the influence of a magnetic field, is widely used as the generator for such high frequency waves. The device which causes the output energy of this magnetron to be generated in short pulses is termed a modulator or “pulser.” For use with a magnetron, a pulser must supply relatively high voltage pulses of extremely short duration. Furthermore, for stable magnetron performance, the pulse applied to the magnetron

<sup>o</sup> RECORD, June, 1946, page 219.

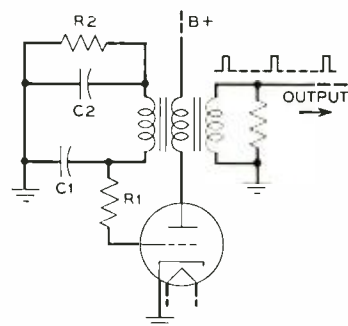

*Fig. 1—Simple form of blocking oscillator circuit: output is a series of pulses separated by relatively long time intervals.*

must rise to its maximum value at a specified rate.

Pulsers used with the first radar units were generally of the “hard tube” (high vacuum) types. Since, up to that time, power triodes and tetrodes were normally used for continuous-wave applications, certain difficulties were encountered when these were used in pulsers. The high power needed to pulse a magnetron required a large circuit to drive the grid of the tube in the final stage. Also, since transformers for raising the voltage of the pulses were not then available, excessively high voltages had to be used in the plate power supplies. The result was that the hard tube pulser became a rather large and inefficient device. It had the advantage, however, that it provided the type of pulse necessary for stable magnetron performance.

The search for a smaller and more efficient pulser finally resulted in the prevalent use of the hydrogen thyratron tube in the line-type pulser circuit. With this type pulser which uses an unterminated transmission line as the pulse forming element, however, the potential applied to the magnetron rises to its maximum value at a much faster rate than is consistent with stable magnetron performance. With such a rapid increase in voltage, the magnetron may not start to oscillate when the voltage reaches the normal operating value, but may start at some higher voltage. This higher voltage may cause the magnetron to oscillate at an incorrect frequency,

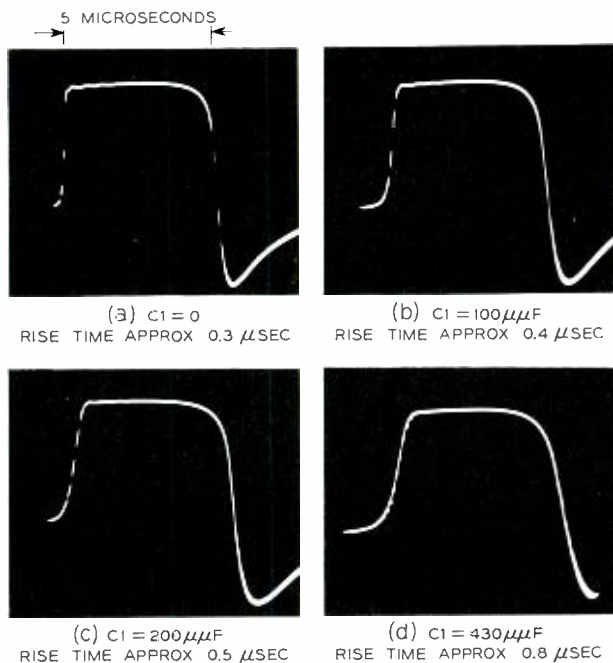
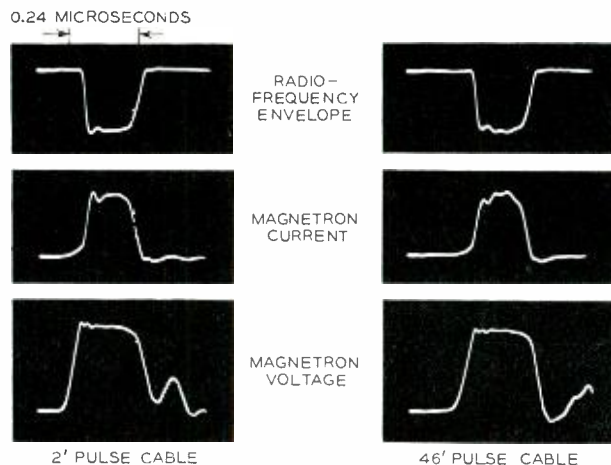

Fig. 2 — Output waveforms of simple blocking oscillator. Note adjustability of pulse rise time.

or it may cause arcing within the magnetron. In most cases, therefore, it has been necessary to provide tailor-made circuits to reduce the rate of voltage rise and thereby stabilize magnetron performance. Hydrogen thyatron pulsers also have appreciably more "jitter" (erratic firing time) and drift in firing time than the hard tube types.

The development of new electronic components, along with the increasing demand for better radar performance, has therefore reopened consideration

Fig. 3 — Waveforms from hard tube pulser and magnetron, (left) using 2-foot interconnecting pulse cable, and (right) using 46-foot interconnecting pulse cable.



of hard tube modulators for pulsing magnetrons. Other factors in the consideration of hard tube modulators are the development of pulse transformers, of high-emission cathodes, and of triodes and tetrodes requiring lower grid driving power. Also important is the use of the blocking oscillator circuit for the generation of high power pulses.

Fundamentally, the blocking oscillator, as shown in simplified schematic form in Figure 1, is a self-excited, over-driven oscillator. During the conducting period a relatively high positive grid potential causes a flow of grid current, which results in a biasing potential developing across capacitor  $c_2$ . This potential reaches a value which blocks or stops the conducting cycle, thus the name blocking oscillator. Capacitor  $c_2$  discharges through resistor  $R_2$  to the point where the tube again starts the conducting cycle. Generally, the interval during which the tube is not conducting is very long as compared

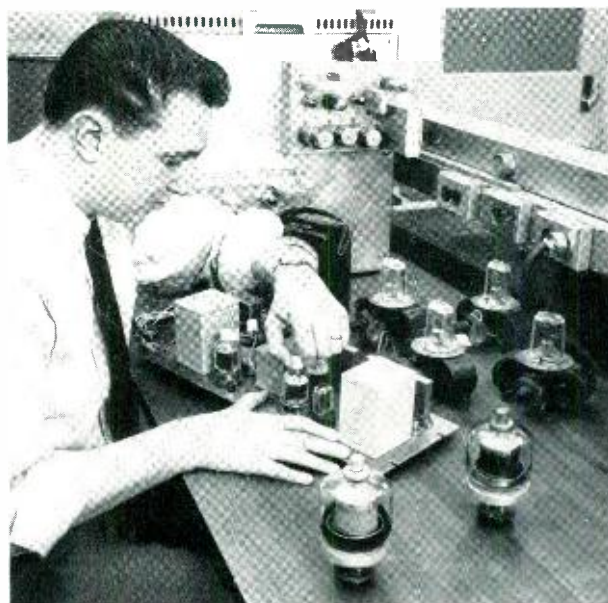

Fig. 4 — H. J. Betzel attaching plate lead to pulser tube. In higher power circuits, magnetrons (shown in the background) are pulsed by larger hard tubes (shown in the foreground).

with the interval during which it is conducting.

The blocking oscillator circuit is not new, but its use has generally been restricted to receiver-type tube circuits. It is found, for example, in radar equipment and in present-day television sets. This circuit, plus the newly developed components noted above, make possible a hard tube modulator that in size and efficiency is comparable to the hydrogen thyatron type of modulator. The hard tube modu-

lator of the past generally consisted of a pulse-forming circuit followed by a power amplifier stage. This pulse-forming circuit had to supply all of the grid driving power required by the power amplifier stage. The blocking oscillator circuit, however, can be used in the final or power stage, and requires only sufficient driving power to start the pulse cycle. The major part of the grid driving power is then obtained by means of positive feedback from the plate circuit.

Figure 2 shows some typical square-wave pulses produced by the blocking oscillator circuit of Figure 1, as photographed on an oscilloscope screen. For the circuit in Figure 1 the pulse length is governed by capacitor  $C_2$  and, for a given value of capacitance, the rate of repetition of these pulses is controlled by resistor  $R_2$ . The four photographs

oscillator tubes must be biased to cutoff. That is, the tubes must be held inoperative except when triggered for a particular pulse.

As indicated in Figure 5, a low-powered pulse generator, called a "program generator," applies pulses to stage  $V_1$ . This stage amplifies the pulses to a level sufficient to operate the next or preliminary blocking oscillator stage  $V_2$ . The circuit indicated by  $V_3$  provides power amplification and also serves to isolate the two blocking oscillators and thus prevent interference by stray electrical effects. The output of the final blocking oscillator,  $V_4$ , will be of sufficient power to pulse the magnetron, either directly or through a pulse cable as indicated by the alternative output circuit in Figure 5.

The peak plate efficiency (ratio of output power to plate-supply power) of a blocking oscillator mod-

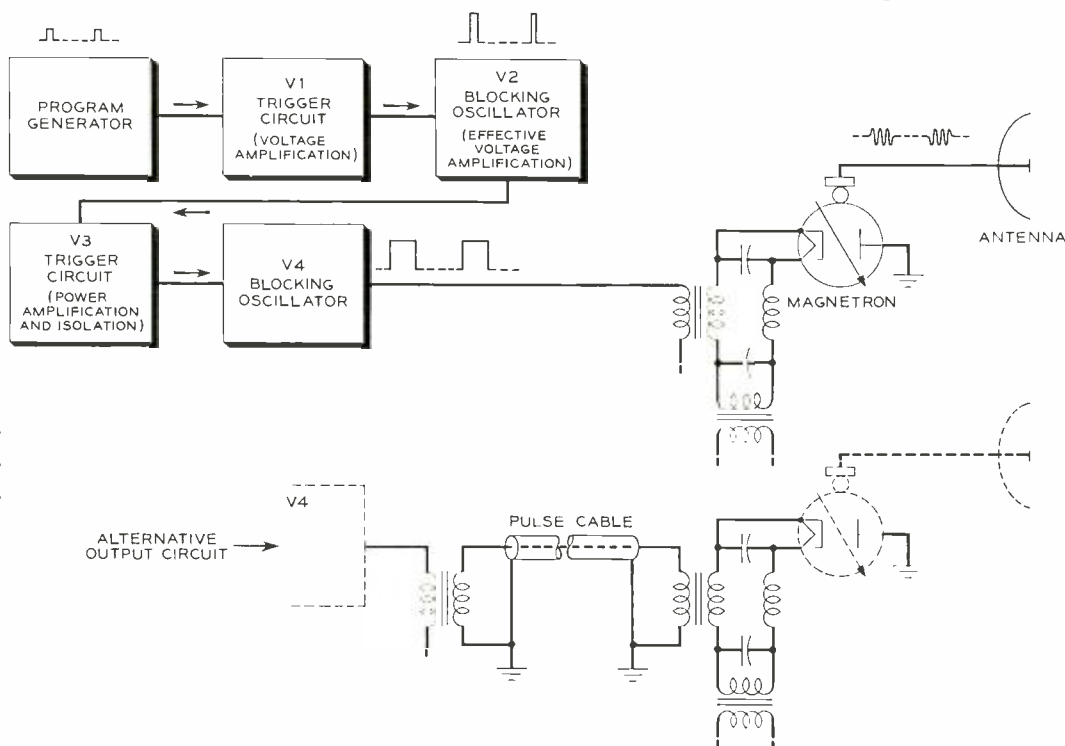

Fig. 5—Block diagram of more complex circuit required for accurately controlled pulses.

show a range of rise times from 0.3 microsecond at the upper left to 0.8 microsecond at the lower right, as a result of using different values of capacitance for  $C_1$ . In a magnetron application, a method as simple as this can be used to reduce the rate of rise of the magnetron voltage pulse.

In some pulser applications, circuits of the type shown in Figure 1 will give very good magnetron performance. In applications that require highly accurate control of timing, however, it becomes necessary to use a circuit like that indicated in block form in Figure 5. In this circuit, the blocking

oscillator can be made to approach ninety per cent. This is based on a rectangular pulse form, on a plate potential as high as the modulator tubes will permit, and on a grid driving voltage that will result in a relatively low tube drop. However, since instead of being rectangular the pulses are somewhat trapezoidal, and since the magnetron essentially draws current only at the peak of the pulse, the modulator efficiency is reduced to about seventy-five per cent. In an actual modulator of the type indicated by the block diagram of Figure 5, the efficiency was sixty per cent, because of the relatively

low plate potential in the equipment for which the modulator was designed.

The results obtained by pulsing a magnetron (Type 2J51) with this modulator are seen in Figure 3. Two sets of photographs are shown, illustrating output pulses when two different lengths of coaxial cable were used between the last blocking oscillator stage and the magnetron. As the photographs indicate, a minor amount of pulse deterioration exists when a long pulse cable is used.

At the present time there are only a limited number of hard tubes applicable to this type of modulator, thus limiting the output powers that can be obtained. By designing a series of tubes for existing magnetron applications, the size, efficiency, cost, and weight of the blocking oscillator modulator could be made comparable to that of the hydrogen

thyatron type, now widely used in radar systems.

The major disadvantage of the blocking oscillator modulator is the relatively high plate potential required. This potential, however, is comparable with the voltage found in the common household television set. By contrast, this type of modulator has many advantages. The variation in pulse output time with respect to trigger input time is minimized. With the hard tube pulser the magnetron will not be subjected to the large over-voltages that can exist when using a line-type modulator. A desirable pulse form can also be obtained more readily from the pulser, resulting in greater magnetron stability.

At present a few hard tube modulators are being designed at the Laboratories for military applications. The limited tests that have been made to date have substantiated the expected advantages.

---

#### THE AUTHOR

H. A. REISE received a B.S. degree from the University of Washington in Seattle in 1928, and joined the Laboratories in 1929. Except for a period during World War II when he was engaged in the design of pulse transmitters for radar systems, Mr. Reise has been primarily concerned with the development of broadcast transmitters. Prior to 1951, he was responsible for electrical design of a number of transmitters including 250-watt, 1-kilowatt, and 10-kilowatt units, and the driver for 50-kilowatt units. Since 1951, he has been engaged in the electrical design of military electronic equipment. Mr. Reise is a member of the I.R.E.



---

### *Improved Tube Used in TD-2 Radio Relay System*

Modifications made by the Laboratories and the Western Electric Company in a triode electron tube used in the TD-2 radio relay system have resulted in significant improvements in the operation of that system. Earlier models of this tube had an average life of about 4,500 hours, and the new tube with an average life well in excess of 10,000 hours has reduced the number of "in service" tube failures by more than five to one. About 23,000 of these improved tubes are now in service in the TD-2 system. More than 600 of these tubes are used between New

York and San Francisco for a single TD-2 channel.

This tube is unique in that it was the first commercial triode for general radio relay applications built to operate at frequencies as high as 4,000 megacycles. Such operation was made possible by using very fine wire — the grid wire is only 0.0003 inch in diameter wound a thousand turns to the inch — and by maintaining extremely small clearances between tube elements — only 0.0005 inch between the grid wires and the cathode under operating conditions with the cathode heated.

## ***Dr. M. J. Kelly Awarded Swedish Royal Academy Diploma***

Dr. M. J. Kelly recently flew to Sweden to receive his diploma as a foreign member of the Swedish Royal Academy of Sciences. Dr. Kelly, elected to the Academy earlier this year, was cited for his “. . . masterly researches in the domain of Electronics and Electrotechnics . . .”

The illustration at the right shows Dr. Kelly at the Royal Academy examining a group of memory tubes he brought to Sweden, with Haakan Sterky, head of the Swedish Telegraph Service, left, and Professor Carl Skottsberg, center.

During his visit, Dr. Kelly addressed both the Royal Academy and the Swedish Society of Electrical Engineers.

## ***Submarine Cable Repeaters Tested With Radioisotopes***

A key to the successful operation of the transatlantic submarine cable system now being installed between Clarenville, Newfoundland, and Oban, Scotland, is the series of repeaters built into the cable at forty-mile intervals. These repeaters, designed by the Laboratories to last indefinitely, are assembled under the most carefully controlled conditions at Western Electric's Hillside, New Jersey, plant.

In operation, these repeaters are subjected to water pressures exceeding 6,000 pounds per square



inch (at 2,300 fathoms), and since any appreciable accumulation of moisture within them will seriously affect their operation, they are put through extremely comprehensive tests. Perhaps the most unusual of these tests is based on the use of radioisotopes to determine whether an encased repeater is completely waterproof.

After assembly operations in which precision-machined steel rings and an enveloping copper tube have been slipped over the repeater unit, and the ends closed by a succession of glass and rubber seals, a series of preliminary tests is carried out. Following this, a final test must be performed to assure that the repeater is completely sealed. This test is carried out by filling the space around the seals with a radioisotope solution. A rubber “sock” is then slipped over the end of the repeater and filled with water. The entire unit is then placed in a pressure chamber and water is introduced around it at a pressure of 9,000 pounds per square inch. The repeater remains in this pressure bath for sixty hours. At the end of this period, it is removed, thoroughly washed, and minutely examined with a Geiger counter. If none of the radioactive solution has been forced into the repeater during the test, results of the examination with a Geiger counter will be negative, and the seal is known to be water tight.

To insure that this crucial test is performed properly, verbal instructions have been recorded on tape by an engineer so that the two operators are continuously instructed in the proper procedure for the sequence of operations being carried out.



*Western Electric Technician Fred Payne examines repeater  
ass seal with a Geiger counter.*

---

## *Papers Published by Members of the Laboratories*

Following is a list of the authors, titles, and place of publication of recent papers published by members of the Laboratories

- Andrus, J., see Bond, W. L.
- Benedict, T. S., Single-Crystal Automatic Diffractometer, Part II, *Acta Cryst.*, **8**, pp. 747-752, Dec. 10, 1955.
- Bond, W. L., Single-Crystal Automatic Diffractometer, Part I, *Acta Cryst.*, **8**, pp. 741-746, Dec. 10, 1955.
- Bond, W. L., and Andrus, J., Photographs of the Stress Field Around Edge Dislocations, *Phys. Rev.*, Letter to the Editor, **101**, p. 1211, Feb. 1, 1956.
- Boyle, W. S., and Haworth, F. E., Glow-to-Arc Transitions, *Phys. Rev.*, **101**, pp. 935-938, Feb. 1, 1956.
- Bridges, H. E., A Modern Semiconductor — Single-Crystal Germanium, *Chem. and Engg. News.*, **34**, p. 220, Jan., 1956.
- Burrus, C. A., and Gordy, W., Millimeter and Submillimeter Wave Spectroscopy, *Phys. Rev.*, **101**, pp. 599-603, Jan. 15, 1956.
- Flaschen, S. S., and Van Uitert, L. G., New Low Contact Resistance Electrode, *J. Appl. Phys.*, Letter to the Editor, **27**, p. 190, Feb., 1956.
- Fry, T. C., Mathematics as a Profession Today in Industry, *Am. Math. Monthly*, **63**, pp. 71-80, Feb., 1956.
- Fuller, C. S., see Reiss, H.
- Hagstrum, H. D., Electron Ejection from Metals by Positive Ions, *Appl. Sci. Res.*, **B5** (Nos. 1-4), pp. 16-17, 1955.
- Haworth, F. E., see Boyle, W. S.
- Herring, C., and Vogt, E., Transport and Deformation Potential Theory for Many-Valley Semiconductors with Anisotropic Scattering, *Phys. Rev.*, **101**, pp. 944-961, Feb. 1, 1956.
- Holden, A. N., Merz, W. J., Remeika, J. P., and Matthias, B. T., Properties of Guanidine Aluminum Sulfate Hexahydrate and Some of its Isomorphs, *Phys. Rev.*, **101**, pp. 962-967, Feb. 1, 1956.
- Lewis, H. W., Superconductivity and Electronic Specific Heat, *Phys. Rev.*, **101**, pp. 939-940, Feb. 1, 1956.
- Matthias, B. T., see Holden, A. N.
- Merz, W. J., see Holden, A. N.
- Olmstead, P. S., QC Concepts Useful in OR, *Ind. Qual. Cont.*, **12**, pp. 11, 14-17, Oct., 1955.
- Owens, C. D., Stability Characteristics of Molybdenum Permalloy Powder Cores, *Elec. Engg.*, **74**, pp. 252-256, Feb., 1956.
- Reiss, H., and Fuller, C. S., The Influence of Holes and Electrons on the Solubility of Lithium in Boron-Doped Silicon, *J. Metals*, **12**, p. 276, Feb., 1956.
- Remeika, J. P., see Holden, A. N.
- Schawlow, A. L., Structure of the Intermediate State in Superconductors, *Phys. Rev.*, **101**, pp. 573-580, Jan. 15, 1956.
- Snoke, L. R., Specific Studies on the Soil-Block Procedure for Bioassay of Wood Preservatives, *Appl. Microbiology*, **4**, pp. 21-31, Jan., 1956.
- Southworth, G. C., Early History of Radio Astronomy, *Sci. Mo.*, **82**, pp. 55-66, Feb., 1956.
- Thomas, E. E., Tin Whisker Studies — Observation of some Hollow Whiskers and Some Sharply Irregular External Forms, Letter to the Editor, *Acta Met.*, **4**, p. 94, Jan., 1956.
- Valdes, L. B., Frequency Response of Bipolar Transistors with Drift Fields, *Proc. I.R.E.*, **44**, pp. 178-184, Feb., 1956.
- Van Uitert, L. G., see Flaschen, S. S.
- Veloric, H. S., and Beachell, H. C., Absorption Isotherms, Isobars and Isoteres of Diborane on Palladium on Charcoal and Boron Nitride, *J. Phys. Chem.*, **60**, p. 102, Jan., 1956.
- Vogt, E., see Herring, C.
- Wernick, J. H., and Davis, H. M., Preparation and Inspection of High-Purity Copper Single Crystals, *J. Appl. Phys.*, **27**, pp. 144-153, Feb., 1956.
- Wood, Mrs. E. A., A Heated Sample-Holder for X-Ray Diffractometer Work, *Rev. Sci. Instr.*, **27**, p. 60, Jan., 1956.
- 

## *Patents Issued to Members of the Laboratories During January*

- Aikens, A. J., Botsford, N., Boysen, A. P., Jr., Dietze, E., Goodale, W. D., Jr., and Inglis, A. H. — *Subscriber Telephone Set* — 2,732,436.
- Anderson, J. R. — *Wave Filter* — 2,732,528.
- Bangert, J. T. — *Wave Transmission Network Using Transistor* — 2,730,680.
- Bangert, J. T. — *Wave Transmission Network Using Transistor* — 2,733,415.
- Blount, F. E. — *Voltage Regulating Circuit* — 2,733,401.
- Botsford, N., see Aikens, A. J.
- Boysen, A. P., Jr., see Aikens, A. J.
- Bredelhoff, H. A. — *Sound Output Control for Telephone Ringers* — 2,733,435.
- Caruthers, R. S. — *Miniaturized Transistor Amplifier Circuit* — 2,730,576.
- Case, R. L., Jordan, H. G., and Kleist, M. R. — *Order Wire and Alarm Circuits for Carrier Systems* — 2,730,579.
- Chen, W. H. — *Connector and Selector Circuits* — 2,733,424.
- Dietze, E., see Aikens, A. J.
- Doba, S., Jr., and Morrison, L. W., Jr. — *Coincidence Circuit* — 2,733,436.
- Fritschi, W. W., and Lucek, C. W. — *Voice-Frequency Signaling System* — Re 24,117 (Original Patent 2,577,614).
- Goodale, W. D., Jr., see Aikens, A. J.
- Goodall, W. M. — *Pulse Code Modulation Coder* — 2,733,410.
- Inglis, A. H., see Aikens, A. J.
-

- Jeanne, A. L., Keller, A. C., and White, S. D. — *Preset Call Transmitter* — 2,731,517.
- Jordan, H. G., see Case, R. L.
- Keller, A. C., see Jeanne, A. L.
- Ketchledge, R. W. — *Electrical Circuits Employing Spark Gaps* — 2,729,753.
- Kleist, M. R., see Case, R. L.
- Kock, W. E. — *Metallic Lens Antennas* — 2,733,438.
- Koenig, W., Jr. — *Bidirectional Amplifiers* — 2,733,303.
- Koenig, W., Jr. — *Bidirectional Amplifiers* — 2,733,304.
- Krom, M. E., and Kuchas, F. C. — *Channel Selecting Circuit* — 2,732,435.
- Kuchas, F. C., see Krom, M. E.
- Lucek, C. W., see Fritsch, W. W.
- Maggio, J. B. — *Automatic Line Switching Circuits* — 2,733,296.
- Marmont, G. H., and Oliver, B. M. — *Timing Circuit* — 2,730,617.
- Matlack, R. C., Metzger, F. W., Miller, J. H., and Vroom, E. — *Multiparty Selective Signaling and Identification System* — 2,733,297.
- Menard, J. Z. — *Means for Bulk Demagnetization* — 2,733,300.
- Metzger, F. W., see Matlack, R. C.
- Miller, J. H., see Matlack, R. C.
- Minnick, R. C. — *Read-Out Arrangement for a Magnetic Core Matrix* — 2,732,542.
- Mitchell, D., Vroom, E., and Young, W. R., Jr. — *Multi-channel Radiant Energy Signaling System* — 2,733,337.
- Morrisou, L. W., Jr., see Doba, S., Jr.
- Ohl, R. S. — *Electrical Contacting Devices* — 2,732,646.
- Oliver, B. M. — *Linear Predictor Circuits* — 2,732,424.
- Oliver, B. M., see Marmont, G. H.
- Pierce, J. R. — *Microwave Amplifier* — 2,730,647.
- Pollard, C. E., Jr. — *Means for Preventing Contact Sticking in Mercury Contact Switches* — 2,732,459.
- Robertson, G. H. — *Electrode Support for Electron Discharge Devices* — 2,733,376.
- Sauer, H. A. — *Wire Coating Apparatus* — 2,730,069.
- Shockley, W. — *Method of Making Semi-Conductor Crystals* — 2,730,470.
- Shower, E. G. — *Method of Making Contact Points* — 2,732,614.
- Slonczewski, T. — *Frequency Control System* — 2,732,496.
- Staples, E. M. — *Selector Switch Circuit* — 2,733,299.
- Vroom, E., see Matlack, R. C.
- Vroom, E., see Mitchell, D.
- White, S. D., see Jeanne, A. L.
- Young, W. R., Jr., see Mitchell, D.

## *Talks by Members of the Laboratories*

During February, a number of Laboratories people gave talks before professional and educational groups. Following is a list of the speakers, titles, and places of presentation.

### PITTSBURGH CONFERENCE ON ANALYTICAL CHEMISTRY AND APPLIED SPECTROSCOPY

Albano, V. J., A Study of the Characteristic Reduction Potentials During the Coulometric Analysis of Films on Metals.

Campbell, Miss M. E., see Luke, C. L.

Jaycox, E. K., and Prescott, Miss B. E., The Spectrochemical Analysis of Cathode Nickel Alloys by a Graphite to Metal Arcing Technique.

Loomis, T. C., see Wright, J. P.

Luke, C. L., Photometric Determination of Tin With Phenylfluorone.

Luke, C. L., and Campbell, Miss M. E., Photometric

Determination of Germanium with Phenylfluorone; and Determination of Traces of Gallium and Indium in Germanium and Germanium Dioxide.

Prescott, Miss B. E., see Jaycox, E. K.

Storks, K. H., see Wright, J. P.

Wright, J. P., and Loomis, T. C., The Spectrophotometric Determination of Very Small Amounts of Iron in Barium Titanate.

Wright, J. P., and Storks, K. H., Determination of Chromium Nickel and Copper in Jute and Paper by X-Ray Fluorescence Methods.

### A.I.E.E. AND I.R.E. TRANSISTOR CIRCUITS CONFERENCE, UNIVERSITY OF PENNSYLVANIA, PHILADELPHIA

Blecher, F. H., see De Graaf, D. A.

De Graaf, D. A., and Blecher, F. H., A Carrier-Frequency Transistor Feedback Amplifier.

Easley, J. W., Transistor Requirements for Direct-Coupled Transistor Logic Circuits.

Harris, J. R., Direct-Coupled Transistor Logic Circuitry in Digital Computers.

Nielsen, E. G., Behavior of Noise Figure in Junction Transistors Over Their Useful Frequency Spectrum:

Waldauer, F. D., Low Frequency Circuits.

### OTHER TALKS

Beck, A. C., Waveguides for Long-Distance Communication, I.R.E. Northern New Jersey Chapter, Professional Group on Microwave Theory and Techniques, Montclair.

Berger, U. S., TD-2 Radio Relay System, A.I.E.E., Newark, New Jersey.

Bescherer, E. A., Future Challenges in the Development and Manufacture of Military Electronic Systems, Pomona Engineers Club, N. C.

Bommel, H. E., and McSkimin, H. J., Ultrasonic Velocity in Superconducting Tin, Physical Society of America, New York City.

---

## Talks by Members of the Laboratories, Continued

- Boyd, R. C., Type P1 Rural Subscriber Carrier System, A.I.E.E., Chicago.
- Bozorth, R. M., Low Temperature Magnetic Properties of Some Compounds of Iron-Group and Rare-Earth Group Elements, American Physical Society, Houston, Texas.
- Brattain, W. H., The Development of Concepts in Semiconductor Research, American Association of Physics Teachers, Joint Session with American Physical Society, Richtmyer Memorial Lecture, Manhattan Center, New York City.
- Brown, W. L., Capacity Changes in the Surface Layer of a Semiconductor, American Physical Society, New York City.
- Dudley, H. W., Speech Synthesis – Theoretical and Practical Aspects, I.R.E. Professional Group on Audio, Franklin Institute Hall, Philadelphia.
- Ferrell, E. B., A Terminal for Data Transmission Over Telephone Circuits, Western Joint Computer Conference, San Francisco, Calif.; and The Control Chart – Modifications and Extensions, American Society for Quality Control, Middle Atlantic Conference, Washington, D. C.
- Finch, T. R., Transistor Circuits for Computer Application, Electrical Engineering Seminar, Iowa State College, Ames; and Student A.I.E.E. and I.R.E., University of Colorado, Boulder.
- Fox, A. G., Power Conservation in Waveguide Systems, National Symposium on Microwave Techniques, University of Pennsylvania, Philadelphia; and Radio Research in the Bell Laboratories, Y.M.C.A., Red Bank, N. J.
- Geballe, T. H., The Nernst Effect in Germanium, Physics Colloquium, New York University, New York City.
- Gordon, J. P., The Maser, Signal Corps Engineering Laboratory, Asbury Park, N. J.
- Harvey, F. K., The Physics of Hearing and Music, A.I.E.E., New Jersey Bell Telephone Company, Newark.
- Herring, C., Thermoelectricity and Thermal Conduction in Semiconductors; and The Nernst Effect in Semiconductors, Cornell University, Ithaca, N. Y.
- Hittinger, W. C., Silicon Diffused Transistors, I.R.E., Northern New Jersey Section, General Electric Auditorium, New York City.
- Jakes, W. C., Jr., Microwave Antennas, A.I.E.E., RCA Institute, New York City.
- Karlin, J. E., User Preference Research in Engineering, A.I.E.E. and I.R.E., Milwaukee; and A.I.E.E., Madison, Wis.
- Loar, H., Semiconductors, A.I.E.E., Baltimore, Md.
- Lovell, C. A., Automation – Its Timing and Impact on Society, University of Florida, Gainesville.
- Marrison, W. A., It's About Time, Y.M.C.A., Summit, N. J.
- Mason, W. P., Physical Acoustics and the Properties of Solids, American Institute of Physics, 25th Anniversary Meeting, New York City.
- McLeod, B. A., see Montgomery, H. C.
- McSkimin, H. J., Wave Propagation and the Measurement of the Elastic Properties of Liquids and Solids, Acoustical Society of America, New York City.
- McSkimin, H. J., see Boummel, H. E.
- Mendizza, A., The Standard Salt Spray Test – Is it a Valid Acceptance Test?, A.S.T.M. Symposium on Electrodeposited Coatings, Buffalo, N. Y.
- Mendizza, A., Teel, R. B. and Sample, C. H., A Comparison of the Corrosion Behavior and Protective Value of Electrodeposited Zinc and Cadmium on Steel, A.S.T.M. Symposium on Electrodeposited Coatings, Buffalo, N. Y.
- Miller, S. E., Multi-Mode Transmission Media, I.R.E. Symposium on Microwave Techniques, University of Pennsylvania, Philadelphia.
- Millman, S., Opportunities for Physicists in Industry, Columbia University, New York City.
- Montgomery, H. C., and McLeod, B. A., Field Effect in Germanium at High Frequencies, American Physical Society, New York City.
- Ohni, E. A., A Broad Band Microwave Circulator, I.R.E. Symposium on Microwave Techniques, Philadelphia.
- Pfann, W. G., Zone Melting of Metals, A.S.M., Oak Ridge Chapter, Tenn.
- Raisbeck, G., The Bell Solar Battery, Plainfield (N. J.) Engineers' Club.
- Read, W. T., Jr., Dislocations in Semiconductors, Rutgers University Physics Colloquium, New Brunswick, N. J.; and A.I.M.E. Semiconductor Symposium, New York City.
- Riley, R. M., Recent Developments at the Bell Telephone Laboratories, Wyoming Engineering Society, Cheyenne.
- Robertson, S. D., Recent Advances in Finline Circuits, I.R.E. Symposium on Microwave Techniques, Philadelphia.
- Rowe, H. E., Information Theory, A.I.E.E. and I.P.E.S., Indiana Bell Telephone Company Auditorium, Indianapolis.
- Rowen, J. H., Ferromagnetism and Its Application at Microwave Frequencies, I.R.E., Ithaca, N. Y.
- Ryder, R. M., Research for Reliability in Solid State Devices, American Ordnance Association, Fire Control Instrument Division, Electronics Committee, Pentagon, Washington, D. C.; and Germanium and Silicon Transistors and Junction Devices, I.R.E., Belleville, Canada, and Cornell University, Ithaca, N. Y.
- Schumacher, E. E., Communications Metallurgy, American Institute of Mining and Metallurgical Engineers, Cleveland Section.
- Smith, K. D., Transistors Today, I.R.E. Subsection, Kansas City, Mo.; and Properties and Applications of Diffused Junction Silicon Rectifiers and Voltage Limiters, Southwestern I.R.E. Conference and Electronics Show, Oklahoma City.
- Theuerer, H. C., Removal of Boron from Silicon by Hydrogen Water Vapor Treatment, A.I.M.E. Semiconductor Symposium, New York City.
- Torrey, Miss M. N., Continuous Sampling Plans, American Society for Quality Control, University of Toronto, Ontario, Canada.
- Uhlir, A., Jr., Gain and Noise in Ideal p-n Junction Frequency Converters – Dependence on Device Structure, Microwave Crystal Rectifier Symposium, Signal Corps Engineering Laboratories, Fort Monmouth, N. J.
- Wadlow, H. V., Determination of Traces of Sulfur, American Chemical Society, Delaware Valley Regional Meeting, Philadelphia.
- Waltz, M. C., Improved Crystal Rectifiers – A Progress Report, Symposium on Microwave Crystal Rectifiers and Their Application, Fort Monmouth, N. J.
- Weiss, M. T., Improved Rectangular Waveguide Resonance Isolators, Symposium on Microwave Techniques, Philadelphia.
- Wernick, J. H., Diffusion Measurements in Liquid Semiconductor Alloys by Temperature-Gradient Zone-Melting, A.I.M.E. Semiconductor Symposium, New York City.
-