

RECORD

VOLUME XXXI

NUMBER 6

JUNE 1953

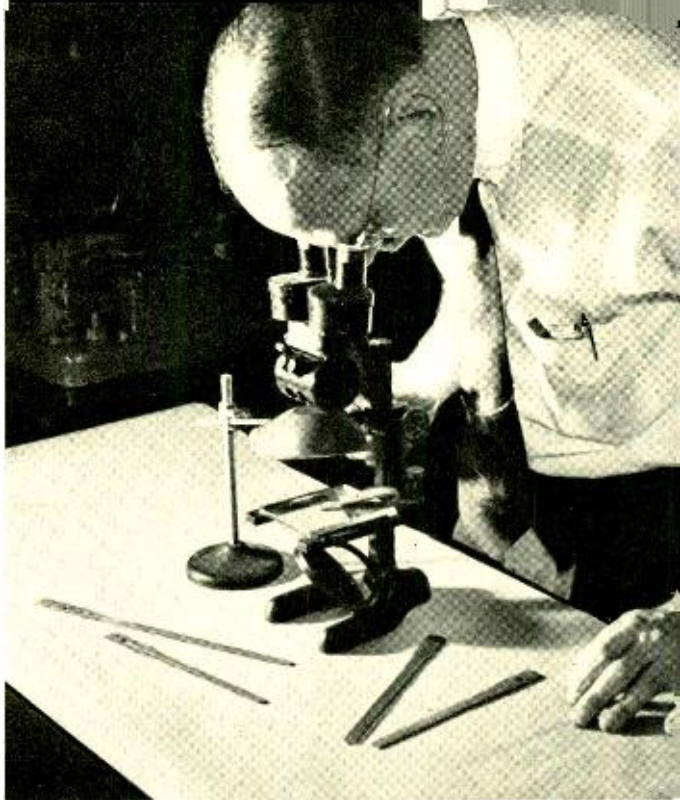

Measuring Changes in Length to One Part in a Million

G. R. GOHN

Metallurgical Research and Engineering

To determine the effect of continuous low stresses on metals, precise measurements of elongation are required. In gas-pressurized lead-covered cable sheaths, particularly, relatively low stresses produce creep and this may eventually cause failure. A new design of extensometer increases the sensitivity 10-fold over the earlier instruments, thus obtaining a corresponding improvement in precision of measurement.

“Creep” of metals, or the change in dimensions of metals under continuous stress over long periods of time, is a factor of major importance in the design of lead and lead-alloy cable sheaths, including the sleeves for covering spliced joints. At stresses appreciably below their tensile strengths, these metals gradually change dimensions over a period of time, and may ultimately fail. Studies of lead and its alloys directed toward selection of suitable materials and the establishment of maximum allowable creep stresses, require a great amount of testing over relatively long periods of time.

In Bell Telephone Laboratories, studies of the behavior of lead and its alloys have

used a number of methods for measuring creep. At high stresses, studied to determine the stress-rupture characteristics, where time-to-failure and elongation after failure are of primary importance, creep generally occurs at a fairly rapid rate. In such cases, the elongation can be measured with sufficient accuracy by placing gauge marks on the specimens of the metal, and periodically measuring the separation of these marks under tensile loads. Measurement of the separation is done with the aid of a cathetometer, a very accurate traveling microscope. For a specimen having a distance of 3 inches between gauge marks, the strain can be read to the nearest ± 0.0013 inch per inch; by increasing the gauge length to eight inches, the accuracy

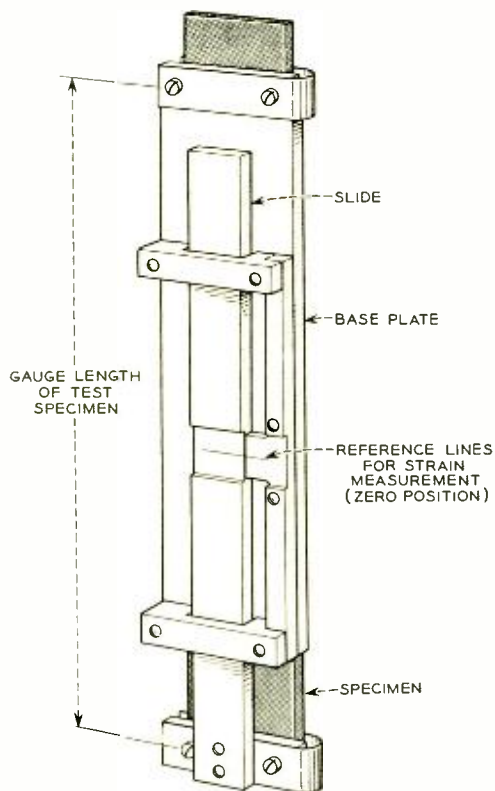

Fig. 1 - Extensometer formerly used for creep studies. The fine line shown across the center section of both the base plate and the slide is shown in the zero (unstressed) position. As the test specimen lengthens under the applied stress, the amount of separation between the lines gives a measure of the strain.

is increased to ± 0.0005 inches per inch.

For creep rate data at intermediate stresses, where the creep rates are small—stresses below about 400 lbs per square inch for lead alloys—more precise methods of measuring strain are required. One way of doing this is by means of an extensometer, designed by S. M. Arnold, shown in Figure 1. An aluminum plate is provided with guides in which a slide is free to move. The plate is fastened to the test specimen near one end of the specimen and the slide is fastened near the other end. When the slide is in its zero position, as indicated in Figure 1, and the specimen is unstressed, the points of contact of the aluminum plate and the slide with the specimen are precisely three inches apart. A fine line across the slide and the stationary part of the extensometer establishes the zero point.

By using a cathetometer with a filar eye piece reading to 50 micro-inches, the strain of a specimen can be determined to ± 30 micro-inches per inch, when three-inch gauge specimens are examined. If an eight-inch gauge specimen is used (with the extensometer accordingly made longer), the precision is increased to ± 12 micro-inches per inch. Since this extensometer is simple in construction and inexpensive to make, it is feasible to apply one of these instruments to each specimen for the duration of a creep test. This has the advantage over previous methods that significant creep rates can be determined in considerably shorter periods of time.

This extensometer has a maximum useful range equal to the diameter of the field of the filar eye piece. This is $\frac{3}{16}$ inch. For practical reasons, only about 60 per cent of the field can be used and this limits the range of this extensometer to about $\frac{1}{8}$ inch.

A new extensometer has recently been developed that increases the sensitivity tenfold. It combines the principle of the Arnold extensometer with that of a mechanical linkage arrangement used by the Engineering Experiment Station of the University of Illinois. This instrument is illustrated in Figure 2, which shows a group in use in the creep laboratory. Details of this instrument are shown in Figure 3.

The device consists essentially of a 10-



the line on the end of the lever is about 0.050 inch below the fixed reference line, a reading is taken, the gauge rod reset to approximately its original position, a new zero reading established, and the test continued. By this means, the strain can be measured to the nearest 1.2 micro-inches per inch (for eight-inch gauge lengths) for any desired total extension; the only limitation is the length of the gauge rod.

The extensometers are calibrated by mounting them on the spindles of a super-micrometer and checking the cathetometer reading against fixed increments of the micrometer. This calibration set-up is shown in Figure 4. In making the calibration, the same cathetometer is used as used for the creep studies.

The high precision of strain measure-

Fig. 2—J. P. Ahrens making measurements using the new 10:1 mechanical extensometer and cathetometer on a group of specimens.

to-1 lever having a horizontal reference line accurately scribed on its free end. This free end moves vertically between the legs of a U-shaped bracket on which a pair of horizontal reference lines are scribed. Separation between the line on the end of the mechanical lever, and one of the other two fixed reference lines is measured with a cathetometer similar to the one used with the earlier extensometer.

In setting up the extensometer for a test, it is placed in a jig which automatically adjusts it to the proper gauge length. The extensometer is then fastened to the specimen with cone-shaped screws that are held in contact with the specimen by two spring-tensioned contact bars. The small gauge rod (shown to the right of the specimen in Figure 3) is then adjusted so that the reference line on the end of the mechanical lever is about 0.050 inch above the fixed reference line. The gauge jig is then removed.

As the specimen extends under the test load, the lever slowly moves from the (—) to the (+) side of the fixed reference line. During extension of the specimen, the creep is measured periodically with the aid of the cathetometer. When

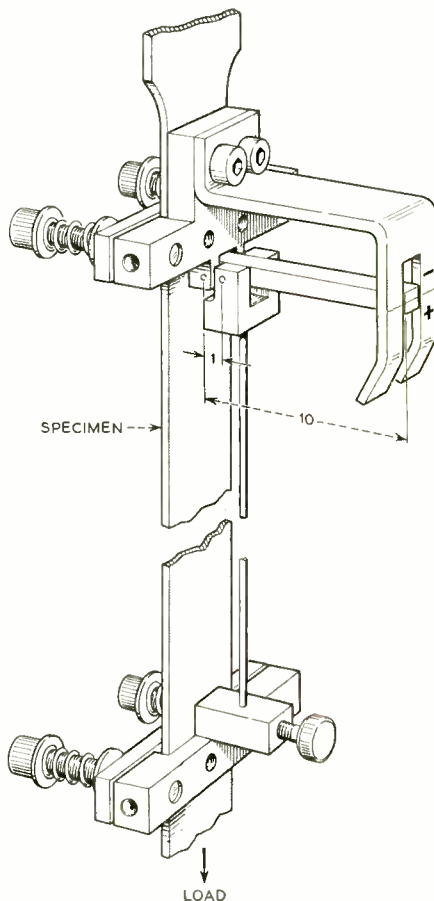

Fig. 3—Details of the 10:1 mechanical extensometer for measuring creep.

ment, 1.2 micro-inches, which is possible with this mechanical extensometer, can only be gained if the test specimens are held at constant temperature throughout the test. For example, the coefficient of linear expansion of the lead alloys tested in the creep laboratory, varies from 28.8 to 29.3 micro-inches per inch per degree C. For stainless steel (which is used in the gauge rod) the coefficient of linear expansion is 16.5 micro-inches per inch per degree C. The difference between the two is equivalent to approximately 12.5 micro-inches per inch per degree C or 7 micro-inches per inch per degree F. Thus a change in temperature of only 1 degree F would cause an apparent increase in strain equal to six times the precision of the instrument. This means that unless the temperature of the test specimens is controlled more closely than 1 degree F, a temperature correction factor must be applied when the strain readings are small. However, since most of the tests are made of stresses that produce strain rates of 0.1 per cent or more per year (1,000 micro-inches per inch) the effect of this temperature variation is such that the error, only 7 micro-inches per inch, is less than 1 per cent of the yearly change. Since an error of 5 per cent is permissible, the test tem-

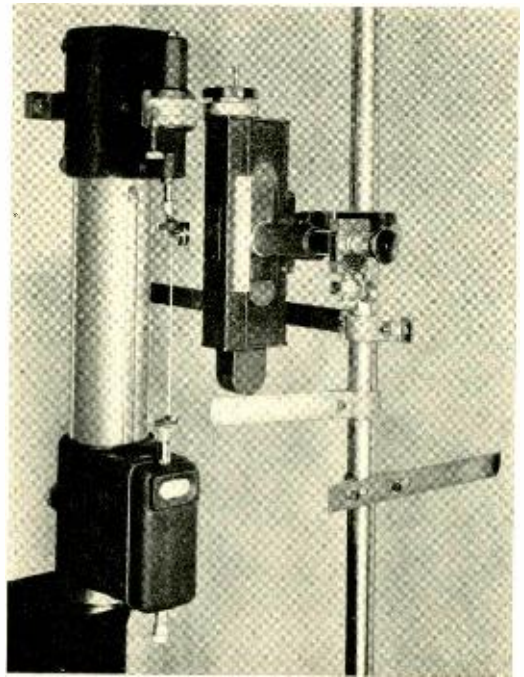

Fig. 4 - Calibration of the new extensometer.

perature need only be controlled within a seven-degree range. In the creep laboratory of Bell Telephone Laboratories, measurements are made in a room in which the temperature is held within a five-degree range, 80 to 85 degrees F. Variations over weekly periods seldom exceed 1 degree F.



THE AUTHOR: GEORGE R. GOHN, a member of the Chemical and Metallurgical Research Department, has been in charge of fatigue and creep studies since 1945. He was graduated from Otterbein College in 1926 with a B.A. degree. In 1929 he received the degrees of B.S. in Engineering and Met. Engr. from Columbia University. That year he joined the Laboratories. His work has been concerned with the investigation of the physical properties of metals, the application of die casting processes to the manufacture of Bell System apparatus, the development of specification requirements for procurement of non-ferrous metals, and the study of creep and fatigue properties of metals.

Precise High-Frequency Crystal Units

A. W. WARNER

Transmission Apparatus Development

To make most efficient use of frequency space in telephone communications, the trend in modern engineering design has been to provide increasing numbers of channels in broad-band carrier systems. High quality transmission demands that these channel frequencies be extremely stable. To provide this stability, for these and other uses, precise, high-frequency crystal oscillator units that could be made available for relatively general use were needed. New designs and refinements have indicated that relatively inexpensive and rugged units, as much as one thousand times more precise than any previously available, may be manufactured on a commercial scale.

Until rather recently, a wide gap has existed between the frequency accuracy available in commercial crystal units, such as those used in most communications equipment, and the 100-kc unit of the type used in the Bell System Primary Standard of Frequency at Murray Hill. At the present time, this standard does not vary in frequency more than one part in 100 million during a thirty-day period. Crystal units for such standards, however, must be individually fabricated at considerable expense and used in elaborate and complex circuits. These factors limit the use of such oscillators to a very few special installations, and precise frequency standards for anything approaching general use are not available. To fill an urgent need for highly accurate frequency standards that are sufficiently rugged and inexpensive to have reasonably widespread use, the crystal units described in this article have been designed to be manufactured commercially. Through the use of a new crystal shape and refinements in fabrication, these crystal units are expected to make possible high-frequency oscillators for relatively general use that approach in precision those of the very few

The author (rear) and J. R. Merchant operating the vapor-plater used to deposit initial electrodes on the crystal units.



June, 1953

205



Fig. 1—Precise high-frequency crystal unit. The unit is sealed in the glass envelope. A completed unit is shown in the foreground.

primary frequency standards now in existence.

These new crystal units have important applications in the Bell System. At present, sections of broadband carrier systems such as the L3 are synchronized by a common frequency standard to provide the required degree of stability. Development of circuits using the crystal units described in this article, however, would provide for operating these systems without synchronization. This would not only eliminate the equipment required for the synchronization, but also permit these systems to operate as independent sections under emergency or disaster conditions. In addition, single side-band radio systems such as overseas radio operate more efficiently with increased privacy and continuity of service when the frequency stability is sufficient to eliminate the need for transmitting a carrier signal. For overseas radio, this requires a stability of one part in ten million—well within the capabilities of the new crystal units.

These high-frequency units are based on AT-cut quartz crystal plates* ranging in

* A bibliography on quartz crystal articles appears on page 210.

frequency from 1 to 100 megacycles. The quartz plates have gold electrodes deposited on the two major faces, and are illustrated in Figure 1. When a crystal of this type is placed in a suitable circuit, high-frequency shear (transverse) vibrations are established as illustrated in Figure 2. The frequency of these vibrations is determined largely by the natural resonant frequency of the quartz plate, which is determined, in turn, by the thickness of the plate. A high-frequency crystal unit of this type can be designed to vibrate at its fundamental resonant frequency or at an overtone of that frequency. In the latter case, it behaves very much as though it were a stack of plates, each vibrating at its fundamental frequency as illustrated in Figure 3. The five plates indicated in this diagram would correspond to a single plate vibrating at its fifth overtone.

Several characteristics of the crystal units govern the accuracy of these high-frequency oscillators. In the first place, the unit must have a very high Q; that is, the ratio of the energy stored in the crystal to the energy lost must be very high. A high Q crystal requires a relatively small amount of energy from the associated circuit to maintain its operation at a given amplitude of vibration. This isolation allows the crystal unit itself to establish the frequency output without being appreciably affected by variables in the circuit. The crystal

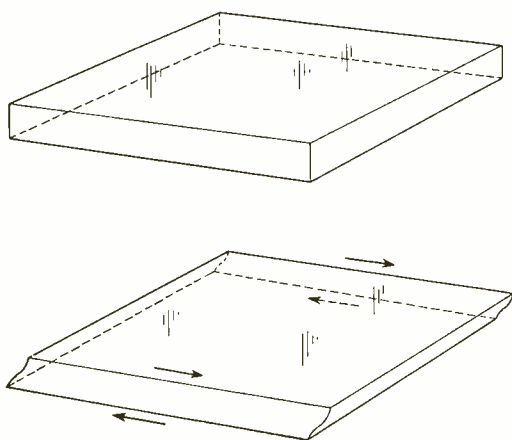

Fig. 2—A diagram illustrating the way shear vibrations distort a crystal plate.

unit must also possess a high degree of physical stability to keep frequency aging — change in the resonant frequency with the age of the crystal — to a minimum. In addition, the change in frequency with a change in temperature must be kept very small. In other words, the crystal must have a low coefficient of frequency versus temperature.

For very precise crystal units, there is no particular order of importance among these factors, since neglect of any one feature will nullify the precision that would be attainable through the use of extreme care with the others. A carefully balanced design is required; that is, a design in which no one limiting factor predominates. To achieve these results, considerable refinement in the equipment and methods normally used in the manufacture of AT type crystal units was necessary. With this refinement, however, some rather remarkable results have been attained. Crystals with Q values ranging from one to three million at five megacycles can be readily produced. These values are of the same order as those obtained in primary frequency standard crystals and exceed those of any commercially available crystals by a factor of about ten. The frequency aging characteristics that have been made possible are illustrated in Figures 4 and 5. The data for the graph in Figure 4 were obtained from a 10-mc crystal unit made in 1949 and tested in the indicated circuit and a one-stage oven to maintain a constant temperature. As shown, the frequency change during the course of almost a year amounted to only about one part in ten million. The sharp initial drop in this curve is characteristic of the warm-up period during the first few days of the test and the broken line areas indicate an absence of data brought about by interruptions in the testing process. Figure 5 illustrates the aging of a 5-mc crystal unit alone, tested in 1951 during the first three weeks of its life — a period when the effect of frequency aging is likely to be at its worst. The frequency change due to aging is seen to be only about one part in a hundred million during the period tested.

The temperature coefficient in these units

can be made such that the frequency changes less than one part in ten million per degree change in temperature. Any one of several available one-stage ovens can be used, therefore, to maintain the temperature to within one-tenth of a degree centigrade and thus provide for a frequency output that is accurate to within one part in a hundred million.

Crystal units capable of achieving such precision require that extreme care be exercised in forming the crystal plates themselves and the gold films that serve as electrodes. In shaping these crystals, a conventional plane parallel plate is modified by generating a spherical contour on one surface. The resulting crystal, similar in appearance to a plano-convex lens, is a new development in the design of precise

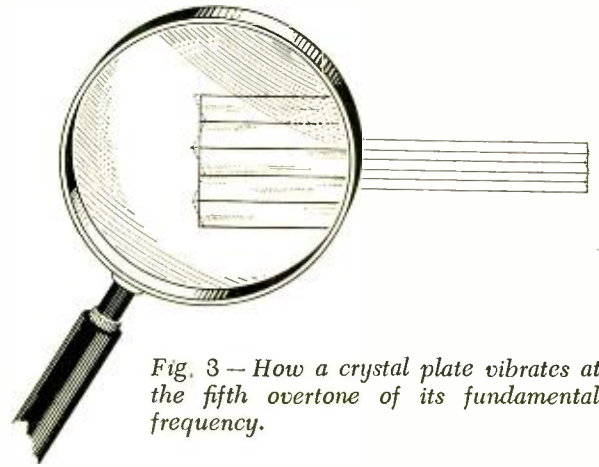

Fig. 3 — How a crystal plate vibrates at the fifth overtone of its fundamental frequency.

crystal oscillators. It has been found that this contour on the finished crystal restricts the characteristic mechanical vibrations to the center of the plate and thus effectively isolates the vibrating portion of the crystal from the mounting wires. In this way, none of the crystal energy is lost through the mount, and hence the Q value is greatly increased.

In designing a crystal unit for a particular frequency response, it is advantageous to use as high an overtone order as possible. If a high overtone is used, a crystal with a relatively low natural resonant frequency can be employed and such a crystal will be considerably thicker than one de-

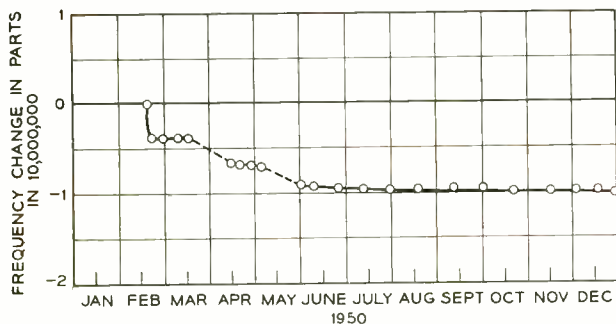
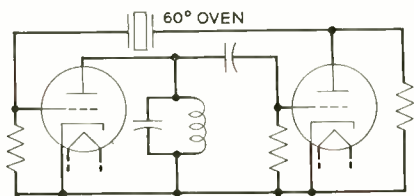

Fig. 4—Graph indicating the frequency aging characteristics of a 10-mc crystal unit enclosed in a 60 degree oven and tested in the indicated circuit.

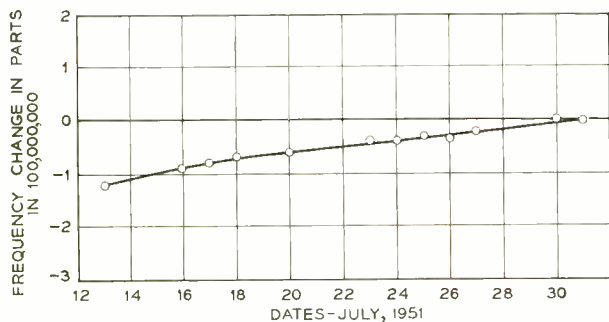

Fig. 5—Frequency aging characteristics of a 5-mc crystal unit during the first three weeks of its life.

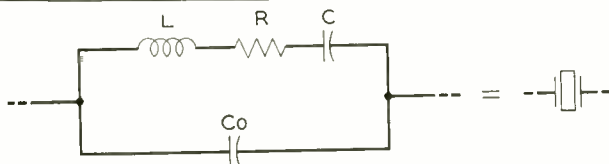

Fig. 6—Electric circuit with characteristics equivalent to those of a vibrating crystal.

signed to deliver the desired frequency as its fundamental mode of vibration. The advantages of using a thicker plate in this way are that it is more stable, more easily calibrated to frequency, and is less affected by contamination than a thin one.

There are limitations to the use of this

overtone operation, however, that can best be described by drawing an analogy between the characteristics of the crystal and an equivalent electric circuit as shown in Figure 6. The corresponding Q value in this case is $Q = \omega_r L / R$, where ω_r is proportional to the resonant frequency. In this equivalent circuit, R , representing the crystal resistance, increases with the cube of the overtone order, and its maximum allowable value is established by the impedance limitations dictated by the circuit associated with the crystal unit. To employ a high overtone order and hence a thick crystal, R must be kept to its minimum value.

If the equation given above is rewritten in the form $R = \omega_r L / Q$, it can be seen that the value of R will decrease as L decreases and Q increases. Both L and Q , however, depend on the shape of the spherical contour developed on the crystal plate.

As the contour first departs from flatness when a spherical surface is being formed on a crystal plate, its Q value is increased because the energy loss through the mounting is decreased. The inductance, L , however, is little affected, as illustrated by the graphs in Figure 7(a). As sharper contours are developed—the radius of curvature is decreased—the inductance, L , increases much more rapidly and the rate of increase in Q tapers off. As a result, the resistance, R , is a minimum at some particular value of the radius of curvature where the increased Q value is balanced by the increased inductance. A typical balance point of this type is illustrated in Figure 7(b) for a 9-mc crystal operating at its third overtone. As seen, the optimum radius of curvature in this case is about 80 inches. The values of the contours for minimum R are limited to a crystal of a particular design, however, since the balance point between L and Q that provides a minimum R is affected to some extent by the crystal plate size, the size of the electrodes, and the type of mounting.

To produce a highly precise crystal, in addition to increasing the Q value by shaping, it was necessary to devise a means of achieving a better frequency-temperature coefficient by a closer control of the orientation of the crystal plate with respect to its

crystallographic axes. This was done through the use of refined X-ray measuring equipment and closer control of quartz processing methods. By these methods cut plates accurate to within less than two minutes of arc can be attained.

In forming these units, it is extremely important that the unwanted effects of grinding and lapping the crystal plate be removed. These include loose, strained, or powdered material on a surface marred by cracks, fissures, and scratches. In addition, some method must be devised to reduce the ever-present contamination by foreign materials on the surface of the plate. To remove this foreign material and the effects of grinding, and to be able to observe that they have been removed, it was necessary to polish the surfaces of the quartz plate to optical smoothness. By the optical means employed even the smallest scratches — called *sleeks* — can be readily seen on a polished plate and a continual check kept on the finishing process. An optically polished surface is also easier to keep clean since the contaminants are not imbedded in tiny crevices and can be removed by relatively short exposures to commonly used solvents. In addition, these polished plates have less surface area than lapped plates and hence the mass of foreign material per unit volume of quartz is decreased by a ratio of as much as five to one.

No matter how much care is exercised in shaping and polishing the crystal, however, a high degree of accuracy cannot be obtained from a crystal unit unless compact, pure, gold film electrodes are applied with equal care. The process of depositing these electrodes onto the quartz plates can be divided into two general phases. First, a base electrode, common to all units, is deposited simultaneously on a group of plates, and second, a precisely controlled amount of gold is added to each unit individually to ensure that its resonant frequency will be correct. The first phase of the process is readily accomplished since a conventional vacuum system and relatively high temperatures can be employed. In this phase, a predetermined weight of gold is evaporated in a vacuum onto the clean, masked surfaces of the quartz plates.

In the second phase, a final amount of gold is added to bring the unit to the desired frequency. During this phase, the frequency of the crystal unit must be measured continuously to determine the correct weight of gold required to an accuracy of about 1/100 of a microgram. In this process, high temperatures cannot be used since they will affect the frequency response being measured and the pumping time in the vacuum system must not be excessive since only one unit can be adjusted at a time.

The apparatus used in this second phase

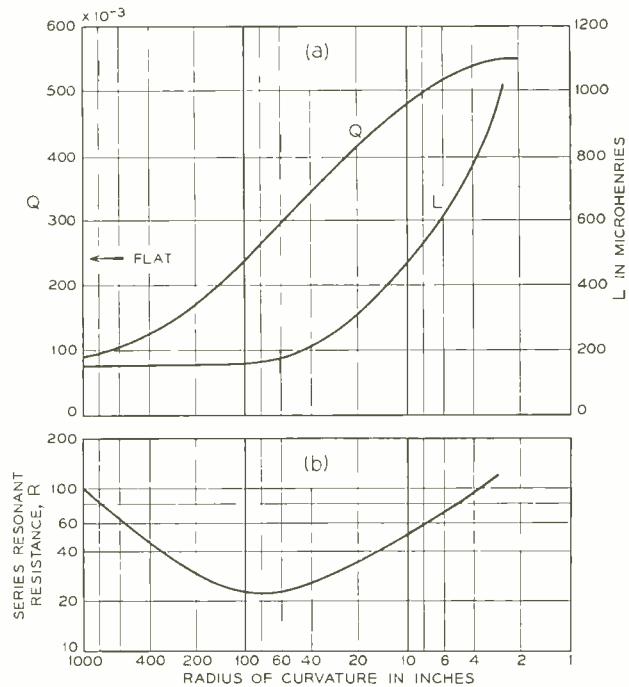

Fig. 7 — Graphs showing the relation between Q , L , and R and the curvature of a crystal plate. Section (a) illustrates the increase in L and Q with decreased curvature and (b) indicates a resulting optimum curvature value producing a minimum R .

was designed for extremely rapid pumping and is equipped with both large and small ducts and easily degassed chambers. Multiple chambers are also provided to ensure that the pumps will never be idle. An elaborate system of traps is included to reduce the possibility of foreign material contaminating the gold film. All the controls in this system are automatically oper-

BIBLIOGRAPHY OF RECORD ARTICLES ON CRYSTALS

- An Uncut Quartz Crystal and Photomicrographs of Surfaces Cut
at Different Orientations (Picture) February, 1936, facing page 193
- Cleaning Quartz Crystals (Picture) April, 1936, facing page VIII
- Elastic Vibrations of Quartz, *G. W. Willard* April, 1936, page 250
- Crystals of Quartz, *W. P. Mason* February, 1944, page 282
- Inspecting and Determining the Axis Orientation of Quartz
Crystals, *G. W. Willard* March, 1944, page 320
- Hand Lapper for Quartz, *G. M. Thurston* July, 1944, page 452
- Quartz Crystal Plating, *H. G. Wehe* December, 1945, page 475
- Checking Sense of Cut in Quartz Crystals, *D. M. Ruggles* . . . November, 1949, page 399
- Improvements in Crystal Units for Precise Frequency Control,
A. W. Warner June, 1950, page 254
- Degasser for Small Parts, *D. M. Ruggles* October, 1951, page 452
- High Stability 100-KC Crystal Units for Frequency Standards,
J. P. Griffin November, 1952, page 433
-

ated by electrical means for fast, safe operation in producing gold electrodes with a high order of precision.

In designing a crystal unit as described, advantage is taken of optimum overtone, contour, and surface finish, as well as advanced manufacturing techniques to obtain high Q values, low aging, low temperature coefficients, and small frequency tolerances. In this way, performance is obtained that is 10 to 1,000 times better than

was previously possible with any commercially available crystal. The crystal units still retain much of the conventional design; basically, the same types of tools and techniques are used for lapping, plating, mounting, and adjusting the units as had previously been used for conventional units, but the result is a new, very precise, frequency-standard crystal unit that is small, rugged, and inexpensive as compared to other units of comparable precision.

THE AUTHOR: A. W. WARNER received the B.A. degree in Physics and Mathematics from the University of Delaware in 1940 and the M.S. degree in Physics from the University of Maryland in 1942. He spent one year as instructor in physics at Lehigh University and another in the Engineering Department of Western Electric engaged in the design of testing equipment for quartz crystal units for the armed services. In 1943 he joined the Technical Staff of the Laboratories and engaged in the development of high-frequency quartz crystal units. At present he is designing crystal units for Bell System and for military use.



Measuring the Pull of Relays

R. L. PEEK, JR.

Switching Apparatus Development

Fig. 1 — R. Calame operating relay pull tester.

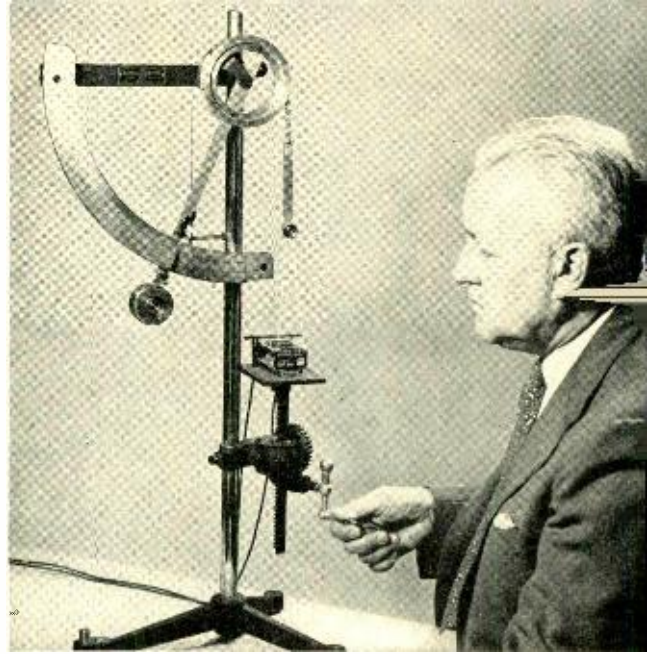

In telephone relays the contacts are opened or closed by the motion of springs on which they are mounted. The springs are moved by the relay armature when it is operated, and restore the armature to its unoperated position on release. The force which the armature must exert to move the springs varies with its position, which is defined by the size of the armature gap. The relation between the required force and the gap is called the load curve. The magnetic pull acting on the armature also varies with the gap, and must exceed the spring load throughout the armature motion. Measurements of both load and pull are therefore required in relay development studies. An improved machine for making pull measurements is shown in Figure 1.

The pull is measured with a constant current flowing through the winding. This pull varies with both the armature gap and the current, or the corresponding ampere turn value, and is defined by a family of pull curves, each curve showing the relation between pull and gap for a particular

Engineering of a relay as a circuit element consists of designing a winding capable of providing the necessary magnetic pull to operate the contact springs. To guide this design, many measurements of the pull of relays are required because of the varied conditions of spring loads, displacement, and operating speed. Recently, a faster and more accurate technique has been developed for determining pull.

ampere turn value. This is illustrated in Figure 2, which shows typical load and pull curves for the wire spring relay. The load curve starts from the open gap, or unoperated position, with the force of the back tension, which positions the armature in release. The load rises as the gap is closed, gradually while the springs are merely deflected, and sharply when contacts are opened or closed.

For assured operation, an ampere turn value must be selected corresponding to a pull curve which lies above the load curve at all points. To cover the different levels of load which may arise in different applications, the pull measurements should cover the full range of ampere turn values of interest, as in the curves of Figure 3(a). To determine the pull versus ampere turn relation at specific gaps, for example, at the point where load and pull curves approach each other most closely, the pull relation is plotted in the alternative form of Figure 3(b).

Of several methods which have been used for pull measurements, the one most

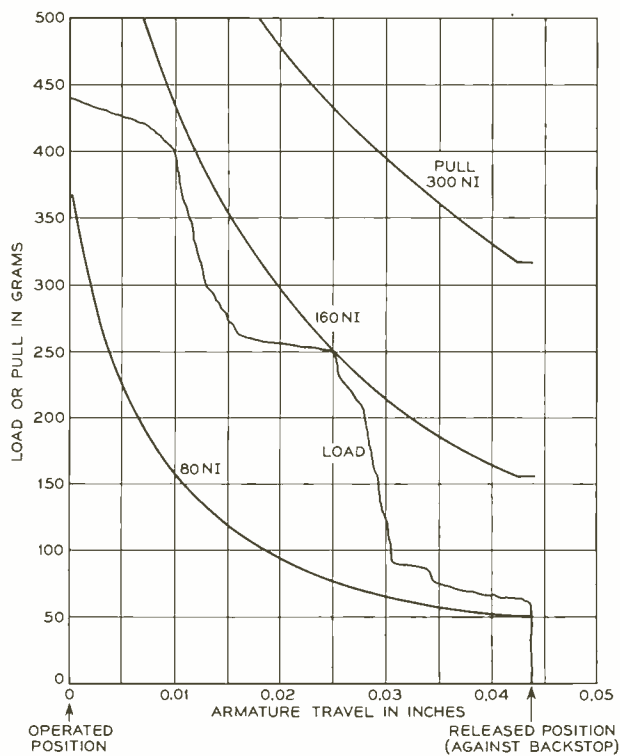

Fig. 2 — Typical pull and load curves for wire spring relay. Discontinuities in load curve indicate points at which contacts operate. Comparison of pull curves shows that a minimum NI of 160 is required to operate the relay.

commonly employed in the past is that shown in Figure 4. In this, a weight is suspended from the armature, with the latter supported at a selected gap opening. In the case shown, this support is furnished by an adjustable back stop nut. Winding current is applied and gradually increased until the pull overcomes the force of the weight, and the armature operates. By changing weights and repeating the determination of the current required for operation, the relation between pull and ampere turns can be determined for the selected gap opening. By repeating this procedure for other gap openings a family of curves is obtained as shown in Figure 3(b).

A more convenient procedure is provided by the use of the machine shown in Figure 5. This device is a modification of a tensile tester used to measure the strength of paper and other strip materials. Its essential element is the pendulum arm which moves over a graduated scale, and is fastened to a pulley over which a chain is passed. If tension is applied to this chain, the pendulum arm is displaced from its vertical position by an amount corresponding to the tension on the chain. The scale is graduated to read this tension directly.

In measuring relay pull, the chain is connected by a string or wire to the armature of the relay, so mounted that the pull

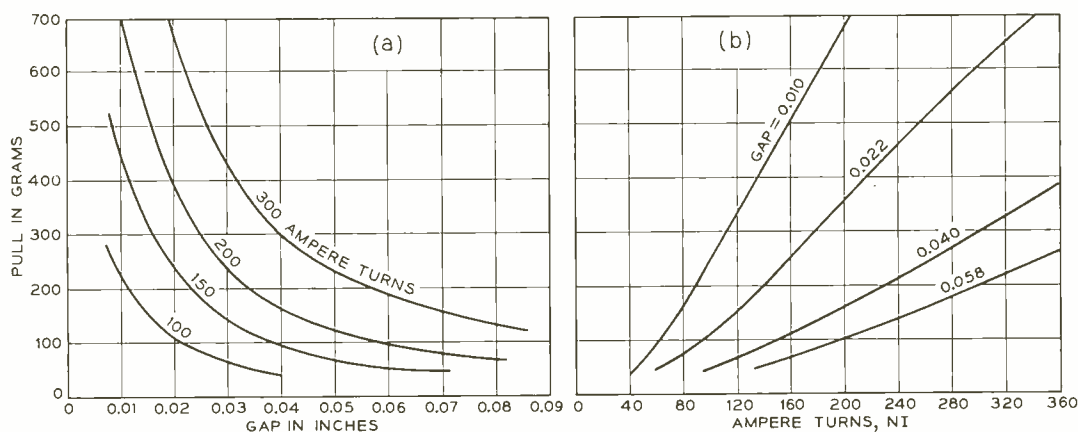

Fig. 3 — Two forms in which pull characteristics are plotted.

of the string tends to open the armature gap. The relay is fastened to a table which can be moved vertically by a handwheel, as illustrated in Figure 1. The gap for the measurement is determined by the thickness of a shim inserted between the armature and the core. A selected current is applied and the armature is pulled magnetically against the shim. The relay table is lowered by means of the handwheel, applying tension to the pulley chain, thus moving the pendulum arm and gradually increasing the tension of the chain. When this force exceeds the pull, the armature opens. Pawls on the pendulum arm lock it in the position it attained when the tension was relieved by the release of the armature, and the pull can be read from the scale.

The magnet table and pendulum arm can now be restored to their original positions and another (higher) current applied. The pull for this current is measured, and the process repeated for successively higher current values. A similar series can be made for each of several shim thicknesses, or gap values, providing a complete determination of the pull characteristics.

As compared with the weight method of Figure 4, the use of this machine provides a more convenient experimental procedure, as it eliminates the need for adding and removing weights. It has two further ad-

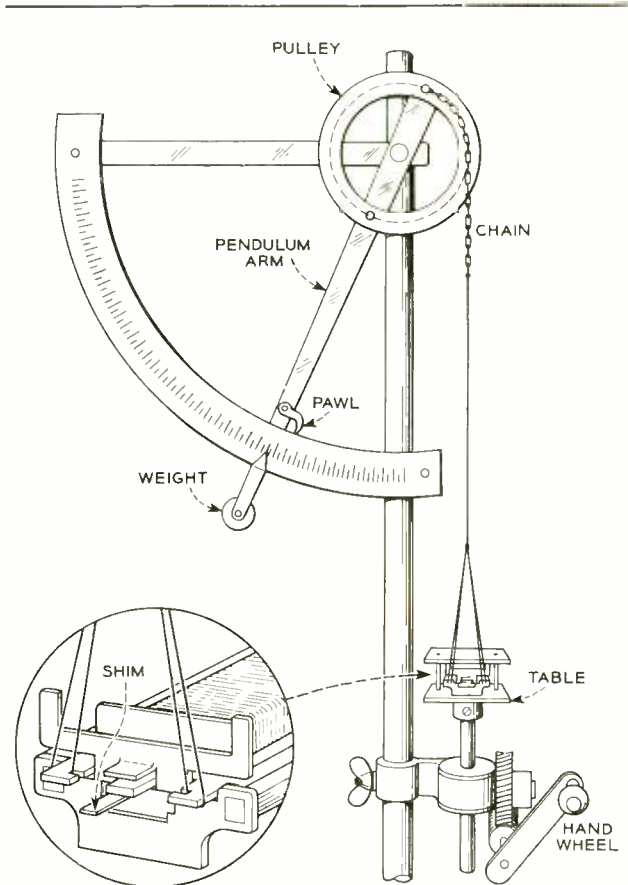

Fig. 5 - Pendulum method for measuring relay pull.

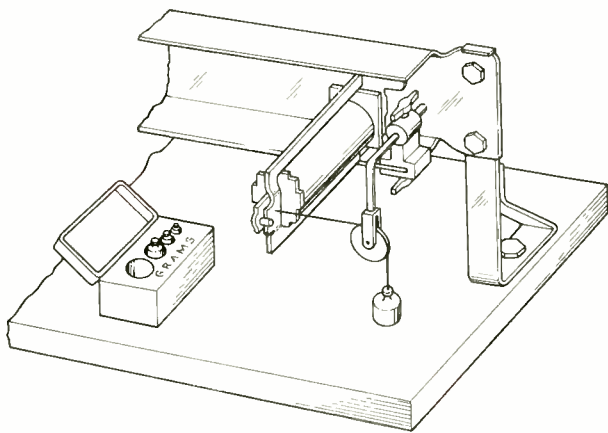

Fig. 4 - Weight method for measuring relay pull.

vantages of greater importance, one relating to the procedure with respect to demagnetization, the other to the form in which the results are obtained.

The magnetic field developed when a relay is operated does not wholly disappear when it is released. A residual field, similar to that of permanent magnets but much weaker, remains, producing a corresponding small pull. When the coil is again energized, the magnetic field developed and the corresponding pull are changed by this residual magnetism, and the observed pull is greater than that observed when the relay has been demagnetized prior to the measurement. Since the extent to which residual magnetism affects the pull of relays in actual use is variable, the pull measurements used for engineering purposes



Fig. 6 – With pull machine set up to measure load, Dorothy Lapidus observes armature displacements corresponding to various restoring spring forces or loads.

are obtained with the relay initially demagnetized – a condition obtained by passing alternating current through the winding and gradually decreasing its amplitude.

With the weight method, the armature is operated in each measurement and closes the gap, resulting in a stronger magnetic field than existed before this motion. It is therefore necessary to demagnetize after each measurement. With the pendulum machine, the armature opens its gap when it is pulled from the shim, and the field decreases. When the armature is restored to the shim and the current increased, the field increases as it would if the armature had not moved and the current had been raised directly to that of the next measurement. A series of measurements with increasing current can therefore be made

without demagnetization, and the latter need only be employed when the shim is changed, at the start of the series of measurements for another gap.

The other advantage relates to plotting the results. As shown in Figure 3, these may be plotted either as pull versus gap, with ampere turns constant for each curve, or as pull versus ampere turns, with the gap constant for each curve. In the machine procedure, both current and gap can be selected in making the measurements, and can be chosen as combinations of conveniently spaced sets of ampere turn and gap values. The results can then be plotted directly in either of the two forms shown in Figure 3. With the weight method, the pull (or weight) and the gap are the only selectable quantities, and the ampere turn value is observed. The observed values, in general, all differ from one another, and there are no sets of observations at a constant ampere turn value which can be plotted as pull versus gap, as in Figure 3(a). Results from the weight method can therefore be plotted directly only in the form in which the selected gap values serve as curve constants, as in Figure 3(b).

While developed and used primarily for pull measurements, the pendulum machine can also be used in measuring load. An arrangement for load measurements is shown in Figure 6. Here tension corresponding to the pendulum displacement is applied to pull the armature against the spring load by means of the string connection shown. This tension can be varied by moving the pulley mounted on the handwheel rack. The corresponding motion of the armature is measured with the traveling microscope.

THE AUTHOR: R. L. PEEK, JR., joined the Laboratories in 1924. He spent several years in the Chemical Research Department, studying special methods of physical testing in connection with materials development. He then transferred to the materials testing group in the Apparatus Development Department, where he carried out similar studies. Since 1936, Mr. Peek has been engaged in relay and other apparatus development projects, including the wire spring relay and, during the war years, underwater ordnance and magnetostriction sonar. Mr. Peek received A.B. (1921) and Met.E. (1923) degrees from Columbia University.



Bell Laboratories Record

Measuring the Load-Displacement in Relays

T. E. DAVIS

Switching Apparatus Development

Relays are required to operate against an opposing load produced by the deflection of the contact springs. To design relays having sufficient magnetic pull to overcome these loads, it has been customary in the past to measure the loads by applying known loads to the springs and measuring the resulting deflections with a traveling microscope. By means of a new spring balance and improved methods of observing spring displacement, both load and displacement may be quickly and precisely determined.

When a telephone relay operates, magnetic pull on an armature overcomes a load produced by spring tension. The pull must always exceed the load, which increases as the armature is displaced from its unoperated or released position. To ascertain the pull needed to operate a relay for all armature positions, load must be measured as a function of armature displacement. The measurement of load versus displacement

requires means of applying a known deflecting force to the springs, and a means for observing the resulting displacement. The usual way has been to apply the deflecting force by means of a loaded scalepan attached to the springs, and to observe the displacement with a traveling microscope. This technique involves the labor of totaling up the weights in the scale pan for each measurement, and the added dis-

Fig. 1 — J. L. Agterberg applies calibrated tension to relay springs as an optical system registers the resulting displacements.

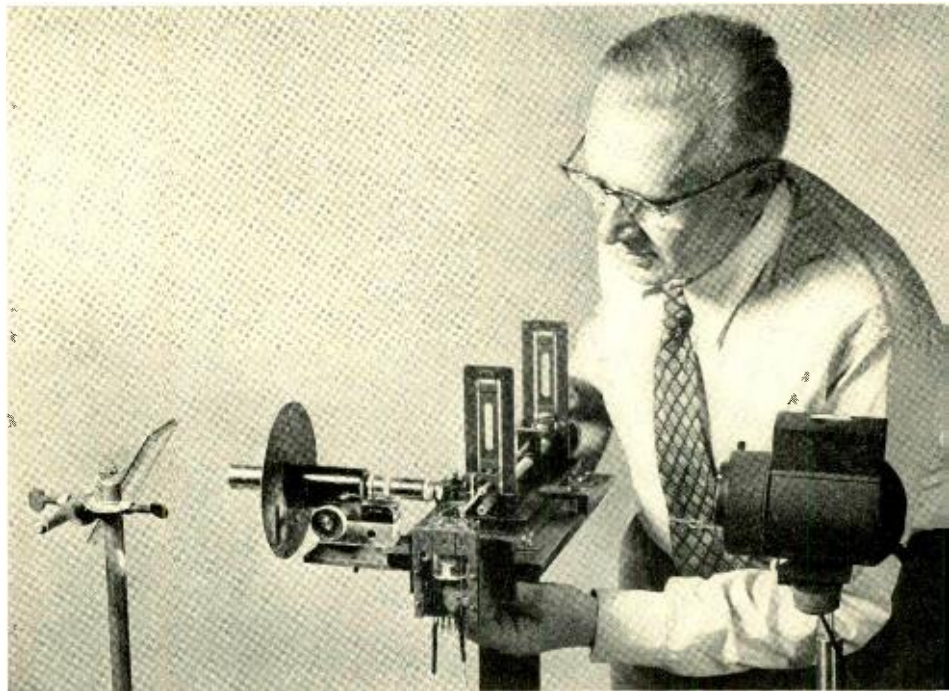

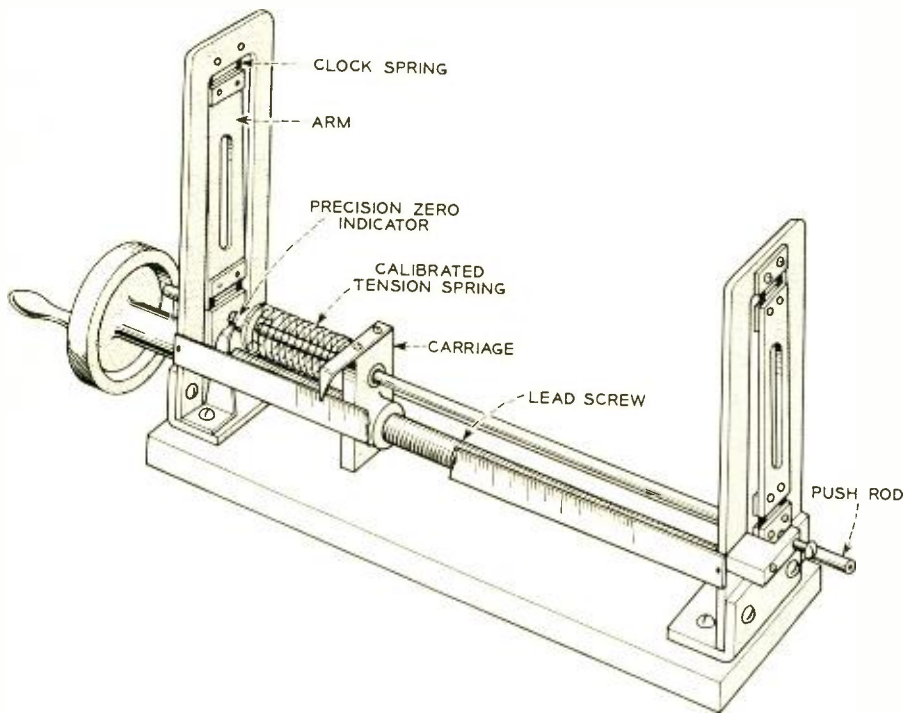

Fig. 2 — Frictionless spring balance.

advantage that the load is not continuously variable; also the microscope must be readjusted for each measurement. Continuously variable tension can be applied to a relay by adapting the pull tester described in the companion article but there is the inconvenience of attaching a string, the tension is variable only in an increasing direction, and a microscope is again needed to observe the displacement. With the new machine shown in Figure 1, the deflecting force can be continuously and precisely decreased as well as increased and, through a magnifying optical system, the displacement is directly observable as the deflection of a spot on a scale.

To apply continuously variable force a special spring balance was devised. In a spring balance, force of known magnitude is exerted on a rod by means of a calibrated spring. However in spring balances of the conventional type, there is friction between the rod and the spring and stationary parts of the balance. This frictional resistance is likely to be of the same order of magnitude as the smallest forces it is desired to apply to the relay; also it varies unpredict-

ably, hence cannot be reliably corrected for. The new balance shown in Figure 2 eliminates friction altogether.

Instead of resting on bearings, the push rod is held in suspension. Each suspension arm hangs by a hinge of spring steel and a similar hinge attaches the lower end of the arm to the rod. The stiffness of the hinges is designed to restrict motion except along the axis of the rod. When the arms swing away from the vertical, the lower ends describe an arc but this is too short to involve significant vertical motion. One end of the helical spring which applies force to the push rod is attached to the left end of the rod; the other end is attached to a carriage which can be continuously moved by turning a lead screw with a handwheel. Motion of the carriage toward the right stretches the spring so that force is applied to the rod in a right-hand direction. A pointer on the carriage indicates the amount of extension of the spring, and hence the force exerted on the push rod. Initially the helical spring is calibrated by applying known forces to it by means of a loaded scale pan. Errors in the scale read-

Fig. 3 — Diagram illustrating operation of relay load-displacement tester shown in Fig. 1.

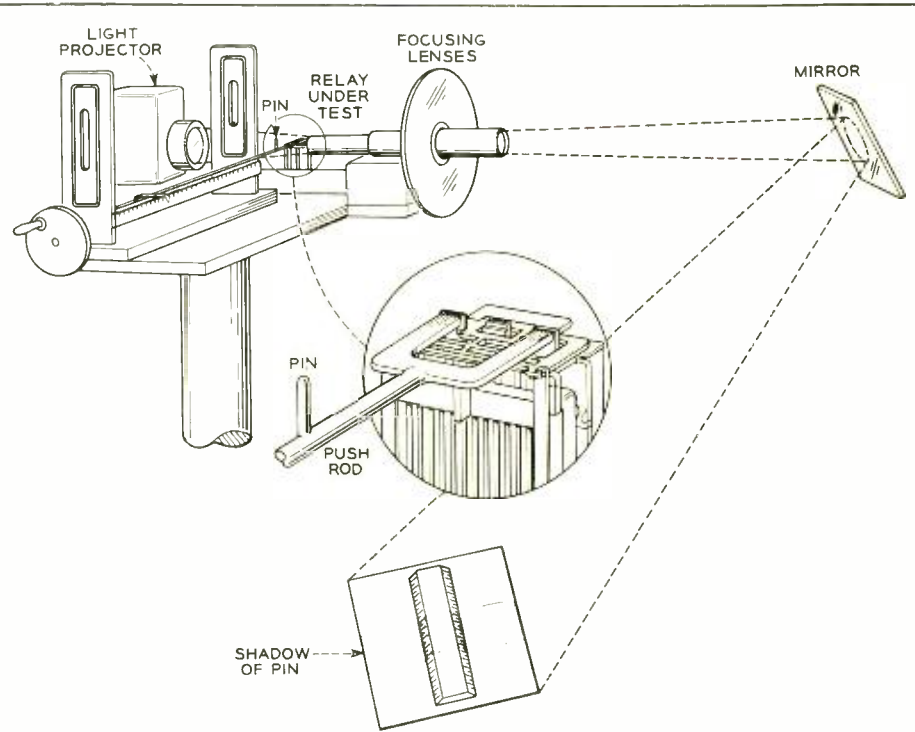

ing due to the increasing restorative force of the spring hinges as they are deflected are usually negligibly small. Corrections may be calculated from the deflection and known stiffness of the hinges.

As shown in Figure 3, the spring balance is set up with its push rod resting against the armature of the relay under test. As the push rod and armature move there is a corresponding motion in the vertical pin attached to the rod. A beam of light is concentrated on the pin by the projector at the left. The image of the pin is transmitted through focusing lenses to the mirror at the right, whence it is reflected to cast a shadow

on a scale on the table. With the magnification of 50 diameters, a displacement of only one mil in the armature yields on the scale an easily readable deflection of nearly one-sixteenth inch.

The machine is also employed to determine the points of armature travel at which contacts open or close. To obtain this information, the armature is slowly moved until a light in series with the contacts operates. The "contact operate point" is then read off the scale on the table. Primarily designed for relay testing, the machine can also be used to obtain force-deflection curves for other small apparatus.



THE AUTHOR: After receiving a B.S. degree in E.E. from the University of Arizona in 1928, T. E. DAVIS joined the Laboratories. Since then he has been concerned with various apparatus development projects, including those related to microphones, handsets, echo suppressors for long telephone lines, and since 1945, the wire spring relay. During World War II, Mr. Davis worked on an underwater sound system for the Navy. From 1922-26, he was associated with the Clarkdale Copper Company.

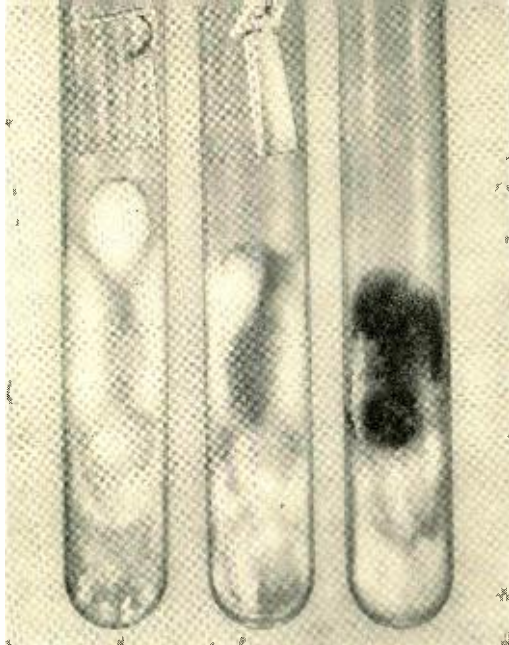

Wood Stimulates Its Own

It has been known for many years that certain fungi, particularly those of the mushroom type, cause the rotting of wood, but it has been discovered only recently that the very presence of wood seems to actually stimulate growth of the fungi that cause its decay. This effect was reported in 1951 by Osmo Suolahti at the State Technological Institute in Helsinki, Finland. Some of his experiments were repeated and the results confirmed in the bioassay laboratory at Murray Hill by L. R. Snoko.

To investigate this effect, cultures of a fungus *Lenzites trabea* (Madison 617) were grown on malt-agar media in a series of test tubes. Pieces of untreated southern pine sapwood of various sizes were suspended above the cultures in some of the tubes and after incubation in a warm, moist room for eighteen days, the growth of the fungus was observed. The results are graphically portrayed in the photograph shown above. There is no wood in the tube at the right and after two weeks of growth the fungus has already passed through the vegetative phase which causes decay in the wood, and has entered the reproductive phase, characterized by the dark growth visible in the illustration. The center tube contains a small piece of wood. The fungus in this tube has grown somewhat higher and is more luxuriant with dense folds of the cotton-like growth extended toward the wood block. There is little or no evidence of the dark growth typical of the reproduc-

tive phase in this culture, indicating that the mere presence of the wood seems to encourage the damaging vegetative phase as well as actually stimulating the fungus. This is even more evident in the tube at the left which contains a block of wood twice as large as that in the center tube. The fungus seems more stimulated by the sample and there is no indication of the reproductive phase in the dense growth.

Similar tests were made using blocks of wood that had been impregnated with creosote or pentachlorophenol, to discover whether or not the presence of a wood preservative eliminates this growth stimulus. The results showed that the effect persists even with treated wood, but that sufficient concentration of a preservative will prevent any actual attack by the organism.

Just what it is that promotes the vigorous growth is not known, but Suolahti has postulated that some volatiles coming from unsaturated fatty acids in the wood may be responsible. Investigations leading to further information on the factors influencing the physiology of the test fungi are important in interpreting their behavior in rotting wood and may yield some further knowledge on how this biological phenomenon comes about.

The full implications of this unusual encouragement by wood are not clear, but it is hoped that continued research may enable man to find the solution of this — another of nature's puzzles.

Destroyer



Preparing cultures at Murray Hill bioassay laboratory to study Suolahti effect.

Above, L. R. Snoke preparing wood blocks to be suspended in tubes.

Below, Miss P. M. Hazard sterilizes wood blocks while Mr. Snoke prepares malt-agar medium.

Left and right, In inoculation room, Mr. Snoke transplants test fungus from petri dish to test tube.



Switchboards for the Blind

When the switchboard comes alive with a subdued "buzz," the operator's left hand moves swiftly across a horizontal board attached to the left side of the key shelf. On this board are small aluminum buttons, one of which has popped up. Quickly the operator's deft fingers find it, identify it, and a few words and seconds later the call is completed.

So rapidly and efficiently is the call handled that no caller could guess that the operator with whom he talks is blind and her switchboard is a special Braille board—one of approximately 50 such boards in use within the United States. These compact Braille switchboards were developed by Bell Laboratories some years ago in response to special requests from telephone companies and have been manufactured by Western Electric, as needed. The most recent installation took place early this year at a Lighthouse Industries plant in New York City.

Looking very much like any standard PBX, a Braille switchboard can also be operated by a person with sight. Its distinguishing characteristic, of course, is the special cabinet mounted adjacent to and flush with the keyshelf. This cabinet weighs about fifty pounds, measures thirteen by seventeen inches and is about six inches deep. Its aluminum buttons, popping up as calls come in, are identified by Braille characters spelled out with small brass studs.

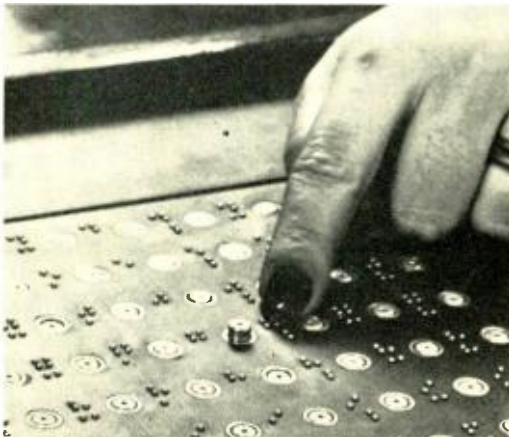

Mounted on the face of the switchboard and hardly noticeable are transparent plastic strips with raised Braille figures on them, too. These enable an operator to find by touch the proper jacks to use in initiating or completing calls. When a call comes in, an operator matches the Braille figure above the popped-up button with the corresponding number on the face of the switchboard, and plugs in. When the call is finished, the board signals with a slightly different sounding "buzz," the disconnect button for the cord circuit used for the call pops up, and the operator goes through the standard disconnecting procedure.



Above— A Braille switchboard was installed recently in a Lighthouse Industries plant in Long Island City and is operated by Mrs. Frank Castrigno, who is partially blind. When a call comes in, one of the 110 aluminum buttons of the Braille board on the left pops up. Mrs. Castrigno finds the button by touch, identifies it with the help of Braille figures, finds similar figures on plastic strips on the face of the upright switchboard, and plugs in the proper trunk or connection.

Left— This Braille board, attached to a standard PBX switchboard, helps sightless telephone operators handle calls efficiently and speedily.



Teletypewriter

Word Counter

W. Y. LANG
Telegraph Development

Traffic measurement and control is equally as important in teletypewriter service as in telephone service. A count of the words transmitted in any interval makes it possible to obtain data for determining improvements in service and also, when desired, to apportion charges to several organizations using the same equipment. A versatile new teletypewriter word counter permits traffic measurements on the subscriber's premises, is small and compact, and is easily installed and read.

In studying the efficiencies of private line teletypewriter circuits, and in considering possible rearrangements for greater efficiency and less peak load delay, it is often desirable to determine the load from hour to hour. Some kind of traffic meter, such as a word counter, that can be applied to any desired circuit at any time is most convenient for securing such data. Recently an electrical word counter suitable for this purpose (Figure 1), was designed by the Laboratories and adapted for manufacture by the Teletype Corporation. It is a small, portable unit, accurate yet relatively inexpensive, that may be used with any usual teletypewriter circuit whether the circuit appears on terminals or a jack. It may be placed on a supervisor's desk or service observing desk remotely located from the teletypewriters, if desirable. Since several counters may be used in a single office,

the units are designed with small feet and have tops equipped with recesses to permit the stacking of one counter on top of another.

Counting the number of words, sent or received, by mechanical or electrical means has been done to some extent in the past, but neither of the two types of mechanisms that have been used are capable of filling the needs completely. One of them is the pen type recorder, which is used at a central test board in the Long Lines Division of the American Telephone and Telegraph Company. The pen in this instrument marks a moving tape, recording whether the circuit is busy or idle. Since the speed of the teletypewriters used on the circuit is known, the operating time may be converted into an equivalent word count, but this is not entirely accurate and requires considerable computation effort.

A mechanical mechanism which may be attached to the mechanism of the 15 or 19 type* page teletypewriter has also been in use. This unit is built into the typing unit of the customer's teletypewriter, and gives a direct reading in words on a mechanical or electrical counter. It can be applied only to a page type teletypewriter. However, page teletypewriters are not always used on circuits on which word counts are desired and this solution is often not economical or desirable, especially where only occasional traffic counts are required.

In telegraph practice experience has shown that a good approximation of a "word" is six characters or five characters and a space. Each of these characters in the teletypewriter code is transmitted by a group of seven pulses: a start pulse, a character group of five pulses, and a stop pulse. In a teletypewriter with the circuit in the idle condition — closed line — the frictionally driven selector cam is held from rotating. When the start pulse, a current off pulse, is received, the cam is released and begins to rotate. The speed of rota-

tion of this cam is such that it completes one revolution by the time the stop pulse is received. At that time a projection on the cam intercepts a stop pawl, preventing further movement. The five pulses of the code group may be either current-on or current-off. They have no effect on the rotation of the cam, but this rotation, in cooperation with the movement of an armature extension, causes the selection or printing of the desired character.

A modification of this selector is used in the new word counter. It operates at one-sixth the speed of the teletypewriter selector. This lower speed permits the use of smaller components and reduces wear of parts. The "selector cam" of the word counter has six stop positions in one revolution; thus one revolution is equivalent to six characters, or one word. A small synchronous motor (Figure 2 and 3) drives the cam through a friction clutch and the cam is coupled to a shaft operating a mechanical counter. One rotation of the cam results in a count of one on the counter, thus giving a direct reading in words at the front of the unit. The counter (Figure 1) may be reset to zero at any time by a single turn

* RECORD, October, 1938, page 530.

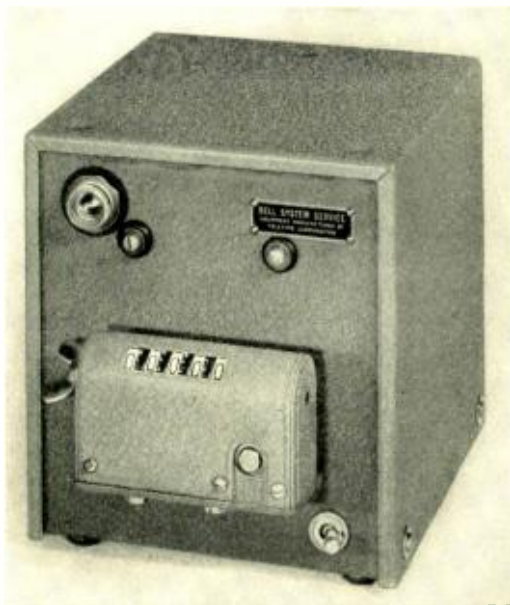

Fig. 1 — The new electrical word counter for measuring teletypewriter traffic may be reset at any time.

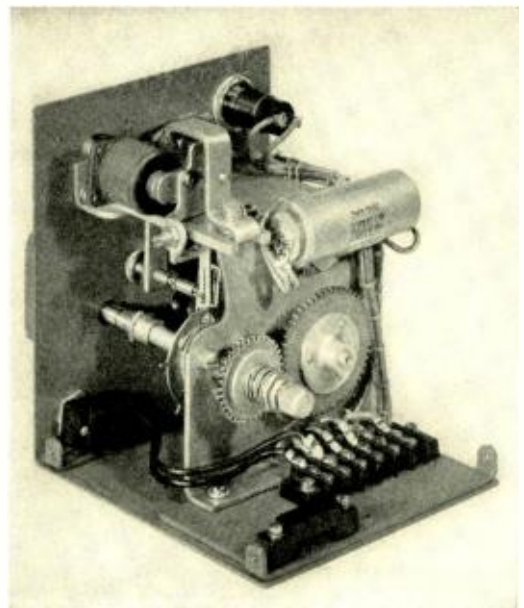

Fig. 2 — The synchronous drive motor drives the right-hand gear from behind the mounting bracket.

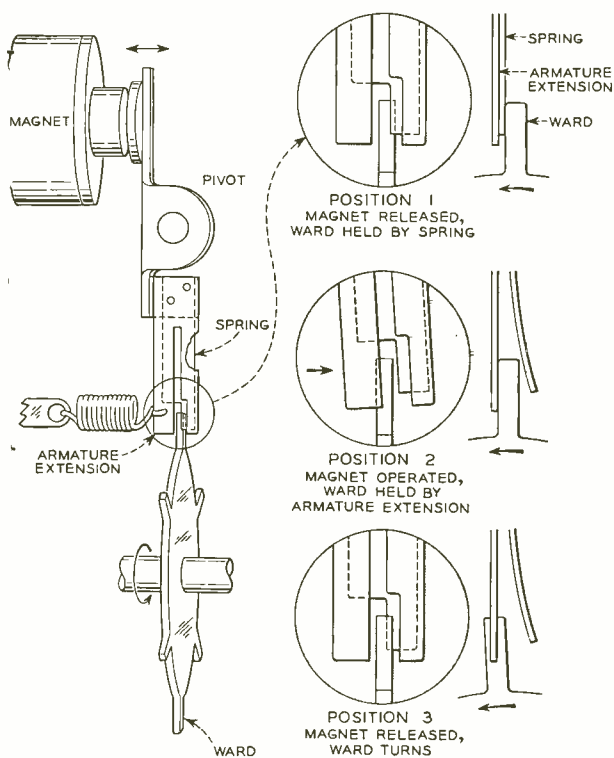

Fig. 3—Simplified diagram illustrating the operation of the control magnet, its armature extension, and the ward.

of the wing nut at the left. A small lamp on the panel indicates when the unit is in operation and is ready for counting.

The six small projections, called *blocking wards*, on the cam, are spaced equally on its periphery. A magnet is connected in series with the line, and when in the operated position, an extension of its arma-

ture blocks the path of the wards. This extension, evident in Figure 2 but shown more clearly at the left of Figure 3, is a rigid, flat piece of metal with a slot down its center barely wide enough for a ward on the cam to pass through. Only when the magnet is released is the extension in such a position that the ward can pass through the slot. A start pulse releases the magnet, the armature extension moves out of the path of the wards, and the cam rotates. By the time the next ward has reached the armature extension, a stop (current-on) pulse has been received and the path is again blocked. Operation of the magnet by the five code-pulses has no effect on the rotation of the cam since the armature extension simply moves back and forth above the circular edge of the cam. The time for the next ward to move into position is synchronized with the teletypewriter speed so as to count one character.

In the event that the circuit should become open for any reason, such a selector mechanism would "run away" and count continuously. The armature extension would move out of the path of the wards and permit free rotation. To prevent this, it is desirable to have a blocking ward to stop the mechanism in both the open and closed circuit conditions. An ingenious mechanism has been designed by the Teletype Corporation to accomplish this. One end of a piece of clock-spring steel is riveted to the upper end of the armature extension so as to partially cover the slot, as shown in Figure 3. The spring is curved away from the rigid extension so that normally

THE AUTHOR: W. Y. LANG is a member of the station engineering group of the Telegraph Development Department. After joining the Laboratories' Design Drafting Department in 1920, he took the course for technical assistants, meanwhile attending City College and, later, Columbia University. He then spent a year with the Specifications Department and a few years with the Precision Apparatus Laboratory. Since 1927 when he became a member of the technical staff, he has been engaged in the design of printing telegraph apparatus, except for the war years when he worked in sonar development and was responsible for the development of indicator and control units as well as keying and training units.



the lower, or free end stands far enough away from the slot to clear the ward when it is stopped by the rigid armature extension.

As the cam rotates under an open-line condition, a ward approaches the extension on the spring side. It strikes the spring and forces it against the rigid armature extension, stopping rotation of the cam. This condition, indicated at the upper right of Figure 3, will be maintained as long as the line is open. When a current-on pulse is received, the armature is attracted, and as the armature extension and spring move out, the ward slips by the offset end of the

the cam upon receipt of a start pulse.

Insofar as the teletypewriter circuit is concerned, the word counter appears as a selector magnet having approximately one-fourth the inductance of the standard pull-type magnet. Because of this low inductance magnet, the unit is applicable only to 0.060-ampere circuits. These, however, may be either sixty or seventy-five word per minute circuits and the shift from one speed to the other is accomplished in the word counter by means of interchangeable gears. On half-duplex circuits the unit counts both transmitted and received signals; on full-duplex circuits, either the sent

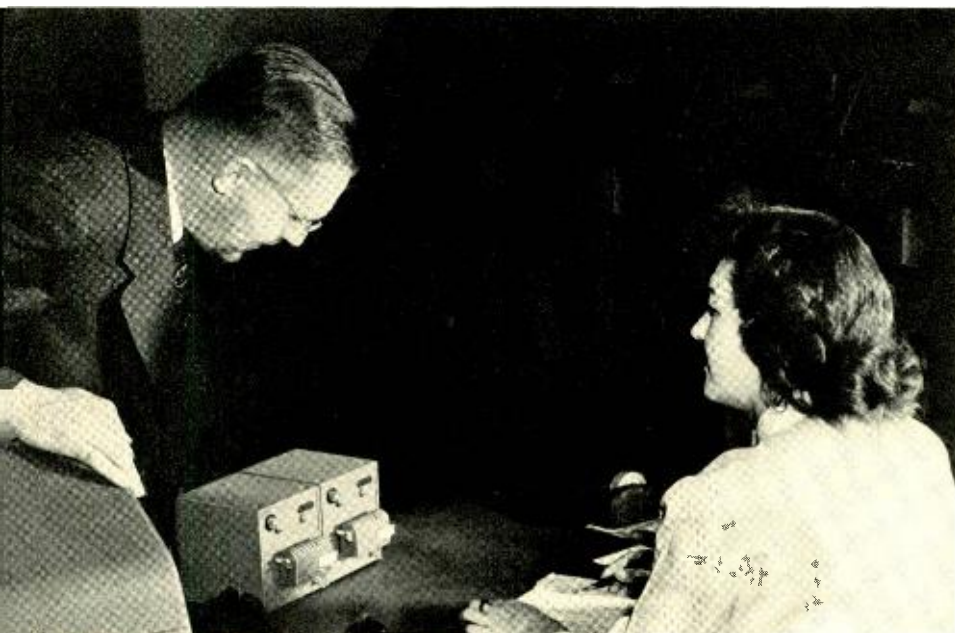
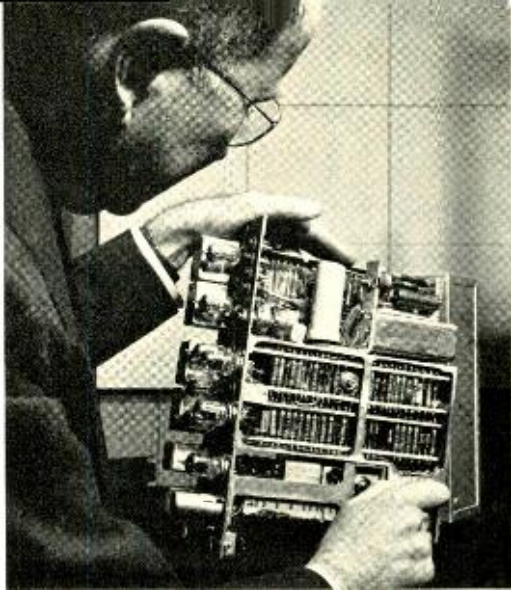

Fig. 4 — Margaret Parker, Teletype operator of the Western Electric Company at 195 Broadway, taking semi-hourly reading of two of the new word counters while W. Y. Lang looks on.

spring but is stopped from further rotation by the extension itself. This condition is shown at the middle right of Figure 3. The spring snaps back to its normal position behind the ward and thus will not interfere with the movement of the armature or

or received signals. Since the unit is a self-contained mechanism, simple and compact, and since it is not necessary to have it closely associated with other teletypewriter apparatus, it is a desirable instrument for traffic studies.



Engineering of communications equipment is constantly directed toward miniaturization in order to conserve space, lighten weight, and reduce cost. Miniaturization, however, poses a problem in how to get rid of the heat generated, without impairing equipment operation, as more and more apparatus is crowded into a small volume. Use of blowers, combined with careful arrangement of components, goes a long way toward effective heat removal. Refrigerative air conditioning, with apparatus components located so as to take full advantage of it, is economically feasible in some instances.

Heat Dissipation from Toll Transmission Equipment

J. A. COY
*Transmission
 Apparatus
 Development*

Recent trends in miniaturization of apparatus, the liberal use of electron tubes, and the concentration of equipment into "cubic units," rather than on flat panels, has brought about a concentration of heat that must be dissipated. Although this situation is typified by type-N carrier terminals, it is by no means limited to this type of equipment. The latest telegraph and toll transmission equipments present a similar problem, and future types will have the same tendency as miniaturization is extended and even smaller components become available. Use of transistors instead of electron tubes will substantially reduce the heat developed per individual circuit, but further reduction in size of the equipment, together with the increase in number of circuits to meet the present demands for toll service and to take care of toll dialing instead of manual operation, will increase markedly the heat to be dissipated in a single office.

Installations of 120 or more type-N carrier terminals in one central office will soon be commonplace. In such an installation, in a room space of perhaps 20 by 30 feet, 42 kw of energy will be released — an

amount equivalent to that resulting from the perfect combustion of 720 gallons of fuel oil, or 7,200 pounds of coal per month; enough to heat two ordinary houses in mid-winter.

Satisfactory disposal of this heat falls naturally into two stages. First, the heat must be removed from the point where it is generated to the atmosphere, or other general cooling medium, without impairing the operation or reducing the life of any component apparatus. Second, the total

Fig. 1 (at top of page) — The author examines a type-N1 carrier channel unit.

Fig. 2 — Front view of N1 carrier channel unit.

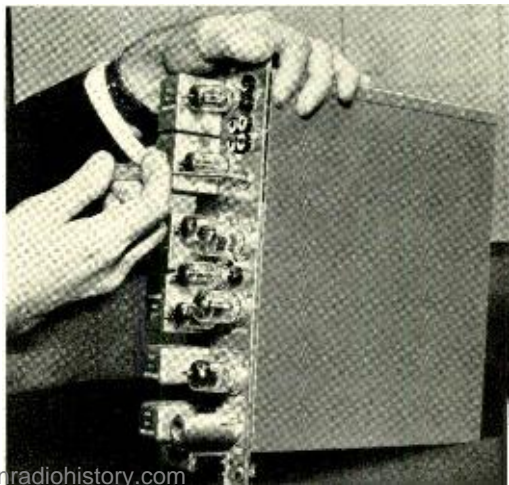

June, 1953

heat generated must be disposed of outside the office without increasing the room temperature to the point where it will adversely affect the operating personnel or the equipment.

Nearly all the heat generated in a type-N carrier terminal originates in the electron tubes, and for this reason, the tubes are mounted on the fronts of the units where the maximum amount of heat is carried away by conduction and radiation, and the

minimum amount reaches the body of the unit. Within this body are mounted the elements that do not produce appreciable heat, including the thermistors and varistors whose operation is most affected by temperature. One of the plug-in units is shown in Figure 1 (side view) and Figure 2 (front view). The coils that are mounted on the face of a unit are placed there for electrical separation from other elements inside the unit.

To reduce the temperature of the units, a small blower is mounted just below the bottom terminal in each relay rack bay of equipment, as illustrated by Figure 3. Air from this blower is conducted through two rectangular ducts up the sides of the bay and discharged in jets just below the areas where the electron tubes are concentrated. One of the jet discharge openings may be seen in Figure 3 on the right-hand duct near the clamp. Velocity of the air jets (2,700 to 4,100 feet per minute) is sufficient to spread the air well across the bay.

The blower delivers about 100 cubic feet of air per minute to the entire bay, five to eight cubic feet per minute through each of the fifteen jets, nine on the left-hand side and six on the right. The temperature rise in the units is thereby reduced to half the amount that would occur with only natural cooling. With this arrangement, good operation of the equipment may be expected with an ambient temperature up to 105 degrees F measured in the center of the aisle in front of the N carrier terminals at a height of 6 feet above the floor. Permanent injury of the equipment is unlikely even if the room temperature should rise as high as 130 degrees F with the blowers operating, or to 100 degrees F with the blowers stopped. This is true even in a large installation with bays back-to-back in each line and facing each other across the aisle. Operation of the blowers on gas engine generator emergency supply is recommended in case of commercial power failure, where such supply is available, but it does not appear necessary to provide an emergency supply especially for the blowers, particularly in the smaller offices. In the latter case, the rate of temperature rise in the room and in the equip-

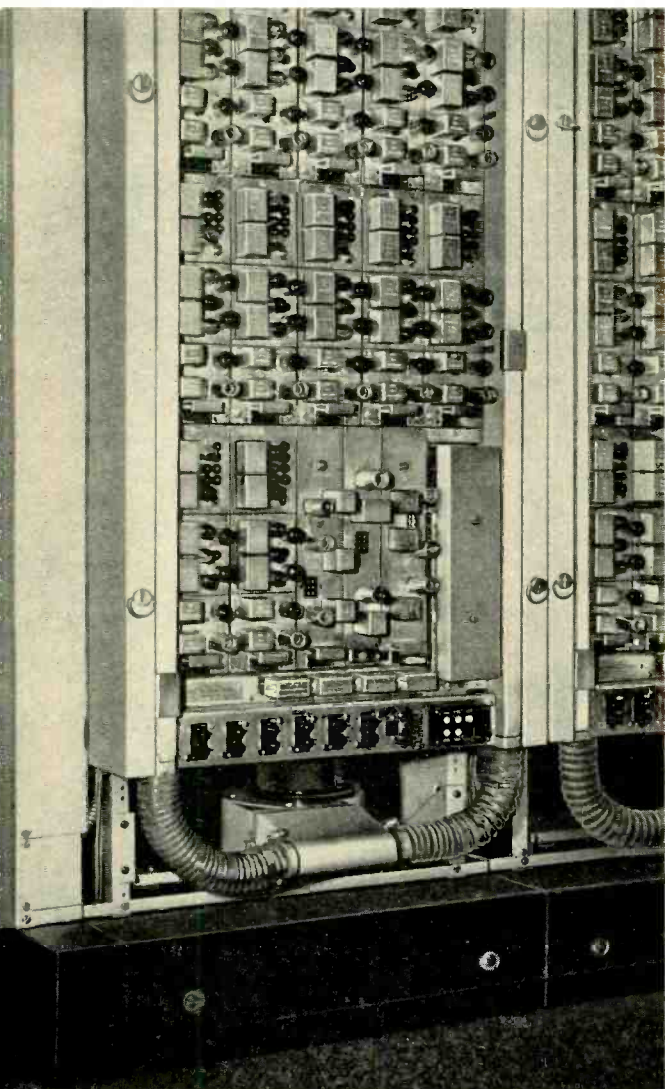

Fig. 3—Each relay rack bay of type-N carrier equipment is provided with a small blower. Air from this blower is conducted through the rectangular ducts at the sides of the bay and discharged near where the electron tubes are concentrated.

ment will be slow enough to cover a considerable period of power failure. After all, long power outages are least likely in hot weather.

On the left side of Figure 4, the heat generated in type-N carrier terminals and in various other types of equipment are compared on the basis of watts per cubic foot of room volume. Room volumes per bay, shown at the top of the chart, have been

board, and 2,600-cycle ringers are all heavy producers of heat, but the older types of equipment produce relatively small amounts per unit space. V3 amplifiers are heavy producers of heat, but these are likely to be associated with voice frequency line and balancing equipment, four-wire terminating equipment, and other auxiliary inert equipment to compose V3 repeaters, which appear well down on the chart.

Fig. 4 — Heat generation and dissipation in Type-N terminal offices.

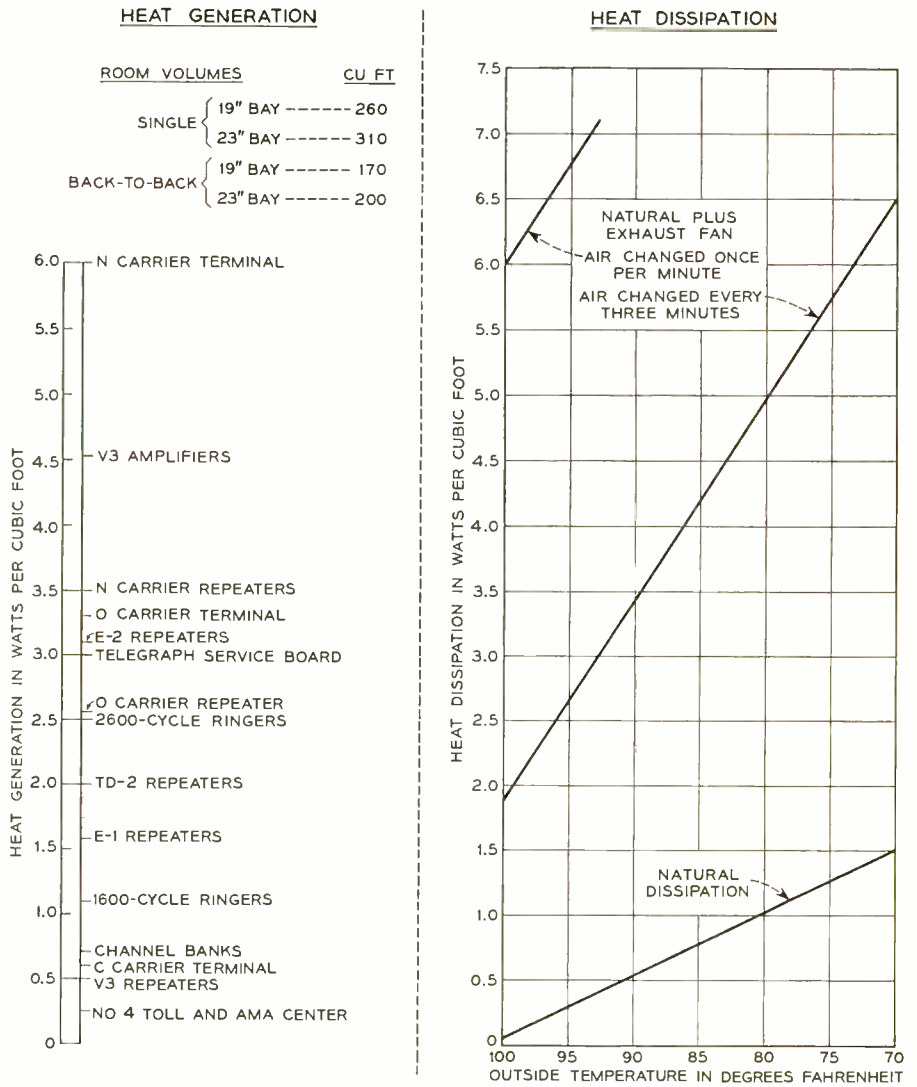

assumed for various types of bay arrangements. They include allowances for lockers, bench or desk for attendants, and aisle spacings. It will be noticed that the more recent developments, such as type-N and type-O carrier, E2 repeaters, telegraph service

By designing transformers and thermistors to withstand a maximum temperature of 155 degrees F, using varistors in circuit arrangements that will operate up to 140-150 degrees, and selecting resistors and capacitors workable to 150 degrees, the use

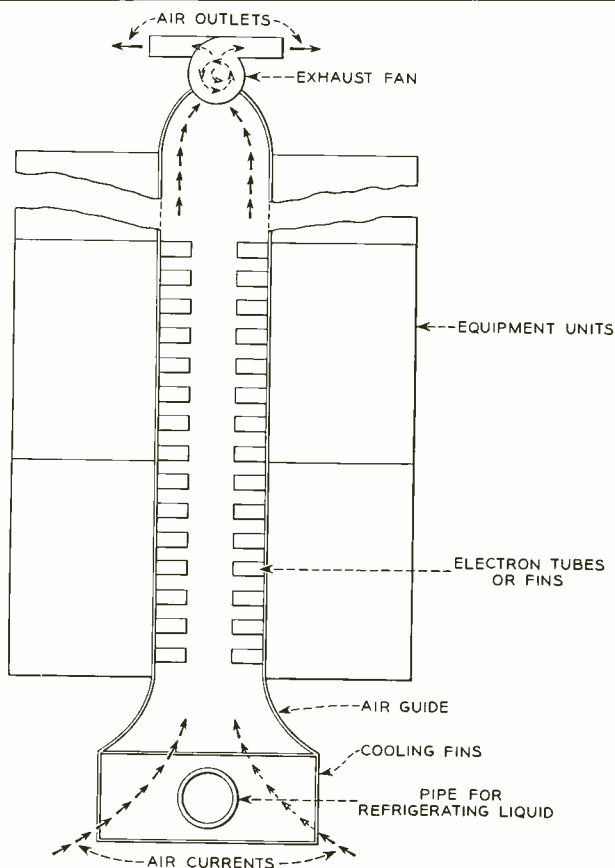

Fig. 5 - A suggested method of heat removal is to mount the heat-producing elements in a duct space between equipment bays and blowing the air around them.

of blowers for hot spot temperature reduction has been avoided in type-N carrier repeaters and type-O carrier terminals and repeaters, except those type-O carrier repeaters that are installed in pole-mounted cabinets. In the latter, fans are provided to keep the filters containing ferrite core inductors below 140 degrees F.

The heat generated in the equipments must eventually be removed from the building. There are three ways of accomplishing this: natural dissipation, circulation of outside air through the room by means of an exhaust fan, and refrigerative cooling.

Obviously, natural heat dissipation becomes ineffective as the outside temperature approaches the maximum temperature to be allowed within the office, particularly

with the windows closed. As indicated by the right-hand chart of Figure 4, it cannot under these circumstances, be depended upon to any considerable extent in summer.

Very effective heat removal can be accomplished by using an exhaust fan to take the hot air out of the room and by providing grills for entering air. A rather conservative assumption of an air flow that will completely replace the air in the room every three minutes, will give a heat dissipation varying from 2 watts per cubic foot with an outside temperature of 100 degrees, to $6\frac{1}{2}$ watts with an outside temperature of 70 degrees (Figure 4). A recent experiment in one of the New York offices indicated that an air flow as high as one change per minute can be tolerated. This, also indicated on Figure 4, will provide a heat dissipation of 6 watts per cubic foot even at 100 degrees outside temperature. These dissipations, of course, are based on the assumed office temperatures of 100 degrees at the floor and 115 degrees at the ceiling. These correspond to the 105 degree F temperature that has been established as tolerable for NI carrier terminals with blowers. Careful engineering is required to introduce and distribute air at these high rates so as to cool the equipment with the least disturbance to personnel. In the example mentioned, an air change of once per minute is not unpleasant on a hot day. As the outside temperature falls, the air volume can be reduced in proportion to the difference between the outside temperature and the maximum allowed in the room, so as to avoid too strong blasts of cold air.

Air changes as rapid as once per minute for a room of any size are inexpensive only if air can be drawn in directly from and exhausted directly to the outside of the building. For runs of any considerable length to the outside atmosphere, the cost of the large ducts that would be required is prohibitive. Under these circumstances, the provision of refrigerative cooling becomes necessary. This type of air conditioning is not, however, considered so formidable as it was even a few years ago.

Refrigerative air conditioning may be provided for either or both of two purposes; first, for personnel comfort in operating

rooms or operators' quarters, and second, for the improvement of equipment operation, primarily in switching and terminal rooms. Both temperature control and humidity control are ordinarily provided in these installations. The air is filtered, cooled and dehumidified to the required degree in a common equipment room from which it is circulated through the space to be conditioned and returned to the cooling unit with the introduction of a small amount of outdoor air for freshening purposes. Installations of this type are generally engineered to provide a fairly uniform distribution of air over the entire space to be conditioned. The balance is seriously upset when a large concentration of heat is introduced in a small part of the space. Consequently, it is generally preferable to partition off high heat producing equipment from the remainder of the office or locate it in a room by itself. If office air conditioning is available, this can be drawn upon for part of the cooling required and supplemented as may be needed by packaged type unit air conditioners within the partitioned space. If no office air conditioning is available, packaged type air conditioners can be used for the full duty and located in the room with the heat producing equipment. The unit conditioners can be operated with only thermostatic control for toll transmission equipment since humidity control is not particularly important.

If it is assumed that just enough refrigerating capacity is provided to care for the heat generated in the equipment, then the refrigerative capacity for 120 terminals, for

example, in a location where the heat conditions are as represented in Figure 4, will be approximately 12 tons. One ton of refrigerating capacity is defined as the loss of heat required to freeze one ton of water at 32 degrees F per 24 hours. This is equivalent to 12,000 B.T.U. per hour. The cost of such refrigerating equipment is not prohibitive. It will probably amount to a little more than the cost of building space for the same equipment. In other terms, it will be, for type-N carrier terminals, about 2 to 3 per cent of the cost of the equipment itself.

Another method of heat removal that has been suggested is, in effect, to turn a pair of back-to-back equipment bays "inside out," so that the electron tubes, instead of being in the aisle, project into a duct space between the two bays. Such an arrangement is shown in Figure 5. It is here assumed that the equipment units, which might be of the same general form as type-N or type-O carrier units or some of the telegraph units, are mounted on two sets of bay uprights, more or less like the present standard cable duct type, with the heat producing elements in the space formed by placing the two bays together. This space is completely enclosed; air is introduced at the bottom and exhausted at the top. There is provided through the base of the pairs of bays a finned pipe through which a refrigerant flows, or preferably through which a cold liquid from a refrigerating machine is circulated. The cooling pipe should have a temperature above freezing so that frost will not form. There will, of course, be condensation of moisture from the air so that a

THE AUTHOR: J. A. Coy is in charge of the development of N and O carrier repeaters in Transmission Systems Development I. Mr. Coy received an E.E. degree from Syracuse University in 1915. From 1916 to 1928 he worked in Long Lines' Plant and Engineering Department, maintaining toll transmission and telegraph plant. In 1928 he became a member of the Equipment Development Department of the Laboratories. He has been associated with the development of equipment for toll transmission systems including voice-frequency cable and open-wire carrier, coaxial carrier, and overseas and mobile radio systems for Bell System use as well as voice-frequency, open-wire carrier and spiral-four cable carrier systems for the armed forces.



drip pan and drain are needed. It does not appear necessary to dry the air since the equipment is so much warmer than the saturated air that it will not be damaged by it. A fan exhausts the air at the top from the enclosed space. Inlet openings at the bottom of the bays admit room air to flow over the cooling unit. As an alternative, to save refrigeration, it may be preferable to feed the exhaust air back into the base of the bay, that is, recirculate it.

The practicability of such an arrangement may be investigated by looking at the type-N1 carrier terminal bays. In a pair of these bays 2,100 watts or 7,200 B.T.U. per hour will be generated. If it be assumed that the temperature of the cold pipe is 42 degrees F, and the air exhausted at the top of the bay is 90 degrees, there will be a temperature difference of 48 degrees to divide between (a) a cold pipe to cooled air differential, and (b) the air temperature gradient of the bay. By using a simple exhaust fan, for example, a duplex unit with two 3-inch Torrington wheels, driven by a 1/8 hp motor, an air flow of 200 cubic feet per minute can be obtained. Calculations indicate that this air flow past the cooling unit and past the equipment area will give about the air temperature differentials assumed, and that the maximum temperature rise in any piece of apparatus will be kept down to a satisfactory limit.

An alternative to circulating refrigerant through the base of the bays, would be to bring in cooled air from a refrigerating machine placed, for example, at the end of a line of bays. This appears practicable at

least for moderate heat dissipations; perhaps a total of 10 kilowatts in a line of bays, requiring about 3 tons refrigerating capacity. A cold air duct would distribute the air from the machine through the base of the bays; a return duct would bring the hot air back from the top of the bays.

The amount of refrigeration required by either of these methods would be about the same as that previously described for conventional equipment arrangements, provided it is assumed that the refrigeration simply removes the amount of heat generated in the equipment. Neither method should be objectionable as regards the comfort of attendants.

Various other methods of arranging equipment have been suggested, but these seem typical of any that would adequately remove large quantities of heat. Although the arrangement of inside-out bays appears practicable, it will be realized that there are formidable difficulties in the development and "sale" not only of radically new equipment unit designs but also of new frameworks, methods of cabling, office layouts, and other factors that will become apparent as such a development proceeds. In this preliminary view, at least, the inside-out arrangement shows no great advantage over a conventional arrangement with the equipment segregated in a room that can be air conditioned.

Heat generated by toll transmission equipment can be disposed of with no serious penalty if adequate attention is given to the problem both by the equipment designer and by the office planner.

40 Million Telephones

In a letter to share owners accompanying the earnings statement for the first quarter of 1953, Cleo F. Craig, President of A T & T, announced that the Bell System is now serving nearly 40 million telephones, an increase of 540,000 during the first three months of 1953.

"It is startling to realize that half of all these telephones have been added since the end of 1942," Mr. Craig said. "To put it another way—the Bell System gained its first 20 million telephones over a period of

more than 66 years, beginning in 1876; the second 20 million have been added in just a little over 10 years, and all but two million of these have been placed in service during the postwar period."

Despite this phenomenal growth in service, there is no indication of a let-up as yet, he said. In fact, demand in the first quarter of 1953 was greater than in the corresponding period of 1952. The volume of local and long distance conversations has also continued to rise, Mr. Craig stated.

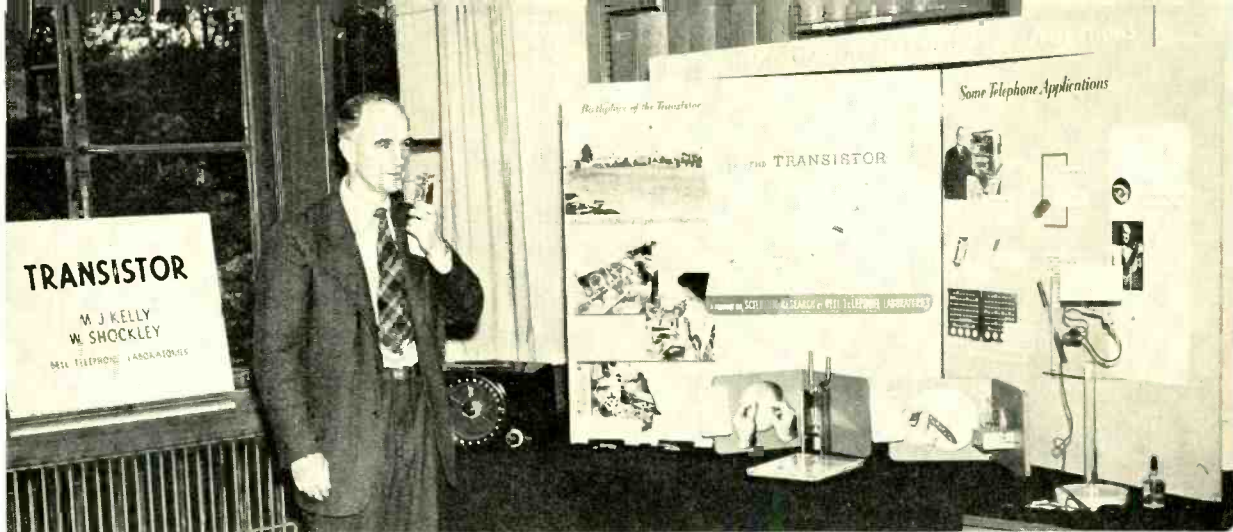

William Shockley is shown demonstrating a miniature transistorized radio transmitter, complete with batteries, that may be held in the hand. One of these transmitters was successfully used on Constitution Avenue while the received voice was heard inside the building.

At the National Academy of Sciences

At their annual meeting in Washington, D. C., on April 27, the National Academy of Sciences presented a group of scientific exhibits provided by educational and industrial institutions. One of the popular exhibits was that of the Laboratories on transistors and their uses, together with a maze solver developed here. Following the presentation of Academy medals, members and their guests viewed the exhibits. This, the first attempt of the Academy to display scientific exhibits, was termed a definite success and such displays are expected to

Claude Shannon demonstrates his maze solver, a wooden "mouse" doing the solving and remembering the solution.



become an important part of the annual meeting. O. E. Buckley, a member of the Board of Directors of the Laboratories and former president, and H. E. Ives, one of the Laboratories pioneers in television, were interested onlookers.

Two exhibits were presented by the Laboratories. One of these consisted of working demonstrations of miniature transistorized radios, transistor oscillators, and a display of recent transistor devices used in the Bell System. This display was sponsored by M. J. Kelly, President of the Laboratories, and William Shockley, both members of the Academy. The displays were constructed under the direction of H. J. Kostkos of the Publication Department.

The second Laboratories exhibit was a maze solver, presented by its designer, Claude Shannon, and also under the sponsorship of Dr. Kelly. The maze consists of sectional metal walls which may be readily changed to create different paths. Actually, the working parts and the "memory" of the maze are contained in the box on which the maze is built. Ninety relays of the type used in dial telephone service control the maze solver. A wooden "mouse" containing a bar magnet solves the maze, determines the correct path, and remembers his solution. On a second trial the "mouse" goes directly to the "piece of cheese" (a metal post) without entering any wrong corridors.



A "reporter's-eye" view of the annual meeting. The TV camera was used to present theater-size TV views of the proceedings over a closed circuit.

Mr. Craig Addresses Share Owners

At the annual meeting of AT&T on April 15, Cleo F. Craig, President of the company, gave some 1,200 share owners in attendance a brief look into the future of the telephone business.

"The Directors are trustees for the savings of the owners. It is their responsibility that the company shall prosper," Mr. Craig said "They are sure the only way to prosper is to provide the best possible telephone service. Such service is necessary to the people of the United States, and to the nation's security. Our responsibility for providing it constitutes a public trust."

He pointed out that "we know the country's strength is in its industry — its productive power — and that industry would be crippled without the telephone. We know also that the armed forces must have the best possible telephone service and a great deal of it . . . and some very important weapons needed for defense depend largely on telephone research.

"Today several thousand people at Bell Telephone Laboratories are working on research and development projects ordered by the Army, Navy, and Air Force which will total about \$45 million a year." He said further that "this work divides into

two parts. One is the development and production of improved military communication. The other includes what I shall call electronic weapon systems.

"The people of Bell Laboratories did not create systems of this kind in order that they might thereby be able to aim weapons, or guide the flight of missiles of war. Their purpose was to provide better telephone service. Nevertheless, the ability to de-

Share-owners in two adjoining rooms saw the proceedings on one of these theater-size screens, presented by closed circuit TV. Viewers could also direct questions to the chair or present proposals to the meeting, even though in another room.



fend ourselves against aggression has come to depend more and more on the application of communication techniques. We believe therefore that part of our duty, as we improve those techniques, is to apply them in whatever ways will best serve the nation's defense.

“The second thought that I wanted to discuss,” Mr. Craig continued, “is the idea that we must act for the long run. This is true with respect to financing, earnings, operations, research, the building of our human organization—everything we do and everything we are.”

He pointed out that the present nationwide television network of coaxial cables and microwave radio relay is the result of development started many years ago. Mr. Craig emphasized the fact that research and development at the Laboratories today will make itself felt in the

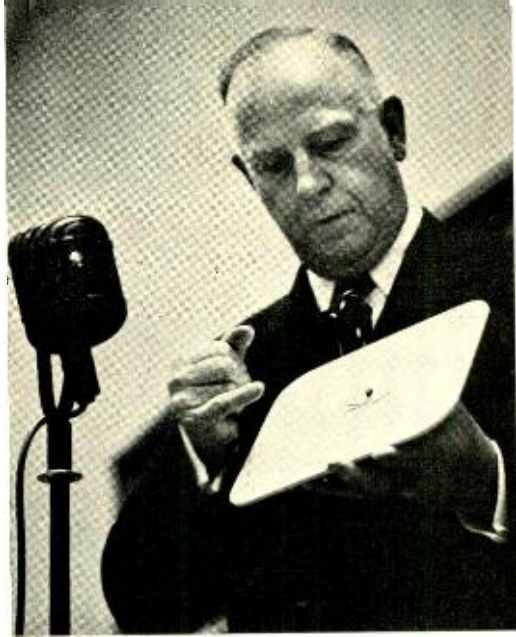

A diminutive transistor is shown to the meeting by Mr. Craig, with the prediction that it will have many important telephone uses.



Mr. Craig is seen talking with one of the shareholders after the meeting.

future. He showed the assembled stockholders several examples of present development which will affect future telephone service. Among these was a transistor, and Mr. Craig explained that transistor development has made possible small experimental amplifiers for coaxial cables. A laboratory model of a miniature coaxial cable with a tiny transistor amplifier built right into the cable, was shown. Another

device, a thin barium titanate crystal less than a quarter of an inch square was shown as an experimental information storage device that could replace one hundred relays and do the job faster.

“I hope none of you gains the impression,” Mr. Craig said, “that all our research and development work points many years ahead. It doesn’t. We have new things in almost every stage of development—from the just begun to the nearly done. But to keep in that situation, we always have to be working on some ideas that may take years to mature.

“New devices and methods are themselves but one result of the work of Bell System people, and they represent only one aspect of the effort of telephone men and women to provide the best possible service.” Mr. Craig concluded, “We are convinced that not alone in research, but in all our undertakings, the policy of acting for the long run will best serve the advantage of everyone who has a stake in this business.”

The meeting was held in the assembly room at 195 Broadway. A closed-circuit television broadcast of the proceedings in the assembly room was shown on theater-sized screens in two other rooms to accommodate the overflow gathering.

Dr. Kelly Heads Committee

M. J. Kelly, President of the Laboratories, has been named chairman of a committee of scientists, formed at the request of Secretary of Commerce Sinclair Weeks, to evaluate the present functions and operations of the National Bureau of Standards in relation to the present national needs. The committee will operate under the National Academy of Sciences.

The following professional societies were also asked to nominate representatives to serve on the committee with Dr. Kelly: the Institute of Radio Engineers, American Institute of Electrical Engineers, American Society of Mechanical Engineers, American Chemical Society, American Institute of Physics, American Mathematical Society, and American Institute of Mining and Metallurgical Engineers.

Field Engineers Confer

Members of the Field Engineering Force, Quality Assurance Department, gathered in New York during the week of April 20 to renew personal contacts, discuss various phases of the Field Engineering job, and be briefed on some of the current Laboratories developments and activities. In the early part of the week instructive talks were given concerning the work of several of the Laboratories departments — the Personnel Department (F. D. Leamer), Publications (R. K. Honaman), Patent (H. A. Blake), and Outside Plant (R. J. Nossaman). Also, W. Keister gave a brief exposition on the philosophy of switching circuits; J. B. Newsom and E. Jacobitti described the function and operation of the card translator; and W. H. Martin discussed the Laboratories position, and recent developments, in the matter of special devices for use at subscriber stations.

One of the high spots of the conference was a dinner on Tuesday night at the Harvard Club, attended by administrative members of the Laboratories, with H. I. Romnes and W. H. Nunn of the A T & T and J. N. Cost and Clifford W. Smith of Western Electric, as guests. Dr. Kelly spoke briefly of the unique position of the Field Engineers in affording an opportunity for en-

hancing and maintaining good inter-Company relations, particularly at the working levels in the Operating Companies.

On Wednesday, the group went to Allentown, where V. L. Ronci and S. O. Ekstrand had arranged a comprehensive tour of the Allentown plant, and a series of talks and discussions on vacuum tubes and allied subjects. Back in New York, the rest of the week was given over to discussion of such matters as customer dialing and toll diversion (A. M. Elliott), detached contact schematics (F. T. Meyer), current drain studies (E. A. Looney), and storage batteries (U. B. Thomas and R. D. deKay).

On Friday, in addition to a round-table discussion of Field Engineering with M. H. Cook, the closing day of the conference was featured by an informal talk by Dr. Kelly emphasizing the fact that the Laboratories effort on Bell System developments is being maintained at a normal level, with the considerable military load being handled in addition to the Bell System work.

Visits to Operating Companies

A team representing the Operations and Engineering Department of A T & T and the Laboratories has visited several of the operating companies since December, to better assess the priority assignments of Laboratories projects. One- and two-day conferences were held at the offices of the operating companies by the team of five or six men. These gave the representatives a chance to outline the status of development projects and to obtain the operating companies' ideas at first hand. Other conferences are anticipated in the future.

Joint heads of the project are A. B. Clark, Vice President of the Laboratories, and W. H. Nunn, Assistant Chief Engineer in the O & E Department. Accompanying Mr. Clark and Mr. Nunn on one or more of these meetings were G. W. Gilman, F. J. Singer, M. L. Almquist, P. W. Blye, R. J. Nossaman, A. F. Bennett, F. F. Farnsworth, and G. H. Baker. From the O & E Department were L. E. Kittredge, H. R. Huntley, C. E. Schooley, R. F. Davis, E. L. King, F. A. Parsons, Z. T. Crouch, G. A. Hemingway, M. C. Fruehauf, and R. J. Brady.

Fifth Anniversary of Network TV

Just five years ago May 1, the Bell Telephone System opened for commercial use 916 miles of television channels to provide network service to 12 stations in five cities.

A recent survey by the Long Lines Department of the American Telephone and Telegraph Company shows that these facilities have now been extended to some 34,000 channel miles, enabling more than 130 stations in 87 cities to receive "live" network television programs. And, according to plans, another 13,000 channel miles will be added by the end of the year.

The survey shows there are now about 170 TV stations on the air, broadcasting to an estimated potential audience of 95,000,000. These stations — 62 of which have been constructed since July of 1952 — are located in some 120 cities. To meet the anticipated increased requirements of broadcasters, Bell System people are engaged in an extensive and progressive program designed to expand network facilities.

The telephone companies' statistics showed that while only Boston, New York, Philadelphia, Washington, and Baltimore were linked for network service in May of 1948, facilities were extended more than 2,500 channel miles by the end of that year to transmit network programs to thirty stations in thirteen cities. Over each of the next four years, an average of 7,000 channel miles were added to Bell System TV facilities. Construction this year, according to present plans, will almost double that of any previous year.

These facilities, however, are not only used to bring television to the home, the announcement pointed out. They are also used to provide theaters and other locations with telecasts of entertainment, civic, business and educational events. Since 1948, theaters have been linked for TV service on 117 occasions.

The transmission facilities used to carry network programs from city to city are of two types — coaxial cable and radio-relay.

A coaxial cable, which is about the size of a man's wrist, contains from two to eight coaxial tubes plus a number of wire conduc-

tors. With most of the present L-1 equipment, each pair of coaxial tubes is capable of carrying 600 telephone conversations or one television program in each direction. The L-3 system recently developed will enable each pair of coaxials to carry 600 telephone conversations and one television program in each direction, or as many as 1,800 telephone conversations.

In the radio-relay method of transmission, microwave signals are beamed across the country from tower to tower. Distances between towers average about thirty miles, depending upon topography. When fully developed, a relay system has a capacity of twelve channels, six in each direction. Each channel can carry one TV program or two channels can handle as many as 600 telephone conversations simultaneously.

These were the major milestones in the rapid growth of network television since May 1, 1948:

The national political conventions were telecast to eighteen stations in nine eastern cities in July, 1948.

A section of TV facilities was opened in the midwest in September, 1948, serving seven major cities from Buffalo to St. Louis.

The east and midwest networks were linked in January, 1949.

Coast-to-coast television was inaugurated in September, 1951, with the opening of a radio-relay system that carried telecasts of the Japanese Peace Treaty Conference.

Telecast of political conventions in July of 1952 to 107 stations in 65 cities.

In September, 1952, fifty theaters in thirty cities were linked on a closed circuit for the Walcott-Marciano heavyweight fight.

First coast-to-coast telecast of election return programs, November, 1952.

January, 1953, another first — coast-to-coast telecast of the Presidential Inaugural ceremonies. An estimated potential audience of 75,000,000 witnessed this event.

Also in January, 1953, Bell System network facilities were extended to Toronto, Canada, establishing the first regular video link between the two countries.

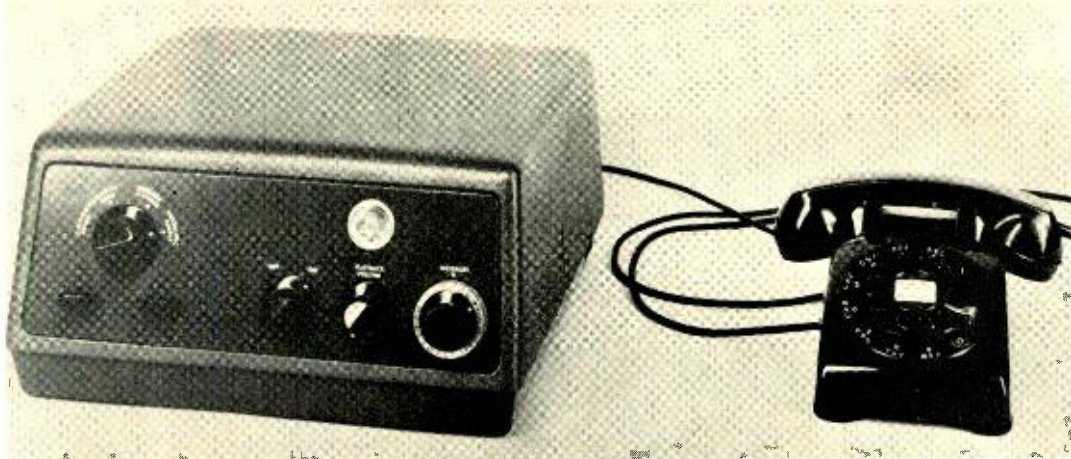

Robot Secretary

An automatic telephone answering device—a sort of “robot secretary”—which can take incoming calls and give a caller a message, has been developed by Bell Telephone Laboratories. Known as the “1A Telephone Answering Set,” the device, it is believed, will provide a useful service to professional people, one-man offices and shops, and similar businesses.

When connected to a telephone, the user can record a message up to thirty seconds in length, which he may check, erase, or change as desired. He uses the telephone to make his recording. Before he leaves his office or place of business, he switches the telephone to the automatic machine, which takes over in his absence.

In response to an incoming ring, the machine answers with the pre-recorded message after which it switches to a recording condition. Tone signals tell the caller when he can proceed with his message. After twenty-five seconds, tones are transmitted to indicate that the recording period is almost at an end. About three seconds later, the machine releases the line and resets for the next call. Maximum time for an incoming recording is twenty-eight seconds. The recording mechanism has a capacity of twenty received messages.

All recording and reproducing is done by means of magnetic neoprene drums. Playback of the messages is through the telephone receiver.

Talks by Members of the Laboratories

During the month of April, a number of Laboratories people gave talks before professional and educational groups. Following is a list of the speakers, titles, and place of presentation.

Anderson, O. L., Diffusion in Silica Glasses, Ceramic Society Annual Meeting, New York.

Becker, J. A., Chemisorption of Oxygen on Tungsten as Observed in the Field Emission Electron Microscope, Catalysis Club and Institute of Metals, Chicago, Illinois.

Becker, J. A., The Life History of Adsorbed Molecules, Atoms and Ions on Metal Surfaces, Gulf Research and Development Co., Harnarville, Pa.

Bomberger, D. C., Basic Operations of DC Computers, A.I.E.E. Lecture, International Business Machines, New York City.

Campbell, W. E., Solid Lubricants, American Society of Lubrication Engineers, Boston. Requirements for a Specification on Solid Lubricants, Air Force, Navy, and Industry Conference on Lubricants, Wright Field, Dayton, O., and Analysis of

Films on Metal Surfaces by Electrolytic Reduction, Graduate Seminar, M.I.T., Cambridge.

Chapanis, A., Reconstruction of Abbreviated Printed Messages, Annual Meeting, Eastern Psychological Association, New York City.

Christopher, A. J., see D. A. McLean.

Dacey, G. C., The Field Effect Transistor, Physics Club, Yale University, New Haven.

Darnell, P. S., Transistors and Miniaturization of Electronic Equipment, Convention of the Petroleum Industry Electric Association, Houston, Texas.

Dodge, H. F., Sampling Inspection, American Society for Quality Control, Bethlehem Section, Allentown, Pa.

Doherty, W. H., Research in Broadband Transmission, Student A.I.E.E. Section, Catholic University of America, Washington, D. C.

Evans, H. W., TD-2 Radio Relay Systems, A.I.E.E. - I.R.E. Student Branches, Rensselaer Polytechnic Institute, Troy, N. Y.

Fleckenstein, W. O., Switching Circuits for Automatic Control, Electrical Engineering Department, Seminar Iowa State College, Ames, Iowa.

Cause, G. R., Some Basic Principles of Sampling as Developed by the Laboratories, American Society for Quality Control, Hempstead, Long Island.

Getz, E. L., Magnetic Drum Digital Data Storage Systems, A.I.E.E. Communication Division, New York, N. Y.

Greenidge, R. M. C., The Case of Reliability Versus Defective Components, Electronics Component Symposium, Pasadena, Calif.

Guldner, W. G., Chemistry and Chemical Engineering as a Vocation, Bernardsville High School.

Haynes, J. R., see C. S. Smith.

Herbert, N. J., Transistors, I.R.E. Subcommittee, Lehigh University, Allentown, Pa.

Hornbeck, J. A., Photoconductivity and the Trapping of Minority Carriers in Silicon, Physics Colloquium, M.I.T., Cambridge.

Janssen, W. F., Precision Ceramics, Symposium on Ceramics and Ceramic to Metal Seals, Rutgers University, New Brunswick, N. J.

Karlin, J. E., Some Experimental Observations on the Relation of Subjective Height Scales to Certain Real Life Situations, Eastern Psychological Association, Boston, Mass.

Kircher, R. J., Transistor Properties and Applications, Physics Club of New York.

Legg, V. E., Magnetic Materials and Their Applications, American Society for Metals, Schenectady.

McLean, D. A., and A. J. Christopher, Stabilized Paper Dielectric Capacitors, Electronic Components Symposium, Pasadena, Calif.

Moose, L. F., Aspects of Microwave Radio Relay, Springfield Township Lions Club, Springtown, Pa.

Murphy, O. J., Magnetic Drum Digital Data Storage Systems, A.I.E.E., New York City.

Pfann, W. G., Application of Zone-Melting Techniques to the Preparation of Rare Metals, Electrochemical Society, Semi-Conductor Symposium of the Rare Metals Group, New York, N. Y.

Reiss, H., Chemical Effects Due to the Ionization of Impurities in Semi-Conductors, Physics

Colloquium, Brookhaven National Laboratory, Brookhaven, Long Island, N. Y.

Robbins, R. L., Measurements of Path Loss Between Miami and Key West at 3675 Megacycles, I.R.E. Professional Group on Antennas and Propagation, Washington, D. C.

Ross, I. M., The Field Effect Transistor, M.I.T., Cambridge.

Ryder, R. M., and W. R. Sittner, Reliability of Transistors, Electronic Components Symposium, Pasadena, Calif.

Schimpf, L. G., Transistor Applications, University of the State of New York, Brooklyn, N. Y.

Sears, R. W., Secondary Electron Emission in Storage Tubes, Research and Development Board, Washington, D. C.

Seckler, H. N., Digital Systems for Automatic Control, A.S.M.E., Junior Members, New York City, and Electrical Logic and Memory, Physics Club of New York.

Shockley, W., Transistor Physics and Chemistry, Electrochemical Society, Richards Memorial Lecture, New York, N. Y.

Sittner, W. R., see R. M. Ryder.

Smith, C. S., and J. R. Haynes, Piezo-Resistance Effect in Germanium, American Physical Society, Washington, D. C.

Sparks, Morgan, Basic Principles of Transistor Electronics, A.I.E.E., New England Section, Boston.

Straube, H. M., see R. L. Taylor.

Struthers, J. D., Trace Element Analysis, Course on Radioisotope Technique in Industry, Oak Ridge Institute, Oak Ridge, Tenn.

Taylor, R. L., D. R. Turner, and H. M. Straube, A Demonstration of The Lillie Iron Wire Nerve Conduction Model, Electrochemical Society Symposium on Application of Electrochemistry to Biology and Medicine, New York City.

Terry, M. E., Discussion of Papers on the Session on Statistics in the Physical Sciences, Meeting of the Institute of Mathematical Statistics and Biometric Society, Washington, D. C.

Turner, D. R., see R. L. Taylor.

Wallace, R. L., Transistors, Instrument Society of America, Charleston, W. Va.

Wallace, R. L., Transistors as Circuit Elements, A.I.F.E.E., Boston.

Wannier G. H., The Threshold Law for Ionization by Electrons, Johns Hopkins University Colloquium, Baltimore, Md.

Recorded Stock Quotations

A new automatic announcing system using recorded announcements was recently installed in the New York Stock Exchange. This new system permits members to receive the latest bids and prices on 204 stocks by dialing a three-digit code over a private line to the Exchange.

Several years ago, at the request of the New York Stock Exchange, a Bell System Committee was formed to study the operation of the Exchange and to recommend improvements in its communication system. The new announcing system is the result of a joint development by engineers of the Laboratories and of the New York Telephone Company.

Thirty-four record-reproduce machines, each handling six channels, provide for the 204 stocks. These machines are magnetic recording devices using a special magnetic rubber as the recording medium. Each of the eighteen trading posts on the Exchange floor is connected with the recording sys-

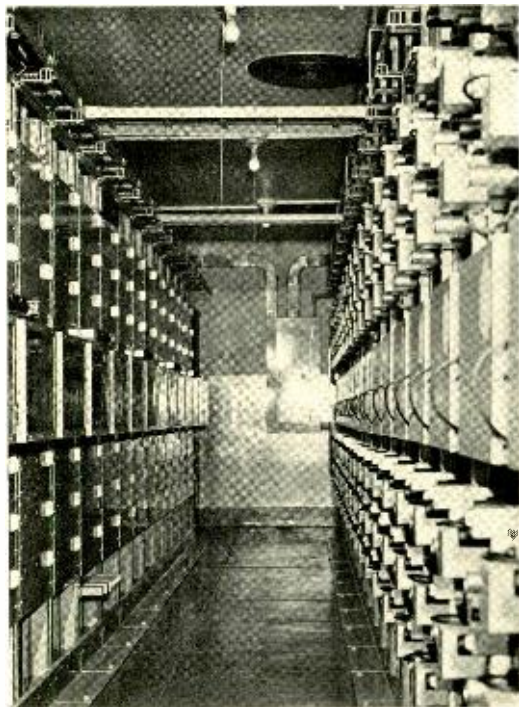

A view of the bays containing the thirty-four record-reproduce machines, amplifiers, and associated equipment required by the system.

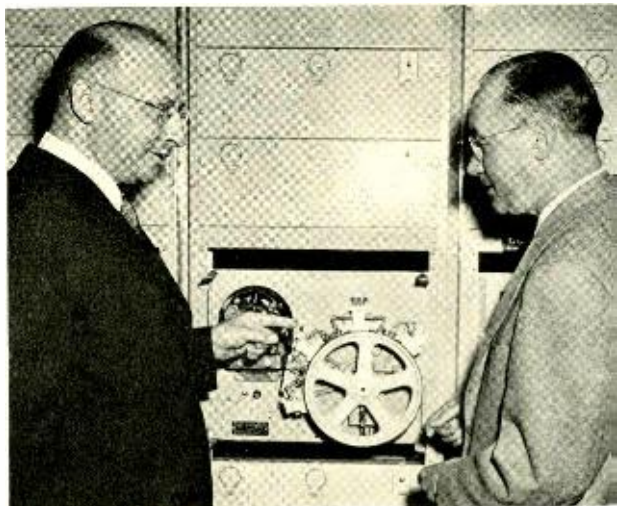

Edward De Laura, communications director of the New York Stock Exchange, points to one of the magnetic recording machines. Interested onlooker is William H. De Knecht, senior service engineer of the New York Telephone Company.

tem by special key-turrets. Quotation clerks make the recordings directly. Each new quotation automatically wipes out any previous quotation on that particular stock; a chief operator's turret permits supervisors to monitor the recordings and make corrections if necessary.

About forty per cent of all requests for quotations will be handled by the machines covering only 204 stocks. Over 1,300 less active stocks will still be handled by the system used by the Exchange for twenty years. In this older system, quotation clerks give the information to a group of teleregister operators who in turn set it up on a teleregister bulletin board in each of eighty-five turrets. Brokers requesting information call one of these turrets and the operator gives him the latest price shown on the teleregister board.

The magnetic recording machines have been used previously in the Bell System to give recorded announcements of delays on overloaded toll lines, and have been adapted to the new stock announcing system. Engineers at the Laboratories concerned with development of the system include, among others, C. R. Keith, F. Dermond, W. J. Brown, H. W. Augustadt, H. H. Abbott, P. V. Welch, P. L. Wright, and F. W. Treptow.

Deal-Holmdel Colloquium

A meeting on May 1 concluded the Deal-Holmdel Colloquium for the season. Speaker was K. Bullington, who discussed "Overreach Propagation." After the meeting a dinner and social evening were held at the Willowbrook Restaurant's Rathskeller in Fair Haven.

American Physical Society

Several Bell Telephone Laboratories men made important contributions to the Washington Meeting of the American Physical Society, in Washington, April 30 through May 2. Conyers Herring of the Physical Research Department presided over the session for Invited Papers in Solid-State Physics. At the North Carolina Meeting at Chapel Hill in March, Mr. Herring was

elected a member of the executive committee of the Division of Solid-State Physics. Charles S. Smith presided at the session on Semiconductors, and was co-author with J. R. Haynes of a paper on *Piezoresistance Effect in Germanium*. F. L. Vogel gave an Invited Paper on *Dislocations in Low Angle Crystal Boundaries* at the session over which Mr. Herring presided. J. B. Johnson, formerly of the Laboratories, presided at the session on Electron Physics.

Transistor Short Course

W. H. Brattain, co-inventor of the point-contact transistor, will teach a short course on *Transistors and Semi-Conductors* at the University of Minnesota this summer. The course is one of several to be included in the University's Institute for College Teachers of Physics.

Patents Issued to Members of Bell Telephone Laboratories During March

- Anderson, F. B. — *Variable Frequency Oscillator* — 2,633,534.
- Beck, A. C. and Friis, H. T. — *Wave Guide Joint* — 2,630,489.
- Becker, J. A. and Christensen, H. — *High-Temperature Coefficient Resistor and Method of Making It* — 2,633,521.
- Boothby, O. L. and Wemy D. H., Jr. — *Method of Producing Soft Magnetic Materials* — 2,631,118.
- Bostwick, L. G. — *Tuned Vibrating Reed Selective Circuit* — 2,630,482.
- Brown, H. B. — *Control for Stepping Mechanism* — 2,630,465.
- Buch, P. E. — *Relay* — 2,630,506.
- Carpenter, W. W. and Murphy, P. B. — *Mechanical Communication Switch-Board* — 2,633,502.
- Garfield, O. R. — *Transmission Control in Two-Way Signaling System* — 2,632,052.
- Gibson, E. S. — *Common Timing Circuit* — 2,630,564.
- Gray, F. — *Pulse Code Communication* — 2,632,058.
- Holden, W. H. T. — *Electronic Code Pulse Receiving Circuit* — 2,633,495.
- Joel, A. E., Jr. — *Automatic Accounting Device* — 2,630,269.
- Joel, A. E., Jr. and Rippere, R. O. — *Automatic Accounting Device* — 2,630,270.
- Kock, W. E. — *Transistor Frequency Modulation* — 2,632,146.
- Koenig, W., Jr. — *Signal Transmission* — 2,632,057.
- Mason, W. P. — *Light Valve for Television System* — 2,632,048.
- Merrill, J. L., Jr. — *Balancing Network for Loaded Transmission Lines* — 2,632,051.
- Mohr, M. E. — *Communication System Employing Pulse Code Modulation* — 2,632,147.
- Montgomery, H. C. — *Semiconductor Transducer* — 2,632,062.
- Morrison, J., Jr. — *Cold Cathode and Method of Preparing Same* — 2,631,945.
- Quarles, D. A. — *Reduction of Noise in Transmission Systems* — 2,632,101.
- Rieke, J. W. — *Low-Frequency Restoration Circuit* — 2,630,486.
- Ring, D. H. — *Guided Wave Frequency Range, Frequency Selective and Equalizing Structure* — 2,633,492.
- Schneekloth, H. H. — *Selecting and Two-Way Translating System* — 2,633,498.
- Shower, E. G. — *Method of Fabricating Cathode Assemblies* — 2,633,159.
- Sparks, M. and Teal, G. K. — *Method of Making P-N Junction in Semi-conductor Materials* — 2,631,356.
- Stieritz, W. G. — *Multicathode Gaseous Discharge Device* — 2,633,550.

Papers Published by Members of the Laboratories

Following is a list of the authors, titles, and place of publication of recent papers published by members of the Laboratories:

- Anderson, F. B., Gain and Phase Angle Measuring Set, *Elec. Engg.*, **72**, p. 245, March 1953.
- Beck A. C., and S. E. Miller, Low-Loss Waveguide Transmission, *I.R.E., Proc.*, **41**, pp. 348-358, March, 1953.
- Becker, J. A. and C. D. Hartman, Field Emission Microscope and Flash Filament Techniques for the Study of Structure and Adsorption on Metal Surfaces, *J. Phys. Chem.*, **57**, pp. 153-159, Feb., 1953.
- Bennett, A. F., An Improved Circuit for the Telephone Set, *Bell Sys. Tech. J.*, **32**, pp. 611-626, May, 1953.
- Bozorth, R. M., and R. W. Hamming, Measurement of Magnetostriction in Single Crystals, *Phys. Rev.*, **89**, pp. 865-869, Feb. 15, 1953.
- Bozorth, R. M., and J. G. Walker, Magnetic Crystal Anisotropy and Magnetostriction of Iron-Nickel Alloys *Phys. Rev.*, **89**, pp. 624-628, Feb. 1, 1953.
- Burns, R. W., and J. W. Dehn, Automatic Line Insulation Test Equipment for Local Crossbar Systems, *Bell Sys. Tech. J.*, **32**, pp. 627-646, May, 1953.
- Clos, Charles, A Study of Non-Blocking Switching Networks, *Bell Sys. Tech. J.*, **32**, pp. 406-424, March, 1953.
- Colley, R. H., The Evaluation of Wood Preservatives - Part II, *Bell Sys. Tech. J.*, **32**, pp. 425-505, March, 1953.
- Darrow, K. K., Magnetic Resonance: Part II - Magnetic Resonance in Electrons, *Bell Sys. Tech. J.*, **32**, pp. 384-405, March, 1953.
- Dehn, J. W., see R. W. Burns.
- Frost, G. R., William Keister and A. E. Ritchie, A Throwdown Machine for Telephone Traffic Studies, *Bell Sys. Tech. J.*, **32**, pp. 265-291, March, 1953.
- Goucher, F. S., and M. B. Prince, Interpretation of α - values in *p-n* Junction Transistors., *Phys. Rev.*, **89**, pp. 651-653, Feb. 1, 1953.
- Hamming, R. W., see R. M. Bozorth.
- Hartman, C. D., see J. A. Becker
- Hewitt, W. P., see W. P. Mason.
- Hulm, J. K., see B. T. Matthias.
- Keister, William, see G. R. Frost.
- Mallina, R. F., Solderless Wrapped Connections - Part I - Structure and Tools, *Bell Sys. Tech. J.*, **32**, pp. 525-556, May, 1953.
- Mason, W. P., Hewitt W. H. and R. F. Wick, Hall Effect Modulators and "Cyrators" Employing Magnetic Field Independent Orientations in Germanium, *J. Applied Phys.*, **24**, pp. 166-175, Feb., 1953.
- Mason, W. P., and T. F. Osmer, Solderless Wrapped Connections - Part II - Necessary Contacts for Obtaining a Permanent Connection, *Bell Sys. Tech. J.*, **32**, pp. 557-590, May, 1953.
- Matthias, B. T., and J. K. Hulm, Superconducting Properties of Cobalt Disilicide. *Phys. Rev.*, **89**, pp. 439-441, Jan. 15, 1953.
- McRae, J. W., Solderless Wrapped Connections - Introduction, *Bell Sys. Tech. J.*, **32**, pp. 523 and 524, May, 1953.
- Miller, R. L., Auditory Tests With Synthetic Vowels, *Accoust. Soc. Am. J.*, **25**, pp. 114-121, Jan., 1953.
- Miller, S. E., and A. C. Beck, Low-Loss Waveguide Transmission, *I.R.E., Proc.*, **41**, pp. 348-358, March, 1953.
- Olsen, K. M., see W. G. Pfann.
- Osmer, T. F., see W. P. Mason.
- Owens, C. D., Analysis of Measurements on Magnetic Ferrites, *I.R.E., Proc.*, **41**, pp. 359-365, March, 1953.
- Pfann, W. G., and K. M. Olsen, Purification and Prevention of Segregation of Single Crystals of Germanium, *Phys. Rev.*, **89**, pp. 322-323, Jan. 1, 1953.
- Prim, R. C., DC Field Distribution in a "Swept Intrinsic" Semi-Conductor Configuration, *Bell Sys. Tech. J.*, **32**, pp. 665-694, May, 1953.
- Prince, M. B., see F. S. Goucher.
- Reed, E. D., A Coupled Resonator Reflex Klystron, *Bell Sys. Tech. J.*, **32**, pp. 715-766, May, 1953.
- Ritchie, A. E., see G. R. Frost.
- Stone, H. A., Ferrite Core Inductors, *Bell Sys. Tech. J.*, **32**, pp. 265-291, March, 1953.
- Suhl, Harry, Theory of Magnetic Effects on the Noise in a Germanium Filament, *Bell Sys. Tech. J.*, **32**, pp. 647-664, May, 1953.
- Vaage, E. F., Transmission Properties of Laminated Klystron Type Conductors, *Bell Sys. Tech. J.*, **32**, pp. 695-714, May, 1953.
- Van Horn, R. H., Solderless Wrapped Connections - Part III - Evaluation and Performance Tests, *Bell Sys. Tech. J.*, **32**, pp. 591-610, May, 1953.
- Varney, R. N., Drift Velocity of Ions in Oxygen, Nitrogen, and Carbon Monoxide, *Phys. Rev.*, **89**, pp. 708-711, Feb. 15, 1953.
- Walker, J. G., see R. M. Bozorth.
- Wick, R. F., see W. P. Mason.
- Wilkinson, R. I., Working Curves for Delayed Exponential Calls Served at Random, *Bell Sys. Tech. J.*, **32**, pp. 292-359, March, 1953.