

BELL LABORATORIES RECORD

JUNE 1944

VOLUME XXII

NUMBER X

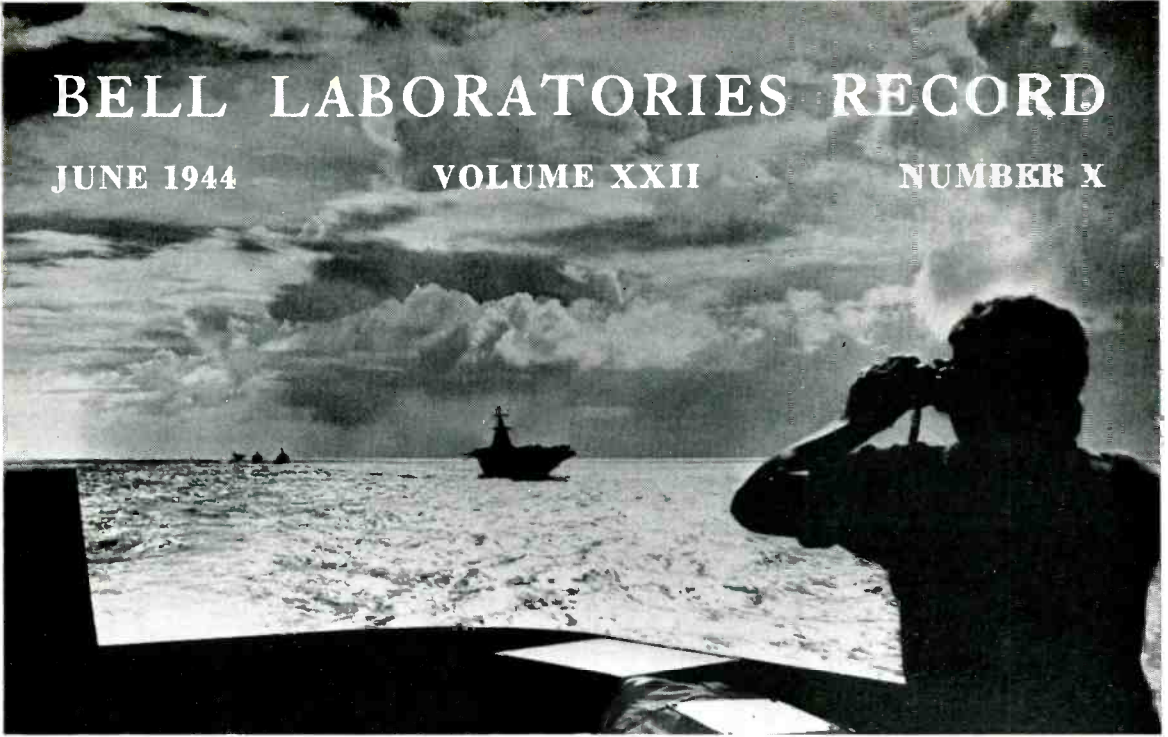

War Bonds Buy

Carriers Airplanes

Headsets Switchboards

Rifles Bayonets Grenades

BUY MORE BONDS!





To the Four Co
go telephones, switchboards, radio sets, Spiral-Four, radio-equipped life rafts, poles, terminal boards, and still more telephones. Many of them we have designed; many are made by Western Electric. With them have gone 783 of our own men and

That's Why We Wi





ers of the Earth

women; 54,000 from the Bell Sys-
em. Our bond buying tells them that
"Back the Boys" is more than talk.
That we are tightening our belts now
and doing without some of the things
we might buy so that a prosperous
America can welcome them home.



Buy More Bonds Now



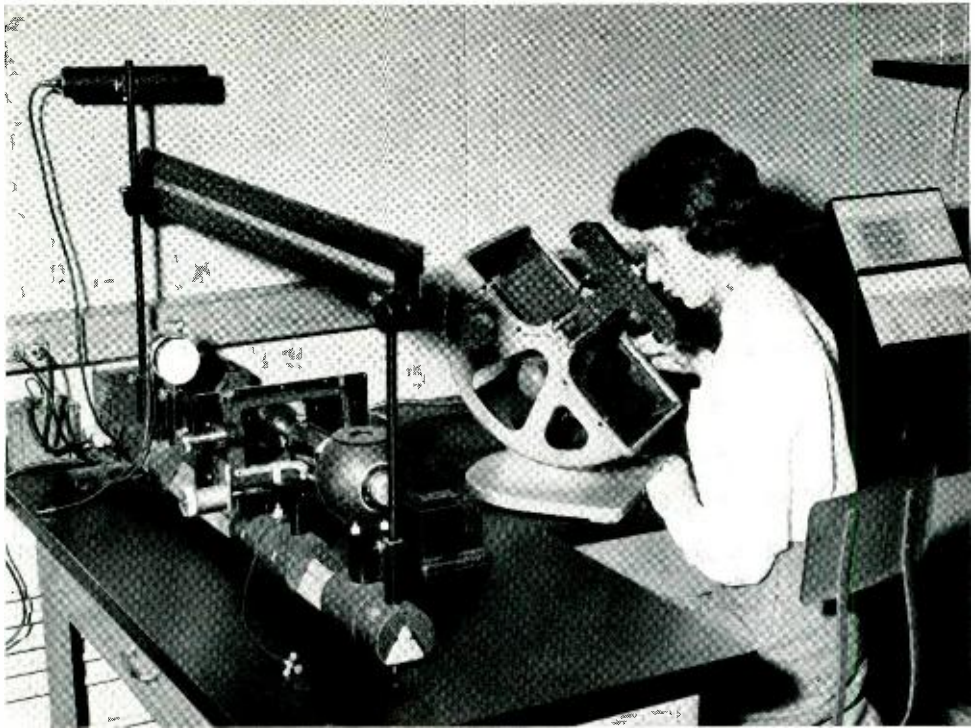

Spectrochemistry

By EDWIN K. JAYCOX
Chemical Laboratories

MANY of the elements, particularly the metals, the metalloids and the gases, can be made to emit light. The spectrograph spreads this light into a spectrum which consists of lines and bands characteristic of the material and recordable on a photographic plate, or on a sheet of paper with a pen controlled automatically by a photoelectric cell. From these records the elements may be identified and their amounts in the source determined.

In addition to the spectrograph, equipment is required to excite the spectra and for the interpretation of the spectrographic record. As sources of light, direct and alternating current arcs, high-voltage sparks and Geissler discharges are used, depending on the analysis made. For the interpretation of spectra, there are viewing boxes, magnifiers, standard reference plates, tables and charts of spectrum lines, comparators and densitometers, with which spectrum lines

can be identified and the amounts of elements present in a sample determined. At the Murray Hill laboratory there is also apparatus for obtaining absorption spectra which are used to identify and determine many organic and inorganic compounds. Other equipment there includes a fully equipped dark room, a chemical hood, services such as gas, high- and low-pressure air, vacuum, oxygen, distilled water and electric power. The illustration at the head of this article shows the densitometer, comparator and table for interpreting plates.

Approximately a quarter of the jobs handled by the analytical department of the Laboratories are done wholly or in part by spectrochemical methods. In most of this work emission spectra are used to analyze metals, compounds with metallic constituents, and gases in discharge tubes. Qualitative reports of the results include estimates of the amounts of the components present.

These are based on experience and knowledge of the behavior of the elements involved. Although often of great value to the engineer for whom the analysis was made, the estimates should not be taken as quantitative determinations.

Quantitative spectrochemical analyses are made of most of the commonly occurring metals and their alloys, and of many compounds for metallic constituents. These usually range in concentration from 0.0001 to 1.0 per cent, but in some cases major components are also determined. On a single plate are recorded the spectra of the sample under test and, for reference, those from a series of known concentrations of the same elements. By comparing the densities of a selected line in the reference spectrograms with that of the same line in the sample, the amount of the corresponding element is found.

There are two generally used methods of interpreting the photographic record. In one, the comparison standard method, a plot is prepared of the logarithm of the density of a line in the reference spectrum for a range of concentration of the element to be determined. From the measured density of the same line in the sample the amount of that

element can be found from the plot. The procedure with the other, the internal standard method, is the same except that the ratio of the densities of a line of a major or added component to that of the element sought is used. This corrects for differences in the spectrograms caused by variations in the intensity of the light source or the time of exposure.

It is very important that the standards and samples be in exactly the same physical and chemical condition prior to excitation, i.e., in solid, solution or powder form, otherwise the intensities of the recorded spectral lines will not be comparable. Non-metallic components, although not themselves excited, often influence the excitation of the metals and must likewise be considered. There are many techniques used in preparing samples for excitation, the choice of which depends on the nature of the sample and the availability of suitable standards. Analyses of some of the more commonly used alloys, among them certain of the aluminum, magnesium, lead and zinc base alloys, and steels, are made by sparking the alloy directly. Such analyses are usually rapid and precise but can be made only when solid standards are available, or if samples of sufficient size

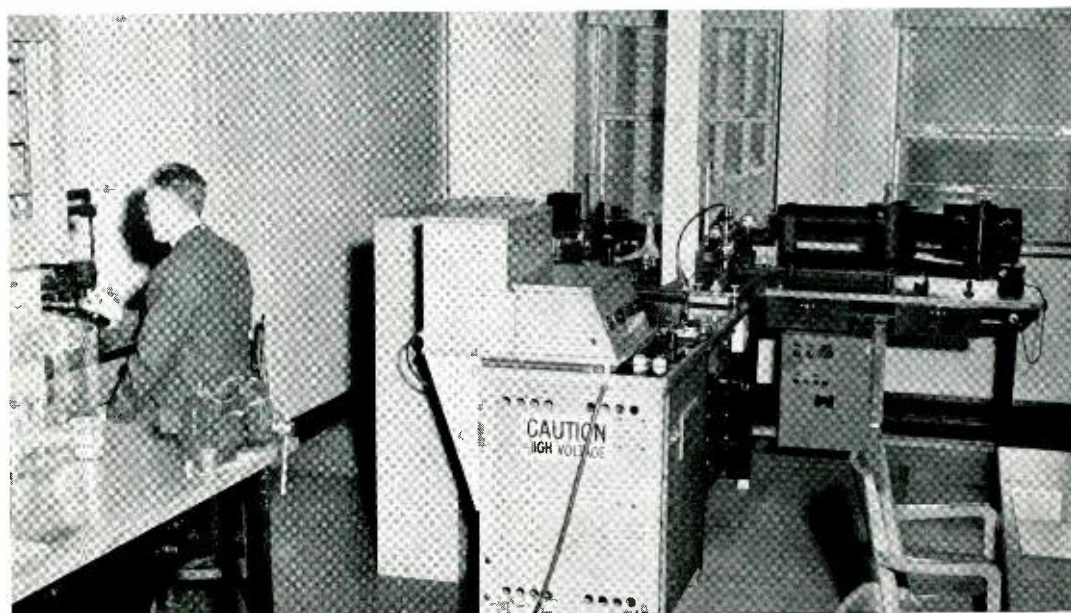

The spectrochemical laboratory at Murray Hill showing spectrograph, arc and spark stand, balance, preparation desk and supplies

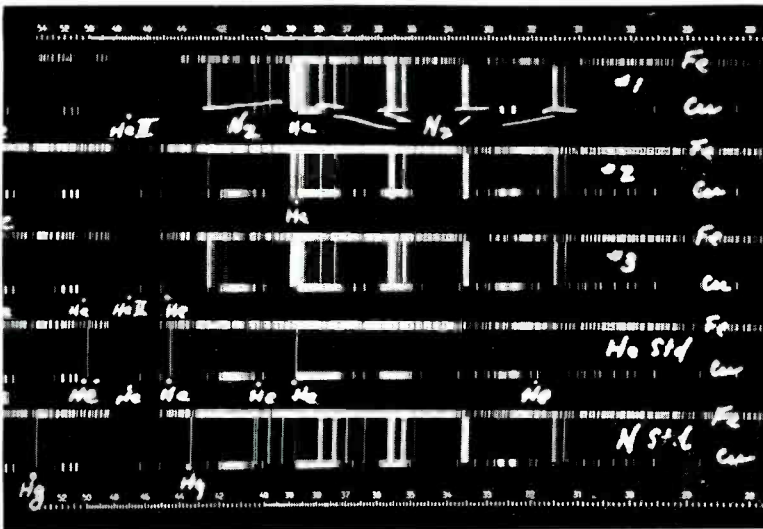
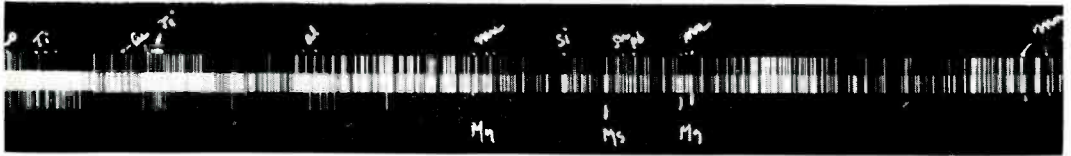
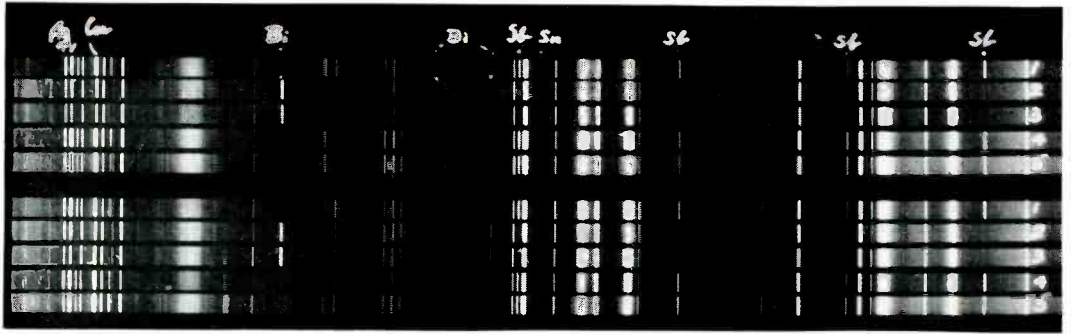

The illustration at the top shows spectrograms of samples of telephone and power cables. The second illustration shows an analysis of a ceramic. The third shows qualitative spectro-analyses of three samples of helium. The bottom one shows a typical quantitative analysis of a zinc-base alloy for cadmium, iron, magnesium, tin and lead



can be fashioned into suitable shape. There must also be no segregation of the elements. At the Laboratories, samples are frequently dissolved in a reagent and aliquots are arced or sparked after being dried from solutions onto graphite electrodes; or as powdered salts, placed in their craters. With these techniques synthetic standards can be quickly and accurately made from stocks of solutions kept on hand. Concentrations are readily controlled and the effect of non-uniform distribution of the elements is minimized. Where desirable, a buffer material can be added to stabilize the excitation by supplying ions for the arc, thus permitting more precise analyses.

An analysis involving the identification of alloys from differences in their composition is shown at the top of page 418. An operating telephone company had lead-antimony sheathed cable stolen from reels left on job locations. A suspect was found who had in his possession large quantities of recovered lead which he claimed had been obtained by purchasing old cable from the nearby power company, but he could not substantiate his statement. Samples of lead were taken for analysis from the suspect and also from the power company's cable. Referring to the illustration at the top of page 418, spectrogram 1 is that of standard lead-antimony telephone cable sheath. Samples 2 and 3 are from power company cable

THE AUTHOR: EDWIN K. JAYCOX entered the Physical Research Department of the Western Electric Company at West Street in 1919. Here he studied the properties and characteristics of many types of thermionic emitters, vacuum pumping systems and varistors. He continued this work after this department became part of Bell Telephone Laboratories in 1925. In 1936 Mr. Jaycox transferred to the Chemical Department where he has been engaged in chemical spectroscopy. At present he has charge of the spectrochemical laboratories at West Street and at Murray Hill.



June 1944

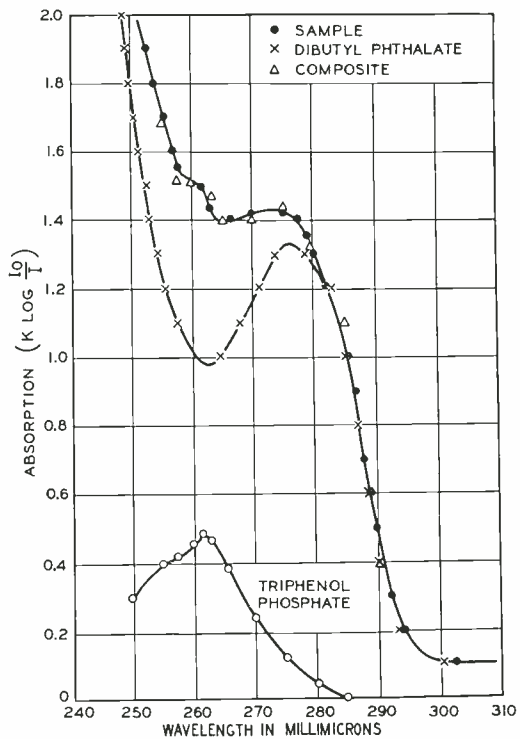

Absorption curve of cellulose acetate for light of different wavelengths. From it the amounts of dibutyl phthalate and triphenol phosphate present can be calculated

sheaths. Sample 4 is some of the lead taken from the suspect, and 5 is lead scraped from the floor of the room where the melting had been done. A glance at the spectrograms shows that samples 1, 4 and 5 are the same alloy, and that they are different from samples 2 and 3. The Bell System cable is identified by its high antimony content; the power company's by the bismuth present. There is also more silver and copper in the telephone cable. From this evidence there is no question but that the lead found on the suspect's premises was from telephone cable.

A spectrogram that represents a typical qualitative analysis of a ceramic is shown in the second illustration on page 418. The material was ground to a fine powder, mixed with pure carbon dust, placed in the crater of a graphite cup and vaporized in a direct-current arc. The first spectrogram is that of iron which was used as a reference and for determining wavelengths. The second and third are from the sample. Measurements of this plate showed the presence of more

than 10 per cent of iron; over 1 per cent of aluminum, silver and titanium; from 0.10 to 0.3 per cent of manganese, calcium, chromium, magnesium and sodium as impurities; and traces of silver, boron, cobalt, copper, lead, tin and vanadium.

Qualitative analyses of three samples of helium are shown in the third illustration on page 418, with spectrograms of pure helium and nitrogen for reference. There were appreciable amounts of nitrogen in the helium. Spectrograms of iron and copper were also taken in juxtaposition with those of the gases to aid in identifying lines and for the determination of wavelengths.

A typical quantitative analysis of a zinc-base alloy for cadmium, iron, magnesium, tin and lead is illustrated at the bottom of page 418. The standards and samples were in chloride solutions, one-tenth milliliter aliquots of which were pipetted to waterproofed graphite cups where they were dried and then vaporized in a direct-current arc. Spectrograms of four aliquots of the sample and a graduated series of standards, containing from 0.001 to 0.10 per cent of each element sought, are recorded on the plate.

Determinations of the calcium in a number of samples of lead cable sheath by both spectrochemical analyses and chemical methods showed an average difference of less than 0.001 per cent when the calcium content was approximately 0.03 per cent. Solid standards and samples were used in making these analyses, with controlled spark exci-

tation between a flat surface of the alloy and a pointed graphite counter electrode. The accuracy of this analysis is exceptional and it should be stressed that such results can be obtained only after all of the factors in the procedure have been thoroughly studied so that exact techniques can be chosen.

Another useful application of the spectrograph in an analytical laboratory is to identify and determine the amounts of organic and inorganic compounds in samples by measuring their absorption characteristics; for example, the amount of plasticizer in cellulose acetate products. The graph on page 419 shows, identified by the dark dots, the absorption curve of a sample of cellulose acetate. A composite curve, indicated by triangles, was calculated from absorption data on the separate components of the plastic and it fits the curve for the sample well. From these graphs the amounts of dibutyl phthalate and triphenol phosphate in the plastic can be determined to about 50 parts per thousand. Absorption is expressed in terms of the logarithm of the ratio of the incident to the emergent light intensity.

With its attendant auxiliary apparatus the spectrograph has become an indispensable tool in most industrial and research chemical laboratories. Its applications to chemical analysis are wide and varied in the fields of emission and absorption spectra. Its usefulness in the physical laboratory also is outstanding.

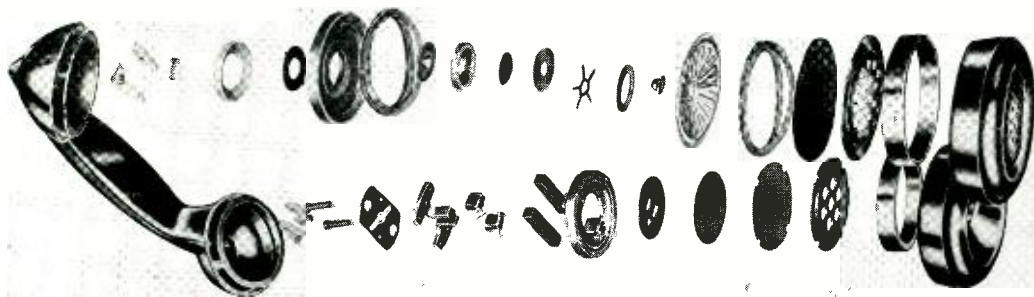

If you have ever seen a magician do card tricks, you'll wonder if the same fellow set up this picture. But the parts didn't fly out of the transmitter and receiver with a left sweep of the hand: J. H. Waddell patiently placed them on holders, which Photographic patiently retouched out of the picture. Purpose: to illustrate the substitution of less-scarce materials in many items. Enlarged, the picture will find a place in a permanent exhibition in WPB headquarters

Magneto-Striction Noise from Telephone Wires

By M. T. DOW

Transmission Engineering

WHEN magnetic material is subjected to a mechanical force, its magnetization is changed, and conversely, if its magnetization is changed, the material will expand or contract. There is a relationship, in other words, between the state of stress and the state of magnetization of magnetic materials much as there is between the states of stress and electrification in crystals such as quartz and Rochelle salts. In the latter materials the relationship is known as the piezoelectric effect while in magnetic materials it is called magnetostriction. The phenomenon of magnetostriction has been known for a long time, and is the basis for a number of important practical applications in recent years, but for the most part it has been of theoretical rather than of practical importance where telephone wires are concerned. Some eight years ago, however, noise encountered on certain western telephone lines was found to be caused by vibrations set up by wind in a long river crossing consisting of steel conductors. Experiments by W. O. Pennell and H. P. Lawther of the Southwestern Bell Telephone Company indicated clearly that the noise was due to magnetostriction. With this discovery, magnetostriction made its first appearance as a practical line telephone problem. The alternating stresses in the taut wires vibrating under the influence of wind resulted in corresponding changes in the magnetization of the steel wires, and these magnetic fluctuations induced voltages in the wires that appeared as noise at the ends of the line.

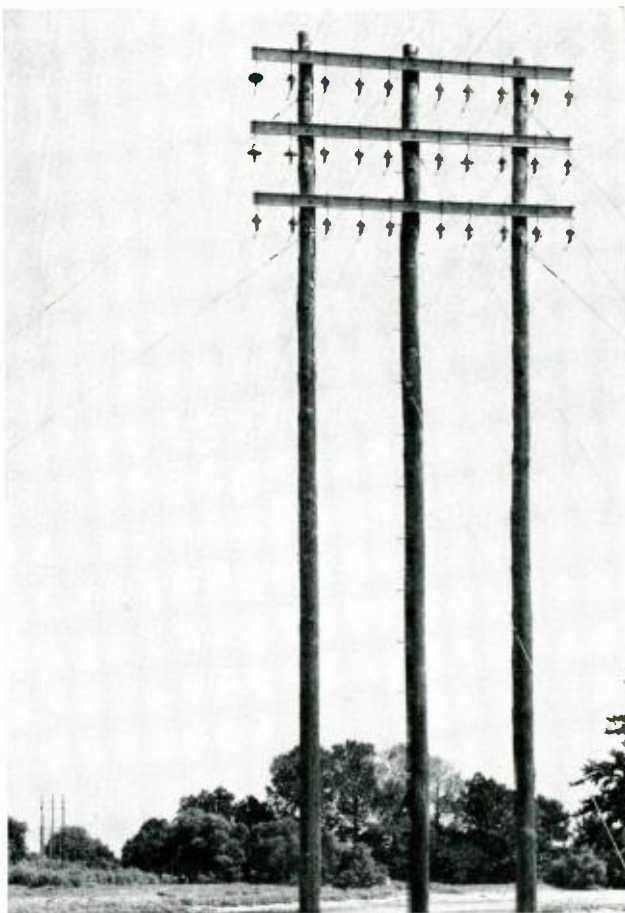

Bell System lines generally are of copper, and, although they may hum loudly in the wind, there is no magnetic material to convert their vibrational strains into electric currents. The use of steel has been limited in the past chiefly to short local circuits or to long spans over rivers, or to other exceptional conditions. With the shortages of copper due to war demands, however, it has frequently been necessary to use only enough copper to secure the required conductivity, and to add steel for strength. As a result, the use of steel-core conductors has increased during the past few years, and many projects use steel wire with an outer shell of copper for telephone circuits.

It was recognized that magnetostriction effects would occur in copper-steel lines, but available information indicated that the noise would probably be relatively minor. Magnitudes of magnetostriction noise likely to be troublesome had been observed in the

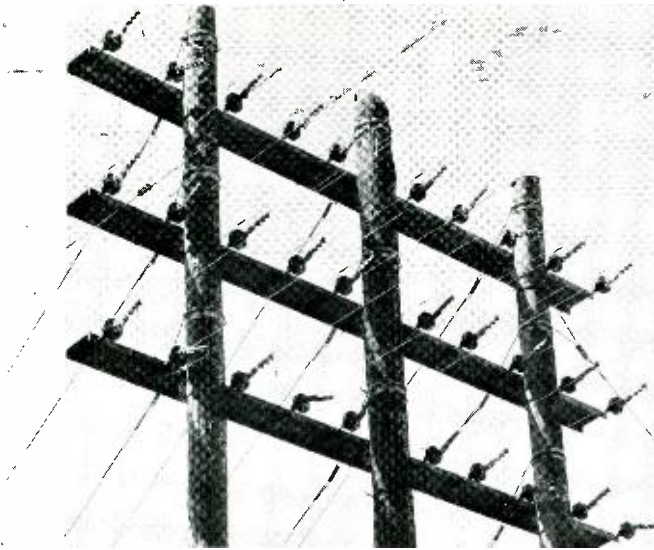

Crossarms at one end of span where magneto-striction noise was first encountered

past only under unusual conditions even on all-steel conductors. Considerably lower values of noise on copper-steel conductors were expected. The greatly increased use of copper-steel wires that was expected made it seem desirable, however, to determine more exactly just how great magneto-striction noise might be, and just what conditions enhanced or reduced it. With this objective in view, several series of tests were undertaken and carried to completion during 1942 and the early months of 1943. Some of these studies were made by the author, and others by A. J. Aikens and J. L. Lindner, but all led to the same general conclusions.

Tests were made in various locations and at different times of the year so as to include a wide variety of conditions. Different lengths of line and sizes of wire were also employed. Measurements were made with the 2B noise meter, which is a modification of the 2A noise meter already described in the RECORD,* and with various other types of equipment. In all tests the velocity and direction of wind as well as the temperature and other atmospheric conditions were recorded so that the noise found could be correlated with the several factors that were likely to influence the results.

Disc recordings were also made of the

*RECORD, April, 1937, p. 252.

magneto-striction noise encountered, to be available for laboratory and demonstration purposes. A variety of noise samples was obtained. One sample resembles the medley of sound any lonely individual might expect to hear on a dark stormy night with a blustery wind howling and whistling around the house; it is a record of magneto-striction noise generated in a turbulent wind. The noise from steadier winds usually comprises one or more discrete tones, and the quality of sound is such as to be readily identified as the hum of telephone wires. Sometimes a single outstanding frequency will persist steadily for several hours at a time; generally, however, frequencies come and

go, first building up to a peak only to die down and be replaced with others as changes in the wind take place. Very often several frequencies beating together produce the throbbing rhythm which can also be heard under the telephone line itself. The recorded samples of noise include cases where frequencies as high as 1,350 cycles per second are dominant.

The disturbing effect of noise depends not only on its magnitude, but also on its frequency distribution, because sounds of the same magnitude are much more disturbing at some frequencies than at others. Since the voltages induced by magneto-striction vary at rates which depend on the rates of change in stress in the wire, the noise frequencies are related to the frequencies of vibration of the wire, and these in turn are determined largely by the size of the wire and the velocity of the wind; wire tension, span length, and other such factors also have some effect. It was found that practically all frequencies of the magneto-striction noise were in the voice range, and under certain conditions the dominant frequency was in the neighborhood of 1,000 cycles per second, which is in the range producing the greatest disturbing effect. The test results confirmed a simple relationship suggested by theory between the more important factors in-

volved; this may be expressed as $f = 7 \times v/d$, where f is the principal noise frequency in cycles per second, v the wind velocity in miles per hour, and d the diameter of the wire in inches. To produce a 1,000-cycle noise, therefore, the wind velocity is given by the expression $v = 14.3d$. Commonly used copper-steel wires are of 0.104 and 0.128 inch in diameter; for these two sizes the wind velocities to give 1,000-cycle noise are about 15 and 18 miles per hour, respectively. These are velocities commonly encountered.

For the same velocity of wind, the greatest effect is experienced when the wind is approximately at right angles to the direction of the wires. Taut wires with sags less than 8 or 10 inches in 130-ft. spans favor the generation of magnetostriction noise. Fairly steady winds with velocities around 20 to 35 miles per hour produce the highest values of noise. Winds in this range of velocity favor the building up of resonance, which leads to high amplitudes, and also are likely to produce frequencies of the greatest disturbing effect. Turbulent winds, with veloci-

ties up to as high as 64 miles per hour, seem to inhibit the building up of resonance, and thus are less effective in producing noise. The effect is greatest in all-steel wires, and becomes less the greater the relative amount of copper.

An estimate based on a study of the results obtained indicates that for tight wires in an exposure of 25 miles or more in length where conditions favor magnetostriction noise, the unamplified noise generated during windy periods would probably average around 28 db above reference noise, which is 10^{-12} watts. Occasionally maximums might reach as high as 36 db above reference noise. Both of these figures are for tight, copper-clad wire of 40 per cent conductivity; the corresponding figures for wire of 30 per cent conductivity would be about 3 db higher. Under similar conditions, the noise for all-steel wire is likely to be 10 db to 25 db higher. Actually, while magnetostriction noise has been experienced with steel wire, none has ever been reported on circuits employing copper-clad wire.

In making the tests, the noise was measured with known amounts of gain, which were taken into account in arriving at the figures given above for unamplified noise. In estimating the amount of magnetostriction that may be expected on any particular line, the unamplified noise must be considered along with the effect of existing gains or losses. The noise currents generated by magnetostriction are, of course, subject to the same attenuations and gains as are the voice currents, and the actual noise experienced on a telephone circuit will depend on the point along the repeater section at which the noise is generated, and whether gain exists between this point and the receiving terminal.

One effective way of reducing the magnetostriction noise is to wrap a piece of insulated wire loosely around each line wire for about 18 inches each side of the insulators. This method of damping, originated by R. C. Silvers, A T & T, has been used to reduce vibration where that has been excessive, and by thus reducing vibration, the magnetostriction noise is also reduced.

With the sensitive testing apparatus employed, it was found that the magnetostriction noise gave clear evidence of any

THE AUTHOR: M. T. DOW was graduated from Ottawa University, Kansas, in 1917 with the



B.S. degree. He received a Master's degree in Physics at the University of Pennsylvania in 1921. For several years Mr. Dow was an instructor at M.I.T. and Harvard University while doing graduate work there. After two summers with the Development and Research

Department of the American Telephone and Telegraph Company, he joined that Department in 1927 and for six years worked on inductive coordination problems with the Joint Subcommittees of the Bell System and Edison Electric Institute. In this connection he developed methods of measuring the influence of power lines and of calculating noise in exposed telephone lines. In 1934 he transferred to the Laboratories. Since 1933 Mr. Dow has been concerned with noise studies in connection with carrier telephone systems and open-wire telephone lines. During the past year and a half he has been concerned with war work.

vibration imparted to the wire. A lineman climbing a pole could readily be detected. The impact of his spurs entering the pole set up corresponding vibrations in the wire, which were converted to equivalent magnetostriction noise. Even birds alighting on the wires or leaving them could be heard. Through the magnetostriction effect, a

steel or copper-steel telephone line acts much like a microphone and generates noise when mechanically disturbed. Fortunately this magnetostriction "microphone" is not highly efficient, and under ordinary conditions, no special precautions have been necessary in engineering the line to avoid noise from this source.

SOLDERING SILICON CARBIDE VARISTORS

Silicon carbide varistors show large changes of resistance with changes of voltage. This property is useful in the protection of electrical apparatus from overload. The varistors are made, usually in disc form, by mixing granular silicon carbide with clay and a little graphite and compressing the mass to the desired shape and size in a tableting machine. Then they are fired in an electric furnace. In the accompanying illustrations, A. R. Saunders is shown soldering a wire terminal to the face of a varistor unit.

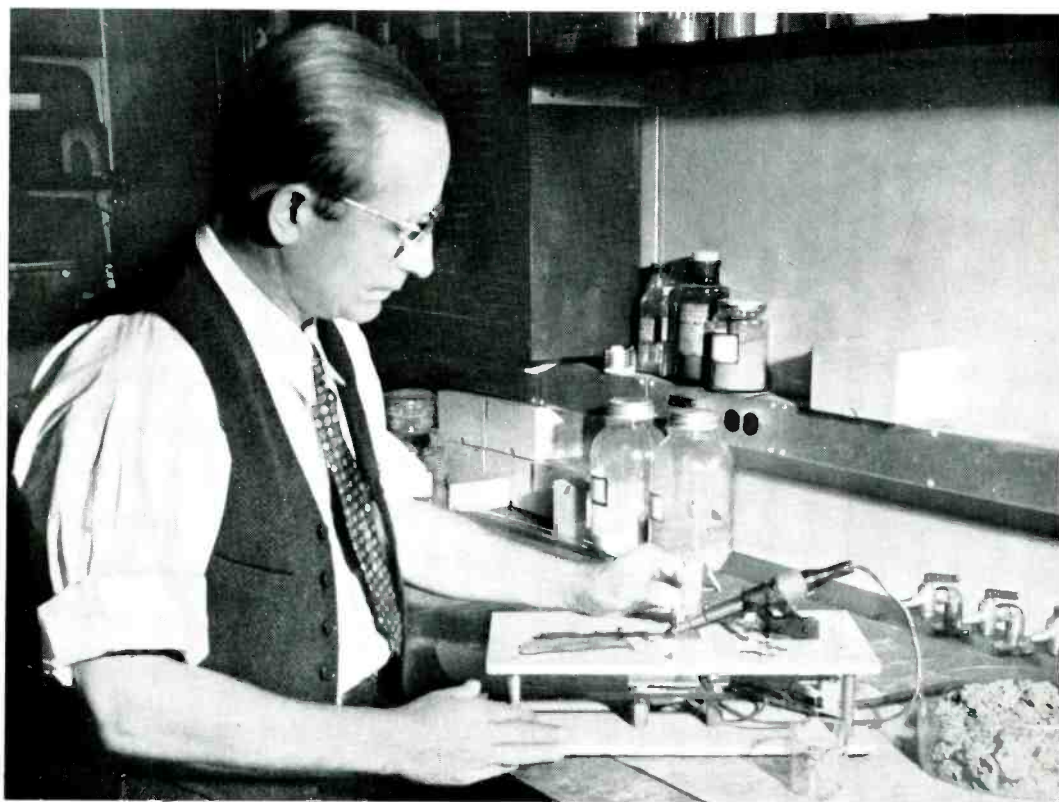
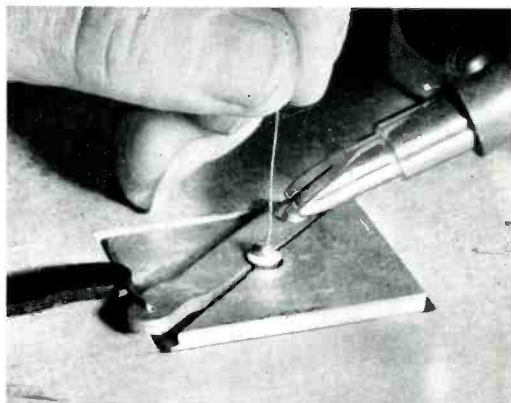



Signal Corps Photo

Wire Communications in Military Operations

ALTHOUGH radio was widely used during military operations and will continue to be used in the Mediterranean area of Combat, wire remains the basic medium of combat communications according to recent reports made to the War Department.

The ability of wire-laying units to maintain communications at a pace which matched that of advancing infantry was emphasized, as was the security and accuracy with which a large volume of traffic was carried through wire communications lines.

Wire communications may be likened to the quarterback on the football field who calls the signals and puts into play certain formations planned by the coach to meet playing conditions. Likewise, wire communications is the quarterback of the battlefield—for it is the means by which vital orders, that fit into a definite strategical plan of attack, can be transmitted to all sectors of the battlefield.

Here are the reports of a number of cases as reported from Sicily:

“As soon as the roads to Licata and Regusa were cleared of enemy troops, work was

started on rehabilitation of two open-wire circuits each way. Considerable damage was done to all overhead wires in this area by the retreating enemy. Open-wire circuits were established as rapidly as possible and improvements then were attempted. As was expected, many circuits were of such length that communications were difficult until improvements were completed. Improvements included soldering splices, transposing circuits to avoid cross-talk, etc.”

Another report states: “By July 14 the beachhead had been sufficiently extended . . . and wire communications were maintained with major units. A line was laid to Army headquarters at Gela, and one to the Ranger battalion which had moved so rapidly toward and beyond Butera that it was necessary to attach a wire team to them. One two-and-a-half-ton wire-line truck, complete with reel unit and 30 miles of wire W-110* on a landing ship, receiving a direct hit, was destroyed. Also destroyed was

*Twisted pair, stranded steel and copper conductor, for short-range communications, weight 1.38 lbs. per mile, loss 1.7 db per mile.

another two-and-a-half-ton truck loaded with miscellaneous supplies.

"By July 18 the advance of the Seventh Army had progressed so rapidly that a move of the command post was necessary. . . . Wire communications were extended northward, and efforts were redoubled to keep pace with the rapid advance of the II Corps. This was accomplished by the various crews working from dawn to well into the night.

"Command post moved to Palermo on July 25. Local city telephone equipment was found dirty and dusty from the bombings and badly in need of maintenance. Walls and windows of the telephone building were repaired by Signal troops. The use of the local dial system was found unsatisfactory, and a three-position switchboard was installed. Considerable destruction, due to bombings of underground cables and open-wire circuits, was encountered within the city of Palermo. The rehabilitation of the open-wire circuits, which inside the city were mostly placed over the tops of three and four-story buildings, presented quite a problem until it was solved by the use of the local Fire Department's extension ladder.

"From Palermo to Messina, the Signal troops were confronted with a new and more serious handicap in the form of hundreds of

mines placed along pole lines and along the railroad right-of-way and between ties, where it was necessary to work, as most of the wire leads followed the railroad tracks. Special signalmen had been trained in the use of mine detectors, and rendered immense service in finding and in many cases removing these deadly weapons. The low casualty rate of Signal personnel from mines was due to the excellent work performed by these men. Wire construction continued along this coastal route, practically all being along the railroad tracks, with spiral-four or long-range wire being used to rehabilitate the open-wire lines."

The ingenuity and inventiveness of the Signal Corps men came into conspicuous play when, "At this time the signal battalion succeeded in conveying several bicycle-type railroad hand cars into motor-driven hand cars to be used along the right-of-way to rehabilitate the telephone circuits. This was accomplished by removing the engines of captured German motorcycles and installing them on the hand cars. These cars greatly speeded the construction and maintenance control of wire lines."

The difficulties of the terrain are clearly brought out in the following report, "In one instance, during the battle for San Fratello,

it was found necessary to lay a five-mile line of wire W-130* over rocky, trackless, mountainside over which a man could move only by the frequent use of his hands, and for fifteen miles where wire could be transported only by pack animals and laid only by hand. In another instance, on a march from San Marco to Mirto to Maso, a twenty-mile line was laid entirely by hand. In a third instance, from St. Angelo di Brolo to Patti, two lines of wire W-130 were laid for a distance of fifteen miles completely clear of the trails used by men and pack animals. This line was laid at the

*Sometimes called "assault wire." Twisted pair, 1 copper, 6 steel conductors, weight 32 lbs. per mile, loss 3.07 db per mile.



Signal Corps Photo

Men and wires traverse rough beach terrain

rate of advance of the pack train carrying the wire. One six-mile wire line from the coast road to San Marco required twenty-four hours to put it in continuous operation because the winding, narrow mountain road on which it was laid was under constant shellfire."

One front-line Infantry commander reported on wire communications in his sector thusly, "During the operation, wire communications were desirable down to rifle companies and battalion observation posts. The terrain was very mountainous, and the highways impassable to vehicles, due to blown bridges and anti-tank mines. Therefore it was necessary for the battalion communications platoons to carry their wire and equipment by hand. Since each battalion was authorized four linemen, it was practically impossible for them to install and maintain the wire lines desired by the battalions. Lines were frequently broken by artillery and mortar fire, by animals, vehicles and in a few instances by enemy patrols."

When the last gun in the Sicilian campaign had been fired it was found that the victorious Seventh Army had rehabilitated wire lines as follows: 950 pole line miles, 24,588 circuit miles, 49,176 wire miles, and laid more than 1,800 miles of spiral-four cable.

Pioneers to Visit Telephone People in Military Hospitals

The Telephone Pioneers of America have launched a coördinated program of visiting telephone people in military service who are patients in Government hospitals in the United States and Canada. Fifty-one chapters in this country and six Canadian chapters are expected to take part. The Pioneers are particularly concerned with the sick or wounded telephone people in hospitals which are not near enough their homes for relatives and friends to visit them.

Here's how the plan will work: Since relatives or friends are usually the first to learn of a man's arrival at a hospital, they are asked to forward the information immediately, by air mail letter or by teletype, to the Association secretary, Samuel T. Cushing, at 195 Broadway, New York. If more convenient they will notify the



Acme Photo

A worm's-eye view of a sapper at work on the Italian front. He "sweeps" the ground in Cassino Valley free of enemy land mines, preparatory to laying telephone lines. Sappers move in just as the enemy moves out. Electrical apparatus, including batteries, are contained in the box which hangs at his side. He watches a dial and listens for a buzz in his earphones—warning signals that the sweeper has detected the metal of a mine

secretary of the Pioneer Chapter in their territory, and the chapter secretary will pass the notice on to Mr. Cushing. In either case, Mr. Cushing relays the information on to the Pioneer Chapter in whose territory the hospital is situated.

The chapter secretary then turns the name of the patient over to his members who are in charge of visitation. If a chapter secretary learns about a telephone man in a hospital in the chapter's territory, plans for the visit will proceed locally, and then, as a matter of record, the secretary will notify Mr. Cushing in New York.

Arrangements for the hospital visits will be made through the Red Cross field director at the hospital or at the camp where the

hospital is located. This procedure is necessary in order that proper judgment be exercised on whether the patient is in condition to receive visitors.

Emphasis has been placed on selecting visitors who are at ease in a hospital room and who are able to make the visit pleasant and cheerful.

The Pioneers have asked that the following information be sent in with the name of each person to be visited: the patient's home address; name of the company he worked for; nature of disability; name and address of hospital; name, address and telephone number of person originating the information, and the relationship of that person to the patient.

Bell Laboratories Goes to Sea

To carry on experiments, the Bell Telephone Laboratories has under charter two

boats, the 55-foot *Elcovee* and the 64-foot *Elcobel*. Both boats have well-equipped laboratories and carry ship-to-shore telephones. The work on them is in general charge of W. H. MARTIN.

The *Elcovee* is used for projects formerly under the direction of F. M. RYAN, now carried on by A. C. KELLER. It carries a crew of two. Closely associated with the activities of the *Elcovee* are S. M. SUTTON, C. A. CHASE, I. S. RAFUSE and F. A. BROOKS.

The work on the *Elcobel* is under the direction of A. H. INGLIS. This boat carries a crew of three and has accommodations for three engineers. A. HERCKMANS, E. F. ENNIS, W. D. GOODALE, F. F. ROMANOW, W. R. HARRY and J. J. PAUER are often at work on this boat.

In addition to these two boats, the *Decibel*, a small auxiliary, is used to assist in making various kinds of experiments.

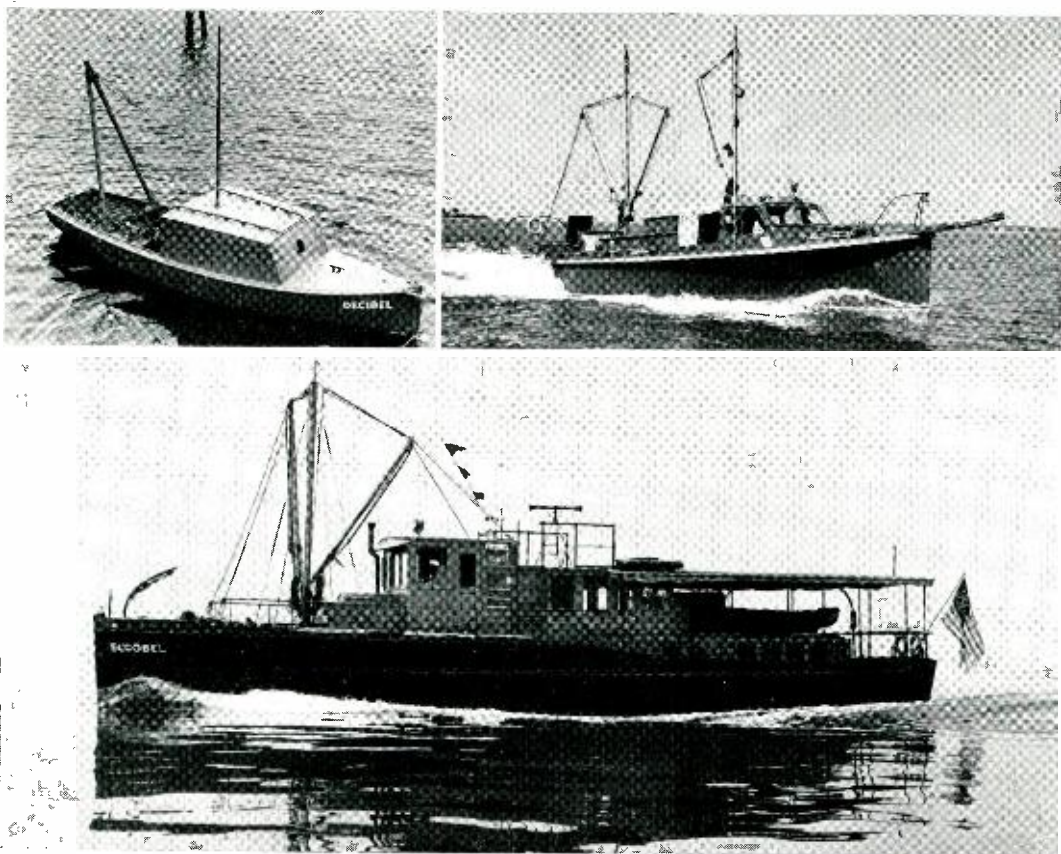

Boats, chartered by the Laboratories to carry on experiments, are well equipped and have ship-to-shore telephones. At the upper left is shown the "Decibel," a small auxiliary, while at the right is the 55-foot "Elcovee." The 64-foot "Elcobel" is shown at the bottom



Around the World With Our Armed Forces

John J. Lordan

"I have had a few experiences since I arrived on the Anzio beachhead. One night very soon after I arrived I was just beginning to get settled when we had a raid. I had a nice comfortable foxhole dug for just such an emergency as I thought. Along came these babies through the sky intent on committing mayhem on us. We had a little surprise for them so that made us even. A man from the Western Electric Company at Kearny and I were sitting on the edge of the hole watching the tracers fly when a German came in on his run. He must have been a little anxious to unload and get away as he let his egg go too soon. At the time of the explosion I was just coming up for another look but I never got up because the lad from Western Electric was on his way down and he had the element of surprise and force on his side. I was knocked flying and lost my helmet. That boy was really traveling down when he hit me. From the latest reports, he was diving at a greater speed than a P47. I had missed seeing the first bomb that dropped. The enemy must have known that I missed it because he came back again and I didn't miss this one. It wasn't as bad as I had expected but it was a good sight. By this time we were handing him our surprise and the best sight followed—he disappeared in midair. Germany must have given out the same story 'One of our aircraft is missing'."

Major Harry W. Holmlin

"My last move was from Camp Swift, Texas, to Camp Shelby, Miss. Finally sent for and married the 'one and only' from Texas several months ago. At the time the accompanying photograph was taken I was Engineer Director for a thirty-day maneuver in the De Soto National Forest near the

Gulf of Mexico in Mississippi. My best regards to those at Murray Hill."

Lieut. Col. Robert W. Harper

"I am getting along very well here among the numerous islands of the South Seas. Our job is to install radio aids to air, navigation and weather stations. Here I can use to the fullest what I was taught at the Labs. It is great to see the creations of B.T.L., in the finished products of Western Electric, doing their stuff among the cocoanut trees and close to the Japs."

Lieut. Herman E. Manke

"As I write this letter I am sitting in the dugout on alert. I am one of the night fighters down here in the South Pacific doing my best to keep the skies clear of enemy planes at night."



Major Harry W. Holmlin on maneuvers

"The boys are doing a splendid job of pushing back the Japs, island by island. It's uncanny how the enemy can dig itself in the ground like rats. It's a hard cruel war they are fighting here because the enemy is seldom seen. When they are seen they are dead."



LT. G. BUKUR

G. J. WOLTERS

George J. Wolters

"Greetings from New Guinea. I imagined living here would be kind of rough. To the contrary we are living quite well. It's taken a lot of work to get our new home in shape and at the present writing we're still working on it. The progress we've made is certainly gratifying. We have cold running showers that can be called ultra-modern in this neck of the woods. The water is piped from a well into a huge vat and from there it passes into another pipe containing seven shower outlets. All we lack is a tile floor to give it that 'homey' touch. Our mess hall leaves nothing to be desired in the way of mess halls. It is entirely screened in, has a cement kitchen floor and work has just been completed on the tables and benches. We have an electric plant that furnishes us light in all our quarters. Pretty snazzy, what! Prior to the incandescent era we relied on candles for our light. Beats me how Lincoln could do it.

"The first peculiarity I noticed when I hit this island, was the army cars were driven on the left side of the road. At

first I thought they had women drivers.

"The 'Aussies' are very friendly and certainly have proved they are more than able to take care of themselves. The natives look just the way you'd expect them to look. They are strictly Jap haters which makes me very happy. The natives don't go in much for clothes. We have to wear a full uniform at all times as protection against the many diseases, insects, etc., that make their home on this island.

"Incidentally the natives are all in the Australian army and receive a pay of a little more than two dollars a month. Could be they live on love, no?"

Lieut. George Bukur

"After a long journey I am somewhere in India—the strange and fascinating country that so many authors write about. Sometimes I wonder if any of these authors ever took time off to come here and see what a stinking place it really is. Fabulous India they say—well I have a better word for it but it doesn't look good in print. If I ever figure out this money exchange I'll probably be able to spend some money.

"The food at present is not bad at all because it is good American G.I. food. Around the mess halls we have some hawk-like birds that would swoop down and take anything out of your mess kit. The other



Girls who replaced these men talk it over with them and W. J. Szmekal in the 4C Shop. Left to right—Lieut. Robert L. Norton, Gloria Weiman, Ensign Richard H. Koehn, Mary Schladt and Mr. Szmekal

day one of the G.I.'s got a little peeved at this so he took a slice of Spam (G.I. steak) and laid it on the ground, he then got a pole and whenever one of these hawks would swoop down he'd hit it for a home run. We eat a lot of water buffalo meat and it's not too bad when it is prepared properly. I wish that you fellows would write. I haven't heard from any of the fellows yet so I'm still wondering how and where."

Charles R. Storin

"After four months in Italy I am finally getting used to the weather. At present we are having a little more sunshine than rain, and it's getting warmer, which to me is very pleasing. Give my regards to the gang in Department 1930."

Raymond S. Yerden

"It is surely good to receive the RECORD every month and it has gained in popularity with my buddies. The pictures of all the

Leaves of Absence

There were 783 members of the Laboratories on military leaves of absence and 18 members on merchant marine leaves as of April 30, 1944:

Army 479 Navy 225 Marines 28
Women's Services 51 Merchant Marine 18

Recent Leaves

United States Army

Thomas J. Comparetta	David W. Jones
John P. Fraser	William G. Schiff
John Huntley, Jr.	Joseph E. Sileo, Jr.
	Rudolph A. Wills

United States Navy

Henry J. Bentele, Jr.	Warren J. Goldstein
Cornelius J. D'Arcy	Walter W. Grote
Edward F. Downes	Isabelle M. Kennedy
Rudolph Droppa	Vincent J. McCarthy
Josephine T. Gallo	Marie J. Marti
Thomas P. Gannon	Joseph Mazzi

United States Marines

Jean Sanderson

Merchant Marine

Walter E. Gilson	Joseph T. Neville
James H. Riley	

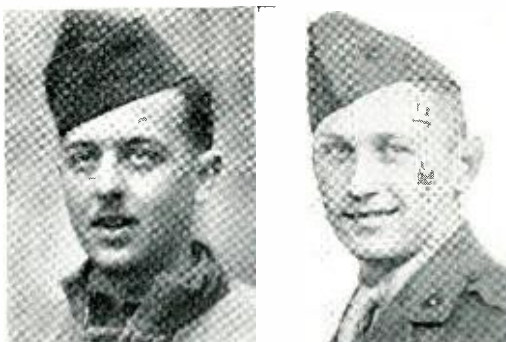

C. R. STORIN

D. F. O'SULLIVAN

pretty girls 'has 'em snowed.' For me though, it is like a letter from home and a chance, as well, to keep in touch with my friends in the Labs and in service.

"By the way, there certainly isn't much use spending money to advertise the Laboratories, I think. The Japs have been paying a good share of it right along."

Chief Warrant Officer Joseph F. Daly

"I can talk more freely of the places I've been in the last two years. I've been to the Fiji and Tonga Islands. My last station still is unmentionable.

"During my stay at the Fijis, I lived very close to the natives out in the jungles, ate their dishes, learned their customs, and tried my hand as a linguist. It's strictly a phonetic language, however, quite a strain on the vocal cords. One word which I believe will come into our English via the soldiers is Bula, means hello, good morning—a pleasing greeting. The word is as generous as the Fijians are with their broad grins. Grins or no grins, these Fijians are wonderful scouts, in fact, the savior in guerilla warfare.

"While at Tonga, I had the pleasure to meet the Queen and the Crown Prince. Both highly educated and most hospitable. You may remember the Queen, Salote Tuban, celebrated her 25th anniversary last year. The island is a paradise, both for its beauty and its ability to grow wonderful fruits and vegetables. The women are dynamic and very friendly. A factor the enlisted men enjoy to the fullest."

John E. Galbraith

"Just thought I'd drop you a line and try to make everyone jealous. Have been



Girls of the Medical Staff at West Street gather J. S. Edwards into a close-knit group to greet Lieut. Helen Adams. Left to right: Margaret Boyce, Margaret Allen, Lieut. Adams, Mr. Edwards, Ella Good and Kathryn Poellman

down here in Trinidad for a short time. Quite a nice place to spend a winter—tropical sun, waving palm trees, beautiful beaches. Just the same it can't compare to the good old U. S. A. I still get the RECORD and it sure is swell to know what the Labs is doing. Makes a fellow feel that he still 'belongs'."

John E. Sienko

"I was evacuated from a hospital in Hawaii and am now at Mare Island in the Naval Hospital. Have improved a great deal and am almost well, so I don't expect to be here much longer. As soon as I have a picture that resembles me, I'll send it along. Meanwhile give my regards to all my friends at the Labs."

Henry Algarin

"I like to hear from you people at the Labs and to get the latest issue of the RECORD. It seems like a dream with no end when I get to see so many familiar faces and read about all that they have gone through. I have read that many of my friends in Department 7524, while in the service, are getting a pretty good chance to

see the country from north to south and east to west.

"It isn't so bad as most of you boys think to be in this part of the globe except that you miss your loved ones. I have been here since last July, in a base somewhere in North Africa where we supply the Fleet with men and material. We all dig in and try to do the job that lies ahead so that we'll have a chance to live normally once more when we get back."

Harry J. Stewart

"We are now in our last few weeks of basic training here in Mississippi and according to all the rumors the hard work is just about to begin. That can't be, because I'm busy as an octopus, only he has eight arms to my two. We are out in the woods every week now

on radio problems. Haven't seen any snakes yet but expect to wake up any morning and find one parked on my chest. I'm still trying to find out what branch of the Army to consult in a case like that. We have a splendid group of officers and non-commissioned officers. The fellows are a grand body of men."

Lieut. Helen G. Adams

LIEUT. HELEN G. ADAMS, formerly a nurse in the Medical Department at West Street, is now stationed at Halloran General Hospital, Staten Island. When she visited



C. A. HAAS



H. ALGARIN



J. H. ISLEIB

H. A. LAMPERTY

West Street, Lieut. Adams had just completed a period of night duty in which she also relieved the night supervisor once a week. Her assignment now is clean surgery.

Robert J. Erny

"In Italy, I have fought at Cassino and on the Anzio beachhead where I saw some tough fighting. At present I am in the hospital, but expect to be out soon. Have been overseas nearly two years, but it doesn't seem that long to me. I wish to thank all the members of the Laboratories for the work they are doing for us."

Jack Roback

"I've been to only one island other than the one I'm on now and that was only for a period of a few days. They have recently clamped down a censorship on talking about where we are, so I guess that covers it completely cause I can't say what I work at either.

"We live in tents, but it is OK now that the mud here came down to a level in which we needn't worry about drowning. The bugs are very clean and will only bite you if you are freshly showered (at least a month ago); the most plentiful of these bugs are a type of flying cockroaches. We manage to laugh at it though."

Jack I. Picard

"I have a new ship and think it is swell. We go as far as Canada and back to base

and we visit quite a few small towns in Maine. Sure would like to hear from some of you as there are so many nights when we cannot go ashore."

June Military News

"OUTSIDE OF A letter now and then from the gang at the Labs," JAMES C. STUHLMAN writes, "the RECORD is the only way I feel I'm still in contact with B.T.L." Mr. Stuhlman is an ARM 3/c with a Naval Squadron in the Atlantic.

WITH THE CLOSING of the A.S.T.P., EDWARD J. SCHNABEL was transferred to Camp Barkeley; HENRY A. LAMPERTY to Fort Pierce where he is with the famous "Jungle Cats"; and CHARLES E. KLEIN to Camp Maxey and "the best division in the country."

CARL G. PETERSON is stationed at Camp Claiborne, La., in the Railroad Division of the Transportation Corps.

EUGENE J. FLANNERY writes from Catawba College, Salisbury, N. C., "This is certainly the ideal spot for preparing young men for further studies in the various branches of aviation."

CASIMIR J. OSIECKI, naval aviation cadet, is hospitalized at Bloombsurg, Pennsylvania, with a broken ankle.

A. L. THURAS was granted a leave from the Laboratories in July, 1941, to join the Underwater Sound Laboratory of NDRC



E. J. FLANNERY

A. L. THURAS

C. G. PETERSON

C. J. OSIECKI



J. OLESKO

LT. T. M. PEPE

at New London. In a letter with the photograph shown herewith, Mr. Thuras said "carrying on some experiments on the Atlantic Patrol, weather was not good."

HAROLD V. BERLIN has a San Francisco APO number; LAWSON F. COOPER is at Turner Field, Ga.; and H. E. SEAMAN is at Camp Crowder, Mo.; DANIEL F. O'SULLIVAN is at Camp Lejeune, New River, N. C.; CHARLES A. HAAS has been at the Laboratories' School for War Training; and J. H. ISLEIB is at Camp Hood, Texas.

WILLIAM R. SULTZER has begun training as an aviation cadet in the Army Air Forces training command school at Yale University. He is the son of LIEUT. COL. and MRS. MORTON SULTZER. (From the Mt. Vernon, N. Y., *Argus*, March 24, 1944.)

WILBUR G. SAUER in a card from England writes, "I am training hard for the big job ahead. Just tell the folks at the Labs to keep up the good work and support the War Bond Drive. Hard work on the home front and on the field will decide the issue."

BEFORE BECOMING an Infantryman at Camp Pickett, WILLIAM V. FLUSHING had completed nine months of college training in the A.S.T.P.

HARRY J. RAIMERT of the Navy had many stories to tell about his travels prior to his recent visit to West Street.

ALTHOUGH THE WEATHER is quite warm where ROBERT H. FUNCK is operating with the Pacific Fleet, it promises to get much "hotter" as the Navy moves on into more hostile waters.

JOSEPH SCIORTINO is now with the Fleet somewhere in the Pacific.

L. CHARLES BROWN is taking the final course in Airborne * * * Equipment in

Florida. "I'm working almost entirely on Western Electric equipment and feel right at home with it. Most of the equipment is Labs designed and the officers and men think highly of it."

LIEUT. THOMAS M. PEPE returned to visit the Systems Development Drafting Department after receiving his wings.

CHARLES A. KOSSMANN, a former A.S.T.P. student, visited West Street during a recent furlough. He had previously been stationed at Fort Benning.

JOHN OLESKO also visited West Street recently when on furlough from Camp Robinson, Arkansas.



R. H. MEUSER

C. A. KOSSMANN

ROBERT H. MEUSER, a communications and radio operator, called at West Street recently. Word has been received that he is now in North Africa.

LT. COL. A. M. ELLIOTT is at Fort Monmouth attending a class on a certain phase of communications.

"BEING A MECHANIC is such fun," according to HELEN ANISKO of the Waves. "Constantly dirty grimy hands, but a whole new world to explore—and in the most ridiculous positions!"

ANDREW F. BARTINELLI has gone back to his outfit again and is presumably in Italy.

FROM SOMEWHERE in the South Pacific, EDWARD J. BUCKLEY sends regards to all.

LIEUT. WILLIAM N. BUTLER is in Alabama for transition training on B-24 Liberators.

ROBERT C. EISELE has been transferred to an Air Ferry Unit in Tennessee.

"MY WORK WITH the 'landing craft infantry' is exciting and interesting." From ROBERT KUENSTNER, a radio technician at an amphibious training base.

EVELYN R. JOSD of the Waves is now an I.B.M. machine operator in the Bureau of Medicine and Surgery, Washington, D. C.

GERARD V. SMITH is now in Italy.

"CALIFORNIA is beautiful, and liberty is something to look forward to," WILLIAM M. EHLEH writes. He is with the Marines in San Diego.

PATRICK S. BENNETT's transfer from A.S.T.P. is an assignment with the Engineers at Fort Jackson.

"I AM LOOKING forward to advanced training as a fighter pilot," WILLIAM F. ARCHBOLD of the Army says in a recent letter from Napier Field.

"THE FIRST WAVE at Key West, I have had a very interesting and exciting time," says ENSIGN DORIS H. COLSH, who is in communications.

CHARLES HEMPEL sends regards to the men in Department 7521 from his station, Camp Blanding, Florida.

MANY OF THE instruments which JOSEPH E. O'KEEFE carried around at the Laboratories are now being studied by him in a Navy training school in Boston.

LIEUT. FRANK ZYLLA's latest assignment is the Naval Research Laboratory.



J. J. YOSTPILLE

L. F. COOPER

JOHN PHILLIPS sends a line to say, "Everything is OK by me. Am working here in Burma behind the Chinese who are kicking hell out of the Japs."

HAROLD E. GEORGENS of the Signal Corps has been in England a few months and has had some experiences he's sure he won't forget for a while.

LIEUT. RALPH D. HORNE is also stationed in England.

JOHN J. YOSTPILLE of the Naval Air Corps

June 1944

V12 program visited West Street during his mid-semester leave.

CHARLES J. CHRISTOPH, formerly a service clerk in the School for War Training, returned to visit West Street while on leave from Sampson.

LT. COL. ROBERT HARPER and CHARLES T. BOLGER are at the same APO number and both are very close to the Jap lines.

EDWARD FISCHER sends greetings from the fascinating island of New Guinea. "Looks as if we'll get our teeth into some real radio work soon. I'm waiting to see something like Dorothy Lamour instead of native girls."

MEMBERS OF THE Laboratories recently promoted to a higher rank in the Armed Forces were: LIEUT. COL. ROBERT HARPER; ENSIGN ALBERT VABULAS; LIEUT. FRED J. SCHWETJE; LIEUT. FRANK ZYLLA; LIEUT. ARTHUR J. PALMER; T/5 CHARLES A. HAAS.

"THESE GLAMOROUS TROPICS look swell in the movies," LIEUT. CHARLES J. McDONALD writes, "but that's as far as it goes. Some people here became nasty recently so we slapped them around plenty."

"RECEIVE THE RECORD regularly here in the F. T. O. and enjoy it very much," says EINO A. PASANEN. "Keep up the good work the Laboratories is doing so that we will all get back home soon."

PETER WARGO has entered the Army Air Forces training command school at Yale University as an aviation cadet and is specializing in communications.

ENSIGN MAYWOOD K. ASDAL made a visit to West Street recently.

THE FOLLOWING MEN have written to the RECORD from their new assignments: T. J. BOLAND, Great Lakes Naval Training Station; FRANK NAVRATIL, Camp Croft;



C. J. CHRISTOPH

H. E. SEAMAN

428G

BILL SPENNINGER, Ellington Field; A. J. McNAUGHTON, Camp Hood; NORMAN SORGER, Infantryman, overseas; E. A. HULTS, Casco Bay; HAROLD PHARES, Columbia Replacement Depot; J. G. PHILLIPS, Oxnard, California; A. J. OSINSKI, Muroc



George W. Wheeler, formerly an M.P. at Fort Knox, visited West Street with his wife before going to Camp Reynolds. He expects to go overseas shortly

Air Base; C. S. GRAHAM, Camp Swift; J. A. LASCO, overseas in the South Pacific; M. F. COFFEY, F. M. School, Service Schools Area, Bainbridge, Md.

WILLIAM H. OLPP has been assigned to Camp Campbell, Kentucky, as a topographical draftsman and camouflage expert.

LOUIS W. TELFER completed his training in Electrician School, Sampson, during May.

W. E. GILSON and WILBUR INSULL visited the Laboratories during recent leaves.

"I'VE SEEN a good part of England and have visited London several times," MARTIN E. POULSEN writes. "Although it's quite interesting I wish I were back in R252. Give my regards to 1420 and tell the gang I'd appreciate hearing from them."

THOMAS J. CALVANI has been to a number of different air bases in England lately and he finds that as time goes by he becomes more and more interested in airplane work. He also has an opportunity to travel through the many, varied sections of the island.

AS A MEMBER of an Army Postal Unit in England, JOHN P. RENEHAN finds his work interesting and is gradually becoming accustomed to the blackout.

ENSIGN GRAHAM FREER paid a call on friends at West Street during his past leave.

COMMANDER RODMAN DE KAY writes: "Having a command of one of these destroyer escorts is lots of fun, but I'll settle for a desk job at the Laboratories when the work is done out here in the Pacific."

"AM STATIONED in England," DAVID H. WRIGHT's V-mail reads, "and it is a beautiful country. The people are swell to the Yanks. Best regards to my friends at the Laboratories."

RICHARD G. DOLBEAR is somewhere in England. "All is well with me," he says. "I sure appreciate hearing from the Labs and getting the news of what is happening at home. Regards to Whippany."

WORD HAS BEEN received from CHARLES GRAHAM that he is taking three weeks of basic training to get back into shape after his easy college life.

FRIENDS OF LIEUT. ROBERT J. KOECHLIN will be pleased to learn that he has been released from McCloskey General Hospital and is now with an Officers' Replacement Pool awaiting further Army duty. Since most of Lieut. Koechlin's three years of military service were spent in the South Pacific area, it is not expected that he will be sent overseas again.

OTHER MEMBERS of the Laboratories who have written to the RECORD are:

E. J. Zillian, H. C. DeValve, Capt. E. Reinberg, T. J. Gilchrest, R. G. Dolbear, G. F. Hall, R. A. Dryden, S. G. Reed, A. O. Schmitz, H. C. Meier, George Seibel, F. A. Braun, J. C. Ptacek, T. J. West, J. J. Sweeney, R. S. Williams, W. T. Reck, Philip Watts, G. E. Campbell, E. H. Bueb, H. J. Boyle, E. E. Francois, C. J. Keyser, H. H. Hoffman, W. H. Bauer, H. W. Menzel, J. H. Devereaux.

Votes for Fighters

With the May issue of the RECORD a post card, addressed to the New York State War Ballot Commission, 80 Centre Street, New York 13, N. Y., was sent to all in military service. If lost, any card with military and home addresses sent to the Commission will be sufficient.

Don't Delay—Send Today

News Notes

F. B. JEWETT attended the annual meeting of the National Academy of Sciences held in Washington April 24 and 25. He also attended the Bell System Presidents' conference held in New York from April 11 to 13.

H. J. VAN DER BIJL, who was a member of the Research Department in the early days of electronic development, and who wrote one of the first texts on the vacuum tube, has been made a Fellow of the Royal Society (London). He is at present vice-chancellor of Pretoria University and director of war supply, Union of South Africa.

ADMIRAL G. F. HUSSEY recently visited the Murray Hill laboratory to take part in an engineering conference. Those attending included R. L. JONES, M. J. KELLY, HARVEY FLETCHER, O. M. GLUNT, R. A. HAINSLIP, W. H. MARTIN, R. R. WILLIAMS, A. F. BENNETT, W. H. DOHERTY, A. H. INGLIS, R. E. POOLE, H. O. SIEGMUND, J. W.

SMITH, J. C. STEINBERG, G. N. THAYER, W. C. TINUS and C. F. WIEBUSCH.

T. C. FRY has been made a non-resident fellow of the Rochester Museum Association in recognition of his work with the National Defense Research Committee.

STEPHEN O. RICE, on April 25, spoke on the *Application of Contour Integration* before the Mathematics Symposium of the Basic Science Group, A.I.E.E., New York Section. This was the sixth and last lecture sponsored by the Group.

J. A. BECKER spoke on the history, development and uses of the electron microscope at the semi-annual spring meeting of the Catholic Round Table of Science, held at Cathedral College on April 22.

R. M. BURNS presided at the Annual Convention of the Electrochemical Society held in Milwaukee from April 12 to April 15. He presented the Presidential Address on *Electrochemistry in the Post-War World*.

“THE TELEPHONE HOUR”

(NBC, Monday Nights, 9:00 P.M., Eastern War Time)

JUNE 5, 1944

Tu lo sai	<i>Torelli</i>	The Rose and the Nightingale	<i>Rimsky-Korsakoff</i>
Novara la bella	<i>Traditional</i>	Bidu Sayão	
Ezio Pinza		Minuet from “Manon”	<i>Massenet</i>
Long Ago and Far Away	<i>Kern</i>	Orchestra	
from “Cover Girl”		A casinha pequenina	<i>arr. Braga</i>
Orchestra		Hey, Diddle, Diddle	<i>Hughes</i>
Largo from “Sense”	<i>Händel</i>	Bidu Sayão	
Ezio Pinza		Dance of the Comedians	<i>Smetana</i>
Kamarinskaya	<i>Glinka</i>	from “The Bartered Bride”	
Orchestra		Orchestra	
Au Pays	<i>Holmès</i>	Long, Long Ago—	<i>Bayly-Sandoval</i>
Ezio Pinza		with Three Variations	
		Bidu Sayão	

JUNE 12, 1944

Huckleberry Finn	<i>Grofé</i>		
from “Mississippi Suite”			
Orchestra			
Berceuse in D Flat, Op. 57	<i>Chopin</i>		
Etude in A Flat, Op. 25, No. 1	<i>Chopin</i>		
Etude (“Revolutionary”), Op. 10, No. 12	<i>Chopin</i>		
Robert Casadesus			
Malagueña	<i>Sarasate</i>		
Orchestra			
Concertstück in F Minor—	<i>Weber</i>		
beginning at “Adagio”			
Robert Casadesus and Orchestra			

JUNE 19, 1944

Prelude in G Minor	<i>Rachmaninoff</i>		
Orchestra			

JUNE 26, 1944

Baba Yaga	<i>Liadoff</i>		
Orchestra			
Alleluia from “Exsultate Jubilate”	<i>Mozart</i>		
Marian Anderson			
The Crickets Are Calling and	<i>Kern</i>		
The Siren’s Song from “Leave It to Jane”			
Orchestra			
My Way’s Cloudy	<i>Spirituals-</i>		
Hard Trials	<i>arr. Burleigh</i>		
Marian Anderson			
Londonderry Air	<i>Traditional</i>		
Orchestra			
Air de Lia from “L’Enfant Prodigue”	<i>Debussy</i>		
Marian Anderson			

Bell Laboratories' Club has no more tickets for these programs because its limited supply has already been distributed to applicants.

B. L. CLARKE was elected Chairman of the New York Section of the American Chemical Society for 1944-45. He was also appointed Vice-Chairman for the 108th meeting of the American Chemical Society to be held in New York in September. During the month of April Dr. Clarke visited the Aluminum Company of America Research Laboratory at New Kensington, Pennsylvania, to confer on chemical analysis problems. He also attended a convention of the American Chemical Society at Cleveland. On that trip he attended a meeting of the Advisory Board of *Industrial and Engineering Chemistry*.

A SERIES of motion pictures, *A Look at Life and Motion*, was presented before the New York Microscopical Society on April 21, at the Museum of Natural History, by F. F. LUCAS.

E. S. GREINER of the Chemical Laboratories recently received his Ph.D. degree from Columbia University under the Part-Time Graduate Plan of the Laboratories. On May 2, Dr. Greiner and R. G. HUMPHREY, who received his Ph.D. from Columbia in 1929, were initiated into the Columbia University Chapter of Sigma Xi.

H. H. ABBOTT recently attended a meeting of the Ohio State Chapter of Sigma Xi at which he was transferred from an Associate to a full Member.

ROSE KOZAK visited the Airplane Engine Research Laboratories of the National Advisory Committee of Aeronautics at Cleveland, the Gulf Research Laboratories at Pittsburgh and the Naval Research Laboratory in Washington on lubrication research problems.

F. S. MALM and G. N. VACCA were at the Point Breeze plant in connection with insulated wire and cable problems.

Fall Harvest Show

Plans are being shaped by Bell Laboratories Club for a fall harvest and canning show at which you may exhibit your biggest ear of corn, your most luscious tomato or your finest canned fruits and vegetables in competition with other members of the Laboratories.

PROBLEMS RELATING to the manufacture of crystals took W. L. BOND, I. E. FAIR, T. G. KINSLEY, W. P. MASON, H. J. MCSKIMIN, R. A. SYKES and G. W. WILLARD to Hawthorne.

DURING THE month of April R. A. SYKES went to Camp Coles, New Jersey, to discuss quartz crystals; to the Ucinite Company, Newton, Mass., crystal holders; and to the Atlas Spring Company, Chicago, spring details for crystals.

G. G. WINSPEAR spent several days at the Ward Products Company, Cleveland, and at the B. F. Goodrich Company, Akron, in connection with synthetic rubber problems.

C. V. LUNDBERG visited the rubber shop at Hawthorne to observe factory processing of Paracon.

A. C. WALKER attended the convention of the American Chemical Society held in Cleveland. He visited the Brush Development Company while in Cleveland.

PAPERS ENTITLED *Structural Features of GR-S in Relation to Physical Properties*, by A. R. KEMP and W. G. STRAITIFF, and *Pigment Incorporation in GR-S Through Latex*, by W. McMAHON and A. R. KEMP, were presented before the Rubber Division of the American Chemical Society.

P. MERTZ presented the first of six lectures on the general subject *Television* sponsored by the Communication Group, A.I.E.E., New York Section. Mr. Mertz' subject was *Fundamental Principles*.

Fundamentals of Telephony, a book by Arthur L. Albert published by McGraw-Hill, was reviewed by H. A. AFFEL in the April issue of the *Proceedings of the I.R.E.*

D. A. QUARLES has been nominated as a candidate for Director of the A.I.E.E.

THE LABORATORIES were represented in interference proceedings at the Patent Office in Richmond by J. W. SCHMIED and W. F. SIMPSON.

MISS M. C. BRAINARD spoke at the Vocational Conference for junior and senior girls at Hunter College, New York City, on March 29. Her topic was *How to Prepare for Work in the Bell Telephone Laboratories*.

C. D. HANSCOM, on April 18, addressed the Morris County Engineers Club at Morristown, N. J., on *War Developments of Bell Telephone Laboratories*. The talk was illustrated by slides and exhibits. The speaker



O. M. Glunt, Director of Whippany Radio Laboratories, tosses out the first ball at the season's opening game on May 8, when the South Wingers, in an exciting three-inning battle, were nosed out by the Air-Borne Dodgers, 4 to 3

was introduced by O. B. JACOBS of the Laboratories.

LAST MONTH ANNA MULGREW was listed as completing fifteen years of service in the Bell System. Actually, on April 17 she completed ten years of service with the Laboratories and at that time credit was extended for her previous service with the New York Telephone Company, bringing her total service as of that date to twenty-one years and nine months.

M. D. RIGTERINK and G. GOODMAN attended the annual meeting of the American Ceramic Society held at Pittsburgh from April 3 to 5.

G. DEEG and A. B. HAINES visited the Sharon plant of the Westinghouse Electric and Manufacturing Company to observe transformer treatments.

C. J. FROSCH was at Marion, Va., at Grand Rapids, Mich., and at Hawthorne in connection with plastic problems.

AT HAWTHORNE, M. D. RIGTERINK and G. GOODMAN discussed resistors and C. J. CHRISTENSEN, crystals and resistors.

W. O. BAKER visited the Dow Chemical Company, Midland, Mich., and Wayne University, Detroit, in connection with synthetic rubber developments.

AT THE Pittsburgh meeting of the American Physical Society the following papers were presented by members of the Laboratories: *Historical Background of Electron Optics* and *Energy Distribution of Electrons Within Dense Electron Beams* by C. J. CALBICK; *The Magnetically Focused Radial Beam Vacuum Tube* by A. M. SKELLETT; and *Limiting Stable Current in Electron Beams in the Presence of Ions* by J. R. PIERCE.

IN THE March issue of the *Proceedings of the I.R.E.* there are articles by M. BROTHERTON on *Paper Capacitors Under Direct Voltages* and by F. B. LLEWELLYN and L. C. PETERSON on *Vacuum-Tube Networks*.

W. P. MASON was the author of an article, *Low-Frequency Quartz-Crystal Cuts Having Low-Temperature Coefficients*, published in the April *Proceedings of the I.R.E.*

A. J. CHRISTOPHER, at the General Electric Works, Pittsfield, discussed capacitors.

R. W. DEMONTE, J. F. NUNER, F. K. DEVOE and H. P. KNEEN were at the Magnetic Windings Company, Easton, to observe the manufacture of power coils and transformers.

H. A. STONE and J. R. BARDSLEY visited the Eatontown Signal Laboratory, Fort Monmouth, to discuss loading coil problems.

AT THE Hawthorne plant of the Western Electric Company W. J. KING and V. H. HEITZMANN spent considerable time on high-voltage cable and connector problems.

C. A. WEBBER discussed cable and wire problems at Hawthorne and high-voltage cables and connectors at the Aircraft Radio Laboratory, Dayton.

N. INSLEY visited the Stupakoff Company, Latrobe, Pa., in connection with glass-seal terminals.

R. T. STAPLES discussed cord development problems at the Point Breeze plant of the Western Electric Company.

J. H. BOWER visited the battery plants of the National Carbon Company at Fremont and Cleveland.

R. H. COLLEY visited Spartanburg, S. C., in connection with the machine shaving of southern pine poles.

G. Q. LUMSDEN, W. McMAHON and J. LEUTRITZ, JR., inspected wood specimens treated with various preservatives under exposure at the Gulfport, Mississippi, test plot. Mr. Lumsden visited W. C. Meredith Company, wood conduit manufacturers, at Atlanta, Ga. He also witnessed vapor-drying experiments of large-size timbers at the Taylor-Colquitt Company, Spartanburg, S. C.

A. P. JAHN recently inspected the metal samples exposed on outdoor test racks at Bridgeport, Sandy Hook, State College and Pittsburgh. C. D. HOCKER attended the Sandy Hook inspection.

Your Copy of the RECORD

Requirements for servicemen's families are now being met by copies of the RECORD that are being returned by members of the Laboratories when they have finished reading them. Keep up the fine work by placing your copy in the "Correspondence-Out" box when you are through with it.

W. H. S. YOURY recently visited Norfolk to cooperate with the Western Electric Company in examining a lot of friction tape.

C. G. MILLER is accompanying a party of A T & T engineers who are holding a series of conferences with Pacific Company engineers. Meeting in Seattle, San Francisco, and Los Angeles, they will discuss equipment problems and developments which can be included in plans for post-war construction.

G. E. BAILEY went to Boston to study cabling problems for toll switchboards.

J. W. WOODARD and S. F. BUTLER, at Hawthorne, discussed telephone equipment.

W. G. SCHAEER and C. E. MILLER visited the Signal Corps Plant Agency in Philadelphia to discuss Army switchboards.

H. M. SPICER went to the R. W. Cramer Company, Centerbrook, Conn., and to the General Electric Company, Schenectady, on control problems.



Helping to serve nourishing meals to the Laboratories' army of war workers is the work of girls like these. On the left are Margaret Schenck and Lucille Collin at the steam table of the Murray Hill Restaurant. In the picture on the right are Mildred Manuel and Marie Millard with salads they have prepared for lunch at the West Street Restaurant

Women of the Laboratories — Outside Activities



Lillian Guberman

HER DRAFTING WORK over for the day and household chores attended to, LILLIAN GUBERMAN of the Apparatus Development Department turns her hand to painting for relaxation. Mrs. Guberman's favorite medium is water colors, and although she takes up her brush and palette now solely to recreate herself, the time was when her after-hours hobby was remunerative. In those days she always had orders far in advance of her work, and her home in Flatbush was a busy studio. More recently she has done caricatures for and edited the booklet *Horrors of War*, prepared for the Apparatus Drafting Room and its men in service, and

she has done a few sketches for the RECORD. Mrs. Guberman was graduated from the School of Architecture of Pratt Institute and used her training in the field of architecture and then advertising before the war brought her to Bell Laboratories to help in the development of war devices for the Armed Forces.

Graybar-Varick Girls Bring Cheer to the Wounded

On Thursday evenings at five-thirty a group of Bell Laboratories girls from the Graybar-Varick Building may be seen hurrying along to Staten Island to visit wounded soldiers at Halloran General Hospital. They are ANNETTE GAETA, MARGARET SWEENEY, YOLANDA NICASTRI, MARGARET MOORE, and ETHEL LYNN. Before leaving for the hospital they have received ten or twelve dollars in five-cent donations from members of the Laboratories. This sum will buy "cokes" or ice cream for a ward of nearly one hundred men. At the hospital gates, the girls are met by a member of the Bethlehem Steel Company Club who vouches for them and drives them to the hospital.

At this point the Bethlehem Steel group have already gathered, and, having a much larger membership than the Laboratories' group, have brought games and gifts which will help the wounded to rehabilitate themselves and become happy, useful citizens. During the evening the Laboratories girls help the soldiers to use their gifts, wheel them to movies, or just visit them.



LILLIAN GUBERMAN



These girls from the Graybar-Varick Building were ready to visit Halloran General Hospital when their pictures were taken. They are, left to right, Margaret Moore, Annette Gaeta, Yolanda Nicastrì, Margaret Sweeney and Ethel Lynn

Mrs. Gaeta, of Graybar-Varick and now on leave of absence, became interested in the work which that Bethlehem Steel group is doing for wounded servicemen through her husband, who works at Bethlehem Steel. While the part which the Laboratories' girls are playing is small, nonetheless it helps the men a great deal. To "adopt" a ward of wounded men such as Bethlehem Steel has done requires a great deal of time and considerable money. However, it is hoped that more members of the Laboratories will become interested in the work, and that some of them, or their friends, will find collecting funds and buying gifts for a ward an outlet for her energy and ability and a godsend to the soldiers at Halloran General Hospital.

* * * * *

WHEN HER DAY at the drafting board of the Systems Development Department is over, DORIS KNIGHT has little time to do more than knit small items such as socks, helmets and gloves on the train to her home in Glenwood, Long Island. But, when Sunday, her only free day, rolls around she forfeits her rest and her recreation to man

the ambulance of the North Country Community Hospital, Glen Cove, where, as a member of the American Red Cross Motor Corps, she is in charge of the ambulance crew. Before being allowed to clang the bell of an ambulance and race it to emergencies, Miss Knight had to pass with high ratings the Standard and Advanced First Aid Courses; the Motor Mechanics course to learn how to take a car motor apart, repair and assemble it; and the Police Driving Course, which included blackout and obstacle driving such as weaving in and out between stanchions. She also has to help bear the stretchers, no easy task for a crew of girls. Giving up her Sundays does not seem too much to Miss

Knight who until a short time ago spent every other Saturday night from 10:00 P.M. to 7:00 A.M. on Sunday at the hospital ready for ambulance calls, and then did ambulance work in the daytime on alternate Sundays. Without volunteer work



DORIS KNIGHT

such as she does, ambulance service in small communities would have to be discontinued, she says. For her work, the Sea Cliff Branch of the Red Cross has awarded Miss Knight one service stripe for knitting and two for her Motor Corps work.

* * * * *

WRITING POETRY and scripts for radio programs, when time allows, is JOAN MULHERIN's forte after her work in the Benefit Department is over. Recently she has completed a course in radio script writing at Columbia, but so far she has not submitted any of her work for publication. However, her poetry has appeared in the *Washington Post* and has been favorably commented upon in letters of encouragement from Kenton Kilmer, son of Joyce Kilmer and a poet in his own right.

At Marywood College, where Miss Mulherin received her degree in English and Economics, she wrote and took part in plays and contributed to the college magazine. Later she studied Economics at the University of Pennsylvania and Economics and Spanish at the University of Havana. From Cuba she returned to Marywood and after graduation she came directly to the Laboratories where she is engaged in safety and compensation work in the Benefit Department. Having completed basic and advanced First Aid courses in the Laboratories, Miss Mulherin expects to qualify as a First Aid Instructor this fall.



JOAN MULHERIN

Bottled Hosiery

With stockings a major problem in every girl's wardrobe these days, it is well to consider wearing leg make-up instead of the real thing. Bottled hosiery is not only a great saving to one's budget, but most of it is entirely harmless according to medical authorities. *Glamour* in its May issue carries an article *Legs Show* which covers in detail the requirements for using leg make-up. There are a number of types of bottled hosiery available—lotions, creams and dyes—all of which will create the effect of bronzed chiffon-like stocks if they are properly applied. One coat of leg make-up is sufficient—the second application gives too dark an effect, is never flattering and has a tendency to blotch. Those who decide to save money by using bottled hosiery will have to forfeit a few minutes' extra sleep in the morning, because all types take much longer to put on than a pair of hose.

Engagements

Ensign Ernest J. Gsell, U. S. Navy—*Marjorie Albers
Francis J. Ochs—*Kathleen Culbertson
Robert C. Lewis, U. S. Army—*Grace Firsching
Richard A. Kingsley, U. S. Navy—*Katherine Gogarty
Everett Gilbert—*Norma Hyde
*Frank C. Kozak, U. S. Army—Doris Kopec
Louis F. Tremallo, U. S. Army—*Anne Schindo

Weddings

Leon Price—*Ensign Frances Elstein, U. S. Navy
Lt. Col. H. F. McManus, U. S. Army—*Helen Franzé
John Ohl, U. S. Army—*Ensign Claire Muller
*Alexander E. Gerbore, U. S. Army—
*Margaret Portelroy
Ernest Schieferstein, U. S. Army—*Anneliese Weiss

*Members of the Laboratories.

My Experiences in the Farm Cadet Victory Corps

BY ROSALIND STEINBERG

Perhaps you are one of those people who, upon seeing the colorful posters announcing the need for crop gatherers, merely shrug your shoulders and turn away. Possibly you tell yourself that you could be of no assistance to a farmer or that you needn't worry



U. S. Dept. of Agriculture

Are you wondering how to spend your September vacation? Girls like these above will be helping to harvest the apple crop in September. Why not join them?

about a matter seemingly far from our urban lives. "Let the other person do it," is your reaction. The other person, namely the writer, did do it last summer, by being a member of the Farm Cadet Victory Corps and part of a group quartered about thirteen miles below Hudson, New York.

To most of us, city-bred girls and women, farming was a completely different experience, yet to be explored and discovered. We lived a few miles from the Hudson River in small, rustic tourist cabins which, while not luxuriously furnished, were equipped with comfortable beds and chairs, and the necessary closets and protective screening. Across the main highway was a dining room and soda fountain, a popular rendezvous for the local gentry. About a mile away there was a wide creek which afforded many hours of cool and exhilarating swimming after a day in the fields. The surrounding Catskill country was dotted here and there with small towns, the intervening land occupied by farms and hills.

We arose at six every morning—to the insistent ringing of an alarm clock—and by six-thirty were ready to eat huge breakfasts, which kept us sustained until noon. At seven we climbed into waiting cars and trucks and the farmers drove us to their fields, in which there might be growing strawberries, beans, raspberries, tomatoes, cherries, or corn, according to the season.

After learning the proper method of picking or hoeing, we set to work, our sunhats bobbing up and down, our short sleeves and the pants of our jeans rolled up for comfort. We were paid by the quart or bushel at the standard county rate, which usually sufficed to pay our \$10 weekly room and board.

During the heat we sat under shady trees, ravenously consuming box lunches which we washed down with pitchers of creamy milk. At four o'clock, we again piled into the trucks and made the return trip while the wind cooled our perspired faces. After a shower or a swim and a change of

clothes, the late sun saw us comparing the day's experiences in the dining room, each girl trying to out-talk the next.

Saturday, which was our day of rest, was often spent at the creek, hitch-hiking to town for a movie, or just loafing. Other recreation consisted of dancing, church socials, picnics, baseball games with the local farm boys, or a game of darts.

Farming does not consist of crisp white pinafores and dainty fruit baskets, as the fashion magazines claim. It is mainly dirt and sweat, stiff joints and sunburn, but it can also mean a sense of pride in a hard day's work. Be doubly patriotic; work on a farm during your vacation—you'll help Uncle Sam with the food situation and at the same time you'll give yourself renewed vigor for your desk or bench job.

Remember—Food Will Win the War!

Victory Gardens

A few hundred copies of "Your Victory Garden Work Sheets," a very simple and yet comprehensive pamphlet on how to grow vegetables, are available and may be obtained from Mrs. C. A. Smith, Room 159, Extension 1449.

Mrs. Smith also has available a supply of application forms for Victory Vacationists.

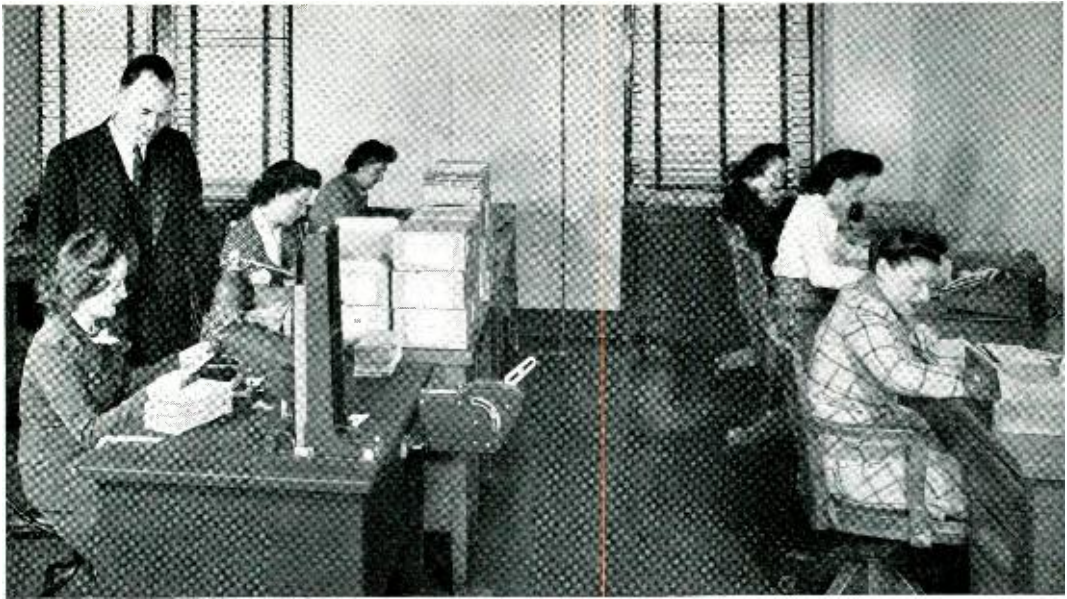

On April 2 the bond group of the General Accounting Department issued approximately 8,200 bonds with a maturity value of \$400,000, a record number issued at one time. 3,100 bonds with a value of \$157,000 represented bonds purchased on the Payroll Deduction Plan during the Fourth War Loan Campaign. 5,100 bonds with a value of \$243,000 were bonds purchased on the regular Payroll Deduction Plan. In the photograph, from left to right, are Gertrude McCormick, W. J. Darlington, supervisor of the bond group, Harriet Shadegg, Elsie Burger, Katherine Verry, Beatrice Haas and Millie Fenton

OWI Report on the Rehabilitation of Disabled Soldiers and Sailors

With the return home of wounded soldiers and sailors who have conspicuous physical disfigurements, disabilities or nervous manifestations, the Office of War Information advises that their readjustment and happiness will depend in large measure on the way their family, friends and the public behave toward them. The United States Government is affording them the most modern medical and psychiatric care, finest surgery and appliances, expert rehabilitation, vocational training and employment opportunities. However, much of this good work can be undone or will remain incomplete if the men's families, their friends and the public at large fail to behave with restraint, intelligence and consideration.

"It is only natural that maimed young men should think bitter thoughts, lose their self-confidence; it is the exceptional man who does not," the OWI advises. And so it passes along a number of suggestions, made by the Surgeon General of the Army, con-

cerning everyday behavior on the part of the public and acquaintances to lessen the inevitable difficulties of the adjustment of disfigured or disabled veterans. Briefly the suggestions are:

1. *Treat the maimed person as the normal person he was and continues to be.* The loss of an arm or a jaw or an ear may change the appearance of a man, but personality and character are not necessarily changed. It is true that he is most certain to be affected superficially and temporarily, until self-confidence is restored; but after that point his personality may even grow as a result of his knowledge that he has overcome his handicap and has won the respect of others.

2. *Don't ask questions or give advice.* The man who has been disabled or disfigured may want to talk about himself, or he may not. Respect his wishes. Do not mention his disfigurement unless he does. If he does not want to talk about himself, talk about things he is interested in or about objects in the room, or hobbies or details of common interest. Don't talk about the war or about

subjects related to his injury. Don't hint or pry. If he is eager to talk about himself, listen and try to understand what he wants to express.

3. *Be casual and realistic—not over cheery.* The man you go to visit may feel depressed. It is his right to feel so. It is an offense to his dignity and to his common sense to go into a routine of transparent “cheeriness.” Nor is it convincing or beneficial to try to minimize the crippling effect of maiming. By facing the reality of a man's disability yourself, you can help him to face it. Personal anxieties of all kinds lose their capacity to frighten if they are brought out into the

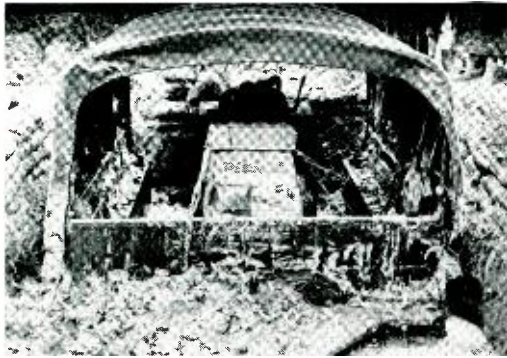

The protection of a deep emplacement proved the undoing of this truck carrying the computer for an M9 Electrical Director when a cloudburst descended

open are faced squarely and realistically.

4. *Don't wait on the injured man too much.* Even though a disabled soldier or sailor be surrounded by sympathy, waited on hand and foot by nurses and given countless attentions, he may still despair. He may view himself as a martyr. But if his faith in his ability to do things for himself is restored, the rest of the treatment is easy. One way to help him toward this is to repress the natural desire to help him at every turn. Don't keep offering to do things. Even if a man eats clumsily or holds a telephone with difficulty, let him do these things, within reason, of course. If there is something the patient can do for you, let him do it. Helping others is an important part of rehabilitation. The families of men who have returned to their homes will greatly cooperate by letting it be seen that they expect the wounded man to be self-reliant and cooperative, and by not being pessimistic or oversolicitous.

Gun Director Gets Mud Bath

During maneuvers in this country some months ago, two anti-aircraft batteries were set up on flat ground. Emplacements a few feet deep were dug for the M9 Electrical Gun Directors, and the walls revetted with sandbags. Suddenly a cloudburst descended, and before the equipment could be moved it was submerged in muddy water which filled the emplacement. While the engineers



After some of the mud was dug away, tow lines were attached and the trailer with its Electrical Director was hauled out of the mud hole

of the Bell Telephone Laboratories, who designed the equipment, had never planned on making such installations under water, they knew that certain vital parts must be wholly sealed against all moisture, to be usable in combat areas in the tropics. For the rest, automatic central offices of their design had been flooded, in Pittsburgh and elsewhere, and had been cleaned out and put back into service. So they made some suggestions, and the Ordnance Department troops got on with the job. As soon as the flood had receded, the gun crews dug the mud away and by means of chains dragged out the trucks containing the computers and altitude converters. After washing the exterior of the apparatus, the covers were removed, and the mud thoroughly washed out with a hose. Each part was cleaned and dried, a few replacements made and the whole re-assembled. On final test, everything functioned perfectly, and when visited some months later by an engineer of the Laboratories no latent troubles had developed. It is understood that at least one of these Directors has since gone overseas to a combat area.

H. C. Caverly Retires

H. C. CAVERLY of the Systems Development Department, with over forty-four years of Bell System service, retired at his own request on May 31 with a Class A pension. His association with the telephone industry began with the New England Telephone and Telegraph Company in 1900. His first work in the



Central Division, which at that time included Massachusetts and New Hampshire, was subscriber-station installing on which he worked for three years. He was appointed Manager of the Southbridge Central Office in 1903, and in 1906 assumed similar charge at Marlboro.

In 1909 Mr. Caverly went to Worcester as private-branch exchange and central-office installer, and came from that city to

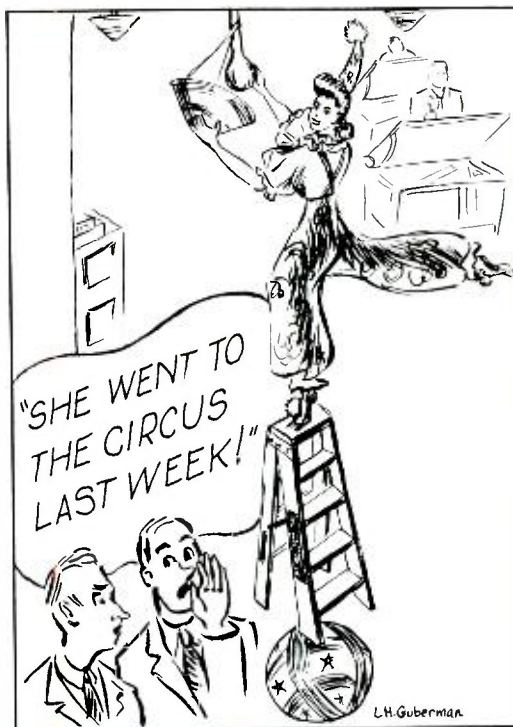

what is now the Laboratories in 1919. His work in the Switching Development Department since that time has been devoted entirely to sender and decoder development of the panel and crossbar local dial and tandem systems.

Bond Buyers Make Good Showing

For the month of March, the latest on which figures are available, the Laboratories stood fourth among Bell System companies in percentage of eligible employees participating in payroll deduction purchases of war bonds: 94.23 per cent. In ratio of deductions to wage payments, we were second with 10.64 per cent.

March figures included the special allotments made at the time of the previous war bond campaign.

New Western Electric Plant at Scranton

Under an agreement made on May 11, the Western Electric Company will take possession of the Defense Plant Corporation's factory at Scranton, Pennsylvania. This expansion of the Company's war production was arranged through the Signal



The Annual Journal Award of the S.M.P.E. was presented to W. L. Bell (left) and R. R. Scoville on April 19 in recognition of their joint paper "Design and Use of Noise-Reduction Bias Systems"

Corps. It will enable Western Electric to transfer a portion of its wire and wire-products operations from the Point Breeze plant in Baltimore, Md., where additional production for the Armed Forces will then be undertaken.

The Scranton plant adds approximately 87,000 square feet of manufacturing space to Western Electric's facilities. Training of

employees at the new location will begin as soon as equipment formerly used in the production of aircraft piston rings can be removed. Finishing operations on wire, cords and cable, according to Western Electric, will give employment to about 1000 people, most of whom will be women. Shipments from Scranton will begin within 60 days, it is estimated. Present plans anticipate a two-shift, six-day work week.

Flamethrowers Prove Effective Weapons

The Army's flamethrower, designed and made by the Chemical Warfare Service, has proved an effective weapon in dislodging holed-in Japs because its tongue of fire can dart through the narrow slits of the pillboxes that are holding up an advance. Out of action, the flamethrower looks like a harmless gadget for spraying insecticide, but in action it resembles a giant blowtorch. The M1A1 portable flamethrower consists of fuel and pressure tanks strapped to the operator's back like an infantry pack and connected by a short hose to a rodlike discharge piece carried in the hands like a rifle. The pair of steel fuel tanks holds heavy oil, and an attached cylinder contains compressed air or nitrogen. In addition, there is a small cylinder fixed to the flamegun containing hydrogen, which is

May Service Anniversaries of Members of the Laboratories

<p>10 Years</p> <p>Daniel Breen Elsie Cooper Franklin Dermond Mary-Ellen Kamper Mary MacDonald Justine McDevitt Hazel Norris Lena Penna Albert Rodell J. P. Rulison Frank Schuler W. C. Sturzenegger Dorothy Walsh H. S. Wertz</p>	<p>L. T. Anderson H. I. Bowman Patrick Coleman John Connor E. B. Destler E. K. DeVoe H. F. DuBois T. A. Durkin Ludwig Fichter C. F. Flint O. R. Garfield William Gulker Ernest Guzmich W. L. Hardardt A. O. Koestle Francis McConville J. F. Middleton Theodor Olsen E. L. Owens</p>	<p>R. E. Ressler R. A. Sykes G. W. Turner David Westbrook J. F. Wursch G. E. Yeaton C. S. Yeutter</p> <p>20 Years</p> <p>C. E. Fordham L. W. Giles W. F. Kannenberg W. D. Mischler</p> <p>25 Years</p> <p>J. L. Agterberg</p>	<p>F. G. Colbath P. B. Fairlamb R. H. Galt F. J. Given J. L. Hysko F. A. Kuntz G. T. Lewis M. B. Long J. T. O'Leary Eugene Peterson Leonard Vieth J. F. Wentz</p> <p>30 Years</p> <p>Frank Wallenius</p> <p>35 Years</p> <p>W. H. Long</p>
--	--	---	--

used to ignite the fuel oil much as a pilot-light starts a kitchen stove.

Just before the flamethrower goes into action, valves on each of these tanks are opened to release the chemicals into the working end of the gun. As the operator approaches his target, he presses a button which releases a stream of hydrogen from the brass nozzle and, at the same time, actuates a spark plug to ignite the hydrogen. Within range of the target, the operator fires by squeezing a trigger valve at the rear of the flamegun. This valve allows the fuel oil to spurt through the nozzle, catching fire as it mixes with the hydrogen flame.

With Diesel-type oil, the M1A1 has a moderate range in still weather. The blazing oil emerges as a narrow lance which starts to taper into a cone of flame. At the receiving end, the flames form a ball of fire several feet in diameter. A newer type fuel, consisting of jellied oil which clings to its target as it burns, gives the flamethrower a longer range. The flamethrower is capable of a sustained burst lasting about 15 seconds but is generally fired in a series of two-second bursts. The tanks, filled, weigh about 60 pounds and the flamegun about eight pounds more.

The flamethrower was introduced by the Germans in World War I. One of the first recorded uses of the American M1A1 in the current war was on Guadalcanal in 1942. There, soldiers trained on the spot by chemical officers destroyed Jap pillboxes that had withstood aerial bombardment and heavy shelling. Fifty-four Jap bunkers were captured in the New Georgia sector with flamethrowers.

On Guadalcanal, the flamethrowers were used on concealed Jap nests. The flanking flamethrowers opened fire first, burning a path through the dense vegetation to give the pivot flamethrower a clear shot into the embrasure. In a New Georgia operation, three adjoining pillboxes were knocked out in two minutes with flamethrowers.

June 1944

Motion Picture Camera Club

Prize-winning pictures in the annual contest that was conducted by the Motion Picture Camera Club were:

Scenario or Story Class: "Auntie in Moccasins," J. J. HARLEY, first prize; and "An O.D.T. Convention," J. R. HEFELE, second.

Family or Documentary Class: "Pastoral Symphony," F. FRAMPTON, who also received the Grand Award for his picture.

Travel or Pictorial Class: "Florida," J. S. LEONARD, first prize; "Lake Placid," J. J. HARLEY, second; and "World's Fair," J. R. LEONARD.

Officers elected at the May 17 meeting to serve during the 1944-1945 season were J. C. VOGEL, chairman; HELEN CRUGER, secretary, and, as members of the committee, R. R. BLAIR, H. L. BOWMAN, F. FRAMPTON, R. J. GOTTA, F. H. GRAHAM, J. J. HARLEY, J. R. HEFELE, A. L. JOHNSRUD and G. S. MUELLER.

* * * * *

T. C. M. WOODBURY of the Apparatus Development Department died on May 4. Mr. Woodbury graduated from Wentworth Institute, Boston, in 1916. In 1931 he received the LL.B. degree from St. Johns College and the LL.M. from St. Lawrence University in 1933 and was admitted to the New York bar in 1934. He joined the Apparatus Drafting Department of the Labora-



Signal Corps Photo

Flames on enemy fort caused by flamethrower during maneuvers at Camp Bullis, Texas

433



T. C. M. WOODBURY
1896-1944



A. F. HARPER
1896-1944

tories in 1924, after spending several years with the B. F. Sturtevant Company and the Holtzer-Cabot Electric Company. From 1931 to 1940 he was instrumental in establishing the common drafting standards and the associated common drawing system now in use by the Western Electric Company and the Laboratories. It is this system of standards which makes it possible for the Laboratories' drawings to be used for manufacturing purposes, thus eliminating much of the drafting duplication existing up to that time. Since then, in the materials standards group of the Switching Apparatus Development Department, he had been engaged in laboratory work on standardization problems. His most recent activity was the determination of basic characteristics of insulating materials in the arrangement of this information so as to permit its ready use in design problems.

A. F. HARPER of the Radio Research Department died suddenly on April 28. Mr. Harper received the E.F. degree from Stevens Institute of Technology in 1922. His college work was interrupted in 1917 and 1918 when he served in the Signal Corps. He joined the Research Department of the Laboratories in 1922 and for a short time was at the Deal radio laboratories. Late in 1923 he transferred to the AT&T where, in the D & R, he was concerned with measurements pertaining to long-wave transatlantic radio. In this connection he spent several years at Belfast and Houlton, Maine.

When the D & R consolidated with the Laboratories in 1934, Mr. Harper became a member of the High-Frequency Transmission Department where he was engaged in the development of ultra-short-wave radio. Three years later he transferred to Radio Research and was associated with the design of the equipment for the Musa installed at Manahawkin in 1939. Following this he was concerned with general short-wave radio development and, since 1941, with the preparation of instruction bulletins covering radio equipment for the Armed Forces.

Mr. Harper was the author of the book *Rhombic Antenna Design* (Van Nostrand) and of several technical papers.

* * * * *

ALBERT LAUDAN, a lathe operator in the Development Shop Department, died on April 29. Mr. Laudan came to the Laboratories early in 1942 and, since September, 1943, had been on a disability leave.

During the Months of March and April the United States Patent Office Issued Patents on Applications Previously Filed by the Following Members of the Laboratories

- | | | | |
|---------------------|--------------------|---------------------|------------------|
| F. B. Anderson | H. W. Goff | R. F. Mallina | H. W. Nylund |
| G. E. Atkins | K. E. Gould | W. P. Mason | H. Nyquist |
| R. S. Bailey (2) | C. B. Green | W. H. Matthies | W. A. Phelps |
| M. W. Baldwin, Jr. | E. I. Green | B. McKim | K. W. Pflieger |
| J. R. C. Brown, Jr. | N. I. Hall | O. Myers | L. D. Plotner |
| J. R. Davey | R. V. L. Hartley | C. G. Miller | S. P. Shackleton |
| C. Depew | C. N. Hickman | M. E. Mohr | F. F. Shipley |
| T. L. Dowey | F. A. Hubbard (3) | N. Monk | F. J. Singer |
| A. S. Dubuar | F. A. Kuntz | D. L. Moody | B. S. Swezey |
| W. A. Edson | W. Y. Lang | C. R. Moore | O. L. Walter |
| F. S. Entz | C. A. Lovell | I. W. Morrison, Jr. | G. W. Willard |
| E. B. Ferrell | J. J. Mahoney, Jr. | N. D. Newby | S. B. Wright |
| E. W. Gent | | | G. R. Yenzen |

Flatness and Parallelism in Quartz Plates

By G. M. THURSTON
Radio Development

USING a good plane and his technical skill, a carpenter can finish a board so that its two surfaces will be flat and parallel—flat and parallel, that is, to the requirements of any use to which the board is likely to be put. Precise measurements would probably show deviations from true parallelism by one or two-hundredths of an inch at least, but for practical purposes in carpentry, such small deviations may be neglected. Working with steel and machine tools, one could with care reduce the deviations in parallelism to a few thousandths of an inch, or even a few ten-thousandths, where the best tools and techniques are employed. Perfection in flatness might almost seem to have been obtained. In a crystal plate used for controlling an electrical oscillator, however, deviations in parallelism of a few ten-thousandths of an inch would be gross and intolerable. For most of the crystal plates now being produced in large quantities by the Western Electric Company for our Armed Forces, deviations in parallelism cannot be allowed to be more than a few millionths of an inch.

In cutting the plates from the original quartz crystals, many surfacing steps are required as already described in the RECORD,* but it is only after the plate has attained approximately its final size that these very high precisions become necessary. At all stages the surfacing is done by lapping, but the particular method used varies with the stage in the process at which it occurs. For the final stage, extreme care must be taken to secure the required precision. The method



that has long been in use employs two annular shaped laps of gridded cast iron between which eighteen or twenty crystals are placed. The crystals are held in position by a “nest”—a sheet of zinc or fiber slightly thinner than the finished crystal, and with rectangular or pentagonal holes in it at evenly spaced intervals to hold the crystals. One lap and the nest are as indicated in the upper part of Figure 1. As set up for use, these would be as shown in the lower diagram. The nest is rotated eccentrically by a pin through its central hole projecting down from an arm which is attached to the shaft of a drill press.

As the drill press turns, the center of the nest is rotated in a circle of radius equal to the length of the arm connected to the drill press shaft. If the nest were held so that any diameter retained the same direction as the drill press turned, each crystal would follow a path like that indicated by the circle A in Figure 2. If, on the other hand, the connecting pin were rigidly fastened to the nest so that the nest rotated with the driving arm, each crystal would rotate in a path

*RECORD, April, 1944, p. 359.

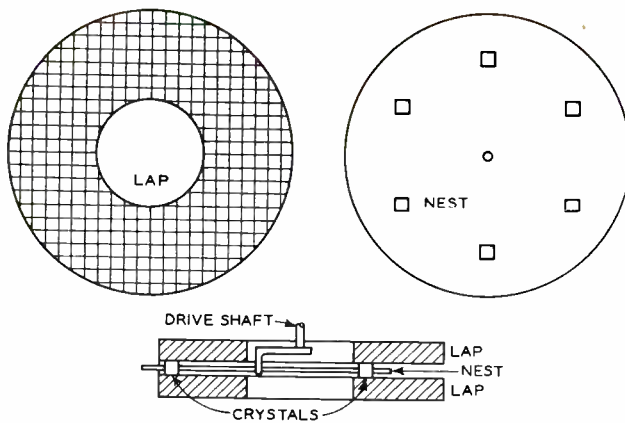

Fig. 1—Above and at the left is one of the two laps used for surfacing crystals; at the right is the “nest” in which the crystals are placed; in the lower illustration, a cross-section of nest, crystals, and laps, with eccentric drive for nest is shown

concentric with the center of the drill press shaft as indicated for one crystal by circle B. Actually, the crank pin is free to turn in the nest, and as the nest rotates, the friction between crystal and lap, and between the pin and the nest, exerts forces, with the result that the path of the crystal is a compromise between these two circles, and takes the general form of curves C and D. Because the frictions between crystals and lap vary, however, the path followed may change from moment to moment, and there is no assurance that all points of the lap will be passed over by the crystals. It is almost inevitable that certain regions will get more wear and others less. High and low regions tend to form on the lap as a result, and having formed, increase. These in turn lead to uneven grinding of the crystals. To secure better results, a positive control of the motion of the crystal was needed that would insure that the crystal passed over all points of the lap on a regular cycle. To explore the possibility of meeting this objective, engineers of the Laboratories undertook the de-

velopment of a modified machine.

Curves of the form C and D result from combining two rotations of the crystal: one around a circle such as A, and the other around a circle such as B. By controlling the relative directions and speeds of these two rotations, the resulting path can be made either of form C or D and with the loops as wide or narrow as desired. In designing a new lapping machine, therefore, mechanisms were provided to impart two positive controlled rotations to the crystal, one corresponding to curve A, and the other to curve B. The relative speeds of the two rotations were selected so that over one complete cycle, each crystal would pass over every part of the lap. In this way, the variations in the path of the crystal that lead to irregularities in grinding are avoided.

The two motions desired are secured by inserting, between the drive shaft and the pin that moves the nest, the gear train and linkage shown in Figure 3. The motor drive shaft is connected to gear B which is fastened

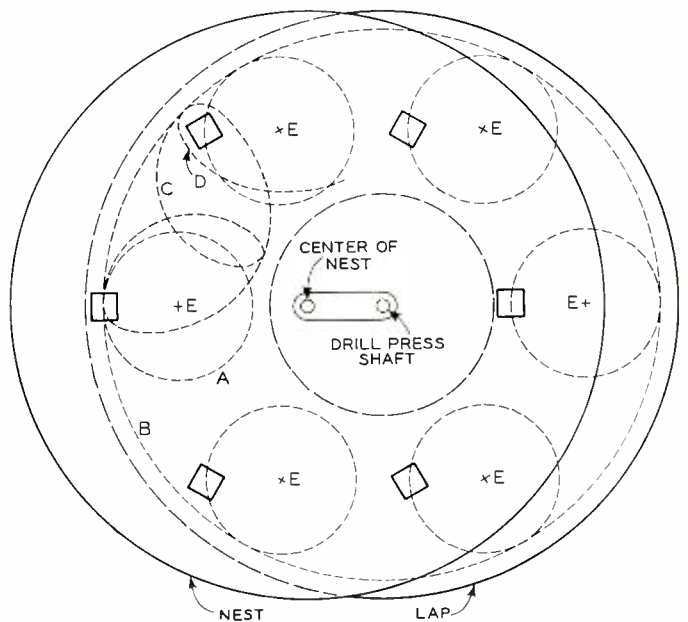

Fig. 2—Crystals may follow various tracks, such as those shown by dashed lines C and D, on the lap, depending on the speed of rotation of the nest around its own axis relative to its rotation about the center of the lap

to the flat cylinder *J*. This cylinder carries an arm *G* which has a pin near one end that fits into a hole in the lower end of *L*. The eccentric distance of this pin from the axis of the motor drive shaft may be adjusted by moving *G* in slides fastened to *J*. The flattened end of *M*, which is rigidly fastened to *K* and *L*, fits into a rectangular slot in the center of the nest, and thus the nest does not turn around *L*.

The motor drive shaft carrying gear *B* passes through a hole in a circular plate *A* that is mounted so as to be free to rotate, but is not attached to the drive shaft. Plate *A* carries two spindles; on one is gear *C*, and on the other gears *D* and *E*. Gears *B*, *C*, and *D* are in mesh, and as gear *C* has the same number of teeth as gear *B*, it rotates at the same speed—driven through gear *D*. Gear *C* carries an arm *H*, which, in turn, has a pin *N* the same distance from the axis of *C* as *L* is from the axis of *B*. Pin *N* in turn fits into a slot in the end of *K*, thus *M*, *K*, and *N* move as do the two driving wheels and the connecting rod of a locomotive. This is shown more clearly in Figure 4. Here one position is shown in heavy lines and other positions in dotted lines. With such a linkage, the arm *K* maintains the same direction at all times, and the flattened end of *M*, which fits into the nest, similarly maintains the same direction. If these were the only elements involved, the motion of a single crystal would be like curve *A* of Figure 2, each crystal being rotated around a center such as *E*. This motion is modified, however, by the action of gear *E*.

As the latter gear turns, it travels around the ring gear *F*, and in doing so, it rotates the plate *A*, turning it around the motor drive shaft. As plate *A* rotates, it carries *C* and *D* with it, and thus has the effect of rotating the centers *E* of Figure 2 a certain angular distance around the drive shaft for each revolution of the crystals around circle *A*. The gear ratios are such that plate *A* makes one

revolution for each thirty revolutions of gear *B*, and thus for each rotation of the crystal, the center *E* around which it is rotated is moved 12 degrees around the axis of the drive shaft. This results in a path of the crystal on the lap similar to *c* of Figure 2, and insures the uniformity of motion needed to get equal wear on all parts of the lap.

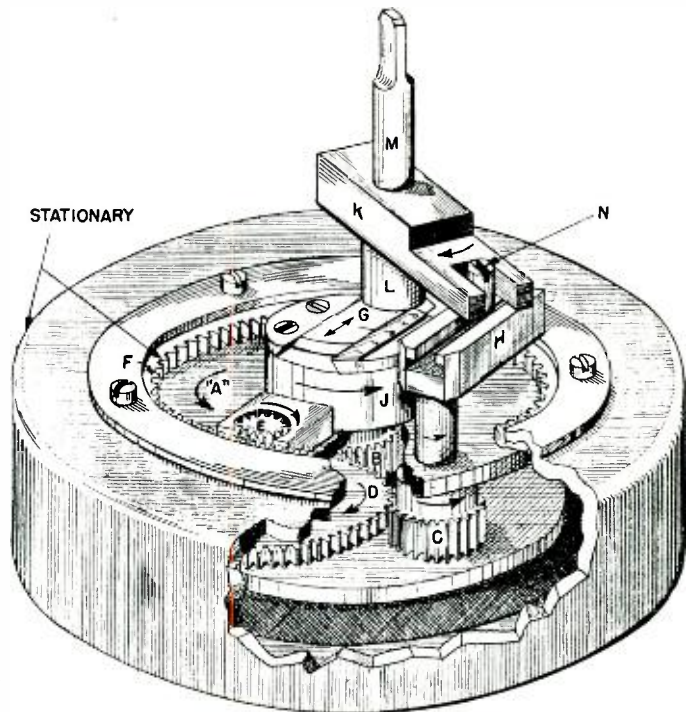

Fig. 3—Driving linkage used for the new lapping machine to obtain even grinding of crystals

These features were incorporated to obtain more uniform wear on the laps. Two other modifications were incorporated, however, to obtain more uniform abrasion on all parts of the crystal. Instead of placing the crystals directly in the openings of the cage, they are placed in small disc retainers of the same thickness as the nest, and these retainers are placed in circular openings in the nest. If a round crystal is to be lapped thin the retainers are omitted. The effect of the relative motion between plate and lap is to rotate the crystals and their retainers within the nest, and thus as the crystal goes through its positively controlled motion, it also turns on its own axis. A similar rotation has been secured by making the openings in the nest pentagonal and somewhat larger

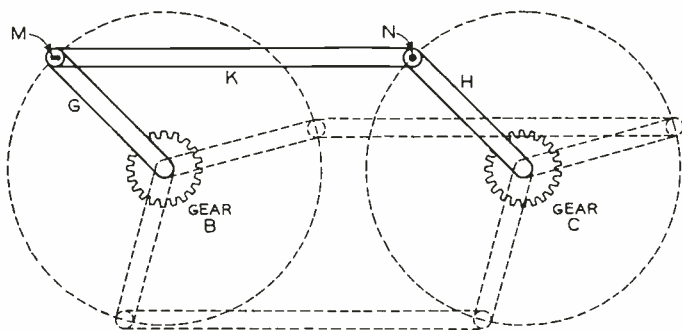

Fig. 4—By using two rotating arms of equal lengths, tied together by a connecting rod at their ends, parallel motion is secured for a pin connected to the connecting rod. Various positions are shown by the solid and dashed lines

than the crystals so that the crystals can rotate within them. With this method, however, there is danger of damaging the corners of the crystal as they hit against the surfaces of the pentagonal nest opening, while with the new method, the corners and edges of the crystal are protected by their retainers.

One other cause of possible uneven grinding of the crystals is that the abrasive which is painted over the surface of the lap is forced under the edge of the crystal as the latter moves over the lap. Each particle of abrasive that reaches the center of the crystal does so only after passing first over some part of the outer section of the crystal. The particles of abrasive that reach the center of the crystal, therefore, are somewhat more worn, and thus less effective in cutting, than they were while grinding the outer sections. There is thus a tendency for the crystal to grind convex—less material being removed from the center than from the periphery.

This effect is corrected in the new lapping machine by reducing the width of the lap surface, and by arranging the motions so that part of the crystal is off the lap at both the outer and inner portions of its travel. The central part of the crystal is thus being worn all the time, while the outer section has a rest period at the outer and inner positions of its curve of travel. By properly proportioning the width of the lap surface to the amount the crystal overshoots it, the tendency to convex grinding can be corrected. If it is desired to produce crystals with varying degrees of convexity, which is some-

times the case, the symmetry of the convexity can be held very accurately.

With these various provisions there still remains one effect that might lead to small irregularities in grinding. If both upper and lower laps were held fixed, any residual tendencies to uneven wear would affect both upper and lower lap over the same regions, and thus there would be a tendency for regions to appear where the distance between the laps would not be uniform. To some extent, this

is self-correcting, since the regions of small separation would tend to grind faster because of their greater pressure on the crystal. To avoid this tendency altogether, the upper lap is held fixed, but the lower lap is slowly rotated by a chain drive connected through reducing gears to the motor. The position of the lower lap is thus constantly changed relative to the upper, and any tendency to uneven separation is avoided.

THE AUTHOR: G. M. THURSTON of the Commercial Products Development Department entered the student course of the Engineering Department of the Western Electric Company in 1919. He then joined the radio research group where he was concerned with circuit development. He was associated with the development of transatlantic radio and in this connection made a field survey of the transatlantic short-wave project. He was also closely associated with the development of ship-to-shore radio, particularly the initial installation on the *Leviathan*.



From 1922 to 1926 he studied at Columbia University and in 1927 at the Polytechnic Institute of Brooklyn. Since 1930 most of Mr. Thurston's work has been concerned with investigations of quartz crystals. This has covered dimensioning and lapping techniques and the development of testing equipment.

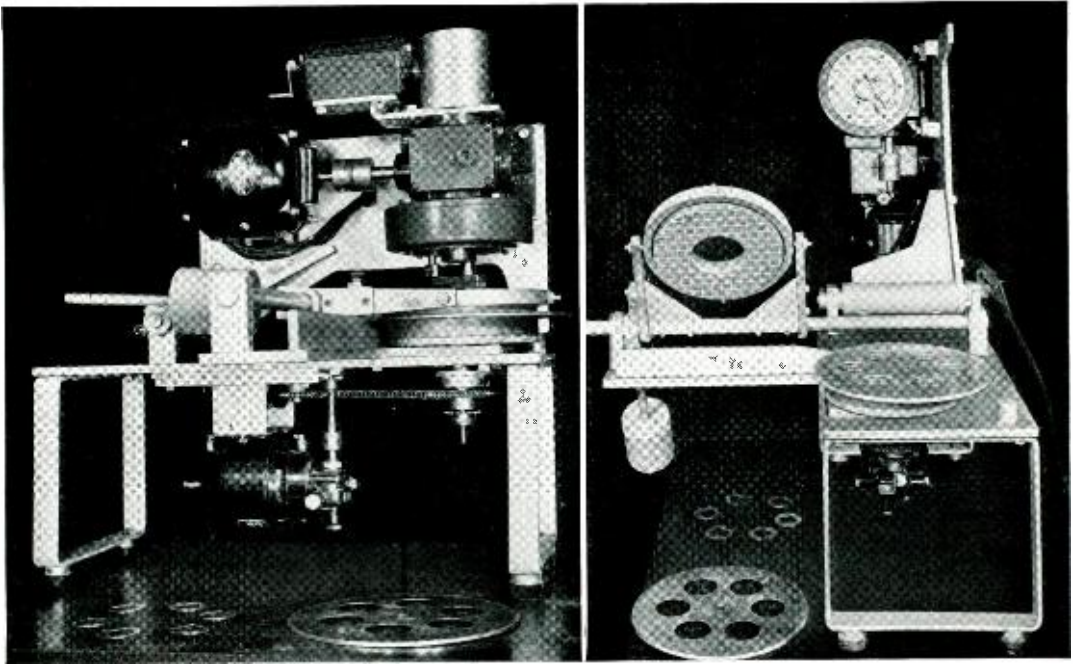

Fig. 5—The lapping machine as arranged for lapping is shown at the left while at the right it is shown with drive and upper lap tipped back

This new machine in operating position is shown at the left in Figure 5, while, at the right, it is shown with the motor drive and upper lap tipped back to allow the crystals to be placed in the nest. The upper lap is mounted in gimbels, and may be tipped

around a shaft in a frame that is counter-balanced by a sliding weight. The gimbels permit the upper lap to line itself up with the lower one, and the adjustable counter-balancing weights permit the downward pressure of the upper lap to be adjusted.

“The service man overseas, hearing as he does of strikes and wage disputes and suffering psychologically, too, from absence from loved ones, develops the impression that everything that he used to know in the States is no more. Honestly, in view of what I had heard and read, I had not even expected to be able to telephone long distance when I got here. But here, after all, was the old familiar telephone booth—and no restrictions. Well—that, somehow, put the old States right again. And the thrill of hearing my wife’s voice? Say—after that I wondered why they’d sent me to a hospital at all!”

—From a sailor in the U. S. Naval Hospital, Oakland, California.

Historic Firsts

THE HORIZONTAL RHOMBIC ANTENNA

FOR very long radio circuits, it is desirable to use directional antennas. At the transmitting end, they serve to concentrate the greater part of the power in the direction of the receiver, and thus result in a higher signal-to-noise ratio; and at the receiving end they accomplish a similar result by largely eliminating noise and other radio disturbances from all directions except that of the transmitter. In becoming selective in its direction characteristics, however, an antenna also may become more selective in its frequency characteristics. So far as securing a higher signal-to-noise ratio at a particular frequency is concerned, this double selectivity is helpful rather than otherwise. Short-wave radio circuits, however, usually operate at a number of frequencies, since some are better at night and others during the day, and even at different hours of the day some frequencies give better transmission than others. At the Netcong receiving station in 1930, for example, ten antennas were employed, all directed toward England but each selective at a different frequency. Not only was there the cost of operating and maintaining a large number of antennas, but the antennas themselves were cumbersome and expensive.

Studies were therefore undertaken to find a more economical solution of the directivity problem. As a result of this work an entirely new type of antenna was developed. From its shape, it became known as the horizontal rhombic antenna. Patent applications on this antenna were filed on October 11, 1929, and February 3, 1941, and patents Nos. 1899410 and 2285565 were granted to E. Bruce of these Laboratories on February 28, 1933, and June 6, 1942, respectively. An antenna of this type was used experimentally

at Holmdel, New Jersey, to receive short-wave transmission from England. A few months later it was used at Forked River, New Jersey, to receive short-wave transmission from ships at sea.

The rhombic antenna maintains the directional selectivity of the earlier antennas, but its frequency selectivity is greatly reduced—so much so that a single antenna can receive the range of frequencies that required ten antennas before. Moreover, it is simple to build.

Four poles at the corners of the rhombus provide the only supporting structure that is needed.

The principles on which the new antennas are based were described in the RECORD for April, 1932. A straight vertical wire is most effective as an antenna when it is one-half wave-length long, but by tilting the wire in the direction of transmission, longer lengths of wire may be even more effective, and at the same time will acquire a directional characteristic. Such an antenna also has a frequency selectivity, but by making the wire long relative to the wave length, this effect may be reduced, and part of the remaining frequency selectivity may be cancelled by connecting another wire sloping in the opposite direction in tandem with it and grounding the far end through a resistance. Then by tipping this inverted "V" into a horizontal plane, and employing an equal and opposite "V" to form a rhombus, the ground connection with its irregularities is avoided without destroying the directional selectivity of the antenna or deteriorating its frequency characteristics. Such is the rhombic antenna. Because of its outstanding advantages, the horizontal rhombic antenna is now used for practically all of the very long distance short-wave channels of the Bell System.

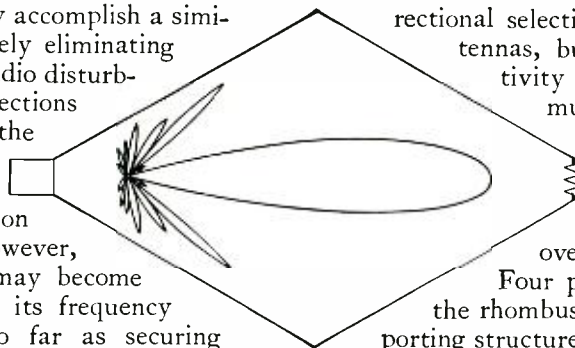



Field-Laboratory Tests of Alloy Cable Sheath

By F. B. LIVINGSTON

Outside Plant Development

WHILE laboratory tests will tell a great deal about the usefulness of a new product, nothing equals the full-scale field trial as a final check. This is particularly true of telephone cable sheath whose crystalline structure continues to change, sometimes for years after it has been placed in service. Lead-calcium alloy sheaths showed outstanding resistance to fatigue, according to laboratory tests, but those tests could not duplicate the complex effects of time and weather. Comparison of different alloys, by observations of typical installations in the field, was considered inadequate because local variations, over a long time, might contribute more to determining the relative life of the cables than differences in sheath composition or thickness.

An experimental outdoor installation was therefore made so that the cables could be kept under continual observation and the various alloys be subjected to identical exposure conditions. It took form in the pole line shown in the headpiece, which was erected at the field laboratory at Chester, N. J., in 1932. This installation is providing data, obtainable in no other way, on the

relative importance and the effect on sheath life of such usual hazards as expansion and contraction of the cable with temperature change, scratches, ring-chatter marks or other blemishes incident to installation and maintenance, and ring scores due to wind vibration. The installation is also valuable for studying methods of repairing faults in cable sheath.

Aerial cable sheath has been generally satisfactory but occasional installations have shown abnormally high trouble rates after a few years. Studies indicated that the method of installation was usually at fault in those cases. In many instances the cable had been placed and spliced with insufficient tension during winter weather and the strand from which it was suspended had been installed under excessive tension. Under these conditions, the steel strand changed in length with temperature much less than the cable, thus producing an excess of cable during the summer, which frequently caused it to lift from the supporting rings and to bow at the poles. In some cases it actually pushed up higher than the strand, as is shown in Figure 1. Failures occurred more rapidly at



Fig. 1 (above)—Bowings of aerial cable at a pole, caused by differential expansion between the cable and the strand

Fig. 2 (below)—Bowling of aerial cable away from a pole. The cable shown in Figure 1 viewed from below

the bows. Studies of the condition which caused bowing led to the adoption of lower strand tensions and to tensioning of the cable when installed in cold weather to compensate for the greater expansion of the sheath at high temperatures. This has prevented most of the bowing, and has greatly mitigated the cracking of cable sheaths, but it has not eliminated all of the causes of sheath failure. Highly stressed strand construction was used at Chester, however, to simulate those installations in which early cable failure occurred, and thus to hasten the answer on comparative sheath quality under field conditions.

Six experimental pole lines were set in an open right-of-way about 200 feet wide and 1,500 feet long. They run north and south, to afford maximum exposure to the prevailing winds across land which lies at an average elevation of 850 feet. Six different thicknesses of each composition of cable sheath were tested. Extreme bowing developed in some of the cables at certain poles during the first summer, shown in Figure 1 as viewed from the side, and in

Figure 2 looking up the pole. The bowing did not occur uniformly along the lines, however, so that all degrees are represented in this installation.

Since these cables were installed there have been a number of failures in the sheaths of both compositions, mostly in the thinner ones. Ring scores, ripples and buckles in the region of the pole have been responsible for most of the failures. These irregularities cause failure by localizing the stresses. Figure 3A is a typical ring score area near a pole where bowing stresses have concentrated. Fine cracks extend entirely through the sheath. In Figure 3B is shown the effect of stress concentration at the end of a repair sleeve, which resulted in failure at the junction of the cable and sleeve.

A type of failure that had not been charted before is the gradual formation of ripples along the concave side of the bowed cable which is subjected to the greatest compression, Figure 3C. Over a distance of from six to eighteen inches very shallow ripples appear spaced quite uniformly, a little more than an

THE AUTHOR: F. B. LIVINGSTON received the B. S. degree in electrical engineering from Kansas



State College in 1912 and the E.E. degree there in 1933. On graduation he joined the student course of the Western Electric Company at Hawthorne and was assigned, on its completion, to the lead-covered cable development group. Mr. Livingston has been engaged in cable work

continuously since that time. In addition to a variety of cable development problems he has been responsible for several years for the conduct of the outdoor experiments at Chester described on these pages.

inch from hump to hump. After some months one of the humps usually begins to increase in size and failure soon follows by fatigue cracking either along the ridge of the hump or its adjacent valley. This type of failure first appeared in the thinner sheaths.

Figure 3E is a close-up which shows the granular appearance and fine cracks that are typical of ripple failure in lead-antimony sheath. The lead-calcium sheaths do not ripple to the same extent as the lead-antimony, but they seem more susceptible to

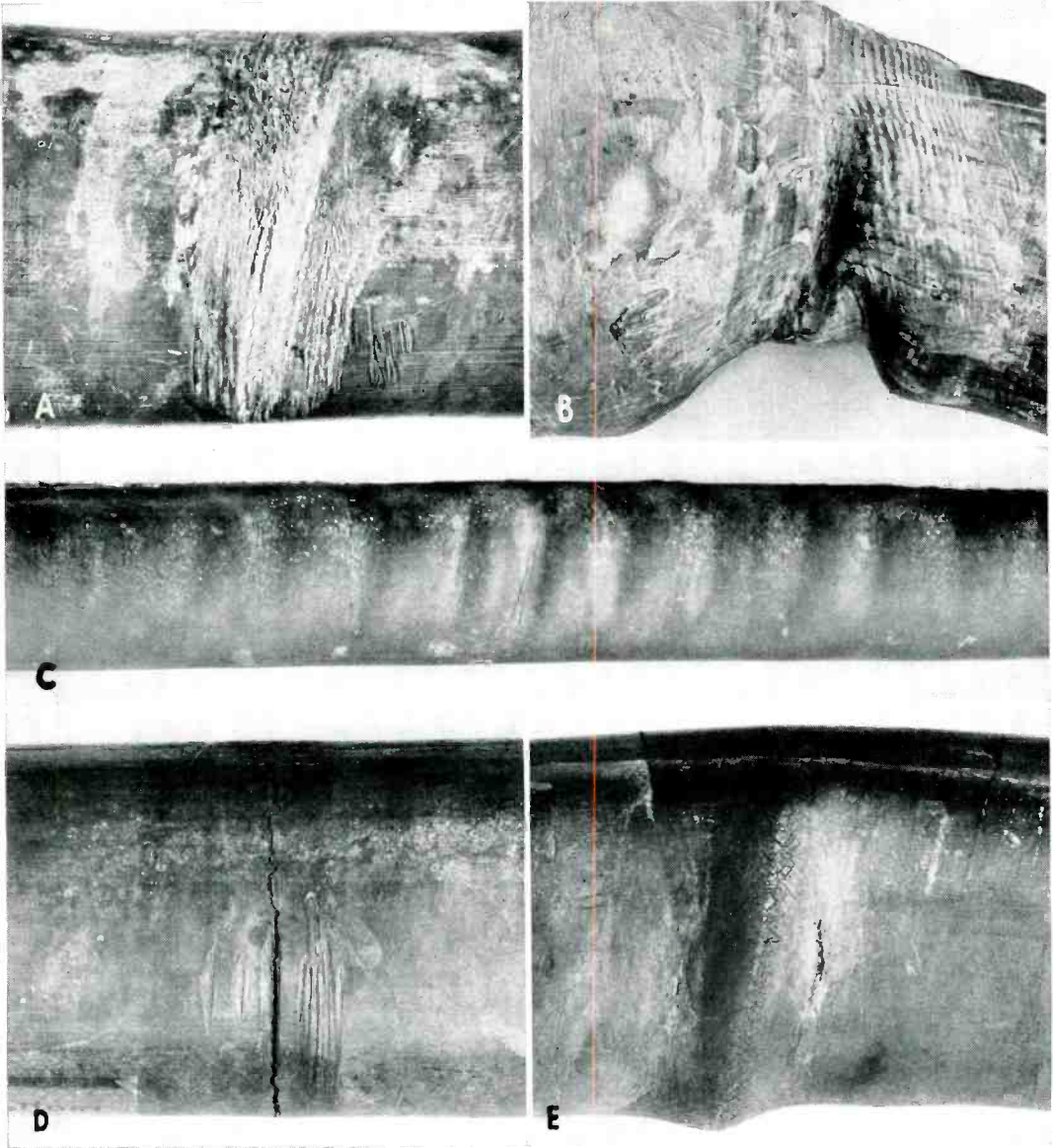

Fig. 3A—A typical ring score. Fine cracks extend entirely through the sheath

Fig. 3B—Stress concentrated at the end of a repair sleeve caused this failure at the junction of the cable and sleeve

Fig. 3C—Ripples along the underside of a bowed cable shown enlarged in Figure 3E

Fig. 3D—Crack in lead-calcium sheath that was apparently caused by shallow circumferential scratches

Fig. 3E—Enlarged view of one of the humps of Figure 3C, showing granular appearance and fine cracks. This type of failure occurred in thin lead-antimony sheath

fatigue failure through stress concentration at shallow circumferential scratches. Figure 3D illustrates a failure in calcium-alloy sheath, apparently caused by shallow scratches, which would hardly appear deep enough to produce a concentration of stress.

This pole line experiment has been in progress for ten years. In addition to the information previously mentioned, much valuable data have been obtained on the amounts and rates of change of stresses in

aerial cables and the causes of sheath failure. The stress data are valuable as a guide in interpreting laboratory test results already accumulated, and indicate changes in test procedures which will make them simulate field conditions more closely. The normal life of cable sheath is so great, however, that further tests are required to evaluate all the factors involved in determining the relative life of lead-antimony and lead-calcium alloys and the effect of different thicknesses.



Signal Corps Photo

Installed at the Signal Center for the 5th Army in Italy is the carrier communication equipment shown above. The two bays at the left are CF-2-A carrier telegraph terminals described in last month's issue, while the third bay of this group is a CF-1-A carrier telephone terminal described on page 168 of the RECORD for December, 1942. At the extreme right is the EE-100-A ringing equipment referred to in the latter article. The TG-7 printer in front of the carrier terminals uses its own carrying case as a table