

# BELL LABORATORIES RECORD



LOUDNESS  
MEASUREMENTS  
W. A. MUNSON

LINE-BUSY RECORDER  
A. S. KING

COAXIAL CABLE  
C. KREISHER  
T. C. HENNEBERGER

JUNE 1937 Vol. XV No. 10

# BELL LABORATORIES RECORD

---

*Published Monthly by BELL TELEPHONE LABORATORIES, INC.*

---

PAUL B. FINDLEY, *Managing Editor*      PHILIP C. JONES, *Associate Editor*

*Board of Editorial Advisors*

H. A. AFFEL	H. M. BASCOM	B. C. BELLOWS	W. FONDILLER
H. A. FREDERICK	O. M. GLUNT	M. J. KELLY	W. H. MARTIN
W. H. MATTHIES	JOHN MILLS	D. A. QUARLES	J. G. ROBERTS
	G. B. THOMAS	R. R. WILLIAMS	

---

SINGLE COPIES \$0.25; subscriptions are accepted at \$2.00 per year; foreign postage \$0.60 extra per year. Subscriptions should be addressed to Bell Laboratories Record, 463 West Street, New York City

---

*In this Issue*

Loudness Measurements . . . . .	306
<i>W. A. Munson</i>	
Volume Limiter Circuits . . . . .	311
<i>G. W. Cowley</i>	
A Line-Busy Recorder . . . . .	316
<i>A. S. King</i>	
The Surface Wave in Radio Transmission . . . . .	321
<i>C. R. Burrows</i>	
Construction of the Coaxial Cable . . . . .	325
<i>C. Kreisher</i>	
Installing the Coaxial Cable . . . . .	329
<i>T. C. Henneberger</i>	
Individualism in Research . . . . .	333
<i>F. B. Jewett</i>	

*Volume 15—Number 10—June, 1937*

# BELL LABORATORIES RECORD



*Studying the gases generated by the thermal and electrolytic decomposition of paper*

JUNE, 1937

VOLUME FIFTEEN—NUMBER TEN



## Loudness Measurements

By W. A. MUNSON

*Physical Research*

THE word loudness is familiar to everyone and is used very frequently to describe the magnitude of a sound. We say that some sounds are "twice as loud" as others or "only half as loud," but in doing so it is seldom appreciated that such statements really depend upon personal judgment and cannot be verified with a meter or other measuring apparatus. The only true loudness meter is the person who hears the sound. Many experiments have been made to find a scale of loudness that could be used with a person's loudness estimations, and the work done during recent years at the Laboratories on this subject will be described here.

The lack of precision in loudness

estimations does not mean that the human ear is a crude mechanism. On the contrary, its construction and operation is very complex. The parts of the ear involved from the time a sound wave strikes it until the stimulus arrives at the brain and we become conscious of its presence are illustrated schematically in Figure 1. The motion of the air particles is gathered in by the outer ear and focussed on the ear drum. This makes the membrane move to and fro. The motion is carried through the middle ear into the inner ear by means of a delicate chain of small bones attached to the ear drum at one end and terminating in an opening into the inner ear at the other end. The inner ear is

filled with a liquid to which the stimulus is transferred from the chain of bones as shown in Figure 1.

Submerged in the liquid is an elaborate keyboard called the "basilar membrane" and figuratively speaking, the incoming stimulus taps out its tune on this keyboard and thus it is telegraphed through nerve fibres to the brain. The keyboard consists of hundreds of nerve endings arranged much like the keys of a piano in that the high notes are at one end and the low notes at the other. When the nerve endings are agitated by motion of the liquid, pulses of nerve energy are started on their journey through connecting nerve fibres to the brain. The fibres, bundled together with insulating sheaths, form a cable similar in many respects to modern telephone cables; the pulses of nerve energy carried by the fibres are electro-chemical in nature, and consequently can be measured just like an electric current in a telephone wire.

It has long been the ambition of those working in this field to connect the cable of nerve fibres in the human hearing mechanism to electrical apparatus and investigate what happens when the ear is stimulated with a sound. With precise information about the messages sent to the brain by the basilar membrane keyboard, it is possible that the problem of what it is that determines the loudness of a sound could be solved. Of course, the surgical operation necessary to bare the auditory nerve and tap the cable is

much too serious to be undertaken for experimental purposes, but it has been done elsewhere with animals under anesthesia, and very interesting results obtained. Fortunately, there are other methods of investigating the subject of the loudness of sounds, and these are employed in the work done at the Laboratories.

It is apparent that a listener would experience great difficulty in deciding exactly how much louder one sound is than another. Several years ago Dr. Harvey Fletcher suggested a method of obtaining a rational scale of loudness values that did not involve this difficulty. It was based on the idea that the stimulus sent to the brain, and the resulting sensation, is cut in half when only one ear is used for listening to a sound. To understand how this can be utilized to obtain a scale of loudness values that will show how much louder one sound is than another, it will be necessary to follow through the actual procedure of obtaining a loudness measurement from a person listening to a sound.

If, for instance, the loudness of a

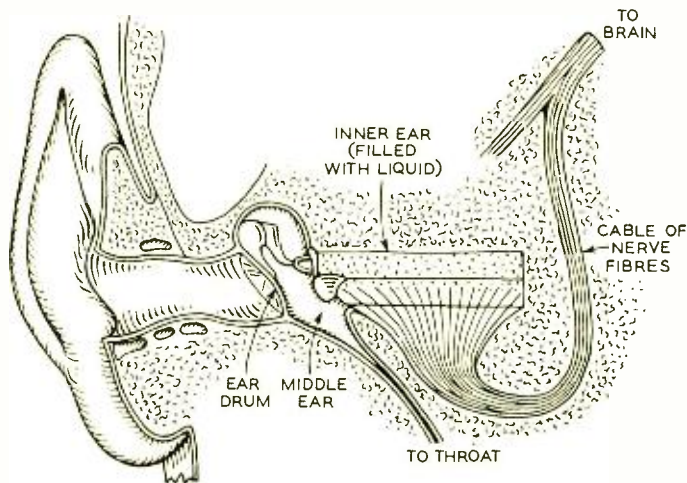

Fig. 1—Cross-section of the ear showing schematically how sound is transmitted by the ear drum to the liquid in the inner ear and then to the auditory nerves

noise were being measured, the observer would listen first to the noise and then to a standard reference tone of 1000 cycles and adjust the intensity of the latter until it was equal in loudness to the noise. A different sound would be measured in the same way, always using the same reference tone, for the standard of comparison. As a matter of fact, the process of adjusting the intensity of the reference tone, as it is usually done in the laboratory, is not as simple as stated above. Actually a rather elaborate apparatus is used to minimize the effect of the

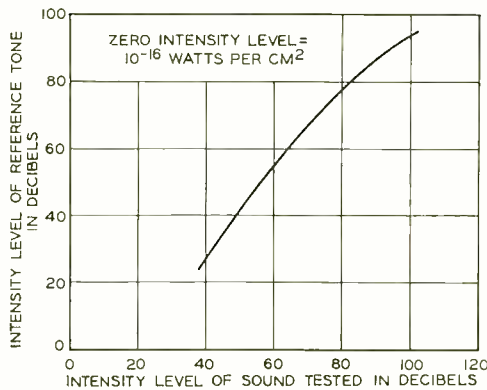

Fig. 2—Intensity level of a test sound compared with that of a 1000-cycle reference tone of equal loudness

psychological factors which influence an observer's judgment during the course of the measurement.

Figure 2 shows the average results of several observers' measurements on a sound recently tested in the laboratory. The horizontal scale shows the intensity level of the sound and the vertical scale gives the intensity level of the 1000-cycle reference tone for the condition of equal loudness.

Having found the intensity of the reference tone which is equal in loudness to the sound being measured, the next step is to associate this intensity

with the loudness scale previously mentioned as having originated in the idea of comparing one-ear listening with two-ear listening. It is easy for persons of normal hearing to confirm the fact that sounds heard with both ears are louder than with one by simply holding a hand over one ear. Actually, tests made on the 1000-cycle reference tone under carefully controlled conditions with earphones gave the results shown in Figure 3. Here the horizontal scale of the curve is the intensity level of the reference tone to which the observers listened with one ear, and the vertical scale shows the intensity level necessary for equal loudness when both ears were used. For instance, a reference tone with an intensity level of 33 db, when listening with both ears, was found to have the same loudness as a reference tone of 40 db intensity level when one

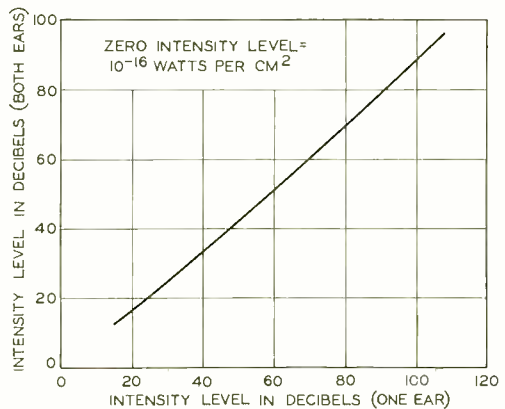

Fig. 3—Comparison of the intensity levels of a 1000-cycle tone when heard as equally loud by one and by both ears

ear was used. If the assumption is made that listening with one ear cuts the loudness in half, then it follows that an intensity level of 33 db is one-half as loud as an intensity level of 40 db. Consequently if an arbitrary number of loudness units, say 1000,

is assigned to an intensity level of 40 db, then 33 db must have 500 units.

In a similar manner an intensity level can be found in Figure 3 which is one-half as loud as 33 db and therefore would have 250 loudness units. Following this procedure throughout the range of reference tone intensity levels results in the curve shown in Figure 4 and this is the relationship that is so necessary for understanding an observer's loudness judgments.

Now we can go back to Figure 2 and with the aid of Figure 4, find out how the loudness of that sound changed with intensity. For instance, when the intensity level is 49 db, the reference tone is 40 db so the loudness must be 1000 units. When the intensity level is 73 db, the reference tone is 70 db and the loudness is 10,000 units. Therefore, the sound is ten times louder at the 73 db level than at 49 db, and the telephone engineer has a method of converting the judgments of his human loudness meter into terms which are intuitively easier for many persons to grasp than figures expressed in db.

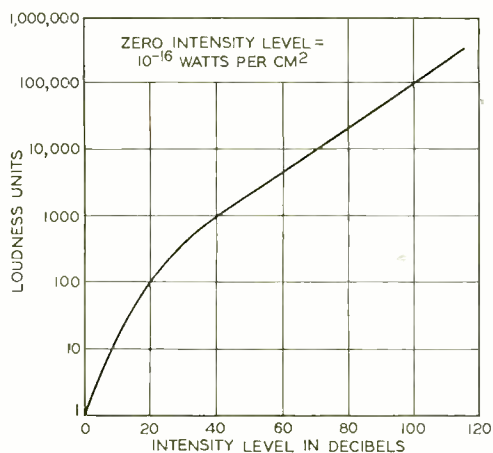

Fig. 4—Loudness of a 1000-cycle tone compared with its intensity

June 1937

While the above procedure for deriving a rational scale of loudness values seems to have a happy ending, the alert reader will immediately point out that the validity of the scale depends on the truth of the one assumption made, namely, that one-ear listening is half as loud as with both ears. Fortunately, confirming evidence from independent work in outside sources is not lacking, and the directness of the proof is quite convincing. For example, tests have been made in which a number of observers were asked to estimate when a sound was twice as loud, half as loud, and other fractions of the original loudness. Averages of these data can be used to obtain loudness scales and no assumptions enter into the derivations.

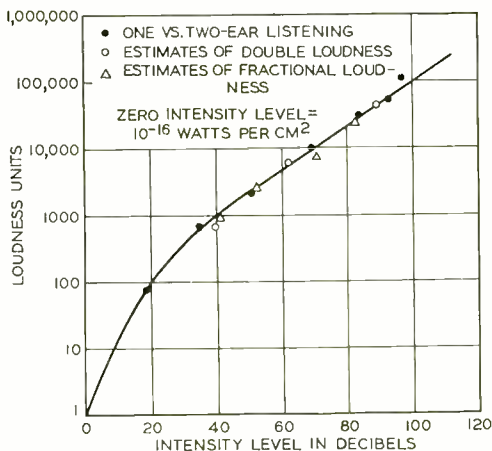

Fig. 5—Estimates of loudness made by a group of individuals agree with loudness values found when a person listens first with one ear and then with both

The results, plotted in Figure 5, clearly show that the scales are essentially the same as that obtained by comparing one- and two-ear listening.

Studies of nerve action show that once a sensation is obtained from an individual nerve, it cannot be increased by increasing the intensity of

the stimulus. This fact brings to light a very pronounced difference between the basilar membrane keyboard of nerve endings and a piano keyboard, where the harder one strikes the keys, the greater the effect. Evidently, a loud sound does something more than stimulate vigorously the same nerve endings that respond to a feeble sound; and the explanation deduced from experiments is that an intense sound is effective over a greater portion of the basilar membrane and thus engages a larger number of nerve endings. In fact, the loudness scale of Figure 4 is thought of as a measure of the number of nerve fibers that a sound has brought into action. In addition to this spreading effect, it is probable that a loud sound activates nerve endings which are insensitive to weak sounds, and thus the total number is increased in this way also.

The musically inclined person may question why the pitch of a sound does not change when the intensity is increased if the position of stimulation on the basilar membrane spreads out. The answer is that it often does change, and the amount has been measured, but the effect is not very noticeable until the sound becomes very loud.

The loudness scale has been found useful in developing a formula for the computation of loudness from a knowledge of the intensity levels of the individual components of steady-state sounds. When the components of such sounds are widely separated, the loudness of the sound is equal to the sum of the loudnesses of the separate components. More complex relations, however, exist when the components are close together or when the sound is highly variable in character.



### *The Morris Liebmann Memorial Prize*

*has been awarded by the Institute of Radio Engineers to W. H. Doherty of the Apparatus Development Department "for his improvement in the efficiency of radio-frequency power amplifiers." The prize was presented to Mr. Doherty at the Silver Anniversary banquet of the Society held in New York on May 12.*



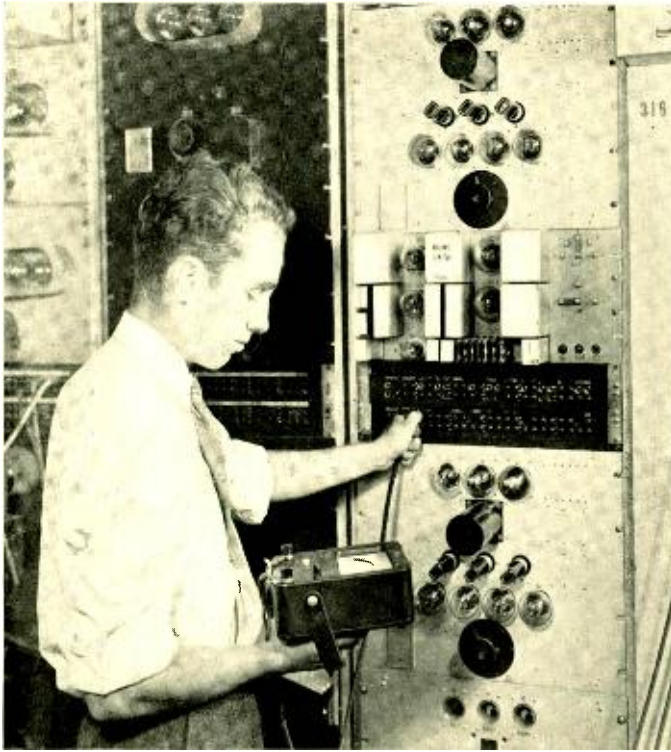

## Volume Limiter Circuits

By G. W. COWLEY  
*Toll Systems Development*

**I**N the Type-C carrier telephone system the three channels in each direction pass through the same amplifiers, and thus speech peaks on one channel, if they are large enough to momentarily overload the amplifiers, may affect the other channels. This is most likely to occur with relatively high-volume talkers whose speech energy peaks are sufficient to overload the vacuum tubes, resulting in a momentary reduction in gain and an increase in inter-channel modulation. As the system is designed, these effects are not sufficiently large to interfere appreciably with conversation on the affected channels. Where it is

desired to substitute a twelve-channel voice-frequency telegraph system for one or two of the speech channels, however, it has been found that undesirable interference with the telegraph channels may result from such effects. To avoid this, a volume limiter circuit was developed by the Laboratories which prevents the volume on a voice channel from rising above a predetermined maximum level.

The volume limiter is a device which introduces neither gain nor loss so long as the volume of speech does not exceed a predetermined value, but beyond this point introduces a loss that increases approximately in pro-

portion to the increase in volume. The circuit first used for the volume limiter, shown in Figure 1, is similar to one proposed by S. Doba, and consists essentially of three parts: a variable gain circuit, a condenser charging circuit, and a condenser discharging circuit. Two of the vacuum tubes that provide gain for the volume limiter,  $V_1$  and  $V_2$ , have a condenser in their grid-biasing circuit, and so long as there is no charge on this condenser, the overall gain of the circuit is zero. The condenser is charged by the two tubes  $V_4$  and  $V_5$ , but the grids of these tubes are biased negatively so that they will charge the condensers only when the output volume, which provides the input to these tubes, is above the limiting value. A relay controlled by the vacuum tube  $V_7$  is provided to discharge the condenser after the volume has fallen below the limiting value.

The input of the charging circuit is supplied through the vacuum tube  $V_6$  and a potentiometer, which—*together with the adjustable input pad ahead of the amplifier tubes*—gives control

of the input level at which the control condenser begins to charge, i.e., the point at which limiting begins. The input pad is adjustable in 2.5-db steps, and is set first to give approximately the limiting point desired, while the potentiometer, adjustable in one-db steps, is used for the final adjustment. Pads, adjusted to obtain zero overall gain at levels below the limiting point, are employed in the output circuit. Vacuum tubes  $V_3$  and  $V_6$  serve only as linear amplifiers to obtain the proper levels in the various parts of the circuit.

When the output volume is below the limiting point, the condenser in the grid circuit of  $V_1$  and  $V_2$  is shunted by a leak resistance, and the net overall gain of the limiter is zero. When the output volume rises above this limiting point, however, the discharge relay is operated through  $V_7$  to open the circuit to the leak resistance, and at a slightly greater volume the condenser begins to charge. As this condenser charges, an additional negative potential is introduced in the grid circuit of  $V_1$  and  $V_2$ , thereby increas-

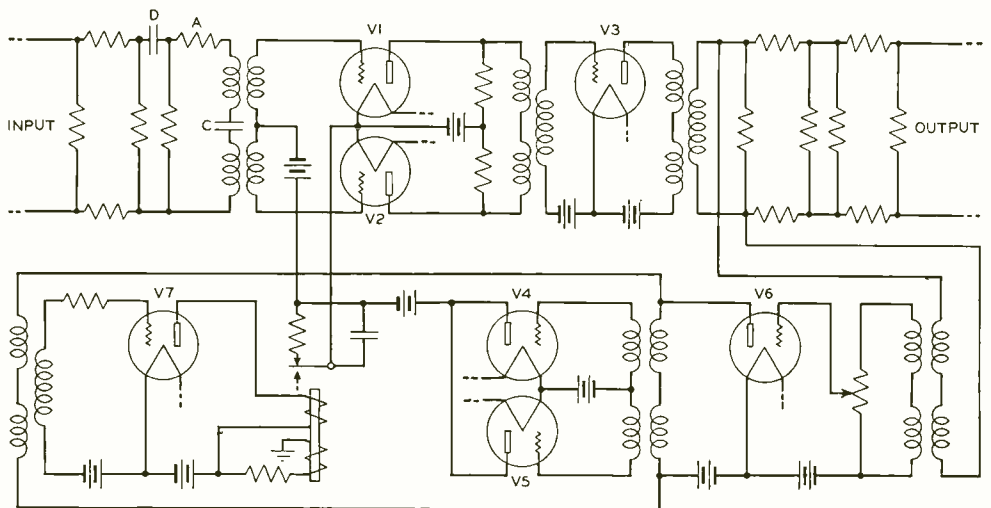

Fig. 1—The VA volume limiter consists essentially of three parts: a variable gain circuit, a charging circuit, and a discharge circuit

ing the plate impedance so that the overall gain is decreased, and the output remains essentially constant. The input-output characteristic of the limiter, as measured with single-frequency test power, is shown in Figure 2. Up to the limiting point the output

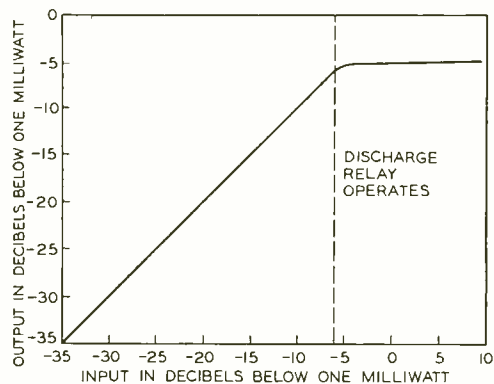

Fig. 2—Single frequency input-output characteristics of the volume limiter

varies directly with the input, but beyond this point the curve becomes nearly horizontal. These changes in gain are accomplished without appreciable distortion of wave shape such as is experienced when a reduction of gain is obtained by use of an overloading amplifier.

Proper timing of the charging and discharging circuits is important to the satisfactory operation of the limiter. If the discharge time is too short the speech will sound choppy, while if it is too long, some of the conversation may be missed if the voice is suddenly lowered after a loud exclamation. It was found by test that a discharge time of between 1.0 and 1.5 seconds gave a good compromise. This time sets the value of the product of the resistance of the leak resistor and the capacitance of the condenser, but for any one value of the RC product there is an infinite number of combinations of R and C

that will give it. A small capacitance is desired to allow the condenser to be charged rapidly, but the smaller the capacitance the larger must be the resistance, and with very high resistance, the shunting insulation resistance of the circuit elements becomes difficult to control. Even with the value of two megohms, which was finally used, special precautions had to be taken, such as the use of rubber-covered wire and special wiring methods for the critical parts of the circuit. The speed of operation obtained is indicated by the oscillogram of Figure 3, which shows the action of the limiter with a single frequency of one thousand cycles when the input level is suddenly raised ten db.

When this volume limiter, which was called the 1A, was developed, it was not known definitely at what value it would be necessary to set the limiting point. It is desirable to allow as high an output level as possible, and yet afford adequate protection to

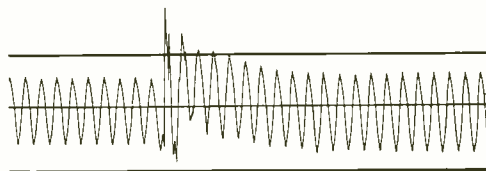

Fig. 3—Illustrating the action of the 1A volume limiter when a 1000-cycle input is suddenly increased about 10 db

the telegraph circuits. It was thus necessary to design a circuit with sufficient margin to provide for a considerable range of adjustment. After laboratory and field tests were made, and the general range of adjustment agreed upon, further study showed that the circuit could be simplified. It was found in particular that there was very little difference whether or not the leak resistance was left in the circuit during the charging period.

Hence, the discharge circuit could be eliminated and the leak resistance permanently connected across the condenser. By changing to a type of tube which gave a greater change in gain for a given change in grid bias, it was found that a single charging tube using half-wave rectification could be employed, and a suitable charging time still maintained. Also, the limit for the level at which limiting action starts that was found satisfactory was sufficiently high so that the amplifier tube ahead of the charge circuit could be omitted.

The new circuit is shown in Figure 4. In addition to the reduction of the number of tubes required, the new tubes are of a type requiring only one-half ampere of filament current. With the 1A volume limiter, two filament circuits each requiring 1.1 amperes were employed, while the new limiter, known as the 1B, employs one 0.5 ampere filament circuit. Its operation is similar to that of the 1A circuit except for the omission of the discharge circuit as mentioned above. The input and output pads are fixed, but a gain potentiometer is included in the input circuit, which is adjustable in one-db steps to give an overall zero gain. The speed of operation is a little faster as

shown by the oscillogram of Figure 5.

In the Type-C carrier system with which the volume limiter is used, 1000-cycle signalling is employed. The 1000-cycle signalling current is applied by relays that are actuated by twenty-cycle ringing current from the switchboard. There is generally a

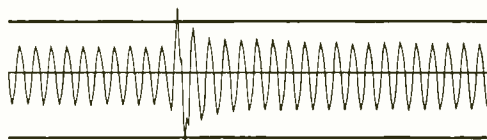

Fig. 5—The 1B volume limiter is somewhat faster than the 1A as may be seen by comparison with Figure 3

short spurt of this twenty-cycle current that gets on the circuit before the relays in the signalling circuit operate. Since it is of sufficient amplitude to actuate the volume limiter, the 1000-cycle signalling current that follows might be reduced sufficiently in volume—through action of the limiter—to make the signal ineffectual. To avoid this, a network is built into the input circuit consisting of condensers C and D, the input transformer primary, and resistance A of Figures 1 and 4. This circuit acts as a high-pass filter to attenuate frequen-

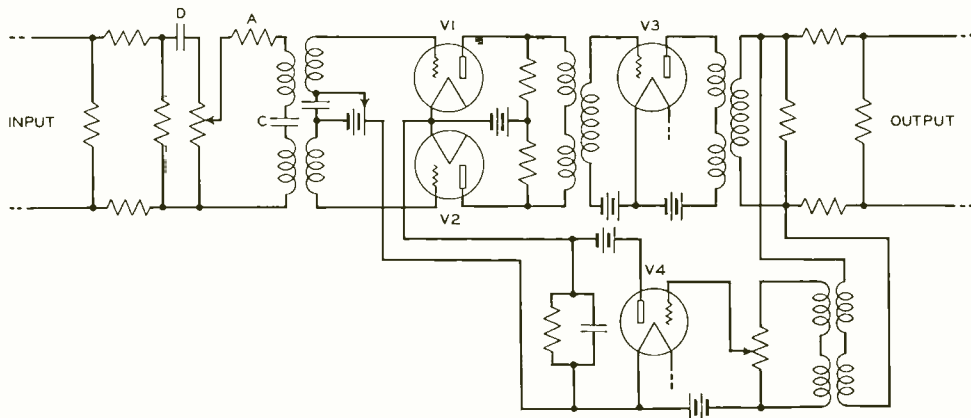
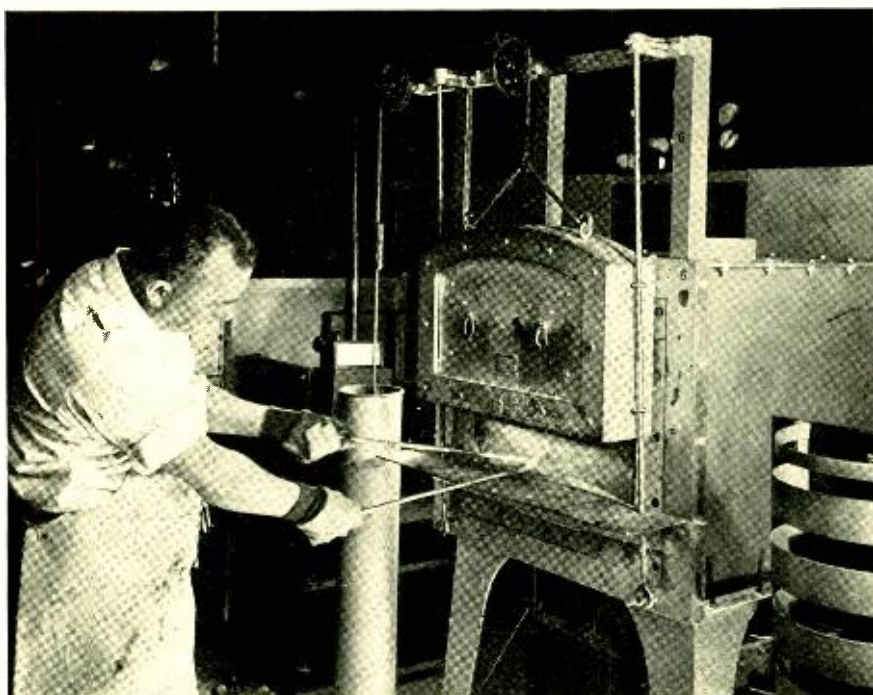

Fig. 4—The 1B volume limiter has no discharge circuit and employs fewer vacuum tubes

cies below 150 cycles, and thus reduces the level of the fundamental and harmonics of the twenty-cycle ringing current to values that will not actuate the limiter. This circuit, although attenuating the very low frequencies, does not affect the frequencies of the voice band, which is limited to the range from 250 to 2750 cycles.

The elimination of the discharge circuit, and the reduction in the number of tubes in the 1B limiter, made it

possible to mount the apparatus on a panel about half the size of that used for the 1A limiter. This is shown in the photograph at the head of this article, where a 1B limiter mounted just above the jack panel may be compared with the 1A limiters which are mounted immediately above and also below. Eight of the 1B volume limiters, with associated dry batteries, may be mounted in one bay, instead of four as with the 1A limiter.



*Heat treatment, an important item in the preparation of magnetic alloys, is carried out by O. J. Barton and others with a group of electric furnaces in the basement of Section H, West Street*

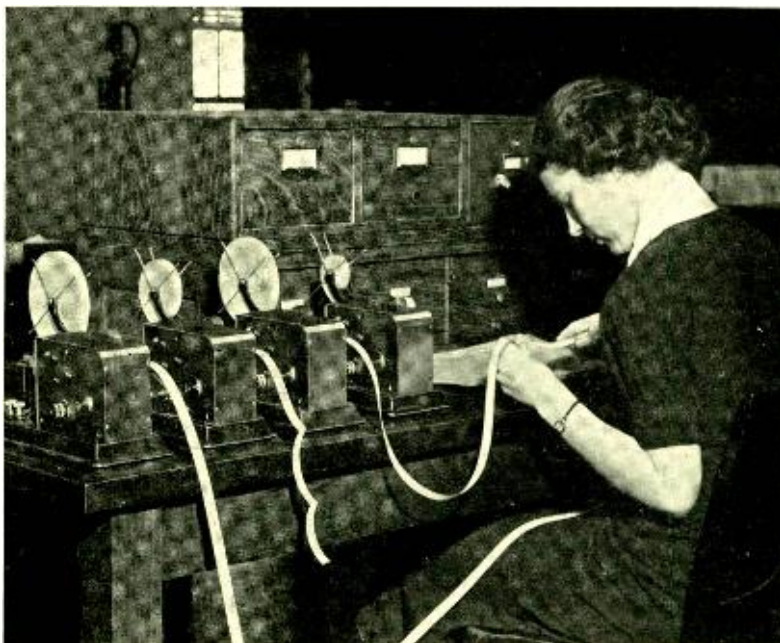

## A Line-Busy Recorder

By A. S. KING

*Equipment Development*

**I**N calling a friend on the telephone, one must expect occasionally to find the line busy, and there is not much that can be done about it because after all a person cannot carry on two conversations at the same time. When one calls a business house, however, a busy line is more of an annoyance because the caller knows that there are plenty of people there who could take his message if there were only a line available. Business houses and professional men realize this situation and attempt to have enough lines so that occasions on which all their lines are busy will be rare. The Bell System aids them by checking from time to time the calls lost due to busy lines.

The method of determining lost calls due to busy lines depends on the

type of service. With private branch exchanges, overflow meters are used to count the calls that fail of completion because all trunks to the PBX are in use at the time. Busy calls to establishments served by individual lines may be counted by operators at manual switchboards or by observers in front of the switches in dial offices. Equipment has recently been developed for automatically recording the number of times that lines are busy in step-by-step central offices.

The equipment is designed to observe a group of one hundred subscriber lines by marking on a tape each number called and whether or not it was found busy. It will be associated with a particular group of lines only long enough to obtain a reasonable sample of traffic to these num-

pers. To allow it to be moved readily from frame to frame in the office, all of the equipment has been arranged compactly on a small table-type wagon as shown in Figure 1.

The records of the calls are made by two double-pen Foote-Pierson registers. One of these registers is connected to a circuit only long enough to record the number called and to give an indication of whether or not the line was busy, and then is automatically disconnected. With this short "holding" time, two registers are ordinarily able to record all the calls to the one hundred lines under study at any one time. In Figure 1, these registers are shown on the top of the wagon, but flexible cords are provided so that they may be located elsewhere if desirable. When recorders are used in a number of offices in an area, the pen registers associated with all of the recorders may be centralized in one office by the addition of auxiliary pulse repeating equipment. Such a centralized installation of the registers that has been made in Richmond, Virginia, is shown in the photograph at the head of this article.

The circuits of the recorder are mounted between the upper and lower trays of the wagon, and are designed for connection to ten connectors, each of which has access to the same group of one hundred lines. These ten connectors are ordinarily mounted on one shelf of the connector frame in the central office, and connection to them is made by ten two-conductor cords

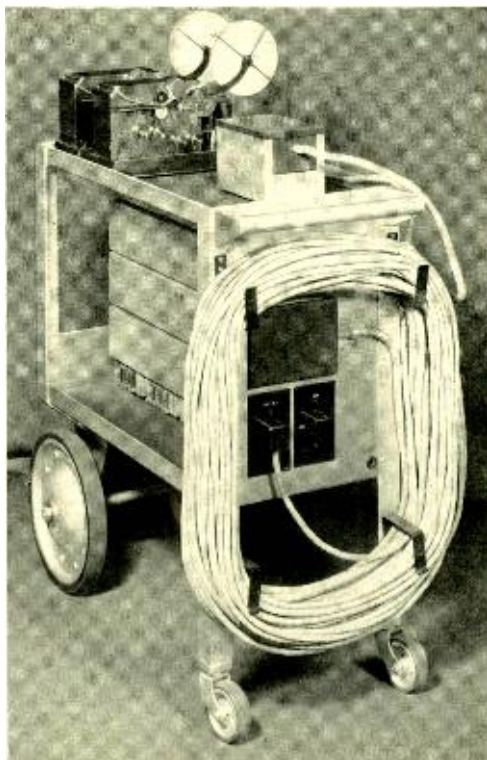

Fig. 1—The line-busy recorder that has been designed for step-by-step offices

that plug into the jack box shown on the top of the wagon in Figure 1. This jack box, however, is connected to the recorder circuits through a long flexible cord so that the wagon can be placed in some convenient position and the jack box carried around to the various connector frames to test successive groups of lines. A power cord is also supplied with the equipment for connecting the recorder to a forty-eight-volt supply.

When an incoming call seizes one of



Fig. 2—Record made for a call to line 35; above, not busy; below, busy

the connectors being checked, the ground that is placed on the connector sleeve is extended over one of the two leads of the cord running to that connector from the recorder. Here, through the circuits provided, it assigns one of the registers to the call. The other conductor of the cord is connected to the pulsing lead of the connector, which is common to both the

vertical and the rotary stepping magnets, and the pulses for the last two digits of the subscriber's number, through relays in the recorder circuit, cause one of the pens of the register to make corresponding marks on the tape. The other digits of the subscriber's number are known, of course, from the central office in which the record is made and from the

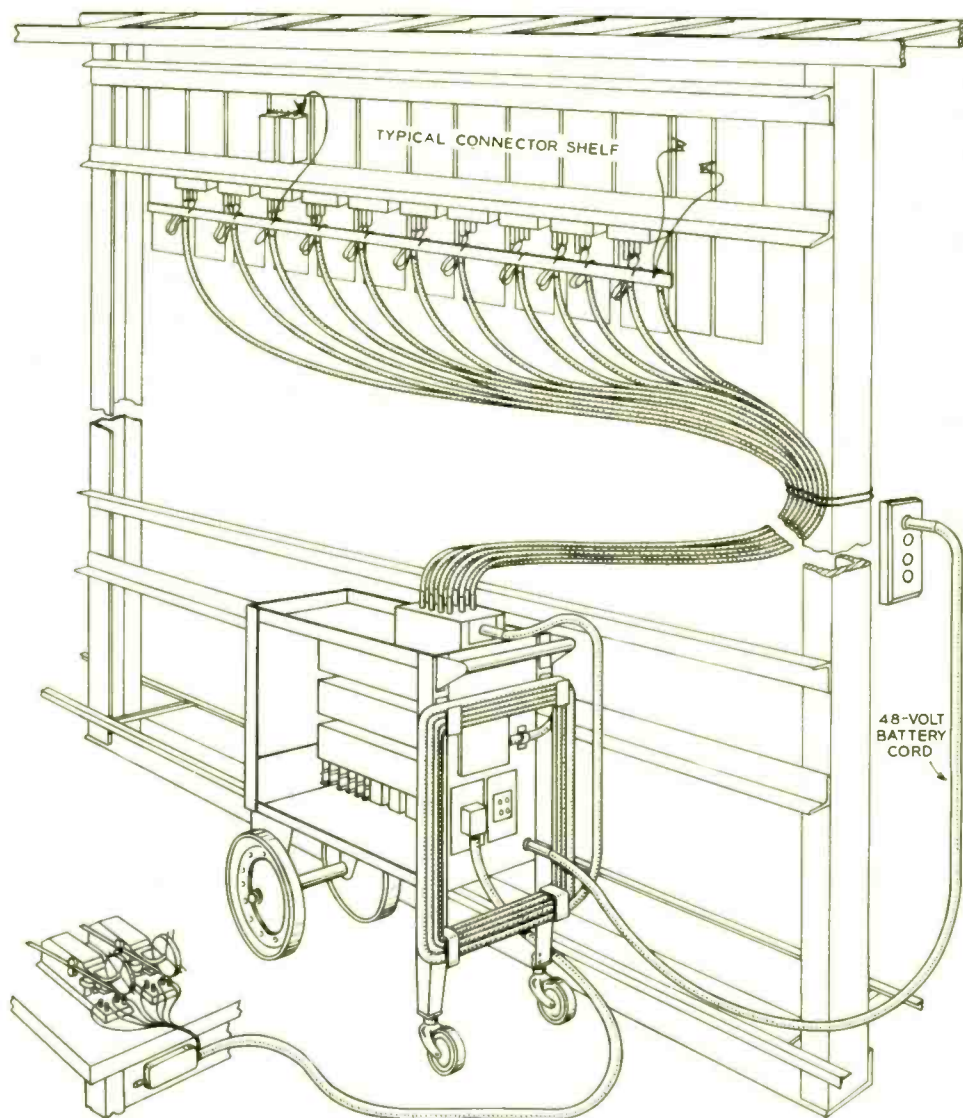

Fig. 3—A typical installation of the line-busy recorder



particular group of connectors connected to the recorder. Shortly after the pulses have been recorded, the recorder circuit causes the pen to make a long dash to indicate the completion of that call, and thus to separate the codes for successive calls on the tape. Following this the register is released to be ready for the next call. Such a tape record where the last two digits were 35 is shown in the upper part of Figure 2.

Besides the ten cords running to the ten connectors, there are two others that plug into the same jack box and connect to terminals on the connector shelf.

One of these connects to the circuit that returns the busy signal to the calling subscriber, and if the line called is busy, a pulse from this circuit will cause the recorder circuit to send a pulse to the second pen on the register to record a long dash on the tape just above that used for recording the code pulses. A busy line will thus give a record such as that shown in the lower part of Figure 2.

As already noted, the recorder circuit releases the register automatically after a short interval after the final digit has been dialed. Occasionally, however, a subscriber will abandon a call before dialing the last digit, or even before completing the next to the last, and under these conditions the register would not be released if provisions for such an oc-

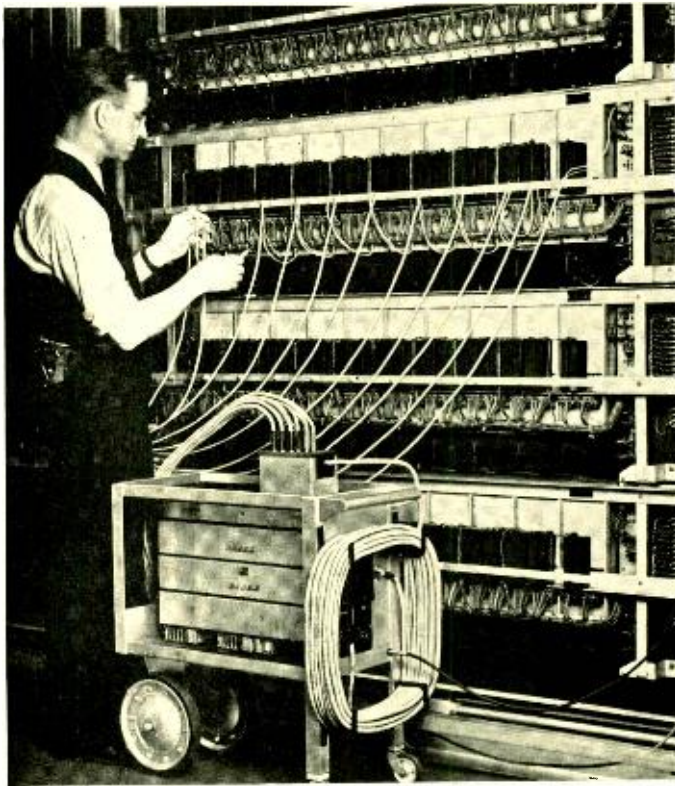

Fig. 4—The line-busy recorder in use in Richmond, Virginia

currence were not made. The second extra cord mentioned above, however, is connected to the ringing supply, and the intermittent pulsing of the ringing current is used to control a timing circuit in the recorder to limit automatically the length of the period that a register is held on each call. As soon as a register is seized, this timing circuit is started and automatically releases the register after a period of from twelve to eighteen seconds if the completion of dialing has not already released it. This insures that under no conditions will a register be held for more than eighteen seconds at a time.

A typical installation where the test wagon, with the jack box on its top shelf, is located adjacent to a connector frame and the registers at a more remote location is shown in

Figure 3. This shows the twelve cords running from the jack box to the connectors as well as the cord to the power supply, and the longer one to the registers. The cords are stranded and covered with a tough cotton

braid to make them flexible and durable. When not in use they are coiled on brackets at one end of the wagon as shown in Figure 1. An application of this equipment in Richmond, Virginia, is shown in Figure 4.



*Direct-current breakdown test being applied to sections of the coaxial cable during manufacture by A. S. Windeler (left) of the Laboratories' Point Breeze staff and J. Brown of the Western Electric Company. (See page 325)*



## The Surface Wave in Radio Transmission

By C. R. BURROWS  
*Radio Research*

**R**ADIO engineers have believed for a number of years that the radiation from a vertical antenna has a component which is guided by the earth as waves are guided by a pair of wires. Recent experiments and mathematical studies by the Laboratories indicate that this component, which has been called "the surface wave," is not present in ordinary radio transmission.

Some years ago, theoretical studies by Zenneck and Sommerfeld suggested that a surface wave existed in radio transmission, and in spite of the fact that an independent theoretical study by Weyl gave quite different results from Sommerfeld's, the surface-wave concept came to be widely accepted because it gave a plausible explanation of the propagation of radio waves

to great distances and around the curvature of the earth. Only since the development of ultra-short wave radio, however, has it been possible for Laboratories' engineers to perform a crucial experiment which would settle the question as to which result was correct. The decision, which has since been confirmed theoretically by S. O. Rice, was found to be in favor of Weyl's formula, which does not contain any term corresponding to the surface wave.

If there were a surface wave of this type it would be most pronounced when transmitted over a good dielectric, the nearest practical approach to which is fresh water. Accordingly the first attempt was made over Budd Lake, New Jersey. The tests indicated that the water was so shallow that the

transmission resembled that over land instead of over fresh water. An experiment over deep fresh water was therefore planned and was successfully performed at Seneca Lake.

There are two properties of the surface wave by which its presence should be observable: It would attenuate rapidly with height above the earth's surface, and it would not diminish in intensity as quickly with distance as an unguided wave. Calculations from the two conflicting formulas indicate that at a distance of one kilometer over Seneca Lake the received field strength, on a wave length of two meters, should be forty-four db greater with a surface wave than without it, and that raising the receiving antenna twenty-five meters above the water would diminish the field three db with a surface wave, whereas this added antenna height would increase the field an amount equal to seventeen db if no surface wave were present.

To determine the variation of the field strength with distance from the transmitter the experimental arrangement shown on page 321 was used. The receiver was installed in a small motor boat and the transmitter towed slowly behind in a row boat, at distances from one to 150 meters. The antennas consisted of two copper rods each ten inches long placed end to end and connected by a coil. The solid circles of Figure 1 are a plot of the experimental data obtained in this manner.

For distances greater

than 150 meters it was necessary to change the experimental procedure slightly. In this case the receiver was located at the end of a pier and the transmitter carried in the motor boat. This introduced additional difficulty in measuring the distance. To minimize the uncertainty in our knowledge of the distance it was measured by three independent methods. First, the motor boat was driven at a constant speed and in a fixed direction across the lake between two points a known distance apart. Second, the distance to a stadia rod erected on the motor boat was measured by a transit located on the receiving pier. And third, the distance was found by determining with a sextant the angle subtended at the boat by two poles on the shore a known distance apart; one at, the other near, the receiver. The angle between the line joining the two poles and the direction to the boat was also determined by means of the transit. The open circles shown in

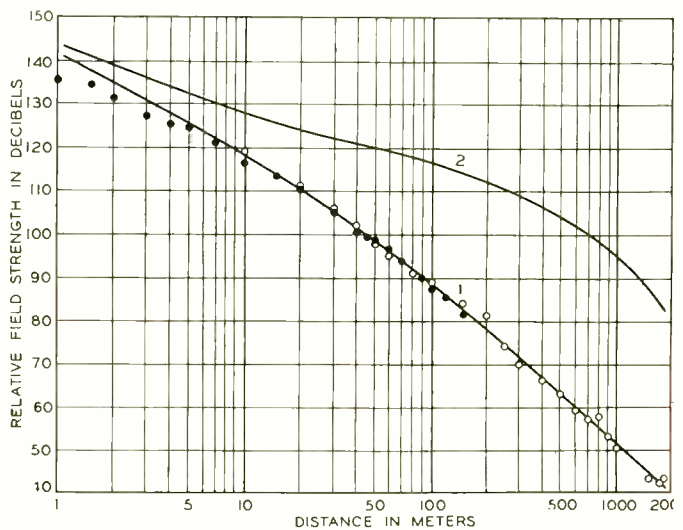
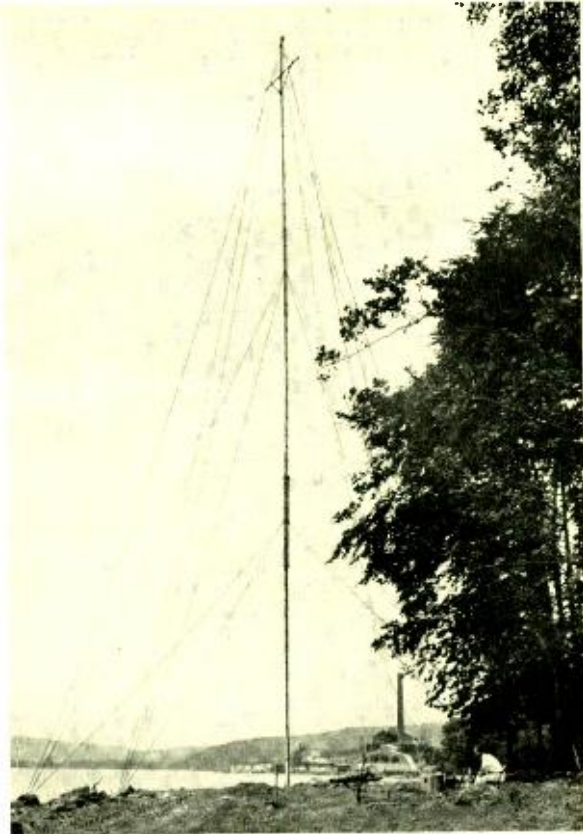

Fig. 1—Experimental points show the actual field strength. They agree with Curve 1 which applies if there is no surface wave. Curve 2 gives calculated values of what the field strength would be if there were a surface wave

Figure 1 represent a plot of the variation of relative field strength with distance from the transmitter as found in these experiments.

The smooth curves 1 and 2 shown in this figure were calculated with the value of the dielectric constant determined from measurements of the temperature of the water and that of the conductivity as measured by L. A. Wooten of our Chemical Laboratories on samples of the lake water. Curve 1, which is plotted from Weyl's formula, is in agreement with the experimental data. As has been stated his formula contains no term corresponding to the surface wave. At distances less than five meters ( $2\frac{1}{2}$  wavelengths) the experimental points lie slightly below the theoretical curve and show a tendency toward oscillation. This is presumably due to the combined effect of the finite size of the antennas and their finite height above the water's surface. These oscillations may be a vestige of the pronounced interference pattern that extends to greater distances with higher antennas. The experimental points lie far below curve 2, which is plotted from Sommerfeld's formula and includes the surface wave. This shows that no such surface wave was present.

To determine the variation of the field strength with the height of the antenna above the water, portable masts twenty-five meters high were erected at opposite sides of the lake, 1800 meters apart. Figure 2 shows the location of the transmitter. With vertical transmitting antennas located 2.5 and 24.8 meters above the



*Fig. 2—One of the portable 25-meter masts from which the antennas were suspended*

water the field strength was determined as a function of the receiving antenna height. These experimental results are compared with theory in Figure 3, which shows how the field strength varies with the height of the receiving antenna above the water, when separated 1800 meters from the transmitter. Curves 1 and 2 give values of the field strength which would be expected from transmitting antenna 2.5 and 24.8 meters above the water, if both transmitting and receiving antennas were vertical and assuming no surface wave was present. Curve 3 shows the variation of the field strength which calculations indicate would be received with a sending

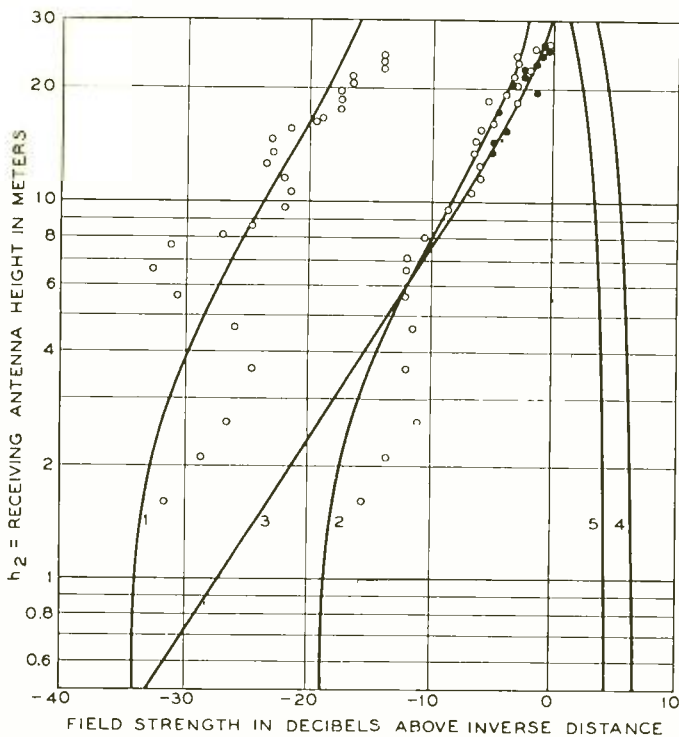

Fig. 3—Calculated and experimental values of the field strength for antennas at different heights above the level of the water and with the transmitter at a distance of 1800 meters. The circles show the experimental results

antenna 24.8 meters above the water if both antennas were horizontal. Curves 4 and 5 give the magnitude of Sommerfeld's surface wave for transmitting antennas at heights of 2.5 and 24.8 meters respectively. The two sets of open circles show experimental values for sending antennas 2.5 and 24.8 meters above the water and the solid circles represent data taken at an elevation of 24.8 meters when both antennas were horizontal. Again the evidence is against the existence of a surface wave. Indeed, the measured value of field strength actually de-

creased as the height of the receiving antenna decreased. The oscillations in the experimental points are presumably due to reflections from the cliffs and trees behind the receiving antenna.

Since we know definitely that no surface wave exists for transmission with horizontal antennas, measurements made with them may be used to calibrate the measuring equipment. This is done in Figure 3 by fitting curve (3) to the solid circles. The position of all the other smooth curves is thus fixed and they show that the absolute magnitude of the received field strength is of the order of a hundredth of

the value which would be expected from the formula which includes a surface wave.

Taken together with Rice's recent review of the work of Sommerfeld and Weyl, which has brought the two in agreement and established the fact that the prediction of a surface wave was due to a mathematical error, these tests prove conclusively that simple antennas do not generate a surface wave and that this time-honored concept must be given up, at least in the sense that radio engineers have customarily used it.

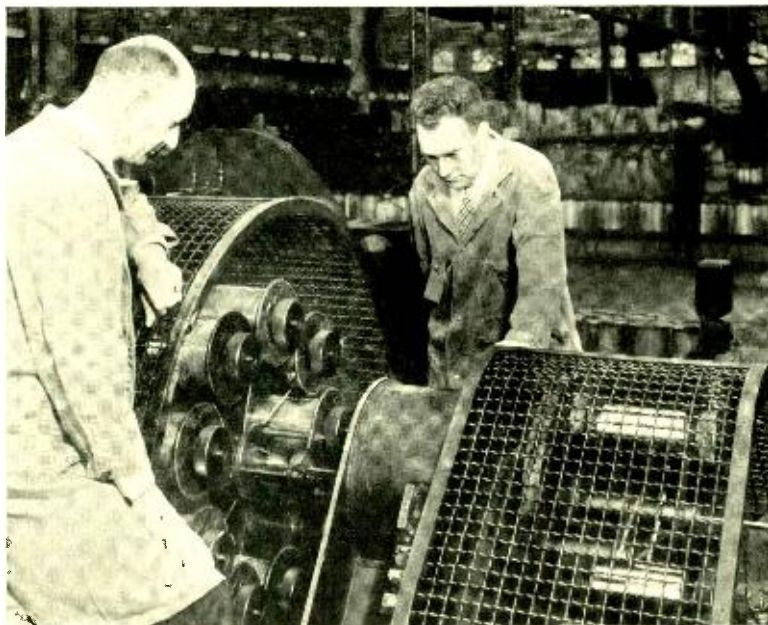

## Construction of the Coaxial Cable

By C. KREISHER

*Cable Development Department*

THE coaxial unit employed for the experimental installation between New York and Philadelphia differs so radically from conducting structures commonly used for telephone transmission that changes were required in practically all previous design and manufacturing practices. New insulating materials had to be found that would meet the electrical and mechanical requirements, and suitable physical characteristics had to be selected for the central conductor. One of the most difficult problems, however, was that of designing an outer conductor that would be flexible enough to withstand the necessary handling, and yet have reasonably low resistance over the frequency range that is required.

Dead soft copper is ordinarily used

for cable conductors, but it was found that harder material would be required for the central conductor of the coaxial unit to give sufficient tensile strength for installation, and to allow the rubber-disc insulators to be snapped on by machine. On the other hand the wire must be soft enough to withstand a certain amount of stretching without breaking. To produce a suitable wire the copper rod was first drawn to a size somewhat larger than the desired diameter. Thereupon it was annealed and then drawn further to the correct size and hardness.

The insulation between the center wire and the outer shell is in the form of slotted discs of rubber that are applied to the wire from the side. An improved hard rubber compound was developed by the Chemical Research

Laboratories for this purpose. When heated to a moderate temperature this rubber is soft enough to allow the discs to be punched from a  $\frac{1}{16}$ -inch sheet, and when cold is sufficiently elastic to permit the discs to be snapped over the wire without cracking, and sufficiently rigid to support the central conductor. The width of the slot at its intersection with the central hole is made somewhat smaller than the diameter of the conductor so that the discs must be forced over the wire and grip it firmly. The machine that is used for applying these discs is shown in Figure 2.

The outer conductor is composed of a number of interlocking copper tapes stranded

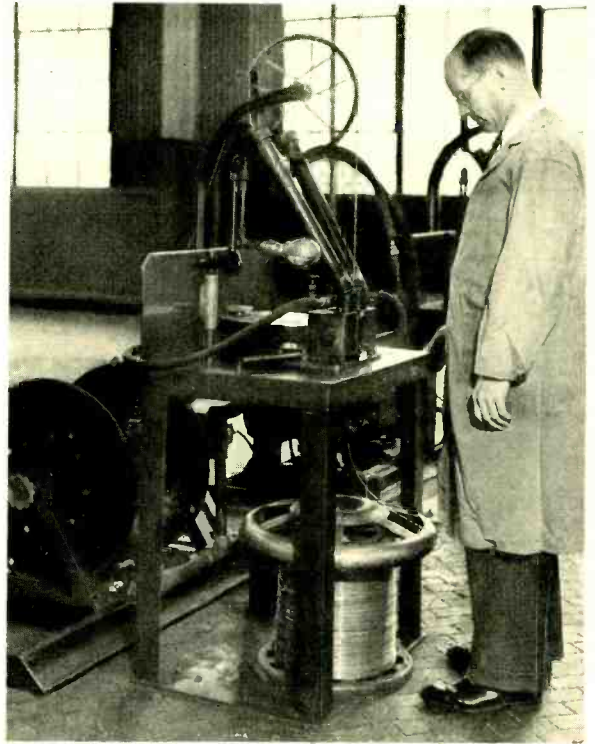

*Fig. 1—S. Thronsen of the Western Electric Company at Point Breeze with machine used to roll the copper tapes to their final shape*

*Fig. 2—G. A. Seeley of the Western Electric Company at Point Breeze with machine for snapping insulating discs of hard rubber over the inner conductor of the coaxial cable at three-quarter-inch intervals*

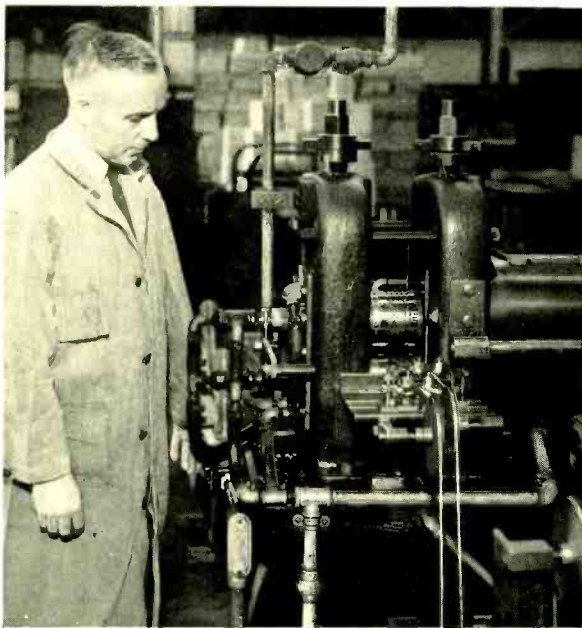

together to form a tube. The tapes are made by drawing a round wire through a series of dies into a comparatively flat oval, and then rolling this oval into a tape with a cross-section as shown in Figure 4. This form was chosen to prevent the tubes from collapsing while they are being formed and during subsequent handling. The machine used in assembling the tapes and forming the coaxial unit is shown in the photograph at the head of this article. Although the tapes are interlocking, the resulting tube could not be bent or handled without an outer binding, and for this purpose



two steel tapes are spiralled over the copper—the second tape being centered on the gaps between turns of the first. In addition to their binding action, these steel tapes improve the shielding of the coaxial unit against interference from the other unit and from outside sources such as lightning, radio, or other disturbances.

The completed coaxial unit is only about a third of an inch in diameter. The nine copper tapes forming the outer conductor are only a sixth of an inch wide and a fiftieth of an inch thick at the central or thickest part. Thirteen-gauge wire is employed for the central conductor, and the rubber insulators are spaced at three-quarter-inch intervals. The two steel tapes are five-sixteenths of an inch wide and six-thousandths of an inch thick. Two of these coaxial units and two quads of nineteen-gauge wire are stranded together, wrapped with two thicknesses of paper, and then sheathed with lead to form the complete coaxial cable. A detailed cross-section is shown in Figure 4, and a photograph of the cable showing its construction in Figure 3.

Some difficulty was experienced in drying such cable. A coaxial unit that had an insulation resistance of several thousand megohm-miles before drying, would often show only a few megohm-miles after the regular vacuum-oven drying process. Apparently part of the moisture from the paper of the quads and of the wrapping was deposited on the rubber discs. To remove this moisture, a drying cycle was devised which subjected the un-sheathed core alternately to dry air and vacuum in a vacuum drying oven.

The covering of ordinary telephone cable with lead is more or less a matter of routine, but the hard rubber insulators in the coaxial cable are af-

ected adversely by heat so that special precautions had to be taken. Both the intensity of the heat and the time of exposure are important factors, and to reduce them to a minimum, the lead press was not recharged during the covering of a section of land cable, since the stopping of the press while recharging would expose the rubber discs to excessive heating. Lengths up to about 1500 feet could be run on a single charge. To reduce the exposure to heat still further, the cable was passed through a bath of cold water as it left the lead press. For two sections of cable, which were to be armored for crossing the Hackensack and Passaic Rivers, the length and sheath thickness required more

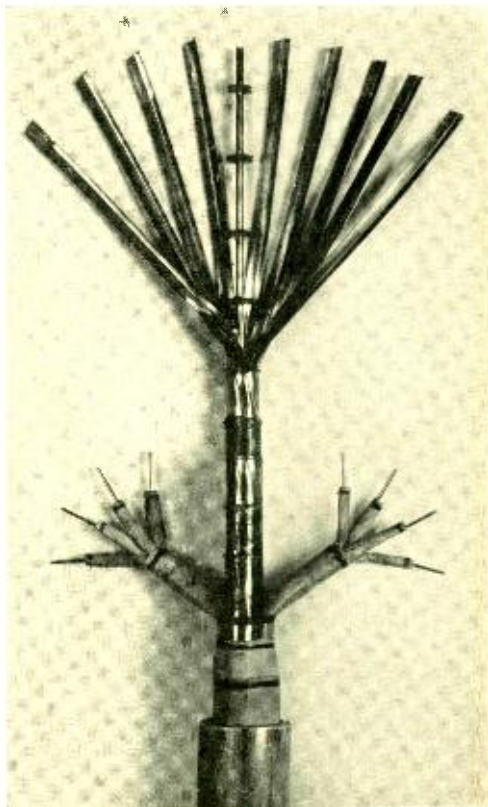

*Fig. 3—The coaxial cable consists of two coaxial units and two quads of 19-gauge wire*

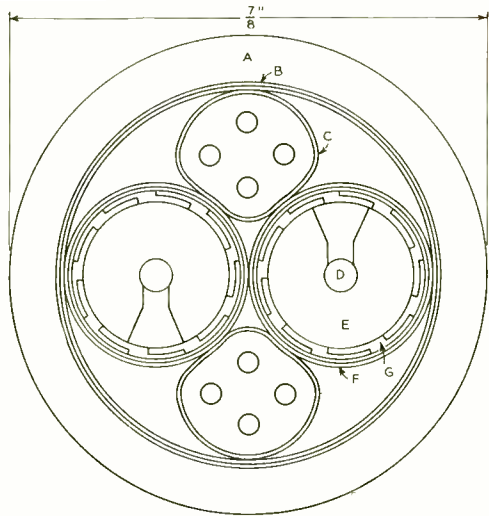

- |   |                                       |
|---|---------------------------------------|
| A—LEAD SHEATH, 0.085 INCH THICK                 | D—COPPER WIRE, NO. 13 A.W. GAUGE      |
| B—TWO LAYERS 0.010-INCH PAPER                   | E—RUBBER DISCS, SPACED 3/4 INCH APART |
| C—NO. 19 GAUGE QUADS, 0.004-INCH PAPER WRAPPING | F—STEEL TAPES                         |
- G—SECTION OF TAPE FOR OUTER CONDUCTOR

Fig. 4—Cross-section of the coaxial cable, above, and of copper tape employed for the outer conductor, below. The overall width of the tape is slightly less than a sixth of an inch

lead than could be extruded in a single charge period. For these two sections special insulating discs of a material less affected by heat though somewhat less efficient electrically were employed in the part of the cable that was in the press during recharging.

The coaxial units in the completed

cables were tested with 2000 volts d-c between the inner and outer conductors for thirty seconds. The special testing set provided for the purpose is shown on page 320. At the first application, breakdown often occurred at comparatively low voltages, but the breakdown voltage increased with successive applications. These lower-voltage breaks were caused by small slivers of copper which extended part way between the outer and the inner conductor. These would be burned off at breakdown. Condensers were employed for applying the potential so that the energy of the discharge was controlled by the size of condenser employed, in this way limiting the size of the arc that could be formed at breakdown.

Some d-c and low-frequency measurements were made on all sections as manufactured, but because of long and complicated reductions required for measurements of the primary constants on long sections of cable at high frequencies, complete data were taken only on 100-foot lengths made from time to time during the manufacture of the cable for the installation between New York and Philadelphia. These were available later for checking against similar measurements made in the field after installation.



## Installing the Coaxial Cable

By T. C. HENNEBERGER  
*Outside Plant Development*

FOR the ninety-five miles between the Long Lines buildings in New York and Philadelphia, the coaxial cable runs underground—for the most part in ducts laid for carrying the more usual, and much larger, type of toll cable. Although in its inner construction the coaxial cable differs radically from the toll cables in adjacent ducts, standard installation apparatus and methods were generally employed in placing it in position. As with any cable, the first step in the installation was to study the cable route, determine the lengths of cable to be furnished on each reel, and arrange to have each reel delivered to the location along the route where it was to be used. The first work in the field was to "rod" the ducts and to equip them with a "pulling" wire, which was done in the standard manner. A series of duct rods, each three feet long, was fed into each conduit section from one end, each rod being

inserted in the duct entrance, pushed ahead, and then coupled to the next succeeding rod until the rods reached through the section from manhole to manhole. The pulling wire was attached to the last rod, and the rods were pulled out of the conduit section from the other end. The pulling wire thus drawn into the duct was left in place for later use.

As the rodding gang progressed along the route, reels of cable were delivered to the job, each reel being placed beside the particular manhole to which it had been allocated. A cable-placing gang followed, which set up a reel of cable on jacks beside the manhole, attached a cable grip to the cable end, and fastened the grip to the pulling wire. The cable was pulled into the duct by a power winch on an automobile, or cable-splicing truck, at the other end of the conduit section. Ordinarily the length of cable delivered on a reel is sufficient to ex-

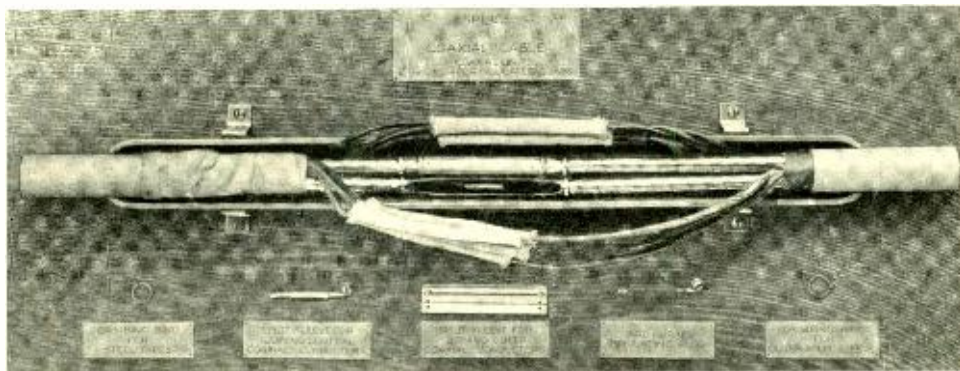
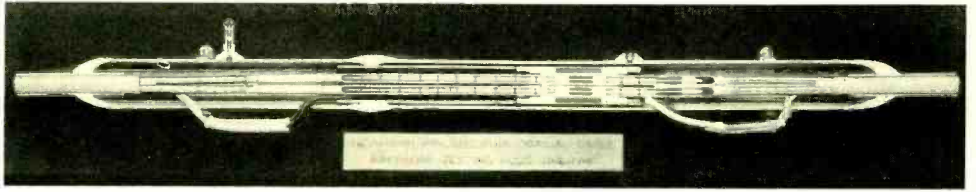

Fig. 1—A coaxial-cable splice in cross-section. The lower coaxial unit has been cut away to show the hard rubber plugs and the splice of the inner conductor



*Fig. 2—Cross-section of gas plug used for sectionalizing the cable*

tend only between two adjacent man-holes, which are normally about 500 feet apart. Because of the small diameter and weight of the coaxial cable, and the resulting low pulling stresses, it was frequently practicable to pull the cable in lengths sufficient to include two or three conduit sections. This had the advantage of reducing the total number of splices necessary.

After each length of cable was pulled in, a valve—similar to an automobile tire valve—was soldered into one end of the cable, which is always sealed with solder at the factory. Through this valve nitrogen gas was admitted for pressure-testing the length. After the pressure had built up to about nine pounds, the supply was disconnected, and from then until the length was opened for splicing, several checks of the pressure were made. If the pressure had dropped, indicating a leak, the length was not spliced until the trouble had been found and repairs made.

The splicing crews, following the cable-placing gang, arranged the cable on the supporting racks in the man-hole, and cut off the ends to the proper length. In the splicing process, after removing the lead sheath from the end of the cable, the steel tapes were first unwound a definite distance and cut off. A ring was then slipped over the tapes and crimped tightly to hold them in place. The outer conductor was then cut to length and a hard rubber plug, with a hole through the

center, was slipped over the inner conductor and inside the outer copper conductor in order to provide for mechanical strength.

Following this, the inner conductors were cut to length and soldered together in a copper sleeve. A split copper sleeve was then slipped over the ends of the outer conductors, and crimped in place by a second pair of rings. This sleeve acts as the outer conductor over the length of the

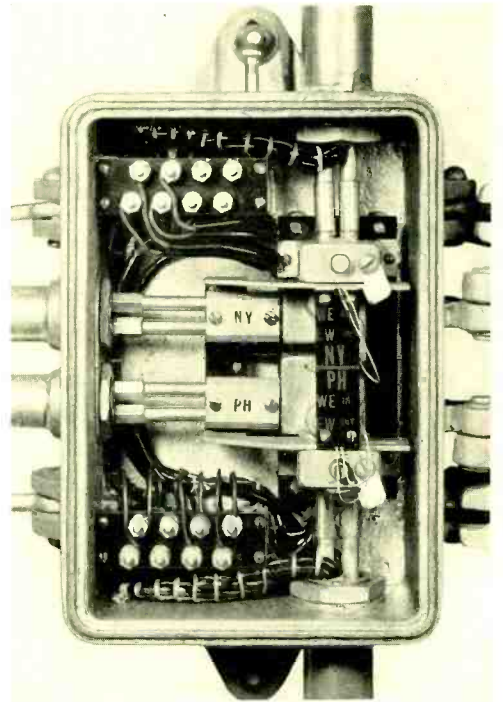

*Fig. 3—The cable terminal unit provides safe and easy access to the coaxial conductors and to the quads*

splice, and is securely joined to both the outer conductor and the steel tapes by soldering. The major features of the splice are illustrated in Figure 1.

The splicing of the paper-insulated quads, the "boiling out" of the splice with hot paraffin to remove moisture, the wrapping of the splice, and the placing of a lead sleeve over the splice were done in essentially the same way as for an ordinary telephone cable. Immediately after the lead sleeve had been soldered in place, a valve was temporarily screwed into a fitting provided on the sleeve, and nitrogen gas was admitted until pressure had been built up in the sleeve. The sleeve was then painted with soap solution to detect any gas leaks, and thus to determine the integrity of the solder work. During the course of the splicing operations, electrical tests were made to detect such faults as low insulation resistance, grounds, and short circuits on the coaxial units and quad wires.

As the splicing progressed, gas pressure apparatus was installed so that the cable, when completed, could be maintained under pressure to give automatic indication of any sheath breaks that might occur. By means of gas-tight plugs, shown in Figure 2, the completed cable is divided into separate gas sections, each sixteen to twenty miles long. Electric alarm gauges, called pressure contactors, are installed at intervals of two miles along each section, and are connected to one of the paper-insulated pairs of the cable, which terminates in alarm equipment at an attended repeater office. Valves for pressure-measuring purposes are installed along the cable

at intervals of about one-half mile. When a sheath break occurs and gas escapes, the pressure contactor nearest the leak operates to give an alarm. A cable man is then sent out to locate and repair the trouble. He makes pressure measurements at the valve

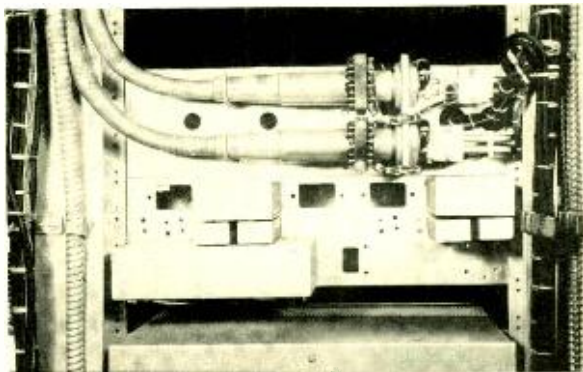

*Fig. 4—Terminating panel located at a repeater office, showing the sliders giving access to the inner conductors of the coaxial cable*

points in the vicinity of the operated contactor, and plots the measurements on a pressure-distance graph. Analysis of this graph gives the approximate location of the leak. The sheath break is then repaired and the cable recharged with gas.

When an electrical fault occurs in ordinary toll cable, as for instance a short circuit between two wires, its position is determined by Wheatstone Bridge measurements made between the attended repeater offices at the two ends of the cable. Since many repeaters of the coaxial cable system are of the auxiliary type, located in manholes or in boxes alongside the cable line, it is necessary to send a man out to them for fault location. At these points cable terminals have been provided that give easy access both to the coaxial conductors and to the quads at each side of the repeater. This unit is shown in Figure 3.

As can be seen in Figure 3, the quads in the cable are connected to binding posts in the terminal where they can be readily reached, and the outer coaxial conductors are also conveniently accessible. The inner coaxial conductors, however, are protected by a guard plate (black rectangular plate) and cannot be reached until the guard release buttons are depressed, which allows the guard plate to be drawn to the left by a coiled spring. Depression of the guard release buttons also places a short-circuit between the inner and outer conductors of each coaxial unit, which can be removed only by the restoration of the guard plate.

Power at a maximum potential of 350 volts to ground for operating the auxiliary repeaters is impressed between the two inner conductors of the coaxial units of the cable. The power supply is so arranged, however, that if an inner conductor is opened, or if it is connected to an outer conductor at any point along the cable, a relay chain at the supply point quickly removes the power. Thus, when the

guard release buttons of a cable terminal are depressed, power is automatically removed from the line, and the cable man has no opportunity of contacting an energized inner conductor. The power can be restored only by inserting a key in a switch at the supply point, and the office attendant at that point is not permitted to use the key until after the cable man has advised him that he has completed his work. A safety arrangement having the same purpose is provided at the cable-terminating panel of each repeater office. A view of this panel is shown in Figure 4.

In addition to its use for testing purposes, the cable terminal serves as the connecting link between the auxiliary repeater and the main cable. The stub cables joining the repeater and terminal can readily be removed, for instance, should it be desired to substitute a new repeater for one already installed. The ends of the main cables where they enter the terminal are made gas-tight to prevent loss of gas from the cable when the terminal cover is open, and a by-pass pipe is

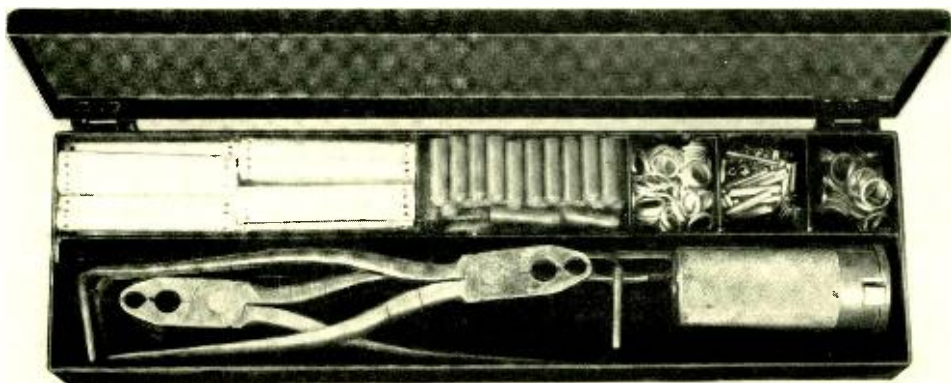

*Fig. 5—The splicing kit includes, from left to right, above, sleeves for the outer conductors, hard rubber plugs, crimping rings for securing the steel tape, splicing sleeves for the inner conductor, and crimping rings for the splicing sleeves of the outer conductor. Below are two crimping pliers, and at the right the tool for cutting off the outer conductor*

connected across the main cables so that the gas section is continuous through the repeater point.

In the coaxial cable installation every effort was made to foresee possible contingencies and to prepare for them. Special tools were required for certain phases of the work, such as the splicing kit shown in Figure 5. The

installation of the cable was carried on by the Long Lines Department, the New York Telephone Company, and the New Jersey Bell Telephone Company. It progressed smoothly and without serious difficulty. Installation was begun in March, 1936, and was completed—except in minor details—during November of the same year.

---

## INDIVIDUALISM IN RESEARCH

*Recent editorials in the New York "Times" (March 25 and April 11) suggested that cancer research might profit by adopting some of the methods of organization developed for industrial research. These editorials excited considerable correspondence and particularly a letter to the editor (April 4) from a prominent research worker on cancer which appeared to "seriously misapprehend certain present day aspects of industrial research." Several directors of industrial research replied in letters to the editor of the "Times." Among these was one from Dr. F. B. Jewett which said:*

It is certainly not true of industrial research in general that "the problem is perfectly concrete, usually set by the director on demands from the manufacturing portion of the plant, and must be either solved or shelved." As regards major problems, the solution of which is the real justification for maintaining an industrial research laboratory, exceedingly few arise from the demands on the manufacturing or operating portion of the business. On the contrary, they flow out of future needs and out of advances in fundamental science. If solved they may become the concern of the manufacturing and operating departments. Until well along toward solution they are rarely concrete. Even more rarely are they propounded by the director of research, though his long experience and

his knowledge of the field entitle him to make occasional suggestions.

Nor so far as my own experience goes is it true, as your correspondent alleged, that men "find themselves on the street" if they fail to do the research job for which they are hired. A man ordinarily gravitates into the channel of research for which he has the greatest liking and aptitude. The constant aim of the director is to find proper places for his personnel. Often a man is transferred to the manufacturing or operating department, where he may be a success as a producer of things discovered in the laboratory.

Every successful director of industrial research knows that the productivity of his staff is dependent upon free and untrammelled creation. Even where the director himself may have

a potentially fruitful idea which must be worked out by others, he seldom, if ever, advances it with anything which savors of command; rather he seeks to enlist the interest of his associates, stimulating them to take the initiative. Lest anything like arbitrary disapproval kill enthusiasm, he frequently authorizes work against his better judgment, content to let time decide.

I must also disagree with the statement regarding secretiveness. In my more than thirty years of activity I have seen the picture change from one in which secretiveness, both internal and external, was the rule to one in which internal secretiveness has almost completely disappeared and external secretiveness has been diminished to an irreducible minimum. As regards publication, we have advanced from a position in which all disclosure of technical results was frowned upon to one in which disclosure is encouraged. Even patents, which are in themselves special publications, are pressed to issue at the earliest possible date. Only in the case of partially or hastily completed work is an industrial research director likely to discountenance publication, and then only to insure against those inaccuracies which might discredit the organization.

For more than sixteen years the Bell Telephone System has published a

technical journal which now has a circulation of about 10,000 copies throughout the world. In it are printed papers on most fundamental subjects. In addition we present an equal or a greater number of papers before various learned societies.

Self-interest, which formerly imagined secrecy and independence to be its protectors, has brought realization that personal reputation is more enhanced by participation in a successful coöperative attack than by individual credit for some part of an uncompleted problem. It is right here that collaboration displays its greatest effectiveness.

Medical men cannot afford to overlook the experience of large industrial laboratories, which proves beyond question that division of labor and collaboration are conducive to the most rapid progress and the greatest productivity. While I can lay no claim to technical competence in suggesting how the intricate problems of cancer can be solved, this very experience leads me strongly to believe that some type of organization, possibly derived from that which has been so successful in the industrial laboratory, would accelerate progress in cancer research. Furthermore, I believe that such an organization will not hinder the free play of creative imagination.





## Contributors to this Issue

C. KREISHER graduated from the State College of Washington in 1921 with the degree of B.S. in Electrical Engineering. Shortly after, he joined the Engineering Department of the Western Electric Company at the Hawthorne plant, and was assigned to what is now the Cable Branch of the Outside Plant Development Department of the Laboratories. He has been continuously associated with this work ever since. In 1929 he was in charge of a group engaged in the development of voice-frequency toll cable. In 1932 he transferred to the Point Breeze factory, where he has been engaged principally in the design of cable for carrier transmission. Mr. Kreisher had a prominent part in the development work that led up to the design used for the experi-

mental coaxial cable between New York and Philadelphia, and was closely associated with the manufacture of this cable.

A. S. KING received the M.E. degree from Lehigh University in 1925 and, after three years as a Cadet Engineer with the Public Service Corporation of New Jersey, joined the Technical Staff of the Laboratories. With the Systems Development Department he has been chiefly engaged in the development of step-by-step

central office and unattended dial-office equipment.

W. A. MUNSON specialized in physics at the University of California at Los Angeles. He graduated there in 1927 and joined the Acoustical Research group of the Laboratories the same year. Since then he has been engaged in articulation studies and



*C. Kreisher*



*A. S. King*



*W. A. Munson*



*C. R. Burrows*



*G. W. Cowley*

investigations of the loudness and masking effects of pure and complex tones.

CHARLES R. BURROWS first worked for the Laboratories during the summer of 1923 while still enrolled as a student at the University of Michigan. After receiving the degree of B.S. in Electrical Engineering in 1924, he re-



*T. C. Henneberger*

turned to the Laboratories and continued work on long-wave transmitters. He began research on short-wave radio with the inception of intensive work along these lines and his analyses of this type of propagation formed the basis for short-wave transoceanic services to Europe and South America.

He has also developed methods of measuring the phase modulation in transmitters and was in charge of a theoretical investigation of the transmission characteristics of multiple timed antennas. Since 1930 he has been in charge of a group investigating the propagation characteristics of ultra-short waves. In 1927 he received the degree of A.M. in Physics from Columbia and in 1935 the Univer-

sity of Michigan conferred on him the degree of Electrical Engineer.

G. W. COWLEY was graduated from the University of Nebraska in the early spring of 1930 with the degree of B.Sc. in Electrical Engineering. He was employed by the Lincoln Telephone and Telegraph Company in the fall of 1923.

About one year was spent in outside plant maintenance and from that time until he was transferred to the Laboratories in 1930, he was engaged in maintenance work on step-by-step equipment. He is now engaged in development of open-wire carrier terminal equipment.

T. C. HENNEBERGER was graduated from Lehigh University in 1921 with the degree of Electrical Engineer. For the following thirteen years he was a member of the D. & R. Department of the A. T. and T. Company, and was engaged in work on outside plant construction and maintenance problems. Since his transfer to the Laboratories in 1934 he has been in charge of the group handling cable splicing and maintenance developments.