

BELL LABORATORIES RECORD



*Experimental terminal apparatus in the Systems laboratory,
through which a call was dialled from Chicago to the
Canal central office in New York during Mr. Grace's recent
Chicago lecture*

VOLUME NINE—NUMBER THREE

for

NOVEMBER

1930

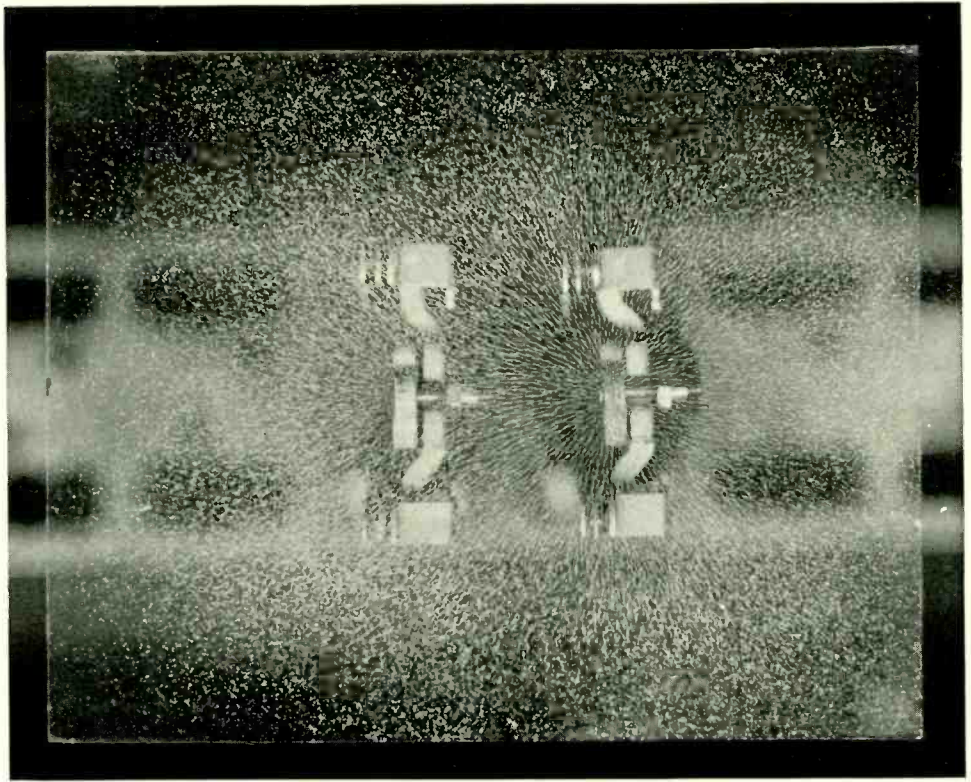

Effect of Magnetic Interference on Relay Operation

By W. BUHLER

Local Systems Development

A RELAY is operated by the magnetic pull between its armature and core. In an "R" type relay, for example—indicated in outline in Figure 1—current flowing through the winding on the core forms (for the direction of current shown) a north pole at the outer end of the core, and a south pole at the end of the armature opposite it. As a result a pull exists between core and armature which depends, among other things, on the number of turns of wire on the core and the amount of current flowing. The pull increases

with increase of current till the core becomes magnetically saturated—beyond this point it is little affected by an increase of current. As the armature is attached to the core at the back end by a flat spring, which readily flexes, the magnetic pull moves the front end over, operating any contacts that may be attached to it.

Although most of the magnetic flux, which causes the pull, is concentrated in the air gap between the front ends of the core and armature, part of it spreads out and returns to the back end of the core over a longer

path through the air. Any iron in the vicinity—due to its high permeability—would become a likely path for this stray flux to follow. Because of this the cores and armatures of nearby relays often serve to conduct stray flux as shown in Figure 2.

In the situation shown here the stray flux that spreads over to the left relay, from the energized relay on the right, exerts a pull on its armature that tends to hold it in the unoperated position. As a result more current will be required to operate the left relay than would be were the adjacent relay not energized. As a large number of relays are required in telephone offices, it is necessary to mount them as close together as possible to conserve floor space, but it has been found that, mounted in this way, their operation may be influenced by magnetic flux straying from adjacent relays or other apparatus.

To make this magnetic interference visibly evident, two similar "R" type relays were mounted side by side on one-inch centers. A glass plate covered with a thin layer of iron filings was then placed over them. When the relay on the right was energized to 350 ampere turns (product of number of turns on the core and the cur-

rent flowing) and that on the left to only fifty, the iron filings aligned themselves as indicated on the head-piece. Here the flux lines from the core of the right relay extend to the armature of that on the left and exert an appreciable pull on it. The core of the left relay exerts a pull tending to

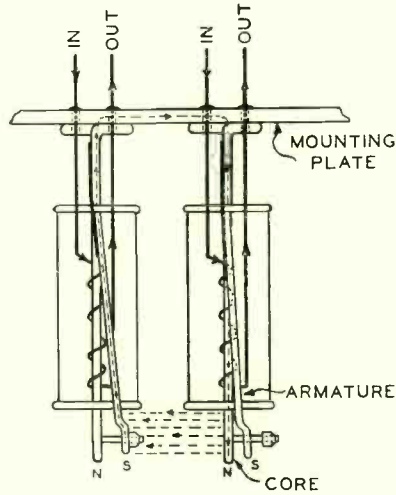

Fig. 2—Magnetic flux from the core of an energized relay will sometimes extend over to an adjacent relay and influence its operation

operate its armature but under the conditions shown the pull is counteracted by the stray flux from the right hand relay.

When the current flowing through the left relay is increased so that it about equals that flowing through the right, the magnetic conditions are those indicated by Figure 3. Under these conditions the two magnetic fields tend to neutralize each other. This indicates, and tests bear out the fact, that relays energized at high ampere turns are little affected by adjacent relays; that only at low ampere turns is there a large magnetic interference effect.

Even at low ampere turns, how-

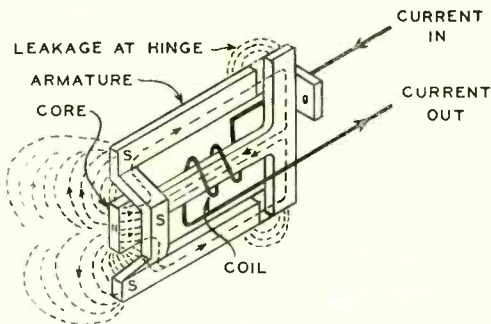

Fig. 1—Operation of a relay is caused by the pull between the magnetic poles which are formed on the front ends of the core and the armature

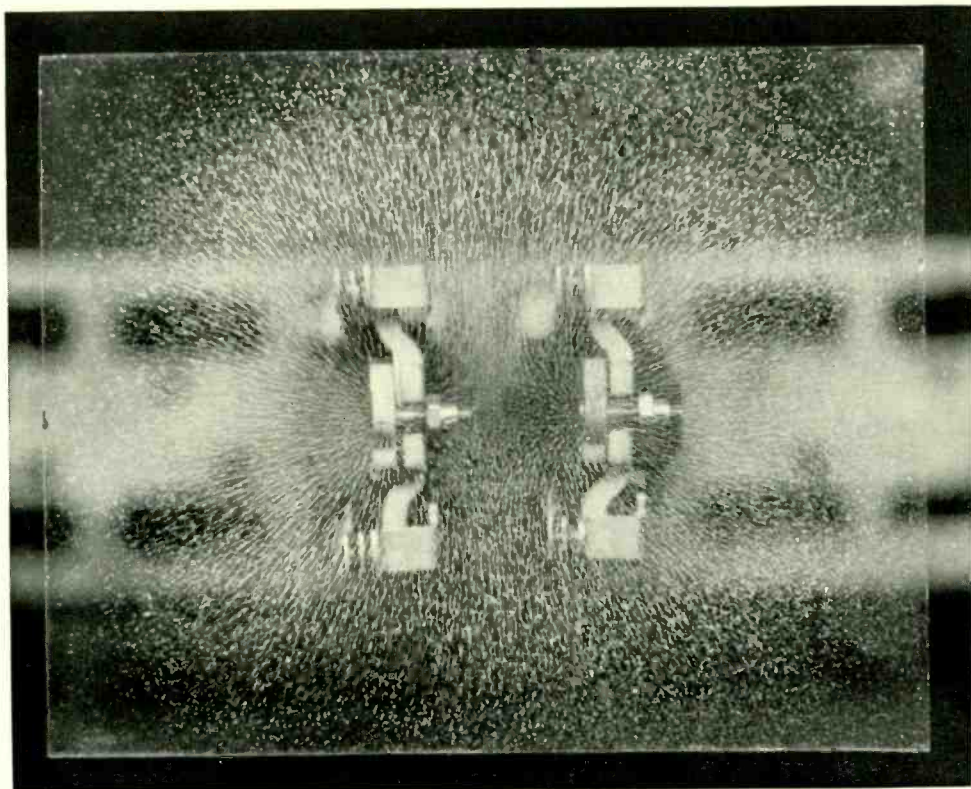

Fig. 3—When both relays are equally energized the magnetic forces counteract each other, as indicated by the lines of force traced by the iron filings

ever, it is ordinarily necessary to consider interference only from adjacent relays, those mounted either directly at one side, above, or below. With the type of relay shown in the illustration it is the relay to the right that has the most effect.

This interference affects the sensitiveness of the relay, and—depending upon its mechanical structure—may cause it to be slower or faster to operate or release, or to remain operated indefinitely. In some cases, it is necessary to increase the circuit operating current to insure operation. On relays requiring low operating current, this increase may reach forty or fifty percent.

In taking critical time measurements in the laboratory to determine

whether under the circuit conditions a relay will operate or release in the time allotted to it, the effect of adjacent apparatus must be taken into consideration. To accomplish this any neighboring relays that may be operated under the actual circuit conditions are energized when the relay's operate or release characteristics are determined. If this is not done, the measurements may show that the relay time is satisfactory, whereas under actual circuit conditions a circuit failure may result due to the change in operating or releasing times caused by magnetic interference.

It has been found by laboratory tests that this interference may be overcome in several ways. An insulating effect may be obtained by using

magnetic materials to form a short circuit path for the magnetic flux. Apparatus is sometimes mounted under covers of magnetic material such as iron or permalloy which produce a shielding effect by providing an easy return path for the lines of force. Such covers act as barriers to the magnetic flux. In some cases a whole strip of relays is protected from the relays below by mounting them as the top relays of a unit, and by placing an iron plate under them. The group of counting relays of a sender circuit, the top two rows of Figure 4, is a good example of this.

Some relays of the slow acting type — such as the 149, 162, and 178* — have in the past been furnished with removable individual brass covers which, since brass is non-magnetic, afford no protection against magnetic interference. Tests made in the laboratory show that when relays are subjected to magnetic interference they may fail to release under some conditions. It was found, however, that by replacing the brass covers with iron ones, the trouble was eliminated.

* BELL LABORATORIES RECORD, October, 1928.

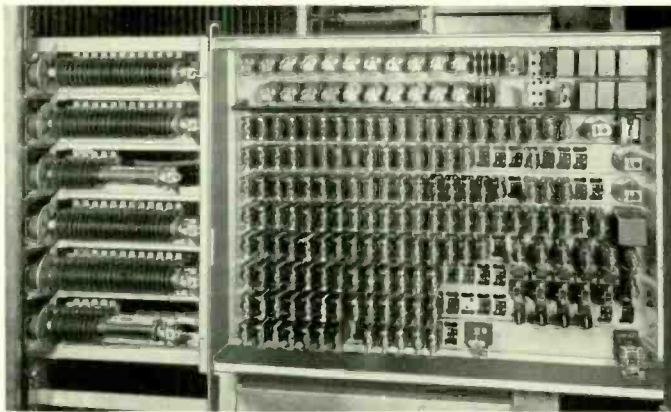

Fig. 4—A sheet iron shelf beneath the two top rows of relays serves as a magnetic shield

Wherever investigation discloses that the magnetic interference is a factor in preventing the proper functioning of a relay, it is usually specified that the relay be equipped with an iron cover which, however, somewhat re-

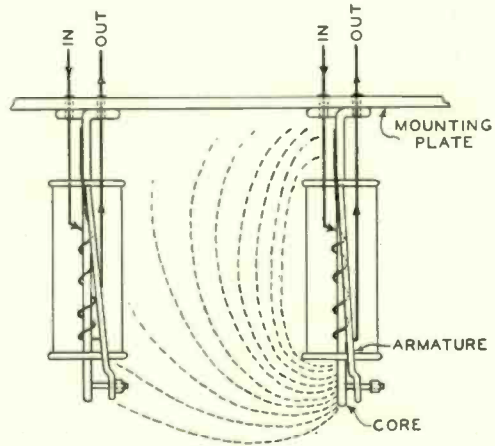

Fig. 5—The effect of magnetic interference may be greatly reduced by increasing the distance between adjacent relays

duces its efficiency. A polarized relay, recently developed, known as the 231 type, is equipped with a cover of magnetic material which is used as the return pole piece. This cover

tends to shield the relay from outside magnetic forces and as a result, where close mounting is required, the 231 relay is often used instead of the 206 type which has a brass cover. The use of an iron cover on the 206-type relay is unsatisfactory because of the loss of capability that results.

It is not always desirable, however to equip relays with

covers of magnetic material, and consequently other means have been resorted to. As the magnetic field extends outward, it becomes weaker; fewer lines of force exist to cause a magnetic pull. It is possible, therefore, to reduce interference by mounting the apparatus farther apart. This is indicated by Figure 5 which should be contrasted with Figure 2. The 206 type polarized relay is a case in point. It has no protection other than a brass dust cover, and due to its mechanical structure and symmetrical magnetic circuit, and the fact that it operates on low ampere turns, it is extremely sensitive to magnetic interference. Although this relay will mount mechanically on $1\frac{3}{4}$ " centers, it should never be mounted closer than $3\frac{1}{2}$ ", either vertically or horizontally, from other relays or magnetic apparatus without considering interference.

Relays such as the "R" type usually mount under a tin-plated steel cover common to 10 or 20 relays. In circuits using large numbers of them,

such as the sender and decoder circuits, they are mounted in large cabinets, all under one cover. Preliminary equipment layouts are usually made ignoring magnetic interference unless it is definitely known from previous studies that a particular relay or relays must be considered. Later, however, a study of each layout is made to insure that all have sufficient margin to overcome interference from adjacent relays which may be energized simultaneously. It is necessary in some cases to revise these layouts after it has been found by laboratory tests or analysis that circuit failures may result. This is done by moving the affected relay to some other location, where the adjacent apparatus will not be energized at the time this particular relay functions. When designing new "R" type relays, the maximum effect of magnetic interference is compensated for by allowing certain margins between the minimum current which may flow through the relay in the circuit and the current to which it is adjusted for that circuit.

Automatic Display Call Indicator System

By W. W. BROWN
Equipment Development

IN the sixteen years since the first commercial installation of call indicators there have been many changes, not only in the indicator itself but in the circuits that actuate it. This evolution has been briefly traced in an earlier issue of the RECORD.* Beginning with the large carriage call indicator controlled by circuits requiring motor-driven sequence switches, it progressed to the relay-type recorder and smaller display apparatus embodied in the key-display system. With this fourth decade of a century there is available a new indicator and a new system. Taking its name from one of the prominent features, it is called the Automatic Display Call Indicator or ADCI for short. Calls are displayed on the indicator automatically in a predetermined sequence.

From an equipment standpoint the ADCI system is divided into two parts, the indicator and seven common control keys located in the keyshelf of the position, and the relay equipment located in the terminal room. In some cases a new indicator is used which is approximately one-half the size of the former, and will be described in a future issue. In positions having four-party ringing keys it is mounted in place of the two middle keys, while in keyless positions it may be inserted parallel to the face of the board, as shown in Figure 1. The relay equipment required to con-

vert an entire position to call indicator has been built into a compact relay-rack unit known as the ADCI applique and is shown in Figure 2. It is manufactured and tested in the shop and is then ready for installation on the usual type of "I" beam relay rack. This unit is cabled to the existing trunk equipment as well as to the common equipment in the position.

The circuits of the ADCI system have been designed on the basis of using 206-type rotary selectors, which reduces the number of relays required per position. These circuits will func-

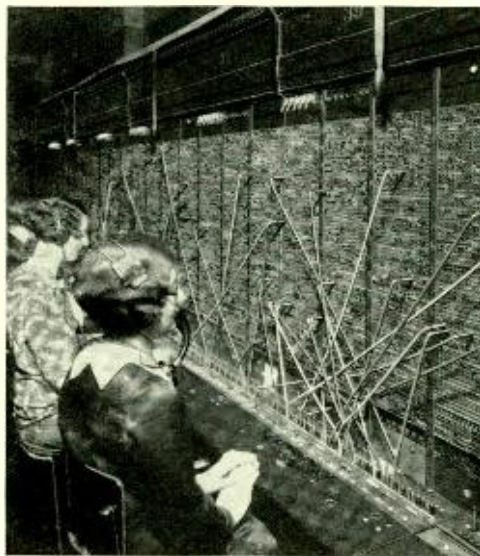

Fig. 1 — Keyshelf equipment required to convert an existing automatic-listening straightforward position to call indicator consists only of the indicator itself and seven keys

* BELL LABORATORIES RECORD, Dec., 1929, p. 171.

tion either as call-indicator, straightforward, or call-circuit trunks. Provision is made for splitting the trunks at a switchboard position into three groups. This permits merging trunks of adjacent ADCI positions and bringing any number of groups under the control of one operator. A grouping circuit is used between ADCI positions and adjacent straightforward or key-display call-indicator positions which provides the same flexibility as splitting does between adjacent ADCI positions. Such an arrangement makes it possible to reduce the number of operators at the trunk board during light load periods. Automatic teamwork is another feature of the system. A call coming in to either end group of a division when the operator is busy will be automatically transferred to the adjacent position, provided that operator is idle. When both operators are busy, an incoming call will wait until one of the operators is idle.

The arrangement of the keyshelf and the method of handling calls is quite similar to that of automatic-listening straightforward positions except for the manner of passing the call

and the teamwork provision. The lighting of the trunk lamp indicates the cord on which there is a call waiting, and if the operator is idle, the number wanted is displayed as illuminated digits on the indicator, and the trunk lamp flashes. As the operator reaches to insert the cord into the required jack, she presses a common release key which allows the next number to be displayed. When operating straightforward, the trunk with the flashing lamp comes from a manual office and the operator receives the number over her head-set instead of on the indicator. Otherwise the operation is the same for both types of calls. The similarity of operation is advantageous in that it enables operators to handle either type of call with a minimum amount of special training.

The advantages of the ADCI over the key-display call indicator become more apparent when the amount of modifications and installing effort required for the latter is considered. The KDCI requires a disconnect lamp, an assignment lamp, and a display key for each trunk. A teamwork key also is usually furnished with

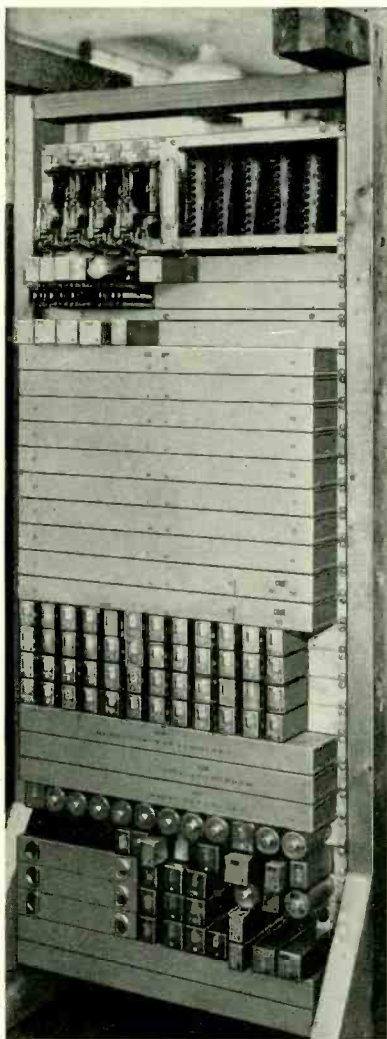

Fig. 2 — Complete additional equipment for a call-indicator position is mounted on an applique unit suitable for relay-rack mounting

each of the first and last ten trunks of the position although some telephone companies have all of the trunks equipped with teamwork keys. An emergency indicator is provided for in the lock rail of each position. The appearance of the keyshelf is shown in Figure 3, which may be compared with the simplified arrangement of the ADCI keyshelf shown in the earlier illustration.

Since the call indicator serves traffic previously handled on a manual basis, existing positions are generally converted. With this in view the ADCI has been designed to re-use as much as possible of the existing manual trunk and position equipment and to add to this the equipment necessary for call-indicator operation. With the additions required for KDCI it was necessary to replace the keyshelf and the position local cable. Complete new trunks were also required. The new system with the smaller amount of equipment added in the keyshelf permits the re-use of an existing position with relatively minor changes. This fact, together with the re-use of existing trunk equipment, and with the

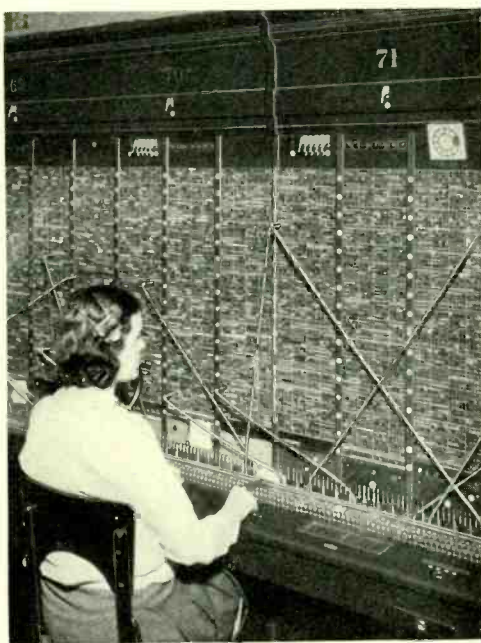
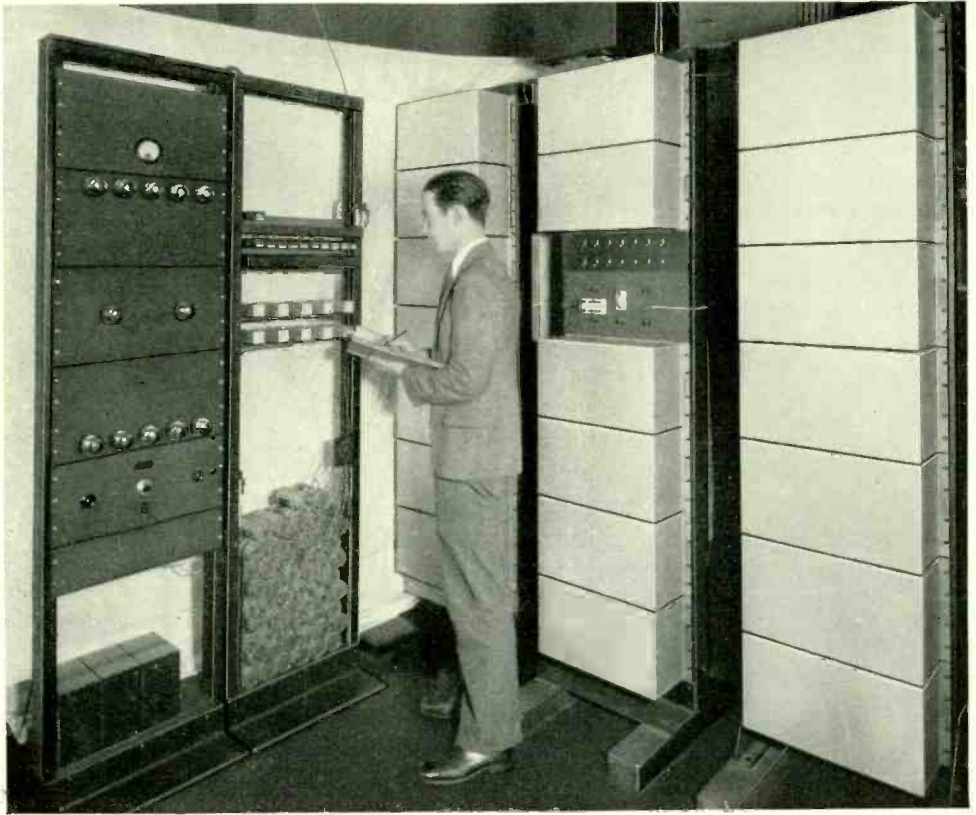

Fig. 3—Switchboard position equipped for the key-display system

convenience of the added equipment on a single shop-wired applique unit, allows a considerably shorter installing interval. These features, and the operating advantages, make the ADCI system a contribution to speedier and more economical operation.



A New Analyser of Speech and Music

By H. K. DUNN

Acoustical Research

SYSTEMS for reproducing sound, which with the rise of broadcasting and sound pictures are becoming increasingly important in modern life, require for their effective engineering a rather complete knowledge of the sounds to be handled. There are two variable quantities in sound which are of fundamental importance. These are frequency of vibration, and amplitude. Ordinarily a sound contains a number of frequencies of various amplitudes. The particular frequencies present, and their relative amplitudes, give the sound its peculiar quality. It is this

which enables one to recognize at once the sound of a piano, a violin, or a human voice, and to distinguish the different sounds of speech. If any one of the components of a sound is not reproduced at its full amplitude, the result is that the reproduced sound is distorted and unnatural. A further characteristic of speech and music is that the different sounds follow each other in succession and are recognized as syllables or notes. In most types of sound which it may be desirable to reproduce, the components are seldom constant for very long, but are changing from moment to moment.

Depending on the use to which it is to be put, knowledge of these characteristics may be determined in different ways. For the engineering of sound reproducing systems it is not usually essential that the magnitude of each separate frequency be known at every moment, but it is very desirable to know the range of frequency and the manner in which the magnitudes vary over different sections of this range. Knowledge of both average and peak magnitudes is desirable, and it is just this information that the new apparatus, performing two types of measurements, is designed to give.

For both types, the sound to be measured is picked up by a condenser transmitter, such as is used in making

sound pictures, and amplified to some convenient level before being passed on to the measuring apparatus. One measurement gives the average amplitude and the other, the peak amplitude. Average amplitudes are taken over alternate 15 second intervals and peak readings over alternate $\frac{1}{8}$

second intervals. Both kinds of measurements may be made on the complete output from the condenser transmitter or on restricted ranges of component frequencies.

To accomplish analysis by bands of frequencies a group of thirteen filters is employed. Eleven of them divide the range from 62.5 to 8,000 cycles into convenient bands; the twelfth passes all frequencies below 62.5 cycles and a thirteenth all above 8,000. A



Fig. 2—H. K. Dunn making and S. D. White recording readings of fluxmeter

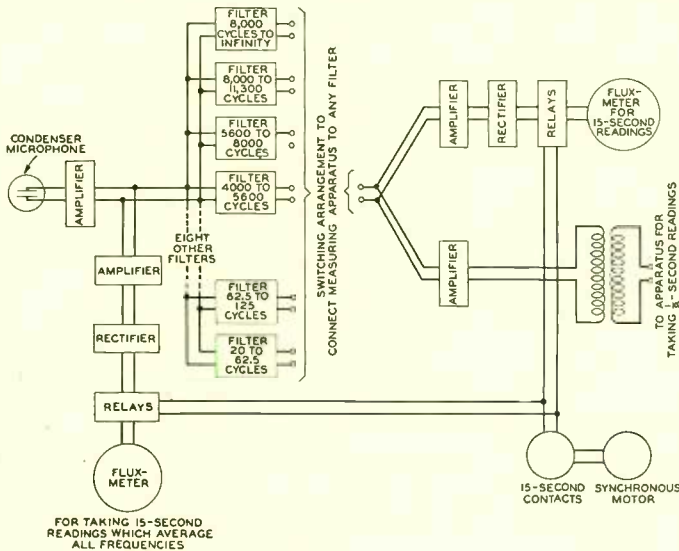

Fig. 1—Arrangement of apparatus for making average and peak readings of amplitude over various frequency bands

fourteenth filter is sometimes used to cover the range from 8,000 to 11,300 cycles. Further amplification is provided after the transmitter output has passed through the filters. Since measurements may be made on only one band at a time the selection being played or the words being spoken must, for complete analysis, be repeated fourteen or fifteen times, once to allow readings for each of the fourteen frequency bands and once for all bands taken together. The general arrangement of apparatus is shown in Figure 1.

The fifteen-second measurements are made by a fluxmeter after the amplified output has been passed through a vacuum-tube rectifier. The fluxmeter, shown in Figure 2, is like a heavily damped galvanometer with very little force tending to return the

moving element to zero. The needle moves while current is flowing and stops when the current ceases. Its deflection at the end of fifteen seconds, therefore, shows the total quantity of electricity—the product of current by time—that has passed through it, and is thus a measure of the average amplitude of the wave during that time. The intervals are timed automatically by a switch driven by a synchronous motor making one revolution per minute. The switch makes contacts every fifteen seconds, which alternately start and stop the fluxmeter. Readings are made over alternate intervals, the intervening periods being used to record the deflections and reset the fluxmeter.

Two complete outfits for measuring fifteen second averages are used simultaneously. One is always connected to the input

side of the filters so that all frequencies register their average amplitudes together. This gives an indication of the general intensity or level. The other may be connected to the output of any one of the filters and can thus be used to measure the average amplitude of any one frequency band.

Peak amplitudes are measured by a set of new gas-filled tubes which flash over between plate and filament whenever the grid voltage exceeds a definite value. At flash-over a heavy current flow starts and con-

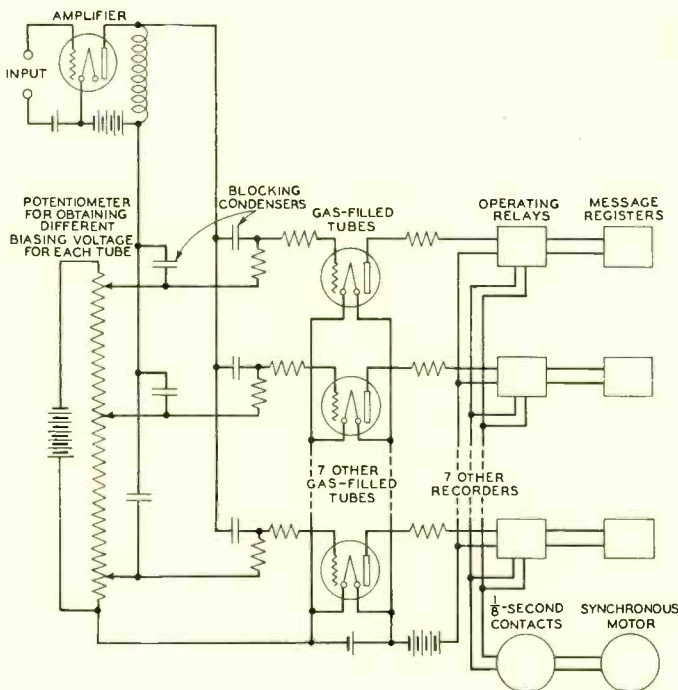

Fig. 3—Peak voltages are determined by the flashing over of ten gas-filled tubes biased to give a rising series of flash-over voltages

tinues until the plate supply is opened. This extremely useful tube is a recent development of the vacuum tube group in the Laboratories. As applied here the current of the flash-over is allowed to operate relays which in turn actuate an electrical counter. Ten such tubes, each connected to its own counter, are used, and each has a different grid-biasing potential so that the voltage at which it flashes over differs from the others. The arrangement, somewhat simplified, is shown in Figure 3. Adjustments are made so that the striking voltages of the tubes are increased in 6-decibel steps: each tube thus flashes over when the input voltage is twice as high as that on the tube next below it in the series. The flash-over amplitude of the 10th tube is therefore 500 times higher than that of the first, a difference of 54 db.

A motor-driven switch, making contacts every eighth of a second, is used to connect all ten tubes into and out of the circuit every alternate eighth second during the test. Since the counters operate every time these tubes flash over, they record the number of times the input has reached the various energy levels during the test, which generally lasts for two or more minutes. Such a set of measurements is made with the measuring apparatus connected to each of the fourteen filters, and to the circuit ahead of the filters so as to get the peaks for all frequencies together.

Tests have been made on speech using both male and female voices, and in various manners of speaking and distances from the microphone. Some measurements have also been

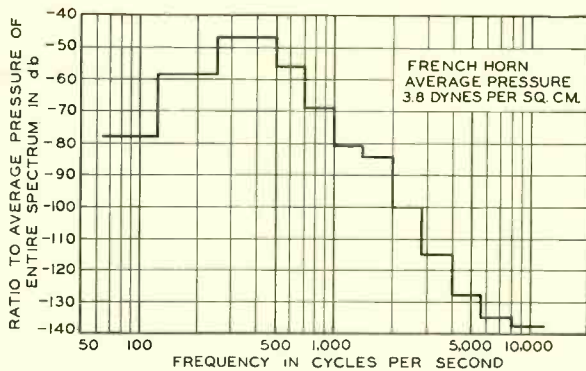

Fig. 4.—Average relative pressures over various frequency bands divided by the width of the band are plotted for all sounds measured

made on street noises. For music, short selections have been played by most of the common instruments, including both piano and organ, and by entire orchestras of different numbers of pieces. For all of these tests the method of recording the information has been the same and may be illustrated by the results obtained from the French horn.

A selection is played fifteen times, once for each filter and once for the selection as a whole, and its duration may be assumed to be 2½ minutes. For each rendition there will thus be five readings of both fluxmeters, taken over alternate fifteen-second periods. These five readings are averaged together to give the average intensity for each frequency band, and for all together, for all of the fifteen tests. The ratio of the intensity for each frequency band is divided by that for the whole and the result plotted as shown in Figure 4. This graph thus shows the ratio of the average intensity for each band to that of the average for all frequencies. For the French horn shown, the most prominent band is 250-500 cycles. Both above and below these frequencies the

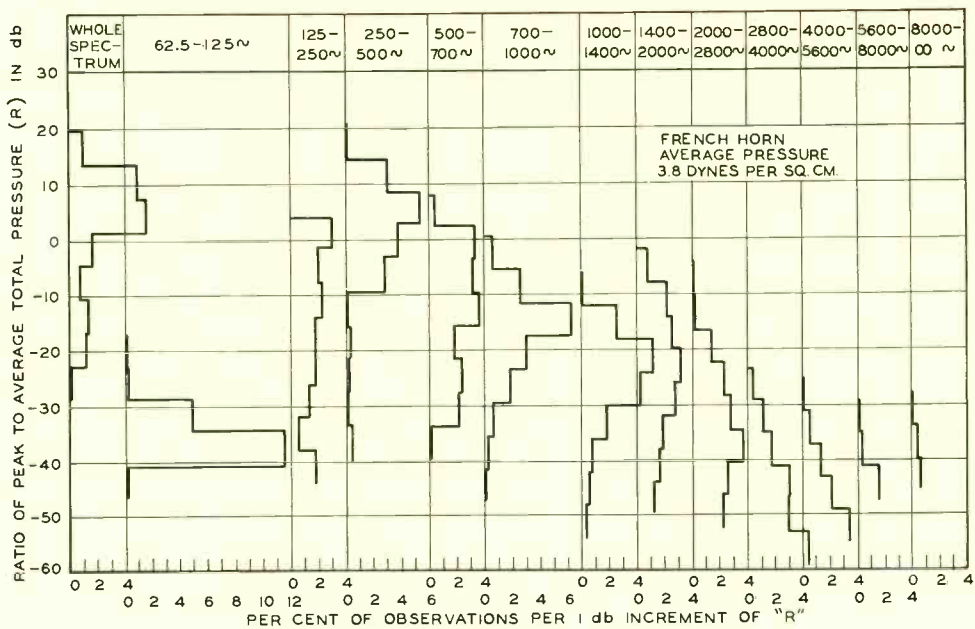

Fig. 5—Peak values of intensity are plotted for each frequency band and for the sound as a whole

intensity falls off rapidly. The average loudness of the selection, measured by the fluxmeter connected to the circuit ahead of the filters, is marked on the graph in pressure units.

In Figure 4 one amplitude level, the average, is given for each band. By use of the peak or $\frac{1}{8}$ -second readings, however, further analysis is made to discover the manner in which the intensity varies from moment to moment within each band. These results for the French horn are shown on Figure 5. A separate curve is drawn for each frequency band and for the selection as a whole. How these curves are to be interpreted may be illustrated by considering the curve for the frequency band from 250 to 500 cycles. Each of the equal length vertical lines represents one of the gas-filled tubes and the horizontal distance of this line from the axis of zero percent indicates the number of times

that that tube flashed over expressed in percent of the total number of $\frac{1}{8}$ -second intervals. The actual percentage is divided by six, because of the six db. zone covered by the tube.

The high point of the curve for this particular band covers amplitude levels from 3 to 9 db. above the average levels for the entire selection. About $\frac{1}{3}$ of all the peaks in this band were of this magnitude. A large number of peaks also occur in the amplitude interval immediately above this and in the two just below, and very few in the rest. Over 90% of the peaks in this frequency band occur in the five highest levels. This is in distinct contrast with the peaks for the band from 125 to 250 cycles, where the peaks are fairly evenly distributed over all the levels, and with the band from 2000 to 2800 where most of the peaks occur in the intermediate or lower levels. In other words the intensities of the various

frequency bands vary in different manners. Some bands are characterized by many very high peaks, others have the majority of their peaks of low magnitude. For each band the distribution of size of peaks differs in the manner shown by Figure 5. Typical of the information gathered from the series of tests already made is that the bass drum gives the greatest volume of sound, both for average and peak values, over the lower frequency bands, and the cymbals the greatest for the higher frequencies.

As used in the Laboratories, the condenser microphone is set up in one of the sound-proof rooms where the selections may be played or the words

spoken into it. In an adjacent room is the measuring apparatus. The arrangement of filters and counters is shown in the headpiece. It is possible also to use the same apparatus to analyse sounds that have been recorded. For such a purpose an electrical reproducer would replace the condenser transmitter. The method also lends itself to studies of speech actually transmitted over commercial circuits and apparatus. In short, it may be applied to any disturbance in the audible frequency range, and provides an effective means of studying the intensity distribution of such a disturbance over convenient groups of frequency bands.

The Enemy, Noise

The first American noise abatement commission, that appointed by New York City's health department, has reported, and its report is important, possibly epochal. If it leads to consistent and practical war against unnecessary noises from now on it will merit the "epochal"

Methods of study and analysis included use of noise-measuring machines of the Bell Telephone Laboratories in every part of the city. It included the most thorough testing of the actual effects of sound on the human organism. The conclusions are that our cities are virtual bedlams, that much of the noise can be eliminated and that the effects of the noise on people is far more injurious than has ever been understood

With more than half our American people now city people, and the proportion increasing, nothing but stubbornness or folly can prolong the period of complete indifference to noises, as if they were inconsequential. It is as truly a matter of national health and of accident prevention as it is one of national efficiency, whether measured by the individual or the group. There is no intelligent reason why even cities much smaller than New York—why Iowa cities, to be specific—should not begin simultaneously a campaign of education against noise and of prevention against its most blatant phases. There is every reason why medical associations, life and health insurance agencies and local health departments should concern themselves first.

—from an Editorial in "Des Moines Register," Oct. 9, 1930.



Reducing Wear at Base-Metal Contacts

By J. R. TOWNSEND

Telephone Apparatus Development

DURING the development of the 200-type selector for the panel dial system, it was observed that the selector brushes and the terminals over which they wipe tended to wear out and disintegrate. In some instances where an arc was drawn between the wiping brush and the terminals of the bank, rapid disintegration of the material took place, and the life of the apparatus under accelerated wear testing in the laboratory was only a small fraction of the desired life of the apparatus in service. An investigation was undertaken to determine the cause of this rapid destruction.

The material used for the brushes and terminals was sheet brass, of nominally 67 percent copper and 33 percent zinc, rolled spring hard. The brushes were .0125-inch thick and the terminals .0140-inch thick. In the accelerated test, loss of tension in the brushes due to wear supplemented the disintegration of the terminals in developing high contact resistance. In some instances the bridging brushes wore away to a point where they no longer bridged adjacent terminals, and the apparatus became inoperative.

Measurements disclosed that in the case of brushes and terminals where there was no arcing, the wear was only about half as great as in the case of the brushes and terminals where arcing took place. This evidence indicated that the arcing was largely responsible for the destruction

of the brushes and terminals. The destructive action of arcing results mainly from the high temperature at the arc, a temperature many times higher than the melting points of the metals of which the brushes and terminals are made. In general the higher the melting point of a metal, the more resistant it is to arcing of this type.

In the case of brass, however, another phenomenon takes place. It is a well known characteristic of zinc that it will volatilize or sublime at temperatures below its melting point. At the high temperature of the arc the zinc contained in the brass will more readily volatilize. The heat of the arcs between the brass brushes and terminals, therefore, caused the volatilization of the zinc, leaving behind the soft copper in roughened and abraded rubbing surfaces. These in turn would cause more arcing, since the rougher the surface the more chance of brushes and terminals becoming separated in action and drawing an arc. Hence resulted a vicious cycle in which abrasion increased arcing and arcing increased abrasion.

The conclusion was that if a more wear-resistant material were employed, free also from a tendency of one of its ingredients to pass off by volatilization, a more satisfactory substance would be obtained. In the case of bronze bearings it has been known for some time that addition of lead to the bronze causes great im-

provement in wearing characteristics. The theory underlying bearings of this nature is that the hard bronze supports the load, and the lead serves as a soft yielding matrix material.

It seemed that lead could not well be employed in sheet bronze, since leaded bronzes are in general "cold short", or in other words are very brittle when cold rolled and would break up on the rolls while being reduced to sheet. Furthermore, since the demand for this type of material was very small, there was no commercial source of supply. Nevertheless, it was considered desirable to determine how much lead could be alloyed with bronze with-

out rendering the material incapable of being rolled into sheets.

Three manufacturers of sheet bronze agreed to attempt production of a phosphor-bronze containing as much lead as the alloy would stand without breaking up on the rolls, and were practically unanimous in concluding that five percent lead was the maximum that could be employed. Orders for a trial lot of materials containing $3\frac{1}{2}$ percent lead, a composition safer for our manufacture and use, brought samples from the suppliers. Figure 1 is a photomicrograph showing the gross structure of the alloy. The numerous elongated black spots in Figure 1 are particles

of lead, which, it will be observed, appear between the grain boundaries, widely distributed in the mass of the metal.

This shows that the lead is not soluble or in solid solution with the balance of the alloy but is in the form of a mechanical mixture and explains

one important characteristic of this sheet metal. To bending across the direction of rolling it is very resistant, and it will not crack unless several sharp right-angle bends are made. On the other hand, if it is bent along the direction of rolling, a bend over even a generous radius will split the material apart. Obviously this is due to the elongated par-

ticles of lead between the grains of the sheet metal, produced by the rolling operation, which form soft areas and lower the metal's strength to longitudinal bending.

It is customary to punch springs from sheet at an angle of 45 degrees to the direction in which the material was rolled. This provides the most favorable grain direction for sheet metal springs, since right-angle bends made in any direction will not parallel the direction of rolling. Experimental selector brushes so punched from the material were too brittle; their brush tips would break off if subjected to more than ordinary abuse by the adjusting tools. It was there-

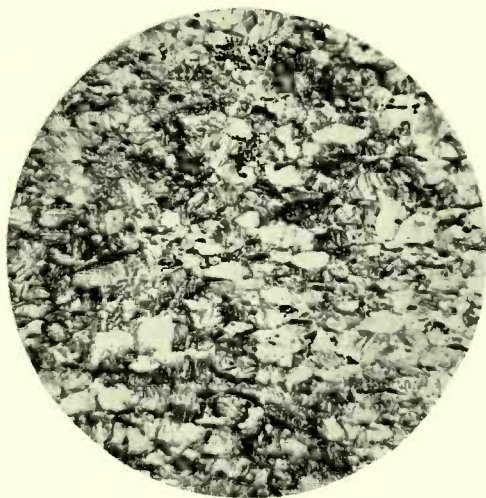

Fig. 1—A photomicrograph of leaded phosphor bronze sheet, at a magnification of 75 diameters, shows clearly the dark elongated areas of lead

fore decided to abandon the idea of using leaded phosphor bronze for the selector brushes and to use instead a five-percent-tin phosphor bronze. When the leaded bronze was tried in the terminals, their soldering lugs broke off easily under the pressure of the soldering iron, if the grain direction of the terminals was transverse to their long dimension. If the grain paralleled the length of the terminals, however, the soldering ends could not be broken off. The leaded phosphor bronze could be used for the bank terminals satisfactorily in the latter way.

Comparative wear tests showed that the substitution of phosphor bronze in the brushes and leaded phosphor bronze in the bank terminals resulted in a five-fold improvement in wear. These materials are now used instead of brass in all 206, 207 and 208 type selectors and their associated 26 and 27 type banks, which replace the 200 and 203 type selectors and their associated 10 and 11 type banks. Lubrication by the lead in the bronze reduces abrasion and thus in turn the amount of arcing, and tends to eliminate the vicious circle aforementioned.

Some experiments were made in which leaded phosphor bronze was used as a contacting material where there was no rubbing action, the contacts being brought together and separated without wiping. It was found that in this type of service the leaded phosphor bronze disintegrated about as rapidly as the phosphor bronze with five percent tin. This experiment illus-

trated further the specific value of the lead in reducing abrasion in wiping contacts. In other words it seems that the sole role of the lead in the terminals is to reduce abrasion and consequently the amount of arcing.

Before the new materials were adopted for selector brushes and bank terminals, a comparative wear and corrosion test measured the behavior of selectors made of these materials and selectors made of brass when exposed to high humidity and high concentrations of sulphur dioxide and hydrogen sulphide. Comparative tests of contact resistance and mechanical performance indicated that the leaded bronze terminals and the phosphor bronze brushes were equal to if not better than the brass from the standpoint of contact resistance.

Leaded phosphor bronze sheet has now been adopted as a standard material for use in telephone apparatus, and is known as Grade "D" phosphor bronze. At the present time it is used in the 26 and 27 type selector banks and for the wiping contacts on the multiple brush, and other uses are contemplated. Although very resistant to wear, and to combined wear and arcing, it has longitudinal weakness. Wherever it is employed, care must be taken to adjust the direction in which the material is used so as to compensate for this inherent weakness. The substitution of the new material in telephone apparatus, especially in the selector, has resulted in large savings, not only in replacement but in maintenance charges.

Panel Selectors

By W. WHITNEY
Local Systems Development

IN completing a telephone call, the line called must be selected from the very large number entering the office, and a connection made between it and the calling line. With manually operated systems, this selection is performed by an operator who may have before her the terminals (jacks) of as many as 10,500 lines. These lines are grouped and numbered so that by a coordination of mental, visual, and muscular effort the selection is readily made. In large areas, having many central offices, two or three of such selective operations may be required in succession. The first may locate an idle

trunk to another central office and the second, the line in that office that is called. Three selections are required when a tandem office intervenes between the calling and called offices. In the design of dial systems, it is not practicable to build a mechanism that in a single operation can select any one of some ten thousand connections. It has been found desirable to subdivide where the selective choice is wide, so that in dial systems a larger number of selective operations are required, each mechanism making a somewhat less extensive choice than the manual operator. With mechanical operations, such as are dealt with

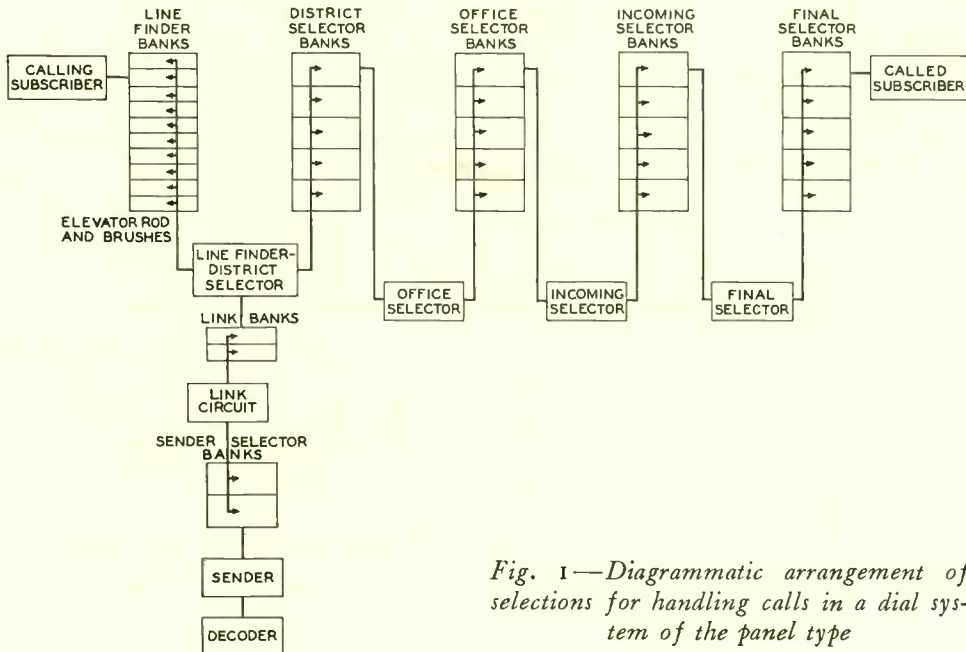

Fig. 1—Diagrammatic arrangement of selections for handling calls in a dial system of the panel type

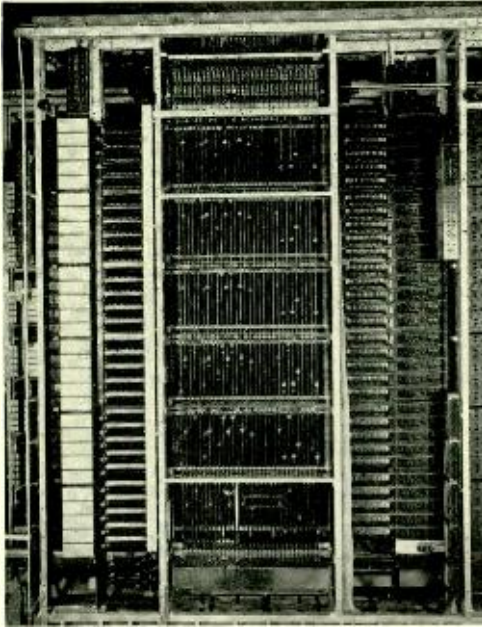

Fig. 2—One side of an incoming selector frame showing elevators, sequence switches, and relays

here, such subdivision presents no important disadvantages as might exist with manual operations.

In the dial system of the panel type—used primarily for very large exchange areas—many different types of selections are required but for the major steps in the completion of the usual call, the selecting mechanisms are similar in their general mechanical features. Functionally they are of four types known as district, office, incoming, and final selectors and to these the following description is chiefly confined. A typical arrangement of these selectors employed in completing a call between two subscribers is shown in Figure 1.

A complete panel selector circuit with its associated control equipment consists of a sequence switch, a group of relays, and an elevator mechanism with its clutch, brush rod, complement of brushes, and commutator.

A group of as many as sixty selector circuits are mounted together to form a selector frame as shown in Figure 2. The elevators are arranged on both sides of a "bank" of terminals of the lines or trunks to which connections are to be made. The banks used comprise one hundred sets of three terminals for each elevator, and five such banks are mounted one above another in each frame.

Each trunk or line in a bank consists of three punched metal sheets, separated by insulation, which have small rectangular terminals projecting in front of each elevator. Brushes carried by the elevators, one for each bank of a frame, make connection with each of the three terminals of a trunk or line. The brush mechanism normally holds the brush contacts away from the lugs but when the selector is in use one of the brushes will be tripped to make contact. The particular brush tripped will depend on which bank includes the line or trunk required for the connection.

In addition to these five bank brushes there is a sixth, located at the top of the frame, carrying eight brush springs sliding over a like number of commutator segments. The commutators are metal strips or segments set in a vertical strip of insulation. Five of the commutators, consisting of continuous metal strips (one of which, however is divided by insulating strips at each group position) are on one side of the insulation, and three of them, built up of metallic segments separated by insulation, are on the other side. The brush frame mounts five brushes on one side and three on the other. The arrangement of brushes and commutators is shown in Figure 3—a photograph of the upper part of a selector frame with

the elevators and commutators at one end removed.

Four of the five commutators on one side are used to connect the talking and control leads to the contacts of the bank brushes. Although there are only three effective contacts on the bank brushes, four commutators are used as the control lead comes through different circuits at certain times. The fifth brush on this side is used for connecting ground, under control of the sequence switch, to certain of the other brushes and commutator segments. The three brushes on the other side are used in conjunction with the sender to control the selection that is to be made. The sequence switch and relays also act in the selection of the proper line or trunk as well as to perform other functions.

To move the elevator rods and brushes up so that a selection may be made among the trunks or lines terminating in the five banks, a drive unit is provided beneath the bottom bank. At the lower end of the elevator rod is a flat perforated strip known as a rack (evident in Figure 2) which may be pressed against a rotating cork roll by the action of an electromagnetic clutch.* A motor, through suitable gearing, drives two or, for some frames, three of these rolls: one for a high-speed up motion, one for a down motion, and one—on the final frames only—for a slow-speed up motion. For each elevator rod there is a clutch for each roll and an additional clutch to operate a vertical rod used for “tripping” the brushes.

The selection of a trunk or line is guided by the sender which uses as auxiliaries the commutator, relays, and sequence switch associated with each selector.

* BELL LABORATORIES RECORD, *Apr.*, 1930, p. 367.

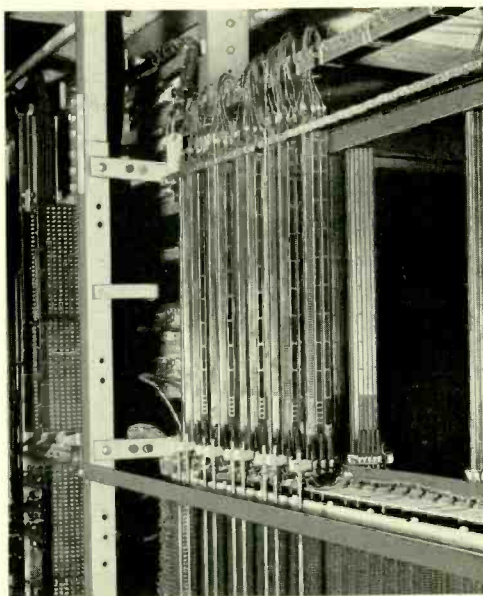

Fig. 3—A group of commutators above a district selector frame

a selector elevator is started upward by the operation of the up-drive clutch. The lower part of the second commutator from the front in Figure 3 controls the brush selection. At each of the lower five segments the brush passes over, a pulse is returned to the sender and if, for example, the third brush is to be tripped, the upward motion of the elevator will be stopped as the brush leaves the third segment and the trip magnet will be operated. The elevator then starts up again and in doing so trips the third brush.

The trunks in a bank are, from a circuit standpoint, divided into groups; eight of ten trunks and two of five on district and office selector banks, and four of 24 trunks on incoming selector banks. The remaining terminals on these banks are used for “overflow terminals” one being required for each trunk group. When more than ten trunks are required for a group on a district or office selector

frame two or more of the groups are combined. A group selection, therefore, follows the brush selection, and is controlled in a similar manner—by pulses from a commutator to the sender. The bank brush then travels over the contacts in a group till the first idle one is found. This is called hunting. Various methods of accomplishing it have already been described in the RECORD.*

With the final selectors no hunting is done (except for hunting an idle trunk in a P.B.X. trunk group) since a definite line must be selected. After the group of ten terminals that contains the line wanted has been found, the motion of the elevator is stopped, and started again through the low speed clutch. A pulse is returned to the sender by the commutator for each line till the right one is reached when the elevator is stopped again.

Certain of the selectors also perform additional functions. The district selector, for instance, provides repeating-coil transmission between subscribers on regular calls, and cuts the subscriber's line directly through on calls to operators. Certain of the district selectors are arranged to collect or return coins on calls from coin-box stations or to operate message registers on calls from message rate lines. The incoming selectors ring the called subscriber's line and also provide repeating coil transmission. The repeating coil is placed here instead

of in the final selector because in most cases there are fewer incoming selectors than finals, and also because this arrangement permits the use of various grades of transmission depending on the type of incoming trunk which is used.

It should be noted that the connection of one line to another by means of panel selectors is not, and in fact could not be made in synchronism with the dial pulses, since such an arrangement would allow only one selection to be made for each digit dialed by the subscriber, whereas there are considerably more than this number of selections necessitated by the trunking arrangement used. The district brush and group selections and, if office selectors are provided, office brush and group selections are determined by the office-code digits dialed by the subscriber. Incoming brush and group selections and final brush, tens, and units selections are determined by the four digits dialed by the subscriber. It is the use of indirect control of the selector (control by the sender instead of by dial pulses) with the consequent elimination of the necessity of limiting the number of trunk groups available to any one selector, together with the large trunk groups which can be provided due to the multiple bank arrangement of the selectors, which makes the panel system desirable for use in areas where extensive trunking is required.

* BELL LABORATORIES RECORD, *Sept.*, 1928, p. 5.

Key Pulsing for No. 3 Toll Boards

By J. B. NEWSOM
Local Systems Development

LONG-DISTANCE calls, on account of their complexity, are handled by operators even in districts where the local calls are completed by dialing. Connections from the long-distance board to subscribers are made over trunks to the local offices; if these offices are manual, the trunk is plugged into the subscriber's jack by the incoming-trunk (B) operator. Trunks to dial offices require dialing—or an equivalent operation—either at a B-board in the local office or at the toll board itself. This last method is frequently the more desirable, and if the area has no manual offices—which is the ultimate objective in many existing dial areas

—it is usually the most economical one since it permits the elimination of all B boards.

Until recently the key-indicator system has been used for directly reaching panel subscribers from toll boards. It requires three wires between the ten-button key, used for writing up the number wanted, and the sender. Two wires—the talking-conductors of the cord and trunk—are available for registering, but the sleeve conductor, on account of other uses, is not. Wires in addition to those of the cord and trunk have therefore been required between the toll board and the mechanical equipment.

To improve the existing equipment

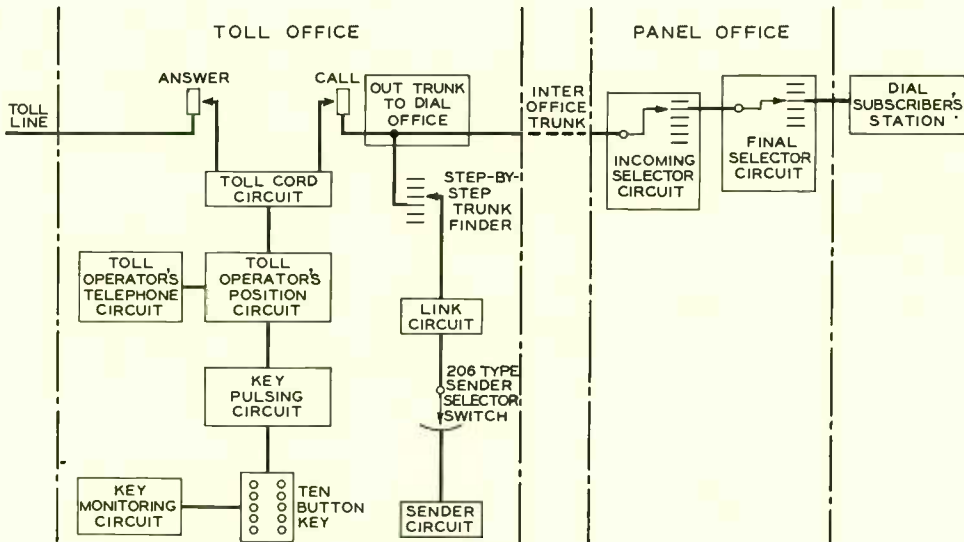

Fig. 1—Key pulsing adjusts itself to the No. 3 toll boards merely by the addition of a key-pulsing circuit at the operator's position and toll switching trunks with their link and sender circuits in the terminal room

and to reduce its cost, a new system for completing calls from toll boards to dial offices in panel areas has recently been developed, known as key pulsing. One of its outstanding features is the use of only two wires for transmitting the number from the key-set to the sender. Only the tip and ring conductors of the cord are used. Also, the circuits are arranged so that the number of links between key-sets and senders is dependent only on the amount of traffic. The employment of a less expensive link in addition to the other improvements makes a much more economical arrangement.

A schematic showing the general arrangement of equipment is given as Figure 1. The toll cord circuit remains unchanged but connected to it is a key-pulsing circuit which includes a ten-button key for writing up the number wanted, and, where desired, a key-monitoring circuit. This latter, used by an instructor, is employed frequently for training new operators. Besides the key-pulsing circuit, there is the toll switching trunk to the panel office associated with which, and at the toll office, are the link and sender circuits. The sender, of course, controls the operation of the incoming

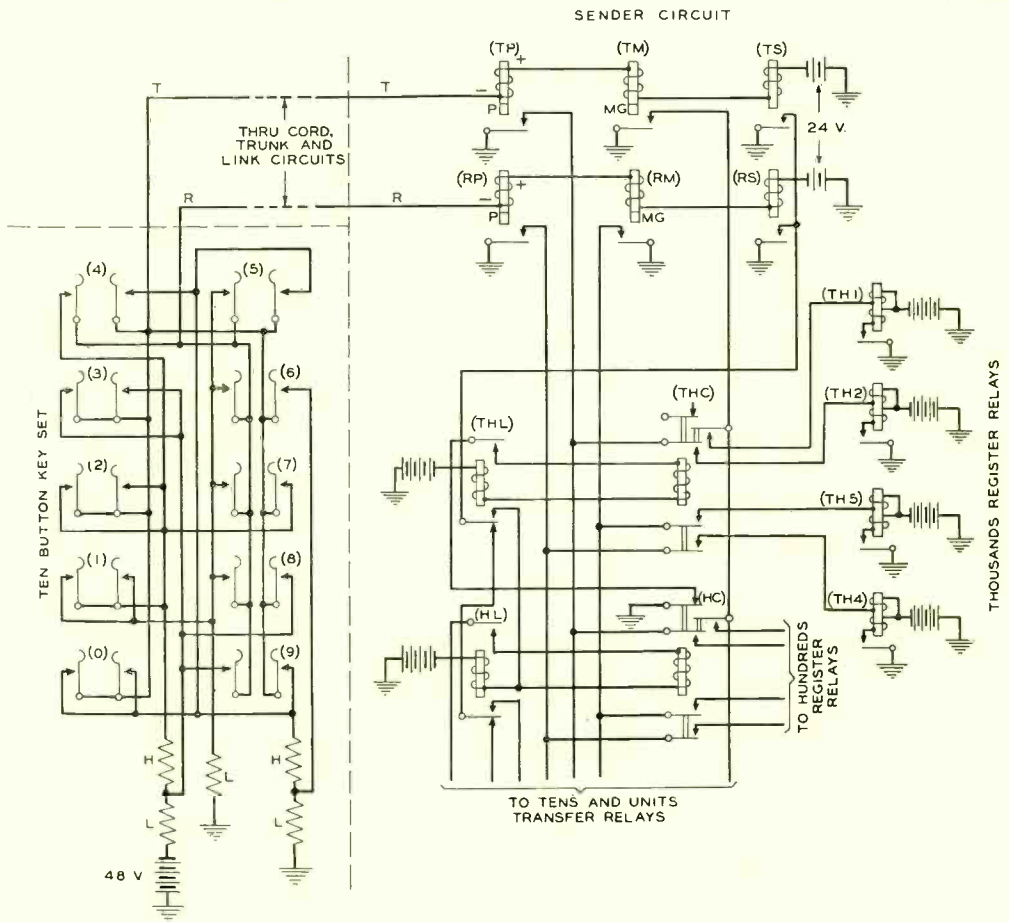

Fig. 2—For key pulsing only the tip and ring conductors are used, in each of which is a polarized, a marginal, and a sensitive relay

and final selectors at the panel office.*

To complete a connection, the toll operator operates a listening key in one of her cord circuits and tests for an idle trunk to the panel office desired by touching the tip of the plug to the sleeve of the various trunks. She then plugs into the first idle trunk, and the link at once starts hunting both for the trunk the operator has plugged into, and for an idle sender. At the same time she operates a positional key which connects the common key-pulsing circuit to the cord whose listening key she has operated. When both trunk and sender have been found, a lamp at the operator's position lights, and the operator proceeds to write up the number on her keyset. As the operator releases the key from the last digit, the sender causes the key circuit to be released from the cord, allowing the operator to proceed with the next call.

A portion of the actual pulsing circuit is shown in Figure 2, and from this the general scheme of operation may be followed. The depression of a key connects 48-volt battery or ground through low or high resistance to either the tip or ring conductors or both. In the sender, 24-volt battery is connected through the windings of three relays to both tip and ring conductors. These relays are differentiated as polarized, marginal, and sensitive. The polarized relay operates with battery connected at the keyset; the marginal, when either battery or ground are connected through low resistance; and the sensitive, under any connection of ground or battery. Thus one or more of these six relays operate with each key depression and their operation causes

the registration of the proper number in the sender.

Suppose, for example, that the number were 2471. The depression of the No. 2 key puts high-resistance battery on the tip conductor and operates both the tip sensitive and tip polarized relays. These relays remain operated only while the key is depressed but they actuate other relays in the sender—shown beneath them in the diagram—some of which, the register relays, lock up and record the number, and others act to transfer the register leads to the next group.

The operation of button No. 4 connects high-resistance battery to the ring conductor—thereby operating the ring sensitive and ring polarized relays—and connects high-resistance ground to the tip conductor and thus operates only the sensitive relay in the tip conductor. The remaining two buttons act in a similar manner so that by the time the number is completely written up the four digits are recorded in the sender. After receiving the first key registration, the sender proceeds to control the incoming and final selectors in the distant office and so complete the call to the subscriber.

The key-pulsing method will be used with the new No. 3 toll board* and requires no changes in it other than the addition of the keyset circuit and the panel switching trunks with their associated links and senders. Supervision of the call by the toll operator is not affected. The new, simpler, and less costly method of key pulsing has been made possible largely by the discovery of a satisfactory method of registering numbers from a keyset over two wires which until this time had not been done.

* BELL LABORATORIES RECORD, *June, 1929.*

* BELL LABORATORIES RECORD, *June, 1927.*

Function of Repeating Coils in Carrier Circuits

By A. G. GANZ

Telephone Apparatus Development

IN the operation of carrier telephone circuits, a number of advantages are secured by interposing a repeating coil, as a transformer used in this manner is called, between certain elements of the line-terminating equipment. Lack of a metallic connection assists in keeping stray noise-producing voltages, picked up by the line and transmitted longitudinally, from passing through the terminal circuits; the repeating coil also allows less-expensive unbalanced apparatus to be used without disturbing the balance of the line wires to ground.

Noise, due to high-frequency electrical disturbances, is a familiar sound to the radio listener. Telephone lines operated at high frequencies are exposed to the same influences, since they usually include long stretches of open-wire lines which act somewhat

as antennas. Currents and potentials induced in the lines are of two kinds. The first, called longitudinal, are those which act in both conductors of a circuit with equal intensity and direction with respect to ground. The second, called metallic circuit currents or potentials, are those acting with equal intensities but in opposite directions through the two conductors of a circuit.

The positions of the two wires of any given telephone circuit are systematically interchanged, or transposed, at short intervals. These transpositions tend to equalize the voltages induced on the two wires, thus minimizing the metallic-circuit induction, but they do not appreciably change the longitudinal circuit voltages and currents, which are therefore propagated along the line to the office at the end of the circuit.

In such an office, the use of a repeating coil is very helpful in minimizing noise at voice as well as at carrier frequencies. This coil consists of two windings with an electrostatic shield between them. The primary winding is connected to the line side of the circuit, the shield to ground, and the secondary winding to the office side. Since the two windings are insulated from each other and from the shield and

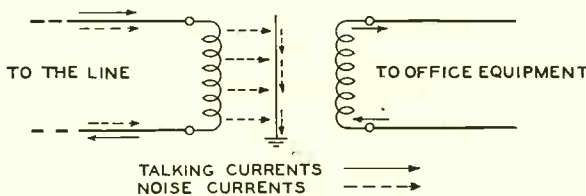

Fig. 1 — Longitudinal-circuit noise currents, because they flow in the same direction in both sides of the circuit, are not transmitted inductively to the office equipment but are led off to ground by the capacity between the primary winding and an electrostatic shield, assuming a balanced transformer winding

ground, the repeating coil effects physical separation of the circuits, and introduces a high impedance, due to the insulating material between primary winding and ground, into the path of the longitudinally induced noise currents.

In separating the longitudinally induced noise currents from the talking currents, advantage is taken of the fact that the disturbing currents flow in the same direction with respect to ground and with equal magnitudes in the two wires of the circuit and that the talking currents flow in opposite directions, that is, out one wire and back on the other. The longitudinally induced potentials are prevented from acting upon the office equipment by the presence of the electrostatic shield, which consists of tin-foil sheets separating the primary from the secondary windings.

Paths of longitudinal-circuit noise and talking currents are shown diagrammatically in Figure 1. The noise currents, shown by dotted arrows, flowing down the open wire line equally in the two wires, are prevented by the coil from reaching the office equipment, and pass instead to ground through the capacitance between the primary winding and shield. The primary winding is so arranged that the currents from the two wires flow effectively through an equal number of turns in opposite directions before passing to ground through the capacitance to the shield, and since the two currents are equal in magni-

tude, no flux is set up in the core. The talking currents on the other hand, since they are in opposite directions in the two line wires, flow through substantially all the turns of the primary

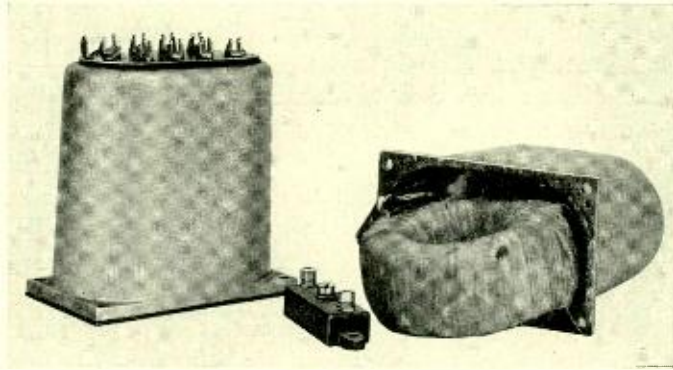

Fig. 2—On the left is a complete repeating coil in its brass case, and on the right a similar one but with the coil partially withdrawn. One of the adjustable condensers is shown in the foreground

winding in series, and set up magnetic flux in the core. This flux produces a voltage in the secondary winding, thereby transferring the energy of the talking currents from the line to the office equipment.

Various factors must be considered in the design of such a repeating coil to insure that noise is not produced in the carrier system in other ways. The operation of carrier circuits, for example, is such that if the repeating coil does not present to the line an impedance equal to that of the office equipment, reflection effects are produced, with consequent detriment to transmission, and increased cross talk.

One of the important causes of modification of the office impedance by a repeating coil is the leakage inductance, the effect of which is practically the same as that of an inductance inserted in series with the open-wire line and the office. This leakage

exists because the primary and secondary windings do not occupy the same space, and in fact are separated by the shield which permits a certain amount of magnetic flux to leak between the windings.

To compensate for such leakage a method is used which is similar to that employed to compensate for the transmission loss due to capacitance of telephone lines. The latter method, called loading, consists in adding series inductance to compensate for the effect of shunt capacitances. In the repeating coil on the other hand, shunt capacitances are added to compensate for series leakage inductances in an analogous manner. This compensation is obtained within the windings, for the most part, by winding the halves of each winding as two wires in parallel. This increases the capacitance between turns, which is always present to some extent, and this tends to offset the leakage reactance. Since both the capacitance between wires and the leakage reactance vary considerably with different coils, it is necessary, in addition, to connect small adjustable condensers across the terminals of the primary and secondary windings within the transformer case. These are adjusted in manufacture to make as close an impedance match as required.

Another example of the various

factors which must be taken into consideration in the design of such a repeating coil is the generation of extraneous frequencies due to the non-linear characteristics of magnetic materials. The design precautions taken to reduce such frequency generation include the use of permalloy as core material—on account of its superior magnetic qualities—and the employment of a case of non-magnetic material such as brass to avoid modulation due to leakage flux.

Some idea of the construction of such repeating coils may be obtained from Figure 2 which shows a typical carrier repeating coil, the 107-A, before assembly. The magnetic core is toroidal and consists of flat rings of 45% permalloy. These rings are stacked to a height of approximately one inch and held together by a layer of tape over which the primary winding is applied. The shield, consisting of sheets of tinfoil, is lapped completely around the primary winding, and the overlapping portions are insulated to prevent the shield from forming a short-circuited turn. The secondary winding is wound over the shield. The completely wound core is given a special drying and sealing treatment and then placed in the case which is filled with an insulating compound to protect the coil against moisture and corrosion.

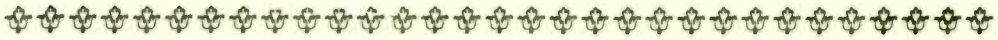

NEWS AND PICTURES

of the

MONTH



The Laboratories Sound Picture truck upon a corner of the estate of H. B. Thayer, with equipment set up ready to record brief addresses by past presidents of the Pioneers

General News Notes

PAST PRESIDENTS OF PIONEERS MAKE SOUND PICTURE TALKS

Through the medium of sound films made by the Laboratories, the Telephone Pioneers of America at their Los Angeles convention heard short addresses by each of their living past presidents, most of whom were unable to attend the convention. Six of the former presidents joined Mr. Thayer at his estate at New Canaan, where individual and group recordings were made with the equipment carried on the Laboratories' sound picture truck. Films of the remaining two past presidents, who were unable to attend the gathering at the Thayer estate, were later made at the Sound Picture Laboratory. All of the past presidents of the Pioneers are still living with the exception of Theodore N. Vail, who was the founder and first president of the organization.

The recordings were made under the direction of C. W. Barrell, Western Electric Motion Picture Director. The equipment on the Sound Picture truck was in charge of R. E. Kuebler and W. T. Pritchard.

INDUSTRY AND BUSINESS HEADS MAKE LABORATORIES TOUR

RESEARCH AND development methods and some of the outstanding achievements resulting from these methods were demonstrated on October seventh to approximately eighty-five leading industrial executives and bankers on an all-day inspection trip through the Laboratories. The Lab-

oratories visit was the first of a week's tour of industrial research laboratories in the eastern half of the country, conducted under the auspices of the Division of Engineering and Industrial Research of the National Research Council. The trip was arranged to demonstrate by personal observation the value and importance of research in industry, to study the philosophy of operation, and to compare procedures in research laboratories of representative industries. In the party were three chairmen of boards, fifteen presidents, sixteen vice-presidents, and twelve chief engineers.

Exhibits of the work of the research and development departments of the Laboratories were disclosed to the visitors, who made the tour of the building in small groups. In addition a two-way television demonstration, permitting each of the guests to converse over the circuit between the building and 195 Broadway, was given. In the Magnetic Materials Laboratories the visitors were shown a diagrammatic representation on a screen of the sound waves of their voices as they spoke into a receiver. The apparatus and experiments which led to the findings by C. J. Davisson and L. H. Germer on the wave properties of electrons were also demonstrated to the visitors. Billions of electrons were directed against the surface of a nickel crystal and then caught in a half-inch container as they were deflected from the crystal and the similarity in properties between the deflected electron stream and wave

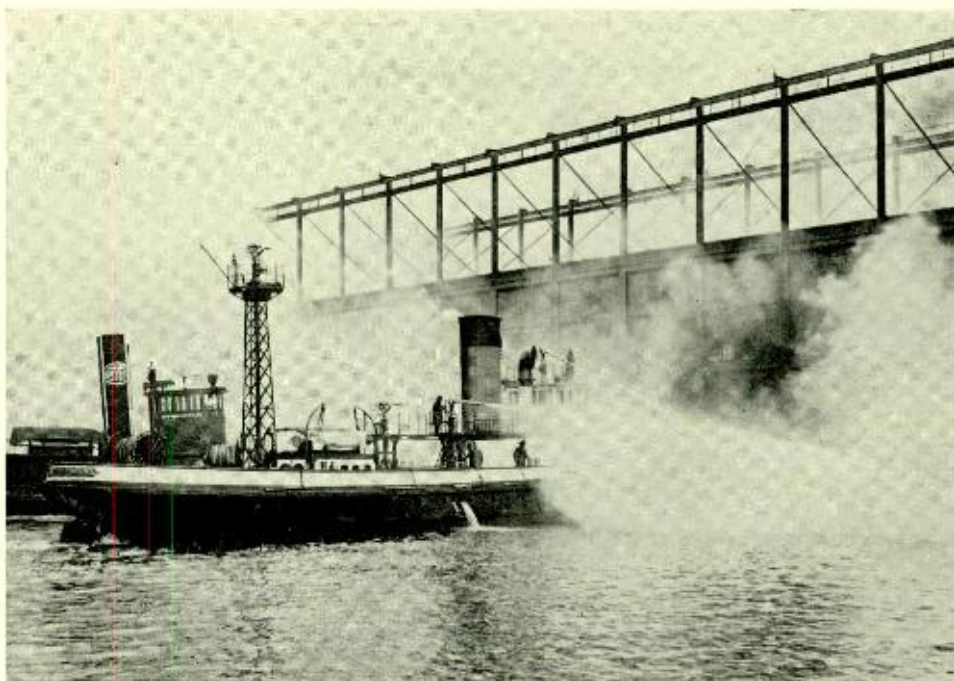

The fireboat John Purroy Mitchell in action at a waterfront fire. An adaptation of the aircraft radio-telephone recently installed on the fireboat permits constant communication with shore base

beams was explained to the onlookers.

The visitors assembled in the auditorium and were greeted by Vice-President Charlesworth. Dr. Jewett was introduced and made a brief talk on the function of research and development activities in the telephone industry. At noon a buffet luncheon was served and a musical program was given. The tour was completed in the late afternoon.

That the visiting executives might be accompanied through the Laboratories by men thoroughly acquainted with its policies and viewpoint, each group was in charge of a member of our executive staff. They included O. M. Glunt, H. H. Lowry, H. A. Frederick, William Fondiller, R. R. Williams, G. D. Edwards, R. H. Wilson, D. A. Quarles, B. W. Kendall, and W. H. Matthies. General arrangements for the reception of the

visitors were in charge of G. F. Fowler of the Publication Bureau.

SHIP-TO-SHORE RADIO SYSTEM ON FIREBOAT DEMONSTRATED

PUBLIC DEMONSTRATION of the two-way radio telephone apparatus installed on the *John Purroy Mitchell*, flagship of New York City's fire fighting fleet, was given on September 25. The fireboat, with Chief John Kenlon and Commissioner John J. Dorman of the New York City Fire Department on board, steamed two miles down the bay, maintaining constant communication with the headquarters of Chief John J. McElligott of the Marine Division at the Battery.

The installation of the two-way communication system on the *John Purroy Mitchell* is the first instance of effective use of radio communication in fire fighting, although one-way



Captain George J. Baum of the New York Fire Department speaking through the radio-telephone equipment in the pilot house of the John Purroy Mitchell. Note the loudspeaker under the shelf supporting the receiver

systems for police use have been in operation for some time past. It is expected that the establishment of radio communication with fireboats will bring about savings of thousands of dollars annually. In addition to savings resulting from conservation of fuel, wear and tear on machinery, and the doing away with responding to needless alarms, the two-way system will permit centralized direction of the marine fire forces and improved coordination with land forces in combating waterfront blazes.

The ship-to-shore communication

system for this new purpose was developed and installed by engineers of our Radio Development group. The apparatus installed at the marine fire headquarters is similar in design to equipment developed for transmission to aircraft and has a power output rating of approximately one kilowatt. The receiving set is a standard aircraft set containing three stages of screen-grid radio-frequency amplification. Aboard the fireboat is an aircraft transmitter having a power rating of 100 watts. Both transmitters are operated from high-tension generators. The transmitter on the fireboat is located below decks and the receiving equipment is mounted on a specially constructed table in the pilot-house.

Reception is through loud speaker and headphones.

Transmission and reception is carried on alternately by the operation of a small button on the side of the telephone transmitter. Pressing the button causes relays to connect the transmitter and receiver to the antenna. The Federal Radio Commission has authorized reciprocal radio stations for this new employment of radio facilities. The land station is designated WCF and the station aboard the fireboat has been accorded the call letters WRBE.

LARGE LABORATORIES DELEGATION AT PIONEERS OUTING

BELL TELEPHONE LABORATORIES was prominently represented at the outing of the Edward J. Hall Chapter of the Telephone Pioneers of America at Asbury Park on September 26 and 27. About 125 men and women Pioneers from the Laboratories with members of their families attended the gathering which was held at the Berkeley-Carteret Hotel. President Jewett was the principal speaker.

Members of the Laboratories appointed to various committees for the occasion included D. D. Haggerty, who was chairman of the Golf Committee and J. F. Toomey who headed the Transportation Committee. In addition W. B. Sanford served on the Reception Committee, R. F. Newcomb on the Hotel Reservation Committee, W. C. F. Farnell on the Entertainment Committee and A. W. Lawrence on the Golf Committee. A. G. Kingman of the Patent Department is President of the Edward J. Hall chapter.

WORK UNDER WAY ON LAND LINES OF TRANSATLANTIC CABLE

ALTHOUGH THE actual laying of the world's first transatlantic telephone cable will not take place until the summer of 1932, when it will be stretched along the ocean bed for 1800 nautical miles from the eastern coast of Newfoundland to the western coast of Ireland, construction of the landward end of the circuit on this side of the water is making rapid progress. Right-of-way is being purchased and cleared, and poles are being set, and already some wire has been placed

along the route of about 860 miles from the Maine-New Brunswick border to the final jumping-off spot in the vicinity of Trinity Bay.

A.I.E.E. COMMUNICATION GROUP MEETS IN AUDITORIUM

THE COMMUNICATION group of the New York section, A.I.E.E., met in our auditorium on October 14, to discuss the *Use of Communication Facilities in Aviation*. A. F. Dixon, chairman of the meeting, introduced the speakers: A. K. Bohman, Pan-American Airways, V. J. Clarke, General Electric Company, H. N. Willets, Western Electric Company, F. C. Doughman of the Westinghouse Electric and Manufacturing Company and C. M. Brentlinger of the Western Union Telegraph Company.



A. G. Kingman of the Patent Department, president of the Edward J. Hall chapter with J. W. Skinkle of the Western Electric Company, secretary, at the Asbury Park outing

MEDAL ANNOUNCEMENT OCCASIONS TRIBUTE TO GENERAL CARTY

THE ANNOUNCEMENT of the John J. Carty medal to be awarded each year for outstanding scientific achievement occasioned a remarkable tribute to General Carty in a recent Sunday edition of the *New York Times*. Referring to the recent chairman of the Laboratories' Board of Directors as a "challenger of space," the *Times* article declared that owing to General Carty's vision and resourcefulness it is now as easy to call San Francisco on the telephone as to get a local number. Or persons in London, Paris, Berlin or Rome may lift their receivers and within a few minutes be speaking with friends in New York. General Carty, the article points out, had a hand in that. Again the symbolic figure of his genius rises behind the first instance of chain broadcasting from Station WEAJ more than five years ago.

"General Carty is one of the miracle men of the telephone," the account states. "Some scientists are content with the employment of the Greek alphabet in formulae to assert that space and time do not exist. General Carty has worked to annihilate space and time. Geography may be the same, but thanks to the telephone wizard distances have become split seconds and split seconds have become thousands of miles; he has made communication easier and space and time incoherent."

The endowment for the John J. Carty medal was subscribed by his associates of long standing in the Bell System. The medal is to be awarded by the National Academy of Sciences "for specific accomplishment in some field of science or for good service

in the advancement of fundamental and applied science."

BRITISH RAILWAY EXECUTIVE VISITS LABORATORIES

SIR HENRY FOWLER, an executive of the London, Midland and Scottish Railway Company, was a visitor to the Laboratories on September 26. He made a short inspection tour of the building, accompanied by P. Norton and G. F. Fowler.

DR. JEWETT was in Los Angeles to attend the Telephone Pioneers of America convention on October 17 and 18. On October 18 he delivered an address *Pioneering with the Pioneers* before the convention. He also attended the Asbury Park meeting of the Edward J. Hall chapter on September 27 and 28 and was the principal speaker at the dinner on September 27. On September 30 Dr. Jewett left New York to attend the Bell System Presidents' Conference which was held this year at the Oyster Harbors Club on Cape Cod. The conference closed October 6, 1930. Later that week Dr. Jewett addressed the first of the Executive Conference Luncheons which are held at the Laboratories.

TWENTY YEARS of service with the Western Electric Company and the Laboratories were completed by Philander Norton, Assistant to President, on October 3.

S. P. GRACE at a luncheon under the joint auspices of the United States Independent Telephone Association and the Illinois Manufacturers Association spoke at the Stevens Hotel, Chicago, on recent communication advances. R. M. Pease of the Apparatus Development Department demonstrated Laboratories developments in conjunction with the talk.

The New College Graduates

THE Laboratories have extended welcome during the past year to over 350 college graduates. Many of these men were recruited from their academic institutions last spring, while others have had experience elsewhere in industry following their graduation. To help lay the foundation for advancement in their new work, a special Introductory Survey was arranged this summer by the Personnel Department which presented a general view of the Laboratories and of its place in the Bell System. Now these men have all taken their places in the Laboratories, an organization that for over fifty years has continuously forwarded the development and research program of the Bell System. They are in fact an essential part of this program, for as President Walter S. Gifford has said, "it is fundamental to the organization plan of the Bell System to have at headquarters and in its laboratories several thousand people whose sole job it is to work for improvement—to engage in studying what is used in the telephone business and how it is used, and to endeavor to find a better thing or a better way."

Although Bell System activities cover the entire country it does not have competition in the ordinary sense of the word, and this situation is essential if it is to render the best possible service to its subscribers. Competition, therefore, is not the spur to its progress, and its publicly announced policy: "to earn no speculative or large profits for distribution as 'melons' or extra dividends," removes the profit-making motive that is so universally assumed to be the urge of industrial progress.

How such an organization has year by year continued to give better and better service has been one of the wonders of the age. Professor Cabot of the Harvard Business School—commenting on the Bell System—said: "The thing is a modern miracle which I can only explain to myself by assuming that the men who conceived, created, and have developed the telephone were men of the rare automotive type whose driving power came from within, and who, therefore, did not need the external stimulation that competition alone can give."

A most important stimulation of Bell System progress arises from the spirit of service—intangible but nevertheless very real—which permeates the entire organization. A more tangible factor is the existence of the System's research and development organizations which strive toward a continually wider, better, and less expensive communication service. The Bell System's stability has always enabled it to take a long term view of its development and research programs without serious limitation by temporary business conditions.

College Graduates Who Have Joined the Technical Staff of the Laboratories Since September, 1929

SOUTHERN STATES					
AGRICULTURAL AND MECHANICAL			UNIVERSITY OF VIRGINIA		
COLLEGE OF TEXAS			Cowan, F. B.S. 1930		
Honnell, P. M.	B.S.	1930	VIRGINIA POLYTECHNIC INSTITUTE		
Johnston, T. F.	B.S.	1930	Haines, A. B. B.S. 1930		
Wick, R. F.	M.S.	1930	WESTERN MARYLAND COLLEGE		
ALABAMA POLYTECHNIC INSTITUTE			Howard, P. L. A.B. 1929		
Brake, P.	B.S.	1930	EASTERN STATES		
Keister, W.	B.S.	1930	BOWDOIN COLLEGE		
CENTENARY COLLEGE OF LOUISIANA			Leutritz, J. Jr. B.S. 1929		
McCain, T. J.	B.S.	1929	BROOKLYN POLYTECHNIC INSTITUTE		
COLLEGE OF WILLIAM AND MARY			Holsten, F. H. E.E. 1930		
Jones, R. J.	B.S.	1930	Romanow, F. F. M.E. 1930		
GEORGIA SCHOOL OF TECHNOLOGY			BROWN UNIVERSITY		
Hillegas, J. W.	B.S.	1930	Anderson, E. W. Ph.B. 1924		
JOHNS HOPKINS UNIVERSITY			Pett, A. W. Ph.B. 1928		
Mattheisz, W. H.	B.E.	1930	Teal, G. K. M.S. 1928		
Merchant, W. J.	B.E.	1930	Watelet, E. L. B.S. 1930		
Singewald, M. L.	B.E.	1930	CARNEGIE INSTITUTE		
LOUISIANA POLYTECHNIC INSTITUTE			Galbreath, R. R. B.S. 1930		
Henry, J. M.	B.S.	1929	CLARK UNIVERSITY		
MISSISSIPPI COLLEGE			Hickman, C. N. Ph.D. 1922		
Barnett, H.	A.B.	1930	CLARKSON MEMORIAL COLLEGE OF TECHNOLOGY		
NORTH CAROLINA STATE COLLEGE			Graves, H. K. B.S. 1928		
Horney, H. W.	B.S.	1930	COLGATE UNIVERSITY		
Jones, J. K.	B.S.	1921	Thompson, H. R. A.B. 1929		
Sims, A. B.	B.S.	1930	COLLEGE OF CITY OF NEW YORK		
UNIVERSITY OF DELAWARE			Lorenzen, R. B.S. 1929		
Vansant, F. T.	B.S.	1924	COLUMBIA UNIVERSITY		
UNIVERSITY OF KENTUCKY			Brill, M. D. M.A. 1930		
Haynes, J. R.	B.S.	1930	Ellwood, W. B. Ph.D. 1930		
Sparks, W. D.	B.S.	1930	Geruso, R. L. Ph.D. 1930		
UNIVERSITY OF MISSOURI			Rodwin, G. E.E. 1925		
Manley, J. M.	B.S.	1930	COOPER UNION		
Sullivan, R. R.	M.A.	1930	Brown, T. B.S. 1926		
UNIVERSITY OF NORTH CAROLINA			Griswold, R. S. B.S. 1918		
Drake, F. E.	B.S.	1930	Metzger, F. W. B.S. 1927		
Lowery, E. L.	B.S.	1930	Ressler, R. E. B.S. 1927		
UNIVERSITY OF SOUTH CAROLINA			Smith, A. K. M.S. 1920		
Parrott, W. L.	M.S.	1928	Vacca, G. N. B.S. 1924		

CORNELL UNIVERSITY

Atwood, J. B.	M.E.	1930
Bornemann, W. E.	E.E.	1930
Clarke, W. J.	B.C.	1924
Dickinson, A. B.	E.E.	1930
Edwards, W. B.	M.E.	1930
Engelhardt, G. B.	E.E.	1930
Kohm, J. A.	B.C.	1917
Schafer, A. H.	E.E.	1925
Stibitz, G. R.	Ph.D.	1930
Taylor, R. M.	M.E.	1927
Worcester, J. A.	E.E.	1930

DARTMOUTH COLLEGE

Hale, L. S.	A.B.	1930
Smith, K. D.	M.A.	1930

HAMILTON COLLEGE

Van Loon, A. D.	A.B.	1930
-----------------	------	------

HARVARD UNIVERSITY

Ashton, R.	B.S.	1922
Black, K. C.	Ph.D.	1927
Gillett, G. D.	B.S.	1921
Grisdale, R. O.	B.S.	1930
King, H. T.	A.B.	1930

LAFAYETTE COLLEGE

Gano, A. S.	B.S.	1930
Linders, J. R.	B.S.	1930
Spatz, W. de V.	B.S.	1930
Walhausen, V.	B.S.	1929

LEHIGH UNIVERSITY

Bowler, C. W.	M.E.	1927
Farnsworth, D. W.	A.B.	1929
Favinger, S. L.	M.E.	1928
Fullagar, J. W.	B.S.	1930
Gordon, M. K. Jr.	B.S.	1927
Greiner, E. S.	M.S.	1930
Pitman, W. C. Jr.	A.B.	1928
Schreiner, L. R.	E.E.	1923
Wenny, D. H. Jr.	Met.E.	1929
Woodward, J. D.	B.S.	1930
Wright, H. O.	M.E.	1921

MARIETTA COLLEGE

Daymont, J. B.	A.B.	1930
----------------	------	------

MASSACHUSETTS INSTITUTE OF TECHNOLOGY

Aldrich, E. E.	B.S.	1927
Blake, A. H.	B.S.	1921
Bryant, N. W.	M.S.	1930
Dietzold, R. L.	Ph.B.	1927
Earle, N. E.	M.S.	1930
Garfield, O. R.	M.S.	1930
Hughes, C. E.	B.S.	1930
Moriarty, J. D.	B.S.	1930
Mosher, R. F.	M.S.	1930

MASSACHUSETTS INSTITUTE OF TECHNOLOGY—Continued

Perkins, E. H.	M.S.	1930
Rockwood, G. H. Jr.	M.S.	1927
Ross, W. S.	M.S.	1922
Sanborn, C. A.	B.S.	1927
Shepherd, A. G., Jr.	B.S.	1930
Souden, A. G.	M.S.	1930
Sykes, R. A.	M.S.	1930

NEWARK COLLEGE OF ENGINEERING

Brader, R. A.	B.S.	1928
Gray, C. S.	B.S.	1929
Hurd, C. P.	B.S.	1929

NEW YORK UNIVERSITY

Braatz, W. O.	B.C.S.	1929
Gabel, W.	B.S.	1930
Triolo, V. P.	Ch.E.	1930
Van Siclen, H. E.	Ch.E.	1923

PENNSYLVANIA STATE COLLEGE

Corbin, J. E.	B.S.	1930
Fahringer, W. R.	B.S.	1930
Herr, C. W.	B.S.	1930
McCabe, H. L.	B.S.	1926
Morris, M. M.	B.S.	1930
Phipps, G. S.	B.S.	1930
Schenck, A. K.	B.S.	1930
Sims, W. S.	B.S.	1929
Skene, A. A.	B.S.	1920

POLYTECHNIC INSTITUTE OF BROOKLYN

Pantaleo, G. P.	M.E.	1919
-----------------	------	------

PRINCETON UNIVERSITY

Hagerman, S. T.	B.S.	1930
Hahner, C. W. F.	A.B.	1927
Harvey, H. H.	A.B.	1917
Hill, C. M.	B.S.	1928
Marshall, R. N.	B.S.	1930

RENSELAER POLYTECHNIC INSTITUTE

Ciccolella, D. F.	E.E.	1930
D'Esopo, F. P.	E.E.	1928
Hanson, G. N.	E.E.	1930
Lang, W. T.	E.E.	1927
Lautier, R. A.	E.E.	1930
Lehde, H. C.	E.E.	1928
Moak, F. C.	E.E.	1927
Robbins, L. R.	E.E.	1929
Smith, G. A.	E.E.	1930
Tyne, G. F. J.	E.E.	1921
Weil, R. G.	E.E.	1930
Wyant, R. A.	E.E.	1930

RUTGERS UNIVERSITY

Friedley, R. E.	B.S.	1930
Morgan, W. E., Jr.	B.S.	1930
Stauber, T. W.	B.S.	1930
Windeler, A. S.	B.S.	1930

CALIFORNIA INSTITUTE OF TECHNOLOGY			SOUTH DAKOTA STATE SCHOOL		
Atwater, Eugene	M.S.	1930	OF MINES		
Carlson, C. F.	B.S.	1930	Babington, W.	B.S.	1925
Holdaway, V. L.	M.S.	1930	Bisbeborn, M. C.	B.S.	1930
Fracker, H. E.	B.S.	1930	STANFORD UNIVERSITY		
Ingram, S. B.	Ph.D.	1928	Dysart, B.	E.E.	1928
King, A. P.	B.S.	1927	Hill, H. E.	E.E.	1930
Nye, L. C.	B.S.	1930	Holbrook, B. D.	M.A.	1925
COE COLLEGE			Low, J. S.	E.E.	1930
Storks, K. H.	B.S.	1930	Ring, D. H.	E.E.	1930
COLORADO STATE AGRICULTURAL			Swickard, A. E.	M.S.	1930
COLLEGE			STATE COLLEGE OF WASHINGTON		
Griffin, J. P.	B.S.	1930	Allan, F. S.	B.S.	1930
IOWA STATE COLLEGE			Blake, D.	M.S.	1930
Allison, C. H.	B.S.	1930	Buchanan, L. C.	B.S.	1930
Bernard, D. W.	B.S.	1930	Cramer, W. W.	B.S.	1930
Campbell, M. P.	B.S.	1930	Erickson, R. H.	B.S.	1930
Hutton, D. B.	M.S.	1930	Gould, W. O.	M.S.	1930
Nash, H. L.	B.S.	1930	Kuntze, E. L.	B.S.	1930
Pryor, P. L.	B.S.	1930	Mathison, T. M.	B.S.	1930
KANSAS STATE AGRICULTURAL COLLEGE			Peterson, R. M.	B.S.	1930
Quigley, G. L.	B.S.	1930	Poland, M. G.	B.S.	1930
MARQUETTE UNIVERSITY			Ryan, K. N.	B.S.	1930
Lukes, F. J.	A.B.	1928	Talbott, A. L.	B.S.	1930
MONTANA STATE COLLEGE			Tessitor, F.	B.S.	1930
Edwards, R. B.	B.S.	1930	Webb, W. L.	B.S.	1929
Hannant, T. N.	B.S.	1930	STATE UNIVERSITY OF IOWA		
Watters, J. A.	B.S.	1930	Campbell, G. C.	M.S.	1930
NORTH DAKOTA STATE COLLEGE			Hoyt, P. F.	B.S.	1930
Torkelson, E. C.	B.S.	1930	Jensen, N. J.	B.E.	1927
OCCIDENTAL COLLEGE			Leamer, F. D.	M.S.	1928
Mosher, H. A.	A.B.	1930	McLarney, W. J.	B.S.	1930
White, A. H.	A.B.	1930	Stewart, W. A.	A.B.	1930
OKLAHOMA CITY UNIVERSITY			UNIVERSITY OF ARIZONA		
Woodward, C. S.	A.B.	1928	Kellogg, W. McK.	M.S.	1927
OREGON STATE AGRICULTURAL COLLEGE			UNIVERSITY OF CALIFORNIA—		
Barnes, G. W.	B.S.	1930	(BERKELEY)		
Bohren, A. K.	B.S.	1930	Allen, A. O.	B.S.	1930
Burelbach, F. M.	B.S.	1929	Berry, M. L.	B.S.	1930
Griffith, B. G.	B.S.	1930	Brearty, C. R.	B.S.	1923
Howell, J. P.	B.S.	1930	Floegel, W. M.	B.S.	1930
Lundstrom, A. A.	B.S.	1928	Hale, S. G.	B.S.	1928
Rice, S. O.	B.S.	1929	Harrison, C. I.	B.S.	1928
Simmonds, W. E.	B.S.	1930	Heilbron, E.	B.S.	1930
Sisson, W. A.	B.S.	1930	Hight, S. C.	B.S.	1930
Tilton, C. S.	B.S.	1930	Mors, C. W.	B.S.	1929
POMONA COLLEGE			Nash, F. M.	B.S.	1930
Whistler, J. P.	A.B.	1929	Norton, F. R.	B.S.	1930
REED COLLEGE			Ramer, E. L.	B.S.	1926
Horsfall, R. B., Jr.	A.B.	1930	Robinson, A. L.	B.S.	1930
RICE INSTITUTE			Shuper, A. H.	B.S.	1930
Kean, C. H.	M.A.	1930	Soorin, A. J.	B.S.	1927
			Wiles, G. M.	B.S.	1923
			Word, J. A.	B.S.	1930

UNIVERSITY OF CALIFORNIA—
(LOS ANGELES)

Alcock, E. D.	A.B.	1930
Fitzgerald, V. J.	A.B.	1930
Paxton, H. C.	A.B.	1930

UNIVERSITY OF COLORADO

Cartwright, R. V.	A.B.	1929
Egerton, L.	B.S.	1928
Horn, F. W.	B.S.	1930
Milner, C. K.	B.S.	1922
Rettenmeyer, F. X.	B.S.	1922

UNIVERSITY OF IDAHO

Grieser, T. J.	B.S.	1930
Hattrup, H. E.	B.S.	1930
Kelley, D. P.	B.S.	1930
Luke, C. L.	B.S.	1930
Ruehle, A. E.	B.S.	1930
Sample, C. H.	B.S.	1930

UNIVERSITY OF KANSAS

Magers, O. N.	B.S.	1930
Wehe, H. G.	M.A.	1923

UNIVERSITY OF MINNESOTA

Allison, R. E.	B.E.E.	1930
Field, W. J.	B.E.E.	1930
French, E. C.	B.E.E.	1930
Friis, R. W.	B.E.E.	1930
Hammerquist, W. L.	B.Ch.	1930
Hastad, C. J.	B.E.E.	1930
Hendrickson, C. T.	B.E.E.	1930
Lehnert, W. E.	B.E.E.	1930
Nygaard, H.	B.E.E.	1930
Stowe, G. E.	B.E.E.	1930
Willard, G. W.	M.A.	1927

UNIVERSITY OF NEBRASKA

Anderson, L. T.	B.S.	1930
Cowley, G. W.	B.S.	1930
Kleinkauf, J. D.	B.S.	1930
Peterson, F. V.	B.S.	1930
Rees, C. H.	B.S.	1926
Vanderlippe, R. A.	B.S.	1930

UNIVERSITY OF NEVADA

Angst, D. C.	B.S.	1930
Ballerstein, W.	B.S.	1930
Lamb, N. W.	B.S.	1930
Lohse, F.	B.S.	1930

UNIVERSITY OF OKLAHOMA

Challenner, A. P.	B.S.	1925
-------------------	------	------

UNIVERSITY OF OREGON

Artau, B. E.	A.B.	1930
--------------	------	------

UNIVERSITY OF SANTA CLARA

Somers, F. J.	B.S.	1930
---------------	------	------

UNIVERSITY OF SOUTHERN CALIFORNIA

Black, C. L.	B.S.	1930
Kinsburg, B. J.	M.A.	1928
McCarter, E. C.	B.S.	1930
Nelson, A. H.	B.S.	1930
Rosen, S.	B.S.	1930

UNIVERSITY OF UTAH

De Lange, O. E.	B.S.	1930
-----------------	------	------

UNIVERSITY OF WASHINGTON

Burrell, J. E.	B.S.	1930
Chapin, D. M.	M.S.	1929
Clausen, J. C.	B.S.	1930
Collins, C. A.	B.S.	1925
Engel, E. D.	B.S.	1930
Garrison, H. D.	B.S.	1930
Hammer, K. E.	B.S.	1930
Henry, E. G.	B.S.	1930
Horn, H. T.	B.S.	1930
Lund, C. W.	B.S.	1930
Meacham, L. A.	B.S.	1929
Miner, V. C.	B.S.	1930
Nelson, J. M.	B.S.	1930
Rauschert, B. L.	B.S.	1930
Strohl, W. MacI.	B.S.	1930
Thomson, H. M.	B.S.	1930

WASHINGTON UNIVERSITY

Hill, A. G.	B.S.	1930
Mallinckrodt, C. O.	B.S.	1930

WILLAMETTE UNIVERSITY

Meyer, J. H.	B.A.	1928
Mumford, W. W.	A.B.	1930

FOREIGN COLLEGES
AND UNIVERSITIES

BRESLIN UNIVERSITY

Osten, W. H.	G	1925
--------------	---	------

CHALMERS UNIVERSITY

Alvog, K. E.	G	1919
Levin, S. A.	E.E.	1923
Peterson, L. C.	E.E.	1920

OLDENBURG STATE COLLEGE

Stockfleth, S. J.	B.S.	1924
-------------------	------	------

OSLO UNIVERSITY

Bostad, J.	A.B.	1919
------------	------	------

ROYAL UNIVERSITY OF ROME

Cecchetti, F. A.	E.E.	1923
------------------	------	------

UNIVERSITY OF COPENHAGEN

Angelo, H. S.	M.S.	1928
---------------	------	------

UNIVERSITY OF TECHNOLOGY IN PRAGUE

Odarenko, T.	E.E.	1928
--------------	------	------

Departmental News

ACOUSTICAL RESEARCH

FROM NEW YORK, Harvey Fletcher addressed the St. Louis League for the Hard of Hearing at their recent convention in that city. Transmitted over a regular telephone circuit, Dr. Fletcher's voice was amplified by a Western Electric system working into headsets.

E. H. BEDELL has returned from Hollywood where he was engaged in making tests on sound-picture recording at the United Artists studio.

B. A. KINGSBURY and D. D. FOSTER attended the meeting of the Society of Motion Picture Engineers in the Victor-Radio Corporation Building at Camden.

LABORATORY ENGINEERING

ON OCTOBER 15, George B. Hamm completed thirty years of service with



George B. Hamm

the Western Electric Company and the Laboratories. His career in the telephone industry began in the pres-

ent building as an office boy and messenger. In 1902 he became a copy clerk in the voucher department and in 1905 he was made claims clerk on purchase record work. In 1906 he was advanced to service clerk in the sales service organization to branch houses.

In 1908 he was transferred to work in connection with putting changes into effect in new and standard apparatus and obtaining approvals from the engineering departments of the first tool-made samples of new designs. He was in charge of this work until 1915 when he returned to the voucher department as voucher auditor. In 1916 Mr. Hamm was transferred to the engineering department and placed in charge of laboratory service work. He is at present in charge of laboratory service for Research Department groups at Canal Street, to which he was transferred in 1929.

RADIO RESEARCH

THE FIRST JOINT monthly meeting of the Holmdel and Deal engineers was held on September 24. E. B. Ferrell read a paper on radio transmitters.

CHEMICAL LABORATORIES

THE MEETING of the American Electrochemical Society at Detroit was attended by R. M. Burns, C. L. Hippensteel, C. W. Borgmann and R. B. Mears. A paper *Outdoor Atmospheric Corrosion of Zinc and Cadmium Electrodeposited Coatings*

on *Iron and Steel* was presented by Messrs. Hippensteel and Borgmann.

W. E. CAMPBELL was in Pittsburgh making friction measurements in connection with his studies of thin-film lubrication.

A VISIT to Hawthorne was made by J. E. Harris and E. E. Schumacher on work related to the development of lead-calcium alloy for cable-sheath use. They later attended the National Metals Congress at Chicago held under the joint A.I.M.M.E. - A.S.S.T. auspices. J. H. White, C. L. Hippensteel and C. W. Borgmann also attended this meeting.

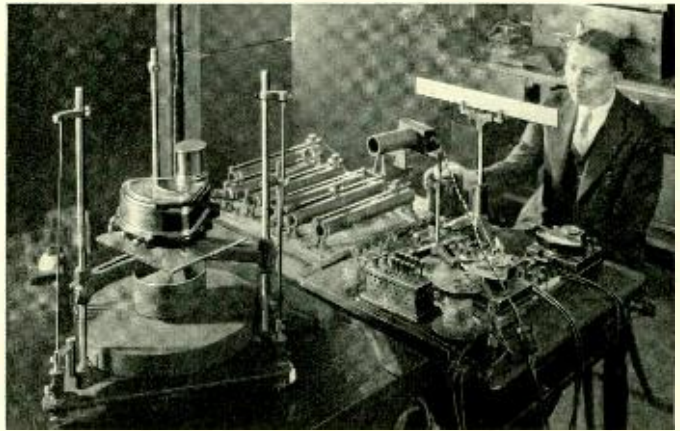

F. A. Lewis in the Magnetic Materials laboratory using fluxmeter for tests on rods at high magnetizing forces

TRANSMISSION INSTRUMENTS

H. A. FREDERICK, H. A. LARLEE, and W. C. JONES were at Hawthorne to attend a conference on carbon and transmitters. H. D. Arnold, Director of Research, accompanied the group and participated in the conference.

H. A. LARLEE later in the month attended the convention of the United States Independent Telephone Association at Chicago and also conferred with Northern Electric engineers on the station handset job.

IN CONNECTION with the beginning of manufacture of the new operator's transmitter, W. G. Breivogel was at Hawthorne for several days during the past month.

AN ARTICLE entitled *The Deoxidation of Copper with Metallic Deoxidizers*, by E. E. Schumacher, W. C. Ellis and J. F. Eckel appeared in the September issue of the magazine *Metals & Alloys*.

J. H. INGMANSON made a trip to the Point Breeze plant of the Western Electric Company on tape-armored cable work. With C. W. Scharf he later visited Hawthorne in connec-

tion with the development of tinsel cord for use on subscribers' sets.

THE FOLLOWING attended the Cincinnati meeting of the American Chemical Society: C. S. Fuller, E. W. Kern, G. T. Kohman, C. W. Scharf, A. E. Schuh, L. T. Smith and R. L. Taylor.

AN INSPECTION tour of the research laboratories of the New Jersey Zinc Company at Palmerton, New Jersey was made by A. E. Schuh, E. W. Kern, and W. J. Clarke.

ELECTRO-OPTICAL RESEARCH

A. L. JOHNSRUD gave a talk on Two-Way Television at the fall meeting in Boston of the Photographers Association of New England.

PERSONNEL

G. B. THOMAS attended the Bell System Personnel and Publicity Conference which was held at the Oyster Harbors Club, Cape Cod.

PUBLICATION

JOHN MILLS attended the Bell System Personnel and Publicity Conference held during the early part of October at the Oyster Harbors Club on Cape Cod.

FOLLOWING THE completion of its inspection trip of the Laboratories on October 7, L. S. O'Roark joined the group of industrialists and bankers making a special tour of research laboratories of leading industries. The tour extended until October 15 and included visits to the following research laboratories: General Electric Company, Schenectady; General Motors Company, Detroit; Wright Aviation Field, Dayton; American Rolling Mill Company, Middleton, Ohio; Aluminum Company of America, New Kensington; National Canners Association, Washington.

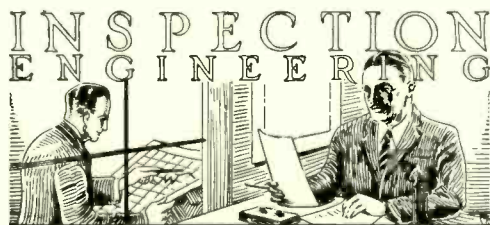

L. E. GAIGE has left for Detroit to take over the activities of R. C. Kamphausen as Field Engineer in that territory. Mr. Gaige is being succeeded in New York by I. W. White-side who has recently returned from Philadelphia where he was Field Engineer. Mr. Kamphausen will return to New York for special assignment work.

H. W. NYLUND, Field Engineer in the San Francisco territory, was in Seattle and Portland during the latter part of September in connection with general inspection matters.

C. A. JOHNSON, Field Engineer for the Chicago territory, was called to a number of cities in Wisconsin in connection with investigations on No. 7 Transmission Test Boards.

R. M. MOODY and J. F. CHANEY recently completed a week of investigation work at the Brooklyn Distributing House of the Western Electric Company. Their work involved a study of coin-collector repair and inspection procedure in effect there, forming part of a program involving the quality survey of repaired coin collectors in general. A little later in the month Mr. Moody in company with H. C. Cunningham attended a quality survey on paper condensers at the Hawthorne plant of the Western Electric Company.

IN CONNECTION with a quality survey on step-by-step switches, C. J. Hendrickson spent a week at the plant of the Automatic Electric Company in Chicago.

J. H. SHEPARD, Field Engineer for the Atlanta territory, visited the recently-installed repeater station located at Greensboro, North Carolina. During the same month R. C. Kamphausen was in Indianapolis, A. J. Boesch was in Harrisburg and Pittsburgh and T. L. Oliver was in Boston and New Haven on similar inspection engineering work.

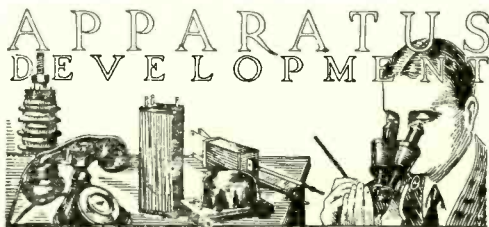

SPECIAL PRODUCTS

W. A. MACNAIR is in Hollywood to confer with West Coast engineers of ERPI on sound recording.

THE FOLLOWING men from the Sound Picture Laboratory staff attended the meeting of the Society of Motion Picture Engineers at Camden; J. B. Harley, C. F. Eyring, R. L. Hanson, R. D. Gibson, C. A. Clarke, N. R. Stryker, W. Herriott, W. R. Goehner, J. R. Boettler, J. Crabtree, W. B. Morehouse, and W. T. Pritchard.

R. M. PEASE spent several days in Boston and Providence making arrangements for proposed lectures and demonstrations to be given by S. P. Grace during the coming season.

W. R. GOEHNER is in Chicago in connection with the manufacture at Hawthorne of light-valve ribbon for Electrical Research Products.

H. M. STOLLER visited the General Electric Company at Fort Wayne, Indiana, to discuss problems in motor design.

RADIO DEVELOPMENT

THE RADIO Development group has moved from Section K to more commodious quarters in the new Graybar-Varick building.

R. E. CORAM and J. C. Herber visited St. Louis to inspect the new 50 kw broadcasting equipment recently installed for Station KMOX, The Voice of St. Louis.

F. M. RYAN together with H. E. Young and H. N. Willets of the Western Electric Company and Elam Miller of the American and Telegraph Company attended a meeting of communication representatives of the air transport companies and airplane radio manufacturers of the United States in Washington. Proposed government regulations covering the design and installation of radio equipment in commercial airplanes were discussed. The return

journey from Washington to New York was made in the Laboratories' plane piloted by Captain A. R. Brooks and P. D. Lucas, with C. T. Garner as mechanic and D. B. McKey in charge of the radio equipment. Two-way radio-telephone communication was maintained with the Whippany laboratory throughout the flight.

AT BALTIMORE the Monumental Radio Company's 1 kw station was inspected by F. E. Nimmcke.

J. H. DEWITT appeared before the Federal Radio Commission at Washington as an expert witness in connection with the application of the National Life and Accident Insurance Company of Nashville for permission to increase the power of their present broadcasting station to 50 kw.

ACCOMPANIED BY A. L. Samuel of the Vacuum Tube Development group, J. G. Nordahl and H. B. Fischer visited the Naval Aircraft station at Bolling Field to assist in the establishment of an aeronautical ground station employing Western Electric radio-telephone equipment.

F. H. MCINTOSH supervised the installation of a 1 kw radio-telephone broadcasting equipment and associated speech input equipment for the *Wisconsin State Journal* at Madison, Wisconsin. He also inspected stations WLS and WMAQ at Chicago and WCBD at Zion, Illinois.

A. B. BAILEY visited stations WTNT, WSM, WFIW, WPTF, WAPI, WMC and WSFA during an inspection tour of Western Electric equipped broadcasting stations in the Southern states.

A FIELD INTENSITY survey of the Consolidated Gas, Electric and Power Company's 5 kw broadcasting station at Baltimore was conducted by J. F. Morrison. O. M. Hovgaard like-

wise visited Baltimore on this survey.

O. W. TOWNER visited stations KNX, KECA and KGEF located in Los Angeles and station KFSD at San Diego, California. Mr. Towner also visited Pasadena to inspect and adjust the 400 watt radio-telephone equipment recently installed by the Pasadena Police Department.

W. L. BLACK visited the station of the Edison Electric Illuminating Company, WEEL, at Boston.

TRANSMISSION APPARATUS

LINE ASSEMBLY of welded loading-coil cases required C. R. Young's attention in a recent trip to Hawthorne.

C. A. WEBBER was at Hawthorne and also at Baltimore in connection with rubber-covered tinsel cords.

PROBLEMS OF rubber-covered cable called P. Komroff to the Simplex Wire and Cable Company in Boston.

A. C. WALKER discussed problems of inspection of purified textile insulation with Hawthorne engineers. He also attended the autumn meeting of the American Chemical Society which was held at Cincinnati.

E. T. HOCH was at Bangor, Maine, installing antenna coupling transformers for the experimental long-wave transatlantic radio. Filters for use in antenna modulation measurements were installed by M. Brotherton and E. E. Aldrich.

MATERIALS DEVELOPMENT

DURING THE last week in September, H. N. Van Deusen, J. M. Wilson and J. R. Townsend were in Chicago where they attended the National Metals Congress.

W. A. EVANS and J. D. CUMMINGS together with B. L. Clarke and J. M. Finch of the Research Department discussed the specifications for cable

paper with Dr. Lamme of the Western Electric Company at Kearny.

ACCOMPANIED BY O. A. Shann, H. I. Beardsley and F. A. Kuntz of the Manual Apparatus group and E. W. Niles of the A. T. & T. Co., W. A. Evans and I. L. Hopkins visited the Queensboro plant of the Western Electric Company on matters concerned with rubber flooring material for telephone booths. E. R. Hauser was also a visitor to the Queensboro plant in regard to the same problems.

C. E. NELSON was at Harrisburg in connection with noise studies on base-metal contacts.

F. F. LUCAS has been invited to deliver the Howe Memorial Lecture of the American Institute of Mining and Metallurgical Engineers. The subject of the lecture will be *The Art of Metallography*.

C. H. WHEELER, who is in charge of analysis of manual apparatus, completed twenty-five years of service on



C. H. Wheeler

October 26. His career with the Western Electric Company and the Laboratories has been devoted almost entirely to design analysis and protection of subscribers' and central office apparatus.

Coincident with his early years with the Western Electric, Mr. Wheeler attended Pratt Institute and completed courses on machine and mechanical design and electrical engineering and design. His first work was in the shop drafting department on general apparatus drafting. He was transferred in 1908 to the engineering department and was placed in charge of life tests on miscellaneous apparatus. After a year and a half he started on general engineering work, handling analysis of models and tool-made samples and general telephone apparatus, such as combined jacks and signals, relays, plugs, and subscriber's station and central-office apparatus. He was engaged on the pioneering work on contact protection, and as the result of several years of activity in which he had a prominent part, much of the present information and methods for contact protection was derived.

During the war he was associated with the development of telephone apparatus used by the Signal Corps and Navy. He was also engaged in the development of microphonic devices for use by the navies of United States and the allied countries in both deep-sea and shallow-draft submarine detection.

In 1920 Mr. Wheeler took over supervisory duties on general apparatus analysis. His group has since expanded and is now engaged in apparatus analysis on coin collectors, manual office, some machine switching, subscriber's station and central-office apparatus.

MANUAL APPARATUS

W. Y. LANG visited the plant of the Teletype Corporation in Chicago in connection with printing telegraph apparatus.

R. A. KIRKPATRICK of the Northern Electric Company visited the Laboratories to confer on matters pertaining to the new telephone booth. In company with F. A. Kuntz he also visited the Queensboro plant of the Western Electric Company where these booths are manufactured.

ACCOMPANIED BY E. W. Niles of the American Telephone and Telegraph Company, F. A. Hoyt visited Chicago to confer on coin collectors with the local telephone people there.

SUBSTATIONS OF the Lackawanna Railroad at Hoboken and Roseville were visited by A. C. Magrath, W. J. Means, and T. Slonczewski with American Telephone and Telegraph engineers, to observe the operation of recording oscillographs.

DIAL APPARATUS

J. N. REYNOLDS attended the National Metals Congress at Chicago.

IN CONNECTION with a trial installation of helical shaft springs on step-by-step switches B. Freile made a recent trip to Atlantic City.

C. R. STEINER visited Hawthorne to discuss modifications of the new slow-release armature for step-by-step relays.



MEMBERS of the Cable Development group have been occupied with trips during the past month, in connection with special installations of cable. C. Kreisher was at Milwaukee where some 1818 pair pulp-insulated

26-gauge cable was installed. At Farmington, New Hampshire, F. B. Livingston observed the installation of 404-pair pulp-insulated 24-gauge cable preliminary to its standardization. R. P. Ashbaugh was at Grand Rapids in connection with the installation of cable with special sheath and later in the month with W. C. Redding he went to Detroit to attend the installation of some 1212-pair pulp-insulated 24-gauge cable.

H. G. RIFE on October 10 completed twenty years of service in the Bell System.

L. W. KELSAY was in Philadelphia with several members of the American Telephone and Telegraph Company to discuss field trials of building terminals.

IN REGARD to the re-design of auxiliary platforms L. H. Burns visited the New Jersey Bell Telephone Company in Newark.

ACCOMPANIED by Mr. E. W. Kane of the American Telephone and Telegraph Company, W. J. Lally and I. C. Shafer, Jr. attended at Hudson, New York, a field trial of methods of handling emergency cable used in open-wire carrier circuits.

R. C. DEHMEL visited the Indiana Steel and Wire Company at Muncie, Indiana, to observe the manufacture of steel line wire. He also visited the Western Electric Company's plant at Hawthorne.

THE EXAMINATION of motor vehicle finishes placed for field trials on Southern New England Telephone trucks occasioned a recent trip by L. H. Campbell to New Haven.

STAFF

JOHN KUNZE, instrument maker in the Development Shop, completed

forty years of service on October 30. Starting in as an apprentice in the Thames Street factory, Mr. Kunze came to the present building when it was first put into service in 1898 and was transferred to the Model Shop, as the present Development shop was then known, in 1911. In the Thames Street shop, he worked on range finders and semaphores for the U. S.



John Kunze

Navy previous to the Spanish-American War. He installed many of these devices at the Brooklyn Navy Yard under the direction of Rear Admiral Bradley A. Fiske, who was at that time a naval lieutenant.

In the period of nearly twenty years that he has been in the Development Shop, Mr. Kunze has had a hand in the mechanical work on some of the most outstanding developments of the Laboratories. He worked on the terminal equipment for the New York-Azores cable, the first permalloy-loaded cable to be put into service. He has also worked on diaphragms for dynamic receivers and transmitters. At the present time, Mr. Kunze handles much of the work related to diaphragms on microphonic devices.

PATENT

DURING the period from September 3, to October 4, 1930, the following members of the Patent Department visited Washington in connection with the prosecution of patents: S. B. Kent, G. C. Lord, P. C. Smith, C. A. Sprague. G. M. Campbell visited Phillipsburg, New Jersey; Chicago and Milwaukee, and A. G. Kingman visited Boston and Portsmouth, New Hampshire.



MANUAL AND TOLL EQUIPMENT

G. F. SHULZE visited the Long Lines repeater station at Wyanet, Illinois, where the first installation of improved pilot-wire regulator equip-

ment is located. Mr. Schulze also visited Chicago, Detroit, Davenport, Iowa City and Des Moines in connection with telephone-repeater and program-supply installations.

ACCOMPANIED BY A. T. & T. engineers, A. Kenner visited Reading and Harrisburg, Pennsylvania, to observe the installation of a new Wheatstone-bridge unit for toll test board No. 5. A major improvement in locating cable faults, this equipment is especially effective in finding high resistance leaks. The equipment was also inspected by L. F. Porter of the Toll Circuit group.

H. M. HAGLAND completed twenty years of service on October 27.

SPECIAL EQUIPMENT DEVELOPMENT

VARIOUS REPEATER stations on the New York to Charlotte, cable were visited by E. W. Sullivan, C. A. Hebert and J. R. Lafferandre in connection with the installation of four-wire repeater equipment.

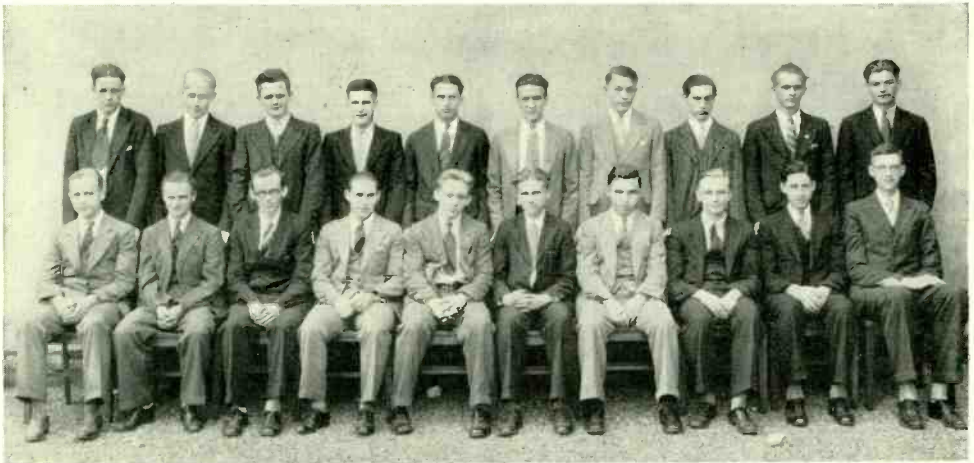

Systems Development Drafting Assistants: Top Row, M. E. Brandin, G. D. Ipsen, W. E. Fischer, D. S. Birnbaum, B. F. Gerner, W. T. Sermeus, J. F. Kubinsky, W. H. Ludwigson, P. Hoehn, F. A. Heindel; Bottom Row, C. T. Ellingsen, G. H. Eschenauer, A. M. Snadye, A. S. Kleitz, O. S. Sterner, R. Hallberg, H. J. Keefer, E. A. Fischer, J. J. McCormack, W. L. Huber



Systems Development Drafting Assistants: Top Row, C. J. Scheuerman, F. J. Hanley, F. W. Campbell, B. Halterbeck, A. E. Latimer, H. Sagefka, G. Koenig; Bottom Row, H. Waterbury, H. Waller, H. MacLean, J. A. Stareski, R. A. Stilwell, C. W. Nelson, W. V. Lysaght, A. R. Morris, W. Corbett

W. F. MALONE is now at Key West and Havana for the purpose of supervising the installation of terminal equipment for the new submarine-cable between those two points.

REPEATER STATIONS on the New York to Chicago cable were visited by G. M. Deyoe in connection with improved gain control equipment.

POWER DEVELOPMENT

A. E. PETRIE discussed power plant matters with local telephone engineers at Chicago.

W. P. SOHN visited the Crouse-Hinds Company's factory at Syracuse to discuss a new line of conduit-fittings which that company is manufacturing.

R. P. JUTSON spent a week at Ocean Gate where he tested and observed the operation of the power plant in the ship-to-shore station.

J. H. SOLE visited Boston and Lynn in connection with the application of improved voltage regulators.

F. F. SIEBERT and H. M. SPICER

discussed various power equipment subjects with General Electric Company engineers at Lynn.

TO OBTAIN information on the use of automatically-started gasoline engines for use in reserve power plants, A. E. Petrie, F. F. Siebert and V. T. Callahan visited the factory of the Weir-Kilby Mfg. Co. at Cincinnati.

L. J. PURGETT discussed general power questions with Western Electric representatives at Hawthorne.

LOCAL CENTRAL OFFICE

THE FIRST commercial installation of 10-party code-ringing connectors arranged for reverting ringing were tested and the operation observed by G. Gottron in one of the step-by-step offices at Wilmington, Delaware.

L. T. COX completed twenty years in the Bell System on October 14.

TESTS ON step-by-step equipment were also made by T. F. Lefevre in Columbus, Ohio.

W. J. LACERTE visited Pittsburgh

in connection with installations of 701-A P.B.X.'s.

I. H. HENRY completed twenty years of service with the Bell System on October 14, 1930.

TOLL CIRCUIT DEVELOPMENT

A. LANG was at Detroit observing the trial installation of group busy-tone circuits.

H. I. ROMNES spent two weeks at Wyanet, Illinois, observing and testing an installation of a new pilot-wire regulating system.

H. M. PRUDEN and A. F. GRENELL spent several days at Ocean Gate testing the wire line terminating equipment at the ship-to-shore station.

TELEGRAPH DEVELOPMENT

TESTS OF a new grid battery circuit for carrier-telegraph terminal sets were made by L. W. Wickersheim on a week's visit to Atlanta.

J. CATOGGE was at the Chester, N. J. test station for about two weeks assisting in adapting printers for use in radio stations.

CARRIER AND REPEATER DEVELOPMENT

REQUIREMENTS FOR terminal circuits on both cable and radio transatlantic telephone circuits were discussed by Mr. H. Beer of the British Post Office in a recent visit to the Laboratories.



Contributors to This Issue

W. W. BROWN received a B.S. degree from the Massachusetts Institute of Technology in 1921 and joined the technical staff of the Laboratories in the following year. For the past eight years he has been with the Systems Development Department and, in the Equipment Group, has been associated with many of the developments pertaining to manual systems.

H. K. DUNN received his A.B. degree from Miami University in 1918 and spent the following four years there as Assistant Professor of Physics. He then went to the California Institute of Technology as a Teaching Fellow and graduate student in physics, and received his Ph.D. in 1925. At this time he joined the Laboratories where he has been associated with the Research Department. He has engaged chiefly in studies on the power component of sounds.

AFTER A YEAR with the inspection department of the New York Telephone Company, W. BUHLER joined the Signal Corps and spent two years over seas. In 1919 he returned to the New York Company but shortly after joined the Laboratories where he was assigned to the Methods-of-Operations Group and engaged in preparing descriptions of the functions of manual and panel circuits. In 1924 he joined the Relay-Requirement Group with which he spent four years. At present he is engaged in development and testing of panel circuits.

A. G. GANZ graduated from Stevens Institute in 1924 with the degree of M.E. and at once joined the Technical Staff of the Laboratories. For the next five years he was with the Apparatus Development Department engaged in designing transformers for a wide variety of uses in the



W. W. Brown



H. K. Dunn



W. Buhler



A. G. Ganz



J. B. Newsom



W. Whitney

Bell System. During two years of this period he took graduate work in Physics at Columbia University. At present he is supervisor of the group designing transformers for carrier and radio-frequency applications.

AFTER four years in the Army, which included World War service, and a year's instruction in the Enlisted Specialists' School, J. B. NEWSOM entered the Systems Development Department of these Laboratories in 1920. For several years he was in the Local circuit laboratory; in 1926 he transferred to local circuit development, where he has been associated with panel A-boards and call-distributing B-boards for panel systems.

W. WHITNEY received a B.S. degree in chemistry from the Kansas State Agricultural College in 1923. He immediately entered the student-training course of the Installations Methods Department at Hawthorne but the department was transferred to 195 Broadway before the completion of the course. After completing the

course he transferred to the Laboratories where he became engaged in the analysis of customers' orders for telephone systems and in the design of circuits for manual, panel, and step-by-step systems.

J. R. TOWNSEND joined the Engineering Department of the Western Electric Company in 1919. He was first concerned with the testing of telephone apparatus, but later he specialized in the development of testing methods and requirements for the materials which composed the apparatus. To further this work, he and the organization of which he is in charge have built up a remarkably complete laboratory and technique for the testing of materials. Last year the American Society for



J. R. Townsend

Testing Materials awarded the Dudley Medal to him, jointly with W. A. Straw of Western Electric and C. H. Davis of the American Brass Company, for their article, "Physical Properties and Methods of Test for some Sheet Non-ferrous metals," published in the proceedings of the A.S.T.M.