

BROADCASTING

The Newsweekly of Radio and Television

TELECASTING

\$5.00
per copy

1950

YEARBOOK

NUMBER

SPOT RADIO SELLS!

the **MARKET** you want

the **STATION** you want

the **PROGRAM** you want

the **TIME** you want

This "pick and choose" philosophy of advertising makes more sense in 1950 than at any time since radio grew to major advertising stature.

One good place to start choosing is the list of these **PERFORMANCE PROVED** stations.

WSB	Atlanta	NBC	KARK	Little Rock	NBC	WOAI	San Antonio	NBC
WBAL	Baltimore	NBC	KFI	Los Angeles	NBC	KOMO	Seattle	NBC
WNAC	Boston	MBS	WHAS	Louisville	CBS	KTBS	Shreveport	NBC
WIGC	Bridgeport	MBS	WTMJ	Milwaukee	NBC	KGA	Spokane	ABC
WBEN	Buffalo	NBC	KSTP	Mpls.-St. Paul	NBC	WMAS	Springfield	CBS
WGAR	Cleveland	CBS	WSM	Nashville	NBC	WAGE	Syracuse	ABC
WFAA	Dallas	NBC	WSMB	New Orleans	NBC	KVOO	Tulsa	NBC
	Ft. Worth	ABC	WTAR	Norfolk	NBC	WSAU	Wausau, Wisc.	NBC
WJR	Detroit	CBS	KOIL	Omaha	ABC	WWVA	Wheeling	CBS
KARM	Fresno	ABC	WIP	Philadelphia	MBS	KFH	Wichita	CBS
KPRC	Houston	NBC	KGW	Portland, Ore.	NBC			
WDAF	Kansas City	NBC	WEAN	Providence	MBS			
KFOR	Lincoln	ABC	WRNL	Richmond	ABC			

THE YANKEE NETWORK
TEXAS QUALITY NETWORK

REPRESENTED NATIONALLY BY

EDWARD PETRY & CO., INC.

NEW YORK • CHICAGO • LOS ANGELES
DETROIT • ST. LOUIS • SAN FRANCISCO
DALLAS • ATLANTA



*Annual Subscription \$7.00 Includes Yearbook Number • Contents Copyrighted 1950 by Broadcasting Publications Inc.

Again in 1950 WLS

WILL

LEAD IN

SERVICE

TO THE 15 MILLION PEOPLE
OF CHICAGO AND MIDWEST AMERICA

CLEAR CHANNEL
Home of the NATIONAL Barn Dance



890 KILOCYCLES, 50,000 WATTS, ABC AFFILIATE, REPRESENTED BY JOHN BLAIR AND COMPANY

SEE NEXT PAGE

RCA BROADCAST EQUIPMENT



**AM • FM • TELEVISION
BROADCAST
EQUIPMENT**

1950 Edition!
OVER 400 PAGES

New BROADCAST CATALOG

Twice as big as 1948-49

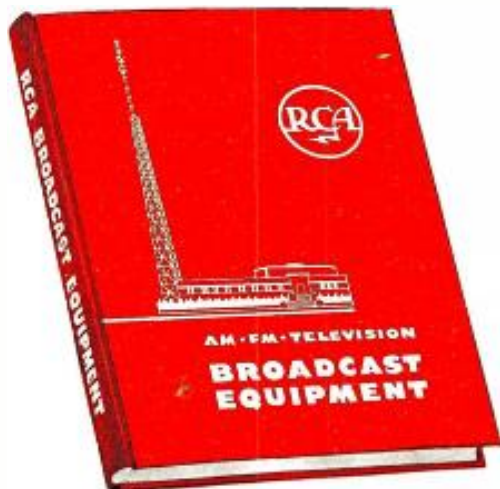

The most complete data book in broadcasting

- Over 400 concise pages of up-to-the-minute specifications and application data.
- 1,068 clear illustrations, easy-to-read curves, and valuable diagrams.
- 1,060 different equipment items covering every broadcast service—audio, AM, FM and TV.

Just off the press—the most complete and authoritative equipment reference ever published for station men.

Containing more than 400 large-size pages of descriptive material, application data, and performance specifications *in a single volume*, the RCA 1950 Broadcast Equipment Catalog covers the entire line of RCA Broadcast Equipment—from Audio, AM, FM and TV equipment to test units.

Each item is described clearly and concisely. Each description includes easy-to-find features, equipment uses, and complete specifications. There are over 40 equipment groupings in all—indexed for quick reference.

If you work with broadcast equipment, here is the book you can put to work the minute you get it.

EQUIPMENT DESCRIBED

Audio Equipment, AM-FM-TV

Microphones
Custom-Built Equipment
Consolettes & Switching
Audio Amplifiers
Remote Equipment
Racks & Rack Equipment
Power Supplies
Turntables
Recorders
Loudspeakers

Video Equipment

Field Equipment
Relay Equipment
Mobile Unit
Studio Cameras
Film Equipment
Studio Control Equipment
Monoscope
Sync Generator
Amplifiers
Power Supplies
Studio Lighting
TV Accessories

Transmitters, AM-FM-TV

AM Transmitters

AM Phasing
FM Transmitters
AM, FM Tubes
TV Transmitters
TV Tubes
Crystals

Antennas, AM-FM-TV

FM Antennas
TV Antennas
Transmission Line Equipment
AM Antenna Tuners
Antenna Towers & Equipment

Test & Measuring Equipment

Measuring Equipment
Monitoring Equipment
Service Test Equipment

Other RCA Products

Sound Equipment
16mm Projectors
Theatre Equipment
Mobile Communications
Equipment



BROADCAST EQUIPMENT
RADIO CORPORATION of AMERICA
ENGINEERING PRODUCTS DEPARTMENT, CAMDEN, N. J.

In Canada: RCA VICTOR Company Limited, Montreal

STATION OWNERS, MANAGERS, CHIEF ENGINEERS!

If you have not yet received your complimentary copy, write us on station letterhead.

For additional copies, mail a coupon with your check or money order for \$2.00.

Dept. 19-A, RCA Engineering Products
Camden, N. J.
Send me ___ new RCA 1950 Broadcast Equipment Catalog(s). I enclose \$_____ (check or money order).
Name _____
Title _____
Address _____
City _____ State _____

Dept. 19-A, RCA Engineering Products
Camden, N. J.
Send me ___ new RCA 1950 Broadcast Equipment Catalog(s). I enclose \$_____ (check or money order).
Name _____
Title _____
Address _____
City _____ State _____

How One Advertising Agency Looks At Television

No one knows all the answers, today.

But it is unsafe, we believe, to regard Television as anything *less* than potentially the greatest advertising medium yet known.

Believing that, we have, in the last five years, spared no effort to develop facilities which will enable Y&R clients to get an outstand-

ing value for every dollar spent in the Television field.

And we have told our clients what we believe ourselves: that outstanding values are now, and will be increasingly, available.

Young & Rubicam supervises and directs TV advertising for the following clients:

TELEVISION SHOWS

CLIENT	PROGRAM
Duffy-Mott Company, Inc.....	"Hollywood Screen Test" (participation)
General Electric Company.....	"The Fred Waring Show"
General Foods Corporation	
Jell-O Family Desserts.....	"The Aldrich Family"
Sanka Coffee.....	"The Goldbergs"
Goodyear Tire & Rubber.....	"Goodyear-Paul Whiteman Revue"
Company, Inc., The	
Gulf Oil Corporation.....	"We, the People"
International Silver Company.....	"Silver Theater"
Lipton, Inc., Thomas J.....	"Arthur Godfrey's Talent Scouts"
Jos. Schlitz Brewing Company.....	"Schlitz Family Parade" (local Milwaukee show)

TELEVISION SPOT CAMPAIGNS

Borden Company, The	General Foods Corporation	O-Cedar Corporation
Bristol-Myers Company	Johnson & Johnson	Petri Wine Company
Duffy-Mott Company, Inc.		Simmons Company

YOUNG & RUBICAM, INC.

ADVERTISING • New York Chicago Detroit San Francisco
Hollywood Montreal Toronto Mexico City London

INDEX TO CONTENTS OF 1950 YEARBOOK NUMBER

A

Advertest Research	518
Advertisers Index	543
Advertising—	
ABC, List of Advertisers	392
Agencies Handling Radio & TV	341
Associations	515
Books Relating to	527
CBS, List of Advertisers	397
DuMont, List of Advertisers	382
Index of Advertisers in 1950 Yearbook	543
MBS, List of Advertisers	403
National & Regional Radio & TV Advertisers, List of	364
NBC, List of Advertisers	405
Radio-TV Analyses	11
Advertising Assn. of the West	515
Advertising Council Inc.	515
Advertising Federation of America	515
Advertising Research Foundation Inc.	518
Agencies—	
Advertising, U. S., Handling Radio & TV	341
Placing ABC Accounts	392
Placing CBS Accounts	397
Placing DuMont Accounts	382
Placing MBS Accounts	403
Placing National & Regional Radio & TV Accounts	364
Placing NBC Accounts	405
Air Force, Dept. of	529
Alabama, AM, FM, TV Stations	69
Alabama Broadcasters Assn.	531
Alabama State Group	64
Alaska, Radio Stations	326
David O. Alber Assoc.	516
Alberta, Radio Stations	330
Allied Arts, Consultants	517
Allied Services, Radio	515
Aloha Network, The	64
American Assn. of Advertising Agencies	515
American Broadcasting Co.—	
Advertisers Using During 1949	392
Billings, 1949	21
Executives and Staff	378
Map of Network	379
Owned & Managed Stations	532
American Marketing Assn.	515
American Newspaper Publishers Assn.	515
American Radio Publications	516
American Radio Relay League	516
American Research Bureau	518
American Society of Composers, Authors & Publishers (ASCAP)	515
American Television Society	38, 516
AM Equipment Manufacturers	448
AM Stations—	
Bahamas, by Cities	510
By Call Letters, Canada	510
By Call Letters, U. S.	500
By Frequencies, Canada	499
By Frequencies, U. S.	488
By States	69
Cuban by Cities	510
Dominican Republic, by Cities	511
Haiti, by Cities	511
Labrador, by Cities	512
Mexico, by Cities	511
Newfoundland, by Cities	512
Analysis of 1949 Radio-TV Advertising	11
Applications, TV Pending	520
Arizona, AM, FM, TV Stations	72
Arizona Broadcasting System	64
Arizona Network	64
Arkansas, AM, FM, TV Stations	74
Arkansas Broadcasters Assn.	531
Arkansas Network	64
Army, Dept. of	529
Arrowhead Network	64
ASCAP	515
Assignments, Involuntary, FCC Rules Governing	486
Assn. of Canadian Advertisers	515

QUICK INDEX TO MAJOR DIRECTORIES AND DATA

Advertising	
Network	392
Regional & Spot	364
Advertising Agencies	341
Audience Analyses for 1949	24
Awards & Citations	529
Billings, Network	21
Broadcast Advertising Analyses	11
Broadcasting Stations	
AM by States	69
AM by Call Letters	500
AM by Frequencies	488
FM by States	69
FM by Call Letters	506
TV by States	69
TV by Call Letters	506
Equipment Manufacturers	448
FCC Executive Personnel	540
FCC Rules	462
Highlights of 1949, Radio & TV	61
National Assn. of Broadcasters	32
Newspaper-Radio Ownership Affiliation	521
Regional Networks	64
Station Representatives	40
Transcription Producers, Program, TV Film & Talent	414
Assn. of Federal Communications Consulting Engineers	516
Assn. of National Advertisers	515
Associated Music Publishers	515
Associated Press	519
Associations Dealing with Radio	516
Associations of Broadcasters by States	531
AT&T Long Lines Dept.	515
Attorneys, Radio & TV	55
Audience, Radio Analyses	24
Audit Bureau of Circulations	518
Awards in Radio	529
Broadcasters Promotion Service	516
Broadcasting Corp. of America's Western Network	64
Broadcasting, FCC Rules Governing	462
Broadcasting, Services Related to	515
Paul Bunyan Network	64
Bureau of Broadcast Measurement	518
Walter P. Burn	518
Carl Byoir & Assoc.	516
Bahamas, Stations under NARBA	510
William J. Bailey	516
Bell Telephone Labs.	515
Billings—	
ABC, 1949	21
MBS, 1949	22
Blackburn-Hamilton Co.	517
BMI	515
Books, Radio & TV	527
Booz, Allen & Hamilton	517
Brand Names Foundation	516
British Columbia, Radio Stations	330
British United Press Ltd.	519
Broadcast Advertising, Analysis of	11
Broadcast Equipment Manufacturers	448
Broadcast Measurements Bureau	518
Broadcast Music Inc.	515
Broadcast Service Bureau Inc.	517
Broadcast Stations—	
Canadian AM by Frequencies	499
Canadian by Call Letters	510
Canadian by Provinces	330
Canadian International by Call Letters	509
European	514
U. S. AM by Call Letters	500
U. S. AM by Frequencies	488
U. S. FM by Call Letters	506
U. S. TV by Call Letters	506
U. S. International by Call Letters	509
U. S. Stations by States (See State Listing)	
Under NARBA	510
Broadcasters' Associations by States	531
California, AM, FM, TV Stations	78
California Northern Group	64
California State Broadcasters Assn.	531
Call Letters—	
Canadian International Stations	509
Canadian Stations	510
U. S. AM Stations	500
U. S. FM Stations	506
U. S. International Stations	509
U. S. TV Stations	506
Canada—	
Assn. of Broadcasters	516
International Stations by Call Letters	509
Station Representatives	52
Stations by Call Letters	510
Stations by Frequencies	499
Stations by Provinces	330
Canadian Assn. of Broadcasters	516
Canadian Broadcasting Corp., Executives & Staff	412
Canadian National Telegraphs	515
Canadian Pacific Communications	515
Cartoon, Producers for TV	414
Censorship, FCC Rules Governing	486
Citations in Radio, 1949	529
City College Broadcasting Awards	529
Clear Channel Broadcasting Service	516
Cleveland Plain Dealer Stations	532
Coast Guard	529
College Networks	517
Colorado, AM, FM, TV Stations	100
Columbia Broadcasting System—	
Advertisers Using During 1949	397
CBS—(Continued)	
Executives & Staff	380
Map of Network	381
Owned Stations	532
Columbine Network	64
Common Carriers	515
Composers, Authors & Publishers Assn. of Canada Ltd.	516
Congress, Radio Correspondents Galleries of	377
Robert S. Conlan & Assoc.	518
Connecticut, AM, FM, TV Stations	102
Connecticut State Network	64
Consultants, Allied Arts	517
Consulting Radio & TV Engineers	55
Corn Belt Wireless Rebroadcasting Service	64
Correspondents, Radio Galleries of Congress	377
Cost of Operation, Radio	14
Costs, Radio Compared to Other Media	18
G. W. Covington Stations	532
James A. Cowan	516
Cowles Stations	532
James M. Cox Stations	532
Ed Craney Stations	532
Crosley Broadcasting Co.	532
Cuba—	
Networks	511
Stations Under NARBA	510
Curtis Radiocasting Corp. Stations	532
Dairyland Network	64
Smith Davis Corp.	517
Delaware, AM, FM, TV Stations	106
Dept. of Agriculture	528
Dept. of Commerce	528
Dept. of Interior	528
Dept. of Justice	528
Dept. of State	529
Distribution of Radio Sets	539
District of Columbia, AM, FM, TV Stations	106
Dixie Network	64
Dominican Republic, Stations Under NARBA	511
Don Lee Broadcasting System	532
DuMont Television Network—	
Advertisers Using During 1949	382
Executives & Staff	382
Map of Network	383
duPont Awards	529
Educational, Noncommercial FM Stations	388
Educational Radio Awards	529
Elliott-Haynes Ltd.	518
Engineering Schools, Radio	534
Engineers, Radio & TV, Consulting	55
Equipment Manufacturers, AM, FM, TV	448
European Broadcast Stations by Frequency Allocations	514
European Broadcasting Convention, Stations Covered	514
Executive Office of the President	528
Executives of Networks (See separate network listings).	
Facsimile, FCC Rules Governing	474
Faulstich Co., The	516
Federal Communications Bar Association	55, 517
Federal Communications Commission—	
Attorneys Practicing Before	55
District Offices	541
Executives & Staff	540
Field Offices	541
Former Members	540
How to Apply for Station	54

D	
Dairyland Network	64
Smith Davis Corp.	517
Delaware, AM, FM, TV Stations	106
Dept. of Agriculture	528
Dept. of Commerce	528
Dept. of Interior	528
Dept. of Justice	528
Dept. of State	529
Distribution of Radio Sets	539
District of Columbia, AM, FM, TV Stations	106
Dixie Network	64
Dominican Republic, Stations Under NARBA	511
Don Lee Broadcasting System	532
DuMont Television Network—	
Advertisers Using During 1949	382
Executives & Staff	382
Map of Network	383
duPont Awards	529
E	
Educational, Noncommercial FM Stations	388
Educational Radio Awards	529
Elliott-Haynes Ltd.	518
Engineering Schools, Radio	534
Engineers, Radio & TV, Consulting	55
Equipment Manufacturers, AM, FM, TV	448
European Broadcast Stations by Frequency Allocations	514
European Broadcasting Convention, Stations Covered	514
Executive Office of the President	528
Executives of Networks (See separate network listings).	
F	
Facsimile, FCC Rules Governing	474
Faulstich Co., The	516
Federal Communications Bar Association	55, 517
Federal Communications Commission—	
Attorneys Practicing Before	55
District Offices	541
Executives & Staff	540
Field Offices	541
Former Members	540
How to Apply for Station	54

(Continued on page 4)

We're busy as

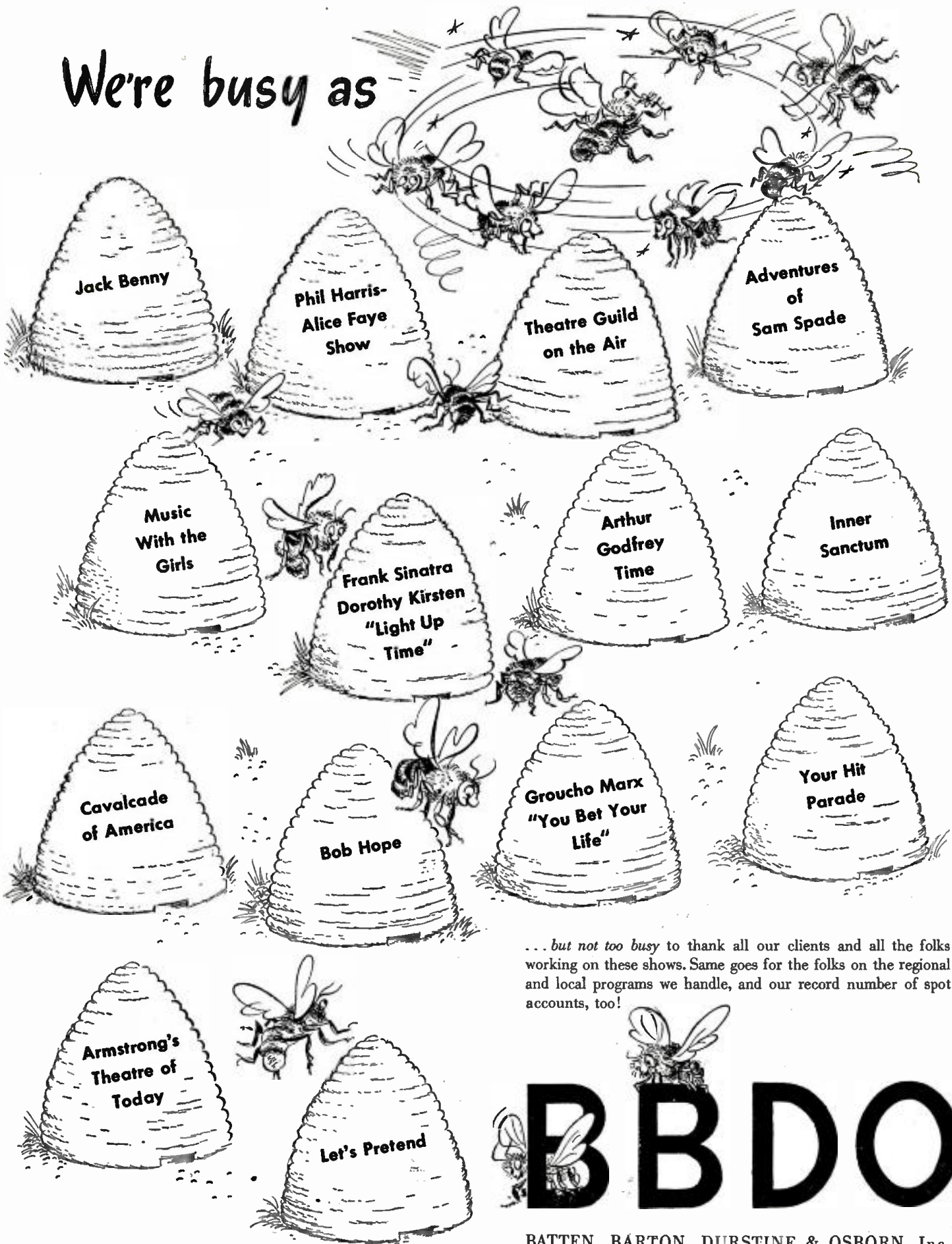

Jack Benny

Phil Harris-
Alice Faye
Show

Theatre Guild
on the Air

Adventures
of
Sam Spade

Music
With the
Girls

Frank Sinatra
Dorothy Kirsten
"Light Up
Time"

Arthur
Godfrey
Time

Inner
Sanctum

Cavalcade
of America

Bob Hope

Groucho Marx
"You Bet Your
Life"

Your Hit
Parade

Armstrong's
Theatre of
Today

Let's Pretend

... but not too busy to thank all our clients and all the folks working on these shows. Same goes for the folks on the regional and local programs we handle, and our record number of spot accounts, too!

B B D O

BATTEN, BARTON, DURSTINE & OSBORN, Inc.
NEW YORK • BOSTON • BUFFALO • CHICAGO • CLEVELAND • PITTSBURGH
MINNEAPOLIS • SAN FRANCISCO • HOLLYWOOD • LOS ANGELES • DETROIT

**This
We
Believe**

About Radio...

that it is still, and will continue to be,
a vital, mass-producing advertising tool . . . that
like all dynamic media its use must be tempered, revised,
refitted to the changing demands of the
economic world.

About Television...

that it is fast becoming one of the most powerful,
impelling mediums in the history of advertising . . . that
it neither wholly obsoletes nor wholly replaces
other good advertising media, but that,
like other media, it requires selective application,
experienced supervision, and clear-headed judgment.

Foote, Cone & Belding

New York • Chicago • Los Angeles • San Francisco

*A New High
in Popularity!*

1945
1946
1947
1948
1949
1950

Theatre Guild on the Air

During the past season, *Theatre Guild on the Air* reached a new peak in listener-ship. This is particularly gratifying to all who have participated in attaining this goal.

For our part, we'd like to take time out to say "Thanks" to the outstanding stars of stage and screen and all others who have helped us present full-hour programs of top-flight entertainment to our many new and old friends across the nation.

We plan to continue to present radio drama at its best—over the 164 coast-to-coast stations of the NBC network.

UNITED STATES STEEL HOUR



REPORT FOR 1949 ON

M^CCANN • ERICKSON

39 clients in Radio

Altes Brewing Company	The Maytag Company
American Molasses Company	Milk Foundation, Inc.
American Trust Co. (San Francisco)	National Biscuit Company
Bell Brand Foods, Ltd.	The National City Bank of Cleveland
Beverwyck Breweries, Inc.	The Ohio Bell Telephone Company
Broadway Department Store, Inc.	Pacific Coast Borax Co.
California Packing Corporation	Pacific Power & Light Co.
Chesebrough Mfg. Co., Cons'd	Portland Gas & Coke Co.
Chrysler Sales Division	Renuzit Home Products Co.
Coldstream Products Co.	Richman Brothers Co.
Columbia Records, Inc.	San Francisco Baseball Club
Cowles Magazines, Inc.	The S. O. S. Company
Cresta Blanca Wine Company	The Soil-Off Company
W. P. Fuller & Co.	Southern California and Southern
Griesedieck Western Brewery Co.	Counties Gas Companies
International Harvester Company	Standard Oil Co. (Indiana)
"Junket" Brand Foods	The Standard Oil Co. (Ohio)
Lehn & Fink Products, Corp.	Swift & Company
Leisy Brewing Company	TruVal Manufacturers, Inc.
Lucky Lager Brewing Co.	Westinghouse Electric Corporation

IN RADIO-TV:

18 clients in Television

Altes Brewing Company
Bell & Howell Company
Beverwyck Breweries, Inc.
Broadway Department Store, Inc.
Chesebrough Mfg. Co., Cons'd
Chrysler Sales Division
Coldstream Products Co.
Leisy Brewing Company
National Biscuit Company

Perfection Stove Company
Renuzit Home Products Co.
Richman Brothers Co.
The S. O. S. Company
Southern Counties Gas Companies
Standard Oil Company (Indiana)
The Standard Oil Company (Ohio)
Swift & Company
Westinghouse Electric Corporation

McCANN-ERICKSON, INC., Advertising

NEW YORK • CHICAGO • SAN FRANCISCO • BOSTON • CLEVELAND
DETROIT • LOS ANGELES • HOLLYWOOD • PORTLAND

FREE & PETERS

Pioneer Radio and Television Station Representatives Since 1932



RADIO

TELEVISION

EXCLUSIVE NATIONAL REPRESENTATIVES:

EAST, SOUTHEAST

WBZ-WBZA	Boston-Springfield	NBC	50,000
WGR	Buffalo	CBS	5,000
WMCA	New York	IND.	5,000
KYW	Philadelphia	NBC	50,000
KDKA	Pittsburgh	NBC	50,000
WFBL	Syracuse	CBS	5,000
WCSC	Charleston, S. C.	CBS	5,000
WIS	Columbia, S. C.	NBC	5,000
WGH	Norfolk	ABC	5,000
WPTF	Raleigh	NBC	50,000
WDBJ	Roanoke	CBS	5,000

MIDWEST, SOUTHWEST

WHO	Des Moines	NBC	50,000
WOC	Davenport	NBC	5,000
WDSM	Duluth-Superior	ABC	5,000*
WDAY	Fargo	NBC	5,000
WOWO	Fort Wayne	ABC	10,000
WISH	Indianapolis	ABC	5,000
KMBC-KFRM	Kansas City	CBS	5,000
WAVE	Louisville	NBC	5,000
WTCN	Minneapolis-St. Paul	ABC	5,000
KFAB	Omaha	CBS	50,000
WMBD	Peoria	CBS	5,000
KSD	St. Louis	NBC	5,000
KFDM	Beaumont	ABC	5,000
KRIS	Corpus Christi	NBC	1,000
WBAP	Ft. Worth-Dallas	NBC-ABC	50,000
KXYZ	Houston	ABC	5,000
KTSA	San Antonio	CBS	5,000

MOUNTAIN AND WEST

KOB	Albuquerque	NBC	50,000
KDSH	Boise	CBS	5,000
KVOD	Denver	ABC	5,000
KGMB-KHBC	Honolulu-Hilo	CBS	5,000
KEX	Portland, Ore.	ABC	50,000
KIRO	Seattle	CBS	50,000

WOC-TV	Davenport
WBAP-TV	Fort Worth-Dallas
WAVE-TV	Louisville
WTVJ	Miami
WTCN-TV	Minneapolis-St. Paul
WPIX	New York
KSD-TV	St. Louis
KRON-TV	San Francisco

* CP

FOR LATEST INFORMATION, CALL

NEW YORK
444 Madison Ave.
Plaza 9-6022

CHICAGO
180 N. Michigan Ave.
Franklin 2-6373

DETROIT
Penobscot Bldg.
Woodward 1-4255

ATLANTA
Palmer Bldg.
Main 5667

FT. WORTH
406 W. Seventh St.
Fortune 3349

HOLLYWOOD
6331 Hollywood Blvd.
Hollywood 9-2151

SAN FRANCISCO
58 Sutter St.
Sutter 1-4353

BROADCASTING

TELECASTING

1950 Yearbook Number

Copyright 1950, by Broadcasting Publications, Inc.

Vol. 37—No. 16-YB

WASHINGTON, D. C., JANUARY 16, 1950

\$7.00 Per Year, Yearbook Number Included

Analysis of 1949 Radio-TV Advertising

NET REVENUES from the sale of broadcast time in 1949 reached an estimated \$429 million. Total net time sales* increased a flat 3% over the previous year, in spite of a lot of scare talk about recession.

The three per cent gain should be compared with a gain of 11.4% in 1948.

It was a year of the jitters, in radio and elsewhere, but, like most other business, radio wound up 1949 with an excellent revenue picture.

On a dollar volume basis the year's increase represented more than \$12 million. It should be remembered, however, that 1949 was a year of expanding television revenue, and some advertisers were putting cash on the line for television shows, expensive ones, and radio's cash receipts were bound to show the effects of that new development.

The 3% increase in net time sales is the smallest percent gain in revenues of any year since the war's end. But 1949 was a year in which other indices of business prosperity dropped off sharply, especially during the summer and early fall. It was a year that

Editor's note: Statistical material in the BROADCASTING Business Index is derived from data gathered in an extensive, nationwide sample of all classes of stations. Methods employed are those developed and applied by BROADCASTING with marked accuracy for the past 15 years and were founded upon the formula originally developed by Dr. Herman S. Hettinger, nationally-known economist specializing in the radio field. Statistical data was audited by the firm of Sinrod & Tash, Washington certified public accountants, which turned over to BROADCASTING only weighted averages in each station and business category, in conformity with the canons of the American Institute of Certified Public Accountants.

TABLE I
RADIO NET TIME SALES 1948-1949

Class of Business	1948	% Total	1949 (Estimated)	% Total
National Network	\$133,723,098	32.1	\$127,590,000	29.8
Regional & Miscellaneous Networks*	7,329,255	1.7	7,500,000	1.8
National & Regional Non-Network	104,759,761	25.1	112,000,000	26.2
Local	170,908,165	41.1	181,900,000	42.2
TOTAL	\$416,720,279	100.0	\$428,990,000	100.0

*Includes miscellaneous network and stations.

would total about \$22 million, bringing the total of radio's gross revenues to \$451 million. Add to this an estimated \$77 million spent by advertisers for talent and programs on their own account, and the 1949 expenditures for advertising total of \$528 million.

One of the significant developments of the first half-century has been the advent of radio and its growth to the most widespread medium of entertainment, education and enjoyment the world has ever known. Consequently, in the United States it has also become one of the most effective advertising media known to businessmen. Since its faltering beginning in the early '20's, radio has grown by leaps and bounds, until now it is well on its way to a \$500 million net time sales total.

Broadcast advertising is a widening picture now, with the development of television. It is proper to consider television's great potential as an outgrowth of radio. Where television will stop, no one dares to predict, but it is reasonable to assume that the combined forcefulness of radio and television will attract many millions more in advertising dollars within the next decade.

TV Development

With a full two years of rapid commercial television development

ing. Another \$8,600,000 was spent by spot advertisers on television, and the remaining \$6,250,000 was spent in television by local advertisers.

There is no doubt that a fair portion of this \$25 million is new money to broadcasting. Surveys among advertisers have shown that for the most part, television budgets are an additional appropriation, rather than a deduction from AM appropriations.

Trends Within Radio (Table II)

Local advertising is still the bedrock of the radio revenue picture, but national non-network (spot) advertising showed the biggest gain in 1949. Its 7% gain barely exceeded the 6.4% gain in local advertising. Spot advertising was an excellent source of revenue this year, largely because it is a flexible way to use radio. In a year when many businessmen were anxious to avoid long-term commitments, spot advertising became a handy short-run medium, used extensively to promote new car models, foods and beer and wine.

(Continued on page 12)

TV ADVERTISING EXPENDITURES, 1949	
Network	\$9,900,000
Spot	8,600,000
Local	6,250,000
TOTAL	\$24,750,000

showed a marked rise in unemployment, and a general feeling of insecurity among businessmen.

Time salesmen, like salesmen in many other lines, reported a definite return of a buyers market, and the going was at times pretty tough for many stations.

The \$429 million figure doesn't tell the whole story of the radio revenue picture by any means. Receipts from the sale of talent and other sources are hard to estimate on a sample basis. Past experience would indicate that these receipts

*Net time sales represent gross billings less frequency and promotional discounts and therefore comprise the gross receipts of the medium from the sale of time in all categories. These receipts are before deduction of agency commissions which are considered an expense of sales.

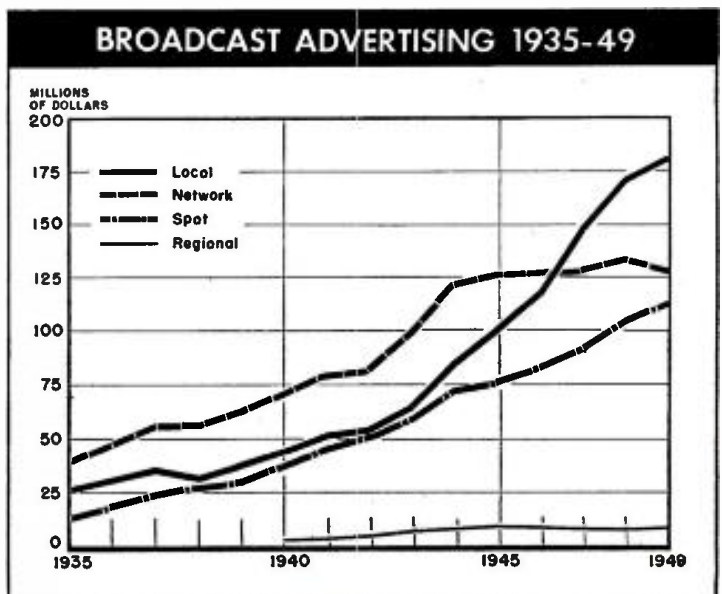

TABLE II
RADIO NET TIME SALES—1935-1949

Year	Increase over previous year		Increase over previous year		Local	Total	Increase over previous year	
	National Network	%	Regional Network	Non-Network			%	%
1935 ¹	\$39,737,867	1.....	\$13,805,200	\$26,074,476	\$79,617,543
1936 ²
1937	56,192,396	41.4	2,854,047	23,117,136	67.4	35,745,394	37.1	117,908,973
1938	56,612,925	0.7	28,109,185	21.6	32,657,349	(-8.7)	117,379,459
1939	62,621,689	10.6	30,030,563	6.8	37,315,774	14.2	129,968,026
1940*	71,919,428	13.1	1,869,583	37,140,444	23.8	44,756,792	20.0	155,686,247
1941	79,621,534	10.7	2,752,073	45,681,959	23.0	51,697,651	15.5	179,753,217
1942	81,744,396	2.7	3,444,581	51,059,159	11.8	53,898,916	4.2	190,147,052
1943	99,389,177	21.6	6,256,508	59,352,170	16.2	64,104,309	18.9	228,102,164
1944	121,757,135	22.5	7,612,366	73,312,899	23.5	84,960,347	29.3	287,642,747
1945	125,671,834	3.2	8,301,702	76,696,468	4.6	99,814,042	17.5	310,484,046
1946	126,737,727	0.8	8,043,381	82,917,505	8.1	116,380,301	16.6	334,078,914
1947	127,713,942	0.8	7,012,689	91,581,241	10.4	147,778,814	27.0	374,086,686
1948	133,723,098	4.5	7,329,255	104,759,761	14.4	170,908,165	15.6	416,720,279
1949†	127,590,000	-4.6	7,500,000	112,000,000	7.0	181,900,000	6.4	428,990,000

¹ Nation-wide and regional networks combined.
² Data not available.

* Figures prior to this date not comparable in all categories.
† 1949 figures estimated.

Local advertising's 6.4% gain is remarkable, even though it is a smaller gain than that reported in 1948 for this type of advertising. Small businessmen, who use local advertising extensively, are prone to shave slim advertising budgets drastically at any sign of economic down-turn. Instead, in 1949, local advertising surpassed its record of \$171 million in 1948, by about \$11 million.

Network advertising showed its first decline in 1949. After a bad summer, in which time sales dropped to 10% below the 1948 level, the networks rallied in the fall to gain some of the lost revenue back. Nevertheless, it is estimated that network revenues dropped about 4.6% during the year.

Network time sales have never shown astounding gains or losses, and have increased steadily to a peak of \$133 million in 1948. The 1949 total is estimated to be about equal to the 1947 figure.

Estimates of network receipts are based on net time sales less certain duplications inherent in network operations but which are not usually determined until publication of FCC data later in the year.

Regional network revenues show a slight rise in 1949, to reach an estimated \$7,500,000. This figure includes revenues of some of the miscellaneous football and baseball networks. Regional networks have not returned to their peak of \$8,300,000 reached in 1945, but have added a million dollars in revenue since the postwar low of \$6,600,000 reached in 1947.

Local advertising accounted for 42.2% of the total net time sales of broadcasters in 1949. It was an increase of 1.1% in this respect. Spot advertising is coming close to

TABLE III

ESTIMATED GROSS BILLINGS—1949

Class of Business	Estimated Gross Billings
National Network	\$192,500,000
Regional & Miscellaneous Network	10,100,000
National Non-Network	160,000,000
Local	274,600,000
Total	\$637,200,000

TABLE IV
ESTIMATED RADIO GROSS BILLINGS
1927-1949
(000's omitted)

Year	National network	Others	Total
1927	\$3,833	\$987	\$4,820
1928	10,227	3,873	14,100
1929	19,196	7,604	26,800
1930	27,694	12,806	40,500
1931	37,502	18,498	56,000
1932	39,107	22,793	61,900
1933	31,516	25,484	57,000
1934	42,659	30,228	72,887
1935	49,315	38,209	87,524
1936	59,671	47,880	107,551
1937	68,828	75,314	144,142
1938	71,728	78,390	150,118
1939	83,114	88,000	171,114
1940	96,456	123,344	219,800
1941	106,900	154,274	261,174
1942	118,200	167,280	285,480
1943	151,791	200,499	352,290
1944	190,677	256,033	446,710
1945	190,747	288,583	479,330
1946	193,010	319,400	512,410
1947	190,930	364,470	555,400
1948	198,996	417,600	616,500
1949	192,500	444,700	637,200

network as a percentage of the total radio revenues. Spot advertising total of \$112 million is about 26.2% of the total net revenues from time sales.

Network revenues as a percent of the total revenues were down in 1949 by about 2.3%.

With television in the picture it is hard to estimate future trends within the broadcasting medium itself, but it is thought that spot revenues will go right on increasing within the next few years. Spot has shown a rapid post-war rise in popularity among advertisers, and there is nothing in the broadcasting picture which would indicate that this trend would be halted in the immediate future.

FM has troubles. Yet, it is gaining slowly year by year as a revenue source. Some successful FM stations in both rural and metropolitan areas have managed to keep well above water in 1949. Total FM revenues would fall between \$6 and 7.5 million, according to most experts. It is difficult to gain any insight into the FM revenue picture without having a complete division of revenues where AM and FM stations are op-

erated in conjunction with each other. Of course many AM-FM stations sell FM as a bonus to AM broadcasting. With these difficulties present, any time sales figure is a very rough estimate.

Radio Gross Billings
(Tables III and IV)

Estimated gross billings for radio advertising time in 1949 were \$637,200,000. Gross billings represent radio advertising volume at the one time rate, and therefore are of limited value in comparing radio advertising volume with other media. Discount structures vary greatly from medium to medium and comparisons of gross billings by no means accurately reflect media positions or trends.

Estimated gross billings for 1949 are given in Table III and network billings for 1927-49 are given in Table IV.

Comparison With Other Media

Ten-month figures for newspaper advertising show that newspaper advertising increased 2% over the same period in 1948. This increase

TABLE V

Product Groups	1948		1949	
	Gross Billings	%* Total	Est. Gross Billings	%* Total
1. Agriculture & Farming	1,531,531	.8	1,540,000	.8
2. Apparel, Footwear & Access.	1,431,589	.7	1,350,000	.7
3. Automotive, Automotive Equip. & Access.	7,696,776	3.9	6,930,000	3.6
4. Aviation, Aviation Access. & Equip.
5. Beer, Wine & Liquor	1,116,697	.6	1,550,000	.6
6. Building Material, Equipment & Fixtures	988,686	.5	770,000	.4
7. Confectionary & Soft Drinks	7,655,484	3.8	7,500,000	3.9
8. Consumer Service	2,549,586	1.3	2,310,000	1.2
9. Drugs & Remedies	22,566,488	11.3	22,140,000	11.5
10. Entertainment & Amusements	5,215
11. Food & Food Products	47,208,282	23.7	45,800,000	23.8
12. Gasoline, Lubricants & Other Fuels	5,969,057	3.0	5,582,000	2.9
13. Horticulture	98,946	.1
14. Household Equip. & Supplies	6,628,906	4.3	8,280,000	4.3
15. Household Furnishings	1,331,840	.7	1,350,000	.7
16. Industrial Materials	1,747,826	.9	1,540,000	.8
17. Insurance	4,238,745	2.1	4,040,000	2.1
18. Jewelry, Optical Goods & Cameras	1,201,942	.6	960,000	.5
19. Office Equipment, Writing Supplies & Stationery	2,317,072	1.2	2,310,000	1.2
20. Political	1,213,282	.6	1,550,000	.6
21. Publishing & Media	1,450,097	.7	1,540,000	.8
22. Radios, Phonographs, Musical Instruments & Access.	1,560,098	.8	1,540,000	.8
23. Retail Stores & Shops
24. Smoking Materials	20,323,300	10.2	19,635,000	10.2
25. Soaps, Cleaners & Polishers	20,767,670	10.4	19,830,000	10.3
26. Sporting Goods & Toys	81,469	.1
27. Toiletries	32,145,225	16.1	31,380,500	16.3
28. Transportation, Travel & Resorts	333,616	.2	190,500	.1
29. Miscellaneous	2,836,308	1.4	2,850,000	1.6
TOTAL	198,995,742	192,500,000

* % will not necessarily add to 100 because of rounding.

is far below the 1948 increase of 13%.

Among the various classes of newspaper advertising, automotive advertising was the biggest gainer, showing a 27.3% increase over the previous year. Minor gains were shown in other categories of newspaper advertising, notably classified advertising, 7.6%; and general advertising, which increased 6%.

No type of newspaper advertising showed a loss compared to the same ten-month period in the previous year. In most categories, however, the gains were minor over 1948.

These figures are from Media Records Inc.'s 52-city summary of newspaper advertising lineage.

General magazine advertising dropped off about 3%, farm paper advertising remained nearly the same as in 1948 and Sunday magazine space sales showed a modest increase.

These ten-month trends are shown in reports from Publishers Information Bureau.

Network Advertising by Class of Product (Table V)

There was no significant change in the spread of the network advertising dollar by product groups from 1948 to 1949. On the basis of a PIB report for the first ten months of 1949, the figures in Table V are estimated for the year 1949.

Note that the table shows the new categories of product groups adopted by PIB two years ago, expanding the total number of groups from 21 to 29. The new classification allows for a more careful distinction between some of the major advertisers. Drug and Toilet Goods advertising, which was formerly in one category, is now separated into two groups, one for Drugs and Remedies, the other for Toiletries of all kinds.

Food products lead the list among network radio advertisers. Nearly one fourth (23.8%) of all

(Continued on page 14)



**if you
want to
cover the country...**

talk to Du Mont. 99% of the
television receivers in the country
can receive your program
over the Du Mont Television Network,
either live or by teletranscription.



America's Window on the World

515 Madison Ave., New York 22, N.Y.

**Du Mont programs shown
live on these stations**

- WAAM.....Baltimore, Md.
- WNAC-TV.....Boston, Mass.
- WBEN-TV.....Buffalo, N. Y.
- WGN-TV.....Chicago, Ill.
- WCPO-TV.....Cincinnati, Ohio
- WXEL-TV.....Cleveland, Ohio
- WTVN.....Columbus, Ohio
- WHIO.....Dayton, Ohio
- WJBK-TV.....Detroit, Mich.
- WICU.....Erie, Pa.
- WLAV-TV.....Grand Rapids, Mich.
- WJAC-TV.....Johnstown, Pa.
- WGAL.....Lancaster, Pa.
- WTMJ-TV.....Milwaukee, Wis.
- WNHC-TV.....New Haven, Conn.
- WABD*.....New York, N. Y.
- WFIL-TV.....Philadelphia, Pa.
- WDTV*.....Pittsburgh, Pa.
- WTVR.....Richmond, Va.
- WHAM-TV.....Rochester, N. Y.
- WRGB.....Schenectady, N. Y.
- KSD-TV.....St. Louis, Mo.
- WHEN.....Syracuse, N. Y.
- WSPD-TV.....Toledo, Ohio
- WTTG*.....Washington, D. C.
- WDEL-TV.....Wilmington, Del.

**Programs shown on these
stations by Du Mont
teletranscription**

- KOB-TV.....Albuquerque, N. M.
- WAGA-TV.....Atlanta, Ga.
- WNBF-TV.....Binghamton, N. Y.
- WBRC-TV.....Birmingham, Ala.
- WTV.....Bloomington, Ind.
- WBTW.....Charlotte, N. C.
- KBTW.....Dallas, Tex.
- WFMY-TV.....Greensboro, N. C.
- KLEE.....Houston, Tex.
- WSAZ-TV.....Huntington, West Va.
- WFBS-TV.....Indianapolis, Ind.
- WMBR-TV.....Jacksonville, Fla.
- KTSL.....Los Angeles, Cal.
- WAVE-TV.....Louisville, Ky.
- WMCT.....Memphis, Tenn.
- WTVJ.....Miami, Fla.
- WTCN-TV.....Minneapolis, Minn.
- WDSU-TV.....New Orleans, La.
- WKY-TV.....Oklahoma City, Okla.
- KMTV.....Omaha, Nebr.
- KPHO-TV.....Phoenix, Ariz.
- WHBF-TV.....Rock Island, Ill.
- KSL-TV.....Salt Lake City, Utah
- KEYL.....San Antonio, Tex.
- KPIX.....San Francisco, Cal.
- KING-TV.....Seattle, Wash.
- KOTV.....Tulsa, Okla.

**Du Mont owned and operated stations*

Analysis

(Continued from page 12)

network advertising is bought by food and food products manufacturers.

This type of advertising showed a slight dollar drop, but as a percent of total network business, it gained a tenth of a percent.

Toiletries accounted for another 16.3% of the total network gross billings. Last year Toiletries ac-

counted for just 16.1% of the total. Here again, though, there was a slight drop in dollar volume from the previous year.

Drug advertising is estimated to be about \$400,000 off its 1948 total, accounting for about 11.5% of the total gross network time sales. This compares with 11.3% for 1948.

Tobacco advertising accounted for 10.2% of the total, compared with the same amount in 1948; and Soap, Cleaners and Polishes

dropped dollarwise from \$20.7 million to \$19.8 estimated, and as a result declined in percent of total from 10.4% to 10.3%.

Auto advertising on the networks dropped from \$7.6 million in 1948 to an estimated \$6.9 million in 1949. Some of this loss is thought to be the result of higher national spot usage among the automobile advertisers.

Confectionery and soft drink advertising remained relatively constant from 1948 to 1949. As a per-

cent of total network business, this group dropped off fractionally.

Considering the network advertising picture as a whole, it can be seen that the five top product groups—food advertising, toiletries, drugs, soap cleaners and polishes, and tobacco advertising—taken together accounted for 72.1% of all network time sales.

In 1948, these same product groups were responsible for an even larger share of the total network revenues—74.3%.

Radio's Payroll and Operating Costs

INCREASE of 17% in employment during a one-year period was shown by the FCC's latest tabulations. The figures cover a sample work week in October 1948 compared with a sample week for the

same month in 1947.

The FCC reported figures covering 1,613 AM stations, four nationwide networks and three regional networks, who employed 39,572 persons fulltime.

During the year aggregate week-

ly payrolls rose about 20%, or from \$2,508,000 in 1947 to \$3,003,111 in 1948. The average weekly pay was \$71.22 in the 1948 week compared to \$72.40 the previous year. Total work hours averaged 40.27 in 1948 compared to 39.4

hours in 1947. These figures do not include hours of work for executives because data were not reported.

At networks and their key stations average weekly pay was (Continued on page 536)

WHERE DO YOUR BROADCAST DOLLARS GO? By Class of Station Income As Analyzed by NAB

A. Broadcast Revenue = 100%; major items of operating expense and profit margin (before taxes) shown as percent of revenue for each class of station income.

	Below \$50,000	\$50,000 to \$75,000	\$75,000 to \$100,000	\$100,000 to \$125,000	\$125,000 to \$150,000	\$150,000 to \$200,000	\$200,000 to \$350,000	\$350,000 to \$1,000,000	Over \$1,000,000
Total Broadcast Revenue	100.00	100.00	100.00	100.00	100.00	100.00	100.00	100.00	100.00
Total Operating Expenses	88.70	86.67	85.05	83.65	83.47	85.19	81.45	76.02	74.00
Miscellaneous Expenses	17.83	17.28	14.59	13.98	12.43	12.29	13.20	11.48	11.46
Other Administrative Expenses	13.07	11.37	12.32	11.83	13.09	12.45	10.87	10.79	10.40
Depreciation	5.17	4.52	5.13	4.42	3.59	5.01	4.32	3.38	3.07
Professional Services	.99	1.15	1.07	1.49	1.76	1.29	1.66	1.21	1.09
Administrative Salaries	10.89	11.26	11.62	12.54	12.86	12.87	11.86	8.33	7.11
Other Selling Expenses	2.32	2.53	2.84	3.91	3.15	4.45	4.42	5.87	6.49
Sales Salaries	7.68	7.82	8.38	8.91	7.49	8.67	7.38	5.05	3.44
Talent	1.48	1.61	1.94	2.74	3.41	2.96	3.48	9.88	12.74
Program Salaries	16.48	15.66	15.02	13.16	14.04	15.52	13.70	10.28	8.72
Technical Salaries	12.79	13.47	12.14	10.67	11.65	9.68	10.56	9.75	9.48

Sherman & Marquette

ADVERTISING



CHICAGO • NEW YORK • HOLLYWOOD



Burr Tillstrom with Kukla, Ollie and Fran Allison

“KUKLA, FRAN and OLLIE”

Musical Director

JACK FASCINATO

Producer

BEULAH ZACHARY

Director

LEWIS GOMAVITZ

N.B.C. Television Network

Still the best mouse trap...

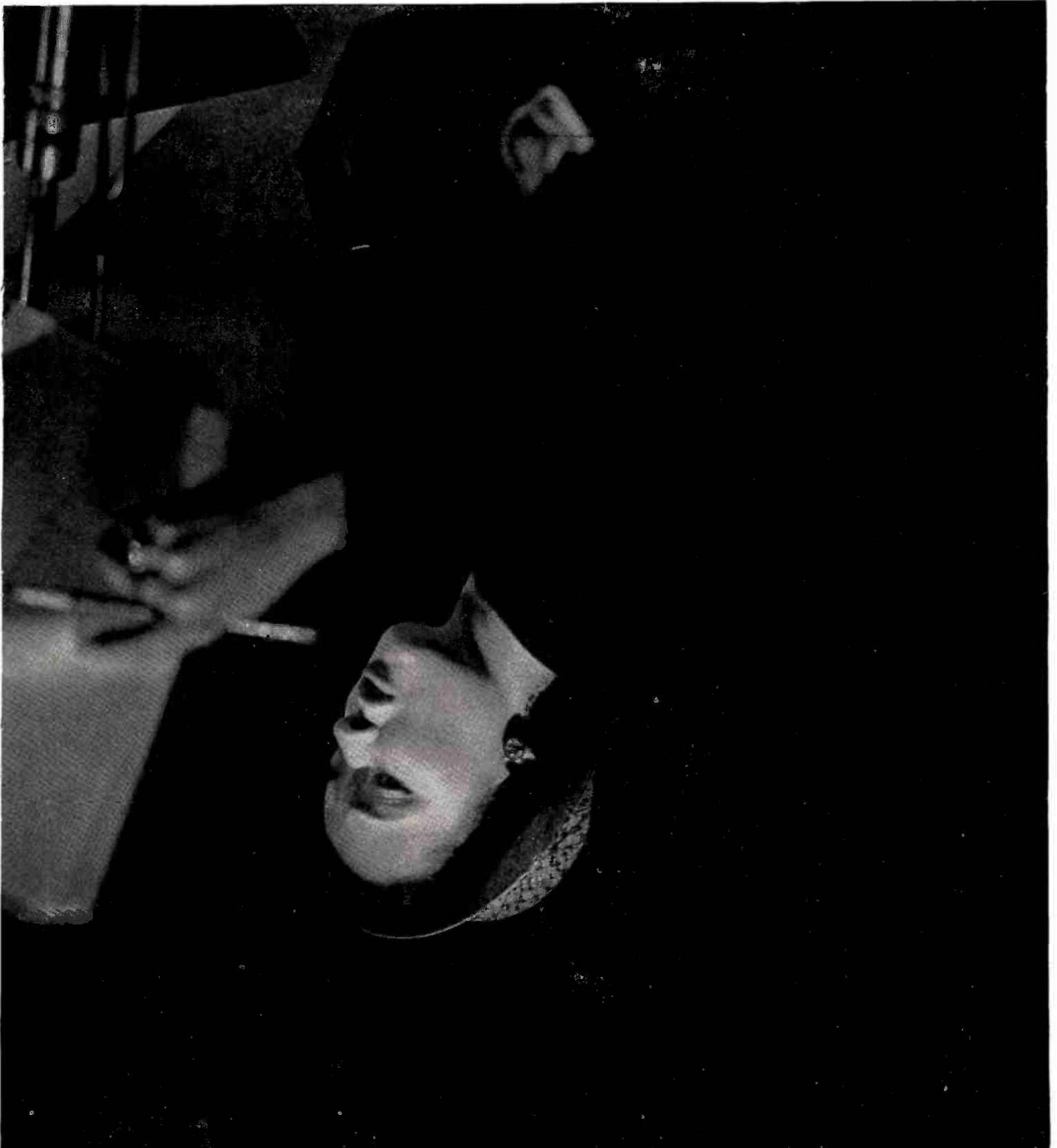



In all advertising, there's only one medium where one advertiser reaches over half the population of the country... 21,000,000 families!... with one program in one month. He does it with Network Radio... on CBS.*

The Columbia Broadcasting System

*And forty-nine other CBS advertisers reach their customers... everywhere in America week in, week out... at an average cost of approximately 85¢ per thousand people: the lowest cost of actual "advertiser circulation" in all advertising today.

How Do Radio Results Compare With Those of Other Media?

By MAURICE B. MITCHELL
Director, Broadcast Advertising Bureau

STOP ANY advertising salesman and ask him which medium he thinks will do the best job. He'll pick his own medium and *prove he's right*. And in most cases he'll demonstrate that he's earning a good living—usually based on commissions—*selling his kind of advertising*.

What does this prove? That all media are best? Impossible! Instead, it proves that *salesmanship* is the real key to obtaining a satisfactory share of the total advertising dollar. And the successful advertising salesman is usually the man who is best informed about all the other media to which his clients may be exposed.

The need for this kind of selling is perhaps greatest in radio for two reasons. First, our industry has grown faster than its capacity to produce well-trained selling representatives. Out selling for dozens of stations around the nation are men who, for lack of sound advertising background in general and a working understanding of *other competitive media* in particular, have devoted their efforts to selling business away from other stations. This does nothing to increase the size of radio's share of the total advertising dollar, and leads to the rate-cutting and other unethical selling practices which have become such a nuisance.

Second, radio has always been a football for other media. Newspapers have never recovered from the shock of finding another major medium selling beside them on Main Streets across the country, and many publishers still use the destructive selling tactics they first stooped to when this new bogey-man appeared. Magazines first sniffed cautiously at radio, settled down with an attitude of amused condescension, but finally began to refer to their readers as an "audience." Other media paused to criticize, ended by aping some of radio's most effective selling and research techniques.

All Successfully Selling

All these media are successfully selling their wares in places where effective radio selling can drastically reverse media decisions. And this kind of radio selling can best be done by the radio representative—local or national—who can incorporate these facts into his selling story:

1. *Radio does the best job of describing its audience.* Magazines and newspapers use "net-paid" circulation figures. These are comfortable indices on a space-buyer's desk, handy facts for an advertising manager. But they're really meaningless, as informed buyers of advertising will admit. They don't measure the audience the

advertiser *really* wants to know about. Advertisers want to buy *impressions*—not just advertising.

Both newspapers and magazines have taken a cautious peek at the real size of the *impressions* they deliver to an advertiser. The facts were shocking—2% actual readership to a 70-line newspaper ad—a 5% average actual readership to a full-page black and white advertisement in LIFE. This was a hard story to tell to advertisers who were sold on printed media's favorite laissez-faire basis, sometimes known as "transportation," most of whom firmly believed they were getting, as readers, the total paid circulation! It was, in fact, too hard a story to tell. Thousands of advertisers, large and small, have yet to hear it. And dozens of others are still accepting advertising agency coverage and cost comparisons which match this meaningless "net paid" data against radio's count of actual exposure to advertising.

Best Argument

Yet in the hands of every radio station equipped with a BMB measurement, or even with a diary study, telephone coincidental, or other form of audience measurement, is the best argument of all—a count of the audience to the advertiser's message! No radio salesman has adequately represented his medium in a competitive situation until he has invited comparison on this basis.

Radio's research bill in its short 30 years of existence far exceeds the combined research investment of all other media since their inception. First really to care about the audience to its advertisers' messages, first to tailor its listener services to the proven likes and dislikes of its audience, radio has been and will apparently continue to be America's most open-faced advertising medium. There are no skeletons, no "reducible factors" in radio's standard measurement totals.

2. *Radio gets the most attention.* In the average radio family, listening averages 5 hours 53 minutes *daily*. Newspapers' best claim, made by the defunct A.N.A.N., reached 3 hours, 18 minutes per family per day but few papers care to try to document these figures. A recent diary study in a major market showed an average reading time of 58 minutes per day per *adult*—only 7 minutes of newspaper reading per day for those under 18. And magazines just don't belong in this league. A recently *Saturday Evening Post* survey, triumphantly disseminated by that periodical, claimed top readership among magazines with 2 hours 54 minutes of total reading per weekly issue!

Of all these attention measurements, only BMB's radio data seems to have been produced in

the *regular research channels* by a continuing research arm of the industry! When other media get into this kind of self-examination, they do it in the manner of a woman with a "new look" short haircut—can't wait for it to grow long again!

N.O.R.C. Studies

"The People Look At Radio," "Radio Listening in America" (both of them N. O. R. C. studies available through NAB's Research Department), and the March 1949 *Fortune* study of radio listening, are good reading for the salesman who wants full details on the extent of the attention paid radio by American listeners.

3. *Radio's penetration is deepest.* Radio offers figures, again produced by an established, continuing industry source, to document this fact. BMB data—produced by the joint efforts of broadcasters, agencies and advertisers alike—show 83,000,000 radios in 39,280,000 American homes—or 94.2% of all American homes. Newspapers, with a 1% circulation increase in 1949 over 1948, show a total aggregate daily net paid circulation of over 52,000,000. That this penetration is much shallower than radio's is borne out by examination of the facts in individual cities, as well as by the obvious 30,000,000 differential between sets and newspapers. In one major Eastern city, 25% of the total population, when asked *by the newspapers*, reported that they saw no newspapers at all!

Magazine Circulation

Magazines can be dismissed as having only splinter circulation. As even the Bureau of Advertising of A.N.P.A. has pointed out, the eight great circulation leaders among American magazines can deliver a combined audience of only 24,000,000 homes. And even if an advertiser bought all 45 of the top magazines, he'd be missing 17.5% of the homes—homes that *get no magazines at all!*

This comparison of the penetration of major media will prove out in practically any market you select. Note the way NBC nails the point home in its promotion for two areas in which it operates stations:

NEW YORK AREA—	
Radio—total WNBC Audience—Daytime (BMB—1946) . . .	3,077,190
Magazines—total Circulation in area (nation's largest magazine)	1,301,673
Newspapers—total Circulation in area (New York's largest newspaper)	2,320,466
WASHINGTON, D. C. AREA—	
Radio—total WRC Audience—Daytime (BMB—1946)	316,580
Magazines—total Circulation in area (nation's largest magazine)	156,421
Newspapers—total Circulation in area (Washington's largest newspaper)	245,246

This difference in radio's penetration as compared with other major media becomes even more

pronounced in less urban areas, where newspaper circulation thins out quickly outside of the city zone, and where individual magazine circulations are negligible factors in covering the whole market.

Circulation measurements are more than a definition of the size of an advertising medium. A manufacturer, for example, should look at circulation figures to prove to himself that he is spending advertising dollars for impressions made *where his products are sold*—not just in the areas where the newspaper or magazine is sold. Will his advertising work for all his dealers, for all his company salesmen? Radio will pass this and other tests with a far higher score than printed media.

Retailers Disturbed

Retailers, too, are becoming increasingly disturbed by the failure of *local* newspapers to follow the spreading outlines of their trading areas. Newspaper space costs zoom astonishingly when it becomes necessary to buttress the local paper's coverage by buying a flock of community papers in outlying areas. The swift appearance of these community sheets is documentary evidence of the newspaper's failure to offer a service in these new-born communities, and the new publishers well know that with only the slimmest news and feature service, liberally sprinkled with "local personals," they can soon build a better coverage and acceptance story than the adjoining city newspaper. Big city retailers in particular are turning to radio in increasing numbers to solve this problem.

The very "bigness" of the radio coverage picture—and it keeps growing all the time!—makes some advertisers feel that radio must be an expensive medium. Yet, despite its high impact and deep penetration, radio is the least expensive of all major media.

4. *Radio costs less.* It costs less no matter how you figure it, but if you toss aside the concept of cost that printed media have been peddling for these many years, and measure the *actual cost of the goods delivered to the buyer*, then the cost picture in favor of radio is astounding. When the advertiser begins to measure what he is really buying—*impressions*—then radio's genuine economy becomes dramatically apparent. And radio salesmen can prove this point by asking advertisers to do this simple bit of arithmetic:

To compute radio's cost-per-thousand: Find the audience (number of people) to a specific radio program. Divide this figure into the time cost. *Result:* The actual cost of making a thousand advertising impressions on listeners to

(Continued on page 20)

PREFERRED BY 68* TV STATIONS!



*As of December, 1949

... Productive for these result-minded sponsors!

Coca-Cola
Ruppert's Beer
Phillips Soups
Interstate Bakeries
Abbott Dairies
Omaha Power District
Los Angeles Times

Chicago Tribune
H. G. Hill Stores
Cincinnati Enquirer
Dodge Dealers
Esslinger Beer
Kansas City Power & Light Co.
Standard & Humpty-Dumpty Super Markets

Get the facts on these result-producing ZIV-TV shows:

- SPORTS ALBUM** 5-minute series on: Baseball, Football, Wrestling, Boxing, etc.
- YESTERDAY'S NEWSREEL** ... 15-minute shows, highlighting headline events of yesteryear.
- CISCO KID** ½-hour Western (O. Henry's famous Robin Hood of the range!)
- EASY ACES** 15-minute hilarious comedy of domestic life.
- CARTOONS** 39 films featuring Woody Woodpecker, Andy Panda, etc.
- FEATURES** 1-hour, full-length movies.
- WESTERNS** 1-hour, full-length movies.

Write, wire or phone today!

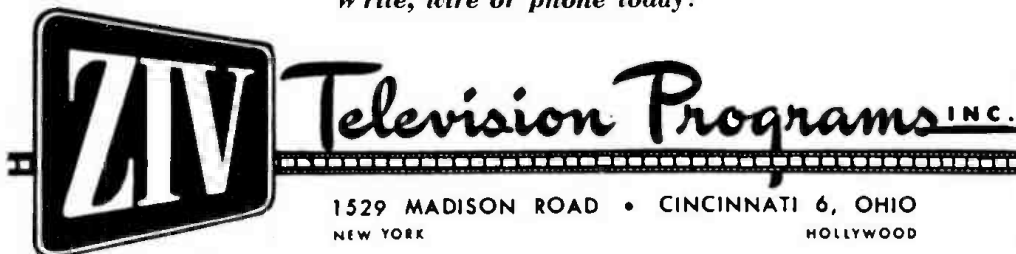

KOB-TV
WAGA-TV
WCON-TV
WAAM-TV
WBAL-TV
WAFM-TV
WBRC-TV
WNAC-TV
WBZ-TV
WBEN-TV
WBKB
WGN-TV
WENR-TV
WKRC-TV
WLW-T
WNBK
WEWS
WXAL-TV
WBNS-TV
WLW-C
KRLD-TV
KBTW
WLW-D
WHIO-TV
WJBK-TV
WWJ-TV
WXYZ-TV
WICU
KLEE-TV
WFBM-TV
WMBR-TV
KECA-TV
KTLA
KFI-TV
KTTV
KLAC-TV
WAVE-TV
WMCT
WTMJ-TV
WTCN-TV
WATV
WABD-TV
WDSU-TV
WCBS-TV
WJZ-TV
WNBT
WPIX-TV
WKY-TV
WOW-TV
KMTV
WCAU-TV
WFIL-TV
WDTV
WJAR-TV
WTVR-TV
WOAI-TV
KGO-TV
KPIX-TV
KING-TV
KSD-TV
WHEN-TV
KOTV
WMAL-TV
WNBW-TV
WSB-TV
WCPO-TV
WXEL-TV
WSPD-TV

Radio Results

(Continued from page 18)

that program—not to the entire station program schedule!

The formula:

$$\frac{\text{Time Cost}}{\text{Program Audience}} = \text{Cost-per-thousand impressions}$$

To compute newspaper's actual cost-per-thousand: Translate newspaper "net paid" circulation into "readership" by multiplying circulation by 2.3 readers per copy (this is a most generous multiplier, by the way!). Reduce this readership total to the actual readership of the specific advertisement. (Newspapers can now furnish this data. So can the hundreds of radio salesmen who have been "The Continuing Study of Newspaper Reading"). This gives you the actual number of people who have "noted" this ad. Divide this figure into the space cost. *Result:* The actual cost of making a thousand advertising impressions on readers of that ad.

The formula:

1. ABC circulation x 2.3 = total readership.
2. Readership of paper x % readership to specific ad = actual advertising impression.
3. Space cost

$$\frac{\text{Actual advertising impressions}}{\text{Actual advertising impressions}} = \text{cost-per-thousand impressions}$$

To compute magazines cost-per-

thousand: The same formulas used to compute newspaper cost will work on magazines.

This is the only honest method of comparing the costs of these three media. When agencies and advertisers alike put these formulas to work, radio will take its proper place in the cost picture with its competitors. This is an assignment which every radio salesman might well undertake in 1950.

Here is one of dozens of illustrations that might be worked out to demonstrate radio's low cost as compared with other major media. Let's take St. Louis, as a large, fairly typical, centrally-located market. A leading St. Louis radio station is reported by BMB (1946) as reaching 616,080 radio homes in the 77 Illinois and Missouri counties comprising the St. Louis area. Using this as a base, how does *LIFE* magazine—the nation's largest—compare? Its circulation in these same 77 counties is 59,053. Radio (one station) reaches ten St. Louis homes to every *LIFE* copy sold.

But *LIFE* claims a total "audience" far greater than its circulation. It uses a 5.1 multiplier to produce its total readership. Let's project *LIFE*'s 59,053 copies into "audience." *Result:* 301,170 readers. How about the radio audience? Using the normally-accept-

ed figure of 2.9 persons per family, radio reaches a total of 1,786,632 people in this same area. In terms of people reached in this area, one radio station outreaches *LIFE*, six to one!

Now how does a newspaper advertiser fare in St. Louis? His space bill for a 525 line advertisement in a leading St. Louis newspaper would total \$315, for which he could expect 54,209 readers to his advertisement. Cost per thousand—\$5.83. A little more spent in radio—\$337.50 on a leading station, to be exact—would bring him 470,771 listening impressions. Cost per thousand impressions—72¢.

Costs of Preparation

Omitted from these formulas are the costs of preparing the advertising itself. Some day radio's selling force will sit down with advertisers and persuade them to compare the soaring costs of simply preparing printed advertising with that of getting radio advertising on the air. In the nation's dry goods emporiums alone, literally millions of dollars charged against advertising are frittered away on specialized help in the preparation of copy that is read far more lightly than most graphic advertising experts dare to dream. The same facts apply to other local advertisers and equally well to the regional, the national spot, and the truly national advertiser.

5. *Results.* Every medium has its catalogue of astonishing result

stories. The fact that all media men make such a fuss over good results is a pretty good indication of their concern with the possibility that there will be no results. This fear rarely stems from a lack of confidence in the medium; rather, it arises from a lack of confidence in their ability to use the medium correctly.

Newspapers have been selling advertising in this country for 245 years—magazines even longer. Yet neither are known for their contribution to the techniques of successful advertising. It's a fact that printed media men leave this function to the agency, the advertiser's own staff, the mat or "idea" service. They are content—and this only at the local level—to translate the advertiser's message into the tired, long-used, stereotyped forms characteristic of their media. Beyond this, the printed media go only as far as offering—at a premium price!—to deliver a clumsy association between editorial matter and advertising known as "position." When an advertiser has paid an additional 25% for the privilege of placing his soap advertisement on the woman's page, he has squeezed the last ounce of technique available to him from the newspaper end of his contract.

When you compare this to radio, where the advertiser assumes that the selection of position, time, audience composition, editorial,

(Continued on page 66)

We gotta NEW one!
Wanta hear it?

Raymond R. Morgan

Gross Billings for 1949

American Broadcasting Co. Gross AM Billings by Months

Month	1949	1948
January	\$4,067,907	\$3,989,001
February	3,845,610	3,792,256
March	4,238,780	4,076,207
April	3,893,736	3,997,640
May	4,030,915	4,045,384
June	3,387,939	3,488,474
July	2,788,103	2,753,180
August	2,544,141	2,787,805
September	3,076,900	3,164,857
October	3,404,713	4,279,369
November	3,406,989	3,908,034
December	3,656,492	3,981,169
Total	\$42,342,225	\$44,303,376

By Advertisers

General Mills, Inc.	\$4,805,036
Sterling Drug, Inc.	2,392,910
Swift & Company	2,236,448
P. Lorillard Company	2,122,919
Pillsbury Mills, Inc.	2,054,216
Philo Corporation	1,964,929
The Quaker Oats Co.	1,631,713
Pepsi-Cola Company	1,438,414
Libby, McNeill & Libby	1,335,742
The Procter & Gamble Co.	1,074,456
Appliance and Merchandise Department of The General Electric Company	977,168
Equitable Life Assurance Society of the U.S.	909,025
Westinghouse Electric Corporation	904,137
The Norwich Pharmacal Co.	809,838
Association of American Railroads	776,344
Gillette Safety Razor Co.	731,151
The Texas Company	677,225
United States Steel Corporation of Delaware	670,775
Derby Foods, Inc.	636,198
Kaiser-Frazier Sales Corp.	623,292
Bristol-Myers Company	607,492
General Motors Corporation	603,420
The Andrew Jergens Co.	602,382
Pacific Coast Borax Co.	584,620
Seeman Brothers, Inc.	537,160
Speidel Co.	519,469
Nash-Kelvinator Corporation	492,976
The Goodyear Tire & Rubber Company, Inc.	436,736
The Frank H. Lee Company	428,351
Phillip Morris & Co., Ltd., Inc.	407,425
American Oil Company	396,722
Carter Products, Inc.	385,558
Chesebrough Mfg. Co., Cons'd.	380,148
Geo. A. Hormel & Co.	377,456
Eversharp, Inc.	365,533
United Electrical, Radio & Machine Workers of America	360,352
Revere Camera Co.	355,238
Gospel Broadcasting Assn.	344,384
Richfield Oil Corp.	324,724
The Christian Science Publishing Society	324,448
Elgin-American Division of Illinois Watch Case Company	288,870
Champion Spark Plug Co.	283,954
Smith Brothers	278,573
Bruner-Ritter, Inc.	265,580
Fruehauf Trailer Co.	225,631
Serutan Co.	218,168
H. J. Heinz Company	214,224
Phillips Petroleum Co.	202,341
Toni, Inc., Div. of Gillette Safety Razor Co.	199,683
General Foods Corporation	195,006
William H. Wise & Co., Inc.	180,587
The Drackett Co.	146,971
Club Aluminum Products Company	143,352
Adam Hat Stores, Inc.	140,685
Miller Brewing Company	137,811
American Bakeries Company	134,154
Servel, Incorporated	130,544
Voice of Prophecy, Inc.	125,389
Lutheran Laymen's League	105,722
Petri Wine Company	101,943
Radio Offers Company	85,485
Farnsworth Television & Radio Corp.	74,727
The U. S. Air Force Recruiting Service	67,021
The Southern Baptist Convention	59,544
P. J. Ritter Co.	58,711
Globe Mills, Pillsbury Mills, Inc.	53,199
Waltham Watch Company	48,813
Dawn Bible Students Association	48,757
Langendorf United Bakeries, Inc.	44,160
The Anahist Co.	41,400
Richfield Oil Corp. of N. Y.	41,015
First National Stores, Inc.	38,472
Wilson Sporting Goods, Co.	27,806
Doubleday & Company, Inc.	24,995
Stanley Home Products, Inc.	24,909
Beauty Factors, Inc.	24,704

Politicals	24,428
Greystone Press	23,992
Pacific Greyhound Lines	21,160
California Medical Association	20,596
Whitehall Pharmacal Company	18,598
National Assn. of Mfrs.	17,482
Safeway Stores, Incorporated	14,030
U. S. Sixth Army Command	13,546
Fisher Flouring Mills Co.	13,352
Budget Finance Plan, Inc.	13,260
Dr. A. Posner Shoes, Inc.	13,164
Inland Steel Co.	11,764
United Steel Workers of America	11,740
The Textile Workers Union of America	11,184
Green Spot, Inc.	11,036
Butler Packing Company	6,720
Institute of Religious Science	6,240
Regal-Amber Brewing Co.	5,984
R. C. W. Enterprises	4,969
Fisher Body Division General Motors Corp.	4,022
Dr. Hiss Shoe Stores	2,160
Mode O'Day Corp.	1,410
General Petroleum Corp. of California	1,050
Total	\$42,342,225

By Agencies

Dancer - Fitzgerald - Sample, Inc.	\$5,485,036
J. Walter Thompson Company	3,586,220
McCann-Erickson, Inc.	2,202,688
Lennox & Mitchell, Inc.	2,122,919
Hutchins Advertising Corporation, Inc.	1,964,929
Leo Burnett Company, Inc.	1,916,784
The Blow Company, Inc.	1,848,107
William H. Weintraub & Company, Inc.	1,590,396
Kudner Agency, Inc.	1,551,131
Young & Rubicam, Inc.	1,404,954
Batten, Barton, Durstine & Osborn, Inc.	1,178,775
Compton Advertising, Inc.	1,074,456
Tatham-Laird, Inc.	1,036,808
Warwick & Legler, Inc.	983,752
Maxon, Incorporated	945,375
Cecil & Presbrey, Inc.	926,894
C. J. La Roche & Co., Inc.	818,438
Sherman & Marquette	813,275
Benton & Bowles, Inc.	809,960
Lawrence C. Gumbinner Advertising Agency, Inc.	809,838
Knox Reeves Advertising, Inc.	678,919
Sullivan, Stauffer, Colwell & Bayles, Inc.	664,231
Needham, Louis and Brorby, Inc.	636,198
Doherty, Clifford & Shenfield, Inc.	607,494
Robert W. Orr & Associates, Inc.	602,382
Geyer, Newell & Ganger, Inc.	492,976
The Joseph Katz Company	396,722
Weinstein & Company	360,352
Roche, Williams & Cleary, Inc.	355,238
H. B. Humphrey Company	348,440
R. H. Alber Company	344,384
Hixson & Jorgensen, Inc.	324,724
Weiss & Geller, Inc.	288,870
MacManus, John & Adams, Inc.	283,954
Raymond Spector Company, Inc.	266,580
Foote, Cone & Belding	241,083
Zimmer-Keller, Inc.	225,631
Roy S. Durstine, Inc.	218,168

(Continued on page 22)



..... Sell Merchandise Because They **KNOW** Their Respective Audiences and Program Accordingly!



- KFDA is an ABC affiliate, and is managed by Howard P. Roberson. Established 1939.



- WBIR is an ABC affiliate, and is managed by John P. Hart. Established 1941.

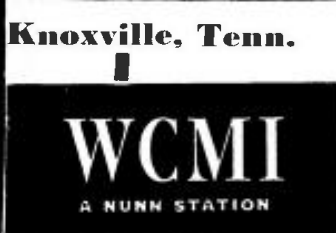

- WCMI is a CBS affiliate, and is managed by C. C. Warren. Established 1935.

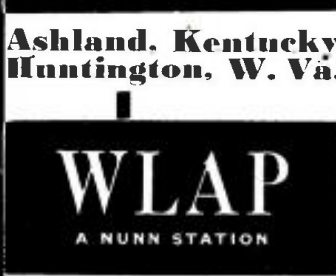

- WLAP is an ABC affiliate, and is managed by J. E. Willis. Established 1922.

JOHN BALLARD, NATIONAL SALES MANAGER, THE NUNN STATIONS.

The NUNN STATIONS are owned and operated by Gilmore N. Nunn and J. Lindsay Nunn

"THESE audience ratings mean 'business' in the Elkhart-South Bend, Ind. market!"

47.3—Morning
40.9—Afternoon
39.4—Evening

Ask Burn-Smith, Inc. or

WTRC
Elkhart, Indiana

ABC Billings

(Continued from page 21)

Lambert & Feasby, Inc.	202,341
Buchanan & Company, Inc.	170,272
Thwing & Altman, Inc.	150,587
Grey Advertising Agency, Inc.	139,592
Klau-Van Pietersom - Dunlap Associates	137,811
Tucker Wayne & Company	134,154
Western Advertising Agency, Inc.	125,389
Huber Hoge & Sons	110,480
Gotham Advertising Company, Inc.	105,722
Gardner Advertising Co.	67,021
Hirshon-Garfield, Inc.	61,977
Liller, Neal and Battle Advertising Agency	59,544
The Clements Company, Inc.	58,711
W. L. Gleeson & Company	48,757
Morey, Humm & Johnstone, Inc.	41,015
John C. Dowd, Inc.	38,472
Ewell & Thurber Associates	27,807
MacKenzie-Advertising	24,704
Polittals	24,428
Beaumont & Hohman, Inc.	21,160
Lockwood - Shackleford Advertising Agency	20,596
John F. Murray Advertising Agency, Inc.	15,780
Russell Harris & Wood, Inc.	13,546
Pacific National Advertising Agency	13,352
Irwin - McHugh Advertising Agency, Inc.	13,260
Charles W. Hoyt Company, Inc.	13,101
No Agency	11,808
Hill & Knowlton, Inc.	11,764
Wiltman & Callahan	11,740
Furman, Feiner & Company, Inc.	11,184
Philip J. Meany Company	11,036
Brisacher, Van Norden & Staff, Inc.	6,720
Raymond R. Morgan Company	6,240
Abbott Kimball Co., Inc., of California	5,984
Cowan & Whitmore Advertising Agency	4,989
Honig-Cooper Company	2,160
Glasser-Galley, Incorporated	1,410
West-Marquis, Inc.	1,050
Total	\$42,342,225

Billings by Month

Month	1949
January	\$ 6,273

February	18,674
March	26,352
April	47,359
May	132,146
June	119,835
July	119,674
August	115,902
September	155,480
October	217,199
November	214,660
December	219,337
Total	\$1,391,991

TV Advertisers

The B. F. Goodrich Company	\$132,595
Time, Inc.	151,053
The Kellogg Company	128,712
Admiral Corporation	123,169
P. Lorillard Company	114,941
Canada Dry Ginger Ale, Inc.	114,941
General Mills, Inc.	75,027
Sun Oil Company	72,958
International Cellulocotton Products Co.	61,512
Bristol-Meyers Company	60,166
The Goodyear Tire & Rubber Company	56,855
Pal Blade Co., Inc.	52,452
Derby Foods, Inc.	47,588
Blatz Brewing Co.	34,770
Chesebrough Mfg. Co. Consolidated	33,297
Young People's Church of the Air	31,271
Bell & Howell Co.	29,752
Chevrolet Dealers Association, Inc.	24,813
Libby, McNeill & Libby	24,780
A. Stein & Company	22,844
The Delta Mfg. Company	11,643
Div. of Rockwell Mfg. Co.	10,960
A. Sagner's Son, Inc.	8,910
American Bakeries Company	7,490
The Texas Company	4,146
R. J. Reynolds Tobacco Co.	1,560
The Lionel Corporation	1,485
American Jewish Congress	1,485
Gillette Safety Razor Co.	1,150
Total	\$1,391,991

TV Agencies

Young & Rubicam, Inc.	\$187,918
Batten, Barton, Durstine & Osborn, Inc.	132,595
Kudner Agency, Inc.	130,659
N. W. Ayer & Son, Inc.	128,712
Lennen & Mitchell, Inc.	114,941
J. M. Mathes, Incorporated	86,082
Dancer - Fitzgerald - Sample, Inc.	75,027

Hewitt, Ogilvy, Benson & Mather, Inc.	72,958
Foote, Cone & Belding	61,512
Doherty, Clifford & Shenfield, Inc.	60,166
Al Paul Lefton Co., Inc.	52,452
Needham, Louis and Brorby, Inc.	47,588
Kastor, Farrell, Chesley & Clifford, Inc.	34,770
McCann-Erickson, Inc.	33,297
J. M. Camp and Company	31,271
Henri, Hurst & McDonald, Inc.	29,752
Campbell - Ewald Company, Inc.	24,813
J. Walter Thompson Company	24,780
Louis A. Smith Company	22,844
Hoffman & York, Inc.	11,643
I. A. Goldman & Company	10,960
Tucker Wayne & Company	8,910
William Esty Company, Inc.	4,146
Reiss Advertising	1,560
No Agency	1,485
Maxon, Incorporated	1,150
Total	\$1,391,991

MUTUAL BROADCASTING SYSTEM

1949 Gross Billings

Month	Monthly	Cumulative
January	\$1,876,124	\$1,876,124
February	1,677,257	3,553,381
March	1,775,790	5,329,171
April	1,757,432	7,086,603
May	1,788,790	8,875,393
June	1,403,880	10,279,273
July	1,133,315	11,412,588
August	1,119,364	12,531,952
September	1,178,384	13,710,340
October	1,667,482	15,377,822
November	1,316,963	16,694,785
December	1,376,910*	18,071,695

* December billings estimated

By Advertisers

Miles Laboratories, Inc.	\$1,316,129
Philip Morris & Co., Ltd.	1,310,050
Johns-Manville Corp.	1,211,655
Ralston-Purina Co.	1,196,956
Ronson Art Metal Works	1,142,964
National Biscuit Co.	1,066,566
Quaker Oats Co.	956,559
Bayuk Cigars, Inc.	919,124
General Foods Corp.	757,195
U. S. Tobacco Co.	688,810
Serutan Co.	568,737
Cudahy Packing Co.	490,180
R. E. Semler Inc.	461,612
Lutheran Laymen's League	428,589
Williamson Candy Co.	402,204

Wander Co.	387,239
Mutual Benefit Health & Accident Ass'n of Omaha	373,394
Mail Pouch Tobacco Co.	369,905
Helbros Watch Co.	363,201
Noxema Chemical Co.	336,079
Radio Bible Class	322,481
Voice of Prophecy Inc.	299,130
Gillette Safety Razor Corp.	278,918
Christian Reformed Church	255,486
Doubleday & Co.	197,337
Trimount Clothing Co.	179,099
Rhodes Pharmacal Co.	172,332
Shotwell Manufacturing Co.	143,200
Carter Products Inc.	139,458
National Council of Protestant Episcopal Churches	128,874
Grove Laboratories, Inc.	122,688
Kaiser-Frazier Corp.	103,194
Delaware, Lackawanna & Western Coal Co.	83,584
Piedmont Shirt Co.	72,016
Benjamin Moore & Co.	70,080
Murline Co.	69,248
Conti Products Co., Inc.	67,070
Universal Carloading & Distributing Co.	63,048
Wilson Spung Goods Co.	62,774
First Church of Christ Scientist	58,875
Burrus Mill & Elevator Co.	49,939
Miami Margarine Co.	45,960
Fram Corp.	44,405
Greystone Press	41,729
R. J. Reynolds Tobacco Co.	32,866
International Milling Co.	30,740
H. C. Cole Milling Co.	27,795
George A. Hornel Co.	25,560
American Bird Products, Inc.	23,554
Ace Markets, Inc.	20,488
Perfect Circle Co.	18,759
Political	11,511
Capehart-Farnsworth, Inc.	11,352
Radio Offer Co.	8,962
Hudson Motor Co.	8,811
Hallcrafters Corp.	8,800
Faydrex Corp.	5,876
Shipstead & Johnson	5,340
White King Soap Co.	5,421
Wally Frank, Ltd.	4,904
Brown Shoe Co.	4,518
Charles B. Silver Co.	4,096
Paramount Pictures, Inc.	2,904
Twentieth Century-Fox Corp.	1,371
Total	\$18,071,695

Note: December billings estimated

By Agencies

Cecil & Presbrey, Inc.	\$1,872,202
Waide Advertising Agency	1,459,329
J. Walter Thompson Co.	1,211,655

(Continued on page 51)

DOMINATING MARYLAND'S *SECOND MARKET

WBOC

SALISBURY
MARYLAND

IS

"ONE OF AMERICA'S *Finer* RADIO STATIONS"

WBOC

1000 W 960 KC
FULL TIME
ESTABLISHED 1940

* The Eastern Shore of Maryland, Southern Delaware, and Eastern Shore of Virginia . . . a market second only to Baltimore. \$300,000,000 annual retail sales and growing rapidly. An urban-rural area offering advertisers an ideal test market.

WBOC-FM

12 KW E.R.P. 97.5 MC
CHANNEL 248
ESTABLISHED 1948

ASK US OR BURN-SMITH CO., INC., FOR FULL INFORMATION

OUT-OF-TOWN STUDIOS:
POCOMOKE CITY, MD.
SEAFORD, DEL.

President: John W. Downing



OWNED AND OPERATED BY
THE PENINSULA BROADCASTING CO.
RADIO PARK, SALISBURY, MD.

General Manager: Charles J. Truitt

MEMBER MUTUAL BROADCASTING SYSTEM

RADIO CORPORATION OF AMERICA

30 ROCKEFELLER PLAZA, NEW YORK 20, N. Y. Tel.: Columbia 5-5900

BOARD OF DIRECTORS

Arthur E. Braun
John T. Cahill
Gano Dunn
Frank M. Folsom
John Hays Hammond Jr.
George L. Harrison

Harry C. Ingles
Charles B. Jolliffe
Edward F. McGrady
Edward J. Nally
David Sarnoff
Niles Trammell

OFFICERS

David Sarnoff, *Chairman of the Board*
Frank M. Folsom, *President*
Charles B. Jolliffe, *Vice President in Charge of RCA Laboratories Division*
John G. Wilson, *Executive Vice President in Charge of RCA Victor Division*
Edward F. McGrady, *Vice President in Charge of Labor Relations*
George S. De Sousa, *Vice President*
Joseph V. Heffernan, *Vice President & General Attorney*
Orrin E. Dunlap Jr., *Vice President in Charge of Advertising & Publicity*
Glen McDaniel, *Vice President*
Conway P. Coe, *Vice President*
Walter A. Buck, *Operating Vice President of the RCA Victor Division*
J. B. Elliott, *Vice President in Charge of Consumer Products, RCA Victor Division*
Henry G. Baker, *Vice President and General Manager Home Instruments Dept.*
Richard T. Orth, *Vice President and General Manager Tube Department*
P. A. Barkmeier, *Vice President and General Manager of the Record Department*
E. W. Engstrom, *Vice President in Charge of Research, RCA Laboratories Division*
E. C. Anderson, *Vice President in Charge of Commercial Department, RCA Laboratories Division*
Henry A. Sullivan, *Controller*
Lewis MacConnach, *Secretary*
L. W. Teegarden, *Vice President in Charge of Technical Products, RCA Victor Division*
Walter W. Watts, *Vice President in Charge of the Engineering Products Department of RCA Victor Division*
Dominic F. Schmit, *Vice President in Charge of the Engineering Department of RCA Victor Division*
John S. Carter, *Vice President and Director of the Finance Department*
John K. West, *Vice President in Charge of Public Relations of RCA Victor Division*
V. DeP. Goubeau, *Vice President in Charge of Materials Department of RCA Victor Division*
Charles M. Odorizzi, *Vice President in Charge of Service of RCA Victor Division*
Robert A. Seidel, *Vice President in Charge of Distribution of RCA Victor Division*
Harold R. Maag, *Vice President and Western Manager of the RCA Victor Division*
Meade Brunet, *President & Managing Director of RCA International Division*
Vladimir K. Zworykin, *Vice President & Technical Consultant of RCA Laboratories Division*
Ernest B. Gorin, *Treasurer*

Divisions of RCA

RCA LABORATORIES DIVISION

Administration
C. B. Jolliffe, *Executive Vice President*
Research Department
E. W. Engstrom, *Vice President in Charge of Research*
Patent Department
Clarence D. Tuska, *Director*
Commercial Department
Ewen C. Anderson, *Vice President*
RCA Frequency Bureau
Phillip F. Siling, *Engineer-in-Charge*
Accounts & Finance Department
C. W. Zemke, *Director*
RCA Review
George M. K. Baker, *Manager*

RCA VICTOR DIVISION

Office of the Executive Vice President
J. G. Wilson, *Executive Vice President*
Office of the Operating Vice President
Walter A. Buck, *Operating Vice President*
Accounting Department
D. L. Trouant, *Director*
Engineering Department
D. F. Schmit, *Vice President in Charge of the Engineering Department*
Finance Department
J. S. Carter, *Vice President and Director of the Finance Department*
Law Department
E. Samuel Ewing, *General Attorney*
Materials Department
V. DeP. Goubeau, *Vice President in Charge of Material Department*
Personnel Department
E. M. Tuff, *Director of Personnel*
Plant Engineering Department
Frank Sleetor, *Director of Plant Engineering Department*
Public Relations Department
John K. West, *Vice President in Charge of Public Relations*
RCA Exhibition Hall
H. L. Davis, *Manager*

Consumer Products Department

Office of the Vice President in Charge of Consumer Products
J. B. Elliott, *Vice President in Charge of Consumer Products*
Home Instrument Department
H. G. Baker, *Vice President and General Manager*

Victor Record Department
P. A. Barkmeier, *Vice President and General Manager*

Distribution Department

Office of the Vice President in Charge of Distribution
R. A. Seidel, *Vice President in Charge of Distribution*
Harold R. Maag, *Vice President and Western Manager of the RCA Victor Division*
Advertising Department
R. H. Coffin, *Director of Advertising*

Technical Products Department

Office of the Vice President in Charge of Technical Products
L. W. Teegarden, *President in Charge of Technical Products*
Tube Department
R. P. Orth, *Vice President and General Manager*
Engineering Products Department
W. W. Watts, *Vice President in Charge of Engineering Products Department*
RCA Service Company, Inc.
E. C. Cahill, *President*

Manufacturing Plants

A. L. Malcarney, *General Plant Manager*

RCA INTERNATIONAL DIVISION

Meade Brunet, *Managing Director*
Merchandising Department
H. C. Edgar, *Director*
Finance & Accounting Department
A. F. Dollar, *Controller*
Law Department
H. T. Brunn, *Counsel*
Licensing Department
Dr. B. E. Shackelford, *Director*
Manufacturing & Engineering Services Department
H. G. Stenshorn, *Director*

SUBSIDIARY COMPANIES & OFFICERS

National Broadcasting Company, Inc., 30 Rockefeller Plaza, New York City. Telephone: Circle 7-8300. Board of Directors: Arthur E. Braun, John T. Cahill, Charles R. Denny, Gano Dunn, Frank M. Folsom, George L. Harrison, Harry C. Ingles, Charles B. Jolliffe, Joseph H. McConnell, Edward F. McGrady, Edward J. Nally, David Sarnoff. Officers: Niles Trammell, *Chairman of the Board*; Joseph H. McConnell, *President*; Charles R. Denny, *Executive Vice President*; Harry C. Kopf, *Administrative Vice President*; John H. MacDonald, *Administrative Vice President & Assistant Secretary*; Sidney N. Strotz, *Administrative Vice President*, Hollywood; William Brooks, *Vice President*; Sydney H. Elges, *Vice President*; Charles P. Hammond, *Vice President*; O. B. Hanson, *Vice President*; William S.

Hedges, *Vice President*; Gustav B. Margraf, *Vice President & General Attorney*; John F. Royal, *Vice President*; Frank M. Russell, *Vice President*; I. E. Showerman, *Vice President*; Sylvester L. Weaver, *Vice President*; H. F. McKeon, *Controller*; R. J. Teichner, *Treasurer & Assistant Secretary*; Lewis MacConnach, *Secretary*; Wayne Mason, *Assistant Secretary*.

(For complete listing see page 390)

Radiomarine Corporation of America, 75 Varick Street, New York City. Telephone: Walker 5-3716. Board of Directors: Walter A. Buck, Meade Brunet, Frank M. Folsom, Vincent DeP. Goubeau, George F. Shecklen, Arthur B. Tuttle, Walter W. Watts, Thomas P. Wynkoop. Officers: Frank M. Folsom, *Chairman of the Board*; Thomas P. Wynkoop, *President*; George F. Shecklen, *Executive Vice President*; Bruce W. Dold, *Vice President & Controller*; William F. Vogt, *Vice President & Treasurer*; I. F. Byrnes, *Vice President in Charge of Engineering*; A. J. Costigan, *Vice President in Charge of Communications*; H. A. Saul, *Vice President in Charge of Production*; Robert C. Proppe, *Secretary*; Charles A. Carney, *Assistant Controller*; Charles F. Valentine, *Assistant Treasurer & Assistant Secretary*; Wayne Mason, *Assistant Secretary* (for FCC Licenses).

RCA Institutes Inc., 350 West 4th Street, New York City. Telephone: Watkins 4-7845. Board of Directors: Walter A. Buck, Edward C. Cahill, Orrin E. Dunlap Jr., Gano Dunn, Joseph V. Heffernan, Harry C. Ingles, David Sarnoff, George L. Van Deusen, Thomas P. Wynkoop. Officers: David Sarnoff, *Chairman of the Board*; George L. Van Deusen, *President*; George F. Maedel, *Vice President & General Superintendent*; William F. Vogt, *Treasurer*; Lewis MacConnach, *Secretary*; Charles F. Valentine, *Assistant Treasurer*; Robert C. Proppe, *Assistant Secretary*.

RCA Communications, Inc., 66 Broad Street, New York City. Telephone: Hanover 2-1811. Board of Directors: John T. Cahill, Gano Dunn, George L. Harrison, Joseph V. Heffernan, Harry C. Ingles, Charles B. Jolliffe, Edward F. McGrady, Thompson H. Mitchell, Edward J. Nally, David Sarnoff. Officers: David Sarnoff, *Chairman of the Board*; Harry C. Ingles, *President*; Thompson H. Mitchell, *Executive Vice President in Charge of Operations*; William H. Barsby, *Vice President in Charge of Administration*; Harold H. Beverage, *Vice President in Charge of Research & Development*; Lon A. Cearley, *Vice President & Controller*; Chester W. Latimer, *Vice President in Charge of Engineering*; Sidner W. Sparks, *Vice President in Charge of Commercial Activities*; Samuel M. Thomas, *Vice President in Charge of New York District*; Frederick J. Sager, *Treasurer & Assistant Secretary*; Henry Heisel, *Assistant Treasurer*; Lewis MacConnach, *Secretary*; Felix Schleenvoigt, *Assistant Secretary*.

BROADCASTING
24 YEARS
WMBI
AM AND FM



PIONEER
CHRISTIAN
STATION

ORIGINATING NEARLY
250 PROGRAMS
EVERY WEEK

MOODY BIBLE INSTITUTE
153 INSTITUTE PLACE
CHICAGO 10, ILLINOIS

FM BROADCASTING
SINCE 1941

1949 RADIO AUDIENCE ANALYSES

THE HOOPER METHOD

BASIC BROADCAST audience data is obtained by C. E. Hooper Inc. through a coincidental telephone check of listeners in the metropolitan areas of 36 cities where the four major networks have local outlets. These Network Program Hooperatings, published twice monthly (15th and 30th) establish a continuing record of comparative popularity of sponsored network radio programs.

Hooper representatives make a total of 1470 calls during each half-hour broadcast or over ten and a half million calls yearly. From these calls the following basic information is obtained: Available homes, homes using sets, Hooperating, sponsor identification, and audience composition.

The Hooperating is the percent of total homes called which reported listening to a particular program.

The Hooper Broadcast Audience Measurements include six fundamental services. They are: Program Hooperatings (network talent "popularity" ratings); U. S. Hooperatings (quantitative and qualitative analysis of U. S. network program audiences nationally); City Hooperatings (period by period, sets-in-use and station audiences published continuously for up to 100 cities); Area Coverage Indexes (radio and/or TV station listening audience comparisons county-by-county or within a station's "coverage" area); TV-Network Hooperatings (random-home-based ratings "projectable" to random homes, TV-Home based ratings "projectable" to TV-homes); City Teleratings (sets-in-use and station ratings in "advanced" TV cities, Share of Audience Indexes in "new" TV-cities).

* * *

* * *

* * *

* * *

THE NUMBER of U.S. radio families is steadily edging up toward the total number of families in the country. Latest BMB survey of radio homes, made early in 1949, shows 39,281,230, an increase of 1,658,230 or 4.2% over the 37,673,000 radio homes found by BMB the year before.

This means that 94.2% of all U.S. homes were radio-equipped at the beginning of 1949. Most of the millions of sets manufactured and sold during the year doubtless replaced wornout receivers or became second sets in homes already containing radios, but it is probable that by now more than 95% of all American families are radio owners.

In 1949, for the first time in recent years, the increase in radio ownership was not matched by a rise in average listening time. Instead, last year, it was offset by a decline in average radio listening. Data collected by A. C. Nielsen Co.

Chart I

PATTERN OF OVERALL RADIO USAGE (NATIONAL)

Hours of Listening (avg. home - avg. day)

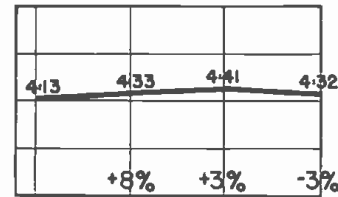

No. of Radio Homes (estimates -'000,000)

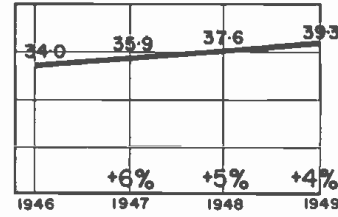

Advertiser Potential (homes x hours '000,000)

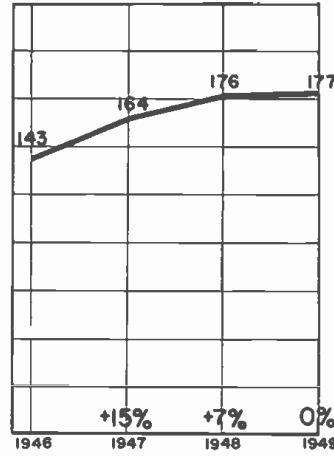

41 minutes. But in 1949 the average listening had dropped off to 4 hours, 32 minutes.

Overall, the increased number of radio homes and the decreased average listening in each balanced off, with the result that radio's national advertising potential in 1949 was just about on the 1948 level. That means in terms of homes and hours the advertiser in 1949 got about the same return—nationally—for his radio dollar as he did in 1948 (Chart I, Nielsen).

When average listening time is analyzed by size of city and time of day (Chart II), Nielsen reports that from 1948 to 1949 (using the first six months average for both years), listening in small cities rose 3 minutes a day, while in medium size cities it fell 1 minute and in large cities it fell 16 minutes. Morning listening dropped 1 minute from 1948 to 1949; afternoon listening was 3 minutes off; evening listening declined 6 minutes.

The largest decrease in average daily listening occurred in large cities and during the evening hours. Chart III (Nielsen) shows metropolitan listening off 4.6% in the evening, as against a drop of

(Continued on page 26)

show that the typical American family used its radio an average of 4 hours, 13 minutes a day in 1946. The next year, 1947, the average daily listening time had risen to 4 hours, 33 minutes, and in 1948 it rose again, to 4 hours,

First Fifteen Evening Hooperatings (Nov. 1-7, 1949)

	Hooperating	Nov. 1-7, 1948 Position	Nov. 1-7, 1947 Position
1. Radio Theatre	25.0	2	4
2. Arthur Godfrey's Talent Scouts	22.2	6	18
3. Jack Benny	20.6	4	3
Original Broadcast 18.7			
Added by 2nd Broadcast 1.9 *			
4. My Friend Irma	20.1	7	12
5. Fibber McGee & Molly	18.6	3	1
6. Walter Winchell	17.3	1	11
Original Broadcast 15.5			
Added by 2nd Broadcast 1.8 *			
7. Crime Photographer	15.9	13	42
8. Bing Crosby	15.6	18	17
9. Suspense	15.3	24	46
10. Charlie McCarthy	15.3	19	5
Original Broadcast 13.0			
Added by 2nd Broadcast 2.3 *			
11. F.B.I. in Peace & War	15.2	23	80
12. Dennis Day	15.0	22	24
13. Bob Hope	14.9	5	2
14. People Are Funny	14.7	12	33
15. Mr. & Mrs. North	14.7	52	38
16. Amos 'n' Andy	14.7	38	6
17. Mr. Keen	14.7	14	55

* Second broadcast on same day in some cities provides more than one opportunity to hear program.

Top Ten Daytime Hooperatings (Nov. 1-7, 1949)

	Hooperating	Nov. 1-7, 1948 Position	Nov. 1-7, 1947 Position
1. Ma Perkins (CBS)	7.2	1	6
2. Big Sister	7.1	9	12
3. Young Widder Brown	6.8	3	3
4. Arthur Godfrey (10:15-11:30) (11:00-11:30, 7.8); (10:45-11:00, 7.3); (10:30-10:45, 5.9); (10:15-10:30, WF, 4.2); (10:15-10:30, MTT, 3.7)	6.5	5	21
5. Pepper Young's Family	6.5	10	8
6. Our Gal, Sunday	6.5	12	1
7. Aunt Jenny	6.2	17	2
8. Romance of Helen Trent	6.1	11	4
9. Right to Happiness	6.1	8	9
10. Wendy Warren	6.0	20	36

Arthur Godfrey's ratings in 1948 and 1947 are not for exactly same time periods.

WJAS
loves
Columbia

and
PITTSBURGH
loves
WJAS

SINCE 1921



1320

5000 WATTS
FM 99.7 MC

H. K. BRENNEN Pres. and Gen. Mgr.

Represented by HOLLINGBERY

AUDIENCE ANALYSIS

(Continued from page 24)

less than 1% during the day. This combination would lead to the suspicion that television, which is largely a night-time big city phenomenon and Chart IV (Nielsen) confirms that idea.

The entire broadcast audience, including TV as well as AM and FM, follows a seasonal trend from a peak in January to a low point in July that is repeated without much deviation from year to year. Sets-in-use charts (V and VI) based on Hooper 36-city data and covering the three-year span from November 1946 to the same month in 1949, show last year's evening audiences running slightly ahead of previous years during the summer and fall; 1949 daytime audiences were larger than those in 1947 and 1948 during the summer months, but lagged behind those years in the fall.

COMPARISON OF AVERAGE RATINGS

Sponsored Evening Programs

	Program Hooperatings		
	1947	1948	1949
March 15 . . .	11.4	11.4	10.6
July 15 . . .	4.9	4.6	4.7
Nov. 15 . . .	9.8	9.8	10.1

Sponsored Daytime Programs

March 15 . . .	5.2	5.3	5.0
July 15 . . .	3.3	3.8	4.0
Nov. 15 . . .	4.1	4.6	4.2

The average Hooperating of all nighttime commercial network programs in March of last year (10.6) was a little lower than the average for that month in 1947 and 1948 (11.4 both years). In July the three years' average ratings were just about on a par, but by November the 1949 average had drawn ahead of the earlier years, 10.1 as against 9.8 in both 1947 and 1948.

Daytime average Hooperatings of network sponsored shows in March was slightly lower for 1949 than for the two previous years.

Chart II TREND OF OVERALL RADIO USAGE - BY MARKET DIVISIONS

Average hours listened per home per day, - January - July 1948 & 1949

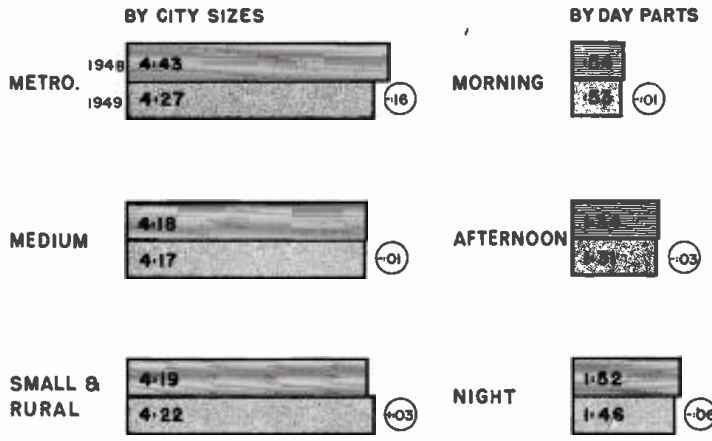
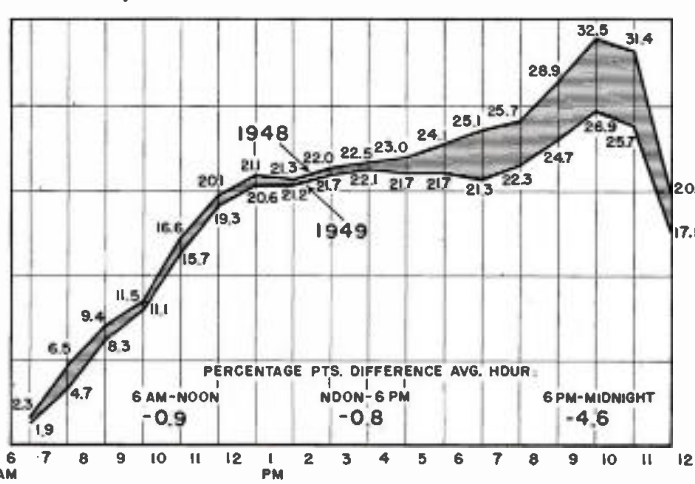

Chart III AVERAGE AUDIENCE HOMES USING RADIO - ALL METRO. AREAS



In July the 1949 daytime average rating was somewhat ahead of 1948 and appreciably better than 1947. By November 1949 the average had fallen below the November

1948 level and was just about even with 1947.

If there was any change in the listening public's program preferences during 1949 it was not substantial enough to make any impression on the lists of top-ranking programs. Every program among the Hooper "First 15" and "Top

Ten" lists of most-listened-to network commercial shows, evening and daytime, last November, had been on the air for at least two years. Ten of the "First 15" for November 1949 (actually 17 because of a 4-way tie) were also included in that honor roll for November 1948 and eight of them in 1947. Of the daytime top-tenners in November 1949, six made this list in November 1948 and seven in November 1947. (See tables for full details.)

Hooper's TV program ratings, which in 1948 had been limited to the New York metropolitan area, in 1949 were extended to cover all cities receiving TV network service, either simultaneously by coaxial cable or radio relay, or by kinescopic recordings for delayed broadcast. Based on coincidental telephone calls like the radio program Hooperatings, the TV ratings are figured on calls to video homes only.

The following programs got the top Hooper TV-Network Teleratings in October 1949:

Program	Telerating
1. Texaco Star Theatre (30 NBC-TV cities)	69.4
2. Arthur Godfrey's Talent Scouts (8 CBS-TV cities)	55.8
3. Arthur Godfrey and His Friends (33 CBS-TV cities)	49.7
4. Toast of the Town (16 CBS-TV cities)	45.6
5. Fireball Fun for All (32 NBC-TV cities)	40.9
6. Fireside Theatre (17 NBC-TV cities)	39.2
7. Philco TV Playhouse (36 NBC-TV cities)	38.7
8. Stop the Music (8-9 p.m.) (15 ABC-TV cities, 8-8:30) (13 ABC-TV cities, 8:30-9)	37.6
9. Original Amateur Hour (15 NBC-TV cities)	35.4
10. Cavalcade of Stars (17 Du Mont-TV cities)	35.3

Some interesting data on the effect of the introduction of a television set into a radio home is provided by Nielsen (Chart VII). This research company last year began producing a Television Index (Continued on page 28)

Chart IV

HOUR BY HOUR TV USAGE COMPARED TO AM

Homes using sets Mon.-Fri. - Feb. 1949

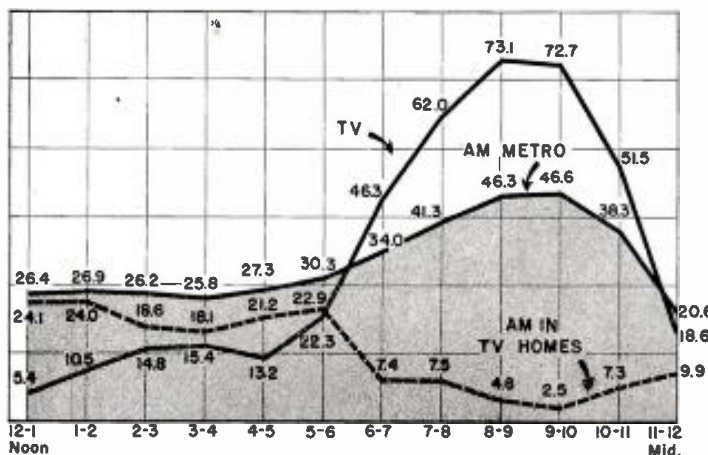

Page 26 • 1950 Yearbook Number

Chart V

Hooper Basic Audience Trends
SETS - IN - USE INDEX - DAYTIME
December 15, 1946 thru November 15, 1949

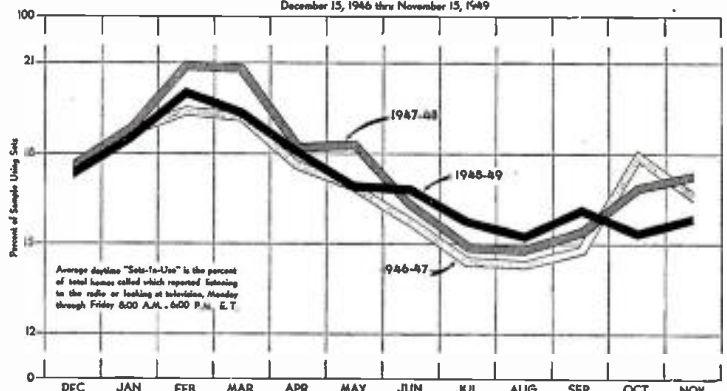

Average daytime "Sets-In-Use" is the percent of total homes called which reported listening to the radio or looking at television, Monday through Friday 8:00 A.M. - 6:00 P.M. E.T.

THAT'S RIGHT!

Quiz Kids



This may be news to you—but the happy fact is that the famous Quiz Kids program may be sponsored by *you* in *your* territory! (Of course, the great national show goes merrily on . . . in its tenth year for the same sponsor.)

It's as simple as A-B-C! Local Quiz Kid shows are easily produced with letterperfect scripts and complete promotion kits produced by the network Quiz Kids staff. All you have to do is choose the children and the emcee!

If you'd care to know how these local Quiz Kids programs are doing, just look over the record below. And then get in touch with us. The cost is extremely modest.

**AVAILABLE
FOR LOCAL
SPONSORSHIP!**

THESE ARE RESULTS!

NEW YORK CITY, (WNBC) Savings Bank Association of Greater New York.
Highest rating in its time slot in competition with 9 other stations.

EAU CLAIRE, WISCONSIN, (WEAU) A. F. Schwahn Sausage Company.
60.9% of all listeners at end of first month.

BATON ROUGE, LA., (WJBO) Jack's Cookie Company
Highest rating in its time slot in competition with Baton Rouge station and New Orleans stations.

ROCHESTER, MINN., (KROC) Good Foods, Inc. (Skippy Peanut Butter).
In face of nation-wide decline in peanut butter sales, Skippy sales increased 6 per cent in Rochester area.

ELKHART, INDIANA, (WTRC) 1st National Bank
Ending second year for same sponsor.

WICHITA, KAN., (KANS) Henry Clothing.
Sponsor well pleased and theater from which show originates reports big box office increase on those nights.

LITTLE ROCK, ARK., (KARK) Colonial Baking Company.
Following highly successful series last year with top rating in its time slot renewed this year under same sponsorship.

LAUREL, MISS., (WAML) Carter-Heide Dept. Store.
Same sponsor completing second year.

SYRACUSE, NEW YORK, (WSYR) Banking Association of Greater New York.
Started after same sponsor's success in New York City

SAN DIEGO, CALIFORNIA, Dairy Mart Farms.
Sponsor very happy with program and show assured a long life.

LOUIS G. COWAN, INC.

BROADCASTING • Telecasting

8 South Michigan Avenue
Chicago, Illinois

● 485 Madison Avenue
New York, New York

1950 Yearbook Number • Page 27

Audience Analysis (Continued from page 26)

for the New York area and plans shortly to extend it.

Prior to the advent of television into a home, Nielsen reports, the family radio was on for an average of 2 hours, 29 minutes during the daytime hours and for 1 hour, 39 minutes at night. After the family got a video set, its total broadcast reception time between 6 a.m. and 6 p.m. went up to 2 hours, 59 minutes of which 50 minutes went to TV, with the radio listening time dropping to 2 hours, 9 minutes. In the evening the family devoted 3 hours, 55 minutes to combined radio-TV use, but radio got only 27 minutes of this total, with 3 hours, 28 minutes spent watching video.

Both Nielsen and Hooper provide analyses of network radio commercial programs by program types. Hooper, in Chart VIII, shows the distribution of nationally sponsored network time among the various types of programs in November 1948 and November 1949. Nielsen reports the average ratings for the various types of network commercials and then calculates the number of homes reached by each type of commercial show per dollar of advertising expenditures for time and talent.

The different amount of time allotted each commercial program class in 1949 as compared with 1948 (which might be considered a measure of their popularity with advertisers, or their "sponsor ratings") reveals that mysteries replaced variety shows as the top program category. Mystery programs in November 1949 occupied 16.0% of all network evening commercial time, a gain of 21.2% over the same month of 1948, when they ranked third, taking up 13.2% of network evening sponsored time. Variety shows in the same yearly interval dropped from first to third rank and from 16.9% to 12.6% of all evening network commercial time, a loss of 25.4%.

News and commentators ranked second both years, registering a

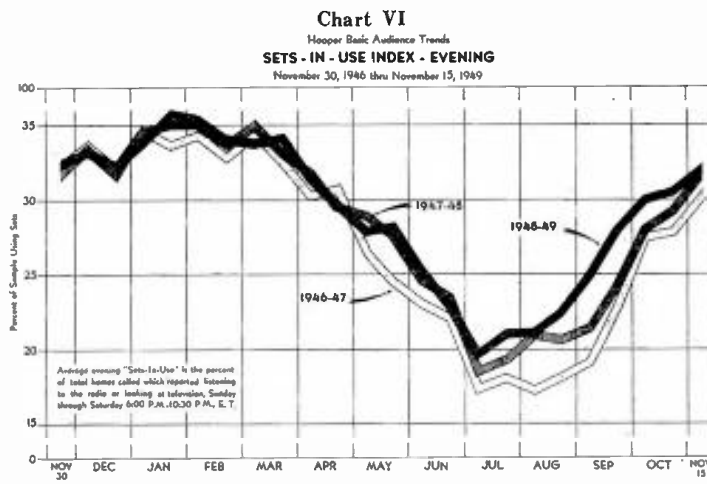
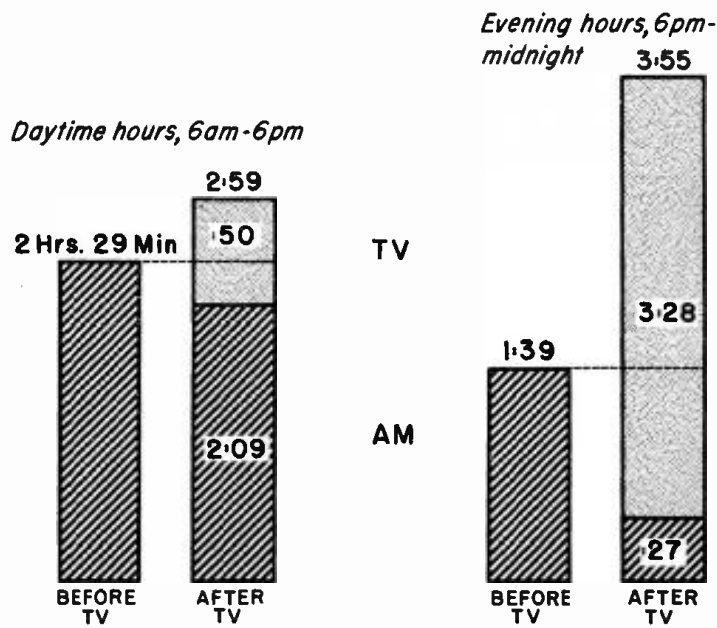

Chart VII
EFFECT OF TV ON LISTENING HABITS
THE AVERAGE TV HOME - through June 1949 (seasonally adjusted)



slight gain from 15.4% of the total evening network commercial time in November 1948 to 15.7% a year

later. Situation comedy moved up from seventh place (9.1%) to a tie for third (12.6%); plays dropped

from fourth (12.5%) to seventh position (9.9%).

In the daytime, serials increased in percentage of sponsored network time from 51.7% in November 1948 to 57.1% a year later, more than double the commercial daytime allotted to network audience participation shows, which accounted for 25.7% in 1948 and 25.1% in 1949. News and commentary broadcasts made up only 2.6% of the sponsored daytime hours on the networks last November, a drop of 50% from the 5.2% it comprised the year before. Similarly popular music program time shrank from 3.7% to 1.5% of commercial network daytime during the year.

Analyzing the various types of commercial programming by ratings, instead of time allotments, Nielsen found that of all evening network sponsored programs of 25 minutes or longer on the air last September, variety-comedy shows have the highest group acceptance with an average rating of 13.0. Highest rated single program was a dramatic show with 24.2, but as a group this class averaged only 9.6. Mystery dramas ranked second with an average rating of 12.5, while comedy dramas ranked third with an average rating of 10.3. Lowest rated single program was a quiz show which Nielsen rated 2.2.

Among the three types of daytime programs charted by Nielsen, adult serials had the highest average rating, 5.9, and also the highest and lowest individual program ratings, 8.1 and 1.4. Juvenile programs on the average were rated 3.7, daytime quizzes 3.9.

On a cost-per-listener basis, daytime serials are by far the most efficient vehicle for the advertiser, according to Nielsen calculations, which show this type of program reaching on the average 628 homes per dollar spent for time and talent. One program of this class reached 865 homes per dollar and even the lowest of the 28 daytime serials included in this report reached 200 homes per dollar. This seems to be a good explanation of the widespread use of this program class by advertisers wanting

(Continued on page 31)

A NEW VOICE IN NORTHERN OHIO

1260 kc



5000 WATTS
DAY and NIGHT

1515 Euclid Ave.

Cleveland's OK Station

Memo

Call

Frazier & Peter

for exploratory

conference

Re-our problems



PRIVATE - CONFIDENTIAL MANAGEMENT CONSULTANTS

This is our fifth year of pioneering in the field of television and radio management consultant service. We have served many clients, ranging from the largest to the smallest aural and television operations, with a great variety of problems offered for solution. In meeting those assignments we have gained current experience (supplementing forty-six years' cumulative radio experience of the two partners) enhancing our usefulness in solving the problems of an increasingly competitive business.

WHY WE CAN HELP

We have:

TIME—to study a client's problem uninterrupted by daily routine;

UNDERSTANDING—of the principles necessary to profitable operation and the great importance of the human element to the success of business enterprise;

EXPERIENCE—gained from serving many broadcasters in varied markets;

PERSPECTIVE—an interested, impartial attitude because of an outside point of view;

ABILITY—a highly developed aptitude for digging into problems, unearthing facts, analyzing and interpreting them;

COMPARATIVE KNOWLEDGE—of what has happened in similar situations in other stations;

INDEPENDENCE—that enables us to say plainly from the outside what cannot always be said safely from within;

TECHNIQUE—an ability to work quickly and effectively within a client's organization without disturbing either the personnel or their work;

FREEDOM—from suspicion of prejudice or favoritism due to our completely detached position as professional men.

WHAT WE DO

The most commonly encountered assignments are as follows:

- Station Management and Organizational Studies
- Station Appraisal
- Preparation of Exhibits for Presentation to Federal Agencies and the Courts
- Market Data Reports
- Program Analysis

- Market Evaluations
- Rate Recommendations
- Cost and Profit Studies
- Expert Testimony before Federal Agencies and the Courts
- Program Policy Studies
- Traffic Control System

FRAZIER & PETER

Television and Radio Management Consultants

Suite 724 Bond Building

Washington 5, D. C.

NAtional 2173

correction,
Mr. Crosby!

NBC with its enormously popular entertainers and magnificent coverage draws only about 1,500,000 letters a year. The Mutual Broadcasting System...gets 3,500,000. This is because Mutual is loaded with controversial commentators who pull a lot of mail, and also because Mutual has a habit of asking people to tear off a box top and send it in with a dime.

—JOHN CROSBY IN COLLIER'S FOR DECEMBER 10, 1949

Provocative programming? Indeed yes—but that boxtop-asking habit is not ours. It's our *sponsors'*, and they find it enormously sales-productive.

We guess a prime reason this network is so much more response-able than others is the way our 500 stations—300 of them being the only network voice in town—make a neighborhood of a nation.



AUDIENCE ANALYSIS

(Continued from page 28)

to reach the American housewife with their selling messages.

Mystery dramas on the average delivered 301 homes per dollar, Nielsen reports. Daytime kid shows

averaged 282 and daytime quiz shows 279 homes per dollar; variety musical shows 234, general drama 226, evening quiz and audience participation shows 218, comedy dramas 193, variety comedy 181, popular music 108, concert music 95.

No summary of last year's pro-

gram trends would be complete without some mention of giveaway programs. During 1949 these shows became so numerous and their sponsors grew so lavish in the amount of money and merchandise distributed to lucky contestants that the FCC decided to call a halt to them as violations of the federal lottery laws. Giveaways are still on the air, with the Commission

(Continued on page 542)

Chart IX

VARIATIONS IN PROGRAM PREFERENCE - PHONE vs. NONE - PHONE HOMES, STOP THE MUSIC, TOTAL U.S. AVERAGE AUDIENCE BASIS MAY 1949

COMPOSITE PHONE HOMES NON-PHONE HOMES

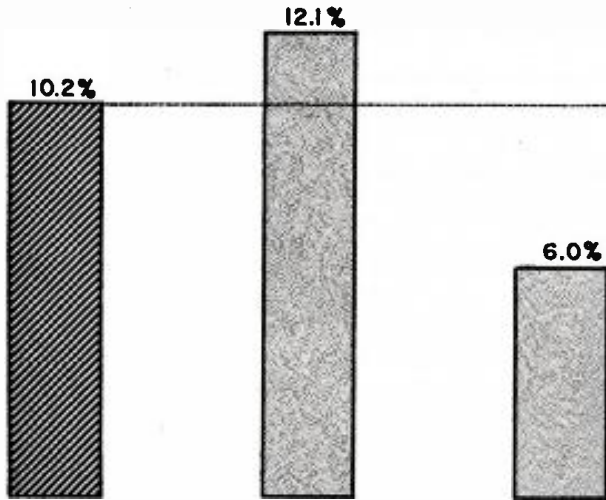

Evans Associates Co.	113,818
Batten, Barton, Durstine & Osborn, Inc.	100,528
St. Georges & Keyes, Inc.	70,980
Birmingham, Castleman & Pierce, Inc.	67,070
Raymond Spector, Inc.	63,048
Ewell & Thurber Associates	62,774
Tracy-Locke Co., Inc.	49,939
Ralph H. Jones, Co.	45,960
Van Sant, Dugdale & Co., Inc.	44,405
William Esty Co., Inc.	32,860
Crook Advertising Agency	30,740
Weston-Barnett, Inc.	23,554
Klinger Advertising Corp.	20,488
Henri, Hurst & McDonald, Inc.	18,759
Charles W. Hoyt Co., Inc.	14,560
J. M. Mathes, Inc.	11,352

Mutual Billings

(Continued from page 22)

McCann-Erickson, Inc.	1,066,566
Sherman & Marquette, Inc.	956,559
Neal D. Ivey Co.	919,124
Gardner Advertising Co., Inc.	864,449
Benton & Bowles, Inc.	757,195
Kudner Agency, Inc.	688,810
Grey Advertising Agency, Inc.	580,802
Roy S. Durstine, Inc.	566,737
William H. Weintraub Co., Inc.	561,593
Grant Advertising, Inc.	490,180
Sullivan, Stauffer, Colwell & Bayles, Inc.	475,537
Erwin, Wasey & Co., Inc.	461,612
Ruthrauff & Ryan, Inc.	458,978
Gotham Advertising Co., Inc.	428,589
Aubrey, Moore & Wallace, Inc.	402,204
Hill Blackett & Co.	387,239
Brown Radio Productions, Inc.	360,302
Walker & Downing	355,345
Stanley G. Boynton Advertising Co.	322,481
Western Advertising, Inc.	299,130
Maxon, Inc.	278,918
H. B. Humphrey Co.	221,478
Hoge, Huber & Sons	211,203
O'Neil, Larson & McMahon	172,332
Dorland, Inc.	155,917
Glenn-Jordan-Stoetzel, Inc.	141,668
Harry B. Cohen Advertising Co.	122,688

Brook, Smith, French & Dorrance, Inc.	8,811
Sorensen & Co.	8,800
Counselors Advertising Co.	5,876
Furman & Feiner Co., Inc.	5,801
Raymond R. Morgan Co.	5,421
Smith, Bull & McCreery, Inc.	5,340
Leo Burnett Co., Inc.	4,518
Brooks & Co.	4,096
Buchanan & Co., Inc.	2,904
Charles Schlaifer & Co., Inc.	1,371
Total	\$18,071,695

Note: December billings estimated

By Product Classifications

Foods & Food Beverages	\$4,548,605
Cigars, Cigarettes & Tobacco	3,325,653
Drugs & Toilet Goods	3,251,353
Jewelry & Silverware	1,506,165
Religious	1,485,435
Building Materials	1,211,655
Confectionary & Soft Drinks	545,404
Laundry & Household Supplies	495,601
Finance & Insurance	373,394
Paints & Hardware	348,998
Clothing & Dry Goods	255,633
Stationery & Publishers	239,066
Automobiles & Accessories	175,169
Miscellaneous	143,654
Lubricants, Petroleum & Fuel	83,584
Sporting Goods	62,774
Radio & Phonographs	20,152
Total	\$18,071,695

ROCHESTER, NEW YORK

Interested in the Rochester, N. Y. market? We think you're using good judgment. Business prosperity and consumer income here flow from an unusually wide variety of skilled industry, such as Eastman Kodak, Bausch and Lomb, Taylor Instrument, Hickey-Freeman, Bond Clothes, etc. Plus a very rich surrounding farm country. Your choice of any form of short or long-term air campaign in this rich area will lead you inevitably to the Stromberg-Carlson stations, WHAM and WHAM-TV. WHAM is Rochester's oldest, leading station. It is upstate New York's only 50,000-watt, clear channel outlet—the only Rochester station with primary coverage of 17 rich counties and strong secondary coverage far beyond that. WHAM-TV is Rochester's only television station; affiliated with all four networks. Tower location, signal and coverage are all unusually good. Ask the GEORGE P. HOLLINGBERRY CO., in New York, Chicago, Atlanta or San Francisco for complete details.

National Association of Broadcasters: 1950 Officers and Committees

Headquarters Office: 1771 N. Street, N.W., Washington 6, D. C. Phone: DEcatur 9300

Executive Staff of NAB

Justin Miller, *President*
 C. E. Arney Jr., *Secretary-Treasurer*

Administrative Staff
 Kenneth H. Baker, *Director, Research Department*
 Charles A. Batson, *Assistant Director, Broadcast Advertising Bureau*
 James Dawson, *Assistant Director, Public Affairs Department*
 Richard P. Doherty, *Director, Employe-Employer Relations Department*
 Bette Doolittle, *Acting Executive Secretary Assn. of Women Broadcasters*
 Donald S. Farver, *Auditor*
 Ralph W. Hardy, *Director, Radio Division (AM-FM)*
 Lee Hart, *Assistant Director, Broadcast Advertising Bureau*
 Richard W. Jencks, *Attorney*
 Robert M. McGredy, *Assistant Director, Broadcast Advertising Bureau*
 Neal McNaughten, *Director, Engineering Department*
 G. Emerson Markham, *Director, Television Division*
 Maurice B. Mitchell, *Director, Broadcast Advertising Bureau*
 Donald E. Petty, *General Counsel*
 Everett E. Revercomb, *Assistant Treasurer*
 Robert K. Richards, *Director, Public Affairs Department*
 Edward L. Sellers, *in Charge of FM, Radio Division*
 Arthur C. Stringer, *Director of Special Services*
 C. Meryl Sullivan, *Assistant Director, Research Department*
 Charles H. Tower, *Assistant Director, Employe-Employer Relations Department*
 Vincent Wasilewski, *Attorney*

Board of Directors

Harold E. Fellows, *WEEI Boston*
 (District 1: Connecticut, Maine, Massachusetts, New Hampshire, Rhode Island, Vermont)
 Michael R. Hanna, *WHCU Ithaca, N. Y.*
 (District 2: New York, New Jersey)
 George D. Coleman, *WGBI Scranton, Pa.*
 (District 3: Delaware, Pennsylvania, Maryland)
 Campbell Arnoux, *WTAR Norfolk, Va.*
 (District 4: District of Columbia, North Carolina, South Carolina, Virginia, West Virginia)
 Allen M. Woodall, *WDAK Columbus, Ga.*
 (District 5: Alabama, Florida, Georgia, Puerto Rico)
 H. W. Slavick, *WMC Memphis*
 (District 6: Arkansas, Louisiana, Mississippi, Tennessee)

Presidents of NAB

Eugene F. McDonald Jr. (WJAZ) 1923-1925
 Frank W. Elliott (WHO) 1925-1926
 Earle C. Anthony (KFI) 1926-1928
 William S. Hedges (WMAQ) 1928-1930
 Walter J. Damm (WTMJ) 1930-1931
 *Harry Shaw (WMT) 1931-1932
 Alfred J. McCosker (WOR) 1932-1934
 J. Truman Ward (WLAC) 1934-1935
 Leo J. Fitzpatrick (WJR) 1935-1936
 *Charles W. Myers (KOIN) 1936-1937
 John Elmer (WCBM) 6-23-37-2-16-38
 Mark Ethridge (WHAS) 3-30-38-7-1-38
 Neville Miller 7-1-38-3-1-44
 J. Harold Ryan (WSPD) 4-15-44-9-30-45
 Justin Miller 10-1-45—

* Deceased

Gilmore N. Nunn, *WLAP Lexington, Ky.*
 (District 7: Kentucky, Ohio)
 Harry M. Bitner Jr., *WFBM Indianapolis*
 (District 8: Indiana, Michigan, excluding the counties of Otonagon and Gogebic)
 Charles C. Caley, *WMBD Peoria*
 (District 9: Illinois; Wisconsin, excluding the counties of LaCrosse, Monroe, Juneau, Adams, Marquette, Waushara, Portage, Wood, Jackson, Trempealeau, Buffalo, Pepin, Pierce, St. Croix, Dunn, Chippewa, Eau Claire, Clark, Marathon, Lincoln, Taylor, Rusk, Barron, Polk, Burnett, Washburn, Sawyer, Price, Oneida, Vilas, Iron, Ashland, Bayfield and Douglas)
 William B. Quarton, *WMT Cedar Rapids*
 (District 10: Iowa, Missouri, Nebraska)
 John F. Meagher, *KYSM Mankato, Minn.*
 (District 11: Minnesota; North Dakota; South Dakota, excluding the counties of Fall River, Shannon, Bennett, Todd, Mellette, Waushabaugh, Washington, Custer, Pennington, Jackson, Jones, Stanley, Haakon, Meade, Lawrence, Butte, Harding, Perkins, Ziebach, Armstrong, Dewey and Corson; Wisconsin including the counties of LaCrosse, Monroe, Juneau, Adams, Marquette, Waushara, Portage, Wood, Jackson, Trempealeau, Buffalo, Pepin, Pierce, St. Croix, Dunn, Chippewa, Eau Claire, Clark, Marathon, Lincoln, Taylor, Rusk, Barron, Polk, Burnett, Washburn, Sawyer, Price, Oneida, Vilas, Iron, Ashland, Bayfield and Douglas; Michigan, including the counties of Ontonagon and Gogebic)
 Robert Enoch
 (District 12: Kansas, Oklahoma)
 Clyde W. Rembert, *KRLD Dallas*
 (District 13: Texas)
 Hugh B. Terry, *KLZ Denver*
 (District 14: Colorado, Idaho, New Mexico, Utah, Wyoming, Montana, South Dakota, including the counties of Fall River, Shannon, Bennett, Todd, Mellette, Waushabaugh, Washington, Custer,

Pennington, Jackson, Jones, Stanley, Haakon, Meade, Lawrence, Butte, Harding, Perkins, Ziebach, Armstrong, Dewey and Corson)

Glenn Shaw, *KLX Oakland, Calif.*
 (District 15: California, excluding the counties of San Luis Obispo, Kern, San Bernardino, Santa Barbara, Ventura, Los Angeles, Orange, Riverside, San Diego and Imperial; Nevada and Hawaii)
 Calvin J. Smith, *KFAC Los Angeles*
 (District 16: Arizona; California, including the counties excepted in District 15)
 Harry R. Spence, *KXRO Aberdeen, Wash.*
 (District 17: Alaska, Oregon, Washington)

Directors at Large

Large Stations

Howard Lane, *WJJD Chicago*
 James D. Shouse, *WLW Cincinnati*

Medium

G. Richard Shafto, *WIS Columbia, S. C.*
 Kenyon Brown, *KWFT Wichita Falls, Texas*

Small

Clair R. McCollough, *WGAL Lancaster, Pa.*
 Merrill Lindsay, *WSOY Decatur, Ill.*

FM Stations

Everett L. Dillard, *KOZY Kansas City*
 Frank U. Fletcher, *WARL-FM Arlington, Va.*

Television Stations

Robert D. Swezey, *WDSU-TV New Orleans*
 Eugene S. Thomas, *WOIC (TV) Washington*

NAB BOARD SUB-COMMITTEES

1949-1950

By-Laws

Hugh B. Terry, *KLZ Denver, Chairman*; G. Richard Shafto, *WIS Columbia*; Allen M. Woodall, *WDAK Columbus.*

Convention Sites and Policy

Howard Lane, *WJJD Chicago, Chairman*; James D. Shouse, *WLW Cincinnati*; Charles C. Caley, *WMBD Peoria, Ill.*

Finance

John F. Meagher, *KYSM Mankato, chairman*; Harold E. Fellows, *WEEI Boston*; Clyde W. Rembert, *KRLD Dallas*; William B. Quarton, *WMT Cedar Rapids, Iowa*; Harry R. Spence, *KXRO Aberdeen, Wash.*

Membership

Gilmore N. Nunn, *WLAP Lexington, Ky., chairman*; H. W. Slavick, *WMC Memphis*; Merrill Lindsay, *WSOY Decatur, Ill.*

NAB Committees

(Editor's Note: Committee appointments were incomplete as the 1950 Yearbook went to press. Following is a partial list.)

RADIO COMMITTEE—Simon R. Goldman, *WJTN Jamestown, N. Y., chairman*; Walter W. Wagstaff, *KIDO Boise, Idaho*; William B. Quarton, *WMT Cedar Rapids, Ia.*; Robert T. Mason, *WMRN Marion, Ohio*; Armand Hunter, *WFIL Philadelphia*; Lester W. Lindow, *WFDF Flint, Mich.*; Kenyon Brown, *KWFT Wichita Falls,*

Tex.; Owen F. Uridge, *WQAM Miami*; Glenn Shaw, *KLX Oakland.* Alternates—Hugh B. Terry, *KLZ Denver*; Lawrence W. McDowell, *KFOX Long Beach, Calif.*

TELEVISION COMMITTEE—Eugene S. Thomas, *WOIC (TV) Washington, chairman*; Robert D. Swezey, *WDSU-TV New Orleans*; George M. Burbach, *KSD-TV St. Louis*; John M. Outler Jr., *WSB-TV Atlanta*; Hugh M. Beville, *WNBT (TV) New York*; Ewell K. Jett, *WMAR-TV Baltimore*; Donald Tatum, *KTSL Los Angeles*; Dwight Martin, *WLWT (TV) Cincinnati.* Alternates—Roger W.

Clipp, *WFIL-TV Philadelphia*; B. J. Rowan, *WRGB (TV) Schenectady*; J. Gorman Walsh, *WDEL-TV Wilmington, Del.*

BROADCAST ADVERTISING COMMITTEE—William B. Ryan, *KFI Los Angeles, chairman*; Gordon Gray, *WIP Philadelphia*; F. C. Sowell, *WLAC Nashville*; Howard Lane, *WJJD Chicago*; Frank U. Fletcher, *WARL Arlington, Va.* Alternate—Robert Enoch.

UNAFFILIATED STATIONS COMMITTEE—Ted Cott, *WNEW New York, chairman*; Melvin Drake, *WDGY Minneapolis*; Lee W. Jacobs, *KBKR Baker, Ore.*

Patt McDonald, *WJHM Memphis*; Glenn Shaw, *KLX Oakland.* Alternates—Robert Maynard, *WSVS Crewe, Va.*; Ben Strouse, *WWDC Washington.*

ENGINEERING COMMITTEE—A. James Ebel, *WMBD Peoria, Ill., chairman*; John H. DeWitt, *WSM Nashville*; Oscar C. Hirsch, *KFVS Cape Girardeau, Mo.*; Merle Lindsay, *WSOY Decatur, Ill.* Alternates—Jack R. Poppele, *WOR New York*; K. W. Pyle, *KFBI Wichita.* Network Advisory Members—Frank Marx, *ABC*; O. B. Hanson, *NBC*; Earl Johnson, *MBS.*



That's
coverage

In this area, WLW reached four fifths of all the 3,644,800 radio homes between 6 a.m. and midnight.* *That's coverage!*

Of these homes, WLW in four weeks . . .
 reaches 65.8% between 6 AM and 6 PM
 reaches 74.5% between 6 PM and Midnight
 reaches 80.7% between 6 AM and Midnight

THAT'S COVERAGE!

For further information, contact any of these WLW Sales Offices . . .
 140 West 9th St., Cincinnati 2, Ohio
 360 N. Michigan, Chicago 1, Ill.
 630 Fifth Avenue, New York 20, N. Y.
 6381 Hollywood Blvd., Hollywood 28, Calif.

* Nielsen Radio Index February-March, 1949

when you want
coverage you want



CROSLY BROADCASTING CORPORATION



That's dominance



Of the 3,644,800 radio homes in this area, WLW reached 80.7% between 6 a.m. and midnight. *That's coverage.*

Of the 258 stations heard in WLW-land, The Nation's Station received *one-sixth* of all listening to all stations. During a 4-week's period*, WLW's share was . . .

- 15.6% between 6 AM and 6 PM
- 18.1% between 6 PM and Midnight
- 16.6% between 6 AM and Midnight

AND THAT'S DOMINANCE!

Write or call any of the following WLW Sales Offices for complete information:

140 West 9th St., Cincinnati 2, Ohio
 360 N. Michigan, Chicago 1, Ill.
 630 Fifth Avenue, New York 20, N. Y.
 6381 Hollywood Blvd., Hollywood 28, Calif.

*Nielsen Radio Index February-March, 1949

when you want
dominance you want



CROSLY BROADCASTING CORPORATION

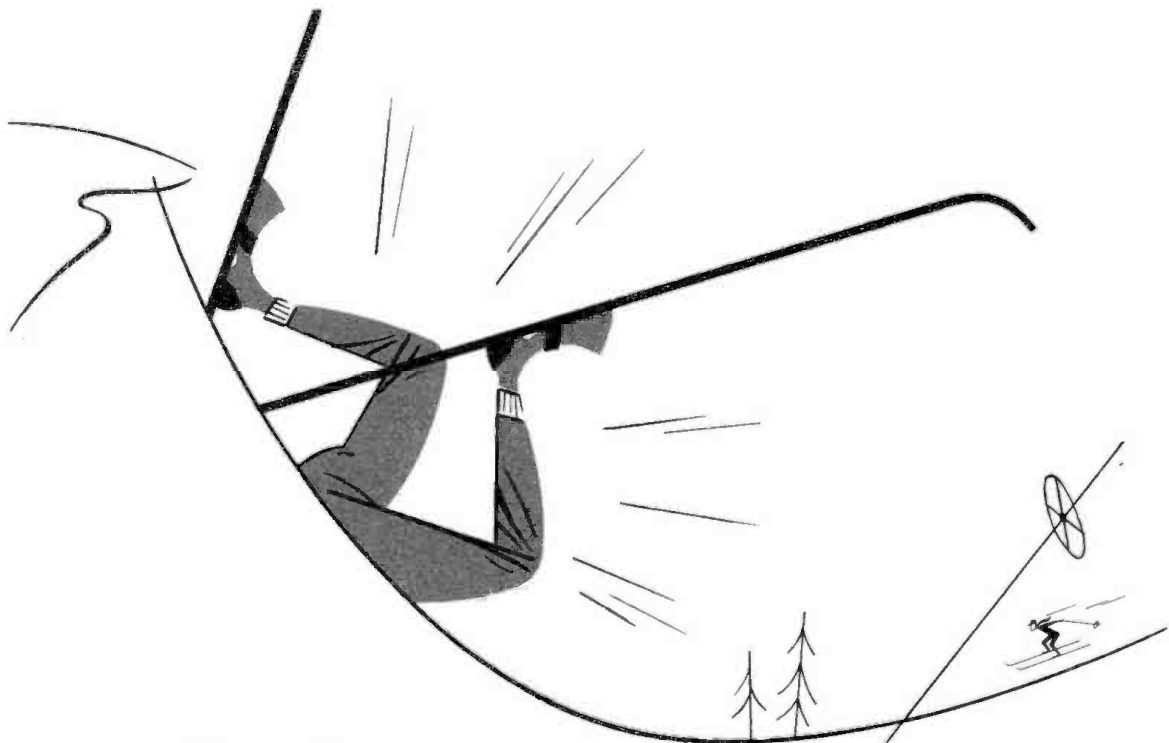

That's penetration



Among all of the 258 stations heard within the WLW Merchandise-Able Area, The Nation's Station received five and one-half hours of *all* listening during an average week between 6 AM and Midnight—as compared to an average of less than one hour to the nine major competitive stations.*

THAT'S PENETRATION!

Listeners were tuned to...

WLW	Average of Nine Major Competitive Stations
184 minutes—6 AM to 6 PM	—30 minutes
143 minutes—6 PM to Midnight	—22 minutes
327 minutes—6 AM to Midnight	—52 minutes

WE REPEAT, that's penetration!

Complete information may be obtained at any of the WLW Sales Offices:

- 140 West 9th St., Cincinnati 2, Ohio
- 630 Fifth Avenue, New York 20, N. Y.
- 360 North Michigan, Chicago 1, Ill.
- 6381 Hollywood Blvd., Hollywood 28, Calif.

*Nielsen Radio Index, February - March, 1949

when you want
penetration you want



CROSLY BROADCASTING CORPORATION



That's impact

Small wonder so many new products and advertising campaigns are launched over WLW. For its over-all performance is remarkable.

In four weeks, The Nation's Station reached **FOUR-FIFTHS—80.7%** — of all the 3,644,800 radio homes within the WLW Merchandise-Able Area between 6 a.m. and midnight.* **That's coverage!**

Of all listening among all radio homes between 6 a.m. and midnight during an average week, WLW received six times **MORE** listening than the average of the nine major competitors.* **That's penetration!**

Of the 258 stations heard in WLW-land, The Nation's Station received **ONE-SIXTH—16.6%** — of all listening to all stations.* **That's dominance!**

And when you put coverage, penetration and dominance together... **THAT'S IMPACT!**

If you are planning to launch a new product or advertising campaign, talk it over first with The Nation's Station. Write or call any of the following WLW Sales Offices:

140 West 9th St., Cincinnati 2, Ohio
 360 N. Michigan, Chicago 1, Ill.
 630 Fifth Avenue, New York 20, N. Y.
 6381 Hollywood Blvd., Hollywood 28, Calif.

*Nielsen Radio Index, February-March, 1949

when you want
impact you want



CROSLY BROADCASTING CORPORATION

NAB STANDARDS OF PRACTICE FOR AMERICAN BROADCASTERS

(Effective July 1, 1948)

THE BROADCASTERS' CREED

We Believe:

That American Broadcasting is a living symbol of democracy; a significant and necessary instrument for maintaining freedom of expression, as established by the First Amendment to the Constitution of the United States;

That its influence in the arts, in science, in education, in commerce and upon the public welfare, generally, is of such magnitude that the only proper measure of its responsibility is the common good of the whole people;

That it is our obligation to serve the people in such manner as to reflect credit upon our profession and to encourage aspiration toward a better estate for all mankind; by making available to every person in America, such programs as will perpetuate the traditional leadership of the United States in all phases of the broadcasting art;

That we should make full and ingenious use of man's store of knowledge, his talents and his skills and exercise critical and discerning judgment concerning all broadcasting operations to the end that we may, intelligently and sympathetically:

- ¶ Observe the proprieties and customs of civilized society;
- ¶ Respect the rights and sensitivities of all people;
- ¶ Honor the sanctity of marriage and the home;
- ¶ Protect and uphold the dignity and brotherhood of all mankind;
- ¶ Enrich the daily life of the people through the factual reporting and analysis of the news, and through programs of education, entertainment and information;
- ¶ Provide for the fair discussion of matters of general public concern; engage in works directed toward the common good; and volunteer our aid and comfort in times of stress and emergency;
- ¶ Contribute to the economic welfare of all, by expanding the channels of trade; by encouraging the development and conservation of natural resources; and by bringing together the buyer and seller through the broadcasting of information pertaining to goods and services.

Therefore:

As a guide for the achievement of our purposes, we subscribe to the following Standards of Practice*:

* Standards for broadcasting can never be final or complete. Broadcasting is a creative art, still in the process of development, and as such it must always seek new ways to achieve greater advances. Therefore, any standards promulgated must be subject to change.

PROGRAM STANDARDS

News

News reporting should be factual, fair and without bias. Commentary and analysis should be clearly identified as such.

Good taste should prevail in the selection and handling of news. Morbid, sensational or alarming details not essential to the factual report, especially in connection with stories of crime or sex, should be avoided. News should be broadcast in such a manner as to avoid panic and unnecessary alarm.

Broadcasters should exercise due care in their supervision of content, format, and presentation of news broadcasts originated by them; and in their selection of newscasters, commentators and analysts.

Broadcasters should exercise particular discrimination in the acceptance and placement of advertising in news programs. Such advertising should be appropriate to the program, both as to content and presentation, and should be distinctly set apart from the news content.

In programs of news, news commentary and news analysis which are less than ten minutes in length, no more than two commercial announcements should be used and they should be given at or near the beginning and end of the program.

Agricultural and market news-casts should be governed by the same general standards applicable to news broadcasts.

Political Broadcasts**

Political broadcasts, or the dramatization of political issues designed to influence an election, should, if accepted, be properly identified as such.

Public Affairs and Issues

A broadcaster, in allotting time for the presentation of public questions, including those of a controversial nature, should use his best efforts to insure fair presentation. Such time should be allotted with due regard to all other elements of balanced program schedules, and to the degree of interest on the part of the public in the questions to be presented.

Discussions of controversial public issues should be presented on programs specifically intended for that purpose, and they should be clearly identified as such.

The presentation of controversial public issues should be made by properly identified persons or groups.

Freedom of expression of opinion in broadcasts of controversial

** Because of the present confusion concerning the laws with respect to political broadcasts, broadcasters are advised to consult their lawyers in all cases where they have the least doubt as to the proper method of handling.

public issues should be carefully maintained, but the right should be reserved to refuse them for non-compliance with laws such as those prohibiting defamation and sedition.

Religious Programs

Broadcasting, which reaches men of all creeds simultaneously, should avoid attacks upon religion.

Religious programs should be presented respectfully and accurately, and without prejudice or ridicule.

Religious programs should be presented by responsible individuals, groups and organizations.

Religious programs place emphasis on broad religious truths, excluding the presentation of controversial or partisan views not directly or necessarily related to religion or morality.

Children's Programs

Children's programs should be based upon sound social concepts and should reflect respect for parents, law and order, clean living, high morals, fair play and honorable behavior.

They should convey the commonly accepted moral, social and ethical ideals characteristic of American life.

They should contribute to the healthy development of personality and character.

There should be no appeals urging children to purchase the product in order to keep the program on the air, or which for any purpose encourage children to enter strange places or to converse with strangers.

Educational

Every radio program performs an educational function. Broadcasters should recognize the great responsibilities thus imposed, in planning their programs, to insure the most beneficial service to all listeners.

Broadcasters should cooperate with educators and with educational groups in developing improved techniques of broadcasting, as well as those processes of education best calculated to produce expert and skillful personnel.

Crime and Mystery Programs

In determining the acceptability of any program containing any element of crime, horror or mystery, due consideration should be given to the possible effect on all members of the family.

If the techniques and methods of crime are presented it should be done in such a way as not to encourage imitation; criminals should be punished, specifically or by implication; and programs which tend to make the commission of

crime attractive should not be permitted.

Such programs should avoid the following subject matter:

¶ Detailed presentation of brutal killings, torture or physical agony, horror, the use of supernatural or climatic incidents likely to terrify or excite unduly.

¶ Episodes involving the kidnapping of children.

¶ Sound effects calculated to mislead, shock or unduly alarm the listener.

¶ Disrespectful portrayal of law enforcement; and characterization of officers of the law as stupid or ridiculous.

¶ Suicide as a satisfactory solution to any problem.

General

Sound effects and expressions characteristically associated with news broadcasts (such as "bulletin," "flash," etc.) should be reserved for announcement of news, and the use of any deceptive techniques in connection with fictional events and non-news programs should be unacceptable.

When plot development requires the use of material which depends upon physical or mental handicaps it should be used in such a way as to spare the sensibilities of sufferers from similar defects.

The regular and recurrent broadcasting, in advance of sports events, of information relating to prevailing odds, the effect of which could be expected to encourage gambling, should not be permitted.

Simulation of court atmosphere or use of the term "Court" in a program title should be done only in such a manner as to eliminate the possibility of creating the false impression that the proceedings broadcast are vested with judicial or official authority.

In cases of programs broadcast over multiple station facilities, the originating station should assume responsibility for conforming such programs to these Standards of Practice.

ADVERTISING STANDARDS

Advertising is the life blood of the free, competitive American system of broadcasting. It makes possible the presentation, to all the American people, of the finest programs of entertainment, information and culture.

(Continued on page 38)

STANDARDS OF PRACTICE

(Continued from page 37)

Diligence should be exercised to the end that advertising copy accepted for broadcasting complies with pertinent federal, state and local laws. Acceptance of advertising should be predicated upon such considerations as the integrity of the advertiser, the quality of the product, the value of service, and the validity of claims made.

In accepting advertising the broadcaster should exercise great care that he is not conveying to his audience information which is misleading, dangerous to health or character, distasteful or contrary to the proprieties and customs characteristic of his audience, or in violation of business and professional ethics.

Advertising copy should contain no claims intended to disparage competitors, competing products, or other industries, professions or institutions.

Advertising copy should contain no claims that a product will effect a cure.

Good taste should always govern the content, placement and presentation of announcements. Disturbing or annoying sound effects and devices, blatant announcing and over-repetition should be avoided.

Time Standards for Advertising Copy

As a guide to the determination of good broadcast advertising practice, the time standards for advertising copy are established as follows:

The maximum time to be used for advertising, allowable to any single sponsor, regardless of type of program, should be:

Between 6:00 p.m. and 11:00 p.m.	
5 minute programs	1:00
10 minute programs	2:00
15 minute programs	2:30
25 minute programs	2:50
30 minute programs	3:00
45 minute programs	4:30
60 minute programs	6:00

All Other Hours

5 minute programs	1:15
10 minute programs	2:10
15 minute programs	3:00
25 minute programs	4:00
30 minute programs	4:15
45 minute programs	5:45
60 minute programs	7:00

The time standards allowable to a single advertiser do not affect the established practice of allowance for station breaks between programs.

All multiple sponsorship or announcement programs, except as hereinafter provided, are subject to the limitation of a maximum of three minutes of advertising per fifteen minute segment, excluding station breaks. Such programs of half hour, three-quarter hour and hour duration are subject to appropriate multiples of that limitation.

Recognizing that such programs as shopping guides, market information, rural news, and the like render a definite service to the listening public; time standards for such programs may be waived for a total of one hour a broadcast day, but care should be exercised to preserve proper program balance in their distribution.

While any number of products may be advertised by a single sponsor within the specified time stand-

ards, advertising copy for these products should be presented within the framework of the program structure. Accordingly the use on such programs of simulated spot announcements which are divorced from the program by preceding the introduction of the program itself, or by following its *apparent* sign-off should be avoided. To this end the program itself should be announced and clearly identified *before* the use of what have been known as "cow-catcher" announcements and the program should be signed off *after* the use of what have been known as "hitch-hike" announcements.

Any casual reference in a program to another's product or service under any trade name, or language sufficiently descriptive to identify it, should, except for normal guest identifications, be avoided. If used, it should be considered as advertising copy and, as such, a part of and included in the total time allowances as herein provided.

The placement of more than one commercial announcement between two commercial programs should not be permitted except in those instances when one of the two announcements is a sponsored time signal, weather report, station promotion or location announcement of not to exceed a total of ten seconds in length.

Contests

Any broadcasting designed to "buy" the radio audience, by requiring it to listen in hope of reward, rather than for the quality of its entertainment should be avoided.

Contests should offer the opportunity to all contestants to win on

the basis of ability and skill, rather than chance.

All contest details, including rules, eligibility requirements, opening and termination dates should be clearly and completely announced or easily accessible to the listening public; and the winners' names should be released as soon as possible after the close of the contest.

When advertising is accepted which requests contestants to submit items of product identification or other evidence of purchase of product, reasonable facsimiles thereof should be made acceptable.

All copy pertaining to any contest (except that which is required by law) associated with the exploitation or sale of the sponsor's product or service, and all references to prizes or gifts offered in such connection should be considered a part of and included in the total time allowances as herein provided.

Premiums and Offers

Full details of proposed offers should be submitted to the broadcaster for investigation and approval before the first announcement of the offer is made to the public.

A final date for the termination of an offer should be announced as far in advance as possible.

If a consideration is required, the advertiser should agree to honor complaints indicating dissatisfaction with the premium by returning the consideration.

There should be no misleading descriptions or comparisons of any premiums or gifts which will distort or enlarge their value in the minds of the listeners.

Television Broadcasters Assn. Inc.

500 Fifth Ave., New York 18.

Telephone: LACKAWANNA 4-4788

Officers

J. R. Poppele, *President*
Will Baitin, *Secretary-Treasurer*
Paul Raibourn, *Ass't. Secretary-Treasurer*

Directors

Dr. Allen B. DuMont
Frank M. Russell
Paul Raibourn
Curtis W. Mason
J. R. Poppele
Robert E. Kintner
Robert Coe
Ernest B. Loveman
Lawrence W. Lowman

Membership

ACTIVE

Fort Industry Co.
General Electric Co.
Philco Radio and Television Corp.
National Broadcasting Co., (New York, Chicago and Washington television stations)

Farnsworth Television & Radio Corp.
RCA Victor Div. Radio Corp. of America
Allen B. DuMont Laboratories Inc.
Bamberger Broadcasting Service
WBSN-TV
Earle C. Anthony Inc.
Crosley Corp.
Television Productions Inc.
Balaban & Katz Corp.
Detroit News
ABC
CBS
Associated Broadcasters, Inc.
WDSU
News Syndicate Co.
Baltimore Sun
Milwaukee Journal Co.
Pulitzer Publishing Co.
Dallas Morning News
Hearst Radio Inc.
Jefferson Standard Broadcasting Co.
WKAL
Kansas City Star Co.
The Houston Post Co.
Twentieth Century Fox

AFFILIATE

Buchanan & Company Inc.

Cecil B. DeMille Productions
William Morris Agency
Weed & Co.
North American Phillips Co. Inc.
General Electric Co.
E. I. du Pont de Nemours & Co.
American Television Labs. Inc.
Federal Telephone & Radio Corp.
American Telephone & Telegraph Co.
Telicon Corp.
Belmont Electric Co.
Mutual Broadcasting Corp.
McCann-Erickson Inc.
The Katz Agency
Marschalk & Pratt Agency
C. E. Hooper Inc.

EDUCATIONAL

Yale University
Rutgers University
Syracuse University
Western Reserve University
Capitol Radio Engineering Institute
National Radio Institute
New York Technical Institute of N. J.
Television Workshop
Twin City TV Labs.

American Television Society

17 E. 45th St., New York 17

Officers

David Hale Halpern, *President*
Donald E. Hyndman, *Vice-President*
Reynold R. Kraft, *Secretary*
Archibald U. Braunfeld, *C.P.A., Treasurer*

Directors

Ralph B. Austrian
Halsey V. Barrett
Jerry Danzig
Charles J. Durban
E. P. H. James
George T. Shupert
Maurice E. Strieby

TYPE	TITLE	MINUTES	DAYS
BASIC NEWS	World News Roundup	15	Weekdays, 7 times Sunday, 6 times
	News of the World in Brief	5	Weekdays, 12 times Sunday, 11 times
	The World in a Nutshell	1	Weekdays, 7 times Sunday, 6 times
SPORTS	Speaking of Sports	5	Mon. through Saturday
	The Sports Lineup	5	Every day
	Great Moments in Sports	5	Mon. through Saturday
	Sizing Up Sports	15	Sunday
FOR WOMEN	In the Woman's World	5	Mon. through Saturday
	Women in the News	5	Mon. through Saturday
	Mainly for Women	5	Mon. through Friday
	Your Home	15	Sunday
HUMAN INTEREST	Names in the News	5	Mon. through Saturday
	Time Out	5	Mon. through Saturday
	In Your Neighborhood	5	Every day
	In Movieland	5	Mon. through Saturday
FARMING	On the Farm Front	5	Every day
	Daily Farm Market Survey	5	Mon. through Saturday
	Rural Roundup	5	Tues. through Saturday
COMMENTARY	Today's United Press Commentary	5	Every day
	Under the Capitol Dome	5 15	Mon. through Saturday Sunday
	Highlights of the Week's News	15	Sunday
	United Press Reporting	15	Sunday
BUSINESS & PROGRESS	Weekly Business Review	5	Saturday
	Tomorrow's Business	5	Friday or thereafter
	World of Tomorrow	10	Sunday

United Press News Programs for Radio

At the top teletype speed of a word a second, United Press 24-hour, coast-to-coast leased wires deliver every day to more than 1100 radio stations an average of 40 scheduled basic news programs and news features — plus hundreds of extra shows yearly of special seasonal and topical interest. Broadcasters sell U.P. programs to 200 kinds of sponsors. Your nearest United Press bureau is ready to supply further information.



Directory of RADIO AND TELEVISION STATION REPRESENTATIVES

With Lists of Stations Represented

List of stations supplied by each firm; dagger (†) indicates firm is also newspaper representative

ABC SPOT SALES

(American Broadcasting Company)

Ralph E. Dennis, Manager

New York—7 W. 66th St. Tel. Trafalgar 3-7000. Eastern Mgr.: Earl B. Salmon.
Chicago—20 N. Wacker Drive. Tel.: Delaware 5-1900. Mgr.: Roy McLaughlin.
Hollywood—6363 Sunset Blvd. Tel.: Hudson 2-3141. Mgr.: Amos Baron.
Detroit—Stroh Bldg. Tel.: Cherry 8321. Mgr.: Harold Christian.
San Francisco—155 Montgomery St. Tel.: Exbrook 6544. Mgr.: Vincent Francis.

STATION REPRESENTATIVES

(Continued from page 40)

†THE BRANHAM COMPANY

Chicago—360 N. Michigan Ave. Tel.: Central 6-5726. Mgr.: C. B. Peterson.
New York—230 Park Ave. Tel.: Murray Hill 6-1860. Mgr.: Joseph F. Timlin.
Atlanta—Rhodes-Haverty Bldg. Tel.: Walnut 3025. Mgr.: H. L. Ralls.
St. Louis—Arcade Bldg. Tel.: Chestnut 6192. Mgr.: J. E. Nicholson.
Dallas—First National Bank Bldg. Tel.: Riverside 4884. Mgr.: George Harding.
Detroit—General Motors Bldg. Tel.: Trinity 1-0440. Mgr.: H. A. Anderson.
Charlotte, N. C.—Commercial National Bank Bldg. Tel.: 8838. Mgr.: B. C. Finch.
San Francisco—5 Third St. Tel.: Garfield 1-6740. Mgr.: G. D. Close.
Los Angeles—2978 Wilshire Blvd. Tel.: Dunkirk 8-8158. Mgr.: Chet Doyle.
Memphis—Sterick Bldg. Tel.: 8-2344. Mgr.: Sidney Nichols.

Represents Radio

WABB Mobile, Ala.	WDEF Chattanooga, Tenn.	KAND Corsicana, Tex.
KTHS Hot Springs, Ark.	WTJS Jackson, Tenn.	KRLD Dallas
KFMB San Diego, Calif.	WNOX Knoxville, Tenn.	WCHS Charleston, W. Va.
WGFA Columbus, Ga.	WMC Memphis	WBLK Clarksburg, W. Va.
KWKH Shreveport, La.	KRNC Beaumont, Tex.	WSAZ Huntington, W. Va.
WRBC Jackson, Miss.	KWBU Corpus Christi, Tex.	WPAR Parkersburg, W. Va.
WCPO Cincinnati		

Represents TV

KFMB-TV San Diego, Calif.	WCPO-TV Cincinnati	WMCT(TV) Memphis
	WEWS(TV) Cleveland	KRLD-TV Dallas

HOWARD C. BROWN CO.

Hollywood 38—6059 Melrose Ave. Tel.: Hollywood 6045. Mgr.: Howard C. Brown.

Represents

3XY Melbourne, Australia

BULMER AND JOHNSON Inc.

Minneapolis 2—WCCO Bldg. Tel.: Lincoln 7017.

(Stations represented not reported)

BLRN-SMITH CO. Inc.

New York 18—19 W. 44th St. Tel.: Murray Hill 2-3124. Mgr.: C. Stanley Bailey.
Chicago 1—307 N. Michigan Ave. Tel.: Central 6-4437. Mgr.: John A. Toothill.
Los Angeles 15—Chamber of Commerce Bldg. Tel.: Richmond 5184. Mgr.: Clark Barnes.

Represents

WELL Battle Creek, Mich.	WHLN Harlan, Ky.	WKOP Binghamton, N. Y.
WMRF Lewistown, Pa.	WIBU Madison, Wis.	WAIM Anderson, S. C.
WLAB Albany, Ga.	WCNC Elizabeth City, N. C.	WENK Union City, Tenn.
WRUF Gainesville, Fla.	WGBC Greensboro, N. C.	WKBZ Muskegon, Mich.
WJSW Altoona, Pa.	WMFR High Point, N. C.	WKLA Ludington, Mich.
WEPM Martinsburg, W. Va.	WFTC Kinston, N. C.	KSON San Diego
WMRC Greenville, S. C.	WCBT Roanoke Rapids, N. C.	WWOK Flint, Mich.
KWJJ Portland, Ore.	WSTP Salisbury, N. C.	WDXI Jackson, Tenn.
WBAX Wilkes-Barre, Pa.	WMPD Wilmington, N. C.	WCAV Norfolk, Va.
WTRC Elkhart, Ind.	WCMW Canton, Ohio	WXGI Richmond, Va.
WFVA Fredericksburg, Va.	KFOX Long Beach, Calif.	KLX Oakland, Calif.
WSSV Petersburg, Va.	WBOC Salisbury, Md.	WWXL Peoria, Ill.
WCMA Corinth, Miss.	WJVA South Bend, Ind.	KCRG Cedar Rapids, Ia.
WOPi Bristol, Tenn.	WBGJ Atlanta	WFLK Lexington, Ky.
WOMI Owensboro, Ky.	WKYW Louisville	WFLB Fayetteville, N. C.
WLBj Bowling Green, Ky.	WROV Roanoke, Va.	WWPA Williamsport, Pa.
		WHAN Charleston, S. C.
		WATO Oak Ridge, Tenn.

†CAPPER PUBLICATIONS

New York City—420 Lexington Ave. Tel.: Lexington 2-3280. Mgrs.: Philip Zach, W. L. McKee

Chicago—180 N. Michigan Ave. Tel.: Central 8-5977. Mgr.: Frank Gaughen, Terry Hughes

Kansas City—21 W. Tenth St. Tel.: Harrison 4700. Mgr.: Joe Story.

San Francisco—Russ Bldg. Tel.: Douglas 5220. Mgr.: Fred Jameson.

Represents

KCKN Kansas City, Kan. WIBW Topeka, Kan.

HIL F. BEST

Detroit 26—131 W. Lafayette Blvd. Tel.: Woodward 2-7298.
Chicago 1—360 N. Michigan Ave. Tel.: State 2-4471.
New York 17—101 Park Ave. Tel.: Lexington 2-3783.
Los Angeles 48—521 N. La Cienega Blvd. Tel.: Crestview 5-2022.
San Francisco 4—544 Russ Bldg. Tel.: Douglas 2-4586.

Texas stations:

KRUN Ballinger	KULP El Campo	KOGT Orange
KFYB Bonham	KNAF Fredericksburg	KEYE Perryton
KNEL Brady	KSIJ Gladewater	KFRD Rosenberg
KSTB Breckenridge	KGVL Greenville	KCNY San Marcos
KBOR Brownsville	KGRI Henderson	KWED Sequin

CLARK-WANDLESS-MANN Inc.

New York 17—205 E. 42nd St. Tel.: Oregon 9-1575. Pres.: H. J. Wandless. V. P.: S. A. Mann
WKAQ San Juan, P. R. WKJB Mayaguez, P. R.

(Also represents stations in Argentina, Cuba, Panama, Colombia, Ecuador, Costa Rica, Honduras, Guatemala, Nicaragua, El Salvador, Uruguay)

CONTINENTAL RADIO SALES

Philadelphia—Drexel Bldg. 111 S. 5th St. Tel.: Lombard 3-0882. Mgr.: Roberta Butche.

New York—285 Madison Ave. Tel.: Lexington 2-2450. Mgr.: Miss Stephanie Matyas.
Chicago—228 N. LaSalle St. Tel.: Franklin 2-2095. Mgr.: Mrs. Ruth Olsen.

Represents

KXJK Forest City, Ark.	KVOB Alexandria, La.	WAND Canton, Ohio
WEBJ Brewton, Ala.	WJMB Brookhaven, Miss.	KYHW Altus, Okla.
WJYZ Greenville, Ala.	WRJW Picayune, Miss.	KWCD Chickasha, Okla.
KFFA Helena, Ark.	WJWJ Wyandotte, Mich.	KMUS Muskogee, Okla.
KELD Eldorado, Ark.	WAGM Presque Isle, Me.	KLPR Oklahoma City, Okla.
WJOI Florence, Ala.	WASA Havre de Grace, Md.	WKCA New Kensington, Pa.
KDRS Paragould, Ark.	KICA Clovis, N. M.	WKOK Sunbury, Pa.
WTBF Troy, Ala.	WTVG Fuquay Springs, N. C.	WLEB Lebanon, Pa.
KTYL Mesa, Ariz.	WSIC Statesville, N. C.	WPRR Mayaguez, P. R.
KICO, Calexico, Calif.	WBUV Lexington, N. C.	KGFX Pierre, S. D.
WTOR Torrington, Conn.	KCHS Hot Springs, N. M.	WTND Orangeburg, S. C.
KGFN Grass Valley, Calif.	WNNC Newton, N. C.	WJMM Lewisburg, Tenn.
WCFM Washington	WTSB Lumberton, N. C.	WHBT Hiram, Tenn.
WWVF Palatka, Fla.	WHKP Hendersonville, N. C.	WLAR Athens, Tenn.
WSWN Belle Glade, Fla.	WHPE High Point, N. C.	WHUB Cookeville, Tenn.
WDEC Americus, Ga.	WHED Washington, N. C.	KRBA Lufkin, Tex.
WMLT Dublin, Ga.	WGNM Gastonia, N. C.	KDWT Stamford, Tex.
WBLJ Dalton, Ga.	WFLB Fayetteville, N. C.	WIGM Medford, Wis.
WSGC Elberton, Ga.		
KRPL Moscow, Idaho		
KCLD Leavenworth, Kan.		

PIERCE W. COOK

(Associated with Ward-Griffith Co. Inc., Newspaper Representative)

Atlanta 22—Marietta S. Bldg. Tel.: Walnut 1231. Mgr.: Pierce W. Cook.

(Representation in the South only)

WALB Albany, Ga. WSTP Salisbury, N. C.

DONALD COOKE Inc.

New York 17—551 Fifth Ave. Tel.: Murray Hill 2-7270. Mgr.: Donald Cooke.
Chicago 1—228 N. La Salle St. Tel.: State 2-5086. Mgr.: Fred R. Jones.
Los Angeles 36—321 N. LaCienega Blvd. Tel.: Crestview 5-2022. Mgr.: Lee F. O'Connell.

Cleveland—402 Swetland Bldg. Mgr.: Howard McClenahan.
Detroit—1323 Penobscot Bldg. Mgr.: Charles J. Sheppard.

Represents Radio

KFVD Los Angeles	KOCS Ontario, Calif.	KROX Crookston, Minn.
KVSM San Mateo, Calif.	KPAS Banning, Calif.	KLAS Las Vegas, Nev.
KTIP Porterville, Calif.	KWTC Barstow, Calif.	WOKO Albany, N. Y.
KBOW Butte, Mont.	KRNO San Bernardino, Calif.	WWSC Glens Falls, N. Y.
WPAT Paterson, N. J.	KTED Laguna Beach, Calif.	WDRR Syracuse
WVAL Rome-Utica, N. Y.	KTLN Denver	WVOS Liberty, N. Y.
WBEK Knoxville, Wis.	KDZA Pueblo, Col.	WGYA Geneva, N. Y.
WOSH Oshkosh, Wis.	WINK Fort Myers, Fla.	WSTS Southern Pines, N. C.
WLOU Louisville	WWPB Miami	WHJB Greensburg, Pa.
WXRA Buffalo	WEAT Lake Worth, Fla.	WKPT Kingsport, Tenn.
WFFB Middletown, Ohio	WIMS Michigan City, Ind.	KPAC Port Arthur, Tex.
KASH Eugene, Ore.	KSEK Pittsburg, Kan.	KCTI Gonzales, Tex.
WCMB Harrisburg, Pa.	WBR Baton Rouge, La.	WAYB Waynesboro, Va.
WUSN Charleston, S. C.	WTAO Cambridge, Mass.	WHAW Weston, W. Va.
KBKI Alice, Tex.	KAUS Austin, Minn.	KBYR Anchorage, Alaska
KFRO Longview, Tex.		
WKAB Mobile, Ala.		

Represents TV

WKTU (TV) Utica, N. Y.

Canadian Stations

Quebec French Radio Group

CKMO Vancouver	CKOY Ottawa, Ont.	CHLO St. Thomas, Ont.
CJIB Vernon, B. C.	CKFI Fort Frances, Ont.	CKGB Timmins, Ont.
CKOK Penticton, B. C.	CJOY Guelph, Ont.	CKEY Toronto
CHUB Vancouver, B. C.	CJRL Kenora, Ont.	CKVL Verdun



Knox Larue



Dan Schmidt



Frank McCarthy



Warren Nelson



Frank Fitzpatrick



Harry Wise



Dick Hunter



Carlos McAbee



Ray Trotter



Bill Stark



Paul Senft

**“Moving products FASTER
is a specialty of ours!”**

So, think it over. If your sales are sluggish in important markets, think of the help these Hollingbery men can give you.

These men, averaging over six years with the Hollingbery Company, previously gained invaluable marketing and merchandising experience with such organizations as Westinghouse, NBC, The Chicago Tribune, McGraw-Hill, B.B.D. & O., International Harvester, and Hearst. Also both small and big market radio stations.

Nowhere will you find men better qualified to show you how to increase your sales with radio and television. To make your product move faster, ask a Hollingbery man—any one of these Hollingbery men.



Ed Spencer



Fred Hague

George P. Hollingbery Company



George P. Hollingbery

Offices in

CHICAGO, 307 N. Michigan Ave.

NEW YORK, Graybar Bldg., 420 Lexington Ave.

LOS ANGELES, 411 W. 5th Street

SAN FRANCISCO, Russ Bldg., 235 Montgomery Street

ATLANTA, Whitehead Bldg., 223 Peachtree Street

STATION REPRESENTATIVES

(Continued from page 40)

†THE BRANHAM COMPANY

Chicago—360 N. Michigan Ave. Tel.: Central 6-5726. Mgr.: C. B. Peterson.
 New York—230 Park Ave. Tel.: Murray Hill 6-1860. Mgr.: Joseph F. Timlin.
 Atlanta—Rhodes-Haverty Bldg. Tel.: Walnut 3025. Mgr.: H. L. Ralls.
 St. Louis—Arcade Bldg. Tel.: Chestnut 6192. Mgr.: J. E. Nicholson.
 Dallas—First National Bank Bldg. Tel.: Riverside 4884. Mgr.: George Harding.
 Detroit—General Motors Bldg. Tel.: Trinity 1-0440. Mgr.: H. A. Anderson.
 Charlotte, N. C.—Commercial National Bank Bldg. Tel.: 8839. Mgr.: B. C. Finch.
 San Francisco—5 Third St. Tel.: Garfield 1-6740. Mgr.: G. D. Close.
 Los Angeles—2978 Wilshire Blvd. Tel.: Dunkirk 8-8158. Mgr.: Chet Doyle.
 Memphis—Sterick Bldg. Tel.: 8-2344. Mgr.: Sidney Nichols.

Represents Radio

WABB Mobile, Ala.	WDEF Chattanooga, Tenn.	KAND Corsicana, Tex.
KTHS Hot Springs, Ark.	WTJS Jackson, Tenn.	KRLD Dallas
KFMB San Diego, Calif.	WNOX Knoxville, Tenn.	WCHS Charleston, W. Va.
WGFA Columbus, Ga.	WMC Memphis	WBLK Clarksburg, W. Va.
KWKH Shreveport, La.	KRIC Beaumont, Tex.	WSAZ Huntington, W. Va.
WRBC Jackson, Miss.	KWBU Corpus Christi, Tex.	WPARK Parkersburg, W. Va.
WCPO Cincinnati		

Represents TV

KFMB-TV San Diego, Calif.	WCPO-TV Cincinnati	WMCT(TV) Memphis
	WEWS(TV) Cleveland	KRLD-TV Dallas

HOWARD C. BROWN CO.

Hollywood 38—6059 Melrose Ave. Tel.: Hollywood 6045. Mgr.: Howard C. Brown.

Represents

3XY Melbourne, Australia

BULMER AND JOHNSON Inc.

Minneapolis 2—WCCO Bldg. Tel.: Lincoln 7017.

(Stations represented not reported)

BURN-SMITH CO. Inc.

New York 18—19 W. 44th St. Tel.: Murray Hill 2-3124. Mgr.: C. Stanley Bailey.
 Chicago 1—307 N. Michigan Ave. Tel.: Central 6-4437. Mgr.: John A. Toothill.
 Los Angeles 15—Chamber of Commerce Bldg. Tel.: Richmond 6184. Mgr.: Clark Barnes.

Represents

WELL Battle Creek, Mich.	WHLN Harlan, Ky.	WKOP Birmingham, N. Y.
WMRF Lewistown, Pa.	WIBU Madison, Wis.	WAIM Anderson, S. C.
WALB Albany, Ga.	WCNC Elizabeth City, N. C.	WENK Union City, Tenn.
WRUF Gainesville, Fla.	WKBZ Muskegon, Mich.	WKBJ Muskegon, Mich.
WFSW Altoona, Pa.	WGBG Greensboro, N. C.	WKLA Ludington, Mich.
WEPM Martinsburg, W. Va.	WMFR High Point, N. C.	KSON San Diego
WMRC Greenville, S. C.	WFTC Kinston, N. C.	WVOK Flint, Mich.
KWJJ Portland, Ore.	WCBT Roanoke Rapids, N. C.	WDXI Jackson, Tenn.
WBAX Wilkes-Barre, Pa.	WSTP Salisbury, N. C.	WCAV Norfolk, Va.
WTRC Elkhart, Ind.	WMFD Wilmington, N. C.	WXGI Richmond, Va.
WFVA Fredericksburg, Va.	WCMW Canton, Ohio	KLX Oakland, Calif.
WSSV Petersburg, Va.	KRWJ Long Beach, Calif.	WVXL Peoria, Ill.
WCMA Corinth, Miss.	WBEC Salisbury, Md.	KCRG Cedar Rapids, Ia.
WOPI Bristol, Tenn.	WJVA South Bend, Ind.	WVTK Lexington, Ky.
WOMI Owensboro, Ky.	WBGE Atlanta	WFLB Fayetteville, N. C.
WLBZ Bowling Green, Ky.	WKYV Louisville	WWPA Williamsport, Pa.
	WROV Roanoke, Va.	WHAN Charleston, S. C.
		WATO Oak Ridge, Tenn.

†CAPPER PUBLICATIONS

New York City—420 Lexington Ave. Tel.: Lexington 2-3280. Mgrs.: Philip Zach, W. L. McKee

Chicago—180 N. Michigan Ave. Tel.: Central 6-5977. Mgr.: Frank Gaughen, Terry Hughes

Kansas City—21 W. Tenth St. Tel.: Harrison 4700. Mgr.: Joe Story.

San Francisco—Russ Bldg. Tel.: Douglas 5220. Mgr.: Fred Jameson.

Represents

KCKN Kansas City, Kan. WIBW Topeka, Kan.

THOMAS F. CLARK. Inc.

New York 17—205 E. 42nd St. Tel.: Murray Hill 4-6317. Mgr.: Thomas F. Clark.

Chicago—35 E. Wacker Dr. Tel.: Central 6-1112. Mgr.: Paul Eisberry.

Represents

KOKO La Junta, Col.	KGIW Alamosa, Col.	WKLE Clanton, Ala.
KGEK Sterling, Col.	WRHP Tallahassee, Fla.	KVRH Salda, Col.
WMOG Brunswick, Ga.	WENC Whiteville, N. C.	WTKG Thomasville, Ga.
WMJM Cordele, Ga.	WOOB Anniston, Ala.	WKIC Hazard, Ky.
WRLC Toccoa, Ga.	WLSA Hammond, La.	WPAQ Mt. Airy, N. C.
WMGA Moultrie, Ga.	WSGM St. Genevieve, Mo.	WFLO Farmville, Va.
WSNJ Bridgeton, N. J.	KDSJ Deadwood, S. D.	KPHC Walsenburg, Col.
WNBZ Saranac Lake, N. Y.	KVVC Vernon, Tex.	WLDY Ladysmith, Wis.
WMBO Auburn, N. Y.	WGNC Gastonia, N. C.	WFRP Savannah, Ga.
WWRL Woodside, N. Y.	WSTS Southern Pines, N. C.	
WEGO Concord, N. C.		

CLARK-WANDLESS-MANN Inc.

New York 17—205 E. 42nd St. Tel.: Oregon 9-1575. Pres.: H. J. Wandless. V. P.:

S. A. Mann
 WKAQ San Juan, P. R. WKJB Mayaguez, P. R.

(Also represents stations in Argentina, Cuba, Panama, Colombia, Ecuador, Costa Rica, Honduras, Guatemala, Nicaragua, El Salvador, Uruguay)

CONTINENTAL RADIO SALES

Philadelphia—Drexel Bldg. 111 S. 5th St. Tel.: Lombard 3-0882. Mgr.: Roberta Butche.

New York—285 Madison Ave. Tel.: Lexington 2-2450. Mgr.: Miss Stephanie Matyas.

Chicago—228 N. LaSalle St. Tel.: Franklin 2-2095. Mgr.: Mrs. Ruth Olsen.

Represents

KXJK Forest City, Ark.	KVOB Alexandria, La.	WAND Canton, Ohio
WEBJ Brewton, Ala.	WJMB Brookhaven, Miss.	KYHW Altus, Okla.
WJYZ Greenville, Ala.	WRJW Picaune, Miss.	KWCD Chickasha, Okla.
KFFA Helena, Ark.	WJWJ Wyandotte, Mich.	KMUS Muskogee, Okla.
KELD Eldorado, Ark.	WAGM Presque Isle, Me.	KLPR Oklahoma City, Okla.
WJOI Florence, Ala.	WASA Havre de Grace, Md.	WKCA New Kensington, Pa.
KDRS Paragould, Ark.	KICA Clovis, N. M.	WKOK Sunbury, Pa.
WTEF Troy, Ala.	WVFG Fuquay Springs, N. C.	WLRB Lebanon, Pa.
KTYL Mesa, Ariz.	WSIC Statesville, N. C.	WPRA Mayaguez, P. R.
KICO Calexico, Calif.	WBUY Lexington, N. C.	KGFX Pierre, S. D.
WTOR Torrington, Conn.	KCHS Hot Springs, N. M.	WTND Orangeburg, S. C.
KGFN Grass Valley, Calif.	WNNC Newton, N. C.	WJLM Lewisburg, Tenn.
WCFM Washington	WTSB Lumberton, N. C.	WHBT Harriman, Tenn.
WWPF Palatka, Fla.	WHKP Hendersonville, N. C.	WLAB Athens, Tenn.
WSWN Belle Glade, Fla.	WHEP High Point, N. C.	WHUB Cookeville, Tenn.
WDEC Americus, Ga.	WSGC Elberton, Ga.	KRBA Lufkin, Tex.
WMLT Dublin, Ga.	WGNC Gastonia, N. C.	KDWT Stamford, Tex.
WBLJ Dalton, Ga.	WLB Fayetteville, N. C.	WIGM Medford, Wis.
WGC Elberton, Ga.		
KRPL Moscow, Idaho		
KCLD Leavenworth, Kan.		

PIERCE W. COOK

(Associated with Ward-Griffith Co. Inc., Newspaper Representative)

Atlanta 22—Marietta S. Bldg. Tel.: Walnut 1231. Mgr.: Pierce W. Cook.

(Representation in the South only)

WALB Albany, Ga. WSTP Salisbury, N. C.

DONALD COOKE Inc.

New York 17—551 Fifth Ave. Tel.: Murray Hill 2-7270. Mgr.: Donald Cooke.

Chicago 1—228 N. La Salle St. Tel.: State 2-5096. Mgr.: Fred R. Jones.

Los Angeles 36—321 N. LaCienega Blvd. Tel.: Crestview 5-2022. Mgr.: Lee F. O'Connell.

Cleveland—402 Swetland Bldg. Mgr.: Howard McClenahan.

Detroit—1223 Penobscot Bldg. Mgr.: Charles J. Sheppard.

Represents Radio

KFVD Los Angeles	KOCS Ontario, Calif.	KROX Crookston, Minn.
KVSM San Mateo, Calif.	KPAS Banning, Calif.	KLAS Las Vegas, Nev.
KTIP Porterville, Calif.	KWTC Barstow, Calif.	WOKO Albany, N. Y.
KBOW Butte, Mont.	KRNO San Bernardino, Calif.	WWSC Glens Falls, N. Y.
WPAT Paterson, N. J.	KTED Laguna Beach, Calif.	WNDR Syracuse
WKAL Rome-Utica, N. Y.	WIBK Knoxville, Tenn.	WVOS Liberty, N. Y.
WOSH Oshkosh, Wis.	WLOU Louisville	WVGA Geneva, N. Y.
WXRK Buffalo	WFLB Fayetteville, N. C.	WSTS Southern Pines, N. C.
WVFB Middletown, Ohio	WATL Tallahassee, Fla.	WHJB Greensburg, Pa.
KASH Eugene, Ore.	WVWB Miami	WKPT Kingsport, Tenn.
WVMB Harrisburg, Pa.	WEAT Lake Worth, Fla.	KPAC Port Arthur, Tex.
WVSN Charleston, S. C.	WIMS Michigan City, Ind.	KCTI Gonzales, Tex.
KBKI Alice, Tex.	KSEK Pittsburg, Kan.	WAYB Waynesboro, Va.
KFRO Longview, Tex.	WBER Baton Rouge, La.	WHLAW Weston, W. Va.
WKAB Mobile, Ala.	WTAO Cambridge, Mass.	KBVR Anchorage, Alaska
	KAUS Austin, Minn.	

Represents TV

WKTV (TV) Utica, N. Y.

Canadian Stations

Quebec French Radio Group

CKMO Vancouver	CKOY Ottawa, Ont.	CHLO St. Thomas, Ont.
CJTB Vernon, B. C.	CKFI Fort Frances, Ont.	CKGB Timmins, Ont.
CKOK Penticton, B. C.	CJOY Guelph, Ont.	CKEY Toronto
CHUB Nanaimo, B. C.	CJRL Kenora, Ont.	CKVL Verdun
CKSB St. Boniface, Man.	CKWS Kingston, Ont.	CKCV Quebec
CKX Brandon, Man.	CJKL Kirkland Lake, Ont.	CHLT Sherbrooke
CJOB Winnipeg	CFCH North Bay, Ont.	CHFF Granby
CKBW Bridgewater, N. S.	CHEX Peterborough, Ont.	CHLN Three Rivers
CJCH Halifax, N. S.	CHOK Sarnia, Ont.	CJSO Sorel

HARRY E. CUMMINGS

Jacksonville, Fla.—Barnett Bank Bldg. Tel.: 3-0381. Mgr.: Harry E. Cummings.

Southeastern Representative

WJAX Jacksonville, Fla.	WTAL Tallahassee, Fla.	WQAM Miami, Fla.
WDIG Dothan, Ala.	WROL Knoxville, Tenn.	WHIO Dayton, Ohio
WSPA Spartanburg, S. C.	WDBO Orlando, Fla.	WFLA Tampa, Fla.

(Continued on page 44)

HEADLEY—REED COMPANY

REPRESENTING RADIO AND TELEVISION STATIONS EXCLUSIVELY

NEW YORK CHICAGO DETROIT ATLANTA HOLLYWOOD SAN FRANCISCO
ALL OFFICES COMPANY OWNED AND OPERATED

STATION REPRESENTATIVES

(Continued from page 42)

DORA C. DODSON

Atlanta, Ga.—319 Mortgage Guarantee Bldg. Tel.: Walnut 5642. Pres.: Mrs. Dora C. Dodson.

Represents in South

WKAB Mobile, Ala.	WKLY Hartwell, Ga.	WHKY Hickory, N. C.
WJOI Florence, Ala.	WGIG Brunswick, Ga.	WRFC Athens, Ga.
WOOB Anniston, Ala.	WRHP Tallahassee, Fla.	WPAL Charleston, S. C.
WGOV Valdosta, Ga.	WAIM Anderson, S. C.	Joseph Hershey McGillvra Inc.
WGGA Gainesville, Ga.	WKPT Kingsport, Tenn.	Forjoe & Co.
	WSAT Salisbury, N. C.	

EVERETT-McKINNEY Inc.

New York 17—40 E. 49th St. Tel.: Plaza 9-3747.
Chicago 11—400 N. Michigan Ave. Tel.: Superior 7-9866.
San Francisco 5—681 Market St. Tel.: Douglas 2-4775.
Hollywood 28—7079½ Hollywood Blvd. Tel.: Hillside 3362.

Represents

WTHH Hartford, Conn.	KDTH Dubuque	WENY Elmira, N. Y.
WSTC Stamford, Conn.	KVFD Ft. Dodge	WGLN Glens Falls, N. Y.
WROM Rome, Ga.	KOKX Keokuk	WHDL Olean, N. Y.
WDAN Danville, Ill.	KFJB Marshalltown	WHCC Rochester
Iowa Tall Corn Network & individually	KICM Mason City	WHNC Henderson, N. C.
KWCR Cedar Rapids	KWPC Muscatine	WLEC Sandusky, Ohio
KROS Clinton	KCOM Sioux City	KFLW Klamath Falls, Ore.
KSWI Council Bluffs	KICD Spencer	KORE Eugene, Ore.
KSIB Creston	KAYX Waterloo	WPAM Pottsville, Pa.
KSTT Davenport	KWHK Hutchinson, Kans.	WRBK Williamsport, Pa.
KDEC Decatur	WLAM Lewiston, Me.	KCOR San Antonio
KWDM Des Moines	WBEC Pittsfield, Mass.	KWTX Waco, Tex.
	WABY Albany, N. Y.	WLIF Kenosha, Wis.

FORJOE & CO.

New York 18—19 W. 44th St. Tel.: Murray Hill 7-5343. Pres.: Joseph Bloom. Gen. Mgr.: Joseph Ruggiero. Sales Mgr.: Bernard Howard, William Wyatt.
Chicago 1—228 N. La Salle St. Tel.: Andover 3-5364. Sales Mgr.: Robert Balfour.
Los Angeles 14—1127 Wilshire Blvd. Tel.: Madison 6-8329. Mgr. Lawrence Krasner.
San Francisco 5—607 Market St. Tel.: Sutter 1-7569. Mgr.: Harold Hoffman.
Philadelphia 7—1509 Widener Bldg. Tel.: Rittenhouse 6-6233. Mgr.: Robert Dome.
Atlanta 3—319 Mortgage Guarantee Bldg. Tel.: Walnut 5642. Mgr.: Mrs. Dora C. Dodson.

(Stations represented not reported)

FREE & PETERS Inc.

New York 22—444 Madison Ave. Tel.: Plaza 9-6022. Mgr.: H. Preston Peters.
Chicago 1—180 N. Michigan Ave. Tel.: Franklin 2-6373. Mgr.: Lloyd Griffin.
Atlanta 3—Palmer Bldg. Tel.: Main 5667. Mgr.: James M. Wade.
Detroit 26—Penobscot Bldg. Tel.: Woodward 1-4225. Mgr.: W. W. Bryan.
Fort Worth 2—406 W. 7th St. Tel.: 36-3349. Mgr.: Joseph W. Evans.
Hollywood 28—6331 Hollywood Blvd. Tel.: 9-2151. Mgr.: Hal W. Hoag.
San Francisco 4—58 Sutter St. Tel.: Sutter 1-4353. Mgr.: A. Leo Bowman.

Represents Radio

WGR Buffalo, N. Y.	WDBJ Roanoke, Va.	WBAP Fort Worth-Dallas
WOC Davenport, Ia.	WAVE Louisville	KGMB-KHBC Honolulu-Hilo
WHO Des Moines	KOB Albuquerque, N. M.	WGH Norfolk
WDAY Fargo, N. D.	KIRO Seattle	WBZ-WBZA Boston-Springfield
KMEC-KFRM Kansas City	KRIS Corpus Christi, Tex.	WOWO Ft. Wayne
WISH Indianapolis	KXYZ Houston	KYW Philadelphia
WTCN Minneapolis-St. Paul	KDSH Boise, Idaho	KDKA Pittsburgh
KSD St. Louis	KFDM Beaumont, Tex.	WDZ Decatur, Ill.
WFBL Syracuse	KVOD Denver	WMBD Peoria, Ill.
WCSC Charleston, S. C.	WDSM Duluth-Superior	KTSA San Antonio
WIS Columbia, S. C.	WMCA New York	
WPTF Raleigh, N. C.	KFAB Omaha	
	KEX Portland, Ore.	

Represents TV

WOC-TV Davenport	WTVJ-TV Miami, Fla.	WPIX-TV New York
WBAP-TV Ft. Worth-Dallas	WTCN-TV Minneapolis-St. Paul	KSD-TV St. Louis
WAVE-TV Louisville		KRON-TV San Francisco

THE FRIEDENBERG AGENCY Inc.

New York 19—165 W. 46th St. Tel.: Longacre 3-4474. Mgr.: H. A. Friedenberg.
Chicago—112 E. Walton St. Tel.: Andover 3-6686. Mgr.: Alvin Eicoff.

Represents

Georgia State Network. GALS Members: WGLS Atlanta, WBBQ Augusta, WDEC Americus, WEAU Athens, WLBK Carrollton, WBHF Cartersville, WGAA Cedartown, WBLJ Dalton, WMJM Covington, WDWD Dawson, WMLT Dublin, WDUN Gainesville, WKEU Griffin, WFOM Marietta, WROM Rome, WFRF Savannah, WWNS Statesboro, WSFT Thomaston, WKTG Thomasville, WWGS Tifton, WRLC Toccoa, WRON Vidalia, WAYX Waycross, WRLD West Point, WMVG Milledgeville, WMGA Moultrie, WBHB Fitzgerald, WIBB Macon, WGBA Columbia, WFAK Charleston, S. C.

KGRH Fayetteville, Ark.	WHOM New York	KWSL Lake Charles, La.
WCNX Middletown, Conn.	WSKY Asheville, N. C.	WJEF Hagerstown, Md.
WOOK Washington, D. C.	WFNS Burlington, N. C.	KXLO Lewiston, Mont.

Page 44 • 1950 Yearbook Number

WIDE Biddeford, Me.	WWNF Fayetteville, N. C.	KOJM Havre, Mont.
WBKA Brockton, Mass.	WSSB Durham, N. C.	KBRL McCook, Neb.
WKOX Framingham, Mass.	KOLE Port Arthur, Tex.	WJEL Springfield, Ohio
WHAV Haverhill, Mass.	KOPP Ogden, Utah	WLOA Pittsburgh, Pa.
WEXL Royal Oak, Mich.	WHTN Huntington, W. Va.	WHYU Newport News, Va.

PAUL GIRARD CO.

Dallas 1—407 Tower Petroleum Bldg. Tel.: Riverside 3518. Owner: Paul Girard.

Represents

KOMA Oklahoma City	KHUZ Borger	KVET Austin
KTUL Tulsa, Okla.	KCTX Childress	KMAC San Antonio
KGLC Miami, Okla.	KWPT Wichita Falls	KTLL Texas City
WGVM Greenville, Miss.	KEFO El Paso	KIOX Bay City
KWHN Ft. Smith, Ark.	KSXY Dallas	KLTI Longview
Texas stations:	KWBC Ft. Worth	KTRM Beaumont
KLYN Amarillo	KTFS Texarkana	KSFA Nacogdoches
KPDN Pampa	KGKB Tyler	KECK Odessa
KCBD Lubbock		

GENE GRANT & CO.

Los Angeles 36—5225 Wilshire Blvd. Tel.: York 8812.
San Francisco 5—681 Market St. Tel.: Yukon 6-0621.

Represents

KFFA Helena, Ark.	KTTP Porterville, Calif.	KASH Medford, Ore.
KOKO La Junta, Col.	KVSM San Mateo, Calif.	KWIN Ashland, Ore.
WHLB Port Huron, Mich.	KFVD Los Angeles	KWRO Coquille, Ore.
KLOK San Jose, Calif.	KPAS Banning, Calif.	KCTI Gonzales, Tex.
KBOW Butte, Mont.	KWTC Barstow, Calif.	KRNO San Bernardino, Calif.
KWKB McComb, Miss.	KICO Calexico, Calif.	KTED Laguna Beach, Calif.
WBBB Burlington, N. C.	KASH Eugene, Ore.	KBYR Anchorage, Alaska
KGKB Tyler, Tex.	KOCS Ontario, Calif.	CKFI Fort Frances, Ont.
WBTH Williamson, W. Va.	KSPA Santa Paula, Calif.	
	KNOG Nogales, Ariz.	

W. S. GRANT CO. Inc.

San Francisco—703 Market St. Tel.: Exbrook 2-6685. Gen. Mgr.: W. S. Grant.
Los Angeles—412 W. 6th St. Tel.: Vandike 6341. Mgr.: Walter O. Miles.
New York—33 W. 42nd St. Tel.: Bryant 9-1374. Mgr.: Jack Davis.
Chicago—180 N. Michigan Ave. Tel.: Dearborn 2-7869. Mgr.: Frank Back

Represents

KPMC Bakersfield, Calif.	KUGN Eugene, Ore.	WMNB North Adams, Mass.
KHSL Chico, Calif.	KUIN Grants Pass, Ore.	WHTC Holland, Mich.
KMYC Marysville, Calif.	KSMO San Mateo, Calif.	KGVO Missoula, Mont.
KYOS Merced, Calif.	KVOE Santa Ana, Calif.	KENO Las Vegas, Nev.
KTRB Modesto, Calif.	KSRO Santa Rosa, Calif.	WMOA Marietta, Ohio
KPRL Paso Robles, Calif.	KVVC Ventura, Calif.	KELA Centralia-Chehalis, Wash.
KEEN San Jose, Calif.	WFTM Maysville, Ky.	KVWK Longview, Wash.
KCRB Sacramento, Calif.	KFJL Klamath Falls, Ore.	KGY Olympia, Wash.
KVCV Redding, Calif.	KYJC Medford, Ore.	KUJ Walla Walla, Wash.
WPTW Plaquemine, Ohio	KSLM Salem, Ore.	KYAK Yakima, Wash.
WBEX Chillicothe, Ohio	WNAW Norristown, Pa.	KOWB Laramie, Wyo.
KVEE San Luis Obispo	KJAM Vernal, Utah	KDON Monterey, Calif.
KWHW Altus, Okla.	WSKI Montpelier, Vt.	KRLC Lewiston, Ida.
KRND Bend, Ore.	KXRO Aberdeen, Wash.	
KRUL Corvallis, Ore.		

IRENE GRIFFITH

Hollywood 28—7079½ Hollywood Blvd. Tel.: Hudson 2-7391.
San Francisco 4—681 Market St. Tel.: Douglas 4475.

(Stations represented not reported)

MELCHOR GUZMAN CO. Inc.

New York—45 Rockefeller Plaza. Tel.: Circle 7-0624. Mgr.: A. M. Martinez.
(Represents stations in Cuba, Mexico, Puerto Rico, Central and South America)

†ARTHUR H. HAGG ASSOCIATES Inc.

Chicago 1—360 N. Michigan Ave. Tel.: Central 6-7553. Mgr.: Arthur H. Hagg.
New York 17—366 Madison Ave. Tel.: Murray Hill 2-8865. Mgr.: Phil Broderick.

Represents

KGNO Dodge City, Kan.

HARRINGTON, RIGHTER & PARSONS Inc.

New York 17—270 Park Ave. Tel.: Murray Hill 8-1185. Pres.: John E. Harrington Jr. V. P.-Treas.: Volney Righter. V. P.-Sec.: James O. Parsons Jr.

Represents TV

WFMY-TV Greensboro, N. C.	WBEN-TV Buffalo, N. Y.
WAAM (TV) Baltimore	WTMJ-TV Milwaukee

(Continued on page 46)

... represented by NBC Spot Sales

Every day, this phrase is seen by the men and women who buy radio and television time.

Every day, it is their unfailing guide to major stations in major markets—expertly programmed, hard-selling stations.

And every day, NBC Spot Sales is unsurpassed in the wealth of information presented to agencies . . . in the assistance needed for successful schedules.

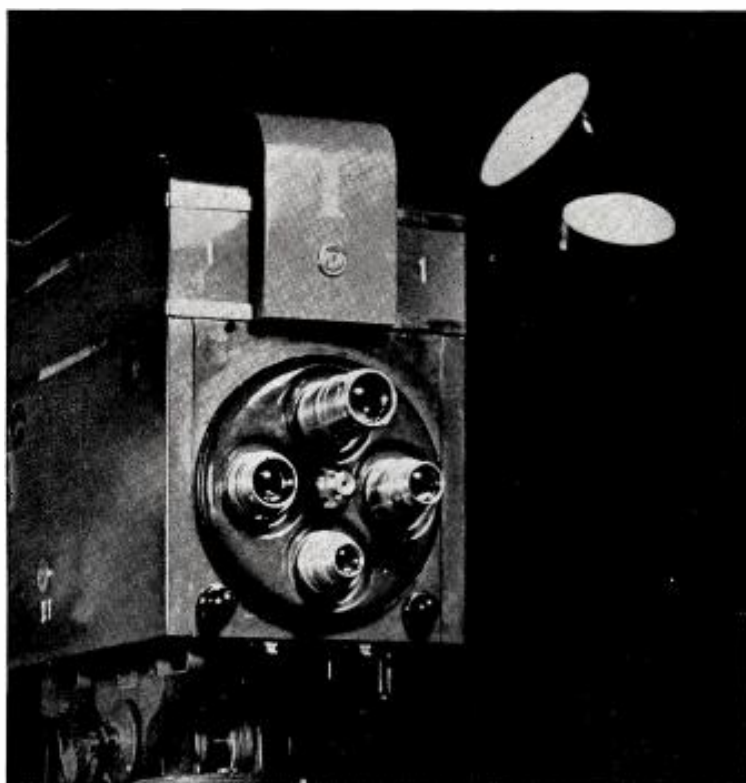

NBC SPOT SALES

NEW YORK • CHICAGO • CLEVELAND • HOLLYWOOD • SAN FRANCISCO • WASHINGTON • DENVER

Representing RADIO STATIONS:

WNBC, New York	WTAM, Cleveland
WMAQ, Chicago	WRC, Washington
KNBC, San Francisco	KOA, Denver
WGY, Schenectady	

Representing TELEVISION STATIONS:

WNBT, New York	WBZ-TV, Boston
WNBQ, Chicago	WNBK, Cleveland
KNBH, Hollywood	WNBW, Washington
WPTZ, Philadelphia	WRGB, Schenectady

STATION REPRESENTATIVES

(Continued from page 44)

HEADLEY-REED CO.

New York—420 Lexington Ave. Tel.: Murray Hill 3-5467. Mgr.: Frank M. Headley.
 Chicago—180 N. Michigan Ave. Tel.: Franklin 2-4686. Mgr.: Dwight S. Reed.
 Detroit—Penobscot Bldg. Tel.: Woodward 2-7371. Mgr.: Harold V. Barrett.
 Atlanta—Palmer Bldg. Tel.: Cypress 4311. Mgr.: E. W. Sweatman Jr.
 San Francisco—300 Montgomery St. Tel.: Yukon 6-1285. Mgr.: Ralph W. Mitchell.
 Hollywood—Taft Bldg. Tel.: Hillside 7738. Mgr.: Harold Lindley.

Represents Radio

WSGN Birmingham, Ala.	KMMJ Grand Island, Neb.	WJAC Johnstown, Pa.
WALA Mobile, Ala.	WBAB Atlantic City	WAO Chatanooga
WSFA Montgomery, Ala.	WHLI Niagara Falls	WSYR Syracuse, N. Y.
KJBS San Francisco	WSOC Charlotte, N. C.	WTRY Troy, N. Y.
WELI New Haven	WSJS Winston-Salem, N. C.	WHBS Huntsville, Ala.
WCON Atlanta	WWNC Asheville, N. C.	WONE Dayton, Ohio
WDAK Columbus, Ga.	WKOW Madison, Wis.	WLAN Lancaster, Pa.
WROK Rockford, Ill.	WTVW Cleveland	WEEK Peoria, Ill.
WGL Ft. Wayne, Ind.	WCOL Columbus, Ohio	WEMP Milwaukee
KSO Des Moines	WFMJ Youngstown, Ohio	WEEU Reading, Pa.
WITH Baltimore	WSAN Allentown, Pa.	KOL Seattle
WSAR Fall River, Mass.	WFBG Altoona, Pa.	WTOD Toledo, Ohio
WSAM Saginaw, Mich.		WFAS White Plains, N. Y.
KFEQ St. Joseph, Mo.		

Represents TV

WICU (TV) Erie, Pa. WTVN (TV) Columbus, O.
 WJAC-TV Johnstown, Pa.

GEORGE P. HOLLINGBERY CO.

Chicago 1—307 N. Michigan Ave.: Tel.: Andover 3-2636. Mgr.: George P. Hollingbery.
 New York 17—420 Lexington Ave. Tel.: Oregon 9-2660. Mgr.: F. E. Spencer Jr.
 Atlanta 3—223 Peachtree St. Tel.: Cypress 1489. Mgr.: Dan Schmidt, III.
 San Francisco 4—235 Montgomery St. Tel.: Douglas 2-7192. Mgr.: Knox LaRue.
 Los Angeles 13—411 W. Fifth St. Tel.: Madison 6-3633. Mgr.: Harry H. Wise Jr.

Represents Radio

WADC Akron, Ohio	WIOD Miami, Fla.	WINR Binghamton, N. Y.
WRDW Augusta, Ga.	WHAM Rochester, N. Y.	KOPR Butte, Mont.
WBO Baton Rouge, La.	WBAY Savannah, Ga.	KOLO Reno, Nev.
WBCM Bay City, Mich.	WARM Scranton, Pa.	KIST Santa Barbara, Calif.
WTMA Charleston, S. C.	KSCJ Sioux City, Ia.	KNEW Spokane, Wash.
WAAF Chicago	WSPR Springfield, Mass.	KSJB Jamestown, N. D.
WRBL Columbus, Ga.	KGBX Springfield, Mo.	KGHI Little Rock, Ark.
WHIO Dayton	KVI Tacoma, Wash.	WLVA Lynchburg, Va.
WWJ Detroit	WBTM Danville, Va.	WWEZ New Orleans, La.
WEBC Duluth	KOOL Phoenix, Ariz.	WISC Madison, Wis.
WEAU Eau Claire, Wis.	WJAS Pittsburgh	KCBQ San Diego
KTSM El Paso, Tex.	KITO San Bernardino, Calif.	WABE Allentown, Pa.
WBIG Greensboro, N. C.	WGST Atlanta, Ga.	WHUM Reading, Pa.
WJDX Jackson, Miss.		KPOA Honolulu

Arizona Network
 Arrowhead Network
 Georgia Quartet
 Rocky Mountain Network

Represents TV

WWJ-TV Detroit
 WHAM-TV Rochester, N. Y.

HAL HOLMAN COMPANY

Chicago 1—360 N. Michigan Ave. Tel.: Franklin 2-0016. Mgr.: Hal Holman.
 New York—4 E. 41st St. Tel.: Murray Hill 3-3421.
 Los Angeles 28—6381 Hollywood Blvd. Tel.: Hollywood 5048. Mgr.: Tracy Moore.

Represents

WTCM Traverse City, Mich.	WCLE Clearwater, Fla.	KWBM Williston, N. D.
WATT Cadillac, Mich.	WGNS Murfreesboro, Tenn.	WHFB Benton Harbor, Mich.
WATZ Alpena, Mich.	KSEL Lubbock, Tex.	WHOW Clinton, Ill.
WMBN Petoskey, Mich.	KPKJ Grand Junction, Colo.	WLBH Mattoon, Ill.
*WIBM Jackson, Mich.	WPAG Ann Arbor, Mich.	WLDS Jacksonville, Ill.
WMUS Muskegon, Mich.	WKNX Saginaw, Mich.	WCRK Morristown, Tenn.
WHLB Port Huron, Mich.	WSIV Pekin, Ill.	WTPR Paris, Tenn.
WCAZ Carthage, Ill.	WTWT Stevens Point, Wis.	WKCT Bowling Green, Ky.
WKAN Kankakee, Ill.	WCBC Anderson, Ind.	WMIK Middlesboro, Ky.
WIBV Belleville, Ill.	WHIR Danville, Ky.	KWAL Wallace, Idaho
WVVL Olney, Ill.	KNEB Scottsbluff, Neb.	*KOWL Santa Monica, Calif.
*WLBC Muncie, Ind.		
WAYX Waycross, Ga.		

Paul Bunyan Network

(WCTM WATT WATZ WMBN)

* Represented in Midwest only.

INDEPENDENT METROPOLITAN SALES

New York 18—55 W. 42nd St. Tel.: Longacre 3-6741. Pres.: Jack Koste.

Represents

KATL Houston	WACE Springfield, Mass.	WNOR Norfolk, Va.
KITE San Antonio	WARL Arlington, Va.	WPAL Charleston, S. C.
KNAK Salt Lake City	WFTW Ft. Wayne	WWSO Springfield, Ohio
KSTL St. Louis	WRHM Memphis	WXLW Indianapolis
KTBI Tacoma, Wash.	WIKY Evansville, Ind.	

Page 46 • 1950 Yearbook Number

INTER-AMERICAN PUBLICATIONS Inc.

New York 17—41 E. 42nd St. Tel.: Murray Hill 2-0886.

Represents

WKAQ San Juan, P. R.

THE KATZ AGENCY

New York 18—500 Fifth Ave. Tel.: Wisconsin 7-8620. Sales Mgr.: George Brett.
 Chicago 1—307 N. Michigan Ave. Tel.: Central 6-4006. Mgr.: Gerald H. Gunst.
 Detroit 2—General Motors Bldg. Tel.: Trinity 2-7685. Mgr.: Ralph Bateman.
 Kansas City 6—Bryant Bldg. Tel.: Victor 7095. Mgr.: Thomas J. Flanagan Jr.
 Atlanta 3—22 Marietta St. Bldg. Tel.: Alpine 1637. Mgr.: Fred M. Bell.
 Dallas 1—Republic Bank Bldg. Tel.: Central 7936. Mgr.: Frank Brimm.
 San Francisco 5—Monadnock Bldg. Tel.: Sutter 1-7434. Mgr.: Donald C. Staley.
 Los Angeles 14—530 W. 6th St. Tel.: Tucker 3219. Mgr.: Stanley J. Reulman.

Represents Radio

KLZ Denver	WNAX Sioux City-Yankton	WREC Memphis
WGBS Miami, Fla.	WWL New Orleans	WSIX Nashville
WDAE Tampa	WCOP Boston	KHQ Spokane, Wash.
*WAGA Atlanta	KGHL Billings, Mont.	WMMN Fairmont, W. Va.
*WMAZ Macon, Ga.	WXXW Albany, N. Y.	WISN Milwaukee
*WTOC Savannah	WARC Rochester, N. Y.	WJBK Detroit
KGU Honolulu	WKRC Cincinnati	WFDF Flint, Mich.
WIND Chicago	WSPD Toledo, Ohio	WOOD Grand Rapids, Mich.
WPDQ Jacksonville, Fla.	WKY Oklahoma City	KWK St. Louis
WEOA Evansville, Ind.	WKST New Castle, Pa.	WEBR Buffalo, N. Y.
WFBM Indianapolis	WFIL Philadelphia	WHIS Bluefield, W. Va.
WMT Cedar Rapids	WCAE Pittsburgh	
KRNT Des Moines		

Represents TV

KLAC-TV Los Angeles	WMAR-TV Baltimore	WHIO-TV Dayton, Ohio
WNHC-TV New Haven, Conn.	WJBK-TV Detroit	WSPD-TV Toledo, Ohio
WAGA-TV Atlanta, Ga.	WHEN (TV) Syracuse	WKY-TV Oklahoma City
WFBM-TV Indianapolis	WKRC-TV Cincinnati	WFIL-TV Philadelphia
	WXEL (TV) Cleveland	

*The Georgia Trio

KEENAN AND EICKELBERG

San Francisco 4—235 Montgomery St. Tel.: Douglas 2-1323. Mgr.: W. Hubbard Keenan.
 Los Angeles 5—2978 Wilshire Blvd. Tel.: Fairfax 8458. Mgr.: Wilbur Eickelberg.
 Portland 4, Ore.—333 S. W. Oak St. Tel.: Broadway 3210. Mgr.: Frank J. McHugh Jr.

Represents

WOR New York Taylor-Boroff WGN Chicago

JOHN KEATING

Portland, Ore.—Alderway Bldg. Tel.: Beacon 4107. Mgr.: John D. Keating.
 Seattle, Wash.—2nd & Pine Bldg. Tel.: Elliott 6520. Mgr.: James A. McLoughlin.

Special regional representation of Oregon, Washington and Idaho stations

KAST Astoria, Ore.	KFXD Boise-Nampa, Idaho	KVOS Bellingham, Wash.
KRNR Roseburg, Ore.	KTFI Twin Falls, Idaho	KPQ Wenatchee, Wash.
KFJI Klamath Falls, Ore.	KBIO Burley, Idaho	KUJ Walla Walla, Wash.
KOCO Salem, Ore.	KSRV Ontario, Ore.	KOL Seattle, Wash.
KOOS Coos Bay, Ore.	KIT Yakima, Wash.	KGA Spokane, Wash.
KBNB Bend, Ore.	KWRC Pendleton, Ore.	KIEM Eureka, Cal.
KBKR Baker, Ore.	KODL The Dalles, Ore.	KRKO Everett, Wash.
KORE Eugene, Ore.	KWIL Albany, Ore.	KONP Port Angeles, Wash.
KMED Medford, Ore.	KRLC Lewiston, Idaho	KVAN Vancouver, Wash.
KUIN Grants Pass, Ore.	KWLK Longview, Wash.	KPOJ Portland, Ore.
KLBM LaGrande, Ore.	KELA Centralia, Wash.	KPKW Pasco, Wash.
KWIN Ashland, Ore.	KGY Olympia, Wash.	KBRC Mt. Vernon, Wash.
KTIL Tillamook, Ore.	KXRO Aberdeen, Wash.	KMO Tacoma, Wash.
		KNPT Newport, Ore.

KETTELL-CARTER

Boston—Park Square Bldg. Tel.: Liberty 2-5799. Partners: Elmer Kettell, Marjorie Carter.

Represents in New England and New York State Radio

WOR New York*	WHIM Providence, R. I.	WALE Fall River, Mass.
WHCU Ithaca, N. Y.*	WSKI Montpelier, Vt.	WSYR Syracuse, N. Y.*

Pine Tree Group of Maine (WABI-WLAM-WPOR-WTVL)
 New Hampshire Group (WFEA-WKNE-WLNH-WMOU)
 Boston Supplement Group (WBKA-WHAV-WKOK)
 New England Broadcasting System
 Bay State Group of Mass. (WACE-WALE-WBEC-WBKA-WEIM-WHAV-WKOX-WNEB)

Television

WOR-TV New York* WSYR-TV Syracuse, N. Y.* WOIC (TV) Washington*

* New England only.

A. LEWIS KING

New York 17—527 Lexington Ave. Tel.: Plaza 9-1389.

WBNX New York WINX Washington WHAT Philadelphia

(Continued on page 48)

BROADCASTING • Telecasting

Stimulate Local Sales... NOW!

THIS PROVEN STATION
PROMOTION PLAN
IS **WORKING**
COAST-TO-COAST!

VEOA...
WGAY...KW...
WCON...WSGN
WLOI...WCSS...
KMYR...WEAM...WE...
KMLB
WMEY...
WWSG...
KCOL...WM...
KVOX...KI...
WOB...
WEAW...
KFGO...
WWWB...
KWBG...
WFIG...WMIS...
WTND...
WAAF...W...
WEVE...
KLER...
KTFS...
NMFT...
WKC...
WHLB...
WTYC...
WMEV...
WDOV...WE...
KTRY...KBOL...
WGVM...
KT...
WESC...
KB...
WFAM...
WJMC...
WALOA...
WOB...
WDOV...WE...
KTRY...KBOL...
WGVM...
KT...
WESC...
KB...
WFAM...
WJMC...
WALOA...
WOB...
WDOV...WE...
KTRY...KBOL...
WGVM...
KT...
WESC...
KB...
WFAM...
WJMC...



We Cordially Invite
YOUR INQUIRY

about a proven and effective plan, specifically created to enhance your station promotion, under a guaranteed exclusive service for your listening area. We ask the privilege of a personal interview at your convenience, or if you prefer, wire or phone us collect for more details.

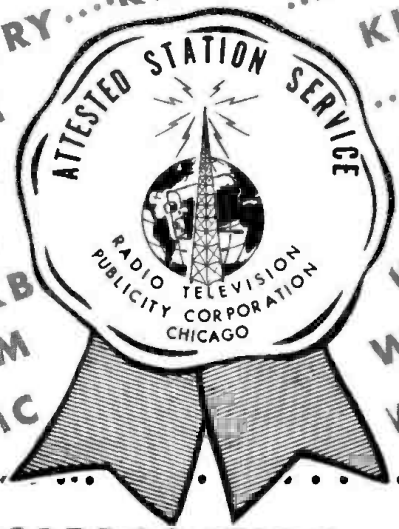

RADIO TELEVISION PUBLICITY CORPORATION

EXECUTIVE OFFICES: 159 EAST CHICAGO AVENUE • CHICAGO 11, ILLINOIS
Member National Association of Broadcasters

STATION REPRESENTATIVES

(Continued from page 46)

ORVILLE LAWSON & ASSOC.

Minneapolis 2—814 National Bldg. Tel.: Geneva 9631. Owner: Orville F. Lawson.
Office Mgr.: Mrs. Edna H. Brautigam. Acct. Exec.: A. M. Oleston Jr.

(Stations represented not reported)

JOSEPH HERSHEY MCGILLVRA Inc.

New York 17—366 Madison Ave. Tel.: Murray Hill 2-8755. Pres.: Joseph Hershey
McGillvra.

Chicago 1—185 N. Wabash Ave. Tel.: State 2-5282. Mgr.: Rex S. Gay Jr.

Los Angeles 5—684 S. Lafayette Park Pl. Tel.: Drexel 4388. Mgr.: Robert W.
Walker

San Francisco 4—68 Post St. Tel.: Sutter 1-5568. Mgr.: Roger P. Parratt.

Atlanta—319 Mortgage Guarantee Bldg. Tel.: Walnut 5642. Mgr.: Dora Dodson.

(Stations represented not available)

FRANK J. McHUGH JR.

Portland 4—710 Lewis Bldg. Tel.: Broadway 3210.

Represents for Oregon and Washington

KFLW Klamath Falls, Ore. KWIE Kennewick, Wash. KGO San Francisco
KSLM Salem, Ore. KWVB Walla Walla, Wash. KECA Los Angeles
KUGN Eugene, Ore. KJYC Medford, Ore.

ABC Pacific Network

MEDIA REPRESENTATIVES Inc.

New York 17—270 Park Ave. Tel.: Murray Hill 8-4777. William J. Chase, U. S.
Representative; Albert C. Capotosto, Manila Representative.

Represents

Philippine Broadcasting Corp., Manila

ROBERT MEEKER ASSOC. Inc.

New York 17—521 Fifth Ave. Tel.: Murray Hill 2-2170. Gen. Mgr.: Robert D. C.
Meeker. Mgrs.: Louis J. F. Moore, Robert L. Dreher.

Chicago 1—333 N. Michigan Ave. Tel.: Central 6-1742. Mgr.: Donald L. Pontius.
Lola Thompson.

San Francisco—79 Post St. Tel.: Exbrook 8033. Mgr.: Frances Donahue.

Los Angeles 28—6381 Hollywood Blvd. Tel.: Hollywood 9-5408. Mgr.: Tracy Moore.

Represents Radio

WMBS Uniontown, Pa.	WORK, York, Pa.	WJPS Evansville, Ind.
WMGY Montgomery, Ala.	WEST Easton, Pa.	WGFG Kalamazoo, Mich.
WGAL Lancaster, Pa.	WAZL Hazleton, Pa.	WJIM Lansing, Mich.
WDEL Wilmington, Del.	WJNO West Palm Beach, Fla.	WKBY Richmond, Ind.
WKBO Harrisburg, Pa.	WRAW Reading, Pa.	WCOM Cumberland, Md.
WDWS Champaign, Ill.	WBSR Pensacola, Fla.	WGKV Charleston, W. Va.
WKBB Dubuque, Iowa	WHEL Sheboygan, Wis.	KCRA Sacramento, Calif.
WRTA Altoona, Pa.	WHOL Allentown, Pa.	KVOL Lafayette, La.
WMAM Marinette, Wis.		

Represents TV

WDEL-TV Wilmington, Del. WGAL-TV Lancaster, Pa.

NATIONAL BROADCASTING CO. [NBC SPOT]

(National Spot Sales Dept.)

New York—30 Rockefeller Plaza. Tel.: Circle 7-8300. Director: J. V. McConnell.
Mgr.: J. S. de Russy. Prom. Adv. Mgr.: J. A. Evans.

Chicago—Merchandise Mart. Tel.: Superior 7-8300. Mgr.: O. Morton.

Cleveland—815 Superior Ave. N.E. Tel.: Cherry 0942. John C. Treacy.

Denver—1625 California St. Tel.: Main 6211. L. Berry Long.

Hollywood—Sunset & Vine. Tel.: Hollywood 9-6161. Mgr.: Robert Howard.

San Francisco—Taylor & O'Farrell Sts. Tel.: Graystone 4-8700. Carl Nielsen.

Washington—Trans-Lux Bldg. Tel.: Republic 4000. Mahlon Glascock.

Represents Radio

WNBC New York	KNBC San Francisco	WGY Schenectady
WMAQ Chicago	WRC Washington	KOA Denver
WTAM Cleveland		

Represents TV

WNBT(TV) New York	WNEK(TV) Cleveland	WBZ-TV Boston
WNBQ(TV) Chicago	WPTZ(TV) Philadelphia	WRGB(TV) Schenectady
KNBH(TV) Hollywood	WNBW(TV) Washington	WTVR(TV) Richmond, Va.

HARLAN G. OAKES & ASSOC.

Los Angeles 5—672 S. Lafayette Park. Tel.: Fairfax 3200.
San Francisco 4—Monadnock Bldg. Tel.: Douglas 4475.

Represents on Pacific Coast Only

WATT Chicago	KEXO Grand Junction, Colo.	CFRN Edmonton, Alta.
WMP5 Memphis		CFQL Saskatoon, Sask.
WCIL Carbondale, Ill.	CFCN Calgary, Alta.	CKPR Ft. William, Ont.

Page 48 • 1950 Yearbook Number

LEE F. O'CONNELL CO.

Los Angeles 48—521 N. La Cienega Blvd. Tel.: Crestview 5-2022. Pres.-Mgr.: Lee
F. O'Connell.

San Francisco 4—544 Russ Bldg. Tel.: Douglass 2-4586. Mgr.: William A. Ayers.

(Stations represented not reported)

ORTALE CO. Inc.

Pittsburgh 22—72 First Ave.

Represents

WHOD Homestead, Pa.

PACIFIC NORTHWEST BROADCASTERS

Portland 7—Orpheum Bldg. Tel.: Broadway 6451.
New York 17—551 Fifth Ave. Tel.: Murray Hill 2-7986.
Chicago 1—360 N. Michigan Ave. Tel.: Andover 3-5771.
Kansas City—15 W. 10th St. Tel.: Victory 0021.
Hollywood 28—6381 Hollywood Blvd. Tel.: Hollywood 5408.
San Francisco 4—79 Post St. Tel.: Exbrook 8038.
Spokane 8—Symons Bldg. Tel.: Main 1218.

(Stations represented not listed)

PAN AMERICAN BROADCASTING CO.

New York—330 Madison Ave. Tel.: Murray Hill 2-0810. Mgr.: E. Bernald.
Chicago—228 N. LaSalle St. Tel.: State 2-5086. Mgr.: Fred Jones.
Hollywood—6912 Hollywood Blvd. Tel.: Hollywood 6281. Mgr.: Homer Griffith.
San Francisco—Mills Bldg. Mgr.: Duncan A. Scott.

Represents Stations in

Alaska	El Salvador	Angola
Belgian Congo	Guatemala	North Africa
Bolivia	Haiti	South Africa
British Guiana	Honduras	China
Chile	Nicaragua	Iceland
Colombia	Panama	India Pakistan
Costa Rica	Paraguay	Fiji Islands
Dominican Republic	Peru	France
Dutch Guiana	Puerto Rico	Portugal
Ecuador	Venezuela	

JOHN E. PEARSON CO.

New York 17—250 Park Ave., Tel.: Plaza 8-2255. Pres.: John E. Pearson, Mgr.
Russell Walker Jr.

Chicago 1—360 N. Michigan Ave. Tel.: Franklin 2-2359. Mgr.: Frank Breslin.

Los Angeles—684 S. Lafayette Park Pl. Tel.: Drexel 4388. Mgr.: R. W. Walker.

San Francisco—68 Post St. Tel.: Sutter 5568. Mgr.: Roger Parratt.

Represents Radio

KCMO Kansas City	WCAR Pontiac, Mich.	WCMI Ashland, Ky.
KOAM Pittsburgh, Kan.	KSAL Salina, Kan.	KKCL San Angelo, Tex.
KELQ Sioux Falls, S. D.	KKOL Fort Worth, Tex.	KBST Big Spring, Tex.
KVBC Great Bend, Kan.	Oscar Hirsch Stations	KCRS Midland, Tex.
WEW St. Louis	WJHL Johnson City, Tenn.	KTRN Wichita Falls, Tex.
KRRV Sherman, Tex.	WMIX Mt. Vernon, Ill.	KYSM Mankato, Minn.
WHIZ Zanesville, O.	KWOC Poplar Bluff, Mo.	KWLM Willmar, Minn.
WAOV Vincennes, Ind.	KPAB Laredo, Tex.	KATE Albert Lea, Minn.
WJPF Herrin, Ill.	WLAV Grand Rapids, Mich.	WSPB Sarasota, Fla.
WIRE Indianapolis	WGOV Valdosta, Ga.	WLAP Lexington, Ky.
WMMJ Peoria, Ill.	KCBD Lubbock, Tex.	KNOW Austin, Tex.
KHMO Hannibal, Mo.	WTSP St. Petersburg, Fla.	WEAS Atlanta, Ga.
West Texas Group	California Valley Group	WEDR Birmingham, Ala.
KMAC San Antonio	WFLA Lakeland, Fla.	KRBC Abilene, Tex.
WDIA Memphis	KFTA Amarillo, Tex.	KPLT Paris, Tex.
KGKB Tyler, Tex.		KWNO Winona, Minn.
KWTO Springfield, Mo.		KMHL Marshall, Minn.
KLCN Blytheville, Ark.		

Represents TV

WLAV-TV Grand Rapids, Mich.

JOHN H. PERRY ASSOCIATES

New York 17—310 E. 45th St. Tel.: Murray Hill 4-1647. Gen. Mgr.: William K.
Dorman.

Philadelphia 7—12 S. 12th St. Tel.: Walnut 2-3555. Mgr.: Robert Hitchens.

Chicago 3—122 S. Michigan St. Tel.: Harrison 7-8085. Mgr.: F. W. Thurnau.

Detroit 2—655 Atkinson Ave. Tel.: Trinity 1-5793. Mgr.: John F. Cole.

Atlanta 3—72 11th St. N.E. Tel.: Walnut 1334. Mgr.: Mrs. Alice S. Grant.

Represents

WCOA Pensacola, Fla.	WWPG Palm Beach	WTMC Ocala, Fla.
WJHP Jacksonville, Fla.	WINZ Miami Beach	WDLF Panama City, Fla.
WALT Tampa		

EDWARD PETRY & CO. Inc.

New York 17—17 E. 42nd St. Tel.: Murray Hill 2-4400. Mgr.: Henry I. Christal.

New York 22—488 Madison Ave. (approx. March 1, 1950)

Chicago 11—400 N. Michigan Ave. Tel.: Delaware 7-8600. Mgr.: Edward E. Voynow.

Detroit 2—General Motors Bldg. Tel.: Madison 1035. Mgr.: William Cartwright.

San Francisco 4—Russ Bldg. Tel.: Garfield 1-4082. Mgr.: Earle H. Smith.

Los Angeles 13—601 W. Fifth St. Tel.: Michigan 8729. Mgr.: Chester G. Matson.

St. Louis 3—Shell Bldg. Tel.: Chestnut 7191. Mgr.: George Kercher.

Atlanta 3—New Palmer Bldg. Tel.: Lamar 2080. Mgr.: Charles F. Grisham.

Dallas 2—M & W Tower, 311 S. Akard. Tel.: Prospect 7-3593. Mgr.: Buell Herman.

BROADCASTING • Telecasting

Represents Radio

Yankee Network
WSB Atlanta
WNAC Boston
WICC Bridgeport
WBEN Buffalo
WGAR Cleveland
WFAA Dallas-Ft. Worth
WJR Detroit
KPRC Houston
WDAF Kansas City
WAGE Syracuse, N. Y.
KARM Fresno, Calif.
KFOR Lincoln, Neb.

KGA Spokane
WBAL Baltimore
KARK Little Rock, Ark.
KFI Los Angeles
WHAS Louisville
WTMJ Milwaukee
KSTP St. Paul
WSM Nashville
WSMB New Orleans
WTAR Norfolk
KOIL Omaha
WWVA Wheeling

KGW Portland, Ore.
Texas Quality Network
WEAN Providence
WRNL Richmond
WOAI San Antonio
KOMO Seattle
WMAZ Springfield, Mass.
KVOO Tulsa, Okla.
KFH Wichita, Kan.
KTBS Shreveport, La.
WIP Philadelphia
WSAU Wausau, Wis.

Represents TV

New York 17—343 Lexington Ave. Tel.: Murray Hill 4-7068. Mgr. TV Sales: Keith Kiggins.

New York 22—488 Madison Ave. (approx. March 1, 1950)

WBAL-TV Baltimore
WNAC-TV Boston
WSB-TV Atlanta
WDAF-TV Kansas City

WTAR-TV Norfolk
KSTP-TV Minneapolis-St. Paul.

KFI-TV Los Angeles
WOAI-TV San Antonio
WHAS-TV Louisville

RADIO REPRESENTATIVES, Inc.

New York—480 Lexington Ave. Tel.: Murray Hill 8-4342. Harry S. Goodman, Pres. Peggy Stone, V. P. in charge, New York.

Chicago—737 North Michigan Blvd. John North, V. P. in charge, Chicago.

(Stations represented not listed)

RADIO SALES

(Radio and Televisions Stations Representatives—a division of CBS)

New York—485 Madison Ave. Tel.: Plaza 5-2000. Carl Burkland, Gen. Sales Mgr.; H. A. Carlborg, East'n Sales Mgr. Radio; George R. Dunham, East'n Sales Mgr. TV.

Chicago—410 N. Michigan Ave. Tel.: Whitehall 4-6000. Mgr.: Gordon Hayes.
Los Angeles—Columbia Sq. Tel.: Hollywood 9-1212. Mgr.: Richard C. Elpers.
San Francisco—Palace Hotel. Tel.: Yukon 2-7000. Mgr.: Edwin W. Buckalew.
Memphis—63 S. Main St. Tel.: 37-8612. Mgr.: H. H. Holtshouser.
Detroit—Fisher Bldg. Tel.: Trinity 2-5500. Mgr.: Ralph H. Patt Jr.

Represents Radio

KMOX St. Louis
KNX Los Angeles
KSL Salt Lake City
WAPI Birmingham
CBS Pacific Network

WBBM Chicago
WBT Charlotte
WCBS New York
WCAU Philadelphia
CBS California Network

WCCO Minneapolis
WEEL Boston
WRVA Richmond
WTOP Washington
KCBS San Francisco

Represents TV

WCBS-TV New York
KTTV(TV) Los Angeles
WCAU-TV Philadelphia

WBT(TV) Charlotte, N. C.

KSL-TV Salt Lake City
WAFM-TV Birmingham

THE RICHARD RAILTON CO.

San Francisco 5—681 Market St. Tel.: Garfield 1-5426. Mgr.: Richard S. Railton.

Represents TV

WABD(TV) New York

WDTV(TV) Pittsburgh

WTTG(TV) Washington

(Continued on page 50)

**THE
BRANHAM
COMPANY**

representing

CHICAGO
NEW YORK
DETROIT
DALLAS
ATLANTA
CHARLOTTE
ST. LOUIS
MEMPHIS
SAN FRANCISCO
LOS ANGELES

WABB RADIO
KTHS Mobile, Ala.
KFMB Hot Springs, Ark.
WGBA San Diego, Calif.
WNEX Columbus, Ga.
KWKH Macon, Ga.
WRBC Shreveport, La.
WCPO Jackson, Miss.
WDEF Cincinnati, Ohio
WTJS Chattanooga, Tenn.
WNOX Jackson, Tenn.
WMC Knoxville, Tenn.
KFDA Memphis, Tenn.
KRIC Amarillo, Texas
KWBU Beaumont, Texas
KAND Corpus Christi, Texas
KRLD Corsicana, Texas
WCHS Dallas, Texas
WBLK Charleston, W. Va.
WSAZ Clarksburg, W. Va.
WPAR Huntington, W. Va.
Parkersburg, W. Va.

TELEVISION
KFMB-TV San Diego, Calif.
WCPO-TV Cincinnati, Ohio
WEWS Cleveland, Ohio
WMCT Memphis, Tenn.
KRLD-TV Dallas, Texas

STATION REPRESENTATIVES

(Continued from page 49)

WILLIAM G. RAMBEAU CO.

Chicago 1—360 N. Michigan Ave. Tel.: Andover 3-5566. Mgr.: William G. Rambeau.
New York 17—Chanin Bldg. Tel.: Lexington 2-1820. Mgr.: William M. Wilson.
Los Angeles 5—672 S. Lafayette Park Pl. Tel.: Exposition 8281. Mgr.: Dama W. Porter.
San Francisco 5—605 Market St. Tel.: Douglas 0668. Mgr.: Gaylord C. Harding.

Represents

WIL St. Louis	KSWM Joplin, Mo.	WJOY Burlington, Vt.
KFWB Los Angeles	WHOB Gardner, Mass.	WGEZ Beloit, Wis.
WNAB Bridgeport, Conn.	WCLO Janesville, Wis.	WLBR Lebanon, Pa.
KMYR Denver	KSAN San Francisco	WPEN Philadelphia, Pa.
WATR Waterbury, Conn.	WJBW New Orleans	WQUA Moline, Ill.
WJTN Jamestown, N. Y.	KLUF Galveston, Tex.	WTTS Bloomington, Ind.
WMEX Boston	WQQW Washington, D. C.	KJAY Topeka, Kan.
WVJS Owensboro, Ky.	KWQC Fort Worth, Tex.	WLS Lansing, Mich.
WAGC Chattanooga	WPTR Albany, N. Y.	WJPG Green Bay, Wis.

RA-TEL REPRESENTATIVES Inc.

New York 17—420 Lexington Ave. Tel.: Murray Hill 4-2549. Mgr.: James W. LeBaron.
Chicago 1—360 N. Michigan Ave. Tel.: Franklin 2-3719. Mgr.: Martin McGeehan.
Dallas 1—306 Empire State Bank Bldg. Tel.: Prospect 7-5280. Mgr.: Kenneth Sibson.
Los Angeles 28—607 S. Hill St. Tel.: Vandyke 7386. Mgr.: J. V. Fisler.
Atlanta 3—Rhodes Haverly Bldg. Tel.: Walnut 1334. Mgr.: Mrs. A. S. Grant.
Oklahoma City 1—First National Bldg. Tel.: 7-7417. Mgr.: C. M. Lintecum.
San Francisco 4—300 Montgomery St. Tel.: Douglas 4393. Mgr.: R. J. Birch.

Represents

WKYB Paducah, Ky.	WSAP Portsmouth-Norfolk, Va.	KBON Omaha
WLCS Baton Rouge, La.	WGIL Galesburg, Ill.	KORN Fremont, Neb.
WGNH Gadsden, Ala.	WFPG Atlantic City, N. J.	KOLN Lincoln, Neb.
WFOX Milwaukee	KXLR Little Rock, Ark.	WBMS Boston
WHBU Anderson, Ind.	KWEM West Memphis, Ark.	WIBX Utica, N. Y.*
WHOO Orlando, Fla.	WNOE New Orleans, La.	WPIR Pittsburgh
KNOE Monroe, La.		WHHH Youngstown, O.
KGBS Harlingen, Tex.		KTOP Topeka, Kan.
KSYL Alexandria, La.		

* Outside New York City.

PAUL H. RAYMER CO. Inc.

New York 17—366 Madison Ave. Tel.: Murray Hill 7-6540. Mgr.: Paul Tiemer.
Chicago 11—435 N. Michigan Ave. Tel.: Superior 7-4473. Partner: Fred C. Brokaw.
Boston 16—Statler Office Bldg. Tel.: Hubbard 2-3225. Mgr.: Robert C. Foster.
Detroit 26—28 W. Adams Ave. Tel.: Woodward 3-0764. Mgr.: Robert B. Rains.
San Francisco 4—Russ Bldg. Tel.: Douglas 2-8909. Mgr.: L. Ray Rhodes.
Hollywood 28—1680 N. Vine St. Tel.: Hudson 2-2376. Mgr.: Jack Gale.

Represents McClatchy Beeline, Arizona Broadcasting System

New England Major Market Group

WPRO Providence*	WAPA San Juan, P. R.	WBSB South Bend, Ind.*
WLAC Nashville	KFBK Sacramento, Calif.*	WGAN Portland, Me.*
WDRS Hartford*	KERN Bakersfield, Calif.*	WGUW Bangor, Me.*
KTAR Phoenix	KMJ Fresno, Calif.	WHK Cleveland*
KVOA Tucson	KWG Stockton, Calif.	WTAG Worcester, Mass.*
KTMS Santa Barbara, Calif.	WCAO Baltimore*	KXO El Centro, Calif.*
KCOY Santa Maria, Calif.	WBRC Birmingham*	WHKC Columbus, Ohio*
WKBN Youngstown, Ohio*	WDDO Chattanooga*	WHKK Akron
KMPC Los Angeles*	WTAC Flint, Mich.	WKJG Fort Wayne, Ind.*
WLOF Orlando, Fla.	WTOL Toledo*	WLAW Lawrence, Mass.*
WDNC Durham, N. C.*	KOH Reno	KIHO Sioux Falls, S. D.
WQXR New York, N. Y.*	KSPD San Diego*	KIOA Des Moines

* FM also.

SCHEERER & CO.

Chicago 1—35 E. Wacker Dr. Tel.: State 2-7942.
Detroit 2—3049 E. Grand Blvd. Tel.: Trinity 2-3914.
New York 17—441 Lexington Ave. Tel.: Murray Hill 2-2423.
WCTW (FM) New Castle, Ind. WSRK (FM) Shelbyville, Ind.

DUNCAN A. SCOTT AND CO.

Los Angeles 5—2978 Wilshire Blvd. Tel.: Dunkirk 8-4151. Mgr.: A. O. Dillenbeck Jr.
San Francisco 4—Mills Bldg. Tel.: Garfield 1-7950. Mgr.: Duncan A. Scott.

Represents

KMO Tacoma, Wash. KLAS Las Vegas, Nev.

Alaska Broadcasting System

Adam J. Young Jr. Inc. Pan American Broadcasting Co.

SEARS & AYER Inc.

Chicago—612 N. Michigan Ave. Tel.: Superior 7-8177.
New York—295 Madison Ave. Tel.: Murray Hill 9-2586-87-88.
Kansas City—15 W. Tenth St. Tel.: Victor 0021.
San Francisco—681 Market St. Tel.: Yukon 6-0621.
Los Angeles—5225 Wilshire Blvd. Tel.: York 8812.

Page 50 • 1950 Yearbook Number

Represents

WRFS Alexander City, Ala.	WSON Henderson, Ky.	KSDN Aberdeen, S. D.
WHMA Anniston, Ala.	WHOP Hopkinsville, Ky.	WLPM Suffolk, Va.
WLD Bessemer, Ala.	WCIF Madisonville, Ky.	WPUV Pulaski, Va.
WOLF Dothan, Ala.	WKTM Mayfield, Ky.	KSPR Casper, Wyo.
WJOI Florence, Ala.	WPAD Paducah, Ky.	KSDO San Diego, Calif.
WJBY Gadsden, Ala.	WROX Clarksdale, Miss.	WBYS Canton, Ill.
WFUN Huntsville, Ala.	WCBI Columbus, Miss.	WFRL Freeport, Ill.
WHBB Selma, Ala.	WGCM Gulfport, Miss.	KWFO Opelousas, La.
WTBC Tuscaloosa, Ala.	WMOX Meridian, Miss.	WGRO Bay City, Mich.
KWFC Hot Springs, Ark.	WJPR Greenville, Miss.	WNAG Grenada, Miss.
WLCR Torrington, Conn.	WELO Tupelo, Miss.	KIRX Kirksville, Mo.
WOKZ Alton, Ill.	WQBC Vicksburg, Miss.	WWHG Hornell, N. Y.
WCNT Centralia, Ill.	WROB West Point, Miss.	WGAI Elizabeth City, N. C.
WCVS Springfield, Ill.	KWOS Jefferson City, Mo.	KPDI Pampa, Tex.
WTOM Bloomington, Ind.	WMBH Joplin, Mo.	KTFS Texarkana, Tex.
	KTTS Springfield, Mo.	

Mid-South Network

WROX Clarksdale, Miss. WMOX Meridian, Miss. WROB West Point, Miss.
WCBI Columbus, Miss. WELO Tupelo, Miss. WNAG Grenada, Miss.

TAYLOR-BORROFF & COMPANY Inc.

Chicago 1—360 N. Michigan Ave. Tel.: State 2-5260. E. R. Borroff, Pres.; O. L. Ted Taylor, V. P.; Era Lewis, Secy.-Treas.
Atlanta 3—Palmer Bldg. Tel.: Cypress 1323. Mgr. Tony West.
Chicago 1—360 N. Michigan Ave. Tel.: State 2-5260. Mgr. Tom Peterson.
Dallas 1—M & W Tower. Tel.: Riverside 5663. Mgr.: Clyde Melville.
Los Angeles 13—2978 Wilshire Blvd. Tel.: Michigan 7571. Mgr.: Wilbur Eickelberg.
New York 18—500 Fifth Ave. Tel.: Pennsylvania 6-6857. Mgr.: John D. Allison.
Portland—4th & Oak Sts. Tel.: Broadway 3210. Mgr.: Frank J. McHugh Jr.
San Francisco—235 Montgomery St. Tel.: Douglas 2-1323. Mgr.: Hubbard Keenan.

Represents

KANS Wichita, Kan.	WKGW Weslaco, Texas	WIKK Erie, Pa.
KBUR Burlington, Iowa	KRMD Shepovort, La.	WINN Louisville, Ky.
KCMC Texarkana, Tex.	KROD El Paso, Tex.	WKBH La Crosse, Wisc.
KCSJ Pueblo, Col.	KTBC Austin, Tex.	WLIZ Bridgeport, Conn.
KEYS Corpus Christi, Tex.	KTBI Tacoma, Wash.	WLOS Asheville, N. C.
KFDY Wichita Falls, Tex.	KTKO Oklahoma City	WMAN Mansfield, Ohio
KFNF Shenandoah, Iowa	KTRE Luifkin, Tex.	WORD Spartanburg, S. C.
KFSA Fort Smith, Ark.	KTEI Sioux City, Iowa	WPAY Portsmouth, Ohio
KGGM Albuquerque, N. M.	KTSA San Antonio, Tex.	WTNB Birmingham, Ala.
KGNC Amarillo, Texas	KVSF Santa Fe, N. M.	WTNT Augusta, Ga.
KLRA Little Rock, Ark.	KWKC Abilene, Tex.	WTOB Winston-Salem, N. C.
KMLB Monroe, La.	WBML Macon, Ga.	Oklahoma Network, Okla.
KOME Tulsa, Okla.	WCOS Columbia, S. C.	Southwest Network, Tex.
KPHO Phoenix, Ariz.	WCOV Montgomery, Ala.	and New Mexico
	WDUZ Green Bay, Wisc.	
	WHBC Canton, Ohio	

WILLIAM TEMPLE

Kansas City, Mo.—15 W. 10th St. Tel.: Victor 0021.
(See The Walker Co. and Sears & Ayers lists)

TRACY-MOORE & ASSOC.

Los Angeles 28—6381 Hollywood Blvd. Tel.: Hollywood 9-5408.
San Francisco 4—79 Post St. Tel.: Exbrook 2-8033.
(Stations represented not available)

TRANSIT RADIO Inc.

Cincinnati 2—Union Trust Bldg. Tel.: Dunbar 7775. Board Chairman: Hulbert Taft Jr. Exec. V. P.: Richard C. Crisler. Asst.: Arnold C. Nygren.
St. Louis 1—800 N. 12th Blvd. Tel.: Chestnut 3700. Pres.: C. L. Thomas.
New York 17—250 Park Ave. Tel.: Murray Hill 8-3780. V. P. Charge Sales: Frank E. Pellegrin. East'n Sales Mgr.: William H. Ensign.
Chicago 1—35 E. Wacker Drive. Tel.: Financial 6-4281. West'n Sales Mgr.: Carlin S. French.

Represents

KCBC Des Moines	WBUZ (FM) Bradbury Heights, Md.	WIZZ (FM) Wilkes-Barre, Pa.
KCMO-FM Kansas City, Mo.	WCTS (FM) Cincinnati	WMAR-FM Baltimore
KPRC-FM Houston	WFMZ (FM) Allentown, Pa.	WMLL (FM) Evansville, Ind.
KTNV (FM) Tacoma, Wash.	WGTR (FM) Worcester, Mass.	WKJF (FM) Pittsburgh
KXOK-FM St. Louis	WIBW-FM Topeka, Kan.	WPHL Huntington, W. Va.
		WWDC-FM Washington

THE WALKER CO.

New York 17—347 Madison Ave. Tel.: Murray Hill 3-5830. Mgrs.: Wythe Walker, C. Otis Rawalt, Frederic E. Lake.
Chicago 1—360 N. Michigan Ave. Tel.: Andover 3-5771. Mgrs. Wythe Walker, A. Wm. Lee.
Kansas City 6—15 W. 10th St. Tel.: Victory 992. Mgr.: William Temple.
Los Angeles 5—672 S. Lafayette Park Pl. Tel.: Fairfax 3200. Mgr.: Harlan Oakes.
San Francisco 4—681 Market St. Tel.: Douglas 2-4475. Mgr.: J. Leslie Meek.
Boston—Little Bldg. Tel.: Hubbard 4419. Mgr.: Bertha Bannon.
Atlanta—333 Candler Bldg. Tel.: Lamar 7050. Mgrs.: Royal E. Penny, Frederic E. Lake.

Represents

WOLF Syracuse, N. Y.	WDEV Waterbury, Vt.	WAPX Montgomery, Ala.
WELM Elmira, N. Y.	WSCR Scranton, Pa.	WJRD Tuscaloosa, Ala.
WENE Binghamton-Endicott, N. Y.	WOTW Nashua, N. H.	KBWD Brownwood, Tex.
WSAY Rochester, N. Y.	KOCY Oklahoma City	KWRN Reno, Nevada
WDOS Oneonta, N. Y.	KAKC Tulsa, Okla.	WPJB-FM Providence, R. I.
WBRK Pittsfield, Mass.	KSEI Pocatello, Idaho	KXL Spokane, Wash.
WHYN Holyoke, Mass.	KFPW Ft. Smith, Ark.	KING Seattle, Wash.
	WJMS Ironwood, Mich.	

BROADCASTING • Telecasting

THE WALKER CO.—(Continued)

WNBH New Bedford, Mass.	WKIB Iron Mountain, Mich.	KXL Portland, Ore.
WLCB Muncie, Ind.	WDBC Escanaba, Mich.	KXLF Butte, Mont.
WJAG Norfolk, Neb.	WHDF Calumet, Mich.	WSPC Anniston, Ala.
KLPM Minot, N. D.	WWOD Lynchburg, Va.	WBBQ Augusta, Ga.
WRJN Racine, Wis.	KENT Shreveport, La.	WGEM Quincy, Ill.
WATW Ashland, Wis.	KLOU Lake Charles, La.	KAKE Wichita, Kan.
WGRG Louisville, Ky.	WTPS New Orleans, La.	WAFB Baton Rouge, La.
WKLX Lexington, Ky.	WTRF Bellaire-Wheeling, W. Va.	KFSB Joplin, Mo.

Upper Minnesota Broadcasting System
Pacific Northwest Broadcasters
Z Network, Montana
Georgia Economy Group
Oklahoma Group Broadcasters
The Aloha Network Hawaii

GEORGE W. WEBBER

Des Moines 9—407 5th Ave. Tel.: 2-0225.

Represents Iowa Stations

KWCR Cedar Rapids	KDEC Decorah	KFJB Marshalltown
KROS Clinton	KWDM Des Moines	KWPC Muscatine
KSWI Council Bluffs	KDTH Dubuque	KCOM Sioux City
KSIB Creston	KVFD Fort Dodge	KAYX Waterloo
KSTT Davenport	KOKX Keokuk	KBIZ Ottumwa
KICD Spencer		

WEED & CO.

New York—350 Madison Ave. Tel.: Murray Hill 7-7772. Mgr. Joseph J. Weed.
Chicago—203 N. Wabash Ave. Tel.: Randolph 6-7730. Mgr. C. C. Weed.
Detroit—Book Bldg. Tel.: Woodward 2-5382. Mgr.: Bernard Pearce.
San Francisco—68 Post St. Tel.: Yukon 6-1899. Mgr.: Lincoln T. Simonds.
Boston—Statter Bldg. Tel.: Hubbard 2-5677. Mgr.: Dana Baird.
Hollywood—6331 Hollywood Blvd. Tel.: Hillside 8611. Mgr.: Lincoln P. Simonds.
Atlanta—Palmer Bldg. Tel.: Cypress 4081. Mgr.: George Sweringen.

Represents Radio

WARD Johnstown, Pa.	KFBB Great Falls, Mont.	WCBM Baltimore, Md.
KIMA Yakima, Wash.	WMUR Manchester, N. H.	WVET Rochester, N. Y.
WTAD Quincy, Ill.	WMSA Massena, N. Y.	WLSL Roanoke, Va.
WKNA Charleston, W. Va.	WWNY Watertown, N. Y.	KCBC Des Moines, Ia.
WKMH Dearborn, Mich.	WRAL Raleigh, N. C.	WJMJ Montgomery, Ala.
WORZ Orlando, Fla.	WAKR Akron, O.	WIOU Kokomo, Ind.
WTIC Hartford, Conn.	WING Dayton, O.	WPLC Lake Charles, La.
WSUN St. Petersburg, Fla.	WIZE Springfield, O.	WGTM Wilson, N. C.
KTFY Twin Falls, Ida.	WERC Erie, Pa.	WIMA Lima, O.
WSOY Decatur, Ill.	WHGB Harrisburg, Pa.	KOME Tulsa, Okla.
WTAX Springfield, Ill.	KQV Pittsburgh, Pa.	WVAM Altoona, Pa.
WGBF Evansville, Ind.	WJAR Providence, R. I.	KSDN Aberdeen, S. D.
WBOW Terre Haute, Ind.	WACO Waco, Tex.	KRIO McAllen, Tex.
KGLO Mason City, Iowa	WCAX Burlington, Vt.	WJLS Beckley, W. Va.
KGGF Coffeyville, Kan.	WKWK Wheeling, W. Va.	WKTY La Crosse, Wis.
KALB Alexandria, La.	WBAY Green Bay, Wis.	WREN Topeka, Kan.
WRDO Augusta, Me.	New England Regional Network	WREX Duluth, Minn.
WLEZ Bangor, Me.	Texas State Network	WAAT Newark, N. J.
WCSH Portland, Me.	WKAT Miami Beach	WMAK Nashville, Tenn.
WORC Worcester, Mass.	WTMV East St. Louis, Ill.	WHBQ Memphis, Tenn.
WSLI Jackson, Miss.		

Represents TV

KTLA (TV) Los Angeles
WBKB (TV) Chicago
WATV (TV) Newark, N. J.
WJAR (TV) Providence, R. I.

Canadian Stations

CFAC Calgary, Alta.	CJCB Sydney, N. S.	CFCY Charlottetown, P. E. I.
CJCA Edmonton, Alta.	CKRC Winnipeg, Man.	CHAT Medicine Hat, Alta.
CFGP Grand Prairie, Alta.	CKSO Sudbury, Ont.	CFPL London, Ont.
CJOC Lethbridge, Alta.	CKOC Hamilton, Ont.	CFRA Ottawa, Ont.
CJAT Trail, B. C.	CKBI Prince Albert, Sask.	CKCV Quebec City
CKWX Vancouver, B. C.	CHAB Moose Jaw, Sask.	CKRM Regina, Sask.
CJVI Victoria, B. C.	CKCK Regina, Sask.	CKRN Kamloops, B. C.
CFBC St. John, N. B.	CKNB Campbellton, N. B.	CFJC Kelowna, B. C.
CFPA Port Arthur, Ont.	CFNB Fredericton, N. B.	CJCS Stratford, Ont.
CHNS Halifax, N. S.	CFCF Montreal, Que.	

GILBERT A. WELLINGTON

Seattle 4—1014 American Bldg. Tel.: Seneca 6882. Natl. Adv. Mgr.: Gilbert A. Wellington.

KFAR Fairbanks

KENI Anchorage

WESTERN RADIO SALES

San Francisco—79 Post St. Tel.: Yukon 6-4112. Mgr.: Jack Q. Hall.
Los Angeles—1213 No. Highland Ave. Tel.: Granite 0656. Mgr.: Benton Paschall.

Represents

KATO Reno, Nev. and following Calif. stations:	KXOC Chico	KVEN Ventura
KXOA Sacramento	KVON Napa	KSDO San Diego
KXOB Stockton	KVOE Santa Ana	KXRX San Jose
KYNO Fresno	KWSD Mount Shasta	KHUM Eureka
KSBW Salinas	KRNO San Bernardino	KCMJ Palm Springs
KCOK Tulare		
KAFY Bakersfield		

HELEN WOOD & COLTON

New York 17—551 Fifth Ave. Tel.: Murray Hill 7-5341.

Represents

WIBX Utica, N. Y.*	WHAT Philadelphia	WETB Johnson City, Tenn.
WCCM Lawrence, Mass.	WFKY Frankfort, Ky.	WSFC Somerset, Ky.
WBET Brockton, Mass.	WBTA Batavia, N. Y.	
WATN Watertown, N. Y.		

* New York area only.

BROADCASTING • Telecasting

WGN Chicago

New York—220 E. 42nd St. Tel.: Murray Hill 2-3033. Mgr.: Ben H. Berentson.

WLW Cincinnati

Chicago—360 N. Michigan Ave. Tel.: State 2-0366. Mgr.: Harry F. Albrecht.
New York—630 Fifth Ave. Tel.: Circle 6-1750. Mgr.: Warren Jennings.

Represents Radio

WLW Cincinnati

Represents TV

WLWT (TV) Cincinnati WLWC (TV) Columbus WLWD (TV) Dayton

ADAM J. YOUNG JR. Inc.

New York 16—22 E. 40th St. Tel.: Longacre 3-4660. Mgr.: Adam J. Young Jr.
Chicago 2—55 E. Washington St. Tel.: Andover 3-5448. Mgr.: Wm. J. Reilly.
Los Angeles 5—2987 Wilshire Blvd. Tel.: Michigan 6203. Mgr.: A. O. Dillenbeck Jr.
San Francisco 4—Mills Bldg. Tel.: Garfield 1-7950. Mgr.: Duncan A. Scott.

Represents Radio

CKLW Detroit, Mich.	WIBG Philadelphia, Pa.	WNOV York, Pa.
KLAC Los Angeles, Calif.	WJMO Cleveland, Ohio	KLER Rochester, Minn.
KYA San Francisco, Calif.	WKNE Keene, N. H.	KLIF Dallas, Tex.
WABI Bangor, Maine	WKRG Mobile, Ala.	WDAR Savannah, Ga.
WBNY Buffalo, N. Y.	WNEB Worcester, Mass.	WSNY Schenectady, N. Y.
WENT Gloversville, N. Y.	KRSC Seattle, Wash.	WPIC Youngstown, O.
WHIM Providence, R. I.	WFEA Manchester, N. H.	

Represents TV

KBTB (TV) Dallas KLEE-TV Houston KOTV (TV) Tulsa, Okla.
KING-TV Seattle

Canadian Stations

CFAB Windsor, N. S.	CHOV Pembroke, Ont.	CJOR Vancouver, B. C.
CFAR Flin Flon, Man.	CHRC Quebec, P. Q.	CKAC Montreal, Que.
CFCN Calgary, Alta.	CHSJ Saint John, N. B.	CKCH Hull, Que.
CFMV Brockville, Ont.	CJAD Montreal, Que.	CKLN Nelson, B. C.
CFOS Owen Sound, Ont.	CJBQ Belleville, Ont.	CKLW Windsor, Ont.
CFQC Saskatoon, Sask.	CJBR Rimouski, Que.	CKPR Fort William, Ont.
CFRB Toronto, Ont.	CJEM Edmundston, N. B.	CKRS Jonquiere, Que.
CFRN Edmonton, Alta.	CJFP Riviere de Loup, Que.	CHNO Sudbury, Ont.
CHLN Three Rivers, Que.		CHLT Sherbrooke, Que.
CHML Hamilton, Ont.	CJFX Antigonish, N. S.	CKTS Sherbrooke, Que.
CHNC New Carlisle, Que.	CJGX Yorkton, Sask.	CKRD Red Deer, Alta.

Smith-Davis



Directory of CANADIAN BROADCASTING STATION REPRESENTATIVES

JAMES L. ALEXANDER

Toronto, Ont.—100 Adelaide St., W. Tel.: Adelaide 9594. Mgr.: J. L. Alexander.
Montreal, Que.—Drummond Bldg. Tel.: Harbour 6448. Mgr.: Frank Edwards.

Represents

CKPC Brantford, Ont.	CJIC Sault Ste. Marie, Ont.	CKEN Kentville, N. S.
CKFI Fort Frances, Ont.	CHUM Toronto	CFAB Windsor, N. S.
CHVC Niagara Falls, Ont.	CKNX Wingham, Ont.	CFBC Saint John, N. B.
CKDO Oshawa, Ont.	CHLP Montreal	CJCY Calgary, Alta.

ALL-CANADA RADIO FACILITIES Ltd.

Toronto—Victory Bldg. Tel.: Elgin 2464. Mgr.: G. F. Herbert.
Montreal—Dominion Square Bldg. Tel.: Lancaster 6400. Mgr.: Burt Hall.
Winnipeg—Childs Bldg. Tel.: 926-861. Mgr.: P. H. Gayner.
Calgary, Alta.—Taylor, Pearson & Carson Bldg. Tel.: M-7691. Mgr.: H. R. Carson.
Vancouver, B.C.—198 W. Hastings St. Tel.: Marine 9542. Mgr.: J. E. Baldwin.

Represents

CJVI Victoria, B. C.	CFAC Calgary, Alta.	CFRB Toronto
CKWX Vancouver, B. C.	CJOC Lethbridge, Alta.	CJCS Stratford, Ont.
CHWK Chilliwack, B. C.	CHAT Medicine Hat, Alta.	CFRA Ottawa
CKPG Prince George, B. C.	CKBI Prince Albert, Sask.	CFCF Montreal
CFJC Kamloops, B. C.	CKCK Regina, Sask.	CFNB Campbellton, N. B.
CKOV Kelowna, B. C.	CKRM Regina, Sask.	CFNB Fredericton, N. B.
CJAT Trail, B. C.	CKRW Winnipeg, Man.	CFCY Charlottetown, P. E. I.
CFGP Grande Prairie, Alta.	CFPL London, Ont.	CJLS Yarmouth, N. S.
CJCA Edmonton, Alta.	CKSO Sudbury, Ont.	CHNS Halifax, N. S.
	CKOC Hamilton, Ont.	CJCB Sydney, N. S.

ASSOCIATED BROADCASTING CO. Ltd.

Toronto, Ont.—1139 Bay St. Tel.: Princess 1111. Mgr.: M. Raymond.
(General Canadian station representation non-exclusive)

CANADIAN BROADCASTING CORPORATION

Toronto—354 Jarvis St. Tel.: Midway 5481. Commercial Mgr.: E. A. Weir.
Montreal—1231 St. Catherine St., W. Tel.: Plateau 7181. Commercial Mgr.—French Network: M. Valiquette.

Represents CBC-owned stations

CBN St. John's, Nfld.	CBJ Chicoutimi, Que.	CBW Manitoba
CBG Gander, Nfld.	CBV Quebec, Que.	CBK Watrous, Sask.
CBT Grand Falls, Nfld.	CBM Montreal, Que.	CBX Alberta
CBY Corner Brook, Nfld.	CBF Montreal, Que.	CBR Vancouver, B. C.
CBI Sydney, N. S.	CBO Ottawa, Ont.	CFPR (leased), Prince Rupert, B. C.
CBH Halifax, N. S.	CBL Toronto, Ont.	
CBA Sackville, N. B.	CJBC Toronto, Ont.	

RADIO ADVERTISERS

We represent 22 important markets, covered by 23 live Independent Radio Stations. Their keynote—and ours—is Service to their advertisers. May we discuss your radio plans with you?

HORACE N. STOVIN

AND COMPANY

Radio Station Representatives

Montreal • Toronto • Winnipeg

JOS A. HARDY & CO., Ltd.

Quebec—39 St. John St. Tel.: 3-6693.
Montreal—1015 Dominion Square Bldg. Tel.: Harbour 2515.
Toronto—80 Richmond St., W. Tel.: Adelaide 8482.

Represents

CHRC Quebec	CKTS Sherbrooke, Que.	CKRS Jonquiere, Que.
CHNC New Carlisle, Que.	CHLN Trois-Rivieres, Que.	CKBL Matane, Que.
CHLT Sherbrooke, Que.		

Trans-Quebec Radio Group

JOHN N. HUNT & ASSOC.

Vancouver, B. C.—505 Dunsmuir St. Tel.: Pacific 2888. Mgr. John Hunt.

Represents in Vancouver

CKFI Fort Frances, Ont.	CKGB Timmins, Ont.	CHEF Granby, Que.
CFPA Port Arthur, Ont.	CJAD Montreal, Que.	CKCV Quebec City, Que.
CKEY Toronto, Ont.	CHAD Amos, Que.	CJSO Sorel, Que.
CKWS Kingston, Ont.	CKRN Rouyn, Que.	CFAB Windsor, N. S.
CJKL Kirkland Lake, Ont.	CKVD Val d'Or, Que.	CHML Hamilton, Ont.
	CHGB Ste Anne de la Pocatiere	CJCH Halifax, N. S.
CFCH North Bay, Ont.	CHUB Nanaimo, B. C.	CKOK Penticon, B. C.
CHEX Peterborough, Ont.	CKOY Ottawa, Ont.	CHVC Niagara Falls, Ont.
CHOK Sarnia, Ont.	CKCH Hull, Que.	CKSB St. Boniface, Man.
CKTB St. Catharines, Ont.		CKNX Wingham, Ont.

(Also see Radio Representatives Ltd. list)

NATIONAL BROADCAST SALES

Toronto—Canadian Bank of Commerce Bldg. Tel.: Adelaide 8895. Mgr.: Jack M. Davidson.
Montreal—Medical Arts Bldg. Tel.: Fitzroy 2439. Mgr.: R. A. Leslie.

Represents

CFCH North Bay, Ont.	CKBB Barrie, Ont.	CKMO Vancouver, B. C.
CKGB Timmins, Ont.	CHAD Amos, Que.	CHUB Nanaimo, B. C.
CKVD Val d'Or, Que.	CKEY Toronto (Montreal only)	CJCH Halifax
CJKL Kirkland Lake, Ont.	CFPA Port Arthur, Ont.	CJFX Antigonish
	CJAD Montreal	CHML Hamilton (Montreal only)
CKWS Kingston, Ont.	CKTB St. Catharines, Ont.	ZFY Georgetown, Br. Gulana
CKRN Rouyn, Que.	CHOK Sarnia, Ont.	
CHEX Peterborough, Ont.		
CKOY Ottawa, Ont.		

RADIO REPRESENTATIVES, Ltd.

Toronto—4 Albert St. Tel.: Waverly 6151. Mgr.: J. Slatter.
Montreal—Dominion Sq. Bldg. Tel.: Harbour 7811. Mgr.: W. Dippie.
Vancouver—505 Dunsmuir St. Tel.: Pacific 2888. Mgr.: John Hunt.
Winnipeg—Lindsay Bldg. Tel.: 9-6374. Mgr. A. J. Messner.

Toronto, Montreal, Winnipeg and Vancouver Representation

CFCN Calgary, Alta.	CKRD Red Deer, Alta.	CJIB Vernon, B. C.
CFRN Edmonton, Alta.	CKPR Fort William, Ont.	CKX Brandon, Man.
CKNW New Westminster, B. C.	CJAV Port Albert, B. C.	CHLO St. Thomas, Ont.
	CJOB Winnipeg, Man.	CJOY Guelph, Ont.
CFQC Saskatoon, Sask.	CJDC Dawson Creek, B. C.	CKBW Bridgewater, N. S.
CJRW Summerside, P.E.I.		

OMER RENAUD & CO. Ltd.

Montreal—1411 Stanley St. Tel.: Belair 9541. Mgr.: Omer Renaud.
Toronto—53 Yongue St. Tel.: Plaza 2681. Mgr.: John R. Fox.

Represents

CKCH Hull, Que.	CKRN Rouyn, Que.	CHEF Granby, Que.
CJSO Sorel, Que.	CKVD Val d'Or, Que.	CKBL Matane, Que.
CHGB Ste. Anne de la Pocatiere, Que.	CHAD Amos, Que.	CKSB St. Boniface, Man.
CJFP Riviere du Loup, Que.	CKCV Quebec	CHFA Edmonton, Alta.
		CHRL Ruberval, Que.

HORACE N. STOVIN & CO.

Toronto—Victory Bldg. Tel.: Adelaide 9184. Mgr.: H. N. Stovin.
Montreal—Keefe Bldg. Tel.: Plateau 8749. Mgr.: R. J. Judge.
Winnipeg—Radio Station CKY. Mgr.: J. A. Whitehouse.
Vancouver—846 Howe St. Tel.: Marine 6464. Mgr.: J. W. Stovin.

Represents

CKY Winnipeg	CJBQ Belleville, Ont.	CJRL Kenora, Ont.
CFAR Flin Flon, Man.	CKVL Verdun, Que.	CHOV Pembroke, Ont.
CHSJ St. John, N. B.	CKSF Cornwall, Ont.	CFJM Brockville, Ont.
CKCW Moncton, N. B.	CJBR Rimouski, Que.	CJBC Toronto
CFOS Owen Sound, Ont.	CFOR Orillia, Ont.	CJNB North Battleford, Sask.
CFPR Prince Rupert, B. C.	CJEM Edmundston, N. B.	CHAB Moose Jaw, Sask.
CJGK Yorkton, Sask.	CJOR Vancouver, B. C.	CKPR Fort Williams (Winnipeg only)
(Toronto and Montreal only)	CKLW Windsor, Ont.	WOCM St. John's, Nfld.
	(Toronto, Montreal, Winnipeg, Vancouver)	

WILLIAM WRIGHT

Toronto—Victory Bldg. Tel.: Adelaide 8481. Mgr.: William Wright.
Montreal—Empire Life Bldg. Tel.: Harbour 7240. Mgr.: Walter Dales.

Represents

CKCL Truro, N. S.	CKOX Woodstock, Ont.	CKOK Penticon, B. C.
CKCR Kitchener, Ont.	(For Toronto & Montreal)	(For Toronto & Montreal)
CKAC Montreal (In Toronto only)	CHNO Sudbury, Ont. (For Toronto & Montreal)	CKMR Newcastle, N. B.

This is what it takes to make good broadcast equipment

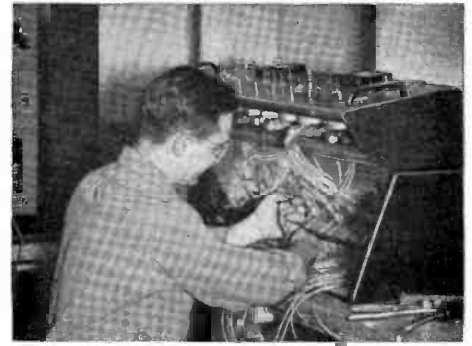

Console Assembly. Skilled workmanship that is assured by having experienced employees, trained to build equipment just one way—the best.



Welding aluminum by the inert arc method. Modern processes that save time and at the same time assure better construction. By these means savings are made and passed on in the form of high quality products.

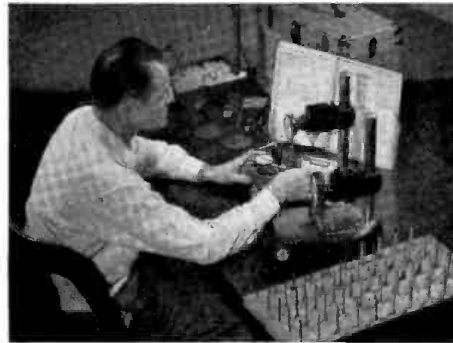

Checking tolerances on production machined parts. Precision testing at every step of manufacturing to be sure each part meets specifications and will perform at top efficiency in the finished product.



Taking performance data on a 1 kilowatt broadcast transmitter. Final test of the completed product using the latest and best apparatus known. This assures the finest overall performance.

Collins Main Plant. A modern plant to provide the best working conditions and every technique of research, engineering and manufacturing related to the present skill and future refinement of broadcasting.



COLLINS RADIO COMPANY, Cedar Rapids, Iowa

11 West 42nd St.
NEW YORK 18

2700 West Olive Ave.
BURBANK

M & W Tower
DALLAS 1

Dogwood Rd., Fountain City
KNOXVILLE

HOW TO APPLY FOR A BROADCAST STATION LICENSE

Pertaining to AM, FM, Television and Related Services

Any qualified citizen, firm or group may apply to the Federal Communications Commission for authority to construct a commercial standard, frequency modulation or television broadcast station.

Licensing of these facilities is prescribed by the Communications Act of 1934, which sets up certain basic requirements. In general, applicants must satisfy the Commission that they are legally, technically and financially qualified, and that operation of the proposed station would be in the public interest, convenience and necessity.

The application procedure is substantially the same whether the facility sought is an FM, television or standard broadcast station.

The licensing procedure is detailed in Part 1 of the Commission's "Rules Relating to Organization and Practice and Procedure," while station operation is covered by Part 3, "Rules Governing Broadcast Services," and "Standards of Good Engineering Practice."

Selecting a Frequency

The Communications Act recognizes broadcasting as a competitive industry and invests the Commission with the responsibility of allocating facilities so as to provide a fair, efficient and equitable distribution of radio service.

Standard broadcast stations operate on "local," "regional," or "clear" channels. Local stations are of 100 to 250 watts power and serve smaller communities; stations of 500 watts to 5 kilowatts cover larger centers of population and surrounding areas; stations of 10 to 50 kilowatt maximum power are for large area coverage, particularly at night.

To determine whether an AM frequency is available for assignment in a particular area, it is necessary for the applicant to have a channel study made by a competent engineer. The Commission's engineering personnel cannot undertake to make such studies for prospective applicants.

In the case of FM, the Commission has tentatively allocated geographic blocks of frequencies to accommodate Class A stations (community) and Class B stations (metropolitan and rural). Except in the larger cities, the demand for FM stations has not yet exceeded the supply of available frequencies.

Television channels are apportioned for "metropolitan," "community," and "rural" service. For more than a year, however, TV applications have been held up pending a review of engineering standards and allocations, final action on which is expected in 1950.

Applying for a Construction Permit

Once a prospective licensee has decided the type of station he wants to apply for, the next step is to make application for a construction permit. This application must be in writing, on a form (No. 301) supplied by the Commission. This form requires information about the citizenship and character of the applicant, as well as his financial, technical and other ability to construct and operate a station, plus details about the transmitting apparatus to be used and the proposed new service. Triplicate copies are required, two of which must be executed under oath or affirmation.

Application Processing

Applications are, in turn, studied by the Commission's Engineering, Law, and Accounting Bureaus, which make their respective recommendations to the Commission. The system of processing is so designed that applications are considered by different categories in the order in which received.

If, upon examination of an application, the Commission determines that there are no engineering conflicts and that all other requirements are met, the application is granted and a construction permit is issued.

Television and FM stations are permitted interim operation with less than the prescribed power.

All construction authorizations are subject to approval of transmitter site and antenna system by Civil Aeronautics Administration.

Hearings

However, where it appears that interference would be caused to another station above the degree prescribed in the Commission's "Standards of Good Engineering Practice," or if other serious questions are involved, a hearing is usually required before a determination can be made. Sometimes, also, a hearing is necessary because two or more applicants request the same frequency.

In designating an application for hearing, the Commission gives public notice of the issues raised for the information of the applicant and other

CONCERNING FCC RULES & REGULATIONS

"How to Apply for a Broadcast Station License" is a comprehensive and concise statement prepared with the assistance of the FCC Law Bureau which explains in lay language the procedures involved in making application for the various types of broadcast licenses.

Published in easy reference form starting on page 462 are excerpts of the FCC Rules and Regulations most frequently used. Further information concerning rules and regulations may be obtained at the office of the Secretary, FCC, New Post Office Bldg., Washington 25, D. C.

parties who may be concerned. Prior to the hearing, requests may be made for enlargement of the issues, to amend the application, or to permit other parties to intervene.

Usually the hearing date is not fixed until after the applicant agrees to such a hearing and has filed for his appearance. It may, however, be designated in the original notice. The notice generally allows the applicant a period of 30 days or more in which to prepare. Even after being designated for hearing, an applicant may find it possible to satisfy the issues raised by amending his application, especially if there are engineering considerations.

Hearings are customarily conducted by an examiner. Individual or partnership applicants may appear in person or by counsel, but corporation applicants must be represented by attorney.

Request for Argument

Within 20 days after the close of the hearing, each party, as well as the FCC general counsel, has the privilege of filing proposed findings of fact and conclusions in support of his contentions. After review of evidence and statements, the hearing examiner issues an initial decision.

If he wishes to contest the initial decision, the applicant or any other interested party has 20 days from the announcement of the decision to file exceptions and ask for oral argument before the Commission. In all cases heard by an examiner the Commission will hear oral argument on request of either party. After oral argument the Commission may adopt, modify or reverse the examiner's initial decision. Within 20 days thereafter, any party involved may petition for rehearing.

If no exceptions are filed and the Commission does not initiate a review, the examiner's initial decision becomes effective 40 days after it is issued, unless otherwise ordered by the Commission.

Construction Permit

When and if an application meets statutory and other requirements, it is granted and a construction permit is issued. The latter specifies a date for commencement and another for completion of construction. A maximum of 60 days from date of grant is provided in which construction shall begin, and a maximum of six months thereafter as the time for completion (or 8 months in all). If the permittee is unable to build his station within the time specified he can apply (on Form 701) for additional time, stating the reasons. Upon completion of construction, the permittee can engage in equipment tests.

License

The final step is to apply (on Form 302) for the actual license. The applicant must show compliance with all terms, conditions, and obligations set forth in the application and the construction permit. After applying for a license, the holder of a construction permit can conduct program tests. A station license is then issued if no new cause or circumstance has come to the attention of the Commission that would make operation of the station contrary to the public interest.

Standard and FM stations are licensed for the statutory limit of three years; television stations for one year. Applications for renewal of license are made on Form 303.

(FCC Rules and Regulations on Page 462)

BROADCASTING • Telecasting

CONSULTING RADIO AND TELEVISION ENGINEERS

GEORGE P. ADAIR—1833 M St., N.W., Washington 6, D. C. Tel.: Executive 1230. Associated Engineers: Robert E. Ritch, Warren Taylor, Roy Robbins, Edward J. Mueller.

BEN ADLER—720 Milton Road, Rye, N. Y. Tel.: 7-1413. (Engineering design and construction.)

ANDREW CORP.—363 E. 75th St., Chicago 19. Tel.: Triangle 4-4400.

STUART L. BAILEY—Jansky & Bailey, Executive Offices: National Press Bldg., Washington 4, D. C. Tel.: Metropolitan 5411. Laboratories: 1339 Wisconsin Ave., N.W., Washington 7, D. C. Tel.: Adams 2414. Partner: C. M. Jansky Jr. Senior Radio Engineers: Delmar C. Ports, Frank T. Mitchell Jr., Oscar W. B. Reed Jr., Dan O. Hunter, Edward Webster, William B. Frazier, Neil J. Schairer, Raymond E. Rohrer, John J. Renner.

GEORGE B. BAIREY—1757 K St., N.W., Washington 6, D. C. Tel.: National 0196.

LEE E. BAKER—826-828 Landers Bldg., Springfield 4, Mo. Tel.: 2-1951.

WILLIS C. BEECHER—Kear & Kennedy, 1703 K St., N.W., Washington 6, D. C. Tel.: Sterling 7932.

WILLIAM E. BENNS JR.—3738 Kanawha St., N.W., Washington, D. C. Tel.: Ordway 8071.

BERNARD ASSOCIATES—5010 Sunset Blvd., Hollywood 27. Tel.: Normandy 2-6715. Branch: Edward Iannelli, associate field office: 86 Webster Ave., Harrison, N. Y.

A. R. BITTER—4125 Monroe St., Toledo 6, Ohio. Telephone: Kingswood 7631. A. R. Bitter, president.

CARMINE & BITTER ENGINEERS—2332 Ontario Rd., N.W., Washington 9, D. C. Tel.: Hudson 7513. Partners: Robert L. Carmine, Ralph H. Bitter.

CHAMBERS & GARRISON—1519 Connecticut Ave., Washington 6, D. C. Tel.: Michigan 2261.

COMMERCIAL RADIO EQUIPMENT CO.—Eastern Office: International Bldg., Washington 4, D. C. Tel.: District 1319. Everett L. Dillard, general manager; Edward F. Lorentz and Irl T. Newton, associate engineers. Midwest Office: Porter Bldg., Kansas City 2, Mo. Tel.: Logan 8821. Allocation engineering: Robert Wolfskill, manager.

CRAVEN, LOHNES & CULVER—Munsey Bldg., Washington 4, D. C. Tel.: District 8215. T. A. M. Craven, George M. Lohnes, Ronald H. Culver, LaVerne M. Poast, Max V. Holley.

JOHN CREUTZ—Room 319, Bond Bldg., Washington 5, D. C. Tel.: Republic 2151.

MURRAY G. CROSBY—Crosby Labs, 126 Old Country Rd., Mineola, N. Y. Tel.: Garden City 7-0284. Associates: John F. Dreyer Jr., C. Hunter McShan. A. EARL CULLUM JR.—Highland Park, Dallas 5, Tex. Tel.: Justin 8-6108. D. A. Peterson, C. M. Daniell, R. L. Hammett, partners; J. G. Rountree, O. S. Droke, L. E. Cox, associate engineers.

GEORGE C. DAVIS—Munsey Bldg., Washington 4, D. C. Tel.: District 8456. Associates: Joe W. Collier, Julius Cohen, Albrecht P. Barsis, Ralph Dippeil, A. F. Barghausen, Walter L. Davis.

DOOLITTLE RADIO INC.—7421 S. Loomis Blvd., Chicago 36, Ill. Tel.: Radcliffe 3-4100. Officials: E. M. Doolittle, president.

A. JAMES EBEL—212 S. Jefferson St., Peoria, Ill. Tel.: 7133. Associates: George Pyle, Willard Hall, and Dale King.

WILLIAM L. FOSS INC.—927 15th St., N.W., Washington 5, D. C. Tel.: Republic 3883. William L. Foss, president; John A. Moffett, vice-president; Edmund E. Pendleton, Harold D. Plunkett, radio engineers.

GAUTNEY, RAY & PRICE—1052 Warner Bldg., Washington 4, D. C. Tel.: National 7757. Partners: George E. Gautney, Homer A. Ray Jr., John C. Price.

GILLE BROS.—1108 Lillian Way, Hollywood 38. Tel.: Gladstone 6178. Benson D. Gilie, C. E. Taylor.

GLENN D. GILLET & ASSOC.—National Press Bldg., Washington 4, D. C. Tel.: National 3373. Partners: Glenn D. Gillett, William E. Plummer, E. M. Hinsdale Jr., Paul Bergquist.

PAUL F. GODLEY—Paul Godley Co., P. O. Box "J", Upper Montclair, N. J. Tel.: Montclair 3-3000. Laboratories: Great Notch, N. J. Tel.: Little Falls 4-1000. Associates: Barton C. Coffman, Paul F. Godley Jr., Robert F. Holtz, Carson W. Kaufman, J. G. Littlefield, George H. Wagner.

DR. ALFRED N. GOLDSMITH—597 Fifth Ave., New York 17. Tel.: Plaza 3-4150.

JOHN B. HEFFELFINGER—815 E. 83rd St., Kansas City 5, Mo. Tel.: Hilland 7010.

JOHN V. L. HOGAN—155 Perry St., New York 14. Tel.: Chelsea 2-7655.

W. J. HOLEY—1146 Briarcliff Pl., N. E., Atlanta, Ga. Tel.: Atwood 3328.

ROYAL V. HOWARD—Honolulu, Hawaii.

FREDERICK S. HOWES, PH.D.—McGill Univ. Engineering Bldg., Montreal, Que., Canada.

GUY C. HUTCHESON—1100 W. Abram St., Arlington, Tex. Tel.: 1218.

C. M. JANSKY JR.—Jansky & Bailey, Executive Offices: National Press Bldg., Washington 4, D. C. Tel.: Metropolitan 5411. Laboratories: 1339 Wisconsin Ave., N.W., Washington 7, D. C. Tel.: Adams 2414. Partner: Stuart L. Bailey, Senior Radio Engineers: Delmar C. Ports, Frank T. Mitchell Jr., Oscar W. B. Reed Jr., Dan O. Hunter, Edward Webster, William B. Frazier, Neil J. Schairer, Raymond E. Rohrer, John J. Renner.

WALTER F. KEAN—40 East Ave., Riverside, Ill. Tel.: Riverside 6652. Associate: W. J. Gemulla.

FRANK G. KEAR—Kear and Kennedy, 1703 K St., N.W., Washington 6, D. C. Tel.: Sterling 7932.

JOHN J. KEEL—Warner Bldg., Washington 4, D. C. Tel.: National 6513. Associates: Paul L. Mueller.

ROBERT L. KENNEDY—Kear & Kennedy, 1703 K St., N.W., Washington 6, D. C. Tel.: Sterling 7932.

WORTHINGTON C. LENT—5209 Roosevelt St., Bethesda 14, Md. Tel.: Oliver 8200.

RUSSELL P. MAY—1422 F St., N.W., Washington 4, D. C. Tel.: Republic 3984.

McINTOSH & INGLIS—710 14th St., N.W., Washington 5, D. C. Tel.: Metropolitan 4477. Laboratory: 910 King St., Silver Spring, Md. Tel.: Juniper 7-9200. Partners: Frank H. McIntosh, Andrew F. Inglis, Associates: James R. Croy, Robert E. Baluta, Elizabeth L. Dahlberg, Ambrose J. Cavegn, Laboratory Engineers: Gordon J. Gow, Maurice L. Finchaud, Kenneth Owen, Robert E. Aukers.

DIXIE B. MCKEY AND ASSOC.—1820 Jefferson Pl., N.W., Washington 6, D. C. Tel.: Republic 7236.

McNARY & WRATHALL—National Press Bldg., Washington 4, D. C., and Santa Cruz, Calif. Washington Tel.: District 1205. James C. McNary, Grant R. Wrathall; Santa Cruz, 1407 Pacific Ave. Tel.: 5040.

PHILIP MERRYMAN & ASSOC.—Ardsley, N. Y. Tel.: Dobbs Ferry 3-2373.

E. C. PAGE CONSULTING RADIO ENGINEERS—Bond Bldg., Washington 5, D. C. Tel.: Executive 5670. Partners: Estery C. Page, Joseph A. Waldschmitt.

DALE POLLACK—352 Pequot Ave., New London, Conn. Tel.: 2-4224.

PREISMAN & BISER—3308 14th St., N. W., Washington 10, D. C. Tel.: Adams 7299.

RADIO ENGINEERING CO.—1355 Market St., San Francisco. Tel.: Market 1-8173. Owner: Norwood J. Patterson.

GARO W. RAY—Hilltop Drive, Stratford, Conn. Tel.: 7-2465.

WILLIAM E. RICHARDSON—1935 S. W. Moss St., Portland 1, Ore. Tel.: Cherry 4070. Officers: Wm. E. Richardson, Howard Endicott.

ANDREW D. RING—A. D. Ring & Co., Munsey Bldg., Washington 4, D. C. Tel.: Republic 2347, Andrew D. Ring, Associates: Howard T. Head, Stephen W. Kasher, Raymond P. Aylor Jr., Charles L. Keller, Charles S. Wright, Raymond Dordal, David W. Dinwoode.

HAROLD B. ROTHROCK—Citizens National Bank Bldg., Bedford, Ind. Tel.: 4270.

SILLIMAN & BARCLAY—1011 New Hampshire Ave., Washington, D. C. Tel.: Republic 6646.

HAROLD C. SINGLETON—2073 S.W. Park Ave., #127, Portland 1, Ore.

LYNNE C. SMEBY—820 13th St., N.W., Washington 5, D. C. Tel.: Executive 8073.

T & T RADIO MEASUREMENTS CO.—1228 East Compton Blvd., Compton 1, Calif. Tel.: Nevada 6-3170. Jay E. Tapp and Raymond B. Torian, co-owners.

ARCHER S. TAYLOR—P. O. Box 1479, Missoula, Mont. Tel.: 8562.

UNIVERSAL RESEARCH LABS.—One Nob Hill Circle, San Francisco 6, Tel.: Douglas 2-5390. Alfred E. Towne and Staff.

WELDON & CARR—1605 Connecticut Ave., N.W., Washington 9, D. C. Tel.: Michigan 4151. Branch Office: 1728 Wood St., Dallas 1, Tex. Tel.: Riverside 3611. James O. Weldon, Lester H. Carr, B. Ross Hilker, Jules Cohen, Edward N. Sidor, Eugene E. Arnold, James E. Hardwick, B. W. Griffith Jr., C. A. Brauner Jr.

HERBERT L. WILSON—1025 Connecticut Ave., N.W., Washington 6, D. C. Tel.: National 7161.

W. M. WITTY—6923 Snider Plaza, Dallas 5, Tex. Tel.: Lakeside 7118.

MARTIN R. WILLIAMS—1131 N. Delaware St., Indianapolis 2, Tel.: Riley 8057.

NATHAN WILLIAMS—20 Algoma Blvd., Oshkosh, Wis. Tel.: Blackhawk 22. Engineers: Robert Zehlke, Harold Zimmerman.

RAYMOND M. WILMOTTE—Raymond M. Wilmotte Inc., 1469 Church St., N.W., Washington 5, D. C. Tel.: Decatur 1231.

MEMBERS OF THE FEDERAL COMMUNICATIONS BAR ASSOCIATION

(For Officers see page 517)

A
Adams, Merl G., 135 S. LaSalle St., Chicago.
Ameck, Gordon Burt, 40 N. Main St., Salt Lake City.
Albertson, Fred W., Dow, Lohnes & Albertson, Munsey Bldg., D. C.
Alter, William, Alter & Wadell, Alamo Natl. Bldg., San Antonio.
Ashby, A. L., 7 Sunny Brae Place, Bronxville 8, N. Y.
Askins, Gerson, 175 State St., Springfield, Mass.

B
Bailey, Clyde S., Independent Telephone Assn., Munsey Bldg., D. C.
Baker, Philip M., Baker & Thompson, 1411 Pa. Ave., N. W., D. C.
Baldwin, James W., Office of Chief Signal Officer, Pentagon Bldg., D. C.
Barnes, Maurice R., Barnes & Neilson, Munsey Bldg., D. C.
Baron, Theodore, Arthur W. Scharfeld, Natl. Press Bldg., D. C.
Beebe, Raymond N., Davies, Richberg, Beebe, Busick & Richardson, 815 15th St., N. W., D. C.
Beelar, Donald C., Kirkland, Fleming, Green, Martin & Ellis, Natl. Press Bldg., D. C.
Bennett, Andrew W., 820 13th St., N. W., D. C.

Bergson, Philip, Woodward Bldg., D. C.
Berk, S. Bernard, First Central Tower, Akron, O.
Berkman, Jack N., Sinclair Bldg., Steubenville, O.
Beznor, Lee K., 808 N. 3d St., Milwaukee, Wis.
Bingham, Herbert M., Bingham, Collins, Porter & Kistler, Tower Bldg., D. C.
Bittinger, Harvey, Insurance Exchange Bldg., Des Moines.
Blanton, Wm. N., Jr., Butler & Binion, Gulf Bldg., Houston.
Bloch, Roger S., 77 W. Washington St., Chicago.
Blodgett, Harold E., 408 State St., Schenectady.
Blum, William, Jr., 1741 K St., N. W., D. C.
Bohannon, Ross, Gormley, Bohannon, Ragsdale & Prescott, 1517 Commerce St., Dallas.
Booth, Robert M., Jr., Bingham, Collins, Porter & Kistler, Tower Bldg., D. C.
Borut, Frank, 222 Broadway, New York.
Boyle, Thomas F., Boyle, Feller, Stone & McGivern, 25 Broad St., New York 4.
Brady, John B., Colorado Bldg., D. C.
Brauner, Julius F., CBS, 485 Madison Ave., New York.

Breene, Samuel A., Breene & Jobson, First Natl. Bank Bldg., Oil City, Pa.
Brenner, Jacob, 393 7th Ave., New York 1.
Bronson, William H., Commercial Bldg., Shreveport, La.
Brown, James Harvey, 364 N. Ridgewood Pl., Los Angeles 4.
Brown, Thad H., Jr., Roberts & McInnis, Mayflower Office Bldg., D. C.
Bugay, Paul E., Evans Bldg., D. C.
Burgess, Kenneth F., Ill. Bell Tel. Co., 212 W. Washington St., Chicago 6.
Burke, Eugene L., Hayes & Hayes, Munsey Bldg., D. C.
Burney, Cecil E., Driscoll Bldg., Corpus Christi.
Burstein, Herbert, 200 W. 34th St., New York.
C
Caldwell, Louis G., Kirkland, Fleming, Green, Martin & Ellis, Natl. Press Bldg., D. C.
Callister, Reed E., 650 S. Spring St., Los Angeles.
Canfield, Austin F., Woodward Bldg., D. C.
Cannon, David H., 650 S. Spring St., Los Angeles.
Carr, John P., Dow, Lohnes & Albertson, Munsey Bldg., D. C.
Carrigan, Joe B., KWFT, Wichita Falls, Tex.
Carson, Byron G., Tower Bldg., D. C.

Carter, Chauncey P., Jr., Kirkland, Fleming, Green, Martin & Ellis, Natl. Press Bldg., D. C.
Case, Norman S., Southern Bldg., D. C.
Chopnick, Max, 9 E. 46th St., New York.
Claggett, John F., Claggett & Schilz, 1424 K St., N. W., D. C.
Cleary, Leslie A., Cleary & Zeff, Stanislaus County Office Bldg., Modesto, Calif.
Clinton, John Hart, Crocker Bldg., San Francisco.
Cobb, A. Dale, Justice Dept., D. C.
Cohen, Lester, Hogan & Hartson, Colorado Bldg., D. C.
Cohen, Wallace M., 1822 Jefferson Pl., D. C.
Cohn, Marcus, Cohn & Marks, 1420 New York Ave., N. W., D. C.
Coleman, James J., Canal Bank Bldg., New Orleans.
Collin, Ralph F., Rosenman, Goldmark, Cohn & Kaye, 165 Broadway, New York.
Colladay, E. F., Colladay, Colladay & Wallace, 1331 G St., N. W., D. C.
Collins, Clayton Braswell, 1025 Vermont Ave., N. W., D. C.
Compre, Thomas H., NBC, Merchandise Mart, Chicago.
Conrad, Edwin, Gay Bldg., Madison, Wis.

(Continued on page 58)

a symbol of . . .

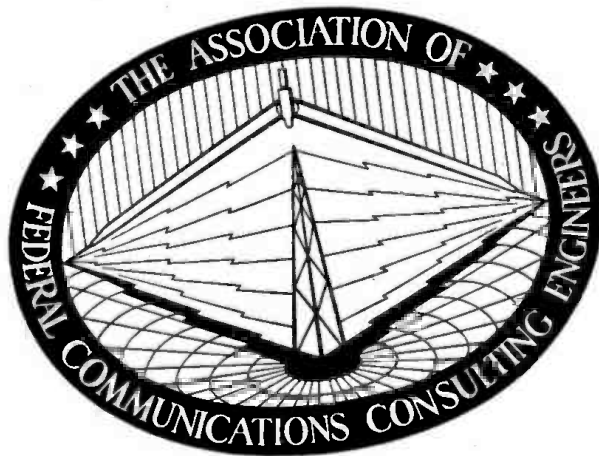

THIS ASSOCIATION WAS FOUNDED TO ENCOURAGE
AND MAINTAIN HIGH STANDARDS OF COMPETENCE
AND INTEGRITY OF PROFESSIONAL CONDUCT, IN
ORDER THAT THE BEST INTERESTS OF THE
PUBLIC AND THE INDUSTRY SHALL BE SERVED.

The Association of
FEDERAL COMMUNICATIONS CONSULTING

ENGINEERING INTEGRITY

ARTICLE XII CANONS OF ETHICS

Foreword

"Honesty, justice and courtesy form a moral philosophy which, associated with mutual interest between men, constitutes the foundation of ethics. The engineer should recognize such a standard, not in passive observance, but as a set of dynamic principles guiding his conduct and way of life. It is his duty to practice his profession according to those Canons of Ethics.

"As the keystone of professional conduct is integrity, the engineer will discharge his duties with fidelity to the public, his employers and clients, and with fairness and impartiality to all. It is his duty to interest himself in public welfare, and to be ready to apply his special knowledge for the benefit of mankind. He should uphold the honor and dignity of his profession and also avoid association with any enterprise of questionable character. In his dealings with fellow engineers he should be fair and tolerant.

THE ASSOCIATION has adopted the seal shown here and provided that it may be used by members on their letter-heads and in their professional cards to attest their membership in the Association and their acceptance of the obligations imposed thereby.



Engineers

Members

Stuart L. Bailey
Jansky & Bailey
Clyde H. Bond
Clyde H. Bond
Lester H. Carr
Weldon & Carr
Joseph A. Chambers
Chambers & Garrison
T. A. M. Craven
Craven, Lohnes & Culver
John Creutz
John Creutz
Ronald H. Culver
Craven, Lohnes & Culver
George C. Davis
George C. Davis
Everett L. Dillard
Commercial Radio Equip. Co.
Millard M. Garrison
Chambers & Garrison
Glenn D. Gillett
Glenn D. Gillett & Assoc.
Paul F. Godley
Paul Godley Co.
C. M. Jansky, Jr.
Jansky & Bailey
Frank G. Kear
Kear & Kennedy
Robert E. L. Kennedy
Kear & Kennedy
Worthington C. Lent
Worthington C. Lent
George M. Lohnes
Craven, Lohnes & Culver
Frank H. McIntosh
McIntosh & Inglis
James C. McNary
McNary & Wrathall
Russell P. May
Russell P. May
E. C. Page
E. C. Page
William E. Plummer
Glenn D. Gillett & Assoc.
A. D. Ring
A. D. Ring & Co.
James O. Weldon
Weldon & Carr
Grant R. Wrathall
McNary & Wrathall

Associate Members

William S. Duttera
National Broadcasting Company
Raymond F. Guy
National Broadcasting Company
Earl M. Johnson
Mutual Broadcasting System
William B. Lodge
Columbia Broadcasting System
Frank L. Marx
American Broadcasting Company
John G. Preston
American Broadcasting Company
Philip F. Siling
Radio Corporation of America
Carl E. Smith
United Broadcasting Company
Jay W. Wright
Columbia Broadcasting System

FCC BAR ASSOCIATION

(Continued from page 55)

Courtney, Jeremiah, 1707 H. St., N. W., D. C.
 Cowgill, Harold G., Segal, Smith & Hennessey, 816 Conn. Ave., D. C.
 Cragun, John W., Transportation Bldg., D. C.
 Cressy, Warren F., Cressy, Bartram, Melvin & Sherwood, 300 Main St., Stamford, Conn.
 Crook, Omar L., Wheat, May & Shannon, Shoreham Bldg., D. C.
 Curry, John R., 1135 16th St., N. W., D. C.

D

Daly, Harry J., Metropolitan Bank Bldg., D. C.
 David, Alan B., Bond Bldg., D. C.
 David, Nathan H., 1625 K St., N. W., D. C.
 Davis, John Morgan, Lincoln Liberty Bldg., Philadelphia.
 Dechert, Philip, Tioga & C Sts., Philadelphia.
 Dempsey, William J., Dempsey & Koplovitz, 815 15th St., N. W., D. C.
 Denslow, L. Alton, LeRoy & Denslow, Washington Bldg., D. C.
 Diamond, Milton, Poletti, Diamond, Freidin & Mackay, 598 Madison Ave., New York.
 Dixon, James A., First Natl. Bldg., Miami.
 Drain, Dale D., Drain & Weaver, 1422 F St., N. W., D. C.
 Driscoll, Hugh D., 15153 Ventura Blvd., Sherman Oaks, Calif.
 Dunbar, Frank C., A. I. U. Bldg., Columbus, O.
 Duvall, Charles F., Fisher, Wayland, Duvall & Southmayd, Warner Bldg., D. C.

E

Eagan, R. Russell, Kirkland, Fleming, Green, Martin & Ellis, Natl. Press Bldg., D. C.
 Eggmann, Horace J., Jr., Metropolitan Bldg., E. St. Louis, Ill.
 Egoif, Willard D., 5 Wilson Lane, Bethesda, Md.
 Emerson, Walter L., 20 N. Wacker Dr., Chicago.
 Emison, John Rabb, Oliphant Bldg., Vincennes, Ind.
 Ernst, Morris L., Greenbaum, Wolf & Ernst, 285 Madison Ave., New York 17.
 Esterhai, John L., Philco Corp., Tioga & C Sts., Philadelphia 34
 Estes, Robert M., 701 Myrtle St., Syracuse, N. Y.
 Etherton, Seddon L., Michigan Bank Bldg., Detroit 26.

F

Fanelli, Joseph A., 729 15th St., N. W., D. C.
 Farris, Frank M., Jr., 3d Natl. Bank Bldg., Nashville, Tenn.
 Feen, A. Fearley, 119 S. Winooski Ave., Burlington, Vt.
 Fischer, Henry G., Fischer, Willis & Panzer, DuPont Circle Bldg., D. C.
 Fisher, Ben S., Fisher, Wayland, Duvall & Southmayd, Warner Bldg., D. C.
 Fletcher, Frank U., Munsey Bldg., D. C.
 Fly, James Lawrence, Fly, Fitts & Shuebruk, 30 Rockefeller Plaza, New York 20.
 Foley, James, Stoneleigh Courts, D. C.
 Foote, Edward A., Foote & Cutler, 1028 Conn. Ave., N. W., D. C.
 Ford, Aaron L., Munsey Bldg., D. C.
 Fortas, Abe, Arnold, Fortas & Porter, 1200 18th St., N. W., D. C.
 Freehill, Joseph H., Schoene, Freehill, Kramer & Davis, 1625 K St., N. W., D. C.
 Freedman, Walter, Freedman & Levy, Washington Bldg., D. C.
 Freston, Arthur, 650 S. Spring St., Los Angeles 14.

G

Gallagher, James E., Jr., Real Estate Trust Bldg., Philadelphia.
 Gallier, O. R., Jr., P. O. Box 205, Bristol, Va.
 Gardner, Addison L., Jr., 231 S. La Salle St., Chicago.
 George, Arthur T., 1425 New Montgomery St., San Francisco.
 George, Carl E., Hotel Statler, Cleveland.
 Gerrity, Harry J., Hill Bldg., D. C.
 Gerth, Theodore P., 1025 Connecticut Ave., N. W., D. C.
 Gibbons, John F., 67 Broad St., New York.
 Gibbs, Delbridge L., Florida Bank Bldg., Jacksonville, Fla.
 Gillig, Harry, Jr., Kaufman Bldg., Wichita, Kans.
 Goldfarb, Aaron, City Natl. Bank Bldg., Houston.
 Goldstein, David, Electric Bldg., Asbury Park, N. J.
 Goodman, E. M., 1404 W. Wisconsin Ave., Milwaukee.

Goodrich, Pierre F., Electric Bldg., Indianapolis.
 Goodwin, Bernard, 1501 Broadway, New York.
 Gordon, Spencer, Covington, Burling, Rublee & Shorb, Union Trust Bldg., D. C.
 Granik, Theodore, 1627 K Street, N. W., D. C.
 Griffith, Kelly E., Kirkland, Fleming, Green, Martin & Ellis, Natl. Press Bldg., D. C.
 Guider, John W., "Adair," Littleton, N. H.

H

Haley, Andrew G., Haley, McKenna & Wilkinson, 1101 Conn. Ave., D. C.
 Hall, Charles M., 305 Broadway, New York.
 Hallen, Billie (Miss), E & C Bldg., Denver.
 Hamilton, Fowler, 52 Wall St., New York.
 Hamlyn, John J., McClatchy Bcstg. Co., Sacramento, Calif.
 Hand, Frank B., Jr., Wrape & Hernly, 1624 Eye St., D. C.
 Hannon, William A., 21 W. 10th St., Kansas City, Mo.
 Harris, C. Walter, Washington Bldg., D. C.
 Harry, Laurence W., First Natl. Bank Bldg., Fostoria, O.
 Harter, Dow W., Washington Bldg., D. C.
 Hartman, John A., Jr., 67 Broad St., New York.
 Haupt, William H., 458 S. Spring St., Los Angeles 13.
 Hausman, Howard A., CBS, 485 Madison Ave., New York 22.
 Hawley, Edmund S., 195 Broadway, New York 7.
 Hayes, John C., Hayes & Hayes, Munsey Bldg., D. C.
 Hayes, Raymond Kyle, 309 Ninth St., N. Wilkesboro, N. C.
 Heald, Robert L., Welch, Mott & Morgan, 710 14th St., D. C.
 Hearne, John P., Market at 3d St., San Francisco 3.
 Heffernan, Joseph V., RCA Bldg., New York 20.
 Hennessey, Philip J., Segal, Smith & Hennessey, 816 Conn. Ave., D. C.
 Herman, A. M., Electric Bldg., Fort Worth, Tex.
 Herriott, Irving, 120 S. LaSalle St., Chicago.
 Hickman, Charles M., 160 N. LaSalle St., Chicago 1.
 Hilmer, Lucien, Commonwealth Bldg., D. C.
 Hilton, Henry M., 134 N. LaSalle St., Chicago 2.
 Hindin, Maurice J., Hindin, Girard, Lewis & Green, 111 W. 7th St., Los Angeles.
 Hodson, Robert E., Pierson & Ball, Ring Bldg., D. C.
 Hogan, Robert G., Stangenwald Bldg., Honolulu, T. H.
 Howard, Benjamin C., O'Sullivan Bldg., Baltimore 2.
 Howell, Boyte, Jr., Harsh & Pierce, Commerce Title Bldg., Memphis.
 Hoyt, John Charles, Majestic Bldg., San Antonio.
 Huggett, Kenneth K., 63 N. Howell St., Hillsdale, Mich.
 Hurt, Willson, 1275 Pontiac St., Denver.

I

Irwin, Ellis C., Richards Bldg., New Orleans.
 Irwin, Robert L., Dow, Lohnes & Albertson, Munsey Bldg., D. C.

J

Jacobs, Carl M., Union Central Bldg., Cincinnati.
 Jacobs, Samuel, 75 State St., Albany, N. Y.
 Jameson, Guilford, Investment Bldg., D. C.
 Jansky, Maurice M., Loucks, Zias, Young & Jansky, 1317 F St., N. W., D. C.
 Jeneroff, Meyer A., 100 State St., Albany, N. Y.
 Johnson, J. Edward, Brownwood, Tex.
 Johnston, E. D., Kirkland, Fleming, Green, Martin & Ellis, Natl. Press Bldg., D. C.
 Jorgensen, Norman E., Krieger & Jorgensen, 1707 H. St., N. W., D. C.
 Joslyn, David R., Joslyn, Parker & Van Doren, 116 Benton St., Woodstock, Ill.

K

Kahn, Alexander, 175 E. Broadway, New York.
 Kaye, Sydney M., Rosenman, Goldmark, Collin & Kaye, 165 Broadway, New York.
 Kehoe, William A., Jr., Dempsey & Koplovitz, 815 15th St., N. W., D. C.
 Keller, Joseph E., Dow, Lohnes & Albertson, Munsey Bldg., D. C.

Kellough, Robert W., McBirney Bldg., Tulsa, Okla.
 Kendall, John C., U. S. Natl. Bank Bldg., Portland, Ore.
 Kenehan, Edward F., Welch, Mott & Morgan, 710 14th St., N. W., D. C.
 Kennedy, James A., 67 Broad St., New York 4.
 King, John P., 544 E. 89th St., New York 28.
 Knowles, Miles H., 1029 Vermont Ave., N. W., D. C.
 Kopietz, Frank M., Natl. Bank Bldg., Detroit.
 Koplovitz, William C., Dempsey & Koplovitz, 815 15th St., N. W., D. C.
 Kotech, Bernard, Cohn & Marks, 1420 New York Ave., N. W., D. C.
 Kowal, Leon J., 11 Beacon St., Boston.
 Kramer, Milton, Schoene, Freehill, Kramer & Davis, 1625 K St., N. W., D. C.
 Krieger, Seymour, Krieger & Jorgensen, 1707 H. St., N. W., D. C.
 Kurrie, Thompson, State Life Bldg., Indianapolis.

L

LaBrum, Harry J., Packard Bldg., Philadelphia.
 Ladner, Henry, 30 Rockefeller Plaza, New York.
 Lamb, Edward, Edison Bldg., Toledo.
 Lamb, William H., 1835 Arch St., Philadelphia.
 Lamprey, William B., 31 State St., Boston.
 Lancaster, Emery, W.C.U. Bldg., Quincy, Ill.
 Landa, Alfons B., Davies, Richberg, Beebe, Busick & Richardson, 815 15th St., N. W., D. C.
 Landon, S. Whitney, 32 6th Ave., New York.
 Lavine, Richard A., 6331 Hollywood Blvd., Hollywood 28.
 Lawton, Samuel T., 7 S. Dearborn St., Chicago 3.
 Leahy, William E., 821 15th St., N. W., D. C.
 Leonard, Donald S., Commissioner, Michigan State Police, E. Lansing, Mich.
 Levine, J. L., Volunteer Bldg., Chattanooga.
 Levinson, Louis, 1622 Chestnut St., Philadelphia.
 Levy, Isaac D., 1622 Chestnut St., Philadelphia.
 Lewis, Ralph E., 650 S. Spring St., Los Angeles.
 Linkin, Max J., Jefferson Bldg., Peoria, Ill.
 Littell, Norman M., 1422 F St., N. W., D. C.
 Littlepage, James H., Littlepage & Littlepage, Investment Bldg., D. C.
 Littlepage, John M., Littlepage & Littlepage, Investment Bldg., D. C.
 Littlepage, Thomas P., Jr., Littlepage & Littlepage, Investment Bldg., D. C.
 Lockwood, Corwin R., Jr., Hogan & Hartson, Colorado Bldg., D. C.
 Lohnes, Horace L., Dow, Lohnes & Albertson, Munsey Bldg., D. C.
 Loucks, Philip G., Loucks, Zias, Young & Jansky, 1317 F St., N. W., D. C.
 Lovett, Eliot C., Hanson, Lovett & Dale, 729 15th Street, N. W., D. C.
 Lynch, Paul B., NBC, 30 Rockefeller Plaza, New York 20.

M

Margraf, Gustav B., NBC, 30 Rockefeller Plaza, New York.
 Marks, Leonard H., Cohn & Marks, 1420 New York Ave., N. W., D. C.
 Marku, Novak N., Commercial Bldg., Canton, O.
 Masters, Keith, 33 N. LaSalle St., Chicago.
 Mather, E. Everett, Jr., 1835 Arch St., Philadelphia.
 Matthews, Francis Patrick, Secy. of Navy, D. C.
 Maulsby, William E., Holt, 105 Ridgewood Rd., Baltimore.
 May, Philip S., Lynch Bldg., Jacksonville, Fla.
 May, Robert E., Wheat, May & Shannon, Shoreham Bldg., D. C.
 Mayer, J. Gerald, Mayer, Rigby & Ryan, 1010 Vermont Ave., N. W., D. C.
 Mayer, Henry, 19 W. 44th St., New York 18.
 McCabe, Thomas M., McCabe, Gruber, Clure, Donovan & Crassweller, Torrey Bldg., Duluth, Minn.
 McCauley, Raymond F., 959 8th Ave., New York.
 McDonald, Joseph A., ABC, 30 Rockefeller Plaza, New York 20.
 McDonnell, W. Barrett, Dempsey & Koplovitz, 815 15th St., N. W., D. C.
 McDonough, Francis X., Dow, Lohnes & Albertson, Munsey Bldg., D. C.
 McDowell, C. Blake, First Central Tower, Akron, O.
 McDowell, James L., 4942 Arlington Ave., Riverside, Calif.
 McKenna, James A., Jr., Haley, McKenna & Wilkinson, 1101 Conn. Ave., D. C.
 McKinney, Hayes, 105 W. Adams St., Chicago.
 McLeod, W. J., Jr., Jefferies Blvd. & Washington St., Walterboro, S. C.

Meurer, Raymond J., 1800 Stroh Bldg., Detroit 26.
 Meyer, Daniel W., 1776 Broadway, New York.
 Meyers, Milton H., 182 Grand St., Waterbury, Conn.
 Miles, John, Munsey Bldg., D. C.
 Miller, Clarence W., Baltimore Trust Bldg., Baltimore.
 Miller, John Roberts, Sullivan & Cromwell, 48 Wall St., New York 5.
 Miller, Justin, NAB, 1771 N St., N. W., D. C.
 Miller, Neville, Miller & Schroeder, Munsey Bldg., D. C.
 Miller, Reed, 1200-18th St., N. W., D. C.
 Miller, Samuel, Cohn & Marks, 1420 New York Ave., N. W., D. C.
 Miller, William E., Union Bank Bldg., Pittsburgh.
 Mooney, William E., Insurance Bldg., Omaha 2.
 Morgan, Edward P., Welch, Mott & Morgan, 710 14th St., N. W., D. C.
 Morgan, Gerald D., Morgan & Calhoun, Washington Bldg., D. C.
 Morgan, Robert E., 1825 Gadsden St., Columbia, S. C.
 Moser, J. G., 6331 Hollywood Blvd., Hollywood 28.
 Moser, John B., 360 N. Michigan Ave., Chicago 1.
 Mott, Harold E., Welch, Mott & Morgan, 710 14th St., N. W., D. C.
 Munger, Alfred C., First Nat'l Bank Bldg., Omaha.
 Myse, Daryal A., Awalt, Clark & Sparks, 822 Conn. Ave., N. W., D. C.

N

Neu, James Henry, CBS, 485 Madison Ave., New York.
 Niner, Isidor, 366 Madison Ave., New York.
 Norris, George Jr., CBS, 485 Madison Ave., New York.

O

O'Brien, Seymour, Baltimore Trust Bldg., Baltimore.
 O'Bryan, Paul A., Dow, Lohnes & Albertson, Munsey Bldg., D. C.
 O'Callaghan, Robert Dennis, Nat'l Bank of Commerce Bldg., San Antonio 5.
 Ockershausen, Harry J., Dempsey & Koplovitz, 815 15th St., N. W., D. C.
 O'Connor, John A., Jr., Crumpler & O'Connor, 402 N. Washington Ave., El Dorado, Ark.
 Oehler, Karl F., 1365 Cass Ave., Detroit.
 O'Hara, Francis James, Jr., Summers & O'Hara, 1425 K St., N. W., D. C.
 O'Hara, Thomas W., Chairman, Motor Carrier Claims Commission, Kansas City.
 O'Hare, Richard C., Maguire, Roche & O'Hare, 199 Washington St., Boston.
 Oppenheimer, Monroe, Miller, Sher & Oppenheimer, Woodward Bldg., D. C.

P

Patrick, Duke M., Hogan & Hartson, Colorado Bldg., D. C.
 Peck, Herbert M., 500 N. Broadway, Oklahoma City.
 Pefferle, Leslie G., Reisch Bldg., Springfield, Ill.
 Peterson, Ivar H., 5002 14th St., North, Arlington, Va.
 Petty, Don, NAB, 1771 N St., N. W., D. C.
 Peycke, Tracy J., Telephone Bldg., Omaha.
 Pierson, W. Theodore, Pierson & Ball, Ring Bldg., D. C.
 Pilaftian, James, 566 N. E. 15th St., Miami.
 Pischke, Vail W., 724 9th St., N. W., D. C.
 Plock, Richard H., Tama Bldg., Burlington, Iowa.
 Porter, Paul A., Arnold, Fortas & Porter, 1200 18th St., N. W., D. C.
 Porter, William A., Bingham, Collins, Porter & Kistler, Tower Bldg., D. C.
 Powell, Bolling R., Jr., Paul V. McNutt, 910 17th St., N. W., D. C.
 Powell, Garland W., WRUF Gainesville, Fla.
 Price, T. Brooke, 195 Broadway, New York.
 Prince, D. F., 815 15th St., N. W., D. C.

Q

Quigley, Frank, 195 Broadway, New York.
 Quinlan, William A., 1317 F St., N. W., D. C.
 Quinn, Frank B., Erie Bldg., Erie, Pa.
 Quisenberry, John T., 725 13th St., N. W., D. C.

R

Ray, John H., 195 Broadway, New York.
 Ream, Joseph H., CBS, 485 Madison Ave., New York.
 Reams, Frazier, 303 Bell Bldg., Toledo.
 Redmond, William P., 610 S. Broadway, Los Angeles 14.
 Reilly, John F., Reilly & Neumann, 1507 M St., N. W., D. C.
 Rennekamp, Kenneth E., Berger Bldg., Pittsburgh.
 Reynolds, Charles R., Jr., 725 13th St., N. W., D. C.
 Rhyne, Charles S., 730 Jackson Pl., N. W., D. C.
 Rigby, Scott G., Mayer, Rigby & Ryan, 1010 Vermont Ave., N. W., D. C.

Roberson, Frank, Spearman & Roberson, Munsey Bldg., D. C.
 Roberts, Glenn D., 110 E. Main St., Madison, Wis.
 Roberts, William A., Roberts & McAnnis, Mayflower Office Bldg., D. C.
 Robinson, C. Ray, Bank of America Bldg., Merced, Calif.
 Rollo, Reed T., Kirkland, Fleming, Green, Martin & Ellis, Nat'l Press Bldg., D. C.
 Ronon, Gerald, Real Estate Trust Bldg., Philadelphia.
 Rorer, Dwight E., Dow, Lohnes & Albertson, Munsey Bldg., D. C.
 Rosen, Leo, Greenbaum, Wolff & Ernst, 295 Madison Ave., New York 17.
 Rosenbaum, Samuel R., Land Title Bldg., Philadelphia 10.
 Rosenberg, Allan R., Bowen Bldg., D. C.
 Rosenman, Samuel I., Rosenman, Goldmark, Colin & Kaye, 165 Broadway, New York.
 Rowell, Russell, Spearman & Roberson, Munsey Bldg., D. C.
 Russell, Percy H. Jr., Kirkland, Fleming, Green, Martin & Ellis, Nat'l Press Bldg., D. C.
 Ryan, William, 122 W. Washington Ave., Madison, Wis.

S

St. Clair, Orla, Mills Tower, San Francisco 4.
 Salant, Richard S., Rosenman, Goldmark, Colin & Kaye, 165 Broadway, New York.

Salisbury, Franklin C., Munsey Bldg., D. C.
 Sarpy, Leon, Chaffe, McCall, Bruns, Toler & Phillips, Whitney Bldg., New Orleans.
 Schapira, Maurice, 17 Academy St., Newark, N. J.
 Scharfeld, Arthur W., Nat'l Press Bldg., D. C.
 Schindler, C. E., Kenyon Bldg., Louisville, Ky.
 Schroeder, Arthur H., Miller & Schroeder, Munsey Bldg., D. C.
 Shuebruk, Peter, Fly, Fitts & Shuebruk, 30 Rockefeller Plaza, New York 20.
 Segal, Paul M., Segal, Smith & Hennessey, 816 Conn. Ave., N. W., D. C.
 Seward, P. W., Warner Bldg., D. C.
 Shannon, Charles V., Wheat, May, & Shannon, Shoreham Bldg., D. C.
 Shea, George F., Tower Bldg., D. C.
 Shipley, Carl L., Arthur W. Scharfeld, Nat'l Press Bldg., D. C.
 Siegfried, Cedric, 217 W. Lexington Ave., Independence, Mo.
 Simmons, J. Benjamin, Ward, Simmons & Horton, Tower Bldg., D. C.
 Sirica, John J., Hogan & Hartson, Colorado Bldg., D. C.
 Slaughter, Harrison T., Pierson & Ball, Ring Bldg., D. C.
 Smith, Andrew A., Volunteer Bldg., Atlanta.
 Smith, Bernard B., 551 5th Ave., New York.
 Smith, George S., Segal, Smith & Hennessey, 816 Conn. Ave., N. W., D. C.
 Smith, Karl A., Hogan & Hartson, Colorado Bldg., D. C.

Smith, Quayle, Segal, Smith & Hennessey, 816 Conn. Ave., N. W., D. C.
 Smith, Wm. Montgomery, Union Trust Bldg., D. C.
 Smith, William P., Metropolitan Bank Bldg., D. C.
 Snyder, Sherwood M., 6 State St., Rochester, N. Y.
 Socolow, A. Walter, 580 5th Ave., New York.
 Souhami, Edmund, NBC, 30 Rockefeller Plaza, New York 20.
 Southmayd, John P., Fisher, Wayland, Duval & Southmayd, Warner Bldg., D. C.
 Sovik, Laurence, University Bldg., Syracuse.
 Spearman, John C., Spearman & Roberson, Munsey Bldg., D. C.
 Spearman, Paul D. P., Spearman & Roberson, Munsey Bldg., D. C.
 Spears, Adrian A., Majestic Bldg., San Antonio, Tex.
 Sprague, E. Stuart, 36 W. 44th St., New York.
 Steen, J. W., 1625 K St., N. W., D. C.
 Stein, Abe L., Warner Bldg., D. C.
 Stempli, I. William, Washington Loan & Trust Bldg., D. C.
 Stephens, E. Edward, Munsey Bldg., D. C.
 Stollenwerck, Frank, Nat'l Press Bldg., D. C.
 Stout, Clair L., Dow, Lohnes & Albertson, Munsey Bldg., D. C.
 Stover, C. Clark Jr., 49 Wall St., New York 5.
 Strauss, Samuel W., 300 Broadway, Camden, N. J.
 Strong, George E., Shoreham Bldg., D. C.
 Sullivan, Francis C., Alworth Bldg., Duluth 2, Minn.
 Sutton, George O., Nat'l Press Bldg., D. C.
 Swezey, Robert D., WDSU, Hotel Monteleone, New Orleans.
 Syring, William J., Albee Bldg., D. C.

Tolman, David E., Segal, Smith & Hennessey, 816 Conn. Ave., N. W., D. C.
 Topper, Isadore, Topper & Alloway, Huntington Bank Bldg., Columbus, O.
 Tucker, John H., Commercial Bldg., Shreveport, La.
 Tuhy, Stephen Jr., Albee Bldg., D. C.
 Tumulty, Joseph P. Jr., Tumulty & Tumulty, 1317 F St., N. W., D. C.
 Turner, George B., 15 Broad St., New York.
 Tyler, Varro E., 109 S. 9th St., Nebraska City, Nebr.

Y

Van Allen, John W., Liberty Bank Bldg., Buffalo, N. Y.
 Van Orsdel, Ralph, 240 E. Bellevue Ave., San Mateo, Calif.
 Van Meter, William G., 730 Jackson Place, D. C.
 Vesey, Howard W., Patton Bldg., Leesburg, Va.

W

Walker, Henry B., Old Nat'l Bank Bldg., Evansville, Ind.
 Walker, Ralph L., Pierson & Ball, Ring Bldg., D. C.
 Wallace, Harold E., Judge Bldg., Salt Lake City.
 Walton, Frederick H. Jr., Dempsey & Koplovitz, 815 15th St., N. W., D. C.
 Warner, Harry P., Segal, Smith & Hennessey, 816 Conn. Ave., N. W., D. C.
 Wright, J. Warren, Bureau of Aeronautics, Electronics Div., Navy Dept., D. C.
 Wayland, Charles V., Fisher, Wayland, Duval & Southmayd, Warner Bldg., D. C.
 Weaver, Henry B. Jr., Tower Bldg., D. C.
 Weber, Arthur W., Spitzer Bldg., Toledo.
 Webster, Bethuel M., 15 Broad St., New York.
 Weiner Joseph L., 52 Wall St., New York 5.
 Welch, Francis X., Munsey Bldg., D. C.
 Welch, Vincent B., Welch, Mott & Morgan, 710 14th St., N. W., D. C.
 Wender, Harry S., Woodward Bldg., D. C.
 Wheat, Carl I., Wheat, May & Shannon, Shoreham Bldg., D. C.
 Wheeler, Edward K., Wheeler & Wheeler, 805 15th St., N. W., D. C.
 Whissell, George B., Telephone Bldg., St. Louis.

(Continued on page 66)

TELEVISION SUMMARY

Corrected to Jan. 1, 1950

City	Outlets On Air	Number Sets	Source of Estimate
Albuquerque	KOB-TV	1,500	Station
Atlanta	WAGA-TV, WSB-TV	20,300	Distributors
Baltimore	WAAM, WBAL-TV, WMAR-TV	112,317	TV Circ. Comm.
Binghamton	WNBF-TV	2,300	Dealers
Birmingham	WAFA-TV, WBRC-TV	6,750	Distributors
Bloomington	WTIV	2,000	Dealers
Boston	WBZ-TV, WNAC-TV	215,424	TV Comm.
Buffalo	WBEN-TV	20,100	Buff. Elec. Co.
Charlotte	WBTV	9,300	Distributors
Chicago	WBKB, WENR-TV, WGN-TV, WNBQ	266,460	TV Comm.
Cincinnati	WCPO-TV, WKRC-TV, WLWT	50,000	Distributors
Cleveland	WEWS, WNBK, WXEL	119,103	West. Res. U.
Columbus	WBNS-TV, WLWC, WTVN	39,070	Distributors
Dallas			
Ft. Worth	See Ft. Worth-Dallas listings.		
Davenport	WOC-TV	5,030	Distributors
Quad Cities:	Includes Davenport, Moline, Rock Island, East Moline.		
Dayton	WHIO-TV, WLWD	23,800	Stations
Detroit	WJBK-TV, WWJ-TV, WXYZ-TV	145,000	Distributors
Erie	WICU	18,100	Station
Ft. Worth-Dallas			
Dallas	WBAP-TV, KBTW, KRLD-TV	22,000	Dist. & Deal.
Grand Rapids	WLAV-TV	9,000	Distributors
Greensboro	WFMY-TV	7,325	Distributors
Houston	KLEE-TV	10,000	Distributors
Huntington			
Charleston	WSAZ-TV	3,750	Distributors
Indianapolis	WFBN-TV	14,000	Dist. & Deal.
Jacksonville	WMBR-TV	4,160	Wholesalers
Johnstown	WJAC-TV	7,850	Distributors
Kalamazoo			
Battle Creek		3,500	Dealers
Kansas City	WDAF-TV	20,434	Distributors
Lancaster*	WGAL-TV	19,011	Dealers
Los Angeles	KLAC-TV, KNBH, KTLA, KTLI, KFI-TV, KTTV, KECA-TV	302,635	Rad. & Appl. Assn.
Louisville	WAVE-TV	16,604	Station
Memphis	WMCT	12,210	Distributors
Miami	WTWJ	12,300	Station
Milwaukee	WTMJ-TV	60,564	Distributors
Minn.-St. Paul	KSTP-TV, WTCN-TV	50,200	Stations
New Haven	WNHC-TV	58,400	Station
New Orleans	WDSU-TV	10,273	N. O. Pub. Serv.
New York	WABD, WCBS-TV, WJZ-TV, WNBZ, WOR-TV, WPIX, WATV	875,000	Stations
Newark		1,001	Distributors
Norfolk		14,340	Distributors
Oklahoma City	WKY-TV	11,989	Distributors
Omaha	WOW-TV, KMTV	315,000	Elec. Assn.
Philadelphia	WCAU-TV, WFIL-TV, WPTZ	3,000	Dealers
Phoenix	KPHO-TV	53,000	Dist. & RMA
Pittsburgh	WDTV	606	Eng. Est.
Portland, Ore.	WJAR-TV	19,750	Distributors
Providence	WTWR	20,000	Distributors
Richmond	WHAM-TV	15,931	Distributors
Rochester	KDYL-TV, KSL-TV	7,000	Station
Salt Lake City	WOAI-TV	2,150	Station
San Antonio	KFMB-TV	12,750	Station
San Diego	KGO-TV, KPX, KRON-TV	22,000	N. Cal. Elec. Assn.
San Francisco	WRGB	44,200	Distributors
Schenectady	KING-TV	15,800	Distributors
Seattle	KSD-TV	67,700	Union Elec. Co.
St. Louis	WHEN	19,132	Distributors
Syracuse**	WSPD-TV	28,000	Dealers Assn.
Toledo	KOTV	7,800	CPA Audit
Tulsa	WKTV	4,500	Dealers
Utica-Rome	WMAL-TV, WNBW, WOIC, WTTG	78,700	TV Cir. Comm.
Washington	WDEL-TV	21,804	Dealers
Wilmington			

Total Markets on Air 58; Stations on Air 98; Sets in Use 3,395,407

** Also claims coverage in Utica-Rome.
 * Lancaster and contiguous areas.

Editor's Note: Sources of set estimates are listed for each city as available. Total sets in all cities surveyed is necessarily approximate since two areas may overlap. To offset this there are many scattered sets in areas not included in the survey.



***THE KING OF THEM ALL**

"MUSICAL TUNE-O"

*Radio's most sensational local give-away show. Currently sold 200 markets. Open for hundreds of additional radio stations.

WRITE OR WIRE:

RICHARD HULLMAN, INC.
 295 DELAWARE AVE.
 BUFFALO, N. Y.

RETAIL RADIO SALES IN THE UNITED STATES, 1922-1949

(Compiled for the 1950 BROADCASTING YEARBOOK by O. H. Caldwell, Editor of "Tele-Tech.")

Total Sets Sold		Total Tubes Sold		Auto Sets Sold		Total Sales of Broadcast Receivers, Tubes, Batteries, Parts	Homes with Radio Sets	Auto Sets in Use	Total Radio Sets in Use in U. S.
Number	Value	Number	Value	Number	Value	Value	Number	Number	
1922	100,000	\$5,000,000	1,000,000	\$6,000,000		\$60,000,000	260,000		400,000
1923	550,000	15,000,000	4,500,000	12,000,000		136,000,000	1,000,000		1,100,000
1924	1,500,000	100,000,000	12,000,000	36,000,000		358,000,000	2,500,000		3,000,000
1925	2,000,000	185,000,000	20,000,000	48,000,000		430,000,000	3,500,000		4,000,000
1926	1,750,000	200,000,000	30,000,000	58,000,000		506,000,000	5,000,000		5,700,000
1927	1,350,000	168,000,000	41,200,000	67,300,000		425,600,000	6,500,000		7,000,000
1928	3,281,000	400,000,000	50,200,000	110,250,000		690,550,000	7,500,000		8,500,000
1929	4,428,000	600,000,000	69,000,000	172,500,000		842,548,000	9,000,000		10,500,000
1930	3,827,800	300,000,000	52,000,000	119,600,000	34,000	496,432,000	12,048,782		13,000,000
1931	3,420,000	225,000,000	53,000,000	69,550,000	108,000	5,940,000	300,000,000	100,000	15,000,000
1932	3,000,000	140,000,000	44,300,000	48,730,000	143,000	7,150,000	200,000,000	16,809,582	18,000,000
1933	3,806,000	180,500,000	59,000,000	49,000,000	724,000	28,588,000	300,000,000	20,402,389	22,000,000
1934	4,084,000	214,500,000	58,000,000	36,600,000	780,000	28,000,000	350,000,000	21,456,000	26,000,000
1935	6,026,800	330,192,480	71,000,000	50,000,000	1,125,000	54,562,500	370,000,000	22,889,000	30,500,000
1936	8,248,000	450,000,000	98,000,000	69,000,000	1,412,000	69,188,000	500,000,000	24,600,000	33,000,000
1937	8,064,780	450,000,000	91,000,000	85,000,000	1,750,000	87,500,000	537,000,000	26,666,500	37,600,000
1938	6,000,000	210,000,000	75,000,000	93,000,000	800,000	32,000,000	320,000,000	28,000,000	40,800,000
1939	10,500,000	354,000,000	91,000,000	114,000,000	1,200,000	48,000,000	375,000,000	28,700,000	45,300,000
1940	11,800,000	450,000,000	115,000,000	115,000,000	1,700,000	80,000,000	584,000,000	29,200,000	51,000,000
1941	13,000,000	460,000,000	130,000,000	143,000,000	2,000,000	70,000,000	610,000,000	29,700,000	58,000,000
1942	4,400,000	154,000,000	87,700,000	94,000,000	350,000	12,250,000	360,000,000	30,800,000	59,340,000
1943	700,000	24,000,000	17,000,000	19,000,000			75,000,000	32,500,000	57,000,000
1944			22,000,000	25,000,000			85,000,000	33,100,000	55,000,000
1945	500,000	20,000,000	30,000,000	35,000,000			105,000,000	34,000,000	56,000,000
1946	14,000,000	700,000,000	170,000,000	200,000,000	150,000	9,000,000	825,000,000	35,000,000	60,000,000
1947	17,000,000	800,000,000	220,000,000	260,000,000	2,500,000	150,000,000	1,100,000,000	37,000,000	68,000,000
1948	16,000,000	600,000,000	200,000,000	230,000,000	3,500,000	210,000,000	950,000,000	40,000,000	74,000,000
1949	8,500,000	340,000,000	230,000,000	300,000,000	3,500,000	210,000,000	750,000,000	42,000,000	81,000,000

¹ Includes home-built sets.

² Figures for sets include value of tubes in receivers. Totals include exports. In normal years, replacement tubes have run from 25% to 40% of total tube sales. All figures are at retail value.

³ Based on Survey of Consumer Requirements, made at the request of the War Production Board Office of Civilian Requirements by the Bureau of the Census, U. S. Dept. of Commerce, Dec. 1943 (BROADCASTING, Dec. 20, 1943). Estimate of 700,000 sets sold includes 350,000 new and 350,000 used sets.

⁴ Based on WPB Survey of Consumer Requirements (BROADCASTING, Dec. 20, 1943).

⁵ Based on NAB estimate which includes homes possessing a usable radio set in any condition either working or temporarily not working because of missing tube or other part.

**A Young Station
Doing Big Things
In A Bright Market**

WERI

WESTERLY, RHODE ISLAND

In the WERI market there are more than 150,000 people who spend about \$175,000,000 each year. An additional 40,000 visit the area each week during the summer. Let WERI help you get your share of sales.

**Write For
Complete
Consumers
Report**



LOOK

Start now to break into the bright WERI market where retail sales in food were over \$52,000,000 in 1948, automotive sales over \$30,000,000 and farm income over \$22,000,000 according to SRDS Consumers' Market. WERI thoroughly covers Washington County in Rhode Island, most of New London County in Connecticut and the eastern section of Long Island. In operation since July 1, 1949, WERI is already doing big things for hundreds of happy advertisers. Go after your share of business in this bright and lucrative market.

WERI

The Full Time Family Station

In Westerly, R. I. 1230 kc

W. Paul Oury, General Manager

RADIO AND TV HIGHLIGHTS OF 1949

AS REPORTED IN BROADCASTING

Jan. 2—Network battle for Sunday evening audience begins as Jack Benny goes to CBS.

Jan. 9—FCC reports to Congress that 239 AM stations were authorized in 1948, bringing total to 2,034; 102 FM, making total 1,020; and 43 TV, making total 109.

Jan. 10—U. S. broadcasters' operating expenses rose to 79c out of every dollar of total revenue in 1947, according to annual study made by Dr. Kenneth H. Baker, NAB research director.

Jan. 11—Coaxial cable connects Pittsburgh and Cleveland linking East Coast with Midwestern video network.

Jan. 11—Executive Committee of BMB announces resignation of John Churchill and loan of NAB director of research, Dr. Kenneth H. Baker, to organization to supervise second nationwide study.

Jan. 17—Study of Baltimore radio market published.

Jan. 20—Radio, video coverage of inauguration unprecedented.

Jan. 24—Radio's net revenues \$402,826,000 according to BROADCASTING YEARBOOK estimates.

Jan. 26—Five Baltimore stations fined for contempt of court in Baltimore gag rule. Decision appealed.

Jan. 28—Two-man Senate Interstate Commerce subcommittee recommends that clear channels be broken down and power ceiling be kept at 50 kw.

Feb. 4—Television Broadcasters Assn. plans expansion of services.

Feb. 7—NBC relaxes ban on transcriptions and plans other changes in code.

Feb. 14—NAB Board of Directors meets in New Orleans and plans super radio survey, sets up separate corporation to handle all-radio presentation and takes other important steps.

Feb. 23—Representatives of 170 NBC affiliates meet in Chicago to hear network plans.

Feb. 28—BROADCASTING TRENDS shows managers increasingly fearful of monopoly and majority favor government regulation of ownership. All oppose censoring program content.

Feb. 28—Survey by Elmo Roper for Fortune magazine shows radio is nation's No. 1 pastime.

Feb. 28—FCC hearing begins on sale of WHAS to Crosley.

Mar. 4—Hugh Feltis resigns as president of BMB effective April 15.

Mar. 7—Study of San Francisco radio market published.

Mar. 14—Study of St. Louis radio market published.

Mar. 21—TRENDS survey shows radio rise is tapering off.

Mar. 22—BMB appoints Dr. Kenneth H. Baker as acting president.

Mar. 23—Assn. of National Advertisers at Hot Springs, Va., meet, ask what they are getting for their radio and television dollars.

Mar. 28—Survey shows withdrawals for first three months of 1949 of 8 AMs, 48 commercial FM authorizations and 2 TVs.

Mar. 28—Study of New Orleans radio market published.

April 1—North American Regional Broadcasting Agreement expires. Mexicans indicate they would like one-year postponement of Sept. 13 Montreal conference at which new agreement will be proposed. Postponement was rejected.

April 6—Engineers review technical progress as annual NAB Engineering convention opens.

April 8—Frank White named president of MBS; Ed Kobak to become a consultant.

April 11—Network gross for January 1949 total \$17,722,450 as compared with \$17,544,580 in January 1948. Total spot business for 1948 estimated at a net of \$99,431,000. Breakdown and analysis of product groups made for year.

April 11—NAB board votes \$75,000 loan to BMB, at NAB convention. Industry prepares for intermedia competition; sets up plans for BAB, Jack Koste heads AIMS group; Independents meet.

April 18—Sen. Johnson introduces bill to boost Commissioners' salaries each to \$15,000 then accuses FCC on floor of "prostituting" democratic principles by practices that are "scandalous, shocking and disgusting."

April 20—CBS net shows 45% drop in first quarter of 1949 due to increased television costs and cut in record making profits.

April 20—Counsel for G. A. Richards files application for consent to transfer of control of his three stations to three trustees.

April 30—Tentative CAA antenna standards stir up storm of protest.

May 2—TRENDS survey shows spot and local business gaining.

May 2—AP, UP and INS show big increase in radio members.

May 2—Total television time sales for first quarter of 1949 are \$5,240,655.

May 3—Daytime television for WJZ-TV New York to be extended to all ABC owned and operated stations as soon as possible, it is announced by Robert E. Kintner, executive vice president.

May 4—U. S. Court of Appeals for the District of Columbia raps FCC for failure to show basis for its decisions and for inconsistency in applying its yardsticks to rival applicants.

May 5—In speech before Institute for Education by Radio FCC Chairman Wayne Coy places date for television dominance over radio as 1954.

May 6—NAB rejects ASCAP arbitration plan.

May 6—Federal Bureau of Internal Revenue issues what amounts to an adverse ruling on proposed contract with capital gains features for Fibber McGee and Molly and NBC.

May 11—Frank Stanton signs 10-year contract with CBS at base salary of \$100,000 a year.

May 12—WJZ-TV and Harry S. Goodman Productions sign 10-year contract for more than a million to cover purchase of Television Telephone Game.

May 12—45-station Don Lee network realigns top personnel with elevation of Lewis Allen Weiss to chairman of the board. Willet H. Brown is named president.

May 13—FCC by 4-to-2 vote grants regular license to Arde Bulova's WOV and WNEW.

May 19—NAB code becomes fully operative.

May 23—FCC calls UHF, VHF television hearings for late August.

May 23—Donald Thornburgh, CBS Western Division vice president to become president and general manager of WCAU Philadelphia.

May 24—Video spot accounts for 38.3% of television revenue for first four months of 1949.

June 2—Editorializing by radio stations within undefined limits of fairness and balance authorized by FCC to reverse Mayflower decision.

June 2—Sen. E. W. McFarland (D-Ariz.) introduces bill to reorganize FCC staff, Commission.

June 3—Thomas McCray, NBC national program director, succeeds Ken R. Dyke as head of network's program department on Mr. Dyke's resignation.

June 3—RMA reassures public that present TV sets will not be made obsolete by UHF or color.

June 6—Study of Milwaukee radio market published.

June 7—Gordon Gray, president and publisher of the Piedmont Publishing Co., Winston-Salem, N. C. which owns and operates WSJS Winston-Salem, the Winston-Salem Journal and Twin City Sentinel and owner of WMTT, appointed Secretary of the Army.

June 7—Gordon Gray, vice president of WIP Philadelphia elected president of newly incorporated All-Radio Presentation Committee.

June 9—FCC repeals outright Avco rule on station sales.

June 9—Lower court and Maryland court of Appeals reversed on gag rule in Baltimore case.

June 17—Investigation of possible monopoly in broadcasting field is underway in Justice Dept. Anti-Trust division. Senate Interstate and Foreign Commerce Committee is told.

June 17—\$50,000,000 worth of network radio programming put behind public service campaigns of The Advertising Council in 1948.

June 17—WMOB Mobile, Ala., ceases operations, assets sold and it goes off air. Costs and union troubles cited as reason.

June 24—ABC asks changes in its contracts with affiliates.

June 27—TRENDS survey shows 54.5% think NAB work is only average. 55% of all replies place Miller's stewardship as excellent.

July 1—Joseph H. McConnell, vice president in charge of Finance of RCA was elected executive vice president of the corporation.

July 4—John W. Craig, vice president Avco Mfg. Corp., General Manager Crosley Division, tells how Buyers Market can mean Business for Broadcasting. The first of a series.

July 4—Trends survey shows majority of members favor dividing NAB into AM, FM and TV divisions.

July 11—Hecht Co. of Washington uses radio to make new Silver Spring branch success.

July 15—Jess Willard declines NAB video division directorship. Resigns executive vice presidency as of Aug. 1.

July 15—Streamlined NAB format is announced by Judge Miller.

July 15—FCC announces proposed new UHF VHF television allocations.

July 21—McFarland Bill to reorganize FCC procedures is reported to the Senate.

July 21—Royal V. Howard resigns as director of NAB engineering department.

Aug. 1—Detroit radio market is analyzed.

Aug. 12—Further expansion of AT&T television relays is approved by FCC.

Aug. 15—BROADCASTING 1949 Marketbook with Spot Rate Finder is published.

Aug. 19—FCC announces that giveaways will be banned as of Oct. 1; NAB, ABC defy ruling.

Aug. 22—PIB figures show network sales are steady through second quarter.

Aug. 26—FCC urges all manufacturers or experimenters equipped to produce color TV receivers or adaptors to get them out with all possible speed preparatory to the Sept. 26 all-inclusive TV allocations proceedings.

Sept. 5—Fall business outlooks bright; spot business may run 10% ahead of last year.

Sept. 8—First NAB district meeting of the year held at Cincinnati. Theme proves to be all-out battle for bigger chunk of the advertisers dollar.

Sept. 9—NBC plans major split into AM and TV divisions.

Sept. 16—Cuba calls for breakdown of clear channels as Montreal NARBA meeting gets underway.

Sept. 16—Petty Co. announces expansion program calling for outlay of additional \$250,000 yearly.

Sept. 23—FCC turns down proposed sale of WHAS Louisville to WLW.

Sept. 23—Justice department files suit against Lorain (Ohio) Journal charging unfair practices in competing with WEOL and weekly paper.

Sept. 23—FCC giveaway ban is suspended pending court test.

Sept. 28—FCC Color television hearings get underway.

Oct. 3—Gallup poll shows that public favors giveaway shows.

Oct. 5—695 AM and 49 TV outlets broadcast 1949 World Series.

Oct. 7—Joseph H. McConnell is elected President of NBC. Niles Trammell becomes chairman of the NBC Board.

Oct. 10—RCA demonstrates its electronic color process to members of FCC and other guests.

Oct. 17—Free and Peters research staff announces survey showing spot radio initial costs have gone up 37% since 1943 but the number of set owners has increased 40%.

Oct. 26—Chief Judge William H. Kirkpatrick, U. S. District Court for Eastern District of Pennsylvania, rules State Board of Censors has no power to censor motion pictures used by Philadelphia TV stations.

Oct. 28—FCC orders comparative TV color demonstrations.

Nov. 1—Explosion and fire damages FCC record rooms and offices.

Nov. 7—U. S. Supreme Court in effect upholds Little Rock, Ark., \$250 annual tax on generation of radio waves and \$50 tax on each solicitor of advertising for radio.

Nov. 7—Mutual announces million-dollar contract for radio rights to World Series and All-Star baseball games for seven years.

Nov. 18—NAB Board demands NARBA treaty that will stop "severe damage" to U. S. station coverage and moves to strengthen BAB and BMB.

Nov. 18—WNEW is sold by Arde Bulova and associates to new corporation headed by William S. Cherry Jr.

Nov. 16—Television Authority, big talent union, formed.

Nov. 28—Defense forces muster to fight Arkansas tax ruling.

Nov. 28—NAB District 16 calls for abolition of annual convention and a study of the entire association.

Dec. 5—U. S. Supreme Court refuses rehearing petition in Arkansas tax case.

Dec. 11—Montreal NARBA meeting takes four-month recess after U. S. refuses to yield on channel concessions. Will resume in U. S.

Dec. 12—Newell-Emmett Co., with \$26 million annual billing announces dissolution of partnership as of Dec. 31. Cunningham and Walsh formed to carry on business.

Dec. 19—1950 automobiles bring AM and TV time purchases.

Dec. 19—Operating stations in U. S. reach all-time high during 1949. 169 new AM stations approved, 60 AM deletions, 38 new FM's granted and 209 deleted, 13 TV permits cancelled.

Dec. 26—Leading industry figures predict broadcasting will set new records in 1950. Comments from more than 300.

Dec. 23—FCC reports AM revenue up 11.9% during 1948 while costs rose 17.5%.

Dec. 26—Year-end television set summary shows 3,376,625 sets in actual use.

**EVERYBODY
EVERYWHERE
PERFORMS
BMI-LICENSED
MUSIC**

BMI

BROADCAST MUSIC, INC.

580 FIFTH AVENUE • NEW YORK 19, N. Y.

New York • Chicago
Hollywood • Toronto
Montreal

BMI

10th

ANNIVERSARY

1940

1950

Each succeeding year finds BMI service to broadcasters building and expanding. Year by year the BMI catalogue grows steadily in size and in value.

BMI has had the hearty support of broadcasters from its very inception, not only because its combined catalogs contain a well-rounded store of great music but because it has created strong competition in publishing and in the field of performance rights.

With its current licenses running until 1959, BMI more than ever stands as enduring proof of the power and determination of American enterprise to create and maintain the right of free trade in a competitive market.

BROADCAST MUSIC, INC.

580 FIFTH AVENUE • NEW YORK 19, N. Y.

New York • Chicago
Hollywood • Toronto
Montreal

REGIONAL NETWORKS of the UNITED STATES

ALABAMA STATE GROUP—Comprising WOAB Aniston; WTBF Troy; WMFT Florence; WFUN Huntsville; WGAD Gadsden; WKUL Cullman; WTBC Tuscaloosa; WVOK Birmingham; WXAL Demopolis; WMGY Montgomery; WJHO Opelika; WKAB Mobile; WEBJ Brewton; WDIG Dothan and WVVW Jasper. Office: Bankhead-Long Bldg., Jasper, Ala. Tel.: 100. James E. Reese, manager of operations.

THE ALIHA NETWORK—Comprising KIPA Hilo; KTOH Lihue; KHON Honolulu and KMVI Wailuku. Headquarters: P. O. Box 1380, Honolulu 42. Tel.: 9-5295. A. H. Green, general manager. Represented by The Walker Co.

ARIZONA BROADCASTING SYSTEM—Comprising KTAR Phoenix; KVOA Tucson; KYUM Yuma; KGLU Safford; KWJB Globe; KYCA Prescott; KAWT Douglas. Executive officers: R. B. Williams, KVOA, president; Dick Lewis, KTAR, manager; Bill Harvey, KTAR, commercial manager; J. Howard Kyle, KTAR, program manager; Fred Gerletti, KVOA, promotion manager; John Snow, KTAR, news editor. Represented nationally by Paul H. Raymer Co.

ARIZONA NETWORK—Comprising KOY Phoenix; KTUC Tucson; KSUN Lowell. Available as a regional network. Represented nationally by John Blair & Co. Executive officers: Albert Johnson, KOY; Lee Little, KTUC; Carl Morris, KSUN; John L. Hogg, KOY, commercial manager.

ARKANSAS NETWORK—Comprising KARK Little Rock and all other stations in the State of Arkansas. Two or more stations may be used; one or more outlets in cities with multiple stations. Costs are combined station time and line charge.

ARROWHEAD NETWORK—Comprising WEBC Duluth, Minn.; WMFG Hibbing, Minn.; WHLD Virginia, Minn.; WEAU Eau Claire, Wis.; WJMC Rice Lake, Wis.; WISN Madison, Wis., available as a hookup. Represented nationally by George F. Hollingsbery Co. Headquarters: WEBC Bldg., Duluth 2, Minn. Executive officers: Walter C. Bridges, WEBC, manager; Marlin E. Smythe, national sales manager.

BROADCASTING CORP. OF AMERICA'S WESTERN NETWORK—Comprising KPRO Riverside and San Bernardino; KROP Brawley and El Centro; KREO Indio; KYOR Blythe; KPOR(FM) San Bernardino and Riverside. Supplements: KICO Calexico; KPAS Banning; KVOE Santa Ana; KPFV Los Angeles; KPMO Pomona; KSEF Needles; KSDO San Diego. Office: 3401 Russell St., Riverside. W. L. Gleason, president and general manager.

PAUL BUNYAN NETWORK—Michigan regional network comprising WTCM Traverse City; WATT Cadillac; WATA Alpena; WMEN Petoskey. Headquarters: WTCM Les Biederam, president and general manager.

CALIFORNIA NORTHERN GROUP—KSYC Yreka; KBLF Red Bluff; KSUE Susanville. Jack Wagner, KSYC, manager.

COLUMBINE NETWORK—Comprising KMYR Denver; KCOL Fort Collins; KBOL Boulder; KEXO Grand Junction; KCSF Pueblo; KYOU Greeley; KRDO Colorado Springs. All in Colorado. Headquarters: 1626 Stout St., Denver. Albert G. Myer, general manager; Gene Amole, program director; Edward Koepke, commercial manager.

CONNECTICUT STATE NETWORK—Regional network comprising WSTC Stamford; WNAB Bridgeport; WHTT Hartford; WNEC New Haven; WNLN New London; WATR Waterbury; WTOR Torrington. Headquarters: WHTT. C. Glover DeLaney, president.

CORN BELT WIRELESS REBROADCASTING SERVICE—This is a service for rebroadcasting WHO studio programs without the use of lines during daytime hours by other stations located within 225 miles of Des Moines. Basic stations are WHO Des Moines; WOC Davenport, and KMA Shenandoah. Rate is a combination of the spot broadcasting rate of each station used without any charge for lines. Contracts are made direct with individual stations as this is not an organized network but provides for exchange of programs and intensive regional coverage. Paul A. Loyet, WHO, resident manager; Harold W. Fulton, WHO, sales manager. National representatives: Free & Peters Inc.

DAIRYLAND NETWORK—Comprising WTCN Minneapolis-St. Paul; KATE Albert Lea; KWLM Wilmar, and KWNO Winona. All in Minnesota. Headquarters: Radio City, 50 South 9th St., Minneapolis 2. Telephone: Lincoln 0552.

DIXIE NETWORK—Comprising KOTL Houston; KREL Baytown; KRIC Beaumont. All in Texas. Headquarters: State National Bldg., Houston 2. Robert Mathers, president; H. Davis, vice president; King H. Robinson, secretary-treasurer.

DON LEE BROADCASTING SYSTEM—Southern California; KTLA Los Angeles; KGB San Diego; KDB Santa Barbara; KFXM San Bernardino; KAFY Bakersfield; CKOK Tulare-Visalia; KVOE Santa Ana; KXO El Centro; KVEC San Luis Obispo; KPRL Paso Robles. Northern California; KFRC San Francisco; KMYC Marysville; KSBW Salinas-Monterey; KIEM Eureka; KHSL Chico; KVCV Redding; KYNO Fresno; KYOS Merced; KXOA Sacramento; KXOB Stockton, Northwest (Oregon); KPOJ Portland; KRNR Roseburg; KFJI Klamath Falls; KORE Eugene; KOOS Coos Bay; KAST Astoria; KUIN Grants Pass; KWIL Albany; KBNB Bend; KSLM Salem. Northwest (Washington): KVT Seattle-Tacoma; KYAK Yakima; KKRO Aberdeen; KPUG Bellingham; KGY Olympia; KELA Centralia; KRKO Everett; KWLK Longview; KNEW Spokane; KUJ Walla Walla; KWNW Wenatchee; KWAL Wallace, Ida.; KRLC

Lewiston, Ida.; KVNI Coeur d'Alene, Ida.; KATO Reno, Nev. Represented nationally by John Blair & Co. Headquarters: KHJ Los Angeles. Executive officers: Willet H. Brown, president; Ward D. Ingram, vice president in charge of sales; Patrick Campbell, vice president station relations.

FOREIGN LANGUAGE QUALITY NETWORK—Comprising stations broadcasting to major Italian, Polish and other foreign language markets in the United States. Headquarters: 70 E. 45th St., New York 17. Tel.: Murray Hill 6-0238. Claude Barrere, secretary.

GEM STATE NETWORK—Comprising KGEM Boise; KBOI Burley; KIFI Idaho Falls; KEIO Pocatello and KLIX Twin Falls. All in Idaho.

GEORGIA ASSN. OF LOCAL STATIONS—29 station regional network with WGLS Atlanta-Deerhurst as originating station. WDEC Americus; WCAU Athens; WBBQ Augusta; WLBB Carrollton; WBHF Cartersville; WGGa Cedartown; WMJM Cordele; WMOC Covington; WBLJ Dalton; WMLT Dublin; WKBU Griffin; WFOM Marietta; WFRP Savannah; WWNS Statesboro; WWGS Tifton; WLET Toccoa; WYOP Vidalia; WAYX Waycross; WRLD West Point; WMVG Milledgeville; WMGA Moultrie; WROM Rome; WDWD Dawson; WBEH Fitzgerald; WDUW Gainesville; WSFT Thomaston; WKTC Thomasville; WBBB Macon. Headquarters: WGLS Atlanta. Tom Carr, sales director.

GEORGIA MAJOR MARKET TRIO—Comprising WAGA Atlanta; WTOG Savannah; WMAZ Macon. Available individually and in group. National Representatives: The Katz Agency Inc.

THE GEORGIA QUARTET—Comprising WGST Atlanta; WRDW Augusta; WSAV Savannah; WRBL Columbus. Headquarters: Forsyth Bldg., Atlanta. Represented by George F. Hollingsbery Co.

GRANITE STATE NETWORK—Comprising WOTW Nashua; WKBR Manchester; WNH1 Rochester; WTSV Claremont; all in New Hampshire. Also WUSA Brattleboro. Vt. Headquarters: 155 Front St., Manchester. Arthur A. Newcomb, WOTW, president; Ralph Gottlieb, WKBR, manager; William Rust Jr., WKBR, treasurer; Al Mallin, WNH1, secretary.

GREAT NORTHERN BCSTG. SYSTEM—Comprising KVOX Moorhead, Minn.; KWLM Wilmar, Minn.; KMHL Marshall, Minn.; KGDE Fergus Falls, Minn.; KLPF Minot, N.D.; KABR Aberdeen, S.D.; KGCU Mandan, N.D.; KOVC Valley City, N.D.; KDLE Devils Lake, N.D.; KGXC Sidney, Mont.; KDHL Faribault, Minn.; KNOX Grand Forks, N.D.; Headquarters: KGCU Mandan, N.D. M. M. Margett, president.

GREAT WEST NETWORK—Comprising KVER Albuquerque; KSVP Artesia, New Mexico. Headquarters: Box 1388, Albuquerque. William T. Kemp, general manager.

INTERMOUNTAIN NETWORK—Utah Group: KALL Salt Lake City; KLO Ogden; KOVO Provo; KUNU Logan; KOAL Price; KSVU Richfield; KSUB Cedar City. Idaho Group: KEXY Pocatello; KID Idaho Falls; KVMV Twin Falls; KFXD and KFXD-FM Nampa-Boise. Wyoming Group: KVRS Rock Springs; KSPR Casper; KPOW Powell; KWYO Sheridan; KOWB Laramie; KOVE Lander. Montana Group: KBMY Billings; KRJF Miles City; KMON Great Falls. Nevada Group: KRAM Las Vegas. Main office: 146 S. Main St., Salt Lake City. Officers: George C. Hatch, president; Alvin G. Pack, executive vice president; Lynn L. Meyer, vice president in charge of sales; Jack Paige, vice president in charge of programs; Craig Rogers, sales service director; W. D'Ort Cozzens, director of engineering; Gordon Owen, director homemaker's programs.

IOWA TALL CORN NETWORK—An Iowa network comprising KCRI Cedar Rapids; KROS Clinton; KSWI Council Bluffs; KSIB Creston; KSTT Davenport; KDEC Decorah; KWDM Des Moines; KDTH Dubuque; KVED Fort Dodge; KOKX Keokuk; KFJB Marshalltown; KWPC Muscatine; KTRI Sioux City; KICD Spencer; KAYX Waterloo. Operating committee managers of the member stations: Hugh Norman, W. J. Teich, William Ware, E. M. Horning, William Croker, Robert L. Webber, K. S. Gordon, Edward Breen, George Adkisson, Paul Millen, George Volger, Dietrich Dirks, Ben Sanders, Al Triggs. Manager and central area representative: George W. Webber, 407 Fifth Ave., Des Moines. National representative for network and individual stations: J. P. McKinney & Son.

LIBERTY BROADCASTING SYSTEM—Headquarters: 2008 A Jackson St., Dallas. Tex. Comprising WKAB Mobile, Ala.; WJRD Tuscaloosa, Ala.; KWHN Fort Smith, Ark.; KVIC Little Rock, Ark.; KTLN Denver, Colo.; KDZA Pueblo, Colo.; KWHI Hutchinson, Kans.; KINL Independence, Kans.; KSEF Pittsburg, Kans.; WBR Baton Rouge, La.; WNOE New Orleans, La.; KSLP Ocala, Fla.; KSYL Alexandria, La.; KNOE Monroe, La.; WCGM Gulfport, Miss.; WHSY Hattiesburg, Miss.; WJXN Jackson, Miss.; WVIM Vicksburg, Miss.; KSEO Durant, Okla.; KTOW Oklahoma City, Okla.; KFMJ Tulsa, Okla.; KVLV Alpine, Tex.; KPXB Beaumont, Tex.; KAND Corsicana, Tex.; KXIT Dalhart, Tex.; KDSX Denison, Tex.; KULP El Campo, Tex.; KLIF Dallas, Tex.; KXOL Fort Worth, Tex.; KCLW Hamilton, Tex.; KATL Houston, Tex.; KEVT Kerrville, Tex.; KLIJ Longview, Tex.; KCBP Lubbock, Tex.; KORB Mineral Wells, Tex.; KVKM Mathams, Tex.; KRIG Odessa, Tex.; KIUN Pecos, Tex.; KNAL Victoria, Tex.; KTRN Wichita Falls, Tex. Gordon B. McLendon, president and James Foster, general manager.

LONE STAR CHAIN—Texas regional network comprising WBAP Fort Worth; KTBC Austin; KTSa

San Antonio; KXYZ Houston; KROD El Paso; KTXL San Angelo; KWKC Abilene; KOSA Odessa; KFTM Beaumont; KRGV Weslaco; KEYS Corpus Christi; KTRE Lufkin; KTEB Tyler; KGAC Amarillo; KKYO Lubbock; KFDX Wichita Falls. Headquarters: M & W Tower Bldg., Dallas 1. Tel.: Riverside 5663. Harold V. Hough, president; Fred J. Nahas, vice president; O. L. (Ted) Taylor, secretary-treasurer; Howard H. Dunavan, gen. mgr.

LONG TEXAS GROUP—Comprising KIOX Bay City; KVIC Victoria; KSAM Huntsville; and KTLW Texas City. All in Texas and available as a package group. J. G. Long, managing director.

MAIL ORDER NETWORK—Specialized group linked largely by transcription and devoted to selling products by mail. Supplies affiliates with programming including commercial announcements, handles negotiations with sponsors, arranges program promotion and acts as clearing house for offers, copy and products. Headquarters: 1440 Broadway, New York 18, N. Y. Tel.: Pennsylvania 6-2367. Harold Kaye, president.

MAINE BROADCASTING SYSTEM—Comprising WCSH Portland; WLBS Bangor; WRDO Augusta. William Rines, WCSH, manager. Represented by Weed & Co. and Bertha Bannan.

McCLATCHY BEELINE—Comprising KFBK, KFBK-FM Sacramento; KMJ and KMJ-FM Fresno; KWG Stockton; KERN and KERN-FM Bakersfield; KOH Reno, Nev. and KBEE (FM) Modesto. Headquarters: 911 Seventh St., Sacramento, Calif. Eleanor McClatchy, president; Leo O. Ricketts, sales director.

THE MICHIGAN FM NETWORK—Comprising WPAG and WPAG-FM Ann Arbor; WUOM-FM Ann Arbor; WTHH and WTHH-FM Port Huron; WBCK Battle Creek; WKZO Kalamazoo; WJEF Grand Rapids; WHPE and WHPE-FM Benton Harbor; WTVB and WTVB-FM Grand Haven; WABJ and WABJ-FM Adrian; WKNX Saginaw and WMUS and WMUS-FM Muskegon. Headquarters: WPAG Hutzel Bldg., Ann Arbor, Mich. Edward F. Baughn, executive.

MICHIGAN RADIO NETWORK—Comprising WXYZ Detroit (key station); WBCM Bay City; WYDF Flint; WJIM Lansing; WIBM Jackson; WELL Battle Creek; WLAV Grand Rapids; WSOO Sault Ste. Marie; WKBS Muskegon; WKLA Ludington; WGFG Kalamazoo; WHRV Ann Arbor. Available as a regional network and also sold as a unit of ABC Network. Headquarters: Stroh Bldg., Detroit. Executives: James G. Riddell, general manager.

THE MID SOUTH NETWORK—Comprising WCBI Columbus; WELU Tupelo; WMOX, WMOX-FM Meridian; WROK, WROK-FM Grenada; WCOB West Point; WSSO Starkville. All in Mississippi. Headquarters: WCBI Columbus. Bob McRaney, general manager.

MIDWEST FM NETWORK—Comprising WKY-FM Evansville, Ind.; WCSB Columbus, Ind.; WXLW FM Indianapolis; WFTW-FM Fort Wayne; WCTS Cincinnati, Ohio; WFAM Lafayette, Ind.; WSUA-FM Bloomington, Ind.; WEAW Evanston, Ill.

NEW ENGLAND BROADCASTING SYSTEM—Comprising WABI Bangor; WLAM Lewiston-Auburn; WPOR Portland; WTVL Waterville; All in Maine. WFEA Manchester; WKNE Keene; WLNH Laconia; WMOU Berlin. All in New Hampshire. WJOY Burlington; WSKI Montpelier-Barre. All in Vermont. WACE Chicopee-Springfield; WALE Fall River; WBEC Pittsfield; WBKA Brockton; WBSM New Bedford; WEIM Fitchburg; WHAV Haverhill; WKOK Framingham; WNEB Worcester. All in Massachusetts. Also WHTM Providence, R. I., and WHTT Hartford, Conn. Headquarters: Kettell-Carter, Park Square Bldg., Boston 16.

NEW ENGLAND MAJOR MARKETS GROUP—Comprising WLAW Lawrence, Mass.; WPRO Providence; WDRS Hartford; WTAG Worcester, Mass.; WGAN Portland, Me.; WGUY Bangor, Me. E. E. Hill, permanent chairman. Represented by Paul H. Raymer Co.

NEW ENGLAND REGIONAL NETWORK—Special regional network of NBC-affiliated stations, comprising WTTT Hartford; WBZ Boston; WJAR Providence; WCSH Portland; WLBS Bangor; WRDO Augusta, Me. Directors: Paul W. Morency, WTTT, chairman; J. B. Conley; Westinghouse Radio Stations; John J. Boyle; WJAR; William E. Rines, WCSH. Operations Director: Paul W. Morency. Represented nationally by Weed & Co.

NORTHWEST NETWORK—Comprising KSTP St. Paul; KROC Rochester, Minn.; KYSM Mankato, Minn.; KFAM St. Cloud, Minn.; WEAU Eau Claire, Wis.; WDVA Fargo, N.D.; KFYZ Bismark, N.D.; WEBC Duluth, Minn.; WMFG Hibbing, Minn.; WHLB Virginia, Minn.; WJMC Rice Lake, Wis. Headquarters and sales office: 3415 University Ave., KSTP Minneapolis-St. Paul. Officials: Stanley E. Hubbard, general manager; Kenneth M. Hance, treasurer; Miller Robertson, sales manager.

OHIO NETWORK—Comprising WKRC-TV Cincinnati; WHIO-TV Dayton; WBNT(TV) Columbus.

OKLAHOMA GROUP BROADCASTERS—Comprising KOCY Oklahoma City; KAKC Tulsa; KCRC Enid; KSWO Lawton; KVSO Ardmore; WBBZ Ponca City; KWON Bartlesville and KMUS Muskogee; KSMI Seminole; KSPI Stillwater; KSEO Durant; KWCO Chickasha; KGFF Shawnee; KWOE Clifton; KVLH Pauls Valley; KTCM McAlester; KWHW Afton, and KHRG Okmulgee; all in Oklahoma. Headquarters: KOCY Oklahoma City. H. H. Bonebrake, general manager. Represented by The Walker Co.

(Continued on page 66)



LIBERTY RINGS THE BELL!

BRINGING YOU INTENSE COVERAGE OF ONE OF THE RICHEST NINE-STATE
AREAS IN THE UNITED STATES . . . OVER 71 LOCAL AND REGIONAL STATIONS!

Liberty Broadcasting System is the fastest growing network in America today . . . but every step of its growth has been, and will be, carefully controlled. With sports and special events its keystone, Liberty has the *largest baseball network in the history of radio!* Proof of its phenomenal success, listener-wise, is the fact that many national sponsors have purchased large time blocks on the Liberty Broadcasting System—*without solicitation from the network.*

The Liberty Broadcasting System reaches millions of better-able-to-buy people in a vast, prosperous nine-state area who have money in their pockets and are ready to buy everything from soap to washing machines to new cars. To get the most from your advertising dollar . . . to get intense coverage of one of the richest areas in the United States . . . let LIBERTY ring the bell for you!

LIBERTY BROADCASTING SYSTEM

Gives intense coverage of these 9 rich, progressive states . . .

TEXAS
OKLAHOMA
ARKANSAS
LOUISIANA
ALABAMA

TENNESSEE
MISSISSIPPI
COLORADO
KANSAS

*Represented Nationally by
Adam Young, Jr., Inc.
New York • Chicago • Los Angeles • San Francisco*

THE LIBERTY BROADCASTING SYSTEM

DALLAS, TEXAS

Gordon McLendon
President

Barton R. McLendon
Chairman of the Board

James H. Foster
General Manager

REGIONAL NETWORKS

(Continued from page 64)

OKLAHOMA NETWORK—Comprising KTOK Oklahoma City; KOME Tulsa; KCRC Enid; KBX Muskogee; KGF Shawnee; KADA Ada; KVSQ Ardmore; KTMK McAlister; KSWO Lawton. All stations affiliated with American Network. Available as a regional network. Headquarters: 1800 W. Main St., Oklahoma City. Managing Director: Robert D. Enoch, KTOK. Represented nationally by Taylor-Borhoff Inc.

THE OREGON TRAIL NETWORK—Owned and operated by Inland Radio Inc. KSRV Ontario; KBKR Baker, and KLEB LaGrande. Lee W. Jacobs, general manager.

QUAKER NETWORK—Pennsylvania regional hookup comprising WFIL Philadelphia; WRAW Reading; WSN Allentown; WEST Easton; WORK York; WAZL Hazleton; WGAL Lancaster; WGBI Scranton; WBRE Wilkes-Barre; WKBO Harrisburg; WKOK Sunbury; WRAC Williamsport; WFBG Altoona; WJAC Johnstown; WLEU Erie; WWSW Pittsburgh; WKST New Castle. Operates as network or split as desired. Other cities available on order. Headquarters: WFIL Philadelphia. General Manager: Roger W. Clipp; Sales Manager: John E. Surrick.

RADIO NETWORK OF ARIZONA—Comprising KOOL Phoenix; KCNA Tucson; KCYK Coolidge. Charles H. Garland, general manager; Miles Reed, sales manager.

REBEL NETWORK—Mississippi regional network comprising WJDX Jackson; WAML Laurel; WFOR Hattiesburg; WTOK Meridian; WGCM Gulfport. Frank Gentry, business manager.

ROCKY MT. BCSTG. SYSTEM—Comprised of six owned and operated stations: KUTA Salt Lake City; KGEM Boise; KLIX Twin Falls; KEIO Pocatello; KIFI Idaho Falls; KOPR Butte, Mont.; and nine affiliated stations: KMOM Great Falls; KOOK Billings; KPRK Livingston, Mont.; KELK Elko; KENO Las Vegas; KFBC Cheyenne; KRAL Rawlins; KVOC Casper, Wyo.; KBIO Burley, Idaho; and independents: KWOG Ogden and KCSU Provo, Utah. Offices: KUTA Salt Lake City, Utah. Officers: Frank C. Carman, president; S. John Schlie, vice president in charge of sales. Represented nationally by George P. Hollingbery Co.

RURAL RADIO NETWORK—Owns and operates WFNF Wethersfield; WVBST Bristol Center; WVCN Derby; WVCV Cherry Valley; WVEN Turin. It also has as affiliates: WFCU-FM Ithaca; WFLY Troy; WHLD-FM, Niagara Falls and WSLB, Ogdensburg. Headquarters: Ithaca, N.Y. R. Bruce Gervan, general manager.

SOUTH CENTRAL QUALITY NETWORK—Regional network comprising WMC Memphis; KARK Little Rock; KWKH Shreveport; WJDX Jackson, Miss.; WSMB New Orleans. Special hookup of any or all

available at combined national rates of each station. plus line charges. Headquarters, each station.

SOUTHWEST NETWORK—Comprising KROD El Paso; KAVE Carlsbad, N.M.; KSL Silver City, N.M.; KOSA Odessa, Tex.; KIUN Pecos, Tex.; KVKM Monahans, Tex.; KVLV Alpine, Tex.; KGFL Roswell, N.M.; KWEW Hobbs, N.M. Headquarters 202 Radio Bldg., El Paso, Tex. Dorrance D. Roderick, president; Val Lawrence, vice president and managing director; Robert Hughes, commercial manager.

THE STANDARD NETWORK—Comprising WJW Cleveland (originating station); WATG (FM) Ashland; WTFM (FM) Tiffin; WCMW, WCMW-FM Canton; WFRO (FM) Fremont; WFOB (FM) Fostoria; WFIN, WFIN-FM Findlay; WCTL (FM) Newark; WTNS, WTNS-FM Coshocton; WWSST, WWSST-FM Wooster; WIMA, WIMA-FM Lima; WLIO East Liverpool; WLEC Sandusky; WFAH (FM) Alliance; WQNW Defiance; WTRF Bellair; WMOA Marietta; WBEW Youngstown; WICA Ashtabula; and WJEL Springfield; all in Ohio; WMGW Meadville, Pa.

STEINMAN STATIONS (Mason Dixon Radio Group)—Regional group comprising WDEL Wilmington, Del.; WORK York, Pa.; WGAL Lancaster, Pa.; WRAW Reading, Pa.; WEST Easton, Pa.; WKBO Harrisburg, Pa.; WGAL-TV Lancaster, Pa.; WDEL-TV Wilmington, Del. Represented nationally by Robert Meeker Assoc. Headquarters: WGAL Lancaster. General Manager: Clair R. McCollough.

TEXAS BROADCASTING SYSTEM (TBS)—Regional network comprising KRDL Dallas; KABC San Antonio and KTRH Houston. Headquarters: Adolphus Hotel, Dallas. Clyde W. Rembert, general manager.

TEXAS QUALITY NETWORK—Comprising WFAA Dallas; WOAI San Antonio; KPRC Houston. Associated stations: KRIS Corpus Christi; KRGV Brownsville, Tex.; KTBS Shreveport, La. Available as a cooperative regional network. Represented nationally by Edward Petry & Co. Headquarters: Any station, each acting as sales office. Directors: Martin Campbell, WFAA; Hugh A. L. Hall, WOAI; Jack Harris, KPRC.

TEXAS STATE NETWORK—Regional network comprising KFJZ Fort Worth; WRR Dallas; KABC San Antonio; KBST Big Spring; KGKL San Angelo; KRBC Abilene; KPLT Paris; KRRV Sherman; KCMC Texarkana; WACO Waco; KNOW Austin; KFRO Longview; KBWD Brownwood; KMAC San Antonio; KCRS Midland; KGVN Greenville; KTHH Houston. Gene L. Cagle, president. Headquarters: 1201 W. Lancaster, Fort Worth 1.

THE TOBACCO NETWORK INC.—Regional North Carolina network comprising WRAL Raleigh; WTIK Durham; WFNC Fayetteville; WCEC Rocky Mount; WGTC Greenville; WHIT New Bern; WJNC Jacksonville; WGNi Wilmington. Executives: Floyd Fletcher, WTIK, president; Louis N. Howard, WHIT, vice president; Hartwell Campbell, WGTC, secretary and treasurer; R. K. Scott, general sales manager and chairman program committee. Headquarters: Box 1988, Raleigh, N. C. Tel.: 885. Represented nationally by Forjoe & Co.

UNION BROADCASTING SYSTEM—Comprising WXRA Buffalo, N.Y.; WOKO Albany Park, N.Y.;

WCSS Amsterdam, N.Y.; WWSC Glen Falls, N.Y.; WENT Gloversville, N.Y.; WHUC Hudson, N.Y.; WKNY Kingston, N.Y.; WKIP Poughkeepsie, N.Y.; WDOS Oneonta, N.Y.; WKOP Binghamton, N.Y.; WELM Elmira, N.Y.; WGAT Utica, N.Y.; WNDR Syracuse, N.Y.; WICY Malone, N.Y.; WEAV Plattsburgh, N.Y.; WNBZ Saranac Lake, N.Y.; WLEC Pittsfield, Mass.; WACE Chichester, Mass.; WABC Fall River, Mass.; WVOM Boston, Mass.; WSYB Rutland, Vt.; WJOY Burlington, Vt.; WWCO Waterbury, Conn.; WTON Torrington, Conn.; WFAU Augusta, Me.; WJOR Bangor, Me.; WKNE Keene, N.H. Headquarters: WOKO Albany, N.Y. Jim Healey, general manager.

WEST TEXAS PACKAGED STATIONS—Comprising KRBC Abilene; KBST Big Spring; KGKL San Angelo; KTRN Wichita Falls.

WEST VIRGINIA GROUP—Comprising WKOY Bluefield; WCAW Charleston; WVUV Fairmont; WHTN Huntington and WOAY Oak Hill. Harold B. Shaw, WOAY Oak Hill, traffic manager. Represented by The Friedenberg Agency.

WISCONSIN NETWORK—Network comprising WHBY Appleton; KFIZ Fond du Lac; WCLD Janesville; WIBU Poyntette-Madison; WRJN Racine; WHBL Sheboygan; WFRH Wisconsin Rapids; WJPG Green Bay; WGEZ Beloit. Supplementary Stations: WMAM Marinette; WBIZ Eau Claire; WJMS Ironwood, Mich.; WATW Ashland; WSRB Superior; WISN Milwaukee; WKBH La Crosse; WOSH Oshkosh; WJMC Rice Lake; WOET Appleton; WATK Antigo. Main office: Wisconsin Rapids. George T. Frechette, WFRH, managing director and secretary-treasurer.

YANKEE NETWORK—Comprising WNAC Boston; WONS Hartford, Conn.; WEAN Providence, R.I.; WCOO Waterbury, Conn.; WHYN Holyoke-Springfield, Mass.; WAAE Worcester, Mass.; WICC Bridgeport, Conn.; WMTW Portland, Me.; WLLH Lowell-Lawrence, Mass.; WALE Fall River, Mass.; WJOR Bangor, Me.; WKBR Manchester, N.H.; WBRK Pittsfield, Mass.; WNLN New London, Conn.; WLNH Laconia, N.H.; WFAU Augusta, Me.; WCOU Lewiston, Me.; WHAL Greenfield, Mass.; WEIM Fitchburg, Mass.; WSYB Rutland, Vt.; WHEB Portsmouth, N.H.; WDEV Waterbury, Vt.; WKXL Concord, N.H.; WTSV Claremont, N.H.; WIDE Biddeford, Me.; WWOV Woonsocket, R.I.; WNBH New Bedford, Mass.; WOCB Hyannis, Mass. Represented nationally by Edward Petry & Co. Headquarters: 21 Brookline Ave., Boston. Officers: William O'Neil, president; Linus Travers, executive vice president; George W. Steffy, vice president; Tom O'Neil, vice president; William O'Neil, treasurer; Robert F. Ide, assistant treasurer; Frank Knowlton, secretary.

Z-BAR-NET—Comprising KXLF Butte, Mont.; KKLJ Helena, Mont.; KXJQ Bozeman, Mont.; KXKL Great Falls, Mont.; KXLL Missoula, Mont. Available as a hookup. Managing Director: Ed Crane, KXLF.

ZIA NETWORK—Comprising KOAT Albuquerque; KTRC Santa Fe; KSWR Roswell and KGAK Gallup. All in New Mexico.

FCC BAR

(Continued from page 59)

Wilder, Gaston H. Jr., Goodhue Bldg., Beaumont, Tex.
Wilkinson, Glen A., Ernest L. Wilkin-son, 744 Jackson Pl., D. C.
Williams, A. Rea, Investment Bldg., D. C.
Wills, John W., Fischer, Willis & Panzer, Dupont Circle Bldg., D. C.
Winer, Morton H., Woodward Bldg., D. C.
Wilson, George O., Magnolia Bldg., Dallas.
Wilson, James E., Roberts & McInnis, Mayflower Office Bldg., D. C.
Wilson, Thomas W., Dow, Lohnes & Albertson, Munsey Bldg., D. C.
Winter, Harrison L., 10 Light St., Baltimore.
Wittenberg, Ralph K., Hilp Bldg., Reno, Nev.
Wolff, Sanford I., Riskind & Wolff, 134 N. LaSalle St., Chicago.
Wozencraft, Frank H., Southern Bldg., D. C.
Wrape, James W., Sterick Bldg., Memphis.
Wyatt, Wilson W., Marion E. Taylor Bldg., Louisville, Ky.

Y

Yates, Carlyle E., RCA, 30 Rockefeller Plaza, New York 20.
Yost, Leland L., Justice Dept., D. C.
Young, Verne R., Loucks, Zias, Young & Jansky, 1317 F St., N. W., D. C.
Younger, Donald, 1311 Pacific Ave., Santa Cruz, Calif.
Yourd, Kenneth L., CBS, Columbia Square, Los Angeles 28.

Z

Zagon, Samuel S., 6263 Hollywood Blvd., Los Angeles.
Zias, Joseph F., Loucks, Zias, Young & Jansky, 1317 F St., N. W., D. C.

RADIO RESULTS

(Continued from page 20)

content, mood, and a dozen other factors are natural parts of his service from the medium, you begin to see why radio and results are terms in common. The advertiser who prefaces his advertising contract with considerations like these is drawing upon a vast store of techniques created by broadcasters with the improvement of their art in mind. He is thinking about results, trying to control or dictate results. And he gets results.

Common Practice

It is common practice for advertisers—local and national—to depend upon radio and only radio for the selection of those factors that can best produce results for them. That is why radio is sold, much in the manner of a custom-tailored suit fitted to the individual buyer, while printed media are bought. "What are your availabilities?" is a question peculiar to radio. In what other medium does the buyer preface his purchase with a question inviting basic advice on how best to place his advertising? It doesn't do to reply

that others work regardless of where or how they're used. They don't.

Radio results follow the basic media rule—they increase in direct proportion to the effectiveness with which the medium is used. Possessed of an overwhelming advantage over other major media in every department, radio has not failed to produce staggering results wherever it has been properly used.

The close relationship between proper techniques and good results which exists in radio makes a thorough understanding of the medium essential to every person who handles radio advertising. The medium has suffered from the sins of many of its own people, and only careful selection and supervision by radio's management will reduce this waste.

Selling on superiority alone isn't the answer to a prosperous radio station operation. The salesman who wins all the arguments doesn't always bring back all the contracts. Naturally, the advertiser likes to buy with confidence in his selection of a medium. But this

confidence never lasts long in the face of the importunities of competitive salesmen. When this early confidence based on the selling story is translated into satisfaction with the results, then a long-term account has been born.

Challenging Job

This is the radio salesman's most challenging job. He delivers best results when, with the advertiser, he carefully works out an advertising plan, based on known objectives, even before a word of advertising is heard on the air. And to set up this plan he should be capable of drawing on his understanding of the advertiser's business, of advertising in general, of radio advertising in particular—and finally on his knowledge of the special ability of his station to deliver the audience and the program most likely to succeed.

With this equipment, plus a sound understanding of the reasons behind radio's superiority over other media, the radio salesman should not only be able to win the order, but convert it into lasting income through satisfactory performance.

THE ASCAP CREDO

ASCAP is a useful, progressive Citizen. It acts in the best interest of the Public, while faithfully serving its Customers and Membership.

ASCAP is frank and friendly.

ASCAP fosters and safeguards the musical talent of American youth, by increasing incentives, providing security and protecting their creative product.

ASCAP aspires to preserve the American freedom of thought and expression, for only in such climate—free from social, economic and political pressure—can creative talent reach its full height.

ASCAP realizing that talent is not the property of any single group, accepts composers and authors to membership without regard to race, creed or color.

ASCAP strives to bring to an ever-widening audience a fuller appreciation of America's rich musical heritage. THE SOCIETY freely fosters the performance of its members' music without compensation, for diverse public, educational, therapeutic and charitable uses.



The American Society of Composers, Authors and Publishers

30 ROCKEFELLER PLAZA, NEW YORK 20, N. Y.

1000 Watts

WSPC

1390 Kc.

24 hour operation
ANNISTON ALABAMA

"Industrial Hub of the Rich Coosa Valley"

Directory of AM, FM and TV STATIONS OF THE UNITED STATES

AP—Associated Press.

INS—International News Service.

TP—Transradio Press.

UP—United Press.

(Data corrected to December 6, 1949)
If executives or services for FM or TV stations are same as AM affiliate names are not repeated.

ALABAMA

City	Call Letters	Chan. or Freq. Power	Name of Licensee Headquarters Address Telephone Number	Network Representative	Executive Personnel	Transc. Library News Service Transmitter Make
ALBERTVILLE						
	WAVU 1948	630 500-D	Sand Mountain Bcstg. Service P. O. Box 149 630		Pat M. Courington, Pres. & Gen. Mgr. Eaton P. Govan Jr., Coml. Mgr.	(Mrs.) Vinette B. Govan, Prog. Dir. Richard C. Payne, Chief Engr. World AP Gates
	WAVU-FM 1949	Ch. 286 (B) 105.1mc 6.4kw			 Western Electric
ALEXANDER CITY						
	WRFS 1947	1050 1,000-D	Piedmont Service Corp. Main St. 1050	ABS Sears & Ayer	James L. Coley, Pres. Gen. & Coml. Mgr. Bob McKinnon, Prog. Dir.	Lem Coley, Prom. Mgr. James W. Whatley, Chief Engr. Thesaurus UP Raytheon REL
	WRFS-FM 1949	Ch. 291 (B) 106.1mc 4.6kw			 RCA
ANDALUSIA						
	WCTA 1946	1340 250	Andalusia Bcstg. Co. Inc. Sanford Rd. 844	MBS KBS	J. Dige Bishop, Exec. V. P., Gen. & Coml. Mgr. & Chief Engr.	Kristine Hardage, Prog. Dir. World UP RCA
ANNISTON						
	WHMA 1938	1450 250	Anniston Bcstg. Co. Radio Bldg. 2380	ABC Sears & Ayer	Harry M. Ayers, Pres. Malcolm Street, Gen. Mgr. Bob Sanders, Prog. Dir.	Harry Mabry, Prom. Mgr. James Hudson, Chief Engr. Lang-Worth UP Collins General Electric
	WHMA-FM 1947	Ch. 263 (B) 100.5mc 21kw			 AP Gates Standard AP Collins
	WOOB 1947	1490 250	W. S. Weatherly 1001½ Noble St. 3210	MBS	W. S. Weatherly, Pres. & Gen. Mgr. Lee Blaine, Prog. Dir.	David Vowell, Prom. Mgr. Tommy Atkins, Chief Engr. AP Gates Standard AP Collins
	WSPC 1949	1390 1,000 DA-1	Model City Bcstg. Co. Jefferson Davis Hotel 1850	LBS Walker	Stanton B. Ingram, Pres. Ganus C. Scarborough, Gen. & Prom. Mgr. & Prog. Dir.	Ross Charles, Coml. Mgr. Raymond Watson Jr., Chief Engr.
ATHENS						
	WJMW 1948	1010 250-D	Athens Bcstg. Co. Inc. P. O. Box 383 565	ABS	Homer F. Dunnavant, Pres., Gen. & Coml. Mgr.	Robert V. Dunnavant, Prog. Dir. & Prom. Mgr. Capitol AP Gates
ATMORE						
	WATM (CP)	1580 250-D	Southland Bcstg. Co. Atmore		J. B. McCrary, Pres. C. W. Reddoch, Gen. Mgr. & Chief Engr.	Robert Dietz, Coml. Mgr. Capitol UP RCA
AUBURN						
	WAUD 1947	1230 250	Auburn Bcstg. Co. Box 350 1240	ABS	Elmer G. Salter, Pres., Gen. & Coml. Mgr. Dave Sherrell, Prog. Dir.	Frances Hubbard, Prom. Mgr. Charlie Herman, Chief Engr. World Lang-Worth AP Gates
BESSEMER (Birmingham)						
	WJLD 1942	1400 250	Johnston Bcstg. Co. P. O. Box 147 2300		George Johnston Jr., Pres. James E. Connolly, Sta. Mgr. Clay Coe, Coml. Mgr.	Joan Jetton, Prog. Dir. Jane Shaddix, Prom. Mgr. Maurice E. McKinney, Chief Engr. INS Gates World RCA
	WJLN(FM) 1948	Ch. 284 (B) 104.7mc 23kw	6-8172		 RCA
 (CP)	1450 250	Bessemer Bcstg. Co. 1824 Second Ave.		 RCA
BIRMINGHAM						
	WAPI 1922	1070 5,000 DA-N	Voice of Alabama Inc. 2029 First Ave., N. 3-8116	CBS Radio Sales	Ed Norton, Chmn. of Bd. Thad Holt, Pres., Treas. & Gen. Mgr. Maury Farrell, Prog. Dir. Clinton L. Blakely, Coml. Mgr.	C. P. Persons Jr., Coml. Mgr. Lionel F. Baxter, Prom. Mgr. James L. Evans, Chief Engr. Norman S. Heurley, Chief Engr. World UP Western Electric
	WAFM(FM) 1947	Ch. 258 (B) 99.5mc 540kw	(WAPI, AM Affiliate)		 Winik Pictorial RCA
	WAFM-TV 1949	Ch. 13 210-218mc 13.6kw-aur.; 26kw-vis.	(WAPI, AM Affiliate)	ABC CBS	 Standard Lang-Worth Capitol AP, INS RCA DuMont Ziv Goodman DuMont
	WBRC 1925	960 5,000 DA-N	Birmingham Bcstg. Co. WBRC Bldg. 4-7741	NBC Raymer	Eloise S. Hanna, Pres. Howell C. Cobb, Gen. Mgr. Don D. Campbell, Coml. Mgr.	M. D. Smith, Prog. Dir. John Orr, Prom. Mgr. G. P. Hamann, Chief Engr.
	WBRC-TV 1949	Ch. 4 66-72mc 7.2kw aur.; 14.5kw vis.		DuMont NBC Blair TV	G. P. Hamann, Gen. Mgr. Raytheon
	WEDR 1949	1220 1,000-D	Magic City Bcstg. Co. 1417 4th Ave. N. 4-0925		J. E. Reynolds, Pres. & Gen. Mgr. (Mrs.) Leah L. Doss, V. P. John A. Thompson, Secy.-Treas. & Coml. Mgr.	Lloyd Williams, Prog. Dir. John H. Cram, Chief Engr.
	WJLN(FM) 1945	(See Bessemer, Ala. Listing)			 AP Gates
	WKAX 1945	900 1,000-D	Courier Bcstg. Service 216½ N. 21st St. 54-2541	McGillivra	Dr. Glenn V. Tingley, Pres. Emmet Gibbs, Coml. Mgr.	(Mrs.) Dorothy Alexander, Prog. Dir. Stanley Hawkins, Chief Engr.
	WKAX-FM (CP)	Ch. 250 (B) 97.9mc 8.9kw			 AP Gates

DA-N Directional Antenna, night only. FM's in italic.
DA-1 Directional Antenna, same pattern day and night.
DA-2 Directional Antenna, different pattern day and night.

*—Non-Commercial Station D—Day N—Night ST—Share Time SH—Specified Hours.
U—Unlimited CP—Construction Permit Issued. LS—Local Sunset.
L—Limited Time with Dominant Station. SA—Special Authorization.

DIRECTORY OF AM, FM, and TV STATIONS OF THE UNITED STATES

*(Data corrected to December 6, 1949)
If executives or services for FM or TV stations are same as AM affiliate names are not repeated.*

ALABAMA—(Continued)

City Call Letters Established	Chan. or Freq. Power	Name of Licensee Headquarters Address Telephone Number	Network Representative	Executive Personnel	Transc. Library News Service Transmitter Make	
BIRMINGHAM—(Continued)						
WSGN 1927	610 5,000-LS 1,000-N DA	The Birmingham News Co. Radio Park, 4-3434	ABC Alabama Headley-Reed	Henry P. Johnston, Gen. Mgr. Julian A. Flint, Coml. Mgr. Eugene M. Plumstead, Prog. Dir.	Mary F. Childers, Prom. Mgr. J. V. Sanderson, Chief Engr.	AP
WSGN-FM 1947	Ch. 229 (B) 93.7mc 16.9kw					
WTNB 1949	1490; 250 CP-850; 5,000-LS; 1,000-N (DA)	Pilot Bcstg. Corp. WTNB Bldg. 4-4511	MBS Taylor-Borroff	(Mrs.) Evelyn S. Hicks, V. P. & Gen. Mgr.	Ira L. Leslie, Prog. Dir.	SESAC, World AP
WVOK 1947	690 50,000-D 1,000-N DA	Voice of Dixie Inc. P. O. Box 2468 6-2924		Iralee W. Bennis, Pres. & Gen. Mgr. William J. Brennan, Coml. & Prom. Mgr.	Ira Leslie, Prog. Dir. Bill Brennan, Chief Engr.	Capitol UP
BREWTON						
WEBJ 1947	1240 250	Brewton Bcstg. Co. Brewton 553	KBS ABS	W. Emmett Brooks, Pres. & Gen. Mgr. J. M. Miller Jr., Coml. Mgr.	William E. Brooks Jr., V. P. Robert Salles, Chief Engr.	Associated Lang-Worth SESAC, AP Gates
CLANTON						
WKLF 1947	980 1,000-D	Southeastern Bcstg. Co. P. O. Box 546 449	KBS ABS Clark	Dr. J. Kelley Robinson, Pres. Robert B. Taber, Gen. Mgr. Jesse A. Culp, Coml. Mgr.	Paul Reid, Prog. Dir. Lester Carter, Chief Engr.	World AP Gates
CULLMAN						
WFMH(FM) 1946	Ch. 265 (A) 100.9mc 0.36kw	The Voice of Cullman				
WKUL 1946	1340 250	Cullman Bcstg. Co. P. O. Box 211 863	KBS ABS	Hudson C. Millar Jr., Gen. Mgr. Lon Waters, Prog. Dir.	Alexander B. Millar, Secy. Treas. Arthur Bachmann, Chief Engr.	World AP Western Electric
DECATUR						
WHOS 1948	800 1,000-D	North Alabama Bcstg. Co. 212 Jackson St. 991	ABS	H. H. Kinney & D. T. Kinney, Partners D. T. Kinney, Gen. Mgr. Rosebud Waldrop, Coml. Mgr.	Jack Gray, Prog. Dir. Bill Mapes, Prom. Mgr. Franklin Norris, Chief Engr.	Capitol UP Western Electric
WMSL 1938	1400 250	Tennessee Valley Bcstg. Co. Mutual Savings Life Bldg. 802	MBS KBS	Melvin Hutson, Pres. & Gen. Mgr. Louis Blizzard, Prog. Dir.	J. V. Roser, Chief Engr.	World AP Gates
WMSL-FM (CP)	Ch. 223 (B) 92.5mc 3.1kw					
DEMOPOLIS						
WXAL 1947	1400 250	Demopolis Bcstg. Co. Radio Bldg. 400	MBS KBS	T. H. Gaillard Jr., W. M. Jordan, Partners T. H. Gaillard Jr., Sta. Mgr.	W. M. Jordan, Gen. Mgr. Leo Hart, Prog. Dir. John T. Larkin Jr., Chief Engr.	World AP RCA
DOTHAN						
WAGF 1932	1320 1,000 DA-N	Dothan Bcstg. Co. 204½ E. Main St. 2-29100	MBS McGillvra	Julian C. Smith, Gen. Mgr. Fred C. Moseley, Coml. Mgr.	J. A. Creamer, Prog. Dir. & Prom. Mgr. John T. Hubbard, Chief Engr.	World AP Gates
WDIG 1947	1450 250	Houston Bestrs. 107 E. Adams St. 3-4100	ABC Cummings	Jess Swicegood, Pres., Gen. & Coml. Mgr.	John Ingersoll, Prog. Dir. Charles Laushe, Chief Engr.	Lang-Worth UP Raytheon
WEOF 1948	560 1,000-D	Dowlander Bcstg. Co. 110 S. Foster 3-5300	KBS ABS Sears & Ayer	R. A. Dowling Jr., Pres., Gen. & Coml. & Prom. Mgr.	Tom Underwood, Prog. Dir. Wiley Grissom, Chief Engr.	Capitol UP Gates
ENTERPRISE						
WIRB 1948	1230 250	The Wiregrass Bcstg. Co. Dothan Highway 30		R. E. & F. H. James & R. M. Stan- ford, Partners J. Wesley Gardner, Gen. & Coml. Mgr.	Harry Gilder, Prog. Dir. James C. Smith, Chief Engr.	World UP Gates
EUFULA						
WULA 1948	1240 250	Alabama-Georgia Bcstrs. Inc. Radio Bldg. 745	KBS	M. M. Moulthrop, Pres. & Gen. Mgr. Lee S. Bullis, Coml. & Prom. Mgr. & Prog. Dir.	Hugh G. Chastain, Chief Engr.	World UP Collins
FAYETTE						
WWWF 1949	990 1,000-D	Bankhead Bcstg. Co. Inc.				
FLORENCE						
WJOI 1946	1340 250	Florence Bcstg. Co. Inc. 850 South Court St. 2608	ABC ABS	Joe T. VanSandt, Pres. & Gen. Mgr. Oscar D. Lewis, Coml. Mgr.	David E. Bigley, Prog. Dir. & Prom. Mgr. Enoch S. Bingham, Chief Engr.	World AP Gates
WMFT 1948	1240 250	Tri-Cities Bcstg. Co. Radio Center 42	KBS Alabama Friedenburg	Milton S. Killen, Pres. Franklin L. Bush, Gen. Mgr. Jim Garrett, Prog. Dir.	Nathan M. Graham Jr., Prom. Mgr. Edwin R. Miller, Chief Engr.	Associated World, AP Gates
FORT PAYNE						
WFPA (CP)	1290 500-D	James L. Killian Burkhart Bldg. 850		James L. Killian, Pres. & Gen. Mgr. Martha S. Killian, Prog. Dir.	J. C. Durham, Prom. Mgr. Jim Bell, Chief Engr.	Lang-Worth INS Collins
WZOB (CP)	1250 1,000-D	Ft. Payne on the Air P. O. Box 255				
GADSDEN						
WGAD 1946	1350 5,000-LS 1,000-N DA	Coosa Valley Bcstg. Co. 817 Forrest Ave. 5641	MBS McGillvra	E. L. Roberts, Pres. J. W. Buttram, Gen. & Coml. Mgr.	Frances Seale, Prog. Dir. J. C. Vessels, Chief Engr.	UP
WGNH 1947	1400 250	General Newspapers Inc. Box 351 2571	ABC Ra-Tel	Carmage Walls, Pres. Joel Robertson, Gen. & Prom. Mgr.	Hall Wray, Prog. Dir.	World INS Gates
WGWD 1947	570 1,000-D	G. W. Covington Estate P. O. Box 128 6-6301	Alabama Taylor-Borroff	Edwin H. Estes, Gen. Mgr. Kenneth L. Wood, Coml. Mgr. Ray Estes, Prog. Dir.	Sylvia Boone, Prom. Mgr. Gaston Anderson, Chief Engr.	Associated UP Gates
WJBY 1928	1240 250	Gadsden Bcstg. Co. Inc. 108 Broad St. 6-3381	ABS Sears & Ayer	Bascom H. Hopson, Pres. Beatrice Tate Benton, Gen. Mgr. & Prog. Dir.	Sam A. Benton, Coml. Mgr. Glenn Nichols, Chief Engr.	AP
WJBY-FM 1948	Ch. 279 (B) 103.7mc 1.5kw					Federal

DA-N Directional Antenna, night only. FM's in italic. *—Non-Commercial Station D—Day. N—Night. ST—Share Time. SH—Specified Hours.
DA-1 Directional Antenna, same pattern day and night. U—Unlimited. CP—Construction Permit Issued. LS—Local Sunset.
DA-2 Directional Antenna, different pattern day and night. L—Limited Time with Dominant Station. SA—Special Authorization.

City Call Letters Established	Chan. or Freq. Power	Name of Licensee Headquarters Address Telephone Number	Network Representative	Executive Personnel	Transc. Library News Service Transmitter Make	
GREENVILLE						
WGYV 1948	1400 250	Greenville Bcstg. Corp. P. O. Box 227 585	ABS Continental	Dr. Vernon Stabler, Pres. Charles D. McNamee, Gen. Mgr. Charles T. Britt, Coml. Mgr.	George Carr, Prog. Dir. Elmo Cronk, Chief Engr.	World UP Gates
GUNTERSVILLE						
WGSV (CP) 1947	1270 1,000-D	Guntersville Bcstg. Co.				
HALEYVILLE						
WJBB 1949	1230 250	Haleyville Bcstg. Co. P. O. Box 151 389	ABS	H. E. Ray } Partners Guy Ray } Roy Mayhall }	S. L. Masden Jr., Gen., Coml. & Prom. Mgr. & Prog. Dir. Chris Christensen, Chief Engr.	Capitol UP RCA
HUNTSVILLE						
WBHP 1937	1230 250	Wilton H. Pollard 318 W. Clinton St. 313	MBS KBS	Wilton H. Pollard, Pres. William G. Harris, Gen. Mgr., Prog. Dir. & Chief Engr.	Mrs. Ruth Harris, Coml. Mgr. Dewey L. Webb, Prom. Mgr.	Capitol UP
WFUN 1946	1450 250	Huntsville Bcstg. Co. Inc. 410 West Holmes St. 2424	ABS Sears & Ayer	J. B. Falt Jr., & John Garrison, Principles J. B. Falt Jr., Pres.	John Garrison, Secy.-Treas. Prog. Dir. & Chief Engr.	AP Gates
WHBS 1946	1490 250	Huntsville Times Co. 207 W. Clinton St. 2345	ABC Headley-Reed	Henry P. Johnston, Pres. Richard Warner, Gen. Mgr. Paul Bumgardner, Coml. Mgr.	N. C. Milwee, Prog. Dir. Ray Roberts, Chief Engr.	AP
WHBS-FM 1947	Ch. 236 (B) 95.1mc 16kw					RCA
JASPER						
WWWB 1946	1240 250	Bankhead Bcstg. Co. Bankhead-Long Bldg. 100	ABS	W. W. Bankhead, Pres. Charles T. Metcalfe, Mgr. James E. Reese, Coml. Mgr.	Robert W. Jones, Prog. Dir. Barbara Bankhead, Prom. Mgr. Jack Copeland, Chief Engr.	AP W. E.
LANETT						
WRLD 1947	1490 250	(See West Point, Ga.)				
MOBILE						
WABB 1948	1480 5,000 DA-2	The Mobile Press Register Inc. Radio Center	ABC, MBS Alabama Branham	R. B. Chandler, Pres. John Screen, Coml. Mgr. W. J. Hearin, Exec. V. P.	Anthony Leighton, Prog. Dir. Wm. Murphree, Chief Engr.	Associated SESAC AP Western Electric
WABB-FM 1949	Ch. 267 (B) 102.1mc 50kw					
WALA 1930	1410 5,000 DA-N	Pape Bcstg. Co. Inc. 210 Government St. 3-3756	NBC Headley-Reed	W. O. Pape, Pres. H. K. Martin, V. P. & Gen. Mgr. Albert Treadway, Coml. Mgr.	Al Holman, Prog. Dir. R. B. Hurley, Chief Engr.	Standard AP RCA
WKAB 1947	840 1,000-D	Pursley Bcstg. Service 354 St. Francis St. 24561	LBS Cooke	Louise P. Pursley, Pres. & Gen. Mgr. R. H. Moore, Coml. & Prom. Mgr.	J. T. Jackson, Prog. Dir. Eugene Miller, Chief Engr.	Lang-Worth MacGregor SESAC INS
WKRG 1946	710 1,000-LS 250-N-DA	Giddens & Rester P. O. Box 1184 2-6789	CBS Alabama Young	Kenneth R. Giddens & T. J. Rester, Owners F. E. Busby, Gen. Mgr. John E. Waller, Coml. Mgr.	Guy Harris Jr., Prog. Dir. (Mrs.) Marguerite Shea, Prom. Mgr. Richad M. Cole, Chief Engr.	Standard Lang-Worth AP RCA
WKRG-FM 1947	Ch. 260 (B) 99.9 mc 3kw					Western Electric
MONTGOMERY						
WAPX 1947	1600 1,000 DA-N	United Bcstg. Co. 116 Catoma St. 3-7569	ABC Walker	Thomas E. Martin, Pres. & Gen. Mgr. Hoke S. Williford, Coml. & Prom. Mgr.	Dave Manners, Prog. Dir. Owen Lehr, Chief Engr.	Lang-Worth SESAC UP RCA
WCOV 1939	1240 250	Estate of G. W. Covington Jr. Exchange Hotel 5781	CBS Taylor-Borroff	J. W. Kirkpatrick, Gen. & Coml. Mgr.	W. L. Steadman, Prog. Dir. John Townshend, Chief Engr.	Associated UP Collins
WCOV-FM 1948	Ch. 233 (B) 94.5mc; 4.1kw					

3 WAY COVERAGE OF A \$2 BILLION MARKET

THREE STRATEGICALLY LOCATED STATIONS

Almost all of Alabama is within the good listening area of the Covington stations. It's an area 647,700 radio families wide who spend \$2 billion annually for retail purchases.

You can sell Alabama at 20% off by buying all three Covington stations: WCOV and WGWC, (both CBS) and WGWD, Gadsden's independent on 570. Or, two stations entitle you to 10% discount.

For sales in Alabama, it's the Covington Stations. For the proof . . . Taylor-Borroff.



WCOV (CBS)
MONTGOMERY

WGWD (IND.)
GADSDEN

WGWC (CBS)
SELMA

Represented Nationally by Taylor-Borroff

DIRECTORY OF AM, FM, and TV STATIONS OF THE UNITED STATES

*(Data corrected to December 6, 1949)
If executives or services for FM or TV stations are same as AM affiliate names are not repeated.*

ALABAMA—(Continued)

City Call Letters Established	Chan. or Freq. Power	Name of Licensee Headquarters Address Telephone Number	Network Representative	Executive Personnel	Transc. Library News Service Transmitter Make	
MONTGOMERY—(Continued)						
WJJB 1948	1170 10,000-LS 1,000-N DA-2	Southern Bcstg. Co. Inc. 115½ Commerce St. 3-4471	MBS Weed	Joseph G. Mathews, Pres. John C. Hughes, Gen. Mgr. Herbert A. McLendon, Coml. Mgr.	E. Caldwell Stewart, Prog. Dir. E. J. Duke, Prom. Mgr. A. Fred Wright, Chief Engr.	Thesaurus INS Raytheon
WMGY 1946	800 1,000-D	Dixie Bcstg. Co. 2½ South Perry St. 5245	LBS Meeker	Dr. S. D. Suggs, Pres. Thomas W. Sewell, Gen. Mgr. E. B. Ingle, Coml. Mgr.	Frank Montelleone, Prog. Dir. John D. Lamar, Chief Engr.	World INS Gates
WSFA 1930	1440 1,000 DA-N	Montgomery Bcstg. Co. Inc. P. O. Box 1031 8361	NBC Headley-Reed	Howard E. Pill, Pres. & Nat'l. Sales Mgr. W. W. Hunt, Local Sales Mgr.	Lee Gooch, Prog. Dir. Alice Mayfield, Prom. Mgr. C. I. Shelkofsky, Chief Engr.	Standard AP Collins
MUSCLE SHOALS						
WLAY 1933	1450 250	Muscle Shoals Bcstg. Corp. 620 E. Second St. Sheffield, Ala. 1450	MBS	Frank M. Farris Jr., Pres. William A. Reeves Jr., Gen. & Prom. Mgr.	Eulus O. Whitehead, Coml. Mgr. Charles Welsh, Prog. Dir. Lynn V. McMoran, Chief Engr.	UP Gates
OPELIKA						
WJHO 1940	1400 250	Opelika-Auburn Bcstg. Co. Box 710 712	MBS KBS	F. Marion Hyatt, Gen. Mgr. William A. McGuirt, Coml. Mgr.	Anne Davis, Prog. Dir. William E. Welch, Chief Engr.	Standard UP Collins
ROANOKE						
WELR 1949	1360 1,000-D	Roanoke Bcstg. Co. 801 Main St. 384	ABS Dodson	J. W. Buttram, Pres., Gen. & Coml. Mgr.	John Hodges, Prog. Dir. & Chief Engr.	Western Electric
RUSSELLVILLE						
WWWR 1949	920 1,000-D	Bankhead Bcstg. Co. Inc.				
SELMA						
WGWC 1946	1340 250	Estate of G. W. Covington North Broad St. 2746	CBS Taylor-Borroff	Hugh M. Smith, Gen. & Coml. Mgr.	John Townshend, Prog. Dir. & Chief Engr. John Frazier, Prom. Mgr.	Gates
WHBB 1935	1490 250	Selma Bcstg. Co. Inc. 209 Washington St. 1233	MBS ABS Sears & Ayer	B. H. Hopson, Pres. Julien Smith Jr., Gen. & Coml. Mgr.	Julia Craig Miller, Prog. Dir. T. F. Kelly Jr., Chief Engr.	
SYLACAUGA						
WFEB 1944	1340 250	Alabama Bcstg. Co. 527 North Broadway 160	MBS	E. E. Forbes, Pres. Chris J. Weber, Gen. & Coml. Mgr.	Joyce Nealeans, Prog. Dir. Howell E. Peabworth, Chief Engr.	
WMLS 1948	1290 1,000-D	Marble City Bcstg. Co. P. O. Box 511 1290	ABS	James S. Stowers Jr., Pres. & Chief Engr. Curtis O. Liles, Gen. Mgr.	Henry J. Darden Jr., Coml. Mgr. Ed J. Smith, Prog. Dir.	Lang-Worth Capitol AP Raytheon
TALLADEGA						
WHTB 1945	1230 250	Voice of Talladega Inc. Box 974 3733	MBS KBS ABS	R. A. Davidson, Pres., Gen. & Coml. Mgr.	Lillian S. Davidson, Prog. Dir. John Lester Fisher, Chief Engr.	Standard AP Collins
TROY						
WTFB 1947	1490 250	Troy Bcstg. Corp. College Dr. 980	MBS KBS ABS	J. Roy Crow, Pres. William C. Needham, Gen. & Coml. Mgr.	Jesse Jordan, Prog. Dir. & Prom. Mgr. Joe W. Gilchrist, Chief Engr.	World AP SESAC Western Electric
TUSCALOOSA						
WJRD 1936	1150 5,000-LS 1,000-N DA	Estate of James R. Doss Jr. First Nat'l Bank Bldg. 4464	ABS Walker	Mrs. James R. Doss Jr., Gen. Mgr. Mamie Kimbrell, Prog. Dir.	J. C. Cobble, Chief Engr.	World Capitol UP Gates
WTBC 1946	1230 250	Tuscaloosa Bcstg. Co. City Hall Bldg. 5523	MBS KBS Sears & Ayer	Bert Bank, Gen. Mgr. J. C. Cooper Jr., Coml. Mgr.	Una King, Prog. Dir. T. H. Todd, Chief Engr.	Thesaurus AP RCA

ARIZONA

BISBEE						
KSUN 1933	1230 250	Carleton W. Morris Drawer C 9	CBS Ariz. Net. Blair	Carleton W. Morris, Pres. Jack Murphy, Gen. Mgr.	Ray Helgesen, Prog. Dir. Ben Strotman, Chief Engr.	World UP
CLIFTON						
KCLF (CP)	1400 250	Dwight Harkins Amuse- ment Enterprises, Inc.				
COOLIDGE						
KCKY 1948	1150 1,000 DA-N	Gila Bcstg. Co. Roosevelt & Main Sts. 4451	MBS Don Lee Ariz. Net.	Louis F. Long, Pres. Paul Merrill, Gen. Mgr. Bill Parady, Sta. Mgr. Pete Dillman, Coml. Mgr.	Jim Murdock, Prog. Dir. Jack Lyon, Prom. Mgr. Wayne Fernyhough, Chief Engr.	Associated UP Western Electric
DOUGLAS						
KAWT 1946	1450 250	Carleton W. Morris Douglas 173	NBC Ariz. Bcstg. Raymer	Carleton W. Morris, Pres. John King, Gen. & Coml. Mgr.	Lee Boner, Prog. Dir. & Prom. Mgr. Rick Hendricks, Chief Engr.	Associated AP, UP Western Electric
FLAGSTAFF						
KWRZ 1947	1340 250	Grand Canyon Bcstg. Co. 220 E. Birch 899		Agnes McGillvra, Sta. Mgr.	Selwyn Kirby, Sta. Dir.	
GLOBE						
KWJB 1938	1240 250	Gila Bcstg. Co. Globe-Miami Highway 41	NBC Ariz. Bcstg. Raymer	Louis F. Long, Pres. Willard Shoecraft, Sta. Mgr.	John D. Seater Jr., Coml. Mgr. Herbert Hanes, Chief Engr.	Standard Capitol Western Electric
KINGMAN						
KGAN 1949	1230 250	J. James Glancy P. O. Box 871 Blue 482		J. James Glancy, Pres. & Gen. Mgr. C. R. Waters, Coml. Mgr.	W. E. Adams, Prom. Mgr. Ben Summerville, Prog. Dir. Harry L. Woodley, Chief Engr.	UP RCA
MESA						
KTYL 1946	1490 250	Sun Valley Bcstg. Co. Chandler Rd. 4541		Dwight Harkins, Gen. Mgr.		Associated Standard UP

DA-N Directional Antenna, night only. FM's in italic.
DA-1 Directional Antenna, same pattern day and night.
DA-2 Directional Antenna, different pattern day and night.

*-Non-Commercial Station D-Day, N-Night, ST-Share Time. SH-Specified Hours.
U-Unlimited. CP-Construction Permit Issued. LS-Local Sunset.
L-Limited Time with Dominant Station. SA-Special Authorization.



KOOL

THE *Gene Autry* STATION IN PHOENIX

Clever, Unique Promotion
Better Programming
Superior Merchandising

AGGRESSIVE MANAGEMENT!
and
A loyal, responsive audience
that annually spends more than
HALF A BILLION DOLLARS
in KOOL's retail area

Key Station of the
Radio Network of Arizona.
KOOL, Phoenix
KCKY, Coolidge
KOPO, Tucson

Covering 75% of the popula-
tion of Arizona's richest area.

Arizona's **FIRST** *Station*
5,000 WATTS DAY AND NIGHT - 960 KCs

NATIONAL REPRESENTATIVES . . . **George P. Hollingberry Co.**
NEW YORK • CHICAGO • LOS ANGELES • SAN FRANCISCO • ATLANTA

DIRECTORY OF AM, FM, and TV STATIONS OF THE UNITED STATES

*(Data corrected to December 6, 1949)
If executives or services for FM or TV stations are same as AM affiliate names are not repeated.*

ARIZONA—(Continued)

City Call Letters Established	Chan. or Freq. Power	Name of Licensee Headquarters Address Telephone Number	Network Representative	Executive Personnel	Transc. Library News Service Transmitter Make	
NOGALES						
KNOG 1948	1340 250	Border Bcstg. Co. Inc. Rancho Grande Hotel 770	Gene Grant Cooke	Robert Marcus, Pres. Harry Hambleton, Gen. & Coml. Mgr.	(Miss) Margo Guerrero, Prog. Dir. Jose Jesus Mares, Prom. Mgr. T. B. Greenhaw, Chief Engr.	World UP Western Electric
PHOENIX						
KIFN (CP)	860 250-D	Western Bcstg. Co.				
KOOL 1947	960 5,000 DA-N	Maricopa Bcstrs. Inc. Adams Hotel 21748	CBS† Ariz. Net. Hollingbery	Gene Autry, Pres. Charles H. Garland, Gen. Mgr. Miles Reed, Coml. Mgr.	Vic Lundberg, Prog. Dir. Larry Jonas, Prom. Mgr. Miles Shepherd, Chief Engr.	MacGregor UP RCA
KOY 1922	550 5,000-LS 1,000-N	Salt River Valley Bcstg. Co. 836 N. Central Ave., 4-4144	Ariz. Net.† Blair	John L. Hogg, Pres. & Coml. Mgr. Albert D. Johnson, Gen. Mgr.	John R. Williams, Prog. Dir. Clifford R. Miller, Chief Engr.	World Associated, UP Western Electric
KPHO 1940	910 5,000 DA-N	Phoenix Bcstg. Co. Inc. Adams Hotel 4-7367	ABC	Rex Schepp, Pres. & Gen. Mgr. Richard Heath, Coml. Mgr. William Reddick, Prog. Dir.	Frank Orth, Prom. Mgr. Cliff Baker, Chief Engr.	Lang-Worth INS Western Electric
KPHO-TV 1949	Ch. 5 76-82mc 8.7kw-aur.; 17.5kw-vis.		ABC, CBS, NBC Dumont		 DuMont
KRUX 1947	1340 250	Gene Burke Brophy Hotel Westward Ho 2-2371		Gene Burke Brophy, Owner, Gen. & Coml. Mgr. & Prog. Dir.	Marvin Edwards, Chief Engr.	Associated UP Collins
KTAR 1922	620 5,000 DA-N	KTAR Bcstg. Co. 711 Heard Bldg. 4-4161	NBC Arizona Bcstg. Raymer	John J. Louis, Chmn. of Bd. Richard O. Lewis, Pres. & Gen. Mgr. E. W. Harvey, V. P. & Coml. Mgr.	J. Howard Pyle, V. P. & Prog. Dir. Robert Pollard, Prom. Mgr. A. C. Anderson, V. P. & Chief Engr.	Thesaurus Standard, Capitol, AP Western Electric
PRESCOTT						
KYCA 1940	1490 250	Southwest Bcstg. Co. E. Gurley St. 244	NBC Arizona Bcstg. Raymer	Harold Ritter, Pres. & Gen. Mgr. Roberta M. Pfister, Prog. Dir.	John E. Nagley, Chief Engr.	Capitol AP, INS RCA
SAFFORD						
KGLU 1938	1480 1,000	Gila Bcstg. Co. Safford 15	NBC Arizona Bcstg. Raymer	L. F. Long, Pres. Paul Merrill, Gen. Mgr. Edward E. Furman, Coml. Mgr.	Lester McBride, Prog. Dir. Donald Graham, Prom. Mgr. Wallace R. Hitt, Chief Engr.	World AP, UP, INS Western Electric
TUCSON						
KCNA 1947	1340 250	Catalina Bcstg. Co. Box 2348 2-4664	Arizona Net. Hollingbery	Ersine Caldwell, Pres. Wayne Sanders, Gen. Mgr. Harry B. Chambers, Coml. Mgr.	Robert A. Keyworth, Prog. Dir. William J. Karpisek, Chief Engr. AP RCA
KOPO 1947	1450 250	Old Pueblo Bcstg. Co. 115 W. Drachman 4-0431	CBS† Forjoe	Gene Autry, Chief Owner E. S. Mittendorf, Gen. Mgr. Paul Plunkett, Coml. Mgr.	Matt Lemen, Prog. Dir. B. L. Anderson, Prom. Mgr. Vernard Cimmiotti, Chief Engr.	MacGregor AP Raytheon
KTKT 1949	1490 250	Thomas J. Wallace 500 West Elm 3-5361	KBS Free & Peters	Thomas J. Wallace, Owner Phillip R. Huribut, Gen. Mgr. & Prog. Dir. & Chief Engr.	Gall Hummel, Coml. Mgr.	Lang-Worth UP Gates
KTUC 1929	1400 250	Tucson Bcstg. Co. 900 E. Broadway 2-3344	Ariz. Net.† Blair	Lee Little, Pres. & Gen. Mgr. John Crowley, Bus. Mgr.	Gerry O'Brien, Prog. Dir. Cliff Livingston, Chief Engr.	Associated World, UP Western Electric
KVOA 1929	1290 1,000	Arizona Bcstg. Co. 48 E. Broadway 3-2555	NBC Arizona Bcstg. Raymer	R. B. Williams, Gen. Mgr. Ben L. Slack Jr., Prog. Dir.	Fred J. Gerletti, Prom. Mgr. Ray H. Holsclaw, Chief Engr.	Capitol Standard Thesaurus, AP, RCA
YUMA						
KYMA (CP)	1240 250	Salt River Valley Bcstg. Co.				
KYUM 1940	1240; CP-560 250; CP-1,000 DA-N	Yuma Bcstg. Co. 1901 First St. 88	NBC Arizona Bcstg. Raymer	R. N. Campbell, Pres. Ray C. Smucker, Gen. Mgr. Roy Jorgensen, Coml. Mgr.	Paul Dawson, Prog. Dir. Don Metcalf, Prom. Mgr. Leavenworth Wheeler, Chief Engr.	Thesaurus Capitol AP RCA
ARKANSAS						
ARKADELPHIA						
KVRC 1947	1240 250	Arkadelphia Bcstg. Co. 506 Main St. 789	MBS, KBS	Cecil W. Cupp, Pres. J. M. Moore, Gen. & Coml. Mgr.	Bill Deaton, Prog. Dir. & Prom. Mgr. E. H. Summers, Chief Engr.	World AP RCA
BATESVILLE						
KBTA (CP)	1340 250	White River Valley Bcstrs. 307 Main St.				
BLYTHEVILLE						
KLCN 1922	900 1,000-D	Harold L. Sudbury Sudbury Bldg. 2093	Arkansas Pearson	Harold L. Sudbury, Pres. Gen. & Coml. Mgr. John Hamilton, Prog. Dir.	J. T. Sudbury, Prom. Mgr. Marion Skinner, Chief Engr.	Lang-Worth AP Gates
KLCN-FM 1948	Ch. 241 (B) 96.1mc 21kw					
CAMDEN						
KAMD 1946	1450 250	Camden Radio Inc. P. O. Box 5859 6791	MBS	Walter E. Hussman, Pres. David Crockett, Gen. Mgr. James Blaine, Coml. Mgr.	Callis Carter, Prog. Dir. Dorris C. Hunter, Chief Engr. Frank O. Myers, Mngng. Dir.	Capitol AP RCA
CONWAY						
KDWN(FM) (CP)	Ch. 249 97.7mc 0.97kw	Conway Bcstg. Co. Ark. State Teachers College				
EL DORADO						
KELD 1935	1400; CP-690 250; CP-1,000 DA-N	Radio Enterprises Inc. Home Finance Bldg. 3-8126	ABC Arkansas Continental	W. N. McKinney, Pres. & Prog. Dir. Leon M. Sipes, V. P., Gen. & Coml. Mgr.	J. R. Duerson, Prom. Mgr. John Long, Chief Engr.	World AP RCA
FAYETTEVILLE						
KGRH 1946	1450 250	Fayetteville Bcstg. Co. Inc. 922 Leverett St. 862	MBS, KBS Ra-Tel	Hayden McIlroy, Pres. Fred J. Stevenson, Gen. Mgr. Edwin G. Gideon, Coml. Mgr.	Albert H. Rowe, Prog. Dir. George W. Dotson, Chief Engr.	SESAC AP Gates

†Editor's Note: Network assignments are those planned for Jan. 1, 1950, but at press time litigation was pending looking toward retention of CBS affiliation for KOY and KTUC.

DA-N Directional Antenna, night only. FM's in italic.
DA-1 Directional Antenna, same pattern day and night.
DA-2 Directional Antenna, different pattern day and night.

*-Non-Commercial Station D-Day N-Night ST-Share Time SH-Specified Hours.
U-Unlimited. CP-Construction Permit Issued. LS-Local Sunset.
L-Limited Time with Dominant Station. SA-Special Authorization.

Certainly WE HAVE MOUNTAINS—

-- AND MARKETS TOO!

Arizona's San Francisco Peaks - 12,794 ft.

Arizona's 1949 Market Peaks—

- \$1,200,000,000 spent for goods, services and taxes.
- Over \$700,000,000 in retail sales (\$175,000,000 in 1940)
- Over \$420,000,000 in bank deposits (\$99,000,000 in 1940)

Per capita sales over \$1,000.00
(National average, \$860.00)

Research Department
Valley National Bank

You'll want to use Arizona's most effective approach to this rich market . . . the seven line-connected NBC stations of the Arizona Broadcasting System, the state's largest network.

KTAR
PHOENIX
5000 Watts-620 KC

KVOA
TUCSON
1000 Watts-1290 KC

KYUM
YUMA
250 Watts-1240 KC

KYCA
PRESCOTT
250 Watts-1490 KC

KGLU
GLOBE
1000 Watts-1485 KC

KWJB
GLOBE-MIAMI
250 Watts-1140 KC

KAWT
DOUGLASS-BUWEE
250 Wts 5-1140 KC



PHOENIX, ARIZONA

National Representative
Paul H. Raymer Company NEW YORK • CHICAGO • BOSTON • ATLANTA • DETROIT • SAN FRANCISCO • LOS ANGELES

DIRECTORY OF AM, FM, and TV STATIONS OF THE UNITED STATES

*(Data corrected to December 6, 1949)
If executives or services for FM or TV stations are same as AM affiliate names are not repeated.*

ARKANSAS—(Continued)

City Call Letters Established	Chan. or Freq. Power	Name of Licensee Headquarters Address Telephone Number	Network Representative	Executive Personnel	Transc. Library News Service Transmitter Make	
FORREST CITY						
KXJK 1949	950 1,000-D	Forrest City Bcstg. Co. Inc. Forrest City 950	KBS Continental	William Fogg, Pres. & Gen. Mgr. Roger Davison, Coml. Mgr.	Frank Kelley, Prog. Dir. & Prom. Mgr. James Thompson, Chief Engr.	AP Gates
FORT SMITH						
KFPW 1930	1400; CP-1230 250	Southwestern Hotel Co. 2917 Rogers Ave.	MBS Arkansas Walker	John A. England, Pres. & Gen. Mgr. J. E. Garner, Sta. & Prom. Mgr. Al Godwin, Coml. Mgr.	Dorothy Gibson, Prog. Dir. Willard E. Kunkel, Chief Engr.	World AP, UP RCA
KFPW-FM 1948	Ch. 235 (B) 94.9mc 14kw					General Electric
KFSA 1947	950 1,000-LS 500-N DA	Southwestern Pub. Co. 920 Rogers Ave. 3126	ABC Taylor-Borroff	Donald W. Reynolds, Pres. Waldon Stamps, Gen. & Coml. Mgr. Doris Grayson, Prog. Dir.	Duard Goldsborough, Prom. Mgr. Bob Platt, Chief Engr.	UP Collins
KFSA-FM 1947	Ch. 299 (B) 107.7mc 497kw					General Electric
KWHN 1947	1320 5,000 DA-N	KWHN Bcstg. Co. Inc. 421 Garrison Ave. 8967	LBS Pearson	Allen Whiteside, Pres. Gene W. Dennis, Gen. Mgr. Virgil Evans, Coml. Mgr.	Glenn O'Neal, Prog. Dir. William Bryant, Prom. Mgr. Frank Tate, Chief Engr.	Associated Standard Capitol AP Western Electric
HARRISON						
KHOZ 1946	1240 250	Harrison Bcstg. Corp. Radio City Addition 1240	KBS, MBS Arkansas	Roy Milum, Pres. Robert S. Wheeler Jr., Gen. & Coml. Mgr.	Don Causey, Prog. Dir. & Chief Engr.	Standard SESAC UP Gates
HELENA						
KFFA 1941	1360 1,000 DA-N	Helena Bcstg. Co. 215 York St. M59	MBS, KBS Continental	Sam W. Anderson, Pres. & Gen. Mgr. Bill Bigley, Coml. Mgr.	Hugh Smith, Prog. Dir. A. P. Decker, Chief Engr.	Lang-Worth AP Gates
HOPE						
KXAR 1947	1490 250	Hope Bcstg. Co. P. O. Box 131 508	MBS, KBS	A. H. Washburn, Pres. L. B. Tooley, Gen. & Coml. Mgr. & Chief Engr.	George Frazier, Prog. Dir.	Lang-Worth AP Collins
HOT SPRINGS						
KTHS 1924	1090 10,000-LS 1,000-N	Radio Bcstg. Inc. 135 Benton St. 1160	ABC Branham	John D. Ewing, Pres. J. John Wolever, Gen. & Coml. Mgr.	Jon F. Karber, Prog. Dir. Cecil L. Suitt, Chief Engr.	Lang-Worth UP
KWFC 1940	1340 250	SPA Bcstg. Co. Inc. 819½ Central Ave. 412	MBS Sears & Ayer	Frank A. Browne, Gen. Mgr. Betty Hildebrandt, Prog. Dir.	Tom Wilson, Chief Engr.	AP General Electric
JONESBORO						
KBTM 1930	1230 250	Regional Bcstg. Co. 603 Madison St. 5597	MBS	Jay P. Beard, Pres. & Gen. Mgr.		World SESAC AP
KBTM-FM 1948	Ch. 270 (B) 101.9mc 8.1kw					
LITTLE ROCK						
KARK 1928	320 5,000 DA-N	Arkansas Radio & Equipment Co. 112-14 East Capitol Ave. LD 99	NBC Arkansas Southcentral Petry	T. H. Barton, Chmn. of Bd. G. E. Zimmerman, Gen. Mgr. Julian F. Haas, Coml. Mgr.	Douglas J. Romine, Prog. Dir. A. C. Dowden, Prom. Mgr. Dan L. Winn, Chief Engr.	Standard AP, UP RCA
KGHI 1927	1250 1,000-LS 500-N DA	KGHI Bcstg. Service 306 W. 3rd St. 9166	ABC Hollingbery	A. L. Chilton L. H. Chilton } Partners S. C. Vinsonhaler } S. C. Vinsonhaler, Gen. Mgr.	Don Corbet, Coml. & Prom. Mgr. Virginia Ewing, Prog. Dir. V. O. Van Dusen, Chief Engr.	Raytheon
KLRA 1927	1010 10,000-LS 5,000-N DA	Arkansas Bcstg. Co. Gazette Bldg. 2-5427	CBS Taylor-Borroff	J. N. Heiskell, Pres. Ed Murphy, Gen. Mgr. Harris Owen, Prog. Dir.	Mina Madden, Prom. Mgr. Kermit Tracey, Chief Engr.	Lang-Worth Thesaurus AP, UP RCA
KVLC 1948	1050 1,000-D	Southwestern Bcstg. Co. Southern Nat'l Bldg. 5-5321	LBS Forjoe	Leonard Coe, Gen. Mgr. Robert Harrison, Coml. Mgr. Marshall Hendrix, Prog. Dir.	John Pankey, Prom. Mgr. W. S. Miller, Chief Engr.	World UP Gates
KVLC-FM 1949	Ch. 231 (B) 94.1mc 9kw					
MAGNOLIA						
KVMA 1948	630 1,000-D	Magnolia Bcstg. Co. 212 N. Jefferson St. 630	MBS	C. A. Bill Humbert Jr., Gen. Mgr. James H. Jones & Vernon Arnette, Local Sales Mgrs.	Bill Humbert, Prom. Mgr. Ray H. Wells, Chief Engr. William F. Tibbels, Prog. Dir.	Lang-Worth UP Raytheon
NEWPORT						
KNBY 1949	1280 1,000-D	Newport Bcstg. Co. Newport 749		Dick Wiethan, Gen. Mgr. Gene Howe, Coml. Mgr.	J. C. Clayton, Chief Engr.	Standard UP RCA

DA-N Directional Antenna, night only. FM's in italic. *—Non-Commercial Station D—Day. N—Night. ST—Share Time. SH—Specified Hours.
DA-1 Directional Antenna, same pattern day and night. U—Unlimited. CP—Construction Permit Issued. LS—Local Sunset.
DA-2 Directional Antenna, different pattern day and night. L—Limited Time with Dominant Station. SA—Special Authorization.

City Call Letters Established	Chan. or Freq. Power	Name of Licensee Headquarters Address Telephone Number	Network Representative	Executive Personnel	Transc. Library News Service Transmitter Make	
NORTH LITTLE ROCK						
KXLR 1946	1450 250	Arkansas Airwaves Co. Box 89 2-2155	MBS Ra-Tel	John F. Wells, Pres. Emil J. Pouzar, Gen. Mgr. Clyde Gray, Coml. Mgr.	Dorothy Jung, Prog. Dir. Earl Butler, Chief Engr.	Standard Capitol UP Gates
OSCEOLA						
KOSE 1949	860 1,000-D	H. F. Ohlendorf Highway 61, South 860		H. F. Ohlendorf, Pres. Ted Woods, Gen. Mgr. Johnny Fox, Coml. Mgr.	Leon Little, Prog. Dir. Ann Edrington, Prom. Mgr. Harold M. Jones, Chief Engr.	Standard AP RCA
PARAGOULD						
KDRS 1947	1490 250	Progressive Bcstg. Co. P. O. Box 491 627	KBS	T. M. Self & Ted Rand, Owners Ted Rand, Gen. Mgr. T. M. Self, Bus. Mgr.	Ray Dexter, Prog. Dir. Adrian White, Prom. Mgr. Jesse Jackson, Chief Engr.	Standard AP Gates
PINE BLUFF						
KCLA 1949	1400 250	Radio Engineering Service 2900 W. 28th St. 1900	ABC	Kenneth Kesterson & Charles Penix, Partners Kenneth Kesterson, Gen. Mgr.	Clyde Martin Sr., Coml. Mgr. Ozzie Pence, Prog. Dir. Charles Penix, Chief Engr.	Lang-Worth AP Gates
KOTN 1934	1490 250	Universal Bcstg. Corp. 505½ Main St. 721	MBS	B. J. Parrish, Pres., Gen. Mgr. & Chief Engr. Joe Wallace, Coml. Mgr.	R. W. Etter, Asst. & Prom. Mgr. Lois Sloan, Prog. Dir.	Thesaurus AP RCA
RUSSELLVILLE						
KXRJ 1947	1490 250	Valley Bcstrs. Russellville	MBS, KBS	C. R. Horne, Pres. & Gen. Mgr. R. L. McCarkell, Coml. Mgr.	Jim Lipsy, Prog. Dir. William Sneed, Chief Engr.	----- AP Raytheon

DA-N Directional Antenna, night only. FM's in italic.
DA-1 Directional Antenna, same pattern day and night.
DA-2 Directional Antenna, different pattern day and night.

*—Non-Commercial Station D—Day. N—Night. ST—Share Time. SH—Specified Hours.
U—Unlimited. CP—Construction Permit Issued. LS—Local Sunset.
L—Limited Time with Dominant Station. SA—Special Authorization.

IN ARKANSAS

IT'S
KARK



"Arkansas' Preferred Station"

5,000 WATTS
DAY AND NIGHT
920 KILOCYCLES

ED ZIMMERMAN,
VICE PRESIDENT
& GEN. MANAGER

KARK

ASK ANY PETRY MAN!

NBC FOR ARKANSAS • LITTLE ROCK

DIRECTORY OF AM, FM, and TV STATIONS OF THE UNITED STATES

*(Data corrected to December 6, 1949)
If executives or services for FM or TV stations are same as AM affiliate names are not repeated.*

ARKANSAS—(Continued)

City Call Letters Established	Chan. or Freq. Power	Name of Licensee Headquarters Address Telephone Number	Network Representative	Executive Personnel	Transc. Library News Service Transmitter Make
SILOAM SPRINGS					
KUOA 1923	1290 5,000-D	KUOA Inc. Siloam Springs 77	MBS	John E. Brown, Pres. Storm Whaley, Gen. Mgr. Clinton Fowler, Asst. Mgr.	Ralph Kennedy, Prog. Dir. Cecil Smith, Chief Engr. World SESAC UP Western Electric General Electric
KUOA-FM 1947	Ch. 289 (B) 105.7mc 2.6kw				
SPRINGDALE					
KBRS 1949	1340 250	Southwestern Pub. Co. Highway 71 675	ABC	Donald W. Reynolds, Pres. William F. Hession, Gen. & Coml. Mgr.	AP Gates
STUTT GART					
KWAK 1948	1240 250	Stuttgart Bcstg. Corp. 1818 South Buerkle 842	MBS KBS	Beloit Taylor, Pres. Melvin P. Spann, Gen. Mgr. Carroll C. Lee, Coml. Mgr.	June S. Spann, Prog. Dir. Jack Warden, Chief Engr. Capitol UP Gates
WEST MEMPHIS					
KWEM 1947	990 1,000-D	West Memphis Bcstg. Corp. 229 Broadway 463	Ra-Tel	J. C. Johnson, Pres. Vernon L. Dillaplain, Sta., Coml., & Prom. Mgr. & Prog. Dir.	E. T. Beck, Chief Engr. Lang-Worth Capitol UP Gates

CALIFORNIA

AUBURN					
KDIA (CP)	1490 250	Charles E. Halstead P. O. Box 992			
BAKERSFIELD					
KAFY 1946	1490; CP-550 250; CP-1,000 DA-1	Bakersfield Bcstg. Co. 2013 Chester Ave. 88700	MBS Don Lee Pearson	George B. Crome, Pres. Sheldon Anderson, Gen. Mgr. Frank Wilbur, Sta. Mgr.	Naum Healy, Prog. Dir. Martha Thompson, Prom. Mgr. Ted Froming, Chief Engr. Lang-Worth UP Raytheon
KERN 1932	1410 1,000	McClatchy Bcstg. Co. Elks Bldg. 8-8431	CBS Raymer	Eleanor McClatchy, Pres. Walter L. Bazluk, Mgr.	Luverne Shatto, Chief Engr. World AP, UP, INS General Electric
KERN-FM 1948	Ch. 231 (A) 94.1mc 9.8kw				
KERO 1946	1230 250	Paul R. Bartlett 1420 Truxtun Ave. 44548	NBC Avery-Knodel	Paul R. Bartlett, Owner Gene DeYoung, Mgr. & Coml. Mgr.	Warren Mead, Prog. Dir. Ken Croes, Prom. Mgr. Thad Bulkeley, Chief Engr. Standard UP RCA
KMAR(FM) 1948	Ch. 223 (B) 92.5mc 5kw	Marmat Radio Co. 957 Oak St. 2-1465			Capitol UP Collins
KPMC 1933	1560 1,000	Pioneer Mercantile Co. 307 E. 21st St. 8-8157	ABC Grant	L. A. Schamblin, Pres., Gen. Mgr. & Prog. Dir.	C. C. Sturm, Coml. Mgr. Paul R. Biermann, Prom. Mgr. L. P. Jarvis, Chief Engr. Thesaurus UP RCA
BANNING					
KPAS 1947	1490 250	William T. Smith 4425 W. Ramsey 515	Grant	William T. Smith, Pres. Carleton Anderson, Gen. Mgr.	Marvin H. Patchen, Coml. Mgr. John L. Lockhart, Prog. Dir. Searcy Woodworth, Chief Engr. World AP Raytheon
BARSTOW					
KWTC 1947	1230 250	Mojave Valley Bcstg. Co. P. O. Box 1230 4001	Gene Grant	W. T. Brown, Pres. L. E. Scheer, Gen. Mgr. W. T. Abbett, Coml. Mgr.	H. S. White, Prog. Dir. S. Willing, Prom. Mgr. E. Fulwood, Chief Engr. World UP Western Electric
BERKELEY					
*KPFA (FM) 1949	Ch. 261 (A) 100.1mc 1kw	Pacifica Foundation 2054 University Ave. Ashberry 3-6767		Lewis Hill, Gen. Mgr. Eleanor Moore, Prog. Dir.	Edward Meece, Chief Engr. INS RCA
KRE 1922	1400 250	Central Calif. Bcstrs. Inc. 601 Ashby Ave. 3-7115		Arthur Westlund, Pres. & Gen. Mgr. Don Hambly, Coml. Mgr.	Les Avery, Prog. Dir. Standard AP Western Electric
KRE-FM 1949	Ch. 275 (B) 102.9mc 6.8kw				
BLYTHE					
KYOR 1947	1450 250	Bcstg. Corp. of America P. O. Box 688 2231	Ayres	W. L. Gleeson, Pres. & Gen. Mgr.	AP

DA-N Directional Antenna, night only. FM's in italic.
DA-1 Directional Antenna, same pattern day and night.
DA-2 Directional Antenna, different pattern day and night.

*—Non-Commercial Station D—Day. N—Night. ST—Share Time. SH—Specified Hours.
U—Unlimited. CP—Construction Permit Issued. LS—Local Sunset.
L—Limited Time with Dominant Station. SA—Special Authorization.

The Tale of Two Cities . . .

***Siloam Springs, Ark.**

1290 KUOA K.C.

The KUOA primary (Oklahoma—6 counties; Missouri—4 counties, Arkansas—5 counties) is worth covering! It's a bright white spot in the nation's market picture. KAMOLAND's many sources of income—poultry, dairy, cattle, vegetables and fruit, oil, lead, zinc and coal—add up to an annual \$200,000,000 buying power.

Area Population	1,220,958
Radio Homes in	
KUOA Primary	80,540
% Increase 1940-49	164%
National	136%
% Increase Retail Sales	
in KUOA Primary 1939-48	346%*
% Increase Retail Sales, Nat.	309%*
* 1949-50 "Consumer Markets."	
KUOA Daytime Audience	
1949 Area Conlan	34.5%
(45-Mile Circle)	

KUOA'S MORNING AUDIENCE WAS MORE THAN TWICE THAT OF ITS NEAREST COMPETING STATION! THE PEOPLE ARE HERE—THE MONEY IS HERE—THE MARKET IS HERE!

5000 W. **KUOA** 1290
MUTUAL **KUOA** K.C.

Razorback Network—Liberty Broadcasting System

The Voice of . . . *

KAMOLAND

KANSAS-ARKANSAS-MISSOURI-OKLAHOMA

Owned by
the John Brown Schools of
Arkansas and California

***Long Beach, Calif.**

1390 KGER K.C.

Don't let the proximity of Los Angeles blind you to the booming Retail sales of the \$400,000,000 Long Beach market when placing national radio campaigns in Southern California!

Long Beach Population	305,000
Total Families	93,900
Radio Families	92,960
% Radio Families	99%
Leading Independent in	
Long Beach Market	84%
Leads other local station in	
497 out of 504 quarter	
hour periods.	

. . . AND KGER DELIVERS THE LONG BEACH AUDIENCE TO ADVERTISERS AT A LOWER "COST PER THOUSAND!"

5000 W. **KGER** 1390
W. **KGER** K.C.

**The Station of
THE AMERICAN HOME**

DIRECTORY OF AM, FM, and TV STATIONS OF THE UNITED STATES

(Data corrected to December 6, 1949)
If executives or services for FM or TV stations are same as AM affiliate names are not repeated.

CALIFORNIA—(Continued)

City Call Letters Established	Chan. or Freq. Power	Name of Licensee Headquarters Address Telephone Number	Network Representative	Executive Personnel	Transc. Library News Service Transmitter Make
BRAWLEY KROP 1946	1300 1,000-LS 500-N	Bcstg. Corp. of America Box 238 1300	Pearson	W. L. Gleeson, Pres. & Gen. Mgr. Glenn G. Dunham, Sta. Mgr.	Herb Booth, Prog. Dir. Don Dotson, Chief Engr. AP Collins
BURBANK KWIK 1946	1490 250	Burbank Bcstrs. Inc. 20 W. Burbank Blvd. Charleston 02111		Paul Sutton, Sta. Dir. Roger Patrick, Prog. Dir.	Buell Dalton, Chief Engr. UP Western Electric
CALEXICO KICO 1947	1490 250	Charles Love P. O. Box 786 918		Charles Love, Pres. W. A. Geddes, Gen. Mgr.	Robert Cain, Prog. Dir. Richard Gunn, Chief Engr. AP Raytheon
CHICO KHSL 1935	1290 5,000 DA-N	The Golden Empire Bcstg. Co. Inc. Moorhead Bldg. 237	Don Lee MBS Grant	Hugh McClung, Pres. & Gen. Mgr. J. A. Pero, Coml. Mgr. Loring Curtis, Prog. Dir.	M. F. Woodling, Sta. Mgr. Henry Hanna, Prom. Mgr. Russell B. Pope, Chief Engr. Lang-Worth World UP RCA
KVCI (FM) 1947	Ch. 266 (B) 101.1mc 11kw				
KXOC 1949	1150 5,000 DA-N	Sacramento Bcstrs. Inc. Radio Lane 3200	CBS Pearson	Lincoln Dellar, Pres. Ted Hall, Gen. & Coml. Mgr.	Neil McIntyre, Prog. Dir. Lester Berryman, Prom. Mgr. Walter Berger, Chief Engr. Associated Standard UP Collins
COALINGA KCOI (CP)	1470 500-D	KCOI Bcstg. Co.			
CORONA KBUC 1948	1370 500 DA-1	American Pacific Radio Bcstg. Co. Box 111 1370	Grant	Elmer J. & John G. Bucknum, Partners Elmer J. Bucknum, Gen. Mgr. Mary Bucknum, Coml. Mgr.	Jack A. Richardson, Prog. Dir. H. J. Ridinger, Chief Engr. Lang-Worth MacGregor UP General Electric
DELANO KCHJ (CP)	1010 1,000-D	Charles Herman Johnes P. O. Box 262 9411		Charles Herman Johnes, Pres. Gen. Mgr. & Chief Engr.	Jean Johnes, Prog. Dir. UP

DA-N Directional Antenna, night only. FM's in italic.
DA-1 Directional Antenna, same pattern day and night.
DA-2 Directional Antenna, different pattern day and night.

*—Non-Commercial Station D—Day N—Night ST—Share Time SH—Specified Hours.
U—Unlimited CP—Construction Permit Issued. LS—Local Sunset.
L—Limited Time with Dominant Station. SA—Special Authorization.

Reach
and **SELL**
Southern California's
**TOP
QUARTER
MILLION**
with **KFMV (FM)**
58,000 Watts 94.7 mc.



Pay only for the
listeners who can
afford your product

KFMV
UNION BROADCASTING CORPORATION
6540 Sunset Blvd.,
Hollywood 28, California

**THIS AIN'T
NO BULL!**



The cows at one of the San Fernando Valley dairies had to work overtime to meet the increased production demand after their boss advertised on KWIK!

In just two short weeks this dairy gained more than 100 new "delivery every day" customers by sponsoring a children's show on "The Voice of the San Fernando Valley", proving results are KWIK on

KWIK
1490 Kc. Burbank, Calif.

City Call Letters Established	Chan. or Freq. Power	Name of Licensee Headquarters Address Telephone Number	Network Representative	Executive Personnel	Transc. Library News Service Transmitter Make
DINUBA					
KRDU 1946	1240 250	Radio Dinuba Co. Box 157 500		Egon Hofer, Chief-Owners Dave Hofer Jr. (Chief-Owners Egon Hofer, Gen. & Coml. Mgr.	Harold Sparks, Prog. Dir. Forrest W. Hughes, Chief Engr. Lang-Worth AP
EL CENTRO					
KXO 1927	1230 250	Valradio Inc. South 4th St. 1100	MBS Don Lee Raymer	Paul A. Jenkins, Pres. Riley R. Gibson, Gen. Mgr.	Belle Hovey, Coml. Mgr. F. J. Wineriter, Prog. Dir. Dick Jacobsen, Chief Engr. Thesaurus UP RCA
EUREKA					
KHUM 1947	1240 250	Carroll R. Hauser Vance Hotel 3900	ABC Western Radio	Carroll R. Hauser, Pres., Gen. & Coml. Mgr.	Burke Ormsby, Prog. Dir. & Prom. Mgr. Edward P. Strople, Chief Engr. Capitol AP Collins
KIEM 1933	1480 1,000	Redwood Bcstg. Co. Inc. Radio Center 4000	MBS Don Lee Blair	Wm. B. Smullin, Pres. & Gen. Mgr. Don Telford, Coml. Mgr.	Charles Paul Corbin, Prog. Dir. Bob Stach, Prom. Mgr. John G. Bauriedel, Tech. Dir. World UP Western Electric
KRED (FM) 1948	Ch. 242 (B) 96.3mc 4.6kw	(KIEM, AM Affiliate)			
FORT BRAGG					
KDAC 1948	1230 250	Mendocino Coast Bcstrs. 2100 East Oak St. 822	Forjoe	Edward Mertle, Pres. Tony R. Amerante, Gen. Mgr. Paul L. Singer, Coml. & Prom. Mgr.	Art Leavitt, Prog. Dir. Craig N. Smith, Chief Engr. Capitol World AP Collins

1000 Watts AM

4600 Watts FM

KIEM-KRED FM Eureka, California

"Voice of the Redwoods" Since 1933

Serving Northwestern California's
\$100,000,000 Market

People	100,200	Families	32,380
Radio Families	29,596	Retail Sales	100 Million Dollars (Calif. Sales Tax)
Bonus Listening	600,000	Redwood Tourists June, July, August Each Year.	
Conlan Surveys	KIEM has Double Audience	Any Other Station Serving Area.	

Affiliated Mutual Don-Lee Broadcasting System

Ask John Blair & Company

Chicago

New York

Los Angeles

San Francisco

DIRECTORY OF AM, FM, and TV STATIONS OF THE UNITED STATES

(Data corrected to December 6, 1949)
 If executives or services for FM or TV stations are same as AM affiliate names are not repeated.

CALIFORNIA—(Continued)

City Call Letters Established	Chan. or Freq. Power	Name of Licensee Headquarters Address Telephone Number	Network Representative	Executive Personnel	Transc. Library News Service Transmitter Make	
FRESNO						
KARM 1938	1430 5,000 DA-1	KARM, The George Harm Station 1333 Van Ness Ave. 4-2966	ABC Petry	Hattie Harm, Pres. Clyde F. Coombs, Gen. Mgr.	John Garrick, Prog. Dir. Eldora Roth, Prom. Mgr. Elbert H. Dean, Chief Engr.	Standard AP, INS RCA
KARM-FM 1948	Ch. 270 (B) 101.9mc 7.4kw				
KFRE 1937	940 50,000 DA-2	Calif. Inland Bcstg. Co. T. W. Patterson Bldg. 4-5001	CBS Avery-Knodel	Paul R. Bartlett, Pres. Ed J. Frech, Prog. Dir.	Keith L. Mealey, Chief Engr.	General Electric Associated World UP General Electric
KRFM (FM) 1946	Ch. 227 (B) 93.7mc 70kw	(KFRE, AM Affiliate)			
KGST 1949	1600 1,000-D	Baker Bcstg. Co. 1018 Broadway		John Baker, Gen. Mgr.	Robert L. Howell, Sta. Mgr.	Standard UP
KMJ 1922	580 5,000	McClatchy Bcstg. Co. 1559 Van Ness Ave. 3-6277	NBC Raymer	Eleanor McClatchy, Pres. Hal Brown, Gen. Mgr. Coyle Chambers, Coml. Mgr.	Joe Tomes, Prog. Dir. Milt Cook, Prom. Mgr. William N. Wallace, Chief Engr.	Capitol AP, UP RCA
KMJ-FM 1949	Ch. 250 (B) 97.9mc 7.3kw				
KYNO 1947	1300 1,000 DA-2	Schuler, Anderson, Chenault & Williamson Hotel Fresno 2-6141	MBS Don Lee Pearson	Robert Schuler, Pres. Gene Chenault, Gen. Mgr. Joe Hinman, Coml. Mgr.	Leo Goldman, Prog. Dir. Wanda Woods, Prom. Mgr. Bert Williamson, Chief Engr.	Westinghouse UP Raytheon
GLENDALE						
KIEV 1933	870 250-D	Cannon System Ltd. 102 N. Glendale Blvd. Citrus 1-1133		David H. Cannon, Pres.	Cal Cannon, Gen. Mgr.
GRASS VALLEY						
KGFN 1947	1400 250	Joe D. Carroll P. O. Box 924 1400	Grant	Joe D. Carroll, Pres. Claude F. Jones, Gen. Mgr.	Loyd L. McQueary, Chief Engr.	World UP Western Electric
HANFORD						
KNGS 1946	620 1,000 DA-N	Hanford Pub. Co. P. O. Box 620 620	Grant	Mr. and Mrs. Samuel M. Beaubaire, Partners Don C. Reeves, Gen. Mgr. & Chief Engr.	John Cohan, Coml. Mgr. E. C. Balthis, Prog. Dir.	Associated World UP, INS Raytheon
HOLLYWOOD (See Los Angeles Listing)						
INDIO						
KREO	1400 250	Bcstg. Corp. of America P. O. Box 707, 73403	Ayres	W. L. Gleeson, Pres. & Gen. Mgr.		AP

DA-N Directional Antenna, night only. FM's in italic. *—Non-Commercial Station D—Day, N—Night, ST—Share Time, SH—Specified Hours.
 DA-1 Directional Antenna, same pattern day and night. U—Unlimited. CP—Construction Permit Issued. LS—Local Sunset.
 DA-2 Directional Antenna, different pattern day and night. L—Limited Time with Dominant Station. SA—Special Authorization.

KARM

Fresno, California

ABC's Station for Central California

Represented Nationally By

EDWARD PETRY & CO., Inc. New York — Chicago — Detroit — St. Louis — Los Angeles — San Francisco

City Call Letters Established	Chan. or Freq. Power	Name of Licensee Headquarters Address Telephone Number	Network Representative	Executive Personnel	Transc. Library News Service Transmitter Make	
LAGUNA BEACH						
KTED 1949	1520 1,000-LS DA-1 250-N	Universal Radio Features Syndicate 424 Glenneyre 1520	Gene Grant	Tom E. Danson, Pres. & Gen. Mgr. James M. Matheny, Coml. & Prom. Mgr.	Richard S. Morgan, Chief Anncr. Allan L. Campbell, Chief Engr.	Thesaurus World AP Collins
LODI						
KCVR 1946	1570 1,000-D	Central Valley Radio P. O. Box 600 1700	KBS	Herbert W. & David A. Brown, Owners Herbert W. Brown, Gen., Coml. & Prom. Mgr.	Lois Veit, Prog. Dir. Bill Bauer, Chief Engr.	Standard UP Raytheon
LONG BEACH						
KFOX 1924	1280 1,000	Nichols & Warinner Inc. 220 E. Anaheim 672-81	Burn-Smith	Hal G. Nichols, Pres., Gen. Mgr. & Prog. Dir.	Lawrence W. McDowell, Coml. Mgr. & Chief Engr. Norman Masterson, Prom. Mgr. UP Western Electric
KGER 1926	1390 5,000 DA-N	John Brown Schools of Calif. Inc. 435 Pine Ave. 72785	McGillvra	Dr. John E. Brown, Pres. Galen O. Gilbert, Gen. Mgr.	William George, Prog. Dir. & Prom. Mgr. Luther Crumbaugh, Chief Engr.	Lang-Worth SESAC AP RCA
KNOB (FM) 1949	Ch. 276 (A) 103.1mc 0.32kw	The Cerritos Bcstg. Co. 1120 Pine Ave. 855-19		Jay E. Tapp, Gen. Mgr. John W. Doran, Coml. Mgr.	Gary Floyd, Prog. Dir. Raymond B. Torian, Chief Engr. Raytheon
LOS ANGELES						
KECA 1929	790 5,000 DA-N	American Bcstg. Co. Inc. Prospect & Talmadge Normandy 33311	ABC ABC Spot Sales	Mark Woods, ABC Pres. Clyde P. Scott, Gen. Mgr. Amos T. Baron, Coml. Mgr.	R. W. Hunter, Prog. Dir. J. Norman Nelson, Prom. Mgr. P. G. Caldwell, Chief Engr.	Lang-Worth AP, UP, INS RCA
KECA-FM 1947	Ch. 238 (B) 95.5mc 4.75kw				 General Electric
KECA-TV 1949	Ch. 7 174-180mc 14.7kw aur.; 29.4kw vis.			Philip Booth, Prog. Dir.	 General Electric
KFAC 1931	1330 5,000 DA-1	Los Angeles Bcstg. Co. Inc. 645 South Mariposa Ave. Dunkirk 4-1231		Calvin J. Smith, Pres., Gen. & Coml. Mgr. Howard Rhines, Prog. Dir. & Prom. Mgr.	Ron Oakley, Chief Engr.	Associated AP RCA
KFAC-FM 1949	Ch. 238 (B) 104.3mc 8.8kw					

LONG HAIR MUSIC IS OUR BUSINESS

And business is a pleasure—because our audience forms an important segment of an important market—served exclusively in the field of better music by KFAC.

PULSE* REPORTS PROGRESS

The progressively growing appeal of fine music, beamed twenty-four hours daily at 5—12% of the audience—in the nation's third largest market.

Check our cost per listener—one of the country's lowest.

*THE PULSE, INC.
110 Fulton St.,
N. Y. 7, N. Y.

KfAC
5 KW

AM—FM

The Music Station
FOR SOUTHERN CALIFORNIA

1330 KC

LOS ANGELES BROADCASTING CO., INC.
645 MARIPOSA, LOS ANGELES 5

For Information, phone or wire collect

DIRECTORY OF AM, FM, and TV STATIONS OF THE UNITED STATES

(Data corrected to December 6, 1949)
 If executives or services for FM or TV stations are same as AM affiliate names are not repeated.

CALIFORNIA—(Continued)

City Call Letters Established	Chan. or Freq. Power	Name of Licensee Headquarters Address Telephone Number	Network Representative	Executive Personnel	Transc. Library News Service Transmitter Make	
LOS ANGELES—(Continued)						
KFI 1922	640 50,000	Earle C. Anthony Inc. 141 N. Vermont Ave. Dunkirk 2-2121	NBC Petry	Earle C. Anthony, Pres. W. B. Ryan, Gen. Mgr. Kevin B. Sweeney, Coml. & Prom. Mgr.	Pat Kelly, Prog. Dir. H. L. Blatterman { Co-Chief Curtis Mason { Engrs.	World, Capitol Associated AP, UP RCA
KFI-FM 1947	Ch. 290 (B) 105.9mc 287kw					General Electric
KFI-TV 1948	Ch. 9 186-192mc 15.7kw aur.; 31kw vis.		Haan J. Tyler, Mgr.		Kenneth C. Higgins, Prog. Dir.	RCA
KFMV (FM) 1948	Ch. 234 (B) 94.7mc 58kw	Union Bcstg. Corp. of Calif. 6540 Sunset Blvd. Hillside 7406		Cliff P. Mayer, Pres. Cliff Gill, Gen. Mgr.	Dan Russell, Prog. Dir. Samuel Margolin, Chief Engr.	Associated AP RCA
*KFSG 1924	1150 2,500-LS 1,000-N S-KRKD	Echo Park Evangelistic Assn. 1100 Glendale Blvd. Exposition 1141		Dr. Rolf K. McPherson, Pres. Rev. M. D. Buchen, Gen. & Prom. Mgr. & Prog. Dir.	C. Harvey Haas, Chief Engr.	Western Electric
KKLA (FM) 1948	Ch. 246 (B) 97.1mc 58kw	(KFSG, AM Affiliate)		James Fitch, Prog. Dir. Rev. M. D. Buchen, Coml. Mgr.		Associated AP Collins
KFVD 1925	1020 5,000 L-KDKA	Standard Bcstg. Co. 338 S. Western Ave. Dunkirk 8-2345		J. Frank Burke, Pres. Frank Burke Jr., Gen. Mgr. Harry Patterson, Coml. Mgr.	Carl Brewster, Prog. Dir. & Prom. Mgr. Leonard Reeves, Chief Engr.	Lang-Worth UP

DA-N Directional Antenna, night only. FM's in italic.
 DA-1 Directional Antenna, same pattern day and night.
 DA-2 Directional Antenna, different pattern day and night.

*—Non-Commercial Station D—Day. N—Night. ST—Share Time. SH—Specified Hours.
 U—Unlimited. CP—Construction Permit Issued. LS—Local Sunset.
 L—Limited Time with Dominant Station. SA—Special Authorization.

WE DELIVER

Southern California's
 most responsive ^{buying} audience

Check **KFVD**

5000
WATTS

1020
K. C.

THE CENTER OF YOUR DIAL LOS ANGELES, CALIFORNIA



Pot Bishop



Burritt Wheeler



Ted Meyers

they are not too dainty at KFI !

Johnny Murray



Stu Wilson



Bill Stullo



KFI's personalities are not too dainty to personally do the commercials on their programs.

You know how much more effective a sales message is when the star of your program throws his influence behind the product.

That's why KFI's stars, who take their selling chores as seriously as they take the job of entertaining their listeners, always voice their own sales messages.

Each of these six personalities has proved his ability as a salesman with dozens of products on KFI.

One more reason advertisers are more successful on KFI.



Barclay C. Anthony, Inc.

NBC FOR LOS ANGELES • 640 KC CLEAR CHANNEL

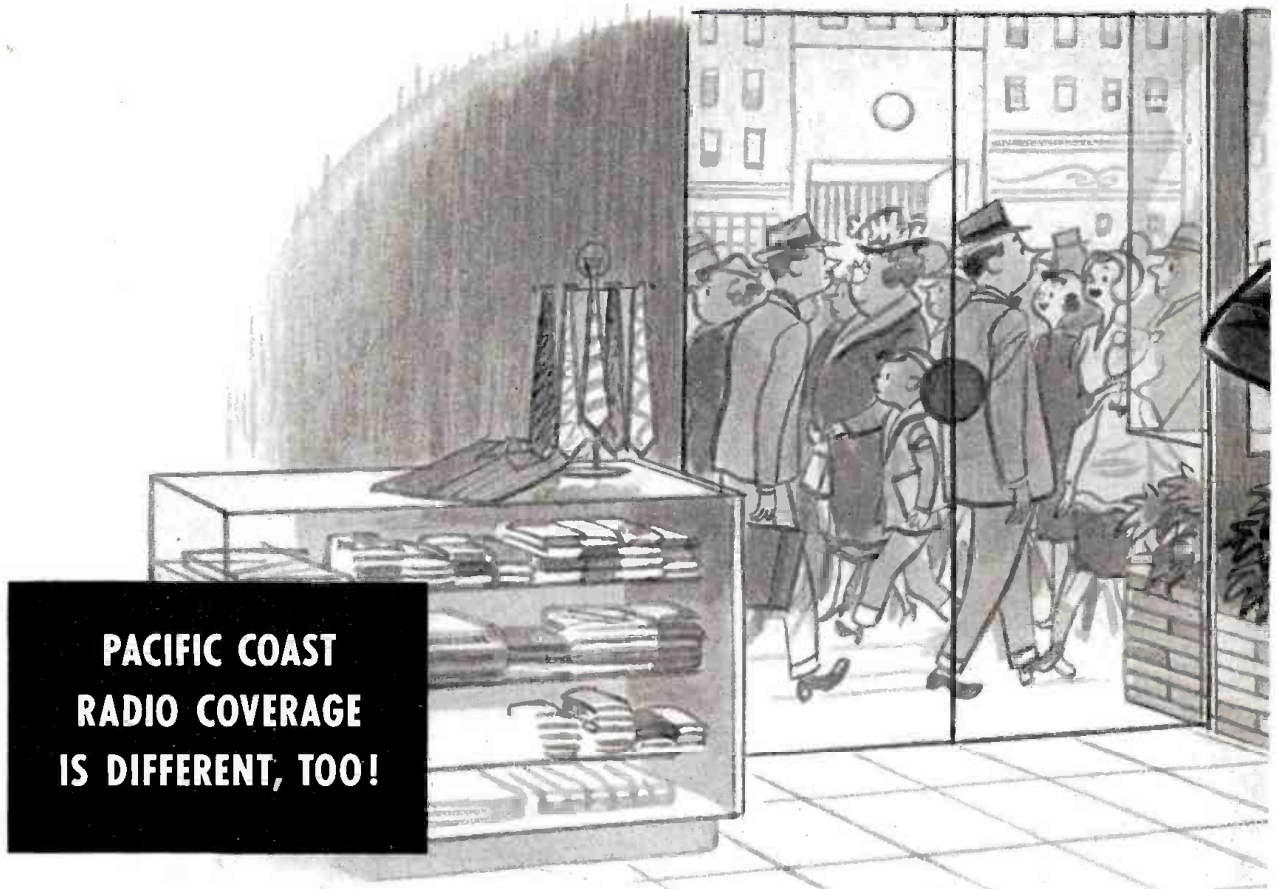

**PACIFIC COAST
RADIO COVERAGE
IS DIFFERENT, TOO!**

FOR THAT MATTER, even the Pacific Coast is different from any other area in the United States. It's big, it's almost entirely covered with mountains up to 14,495 feet high, and its markets are far apart.

To cover this vast, rich area is a different coverage problem. The great distances, the mountains, the low ground conductivity make long-range broadcasting impractical...yet Don Lee is the only network that does not rely on long-range broadcasting.

Only Don Lee is especially *designed* for the Pacific Coast.

Only Don Lee offers coverage that gives each market a local network outlet of the proper size

LEWIS ALLEN WEISS, *Chairman of the Board* · WILLET H. BROWN, *President* · WARD D. INGRIM, *Vice-President in Charge of Sales*
1313 NORTH VINE STREET, HOLLYWOOD 28, CALIFORNIA · *Represented Nationally by JOHN BLAIR & COMPANY*

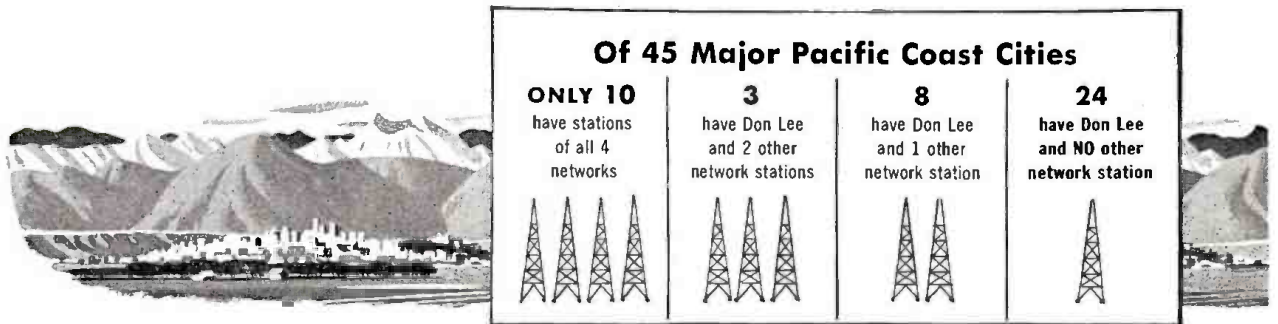

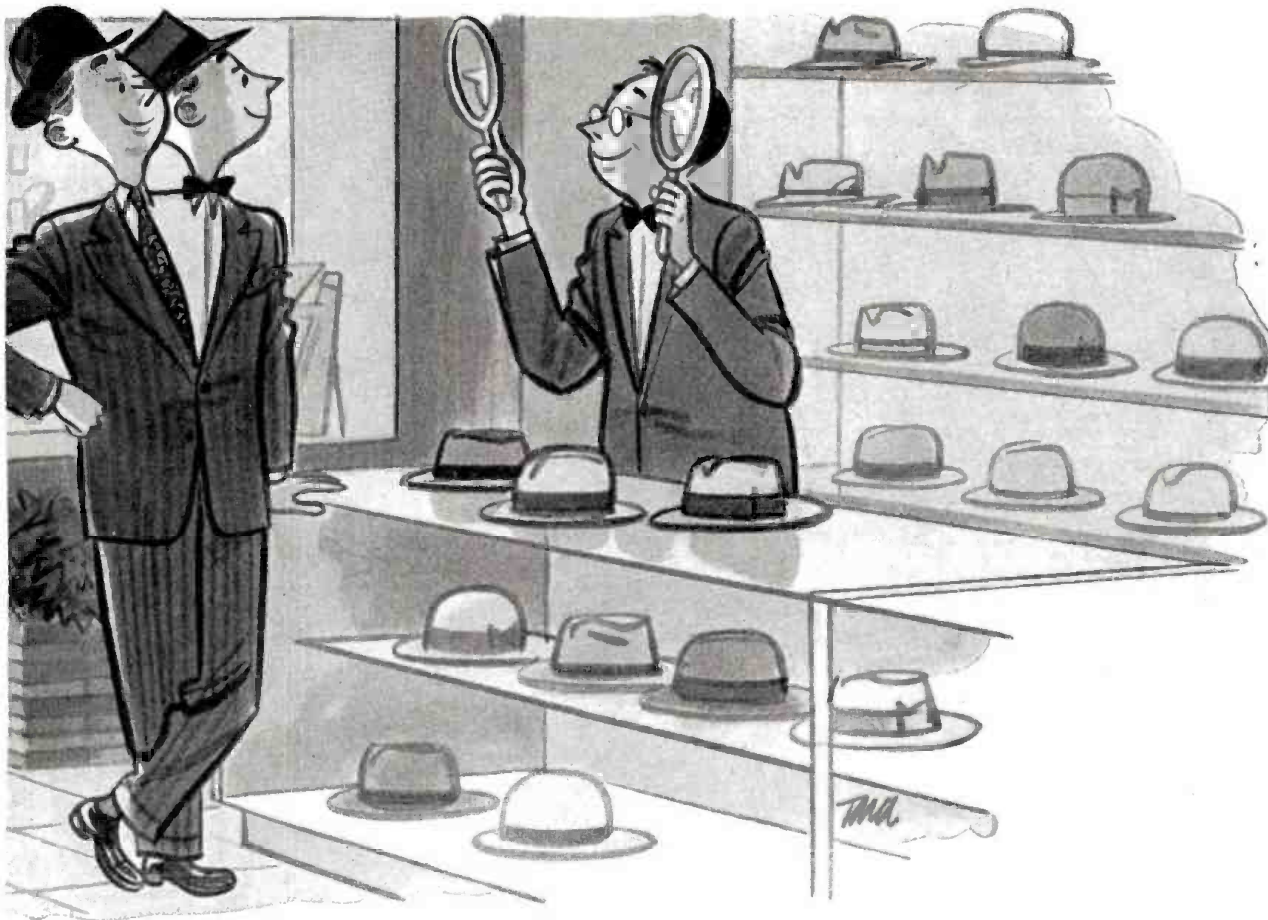

to completely cover that market for the least possible money expended.

Only with Don Lee can you tailor your network radio coverage to your distribution. You can buy all or part of Don Lee's 45 stations to match your distribution requirements, with no waste.

There are about 14 million people on the Pacific Coast. Only Don Lee sells them where they live—where they spend their 15½ billions per year, and Don Lee sells them from their own local network stations with all the local selling influence enjoyed by such a station.

If selling the Pacific Coast is your problem, remember coverage is *different* on the Pacific Coast. Use the *only* radio network especially *designed* for the Pacific Coast: DON LEE.

The Nation's Greatest Regional Network



DIRECTORY OF AM, FM, and TV STATIONS OF THE UNITED STATES

(Data corrected to December 6, 1949)

If executives or services for FM or TV stations are same as AM affiliate names are not repeated.

CALIFORNIA—(Continued)

City Call Letters Established	Chan. or Freq. Power	Name of Licensee Headquarters Address Telephone Number	Network Representative	Executive Personnel	Transc. Library News Service Transmitter Make	
LOS ANGELES—(Continued)						
KFWB 1925	980 5,000	Warner Bros. Bcstg. Corp. 5833 Fernwood Ave. Hemsted 5151	Rambeau	Harry M. Warner, Pres. Harry Maizlish, Gen. Mgr. Doty Wm. Edouarde, Coml. Mgr.	William V. Ray, Prog. Dir. Gene Gach, Prom. Mgr. Harry Myers, Chief Engr.	AP, UP, INS
KGFJ 1926	1230 250	Ben S. McGlashan 6314 Sunset Blvd. Hollywood Hillside 0201		Ben S. McGlashan, Pres. Thelma Kirchner, Gen. Mgr.	James Strain, Coml. Mgr. Homer Obuchon, Chief Engr.	Associated UP Western Electric
KHJ 1922	930 5,000 DA-1	Don Lee Bcstg. System 1313 N. Vine St. Hudson 2-2133	MBS Don Lee Blair	Willet H. Brown, Pres. Ward D. Ingram, V. P. Chg. Sales George Whitney, Sales Mgr.	Mark Finley, Prom. Mgr. Walter Carruthers, V. P. Chg. of Engr.	World AP, INS Western Electric
KHJ-FM 1941	Ch. 216 (B) 101.1mc 4.8kw	KHJ, AM affiliate				
KTSL (TV) 1931	Ch. 2 54-60mc 11.4kw aur.; 22.75kw vis.	KHJ, AM affiliate	DuMont	Charles Glett, V. P. in Chg. TV Robert Hoag, Sales Mgr.	Cecil Barker, Prog. Dir.	RCA
KLAC 1924	570 5,000-LS 1,000-N	KMTR Radio Corp. 1000 N. Cahuenga Blvd. Hollywood Hudson 2-7311	Young	Don J. Feddersen, Gen. Mgr. David E. Lundy, Coml. Mgr. Fred Henry, Prog. Dir.	Jack Miller, Prom. Mgr. Carl Olson, Chief Engr.	Capitol AP, UP, INS RCA
KLAC-TV 1948	Ch. 13 210-216mc 16.22kw aur.; 30.8kw vis.		Katz			
KMGM (FM) 1948	Ch. 254 (B) 98.7mc 49kw	Metro-Goldwyn-Mayer Studios Inc. MGM Studios Culver City Texas 03311		Bertram Lebharr Jr., Dir. W. F. MacCrystall, Gen. Mgr.	Elmitt Eastcott, Coml. Mgr. Rex R. Morrow, Chief Engr.	Associated UP General Electric
KMPC 1927	710 50,000-LS 10,000-N-DA CP-50,000 DA-N	The Station of the Stars Inc. 5939 Sunset Blvd. Hollywood Hollywood 9-5341	Raymer	G. A. Richards, Owner R. O. Reynolds, V. P. & Gen. Mgr. Earl E. Gibbs, V. P.	Andy Wilson, Continuity Dir. John Baird, Prog. Supvsr. Lloyd C. Sigmon, Chief Engr.	Associated AP, UP, INS RCA
KMPC-FM 1947	Ch. 262 (B) 100.3mc 2kw					REL
KNBH (TV) 1949	Ch. 4 66-72mc 8kw aur.; 15kw vis.	National Bcstg. Co. 1500 N. Vine, Hollywood Hollywood 9-6161	NBC	Joseph H. McConnell, NBC Pres. Sidney N. Strotz, V. P. Western Div. Harold J. Bock, Gen. Mgr.	Frank A. Berend, Coml. Mgr. Robert V. Brown, Prog. Dir. Alfred H. Saxton, Chief Engr.	Thesaurus AP, UP, INS RCA
KNX 1924	1070 50,000	Columbia Bcstg. System 6121 Sunset Blvd., Hollywood Hollywood 9-1212	CBS Radio Sales	Howard S. Meighan, V. P. & Gen. Exec. Merle S. Jones, Gen. Mgr. Wayne Steffner, Sales Mgr.	George Allen, Prog. Dir. Ralph Taylor, Prom. Mgr. Les Bowman, Chief Engr.	Lang-Worth AP, UP
KNX-FM 1948	Ch. 226 (B) 93.1mc 60kw					
KRKD 1927	1150 5,000-LS 1,000-N S-KFSG	Radio Bcstrs. Inc. 541 S. Spring St. Tucker 7111		Ned Connor, Gen. & Coml. Mgr. Charles Clifton, Prog. Dir.	Willis O. Freitag, Chief Engr.	SESAC RCA
KRKD-FM 1949	Ch. 242 (B) 96.3mc 15kw					Western Electric
KTLA (TV) 1942	Ch. 5 76-82mc 15kw aur.; 30kw vis.	Paramount Television Productions Inc. 5451 Marathon St. Hudson 2-2301	Weed	Paul Raibourn, Pres. Klaus Landsberg, Gen. Mgr. Harry Maynard, Coml. Mgr.	Gordon Wright, Prod. Coordinator Gordon Minter, Sr. Dir. Raymond M. Moore, Chief Engr.	Telenews UP
KTTV (TV) 1949	Ch. 11 198-204mc 16.6kw aur.; 31.5kw vis.	KTTV Inc. 1025 N. Highland Ave. Hudson 2-1301	CBS Radio Sales	Norman Chandler, Pres. Frank G. King, Sales Mgr.	Robert H. Forward, Prog. Dir. Raymond Monfort, Chief Engr.	AP RCA
MARYSVILLE						
KMYC 1940	1450 250	Marysville-Yuba City Bcstrs. Inc. Box 631 2080	MBS Don Lee Grant	Horace E. Thomas, Pres. Joe D. Carroll, Gen. & Coml. Mgr.	William R. Cleveland, Prog. Dir. Lloyd McQueary, Chief Engr.	World UP RCA
KMYC-FM 1947	Ch. 261 (B) 99.9mc 4.7kw					General Electric
MERCED						
KYOS 1936	1480 5,000 DA-N	Merced Bcstg. Co. P. O. Box 717 1430	MBS Don Lee Grant	Hugh McClung, Pres. & Gen. Mgr. Charles H. Kinsley Jr., Sta. Mgr.	A. J. Krisik, Coml. & Prom. Mgr. Joel Buffington, Prog. Dir. Russell B. Pope, Chief Engr.	World UP RCA
KVME (FM) 1948	Ch. 248 (B) 97.5mc 8.9kw					
MODESTO						
KBEE (FM) 1948	Ch. 277 (B) 103.3mc 11.5kw	McClatchy Bcstg. Co. 815-17 11th St. 2-200	Raymer	Eleanor McClatchy, Pres. William Endicott, Sta. Mgr.	J. B. Hancock, Chief Engr.	Associated Capitol UP, AP RCA
KMOD (CP)	1360 1,000-DA-N	Radio Modesto. Inc. 911 11th St.				
KTRB 1933	860 5,000-LS 1,000 DA-N	KTRB Bcstg. Co. Inc. P. O. Box 593 774	Grant	William H. Bates Jr., Pres. Gen. Mgr. & Chief Engr.	James Van Parks, Coml. & Prom. Mgr. Milt Hibdon, Prog. Dir.	Lang-Worth Cole Standard UP, INS General Electric
KTRB-FM 1949	Ch. 281 (B) 104.1mc 46kw					
MONTEREY						
KMBY 1949	1240 250	Monterey Bcstg. Co. Hotel San Carlos 8541	KBS	L. John Miner } Partners Taft R. Wrathall } L. John Miner, Gen. Mgr. John F. W. Tyler, Coml. Mgr.	Ford Warner, Prog. Dir. Emil A. Trojak, Chief Engr.	World Associated UP RCA

DA-N Directional Antenna, night only. FM's in italic.
DA-1 Directional Antenna, same pattern day and night.
DA-2 Directional Antenna, different pattern day and night.

*—Non-Commercial Station D—Day, N—Night, ST—Share Time, SH—Specified Hours.
U—Unlimited, CP—Construction Permit Issued, LS—Local Sunset.
L—Limited Time with Dominant Station. SA—Special Authorization.

your all-star DISC JOCKEY TEAM

BILL LEYDEN—6 to 8 AM



PETER POTTER—10 to Noon



Showmanship

Audience

BILL ANSON—
Noon to 3 PM

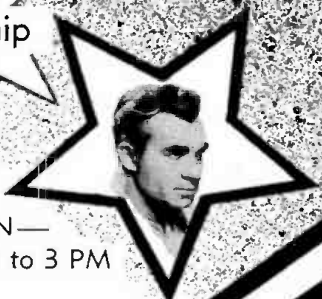

HOLLYWOOD ★

★ **KFWB** ★

Sales

★ WARNER BROS. ★

MAURICE HART—
3 to 4:15 PM



FRANK BULL—
6:30 to 7:30 PM



Results

GENE NORMAN—



10 to 12 PM

Warner Bros. KFWB in Hollywood offers you the nation's greatest array of disc jockeys. These six stellar personalities offer you showmanship and a vast audience, bringing you outstanding sales and sponsorship satisfaction. For further details contact your nearest William G. Rambeau Company or your KFWB account executive.

DIRECTORY OF AM, FM, and TV STATIONS OF THE UNITED STATES

*(Data corrected to December 6, 1949)
If executives or services for FM or TV stations are same as AM affiliate names are not repeated.*

CALIFORNIA—(Continued)

City Call Letters Established	Chan. or Freq. Power	Name of Licensee Headquarters Address Telephone Number	Network Representative	Executive Personnel	Transc. Library News Service Transmitter Make	
MT. SHASTA						
KWSD 1947	1340 250	Shasta Cascade Bcstg. Corp. East Alma St. 2124	Western	Arthur Adler, Co-owner, Gen. & Coml. Mgr.	Iola Huntingdon, Prog. Dir. Raymond Conners, Prom. Mgr. David H. Rees, Co-owner & Chief Engr.	Standard AP RCA
NAPA						
KVON 1947	1440 500 DA-1	Napa Bcstg. Co. Inc. Foster Rd. 6-7421	Forjoe	W. S. Quinn, Pres. & Gen. Mgr. Grant Pollock, Sta. Mgr.	Harlan McCoy, Coml. Mgr. Robert O'Brien, Prog. Dir. H. B. Vanderbeek, Chief Engr.	World Associated AP Collins
NEEDLES						
KSFE 1948	1340 250	Oscar D. Shelley 821 Broadway 1260		Oscar D. Shelley, Owner, Mgr. & Chief Engr. INS RCA	
OAKLAND						
KLX 1922	910- 1,000	Tribune Bldg. Co. 13th & Franklin Glencourt 1-0660	Burn-Smith	J. Russell Knowland Jr., Pres Glenn C. Shaw, Gen. Mgr.	Jerry Morton, Prog. Dir. Roswell Smith, Chief Engr.	World AP Western Electric
KLX-FM 1948	Ch. 267 (B) 101.3mc 20kw					
KROW 1925	960 1,000 CP-5,000 DA-1	KROW Inc. 464 19th St. Twinoaks 3-9600		Sheldon F. Sackett, Pres. Wilton Gunzendorfer, Gen. & Coml. Mgr.	Russ Coughlan, Prog. Dir. Mercedes Prosser, Prom. Mgr. C. E. Downey, Chief Engr.	Associated Standard UP Western Electric
KWBR 1921	1310 1,000	Warner Brothers 327 21st St. Higate 4-1212		Stafford W. Warner, Gen. Mgr. & Partner F. Wellington Morse, Sta. Mgr.	E. W. Malone, Coml. Mgr. Wanda Ramey, Prog. Dir. Paul E. Gregg, Chief Engr.	Lang-Worth Standard RCA
ONTARIO						
KOCS 1947	1510 250-D	The Daily Report Co. 222 E. B St. 627-54	Gene Grant Cooke	Jerene Appleby Harnish, Pres. Stanley G. Davis, Gen. Mgr.	George Crofford, Prog. Dir. Floyd Hall, Chief Engr.	Associated Capitol UP General Electric
KEDO (FM) 1947	Ch. 228 (A) 93.5mc 0.31kw	(KOCS, AM affiliate)				
OROVILLE						
KDAN 1948	1340 250	Mercury Bcstg. Co. Box 231 1340		Arden Booth, Gen. Mgr. & Prog. Dir.	Ray Partridge, Asst. Mgr. & Chief Engr.	Lang-Worth UP
OXNARD						
KVNE (CP)	910 1,000-D	Eva Miller Grimes				
PALM SPRINGS						
KCMJ 1946	1340 250	Palm Springs Bcstg. Co. Palm Springs 2253	CBS Pearson	Donald C. McBain, Pres. & Chief Engr. Roland B. Valle, Gen. Mgr.	Harry Davis, Coml. Mgr. Dorothy Fanning, Prog. Mgr. Ann Gerald, Prom. Mgr. UP
PALO ALTO						
KIBE 1946	1220 250-D	D & K Bcstg. Co.				
PASADENA						
KAGH 1948	1300 1,000 DA-N	KAGH Inc. 800 N. Sierra Madre Villa Ave. Sycamore 2-2196 (KAGH, AM Affiliate)		Aubrey H. Ison, Gen. Mgr. Ben Left, Chief Engr.	 UP Collins
KARS (FM) 1947	Ch. 252 (A) 98.3mc 0.33kw				 General Electric
*KPPC 1924	1240 100 SH	Pasadena Presbyterian Church Inc. 585 E. Colorado St. Sycamore 3-2191		Dr. Eugene Carlson Blake, Pres. Leon Hall, Prog. Dir. & Gen. Mgr.	Clayton Blake, Chief Engr. RCA
KWKW 1942	1430 1,000 D-DA	S. California Bcstg. Co. 425 E. Green St. Ryan 1-6744	Forjoe	Marshall S. Neal, Pres. William J. Beaton, Gen. Mgr. Charles L. Johnston, Coml. Mgr.	Crowell Beech, Prog. Dir. Claire Hughes, Prom. Mgr. Paul W. Spargo, Chief Engr.	Capitol UP RCA
KXLA 1942	1110 10,000 DA-1	Pacific Coast Bcstg. Co. 1401 S. Oak Knoll Ave. Ryan 1-6991		Loyal K. King, Pres. & Gen. Mgr. Richard Scofield, Prog. Dir.	Jack Reeder, Chief Engr.	World Associated AP Western Electric
PASO ROBLES						
KPRL 1946	1230 250	Leslie H. Hacker 32nd & Oak Sts. 204	MBS KBS Don Lee Grant	Leslie H. Hacker, Owner & Gen. Mgr.	Robert S. Wilton, Sta. Mgr. Jack B. Wasson & J. B. Shuttle- worth, Coml. Mgrs. RCA
PETALUMA						
KAFP (CP)	1490 250	Petaluma Bcstrs. Petaluma		Harold A. Sparks, Pres., Gen. & Coml. Mgr. Catherine E. Sparks, Prog. Dir. & Prom. Mgr.	Forrest W. Hughes, Chief Engr.	World, Thesaurus UP Gates
PITTSBURG						
KECC 1949	990 1,000 DA-N	Pittsburg Bcstg. Co. Inc. 235 Railroad Ave. 1638		Mel D. Marshall, Gen. Mgr. John C. McFarland, Coml. Mgr.	Dean Mell, Prog. Dir. Merlin W. Haag, Chief Engr.	World UP Western Electric
POMONA						
KPMO 1947	1600 500	Valley Bcstg. Co. 1240 E. Holt Lycoming 2-1293		Dean W. Wickstrom, Pres. & Gen. Mgr.	Jim Oliver, Coml. & Prom. Mgr., Prog. Dir. Buck Rogers, Chief Engr.	World Standard Raytheon
PORTERVILLE						
KTPP 1946	1450 250	J. F. Tighe P. O. Box 1312 1450	Cooke Gene Grant	J. F. Tighe, Pres. Ward E. Fritch, Gen. & Coml. Mgr.	Dave Belman, Prog. Dir. Hampton McKinney, Chief Engr.	World UP
RED BLUFF						
KBLF 1946	1490 250	R. G. Frey 346 Oak St. 354	Moore	Arvo Haapanen, Gen. Mgr. Edward Headrick, Coml. Mgr.	Herb Clark, Prog. Dir. Lane King, Chief Engr.	World UP

DA-N Directional Antenna, night only. FM's in italic. *—Non-Commercial Station D—Day. N—Night. ST—Share Time. SH—Specified Hours.
DA-1 Directional Antenna, same pattern day and night. U—Unlimited. CP—Construction Permit Issued. LS—Local Sunset.
DA-2 Directional Antenna, different pattern day and night. L—Limited Time with Dominant Station. SA—Special Authorization.

THE WEST'S MOST POWERFUL INDEPENDENT



SPORTS STARS HEARD EXCLUSIVELY



BOB KELLEY, Sports Director, who presents the "Parade of Sports" for Firestone Tires and PDQ Gasoline. The sportscaster for KMPC's exclusive broadcasts of the Los Angeles Angels baseball club, the Los Angeles Rams National League Professional football club and the Los Angeles Open Golf tournament.

HAL BERGER, the "Dean of West Coast Sportscasters", who for many years has presented a daily major league baseball game. Picking the outstanding game of the day, Hal Berger recreates the contest to big audiences throughout Southern California.



JOE HERNANDEZ, a noted track authority, recreates the racing program from one of California's favorite tracks daily. The Joe Hernandez program, for many years, has been a top audience leader among all programs produced locally in Los Angeles.



Other sportscasts aired exclusively in Los Angeles over KMPC:
 National Open Golf Tournament • P. G. A. Golf Tournament
 Davis Cup Matches • Glendale Open Golf Tournament
 • National Tennis Championship Matches

KMPC "THE WEST'S MOST POWERFUL INDEPENDENT"
 - *Leading in Sports* -

50,000 WATTS
 10,000 watts
 at night

★ PAUL H. RAYMER CO., NATIONAL REPRESENTATIVE ★

DIRECTORY OF AM, FM, and TV STATIONS OF THE UNITED STATES

(Data corrected to December 6, 1949)
If executives or services for FM or TV stations are same as AM affiliate names are not repeated.

CALIFORNIA—(Continued)

City Call Letters Established	Chan. or Freq. Power	Name of Licensee Headquarters Address Telephone Number	Network Representative	Executive Personnel	Transc. Library News Service Transmitter Make
REDDING					
KVCV 1938	600 1,000 DA-1	Golden Empire Bcstg. Co. Redding 1646 (KVCV, AM Affiliate)	MBS Don Lee Grant	Hugh McClung, Pres. Fred M. Stuelpnagel, Gen. Mgr. H. E. McCarty, Coml. Mgr.	Lyle Mathys, Prog. Dir. Ray Hullinger, Prom. Mgr. Russel Pope, Chief Engr. Standard World UP RCA
KVRE (FM) 1948	Ch. 280 (A) 103.9mc, 1kw				
REDLANDS					
KZYZ 1941	990 1,000-D	Orange Empire Bcstg. Co. 208½ Orange St.			
RIVERSIDE					
KPRO 1941	1440 1,000	Bcstg. Corp. of America 3401 Russell St., 6290	Ayres	W. L. Gleeson, Pres. & Gen. Mgr.	AP
KPOR (FM) 1941	Ch. 248 (B) 97.5mc 80kw	(KPRO, AM Affiliate)			
SACRAMENTO					
KCRA 1945	1320 1000 DA-1	KCRA Inc. 1010 11th St. Gilbert 2-0758	NBC Meeker Grant	Ewing C. Kelly, Pres. & Gen. Mgr. John P. Dupell, Coml. Mgr.	Howard J. Smiley, Sta. Mgr. & Prog. Dir. Irma Davis, Prom. Mgr. Paul E. Leake, Chief Engr. World AP Western Electric
KCRA-FM 1947	Ch. 241 (B) 96.1mc, 15kw				General Electric
KFBK 1922	1530 50,000 DA-1	McClatchy Bcstg. Co. 708 Eye St. Gilbert 3-1745	ABC Raymer	Eleanor McClatchy, Pres. Keith B. Collins, Sta. Mgr. Leo Ricketts, Coml. Mgr.	Richard S. Burdick, Prog. Mgr. Tom Flynn, Prom. Mgr. Stam Sronce, Chief Engr. Capitol AP, UP
KFBK-FM 1947	Ch. 245 (B) 96.9mc, 5.4kw				RCA
KROY 1937	1240 250	Harmco Inc. Sacramento Hotel Gilbert 3-2525	CBS Avery-Knodel	Clyde F. Coombs, V. P. & Gen. Mgr. Byron H. Nelson, Coml. Mgr.	William J. Ratcliff, Prog. Dir., Asst. & Prom. Mgr. Howard Martineau, Chief Engr. UP, INS Western Electric
KROY-FM (CP) 1945	Ch. 233 (B) 94.5mc, 12.6kw				
KXOA 1945	1470 1,000 DA-1	Sacramento Bcstrs. Inc. 1617 30th St. Hillcrest 6-4728	MBS Don Lee Pearson	Lincoln Dellar, Pres. Herb Ferguson, Gen., Coml. & Prom. Mgr.	Martin Dean Wickett, Dir. of Oprs. Ewald W. Berger, Chief Engr. Associated UP Raytheon
KXOA-FM 1949	Ch. 300 (B) 107.9mc, 13kw				General Electric

DA-N Directional Antenna, night only. FM's in italic. *—Non-Commercial Station D—Day. N—Night. ST—Share Time. SH—Specified Hours.
DA-1 Directional Antenna, same pattern day and night. U—Unlimited. CP—Construction Permit Issued. LS—Local Sunset.
DA-2 Directional Antenna, different pattern day and night. L—Limited Time with Dominant Station. SA—Special Authorization.

KROY

Sacramento, California

Columbia's Basic Station for California's Capital

Represented Nationally By

EVERY-KNODEL, Inc. New York — Chicago — San Francisco — Los Angeles



KTLA

CHANNEL 5 - LOS ANGELES
— YOUR No. 1 SALESMAN
in the World's Fastest Growing Market

Lita Baron,
featured vocalist
in KTLA's
"Latin Cruise"

46.3% of the Los Angeles TV audience* is tuned to KTLA all evening, every evening. KTLA's average share-of-evening-TV-audience nearly equals the total average audience of all six other Los Angeles TV stations combined... is more than three times the following of its nearest competitor!

*September-October Hooper Measurement of the Broadcast Audience Served by 7 TV Stations.

KTLA Studios • 5451 Morathon St., Los Angeles 38, Calif. • HOLLYWOOD 9-6363
New York Sales Offices • 1501 Broadway • BRyant 9-8700



KEY STATION OF THE PARAMOUNT TELEVISION NETWORK

DIRECTORY OF AM, FM, and TV STATIONS OF THE UNITED STATES

(Data corrected to December 6, 1949)
 If executives or services for FM or TV stations are same as AM affiliate names are not repeated.

CALIFORNIA—(Continued)

City Call Letters Established	Chan. or Freq. Power	Name of Licensee Headquarters Address Telephone Number	Network Representative	Executive Personnel	Transc. Library News Service Transmitter Make
SALINAS					
KSBW 1947	1380 1,000 DA-1	Salinas Bcstg. Corp. P. O. Box 1651 8071	MBS Don Lee Pearson	J. M. Hall, Pres. Gen. Mgr. & Chief Engr. Ken Randolph, Asst. Gen. Mgr.	Don Wells, Prog. Dir. Standard AP RCA
KSNI (FM) 1948	Ch. 233 (B) 94.5mc 3.2kw	Monterey Peninsula Bcstg. Co. 123 W. Alisal St. 6451	Calif. FM	Merritt C. Speidel, Pres. Gilbert V. Baymiller, Gen. Mgr.	Ronald Panton, Prog. Dir. & Chief Engr. World General Electric
SAN BERNARDINO					
KBMT (FM) 1947	Ch. 260 (B) 99.9mc 6.4kw	The Sun Co. of San Bernardino 399 "D" St. 2121		James A. Guthrie, Pres. Paul C. Lynde, Gen. Mgr.	Ted Emm, Chief Engr. Capitol UP General Electric
KCSB 1947	1350 500-DA-N	Mrs. Essie Binkley West 770 Mills St. 822-45		Mrs. Essie Binkley West, Pres. & Gen. Mgr. Dave W. Adams, Coml. & Prom. Mgr.	Chap Rollins, Prog. Dir. Walter Bronson, Chief Engr. AP, UP General Electric
KFXM 1929	590 1,000 DA-2	Lee Bros. Bcstg. Corp. 512 5th St. 4761	MBS Don Lee Blair	J. Clifford Lee, Pres. Gene W. Lee, V. P. & Gen. Mgr. Don S. Cummings, Coml. Mgr.	Sally Stocker, Prog. Dir. Lowell Smith, Prom. Mgr. George Ewing, Chief Engr.
KITO 1947	1290 5,000 DA-2	San Bernardino Bcstg. Co. Inc. 569 4th St. 7807	ABC Hollingbery	Carl E. Haymond, Pres. George E. Lindman, Gen. & Coml. Mgr.	Arnold Benum, Prog. & Prom. Dir. J. T. Bindner, Chief Engr.
KRNO 1948	1240 250	Western Empire Bcstrs. Inc. 990 Colton Ave. 8-2771		Van C. Newkirk, Pres. Norman H. Rogers, V. P. & Gen. Mgr. James W. Gerrard, Prom. & Coml. Mgr.	Robert Stone, Prog. Dir. George W. Brock, V. P. & Chief Engr. Standard SESAC AP RCA
SAN BRUNO					
KSBR (FM) 1947	Ch. 263 (B) 100.5mc 125kw	Radio Diablo Inc. 798 San Mateo Ave. Juno 8-1465		Orrin H. Brown, Pres. Franklin M. Evans, Gen. Mgr.	Arthur Arrigoni, Chief Engr. Standard
SAN DIEGO					
KCBQ 1946	1170 5,000-LS DA-1 1,000-N	Charles E. Salik 1405 Fifth Ave. Franklin 1315	CBS Hollingbery	Charles E. Salik, Pres. & Gen. Mgr. Graham H. Moore, Coml. Mgr.	Grady Edney, Prog. Dir. & Prom. Mgr. Charles Sherburne, Chief Engr. Standard SESAC UP RCA

DA-N Directional Antenna, night only. FM's in italic.
 DA-1 Directional Antenna, same pattern day and night.
 DA-2 Directional Antenna, different pattern day and night.

*—Non-Commercial Station D—Day. N—Night. ST—Share Time. SH—Specified Hours.
 U—Unlimited. CP—Construction Permit Issued. LS—Local Sunset.
 L—Limited Time with Dominant Station. SA—Special Authorization.



KCBQ

San Diego's Quality Station

in
California's Third Market

5000 WATTS CLEAR CHANNEL

Represented Nationally By
The George P. Hollingbery Co.

Come on In—



City Call Letters Established	Chan. or Freq. Power	Name of Licensee Headquarters Address Telephone Number	Network Representative	Executive Personnel	Transc. Library News Service Transmitter Make	
SAN DIEGO—(Continued)						
KFMB 1941	550 1,000 DA-1	Jack Gross Bcstg. Co. 1375 Pacific Blvd. Main 2114	ABC Branham	Jack O. Gross, Pres. & Gen. Mgr. W. O. Edholm, Coml. Mgr. John Bainbridge, Prog. Dir.	Paul L. Dodd, V. P. Thornton Chew, Chief Engr.	World AP General Electric
KFMB-FM 1947	Ch. 268 (A) 101.5mc 0.25kw				Bob Lee, Chief Engr.	
KFMB-TV 1949	Ch. 8 180-186mc 18.5kw aur.; 20kw vis.		ABC CBS NBC	Al Flanagan, Prog. Dir.		
KFSD 1928	600 5,000 DA-1	Airfan Radio Corp. Ltd. 326 Broadway Franklin 6353	NBC Raymer	Thomas E. Sharp, Pres. John C. Merino, Sta. Mgr.	Fred T. Foster, Acct. Exec. Tom Hotchkiss, Prog. Dir.	Thesaurus UP RCA
KFSD-FM 1948	Ch. 231 (B) 94.1mc 33kw					
KGB 1927	1360 1,000	Don Lee Bcstg. System 1017 1st Ave. Franklin 6151	MBS Don Lee Blair	Willet H. Brown, Pres. F. D. Ide, Gen. Mgr.	Hobby Myers, Coml. Mgr. Jerry Lee Pecht, Prog. Dir. Wm. G. Collins, Chief Engr.	World UP
KSDO 1947	1130 5,000 DA-2	San Diego Bcstg. Co. 1029 Second Ave. Main 2041	Sears & Ayer	Jack Heintz, V. P. & Gen. Mgr. Wilson Edwards, Prog. Dir.	Vern Milton, Chief Engr.	Standard AP, UP Westinghouse
KSDO-FM 1948	Ch. 243 (B) 96.5mc 48kw					

DA-N Directional Antenna, night only. FM's in italic.
DA-1 Directional Antenna, same pattern day and night.
DA-2 Directional Antenna, different pattern day and night.

*—Non-Commercial Station D—Day. N—Night. ST—Share Time. SH—Specified Hours.
U—Unlimited. CP—Construction Permit Issued. LS—Local Sunset.
L—Limited Time with Dominant Station. SA—Special Authorization.

am
1000 Watts
550 kc

fm
101.5
Megacycles

tv
Channel
8

KFMB is all-embracing

No favorites at KFMB—but KFMB is a favorite in California's third-largest market.

- AM-FM-TV audiences get their choice
- Advertisers get a choice market

Wire or write for availabilities

in SAN DIEGO!

KFMB (AM
FM
TV

1375 Pacific Blvd., San Diego, Calif.

Owned and managed by Jack Gross
Represented by The Branham Co.

DIRECTORY OF AM, FM, and TV STATIONS OF THE UNITED STATES

(Data corrected to December 6, 1949)
If executives or services for FM or TV stations are same as AM affiliate names are not repeated.

CALIFORNIA—(Continued)

City Call Letters Established	Chan. or Freq. Power	Name of Licensee Headquarters Address Telephone Number	Network Representative	Executive Personnel	Transc. Library News Service Transmitter Make	
SAN DIEGO—(Continued)						
KSON 1947	1240 250	Studebaker Bcstg. Co. 630 F St. Franklin 5175	KBS Burn-Smith	John Ward Studebaker, Pres. John Gordon Studebaker, V. P. & Coml. Mgr. Fred Rabell, V. P. & Gen. Mgr.	Dorothy Johnson, Asst. Mgr. & Prog. Dir. William Tomberlin, Chief Engr.	Standard SESAC AP RCA
KWFM (FM)	Ch. 284 (B) 104.7mc 0.25kw	(KSON, AM Affiliate)				
SAN FERNANDO						
KGIL 1949	1260 1,000 DA-1	San Fernando Valley Bcstg. Co. 4919 Van Nuys Blvd. Sherman Oaks State 4-6291		F. J. Smalley Jr., Pres. & Gen. Mgr. Howard P. Gray, Coml. Mgr. Allan McKee, Prog. Dir.	Cal Frisk, Chief Engr.	UP RCA
SAN FRANCISCO						
KCBS 1912	740 5,000 DA-1 CP-560 CP-5,000 DA-N	Columbia Bcstg. Co. Inc. 140 Jessie St. Yukon 2-7000	CBS Radio Sales	Frank Stanton, Pres. Arthur Hull Hayes, V. P. & Gen. Mgr. Fred Ruegg, Prog. Dir.	Jules Dundes, Sales & Sales Prom. Mgr. Walter Conway, Prom. Mgr. Al Cormack, Chief Engr.	Standard AP, UP Western Electric
KCBS-FM 1948	Ch. 279 (B) 103.7mc, 4.2kw					
KDFC (FM)	(See Sausalito, Calif. Listing)					
KFRC 1924	610 5,000	Don Lee Bcstg. System 1000 Van Ness Ave. Prospect 5-0111	MBS Don Lee Blair	William D. Pabst, V. P. & Gen. Mgr. Merwyn L. McCabe, Coml. & Sales Mgr. Mel Venter, Prod. & Prog. Dir. Mark Woods, Pres. Gayle V. Grubb, Gen. Mgr. Vincent Francis, Coml. Mgr.	Dink Templeton, Prom. Mgr. E. G. Underwood, Chief Engr.	World AP, INS
KGO 1924	810 50,000 DA-1	American Bcstg. Co. 155 Montgomery St. Exbrook 2-6544	ABC Spot		Bloyce Wright, Prog. Dir. & Prom. Mgr. A. E. Evans, Chief Engr.	Capitol Associated Standard AP, UP, INS Westinghouse
KGO-FM 1947	Ch. 291 (B) 106.1mc 50kw					General Electric
KGO-TV 1949	Ch. 7 174-180mc 13.7kw aur.; 25.4kw vis.		ABC ABC Spot			General Electric

DA-N Directional Antenna, night only. FM's in italic. *—Non-Commercial Station D—Day. N—Night. ST—Share Time. SH—Specified Hours.
DA-1 Directional Antenna, same pattern day and night. U—Unlimited. CP—Construction Permit Issued. LS—Local Signif.
DA-2 Directional Antenna, different pattern day and night. L—Limited Time with Dominant Station. SA—Special Authorization.

ARE YOU WONDERING WHETHER TO BUY

WATTS OR LISTENERS?

KSON—San Diego's Only 24 Hour Music Station

HAS ALWAYS LED THE FIELD IN LISTENERS PER DOLLAR SPENT—FOR EXAMPLE . . .

From July 1947 to October 1949

IN THE BULK OF THE TIME, 10 HOURS A DAY, FROM 8 A.M. TO 6 P.M. MONDAY THROUGH FRIDAY, ACCORDING TO HOOPER STATION AUDIENCE INDEXES

KSON
5.09%

INDEPENDENT COMPETITION
2.64%

THERE'S ALWAYS A REASON—AND AT KSON IT'S PROGRAM PERSONALITIES
LED OFF BY

San Diego's Top Early Morning Show

WAKE UP SAN DIEGO

WITH

FRED RABELL AND DOTTIE JOHNSON



City Call Letters Established	Chan. or Freq. Power	Name of Licensee Headquarters Address Telephone Number	Network Representative	Executive Personnel	Transc. Library News Service Transmitter Make	
SAN FRANCISCO—(Continued)						
KGSF (FM) 1947	Ch. 247 (B) 97.3mc 10kw	Warner Bros. (KWBR) 327 21st St. Oakland Higate 4-1212		S. W. Warner, Gen. Mgr. F. W. Morse, Sta. Mgr. Wanda Ramey, Prog. Dir.	Paul Gregg, Chief Engr.	Lang-Worth Standard UP General Electric
KJBS 1925	1100 1,000 L-WTAM	KJBS Bcstrs. 1470 Pine St. Ordway 3-4148	Headley-Reed	E. P. Franklin, Chief Owner & Gen. Mgr. Stanley G. Breyer, Coml. Mgr.	C. F. Pendleton, Prog. Dir. & Prom. Mgr. Wayne Berthold, Chief Engr.	Lang-Worth Assoc., MacG. Standard AP, INS Western Electric
KJBS-FM 1946	Ch. 255 (B) 98.9mc 35kw					
KNBC 1922	680 50,000	National Bcstg. Co. Taylor & O'Farrell St. Graystone 4-8700	NBC NBC Spot	John W. Elwood, Gen. Mgr. Alfred W. Crapsey, Coml. Mgr. Paul Speegle, Prog. Dir.	Ethel Gulchrist, Prom. Mgr. Curtis D. Peck, Chief Engr.	Thesaurus AP, UP, INS RCA
KNBC-FM 1949	Ch. 259 (B) 99.7mc 45kw					
KRON-FM 1947	Ch. 243 (B) 96.5mc 12kw	The Chronicle Pub. Co. 901 Mission St. Garfield 1-1100		Charles Theriot, Gen. Mgr. Harold See, Dir. of Tel. Patrick Crafton, Prog. Dir.	Norman Louvan, Coml. Rep. Al Isberg, Chief Engr.	AP, UP RCA
KRON-TV 1949	Ch. 4 66-72mc 7.7kw aur.; 14.5kw vis.		NBC Free & Peters	Harold P. See, Dir. of TV Pat Crafton, Prog. Dir.	A. H. Isberg, Chief Engr.	
KSAN 1922	1450 250	Golden Gate Bcstg. Co. 1355 Market Market 1-8171	Rambeau	S. H. Patterson, Pres. Lee Mikesell, Gen. & Coml. Mgr.	Clint Sherwood, Prog. Dir. & Prom. Mgr. Norwood Patterson, Chief Engr.	Lang-Worth AP, UP RCA
KSFH (FM) 1947	Ch. 235 (B) 94.9mc 15.8kw	Pacific Bcstg. Co. 690 Market St. Garfield 1-0104		Charles A. Gibson, Pres. Patricia N. Gibson, Gen. Mgr. Paul E. Moore Jr., Sta. Mgr. & Prog. Dir.	Walter T. Selsted, Chief Engr.	Associated Standard UP RCA
KSFO 1925	560 5,000-LS 1,000-N CP-740; CP-50,000 DA-2	The Associated Bcstrs. Inc. Mark Hopkins Hotel Exbrook 2-4567	Bolling	Wesley I. Dumm, Pres. Philip G. Lasky, V. P. & Gen. Mgr. John G. Campbell, Sales Mgr.	Robert Hansen, Prog. Dir. Kay Mulvihill, Prom. Mgr. A. E. Towne, Chief Engr.	Associated Standard UP, INS Western Electric
KPIX (TV) 1948	Ch. 5 76-82mc 15.4kw aur.; 29.9kw vis.	(KSFO, AM Affiliate)	CBS DuMont NBC	Lou Simon, Coml. Mgr. Sanford Spillman, Prog. Dir.		RCA
KYA 1926	1260 5,000-LS 1,000-N	Palo Alto Radio Station Inc. Fairmont Hotel Douglas 2-2536	Young	Dorothy S. Schiff, Pres. Don Feddersen, Gen. Mgr. David E. Lundy, Coml. Mgr.	R. F. Horgan, Asst. Mgr. & Prom. Dir. Paul C. Schulz, Chief Engr.	UP RCA

It takes the ol'



to throw a real sales punch in San Francisco

One for the *money* and two for the *show*...combined or separately, KSFO and KPIX Television in San Francisco will deliver more audience for the *money* and *show* more profits for the audience than any station or combination of stations (AM and TV) in the entire Bay Area... and we've the figures to prove it.

KSFO... the music and major sports station... is the Bay Area's leading AM independent, and KPIX, its sister station, is the Bay Area's pioneer television station... and the only TV station in the area which can point to a year-long* history of accomplishment.

*on the air from December 15, 1948

Put 'em together and you have the "ol' one-two"... a combination that'll lick most any sales problem in the San Francisco Bay Area. Want to learn MORE... ask your Bolling representative.



Wesley I. Dumm, President
Philip G. Lasky, Vice President and General Manager
REPRESENTED NATIONALLY BY THE BOLLING COMPANY

KPIX is affiliated with CBS and Dumont networks

DIRECTORY OF AM, FM, and TV STATIONS OF THE UNITED STATES

*(Data corrected to December 6, 1949)
If executives or services for FM or TV stations are same as AM affiliate names are not repeated.*

CALIFORNIA—(Continued)

City Call Letters Established	Chan. or Freq. Power	Name of Licensee Headquarters Address Telephone Number	Network Representative	Executive Personnel	Transc. Library News Service Transmitter Make	
SANGER						
KSGN 1947	900 1,000-D	Radio Sanger Co. P. O. Box 338 490	Moore	Bob Rogers, Gen. Mgr. Bob Jones, Coml. Mgr.	Denny Whitney, Prog. Dir. Julian Nielsen, Chief Engr.	Capitol World UP Collins
SAN JOSE						
KEEN 1947	1370 1,000 DA-1	United Bcstg. Co. Inc. Hotel De Anza Cypress 4-0344	Grant	George M. Mardikian, Pres. Floyd Farr, Gen. Mgr. George Snell, Prog. Dir.	Harold Wooley, Prom. Mgr. Lee Johnston, Chief Engr.	Associated UP Raytheon
KLOK 1946	1170 5,000-D	Valley Bcstg. Co. 40 W. San Antonio Cypress 3-3445	Gene Grant	E. L. Barker, Pres. & Gen. Mgr. Richard E. Ryan, Coml. Mgr.	Ruth A. Poindexter, Prog. Dir. Billy Cunningham, Chief Engr.	AP RCA
KRPO (FM) 1949	Ch. 222 (B) 92.3mc 1kw	FM Radio & Television Corp. 3654 Main St. Riverside Riverside 6731	Ayres	W. L. Gleeson, Pres. & Gen. Mgr.		AP Collins
KSJO 1946	1590 1,000-LS 500 N-DA	Santa Clara Bcstg. Co. P. O. Box 995 Cypress 3-8030	Forjoe	Patrick H. Peabody, Pres. & Owner Charles F. Mallory, V. P. & Gen. Mgr. R. W. O'Donnell, Sales Mgr.	Norman Paul, Prog. Dir. & Prom. Mgr. Wesley I. Shellhammer, Chief Engr.	World UP Western Electric
KSJO-FM 1947	Ch. 237 (A) 95.3mc 1kw					General Electric
KXRK 1948	1500 1,000 DA-1	San Jose Bcstg. Co. P. O. Box 167 Cypress 2-5080	Western Radio	Joe E. Levitt, Pres. & Gen. Mgr. Gordon Graham, Coml. Mgr. Glen Hill, Prog. Dir.	Peggy Ring, Prom. Mgr. Frank Glass, Chief Engr.	UP RCA
SAN LUIS OBISPO						
KMNS 1949	1340 250	Pacific Bcstg. Co. 1130 Garden St. 3171	Moore	Marc H. Spinelli, Pres. & Gen. Mgr.	Esther Wright, Coml. Mgr. Harriette Dunbar, Prog. Dir. Rodney C. Myers, Chief Engr.	World UP Raytheon
KVEC 1937	920 1,000-LS 500-N	Valley Electric Co. Mt. View & Hill St. 1100	MBS, KBS Don Lee Grant	Christina M. Jacobson, Owner Les Hacker, Gen. Mgr. Joseph W. Shuttleworth, Coml. & Prom. Mgr.	Karl Brindle, Prog. Dir. Wilce Tognazini, Chief Engr.	Standard AP RCA
KVEC-FM 1948	Ch. 260 (B) 99.9mc 16.3kw					

DA-N Directional Antenna, night only. FM's in italic. *—Non-Commercial Station D—Day. N—Night. ST—Share Time. SH—Specified Hours.
DA-1 Directional Antenna, same pattern day and night. U—Unlimited. CP—Construction Permit Issued. LS—Local Sunset.
DA-2 Directional Antenna, different pattern day and night. L—Limited Time with Dominant Station. SA—Special Authorization.

BROADCAST • TELEVISION • RECORDING ENGINEERS

**INTERNATIONAL BROTHERHOOD OF ELECTRICAL WORKERS
LOCAL UNION 45**

1591 CROSS ROADS OF THE WORLD
HOLLYWOOD 28, CALIFORNIA

GLADSTONE 8889

December 31, 1949

TO ALL RADIO ADVERTISERS:

The West's greatest radio market offers the greatest array of services to be found anywhere in the world.

CINEMASCOPE RECORDING by KLAC-TV • KINESCOPE RECORDING BY CBS

If it's live shows on TV we have:

KTTV—LA TIMES—CBS • KTSL—DON LEE BROADCASTING SYSTEM
KLAC-TV, plus Cinemascope films

KNX—KNX-FM—THE COLUMBIA BROADCASTING SYSTEM
KHJ—KHJ-FM—THE DON LEE BROADCASTING SYSTEM

KMPC—HOLLYWOOD
KFMV—HOLLYWOOD
KFWB—HOLLYWOOD
KMGM—LOS ANGELES
KFAC—LOS ANGELES

KRKD—LOS ANGELES
KGFJ—LOS ANGELES
KFVD—LOS ANGELES
KAGH—PASADENA
KXLA—PASADENA
KWKW—PASADENA

KFOX—LONG BEACH
KGER—LONG BEACH
KIEV—GLENDALE
KWIK—BURBANK
KGIL—SAN FERNANDO

6000 SUNSET RADIO—TELEVISION CENTER
UNIVERSAL RECORDERS

Sincerely,
ROY TINDALL, Business Manager
Local Union 45 I.B.E.W.

City Call Letters Established	Chan. or Freq. Power	Name of Licensee Headquarters Address Telephone Number	Network Representative	Executive Personnel	Transc. Library News Service Transmitter Make
SAN MATEO					
KSMO 1949	1550 1,000 DA-N	Amphlett Printing Co. 811 So. B St. Diamond 4-2594	Grant	J. Hart Clinton, Pres. George Arnold, Gen. Mgr.	Bill Delmar, Prog. Dir. H. Neil Black, Chief Engr. AP, UP Raytheon World UP Temco
KVSM 1946	1050 250-D	San Mateo County Bcstrs. 279 Baldwin Ave. Diamond 4-2541		H. H. Smith Sr., Pres. Merwyn F. Planting, Gen. Mgr. & Chief Engr.	
SAN RAFAEL					
KTIM 1947	1510 1,000-D	Marin Bcstg. Co. Inc. 1117 5th Ave. 1510		Roy A. Brown, Pres. Hugh Turner, Gen. Mgr. Clifford Trotter, Coml. Mgr.	Peter Miller, Prog. Dir. Gene Dean, Prom. Mgr. Melvin Murphy, Chief Engr. AP Raytheon
SANTA ANA					
KVOE 1923	1480 1,000 DA-1	The Voice of the Orange Empire Inc. Ltd. 105 East 5th St. Kimberly 27191	MBS Don Lee Grant	Ernest L. Spencer, Pres. & Gen. Mgr. Donner P. Spencer, Coml. Mgr.	Wallace S. Wiggins, Prog. Dir. William J. Burrud, Prom. Mgr. Stanley G. Guenther, Chief Engr. Standard MacGregor INS RCA
KVOE-FM 1949	Ch. 244 (A) 96.7mc 1kw			William F. Steen, Prog. Dir.	General Electric
SANTA BARBARA					
KDB 1921	1490 250	Don Lee Bcstg. System Radio Square 4131	MBS Don Lee Blair	Willett H. Brown, Pres. Edward K. Kemble, Gen. & Prom. Mgr. James S. Blomfield, Coml. Mgr.	Donald C. Roberts, Prog. Dir. Forrest T. Choate, Chief Engr. World UP Western Electric
KIST 1946	1340 250	Radio KIST Inc. Balboa Bldg. 3981	NBC Hollingbery	Harry C. Butcher, Pres. Fin Hollinger, Gen. & Coml. Mgr. Mary Ann Casey, Prog. Dir.	Michael J. McKeogh, Prom. Mgr. Stanley Sauerssig, Chief Engr. UP RCA
KTMS 1937	1250 1,000 DA-1	News Press Pub. Co. de la Guerra Plaza 3925	ABC Raymer	Thomas M. Storke, Pres. Kenneth E. Peters, Gen. Mgr. William L. Simpson, Coml. Mgr.	Ted Scott, Prog. Dir. John Willis, Prom. Mgr. Albert Nicolay, Chief Engr. Lang-Worth AP
SANTA CRUZ					
KDON 1935	1460 1,000 DA-1	Central Coast Counties Radio Inc. 1407 Pacific Ave. 5140	Grant	Paul Caswell, V. P. & Treas. Gilbert V. Baymiller, Gen. Mgr. Les Jacobson, Coml. Mgr.	Orel Phillips, Prog. Dir. Omer Wright, Chief Engr. World Standard UP
KSCO 1947	1080 1,000-LS 500-N DA	Radio Santa Cruz P. O. Box 1080 1080		Charles Vernon Berlin, Mngng. Partner, Gen. & Coml. Mgr. & Chief Engr.	Standard Thesaurus AP RCA
SANTA MARIA					
KCOY 1946	1400 250	News-Press Pub. Co. 114 W. Cook St. 104	ABC Raymer	Charles A. Stroke, Gen. Mgr.	Jo W. Benes, Mgr. Lang-Worth
KSMA 1946	1450; CP-1240 250	John H. Poole 510 W. Morrison St. 43	KBS O'Connell	John H. Poole, Pres. Laurence W. Harry, Gen. Mgr. & Chief Engr.	F. Clinton Jones, Coml. Mgr. World AP, UP
KSMB (FM) 1947	Ch. 276 (A) 103.1mc 0.34kw	(KSMA, AM Affiliate)			General Electric
SANTA MONICA					
KOWL 1947	1580 5,000-D	KOWL Inc. Pico at Ocean 46761	Holman	Arthur H. Croghan, Pres., Gen. & Coml. Mgr.	Warren Deem, Prog. Dir. John Morecroft, Chief Engr. Associated UP Western Electric
SANTA PAULA					
KSPA 1948	1400 250	Ventura County Radio Center Inc. 110 North Middle Rd. 940		Neal Van Sooy, Gen. Mgr. Bob Reel, Sta. Mgr.	Donald Seymour, Coml. Mgr. John Rayworth, Chief Engr. World AP Collins
SANTA ROSA					
KSRO 1937	1350 1,000 DA-1	Mrs. Ruth W. Finley 427 Mendocino Ave. 110	Grant	(Mrs.) Ruth W. Finley, Owner Charles F. Scott, Gen. Mgr. Lee Fleming, Coml. Mgr.	Russ Siner, Prog. Dir. William Lambert, Prom. Mgr. Vern Hassett, Chief Engr. Standard AP, UP
SAUSALITO					
KDFC (FM) 1948 (CP) (To move to San Fran- cisco)	Ch. 271 (B) 102.1mc 33kw	Sundial Bcstg. Corp. Box 33 1400		William R. Crocker, Pres. & Gen. Mgr. Edward Davis, Coml. Mgr.	Edward G. K. Deverill, Prog. Dir. Herbert C. Florance, Chief Engr. Associated Capitol AP Western Electric
SONORA					
KROG 1949	1450 250	Mother Lode Bcstg. Co. Sonora 426		Ianthe Densmore, Owner & Gen. Mgr. Neal Edmondson, Prog. Dir.	Casper Tressi, Chief Engr. Standard SESAC AP Raytheon
STOCKTON					
KGDM 1926	1140 5,000 DA-N	E. F. Peffer 519 E. Market St. 4-4551	CBS Blair	E. F. Peffer, Pres. E. Smith, Gen. & Coml. Mgr. V. Swan, Prog. Dir.	B. Hill, Prom. Mgr. M. Bey Greene, Chief Engr. World INS Westinghouse
KGDM-FM 1946	Ch. 225 (B) 92.9mc 1kw				REL
KSTN 1949	1420 1,000 DA-1	San Joaquin Bcstg. Co. Hotel Clark 4-4689	Hollingbery	Knox La Rue, Pres. D. M. Greene, Gen. Mgr.	Walter Lind, Prog. Dir. Ken Hollingsworth, Chief Engr. UP Collins
KWG 1921	1230 250	McClatchy Bcstg. Co. 612 East Market 5-5728	ABC Raymer	Eleanor McClatchy, Pres. Howard Bailey, Sta. Mgr.	James Longe, Prog. Mgr. Frank Nesmith, Chief Engr. Capitol AP, UP
KXOB 1947	1280 1,000 DA-N	Valley Bcstg. Co. 2013 Pacific Ave. 5-5896	MBS Pearson	Lincoln Dellar, Pres. Keith Pinion, Asst. Mgr. Herb Ferguson, Gen. Mgr.	Earle Russell, Prog. Dir. Ewald Berger, Chief Engr. INS, UP Raytheon
SUSANVILLE					
KSUE 1948	1240 250	Hallowell & McKahan Chestnut & Weatherlow 354-B	Cooke	Nolan Hallowell & J. E. McKahan, Partners William B. Murphy, Gen. & Prom. Mgr.	Zeke White, Coml. Mgr. Wayne H. Thornton Jr., Prog. Dir. Harold C. Houston, Chief Engr. World UP
TAFT					
KTKR 1948	1310 500-D	Taft Bcstg. Co. P. O. Box "WW" 5-3101	O'Connell	Kenneth Aitken, Pres., Gen. Mgr. & Prog. Dir. George Flansburg, Coml. Mgr.	James R. Welch, Chief Engr. World UP
TULARE					
KCOK 1945	1270 1,000 DA-N	Herman Anderson P. O. Box 119 6-2866	MBS Don Lee Western Radio	Herman Anderson, Pres. Sheldon Anderson, Gen. Mgr. R. A. Wegener, Coml. Mgr.	Paul Salvo, Prog. Dir. Dan Corrigan, Prom. Mgr. James C. Morrison, Chief Engr. UP Collins

DIRECTORY OF AM, FM, and TV STATIONS OF THE UNITED STATES

(Data corrected to December 6, 1949)
If executives or services for FM or TV stations are same as AM affiliate names are not repeated.

CALIFORNIA—(Continued)

City Call Letters Established	Chan. or Freq. Power	Name of Licensee Headquarters Address Telephone Number	Network Representative	Executive Personnel	Transc. Library News Service Transmitter Make	
TURLOCK						
KTUR 1949	1390 1,000 DA-N	Turlock Bcstg. Corp. P. O. Box 526 4-3430	O'Connell	W. N. Lindskoog, Pres. H. Ansell McMillen, Gen. & Coml. Mgr.	Rusty Simmons, Prog. Dir. Maxon B. Sayre, Chief Engr.	Lang-Worth UP Raytheon
VALLEJO						
KGWV 1947	1190 250-D	Calif.-Nev. Bcstg. Co. 3287 Sonoma Blvd. 3-5667	Moore	Hubert Q. Joucken, Pres. David McKay, Gen. Mgr. Ralph Stillings, Coml. & Prom. Mgr.	Victor Paulsen, Prog. Dir. William Roberts, Chief Engr.	UP
VENTURA						
KVEN 1948	1450 250	Coast Ventura Co. P. O. Box 1811 Miller 3-8875	Western Radio	Mort Werner, Gen. Mgr. Harry Engel, Coml. Mgr.	Dana Marble, Prog. Dir. Joe Thompson, Prom. Mgr. Dick Stanton, Chief Engr.	Capitol UP Collins SESAC Standard AP RCA
KVVC 1948	1590 1,000 DA-1	KVVC The Voice of Ventura County P. O. Box 1411 Miller 3-6185	KBS Grant	William H. Haupt, Pres. & Gen. Mgr. Larry S. Nicholson, Coml. & Prom. Mgr.	Ed Rock, Prog. Dir. Charles Farmer, Chief Engr.	Standard AP RCA
VICTORVILLE						
KVRV (CP) 1948	960 5,000-D	Francisco Rental Co.				
VISALIA						
KKIN 1946	1400 250	KKIN Inc. P. O. Box 1589 4-5811	Forjoe	Lyman Treaster, Gen. Mgr. & Chief Engr. Al Blain, Coml. & Prom. Mgr.	George Lindsey, Prog. Dir.	Standard UP
WATSONVILLE						
KHUB 1937	1340 250	Luther E. Gibson Atkinson Lane 1700		Luther E. Gibson, Pres. C. Tony Bernhard, Coml. Mgr.	George Grayson, Prog. Dir. Farrell A. Buckley, Chief Engr.	Lang-Worth AP RCA
YREKA						
KSYC 1947	1490 250	Siskiyou County Bcstg. Co. Inc. Lawrence Lane & South Oregon 624	Moore	E. G. Millbourn, Pres. H. C. Wardrip, Gen. Mgr. Jack R. Wagner, Sta. Mgr.	Jack Matranga, Prog. Dir. William Maginnis, Chief Engr.	World AP RCA
YUBA CITY						
KUBA 1948	1600 1,000-LS 500-N	Peachbowl Bcstrs. Inc. Box 309 1600	KBS Griffith Friedenburg	Chester V. Ulkom, Pres. & Gen. Mgr. Clyde L. Goodnight, Coml. Mgr.	John Rolih, Prog. Dir. Dave Harris, Prom. Mgr. Roy Swanson, Chief Engr.	Standard Capitol AP Gates

COLORADO

ALAMOSA						
KALC (CP) 1929	1490 250	San Luis Valley Bcstg. Co.	KBS	E. L. Allen, Pres. & Gen. Mgr. Lloyd Allen, Coml. Mgr. & Prog. Dir.	Charles Dynes, Prom. Mgr. Robert Paige, Chief Engr.	SESAC UP Gates
BOULDER						
KBOL 1947	1490 250	Boulder Radio KBOL Inc. 1617 Pearl St. 1430	Columbine Donahue	Herb Hollister, Pres. Russel Shafer, Gen & Coml. Mgr.	Ed Hinkle, Prog. Dir. Blair Dobbins, Chief Engr.	Lang-Worth Standard AP Collins
CANON CITY						
KRLN 1947	1400 250	Royal Gorge Bcstrs. Inc. 1615 Central Ave. 1100	KBS	Raymond M. Beckner, Pres. Gen. & Coml. Mgr. Guy C. Underhill, Prog. Dir.	O. J. Birdsong, Chief Engr.	Cole UP
COLORADO SPRINGS						
KRDO 1947	1240 250	Pikes Peak Bcstg. Co. Alta Vista Hotel Main 1125	Columbine	Joseph H. Rohrer, Pres. Gen. & Prom. Mgr. Harry Hoth, Coml. Mgr.	Jean Gitz, Prog. Dir. Bob Fitzmorris, Chief Engr.	Lang-Worth Cole Standard AP RCA
KVOR 1923	1300 1,000	Voice of the Rockies Inc. Exchange Nat'l Bank Bldg. Main 278	CBS Katz	James D. Russell, Pres. & Gen. Mgr. Everett Shupe, Sta. & Coml. Mgr. Bob Cooke, Prog. Dir.	Jack O'Brien, Prom. Mgr. Cozine Strang, Chief Engr.	World AP Western Electric
CRAIG						
KRAI 1948	1230 250	Northwestern Colorado Bcstg. Co. P. O. Box 1027 707		G. N. Winder, Pres. Richard A. Miner, Gen. Mgr.	Richard S. Fox, Coml. Mgr. Sidney C. Wood, Prog. Dir.	UP Western Electric
DENVER						
KFEL 1923	950 5,000 DA-1	Eugene P. O'Fallon Inc. Albany Hotel Alpine 4681	MBS Blair	Gene O'Fallon, Gen. Mgr. Frank Bishop, Mngng. Dir. W. H. Conklin, Coml. Mgr.	Dale Morgan, Prog. Dir. Thomas G. Morrissey, Chief Engr.	Associated Cole SESAC Standard INS Western Electric
KFEL-FM 1948	Ch. 247 (B) 97.3mc 6kw					
KGMI (CP) 1948	1430 1,000-D	Gifford Phillips 222 C. A. Johnson Bldg. Alpine 0441		Gifford Phillips, Pres. Harry C. Schnibbe, Gen. Mgr.	Richard Rutherford, Coml. Mgr.	Associated Gates
KLZ 1922	560 5,000 DA-1	Aladdin Radio & Television Co. Shirley-Savoy Hotel Main 4271	CBS Katz	Harry E. Huffman, Pres. Hugh B. Terry, V.P. & Gen. Mgr. Charles Roberts, Prog. Dir.	R. Main Morris, Coml. Mgr. John Connors, Prom. Mgr. Harvey Wehrman, Chief Engr.	Capitol Standard AP, INS Western Electric
KLZ-FM 1949	Ch. 231 (B) 94.1mc 5.3kw					

DA-N Directional Antenna, night only. FM's in italic.
DA-1 Directional Antenna, same pattern day and night.
DA-2 Directional Antenna, different pattern day and night.

*—Non-Commercial Station D—Day. N—Night. ST—Share Time. SH—Specified Hours.
U—Unlimited. CP—Construction Permit Issued. LS—Local Sunset.
L—Limited Time with Dominant Station. SA—Special Authorization.

City Call Letters Established	Chan. or Freq. Power	Name of Licensee Headquarters Address Telephone Number	Network Representative	Executive Personnel	Transc. Library News Service Transmitter Make
DENVER—(Continued)					
KMYR 1949	1340 250	KMYR Bcstg. Co. 1823 Stout St. Main 4101	Columbine	F. W. Meyer, Pres. A. G. Meyer, Gen. Mgr. Ed Koepke, Coml. Mgr.	World AP, UP Western Electric
KOA 1924	850 50,000	National Broadcasting Co. 1625 California St. Main 6211	NBC NBC Spot	Joseph H. McConnell, (NBC) Pres. Lloyd E. Yoder, Gen. Mgr. L. Berry Long Jr., Sales Mgr.	Thesaurus Associated AP, UP, INS General Electric
KOA-FM 1948	Ch. 239 (B) 95.7mc 43kw			 RCA
*KPOF	910 5,000-LS 1,000-N ST-KFKA	Pillar of Fire 1845 Champa St			
KTLN 1948	997 1,000-D	KTLN Bcstg. Co. Park Lane Hotel Race 4636	LBS Cooke	Jack Helling, Prog. Dir. Oran Kelly, Chief Engr.	Standard UP Gates
KVOD 1925	630 5,000 DA-1	Colorado Radio Corp. 1022 Midland Savings Bldg. Tabor 2291	ABC Free & Peters	W. D. Pyle, Pres. T. C. Ekrem, Sta. Mgr. Con Hecker, Coml. Mgr.	V. W. Corbett, Prog. Dir. T. C. Ekrem & W. D. Pyle Chief Engrs. Associated UP RCA
DURANGO					
KIUP 1935	1400 250	San Juan Bcstg. Co. 2800 Main Ave. 117	Clark	M. L. Cummins, Pres. R. E. O'Brien, Gen. Mgr. Ralph Bennett, Coml. Mgr.	Lee O'Brien, Prog. Dir. John Merrill, Prom. Mgr. Harold Hoffman, Chief Engr.
ENGLEWOOD					
KCRO (CP)	1380 1,000-D	Colorado Bcstg. Co. P. O. Box 115 Sunset 1-5001		B. C. Cunningham, Pres.	FESAC Capitol Lang-Worth INS
FORT COLLINS					
KCOL 1947	1410 1,000 DA-N	Northern Col. Bcstg. Co. 1600 La Porte Ave. 2600	Columbine Donahue	Herb Hollister, Pres. Douglas D. Kahle, Gen. Mgr. Dave Schlothauer, Coml. Mgr.	Jack Hitchcock, Prog. Dir. & Prom. Mgr. Harold Austin, Chief Engr.
FORT MORGAN					
KFTM 1949	1260 500-D	Ft. Morgan Bcstg. Co. P. O. Box 702 1000	Columbine	Robert H. Dolph, Pres. & Gen. Mgr. Rainsford J. Winslow, Coml. Mgr.	Frank Allen, Prog. Dir. Robert D. LaRue, Chief Engr.
GRAND JUNCTION					
KEXO 1948	1230 250	Voice of Western Colorado Inc. 2501 North Ave. 1230	Columbine	G. Spencer Grow, Pres. H. Abbott Tessman, Gen. & Prom. Mgr.	Harold Roper, Coml. Mgr. Robert A. Collins, Prog. Dir.
KFXJ 1926	920 1,000-LS 500-N	Western Slope Bcstg. Co Hillcrest Manor 1300	MBS Holman	R. G. & Charles Howell, Co-owners Rex Howell, Gen. Mgr.	Charles Howell, Prog. Dir. Charles Hay, Chief Engr.

GALLUCCI BROTHERS . . . and ASSOCIATES



J. G. GALLUCCI
President



N. T. GALLUCCI
Gen'l Manager



L. W. GALLUCCI
Sales Manager



JO GALLUCCI
Secretary

America's NUMBER ONE SPECIAL RADIO FEATURES

727 Meriden Road
Waterbury, Connecticut



P. O. Box 1224
Denver, Colorado

DIRECTORY OF AM, FM, and TV STATIONS OF THE UNITED STATES

(Data corrected to December 6, 1949)
If executives or services for FM or TV stations are same as AM affiliate names are not repeated.

COLORADO—(Continued)

City Call Letters Established	Chan. or Freq. Power	Name of Licensee Headquarters Address Telephone Number	Network Representative	Executive Personnel	Transc. Library News Service Transmitter Make
GREELEY					
KFKA 1921	1310 1,000 DA-N	Mid-Western Radio Corp. 620 8th Ave., 450		Francis Price, Pres. & Gen. Mgr. Jack Redus, Prog. Dir.	Harry Brewer, Chief Engr. Lang-Worth Cole, SESAC UP, W. E.
KYOU 1948	1450 250	Meroco Bcstg. Co. 2424 6th Ave. 3275	Columbine Donahue	Elwood H. Meyer, Pres. & Gen. Mgr. Frank Thomas, Coml. Mgr.	Jack Hull, Prog. Dir. Paul Emrich, Chief Engr. World AP Federal
LA JUNTA					
KOKO 1937	1400 250	Southwest Bcstg. Co. La Junta 42	Gene Grant Clark	Ellis P. Lupton, Pres. John M. Boyd, Gen. & Coml. Mgr.	Carma Haselmire, Prog. Dir. R. G. Ryan, Prom. Mgr. Loyd Wilson, Chief Engr. Lang-Worth UP Gates
LAMAR					
KLMR 1948	1340 250	Southeast Colorado Bcstg. Co. P. O. Box 232, 804	Columbine	Ralph E. Eaton, Pres. L. K. Christolear, Mngng. Dir. Don Stephens, Coml. Mgr.	Robert L. McGrath, Prog. Dir. D. E. Towne, Chief Engr. World AP General Electric
LONGMONT					
KLMO 1949	1050 250-D	Longmont Bcstg. Co. Box 827 1461		Jack P. Dubberley, Pres. & Gen. Mgr. Pellon R. Walker, Coml. Mgr.	James A. Hillis, Prog. Dir. Robert R. Blanchard, Chief Engr. Standard UP Gates
MONTROSE					
KUBC 1947	1240 250	Uncompaghere Bcstg. Co. P. O. Box 179 199	KBS Gene Grant	F. J. Hartman, Pres. George Cory, Gen. Mgr. Louis Benedict, Coml. Mgr.	Vern Friesen, Prog. Dir. Jack Glynn, Prom. Mgr. Don Anderson, Chief Engr. UP Raytheon
PUEBLO					
KCSJ 1947	590 1,000 DA-N	Star Bcstg. Co. 211 W. 5th St. 8522	MBS Columbine Taylor-Boroff	Frank Hoag Jr., Pres. Dale Scott, Gen. Mgr. Jack Cobb, Coml. Mgr.	Roy Borden, Prog. Dir. & Prom. Mgr. Gerald Kounter, Chief Engr. Maxson I. Bevans, Coml. Mgr. Associated Western Electric
KDZA 1947	1230 250	Pueblo Radio Co. Inc. 3011 Elizabeth 8551	LBS Cooke	Dee B. Crouch, Pres., Gen. Mgr., Prog. & Prom. Dir. & Chief Engr.	Cliff Hendrix, Prog. Dir. Howard Myers, Prom. Mgr. Willis C. Shanks, Chief Engr. Capitol Standard AP, Gates World, SESAC UP Gates
KGHF 1928	1350 5,000-LS 1,000-N DA	Colorado Bcstg. Co. Inc. Pueblo Savings & Trust Co., Bldg., 3877	ABC McGillvra	Gifford Phillips, Pres. Robert D. Ellis, Gen. Mgr. Kenneth C. Russell Coml. Mgr.	Vir N. James, Owner & Gen. Mgr. Ted A. Kerndt, Coml. Mgr. Henry Long, Prog. Dir. Don Perkins, Prom. Mgr. T. L. Kidd, Chief Engr. UP RCA
SALIDA					
KVRH 1948	1340 250	Vir N. James Salida 30	KBS Columbine Clark	Vir N. James, Owner & Gen. Mgr. Ted A. Kerndt, Coml. Mgr. Henry Long, Prog. Dir.	Don Perkins, Prom. Mgr. T. L. Kidd, Chief Engr. UP RCA
STERLING					
KGEK 1925	1230 100-D	Elmer G. Beehler Fleming Rd. 1175	KBS Clark	Elmer G. Beehler, Pres., Gen. Mgr. & Chief Engr.	Al. Ross, Coml. & Prom. Mgr. & Prog. Dir. MacGregor Cole UP
TRINIDAD					
KCRT 1946	1240 250	Mel-Bert Bcstg. Co. P. O. Box 772 338	KBS Columbine	Herman L. Corley, Pres. & Chief Engr. Ernest M. Cooper, Gen. Mgr.	Millie J. Coyle, Prog. Dir. Rembert O. Coyle, Coml. Mgr. Lang-Worth UP Gates
KSFT 1946	1280 1,000-LS 500-N	Trinidad Bcstg. Corp. P. O. Box 787 414	MBS Forjoe	Ellis P. Lupton, Pres. Paul D. George, Gen. & Coml. Mgr.	Calvin A. Watson, Prog. Dir. & Prom. Mgr. Lloyd L. Wilson, Chief Engr. UP Gates
WALSENBURG					
KPHC 1948	1450 250	Walsenburg Bcstg. Corp. 10th & Main Sts. 79	Columbine Clark	Thomas G. Banks Jr., Pres. Harold G. Reed, Gen. & Coml. Mgr.	Bette Lessar, Prog. Dir. John W. Fical, Chief Engr. UP Tempco

CONNECTICUT

BRIDGEPORT					
WCC 1928	800 1,000-LS DA-1 500-N	Yankee Network Inc. Stratfield Hotel 8-1121	MBS Yankee Petry	Dickens J. Wright, Gen. Mgr. Charles W. Parker, Coml. Mgr. James W. Evans, Prog. Dir.	John R. Montgomery, Prom. Mgr. Winthrop Crawford, Chief Engr. Standard AP
WLIZ 1947	1300 1,000-D	Bridgeport Bcstg. Co. 114 State St. 5-4144	Taylor-Boroff	William Elliott, Pres., Gen. & Prom. Mgr. Emanuel S. Slotnick, Coml. Mgr.	Wallace B. Dunlap, Prog. Dir. Sol Robinson, Sales Mgr. Ralph Winquist, Chief Engr. Thesaurus AP Raytheon
WNAB 1941	1450 250	WNAB Inc. 991 Broad St. 3-3112	ABC Conn.-State Rambeau	Harold Thomas, Pres. & Chief Engr. Levon Thomas, Gen. Mgr.	Jack Dahlby, Prog. Dir. Jean O'Shea, Prom. Mgr. William Rankin, Coml. Mgr. UP Collins
BRISTOL					
WBIS 1948	1440 500-D	The Bristol Bcstg. Corp. 183 Main St. 9265		Frederick W. Beach, Pres.	Fay Clark, Gen. Mgr. Standard UP Gates
DANBURY					
WFIR (CP) 1947	550 1,000-LS 500-N DA	Fairfield Bcstg. Corp.		Robert C. Doran, Pres. John P. Previdi, Gen. Mgr. J. Thomas Mathers, Coml. Mgr.	Jerry Arthur, Prog. Dir. & Prom. Mgr. Lawrence L. Bailey, Chief Engr. World UP
WLAD 1947	800 250-D	Berkshire Bcstg. Corp. 207 Main St. 8-0580		Robert C. Doran, Pres. John P. Previdi, Gen. Mgr. J. Thomas Mathers, Coml. Mgr.	Jerry Arthur, Prog. Dir. & Prom. Mgr. Lawrence L. Bailey, Chief Engr. World UP
GREENWICH					
WGCH-FM 1948	Ch. 240(A) 95.9mc 0.34kw	Greenwich Bcstg. Corp. 25 Greenwich Ave. 8-4200		Walter S. Lemmon, Pres. William B. MacRae, Gen. Mgr.	Jack Hines, Prog. Dir. Thomas F. Middleton Jr., Chief Engr. Associated UP Raytheon
HARTFORD					
WCCC 1946	1290 500-D	Greater Hartford Bcstg. Hotel Bond 5-6848		William M. Savitt, Pres. Max M. Savitt, Treas. Syd Byrnes, Prog. Dir.	William Calvert, Prom. & Sales Mgr. John Rameika, Chief Engr. UP General Electric
WDRC 1922	1360 5,000 DA-1	Conn. Bcstg. Co. 750 Main St. 7-1188	CBS New England Raymer	Franklin M. Doolittle, Pres. Walter B. Haase, Sta. Mgr. William F. Malo, Coml. Mgr.	Harvey Olson, Prog. Mgr. Italo A. Martino, Chief Engr. UP Western Electric
WDRC-FM 1939	Ch. 229 (B) 93.7mc 7kw				REL
WONS 1935	1410 5,000 DA-2	Yankee Network Inc. 54 Pratt St. 7-9131	MBS Yankee	William O'Neil, Pres. Robert L. Kennett, Gen., Coml. & Prom. Mgr.	Ralph Klein, Prog. Dir. Rogers Holt, Chief Engr. Standard UP Westinghouse

DA-N Directional Antenna, night only. FM's in italic.
DA-1 Directional Antenna, same pattern day and night.
DA-2 Directional Antenna, different pattern day and night.

*-Non-Commercial Station D-Day. N-Night. ST-Share Time. SH-Specified Hours.
U-Unlimited. CP-Construction Permit Issued. LS-Local Sunset.
L-Limited Time with Dominant Station. SA-Special Authorization.



**WTIC
DOMINATES
THE PROSPEROUS
SOUTHERN NEW ENGLAND
MARKET**

**WTIC
DOMINATES
THE PROSPEROUS
SOUTHERN NEW ENGLAND
MARKET**

Paul W. Morency, Vice-Pres.—Gen. Mgr.

Walter Johnson, Asst. Gen. Mgr.—Sales Mgr.

WTIC's 50,000 WATTS REPRESENTED NATIONALLY BY WEED & CO.

DIRECTORY OF AM, FM, and TV STATIONS OF THE UNITED STATES

(Data corrected to December 6, 1949)
If executives or services for FM or TV stations are same as AM affiliate names are not repeated.

CONNECTICUT—(Continued)

City Call Letters Established	Chan. or Freq. Power	Name of Licensee Headquarters Address Telephone Number	Network Representative	Executive Personnel	Transc. Library News Service Transmitter Make
HARTFORD—(Continued)					
WTHT 1936	1230 250	The Hartford Times 555 Asylum St. 2-0237	ABC Conn-State McKinney	Francis S. Murphy, Pres. C. Glover DeLaney, Gen. Mgr. L. R. Schoenfeld, Coml. Mgr.	Phillip Becker, Prog. Dir. C. S. Masini, Chief Engr. Standard AP, Reuters RCA
WTHT-FM 1948	Ch. 291 (B) 106.1mc 5.6kw			 General Electric
WTIC 1925	1080 50,000 DA-N	Travelers Bcstg. Service Corp. 26 Grove St. 2-3181	NBC New England Weed	Paul W. Morency, V. P. & Gen. Mgr. Walter Johnson, Asst. Gen. Mgr. in charge of Sales Irwin Cowper, Asst. Sales Mgr. Paul Lucas, Prog. Mgr.	Leonard J. Patricelli, Prog. Mgr. Bernard Mullins, Dir. of Pub. Rel. Herman D. Taylor, Chief Engr. Lang-Worth AP, INS Westinghouse
WTIC-FM 1940	Ch. 243 (B) 96.5mc 8kw			 REL
MERIDEN					
WMMW 1947	1470 1,000-D	Silver City Crystal Co. Inc. Palace Bldg. 5-5747		Carl A. Schultz, Pres. & Gen. Mgr. Carl W. Schultz, Sta. Mgr. G. A. Kruttschnitt, Coml. Mgr.	John Zane, Prog. Dir. James Woodburn, Prom. Mgr. Gabriel Langfelder, Chief Engr. Lang-Worth World UP
WMMW-FM 1948	Ch. 239 (B) 95.7mc 20kw			 Gates
MIDDLETOWN					
WCNX 1948	1150 500-D	Middlesex Bcstg. Co. 462 Main St. 5821	Friedenberg	Richard J. O'Brien & William J. O'Brien, Mngng. Dirs.	Ernest Watso, Prog. Dir. Lou Brooks, Prod. Chief UP
NEW BRITAIN					
WHAY 1949	910 5,000 DA-2	Central Conn. Bcstg. Co. 22 Grove Hill 3-2721	Radio Reps.	Hillis W. Holt, Gen. Mgr. & Chief Engr. Frederick E. Bieber, Sales Mgr.	William T. Walker, Prog. Dir. Lang-Worth Capitol UP RCA
WKNB 1946	840 1,000-D	The New Britain Bcstg. Co. ?13 Main St. 3-3803	Forjoe	Julian Gross, Pres. & Gen. Mgr. Peter B. Kenney, Coml. Mgr.	Bernard Moore, Prog. Dir. Associated AP Raytheon
WFHA(FM) 1946	Ch. 279 (B) 103.7mc 20kw	(WKNB, AM Affiliate)		Lewis G. House, Tech. Supvr. General Electric
NEW HAVEN					
WAVZ 1947	1260 1,000-D	WAVZ Bcstg. Corp. 152 Temple St. 7-0171		Victor W. Knauth, Pres. Daniel Kops, V. P. & Gen. Mgr.	George J. Peters, Coml. Mgr. Richard E. Barrett, Prog. Dir. Ernest S. Gellman, Chief Engr. World UP Raytheon

DA-N Directional Antenna, night only. FM's in italic.
DA-1 Directional Antenna, same pattern day and night.
DA-2 Directional Antenna, different pattern day and night.

*-Non-Commercial Station D-Day. N-Night. ST-Share Time. SH-Specified Hours.
U-Unlimited. CP-Construction Permit Issued. LS-Local Sunset.
L-Limited Time with Dominant Station. SA-Special Authorization.

..... In New Haven It's

AM
FM
1260 KC

WAVZ

1000 WATTS
AN
INDEPENDENT
STATION

THE NEWSPAPER OF THE AIR

SOMETHING NEW IN RADIO THAT KEEPS LISTENERS IN THE GREATER NEW HAVEN AREA AT THEIR SETS FOR THE LOCAL AND NATIONAL NEWS AS IT COMES TO LIFE ON THE NEWSPAPER OF THE AIR.

RESULTS COUNT AND WE HAVE THE SUCCESS STORIES!

THE WAVZ BROADCASTING CORP., 152 TEMPLE ST., NEW HAVEN, CONN.

City Call Letters Established	Chan. or Freq. Power	Name of Licensee Headquarters Address Telephone Number	Network Representative	Executive Personnel	Transc. Library News Service Transmitter Make
NEW HAVEN—(Continued)					
WAVZ-FM 1948	Ch. 236 (B) 95.1mc 20kw			 Gates
WBIB-FM 1947	Ch. 264 (B) 100.7mc 20kw	Colony Bcstg. Corp. 157 Church St. 5-5413	Continental-FM	Samuel Botwinik, Pres. Sol Chain, Gen. & Coml. Mgr. AP General Electric
WELI 1935	980 1,000 DA-N	Conn. Radio Foundation Inc. 221 Orange St. 8-1133	ABC Headley-Reed	H. C. Wilder, Pres. Richard W. Davis, Gen. Mgr. E. H. Schweitzer, Coml. Mgr. Lang-Worth UP RCA
WELI-FM 1948	Ch. 300 (B) 107.9mc 20kw			
WNHC 1944	1340 250	Elm City Bcstg. Corp. 1110 Chapel St. 8-0196	Conn. State Katz	Patrick J. Goode, Pres. James T. Milne, Gen. Mgr. Vincent Callanan, Coml. & Prom. Mgr. Standard AP Collins
WNHC-FM	Ch. 256 (B) 99.1mc 19.5kw			
WNHC-TV 1948	Ch. 6 82-88 mc 957 kw-aur. 1.82 kw-vis.		ABC, NBC, CBS & DuMont	Jean O'Brien, Prog. Dir. General Electric DuMont
NEW LONDON					
WNLC 1936	1490 250	The Thames Bcstg. Corp 281 State St. 2-4365	MBS Yankee	Roderick L. Morey, Pres. Gerald J. Morey, Gen. & Coml. Mgr. & Chief Engr. UP Collins
WNLC-FM 1947	Ch. 258(B) 99.5mc 20kw			
NORWALK					
WNLK 1947	1350 500-DA-N	Norwalk Bcstg. Co. Main & Wall Sts. 62542	McGillvra	Benjamin Ginzburg, Pres., Gen. & Coml. Mgr. Milton Warren, Prog. Dir. Associated UP Raytheon
NORWICH					
WICH 1946	1400 250	Eastern Conn. Bcstg. Co. 91 Main St. 345		John Deme, Pres. & Gen. Mgr. Noel C. Breault, Coml. Mgr. World AP Raytheon
STAMFORD					
WSTC 1941	1400 250	Western Conn. Bcstg. Co 270 Atlantic St. 4-7575	ABC Conn.-State McKinney	Kingsley Gillespie, Pres. Julian Schwartz, Gen. Mgr. Wharton Ford, Coml. Mgr. World AP RCA
WSTC-FM 1947	Ch. 244 (A) 96.7mc 0.65kw			
TORRINGTON					
WLCR 1948	990 1,000-D	Litchfield County Radio Corp. 23 Main St. 4173	Sears & Ayer	J. Richard Dobbins, Pres. James E. Cipriano, Gen. Mgr. John Ward, Coml. Mgr. World UP RCA
WTOR 1948	1490 250	Torrington Bcstg. Co. 93 Main St. 4181	Conn.-State Continental	Joseph R. Schifini, Pres. Gerardo T. Schifini, Gen. Mgr. Frederick R. Menzies, Coml. Mgr. Richard C. Kilbourn, Prog. Dir. Joseph J. Pasakarnis, Chief Engr. INS Gates
WATERBURY					
WATR 1934	1320 1,000 DA-1	The WATR Co., Inc. 440 Meadow St. 3-5161	ABC Conn.-State Rambeau	Harold Thomas, Pres. S. R. Elman, Gen. & Coml. Mgr. UP Collins
WBRV 1934	1590 5,000 DA-1	American-Republican Inc. 136 Grand St. 3-1125	CBS Avery-Knodel	William J. Pape, Pres. J. Maxim Ryder, Mgr. & Prom. Mgr. World AP RCA
WWCO 1946	1240 250	Mattatuck Bcstg. Co. 119 West Main St. 45141	MBS Yankee	Milton H. Meyers, Pres. & Gen. Mgr. Ford Billings, Coml. Mgr. Thesaurus AP Collins

WICH
FULL TIME
1400 KC 250 W
NORWICH

JOHN DEME
PRES. & GEN. MGR.

EASTERN
CONNECTICUT
BROADCASTING
COMPANY

NOEL BREAUlt
SALES MGR.

We do not cover all of Connecticut, but we DO cover* NORWICH and most of New London county . . . 1948 retail sales \$129,364,000.00.

Have you been bypassing this market? Remember you can BUY it on a station that has ONE rate both day and night.

*You'd be surprised at our coverage in New London.

DIRECTORY OF AM, FM, and TV STATIONS OF THE UNITED STATES

*(Data corrected to December 6, 1949)
If executives or services for FM or TV stations are same as AM affiliate names are not repeated.*

DELAWARE

City Call Letters Established	Chan. or Freq. Power	Name of Licensee Headquarters Address Telephone Number	Network Representative	Executive Personnel	Transc. Library News Service Transmitter Make	
DOVER						
WDOV 1948	1410 1,000-D	William Courtney Evans Bradford & Loockerman Sts. 5816	McGillvra	William Courtney Evans, Pres. A. Harry Zoog, Gen. & Coml. Mgr.	Elizabeth Evans, Prog. Dir. & Prom. Mgr. Russell F. Lee, Chief Engr.	Capitol AP Gates
WILMINGTON						
WAMS 1948	1380 1,000 DA-1	Wilmington Tri-State Bcstg. Co. Inc. 414 French 4-8881	MBS	Frank S. Carrow, Pres. Emerald Dalton, Gen. Mgr.	W. S. Ewing, Coml. Mgr. Herbert Eckstein, Chief Engr.	AP Western Electric
WAMS-FM 1948	Ch. 241 (B) 96.1mc 20kw					Lang-Worth Standard
WDEL 1922	1150 5,000 DA-2	WDEL Inc. 10th & King Sts. 7268	NBC Meeker	Clair R. McCollough, Sta. Exec. J. Gorman Walsh, Gen. Mgr. J. Robert Gulick, Gen. Sales Mgr.	Harvey Smith, Prog. Dir. Richard Aydelotte, Prom. Mgr. J. E. Mathiot, Tech. Dir.	World UP
WDEL-FM (CP)	Ch. 229 (B) 93.7mc 20kw					
WDEL-TV 1949	Ch. 7 174-180mc. .5kw aur.; 1kw vis.			James Adshead, Prog. Dir.		
WILM 1925	1450 250	Delaware Bcstg. Co. 920 King St. 4-7771	ABC Bolling	Ewing B. Hawkins, Pres., Gen. & Coml. Mgr. Frank Gallagher, Prog. Dir.	Robert J. McFann, Prom. Mgr. H. Edwin Kennedy, Chief Engr.	Lang-Worth AP Western Electric
WILM-FM (CP)	Ch. 258 (B) 99.5mc 20kw					
WTUX 1949	1290 500-D	Port Frere Bcstg. Co. Inc. 1326 Market St. 5-8821	Forjoe	Gordon K. MacIntosh, Pres. & Prog. Dir. Howard R. Robinson, Gen. Mgr.	Sidney Schulman, Coml. Mgr. Wayne Neuhaus, Chief Engr.	World AP Raytheon

DISTRICT OF COLUMBIA

WASHINGTON

WARL (AM-FM)		(See Arlington, Va. listing)				
WASH (FM) 1947	Ch. 246 (B) 97.0mc 15kw	Everett L. Dillard 1319 F St. NW District 1356	Continental	Everett L. Dillard, Pres. & Gen. Mgr. Hudson Eldridge, Coml. Mgr. & Prog. Dir.	Don Hoefler, Chief Engr.	Standard TF RCA
WBCC (AM-FM)		(See Bethesda-Chevy Chase, Md.)				
WBUZ (FM)		(See Bradbury Heights, Md. listing)				
WCFM (FM) 1948	Ch. 258 (B) 99.5mc 20kw	Cooperative Bcstg. Assn. 1120 Connecticut Ave. NW REpublic 8688	Continental	George A. Bernstein, Gen. Mgr. Louis Aiken Jr., Coml. Mgr.	Sid Slappey, Prog. Dir. Warren E. McDowell, Chief Engr.	Associated World UP Federal
WEAM		(See Arlington, Va. listing)				
WFAX		(See Falls Church, Va. listing)				
WGAY (AM-FM)		(See Silver Spring, Md. listing)				
WHIP (FM)		(See Silver Spring, Md. listing)				
WHMB (FM) (CP)	Ch. 262 (B) 100.3mc 19kw	Theodore Granik				
WINX 1940	1340 250	Banks Independent Bcstg. Co. 8th & Eye Sts. NW REpublic 8000	King	William A. Banks, Pres. & Gen. Mgr. Dolly Banks, Asst. Gen. Mgr. Charles Trippe, Coml. Mgr.	Lynn Wilson, Prog. Dir. Ralph Cannon, Chief Engr.	AP, UP RCA
WMAL 1925	630 5,000 DA-1	Evening Star Bcstg. Co. 724 14th St. NW NAtional 5400	ABC ABC Spot	S. H. Kauffman, Pres. K. H. Berkeley, V. P. & Gen. Mgr. Ben B. Baylor Jr., Coml. Mgr.	Charles Kelly, Prog. Dir. Howard Bell, Prom. Mgr. Frank Harvey, Chief Engr.	Standard World AP, UP RCA
WMAL-FM 1948	Ch. 297 (B) 107.3mc 20kw					
WMAL-TV 1947	Ch. 7 174-180mc 12kw aur.; 22kw vis.					
WOIC (TV) 1949	Ch. 9 186-192mc 14.4kw aur.; 27.3kw vis.	Bamberger Bcstg. Service Inc. Barr Bldg. STERling 0600	CBS, MBS WOR Sales	Eugene S. Thomas, Gen. Mgr. William D. Murdock, Coml. Mgr. James S. McMurry, Prog. Dir.	John F. Hardesty, Dir. of Adv. & Special Events Robin D. Compton, Chief Engr.	CBS Films World UP RCA
WOL 1924	1260 5,000 DA-I	Cowles Bcstg. Co. 1627 K St. NW MEtropolitan 0010	MBS Katz	Gardner Cowles, Pres. Phil Hoffman, V. P., Gen. & Sales Mgr.	Stephen J. McCormick, Prog. Dir. & Prom. Mgr. Harold Reed, Chief Engr.	Associated AP, UP
WOL-FM 1948	Ch. 254 (B) 98.7mc 20kw					

DA-N Directional Antenna, night only. FM's in italic.
DA-1 Directional Antenna, same pattern day and night.
DA-2 Directional Antenna, different pattern day and night.

*—Non-Commercial Station D—Day. N—Night. ST—Share Time. SH—Specified Hours.
U—Unlimited. CP—Construction Permit Issued. LS—Local Sunset.
L—Limited Time with Dominant Station. SA—Special Authorization.

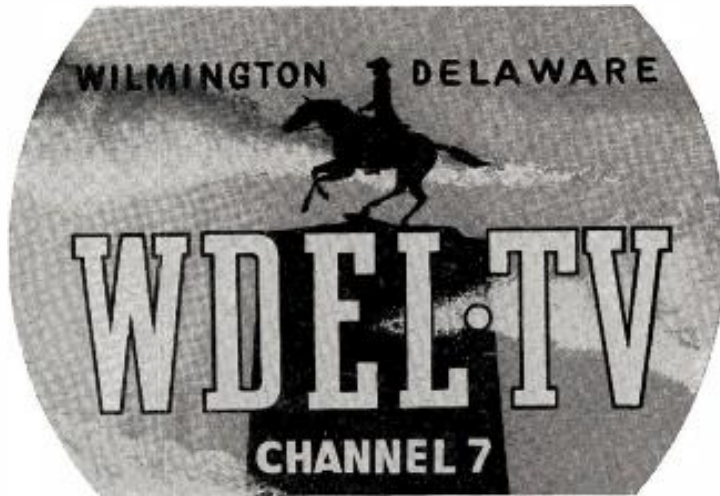

IDENTIFICATION

Confident in what lies ahead
Pledged to the People

In the heart of Wilmington there is a statue of Caesar Rodney, the Delaware Colonial patriot who had faith in the future and served the people well. WDEL-TV, in the same spirit, has established the first television station in Delaware, using a silhouette of Caesar Rodney's statue as its station identification.

WDEL-TV is the only TV station located in this prosperous trade area. A fast-growing audience appreciates WDEL-TV's clearer picture, good local programming, and NBC, DuMont and other network shows. Consider the importance of including this rich market in your TV sales planning.

It was Caesar Rodney who, in 1776, after a furious night-long ride on horseback, arrived in Philadelphia just in time to cast the deciding vote for the Colonies' independence.

Represented by

ROBERT MEEKER ASSOCIATES

Chicago

San Francisco

New York

Los Angeles



A
STEINMAN
STATION



DIRECTORY OF AM, FM, and TV STATIONS OF THE UNITED STATES

*(Data corrected to December 6, 1949)
If executives or services for FM or TV stations are same as AM affiliate names are not repeated.*

DISTRICT OF COLUMBIA—(Continued)

City Call Letters Established	Chan. or Freq. Power	Name of Licensee Headquarters Address Telephone Number	Network Representative	Executive Personnel	Transc. Library News Service Transmitter Make	
WASHINGTON—(Continued)						
WOOK WPIK WQQW 1947	(See Silver Spring, Md., listing) (See Alexandria, Va., listing) 570 1,000-D	Radio Station WQQW Inc. 1125 Vermont Ave., NW Executive 8876	Rambeau	Morris Rodman, Pres. M. Robert Rogers, V. P. & Gen. & Prom. Mgr. Robert B. Martin, Chief Engr.	Perry Walders, Coml. Mgr. Pierson Underwood, Prog. Dir.	Associated AP Collins
WQQW-FM 1948	Ch. 278 (B) 103.5mc 19kw					
WRC 1923	980 5,000 DA-N	National Bcstg. Co. Trans-Lux Bldg. REpublic 4000	NBC NBC Spot	Joseph H. McConnell, Pres. (NBC) Frank M. Russell, V. P. William R. McAndrew, Gen. Mgr. Eugene Juster, Dir. of Prog. Thomas D. Geoghegan, Prom. Mgr.	George Y. Wheeler, Asst. to Gen. Mgr. George H. Sandefer, Bus. Mgr. Mahlon A. Glascock, Coml. Mgr. Donald Cooper, Chief Engr.	Thesaurus Standard Associated AP, UP, INS RCA
WRC-FM 1947	Ch. 230 (B) 93.9mc 20kw					
WNBW (TV) 1947	Ch. 4 66-72mc 10.5kw aur.; 20.5kw vis.	(WRC, AM Affiliate)				
WTOP 1932	1500 50,000 DA-2	WTOP Inc. Warner Bldg. METropolitan 3200	CBS Radio Sales	Philip L. Graham, Pres. John S. Hayes, V.P. & Gen. Mgr. George Hartford, Dir. of Sales	Hazel Markel, Dir. of Prog. Services Cody Pfenstiehl, Dir. of Press Inf. & Prom. Clyde Hunt, Chief Engr.	Lang-Worth AP, UP, INS Western Electric
WTOP-FM 1938	Ch. 242 (B) 96.3mc 20kw					
WTTG (TV) 1945	Ch. 5 76-82mc 10.5kw aur.; 17.5kw vis.	Allen B. DuMont Labs. Inc. 12th & E Sts. NW STERling 5300	DuMont Net DuMont	Allen B. DuMont, Pres. Walter Compton, Gen. Mgr. Harold Sheffers, Coml. Mgr.	Roger M. Coelos, Prog. Dir. M. M. Burleson, Chief Engr.	REL Associated TP DuMont
WWDC 1941	1450 250	Capital Bcstg. Co. 1000 Connecticut Ave. NW NATIONAL 7203	Forjoe	Joseph Katz, Pres. Ben Stro'se, Gen. Mgr. Herman Paris, Coml. Mgr.	Norman Reed, Prog. Dir. Irving Lichtenstein, Prom. Mgr. Ross H. Beville, Chief Engr.	Standard Capitol AP, UP Western Electric
WWDC-FM 1947	Ch. 266 (B) 101.1mc 20kw		Transit Radio	Helen Mobberley, Coml. Mgr.		

DA-N Directional Antenna, night only. FM's in italic.
DA-1 Directional Antenna, same pattern day and night.
DA-2 Directional Antenna, different pattern day and night.

*—Non-Commercial Station D—Day N—Night ST—Share Time. SH—Specified Hours.
U—Unlimited. CP—Construction Permit Issued. LS—Local Sunset.
L—Limited Time with Dominant Station. SA—Special Authorization.

FOR SPORTS, NEWS & SWEET MUSIC
— FOR SALES IMPACT! —



A CLEAR CHANNEL INDEPENDENT STATION ON 730 KC
WASHINGTON, D. C.

AND ALEXANDRIA, VIRGINIA

BUSINESS OFFICE: VIRGINIA THEATER BLDG., ALEXANDRIA, VA.

HOWARD B. HAYES, President

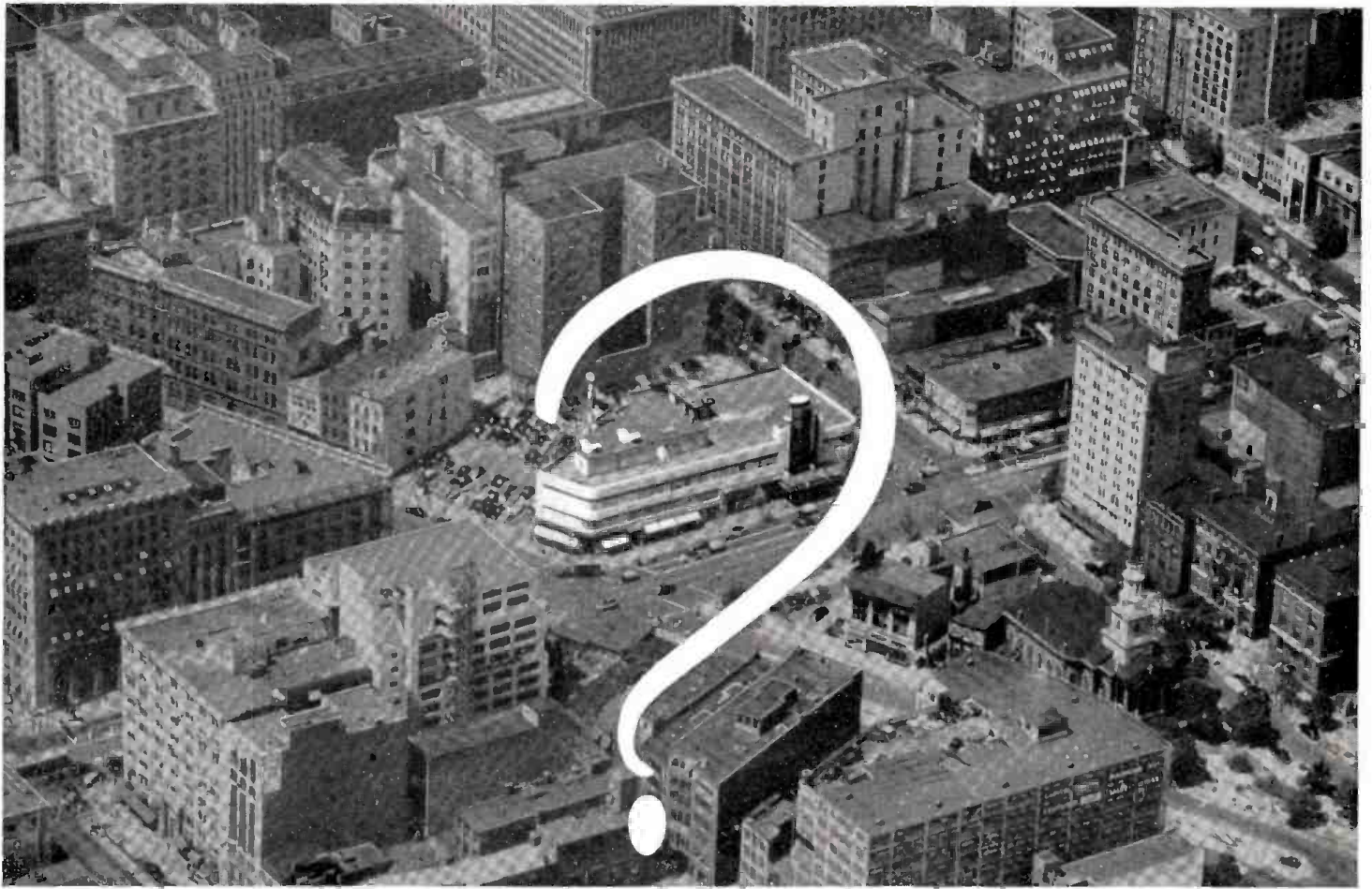

Washington, D. C.!

... is a major buying market, not merely a world capital of parks, monuments and government buildings.

WRC is the dominant selling voice in this area of over 1,400,000.

Success stories, low cost-per-listener facts and hard-hitting sales results are available on WRC if you have an interest in the Washington market. Programs and spots with the interesting knack of SELLING, day in and day out, are worth more than passing consideration. Things have changed in the nation's capital ... in a big way. Take another look at this picture and another look at your market problems. They both represent dollar volume in Washington.

Sales representatives of WRC or NBC Spot Sales can tell you the NEW story of Washington and WRC.

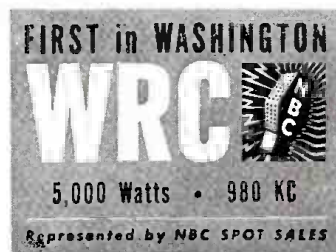

NATIONAL BROADCASTING COMPANY

DIRECTORY OF AM, FM, and TV STATIONS OF THE UNITED STATES

*(Data corrected to December 6, 1949)
If executives or services for FM or TV stations are same as AM affiliate names are not repeated.*

FLORIDA

City Call Letters Established	Chan. or Freq. Power	Name of Licensee Headquarters Address Telephone Number	Network Representative	Executive Personnel	Transc. Library News Service Transmitter Make	
BELLE GLADE						
WSWN 1947	900 1,000-D	Seminole Bcstg. Co. Box 355 2063	Ashcroft & Banninger	Tom Watson Jr., Pres. & Gen. Mgr. (Mrs.) Mary Foy, Coml. Mgr.	Tom Lloyd, Prog. Dir. C. S. Clemens, Chief Engr.	Associated World UP, Gates
BRADENTON						
WDHL 1946	1490 250	Manatee Bcstg. Co. Memorial Pier 37-561	KBS	L. E. Jacobson, Pres. & Gen. Mgr.	Atch McCabe, Coml. & Prom. Mgr. Edwin Hill, Chief Engr.	Associated Gates AP
CLEARWATER						
WCLE 1946	880 1,000-D	Clearwater Bcstg. Co. Whitcomb Bldg. 3-2373	Holman	Houston Cox Jr., Gen. Mgr.		Associated AP
WTAN 1947	1340 250	Clearwater Radio Bcstrs. Inc. P. O. Box 1109, 33084	KBS McGillvra	Otis E. Pruitt, Pres. Clifford A. McKay, (acting) Gen. & Coml. Mgr.	Louis Harnold Falconnier, Prog. Dir. & Prom. Mgr. Arthur Betts, (acting) Chief Engr.	World UP Collins
CORAL GABLES						
WTTT 1946	1490 250	Atlantic Shores Bcstg. 350 Aragon Ave. 83-4683	McGillvra	David H. Freedman, Gen. Mgr. Edwin C. Derryberry, Coml. Mgr.	Milt Mitler, Prom. Mgr. David T. Golden, Sales Mgr.	Associated UP
WVCG 1948	1070 1,000-D	Peninsular Bcstg. Corp. 223 Aragon Ave. 48-7411	Ashcroft & Banninger	George W. Thorpe, Pres. & Gen. Mgr. Edward S. Gaylor, Prog. Dir.	Barbara L. Binns, Prom. Mgr. Lawrence Mennitt, Chief Engr.	Associated AP RCA
CRESTVIEW						
WCNU 1949	1010 1,000-D	Gulf Shores Bcstg. Co. P. O. Box 518 3511	KBS	Cyril W. Reddoch, Pres. John B. McCrary, Gen. Mgr. John French, Coml. Mgr.	Sam Townsend, Prog. Dir. Grady O'Neal, Prom. Mgr. Franklin Prestwood, Chief Engr.	Lang-Worth AP Gates
DAYTONA BEACH						
WMFJ 1935	1450 250	W. Wright Esch 444 N. Beach St. 6491	ABC McGillvra	W. Wright Esch, Owner Billee E. Esch, Gen. Mgr. Ray Clancy, Sta. Mgr.	John S. Pitts, Coml. Mgr. Webster K. Ellenwood, Chief Engr.	Lang-Worth INS RCA
WNDB 1948	1150 1,000-D	News-Journal Corp. Daytona Beach 2-3601	Perry	Jerry Stone, Gen. & Prom. Mgr. John H. Cummins, Coml. Mgr.	W. H. Trimble, Prog. Dir. Fred F. Moore, Chief Engr.	Standard World AP
WNDB-FM 1947	Ch. 233 (B) 94.5mc 8.5kw					General Electric
WROD 1947	1340 250	Daytona Beach Bcstg. Wilder Blvd. & S. Beach 4626	MBS	E. J. Sperry, Pres. & Gen. Mgr. R. Y. Huffman, Coml. Mgr.	Suzanne Baldwin, Prog. Dir. Lyman W. Menard, Chief Engr.	Associated UP Collins

DA-N Directional Antenna, night only. FM's in italic.
DA-1 Directional Antenna, same pattern day and night.
DA-2 Directional Antenna, different pattern day and night.

*-Non-Commercial Station D-Day, N-Night, ST-Share Time, SH-Specified Hours.
U-Unlimited, CP-Construction Permit Issued, LS-Local Sunset.
L-Limited Time with Dominant Station, SA-Special Authorization.

VACATION LAND SUMMER AND WINTER

WMFJ

FIRST RADIO STATION IN

DAYTONA BEACH, FLA.

Affiliated with the American Broadcasting Company

JOSEPH HERSHEY MCGILLVRA, INC.,
NATIONAL REPRESENTATIVES

ROBERT S. KELLER,
AGENCY COORDINATOR

City Call Letters Established	Chan. or Freq. Power	Name of Licensee Headquarters Address Telephone Number	Network Representative	Executive Personnel	Transc. Library News Service Transmitter Make	
DADE CITY (CP)	1310 1,000-D	Seminole Bcstg. Co.				
DELAND WDLF 1948	1490 250	DeLand Bcstg. Co. 220 E. Hubbard Ave. 1490	MBS	Lyle Van Valkenburg, Pres. James H. Knox, Gen. & Coml. Mgr.	Robert Walton, Prog. Dir. & Prom. Mgr. Loren Mickle, Chief Engr.	Associated AP Collins
FT. LAUDERDALE WFTL 1948	1400 250	Gore Pub. Co. 100 E. Las Olas Blvd. 3-2511 (WFTL AM Affiliate)	Sears & Ayer	R. H. Gore Sr., Pres. E. T. Gore, Gen. Mgr. Paul Taylor, Prog. Dir.	Carter Holmes, Prom. Mgr. Howard Sheets, Chief Engr. J. W. Dickey, Exec. V. P.	World UP General Electric
WGOR (FM) 1950	Ch. 293 (B) 106.5mc 9.26kw					
WSLN (CP)	1580 250-D	Geo. D. Gartland				
FORT MYERS WINK 1939	1240 250	Fort Myers Bcstg. Co. 54 E. First St. 818	CBS, KBS Cooke	Arthur B. McBride, Pres. Arthur B. McBride Jr., Exec. V. P. August J. Bauer, Gen., Coml. & Prog. Mgr.	E. Whitfield, Prom. Mgr. John Vance Jr., Chief Engr. AP RCA
FORT PIERCE WIRA 1946	1400 250	Indian River Bcstg. Co. 1400 Melody Lane 870	MBS	Douglas Silver, Pres. & Gen. Mgr. Marjorie B. Silver, Coml. Mgr. & Prog. Dir.	Kingsley Butt, Prom. Mgr. James Sowinski, Chief Engr.	Standard UP Gates
GAINESVILLE WGGG 1948	1230 250	Alachua County Bcstg. Co. Inc. 1230 Waldo Rd. 5791	Ashcroft & Banninger	R. M. Chamberlin, Pres., Gen. Mgr. & Chief Engr. Leon E. Mims, Coml. & Prom. Mgr.	S. Scott Sutton, Prog. Dir.	Associated Capitol AP
WRUF 1928	850 5,000 DA-N	U. of Florida Radio Station WRUF 3261	MBS Burn-Smith	Garland Powell, Dir. Al Cone, Coml. Mgr. Sewell S. Brown, Prog. Dir.	Otis Boggs, Prom. Mgr. Ovid Gano, Chief Engr.	Lang-Worth SESAC, AP RCA Western Electric
WRUF-FM 1948	Ch. 281 (B) 104.1mc 12kw					
HOLLYWOOD WINZ 1946	940 1,000 DA-1	Hollywood Bcstg. Co. WINZ Bldg.	Perry	Jonas Weiland, Pres.		Lang-Worth AP
JACKSONVILLE WIVY 1948	1050 1,000-D	WIVY Inc. 135 Riverside Ave. 4-7722		Frank L. Denton, Pres. & Coml. Mgr.	Al Keirse, Gen. Mgr. & Prog. Dir. James W. Knoche, Chief Engr.	MacGregor INS Thesaurus AP Western Electric
WJAX 1925	930 5,000 DA-N	City of Jacksonville 1 Broadcast Pl. 4-1681	NBC Blair	John T. Hopkins III, Gen. & Coml. Mgr. & Chief Engr.	Evelyn Boote, Prog. Dir.	
WJAX-FM 1948	Ch. 236 (B) 95.1mc 11.5kw					

**FIRST
IN LISTENER PREFERENCE
IN
FABULOUS FLORIDA'S
FIRST
CITY OF YEAR-ROUND SALES, AND
FIRST
IN COVERAGE IN NORTH FLORIDA AND SOUTH GEORGIA**

W - J - A - X

930 kc — 5,000 watts

W - J - A - X - F M

95.1 mg

JACKSONVILLE, FLORIDA'S MUNICIPAL STATIONS

J. D. Kennedy, Commissioner in Charge

John T. Hopkins III, Manager

AN **N B C** AFFILIATE

NATIONAL REPRESENTATIVES: JOHN BLAIR & CO. — SOUTHEAST: HARRY E. CUMMINGS

DIRECTORY OF AM, FM, and TV STATIONS OF THE UNITED STATES

*(Data corrected to December 6, 1949)
If executives or services for FM or TV stations are same as AM affiliate names are not repeated.*

FLORIDA—(Continued)

City Established	Call Letters	Chan. or Freq. Power	Name of Licensee Headquarters Address Telephone Number	Network Representative	Executive Personnel	Transc. Library News Service Transmitter Make	
JACKSONVILLE—(Continued)							
	WJAX-TV (CP)	Ch. 2; 54-60mc. 7.5kw-aur.; 15kw vis.					
	WJHP 1940	1320 5,000 DA-N	The Metropolis Co. P. O. Box 4878 4-7711	MBS Perry	John H. Perry, Pres. Reggie Martin, Gen. & Coml. Mgr.	Ron Tuten, Prog. Dir. & Prom. Mgr. Beecher Hayford, Chief Engr.	Lang-Worth UP RCA
	WJHP-FM 1947	Ch. 245 (B) 96.9mc 32kw					
	WMBR 1927	1460 5,000 DA-N	Florida Bcstg. Co. 605 S. Main St. 9-4477	CBS Avery-Knodel	Frank M. King, Pres. & Gen. Mgr. Charlie Stone, Coml. Mgr.	Roger Van Duzer, Prog. Dir. Ted Chapeau, Prom. Mgr. E. B. Vordermark, Chief Engr.	World Associated Lang-Worth UP, Collins Western Electric
	WMBR-FM 1948	Ch. 241 (B) 96.1mc 63kw					
	WMBR-TV 1949	Ch. 4 89-72mc 7.4kw-aur.; 14.8kw-vis.		ABC, CBS DuMont NBC	Glenn Marshall Jr., Secy.-Treas., Gen. & Coml. Mgr. Paul Acosta, Prog. Dir. INS General Electric	
	WOBS 1948	1360 1,000-D	Southern Radio & Equipment Co. 10 E. Forsyth St. 6-4231	Forjoe	J. R. Sharpe, Pres. Jim Macri, Gen. Mgr. R. H. Gunckel Jr., Coml. Mgr.	Wayne Farrell, Prog. Dir. Fred Murphy, Prom. Mgr. Bill Askew, Chief Engr. AP Gates
	WPDQ 1942	600 5,000 DA-N	Jacksonville Bcstg. Corp. P. O. Box 1468 4-4421	ABC Katz	James R. Stockton, Pres. Linton D. Baggs, V. P. Robert R. Feagin, Gen. Mgr. Frank Taylor Jr., Coml. Mgr.	James O. Hardin Jr., Prog. Dir. (Mrs.) Edith B. Hoskinson, Prom. Mgr. James R. Donovan, Chief Engr.	Standard AP RCA
	WRHC (CP)	1400 250	Radio South				
JACKSONVILLE BEACH							
	WJVB 1947	1010 250-D	Jacksonville Beach Bcstg. Co. 211 1st Ave. North 3674		H. A. Prather, Pres. Lester M. Combs, Gen. Mgr.	P. Combs, Coml. Mgr. A. T. Kindell, Chief Engr. Raytheon
KEY WEST							
	WKWF 1945	1600 500	John M. Spottswood P. O. Box 891 510	MBS, KBS	John M. Spottswood, Pres., Gen. & Coml. Mgr. & Prog. Dir.	John D. Miller, Chief Engr. UP RCA
LAKE CITY							
	WDSR 1946	1340 250	Deep South Radioways 126 N. Marion St. 5250		Alfred H. Temple, Pres. Michael M. Davis, Gen. & Coml. Mgr.	Owen W. Parnacott, Prog. Dir. Bruce E. Singleton, Chief Engr. Associated AP
LAKELAND							
	WLAK 1946	1430 1,000	Lakeland Bcstg. Corp. P. O. Box 1211 2127	NBC Pearson	S. O. Ward, Pres. & Gen. Mgr. Powell Adams, Coml. Mgr.	Maxine Tyner, Prog. Dir. William P. Lee, Prom. Mgr. & Chief Engr.	Associated UP RCA
	WONN 1949	1230 250	Coastal Bcstg. Co. New Florida Hotel 5117	MBS	Robert S. Taylor, Ted Covington, Duane McConnell, Co-owners Robert S. Taylor, Pres.	Tom Barber, Coml. Mgr. Ted Covington, Prog. Dir. Duane McConnell, Chief Engr.	Lang-Worth AP Gates
LAKE WORTH							
	WEAT 1948	1490 250	Robert W. Rounsaville S. Ocean Blvd. 1200	NBC	Robert W. Rounsaville, Owner Virgil K. Trimm, Sta. Mgr. C. J. Bennett, Coml. Mgr.	George Eubanks, Prog. Dir. Andrew Keicher, Chief Engr. AP Raytheon
LEESBURG							
	WLBE 1949	790 1,000 DA-1	Paul Hunter 1240 Floradell Ave. 552		Paul Hunter, Pres. Robert Clinton, Gen. & Coml. Mgr.	Pamela Clinton, Prog. Dir. Charles Castle, Chief Engr.	Lang-Worth AP Collins
LIVE OAK							
	WNER 1949	1450 250	Live Oak Bcstg. Co. P. O. Box 655 1450		John A. Boling, Pres. & Coml. Mgr. James W. Hayes, Gen. & Prom. Mgr.	V. L. Randolph, Prog. Dir. C. S. Parker, Chief Engr.	Lang-Worth UP RCA
MARIANNA							
	WTYS 1948	1340 250	John H. Phipps P. O. Box 565 650	Cummings	John H. Phipps, Pres. L. Herschel Graves, Gen. Mgr. H. C. Harris Jr., Coml. Mgr.	Leslie Carrol, Prog. Dir. W. A. Snowden Jr., Chief Engr.	Standard AP
MELBOURNE							
	WMMB 1948	1050 250-D	Melbourne Bcstg. Co. P. O. Box 235, 575		William Shakespeare Jr., Pres. Austin V. Catterton, Gen. Mgr.	Victoria C. Martin, Prog. Dir. Kenneth E. Waltz, Chief Engr.	World UP, Collins
MIAMI							
	WFEC 1949	1220 250-D	Florida East Coast Bcstg. Co. 350 N. E. 71st St. 89-7534		J. Lyle William Jr., Gen. Mgr. Lee K. Beznor, Exec. Dir. Richard D. Ward, Coml. Mgr.	Robert Lyons, Prog. Dir. Beverly Deming, Prom. Mgr. George J. Henke, Chief Engr.	Cole UP Western Electric
	WGBS 1939	710 50,000-LS-DA-2 10,000 N	The Fort Industry Co. 1605 Biscayne Blvd. 9-2401	CBS Katz	George B. Storer, Pres. Stanton P. Kettler, Gen. Mgr. Miller N. Babcock, Coml. Mgr.	Ewald Kockritz, Prog. Dir. Frank Jaffe, Prom. Mgr. Albert Shropshire, Chief Engr.	Lang-Worth AP RCA
	WGBS-FM 1948	Ch. 242 (B) 96.3mc 1.4kw					
	WIOD 1926	610 5,000 DA-2	Isle of Dreams Bcstg. Corp. 600 Biscayne Blvd. 3-6444	NBC Hollingbery	Daniel J. Mahoney, Pres. James M. LeGate, Gen. Mgr. Robert L. Fidiar, Coml. Mgr.	Scott Bishop, Prog. Dir. Martha Henriquez, Prom. Mgr. Milton Scott, Chief Engr.	Standard Associated AP, UP, INS Western Electric RCA
	WIOD-FM 1946	Ch. 248 (B) 97.3mc 53kw					
	WMIE 1948	1140 10,000-LS DA-2 5,000-N	Sun Coast Bcstg. Corp. Biscayne Blvd. at 3rd St. 3-5556	Forjoe	J. Allen Brown, Pres. Bob Venn, Gen. Mgr. John Allen, Coml. Mgr.	Ted Anthony, Prog. Dir. Roland Jones, Prom. Mgr. Russell Bennett, Chief Engr.	Associated UP, INS RCA
	WPJV (FM) (CP)	Ch. 286 (B) 105.1mc:13.5kw	Hollywood Bcstg. Co. Hollywood Beach Hotel				
	WQAM 1920	560 5,000-LS 1,000-N	Miami Bcstg. Co. 1723 duPont Bldg. 2-6121	ABC Blair	John S. Knight, Pres. Owen F. Uridge, Gen. Mgr. Harry Camp, Coml. Mgr.	Marjorie Christopher, Prog. Dir. & Prom. Mgr. Gene Rider, Chief Engr.	World Associated AP, G. E.

DA-N Directional Antenna, night only. FM's in italic.
DA-1 Directional Antenna, same pattern day and night.
DA-2 Directional Antenna, different pattern day and night.

*—Non-Commercial Station D—Day. N—Night. ST—Share Time. SH—Specified Hours.
U—Unlimited. CP—Construction Permit Issued. LS—Local Sunset.
L—Limited Time with Dominant Station. SA—Special Authorization.

City Call Letters Established	Chan. or Freq. Power	Name of Licensee Headquarters Address Telephone Number	Network Representative	Executive Personnel	Transc. Library News Service Transmitter Make
MIAMI—(Continued)					
WQAM-FM 1946	Ch. 235 (B) 94.9mc 60kw				
WTVJ(TV) 1949	Ch. 4 86-72mc 2.5kw-aur.; 5kw-vis.	Southern Radio & Tele. Equip. Co. Inc. 17 N. W. 3rd St. 82-6671	ABC, CBS DuMont NBC Free & Peters	Mitchell Wolfson, Pres. Lee Ruwitch, Acting Mgr. Clyde N. Lucas, Prog. Mgr.	Arthur L. Gray, Prom. Mgr. Earl W. Lewis, Chief Engr.
WWPB 1947	1450 250	Paul Brake 414 S. W. 2nd Ave. 3-7405	Cooke	Paul Brake, Owner, Gen. & Coml. Mgr.	Bill Johns, Prog. Dir. Ed Derryberry, Prom. Mgr. Jack Wilson, Chief Engr.
WWPB-FM 1948	Ch. 268 (B) 101.5mc 8.5kw				World AP Western Electric Westinghouse
MIAMI BEACH					
WKAT 1937	1360 5,000-LS 1,000-N	WKAT Inc. 1759 Bay Rd. 5-5711	MBS Weed	A. Frank Katzentine, Pres. John I. Prosser, Gen. & Coml. Mgr.	Gordon N. Waltz, Prog. Dir. Arthur P. Smith Jr., Chief Engr.
WKAT-FM 1947	Ch. 226 (B) 93.1mc 324kw				Standard Cole UP Western Electric
WLRD (FM) 1948	Ch. 230 (B) 93.9mc 13kw	Mercantile Bcstg. Co. 420 Lincoln Rd. 58-6334		Alan H. Rosenson, Pres., Gen. Mgr. & Chief Engr.	Richard H. Wright, Coml. Mgr. Marshall J. Simmons, Prog. Dir.
WMBM 1947	800 1,000-D	Biscayne Bcstg. Co. MacArthur Causeway Terminal 5-5586	Ra-Tel	Kenneth S. Keyes Sr., Pres. Kenneth S. Keyes Jr., Gen. & Coml. Mgr. George Chamberlin, Prog. Dir.	Dick Parker, Prom. Mgr. Jack D. Miller, Chief Engr.
OCALA					
WTMC 1939	1290 1,000 DA-N	Ocala Bcstg. Co. Inc. 1 Broadcast Pl. 128	MBS Perry	John H. Perry, Pres. T. S. Gilchrist, Gen. Mgr. John Nicholson, Asst. Mgr.	C. J. Rinehardt, Coml. Mgr. W. P. Callahan, Chief Engr.
ORLANDO					
WDBO 1924	580 5,000 DA-N	Orlando Bcstg. Co. Inc. 30 S. Ivanhoe Blvd. E. 6181	CBS Blair	George C. Johnston, Pres. & Gen. Mgr. Harold P. Danforth, V. P. & Sta. Mgr.	W. G. McBride, Nat'l. Sales Dir. J. E. Yarbrough, Chief Engr.
WDBO-FM 1949	Ch. 222 (B) 92.3mc 34kw				Associated Thesaurus World AP, UP Western Electric
WHOO 1947	990 10,000-LS 5,000-N DA	Radio Station WHOO Fort Gatlin Hotel 9900	ABC Ra-Tel	Martin Andersen, Pres. Clarence H. Bracey, Gen. & Coml. Mgr.	Tom Sawyer, Prog. Dir. (Mrs.) Betty Jean Kline, Prom. Mgr. Gene Dashiell, Chief Engr.
WHOO-FM 1948	Ch. 243 (B) 96.5mc 59kw				Standard AP RCA Federal

WDBO

(Established 1924)

Central Florida's Pioneer Radio Station

"Serving the Sun Empire"

In the competitive field of Orlando . . . WDBO has more listeners than the three other network stations in Orlando combined.

(Hooper Fall 1948)

WDBO's Radio Families in 22 counties total:

93,473 Day

81,881 Night

(Broadcast Measurement Bureau)

Retail Sales in counties covered by WDBO in 1948 were valued at \$402,679,000.

(1949 Sales Management)

WDBO 580 KC 5,000 Watts

In simultaneous operation

WDBO-FM 92.3 MCS 35,000 Watts

Represented

Nationally By
John Blair & Co.

Southeast By
Harry E. Cummings

Columbia Broadcasting System Affiliate

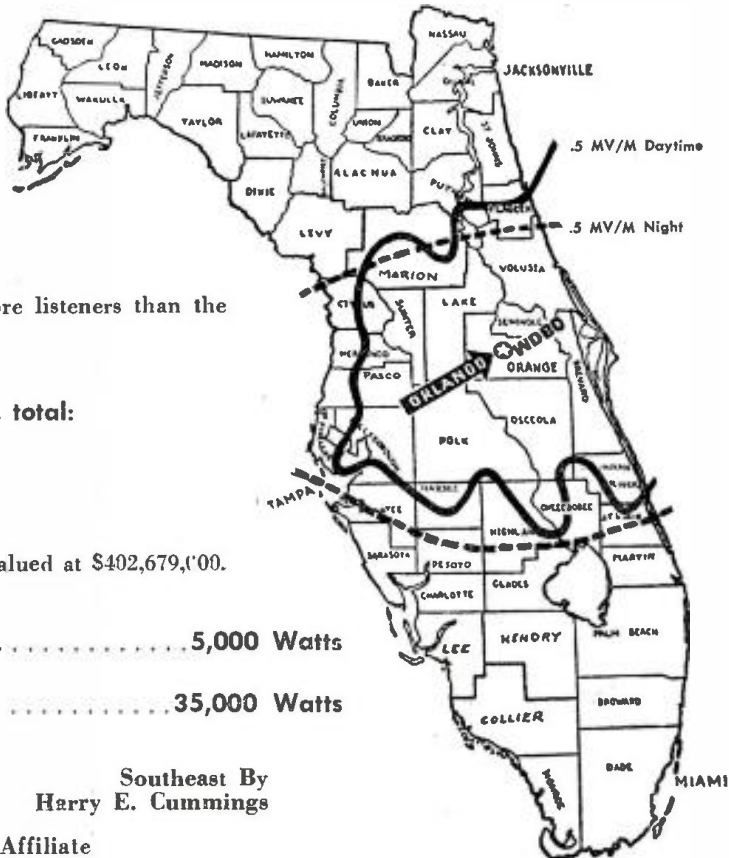

DIRECTORY OF AM, FM, and TV STATIONS OF THE UNITED STATES

*(Data corrected to December 6, 1949)
If executives or services for FM or TV stations are same as AM affiliate names are not repeated.*

FLORIDA—(Continued)

City Call Letters Established	Chan. or Freq. Power	Name of Licensee Headquarters Address Telephone Number	Network Representative	Executive Personnel	Transc. Library News Service Transmitter Make	
ORLANDO—(Continued)						
WLOF 1940	950 5,000 DA-N	Hazlewood Inc. Angebilt Hotel Bldg. 8163	MBS Raymer	William Joe Sears, Pres. Walter C. Shea, Secy.-Treas. J. Allen Brown, Exec. V. P. & Gen. Mgr.	Donn R. Colee, Coml. Mgr. Ruth Donahue, Prog. Dir. Ruth Bartelt, Sales Prom. Mgr. W. Dodd Daniel, Chief Engr.	Lang-Worth UP RCA
WORZ 1946	740 1,000 DA-2	Central Fla. Bcstg. Co. 740 N. Orange Ave. 2-2451	NBC Weed	James Dandelake, Pres. Eugene D. Hill, Gen. & Coml. Mgr.	W. O. Murrell Jr., Mgr. Tony Chastain, Prog. Dir.	Standard AP
PALATKA						
WWFF 1947	800 250-D	Palatka Bcstg. Co. 900 River St. 3-5-4	Holman	J. E. Massey, Partner L. C. McCall, Partner, Gen. Mgr. & Chief Engr.	Herbert M. Young, Coml. Mgr. Bruce E. Wilson, Prog. Dir.	Lang-Worth SESAC UP Collins
PALM BEACH						
WWFG 1941	1340 250	Palm Beach Bcstg. Corp. 3000 S. Ocean Blvd. 2-1515	ABC Perry	Charles E. Davis, Pres. Donald S. Greenleaf, Coml. Mgr.	Clyde Walkden, Chief Engr.	World Lang-Worth AP Gates
WWPG-FM 1946	Ch. 250 (B) 97.9mc 22kw					Federal
PANAMA CITY						
WDLP 1940	590 1,000 DA-N	Panama City Bcstg. Co. Inc. West Beach Dr., 777	MBS, LBS Perry	John H. Perry, Pres. Byron Hayford, Gen. & Coml. Mgr. & Prog. Dir.	John Thomas, Prom. Mgr. Elmer Scott, Chief Engr.	World UP Raytheon
WPCF 1949	1400 250	Bay County Bcstg. Co. 15th & McKenzie, 2662	ABC	E. L. Dukate, Pres. & Gen. Mgr.	Eleanor Whitelaw, Prog. Dir. E. G. Holmes, Chief Engr.	Thesaurus AP, Collins
PENSACOLA						
WBSR 1946	1450 250	Escambia Bcstg. Co. San Carlos Hotel 6173	ABC Meeker	Ruth Braden, Pres.	Jack Rathbun, Sta., Prom. & Coml. Mgr. & Prog. Dir. G. E. Meade, Chief Engr.	Lang-Worth AP
WCOA 1926	1370 5,000 DA-N	Pensacola Bcstg. Co. San Carlos Hotel 4111	NBC Perry	John H. Perry, Pres. J. Holliday Veal, Gen. Mgr. Irving Welch, Coml. Mgr.	Russell Hirsch, Prog. Dir. Ann Martin, Prom. Mgr. Harold Heath, Chief Engr.	World UP RCA
WCOA-FM 1947	Ch. 250 (B) 98.9mc 5.4kw					
WEAR 1947	1490 250	Gulfport Bcstg. Co. Inc. 5 East Gregory St. 8-4449	MBS, LBS Pearson	T. J. Carroll, Pres. Earle Fletcher, Gen. & Coml. Mgr.	Vinnie Wheeler, Prog. Dir. Howard Grove, Chief Engr.	Capitol AP Gates
PLANT CITY						
WPLA 1949	1570 250-D	W. A. Smith Hopewell Rd. 526		Leon Lloyd, Mgr.		UP
QUINCY						
WCNH 1948	1230 250	Quincy Bcstg. Corp. Box 190 300		Richard J. Gardner, Pres. A. B. Letson, Gen. Mgr. & Chief Engr.	R. A. Bush, Coml. Mgr. Louis P. Harris, Prog. Dir.	Lang-Worth AP Western Electric
ST. AUGUSTINE						
WFOY 1934	1240 250	Fountain of Youth Bcstg. Co. P. O. Box 588, 1622	CBS Avery-Knodel	J. C. Bell, Pres. John E. Bernhard Jr., Gen. & Coml. Mgr.	Frankie C. Walker, Prog. Dir. & Prom. Mgr. Ernest Raistrick, Chief Engr.	UP Western Electric
ST. PETERSBURG						
WSUN 1928	620 5,000 DA-N	City of St. Petersburg Recreation Pier	ABC Weed	George D. Robinson, Mgr.		
WTSP 1939	1380 5,000 DA-N	Pinellas Bcstg. Co. P. O. Box 691 7-8108	MBS Pearson	Nelson B. Poynter, Chief Owner F. Joseph Kelley, V. P. & Gen. Mgr.	L. L. Wildman, Coml. Mgr. Jack Faulkner, Prog. & Prom. Dir. William Mangold, Chief Engr.	World Capitol
WTSP-FM 1948	Ch. 273 (B) 102.5mc 37kw					Western Electric
SANFORD						
WTRR 1947	1400 250	Radio Station WTRR P. O. Box 1541 999	KBS Clark	Myron A. Reck, Owner & Gen. Mgr. Dick Aiken, Coml. Mgr.	J. Marion Harman Sr., Prog. Dir. & Prom. Mgr. Emerson Browne, Chief Engr.	UP Collins
SARASOTA						
WKXY 1949	1540 1,000-D	Sarasota Bcstg. Co. P. O. Box 2431 3666		A. G. Fernandez, William P. Carey, C. J. Fernandez, G. Fernandez, Co-owners	A. G. Fernandez, Gen. Mgr. & Chief Engr. William P. Carey, Coml. Mgr. Robert W. Hanesworth, Prog. Dir.	Capitol AP Gates
WSPB 1939	1450 250	W S P B Inc. P. O. Box 1110 2565	CBS Pearson	Robert C. Jones Jr., Pres. John B. Browning, Gen. Mgr. Jack Bennett, Coml. Mgr.	David C. Hale, Prog. Dir. James E. Grant, Chief Engr.	Lang-Worth UP RCA
SEBRING						
WJCM (CP)	1340 100	Highlands Bcstg. Co.				
TALLAHASSEE						
WTAL 1935	1270 5,000 DA-N	John H. Phipps Cherokee Hotel 2161	CBS, MBS Blair	John H. Phipps, Pres. L. Herschel Graves, Gen. Mgr.	Joe Hosford, Prog. Dir. W. A. Snowden Jr., Chief Engr.	Lang-Worth AP
WTAL-FM 1947	Ch. 280 (A) 103.9mc 0.75kw					
WTNT 1946	1450 250	Tallahassee Appliance Corp. Hotel Floridan 2691	ABC, KBS Clark	Frank W. Pepper, Pres. & Gen. Mgr. Frank W. Hazelton, Coml. Mgr. Elaine McDaniel, Prog. Dir.	(Mrs.) Ruby S. Meigs, Prom. Mgr. Charles L. Clifton, Chief Engr.	World UP Gates
TAMPA						
WALT 1946	1110 1,000-D	Tampa Bcstg. Co. 401 W. Tyler St. 2-7921	Perry	W. Walter Tison, Pres., Gen. & Coml. Mgr. Eva Byron, Prog. Supvr.	Coburn Gum, Prom. Mgr. J. B. Tison, Chief Engr.	Lang-Worth SESAC AP RCA

DA-N Directional Antenna, night only. FM's in italic.
DA-1 Directional Antenna, same pattern day and night.
DA-2 Directional Antenna, different pattern day and night.

*—Non-Commercial Station D—Day. N—Night. ST—Share Time. SH—Specified Hours.
U—Unlimited. CP—Construction Permit Issued. LS—Local Sunset.
L—Limited Time with Dominant Station. SA—Special Authorization.

DELIVERS THE **BIG** AUDIENCE

in Florida's fastest growing market

You sell more people when you tell more people . . . And WFLA delivers the big audience in the Tampa-St. Petersburg market — Florida's fastest growing, year 'round market.

With its amazing population growth and greatly increased industrial and agricultural production, the Tampa-St. Petersburg trade area is one of the most important markets in Florida. The substantial payrolls of its diversified business activities build steady buying power right around the calendar.

The so-called "tourist season", at one time of three-months duration, is now year 'round in character. Last summer, the Florida West Coast had the biggest vacation business in its history.

For more listeners, for more sales, in the Tampa-St. Petersburg market, use WFLA—the most-listened-to station in the heart of Florida's richest, most heavily populated trade area.

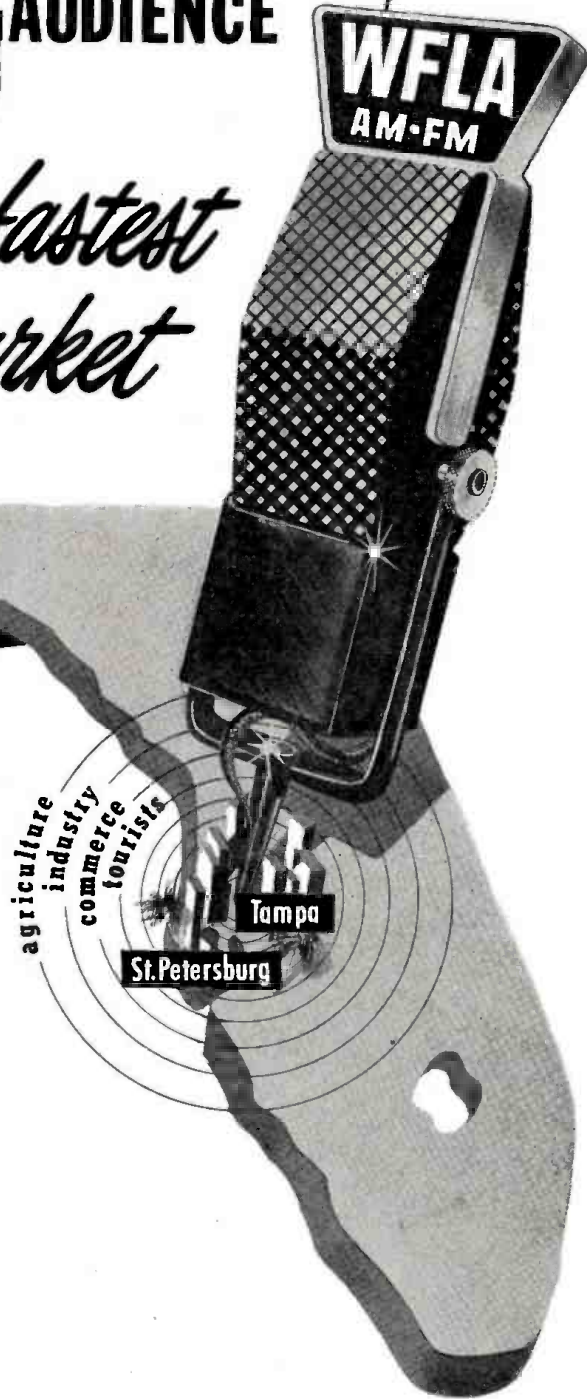

NBC AFFILIATE

WFLA



NATIONAL REPRESENTATIVE
JOHN BLAIR & CO.

AM *The Tampa* Tribune Stations FM

SOUTHEASTERN REPRESENTATIVE
HARRY E. CUMMINGS
JACKSONVILLE, FLORIDA

DIRECTORY OF AM, FM, and TV STATIONS OF THE UNITED STATES

(Data corrected to December 6, 1949)
If executives or services for FM or TV stations are same as AM affiliate names are not repeated.

FLORIDA—(Continued)

City Call Letters Established	Chan. or Freq. Power	Name of Licensee Headquarters Address Telephone Number	Network Representative	Executive Personnel	Transc. Library News Service Transmitter Make	
TAMPA—(Continued)						
WDAE 1922	1250 5,000 DA-1	Tampa Times Co. 114 N. Franklin St. 2-2911	CBS Katz	David E. Smiley, Pres. L. Spencer Mitchell, Gen. & Coml. Mgr.	Kenneth W. Skelton, Prog. Dir. & Prom. Mgr. William Pharr Moore, Chief Engr.	Associated AP General Electric Western Electric
WDAE-FM 1947	Ch. 289 (A) 105.7mc 1kw					
WEBK (CP)	1580 1,000-D	Hillsboro Bestg. Co. 1503 Franklin St.				
WFLA 1941	970 5,000 DA-N	The Tribune Co. P. O. Box 1410 H 1828	NBC Blair	Charles G. Baskerville, Gen. Mgr. Bert Arnold, Coml. Mgr. Paul M. Jones, Prog. Dir.	Tom Matthews, Prom. Mgr. Joseph Mitchell, Chief Engr.	Thesaurus Lang-Worth UP RCA Westinghouse
WFLA-FM 1948	Ch. 227 (B) 93.3mc 53kw					
WHBO 1948	1050 250-D	Sulphur Springs Bcstrs. Co. 8122 Nebraska Ave. 33-2251		Harold A. Dunlap, Partner, Pres. & Gen. Mgr. Harry J. Dunlap, Partner & Bus. Mgr.	Ann Bowman, Prog. Dir. Betty Strong, Traffic Mgr. Maurice Scott, Chief Engr.	AP Gates
WEST PALM BEACH						
WIRK 1947	1290 1,000 DA-2	Ken-Sell Inc. Citizens Bldg. 2-1744	MBS McGillvra	Joseph S. Field, Pres., Gen. & Coml. Mgr.	James C. Steele Jr., Prog. Dir. & Prom. Mgr. William P. Heintzman, Chief Engr.	Associated UP Collins
WJNO 1936	1230 250	WJNO Inc. 1500 N. Flagler Dr. 2-3638	CBS Meeker	Marshall Heminway, Pres. Stephen P. Willis, Gen. & Coml. Mgr.	Elizabeth Miller, Prog. Dir. Harry Forster, Prom. Mgr. Otis C. Wright, Chief Engr.	Lang-Worth UP RCA
WINTER HAVEN						
WSIR 1947	1490 250	Citrus Belt Bcstrs. Inc. 132 Third St. S. W. 31-313	MBS	Fred L. Allman, Pres. Larry Rollins, Gen. Mgr. Earl Sturgeon, Coml. Mgr.	Dick Eyrich, Prog. Dir. L. Orden Craig, Chief Engr.	UP Raytheon
GEORGIA						
ALBANY						
WALB 1940	1590 1,000 DA-N	Herald Pub. Co. Albany 1590	MBS Burn-Smith	James H. Gray, Pres. H. L. Tallman, Gen. & Coml. Mgr.	David K. Fulton, Prog. Dir. & Prom. Mgr. Ernest Ruckle, Chief Engr.	World AP Collins
WGPC 1933	1450 250	Albany Bestg. Co. New Albany Hotel 1370	CBS Hollingbery	J. W. Woodruff Sr., Pres. J. W. Woodruff Jr., Exec. Mgr. L. M. George, Sta. & Prom. Mgr.	Walter H. Flint, Prog. Dir. Redus Carlton, Chief Engr.	Standard UP RCA
AMERICUS						
WDEC 1947	1230 250	The Americus Bestg. Co. 109½ Windsor Ave. 3681	MBS GALS Continental	James Blair, Pres. & Gen. Mgr. Charles C. Smith, Sta. Mgr. & Prog. Dir.	Lloyd E. McKinney, Chief Engr.	AP Raytheon
ATHENS						
WGAU 1938	1340 250	J. K. Patrick & Co. Bobbin Mill Rd. 1741	CBS, KBS GALS	J. K. Patrick, Pres. R. Lewis Doser, Gen., Coml., & Prom. Mgr. & Prog. Dir.	Bill Evans, Chief Engr.	Standard AP Collins
WGAU-FM 1949	Ch. 258 (B) 89.5mc 4.4kw					
WRFC 1948	960 1,000-D	Radio Athens Inc. 279½ N. Lumpkin St. 446	Dodson	L. H. Christian, Pres. & Gen. Mgr. Claude Williams Jr., Coml. Mgr.	Charles A. McClure, Prog. Dir. & Prom. Mgr. L. D. Drewry, Chief Engr.	General Electric Associated UP Gates
ATLANTA						
WAGA 1937	590 5,000 DA-N	Fort Industry Co. 56 Marietta St. Main 5900	CBS Katz	George B. Storer, Pres. James E. Bailey, Gen. Mgr. Claude Frazier, Coml. Mgr.	William H. McCain, Prog. Dir. Lidie Lee, Prom. Mgr. Paul Cram, Chief Engr.	AP Westinghouse Western Electric
WAGA-FM 1948	Ch. 277 (B) 103.3mc 50kw					
WAGA-TV 1949	Ch. 5 76-82mc 9.5kw-aur.; 18kw-vis.	Fort Industry Co. 1018 W. Peachtree St. Emerson 2541	CBS, DuMont	George B. Storer Jr., Gen. Mgr.	Bill Terry, Prog. Dir.	RCA
WATL 1931	1380 5,000 DA-N	Atlanta Bestg. Co. Henry Grady Bldg. Walnut 4377	Forjoe	J. W. Woodruff Sr., Pres. Maurice C. Coleman, Gen. Mgr.	David Ruark, Prog. Dir. Ellis Bryant Jr., Chief Engr.	Lang-Worth Standard UP Western Electric
WATL-FM 1948	Ch. 248 (B) 97.5mc 44kw					
WBGE 1947	1340 250	General Bestg. Co. Georgian Terrace Hotel Vernon 1194	Burn-Smith	Mike Benton, Pres. David J. Holt, Gen. Mgr. & Chief Engr. Samuel Kane, Sales Mgr.	Marilyn Bradham, Prog. Dir. Ralph Black, Prom. Mgr. Howard Parrish, Asst. Chief Engr.	Lang-Worth AP General Electric
WBGE-FM 1947	Ch. 238 (B) 95.5mc 14kw					
WCON 1947	550 5,000 DA-N	The Constitution Pub. Co. 11 Forsyth St. S.W. Lamar 4545	ABC Headley-Reed	Major Clark Howell, Pres. David Carpenter, Gen. Mgr. Crenshaw Bonner, Sales Mgr.	Marguerite Taylor, Prog. Dir. Edwin Pentecost, Prom. Mgr. Harvey Aderhold, Chief Engr.	World AP, UP Western Electric
WCON-FM 1948	Ch. 253 (B) 98.5mc 54kw					
WCON-TV (CP)	Ch. 2 54-60mc 2.5kw-aur.; 4.9kw-vis.					
WEAS 1947						
WERD 1949	860 1,000-D	Radio Atlanta Inc. 274½ Auburn Ave. N.E. Lamar 0666	(See Decatur listing)	J. B. Blayton Sr., Pres. J. B. Blayton Jr., Gen. & Prom. Mgr.	Clayton J. Cosse, Coml. Mgr. Adrian K. Knight, Prog. Dir. William F. Kennedy, Chief Engr. Western Electric

DA-N Directional Antenna, night only. FM's in italic.
DA-1 Directional Antenna, same pattern day and night.
DA-2 Directional Antenna, different pattern day and night.

*—Non-Commercial Station D—Day. N—Night. ST—Share Time. SH—Specified Hours.
U—Unlimited. CP—Construction Permit Issued. LS—Local Sunset.
L—Limited Time with Dominant Station. SA—Special Authorization.

CBS IN ATLANTA CBS AND DUMONT TV



If you're after business in Atlanta and Georgia (and you should be) . . . If your plans include seizing the ever increasing opportunities being afforded you in the South (and they should) . . . Then by all means, call a KATZ Agency man for the story of Atlanta's promotion-minded stations—WAGA and WAGA-TV . . . where CBS teams up with local know-how to go after results for you with “the best shows of all!”



Represented Nationally by THE KATZ AGENCY, INC.

NEW YORK * CHICAGO * DETROIT * KANSAS CITY
ATLANTA * DALLAS * SAN FRANCISCO * LOS ANGELES

10,000 WATTS

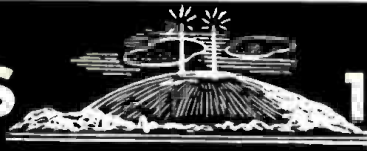

10 • 10 ON YOUR DIAL

WEAS

ATLANTA • DECATUR

RACE • RURAL • RELIGION

- ★ Georgia's most powerful Independent Station
- ★ Georgia's largest mail pull station

ATLANTA HOOPER RATING

	NET STATION	INDEPENDENT	NET STATION	NET STATION	NET STATION
	NBC 23.9	WEAS 17.2	CBS 15.2	ABC 14.1	MBS 11.5

COVERAGE

ATLANTA

WEAS

Listener mail-Response Area
05 MV

NATIONAL RATE CARD 2
EFFECTIVE JULY 1, 1949

	1 HR.	½ HR.	15 MIN.	5 MIN.	1 MIN.	35 SEC.
1	\$112.50	\$67.50	\$40.50	\$24.75	\$18.00	\$15.75
26	106.90	64.15	38.50	23.55	17.10	15.00
52	101.55	60.95	36.60	22.40	16.25	14.25
104	96.50	57.90	34.80	21.30	15.45	13.55
156	92.70	55.00	33.05	20.25	14.70	12.90
260	88.15	52.25	31.40	19.25	14.00	12.25
312	83.75	49.65	29.85	18.30	13.30	11.70
520	79.60	47.20	28.35	17.40	12.65	11.10

1. Georgia's largest labor, working-class, and rural audience.
2. Largest percentage of Georgia's 1,083,000 Negro listeners.
3. Georgia's largest religious audience.
4. No alcoholic beverage or dance-hall advertising accepted.
5. Distinctive block programming with no overlapping.
6. Mail, survey, sponsor-business-growth reports available upon request.

WEAS has a consistent mail-pull coverage of the entire state of Georgia and its retail market area.

1948 Retail Sales: \$2,104,951,000. % Negro: \$463,089,844.

WEAS blankets, with a strong 5-mv signal, the 50-odd counties comprising the Atlanta retail market area.

1948 Retail Sales: \$1,166,387,000. % Negro: \$243,405,140.

**No coverage of the Georgia Market
is complete without WEAS**

THE FAMILY STATION

NATIONAL REPRESENTATIVE JOHN E. PEARSON CO.

DIRECTORY OF AM, FM, and TV STATIONS OF THE UNITED STATES

(Data corrected to December 6, 1949)
 If executives or services for FM or TV stations are same as AM affiliate names are not repeated.

GEORGIA—(Continued)

City Call Letters Established	Chan. or Freq. Power	Name of Licensee Headquarters Address Telephone Number	Network Representative	Executive Personnel	Transc. Library News Service Transmitter Make
ATLANTA—(Continued)					
WGST 1923	920 5,000-LS 1,000-N	Georgia Institute of Tech. Forsyth Bldg. Walnut 8441	MBS Hollingbery	F. M. Spratlin, Chmn. Radio Comm. John Fulton, Gen. & Coml. Mgr. Jack Kelly, Prog. Dir.	Paul Sanford, Prom. Mgr. Ben Akerman, Chief Engr. Lang-Worth AP RCA
WGST-FM 1947	Ch. 231 (B) 94.1mc 345kw				General Electric World UP RCA
WQXI (Buckhead) 1948	790 5,000-D	Robert W. Rounsaville Peachtree at Mathieson Cherokee 2196		R. W. Rounsaville, Owner & Gen. Mgr. Sam R. Davis, Coml. Mgr.	Bob Corley, Prog. Dir. Ray McCay, Prod. Mgr. Harold Price, Chief Engr.
WSB 1922	750 50,000	The Atlanta Journal Co. 10 Forsyth St. N. W. Hemlock 1045	NBC Petry	James M. Cox Jr., Chmn. of Board J. Leonard Reinsch, Mng. Dir. John M. Outler Jr., Gen. Mgr. Marcus Bartlett, Prog. Dir.	Frank Gaither, Coml. Mgr. Wayne Anderson, Prom. Mgr. C. F. Daughtery, Chief Engr. Associated Standard AF, UP Western Electric
WSB-FM 1949	Ch. 283 (B) 104.5mc 48.5kw				Westinghouse RCA
WSB-TV 1948	Ch. 8 180-186mc 12.5kw-aur., 23.8kw-vis.				
AUGUSTA					
WBBQ 1947	1340 250	Savannah Valley Bcstg. Co. 515 Jefferson Davis Ave. 4-5441	MBS, LBS GALS Walker	George G. Weiss, Pres. & Gen. Mgr. John W. Watkins, Coml. Engr.	Russell E. Poteet, Prom. Mgr. Marvin W. Tarpley, Chief Engr. George M. Scott, Prog. Dir. AP Gates
WGAC 1940	580 5,000-LS 1,000-N DA	Twin States Bcstg. Co. WGAC Bldg. 22692	ABC Avery-Knodel	A. D. (Jess) Willard, Pres. & Gen. Mgr.	Warren Hites, Prog. Dir. John B. Vance, Prom. Mgr. John Jopling, Chief Engr.
WJBF 1946	1230 250	The Georgia-Carolina Bcstg. Co. WJBF Bldg. 4-2421	NBC Taylor-Borroff	J. B. Fuqua, Pres. & Gen. Mgr. D. M. Kelly Jr., Sta. Mgr. Steve D. Manderson, Coml. Mgr.	John B. Vance, Prog. Dir. Fred Runde, Prom. Mgr. C. M. Callicott, Chief Engr. World UP Raytheon
WRDW 1930	1480 5,000 DA-N	Radio Augusta Inc. 8th & Broad Sts. 2-8805	CBS Hollingbery	W. R. Rington, Mgr.	Wm. B. Smart, Sales Mgr. Lang-Worth World UP
BAINBRIDGE					
WMGR 1946	1490 250	S. Marvin Griffin Faceville Highway	MBS	S. Marvin Griffin, Gen. Mgr.	

DA-N Directional Antenna, night only. FM's in italic. *—Non-Commercial Station D—Day N—Night. ST—Share Time. SH—Specified Hours.
 DA-1 Directional Antenna, same pattern day and night. U—Unlimited. CP—Construction Permit Issued. LS—Local Sunset.
 DA-2 Directional Antenna, different pattern day and night. L—Limited Time with Dominant Station. SA—Special Authorization.

PENETRATION!

399,130 RADIO HOMES*

1st MARKET IN SOUTHEAST

**82% PENETRATION OF RADIO FAMILIES
IN GREATER ATLANTA AREA AT LOWEST
COST PER THOUSAND***

**RIGHT COMBINATION OF LOCAL
AND NET PROGRAMS**

LOCAL RESULTS

ATLANTA MERCHANTS USE THE
STATION THAT REACHES THE PEOPLE
WHO BUY! WGST HAS 234
LOCAL ACCOUNTS TOTALING
73,008 SPOTS AND PROGRAMS

BROADCAST MEASUREMENT
BUREAU

GEO. HOLLINGBERY
NATIONAL REPRESENTATIVE

WGST

MBS

Atlanta, Georgia

5,000 W · 920 KC

* 1,000 W NIGHT



Premiered Sept. 29, 1948

FIRST in the South

wsb-tv

ON PEACHTREE STREET

BEST in the South

*WSB, AM and FM, and WSB-TV are
affiliates of The Atlanta Journal*

DIRECTORY OF AM, FM, and TV STATIONS OF THE UNITED STATES

*(Data corrected to December 6, 1949)
If executives or services for FM or TV stations are same as AM affiliate names are not repeated.*

GEORGIA—(Continued)

City	Call Letters Established	Chan. or Freq. Power	Name of Licensee Headquarters Address Telephone Number	Network Representative	Executive Personnel	Transc. Library News Service Transmitter Make	
BRUNSWICK							
	WGIG 1949	1440 1,000 DA-N	Brunswick Bcstg. Corp. 1514 Union St. 2714		Alan Burke, Gen. Mgr. John Lane, Coml. Mgr.	Ted Booth, Prog. Dir. Herman Lange, Chief Engr.	Associated AP Gates
	WMOG 1940	1490 250	Coastal Bcstg. Co. Inc. St. Simons Island Causeway 1500	MBS	(Mrs.) Alma W. King, Pres. Kenneth E. White, V. P., Gen. & Coml. Mgr.	Sidney Hargraeves, Chief Engr.	Lang-Worth UP RCA
CAIRO							
	WGRA (CP) 1947	1300 1,000-D	Grady-Mitchell Bcstg. Co.				
CARROLLTON							
	WLBB 1947	1100 250-D	Carroll Bcstg. Co. Peoples Bank Bldg. 980	GALS	Tom K. Vassey, Gen. Mgr. Chesley Hooper, Coml. Mgr. & Chief Engr.	James C. Dunaway, Prog. Dir. Dale Smith, Prom. Mgr.	Lang-Worth, SESAC UP Raytheon
CARTERSVILLE							
	WBHF 1946	1450 250	W. Ryan Frier Cartersville 1200	MBS, KBS GALS	W. Ryan Frier, Owner & Gen. Mgr.	James H. New, Prom. Mgr. John Doherty, Chief Engr.	Lang-Worth UP
CEDARTOWN							
	WGAA 1941	1340 250	Northwest Georgia Bcstg. Co. West Theatre Bldg., 777	ABC KBS GALS	O. C. Lam, Pres. William B. Estes, Gen. & Coml. Mgr.	Rowena W. Murphy, Prog. Dir. Paul Mason, Prom. Mgr. Gary C. Hunt, Chief Engr.	World AP RCA
	WGAA-FM 1948	Ch. 241 (B) 96.1mc 5.5kw					
COLUMBUS							
	WDAK 1940	1340 250	Radio Columbus Inc. Martin Bldg. 5447	NBC Headley-Reed	Allen M. Woodall, Pres. Miles H. Ferguson, Mgr. W. S. Massie, Coml. Mgr.	John Nolan, Prom. Mgr. & Prog. Dir. Hudie Brown, Chief Engr.	World AP RCA
	WDAK-FM 1948	Ch. 300 (B) 107.9mc 10kw					
	WGBA 1947	1460 1,000 DA-1	Georgia-Alabama Bcstg. Corp. 1213½ Broadway	ABC, MBS Branham	Walter M. Windsor, Gen. Mgr.		Associated Lang-Worth Capitol, AP, UP
	WGBA-FM 1946	Ch. 236 (B) 95.1mc 9kw					
	WRBL 1928	1420 5,000 DA-N	Columbus Bcstg. Co. 13th Ave. & 14th St. 2-0601	CBS Hollingbery	J. W. Woodruff Sr., Pres. J. W. Woodruff Jr., Exec. & Coml. Mgr.	George A. Gingell, Prog. Dir. Walter Mitchell, Prom. Mgr. Joe A. Gamble, Chief Engr.	Standard UP, INS Western Electric General Electric
	WRBL-FM 1946	Ch. 277 (B) 93.3mc 46.2kw					
CORDELE							
	WMJM 1940	1490 250	Southeastern Bcstg. System 20th Ave. & B St. 666	MBS, KBS	James S. Rivers, Pres. William E. Blizzard Jr., Gen. Mgr. Willard Belote, Coml. & Prom. Mgr.	Bryant Lane, Prog. Dir. Reo Chirland, Chief Engr. UP RCA
COVINGTON							
	WMOC 1946	1490 250	The Covington News Inc. 615 Monticello St. 2275	MBS	A. Belmont Dennis, Pres.		
DALTON							
	WBLJ 1940	1230 250	Dalton Bcstg. Corp. Kenemer Bldg. 1180	MBS, KBS GALS	H. C. Kenemer, Pres. J. F. McGinley, Gen. Mgr.	John S. Andrews, Chief Engr.	Capitol, SESAC UP Gates
DAWSON							
	WDWD 1948	990 1,000-D	Dawson Bcstg. Co. Parrot 415	GALS	Ed Stevens, Pres. W. C. Woodall Jr., Gen. & Coml. Mgr.	Olyn L. Gee, Prog. Dir. Joe Stephens, Chief Engr.	Lang-Worth UP Collins
DECATUR							
	(Atlanta) WEAS 1947	1010 10,000-D DA	E. D. Rivers Jr. 217 W. Ponce De Leon Ave. Dearborn 2521	Pearson	E. D. Rivers Jr., Owner & Gen. Mgr. Warren Roberts, Prog. Dir.	Ben Gunn, Prom. Mgr. Wm. H. Keller, Chief Engr.	World AP RCA
	WGLS 1949	970 1,000-D	DeKaib Bcstg. Co. 548 N. McDonough St. Crescent 6471	GALS, LBS Friedenberg	Frank G. Thomas, Pres. A. R. Bruckner Jr., Sta. Mgr. Robert W. Mock, Coml. Mgr.	Preston Charles, Prog. Dir. Robert W. Minton, Chief Engr.	Standard UP Gates
DOUGLAS							
	WDMG 1947	860 1,000-D	WDMG Inc. 118 So. Madison Ave. 564		Downing Musgrove, Pres. B. F. J. Timm, Gen. Mgr.	Terry Kleithy, Prog. Dir. Al Woodson, Chief Engr.	SESAC, World UP Raytheon
	WDMG-FM (CP)	Ch. 239 (B) 95.7mc.; 4.9kw					
DUBLIN							
	WMLT 1945	1340 250	Dublin Bcstg. Co. Dublin 871	MBS, KBS GALS Continental	George T. Morris, Pres. W. Newton Morris, Gen. Mgr. J. Marion Kendrick, Coml. Mgr.	Roy M. Hubbard, Prog. Dir. Charles R. Lord, Chief Engr.	Thesaurus AP
EAST POINT							
	WTJH 1949	1260 1,000-D	Southeastern Bcstg. System P. O. Box 72	KBS	James S. Rivers, Pres. & Gen. Mgr. James Brown, Coml. & Prom. Mgr.	Jack Barton, Prog. Dir. Bruce Smith, Chief Engr. INS RCA
ELBERTON							
	WSGC 1946	1400 250	Elberton Bcstg. Co. Elberton	MBS, KBS Continental	Melvin C. Gorman, Mgr.	 AP
FITZGERALD							
	WBHB 1946	1240 250	Ben Hill Bcstg. Corp. 601 W. Roanoke Dr. 740	MBS	Arthur Carpenter Jr., Pres. Thomas R. Hanssen, Gen. Mgr. & Chief Engr.	Charles W. Dowdy, Coml. Mgr. Mavis Mobley, Prog. Dir. AP Gates

DA-N Directional Antenna, night only. FM's in italic.
DA-1 Directional Antenna, same pattern day and night.
DA-2 Directional Antenna, different pattern day and night.

*—Non-Commercial Station D—Day, N—Night, ST—Share Time, SH—Specified Hours.
U—Unlimited, CP—Construction Permit Issued, LS—Local Sunset.
L—Limited Time with Dominant Station, SA—Special Authorization.

Only a combination of stations can cover Georgia's first three markets

WAGA
ATLANTA
5000 W • 590 Kc

WMAZ
MACON
10,000 W • 940 Kc

WTOC
SAVANNAH
5000 W • 1290 Kc

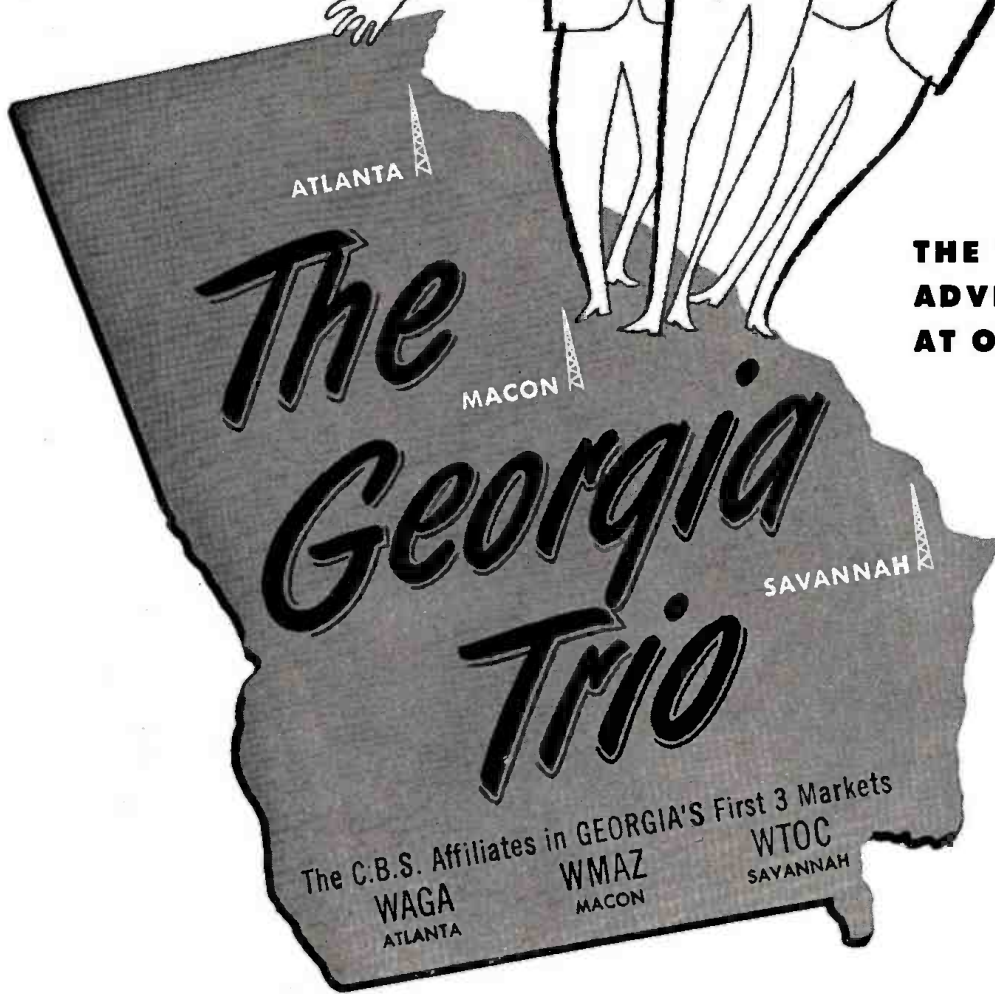

THE TRIO OFFERS ADVERTISERS AT ONE LOW COST:

- Concentrated coverage
- Merchandising assistance
- Listener loyalty built by local programming
- Dealer loyalties

— in Georgia's first three markets

THE KATZ AGENCY, INC. Represented, individually and as a group, by
New York • Chicago • San Francisco • Dallas
Atlanta • Detroit • Kansas City • Los Angeles

DIRECTORY OF AM, FM, and TV STATIONS OF THE UNITED STATES

*(Data corrected to December 6, 1949)
If executives or services for FM or TV stations are same as AM affiliate names are not repeated.*

GEORGIA—(Continued)

City Call Letters Established	Chan. or Freq. Power	Name of Licensee Headquarters Address Telephone Number	Network Representative	Executive Personnel	Transc. Library News Service Transmitter Make	
GAINESVILLE						
WDUN 1949	1400 250	Northeast Georgia Bcstg. Co. 217½ South Main St. 2341	GALS, LBS	Paul C. Plaginos, Pres. John W. Jacobs Jr., Gen. Mgr. David A. Rankin, Coml. Mgr.	Hub Terry, Prog. Dir. Jackson A. Dodd, Chief Engr.	Capitol AP General Electric
WDUN-FM 1949	Ch. 280 (A) 103.9mc 0.3kw					
WGGA 1941	1240 250	Blueridge Bcstg. Co. 2400 Athens Rd. 1600	MBS KBS	Charles Smithgall, Pres. & Gen. Mgr. E. F. MacLeod, Coml. Mgr.	Robert Schwab, Prog. Dir. Harold Keen, Prom. Mgr. F. Keith Brown, Chief Engr.	Lang-Worth UP RCA
GRIFFIN						
WKEU 1934	1450 250	Radio Station WKEU P.O. Box 155 5507	MBS, KBS GALS Sears & Ayer	A. W. Marshall Jr., Pres. & Gen. Mgr.	G. H. Whitley Jr., Coml. Mgr., Prog. Dir. & Chief Engr.	UP Gates
HARTWELL						
WKLY 1947	980 1,000-D	Louie L. Morris Box 189 71		Louie L. Morris, Pres. Max G. Pfaender, Exec. V. P. Joe B. Wilder, Asst. Mgr.	Carroll S. Lee, Prog. Dir. Ernest Church, Chief Engr.	Capitol UP Gates
JESUP						
WBGR 1949	1370 1,000-D	The Altamaha Bcstg. Co. Jesup 2444	KBS	W. Glenn Thomas, Pres. & Gen. Mgr. Fred Milikin, Coml. Mgr.	Fredric Kea, Prog. Dir. & Prod. Mgr. D. A. Nichols, Chief Engr.	Standard UP Raytheon
LaGRANGE						
WLAG 1941	1240 250	LaGrange Bcstg. Co. 305 Broome St. 3505	MBS McGillvra	Roy C. Swank, Pres. Edwin Mullinax, Gen. & Coml. Mgr.	John Boggess, Prog. Dir. Herb Wells, Prom. Mgr. J. M. McKay, Chief Engr.	Standard UP Gates
WLAG-FM 1948	Ch. 238 (B) 104.1mc 5.1kw	8222				
MACON						
WBML 1940	1240 250	Middle Ga. Bcstg. Co. Ficking & Walker Bldg. 2728	ABC Taylor-Borroff	E. D. Black, Pres. Charles W. Pittman, Gen. Mgr. Walter Graham, Coml. Mgr.	Mary H. Richardson, Prog. Dir. Lewis Smith, Prom. Mgr. H. S. Goodrich, Chief Engr.	World AP RCA
WBML-FM 1947	Ch. 264 (B) 100.7mc 15kw					
WIBB 1948	1280 1000-D	Peach State Bcstg. Co. Inc. Professional Bldg. Ivy 2716	LBS GALS	M. O. Thornburg Jr. } Owners Thomas H. Maxwell } M. O. Thornburg Jr., Gen. Mgr. George W. Patton, Coml. Mgr.	Marion Bragg, Prog. Dir. Donald C. Frost, Prom. Mgr. Thomas H. Maxwell, Chief Engr.	Thesaurus UP Raytheon
WMAZ 1922	940 10,000 DA-2	Southeastern Bcstg. Co. Bankers Insurance Bldg. 3131	CBS Katz	George P. Rankin, Pres. & Chief Engr. Wilton Cobb, Gen. Mgr. & Prog. Dir.	Frank Crowther, Coml. & Prom. Mgr.	Lang-Worth INS General Electric
WMAZ-FM 1947	Ch. 256 (B) 99.1mc 32kw					
WNEX 1945	1400 250	Macon Bcstg. Co. Bibb Bldg. 8211	MBS Georgia ForJoe	E. M. Lowe, Pres. Alfred Lowe, Gen. Mgr. & Prog. Dir.	James H. Weathers, Coml. Mgr. Wm. M. Moore Jr., Chief Engr.	Capitol AP Western Electric
WNEX-FM 1948	Ch. 245 (B) 96.9mc 41kw					
MARIETTA						
WFOM 1946	1230 250	Chattahoochee Bcstrs. S. Cobb Dr. 1746	GALS	Fred B. Wilson } Owners Channing Cope } Albert L. Jones, Gen. Mgr.	John Bacheller, Coml. Mgr. Gloria Rogerson, Prog. Dir. Lynne Brannen, Chief Engr. AP Raytheon
MILLEDGEVILLE						
WMVG 1946	1450 250	Jere N. Moore Georgia Military College 250	MBS, KBS Georgia GALS Griffith	Jere N. Moore, Pres. Michael T. Landy, Gen., Coml. & Prom. Mgr.	Josephine Ragsdale, Prog. Dir. Robbie O. Hattaway, Chief Engr.	World UP Gates
MOULTRIE						
WMGA 1939	1400 250	John F. Pidcock Moultrie 999	KBS GALS Clark	John F. Pidcock, Pres. & Gen. Mgr. Roy F. Zess, Sta. & Prom. Mgr. & Prog. Dir.	A. Wandell Murphy, Coml. Mgr. Lamar Beaty, Chief Engr. UP RCA
NEWMAN						
WCOH 1947	1400 250	Newman Bcstg. Co. 11 Court Sq. 1400		James Thomasson, } Ida Thomasson } Partners E. W. Thomasson } D. T. Manget }	James Thomasson, Gen. & Coml. Mgr. Betty Bonner, Prog. Dir. Walter O. Welch, Chief Engr.	World AP Collins RCA
WCOH-FM 1947	Ch. 222 (B) 92.3mc 4.2kw					
QUITMAN						
WKMA 1947	1490 250	Radio South Walker Bldg. 4811		John R. Barlett, Owner & Coml. Mgr.	Elizabeth Barlett, Prog. Dir. Jack V. Lo Presti, Chief Engr. UP RCA
ROME						
WLAQ 1947	670; CP-1410 1,000-D; CP-1,000 DA-N	News Tribune Pub. Co. Rome 21511	KBS	Burgett Mooney Sr., Pres. Robert C. Leach, Gen. & Coml. Mgr.	William B. Davies, Prog. Dir. George W. Rice, Prom. Mgr. Dan Scott, Chief Engr.	Capitol AP, UP, INS Raytheon
WRGA 1929	1470 5,000 DA-N	Rome Bcstg. Co. Nat'l. City Bank Bldg. 2-2411	MBS Walker	John W. Quarles, Pres. Happy Quarles, Gen. Mgr. Mather Payne, Sta. Mgr. Pinkie Talley, Coml. Mgr.	Jim Roberts, Prog. Dir. & Prom. Mgr. R. L. Starr, Chief Engr.	Lang-Worth UP Westinghouse General Electric
WRGA-FM 1947	Ch. 293 (B) 106.5mc 1.4kw					
WROM 1946	710 1,000-D	Coosa Valley Radio Co. 121½ Broad St. 9075	McKinney	Dean Covington, Pres. & Coml. Mgr. Edward McKay, Gen. & Prom. Mgr.	Charles Doss, Prog. Dir. Van Murray, Chief Engr. AP Raytheon

DA-N Directional Antenna, night only. FM's in italic.
DA-1 Directional Antenna, same pattern day and night.
DA-2 Directional Antenna, different pattern day and night.

*—Non-Commercial Station D—Day. N—Night. ST—Share Time. SH—Specified Hours.
U—Unlimited. CP—Construction Permit Issued. LS—Local Sunset.
L—Limited Time with Dominant Station. SA—Special Authorization.

DIRECTORY OF AM, FM, and TV STATIONS OF THE UNITED STATES

(Data corrected to December 6, 1949)
If executives or services for FM or TV stations are same as AM affiliate names are not repeated.

GEORGIA—(Continued)

City Call Letters Established	Chan. or Freq. Power	Name of Licensee Headquarters Address Telephone Number	Network Representative	Executive Personnel	Transc. Library News Service Transmitter Make
TOCCOA					
WLET 1941	1450 250	R. G. LeTourneau 423 Prather Bridge Rd. 544	MBS, KBS GALS Clark	R. G. LeTourneau, Pres. Virgle E. Craig, Gen. Mgr. Sam A. Gaines, Coml. Mgr.	Roy E. Gaines, Prog. Dir. Charles H. Gaines, Prom. Mgr. J. Carl Meeks, Chief Engr. UP Gates General Electric
WLET-FM 1947	Ch. 291 (B) 106.1mc 10kw				
VALDOSTA					
WGAF (CP) 1940	910 5,000 DA-N	Valdosta Bcstg. Co.			
WGOV 1940	950 5,000-LS 1,000-N DA-2	E. D. Rivers Hotel Daniel Ashley 1420	MBS Pearson	E. D. Rivers, Owner Mrs. E. D. Rivers, Gen. Mgr. Mary Gorman, Bus. Mgr.	John V. Evans, Prog. Dir. Ralph M. Dennis, Chief Engr. UP Raytheon
WGOV-FM 1948	Ch. 223 (B) 92.5mc 7kw				
VIDALIA					
WVOP 1946	1450 250	Vidalia Bcstg. Co. Mt. Vernon Rd. 327	KBS GALS	M. F. Brice, Pres. Howard C. Gilreath Jr., Gen. Mgr. Jack Kirkland, Coml. Mgr.	Eileen Browning, Prog. Dir. Art Peterson, Prom. Mgr. Warren Smith, Chief Engr. World UP Gates
WAYCROSS					
WAYX 1936	1230 250	Jack Williams 1600 Carswell Ave. 965	MBS, KBS GALS Holman	Jack Williams, Owner John J. Tobola, Gen. & Coml. Mgr.	Gwen Thomas, Prog. Dir. & Prom. Mgr. John E. Legare, Chief Engr. World, Cole UP RCA
WEST POINT					
(Lanett, Ala.) WRLD 1940	1490 250	Valley Bcstg. Co. Inc. West Point 437	ABC, KBS GALS	J. C. Henderson, Pres. & Gen. Mgr. Capers E. Lifsey, Coml. Mgr.	Aileen Love, Prog. Dir. & Prom. Mgr. R. R. Magill, Chief Engr. World AP Western Electric RCA
WRLD-FM 1947	Ch. 275 (B) 102.9mc 10.2kw				
BOISE					
KDSH 1947	950 5,000 DA-N	Boise Valley Bcstrs. Inc. 311 North 10th St. 6820	CBS Free & Peters	Saul Haas, Pres. Westerman Whillock, Gen. Mgr.	Earl Glade Jr., Prog. Dir. & Prom. Mgr. James Johntz Jr., Chief Engr. UP Westinghouse
KGEM 1948	1340 250 CP-1140 10,000 DA-1	Idaho Bcstg. & TV Co. Owyhee Hotel 533	ABC, KBS Rocky Mtn. Hollingbery	Frank C. Carman, Pres. Milo J. Petersen, Gen. Mgr. Al Biorge, Coml. Mgr.	Robert Fleming, Prog. Dir. Hal Cunningham, Prom. Mgr. Richard Eggeston, Chief Engr. Lang-Worth World AP Gates Standard AP, UP RCA
KIDO 1928	1380 2,500-LS 1,000-N	KIDO Inc. Chamber of Commerce Bldg. 660	NBC Blair	Georgia M. Davidson, Pres. Walter Wagstaff, Gen. Mgr. Hugh Shelley, Coml. Mgr.	James McKibben, Prog. Dir. Peter Brooks, Prom. Mgr. Harold Toedtemeyer, Chief Engr.
KIDO-FM 1947	Ch. 291(B) 106.1mc 7kw				
BURLEY					
KBIO 1946	1230 250	KBIO Inc. Box 461 10	ABC Gem Rocky Mtn.	Jessica L. Longston, Pres. Donald R. Pinney, Gen. Mgr. & Chief Engr.	Tess M. Williams, Prog. Dir. & Prom. Mgr. Rudy Rankin, Coml. Mgr. World Lang-Worth UP Western Electric
CALDWELL					
KCID 1947	1490 250	Caldwell Bcstg. Co. Inc. Drawer 1052 1540	Keating Biddick	J. T. LaFond, Pres. H. R. McCosh, Gen. & Coml. Mgr.	Jack J. Link, Prog. Dir. & Prom. Mgr. Jerry Burgess, Chief Engr. World UP RCA
COUER d'ALENE					
KVNI 1946	1240 250	Coeur d' Alene Bcstg. Co. Blackwell Island 1250	MBS Don Lee Hollingbery	Burl C. Hagadone, Pres. Wayne E. Olsen, Mgr. Bernard V. Merriman, Asst. Mgr. in Charge Prod.	Howard Olsen, Chief Engr. Lang-Worth AP RCA
IDAHO FALLS					
KID 1927	1350 5,000-LS 500-N	Idaho Radio Corp. Hotel Bonneville 4	MBS Intermountain Avery-Knodel	Joseph E. Williams, Pres. C. N. Layne, Gen. Mgr. & Chief Engr.	Leonard Wasden, Coml. Mgr. Eugene A. Ackerley, Prog. Dir. & Prom. Mgr. World MacGregor UP
KIFI 1947	1400 250	Eastern Ida. Bcstg. & Telev. Co. 339 Broadway 1054	ABC KBS Rocky Mtn. Hollingbery	J. M. Brady, Pres. & Gen Mgr. Dan W. Kelly, Coml. Mgr. Ken Petersen, Prog. Dir.	James McKague, Prom. Mgr. Blair Nelson, Chief Engr. AP Gates
LEWISTON					
KRLC 1935	1350 1,000 DA-N	H. E. Studebaker Lewis-Clark Hotel 1950	MBS Don Lee Grant	H. E. Studebaker, Pres. Donald Thomas, Gen. Mgr. Robert Taylor, Coml. Mgr.	Bill Dodel, Prog. Dir. Elizabeth Pring, Prom. Mgr. Gene Wilson, Chief Engr. Lang-Worth UP RCA
MOSCOW					
KRPL 1949	1400 250	Interstate Radio Inc. P. O. Box 207 2283	Biddick Continental	T. R. Farrier, Pres. Bert McAllister, Gen. & Prom. Mgr. & Prog. Dir. Jack H. Goetz, Coml. Mgr.	H. C. Young, Chief Engr. World Cole AP
NAMPA					
KFXD 1922	580 1,000 DA-1	Frank E. Hurt & Son Inc. 1024 12th Ave. So. 1200	MBS Intermountain Avery-Knodel	Frank E. Hurt, Pres. & Gen. Mgr. Doyle H. Cain, Coml. Mgr.	W. S. Black, Prog. Dir. & Prom. Mgr. Edward P. Hurt, Chief Engr. Thesaurus Lang-Worth SESAC UP Western Electric General Electric
KFXD-FM 1946	Ch. 270 (B) 101.9 mc 2.5 kw				
POCATELLO					
KEIO 1947	1440 1,000 DA-1	Eastern Idaho Bcstg. & TV Co. Hotel Bannock 3400	ABC, KBS Rocky Mtn. Gem Hollingbery	J. M. Brady, Pres. Chick Crabtree, Gen. Mgr. Jim Schoonover, Coml. Mgr.	Steve Shepard, Prog. Dir. Don Burden, Prom. Mgr. Denzil Musulin, Chief Engr. World AP Gates
KEYY 1946	1240 250	Radio & TV Bcstg. Co. of Ida. 1140 Yellowstone Ave. 1240	MBS Intermountain Avery-Knodel	F. M. Bistline, Pres. Louis F. Haller, Gen. & Coml. Mgr.	Doris MacBride, Prog. Dir. & Prom. Mgr. J. Julian Dennis, Chief Engr. World

DA-N Directional Antenna, night only. FM's in italic.
DA-1 Directional Antenna, same pattern day and night.
DA-2 Directional Antenna, different pattern day and night.

*-Non-Commercial Station D-Day. N-Night. ST-Share Time. SH-Specified Hours.
U-Unlimited. CP-Construction Permit Issued. LS-Local Sunset.
L-Limited Time with Dominant Station. SA-Special Authorization.

City Call Letters Established	Chan. or Freq. Power	Name of Licensee Headquarters Address Telephone Number	Network Representative	Executive Personnel	Transc. Library News Service Transmitter Make
POCATELLO—(Continued)					
KSEI 1926	930 5,000 DA-N	Radio Service Corp. Hotel Whitman 4000	NBC Walker	O. P. Soule, Pres. Henry H. Fletcher, Gen. & Coml. Mgr. Ruthe A. Fletcher, Prog. Dir.	Olive M. Leeney, Prom. Mgr. Ellis W. Call, Chief Engr. Lang-Worth Standard, Cole UP RCA
KSEI-FM 1947	Ch. 243(B) 96.5 mc 1.8 kw				
PRESTON					
KPST 1948	1340 250	Voice of the Rockies Inc. Preston 600	KBS	Rulan Dunn, Mgr.	N. Pratt Smith, Coml. Mgr. Associated Lang-Worth AP
SANDPOINT					
KSPT 1949	1400 250	Bauer Bcstg. Co. Sandpoint 555	KBS	Norman E. & Ione M. Bauer, Partners Norman E. Bauer, Gen. Mgr. Jack Hatch, Asst. & Coml. Mgr.	Ione M. Bauer, Prog. Dir. Marie Rossmiller, Prom. Mgr. Carl I. Hill, Chief Engr. Standard UP Western Electric
TWIN FALLS					
KLIX 1946	1340 250	Southern Idaho Bcstg. & TV Co. Elizabeth Blvd. 2484	ABC Gem, Rocky Mtn. Hollingsbery	Frank C. McIntyre, Pres. & Gen. Mgr. Juneau H. Shinn, Coml. Mgr.	Ian Elliot, Prom. Mgr. Lloyd James, Chief Engr. Capitol World AP
KTFI 1928	1270 5,000-LS 1,000-N	Radio Bcstg. Corp. 241 Main Ave. W. 2400	NBC Weed, Keating	O. P. Soule, Pres. F. M. Gardner, Gen. & Coml. Mgr.	Lenore Parker, Prog. Dir. & Prom. Mgr. Marvin Hartley, Chief Engr. Lang-Worth Standard UP RCA
KTFI-FM 1947	Ch. 259(B) 99.7 mc 3 kw				
KVMV 1946	1450 250	Radio Sales Corp. P.O. Box 511 2002	MBS Intermountain Avery-Knodel	Jack H. Sole, Gen. Mgr.	World UP Collins
WALLACE (Kellogg)					
KWAL 1939	620 1,000 DA-N	Silver Bcstg. Co. Wallace 2111	MBS Holman	Dr. J. R. Binyon, Pres. Robert G. Binyon, Gen. Mgr.	W. Mondell Spencer, Prog. Dir. G. T. Dreher, Chief Engr. World SESAC General Electric
WEISER					
KWEI 1947	1240 250	Inland Bcst. Co. Weiser 700	KBS	Frank Gwilliam, Pres. Claude Cain, Gen. Mgr. Wendall Long, Coml. Mgr.	Don Jones, Prog. Dir. James Carlson, Chief Engr. Lang-Worth Standard AP Western Electric
ILLINOIS					
ALTON					
WOKZ 1948	1570 1,000-D	WOKZ Inc. Hotel Stratford 35506	Sears & Ayer	R. C. Goshorn, Pres. R. L. Rose, Gen. & Coml. Mgr.	Ray Washabaugh, Prog. Dir. Thomas Payton Jr., Chief Engr. Lang-Worth AP Collins
WOKZ-FM 1948	Ch. 260 (B) 99.9mc 9.1kw				
AURORA					
WBNU (FM) 1948	Ch. 280 (A) 103.9mc 1kw	Copley Press Inc. Leland Hotel 4040	Sears & Ayer	Bob Diller, Gen. Mgr. Chick Hearn, Coml. Mgr.	Jack Cunningham, Chief Engr. World AP RCA
WMRO 1938	1280 250-D	Martin R. O'Brien 184 S. River St. 4215		Martin R. O'Brien, Owner & Mgr. Vincent G. Cofey, Gen. Mgr. Jeanne M. Doran, Prog. Dir.	James D. O'Brien, Coml. & Prom. Mgr. John Kitner, Chief Engr. Lang-Worth INS RCA
BELLEVILLE					
WIBV 1947	1060 250-D	Belleville Bcstg. Co. 2100 West Main 5000		P. A. Wnorowski, Gen. Mgr. L. C. Smith, Coml. Mgr.	R. W. Wagner, Prog. Dir. M. M. Mollring, Chief Engr. Thesaurus World AP
BLOOMINGTON					
WJBC 1924	1230 250	Bloomington Bcstg. Corp. 209 East Washington 5281	ABC Pearson	Loring Merwin, Pres. Ellis Atteberry, Gen. Mgr. Joe Hannie, Coml. Mgr.	Fred Muxfeld, Prog. Dir. Nancy Hoose, Prom. Mgr. Ted Bailey, Chief Engr. Lang-Worth SESAC UP RCA
WJBC-FM 1947	Ch. 268 (B) 101.5mc 3.1kw				
BLUE ISLAND					
WRBI (FM) (CP)	Ch. 232 (A) 94.3mc 1kw	South Suburban Bcstg. Co. 12247-49 S. Western Ave.			
BROOKFIELD					
WRGK (FM) 1947	Ch. 276 (A) 103.1mc 1kw	WRGK Inc. 4221 Arthur Ave. 6519		George M. Ives, Pres. & Gen. Mgr. Elmer Mattson, Coml. Mgr.	Rose T. Ives, Prog. Dir. Lee Bigos, Chief Engr. World
CAIRO					
WKRO 1942	1490 250	Oscar C. Hirsch Box 311 1490	MBS Pearson	Oscar C. Hirsch, Pres. Merrill C. Currier, Gen. Mgr.	Charles Housewright, Prog. Dir. UP Gates
CANTON					
WBYS 1947	1560 250-D	Fulton County Bcstg. Co. P. O. Box 554 1877	Sears & Ayer	Harold R. Winsor, Pres. Robert L. Odson, Gen. Mgr. Lee Kramer, Coml. & Prom. Mgr.	Ken Schleifer, Prog. Dir. & Asst. Mgr. John M. Stockberger, Chief Engr. Lang-Worth World AP Gates
WBYS-FM 1948	Ch. 265 (A) 100.9mc 0.65kw				
CARBONDALE					
WCIL 1946	1020 1,000-D	Southern Ill. Bcstg. 219 W. Main St. 167		Paul F. McRoy, Mgr. & Prog. Dir. Walter C. Shafer, Coml. Mgr.	Marlon Sawyer, Chief Engr. Capitol AP Collins Western Electric
WCIL-FM 1948	Ch. 264 (B) 100.7mc 6kw				
CARMI					
WROY 1948	1460 1,000-D	Carmi Bcstg. Co. 101 S. Walnut St. 682		Roy Clippinger, Pres. Thomas S. Land, Gen. Mgr. Howard M. Reedy, Coml. Mgr.	Ken Boultinghouse, Prog. Dir. Harold Vandament, Chief Engr. Lang-Worth UP Collins
CARTHAGE					
WCAZ 1921	990 1,000-D	Superior Bcstg. Service 502 Wabash Ave. 520	Holman	Bob Compton, Pres.	John Palmer, Mgr.

RANDY BLAKE
ON
SUPPERTIME
FROLIC

CHUCK BILL
ON
BREAKFAST
FROLIC

America's
greatest
mail-order
programs
every day ★ 52 weeks a year

WJJD
Chicago
50,000 WATTS
1160 on your dial

26,521 One Dollar subscriptions to
Southern Farmer Publication in 2 weeks.



163,953 responses from 41 states and Canada
in 2½ weeks for McCoy's Cod Liver Oil Tablets.



34,292 orders for a \$2.98 Bible in five weeks.



A One Dollar toy gun received
113,584 orders in 26 weeks.



In 13 weeks 29,858 orders were
received for a \$5.95 midget camera.



40,291 orders for \$1.29 seven strand
necklace in fourteen weeks.

A MARSHALL FIELD STATION, REPRESENTED NATIONALLY BY AVERY-KNODEL

ILLINOIS—(Continued)

City Call Letters Established	Chan. or Freq. Power	Name of Licensee Headquarters Address Telephone Number	Network Representative	Executive Personnel	Transc. Library News Service Transmitter Make	
CENTRALIA WCNT 1946	1210 1,000-D	WCNT Inc. Route 50 234	Sears & Ayer	George F. Isaac, Pres. J. J. Flanigan, Gen. & Coml. Mgr.	Jay Giles, Prog. Dir. Dwight North, Chief Engr.	Standard UP Gates
WCNT-FM 1948	Ch. 243 (B) 93.5mc 67kw					
CHAMPAIGN WDWS 1937	1400 250	The Champaign News-Gazette Inc. 48 Main St. 6-1855	CBS Mceker	Marc Howard, Coml. Mgr.	Robert Schenke, Chief Engr.	World UP General Electric
WDWS-FM 1948	Ch. 248 (B) 97.5mc 27kw					
CHICAGO WAAF 1922	950 1,000-D CP-5,000 DA-2	Corn Belt Pub. Inc. (Drovers Journal Div.) 221 N. La Salle St. Randolph 6-1932	Hollingbery	Ward A. Neff, Pres. W. E. Hutchinson, Gen. Mgr. Bradley Eldmann, Coml. Mgr.	Del Hester, Prog. Dir. Ben Kirk, Prom. Mgr. Carl Ulrich, Chief Engr.	Standard UP RCA Capitol SESAC Lang-Worth UP Western Electric Associated Lang-Worth World AP, UP, INS Federal World SESAC Associated UP RCA
WAAF-FM 1949	Ch. 230 (B) 93.9mc 28kw					
WAIT 1940	820 5,000 L-LS, Dallas	Radio Station WAIT 350 N. Michigan Ave. Franklin 2-0680	Radio Reps	Gene T. Dyer, Pres. Sil M. Aston, Gen. & Coml. Mgr.	Rosemary Petru, Prog. Dir. E. W. Jacker, Chief Engr.	
WBBM 1923	780 50,000	Columbia Bestg. System Inc. 410 N. Michigan Ave. Whitehall 4-6000	CBS Radio Sales	H. Leslie Atlas, V. P. & Gen. Mgr. Frank B. Falknor, Sta. Mgr. Robert Livingston, Sales Mgr.	Al Morey, Prog. Dir. Ralf Brent, Prom. Mgr. George V. Sherman, Chief Engr.	
WBBM-FM 1941	Ch. 246 (B) 97.1mc 13.5kw					
WBIK (FM) 1948	Ch. 242 (B) 95.3mc 19.1kw	Balaban & Katz Corp. 190 N. State St. Randolph 6-8210		John H. Mitchell, Gen. Mgr. E. Jonny Graff, Prog. Dir.	William P. Kusack, Chief Engr.	
WBKB(TV) 1941	Ch. 4 66-72mc 7.5kw-aur.; 11kw-vis.	(WBIK(FM) Affiliate)	CBS Weed	John H. Mitchell, Gen. Mgr. E. Jonny Graff, Prog. Dir.	Wm. Ryan, Prod. Mgr. S. C. Quinlan, Prom. & Pub. Mgr. William P. Kusack, Chief Engr.	

DA-N Directional Antenna, night only. FM's in italic.
DA-1 Directional Antenna, same pattern day and night.
DA-2 Directional Antenna, different pattern day and night.

*—Non-Commercial Station D—Day N—Night ST—Share Time. SH—Specified Hours.
U—Unlimited. CP—Construction Permit Issued. LS—Local Sunset.
L—Limited Time with Dominant Station. SA—Special Authorization.

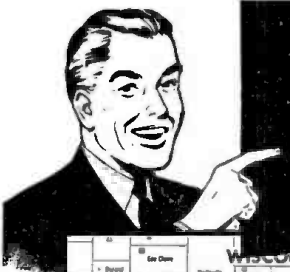

**What does a
coverage map mean?**

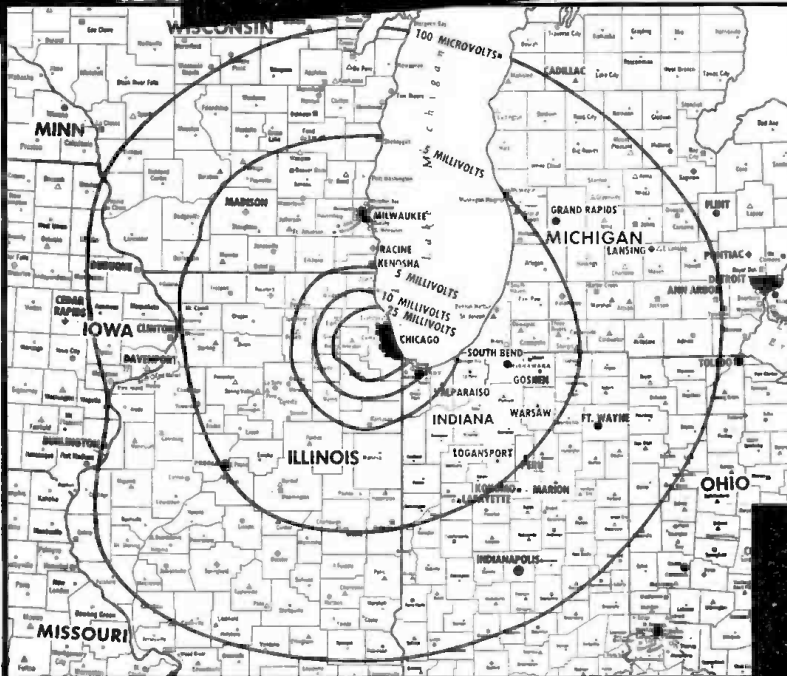

***PLENTY* WHEN YOU'RE SELLING
CHICAGO AND 251 KEY MID-WESTERN
COUNTIES ON WCFL!**

Your sales story on WCFL goes out to Chicago and 251 Key-Counties in 5 rich, middle-western states. This actual audience coverage is based on a 30,000 letter-pattern.

8,289,763 consumers in the *primary*! 5,421,020 in the *secondary*!

**A POTENTIAL \$15,000,000,000
ANNUAL MARKET**

As the *Voice of Labor*, WCFL has a *special tie* with the well-paid craftsman and wage-earners in this prosperous, industrial area.

For full information, contact WCFL or The Bolling Company.

WCFL 50,000 watts
1000 on the dial
THE VOICE OF LABOR An ABC Affiliate

666 Lake Shore Drive, Chicago, Ill.
Represented by The Bolling Company, Inc.

DIRECTORY OF AM, FM, and TV STATIONS OF THE UNITED STATES

(Data corrected to December 6, 1949)
If executives or services for FM or TV stations are same as AM affiliate names are not repeated.

ILLINOIS—(Continued)

City Call Letters Established	Chan. or Freq. Power	Name of Licensee Headquarters Address Telephone Number	Network Representative	Executive Personnel	Transc. Library News Service Transmitter Make	
CHICAGO—(Continued)						
WCBD 1947	820 5,000 SH	Micheal J. Mintern Administration Bldg. Zion, Ill. 521		M. J. Mintern, Mngng. Dir. Carl Q. Lee, Coml. Mgr.		
WCFL 1926	1000 50,000 DA-2	Chicago Federation of Labor 666 Lake Shore Dr. Mohawk 4-2400	ABC Bolling	William A. Lee, Pres. George F. Isaac, Coml. Mgr.	Robert A. Platt, Prog. Dir. Frank McGivern, Prom. Mgr. Charles Willett, Chief Engr.	Standard UP RCA
WCRW 1926	1240 100 SH. WEDC, WSBC	Clinton R. White 2756 Pine Grove Ave. Eastgate 7-6860		Clinton R. White, Owner & Chief Engr.	J. A. White, Gen. & Coml. Mgr. & Prog. Dir.	MacGregor
WEDC 1926	1240 250 SH. WCRW, WSBC	Emil Denemark Inc. 3860 W. Ogden Ave. Crawford 7-4100		Emil Denemark, Pres. Frank J. Kotnour, Gen. & Coml. Mgr.	Bill Mack, Prog. Dir. & Prom Mgr. Dan Ely, Chief Engr. UP
WEFM (FM) 1940	Ch. 258 (B) 99.5mc 30kw	Zenth Radio Corp. 135 S. LaSalle St. State 2-1357		E. F. McDonald Jr., Pres. Ted Leitzell, Gen. Mgr.	Violet Kmety, Prog. Dir. Ross Utter, Chief Engr	Thesaurus Standard
WEHS (FM) (See Cicero)						
WENR 1923	890 50,000 ST-WLS	American Bcstg. Co. 20 N. Wacker Dr. Andover 3-7800	ABC ABC Spot	John H. Norton Jr., V. P. in Chg. Genl. Div. James L. Stirtton, Gen. Mgr. Roy McLaughlin, Coml. Mgr.	Harold Stokes, Prog. Dir. Karl R. Sutphin, Prom. Mgr. E. C. Horstman, Chief Engr. AP, UP, INS RCA
WENR-FM 1948	Ch. 234 (B) 94.7mc 25kw					
WENR-TV 1948	Ch. 7 174-180mc 14kw-aur.; 25kw-vis.			Fred Kilian, Prog. Dir.		
WFJL (FM) 1949	Ch. 226 (B) 93.1mc 29kw	Lewis College of Science & Technology 75 E. Wacker Dr. Financial 6-2121		Rev. Bernard J. Sheil, Pres. Jerry Keefe, Gen. Mgr.	Jim Ameche, Prog. Dir. James J. Krakora Jr., Chief Engr.	World UP General Electric
WGES 1924	1390 5,000 DA-1	Radio Station WGES 2708 Washington Blvd. Sacramento 2-1700		John A. Dyer, Gen. Mgr. Elizabeth M. Hinzman, Coml. Mgr.	Herbert Rudolph, Prog. Dir. K. P. Freda, Prom. Mgr.	Associated UP Western Electric
WGN 1924	720 50,000	WGN Inc. 435 N. Michigan Dr. Superior 7-0100	MBS Keenan- Eickelberg	Col. Robert R. McCormick, Pres. Frank P. Schreiber, Gen. Mgr. Bruce Dennis, Asst. Mgr. William A. McGuineas, Coml. Mgr.	James G. Hanlon, Pub. & Public Relations Dir. Carl J. Meyers, Chief Engr.	Standard AP, UP
WGNB (FM) 1941	Ch. 254 (B) 98.7mc 35kw	(WGN, AM affiliate)		Marton Claire, Dir. Marie Grace, Asst. to Dir.	 General Electric
WGN-TV 1948	Ch. 9 186-192mc 7.2kw-aur.; 11.2kw-vis.		Dumont	Jay Faraghan, Prom. Dir.	 UP General Electric
WIND 1933	560 5,000 DA-2	Johnson-Kennedy Radio Corp. 400 N. Michigan Ave. Whitehall 4-2170	Katz	Paul Harper, Pres. Ralph L. Atlass, Gen. Mgr. John T. Carey, Coml. Mgr.	H. Leslie Atlass Jr., Prog. Dir. Constance Kimble, Prom. Mgr. Kenneth Shirk, Chief Engr.	Standard AP, UP RCA
WJJD 1934	1160 50,000 DA-1 L-KSL	WJJD Inc. 230 N. Michigan Ave. State 2-5466	Avery-Knodel	Marshall Field, Pres. Arthur F. Harre, Gen. Mgr. & Prog. Dir.	Frederick G. Harm, Coml. Mgr. Ed Short, Prom. Mgr. Walter F. Myers, Chief Engr.	Capitol, World Associated Standard UP RCA
WFMF (FM) 1948	Ch. 262 (B) 100.3mc 33kw	(WJJD, AM affiliate)		Ed Wiebe, Prog. Dir.	 Westinghouse
WLS 1924	890 50,000 ST-WENR	Agricultural Bcstg. Co. 1230 Washington Blvd. MOnroe 6-9700	ABC Blair	James E. Edwards, Pres. Glenn Snyder, V. P. & Gen. Mgr. Charles M. Freeman, Coml. Mgr. Harold Safford, Prog. Dir.	John C. Drake, Prom. & Publ. Mgr. Thomas L. Rowe, Chief Engr.	Standard Lang-Worth AP, UP, TP
WMAQ 1922	670 50,000	National Bcstg. Co. Merchandise Mart Superior 7-8300	NBC NBC Spot	Joseph H. McConnell (NBC), Pres. I. E. Showerman, V. P. & Gen. Mgr. Oliver Morton, Sales Mgr.	Arthur Jacobsen, Prog. Dir. Harold A. Smith, Prom. Mgr. Howard Luttgens, Chief Engr.	Standard Thesaurus AP, UP, INS Westinghouse
WMAQ-FM 1948	Ch. 266 (B) 101.1mc 24kw				 RCA
WNBQ (TV) 1949	Ch. 5 76-82mc 11.8kw-aur.; 22.8kw-vis.	(WMAQ, AM affiliate)		Edwin S. Mills, Prog. Dir.		
*WMBI 1926	1110 5,000 L-KFAB, WBT	The Moody Bible In- stitute of Chicago 153 Institute Pl. Michigan 2-1570		Dr. William Culbertson, Pres. R. L. Constable, Gen. Mgr. Robert H. Parsons, Prog. Dir.	John Raymond, Prom. Mgr. A. Paul Frye, Chief Engr.	World UP Western Electric
*WMBI-FM 1949	Ch. 238 (B) 95.5mc 50kw					
WMOR (FM) 1949	Ch. 274 (B) 102.7mc 40kw	Metropolitan Radio Corp. of Chicago, Inc. 188 W. Randolph Andover 3-6050		Ralph J. Wood Jr., Pres. & Gen. Mgr. David Edelson, Coml. Mgr.	Jules Pewowar, Prog. Dir. David B. Pivan, Chief Engr.	Capitol World UP, TP General Electric
WOAK (FM) 1948	Ch. 290 (B) 105.9mc 9.3kw	Gale Bcstg. Co. 4000 Washington Blvd. Sacramento 2-6272		Bernard Jacobs, Pres. & Gen. Mgr.	Jack Shefrin, Prog. Dir.	World AP General Electric

DA-N Directional Antenna, night only. FM's in italic.
DA-1 Directional Antenna, same pattern day and night.
DA-2 Directional Antenna, different pattern day and night.

*—Non-Commercial Station D—Day. N—Night. ST—Share Time. SH—Specified Hours.
U—Unlimited. CP—Construction Permit Issued. LS—Local Sunset.
L—Limited Time with Dominant Station. SA—Special Authorization.



YES! . . . everyone knows the answer to that question. And the answer, year after year, has been the same—**WGN***

This means that advertisers have a better opportunity of having their messages heard on WGN than thru any other Chicago station. This impact

*Nielsen Annual Coverage Report, Feb.-Mar., 1946, 1947, 1948, 1949.

is made possible thru the power, prestige, and programs that are synonymous with WGN.

Sure, surveys point out that WGN is the outstanding station in Chicago, but we've got even more—sales success stories and listener response that prove WGN's effectiveness on that great intangible . . . the listening audience.

Make your next buy, your best buy—WGN

*A Clear Channel Station . . .
Serving the Middle West*

WGN

Chicago 11
Illinois
50,000 Watts
720
On Your Dial



MBS

Eastern Sales Office: 220 East 42nd Street, New York 17, N. Y.

West Coast Representatives: Keenan and Eickelberg
235 Montgomery St., San Francisco 4 • 2978 Wilshire Blvd., Los Angeles 5
710 Lewis Bldg., 333 SW Oak St., Portland 4

DIRECTORY OF AM, FM, and TV STATIONS OF THE UNITED STATES

(Data corrected to December 6, 1949)
If executives or services for FM or TV stations are same as AM affiliate names are not repeated.

ILLINOIS—(Continued)

City Call Letters Established	Chan. or Freq. Power	Name of Licensee Headquarters Address Telephone Number	Network Representative	Executive Personnel	Transc. Library News Service Transmitter Make	
CHICAGO—(Continued)						
WSBC 1925	1240 250 SH WCRW, WEDC	Radio Station WSBC 2400 W. Madison St. Monroe 6-9060	Forjoe	Robert O. Miller, Gen. Mgr. & Prog. Dir.	Julius Miller, Coml. Mgr.	Associated SESAC UP
WXRT (FM) 1948	Ch. 270 (B) 101.9mc 25kw	(WSBC, AM Affiliate) 505 North Michigan Ave. Whitehall 4-1711			 Western Electric
CHICAGO HEIGHTS						
WCHI (FM) 1949	Ch. 240 (A) 95.9mc 0.40kw	Chicago Heights Bcstg. Co. 164 E. 23rd St. 3049		Anthony Santucci, Pres. & Chief Engr.	Dr. F. J. Armbruster, Gen. Mgr. Henry E. Bruns, Prog. Dir.	
CICERO						
WHFC 1925	1450 250	WHFC Inc. 6138 W. Cermak Rd. Olympic 4305	Holman	R. W. Hoffman, Gen. Mgr.		
WEHS (FM)	Ch. 258 (B) 97.9mc 16kw	(WHFC, AM Affiliate)				
CLINTON						
WHOW 1947	1520 1,000-D	Cornbelt Bcstg. Co. 401 South Side of Square 305	Holman	Dr. Keith Rhea, Pres. Frank C. Jennings, Gen. Mgr. Jim Williams, Coml. Mgr.	Jack Carson, Prog. Dir. William Wilson, Chief Engr.	Standard UP RCA
DANVILLE						
WDAN 1938	1490 250	Northwestern Pub. Co. 1500 N. Washington Ave. 1700	CBS McKinney	E. C. Hewes, Gen. Mgr. Robert J. Burrow, Sta. & Prom. Mgr.	(Miss) Honore E. Ronan, Prog. Dir. T. G. Magin, Chief Engr.	World UP RCA
DECATUR						
WDZ 1921	1050 1,000-D	WDZ Bcstg. Co. 265 S. Park St.	Free & Peters	Charles C. Caley, Pres. Frank C. Schroeder Jr., Gen. Mgr. Edgar L. Bill, V. P.	Howard G. Bill, Coml. Mgr. William F. Miller, Prog. Dir. A. James Ebel, Chief Engr.	World, Capitol UP Gates
WSOY 1925	1340 250	Illinois Bcstg. Co. Rt. 48 at N Jasper St. 5371	CBS Weed	F. W. Schaub, Pres. Merrill Lindsay, Gen. Mgr. Charles F. Bruce, Coml. & Prom. Mgr.	Bernard J. Johnson, Prog. Dir. Milburn H. Stuckwish, Tech. Dir.	Lang-Worth AP Temco
WSOY-FM 1946	Ch. 271 (B) 102.1mc 31.2kw				 RCA

DA-N Directional Antenna, night only. FM's in italic.
DA-1 Directional Antenna, same pattern day and night.
DA-2 Directional Antenna, different pattern day and night.

*—Non-Commercial Station D—Day. N—Night. ST—Share Time. SH—Specified Hours.
U—Unlimited. CP—Construction Permit Issued. LS—Local Sunset.
L—Limited Time with Dominant Station. SA—Special Authorization.

NEW Sales
with the **NEW**



Audience in Chicago

Good music loving homes — with higher income families — are served exclusively by WXRT. Preference for WXRT programs is 438%* greater than all other competitive stations combined and 70%* of good music loving families listen to WXRT more than to all others combined. Most important — these families buy WXRT advertised goods and services* Join the many advertisers now profiting from this NEW Chicago Area Market.

WXRT "The Good Music Station" at 101.9 on the FM dial

SHERATON HOTEL + 505 N. MICHIGAN AVE. + CHICAGO 11, ILLINOIS + Whitehall 4-1711

*Send for the facts and figures and the advertisers' success stories in the WXRT SURVEY of this NEW Chicago Area Audience.

City Call Letters Established	Chan. or Freq. Power	Name of Licensee Headquarters Address Telephone Number	Network Representative	Executive Personnel	Transc. Library News Service Transmitter Make
DE KALB					
WLBK 1947	1360 500-D	De Kalb Radio Studios 153½ N. Third St. 2877	Ra-Tel	Ted Lanes, Bus. Mgr.	AP
EAST ST. LOUIS					
WTMV 1935	1490 250	WTMV On the Air Inc. Hotel Broadview Bridge 4625	Weed	Alvin O. Eades, Pres. Frank J. Prendergast, Gen. & Coml. Mgr. Elmer F. Wiltrich, Asst. Mgr.	World UP RCA
WTMV-FM 1949	Ch. 273 (B) 102.5mc 33.2kw				
EFFINGHAM					
WCRA 1946	1090 250-D	Effingham Bcstg. Co. 112½ N. Banker 1090		Joseph E. McNaughton, Pres. & Gen. Mgr. Joseph M. Sutter, Coml. Mgr.	Stuart N. Sanders, Prog. Dir. Paul E. Harris, Chief Engr.
ELGIN					
WRMN 1949	1410 500-D	The Elgin Bcstg. Co. Fox Hotel 6930	McGillvra	George A. Ralston & Jerry C. Miller, Partners	George A. Ralston, Gen. & Coml. Mgr. & Chief Engr. Kay Nysten, Prog. Dir.
ELMWOOD PARK					
WLEY (FM) 1948	Ch. 296 (A) 107.1mc 1kw	Elmwood Park Bcstg. Corp. 2526 N. Harlem Ave. Gladstone 3-5466		Zeb Zarnecki, Pres., Gen. & Coml. Mgr. & Prog. Dir.	Walter J. Troftmuk, Chief Engr.
EVANSTON					
WEAW (FM) 1948	Ch. 286 (B) 105.1mc 36kw	Northshore Bcstg. Co. Inc. 2425 Main St. University 4-4606	Continental FM	Edward A. Wheeler, Pres. & Gen. Mgr. Robert Moran, Coml. Mgr.	Doris Peterson, Prog. Dir. Sidney Schneider, Chief Engr.
WNMP 1947	1590 1,000-D	Evanston Bcstg. Co. 2201 Oakton St. Sheldrake 3-1590		Fred S. Newton, Pres. Angus D. Pfaff, Gen. & Coml. Mgr.	Frederick H. Schmutz, Prod. Mgr. L. J. Schnedorf, Chief Engr.
WTQS (FM) (CP) 1947	Ch. 300 (B) 107.9mc 30kw	Lake Shore Bcstg. Co.			Thesaurus INS RCA
FREEPORT					
WFJS (FM) 1946	Ch. 273 (B) 102.5mc 9kw	Freeport Journal-Standard Pub. Co. 217 West Exchange St. 504		Donald L. Breed, Pres. John D. Holmes, Sta. Mgr.	Les Boret, Coml. Mgr. & Prog. Dir. Floyd Linneman, Chief Engr.
WFRL 1947	1570 1,000-D	Freeport Bcstg. Co. Inc. 9 N. Chicago Ave. State 438	Sears & Ayer	Vincent S. Barker, Pres., Gen. Mgr. & Chief Engr.	Dave Taylor, Coml. Mgr. Arthur Hanstrom, Prog. Dir.

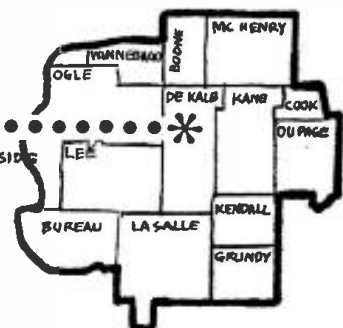

*The "Corn Capital City"
of the Nation
DE KALB, ILL.
Home of Famous Dekalb Hybrids

*is the Key to the Rich
Agricultural and Industrial
Market of Northern Illinois . . .*

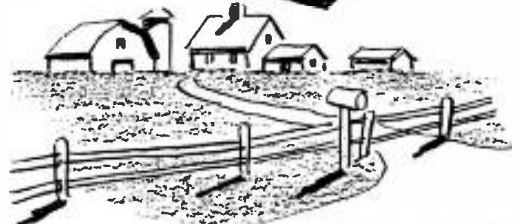

● POTENTIAL OF
192,188 RADIO HOMES
23,367 FARMS

● OFFERING
1,000 FAMILIES
CIRCULATION FOR 12 CENTS

1360 kc

500 watts

WRITE - WIRE - PHONE TODAY! RA-TEL Representatives

DIRECTORY OF AM, FM, and TV STATIONS OF THE UNITED STATES

*(Data corrected to December 6, 1949)
If executives or services for FM or TV stations are same as AM affiliate names are not repeated.*

ILLINOIS—(Continued)

City Call Letters Established	Chan. or Freq. Power	Name of Licensee Headquarters Address Telephone Number	Network Representative	Executive Personnel	Transc. Library News Service Transmitter Make	
GALESBURG						
WGIL 1938	1400 250	Galesburg Bcstg. Co. 312 Hill Arcade 4626	MBS McGeehan & O'Mara	Mrs. Milton Schmith, Pres. R. W. Frudeger, Gen. & Coml Mgr.	Elizabeth Harler, Prog. Dir. E. D. Scandrett, Chief Engr.	Standard UP
HARRISBURG						
WEBQ 1923	1240 250	Harrisburg Bcstg. Co. 100 E. Poplar St. 28	KBS	Inglis M. Taylor, Gen. & Coml. Mgr. Norma Alexander, Prog. Dir.	Ken Hamilton, Prom. Mgr. Elmer Gladson, Chief Engr.	UP Western Electric Federal
WEBQ-FM 1948	Ch. 260 (B) 99.9mc 4.2kw					
HERRIN						
WJPF 1940	1340 250	Orville W. Lyerla P. O. Box 179 382	MBS Pearson	Orville W. Lyerla, Pres. Chas. R. Cook, Gen. & Coml. Mgr.	Ryburn Vandell, Chief Engr. Fred Simmons, Local Sales Mgr.	Lang-Worth UP RCA
WJPF-FM 1947	Ch. 253 (B) 98.5mc 0.5kw					
JACKSONVILLE						
WLDS 1949	1180 1,000-D	Edge & Korsmeyer Fox III. Theatre Bldg. 1180	Holman	Milton Edge & E. J. Korsmeyer, Owners E. J. Korsmeyer, Gen. & Coml. Mgr.	T. J. Fairburn, Prog. Dir. G. J. Cassens, Chief Engr.	Standard UP Gates
WLDS-FM 1949	Ch. 263 (B) 100.5mc 7.3kw					
JOLIET						
WJOL 1929	1340 250	Joliet Bcstg. Co. 801 Walnut St. 4781	McGillivra	Calvin Wilson, Pres. Joseph J. Garvey, Gen. & Coml. Mgr.	Eileen Caron, Prog. Dir. William Charnley, Prom. Mgr. Lester DeCosta, Chief Engr.	Lang-Worth UP Gates
KANKAKEE						
WKAN 1947	1320 1,000-D	Kankakee Daily Journal Co. 183 N. Schuyler Ave., 3-6633 (WKAN, AM affiliate)	Holman	Leslie C. Small, Pres. Burrell Small, Gen. Mgr. Bruce Brown, Sta. Mgr.	Wayne Center, Prog. Dir. Robert Harrell, Chief Engr.	AP World, Stand. Raytheon Federal
WKIL (FM) 1947	Ch. 264 (B) 100.7mc 73kw					
LASALLE						
WFMX (FM) 1947	Ch. 295 (B) 106.9mc; 13kw	Radio Bcstg. Corp. 945 Bluff St., Peru, Ill.				
WLPO 1947	1220 250-D	LaSalle County Bcstg. Corp. P. O. Box 399, 3100		Ruth Elizabeth Miller, Pres. William Holm, Gen. & Coml. Mgr.	Joseph Terrando, Prog. Dir. & Prom. Mgr. Lawrence McCann, Chief Engr.	Lang-Worth World AP. Gates
LINCOLN						
WPRC 1949	1370 500-D	Prairie Radio Corp. P. O. Box 406 209		Ray F. Knochel, Pres. & Chief Engr. John H. Deal, Acting Coml. Mgr.	Allyne V. Nugent, Prog. Dir. & Prom. Mgr. Lee N. Hamm, Acting Prom. Mgr.	AP Collins
MACOMB						
WKAI 1947	1510 250-D	Macomb Bcstg. Co. 113 E. Carroll 1350		James C. Bailey, Pres. Lyle B. Landis, V. P., Gen. & Coml. Mgr.	Eugene F. Spry, Prog. Dir. James C. Bailey, Prom. Mgr. Maurice Riggins, Chief Engr.	Thesaurus SESAC UP. Gates
MARION						
WGGH 1947	1150 500-D	Marion Bcstg. Co. R. R. #4 824		Hartley Grisham, Partner & Gen. Mgr.	George W. Dodds, Partner & Chief Engr. John Owen Weaver, Prog. Dir.	Associated AP Gates
MATTOON						
WLBH 1946	1170 250-D	Mattoon Bcstg. Co. 17th & Broadway Ave. 3800	Holman	J. R. Livesay, Pres. & Gen. Mgr. R. O. Looper, Coml. Mgr. R. F. LaMere, Prog. Dir.	Dwain Bower, Prom. Mgr. Ray Livesay, Chief Engr.	Capitol AP Raytheon Gates
WLBH-FM 1949	Ch. 245 (B) 96.9mc 23kw					
MOLINE						
WQUA 1946	1230 250	Moline Bcstg. Corp. 1319 5th Ave. 7000	MBS Rambeau	Bruff W. Olin Jr., Pres., Treas. & Gen. Mgr. G. V. LaVerne Flambo, Exec. V. P. & Coml. Mgr.	Jack Davis, Prog. Dir. Lawrence J. Lynch, Chief Engr.	World AP Collins
MT. CARMEL						
WVMC 1948	1360 500-D	Mt. Carmel Bcstg. Co. 114½ W. 4th St. 937		Charles Vandever, Pres. & Owner Jerrill Henry, Gen. & Coml. Mgr. & Prog. Dir.	Raymond E. Luth, Chief Engr.	Capitol UP Gates
MT. VERNON						
WMIX 1947	940 1,000-D	Mt. Vernon Radio & Tele. Co. Mt. Vernon, 3500	Pearson	John R. Mitchell, Pres.		Lang-Worth AP Western Electric General Electric
WMIX-FM 1947	Ch. 231 (B) 94.1mc 15.2kw					
OAK PARK						
WEBS (CP)	1490 250	Village Bcstg. Co.				
WNOI (FM)	Ch. 272 (A) 102.3mc; 1kw	% Wm. L. Klein 301 E. Erie St., Chicago				
WOAK (FM)	Ch. 290 (B) 105.9mc; 9.3kw	Gale Bcstg. Co. % Bernard Jacobs 4000 W. Washington Blvd., Chicago, Ill.				
OLNEY						
WVLN 1947	740 250-D	Olney Bcstg. Co. Olney 935	Holman	Marshall H. Poole, Pres., Gen. & Coml. Mgr.	James H. Butler, Prog. Dir. James H. Weber, Chief Engr.	Standard AP Collins
PEKIN						
WSIV 1946	1140 1,000-D	Pekin Bcstg. Co. Inc. 16 So. Capitol 1747	Holmar	W. Kenneth Patterson, Pres. & Gen. Mgr. J. Ed Henry, Coml. Mgr.	Robert R. Snow, Prog. Dir. George C. Udry, Prom. Mgr. Emil Prandoni, Chief Engr.	AP Gates

DA-N Directional Antenna, night only. FM's in italic.
DA-1 Directional Antenna, same pattern day and night.
DA-2 Directional Antenna, different pattern day and night.

*-Non-Commercial Limited Time with Dominant Station. SA-Special Authorization.
U-Union Station D-Day. N-Night. ST-Share Time. SH-Specified Hours.
L-ited. CP-Construction Permit Issued. LS-Local Sunset.

City Call Letters Established	Chan. or Freq. Power	Name of Licensee Headquarters Address Telephone Number	Network Representative	Executive Personnel	Transc. Library News Service Transmitter Make	
PEORIA						
WEEK 1947	1350 1,000 DA-2	West Central Bcstg. Co. 1000 Comm'l. Nat'l. Bank Bldg. 3-3683	NBC Headley-Reed	Sen. Robert S. Kerr, Pres. Fred C. Mueller, Gen. Mgr. Tom Greer, Coml. Mgr.	George Cremeens, Prog. Dir. Montez Tjaden, Prom. Mgr. Wayne Lovely, Chief Engr.	World AP Gates
WIRL 1948	1290 5,000 DA-2	Illinois Valley Bcstg. Co. 115 N. Jefferson Ave. 4-9239	ABC Avery-Knodel	Timothy W. Swain, Pres. Robert B. Jones Jr., Gen. Mgr. Thomas Gavin, Coml. Mgr.	Harlan E. Ralston, Prog. Dir. Jack Lawrence, Prom. Mgr. Rudolph Luukinen, Chief Engr.	Standard UP Westinghouse
WMBD 1927	1470 5,000 DA-N	Peoria Bcstg. Co. 212 S. Jefferson Ave. 6-0711	CBS Free & Peters	Edgar L. Bill, Pres. Charles C. Caley, Exec. V. P. Don D. Kynaston, Coml. Mgr.	Charles Barnhart, Prog. Dir. Florence F. Luedeke, Prom. Mgr. A. James Ebel, Chief Engr.	Thesaurus AP, UP Raytheon
WMBD-FM 1947	Ch. 225 (B) 92.5mc 20kw				 Western Electric
WMMJ 1946	1020 1,000-D	Midstate Bcstg. Co. Fulton & Jefferson Sts. 9164	MBS Pearson	William J. Kutsch, Pres. & Gen. Mgr.		
WWXL 1947	1590 1,000 DA-2	Central Ill. Radio Corp. Hotel Jefferson 9106	Burn-Smith	Joseph Giddan, Pres. Michael Henry, Gen. Mgr. Dodd Boyer, Coml. Mgr.	Pat Zimmerle, Prog. Dir. Carl Horine, Chief Engr.	SESAC INS Raytheon
QUINCY						
WGEM 1948	1440 1,000 DA-2	Quincy Bcstg. Co. Hotel Quincy 6840	ABC Walker	T. C. Oakley, Pres. Joseph Bonansinga, Gen. Mgr.	Paul McClelland, Prog. Dir. John Haerle, Chief Engr.	Lang-Worth UP Gates
WQDI (FM) 1947	Ch. 286 (B) 105.1mc 10kw	(WGEM, AM affiliate)				
WTAD 1926	930 1,000 DA-N	Lee Bcstg. Co. W.C.U. Bldg. 6200	CBS Weed	Lee P. Loomis, Pres. Walter Rothschild, Gen. & Natl. Sales Mgr. William T. Burghart, Local Sales Mgr.	Merritt Milligan, Prog. Dir. John Phillips, Prom. Mgr. Urlin Whitman, Chief Engr.	Associated AP, UP Gates
WTAD-FM 1948	Ch. 258 (B) 99.5mc 53kw				 RCA
ROCKFORD						
WROK 1929	1440 1,000-LS 500-N	Rockford Bcstrs. Inc. Newstower 2-6621	ABC Headley-Reed	Albert G. Simms, Pres. Walter M. Koessler, Gen. Mgr. John J. Dixon, Coml. Mgr.	Maurice P. Owens, Prog. Dir. Betty L. Thro, Prom. Mgr. Wilfred L. Smith, Chief Engr.	Standard AP RCA
WROK-FM 1949	Ch. 248 (B) 97.5mc 16kw					
ROCK ISLAND						
WHBF 1927	1270 5,000 DA-N	Rock Island Bcstg. Co. Safety Bldg. 918	ABC Avery-Knodel	Ben H. Potter, Pres. Leslie C. Johnson, Gen. Mgr. Maurice Corken, Coml. Mgr.	Forest W. Cooke, Prog. Dir. Fern Hawks, Prom. Mgr. Robert J. Sinnett, Chief Engr.	Associated Lang-Worth AP, UP Collins
WHBF-FM 1947	Ch. 255 (B) 98.9mc 37kw				 Western Electric
WHBF-TV 1950	Ch. 4 66-72mc 7.6kw-auf.; 13.6kw-vis.				 DuMont
SPRINGFIELD						
WCVS 1925	1450 250	WCBS Inc. 523 East Capitol 9855	ABC Sears & Ayer	Harold L. Dewing, Pres. C. W. Neeld, Gen., Coml. & Prom. Mgr.	John Geil, Prog. Dir. R. Ashenfelter, Chief Engr.	World AP RCA
WCVS-FM 1925	Ch. 275 (B) 102.9mc 25kw					
WTAX 1930	1240 250	WTAX Inc. US 66, at E. Cook St. 2-4441	CBS Weed	Oliver J. Keller, Pres. & Gen. Mgr. O. J. Keller Jr., Coml. Mgr.	Gladys McGrew, Prog. Dir. S. T. Harbison, Prom. Mgr. E. C. Swaringen, Chief Engr.	Lang-Worth UP RCA
WTAX-FM 1948	Ch. 279 (B) 103.7mc 6.7kw					
ST. CHARLES						
WEXI (FM) 1949	Ch. 292 (A) 106.3mc 0.25kw	Greater Illinois Bcstg. Co. P. O. Box 269 2963		John A. Schroeder, Pres. & Chief Engr.	Mason Evans III, Gen. Mgr. & Prog. Dir. Gerald F. Kraus, Coml. Mgr.	Lang-Worth INS Raytheon
STERLING						
WSDR 1949	1240 100	Blackhawk Bcstg. Co. Lawrence Bldg. Main 3400		Sam Bartlett, Pres. & Gen. Mgr. Lillian Bartlett, Coml. Mgr.	Todd Branson, Prog. Dir.	Standard UP Gates
TAYLORVILLE						
WTIM (CP)	1410 1,000-D DA	Christian County Bcstg. Co.				

We proved it before . . . WE'VE PROVED IT AGAIN!

ROCKFORD, ILLINOIS (Pop. 122,000) LISTENS TO

W R O K - A M & F M

in a poll just completed in Rockford's two public high schools

87% OF THE STUDENTS WERE FOUND TO BE REGULAR LISTENERS!

WROK, an ABC affiliate, is represented nationally by HEADLEY-REED CO.

DIRECTORY OF AM, FM, and TV STATIONS OF THE UNITED STATES

(Data corrected to December 6, 1949)
If executives or services for FM or TV stations are same as AM affiliate names are not repeated.

ILLINOIS—(Continued)

City Call Letters Established	Chan. or Freq. Power	Name of Licensee Headquarters Address Telephone Number	Network Representative	Executive Personnel	Transc. Library News Service Transmitter Make	
URBANA						
*WILL 1922	580 5,000-D DA	U. of Illinois 1010 S. Wright St. 7-6611		George D. Stoddard, Pres. Frank E. Schooley, Gen. Mgr.	Harold E. Hill, Prog. Dir. John R. Brugger, Chief Engr.	Associated AP, UP RCA
WKID 1948	1580 250-D	University City Bcstg. C 113 N. Main St. 7-8431		Elwood Fabert, Pres. Robert Lee, Coml. & Prod. Mgr.	G. Max Kimbrel, Gen. Mgr. & Chief Engr.	Lang-Worth UP Gates
WKID-FM 1948	Ch. 277 (B) 103.3mc 2.4kw					
WAUKEGAN						
WKRS 1949	1220 1,000-D DA	News Sun Bcstg. Co. P. O. Box 500 Ontario 9000	McGillvra	Frank H. Just, Pres. Joseph B. Kirby, Gen. Mgr. Donald DeThorn, Coml. Mgr.	Fritz Sorenson, Prog. Dir. M. D. Hunnicutt Jr., Chief Engr.	World Standard AP Gates Western Electric
WKRS-FM 1948	Ch. 294 (B) 106.7mc 12kw	Keystone Printing Service 116-120 Madison St.				
WOODSTOCK						
WILA (FM) 1948	Ch. 221 (A) 92.1mc 1kw	Northern Ill. Bcstg. Co. Woodstock 1606 R-1		H. Z. Benton, Gen. Mgr. & Chief Engr.	Paul Collin, Coml. Mgr. C. E. Paetow, Prog. Dir.	Associated World UP General Electric
ANDERSON						
WCBC 1947	1470 1,000-D	Civic Bcstg. Corp. 116 W. 12th St. 8822	Holman	Lloyd B. Gallimore, Pres. Gerald Quick, Coml. Mgr. Tom Thornburg, Prog. Dir.	Fayola Mauck, Prom. Mgr. Robert Simmons, Chief Engr.	World AP Collins
WCBC-FM 1947	Ch. 292 (A) 106.3mc 0.32kw					
WHBU 1923	1240 250	Anderson Bcstg. Corp. 640 Citizens Bank Bldg. 7791	ABC Ra-Tel	C. Bruce McConnell, Pres. John R. Atkinson, Gen. Mgr.	E. R. McCord, Prog. Dir. L. M. Shroyer, Chief Engr.	Standard UP Gates
BEDFORD						
WBIW 1948	1340 250	Radio Bedford Inc. Radio Farm 4421	Ra-Tel	William C. Smith Jr., Pres. & Gen. Mgr. Louis E. Gaines, Coml. Mgr.	Barbara Leahy, Prog. Dir. Carl Finger, Chief Engr.	Lang-Worth Capitol AP Collins

INDIANA

DA-N Directional Antenna, night only. FM's in italic. *—Non-Commercial Station D—Day. N—Night. ST—Share Time. SH—Specified Hours.
DA-1 Directional Antenna, same pattern day and night. U—Unlimited. CP—Construction Permit Issued. LS—Local Sunset.
DA-2 Directional Antenna, different pattern day and night. L—Limited Time with Dominant Station. SA—Special Authorization.

MORE news of all radio

AM • FM • TV

... than all other publications combined! Complete radio news coverage PLUS such extra money-making features as "Broadcasting Trends," Merchandising Narratives, Comparative Network Schedules (AM & TV); weekly Telecasting inserts.

\$7 FOR 52 WEEKLY ISSUES AND YEARBOOK

4 STATION COVERAGE

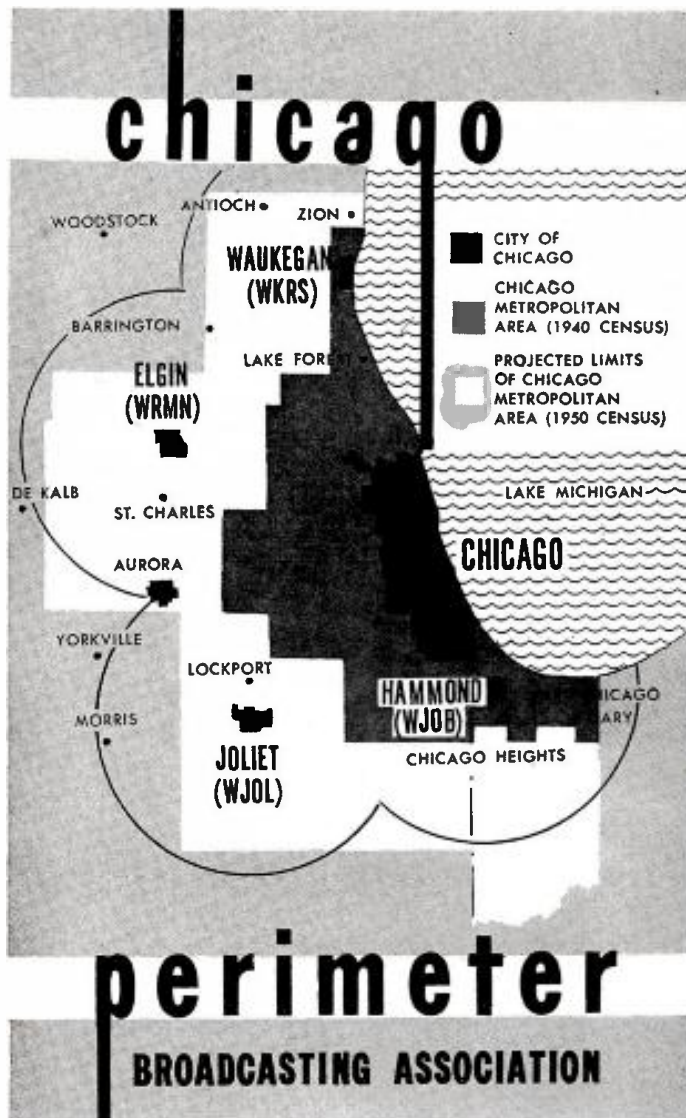

SOLD IN COMBINATION

WJOL WKRS WJOB WRMN

JOLIET

WAUKEGAN

HAMMOND

ELGIN

chicago perimeter

BROADCASTING ASSOCIATION, 185 N. WABASH AVE., CHICAGO (1), ILL

the answer to your spot radio needs
 contact JOSEPH HERSHEY MCGILLVRA INC.

DIRECTORY OF AM, FM, and TV STATIONS OF THE UNITED STATES

(Data corrected to December 6, 1949)
If executives or services for FM or TV stations are same as AM affiliate names are not repeated.

INDIANA—(Continued)

City Call Letters Established	Chan. or Freq. Power	Name of Licensee Headquarters Address Telephone Number	Network Representative	Executive Personnel	Transc. Library News Service Transmitter Make
BLOOMINGTON					
WSUA 1946	1010 1,000-D	Radio Station WSUA Inc. 117½ W. Kirkwood 7277	Midwest McGillvra	L. C. J. Yeager, Pres. Gordon Ford, V. P. A. E. Tyles, Gen. Mgr.	James C. Warren, Secy.-Treas. World Standard UP Gates General Electric
WSUA-FM 1949	Ch. 279 (B) 103.7mc 12kw				
WTOM 1947	1490 250	Fred O. Grimwood Henderson Bldg. 7871	Sears & Ayer	Fred O. Grimwood, Owner Maurice Latimer, Gen. Mgr. Paul Lennon, Coml. Mgr.	Marc Williams, Prog. Dir. Theodore May, Chief Engr. Lang-Worth AP Gates
WTTS 1949	1370 1,000-LS 500-N DA	Sarkes & Mary Tarzian 535 South Walnut St. 2-3366	Rambeau	Sarkes & Mary Tarzian, Owners Glenn Van Horn, Gen. Mgr. Robert Petranoff, Prog. Dir.	Robert Lemon, Prom. Mgr. Morton L. Weigel, Chief Engr. Associated Thesaurus AP Raytheon
WTTV(TV) 1949	Ch. 10 192-198mc 3.31kw-aur.; 6.38kw-vis.	(WTTS, AM affiliate)	ABC, CBS		Robert Lemon, Coml. Mgr.
COLUMBUS					
WCSI(FM) 1947	Ch. 229 (B) 93.7mc 71kw	Syndicate Theatres Inc. Artcraft Theatre Bldg. Franklin, Ind. 564	Ra-Tel	Joe Finneran, Pres. Graeme Zimmer, Gen. Mgr. Bernard W. Jasper, Coml. Mgr.	Richard Jewell, Prog. Dir. Russell Newman, Chief Engr. Harold Arthurs, Asst. Mgr. Associated World AP Federal
CONNERSVILLE					
WCNB 1948	1580 250-D	The News-Examiner Co. 406 Central Ave. 1950		Emmett M. Jackson, Gen. & Coml. Mgr. Alan G. Thompson, Prog. Dir.	Al Edmonds, Prom. Mgr. James C. Wulliman, Chief Engr. Capitol World UP General Electric
WCNB-FM 1948	Ch. 262 (B) 100.3mc 10kw				
CRAWFORDSVILLE					
WFMU(FM) 1948	Ch. 275 (B) 102.9mc 13kw	Journal-Review Inc. South Blvd.	Campbell	Foster Fudge, Owner Max Jones, Sta. Mgr.	W. Addington Vance, Partner Standard AP
ELKHART					
WTRC 1931	1340 250	Truth Pub. Co. 116 S. Second St. 948	NBC Burn-Smith	Richard W. Holloway, Gen. Mgr. Henry J. Davis, Prog. Dir.	Dorothy Fleck, Prom. Mgr. Lester Zellmer, Chief Engr. World Standard Associated UP RCA Federal
WTRC-FM 1948	Ch. 264 (B) 100.7mc 33kw				
EVANSVILLE					
WEOA 1936	1400 250	WFBM Inc. 24 N. W. Third St. 4-9215	CBS Katz	Harry M. Bitner Jr., Pres. Don Menke, Gen. & Coml. Mgr.	Bill Fall, Prog. Dir. & Prom. Mgr. Robert A. Wilson, Chief Engr. Lang-Worth INS RCA
WGBF 1923	1280 5,000-LS 1,000-N DA	On The Air Inc. 519 Vine St. 21171	NBC Weed	Clarence Leich, Gen. Mgr. Martin L. Leich, Oprs. Mgr. (Mrs.) Pat Roper, Prog. Dir.	Del Greenwood, Prom. Mgr. Erwin Schoeny, Chief Engr. World UP Collins Associated
WMLL(FM) 1941	Ch. 233 (B) 94.5mc 20kw	(WGBF, AM affiliate)	Transit Radio		
WIKY 1947	820 250-D	South Central Bcstg. Corp. Mt. Ashburn Rd. 48284	Midwest IMS	John A. Engelbrecht, Pres. & Gen. Mgr.	George F. Stoltz, Chief Engr. Capitol AP Collins Federal
WIKY-FM 1948	Ch. 281 (B) 104.1mc 20kw				
WJPS 1948	1330 5,000-LS 1,000-N DA-2	WJPS Inc. 206 Main St. 5-2221	ABC Meeker	Robert S. Davis, Pres. Robert J. McIntosh, Gen. & Coml. Mgr.	Jack McLean, Prog. Dir. E. Ward Crane, Prom. Mgr. Gilbert Hoffman, Chief Engr. Standard UP Federal
FORT WAYNE					
WANE 1948	1450 250	Radio Fort Wayne Inc. 1205 Ft. Wayne Bank Bldg. Anthony 6212	CBS Bolling	C. Bruce McConnell, Pres. Robert B. McConnell, Gen. Mgr. Glenn R. Thayer, Coml. Mgr.	Warren Cook, Prog. Dir. Seymour Kaplan, Prom. Mgr. Wm. W. Warren, Chief Engr. Standard AP
WGL 1924	1250 1,000 DA-2	The News-Sentinel Bcstg. Co. Inc. 201 W. Jefferson St. Eastbrook 3366	NBC Headley-Reed	Helene R. Foellinger, Pres. Pierre Boucheron, V.P. & Gen. Mgr. M. C. Johnson, Coml. Mgr.	Norman C. Widenhofer, Prog. Mgr. Don Holzapfel, Chief Engr. Standard Lang-Worth AP RCA
WKJG 1947	1380 5,000 DA-2	Northeastern Indiana Bcstg. Co. Inc. 3802 S. Calhoun St. * Harrison 6111	MBS Raymer	Clarence L. Schust, Pres. Edward R. Thoms, Gen. Mgr.	Calo Mahlock, Prog. Dir. T. J. Copeland, Chief Engr. World UP RCA
WKJG-FM 1948	Ch. 291 (B) 106.1mc 30kw				

DA-N Directional Antenna, night only. FM's in italic.
DA-1 Directional Antenna, same pattern day and night.
DA-2 Directional Antenna, different pattern day and night.

*-Non-Commercial Station D-Day. N-Night. ST-Share Time. SH-Specified Hours.
U-Unlimited. CP-Construction Permit Issued. LS-Local Sunset.
L-Limited Time with Dominant Station. SA-Special Authorization.

THEY HAD THE WHOLE TOWN TALKING

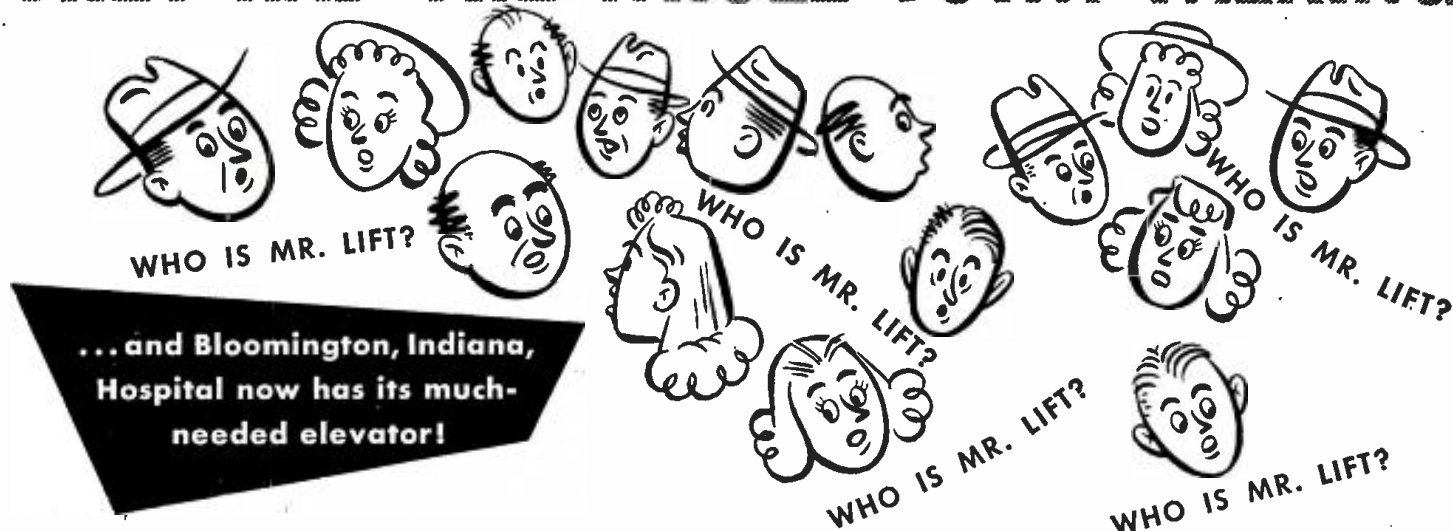

● Some months ago, at a meeting of Bloomington automotive dealers, one of the members said he thought the group should do something about providing an elevator in the local hospital. No immediate action was taken, but that same day this prominent member died suddenly.

As a tribute to the deceased member, the automotive association opened a fund-raising drive in his name. Fifteen thousand dollars was needed for the hospital project.

The plan progressed slowly, and all but bogged down. Then, WTTS came into the picture and offered a plan and all station facilities for raising the needed amount.

They put on a contest. A "WHO IS MR. LIFT?" contest. The movie star, William Bendix, was up around Indianapolis at the time, working on the "Johnny Holliday" film. They put his voice on transcription, and the contest was on. It was the same, old formula: listeners send in donations to the fund, "with a letter of not more than 25 words." Follow up telephone calls were made from the station to letter writers, and prizes—finally totalling over \$3,500—were donated by local merchants.

It was still the automotive dealers' project. WTTS provided the vehicle, the plan and promotion as a community service. The town was plastered with "WHO IS MR. LIFT?" They used billboards . . . cab signs . . . menu covers . . . signs on sidewalks . . . newspaper space, display and editorial . . . signs in merchants' windows and car dealers' windows . . . banners across the main streets . . . stickers for letterheads and windshields, and, of course, WTTS plugged it on the air. The whole town was talking about "MR. LIFT."

To make the story short, the contest was a big success and the fund was oversubscribed in six weeks.

Although different, the "MR. LIFT" contest isn't an isolated case. The station owners and operators are sincere in offering station facilities for community betterment. That's why much time is devoted to local school and church activities . . . 4-H Club promotion . . . civic and community happenings. And, that's why WTTS is known as "the public service station." And, another reason why WTTS—in less than a year on the air—has become the leading station in the area.

LET OUR NATIONAL REPS. GIVE YOU THE COMPLETE STORY



RADIO AND TELEVISION CENTER • BLOOMINGTON, INDIANA

Owned and Operated by Sarkes and Mary Tarzian



Represented Nationally by
WILLIAM G. RAMBEAU CO.
360 N. Michigan Avenue, Chicago

National Representatives
BARNARD & THOMPSON, INC.
299 Madison Avenue, New York

DIRECTORY OF AM, FM, and TV STATIONS OF THE UNITED STATES

(Data corrected to December 6, 1949)
If executives or services for FM or TV stations are same as AM affiliate names are not repeated.

INDIANA—(Continued)

City Call Letters Established	Chan. or Freq. Power	Name of Licensee Headquarters Address Telephone Number	Network Representative	Executive Personnel	Transc. Library News Service Transmitter Make	
FORT WAYNE—(Continued)						
WOWO 1925	1190 10,000	Westinghouse Radio Stations Inc. 925 S. Harrison St. Anthony 2136	ABC Free & Peters	Walter Evans, Pres. Paul E. Mills, Sales Mgr. J. B. Conley, Gen. Mgr.	Robert G. Duffield, Sta. Mgr. Carl Vandagriff, Prog. Mgr. Bruce Ratts, Chief Engr.	Capitol UP
WOWO-FM 1941	Ch. 241 (B) 96.1mc; 16.5kw					
GARY						
WGRY (CP) 1949	1370 500-D	Steel City Bcstg. Co.				
WWCA 1949	1270 1,000 DA-1	Lake Bcstg. Co. Inc. Hotel Gary 9171		Dee O. Coe, Pres., Gen. & Coml. Mgr. Todd Branson, Prog. Dir.	Shaun F. Murphy, Prom. Mgr. Victor H. Voss, Chief Engr.	AP Collins
HAMMOND						
WJOB 1928	1230 250	South Shore Bcstg. Corp. 449 State St. Sheffield 8400	McGillvra	Robert C. Adair, Gen. Mgr. L. B. Weller, Sta. Mgr. Al Halus, Coml. Mgr.	Wilbert Wobus, Prog. Dir. Glen Thomas, Prom. Mgr. Jess Peters, Chief Engr.	Associated SESAC Capitol UP Raytheon
WJIZ(FM) 1948	Ch. 222 (B) 92.3mc 9.3kw	(WJOB, AM affiliate)				
INDIANAPOLIS						
WFBM 1924	1260 5,000 DA-N	WFBM Inc. 48 Monument Circle Lincoln 8506	CBS Katz	H. M. Bitner, Chief Owner Harry M. Bitner Jr., Gen. Mgr. William F. Kiley, Prom. & Coml. Mgr.	Frank O. Sharp, Prog. Dir. Harold Holland, Chief Engr.	Associated AP, INS RCA
WFBM-TV 1949	Ch. 6 82-88mc 18.1kw-aur. 28.2kw-vis.		ABC, CBS DuMont, NBC			
WIBC 1938	1070 50,000-LS 10,000-N DA-2	WIBC Inc. 30 W. Washington St. Lincoln 2305	MBS Blair	R. M. Fairbanks, Pres. Kenneth W. Church, V.P. & Gen. Mgr.	William L. Dean, Prog. Dir. Estel Freeman, Prom. Mgr. Harry Adams, Chief Engr.	World AP RCA
WIRE 1924	1430 5,000 DA-N	Indianapolis Bcstg. Inc. 307 N. Pennsylvania St. Riley 1541	NBC Pearson	Eugene C. Pulliam, Pres. Willard C. Worcester, V.P. & Gen. Mgr. Daniel C. Park, Coml. Mgr.	M. Wayland Fullington, Prog. Dir. James N. Willingham, Prom. Mgr. Eugene E. Alden, Chief Engr.	World Thesaurus AP, UP RCA Standard AP RCA
WISH 1941	1310 5,000-LS 1,000-N DA	Universal Bcstg. Co. 215 Board of Trade Bldg., Market 6345	ABC Free & Peters	Frank E. McKinney, Pres. George J. Higgins, Gen. & Coml. Mgr.	William Frosch, Prog. Dir. Reid Chapman, Prom. Mgr. Stokes Gresham Jr., Chief Engr.	Standard AP RCA

DA-N Directional Antenna, night only. FM's in italic. *—Non-Commercial Station D—Day. N—Night. ST—Share Time. SH—Specified Hours.
DA-1 Directional Antenna, same pattern day and night. U—Unlimited. CP—Construction Permit Issued. LS—Local Sunset.
DA-2 Directional Antenna, different pattern day and night. L—Limited Time with Dominant Station. SA—Special Authorization.

**NO. 1 RETAIL SALES
OPPORTUNITY in INDIANA**



WWCA

GARY, INDIANA

WWCA

PROGRAMMED LOCALLY
TO OVER 400,000
RESPONSIVE LISTENERS...
50,000 RURAL PEOPLE,
30,000 NEGROS, 100,000
INDUSTRIAL WORKERS AND
FOUR NATIONALITY GROUPS.

WWCA

THE ONLY ADVERTISING
MEDIUM LOCALLY
SERVING AND SELLING
ALL THE RICH
LAKE-PORTER
COUNTY MARKET

WWCA

1000 WATTS FULLTIME
1270 KC
Dee O. Coe
President-General Manager
Hotel Gary - Phone 9171

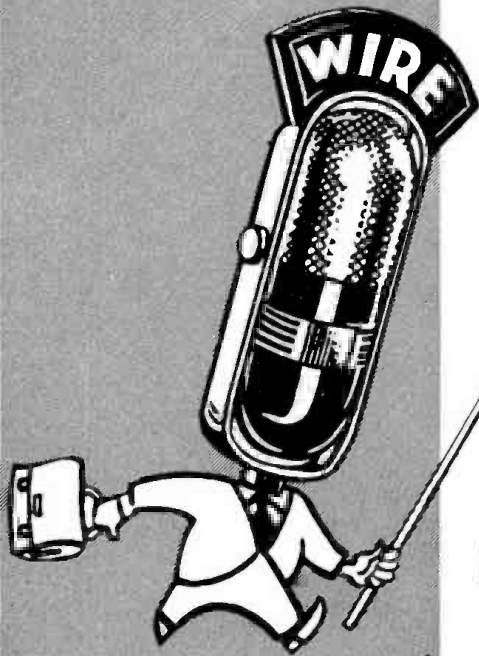

WIRE

Basic NBC • 5,000 WATTS
1430 KC.
INDIANAPOLIS, INDIANA

Nationally Represented By
John E. Pearson Company

•
Affiliated With
The Indianapolis Star
and
The Indianapolis News



INFANT
OR
FULL-GROWN

is the *Buy*-word
in Indiana for *You*

If your business is in its infancy or if it is full-grown . . . W I R E has a "tailored" plan for your Indiana radio schedule.

W I R E is located at the hub of the "Great Hoosier Market" . . . covering 20 out of the 25 retail-trading-area counties . . . 404,300 radio families with a buying power of \$1,921,798. These thousands of purchasers with the "1430" habit can be yours with W I R E 's "tailored" radio plan.

County by county . . . W I R E is your best salesman in the "Great Hoosier Market."

WIRE YOUR BEST SALESMAN IN THE GREAT HOOSIER MARKET

DIRECTORY OF AM, FM, and TV STATIONS OF THE UNITED STATES

*(Data corrected to December 6, 1949)
If executives or services for FM or TV stations are same as AM affiliate names are not repeated.*

INDIANA—(Continued)

City Call Letters Established	Chan. or Freq. Power	Name of Licensee Headquarters Address Telephone Number	Network Representative	Executive Personnel	Transc. Library News Service Transmitter Make	
INDIANAPOLIS—(Continued)						
WXLW 1948	1590 1,000-D	Radio Indianapolis Inc. 3003 Kessler Blvd. Highland 6494	IMS	John C. Appel, Pres. Gene S. Kelly, Gen. Mgr.	Shirl K. Evans Jr., Prog. Dir. Edward C. Lockwood, Chief Engr.	Capitol, World UP RCA
WXLW-FM 1948	Ch. 234 (B) 94.7mc 20kw				 Federal
JASPER						
WITZ 1948	990 1,000-D	Jasper on the Air Inc. Jasper 678		Gilbert E. Metzger, Pres. Dale S. Phares, Gen. & Prom. Mgr.	Dennis Keller, Coml. Mgr. Bryan Davidson, Prog. Dir. Bill Richardson, Chief Engr.	Associated UP
KOKOMO						
WIOU 1948	1350 1,000 DA-2	North Central Indiana Bcstg. Corp. Radio Center 6194	CBS Weed	Richard Blackledge, Pres. John Carl Jeffrey, V.P. & Gen. Mgr.	James Muse, Prog. Dir. Chester Rector, Chief Engr.	Thesaurus AP General Electric
LAFAYETTE						
WASK 1941	1450 250	WFAM Inc. Wallace Bldg. 4300	MBS	O. E. Richardson, Pres., Gen. & Coml. Mgr. A. E. Morehouse, Prog. Dir.	H. M. Shumway, Prom. Mgr. Harry Garba, Chief Engr.	World UP Raytheon
WFAM(FM)	Ch. 236 (B) 95.1mc 1.2kw	(WASK, AM affiliate)				
*WBAA 1922	920 5,000-LS 1,000-N DA	Purdue U. Lafayette 92-2147		F. L. Hovde, Pres. Jim Miles, Gen. Mgr.	John DeCamp, Prog. Dir. Ralph Townsley, Chief Engr.	Associated SESAC UP Collins
LaPORTE						
WLOI 1948	1540 250-D	LaPorte County Bcstg. Inc. Ramey Hotel Bldg. 3734		Hoyt Scott, Pres. William Whitlock, Gen. Coml. & Prom. Mgr. & Prog. Dir.	Ray Mould, Chief Engr.	Capitol INS Raytheon
LOGANSPORT						
WSAL 1949	1230 250	Logansport Bcstg. Corp. 216 Fourth St.		Joe Jordan, Gen. Mgr.	Willis Searfoss, Sales Mgr.	
MARION						
WBAT 1947	1600 500-D	Marion Radio Corp. P.O. Box 309 5500		John H. Bone, Pres. & Gen. Mgr. Kermit A. Botkin, Coml. Mgr. H. G. Hipps, V.P. & Ass't. Gen. Mgr.	Lenore Fuller, Prog. Dir. & Prom. Mgr. Charles Westfall, Chief Engr.	World AP Western Electric
WMRI(FM) 1948	Ch. 295 (B) 106.9mc 34kw	Chronicle Pub. Co. Inc. 610 S. Adams St. 5705		Gardner J. Thomas, Pres. Guy B. Farnsworth, Gen. & Coml. Mgr.	A. R. Engel, Prog. Dir. George Hoffman & Bernard Hobbs, Engrs.	Capitol, Lang-Worth UP Westinghouse
MICHIGAN CITY						
WIMS 1947	1420 1,000-D CP-1,000-LS CP-500-N DA	Northern Indiana Bcstg. Inc. 415 Franklin 4980		O. E. Richardson, Pres. E. R. Herkner, Gen. Mgr.	R. S. Olson, Prog. Dir. R. J. Schilling, Chief Engr.	World UP Raytheon
WIMS-FM 1949	Ch. 228 (A) 93.5mc 1kw					
MUNCIE						
WLBC 1926	1340 250	Tri-City Radio Corp. P. O. Box 271 4403	CBS Walker	D. A. Burton, Pres. & Gen. Mgr. W. F. Craig, Coml. Mgr.	Lee Allerton, Prog. Dir. M. M. Crain, Chief Engr.	Standard AP Doolittle General Electric
WMUN(FM) 1947	Ch. 281 (B) 104.1mc 7.4kw	(WLBC, AM affiliate)				
NEW ALBANY						
WLRP 1949	1570 1,000-D	Ohio Valley Bcstg. Co. 1216 Slate Run Rd. 4-2235		Roy L. Hickox, Pres. & Gen. Mgr. John M. Fouts, Coml. Mgr.	Robert Parmenter, Chief Engr.	Lang-Worth UP Raytheon
NEW CASTLE						
WCTW(FM) 1947	Ch. 273 (B) 102.5mc 4kw	Courier-Times Inc. 202½ S. 14th St. 2600	Campbell	Walter S. Chambers Sr., Pres. Scott B. Chambers, Gen. Mgr. Edwin D. Osborne, Sta. Mgr.	John F. Bundy, Coml. Mgr. William E. Turner, Prog. Dir. O. R. Atkinson, Chief Engr.	World Capitol AP General Electric
PRINCETON						
WPRN(FM) (CP) 1947	Ch. 244 (A) 96.7mc 1kw	Princeton Pub. Co.				
RICHMOND						
WKBV 1926	1490 250	Central Bcstg. Corp. 25 S. Ninth St. 1156	MBS Meeker	H. W. Bockhoff, Pres. G. F. Albright, Gen. Mgr. A. F. Schroy, Prog. Dir.	R. L. Nusbaum, Coml. & Prom. Mgr. L. J. Duning, Chief Engr.	Lang-Worth SESAC UP RCA
SEYMOUR						
WJCD 1949	1390 500-D	Dr. Azra C. Baker Seymour 1212		Azra C. Baker, Pres. & Gen. Mgr. Clement Cockrel, Prog. Dir.	Arnold Haun, Chief Engr.	SESAC Standard AP Gates
SHELBYVILLE						
WSRK(FM) 1947	Ch. 267 (B) 101.3mc 5kw	Shelbyville Radio Inc. 125 E. Washington St. 1776	Campbell	John C. DePrez, Pres. & Gen. Mgr. Donald H. Sexton, Coml. Mgr.	Victor B. Muth, Prog. Dir. Harry J. Gourley, Chief Engr.	Standard Thesaurus UP General Electric

DA-N Directional Antenna, night only. FM's in italic.
DA-1 Directional Antenna, same pattern day and night.
DA-2 Directional Antenna, different pattern day and night.

*—Non-Commercial Station D—Day. N—Night. ST—Share Time. SH—Specified Hours.
U—Unlimited. CP—Construction Permit Issued. LS—Local Sunset.
L—Limited Time with Dominant Station. SA—Special Authorization.

City Call Letters Established	Chan. or Freq. Power	Name of Licensee Headquarters Address Telephone Number	Network Representative	Executive Personnel	Transc. Library News Service Transmitter Make	
SOUTH BEND						
WHOT 1945	1490 250	South Bend Bcstg. Corp. 434 S. St. Joseph St. 3-4155	ABC Bolling	C. Bruce McConnell, Pres. William H. Spencer, Gen. & Coml. Mgr.	Robert Bell, Prog. Dir. C. J. Pajakowski, Prom. Mgr. David B. Maltby, Chief Engr.	Associated AP Collins UP
WJVA 1947	1580 250-D	St. Joseph Valley Bcstg. Corp. 214 W. Wayne St. 3-8668	Burn-Smith	B. W. Redifer, Pres. William B. Oliver, Sta. Mgr.	Dale Roberts, Coml. Mgr. UP
WSBT 1922	960 5,000 DA-2	South Bend Tribune South Bend 3-6161	CBS Raymer	F. A. Miller, Pres. R. H. Swintz, Gen. Mgr. N. B. Welch, Coml. Mgr.	R. J. Drain, Prog. Dir. W. A. Sweitzer, Prom. Mgr. H. G. Cole, Chief Engr.	Capitol Standard UP RCA Federal
WSBT-FM 1942	Ch. 267 (B) 101.3mc 20kw				 Federal
TELL CITY						
WTCJ 1948	1230 250	James R. Brewer Tell City 740	KBS	James R. Brewer, Owner & Mgr.	 AP
TERRE HAUTE						
WBOW 1927	1230 250	Banks of the Wabash Inc. 303 S. 6th St. Crawford 5034	NBC Weed	Alvin Eades, Pres. William F. Rippetoe, Gen. & Coml. Mgr.	Leo J. Baxter, Prog. Dir. Madeline K. Barry, Prom. Mgr. Howard Stewart, Chief Engr.	World AP, UP
WBOW-FM 1947	Ch. 266 (B) 101.1mc 20kw				
WTHI 1946	1480 1,000 DA-2	Wabash Valley Bcstg. Corp. 120 S. 7th St. Crawford 9481	CBS Bolling	Anton Hulman Jr., Pres. J. M. Higgins, Gen. & Coml. Mgr. Arnold C. Johnson, Prog. Dir.	Earl Johnson, Prom. Mgr. T. R. Felts, Chief Engr.	Lang-Worth UP RCA
WTHI-FM 1948	Ch. 260 (B) 99.9mc 7.4kw				
VINCENNES						
WAOV 1940	1450 250	Vincennes Sun Co. 320 Busseron St. 787	MBS Pearson	Eugene C. Pulliam, Pres. Howard N. Greenlee, Gen. Mgr. Samuel J. Dodd, Sta. & Sales Mgr.	Don Sherwood, Prog. Dir. Al Vare, Prom. Mgr. Ralph Baldwin, Chief Tech.	Lang-Worth UP Western Electric
WABASH						
WWNI(FM) 1948	Ch. 248 (B) 97.5mc 71kw	Syndicate Theatres Inc. Eagles Theatre Bldg. 1701	Midwest McGeehan & O'Mara	Trueman T. Rembusch, Pres. Richard L. Pyles, Gen. & Coml. Mgr. & Prog. Dir.	Paul C. Kelley, Chief Engr.	Associated AP Federal
WARSAW						
WKAM 1949	1220 250-D	Kosciusko Bcstg. Corp. R. F. D. #1 65		J. W. Autenrieth Jr., Pres. & Gen. Mgr. Lynn M. Miller, Prog. Dir.	Charles F. Stinson, Chief Engr.	MacGregor Cole AP Raytheon
WRWS(FM) 1948	Ch. 297 (B) 107.3mc 34kw	Reub Williams & Sons Inc. Times Bldg.	Campbell	Fred Gresso, Sta. Mgr. William K. Mollenhour Jr., Coml. Mgr.		Capitol Lang-Worth Standard UP
WASHINGTON						
WFML(FM) 1948	Ch. 293 (B) 106.5mc 14kw	Washington Radio Inc. 615 S. E. 11th St. 1810	Campbell	Paul R. Bausman, Pres. Ted Vernasco, Gen. & Coml. Mgr.	Joseph Edwards, Prog. Dir. Roger L. Dyer, Chief Engr.	Standard AP General Electric
IOWA						
AMES						
KASI 1948	1430 1,000-D	Ames Bcstg. Co. 328½ Main St. 3480		W. S. Rupe, Pres. Arthur A. Skinner, Gen. Mgr.	H. M. Cleveland, Coml. Mgr. Chuck Forbes, Prog. Dir. Doyle D. Kelso, Chief Engr.	Capitol Thesaurus UP Raytheon
KASI-FM	Ch. 238 95.5mc; 43kw				
*WOI 1921	840 5,000-D	Iowa State A&M Service Bldg., ISC Cam- pus, 2500		Richard B. Hull, Gen. Mgr. Robert C. Mulhall, Oprs. Mgr. W. D. Donaldson, Prog. Mgr.	Edward P. Wegener, Prod. Mgr. Louie L. Lewis, Chief Engr.	World Standard SESAC AP, UP RCA General Electric
WOI-TV 1950	Ch. 4; 66-72mc 10.4kw-aur.; 13kw-vis.				 General Electric
BOONE						
*KFGQ 1927	1260 250-D	Boone Biblical College Boone			
KFGQ-FM	Ch. 238 (B) 95.5mc; 0.31kw				
KWBG (CP)	1590 1,000-D	Boone Bcstg. Co.			
BURLINGTON						
KBUR 1941	1490 250	Burlington Bcstg. Co. Natl. Bank Bldg. 680	ABC Taylor-Borroff	G. B. McDermott, Pres. & Gen. Mgr. S. F. Harris, V. P. Richard Mosena, Prog. Dir.	R. H. Plock, Secy.-Treas. David Steinle, Coml. & Prom. Mgr. John Gallino, Chief Engr.	Standard UP RCA Westinghouse
KBUR-FM 1947	Ch. 225 (B) 92.9mc; 53kw				 Westinghouse
CEDAR RAPIDS						
KCRG 1947	1600 5,000 DA-N	The Gazette Co. 104 First St., S.W. 4194	MBS Burn-Smith	J. F. Hladky Jr., V. P. Fred W. Wagenvoord, Gen. & Coml. Mgr.	Wade S. Patterson, Prog. Dir. Edna A. Herbst, Dir. Prom. & Pub. Kenneth M. Caldwell, Chief Engr.	Standard, World Associated AP, INS Collins
KCRK(FM) 1949	Ch. 245 (B) 96.9mc; 276kw	(KCRG, AM affiliate)			
KWCR 1949	1450 250	Cedar Rapids Bcstg. Corp. 211 1st St., S.W., 3-8285	Tall Corn McKinney	William J. Barron, Pres. Paul E. Millen, Gen. Mgr.	Ralph Willey, Prog. Dir. James A. Dickens, Chief Engr.	Capitol Thesaurus UP, Collins

DA-N Directional Antenna, night only. FM's in italic.
DA-1 Directional Antenna, same pattern day and night.
DA-2 Directional Antenna, different pattern day and night.

*—Non-Commercial Station D—Day. N—Night. ST—Share Time. SH—Specified Hours.
U—Unlimited. CP—Construction Permit Issued. LS—Local Sunset.
L—Limited Time with Dominant Station. SA—Special Authorization.

DIRECTORY OF AM, FM, and TV STATIONS OF THE UNITED STATES

(Data corrected to December 6, 1949)
If executives or services for FM or TV stations are same as AM affiliate names are not repeated.

IOWA—(Continued)

City	Call Letters Established	Chan. or Freq. Power	Name of Licensee Headquarters Address Telephone Number	Network Representative	Executive Personnel	Transc. Library News Service Transmitter Make	
CEDAR RAPIDS—(Continued)							
WMT	1922	600 5,000 DA-N	American Bcstg. Stations Inc. Paramount Theatre Bldg. 6127	CBS Katz	Mrs. Helen S. Mark, Owner Wm. B. Dolph, Exec. V. P. William B. Quarton, Gen. Mgr.	Lew Van Nostrand, Coml. Mgr. Douglas B. Grant, Prog. Dir. Leo F. Cole, Prom. Mgr. George P. Hixenbaugh, Chief Engr.	World Lang-Worth MacGregor AP, UP, INS
CENTERVILLE							
KCOG	1949	1400 100	Centerville Bcstg. Co. 1910 S. Main St. 131		Robert K. Beck, Pres. Robert G. Irwin, Gen. Mgr.	John McCaughey, Prog. Dir. Robert Moore, Chief Engr.	Lang-Worth AP RCA
CHARLES CITY							
KCHA	1949	1580 250-D	Inland Bcstg. Corp. Charles City 787		Dean Hollingsworth, Pres.	Robert Weiry, Chief Engr. Collins
CLINTON							
KROS	1941	1340 250	Clinton Bcstg. Corp. Jacobson Bldg. 448	MBS Tall Corn McKinney	W. S. Jacobsen, Pres. W. J. Teich, Gen. Mgr.	Emmett Hassett Jr., Prog. Dir. Gilbert Andrews, Chief Engr.	Standard UP Collins RCA
KROS-FM	1948	Ch. 241 (B) 96.1mc 13kw					
COUNCIL BLUFFS							
KSWI	1947	1560 500-D	Nonpareil Bcstg. Co. Strand Theatre Bldg. 4041	Tall Corn McKinney	Robert R. O'Brien, Pres. Robert L. Davis, Gen. & Coml. Mgr.	Harold Hughes, Prog. Dir. Robert W. Hall, Chief Engr.	Associated Lang-Worth AP, Collins General Electric
KFMX(FM)	1947	Ch. 241 (B) 96.1mc; 12kw	(KSWI, AM affiliate)				
CRESTON							
KSIB	1946	1520 1,000-D	Southwest Iowa Bcstg. Co. Creston, 55	KBS Tall Corn McKinney	Arthur Horning, Pres. E. M. Horning, Gen. & Coml. Mgr. Carl Schafer, Prog. Dir.	Ted Griffin, Prom. Mgr. Jean Poole, Chief Engr.	Thesaurus SESAC AP, Raytheon
DAVENPORT							
KFMA (CP)	1946	1580 250-D	L. W. Andrews Inc. 219 Whitaker Bldg. Davenport Bcstg. Co. 324 Main St. 35642	MBS Tall-Corn McKinney	L. W. Andrews, Gen. Mgr. Hugh R. Norman, Pres. & Gen Mgr. Herbert Peterson, Coml. Mgr.	Pat Alan, Prog. Dir. A. M. McGregor, Chief Engr.	MacGregor UP Gates
KSTT	1946	750; CP-1170 250-D; CP-1,000 DA-2		NBC Free & Peters	Col. B. J. Palmer, Pres. Ernie Sanders, Mgr. Charles Freburg, Prog. Dir. Paul Ives, Prom. Mgr.	D. D. Palmer, V. P. & Treas. Ralph Evans, V. P. Wm. D. Wagner, Secy. Paul Arvidson, Chief Engr.	Lang-Worth Thesaurus UP Collins
WOC	1922	1420 5,000 DA-2	Tri-City Bcstg. Co. 1002 Brady St. 3-3861				

DA-N Directional Antenna, night only. FM's in italic.
DA-1 Directional Antenna, same pattern day and night.
DA-2 Directional Antenna, different pattern day and night.

*-Non-Commercial Station D-Day, N-Night, ST-Share Time, SH-Specified Hours.
U-Unlimited, CP-Construction Permit Issued, LS-Local Sunset.
L-Limited Time with Dominant Station. SA-Special Authorization.



22.9 Kw. Video
12.5 Kw. Audio

Basic NBC Affiliate
Davenport, Iowa

FACILITIES:
Studio (18 x 35 ft.), 2 camera chains; Remote Unit, 2 field cameras; 2 Film Projectors (16 mm.), Slide Projector, Multi-scope.

PROGRAMMING:
WOC-TV is now programming 16 hours per week with NBC-TV network (non-interconnected), local and film programs. Staff available for local production of live and puppet programs, and development of program ideas.

FIRST in the QUAD CITIES
DAVENPORT, ROCK ISLAND, MOLINE, EAST MOLINE
The only TV station in one of the country's richest markets

In the prosperous Quad Cities market . . . television is WOC-TV . . . the first video station in Iowa.

As the center for diversified major industries . . . and for a rich, productive agricultural area . . . the Quad Cities rate higher than the national average in retail sales . . . total buying income . . . per capita income . . . according to Sales Management figures. *The Quad Cities market is the largest and richest market in the prosperous quadrangle formed by Chicago, Minneapolis, St. Louis and Omaha.*

Latest figures show more than 5,000 television receivers in the Quad Cities alone . . . with the number increasing every month. And there are hundreds more in the 75 air-mile radius which reports good visual and aural reception of WOC-TV.

NBC-TV affiliation (non-interconnected) brings top network programs to this audience. Through WOC-TV national spot and local advertisers now effect direct home penetration through eye and ear . . . to sell this rich, industrial-agricultural area.

Col. B. J. Palmer, President . . . Ernest Sanders, Resident Manager
Free & Peters, Inc., Exclusive National Representatives

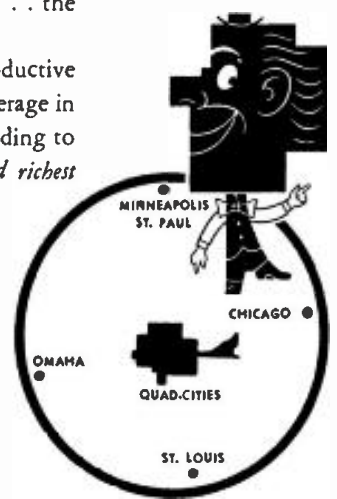

WMT SERVES EASTERN IOWA

with exclusive CBS programming

Arthur Godfrey, Groucho Marx, Bob Hawk, Jack Smith, Jack Benny, Marie Wilson, Bing Crosby, to name just a few of the stars heard exclusively in Eastern Iowa via WMT



intensive news coverage

AP, UP, INS services, plus regional Iowa news from WMT correspondents, provide complete data for WMT's own News Center



interesting farm events

Farm broadcasts, special events attracting tens of thousands of spectators, complete farm market reports, helpful educational features, highlight WMT farm services



WMT SERVES ADVERTISERS

- with a loyal audience (1,121,782 people within our 2.5 mv line)
- a prosperous audience (last year's Iowa per capita income increased more than that of any other state)
- a balanced farm-and-industrial audience

When you have something to say—and something to sell—in Iowa, tell WMT's loyal audience and watch results! Ask the Katz man for full details.

WMT
CEDAR RAPIDS
 5000 Watts 600 K.C. Day & Night
 BASIC COLUMBIA NETWORK

DIRECTORY OF AM, FM, and TV STATIONS OF THE UNITED STATES

(Data corrected to December 6, 1949)
If executives or services for FM or TV stations are same as AM affiliate names are not repeated.

IOWA—(Continued)

City Call Letters Established	Chan. or Freq. Power	Name of Licensee Headquarters Address Telephone Number	Network Representative	Executive Personnel	Transc. Library/ News Service Transmitter Make
DAVENPORT—(Continued)					
WOC-FM 1948	Ch. 279 (B) 103.7mc 47kw				RCA
WOC-TV 1949	Ch. 5 76-82mc 22.9kw-aur.; 22.9kw-vis.				RCA
DECORAH					
KDEC 1947	1240 250	Telegraph-Herald 301 W. Broadway 1240	MBS Tall Corn McKinney	Fred Woodward, Pres. William J. Croker, Gen. Mgr. George Dorrington, Coml. Mgr.	Standard AP RCA
*KWLC 1926	1240 250 SH	Luther College 600 Leif Erickson Dr. 690		J. W. Ylvisaker, Pres. Paul Borge, Gen. Mgr. & Prog. Dir.	SESAC RCA
DES MOINES					
KBIG (CP) 1947	740 250-D	Radio Station Des Moines Inc.			
KCBC 1947	1390 1,000 DA-1	Majestic Bcstg. Co. 2323 Grand Ave. 4-3151	Weed	Karl Peters, Pres. Rollo H. Bergeson, Gen. Mgr. Claire E. Grant, Coml. Mgr.	AP Raytheon
KCBC-FM 1949	Ch. 231 (B) 94.1mc 1.5kw			Claire Grant, Mgr.	Western Electric
KIOA 1948	940 10,000-LS 5,000-N DA-2	Independent Bcstg. Co. 10th & Mulberry 2-9191	MBS Raymer	H. E. Baker, Pres., Gen. & Coml. Mgr. William A. Wallace, Prog. Dir.	World UP, INS RCA
KRNT 1935	1350 5,000 DA-N	Cowles Bcstg. Co. 715 Locust St. 3-2111	ABC Katz	Gardner Cowles, Pres. Robert W. Dillon, Sta. Mgr. Paul M. Elliott, Coml. Mgr.	Standard Associated AP, UP RCA
KRNT-FM 1948	Ch. 283 (B) 104.5mc 17kw				Westinghouse
KSO 1932	1480 5,000 DA-N	Murphy Bcstg. Co. 10th & Grand Ave. 3-0571	CBS Headley-Reed	Kingsley H. Murphy, Pres. S. H. McGovern, Sta. & Coml. Mgr.	Capitol AP RCA

DA-N Directional Antenna, night only. FM's in italic. *—Non-Commercial Station D—Day. N—Night. ST—Share Time. SH—Specified Hours.
DA-1 Directional Antenna, same pattern day and night. U—Unlimited. CP—Construction Permit Issued. LS—Local Sunset.
DA-2 Directional Antenna, different pattern day and night. L—Limited Time with Dominant Station. SA—Special Authorization.

IT WAS DON BELL'S 3rd ANNIVERSARY AT KRNT —

4500 IOWANS GOT OUT OF BED FOR 6 O'CLOCK

"BREAKFAST WITH BELL"

TAKES PLENTY OF PULL & POWER TO DRAW PEOPLE OUT AT DAYBREAK ONLY IOWA'S GREATEST WAKE-UP SHOW COULD DO IT THATS THE "DON BELL SHOW" HUNDREDS DROVE MILES BEFORE DAWN TO SEE THE DISC JOCKEY IN ACTION AS THE MUSIC-AND-MIRTHMASTER THAT HE IS! SUCH POPULARITY MUST BE DESERVED



ASK A KATZ MAN ABOUT The Register and Tribune Station in DES MOINES

KRNT

BY EVERY MEASUREMENT, WHO IS IOWA'S OUTSTANDING LEADER

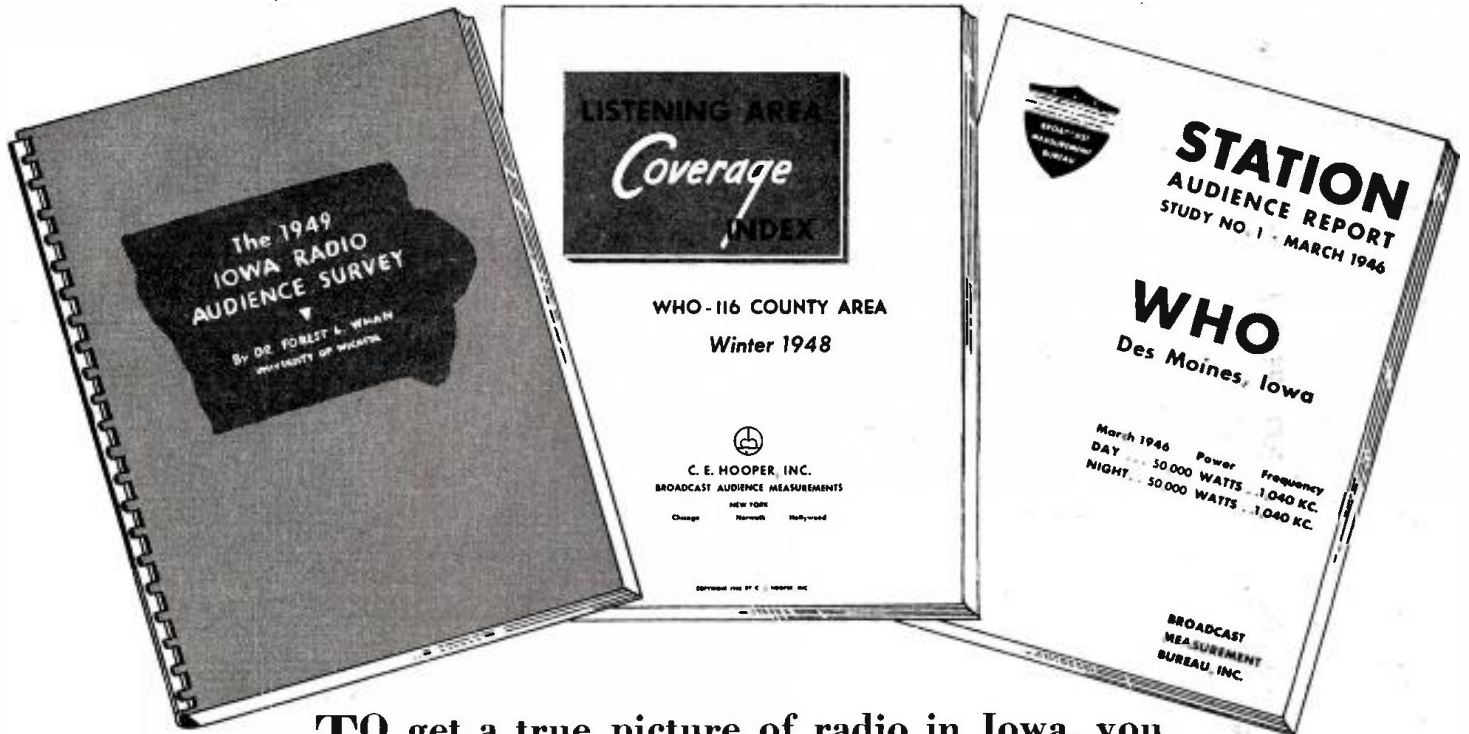

TO get a true picture of radio in Iowa, you need only to read one, two, or "all three" of the three greatest audience-study projects ever carried on in this State. . . .

The Winter 1948 Listening Area Coverage Index by C. E. Hooper gives station-preference for 116 counties in Iowa, Minnesota and Missouri—credits WHO with 3 times as many first-preference votes (Morning, Afternoon and Evening) as the next Iowa station.

The 1949 Iowa Radio Audience Survey gives the same overwhelming evidence of WHO's leadership throughout Iowa. In Iowa's 99 counties, WHO is "heard regularly" by 76.5% of daytime listeners, as against 32.8% for the next station.

The 1946 BMB Station Audience Report credits WHO with a daytime audience in 229 counties,

representing 764,400 families. WHO has a 30% or better penetration in 114 of these counties.

By any standard, WHO is Iowa's first station, and one of the top stations in America. Write us or ask Free & Peters for all the evidence.

WHO

+ for Iowa PLUS +

Des Moines . . . 50,000 Watts

Col. B. J. Palmer, President
P. A. Loyet, Resident Manager



FREE & PETERS, INC.
National Representatives

DIRECTORY OF AM, FM, and TV STATIONS OF THE UNITED STATES

*(Data corrected to December 6, 1949)
If executives or services for FM or TV stations are same as AM affiliate names are not repeated.*

IOWA—(Continued)

City Call Letters Established	Chan. or Freq. Power	Name of Licensee Headquarters Address Telephone Number	Network Representative	Executive Personnel	Transc. Library News Service Transmitter Make	
DES MOINES—(Continued)						
KSO-FM 1947	Ch. 247 (B) 97.3mc 15.5kw					
KWDM 1947	1150 1,000 DA-2	Des Moines Bcstg. Corp. 407 Fifth Ave.	Tall Corn McKinney	George W. Webber, Pres. & Natl. Sales Mgr. Ira L. Johnson, Prom. Mgr.	Robert L. Webber, Sta. Mgr. H. R. Hurd, Coml. Mgr. Edith D. Webber, Prog. Dir. Werner Schwarz, Chief Engr.	Capitol, Cole Associated UP, INS
WHO 1924	1040 50,000	Central Bcstg. Co. 914 Walnut St. 3-7147	NBC Free & Peters	Col. B. J. Palmer, Pres. Paul A. Loyet, V. P. & Res. Mgr. Jack Kerrigan, Prog. Dir.	Harold Fulton, Coml. Mgr. John Schweiker, Prom. Mgr. Reed E. Snyder, Chief Engr.	Thesaurus SESAC AP, UP, INS Westinghouse
WHO-FM 1948	Ch. 262 (B) 100.3mc 5kw					
DUBUQUE						
KDTH 1941	1370 1,000 DA-N	Telegraph Herald 8th & Bluff Sts. 1603	MBS Tall Corn McKinney	F. W. Woodward, Pres. K. S. Gordon, Gen. Mgr.	Arnie Sherman, Prog. Dir. Robert Hancock, Chief Engr.	Associated Standard AP Collins
KDTH-FM 1948	Ch. 263 (B) 100.5mc 180kw				Western Electric	
WKBB 1933	1490 250	Dubuque Bcstg. Co. 505 Main St. 572	ABC Meeker	James D. Carpenter, Pres. & Gen. Mgr. Harry Hatzenbuehler, Coml. Mgr.	Gleason E. Kistler, Prog. Dir. & Prom. Mgr. John Uyeoka, Chief Engr.	Lang-Worth UP Collins
WDBQ(FM) 1948	Ch. 277 (B) 103.3mc 15kw	(WKBB, AM affiliate)			RCA	
FORT DODGE						
KVFD 1939	1400 250	Northwest Bcstg. Co. Warden Bldg. Walnut 3761	MBS Tall Corn McKinney	Edward Breen, Pres. & Gen. & Prom. Mgr. Mae Challberg, Office Mgr. Max Landes, Sales Mgr.	Drexel Peterson, Prog. Dir. David Sinclair, Chief Engr.	Lang-Worth UP, INS RCA
KFMY(FM) 1947	Ch. 274 (B) 102.7mc 10kw	(KVFD, AM affiliate)				
FORT MADISON						
KXGI 1948	1360 500-D	Carson Radio Marquette Bldg. 1360		A. Orrie Carson, Pres. Robert M. Carson, Gen. Mgr.	Milton H. Cohen, Res. Mgr. Hubert J. Marshall, Chief Engr.	Capitol AP Raytheon
IOWA CITY						
KXIC 1948	800 1,000-D DA	Johnson City Bcstg. Corp. 108½ E. Washington St. 8-1181		Robert Snyder, Pres. Larry Butler, Coml. & Prom. Mgr.	Gene Claussen, Gen. Mgr. Herb Olson, Prog. Dir. Elliott Full, Chief Engr.	Lang-Worth Standard UP Collins
*WSUI 1919	910 5,000 DA-1	The State U. of Iowa Iowa City 80511		Carl H. Menzer, Gen. Mgr. Richard Setterberg, Prog. Dir.	S. J. Ebert, Chief Engr.	Thesaurus AP, UP RCA
KEOKUK						
KOKX 1947	1310 250-D	Keokuk Bcstg. Co. 500½ Main St. 235	Tall Corn McKinney	H. W. Stadler, Pres. George B. J. Adkisson, Gen. & Prom. Mgr.	Guy Eccles, Coml. Mgr. C. C. Andrews, Prog. Dir. George W. Henderson, Chief Engr.	Lang-Worth World UP RCA
KOKX-FM 1948	Ch. 274 (B) 102.7mc 3.7kw					
MARSHALLTOWN						
KFJB 1923	1230 250	Marshall Electric Co. 133 E. Main St. 3361	MBS Tall Corn McKinney	D. W. Norris, Pres. William P. White, Gen. Mgr. Ronald W. Brown, Coml. Mgr.	Ray P. Bennett, Prog. Dir. Allan N. Schrock, Prom. Mgr. Herbert G. Anderson, Chief Engr.	Standard UP RCA
MASON CITY						
KGLO 1937	1300 5,000 DA-N	Lee Radio Inc. 12½ Second St., N.E. 3800	CBS Weed	Lee P. Loomis, Pres. Herbert R. Ohrt, Exec. V. P. H. B. Hook, Gen. Mgr. Don Harrer, Prom. Mgr.	Lloyd Loers, Coml. Mgr. Bud Suter, Prog. Dir. Roger Sawyer, Chief Engr.	Standard AP, UP RCA
KGLO-FM 1948	Ch. 266 (B) 101.1mc 16kw					
KICM 1948	1490 250	Mason City Bcstg. Co. 5 Second St., S.W. 5400	MBS Tall Corn McKinney	Charles E. Jones, Gen. Mgr. Al Tighe, Prog. Dir.	Bob Thompson, Prom. Mgr. Larry Lawson, Chief Engr.	World AP Collins
KSMN 1948	1010 1,000-D	Mohawk Bcstg. Co. Mason City 5420		Robert M. Carson, Pres. & Gen. Mgr. Norman W. Rice, Coml. Mgr.	Al Heinz, Prog. Dir. Jack H. Duncan, Chief Engr.	Lang-Worth UP Raytheon

DA-N Directional Antenna, night only. FM's in italic.
DA-1 Directional Antenna, same pattern day and night.
DA-2 Directional Antenna, different pattern day and night.

*—Non-Commercial Station D—Day, N—Night, ST—Share Time, SH—Specified Hours.
U—Unlimited, CP—Construction Permit Issued, LS—Local Susst.
L—Limited Time with Dominant Station. SA—Special Authorization.

City Call Letters Established	Chan. or Freq. Power	Name of Licensee Headquarters Address Telephone Number	Network Representative	Executive Personnel		Transc. Library News Service Transmitter Make
MUSCATINE						
KWPC 1947	860 250-D	Muscatine Bcstg. Co. Mulberry & Houser Sta. 860	Tall Corn McKinney	George J. Volger, Gen. & Coml. Mgr.	Thelma Volger, Prog. Dir. Edward Edenson, Chief Engr.	Thesaurus Associated UP Collins
KWPC-FM 1949	Ch. 259 (B) 99.7mc 9.3kw					
OELWEIN						
KOEL (CP)	950 500-D DA	Northeast Iowa Radio Corp.				
OTTUMWA						
KBIZ 1941	1240 250	KBIZ Inc. 2513 N. Court Rd. 5600	MBS	James J. Conroy, Pres. & Gen. Mgr. Eleanor M. Haling, Sta. Mgr.	Richard Meier, Coml. Mgr. Del Donahoo, Prog. Dir. Berg Allison, Prom. Mgr. Wayne Hatchett, Chief Engr.	World AP Collins
RED OAK						
KRAO (CP)	1600 500-D	Red Oak Radio Corp.				
SHENANDOAH						
KFNF 1924	920 1,000-LS 500-N ST-KUSD	Capital Bcstg. Co. Shenandoah 1302	MBS Taylor-Boroff	C. J. Abbot, Pres. C. Earl Williams, Gen. Mgr.	Mark W. Bullock, Coml. Mgr. Earl Blakeslee, Prog. Dir. William I. Hutton, Chief Engr.	World AP Collins
KMA 1925	960 5,000 DA-N	May Bcstg. Co. Shenandoah 192	ABC Avery-Knodel	Edward W. May, Pres. Owen Saddler, Gen. Mgr. Glenn E. Harris, Prog. Dir.	Howard O. Peterson, Sales Mgr. James L. Moore, Prom. Mgr. R. J. Schroeder, Chief Engr.	Capitol AP, UP RCA
SIoux CITY						
KCOM 1949	620 1,000 DA-2	KCOM Bcstg. Co. 620 Insurance Exchange Bldg. 8-0628	Tall Corn McKinney	Dietrich Dirks, Pres. & Mgr. Sheldon Singer, Coml. Mgr.	Don Soliday, Prog. Dir. Al Smith, Chief Engr.	Standard UP Raytheon
KSCJ 1927	1360 5,000 DA-N	Perkins Bros. Co. 415 Douglas St. 5-7993	CBS Hollingbery	W. R. Perkins, Pres. Eugene T. Flaherty, Gen. & Coml. Mgr.	Elizabeth Sammons, Prog. Dir. Jean Harraday, Prom. Mgr. S. C. Dier, Chief Engr.	World Lang-Worth Cole AP RCA
KSCJ-FM 1947	Ch. 235 (B) 94.9mc 280kw					
KTRI 1938	1470 5,000 DA-2	Sioux City Bcstg. Co. Commerce Bldg. 8-0165	MBS Taylor-Boroff	John C. Kelly, Pres. E. J. Huber, Gen. & Coml. Mgr.	Bob Hansen, Prog. Dir. Lennon Kelly, Prom. Mgr. Willard Easterly, Chief Engr.	Thesaurus UP RCA
SPENCER						
KICD 1941	1240 250	Iowa Great Lakes Bcstg. Co. Highway 71 1240	MBS Tall Corn McKinney	Ben B. Sanders, Pres. & Gen. Mgr. Henry P. Cate, Sales Mgr.	Mason Dixon, V. P. & Prog. Dir. John Blackwell, Chief Engr.	Associated Standard AP Collins
STORM LAKE						
KAYL 1948	990 250-D	Cornbelt Bcstg. Co. Park Bldg. 1490		Oscar J. Grau, Pres. Lee Gordon Rasmussen, Gen. Mgr. & Prog. Dir.	James I. McCord, Coml. Mgr. Howard C. Carlson, Chief Engr.	Thesaurus Capitol AP Gates
KAYL-FM 1949	Ch. 234 (B) 101.5mc 8.9kw					
WATERLOO						
KAYX 1947	1090 1,000-D; CP: 1280 CP: 1,000 DA-2	Waterloo Bcstg. Co. 620 1/2 Lafayette St. 6851	Tall Corn McKinney	Clair R. Miller, Pres. Loren R. Nuss, Gen. Mgr.	L. F. Podhaski, Coml. Mgr. Charles R. Shafter, Chief Engr.	Lang-Worth UP Raytheon
KWWL 1947	1330 5,000-LS 1,000-N DA-2	Black Hawk Bcstg. Co. Hotel Russell Lamson 4406		R. J. McElroy, Pres. & Gen. Mgr. W. Lyle Harvey, Coml. Mgr.	Howard F. Burgess, Chief Engr.	Associated AP Collins
KXEL 1942	1540 50,000 DA-N	Josh Higgins Bcstg. Co. Insurance Bldg. 3-3371	ABC Avery-Knodel	Joe DuMond, Pres. & Gen. Mgr. A. J. DuMond, Coml. Mgr.	Emlyn Owen, Prog. Dir. Elizabeth Gahre, Prom. Mgr. Don Kassner, Chief Engr.	SESAC INS Westinghouse
KXEL-FM 1947	Ch. 289 (B) 105.7mc 540kw					
WEBSTER CITY						
KJFJ 1949	1570 250-D	Land O'Corn Bcstg. Co. 623 2nd St. 1300		Charles V. Warren, Pres.	 AP
KANSAS						
ARKANSAS CITY						
KSOK 1947	1280 1,000-D	KSOK Bcstg. Co. Inc. Home Nat'l Bank Bldg. 2666		Oscar S. Stauffer, Pres. S. C. Thompson, V. P., Gen. & Coml. Mgr.	Donald D. Chadd, Prog. Dir. Edward H. Howe, Chief Engr.	Lang-Worth AP Raytheon
ATCHISON						
KVAK 1939	1470 1,000 DA-1	S. H. Patterson 622 1/2 Commercial 1420	KBS	S. H. Patterson, Owner & Gen. Mgr. Max Habecker, Coml. Mgr.	Mary Sawyer, Prog. Dir. Luke McNeally, Prom. Mgr. Laudon Gingery, Chief Engr. AP Western Electric

DIRECTORY OF AM, FM, and TV STATIONS OF THE UNITED STATES

(Data corrected to December 6, 1949)
 If executives or services for FM or TV stations are same as AM affiliate names are not repeated.

KANSAS—(Continued)

City Call Letters Established	Chan. or Freq. Power	Name of Licensee Headquarters Address Telephone Number	Network Representative	Executive Personnel	Transc. Library News Service Transmitter Make	
COFFEYVILLE						
KGGF 1930	690 1,000-LS 500-N CP: 10,000-LS 5,000-N DA-2	The Midwest Bcstg. Co. Inc. 8th & Elm 147	ABC Weed	Fay N. Seaton, Pres. Richard M. Seaton, Gen. Mgr. Robert L. Pratt, Sta. & Prom. Mgr.	E. B. Spoonamore, Coml. Mgr. Roger H. Stoner, Prog. Dir. J. Sarto Jaminet, Chief Engr.	World AP Western Electric
COLBY						
KXXX 1947	790 5,000-D	Western Plains Bcstg. Co. Cooper Hotel 790		George A. Nickson, Gen. & Coml. Mgr.	William Morse, Prog. Dir. U. L. Lynch, Chief Engr.	Associated Capitol INS Collins
DODGE CITY						
KGNO 1930	1370 1,000-LS 250-N	Dodge City Bcstg. Co. Globe Bldg. 1370	Hagg	J. C. Denious, Pres. & Gen. Mgr. Isadore Salm, Coml. Mgr.	Herschel Holland, Prog. Dir. Henry McClintock, Chief Engr.	Lang-Worth AP Collins
EMPORIA						
KTSW 1939	1400 250	Emporia Bcstg. Co. 613 Merchant St. 153	MBS Kansas	Owen H. Balch, Gen. Mgr. Adele Corey, Prog. Dir.	C. Dale Allen, Chief Engr.	World AP Collins
GARDEN CITY						
KGAR 1948	1050 1,000-D	Ark. Valley Bcstg. Co. Inc. P.O. Box 878		Dale E. Kern, Gen. Mgr.		
KGAR-FM	Ch. 257 (A) 93.3mc 0.8kw					
KIUL 1935	1240 250	Telegram Pub. Co. Inc. 509½ Main St. 4581	MBS KBS	Robert Wells, Gen. Mgr. Jan Dellinger, Coml. Mgr.	Tom Lanman, Prog. Dir. & Prom. Mgr. Robert Bryant, Chief Engr.	World AP Gates
GOODLAND						
KWGB 1947	730 1,000-D	Goodland Bcstg. Co. Hotel Goodland		James E. Blair, Owner & Gen. Mgr.	Dick Eldridge, Coml. Mgr.	Lang-Worth World UP
GREAT BEND						
KVGB 1937	1590 5,000 DA-N	KVGB Inc. Cork Bldg. 4317	MBS Pearson	Helen T. Coogan, Pres. Grover C. Cobb, Gen. Mgr. & V. P. Sherwood R. Parks, Asst. Mgr.	Bill J. Jarvis, Coml. Mgr. Ray H. Beals, Prog. Dir. Chester A. Wallack, Chief Engr.	Lang-Worth UP Raytheon

DA-N Directional Antenna, night only. FM's in italic. *—Non-Commercial Station D—Day. N—Night. ST—Share Time. SH—Specified Hours.
 DA-1 Directional Antenna, same pattern day and night. U—Unlimited. CP—Construction Permit Issued. LS—Local Sunset.
 DA-2 Directional Antenna, different pattern day and night. L—Limited Time with Dominant Station. SA—Special Authorization.

NOW - GREATLY INCREASED COVERAGE



★
 A NEW SITE
 A NEW TOWER
 AND A NEW
 BUILDING!

KWBW KWBW-FM

HUTCHINSON, KANSAS

Serving Central Kansas 15 Years

NBC Affiliates

Write, wire or phone WILLIAM WYSE FOR AVAILABILITIES

City Call Letters Established	Chan. or Freq. Power	Name of Licensee Headquarters Address Telephone Number	Network Representative	Executive Personnel	Transc. Library News Service Transmitter Make	
HAYS						
KAYS 1948	1400 250	KAYS Inc. Hays 200		Frank Motz, Pres. Duane W. Hoisington, Gen. & Coml. Mgr. Bob Schmidt, Coml. Mgr.	Paul F. Kelly, Prog. Dir. Janie Roth, Prom. Mgr. Glenn Barnett, Chief Engr.	Standard Capitol AP RCA
HUTCHINSON						
KIMV(FM) 1947	Ch. 233 (B) 94.5mc 40kw	Hutchinson Pub. Co. 28 East Second 4400	MBS	J. P. Harris, Pres. George E. Aiden, Gen. & Coml. Mgr.	Keith Bretz, Prog. Dir. J. Lamar Dunn, Chief Engr.	World AP Western Electric
KWBW 1935	1450 250	Nation's Center Bcstg. Co. 101 E. Ave. 5202	NBC	William Wyse, Pres. & Gen. Mgr. Robert Rives, Coml. Mgr.	Paul Bernard, Prog. Dir. & Prom. Mgr. John Swofford, Chief Engr.	Lang-Worth AP Collins
KWBW-FM 1947	Ch. 226 (B) 93.1mc 3kw					
KWHK 1946	1190 1,000-D	KWHK Bcstg. Co. Inc. 18 West 5th St. 3100	KBS McKinney	James E. Murray, Pres. Vern Minor, Gen. Mgr. & Secy.-Treas.	Gren Darling, Coml. & Prom. Mgr. Paul Cochran, Prog. Dir. Millard H. Clary, Chief Engr.	Standard AP Gates
INDEPENDENCE						
KIND 1947	1010 250-D	Central Bcstg. Inc. Professional Bldg. 1010	KBS LBS	J. Nelson Rupard, Pres. & Gen. Mgr.	Ernest Ketterman, Chief Engr.	Lang-Worth AP General Electric
JUNCTION CITY						
KJCK 1949	1570 1,000-D	Junction City Bcstg. Co. 724½ N. Washington 1477	Kansas	Ralph L. Weir Jr., Co-owner, Gen. & Coml. Mgr.	Richard P. Meek, Co-owner, Prog. Dir. & Chief Engr.	Lang-Worth UP Collins
KANSAS CITY						
KCKN 1925	1340 250	(See Kansas City, Mo.)				
LAWRENCE						
*KFKU 1924	1250 5,000-DA-N ST-WREN	U. of Kansas.				
LEAVENWORTH						
KCLO 1948	1410 500-D	Leavenworth Bcstg. Co. Inc. 418½ Cherokee 3620	Continental	Hon. Alf M. Landon, Pres. M. L. Gleason, Gen. & Coml. Mgr.	Ron Barkley, Prog. Dir. David L. Reed, Chief Engr.	Capitol UP Collins
LIBERAL						
KSCB 1948	1270 1,000-D	Seward County Bcstg. Co. Inc. East 8th St. 385		Hon. Alf M. Landon, Pres. Leon S. Salathiel, Gen. Mgr. Neil Lovett, Coml. Mgr.	Ben Berry, Prog. Dir. Wayne Pash, Chief Engr.	Standard UP Collins
MANHATTAN						
KMAN (CP) 1924	1350 500-D	Manhattan Bcstg. Co. 114 North 4th St.				
*KSAC 1924	580 5,000-LS 500-N ST-WIBW	Kansas State College Manhattan 5661				
MCPHERSON						
KNEX 1949	1540 250-D	McPherson Bcstg. Co. Inc. P. O. Box 186 1540		Evert Mills, Pres. Dan Bellus, Gen. Mgr. Vance Archer, Coml. Mgr.	Henry Dais, Prog. Dir. Claude Hughes, Chief Engr.	Capitol SESAC AP Gates
KNEX-FM 1949	Ch. 276 (A) 103.1mc 0.16kw					
OLATHE						
KPRS 1949	1590 500-D	Johnson County Bcstg. Co. Inc. 131 East Park St. 1200		L. H. Witherspoon, Pres., Gen. & Coml. Mgr.	S. P. Madden, Prog. Dir. Daniel Reed, Chief Engr.	Capitol AP RCA
OTTAWA						
KOFO 1949	1220 250-D	Ottawa Bcstg. Co. P. O. Box 46 1045		James N. Jobs, Pres., Gen. Mgr. & Prog. Dir.	Tommy Ruble, Coml. Mgr. Daniel W. Coltrane, Chief Engr.	Capitol UP Gates
PARSONS						
KLKC 1948	1540 250-D	Community Bcstg. Co. Inc. 1904 Broadway 4050		Clyde M. Reed Jr., Pres. Kern Trimble, Gen. & Coml. Mgr.	Rae Drenner, Prog. Dir. James L. Teats, Chief Engr.	Standard AP Collins
PITTSBURG						
KOAM 1937	860 10,000-LS 5,000-N DA	Pittsburg Bcstg. Co. Inc. Commerce Bldg. 2165	NBC Pearson	E. V. Baxter, Pres. R. E. Wade, Gen. & Coml. Mgr.	G. L. Wade, Prom. Mgr. Leo S. Stafford, Chief Engr.	World AP Westinghouse
KSEK 1947	1340 250	Pittsburg Pub. Co. Hotel Besse Bldg. 742	Cooke	Oscar S. Stauffer, Pres. Thad M. Sandstrom, Gen. Mgr.	C. Warren Stout, Coml. Mgr. W. D. Bresseau, Chief Engr.	Standard AP General Electric
SALINA						
KSAL 1937	1150 5,000 DA-N	KSAL Inc. Journal Bldg. 3701	MBS Pearson	Robert J. Laubengayer, Pres. Ray V. Jensen, Sta. & Coml. Mgr.	Al Thompson, Prog. Dir. J. D. Hill, Prom. Mgr. N. E. Vance, Chief Engr.	Standard Lang-Worth AP Western Electric
TOPEKA						
KJAY 1949	1440 5,000-LS 1,000-N DA-1	S. H. Patterson 908 Kansas Ave. 3-1336	Rambeau	S. H. Patterson, Norwood J. Patterson, Owners. Allan Curnutt, Sta. & Coml. Mgr.	Craig Lawson, Prog. Dir. & Prom. Mgr. Norwood J. Patterson, Chief Engr. INS Gates
KTOP 1947	1490 250	Collinson Bcstg. Co. 212-14 West 6th St. 4-3444	MBS Ra-Tel	T. Hall Collinson, Owner & Gen. Mgr. Marie M. McKinney, Asst. Gen. Mgr.	Richard C. Scheele, Coml. Mgr. Jack-Warren Ostrode, Prog. Dir. Thomas Gregg, Prom. Mgr. Leo Born, Chief Engr.	Capitol Associated AP General Electric

DIRECTORY OF AM, FM, and TV STATIONS OF THE UNITED STATES

(Data corrected to December 6, 1949)

If executives or services for FM or TV stations are same as AM affiliate names are not repeated.

KANSAS—(Continued)

City Call Letters Established	Chan. or Freq. Power	Name of Licensee Headquarters Address Telephone Number	Network Representative	Executive Personnel	Transc. Library News Service Transmitter Make	
TOPEKA—(Continued)						
WIBW 1926	580 5,000 DA-N	Topeka Bcstg. Assn. Inc. 1035 Topeka Blvd. 3-2377	CBS Capper	H. S. Blake, Pres. Ben Ludy, Gen. Mgr. Hilton Hodges, Coml. Mgr.	Maude Carlson, Prog. Dir. Allan Young, Prom. Mgr. Lewis Dickensheets, Chief Engr.	Lang-Worth Standard AP, UP Western Electric
WIBW-FM 1946	Ch. 273 (B) 102.5mc 2.9kw					World General Electric
WREN 1927	1250 5,000 DA-N	WREN Bcstg. Co. Inc. 411 10th St. 20505	ABC Kansas Weed	R. C. Jackman, Pres. John S. Major, Gen. Mgr. Bailey Axton, Coml. Mgr.	Fred L. Conger, Prog. Dir. William P. Yearout Jr., Prom. Mgr. Carl Bliesner, Chief Engr.	Thesaurus UP Westinghouse
WICHITA						
KAKE 1947	1240 250	KAKE Bcstg. Co. Inc. 418 W. Douglas 4-9369	MBS Walker	Jack Todd, Gen. Mgr. Martin Bass, Coml. Mgr.	Graeme Fletcher, Prog. Dir. Harold Newby, Chief Engr.	World AP RCA
KANS 1936	1480 5,000-LS 1,000-N DA-2	Taylor Radio and Television Corp. 1015 North Broadway 4-2387	NBC Taylor-Boroff	O. L. Ted Taylor, Pres. & Owner Archie J. Taylor, Gen. Mgr. Frank Mathews, Coml. Mgr.	Paul Wilson, Prog. Dir. H. W. Allen, Prom. Mgr. Ted Heithecker, Chief Engr.	Standard AP, UP Collins
KFBI 1923	1070 10,000-LS 1,000-N DA	KFBI Inc. 200 East First St. 2-1447	ABC Avery-Knodel	Howard Lane, Pres. Hale Bondurant, Gen. Mgr. D. W. McCoy Sr., Sales Mgr.	J. B. Bradshaw, Prog. Dir. Harry Hulse, Prom. Mgr. K. W. Pyle, Chief Engr.	Capitol UP RCA
KFH 1922	1330 5,000 DA-N	Radio Station KFH Co. KFH Bldg. 24491	CBS Petry	John Rigby, Pres. Marcellus Murdock, V. P. Frank V. Webb, Gen. Mgr. Robert Hix, Coml. Mgr.	Thomas Bashaw, Prog. Dir. Russel Lowe, Prom. Mgr. Amos Dadisman, Chief Engr.	Lang-Worth AP, UP RCA
KFH-FM	Ch. 262 (B) 100.3mc 11kw					
KWBB (CP)	1410 1,000 DA-2	Wichita Bcstg. Co.				

DA-N Directional Antenna, night only. FM's in italic. DA-1 Directional Antenna, same pattern day and night. DA-2 Directional Antenna, different pattern day and night. *—Non-Commercial Station D—Day. N—Night. ST—Share Time. SH—Specified Hours. U—Unlimited. CP—Construction Permit Issued. LS—Local Sunset. L—Limited Time with Dominant Station. SA—Special Authorization.

1st PLUS MINUS HALF THE COST

equals = BETTER BUY!

WREN

an ABC affiliate **1250 KC**

5000 WATTS

The Peak in Topeka

ASK A WEED MAN

SOURCES:
1949 SALES MANAGEMENT-CONLAN





"Ready with your Kansas Market"

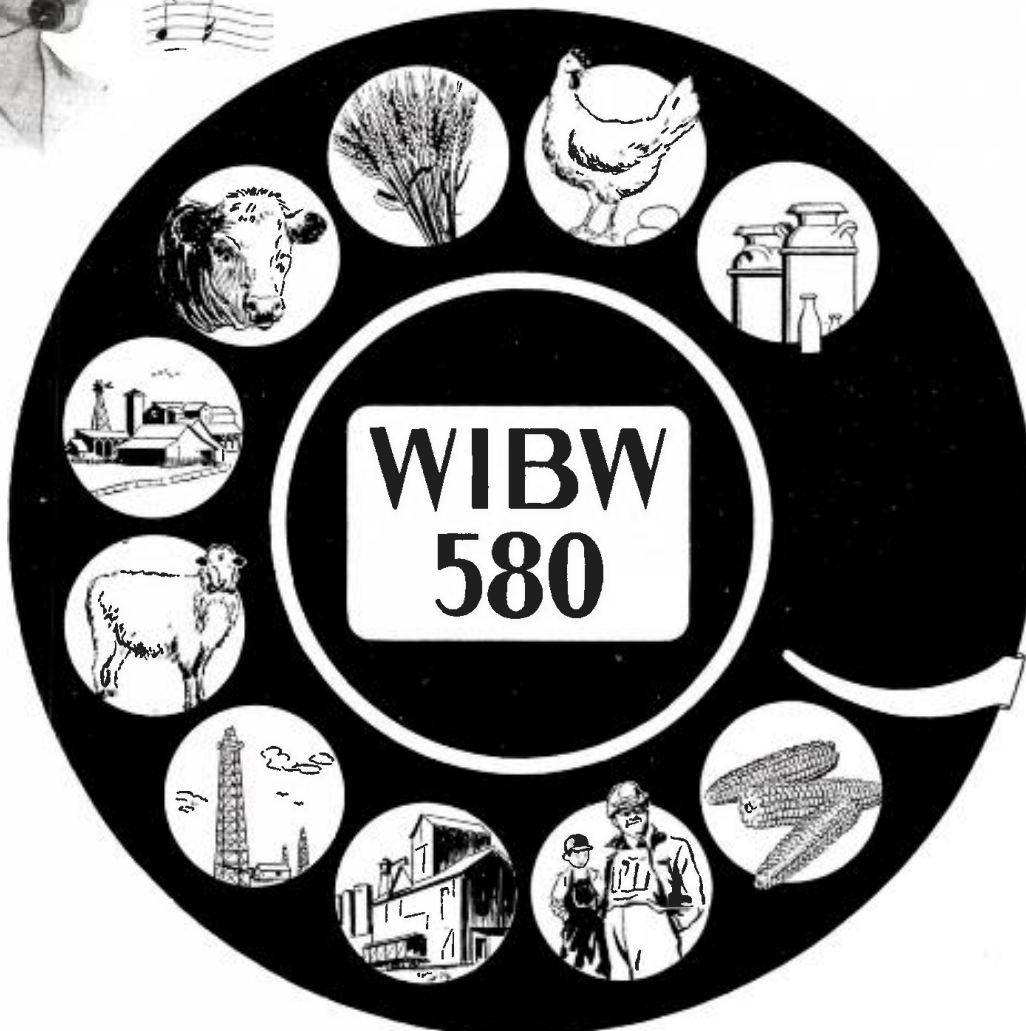

"Go ahead, please!"

. . . and it's person-to-person . . . straight to the man with the money. Over WIBW, you're talking direct to the farm and small town folks who do the biggest part of the buying in Kansas. You see, these families have been dialing WIBW on 580 kc. ever since they can remember . . . dialing WIBW in preference to any other station.*

That's because WIBW is a farm and small town station. We've never been anything else. We build our programs, features and services exclusively for this audience. We always give first thought to *their* needs, *their* preferences, *their* listening convenience . . . and it's paying off BIG for our advertisers.

Our listeners show their appreciation by giving first choice to WIBW-advertised products every time they shop. And they have plenty of money to shop with . . . thanks to a decade of high prices for all farm products.

So—whenever you're ready to sell your product to this state-wide family of buyers . . . WIBW is "Ready with your Kansas market."

** Kansas Radio Audience, 1949.*

W I B W

SERVING AND SELLING

"THE MAGIC CIRCLE"

WIBW - TOPEKA, KANSAS - WIBW-FM



C
B
S

Rep: CAPPER PUBLICATIONS, Inc. • BEN LUDY, Gen. Mgr. • WIBW • KCKN

DIRECTORY OF AM, FM, and TV STATIONS OF THE UNITED STATES

(Data corrected to December 6, 1949)
If executives or services for FM or TV stations are same as AM affiliate names are not repeated.

KENTUCKY

City Call Letters Established	Chan. or Freq. Power	Name of Licensee Headquarters Address Telephone Number	Network Representative	Executive Personnel	Transc. Library News Service Transmitter Make	
ASHLAND						
WCMJ 1935	1340 250	Ashland Bcstg. Co. P. O. Box 949 3010	CBS Pearson	Gilmore N. Nunn, Pres. Charles C. Warren, Gen. & Coml. Mgr.	W. R. Martin, Prog. Dir. C. W. Weaver, Chief Engr.	Thesaurus World UP RCA Western Electric
WCFM-FM 1948	Ch. 229 (B) 93.7mc 4.3kw					
BOWLING GREEN						
WKCT 1947	930 1,000-D	Daily News Bcstg. Co. 415 Park Row 2640	Holman	Paul R. Huddleston, Gen. Mgr. Houston Griffin, Coml. Mgr.	Alvis H. Temple, Prom. Mgr.	Associated Standard AP, UP
WLBJ 1940	1340 250	Bowling Green Bcstg. Corp. 901 Fairview Ave. 1340	MBS, KBS Burn-Smith	Ken D. Given, Pres. & Gen. Mgr. Elmer A. Finley, Coml. Mgr. William Kuznitsov, Prog. Dir.	Joe Hamilton, Prom. Mgr. Rondal Lee Miller, Chief Engr.	Capitol AP RCA General Electric
WBON (FM) 1948	Ch. 266 (B) 101.1mc 8.4kw	(WLBJ, AM Affiliate)				
CAMPBELLSVILLE						
WTCO 1948	1150 1,000-D	So. Central Kentucky Bcstg. Co. 203 E. Main St. 250		H. T. Parrott, Pres. Jack Shacklette, Gen. Mgr. John Adkins, Prog. Dir.	William J. Harris Jr., Prom. Mgr. J. B. Crawley, Chief Engr.	Capitol, Cole World UP Gates
CORBIN						
WCTT 1947	1400 250	Corbin Times-Tribune 308 S. Main St. 1071	MBS, KBS	John L. Crawford, Gen. Mgr. Kenneth Z. Turner, Sta. Mgr. & Prog. Dir.	S. G. Hembree, Coml. & Prom. Mgr. Russell Henson, Chief Engr. AP Raytheon
COVINGTON						
WZIP 1949	1050 250-D	WZIP Inc. Sixth & Madison Ave. Juniper 5300	KBS	Arthur L. Eilerman, Pres., Gen. & Coml. Mgr. Steve Crane, Prod. Mgr.	Lloyd W. Baldwin, Prog. Dir. & Prom. Mgr. Julian Koenig, Chief Engr.	SESAC World AP RCA
DANVILLE						
WHIR 1949	1230 250	Commonwealth Bcstg. Corp. P. O. Box 234 1230	KBS Holman	W. T. Isaac, Pres. & Coml. Mgr. David B. Highbaugh, V. P. & Prog. Dir.	Henry C. Lovell, Chief Engr.	World Capitol AP Collins
ELIZABETHTOWN						
WIEL (CP)	1400 250	Elizabethtown Bcstg. Co.				
FRANKFORT						
WFKY 1945	1490 250	Frankfort Bcstg. Co. 104 East Main St. 2509	MBS Wood & Colton	B. C. Edwards, Pres. W. Wallace Robinson, Gen., Coml. & Prom. Mgr. & Prog. Dir.	John Hudimac, Chief Engr.	World AP Gates
GLASGOW						
WKAY 1946	1490 250	Glasgow Bcstg. Co. Happy Valley Rd. 598		Gordon E. Brown, Pres. Louis R. Rayburn, Gen. & Coml. Mgr.	Lee Redford, Prog. Dir. & Prom. Mgr. C. H. Hulse, Chief Engr.	World Standard AP Western Electric
HARLAN						
WHLN 1941	1230 250	Blanfox Radio Co. Inc. Harlan 625	MBS, KBS Burn-Smith	R. B. Helms & J. Francke Fox Jr., Co-Owners R. B. Helms, Pres., Gen. & Prom. Mgr.	J. Francke Fox Jr., V. P. James Morgan, Coml. Mgr. & Prog. Dir. John Greenwood, Chief Engr.	SESAC AP Collins
HAZARD						
WKIC 1949	1340 250	BMG Bcstg. Corp. Peoples Bank Bldg. Main 720	MBS Clark	Fred B. Bullard, Pres. & Gen. Mgr. Richard H. Goodlette, Coml. Mgr.	Charles W. Metcalf, Prog. Dir. Paul Combs, Prom. Mgr. James C. French, Chief Engr.	World AP Collins
HENDERSON						
WSON 1941	860 500-D	Henderson Bcstg. Co. Inc. Zion Rd. 3923	MBS Sears-Ayer	Hecht S. Lackey, Pres., Gen. & Coml. Mgr.	Martin E. Schaeffer, Prog. Dir. Vernon R. Nunn, Chief Engr.	World AP Gates
WSON-FM 1947	Ch. 258 (B) 99.5mc 20kw				 Federal
HOPKINSVILLE						
WHOP 1940	1230 250	Hopkinsville Bcstg. Co. Inc. Cadiz Rd. 1025	CBS Sears & Ayer	F. Ernest Lackey, Pres. & Gen. Mgr. Katherine G. Peden, Coml. Mgr.	Charles W. Stratton, Prog. Dir. Ann H. Hayes, Prom. Mgr. Leo Y. Wilson, Chief Engr.	Lang-Worth UP General Electric
WHOP-FM 1948	Ch. 254 (B) 98.7mc 22kw					
LEXINGTON						
WKLX 1946	1300 1,000-DA-N	Fayette Bcstg. Co. Inc. Phoenix Hotel 8115	Walker	E. F. Prichard Sr., Pres. Ted Grizzard, Gen. & Coml. Mgr.	Jack Brooks, Prog. Dir. William Yount, Chief Engr.	Lang-Worth, Standard AP Western Electric
WLAP 1922	1450 250	American Bcstg. Corp. Radio Bldg. 1721	ABC Pearson	Gilmore N. Nunn, Pres. J. E. Willis, Gen. Mgr. Miller A. Welch, Coml. Mgr.	J. B. Faulconer, Prog. Dir. Jimmy Young, Prom. Mgr. Henry C. Lockler, Tech. Supvr.	Capitol, World UP Western Electric
WLEX 1946	1340 250	Central Kentucky Bcstg. Co. Russell Cave Pike 3-1977	Ra-Tel	J. D. Gay Jr., Pres. & Owner Carroll Gardner, Gen. Mgr.	Bob Kimbro, Prog. Dir. Otho Warner, Chief Engr.	Associated UP Western Electric
LOUISVILLE						
WAVE 1933	970 5,000 DA-1	WAVE Inc. 334 East Broadway Wabash 2201	NBC Free & Peters	George W. Norton Jr., Pres. Nathan Lord, Gen. Mgr. James F. Cox, Coml. Mgr.	George Patterson, Prog. Dir. Robert Elverman, Prom. Mgr. Wilbur Hudson, Chief Engr.	Lang-Worth Thesaurus AP RCA

DA-N Directional Antenna, night only. FM's in italic.
DA-1 Directional Antenna, same pattern day and night.
DA-2 Directional Antenna, different pattern day and night.

*-Non-Commercial Station D-Day. N-Night. ST-Share Time. SH-Specified Hours.
U-Unlimited. CP-Construction Permit Issued. LS-Local Sunset.
L-Limited Time with Dominant Station. SA-Special Authorization.

WAVE-TV

PAYS OFF

IN THE RICH

LOUISVILLE

TRADING AREA!

WAVE-TV has had its shakedown cruise—is now strictly big-time, in America's *twenty-sixth* market.

As this Yearbook "copy" is written, WAVE-TV has racked up an outstanding record, in just a little more than a year of operation:

1. Exceptional local programming, including the nationally-known Pee Wee King Show, Carl Bonner, the Kentucky Derby, collegiate and high-school football and basketball, professional baseball and hockey, and *dozens* of other outstanding sports events, with remotes alone totalling almost 400 hours.
2. Topnotch television network affiliates—NBC, ABC and Dumont.
3. An impressive and growing list of sponsors, both local and national.
4. Kentucky's *first* TV station by more than a year.

Write to us or Free & Peters for all the dope. *The facts will amaze you!*

WAVE
(AM)

WAVE-TV
(CHANNEL 5)

WRXW
(FM)

FREE & PETERS, INC.



NATIONAL REPRESENTATIVES

BROADCASTING • Telecasting

1950 Yearbook Number • Page 155

DIRECTORY OF AM, FM, and TV STATIONS OF THE UNITED STATES

(Data corrected to December 6, 1949)
If executives or services for FM or TV stations are same as AM affiliate names are not repeated.

KENTUCKY—(Continued)

City	Call Letters	Chan. or Freq. Power	Name of Licensee Headquarters Address Telephone Number	Network Representative	Executive Personnel	Transc. Library News Service Transmitter Make
LOUISVILLE—(Continued)						
	WRXW (FM)	Ch. 236 (B) 1947 95.1mc 16.2kw	(WAVE, AM Affiliate)			
	WAVE-TV	Ch. 5 1948 78-82mc 5kw-aur.; 7kw-vis.		ABC, CBS, NBC DuMont		INS
	WGRC	1400 250 CP: 790, 5,000-LS 1,000-N DA-2	Northside Bcstg. Corp. Kentucky Home Life Bldg. Wabash 8871 (WGRC, AM Affiliate)	MBS Walker	J. Porter Smith, Pres. & Coml. Mgr. Charles L. Harris, V. P. & Gen. Mgr.	Ward Hatcher, Prog. Dir. Harry R. Hunter, Prom. Mgr. Perry W. Esten, Chief Engr.
	WBOX (FM)	Ch. 264 (B) 1947 100.7mc 29.8kw				Lang-Worth Standard UP RCA
	WHAS	840 1922 50,000	WHAS Inc. 8th & Broadway Wabash 2211	CBS Petry	Barry Bingham, Pres. Victor A. Sholis, Dir. Neil Cline, Sales Dir.	Harold Fair, Prog. Dir. Sandy Sanders, Publ. Dir. Orrin W. Towner, Tech. Dir.
	WHAS-FM	Ch. 259 (B) 1944 99.7mc 24kw				Federal Associated AP, UP Western Electric
	WHAS-TV	Ch. 9 1950 186-192mc 7.2kw-aur.; 9.6kw-vis.				General Electric
	WINN	1240 1940 250	Kentucky Bcstg. Corp. Earle Hotel Wabash 5148	ABC Taylor-Borroff	Harry McTigue, Pres. & Gen. Mgr. G. F. Bauer, Coml. Mgr. Katherine McCarten, Prog. Dir.	Helen Roberts, Prom. Mgr. Melvin C. Scarsdale, Chief Engr.
	WKLO	1080 1948 5,000-LS DA-2 1,000-N	Mid-America Bcstg. Corp. Henry Clay Hotel Clay 4441	Blair	James F. Brownlee, Pres. Joe Eaton, Gen. & Coml. Mgr. W. Gerard Bortoff, Prog. Dir.	(Mr.) Jean Clos, Prom. Mgr. D. C. Summerford, Chief Engr.
	WKYW	900 1947 1,000-D	Radio Kentucky Inc. 431 West Jefferson St. Clay 4811	Burn-Smith	F. Eugene Sanford, Pres. & Treas. Edwin E. S. Weldon, V. P. & Sta. Mgr.	S. A. Cisler Jr., V. P. & Oprs. Mgr. David M. Wilburn, Prog. Dir. Nolan Pontrich, Chief Engr.
	WLOU	1350 1948 1,000-D	Louisville Bcstg. Co. 2549 South 3rd St. Calhoun 3680	Cooke	Mrs. J. E. Messervy, Pres., Gen. & Coml. Mgr.	Lee Smith, Prog. Dir. & Prom. Mgr. Steve Dawson, Chief Engr.
MADISONVILLE						
	WCIF	730 1947 250-D	Madisonville Bcstg. Co. Inc. P. O. Box 27 1297	Sears & Ayer	Pierce E. Lackey, Pres. T. E. Brewer, Gen. & Coml. Mgr.	Conrad Brewer, Prog. Dir. Evers Mick, Chief Engr.
	WCIF-FM	Ch. 285 (A) 1949 104.9mc 0.42kw				Standard, World AP Gates
	WFMW (FM)	Ch. 276 (A) 1949 103.1mc 1kw	Messenger Bcstg. Co. Inc. Main and Center Sts. 1885		Edgar Arnold Sr., Pres. Elmer Kelley, V. P. & Coml. Mgr.	Richard Rembert, Chief Engr. H. W. Wells, Gen. Mgr., Secy- Treas. & Prog. Dir.
MAYFIELD						
	WKTM	1050 1946 1,000-D	Mayfield Bcstg. Co. Inc. Hotel Mayfield 46	Sears & Ayer	Frank Evens, Pres. Wayne R. Morgan, Gen. Mgr. Bill Shelton, Coml. Mgr.	Margaret Dowdy, Prog. Dir. Joe Hargrove, Chief Engr.
	WNGO	1320 1948 1,000-D	West Kentucky Bcstg. Co. Inc. P. O. Box 26 1204	Friedenberg	Rev. H. M. Suthard, Pres. Boyce Swann, Gen. Mgr.	J. B. Fowler, Prog. Dir. & Prom. Mgr. Eural Wadlington, Chief Engr.
MAYSVILLE						
	WFTM	1240 1948 250	Standard Tobacco Co. Inc. 626 Forest Ave. 1400	Grant	Charles P. Clarke, Pres. James M. Finch Jr., Secy.-Treas. J. W. Betts, Gen. Mgr. Horace Simpson, Coml. Mgr.	Gene Waters, Prog. Dir. Hal Sagraves, Prom. Mgr. Harvey Cross, Chief Engr.
MIDDLESBORO						
	WCPM	580 1948 500-D	Tri-State Bcstg. Co. P. O. Box 515 1520		Elmer D. Smith, Pres. Walt T. Gaines, Gen. Mgr.	Robert Thomson, Prog. Dir. John Calor, Chief Engr.
	WMIK	1490 1948 250	Cumberland Gap Bcstg. Co. Inc. P. O. Box 698 980	Holman	Hal Falter, Gen. Mgr. H. Webster Taylor, Prog. Dir. & Prom. Mgr.	Edward Pipes, Chief Engr.
MURRAY						
	WNBS	1340 1948 250	Murray Bcstg. Co. Inc. P. O. Box 548 1340		Ed Griffin, Sta. Mgr.	World AP
NEWPORT						
	WNOP	740 1948 1,000-D DA	Tri-City Bcstg. Co. 606 Monmouth St. Juniper 7100	Forjoe	James G. Lang, Pres. Anna Mae Rolles, Gen. Mgr. David Brennan, Coml. Mgr.	Jack Baker, Prog. Dir. Elmer C. Drake, Chief Engr.
OWENSBORO						
	WOMI	1490 1937 250	Owensboro Bcstg. Co. Byars Ave. & Livermore Rd. 420	MBS, KBS Burn-Smith	Lawrence W. Hager, Pres. Hugh O. Potter, Gen., Coml. & Prom. Mgr.	Norman Hall, Prog. Dir.
	WOMI-FM	Ch. 223 (B) 1948 92.5mc 60kw				Harold I. Peters, Chief Engr.
	WVJS	1420 1947 1,000 DA-2	Owensboro On The Air Inc. 324 Allen St. 3408	Rambeau	V. J. Steele, Pres. Malcolm Greep, Gen. Mgr. John T. Rutledge, Coml. Mgr.	Lee C. Meredith, Prog. Dir. Leola C. Hayden, Prom. Mgr. Robert Earl Jagoe, Chief Engr.
	WVJS-FM	Ch. 241 (B) 1948 96.1mc 45kw				General Electric World UP General Electric

DA-N Directional Antenna, night only. FM's in italic. *—Non-Commercial Station D—Day, N—Night, ST—Share Time, SH—Specified Hours.
DA-1 Directional Antenna, same pattern day and night. U—Unlimited. CP—Construction Permit Issued. LS—Local Sunset.
DA-2 Directional Antenna, different pattern day and night. L—Limited Time with Dominant Station. SA—Special Authorization.

a growing
as a member of Society...

MORE SERVICE

AUDIENCE SHOWS

During the first six months of broadcasting from its new studios, WHAS played host to almost 30,000 people. The most popular audience shows have been "Coffee Call" (11,121), "Ballard's Bazaar" (7,110) and "Circle Star Ranch" (3, 214).

COMMUNITY SERVICE

"Polio Dallar Day" raised over \$14,000 for the emergency polio drive. "A Chance to Live" sold fire prevention to 600,000 school children. "Music Under the Stars" boosted lagging ticket sales for civic musicals at Louisville's Iroquois Amphitheatre

FARM SERVICE

"Tomorrow's Tobacco" focuses the Burley-belt's best brains on each seasonal problem as it arises. "Market Digest" and "Frank Cooley's Form News" supply a daily general farm news service.

SPORTS COVERAGE

In football - the University of Kentucky Wildcats. In basketball - Kentuckiano's many great teams all the way to Madison Square Gardens. In general-sports round-ups at 5:15 and 10:15 nightly

NEWS COVERAGE

The only local news programs recommended by the Louisville Radio Council's "Guide to Good Listening." Winner of the National Association of Radio News Directors' 1949 Award for the most distinguished news service to its community

TO MORE LISTENERS

KENTUCKIANA RADIO FAMILIES

1946

588,740

1949

701,870

a 19.2% increase



and therefore Selling

50,000 WATTS * 1A CLEAR CHANNEL * 840 KILOCYCLES
 VICTOR A. SHOLIS, Director * NEIL D. CLINE, Sales Director
 REPRESENTED NATIONALLY BY
 EDWARD PETRY AND COMPANY

THE ONLY RADIO STATION SERVING ALL OF THE RICH KENTUCKIANA MARKET

BROADCASTING • Telecasting

1950 Yearbook Number • Page 157

DIRECTORY OF AM, FM, and TV STATIONS OF THE UNITED STATES

(Data corrected to December 6, 1949)
If executives or services for FM or TV stations are same as AM affiliate names are not repeated.

KENTUCKY—(Continued)

City Call Letters Established	Chan. or Freq. Power	Name of Licensee Headquarters Address Telephone Number	Network Representative	Executive Personnel	Transc. Library News Service Transmitter Make	
PADUCAH						
WKYB 1946	800 1,000-D CP-570 DA	Paducah Newspapers Inc. 504 Kentucky Ave. 800	MBS Ra-Tel	E. J. Paxton Jr., Gen. Mgr. Sam Livingston, Coml. Mgr.	Zack Hill, Prog. Dir. C. G. Sims, Chief Engr.	Standard Associated AP Gates
WKYC (FM) 1947	Ch. 227 (B) 93.3mc 32kw	(WKYB, AM Affiliate)			 RCA
WPAD 1930	1450 250	Paducah Bcstg. Co. Inc. Taylor Bldg. 4100	CBS Sears & Ayer	Pierce E. Lackey, Pres. Prewitt Lackey, Gen. & Coml. Mgr.	Ray Mofield, Asst. & Prom. Mgr. Evelyn Carroll Stahl, Prog. Dir. U. C. Morris, Chief Engr.	Lang-Worth AP Gates World Federal
WPAD-FM 1946	Ch. 245 (B) 96.9mc 18kw				 Federal
PAINTSVILLE						
WSIP 1949	1490 250	W. Howes Meade Paintsville 1196		W. Howes Meade, Pres. Pat Mulvihill, Gen. & Coml. Mgr.	E. F. Shadburne, Prog. Dir. James A. Noonan, Chief Engr.	Lang-Worth Standard UP Raytheon
PIKEVILLE						
WLSI 1949	900 1,000-D	Cumberland Pub. Co. Pikeville 161		W. J. Ward, Pres. Meyer Layman, Gen. & Prom. Mgr. & Prog. Dir.	John Ward, Coml. Mgr. Guy N. Ferrell, Chief Engr.	Lang-Worth UP Gates
WPKE 1949	1240 250	East Kentucky Bcstg. Corp. Pikeville 1280	MBS	Dr. O. W. Thompson, Pres. C. W. Powers, Gen. & Coml. Mgr. & Prog. Dir.	T. K. Smith, Chief Engr.	Standard AP RCA
PRESTONSBURG						
WPRT (CP) 1949	960 1,000-D	Kentucky Mountain Bcstg. Co.			 Gates
PRINCETON						
WPKY 1949	1580 250-D	Princeton Bcstg. Co. Princeton		Leslie Goodaker, Pres. & Gen. Mgr.	(Mrs.) Leslie Goodaker, Prog. Dir. Garland West, Chief Engr. AP Gates
SOMERSET						
WSFC 1947	1240 250	Southeastern Bcstg. Co. Inc. Somerset 907	MBS Wood & Colton	Alonzo Carter, Pres. Don Orwin, Prog. Dir.	John Agostine, Chief Engr.	World AP Gates
VANCLEVE						
WMTG 1949	730 1,000-D	Kentucky Mountain Holiness Assn. Vancleve 3		Dr. Lena G. McConnell, Pres. Wilfred Fisher, Gen. Mgr.	Violet Person, Prog. Dir. M. E. Picazo, Chief Engr.	World AP Raytheon
VERSAILLES						
WVLK 1947	590 1,000 DA-1	Bluegrass Bcstg. Co. Logan-Helm Memorial Library 654	MBS Rambeau	A. B. (Happy) Chandler, Pres. W. S. Lukenbill, Gen. Mgr. Lynn E. Knox, Coml. Mgr.	Donald J. Horton, Prog. Dir. Paul Dunbar, Chief Engr. Gates
LOUISIANA						
ABBEVILLE						
KROF 1948	960 1,000-D	Abbeville Bcstg. Service Inc. Box 306 90		George Phillip Martin, Gen. & Coml. Mgr.	Ebba Lou Martin, Prog. Dir. C. E. Hook, Chief Engr.	World AP Western Electric
ALEXANDRIA						
KALB 1935	580 5,000-LS 1,000-N DA	Alexandria Bcstg. Co. Inc. 505½ Johnston St. 2-3335	ABC Weed	Walter H. Allen, Pres. Willard L. Cobb, Gen. Mgr. Walter Melson, Coml. Mgr. Harold H. Carr, Sta. Dir.	Harper Clark, Prog. Dir. & Prom. Mgr. Jesse R. Sexton, Chief Engr.	World UP RCA
KALB-FM 1948	Ch. 245 (B) 95.9mc 11.5kw				 REL
KSYL 1947	1400 250	Radio Station KSYL P. O. Box 1489 6611	NBC Ra-Tel	Sylvan Fox & Harold Wheelahan, Partners Paul H. Goldman, Gen. Mgr. Milton Fox, Coml. Mgr.	Bruce Rainey, Prog. Dir. Jack McCall, Prom. Mgr. Earl Eggers, Chief Engr.	Lang-Worth AP Gates
KVOB 1948	970 1,000 DA-N	Central Louisiana Bcstg. Corp. 1710 Jackson St. 2-0481	MBS, KBS Louisiana McGillivra	Roy O. Martin, Pres. John H. Allen Jr., Gen. & Coml. Mgr.	Franklin Whitehead, Sta. Dir. & Prom. Mgr. John H. Crawford, Chief Engr.	Associated Thesaurus AP Gates REL
KVOB-FM 1947	Ch. 259 (B) 92.7mc 5kw				 REL
BASTROP						
KTRY 1948	730 250-D	Morehouse Bcstg. Co. Enterprise Bldg. 1400	Friedenberg	Nathan Bolton, Pres.	Sal Scarpino, Coml. Mgr.	Capitol Lang-Worth AP
BATON ROUGE						
WAFB 1948	1460 5,000 LS 1,000-N DA	Modern Bcstg. Co. of Baton Rouge 1048 Florida St. 4-8571	MBS Walker	Louis S. Prejean, Pres. Tom E. Gibbens, Gen. Mgr. Frank Parton, Coml. Mgr.	Max Fetty, Prog. Dir. & Prom. Mgr. Donald Allan, Chief Engr. AP Western Electric
WAFB-FM 1948	Ch. 282 (B) 104.3mc 3kw				 Western Electric
WIBR 1948	1220 250-D	Community Bcstg. System P. O. Box 1228 4-9493	LBS Cooke	G. T. Owen & Owen W. Ware, Partners H. W. Bumpas, Gen., Coml. & Prom. Mgr.	Scott W. Erwin, Prog. Dir. Edward Case, Chief Engr.	Lang-Worth UP Western Electric

DA-N Directional Antenna, night only. FM's in italic.
DA-1 Directional Antenna, same pattern day and night.
DA-2 Directional Antenna, different pattern day and night.

*—Non-Commercial Station D—Day. N—Night. ST—Share Time. SH—Specified Hours.
U—Unlimited. CP—Construction Permit Issued. LS—Local Sunset.
L—Limited Time with Dominant Station. SA—Special Authorization.

**IT'S EASY,
IF YOU
KNOW HOW!**

YOU don't have to dive into a sea of statistics to understand why KWKH does such a superlative job in this rich Southern market. It's a question of programming *Know-How*, combined with topnotch promotion.

Programming—especially in Dixie—is a specialized art that can't be acquired overnight. 24-year-old KWKH has mastered this art, and the March-April '49 Shreveport Hoopers prove it:

In the Morning, KWKH gets a 70% greater Share of Audience than the next station—in the Afternoon, 7%—in the Evening, 47%!

Even more important than this *Shreveport* superiority, KWKH delivers an amazingly large and loyal *rural* audience throughout our prosperous "New South" market. Write to us or to The Branham Company for all the facts!



KWKH

SHREVEPORT **Texas**
LOUISIANA
Arkansas
Mississippi

The Branham Company
Representatives

Henry Clay, General Manager

50,000 Watts • CBS •

DIRECTORY OF AM, FM, and TV STATIONS OF THE UNITED STATES

(Data corrected to December 6, 1949)
If executives or services for FM or TV stations are same as AM affiliate names are not repeated.

LOUISIANA—(Continued)

City Call Letters Established	Chan. or Freq. Power	Name of Licensee Headquarters Address Telephone Number	Network Representative	Executive Personnel	Transc. Library News Service Transmitter Make	
BATON ROUGE—(Continued)						
WJBO 1934	1150 5,000 DA-1	Baton Rouge Bcstg. Co. Inc. 444 Florida St. 2-5271	NBC Louisiana Hollingbery	Douglas L. Manship, Pres. Roy Dabadie, V. P. & Gen. Mgr. Charles C. Garvey, Sales Mgr.	Ralph H. Sims, Prog. & Prom. Mgr. Vernon E. Dudley, Chief Engr.	World AP, UP RCA
WBRL (FM) 1941	Ch. 251 (B) 98.1mc 7.6kw	(WJBO, AM Affiliate)				Western Electric
WLCS 1946	1400 250	Air Waves Inc. 204 North St. 2-4411	ABC Ra-Tel	Harry B. Nelson, Pres. Earl H. Smith, Gen. Mgr. Lemar Simmons, Coml. Mgr.	Quitman Henley, Prog. Dir. J. E. Van Valkenburg, Chief Engr.	Capitol SESAC Cole AP, INS Western Electric
WLCS-FM 1948	Ch. 266 (B) 101.1mc 0.9kw					
BOGALUSA WKIC 1947	1490 250	I. K. Corkern Jr. P. O. Box 811 1906	MBS Louisiana	I. K. Corkern Jr., Pres. & Gen. Mgr.		AP
CROWLEY KSIG 1947	1450 250	Acadia Bcstg. Co. 101 N. Parkerson Ave. 1450	Louisiana McGillvra	Max J. Thomas, Pres. & Prom. Mgr. B. Hillman Bailey Jr., Gen. Mgr.	L. R. Stagg, Coml. Mgr. Freda S. Thomas, Prog. Dir. Clovis L. Bailey, Chief Engr.	Lang-Worth AP Gates
HAMMOND WIHL 1947	730 250-D	WIHL Bcstg. Co.				
HOUMA KCIL 1946	1490 250	Charles W. Lamar Jr. P. O. Box 1031 6828	MBS McGeehan & O'Mara	Charles W. Lamar Jr., Pres. Frank Conwell, Gen. Mgr. Joseph Strada & Frank King, Coml. Mgrs.	George Arceneaux Jr., Prog. Mgr. Donald Jones, Chief Engr.	World AP Gates
LAFAYETTE KLFY (CP) 1935	1390 250-D 1340 250	Camellia Bcstg. Co. Evangeline Bcstg. Co. Inc. P. O. Box 1070 5111	NBC Meeker	Morgan Murphy, Pres. George H. Thomas, Gen. Mgr.	Evan H. Hughes, Mgr. & Prom. Mgr. Louis Pilcher, Chief Engr.	Thesaurus AP Collins
KVOL-FM 1949	Ch. 241 (B) 96.1mc 15kw					RCA

DA-N Directional Antenna, night only. FM's in italic. DA-1 Directional Antenna, same pattern day and night. DA-2 Directional Antenna, different pattern day and night. *—Non-Commercial Station D—Day. N—Night. ST—Share Time. SH—Specified Hours. U—Unlimited. CP—Construction Permit Issued. LS—Local Sunset. SA—Special Authorization. L—Limited Time with Dominant Station.

WJBO

DOMINATES BATON ROUGE



BATON ROUGE IS NOW 103rd AMONG THE NATIONS TOP 200 MAJOR METROPOLITAN MARKETS

All figures Copr. 1949. Sales Management Survey of Buying Power; further reproduction not licensed.

	Rank Nationally
Population	118,500 93rd
Retail Sales	\$139,411,000 104th
Drug Store Sales.....	\$ 5,016,000 87th
Food Store Sales.....	\$ 24,101,000 147th
Furniture, Household, Radio Sales...	\$ 10,417,000 93rd
General Merchandise Store Sales....	\$ 19,284,000 113th

All figures Copr. 1949. October 1 issue of Sales Management; further reproduction not licensed.

Highest City Index	1949 vs. 1939	551.4
Highest City Index	1949 vs. 1948	111.8
Highest City-National Index ..	1949 vs. 1948	114.2

(AM) **WJBO** 5,000 Watts
 **WBRL** (FM) 7,600 Watts
 Baton Rouge, Louisiana

Affiliated with State-Times and Morning Advocate
 Representatives: George P. Hollingbery Co.

...the Nation's Newest Blue Ribbon Market

City Call Letters Established	Chan. or Freq. Power	Name of Licensee Headquarters Address Telephone Number	Network Representative	Executive Personnel	Transc. Library News Service Transmitter Make	
LAKE CHARLES						
KLOU 1947	1580 1,000 DA-1	Pelican Bcstg. Co. Inc. 134 Clarence St. 7277	CBS Louisiana Walker	E. R. Anderson, Pres. & Gen. Mgr. Eugene Cuny, Coml. Mgr. William Nail, Prog. Dir.	Lucille Storer, Prom. Mgr. Andrew Vargo, Chief Engr.	Capitol AP
KPLC 1935	1470 5,000-LS 1,000-N DA	Calcasieu Bcstg. Co. P. O. Box 1521 2713	NBC Louisiana Weed	T. B. Lanford, Pres. David Wilson, Gen. Mgr. P. E. Mills Jr., Coml. Mgr.	Lynn Williams, Prog. Dir. Tom B. Journeay, Prom. Mgr. A. B. Craft, Chief Engr.	World AP RCA
KWSL 1947	1400 250	A. Stanford Dudley 1 Mill St. 8-1401	MBS, LBS Friedenberg	A. Stanford Dudley, Owner Alva P. Frith, Mgr. Thomas A. Gresham, Salesman	Roy K. Rhodes, Prog. Dir. LaVance Carson, Chief Engr.	Lang-Worth Cole UP Raytheon
MONROE						
KLIC (CP)	1230 250	Dr. Frank P. Cerniglia				
KMLB 1930	1440 5,000-LS 1,000-N DA	Liner's Bcstg. Station Inc. Hotel Frances, 4321	ABC Louisiana Taylor-Borroff	J. C. Liner, Pres. Charles Price, Gen. & Coml. Mgr.	(Mrs.) Marjorie Watson, Prog. Dir. O. L. Morgan, Chief Engr.	World UP Gates
KMFM(FM) 1947	Ch. 281 (B) 104.1mc; 17kw	(KMLB, AM Affiliate)				
KNOE 1944	1390 5,000 DA-N	James A. Noe Bernhardt Bldg. 912	NBC Ra-Tel	James A. Noe, Pres. Robert W. Dumm, Gen. Mgr. Lloyd Lenard, Coml. Mgr.	Bid Causey, Prog. Dir. Jack Ratliff, Chief Engr.	Associated AP RCA
KNOE-FM (CP)	Ch. 277 (B) 103.3mc; 1.8kw					
NATCHITOCHES						
KWCJ 1947	1450 250	Natchitoches Bcstg. Co. Inc. P. O. Box 232, 2353	MBS, KBS	W. H. Pierson, Pres. Charles L. Planchard, Gen. & Coml. Mgr.	Kenneth M. Dowty, Prog. Dir. Carroll Crew, Chief Engr.	Lang-Worth AP Gates
NEW IBERIA						
KANE 1946	1240 250	New Iberia Bcstg. Co. P. O. Box 383 965	MBS	George H. Thomas, Gen. Mgr. Dierrell Hamm, Mgr. J. R. MacEachron, Coml. Mgr.	Dorothy Hartsell, Prog. Dir. Donald Bonin, Prom. Mgr. L. M. Blackmon, Chief Engr.	Capitol SESAC Collins
NEW ORLEANS						
WCHF (CP)	1540 50,000-LS DA-2 25,000-N	Louisiana Bcstg. Co.				
WDSU 1924	1280 5,000 DA-1	WDSU Bcstg. Service Hotel Monteleone Tulane 4371	ABC Southern Blair	Edgar B. Stern Jr., Pres. Robert D. Swezey, Gen. Mgr. A. Louis Read, Coml. Mgr.	Stanley Holiday, Mgr. Prog. Ops. Ray Liuzza, Publ. & Prom. Dir. Lindsey Riddle, Chief Engr.	Associated AP, UP RCA
WDSU-FM 1949	Ch. 287 (B) 105.3mc; 19kw					
WDSU-TV 1948	Ch. 6 82-88mc 31kw aur.; 31kw vis.		ABC, CBS, DuMont, NBC			
WJBW 1926	1230 250	Louise C. Carlson Cigali Bldg. Magnolia 3488	Rambeau	Mrs. Louise C. Carlson, Owner & Gen. Mgr. Pat Shannon, Coml. Mgr.	Jim Warren, Prog. Dir. C. L. Whitney, Chief Engr.	Capitol AP, INS General Electric
WJBW-FM (CP)	Ch. 298 (B) 107.5mc 5kw					

Man or Mouse . . . In New Orleans

Nearly Everybody

STOPS -
LOOKS -
and LISTENS

To

WDSU

AM - TV - FM

NEW ORLEANS

DIRECTORY OF AM, FM, and TV STATIONS OF THE UNITED STATES

(Data corrected to December 6, 1949)
If executives or services for FM or TV stations are same as AM affiliate names are not repeated.

LOUISIANA—(Continued)

City Call Letters Established	Chan. or Freq. Power	Name of Licensee Headquarters Address Telephone Number	Network Representative	Executive Personnel	Transc. Library News Service Transmitter Make	
WJMR 1947	990 250-D	Supreme Bcstg. Co. Inc. 1500 Canal St. Canal 0356	Continental Forjoe	William Cortada, Pres. Stanley W. Ray & George A. Mayoral, Gen. & Coml. Mgrs. W. John Bleckley, Prog. Dir.	S. W. Ray, Prom. Mgr. George Mayoral & Wm. C. Nevill, Chief Engrs.	Associated Lang-Worth UP RCA REL
WRCM (FM) 1946	Ch. 248 (B) 97.1mc; 61.2kw	(WJMR, AM Affiliate)				
WMRY (CP) WNOE 1922	600 500-D 1060 50,000-LS 5,000-N DA-2	Southland Bcstg. Co. James A. Noe St. Charles Hotel Raymond 0423	MBS Ra-Tel	James A. Noe, Pres. James E. Gordon, Gen. & Prom. Mgr.	Paul Beville, Coml. Mgr. Beverly C. Brown, Prog. Dir. A. J. Bourgeois, Chief Engr.	Standard AP, UP RCA
WRTV (TV) (CP)	Ch. 4 66-72mc 7.6kw aur. 14.5kw vis.	Maison Blanche Co.				
WSMB 1925	1350 5,000 DA-N	WSMB Inc. Maison Blanche Bldg. Magnolia 5921	NBC Petry	E. V. Richards, Pres.	H. Wheelahan, Gen. Mgr.	
WSMB-FM	Ch. 274 (B) 102.7mc 270kw					
WTPS 1947	940 1,000-D CP-1,000-LS CP-500 N-DA	The Times Picayune Pub. Co. 615 Howard Ave. Canal 5561	Walker	L. K. Nicholson, Pres. H. F. Wehrmann, Gen. Mgr. J. R. O'Meallie, Coml. Mgr.	M. J. Clarke, Prog. Dir. G. W. DeBlieux, Chief Engr.	Associated Capitol, World AP Western Electric
WTFS-FM 1946	Ch. 239 (B) 95.7mc 55kw					
WWEZ 1947	690 5,000 DA-2	Sky Bcstg. Service Hotel New Orleans Canal 3421	Hollingbery	A. L. Chilton, Pres. Joe A. Oswald, Gen. & Coml. Mgr.	Ken Elliott, Prog. Dir. Harrison C. Mondy, Chief Engr.	Associated AP Westinghouse
WWL 1922	870 50,000 DA-1	Loyola U. Roosevelt Hotel Raymond 2194	CBS Katz	Thomas J. Shields, Pres. W. H. Summerville, Gen. Mgr. Larry Baird, Coml. Mgr.	Ed Hoerner, Prog. Dir. Jack Halliday, Prom. Mgr. J. D. Bloom, Chief Engr.	World Standard AP, UP RCA Federal
WWLH (FM) 1946	Ch. 262 (B) 100.3mc 2kw	(WWL, AM Affiliate)				
OPELOUSAS						
KSLO 1947	1230 250	KSLO Bcstg. Co. P. O. Box 392 2633	MBS, KBS LBS Louisiana Sears & Ayer	W. E. Jones, Gen. Mgr. Pat McCusker, Prog. Dir.	James Wethington, Coml. Mgr. Freddie Hebert, Chief Engr.	World UP Western Electric
RUSTON						
KRUS 1947	1490 250	Clarence E. Faulk Jr. 105 N. Railroad Ave. 1490	MBS	Clarence E. Faulk Jr., Pres. Lloyd A. Goodin, Gen. & Coml. Mgr.	Eloise Fowler, Traffic Mgr. Ken Whitaker, Prog. Dir. Chester Gillespie, Chief Engr.	Lang-Worth UP Collins
SHREVEPORT						
KCIJ (CP)	980 5,000-D	Southland Bcstg. Co.				
KENT 1947	1550 1,000-LS 500-N DA	Frank H. Ford 311 Milam St. 3-3681	MBS Walker	Frank H. Ford, Owner Frank H. Ford Jr., Coml. Mgr. Joe Monroe, Prog. Dir.	Bill Monroe, Prom. Mgr. L. J. Carlson, Chief Engr.	Standard AP Raytheon
KRMD 1928	1340 250	Radio Station KRMD New Jefferson Hotel 6171	ABC Taylor-Boroff	Glenn V. Wilson, Mgr.	Wm. L. Switzer, Sta. Dir.	
KRMD-FM	Ch. 266 (B) 101.1mc 11kw					
KTBS 1922	710 10,000-LS 5,000-N DA-2	Radio Station KTBS Inc. 312 East Kings Highway 7-3644	NBC Texas Quality Petty	Allen D. Morris, Pres. C. K. Beaver, Gen. Mgr.	Deane Flett, Prog. Dir. C. W. Doebler, Prom. Mgr. C. H. Maddox, Chief Engr.	Associated AP, UP RCA
KWKH 1925	1130 50,000 DA-N	International Bcstg. Corp. Commercial Bldg. 2-8711	CBS South Central Branham	John D. Ewing, Pres. Henry B. Clay, Gen. Mgr. B. G. Robertson, Coml. & Asst. Mgr.	Horace Logan, Prog. Dir. James T. Briggs, Prom. Mgr. W. E. Antony, Chief Engr.	Lang-Worth AP, UP Westinghouse
KWKH-FM 1948	Ch. 233 (B) 94.5mc; 43kw					

MAINE

AUGUSTA						
WFAU 1946	1340 250	Twin City Bcstg. Co. Inc. 180 Bangor St. 2540	MBS Yankee Forjoe	Faust Couture, Pres. Robert I. Payne, Gen. Mgr.	Norman G. Gallant, Prog. Dir. Robert H. Parker, Chief Engr. AP Raytheon
WRDO 1932	1400 250	WRDO Inc. 175 Water St. 2285	NBC Maine New England Weed	Adeline B. Rines, Pres. Jack S. Atwood, Gen. Mgr. Donald K. Powers, Coml. Mgr.	Leslie R. Hubley, Prog. Dir. & Prom. Mgr. Harold T. Dinsmore, Chief Engr.	Thesaurus UP RCA
BANGOR						
WABI 1922	910 5,000 DA-N	Community Bcstg. Serv- ice 57 State St. 6446	ABC Young	F. B. Simpson, Pres. Murray Carpenter, Gen. Mgr. Harold W. Dorr, Prog. Dir.	Leon P. Gorman Jr., Coml. & Prom. Mgr. Walter Dickson, Chief Engr.	AP
WGUY 1947	1450 250	Guy Gannet Bcstg. Serv- ice P.O. Box 732 7354	CBS Raymer	Guy P. Gannett, Pres. Lawrence C. Stubbs, Gen. Mgr. Samuel G. Henderson Jr., Mgr. Harvey M. Grant, Coml. Mgr.	(Mrs.) Elisabeth A. Kihlmiere, Prog. Dir. Lauris P. MacGown, Supvr. Engr. Roger W. Hodgkins, Chief Engr.	Lang-Worth AP General Electric
WGUY-FM 1947	Ch. 226 (B) 93.1mc; 11kw					
WJOR 1946	1230 250	Bangor Bcstg. Service Inc. 22 State St. 5612	MBS, KBS Yankee Forjoe	Stephen Velardi, Pres. & Chief Engr.	Lawrence Slon, Mgr. & Prog. Dir.	World AP
WLBZ 1926	620 5,000 DA-N	Main Bcstg. Co. 100 Main St. 6023	NBC Maine New England Weed	Adeline B. Rines, Pres. Edward E. Guernsey, Gen. & Coml. Mgr.	Irving S. Hunter, Prog. Dir. George Chapman, Prom. Mgr. John H. Wibby, Chief Engr.	Thesaurus UP Western Electric

DA-N Directional Antenna, night only. FM's in italic.
DA-1 Directional Antenna, same pattern day and night.
DA-2 Directional Antenna, different pattern day and night.

*-Non-Commercial Station D-Day, N-Night, ST-Share Time, SH-Specified Hours.
U-Unlimited, CP-Construction Permit Issued, LS-Local Sunset.
L-Limited Time with Dominant Station. SA-Special Authorization.

City Call Letters Established	Chan. or Freq. Power	Name of Licensee Headquarters Address Telephone Number	Network Representative	Executive Personnel	Transc. Library News Service Transmitter Make	
BIDDEFORD						
WIDE 1948	1400 250	Biddeford Bcstg. Corp. 234 Main St. 4-4566	MBS Yankee Friedenberg	Gordon J. Lewis, Pres. & Gen. Mgr. James A. Gates, Prom. & Coml. Mgr.	Lucien Dumont, Prod. Mgr. Arthur A. Deters, Chief Engr.	Capitol UP Gates'
LEWISTON						
WCOU 1938	1240 250	Twin City Bcstg. Co. Inc. 223 Lisbon St. 4-6921	MBS Yankee Forjoe	Faust Couture, Pres. John C. Libby, Gen. Mgr. Oscar J. Normand, Coml. Mgr.	Herbert Fontaine, Prog. Dir. Guy P. Ladouceur, Prom. Mgr. Donald Mason, Chief Engr.	Standard SECAC UP RCA
WCOU-FM 1949	Ch. 230(B) 93.9 mc 13.2 kw					Westinghouse
WLAM 1947	1470 5,000 DA-1	Lewiston-Auburn Bcstg. Corp. 129 Lisbon St. 4-5401	ABC McKinney	Frank S. Hoy, Gen. Mgr. Elden H. Shute Jr., Sta. Mgr. Gerald T. Higgins, Coml. & Prom. Mgr.	William Finkeldey, Prog. Dir. Leslie R. Hall, Chief Engr.	Capitol AP RCA
PORTLAND						
WCSH 1925	970 5,000 DA-N	Congress Square Hotel Co. 157 High St. 2-0181	NBC Maine New England Weed	Adeline B. Rines, Pres. William H. Rines, Gen. Mgr. Albert W. Smith, Coml. Mgr.	Arthur Owens, Prog. Dir. Linwood T. Pitman, Prom. Mgr. George F. Crandon, Chief Engr.	Thesaurus AP, UP RCA
WGAN 1938	560 5,000-DA-1	Guy Gannett Bcstg. Services 390 Congress St. 2-7423	CBS New England Raymer	Guy P. Gannett, Pres. Creighton E. Gatchell, Gen. Mgr. Arthur K. Atherton, Coml. Mgr.	Richard E. Bates, Prog. Dir. Francis H. Farnum Jr., Prom. Mgr. Roger W. Hodgkins, Chief Engr.	Lang-Worth AP, UP RCA
WMTW 1946	1490 250	Yankee Network 212 Middle St. 4-2649	MBS Yankee	William O'Neill, Pres. Linus Travers, Gen. Mgr.	Allan Bonney, Coml. Mgr. Albert Green, Chief Engr.	Standard- Sesac AP, UP Raytheon
WPOR 1946	1450 250	Oliver Bcstg. Corp. Chapman Bldg. 3-8111	ABC Young	Harold H. Meyer, Gen. Mgr. William J. Mullen, Coml. Mgr. S. Blake Ellis, Dir. Sp. Events	Anne Bradford, Prom. Mgr. Roger L. Perry, Chief Engr.	Standard AP
PRESQUE ISLE						
WAGM 1932	1450 250	Aroostook Bcstg. Corp. 181 State St. 8821	Continental	H. E. Umphrey, Pres. H. D. Glidden, Gen. Mgr. Forrest Craig, Coml. Mgr.	Ted Coffin, Prog. Dir. L. E. Hughes, Chief Engr.	Associated SESAC UP
WATERVILLE						
WTVL 1946	1490 250	Kennebec Bcstg. Co. 36 Silver St. 2700	ABC Meeker	Carleton D. Brown, Pres. & Gen. Mgr. Harold L. Vigue, Coml. & Prom. Mgr.	Paul R. Huber, Prog. Dir. Donald H. Sutherland, Chief Engr.	Standard AP RCA
MARYLAND						
ANNAPOLIS						
WANN 1947	1190 1,000-D	Annapolis Bcstg. Corp. 25 School St. 2500		Morris H. Blum, Pres. & Gen. Mgr. Thomas S. Carr, Sta. & Coml. Mgr.	Bruce W. Harris, Chief Engr.	Lang-Worth UP Raytheon
WASL 1946	810 250-D	Chesapeake Radio Corp. P. O. Box 508 9211		Robert L. Blalock, Pres. & Gen. Mgr. Gene Gosch, Coml. Mgr.	Muriel E. Blalock, Prog. Dir. Stanley C. Leek Jr., Chief Engr.	World AP Collins
WNAV 1949	1430 500 DA-N	Capital Bcstg. Co. 89 West St. 2639	McGillvra	Albert H. MacCarthy, Pres. H. Philip Nesbitt, Gen. Mgr. William T. O'Connor, Coml. Mgr.	Patricia C. Scible, Prog. Mgr. Charles Mannel, Prod. Mgr. Paul C. Jones, Chief Engr.	Associated Capitol AP General Electric
WNAV-FM 1948	Ch. 256 (B) 99.1mc 16.6kw					Westinghouse
BALTIMORE						
WAAM (TV) 1948	Ch. 13 210-216mc 13.8kw-aur.; 26.1kw-vis.	Radio-Television of Bal- timore Inc. 3725 Malden Ave. Mohawk 7600	ABC DuMont Harrington, Richter & Parsons	Samuel Carlner, Exec. V. P. Norman C. Kal, Gen. Mgr.	Armand Grant, Coml. Mgr. Herb Caham, Prog. Dir. Glenn Lahman, Acting Chief Engr.	UP, TP
WBAL 1945	1090 50,000 DA-N	Hearst Radio Inc. 2610 N. Charles St. Hopkins 3000	NBC Petry	Charles B. McCabe, Pres. Harold C. Burke, Gen. Mgr. Leslie H. Peard Jr., Coml. Mgr.	Fred S. Heywood, Adv., Prom. & Pub. Mgr. Willis K. Freiert, Prog. Mgr. William C. Bareham, Chief Engr.	Thesaurus AP, UP, INS RCA
WBAL-TV 1948	Ch. 11 198-204mc 18kw-aur.; 32.6kw-vis.					
WBMD 1947	750 1,000-D	Key Bcstg. Corp. 4 W. Eager St. Mulberry 7095	McGillvra	George E. Hull, Pres. H. Shelton Earp Jr., Gen. Mgr. Merrill L. Carroll, Coml. Mgr.	Thomas O'Connor, Prog. Dir. Russell Morgan, Chief Engr.	AP RCA
WCAO 1922	600 5,000 DA-1	The Monumental Radio Co. 1102 North Charles St. Mulberry 0600	CBS Raymer	Lewis M. Milbourne, Pres. L. Walters Milbourne, Exec. V. P. & Gen. Mgr. George L. Filling, Prog. Dir.	Robert M. Richmond, Coml. & Prom. Mgr. Martin L. Jones, Chief Engr.	World AP Westinghouse
WCAO-FM 1948	Ch. 274 (B) 102.7mc 20kw					
WCBM 1949	1400 250	Baltimore Bcstg. Corp. North & Harford Aves. Belmont 8400	MBS Weed	John Elmer, Pres. & Coml. Mgr.	George H. Roeder, Gen. Mgr.	
WCBM-FM 1949	Ch. 226 (B) 93.1mc 3kw					
WFBR 1922	1300 5,000 DA-1	The Baltimore Radio Show Inc. 10 E. North Ave. Mulberry 1300	ABC Blair	Robert S. Maslin, Pres. J. H. L. Trautfelter, V. P. & Acting Gen. Mgr. William S. Pirie Jr., Dir. Natl. Sales	W. Bert Hanauer, Prog. Dir. Robert S. Maslin Jr., Dir. of Publ. William Q. Ranft, Chief Engr.	World AP, UP RCA
WFBR-FM 1948	Ch. 270 (B) 101.9mc 20kw					
WITH 1941	1230 250	Maryland Bcstg. Co. 7 East Lexington St. Lexington 7808	Headley-Reed	Thomas G. Tinsley Jr., Pres. & Gen. Mgr. Robert C. Embry, V. P. & Coml. Mgr.	Marilee Considine, Prog. Dir. James S. Duff, Chief Engr.	Standard AP Western Electric
WITH-FM 1944	Ch. 282 (B) 104.3mc 20kw					

DA-N Directional Antenna, night only. FM's in italic.
DA-1 Directional Antenna, same pattern day and night.
DA-2 Directional Antenna, different pattern day and night.

*-Non-Commercial Station D-Day N-Night ST-Share Time SH-Specified Hours.
U-Untimed CP-Construction Permit Issued LS-Local Sunset.
L-Limited Time with Dominant Station SA-Special Authorization.

DIRECTORY OF AM, FM, and TV STATIONS OF THE UNITED STATES

(Data corrected to December 6, 1949)
If executives or services for FM or TV stations are same as AM affiliate names are not repeated.

MARYLAND—(Continued)

City Call Letters Established	Chan. or Freq. Power	Name of Licensee Headquarters Address Telephone Number	Network Representative	Executive Personnel	Transc. Library News Service Transmitter Make
BALTIMORE—(Continued)					
WMAR-FM 1948	Ch. 250 (B) 97.9mc 20kw	The A. S. Abell Co. Baltimore & Charles Sts. Lexington 7700	Transit Radio	Paul Patterson, Pres. E. K. Jett, V. P. & Radio Dir. Ernest A. Lang, Coml. Mgr.	Robert B. Cochrane, Prog. Dir. Carlton G. Nopper, Chief Engr. Associated Lang-Worth AP RCA
WMAR-TV 1947	Ch. 2 54-60mc 10kw-aur.; 17.1kw-vis.		CBS Katz		TP
WMCP (FM) 1948	Ch. 234 (B) 94.7mc 20kw	Belvedere Bcstg. Corp. 5740 Reisterstown Rd. Mohawk 4400		Thomas F. McNulty, Pres. & Gen. Mgr. M. J. Porter, Coml. Mgr. & Prog. Dir.	H. A. Kemp, Chief Engr. Associated AP Westinghouse
WSID 1948	1570 1,000-D	United Bcstg. Co. 109 W. Baltimore St. Saratoga 8250	Forjoe	Richard Eaton, Pres. & Gen. Mgr. Albert R. Lamphear Asst. Gen. & Coml. Mgr. & Prog. Dir.	Helen Wherley, Prom. Mgr. Benjamin Wolfe, Chief Engr. AP Collins
BETHESDA					
(Chevy Chase) WBCC 1947	1120 250-D	Broadcast Management Inc. 5 Wilson Lane Oliver 2800		Willard D. Egolf, Pres. Cecil Richards, Coml. Mgr. Grace Campbell Egolf, Prog. Dir.	Phil Davison, Prom. Mgr. Donald Herr, Chief Engr. Associated Lang-Worth UP Collins
WBCC-FM 1949	Ch. 276 (A) 103.1mc 0.5kw				
BRADBURY HEIGHTS					
WBUZ (FM) 1948	Ch. 244 (A) 96.7mc 0.42kw	Chesapeake Bcstg. Co. Inc. 4421 Southern Ave., S.E. Hillside 3800	Transit Radio	Leslie L. Altmann, Pres. & Gen. Mgr. R. John Hugh, Prog. Dir.	Vernon Story, Chief Engr. World Lang-Worth AP Gates
CAMBRIDGE					
WCEM 1947	1240 100	The Cambridge Co. Box 333 1580	MBS	John W. Downing, Pres. James H. Wood, Coml. Mgr.	Edward H. Brigham, Gen. Mgr. & Prog. Dir. Jerrald Merritt, Chief Engr. Standard UP Collins
CUMBERLAND					
WCUM 1948	1460 100	Karl F. Steinmann P. O. Box 360 5400	CBS Meeker	Karl F. Steinmann, Pres. & Owner William M. Leach, Gen. Mgr.	Al Whitehouse, Coml. Mgr. Robert E. Dressler, Prog. Dir. Lee Davies, Chief Engr. Standard AP, TP RCA
WCUM-FM 1948	Ch. 275 (B) 102.9mc 1kw				
WDYK 1949	1230 250	R. A. Raese 450 Byrd Ave. 5727	ABC	R. A. Raese, Pres. & Gen. Mgr. George J. Kapel, Coml. Mgr.	William A. Vaughn, Prog. Dir. Ernest Norman Butler, Prom. Mgr. Lang-Worth AP Collins
WTBO 1928	1450 250	Cumberland Bcstg. Co. 31 Frederick St. 299	NBC	Mrs. Aurelia S. Becker, Chief Owner, Gen., Coml. & Prom. Mgr.	Edwin F. Hinkle, Prog. Dir. William R. Selleck, Chief Engr. World AP, UP Westinghouse
WTBO-FM 1949	Ch. 295 (B) 106.9mc 1kw				
FREDERICK					
WFMD 1945	930 500 DA-N CP 1,000 DA-N	Monocacy Bcstg. Co. E. Church St. 1626	CBS	Laurence Leonard, Pres. James W. Robertson, Mgr.	William Hardy, Coml. Mgr. Evelyn Leonard, Prog. Dir. James W. Robertson, Chief Engr. World AP Western Electric
WFMD-FM 1947	Ch. 268 (B) 101.5mc 2kw				
HAGERSTOWN					
WARK 1947	1490 250	Antietam Bcstg. Corp. 128 S. Prospect St. 4500	ABC	Raymond J. Funkhouser, Chmn. of Board Stewart W. Phillips, Gen. Mgr. Samuel E. Phillips Jr., Coml. Mgr.	Hunter Reams, Prog. Dir. Eddie Grout, Prom. Mgr. G. Harold Brewer, Chief Engr. AP General Electric
WJEJ 1932	1240 250	Hagerstown Bcstg. Co. Franklin Court 2323	MBS Friedenberg	Grover C. Crilley, Pres. & Gen. Mgr. William H. Paulsgrove, Coml. Mgr.	Robert Leshner, Prog. Dir. George W. McIntire, Chief Engr. Lang-Worth World SESAC AP, TP General Electric
WJEJ-FM 1947	Ch. 284 (B) 104.7mc 1kw				
HAVRE DE GRACE					
WASA 1948	1330 1,000-D	The Chesapeake Bcstg. Corp. P. O. Box 97 800	KBS Continental	Jason T. Pate, Pres. & Gen. Mgr. Charles W. Irwin, Coml. Mgr.	Jack Steinhart, Prog. Dir. & Prom. Mgr. William C. Kuntz, Chief Engr. World UP Raytheon
SALISBURY					
WBOC 1940	960 1,000 DA-N	The Peninsula Bcstg. Co. Radio Park 5131	MBS Burn-Smith	John W. Downing, Pres. Charles J. Truitt, Gen. & Coml. Mgr.	John W. Downing Jr., Prog. Dir. Jack W. Ward, Chief Engr. World Thesaurus AP RCA
WBOC-FM 1948	Ch. 248 (B) 97.5mc 12kw				
SILVER SPRING					
WGAY 1946	1050 1,000-D	Tri-Suburban Bcstg. Corp. Kemp Mill Rd. Shepherd 1050		John W. Kluge, Pres. Manning U. Hoffman, V. P. Joseph L. Brechner, Gen. & Coml. Mgr.	Ernie Tannen, Prog. Dir. & Prom. Mgr. Nicholas J. Chaconas, Chief Engr. World AP, TP Collins RCA
WGAY-FM 1946	Ch. 272 (A) 102.3mc 0.44kw				
WHIP (CP)	Ch. 290 105.9mc 14.5 kw	Montgomery FM Bcstg. Corp. 1005 Bonifant St.			
WOOK 1949	1590 1,000-D	United Bcstg. Co. 1143 Conn. Ave., N. W., Washington, D. C. Sterling 7265		Richard Eaton, Pres., Gen. & Coml. Mgr. Arnold B. Fort, Prog. Dir. & Prom. Mgr.	Vernon E. Story, Dir. of Engrg. UP Collins

DA-N Directional Antenna, night only. FM's in italic.
DA-1 Directional Antenna, same pattern day and night.
DA-2 Directional Antenna, different pattern day and night.

*-Non-Commercial Station D-Day, N-Night, ST-Share Time, SH-Specified Hours.
U-Unlimited. CP-Construction Permit Issued. LS-Local Sunset.
L-Limited Time with Dominant Station. SA-Special Authorization.

--- Of Time and a Tower ---

Now in its third year on the air WMAR-TV, Baltimore's first television station, plays to an ever increasing audience in Maryland, and continues to yield a tremendous bonus of viewers from Harrisburg to Wilmington to Washington.

Many a fine tradition built through mellow decades by *The Sunpapers* now applies to programs on Channel Two . . . just one of the reasons why, in Maryland, most people watch WMAR-TV.



WMAR-TV

Represented by

THE KATZ AGENCY, INC.

NEW YORK • DETROIT • KANSAS CITY • SAN FRANCISCO
CHICAGO • ATLANTA • DALLAS • LOS ANGELES

TELEVISION AFFILIATE OF THE COLUMBIA BROADCASTING SYSTEM

DIRECTORY OF AM, FM, and TV STATIONS OF THE UNITED STATES

*(Data corrected to December 6, 1949)
If executives or services for FM or TV stations are same as AM affiliate names are not repeated.*

MASSACHUSETTS

City Call Letters Established	Chan. or Freq. Power	Name of Licensee Headquarters Address Telephone Number	Network Representative	Executive Personnel	Transc. Library News Service Transmitter Make	
BEVERLY						
WIBL (CF) 1948	1540 250-D	Conant Bcstg. Co. Inc.				
BOSTON						
WBMS 1946	1090 1,000-D	WBMS INC. 35 Court St. Lafayette 3-5616	RaTel	Jack N. Berkman, Pres. George Lasker, V. P. Arthur E. Haley, Gen. Mgr. Frederic S. Bailey, Coml. Mgr.	John R. Thornton, Prog. Dir. & Prom. Mgr. J. Herbert Rattigan, Chief Engr.	Associated UP Western Electric
WBMS-FM 1948	Ch. 281 (B) 104.1mc 20kw			 Gates	
WBZ 1921	1030 50,000 DA-1	Westinghouse Radio Stations Inc. 1170 Soldiers Field Rd. Algonquin 4-5670	NBC New England Free & Peters	Walter Evans, Pres. Walter E. Benolt, V. P. J. B. Conley, Gen. Mgr. W. C. Swartley, Sta. Mgr. C. Herbert Masse, Sales Mgr.	W. Gordon Swan, Prog. Mgr. W. A. Davis, Pub. Mgr. John Stilli, Prom. Mgr. W. H. Hauser, Chief Engr.	Thesaurus Associated AP, UP Westinghouse
WBZ-FM 1942	Ch. 225 (B) 92.9mc 20kw				
WBZ-TV 1948	Ch. 4 66-72mc 7.13kw-vis. 14.3kw-vis.		NBC NBC Spot		RCA	
WCOP 1935	1150 5,000 DA-2	Mass. Bcstg. Corp. 485 Boylston St. Copley 7-0123	ABC Katz	John Cowles, Pres. Craig Lawrence, Gen. Mgr. A. N. Armstrong Jr., Coml. Mgr.	Gene King, Prog. Dir. John Wilkoff, Prom. Mgr. Roland C. Hale, Chief Engr.	Standard AP, UP, INS Western Electric
WCOP-FM 1948	Ch. 284 (B) 100.7mc 20kw				
WEEI 1924	590 5,000 DA-1	Columbia Bcstg. System 182 Tremont St. Hubbard 2-2323	CBS New England Radio Sales	Frank N. Stanton (CBS.) Pres. Harold E. Fellows, Gen. Mgr. Wilbur S. Edwards, Asst. Gen. & Coml. Mgr.	Raymond G. Girardin, Prog. Dir. Charles B. H. Vail, Prom. Mgr. Harold A. Dorschug, Chief Engr.	General Electric Lang-Worth AP, UP Western Electric
WEEI-FM 1948	Ch. 277 (B) 103.3mc 20kw			 General Electric	
WHDH 1926	850 50,000 DA-1	Matheson Radio Co. Inc. 6 St. James Ave. Hancock 6-5500	Blair	Robert B. Choate, Pres. William B. McGrath, Gen. Mgr. Arthur T. Brush, Coml. Mgr.	George M. Perkins, Prog. Dir. William W. Warner, Sales Mgr. Philip K. Baldwin, Chief Engr.	Standard AP, UP Westinghouse
WHDH-FM 1948	Ch. 233 (B) 94.5mc 20kw	Liberty 2-9044		 Western Electric	
WMEX 1934	1510 5,000 DA-1	The Northern Corp. 70 Brookline Ave. Commonwealth 6-3900	Rambeau	John E. Reilly, Pres. & Prog. Dir. William S. Pote, Gen. Mgr.	Lawrence J. Flynn, Coml. Mgr. George Kaplan, Prom. Mgr. John Memishian, Chief Engr.	Associated Lang-Worth SESAC, INS RCA

DA-N Directional Antenna, night only. FM's in italic. *—Non-Commercial Station D—Day. N—Night. ST—Share Time. SH—Specified Hours.
DA-1 Directional Antenna, same pattern day and night. U—Unlimited. CP—Construction Permit Issued. LS—Local Sunset.
DA-2 Directional Antenna, different pattern day and night. L—Limited Time with Dominant Station. SA—Special Authorization.

WMEX

MEANS

EXTRA

SALES

IN BOSTON

WILL MEAN EXTRA SALES IN

BOSTON

WWLAW

**NEW ENGLAND'S BIG POWERFUL
STATION DELIVERS THE
GOODS WITH ITS**

50,000 WATTS

DIRECTORY OF AM, FM, and TV STATIONS OF THE UNITED STATES

(Data corrected to December 6, 1949)
If executives or services for FM or TV stations are same as AM affiliate names are not repeated.

MASSACHUSETTS—(Continued)

City Call Letters Established	Chan. or Freq. Power	Name of Licensee Headquarters Address Telephone Number	Network Representative	Executive Personnel	Transc. Library News Service Transmitter Make	
WNAC 1922	1260 5,000 DA-N	The Yankee Network 21 Brookline Ave. Commonwealth 6-0800	MBS Yankee Petry	William O'Neil, Pres. Linus Travers, V. P., Gen. & Coml. Mgr. George W. Steffy, V. P. & Prog. Dir.	Tom O'Neil, V. P. Charles Curtin, Prom. Mgr. Irving B. Robinson, Chief Engr.	Standard AP, INS Western Electric
WNAC-FM 1948	Ch. 253 (B) 98.5mc 20kw				REL	
WNAC-TV 1948	Ch. 7 174-180mc 13.3kw-aur.; 26.6kw-vis.		ABC, CBS DuMont	Harry Whittemore, Chief Engr.	World Capitol UP General Electric	
WVOM 1948	1600 5,000 DA-1	The Boston Bcstg. Corp. 1 Harvard St. Beacon 2-5650	McGillvra	Benjamin Bartzoff, Exec. V. P. & Gen. Mgr.	Erwin Crandell, Chief Engr.	UP Raytheon
BROCKTON						
WBET 1946	990 1,000-D	Enterprise Pub. Co. 60 Main St. 7062	Wood & Colton	Charles A. Fuller, Gen. Mgr. Earle G. Clement, Coml. Mgr.	Joseph G. Quill, Prod. Dir. Mark L. MacAdam, Tech. Dir.	Thesaurus Lang-Worth World; SESAC AP Collins
WBET-FM 1948	Ch. 249 (A) 97.7mc 0.8kw				General Electric	
WBKA 1948	1450 250	Cur-Nan Co. 205 E. Ashland St. 8-0621	Friedenberg	Joseph F. Curran, Pres. Harlan W. Newell, Gen. Mgr.	William W. Pierce III, Prog. Dir. Philip James, Chief Engr.	Associated UP, TP General Electric
WBKA-FM 1948	Ch. 296 (A) 107.1mc 0.8kw				AP	
CAMBRIDGE						
WTAO 1948	740 250-D	Middlesex Bcstg. Corp. 439 Concord Ave.	Cooke	Frank S. Lyman Jr., Pres. Paul J. Perreault, Gen. & Prom. Mgr.	Larry Anderson, Coml. Mgr. Arthur Tacker, Prog. Dir. Arthur W. Richardson, Chief Engr.	World AP Temco
WXHR (FM) 1947	Ch. 245 (B) 96.9mc 20kw	(WTAO, AM Affiliate)	Continental			Harvey
CHICOPEE						
WACE 1946	730 1,000-D	Regional Bcstg. Co. Radio Center Chicopee 2330	IMS Kettell-Carter	David Hayes, Pres. John S. Begley, Treas. Ralph J. Robinson, Exec. V. P., Gen. & Coml. Mgr.	Charles J. O'Malley, Prog. Dir. Richard Glunka, Chief Engr.	World AP RCA
WACE-FM 1947	Ch. 262 (B) 100.3mc 3.2kw				Warren Barrett, Chief Engr.	
FALL RIVER						
WALE 1948	1400 250	Narragansett Bcstg. Co. 374 Central St. 4-1400	MBS Yankee Walker	George L. Sisson Jr., Pres. & Mngng. Dir. J. Buz Way, Asst. Mgr.	Nellie F. McCain, Prog. Dir. Norman P. Guimond, Chief Engr.	Associated UP Raytheon
WSAR 1921	1480 5,000 DA-2	The Fall River Bcstg. Co. Inc. Academy Bldg. 7-9477	ABC Headley-Reed	Melvin Lahr, Pres. & Gen. Mgr. John Harrington, Coml. Mgr.	Angus Bailey, Prog. Dir. John Crowley, Prom. Mgr. John Pavao, Chief Engr.	Lang-Worth Standard UP Westinghouse

DA-N Directional Antenna, night only. FM's in italic. *—Non-Commercial Station D—Day. N—Night. ST—Share Time. SH—Specified Hours.
DA-1 Directional Antenna, same pattern day and night. U—Unlimited. CP—Construction Permit Issued. LS—Local Sunset.
DA-2 Directional Antenna, different pattern day and night. L—Limited Time with Dominant Station. SA—Special Authorization.

W E

E XCEL

I N PROMOTION AND

M ERCHANDISING SERVICE

BUY WEIM

for *plus values* in the
Fitchburg — Leominster
\$72,000,000 retail sales
market. Over 150 regular
local advertisers can't be
wrong!

1340 kilocycles
250 watts
Yankee
MBS

Robert S. Keller, Inc.
Promotion Representative-New York City

Henry G. Molina, Jr.
General Manager-Fitchburg, Mass.

City Call Letters Established	Chan. or Freq. Power	Name of Licensee Headquarters Address Telephone Number	Network Representative	Executive Personnel	Transc. Library News Service Transmitter Make
FITCHBURG					
WELM 1941	1340 250	WELM Fitchburg Inc. 717 Main St. 1600	MBS Yankee Kettell-Carter	Henry G. Molina Jr., Gen. Mgr.	Thesaurus AP
WELM-FM 1948	Ch. 284 (B) 104.7mc; 9kw				
WFGM (CP)	1580 1,000-D	Wachusett Bcstg. Co.			
FRAMINGHAM					
WKOX 1947	1190 1,000-D	Suburban Bcstg. Co. Smith Bldg. 7400	Friedenberg	Richard E. Adams, Sta. Mgr. James H. Shoemaker, Coml. Mgr.	Lee Emmerich, Prog. Dir. Francis Bartol, Chief Engr.
GARDNER					
WHOB 1946	1490 250	The Gardner Bcstg. Co. 39 Pleasant St. 1490	Rambeau	David M. Richman, Pres. & Gen. Mgr. Milton Savitt, Coml. Mgr.	West W. Willcox, Prog. Dir. F. W. Hull, Sta. Mgr. Parker Vincent, Chief Engr.
GREENFIELD					
WHAI 1938	1240 250	John W. Haigis 356 Main St. 4301	MBS Yankee Walker	John W. Haigis, Owner John W. Haigis Jr., Gen. Mgr. Horace W. Nichols, Coml. Mgr.	Lawrence A. Coney, Prog. Dir. Thomas J. Kelly, Prom. Mgr. Leland F. Wheeler, Chief Engr.
WHAI-FM 1948	Ch. 252 (A) 98.3mc 1kw				Associated Thesaurus AP; Collins REL
HAVERHILL					
WHAV 1947	1490 250	Haverhill Gazette Co. 30 How St. 44733	Friedenberg	John T. Russ, Pres. & Gen. Mgr. Robert I. Kimel, Coml. Mgr.	Warren M. Greenwood, Prog. Dir. Paul A. Hurd, Chief Engr.
WHAV-FM 1948	Ch. 223 (B) 92.5mc 20kw		Kettell-Carter		Associated SESAC; World AP; Raytheon Western Electric
HOLYOKE					
WHYN 1941	560 1,000 DA-1	Hampden-Hampshire Corp. 180 High St. 8238	MBS Yankee Walker	Charles N. DeRose, Gen. Mgr. Jay Hetlin, Prog. Dir. & Prom. Mgr.	Patrick J. Montague, Coml. Mgr. Jack Paley, Chief Opr.
WHYN-FM 1947	Ch. 226 (B) 93.1mc 20kw				Charles Tamm, Chief Opr. Lang-Worth Standard UP; RCA General Electric
WREB (CP)	930 500-D	Valley Bcstg. Corp.			
LAWRENCE					
WABW (CP)	980 1,000-D	Northeast Radio Inc.			
WCCM 1947	800 1,000-D	The Lawrence Bcstg. Co. 54 Essex St. 37171	Wood & Colton	George H. Jaspert, Pres. & Gen. Mgr. Thomas C. May Jr., Prog. Dir.	William C. Engel, Coml. & Prom. Mgr. Harold W. Davis, Chief Engr.
WLAW 1937	680 50,000 DA-1	Hildreth & Rogers Co. 278 Essex St. 4107	ABC New England Raymer	Irving E. Rogers, Pres. & Gen. Mgr. David M. Kimel, Coml. Mgr.	Frederick P. Laffey, Prog. Dir. Fred A. Sullivan, Prom. Mgr. George A. Hinckley, Chief Engr.
WLAW-FM 1948	Ch. 229 (B) 93.7mc; 20kw				Western Electric Raytheon
LOWELL					
WLLH 1934	1400 250	Merrimac Bcstg. Co. Inc. 39 Kearney Sq.; 8715	MBS Yankee	Gerald Harrison, Pres. Carl S. Wheeler, V. P. Dana W. Fitzgerald, Gen. Mgr.	Haskell Bloomberg, Coml. Mgr. Tom Clayton, Prog. Dir. A. G. Michaels, Chief Engr.
WLLH-FM 1948	Ch. 258 (B) 99.5mc 12.2kw				Associated UP Western Electric
LYNN					
WLYN 1947	1360 500-D	Puritan Bcst. Serv- ice Inc. 7 Willow St.: 5-6200		A. M. Morgan, Pres. & Gen. Mgr. Cyril Morgan, Prog. Dir. & Sta. Mgr.	Ethel Adams, Prom. Mgr. John W. Parker, Chief Engr.
WLYN-FM 1949	Ch. 288 (A) 105.5mc 0.5kw				Associated SESAC UP; Collins
NEW BEDFORD					
WBSM (CP)	1230 100	Bay State Bcstg. Co. Pope's Island 3-1767		Joseph P. Duchaine, Pres. Otto F. A. Arnold, Gen. Mgr. Harrison Moore Jr., Coml. Mgr.	Edward L. Merritt Jr., Prog. Dir. Harold H. Hoover Jr., Chief Engr.
WBSM-FM 1949	Ch. 247 (B) 97.3mc 20kw				MacGregor UP RCA
WNBH 1921	1340 250	Bristol Bcstg. Co. Inc. 588 Pleasant St. 8-5228	MBS Yankee Walker	Basil Brewer, V. P. & Treas. James M. Patt, Mgr. Theo M. Healy, Coml. Mgr.	Edward Boghosian, Prog. Dir. Gerald L. Staten, Prom. Mgr. Stanley S. Emery, Chief Engr.
WFMR (FM) 1946	Ch. 251 (B) 98.1mc 20kw	(WNBH, AM Affiliate)			Associated World AP RCA
NORTH ADAMS					
WMNB 1947	1230 100	Northern Berkshire Bcstg. Co. 466 Curran Highway 1230	Grant	J. Gordan Keyworth, Gen. & Coml. Mgr. & Chief Engr.	Benjamin A. Hubley, Prog. Mgr. Richard J. O'Brien, Coml. Rep.
WMFM (FM) 1948	Ch. 248 (B) 97.5mc 2.4kw	(WMNB, AM Affiliate)			World AP Raytheon General Electric
WNAW 1949	860 250-D	Neal W. Welch 20 State St. 860		Neal W. Welch, Pres. James H. McKnight, Gen. & Coml. Mgr.	E. Norman Bailey, Prog. Dir. Gerald O'Grady, Chief Engr.
NORTHAMPTON					
WHMP (CP)	1400 250	Pioneer Valley Bcstg. Co.			Lang-Worth AP General Electric Raytheon
PITTSFIELD					
WBEC 1947	1490 250	Western Mass. Bcstg. Co. 30 Eagle St. 8292	ABC McKinney	Donald B. Miller, Pres. W. Wendell Budrow, Gen., Coml. & Prom. Mgr.	Maurice McGarry, Prog. Dir. Walton Ayers, Chief Engr.
WBEC-FM 1948	Ch. 232 (A) 94.3mc 1kw				Lang-Worth AP General Electric Raytheon
WBRK 1938	1340 250	Greylock Bcstg. Co. 8 Bank Row 2-1553	MBS Yankee Walker	Leon Podolsky, Pres. John T. Parsons, Gen. Mgr. Walter Kearsey, Coml. Mgr.	Daniel Healy, Prog. Dir. Richard Bolander, Prom. Mgr. Leonard Lavendol, Chief Engr.
QUINCY					
WJDA 1947	1300 1,000-D	South Shore Bcstg. Co. 29 Brackett St. Mayflower 9-1300		Joseph H. Tobin, Pres., Sta. Mgr. & Prog. Dir.	James D. Asher, Treas., Coml. & Prom. Mgr. & Chief Engr.

DIRECTORY OF AM, FM, and TV STATIONS OF THE UNITED STATES

(Data corrected to December 6, 1949)
If executives or services for FM or TV stations are same as AM affiliate names are not repeated.

MASSACHUSETTS—(Continued)

City Call Letters Established	Chan. or Freq. Power	Name of Licensee Headquarters Address Telephone Number	Network Representative	Executive Personnel	Transc. Library News Service Transmitter Make
SALEM					
WESX 1939	1230 250	North Shore Bcstg. Co. 49-53 Wash. St. 5670		C. W. Phelan, Pres. & Treas. E. L. Phelan, Mgr.	Robert Rogers, Coml. Mgr.
SPRINGFIELD					
WBZA 1925	1030 1,000	Westinghouse Radio Stations Inc. 140 Chestnut St. 6-8366	Free & Peters	Walter Evans, Pres. Walter E. Benoit, V. P. J. B. Conley, Gen. Mgr.	W. C. Swartley, Sta. Mgr. John Stilli, Prom. Mgr. H. E. Randol, Chief Engr.
WBZA-FM 1943	Ch. 246 (B) 97.1mc, 20kw				Associated
WMAS 1932	1450 250	WMAS Inc. 1757 Main St. 7-1414	CBS Petry	Gerald Harrison, Pres. Robert Donahue, Mgr. Robert M. Feldman, Sales Mgr.	F. Turner Cooke, Prog. Dir. John Michnovetz, Chief Engr.
WMAS-FM 1947	Ch. 234 (B) 94.7mc 3.2kw				Associated UP Western Electric
WSFL 1948	1600 5,000-D-DA	Springfield Bcstg. Co. 137½ State St. 2-7488		G. A. Askinas, Pres. & Co-owner C. M. Manitsas, Co-owner & Prog. Dir.	Earle G. Hewinson, Co-owner, Coml. Mgr. & Chief Engr. Paul Rogers, Prom. Mgr.
WSFL-FM 1948	Ch. 270 (B) 101.9mc 11kw				World UP, TP RCA
WSPR 1936	1270 1,000-DA-1	WSPR Inc. 63 Chestnut St. 6-2757	ABC Hollingbery	Quincy A. Brackett, Pres. & Gen. Mgr. Milton W. Stoughton, V. P. & Coml. Mgr.	Wayne Henry Latham, Prog. Dir. Howard S. Keefe, Prom. Mgr. George Townsend, Chief Engr.
WSPR-FM 1949	Ch. 250 (B) 97.9mc 13kw			 RCA
TAUNTON					
WPEP (CP)	1570 1,000-D	Silver City Bcstg. Corp. Roseland Ballroom		J. Marshall McGregor, J. Milton Hammond, Co-owners	J. Milton Hammond, Gen. Mgr. Arthur Gordon, Coml. Mgr.
WALTHAM					
(Newton) WCRB 1948	1330 500-D	Charles River Bcstg. Co. 4 Gordon St. 5-7080	Bannan	Richard C. O'Hare, Pres. Deuel Richardson, Gen. Mgr. Ted Jones, Exec. Mgr.	W. H. Sherman, Prog. Dir. J. Frank McArdle, Prom. Mgr. J. H. Bonney, Chief Engr.
WRTB (TV) (CP)	Ch. 2 54-60mc 30.7kw-aur. 50kw-vis.				Lang-Worth UP Raytheon
WARE					
WARE 1948	1250 1,000-D	Donald W. Howe East St. 23		Donald W. Howe, Pres. Ansel E. Gridley, Gen., Prom. & Coml. Mgr.	Tom Colton, Prog. Dir. Fred Joslin, Chief Engr.
WEST SPRINGFIELD					
WTXL 1949	1490 250	Telecolor Corp. 34 Sylvan St. 9-4768	Cooke	Lawrence A. Reilly, Pres., Gen. & Prom. Mgr. Alexander W. Milne, Coml. Mgr.	James L. Spates, Prog. Dir. & Chief Engr.
WEST YARMOUTH					
WOCB 1944	1240 250	Bristol Bcstg. Co. Inc. South Sea Ave. Hyannis 502	MBS Yankee Walker	Basil Brewer, V. P. David J. Shurtleff, Mgr.	Michael Graham, Prog. Dir. Stanley S. Emery, Chief Engr.
WOCB-FM 1948	Ch. 232 (A) 94.3mc 1kw	E. Anthony & Sons Inc. 555 Pleasant St. New Bedford			World AP Collins RCA
WORCESTER					
WAAB. 1931	1440 5,000 DA-1	Radio Enterprises 34 Mechanic St. 2-5611	MBS Yankee Ra-Tel	John Baybutt, Pres. Raymond Brown Jr., Gen. & Coml. Mgr.	W. Eccles Huff, Prog. Dir. William R. Sweeney, Prom. Mgr. Norman Ogg, Chief Engr.
WGTR (FM) 1949	Ch. 256 (B) 99.1mc 20kw	Eastern Bcstg. Corp. Worcester 2-8713	Transit Radio	Robert Manby, Gen. Mgr.	Maurice J. Mahoney, Coml. Mgr.
WNEB 1946	1230 250	New England Bcstg. Co. Park Bldg. 6-4672	Bolling	Paul C. Lytle, Pres. & Bus. Mgr. John J. Hurley, Gen. Mgr. & Treas.	Edward T. McCann Jr., Coml. Mgr. John F. Morse, Prog. Dir. Vernon P. Wilson, Chief Engr.
WORC 1925	1310 1,000 DA-1	Alfred Frank Klein- dienst 65 Elm St.: 5-3101	ABC Weed	Alfred Frank Kleindienst, Chief Owner	Mildred P. Stanton, Dir. & Coml. Mgr.
WTAG 1924	580 5,000 DA-2	WTAG Inc. 18 Franklin St. 5-4321	CBS New England Raymer	E. E. Hill, Exec. V. P. Robert W. Booth, V. P. & Gen. Mgr. Herbert L. Krueger, Coml. Mgr.	A. J. Brissette, Prog. Dir. Andrew C. Fuller, Prom. Mgr. E. A. Browning, Chief Engr.
WTAG-FM 1940	Ch. 241 (B) 96.1mc 10kw			 General Electric

MICHIGAN

ADRIAN					
WABJ 1946	1500 250-D	James Gerity Jr. 2982 Treat Rd. 9000	Ra-Tel	James Gerity Jr., Pres. O. William Myers, Gen. Mgr.	Harley West Jr., Coml. Mgr. Larry Payne, Prog. Dir. Elwood Brown, Chief Engr.
ALMA					
WFYC 1948	1280 1,000-D	Alma Bcstg Co. 480 Gratiot 95		Reid Brazell, Pres. William B. Ogden, V.P. & Gen. Mgr.	Raymond A. Plank, Asst. Gen. Mgr. & Chief Engr. Chester Waddell, Prog. Dir.
ALPENA					
WATZ 1946	1450 250	Midwestern Bcstg. Co. Alpena 1049	MBS KBS Bunyan Holman	Les Biederman, Pres. A. B. Crow Jr., Coml. Mgr.	Drew McClay, Gen. Mgr.
ANN ARBOR					
WHRV 1947	1600 1,000 DA-1	Huron Valley Bcstrs. Inc. 4230 Packard Rd. 2-4573	ABC Forjoe	J. F. Hopkins, Pres. Douglas Campbell, Gen. & Coml. Mgr.	Amy Wilcox, Prog. Dir. James Alien, Chief Engr.

DA-N Directional Antenna, night only. FM's in italic. *—Non-Commercial Station D—Day. N—Night. ST—Share Time. SH—Specified Hours.
DA-1 Directional Antenna, same pattern day and night. U—Unlimited. CP—Construction Permit Issued. LS—Local Sunset.
DA-2 Directional Antenna, different pattern day and night. L—Limited Time with Dominant Station. SA—Special Authorization.



WWJ-TV

has a 2-year
lead in Detroit

Starting new things in Detroit is nothing new with WWJ-The Detroit News . . . first AM station in 1920, first FM station in 1940, and first with TV in 1946.

With a 2-year lead in television, WWJ-TV today is doing the most effective job of engineering, production and programming . . . sending out the clearest signals . . . reaching the largest audience . . . producing the best results for its many advertisers.

This year WWJ-TV is planning a more ambitious schedule than ever, and advertisers' demands are reaching unprecedented proportions. Better formulate your Detroit plans NOW . . . to include WWJ-TV.

FIRST IN MICHIGAN

Owned and Operated by THE DETROIT NEWS

National Representatives: THE GEORGE P. HOLLINGBERY COMPANY

ASSOCIATE AM-FM STATION WWJ

BROADCASTING • Telecasting

WWJ-TV

NBC Television Network

1950 Yearbook Number • Page 171

DIRECTORY OF AM, FM, and TV STATIONS OF THE UNITED STATES

(Data corrected to December 6, 1949)
If executives or services for FM or TV stations are same as AM affiliate names are not repeated.

MICHIGAN—(Continued)

City Call Letters Established	Chan. or Freq. Power	Name of Licensee Headquarters Address Telephone Number	Network Representative	Executive Personnel	Transc. Library News Service Transmitter Make	
ANN ARBOR—(Continued)						
WPAG 1945	1050 1,000-D	Washtenaw Bcstg. Co. Hutzell Bldg. 2-5517	Holman	Arthur E. Greene, Pres. Edward F. Baughn, Exec. V. P. & Gen. Mgr.	Ted Turner, Coml. Mgr. Pat Quinn, Prog. Dir. George D. Stearns, Chief Engr.	Standard AP Western Electric
WPAG-FM 1947	Ch. 254 (B) 98.7mc 2.2kw					REL
BAD AXE						
WLEW (CP) 1948	1540 250-D	Saginaw Bcstg. Co.				
BATTLE CREEK						
WBCK 1948	930 1,000 DA-2	Michigan Bcstg. Co. Security Nat'l Bank Bldg.; 3-5555	MBS	Robert H. Holmes, Pres., Gen. & Coml. Mgr.	Adrian R. Cooper, Prog. Dir. & Prom. Mgr. Arrie J. Geranis, Chief Engr.	Associated Capitol UP; RCA
WELL 1925	1400 250	Federated Publications Michigan Nat'l Bank 5655	ABC Bolling	D. E. Jayne, Gen. Mgr. E. P. Mills Jr., Coml. Mgr.	F. F. Owen, Prog. Dir. E. J. Stone, Chief Engr.	Standard Lang-Worth AP
WELL-FM 1947	Ch. 271 (B) 103.1mc; 45kw					Western Electric
BAY CITY						
WBCM 1925	1440 1,000-LS 500-N	Bay Bcstg. Co. Inc. 100 Center Ave. 7551	ABC Hollingbery	Harley D. Peet, Pres. H. A. Giesel, Gen. & Coml. Mgr.	Charles E. Anthony, Prog. Dir. Ralph H. Carpenter, Chief Engr.	Lang-Worth World UP Western Electric
WBCM-FM 1946	Ch. 241 (B) 96.1mc; 41kw					
WGRO 1949	1260 500-D	Griner-Dillon Bcstg. Co. 920 N. Water St. 3-1260	Sears & Ayer	Gail D. Griner, Pres. & Gen. Mgr. Edward T. Dillon, Coml. Mgr. & Chief Engr.	Gerry Lansing, Prog. Dir.	Capitol INS
BENTON HARBOR						
WHFB 1947	1060 1,000-D	Palladium Pub. Co. Wall St. 5-2113	Holman	Stanley R. Banyon, Pres. Jacob P. Scherer, Gen. Mgr.	Virginia Allen, Coml. Mgr. Phil Molloy, Prog. Dir. Munson Robinson, Chief Engr.	Lang-Worth Capitol AP; RCA
WHFB-FM 1947	Ch. 260 (B) 99.9mc; 9.2kw					
CADILLAC						
WATT 1945	1240 250	Midwestern Bcstg. Co. Cadillac	MBS, KBS Wolverine Bun.; Holman	Les Biederman, Gen. Mgr.		
COLDWATER						
WTVB 1949	1590 1,000 D-DA	Twin Valley Bcstrs. Inc. Box 32 1230		James W. Wilson, Pres. E. Harold Munn Jr., Sta. Dir. & Chief Engr.	Arnold K. Walkup, Sales Dir. Richard W. Lee, Prog. Dir.	Associated Cole AP; Gates
DEARBORN						
WKMH 1946	1310 1,000 DA-N	WKMH Inc. WKMH Bldg. Logan 2-4000	Weed	Fred A. Knorr, Pres. & Gen. Mgr. Frank Sims, Prog. Dir.	Walter Patterson, Coml. & Prom. Mgr. Jerrold Martin, Chief Engr.	Lang-Worth UP, INS RCA
WKMH-FM 1948	Ch. 262 (B) 100.3mc; 7.7kw					
DETROIT (Windsor)						
CKLW 1932	800 50,000	Western Ont. Bcstg. Co. 3300 Guardian Bldg. Woodward 1-7200	MBS Young	J. E. Campeau, Pres. & Gen. Mgr. E. W. Wardell, Coml. Mgr. S. Campbell Ritchie, Prog. Dir.	Barbara McFarland, Prom. Mgr. W. J. Carter, Chief Engr.	World Standard INS, BUP RCA
WDET (FM) 1949	Ch. 270 (B) 101.9mc 52kw	UAW-CIO Bcstrs. Corp. of Mich. Radio Place (See Royal Oak Listing)		Ben Hoberman, Gen. Mgr. J. A. Harrington, Coml. Mgr.	Paul Morris, Prog. Dir. Ted Andras Jr., Chief Engr.	Associated AP General Electric
WEXL 1923	1340 250					
WJBK 1925	1490 250	Vermont 8-3048 The Fort Industry Co. 500 Temple Ave. Temple 3-7900	Katz	George B. Storer, Pres. Richard E. Jones, Gen. & Coml. Mgr.	E. Hal Hough, Prog. Dir. Joyce M. Chapman, Prom. Mgr. Paul O. Frincke, Chief Engr.	Lang-Worth UP RCA
WJBK-FM 1947	Ch. 226 (B) 93.1mc 30kw		Forjoe			Western Electric
WJBK-TV 1949	Ch. 2; 54-60mc. 8.3kw aur. 16.5 vis.					
WJLB 1925	1400 250	Booth Radio & Tele. Station Inc. David Broderick Tower Woodward 5-2000		John L. Booth, Pres. & Gen. Mgr. Eric V. Hay, Coml. Mgr. George Kendall, Prog. Dir.	William J. Jory, Prom. Mgr. Edward H. Clark, Chief Engr.	Capitol Standard, World AP Western Electric
WJLB-FM 1941	Ch. 250 (B) 97.9mc 30kw					RCA
WJR 1927	760 50,000	WJR The Goodwill Station Inc. Fisher Bldg. Trinity 5-4440	CBS Petry	G. A. Richards, Chmn. of Board Harry Wismer, Asst. to Pres. & Gen. Mgr. Worth Kramer, Asst. Gen. Mgr. Wm. G. Seibert, Secy.-Treas.	Arch Shawd, Coml. Mgr. Franklin Mitchell, Prog. Dir. James Quello, Prom. Mgr. G. F. Leydorf, V. P. & Chief Engr.	Thesaurus Associated Lang-Worth AP, UP, INS Western Electric
WJR-FM 1948	Ch. 242 (B) 96.3mc 24kw					
WKMH 1946	1310 1,000 DA-N	(See Dearborn Listing)				
WLDM (FM) 1949	Ch. 238 (B) 95.5mc; 20kw	Lincoln Bcstg. Co. 24750 Greenfield Rd.	Michigan FM	Ellis C. Thompson, Gen. Mgr. Harold I. Tanner, Coml. Mgr.	Clifford A. Gordon, Prog. Dir. Jerome F. Steadley, Chief Engr.	Associated AP REL
WWJ 1920	950 5,000 DA-N	The Evening News Assn. 622 W. Lafayette Woodward 2-2000	NBC Hollingbery	W. E. Scripps, Pres. Harry Bannister, Gen. Mgr. Willard E. Walbridge, Gen. Sales Mgr. & Asst. Gen. Mgr.	Melvin C. Wissman, Gen. Prog. Mgr. William Lane, Publ. Mgr. E. J. Love, Gen. Engr. Mgr.	Lang-Worth Standard UP Western Electric
WWJ-FM 1941	Ch. 246 (B) 97.1mc; 8.7kw					REL
WWJ-TV 1947	Ch. 4 66-72mc; 8.5kw-aur.; 18kw-vis.					
WXYZ 1930	1270 5,000 DA-N	WXYZ Inc. 1700 Stroh Bldg. Woodward 3-8321	ABC Michigan ABC Spot	Mark Woods, Pres. (ABC) James G. Riddell, Gen. Mgr. Harold Christian, Coml. Mgr.	Jack McCarthy, Prog. Dir. Dean D. Linger, Prom. Dir. Charles Kocher, Chief Engr.	DuMont Standard Lang-Worth World; AP, UP RCA

DA-N Directional Antenna, night only. FM's in italic. *—Non-Commercial Station D—Dav. N—Night. ST—Share Time. SH—Specified Hours. DA-1 Directional Antenna, same pattern day and night. U—Unlimited. CP—Construction Permit Issued. LS—Local Sunset. DA-2 Directional Antenna, different pattern day and night. L—Limited Time with Dominant Station. SA—Special Authorization.

HOME
SWEET
HOME

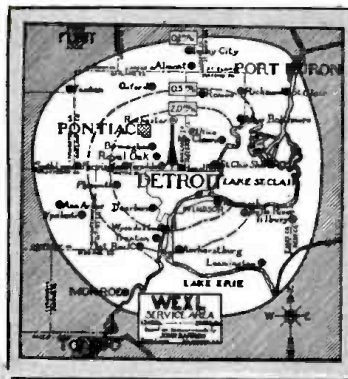

"HOME STATION" *in the Detroit area*

"Home"

For more than half the total radio homes in Michigan.

"Home"

For the most loyal listeners in Detroit.

"Home"

For the lowest rate per 1,000 listeners in Metropolitan Detroit area.

Phone Jordan
46523
Royal Oak, Michigan

WEXL

A.M. 1340 K.C.
F.M. 104.3 M.C.

REPRESENTED NATIONALLY BY THE FRIEDENBERG AGENCY, INC.

DIRECTORY OF AM, FM, and TV STATIONS OF THE UNITED STATES

(Data corrected to December 6, 1949)
 If executives or services for FM or TV stations are same as AM affiliate names are not repeated.

MICHIGAN—(Continued)

City Call Letters Established	Chan. or Freq. Power	Name of Licensee Headquarters Address Telephone Number	Network Representative	Executive Personnel	Transc. Library News Service Transmitter Make
DETROIT—(Continued)					
WXYZ-FM 1948	Ch. 266 (B) 101.1mc 30kw				General Electric
WXYZ-TV 1948	Ch. 7 174-180mc 13.9kw-aur.; 27.9kw-vis.	ABC Television Center Temple 3-8000	ABC ABC Spot	John Pival. Prog. Dir.	Monogram Flamingo World RCA
EAST LANSING					
*WKAR 1922	870 5,000-D	Michigan State College East Lansing 8-1511		Robert J. Coleman, Gen. Mgr. Lawrence Frymire, Prog. Dir.	Thesaurus SESAC AP Western Electric
ESCANABA					
WDBC 1941	680 1,000 DA-2	Delta Bestg. Co. P. O. Box 419 3190	MBS Walker	John P. Norton, Pres. George D. Lindenthal, Gen. & Coml. Mgr.	Jack Foster, Prog. Dir. & Chief Engr. Tony Flynn, Prom. Mgr. RCA

DA-N Directional Antenna, night only. FM's in italic. *—Non-Commercial Station. D—Day. N—Night. ST—Share Time. SH—Specified Hours.
 DA-1 Directional Antenna, same pattern day and night. U—Unlimited. CP—Construction Permit Issued. LS—Local Sunst.
 DA-2 Directional Antenna, different pattern day and night. L—Limited Time with Dominant Station. SA—Special Authorization.

CKLW
Now 50,000
Watts

5,000 WATTS

**COVERS 198 COUNTIES IN 5 STATES
 ... PLUS 24 COUNTIES IN CANADA**

WINDSOR
 DETROIT
 LANSING
 FLINT
 TROY
 WARREN
 ANN ARBOR
 Kalamazoo

Guardian Building, Detroit 16 • Mutual System
 National Rep. Adam J. Young, Jr., Inc.
 Canadian Rep. H. N. Stovin & Co.

MIDDLE OF THE DIAL
800
K I C

First in Flint



WFDF is the *oldest* station in Flint . . . according to the Hooper Winter-Spring Report, 1949, it's the *most listened-to* station . . . morning, noon and night.

That's why WFDF is the number one choice of saleswise local retailers and national advertisers. They know it's the best medium for selling the quarter of a million people who spend \$288,000,000 annually in Flint's retail stores. (Please note: the average effective buying income per family in Flint is \$5,764.)

Get your share of Flint's big purchasing power. Get your sales story on WFDF—the *favorite listening post of a lot of people with plenty of money to spend!*

WFDF AMERICAN BROADCASTING COMPANY
FLINT, MICHIGAN

REPRESENTED BY THE KATZ AGENCY
Associated with: WOOD Grand Rapids—WFBM Indianapolis—WEOA Evansville

910 Kilocycles



DIRECTORY OF AM, FM, and TV STATIONS OF THE UNITED STATES

*(Data corrected to December 6, 1949)
If executives or services for FM or TV stations are same as AM affiliate names are not repeated.*

MICHIGAN—(Continued)

City Call Letters Established	Chan. or Freq. Power	Name of Licensee Headquarters Address Telephone Number	Network Representative	Executive Personnel	Transc. Library News Service Transmitter Make
FLINT					
WAJL (FM) 1948	Ch. 296 (A) 107.1mc 0.40kw	Advertisers Press Inc. 403 Citizens Bank Bldg. 2-0294	Cooke	Myron Weingarden, Pres. Joseph Sova, Gen. & Coml. Mgr.	Lew Stoner, Chief Engr. Lang-Worth AP General Electric
WBBC 1947	1330 1,000 DA-2	Booth Radio Station Inc. 112 West Water St. 9-8886	MBS Forjoe	John Lord Booth, Pres. W. Eldon Garner, Gen. & Coml. Mgr.	Jerry Schroeder, Prog. Dir. G. Ellwood Ryan, Chief Engr. World AP Collins
WFDF 1922	910 1,000 DA-1	The Trebit Corp. Mott Foundation Bldg. 2-7158	ABC Michigan Katz	Harry M. Bitner Sr., Pres. Lester W. Lindow, Gen. Mgr. Elmer A. Knopf, Prog. Dir.	Marvin Levey, Sales Prom. Mgr. Frank D. Fallain, Chief Engr. Capitol Lang-Worth Standard Thesaurus AP; RCA
WMRP 1946	1510 250-D	Methodist Radio Parish 573 Mary St. 3-5112	KBS	Daniel M. Robins, Pres. William H. Morford, Gen. Mgr.	Homer Blumerich, Chief Engr. Standard SESAC Temco
WTAC 1946	600 1,000-LS 500-N DA-1	Trendle-Campbell Bcstg. Corp. 740 S. Saginaw St. 2-1136	NBC Raymer	George W. Trendle, Pres. H. Allen Campbell, V. P. & Gen. Mgr. Raymond J. Meurer, Secy.	J. R. McKinley, Mgr. Laurence Arnold, Prog. Dir. Darrell Jones, Chief Engr. Lang-Worth UP
WWOK 1947	1470 1,000 DA-1	Cooperative Radio Co. 432 N. Saginaw St. 4-1691	Burn-Smith	Herbert L. Crate, Pres. Douglas Woody, Gen. & Coml. Mgr.	Pat Chamburs, Prog. Dir. & Prom. Mgr. Edsel Forsythe, Chief Engr. Capitol UP Gates
GRAND RAPIDS					
WFRS (FM) 1947	Ch. 223 (B) 92.5mc 10.5kw	Grand Rapids Bcstg. Corp. 316 Murray Bldg. 8-4222		Robert L. Epstein & Gerald R. Loop, Owners & Gen. Mgrs. George A. Miller, Coml. Mgr.	Robert L. Epstein, Prog. Dir. Ben Winski, Chief Engr. Associated UP Federal
WFUR 1947	1570 1,000-D	Furniture City Bcstg. Corp. 430 Federal Square Bldg. Glendale 6-9541		S. W. Oppenhuizen, Gen. Mgr. Arthur M. Swift, Sales Mgr.	Bob Geerdes, Prog. Dir. Jack Timmer, Chief Engr. Lang-Worth AP Raytheon
WGRD 1947	1410 1,000-D	Music Bcstg. Co. 35 Lafayette Ave., N.E. 9-4111	McGillvra	Paul F. Eichhorn, Pres. & Gen. Mgr. Bob Kirby, Prog. Dir.	Nadine Miller, Prom. Mgr. Dick Groenevelt, Chief Engr. AP Western Electric
WJEF 1945	1230 250	Fetzer Bcstg. Co. 124 West Michigan Ave. Kalamazoo, Mich. Glendale 6-8512	CBS Avery- Knodel	John E. Fetzer, Pres. & Gen. Mgr. John W. O'Harrow, Gen. Sales & Prom. Mgr.	Edward E. McKean, Prog. Dir. Carl E. Lee, Chief Engr. Capitol AP Western Electric
WJEF-FM (CP)	Ch. 229 (B) 93.7mc 550kw				
WLAV 1940	1340 250	Leonard A. Versluis 6 Fountain St., N.E. Glendale 6-5461	ABC Michigan Pearson	Leonard A. Versluis, Owner Hy M. Steed, Gen. & Coml. Mgr.	Lee G. Stevens, Chief Engr. Standard UP RCA Federal
WLAV-FM 1947	Ch. 245 (B) 96.9mc 50kw				
WLAV-TV 1949	Ch. 7 174-180mc 10kw-aur.; 20kw-vis.		ABC, CBS, NBC DuMont	Hal Kaufman, Prog. Dir. RCA
WOOD 1924	1300 5,000 DA-N	Grandwood Bcstg. Co. 1408 Grand Rapids Nat. Bank Bldg. 9-4211	NBC Katz	Harry M. Bitner Sr., Pres. Stanley W. Barnett, Gen. Mgr. Walter A. Bass, Coml. Mgr.	Sandy Meek, Prog. Dir. Lenore Little, Prom. Mgr. Fred W. Russell, Chief Engr. World Lang-Worth UP RCA
HILLSDALE					
WJOE 1947	Ch. 256 99.1mc 2.5kw	Hillsdale Bcstg. Co. 63 N. Howell St.			
HOLLAND					
WHTC 1948	1450 250	Holland Bcstg. Co. 1 East 8th St. 66610	Grant	M. C. Westrate, Pres. & Chief Engr. Paul W. Nesper Jr., Gen. & Prom. Mgr.	Kenneth Welch, Coml. Mgr. W. C. Wichers, Prog. Dir. Lang-Worth World AP Collins
HOUGHTON					
WHDF 1929	1400 250	Upper Michigan Bcstg. Co. Douglass House 1	MBS Bunyan Walker	George L. Burgan, Pres. & Chief Owner Albert W. Payne, Gen. Mgr.	Earl Norden, Prog. Dir. World AP Doolittle & Falknor
IRON MOUNTAIN					
WMIQ 1947	1450 250	Iron Mountain-Kingsford Bcstg. 211 East Ludington St. 2031	ABC Northern	Frank J. Russell, Pres. Russel J. Staffeld, Gen. Mgr. William C. Johnson, Coml. Mgr.	Merv Baldrice, Prog. Dir. Frank J. Thibert, Prom. Mgr. Paul Anick, Chief Engr. Capitol UP Gates
IRON RIVER					
WIKB 1949	1230 250	WIKB Inc. Iron River Nat. Bank 102	MBS Bunyan Walker	William L. Johnson, Pres. J. W. Huss, V. P. & Gen. Mgr. Jim Kauper, Sta. Mgr.	Bob Sorenson, Prog. Dir. Gene Callahan, Coml. Mgr. Eugene Kaari, Chief Engr. World UP Gates
IRONWOOD					
WJMS 1931	630 1,000 DA-N	Upper Mich.-Wisc. Bcstg. Co. Inc. 124 E. McLeod Ave. 20	MBS Bunyan Walker	William L. Johnson, Pres. J. W. Huss, V. P. & Gen. Mgr. Donald R. Hoover, Sta. Mgr.	Laura Johnson, Prog. Dir. Arne Dahlbacka, Chief Engr. World UP Collins
ISHPEMING					
WJPD 1947	1240 250	Ishpeming Bcstg. Co. Jenks Block 1892	Bunyan	James P. Deegan, Pres., Gen. & Coml. Mgr. Paul C. Crowley, Prog. Dir.	Carl B. Tupala, Prom. Mgr. Bernard R. Maloney, Chief Engr. Lang-Worth AP Raytheon
JACKSON					
WIBM 1925	1450 250	WIBM Inc. 2511 Kibby Rd. 6121	ABC Forjoe Holman	Herman Radner, Pres. Roy Radner, V. P. William Cizek, Sta. Mgr.	Jack Underwood, Prog. Dir. C. W. Wirtanen, Chief Engr. RCA
WIBM-FM 1948	Ch. 222 (B) 92.3mc 16kw				

DA-N Directional Antenna, night only. FM's in italic.
DA-1 Directional Antenna, same pattern day and night.
DA-2 Directional Antenna, different pattern day and night.

*-Non-Commercial Station. D-Day. N-Night. ST-Share Time. SH-Specified Hours.
U-Unlimited. CP-Construction Permit Issued. LS-Local Sunset.
L-Limited Time with Dominant Station. SA-Special Authorization.

WOOD

IS

SOLID

IN WESTERN MICHIGAN...

WOOD is solid with Grand Rapids merchants. They've lived with WOOD for 25 years. They have bought more time on WOOD than any other station—year after year after year. A majority of WOOD's local advertisers have been on the station for five, ten, fifteen years and more.

And WOOD is solid with national advertisers. Year after year, they place more advertising on WOOD than on any other Grand Rapids station, by far.

Naturally, WOOD is solid with its listeners. Twenty-five years of leadership has made WOOD the listening habit in Western Michigan.

At WOOD, this solid acceptance by those we serve is our proudest possession. And our pleasant day to day job is continuing to merit their confidence.



OUTSTATE MICHIGAN'S GREATEST STATION

Represented by the Katz Agency, Inc.

5000 WATTS

Associated with WFDF Flint — WFBM Indianapolis — WEOA Evansville

DIRECTORY OF AM, FM, and TV STATIONS OF THE UNITED STATES

(Data corrected to December 6, 1949)
If executives or services for FM or TV stations are same as AM affiliate names are not repeated.

MICHIGAN—(Continued)

City Call Letters Established	Chan. or Freq. Power	Name of Licensee Headquarters Address Telephone Number	Network Representative	Executive Personnel	Transc. Library News Service Transmitter Make	
KALAMAZOO						
WGFG 1947	1360 1,000 DA-N	Southwestern Michigan Bcstg. Co. State Theatre Bldg. 4-0111	ABC Michigan Meeker	Harold F. Gross, Pres. & Gen. Mgr. Irene A. Ginther, Coml. Mgr.	Warren A. Anderson, Prog. Dir. Carl E. Stephens, Chief Engr.	Standard UP Raytheon
WKZO 1923	590 5,000 DA-N	Fetzer Bcstg. Co. 124 West Michigan Ave. 3-1223	CBS Avery- Knodel	John E. Fetzer, Pres. & Gen. Mgr. John W. O'Harrow, Coml. & Prom. Mgr.	Edward E. McKean, Prog. Dir. Carl E. Lee, Chief Engr.	Capitol AP RCA
WKZO-TV 1950	Ch. 3 60-66mc 8kw-aur.; 8kw-vis.				 Federal
LANSING						
WLS 1947	1430 500-D CP-1320 1,000 DA-N	Lansing Bcstg. Co. 407 N. Washington 2-1655	MBS Rambeau	W. A. Pomeroy, Pres., Gen., Coml. & Prom. Mgr. Alex Dillingham, Prog. Dir.	John C. Pomeroy, Chief Engr.	Lang-Worth AP RCA
WJIM 1949	1240 250	WJIM Inc. 1500 Bank of Lansing Bldg. 2-1335	ABC Michigan Meeker	Harold F. Gross, Pres. & Coml. Mgr.	Howard K. Finch, Gen. & Prom. Mgr. & Prog. Dir.	Standard World UP RCA
WJIM-TV (CP)	Ch. 6 82-88mc 2.5kw-aur.; 5kw-vis.		NBC			
LAPEER						
*WMPC 1926	1230 250; SH	The Liberty Street Gos- pel Church of Lapeer				
LUDINGTON						
WKLA 1944	1450 250	Ludington Bcstg. Co. Stearns Bldg. 842	ABC; KBS Michigan Burn-Smith	K. L. Ashbacher, Partner, Pres., Gen. & Coml. Mgr. G. F. Ashbacher, Partner	Peter A. Mars, Prog. Dir. & Prom. Mgr. John F. Pelters, Chief Engr. UP Western Electric
MARQUETTE						
WDMJ 1931	1340 250	Lake Superior Bcstg. Co. 4th & Washington Sts. 616	MBS Northern	Frank J. Russell Jr., Pres. Leo Brott, Gen. Mgr. Raymond G. Ulbrich, Studio Mgr. John Harvey, Coml. Mgr.	Eldon Wallace, Prog. Dir. Jon Dahl, Prom. Mgr. Gordon Brozek, Chief Engr.	Capitol UP Gates

DA-N Directional Antenna, night only. FM's in italic. *—Non-Commercial Station. D—Day. N—Night. ST—Share Time. SH—Specified Hours.
DA-1 Directional Antenna, same pattern day and night. U—Unlimited. CP—Construction Permit Issued. LS—Local Sunset.
DA-2 Directional Antenna, different pattern day and night. L—Limited Time with Dominant Station. SA—Special Authorization.

**YOU MIGHT BAG A 6-FOOT
MOUNTAIN LION* —
BUT . . . YOU NEED WKZO-WJEF
TO CAPTURE
WESTERN MICHIGAN!**



The easiest, most effective, most economical way to "set your sights" on Western Michigan is to use WKZO, Kalamazoo, and WJEF, Grand Rapids.

BMB audience figures show that these two CBS stations do a top-notch job throughout Western Michigan. And consistently throughout 1949, they had the highest Hoopers in their home cities. By projection, you can easily figure that these two stations give you more than 40% more urban listen-

ers than the next-best two-station combination—yet give you this great bonus audience at about 20% less than the next-best combination.

Either we or Avery-Knodel would welcome an opportunity to show you *all* the facts.

* J. R. Patterson killed a 276-lb. mountain lion at Hillside, Arizona, in March, 1917.

AVERY-KNODEL, INC.
Exclusive
National
Representatives

WKZO
first IN KALAMAZOO
and GREATER WESTERN MICHIGAN
(CBS)

WJEF
first IN GRAND RAPIDS
AND KENT COUNTY
(CBS)

**BOTH OWNED
AND OPERATED
BY FETZER
BROADCASTING CO.**

City Call Letters Established	Chan. or Freq. Power	Name of Licensee Headquarters Address Telephone Number	Network Representative	Executive Personnel	Transc. Library News Service Transmitter Make	
MIDLAND						
WMDN 1948	1490 250	Rich Pub. House 298 S. Swede Rd. 4000		Phillip T. Rich, Pres. Spencer Denison, Gen. & Coml. Mgr.	Dick Fansler, Prog. Dir. & Prom. Mgr. Peter Wolf, Chief Engr.	Lang-Worth AP Gates
MT. CLEMENS						
WMLN (FM) 1947	Ch. 292 (A) 106.3mc 0.34kw	Macomb Pub. Co. 67 Cass Ave. 3-1501		Paul W. McKee, Pres. Mark T. McKee Jr., Mgr.	John Schmidley, Coml. Mgr. Wilbur Schatler, Chief Engr.	World UP General Electric
MT. PLEASANT						
WCEN 1949	1150 500-D	Paul A. Brandt 112½ E. Broadway 33171		Paul A. Brandt, Pres. Walter Maxwell, Gen. Mgr. & Chief Engr.	J. Lynn Leet, Coml. Mgr. Robert Meskill, Prog. Dir.	World AP Gates
MUSKEGON						
WKBZ 1926	850 1,000 DA-1	Ashbacker Radio Corp. 432 Apple Ave. 2-8051	ABC Burn-Smith	Grant F. Ashbacker, Pres., Gen. & Coml. Mgr. Robert Johnson, Prog. Dir.	B. L. Bennett, Prom. Mgr. K. B. Pendleton, Chief Engr.	Lang-Worth UP Raytheon
WKBZ-FM 1949	Ch. 293 (B) 106.5mc 4.7kw					
WMUS 1947	1090 1,000-D	Greater Muskegon Bcstrs. Inc. 1769 Peck St. 2-7608	Holman	F. M. VanCampen, Pres. & Gen. Mgr. Henry Veenstra, Coml. Mgr.	Miles M. Olsen, Prog. Dir. & Prom. Mgr. George Krivitsky, Chief Engr.	Associated Capitol UP Western Electric Federal
WMUS-FM 1947	Ch. 263 (B) 100.5mc 3.2kw					
OAK PARK						
WLDM (FM) 1948	Ch. 238 (B) 95.5mc; 20kw	(See Detroit listing)				
OWOSSO						
WOAP 1948	1080 250-D	Argus Press Co. 2300 N. Shiawasse St. 980	McGillvra	J. E. Campbell, Pres. M. H. Wirth, Gen. & Coml. Mgr.	Merrill Walker, Prog. Dir. & Prom. Mgr. Maynard Carson, Chief Engr.	Lang-Worth AP General Electric
WOAP-FM 1948	Ch. 276 (A) 103.1mc; 1kw					
PETOSKEY						
WMBN 1946	1340 250	Midwestern Bcstg. Co. Petoskey	MBS, KBS Bunyan Wolverine Holman	Les Biederman, Gen. Mgr.		
PONTIAC						
WCAR 1939	1130 1,000-D	WCAR Inc. 2146 S. Telegraph Rd. Federal 3-7141	Pearson	H. Y. Levinson, Pres. & Gen. Mgr. Wayne N. Cook, V. P. & Tech. Dir.	Clo Pipe, Natl. Sales Dir. Frank F. Firnschild, Prog. Dir.	Standard AP, INS RCA
WCAR-FM 1948	Ch. 283 (B) 99.5mc 20kw					



Yep, if'n thers anything us prospectors crave, it's action! And action is what ya'll get. If y' all get a tough 'un, drop us a line, or tellyphone (collect o' course) and we 'uns 'll jump to 'er. Y'know, when y' approach a problem f'm more'n one direction to oncet, it sorta winds up with plenty o' ree-sults—one way er 'nother. So when y' need help . . . don't make no nevermind whether hits buildin' a fire under a stubborn jackass, er a sales drive, call on the three who c'n get y' what y' want! And if'n we aint mistook . . . we all want the same durn thing!

WSOO - ABC
SAULT STE. MARIE, MICHIGAN

★

WDMJ - MBS
MARQUETTE, MICHIGAN

★

WMIQ - ABC
IRON MOUNTAIN, MICHIGAN



STUDIO AND
BUSINESS OFFICE
107 W. PORTAGE AVENUE
SAULT STE. MARIE, MICHIGAN
PHONE 3000
★
SALES OFFICE
211 E. LUDINGTON STREET
IRON MOUNTAIN, MICHIGAN
PHONE 2031

DIRECTORY OF AM, FM, and TV STATIONS OF THE UNITED STATES

*(Data corrected to December 6, 1949)
If executives or services for FM or TV stations are same as AM affiliate names are not repeated.*

MICHIGAN—(Continued)

City	Call Letters Established	Chan. or Freq. Power	Name of Licensee Headquarters Address Telephone Number	Network Representative	Executive Personnel	Transc. Library News Service Transmitter Make	
PORT HURON							
	WFLS 1938	1450 250	Port Huron Bcstg. Co. 832 Military St. 28536	MBS Holman	Harmon LeRoy Stevens, Herman LeRoy Stevens, Partners (Miss) Helen Nelson, Gen. Mgr.	R. J. McIntosh, Coml. & Prom. Mgr. Lyle Patterson, Prog. Dir. Leslie Conant, Chief Engr.	Lang-Worth World UP RCA
	WTHH 1947	1380 1,000 DA-1	The Times Herald Co. 903 6th St. 5171		Louis A. Weil, Pres. F. Granger Weil, Gen. Mgr. William L. Weil, Coml. Mgr.	Alice Anderson, Prog. Dir. Marion Stoner, Chief Engr.	Capitol Standard AP Gates Associated
	WTHH-FM 1947	Ch. 256 (B) 99.1mc 22kw				
ROGERS CITY							
	WHAK 1949	960 1,000-D	Rogers City Bcstg. Co. Moltke Dr. 175		Harvey A. Klann, Pres. & Gen. Mgr. & Chief Engr. Nichols Mazzei, Coml. Mgr.	Harry E. Brege, Prog. Dir. Albert Klann, Prom. Mgr.	World Lang-Worth UP Raytheon
ROYAL OAK							
	WEXL 1923	1340 250	Royal Oak Bcstg. Co. 212 W. Sixth St. Jordan 4-6523	Friedenberg	George B. Hartrick, Pres. Jacob B. Sparks, Gen. Mgr. Calvert M. Hill, Coml & Prom Mgr.	Gordon A. Sparks, Prog. Dir. Garnet G. Sparks, Chief Engr.	Standard Associated AP, INS Raytheon General Electric
	WEXL-FM 1948	Ch. 282 (B) 104.3mc 18kw				
SAGINAW							
	WKNX 1949	1210 1,000-D	Lake Huron Bcstg. Co. 221 S. Washington Ave. 3-4471	Holman	W. J. Edwards, O. J. Kelchner, Howard H. Wolfe, Co-owners O. J. Kelchner, Gen. Mgr.	W. J. Edwards, Coml. Mgr. Ernest T. Guy, Prog. Dir. Howard H. Wolfe, Prom. Mgr. Max W. Thomas, Chief Engr.	Lang-Worth UP Raytheon
	WSAM 1940	1400 250	Saginaw Bcstg. Co. 117 West Genesee Ave. 2-8161	NBC Headley-Reed	Milton L. Greenebaum, Pres. & Gen. Mgr. Vincent Picard, Sales Mgr.	Phil Wood, Asst. Gen. Mgr. Meredith L. Koerner, Eeng. Dir. AP RCA Standard
	WSAM-FM 1947	Ch. 251 (B) 98.1mc 1.7kw				
	WSGW (CP)	790 1,000 DA-2	Booth Radio & Television Stations Inc. Mason Bldg.		John L. Booth, Pres. Robert W. Phillips, Gen. Mgr.	Jack D. Parker, Prog. Dir. & Prom. Mgr. John T. Travers, Chief Engr.	World AP Western Electric
SAULT STE. MARIE							
	WSOO 1940	1230 250-LS 100-N	Hlawathaland Bcstg. Co. 107 W. Portage Ave. 3000	ABC Northern Michigan	Stanley R. Pratt, Pres. R. Y. Burnett, Gen. & Coml. Mgr. Ed L. Krieger, Prog. Dir.	James Shields, Prom. Mgr. William Morris, Chief Engr.	Lang-Worth SESAC AP RCA
TRAVERSE CITY							
	WTCM 1941	1400 250	Midwestern Bcstg. Co. Paul Bunyan Bldg. 2700	MBS, KBS Bunyan Wolverine Holman	Les Biederman, Gen. Mgr.		
WYANDOTTE							
	WJJW(FM) 1947	Ch. 276 (A) 103.1mc 1kw	The Wyandotte News Co. 3042 First St. 1166		Strauss Gantz, Pres. & Gen. Mgr. Warren Lalonde, Prog. Dir.	Raymond Wardell, Chief Engr.	Associated Capitol UP

DA-N Directional Antenna, night only. FM's in italic. *—Non-Commercial Station. D—Day. N—Night. ST—Share Time. SH—Specified Hours.
DA-1 Directional Antenna, same pattern day and night. U—Unlimited. CP—Construction Permit Issued. LS—Local Sunset.
DA-2 Directional Antenna, different pattern day and night. L—Limited Time with Dominant Station. SA—Special Authorization.

NBC FOR NORTHEASTERN MICHIGAN **MICHIGAN'S FARM STATION**

SAGINAW **BAD AXE**



WSAM

(ESTABLISHED 1940)

SERVING SAGINAW —
BAY CITY — MIDLAND

COMBINE THESE TWO MARKETS INDUSTRY AND AGRICULTURE

SAGINAW BROADCASTING CO.

SAGINAW

WLEW

COVERS THE RICH "THUMB"
23 MILLION DOLLAR MARKET

ON THE AIR
FEBRUARY 4, 1950



RADIO BLDG. MICHIGAN
REPRESENTED BY HEADLEY REED CO.

DIRECTORY OF AM, FM, and TV STATIONS OF THE UNITED STATES

(Data corrected to December 6, 1949)
If executives or services for FM or TV stations are same as AM affiliate names are not repeated.

MINNESOTA

City Call Letters Established	Chan. or Freq. Power	Name of Licensee Headquarters Address Telephone Number	Network Representative	Executive Personnel	Transc. Library News Service Transmitter Make
ALBERT LEA					
KATE 1937	1450 250	Albert Lea-Austin Bcstg. Co. 332 S. Broadway; 2338	ABC Pearson	Bennett O. Knudson, Pres. George Wolf, Secy.-Treas. Anson Vann, Gen. & Coml. Mgr.	Danny Gilbert, Prog. Dir. Robert Holt, Chief Engr. Capitol. SESAC UP Collins
ALEXANDRIA					
KXRA 1949	1490 250	Alexandria Bcstg. Corp. 1000		R. C. Brown, Gen. Mgr. Everette Q. Walters, Coml. Mgr.	Kenneth Bechtel, Prog. Dir. Gerald Lentz, Chief Engr. Lang-Worth UP; Collins
AUSTIN					
KAUS 1948	1480 1,000 DA-2	Cedar Valley Bcstg. 405 A. North Main 8836	MBS	Harry Smith, Pres. L. L. McCurnin, Gen. Mgr. Thomas Steensland, Sales Mgr.	Donald M. Richardson, Prog. Dir. Glen Klein, Chief Engr. AP General Electric
BEMIDJI					
KBUN 1946	1450 250	Butler Bcstg. Co. Inc. 419½ Beltrami Ave. 1900	MBS Lawson	Edward W. Butler, Pres., Gen. & Coml. Mgr.	Gwenyth Butler, Prog. Dir. & Prom. Merrill Jacobs, Chief Engr. Lang-Worth UP Raytheon
BRainerd					
KLIZ 1946	1400 250	Brainerd Bcstg. Co. 2700 E. Oak St. 4050	Walker	E. T. O'Brien, Pres. & Gen. Mgr. Edward J. Wilder, Coml. & Prom. Mgr.	Lucille Grosse, Prog. Dir. Art Vandersluis, Chief Engr. Standard AP
BRECKENRIDGE					
KBMW 1948	1450 250	Interstate Bcstg. Corp. 519 Dakota Ave.; 527	Bulmer & Johnson	K. E. Bower, Pres. & Gen. Mgr.	Thesaurus Standard; UP
CLOQUET					
WKLK (CP)	1450 250	Cloquet Bcstg. Co.			
CROOKSTON					
KROX 1948	1050 1,000-D	Crookston Bcstg. Co. Eagles Bldg. 1050	Cooke	D. A. McKenzie, Pres. Roger Briden, V. P. & Gen. Mgr. Garfield L. Fox, Oprs. Mgr.	Jerome A. Dahlberg, Prog. Dir. William J. Kiewel, Chief Engr. Lang-Worth UP Raytheon

DA-N Directional Antenna, night only. FM's in italic. *—Non-Commercial Station. D—Day. N—Night. ST—Share Time. SH—Specified Hours.
DA-1 Directional Antenna, same pattern day and night. U—Unlimited. CP—Construction Permit Issued. LS—Local Sunset.
DA-2 Directional Antenna, different pattern day and night. L—Limited Time with Dominant Station. SA—Special Authorization.

OTTO MATTICKALLY
IN THE BAG

DULUTH, MINN.—“It’s in the bag all right,” reports KDAL’s Otto Mattick as he rolls along on his merry tricycofoodmobile. It’s America’s 51st Food Market he’s talking about. They’re big eaters here in the Duluth-Superior area. Great radio listeners, too. And most of them listen to KDAL. Mr. Hooper’s ratings will tell you that. That’s why KDAL is the most effective medium to sell food products in this important food market. Why don’t you put KDAL on the list for your next campaign. Then we can start increasing sales for your food product, too.

Success stories by the score about KDAL’s terrific job in selling America’s 51st Food Market are available from Avery-Knodel. Their nearest office will be glad to give you full details.

K D A L
DULUTH-SUPERIOR
CBS ★ 5,000 WATTS ON 610



DIRECTORY OF AM, FM, and TV STATIONS OF THE UNITED STATES

(Data corrected to December 6, 1949)
If executives or services for FM or TV stations are same as AM affiliate names are not repeated.

MINNESOTA—(Continued)

City Call Letters Established	Chan. or Freq. Power	Name of Licensee Headquarters Address Telephone Number	Network Representative	Executive Personnel	Transc. Library News Service Transmitter Make	
DULUTH						
KDAL 1936	610 5,000 DA-N	Red River Bcstg. Co. 218 Bradley Bldg. Melrose 2628	CBS Avery-Knodel	Dalton A. Le Masurier, Pres. & Gen. Mgr. Odin S. Ramsland, Coml. Mgr.	Richard Lawrence, Prog. Dir. Jeanne Hudson, Prom. Mgr. Robert Dettman, Chief Engr.	Lang-Worth AP RCA
WEBC 1924	1320 5,000 DA-N	Head of the Lakes Bcstg. Co. WEBC Bldg. Melrose 2873	NBC Arrowhead Northwest Hollingbery	Morgan Murphy, Pres. Walter C. Bridges, Gen. Mgr. Marlin Smythe, Res. & Prom. Mgr.	William E. Conner, Prog. Dir. Norman P. Gill, Chief Engr.	Associated SESAC UP
WEBC-FM 1940	Ch. 222 (B) 92.3mc 62kw					
WREX 1948	1080 10,000-LS DA-2 5,000-N	Lake Superior Bcstg. Co. 213 East Superior St. Radisson 2911	MBS Weed	James R. King, Gen. Mgr.	William H. Lounsbury, Chief Engr.	World UP RCA
ELY						
WXLT 1948	1450 250	Ely Bcstg. Co. Inc. Ely 226	KBS Lawson	Lynn Thompson, Pres. Don Mortwedd, Gen. Mgr. & Prog. Dir.	Edward B. Nichols, Bus. Mgr. Darrel Gander, Chief Engr.	Cole MacGregor UP RCA
EVELETH						
WEVE 1947	1340 250	R'dson Inc. 921 Tower Ave. Superior, Wis.	Free & Peters	Robert B. Ridder, Pres. Carl Bloomquist, Gen. Mgr.	Elden Soberg, Coml. Mgr. J. Melvin Laskey, Chief Engr.	Lang-Worth
FARIBAULT						
KDHL 1948	920 1,000 DA-2	Lee-Smith Bcstg. Co. Box 247 2312	Walker	Herbert H. Lee Palmer Dragsten } Partners John E. Hyde Jr. Herbert H. Lee, Gen. Mgr.	Palmer Dragsten, Coml. & Prom. Mgr. Jergen Nash, Prog. Dir. John E. Hyde Jr., Chief Engr.	Standard AP Raytheon
FAIRMONT						
KSUM 1949	1370 1,000 DA-2	Fairmont Bcstg. Co. 103 S. North Ave. 1370	MBS Tall Corn Lawson	Leo J. Seifert, Pres. Frank W. Endersbe, Mgr.	Everett R. Ohrt, Prog. Dir. Walton W. Wilson, Chief Engr. UP RCA
FERGUS FALLS						
KGDE 1926	1230 250	Fergus Radio Corp. Highway 3 3986	MBS Great Northern Walker	Harold L. Dell, Exec. Dir. & Secy.- Treas.	Don L. Albertson, Gen. Mgr. Harold E. Allen, Chief Engr. AP
GRAND RAPIDS						
KBZY 1948	1490 250	Itasca Bcstg. Co. 207 N. 1st Ave. W. 198	MBS	Robert D. Kennedy, Gen. & Coml. Mgr.	Ross Fessenmeyer, Chief Engr.	Lang-Worth UP Collins
HIBBING						
WMFG 1935	1240 250	Head of the Lakes Bcstg. Co. Fifth & Howard 1150	NBC Arrowhead Northwest Hollingbery	Morgan Murphy, Pres. Walter C. Bridges, Gen. Mgr. Oscar H. Peterson, Coml. Mgr.	Ruth E. Coe, Prog. Dir. & Prom. Mgr. Norman Gill, Chief Engr.	Associated UP
MANKATO						
KTOE (CP)	1420 1,000 DA-N	Minnesota Valley Bcstg. Co. Mankato		H. W. Linder, Pres. Donald O. Linder, Exec. V. P.	H. Willard Linder Jr., Secy.-Treas.
KYSM 1938	1230 250	F. B. Clements & Co. 101 N. Second St. 4673	NBC Northwest Pearson	John F. Meagher, Gen. & Coml. Mgr. Bob Gardner, Prog. Dir.	John Gallos, Prom. Mgr. Jim Houts, Chief Engr.	Thesaurus Standard UP RCA
KYSM-FM 1948	Ch. 278 (B) 103.5mc 47kw				 General Electric
MARSHALL						
KMHL 1946	1400 250	Harry W. Linder KMHL Bldg. 2282	MBS Pearson	Harry W. Linder, Owner Gilmore F. Frayseth, Gen. & Coml. Mgr.	Homer L. Lane, Prog. Dir. H. Willard Linder, Chief Engr. UP Raytheon
MINNEAPOLIS—ST. PAUL						
KEYD 1948	1440 5,000-D	Family Bcstg. Corp. 15 N. 9th St. Lincoln 8451	Forjoe	Lee L. Whiting, Gen. Mgr. Harold A. Winther, Coml. Mgr. Irving Tingley, Prog. Dir.	Wendell Husebo, Prom. Mgr. Harvey Headen, Chief Engr.	Standard AP RCA
KSTP 1928	1500 50,000 DA-N	KSTP Inc. 3415 University Ave. S.E. Prior 2717	NBC Northwest Petry	Stanley E. Hubbard, Pres. & Gen. Mgr. K. M. Hance, Exec. V. P. & Treas. Miller C. Robertson, V. P. in Chg. of Sales	C. Brooks Henderson, Prod. Sup- ervisor Joseph C. Cook, Prom. & Publ. Dir. John McMahon, Tech. Supvsr.	Lang-Worth World Thesaurus AP, UP
KSTP-FM 1946	Ch. 271 (B) 102.1mc 57kw				
KSTP-TV 1948	Ch. 5 76-82 mc 17.3 kw aur.; 24.7 kw vis.				Dell Franklin, Prog. Dir.
*KTIS 1949	900 1,000-D	Northwestern Schools Bible School Seminary College Lincoln 7881		Dr. William Graham, Pres. Loren F. Bridges, Gen. Mgr.	Clarence LaBoute, Chief Engr.	Associated SESAC UP Western Electric
KTIS-FM 1949	Ch. 290 (B) 105.9mc 5.3kw				
*KUOM 1922	770 5,000-D ST-WCAL	U. of Minnesota Eddy Hall MA 8177 Ext. 419		Burton Paulu, Mgr. & Prog. Dir.	Berten A. Holmberg, Chief Engr. UP RCA
WCCO 1924	830 50,000	Columbia Bcstg. System Inc. 625 Second Ave. So. Main 1202	CBS Radio Sales	Wendell B. Campbell, Gen. Mgr. Alfred J. Harding, Coml. Mgr. Gene Wilkey, Asst. Gen. Mgr. & Gen. Sis. Mgr.	Lee Blund, Prog. Mgr. Tony Moe, Prom. Mgr. J. J. Beloungy, Chief Engr.	Lang-Worth AP, UP Western Electric
WDGY 1923	1130 50,000-LS DA-2 25,000-N	Twin Cities Bcstg. Corp. Hotel Nicolet Bridgeport 2271	Avery-Knodel	James Stuart, Pres. Melvin Drake, Gen. Mgr. Robert W. Owens, Coml. Mgr.	Bob Allen, Prog. Dir. Charles G. Dinkel, Chief Engr.	Standard AP Westinghouse

DA-N Directional Antenna, night only. FM's in italic.
DA-1 Directional Antenna, same pattern day and night.
DA-2 Directional Antenna, different pattern day and night.

*—Non-Commercial Station. D—Day. N—Night. ST—Share Time. SH—Specified Hours.
U—Unlimited. CP—Construction Permit Issued. LS—Local Sunset.
L—Limited Time with Dominant Station. SA—Special Authorization.

SILENT CAL STARTED THE NORTHWEST'S BIGGEST VOICE

In 1928 President Calvin Coolidge touched a golden key at the White House that put KSTP on the air. In December of 1928 KSTP joined N.B.C. and Northwestern listeners enjoyed the popular Ipana Troubadors, the Sieberling Singers and Amos 'n Andy. KSTP maintained its own 25 piece orchestra, too. In these 22 years KSTP has come a long way, scoring many national and regional "firsts" in the development of broadcasting. In 1930, KSTP designed the nation's first shortwave mobile unit. In 1932 KSTP offered its listeners the first



complete election coverage, and in 1933 introduced the first motor mobile unit. KSTP was the first station in the country to create a special full-time news bureau for the sole purpose of gathering and disseminating news for radio... the first in the Northwest to win a Variety Showmanship plaque.

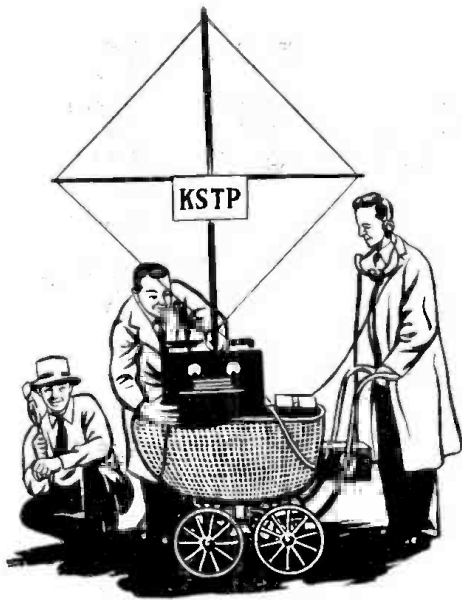

Scores of innovations led to KSTP's entrance into the television picture in 1939. Operating commercially since April, 1948, KSTP has proved again and again that its pioneering leads to market dominance.

In its new Radio City home, KSTP and KSTP-TV offers the most complete radio and television service in the entire area.

Be it AM or TV—KSTP was, is and will be the best advertising buy in the important Minneapolis-St. Paul market.



AM

TV

FM

KEY STATION FOR THE NORTHWEST NETWORK
50,000 WATTS—CLEAR CHANNEL • EXCLUSIVE NBC AFFILIATE FOR THE TWIN CITIES
REPRESENTED NATIONALLY BY EDWARD PETRY & CO.

KSTP
MINNEAPOLIS ... ST. PAUL

DIRECTORY OF AM, FM, and TV STATIONS OF THE UNITED STATES

(Data corrected to December 6, 1949)
If executives or services for FM or TV stations are same as AM affiliate names are not repeated.

MINNESOTA—(Continued)

City	Call Letters Established	Chan. or Freq. Power	Name of Licensee Headquarters Address Telephone Number	Network Representative	Executive Personnel	Transc. Library News Service Transmitter Make	
MINNEAPOLIS-ST. PAUL—(Continued)							
WLOL	1940	1330 5,000 DA-1	Independent Merchants Bcstg. Co. 1730 Hennepin Ave. Atlantic 0406	MBS Blair	Ralph L. Atlass, Chief Owner. V. P. & Treas. C. T. Hagman, Pres. & Gen. Mgr. Jack Swenson, Prog. Dir. & Prom. Mgr.	Samuel N. Nemer, Coml. Mgr. Merle Bjork, Chief Engr.	UP RCA
WMIN	1936	1400 250	WMIN Bcstg. Co. 538 Hamm Bldg. Garfield 1361	Radio Reps	Frank M. Devaney, Gen. & Coml. Mgr. Grace G. Guarnera, Prog. Dir.	Richard Stevens, Prom. Mgr. Warren B. Fritze, Chief Engr.	Associated AF Western Electric
WMIN-FM	1948	Ch. 258 (B) 99.5mc 100kw					Federal
WPBC	1949	980 500-D	People's Bcstg. Co. 1133 Stenson Blvd. Granville 7236		William V. Stewart, Pres., Gen. Mgr. & Prog. Dir. John W. Ware, Coml. Mgr.	Thomas K. McCrum, Prod. Mgr. Harry Vose, Chief Engr.	Lang-Worth UP Collins
WTCN	1931	1280 5,000-LS 1,000-N	Minnesota Bcstg. Corp. 50 So. 9th St. Lincoln 0552	ABC Dairyland Free & Peters	W. J. McNally, Pres. F. Van Konynenburg, Gen. Mgr. R. N. Ekstrum, Coml. Mgr.	Judy Bryson, Prog. Dir. C. J. Rian, Prom. Mgr. John M. Sherman, Chief Engr.	Capitol Associated AP, UP Western Electric
WTCN-FM	1946	Ch. 246 (B) 97.1mc 400kw					RCA
WTCN-TV	1949	Ch. 4 66-72mc 9.2kw-aur. 17.9kw-vis.:		ABC, CBS DuMont			World Ideal Fairbanks AF, UP, INS RCA
MOORHEAD							
KVOX	1937	1340 250	KVOX Bcstg. Co. 818 Center Ave. 3-1523	MBS Great Northern Walker	E. J. McKellar, Chief Owner M. M. Marget, Gen. Mgr. J. McKnight, Coml. Mgr.	Sterling Kuhlmeier, Prog. Dir. Don Gelken, Chief Engr.	World UP Western Electric
NEW ULM							
KNUJ	1949	860 1,000-D	Brown County Journal Inc. 308½ North Minn. St. 905		W. K. Mickelson, Pres. E. M. Tobin, Gen. Mgr. Warren Ascher, Coml. Mgr.	Dennis Hayes, Prog. Dir. George Korenchen, Prom. Mgr. Leon Brauhn, Chief Engr.	Lang-Worth AP Gates
NORTHFIELD							
*WCAL	1918	770 5,000-D	St. Olaf College Northfield 500		Milford Jensen, Oprs. Dir. William Lundquist, Prog. Dir. David Monson, Sales Mgr.	Martin Hegland, Prom. Dir. M. C. Jensen, Chief Engr.	Associated AP Westinghouse
WCAL-FM	1949	Ch. 239 (B) 95.7mc 49kw					
RED WING							
KAAA	1949	1250 1,000-D	Red Wing Bcstg. Co. Red Wing 1536		Fred C. Clarke, Pres., Prog. Dir. & Chief Engr.	Maxine Jacobs, Gen. Mgr. Charles E. Wright, Coml. Mgr.	Associated AP Gates
ROCHESTER							
KLER	1948	970 500-LS 1,000-N DA-2.	Rochester Bcstg. Co. 223 1st. Ave. S. W. 2-2757	ABC Young	Alice P. Mayo, Pres. Walter T. Bruzek, Gen. & Prom. Mgr.	Robert A. Fick, Coml. Mgr. R. C. Bouchier, Prog. Dir. Boynton Hagaman, Chief Engr.	Standard UP RCA
KROC	1935	1340 250	So. Minn. Bcstg. Co. 100 1st Ave. Bldg. 3924	NBC Northwest	Mrs. G. P. Gentling, Pres. G. David Gentling, Gen. & Coml. Mgr.	Cal Smith, Prog. Dir. & Sta. Mgr. Bob Wold, Prom. Mgr. Bob Cross, Chief Engr.	World UP Collins
KROC-FM	1946	Ch. 234 (B) 94.7mc 20kw		Ra-Tel			RCA
ST. CLOUD							
KFAM	1938	1450 250	Times Pub. Co. Weber Bldg. 3330	NBC Northwest	Frederick C. Schilplin, Pres. & Gen. Mgr. John F. Green, Coml. Mgr.	Avis Russell, Prog. Dir. & Prom. Mgr. Robert Witschen, Chief Engr.	Thesaurus Lang-Worth AP RCA
KFAM-FM	1948	Ch. 284 (B) 104.7mc 50kw					
WJON (CP)		1240 250	Granite City Bcstg. Co.				
ST. PAUL (See Minneapolis Listing)							
STILLWATER							
WSHB	1949	1220 250-D	St. Croix Bcstg. Co. 126 S. Main St. 46	Bulmer & Johnson	William F. Johns Jr., Gen. Mgr. Victor Tedesco, Sta. Mgr.	John Lohmer, Coml. Mgr.	Lang-Worth UP
THIEF RIVER FALLS							
KTRF	1946	1230 250	Henry K. Arneson Box 69	Bulmer & Johnson	Henry K. Arneson, Owner W. J. Taylor, Prom. Mgr.	T. E. Speer, Sta. Mgr.	Thesaurus UP
VIRGINIA							
WHLB	1936	1400 250	Head of the Lakes Bcstg. Co. 17th St. & 6th Ave. S. 2000	NBC Northwest Arrowhead Hollingbery	Morgan C. Murphy, Pres. Walter C. Bridges, Gen. Mgr. Arthur F. Nelson, Res. & Prom. Mgr.	Alys Mae McBride, Prog. Dir. Norman Gill, Chief Engr.	Associated SESAC UP
WADENA							
KWAD	1948	920 1,000 DA-N	Associated Bcstrs. Inc. First Nat'l. Bank Bldg. 920	MBS Bulmer & Johnson	C. V. Phillips, Pres. H. G. Alexander, Gen. Mgr. Carl E. Holt, Sales Mgr.	James Buchan, Prog. Dir. Ralph T. Doggett, Chief Engr.	Capitol Cole UP Gates
WILLMAR							
KWLM	1940	1340 250	Lakeland Bcstg. Co. 307 West 6th St. 1340	ABC Dairyland Pearson	H. W. Linder, Pres. & Chief Owner H. Willard Linder, Exec. V. P. John C. Lynch, Coml. Mgr.	James A. Martinson, Prog. Dir. Willard J. Smith, Prom. Mgr. Willard Linder, Chief Engr.	Cole UP Western Electric
WINONA							
KWNO	1938	1230 250	Winona Radio Service 216 Center St. 3314	ABC Pearson	M. H. White, Pres. Ken Marsh, Gen. & Coml. Mgr.	Ethel Holte, Prom. Mgr. Stanley Johnson, Chief Engr.	World AP RCA
KWNO-FM	1948	Ch. 248 (B) 97.5mc 55kw					General Electric
WORTHINGTON							
KWOA	1947	730 1,000-D	Worthington Bcstg. Co. Hotel Thompson 2-7301	Bulmer & Johnson	R. W. Olson, Pres. Ralph E. Shepard, Gen. Mgr. George Lasley, Coml. Mgr.	Roger Russell, Prog. Dir. Clinton Knapp, Chief Engr.	Lang-Worth UP Raytheon

DA-N Directional Antenna, night only. FM's in italic.
DA-1 Directional Antenna, same pattern day and night.
DA-2 Directional Antenna, different pattern day and night.

*—Non-Commercial Station. D—Day. N—Night. ST—Share Time. SH—Specified Hours.
U—Unlimited. CP—Construction Permit Issued. LS—Local Sunset.
L—Limited Time with Dominant Station. SA—Special Authorization.

Serving The

NORTHWEST EMPIRE

with

50,000 WATTS (DAY)

25,000 WATTS (NIGHT)

*New Opportunity for Shrewd Time Buyers . . .
to get choice time at favorable rates—on
a long-established station that has just en-
tered a new era of expansion and progress.*

1130 KC

W D G Y

MINNEAPOLIS • ST. PAUL

Represented Nationally by Avery-Knodel, Inc.

DIRECTORY OF AM, FM, and TV STATIONS OF THE UNITED STATES

(Data corrected to December 6, 1949)
If executives or services for FM or TV stations are same as AM affiliate names are not repeated.

MISSISSIPPI

City Call Letters Established	Chan. or Freq. Power	Name of Licensee Headquarters Address Telephone Number	Network Representative	Executive Personnel	Transc. Library News Service Transmitter Make	
BILOXI						
WLOX 1948	1490 250	WLOX Bcstg. Co. Inc. Hotel Buena Vista 5582	MBS Rambeau	J. S. Love Jr., Pres. Gene Tibbett, Gen. & Prom. Mgr. Douglas M. Gabrielson, Prog. Dir.	Thomas B. Majure, Coml. Mgr. & Chief Engr.	Standard UP Western Electric
WVMI (CP)	570 1,000-D	Radio Associates				
BROOKHAVEN						
WJMB 1948	1340 250	Brookhaven Bcstg. Co. West Chicasaw St. 1298	Continental	Tullius Brady, Pres., Gen. & Prom. Mgr. Chuck Allen, Coml. Mgr. & Prog. Dir.	Tom Pharris, Chief Engr.	Lang-Worth World AP Gates
CLARKSDALE						
WROX 1943	1450 250	Birney Imes Delta Ave. 1566	MBS, KBS Mid-South Sears & Ayer	Birney Imes, Owner Bob McRaney, Gen. Mgr. P. B. Hinman, Sta. Mgr.	Helen Sugg, Prog. Dir. C. D. Graves, Chief Engr.	AP RCA
CLEVELAND						
WCLD 1949	1490 250	Cleveland Bcstg. Co. Cleveland 990		Cy Bahakel, Pres. & Gen. Mgr.	Gene Sodouth, Chief Engr.	
COLUMBIA						
WCJU 1946	1450 250	WCJU Inc. South Main St. 755	MBS	Lester Williams, Pres., Gen. & Coml. Mgr. Charles E. Newman Jr. Asst. Mgr.	Ray Tolar, Chief Engr.	Gates
COLUMBUS						
WACR (CP)	1050 250-D	Miss. Bcstg. Co. Inc. Columbus	Miss.	Withers Gavin, Pres. & Gen. Mgr.		
WCBI 1940	1340 250	Birney Imes Jr. Gilmer Hotel 1430	MBS, KBS LBS Mid-South Sears & Ayer	Birney Imes Jr., Pres. Bob McRaney, Gen. & Prom. Mgr.	James Eatherton, Coml. Mgr. Martha Morris, Prog. Dir. Thos. McFerrin, Chief Engr.	AP RCA
CORINTH						
WCMA 1946	1230 250	Corinth Bcstg. Co. Inc. Ray Bldg. 5575	KBS, MBS Dixie Burn-Smith	Frank M. Davis, M.D., Pres. Aaron B. Robinson, V. P. & Gen. Mgr. John E. Bell, Sta. Mgr.	William T. McLain, Prog. Dir. Joe VanDyke, Prom. Mgr. William M. Essary, Chief Engr.	World UP Western Electric
GREENVILLE						
WGVM 1948	1260 1,000-D	Cotton Belt Bcstg. Co. 316 Washington Ave. 2910		David M. Segal, Pres. Howard E. Gurney, Gen. Mgr. John B. Carter, Coml. Mgr.	Louis A. Kurtz, Prog. Dir. Welton H. Jetton, Chief Engr.	Lang-Worth UP
WJPR 1939	1340 250	Radio Services Co. 107 South Poplar St. 2434	MBS, KBS Miss. Sears & Ayer	Emmet H. McMurry Jr., Gen. Mgr. Frank W. Baldwin, Coml. Mgr. Edward Guss, Prog. Dir.	Pat Avery, Prom. Mgr. Percy L. Kuhn, Chief Engr.	Associated Capitol, World AP RCA
WJPR-FM 1945	Ch. 270 (B) 101.9mc 19.1kw					General Electric
GREENWOOD						
WABG (CP)	960 1,000-D	Greenwood Bcstg. Co. Greenwood		Cy Bahakel, Pres. & Gen. Mgr.		World
WGRM 1938	1240 250	P. K. Ewing Walnut St. 1900	NBC, KBS Miss.	P. K. Ewing, Pres. F. C. Ewing, Gen. Mgr. Van Power, Coml. Mgr.	Grace Harris, Prog. Dir. Teddy Shanks, Prom. Mgr. Louis Pierce, Chief Engr.	Capitol AP Gates
GRENADA						
WNAG 1948	1400 250	Birney Imes Jr. Barwin Hotel 740	MBS, KBS, LBS Mid-South Sears & Ayer	Birney Imes Jr., Pres. Bob McRaney, Gen. Mgr. Monroe Looney, Sta. & Coml. Mgr.	Don Moore, Prog. Dir. Frank Crawford, Chief Engr.	RCA
GULFPORT						
WGCM 1929	1240 250	WGCM Bcstg. Co. Hewes-Martin Bldg. 1110	ABC, KBS LBS Miss. Sears & Ayer	Hugh O. Jones, Gen. & Coml. Mgr. C. Eddie Vann, Prog. Dir.	Marc Leon, Prom. Mgr. Donovan Murphy, Chief Engr.	AP RCA
WGCM-FM 1949	Ch. 270 (B) 101.5mc 3kw					Western Electric
HATTIESBURG						
WFOR 1926	1400 250	Forrest Bcstg. Co. Inc. 302 Hemphill St. 1866	NBC, KBS Rebel Hollingbery	C. J. Wright Sr., Pres. & Gen. Mgr. C. J. Wright Jr., V. P. & Asst. Mgr. H. L. Patterson, Coml. Mgr.	E. M. Jenkins, Prog. Dir. B. B. McLemore, Chief Engr.	World UP
WFOR-FM 1949	Ch. 250 (B) 97.9mc 2.02kw					RCA
WHSY 1948	1230 250	Hub City Bcstg. Co. Inc. P. O. Box 1008 3180	ABC LBS	Charles W. Holt, Pres., Gen. & Coml. Mgr. Connie Holt, Prog. Dir.	Thomas N. Kern, Prom. Mgr. Dennis E. Connell, Chief Engr.	Lang-Worth AP Gates

DA-N Directional Antenna, night only. FM's in italic.
DA-1 Directional Antenna, same pattern day and night.
DA-2 Directional Antenna, different pattern day and night.

*—Non-Commercial Station. D—Day. N—Night. ST—Share Time. SH—Specified Hours.
U—Unlimited. CP—Construction Permit Issued. LS—Local Sunset.
L—Limited Time with Dominant Station. SA—Special Authorization.

City Call Letters Established	Chan. or Freq. Power	Name of Licensee Headquarters Address Telephone Number	Network Representative	Executive Personnel	Transc. Library News Service Transmitter Make
JACKSON					
WJDX 1929	1300 5,000-LS 1,000-N	Lamar Life Insurance Co. P. O. Box 2171 3-7476	NBC Rebel Hollingbery	Wiley P. Harris, Gen. Mgr. Frank Gentry, Coml. Mgr. Howard Langitt, Prog. Dir.	Percy G. Root, Chief Engr. Capitol World UP
WJDX-FM 1948	Ch. 275 (B) 102.9mc 50kw				Robert R. Smathers, Chief Engr. Western Electric
WJQS 1947	1400 250	Miss. Bcstg. Co. Inc. Edwards Hotel 3-9681	CBS Miss.	Withers Gavin, Pres. & Gen. Mgr.	Standard AP
WJXN 1945	1450 250	Andalusia Bcstg. Co. Deposit Guaranty Bank Bldg. 2-6673		James T. Ownby, Gen. & Coml. Mgr.	AP
WRBC 1947	620 5,000-LS 1,000-N DA	Rebel Bcstg. Co. Inc. 125 S. Lamar St. 5-1562	MBS Branham	J. W. Carlier, Gen. & Coml. Mgr. Forrest Cox, Prog. Dir.	G. G. Benson, Chief Engr. Associated AP Westinghouse
WSLI 1938	930 5,000 DA-N	Standard Life Bcstg. Co. Inc. Robert E. Lee Hotel 3-2788	ABC Weed	W. R. Newman, Pres. L. M. Sepaugh, Gen. Mgr. F. E. Wilkerson Jr., Coml. Mgr.	Bruce K. Smith, Prog. Dir. Maurice B. Wray, Prom. Mgr. C. A. Perkins, Chief Engr. World AP RCA
KOSCIUSKO					
WKOZ 1947	1340 250	Cy N. Bahakel Box 392 782	KBS	Cy N. Bahakel, Pres. Melvin C. Lee, Coml. Mgr. Erlene Leach, Prog. Dir.	Dia Bahakel, Prom. Mgr. George C. Ray, Chief Engr. World AP Collins
LAUREL					
WAML 1932	1340 250	New Laurel Radio Station Inc. 535 Central Ave. 5601	NBC, KBS Hollingbery	Harold M. Matison, Pres. Granville Walters, Gen. Mgr. Morris M. Caver, Coml. Mgr.	Stanley C. Walters, Prog. Dir. Cliff Campbell, Prom. Mgr. Clyne Graves, Chief Engr. Capitol AP Raytheon
WLAU 1946	1490 250	Southland Bcstg. Co. 437½ North Magnolia St. 420	MBS	C. H. Leggett, Pres. & Coml. Mgr. Jimmie Willson, Gen. Mgr.	Dave Kane, Prog. Dir. Teck Jones, Prom. Mgr. Ed Pierce, Chief Engr. UP
MACON					
WMBC 1946	1400 250	Miss. Bcstg. Co. Inc. Hotel Thomas Jefferson 310	Miss.	Withers Gavin, Pres. & Gen. Mgr.	Standard AP
McCOMB					
WAPF 1948	1010 250-D	Southwestern Bcstg. Co. of Miss. Box 604 1884	KBS Miss.	Louis Alford, Pres. & Gen. Mgr. Bill Tyler, Coml. & Prom. Mgr.	Paul Simpkins, Prog. Dir. Phillip Brady, Chief Engr. Lang-Worth UP Gates
WSKB 1939	1250 5,000-LS 500-N DA	McComb Bcstg. Corp. P. O. Box 111 37	LBS Miss. Gene Grant	George Blumenstock & Robert Louis Sanders, Chief Owners George Blumenstock, Gen. & Coml. Mgr.	Julia D. Blumenstock, Prog. Dir. H. Emerson, Prom. Mgr. Robert Louis Sanders, Chief Engr. Associated Capitol AP Western Electric
MERIDIAN					
WCOC 1926	910 5,000-LS 1,000-N	Miss. Bcstg. Co. Inc. Threefoot Bldg. 7714	CBS Miss.	Withers Gavin, Pres. & Gen. Mgr.	Mrs. Withers Gavin, Prog. Dir. Standard UP
WMOX 1946	1240 250	Birney Imes Jr. WMOX Bldg. 2-0171	MBS, KBS Mid-South Sears & Ayer	Birney Imes Jr., Pres. Paul Mowery, Sta. Mgr. Bob McRaney, Gen. Mgr.	Joseph W. Carson, Coml. Mgr. Hal Kirby, Prog. Dir. Al Betmarik, Chief Engr. AP RCA
WMOX-FM 1948	Ch. 253 (B) 98.5mc 3kw				
WTOK 1946	1450 250	Meridian Bcstg. Co. Citizens Nat'l Bank Bldg. 3-1441	ABC Rebel Headley-Reed	Robert F. Wright, Pres. & Gen. Mgr. William B. Crooks, Coml. & Prom. Mgr.	Cecil Germany, Prog. Dir. Joe H. Saxon, Chief Engr. Lang-Worth INS Western Electric
NATCHEZ					
WMIS 1941	1240 250	Natchez Bcstg. Co. 615 Main St. 2800	NBC LBS Miss. Louisiana	P. K. Ewing, Pres. P. K. Ewing Jr., Gen. & Prom. Mgr.	Paul Schilling, Coml. Mgr. Wilna Nichols, Prog. Dir. George Wilson, Chief Engr. Capitol AP Gates
WNAT 1949	1450 250	Old South Bcstg. Co. Shields Lane		H. J. Jennings & M. T. Seale, Partners	H. J. Jennings, Gen. Mgr. Gale Hunt, Chief Engr. Standard UP General Electric
PASCAGOULA					
WPMP (CP)	1580 250-D	Crest Bcstg. Co. Inc. P. O. Box 348 496-W		William R. Guest Jr., Pres., Gen. & Coml. Mgr. T. T. Justice, V. P.	E. H. Craven, Coml. Mgr. Leon V. Hance, Chief Engr. Capitol INS Western Electric
PHILADELPHIA					
WHOC 1948	1490 250	William H. Cole P. O. Box 26 740	KBS	William H. Cole, Pres., Gen. & Coml. Mgr. James A. Sparks, Prog. Dir.	Sturle J. Parks, Prom. Mgr. F. H. Frantz, Chief Engr. World UP Collins
PICAYUNE					
WRJW 1949	1320 1,000-D	Moseley Bros. Ritz Theatre 510	Continental	W. L. & R. E. Moseley, Chief Owners Felix Adams Jr., Mgr.	W. L. Moseley, Gen. Mgr. Charles Tucker, Chief Engr. Capitol UP RCA
STARKVILLE					
WSSO 1948	1230 250	Starkville Bcstg. Co. Starkville 1230		Joe Phillips, Gen. & Coml. Mgr. Mrs. Eva Deen, Prog. Dir.	Travis Palmer, Chief Engr. Capitol AP Western Electric
TUPELO					
WELO 1944	1490 250	Tupelo Bcstg. Co. South Spring St. 1400	MBS, KBS Mid-South Sears & Ayer	Birney Imes Jr., Owner Bob McRaney, Gen. Mgr. Bob Evans, Sta. Mgr. Reeves Whirley, Coml. Mgr.	Gene Gratz, Prog. Dir. & Prom. Mgr. Leroy Green, Chief Engr. AP RCA

DA-N Directional Antenna, night only. FM's in italic.
DA-1 Directional Antenna, same pattern day and night.
DA-2 Directional Antenna, different pattern day and night.

*—Non-Commercial Station. D—Day. N—Night. ST—Share Time. SH—Specified Hours.
U—Unlimited. CP—Construction Permit Issued. LS—Local Sunset.
L—Limited Time with Dominant Station. SA—Special Authorization.

DIRECTORY OF AM, FM, and TV STATIONS OF THE UNITED STATES

*(Data corrected to December 6, 1949)
If executives or services for FM or TV stations are same as AM affiliate names are not repeated.*

MISSISSIPPI—(Continued)

City	Call Letters Established	Chan. or Freq. Power	Name of Licensee Headquarters Address Telephone Number	Network Representative	Executive Personnel	Transc. Library News Service Transmitter Make
VICKSBURG						
	WQBC 1931	1420 1,000-LS 500-N	Delta Bcstg. Co. Inc. Hotel Vicksburg 312	MBS, KBS Sears & Ayer	L. P. Cashman, Pres. Mary Van Cashman, Gen. Mgr. L. L. Miller, Coml. Mgr.	Charlotte Kahn, Prog. Dir. C. E. Drake, Chief Engr. World AP
	WVIM 1948	1490 250	Radio Mississippi Inc. Carroll Hotel 1920		James T. Ownby, Pres. & Gen. Mgr. Thomas Duke, Coml. Mgr.	Mrs. Genevive Johnson, Prog. Dir. Skipper Keith, Chief Engr. Lang-Worth AP Gates
WEST POINT						
	WROB 1947	1450 250	Bob McRaney Sr. Forest St. 807	MBS, KBS Mid-South Sears-Ayer	Bob McRaney Sr., Owner & Gen. Mgr. Ed McRaney, Sales Mgr. John E. King Jr., Prog. Dir. & Chief Engr.	Hugh Shankle, Prom. Mgr. Western Electric
YAZOO CITY						
	WAZF 1947	1230 250	WAZF Inc. 321 S. Main St. 1300	Miss. LBS	Guy Corley, Pres. & Gen. Mgr. Robert A. Novack, Coml. Mgr.	Jack Allyn, Prog. Dir. Don Flinspach, Chief Engr. World AP Gates

MISSOURI

CAPE GIRARDEAU						
	KFVS 1925	960 1,000-LS 500-N DA	Hirsch Bcstg. Co. 324 Broadway 2104	MBS Pearson	Oscar C. Hirsch, Pres. & Chief Engr.	Ralph L. Hirsch, Gen. & Coml. Mgr. UP
	KFVS-FM 1948	Ch. 239 (B) 95.7mc 2.5kw				Western Electric
CARTHAGE						
	KDMO 1947	1490 250	Carthage Bcstg. Co. 1201 East Chestnut 2648	KBS	L. C. McKenney } Co-owners J. J. Daly } L. C. McKenney, Gen. Mgr. J. J. Daly, Coml. Mgr.	Lee Crocker, Prog. Dir Bob Young, Prom. Mgr. J. L. Langford, Chief Engr. Capitol AP Gates
CARUTHERSVILLE						
	(CP)	1370 1,000-D	Pemiscot Bcstrs., Inc.			
CHILLICOTHE						
	KCHI (CP)	1010 250-D	Cecil W. Roberts			
CLAYTON						
	*KFUO 1924	850 5,000-SH	The Lutheran Church— Missouri Synod 801 De Mun Ave. Delmar 3030		Rev. Herman H. Hohenstein, Gen. Mgr. Rev. Elmer J. Knoernschild, Prod. Mgr.	William C. Krato, Bus. Mgr. Albert H. Wiese, Chief Engr. World UP Western Electric
	KFUO-FM 1948	Ch. 281 (B) 104.1mc 58.19kw				
COLUMBIA						
	KFRU 1926	1400 250	KRFU Inc. 13 S. 8th St. 4141	ABC Blair	H. J. Waters Jr., Pres. Mahlon Aldridge Jr., Gen. & Prom. Mgr. Felix J. LeGrand, Dir. of Sales	Harold Douglas, Prog. Dir. Robert Haigh, Chief Engr. Lang-Worth AP RCA
	KUMO (CP)	950 1,000 DA-1	Boone County Bcstg. Co. Inc. Uptown Theatre Bldg.		Jack R. Adams, Pres.	Gates
CONCORDIA						
	KFRM	(See Kansas City listing)				
FARMINGTON						
	KREI 1947	1350 1,000-D	Cecil W. Roberts P. O. Box 270 710	KBS	Cecil W. Roberts, Owner (Mrs.) Mary Burton, Mgr.	Howard G. Rion, Adv. Mgr. Kermit Barker, Chief Engr. Lang-Worth UP Gates
	KREI-FM 1949	Ch. 261 (A) 100.1mc 0.3kw				Raytheon
FESTUS						
	KJCF (CP)	1010 250-D	Jefferson County Radio & Television Co.			
FLAT RIVER						
	KFMO 1947	1240 250	Lead Belt Bcstg. Corp. Flat River 1000	Pearson	Oscar C. Hirsch, Pres. & Chief Engr. Virginia Collins, Prog. Dir.	James F. Collins, Gen., Prom. & Coml. Mgr. UP Collins
HANNIBAL						
	KHMO 1941	1070 5,000-LS DA-2 1,000-N	Courier-Post Pub. Co. 102½ S. Main St. 3450	MBS Pearson	E. L. Sparks, Pres. Wayne W. Cribb, Gen. & Coml. Mgr.	Gene Hoenes, Prog. Dir. & Prom. Mgr. Ben Parrish, Chief Engr. Lang-Worth AP Western Electric

DA-N Directional Antenna, night only. FM's in italic.
DA-1 Directional Antenna, same pattern day and night.
DA-2 Directional Antenna, different pattern day and night.

*—Non-Commercial Station. D—Day. N—Night. ST—Share Time. SH—Specified Hours.
U—Unlimited. CP—Construction Permit Issued. LS—Local Sunset.
L—Limited Time with Dominant Station. SA—Special Authorization.

City Call Letters Established	Chan. or Freq. Power	Name of Licensee Headquarters Address Telephone Number	Network Representative	Executive Personnel	Transc. Library News Service Transmitter Make
INDEPENDENCE					
KIMO 1947	1510 1,000-D	The Blue Valley Co. 310 N. Osage Clifton 9815	Cooke	Craig Siegfried, Gen. Mgr. F. E. Fowler, Bus. Mgr.	J. W. Waddell, Prog. Dir. Eldon Ryan, Chief Engr. Capitol AP Gates
JEFFERSON CITY					
KFAL (CP) 1937	900 250-D 1240 250	Missouri Central Bcstrs. Capital Bcstg. Co. 210 Monroe St. 4000	MBS Sears & Ayer	R. C. Goshorn, Pres. Catherine Roer, Gen. Coml. & Prom. Mgr. & Prog. Dir.	Leroy S. Hackmann, Chief Engr. Lang-Worth AP Collins
KWOS-FM 1948	Ch. 253 (B) 98.5mc 9.2kw				
JOPLIN					
KFSB 1948	1310 5,000-LS 1,000-N DA-2	Four States Bcstrs. Inc. 1025 Main 1310	Walker	Harry Easley, Pres. W. H. Clark, Gen. Mgr.	Ed Johnson, Prog. Dir. Ralph Meador, Chief Engr. Lang-Worth Standard UP Gates
KSWM 1948	1230 250	Air Time Inc. 1928 W. 13th St. 7280	CBS Rambeau	Austin A. Harrison, Pres., Gen. & Coml. Mgr. & Chief Engr.	Noel Ball, Prog. Dir. World UP Gates
WMBH 1925	1450 250	Joplin Bcstg. Co. Frisco Bldg. 330	MBS Sears & Ayer	D. J. Poynor, Pres. & Gen. & Coml. Mgr. (Mrs.) Martha Smith, Prog. Dir.	Everett L. Dodge, Chief Engr. Lang-Worth AP Collins
WMBH-FM 1946	Ch. 241 (B) 96.1mc 70kw			 Federal
KANSAS CITY					
KCKN 1925	1340 250	KCKN Bcstg. Co. Inc. 300 Walthow Bldg. Victor 3864	Capper	W. A. Bailey, Pres. Ben Ludy, Gen. Mgr. Joe Story, Mgr.	George Stump, Prog. Dir. Max Williams, Chief Engr. Standard Lang-Worth AP, UP RCA
KCKN-FM 1946	Ch. 294 (B) 106.7mc 20kw				
KCMO 1936	810 50,000-LS 10,000-N DA	KCMO Bcstg. Co. 1515 Commerce Bldg. Baltimore 1234	ABC Pearson	Tom L. Evans, Pres. E. K. Hartenbower, Gen. & Sales Mgr. C. E. Breazeal, Asst. Mgr.	S. B. Tremble, Prog. Dir. F. C. Strawn, Prom. Mgr. Karl Troeglen, Tech. Dir. Thesaurus AP, UP RCA
KCMO-FM 1948	Ch. 235 (B) 94.9mc 54kw				World
KFRM (Concordia) 1947	550 5,000-D DA	Midland Bcstg. Co. Pickwick Hotel Harrison 2650	Free & Peters	Arthur B. Church, Pres. Karl Koerper, V. P. & Mngng. Dir. Sam H. Bennett, V. P. in Charge of Sales	Roderick Cupp, Prog. Dir. John S. McDermott, Prom. Mgr. A. R. Moler, Chief Engr. World AP, UP RCA
KMBC 1921	980 5,000 DA-N	Midland Bcstg. Co. Pickwick Hotel Harrison 2650	CBS Free & Peters	Arthur B. Church, Pres. Karl Koerper, V. P. & Mngng. Dir. Sam H. Bennett, V. P. in Charge of Sales	Roderick Cupp, Prog. Dir. John S. McDermott, Prom. Mgr. A. R. Moler, Chief Engr. World AP, UP Western Electric

DA-N Directional Antenna, night only. FM's in italic. *—Non-Commercial Station D—Day, N—Night, ST—Share Time. SH—Specified Hours. DA-1 Directional Antenna, same pattern day and night. U—Unlimited. CP—Construction Permit Issued. LS—Local Sunset. DA-2 Directional Antenna, different pattern day and night. L—Limited Time with Dominant Station. SA—Special Authorization.

ARE YOU SELLING IN HANNIBALAND?

(38 counties surrounding Hannibal, Quincy and Keokuk)

...and brother, if you are,
you know that what is spent ain't hay!

No sir, because most of the people in Hannibal land live in the rich rural areas surrounding Hannibal, Quincy and Keokuk. (Population of Hannibal land is 61% rural and 39% urban.) These are the people who have most of the money and who spend the most. These are the people who listen most to KHMO.

So mister, if you want to sell in this large, rich area—you'll get an extra plus and results with KHMO. For the right pitch at this market see your nearest Pearson office or write KHMO, Hannibal, Mo.

K H M O 1070 kc.

MUTUAL NETWORK
5000 Watts
1000 at night

Representative John E. Pearson Co.

Wayne Cribb, General Manager, Hannibal, Mo.

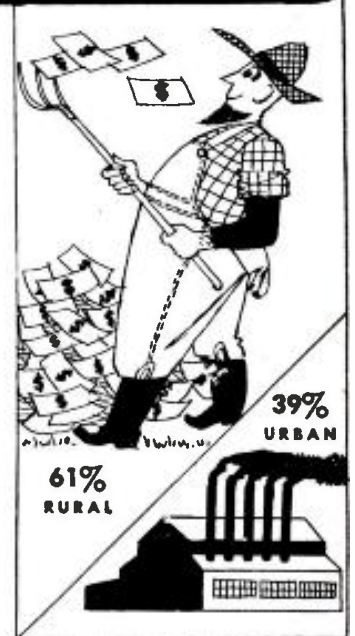

Complete Coverage of Kansas by the KMBC

Even with 500,000 watts power KMBC could not cover the vast Kansas City Primary Trade area, but KMBC at Kansas City, teamed with KFRM in North Central Kansas can do the job!

Since KFRM went on the air December 7, 1947, hundreds of thousands of rural and small town dwellers comprise the population of the Western portion of Kansas City's huge trade territory, and have learned to depend on The KMBC-KFRM Team as their only source of vital information

and cultural and entertainment programs direct from their trade capital.

The 1949 Kansas City Primary Trade Area Radio survey, made at the Missouri and Kansas State Fairs, and at the American Royal in Kansas City, includes a total of 2,122 interviews from The Team area (duplication eliminated).

All mentions from each of the 163 counties within The Team's half-millivolt contours were weighted to give each county its true relative importance according to the number of its radio families.

How The KMBC-KFRM Team ranked with other leading stations in this independent survey is graphically illustrated below:

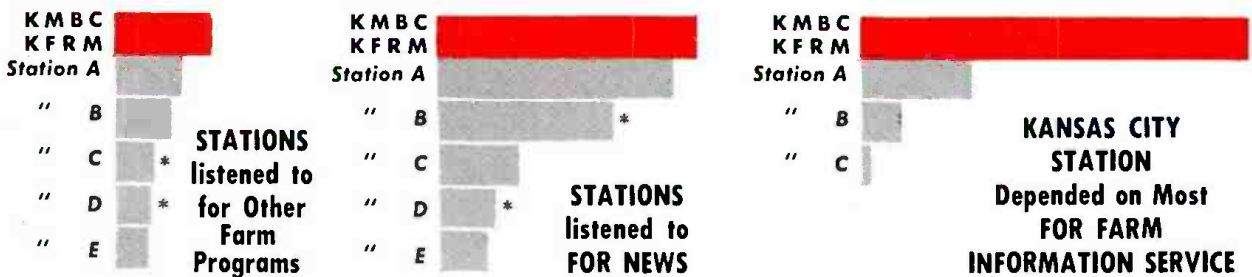

* Other Kansas City Stations



KMBC

of Kansas City
6th Oldest CBS Affiliate

City's VAST TRADE AREA... KFRM Team!

The Kansas City Primary Trade Area Radio Survey's total of 2,122 interviews included 1,548 from persons living on farms, and 574 from those living in towns. The majority of the latter were from towns under 2,500 population.

One hundred sixty-three counties, all within The KMBC-KFRM Team's half-millivolt contour, as illustrated on the map below, included 37 in Missouri, 103 in Kansas, and the remaining 23 in adjoining states.

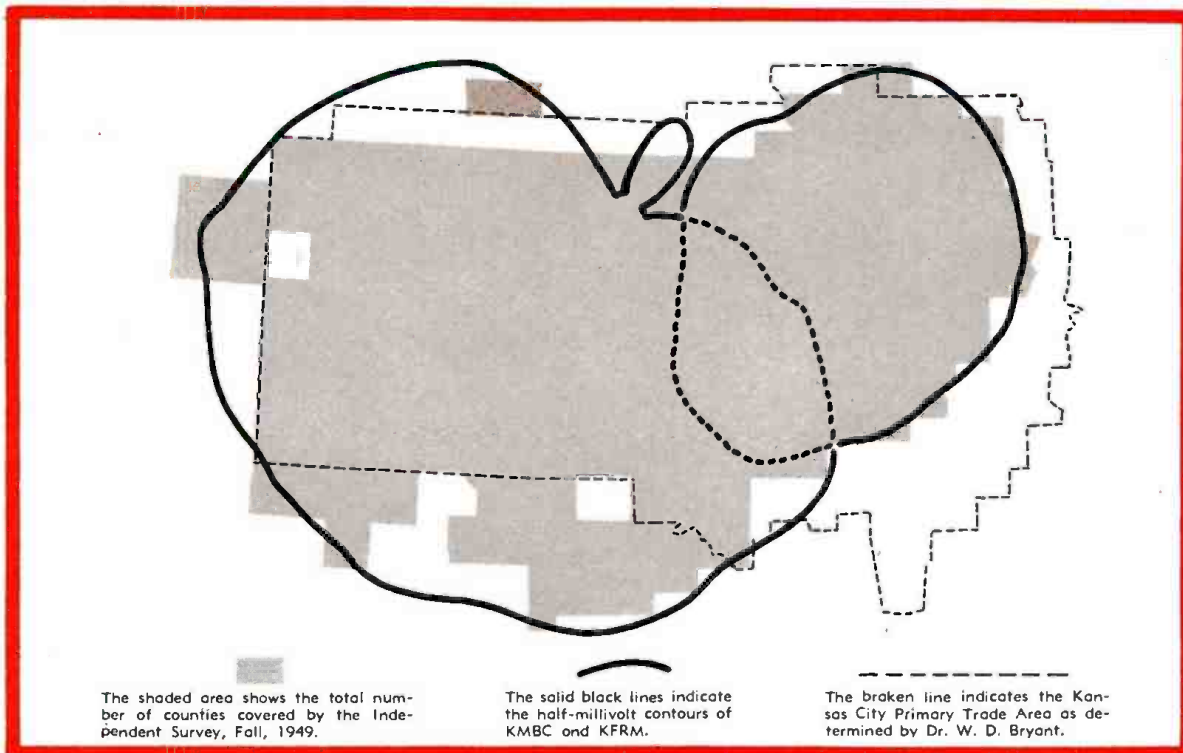

Only The KMBC-KFRM Team delivers complete coverage of the great Kansas City Primary Trade area, and provides radio coverage to over Four Million potential listeners. Latest population figures reveal 1,159,740 radio families living within The Team's half-millivolt contours, as

illustrated above.

Smart advertisers know the great potential sales in this rich agricultural Heart of America! Providing them most effective coverage and top listener loyalty, the most economical and the best buy, is The KMBC-KFRM Team!

KFRM

The Kansas Farm Station
Programmed from Kansas City

DIRECTORY OF AM, FM, and TV STATIONS OF THE UNITED STATES

(Data corrected to December 6, 1949)
If executives or services for FM or TV stations are same as AM affiliate names are not repeated.

MISSOURI—(Continued)

City Call Letters Established	Chan. or Freq. Power	Name of Licensee Headquarters Address Telephone Number	Network Representative	Executive Personnel	Transc. Library News Service Transmitter Make
KANSAS CITY (Continued)					
KOZY (FM) 1942	Ch. 251 (B) 98.1mc 9.7kw	Commercial Radio Equipment Co. Porter Bldg. Logan 8821		Everett L. Dillard, Gen. Mgr. Robert F. Woifskill, Bus. Mgr.	
WDAF 1922	610 5,000	The Kansas City Star Co. 1729 Grand Ave. Harrison 1200	NBC Petry	Roy A. Roberts, Pres. Dean Fitzer, Gen. Mgr. E. Manne Russo, Coml. Mgr. Harry J. Kaufmann, Prog. Dir.	V. S. Batton, Prom. & Asst. Gen. Mgr. J. A. Flaherty, Chief Engr.
WDAF-TV 1949	Ch. 4 66-72mc 11kw aur.; 22kw vis.		ABC, NBC, CBS DuMont	William Bates, Prog. Dir.	Flamingo RCA
WHB 1922	710 10,000-LS 5,000-N DA-2	WHB Bcstg. Co. Scarritt Bldg. Harrison 1161	MBS Blair	Donald D. Davis, Pres. & Coml. Mgr. John T. Schilling, V. P. & Gen. Mgr. Dick Smith, Prog. Dir.	Mori Greiner, Prom. Mgr. Henry Goldenberg, Chief Engr.
WHB-FM 1948	Ch. 271 (B) 102.1mc 6.1kw				Lang-Worth Associated AP RCA
KENNETT					
KBOA 1947	830 1,000-D	Kennett Bcstg. Corp. Kennett 830		Paul C. Jones, Gen. Mgr. William H. Cate, Sta. & Prom. Mgr.	John T. Reeder, Prog. Dir. Robert H. Conner, Chief Engr.
KBOA-FM 1948	Ch. 255 (B) 98.9mc 6.9kw			Chas. Harrison, Prog. Dir.	SESAC, Capitol Standard AP Gates
KIRKSVILLE					
KIRX 1947	1450 250	North Missouri Bcstg. Co. KIRX Bldg. 86	Sears & Ayer	Sam A. Burk, Pres. & Gen. Mgr. John O. Conwell, Coml. Mgr.	Lee Jones, Prog. Dir. Frederick Sheehan, Chief Engr.
LEBANON					
KLWT 1948	1230 250	Lebanon Bcstg. Co. Inc. 221 E. Commercial St. 1015	MBS	Robert C. Fields, Pres. O. R. Wright, Gen. Mgr.	Tom Miller, Prog. Dir. E. L. Hendry, Chief Engr.
MARSHALL					
KMMO 1949	1300 500-D CP: 100-N	Missouri Valley Bcstg. Co. 74 W. Morgan St. 2328		Harold T. Fisher } Co-owners Carl T. Fisher, Gen. Mgr. Harold T. Fisher, Coml. Mgr.	Roderick D. Renick, Prog. Dir. Casey Strong, Prom. Mgr. Charles P. Porter, Chief Engr.
MEXICO					
KXEO 1948	1340 250	Audrain Bcstg. Corp. Highway 54 East 2340	MBS	P. H. Cunningham, Gen. & Coml. Mgr. Richard Carson, Prog. Dir.	Bill Osborne, Prom. Mgr. Al Korabek, Chief Engr.
NEVADA					
KNEM 1949	1240 250	Cecil W. Roberts Farmington 710		Cecil W. Roberts, Pres. William R. Tedrick, Mgr.	Robert R. Stoner, Coml. Mgr. (Mrs.) Audrey Tedrick, Prog. Dir.
POPLAR BLUFF					
KWOC 1938	1340 250	A. L. McCarthy—John Wolpers KWOC Bldg. 3922	MBS, KBS Pearson	A. L. McCarthy, Pres. Byron Kearbey Jr., Sta. Mgr. C. O. Gray Jr., Coml. Mgr.	Ronald Kaiser, Prog. Dir. Don Lidenton, Chief Engr.
KWOC-FM 1948	Ch. 233 (B) 94.5mc 16kw				UP Gates
ROLLA					
KTRR 1947	1490 250	"Show-Me" Bcstg. Co. Soest Rd. 380	KBS	Luther W. Martin, Pres. & Gen. Mgr. Wilson C. Burkhead, Prog. Dir.	Martin M. Mitchum, Chief Engr.
SEDALIA					
KDRO 1939	1490 250	Milton J. Hinlein 2100 W. Broadway 4004	MBS, KBS Forjoe	Milton J. Hinlein, Pres. & Prom. Mgr. Herbert W. Brandes, Gen. Mgr. & Prog. Dir.	James F. Glenn, Coml. Mgr. Leman E. Jones, Chief Engr.
KDRO-FM 1949	Ch. 259 (B) 99.7mc 15kw				UP RCA
SIKESTON					
KSIM 1948	1400 250	Sikeston Community Bcstg. Co. Inc. Highway 60W. 1		L. R. Bowman Jr., Pres. H. C. Young, Gen. & Coml. Mgr.	R. L. Watkins Jr., Prog. Dir. Ralph Hirsch, Chief Engr.
STE. GENEVIEVE					
KSGM 1947	1450 250	Donze Enterprises Inc. 245 Merchant St. 580	KBS	Elmer L. Donze, Pres. & Gen. Mgr. Norbert B. Donze, Coml. & Mgr.	Donald M. Donze, Prom. Mgr. C. M. Poindexter, Prog. Dir. M. L. Rose, Chief Engr.
KSGM-FM 1948	Ch. 289 (B) 105.7mc. 2.9kw				Lang-Worth UP Gates
ST. JOSEPH					
KFEQ 1926	680 5,000 DA-2	KFEQ Inc. KFEQ Bldg. 4-0813	MBS Headley-Reed	Barton Pitts, Gen. Mgr. Glenn G. Griswold, Coml. Mgr. R. Thompson Mable, Prog. Dir.	J. Ted Branson, Prom. Mgr. J. Wesley Koch, Chief Engr.
KFEQ-FM 1948	Ch. 222 (B) 92.3mc 63kw				UP Collins
KRES 1946	1230 250	Missouri Valley Bcstg. Corp. 113 South 7th St. 4-6346	Rambeau	Basil L. Kaufman, Pres. Ken Goodding, Gen., Coml. & Prom. Mgr.	Allen Menefee, Prog. Dir. Charles Wiesemann, Chief Engr.

DA-N Directional Antenna, night only. FM's in italic. *—Non-Commercial Station. D—Day. N—Night. ST—Share Time. SH—Specified Hours. DA-1 Directional Antenna, same pattern day and night. U—Unlimited. CP—Construction Permit Issued. LS—Local Sunset. DA-2 Directional Antenna, different pattern day and night. L—Limited Time with Dominant Station. SA—Special Authorization.

RIGHT down the middle!



Radio and/or Television...

WDAF • WDAF-TV

sell the rich Kansas City market

OWNED AND OPERATED BY THE KANSAS CITY STAR COMPANY

Represented Nationally by EDWARD PETRY & COMPANY

DIRECTORY OF AM, FM, and TV STATIONS OF THE UNITED STATES

(Data corrected to December 6, 1949)
 If executives or services for FM or TV stations are same as AM affiliate names are not repeated.

MISSOURI—(Continued)

City Call Letters Established	Chan. or Freq. Power	Name of Licensee Headquarters Address Telephone Number	Network Representative	Executive Personnel	Transc. Library News Service Transmitter Make	
ST. LOUIS						
KMOX 1925	1120 50,000	Columbia Bcstg. System 401 South 12th St. Central 8240	CBS Radio Sales	Frank Stanton, (CBS) Pres. Erwin H. Shomo, Gen. Mgr. C. Gilman Johnston, Nat'l. Sales Mgr.	T. A. Bland, Prog. Dir. Warren M. Middleton, Prom. Mgr. Harry Harvey, Chief Engr.	Associated AP, UP Westinghouse
KSD 1922	550 5,000 DA-N	Pulitzer Pub. Co. 1111 Olive St. Main 1111	NBC Free & Peters	Joseph Pulitzer, Pres. George M. Burbach, Gen. Mgr. Edward Hamlin, Coml. Mgr.	Harold O. Grams, Prog. Dir. David Pasternak, Prom. Mgr. Pete Yarger, Chief Engr.	World Thesaurus AP RCA
KSD-TV 1947	Ch. 5 76-82mc 8.4kw aur.; 17.1kw vis.		ABC, NBC, CBS DuMont		Edwin Risk, Chief Engr.	
KSTL 1948	690 1,000-D	Radio St. Louis Inc. 6 N. 7th St. Main 0600	IMS	Frank E. Pellegrin, Pres. R. L. Stuffebam, Gen. Mgr. W. A. Knight, Coml. Mgr.	Edward M. Galloway, Prog. Dir. J. H. Fleet, Chief Engr.	Standard UP Raytheon
KWK 1927	1380 5,000 DA-N	Thomas Patrick Inc. 12th & Cole Sts. Main 9100	MBS Katz	Robert T. Convey, Pres. & Gen. Mgr. Ray E. Dady, V. P. & Sta. Dir. V. E. Carmichael, V. P. & Sales Dir.	John W. Tinnea, Asst. Sta. & Prog. Dir. John Traxler, Prod. Mgr. Nick J. Zehr, Chief Engr. AP Western Electric
KWK-FM 1946	Ch. 251 (B) 99.1mc 40kw				 General Electric
KXLW 1947	1320 1,000-D	St. Louis County Bcstg. Co. 8135 Forsythe Blvd. Delmar 1320	Forjoe	Lee J. Sloan, Pres. S. E. Sloan, Gen. Mgr. Myles J. McNally, Coml. Mgr.	Pat O. Bradley, Prog. Dir. Leslie P. Ware, Sta. Dir. Wallace E. St. Vrain, Chief Engr.	Lang-Worth UP Gates
KXLW-FM 1948	Ch. 266 (B) 101.1mc 11.5kw					

DA-N Directional Antenna, night only. FM's in italic. *—Non-Commercial Station. D—Day. N—Night. ST—Share Time. SH—Specified Hours.
 DA-1 Directional Antenna, same pattern day and night. U—Unlimited. CP—Construction Permit Issued. LS—Local Sunset.
 DA-2 Directional Antenna, different pattern day and night. L—Limited Time with Dominant Station. SA—Special Authorization.

Don't Overlook The New WIL!

Regardless of what yardstick you use . . . low cost per listener or results, the new WIL gives you both.

The new WIL is St. Louis' No. 1 independent station, more powerful than all other independents combined . . . now equally as powerful as any St. Louis network station except one.

See us or our representative for the full facts on the new WIL.

5000 WATTS
HOTEL CHASE—SAINT LOUIS
 Represented by Rambeau

WIL

Here Is the **LARGEST** Daytime Half-Millivolt Coverage Area of Any Radio Station in **ST. LOUIS**



Copyright: Hagstrom Company, Inc., New York, 1990

NBC PROGRAMS
AP NEWS
NATIONAL ADVERTISING REPRESENTATIVE:
FREE & PETERS, INC.
TELEVISION AFFILIATION:
KSD-TV
CHANNEL NO. 5 FIRST IN ST. LOUIS

IT'S THE **NEW DAYTIME**
HALF-MILLIVOLT COVERAGE AREA OF

KSD

THE ST. LOUIS POST-DISPATCH STATION

5000 WATTS ON 550 KC

DIRECTORY OF AM, FM, and TV STATIONS OF THE UNITED STATES

(Data corrected to December 6, 1949)
If executives or services for FM or TV stations are same as AM affiliate names are not repeated.

MISSOURI—(Continued)

City Call Letters Established	Chan. or Freq. Power	Name of Licensee Headquarters Address Telephone Number	Network Representative	Executive Personnel	Transc. Library News Service Transmitter Make	
ST. LOUIS—(Continued)						
KXOK 1938	630 5,000 DA-2	Star-Times Pub. Co. 12th & Delmar Sts. Chestnut 3700	ABC Blair	Elzey Roberts, Pres. C. L. Thomas, Gen. Mgr. V. N. Springgate, Coml. Mgr. Harry K. Renfro, Asst. Gen. Mgr.	Elmer G. Muschany, Prog. Dir. Foster H. Brown, Prom. Mgr. Arthur F. Rekart, Chief Engr.	Associated Standard AF, UP Western Electric World RCA
KXOK-FM 1947	Ch. 229 (B) 93.7mc 16kw		Transit			RCA
WEW 1921	770 1,000-D	The St. Louis University 3642 Lindell Blvd. Franklin 5665	Pearson	Very Rev. Paul C. Reinert, Pres. St. Louis U. Nicholas Pagliara, Gen. Mgr.	Leonard Frankel, Coml. Mgr. Don Lochner, Prog. Dir. Joseph A. Volk, Chief Engr.	World, Standard Lang-Worth INS RCA
WEW-FM 1947	Ch. 236 (B) 95.1mc 68.8kw					Federal
WIL 1922	1430 5,000 DA-2	Missouri Bcstg. Corp. Hotel Chase Rosedale 6200	Rambeau	L. A. Benson, Pres. & Gen. Mgr. Robert M. Hetherington, Coml. Mgr. Vern King, Prog. Dir.	Mel Kampe, Prom. Mgr. Edward Goodberlet, Chief Engr.	Standard Lang-Worth AP Gates
SPRINGFIELD						
KGBX 1926	1260 5,000 DA-N	Springfield Bcstg. Co. 605 Boonville Ave. 3-3200	NBC Hollingbery	Tams Bixby Jr., Pres. J. Gordon Wardell, Gen. Mgr. Carl Fox, Prog. Dir.	Dudley Morris, Prom. Mgr. Dennis White, Chief Engr.	Thesaurus AP
KICK 1949	1340 250	Kickapoo Prairie Bcstg. Co. Inc. 610 College St. 4-1581	MBS McGillvra	Floyd W. Jones, Pres. Charles E. Seiferd, V. P. & Gen. Mgr.	Betty Cole, Traffic Mgr. Lee E. Baker, Chief Engr.	Standard UP Gates
KTTS 1942	1400 250	Independent Bcstg. Co. Walnut & Jefferson Sts. 4303	CBS Sears & Ayers	J. H. G. Cooper, Pres. G. Pearson Ward, Gen. & Prom. Mgr.	Bob Burke, Coml. Mgr. Wendell Smith, Prog. Dir. William Curry, Chief Engr.	World AP RCA
KTTS-FM 1948	Ch. 234 (B) 94.7mc 11kw					
KWTO 1933	560 5,000-LS 1,000-N DA	KWTO Inc. 606 St. Louis St. 3-2800	ABC Pearson	Ralph Foster, Pres. & Gen. Mgr. C. Arthur Johnson, V. P. Leslie L. Kennon, Asst. Gen. Mgr. Ray Keltner, City Sales Mgr.	Bill Ring, Prog. Dir. Jean Lightfoot Kappell, Prom. Mgr. Fritz Bauer, Chief Engr.	Lang-Worth UP
WARRENTON						
KWRE 1949	730 250-D	W. T. Zimmerman Warrentown 3701		W. T. Zimmerman, Pres. & Gen. Mgr. Wally Richter, Coml. Mgr.	Norb Moore, Prog. Dir. Calvin Morris, Chief Engr.	Thesaurus UP Gates
WEST PLAINS						
KWPM 1947	1450 250	Robert Neathery E. Abe Taylor Blvd. 700	KBS	Robert Neathery, Pres. & Chief Engr.	Fritz Williams Dixon, Coml. Mgr. John Billingsley, Prog. Dir.	Standard AP Gates

MONTANA

ANACONDA						
KANA 1946	1230 250	Mosby's Inc. Anaconda 136		A. J. Mosby, Pres. T. K. Ryan, Coml. Mgr.	T. L. Frayling, Prog. Dir. & Chief Engr.	Lang-Worth UP Raytheon
BILLINGS						
KBMY 1946	1240 250	Billings Bcstg. Co. Box 2124 3838	MBS Intermountain Avery-Knodel	Don C. Foote, Pres. Franz J. Robischon, Gen. Mgr. Kenneth Nybo, Coml. Mgr.	Charles G. du Bois, Prog. Dir. Theodore A. Hildebrand, Chief Engr.	Lang-Worth AP Gates
KGHL 1928	790 5,000 DA-N	Northwestern Auto Supply Co. Inc. 422 North Broadway 2222	NBC Katz	C. O. Campbell, Pres. E. M. Yocum, Gen. & Coml. Mgr.	V. Braunberger, Prog. Dir. & Prom. Mgr. Jeff Kilchil, Chief Engr.	UP RCA
KOOK (CP)	970 5,000 DA-N	The Montana Network 124 N. 27th St. 6990		C. L. Crist, Pres. K. O. MacPherson, Gen. Mgr. J. Carter Johnson, V. P.	Grant Wrathall, Chief Engr.	
BOZEMAN						
KBMN (CP)	1230 250	Penn Engr. Co.				
KXLQ 1939	1450 250	KRBM Bcstrs. Inc. Bozeman 1420	NBC Z Bar Walker Pacific North- west	E. B. Craney, Pres. Ernest A. Neath, Gen. Mgr. J. Ray Bridges, Coml. Mgr.	Homer Stenersen, Prog. Dir. Ronald Bell, Prom. Mgr. Duane Parker, Chief Engr.	UP RCA
BUTTE						
KBOW 1947	1490 250	Copper City Radio Co. 720 Yale Ave. 7429	CBS Cooke	Frank Reardon, Pres. & Gen. Mgr. Don Anderegg, Mgr.	Margaret Moran, Traffic Mgr.	UP
KOPR 1948	550 1,000 DA-N	Cooper Bcstg. Co. Inc. Hotel Finlen 6546	ABC Intermountain Hollingbery	Frank C. Carman, Pres. Ed Cooney, Gen. & Nat'l. Sales Mgr.	Bill Plummer, Prog. Dir. James Skidmore, Chief Engr.	World UP Gates
KXLF 1929	1370 5,000	KGIR Inc. Box 1956 2-2344	NBC Z Bar Pacific North- west Walker	E. B. Craney, Pres. Arne E. Anzjon, Gen. & Coml. Mgr.	Al Plachta, Prog. Dir. George Weber, Prom. Mgr. W. J. Provis, Chief Engr.	MacGregor UP Hilliard
KYES	610 1,000 DA-N	Treasure State Bcstg. Co.				
GLENDIVA						
KXGN 1948	1400 250	Lewis Wiles Moore S. Pearson Ave. 122		Lewis Wiles Moore, Owner Gordon Hutton, Gen. Mgr. Frank Clements, Coml. Mgr.	Prudence Ertresvaag, Prog. Dir. Donald Powers, Chief Engr.	Capitol UP Collins
GREAT FALLS						
KFBB 1922	1310 5,000 DA-N	Buttrej Bcstg. Inc. Great Falls 4377	CBS Weed	Fred Birch, Pres. J. P. Wilkins, Gen. & Coml. Mgr.	W. J. Towner, Prog. Dir. Wilbur Myhre, Chief Engr.	World UP Western Electric
KMON 1948	560 5,000 DA-N	Montana Farmer Bcstg. Corp. Tribune Bldg. 4382	ABC Intermountain Avery-Knodel	Robert H. Warner, Gen. Mgr. Frank W. Kaull, Coml. Mgr.	Jon D. Duffy, Prog. Dir.	Thesaurus RCA

DA-N Directional Antenna, night only. FM's in italic.
DA-1 Directional Antenna, same pattern day and night.
DA-2 Directional Antenna, different pattern day and night.

*—Non-Commercial Station. D—Day. N—Night. ST—Share Time. SH—Specified Hours.
U—Unlimited. CP—Construction Permit Issued. LS—Local Sunset.
L—Limited Time with Dominant Station. SA—Special Authorization.

influence buyers

in the rich

St. Louis market

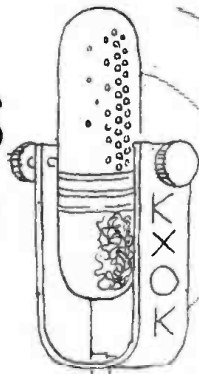

at home

Dollar for Dollar—Hooper for Hooper—KXOK consistently influences buying in the St. Louis market at the lowest-cost-per-thousand of any BIG station. B. M. B.* credits KXOK with legions of listeners in 115 counties in six states, daytime; 98 counties in 4 states, nighttime . . . tangible proof of listener allegiance to KXOK. Buy RESULTS! Buy KXOK! Write, wire, phone for availabilities today!

(*1946 study)

and in transit

Don't miss the bus on KXOK-FM "Transit Radio." "Transit Radio" in St. Louis, is GROWN UP . . . 1,000 transit vehicles are equipped with the finest FM receivers obtainable serving over 1,000,000 rides per day—35,000,000 rides per month. Coverage of this great "going-to-buy" audience is guaranteed by KXOK-FM "Transit Radio" . . . the new, exciting radio medium that sells riders "on-their-way-to-buy." Only "Transit Radio" influences buyers in your favor immediately preceding the actual sale. Act Now! Write, wire, phone for availabilities today!



St. Louis' Transit Radio Station,
93.7 mc, 16,000 watts radiated.
Represented by Transit Radio, Inc.



St. Louis' A. B. C. Station,
630 kc, 5,000 watts, fulltime.
Represented by John Blair & Company.

Owned and Operated by the St. Louis Star-Times

12th and Delmar, St. Louis 1, Mo., Chestnut 3700

DIRECTORY OF AM, FM, and TV STATIONS OF THE UNITED STATES

*(Data corrected to December 6, 1949)
If executives or services for FM or TV stations are same as AM affiliate names are not repeated.*

MONTANA—(Continued)

City Call Letters Established	Chan. or Freq. Power	Name of Licensee Headquarters Address Telephone Number	Network Representative	Executive Personnel	Transc. Library News Service Transmitter Make	
GREAT FALLS—(Continued)						
KXLK 1947	1400 250	Great Falls Bcstg. Co. Park Hotel 2-2453	NBC Z Bar Walker Pacific North- west	J. R. Larcombe, Pres. Paul Hatton, Gen. Mgr.	Eugene R. Kukkola, Chief Engr. UP Gates	
HAVRE KAVR 1946	1240 250	KAVR Inc. Box 672 1240	KBS	Jessica L. Longston, Pres. Jim Hamstreet, Gen. Mgr. John Derrick, Coml. Mgr.	Jean MacLean, Prog. Dir. Jay Barnes, Prom. Mgr. Tad Jones, Chief Engr.	World UP Raytheon
KOJM 1947	730 1,000-D	North Montana Bcstg. Co. P. O. Box 70 1096	Friedenberg Griffith	Dr. Francis W. Aubin, Pres. Larry Gordon, Gen. Mgr. & Prog. Dir.	Charlotte Brader, Coml. Mgr. George H. Bauer, Chief Engr.	Associated Standard UP Western Electric
HELENA KFDW 1949	1340 250	Lewis & Clark Bcstg. Corp. P. O. Box 592 4030		Hon. Lee Metcalf, Pres. George E. Wenstrom, Gen. Mgr. James Crabbe, Coml. Mgr.	Frank Russell, Prog. Dir. Archer Taylor, Chief Engr.	Capitol Associated UP Western Electric
KXLJ 1937	1240 250	Peoples Forum of the Air Inc. 1306 11th Ave. 1240	NBC Z Bar Walker Pacific North- west	Barclay Craighead, Gen. Mgr. Gene Hogan, Prog. Dir.	Ed Goodneau, Chief Engr.	UP RCA
KALISPELL KGEZ 1927	1340 250	Donald C. Treloar 7 Main St. 331		Donald C. Treloar, Pres. Maurice J. Driscoll, Gen. & Coml. Mgr.	Mike McHenry, Prog. Dir. William Patterson, Chief Engr.	World AP Collins
LEWISTOWN KXLO 1947	1230 250	Montana Bcstg. Co. P. O. Box 620 1210	KBS	W. G. Kelly, Pres., Gen. & Coml. Mgr.	Bill Browning, Prog. Dir. Ben Rush, Chief Engr.	World AP Western Electric
LIVINGSTON KPRK 1946	1340 250	Yellowstone Amusement Co. P. O. Box 952 1000	KBS	Paul B. McAdam, Pres. & Gen. Mgr. Jim Duncan, Prog. Dir.	Jack Hinman, Coml. & Prom. Mgr. Norman Penwell, Chief Engr.	SESAC, World UP Gates
MILES CITY KRJF 1941	1340 250	Star Printing Co. 13 N. 6th St. 60	MBS Intermountain Avery-Knodel	Ernest Immel Gen. Mgr. Norm Engstrom, Sta. Mgr.	Jim Carson, Prog. Dir. C. L. Scofield Jr., Chief Engr.	World UP RCA
MISSOULA KGVO 1931	1290 5,000 DA-1	Mosby's Inc. 132 West Front 2155	CBS	A. J. Mosby, Pres. William Sinor, Coml. Mgr. Marion E. Dixon, Prom. Mgr. & Prog. Dir.	Clarence Touw, Chief Engr.	Lang-Worth UP RCA
KXLL 1948	1450 250	Western Montana Assoc. Box 1503 4114	NBC Z Bar Walker Pacific North- west	Pat M. Goodover, Pres. & Gen. Mgr. Frank X. Field, Coml. Mgr.	Ray Kelley, Prog. Dir. Loren Palmer, Prom. Mgr. Dave Green, Chief Engr.	UP RCA
SHELBY KTYT 1947	1230 250	Tri County Radio Corp. Shelby 560	KBS	John J. Hurley & Cedor Aranow, Owners Frank Krshka, Gen. Mgr. Lawrence Wing, Coml. Mgr.	George Potter, Prog. Dir. & Chief Engr. Richard Bannon, Prom. Mgr.	World UP Western Electric
SIDNEY KGCK 1926	1480 5,000 DA-1	E. E. Krebsbach 109 S. Cent. Ave. 408	MBS, KBS Great N'thrn	E. E. Krebsbach, Owner & Gen. Mgr. E. Clair Krebsbach, Coml. Mgr.	Jerry Kariton, Prog. Dir. Roland Dain, Prom. Mgr. Oscar Halvorson, Chief Engr.	Capitol UP RCA

NEBRASKA

ALLIANCE KCOW 1949	1400 250	Sandhills Bcstg. Corp. 1030 West Third St. 1300		Hansford Jagggers, Pres. Charles R. Billyue, Gen. Mgr. & Chief Engr.	Arnold E. Kuhn, Coml. Mgr.	Thesaurus SESAC UP Gates
BEATRICE KWBE 1949	1450 250	Blue Valley Bcstg. Co. Inc. 112½ N. 6th St. 1245		John Thorwald, Pres., Gen. & Coml. Mgr. & Treas. D. Lahodny, Asst. Coml. Mgr.	Paul Schupbach, Prog. Dir. C. H. Brugha, Prom. Mgr. Sam W. Engle, Chief Engr.	World Cole AP Western Electric
BROKEN BOW KCNI 1949	1490 250	Custer County Bcstg. Co.	MBS	Bud Crawford, Mgr. & Chief Engr.	George T. Backe, Coml. Mgr.	
COLUMBUS KJSK 1948	900 1,000-D	George Basil Anderson Columbus 5154		George Basil Anderson, Owner & Gen. Mgr. Florence Anderson, Prog. Dir.	Harold Hardy, Chief Engr.	World SESAC AP Gates
FREMONT KFGT 1939	1340 100	Walker Newspapers Inc. 118 East 5th St. 1060	MBS	Lester A. Walker, Pres. & Gen. Mgr. William H. Baldwin, Coml. & Sta. Mgr.	John Hanlon, Prog. Dir. Mrs. Helen Norwood, Prom. Mgr.	Thesaurus AP Gates
GRAND ISLAND KMMJ 1925	750 1,000 L-WBS	KMMJ Inc. Cedar at Division 703	ABC Headley-Reed	Don Searle, Pres. Wick Heath, Gen. Mgr. Bill Martin, Coml. & Prom. Mgr.	Orle Kerwood, Prog. Dir. Eugene Seier, Chief Engr.	World UP Collins
HASTINGS KHAS 1940	1230 250	Nebraska Bcstg. Co. Tribune Bldg. 1745	MBS	Fred A. Seaton, Pres. Duane L. Watts, Gen. & Coml. Mgr. Eddie Meyer, Prog. Dir.	Ed Skinner, Bus. Mgr. Duane Allison, Chief Engr.	Capitol INS RCA

DA-N Directional Antenna, night only. FM's in italic.
DA-1 Directional Antenna, same pattern day and night.
DA-2 Directional Antenna, different pattern day and night.

*—Non-Commercial Station. D—Day. N—Night. ST—Share Time. SH—Specified Hours.
U—Unlimited. CP—Construction Permit Issued. LS—Local Sunset.
L—Limited Time with Dominant Station. SA—Special Authorization.

City Call Letters Established	Chan. or Freq. Power	Name of Licensee Headquarters Address Telephone Number	Network Representative	Executive Personnel	Transc. Library News Service Transmitter Make	
KEARNEY KGFV 1930	1340 250	Central Nebr. Bcstg. Corp. Federal Annex Bldg. 2-3541	MBS, KBS	Lloyd C. Thomas, Pres. E. Anson Thomas, Gen. & Coml. Mgr.	Peg Biber, Prog. Dir. Jack Lewis, Chief Engr.	Capitol UP Collins
LINCOLN KFOR 1924	1240 250	Cornbelt Bcstg. Corp. Stuart Bldg. 2-6965	ABC Petry	James Stuart, Pres. Harry D. Peck, Gen. & Coml. Mgr. Robert L. Johnson, Prog. Dir.	Dale Berger, Prom. Mgr. C. W. Winkler, Chief Engr.	AP, INS
KFOR-FM 1948	Ch. 275 (B) 102.9mc; 22kw					Capitol Standard Westinghouse
KLMS 1949	1480 1,000 DA-2	Lincoln Bcstg. Corp. 130 North 16th St. 2-7579		Howard A. Shuman, Pres. J. Russell Joynt, Gen. & Prom. Mgr.	Del Brandt, Prog. Dir. H. D. Brandt, Chief Engr.	Thesaurus UP RCA
KOLN 1947	1400 250	Inland Bcstg. Co. Federal Securities Bldg. 2-7218	MBS Ra-Tel	John K. Morrison, Pres. Paul R. Fry, Gen. Mgr. William B. Waugh, Coml. Mgr.	Edwin Smith, Prog. Dir. & Prom. Mgr. Richard Welna, Chief Engr.	World AP Western Electric
McCOOK KBRL 1947	1450 250	The McCook Bcstg. Co. Highway 83 at "J" St. 1450	MBS	W. J. Cox L. W. Lenwell Arthur V. Henri Edward Cooper } Owners	LeRoy W. Lenwell, Gen. Mgr., Prog. Dir. & Chief Engr. Robert Morris, Coml. & Prom. Mgr.	Standard AP Gates
NORFOLK WJAG 1922	780 1,000 L-WBBM	Huse Pub. Co. Norfolk 432	Walker	Gene Huse, Pres. Art Thomas, Gen. & Coml. Mgr. Wayne Larson, Prog. Dir.	Hollis Francis, Prom. Mgr. Frank Wiedenbach, Chief Engr.	Lang-Worth AP Gates
NORTH PLATTE KODY 1930	1240 250	WOW Inc. 1521 W. 12th St. 382	NBC, KBS Blair	John J. Gillin Jr. Pres. John Alexander, Gen. & Prom. Mgr. & Prog. Dir.	Joe di Natale, Local Sales Mgr. H. J. Blakesley, Chief Engr.	Lang-Worth AP, UP
OMAHA KBON 1942	1490 250	Inland Bcstg. Co. 676 Saunders-Kennedy Bldg. JA-8282	MBS Ra-Tel	John K. Morrison, Pres. Paul R. Fry, V. P. & Gen. Mgr. Richard E. Welna, Sta. Mgr. & Prog. Dir.	Ernest S. Priesman, Sales Mgr. Joe H. Baker, Prom. Mgr. Don H. Mehl, Tech. Supvsr.	Associated AP Western Electric
KBON-FM 1948	Ch. 254 (B) 98.7mc; 8.7kw					General Electric Standard SESAC AP, UP Westinghouse
KFAB 1924	1110 50,000-DA-N	KFAB Bcstg. Co 620 Farnam Bldg. JA 3420	CBS Free & Peters	Fred S. Sidles, Pres. Joe W. Seacrest, Chmn. of Bd. Harry Burke, Gen. Mgr.	Harold Soderlund, Coml. Mgr. L. A. Miller, Prog. Mgr. Don Shoemaker, Prom. Mgr.	UP RCA
KMTV (TV) 1949	Ch. 3 60-66mc 8.4kw-aur.; 16.7kw-vis.	May Bcstg. Co. 2615 Farnam St. Harney 9233	ABC, CBS, DuMont Avery-Knode	Edward L. May, Pres. Owen Saddler, Gen. Mgr. Glen Cray, Coml. Mgr.	Glenn Harris, Prog. Dir. R. J. Schroeder, Chief Engr.	UP RCA
KOIL 1925	1290 5,000 DA-N	Central States Bcstg. Co. Omaha Nat'l Bank Bldg. Jackson 7626	ABC Nebraska Petry	James Stuart, Pres. William J. Newens, Gen. & Coml. Mgr. Charles Frandsen, Prom. Mgr.	Virgil V. Sharpe, Asst. Mgr. & Prog. Dir. Charles Winkler, Chief Engr.	Capitol Standard AP, INS RCA
KOWH 1922	660 500-D	Mid-Continent Bcstg. Co Kilpatrick Bldg. Atlantic 2228	Hollingbery	Robert H. Storz, Pres. Todd Storz, Gen. Mgr. B. C. Corrigan, Coml. Mgr.	Gaylord Avery, Prog. Dir. George Armstrong, Prom. Mgr. N. P. Nelson, Trans. Supvsr.	World Associated Standard UP, RCA

Ears to ya!

... the Toast of the Midwest

MEANS MORE COVERAGE **660** A CLEAR CHANNEL

the New!

KOWH

OMAHA, NEBRASKA

Primary coverage diameter 215 miles

Represented by: **Independent Metropolitan Sales**

DIRECTORY OF AM, FM, and TV STATIONS OF THE UNITED STATES

*(Data corrected to December 6, 1949)
If executives or services for FM or TV stations are same as AM affiliate names are not repeated.*

NEBRASKA—(Continued)

City Call Letters Established	Chan. or Freq. Power	Name of Licensee Headquarters Address Telephone Number	Network Representative	Executive Personnel	Transc. Library News Service Transmitter Make	
OMAHA—(Continued)						
KOAD (FM) 1946	Ch. 225 (B) 92.9 mc 70 kw	(KOWH, AM affiliate)			General Electric	
WOW 1923	590 5,000	Radio Station WOW Inc. Insurance Bldg. Webster 3400	NBC Blair	John J. Gillin Jr., Pres., Gen. & Coml. Mgr. Lyle DeMoss, Prog. Dir.	Bill Wiseman, Prom. Mgr. William J. Kotera, Chief Engr.	Thesaurus Standard SESAC AP, UP Western Electric National INS RCA
WOW-TV 1949	Ch. 6 82-88 mc 8.5 kw aur.; 16.2 kw vis.		Blair TV	Joseph Herold, Gen. Mgr.		
SCOTTSBLUFF						
KNEB 1948	970 1,000-D	Platte Valley Bcstg. Corp. Golden Rule Bldg. 1620	Holman	John R. Jirdon, Pres. Russ M. Stewart, Gen. Mgr. Byron Joachim, Coml. Mgr.	Warren McGay, Prog. Dir. Bill Case, Chief Engr.	Capitol World AP General Electric
KOLT 1930	1320 5,000-LS DA-2 1,000-N	Hilliard Co. 1517½ Broadway 856	CBS Donahue	L. L. Hilliard, Pres., Gen. & Coml. Mgr. Bill Walter, Prog. Dir.	Red Davis, Prom. Mgr. Harland Morrison, Chief Engr.	Standard UP Gates

NEVADA

ELKO						
KELK 1948	1340 250	Elko Bcstg. Co. Highway 40 260		C. H. Sheerin, Pres. J. J. Gammick, Gen. Mgr.	J. P. Nims, Prog. Dir. A. H. Vogeler, Chief Engr.	Standard UP Raytheon
LAS VEGAS						
KENO 1940	1400 250	Nevada Bcstg. Co. Box 1310 1400	ABC Grant	Maxwell Kelch, Pres. & Gen. Mgr. Paul R. Gang, Coml. Mgr.	L. A. Newsome Jr., Prog. Dir. James W. Harford, Chief Engr.	Thesaurus INS Collins
KENO-FM 1947	Ch. 280 (A) 103.9mc 0.36kw					General Electric
KLAS 1948	1230 250	Las Vegas Bcstrs. Inc. Box 1510 4646	CBS Cooke Scott	C. L. McCarthy, Pres.	Fred Stoye, Gen. Mgr. Ralph Dow, Chief Engr.	Capitol General Electric
KRAM 1947	920 1,000-LS 500-N DA	Boulder City Bcstg. Co. Flamingo Hotel 920	MBS, KBS Intermountain Avery-Knodel	Edward J. Jansen, Pres. Truman B. Hinkle, Gen. Mgr. Havelyn Jones, Coml. Mgr.	Carl Paige, Prog. Dir. Mary Knecht, Prom. Mgr. Fred Young, Chief Engr.	World UP Collins
RENO						
KATO 1946	1340 250	Sierra Bcstg. Co. Elks Bldg. 24501	MBS Don Lee Pearson	R. K. Wittenberg, Pres. & Chief Engr.	Robert L. Stoddard, Gen. Mgr. Vern McGahan, Prog. Dir.	Graybar
KOH 1928	630 1,000 DA-N CP:5,000 DA-N	McClatchy Bcstg. Co. of Nevada 143 Stevenson St. 5106	NBC Raymer	Eleanor McClatchy, Pres. Hugh Kees, Sta. Mgr.	Wesley Craig, Chief Engr.	World AP, UP
KOLO 1946	920 1,000 DA-1	Reno Bcstg. Co. 33 Sierra St. 2-4516	CBS Hollingbery	David McKay, Pres. H. G. Wells, Gen. Mgr. David Piel, Prod. Mgr.	Jack Kehoe, Prom. Mgr. Merle Peterson, Chief Engr.	Lang-Worth AP, UP
KWRN 1947	1490 250	Reno Newspapers Inc. Gazette Bldg. 6156	ABC Walker	Merritt C. Speidel, Pres. Merrill Inch, Gen. Mgr. John Lang, Coml. Mgr.	Larry Shields, Prog. Dir. Wilbur Comer, Chief Engr.	Associated UP RCA
KWRN-FM 1948	Ch. 234 (B) 95.5mc 10kw					General Electric
KXXL 1947	1230 250	Station KXXL Box 1329 3122				

NEW HAMPSHIRE

BERLIN						
WMOU 1946	1230 250	White Mts. Bcstg. Co. Inc. 40 Main St. 1797	KBS Radio Reps	John W. Guider, Chief Owner Charles S. Holbrook, Pres. & Gen. Mgr.	Wendell C. MacKenzie, Prog. Dir. James Hennessey, Chief Engr.	Associated AP Temco
CLAREMONT						
WTSV 1948	1230 250	Granite State Bcstg. Co. Inc. Washington St. 1800	MBS Granite Yankee Bolling	William J. Barkley, Pres. W. F. Rust Jr., Gen. Mgr. F. C. Stearnes, Coml. Mgr.	F. R. Hill, Prog. Dir. Robert Kelley, Prom. Mgr. A. J. Davis, Chief Engr.	Lang-Worth
WTSV-FM 1947	Ch. 291 (B) 106.1mc 1.5kw					General Electric
CONCORD						
WXLL 1946	1450 250	Hon. Charles M. Dale Eagle Hotel 4180	MBS Yankee Walker	Hon. Charles M. Dale, Chief Owner & Gen. Mgr. Thomas S. Pingree, Asst. Mgr. & Prog. Dir.	George Davis, Chief Engr.	World AP RCA

DA-N Directional Antenna, night only. FM's in italic.
DA-1 Directional Antenna, same pattern day and night.
DA-2 Directional Antenna, different pattern day and night.

*--Non-Commercial Station. D--Day. N--Night. ST--Share Time. SH--Specified Hours.
U--Unlimited. CP--Construction Permit Issued. LS--Local Sunset.
L--Limited Time with Dominant Station. SA--Special Authorization.

Go North, East, South *or* West...young man!

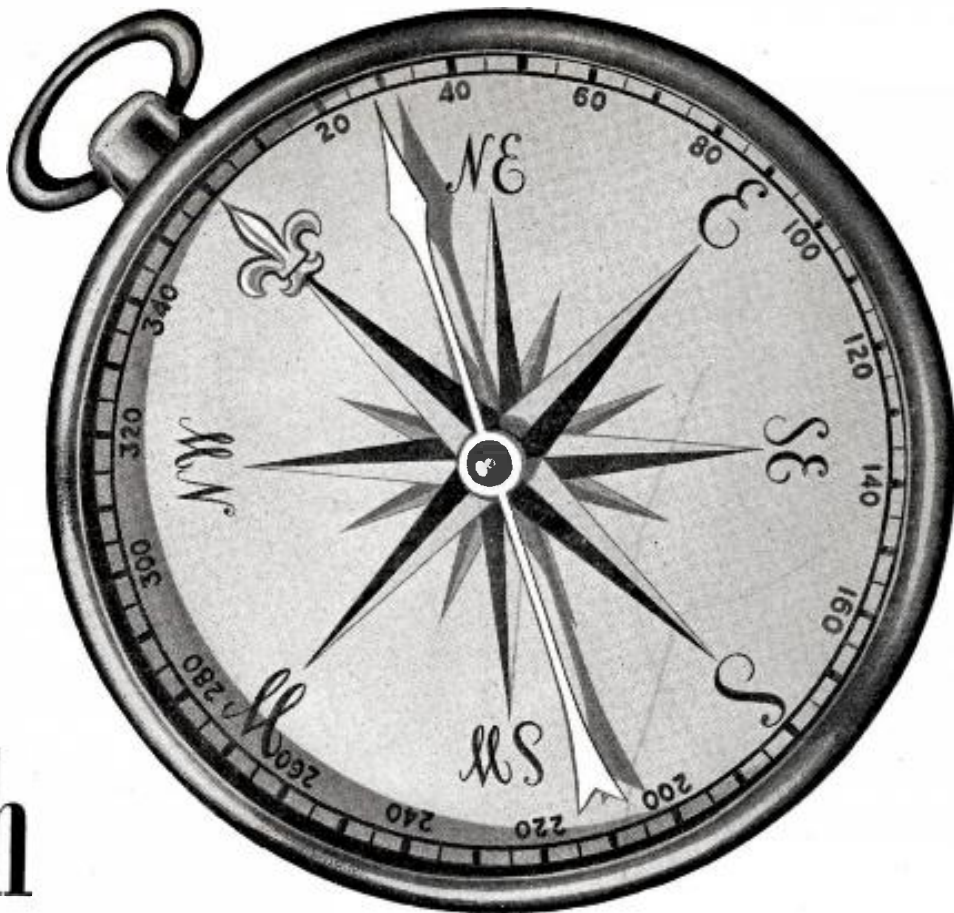

THE BETTER WE PRODUCE,
THE BETTER WE LIVE



"Go West, young man, and grow up with the country." Horace Greeley said it in 1854. He was right . . . but he was also wrong. He was wrong because *all* of America turned out to have room for development then undreamed of.

Let's look at the record:

Here's what's happened all over America just during the last 40 years.

Income: Since 1910 we have increased our annual income per household from an average of less than \$2400 to about \$4000 (in dollars of the same purchasing power), yet—

Work hours: Since 1910 we have cut work hours down an average of 18 per week—equivalent to more than two present work days.

How did we do this? Through —

Machine power: We have increased the supply of machine power $4\frac{1}{2}$ times since 1910. This increased machine power gave us—

Increased productivity: This made it pos-

sible for us to more than *double* the output of each of us for every hour we work.

The best is yet to come

This is what we have done, and this is the way we have done it—to get higher wages, shorter hours, and lower-cost goods for everybody.

And this is the way we can make a still better living in the future—with *greater* use of machine power, *better* machines, *better* distribution, *better* collective bargaining.

Sure, our system still has faults . . . but none that we cannot cure if we all work together to do it.

Like many American firms, we believe that business has a responsibility to contribute to the public welfare. This advertisement is therefore published in the public interest by:

**BROADCASTING
TELECASTING**

Approved for the Public Policy Committee
of The Advertising Council by:

EVANS CLARK,
Executive Director, Twentieth Century Fund
PAUL G. HOFFMAN,
Formerly President, Studebaker Corporation
BORIS SHISHKIN,
Economist, American Federation of Labor



FREE Send for this valuable
booklet today!

Approved by representatives of
Management, Labor and the Public.

In words and pictures it tells you

• How our U. S. Economic System started • Why Americans enjoy the world's highest standard of living • How mass production began • How we have been able to raise wages and shorten working hours • Why the mainspring of our system is productivity • How a still better living can be had for all

MAIL THE COUPON to Public Policy Committee, The Advertising Council, Inc., 25 West 45th St., New York 19, N. Y.

Name _____

Address _____

Occupation _____

DIRECTORY OF AM, FM, and TV STATIONS OF THE UNITED STATES

(Data corrected to December 6, 1949)
 If executives or services for FM or TV stations are same as AM affiliate names are not repeated.

NEW HAMPSHIRE—(Continued)

City Call Letters Established	Chan. or Freq. Power	Name of Licensee Headquarters Address Telephone Number	Network Representative	Executive Personnel	Transc. Library News Service Transmitter Make
KEENE					
WKNE 1928	1290 5,000 DA-2	WKNE Corp. 17 Dunbar St. 2080	CBS Young	Joseph K. Close, Pres. & Gen. Mgr. Robert M. Peebles, Prog. Dir.	Ruth R. Wade, Prom. Mgr. Ernest F. Batchelder Jr., Chief Engr. Thesaurus UP
WKNE-FM (CP)	Ch. 300 (B) 107.9mc 7.2kw				
LACONIA					
WLNH 1922	1340 250	Northern Bcstg. Corp. Masonic Temple Bldg. 2-300	MBS, KBS Kettell-Carter	Warren H. Brewster, Pres., Gen., Coml. & Prom. Mgr.	Al Maffie, Prog. Dir. Walter Avery, Chief Engr. AP Gates
MANCHESTER					
WFEA 1932	1370 5,000 DA-1	N. H. Bcstg. Co. Inc. 286 Franklin St. 5-5491	CBS Young	Morris Silver, Pres. Henry Silver, V. P. Warren H. Journay, Gen. Mgr. & Prog. Dir.	Saul Gross, Coml. Mgr. William Leahy, Prom. Mgr. Reginald A. B. Schow, Chief Engr. Lang-Worth AP
WKBR 1946	1240 250	Granite State Bcstg. Co. Inc. 155 Front St. 4-4075	MBS Granite Yankee Bolling	William J. Barkley, Pres. W. F. Rust Jr., Gen. Mgr. Ralph Gottlieb, Coml. Mgr.	Norman Bailey, Prog. Dir. William Carlisle, Prom. Mgr. Royston Phillips, Chief Engr. Capitol UP Collins
WKBR-FM 1947	Ch. 261 (A) 100.1mc 1kw				
WMUR 1941	610 5,000-LS 1,000-N DA-2	The Radio Voice of N. H. Inc. 1819 Elm St. 5-5788	ABC Weed	Hon. Francis P. Murphy, Pres. Hervey Carter, Gen. & Coml. Mgr. Gordon E. Moore, Asst. Mgr.	Bernie Mack, Prog. Dir. & Prom. Mgr. Vincent H. Chandler, Chief Engr. World AP RCA
WMUR-FM 1947	Ch. 239 (B) 95.7mc 3.3kw				
NASHUA					
WOTW 1947	900 1,000-D	Nashua Bcstg. Corp. Lund Rd. 5000	Granite Walker	Arthur A. Newcomb, Pres., Gen., Coml. & Prom. Mgr.	Robert C. Huse, Prog. Dir. Robert C. Bingham, Chief Engr. World UP Raytheon
WOTW-FM 1948	Ch. 292 (A) 106.3mc 1kw				
PORTSMOUTH					
WHEB 1932	750 1,000 L-WSB	WHEB Inc. Lafayette Rd. 4080	MBS Walker	Charles M. Dale, Pres. & Gen. Mgr. Keith Field, Coml. Mgr.	Win Bettinson, Prog. Dir. William A. Dawson Jr., Prom. Mgr. World AP
ROCHESTER					
WVNH 1948	930 1,000-D	Strafford Bcstg. Corp. Rochester 1400	Granite Bolling	Albin J. K. Malin, Pres. M. C. Ball, Coml. Mgr.	Robert Holmes, Prog. Dir. E. J. Babkes, Chief Engr. Capitol UP Collins
ALPINE					
WFMN (FM) (KE2XCC) 1939	Ch. 226 (I) 93.1mc	Edwin H. Armstrong Alpine Closter 5-1088	Continental	Edwin H. Armstrong, Owner & Gen. Mgr.	Perry H. Osborn, Chief Engr. Associated
ASBURY PARK					
WCAP 1926	1310 250	Radio Industries Bcst. Co. 601 Bangs Ave. 1-1310		Ralph W. Froese, Pres. Walter L. Reid, V. P., Treas. & Gen. Mgr.	Kenneth Leslie, Coml. Mgr. Irving Smith, Prog. Dir. Mathew G. Porter Jr., Chief Engr. Capitol AP RCA
WCAP-FM	Ch. 296 (A) 107.1mc 0.7kw				
WJLK 1947	Ch. 232 (A) 94.3mc 1kw	Asbury Park Press Inc. Press Plaza 2-3000	Continental	Wayne D. McMurray, Pres. Thomas B. Tighe, Sta. Mgr.	Lang-Worth Associated; AP General Electric

NEW JERSEY

DA-N Directional Antenna, night only. FM's in italic. *—Non-Commercial Station. D—Day. N—Night. ST—Share Time. SH—Specified Hours.
 DA-1 Directional Antenna, same pattern day and night. U—Unlimited. CP—Construction Permit Issued. LS—Local Sunset.
 DA-2 Directional Antenna, different pattern day and night. L—Limited Time with Dominant Station. SA—Special Authorization.

NEW HAMPSHIRE'S ONLY NETWORK

ONE Contract
 ONE Time Clearance
 Permanently Interconnected
 Merchandising and Promotion
 Coverage of 90% of New Hampshire Radio Homes
 Intensive Coverage from Within Five Key Markets
 PLUS Bonus Coverage in Maine, Vermont and Massachusetts

THE GRANITE STATE NETWORK, INC.

155 Front St. . . . Manchester, N. H.

WKBR
MANCHESTER, N. H.

WTSV
CLAREMONT, N. H.

WTSA
BRATTLEBORO, Vt.

WOTW
NASHUA, N. H.

WVNH
ROCHESTER, N. H.

Represented Nationally by George Bolling Co.—New England Representative: Bertha Bannan, Boston

City Call Letters Established	Chan. or Freq. Power	Name of Licensee Headquarters Address Telephone Number	Network Representative	Executive Personnel	Transc. Library News Service Transmitter Make	
ATLANTIC CITY						
WBAB 1940	1490 250	Press-Union Pub. Co. 1900 Atlantic Ave. 5-1111	CBS Headley-Reed	Albert J. Feyl, Pres. Monroe L. Mendelsohn, Gen. Prom. & Coml. Mgr.	Ralph Shoemaker, Prog. Dir. Earle Godfrey, Chief Engr.	World AP Collins Federal UP RCA Gates
WBAB-FM 1947	Ch. 264 (B) 100.7mc 13kw					
WFPG 1940	1450 250	Neptune Bcstg. Co. Steel Pier 5-2188	ABC Ra-Tel	John Laux, Pres. Fred Weber, Gen. Mgr. Bill Byrnes, Coml. Mgr.	Alan Owen, Prog. Dir. Lydia Hawksley, Prom. Mgr. Blair K. Thron, Chief Engr.	UP RCA Gates
WFPG-FM 1948	Ch. 253 (B) 98.5mc; 15kw					
WMID 1947	1340 250	Mid-Atlantic Bcstg. Co. Convention Hall 4-1340	MBS ForJoe	Earl M. Johnson, Pres. Jack J. Slotoff, Gen. Mgr.		Associated AP
BRIDGETON						
WSNJ 1937	1240 250	Eastern States Bcstg. Corp. Carl's Corner 1600	KBS Clark	Hon. Elmer W. Wene, Pres. Paul Alger, Gen. Mgr. Jerry Alden, Coml. Mgr.	Joseph McCulley, Prog. Dir. Arthur J. Scholz, Prom. Mgr. Francis Fekel, Chief Engr.	Thesaurus UP RCA
WSNJ-FM 1948	Ch. 255 (B) 98.9mc; 9kw					
CAMDEN						
WCAM 1924	1310 250	City of Camden N. J. City Hall Emerson 5-5600		Mayor George E. Brunner, Dir. Willard C. Schriver, Mgng. Dir. Morton Lowenstein, Coml. Mgr.	Robert Swanson, Prog. Dir. Clarence E. Onens, Chief Engr.	Standard Capitol UP RCA Associated SESAC AP Raytheon
WKDN 1948	800 1,000-D	South Jersey Bcstg. Co. 2881 Mt. Ephraim Ave. Emerson 5-7200		Ranulf Compton, Pres. & Chief Owner Malcolm E. Kennedy, Gen. & Coml. Mgr.	Edwin W. Tucker, Prog. Dir. S. Philip Steen, Chief Engr.	Associated SESAC AP Raytheon
ELIZABETH						
WPOE (FM) 1949	Ch. 244 (A) 96.7mc 1kw	Radio Elizabeth Inc. 1143 E. Jersey St. 2-3460		Robert C. Crane, Pres. William Maron, Gen. Mgr. & Chief Engr.	Norman Bergholm, Coml. Mgr. Sy Dewitt, Prog. Dir.	Associated SESAC UP RCA
JERSEY CITY						
WHOM 1930	1480 5,000 DA-2	Atlantic Bcstg. Co. Inc. 136 W. 52nd St. Circle 8-3900		Generoso Pope, Pres.	Fortune Pope, Exec. V.P.	
MORRISTOWN						
WMTR 1948	1250 500-D	Morristown Bcstg. Corp. P.O. Box 345 4-5700		K. A. Croy, Gen. Mgr. Clem T. Lowden, Coml. Mgr.	John Allen Potts, Prog. Dir. Rudolph C. Prow, Chief Engr.	Associated AP Raytheon
NEWARK						
WAAT 1922	970 5,000 LS 1,000-N DA	Bremer Bcstg. Corp. 1020 Broad St. Mitchell 2-6400	Weed	Irving Robert Rosenhaus, Pres. & Gen. Mgr. Edmund S. Lennon, V.P. Chg. Nat'l. Sales.	George Green, Prog. Dir. James Sondheim, Prom. Mgr. Frank V. Bremer, V.P. Chg. Engrg. AP Collins RCA
WAAT-FM 1947	Ch. 234 (B) 94.7mc 13.5kw					
WATV (TV) 1948	Ch. 13 210-216mc 25kw-aur.; 50kw-vis.	(WAAT, AM affiliate)				
WHBI 1922	1280 2,500-LS 1,000-N S-WOV	May Radio Bcst. Corp. 100 Shipman St. Mitchell 2-7354		James L. Shearer, Pres. & Gen. Mgr. William Masi, Coml. Mgr. Marie Masi, Prog. Dir.	Alfred Kukla, Prom. Mgr. Herman Foster, Chief Engr.	
WNJR 1947	1430 5,000 DA-N	North Jersey Radio Inc. 91-93 Halsey St. Market 3-2700		Edward W. Scudder Jr., Pres. Harry D. Goodwin, Gen. Mgr. Charles G. O'Neill, Coml. & Prom. Mgr.	Steven Van Gluck, Prog. Dir. Peter Testan, Chief Engr.	Capitol World UP, INS RCA Westinghouse
WNJR-FM 1949	Ch. 274 (B) 102.7mc 4.2kw					
WYNJ 1947	620 5,000 DA-2	Newark Bcstg. Corp. 45 Central Ave. 3-7600	Hollingsbery	Ivon B. Newman, V.P. & Gen. Mgr.	Helen Sutton, Sta. Mgr.	UP
NEW BRUNSWICK						
WCTC 1946	1450 250	Chanticleer Bcstg. Co. 385 George St. Charter 7-1450		James L. Howe, Pres. & Gen. Mgr. Robert Bell, Coml. Mgr. Nat. Shoehalter, Prog. Dir.	Edith Brandt, Sales Prom. Dir. Robert L. Williams, Chief Engr.	Associated World UP RCA Collins Lang-Worth UP
WCTC-FM 1948	Ch. 252 (A) 98.3mc 1kw					
WDHN (FM) 1947	Ch. 228 (A) 93.5mc 1kw	Home News Pub. Co. 137 Church St. 2-4000		Hugh N. Bond, Gen. Mgr.		
PATERSON						
WPAT 1941	930 5,000 DA-2	North Jersey Bcstg. Co. Cooke 68 Hamilton St. 6-2945		Dow H. Drukker Jr., Pres.	James V. Cosman, Exec. V.P. & Gen. Mgr.	Associated SESAC
WPAT-FM 1947	Ch. 278 (B) 103.5mc 19kw					
PLAINFIELD						
WXNJ (FM) 1947	Ch. 280 (A) 103.9mc 1kw	WXNJ Inc. 111 E. Front St. 6-7039		H. O. Bishop, Pres. James A. Flynn, Gen. & Coml. Mgr.	F. Thomas Hally, Prog. Dir. David Roland, Chief Engr.	
TRENTON						
WTNJ 1928	1300 250-D	WOAX Inc. 416 Bellevue Ave. 8149		F. J. Wolff, V.P. & Gen. Mgr.		
WTOA (FM) 1947	Ch. 248 (B) 97.5mc 14.5kw	Mercer Bcstg. Co. 558 Ingham Ave. 5-8541		Jerome P. McCarthy, Sta. Mgr. Paul Fireman, Chief Engr.		Associated Lang-Worth UP

DA-N Directional Antenna, night only. FM's in italic.
DA-1 Directional Antenna, same pattern day and night.
DA-2 Directional Antenna, different pattern day and night.

*-Non-Commercial Station. D-Day. N-Night. ST-Share Time. SH-Specified Hours.
U-Unlimited. CP-Construction Permit Issued. LS-Local Sunset.
L-Limited Time with Dominant Station. SA-Special Authorization.

DIRECTORY OF AM, FM, and TV STATIONS OF THE UNITED STATES

(Data corrected to December 6, 1949)
 If executives or services for FM or TV stations are same as AM affiliate names are not repeated.

NEW JERSEY—(Continued)

City Call Letters Established	Chan. or Freq. Power	Name of Licensee Headquarters Address Telephone Number	Network Representative	Executive Personnel	Transc. Library News Service Transmitter Make	
WTTM 1942	920 1,000 DA-1	Trent Bcst. Corp. 541 East State St. 5-8515	NBC Forjoe	Elmer H. Wene, Pres. S. Carl Mark, Exec. V. P. & Gen. Mgr. Fred L. Bernstein, Coml. Mgr.	William R. Griffin, Prog. Dir. Mary C. Wilson, Prom. Mgr. Theodore P. Kilmer, Chief Engr.	UP RCA
VINELAND WWBZ 1946	1360 1,000-D CP 1,000 DA-N	Community Bcstg. Service Inc. 833 Wood St.; 7-1360	McGillvra	Joseph M. Bullock, Pres. Fred M. Wood, Gen. Mgr.	Dorothy H. Carlson, Prog. Dir. C. V. Mullen, Chief Engr.	World UP Collins
ZAREPHATH *WAWZ 1930	1380 5,000-LS 1,000-N DA-1 ST-WBNX	Pillar of Fire Zarephath Bound Brook 9-0102		Arthur K. White, Pres. & Gen. Mgr. Norman Fournier, Prog. Dir.	N. L. Wilson, Chief Engr.	

NEW MEXICO

ALBUQUERQUE KGGM 1927	810 5,000 DA-N	New Mexico Bcstg. Co. Klmo Bldg. 4543	CBS Taylor-Borroff	A. R. Hebenstreit, Pres. J. C. Skillen, Coml. Mgr.	Bob Van Driel, Prog. Dir. Leonard Dodds, Chief Engr.	World AP, UP RCA
KOAT 1946	1450 250	Rio Grande Bcstg. Co. Inc. Box 1419; 5-5501	ABC Zia	Albert E. Buck, Pres. Merle H. Tucker, Gen. & Coml. Mgr.	Bernard Fitzpatrick, Prog. Dir. William H. Carman, Supervising Engr.	Capitol UP RCA
KOB 1921	770 50,000 LS 25,000 N	Albuquerque Bcstg. Co. Fifth & Silver 4411	NBC Free & Peters	T. M. Pepperday, Pres. R. R. Seal, Gen. Mgr. Charles Teas, Coml. Mgr.	Rolf S. Nielsen, Prog. Dir. Jeanne Toncre, Prom. Mgr. George Johnson, Chief Engr.	Thesaurus AP RCA
KOB-TV 1948	Ch. 4 88-72 mc 2.5kw-aur.; 5kw-vis.		ABC, CBS NBC, DuMont	George S. Johnson, Mgr. of TV Dorothy B. Smith, Prog. Dir.		
KVER 1947	1340 250	Westernair Inc. Box 1388 3-1744	MBS Forjoe	William T. Kemp, Pres. & Gen. Mgr. Keith Tye, Sta. Mgr. Ralph Henry & John H. Morrison, Asst. Mgrs.	Paul Kehle, Sales Mgr. Al Mann, Prog. Dir. Ernest Hill, Prom. Dir. Fred Timm, Chief Engr.	UP Gates

DA-N Directional Antenna, night only. FM's in italic. *—Non-Commercial Station. D—Day. N—Night. ST—Share Time. SH—Specified Hours.
 DA-1 Directional Antenna, same pattern day and night. U—Unlimited. CP—Construction Permit Issued. LS—Local Sunset.
 DA-2 Directional Antenna, different pattern day and night. L—Limited Time with Dominant Station. SA—Special Authorization.

KVER THE CHOICE OF THE DIAL IN ALBUQUERQUE



SPORTS— KVER is Albuquerque's sport station covering all local and important national sports events, including baseball, basketball and football.



DRAMA— KVER airs a wide variety of high rating radio shows including the famous Metro-Goldwyn-Mayer Radio Attractions.

LANGUAGE PROGRAMS— KVER is the only Albuquerque station with programs in Spanish directed to Spanish-Americans comprising over 50% of this market's population.

SPECIAL EVENTS— KVER gives complete coverage for all local and national events of public interest, thus assuring a wide audience.

Dollar for dollar you cannot buy better coverage of Albuquerque, the Southwest's fastest growing market, now estimated at 130,000. Check Standard Rate & Data.

FORJOE & CO. — National Representatives

KVER MUTUAL 1340
 WM. T. KEMP, President — KEITH TYE, Manager

City Call Letters Established	Chan. or Freq. Power	Name of Licensee Headquarters Address Telephone Number	Network Representative	Executive Personnel	Transc. Library News Service Transmitter Make	
ARTESIA KSVF 1946	1450 250	Artesia Bcstg. Co. Box 445 650	MBS, KBS	Martin Yates III, Pres. David M. Button, Gen. & Prom. Mgr. & Prog. Dir.	Wayne Griffin, Coml. Mgr. Robert Meeker, Chief Engr.	Capitol Standard AP Gates
BELEN KENE 1949	1230 250	Belen Bcstg. Corp. P. O. Box 604 3021		T. B. Stribling, Pres. D. H. Crandal, Gen. Mgr.	H. R. Granger, Coml. Mgr. Ken Gilmore, Prog. Dir. W. C. Weeks, Chief Engr.	Lang-Worth SESAC AP Gates
CARLSBAD KAWE 1936	1240 250	Carlsbad Bcstg. Corp. 800 South Canal St. 244	CBS Southwest Taylor-Boroff	Val Lawrence, Pres. Norman Loose, Gen. Mgr. Richard Doyle, Coml. Mgr.	Al Pitcaithley, Prog. Dir. William Sene, Chief Engr. AP Gates
	740 1,000-D	McEvoy Brothers				
CLAYTON KLMX (CP)	1450 250	Ari-Ne-Mex Bcstg. Corp. P. O. Box 71		Arthur Jernigan, Pres. Gordon Lack, Gen. Mgr.	Walter Stajduhar, Chief Engr.	Capitol UP Gates
CLOVIS KICA 1931	1240 250	Hugh DeWitt Landis & Ross B. McAllister 6th & Pile 5511	MBS Continental	Hugh DeWitt Landis, Pres. Ross B. McAllister, Gen. Mgr. Al King, Coml. Mgr.	John Kirkwood, Prog. Dir. & Prom. Mgr. Vernon Hughes, Chief Engr. UP
GALLUP KGAH 1946	1230 250	Rio Grande Bcstg. Co. 114 East Coal Ave. 1177	ABC Zia Donahue	Merle H. Tucker, Gen. Mgr. Charles M. Butler, Sta. Mgr. Larry Hoffman, Coml. Mgr.	Lou Emerson, Prog. Dir. James P. Suptic, Chief Engr.	Capitol UP Temco
HOBBS KWEW 1938	1490 250	W. E. Whitmore Hobbs 495	MBS, KBS Southwest Taylor-Boroff	W. E. Whitmore, Pres. Harry McAdams, Gen. Mgr. Phil C. McGee, Coml. Mgr.	Dorthea A. Montgomery, Prog. Dir. Roy T. Evans, Chief Engr.	Lang-Worth MacGregor UP RCA
HOT SPRINGS KCHS 1946	1400 250	Sierra Bcstg. Co. 401 Broadway 161	KBS Continental	Leonard R. Tralner, Pres. & Gen. Mgr. William J. Malloy, Coml. Mgr.	Catherine L. Perry, Prog. Dir. Russell A. Walz, Chief Engr.	Capitol UP Gates
LAS CRUCES KOBK 1947	1450 250	Mesilla Valley Bcstg. Co. Main & Picacho 205	MBS Best	Robert Porter, Pres. Harry H. Stair, Gen. Mgr. Lydia S. Sleppy, Prog. Dir.	Billee Toles, Prom. Mgr. Kenneth M. Dean, Chief Engr.	World AP
LAS VEGAS KFUN 1941	1230 250	Southwest Bcstrs. Inc. Box 710 12	MBS Best	Ernest N. Thwaites, Pres. & Gen. Mgr. Dorothy G. Thwaites, Prog. Dir.	A. F. Schultz, Chief Engr.	Standard, World UP Gates
LOS ALAMOS KRSN (CP)	1490 250	Rio Grande Bcstg. Co. Inc.				
PORTALES KENM (CP)	1450 250	Plains Bcstg. Co.				
RATON KRTN 1948	1490 250	Southwest Bcstrs., Inc. 1128 State St. 875	MBS Best	Ernest N. Thwaites, Pres. & Gen. Mgr. Stanley K. Brown, Sta. Mgr.	Vera Brown, Prog. Dir. A. F. Schultz, Chief Engr.	Standard UP Gates
ROSWELL KGFL 1927	1400 250	KGFL Inc. P. O. Box 1019 2000	MBS, KBS Southwest Taylor-Boroff	W. E. Whitmore, Pres. G. F. Roberts, Coml. Mgr.	Gene Rader, Chief Engr.	Lang-Worth UP Gates
	1230 250	McEvoy Bcstg. Co. Radio Center 2400	ABC Zia Donahue	Paul B. McEvoy, Pres. John A. McBoyle, V. P., Gen. & Prom. Mgr.	M. J. Montgomery, Coml. Mgr. George R. Walsh, Prog. Dir. Ray R. Summersgill, Chief Engr.	Thesaurus AP Raytheon
SANTA FE KTRC 1946	1400 250	The Rio Grande Bcstg. Co. Inc. 208 E. Marcey St. 3003	ABC Donahue Zia	A. E. Buck, Pres. Merle H. Tucker, V. P. & Gen. Mgr.	Hugh M. Gray, Gen. & Coml. Mgr. & Prog. Dir. Al Paul Theil, Prom. Mgr. Odel Nickelson, Chief Engr.	Capitol UP RCA
	1260 1,000	Sante Fe Bcstg. Co. 759 Cerrillos Rd. 2020	CBS Taylor-Boroff	A. R. Hebenstreit, Pres. Jim Maize, Prog. Dir. & Prom. Mgr.	Ivan R. Head, Gen. Mgr. Elvin J. Vanderwood, Chief Engr.	World AP, UP Western Electric
SILVER CITY KSIL 1946	1340 250	Dorrance D. Roderick 17th & Cactus Sts.	Taylor-Boroff	Carl Dunbar, Gen. Mgr. R. C. Hughes, Gen. Adv. Mgr.	Ed Duty, Prog. Dir. AP
TUCUMCARI KTNM 1941	1400 250	The McMa Agency Second & Main Sts. 100	MBS	Grady Maples & R. B. McAlister, Partners Grady Maples, Gen., Coml. & Prom. Mgr.	Richard Dale Wood, Prog. Dir. David Fred White Jr., Chief Engr. UP Gates
NEW YORK						
ALBANY WABY 1934	1400 250	Adirondack Bcstg. Co. Strand Theatre Bldg. 4-4193	McKinney	A. J. McDonald, Pres. Russell B. Wilde, Gen. Mgr. Michael Danyia Jr., Coml. Mgr.	Edward L. Trudeau, Prog. Dir. James H. Corey, Chief Engr.	Standard Thesaurus UP Collins
	1460 1,000-LS 500-N CP: 5,000 DA-2	Gov. Dongan Bcstg. Corp. 136 State St. 3-6638	Union	Jim Healey, Pres. & Gen. Mgr. Al Kellert, Coml. Mgr.	Paul Baron, Prog. Dir. Al Sardi, Chief Engr.	Standard SESAC AP

DIRECTORY OF AM, FM, and TV STATIONS OF THE UNITED STATES

(Data corrected to December 6, 1949)

If executives or services for FM or TV stations are same as AM affiliate names are not repeated.

NEW YORK—(Continued)

City Call Letters Established	Chan. or Freq. Power	Name of Licensee Headquarters Address Telephone Number	Network Representative	Executive Personnel	Transc. Library News Service Transmitter Make	
ALBANY—(Continued)						
WPTR 1948	1540 50,000 DA-1	Patron Bcstg. Co. Inc. 87 State St. 5-3345	Rambeau	J. Myer Schine, Pres. Leonard L. Asch, Gen. & Prom. Mgr.	John F. Jennings, Coml. Mgr. Howard W. Maschmeier, Prog. Dir. Dwelle S. Hoag, Chief Engr.	Capitol SESAC AP, INS General Electric World SESAC UP, INS RCA
WROW 1947	590 5,000-LS 1,000-N DA-2	Hudson Valley Bcstg. Co. Inc. 112 State St. 3-2225	MBS Bolling	Dr. John J. Quinlan, Pres. Harry L. Goldman, Gen. Mgr. Leo Rosen, Coml. & Prom. Mgr.	Johnny Lee, Sta. Mgr. Charles Heisler, Chief Engr.	General Electric World SESAC UP, INS RCA
WROW-FM 1948	Ch. 230 (B) 93.9mc 2.1kw					General Electric
WXKW 1948	850 10,000 DA-1	Champlain Valley Bcstg. Corp. 444 Broadway 6-7676	ABC Katz	Stephen R. Rintoul, Pres. & Gen. Mgr. Gren Rand, Coml. Mgr.	Fred Daiger, Prog. Dir. Eugene Fitzpatrick, Prom. Mgr. George C. Wetmore, Chief Engr.	World UP RCA
WXKW-FM 1948	Ch. 238 (B) 95.5mc 9kw					General Electric
AMSTERDAM						
WCSS 1948	1490 250	Community Service Bcstg. Corp. Amsterdam 4000	Union	Cecil Woodland, Pres., Gen. & Coml. Mgr.	Ray Cheney, Prog. Dir. Guy Rauer, Chief Engr.	World UP, INS Collins
AUBURN						
WMBO 1926	1340 250	WMBO Inc. Metcalf Bldg. 2-3511	MBS Clark	William O. Dapping, Pres. Frederick L. Keesee, Gen. & Coml. Mgr.	Robert Morgan, Prog. Dir. & Prom. Mgr. Herbert House, Chief Engr.	AP RCA
WMBO-FM 1949	Ch. 241 (B) 96.1mc 18kw	Auburn Publ. Co. 34-36 Dill St.				General Electric
BATAVIA						
WBTA 1941	1490 250	Batavia Bcstg. Corp. 90 Main St. 715	MBS	Edmund R. Gamble, Pres. & Gen. Mgr. Robert E. Newstead, Coml. Mgr.	J. Gordon Bridge, Prog. Dir. & Prom. Mgr. Fred Callender, Chief Engr.	Capitol AP RCA
BAY SHORE						
WBEB (CP)	Ch. 296 (A) 107.1mc 0.25kw	Coastal Bcstg. Co. Inc.				
BINGHAMTON (Endicott)						
WENE 1947	1450 250	Empire Newspapers- Radio Inc. 909 E. Main St. Endicott 5-3351	ABC Walker	James H. Ottaway, Pres. Francis H. Brinkley, Mngng. Dir. Stephen W. Ryder, Sta. Mgr.	Harold E. Graves, Prog. Dir. James A. McKechnie, Prom. Mgr. J. Harold Merchant, Chief Engr.	Associated AP General Electric
WENE-FM (CP)	Ch. 269 (A) 101.7mc 0.54kw					
WINR 1946	1460-5 250 100 5cc	Southern Tier Radio Service Inc. Court House Sq. 4-4318	NBC Hollingsbery	Donald Kramer, Pres. E. R. Vadeboncoeur, Sta. Exec. C. A. Bengtson, Gen. Mgr. H. R. Nicholson, Sales Mgr.	Charles Bishara, Prog. Mgr. George O'Connor, Prom. Dir. A. A. Kelley, Chief Engr.	Lang-Worth AP RCA
WINR-FM 1947	Ch. 299 (B) 107.7mc 750 1,000-D	The Binghamton Bcstrs. Inc. 34 Chenango St. 2-3437	MBS Union Burn-Smith	Andrew Jarema, Pres. & Gen. Mgr. Norman T. Stewart, Coml. Mgr.	Wallace J. Buman, Prog. Dir. Charles Hallinan, Chief Engr.	World AP Raytheon
WNBF 1927	1290 5,000 DA-N	Clark Associates Inc. P. O. Box 48 2-3461	CBS Bolling	John C. Clark Sr., Pres. Cecil D. Mastin, Gen. Mgr. Stanley N. Heslop, Coml. Mgr.	Edward M. Scala, Prog. Dir. E. Ray McCloskey, Prom. Mgr. Louveer H. Stantz, Chief Engr.	Capitol UP Westinghouse
WNBF-FM 1942	Ch. 263 (B) 100.5mc 12kw					REL
WNBF-TV 1949	Ch. 12 204-210mc 12kw-aur.; 12kw-vis.		ABC, CBS DuMont NBC			RCA
BRISTOL CENTER						
WVBT (FM) 1948	Ch. 270 (B) 101.9mc 1.3kw	Rural Radio Network Inc. 118 N. Tioga St. Ithaca, N. Y. 3341	Rural Radio	Harold L. Creal, Pres. Michael R. Hanna, Gen. Mgr.	H. Stilwell Brown, Coml. Mgr. Merrill Knapp, Prog. Supvr. Thomas R. Humphrey, Chief Engr.	Standard Associated UP General Electric
BROOKLYN						
*WBEB 1924	1330 5,000 DA-1 S-WEVD WHAZ	Watchtower Bible & Tract Soc. Inc. 124 Columbia Hgts. Main 4-9735		M. A. Howlett, Gen. Mgr. A. M. Cora, Prog. Dir.	R. H. Leffer, Chief Engr.	INS RCA
BUFFALO						
WBEN 1930	930 5,000 DA-N	WBEN Inc. Hotel Statler Cleveland 6400	NBC Petry	Edward H. Butler, Pres. A. H. Kirchofer, V. P. & Gen. Mgr. C. Robert Thompson, Sta. Mgr. Frank W. Kelly, Asst. Mgr. in Chg. of Sales	George R. Torge, Prog. Dir. Robert Rich, Asst. Prog. Dir. Joseph A. Haefner, Prom. Mgr. Ralph J. Kingeley, Chief Engr.	Lang-Worth Standard Thesaurus AP, UP, INS RCA
WBEN-FM 1946	Ch. 293 (B) 106.5mc 105kw					Federal
WBEN-TV 1948	Ch. 4 66-72mc 10.2kw-aur.; 16.2kw-vis.		ABC, CBS, DuMont, NBC Harrington, Righter & Parsons Young	Nicholas J. Malter, Tele. Sales Mgr.	Glenn Beerbower, Asst. Tech. Dir. in Chg. of Tele.	
WBNY 1935	1400 250	Roy L. Albertson 485 Main St. Madison 4000		Roy L. Albertson, Gen. Mgr. Virginia C. Fyda, Sta. Dir.	Howard C. Schellenburg, Coml. Dir.	
WBNY-FM 1947	Ch. 225 (B) 92.9mc 48kw					
WEER 1924	970 5,000 DA-1	WEER Inc. 23 North St. Lincoln 7133	MBS Katz	Cy King, Gen. Mgr. William Doerr Jr., Coml. Mgr. Preston Taplin, Prog. Dir.	William Schweitzer, Prom. Mgr. Frank Ridgeway, Chief Engr.	Standard Western Electric Lang-Worth
WEER-FM 1947	Ch. 245 (B) 96.9mc; 9.5kw					Federal

DA-N Directional Antenna, night only. FM's in italic.
DA-1 Directional Antenna, same pattern day and night.
DA-2 Directional Antenna, different pattern day and night.

*—Non-Commercial Station. D—Day. N—Night. ST—Share Time. SH—Specified Hours.
U—Unlimited. CP—Construction Permit Issued. LS—Local Sunset.
L—Limited Time with Dominant Station. SA—Special Authorization.

POSITIVELY
OR
COMPARATIVELY

by any yardstick you use

there's no substitute for

WBEN

 **AM**

 **FM**

 **TV**

The best service brings the best results. That's the yardstick at WBEN. The service rendered by The Buffalo Evening News stations has created listener-loyalty not only for programs and personalities but loyalty for products and services. The results: WBEN for years has been the Buffalo station most people listen to most of the time • WBEN-FM, Buffalo's first frequency-modulation station, is accorded the same high rating • WBEN-TV, Buffalo's only television station, is one of the nation's standout stations which 280 advertisers in 18 months have used with conspicuous success.

in **BUFFALO**

WBEN, INC.

Representatives:

Radio: Edward Petry & Co., Inc.

Television: Harrington, Righter & Parsons, Inc.

DIRECTORY OF AM, FM, and TV STATIONS OF THE UNITED STATES

(Data corrected to December 6, 1949)
If executives or services for FM or TV stations are same as AM affiliate names are not repeated.

NEW YORK—(Continued)

City Call Letters Established	Chan. or Freq. Power	Name of Licensee Headquarters Address Telephone Number	Network Representative	Executive Personnel	Transc. Library News Service Transmitter Make	
BUFFALO—(Continued)						
WGR 1922	550 5,000 DA-N	WGR Bcstg. Corp. Rand Bldg. Washington 3100	CBS Free & Peters	Leo J. Fitzpatrick, Chmn. of Bd. I. R. Lounsbury, Pres. & Gen. Mgr. N. L. Cohen, Coml. Mgr.	Robert Strigl, Prog. Dir. Ross McPherson, Prom. Mgr. K. B. Hoffman, Chief Engr. F. R. Greene, Asst. Gen. Mgr.	World UP RCA
WKBW 1925	1520 50,000 DA-1	WKBW Inc. 1333 Rand Bldg. Mohawk 1520	ABC Avery-Knodel	Clinton H. Churchill, Pres. & Gen. Mgr. Roger M. Baker, Asst. to Pres.	Paul Martin, Prog. Dir. Alfred E. Anscombe, Prom. Mgr. Leroy Fiedler, Chief Engr.	UP Westinghouse
WWOL 1947	1120 1,000-D	Greater Erie Bcstg. Co. 315 Main St. Mohawk 1200	Forjoe	Leon Wyszatycki, Pres. Stanley Jasinski, Gen. Mgr. Dan Leslie, Coml. & Prom. Mgr.	Ted Wyszatycki, Asst. Gen. Mgr. Pat Vincent, Prog. Dir. Frank Saj, Chief Engr.	World UP Western Electric
WWOL-FM 1949	Ch. 281 (B) 104.1mc 7.7kw					General Electric
WXRA 1948	1080 1,000-D	(See Kenmore, N. Y. listing)				
CHERRY VALLEY						
WVCV (FM) 1948	Ch. 270 (B) 101.9mc 1.3kw	Rural Radio Network 118 N. Tioga St. Ithaca, N. Y.; 3341	Rural Radio	Harold L. Creal, Pres. Michael R. Hanna, Gen. Mgr. H. Stilwell Brown, Coml. Mgr.	Merrill Knapp, Prog. Supvr. Thomas R. Humphrey, Chief Engr.	Standard Associated UP General Electric
COBLESKILL						
WCLB (CP) 1948	1420 1,000-D	Scholarie Co. Community Service Bcstg. Corp.				
CORAM						
WFSS (FM) (CP) 1948	Ch. 277 (B) 103.3mc 1.8kw	Suffolk Bcstg. Corp. Box 82		John T. Tuthill Jr., Pres. W. K. Macy Jr., V. P. & Coml. Mgr.	N. Blair Munhofen, Gen. Mgr.	UP
CORNING						
WCBA 1949	1350 1,000-D	John S. Booth English Keenan Bldg. 2508		John S. Booth, Pres. Samuel J. Handshaw, Asst. Mgr. Eldred P. Carpenter, Local Sales Mgr.	Robert G. Walter, Prog. Dir. John P. Morrissey, Prom. Mgr. Murray J. Hillman, Chief Engr.	Lang-Worth Capitol UP
WKNP (FM) 1947	Ch. 291 (B) 106.1mc 4.2kw	Corning Leader Inc. 114 Walnut St. 1000	ABC Walker	W. Allen Underhill, Pres. Walter Valerius, Gen. Mgr. Paul F. Liston, Coml. Mgr.	Ronald Graham, Prog. Dir. Allen N. Bell, Chief Engr.	Associated AP General Electric
CORTLAND						
WKRT 1947	920 1,000-LS 500-N DA	Cortland Bcstg. Co. Inc. 27 North Main St. 2990	McGillvra	Gerald Mayer, Pres. & Gen. Mgr. William J. Hall, Sta. Mgr. Thomas L. Riley, Coml. Mgr.	Robert Michel, Prog. Dir. William Barron, Chief Engr.	Associated Lang-Worth UP General Electric
WKRT-FM 1947	Ch. 280 (B) 99.9mc 15kw					

DA-N Directional Antenna, night only. FM's in italic. *—Non-Commercial Station. D—Day. N—Night. ST—Share Time. SH—Specified Hours.
DA-1 Directional Antenna, same pattern day and night. U—Unlimited. CP—Construction Permit Issued. LS—Local Sunset.
DA-2 Directional Antenna, different pattern day and night. L—Limited Time with Dominant Station. SA—Special Authorization.

IN THE CENTER OF THE
RICH
CENTRAL NEW YORK FARMING AREA
IT'S ...



**CORTLAND, N. Y.
DAY and NIGHT**

Heard in 65,000 Farm Homes

Selling 1,250,000 Buyers

1000 WATTS • 920 KC • 14.49 KW • 99.9 MG

CORTLAND BROADCASTING CO., INC.

STATE THEATER BUILDING

27 NORTH MAIN STREET

CORTLAND, NEW YORK

TELEPHONES 2990 - 2991

GERALD MAYER, President

Joseph Hershey McGillvra, Inc., National Representatives

MORE COVERAGE...

for your money in Western New York with—



★ 50,000 WATTS

★ ABC NETWORK

ACTION FOR ADVERTISERS!

- ★ Ten times more power than any other Buffalo station
- ★ Largest bonus area for advertisers
- ★ Tops the field in local programs and sports coverage

AVERY-KNODEL
INC.
NATIONAL
REPRESENTATIVES

WKBW

YOUR WESTERN NEW YORK SALESMAN

CLINTON H. CHURCHILL
PRESIDENT AND GEN. MANAGER

DIRECTORY OF AM, FM, and TV STATIONS OF THE UNITED STATES

(Data corrected to December 6, 1949)
If executives or services for FM or TV stations are same as AM affiliate names are not repeated.

NEW YORK—(Continued)

City Call Letters Established	Chan. or Freq. Power	Name of Licensee Headquarters Address Telephone Number	Network Representative	Executive Personnel	Transc. Library News Service Transmitter Make	
DE RUYTER						
WVCN (FM) 1948	Ch. 286 (B) 105.1mc 1.3kw	Rural Radio Network Inc. 118 N. Tioga St. Ithaca, N. Y. 3341	Rural Radio	Harold L. Creal, Pres. Michael R. Hanna, Gen. Mgr. H. Shtuwell Brown, Coml. Mgr.	Merrill Knapp, Prog. Supvr. Thomas R. Humphrey, Chief Engr.	Standard Associated UP General Electric
DUNKIRK						
WFCB 1949	1410 500 DA-N	Dunkirk Bcstg. Corp. 316 Main St. 2355		Alois A. Schmidt, Pres. & Gen. Mgr.	Dal Gray, Prog. Dir. Pearley Tribou, Chief Engr.	Standard Lang-Worth UP Raytheon
ELMIRA						
WELM 1947	1400 250	Corning Leader Inc. 222 East Market St. 2-1400	ABC Union Walker	W. A. Underhill, Pres. Walter Valerius, Gen. Mgr. Claude R. Snyder Jr., Coml. Mgr.	Kenneth Powell, Prog. Dir. Allen Bell, Chief Engr.	Standard AP Raytheon
WENY 1939	1230 250	Elmira Star-Gazette Inc. Mark Twain Hotel 5181	MBS, NBC McKinney	Frank E. Gannett, Pres. Dale Taylor, Gen. Mgr. Phil Cameron, Coml. Mgr.	W. Theodore Hodge, Prog. Dir. Thurlow A. Greene, Chief Engr.	Lang-Worth World UP RCA
WENY-FM 1947	Ch. 259 (B) 106.9mc 5.1kw					General Electric
ENDICOTT						
WENE 1947	1450 250	(See Binghamton, N. Y. listing)				
FREEPORT						
WGBB 1924	1240 100	Harry H. Carman 44 S. Grove St. 9-1400		Harry H. Carman, Pres. & Gen. Mgr. Murray C. Evans, Coml. Mgr.	Ada Cheesman, Prog. Dir. Robert Stirrat, Prom. Mgr. Bob Milos, Chief Engr.	Thesaurus AP
FULTON						
WOSC 1949	1300 1,000-D	Oswego County Bcstg. Co. Inc. 118 Oneida St. 1400	McGillvra	D. J. Kesterke, Pres. & Gen. Mgr. Gerald Mayer, V. P. Leo Brown, Coml. Mgr.	George McCall, Prog. Dir. Cyril Edmunds, Chief Engr.	Lang-Worth AP General Electric
GENEVA						
WGVA 1947	1240 250	Star Bcstg. Co. Inc. 87 Seneca St. 6691	MBS Cooke	M. R. Forman, Pres. Thomas L. Brown, V. P., Gen. & Coml. Mgr.	Robert S. Kieve, Prog. Dir. R. Carleton Greene, Chief Engr.	World AP Collins
GLENS FALLS						
WGLN 1947	1230 100	Glens Falls Publ. Corp. 13 Warren St. 2-1230	ABC McKinney	Louis P. Brown, Pres. William A. Krough, Gen. Mgr. E. M. Frink, Coml. Mgr.	Earl Sharland, Prog. Dir. Steve Davis, Prom. Mgr. Henry O. Worthing, Chief Engr.	Capitol AP Raytheon
WWSC 1946	1450 250 CP-1410, 1,000LS. 500 N-DA	Great Northern Radio Inc. 11 South St. 2-6518	MBS Union Cooke	Martin R. Karig, Pres. Carl W. Mattison, Gen. Mgr. Alfred A. Brown, Coml. Mgr.	Richard P. Weld, Prog. Dir. Kent Jones, Prom. Mgr. Joseph Thomas, Chief Engr.	World UP Temco
GLOVERSVILLE						
WENT 1944	1340 250	Sacadaga Bcstg. Corp. 8 West Fulton St. 4900	CBS Union McGillvra	George F. Bissell, Pres. & Gen. Mgr.	Roger Albright, Asst. & Coml. Mgr. & Prog. Dir. Richard Stewart, Chief Engr.	Thesaurus UP Collins
HEMPSTEAD						
WHLI 1947	1100 250-D	FM Bcstg. Corp. 245 Baldwin Rd. 2-8000		Elias I. Godofsky, Pres. Paul Godofsky, V. P. & Sta. Mgr.	Joseph A. Lenn, V. P. & Sales Mgr. Frank E. Knaack, Chief Engr.	Associated World UP Collins
WHLI-FM 1947	Ch. 252 (A) 98.3mc 1kw					Federal
HORNELL						
WLEA 1948	1320 1,000-D	Canisteo Radio Corp. 99 Main St. 1320	Forjoe	John S. Booth, Pres. Donald J. Sellers, Sta. Mgr. Harold F. McEvoy, Coml. Mgr.	Mark G. Clarke, Asst. Mgr. Murray Hillman, Chief Engr.	Lang-Worth UP Western Electric
WWHG 1949	1590 1,000-D	W. H. Greenhow Co. 85 Canisteo St.				
WWHG-FM 1947	Ch. 287 (B) 105.3mc 8.3kw					
HUDSON						
WHUC 1947	1230 250	The Colgren Bcstg. Co. Union Turnpike 8-3341	KBS Union	John F. Kearney & Robert P. Strakos, Partners. James McDonough, Prog. Dir.	Thomas Stack, Prom. Mgr. Michael Tackach, Chief Engr.	Associated UP Collins
ITHACA						
WHCU 1921	870 1,000 L-WWL	Cornell U. Savings Bank Bldg. 3438	CBS	Michael R. Hanna, Gen. Mgr. Earl S. Cobey, Coml. Mgr.	John H. Deal, Prog. Dir. Norman R. Hoffman, Chief Engr.	Lang-Worth World UP Raytheon
WHCU-FM 1947	Ch. 247 (B) 97.3mc 40kw					Western Electric
JAMESTOWN						
WJOC 1948	1470 1,000-D	Air Waves Inc. 415 West Fourth St. 5-108	McGillvra	Harry E. Layman, Pres., Gen. & Coml. Mgr. & Chief Engr.	Jerry Lawson, Prog. Dir.	Capitol AP Raytheon
WJTN 1924	1240 250	James Bcstg. Co. Hotel Jamestown Bldg. 7-151	ABC Rambeau	Jay E. Mason, Pres. & Prog. Dir. Simon Goldman, Gen., Coml. & Prom. Mgr.	Harold J. Kratzert, Chief Engr.	Standard UP Gates
WJTN-FM 1947	Ch. 227 (B) 93.3mc 9.5kw			J. Ralph Carlson, Prod. Mgr.		General Electric
KENMORE						
(Buffalo) WXRA 1948	1080 1,000-D	Western New York Bcstg. Co. Kenmore Amherst 1181	Union Cooke	Edwin R. Sanders & Thaddeus Podbielniak, Owners Thaddeus Podbielniak, Gen. Mgr. Richard C. Shepard, Coml. Mgr.	James J. Frieling, Prog. Dir. Betty Reif, Prom. Mgr. Edwin R. Sanders, Chief Engr.	Associated AP Collins
WXRC (FM) 1947	Ch. 277 (B) 103.3mc 4.6kw	(WXRA, AM affiliate)				

DA-N Directional Antenna, night only. FM's in italic.
DA-1 Directional Antenna, same pattern day and night.
DA-2 Directional Antenna, different pattern day and night.

*—Non-Commercial Station. D—Day. N—Night. ST—Share Time. SH—Specified Hours.
U—Unlimited. CP—Construction Permit Issued. LS—Local Sunset.
L—Limited Time with Dominant Station. SA—Special Authorization.

City Call Letters Established	Chan. or Freq. Power	Name of Licensee Headquarters Address Telephone Number	Network Representative	Executive Personnel	Transc. Library News Service Transmitter Make	
KINGSTON WKNY 1939	1490 250	Kingston Bcstg. Corp. 601 Broadway 4500	MBS Union	John J. Laux, Pres. Claude S. Middagh, Gen., Coml. & Prom. Mgr.	Richard McCarthy, Prog. Dir. Joseph McNeilis, Chief Engr.	SESAC UP RCA
LIBERTY WVOS 1947	1240 250	Sullivan County Bcstg. Corp. Liberty 1880	Cooke	S. D. Lubin, Pres. & Gen. Mgr. H. G. Borwick, Coml. & Prom. Mgr.	D. Knight, Prog. Dir. J. Benson, Chief Engr.	Associated SESAC UP Western Electric
LOCKPORT WUSJ 1949	1340 250	Union-Sun & Journal Inc. 320 Michigan Ave. 4100		Egbert D. Corson, Pres. Peter Corson, Gen. & Coml. Mgr. Carl J. Raymond, Prog. Dir.	Wallace D. Soderholm, Prom. Mgr. Solomon A. Azar, Chief Engr.	Associated Thesaurus World AP General Electric
WUSJ-FM 1948	Ch. 257 (A) 99.3mc 0.8kw					
MALONE WICY 1946	1490 250	North Country Bcstg. Co. Inc. 65 Woodward St. 187	MBS, KBS Union	Mitchell C. Tackley, Pres., Prod. & Gen. Mgr. Ralph M. Cardinal Jr., Coml. Mgr.	Donald J. Paye, Prog. Dir. Adolf Stromer, Chief Engr.	World UP Gates
MASSENA WMSA 1945	1340 250	The Brockway Co. Central Bldg. 990	ABC Weed	John B. Johnson, Pres. Louis Saff Jr., Gen. Mgr. Thomas R. McHugh, Sta. & Coml. Mgr.	James H. Nash, Prog. Dir. Robert E. Anderson, Prom. Mgr. Michael Tarkulich, Chief Engr.	Associated UP Temco
WMSA-FM 1948	Ch. 287 (B) 105.3mc 13kw				 RCA
MIDDLETOWN WALL 1942	1340 250	Community Bcstg. Corp. 82 North St. 3119		John Morgan Davis, Pres. Paul E. Wagner, Gen. Mgr. Ernest C. Winkler, Coml. Mgr.	George Shepard, Prog. Dir. & Prom. Mgr. Charles Lissner, Chief Engr.	Thesaurus AP Gates
NEWBURGH WGNV 1933	1220 1,000-D	WGNV Bcstg. Co. Inc. 161 Broadway 4600		Merritt C. Spedel, Pres. George W. Bingham, Gen. Mgr. Joseph Rake, Coml. Mgr.	Richard Crans, Prog. Dir. Marvin Selmes, Chief Engr.	Standard UP Westinghouse
NEW ROCHELLE WGNR (FM) 1948	Ch. 228 (A) 93.5mc 1kw	New Rochelle Bcstg. Service Inc. 524 North Ave. 6-8220		Julian H. Gins, Pres. Kenneth Joseph, Sta. Mgr. & Prog. Dir.	Henry J. Geist, Chief Engr.	Lang-Worth UP REL

the Long Island story

\$534,000,000 RETAIL SALES

\$180,500,000 FOOD STORE SALES

\$ 82,000,000 AUTOMOTIVE AND FILLING STATION SALES

\$ 13,650,000 DRUG STORE SALES

That's the Market* in Long Island's NASSAU COUNTY—Where 3 out of 4 Families listen regularly to WHLI . . . And where top Long Island retailers depend upon WHLI for sales!

CONLAN RADIO REPORT

Distribution of Listening Homes Among Stations	
"A" Network, 50,000 w	26.0
W H L I	24.4
"B" Network, 50,000 w	9.8
"C" Network, 50,000 w	18.4
"D" Network, 50,000 w	10.7
Others, FM & TV	10.7

Survey Periods: Sunday thru Saturday—8:00 AM to 4:30 PM
Hempstead, Long Island, New York

* Source: Standard Rate and Data Consumer Markets 1949-1950.

"THE VOICE OF LONG ISLAND"

WHLI 1100 on your dial
WHLI-FM 98.3 MC
HEMPSTEAD, LONG ISLAND, N.Y.
ELIAS I. GODOFSKY, President

DIRECTORY OF AM, FM, and TV STATIONS OF THE UNITED STATES

(Data corrected to December 6, 1949)
If executives or services for FM or TV stations are same as AM affiliate names are not repeated.

NEW YORK—(Continued)

City Call Letters Established	Chan. or Freq. Power	Name of Licensee Headquarters Address Telephone Number	Network Representative	Executive Personnel	Transc. Library News Service Transmitter Make	
NEW YORK WABD(TV) 1947	Ch. 5 75-92mc 9.4kw aur.; 14.5kw vis.	Allen B. DuMont Labs Inc. 515 Madison Ave. Murray Hill 8-2600	DuMont	Mortimer W. Loewi, Dir. Leonard Hole, Gen. Mgr.	Tom Gallery, Sales Mgr.	
WABF (FM)	Ch. 258 (B) 99.5mc 18kw	Metropolitan Bcstg. & Television Inc. 654 Madison Ave. Templeton 8-5400		Ira A. Hirschmann, Pres. Alvin Hirschmann, V. P. & Gen. Mgr.	William Geib, Prog. Dir. Joyce Avery, Chief Engr.	World
WBNX 1928	1380 5,000 DA-1 ST-WAWZ	WBNX Bcstg. Co. Inc. 260 East 161st St. Melrose 5-0333	King	A. L. Haskell, Pres. William I. Moore, V. P. & Gen. Mgr.	E. Ervin & F. Johnson, Prog. Dirs.	SESAC Standard AP; W. E.
WCBS 1924	880 50,000	Columbia Bcstg. System 485 Madison Ave. Plaza 5-2000	CBS Radio Sales	Frank Stanton, Pres. G. Richard Swift, Gen. Mgr. Don Miller, Sales Mgr.	Don Ball, Prog. Dir. Robert Patt, Sales Prom. Mgr. R. G. Thompson, Chief Engr.	AP, UP, INS General Electric
WCBS-FM 1941	Ch. 266 (B) 101.1mc; 5.8kw					
WCBS-TV 1941	Ch. 2 54-60mc 6.8kw-aur; 13.7kw vis.			J. L. VanVolkenburg, V. P. Dir. of Tel. Oprs. Richard J. Redmond, Dir. of Gen. Tele. Oprs.	David V. Sutton, Gen. Sales Mgr. Charles M. Underhill, Dir. of Programs. Paul Wittlig, Dir. Tech. Opera- tions.	
WEVD 1927	1330 5,000 DA-2 ST-WBBR WHAZ	Debs Memorial Radio Fund Inc. 117 West 46th St. Plaza 7-0880 (See White Plains, N.Y., listing)		Adolph Held, Pres. Henry Greenfield, Gen. & Coml. Mgr.	George Field, Prog. Dir. Charles Brown, Chief Engr.	AP
WFAS 1932	1230 250					
WFDR (FM) 1949	Ch. 282 (B) 104.3mc 17kw	WFDR Bcstg. Corp. 1710 Broadway Columbus 5-7000		Frederick F. Umhey, Pres. David Harris, Prog. Dir.	Hartley Samuels, Sales Dir. Bertrand B. Arnou, Chief Engr.	Associated AP; RCA
WGHF (FM) 1946	Ch. 270 (B) 101.9mc 20kw	WGHF Inc. 10 East 40th St. Lexington 2-4927		W. G. H. Finch, Pres. & Gen. Mgr.	J. G. Myers, Prog. Dir. V. K. West, Chief Engr.	SESAC UP Western Electric
WGYN (FM) 1947	Ch. 250 (B) 97.9mc 4kw	WGYN Inc. 70 Pine St. Bowling Green 9-4054		P. K. Leberman, Pres. R. Olerud, Sta. Mgr. & Chief Engr.	Maurice Van Wyck, Coml. Mgr. John MacDougall, Prog. Dir.	Associated UP
WHOM 1930	1480 5,000-LS 500-N DA-2	Atlantic Bcstg. Co. Inc. 136 West 52d St. Circle 6-3900		Generoso Pope, Pres. Generoso Pope Jr., Gen. Mgr. Ralph Nardella, Coml. Mgr.	Ralph Costantino & Charles Baltin, Prog. Dirs. Foreign Languages George Steiger, Chief Engr.	World; UP Western Electric

DA-N Directional Antenna, night only. FM's in italic.
DA-1 Directional Antenna, same pattern day and night.
DA-2 Directional Antenna, different pattern day and night.

*—Non-Commercial Station. D—Day. N—Night. ST—Share Time. SH—Specified Hours.
U—Unlimited. CP—Construction Permit Issued. LS—Local Sunset.
L—Limited Time with Dominant Station. SA—Special Authorization.

**NOBODY BUT NOBODY KNOWS THE
ITALIAN AUDIENCE BETTER THAN**

WHOM

because:

.... WHOM IS OWNED AND OPERATED BY
IL PROGRESSO ITALO-AMERICANO, AMERICA'S
LEADING ITALIAN LANGUAGE NEWSPAPER.

.... WHOM IS MANAGED BY LEADERS IN
AMERICAN AND ITALIAN-AMERICAN PUBLIC
SERVICE, WHO UNDERSTAND AND APPRECIATE
THE PROGRAM NEEDS AND TASTES OF NEW
YORK'S TWO MILLION ITALIANS.

.... WHOM'S ITALIAN STAFF OF WRITERS,
PRODUCERS, ANNOUNCERS, ACTORS, AND
NEWSMEN ARE THE CREAM OF THE CROP IN
THE ITALIAN FIELD.

.... WHOM'S ITALIAN MERCHANDISING SERV-
ICE IS THE GREATEST ADVERTISING PLUS IN
NEW YORK'S ITALIAN RETAIL MARKET.

So--

IF YOU WANT TO REACH THE ITALIAN AUDIENCE IN NEW YORK (AND YOU REALLY CAN'T
AFFORD TO PASS UP TWO MILLION CUSTOMERS) REACH IT THROUGH THE STATION WHICH
KNOWS THE ITALIAN PEOPLE BEST!!!

136 West 52nd St.

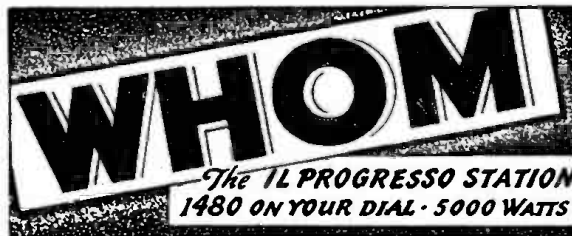

New York 19, N. Y. C1 6-3900

WESTCHESTER The Quality Market of the Nation . .

Westchester Still Wealthiest County in Nation, New Statistics of State Tax Official Reveal

Westchester is still the wealthiest county in the nation.

Its residents earn more on the average than do residents in any other county in the State of New York, which itself ranks highest among the 48 states in annual income.

Westchester's personal income taxes are highest in the state—in fact, on a per capita basis, Westchester's normal and capital gains tax bill is twice as big as is the state average. It is 68 per cent greater than that of New York City, and more than three times that of Erie County which includes the City of Buffalo.

This information and other data, heretofore unavailable, is contained in a study of "Personal Incomes in New York State," by Chester B. Pond, appearing in

For the first time the state bureau furnishes positive information on the degree of Westchester's personal wealth and earning power, since it is obvious that the greater the individual's earnings the greater will be his tax liability. Mr. Pond's study points out graphically that the greatest concentration of upper-bracket incomes are in the New York metropolitan area, with Westchester highest in the area. Tax Here Will be Higher

The average tax bill—not to be confused with the per capita tax bill which is arrived at by dividing the total population into the total tax paid—for Westchester and Nassau was \$92.59, for New York City \$72.29, and for the rest of the State \$38.33. Naturally, with

Area	Population		Average Personal and Capital Gains Tax	
	Number (Thous.)	% of Total	Average (\$)	% of Total
New York State	14,207	100.0	146.91	100.0
New York City	7,835	55.2	95.75	65.6
Suburban Counties	1,047	7.4	20,665	14.2
Nassau	452	3.2	8,466	5.8
Westchester	595	4.2	12,201	8.4
Large Upstate Counties	2,113	14.9	13,656	9.4
Albany	229	1.6	1,383	1.0
Erie	484	3.4	5,555	3.8
Montgomery	467	3.3	3,863	2.6
Oneida	218	1.5	914	0.6
Onondaga	330	2.3	1,811	1.2
Rest of State	3,212	22.6	15,963	10.9

The New York State Department of Health, Bureau of Health Statistics, July 1, 1948.
Distribution of Population and Tax Liability by Areas

Onondaga and Albany counties—8.6 per cent—with these counties comprising 13.4 per cent of the State's population.

Substantiates County's Claim

Such information as Mr. Pond provides is held invaluable since it is the first official data substantiating Westchester's claim to buying power. The radical population shifts and wartime economy throughout the nation formerly confused the true picture of individual wealth by areas, observers hold. Figures on a national scale will be available in the 1950 census.

Currently, however, national area income estimates on projections based on census figures as much as 10 years old. Some researchers base income estimates on home rental and valuations. In this category, too, Westchester exceeded every major county in the country.

Food sales are used by others as a wealth index, since it is argued that families spend a fixed portion of their incomes on the table. This yardstick also showed this county as the highest in the United States.

Federal income tax returns were reported by districts until 1942 but have been unavailable since that year. Now the State Department of Taxation and Finance has taken the guesswork out of a problem which has plagued the nation's outstanding research men for almost a decade, at least as far as New York State as a whole and Westchester specifically are concerned.

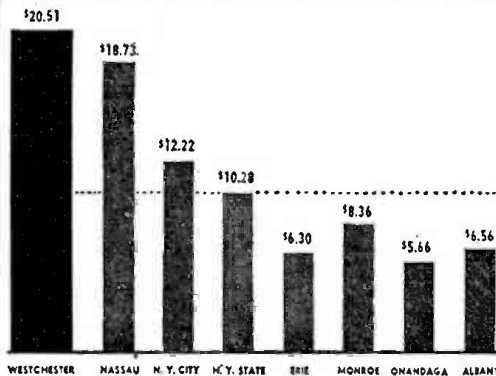

PER CAPITA PERSONAL TAX PAYMENTS, 1947

the Midyear Review of Business issue of the New York State Commerce Review.

Figures Based on 1947 Tax
Mr. Pond, director of Research and Statistics Bureau, N. Y. State Department of Taxation and Finance, provides statistics and an analysis of personal income tax returns of persons subject to tax for 1947 in which only 69 per cent of the personal income tax was imposed. Last year the state returned to a full 100 per cent of income tax collections to meet added state costs.

a 100 per cent income tax this year, Westchester's tax bill will be substantially higher.

Of special interest to Westchester is a comparison of the distribution of population in the various areas in ratio to their personal income tax liabilities. In this is the best indicator of Westchester's greater wealth and earnings, for it shows the county with only 4.2 per cent of the state population but paying 8.4 per cent of the total tax. This equals within two decimal points the combined total tax of Erie, Monroe,

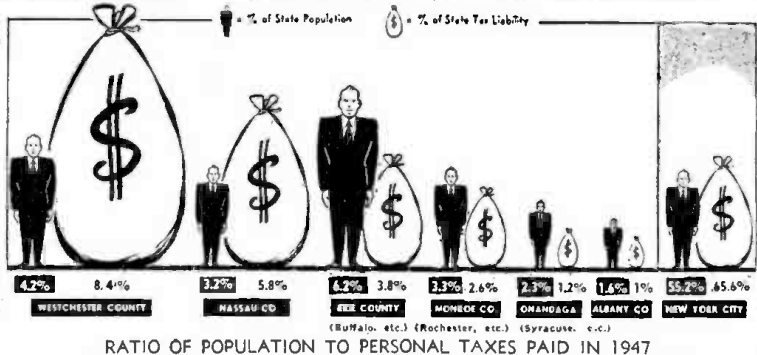

RATIO OF POPULATION TO PERSONAL TAXES PAID IN 1947

Westchester Listens to WFAS WFAS-FM . . . "The Quality Music Stations"

WESTCHESTER BROADCASTING CORPORATION

OFFICES and STUDIOS in the Reporter Dispatch Building, WHITE PLAINS, N.Y.

Represented by HEADLEY-REED CO., New York, N.Y.

DIRECTORY OF AM, FM, and TV STATIONS OF THE UNITED STATES

*(Data corrected to December 6, 1949)
If executives or services for FM or TV stations are same as AM affiliate names are not repeated.*

NEW YORK—(Continued)

City Call Letters Established	Chan. or Freq. Power	Name of Licensee Headquarters Address Telephone Number	Network Representative	Executive Personnel	Transc. Library News Service Transmitter Make	
NEW YORK—(Continued)						
WINS 1932	1010 50,000-LS DA-1 10,000-N	Crosley Bcstg. Corp. 28 West 44th St. Bryant 9-6000	Moore	James D. Shouse, Pres. Wilnot H. Losee, Coml. Mgr.	John Neal, Prog. Dir. Joseph G. Besch, Prom. Mgr. Paul Von Kunitz, Chief Engr.	UP, INS
WJZ 1921	770 50,000	American Bcstg. Co. Inc. 7 W. 66th St. Trafalgar 3-7000	ABC ABC Spot	Mark Woods, Pres. Murray B. Grabhorn, V. P. & Gen. Mgr. Clarence L. Doty, Sales Mgr.	Leonard Rug, Prog. Dir. Alfred E. Cohan, Prom. Mgr. G. O. Milne, Chief Engr.	AP, UP, INS RCA
WJZ-FM	Ch. 238 (B) 95.5mc 6.5kw					General Electric
WJZ-TV 1948	Ch. 7 174-180mc 15kw aur. 30kw vis.				A. Stronach, Prog. Dir.	RCA
WLIB 1942	1190 1,000 L-WOWO	New Bcstg. Co. Inc. 207 E. 30th St. Oregon 9-2720		Morris Novik, Pres. Harry Novik, Gen. Mgr. Vincent G. Pirozzi Jr., Bus. Mgr.	Sam Elfert, Prog. Dir. E. T. Darlington, Chief Engr.	SESAC AP, UP RCA
WMCA 1925	570 5,000 DA-1	WMCA Inc. 1657 Broadway Circle 6-2200	Free & Peters	Nathan Straus, Pres. Norman Boggs, Gen. Mgr. Leon Goldstein, Prog. Dir.	Howard Klarman, Prom. Mgr. James McCafferty, Chief Engr.	World AP RCA
WMCA-FM 1948	Ch. 222 (B) 92.3mc 11kw					General Electric
WMGM 1922	1050 50,000 DA-1	Marcus Loew Booking Agency 711 Fifth Ave. Murray Hill 8-1000	Radio Reps	Bertram Lehtar Jr., Exec. Dir. & Dir. of Sales Frank Roehrenbeck, Gen. Mgr.	Raymond Katz, Prog. Dir. Jo Ranson, Publ. Dir. Paul Fuelling, Chief Engr.	AP, UP Western Electric
WMGM-FM 1942	Ch. 262 (B) 100.3mc 18kw					Associated
WNBC 1922	660 50,000 DA-1	National Bcstg. Co. 30 Rockefeller Plaza Circle 7-8300	NBC NBC Spot	Joseph H. McConnell, Pres. Thomas B. McFadden, Gen. Mgr. Donald A. Norman, Asst. Mgr. John C. Warren, Sales Mgr.	Harvey Gannon, Prog. Dir. Murry Harris, Prom. Mgr. Charles Pheilan, Chief Engr.	Associated Thesaurus AP, UP, INS RCA
WNBC-FM 1944	Ch. 246 (B) 97.1mc 1.6kw					
WNBT (TV) 1939	Ch. 4 66-72mc 5.75kw aur.; 7kw vis.	(WNBC, AM affiliate)			T. J. Buzalski, Chief Engr.	
WNEW 1934	1130 10,000 DA-1 CP-50,000	WNEW Inc. 565 Fifth Ave. Plaza 3-3300	Blair	Bernice Judis, Exec. V. P. & Gen. Mgr. Ira Herbert, V. P. in Chg. of Sales. Ted Cott, V. P. in Chg. of Prog.	Nick Freyberg, Prom. Mgr. Max Weiner, Chief Engr.	Lang-Worth AP
WNYC 1924	830 1,000 DA-1 L-WCCO	City of New York Municipal Bcstg. Co. Municipal Bldg. Worth 2-5800		William O'Dwyer, Pres. Seymour N. Siegel, Gen. Mgr.	John DeProspro, Exec. Officer George Wallach, Prog. Dir. William H. Pitkin, Chief Engr.	Associated Thesaurus AP, UP, TP Western Electric
WNYC-FM 1943	Ch. 230 (B) 93.9mc 20kw					
WOR 1922	710 50,000 DA-1	Bamberger Bcstg. Service 1440 Broadway Longacre 4-8000	MBS Kettell-Carter	Theodore C. Streibert, Pres. Julius F. Seebach Jr., V. P. & Prog. Dir. R. C. Maddux, V. P. in Charge of Sales	Robert Mayo, Dir. of Sales Joseph Creamer, Prom. Mgr. J. R. Poppele, V. P. & Chief Engr.	Associated AP, UP, INS Western Electric
WOR-FM 1940	Ch. 254 (B) 98.7mc 3.4kw					General Electric
WOR-TV 1949	Ch. 9 186-192mc 11kw aur.; 9kw vis.					General Electric
WOV 1926	1280 5,000 DA-1 ST-WHBI	Wodaam Corp. 730 Fifth Ave. Circle 5-7979	Bolling	Ralph N. Well, Gen. Mgr. Herb Schorr, Sales Mgr. Arnold Hartley, Prog. Dir.	Carroll Forbes, Prom. Mgr. Emile Hill, Chief Engr.	MacGregor Standard AP Western Electric
WPIX (TV) 1948	Ch. 11 198-204mc 9.25kw aur.; 18.5kw vis.	News Syndicate Inc. 220 E. 42nd St. Murray Hill 2-1234	Free & Peters	F. M. Flynn, Pres. Robert L. Coe, V. P. & Gen. Mgr. Scott Donahue, Acting Sales Mgr.	Warren Wade, Prog. Mgr. Thomas Howard, Chief Engr.	RCA

DA-N Directional Antenna, night only. FM's in italic.
DA-1 Directional Antenna, same pattern day and night.
DA-2 Directional Antenna, different pattern day and night.

*—Non-Commercial Station. D—Day. N—Night. ST—Share Time. SH—Specified Hours.
U—Unlimited. CP—Construction Permit Issued. LS—Local Sunset.
L—Limited Time with Dominant Station. SA—Special Authorization.

AM

WSYR
570 kc.

WSYR ACUSE

**the Only
COMPLETE
Radio
Institution
in
Central New York**

FM

WSYR
94.5 mg.

TW

**Newest
WSYR
Service**

WSYR ACUSE

NBC Affiliate in Central New York
Headley-Reed, National Representatives

DIRECTORY OF AM, FM, and TV STATIONS OF THE UNITED STATES

(Data corrected to December 6, 1949)
If executives or services for FM or TV stations are same as AM affiliate names are not repeated.

NEW YORK—(Continued)

City Call Letters Established	Chan. or Freq. Power	Name of Licensee Headquarters Address Telephone Number	Network Representative	Executive Personnel	Transc. Library News Service Transmitter Make	
NEW YORK—(Continued)						
WQXR 1934	1560 10,000 DA-1	Interstate Bcstg. Co. Inc. 730 Fifth Ave. Circle 5-5568	Raymer	Arthur Hays Sulzberger, Pres. Elliott M. Sanger, Exec. V. P. & Gen. Mgr. Norman S. McGee, V. P. in Chg. Sales	Eleanor N. Sanger, Prog. Dir. Mary Rice Anderson, Prom. Mgr. Russell D. Valentine, Chief Engr.	Associated Western Electric
WQXR-FM 1939	Ch. 242 (B) 96.3mc 11kw				 Western Electric
WWRL (Woodside) 1926	1600 250; CP: 5,000 DA-1	WWRL Inc. 4130 58th St., Woodside, N. Y. Newtown 9-3300		W. H. Reuman, Pres. Edith Dick, Gen. Mgr. Selvin Donneson, Sales Prom. Mgr.	Fred Barr, Prog. Dir. Walter Kaner, Pub. Rel. Dir. Benton R. Bartlett, Chief Engr.	Associated Capitol AP Western Electric
NIAGARA FALLS						
WHLD 1940	1270 5,000-D-DA	Niagara Falls Gazette Pub. Co. Hotel Niagara 8421	Headley-Reed	Earl C. Hull, V. P. & Gen. Mgr. Richard G. Robbins, Coml. Mgr.	Robert J. Manning, Prog. Dir. Robert J. Wilson, Chief Engr.	World Standard UP Raytheon
WHLD-FM 1946	Ch. 253 (B) 98.5mc 46kw				 Federal
WJLJ 1947	1440 1,000-D	John J. Laux Elks Bldg. 5266	Grant	John J. Laux, Pres. Robert F. Kliment, Gen. Mgr.	Louise Hamrick, Prog. Dir. Gustav Czaplak, Chief Engr.	Lang-Worth UP Gates
OGDENSBURG						
WSLB 1940	1400 250	St. Lawrence Bcstg. Corp. 2315 Knox St.	MBS	J. R. Brandy, Pres. & Coml. Mgr. Harold J. Frank, Secy.-Treas.	Hal Gilman, Prog. Dir. Elsworth Hall, Chief Engr. UP RCA
WSLB-FM 1948	Ch. 291 (B) 106.1mc 13.7kw		Rural Radio		 Federal
OLEAN						
WHDL 1935	1450 250	WHDL Inc. 3219 West State Rd. 4149	ABC, KBS McKinney	E. B. Fitzpatrick, Pres. John R. Henzel, Gen. Mgr. Joseph Eade, Coml. Mgr.	Donald Merriman, Prog. Dir. Otis Atherton, Chief Engr.	World UP Collins
WHDL-FM 1949	Ch. 239 (B) 95.7mc 43kw				 Westinghouse
ONEONTA						
WDOS 1949	1400 250	The Oneonta Star Inc. Hotel Oneonta 2470	MBS Union Walker	James H. Ottaway, Pres. Eugene J. Brown, Gen. Mgr. Francis A. Brinkley, Mngng. Dir.	Walton F. Deming, Sta. Mgr. George R. Smith, Coml. Mgr. Wiley Bates, Chief Engr.	Capitol World AP General Electric
OSWEGO						
WOPT (FM) 1947	Ch. 284 (B) 104.7mc 3kw	Palladium-Times Inc. 174-176 W. 1st St. 8	McGillvra	Clark Morrison, Pres. E. M. Waterbury, Treas. & Gen. Mgr.	Leonard Levitt, Coml. Mgr. Paul Abbott, Prog. Dir. Cyril Edmunds, Chief Engr.	World Lang-Worth AP General Electric

DA-N Directional Antenna, night only. FM's in italic.
DA-1 Directional Antenna, same pattern day and night.
DA-2 Directional Antenna, different pattern day and night.

*—Non-Commercial Station. D—Day. N—Night. ST—Share Time. SH—Specified Hours.
U—Unlimited. CP—Construction Permit Issued. LS—Local Sunset.
L—Limited Time with Dominant Station. SA—Special Authorization.

W W R L
NEW YORK
NOW
5,000 WATTS
Powerfully Selling America's Greatest Market at the Lowest Cost
1600 KC
"The High Spot on the Dial"

Want to reach lots of **CLASS**

and lots of **MASS?**

Class is purchasing power.

Mass is many people.

Combine them, and you have WQXR's audience—a million people, 500,000 music-loving families, 31.6% with incomes in the top two income groups.

If your product needs class-mass, it needs WQXR...because WQXR has sold the class-mass audience successfully for nearly fourteen years.

There's lots more to the WQXR class-mass story. Pulse data shows it, and is available to you by calling Circle 5-5566 or your nearest Raymer representative.

WQXR

AM-1560 FM-96.3
The Radio Station of The New York Times
"Always the Best in Music"

DIRECTORY OF AM, FM, and TV STATIONS OF THE UNITED STATES

*(Data corrected to December 6, 1949)
If executives or services for FM or TV stations are same as AM affiliate names are not repeated.*

NEW YORK—(Continued)

City Call Letters Established	Chan. or Freq. Power	Name of Licensee Headquarters Address Telephone Number	Network Representative	Executive Personnel	Transc. Library News Service Transmitter Make
OYSTER BAY					
WKBS 1948	1520 250-D	Key Bcstg. System Inc. 25 East Main St. 6-2500		R. Lee Hollingsworth, Pres., Gen. & Coml. Mgr. Gertrude Davis, Prog. Dir.	Herbert Stone, Prom. Mgr. John Dawson, Chief Engr. Thesaurus UP Gates
PEEKSKILL					
WLNA 1948	1420 500-D	Highland Bcstg. Corp. Dogwood Rd. 7-2454		Peter C. Houskeeper, Pres. & Chief Engr. Irving E. Cottrell, V. P. & Asst. Chief Engr.	Ralph S. Silver Jr., Gen. & Coml. Mgr. Joel Blake, Prog. Dir. World UP Raytheon
PLATTSBURG					
WEAV 1935	960 1,000 DA-2	Plattsburg Bcstg. Corp. Radio Center 1600	ABC Union McGillvra	George F. Bissell, Pres. & Gen. Mgr.	Martin Mannix, Asst. Mgr. & Prog. Dir. Jack Nazak, Chief Engr. Thesaurus UP Collins
WENT 1944	1340 250	(See Gloversville, N. Y., listing)			
WIRY (CP)	1340 250	Clinton County Bcstg. Co.			
POUGHKEEPSIE					
WEOK 1949	1390 1,000-D	Mid-Hudson Bcstrs. Inc. 385 Main St. 8103		Harold W. Cassill, Pres., Chief Owner & Gen. Mgr. Richard F. Mills, Coml. Mgr.	Harold Hennig, Prog. Dir. Alvin Perlmutter, Prom. Mgr. John P. Burke, Chief Engr. World INS, TP RCA
WKIP 1940	1450 250	Poughkeepsie Newspapers Inc. Memorial Sq. 6800	ABC Union	M. C. Speidel, Pres. George W. Bingham, Gen. Mgr. Henry J. Behre, Coml. Mgr.	Richard Crans, Prog. Dir. & Prom. Mgr. Marvin Selmes, Chief Engr. Standard AP RCA
WHVA (FM) 1947	Ch. 284 (B) 104.7mc 2.3kw	(WKIP, AM affiliate)		 General Electric
ROCHESTER					
WARC 1947	950 1,000 DA-2	WARC Inc. 111 East Ave. Hamilton 8920	ABC Katz	Samuel W. Townsend, Pres. & Gen. Mgr. Harland M. Evans, Coml. Mgr.	Fred L. Essex, Prog. Dir. Frank Lane, Prom. Mgr. Robert Emch, Chief Engr. Associated AP Raytheon
WHAM 1922	1180 50,000	Stromberg-Carlson Co. Rochester Radio City Culver 7240	NBC Hollingbery	William Fay, V. P. & Gen. Mgr. John W. Kennedy Jr., Coml. Mgr. Charles W. Siverson, Prog. Dir.	Arthur Kelly, Asst. Mgr. Armin N. Bender, Prom. Mgr. Kenneth J. Gardner, Chief Engr. World UP Westinghouse
WHFM (FM) 1939	Ch. 255 (B) 98.9mc 20kw	(WHAM, AM affiliate)		 Western Electric
WHAM-TV 1949	Ch. 6 72-88mc 8.7kw aur. 16.7kw vis.		ABC, CBS DuMont NBC	 RCA
WHEC 1925	1460 5,000 DA-N	WHEC Inc. 40 Franklin St. Baker 6740	CBS McKinney	Frank E. Gannett, Pres. Gunnar O. Wiig, Gen. Mgr. Lemoline C. Wheeler, Coml. Mgr.	William J. Adams, Prog. Dir. & Prom. Mgr. Bernard C. O'Brien, Chief Engr. Associated Standard AP Western Electric
WHEC-FM 1940	Ch. 243 (B) 96.5mc 65kw				
WRNY 1947	680 250-D	Monroe Bcstg. Co. Inc. 191 East Ave. Hamilton 9775	Forjoe	George B. Kelly, Pres., Gen., Coml. & Prom. Mgr.	Add Penfield, Prog. Dir. Felix Bonvouloir, Chief Engr. Lang-Worth AP Raytheon
WRNY-FM 1948	Ch. 250 (B) 97.9mc 7.8kw			 General Electric
WSAY 1936	1370 1,000 DA-1 CP: 5,000 DA-N	Federal Bcstg. System Inc. 328 Main St. E. Baker 4870	Walker	Gordon P. Brown, Pres., Gen. Mgr. & Chief Engr.	Clifford Culver, Coml. Mgr. Jack Turner, Prog. Dir. INS RCA
WVET 1947	1280 5,000 DA-N	Veterans Bcstg. Co. Inc. 17 Clinton Ave. S. Hamilton 4820	MBS Weed	William B. Mallefert, Pres., Gen. & Coml. Mgr.	Paul C. Louthier, Prog. Dir. Ervin F. Lyke, Chief Engr. Associated UP Collins
ROME					
WKAL 1946	1450 250	Copper City Bcstg. Corp. Madison Theatre Onelda, N. Y. 3616	MBS Cooke	Myron J. Kallet, Pres. Michael C. Fusco, Gen. Mgr. George Cramer, Coml. Mgr.	Daniel A. Fusco, Prog. Dir. & Prod. Mgr. Joseph Treia, Prom. Mgr. Deforest Layton, Chief Engr. Lang-Worth UP Collins
SARANAC LAKE					
WNBZ 1927	1450 250	Upstate Bcstg. Corp. 88 Main St. 1320	ABC Union	H. Berwind Williams, Gen. Mgr. & Chief Engr. Jacques DeMattos, Coml. Mgr.	John Birmingham, Prog. Dir. Thesaurus AP
SCHENECTADY					
WBCA (FM) 1941	Ch. 266 (B) 101.1mc 1kw	Capitol Bcstg. Co. Inc. 408 State St. 3-1423	Rambeau	Leonard L. Asch, Pres. & Gen. Mgr. Valerie Eaton, Coml. Mgr.	Glen E. Walrath, Prog. Dir. Dwelle S. Hoag, Chief Engr. Associated Capitol, SESAC AP, INS General Electric

DA-N Directional Antenna, night only. FM's in italic.
DA-1 Directional Antenna, same pattern day and night.
DA-2 Directional Antenna, different pattern day and night.

*—Non-Commercial Station. D—Day. N—Night. ST—Share Time. SH—Specified Hours.
U—Unlimited. CP—Construction Permit Issued. LS—Local Sunset.
L—Limited Time with Dominant Station. SA—Special Authorization.

LONG TIME RECORDS FOR LEADERSHIP,-



"BABE" RUTH IN HOME RUNS

60 in the 1927 season, . . . a record never topped since!

LOU GEHRIG IN CONSECUTIVE GAMES

2,130 games 1925-1939, . . . a record never topped since!

JACK CHESBRO IN PITCHING

In 1904 won 41 out of 48, . . . a record never topped since!

HUGH DUFFY IN BATTING AVERAGE..

In 1894 batted .438, . . . a record never topped since!

"TY" COBB IN STOLEN BASES

In 1915 Cobb stole 96 bases, a record never topped since!

WHEC IN ROCHESTER HOOPERATING

In 1943 Rochester's first Hooperating reported the decided preference for WHEC. This station's Hooperatings have never been topped since!



WHEC

of Rochester
N. Y.
5,000 WATTS

Representatives: EVERETT-McKINNEY, Inc., New York, Chicago, HOMER GRIFFITH CO., Los Angeles, San Francisco

DIRECTORY OF AM, FM, and TV STATIONS OF THE UNITED STATES

(Data corrected to December 6, 1949)
If executives or services for FM or TV stations are same as AM affiliate names are not repeated.

NEW YORK—(Continued)

City Call Letters Established	Chan. or Freq. Power	Name of Licensee Headquarters Address Telephone Number	Network Representative	Executive Personnel	Transc. Library News Service Transmitter Make	
SCHENECTADY—(Continued)						
WGY 1922	810 50,000	General Electric Co. 1 River Rd. 3-2121	NBC NBC Spot	R. S. Peare, V. P. & Mgr. B. J. Rowan, Asst. Mgr. R. B. Hanna Jr., Sta. Mgr. E. P. Weil, Supvsr. Sta. Sales	Caleb Paine, Supvsr. Sta. Prog. R. W. O'Brian, Supvsr. Sta. Prom. W. J. Purcell, Chief Engr.	Lang-Worth Thesaurus World AP, UP General Electric
WGFM (FM) 1941	Ch. 258 (B) 99.5mc 6kw	(WGY, AM affiliate)				
WRGB (TV) 1939	Ch. 4 66-72mc 8.16kw aur.; 16.32kw vis.	(WGY, AM affiliate) 60 Wash. Ave. 4-2211, Ext. 4928			A. G. Zink, Prog. Supvsr.	
WSNY 1942	1240 250	Western Gateway Bcstg. Corp. Plaza Theatre Bldg. 3-3622	Young	Winslow Leighton, Gen. Mgr. Robert Wallace, Prog. Dir.	Mary Lazott, Prom. Mgr. Irving Beck, Chief Engr.	AP
SCRIBA						
WOPT (CP) 1941	1220 1,000 D	Palladium-Times Inc.				
SYRACUSE						
WAGE 1941	620 5,000-LS 1,000-N DA	WAGE Inc. Loew Bldg. 2-0277	ABC Petry	William T. Lane, Gen. Mgr. Aaron Beckwith, Gen. Sales Mgr.	Gordon Alderman, Prog. Mgr.	
WAGE-FM 1947	Ch. 253 (B) 95.5mc 2kw					
WFBL 1922	1390 5,000 DA-N	Onondaga Radio Bcstg. Corp. 433 S. Warren St. 21147	CBS Free & Peters	Oscar F. Soule, Pres. Samuel Woodworth, V. P. & Gen. Mgr. Charles Phillips, V. P. & Coml. Mgr.	Ray Gantter, Prog. Dir. Hendrick Soule, Prom. Mgr. James Kelley, Chief Engr.	Cole UP Western Electric
WFBL-FM 1947	Ch. 226 (B) 93.1mc 8.5kw					General Electric
WHEN (TV) 1948	Ch. 8 180-186mc 7.5kw aur.; 15kw vis.	Meredith Syracuse TV Corp. 101 Court St. 3-1126	ABC, CBS DuMont Katz	Paul Adanti, Gen. Mgr. William H. Bell, Coml. Mgr.	Edward P. Roden, Prog. Dir. H. Eugene Crow, Chief Engr.	UP General Electric
WNDR 1947	1260 5,000 DA-N	Syracuse Bcstg. Corp. 308 South Salina St. 2-6101	MBS Raymer	T. Frank Dolan, Pres. Martin Karig, Gen. Mgr. Arthur Cooper, Coml. Mgr.	Robert Gifford, Prog. Dir. Robert Dye, Chief Engr.	World SESAC AP RCA
WNDR-FM 1947	Ch. 273 (B) 102.5mc 8.5kw					
WOLF 1940	1490 250	Civic Bcstg. Corp. Onondaga Hotel 2-7211	Union Walker	T. S. Marshall, Pres. & Gen. Mgr. James J. Coolican, Coml. Mgr.	Hamilton M. Woodle, Prog. Dir. Donald Muir, Chief Engr.	Standard AP
WSYR 1926	570 5,000 DA-2	Central N. Y. Bcstg. 224 Harrison St. 3-7111	NBC Headley-Reed	H. C. Wilder, Pres. E. R. Vadeboncoeur, V. P. & Gen. Mgr.	Bill Rothrum, Prog. Dir. A. G. Belle Isle, V. P. & Chief Engr.	Lang-Worth UP RCA
WSYR-FM 1946	Ch. 233 (B) 94.5mc 9kw			W. R. Alford, Coml. Mgr.		General Electric
WSYR-TV 1946	Ch. 5 76-82mc 12.5kw aur.; 23kw vis.					General Electric
TROY						
WFLY (FM) 1948	Ch. 222 (B) 92.3mc 5.4kw	The Troy Record Co. Hotel Troy 8400	Rural Radio	Frank L. York, Gen. Mgr. Robert C. Goodrich, Sta. Mgr.	Alphonsus A. Pennick, Coml. Mgr. Donald G. Girard, Prog. Dir. Arthur Stuarts Jr., Chief Engr.	Capitol World General Electric
WHAZ 1922	1330 1,000 S-WBBR WEVD	Rensselaer Polytechnic Institute 110 8th St. 6810, Ext. 32		L. W. Houston, Pres. W. J. Williams, Gen. Mgr.	A. Olin Niles, Prog. Dir. W. C. Stoker, Chief Engr.	Western Electric
WTRY 1940	980 5,000 DA-1	Troy Bcstg. Co. Inc. 92 Fourth St. 2100	CBS Headley-Reed	H. C. Wilder, Pres. W. A. Ripple, V. P. & Gen. Mgr. John W. Sutphen Jr., Coml. Mgr.	H. H. Sharpe III, Prog. Dir. James F. Baker Jr., Prom. Mgr. A. H. Chismark, Chief Engr.	Associated Lang-Worth UP RCA
WTRI (FM) 1946	Ch. 274 (B) 102.7mc 3.5kw	(WTRY, AM affiliate)				General Electric
TURIN						
WVBN (FM) 1948	Ch. 299 (B) 107.7mc 1.3kw	Rural Radio Network Inc. 118 N. Tioga St. Ithaca, N. Y., 3341	Rural Radio	Harold L. Creal, Pres. Michael R. Hanna, Gen. Mgr. D. K. deNeuf, Asst. Gen. Mgr.	H. Stillwell Brown, Coml. Mgr. Merrill Knapp, Prog. Supvsr. Thomas R. Humphrey, Chief Engr.	Standard Associated UP General Electric
UTICA						
WGAT 1946	1310 1,000-LS 500-N DA	Central Bcstg. Co. 250 Genesee St. 2-9231	Union Bolling	J. Eric Williams, Pres. & Gen. Mgr.	Roland L. Fowler, Prom. Mgr.	AP Gates
WIBX 1926	950 5,000 DA-1	WIBX Inc. First Nat'l Bank Bldg. 2-2101	CBS Ra-Tel	(Mrs.) Margaret Bowen Stevens, Pres. & Gen. Mgr. N. W. Cook, Coml. & Prom. Mgr.	Elliott Stewart, Exec. V.P., Sta. & Prog. Mgr. John T. Dowdell, Chief Engr.	World UP, INS RCA
WIBX-FM 1946	Ch. 245 (B) 96.9mc 9kw					General Electric
WKTV (TV) 1949	Ch. 13 210-216mc 11.3kw aur.; 13kw vis.	Copper City Bcstg. Corp. Smith Hill Rd. 2-1913	NBC Cooke	Myron J. Kallet, Pres. Michael C. Fusco, Gen. Mgr.	Deforest T. Layton Jr., Chief Engr.	General Electric
WRUN 1948	1150 5,000-LS DA-2 1,000-N	Rome Sentinel Co. 258 Genesee St. 2-5111	ABC Avery-Knodel	Bradley C. Barnard, Pres. Fritz S. Updike, Gen. Mgr. Thomas E. Martin, Sta. Mgr. R. A. Clark, Coml. & Prom. Mgr.	Nick Stemmler, Prog. Dir. C. F. Henry, Studio Supvsr. G. S. Woods, Trans. Supvsr.	Associated AP RCA
WRUN-FM 1946	Ch. 289 (B) 105.7mc 4.3kw					General Electric
WUTA (CP) 1946	1230 250	U.T.K. Radio Corp.				

DA-N Directional Antenna, night only. FM's in italic.
DA-1 Directional Antenna, same pattern day and night.
DA-2 Directional Antenna, different pattern day and night.

*—Non-Commercial Station. D—Day. N—Night. ST—Share Time. SH—Specified Hours.
U—Unlimited. CP—Construction Permit Issued. LS—Local Sunset.
L—Limited Time with Dominant Station. SA—Special Authorization.

fifty-five

ADVERTISERS

WRGB

TELEVISION

CHANNEL 4

REPRESENTED

NATIONALLY

BY NBC

SPOT SALES

utilizing WGY 10 years ago

are using WGY today

... reason?

*They've found
it Pays!*

Serving Eastern
New York, West-
ern New England,
Albany, Troy and
Schenectady.

-810 on your dial
50,000 *Powerful* watts
affiliated with **NBC**

WGY

A GENERAL ELECTRIC STATION

DIRECTORY OF AM, FM, and TV STATIONS OF THE UNITED STATES

*(Data corrected to December 6, 1949)
If executives or services for FM or TV stations are same as AM affiliate names are not repeated.*

NEW YORK—(Continued)

City Call Letters Established	Chan. or Freq. Power	Name of Licensee Headquarters Address Telephone Number	Network Representative	Executive Personnel	Transc. Library News Service Transmitter Make	
WATERTOWN						
WATN 1941	1240 250	Watertown Bcstg. Corp. 118 Washington St. 2424	MBS Wood & Colton	G. Harry Righter, Pres., Gen. Coml. & Prom. Mgr. Hugh L. Cosline, Prog. Dir.	Donald Schryver, Fred Sprague. James Billingsley, Engrs.	Standard AP RCA
WWNY 1941	790 1,000 DA-N	The Brockway Co. Hotel Woodruff 4120	CBS Weed	John B. Johnson, Pres. Louis Saff Jr., Gen. & Coml. Mgr. Earl R. Kelly, Sta. Mgr. James W. Higgins, Asst. Sta. Mgr.	John Cleveland, Prom. Mgr. David G. Graves, Prod. Mgr. Maynard B. Davis, Chief Engr.	Associated World UP RCA
WWNY-FM 1947	Ch. 263 (B) 100.5mc 14.4kw					

WETHERSFIELD						
WFNF (FM) 1948	Ch. 299 (B) 107.7mc 1.3kw	Rural Radio Network Inc. 118 N. Tioga St. Ithaca, N. Y. 3341	Rural Radio	Harold L. Creal, Pres. Michael R. Hanna, Gen. Mgr. D. K. deNeuf, Asst. Gen. Mgr.	H. Stilwell Brown, Coml. Mgr. Merrill Knapp, Prog. Supvr. Thomas R. Humphrey, Chief Engr.	Standard Associated UP General Electric

WHITE PLAINS						
WFAS 1932	1230 250	Westchester Bcstg. Corp. 8 Church St. 9-6400	Headley-Reed	Valentine E. Macy Jr., Pres. Frank A. Seitz, Gen. Mgr. & Chief Engr.	John E. Arens, Coml. Mgr. Randall Kaler, Prog. Dir.	Associated World AP Western Electric REL
WFAS-FM 1947	Ch. 280 (A) 103.9mc 0.12kw					

NORTH CAROLINA

AHOSKIE						
WRCS 1948	970 1,000-D	Roanoke-Chowan Bcstg. Co. N. C. Highway No. 350 333		Chas. H. Jenkins, Pres. P. G. Sewell, Gen., Coml. & Prom. Mgr.	Johnny Palmer, Prog. Dir. John M. Sherwood, Chief Engr.	Associated UP Raytheon

ALBEMARLE						
WABZ 1947	1010 1,000-D	Radio Station WABZ Inc. P. O. Box 226 1100	KBS	M. M. Palmer, Pres. W. J. Page, Gen. Mgr. C. H. Shankle, Coml. Mgr.	J. T. Newman, Prog. Dir. James Wise, Chief Engr.	Capitol UP

ASHEBORO						
WGWR 1947	1260 1,000-D	Asheboro Bcstg. Co. Inc. 303 E. Salisbury St. 800		Roy Cox, Pres. J. R. Marlowe, Gen. & Coml. Mgr.	Anderson B. Brown Jr., Prog. Dir. Ryan Neely, Prom. Mgr. Clyde C. Penny, Chief Engr.	Associated UP Raytheon
WGWR-FM	Ch. 222 (B) 92.3mc 10kw					

ASHEVILLE						
WISE 1939	1230 250	Radio Station WISE Inc. 100 College St. 3-5381	NBC Avery-Knodel	Harold H. Thoms, Pres. & Gen. Mgr. Lloyd B. Leonard, Coml. Mgr. Harold F. Moon Jr., Prog. Dir.	Wilma Moore, Prom. Mgr. Matthew C. Munn, Chief Engr. AP Gates
WLOS 1947	1380 5,000-LS 1,000 DA-N	Skyway Bcstg. Corp. Battery Park Hotel 2-2431	ABC Taylor-Borroff	Charles B. Britt, V.P. Kenneth Beachboard, Sta. Mgr. Edward D. Brandt, Coml. & Prom. Mgr.	William L. Robertson, Prog. Dir. William M. Chambers, Chief Engr.	World UP RCA
WLOS-FM 1947	Ch. 282 (B) 104.3mc 9.2kw					
WSKY 1946	1490 250	Radio Asheville Inc. 12 Church St. 3-4451	Friedenberg	Carl R. Bamford, Pres. Zeb Lee, Gen. Mgr.		Lang-Worth Capitol AP
WWNC 1927	570 5,000 DA-N	Asheville Citizen-Times Co. Inc. 14 O. Henry Ave. 5611	CBS MBS Headley-Reed	Don S. Elias, Pres. Cecil B. Hoskins, Gen. & Prom. Mgr. J. A. Hagan, Sales Mgr.	William F. Melia, Prog. Dir. William H. Hamrick, Acting Chief Engr.	Associated AP, UP RCA

BREVARD						
WPNF (CP) 1947	1240 250	Pisgah Bcstg. Co. Inc. Brevard 7		Ed. M. Anderson, Pres. & Gen. Mgr.	 AP Gates

BURLINGTON						
WBBB 1941	920 1,000-D CP: 1,000 DA-N	Alamance Bcstg. Co. Inc. 310 1/2 S. Main St. 6-6376	MBS KBS Dixie FM McGillivra	E. Z. Jones, Gen. & Prom. Mgr. Phil Eakin, Coml. Mgr.	Ed Brooks, Prog. Dir. Berry Tysor, Chief Engr. AP Western Electric
WBBB-FM 1946	Ch. 266 (B) 101.1mc 34kw				 REL
WFNS 1947	1150 1,000-D CP: 1,000	Burlington-Graham Bcstg. Co. Burlington 6-5536		John C. Hanner, Gen. & Coml. Mgr.	William Sandefur, Prog. Dir. T. H. McIntosh, Chief Engr.	World UP Western Electric
WFNS-FM 1947	Ch. 230 (B) 93.9mc 37kw				 Westinghouse

DA-N Directional Antenna, night only. FM's in italic. DA-1 Directional Antenna, same pattern day and night. DA-2 Directional Antenna, different pattern day and night. *—Non-Commercial Station. D—Day. N—Night. ST—Share Time. SH—Specified Hours. U—Unlimited. CP—Construction Permit Issued. LS—Local Sunset. L—Limited Time with Dominant Station. SA—Special Authorization.



QUESTION: What radio trade publication has the largest paid circulation?

ANSWER: We do . . . over 15,000 copies.

QUESTION: Do you maintain, according to the "readership projection formula", that each copy is read by an average of four people?

ANSWER: We do . . . it means a total readership of over 60,000.

QUESTION: Do you have a convenient circulation breakdown which shows the types of radio people your magazine reaches?

ANSWER: We do . . . **BROADCASTING** reaches them all. These figures are from our sworn circulation statement of June 27, 1949.

Radio Advertisers (National and Regional) . .	2,904
Advertising Agencies (National and Regional)	2,305
Station and Network Personnel	5,695
Representatives and Services	759
Others	3,775
TOTAL	15,438

QUESTION: Do you find, from impartial sources of information (lineage figures, for instance), that **BROADCASTING** is considered the finest advertising buy in the field?

ANSWER: We certainly do.

**LEADERSHIP
MEANS
READERSHIP**

BROADCASTING
The Newsweekly of Radio and Television
TELECASTING

DIRECTORY OF AM, FM, and TV STATIONS OF THE UNITED STATES

(Data corrected to December 6, 1949)
If executives or services for FM or TV stations are same as AM affiliate names are not repeated.

NORTH CAROLINA—(Continued)

City Call Letters Established	Chan. or Freq. Power	Name of Licensee Headquarters Address Telephone Number	Network Representative	Executive Personnel	Transc. Library News Service Transmitter Make	
CHARLOTTE						
WAYS 1942	610 5,000-LS 1,000-N DA-1	Inter-City Adv. Co. of Charlotte, N. C. Inc. 120 E. Third St. 3-7173	ABC MBS Avery-Knodel	George W. Dowdy, Pres. Walter H. Goan, Gen. Mgr. Jack Gainey, Local Coml. Mgr.	Harry C. Barfield, Prog. Dir. J. Norman Young, Prom. Mgr. A. L. Chaney Jr., Chief Engr.	Lang-Worth SESAC INS Collins
WAYS-FM 1947	Ch. 299 (B) 107.7mc 21kw				Federal	
WBT 1922	1110 50,000 DA-N	Jefferson Standard Bcstg. Co. Wilder Bldg. 3-8833	CBS Radio Sales	J. M. Bryan, Pres. Charles H. Crutchfield, V. P. & Gen. Mgr. Keith S. Byerly, Gen. Sales Mgr.	Kenneth Tredwell, Prog. Dir. J. Robert Covington, Prom. Mgr. M. J. Minor, Chief Engr.	World Associated AP, UP RCA
WBT-FM 1947	Ch. 260 (B) 99.9mc 273kw				REL	
WBTV (TV) 1949	Ch. 3 60-66mc 8.2kw aur.; 16.3kw vis. 1600 1,000-D	(WBT. AM affiliate)	ABC CBS DuMont NBC Forjoe	Larry Walker, Asst. Gen. Mgr. Chg. TV & Prog. Dir.	INS	
WGIV 1949	Ch. 284 (B) 104.7mc 50kw	Charlotte Radio & Television Corp. 404½ West Trade St. 2-6669	MBS	Francis M. Fitzgerald, Pres. James Law Epps, Coml. Mgr.	Fred Vinroot, Prog. Dir. Tom Brandon, Chief Engr.	Capitol AP
WIST (FM) 1948	Ch. 295 (B) 106.9mc 75kw	Surety Bcstg. Co. 204 Liberty Life Bldg. 4-7165	MBS	Francis M. Hipp, Pres. Ray A. Furr, Gen. Mgr.	Hugh A. Barnett Jr., Chief Engr.	Associated UP Western Electric
WMIT (FM) 1942	Ch. 295 (B) 106.9mc 75kw	Radio WMIT Winston-Salem 2-4141	Headley-Reed	Gordon Gray, Owner Harold Essex, Gen. Mgr.	John M. Dunnagan, Coml. Mgr. C. M. Smith Jr., Dir. of Engr.	Standard Associated UP, AP General Electric
WSOC 1933	1240 250	Radio Station WSOC Inc. 1925 N. Tryon St. 7138	NBC Headley-Reed	E. J. Gluck, Pres. & Gen. Mgr. Bomar Lowrance, Coml. Mgr. Paul Marion, Prog. Dir.	Clyde Clem, Prom. Mgr. L. L. Caudie Jr., Chief Engr.	Standard Thesaurus AP RCA
WSOC-FM 1946	Ch. 278 (B) 103.5mc 38kw					
CLINTON						
WRZ 1947	880 1,000-D	Radio Station WRZ Inc. Butler Bldg. 2354	ABC Walker	W. R. Roberson Sr., Pres. W. R. Roberson Jr., Exec. V. P. George S. Walston, Gen. & Coml. Mgr.	D. W. Welsh, Prog. Dir. Joseph Tew, Prom. Mgr. Herman Jolitz, Chief Engr.	World AP Gates
CONCORD						
WEGO 1943	1410 1,000-D	The Concord Tribune Inc. P. O. Box 527 2271	KBS	Ray Hull, Mgr.		Standard SESAC Raytheon
DUNN						
WCKB 1946	780 1,000-D	North Carolina Central Bcstrs. Inc. P. O. Box 431 3133	KBS	L. A. Tart Sr., Pres. A. Lincoln Faulk, Gen. & Prom. Mgr. John Ciccone, Coml. Mgr.	Alice Holliday, Prog. Dir. Joe Tatlas, Chief Engr.	Lang-Worth SESAC AP Gates
DURHAM						
WDNC 1934	620 5,000-LS 1,000-N DA-2	Durham Radio Corp. 138½ East Chapel Hill St. R-155	CBS Raymer	C. C. Council, Pres. J. Frank Jarman, Gen. & Prom. Mgr. C. James Woodhouse, Coml. Mgr.	E. R. Higgins Jr., Prog. Dir. George W. Bartlett, Chief Engr.	Associated AP, UP Western Electric
WDNC-FM 1948	Ch. 286 (B) 105.1mc 36kw					
WDUK 1946	1310 1,000-LS 500-N DA	WDUK Inc. P. O. Box 1891 R-101	ABC Avery-Knodel	S. H. Campbell Jr., Pres. Harmon L. Duncan, Gen. Mgr. William S. Turner, Coml. Mgr.	William G. Hall, Prog. Dir. Carolyn M. Dieter, Prom. Mgr. Roy E. Fullen, Chief Engr.	Lang-Worth AP RCA
WSSB 1948	1490 250	Public Information Corp. 211 Rigsbee Ave. 6919-10	Friedenberg	Thomas B. Sawyer, Pres. Thomas O. McCaffrey, Mgr. & Coml. Mgr.	Wally Ausley, Prog. Dir. Frank Baxter, Prom. Mgr. Ed Norman, Chief Engr.	Capitol INS Western Electric
WTK 1946	730 1,000-D	Durham Bcstg. Co. Inc. 211½ East Main St. N 187	Tobacco Forjoe	Floyd Fletcher, Chief Owner & Gen. Mgr. Tom Mitchel, Coml. Mgr.	Ken Corbitt, Prog. Dir. & Prom. Mgr. Arlis A. White, Chief Engr.	World Thesaurus AP Western Electric
ELIZABETH CITY						
WCNC 1938	1240 250	Albemarle Bcstg. Co. Inc. WCNC Bldg. 1400	MBS KBS Burn-Smith	Dr. J. A. Gill, Pres. Robert B. Bingham, Gen. Mgr. Frank Stilwell, Coml. Mgr.	Eleanor S. Bingham, Prog. Dir. R. Burrows Bingham, Prom. Mgr. Fred Wagner, Chief Engr.	SESAC UP Gates
WGAI 1947	560 1,000-LS 500-N DA-2	WGAI Radio Co. Inc. Kramer Bldg. 757	Sears & Ayer	Herbert Peele, Pres. & Chief Owner W. P. Heffernan, Gen. & Coml. Mgr.	Phil Melone, Chief Engr.	World AP
ELKIN						
WIFM (FM) 1949	Ch. 265 (A) 100.9mc 0.35kw	John A. Hinshaw 1141 Elk Spur St. Ext. 739		John A. Hinshaw, Owner & Chief Engr.	George C. Yarbrough, Gen. Mgr.	Capitol UP REL
FAYETTEVILLE						
WFLB 1948	1490 250	Fayetteville Bcstrs. Inc. Ft. Bragg Blvd. 7136	ABC Burn-Smith	Harry B. Stein, Pres. L. W. Allen, Gen. & Coml. Mgr.	James Tucker, Prog. Dir. W. D. Bailey, Chief Engr.	AP RCA
WFNC 1940	1450 250	Cape Fear Bcstg. Co. 114½ Anderson St. 4948	MBS Tobacco Dixie FM Walker	Victor Dawson, Gen. Mgr. Luther A. Gambill, Coml. Mgr. N. R. Martin, Prog. Dir. & Prom. Mgr.	William Alford, Chief Engr.	Associated UP Collins
WFNC-FM 1948	Ch. 251 (B) 98.1mc 12kw					
WWNF 1948	1230 250	Wayne M. Nelson Inc. Huske Bldg. 7101	Friedenberg	Wayne M. Nelson, Pres. & Gen. Mgr. Jack Aley, Coml. Mgr. & Prom. Dir.	E. M. Stanton Jr., Chief Engr.	Lang-Worth AP Raytheon

DA-N Directional Antenna, night only. FM's in italic.
DA-1 Directional Antenna, same pattern day and night.
DA-2 Directional Antenna, different pattern day and night.

*—Non-Commercial Station. D—Day. N—Night. ST—Share Time. SH—Specified Hours.
U—Unlimited. CP—Construction Permit Issued. LS—Local Sunset.
L—Limited Time with Dominant Station. SA—Special Authorization.

for the balanced market ...



BALANCED FACILITIES

Clearest clue to the consistent and growing prosperity of the Carolinas is the healthy balance between agriculture and industry. In balance, too, with the growth of this spotlight market, are the facilities of the Jefferson Standard Broadcasting Company.

To pioneer WBT's 3,500,000 listeners add WBT-FM's rocketing bonus and cap it all with WBTV—the Carolina's first television station which in the second half of 1949 sparked the sale of 10,000 television receivers in 57 Carolina counties. May we tip the sales scales in your favor in the Carolinas?

WBT WBT-FM WBTV
JEFFERSON STANDARD BROADCASTING COMPANY

Represented Nationally by Radio Sales

DIRECTORY OF AM, FM, and TV STATIONS OF THE UNITED STATES

(Data corrected to December 6, 1949)
If executives or services for FM or TV stations are same as AM affiliate names are not repeated.

NORTH CAROLINA—(Continued)

City Call Letters Established	Chan. or Freq. Power	Name of Licensee Headquarters Address Telephone Number	Network Representative	Executive Personnel	Transc. Library News Service Transmitter Make	
FOREST CITY						
WBBO 1947	780 1,000-D	Rutherford County Radio Co. Inc. Forest City 3205		Ed M. Anderson, Pres. & Gen. Mgr. Fred Blanton, Coml. Mgr.	Jane Smith, Prog. Dir. & Prom. Mgr. Merton Iwerks, Chief Engr.	Lang-Worth Capitol AP REL
WBBO-FM 1948	Ch. 227 (B) 93.3mc 1.5kw					
FUQUAY SPRINGS						
WFVG 1949	1460 1,000-D	Wake Bcstg. Co. P. O. Box 95 333	KBS Continental	S. S. Adcock, Owner & Pres.		
GASTONIA						
WGNC 1939	1450 250	F. C. Todd National Bank of Commerce Bldg. 5-0821	ABC Continental	F. C. Todd, Pres. Pat McSwain, Gen. Mgr. F. C. Abernethy, Coml. Mgr.	Fred Gray, Prog. Dir. W. C. Groves Jr., Chief Engr.	Lang-Worth UP Collins RCA
WGNC-FM 1947	Ch. 270 (B) 101.9mc 11.1kw					
WLTC 1948	1370 1,000-D	Gastonia Bcstg. Service Co. P. O. Box 1142 5-1079	Clark	James B. Petty, Pres. & Gen. Mgr. B. C. Morrow, Coml. Mgr.	A. G. Phillips, Prog. Dir. Don Voigt, Chief Engr.	UP Raytheon
GOLDSBORO						
WGBR 1939	1400 250	Eastern Carolina Bcstg. Co. Box 1024 1550	ABC KBS	A. T. Hawkins, Pres. Coleman Scott, Gen. Mgr.	Vassie Balkcum, Coml. Mgr. Daniel Trueblood, Chief Engr.	Associated AP Gates REL
WEQR (FM) 1946	Ch. 227 (B) 93.3mc 35kw	(WGBR, AM affiliate)				
GREENSBORO						
WBIG 1926	1470 5,000 DA-N	North Carolina Bcstg. Co. Inc. O. Henry Hotel Bldg. 6125	CBS Hollingbery	Ralph C. Price, Pres. Gilbert M. Hutchinson, Gen. Mgr. William P. Mitchell, Coml. Mgr.	Alfred J. Rice, Prog. Dir. Aileen Gilmore, Prom. Mgr. Earl F. Allison, Chief Engr.	Thesaurus World AP Western Electric Lang-Worth Thesaurus INS Raytheon
WCOG 1948	1320 1,000 DA-1	Inter-City Adv. Co. of Greensboro, N. C. Inc. 314 S. Greene St. 3-6925	ABC Avery-Knodel	George W. Dowdy, Pres. H. E. Sullivan, Gen. Mgr. Virgil V. Evans Jr., Coml. Mgr.	Wally Williams, Prog. Dir. Jeta A. Pace, Prom. Mgr. Ernest Pate, Chief Engr.	Associated SESAC UP Western Electric Cinetel Film Equities United, World UP DuMont Capitol Associated UP Western Electric REL
WFMY (FM) 1948	Ch. 247 (B) 97.3mc 33kw	Greensboro News Co. 212 N. Davie St. 3-8611		Gaines Kelley, Gen. & Coml. Mgr. T. W. Austin, Prog. Dir.	Norman Gittleson, Prom. Mgr. James F. Winecoff, Chief Engr.	UP Western Electric Cinetel Film Equities United, World UP DuMont Capitol Associated UP Western Electric REL
WFMY-TV 1949	Ch. 2 54-60mc 0.84kw aur. 1.67kw vis.		ABC, CBS DuMont, NBC Harrington, Righter & Parsons			
WGBG 1942	980 1,000-D CP-1400 CP-250	Greensboro Bcstg. Co. Inc. P. O. Box 2280 3-3631	Burn-Smith	Ralph M. Lambeth, Pres., Gen. & Coml. Mgr.	H. Marie Craven, Prog. Dir. Earl O. Sullivan, Prom. Mgr. James M. Stewart, Chief Engr.	UP Western Electric REL
WGBG-FM 1947	Ch. 262 (B) 100.3mc 37kw					
GREENVILLE						
WGTC 1940	1490 250	Carolina Bcstg. System Inc. P. O. Box 898 3182	Tobacco	Earl McD. Westbrook, Pres. A. Hartwell Campbell, Gen. Mgr. Dave Mosier, Coml. Mgr.	R. C. Stokes III, Prog. Dir. Hank Tribble, Prom. Mgr. W. A. Alford, Chief Engr.	World Lang-Worth SESAC AP RCA
HENDERSON						
WHNC 1945	890 1,000-D	Henderson Radio Corp. 219 South Williams St. 738	MBS Griffith	S. S. Stevenson, Pres. Nathan Frank, Gen., Coml. & Prom. Mgr.	Virginia Parham, Prog. Dir. Lewis Hiland, Chief Engr.	Thesaurus, Cole Lang-Worth Capitol, AP Western Electric Westinghouse
WHNC-FM 1948	Ch. 223 (B) 92.5mc 10kw					
HENDERSONVILLE						
WHKP 1946	1450 250	Radio Hendersonville Inc. Staton Bldg. 700	MBS, KBS Continental	Bob Amos, Pres. & Gen. Mgr. W. R. Hill, Coml. Mgr.	Kermit Edney, Prog. Dir. Clifford Inman, Chief Engr. AP Gates
HICKORY						
WHKY 1939	1290 5,000-LS 1,000-N DA	Catawba Valley Bcstg. Co. Radio Bldg. 2294	ABC Dodson	Carl V. Cline, Pres. Edmund S. Long, Gen. Mgr. & Chief Engr. James K. Willis Jr., Coml. Mgr.	Jack Starnes, Prog. Dir. & Prom. Mgr.	Associated World UP Collins Westinghouse
WHKY-FM 1949	Ch. 275 (B) 102.9mc 210kw					
WIRC 1948	630 1,000-D	Foothills Bcstg. Inc. 1423 Eleventh Ave. 2124	McGillvra	Margaret A. Smith, Pres. Edmond H. Smith Jr., Gen. Mgr. & Prog. Dir.	Lee W. Douglas, Coml. Mgr. Mattie Padgett, Prom. Mgr. Elmer H. Troutman, Chief Engr.	Lang-Worth Standard AP Collins
HIGH POINT						
WHPE 1947	1070 1,000-D	High Point Enterprise 305 N. Main St. 3466	KBS	R. B. Terry, Pres. Walter F. Hester, Coml. Mgr.	Nick Lawrence, Prog. Dir. Yancy Cecil, Chief Engr.	Associated Standard AP Gates General Electric
WHPE-FM 1947	Ch. 238 (B) 95.5mc 37kw					
WMFR 1936	1230 250	Radio Station WMFR Inc. 164 South Main St. 4593	ABC Burn-Smith	Frank S. Lambeth, Pres. & Gen. Mgr. Gerald E. Sullivan, Asst. Mgr. Frank L. Smith, Coml. Mgr. Gary C. Davis, Prog. Dir.	Lois Cusworth, Prom. Mgr. Robert L. Moore, Chief Engr.	Lang-Worth Capitol UP Gates REL
WMFR-FM 1946	Ch. 258 (B) 99.5mc 38kw					

DA-N Directional Antenna, night only. FM's in italic.
DA-1 Directional Antenna, same pattern day and night.
DA-2 Directional Antenna, different pattern day and night.

*—Non-Commercial Station. D—Day. N—Night. ST—Share Time. SH—Specified Hours.
U—Unlimited. CP—Construction Permit Issued. LS—Local Sunset.
L—Limited Time with Dominant Station. SA—Special Authorization.

PEOPLE



More people live within 50 miles of Greensboro than in any other area of equal size in the Southeast.

PROSPERITY



These people make more products, earn more wages and get more for their crops.

POWER-PROGRAMS



WBIG serves the No. 1 spot of the South with 5000 Watts, power packed with pulling programs of CBS and fine local talent and news.

**W
C B S
I
G**

"The Prestige Station of the Carolinas"

GREENSBORO, NORTH CAROLINA

Represented by Hollingbery

DIRECTORY OF AM, FM, and TV STATIONS OF THE UNITED STATES

(Data corrected to December 6, 1949)
If executives or services for FM or TV stations are same as AM affiliate names are not repeated.

NORTH CAROLINA—(Continued)

City Call Letters Established	Chan. or Freq. Power	Name of Licensee Headquarters Address Telephone Number	Network Representative	Executive Personnel	Transc. Library News Service Transmitter Make
JACKSONVILLE					
WJNC 1945	1240 250	Lester L. Gould Highway 24 N. 707	MBS Tobacco Forjoe	Lester L. Gould, Pres. & Gen. Mgr. Rodric L. Jones, Coml. Mgr. Dorothy R. Gould, Prog. Dir.	Loretta Furst, Prom. Mgr. James J. Cooney, Chief Engr. Lang-Worth UP Gates
KANNAPOLIS					
WGTL 1947	870 1,000-D	Fred H. Whitley Inc. Kannapolis 870		Fred H. Whitley, Gen. Mgr. Frank H. Bowers, Prog. Dir.	Foy Hinson, Chief Engr. Lang-Worth World UP
KINSTON					
WELS (CP) 1937	1010 1,000-D	Commonwealth Bcstg. Corp.	ABC Burn-Smith	Alban K. Barrus, Pres. William S. Page, Gen. Mgr. B. George Barber, Coml. Mgr.	Bruce Petteway, Prog. Dir. David E. Hardison, Chief Engr. World UP
LAURINBURG					
WEWO 1947	1080 1,000-D	Scotland Bcstg. Co. Chetwynd Hotel Bldg. 770		Edwin Pate, Pres. J. R. Dalrymple Jr., Gen. Mgr.	C. J. Cordes, Coml. Mgr. Paul Wynn, Prog. Dir. Truman Brock, Chief Engr. World UP Raytheon
LEAKSVILLE					
WLOE 1946	1490 250	Douglas L. Craddock "The Blvd." 701	MBS KBS	Douglas L. Craddock, Pres. Gen. & Prom. Mgr. C. Robert Ray, Coml. Mgr.	Kenneth Thomas, Prog. Dir. Eldred Winn, Chief Engr. World AP RCA
LENOIR					
WJRI 1946	1340 250	John P. Rabb Union Nat'l Bank Bldg.	MBS KBS	John P. Rabb, Owner	Thesaurus AP
LEXINGTON					
WBUY 1946	1450 250	Davidson County Bcstg. Co. P. O. Box 359 2716	KBS Continental	Omar G. Hilton } Greely N. Hilton } Partners C. Robert Ray, Sta. Mgr.	Earle Broome, Coml. Mgr. Claude White, Prog. Dir. Fred Honeycutt, Chief Engr. Lang-Worth World AP Gates
WBUY-FM 1949	Ch. 232 (A) 94.3mc 0.31kw				
LUMBERTON					
WTSB 1946	1340 250	Robeson Bcstg. Corp. 112 W. 5th St. 1080	MBS Tobacco Continental	Dr. E. L. Bowman, Pres. Walter James MacNeil, Gen. Coml. & Prom. Mgr.	Clarence W. Hogen, Prog. Dir. William F. Rogers, Chief Engr. Standard AP Western Electric
MADISON-MAYODAN					
WFMB (FM) 1949	Ch. 228 (A) 93.5mc 0.38kw	Mayo Bcstg. Corp. Madison		J. B. Shelton, Pres. W. V. Compton, Gen. Mgr. & Prog. Dir.	C. H. Rumley, Coml. Mgr. C. L. Rhodes, Chief Engr. Lang-Worth UP Gates
MARION					
WBRM 1949	1250 1,000-D	Lake City Bcstg. Corp. 13½ West Court St. 102	Tobacco	W. P. Erwin, Pres. & Gen. Mgr. J. C. Pleasant, Coml. Mgr.	J. L. Reynolds Jr., Asst. Gen. Mgr. & Prog. Dir. J. Ray Horton, Chief Engr. Capitol UP Gates
MONROE					
WMAP 1947	1060 250-D	Union Bcstg. Corp. Walkup Ave. 1060	KBS LBS	J. Ray Shute, Pres. D. E. Marable, Gen. & Coml. Mgr.	R. W. Furman, Prog. Dir. J. Archie Laney, Prom. Mgr. Hilliard Fletcher, Chief Engr. Lang-Worth Associated UP Gates
MOREHEAD CITY					
WMBL 1947	740; CP: 1280 1,000-D	Carteret Bcstg. Co. Box 740 974-0	McGillvra	Grover C. Munden, Pres. & Gen. Mgr. Charles H. Markey & Jimmy Wallace, Coml. & Prom. Mgrs.	Ray Cummins, Prog. Dir. & Chief Engr. World Standard UP Western Electric
MORGANTON					
WMNC 1947	1490 250	Nathan J. Cooper Morganton 1100	MBS	Nathan J. Cooper, Owner & Gen. Mgr. Eugene G. Smith, Coml. Mgr.	(Miss) Gernel Hudson, Prog. Dir. Frank Ballew, Chief Engr. World AP Raytheon
MT. AIRY					
WPAQ 1948	740 1,000-D	Ralph D. Epperson Mt. Airy 682	Clark	Ralph D. Epperson, Pres., Gen. Mgr. & Chief Engr.	Tom Browne, Coml. Mgr. W. F. Crutchley, Prog. Dir. Standard AP Collins
NEW BERN					
WHIT 1942	1450 250	Coastal Bcstg. Co. Inc. Trent Blvd. 4024	MBS Tobacco Forjoe	Louis N. Howard, Pres., Gen. & Coml. Mgr. & Prog. Dir.	Bruce Lee, Prom. & Asst. Mgr. Robert Coddington, Chief Engr. Lang-Worth UP Gates
NEWTON					
WNNC 1948	1230 250	Newton-Conover Bcstg. Co. P. O. Box 606; 930	MBS Continental	Charles Turner, Pres. Earl Holder, Gen. Mgr. & Prog. Dir.	Eugene Henry, Coml. Mgr. Cecil Bost, Prom. Mgr. Dennis Long, Chief Engr. Thesaurus UP Raytheon
NORTH WILKESBORO					
WKBC 1947	810 1,000-D	Wilkes Bcstg. Co. Radio Bldg. 633		(Mrs.) Doris B. Brown, Pres. & Gen. Mgr. Roland B. Potter, Coml. Mgr. John T. Cashion, Prog. Dir.	Charles Wilfong, Prom. Mgr. Robert M. Harvey, Chief Engr. World AP Collins
OXFORD					
WOXF 1949	1340 250	Oxford Bcstg. Corp. Hancock Bldg. 3250		F. W. Hancock Jr., Pres. Jimmie Childress, Gen., Coml. & Prom. Mgr.	Hart Curl, Prog. Dir. Lang-Worth AP Raytheon
RALEIGH					
WNAO 1948	850 5,000 DA-N	News & Observer Pub. Co. 219 S. McDowell St. 2-0321	ABC Avery-Knodel	George T. Case, Gen. & Coml. Mgr. & Prog. Dir.	B. E. Porter, Chief Engr. Standard UP RCA
WNAO-FM 1948	Ch. 241 (B) 96.1mc 25kw				
WPTF 1924	680 50,000 DA-N	WPTF Radio Co. Insurance Bldg. 8311	NBC Free & Peters	J. R. Weatherspoon, Pres. Richard H. Mason, Gen. Mgr. O. L. Carpenter, Sales Mgr. R. W. Youngsteadt, Dir. Adv. & Prom.	Graham B. Poyner, Asst. Gen. Mgr. & Prog. Mgr. Henry Hulick Jr., Chief Engr. Lang-Worth AP UP Westinghouse
WPTF-FM 1949	Ch. 234 (B) 94.7mc; 15kw				

DA-N Directional Antenna, night only. FM's in italic.
 DA-1 Directional Antenna, same pattern day and night.
 DA-2 Directional Antenna, different pattern day and night.

*—Non-Commercial Station. D—Day. N—Night. ST—Share Time. SH—Specified Hours.
 U—Unlimited. CP—Construction Permit Issued. LS—Local Sunset.
 L—Limited Time with Dominant Station. SA—Special Authorization.

**NORTH CAROLINA
IS THE SOUTH'S
No. 1 STATE**

**AND
NORTH
CAROLINA'S**

**No. 1
SALESMAN
IS**

**50,000
WATTS
680 Kc.**

**WPTF NBC
AFFILIATE**

**★ also WPTF-FM ★
RALEIGH, North Carolina**

National Representative FREE & PETERS INC.

DIRECTORY OF AM, FM, and TV STATIONS OF THE UNITED STATES

*(Data corrected to December 6, 1949)
If executives or services for FM or TV stations are same as AM affiliate names are not repeated.*

NORTH CAROLINA—(Continued)

City Call Letters Established	Chan. or Freq. Power	Name of Licensee Headquarters Address Telephone Number	Network Representative	Executive Personnel	Transc. Library News Service Transmitter Make	
RALEIGH—(Continued)						
WRAL 1939	1240 250	Capitol Bcstg. Co. Inc. 130 S. Salisbury St. 6411	MBS Tobacco Dixie FM Pearson	A. J. Fletcher, Pres. Fred Fletcher, Gen. & Coml. Mgr.	Jesse Helms, Prog. Dir. & Prom. Mgr. Virgil Duncan, Chief Engr.	World AP Western Electric
WRAL-FM 1946	Ch. 268 (B) 101.5mc 54kw					REL
REIDSVILLE						
WFRC 1947	1600 1,000 DA-N	Piedmont Carolina Bcstg. Co. Gilmer St. 1573	KBS	H. T. Williams, Pres. Steve Woodson, Gen. & Coml. Mgr. Forrest Bedell, Prog. Dir.	Tiny Turner, Prom. Mgr. L. H. Alexander, Chief Engr.	World Associated AP Raytheon
WREV (FM) 1948	Ch. 271 (B) 102.1mc 1.6kw	Reidsville Bcstg. Co. 114½ N. Scales St. 1818		W. M. & C. R. Oliver, Owners A. W. Nelson, Gen. Mgr. & Prog. Dir.	John J. O'Neill, Coml. Mgr. J. H. Buck, Chief Engr.	Standard UP Federal
ROANOKE RAPIDS						
WCBT. 1939	1230 250	WCBT Inc. 251 Roanoke Ave. R 8551	MBS Burn-Smith	S. E. Crew, Pres. & Gen. Mgr. A. L. Drew, Coml. & Sta. Mgr.	Ken Johnson, Prog. Dir. Jerry Elliot, Prom. Mgr. Claude Meares, Chief Engr.	Lang-Worth UP Western Electric
WCBT-FM 1947	Ch. 254 (B) 98.5mc 16kw					
ROCKINGHAM						
WAYN 1946	900 1,000-D	WAYN Inc. Rockingham 611		Wayne M. Nelson, Pres. Matt F. Gettings, Res. & Coml. Mgr.	William Henley, Chief Engr.	Mac Gregor UP
ROCKY MOUNT						
WCEC 1947	810 1,000-D	Josh L. Horne 115 N. Church St. 2880	KBS Tobacco Ra-Tel	Josh L. Horne, Pres. Mel Warner, Gen. Mgr. Ray Thompson, Coml. Mgr.	Ray Wilkinson, Prog. Dir. Dick Johnson, Prom. Mgr. Harold Aycock, Chief Engr.	Associated Capitol AP Collins
WFMA (FM) 1947	Ch. 264 (B) 100.7mc 33kw	(WCEC, AM affiliate)	Dixie FM			Federal
WEED 1933	1450 250	W. A. Wynne P. O. Box 752 8149	ABC	W. A. Wynne, Pres. & Chief Engr. C. G. Floe, Coml. Mgr.	(Mr.) Eunice Snipes, Prog. Dir.	World AP
WEED-FM 1948	Ch. 221 (A) 92.1mc 0.25kw					
ROXBORO						
WRXO 1949	1430 1,000-D	Roxboro Bcstg. Co. P. O. Box 166 6013		H. W. Winstead, Pres. Harold S. Taylor, Gen. & Coml. Mgr. & Chief Engr.	William D. Gregory, Prog. Dir.	World AP Western Electric
SALISBURY						
WSAT 1948	1280 1,000-D	Mid-Carolina Bcstg. Co. Milford Hills Rd. 276	Dodson	Charles H. Wentz, Pres. John E. Smith Jr., Gen., Coml. & Prom. Mgr.	W. F. Fleming, Prog. Dir. E. L. Sherman, Chief Engr.	World UP Gates
WSTP 1937	1490 250	Piedmont Bcstg. Corp. State Theatre Bldg. 2121	MBS Dixie FM Burn-Smith	Bryce P. Beard, Pres. Alex P. Beard, Gen. & Prom. Mgr. Katherine F. Murphy, Coml. Mgr.	Betty Fisher, Prog. Dir. Carl B. Watson, Chief Engr.	Associated AP Western Electric
WSTP-FM 1947	Ch. 293 (B) 106.5mc 27kw					REL
SANFORD						
WWGP 1946	1050 1,000-D	Lee Bcstg. Corp. Radio Bldg. 860		W. W. Primm, Pres. & Gen. Mgr. L. B. Nelson, Coml. Mgr.	Margaret Blake, Prog. Dir. Cary H. Olive, Chief Engr.	World Capitol UP Gates
SHELBY						
WOHS 1946	730 250-D	Western Carolina Radio Corp. Shelby 340	MBS	Lee B. Weathers, Pres. Robert M. Wallace, Gen. Mgr. & Chief Engr.	Max P. Butler, Coml. Mgr. Hugh Dover, Prog. Dir.	Associated AP Raytheon
WOHS-FM 1947	Ch. 241 (B) 96.1mc 2.6kw					REL
SOUTHERN PINES						
WEEB 1947	1360 1,000-D	Sandhill Community Bcstrs. Inc. Southern Pines 8191	MBS Forjoe	J. S. Younts, Pres. & Gen. Mgr.	Elizabeth M. Younts, Secy-Treas. Melvin Kushner, Chief Engr.	AP Gates
WSTS 1947	990 1,000-D	Sandhill Bcstg. Corp. 115 East Broad St. 5451	KBS Cooke	Frank L. Baber, Pres.	James C. Cole, Gen. Mgr.	UP Gates
STATESVILLE						
WSIC 1947	1400 250	Statesville Bcstg. Co. Radio Rd. 9078	MBS Dixie FM Continental	Dr. James W. Davis, Pres. L. G. Churchill, Gen. Mgr. Charles D. Melton, Coml. Mgr.	Al Watson, Prog. Dir. T. K. Abernethy, Chief Engr.	World AP Temco
WSIC-FM 1947	Ch. 289 (B) 105.7mc 2.4kw					REL
TARBORO						
WCPS 1947	760 1,000-D	Coastal Plains Bcstg. Co. P. O. Box 820 643		V. E. Fountain, Pres. J. T. Snowden Jr., Gen. Mgr. Porter MacNair, Coml. Mgr.	Welcome Stanton, Prog. Dir. Eccles Wall, Prom. Mgr. Charles Chandler, Chief Engr.	AP Raytheon
WCPS-FM 1950	Ch. 282 (B) 104.3mc 3kw					
THOMASVILLE						
WTNC 1947	790 1,000-D	Thomasville Bcstg. Co. Thomasville 902		G. W. Lyles, Pres. Harold Harrison, Gen. & Coml. Mgr.	L. M. Sugg, Chief Engr.	World AP Gates
WTNC-FM 1949	Ch. 252 (A) 98.3mc 0.45kw					RCA

DA-N Directional Antenna, night only. FM's in italic.
DA-1 Directional Antenna, same pattern day and night.
DA-2 Directional Antenna, different pattern day and night.

*—Non-Commercial Station. D—Day. N—Night. ST—Share Time. SH—Specified Hours.
U—Unlimited. CP—Construction Permit Issued. LS—Local Sunset.
L—Limited Time with Dominant Station. SA—Special Authorization.

City Call Letters Established	Chan. or Freq. Power	Name of Licensee Headquarters Address Telephone Number	Network Representative	Executive Personnel	Transc. Library News Service Transmitter Make	
WADESBORO						
WADE 1947	1210 1,000-D	Anson Bcstg. Co. Lyon Bldg. 427		R. P. Lyon, Pres. Jack P. Hankins, Gen. Mgr.	Elbert Mullinix, Coml. Mgr. Cecil Sills, Chief Engr.	Thesaurus UP Gates
WASHINGTON						
WHED 1948	1340 250	Beaufort Bcstg. Co. Inc. Guaranty Bank & Trust Bldg. 278	Tobacco Continental	Lee T. Wynne, Pres. Frank Wynne, V.P. R. B. Armstrong, Gen. & Prom. Mgr.	Richard David, Coml. Mgr. Carl Armstrong, Prog. Dir. John Wilroy, Chief Engr.	Lang-Worth SESAC UP Raytheon
WRRF 1942	930 5,000-D	Tar Heel Bcstg. System Inc. Bank of Washington Bldg.; 403	ABC Forjoe	W. R. Roberson Sr., Pres. W. R. Roberson Jr., V.P. T. H. Patterson, Gen. & Coml. Mgr.	Don Pierce, Prog. Dir. Merril Daniels, Prom. Mgr. I. G. Murphrey, Chief Engr.	World AP Western Electric
WAYNESVILLE						
WHCC 1947	1400 250	Smoky Mtn. Bcstrs. Inc. Main St. 680	MBS	Holt McPherson, Pres. Fred U. Wamble, Gen. Mgr.	Carolyn P. Phillips, Prog. Dir. Frank C. Wilbur, Chief Engr. Raytheon
WHITEVILLE						
WENC 1946	1240 250	Whiteville Bcstg. Co. Whiteville 620	Clark	Josiah Maultsby, Pres. Ward A. Coleman, Gen. Mgr.	Jerry Honeycutt, Prog. Dir. Ovie Boutwell, Chief Engr.	Standard AP
WILLIAMSTON						
WIAM (CP) 1,000-D	900	S. S. Adecock				
WILMINGTON						
WGNI 1946	1340 250	New Hanover Bcstg. Co. Eagle Island 2-2493	MBS Tobacco McGillvra	J. S. Brody, Pres. Allen B. Jones, Sta. Mgr. Tommy Thompson, Coml. Mgr.	Paul Parker, Prog. Dir. Lou Essick, Prom. Mgr. Art Madeley, Chief Engr.	Standard UP Western Electric
WMFD 1935	630 1,000 DA-N	Richard Austin Dunlea P. O. Box 696 4840	ABC Burn-Smith	Richard Austin Dunlea, Pres. & Gen. Mgr. Claude O'Shields, Coml. Mgr. Bruce Buchanan, Prog. Dir.	R. A. Dunlea Jr., Prom. Mgr. E. I. Herring Jr., Chief Engr.	World UP RCA
WMFD-FM 1949	Ch. 242 (B) 96.3mc 11.5kw					
WILSON						
WGTM 1937	590 5,000 DA-2	Watson Industries Inc. Herring Ave. Extension 2188	MBS Weed	Penn T. Watson, Pres. Allen Wannamaker, Gen. & Coml. Mgr. W. E. Jackson Jr., Prog. Dir.	Dan Griffin, Prom. Mgr. W. H. Malone, Chief Engr. Clint Faris, Asst. Mgr.	Standard Lang-Worth UP Raytheon
WVOT 1948	1420 1,000-D CP-1,000-LS 500-N-DA	Wilson Radio Co. Inc. P. O. Box 371 5157		H. W. Anderson, Pres. W. T. Williams, Exec. V.P. Harry Severance, Sta. Mgr. P. O. Barnes, Coml. Mgr.	Joel Lawhon, Prog. Dir. (Mrs.) Lynda Thomas, Prom. Mgr. N. V. Pieler, Chief Engr., Secy- Treas.	Capitol AP RCA
WINSTON-SALEM						
WAIR 1937	1340 250	WAIR Bcstg. Co. Pepper Bldg. 2-1133	ABC Avery-Knodel	George Walker & C. G. Hill, Partners George Walker, Gen. Mgr. Johnny Miller, Sales Mgr.	Doris Pardington, Prog. Dir. Les Forsyth, Prom. Mgr. Lee King, Chief Engr.	World Lang-Worth Capitol, Cole AP Western Electric RCA
WAIR-FM 1947	Ch. 226 (B) 93.1mc 34kw					

THE KING SIZE VOICE of Tobaccoland

**WGTM's primary
area includes:**

1,125,000 population

**National Representative
Joe Weed & Co.**

590 KC



**WGTM's primary
area includes:**

150,000 radio families

**Allen Wannamaker
General Manager**

**5000 WATTS
FULL TIME**

MUTUAL BROADCASTING SYSTEM

DIRECTORY OF AM, FM, and TV STATIONS OF THE UNITED STATES

(Data corrected to December 6, 1949)
If executives or services for FM or TV stations are same as AM affiliate names are not repeated.

NORTH CAROLINA—(Continued)

City Call Letters Established	Chan. or Freq. Power	Name of Licensee Headquarters Address Telephone Number	Network Representative	Executive Personnel	Transc. Library News Service Transmitter Make	
WINSTON-SALEM—(Continued)						
WSJS 1930	600 5,000 DA-2	Piedmont Pub. Co. 419 N. Spruce St. 2-4141	NBC Headley-Reed	Gordon Gray, Pres. Harold Essex, V.P. & Mngng. Dir. Harry B. Shaw, Sales Mgr.	Robert C. Estes, Prog. Mgr. Robert B. Wilson, Prom. Mgr. Phil Hedrick, Dir. of Engrg.	Standard Associated UP Western Electric
WSJS-FM 1947	Ch. 281 (B) 104.1mc 48kw					General Electric
WTOB 1947	710 1,000-D	Winston-Salem Bcstg. Co. Inc. P. O. Box 739 7145	MBS Taylor-Borroff	James W. Coan, Pres. John G. Johnson, Gen. & Coml. Mgr.	Bill Billingsley, Prog. Dir. Russell Spikula, Chief Engr.	Thesaurus AP Gates

NORTH DAKOTA

BISMARCK						
KFYR 1925	550 5,000 DA-N	Meyer Bcstg. Co. 202½ Fourth St. 468	NBC Northwest Blair	P. J. Meyer, Pres. F. E. Fitzsimonds, Sta. Mgr. Robert W. MacLeod, Coml. Mgr.	Cal Culver, Prog. Dir. & Prom. Mgr. Ivar Nelson, Chief Engr.	Thesaurus UP RCA
DEVILS LAKE						
KDLR 1925	1240 250	KDLR Inc. 1025 3rd St. 1090	MBS Great Northern Lawson	Bert Wick, Pres., Gen. & Coml. Mgr. Wilbur Clemenson, Prog. Dir.	Richard Moritz, Chief Engr.	World SESAC UP Western Electric
DICKINSON						
KDIX 1947	1230 250	Dickinson Radio Assn. 28 1st Ave. West 348	KBS Lawson	Dr. P. J. Weir, Pres. Orville F. Burda, Gen. & Prom. Mgr. Eugene A. Spear, Coml. Mgr.	George L. Brooks, Prog. Dir. Quintin V. Prochaska, Chief Engr.	Standard SESAC AP Gates
FARGO						
KFGO 1948	790 5,000 DA-N	Northern States Bcstg. Co. KFGO Bldg. 23291	ABC Bolling	W. R. Haggart, Pres. Charles G. Burke, Gen., Coml. & Prom. Mgr.	Dave Henley, Prog. Dir. Olaf Gabrielson, Chief Engr.	Standard SESAC AP RCA
KVNJ 1945	900 1,000-D	Northwest Bcstg. Co. 217½ Broadway 23201		John Nystul, Sta. Mgr. E. L. Ausman, Coml. Mgr. Hollis Hoff, Prog. Dir.	Robert Schaefer, Chief Engr.	Associated UP General Electric

DA-N Directional Antenna, night only. FM's in italic.
DA-1 Directional Antenna, same pattern day and night.
DA-2 Directional Antenna, different pattern day and night.

*—Non-Commercial Station. D—Day. N—Night. ST—Share Time. SH—Specified Hours.
U—Unlimited. CP—Construction Permit Issued. LS—Local Sunset.
L—Limited Time with Dominant Station. SA—Special Authorization.

WINSTON-SALEM'S

First!

STATION

FIRST

- IN LISTENING (Hooper)
- IN NETWORK (NBC)
- IN POWER (5000 WATTS)
- ON THE DIAL (600)
- ON THE AIR (1930)

Represented by Headley-Reed Company

THE JOURNAL-SENTINEL STATION

WSJS

● AM and FM ●

"LADEEZ AND GENTLEMUN- MEET WDAY, THE NATIONAL HOOPER CHAMP!"

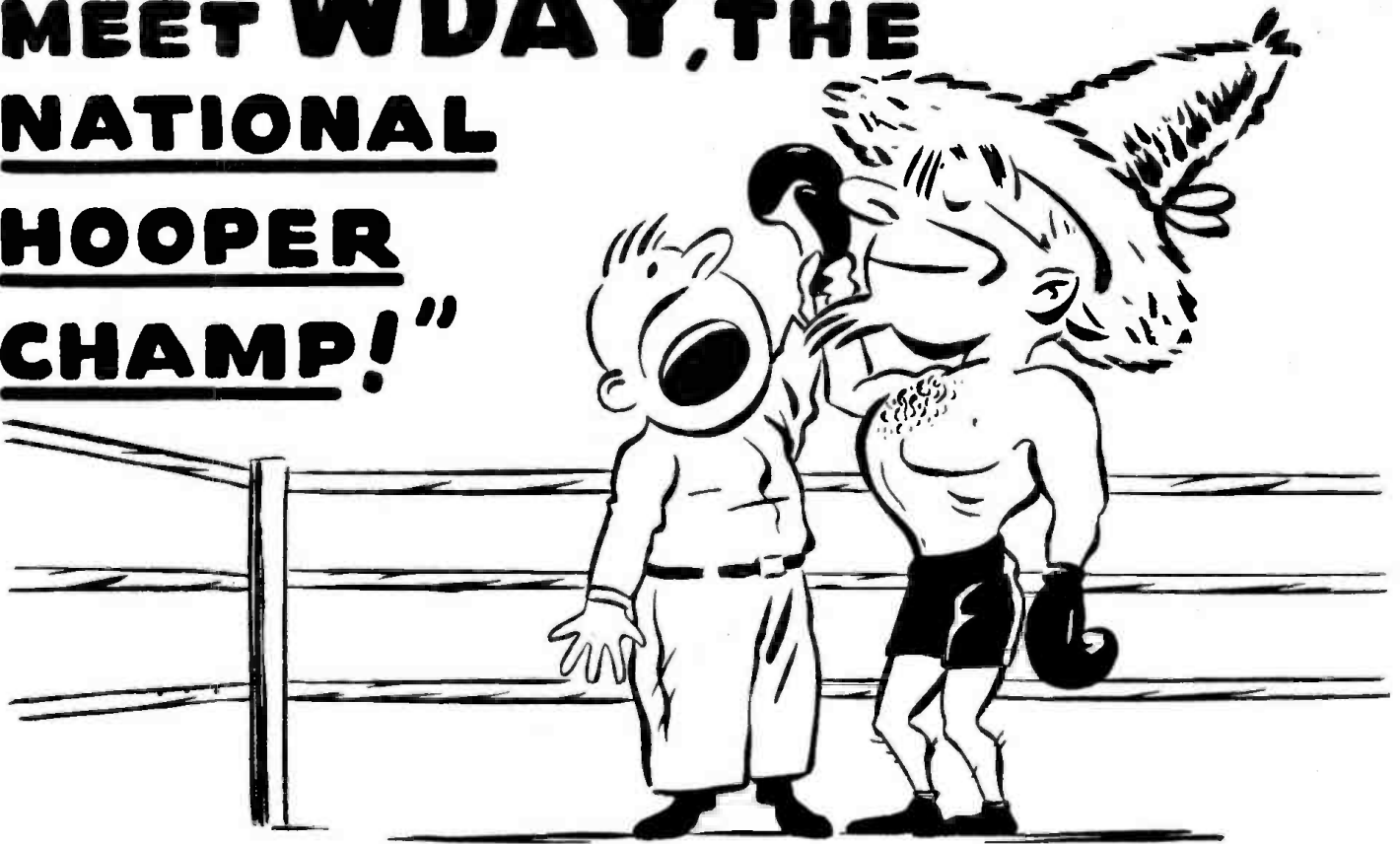

Yessir! WDAY had the greatest Share-of-Audience Hooperatings—Morning, Afternoon and Night—among all stations in the country for the five-month period, Dec. '48—Apr. '49! What's more, as this Broadcasting Yearbook goes to press, we expect to get it again for the next five-month period.

	WDAY	"B"	"C"	"D"
WEEKDAY MORNINGS (MON. THRU FRI.)	66.2	16.8	7.7	4.2
WEEKDAY AFTERNOONS (MON. THRU FRI.)	66.1	11.4	11.9	3.7
EVENINGS (SUN. THRU SAT.)	67.5	14.1	9.2	7.2

Amazing, you bet, but once you see the *additional* facts about our *rural* superiority, you'll agree that WDAY is even more fabulous! Our new booklet gives figures for four typical mail-pull campaigns, together with revealing cost comparisons and statements by sponsors. It gives you down-to-earth proof of WDAY's rural coverage.

Write to us, or ask Free & Peters, for this new booklet! It explains why WDAY is one of the great radio buys of the nation.

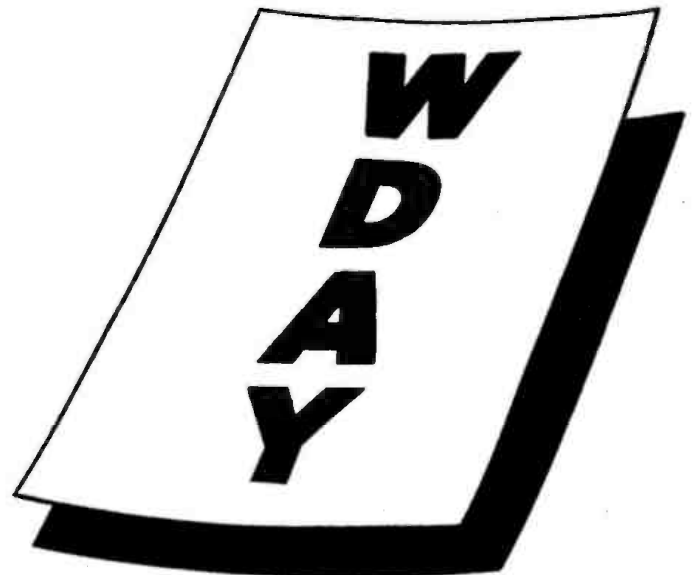

FARGO, N. D.

NBC • 970 KILOCYCLES • 5000 WATTS



FREE & PETERS, INC.
Exclusive National Representatives

DIRECTORY OF AM, FM, and TV STATIONS OF THE UNITED STATES

(Data corrected to December 6, 1949)
If executives or services for FM or TV stations are same as AM affiliate names are not repeated.

NORTH DAKOTA—(Continued)

City Call Letters Established	Chan. or Freq. Power	Name of Licensee Headquarters Address Telephone Number	Network Representative	Executive Personnel	Transc. Library News Service Transmitter Make	
FARGO—(Continued)						
KVNF-FM 1947	Ch. 222 (B) 92.3mc 19kw	WDAY Inc. Black Bldg. 5357	NBC Northwest Free & Peters	Earl C. Reineke, Pres. & Gen. Mgr. Jack Dunn, Sta. Mgr. Tom Barnes, Sales Mgr.	Ken Kennedy, Prog. Mgr. Roy Pedersen, Prom. Mgr. Julius Hetland, Tech. Dir. Juline Savold, Chief Engr.	Thesaurus AP UP RCA
GRAND FORKS						
*KFJM 1923	1440 1,000-LS 500-N ST-KILO	U. of North Dakota University Station 4-6211		Andrew J. Kochman Jr., Sta. Dir. Quentin W. Welty, Prog. Dir.	Arnold Petrick, Chief Engr. Collins
KILO 1941	1440 1,000-LS 500-N ST-KFJM	Grand Forks Herald First Nat'l Bank Bldg. 1200	CBS Avery-Knodel	M. M. Opegard, Pres. J. Warren McClure, Gen. Mgr. William Hyvonen, Asst. to Gen. Mgr.	Roger Lambert, Prog. Dir. Robert Runyon, Prom. Mgr. Arnold Petrick, Chief Engr.	Capitol UP Collins
KNOX 1947	1400 250	Community Radio Corp. Grand Forks 3500	MBS Great Northern	Caroll Day, Pres. Elmer Hanson, Gen. Mgr. Robert Lukkasov, Coml. Mgr.	James Cowan, Prog. Dir. Jack French, Asst. Mgr. Cliff Thomeford, Chief Engr.	World UP Western Electric
JAMESTOWN						
KSJB 1937	800 5,000 DA-1	Jamestown Bcstg. Co. Inc. 429 S. W. 2nd St. 1600	CBS Hollingbery	John W. Boler, Chief Owner Donn A. Clayton, Gen. & Coml. Mgr. Don Kingsley, Prog. Dir.	Gerry Uppman, Prom. Mgr. Robert Ridgeway, Chief Engr.	World UP RCA
MANDAN						
KGCU 1928	1270 1,000-LS 250-N	Mandan Radio Assn. Inc. 200 3rd Ave. N. W. 561	MBS Great Northern Walker	W. S. Russell, Pres. M. J. Reichert, Gen. Mgr.	Mert Bushee, Prog. Dir. Raymond Barnett, Chief Engr.	Lang-Worth AP RCA
MINOT						
KLPM 1929	1390 5,000-LS 1,000-N	Minot Bcstg. Co. Fair Block 41-146	MBS Great Nor. Walker	John B. Cooley, Pres. C. W. Baker, Gen. Mgr. & Chief Engr.	Leslie E. Maupin, Sales & Prom. Mgr. J. J. Hautman, Prog. Dir.	World UP Collins
VALLEY CITY						
KOVC 1936	1490 250	KOVC Inc. 312 Fifth Ave. 408-W	MBS Great Northern	Robert E. Ingstad, Pres., Gen. & Coml. Mgr.	Hugh Thomas, Prog. Dir. Charles Sjostrom, Chief Engr. UP Collins
WILLISTON						
KWBM 1948	1450 250	Williston Bcstg. Co. Williston; 1450	Holman	Raymond Kapp, Pres. & Prog. Dir. A. L. Hellebust, Gen. Mgr.	B. G. Bailey, Coml. Mgr. Irwin Christianson, Chief Engr.	World UP; W.E.
OHIO						
AKRON						
WADC 1925	1350 5,000 DA-1	Allen T. Simmons WADC Bldg. Jefferson 6165	CBS Hollingbery	Allen T. Simmons, Owner- Mgr. Robert B. Wilson, Asst. Mgr.	Fred C. Bock, Coml. Mgr. Harold Hageman, Prog. Dir. Secret Williams, Prom. Mgr. John L. Wildermuth, Chief Engr.	Lang-Worth Standard World UP, TP Collins
WAKR 1940	1590 5,000 DA-N	Summit Radio Corp. First Nat'l Tower Hemlock 6151	ABC Weed	S. Bernard Berk, Pres. & Gen. Mgr. Roger G. Berk, Sta. Dir. Kenneth M. Keegan, Coml. Mgr.	Arthur F. Moore, Prog. Dir. Viola G. Berk, Prom. Mgr. Irwin L. Knopp, Chief Engr.	Associated AP RCA
WAKR-FM 1947	Ch. 248 (B) 97.5mc 14.7kw					
WCUE (CP)	1150 1,000-D-DA	Akron Bcstg. Corp.				
WHKK 1945	640 1,000 DA-1	United Bcstg. Co. 51 W. State St. Blackstone 7101	MBS Raymer	Sterling Graham, Pres. Russell W. Richmond, V. P. & Gen. Mgr. Cecil W. Green, Sales Mgr.	Lew Henry, Prog. Dir. Donal O'Neil, Prom. Mgr. James S. Hill, Chief Engr.	Standard AP Western Electric
ALLIANCE						
WFAH (FM) 1947	Ch. 269 (A) 101.7mc 1kw	Review Pub. Co. 2720 S. Union Ave. 6286	Standard	Alice C. Hoiles, Pres. Frank A. Hoiles, Mgr. Frank LaBarba, Coml. Mgr.	R. A. Gates, Prog. Dir. Art McCracken, Chief Engr.	World Lang-Worth UP General Electric
ASHLAND						
WATG (FM) 1947	Ch. 267 (B) 101.3mc 10.2kw	Beer & Koehl Ashland 1-5751	Standard	Robert M. Beer & Edgar Koehl, Co-owners Robert M. Beer, Gen. Mgr.	Robert Atterholt, Coml. Mgr. Richard Leidy, Prog. Dir. Fred Rosentreter, Chief Engr.	Lang-Worth Thesaurus AP RCA
ASHTABULA						
WICA 1937	970 5,000-LS 1,000-N DA-2	WICA Inc. 221 Center St. 27-181	Standard	R. B. Rowley, Pres. W. W. Walrath, Gen. Mgr. D. W. Fassett, Coml. Mgr.	R. W. Miner, Prog. Dir. F. N. Bernato, Chief Engr.	Thesaurus Lang-Worth UP RCA
WICA-FM 1949	Ch. 279 (B) 103.7mc 52kw				 REL
BELLAIRE						
WTRF 1947	1290 1,000-D	Tri-City Bcstg. Co. The Skyline 1515	MBS Standard Walker	Robert W. Ferguson, Gen. Mgr. Frank Curtis, Prog. Dir.	A. T. Fisher, Prom. Mgr. George Cowen, Chief Engr.	World SESAC AP General Electric
WTRF-FM 1947	Ch. 263 (B) 100.5mc 20kw					
CAMBRIDGE						
WILE 1948	1270 1,000-D	Land O' Lakes Bcstg. Corp. 917 Beatty Ave.; 3545		H. D. McClelland, Pres. Howard A. Donahoe, V.P. & Gen. Mgr.	Richard F. Rose, Coml. & Prom. Mgr. Wesley C. Randles, Chief Engr.	World Capitol AP; Raytheon

DA-N Directional Antenna, night only. FM's in italic. *Non-Commercial Station. D-Day. N-Night. ST-Share Time. SH-Specified Hours.
DA-1 Directional Antenna, same pattern day and night. U-Unlimited. CP-Construction Permit Issued. LS-Local Sunset.
DA-2 Directional Antenna, different pattern day and night. L-Limited Time with Dominant Station. SA-Special Authorization.

City Call Letters Established	Chan. or Freq. Power	Name of Licensee Headquarters Address Telephone Number	Network Representative	Executive Personnel	Transc. Library News Service Transmitter Make	
CANTON						
WAND 1947	900 500-D	P. C. Wilson 106 High Ave., NW 8397	Continental	P. C. Wilson, Pres. & Coml. Mgr. James Wilson, Gen. Mgr. & Prog. Dir.	Robert Bradley, Prom. Mgr. Gene Peterman, Chief Engr.	Associated AP General Electric
WAND-FM 1947	Ch. 223 (B) 92.5mc 15kw					
WCMW 1946	1090 1,000-D	Stark Bcstg. Corp. 317 West Tuscarawas St. 5-9475	Standard Burn-Smith	Merlin R. Schneider, Pres. Arthur W. Davis, Gen. Mgr. Clark L. Dozer, Coml. Mgr.	Alfred P. Sloane, Prog. Dir. S. L. Huffman, Prom. Mgr. Robert A. Rexroad, Chief Engr.	Lang-Worth Standard AP, TP RCA
WCMW-FM 1947	Ch. 235 (B) 94.9mc 3kw					
WHBC 1925	1480 5,000 DA-N	Ohio Bcstg. Co. 550 Market Ave. S. 6-7166	ABC Taylor- Boroff	Roy D. Moore, Pres. Eugene Carr, Dir. of Radio Joseph K. Vodrey, Gen. Mgr. Robert C. Fehlman, Sta. Mgr.	Paul E. Gilmer, Coml. Mgr. Gervis S. Brady, Prog. Dir. Julius Glass, Prom. Mgr. Kenneth L. Sliker, Chief Engr.	Federal Capitol AP, UP
WHBC-FM 1947	Ch. 231 (B) 94.1mc 25kw					
CHILlicothe						
WBEX 1947	1490 250	Shawnee Bcstg. Co. 27 East Second St. 2244	ABC Grant	D. C. Summerford, Pres. J. Harry Callaway, Gen. Coml. & Prom. Mgr. & Prog. Dir.	Ralph Albers, Chief Engr.	World UP
CINCINNATI						
WCKY 1929	1530 50,000 DA-N	L. B. Wilson Inc. Hotel Gibson Cherry 6565		L. B. Wilson, Pres. & Gen. Mgr. C. H. Topmiller, Mgr. & Chief Engr.	Bill Dawes, Prog. Dir.	World Standard INS RCA
WCPO 1928	1230 250	Scripps-Howard Radio Inc. 2345 Symmes St. Capitol 0777	MBS Branham	Jack R. Howard, Pres. M. C. Watters, V. P. & Gen. Mgr. John Patrick Smith, Asst. Gen. Mgr.	Glenn Clark Miller, Sta. Dir. Fred Geisel, Prom. Mgr. Glenn A. Davis, Chief Engr.	Lang-Worth Standard UP Western Electric
WCPO-FM 1949	Ch. 285 (B) 105.1mc 10kw					
WCPO-TV 1949	Ch. 7 174-180mc 12kw aur.; 21kw vis.		ABC, DuMont	Harry LeBrun, Sta. Dir.		General Electric
WKRC 1923	550 5,000-LS 1,000-N DA-1	Radio Cincinnati Inc. Hotel Aims Woodburn 0550	CBS Katz	Hulbert Taft Jr., Pres. Herman E. Fast, Gen. & Coml. Mgr.	Harvey Cary, Prog. Dir. Joel W. Stovall, Prom. Mgr. George A. Wilson, Chief Engr.	Standard AP, INS Western Electric
WCTS (FM) 1947	Ch. 270 (B) 101.9mc 12.6kw	(WKRC, AM affiliate) Times Star Bldg. Garfield 1331	Transit Radio	David G. Taft, Gen. Mgr. Robert F. Bender, Coml. Mgr.	Helen Nugent, Prog. Dir.	World Associated UP RCA
WKRC-TV 1949	Ch. 11 198-204mc 12.3kw aur.; 24.5kw vis.	(WKRC, AM affiliate) 800 Broadway Garfield 1331	Katz	Hulbert Taft Jr., Gen. Mgr.	U. A. Latham, Coml. Mgr. L. Joe Bolles, Prog. Dir.	General Electric
WLW 1922	700 50,000	Crosley Bcstg. Corp. 140 W. Ninth St. Cherry 1822	NBC	James D. Shouse, Chmn. of Bd. R. E. Dunville, Pres. & Gen. Mgr. H. M. Smith, V. P. in Chg. Sales W. P. Robinson, V. P. in Chg. Prog.	David E. Partridge, Dir. Sales Prom. R. J. Rockwell, V. P. in Chg. Engrg.	Thesaurus UP, INS Crosley
WLWA (FM) 1946	Ch. 266 (B) 101.1mc 9kw	(WLW, AM affiliate)				
WLWT(TV) 1948	Ch. 4 66-72mc 19.5kw aur.; 23.5kw vis.	(WLW, AM affiliate)		M. N. Terry, V. P. Chg. TV Activities & Gen. Mgr. William J. McCluskey, Sales Mgr.	Ruth Lyons, Prog. Dir. Calvin Bopp, Chief Engr.	RCA
WSAI 1925	1360 5,000 DA-N	Buckeye Bcstg. Co. 115 E. 4th St. Main 1068	ABC Avery- Knodel	Marshall Field 3rd, Pres. Robert M. Sampson, Gen. Mgr. & Prog. Dir.	Robert H. Boulware, Coml. Mgr. Margaret Mau, Prom. Mgr. William E. Symons, Chief Engr.	Capitol Standard UP Western Electric
WSAI-FM 1948	Ch. 274 (B) 102.7mc 14.7kw					General Electric
CLEVELAND						
WCUO (FM) 1949	Ch. 277 (B) 103.3mc 14kw	UAW-CIO Bcstg. Corp. of Ohio 1025 Chester Ave. Tower 1-1112	Foster & Davies	Ralph M. Wallace, Sta. Mgr. George F. Folts, Sales Mgr.	William A. Watts, Prog. Dir. William B. Hull, Chief Engr.	Associated AP RCA
WDOK 1950	1260 5,000 DA-2	Civic Bcstrs. Inc. 1515 Euclid Ave. Main 9362		R. Morris Pierce, Pres. & Gen. Mgr.	Frederick C. Wolf, Treas. & Sales Mgr.	SESAC INS RCA
WERE 1948	1300 5,000 DA-1	Cleveland Bcstg. Inc. 1501 Euclid Ave. Tower 1-1850		Ray T. Miller, Pres. Fred R. Ripley, V. P. & Gen. Mgr.	Donald G. Stratton, Coml. Mgr.	Lang-Worth World AP, INS
WERE-FM 1948	Ch. 253 (B) 98.5mc 12kw					
WEWS-FM 1947	Ch. 271 (B) 102.1mc 10.3kw	Scripps-Howard Radio Inc. 1816 E. 13th St. Tower 1-5454		Jack R. Howard, Pres. James C. Hanrahan, Gen. Mgr.	J. Harrison Hartley, Sta. Dir. Phillip Rizzo, Prog. Dir.	SESAC Associated UP General Electric
WEWS-TV 1947	Ch. 5 76-82mc 8.1kw aur.; 16.3kw vis.		ABC CBS DuMont Branham	Donald E. Pierce, Prog. Dir.	Joseph B. Epperson, Chief Engr.	DuMont
WGAR 1930	1220 50,000 DA-1	The WGAR Bcstg. Co. Hotel Statler Prospect 0200	CBS Petry	G. A. Richards, Chmn. of Bd. John F. Patt, V. P. & Gen. Mgr. Carl E. George, V. P. & Asst. Gen. Mgr.	R. P. Merridew, Prog. Dir. Ted Boynton, Prom. Mgr. Robert A. Fox, Chief Engr.	Standard UP, INS RCA
WHK 1921	1420 5,000 DA-N	United Bcstg. Co. 1311 Terminal Tower Prospect 5800	MBS Raymer	Sterling E. Graham, Pres. K. K. Hackathorn, Gen. Mgr. J. B. Maurer, Coml. Mgr.	C. M. Hunter, Prog. Dir. William Sprague, Prom. Mgr. R. H. DeLany, Chief Engr.	AP Western Electric
WHK-FM 1947	Ch. 264 (B) 100.7mc 11.5kw					REL
WJMO 1947	1540 1,000-D	WJMO Bcstg. Co. 2157 Euclid Ave. Superior 4424	Young	W. J. Marshall, Pres. Dave Baylor, Gen. Mgr.	Robert De Tchon, Coml. Mgr. Brooke Taylor, Prog. Dir. Larry Shipley, Chief Engr.	Lang-Worth AP, UP Raytheon

DIRECTORY OF AM, FM, and TV STATIONS OF THE UNITED STATES

(Data corrected to December 6, 1949)
If executives or services for FM or TV stations are same as AM affiliate names are not repeated.

OHIO—(Continued)

City Call Letters Established	Chan. or Freq. Power	Name of Licensee Headquarters Address Telephone Number	Network Representative	Executive Personnel	Transc. Library News Service Transmitter Make	
CLEVELAND—(Continued)						
WJW 1943	850 5,000 DA-1	WJW Inc. 1375 Euclid Ave. Superior 0101	ABC Headley-Reed	William M. O'Neil, Pres. Lawrence Webb, Asst. to the Pres. Harold W. Waddell, Nat'l. Sales Mgr.	Charles V. Hunter, Prog. Dir. Frank Blumer, Prom. Mgr. Gerold G. Roberts, Chief Engr.	Standard UP, TP Western Electric
WJW-FM 1949	Ch. 281 (B) 104.1mc 19kw					
WSRS 1947	1490 250	WSRS Inc. 2156 Lee Rd. Erieview 2005	Forjoe	S. R. Sague, Pres., Gen. & Coml. Mgr. H. G. Pabst, Prog. Dir.	Jack Kelly, Prom. Mgr. Ben Whittaker, Chief Engr.	World Lang-Worth SESAC AP RCA
WSRS-FM 1947	Ch. 237 (A) 95.3mc 1kw					
WTAM 1923	1100 50,000	National Bcstg. Co. 815 Superior Ave. Cherry 0942	NBC NBC Spot	John McCormick, Gen. Mgr. Harold Gallagher, Coml. Mgr. Jacob Hines, Prog. Dir.	Howard Barton, Prom. Mgr. S. E. Leonard, Chief Engr.	Thesaurus Associated Standard AP, UP RCA
WTAM-FM 1948	Ch. 289 (B) 105.7mc 20kw					
WNBK (TV) 1948	Ch. 4 86-72mc 20.26kw aur.; 39.22kw vis.	(WTAM, AM affiliate)		Joseph A. Jenkins, Mgr. Philip L. Worcester, Prog. Dir.	A. Hammerschmidt, Oprs. Supvrs.	
WXEL (TV) 1949	Ch. 9 186-192mc 13kw aur.; 21kw vis.	Empire Coil Co. Inc. 4501 Pleasant Valley Rd. Victory 3-8400	Katz	Herbert Mayer, Pres. & Gen. Mgr. Franklin Snyder, Coml. Mgr.	Russell Speirs, Prog. Dir. Thomas B. Friedman, Chief Engr. General Electric

DA-N Directional Antenna, night only. FM's in italic.
DA-1 Directional Antenna, same pattern day and night.
DA-2 Directional Antenna, different pattern day and night.

*-Non-Commercial Station. D-Day. N-Night. ST-Share Time. SH-Specified Hours.
U-Unlimited. CP-Construction Permit Issued. LS-Local Sunset.
L-Limited Time with Dominant Station. SA-Special Authorization.

WSRS

THE *Family* STATION

*
THE LEADING INDEPENDENT
IN THE NATION'S
SIXTH MARKET - - - CLEVELAND

**FORJOE & CO.
NATIONAL REPRESENTATIVES**

**S. R. SAGUE
PRES. & GEN'L. MGR.**

* IN A RECENT CLEVELAND POPULARITY POLL CONDUCTED BY THE CLEVELAND PRESS, WSRS LEADS 3 NETWORK STATIONS AND ALL INDEPENDENTS.

IN THE GREAT CLEVELAND MARKET—

Check **WJW**

Cleveland's Chief Station!

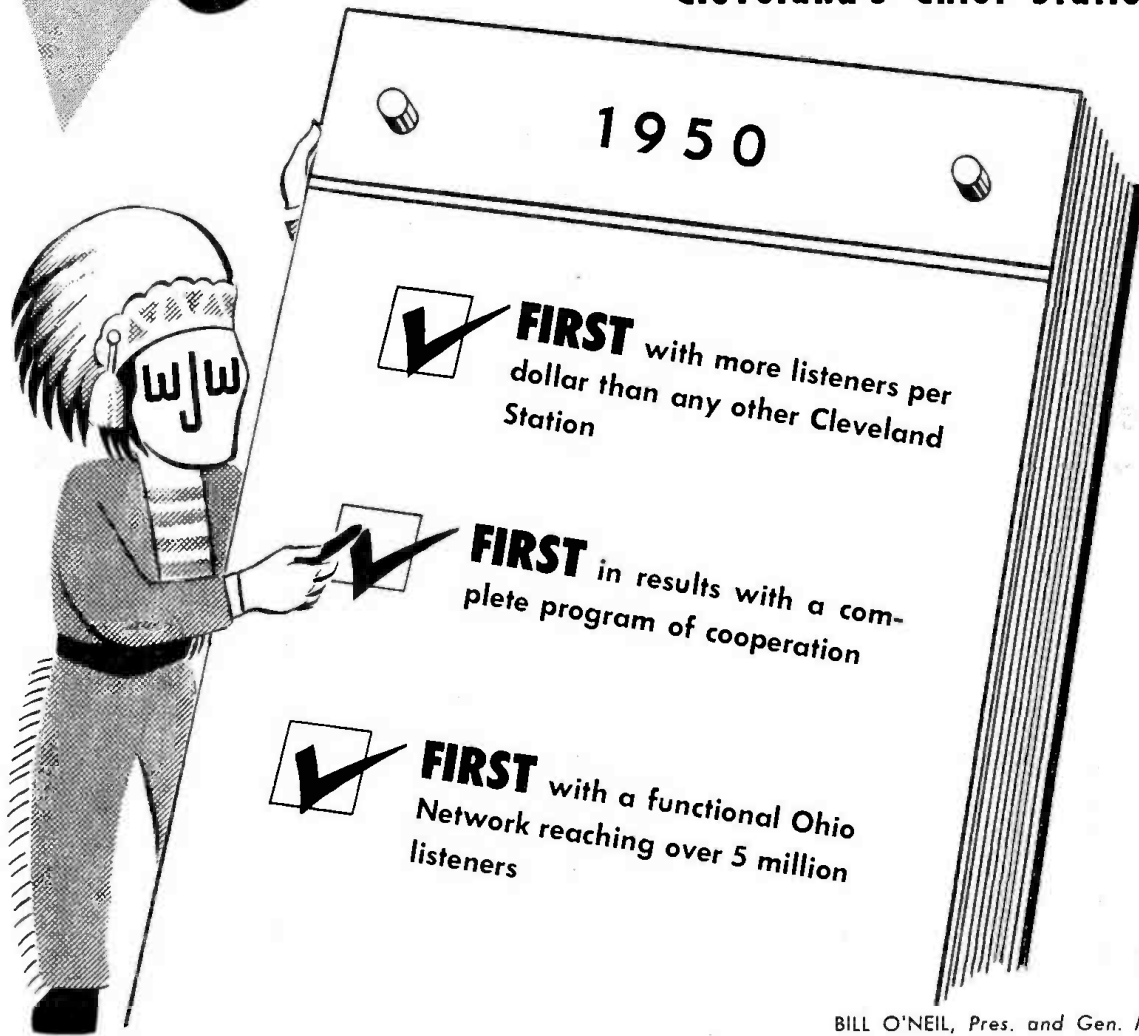

BILL O'NEIL, Pres. and Gen. Mgt.

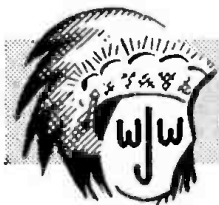

BASIC
ABC Network

WJW

CLEVELAND

850 KC
5000 Watts

REPRESENTED NATIONALLY BY HEADLEY-REED COMPANY

DIRECTORY OF AM, FM, and TV STATIONS OF THE UNITED STATES

(Data corrected to December 6, 1949)
If executives or services for FM or TV stations are same as AM affiliate names are not repeated.

OHIO—(Continued)

City Call Letters Established	Chan. or Freq. Power	Name of Licensee Headquarters Address Telephone Number	Network Representative	Executive Personnel	Transc. Library News Service Transmitter Make
COLUMBUS					
WBNS 1924	1460 5,000-LS 1,000-N DA	Radiohio Inc. 33 N. High St. Adams 9265 (WBNS, AM affiliate)	CBS Blair	Richard A. Borel, Gen. Mgr. W. I. Orr, Sales Dir.	Jerome R. Reeves, Prom. Mgr. Geer Parkinson, Prog. Dir. Lester H. Nafzger, Chief Engr. Capitol World AP; RCA
WELD (FM) 1940	Ch. 246 (B) 97.1mc; 30kw				
WBNS-TV 1949	Ch. 10 192-198mc 14.2kw aurr.; 28.4kw vis.		CBS Blair	Robert D. Thomas, Sales Mgr.	Edward H. Bronson, Prog. Dir. Ashley Dawes, Prod. Dir. World, Flamingo Nationwide
WCOL 1922	1230 250	The Pixleys East Broad at Young St. Main-4581	ABC Headley-Reed	Lloyd A. Pixley, Pres. Al Albinger, Gen. Mgr. Edgar A. Sprague, Prod. Dir.	Robert O. Runnerstrom, Prom. & Coml. Mgr. Leo McConnick, Chief Engr. Lang-Worth Associated AP, UP; RCA
WCOL-FM 1947	Ch. 222 (B) 92.3mc 33kw				Westinghouse
WHKC 1921	610 5,000 DA-N	United Bcstg. Co. 22 East Gay St. Adams 1101	MBS Raymer	Sterling Graham, Pres. Carl M. Everson, Gen. Mgr. Harry H. Hoessly, Coml. Mgr.	John B. Moses, Prog. Dir. William C. Minor, Chief Engr. Lang-Worth UP RCA
WHKC-FM 1948	Ch. 254 (B) 98.7mc 15kw				
WLWF (FM) 1949	Ch. 242 (B) 96.3mc 15kw	Crosley Bcstg. Corp. 3165 Olentangy River Rd. Jefferson 5441	NBC	J. D. Shouse, Chmn. of Bd. R. E. Dunville, Pres. & Gen. Mgr. Richard Rider, Prog. Dir.	James Leonard, Sta. Mgr. George Henderson, Sales Mgr. Charles Sloan, Chief Engr. Thesaurus UP, INS
WLWC(TV) 1949	Ch. 3 60-66mc 12.8kw aurr.; 15.2kw vis.		(WLWF (FM) affiliate)		RCA
*WOSU 1922	820 5,000 L-WFAA WBAP	The Ohio State U. O. S. U. Campus University 3148		Howard L. Bevis, Pres. Robert C. Higgy, Sta. Dir. & Chief Engr.	Glen E. Ellstrom, Prog. Dir. Thesaurus UP RCA
WTVN(TV) 1949	Ch. 6 82-88mc 14.2kw aurr.; 16.8kw vis.	Picture Waves Inc. 3720 LeVeque Lincoln Tower Fletcher 1520	ABC DuMont Headley-Reed	Edward Lamb, Pres. & Chief Owner John Rossiter, Gen. Mgr.	Herb Stewart, Asst. Coml. Mgr. Colin Male, Prog. Dir. James Burke, Chief Engr. AP RCA
WVKO (FM) 1948	Ch. 234 (B) 94.7mc 52.1kw	Sky Way Bcstg. Corp. 274 S. Third St. Main 5247	Standard	Gustav Hirsch, Pres. Robert S. French, Gen. Mgr. Thomas H. Buchanan, Coml. Mgr.	Bert Charles, Prog. Dir. Frederick Eckardt, Chief Engr. Associated Capitol UP, INS Western Electric

DA-N Directional Antenna, night only. FM's in italic. *—Non-Commercial Station. D—Day. N—Night. ST—Share Time. SH—Specified Hours.
DA-1 Directional Antenna, same pattern day and night. U—Unlimited. CP—Construction Permit Issued. LS—Local Sunset.
DA-2 Directional Antenna, different pattern day and night. L—Limited Time with Dominant Station. SA—Special Authorization.



COVERS CENTRAL OHIO

WBNS



COVERS COLUMBUS AND CENTRAL OHIO

IT TAKES WBNS TO RING CASH REGISTERS IN CENTRAL OHIO—

In and around Columbus in central Ohio are 163,550 families who loyally keep their radios tuned to WBNS day and night. They have learned by a quarter of a century of listening that they can believe what they hear on WBNS. This market is not only thoroughly covered by WBNS but there is the extra bonus of program duplication on the affiliated FM station WELD. That's why advertisers who wish to do a complete and profitable selling job in central Ohio naturally select WBNS as their principal radio medium. WBNS has a long list of both local and national advertisers who consistently broadcast their sales messages over this station for year after year to the tune of sweet music on the cash registers.

ASK THE LOCAL ADVERTISERS ABOUT WBNS . . . THEY KNOW—

The local merchants know from experience what radio station pulls returns and which one does not. They get together . . . They com-

ASK JOHN BLAIR

pare notes . . . So ask Roger Jewelers, Carlile Furniture, Hanna Paint, Capital City Products Company, Reubens and dozens of others here in Columbus. Many of them will tell you that they have been using WBNS for twenty-five years and each one will testify that this station always brings in the customers and does the job at low cost too.

YES, AND ALSO ASK THE NATIONAL ADVERTISER ABOUT WBNS—

National advertisers do not spend their money wildly. They test and retest before embarking upon a campaign . . . And here in Central Ohio the field tests supported by Hooperatings prove that WBNS has the audience which does the buying. That's why more national advertisers use WBNS than any other Columbus station.



COVERS CENTRAL OHIO

IN COLUMBUS, OHIO IT'S

WBNS

POWER 5,000 D • 1,000 N CBS



City Call Letters Established	Chan. or Freq. Power	Name of Licensee Headquarters Address Telephone Number	Network Representative	Executive Personnel	Transc. Library News Service Transmitter Make	
COSHOCTON						
WTNS 1947	1560 1,000-D	Coshocton Bcstg. Co. 114 N. 6th St. 1560	Standard	Bruce Wallace, Pres. & Gen. Mgr. James Sigman, Coml. Mgr. John R. Terry, Prog. Dir.	William Kirk, Prom. Mgr. Ben A. Jones, Chief Engr.	Standard Lang-Worth SESAC UP Raytheon
DAYTON						
WHIO 1935	1290 5,000 DA-N	Miami Valley Bcstg. Corp. 45 South Ludlow St. Adams 2261	CBS Hollingbery	James M. Cox Jr., Pres. Robert H. Moody, Gen. Mgr. Harvey R. Young Jr., Coml. Mgr.	Lester G. Spencer, Prog. Dir. (Mrs.) Viloe I. Coleman, Prom. Mgr. Ernest L. Adams, Chief Engr.	World Standard AP, UP, INS Western Electric Associated RCA
WHIO-FM 1948	Ch. 256 (B) 99.1mc 19kw					
WHIO-TV 1949	Ch. 13 210-216mc 13kw aur.; 24kw vis.		ABC, CBS DuMont Katz			
WING 1921	1410 5,000 DA-N	Great Trails Bcstg. Corp. 121 N. Main St. Adams 3288	ABC Weed	Charles Sawyer, Pres. Adna Karns, Gen. Mgr. John Pattison Williams, Exec. V. P.	Arthur Martin, Prog. Dir. Jean Broome, Prom. Mgr. Lloyd House, Chief Engr.	Lang-Worth Capitol AP Thesaurus
WLWB (FM) 1949	Ch. 248 (B) 97.5mc 16kw	Crosley Bcstg. Corp. Frytown & W. Carroll- ton Rds. Meirose 9266	NBC	James D. Shouse, Chmn. of Bd. John T. Murphy, Gen. Mgr. Peter Lasker, Coml. Mgr.	A. Donovan Faust, Prog. Dir. Howard Lepple, Chief Engr. Thesaurus
WLWD (TV) 1949	Ch. 5 76-82mc 8kw aur.; 16kw vis.	(WLWB (FM) affiliate) 4595 S. Dixie Highway Walnut 2101		R. E. Dunville, V. P. & Gen. Mgr.	M. N. Terry, V. P. Chg. TV. Activities UP, INS Crosley
WONE 1949	980 5,000 DA-2	Skyland Bcstg. Corp. 5 S. Jefferson St. Michigan 6501	MBS Headley-Reed	Ronald B. Woodyard, Pres. & Gen. Mgr.	Jack Thornquest, Coml. & Prom. Mgr.	Thesaurus AP RCA
WTWO (FM) 1949	Ch. 284 (B) 104.7mc 43kw	(WONE, AM affiliate)				
DEFIANCE						
WONW 1949	1280 500-D	Defiance Bryan Pauld- ing Bcstg. Co. U. S. Route 24 5227	Standard	R. W. Crowell, Lloyd Basil, Ed W. Kuns, Robert S. Burke, Carl Fox, Partners	Richard E. Kaiser, Gen. Mgr. Gene Mills, Coml. Mgr. Paul Price, Prog. Dir. Kenneth Farrance, Chief Engr.	Thesaurus UP Gates
DOVER						
WJER (CP)	1450 250	Mrs. H. C. Greer 210 Blvd.		Mrs. H. C. Greer, Owner Frank Shaffer, Gen. Mgr.	William McLellan, Chief Engr.	
EAST LIVERPOOL						
WLIO 1948	1570 1,000-D	Pottery Bcstg. Co. Turk Bldg. Main 5190	Standard	Earl D. Eisenhower, Pres. John M. Croft, Gen. & Coml. Mgr.	Cy Newman, Prog. Dir. & Prom. Mgr. Frank Schafer, Chief Engr.	Lang-Worth UP Raytheon
WOHI 1949	1490 250	East Liverpool Bcstg. Co. 516 Market St. Main 1490		Richard V. Beatty, Pres. & Gen. Mgr. Harold J. Fitzgerald, Coml. Mgr.	John W. Ridder, Prog. Dir. David T. Taylor, Chief Engr.	World Thesaurus AP RCA
ELYRIA-LORAIN						
WEOL 1948	930 1,000 DA-2	Elyria-Lorain Bcstg. Co. Elyria Savings & Trust Bldg. 2255		Roy W. Ammel, Pres. H. A. Seville, Gen. & Coml. Mgr. Martin Bouhan, Prog. Dir.	John W. O'Brien, Prom. Mgr. Walter Murawski, Chief Engr.	Lang-Worth Capitol UP RCA
WEOL-FM 1949	Ch. 297 (B) 107.3mc 48kw					
FINDLAY						
WFIN 1941	1330 1,000-D	Findlay Pub. Co. 500½ South Main St. Main 1330	KBS	R. L. Heminger, Pres. Harold H. Heminger, Gen. & Coml. Mgr.	Allen P. Dudley, Prog. Dir. Edgar C. Smith, Chief Engr.	Standard Lang-Worth UP INS Collins
WFIN-FM 1948	Ch. 263 (B) 100.5mc 8.2kw				 General Electric
FOSTORIA						
WFOB (FM) 1946	Ch. 288 (A) 105.5mc 0.45kw	Seneca Radio Corp. 125 South Main St. 4635		Andrew Emerine, Pres. Mel Murray, Gen. Mgr. C. L. Borchers, Coml. Mgr.	James Huth, Prog. Dir. Farrell F. Elsea, Chief Engr.	World INS General Electric
FREMONT						
WFRO (CP)	900 500-D; DA	Robert F. Wolfe Co. 905 W. State St. Main 3401		Robert F. Wolfe, Pres. & Gen. Mgr. J. Weddell Kerr, Coml. Mgr.	Frank Swartz, Prog. Dir. A. C. Kaubie, Chief Engr.	World Thesaurus INS General Electric
WFRO-FM 1946	Ch. 257 (A) 99.3mc 1kw					
HAMILTON						
WMOH 1944	1450 250	Fort Hamilton Bcstg. Co. Second Nat'l Bank Bldg. 4-6543	MBS	Robert Briede, Pres. Joseph E. True, Gen., Coml. & Prom. Mgr. & Prog. Dir.	Don Volkman, Chief Engr.	Standard UP Collins
WMOH-FM 1948	Ch. 278 (B) 103.5mc 8.7kw					
LAKEWOOD						
WLAL (FM)	Ch. 285 (A) 104.9mc 0.5kw	United Garage & Serv- ice Corp.				
LANCASTER						
WHOK 1948	1320 500-D	Hocking Valley Bcstg. Co. Memorial Dr. 4500		Dr. Nelson Embrey, Pres. Donald W. White, Gen. & Coml. Mgr. & Prog. Dir.	Bob Respass, Prom. Mgr. Charles Houston, Chief Engr.	Cole World AP Gates
LIMA						
WIMA 1948	1150 1,000 DA-N	N.W. Ohio Bcstg. Corp. 223 North Main St. 6-3841	MBS ABC Weed	G. E. Hamilton, Pres. R. W. Mack, Gen. Mgr.	C. B. Heller, Coml. Mgr.	Thesaurus INS RCA
WIMA-FM 1948	Ch. 271 (B) 102.1mc 15.5kw				 Westinghouse

DIRECTORY OF AM, FM, and TV STATIONS OF THE UNITED STATES

(Data corrected to December 6, 1949)
If executives or services for FM or TV stations are same as AM affiliate names are not repeated.

OHIO—(Continued)

City Call Letters Established	Chan. or Freq. Power	Name of Licensee Headquarters Address Telephone Number	Network Representative	Executive Personnel	Transc. Library News Service Transmitter Make	
LIMA—(Continued)						
WLOK 1936	1240 250	The Fort Industry Co. Nat'l Bank Bldg. 6-3411	NBC Avery- Knodel	George B. Storer, Pres. J. Robert Kerns, Mgng. Dir. & Prom. Mgr.	Harry Jay, Coml. Mgr. Richard T. Roll, Prog. Dir. Darrel Hunter, Chief Engr.	Lang-Worth AP Western Electric
WLOK-FM 1948	Ch. 277 (B) 103.3mc; 1kw					
MANSFIELD						
WMAN 1939	1400 250	Richland Inc. 140 Park Ave. West 4235	ABC Taylor-Borroff	Mrs. Monroe Rubin, Chief Owner J. M. O'Hara, Pres., Gen. & Coml. Mgr.	Harry C. Lytle, Prog. Dir. Carl Kindt, Prom. Mgr. W. E. Morrison, Chief Engr.	World UP RCA
MARIETTA						
WMOA 1946	1490 250	Marietta Bcstg. Co. P. O. Box 201 6383	MBS, KBS Grant	William G. Wells, Pres. Hugh M. P. Higgins, V. P. & Gen. Mgr.	Aud N. Archer, Coml. Mgr. James L. Ulmer, Prog. Dir. Charles E. Clark, Chief Engr.	Lang-Worth UP Collins
MARION						
WMRN 1940	1490 250	The Marion Bcstg. Co. P. O. Box 518 3226	ABC Standard Stovin	Robert T. Mason, Pres. & Gen. Mgr. Robert Sprouse, Coml. Mgr.	Carey Simpson, Prog. Dir. Francis J. Peters, Chief Engr.	Thesaurus UP RCA
WMRN-FM (CP)	Ch. 295 (B) 108.9mc; 7.6kw					
MIDDLETOWN						
WPFB 1947	910 1,000-LS 100-N	Paul F. Braden Central Ave. 2-3825	Cooke	Paul F. Braden, Pres. & Gen. Mgr. Ranny Daly, Coml. Mgr.	George Lummis, Prog. Dir. Fern Troutvine, Prom. Mgr. Laurace Beckwith, Chief Engr.	Lang-Worth SESAC AP
NEWARK						
WCLT 1949	1430 500-D	Advocate Printing Co. 25 W. Main St. 4007	Standard	Frank W. Spencer, Pres. Thomas A. Rogers, Gen. Mgr. Robert Pricer, Coml. Mgr.	Gene Ragle, Prog. Dir. & Asst. Gen. Mgr. Benjamin Windle, Chief Engr.	World Capitol AP Gates General Electric
WCLT-FM 1947	Ch. 262 (B) 100.3mc; 8.5kw					
PIQUA						
WPTW 1947	1570 250-D	Miami County Bcstg. Co. Inc. 1625 W. Covington Ave. 1420	Grant	Richard E. Hunt, Chief Owner. Gen. & Coml. Mgr. Bob Bupp, Prog. Dir.	Jim Flinn, Prom. Mgr. Byron F. London, Chief Engr.	World SESAC AP Collins
PORTSMOUTH						
WPAY 1935	1400 250	The Scioto Bcstg. Co. 1009 Gallia St. 1010	CBS Taylor-Borroff	Roy D. Moore, Pres. Gerald F. Boyd, Mgr. Carl P. Bodner, Coml. Mgr.	Floyd M. Jackson, Prog. Dir. Ann T. Evans, Prom. Mgr. Maurice L. Myers, Chief Engr.	Lang-Worth AP RCA
WPAY-FM 1948	Ch. 281 (B) 104.1mc; 7kw					

DA-N Directional Antenna, night only. FM's in italic. *—Non-Commercial Station. D—Day. N—Night. ST—Share Time. SH—Specified Hours.
DA-1 Directional Antenna, same pattern day and night. U—Unlimited. CP—Construction Permit Issued. LS—Local Sunset.
DA-2 Directional Antenna, different pattern day and night. L—Limited Time with Dominant Station. SA—Special Authorization.

1940

1941

1942

1943

1944

1945

1946

1947

1948

1949

1950

W M R N

Begins Its Tenth Year

We're looking forward to 1950, for it marks our tenth year of service to this wealthy seven-county area. When you want to sell these more-than-200,000 Ohioans, tell your story over WMRN. They pay attention to their "Friendly Neighbor".

WMRN - MARION, OHIO

AFFILIATED WITH THE AMERICAN BROADCASTING COMPANY

City Call Letters Established	Chan. or Freq. Power	Name of Licensee Headquarters Address Telephone Number	Network Representative	Executive Personnel	Transc. Library News Service Transmitter Make	
PORTSMOUTH—(Continued)						
(CP)	1260 1,000 DA-1	Portsmouth Bcstg. Co.				
RAVENNA						
WKRV (FM) (CP)	Ch. 221 (A) 92.1mc; 1kw	Record Pub. Co.				
SANDUSKY						
WKFM (FM) (CP)	Ch. 233 (B) 94.5mc; 51kw	Sandusky Newspapers Inc.				
WLEC 1947	1450 250	Lake Erie Bcstg. Co. Cleveland Rd. at Huntington 5170	MBS Standard McKinney	Lloyd A. Pixley, Pres. Albert E. Heiser, Gen. Mgr. Louis Mahla, Coml. Mgr.	Jay Wagner, Prog. Dir. Don Dean, Prom. Mgr. Jay Leibach, Chief Engr.	World Lang-Worth Thesaurus AP RCA
SHAKER HEIGHTS						
WIKH (FM) (CP)	Ch. 261 (A) 100.1mc; 0.64kw	Science Education Fnd. Inc.				
SPRINGFIELD						
WIZE 1940	1340 250	Radio Voice of Spring- field Inc. 117 W. High St. 3-4955	ABC Weed	Charles Sawyer, Pres. J. P. Williams, Exec. V. P. A. H. Karns, Gen. Mgr. C. N. Evans, Coml. Mgr.	Robert Christol, Prog. Dir. John McEnaney, Prom. Mgr. Victor Bushong, Chief Engr.	Lang-Worth Standard UP RCA
WJEL 1947	1600 500-D	Champion City Bcstg. Co. 101 N. Fountain 3-4676 (WJEL, AM affiliate)	KBS Standard Friedenberg	Dr. D. J. Parsons, Pres. Frank N. Jones, Gen. & Coml. Mgr.	William B. Burt, Prog. Dir. Mr. McCasland, Chief Engr.	Associated UP RCA
WJEM (FM) 1947	Ch. 280 (A) 103.9mc 1kw					Raytheon
WWSO	1210 250-D	Radio Springfield Inc. Chamber of Commerce Bldg. 3-6488	IMS	Lin Mason, Gen. Mgr.		Cole Thesaurus World AP
STEUBENVILLE						
WSTV 1940	1340 250	The Valley Bcstg. Co. Exchange Realty Bldg. 2-6265	MBS	Jack N. Berkman, Pres. John J. Laux, Gen. & Coml. Mgr. George H. Wilson, Prog. Dir.	Joseph M. Troesch, Asst. Gen. Mgr. & Tech. Dir. Charles S. Shepherd, Chief Engr.	Lang-Worth UP Western Electric
WSTV-FM 1947	Ch. 278 (B) 103.5mc 2kw					Westinghouse
TIFFIN						
WTFM (FM) 1947	Ch. 252 (A) 98.3mc 0.45kw	Tiffin Bcstg. Co. 21 N. Washington St. 3548	Standard	Jay R. David, Pres. Richard T. Roll, Gen. Mgr. Dale M. Schussler, Asst. Gen. Mgr. Wayne Byers, Prog. Dir.	Don Wall, Coml. Mgr. Bob Washka, Asst. Prog. Dir. Richard H. Tolmie, Chief Engr. Ernest Sanders, Asst. Chief Engr.	Capitol UP General Electric
TOLEDO						
WSPD 1928	1370 5,000 DA-N	The Fort Industry Co. 136 Huron St. Adams 3175	NBC Katz	George B. Storer, Pres. J. Harold Ryan, V. P. & Treas. E. Y. Flanigan, Gen. Mgr. Glenn Jackson, Prog. Dir.	Richard Gourley, Prom. Mgr. William Stringfellow, Chief Engr.	Lang-Worth Standard Thesaurus AP, UP, INS Western Electric

MUTUAL

WLEC

1450 KC

ONE OF THE GREATEST LITTLE STATIONS IN THE NATION!

JUST ASK **EVERETT-McKINNEY** AND LEARN

**ONE OF THE GRANDEST VALUES IN
RADIO ADVERTISING TODAY!**

★

MON. THRU FRI.	WLEC	A	B	C	D	E
8 TO 12 NOON	41.6	29.2	15.9	8.5	0.8	1.5
12 TO 6 PM	48.5	25.3	12.4	6.1	2.1	1.6
6 TO 8 PM	35.9	31.1	11.9	10.4	3.0	2.2
8 TO 10 PM	26.1	38.2	18.1	6.8	2.0	2.0



★ WINTER 1949 HOOPER INDEX

ONE OF THE COUNTRY'S MOST STABLE MARKETS—Sandusky, Ohio

DIRECTORY OF AM, FM, and TV STATIONS OF THE UNITED STATES

*(Data corrected to December 6, 1949)
If executives or services for FM or TV stations are same as AM affiliate names are not repeated.*

OHIO—(Continued)

City Call Letters Established	Chan. or Freq. Power	Name of Licensee Headquarters Address Telephone Number	Network Representative	Executive Personnel	Transc. Library News Service Transmitter Make	
TOLEDO—(Continued)						
WSPD-FM 1947	Ch. 268 (B) 101.5mc 10kw			 RCA	
WSPD-TV 1948	Ch. 13 210-216mc 14.4kw aur.; 27.4kw vis.		CBS, DuMont NBC	 RCA	
WTOD 1946	1560 1,000-D	Unity Corp. Inc. 515 Madison Ave. Garfield 5551 (WTOD, AM affiliate)	Headley-Reed	Edward Lamb, Pres. Sunne Miller, Gen. & Coml. Mgr.	Doug Tabner, Prog. Dir. Robert Sowers, Chief Engr.	Lang-Worth AP Raytheon
WTRT (FM) 1947	Ch. 260 (B) 89.9mc 8.8kw			 RCA	
WTOL 1938	1230 250	Community Bcstg. Co. Bell Bldg. Adams 3291	ABC Raymer	Frazier Reams, Pres. Thomas S. Bretherton, Gen. Mgr. Morton Neipp, Coml. Mgr.	Karl R. Nelson, Prog. Dir. Harold Holmes, Chief Engr.	World AP, UP Western Electric
WTOL-FM 1949	Ch. 284 (B) 104.7mc 50kw				
WARREN						
WHHH 1941	1440 5,000 DA-2	The Warren Tribune Radio Station Inc. 108 Main St. 2212-9	MBS Ra-Tel	Helen Hart Hurlbert, Pres. H. R. Farrall, V. P., Gen. & Coml. Mgr.	William M. Brown, Prog. & Prom. Mgr. Hugo A. Bondy, Chief Engr.	Associated SESAC UP Western Electric
WOOSTER						
WWST 1947	960 500-D	Wooster Republican Printing Co. Wooster 760	Standard	E. B. Evans, Gen. & Prom. Mgr. K. S. Gordon, Coml. Mgr.	D. E. Gooding, Prog. Dir. C. R. Grunder, Chief Engr.	Lang-Worth World AP RCA
WWST-FM 1947	Ch. 283 (B) 104.5mc 13kw				
WORTHINGTON						
WRFD 1947	880 5,000-D	Peoples Bcstg. Corp. 649 High St. 2-5342	Standard	James R. Moore, Pres. Edgar Parsons, Gen. Mgr.	Joseph D. Bradshaw, Coml. & Prom. Mgr. Bob Geis, Prod. Mgr. Royce O. Woodward, Chief Engr.	Standard AP, INS RCA
WRFD-FM 1959	Ch. 250 (B) 91.9mc 340kw				
YOUNGSTOWN						
WBBW 1949	1240 250	Mahoning Valley Bcstg. Corp. 260 W. Federal St. 3-2159	Forjoe Standard	John Cherpack Jr., Pres. & Chief Engr. Gene Trace, V. P., Gen. & Coml. Mgr.	Anthony Ross, Prog. Dir. & Prom. Mgr.	Associated Capitol INS RCA
WFMJ 1939	1390 5,000 DA-N	The WFMJ Bcstg. Co. 101 W. Boardman St. 3-4121	ABC Headley-Reed	William F. Maag Jr., Pres. & Gen. Mgr. Leonard E. Nasman, Coml. Mgr.	Robert B. Mackall, Prog. Dir. Frank A. Dieringer, Chief Engr.	Standard Thesaurus SESAC AP, UP RCA
WFMJ-FM 1947	Ch. 285 (B) 105.1mc 50kw				
WKBN 1926	570 5,000 DA-N	WKBN Bcstg. Corp. 17 N. Champion St. 42122	CBS Raymer	W. P. Williamson Jr., Pres. & Gen. Mgr. J. L. Bowden, Sta. Dir.	Howard Rempes, Prom. Mgr. B. T. Wilkens, Chief Engr.	World Lang-Worth UP RCA
WKBN-FM 1947	Ch. 255 (B) 98.9mc 18.5kw			 Westinghouse	
ZANESVILLE						
WHIZ 1924	1240 250	Southeastern Ohio Bcstg. System Inc. Lind Arcade Bldg. 6000	NBC Pearson	Clay Littick, Pres. Vernon A. Nolte, Gen. Mgr. Nate Milder, Coml. Mgr.	Robert D. Maley, Prog. Dir. & Prom. Mgr. William A. Hunt, Chief Engr.	World AP RCA

OKLAHOMA

ADA						
KADA 1934	1230 250	KADA Bcstg. Inc. First Nat'l. Bldg. 12	ABC, KBS Oklahoma Taylor-Borroff	Dr. C. C. Morris, Pres. Billy T. Hoover, V. P. & Gen. Mgr. Brown Morris, Asst. Mgr. & Secy-Treas.	Pat Murphy, Prog. Dir. Betty Hughes Nolen, Prom. Mgr. Harold Walker, Chief Engr.	Standard AP Collins
ALTUS						
KWHW 1947	1450 250	Altus Bcstg. Co. Inc. Altus 1405	MBS, KBS Oklahoma Grant	Frank E. Wimberly, Pres. & Gen. Mgr.	Ernest Baucum, Chief Engr.	Capitol AP Raytheon
ARDMORE						
KVSO 1935	1240 250	John F. Easley 112 N. Washington 3030	ABC, KBS Oklahoma Taylor-Borroff	John F. Easley, Pres. Albert Riesen, Gen. Mgr. J. E. Riesen, Coml. Mgr.	Dolly Dutton, Prog. Dir. D. C. Dillard, Prom. Mgr. Wm. Kolb, Chief Engr.	Associated SESAC AP RCA
KVSO-FM 1948	Ch. 229 (B) 93.7mc 8.2kw				
BARTLESVILLE						
KWON 1941	1400 250	Bartlesville Bcstg. Co. 100 Union Nat'l. Bank 1400	MBS Oklahoma	J. Fred Case, Pres. & Gen. Mgr. John Collins, Coml. Mgr.	Jim Wireman, Chief Engr. AP Western Electric
CHICKASHA						
KWCO 1946	1560 250-D	Washita Valley Bcstg. Co. P. O. Box 744 2899	MBS, LBS Oklahoma Continental	Phil Jackson & Clarence Wilson, Owners Clarence Wilson, Gen. Mgr. & Prog. Dir.	Phil Jackson, Coml. & Prom. Mgr. Neal Allen, Chief Engr. AP Gates

DA-N Directional Antenna, night only. FM's in italic.
DA-1 Directional Antenna, same pattern day and night.
DA-2 Directional Antenna, different pattern day and night.

*—Non-Commercial Station. D—Day. N—Night. ST—Share Time. SH—Specified Hours.
U—Unlimited. CP—Construction Permit Issued. LS—Local Sunset.
L—Limited Time with Dominant Station. SA—Special Authorization.

NOW Covering

the **RUHR-AL** Area

of the Greater Youngstown, Ohio

Iron and Steel district

5 KW-AM 50 KW-FM

Day and Night with 19 hour daily service

W F M J

(Youngstown, Ohio, Warren, Ohio, Sharon & New Castle, Pa.)

Per Dollar, Per "M" Listeners, buy the
Basic **ABC** Station in Youngstown, Ohio

- ★ FOURTH LARGEST STEEL CENTER
- ★ 25 TH MARKET IN AMERICA
- ★ THIRD OHIO MARKET
- ★ RICH FARMING AREA
- ★ MILLION POPULATION

Make Your Advertising Pay with WFMJ!

C. E. HOOPER — BMB
ASCP — BMI
NAB — OAB

ASSOCIATED PRESS
UNITED PRESS

NATIONAL REPRESENTATIVES
HEADLEY-REED COMPANY
New York Los Angeles
Chicago Atlanta
Detroit San Francisco

DIRECTORY OF AM, FM, and TV STATIONS OF THE UNITED STATES

*(Data corrected to December 6, 1949)
If executives or services for FM or TV stations are same as AM affiliate names are not repeated.*

OKLAHOMA—(Continued)

City Call Letters Established	Chan. or Freq. Power	Name of Licensee Headquarters Address Telephone Number	Network Representative	Executive Personnel	Transc. Library News Service Transmitter Make
CLINTON					
KWOE 1949	1320 1,000-D	Western Oklahoma Bcstg. Co. P. O. Box 706 617		Alice Howenstine, Pres. V. M. Preston, Secy-Treas.	Lew Preston, Prog. Dir. Harold Wood, Chief Engr. SESAC Raytheon
DUNCAN					
KRHD 1947	1350 250-LS 100-N	Duncan Bcstg. Co. P. O. Box 1192 1350	MBS	R. H. Drewry, Owner J. P. Burnett, Gen. Mgr. Byron McCall, Coml. Mgr.	Doug Thompson, Prog. Dir. Bill Buford, Chief Engr. Capitol UP Western Electric
DURANT					
KSEO 1947	750 250-D	Democrat Printing Co. P. O. Box 511 102	KBS, LBS	R. F. & Bennett Story, Partners Leroy Moses, Gen. Mgr.	Fred R. Blackburn, Coml. Mgr. L. O. Wilcox, Chief Engr. Thesaurus AP General Electric
KSEO-FM 1949	Ch. 297 (A) 107.3mc 1kw				
EL RENO					
KCHE 1948	1590 500-D	KCHE Bcstg. Co. First Nat'l. Bank Bldg. 2438	KBS	Ross K. Prescott & C. C. Woodson, Partners Harry L. Ward, Gen. Mgr. Hi Roberts, Prog. Dir.	Tom Gilmore, Coml. Mgr. C. H. Standford, Chief Engr. Standard UP Gates
ELK CITY					
KASA 1932	1240 250	Southwest Bcstg. Co. 204 N. Main 730	MBS Friedenberg	V. M. Preston, Mgr.	Lonnie J. Preston, Supvr.
ENID					
KCRC 1929	1390 1,000 DA-1	Enid Radiophone Co. Broadway Tower 447	ABC Oklahoma Taylor-Borroff	Milton B. Garber, Pres. George L. Tarter, Gen. & Prom. Mgr. H. P. Hale, Coml. Mgr.	Edith Longley, Prog. Dir. Murray Coleman, Chief Engr. Standard AP Collins
KCRC-FM 1948	Ch. 274 (B) 102.7mc 5.2kw				
KGWA (CP)	960 1,000 DA-1	Public Bcstg. Service Inc. Enid		George Hutchinson, Pres. H. J. Godschalk, Gen. Mgr.	William Teitzel, Chief Engr. UP Gates
FREDERICK					
KTAT 1948	1570 250-D	Frederick Bcstg. Co. P. O. Box 920 1010	KBS	R. W. Wheeler Jr., J. D. Jones Jr., J. W. Oswalt, W. A. Jones, Partnership Ron Wheeler, Gen. Mgr.	Charles Henson, Prog. Dir. Dan Jones, Coml. Mgr. & Chief Engr. Jack Oswalt, Bus. Mgr. World UP Gates
GUYMON					
KGYN 1948	1220 1,000-D	Plains Bcstg. Co. Inc. 21st & Lella 888		T. M. Raburn Jr., Pres. & Gen. Mgr. J. A. Burke, Chief Engr.	Thesaurus UP Gates
HOBART					
KTJS 1947	1420 250-D	T. J. Shriner 315 E. 11th St. 1070	KBS Oklahoma	T. J. Shriner, Owner & Gen. Mgr. M. J. Shriner, Coml. & Prom. Mgr.	Jack Wickizer, Prog. Dir. Darrel Foss, Chief Engr. AP Gates
HUGO					
KIHN 1948	1340 250	Little Dixie Bcstg. Co. Inc. P. O. Box 248 1140		George L. Malone, Pres. Kruger E. Muse, Gen. & Coml. Mgr. Betsy Muse, Prog. Dir.	Nancye Moore, Prom. Mgr. Milo Holtberg, Chief Engr. Lang-Worth AP Gates
LAWTON					
KSWO 1941	1380 1,000 DA-2	Oklahoma Quality Bcstg. Co. P. O. Box 699 1380	ABC Oklahoma Taylor-Borroff	R. H. Drewry, Pres. Allan Page, Gen. Mgr. E. N. Ashlock, Coml. Mgr.	Morgan Roberts, Prog. Dir. P. N. Goode, Prom. Mgr. William Buford, Chief Engr. Lang-Worth UP Western Electric
McALESTER					
KTMC 1946	1400 250	J. Stanley O'Neill First & Washington Sts. 2411	ABC, KBS Oklahoma Taylor-Borroff	J. Stanley O'Neill, Pres. & Gen. Mgr. Robert Baggett, Coml. Mgr. Betty Heard, Prog. Dir. & Prom. Mgr.	Robert Schlib, Chief Engr. Standard AP Gates
(CP)	1460 1,000-D	Pittsburg Bcstg. Co.			
MIAMI					
KGLC 1948	910 1,000 DA-1	Miami Bcstg. Co. Miami Hotel 3303	Young	John H. Giffin, Pres. Wallace R. Dunn, Gen. Mgr.	AP Western Electric
MUSKOGEE					
KBIX 1936	1490 250	Oklahoma Press Pub. Co. Barnes Bldg. 303	ABC Oklahoma Taylor-Borroff	Tams Bixby Jr., Pres. Ernest I. Watson, Mgr. Wally Weber, Asst. Mgr.	Roger Stoner, Prog. Dir. Eugene O'Brien Edwards, Chief Engr. UP RCA
KBIX-FM 1949	Ch. 253 (B) 98.5mc 3.3kw				
KMUS 1948	1380 1,000-LS 500-N DA	Eastern Oklahoma Bcstg. Corp. 412½ Court St. 658	MBS Continental	Ben T. Childers, Pres. Jimmie Barry, Gen., Coml. & Prom. Mgr.	Harvey Marsh, Prog. Dir. D. W. Hoisington, Chief Engr. UP Gates
KMUS-FM 1947	Ch. 268 (B) 101.5mc 3.7kw	Muskogee Bcstg. Co. 412½ Court St. 658		W. J. Rea Sr., Pres. & Gen. Mgr.	Western Electric
NORMAN					
KNOR 1949	1400 250	Cleveland County Bcstg. Co. P. O. Box 542 474		Tol Dickenson, Chief Owner & Coml. Mgr. Wm. S. Morgan, Owner & Gen. Mgr.	Don Daniel, Chief Engr. Standard UP Collins
*WNAD 1920	640 1,000-D	U. of Oklahoma Faculty Exchange 900		John W. Dunn, Gen. Mgr. Mima Smethers, Prom. Mgr.	Remy M. Perot, Chief Engr. Standard AP Western Electric
OKLAHOMA CITY					
KBYE 1946	890 1,000-D	State Bcstg. Co. 9th & Broadway 3-2323	Radio Reps	Frank J. Lynch, Gen. Mgr.	

DA-N Directional Antenna, night only. FM's in italic.
DA-1 Directional Antenna, same pattern day and night.
DA-2 Directional Antenna, different pattern day and night.

*-Non-Commercial Station. D-Day. N-Night. ST-Share Time. SH-Specified Hours.
U-Unlimited. CP-Construction Permit Issued. LS-Local Sunset.
L-Limited Time with Dominant Station. SA-Special Authorization.



Oklahoma has always
had big ears for

WKY

By any audience measuring stick you care to choose, WKY is the dominant station in Oklahoma's biggest market. Look at Hooper! Look at BMB! Look at "Listener's Diary"! Look at advertisers' results! They all prove the same fact — that only WKY can give you the audience, coverage and results you want and need in Oklahoma's most important market!

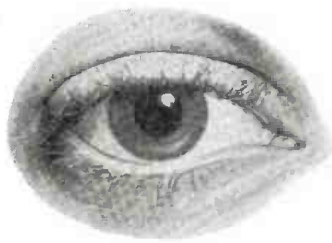

Now it has
big eyes for

WKY-TV

Who said television is just a "big city" medium? Practically a whole STATE is looking at WKY-TV! And here's why. We have a 966 foot antenna . . . an extremely favorable terrain . . . the perfect channel 4 frequency . . . the finest modern equipment, plus the priceless ingredient . . . *listener loyalty* . . . built up over the years by WKY-AM. Your KATZ representative will be glad to give you the facts and figures.

WKY

AM

FM

TV

OKLAHOMA CITY

930 KILOCYCLES • NBC

CHANNEL 4

NBC • CBS • ABC • DUMONT

OWNED AND OPERATED BY

THE OKLAHOMA PUBLISHING CO.

WKY, OKLAHOMA CITY • THE DAILY OKLAHOMAN

OKLAHOMA CITY TIMES • THE FARMER-STOCKMAN

REPRESENTED BY

THE KATZ AGENCY, INC.

DIRECTORY OF AM, FM, and TV STATIONS OF THE UNITED STATES

(Data corrected to December 6, 1949)
If executives or services for FM or TV stations are same as AM affiliate names are not repeated.

OKLAHOMA—(Continued)

City	Call Letters Established	Chan. or Freq. Power	Name of Licensee Headquarters Address Telephone Number	Network Representative	Executive Personnel	Transc. Library News Service Transmitter Make	
OKLAHOMA CITY—(Continued)							
	KLPR 1947	1140 1,000-D	Oklahoma City Bcstg. Co. 132½ W. Commerce 3-6358		Byrne Ross, Pres. & Gen. Mgr. Monty Wells, Coml. & Prom. Mgr.	(Miss) Billie Lynn Davidson, Prog. Dir. Jack Richmond, Chief Engr.	Associated Cole AP Raytheon
	KOCY 1922	1340 250	Plaza Court Bcstg. Co. Plaza Court Bldg. 3-4333	MBS Walker	John D. Thomas, Pres. Matthew H. Bonebrake, Gen. Mgr. George Collisson, Coml. Mgr.	John Steele, Prog. Dir. R. R. Freeland, Chief Engr.	Thesaurus Standard AP Collins
	KOCY-FM 1946	Ch. 234 (B) 94.7mc 70kw					General Electric
	KOMA 1927	1520 50,000 DA-N	KOMA Inc. Biltmore Hotel 2-3291	CBS Avery-Knodel	John Toole Griffin, Pres. J. J. Bernard, Gen. Mgr. W. L. Benham Jr., Coml. Mgr.	Robert M. Eastman, Prog. Dir. Tom Alyea, Prom. Mgr. M. W. Thomas, Chief Engr.	Capitol Standard SESAC UP Western Electric
	KOMA-FM 1948	Ch. 290 (B) 105.9mc 4.06kw					
	KTOK 1937	1000 5,000-LS 1,000-N DA-2	KTOK Inc. 1800 West Main St. 3-8352	ABC Oklahoma Taylor-Borroff	O. L. (Ted) Taylor, Pres. Robert D. Enoch, Gen. Mgr.	Harold M. Shreve, Prog. & Prom. Mgr. Clifford M. Easum, Chief Engr.	World, Cole AP, UP Western Electric
	KTOK-FM 1946	Ch. 282 (B) 104.3mc 43kw					General Electric
	KTOW 1948	800 250-D	Sooner Bcstg. Co. 3300 Apco Tower 2-6367	LBS Forjoe	Ralph Ball, Pres. Cal Perley, Gen. Mgr. Hugh Finnerty, Coml. Mgr.	Bill Bryan, Prog. Dir. Elmo Black, Chief Engr.	World UP General Electric
	WKY 1921	930 5,000 DA-N	WKY Radiophone Co. Skirvin Tower 3-4306	NBC Katz	E. K. Gaylord, Pres. P. A. Sugg, Sta. Mgr. Leo Howard, Coml. Mgr.	Paul Brawner, Prog. Dir. Gene Dodson, Prom. Mgr. H. J. Lovell, Chief Engr.	Associated Standard AP, UP RCA
	WKY-FM 1947	Ch. 255 (B) 98.9mc 48kw					
	WKY-TV 1949	Ch. 4 66-72mc 6.2kw aur.; 12.1kw vis.		ABC, CBS DuMont, NBC			
OKMULGEE							
	KHBG 1937	1240 250	Okmulgee Bcstg. Corp. Oddfellows Bldg. 3646	MBS Oklahoma Walker	Harold E. King, Gen. Mgr. Dan Kenan, Coml. Mgr. Chuck Phillips, Prog. Dir.	Joyce Mann, Prom. Mgr. James H. Smith, Chief Engr.	Lang-Worth AP RCA
PAULS VALLEY							
	KVLH 1947	1470 250-D	KVLH Bcstg. Co. Highway #77 North 1470	LBS, KBS	James T. Jackson, Pres. R. Phil Crenshaw, Gen. Mgr.	H. Edward Walker, Coml. Mgr. George A. Rountree, Chief Engr.	World UP Collins
PONCA CITY							
	WBBZ 1928	1230 250	Ponca City Pub. Co. 615 West Grand 6607	MBS, KBS Oklahoma Ra-Tel	Clyde E. Muchmore, Pres. Paul H. Buening, Gen. Mgr. Gene Sheid, Coml. Mgr.	Sheldon Bonnewell, Prog. Dir. Bob Nelson, Prom. Mgr. Ken Ruppe, Chief Engr.	Standard AP Gates
SEMINOLE							
	KSMI 1948	1260 500-D	Seminole Bcstg. Co. P. O. Box 1351 1260	MBS	Tom Potter, Pres. Jon B. Wagner, Gen. Mgr. Jack Wallace, Coml. Mgr.	Carl L. McDaniel, Prog. Dir. Warren W. Abbott, Chief Engr.	Capitol SESAC UP Collins
SHAWNEE							
	KGFF 1930	1450 250	KGFF Bcstg. Co. Inc. Federal Nat'l. Bldg. 4390	ABC Taylor-Borroff	Oscar S. Stauffer, Pres. Roy J. Bowman, Gen. Mgr. Edwin M. Moore, Coml. Mgr.	William A. Weaver, Prog. Dir. Earl R. Ward, Chief Engr.	Lang-Worth UP Collins
STILLWATER							
	KSPI 1947	780 250-D	Stillwater Pub. Co. P. O. Box 231 311	MBS, LBS Ra-Tel	C. R. Bellatti, Pres. L. F. Bellatti, Gen. Mgr. Ed Harvey, Coml. Mgr.	Braxton L. Combs, Prog. Dir. Bob Burton, Prom. Mgr. Paul McCullom, Chief Engr.	Standard UP Western Electric
	KSPI-FM 1947	Ch. 230 (B) 93.9mc 3.1kw					
TULSA							
	KAKC 1946	970 1,000-LS 500-N DA-2	Public Radio Corp. Avey's Tulsa Coliseum 4-2401	Walker	S. E. Avey, Pres. & Treas. James L. Neal, V. P. & Gen. Mgr. Glen A. Harmon, Coml. Mgr.	John B. Wheeler, Prog. Dir. M. C. Darnaby, Prom. Mgr. M. Y. White, Chief Engr.	Lang-Worth AP Collins
	KAKC-FM 1947	Ch. 238 (B) 95.5mc 8.2kw					
	KFMJ 1946	1050 1,000-D	Fred Jones Bcstg. Co. 1242 S. Boston 5-5555	LBS Forjoe	Fred Jones, Pres. Lawson Taylor, Gen. Mgr. Jack Betz, Coml. Mgr.	M. McGuigan, Prog. Dir. Nate Wilcox, Chief Engr.	Standard UP Western Electric
	KOME 1938	1300 5,000-LS 1,000-N DA-2	Oll Capital Sales Corp. 8th at Main 3-4121	MBS Weed	Harry Schwartz, Pres. Dick Campbell, Gen. Mgr. Howard Engle, Coml. Mgr.	Larry Robertson, Prog. Dir. Ann Fountain, Prom. Mgr.	Standard AP Western Electric
	KOTV (TV) 1949	Ch. 6 82-88mc 8.5kw aur.; 16.55kw vis.	George E. Cameron Jr. 1411 Nat'l. Bank of Tulsa Bldg. 2-9971	ABC, CBS, NBC, DuMont Young	George E. Cameron Jr., Chief Owner Maria Helen Alvarez, Pres. & Gen. Mgr. John Hill, V. P. & Coml. Mgr. Robert S. Kerr, Pres. Robert E. Jones Jr., Gen. & Coml. Mgr.	Ronald C. Oxford, Prog. Dir. George Jacobs, Chief Engr.	UP, INS RCA
	KRMG 1949	740 50,000-LS 10,000-N DA-2	All-Oklahoma Bcstg. Co. 4th & Denver Sts. 5-3291	ABC Blair	Robert S. Kerr, Pres. Robert E. Jones Jr., Gen. & Coml. Mgr.	Frank S. Lane, Sales Mgr. (Miss) Montez Tjaden, Prom. Mgr. Alden F. Wooster, Chief Engr.	UP, INS RCA
	KTUL 1934	1430 5,000 DA-N	Tulsa Bcstg. Co. Boulder-on-the-Park 2-3191	CBS Avery-Knodel	John Griffin, Pres. John Esau, Gen. Mgr. L. A. Blust Jr., Coml. Mgr.	Karl Janssen, Prog. Dir. George L. Ketcham, Prom. Mgr. Robert Snider, Chief Engr.	Lang-Worth Capitol UP Western Electric
	KTUL-FM 1948	Ch. 246 (B) 97.1mc 2.6kw					
	KVOO 1925	1170 50,000 DA-N	Southwestern Sales Corp. 2104 Piltower Bldg. 2-2254	NBC Petry	P. Q. Proctor, Pres. Wm. B. Way, V. P. & Gen. Mgr. Gustav K. Brandborg, Coml. Mgr.	Thomas W. DeVore, Prog. Dir. Charles N. McKinney, Prom. Mgr. L. W. Stinson, Chief Engr.	Standard UP, INS Western Electric
WOODWARD							
	KSIW 1947	1450 250	Woodward Bcstg. Co. 22nd & Cedar Sts. 1450	MBS	Edward A. Ryan & James L. Todd, Co-owners James L. Todd, Sta. Mgr.	Edward A. Ryan, Bus. & Coml. Mgr. John M. Nelson, Chief Engr.	Lang-Worth Cole AP Western Electric

DA-N Directional Antenna, night only. FM's in italic. DA-1 Directional Antenna, same pattern day and night. DA-2 Directional Antenna, different pattern day and night.

*—Non-Commercial Station. D—Day. N—Night. ST—Share Time. SH—Specified Hours. U—Unlimited. CP—Construction Permit Issued. L—Limited Time with Dominant Station. SA—Special Authorization.

CBS evening programs
 have the highest *average*
 rating in radio today*

IN TULSA THESE CBS PROGRAMS ARE ON KTUL AND...



★ The PAT BREENE SHOW



★ KTUL TALENT PARADE



★ EASY DOES IT

... In The Popularity Parade
 in Tulsa don't overlook
 these Top Locally Produced
 shows on KTUL.



★ AL CLAUSER'S MORNING RAMBLE



★ MOST COMPLETE NEWS COVERAGE



★ SOUTHSIDE MATINEE



★ EDDIE COONTZ'S MORNING WATCH

*According to Hooper and Nielsen surveys quoted in CBS advertisement in November 23 Variety.

KTUL TULSA'S EXCLUSIVE RADIO CENTER
 AVERY-KNODEL, INC.
 Radio Station Representatives
 JOHN ESAU, Vice Pres. & Gen. Mgr.

DIRECTORY OF AM, FM, and TV STATIONS OF THE UNITED STATES

(Data corrected to December 6, 1949)
If executives or services for FM or TV stations are same as AM affiliate names are not repeated.

OREGON

City Call Letters Established	Chan. or Freq. Power	Name of Licensee Headquarters Address Telephone Number	Network Representative	Executive Personnel	Transc. Library News Service Transmitter Make	
ALBANY						
KWIL 1941	1240 250	Central Willamette Bcstg. Co. Queen Ave. & Elm Sts. 1234	MBS Don Lee Keating	R. R. Cronise, Pres. Chet Wheeler, Gen. Mgr. Warren Stoffer, Coml. Mgr.	LeRoy Jolley, Prog. Dir. Derwood Smith, Prom. Mgr. Herb Davidson, Chief Engr.	Standard World UP RCA
<i>KWIL-FM</i> 1947	Ch. 269 (A) 101.7mc 0.71kw					
ASHLAND						
KWIN 1946	1400 250	Rogue Valley Bcstg. Co. Inc. 1160 Helman Rd. 2-1351	KBS Gene Grant	M. S. Hamaker, Pres. Edward P. Barnett, Gen. Mgr. B. Lane Bardeen, Coml. & Prom. Mgr.	Charles B. Field, Prog. Dir. Phillip R. George, Chief Engr.	Capitol, World Standard AP Gates
ASTORIA						
KAST 1936	1370 1,000 DA-1	Astoria Bcstg. Co. P. O. Box 445 95	MBS, KBS Don Lee Northwest Keating	Robert B. Chessman, Pres. Robert D. Holmes, Gen. Mgr. Hal E. Chase, Coml. Mgr.	Frances J. Anderson, Prog. Dir. Jay Bruce Whitwell, Chief Engr.	Standard AP Raytheon
BAKER						
KBKR 1939	1490 250	Inland Radio Inc. First & Court St. 140	Oregon Trail	Lee W. Jacobs, Pres. Kenneth B. Lockwood, Gen. Mgr. Milton L. Levy, Coml. & Prom. Mgr.	Kenneth F. Holden, Prog. Dir. Walter A. Bobisud, Chief Engr.	World UP
BEND						
KBND 1938	1340 250	Central Oregon Bcstg. Co. 1101 Wall St. 848	MBS Don Lee Grant	Frank H. Loggan, Pres. & Gen. Mgr. W. H. Barton, Coml. Mgr.	K. R. Cannon, Prog. Dir. Robert Dickinson, Chief Engr.	Lang-Worth UP RCA
COOS BAY						
KOOS 1928	1230 250	KOOS Inc. 505 Hall Bldg. 432	MBS Don Lee	Sheldon F. Sackett, Pres. Fred F. Chitty, Gen. Mgr. Hal Shade, Sta. Mgr.	Jack Irvine, Coml. Mgr. (Mrs.) Sara Spough, Prog. Dir. Roger Spough, Chief Engr. AP RCA
COQUILLE						
KWRO 1949	1450 250	KWRO Inc. Box 396 3961	Gene Grant	Walter L. Read, Pres. William E. Walsh, Secy-Treas.	Robert W. Harris, Sta. Mgr. Dave Riggs, Prog. Dir. William A. Cook, Prom. Mgr.	Associated, Cole AP
CORVALLIS						
*KOAC 1922	550 5,000 DA-2	Oregon State College Corvallis 526		Paul Packer, Dir. James M. Morris, Prog. Dir.	Grant S. Feikert, Chief Engr. UP Western Electric
KRUL 1946	1340 250	Pacific States Radio Co. 1221 S. Fifteenth St. 1504	KBS Grant	J. C. Haley Sr., Pres. C. W. Peck, Gen. & Coml. Mgr.	James Bailey, Prom. Mgr. Jeff E. Evans, Chief Engr.	Lang-Worth AP General Electric
THE DALLES						
KODL 1940	1230 250-LS 100-N	Western Radio Corp. Scenic Dr.	KBS Keating	V. B. Kenworthy, Pres.	Paul E. Walden, Mgr.	
EUGENE						
KASH 1947	1600 1,000 DA-N	Radio Air Ways Inc. P. O. Box 1800 4-2201	NBC KBS	E. L. Kincaid, Pres. & Gen. Mgr. Paul Plank, Sales Mgr.	Don McCutcheon, Prog. Dir. William Riley, Chief Engr.	Capitol UP Collins
KERG 1949	1280 1,000 DA-N	Eugene Bcstrs. Inc. Studio Bldg.		Alton F. Baker, Pres. L. W. Trommlitz, Gen. Mgr. Herbert Michael, Coml. Mgr.	Reginald Roos, Prog. Dir. Calvert Applegate, Chief Engr.	Standard AP Gates
KORE 1927	1450 250	Lane Bcstg. Co. Box 1032 4-4214	MBS Don Lee McKinney	Paul McElwain, Pres. Lee Bishop, Gen. Mgr. Bob Hillyer, Coml. Mgr.	Bob Eubanks, Prog. Dir. Virg Parker, Prom. Mgr. Floyd Viken, Chief Engr.	World AP
KUGN 1946	1400 250	KUGN Inc. P. O. Box 1400 4-6216	ABC Grant	C. H. Fisher, Pres. S. W. McCreedy, Gen. Mgr. L. N. Young, Coml. Mgr.	L. S. Ready Jr., Prog. Dir. & Prom. Mgr. William Green, Chief Engr.	Lang-Worth AP
<i>KUGN-FM</i> 1947	Ch. 256 (B) 99.1mc 8kw				 RCA
GRANTS PASS						
KUIN 1939	1340 250	So. Oregon Bcstg. Co. P. O. Box 148 4477	MBS Don Lee Grant	A. E. Voorhies, Pres. E. A. Malone, Mgr.	J. T. Sivert, Prog. Dir. N. L. Williams, Chief Engr.	World MacGregor AP Western Electric
<i>KGPO(FM)</i> 1948	Ch. 245 (B) 96.9mc 3.1kw	(KUIN, AM affiliate)				
KLAMATH FALLS						
KFJI 1922	1150 5,000-LS 1,000-N DA	W. D. Miller P. O. Box 692 5155	MBS Grant	W. D. Miller, Pres. & Gen. Mgr. Jack Keating, Coml. & Prom. Mgr.	William Wentworth, Prog. Dir. William P. Grimes, Chief Engr.	World UP Collins
KFLW 1946	1450 250 CP 1240	Herald Pub. Co. P. O. Box 941 8115	ABC McKinney	Frank Jenkins, Pres. Bud Chandler, Gen. Mgr.	Aaron Boe, Adv. Dir. Gib Walter, Chief Engr.	Standard AP Gates
<i>KFLW-FM</i> (CP)	Ch. 233 (B) 94.5mc 5kw					
LA GRANDE						
KLBM 1936	1450 250	Inland Radio Inc. Old Oregon Trail 220	Oregon Trail	Lee W. Jacobs, Pres. John G. Jones, Gen. Mgr. Ken Lillard, Coml. Mgr.	Marjorie Simcox, Prog. Dir. Murray M. Durham, Chief Engr.	Lang-Worth UP RCA

DA-N Directional Antenna, night only. FM's in italic.
DA-1 Directional Antenna, same pattern day and night.
DA-2 Directional Antenna, different pattern day and night.

*—Non-Commercial Station. D—Day. N—Night. ST—Share Time. SH—Specified Hours.
U—Unlimited. CP—Construction Permit Issued. LS—Local Sunset.
L—Limited Time with Dominant Station. SA—Special Authorization.

City Call Letters Established	Chan. or Freq. Power	Name of Licensee Headquarters Address Telephone Number	Network Representative	Executive Personnel	Transc. Library News Service Transmitter Make
McMINNVILLE					
KMCM 1949	1260 1,000 DA-N	Yamhill Bcstrs. Lafayette Ave. 3811		Jack B. & Philip N. Bladine, Partners Lou Gillette, Gen. Mgr.	Glasco Branson, Coml. Mgr. G. L. Hathaway, Chief Engr. Capitol Lang-Worth AP Western Electric
MEDFORD					
KMED 1922	1440 5,000-LS 1,000-N	Mrs. W. J. Virgin P. O. Box 1306 4000	NBC	(Mrs.) W. J. Virgin, Pres. & Gen. Mgr. James J. Dunlevy, Coml. Mgr.	Gladys La Mar, Prog. Dir. John S. Duffy, Prom. Mgr. Victor M. Califf, Chief Engr. Standard MacGregor UP RCA
KYJC 1947	1230 250	Medford Printing Co. Barnett Rd. 9200	ABC Grant	Robert W. Ruhl, Pres. Pete Watts, Gen. Mgr. Norbert Miksche, Coml. Mgr.	John Ahern, Prog. Dir. Curtis Burnside, Chief Engr. Cole Lang-Worth UP RCA
NEWPORT					
KNPT 1948	1230 250	Yaquina Radio Inc. P. O. Box 682 580		Tom Becker, Pres. & Gen. Mgr. Joe Kortman, Coml. Mgr.	Silvia Becker, Prog. Dir. Hal Bigger, Chief Engr. World AP Collins
ONTARIO					
KSRV 1946	1450 250	Inland Radio Inc. Old Oregon Trail 212	Oregon Trail	Lee W. Jacobs, Pres. Gordon L. Capps, V. P. & Gen. Mgr. John W. Powell, Coml. Mgr.	Hal Corwin, Prog. Dir. Ray Kozak, Prom. Mgr. Charles E. Harland, Chief Engr. Cole, Capitol World UP RCA
OREGON CITY					
KGON 1949	1230 250	Clackamas Bcstrs. Inc. P. O. Box 391 5249		John H. Fitzgibbon, Pres. Irwin S. Adams, Gen. & Coml. Mgr.	H. I. Jackson, Asst. Mgr. Delmar Lundbom, Prog. Dir. Robert Brower, Chief Engr. World Lang-Worth AP Gates
PENDLETON					
KWRC 1941	1240 250	Western Radio Corp. P. O. Box 178 1425		V. B. Kenworthy, Pres. & Gen. Mgr. Ted A. Smith, Sta. Mgr.	Alvin Zimmerman, Prog. Dir. Russell Fillingier, Chief Engr. UP RCA

DA-N Directional Antenna, night only. FM's in italic. *—Non-Commercial Station. D—Day. N—Night. ST—Share Time. SH—Specified Hours.
 DA-1 Directional Antenna, same pattern day and night. U—Unlimited. CP—Construction Permit Issued. LS—Local Sunset.
 DA-2 Directional Antenna, different pattern day and night. L—Limited Time with Dominant Station. SA—Special Authorization.

250 Watts AM

3000 Watts FM

KUIN—KGPO Grants Pass, Oregon

"The Friendly Voice of Southern Oregon Since 1939"

People 88,350 Families 28,500
 Radio Families 27,520 Retail Sales \$70,000,000

LOCAL NEWS DEPARTMENT

Conlan Surveys Morning 89%, Afternoon 88.5%, Evening 78.5%

National Representative—William S. Grant

Affiliated Mutual Don Lee Broadcasting System

DIRECTORY OF AM, FM, and TV STATIONS OF THE UNITED STATES

*(Data corrected to December 6, 1949)
If executives or services for FM or TV stations are same as AM affiliate names are not repeated.*

OREGON—(Continued)

City Call Letters Established	Chan. or Freq. Power	Name of Licensee Headquarters Address Telephone Number	Network Representative	Executive Personnel	Transc. Library News Service Transmitter Make
PORTLAND					
KBKO 1948	1290 1,000-D	Mercury Bestg. Co. 3908 N. E. Sandy Blvd. Webster 1290	Forjoe	Gordon E. Bambrick, Pres. & Mngng. Dir.	Helen Holiday, Prom. Mgr.
*KBPS 1923	1450 100-SH	Benson Polytechnic School 546 N. E. 12th Ave. Empire 4586		Patricia L. Green, Gen. Coml. & Prom. Mgr. & Prog. Dir.	Charles Weagant, Chief Engr.
KEX 1926	1190 50,000 DA-1	Westinghouse Radio Stations Inc. 1230 S. W. Main Capital 1881	ABC Free & Peters	Walter Evans, Pres. Walter E. Benoit, V. P. J. B. Conley, Gen. Mgr. Eldon Campbell, Sales Mgr. C. S. Young, Sta. Mgr.	Mel Bailey, Prog. Mgr. Charles L. Burrow, Prom. & Publ. Mgr. Thomas Ely, Chief Engr.
KEX-FM 1948	Ch. 222 (B) 92.3mc 56kw				SESAC
KGW 1922	620 5,000 DA-1	Oregonian Pub. Co. 1320 S. W. Broadway Beacon 6364	NBC Petry	M. J. Frey, Pres. H. Quenton Cox, Gen. Mgr. J. N. Wassan, Coml. Mgr.	Homer Welch, Prog. Mgr. Harold Singleton, Chief Engr.
KGW-FM 1946	Ch. 262 (B) 100.3mc 54kw				Lang-Worth World AP, INS Raytheon
KOIN 1925	970 5,000 DA-N	KOIN Inc. P. O. Box 1031 Atwater 3333	CBS Avery-Knodel	Marshall Field, Pres. Harry H. Buckendahl, Gen. Mgr. John L. Palmer, Nat'l Adv. Mgr.	Ted W. Cooke, Prog. Dir. George Wann, Prom. Dir. L. S. Bookwalter, Dir. of Engrg.
KOIN-FM 1948	Ch. 266 (B) 101.1mc 48.6kw				Capitol Associated World AP, UP, INS
KPDQ 1947	800 1,000-D	John W. Davis P. O. Box 800 Vermont 6142	Rambeau	John W. Davis, Owner William E. Richardson, Coml. Mgr.	Donovan Zundel, Prog. Dir. Rodney F. Johnson, Chief Engr.
KPFM (FM) 1946	Ch. 246 (B) 97.1mc 1.5kw	Bcstrs. Oregon Ltd. Box 1230 Broadway 7471		Stanley M. Goard, Gen. & Coml. Mgr. Thomas B. Hoover, Prog. Dir.	Kenneth Dickson, Chief Engr.
KPOJ 1932	1330 5,000 DA-1	KPOJ Inc. 1019 Southwest 10th St. Broadway 3484	MBS Don Lee Blair	P. L. Jackson, Pres. R. M. Brown, Gen. Mgr. Alan L. Torbet, Coml. Mgr.	Thomas J. Swafford, Prog. Dir. Hiram Fitzpatrick, Prom. Mgr. Henry Sturtevant, Chief Engr.
KPOJ-FM 1948	Ch. 254 (B) 98.7mc 44kw				Thesaurus AP, UP
KWJJ 1927	1080 10,000 DA-1	KWJJ Bcst. Co. Inc. 1011 S. W. 6th Ave. Atwater 4393	Burn-Smith	W. J. Jerman, Pres. & Gen. Mgr. Jerry Speerstra, Coml. Mgr.	Rene Bozarth, Prog. Dir. Ben T. Crosby, Prom. Mgr. Dwight D. Loomis, Chief Engr.
KWJJ-FM 1946	Ch. 235 (B) 95.5mc 3.4kw				Lang-Worth Standard UP Westinghouse
KXL 1926	750 10,000 DA-1 L-WSB	KXL Bcstrs. Orpheum Bldg. Broadway 6451	Walker	H. S. Jacobson, Pres. & Gen. Mgr. Paul J. Robinson, Prog. Dir.	Ralph C. Miffin, Chief Engr. James A. Mount, Sales Mgr.
PINEVILLE					
KRCO (CP)	680 1,000-D	Radio Central Oregon			
ROSEBURG					
KRNR 1935	1490 250	Roseburg News-Review 134 N. Jackson 4	Don Lee MBS, KBS Keating	Frank Jenkins, Pres. Leroy Hiatt, Mgr. Carol Kerr, Prom. Mgr.	Warren Ward, Coml. Mgr. Ralph Smith, Chief Engr.
SALEM					
KOCO 1947	1490 250	KOCO Bcstrs. 1426 Edgewater St. 33108	KBS Rambeau	Loring Schmidt, Pres., & Gen. Mgr. Richard Nason, Prog. Dir.	Edward McElroy, Chief Engr.
KSLM 1934	1390 1,000 DA-N	Oregon Radio Inc. Salem 34831	MBS Don Lee Grant	Glenn McCormick, Pres. & Gen. Mgr. Earl Headrick, Coml. Mgr.	Jerry Web, Prog. Dir. Dave Hoss, Prom. Mgr. Clyde Carlton, Chief Engr.
TILLAMOOK					
KTIL 1946	1590 250	Tillamook Bestg. Co. Star Route West 1122		Fred Guyton, Pres. Mel Baldwin, Gen. Mgr. Jim Kelly Jr., Coml. Mgr.	Betty Goeres, Prog. Dir. Larry Bruner, Chief Engr.

DA-N Directional Antenna, night only. FM's in italic.
DA-1 Directional Antenna, same pattern day and night.
DA-2 Directional Antenna, different pattern day and night.

*—Non-Commercial Station. D—Day. N—Night. ST—Share Time. SH—Spec
U—Unlimited. CP—Construction Permit Issued. LS—Lc
L—Limited Time with Dominant Station. SA—Special Au

KGW

**THE ONLY STATION
THAT ACTUALLY DELIVERS**

**COMPREHENSIVE
COVERAGE**

in the

**Fastest Growing
Market in the Nation**

"Oregon's population has increased by 59.3 per cent in the last nine years — the largest growth of any of the 48 states" — (News Release, Nov. 4, 1949). The rich, fertile counties of southwestern Washington, lying within KGW's north-south broadcasting beam, have enjoyed a similar rapid population rise.

These new residents, already familiar with the high quality of NBC programs, have naturally turned to KGW to continue their established listening pattern.

This increasing population creates expanding markets for goods, greater demands for services and facilities of all kinds. Oregon's enlarged population offers an ever-growing advertising opportunity, bringing with it a more urgent need to concentrate effective selling on KGW, the ONLY Portland station that delivers Comprehensive Coverage in the fastest-growing market in the nation.

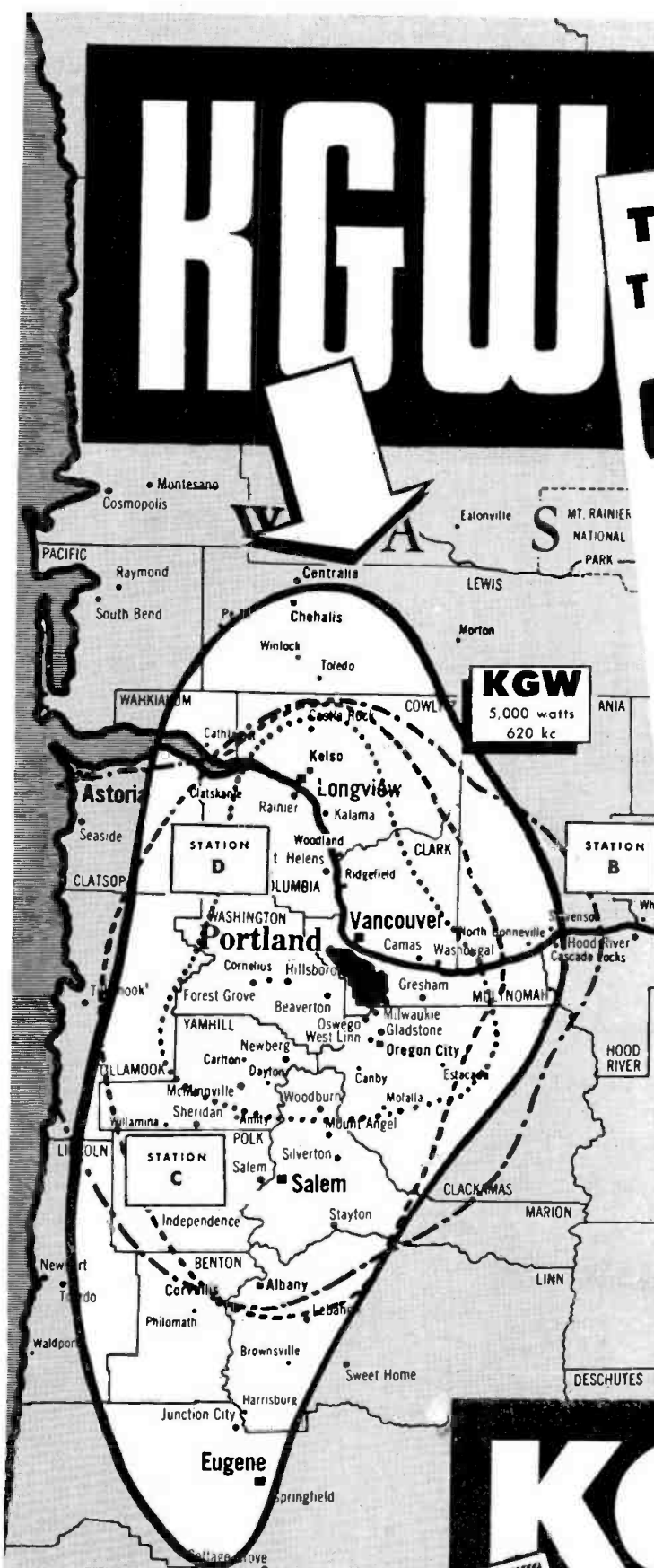

This chart, compiled from official, half-millivolt contour maps filed with the FCC in Washington, D. C., or from field intensity surveys, tells the story of KGW's Concentrated Coverage of the fastest-growing market in the nation.

KGW PORTLAND OREGON



AFFILIATED WITH NBC
REPRESENTED NATIONALLY BY EDWARD PETRY & CO.

DIRECTORY OF AM, FM, and TV STATIONS OF THE UNITED STATES

(Data corrected to December 6, 1949)
If executives or services for FM or TV stations are same as AM affiliate names are not repeated.

PENNSYLVANIA

City Call Letters Established	Chan. or Freq. Power	Name of Licensee Headquarters Address Telephone Number	Network Representative	Executive Personnel	Transc. Library News Service Transmitter Make	
ALLENTOWN						
WAEB 1949	790 500-LS DA-1 1,000-N	WAEB Inc. 7th & Hamilton Sts. 4-9384	ABC Hollingbery	Joseph M. Nassau, Pres. & Gen. Mgr. Howard Wasserman, Coml. Mgr. & Treas.	James A. Nassau, Prog. Dir. Martin Musket, Prom. Mgr. Martin N. Oebbecke, Chief Engr.	Lang-Worth UP Western Electric
WFMZ (FM) 1947	Ch. 284 (B) 100.7mc 6.9kw	Penn-Allen Bcstg. Co. 1524 Linden St. 3-7521	Continental FM	Raymond F. Kohn, Pres. & Gen. Mgr. Horace W. Gross, Coml. Mgr.	William B. Phillips, Prog. Dir. Daniel Houck, Chief Engr.	Associated SESAC AP Collins
WHOL 1948	1230 250	Allentown Bcstg. Corp. 842 Hamilton St. 4-4801	CBS Meeker	Lewis Windmuller, Pres. & Gen. Mgr. Robert Lewis, Prog. Mgr.	C. Robert Glover, Prom. Mgr. Gerald Werst, Chief Engr.	Standard UP Western Electric
WKAP 1947	1580 1,000-D	WKAP Inc. 715 Hamilton St. 3-3166	Forjoe	N. J. Rahall, Pres. O. R. Davles, Gen., Coml. & Prom. Mgr.	Marshall Cleaver, Prog. Dir. C. F. Cordaro, Chief Engr.	World AP Gates
WKAP-FM 1948	Ch. 292 (A) 106.3mc; 0.78kw				 Raytheon
WSAN 1923	1470 5,000 DA-N	Lehigh Valley Bcstg. Co. 39-41 N. Tenth St. 9511	NBC Headley- Reed	J. Calvin Shumberger Sr., Pres. E. Bryan Musselman, Gen. Mgr. Olivia P. Musselman, Coml. & Prom. Mgr.	George Y. Snyder, Prog. Dir. Reuel H. Musselman, Chief Engr.	Thesaurus SESAC AP, UP Western Electric
WSAN-FM 1947	Ch. 260 (B) 99.9mc; 8kw				
ALTOONA						
WFBG 1924	1340 250	Gable Bcstg. Co. 1320 11th Ave. 6467	NBC Headley- Reed	George P. Gable, Pres. John M. Snyder, Gen. & Coml. Mgr.	Mille Michaels, Prog. Dir. George Burgoon, Chief Engr.	World AP Western Electric Federal
WFBG-FM 1948	Ch. 279 (B) 103.7mc; 3.6kw				
WJSW 1947	1290 1,000-LS 500-N DA	Altoona Bcstg. Co. 1413 11th Ave. 9301	MBS Burn-Smith	Herbert T. Wolf, Pres. T. W. Metzger, Gen. Mgr. James E. Moren, Coml. Mgr. & Prog. Dir.	Charles Flynn, Prom. Mgr. C. Irvin Metzger, Chief Engr.	Standard UP Gates
WJSW-FM 1948	Ch. 243 (A) 96.5mc 0.25kw				

DA-N Directional Antenna, night only. FM's in italic.
DA-1 Directional Antenna, same pattern day and night.
DA-2 Directional Antenna, different pattern day and night.

*-Non-Commercial Station. D-Day. N-Night. ST-Share Time. SH-Specified Hours.
U-Unlimited. CP-Construction Permit Issued. LS-Local Sunset.
L-Limited Time with Dominant Station. SA-Special Authorization.

GREATEST primary signal in the
Lehigh Valley...

at lowest cost

per thousand listeners

WAEB delivers a vast listening area of 552,000 population at a cost as low as 6½¢ per thousand.*

The Allentown area is the nation's 41st largest market (43rd last year); center of the largest cement producing district in the U. S. Second in manufacture of silk and rayon. It includes Easton with its diversified industries and slate producing areas. And, of course, WAEB covers Bethlehem, giant industrial city of iron and steel, silk and hosiery, zinc and graphite.

Hollingbery's got the whole story. Get it!

WAEB
Allentown, Pa.

* local 250-time rate

**ABC'S VOICE IN PENNSYLVANIA'S 3RD
LARGEST INDUSTRIAL CENTER**
REPRESENTED BY GEORGE P. HOLLINGBERY COMPANY
JOSEPH M. NASSAU, PRESIDENT

500 WATT DAY **790 KC** 1000 WATTS NIGHT



LANCASTER, PENNA.

IDENTIFICATION

*The Conestoga Wagon...
perpetual symbol of
pioneering and progress*

When America was young, the Conestoga Wagon carried progress wherever it went. WGAL-TV is the pioneer television station in Lancaster, Pennsylvania and uses the Conestoga Wagon as a visual pledge of continuing enterprise, progress and service.

WGAL-TV is the only TV station located in the thriving Lancaster region. Its audience is large and growing every day because of local programs and the best of NBC, ABC, CBS, and DuMont network shows. Many advertisers are enjoying profits from this new, effective coverage. Consider the importance of including this rich market in your TV sales-planning.

Conestoga Wagons were first made in and around Lancaster, Pennsylvania. Broad-wheeled and heavy, they were used to carry the household goods of the pioneers.

For Profitable Selling—
Investigate these other
Steinman Stations

WGAL
Lancaster, Penna.

WKBO
Harrisburg, Penna.

WORK
York, Penna.

WRBW
Reading, Penna.

WEST
Easton, Penna.

Clair R. McCollough, Managing Director



STEINMAN STATIONS

Represented by **ROBERT MEEKER ASSOCIATES**

CHICAGO SAN FRANCISCO NEW YORK LOS ANGELES

DIRECTORY OF AM, FM, and TV STATIONS OF THE UNITED STATES

*(Data corrected to December 6, 1949)
If executives or services for FM or TV stations are same as AM affiliate names are not repeated.*

PENNSYLVANIA—(Continued)

City Call Letters Established	Chan. or Freq. Power	Name of Licensee Headquarters Address Telephone Number	Network Representative	Executive Personnel	Transc. Library News Service Transmitter Make	
ALTOONA—(Continued)						
WRTA 1947	1240 250	Roy F. Thompson 1421 12th Ave. 6646	ABC Meeker	Roy F. Thompson, Pres., Gen. & Coml. Mgr. Dorothy M. Thompson, Prog. Dir.	William S. Clear, Prom. Mgr. George R. Burgoon, Chief Engr.	Thesaurus UP Temco
WVAM 1948	1430 1,000 DA-2	The General Bcstg. Corp. 2801 Edgewood Dr. 8127	CBS Weed	Emanuel S. Leopold, Pres. Will Union, Coml. Mgr.	Mike Grant, Prog. Dir. J. J. Ralston, Chief Engr.	Lang-Worth UP Gates
APOLLO						
WAVL 1947	910 1,000-D	Tri-Borough Bcstg. Co. N. 4th St. & Penna. Ave. 480		C. F. Clifton & Andrew J. West, Partnership	C. F. Clifton, Gen. & Coml. Mgr. H. E. Smith, Chief Engr.	Thesaurus SESAC Cole UP Gates
BEAVER FALLS						
WBVP 1948	1230 250	WBVP Inc. 1216 Seventh Ave. 4100		Frank R. Smith, Pres. & Gen. Mgr. Tom Price, Coml. Mgr.	Chuck Wilson, Prog. Dir. Jean Biggard, Prom. Mgr. Bill Hines, Chief Engr.	Capitol Standard AP, UP Western Electric
BETHLEHEM						
WGPA 1947	1100 250-D	The Bethlehems' Globe Pub. Co. 428 Brodhead Ave. 8-8074		Rolland L. Adams, Pres. Arthur C. McCracken, Sta. Mgr. Stefan George, Prog. Dir.	Frank L. Collie, Coml. & Prom. Mgr. Edwin L. Rybak, Chief Engr.	Capitol World UP RCA
WGPA-FM 1947	Ch. 236 (B) 95.1mc 10kw					
BLOOMSBURG						
WCNR 1947	930 500-D	Columbia Montour Bcstg. Corp. 38 W. Main St. 1700		Robert R. Eyerly, Pres. Ed Darlington, Gen. Mgr. & Prog. Dir.	Clair Kinney, Chief Engr.	Associated AP Raytheon
WLTR 1948	690 1,000-D DA	Bloom Radio Inc. Hotel Magee 1800		H. L. Magee, Pres. C. G. Moss, Gen. Mgr. S. Duy Hutchison, Coml. Mgr.	Mark Jury, Prog. Dir. Park H. Cassady, Chief Engr.	Standard World UP Gates

DA-N Directional Antenna, night only. FM's in italic.
DA-1 Directional Antenna, same pattern day and night.
DA-2 Directional Antenna, different pattern day and night.

*—Non-Commercial Station. D—Day. N—Night. ST—Share Time. SH—Specified Hours.
U—Unlimited. CP—Construction Permit Issued. LS—Local Sunset.
L—Limited Time with Dominant Station. SA—Special Authorization.

first... in total rated time periods*

... and it's a quarter-century old story in Altoona

WFBG leads second network station by over 14 Hooper points

WFBG leads third network station by over 17 Hooper points

WFBG leads fourth network station by over 19 Hooper points

For 25 years, 300,000 listeners have tuned first to WFBG.

Such loyalty comes with understanding of the market and programming for it. What we really sell in Altoona is experience . . . experience in delivering a lot more results for a lot less money.

What's more, we've been doing it for years.

... ask **Headley-Reed**

WFBG



The Gable Broadcasting Co.
ALTOONA PENNA.

WFBG and WFBG-FM

Jack Snyder, Managing Director • Headley-Reed, Nat'l. Reps.

* C. E. Hooper, Oct.-Nov., 1949

City Call Letters Established	Chan. or Freq. Power	Name of Licensee Headquarters Address Telephone Number	Network Representative	Executive Personnel	Transc. Library News Service Transmitter Make	
BRADDOCK						
WLOA 1947	1550 1,000-D	Matta Bcstg. Co. 1233 Braddock Ave. Electric 1-1100	Friedenberg	William G. Matta, Pres. & Gen. Mgr. George Matta, Coml. Mgr.	Paul McCandless, Prog. Dir. George Bozic, Prom. Mgr. Richard Noullet, Chief Engr.	World UP Gates
BRADFORD						
WESB 1947	1490 250	Bradford Pub. Inc. 43 Main St. 3173	MBS Ra-Tel	Joseph M. Cleary, Gen. Mgr. Ernest F. Oliver, Gen. Sales Mgr. Michael J. Cuneen, Prom. Mgr.	David W. Jefferies, Tech. Dir. Joseph V. Lentini, Prog. Dir.	Standard AP Raytheon Federal
WESB-FM 1948	Ch. 248 (B) 97.5mc 3.2kw					
BUTLER						
WBUT 1949	1580 500-D	Eagle Printing Co. Nixon Hotel 53-103		J. Leonard Taylor, Gen. Mgr. Howard George, Coml. Mgr.	James W. Rowe, Prog. Dir. Gerald D. Coleman, Chief Engr.	Thesaurus AP RCA Westinghouse
WBUT-FM 1949	Ch. 280 (A) 103.9mc 0.72kw					
WISR 1941	680 250-D	Butler Bcstg. Co. 357 N. Main St. 4701	Forjoe	David H. Rosenblum, Owner Robert Kaufman, Gen. Mgr. Fred J. Grunert, Coml. Mgr.	Warren Ihlenfeld, Prog. Dir. Joel Rosenblum, Prom. Mgr. Paul Rex, Chief Engr.	Lang-Worth UP RCA Westinghouse
WISR-FM 1948	Ch. 249 (A) 97.7mc 0.56kw					
CARBONDALE						
WC DL 1950	1230 250	Carbondale Bcstg. Co. 11 North Main St.		W. Richard Carlson Jr., Gen. Mgr. William Fletcher, Coml. Mgr.	Robert G. Adams Jr., Chief Engr.	UP
CARLISLE						
WLXW 1948	1380 1,000-D	Phillip Mathews Holly Pike 1786		Phillip Mathews, Pres. Florence Good, Chief Exec.	Henry Palmer, Chief Engr.	Thesaurus UP RCA
CHAMBERSBURG						
WCHA 1949	800 1,000-D	Chambersburg Bcstg. Co. Craft Press Bldg. 1110	Forjoe	John S. Booth, Gen. Mgr. Earl P. Strine, Coml. Mgr. Allan Saunders, Prog. Dir.	Sam Taylor, Prom. Mgr. James McCurdy, Chief Engr.	Associated Thesaurus UP Gates General Electric
WCHA-FM 1948	Ch. 249 (A) 95.9mc 0.82kw					
CHARLEROI						
WESA 1947	940 250-D	Monongahela Bcstg. Co. Inc. P.O. Box 584 36551		Dr. A. S. Sickman, Pres. Charles R. Duvall, Gen. & Coml. Mgr.	Joseph Beljaw, Prog. Dir. & Prom. Mgr. Henry Neiderkofler, Chief Engr.	Standard AP
CHESTER						
WPWA 1947	1590 1,000-D	Lou Poller P.O. Box 30 3-1641		Lou Poller, Pres. Max A. Mandel, Gen. Mgr. Burton Levine, Coml. Mgr.	Robert O. Johnson, Prog. Dir. Mel Levine, Prom. Mgr. Harry Symington, Chief Engr.	World AP Collins
WVCH 1948	740 250-D	James M. Tisdale Wolf Bldg. CHester 2-8861		James M. Tisdale, Owner, Gen. & Coml. Mgr. & Chief Engr.	Edna Whittington, Prog. Dir.	UP RCA

MORE news of all radio

AM • FM • TV

... than all other publications combined! Complete radio news coverage *PLUS* such extra money-making features as "Broadcasting Trends," Merchandising Narratives, Comparative Network Schedules (AM & TV); weekly Telecasting inserts.

\$7 FOR 52 WEEKLY ISSUES AND YEARBOOK

DIRECTORY OF AM, FM, and TV STATIONS OF THE UNITED STATES

*(Data corrected to December 6, 1949)
If executives or services for FM or TV stations are same as AM affiliate names are not repeated.*

PENNSYLVANIA—(Continued)

City Call Letters Established	Chan. or Freq. Power	Name of Licensee Headquarters Address Telephone Number	Network Representative	Executive Personnel	Transc. Library News Service Transmitter Make	
CLEARFIELD						
WCPA 1947	900 1,000-D	Clearfield Bcstrs. Inc. 215 Church St. 5-5541		W. K. Ulerich, Pres. & Gen. Mgr. W. C. Plummer, Coml. Mgr.	W. J. Thomas, Prog. Dir. & Prom. Mgr. L. E. Duck, Chief Engr.	Capitol World Thesaurus UP Gates
COATESVILLE						
WCOJ (CP)	1420 1,000-D	Chester County Bcstg. Co. 703 Chestnut St. 2100		William S. Halpern, Pres. & Gen. Mgr.	Richard Scully Jr., V. P. Louis N. Seitzer, Chief Engr.	UP Gates
CONNELLSVILLE						
WCVI 1947	1340 250	Connellsville Bcstrs. Inc. 126 W. Crawford Ave. 2700		J. Wylie Driscoll, Pres., Gen. & Coml. Mgr.	John Reynolds, Prog. Dir. Robert H. Fasulkey, Chief Engr.	Capitol SESAC UP Gates
DOYLESTOWN						
WBUX 1948	1570 250-D	Charles M. Meredith Hart Bldg. 220		Charles M. Meredith, Pres. William A. Lynch, Gen. & Coml. Mgr.	Frances Vogel, Prog. Dir. Paul Fireman, Chief Engr.	AP General Electric
DUBOIS						
WCED 1941	1230 250	Tri-County Bcstg. Co. Inc. 80 N. Park Pl. 1700	CBS, KBS McGillvra	H. T. Gray, Pres. J. S. Gray, Gen. Mgr. & Prog. Dir.	Les Ryder, Coml. Mgr. Vernon Stahl, Chief Engr.	Lang-Worth UP
WCED-FM 1948	Ch. 271 (B) 102.1mc; 9.5 kw					
EASTON						
WEEX (FM) 1948	Ch. 252 (A) 98.3mc 1kw	Easton Pub. Co. Easton 7171		J. L. Stackhouse, Pres. N. S. Rounstey, Gen. & Coml. Mgr.	Charles R. Thon, Prog. Dir. & Chief Engr.	Associated AP RCA
WEST 1936	1400 250	Associated Bcstrs. Inc. 516 Northampton St. 6131	MBS, NBC Meeker	Clair R. McCollough, Sta. Exec. Elwood C. Anderson, Gen. Mgr. J. Robert Gulick, Gen. Sales Mgr.	Eugene Bethman, Prog. Dir. Jean Fitz, Prom. Mgr. J. E. Mathiot, Tech. Dir.	World UP
WEST-FM 1948	Ch. 300 (B) 107.9mc; 16kw					
ERIE						
WEEL (FM) (CP)	Ch. 246 (B) 97.1mc	Unity Corp. Inc.				
WERC 1941	1230 250 CP-1260 5,000 DA-2	Presque Isle Bcstg. Co. 121 West Tenth St. 26-918	NBC Weed	Jacob A. Young, Pres. Charles E. Denny, Gen. Mgr.	Art Ingram, Sales Mgr.	Associated Lang-Worth
WERC-FM 1947	Ch. 260 (A) 99.9mc 0.25kw					
WICU(TV) 1949	Ch. 12 204-210mc 1.5kw aur.; 2kw vis.	Dispatch Inc. 35th & State St. 2-4084	ABC, CBS DuMont, NBC Headley- Reed	Edward Lamb, Pres. Paul Albracht, Treas. Roger S. Underhill, Gen. & Coml. Mgr.	Gomer Lesch, Prod. Chief Charles Fuller, Adv. Mgr. Donald Lick, Prog. Dir. Michael Cso, Chief Engr.	UP DuMont
WIKK 1948	1330 5,000 DA-2	Community Service Bcstg. Co. 1021 State St. 2-3248	ABC Taylor-Boroff	Ted Nelson, Gen. Mgr. R. L. Dean, Coml. Mgr.	Mac McElroy, Prog. Dir. Clarence Baker, Chief Engr.	Standard UP Collins
WLEU 1933	1450 250	WLEU Bcstg. Corp. Commerce Bldg. 23-327	MBS Quaker	Leo J. Omelian, Pres. V. Hamilton Weir, Gen. & Coml. Mgr.	Claire Theno, Secy. George Roland, Chief Engr.	World Thesaurus AP RCA
WLEU-FM 1948	Ch. 250 (B) 97.9mc; 9kw					
WPLN (CP)	1400 250	Erie Bcstg. Co.				
GETTYSBURG						
WGEY (CP)	1430 250	Times & News Pub. Co.				
GREENSBURG						
WHJB 1934	620 1,000-LS 500-N DA-2	Pittsburgh Radio Supply House 128 N. Pa. Ave. 3740	Cooke	H. K. Brennan, Pres. George J. Podyen, Gen. & Coml. Mgr.	John Howard, Prog. Dir. Lyle L. Allen, Chief Engr.	Lang-Worth UP Western Electric
GROVE CITY						
*WSAJ	1340 100; SH	Grove City College				
HANOVER						
WHVR 1949	1280 1,000-D	Radio Hanover Inc. Hanover Trust Bldg. 3831		John D. Bare, Gen. Mgr. H. Vernon Ferster, Coml. Mgr.	Mack Edwards, Prog. Dir. Philip Rohrbaugh, Chief Engr.	Lang-Worth UP RCA
HARRISBURG						
WABX (FM) 1945	Ch. 265 (A) 100.9mc 1kw	WABX Inc. 2107 North 6th St. 2-5372		Harold O. Bishop, Pres. John F. Walters, Prog. Dir.	Walter A. Deemer, Chief Engr.	Lang-Worth INS
WHGB 1945	1400 250	Harrisburg Bcstg. Co. 112 Market St. 2-3456	ABC Weed	Herbert Kendrick, Pres. Jack Hooper, Gen. & Coml. Mgr. Stan Bowman, Prog. Dir.	Red McCarthy, Prom. Mgr. H. Glenwood Schlegel, Chief Engr.	Thesaurus AP RCA
WHP 1924	1460 5,000-LS 1,000-N DA CP: 580, 5,000	WHP Inc. Telegraph Bldg. 4-3211	CBS Bolling	A. K. Redmond, Gen. & Coml. Mgr.	Beatrice Potteiger, Sales Prom. Dir.	
WHP-FM	Ch. 247 (B) 97.3mc; 4kw					
WKBO 1922	1230 250	Keystone Bcstg. Corp. 31 North Second St. 40191	MBS, NBC Meeker	Clair R. McCollough, Sta. Exec. David J. Bennett Jr., Gen. Mgr. J. Robert Gulick, Gen. Sales Mgr.	Donald Wear, Prog. Dir. George Gottschalk, Prom. Mgr. J. E. Mathiot, Tech. Dir.	World UP

DA-N Directional Antenna, night only. FM's in italic.
DA-1 Directional Antenna, same pattern day and night.
DA-2 Directional Antenna, different pattern day and night.

*—Non-Commercial Station. D—Day. N—Night. ST—Share Time. SH—Specified Hours.
U—Unlimited. CP—Construction Permit Issued. LS—Local Sunset.
L—Limited Time with Dominant Station. SA—Special Authorization.

City Call Letters Established	Chan. or Freq. Power	Name of Licensee Headquarters Address Telephone Number	Network Representative	Executive Personnel	Transc. Library News Service Transmitter Make	
HAZLETON WAZL 1932	1490 250	Hazleton Bcstg. Co. Hazleton Nat'l Bank Bldg. 5400	MBS, NBC Quaker Meeker	Victor C. Diehm, Pres., Gen. & Coml. Mgr. Kathryn E. Kahler, Prom. Mgr.	Don Murray, Prog. Dir. Elwood C. Tito, Chief Engr.	Thesaurus UP Western Electric
WAZL-FM 1949	Ch. 250 (B) 97.9mc 7.6kw					
HOMESTEAD WHOD 1948	860 250-D	Steel City Bcstg. Corp. 105 East 7th Ave. 1-0027	Ortale	Carl Cuda, Pres. Roy Feree, Gen. & Coml. Mgr.	Raymond Scott, Prog. Dir. James Herbert, Chief Engr.	Lang-Worth UP Western Electric
HUNTINGDON WHUN 1947	1400 250	Radio Station WHUN 400 Washington St. 1291	MBS, KBS	John H. Biddle, Pres. Samuel L. Stroh Jr., Gen. & Coml. Mgr.	Richard J. Gill, Prog. Dir. & Prom. Mgr. Ernest A. Craig, Chief Engr.	Lang-Worth SESAC UP Gates
INDIANA WDAD 1945	1450 250	Indiana Bcst. Inc. 637 Philadelphia St. 1780	CBS McGillvra	Paul J. Short, Pres. T. K. Cassel, Sta. & Coml. Mgr. James E. Pattison, Prog. Dir.	Joseph R. McCurdy, Prom. Mgr. R. F. Mihalick, Chief Engr.	Standard AP Western Electric
JOHNSTOWN WARD 1946	1490 250	Central Bcstg. Co. Inc. Porch Bldg. 8-1216	CBS Weed	Paul J. Short, Pres. George D. Gartland, V. P. & Gen. Mgr. Harold Fitzgerald, Coml. Mgr.	Robert R. Nelson, Prog. Dir. & Sta. Mgr. Millard J. Coleman, Chief Engr.	World UP Western Electric
WARD-FM 1948	Ch. 287 (B) 105.3mc 11kw					
WCRO 1947	1230 250	Century Bcstg. Corp. 317 Main St. 7-5255	ABC, MBS Quaker Radio Reps	John J. Keel, Pres. John F. Hanssen, Gen. Mgr.	Dennis Gerken, Coml. Mgr. Rexford Ackley, Chief Engr.	Collins Associated INS Western Electric
WJAC 1926	1400 250	WJAC Inc. 329 Main St. 4-1267	NBC Headley- Reed	W. W. Krebs, Pres. L. W. Barnes, Exec. V. P. & Treas.	John P. Foster, Sta. & Coml. Mgr. Campbell E. Patch, Prog. Dir. N. L. Straub, Chief Engr.	Lang-Worth Thesaurus Standard AP RCA
WJAC-FM 1948	Ch. 238 (B) 95.5mc 8.3kw					
WJAC-TV 1949	Ch. 13 210-218mc 3.7kw air.; 6.5kw vis.		ABC, CBS DuMont NBC	A. D. Schrott, Gen. Mgr.	Frank Cummins, Prog. Dir.	UP
KITTANNING WACB 1948	1380 500-D	Armstrong Co. Bcstg. Corp. 325 Market St. 1380		Lawrence W. Henry, Pres. Ames L. Harper, Gen. Mgr. William T. McKibben, Coml. Mgr.	Charles D. Cassel Jr., Prog. Dir. Richard Adams, Chief Engr.	World INS RCA
WKIN 1949	1600 1,000-D	WKIN Inc. 133 N. Jefferson St. 1350		Julian Louis Liebman, Pres., Gen. & Coml. Mgr. Ernie Kline, Prog. Dir.	Larry Caldwell, Prom. Mgr. Benjamin A. Franklin, Chief Engr.	Standard Lang-Worth UP Raytheon

Something New for 1950

5000 on 580

for

W H P

Harrisburg, Pa.

Where High-hoopers Prevail

DIRECTORY OF AM, FM, and TV STATIONS OF THE UNITED STATES

*(Data corrected to December 6, 1949)
If executives or services for FM or TV stations are same as AM affiliate names are not repeated.*

PENNSYLVANIA—(Continued)

City Call Letters Established	Chan. or Freq. Power	Name of Licensee Headquarters Address Telephone Number	Network Representative	Executive Personnel	Transc. Library News Service Transmitter Make	
LANCASTER						
WGAL 1922	1490 250	WGAL Inc. 8 West King St. 5251	MBS, NBC Meeker	Clair R. McCollough, Pres. Harold E. Miller, Gen. Mgr. J. Robert Gulick, Gen. Sales Mgr.	Roy McCauley, Prog. Dir. Barton Feroe, Prom. Mgr. J. E. Mathiot, Tech. Dir.	World UP
WGAL-FM 1946	Ch. 267 (B) 101.3mc 16kw					
WGAL-TV 1949	Ch. 4 66-72mc .5kw aurr.; 1kw vis.		ABC, CBS NBC	Paul Rodenhauer, Prog. Dir.		
WLAN 1946	1390 1,000 DA-N	Peoples Bcstg. Co. 252 N. Queen St. 7261	ABC Quaker Headley-Reed	Frank H. Altdoerffer, Pres. & Chief Engr.	John D. Hymes, Gen. Mgr. Robert C. Harnish, Prog. Dir.	Lang-Worth AP RCA
WLAN-FM 1946	Ch. 245 (B) 96.9mc; 20kw					
LEBANON						
WLAB (FM) 1948	Ch. 281 (B) 104.1mc 4.4kw	Radio Lebanon FM & Television Inc. 1423 Elm St. 4300		Thomas C. Holston, Pres. & Prog. Dir.	Frank A. Wellman, Coml. Mgr. & Sales Counsellor John Gilbert & Sam Youse, Engrs.	SESAC Capitol Thesaurus Federal World AP RCA
WLBR 1946	1270 1,000-D	Lebanon Bcstg. Co. Central Bldg. 3900	Rambeau	Lester P. Etter, Mngng. Dir. Julian F. Skinnell, Oprs. Mgr. Philip J. Reilly, Coml. Mgr.	Jared Rolston, Prog. Dir. M. Leonard Savage, Chief Engr.	
WLBR-FM 1948	Ch. 261 (A) 100.1mc 0.64kw					
LEMOYNE						
WCMB 1948	960 1,000-D	Rossmoyne Corp. Lemoyne Theatre Bldg. 4-3005	Cooke	Edgar T. Shepard Jr., Pres. Ed K. Smith, Gen. Mgr. John T. Burnite Jr., Coml. Mgr.	Don Jacobs, Prog. Dir. Lew Doolittle, Prom. Mgr. Howard Bair, Chief Engr.	Associated AP Collins
LEWISTOWN						
WKVA 1949	920 1,000-D	Central Pennsylvania Bcstg. Co. 7 North Wayne St. 6771		Paul J. Newton, Pres. Robert L. Wilson, Gen. Mgr. Richard Wetzel, Coml. Mgr.	Elwood E. Erdman, Prog. Dir. Lynn Bloom, Prom. Mgr. John Stormer, Chief Engr.	Lang-Worth UP Gates
WMRF 1941	1490 250	Lewistown Bcstg. Co. Lewistown 6737	NBC Quaker Burn-Smith	J. S. Woods, V. P. T. W. Metzger, Gen. Mgr. W. F. Sager, Asst. Mgr.	Ralph Parker, Mgr. James C. Keyes, Prog. Dir. & Prom. Mgr. Bernard Bopp, Chief Engr.	Standard UP Western Electric
WLTN (FM) 1947	Ch. 250 (B) 97.9mc; 2.25kw	(WMRF, AM affiliate)				
LOCK HAVEN						
WBPZ 1947	1230 250	Lock Haven Bcstg. Corp. 132½ E. Main St. 4038	MBS McGillvra	Don C. Welch, Pres. Harris Lipez, Gen. & Coml. Mgr. Dave King, Prog. Dir.	Joseph E. Nevins, Prom. Mgr. Kenneth B. Caum, Chief Engr.	Standard SESAC AP Raytheon
McKEESPORT						
WEDO 1946	810 1,000-D	Tri City Bcstg. Co. 547 Fifth Ave. 4-7167		Edward J. Hirschberg, Pres. Jan King, Gen. & Coml. Mgr. John Stewart, Prog. Dir.	Mildred Sheridan, Prom. Mgr. Wilkes Hurley, Chief Engr.	Associated Capitol Thesaurus World AP, INS Raytheon
WMCK 1947	1360 1,000 DA-N	Mon-Yough Bcstg. Co. 517 Market St. 4-7193	KBS	George R. Raikes, Pres. Pat Haley, Prog. Dir.	Charles W. White, Chief Engr.	Lang-Worth Standard UP Raytheon
WMCK-FM 1947	Ch. 285 (A) 104.9mc; 0.5kw					Federal
MEADVILLE						
WMGW 1947	1490 250	Meadville Bcstg. Service Inc. First Nat'l Bank Bldg. 46-723		H. C. Winslow, Pres. David Davies, Sta. Mgr. & Prog. Dir.	Irma DePascale, Prom. Mgr. Hoyt H. Stout, Chief Engr.	Thesaurus Lang-Worth SESAC UP General Electric
WMGW-FM 1949	Ch. 262 (B) 100.3mc 10kw					Westinghouse
MORRISVILLE						
WBUO 1947	1490 250	Morrisville Bcstg. Co. 12 S. Pennsylvania Ave. 7107	McGillvra	Verna S. Hardin, Pres. James Stolcz, Coml. Mgr. William F. Hildenbrand, Prog. Dir.	Robert Kent, Prom. Mgr. William A. Brewer, Chief Engr.	World AP
NANTICOKE						
WHWL 1947	730 1,000-D	Radio Anthracite Inc. 38 E. Main St. 1332	Forjoe	Henry W. Lark, Pres. Milton Laughlin, Gen. & Coml. Mgr.	Jones Evans, Prog. Dir.	Standard Capitol SESAC UP
NEW CASTLE						
WKST 1938	1280 1,000 DA-N	WKST Inc. Cathedral Bldg. 5050	MBS, MON Quaker Katz	S. W. Townsend, Pres. A. W. Graham, Sta. & Coml. Mgr. Harry Reith, Prog. Dir.	Al Francis, Prom. Mgr. Robert Emch, Chief Engr.	World UP RCA
WKST-FM 1948	Ch. 266 (B) 101.1mc 3kw					Gates
NEW KENSINGTON						
WKPA 1940	1150 250-D	Allegheny-Kiski Bcstg. Co. 810 Fifth Ave. 3534	Continental	Edward J. Kroen, Gen. & Coml. Mgr. & Prog. Dir.	W. W. Neely, Chief Engr.	Lang-Worth MacGregor Cole UP RCA
NORRISTOWN						
WNAR 1946	1110 500-D	Norristown Bcstg. Co. Inc. 115 W. Main St. 7600	Grant	N. Joe Rahall, Pres. Farris E. Rahall, Exec. Dir.	Norman K. Brooks, Prog. Dir. F. H. Bisbing, Chief Engr.	Lang-Worth UP Gates
OIL CITY						
WKRZ 1946	1340 250	WKRZ Inc. 232 Seneca St. 41-269	Tri-State McGillvra	Kenneth E. Rennekamp, Pres. James P. O'Brien, Gen. Mgr. Roland Phillips, Coml. Mgr.	Richard E. Thompson, Prog. Dir. Betty Mae Winger, Prom. Mgr. Leo Arcoletti, Chief Engr.	World UP RCA
PHILADELPHIA						
KYW 1921	1060 50,000 DA-1	Westinghouse Radio Stations Inc. 1619 Walnut St. Locust 4-3700	NBC Free & Peters	Walter Evans, Pres. Walter E. Benoit, V. P. J. B. Conley, Gen. Mgr. James P. Begley, Prog. Mgr.	Robert E. White, Sta. Mgr. Harvey McCall Jr., Sales Mgr. C. M. Meehan, Prom. & Pub. Mgr. I. N. Eney, Chief Engr.	Associated UP, INS Westinghouse

DA-N Directional Antenna, night only. FM's in italic. *—Non-Commercial Station. D—Day. N—Night. ST—Share Time. SH—Specified Hours.
DA-1 Directional Antenna, same pattern day and night. U—Unlimited. CP—Construction Permit Issued. LS—Local Sunset.
DA-2 Directional Antenna, different pattern day and night. L—Limited Time with Dominant Station. SA—Special Authorization.



**You get coverage where it counts
when you buy WFIL and WFIL-TV.**

WFIL reaches more than 5,011,000 people in Eastern Pennsylvania, Central and Southern New Jersey and Eastern Delaware alone, heart and hinterland of the teeming Philadelphia market. Engineering measurements *prove* that no other Philadelphia station reaches as many people in that area.

From a powerful new transmitting plant in the

population center of the Greater Philadelphia area, WFIL-TV beams its television signal out over a 17-county area in which nearly 4,207,000 persons make their homes. WFIL-TV serves the greatest number of people in the world's second largest television market.

Your sales message on WFIL . . . WFIL-TV . . . gets *Coverage Where it Counts.*

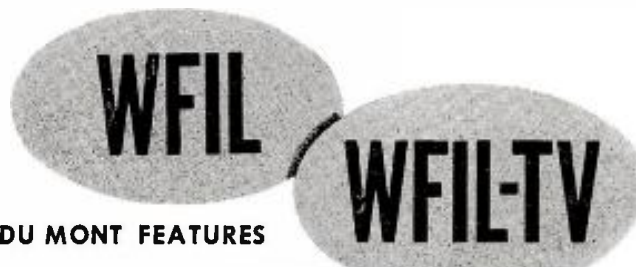

ABC and DU MONT FEATURES

REPRESENTED BY THE KATZ AGENCY

The Philadelphia Inquirer Stations

DIRECTORY OF AM, FM, and TV STATIONS OF THE UNITED STATES

*(Data corrected to December 6, 1949)
If executives or services for FM or TV stations are same as AM affiliate names are not repeated.*

PENNSYLVANIA—(Continued)

City Call Letters Established	Chan. or Freq. Power	Name of Licensee Headquarters Address Telephone Number	Network Representative	Executive Personnel	Transc. Library News Service Transmitter Make	
PHILADELPHIA—(Continued)						
KYW-FM 1942	Ch. 223 (B) 92.5mc 20kw					
WCAU 1922	1210 50,000	WCAU Inc. 1622 Chestnut St. Locust 7-7700	CBS	Donald W. Thornburgh, Pres. & Gen. Mgr. Joseph L. Tinney, V. P. & Asst. Gen. Mgr. Robert N. Pryor, Prom. & Public Relations Dir.	Joseph T. Connolly, V. P. in Chg. of Radio Prog. Alex Rosenman, V.P. in Chg. of Sales John G. Leitch, V. P. in Chge. of Engrg.	Lang-Worth AP, UP RCA
WCAU-FM 1937	Ch. 251 (B) 98.1mc 11kw				General Electric	
WCAU-TV 1948	Ch. 10 192-198mc 14,076kw aur.; 25kw vis.			G. Bennett Larson, V. P. & Tele. Dir. John J. Kelly, Coml. Rep.	John McClay, Prog. Dir. David Kaigler, Prod. Dir. RCA	
WDAS 1922	1400 250	WDAS Bcstg. Station Inc. 1211 Chestnut St. Locust 7-7400	Forjoe	William Goldman, Pres. Lambert B. Beeuwkes, Gen. & Coml. Mgr.	Richard H. Booth, Prog. Dir. M. Leonard Matt, Prom. Mgr. Frank Unterberger, Chief Engr.	Lang-Worth AP RCA
WFIL 1935	560 5,000 DA-2	Triangle Pub. Inc. Widener Bldg. Rittenhouse 6-6900	ABC Quaker Katz	Walter H. Annenberg, Pres. Roger W. Clipp, Gen. Mgr. John E. Surrick, Coml. Mgr.	George A. Koehler, Prom. Mgr. William A. Farren, Prog. Dir. Louis E. Littlejohn, Chief Engr.	Associated AP RCA
WFIL-FM 1941	Ch. 271 (B) 102.1mc 10kw					
WFIL-TV 1947	Ch. 6 82-88mc 13.5kw aur.; 27kw vis.	Evergreen 6-8090	ABC, DuMont	Kenneth W. Stowman, TV Sales Dir. Jack Steck, Prog. Dir.	Henry Rhea, Asst. Chief Engr. Chg. of TV Donald S. Kellett, Admin. Asst. to Gen. Mgr.	Tele-News AP
WFLN (FM) 1949	Ch. 239 (B) 95.7mc 20kw	Franklin Bcstg. Corp. 8200 Ridge Ave. Ivy Ridge 2-6000		L. M. C. Smith, Pres. Raymond S. Green, Gen. Mgr. & Prog. Dir. Donald G. Baird, Sales Mgr.	Mrs. Margaret A. Kane, Coml. Mgr. John K. Thomas II, Chief Engr.	Associated UP Collins
WHAT 1922	1340 250	Independence Bcstg. Co. 1505 Walnut St. Rittenhouse 6-2058		William A. Banks, Pres. & Coml. Mgr. Dolly Banks, Gen. & Prom. Mgr.	Annette Oromaner, Prog. Dir. Arnold Goldman, Chief Engr.	AP
WHAT-FM 1949	Ch. 287 (B) 105.3mc 20kw					
WIBG 1924	990 10,000 DA-2	Seaboard Radio Bcstg. Corp. 1425 Walnut St. Rittenhouse 6-2300	Young	Paul F. Harron, Pres. Edward D. Clery, Gen. & Coml. Mgr. Douglas Arthur, Prog. Dir.	Rupe Werling, Prod. & Prom. Mgr. John H. Henninger, Chief Engr.	Lang-Worth UP Western Electric
WIBG-FM 1948	Ch. 231 (B) 94.1mc 20kw					
WIP 1922	610 5,000 DA-1	Pennsylvania Bcstg. Co. 35 So. 9th St. Walnut 2-6800	MBS Petry	Benedict Gimbel Jr., Pres. & Gen. Mgr. Gordon Gray, V. P. Sam Hill, Coml. Mgr.	Murray Arnold, Prog. Dir. Ralph H. Minton, Prom. Mgr. Clifford C. Harris, Chief Engr.	World AP, UP Western Electric
WIP-FM 1942	Ch. 227 (B) 93.3mc 20kw					
WJMJ 1948	1540 1,000-D	Patrick Joseph Stanton St. James Hotel Kingsley 5-7000	McGillvra	Patrick Joseph Stanton, Owner & Gen. Mgr. Charles Stahl, Coml. Mgr.	Michael Deegan, Prog. Dir. John White, Prom. Mgr. Alec Felton Iles, Chief Engr.	SESAC AP RCA
WPEN 1929	950 5,000 DA-N	William Penn Bcstg. Co. 1528 Walnut St. Kingsley 6-0950	Rambeau	Albert J. Sytk, Pres. Edward C. Obrist, Gen. Mgr. Jules Rind, Prog. Dir.	Wm. B. Caskey, Asst. Mgr. Charles W. Burtis, Chief Engr.	Associated AP, UP
WPEN-FM 1942	Ch. 275 (B) 102.9mc 20kw				RCA	
WPTZ (TV) 1941	Ch. 3 60-66mc 8.1kw aur.; 16.2kw vis.	Philco Television Bcstg. Corp. 1800 Architects Bldg. Locust 4-2244	NBC NBC Spot	Ernest B. Loveman, V. P. & Gen. Mgr. Rolland V. Tooke, Asst. Gen. Mgr.	Alexander W. Dannenbaum Jr., Coml. Mgr. Raymond J. Bowley, Chief Engr.	INS RCA
WTEL 1925	860 250-D	Foulkrod Radio Engrg. Co. 4312 N. Broad St. Gladstone 5-1310		E. Douglass Hibbs, Pres. Henry N. Crocker, Coml. Mgr.	John Field, Chief Engr.	
PITTSBURGH						
KDKA 1920	1020 50,000	Westinghouse Radio Stations Inc. Grant Bldg. Grant 1-4200	NBC Free & Peters	Walter Evans, Pres. Walter E. Benoit, V. P. J. B. Conley, Gen. Mgr.	Joseph E. Baudino, Sta. Mgr. George D. Tons, Sales Mgr. Theodore C. Kenney, Chief Engr.	Thesaurus AP, UP, INS Westinghouse
KDKA-FM 1942	Ch. 225 (B) 92.9mc 9kw					
KQV 1919	1410 5,000 DA-2	Allegheny Bcstg. Corp. 800 Chamber of Com- merce Bldg. Atlantic 1-9100	MBS Weed	Charles T. Campbell, Pres. James F. Murray, Sta. & Coml. Mgr.	Walter Jones & Herb Morrison, Prog. Supvsrs. Frank Orr, Prom. Mgr. James Schultz, Chief Engr.	SESAC, World UP Western Electric
KQV-FM 1948	Ch. 251 (B) 98.1mc 20kw				Federal	
WCAE 1922	1250 5,000 DA-N	WCAE Inc. William Penn Hotel Atlantic 1-6900	ABC Katz	Leonard Kapner, Pres. R. Clifton Daniel, Sta. Mgr. & Prog. Dir. Carl M. Dozer, Coml. Mgr.	William Kelley, Prom. & Publ. Mgr. James Greenwood, Chief Engr.	World AP, INS RCA
WCAE-FM 1948	Ch. 241 (B) 96.1mc 12kw				Westinghouse	
WDTV (TV) 1949	Ch. 3 60-66mc 8.3kw-aur.; 16.6kw-vis.	Allen B. DuMont Labs., Inc. Clark Bldg. Express 1-1071	ABC, CBS DuMont NBC	Allen B. DuMont, Pres. Donald A. Stewart, Gen. & Coml. Mgr.	Leslie Arries Jr., Prog. Dir. Harry Munson, Asst. Prog. Dir. Raymond Rodgers, Chief Engr.	World DuMont

DA-N Directional antenna, night only. FM's in italic.
DA-1 Directional Antenna, same pattern day and night.
DA-2 Directional Antenna, different pattern day and night.

*—Non-Commercial Station. D—Day. N—Night. ST—Share Time. SH—Specified Hours.
U—Unlimited. CP—Construction Permit Issued. LS—Local Sunset.
L—Limited Time with Dominant Station. SA—Special Authorization.

IT'S WCAU

IN RADIO
IN TELEVISION
IN PHILADELPHIA



The Philadelphia Bulletin Stations

WCAU

AM
FM
TV

CBS AFFILIATE

DIRECTORY OF AM, FM, and TV STATIONS OF THE UNITED STATES

(Data corrected to December 6, 1949)
If executives or services for FM or TV stations are same as AM affiliate names are not repeated.

PENNSYLVANIA—(Continued)

City Call Letters Established	Chan. or Freq. Power	Name of Licensee Headquarters Address Telephone Number	Network Representative	Executive Personnel	Transc. Library News Service Transmitter Make	
PITTSBURGH—(Continued)						
WJAS 1921	1320 5,000 DA-N	Pittsburgh Radio Supply House 1406 Chamber of Com- merce Bldg. Grant 1-4880	CBS Hollingbery	H. K. Brennen, Pres. & Gen. Mgr. J. H. Buchheit, Prom. & Coml. Mgr.	James M. Hughes, Prog. Dir. Walter W. McCoy, Chief Engr.	Cole Lang-Worth UP, TP Western Electric
WJAS-FM 1948	Ch. 259 (B) 99.7mc 24kw					
WKJF (FM) 1948	Ch. 229 (B) 93.7mc 20kw	West Virginia Radio Corp. 1715 Grandview Ave. Hubbard 1-2626		Mrs. H. C. Greer, Pres. Charles E. Dewey, Gen. Mgr. Charles F. Kretzler, Coml. Mgr.	A. Roger Kelly, Prog. Dir. Clarence Rulong, Chief Engr.	World AP Western Electric
WLFM (FM)	Ch. 246 (B) 96.9mc; 20 kw	(WLOA, AM affiliate) (See Braddock, Pa. listing)				
WPGH 1947	1080 1,000-D	Pittsburgh Bcstg. Co. 220 N. Highland Ave. Emerson 5000	McGillvra	Harry A. Bergstrom, Pres.	James A. McFarland, Gen. Mgr.	Lang-Worth World AP
WPGH-FM	Ch. 273 (B) 102.5mc; 22kw					
WPIT 1947	730 1,000-D	WPIT Inc. 211 Smithfield St. Grant 1-0794	Ra-Tel	John Laux, Pres. John L. Merdian, Gen. Mgr. Don Ioset, Coml. Mgr. Russell Offhaus, Prog. Dir.	Bill Ewing, Prom. Mgr. & Asst. Prog. Dir. John Berninger, Chief Engr.	UP Gates
WPIT-FM	Ch. 268 (B) 101.5mc; 19kw					
WWSW 1932	970 5,000 DA-2	WWSW Inc. Sheraton Hotel Grant 1-5200	Forjoe	O. M. Schloss Jr., Pres. & Gen. Mgr. Ben W. Muros, Coml. Mgr.	B. Kendall Crane, Prog. Dir. Harold J. Goldstein, Prom. Mgr. Henry R. Kaiser, Chief Engr.	Standard AP Westinghouse General Electric
WWSW-FM 1941	Ch. 233 (B) 94.5mc; 8.5kw					
POTTSTOWN						
WMAC (CP)	1370 1,000-D	Radio Anthracite Inc.				
POTTSVILLE						
WPAM 1947	1450 250	Miners Bcstg. Service 106 South Centre St. 5050	MBS Quaker McKinney	Joseph L. Maguire, Pres. Louis H. Murray, Gen. Mgr. Frank L. Tamulonis, Coml. Mgr.	Joel Fleming, Prog. Dir. Horace Richards, Prom. Mgr. Eugene Handwerk, Chief Engr.	Associated Standard UP; Gates

DA-N Directional Antenna, night only. FM's in italic.
DA-1 Directional Antenna, same pattern day and night.
DA-2 Directional Antenna, different pattern day and night.

*—Non-Commercial Station. D—Day. N—Night. ST—Share Time. SH—Specified Hours.
U—Unlimited. CP—Construction Permit Issued. LS—Local Sunset.
L—Limited Time with Dominant Station. SA—Special Authorization.

TRANSITSPOTS



Put your salesman
on
Pittsburgh
buses

Contact your nearest
TRANSIT RADIO, INC.
Sales Office for details

WKJF

TRANSIT RADIO FOR
PITTSBURGH

- Hits the spot with accurate traffic counts showing how many ACTUAL listeners are reached per hour. Rates based on number of listeners. You know what you're buying and pay proportionately.
- Hits the spot with specific types of listeners reached at specific daily periods, i.e. workers 6:00-7:30 a.m.; professional people 7:30-9:00 a.m.; shoppers and housewives 9:30-4:00 p.m.
- Hits the spot with more for your money in the vast PITTSBURGH market where over 80% of the population uses public transportation. Coverage of the home audience is yours at no additional cost.

PITTSBURGH 11, PA.

HUBBARD 1-2626

City Call Letters Established	Chan. or Freq. Power	Name of Licensee Headquarters Address Telephone Number	Network Representative	Executive Personnel	Transc. Library News Service Transmitter Make
POTTSVILLE—(Continued)					
WPAM-FM 1947	Ch. 238 (B) 95.5mc 5.1kw			 RCA
WPPA 1946	1360 1.000-LS 500-N DA	Pottsville Bcstg. Co. 8 South Second St. 4744		A. V. Tidmore, Owner & Gen. Mgr. John Naylor, Coml. Mgr. & Prog. Dir.	World SESAC AP Western Electric
WPPA-FM 1948	Ch. 270 (B) 101.9mc 2.8kw			
READING					
WEEU 1932	850 1.000 DA-N	Hawley Bcstg. Co. 533 Penn St. 7335	ABC Quaker Headley- Reed	Hawley Quier, Pres. Clifford M. Chafey, Gen. Mgr. K. Richard Creitz, Coml. Mgr.	E. Lester Hoffmaster, Prog. Dir. Harold E. Schearer, Chief Engr. James E. Keller, Exec. V. P.
WEEU-FM 1947	Ch. 225 (B) 92.9mc 9kw				Associated SESAC UP RCA
WHUM 1946	1240 250	Eastern Radio Corp. Berkshire Hotel 44805	CBS Hollingbery	Humboldt J. Greig, Pres. Robert G. Magee, V. P. & Gen. Mgr. Richard G. Fichthorn, Coml. & Prom. Mgr.	George D. Ribble, Office Mgr. Joseph E. McCormack, Chief Engr.
WRAW 1922	1340 250	Reading Bcstg. Co. Inc. 19 North 5th St. 7173	MBS, NBC Meeker	Clair R. McCollough, Sta. Exec. Raymond A. Gaul, Gen. Mgr. J. Robert Gulick, Gen. Sales Mgr.	Frank J. Voss, Prog. Dir. Dick McKay, Prom. Mgr. J. E. Mathiot, Tech. Dir.
ROCHESTER					
WRYO 1949	1050 250-D	Beaver Valley Radio Inc. Cleveland Ave. 4660		Edward J. Reider, Pres. Seymour Harvey Miller, Prog. Dir.	Andrew Macioce, Chief Engr.
SCRANTON					
WARM 1940	1400 250	Union Bcstg. Co. Bowman Bldg. 4-1148	ABC Quaker Hollingbery	Martin F. Memolo, Pres. & Gen. Mgr. William M. Dawson, Coml. & Prom. Mgr.	Joseph H. Salsburg, Prog. Dir. A. W. Oschmann, Chief Engr.
WARM-FM 1948	Ch. 289 (B) 105.7mc 6kw				Thesaurus UP RCA
WGBI 1925	910 1.000-LS 500-N ST-WQAN	Scranton Bcstrs. Inc. 1000 Wyoming Ave. 6296	CBS Quaker Blair	Mrs. M. E. Megargee, Pres. George D. Coleman, Gen. Coml. & Prom. Mgr.	Frank Monaghan, Prog. Dir. Kenneth R. Cooke, Chief Engr.
WGBI-FM 1948	Ch. 267 (B) 101.3mc 1.8kw				World AP Western Electric

DA-N Directional Antenna, night only. FM's in italic. *—Non-Commercial Station. D—Day. N—Night. ST—Share Time. SH—Specified Hours.
 DA-1 Directional Antenna, same pattern day and night. U—Unlimited. CP—Construction Permit Issued. LS—Local Sunset.
 DA-2 Directional Antenna, different pattern day and night. L—Limited Time with Dominant Station. SA—Special Authorization.

The RADIO PICTURE has CHANGED in Pittsburgh

You cannot afford to overlook WWSW!

Now, there's a new, powerful WWSW giving advertisers more and more listeners per dollar in Pittsburgh.

Now, 5000 watts at 970 kilocycles . . . ultra-modern transmission equipment . . . more sports . . . more music—24 hours a day put WWSW in the front ranks of Pittsburgh's leading stations.

Now, phone a Forjoe man — or call Pittsburgh, GRant 1-5200 direct, collect!

W W S W

Now Pittsburgh's POWERFUL Independent

Affiliated with the Pittsburgh Post-Gazette

DIRECTORY OF AM, FM, and TV STATIONS OF THE UNITED STATES

(Data corrected to December 6, 1949)
If executives or services for FM or TV stations are same as AM affiliate names are not repeated.

PENNSYLVANIA—(Continued)

City Call Letters Established	Chan. or Freq. Power	Name of Licensee Headquarters Address Telephone Number	Network Representative	Executive Personnel	Transc. Library News Service Transmitter Make	
SCRANTON—(Continued)						
WQAN 1924	910 1,000-LS 500-N ST-WGBI	The Scranton Times 149 Penn Ave. 5151	Walker	Elizabeth R. Lynett & Edward J. Lynett Jr., Owners	John P. McGoldrick, Gen. Mgr. & Chief Engr. Robert R. Flanagan, Prog. Dir.	Associated SESAC AP, UP RCA
WQAN-FM 1949	Ch. 222 (B) 92.3mc 1.8kw					Western Electric
WSCR 1947	1000 1,000-D	Lackawanna Valley Bcstg. Co. 116 Adams Ave. 5242	Walker	Michael J. Eagen, Pres. Frank S. Blair, Gen. Mgr. Jack Guinan, Prod. Mgr.	Mike Woloson, Prom. Mgr. Willard Shimski, Chief Engr.	Lang-Worth AP Raytheon
SHAMOKIN						
WISL 1948	1480 1,000 DA-N	Radio Anthracite Inc. Rock & Sunbury Sts. 2650	MBS ForJoe	Henry W. Lark, Pres. Charles R. Petrie, Gen. Mgr.	Dick Ownes, Prog. Dir. Bernard Marshal, Chief Engr.	Thesaurus AP RCA
SHARON						
WPIC 1938	790 1,000-D	Sharon Herald Bcstg. Co. P. O. Box 541 4113	Young	John Fahnlne Jr., Pres. & Gen. Mgr. Marc McCulloch, Prog. Dir.	Evelyn L. Keller, Prom. Mgr. A. C. Heck, Chief Engr.	Associated Capitol World Lang-Worth UP Western Electric Federal
WPIC-FM 1948	Ch. 275 (B) 102.9mc 26kw					
SOMERSET						
WVSC (CP)	990 250-D	Scranton Bcstg. Co.				
STATE COLLEGE						
WMAJ 1945	1450 250	Centre Bcstrs. Inc. P. O. Box 888 4959	MBS, KBS	William K. Ulerich, Gen. Mgr. Alethea Jones Mattern, Sta. Mgr. Miriam Krebs, Coml. Mgr.	Milton Bergstein, Prog. Dir. Douglas Beman, Chief Engr.	Lang-Worth AP Gates
STROUDSBURG						
WVPO 1947	840 250-D	Pocono Bcstg. Inc. 578 Main St. 1102	Walker	James H. Ottaway, Pres. Merle C. Ostrom, Gen. Mgr. Francis H. Brinkley, Mngng. Dir.	Elton Hall, Sta. Mgr. Joseph Webster, Prog. Dir. Ernest R. Transue, Chief Engr.	Associated UP Collins
SUNBURY						
WKOK 1933	1240 250	Sunbury Bcstg. Corp. 1150 North Front St. 1325	ABC Quaker Continental	Harry H. Haddon, Pres. Homer R. Smith, Gen. Mgr. W. Robert Trevitt, Coml. Mgr.	Michael J. Kane, Prog. Dir. John Keller, Chief Engr.	Lang-Worth AP Western Electric RCA
WKOK-FM 1948	Ch. 231 (B) 94.1mc 4.4kw					

DA-N Directional Antenna, night only. FM's in italic.
DA-1 Directional Antenna, same pattern day and night.
DA-2 Directional Antenna, different pattern day and night.

*—Non-Commercial Station. D—Day. N—Night. ST—Share Time. SH—Specified Hours.
U—Unlimited. CP—Construction Permit Issued. LS—Local Sunset.
L—Limited Time with Dominant Station. SA—Special Authorization.

W S C R ♦ ♦ THE ONE GRAND STATION
in a billion dollar market



1000 WATTS ON 1000 KC

SCRANTON

WSCR—an even thousand in power and frequency—
covers a prosperous market of 1,190,156 population
which annually spends \$836,540,000 in retail sales.

Ask

The Walker Company

SCRANTON'S news-music-sports station and the
favorite of the area's 286,735 Slavs (38.7% of the
population) and Italians (8.0%). This foreign language
programming is unequalled. It assures the constant
loyalty of nearly 33% of the market . . . and a grand
sales job in the Scranton market.

or

Frank Blair,

General Manager

MEMBER: FOREIGN LANGUAGE QUALITY GROUP

City Call Letters Established	Chan. or Freq. Power	Name of Licensee Headquarters Address Telephone Number	Network Representative	Executive Personnel		Transc. Library News Service Transmitter Make
UNIONTOWN						
WMBS 1937	590 1,000 DA-N	Fayette Bcstg. Corp. Fayette Title & Trust Bldg. 800	CBS Meeker	Joseph C. Burwell, Pres. & Gen. Mgr. Harry C. Burwell, Coml. Mgr.	Sullivan Sages, Prog. Dir. Charles Underwood, Prom. Mgr. William Henzly, Chief Engr.	Thesaurus UP RCA
WMBS-FM 1948	Ch. 289 (B) 105.7mc 1.5kw					
WNIQ (FM) 1948	Ch. 293 (B) 106.5mc 2.2kw	Uniontown Newspapers Inc. 8 E. Church St. 1000		Stanley W. Calkins, Pres. Ed Hamlyn, Gen. Mgr.	Wendell Coffin, Chief Engr.	Capitol Standard UP Westinghouse
WARREN						
WNAE 1946	1310 1,000-D	Northern Allegheny Bcstg. Co. First Nat'l. Bank Bldg. 3033	MBS	A. David Potter Jr., Pres. & Gen. Mgr. James W. Potter, Coml. Mgr.	W. LeRoy Schneck, Prog. Dir. & Prom. Mgr. Homer M. Haines, Chief Engr.	Capitol AP Raytheon
WNAE-FM 1948	Ch. 221 (A) 92.1mc 0.49kw				 Gates
WASHINGTON						
WJPA 1942	1450 250	Washington Bcstg. Co. George Washington Hotel Bldg. 4870	MBS McGillvra	William S. Yard, Pres. A. Boyd Siegel, Gen. Mgr. Peter Stanton, Coml. Mgr.	Mitchell Gray, Prog. Dir. H. E. Cooper, Chief Engr.	World UP Western Electric
WJPA-FM 1949	Ch. 282 (B) 104.3mc 6kw				 Gates
WILKES-BARRE						
WBAX 1922	1240 250	John H. Stenger Jr. 85 W. Union St. 3-0196	MBS Burn-Smith	John H. Stenger Jr., Pres. & Chief Engr. A. W. Grebe, Gen. Mgr.	John H. A. Stenger III, Prog. Dir. John H. Stenger IV, Prom. Mgr.	Associated Standard UP Western Electric
WBRE 1924	1340 250	Louis G. Baltimore 62 S. Franklin St. 3-3101	NBC Quaker	Louis G. Baltimore, Pres. David M. Baltimore, Gen. & Prom. Mgr.	A. C. Baltimore, Coml. Mgr. Frank D. Coslett, Prog. Dir. Charles Sakoski, Chief Engr.	World AP RCA
WBRE-FM 1947	Ch. 253 (B) 98.5mc 2.2kw					
WILK 1947	1450 250	Wyoming Valley Bcstg. Co. 88 North Franklin St. 4-4666	ABC Quaker Avery-Knodel	Dr. I. C. Morgan, Pres. Roy E. Morgan, Gen. Mgr. Thomas P. Shelburne, Sta. Mgr.	Jerry Butler, Coml. Mgr. Hal Berg, Prog. Dir. Chuck Whittier, Prom. Mgr. Theodore French, Chief Engr.	Lang-Worth Thesaurus UP Collins
WILK-FM 1948	Ch. 241 (B) 96.1mc 3.1kw				 Westinghouse
WIZZ (FM) 1946	Ch. 277 (B) 103.3mc 3.1kw	Scranton-Wilkes-Barre- Pittston Bcstg. Co. Inc. 225 S. Main St. 4-3561	Rural Radio Transit Radio	Richard G. Evans, Pres., Gen. & Coml. Mgr.	Joseph P. Roman, Prod. Supusr. Robert G. Love, Chief Engr.	Associated Capitol SESAC AP General Electric
WILLIAMSPORT						
WLYC (FM) 1949	Ch. 286 (B) 105.1mc 3.2kw	Lycoming Bcstg. Co. 331 Pine St. 2-4676		George Lewis, Pres. & Gen. Mgr. Paul Bitler, Coml. Mgr.	Dick Wolf, Prog. Dir. Loyd Matter, Chief Engr.	Thesaurus AP RCA
WRAK 1930	1400 250	WRAK Inc. 244 West Fourth St. 2-6116	NBC McKinney	E. M. Case, Pres. George E. Joy, Gen. Mgr. J. Wright Mackey, Coml. Mgr.	Leon E. Kelly, Prog. Mgr. Everett Rubendal, Prom. Mgr. Glen Sherman, Chief Engr.	Associated Lang-Worth AP RCA

OPERATION

STATION

W I S L

1000 W. - - - Full Time

SHAMOKIN

A
Mutual
Affiliate

Serving Pennsylvania's 8th Market
(Shamokin-Pottsville Area)

SUCCESS!

DIRECTORY OF AM, FM, and TV STATIONS OF THE UNITED STATES

*(Data corrected to December 6, 1949)
If executives or services for FM or TV stations are same as AM affiliate names are not repeated.*

PENNSYLVANIA—(Continued)

City Call Letters Established	Chan. or Freq. Power	Name of Licensee Headquarters Address Telephone Number	Network Representative	Executive Personnel	Transc. Library News Service Transmitter Make
WILLIAMSPORT—(Continued)					
WRAC-FM 1948	Ch. 262 (B) 100.3mc 3.2kw				
WWPA 1948	1340 250	Williamsport Radio Bcstg. Assoc. Inc. 330 Government Pl. 7119	CBS Burn-Smith	Harry J. W. Kiessling, Pres. Woodrow W. Ott, Gen. Mgr. J. David Fleming, Coml. Mgr.	Louis C. Cate, Prog. Dir. James D. Martyn, Chief Engr. World UP RCA
YORK					
WNOW 1948	1250 1,000-D	Broadcast Division, Helm Coal Co. 25 S. Duke St. 2911	Young	Lowell W. Williams, Gen. Mgr. John O. Border, Coml. Mgr. H. E. Daugherty, Prog. Dir.	Murray L. Goldsborough, Prom. Mgr. Willis N. Weaver, Chief Engr. Associated AP RCA
WNOW-FM 1948	Ch. 289 (B) 105.7mc 18kw				
WORK 1932	1350 1,000 DA-N	York Bcstg. Co. Inc. 13 South Beaver St. 6629	MBS, NBC Meeker	Clair R. McCollough, Sta. Exec. Leroy K. Strine, Gen. Mgr. J. Robert Gulick, Gen. Sales Mgr.	James R. Wilson, Prog. Dir. Guy Barry, Prom. Mgr. J. E. Mathiot, Tech. Dir. Coltins Thesaurus UP
WRZE (FM) 1948	Ch. 253 (B) 98.5mc 8kw	White Rose Bcstg. Co. 103 S. George St. 6696	Continental FM	Charles M. Gitt, Pres. Michael B. Robert, Gen. Mgr. John W. Himes, Coml. Mgr.	(Mrs.) Joan B. Richmond, Prog. Dir. Quinten G. Cumeralto, Chief Engr. Associated Standard AP RCA
WSBA 1942	910 1,000 DA-2	Susquehanna Bcstg. Co. ABC P. O. Box 1243 2676	ABC	Louis J. Appell, Pres. Walter J. Rothensies, Exec. V. P. Phillip K. Eberly, Coml. & Prom. Mgr.	Otis Morse, Prog. Dir. Woodrow G. Eberhart, Chief Engr. World AP RCA
WSBA-FM 1947	Ch. 277 (B) 103.3mc 20kw				

RHODE ISLAND

NEWPORT					
WRJM 1948	1540 1,000-D	Aquidneck Bcstg. Co. 204 Thames St. 4673		Columbus O'Donnell, Pres. Gilbert Congdon Jr., Bus. & Coml. Mgr.	Robert A. Brennan, Prog. Dir. & Prom. Mgr. Joseph Britto, Chief Engr. Associated AP Gates

DA-N Directional Antenna, night only. FM's in italic.
DA-1 Directional Antenna, same pattern day and night.
DA-2 Directional Antenna, different pattern day and night.

*—Non-Commercial Station. D—Day. N—Night. ST—Share Time. SH—Specified Hours.
U—Unlimited. CP—Construction Permit Issued. LS—Local Sunset.
L—Limited Time with Dominant Station. SA—Special Authorization.

WWPA

BUY WHERE
THEY'RE LISTENING!

FAVORITE . . .

with over 40,000 radio families in
North Central Pennsylvania!

Advertisers have found in WWPA a successful combination of sound local programming, and the CBS network . . . this in a metropolitan market area topographically situated to deny satisfactory reception of "outside" stations! Sales are created every day by WWPA . . . your BEST salesman, in a great market!

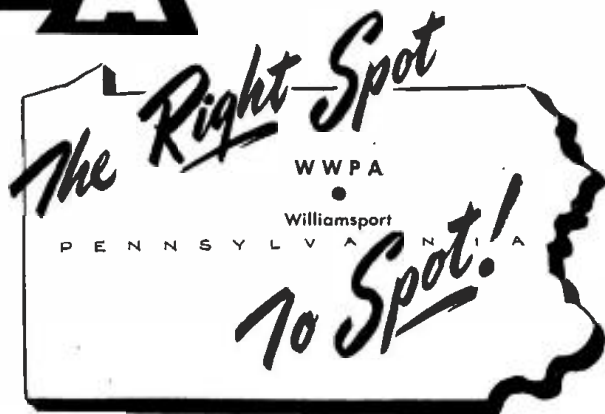

HARRY J. W. KIESSLING, President
WOODROW W. OTT, Manager



WILLIAMSPORT
BURN-SMITH CO. REPRESENTATIVES . . .

PENNSYLVANIA
NEW YORK, CHICAGO, LOS ANGELES

City Call Letters Established	Chan. or Freq. Power	Name of Licensee Headquarters Address Telephone Number	Network Representative	Executive Personnel	Transc. Library News Service Transmitter Make	
PAWTUCKET						
WFCI 1941	1420 5,000 DA-1	Pawtucket Bcstg. Co. 450 Main St. Plantations 1-6565	ABC Avery-Knodel	Howard W. Thornley, Pres. Wallace A. Walker, Gen. & Coml. Mgr.	David W. Brooks, Prog. Dir. Gilbert Johnson, Chief Engr.	Associated AP
WPAW (CP)	1380 500-D	Roger William Bcstg. Co. 32 N. Union St. 5-9000		Neale Murphy & Dominic Hyszko, Partners Dan Hyland, Gen. & Coml. Mgr. & Prog. Dir.	James Bonney, Chief Engr. Gates
PROVIDENCE						
WDEM 1947	1290 500-D	Narragansett Bay Bcstg. Co. Blue Cross Bldg. Jackson 1-6565		Louis A. R. Pieri, Pres. Irving M. Kipnes, Gen. & Coml. Mgr.	Walter Neiman, Prog. Dir. Louis Levin, Prom. Mgr. INS, TP Western Electric
WEAN 1922	790 5,000 DA-1	The Yankee Network Inc. Crown Hotel Temple 1-0800	MBS Yankee Petry	William O'Neil, Pres. Joseph T. Lopez, Gen. & Coml. Mgr.	Don Morton, Prog. Dir. Harry H. Tilley, Chief Engr.	Standard AP Western Electric
WFCI 1941	1420 5,000 DA-1	(See Pawtucket listing)				
WHIM 1947	1110 1,000-D	Inter-City Bcstg. Co. 32 Custom House St. Union 4211	Young		Robert T. Engles, Gen. Mgr.	Capitol AP
WJAR 1922	920 5,000 DA-2	The Outlet Co. 176 Weybosset St. Gaspee 1-1071	NBC New England Weed	Mortimer L. Burbank, Pres. John J. Boyle, Gen. & Coml. Mgr.	M. Sothern Abbott, Prog. Dir. Thomas C. J. Prior, Chief Engr.	World Western Electric
WJAR-FM 1948	Ch. 238 (B) 95.5mc 20kw				 AP
WJAR-TV 1949	Ch. 11 198-204mc 15kw-aur.; 30kw-vis.			James M. Orchard, Prog. Dir.	 UP RCA
WLIV (FM) 1948	Ch. 299 (B) 107.7mc 20kw	Colonial Bcstg. Co. 31 Canal St. Jackson 1-6565		Augustus M. Wilson, Pres. & Gen. Mgr. G. Stanley Shaw, Coml. Mgr.	Arthur Gordon, Prog. Dir. Joseph J. Jakubowski, Chief Engr.	Associated INS General Electric
WPJB (FM) 1948	Ch. 286 (B) 105.1mc 20kw	Providence Journal Co. Walker 75 Fountain St. Dexter 1-0600		George P. Metcalf, Pres. H. William Koster, Gen. Mgr.	Harmon H. Hyde, Prog. Dir. George W. Sharpe, Chief Engr.	Lang-Worth World AP, UP General Electric



When
YOU ENTRUST YOUR
RADIO-DOLLARS TO PROVIDENCE—

— buy the big station with the lower rates and get more ears per penny! ABC programming plus pace-setting local shows and features insure a most favorable reception of your sales-story in this rich, million-listener area. . . . Again, check the rates!

WFCI

MAIN STUDIOS:
THE SHERATON-BILTMORE — PROVIDENCE, R. I.

★

REPRESENTATIVES:
AVERY-KNODEL, INC.
565 Fifth Ave., New York 17, N. Y.

**5,000
WATTS
Day and Night**

The "American" Voice in Rhode Island

DIRECTORY OF AM, FM, and TV STATIONS OF THE UNITED STATES

(Data corrected to December 6, 1949)
If executives or services for FM or TV stations are same as AM affiliate names are not repeated.

RHODE ISLAND—(Continued)

City Call Letters Established	Chan. or Freq. Power	Name of Licensee Headquarters Address Telephone Number	Network Representative	Executive Personnel	Transc. Library News Service Transmitter Make	
PROVIDENCE—(Continued)						
WPRO 1924	630 5,000 DA-N	Cherry & Webb Bcstg. Co. 15 Chestnut St. Plantations 1-9776	CBS New England Raymer	William S. Cherry Jr., Pres. Arnold F. Schoen Jr., Gen. & Coml. Mgr.	John A. Owen Jr., Prog. Dir. John V. Ferri, Chief Engr.	Lang-Worth Thesaurus AP, UP RCA Western Electric
WPRO-FM 1948	Ch. 222 (B) 92.3mc 20kw					
WRIB 1947	1220 250-D	R. I. Bcstg. Co. Narragansett Hotel Union 1-4512	Forioe	Frank Rao, Pres. Nicholas Ruggieri, Gen. Mgr. Anthony Petronella, Coml. Mgr.	Fabian Hume, Prog. Dir. & Prom. Mgr. Richard Buckley, Chief Engr.	Associated SESAC UP Raytheon
WESTERLY						
WERI 1949	1230 250	W. Paul Oury 34 Main St. 2263		W. Paul Oury, Pres. & Gen. Mgr. Phil Rubin, Sta. & Prom. Mgr.	Harry Nelson, Prog. Dir. James F. Nugro, Chief Engr.	Lang-Worth UP Raytheon
WOONSOCKET						
WWON 1946	1240 250	Associated Electronics Corp. 99 Main St. 3900	MBS Yankee	Garo W. Ray, Pres. & Treas. Mitchell F. Stanley, Sta. & Coml. Mgr.	Gene Rousseau, Prod. Mgr. George Travis, Chief Engr.	Standard World AP
WWON-FM (CP)	Ch. 288 (A) 105.5mc 0.39kw					

SOUTH CAROLINA

AIKEN						
WNCA 1949	740 1,000-D	Aiken-Augusta Bcstg. Co. Inc. Greenwood Bank Bldg. 332		J. D. Meehan, Pres. Rutledge Anderson, Mgr. Sam Steiner, Adv. Mgr.	Jane Kennedy, Prog. Dir. Louis Howard, Chief Engr.	Capitol INS Raytheon
ANDERSON						
WAIM 1935	1230 250	Wilton E. Hall Martin St. 800	CBS Burn-Smith	Wilton E. Hall, Pres. Glenn P. Warnock, Gen. Mgr. Charles B. Goodyear, Coml. Mgr.	Bette Warnock, Prog. Dir. G. Paul Browne, Prom. Mgr. H. B. Jack Greene, Chief Engr. INS Western Electric World Associated
WCAC (FM) 1947	Ch. 268 (B) 101.1mc 41kw	(WAIM, AM affiliate)				
WANS 1949	1280 1,000-D	Carolina Bcstrs. P. O. Box 211 3262		J. J. Powell, Pres. & Gen. Mgr. Alfred Robinson, Coml. & Prom. Mgr. & Prog. Dir.	Charles Mewborn, Chief Engr.	Standard UP Western Electric
BENNETTSVILLE						
WBSC 1947	1400 250	Bennettsville Bcstg. Co. 212 Broad St. 780	MBS McGillvra	John W. Orvin, Pres. Malcolm A. Young, Gen. & Coml. Mgr.	Don Bridges, Prog. Dir. & Prom. Mgr. John Gronert, Chief Engr. AP RCA
CAMDEN						
WACA 1948	1590 1,000-D	Camden Bcstg. Corp. Camden 80	KBS McGillvra	Haygood S. Bowden, Pres. Paul F. Myhan, Gen. Mgr. Tom Richards, Coml. Mgr.	John L. McWhorter, Prog. Dir. & Prom. Mgr. Edward Morris, Chief Engr.	Standard UP Gates
CHARLESTON						
WCSC 1930	1390 5,000 DA-N	WCSC Inc. Francis Marion Hotel 7611	CBS Free & Peters	John M. Rivers, Pres. & Gen. Mgr. Roland Weeks, Coml. Mgr. Russell Long, Prog. Dir.	Pearl Baum, Prom. Mgr. Wilbur R. Albee, Chief Engr.	World UP Westinghouse REL
WCSC-FM 1948	Ch. 245 (B) 96.9mc 36kw					
WHAN 1947	1340 250	Charleston Bcstg. Co. 152 Market St. 3-1643	ABC Burn-Smith	S. Lewis Johnson, Pres. C. Wylie Calder, Gen. & Coml. Mgr.	Vernon M. Bushong, Prog. Dir. & Prom. Mgr. William P. Birchfield, Chief Engr.	Lang-Worth UP RCA
WPAL 1947	730 1,000-D	Palmetto Bcstrs. 149 Wentworth St. 3-6428	IMS	George G. Weiss, Senior Partner Laurens P. Moore, Partner & Gen. Mgr. Robert T. Chrystie, Coml. Mgr.	Robert V. Austin, Prog. Dir. Jim Reynolds, Prom. Mgr. Carlton J. Modlin, Chief Engr.	Thesaurus UP Collins
WTMA 1939	1250 5,000-LS 1,000-N DA	Atlantic Coast Bcstg. Co. 133 Church St. 2-2961	NBC Hollingbery	Edward Manigault, Pres. Robert E. Bradham, Gen. Mgr. William N. Abbott, Prog. Dir. & Prom. Mgr.	Grange C. Cuthbert Jr., Coml. Mgr. Douglass M. Bradham, Asst. Mgr. & Chief Engr.	Associated AP Westinghouse
WTMA-FM 1947	Ch. 236 (B) 95.1mc 49kw					
WUSN 1948	1450 250	Southern Bcstg. Co. Inc. P. O. Box 154 2-2652	MBS Cooke	C. Norwood Hastie, Pres. Beverly M. Middleton, V.P. & Gen. Mgr.	J. Drayton Hastie, Coml. Mgr. Henry Hoppe, Prog. Dir. Walter M. Nelson, Chief Engr.	Associated UP Raytheon
CHESTER						
WGCD 1948	1490 250	Craig Bcstg. Co. Radio-Press Bldg. 1171	MBS McGillvra	M. J. Craig, Pres., Gen. & Coml. Mgr. Arthur Cornwall, Prog. Dir.	James Kennedy, Prom. Mgr. Morton E. Green, Chief Engr.	Capitol AP General Electric

DA-N Directional Antenna, night only. FM's in italic.
DA-1 Directional Antenna, same pattern day and night.
DA-2 Directional Antenna, different pattern day and night.

*—Non-Commercial Station. D—Day. N—Night. ST—Share Time. SH—Specified Hours.
U—Unlimited. CP—Construction Permit Issued. LS—Local Sunset.
L—Limited Time with Dominant Station. SA—Special Authorization.

WIS, COLUMBIA, IS THE TOP STATION IN SOUTH CAROLINA!

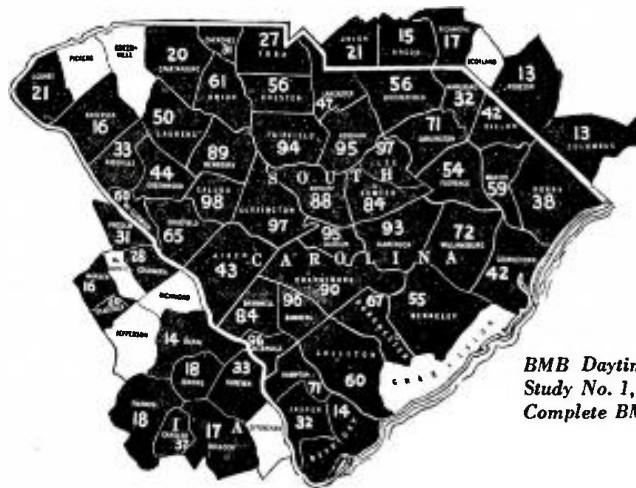

*BMB Daytime Audience.
Study No. 1, 1946
Complete BMB reprint on request.*

If you want *complete* coverage in South Carolina, you'll have to utilize the facilities of three radio stations.

But if you want the greatest coverage obtainable with *one* station, you'll choose WIS in Columbia.

BMB (March, 1946) credits WIS with a regular daytime audience in 43 of South Carolina's 46 counties . . . more counties than the combined total of *any two* other South Carolina stations. On WIS alone you reach more South Carolina families (daytime)—than the total of any station in Greenville and Charleston *combined*—57% more on WIS than on any other South Carolina station.

And in addition to this South Carolina coverage, WIS offers you a BMB audience in 15 Georgia and North Carolina counties as well!

The Columbia Trading Area includes 20 counties; the next largest are Greenville with 7, Charleston with 6 (B.B.D. & O.).

WIS is 5,000 watts at 560 kc. and NBC. There is no station with more than 1,000 watts within approximately 80 miles. In short, WIS is South Carolina's **FIRST STATION**—*individually, or on any list.*

WIS COLUMBIA, S. C.
5000 WATTS • 560 KC
NBC Affiliate

Plus WIS-fm

G. Richard Shafto, General Manager
J. Dudley Saumenig, Managing Director

FREE & PETERS, INC., National Representatives



DIRECTORY OF AM, FM, and TV STATIONS OF THE UNITED STATES

*(Data corrected to December 6, 1949)
If executives or services for FM or TV stations are same as AM affiliate names are not repeated.*

SOUTH CAROLINA—(Continued)

City Call Letters Established	Chan. or Freq. Power	Name of Licensee Headquarters Address Telephone Number	Network Representative	Executive Personnel	Transc. Library News Service Transmitter Make	
GEORGETOWN						
WGTV 1949	1400 250	Georgetown Bcstg. Co. 216 Fraser St. 621		Dr. John Assey Jr., Pres. H. Tom Morris, Gen. & Coml. Mgr.	Joe Maurice, Prog. Dir. Tom Richardson, Chief Engr.	Lang-Worth UP
GREENVILLE						
WESC 1947	660 5,000-D	Greenville Bcstg. Co. 1 College St. 2-8241	MBS, LBS McGillvra	Scott Russell, Pres. & Gen. Mgr. Cliff W. Bowers, Coml. Mgr.	Arthur H. Roberts, Prog. Dir. Lewis Elias, Chief Engr.	Lang-Worth Associated AP Raytheon
WESC-FM 1948	Ch. 223 (B) 92.5mc 12kw					Gates
WFBC 1933	1330 5,000 DA-N	Greenville-News Piedmont Co. Poinsett Hotel Bldg. 2-7616	NBC Avery-Knodel	B. H. Peace, Pres. B. T. Whitmire, Gen. Mgr. R. Q. Glass Jr., Coml. Mgr.	Newton Smyth, Prog. Dir. N. P. Mitchell, Prom. Mgr. William Garrison, Chief Engr.	Thesaurus UP RCA
WFBC-FM 1948	Ch. 229 (B) 93.7mc 240kw					Westinghouse
WMRC 1940	1440 5,000 DA-2	Textile Bcstg. Co. Prevost Bldg. 3-2751	ABC Burn-Smith	Robert A. Jolley Sr., Pres. Guy Zwalen, Gen. Mgr. Clifford B. Denison, Coml. Mgr.	William T. Arrington, Prog. Dir. George D. Tate, Chief Engr.	World SESAC AP Collins
WMRC-FM 1947	Ch. 235 (B) 94.9mc 79kw					Federal
WMUU 1949	1260 1,000 D	Bob Jones U. Greenville		Dr. Bob Jones Jr., Pres. R. K. Johnson, Gen. Mgr. Robert Pratt, Sta. Mgr.	Julia Boyajian, Prog. Dir. Don C. Smith, Chief Engr.	Associated INS Collins
GREENWOOD						
WCBS 1941	1450 250	Greco Inc. P. O. Box 868 4300	NBC McGillvra	Douglas Featherstone, Pres. Dan Crosland, Gen. & Prom. Mgr.	Ralph Norman, Coml. Mgr. Randy Davidson, Prog. Dir. Charles M. Sparks, Chief Engr.	Capitol AP
WCBS-FM 1948	Ch. 239 (B) 95.7mc 8.6kw					Westinghouse
GREER						
WEAB 1949	800 250-D	E. A. Burch & W. R. Frier Greer 1057		E. A. Burch { W. R. Frier { Co-owners	Sam H. Hutchins, Gen., Coml. & Prom. Mgr. & Prog. Dir. Robert D. Webb, Chief Engr.	Lang-Worth UP Gates
HARTSVILLE						
WHSC 1946	1450 250	Hartsville Bcstg. Co. Inc. College Ave. 654	MBS	Charles H. Campbell, Pres. Raymond Caddell, Gen. Mgr.	Earl Caton, Prog. Dir. & Prom. Mgr. Donald A. Brienen, Chief Engr.	Capitol AP Raytheon
KINGSTREE						
WDKD 1949	1300 1,000-D	Palmetto Bcstg. Co. Kingstree 6761		M. L. Few E. G. Robinson Jr. } Partners George C. Blackwell, Gen. & Coml. Mgr.	Thomas B. Williams Jr., Chief Engr.	Lang-Worth INS Gates
LAURENS						
WLBG 1948	860 250-D	WLBG Inc. P. O. Box 642 2-2331	KBS	John Wells Todd, Pres. John F. Arrington Jr., Gen. & Coml. Mgr.	Len L. Ledford, Prog. Dir. Clyde McClure, Chief Engr.	UP Raytheon
MULLINS						
WJAY 1949	1280 1,000-D	Mullins & Marion Bcstg. Co. P. O. Box 41 3901		W. H. Daniel Jr., Pres. W. G. Smith, Coml. Mgr. W. L. Harrelson, Gen. Mgr.	James O. Atkins, Prog. Dir. Jack Ikner, Chief Engr.	Lang-Worth UP Raytheon
WJAY-FM (CP)	Ch. 240 (A) 95.9mc 0.8kw					
MYRTLE BEACH						
WMRA 1948	1450 250	Myrtle Beach Bcstg. Co. Myrtle Beach 137	McGillvra	P. T. Watson, Pres. L. B. Hyman, V.P. & Secy.-Treas. A. E. Sink Jr., Gen. & Prom. Mgr.	S. W. Monroe, Coml. Mgr. Fae Marble, Prog. Dir. Lawrence Martin, Chief Engr.	Capitol AP Gates
NEWBERRY						
WKDK 1946	1240 250	Newberry Bcstg. Co. Inc. 11 Radio Drive 143	MBS KBS	John F. Clarkson, Pres. James F. Coggins, Gen. & Coml. Mgr.	Jim Brownell, Prog. Dir. & Prom. Mgr. Ray Gilliam, Chief Engr.	World AP Raytheon
ORANGEBURG						
WRNO 1946	1450 250	WRNO Inc. Orangeburg 1420	MBS	Charles S. Henercy, Pres. Frank B. Best, Gen. Mgr. Frank B. Best Jr., Coml. Mgr.	James A. Armistead, Prog. Dir. Gus Browning, Chief Engr.	Capitol AP RCA
WTND 1948	1270 1,000-D	Sims Pub. Co. Orangeburg 1600	Continental	J. I. Sims, Pres. G. L. Sims, Gen. Mgr.		Associated Lang-Worth UP RCA
ROCK HILL						
WRHI 1944	1340 250	York County Bcstg. Co. Rock Hill Nat'l Bank Bldg. 2085	MBS, KBS	James S. Beaty Jr. } William C. Beaty } Owners Harper S. Gault } James S. Beaty Jr., Gen. Mgr. & Chief Engr.	William S. Beaty, Sta. Mgr. & Prog. Dir. Harper S. Gault, Prom. Mgr.	World AP RCA
WRHI-FM 1948	Ch. 248 (B) 97.5mc 9.4kw					General Electric
WTYC 1949	1150 1,000-D	Tri-County Bcstg. Co. Rock Hill 3175		W. G. Reid O. Frank Thornton } Owners George P. Cobb, Gen. Mgr.	William P. Linde, Prog. Dir. Thomas L. Byrd, Chief Engr.	Lang-Worth UP Gates
SENECA						
WSNW 1949	1150 1,000-D	Blue Ridge Bcstg. Co. Inc. Seneca 8234		J. A. Gallimore, Pres., Gen. & Coml. Mgr. Thomas J. Whittaker, Prog. Dir.	Chet Munson, Prom. Mgr. Robert W. Mahoney, Chief Engr.	Lang-Worth SESAC UP Gates

DA-N Directional Antenna, night only. FM's in italic.
DA-1 Directional Antenna, same pattern day and night.
DA-2 Directional Antenna, different pattern day and night.

*—Non-Commercial Station. D—Day. N—Night. ST—Share Time. SH—Specified Hours.
U—Unlimited. CP—Construction Permit Issued. LS—Local Sunset.
L—Limited Time with Dominant Station. SA—Special Authorization.



now, let's sum it up...

In New England's rich, second largest market,
radio's largest, most active audience
listens . . . week after week, month after month,
season after season . . . to

WPRO
BASIC . . . **CBS** PROVIDENCE
630KC • 5000 WATTS

Represented by Raymer



DIRECTORY OF AM, FM, and TV STATIONS OF THE UNITED STATES

(Data corrected to December 6, 1949)
If executives or services for FM or TV stations are same as AM affiliate names are not repeated.

SOUTH CAROLINA—(Continued)

City Call Letters Established	Chan. or Freq. Power	Name of Licensee Headquarters Address Telephone Number	Network Representative	Executive Personnel	Transc. Library News Service Transmitter Make	
COLUMBIA						
WCOS 1939	1400 250	Radio Columbia Inc. 1202 Main St. 2-5601	ABC Taylor-Borroff	Ernest D. Black, Pres. James W. Hicks, Gen. Mgr. Dixon Harp, Coml. Mgr.	Stewart Spencer, Prog. Dir. Robert D. Lambert Jr., Chief Engr.	World AP RCA
WIS 1930	560 5,000 DA-N	Surety Life Insurance Co. Columbia 2-2135	NBC Free & Peters	Herman N. Hipp, Pres. G. Richard Shafto, Gen. Mgr. J. Dudley Saumenig, Mngng. Dir.	Frank Harden, Prog. Dir. Steve Libby, Prom. Mgr. Herbert G. Eidson Jr., Chief Engr.	Standard UP Western Electric
WIS-FM 1948	Ch. 233 (B) 94.5mc; 1.3kw					
WKIX 1945	1320 1,000-LS 500-N DA	Inter-City Advertising Co. 1127 Lady St.; 2-8659	CBS Avery-Knodel	George W. Dowdy, Pres. W. C. Bochman, Gen. Mgr.	R. E. Fennel, Prog. Dir. Eugene E. Hampton, Chief Engr.	Lang-Worth UP Collins
WNOK 1947	1230 250	Palmetto Radio Corp. Hotel Jefferson 2-1518	MBS Forjoe	Moody McElveen, Gen. Mgr.	Donald E. Willoughby, Chief Engr. AP RCA
CONWAY						
WLAT 1945	1490 250	Loys M. Hawley & Herman L. Hanks P. O. Box 497 340	MBS McGillvra	Loys M. Hawley, Pres., Gen. & Coml. Mgr.	Herman L. Hanks, Chief Engr. AP
DILLON						
WDSC 1946	800 1,000-D	Border Bcstg. Co. U. S. Highway 301 470	MBS McGillvra	Joseph Martin, Gen. Mgr. R. B. Marshall, Coml. Mgr.	William J. Bunn, Prog. Dir. Mack Herring, Chief Engr.	Thesaurus UP Gates
FLORENCE						
WJMX 1948	970 5,000-D	Atlantic Bcstg. Co. P. O. Box 1211 2495	Walker	Eugene E. Stone, Pres. Paul H. Benson Jr., Gen. & Prom. Mgr.	H. A. Smith Jr., Coml. Mgr. Sam I. Latimer, Prog. Dir. Frank A. Jenne, Chief Engr.	World, Capitol Associated AP Westinghouse
WJMX-FM	Ch. 274 (B) 102.7mc; 11.5kw					
WOLS 1937	1230 250	Florence Bcstg. Co. 129 S. Dargan St. 354	ABC	Melvin Purvis, Pres. & Gen. Mgr. A. P. Skinner, Coml. & Asst. Mgr.	Jim Putnam, Prog. Dir. W. A. Pritchett, Chief Engr. & Asst. Mgr.	Lang-Worth UP
WOLS-FM (CP)	Ch. 291 (B) 106.1mc; 4.5kw					
GAFFNEY						
WFGN 1948	1570 250-D	Cherokee Radio Co. Inc. Box 297 1570	KBS	A. Ray Godshall, Pres. Louis M. Neale Jr., Gen. Mgr. & Chief Engr.	David C. McSwain, Coml. Mgr. Vernon Fox, Prog. Dir. Norman Lassiter, Prom. Mgr.	Lang-Worth UP Raytheon

DA-N Directional Antenna, night only. FM's in italic. *—Non-Commercial Station. D—Day. N—Night. ST—Share Time. SH—Specified Hours.
DA-1 Directional Antenna, same pattern day and night. U—Unlimited. CP—Construction Permit Issued. LS—Local Sunset.
DA-2 Directional Antenna, different pattern day and night. L—Limited Time with Dominant Station. SA—Special Authorization.

These are RUBBER GLOVES
reaching out to industrial progress in Charleston.

Just as the Charleston Rubber Company
has doubled its payroll in the 18 months
since it began operating in Charleston,

so

WCSC

CBS Station in Charleston, South Carolina,
has grown to meet the demands of an increasing market.

CHARLESTON,
whose historic beauty attracts thousands of tourists,
has today achieved new importance
as an industrial and shipping center
where more than 100 new industries have developed
and port business has doubled.

AM—1390 KC WCSC FM—96.9 MC

5000 watts day and night

Represented nationally by Free & Peters, Inc.



WFBC

Reaches 876,900 People Who Annually Spend

\$ 1/2 BILLION

IN THESE RICH PIEDMONT COUNTIES!

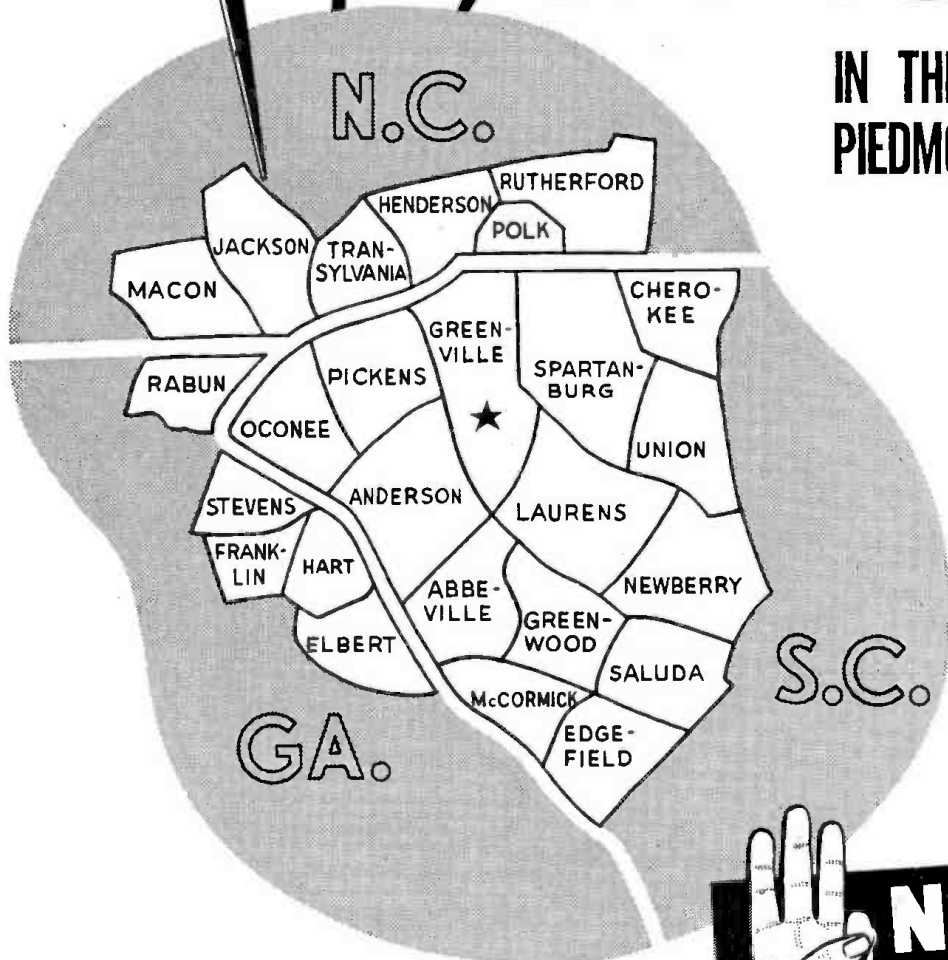

The WFBC Market, with Greenville as the center, embraces the textile industrial section of South Carolina and adjacent counties in North Carolina and Georgia. Population, sales, and incomes in this area are higher than state and regional averages, with *GAINS* for the past year in all three!

POPULATION

876,900 - - UP 2.7%

RETAIL SALES

\$507,606,000 - UP 1.4%

NET BUYING INCOME

\$730,202,000 - UP 3.8%

Figures from Sales Management Survey of Buying Power, 1949

WFBC Greenville's pioneer broadcasting station, enjoys prestige and popularity in this area which helps to tell your sales story and sell your product to an audience whose radio ownership closely approaches the national average of 94.2%.

ASK AVERY-KNODEL, INC. for the Latest Audience Measurement Figures

NBC FOR ALL THREE
GREENVILLE-SPARTANBURG-ANDERSON MARKETS

WFBC
and WFBC-FM
GREENVILLE, S.C.

5000 Watts 19 Hours Daily

THE NEWS-PIEDMONT STATION

DIRECTORY OF AM, FM, and TV STATIONS OF THE UNITED STATES

(Data corrected to December 6, 1949)
If executives or services for FM or TV stations are same as AM affiliate names are not repeated.

SOUTH CAROLINA—(Continued)

City Call Letters Established	Chan. or Freq. Power	Name of Licensee Headquarters Address Telephone Number	Network Representative	Executive Personnel	Transc. Library News Service Transmitter Make	
SPARTANBURG						
WORD 1940	1400 250	The Spartan Radiocasting Co. 291 East Main St. 6000 (WORD, AM affiliate)	ABC Taylor-Boroff	Walter J. Brown, Pres. John Carrington, Gen. Mgr. Joseph W. Parris, Coml. Mgr.	Alan R. Willis, Prog. Dir. & Prom. Mgr. Clyde Burdette, Chief Engr.	World AP RCA
WDXY (FM) 1948	Ch. 263 (B) 100.5mc 12kw					Westinghouse
WSPA 1930	950 5,000 DA-N	Surety Bcstg. Co. 224 E. Main St. 2900	CBS Blair	Francis M. Hipp, Pres. G. Richard Shafto, Gen. Mgr. Roger A. Shaffer, Mngng. Dir.	Guy Vaughan Jr., Coml. Mgr. Ed McGrath, Prog. Dir. Tom Fleming, Prom. Mgr. Harold R. Beckholt, Chief Engr.	Associated UP Western Electric
WSPA-FM 1946	Ch. 255 (B) 98.9mc 4.85kw					General Electric
SUMTER						
WFIG 1940	1340 250	WFIG Inc. Radio Center Bldg. 1340	MBS McGillivra	Hubert D. Osteen, Pres. T. Doug. Youngblood, Gen. Mgr. William H. Moore Jr., Coml. Mgr.	Paul Reidy, Prog. Dir. Harry Fowler, Prom. Mgr. James L. Williams, Chief Engr.	Lang-Worth UP RCA
UNION						
WBCU 1949	1460 1,000 DA-N	Union Carolina Bcstg. Co. 15 East Main St. 1200	MBS	E. H. Hughes, Pres. Milton D. Scarboro, Gen. Mgr. Howard Talbert, Coml. Mgr.	Marylyn Scruggs, Prog. Dir. Bill Strabling, Prom. Mgr. Thomas W. Weathers, Chief Engr.	Capitol UP RCA
WALTERBORO						
WALD 1947	1490 250	Walterboro Bcstg. Co. Walterboro 3861	MBS	R. M. Jefferies, Pres. Charles A. Thoman, Gen. Mgr. Beulah Glover, Coml. Mgr.	Hugh Ward, Prog. Dir. Willie O. Harbeson, Prom. Mgr. Robert Rivers, Chief Engr.	Associated AP Raytheon

SOUTH DAKOTA

ABERDEEN						
KSDN 1948	930 1,000 DA-1	Aberdeen News Co. 12 Third Ave. 4573	MBS South Dakota Weed	Henry J. Schmitt, Pres. Byron McElligott, Gen. Mgr. Russa Osborne, Coml. Mgr.	E. C. Pieplow, Prog. Dir. George Crocker, Chief Engr.	World Capitol AP Western Electric
DEADWOOD						
KDSJ 1947	1450 250	Heart of the Black Hills Station Deadwood 186	KBS Clark	John Daniels } Eli Daniels } Harry Daniels } Partners	Eli Daniels, Gen. Mgr. & Chief Engr.	SESAC World UP Do-Little

DA-N Directional Antenna, night only. FM's in italic. *—Non-Commercial Station. D—Day. N—Night. ST—Share Time. SH—Specified Hours. DA-1 Directional Antenna, same pattern day and night. U—Unlimited. CP—Construction Permit Issued. LS—Local Sunset. DA-2 Directional Antenna, different pattern day and night. L—Limited Time with Dominant Station. SA—Special Authorization.

AVERAGE 5-YEAR CASH INCOME PER FARM, 1944-48

National Rank

1. IOWA
2. NORTH DAKOTA
3. NEBRASKA
4. SOUTH DAKOTA
7. MINNESOTA

That's Big Aggie!

1948 RETAIL SALES PER FAMILY

National Rank

1. NORTH DAKOTA
2. SOUTH DAKOTA
5. MINNESOTA
6. IOWA
8. NEBRASKA

That's Big Aggie!

U.S.D.A. BUREAU OF AG. EC.
1949 Sales Management Survey of Buying Power

REPRESENTED BY KATZ

BIG AGGIE

Serves 308 Counties in the World's Richest Agricultural Area

Big Aggie Land is a unified major market in Minnesota, the Dakotas, Nebraska and Iowa served only by WNAX. Today 385,840 BMB radio families will listen to WNAX . . . will buy WNAX-advertised products.

A 1948 diary study made in 80 counties representing the five states showed, of the 43 stations mentioned, listeners liked WNAX best 94.7% of all daytime quarter hours—78.9% of all evening quarter hours.

Make the WNAX market your market.

WNAX

A Cowles Station
SIOUX CITY • YANKTON
Affiliated with the American Broadcasting Co.
5000 WATTS — 570 KC



City Call Letters Established	Chan. or Freq. Power	Name of Licensee Headquarters Address Telephone Number	Network Representative	Executive Personnel	Transc. Library News Service Transmitter Make
HURON					
KIUV 1947	1340 250	James Valley Bcstg. Co. Inc. 32 2d St. S. E. 765	MBS	Max F. Staley, Pres. & Gen. Mgr. Rex King, Coml. Mgr.	Morrison Parker, Prog. Dir. Roland Marty, Chief Engr. Thesaurus UP
MITCHELL					
KORN 1947	1490 250	Mitchell Bcstg. Assn. 217-19 North Main 621	MBS South Dakota	Ray Eppel, Pres., Gen. Mgr. & Prog. Dir. Robert G. Taylor, Chief Engr.	B. Harland Ohde, Coml. & Prom. Mgr. Lang-Worth UP Western Electric
PIERRE					
KGFX 1916	630 200-D SH	Estate of Dana McNeil 203 West Summit Ave. 2351	KBS Continental	Ida A. McNeil, Gen., Coml. & Prom Mgr. & Prog. Dir.	Charles W. Hobbs, Chief Engr. UP
RAPID CITY					
KOTA 1936	1380 5,000 DA-N	B. H. Bcst. Co. of Rapid City Alex Johnson Hotel 2000	CBS	Robert J. Dean, Pres. & Gen. Mgr. Stan Lieberman, Coml. Mgr. Floyd L. Sparks, Prog. Dir.	Ellen Crilly, Prom. Mgr. A. E. Griffiths, Chief Engr. Capitol, Standard Associated, World UP, RCA
KOTA-FM 1949	Ch. 232 (B) 94.7 mc 16 kw				
*WCAT 1922	1230 100-D SH	School of Mines and Technology 500 East Saint Joseph St. 1603		Warren E. Wilson, Pres. W. Ferron Halvorson, Gen. Mgr., Dir. of Pub. Rela. & Prog. Dir.	Wallace E. Wells, Chief Engr. AP, UP
SIOUX FALLS					
KELO 1937	1320 5,000 DA-N	Midcontinent Bcstg. Co. 8th & Phillips Ave. 6363	NBC Pearson	S. Fantle Jr., Pres. and Gen. Mgr. Evans A. Nord, Coml. Mgr. Jack Douglas, Prog. Dir.	Darlene Nesby, Prom. Mgr. Lester C. Froke, Chief Engr. Capitol UP RCA
KIHO 1948	1270 1,000 DA-1	Big Sioux Bcstg. Co. 218 South Main Ave. 912	MBS Raymer	James E. Sweet & David J. Kempkes, Co-Mgrs.	Fred Schweikher, Prog. Dir. World UP
KISD 1948	1230 250	KISD Inc. 311 S. Phillips Ave. 1300	Cooke	Howard C. Alton, Pres. Verl Thomson, Gen. Mgr. & Prog. Dir. Fred Davis, Coml. Mgr.	John Doyle, Prom. Mgr. Bruce Brodie, Chief Engr. Lang-Worth MacGregor AP RCA
KSOO 1927	1140 5,000 L-WRVA	Sioux Falls Bcst. Assoc. Inc. 317½ South Phillips Ave. 757	Tall Corn Avery-Knodel	Morton H. Henkin, Pres. Geo. R. Hahn, Gen. Mgr. Rollie R. Williams, Gen. Sales Mgr.	Raymond L. Loftesness, Prog. Dir. George Rohn, Prom. Mgr. Max E. Pierce, Chief Engr. Standard Thesaurus AP
VERMILLION					
*KUSD 1922	920 500 ST-KFNF	U. of South Dakota Vermillion 601 J		I. D. Weeks, Pres. Irving R. Merrill, Gen. Mgr. Keith J. Nighbert, Prog. Dir.	Shirley Enquist, Prom. Mgr. James L. Cope, Chief Engr. AP
WATERTOWN					
KWAT 1926	950 1,000 DA-N	Midland Nat'l Life Insurance Co. Watertown 777		Frank Bramble, Pres. Thomas L. Young, Gen. Mgr. Morris Wisott, Coml. Mgr.	Charles H. Swenson, Prog. Dir. Ross E. Case, Prom. Mgr. Francis Alwin, Chief Engr. World SESAC UP Collins
YANKTON					
WNAX 1926	570 5,000 DA-N	Cowles Bcstg. Co. 2d & Capitol Sts. 442	ABC, MBS Katz	Gardner Cowles, Pres. Robert R. Tinchler, V. P. & Gen. Mgr. Donald D. Sullivan, Coml. Mgr.	L. S. Howard, Prog. Dir. Robert B. Donovan, Prom. Mgr. Clifton M. Todd, Chief Engr. Standard Cole AP, UP General Electric

TENNESSEE

ATHENS					
WJAR 1946	1450 250	Athens Bcstg. Co. N. Jackson St. 891	KBS	Lowell F. Arterburn, Pres. Otis Parker, Gen. Mgr. Max Robinette, Coml. Mgr.	James O'Donnell, Prog. Dir. J. W. Turner, Chief Engr. Standard UP
BRISTOL					
WOPI 1929	1490 250	Radiophone Bcstg. Sta- tion WOPI Inc. 310 State St. South 3730	NBC Burn-Smith	W. A. Wilson, Pres. & Gen. Mgr. Jim C. Wilson, Coml. Mgr. Harold Henley, Prog. Dir.	Jane Glavin, Prom. Mgr. R. V. Robinson, Chief Engr. Lang-Worth Capitol UP RCA
WOPI-FM 1946	Ch. 245 (B) 96.9mc 10.4kw				
CHATTANOOGA					
WAGC 1946	1450 250	Tennessee Valley Bcstg. Co. Patten Hotel 7-1128	MBS Rambeau	A. B. Campbell, Gen. Mgr. H. Dennison Parker, Coml. Mgr.	June T. Lewis, Traffic Dir. Charles W. Stokley, Chief Engr. Lang-Worth AP Collins
WAPO 1936	1150 5,000-LS 1,000-N DA	WAPO Bcstg. Service Read House 6-8141	NBC Headley-Reed	Ramon G. Patterson & Louise P. Pursley, Owners R. G. Patterson, Gen. Mgr. Frances Harley, Prog. Dir.	Helen Patterson, Coml. & Prom. Mgr. B. B. Barnes, Chief Engr.
WAPO-FM 1946	Ch. 234 (B) 94.7mc 37.2kw				
WDEF 1940	1370 5,000-LS 1,000-N DA	WDEF Bcstg. Co. 419 Volunteer Bldg. 6-5664	ABC Branham	Joe W. Engel, Pres. Ken Flenniken, Gen. & Coml. Mgr.	Morris Quave, Prog. Dir. & Prom. Mgr. B. C. Baker, Chief Engr. Raytheon Capitol UP RCA
WDOD 1925	1310 5,000 DA-N	WDOD Bcstg. Corp. Hamilton Nat'l Bank Bldg. 6-5117	CBS Raymer	Earl W. Winger, Pres. Norman A. Thomas, V. P. Bryan J. Bush, Coml. Mgr.	Paul Wann, Prog. Dir. Walter H. Stamper Jr., Prom. Mgr. W. Roy Owens, Chief Engr. Standard UP Federal
WDOD-FM 1949	Ch. 243 (B) 96.5mc 42kw				
WDXB 1948	1490 250	J. V. Williams Jr. 539 Vine St. 6-1114	Forjoe	J. V. Williams Jr., Pres. Charles H. Gullickson, Gen. & Coml. Mgr.	Frank Beck, Prog. Dir. Byron E. Fincher, Chief Engr. World INS Raytheon
WVUN (FM) 1948	Ch. 251 (B) 98.1mc 42kw	Unity Bcstg. Corp. 100 Dome Bldg. 7-4463		John S. Martin, Pres. J. Stegel, Prog. Dir.	Jim Byerly, Chief Engr. Associated AP RCA
CLARKSVILLE					
WJZM 1941	1400 250	E. T. Campbell 411 Madison St. 2295	MBS, KBS Tennessee Rural Radio	E. T. Campbell, Pres. & Gen. Mgr. Tom Brooks-Pilling, Coml. Mgr.	Clay Cline Jr., Prog. Dir. & Prom. Mgr. John Bailey, Chief Engr. Capitol AP RCA
CLEVELAND					
WBAC 1945	1340 250	Robert W. Rounsaville 180 Central Ave. 62	MBS	Robert W. Rounsaville, Owner Thad F. Fitch, Sta. Mgr.	Harry W. Sullivan, Prog. Dir. William Stuart, Chief Engr. UP RCA

DA-N Directional Antenna, night only. FM's in italic.
DA-1 Directional Antenna, same pattern day and night.
DA-2 Directional Antenna, different pattern day and night.

*-Non-Commercial Station. D-Day. N-Night. ST-Share Time. SH-Specified Hours.
U-Unlimited. CP-Construction Permit Issued. LS-Local Sunset.
L-Limited Time with Dominant Station. SA-Special Authorization.

BROADCASTING • Telecasting

1950 Yearbook Number • Page 275

DIRECTORY OF AM, FM, and TV STATIONS OF THE UNITED STATES

(Data corrected to December 6, 1949)
 If executives or services for FM or TV stations are same as AM affiliate names are not repeated.

TENNESSEE—(Continued)

City Call Letters Established	Chan. or Freq. Power	Name of Licensee Headquarters Address Telephone Number	Network Representative	Executive Personnel	Transe. Library News Service Transmitter Make	
COLUMBIA						
WKRM 1946	1340 250	Middle Tennessee Bcstg. Co. Inc. P. O. Box 71 1340	MBS, KBS Tennessee	R. M. McKay Jr., Pres., Gen. Coml. & Prom. Mgr.	Albert Knott, Prog. Dir. Revis Hobbs, Chief Engr.	Capitol UP Raytheon
COOKEVILLE						
WHUB 1940	1400 250	WHUB Inc. Cookeville 200	CBS Continental	M. L. Medley, Pres., Gen. Mgr. & Coml. Mgr. Joe Mabry, Prog. Dir.	Stacey Mott, Prom. Mgr. George Daugherty, Chief Engr.	Lang-Worth UP RCA
DYERSBURG						
WDSG 1946	1450 250	State Gazette Bcstg. Co. P. O. Box 58 77	MBS, KBS Dixie Mid-South	Frank Armstrong, Gen. Mgr. Charles R. Bowen, Coml. Mgr.	Norb Beckers, Prog. Dir. & Prom. Mgr.	AP RCA
ELIZABETHTON						
WBEJ 1946	1240 250	Elizabethton Bcstg. Co. P. O. Box 829 21241	MBS	R. W. Rounsaville, Pres. William R. Wagner, Gen. Mgr.	Ruth Ritchie, Prog. Mgr. Condon Bowers, Chief Engr.	UP Raytheon
FAYETTEVILLE						
WEKR 1948	1240 250	Elk River Bcstrs. Inc. Fayetteville 1240	MBS	Arthur D. Smith Jr., Pres. & Gen. Mgr. Hollis Carlton, Sta. Mgr.	Mike Freeland, Prog. Dir. & Prom. Mgr. Ernest Tucker, Chief Engr.	UP Raytheon
GALLATIN						
WHIN 1948	1010 1,000-D	Sumner County Bcstg. Co. Inc. P. O. Box 28 1010		A. B. Perkins, Pres. Charles W. Brewer, Gen. & Coml. Mgr.	Weston Britt, Prog. Dir. Howard Woodard, Chief Engr.	Capitol UP Western Electric
GREENEVILLE						
WGRV 1946	1340 250	Radio Greeneville Inc. Radio Bldg. 797	MBS	Paul O. Metcalfe, Pres. & Gen. Mgr. Hugh Pickel, Coml. & Prom. Mgr.	Tom Lyons, Prog. Dir. Laile Hampton, Chief Engr.	UP Raytheon
HARRIMAN						
WHBT 1946	1230 250	Harriman Bcstg. Co. Devonia at Crescent 850	MBS, KBS	F. L. Crowder, Pres., Gen. & Coml. Mgr. John Fielder, Prog. Dir.	Carl Williams, Prom. Mgr. Kenneth Hargis, Chief Engr.	Standard UP Gates

DA-N Directional Antenna, night only. FM's in italic. *—Non-Commercial Station. D—Day. N—Night. ST—Share Time. SH—Specified Hours.
 DA-1 Directional Antenna, same pattern day and night. U—Unlimited. CP—Construction Permit Issued. LS—Local Sunset.
 DA-2 Directional Antenna, different pattern day and night. L—Limited Time with Dominant Station. SA—Special Authorization.

**IF YOU'RE IN TV
 You should be in Memphis**

WMCT

WMC • WMCF • WMCT

CHANNEL 4 • MEMPHIS
 AFFILIATED WITH NBC • CBS • DUMONT

National Representatives • The Branham Company • Owned and Operated by The Commercial Appeal

City Call Letters Established	Chan. or Freq. Power	Name of Licensee Headquarters Address Telephone Number	Network Representative	Executive Personnel	Transc. Library News Service Transmitter Make	
HUMBOLDT						
WIRJ 1949	740 250-D	Gibson County Bcstg. Co. Inc. 210 North 22nd Ave. 740	Mid-South	J. Frank Warmath & Thomas N. Hobbs, Partners Guy Powell, Coml. Mgr.	Howard E. Byrum, Gen. Mgr. & Prog. Dir. Charles Brown, Chief Engr.	Standard UP Collins
JACKSON						
WDXI 1948	1310 5,000-LS 1,000-N DA	Aaron B. Robinson Williams Bldg. 7-9611	MBS, KBS Dixie Burn-Smith	Aaron B. Robinson, Pres. Bill Winsett, Sta. Mgr. Jack Cecil, Coml. Mgr.	Jim Hoppers, Prog. Dir. Jack Murphy, Prom. Mgr. James Thomas, Chief Engr.	Capitol UP Raytheon
WPLI 1949	1490 250	George Arthur Smith First Nat'l. Bank Bldg. 7-8541	McGillvra	W. E. Williams, Gen. & Prom. Mgr.		Associated Lang-Worth UP
WTJS 1931	1390 1,000 DA-N	Sun Pub. Co. Jackson 7-3316	ABC Midsouth Branham	Albert A. Stone, Pres. Frank S. Proctor, Mgr.	Leslie R. Brooks Jr., Asst. Mgr. Robert M. Gordon, Chief Engr.	World AP, UP RCA
WTJS-FM 1947	Ch. 264 (B) 100.7mc 50kw					
JOHNSON CITY						
WETB 1947	790 1,000-D	East Tennessee Bcstg. Co. Press Bldg. 2993	KBS, LBS	Carl A. Jones Jr., Pres. Cliff Goodman, Gen. Mgr.	Berney Burleson, Prog. Dir. & Asst. Mgr. E. B. Jones, Chief Engr.	World Capitol AP Raytheon
WJHL 1938	910 5,000-LS 1,000-N DA	WJHL Inc. Main St. 1480	ABC Pearson	W. H. Lancaster, Pres. Ray D. Williams, Mgr. & Coml. Mgr.	Walter Heeb, Prog. Dir. Ken Matthews, Prom. Mgr. O. K. Garland, Chief Engr.	Lang-Worth AP, UP
WJHL-FM 1948	Ch. 264 (B) 100.7mc 0.25kw					General Electric
KINGSPORT						
WKPT 1940	1400 250	Kingsport Bcstg. Co. 222 Commerce St. 2870	NBC Cooke	C. P. Edwards Jr., Pres. A. F. Martin, Gen. Mgr.	Paul Overbay, Prog. Dir. Thomas Phillips, Chief Engr.	AP Western Electric
WKPT-FM 1946	Ch. 253 (B) 98.5mc 44kw					Lang-Worth Standard RCA
KNOXVILLE						
WBIR 1941	1240 250	Radio Station WBIR Inc. 618 S. Gay St. 4-3321	ABC Bolling	Gilmore N. Nunn, Pres. John P. Hart, Gen. Mgr. James A. Dick, Coml. Mgr.	Tys Terwey, Prog. Dir. & Prom. Mgr. J. Rex Horton, Chief Engr.	Standard UP RCA
WBIR-FM 1949	Ch. 227 (B) 93.3mc 2.34kw					Western Electric
WIBK 1947	800 1,000-D	Independent Bcstg. Co. 406 W. Church St. 4-9866	KBS Cooke	Marvin I. Thompson, Gen. Mgr.	T. E. Hooper, Chief Engr.	Lang-Worth AP Raytheon

WHBQ-56

FIRST ON YOUR RADIO

MUTUAL in Memphis

Sales Center of the Mighty Memphis Market

WHBQ

Memphis, Tenn.

5,000 Watts Day • 1,000 Watts Night

Here Good Programming Gets Good Coverage

Facts of Interest to all Time Buyers—

- Population 1,720,600
- Buying Income \$1,435,382,000
- Radio Homes 361,377

For rates and availability
Call Wire or Write

WEED and COMPANY

WHBQ MEMPHIS, TENNESSEE • 560 KC • 5000 WATTS DAY
FRANK H. SMITHSON, Chief-Programs Engineer, Memphis, T. C.

DIRECTORY OF AM, FM, and TV STATIONS OF THE UNITED STATES

(Data corrected to December 6, 1949)
If executives or services for FM or TV stations are same as AM affiliate names are not repeated.

TENNESSEE—(Continued)

City Call Letters Established	Chan. or Freq. Power	Name of Licensee Headquarters Address Telephone Number	Network Representative	Executive Personnel	Transc. Library News Service Transmitter Make	
KNOXVILLE—(Continued)						
WKGN 1947	1340 250	WKGN Bcstg. Co. Park Nat'l. Bank Bldg. 4-0766	MBS Forjoe	Clarence Beaman, Pres. & Gen. Mgr. C. R. Watts, Coml. Mgr.	(Mrs.) Marge Trent, Prog. Dir. Lindsey Nelson, Prom. Mgr. Joe E. Broyles, Chief Engr.	Lang-Worth Capitol AP RCA
WNOX 1921	990 10,000 DA-N	Scripps-Howard Radio Inc. 110 S. Gay St.; 3-3171	CBS Branham	Jack R. Howard, Pres. R. B. Westergaard, Gen. Mgr. O. L. Smith, Coml. Mgr.	Charles McMahon, Prog. Dir. Para Lee Brock, Prom. Mgr. Ray Evans, Chief Engr.	Standard UP Western Electric
WROL 1927	620 5,000 DA-2	Stuart Bcstg. Co. 531 South Gay St. 2-7111	NBC Cummings	S. E. Adcock, Owner C. T. DeVois, Gen. Mgr. W. H. Linebaugh, Coml. Mgr.	John Reese, Prog. Dir. Fred M. Andrews, Chief Engr.	World UP RCA
WROL-FM 1945	Ch. 247 (B) 97.3mc 76kw				 REL
LEBANON						
WCOR 1949	900 250-D	Lebanon Bcstg. Co. Inc. 106½ Cumberland St. 1540		Warren G. Gilpin, Pres. & Gen. Mgr.	Roy E. Wood Jr., Coml. Mgr. Roy C. Crocker, Prog. Dir.	Standard UP Raytheon
LEWISBURG						
WJJM 1947	1490 250	Estate of James J. Murray East Hill 780	ABS Continental	Martha, Ida & Lillie Murray, Owners Louis D. Lingner, Gen. Mgr.	Harold W. Twitty, Coml. Mgr. Denny Walker, Prog. Dir. J. E. Sowell, Chief Engr. Collins
MARYVILLE						
WGAP 1947	1400 250-D	Gateway Bcstg. Co. Blount Nat'l. Bank 2490	KBS	V. H. McLean & George R. Dempster, Owners F. H. Corbett, Gen. Mgr. Tom Beam, Coml. Mgr.	Joe Wheeler, Prog. Dir. Sarah Miller, Prom. Dir. Curtis LaMarr, Chief Engr.	Lang-Worth UP
McMINNVILLE						
WMMT 1947	1230 250	McMinnville Bcstg. Co. Inc. P. O. Box 409 401	MBS, KBS Tennessee	Sam J. Albritton, Pres. Royce E. Richards, Gen. Mgr. Winston Clark, Coml. Mgr.	Ernie Richards, Prog. Dir. Henry Trent, Prom. Mgr. Walter A. Duke, Chief Engr.	World UP Raytheon
MEMPHIS						
WDIA 1947	730 250-D	Bluff City Bcstg. Co. 2074 Union Ave. 36-2703	Pearson	E. R. Ferguson & John R. Pepper, Partners Bert Ferguson, Gen. Mgr. John Cleghorn, Gen. Mgr. Bill Grumbles, Sales Prom. Dir. Gordon Lawhead, Prog. Dir.	Harold F. Walker, Coml. Mgr. Don Kern, Prog. Dir. Bob Sassaman, Chief Engr. Betty Faquin, Prom. Mgr. Welton Roy, Chief Engr. UP Gates
WHBQ 1925	560 5,000-LS 1,000-N DA-2	Harding College Hotel Gayoso 8-6868	MBS Weed	P. E. Furlow, Pres. Pat McDonald, Gen. Mgr. Don J. Lynch, Coml. Mgr.	Allan Avery, Prog. Dir. & Prom. Mgr. William Marsh, Chief Engr.	Associated AP RCA
WHHM 1946	1340 250	Mid-South Bcstg. Corp. Sterick Bldg. 37-4422	IMS			Capitol Lang-Worth AP RCA

DA-N Directional Antenna, night only. FM's in italic. DA-1 Directional Antenna, same pattern day and night. DA-2 Directional Antenna, different pattern day and night.
*—Non-Commercial Station. D—Day. N—Night. ST—Share Time. SH—Specified Hours.
U—Unlimited. CP—Construction Permit Issued. LS—Local Sunset.
L—Limited Time with Dominant Station. SA—Special Authorization.

If you're not using
WDIA,
YOU'RE MISSING
HALF*
THE MEMPHIS MARKET

*2 OUT OF 4 WHO ENTER A STORE
IN MEMPHIS ARE NEGROES

WDIA IS THE ONLY STATION SERVING
THIS HALF OF THE POPULATION

SPECIAL HOOPER STUDIES SHOW UP TO
75.6% SHARE OF AUDIENCE!

WDIA

MEMPHIS, TENNESSEE

BERT FERGUSON, GEN. MGR. ★ HAROLD F. WALKER, COM. MGR. ★ JOHN E. PEARSON CO., REP.

HOT ROD HULBERT

WILLA MONROE

SONNY BOY WILLIAMSON

REV. MOORE

THE SONGBIRDS OF THE SOUTH

NAT DEE WILLIAMS

BEE BEE KING

SPIRIT OF MEMPHIS SINGERS

THE SPOT IN MEMPHIS



Where
your
SPOTS
are
Spotlighted

WHHM

INDEPENDENT . . . But Not Aloof
MEMPHIS, TENNESSEE

Patt McDonald, Manager



Representatives: Independent Metropolitan Sales

DIRECTORY OF AM, FM, and TV STATIONS OF THE UNITED STATES

(Data corrected to December 6, 1949)
 If executives or services for FM or TV stations are same as AM affiliate names are not repeated.

TENNESSEE—(Continued)

City Call Letters Established	Chan. or Freq. Power	Name of Licensee Headquarters Address Telephone Number	Network Representative	Executive Personnel	Transc. Library News Service Transmitter Make	
MEMPHIS—(Continued)						
WHHM-FM 1949	Ch. 295 (B) 106.9mc 18kw					
WMC 1923	790 5,000 DA-N	Memphis Pub. Co. P. O. Box 311 8-7464	NBC Mid-South Branham	Enoch Brown, Pres. H. W. Slavick, Gen. Mgr. J. C. Eggleston, Coml. Mgr.	Wilson Mount, Prog. Dir. W. E. Frase, Prom. Mgr. E. C. Frase Jr., Chief Engr.	Thesaurus Lang-Worth SESAC UP RCA
WMCF (FM) 1947	Ch. 259 (B) 99.7mc 260kw	(WMC. AM affiliate)				
WMCT (TV) 1948	Ch. 4 66-72mc 7.12kw aur. 13.6kw vis.	(WMC. AM affiliate)	ABC, CBS DuMont NBC	Bill Brazzil, Prod. Mgr.	INS	
WMPS 1925	680 10,000-LS 5,000-N DA	WMPS Inc. Radio Center 5-2663	ABC Radio Reps	H. R. Krelstein, V. P. & Gen. Mgr. George Faulder, Prog. Dir.	W. B. Rudner, Prom. & Sales Mgr. J. G. Deaderick, Chief Engr.	Standard Lang-Worth Cole AF, UP RCA
WREC 1922	600 5,000 DA-2	WREC Bcstg. Service Hotel Peabody	CBS Katz	Hoyt B. Wooten, Owner & Gen. Mgr.	Hollis Wooten, Coml. Mgr.	
MORRISTOWN						
WCRK 1947	1450 250	Cherokee Bcstg. Corp. Morristown 1450	MBS Holman	Herbert S. Walters, Pres. Howell Ashford Jr., Gen. & Coml. Mgr.	William P. Moore, Prog. Dir. James R. Redden, Chief Engr.	World AF RCA
MURFREESBORO						
WGNS 1947	1450 250	WGNS Inc. P. O. Box 456 1450	MBS Tennessee Holman	Cecil Elrod Jr., Pres. & Gen. Mgr. Neil Lancaster, Coml. Mgr. James W. Tate, Prog. Dir.	Martha Tribble, Prom. Mgr. Charles E. Freeman, Chief Engr.	World UP RCA
NASHVILLE						
WKDA 1946	1240 250	Capitol Bcstg. Co. American Nat'l. Bank Bldg.; 4-0511	Forjoe	T. B. Baker Jr. & A. G. Beaman, Owners	T. B. Baker Jr., Gen. Mgr.	
WLAC 1926	1510 50,000 DA-N	WLAC Bcstg. Service Third Nat'l Bank Bldg. 6-0161	CBS Raymer	J. T. Ward, Owner F. C. Sowell, Gen. & Coml. Mgr.	Paul Oliphant, Prog. Dir. F. D. Binns, Chief Engr.	World UP Western Electric
WMAK 1948	1300 5,000 DA-1	Volunteer State Bcstg. Co. Inc. The Maxwell House 4-3411	MBS. LBS Weed	Frank W. Mayborn, Pres. Frank M. Farris, V. P. Walter P. Speight Jr., Sta. & Coml. Mgr.	Shelton Weaver, Prog. Dir. & Chief Engr. Ed Jones, Prom. Mgr.	Thesaurus UP Western Electric

DA-N Directional Antenna, night only. FM's in italic.
 DA-1 Directional Antenna, same pattern day and night.
 DA-2 Directional Antenna, different pattern day and night.

*-Non-Commercial Station. D-Day. N-Night. ST-Share Time. SH-Specified Hours.
 U-Unlimited. CP-Construction Permit Issued. LS-Local Sunset. SA-Special Authorization.
 L-Limited Time with Dominant Stat'on.

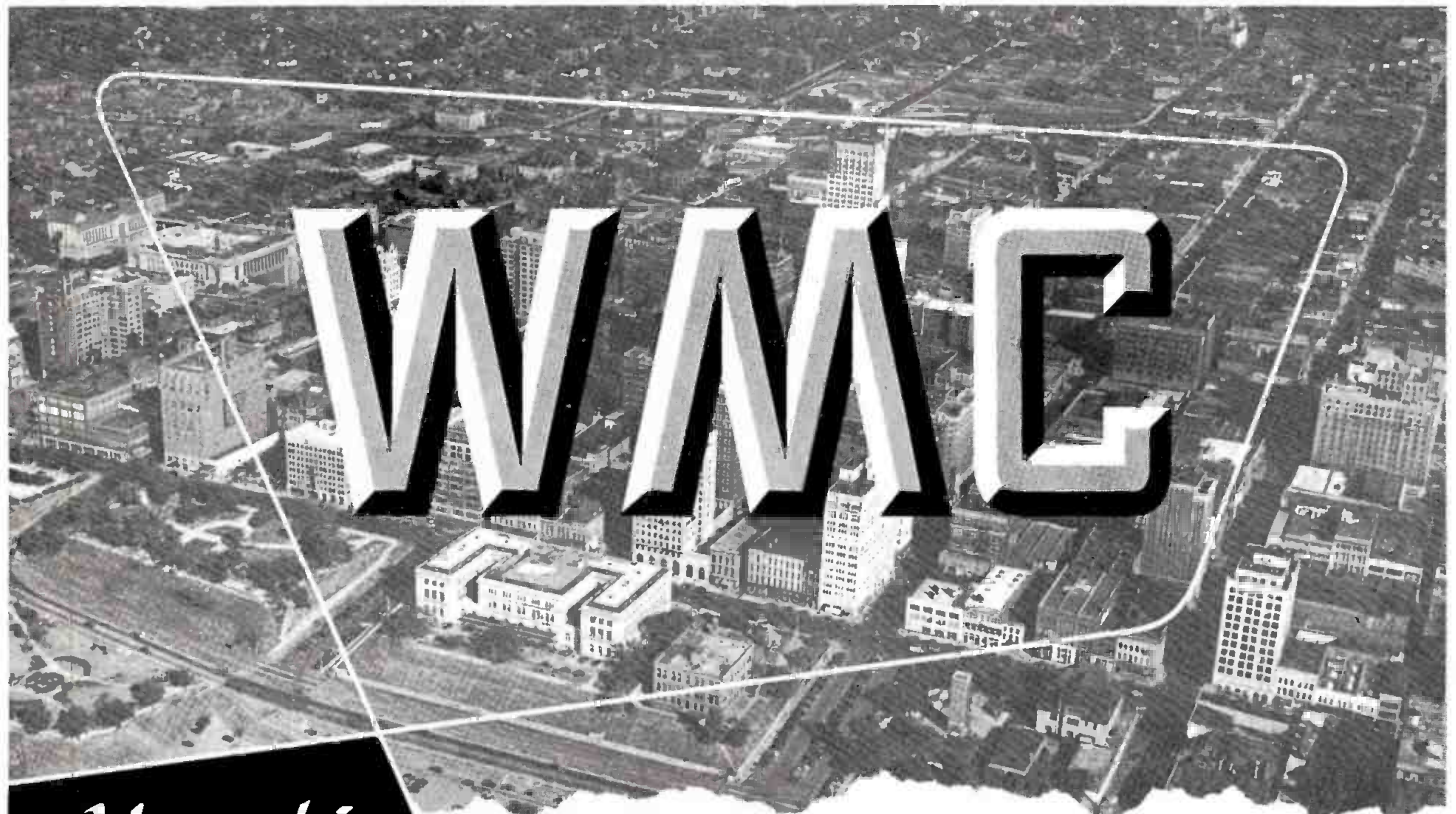

Memphis

**NBC 5000 Watts 790 KC
 WMC • WMCF • WMCT**

National Representatives • The Branham Co.
 Owned and operated by the Commercial Appeal

Family There's Money

in MEMPHIS



*Per Family Net Effective Buying Income**

New York City	\$6,106		Baltimore	\$5,264
Chicago	6,086	MEMPHIS \$5,159	Atlanta	4,817
Los Angeles	5,598		Birmingham	5,024
Detroit	5,766		New Orleans	4,731
St. Louis	5,157		Nashville	4,565

**(Sales Management Estimates, 1948)*

... and here's the pay off

Memphis not only profits by comparison with the nation's largest cities, but actually maintains a position of "undisputed leadership" among the five Southern markets shown above. So don't overlook "your best bet" marketwise, it's Memphis—and be sure to look over "your best bet" media-wise, it's WMPS!

WMPS

10,000 WATTS DAY

5,000 WATTS NIGHT

680 KILOCYCLES

AMERICAN BROADCASTING COMPANY

Represented by

RADIO REPRESENTATIVES, INC.

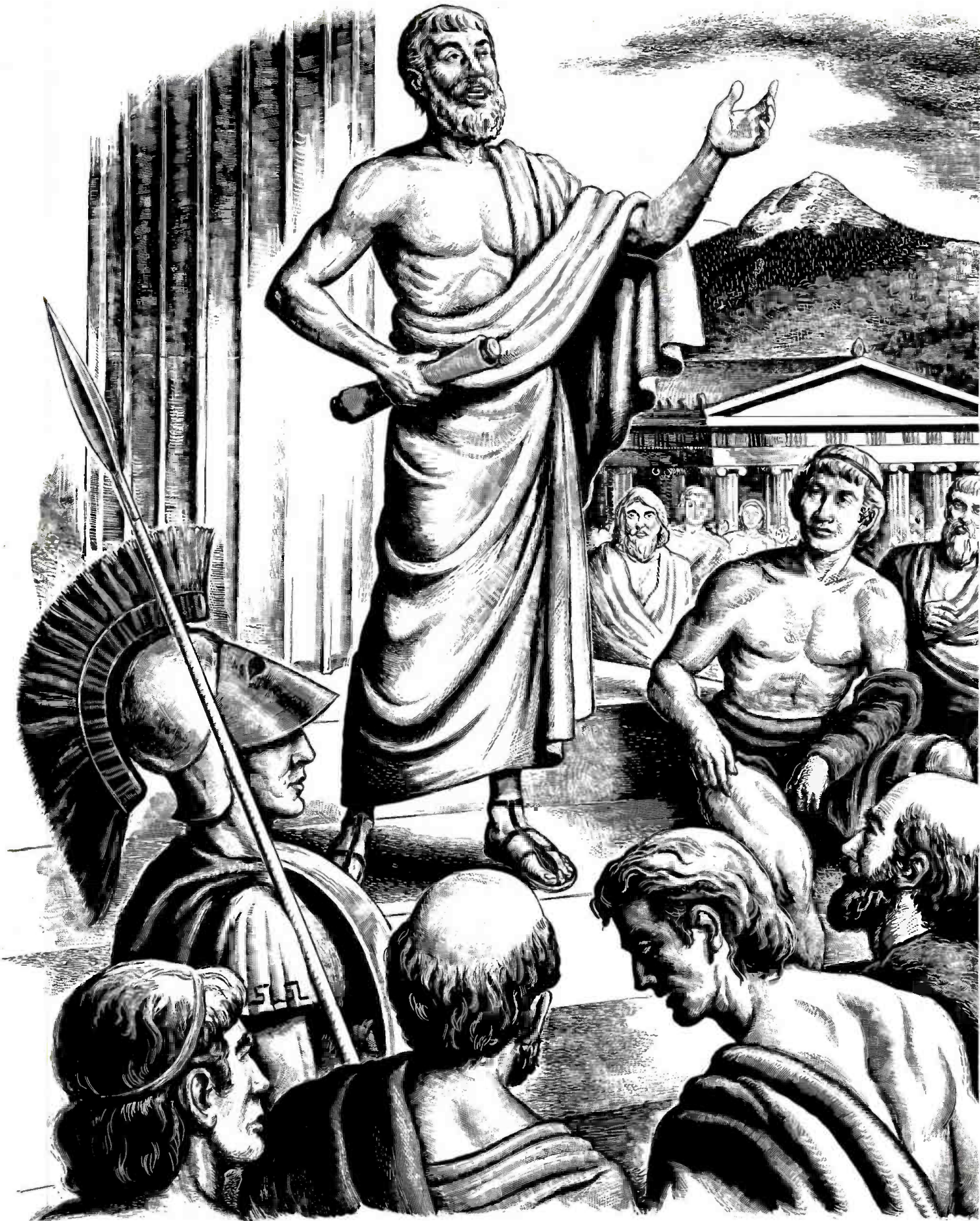



Plato might have called it a REPUBLIC...

Among the classic Greek conceptions of an ideal republic was one where all its citizens could be reached at once by the sound of a single human voice...

Judged by this intensely practical standard, you might well call the Central South a republic. For daily, hourly, the voice of WSM brings this rich segment of middle America into focus as a single unit. What WSM broadcasts, a region hears—and believes. What WSM sells, a region—a “republic” rich beyond Plato’s wildest dreams—believes in—and buys.

For facts and figures, contact Irving Waugh, or any Petry man.

CLEAR CHANNEL
50,000 WATTS



HARRY STONE
General Manager
IRVING WAUGH
Commercial Manager
EDWARD PETRY & CO.
National Representative

DIRECTORY OF AM, FM, and TV STATIONS OF THE UNITED STATES

(Data corrected to December 6, 1949)
If executives or services for FM or TV stations are same as AM affiliate names are not repeated.

TENNESSEE—(Continued)

City Call Letters Established	Chan. or Freq. Power	Name of Licensee Headquarters Address Telephone Number	Network Representative	Executive Personnel	Transc. Library News Service Transmitter Make
NASHVILLE—(Continued)					
WNAH (CP)	1360 1,000-D	Hermitage Bcstg. Corp. 3501 Grayswood 9-1184		V. T. Irwin Jr., Pres. & Gen. Mgr. W. W. Lanier Jr., Coml. Mgr.	Standard UP Gates Standard AP Collins
WSIX 1927	980 5,000 DA-N	WSIX Bcstg. Station Nashville Trust Bldg. 5-5431	ABC Katz	Jack M. & Louis R. Draughon, Co-Owners Jack M. Draughon, Gen. Mgr. E. S. Tanner, Coml. Dir.	Ottis Roush, Prog. Dir. Hillard Brown, Prom. Mgr. Charles R. Duke, Chief Engr.
WSIX-FM	Ch. 248 (B) 97.5mc 71kw				
WSM 1925	650 50,000	WSM Inc. 301 7th Ave. North 6-7181	NBC Petry	J. H. DeWitt Jr., Pres. Harry Stone, Gen. Mgr. Irving Waugh, Coml. Mgr.	Jack Stapp, Prog. Dir. Tom Stewart, Prom. Mgr. George Reynolds, Chief Engr.
WSM-FM 1941	Ch. 277 (B) 103.3mc 66kw				
WSM-TV (CP)	Ch. 4; 66-72mc. 7.2kw aur. 14.4kw vis.				
OAK RIDGE					
WATO 1948	1490 250 CP-1450	WATO Inc. Municipal Market Bldg. 5-3535	MBS Burn-Smith	Marshall H. Pengra, Pres. & Gen. Mgr. Harry C. Weaver, Coml. Mgr.	Arthur J. Metzler, Prog. Dir. James Wilburn, Chief Engr.
PARIS					
WTPR 1947	710 250-D	Kentucky Lake Bcstg. System Inc. 100 1/2 N. Market St. 1700	KBS Mid-South Holman	Dr. Elroy Scruggs, Pres. Parkman R. Feezor, Gen. & Coml. Mgr.	Lorenzo M. Smith, Prog. Dir. & Charles W. Jones, Chief Engr.
PULASKI					
WKSR 1947	730 250-D	Pulaski Bcstg. Co. Patterson Bldg.	MBS Dixie	John R. Crowder, Pres. W. E. Williams, Gen. & Coml. Mgr.	Corky Hoover, Prog. Dir. Carl Tatum, Prom. Mgr. Richard Spruill, Chief Engr.
SHELBYVILLE					
WHAL 1946	1400 250	Shelbyville Bcstg. Co. P. O. Box 622 1400	MBS	Harvard P. Smith, Pres. Charles A. Christian, Gen. & Coml. Mgr.	Frank Huber, Prog. Dir. Teddy Barnes, Prom. Mgr. Timothy Marsh, Chief Engr.
SPARTA					
WOST (CP)	1050 1,000-D	Sparta Bcstg. Co.			

DA-N Directional Antenna, night only. FM's in italic. *—Non-Commercial Station. D—Day. N—Night. ST—Share Time. SH—Specified Hours. DA-1 Directional Antenna, same pattern day and night. U—Unlimited. CP—Construction Permit Issued. LS—Local Sunset. DA-2 Directional Antenna, different pattern day and night. L—Limited Time with Dominant Station. SA—Special Authorization.

COME ON DOWN SOUTH!

Facts About This Rich Market

Population	1,326,400*
Families	351,300*
Radio Homes	301,681**
Retail Sales	\$719,825,000**
Food Sales	\$202,229,000**
Gen'l Mdse.	\$110,397,000**
Drug Sales	\$21,168,000**

Complete BMB County and City Data available on request.



ABC AFFILIATE — 5000 W — 980 KC
and WSIX-FM — 71,000 W — 97.5 MC

National Representative: THE KATZ AGENCY, INC.

*SALES MANAGEMENT, MAY 10, 1949

**WSIX gives you all three:—
MARKET, COVERAGE, ECONOMY**

Advertisers count on WSIX year after year for a big share of the money spent in this rich Tennessee Valley Market . . . \$719,825,000 spent in retail stores alone in 1948.**

WSIX Coverage — 60 BMB Counties . . . Middle Tennessee, Southern Kentucky, Northern Alabama.

SUMMARY DATA — DAYTIME Tabulation by the KATZ AGENCY, INC.			
	BMB County Units	1946 Radio Families	BMB Station Audience Families
Home City Nashville 83%		47,850	39,810
Home County Davidson 85%		67,540	57,610
Percentage Levels			
80% and over	11	98,290	83,520
70% " "	16	107,030	90,130
60% " "	20	128,750	104,010
50% " "	29	159,060	120,030
40% " "	35	180,260	129,760
30% " "	43	195,490	135,120
25% " "	48	216,800	140,900
20% " "	49	224,490	142,470
10% " "	60	252,610	146,690

Based on BMB Study No. 1—March 1946

**SRDS CONSUMER MARKETS, 1949-50

City Call Letters Established	Chan. or Freq. Power	Name of Licensee Headquarters Address Telephone Number	Network Representative	Executive Personnel	Transc. Library News Service Transmitter Make	
TULLAHOMA						
WJIG 1946	740 250-D	Tri-Cities Bcstg. Co. Tulahoma 2607	KBS Tennessee	Raymond L. Prescott Jr., Pres. & Gen. Mgr. Henry L. Wilson, V. P. David Welborne, Coml. Mgr.	Roy Morris, Prog. Dir. & Sta. Mgr. Carl Spraggins, Chief Engr.	Lang-Worth UP Gates
UNION CITY						
WENK 1950	1240 250	Union City Bcstg. Co. Inc. Clymer-Tittsworth Bldg. 1240	MBS, KBS Dixie Burn-Smith	Aaron B. Robinson, Pres. Louis C. Wrather, Gen. Mgr. David Capps, Coml. Mgr.	Lenora Burnette, Prog. Dir. Edwin Kallenberg, Prom. Mgr. James Thomas, Chief Engr.	World UP Western Electric
WINCHESTER						
WCDT 1948	1340 250	Arthur D. Smith Jr. Winchester 2201	MBS	Arthur D. Smith Jr., Pres., Gen. & Prom. Mgr. Joe Donaldson, Prog. Dir.	Joe Brewer, Coml. Mgr. Frank Spencer, Chief Engr.	SESAC UP Raytheon
TEXAS						
ABILENE						
KRBC 1936	1470 5,000-LS 1,000-DA-N	Reporter Bcstg. Co. Abilene 6255	ABC Texas State Pearson	(Mrs.) Eva Mae Hanks, Pres. Howard Barrett, Gen. Mgr.	Forest Lane, Coml. & Prom. Mgr. J. B. Casey, Chief Engr.	Capitol AP Collins General Electric
KRBC-FM 1947	Ch. 245 (B) 96.9mc 46kw					
KWKC 1948	1340 250	Citizens Bcstg. Co. 25th & Butternut 7287	MBS Lone Star Taylor-Borroff	W. P. Wright, Pres. A. C. Etter, Gen. & Coml. Mgr. Leonard L. Johnson, Prog. Dir.	Duane Ramsey, Prom. Mgr. Lewis D. Fisher, Chief Engr.	World AP, UP Western Electric
ALICE						
KBKI 1947	1070 1,000-D	Alice Bcstg. Co. Box 731 2070	Cooke	E. G. Lloyd Jr., Pres. D. C. Houston, Gen. Mgr. A. C. Lloyd Jr., Coml. & Prom. Mgr.	J. A. Frye, Prog. Dir. Leon Smith, Chief Engr.	Capitol World AP Collins
ALPINE						
KVLF 1947	1240 250	Big Bend Bcstrs. P. O. Box 779 37	MBS Southwest Cactus Taylor-Borroff	Charles Van Gundy, Mgr. Gene Hendryx, Asst. Mgr. Elaine Parker, Prog. Dir.	Steve Horvath, Chief Engr.	Lang-Worth AP, UP Gates
AMARILLO						
KAMQ 1947	1010 1,000-LS 500-N DA	Top of Texas Bcstg. Co. 1301 Polk St. 2-6543	MBS LBS Forjoe	Walter G. Russell, Pres. W. J. Dickerson, V. P., Gen. & Prom. Mgr. J. L. Adams, Coml. Mgr.	Wayne Johnston & Tom Higgs, Prog. Dirs. Stewart Parsons, Chief Engr.	Standard AP Raytheon
KFDA 1939	1440 5,000-LS 1,000-N DA	Amarillo Bcstg. Corp. 109 E. 5th St. 5343	ABC Branham	J. Lindsay & Gilmore Nunn, Part-ners Howard Roberson, Gen. Mgr. William Fairley, Coml. Mgr.	Gene Terry, Prog. Dir. Joe Bob Coble, Prom. Mgr. E. Noel Luddy, Chief Engr.	World Capitol UP RCA Western Electric
KFDA-FM 1948	Ch. 262 (B) 100.3mc 3.4kw					
KGNC 1935	710 10,000 DA-2	Plains Radio Bcstg. Co. 8th and Harrison Sts. 4242	NBC Lone Star Taylor-Borroff	Gene A. Howe, Pres. Aubrey Jackson, Gen. Mgr. O. L. (Ted) Taylor, Exec. Gen. Mgr. Tom Kritser, Local Sales Dir.	Bob Watson, Prog. Dir. & Prom. Mgr. William H. Torrey, Chief Engr.	Lang-Worth Cole AP, UP RCA
KGNC-FM 1947	Ch. 282 (B) 104.3mc 47kw					SESAC
KLYN 1947	940 1,000 DA-1	Plains Empire Bcstg. Co. 1014 N. 7th St.	CBS Blair	Carl Benefiel, Gen. Mgr.	Lee Biggs, Coml. Mgr.	
ATHENS						
KBUD 1948	1410 250-D	Henderson County Bcstg. Co. P. O. Box 309 650		J. B. McNutt Jr., Pres., Gen. Mgr. & Chief Engr.		Lang-Worth UP Gates
AUSTIN						
KNOW 1932	1490 250	Pioneer Bcstg. Co. Capital Nat'l. Bank Bldg. 26213	ABC Texas State Pearson	Wendell Mayes, Pres. Louis Cook, Gen. Mgr.	Warren Beaman, Prog. Dir. & Prom. Mgr. J. E. Lewis, Chief Engr.	Capitol AP
KTBC 1939	590 5,000-LS 1,000-N DA	Texas Bcstg. Corp. P. O. Box 717 2-2424	CBS Lone Star Taylor-Borroff	Claudia T. Johnson, Pres. J. C. Kellam, Gen. Mgr. Harvey O. Payne, Prom. Mgr.	Richard C. Pryor, Prog. Dir. Ben Hearn, Chief Engr.	World UP Western Electric
KTXN 1948	1370 1,000-D	Radio KTXN Inc. 309 West 21st St. 7-4476		Thomas G. Harris, Pres., Gen. & Coml. Mgr. & Prog. Dir.	Kerns H. Powers, Chief Engr.	Thesaurus AP RCA
KVET 1946	1300 1,000-DA-N	Austin Bcstg. Co. 113 W. 8th St. 8-8521	MBS, LBS Forjoe	John B. Connally, Pres. Willard Deason, Gen. Mgr. H. W. Dunlop, Asst. Mgr.	Charles L. Howell, Coml. Mgr. Dave Smith, Prog. Dir. & Prom. Mgr. Alfred Scharath, Chief Engr.	Lang-Worth UP Western Electric
BALLINGER						
KRUN 1947	1400 250	Runnels County Bcstg. Co. Zappe Bldg. 3151	MBS	Robert E. Bruce, Pres. & Gen. Mgr. R. F. McGarvey, Coml. Mgr.	W. C. Kelly, Chief Engr.	SESAC Standard AP Gates
BAY CITY						
KIOX 1947	1270 1,000 DA-N	J. G. Long Bay City 642	MBS KBS Girard	J. G. Long, Pres. Harold W. Ewing, Gen. Mgr. John Miller, Coml. Mgr.	La Verne B. Ewing, Prog. Dir. Glenn R. Ellis, Chief Engr.	Capitol AP Western Electric
BAYTOWN						
KRCT 1947	650 250-D	Bay Bcstg. Co. P. O. Box 629 1650	KBS	C. Q. Alexander, Pres. O. J. Howell, V. P. E. H. Keown, Gen. Mgr.	Sylvia McKinstry & Bill Lyons, Coml. Mgrs. Emilio Rodriguez Jr., Chief Engr. AP Collins
KREL 1947	1360 1,000 DA-2	Tri Cities Bcstg. Co. P. O. Box 419 1360	LBS Dixie	Robert Matherne, Pres. W. M. Lightfoot, Gen. Mgr.	Robert T. Nolan, Prog. Dir. M. E. Dougharty, Chief Engr.	Associated Lang-Worth World UP Gates General Electric
KREL-FM 1949	Ch. 221 (A) 92.1mc 1kw					

DIRECTORY OF AM, FM, and TV STATIONS OF THE UNITED STATES

(Data corrected to December 6, 1949)
If executives or services for FM or TV stations are same as AM affiliate names are not repeated.

TEXAS—(Continued)

City Call Letters Established	Chan. or Freq. Power	Name of Licensee Headquarters Address Telephone Number	Network Representative	Executive Personnel	Transc. Library News Service Transmitter Make	
BEAUMONT						
KFDM 1924	5600 DA-N	Beaumont Bestg. Corp. 1420 Calder Ave. 2-7758	ABC Lone Star Free & Peters	D. A. Cannan, Pres. C. B. Locke, Gen. & Coml. Mgr. Dave Russell, Prog. Dir.	H. F. Caldwell, Prom. Mgr. S. H. Jones, Chief Engr.	Lang-Worth Standard UP; RCA
KPBX 1947	1380 1,000-D	KPBX Bcstg. Co. Crosby Hotel 2-0201	LBS Forjoe	Fred L. Benckenstein, Pres. D. K. Maxted, Gen. Mgr. Pat Martin, Coml. Mgr.	Hugh Herrington, Prog. Dir. Lawrence Sanders, Chief Engr.	Standard AP Gates
KRIC 1938	1450 250	The Enterprise Co. 130 Wall 4-9421	Branham	O. Eugene Davis, Pres. E. C. Davis, V. P. & Gen. Mgr. Les Ryder, Mgr. Virginia W. Ryder, Prog. Dir.	J. Edwin Henry, Coml. Mgr. Revis Taylor, Prom. & Pub. Dir. Jack Easterwood, Chief Engr.	Capitol Thesaurus AP Western Electric
KRIC-FM 1948	Ch. 258 (B) 99.5mc; 4.5kw					RCA
KTRM 1947	990 1,000 DA-1	KTRM Inc. 230 Orleans St. 2-8478	Walker	Jack Neil, Pres. & Gen. Mgr. Bill McRae, Coml. Mgr.	Joe Trum, Prog. Dir. & Prom. Mgr. Ben F. Hughes, Chief Engr.	World INS Gates
BEEVILLE						
KIBL 1949	1490 250	Bee Bestg. Co. P. O. Box 948; 1490		John D. & V. L. Rossi, Partners John D. Rossi, Gen. & Coml. Mgr.	Joe W. Caldwell, Prog. & Sta. Mgr. Harry W. Wardwell, Chief Engr.	Capitol AP; Gates
BELTON						
KMHB(FM) 1948	Ch. 246 (B) 97.1mc 12kw	Mary Hardin-Baylor College Belton; 707		Dr. Gordon G. Singleton, Gen. Mgr. Nellie C. Olson, Prog. Dir.	John P. Bloomer, Chief Engr.	SESAC General Electric
BIG SPRING						
KBST 1936	1490 250	Big Springs Bcstg. Co. 702 Johnson St. 1500	ABC Texas State Pearson	William J. Wallace, Pres. & Gen. Mgr. William L. Cox, Coml. Mgr.	Robert Lindley, Prog. Dir. & Prom. Mgr. Andrew M. Jones, Chief Engr.	AP Western Electric
KTXC 1949	1400 100	Leonard R. Lyon Big Spring City Park 3300		Leonard R. Lyon, Pres. & Gen. Mgr. Wayne Robison, Coml. & Asst. Mgr.	Vance Kimble, Prog. Dir. Sid Cambie, Prom. Mgr. Al Thompson, Chief Engr.	UP Gates
BONHAM						
KFYN 1948	1420 250-D	Frank Svoboda				
BORGER						
KHUZ 1947	1490 250	R. G. Hughes 1431 Clayton St. 1600	MBS Girard	R. G. Hughes, Pres. Wayne Phelps, Gen. Mgr. Harry Chilton, Coml. Mgr.	Jack Roberts, Prog. Dir. & Prom. Mgr. Herman Kreiger, Chief Engr.	SESAC Lang-Worth AP; Raytheon
BRADY						
KNEL 1935	1490 250	G. L. Burns Brady 77	KBS Best	G. L. Burns, Pres. & Gen. Mgr. C. D. Reed, Coml. & Prom. Mgr.	Gene Burns, Prog. Dir. Cecil Nelin, Chief Engr.	AP Doolittle

TEXAS **LOUISIANA**

ORANGE
BEAUMONT
PORT ARTHUR

HOUSTON NEW ORLEANS

CORPUS CHRISTI

BROWNSVILLE

5000 WATTS DAY-NIGHT KFDm 560 KC

Serving

THE GOLDEN COAST

Looking at the Beaumont section of The Golden Coast from the AIR-lanes (KFDM), you see a tremendous market. Unquestionably — The Golden Coast — is everything the name implies. Such an opportunity to cover this market through the facilities of KFDM should be uppermost in the advertiser's mind — to capitalize on the sale of consumer goods and services, here, where spendable income is more plentiful. KFDM is first in America's brightest region — Beaumont and The Golden Coast. First, according to Mr. Hooper*, Morning, Noon and Night.

*C. E. Hooper Continuing Measurement, Fall-Winter, 1949.

Market Data		
	DT	NT
Radio Families	177,537	129,119
Population	932,600	
Covers 15 counties in Texas and 12 parishes in Louisiana		
Retail Sales	\$554,000,000	
Net Effective Buying Income	\$807,000,000	

REPRESENTED BY
FREE & PETERS, Inc. • AFFILIATED WITH AMERICAN BROADCASTING CO. • LONE STAR CHAIN

KFDm BEAUMONT, TEXAS

MEMO TO: Advertising Manager
I thought attached from Sponsor Magazine
Would interest you!

selective

Regional networks

**Inherent advantages of sectional webs
boost commercial use throughout nation**

... It's still expensive to cover a market with individual programs, station by station. A regional web can cover a section with a single program and one

billing. A regional set-up permits the great flexibility of selective broadcasting on a broad area base.

In the Southwest
that means TQN!

R. L.

Texas Quality Network includes six of the Southwest's most aggressive stations... guaranteeing 100% coverage of the key metropolitan markets. Highly skilled production staffs create *programs* that SELL merchandise. In fact TQN does more business each year than all other Southwestern regional networks combined. Success means service. For 16 years TQN has meant *top-quality* programming in the area it serves.

TEXAS QUALITY NETWORK

WFAA•Dallas WOAI•San Antonio KRIS•Corpus Christi KPRC•Houston KVAL•Brownsville KTBS•Shreveport

DIRECTORY OF AM, FM, and TV STATIONS OF THE UNITED STATES

*(Data corrected to December 6, 1949)
If executives or services for FM or TV stations are same as AM affiliate names are not repeated.*

TEXAS—(Continued)

City Call Letters Established	Chan. or Freq. Power	Name of Licensee Headquarters Address Telephone Number	Network Representative	Executive Personnel	Transc. Library News Service Transmitter Make
BRECKENRIDGE					
KSTB 1947	1430 1,000-D	Stephens County Bcstg. Co. Inc. Miller Bldg. 1430	KBS Best	R. W. Chapman, Pres. & Gen. Mgr. Gilbert Webb, Coml. Mgr.	Tommy Drake, Prog. Dir. Lang-Worth AP Gates
BRENHAM					
KWHI 1947	1280 1,000-D	Tom S. Whitehead Brenham 655	KBS	Tom S. Whitehead, Pres. & Gen. Mgr. J. C. Price, Coml. Mgr.	Lang-Worth SESAC UP; Gates
BROWNFIELD					
KTFY 1949	1050 250-D	Terry County Bcstg. Co. P. O. Box 1032		Conrad Vernon Jr., Gen. & Coml. Mgr.	R. C. Norris, Prom. Mgr. Standard UP
BROWNSVILLE					
KBOR 1949	1600 1,000-D DA	Brownsville Bcstg. Co. P. O. Box 472; 2-5877		Minor J. Wilson, Pres., Gen. Mgr. & Prog. Dir.	Vance C. Wilson, Coml. Mgr. Willis A. Wilson, Chief Engr.
KVAL 1945	1490 250	KVAL Bcstg. Co. P. O. Box 1792 2-6452	ABC Texas Quality Free & Peters	T. Frank Smith, Pres. T. Frank Smith Jr., Gen. & Coml. Mgr.	Tom Martin, Prog. Dir. & Prom. Mgr. Ed Frazier, Chief Engr. AP AP
BROWNWOOD					
KBWD 1941	1390 1,000-LS 500-N	Brown County Bcstg. Co. 800 Hawkins St. 2401	MBS Texas State Walker	Wendell Mayes, Pres. & Gen. Mgr. Frank Wilson, Coml. Mgr. Wendell Mayes Jr., Prog. Dir.	Pat Brinkley, Prom. Mgr. A. W. Stewart, Chief Engr. Lang-Worth UP RCA
BRYAN					
KORA 1947	1240 250	Bryan Bcstg. Co. P. O. Box 767 2-1451	MBS	David C. Jones Jr., Owner, Gen. Mgr. & Tech. Dir. Frank J. Sosoli, Sta. Mgr.	Euell G. Byers, Coml. Mgr. William J. Zak Jr., Prog. Dir. James R. Smith, Chief Engr. Collins
CENTER					
KDET 1949	930 1,000-D	Center Bcstg. Co. Inc. 205 Austin St. 1199		Tom E. Foster, Pres. Jack Bell, Gen. & Coml. Mgr. & Prog. Dir.	Tolbert Foster, Prom. Mgr. T. McLachlan, Chief Engr. Standard UP Collins
CHILDRESS					
KCTX 1947	1510 250-D	Golden West Bcstg. Co. Inc. 217½ Main St.; 1085	MBS Best	Richard M. Hagan, Pres. George D. Cowan, Gen. Mgr. John M. Carman, Coml. Mgr.	Milly Sikes, Prog. Dir. John B. Braffett, Chief Engr. AP Raytheon
CLEBURNE					
KCLE 1947	1120 250-D	Marti Inc. 919 N. Main; 1025	Best	George W. Marti, Owner & Mgr.	UP
KCLE-FM 1949	Ch. 232 (A) 94.3mc; 0.32kw				
COLEMAN					
KSTA 1947	1000 250-D	Coleman County Bcstg. Co. Coleman; 8406	Best	H. H. Jackson, Pres. Floyd Shelton, Gen. & Coml. Mgr.	Billy Beach, Prog. Dir. A. W. Stewart, Chief Engr. Capitol UP Collins
COLLEGE STATION					
WTAW 1922	1150 1,000-D	A & M College of Texas College Station; 6-6724		Richard L. Webb, Gen. Mgr. & Chief Engr.	John Scogin, Prog. Dir. World AP; Collins
COLORADO CITY					
KVMC (CP) 1949	1320 500-D	Colorado City Bcstg. Co.			
CORPUS CHRISTI					
KEYS 1941	1440 1,000-LS 500-N DA	Nueces Bcstg. Co. P. O. Box 1460 27411	CBS Lone Star Taylor-Boroff	H. B. Lockhart Earl C. Dunn Charles Rossi E. C. Hughes } Partners	Kelly Wofford, Gen. Mgr. Tom Gibson, Coml. Mgr. Ben Blackmon, Prog. Dir. Harold Griffith, Chief Engr. World UP Gates
KRIS 1935	1360 1,000	Gulf Coast Bcstg. Co. P. O. Box 640 6354	NBC Texas Quality Free & Peters	T. Frank Smith, Pres. & Gen. Mgr. W. M. Eikner, Coml. Mgr.	Charles Nethery, Prog. Dir. & Prom. Mgr. Elmer Atkinson, Chief Engr. Standard AP
KSIX 1947	1230 250	Corpus Christi Bcstg. Co. Show Room Bldg.	Forjoe	Vana M. Kennedy, Gen. Mgr.	
KUNO 1949	1400 100	Community Bcstg. Co. P. O. Box 4286		Leslie C. Smith, Pres.	J. H. Mayberry, Gen. Mgr. & Chief Engr. Capitol Collins
KWBU 1944	1030 50,000-D L-KLRA	Baylor U. White Plaza Hotel 5258	Branham	Roy R. Kay, Gen. & Coml. Mgr.	Nestor Cuesta Jr., Chief Engr. AP
CORSICANA					
KAND 1937	1340 250	Alto Inc. State Nat'l Bank Bldg. 2486	LBS Branham	Walter S. Kline, Gen. Mgr.	Donnell D. Dickson Jr., Chief Engr. World UP
CROCKETT					
KIVY (CP) 1949	1570 250-D	Pioneer Bcstg. Co. P. O. Box 313 1570		Hamilton H. Callen & James H. Gibbs, Owners H. H. Callen, Gen. Mgr. & Engr.	James H. Gibbs, Prog. Dir. & Prom. Mgr. World UP Gates
CUERO					
KCFH 1949	1600 500-D	A. M. Respondek Cuero		A. M. Respondek, Pres. & Gen. Mgr. Milton Binz, Coml. Mgr.	Edson Foster, Prog. Dir. E. F. Meyer, Chief Engr. World UP Gates
DALHART					
KXIT 1948	1410 500-D	Dillard Associates 402½ Denrock; 740	LBS	Kenneth B. Bishop, Gen. Mgr.	Bill Smith, Chief Engr. Lang-Worth UP; Gates
DALLAS					
KBTV (TV) 1949	Ch. 8 180-186mc 13.5kw aur.; 27kw vis.	Potter Television Co. M & W Tower Bldg. Riverside 3316	DuMont Young	Tom Potter, Owner Jack I. Potter, Pres. Mortimer S. Dank, Gen. Mgr.	Del Ramey, Coml. Mgr. Larry DuPont, Prog. Dir. Morris Barton, Chief Engr. Telenevs World United Film Equity UP DuMont
KIXL 1947	1040 1,000-D	Variety Bcstg. Co. Inc. 1401 S. Akard St. R-5421	Forjoe	Lee Segall, Pres. & Sta. Mgr. Tom Massey, Asst. Mgr.	T. H. Strauss, Coml. Mgr. World Standard MacGregor
KIXL-FM 1947	Ch. 283 (B) 104.5mc; 34kw				
KLIF 1947	1190 1,000-D	Trinity Bcstg. Corp. 2008 A Jackson St. Riverside 6383	LBS Young	Barton R. McLendon, Pres. Gordon B. McLendon, Gen. & Coml. Mgr.	Bill Weaver, Prog. Dir. & Prom. Mgr. Glenn Callison, Chief Engr. Roy George, Prog. Dir. J. W. Crocker, Prom. Mgr. R. M. Flynn, Chief Engr. Associated UP Raytheon
KRLD 1926	1080 50,000 DA-N	KRLD Radio Corp. Herald Sq. Central 6811	CBS Texas Branham	J. W. Runyon, Pres. C. W. Rembert, Gen. Mgr. W. A. Roberts, Coml. Mgr.	Roy George, Prog. Dir. J. W. Crocker, Prom. Mgr. R. M. Flynn, Chief Engr. Capitol Standard AP, INS Western Electric

DA-N Directional Antenna, night only. FM's in italic.
DA-1 Directional Antenna, same pattern day and night.
DA-2 Directional Antenna, different pattern day and night.

*-Non-Commercial Station. D-Day. N-Night. ST-Share Time. SH-Specified Hours.
U-Unlimited. CP-Construction Permit Issued. LS-Local Sunset.
L-Limited Time with Dominant Station. SA-Special Authorization.

Sales

The ~~Best~~ of
TWO CITIES

DALLAS



Oldest CBS
Affiliate
in Texas

DAY OR NIGHT

KRLD

AM-FM
TV

IS YOUR BEST BUY

DICKENS

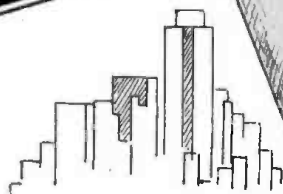

FT. WORTH

Are Tuned to the

Number 1 Station In

DALLAS and FORT WORTH

and the Great Southwest Market

KRLD TV

For Advertising purposes,
Dallas and Fort Worth are
ONE market.

KRLD-TV, with an array of
highest rated CBS shows and
professionally staged studio
productions is beamed to
the largest T-V Market South-
west.

Ask the Branham man for
latest coverage information.

Channel **4**

Sources: Sales Management,
Broadcasting, BMB

Represented by The Branham Company

BROADCASTING • Telecasting

Dallas and Tarrant Counties alone present the largest market and the most
compact urban sales area in the great southwest!

RETAIL SALES \$1,221,203,000.00

RADIO SETS 258,220: Average Coverage 93%

The area within the 100 mile radius of Dallas represents approximately 30%
of the State of Texas total population, and within KRLD's 0.5 Mv line live
50% of the State's population.

Exclusive **CBS** Outlet for Dallas and
Fort Worth



KRLD



The Only **FULL-TIME 50,000-WATT** Station in the
Dallas-Fort Worth Area

The **TIMES HERALD** Station

1950 Yearbook Number • Page 289

DIRECTORY OF AM, FM, and TV STATIONS OF THE UNITED STATES

*(Data corrected to December 6, 1949)
If executives or services for FM or TV stations are same as AM affiliate names are not repeated.*

TEXAS—(Continued)

City Call Letters Established	Chan. or Freq. Power	Name of Licensee Headquarters Address Telephone Number	Network Representative	Executive Personnel	Transc. Library News Service Transmitter Make	
DALLAS—(Continued)						
KRLD-FM 1948	Ch. 223 (B) 92.5mc 42kw			 General Electric	
KRLD-TV 1949	Ch. 4 66-72mc 8kw-aur.; 15.8kw-vis.			 UP General Electric	
KSKY 1941	660 1,000-D	Sky Bcstg. Service 2927 Maple St. Central 6193		A. L. Chilton, Pres. R. G. Terrill, Gen. & Prom. Mgr. R. L. Kanatzar, Coml. Mgr.	Leonard Holland, Prog. Dir. Morris M. Ming, Chief Engr. AP RCA
KYBS(FM) 1949	Ch. 300 (B) 107.9mc 90kw	Baptist General Convention of Texas 603 Baptist Bldg. Riverside 2540		Dr. R. Alton Reed, Gen. Mgr. John Zappfe, Coml. Mgr. & Dir. of Engrg.	Henrietta Morris, Prog. Dir. UP Collins
WFAA ¹ 1922	820 50,000 570 5,000 DA-N ST-WBAP	A. H. Belo Corp. 1122 Jackson St. Riverside 9631	ABC, NBC Texas Quality Petry	E. M. Dealey, Pres. Martin B. Campbell, Gen. Mgr. Ralph W. Nimmons, Coml. Mgr.	Kelly Maddox, Prog. Dir. Robert E. Summers, Prom. Mgr. J. Raymond Collins, Chief Engr.	Lang-Worth SESAC AP, UP RCA
WFAA-FM 1946	Ch. 250 (B) 97.9mc 43kw					
WRR 1920	1310 5,000 DA-N	City of Dallas Municipal Radio Bldg. Tenison 3-6101	MBS Texas State Blair	Dale Drake, Gen. Mgr. Pete Teddlie, Prog. Dir.	D. J. Tucker, Chief Engr. AP
WRR-FM	Ch. 268 (B) 101.1mc 68kw					
DEL RIO						
KDLK 1947	1230 250	Del Rio Bcstg. Co. P. O. Box 1162 1234		J. A. Clements, Pres. Hal Harlan, Gen. Mgr.	Hal Smith, Prog. Dir. Stan Benson, Chief Engr. UP Gates
DENISON						
KDSX 1948	1220 1,000-D	Grayson Bcstg. Corp. Hotel Denison 3-400	LBS	B. V. Hammond Jr., Pres. & Gen. Mgr. George Myers, Coml. & Prom. Mgr.	Bill Burkett, Prog. Dir. Fred Weaver, Chief Engr.	Standard AP Raytheon
DENTON						
KDNT 1938	1450 250	Harwell V. Shepard Radio Center 276	Best	Harwell V. Shepard, Gen. Mgr.		
KDNT-FM	Ch. 291 (B) 106.1mc 3.1kw					
DUMAS						
KDDD 1948	800 250-D	North Plains Bcstg. Corp. P. O. Box 545 2-4411	Best	Lucien W. Spencer, Pres. Ken Duke, Gen. Mgr.	Ray Trent, Prog. Dir. T. D. Atkins, Chief Engr.	Standard AP Gates
EDINBURG						
KURV 1947	710 250-D	James Cullen Looney 217½ S. Clossner 295	Forjoe	James Cullen Looney, Pres. Allen P. Dale, Gen. Mgr. & Prog. Dir.	Perry V. Hoyler, Coml. Mgr. Warren R. Chase, Chief Engr.	World UP Raytheon
KURV-FM 1947	Ch. 285 (A) 104.9mc 1kw				 General Electric
EL CAMPO						
KULP 1948	1390 500-D	Wharton County Bcstg. Co. P. O. Box 1390 1390	LBS Best	Louis T. C. Krueger, Pres. Jack Senter, Gen. Mgr.	Robert R. Hathaway, Bus. Mgr. Joe H. Miller, Chief Engr.	Lang-Worth UP Collins
ELECTRA						
KELT 1949	1050 250-D	Oil City Bcstg. Co. P. O. Box 112 1051		W. M. H. Smith, Gen. Mgr. John Womack, Prog. Dir.	Bill F. Lindsay, Chief Engr.	Standard UP RCA
EL PASO						
KCHC (CP)	860 500-D	Claude H. Craig				
KELP 1947	920 1,000-D	Paso Bcstg. Co. Inc. Hill Bldg.	KBS Pearson	John Thompson, Gen. Mgr.	 UP
KEPO 1948	690 5,000 DA-2	KEPO Inc. 2419 N. Piedras St. 5-2731	ABC Blair	Kenyon Brown, Exec. V. P. Willard L. Kline, Gen. Mgr. Howard W. Baldwin, Coml. Mgr.	E. O. Procter Jr., Prog. Dir. E. Louis Gemoets, Chief Engr.	Standard UP
KROD 1940	600 5,000 DA-N	Roderick Bcstg. Corp. 2201 Wyoming St. 2-6551	CBS Southwest Lone Star Taylor-Borhoff	Dorrance D. Roderick, Pres. Val Lawrence, V. P., Gen. & Coml. Mgr.	Bob Hughes, Prom. Mgr. Edward P. Talbot, Chief Engr.	Standard AP RCA
KSET 1949	1340 250	Sunland Bcstg. Co. 2223 Montana St.		Ted Hunt, Prog. Dir. Vincent W. McConn, Gen. Mgr. G. C. Hoffmann, Sta. Mgr.	C. J. Kaspar, Coml. Mgr. D. H. Hall, Prog. Dir. Wallace V. Rockefeller, Chief Engr.	Lang-Worth AP
KTSM 1929	1380 1,000-LS 500-N	Tri-State Bcstg. Co. Inc. 801 N. Oregon St. 2-5423	NBC Hollingbery	Karl O. Wyler, Pres. & Gen. Mgr. Roy T. Chapman, Coml. Mgr. Jack Chapman, Prog. Dir.	Murray Yeager, Prom. Mgr. Kenneth Walton, Chief Engr.	Lang-Worth Thesaurus UP RCA
FORT WORTH						
KCNC 1947	870 250-D	Blue Bonnet Bcstg. Corp. 705½ Main St. Fortune 7175		J. H. Speck, Pres. & Gen. Mgr. Luther Adkins, Coml. Mgr. Jerry Hahn, Prog. Dir.	Charles St. John, Prom. Mgr. Jack Hopkins, Chief Engr. AP Raytheon
KCUL 1949	1540 5,000-LS DA-1 1,000-N	East-West Bcstg. Co. 3607 Camp Bowie 7-2161		W. Bruce Chambers Jr., Pres. & Gen. Mgr.	Nestor Cuesta Jr., Chief Engr. Associated UP

¹ Note: Stations are assigned fulltime, but divide time between two channels. NBC rides 820 kc clear channel; ABC rides 570 kc regional channel. When WFAA operates on clear channel, WBAP operates on regional and vice versa. Both channels are for combined coverage of Dallas-Ft. Worth market areas.

DA-N Directional Antenna, night only. FM's in italic. *—Non-Commercial Station. D—Day. N—Night. ST—Share Time. SH—Specified Hours.
DA-1 Directional Antenna, same pattern day and night. U—Unlimited. CP—Construction Permit Issued. LS—Local Sunset.
DA-2 Directional Antenna, different pattern day and night. L—Limited Time with Dominant Station. SA—Special Authorization.

"We consider money spent with
WFAA over the last sixteen
years one of our most
fortunate investments."

FANT MILLING CO.

(selling more family flour in Texas than any other miller)

James A. Fant
PRESIDENT

And eleven other more-than-fifteen-years

WFAA advertisers have made the same fortunate investment . . . B & B Cafe, T. W. Burleson & Son Honey, Mrs. Tucker's Foods, W. A. Green Department Store, Linz Brothers Jewelists, Lone Star Gas Company, General Mills and Procter & Gamble. In addition, WFAA has thirteen ten-year and twenty-six five-year advertisers.



DIRECTORY OF AM, FM, and TV STATIONS OF THE UNITED STATES

*(Data corrected to December 6, 1949)
If executives or services for FM or TV stations are same as AM affiliate names are not repeated.*

TEXAS—(Continued)

City Call Letters Established	Chan. or Freq. Power	Name of Licensee Headquarters Address Telephone Number	Network Representative	Executive Personnel	Transc. Library News Service Transmitter Make	
FORT WORTH—(Continued)						
KFJZ 1922	1270 5,000 DA-1	Tarrant Bcstg. Co. 1201 W. Lancaster 3-3473	MBS Texas State Blair	Gene L. Cagle, Pres. & Gen. Mgr. Clyde D. Pemberton, Coml. Mgr.	World AP Western Electric	
KWBC 1946	970 1,000-D	Worth Bcstg. Co. 1003½ Houston 2-9231	Rambeau	P. W. Seward, Pres. Lewis Love, Gen. Mgr. Conrad Dupree, Coml. Mgr.	Ed Hogan, Prog. Dir. Harvey Boyd, Prom. Mgr. Melvin Parsons, Chief Engr.	Standard AP RCA
KXOL 1947	1360 1,000 DA-N	Ft. Worth Bcstg. Co. Inc. 1216 Penna. Ave. 31448	LBS Pearson	F. M. Skinner, Pres. Russ N. Lamb, Gen. Mgr. Herman Clark, Coml. Mgr.	Bob May Berry, Prog. Dir. & Prom. Mgr. Robert Crouse, Chief Engr.	Lang-Worth AP Raytheon
WBAP ² 1922	820 50,000 570 5,000 DA-N ST-WFAA	Carter Publications 3900 Barnett St. Lockwood 1981	ABC, NBC Lone Star Free & Peters	Amon Carter, Pres. Harold Hough, Dir. George Cranston, Gen. Mgr. Roy Bacus, Coml. Mgr.	Ed Lally, Prog. Dir. Jack Rogers, Publ. & Prom. Mgr. R. C. Stinson, Dir. of Engrg.	Associated, Cole AP
WBAP-FM 1948	Ch. 263 (B) 100.5mc 50kw			 RCA	
WBAP-TV 1948	Ch. 5 76-82mc 8.2kw-aur.; 16.4kw-vis.		ABC, NBC	Bob Gould, Prog. Dir. RCA	
FREDERICKSBURG						
KNAF 1947	1340 250	Gillespie Bcstg. Co. Inc. Security State Bank Bldg. 311	MBS Best	Walter McKay, Pres. Arthur Stehling, V. P. Gregg Winters, Gen. Mgr. & Prog. Dir.	Lloyd Breyer, Prom. Mgr. W. J. Thomas, Coml. Mgr. Norbert Fritz, Chief Engr.	SESAC AP Gates
GAINESVILLE						
KGAF 1947	1580 250-D	Gainesville Bcstg. Co. Inc. Gainesville 248	LBS, KBS	Joe M. Leonard Sr., Pres. Joe M. Leonard Jr., Gen. Mgr. Earl Leonard, Coml. Mgr.	Louis Pitchford Jr., Prog. Dir. Cordell Martin, Chief Engr.	Standard AP Raytheon
GALVESTON						
KGBC 1947	1540 1,000-LS 250 N-DA	The Galveston Bcstg. Co. Commerce Bldg. 4329		James W. Bradner Jr., Pres. & Gen. Mgr.	Floyd Smith, Coml. Mgr. James McConnell, Prog. Dir. Jesse Simms, Chief Engr.	Standard AP Raytheon
KLUF 1922	1400 250	KLUF Bcstg. Co. Inc. 300 Haden Bldg. 6676	MBS, LBS Rambeau	George R. Clough, Pres.	L. D. Clough, Gen. & Coml. Mgr., Prog. Dir. & Chief Engr.	World UP RCA General Electric
KLUF-FM 1949	Ch. 259 (B) 98.7mc 8kw			 General Electric	
GLADEWATER						
KSIJ 1949	1430 1,000-D	Gladwater Bcstg. Co. 303 Cotton St. 516	Best	Carl Everett Jr. B. H. Broiles } Partners John Ben Sheppard } Ken Bennett, Gen. Mgr.	Bob Bennett, Coml. Mgr. Tom Perryman, Prog. Dir. Clyde Moore, Prom. Mgr. Lloyd Johnson, Chief Engr.	Standard UP Gates
GONZALES						
KCTI 1947	1450 250	Gonzales Bcstg. Co. 425 St. George St. 770	Gene Grant Cooke	Frank Wilson Jr., & Lawrence M. Walshak, Partners Lawrence M. Walshak, Gen. & Coml. Mgr.	Frank Wilson Jr., Prog. Dir., Prom. Mgr. & Chief Engr.	Capitol AP
GRAHAM						
KSWA 1948	1330 500-D	Graham Bcstg. Co. P. O. Box 748 1200		Clay E. Thompson Jr., Gen. & Prom. Mgr. W. J. Duncan, Coml. Mgr.	Bill Huey, Prog. Dir. H. V. Newsom, Asst. Mgr. & Chief Engr.	Capitol SESAC UP
GREENVILLE						
KGVL 1946	1400 250	Truett Kimzey Graham Fagg Bldg. 2066	MBS, KBS Texas State	Truett Kimzey, Pres. Leo Hackney, Gen. Mgr. Paul D. Robinson, Asst. Mgr.	James D. Jones, Prog. Dir. Tom E. Clyce, Chief Engr.	AP
HAMILTON						
KCLW 1948	900 250-D	Hamilton Bcstg. Co. 111 E. Leslie 500	LBS	Clyde Weatherby, Pres. J. Monroe Coston, Gen. Mgr. & Prog. Dir.	Vernon Grim, Coml. Mgr. Carl Knelly, Chief Engr.	Capitol UP Collins
HARLINGEN						
KGBS 1941	1240 250	Harbenito Bcstg. Co. P. O. Box 711 2200	CBS Ra-Tel	McHenry Tichenor, Pres. Troy McDaniel, Mgr. Dave Bennett, Coml. Mgr.	John Harrison, Prog. Dir. Al Beck, Chief Engr.	Associated Standard UP Western Electric
KGBS-FM 1947	Ch. 234 (B) 94.7mc 3kw				
KSOX (CP)	1530 50,000-LS DA-2 10,000	Texas Star Bcstg. Co.			
HENDERSON						
KGRI 1947	1000 250-D	Henderson Bcstg. Corp. P. O. Box 809 1128		Roy B. Cannon, Pres. W. C. Crawford, Gen., Coml. & Prom. Mgr.	Frank Ledbetter, Prog. Dir. Lynn J. Roy, Chief Engr.	World, SESAC UP Western Electric
HEREFORD						
KPAN 1948	860 250-D	John Blake, Marshall Formby P. O. Box 868: 860	Best	John Blake & Marshall Formby, Partners Marshall Formby, Gen. Mgr.	Hal W. Blymiller, Coml. Mgr. & Prom. Dir. John Ball, Chief Engr.	Standard UP Gates
HILLSBORO						
KHBR 1948	1560 250-D	Hill County Bcstg. Co. 204 E. Franklin; 594		Budd Hill, Owner & Dir. World UP	
HOUSTON						
KATL 1947	1590 5,000 DA-N	Texas Bcstrs. Inc. 412 Main St. Preston 3108	LBS Dixie IMS	William H. Talbot, Pres. King H. Robinson, V. P. & Gen. Mgr. William C. Burks, Coml. Mgr. Robert C. Meeker, Gen. Mgr.	John Edwards, Prog. Dir. Charles Dyer, Prom. Dir. Edwad Martin, Chief Engr. AP, UP Gates
KCOH 1948	1430 1,000-D	Call of Houston Inc. 1 Main St. Ch. 4-1888		 Associated MacGregor World; UP	

Note 2: Stations are assigned full time but divide time between two channels. NBC rides 820 kc clear channel; ABC 570 kc regional channel. When WFAA operates on clear channel, WBAP operates on regional and vice versa. Both channels are for combined coverage of Dallas-Ft. Worth market areas.

DA-N Directional Antenna, night only. FM's in italic. *—Non-Commercial Station, D—Day, N—Night, ST—Share Time. SH—Specified Hours.
DA-1 Directional Antenna, same pattern day and night. U—Unlimited. CP—Construction Permit Issued. L—Local Sunset.
DA-2 Directional Antenna, different pattern day and night. L—Limited Time with Dominant Station. SA—Special Authorization.

**In The Shadow Of The Cowbell,
WBAP Memory Signal Since 1922**

The South's Richest Market

THE FORT WORTH - DALLAS AREA

	Population*	Retail Sales*	Radio Homes*
WBAP - 570 (ABC)	4,528,200	\$3,722,862,000	1,123,538
WBAP - 820 (NBC)	5,435,500	4,329,307,000	1,253,162
WBAP - TV (ABC, NBC)	1,035,571	1,288,703,550	TV Count Monthly

Delivering the South's richest market is a WBAP specialty, as it has been with radio since 1922 and with television since September 29, 1948.

From metropolitan cities to the smallest hamlet, ranch or farm home, WBAP's memory signal cowbell is listened to more by more people in the South's richest market (Fort Worth-Dallas area).

WBAP now has facilities to produce the most difficult program or commercial (live, recorded or film) in its new 70,000 square foot Radio and Television Center.

Complete station and market details are available by contacting WBAP or Free & Peters at any one of the offices listed below.

*Source: Sales Management, 1949, and Consumer Markets 1949-50.

Amon Carter, President
Harold Hough, Director
George Cranston, Manager
Roy Bacus, Com. Manager

WBAP Telephones:
Fort Worth:
LOCKWOOD 1981
Dallas:
Tremont 7-9757

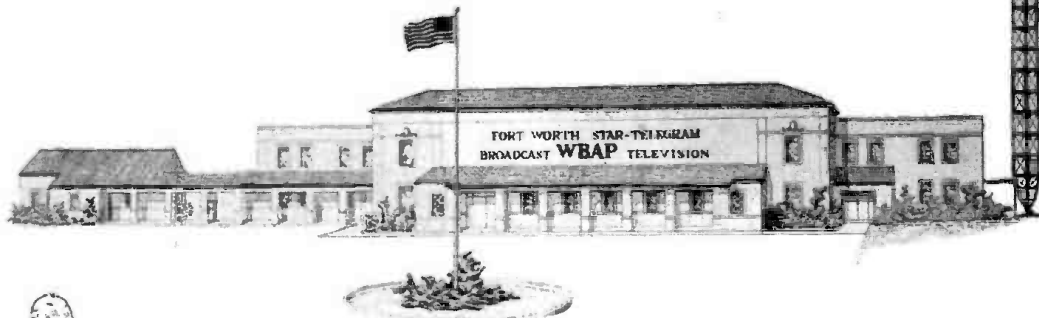

FREE & PETERS, INC. *Exclusive National Representatives*

Fort Worth Detroit Atlanta San Francisco Chicago New York Hollywood

DIRECTORY OF AM, FM, and TV STATIONS OF THE UNITED STATES

(Data corrected to December 6, 1949)
If executives or services for FM or TV stations are same as AM affiliate names are not repeated.

TEXAS—(Continued)

City Call Letters Established	Chan. or Freq. Power	Name of Licensee Headquarters Address Telephone Number	Network Representative	Executive Personnel	Transc. Library News Service Transmitter Make	
HOUSTON—(Continued)						
KLEE 1948	610 5,000 DA-2	W. Albert Lee Milby Hotel Preston 1161	Walker	John H. Pace, Gen. & Coml. Mgr. Bill Newkirk, Prog. Dir.	Associated World	
KLEE-TV 1949	Ch. 2 54-60mc 8.5kw-aur. 16kw-vis.					
KNUZ 1948	1230 250	Veteran's Bcstg. Co. 905 Scanlan Bldg. Central 8801	Forjoe	Max H. Jacobs, Pres. Douglas Hicks, V. P. David H. Morris, Gen. & Coml. Mgr.	Walter Colvin, Prog. Dir. Ednah Forester, Prom. Mgr. O. C. Crossland, Chief Engr.	Capitol Lang-Worth
KPRC 1925	950 5,000 DA-N	Houston Post Co. Lamar Hotel Fairfax 7101	NBC Texas Quality Petry	W. P. Hobby, Pres. Jack Harris, Gen. Mgr. Jack McGrew, Coml. Mgr.	Brook Carroll, Prog. Dir. Robert Carpenter, Prom. Mgr. Harvey Wheeler, Chief Engr.	Standard Thesaurus AP RCA
KPRC-FM 1946	Ch. 275 (B) 102.9mc 57kw		Transit FM	Robert John Mead, Coml. Mgr.	Edward Shaeffer, Chief Engr.	
KTHT 1944	790 5,000 DA-2	Texas Star Bcstg. Co. 4005 Travis Keystone 5535	MBS Texas State Avery-Knodel	Roy Hofheinz, Pres. Bill Bennett, Gen. & Coml. Mgr. Marcel Gau, Prog. Dir.	Lauri Schutt, Prom. Mgr. O. B. Johnson, Chief Engr.	Capitol UP Gates
KTRH 1930	740 50,000 DA-1	KTRH Bcstg. Co. Rice Hotel Preston 4361	CBS Texas Blair	B. F. Orr, Pres. & Gen. Mgr. Ray Herndon, Asst. Gen. Mgr. Ray Bright, Nat'l. Sales Mgr.	Ted Nabors, Prog. Dir. Monte Kleban, Prom. Mgr. Lester Mullan & Tom Hiner, Engrs.	World AP, INS RCA
KTRH-FM 1947	Ch. 266 (B) 101.1mc 33kw					
KXYZ 1930	1320 5,000 DA-N	Shamrock Bcstg. Co. Gulf Bldg. Capitol 6151	ABC Lone Star Free & Peters	Glenn H. McCarthy, Pres. Reese Reinecker, V. P. & Gen. Mgr. Terry Lee, V. P. & Coml. Mgr.	Tom Franklin, Prog. Dir. Lee Hogg, Prom. Mgr. Gerald R. Chinski, Tech. Supvsr.	Lang-Worth Standard AP RCA
KXYZ-FM 1948	Ch. 243 (B) 96.5mc 15kw					General Electric
HUNTSVILLE						
KSAM 1938	1490 250	J. G. Long P. O. Box 312 666	MBS, KBS	J. G. Long, Pres. Bryan Powell, Gen. Mgr. H. C. Balles, Res. Mgr.	Donald L. Gullhur, Prog. Dir. J. C. Dorrell, Coml. & Prom. Mgr. John W. Neathery, Chief Engr.	Capitol AP
JACKSONVILLE						
KEBE 1946	1400 250	Billy A. Laurie Pierce Lane & Lake St. 2211	Ra-Tel	Bill A. Laurie, Owner & Gen. Mgr. J. G. Johnson, Coml. Mgr. Gary Smitherman, Prog. Dir.	(Mrs.) Emo Laurie, Prom. Mgr. Wm. M. McCreary Jr., Chief Engr.	Lang-Worth SESAC UP
JASPER						
KTXJ 1948	1240 250	Jasper Bcstg. Co. Texas Theatre Bldg. 580		Joe J. Fisher, Pres. Ray Sherman, Gen. Mgr.	Bill Tompkins, Coml. & Prom. Mgr. Eddie Lamb, Chief Engr.	Capitol SESAC UP Collins
KERMIT						
KERB (CP)	600 1,000 D DA	Kermit Bcstg. Co.				
KERRVILLE						
KEVT 1948	1230 250	Kerr Co. Bcstg. Co.				
KILGORE						
KOCA 1936	1240 250	Oil Capitol Bcstg. Assn. Inc. 102½ E. North St. 1300	KBS	Roy G. Terry, Pres. H. A. Degner, Gen. Mgr. Lewis W. Christie, Coml. Mgr.	Walton Stewart, Prog. Dir. Karem O. Soule, Chief Engr.	AP Collins
KINGSVILLE						
KINE 1948	1330 1,000-D	Estate of Jack Henry Kidd Jr. 205 E. King 1317	Best	Josephine Pate Kidd, Pres. Ben A. Glusing, Gen. Mgr. Eston R. Pace, Coml. & Sta. Mgr.	Robert R. Freimuth, Prog. Dir. R. T. Whitaker, Chief Engr.	Standard UP Raytheon
LAMESA						
KPET 1947	690 250-D	Lamesa Bcstg. Co. P. O. Box 30 690	KBS	Kermit Ashby, Gen. & Coml. Mgr. (Mrs.) Mary Connor, Prog. Dir.	Clayton Barkhurst, Prom. Mgr. Eugene R. Cornelius, Chief Engr.	AP Gates
LAMPASAS						
KHIT 1948	1450 250	Lampasas Bcstg. Co. Highway 281 721		Sylvester Lewis & Robert O. Easton, Partners Harry Van Slycke, Gen. Mgr. & Prog. Dir.	A. W. Landers, Prom. Mgr. Robert O. Easton, Coml. Mgr. Don Peak, Chief Engr.	Lang-Worth UP Gates
LAREDO						
KPAB 1938	1490 250	Laredo Bcstg. Co. Hamilton Hotel 2124	MBS Pearson	Mark Perkins, Pres. Joe Allison, Gen. Mgr. Barry Stratton, Coml. Mgr.	Dick Smith, Prog. Dir. Hulon Smith, Chief Engr.	Capitol UP Western Electric
LEVELLAND						
KLVT 1949	1230 250	Herald Bcstg. Co. P. O. Box 866 1030		Forrest Weimhold, Owner Bill Spiller, Gen. Mgr. Jack Lee, Coml. & Prom. Mgr.	Fred Collins, Prog. Dir. W. Thomas Davis Jr., Chief Engr.	Standard AP RCA
LITTLEFIELD						
KVOW 1947	1480 250	J. C. Rothwell-J. B. Mc- Shan P. O. Box 191 400		J. C. Rothwell, Pres. J. B. McShan, Gen. Mgr. Norman Gibson, Coml. Mgr.	Othell Witson, Prog. Dir. James Zackery, Chief Engr.	MacGregor AP Gates
LONGVIEW						
KFRO 1934	1370 1,000 DA-N	Voice of Longview Curtis Bldg. 411	ABC, KBS Texas State Cooke	James R. Curfis, Pres.		AP RCA
KLTI 1948	1280 1,000-D	R. G. LeTourneau Inc. P. O. Box 1866 4331	LBS	R. G. LeTourneau, Pres. Lloyd Hawkins, Gen. Mgr. Arthur L. Greene, Coml. Mgr.	Lawrence Birdsong, Prog. Dir. & Prom. Mgr. Kenneth Maxwell, Chief Engr.	Associated UP, INS Raytheon
KLTI-FM 1948	Ch. 290 (B) 105.9mc 10kw					General Electric

DA-N Directional Antenna, night only. FM's in italic.
DA-1 Directional Antenna, same pattern day and night.
DA-2 Directional Antenna, different pattern day and night.

*-Non-Commercial Station. D-Day. N-Night. ST-Share Time. SH-Specified Hours.
U-Unlimited. CP-Construction Permit Issued. LS-Local Sunset.
L-Limited Time with Dominant Station. SA-Special Authorization.

KPRC

FIRST in Hooper... ***FIRST*** in BMB...
FIRST in the South's First Market

KPRC
HOUSTON

950 Kilocycles 5000 Watts
National Representatives: Edward Petry and Company
... Affiliated with NBC and TQN ...
Jack Harris, General Manager.



DIRECTORY OF AM, FM, and TV STATIONS OF THE UNITED STATES

*(Data corrected to December 6, 1949)
If executives or services for FM or TV stations are same as AM affiliate names are not repeated.*

TEXAS—(Continued)

City	Call Letters	Chan. or Freq. Power	Name of Licensee Headquarters Address Telephone Number	Network Representative	Executive Personnel	Transc. Library News Service Transmitter Make	
LUBBOCK							
	KCBD 1947	1590 1,000 DA-2	Caprock Bcstg. Co. 1803 Broadway 6348	MBS Pearson	Joe H. Bryant, Pres. & Gen. Mgr. Leroy Land, Coml. & Prom. Mgr.	Robert L. Snyder, Asst. Mgr. & Prog. Dir. Frank Lee, Chief Engr.	World AP Western Electric
	KFYO 1927	1340 250	Plains Radio Bcstg. Co. 914 Ave. J. 5567	ABC Lone Star Taylor-Borroff	Gene A. Howe, Pres. Gordon Thompson, Gen. Mgr. O. L. Taylor, Exec. Gen. Mgr.	Leete Jackson, Coml. Mgr. W. S. Biedsoe, Chief Engr.	Standard AP, UP RCA
	KFYO-FM 1948	Ch. 258 (B) 99.5mc 13kw					Lang-Worth AP
	KSEL 1946	950 1,000-LS 500-N-DA	Lubbock Bcstg. Co. P. O. Box 1524 6376	Holman	Walter G. Russell, Pres. David P. Pinkston, Gen. Mgr. M. M. Rochester, Coml. Mgr.	S. A. Harral, Prog. Dir. Roger Hively, Chief Engr.	Lang-Worth AP
LUFKIN							
	KRBA 1938	1340 250	Darrell E. Yates Lufkin	KBS Continental	Darrell E. Yates, Owner & Prom. Mgr.		
	KRBA-FM	Ch. 238 (B) 95.5mc 2.9kw					
	KTRE 1947	1420 1,000 DA-N	Forest Capital Bcstg. Co. P. O. Box 701 1420	MBS LBS Lone Star Taylor-Borroff	R. W. Wortham, Pres. Richman G. Lewin, Gen. Mgr. & Prog. Dir.	Kenneth Barfield, Coml. Mgr. Hampton Keathly, Prom. Mgr. Fred C. Hill, Chief Engr.	World AP Raytheon
MARSHALL							
	KMHT 1947	1450 250	Marshall Bcstg. Co. 109 West Rusk 7826	MBS, KBS Texas State	J. P. Duncan, Pres. Myrl Stein, Gen. Mgr. Bob Martin, Coml. Mgr.	Katie Hylton, Prog. Dir. R. L. Clay, Chief Engr.	Lang-Worth AP
McALLEN							
	KRIO 1947	910 1,000 DA-1	Frontier Bcstg. Co. Inc. P. O. Box 1551 1700	ABC, MBS Texas State Weed	Gene L. Cagle, Pres. Ingham S. Roberts, Gen. & Coml. Mgr.	William Crable, Prog. Dir. William Dickson, Prom. Mgr. William Meiners, Chief Engr.	SESAC AP Western Electric
McKINNEY							
	KMAE 1947	1600 1,000-D	McKinney Air Enterprises Inc. 218 East Virginia St. 183	LBS Best	George W. Smith Jr., Pres., Gen. Mgr. & Chief Engr. Jas. M. Carey, Coml. Mgr.	Melvin Belew, Prom. Mgr. (Miss) Denise Adkins, Prog. Dir. & Asst. Mgr.	Lang-Worth AP
MIDLAND							
	KCRS 1935	550 5,000-LS 1,000-N DA-2	Clarence & Ruth Scharbauer 112 W. Missouri 1080	ABC Texas State Pearson	Clarence Scharbauer Jr. & Ruth Scharbauer, Partners J. M. McDonald, Gen. & Prom. Mgr.	G. L. McDonald, Coml. Mgr. Wayne Harrell, Prog. Dir. Tom Yates, Chief Engr.	Standard UP Raytheon
MINERAL WELLS							
	KORC 1946	1140 250-D	Raymond W. River Community Center 319	KBS LBS	Raymond W. River, Pres. & Gen. Mgr. W. W. Wharton, Coml. Mgr.	Bunnette Meyers, Prog. Dir. Raymond Blocker, Chief Engr.	Lang-Worth AP Raytheon
MONAHANS							
	KVKM 1946	1340 250	Monahans Bcstrs. Inc. 317 S. Hoxie 438	MBS Southwest Cactus Taylor-Borroff	Charles W. Stuckey, Pres. & Gen. Mgr. Larry Fischer, Coml. Mgr.	(Miss) Jacqui Tipton, Prog. Dir. John A. Straight, Chief Engr.	World UP Gates
MT. PLEASANT							
	KIMP 1948	960 1,000-D	Mt. Pleasant Bcstg. Co. P. O. Box 990 915	LBS Best	Winston O. Ward, Pres. & Gen. Mgr. Jessie Pate, Coml. Mgr.	Bob Lawrence, Prog. Dir. Henry N. Fones, Chief Engr.	Lang-Worth AP Gates
NACOGDOCHES							
	KOSF 1947	1230 250	Kelly Bell South St.		Kelly Bell, Owner	Robert C. Atherton, Gen. Mgr.	
	KSFA 1947	860 1,000-D	Nacogdoches Bcstg. Co. Inc. 1509 North St. 860	LBS Girard	Wilbur C. Fouts, Pres., Gen. & Coml. Mgr. Ann Simon, Prog. Dir.	Brunel Harvey, Prom. Mgr. George Middlebrook, Chief Engr.	Capitol AP Gates
NEW BRAUNFELS							
	KGNB (CP)	1420 1,000-D	Comal Bcstg. Co. P. O. Box 372 Brownwood, Tex.		Charles W. Scruggs, Claud Scruggs, A. W. Stewart & Franklin T. Wilson, Partners	Alton W. Stewart, Chief Engr.	
ODESSA							
	KECK 1947	920 1,000-D	Ector County Bcstg. Co. P. O. Box 1369 5791		Ben Nedow, Owner, Gen. & Prom. Mgr. Chuck Wilson, Coml. & Sales Prom. Mgr.	Maude Wilson, Prod. Mgr. Roy A. Elsner, Prog. Dir. John Rowlets, Chief Engr.	Lang-Worth Standard AP Raytheon
	KOSA 1947	1230 250	Southwestern Bcstg. Corp. 115 West 6th St. 4301	CBS Southwest Lone Star Taylor-Borroff	Paul Moss, Pres. Cecil L. Trigg, Gen. Mgr. Robert H. Montgomery Jr., Coml. Mgr.	John Vacca, Prog. Mgr. Bill Gillett, Prom. Mgr. James H. Simpson, Chief Engr.	Capitol AP RCA
	KRIG 1946	1410 1,000 DA-N	Oil Center Bcstg. Co. Inc. 111 E. Fifth 6871	MBS Cactus	R. O. Canon, Pres. Jack W. Hawkins, Gen. Mgr. Woody Grove, Coml. Mgr.	Clarence Garmes, Prog. Dir. David Soule, Chief Engr.	World UP Western Electric
ORANGE							
	KOGT 1948	1600 1,000 DA-N	Sabine Area Bcstg. Corp. 407 10th St. 4381	Best	Phillip E. Dusenbury, Gen. & Coml. Mgr.	Larry Dietz, Prog. Dir. Richard E. Suggs, Chief Engr.	Capitol UP Collins
PALESTINE							
	KNET 1936	1450 250	Palestine Bcstg. Corp. 219 Municipal Bldg. 8686	MBS Ra-Tel	B. A. Laurie, Pres. Eddie Evans, Gen. Mgr. Don Norton, Coml. Mgr.	Marvin Crain, Prog. Dir. LaVeda Norris, Prom. Mgr. Jimmie Richardson, Chief Engr. UP Raytheon
PAMPA							
	KPAT (CP)	1230 250	Hugh DeWitt Landis & Ross B. McAlister				
	KPDN 1936	1340 250	C. H., Harry & Jane Holles 212 North Ballard 1100	MBS Sears & Ayer	C. H. Holles Harry Holles Jane Holles Ken Palmer, Gen. Mgr. Jean Peters, Prom. Mgr.	Tom Capps & Elton Lathrop, Coml. Mgrs. Danny Sullivan, Prog. Dir. Garth W. Osborne, Chief Engr.	World AP Gates

DA-N Directional Antenna, night only. FM's in italic.
DA-1 Directional Antenna, same pattern day and night.
DA-2 Directional Antenna, different pattern day and night.

*—Non-Commercial Station. D—Day. N—Night. ST—Shares Time. SH—Specified Hours.
U—Unlimited. CP—Construction Permit Issued. LS—Local Sunset.
L—Limited Time with Dominant Station. SA—Special Authorization.

DOUBLE COVERAGE for DALLAS - FT. WORTH!



s-t-r-e-t-c-h
that Dollar!

Make it do double-duty in a billion dollar market with the famous WRR-KFJZ combination...over-lapping coverage, simultaneous or separate schedules, at a single, economical price!

"THE BILLION DOLLAR AUDIENCE"



KFJZ—FORT WORTH

WRR—DALLAS

NATIONAL REPRESENTATIVE—JOHN BLAIR & CO.
NEW YORK • CHICAGO • DETROIT • ST. LOUIS • LOS ANGELES • SAN FRANCISCO

DIRECTORY OF AM, FM, and TV STATIONS OF THE UNITED STATES

(Data corrected to December 6, 1949)
If executives or services for FM or TV stations are same as AM affiliate names are not repeated.

TEXAS—(Continued)

City Call Letters Established	Chan. or Freq. Power	Name of Licensee Headquarters Address Telephone Number	Network Representative	Executive Personnel	Transc. Library News Service Transmitter Make
PARIS					
KPLT 1937	1490 250	North Texas Bcstg. Co. Inc. Gibraltar Hotel 1124	ABC Texas State Pearson	Julian L. Hill, Gen. Mgr. Ann Nipp, Asst. Mgr. Paul Schlintz, Coml. Mgr.	Ina Sheppard, Prog. Dir. Paul H. Daniels, Chief Engr. AP RCA
PASADENA					
(CP)	1480 1,000-D	Felix Morales			
PECOS					
KIUN 1935	1400 250	Jack Hawkins & Barney Hubbs 308 S. Cedar 21	MBS, KBS Cactus Southwest	Jack Hawkins & Barney Hubbs, Partners Jack Hawkins, Gen. Mgr.	Don Brooks, Coml. Mgr. W. D. Martin Jr., Prog. Dir. Harry Boehnemann, Chief Engr. UP RCA
PERRYTON					
KEYE 1948	1400 250	Great Plains Bcstg. Co. Perryton 377	MBS	Carl Ellis, Pres. Irvin R. Buchanan, Gen. & Coml. Mgr.	Zeb Williams, Prog. Dir. Coy Thompson, Chief Engr. Lang-Worth Capitol AP Gates
PLAINVIEW					
KVOP 1944	1400 250	W. J. Harpole Veigle Bldg. 1400	MBS, KBS	W. J. Harpole, Pres. Rial L. Campbell, Gen. Mgr. Bill Harrell, Coml. Mgr.	Keith Loyd, Prog. Dir. Robert Zellermayer, Prom. Mgr. Clark Norris, Chief Engr. Capitol AP RCA
KPLW (CP)	1570 250-D	West Texas Bcstrs.			
PORT ARTHUR					
KOLE 1947	1340 250	Port Arthur Bcstg. Co. P. O. Box 1126 2-9436	LBS	Socs Vratis, Partner, Gen. Mgr. & Chief Engr.	Mary Ann Petru, Partner, Prog. Dir. & Asst. Mgr. Glenn Hewitt, Coml. Mgr. Lang-Worth AP Gates
KPAC 1934	1250 5,000-LS 1,000-N DA	Port Arthur College 1515 Lakeshore Dr. 7458	MBS	W. D. Mauldin, Pres. Marjorie R. Vickers, Mgr. Corinne Enos, Prog. Dir.	Lee Barras, Prom. Mgr. George Crouchet Jr., Sales Mgr. Morris Glenn Boatright, Chief Engr. Standard World AP RCA
ROSENBERG					
KFRD 1948	980 500-D	Ft. Bend Bcstg. Co. Inc. P. O. Box 832 980	Best	Mart Cole Sr., Pres. Jim Halgrove, Gen. & Coml. Mgr.	Bob Cutting, Prog. Dir. Frank Wood, Chief Engr. Capitol MacGregor UP Gates
SAN ANGELO					
KGKL 1928	960 5,000-LS 1,000-N-DA	KGKL Inc. St. Angelus Hotel 6715	ABC Texas State Pearson	H. C. Ragsdale, Pres. Lewis Seibert, Gen. Mgr. Bob Bradbury, Coml. Mgr.	Jeanne Rau, Prog. Dir. Bill Poteet, Chief Engr. AP RCA
KTKL 1947	1340 250	WesTex Bcstg. Co. P. O. Box 1565 7183	MBS Lone Star Taylor-Borroff	A. D. Rust, Pres. Robert M. Baird, Gen. Mgr. D. J. Hostetter, Coml. Mgr.	Don Phillips, Prog. Dir. & Prom. Mgr. Robert Benson, Chief Engr. Capitol AP Western Electric
SAN ANTONIO					
KABC 1926	680 50,000-LS 10,000-N DA	Alamo Bcstg. Co. Milam Bldg. 10,000-N 3126	ABC Texas State Blair	Gene L. Cagle, Pres. Bill Michaels, Sta. Mgr. E. L. Colbourn, Coml. Mgr.	L. Jerry Spengler, Prom. Mgr. Joseph B. Haigh, Chief Engr. World AP Westinghouse
KBKX (CP)	990 1,000 D	Bexar Bcstg. Co.			
KCOR 1945	1350 5,000-LS 1,000-N DA-2	KCOR Inc. 214 Broadway Cathedral 1301	McKinney	R. A. Cortez, Pres. Charles Harris, Mgr.	Wm. P. Smythe, Coml. Engr.
KEYL(TV) 1949	Ch. 5 76-82mc 9kw-aur.; 17.9kw-vis.	San Antonio TV Co. 1434 M&W Tower Dallas, Tex. Riverside 3128	DuMont Young	H. H. Coffield W. L. Pickens R. L. Wheelock	} Owners DuMont
KITE 1947	930 1,000-D	Charles Balthrope 315 Transit Tower Fannin 0335	IMS	Charles Balthrope, Pres. & Gen. Mgr. Alex Coe, Coml. Mgr.	Alec Chesser, Prog. Dir. John Siercovich, Chief Engr. AP Collins
KIWW 1948	1540 250-D	Good Neighbor Bcstg. Co. 518 W. Houston St. Fannin 5255	McGillvra	Manuel D. Leal, Gen. Mgr. Perez Del Rio, Prog. Dir.	L. E. Richards, Chief Engr. Collins
KMAC 1926	630 5,000 DA-2	The Walmac Co. 222-224 West Commerce St. Cathedral 6211	MBS Texas State Pearson	Howard W. Davis, Owner, Gen. & Coml. Mgr. Anthony S. Bessan, Prog. Dir.	Shirley Ann Minor, Prom. Mgr. Charles L. Brady, Chief Engr. Lang-Worth Cole AP Western Electric
KISS(FM) 1946	Ch. 258 (B) 99.5mc 170kw	(KMAC, AM affiliate)			General Electric
KONO 1927	1400 250	Mission Bcstg. Co. 317 Arden Grove Fannin 5171	Forjoe	Eugene J. Roth, Pres. Jack L. Pink, Gen. Mgr. James M. Brown, Coml. Mgr.	Bob A. Roth, Prom. Mgr. Bob Jenkins, Prog. Dir. George Ing, Chief Engr. World Standard AP, UP
KONO-FM 1948	Ch. 225 (B) 92.9mc 48kw				General Electric
KTSA 1928	550 5,000 DA-N	Sunshine Bcstg. Co. Avenue E & 3rd St. Garfield 3131	CBS Free & Peters	Frank G. Huntress Jr., Pres. Charles D. Lutz, Gen. & Coml. Mgr.	N. E. Thompson, Prog. Dir. W. G. Egerton, Chief Engr. Associated Lang-Worth AP, UP RCA
KTSA-FM 1946	Ch. 268 (B) 101.5mc 72kw				General Electric

DA-N Directional Antenna, night only. FM's in italic.
DA-1 Directional Antenna, same pattern day and night.
DA-2 Directional Antenna, different pattern day and night.

*—Non-Commercial Station. D—Day. N—Night. ST—Share Time. SH—Specified Hours.
U—Unlimited. CP—Construction Permit Issued. LS—Local Sunset.
L—Limited Time with Dominant Station. SA—Special Authorization.

HERE'S THE AREA FROM WHICH 7,653 KABC LISTENERS

WROTE IN RESPONSE
TO A PICTURE OFFER
ON 3 "NOONDAY
JAMBOREE" SHOWS

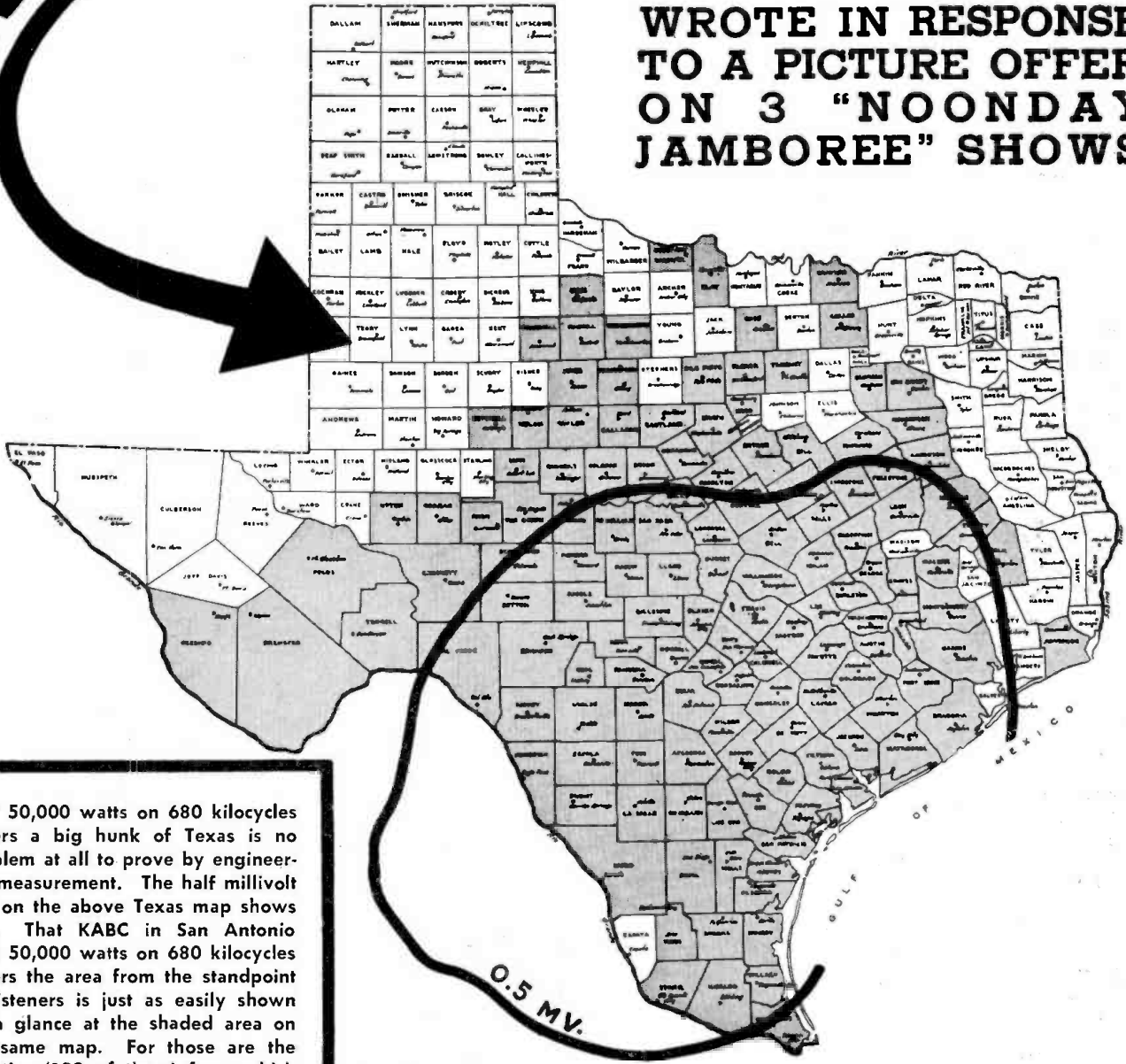

That 50,000 watts on 680 kilocycles covers a big hunk of Texas is no problem at all to prove by engineering measurement. The half millivolt line on the above Texas map shows that. That KABC in San Antonio with 50,000 watts on 680 kilocycles covers the area from the standpoint of listeners is just as easily shown by a glance at the shaded area on the same map. For those are the counties (138 of them) from which eager listeners wrote in to receive a post card picture of KABC's popular "Noonday Jamboree" cast in response to an offer made on only three programs. Power, physical coverage, programming, responsive listeners. They make up a combination well worth investigation with your John Blair man.

50,000 WATTS **RADIO STATION** **680 KC** **KABC** **680 KILOCYCLES**
SAN ANTONIO

AMERICAN BROADCASTING COMPANY

DIRECTORY OF AM, FM, and TV STATIONS OF THE UNITED STATES

(Data corrected to December 6, 1949)
If executives or services for FM or TV stations are same as AM affiliate names are not repeated.

TEXAS—(Continued)

City Call Letters Established	Chan. or Freq. Power	Name of Licensee Headquarters Address Telephone Number	Network Representative	Executive Personnel	Transc. Library News Service Transmitter Make	
SAN ANTONIO—(Continued)						
WOAI 1922	1200 50,000	Southland Industries Inc. P. O. Box 2841 Garfield 4221	NBC Petry	G. A. C. Halff, Chmn. of Bd. Hugh A. L. Halff, Gen. Mgr. Jack Keasler, Coml. Mgr.	Jerry Lee, Prog. Dir. Dallas Wyant, Prom. Mgr. Charles L. Jeffers, Chief Engr.	Capitol UP Standard AP, UP, INS RCA
WOAI-TV 1949	Ch. 4 66-72mc 10.8kw-aur.; 21.6kw-vis.		Petry ABC CBS NBC	J. R. Duncan, Dir. TV Progs.		
SAN MARCOS						
KCNY 1948	1470 250-D	Central Bcstg. Co. P. O. Box 32 888	LBS	Ed C. James, Pres. Frank Stewart, Gen. & Coml. Mgr. Jim Bell, Prog. Dir.	Merl Saxon, Prom. Mgr. & Chief Engr.	Capitol UP Collins
SEGUIN						
KWED 1948	1580 250-D	Weldon Lawson 200 S. Camp St.; 1580		Weldon Lawson, Pres. Garfield Kiel, Gen. Mgr.	Ed Moore, Coml. Mgr. & Prog. Dir. H. H. Callen, Chief Engr.	Lang-Worth UP Raytheon
SHAMROCK						
KEVA 1949	1580 250-D	Shamrock Texas Bcstg. Co. P. O. Box 20; 620		Albert Cooper, Pres. John Kennedy, Gen. Mgr. Charles Cooper, Coml. Mgr.	Acton Tillery, Prog. Dir. & Chief Engr.	Lang-Worth UP Western Electric
SHERMAN						
KRRV (Denison) 1936	910 1,000 DA-1	Red River Valley Bcstg. Corp. Fannin & Owing Sts. (Denison) 421 N. Crockett; (Sherman) 423 (Denison); 201 (Sherman)	MBS Texas Pearson	G. H. Wilcox, Pres. L. L. Hendrick, Gen. & Coml. Mgr. in Sherman Orvin Franklin, Gen. & Coml. Mgr. in Denison	Norman Phillips, Prog. Dir. T. E. Spellman, Sta. Dir. Tom John, Chief Engr.	World Thesaurus UP Western Electric
KTAN 1949	1500 250-D	Sherman Bcstg. Corp. P. O. Box 61; 2910	LBS	E. T. Fant Jr., Pres. & Gen. Mgr. Leon McDonald, Coml. Mgr.	Bill Jaco, Prog. Dir. W. P. Phillips, Chief Engr.	AP; Raytheon
SNYDER						
KSNY 1949	1280 500-D	Blake-Formby Bcstg. Co. Snyder 810	Best	John Blake & Marshall Formby, Owners Marshall Formby, Gen. Mgr.	Clint Formby, Coml. Mgr. & Prog. Dir. Roy Johnson, Chief Engr.	Lang-Worth UP RCA
KVPH (CP) 1947	122v 250-D	Scurry Co. Bcstrs.				
STAMFORD						
KDWT 1947	1400 250	David W. Ratliff Stamford 840	MBS KBS	David W. Ratliff, Pres. & Gen. Mgr. William L. Edwards Jr., Coml. Mgr.	Lahoma Dickson, Prog. Dir. Priscilla Ratliff, Prom. Mgr. Opal Davis, Chief Engr. AP
STEPHENVILLE						
KSTV 1947	1510 250-D	Doyle E. Collup P. O. Box 34	KBS	Doyle E. Collup, Owner	 UP
SULPHUR SPRINGS						
KSST 1947	1230 250	Hopkins County Bcstg. Co. Pulley Bldg. 1230	MBS KBS	William N. Edwards, Pres. Bill Bradford, V. P., Gen. Mgr. & Chief Engr.	Clovis Pinion, Coml. Mgr. Tom Brubaker, Prog. Dir. AP Gates
SWEETWATER						
KKOK 1939	1240 250	Sweetwater Radio Inc. Roby Highway 4655	MBS Best	J. S. McBeath, Pres. J. Harley Hubbard, Gen. Mgr. Elwood Fritsch, Coml. Mgr.	Jack Funk, Prog. Dir. & Prom. Mgr. J. T. Allen, Chief Engr.	Standard UP RCA
TAYLOR						
KTAE 1948	1260 1,000-D	KTAE Inc. 121½ East 2nd St. 1260	LBS	Gillis Conoley, Pres., Gen., Coml. & Prom. Mgr.	Robert S. Heller, Prog. Dir. & Asst. Mgr. Gordon W. Rainey, Chief Engr.	World UP Raytheon
TEMPLE						
KTEM 1936	1400 250	Bell Bcstg. Co. Inc. 17 S. Third St.; 5252	MBS	Frank W. Mayborn, Pres. Burton Bishop, Gen. Mgr.	J. E. Callaway, Coml. Mgr. Curtis Casey, Chief Engr.	Lang-Worth UP; RCA
KTEM-FM 1948	Ch. 298 (B) 107.5mc; 1.9kw					
TEXARKANA						
KCMC 1932	1230 250	KCMC Inc. 317 Pine St. 3-6151	ABC Texas State Taylor-Borroff	Frank O. Myers, Gen. Mgr. Thomas E. Dillahunt, Coml. Mgr.	Herman Cecil, Prog. Dir. Harvey Robertson, Chief Engr.	Lang-Worth AP Western Electric
KCMC-FM 1947	Ch. 251 (B) 98.1mc 40kw			Donald H. Myers, Prod. Mgr.		
KTFS 1946	1400 250	Texarkana Bcstg. Co. 409½ State Line Ave. 35-123	MBS Razorback Sears & Ayer	David M. Segal, Gen. & Coml. Mgr. Les Eugene, Prog. Dir.	David Wommack, Chief Engr.	World UP Collins
TEXAS CITY						
KTLW 1948	920 1,000-D	J. G. Long Show Boat Theatre Bldg. 2240	KBS	J. G. Long, Pres. Joe Brown, Gen. Mgr.	W. R. Pierre, Coml. & Sta. Mgr. & Prog. Dir. Melvin Wagner, Chief Engr.	Capitol Thesaurus UP Gates
TYLER						
KGKB 1930	1490 250	East Texas Bcstg. Co. 115 S. College 2-3875	MBS Pearson Gene Grant	Jas. G. Ulmer, Owner William E. Moore, Coml. Mgr.	J. Edwin Smith, Prog. Dir. Hudson C. Collins, Chief Engr.	World UP General Electric
KGKB-FM 1947	Ch. 268 (B) 101.5mc 10kw					
KTBB 1947	600 500-D	Blackstone Bcstg. Co. Blackstone Hotel 4-7278	Lone Star LBS Taylor-Borroff	S. H. Bothwell, Dir. M. E. Danborn, Gen. & Coml. Mgr. David Bothwell, Asst. Mgr.	Donald Tousch, Prog. Dir. R. A. Wileman, Chief Engr.	Thesaurus UP Western Electric
UVALDE						
KVOU 1947	1450 250	E. J. & W. J. Harpole 1450 Batesville Rd. 717	MBS KBS	Edward J. & W. J. Harpole, Partners Edward J. Harpole, Gen. Mgr.	Bob Hicks, Prog. Dir. & Chief Engr. Joe Watson Jr., Gen. & Prom. Mgr. UP Gates
VERNON						
KVWC 1939	1490 250	Northwestern Bcstg. Co. 1813 Wilbager St.	MBS KBS Clark	John Crabtree, Coml. Mgr.		
KVWC-FM	Ch. 254 (B) 98.7mc 8kw					

DA-N Directional Antenna, night only. FM's in italic.
DA-1 Directional Antenna, same pattern day and night.
DA-2 Directional Antenna, different pattern day and night.

*—Non-Commercial Station. D—Day. N—Night. ST—Share Time. SH—Specified Hours.
U—Unlimited. CP—Construction Permit Issued. LS—Local Sunset.
L—Limited Time with Dominant Station. SA—Special Authorization.

MOST ECONOMICAL MEANS OF SELLING MORE MERCHANDISE TO MORE PEOPLE

In these 65 counties
50-100% of the Radio
Families listen regu-
larly to WOAI both
day and night. (BMB
study No. 1)

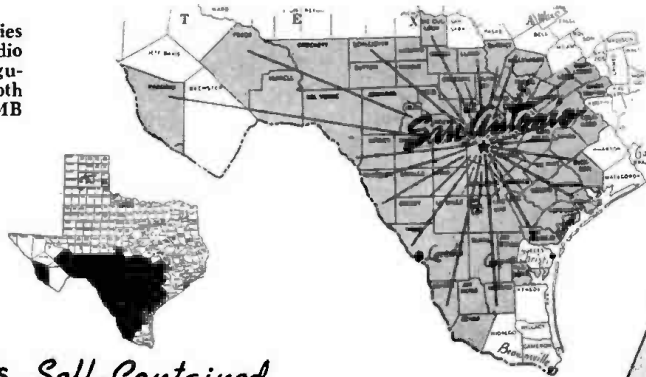

...in this *Self-Contained*

BILLION-DOLLAR MARKET*

For food, clothing and a thousand daily needs 1,337,500° people in these self-contained 65-counties rely for distribution upon a single great city—San Antonio. They comprise 316,700 BMB Radio Families. Retail Sales in 1948 exceeded \$1,000,000,000° . . . up 13.8% over the previous year. And, according to C. E. Hooper's "Listening Area Coverage Index" of Fall 1948, WOAI takes you into more homes in these 65-counties than any other station . . . more by 2 to 1 in daytime . . . more by 3 to 1 at night. Ask your Petry man for the full story!

(°COPR. 1949, SALES MANAGEMENT SURVEY OF BUYING POWER;
FURTHER REPRODUCTION NOT LICENSED.)

WOAI

CLEAR CHANNEL
50,000 WATTS
NBC — TQN

28th
year of
faithful

AM

service
to the great
Southwest

...now maintaining
the same high
standards with

TV

service to South
Texas!

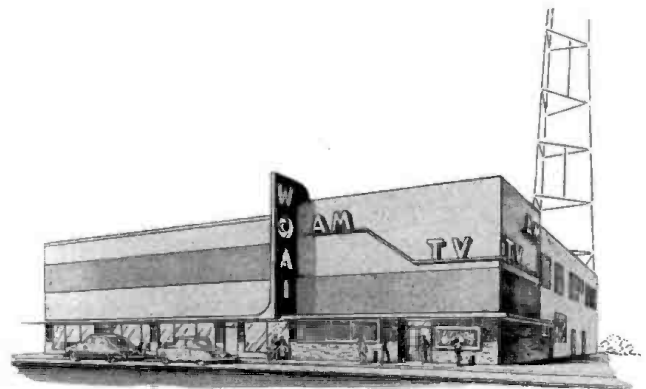

Reputation assures repetition in the life of San Antonio's first television station! The reputation of its management over nearly three decades of AM broadcasting is a precious heritage of WOAI-TV . . . and assures a repetition of its careful operation and conscientious service both to the people of South Texas and to its clients. Ask the Petry representative who calls on you!

ABC — NBC — CBS

OWNED AND OPERATED BY
SOUTHLAND INDUSTRIES, INC.

BOTH STATIONS REPRESENTED BY EDWARD PETRY & COMPANY, INC.

NEW YORK, CHICAGO, LOS ANGELES, DETROIT, ST. LOUIS, SAN FRANCISCO, ATLANTA, DALLAS

WOAI-TV

CHANNEL 4

SAN ANTONIO

DIRECTORY OF AM, FM, and TV STATIONS OF THE UNITED STATES

*(Data corrected to December 6, 1949)
If executives or services for FM or TV stations are same as AM affiliate names are not repeated.*

TEXAS—(Continued)

City Call Letters Established	Chan. or Freq. Power	Name of Licensee Headquarters Address Telephone Number	Network Representative	Executive Personnel	Transc. Library News Service Transmitter Make	
VICTORIA						
KNAL 1949	1410 500-D-DA	Victoria Bcstg. Co. P. O. Box 1410 1410	Best	Truman Belcher, Pres. Pat Reed, Coml. Mgr.	Carruth Palmer, Prog. Dir. & Prom. Mgr. Russell C. Walters, Chief Engr.	World UP Collins
KVIC 1940	1340 250	KVIC Bcstg. Co. Inc. P. O. Box 725 1106	MBS	J. G. Long, Pres. Bob Sharp, Gen. & Prom. Mgr. Jim Truehart, Coml. Mgr.	Dottie Dotson, Prog. Dir. Bob McCown, Chief Engr.	Capitol AP Western Electric
WACO						
KWTX 1946	1230 250	KWTX Bcstg. Co. Inc. 108½ South 6th St. 3-7331	MBS LBS McKinney	M. N. Bostick, Gen. Mgr. J. Mack Brinegar, Coml. Mgr.	Charles Hinkle, Prog. Dir. & Prom. Mgr. Lester R. Grubbs, Chief Engr.	World AP Western Electric
WACO 1922	1460 1,000 DA-N	Frontier Bcstg. Co. Amicable Life Bldg. 2-6571	ABC Texas State Weed	R. Lee Glasgow, Gen. Mgr. Stanley Wilson, Coml. Mgr.	Bob Walker, Prog. Dir. Jesse Dove, Chief Engr.	AP RCA
WAXAHACHIE						
KELL (CP)	1390 500 D-DA	Ellis County Bcstg. Co.				
WESLACO						
KRGV 1927	1290 5,000 DA-N	Taylor Radio & Tele- vision Corp. 201 Border 375	NBC Lone Star Texas Quality Taylor-Borroff	O. L. (Ted) Taylor, Pres. Byron W. Ogle, Gen. Mgr. Phil D. Dixon, Coml. Mgr.	James D. Cook, Prog. Dir. Thelma Pearce, Prom. Mgr. O. Lewis Hartwig, Chief Engr.	Lang-Worth SESAC AP, UP RCA
WICHITA FALLS						
KFDX 1947	990 5,000-LS 1,000-N DA	Wichtex Radio & TV Co. Inc. City Nat'l. Bank Bldg. 2-8668	ABC Lone Star Taylor-Borroff	Darold A. Cannan, Pres. W. P. Hood, Gen. Mgr. George Craig, Prog. Dir.	Sid Grayson, Coml. Mgr. Dorris Schaaf, Prom. Mgr. John Adams, Chief Engr.	Lang-Worth World AP RCA
KTRN 1949	1290 5,000-LS 1,000-N DA	Texoma Bcstg. Co. 917½ Scott St. 2-5214	MBS LBS Pearson	James B. Barnett, Pres. Boyd Kelley, Gen. & Coml. Mgr.	Bill Richie, Prog. Dir. & Prom. Mgr. Bob Harmon, Chief Engr.	Capitol AP Collins
KWFT 1939	620 5,000 DA-N	KWFT Inc. P. O. Box 420 4182	CBS Blair	Kenyon Brown, Pres. Charles E. Clough, Gen. Mgr. Blaine Cornwell, Prog. Dir.	A. L. Pierce, Prom. Mgr. Herbert T. Wiley, Chief Engr.	Standard UP RCA
KWFT-FM 1948	Ch. 260 (B) 99.9mc 9.7kw					

DA-N Directional Antenna, night only. FM's in italic.
DA-1 Directional Antenna, same pattern day and night.
DA-2 Directional Antenna, different pattern day and night.

*—Non-Commercial Station. D—Day. N—Night. ST—Share Time. SH—Specified Hours.
U—Unlimited. CP—Construction Permit Issued. LS—Local Sunset.
L—Limited Time with Dominant Station. SA—Special Authorization.

KWFT
WICHITA FALLS, TEX.
620 KC
5,000 WATTS

KLYN
AMARILLO, TEX.
940 KC
1,000 WATTS

TWO TOP CBS STATIONS
TWO BIG SOUTHWEST MARKETS
ONE LOW COMBINATION

WHEN you're making out that schedule for the Southwest don't overlook this sales-winning pair of CBS stations. For availabilities and rates, write, phone or wire our representatives.

NATIONAL REPRESENTATIVES JOHN BLAIR & CO.

For **THE BEST** in



- REGIONAL PROMOTIONAL CAMPAIGNS
- DIRECT SALES
- VISUAL CLOCK PROMOTION
- VISUAL ALBUM PROMOTION

Our Thanks to

- WESC
- KVWC
- KWHW
- KTXL
- KBST
- KXOX
- KSTV
- KELP
- WEAR
- WANS
- KVSO
- KTAN
- KBWD
- KWFC
- &
- OTHERS!



SPOTLIGHT CAMPAIGNS

GEORGE R. TURPIN *& Associates*

Post Office Box 802

FORT WORTH 1, TEXAS

DIRECTORY OF AM, FM, and TV STATIONS OF THE UNITED STATES

*(Data corrected to December 6, 1949)
If executives or services for FM or TV stations are same as AM affiliate names are not repeated.*

UTAH

City Call Letters Established	Chan. or Freq. Power	Name of Licensee Headquarters Address Telephone Number	Network Representative	Executive Personnel	Transc. Library News Service Transmitter Make
BRIGHAM CITY					
KBUH 1948	800 250-D	Samuel L. Stephens Sr. 948 W. Forest Rd. 948		Samuel L. Stephens Sr., Pres. Samuel L. Stephens Jr., Gen. Mgr. & Chief Engr.	Wade M. Ebeling, Coml. Mgr. J. Donald Stewart, Prog. Dir.
CEDAR CITY					
KSUB 1937	1340 250 CP590 1,000 DA-N	Southern Utah Bcstg. Co. Hotel El Escalante 398	CBS Intermountain	Ivor Sharp, Pres. Roscoe A. Grover, Gen. Mgr.	Arthur L. Higbee, Coml. Mgr. & Prog. Dir. Hurscheil G. Urie, Chief Engr.
LOGAN					
KVNU 1938	610 1,000 DA-N	Cache Valley Bcstg. Co. P. O. Box 264 1400	MBS, KBS Don Lee Intermountain Avery-Knodel	Herschel Bullen, Pres. Reed Bullen, Gen., Coml. & Prom. Mgr.	Don Reber, Prog. Dir. Del Monte Olesen, Chief Engr.
MURRAY					
KMUR 1948	1230 250	Murray Bcstg. Service 4646 South State 1360		Oral J. Wilkenson, Pres. James Peterson, Gen. Mgr. Howard Pingree, Coml. Mgr.	Gil Henry, Prog. Dir. & Prom. Mgr. Fred Weibell, Chief Engr.
OGDEN					
KLO 1929	1430 5,000 DA-1	Interstate Bcstg. Corp. Hotel Ben Lomond 5721	MBS Intermountain Avery-Knodel	A. L. Glasmann, Pres. George B. Morgan, Sta. Mgr. Collin W. Lowder, Coml. Mgr. & Prog. Dir.	Clinton Raymond, Prom. Mgr. Wayne T. Boothe, Chief Engr.
KOPP 1947	730 1,000-D	James B. Littlejohn Route 2	KBS Friedenberg	James B. Littlejohn, Gen. Mgr.	Flo Wineriter, Asst. Mgr.
KOPP-FM 1947	Ch. 280 (A) 103.9mc 1kw				
KVOG 1948	1490 250	United Bcstg. Co. 1538 Gibson Ave. 27535		Arch G. Webb, Pres. & Gen. Mgr.	Joe T. Johnson, Coml. Mgr. Gerald W. Peterson, Prom. Dir. & Chief Engr.
PRICE					
KOAL 1936	1230 250	Eastern Utah Bcstg. Co. Price 200	MBS, KBS Intermountain Avery-Knodel	Jack Richards, Pres., Gen. & Coml. Mgr. & Prog. Dir.	Carl P. Wolfrom, Prom. & Asst. Mgr. Leo E. Reid, Chief Engr.

DA-N Directional Antenna, night only. FM's in italic.
DA-1 Directional Antenna, same pattern day and night.
DA-2 Directional Antenna, different pattern day and night.

*—Non-Commercial Station. D—Day. N—Night. ST—Share Time. SH—Specified Hours.
U—Unlimited. CP—Construction Permit Issued. LS—Local Sunset.
L—Limited Time with Dominant Station. SA—Special Authorization.

IN SALT LAKE CITY

KSL delivers the biggest audience throughout the entire week. Average rating 11.4! 34.9% of all listeners!

IN 73 "OUTSIDE" COUNTY UNITS

KSL also leads in week's listeners. Average weekly rating 9.4! 32.2% of the audience!

THROUGHOUT ALL INTERMOUNTAIN AMERICA

KSL is far ahead of all other stations and regional networks. Commands an average rating of 9.9 . . . 32.9% of all listeners all week long!

These are facts from the KSL Listener Diary, conducted throughout KSL's BMB 50-100% day-night common coverage area by independent Benson & Benson, Inc.

To get customers, use KSL — for KSL costs less per customer than any other station or regional network.

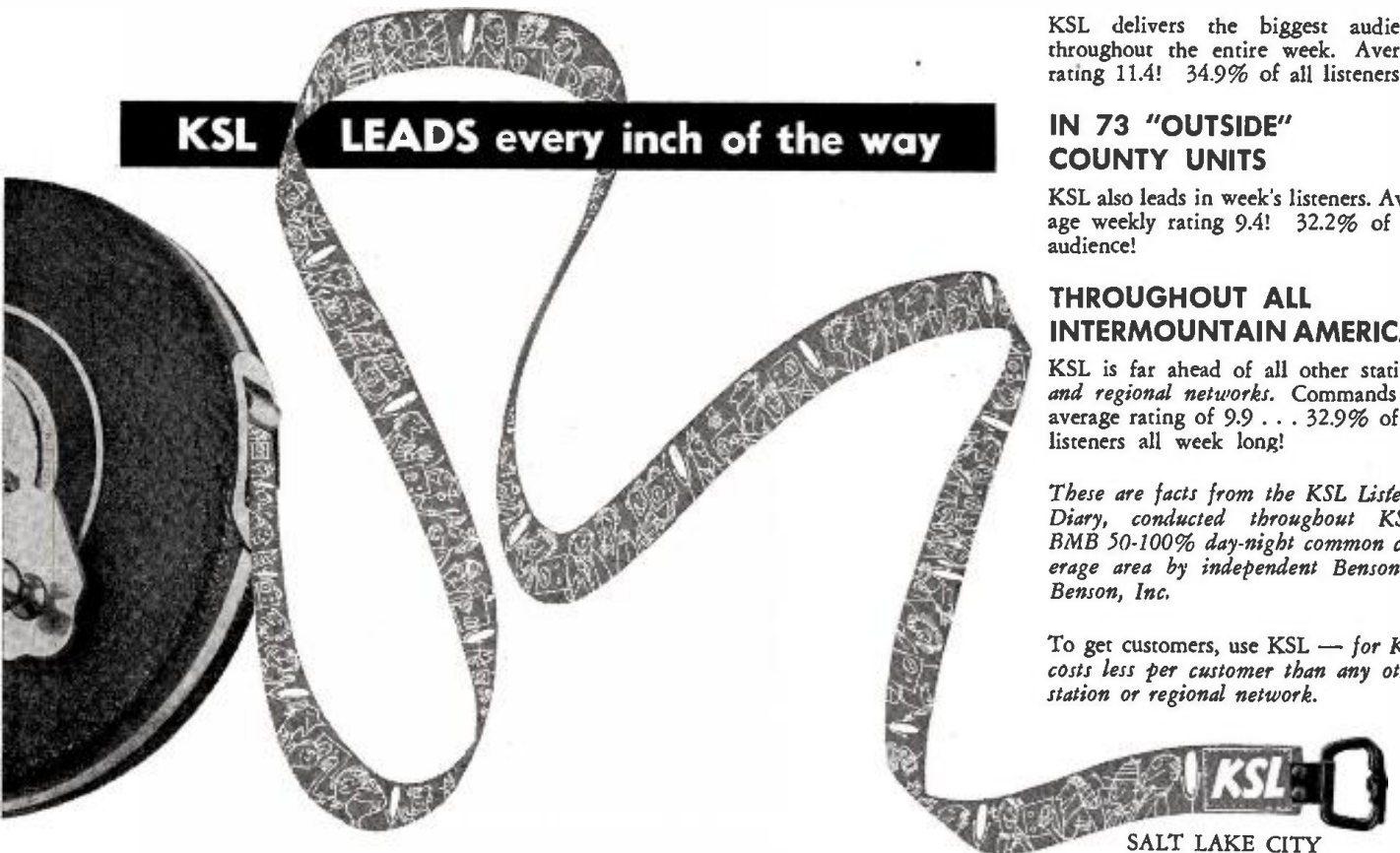

SALT LAKE CITY

50,000 WATTS • CBS • Represented by RADIO SALES

City Call Letters Established	Chan. or Freq. Power	Name of Licensee Headquarters Address Telephone Number	Network Representative	Executive Personnel	Transe. Library News Service Transmitter Make	
PROVO						
KCSU 1947	1490 250	Central Utah Bcstg. Co. Inc. P. O. Box 550 2802	Biddick	Frank A. Van Wagenen, Pres. Harold E. Van Wagenen, Gen. Mgr. & Prog. Dir.	John T. Hyde, Coml. Mgr. Merlin North, Chief Engr.	Standard Capitol UP
KNEU 1949	1450 250	Lester R. Taylor				
KOVO 1939	960 1,000 DA-N	KOVO Bcstg. Co. 108 W. Center St. 1680	MBS Intermountain Avery-Knodel	Clifton A. Tolboe, Pres. Arch L. Madsen, Gen. Mgr. L. H. Curtis, Coml. Mgr.	James H. Lawrence, Prog. Dir. Dewain Silvester, Prom. Mgr. Henry Keyes, Chief Engr.	World AP RCA
RICHFIELD						
KSVC 1947	690 1,000-D	Sevier Valley Bcstg. Co. Richfield 620	Intermountain Avery-Knodel	W. L. Warner Jr., Gen. Mgr. J. R. Warner, Coml. Mgr. Frank Peacock, Prog. Dir.	Bill King, Prom. Mgr. David I. Hansen, Chief Engr.	SESAC World UP Collins
SALT LAKE CITY						
KALL 1945	910 1,000 DA-1	Salt Lake City Bcstg. Co. Inc. 146 S. Main St. 43561	MBS Intermountain Avery-Knodel	George C. Hatch, Pres. Alvin C. Pack, Exec. V. P. & Mgr. Thomas H. Anderson, Coml. Mgr.	Jack Paige, Prog. Dir. Craig Rogers, Prom. Mgr. W. D'Orr Cozzens, Chief Engr.	UP RCA
KDYL 1922	1320 5,000 DA-1	Intermountain Bcstg. & TV Corp. 143 S. Main 5-2991	NBC Blair	S. S. Fox, Pres. & Gen. Mgr. George A. Provol, Coml. Mgr. Emerson Smith, Prog. Dir.	Del Leeson, Prom. Mgr. John M. Baldwin, Chief Engr.	Associated Thesaurus UP, INS
KDYL-FM 1947	Ch. 254 (B) 98.7mc 9kw					
KDYL-TV 1948	Ch. 4 66-72mc 2.0kw aur.; 3.7kw vis.		Blair TV	Dan Rainger, Prog. Dir. Allen Gunderson, Chief Engr.	J. M. Baldwin, Dir. of TV	
KNAK 1945	1280 1,000-LS 500 N-DA	Granite Dist. Radio Bcstg. Co. 219 Continental Bank Bldg. 4-3685		Howard D. Johnson, Pres. Richard F. Connor, Secy.-Treas. & Gen. Mgr. Richard I. Nicholes, Coml. Mgr.	Robert P. Crawford, Prog. Dir. King Harmon, Prom. Mgr. Myron May, Chief Engr.	AP
KSL 1922	1160 50,000	Radio Service Corp. of Utah Union Pacific Bldg. 5-4641	CBS Radio Sales	J. Reuben Clark Jr., Pres. Ivor Sharp, Exec. V. P. C. Richard Evans, Gen. Mgr. Frank McLatchy, Sales Mgr. Lynn McKinlay, Dir. FM Oprs.	Edward B. Kimball, Prog. Dir. Sherril Taylor, Pub. & Prom. Mgr. Vincent E. Clayton, Chief Engr.	Associated World AP, UP Western Electric Collins
KSL-FM 1946	Ch. 262 (B) 100.3mc 5.9kw					
KSL-TV 1949	Ch. 5 76-82mc 9.6kw aur.; 18.4kw vis.		ABC, CBS DuMont	D. Lennox Murdoch, Dir. of TV Oprs.		General Electric
KUTA 1938	570 5,000 DA-1	Utah Bcstg. & Televi- sion Co. 29 S. State St. 3-2737	ABC Rocky Mountain Hollingbery	Frank C. Carman, Pres. & Gen. Mgr. John Schile, Coml. Mgr.	Ray Fadel, Prog. Dir. Allan Thomas, Prom. Mgr. Wendell Bell, Chief Engr.	World Standard AP, UP RCA
VERNAL						
KJAM 1947	1340 250	Uintah Bcstg. Co. Hotel Vernal 494	Grant	James C. Wallentine, Pres. Leland E. Walker, Gen. Mgr. Grant E. Parry, Coml. Mgr.	Erwin W. Boelter, Prog. Dir. & Chief Engr.	UP
VERMONT						
BRATTLEBORO						
WTSA 1450 250		Granite State Bcstg. Co. Brattleboro	Granite State Bolling	William J. Barkley, Pres. W. F. Rust Jr., Gen. Mgr.	Ralph Gottlieb, Coml. Mgr.	
BURLINGTON						
WCAX 1931	620 5,000 DA-2	WCAX Bcstg. Corp. 135 Main St. 2000	CBS Weed	C. P. Hasbrook, Pres. & Gen. Mgr. J. D. Swan, Coml. & Prom. Mgr.	M. R. Slater, Prog. Dir. J. W. Tierney, Chief Engr.	Associated UP Gates
WJOY 1946	1230 250	Vermont Bcstg. Corp. 633 Main St. 5400	ABC Rambeau	David Howe, Pres. A. E. Spokes, Gen. Mgr.	John C. Quill, Prom. Mgr. & Chief Engr.	AP RCA

DA-N Directional Antenna, night only. FM's in italic.
DA-1 Directional Antenna, same pattern day and night.
DA-2 Directional Antenna, different pattern day and night.

*-Non-Commercial Station. D-Day. N-Night. ST-Share Time.
U-Unlimited. CP-Construction Permit Issued.
L-Limited Time with Dominant Station.

SH-Specified Hours.
LS-Local Sunset.
SA-Special Authorization.

VERMONT

is a
\$444,000,000* market

..... and ONLY WCAX covers it!

That's why more and more time buyers use this 5000-watt, CBS Affiliate—Vermont's oldest and most powerful station—to reach the Vermont market at one price. A market where the gross farm income, alone, is over \$100 million and retail sales are over \$344 million! They realize, too, that WCAX's 18 years of leadership have developed programming, facilities, and audience that bring results!



Plus \$158 million in New York Counties across Lake Champlain!

Market figures from Sales Management
Survey of Buying Power, 1949



Represented Nationally by
Weed & Co.

DIRECTORY OF AM, FM, and TV STATIONS OF THE UNITED STATES

*(Data corrected to December 6, 1949)
If executives or services for FM or TV stations are same as AM affiliate names are not repeated.*

VERMONT—(Continued)

City Call Letters Established	Chan. or Freq. Power	Name of Licensee Headquarters Address Telephone Number	Network Representative	Executive Personnel	Transc. Library News Service Transmitter Make	
MONTPELIER-BARRE						
WSKI 1947	1240 250	Montpelier-Barre Bcstg. Co. Inc. Union Mutual Bldg. 1740	Grant	B. M. Jacobsen, Pres. Paul H. Martin, V. P. & Gen. Mgr.	Robert Bannon, Prog. Dir. L. C. Davis, Chief Engr.	Lang-Worth AP
RUTLAND						
WHWB (CP)	1000 1,000-D	Central Vt. Bcstg. Co.				
WSYB 1930	1380 1,000 DA-N	Philip Weiss Music Co. 35 Washington St. 1247	MBS Yankee McGillvra	Philip Weiss, Pres. Jack H. Weiss, Gen. Mgr.	Norval K. Ramson Jr., Chief Engr.	Thesaurus UP Collins
ST. ALBANS						
WWSR 1941	1420 1,000-D	Vermont Radio Corp. 75 N. Main St. 1390	Walker	Lloyd Squier, Pres. Warren Marsden, Gen. Mgr.	Stuart Perry, Prog. Dir. Theodore Boisvert, Chief Engr.	World UP Collins
ST. JOHNSBURY						
WTWN 1949	1340 250	Twin State Bcstrs. Inc. P. O. Box 336 2344	McGillvra	E. Dean Finney, Pres. James F. McKernan & E. Dean Finney, Co-Mgrs.	Gordon James Platt, Prog. Dir. James F. McKernan, Chief Engr.	Lang-Worth SESAC UP Raytheon
WATERBURY						
WDEV 1931	550 1,000 DA-2	L. E. Squier 8 Stowe St. 400	MBS Yankee Walker	L. E. Squier, Pres., Gen. & Coml. Mgr.	Thomas L. Dodd Jr., Prog. Dir. Theodore Boisvert, Chief Engr.	World UP RCA

VIRGINIA

ALEXANDRIA						
WPIK 1945	730 1,000-D	Potomac Bcstg. Corp. Virginia Theatre Bldg. Overlook 3000		Howard B. Hayes, Pres., Gen. & Coml. Mgr.	Carl L. Lindberg, Prog. Dir. & Chief Engr.	Lang-Worth World AP Gates
ARLINGTON						
WARL 1946	780 1,000-D	Northern Virginia Bcstrs. Inc. P. O. Box 391 OWens 7800	IMS	R. Kilbourne Castell & Frank U. Fletcher, Co-Owners. Raymond W. Baker, Gen. Mgr.	William W. Jefferay, Coml. Mgr. John E. Strong, Chief Engr.	Standard Capitol UP Western Electric
WARL-FM 1948	Ch. 288 (A) 105.5mc 1kw					
WEAM 1947	1390 5,000 DA-1	Arlington Fairfax Bcstg. Co. 2030 N. 18th St. OWens 7100	Keller	Harold H. Thoms, Pres. Howard Stanley, Gen. & Coml. Mgr.	Matthew Warren, Prog. Dir. & Prom. Mgr. Sam Aed, Chief Engr.	Lang-Worth AP, TP Collins
BLACKSTONE						
WKLK 1947	1490 250	Nottoway Bcstg. Co. Inc. Community Bldg. 478	MBS Virginia	H. S. Robertson, Pres. Alexander Hudgins, Gen. Mgr. Edward J. Silverman, Coml. Mgr.	Arthur A. Moran Jr., Prog. Dir. Charles M. McCraw, Chief Engr.	AP Gates
BRISTOL						
WCYB 1946	690 10,000-D	Appalachian Bcstg. Corp. Hotel General Shelby North 3560	Bolling	Robert H. Smith, Gen. Mgr. J. Fey Rogers, Sales Mgr. (Mrs.) Grace Fauson, Bus. Mgr.	W. T. Lane Jr., Prog. Supvrs. Bob Dougherty, Transmitter Supvrs.	Associated Cole, World Thesaurus AP, UP Raytheon
WFHG 1946	860 1,000-D	Bristol Bcstg. Co. Hotel Bristol 2730	MBS	Morris B. Brunette, Gen. Mgr. W. L. Ninger, Coml. & Prom. Mgr.	Rex Raney, Prog. Dir. John L. Hughlett Jr., Chief Engr.	Standard UP Raytheon
CHARLOTTESVILLE						
WCHV 1933	1240 250	Barham & Barham Rose Hill Dr. 2-5121	ABC McGillvra	Charles Barham Jr., Owner Randolph Bean, Mgr. Robert C. Walker, Sales Mgr.	R. G. Sketchley Jr., Prog. Dir. Walter W. Gray, Chief Engr.	World AP Raytheon
WINA 1949	1280 1,000-D	Charlottesville Bcstg. Corp. 4th & Main Sts. 3377	MON	Frank T. Parker Jr., Pres Joe Porter, Coml. Mgr.	B. C. Hargreaves, Prog. Dir. & Oper. Mgr. Lawrence Kennedy, Chief Engr.	Standard Capitol UP Raytheon
COVINGTON						
WKEY 1941	1340 250	Earl M. Key Covington 8351	ABC KBS	Earl M. Key, Pres. & Gen. Mgr. Kenneth Bryant, Coml. Mgr. John Davis, Prog. Dir.	Willis Shawer, Prom. Mgr. John Wilson, Chief Engr.	World Western Electric
CREWE						
WSVS 1947	800 1,000-D	Southern Virginia Bcstg. Corp. Crewe 5000		C. S. Willis, Pres. Maxey E. Stone, Gen. & Prom. Mgr.	Harris L. Umstead, Coml. Mgr. C. E. Wilson, Chief Engr.	World AP Raytheon
WSVS-FM 1949	Ch. 284 (B) 104.7mc 14kw					
CULPEPER						
WCVA 1949	1490 250	Culpeper Bcstg. Corp. Radio Bldg. 8238	KBS	Ira C. Hopkins, Pres. George A. Flowers, Gen. & Prom. Mgr.	Mike Moscarello, Coml. Mgr. Homer Quann, Prog. Dir. Benny L. Jones, Chief Engr.	Lang-Worth Standard UP, Gates
DANVILLE						
WBTM 1930	1330 5,000-LS 1,000-N DA	Piedmont Bcstg. Corp. Hotel Danville Bldg. 2350	ABC Hollingbery	L. N. Dibrell, Pres. R. Sanford Guyer, Gen. Mgr. Edward G. Gardner, Asst. Mgr. P. W. Kaufman, Coml. Mgr.	Betty R. Allen, Prog. Dir. Herbert Hodge, Prom. Mgr. Lyle C. Motley, Chief Engr.	Lang-Worth AP RCA

DA-N Directional Antenna, night only. FM's in italic.
DA-1 Directional Antenna, same pattern day and night.
DA-2 Directional Antenna, different pattern day and night.

*—Non-Commercial Station. D—Day. N—Night. ST—Share Time. SH—Specified Hours.
U—Unlimited. CP—Construction Permit Issued. LS—Local Sunset.
L—Limited Time with Dominant Station. SA—Special Authorization.

City Call Letters Established	Chan. or Freq. Power	Name of Licensee Headquarters Address Telephone Number	Network Representative	Executive Personnel	Transc. Library News Service Transmitter Make	
DANVILLE—(Continued)						
WBTM-FM 1947	Ch. 250 (B) 97.9mc 32kw	Virginia-Carolina Bcstg. Co. American Nat'l Bank Bldg. 5300	MBS McGillvra	John D. Pruitt, Pres. Emerson J. Pryor, Gen. Mgr. Roy Springer, Coml. Mgr.	Richard E. Campbell, Prog. Dir. William J. Ashworth, Prom. Mgr. Rush Sawyers, Chief Engr.	Federal Standard UP Collins
WFAX 1948	1220 250-D	Lamar A. Newcomb P. O. Box L Falls Church 0900		Lamar A. Newcomb, Pres. & Gen. Mgr. James S. Hollins, Coml. Mgr.	Genevieve Newcomb, Prog. Dir. Ed Case, Prom. Mgr. Emmett J. Murphy, Chief Engr.	Thesaurus UP Gates
WFLO 1947	870 1,000-D	Colonial Bcstg. Co. P. O. Box 238 600	Clark	Carla B. Keys, Gen. Mgr. Charles R. Maillet, Mgr.	D. M. Shaver, Prog. Dir. Charles K. Chrismon, Chief Engr.	Associated Capitol UP
WFVA 1939	1230 250	Fredericksburg Bcstg. Corp. P. O. Box 269 1261	ABC KBS Burn-Smith	Richard F. Lewis Jr., Exec. V. P. & Gen. Mgr.	Walter F. Harris Jr., Sta. Mgr. William S. Candler, Chief Engr.	Lang-Worth Western Electric
WFTR 1948	1450 250	Sky-Park Bcstg. Corp. John Marshall Highway 750	MBS	Earl C. Pace, Pres. & Gen. Mgr. Ken Gordon, Coml. Mgr. Vernon Carter, Prog. Dir.	Augustine Kloc, Prom. Mgr. Owen Voigt, Chief Engr.	Thesaurus UP, TP Western Electric
WBOB 1947	1400 250	Carroll-Grayson Bcstg. Corp. Poplar Knob Rd. 300	MBS	Robert V. Morris, Pres. Carl E. Duckett, Gen. Mgr. & Chief Engr.	Joe P. Crockett, Coml. Mgr. Muriel Bell, Prog. Dir.	AP Raytheon
WVEC 1948	1050 250-D	Peninsula Bcstg. Corp. P. O. Box 481 6332	KBS	Thomas P. Chisman, Pres. & Gen. Mgr. Harroll A. Braver, Coml. Mgr.	Peter Edman, Prog. Dir. Vernon Carter, Prom. Mgr. James E. Swafford, Chief Engr.	Associated Standard AP Raytheon
WSVA 1935	550 1,000-D	Shenandoah Valley Bcstg. Corp. Newman Bldg. 550	NBC	Frederick L. Allman, Pres. Robert B. Harrington, Coml. & Prom. Mgr.	Richard H. Johnson, Prog. Dir. Warren L. Braun, Chief Engr.	UP
WSVA-FM 1946	Ch. 264 (B) 100.7mc 38kw					
WHAP 1949	1340 250	Hopewell Bcstg. Co. City Point & River Rd. 801		Augustus Robbins Jr., Pres. Hugh Carlyle, Gen. Mgr. George Thomason, Coml. & Prom. Mgr.	Barbara Rich, Prog. Dir. Edward L. Burwell, Chief Engr.	Lang-Worth UP Gates
WREL 1948	1450 250	Rockbridge Bcstg. Corp. 22 S. Main St. 6000	MBS KBS	Marshall L. Wilmer, Pres. Philip B. Hirsch, Gen. & Coml. Mgr.	Andrew P. Petersen, Prog. Dir. Lindley H. Leggett III, Chief Engr.	Capitol AP Ideco
WLVA 1930	590 1,000 DA-2	Lynchburg Bcstg. Corp. Allied Arts Bldg. 2-1242	ABC Hollingbery	Edward A. Allen, Pres. Philip P. Allen, Gen. Mgr. Joseph F. Wright Jr., Coml. Mgr.	William H. Loren, Prog. Dir. & Prom. Mgr. John T. Orth, Chief Engr.	Lang-Worth Associated AP; RCA
WLVA-FM 1947	Ch. 248 (B) 97.5mc 3.7kw					
WWOD 1947	1390 1,000 DA-1	Old Dominion Bcstg. Corp. 10th & Main Sts. 2-3441	MBS Walker	David Hugh Dillard, Pres. Jack Weldon, Gen. Mgr. Norman Simpson, Coml. Mgr.	Jay Seibel, Prog. Dir. & Prom. Mgr. Forest Pinkerton, Chief Engr.	World AP, UP Raytheon
WWOD-FM 1948	Ch. 300 (B) 107.9mc 39kw					Collins

Mr. Hooper Proves WBTM is Danville's First Station!

PERIOD: Winter 1948

HOOPER STATION LISTENING INDEX
City Zone

CITY: Danville, Va.



TIME	Share of Audience				
	WBTM	STATION B	STATION C	STATION D	OTHERS
8:00 AM—12:00 N Mon. thru Fri.	43.9	0.3	42.5	10.0	3.3
12:00 N—6:00 PM Mon. thru Fri.	45.2	1.1	29.0	17.7	7.0
6:00 PM—8:00 PM Sun. thru Sat.	46.0	3.7	38.6	3.2	8.5
8:00 PM—10:00 PM Sun. thru Sat.	44.8	5.6	34.5	8.6	6.5
6:00 PM—10:00 PM Sun. thru Sat.	45.4	4.8	36.3	6.2	7.3

Danville, Virginia is one of the best test markets in the South Atlantic States. Home of the World's Best Tobacco Market and the World's Biggest Textile Mill, (Danville's diversified industry makes it an outstanding distribution center). 1948 per capita retail sales is 43% above the national average. Total retail sales in 1948 surpassed 48 million.

WBTM

Established 1930

1330 kc

5,000 watts (d) 1,000 (n)

R. SANFORD GUYER

General Manager

Ask George Hollingbery & Co., or any ABC salesman

WBTM-FM

Established 1947

98 on your FM dial

32,000 watts

DIRECTORY OF AM, FM, and TV STATIONS OF THE UNITED STATES

(Data corrected to December 6, 1949)
If executives or services for FM or TV stations are same as AM affiliate names are not repeated.

VIRGINIA—(Continued)

City Call Letters Established	Chan. or Freq. Power	Name of Licensee Headquarters Address Telephone Number	Network Representative	Executive Personnel	Transc. Library News Service Transmitter Make	
MARION						
WMEV 1948	1010 1,000-D	Mountain Empire Bcstg. Corp. P. O. Box 470 9001	LBS Cooke	Robert Lane Anderson, Pres. Robert C. Wolfenden, Gen., Coml. & Prom. Mgr.	Mrs. Robert C. Wolfenden, Prog. Dir. William P. Grether, Chief Engr.	World Associated AP Western Electric
MARTINSVILLE						
WMVA 1941	1450 250	Martinsville Bcstg. Co. Inc. Chatham Heights 2152	NBC KBS	William C. Barnes, Pres. John W. Shultz, Gen. Mgr. Charles F. Adams, Coml. & Prom. Mgr.	Barbara Harding, Prog. Dir. Dewey W. Muse, Chief Engr.	AP RCA
WMVA-FM 1949	Ch. 242 (B) 96.3mc 2.70kw					REL
NEWPORT NEWS						
WGH 1929	1310 5,000 DA-1	Hampton Roads Bcstg. Corp. 500 Portlock Bldg. 27031	ABC Free & Peters	Raymond B. Bottom, Pres. Edward E. Bishop, Gen. Mgr. Edward E. Edgar, Coml. Mgr.	John A. Black, Prog. Dir. Charles A. Runyon, Chief Engr.	AP RCA
WGH-FM 1947	Ch. 243 (B) 96.5mc 38kw					
WHYU 1947	1270 1,000-D	Eastern Bcstg. Corp. 114 24th St. 7-1604	Friedenberg	John Doley, Pres. Frederic F. Clair, Sta. Mgr.	T. O. Bradshaw, Prog. Dir. John M. Smith, Prom. Mgr. Arthur F. Perks, Tech. Supvrs.	Capitol UP Gates
NORFOLK						
WCAV 1947	860 1,000-D	Cavalier Bcstg. Corp. Helena Bldg. 23266	Burn-Smith	Joseph Light, Pres. George L. Sutherland, Gen. & Coml. Mgr. William M. Manrow, Asst. Mgr.	Frank Facenda, Prog. Dir. Edward Dillard, Prom. Mgr. Stanley Strickland, Chief Engr.	Standard Lang-Worth UP Western Electric
WLOW 1947	1410 1,000-D	Commonwealth Bcstg. Corp. Pender Bldg. 45678	Forjoe	E. L. Scott, Pres. Robert E. Wasdon, V. P. & Gen. Mgr. W. M. Carpenter, Sta. Mgr.	Robert Drepperd, Prog. Dir. James Campbell, Prom. Mgr. Jack Siegel, Chief Engr.	UP Collins
WNOR 1949	1230 250	Norfolk Bcstg. Corp. 1019 Boissevain Ave. 56761	IMS	Louis H. Peterson, Pres. Earl Harper, Gen. Mgr. Bob Rodgers, Coml. Mgr.	A. Lee Mills, Prog. Dir. & Chief Engr.	Lang-Worth AP Gates
WRVC(FM) 1948	Ch. 273 (B) 102.5mc 7kw	Larus & Brother Co. Inc. 1506 Colley Ave. 4-1100	CBS Radio Sales	C. T. Lucy, Gen. Mgr. William R. Preston, Prog. Dir.	S. T. Terry Jr., Chief Engr. Robert E. Moody, Studio Mgr.	Lang-Worth World UP Western Electric
WTAR 1923	790 5,000 DA-N	WTAR Radio Corp. Natl. Bank of Commerce Bldg. 25671	NBC Petry	Campbell Arnoux, Pres. & Gen. Mgr. John W. New, Coml. Mgr.	Joel Carlson, Prog. Dir. John Peffer, Chief Engr.	Standard AP, UP RCA
WTAR-FM 1947	Ch. 247 (B) 97.3mc 50kw					
WTAR-TV (CP)	Ch. 4 66-72mc 12.25kw aur. 24.5kw vis.		NBC	Pierre Hathaway, Prog. Dir.		
NORTON						
WNVA 1946	1450 250	Blanfox Radio Co. Inc. Coalfield Progress Bldg. 700	MBS KBS	Richard B. Helms, Pres. Jack T. Helms, Gen. Mgr.	Bill Holland, Coml. Mgr. Tom Harrell, Prog. Dir. Gene Tommerdahl, Chief Engr.	Lang-Worth AP Temco
ORANGE						
WJMA 1949	1340 250	James Madison Bcstg. Corp. Orange 7263	MBS	Welford A. Sherman Jr., Pres. Arthur C. Livick Jr., Gen., Coml. & Prom. Mgr.	Charles McGinley, Prog. Dir. Talmadge England, Chief Engr.	UP Gates
PETERSBURG						
WSSV 1945	1240 250	Southside Virginia Bcstg. Corp. 112 W. Tabb St. 3881	MBS Burn-Smith	L. H. Peterson, Pres. Ray L. Moss, Gen. & Coml. Mgr. N. W. Andrews, Asst. Mgr.	Paul Hennings, Prog. Dir. James Lowell, Prom. Mgr. Edward F. Schwarz, Chief Engr.	Capitol AP
PORTSMOUTH						
WSAP 1943	1490 250	Portsmouth Radio Corp. 205 Professional Bldg. 7-3488	MBS Ra-Tel	Tom E. Gilman, Pres. B. Walter Huffington, Gen., Coml. & Prom. Mgr.	David N. Nelson, Prog. Dir. C. R. Sledge, Chief Engr.	Lang-Worth World UP Collins
WSAP-FM 1946	Ch. 259 (B) 99.7mc 100kw					Federal
PULASKI						
WPUV 1946	1230 250	Southwest Bcstg. Corp. P. O. Box 351 3-3931	MBS KBS Sears & Ayer	Howard R. Imboden, Pres. William R. Murray, Gen. Mgr. Allan S. Aden, Sales Mgr.	Robert R. Reiling, Prog. Dir. Eleanor T. Imboden, Prom. Mgr. Fitzgerald McDaniel, Chief Engr.	World AP Collins
RADFORD						
WRAD (CP)	1340 250	Rollins Bcstg. Inc.				
RICHMOND						
WBBL 1924	1450 250 SH	Grace Covenant Presbyterian Church 1627 Monument Ave. 84-2465		C. H. Liesfeld, Gen. Mgr.	R. W. Raabe, Chief Engr. Western Electric
WLEE 1945	1450 250; CP 1480 5,000 DA-2	Lee Bcstg. Corp. Broad-Grace Arcade 3-8741	MBS Forjoe	Thomas G. Tinsley Jr., Pres. Irvin G. Abeloff, Gen. & Coml. Mgr.	Harvey Hudson, Prog. Dir. George W. McGuigan Jr., Chief Engr.	Lang-Worth AP Western Electric
WLEE-FM 1948	Ch. 275 (B) 102.9mc 21kw					
WMBG 1926	1380 5,000 DA-N	Havens & Martin Inc. 3301 W. Broad St. 5-8611	NBC Blair	Wilbur M. Havens, Pres. & Gen. Mgr. Walter A. Bowry Jr., Coml. & Prom. Mgr.	Allan Phaup, Prog. Dir. W. H. Wood, Chief Engr.	Lang-Worth TP RCA

DA-N Directional Antenna, night only. FM's in italic. *—Non-Commercial Station. D—Day. N—Night. ST—Share Time. SH—Specified Hours.
DA-1 Directional Antenna, same pattern day and night. U—Unlimited. CP—Construction Permit Issued. LS—Local Sunset.
DA-2 Directional Antenna, different pattern day and night. L—Limited Time with Dominant Station. SA—Special Authorization.

FIRST



in Virginia...

JUST as Virginia is synonymous with historical firsts, so considered are the Havens and Martin Stations as Pioneers in the Old Dominion.

And rightfully so. In 1926, 5000 watt AM Station WMBG was established. Loyal Virginia listeners for 24 years have grown accustomed to the finest in radio programming and public service . . . a heritage sister station WCOD (FM) is proudly upholding. The first FM station in Virginia, WCOD's 50,000 watt voice penetrates Virginia with a signal unequalled anywhere.

WMBG-WCOD offers national advertisers a truly great service area.

Traditionally, Havens and Martin erected the South's finest television station, and its WTVR is truly one of the Pioneer TV properties in America.

Be it AM-FM-TV, the First Stations of Virginia are your logical media in the economic-stable Richmond market . . . which has seen the manufacturing increase in value by 76% in eight years; where effective buying income is near a half billion.

WMBG AM
WTVR TV
WCOD FM

First Stations of Virginia

Havens and Martin Stations, Richmond 20, Va.
John Blair & Company, National Representatives
Affiliates of National Broadcasting Company

DIRECTORY OF AM, FM, and TV STATIONS OF THE UNITED STATES

(Data corrected to December 6, 1949)
If executives or services for FM or TV stations are same as AM affiliate names are not repeated.

VIRGINIA—(Continued)

City Call Letters Established	Chan. or Freq. Power	Name of Licensee Headquarters Address Telephone Number	Network Representative	Executive Personnel	Transc. Library News Service Transmitter Make	
RICHMOND—(Continued)						
WCOB(FM) 1946	Ch. 251 (B) 98.1mc 47kw	(WMBG, AM affiliate)				
WTVR(TV) 1948	Ch. 6 82-88mc 6.3kw aur.; 12.16kw vis.	(WMBG, AM affiliate)	NBC Blair TV	Conrad Rlanhard, Prog. Dir.		
WRNL 1927	910 5,000 DA-N	Richmond Radio Corp. 111 N. 4th St. 3-3436	ABC Petry	D. Tennant Bryan, Pres. E. S. Whitlock, Gen. Mgr. Joseph H. Sierer, Sales Mgr.	Don Martin, Prog. Dir. E. V. Wolstenholme, Chief Engr.	Standard AP Western Electric
WRNL-FM 1948	Ch. 271 (B) 102.1mc 50kw					
WRVA 1925	1140 50,000 DA-1	Larus & Bro. Co. Inc. Hotel Richmond 3-6633	CBS Radio Sales	C. T. Lucy, Gen. Mgr. Berron Howard, Bus. Mgr.	S. S. Carey, Prog. Service Mgr. John L. Stone Jr., Prom. Mgr. D. C. Woods, Chief Engr.	World Lang-Worth UP Western Electric
WRVB(FM) 1948	Ch. 253 (B) 94.5mc 25kw	(WRVA, AM affiliate)		William R. Preston, Prog. Dir.	S. T. Terry Jr., Chief Engr.	
WXGI 1947	950 1,000-D	Radio Virginia Inc. 100 W. Franklin St. 7-4684	Burn-Smith	D. H. Robertson, Pres. R. E. Mitchell, Gen. Mgr.	Robert J. Jenkins, Prog. Dir. John Sinclair, Prom. Mgr. I. Kay Redd Jr., Chief Engr.	Lang-Worth AP Western Electric
ROANOKE						
WDBJ 1924	960 5,000 DA-N	Times-World Corp. 124 W. Kirk Ave. 8131	CBS Free & Peters	J. P. Fishburn, Pres. R. F. Jordan, Gen. Mgr. J. W. Harkrader, Coml. Mgr.	P. E. Reynolds, Prog. Dir. B. B. Boggs, Pub. Dir. J. E. Newman, Chief Engr.	World Lang-Worth AP, UP; RCA
WDBJ-FM 1948	Ch. 235 (B) 94.9mc 41kw					
WROV 1946	1240 250	Radio Roanoke Inc. 600 Mountain Trust Bldg. 3-4444	MBS Burn-Smith	Leo F. Henebry, Pres. Frank E. Koehler, Gen. & Coml. Mgr.	Gordon R. Phillips, Asst. Mgr. Frank A. Hall, Chief Engr. & Coml. Mgr.	Lang-Worth Capitol UP Western Electric
WROV-FM 1948	Ch. 279 (B) 103.7mc 3kw					

DA-N Directional Antenna, night only. FM's in italic.
DA-1 Directional Antenna, same pattern day and night.
DA-2 Directional Antenna, different pattern day and night.

*—Non-Commercial Station. D—Day. N—Night. ST—Share Time. SH—Specified Hours.
U—Unlimited. CP—Construction Permit Issued. LS—Local Sunset.
L—Limited Time with Dominant Station. SA—Special Authorizatio

WRNL

... saturates a Three-Quarter Billion Dollar Market!

Richmond, VIRGINIA is a steady, GROWING market, an area of STRONG BUYING POWER and ECONOMIC SECURITY, backed by firmly established manufacturing and farming activities.

Effective buying income—the dimes and dollars which buy your product—show a gain of 12.2%. Retail sales have gone up 9.25%. And population figures show a rise of 6.4%.

MORE PEOPLE with MORE MONEY to spend

In 39 of the 72-county WRNL coverage area, the BMB study shows that 50% or more of the radio families listen regularly to WRNL.

- Industrially PROGRESSIVE
- Agriculturally RICH
- Economically SOUND

WRNL is a steady, GROWING station, centered in this rich Richmond Marketing Area. "Radio Center" in Richmond, WRNL's new home, guarantees advertisers the most modern of broadcast facilities, the most complete radio service including simultaneous broadcast on WRNL-FM, and an ever increasing audience. Combined with its key-position in a TOP market, these make WRNL the EFFECTIVE Radio outlet for your advertising dollars.

5000 WATT ABC affiliate

Represented by Edward Petry & Co.

City Call Letters Established	Chan. or Freq. Power	Name of Licensee Headquarters Address Telephone Number	Network Representative	Executive Personnel	Transc. Library News Service Transmitter Make	
ROANOKE—(Continued)						
WLSL 1940	810 1,000 DA-2	Roanoke Bcstg. Corp. Shenandoah Bldg. 9227	ABC Weed	Paul C. Buford, Pres. James H. Moore, Exec. V. P. Horace Fitzpatrick, Asst. & Coml. Mgr.	Bill Saunders, Prog. Dir. Phillip Briggs, Chief Engr.	Thesaurus Associated AP RCA General Electric
WLSL-FM 1947	Ch. 256 (B) 99.1mc 4.7kw					
SOUTH BOSTON						
WHLF 1947	1400 250	Halifax Bcstg. Co. P. O. Box 490 2-9988	ABC KBS	John L. Cole Jr., Owner, Gen. & Coml. Mgr.	Charles B. Davis, Prog. Dir. & Prom. Mgr. David O. Guthrie, Chief Engr.	World AP
STAUNTON						
WTON 1946	1400 250	Charles P. Blackley Morrison Bldg. 5-5555	ABC	Charles P. Blackley, Owner & Gen. Mgr. Charles E. Seebeck, Coml. & Prom. Mgr.	Fulton A. King, Prog. Dir. Rex C. Houser, Chief Engr.	Associated AP
SUFFOLK						
WLPM 1940	1450 250	Suffolk Bcstg. Corp. Suffolk 5431	ABC KBS Sears & Ayer	Fred L. Hart, Pres., Gen. & Coml. Mgr. William W. Kitchen Jr., Prog. Dir.	Earl Hundley, Prom. Mgr. Veryl W. Rupp, Chief Engr.	Thesaurus AP Collins
WLPM-FM 1947	Ch. 299 (B) 107.7mc 10.2kw					
WARSAW						
WNNT 1949	690 250-D	Northern Neck & Tidewater Bcstg. Co. Warsaw 690		Grayson Headley, Pres. & Gen. Mgr. William Redd, Coml. Mgr.	T. F. Craver, Prog. Dir. & Sta. Mgr. Lawrence Bittner, Chief Engr.	Standard UP Gates
WAYNESBORO						
WAYE 1947	1490 250	Waynesboro Bcstg. Corp. 526 Main St. 6068	MBS KBS Cooke	Judson T. Phillips, Pres. N. Wilbur Kidd, Gen. Mgr.	Peter D. DeBoer, Coml. Mgr. Edward R. Goodwin, Chief Engr.	Lang-Worth UP Western Electric
WINCHESTER						
WINC 1941	1400 250	Richard Field Lewis Jr. Winchester 4855	ABC KBS	Richard Field Lewis Jr., Pres. & Gen. Mgr. John Carl Morgan, Coml. Mgr. & Prog. Dir.	Winslow T. Porter, Prom. Mgr. Phillip B. Whitney, Chief Engr.	Associated UP Western Electric Federal
WRFL(FM) 1946	Ch. 223 (B) 92.5mc 14kw	(WINC, AM affiliate)				
WYTHEVILLE						
WYVE 1949	1280 1,000-D	Wythe County Bcstg. Co. P. O. Box 452 840		A. M. Gates & Robert Hennis Epperson, Owners. A. M. Gates Jr., Gen. Mgr. Erle Howery, Coml. Mgr.	Zane Leeper, Prog. Dir. Robert Hennis Epperson, Chief Engr.	Lang-Worth UP Gates

*Are you getting TOP VALUE in Virginia's
TOP MARKET? . . .*

Taking secondary coverage at premium rates? . . .

Looking for results at reasonable cost? . . .

Then sign up for the economy buy for

NORFOLK

PORTSMOUTH

NEWPORT NEWS

* Serving the tri-cities of the great port of Hampton Roads from studios in Norfolk and Portsmouth. Get all the facts about the NEW WSAP-Tidewater's fastest growing station.

WSAP AM
PORTSMOUTH FM

B. Walter Huffington, General Manager

*** Ask Ra-Tel!**

DIRECTORY OF AM, FM, and TV STATIONS OF THE UNITED STATES

(Data corrected to December 6, 1949)
If executives or services for FM or TV stations are same as AM affiliate names are not repeated.

WASHINGTON

City Call Letters Established	Chan. or Freq. Power	Name of Licensee Headquarters Address Telephone Number	Network Representative	Executive Personnel	Transc. Library News Service Transmitter Make
ABERDEEN					
KBKW 1949	1450 250	Ben. K. Weatherwax 701 E. Heron St. 1015		Ben K. Weatherwax, Pres. & Gen. Mgr. Dick Crombie, Coml. Mgr.	Associated AP Collins
KXRO 1928	1320 1,000 DA-N	KXRO Inc. 207½ E. Market St. 4098	KBS MBS Don Lee Grant	Harry R. Spence, Pres. & Gen. Mgr. Frank G. Goddard, Coml. Mgr. UP Raytheon
BELLINGHAM					
KPUG 1948	1170 1,000 DA-1	KPUG Inc. P. O. Box 655 6200	MBS	Jessica L. Longston, Pres. Vicki Zaser, Exec. V. P. Robert E. Pollock, Gen. Mgr.	Associated AP Western-Electric
KVOS 1927	790 1,000 DA-1	KVOS Inc. 1321 Commercial St. 790	ABC McGillvra	Rogan Jones, Pres. & Gen. Mgr. John Clarke, Research Dir.	Lang-Worth MacGregor UP Western Electric
BREMERTON					
KBRO 1947	1490 250	Bruce Bartley 205 Washington 1970	Keating	Bruce Bartley, Pres. Jack Gwyer, Gen. Mgr. Tom Westbrook, Coml. Mgr.	World AP Western Electric
KGIB (CP)	1540 1,000-D	Kitsap G. I. Bcstrs.			
CENTRALIA—CHEHALIS					
KELA 1937	1470 1,000	Central Bcstg. Corp. P. O. Box 720 6-3321	MBS, KBS Don Lee Grant	J. Elroy McCaw, Pres. Joe Chytil, Gen. & Coml. Mgr. Schuyler Hill, Prog. Dir. UP Western Electric
COLFAX					
KCLX (CP)	1450 250	Interstate Radio Inc. P. O. Box 710 780	KBS	T. R. Farrier, Pres. Bert McAllister, Gen. & Prom. Mgr. & Prog. Dir.	Cole AP RCA
ELLENSBURG					
KXLE 1946	1240 250	Central Wash. Bcstrs. Inc. P. O. Box 60 2-1440	Walker	Goodwin Chase Jr., Pres. Joe Kendall, Gen. Mgr. Darrel Burns, Coml. Mgr.	Lang-Worth UP RCA
EPHRATA					
KULE (CP)	730 250-D	Columbia Basin Bcstg. Co.			
EVERETT					
KRKO 1922	1400; 250 CP 1380; 1,000 DA	Everett Bcstg. Co. Inc. KRKO Bldg. Cedar 1144	MBS Don Lee McGillvra	William R. Taft, Pres. & Gen. Mgr. UP Western Electric

DA-N Directional Antenna, night only. FM's in italic. *—Non-Commercial Station. D—Day. N—Night. ST—Share Time. SH—Specified Hours.
DA-1 Directional Antenna, same pattern day and night. U—Unlimited. CP—Construction Permit Issued. LS—Local Sunset.
DA-2 Directional Antenna, different pattern day and night. L—Limited Time with Dominant Station. SA—Special Authorization.



The Newsweekly of Radio and Television

READ

**by more agency-
advertiser executives
than any other
radio or TV journal**

Only **BROADCASTING** brings together the week in radio and TV. Spot news—largely unduplicated elsewhere—new business, agency-advertiser personnel changes, program, promotion ideas, talent news and costs . . . all easily read and quickly grasped.

ADVERTISERS read **BROADCASTING**—to know everything that will make their radio-TV advertising more productive, more economical.

ADVERTISING AGENCIES read **BROADCASTING**—to do a better, more complete job for their clients.

STATIONS, NETWORKS, SERVICES read **BROADCASTING**—to learn quickly and reliably what is happening, week by week, in their business.

76 **YOUR** business concerns radio-television you need **BROADCASTING-TELECASTING**—the only authentic reporter of every significant development in the field of mass radio communications.



NATIONAL PRESS BUILDING WASHINGTON 4, D. C.



WESTERN WASHINGTON

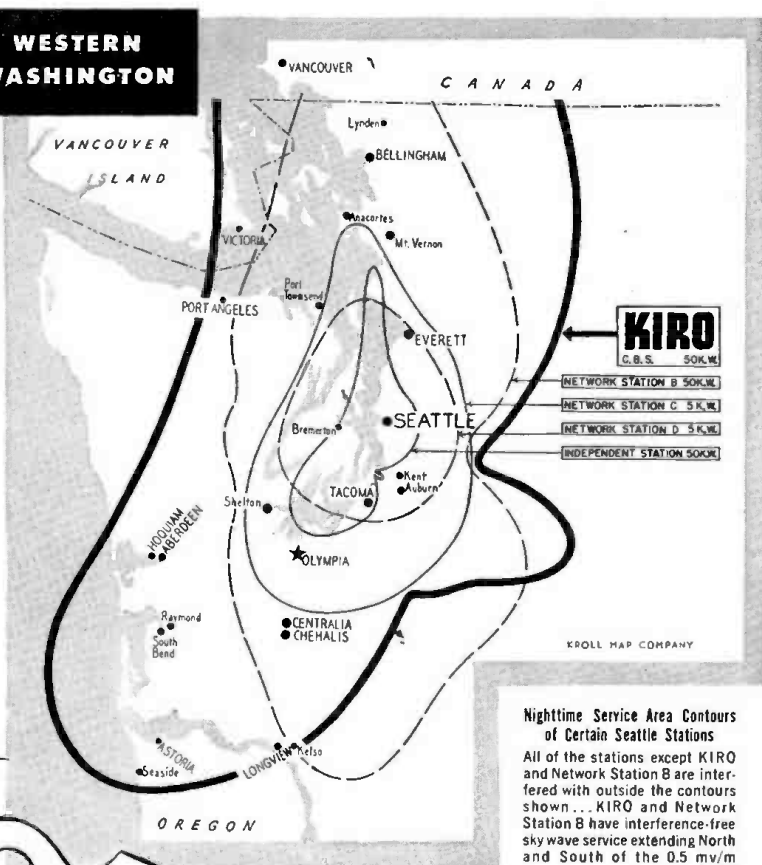

Nighttime Service Area Contours of Certain Seattle Stations
 All of the stations except KIRO and Network Station B are interfered with outside the contours shown... KIRO and Network Station B have interference-free sky wave service extending North and South of the 0.5 mv/m groundwave contours shown for these two stations.

what he uncovered - we cover!

EVER HEAR about the time Paul Bunyan dug Puget Sound and opened up the mouth of the Columbia River... all in the same day?
 Wouldn't be no big Pacific Northwest Market, if it weren't for old Paul.
 You see, Paul was visiting his folks in Maine when he got the call. He picked up Babe, his Blue Ox, somewheres around the Great Lakes and hustled out here to the evergreen country.
 About 3 o'clock that afternoon he'd finished with Puget Sound. Weren't even puffing. So he and Babe strolled down Oregon way, scooped up a channel to let the rain water get to the sea. That's the Columbia.
 Later that evening, when Paul stood ankle-deep in the ocean surveyin' his day's labor, KIRO went to work.
 Our engineers drew a line on the ground 'round Paul's shadow. This, they said, is what we want to cover with our protected 0.5 mv/m ground wave.
 The proper authorities said at the time it was okay. Still is.
 Mighty big job... done in a mighty big way. Two million folks living here now.
 For those two million... and for the advertisers who want to reach them... KIRO is still doing things in a mighty big way.

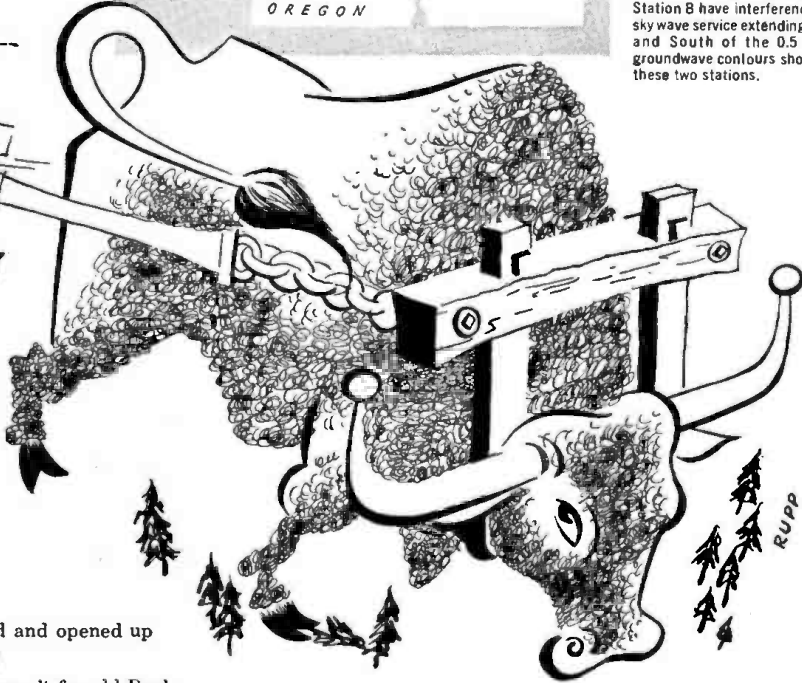

KIRO
 SEATTLE • TACOMA

REPRESENTED NATIONALLY BY FREE & PETERS

CBS FOR THE PACIFIC NORTHWEST **710 KC** 50,000 WATTS'

DIRECTORY OF AM, FM, and TV STATIONS OF THE UNITED STATES

(Data corrected to December 6, 1949)
If executives or services for FM or TV stations are same as AM affiliate names are not repeated.

WASHINGTON—(Continued)

City Call Letters Established	Chan. or Freq. Power	Name of Licensee Headquarters Address Telephone Number	Network Representative	Executive Personnel	Transc. Library News Service Transmitter Make	
KELSO						
KELS 1949	1490 250	Northwest Public Services P. O. Box 90 4900		Roscoe A. Day Jr., Pres. Claire O. Banks, Gen. Mgr. Johnny Carlson, Coml. Mgr.	Norman A. Wallace, Prog. Dir. Russell L. Conrad, Prom. Mgr. John E. Holmes, Chief Engr.	Capitol Standard UP Raytheon
KENNEWICK						
KWIE 1949	1230 250	Mid-Columbia Bcstrs. P. O. Box 437 6961	McHugh	Hal A. Clark, Mgr. & Partner Don E. Seeley, Coml. Mgr. & Partner	Marvin E. Johnston, Prog. Dir. & Partner Ken Waddell, Prom. Mgr. C. J. McCredie, Chief Engr. & Partner	World Associated AP Collins
KIRKLAND						
KRKL 1947	1050 250-D	East Side Bcstg. Co. Civic Center		F. L. Thomhill, Gen. Mgr.		
LONGVIEW						
KWLK 1938	1400 250	Twin City Bcstg. Corp. 14th & Hudson 1500	MBS Don Lee Grant	C. O. Chatterton, Pres. & Gen. Mgr. James Waggoner, Coml. Mgr.	Bob Moran, Prog. Dir. Lyle Laws, Prom. Mgr. Ralph Brown, Chief Engr.	World Associated UP RCA
KWLK-FM 1947	Ch. 280 (A) 103.9mc 0.41kw					
MOSES LAKE						
KSEM 1947	1450 250	KSEM Inc. P. O. Box 97 234	KBS Grant	Jessica Longston, Pres. Don G. Bennett, Gen. & Coml. Mgr.	Janet L. Adriance, Prog. Dir. Don Mas, Prom. Mgr. Roland G. Kissler, Chief Engr.	World UP Western Electric
MOUNT VERNON						
KBRC 1946	1430 500-D	Beckley Radio Co. P. O. Box 240 8955	Keating	Leo H. Beckley, Pres. & Gen. Mgr. Fred Grant, Coml. Mgr.	Bud Clark, Prog. Dir. Marilyn Anderson, Prom. Mgr. Orris Vanerstrom, Chief Engr.	Standard UP Western Electric
OLYMPIA						
KGY 1922	1240 250	Tom Olsen 119 N. Washington St. 6636	MBS Don Lee Grant	Tom Olsen, Pres. & Gen. Mgr. J. Harris Dorr, Coml. Mgr. Eve Knutson, Prog. Dir.	E. J. Holmberg, Prom. Mgr. C. A. Roark, Chief Engr.	World UP Western Electric
OMAK						
KOMW 1947	680 1,000-D	KOMW Inc. Omak	Keating	R. L. McNett, Pres. Dean C. Nichols, Gen. Mgr. C. Nat Harris, Coml. Mgr.	(Miss) Gene Leslie, Prog. Dir. Kirk W. Springer, Chief Engr.	Lang-Worth Capitol UP Western Electric
PASCO						
KPKW 1945	1340 250	Western Radio Corp. Pasco	Keating	A. G. Sanborn, Mgr.		
PORT ANGELES						
KONP 1945	1450 250	Radio Pacific Inc. 313 W. First St.	KBS Keating	C. N. Webster, Gen. Mgr.		World UP
PULLMAN						
*KWSC 1922	1250 5,000 ST-KTW	State College of Washington Arts Hall 9021		Dr. Wilson Compton, Pres. Allen Miller, Gen. Mgr. Eldon C. Barr, Prog. Dir.	Burt Harrison, Prom. Mgr. Robert E. Baird, Chief Engr.	World Associated Capitol AP, UP
RENTON						
KXRN 1947	1220 250-D	Interlake Bcstg. Corp. 7th Ave. & N. Park 5-3424		Robert S. McCaw, Pres. & Gen. Mgr. O. W. Simpson, Coml. Mgr.	Freddie Jensen, Prog. Dir. Frank C. Cook, Chief Engr.	World UP RCA
RICHLAND						
KALE 1950	900 1,000-D	Yakima Bcstg. Corp. P. O. Box 367	Grant	Robert S. McCaw, Pres. Lawrence Dix, Gen., Coml. & Prom. Mgr.	Dave Dorris, Prog. Dir. & Chief Engr.	UP General Electric
SEATTLE						
KING 1927	1090 50,000 DA-1	KING Bcstg. Co. Smith Tower Mutual 1090	Blair Walker Pacific Northwest	Henry B. Owen, Pres. Hugh M. Feltis, Sta. Mgr.	Dave Crockett, Prog. Dir. Arthur A. Shultz, Chief Engr.	Lang-Worth AP General Electric
KING-FM	Ch. 251 (B) 98.1mc 15kw					
KING-TV 1948	Ch. 5 76-82mc 9.79kw-aur.; 18.95kw-vis.		ABC, CBS DuMont NBC Blair TV	(Mrs.) A. Scott Bullitt, Chief Owner Bob Priebe, Oprs. Mgr.	Al Hunter, Coml. Mgr. Lee Schulman, Prog. Dir. George Freeman, Chief Engr.	UP RCA
KIRO 1935	710 50,000 DA-N	Queen City Bcstg. Co. 66 Cobb Bldg. Seneca 1500	CBS Columbia Pacific Free & Peters	Saul Haas, Pres. Loren B. Stone, Gen. Mgr. William F. Tucker, Sales Mgr.	Kenneth E. Yeend, Prog. Dir. Janet Ballantyne, Pub. Dir. James B. Hatfield, Chief Engr.	Standard SESAC AP Western Electric
KIRO-FM 1948	Ch. 264 (B) 100.7mc 5.7kw					UP RCA
KISW(FM)	Ch. 260 (B) 99.9mc; 2.1kw	Ellwood W. Lippincott				
KJR 1922	950 5,000 DA-N	Totem Bcstrs. Inc. Skinner Bldg. Elliott 5890	Avery-Knodel	Marshall Field III, Pres. J. Archie Morton, Gen. Mgr. Arthur Gerbel Jr., Sales Mgr.	Roland Bradley, Prog. Dir. Don Reed, Prom. Mgr. Louis S. Bookwalter, Chief Engr.	World AP RCA
KOL 1922	1300 5,000 DA-1	Seattle Bcstg. Co. Northern Life Tower Main 2312	Headley-Reed	A. G. Taft Sr., Pres. O. A. Runchey, Gen. Mgr. Archie Taft Jr., Coml. Mgr.	John R. Forrest, Prog. Dir. Ruth Yohe, Prom. Mgr. Perry C. Lind, Chief Engr.	Capitol World Standard AP, UP
KOMO 1926	1,000 50,000 DA-N	Fisher's Blend Station Inc. 100 4th Ave. North Seneca 6000	NBC Petry	O. W. Fisher, Pres. & Gen. Mgr. R. D. McCormack, Asst. to Pres. Ray Baker, Coml. Mgr. W. W. Warren, Prog. Mgr.	Richard E. Green, Natl. Sales & Prom. Mgr. F. J. Brott, Chief Engr.	Capitol Associated UP RCA
KOMO-FM 1948	Ch. 225 (B) 98.9mc 14.4kw					
KRSC 1926	1150 1,000	Radio Sales Co. 2939 4th Ave. S. Elliott 2480	Young	P. K. Leberman, Pres. James D. Neidigh Jr., Gen. & Coml. Mgr.	Theo. A. Bell, Prog. Dir. Paul Morris, Chief Engr.	AP RCA

DA-N Directional Antenna, night only. FM's in italic.
DA-1 Directional Antenna, same pattern day and night.
DA-2 Directional Antenna, different pattern day and night.

*—Non-Commercial Station. D—Day. N—Night. ST—Share Time. SH—Specified Hours.
U—Unlimited. CP—Construction Permit Issued. LS—Local Sunset.
L—Limited Time with Dominant Station. SA—Special Authorization.



"No...(Sob!!)...KJR"

KJR
 SEATTLE 5000 WATTS AT 950 KC.

KJR doesn't reach everybody!

But KJR does blanket the rich western Washington market, where 1,321,100 radio listeners enjoy one of the world's richest-per-capita incomes.

Best of all, KJR'S 5000 watts at 950 kc. cover the important area that any 50,000 watts would reach (check your BMB).

And "the beauty of it is"—it costs YOU so much LESS!

★ Talk with **EVERY-KNODEL, Inc.**, about KJR!

A Marshall Field Station for Western Washington ... an Affiliate of the American Broadcasting Company

DIRECTORY OF AM, FM, and TV STATIONS OF THE UNITED STATES

(Data corrected to December 6, 1949)
 If executives or services for FM or TV stations are same as AM affiliate names are not repeated.

WASHINGTON—(Continued)

City Call Letters Established	Chan. or Freq. Power	Name of Licensee Headquarters Address Telephone Number	Network Representative	Executive Personnel	Transc. Library News Service Transmitter Make	
SEATTLE (Continued)						
KTW 1920	1250 1,000 ST-KWSC	First Presbyterian Church 7th Ave. & Spring St. Seneca 0644		W. T. Whitney, Pres. F. Paul McConkey, Gen. Mgr. James S. Ross, Coml. Mgr. & Chief Engr.	Don Bevilacqua, Prog. Dir. Robert S. Voigt, Prom. Mgr.	
KVI 1928	870 5,000	Puget Sound Bcstg. Co. Inc. Camlin Hotel; Seneca 4848	MBS Don Lee Hollingbery	Laura M. Doernbecher, Chief Owner Vernice Irwin, Pres. & Gen. Mgr.	Earl T. Irwin, Coml. Mgr. Harry Long, Prog. Dir. D. M. McDonough, Chief Engr.	Thesaurus Lang-Worth AP; W.E.
KXA 1926	770 1,000 L-WJZ	KXA Inc. 312 Bigelow Bldg. Seneca 1000	Forjoe	W. I. Dumm, Pres. Lincoln W. Miller, Exec. V. P. Robert Kilpatrick, Coml. Mgr.	Ben Harkins, Prog. Dir. John Dubuque, Chief Engr.	Standard AP
SPOKANE						
KFIO 1922	1230 250	Spokane Bcstg. Corp. 526 Riverside Ave. Riverside 8033		Arthur L. Smith, Pres. R. G. McBroom, Gen. Mgr.	Rex King, Prog. Dir. D. G. Gordon, Prom. Mgr.	
KGA 1926	1510 50,000 DA-N	Gonzaga U. Radio Central Bldg. Madison 5383	ABC Petry	Rev. Francis E. Corkery S. J., Pres. Harvey Wixson, Gen. & Coml. Mgr.	Robert E. Plummer, Prog. Dir. A. G. Sparling, Chief Engr.	Standard UP RCA
KHQ 1924	590 5,000	KHQ Inc. Radio Central Bldg. Madison 5131	NBC Katz	Richard O. Dunning, Pres. & Gen. Mgr.	Robert Wesson, Prog. Dir. & Prom. Mgr. John Walker, Chief Engr.	Associated Capitol AP Western Electric
KNEW 1947	1430 5,000 DA-1	Coeur d'Alene Bcstg. Sprague & Wall Riverside 8035	MBS Don Lee Hollingbery	Burl C. Hagadone, Pres. C. E. Rodell, Gen. Mgr. W. C. Rhodes, Coml. Mgr.	Paul Crain, Prog. Dir. & Prom. Mgr. C. W. Evans, Chief Engr.	World AP RCA
KREM 1947	1340 250	Cole E. Wylie 242 W. Riverside Ave. Madison 3333	Forjoe	Cole E. Wylie, Pres., Gen. Mgr. & Chief Engr.	Robert H. Temple, Coml. Mgr. E. W. Thomas, Prog. Dir.	Lang-Worth Cole; AP General Electric
KXLY 1922	920 5,000	Symons Bcstg. Co. 200 Symons Bldg. Madison 1218	CBS Walker Pacific Northwest	E. B. Craney, Pres. & Gen. Mgr. Bryan Woolston, Coml. Mgr. George McGowan, Prog. Dir.	John Funk, Prom. & Natl. Sales Mgr. George Langford, Chief Engr.	Lang-Worth MacGregor UP
SUNNYSIDE						
KREW (CP)	1050 250-D	Cole E. Wylie				

DA-N Directional Antenna, night only. FM's in italic.
 DA-1 Directional Antenna, same pattern day and night.
 DA-2 Directional Antenna, different pattern day and night.

*-Non-Commercial Station. D-Day. N-Night. ST-Share Time. SH-Specified Hours.
 U-Unlimited. CP-Construction Permit Issued. LS-Local Sunset.
 L-Limited Time with Dominant Station. SA-Special Authorization.

GET DOUBLE BARRELED COVERAGE OF THE 207,000 PEOPLE LIVING IN Central Washington

USE JUST ONE MEDIUM BARREL

KYAK YAKIMA 1400 KCS - 250 WATTS

KALE RICHLAND - PASCO KENNEWICK 900 KCS - 1000 WATTS

HIT TWICE ON THE DIAL 900 KC 1400 KC IN YAKIMA COUNTY

125,000,000⁰⁰ RETAIL SALES YAKIMA COUNTY

60,000 METROPOLITAN POPULATION COUNTY POPULATION OVER 100,000

52,000 METROPOLITAN POPULATION RICHLAND - PASCO KENNEWICK

WHERE OVER 1,500,000,000 WILL BE SPENT BY US GOVT IN NEXT BI-ENNUM ON ATOMIC ENERGY DEVELOPMENT

MR. ADVERTIZER! USE BOTH BARRELS

Get a REAL "Low cost per Impression" BUY!

Ask for Combination Rates

NAT'L REP. W.S. GRANT CO. SAN FRANCISCO LOS ANGELES CHICAGO NEW YORK

PRES. Rob't S. McCaw

City Call Letters Established	Chan. or Freq. Power	Name of Licensee Headquarters Address Telephone Number	Network Representative	Executive Personnel	Transc. Library News Service Transmitter Make	
TACOMA						
KMO 1926	1360 5,000	Carl E. Haymond 914½ Broadway Main 4144	McGillvra	Carl E. Haymond, Pres. Jerry Geehan, Gen. Mgr. Ray McKenzie, Coml. & Prom. Mgr.	Ted Knightlinger, Prog. Dir. John L. Boor, Chief Engr.	Standard Capitol UP Gates World UP Western Electric
KTBI 1941	810 1,000-D	Tacoma Bcstrs. Inc. 2715 Center St. Broadway 2241		H. J. Quilliam, Pres. Ed Lovelace, Gen. Mgr. King Mitchell, Coml. Mgr.	Ann Rademaker, Prog. Dir. Dick Velo, Chief Engr.	Western Electric Associated Lang-Worth Capitol AP General Electric
KTNT(FM) 1948	Ch. 247 (B) 97.3mc 10kw	Tacoma News Tribune 1701 S. 11th St. Market 7181	Transit Radio	Frank S. Baker, Pres. Leonard H. Higgins, Sta. & Coml. Mgr.	Warren Reed, Prog. Dir. Max H. Bice, Chief Engr.	
VANCOUVER						
KVAN 1939	910 1,000 DA-1	Vancouver Radio Corp. 707½ Main St. 150		Sheldon F. Sackett, Pres. Fred F. Chitty, Secy. & Gen. Mgr. Mark F. DeLauney, Coml. Mgr.	Rickey Bras, Prog. Dir. George M. Conner, Prom. Mgr. Edgar R. Means, Chief Engr.	World Standard UP Raytheon
WALLA WALLA						
KUJ 1928	1420 5,000 DA-N	KUJ Inc. 55 E. Main St. 1230	MBS Grant	H. E. Studebaker, Pres. & Gen. Mgr. Don Wike, Nat'l. Coml. Mgr. Norval Armes, Local Coml. Mgr.	Howard Rhoads, Prog. Dir. Don Keith Van Velzer, Prom. Mgr. Milton MacLafferty, Chief Engr.	Thesaurus UP RCA
KWWB 1946	1490 250	Walla Walla Bcstg. Co. Book Nook Bldg. 4103	ABC KBS	John W. Kendall, Pres. Kenneth K. Williams, Gen. & Coml. Mgr.	Adaline Bussard, Prom. Mgr. Tyrus T. MacFadden, Chief Engr.	World AP Western Electric
WENATCHEE						
KPQ 1929	560 1,000 DA-N	Wescoast Bcstg. Co. Inc. 2nd & Columbia 2757	ABC McGillvra	Rogan Jones, Pres. J. W. Wallace, V.P. & Gen. Mgr. Pat O'Halloran, Coml. Mgr.	W. M. Green, Prog. Dir. & Prom. Mgr. George Frese, Chief Engr.	Associated Cole World UP Western Electric
KWNW 1948	1340 250	Apple-Land Bcstrs. Inc. P. O. Box 1510 2468	MBS Don Lee	James B. Hatfield, Pres. James H. Lawson, Gen. Mgr. James W. Thain, Coml. Mgr.	William P. Endicott, Prog. Dir. William C. Yeomans, Prom. Mgr. William R. McCoy, Chief Engr.	Standard AP RCA
YAKIMA						
KMA 1944	1460 1,000-LS 500-N	Cascade Bcstg. Co. Inc. P. O. Box 702 6104	CBS Columbia Pac. Weed	A. W. Talbot, Pres. R. Lee Black, Gen. Mgr. T. R. Morrow, Coml. Mgr.	Tom Bostic, Dir. Sta. Oper. Jane Morgen, Prom. Mgr. J. Barry Watkinson, Chief Engr.	Associated Lang-Worth AP Western Electric
KIT 1929	1280 5,000-LS 1,000-N	Carl E. Haymond 414½ E. Yakima Ave. 8115	ABC McGillvra Hollingbery	Carl E. Haymond, Pres. James A. Murphy, Gen. & Coml. Mgr.	James W. Nolan Jr., Prog. Dir. William Moody, Prom. Mgr. H. B. Murphy, Chief Engr.	Capitol UP Gates
KYAK 1947	1400 250	Yakima Bcstg. Corp. Fair & Mead Ave. 2-7143	MBS Grant	Robert S. McCaw, Pres. & Gen. Mgr. Gordon Allen, Coml. Mgr. & Chief Engr.	Ory Willert, Prog. Dir. Gil Lieser, Prom. Mgr.	World UP RCA
WEST VIRGINIA						
BECKLEY						
WCFC(FM) 1946	Ch. 267 (B) 101.3mc 35kw	Beckley Newspapers Corp. 305 Reservoir Rd. 8361		Charles Hodel, Pres. E. J. Hodel, Gen. Mgr. George W. Yazell, Coml. Mgr.	Arnauld Fleming, Prog. Dir. John W. Ecklin, Chief Engr.	Associated AP General Electric
WJLS 1939	560 1,000-LS 500-N DA	Joe L. Smith Jr. Inc. WJLS Bldg. 7311	CBS Weed	Joe L. Smith Jr., Pres. Virginia L. Cooper, Gen. Mgr. George J. Gray, Coml. Mgr.	Bob Brown, Prog. Dir. William R. Barrett, Prom. Mgr. Al J. Ginkel, Chief Engr.	Cole UP Western Electric
WJLS-FM 1946	Ch. 258 (B) 99.5mc 34kw					Federal
WWNR 1946	1450 250	Rahall Bcstg. Co. 1565 Harper Rd. 9300	MBS	N. Joe Rahall, Pres. Tom Douds, Gen. Mgr.	Don Hays, Prog. Dir. Estil Wills, Chief Engr.	Lang-Worth AP
BLUEFIELD						
WHIS 1929	1440 5,000 DA-N	Daily Telegraph Print- ing Co. 623 Commerce St. 7114	NBC Katz	P. T. Flanagan, Gen. Mgr. & Chief Engr. William Hostetter, Asst. Mgr. & Prog. Dir.	Barnes Nash, Prod. Mgr.	Lang-Worth World AP Federal
WHIS-FM 1947	Ch. 283 (B) 104.5mc 186kw					
WKOY 1948	1240 250	Radio Bluefield Co. West Virginian Hotel 7405	MBS	J. Lindsey Alley, Pres. & Gen. Mgr. Odes E. Robinson, V. P.	E. Bernard Jarrett, Secy-Treas. E. E. Ebersole, Prog. Dir. Max Blakemore, Chief Engr.	Associated Capitol UP Collins
CHARLESTON						
WCAW 1947	1400 250	Capitol Bcstg. Co. 1600 McCorkle Ave. 37-503	McGillvra	Garland F. Wilkinson, Pres. John S. Phillips, Gen. Mgr.	Al Walker, Prog. Dir. William D. Stone, Chief Engr.	Lang-Worth Capitol AP Collins
WCHS 1927	580 5,000 DA-N	Charleston Bcstg. Co. WCHS Auditorium 28-131	CBS Branham	Lewis C. Tierney, Pres. John T. Gelder Jr., Gen. & Coml. Mgr.	Morton S. Cohn, Prog. Dir. Harry M. Brawley, Prom. Mgr. Odes E. Robinson, Chief Engr.	Standard AP, UP
WGKV 1939	1490 250	Kanawha Valley Bcstg. Co. P. O. Box 2909 37-541	NBC Meeker	R. M. Venable, Pres. Henry V. Diefenbach, Gen. & Coml. Mgr. C. P. Vogel Jr., Prog. Dir.	Juanita Barker, Prom. Mgr. George C. Whiteman, Chief Engr.	AP Collins
WGKV-FM 1949	Ch. 253 (B) 98.5mc 5kw					REL
WKNA 1947	950 5,000-LS DA-2 1,000-N	Joe L. Smith Jr. 804 Kanwha Blvd. 3-9971	ABC Weed	Joe L. Smith Jr., Pres. James T. Quirk, Gen. & Coml. Mgr. Robert N. Provence, Prog. Dir.	Jack Satterfield, Prom. Mgr. Taylor Marcum, Chief Engr.	AP Federal
WKNA-FM 1949	Ch. 248 (B) 97.5mc 3.6kw					
WTIP 1945	1240 250	Chemical City Bcstg. Co. Capitol at Fife St. 23-136	MBS Forjoe	Gus Zaharis, Pres. Berton Sonis, Gen. & Coml. Mgr.	Bob Bower, Prog. Dir. Paul Sullivan, Chief Engr.	UP RCA

DIRECTORY OF AM, FM, and TV STATIONS OF THE UNITED STATES

(Data corrected to December 6, 1949)
If executives or services for FM or TV stations are same as AM affiliate names are not repeated.

WEST VIRGINIA—(Continued)

City Call Letters Established	Chan. or Freq. Power	Name of Licensee Headquarters Address Telephone Number	Network Representative	Executive Personnel	Transc. Library News Service Transmitter Make
CLARKSBURG					
WBLK 1937	1400 250	News Pub. Co. 444½ W. Pike St. 4-7571	NBC Branham	Austin V. Wood, Pres. George H. Clinton, Gen. Mgr. Fred Zimmerman, Sta. Mgr.	Richard Duncan, Prom. Mgr. Harry S. Brown, Chief Engr. Lang-Worth SESAC AP Collins
WHAR 1947	1340 250	Mountain State Bcstg. Co. Radio Plaza 4-5525	MBS, ABC KBS McGillvra	Glacus G. Merrill, Pres. & Gen. Mgr. Frank T. Gregg, Coml. Mgr. Janice Williams, Prog. Dir.	James L. Harper, Prom. Mgr. Andrew Kovlan, Chief Engr. UP Gates
WPDx 1947	750- 1,000-D	Clarksburg Bcstg. Corp. Clarksburg 4-6425		O. L. Billingsley, Pres. R. C. Warden, Gen. Mgr. J. M. Larosa, Coml. & Prom. Mgr.	D. H. Wyatt, Prog. Dir. R. D. Hough, Chief Engr. World Capitol UP Raytheon
WPDx-FM 1948	Ch. 236 (B) 95.1mc 2kw				Western Electric
ELKINS					
WDNE 1948	1240 250	West Va. Radio Corp. P. O. Box 967 1300	MBS KBS	H. C. Green, Pres. Roger W. Conway, Gen. Mgr.	Ambrose F. White, Coml. Mgr. Robert L. Blagg, Prog. Dir. Standard AP Gates
FAIRMONT					
WMMN 1928	920 5,000 DA-N	Fort Industry Co. 208 Adams St. 3100	CBS Katz	Geo. B. Storer, Pres. Allen L. Hald, V. P. & Gen. Mgr. Chas. E. Smith, Coml. Mgr.	Frank Lee, Prog. Dir. Bill Powell, Prom. Mgr. Joe Strelauski, Chief Engr. Lang-Worth Cole UP Western Electric
WVWV 1948	1490 250	Fairmont Bcstg. Co. Leonard Ave. 5000	ABC MBS Cooke	J. Patrick Beacom, Pres. Numa Fabre Jr., Gen. Mgr. Harry Riley, Prog. Dir.	Frank Watkins, Prom. Mgr. Charles J. Hinkle, Chief Engr. World AP Gates
WVWV-FM 1950	Ch. 222 (B) 92.3mc 14kw				
HUNTINGTON					
WHTN 1947	800 1,000-D	Greater Huntington Radio Corp. 1112½ 4th Ave. 33453		A. B. Hyman, Pres. George Brengel, Gen. Mgr. Arnold Silvert, Coml. Mgr.	Dean Sturm, Prog. Dir. Lan Singer, Prod. Mgr. Harold F. Sturm, Chief Engr. Standard UP RCA

DA-N Directional Antenna, night only. FM's in italic.
DA-1 Directional Antenna, same pattern day and night.
DA-2 Directional Antenna, different pattern day and night.

*—Non-Commercial Station. D—Day. N—Night. ST—Share Time. SH—Specified Hours.
U—Unlimited. CP—Construction Permit Issued. LS—Local Sunset.
L—Limited Time with Dominant Station. SA—Special Authorization.

Powerful Coverage at low cost

from West Virginia's largest city

Base map courtesy of PRINTERS' INK

WHTN's primary coverage area blankets the Huntington Market better than that of any other single station, regardless of power, and at a lower cost-for-coverage, too. Add to this an FM bonus on WHTN-FM, most powerful FM station in the Central Ohio Valley, and you have a high-power, low-cost medium for tapping the gold in these hills. 100,000 families spend \$300,000,000 annually in WHTN's primary area. Better get your share. For rates, availabilities and other information, wire, write or phone Pace-Wiles, Inc., Huntington, W. Va.

1000w. 800 kc. **AM WHTN WHTN FM** 53,000w. 100.5 mc.

HUNTINGTON W. VA.

City Call Letters Established	Chan. or Freq. Power	Name of Licensee Headquarters Address Telephone Number	Network Representative	Executive Personnel	Transc. Library News Service Transmitter Make	
HUNTINGTON (Continued)						
WHTN-FM 1947	Ch. 263 (B) 100.5mc 53kw					
WPLH 1946	1450 250	Huntington Bcstg. Corp. 1105 4th Ave. 33421	MBS Transit Radio	F. J. Evans, Pres. & Gen. Mgr. Bernard Sammons, Coml. Mgr. J. J. Herget, Prog. Dir.	Lillian P. Swann, Prom. Mgr. William R. Haldane, Chief Engr.	Capitol AP Western Electric
WPLH-FM 1947	Ch. 273 (B) 102.5mc 41kw					
WSAZ 1923	930 5,000-LS 1,000-N DA	WSAZ Inc. 912½ Third Ave. 38401	ABC Branham	J. H. Long, Pres. Marshall Rosene, Gen. & Coml. Mgr.	Ted Eiland, Prog. Dir. William Tracey, Prom. Mgr. Leroy Kilpatrick, Chief Engr.	Lang-Worth SESAC AP Collins
WSAZ-FM (CP)	Ch. 233 (B) 94.5mc 51kw					
WSAZ-TV 1949	Ch. 5 76-82mc 8.6kw aur.; 12kw vis.		ABC, CBS, DuMont, NBC Katz	L. H. Rogers, Sta. & Coml. Mgr.	William Packard, Prog. Dir. RCA
LOGAN						
WGYA (CP)	1290 5,000-LS DA-1 1,000 N	Logan Bcstg. Corp.				
WLOG 1940	1230 250	Clarence H. Frey & Robert O. Greever Logan 540				
WLOG-FM 1949	Ch. 277 (B) 103.3mc 2.7kw					
MARTINSBURG						
WEPM 1946	1340 250	Martinsburg Bcstg. Co. People's Trust Co. Bldg. 1146	Burn-Smith	C. M. Zinn } C. Leslie Golliday } Co-Partners C. Leslie Golliday, Gen. Mgr. Edward W. Dockeney, Coml. Mgr.	Charles Rand, Prog. Dir. Robert Brown, Prom. Mgr. Sterling Hell, Chief Engr.	World AP Gates
WEPM-FM 1948	Ch. 232 (A) 94.3mc 0.66kw					
MONTGOMERY						
WMON 1946	1340 250	Fayette Associates Inc. 1028 First Ave. 620	MBS	Arnold M. Vickers, Pres. James G. Holmes, Prog. Dir.	J. C. Craver, Chief Engr. Andrew W. Vickers, Coml. & Prom. Mgr.	World AP Collins
MORGANTOWN						
WAJR 1941	1230 250	West Virginia Radio Corp. 446 Spruce St. 9488	MBS KBS	Mrs. A. J. R. Greer, Owner Ferd Browning, Gen. Mgr. John W. Johns, Coml. Mgr.	Bos Johnson, Prog. Dir. Clarence Rulong, Chief Engr.	World AP RCA
WAJR-FM 1948	Ch. 257 (A) 99.3mc 1kw					
OAK HILL						
WOAY 1947	860 1,000-D	Robert R. Thomas Jr. Oak Hill 851		Robert R. Thomas Jr., Owner, Gen. Mgr. & Chief Engr. J. W. Thompson, Coml. Mgr.	Hugh McPherson, Prog. Dir.	Capitol AP Collins
WOAY-FM 1948	Ch. 231 (B) 94.1mc 20kw					
PARKERSBURG						
WCOM 1947	1230 250	Parkersburg Bcstg. Co. 317 9th St. 7-4491	ABC McGillvra	Joseph M. Handlan, Pres. Richard S. Cotterman, Gen. Mgr. G. R. Abels, Asst. Mgr.	Margaret Stern, Prog. Dir. Buford J. Barrickman, Chief Engr.	World UP Western Electric
WPAR 1935	1450 250	Ohio Valley Bcstg. Corp. 211 5th 75475	CBS Branham	Austin V. Wood, Pres. Geo. H. Clinton, V. P., Gen. & Coml. Mgr. Shermin Grimm, Prog. Dir.	Barbara O'Brien, Prom. Mgr. V. G. Brooks, Chief Engr.	Thesaurus AP Collins
WPAR-FM 1948	Ch. 293 (B) 106.5mc 89kw					
PINEVILLE						
WWYO 1949	970 1,000-D	Wyoming Bcstg. Co. Inc. Pineville 2711		R. D. Bailey, Pres. Jack K. Shipman, Exec. V. P. James J. Goode, Coml. Mgr.	Charles M. Erhard Jr., Prog. Dir. William D. Stone, Chief Engr.	MacGregor Cole UP Collins
PRINCETON						
WLOH 1947	1490 250	Mountain Bcstg. Service Lilly Grove 567	KBS	H. P. Honnicut, Pres. Melvin F. Barnett, Gen. Mgr. James Angel, Coml. Mgr.	James Mayes, Prog. Dir. Duke Bowman, Prom. Mgr. Earl Graham, Chief Engr.	Standard UP General Electric
RONCEVERTE						
WRON 1947	1400 250	William E. Blake Ronceverte 300	MBS KBS McGillvra	William E. Blake, Pres. & Gen. Mgr. Carl E. Lipps, Coml. Mgr.	John Morrissey, Prog. Dir. Herbert Jackson, Chief Engr.	SESAC AP
WEIRTON						
WRTN (CP)	1430 1,000 DA-2	Weirton Bcstg. Co.				
WELCH						
WBRW 1940	1340 250	McDowell Service Co. 10 Riverside Dr. 818	MBS	J. G. Hunt, Pres. Ellis Landreth, Gen. Coml. & Prom. Mgr.	John J. Vallani, Prog. Dir. Howard R. King, Chief Engr.	Standard AP Gates
WESTON						
WHAW 1948	1450 250	Lewis Service Corp. 170 Main Ave. 1555	MBS Cooke	Harold McWhorter, Pres. & Gen. Mgr. Carl Loose, Prog. Dir.	James A. Huff Jr., Chief Engr.	World Associated AP Gates
WHEELING						
WHLL 1949	1600 1,000-D DA	Wheeling Bcstg. Co. P. O. Box 989 8700		Kenneth H. Forney Glenn A. Forney } Owners Erin L. Freeman	Kenneth H. Forney, Gen. Mgr. & Chief Engr. Edward G. Trisler, Prog. Dir.	Capitol UP
WKWK 1941	1400 250	Community Bcstg. Inc. 16th & Market Sts. 5320	ABC Weed	Joe L. Smith Jr., Pres. John B. Reynolds, Secy-Treas. & Gen. Mgr. Alfred Ihlenfeld, Coml. Mgr.	Nancy Hilmes, Prog. Dir. Alan Jasper, Prom. Dir. Fred A. Baker, Chief Engr.	UP RCA
WKWK-FM 1948	Ch. 247 (B) 97.3mc 16kw					

DIRECTORY OF AM, FM, and TV STATIONS OF THE UNITED STATES

(Data corrected to December 6, 1949)
If executives or services for FM or TV stations are same as AM affiliate names are not repeated.

WEST VIRGINIA—(Continued)

City Call Letters Established	Chan. or Freq. Power	Name of Licensee Headquarters Address Telephone Number	Network Representative	Executive Personnel	Transc. Library News Service Transmitter Make	
WHEELING (Continued)						
WWVA* 1926	1170 50,000 DA-N	The Fort Industry Co. Hawley Bldg. 5383	CBS Petry	George B. Storer, Pres. William E. Rine, V. P. & Mngng. Dir. Paul J. Miller, Asst. Mngng. Dir.	Paul A. Myers, Prog. Dir. Howard W. Meagle, Prom. Mgr. Edwin L. Keim, Chief Engr.	Lang-Worth Cole AP RCA
WWVA-FM 1947	Ch. 254 (B) 98.7mc 15.3kw					
WILLIAMSON						
WBTH 1939	1400 250	Williamson Bcstg. Corp. 5½ East Second Ave. 1241	MBS	Clarence Lovitch & Alice Shein, Chief Owners Alice Shein, Gen. & Coml. Mgr.	John T. Blair Jr., Prog. Dir. Robert W. Bullio, Chief Engr.	World UP Collins

WISCONSIN

ANTIGO						
WATK 1947	900 250-D	Antigo Bcstg. Co. Antigo Journal Bldg. 900		A. F. Buner, Pres.		
APPLETON						
WBHY 1925	1230 250	WBHY Inc. 600 S. Lawe St. 3-6639	MBS Wisconsin McKinney	Earl H. Huth, Gen. Mgr. Waldemar C. Porsow, Coml. Mgr. Robert Petrie, Prog. Dir.	F. Douglas Chingo, Prom. Mgr. George Merkl, Chief Engr.	Lang-Worth AP RCA
ASHLAND						
WATW 1940	1400 250	Upper-Mich.-Wisc. Bcstg. Co. Inc. Northern State Bank Bldg. 1680	MBS Buynan Walker	William L. Johnson, Pres. J. W. Huss, V. P. & Gen. Mgr. Todd Hogan, Sta. Mgr.	Arnold Peterson, Prom. Mgr. Mary Jean Ano, Prog. Dir. Otto Link, Chief Engr.	World UP Gates
BELOIT						
WBEL 1948	1380 1,000-D	Beloit Bcstrs. Inc. Newfield Bldg. College 1380 (WBEL, AM affiliate)		Lloyd Burlingham, Pres. Buryl Lottridge, Gen. Mgr. L. O. Fitzgibbons, Bus. Mgr.	John Rhoades, Prog. Dir. Leo Wilson, Chief Engr. AP Raytheon
WBNB(FM)	Ch. 297 (B) 107.3mc 8.7kw					
WGEZ 1948	1490 100	Beloit Bcstg. Co. Hotel Hilton College 6024	MBS Wisconsin Rambeau	Sidney H. Bliss, Pres. Vern W. Williams, Sta. Mgr.	Bill Bessire, Coml. Mgr. Harold Winkwerder, Chief Engr.	Thesaurus Capital AP Western Electric
EAU CLAIRE						
WBIZ 1947	1400 250	WBIZ Inc. 609 Cameron St. 5111	MBS	James J. Conroy, Pres. Alvina M. Britz, Sta. Mgr.	Willard S. Jackson, Prog. Dir. & Prom. Mgr. Claude V. Thomas, Chief Engr.	World UP RCA
WEAU 1937	790 5,000 DA-N	Central Bcstg. Co. 203 So. Barstow St. 6149	NBC Arrowhead Hollingbery	Morgan Murphy, Pres. W. C. Bridges, Gen. Mgr. Harry S. Hyett, Sta. & Coml. Mgr.	Robert E. Nelson, Prog. Dir. T. O. Jorgenson, Chief Engr.	Lang-Worth Associated UP General Electric
WEAU-FM 1948	Ch. 231 (B) 94.1mc 60kw			Zora E. Guenard, Prog. Dir.	 General Electric
WRFW 1948	1050 1,000-D	Chippewa Valley Radio & Television Corp. Rudolph Rd. 21629	Forjoe	Thomas K. Werner, Pres. John E. Kelly, Gen. Mgr. Richard K. Werner, Coml. Mgr.	Betty I. Tobin, Prog. Dir. Rolph D. Tobin, Chief Engr. & Sta. Mgr.	Standard AP Gates
FOND DU LAC						
KFIZ 1922	1450 250	KFIZ Bcstg. Co. 18 W. First St. 356	MBS Wisconsin	A. H. Lange, Pres. Emery W. Martin, Exec. V. P. Lynn N. Fairbanks, Gen. & Coml. Mgr.	Lucille Fairbanks, Prog. Dir. Clarence Goeser, Prom. Mgr. Wendell S. Myers, Chief Engr. UP RCA
GREEN BAY						
WBAY 1922	1360 5,000 DA-N	WBAY Inc. Bellin Bldg. Adams 1	CBS Weed	Haydn R. Evans, Gen. Mgr. Lee Stinson, Coml. Mgr. Clair Stone, Prog. Dir.	Karl Gorsche, Prom. Mgr. Wallace Stangel, Chief Engr. AP RCA
WBAY-FM 1948	Ch. 273 (B) 102.5mc 14kw				 General Electric
WDUZ 1947	1400 250	Green Bay Bcstg. Co. Nicollet Bldg. Howard 6300	ABC Taylor-Borroff	Ben A. Laird, Pres. Robert C. Nelson, Sta. Mgr. Forester M. Cooper, Coml. Mgr.	Donald Arthur, Prog. Dir. & Prom. Mgr. Paul C. Tyrrell, Chief Engr.	Lang-Worth UP Gates
WJPG 1947	810 1,000-D	Green Bay Newspaper Co. P. O. Box 175 Howard 6400	Wisconsin Rambeau	A. B. Turnbull, Pres. John M. Walter, Sta. Mgr. Glen R. Holznecht, Coml. Mgr.	Russ Widoe, Prog. Dir. Elmo Reed, Chief Engr.	Standard AP RCA
WJPG-FM 1947	Ch. 266 (B) 101.1mc 14.4kw					
JANESVILLE						
WCLO 1930	1230 250	Southern Wisconsin Radio Inc. 200 E. Milwaukee St. 3311	MBS Wisconsin Rambeau	Sidney H. Bliss, Pres. Vern W. Williams, Gen. Mgr. Bill Bessire, Coml. Mgr.	Joseph Urban, Asst. Mgr. Wayne Clay, Chief Engr.	World, SESAC Lang-Worth AP Western Electric
WCLO-FM 1947	Ch. 260 (B) 99.9mc 15.5kw				 RCA
KENOSHA						
WLIP 1947	1050 250-D	William L. Lipman 625 57th St. 6162	McKinney	William L. Lipman, Chief Owner & Gen. Mgr. Hugh L. Gately, Sta. Mgr. Bernice Langer, Office Mgr.	Jerome Golden, Prog. Dir. Orlando Rotunda, Chief Engr.	Lang-Worth UP Raytheon

DA-N Directional Antenna, night only. FM's in italic.
DA-1 Directional Antenna, same pattern day and night.
DA-2 Directional Antenna, different pattern day and night.

*—Non-Commercial Station. D—Day. N—Night. ST—Share Time. SH—Specified Hours.
U—Unlimited. CP—Construction Permit Issued. LS—Local Sunset.
L—Limited Time with Dominant Station. SA—Special Authorization.

TWIN CITY MARKET-TWIN STATIONS - TWIN ACTION!

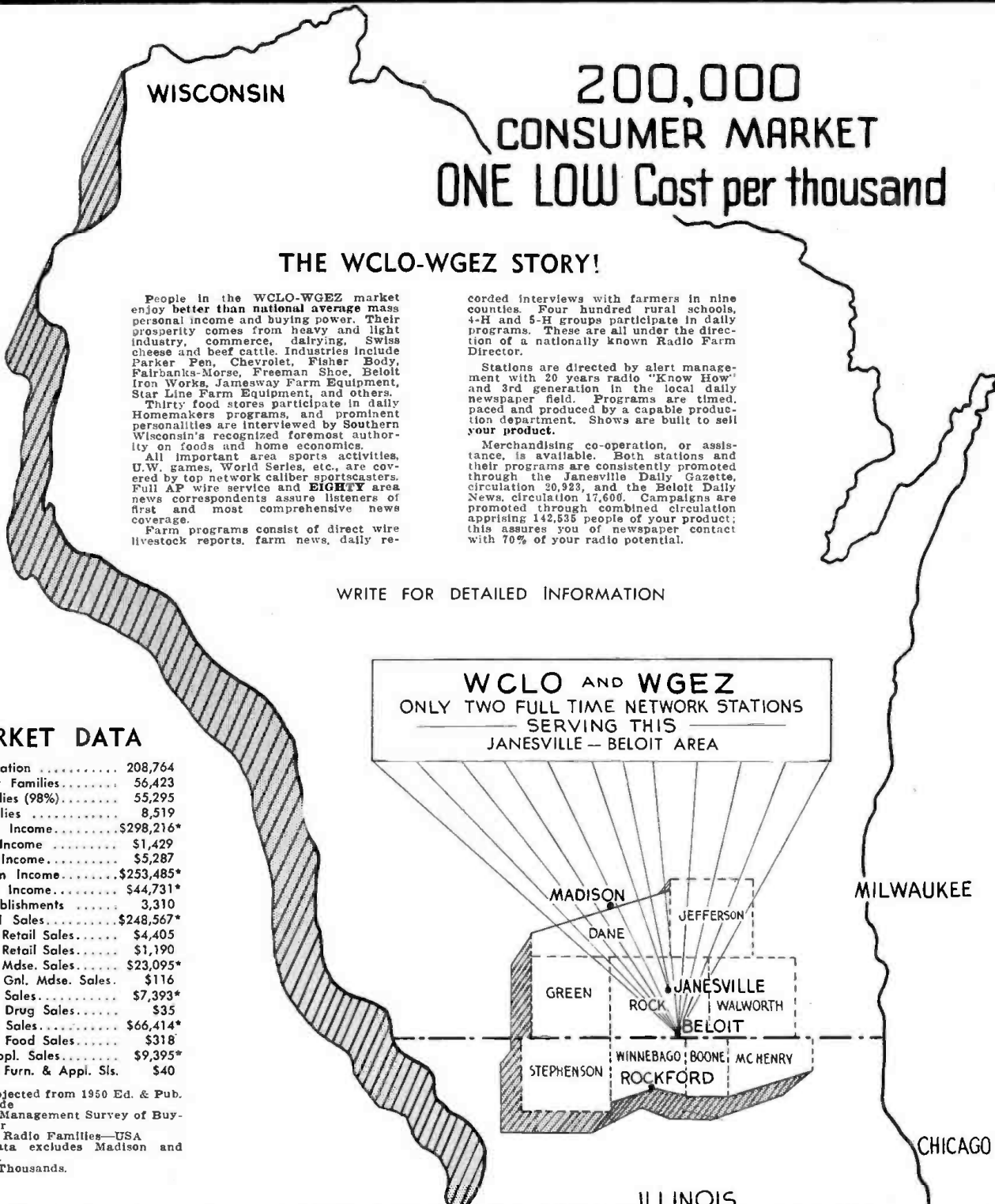

**200,000
CONSUMER MARKET
ONE LOW Cost per thousand**

THE WCLO-WGEZ STORY!

People in the WCLO-WGEZ market enjoy better than national average mass personal income and buying power. Their prosperity comes from heavy and light industry, commerce, dairying, Swiss cheese and beef cattle. Industries include Parker Pen, Chevrolet, Fisher Body, Fairbanks-Morse, Freeman Shoe, Beloit Iron Works, Jamesway Farm Equipment, Star Line Farm Equipment, and others. Thirty food stores participate in daily Homemakers programs, and prominent personalities are interviewed by Southern Wisconsin's recognized foremost authority on foods and home economics. All important area sports activities, U.W. games, World Series, etc., are covered by top network caliber sportscasters. Full AP wire service and **EIGHTY** area news correspondents assure listeners of first and most comprehensive news coverage. Farm programs consist of direct wire livestock reports, farm news, daily re-

corded interviews with farmers in nine counties. Four hundred rural schools, 4-H and 5-H groups participate in daily programs. These are all under the direction of a nationally known Radio Farm Director. Stations are directed by alert management with 20 years radio "Know How" and 3rd generation in the local daily newspaper field. Programs are timed, paced and produced by a capable production department. Shows are built to sell your product. Merchandising co-operation, or assistance, is available. Both stations and their programs are consistently promoted through the Janesville Daily Gazette, circulation 20,923, and the Beloit Daily News, circulation 17,600. Campaigns are promoted through combined circulation apprising 142,535 people of your product; this assures you of newspaper contact with 70% of your radio potential.

WRITE FOR DETAILED INFORMATION

WCLO AND WGEZ
ONLY TWO FULL TIME NETWORK STATIONS
SERVING THIS
JANESVILLE - BELOIT AREA

MARKET DATA

- Area Population 208,764
- Number of Families 56,423
- Radio Families (98%) 55,295
- Rural Families 8,519
- Total area Income \$298,216*
- Individual Income \$1,429
- Per Family Income \$5,287
- Total Urban Income \$253,485*
- Total Rural Income \$44,731*
- Retail Establishments 3,310
- Total Retail Sales \$248,567*
- Per Family Retail Sales \$4,405
- Per Capita Retail Sales \$1,190
- Total Genl. Mdse. Sales \$23,095*
- Per Capita Gnl. Mdse. Sales \$116
- Total Drug Sales \$7,393*
- Per Capita Drug Sales \$35
- Total Food Sales \$66,414*
- Per Capita Food Sales \$318
- Furn. & Appl. Sales \$9,395*
- Per Capita Furn. & Appl. Sis. \$40

• Figures projected from 1950 Ed. & Pub. Mkt. Guide
 • 1949 Sales Management Survey of Buying Power
 • 1949 BMB Radio Families—USA
 • Market data excludes Madison and Rockford.
 * Dollars in Thousands.



WCLO

WGEZ

JANESVILLE

BELOIT

MUTUAL BROADCASTING SYSTEM - WISCONSIN NETWORK

REPRESENTED NATIONALLY BY RAMBEAU

DIRECTORY OF AM, FM, and TV STATIONS OF THE UNITED STATES

*(Data corrected to December 6, 1949)
If executives or services for FM or TV stations are same as AM affiliate names are not repeated.*

WISCONSIN—(Continued)

City Call Letters Established	Chan. or Freq. Power	Name of Licensee Headquarters Address Telephone Number	Network Representative	Executive Personnel	Transc. Library News Service Transmitter Make	
LA CROSSE						
WKBH 1926	1410 5,000 DA-N	WKBH Inc. 409 Main St. 450	NBC Taylor-Borrorf	Howard Dahl, Pres., Gen. & Coml. Mgr. Berneice Callaway, Prog. Dir.	Paul Ziemer, Prom. Mgr. Alvin Leeman, Chief Engr.	World AP RCA
WKTY 1948	580 1,000 DA-1	LaCrosse Bcstg. Co. 112 N. Fourth St. 790	MBS Wisconsin Weed	Verl Bratton, V. P., Gen. & Coml. Mgr.	John Bondeson, Asst. & Prom. Mgr. & Prog. Dir. J. Harold White, Chief Engr.	MacGregor UP
WLCX 1947	1490 250	Bermac Radio Inc. State Bank Bldg. 4379	ABC	James J. Conroy, Pres. Milo G. Knutson, Gen. Mgr. Robert Gaumer, Coml. & Prom. Mgr.	Stanleigh Torgerson, Prog. Dir. Elphin Rinn, Chief Engr.	Standard UP Collins
LADYSMITH						
WLDY 1948	1340 250	Flambeau Bcstg. Co. West Lake Ave. 584	KBS Wisconsin Clark	O. J. Falge, Pres. A. T. Shields, Gen. Mgr. R. I. Foreman, Coml. Mgr.	Joseph Dahlvig, Prog. Dir. Corinne Kopp, Prom. Mgr. Darrel Holbrook, Chief Engr.	World UP General Electric
MADISON						
WFOV(FM) 1948	Ch. 285 (A) 104.9mc 0.93kw	Earl W. Fessler 2047 Winnebago St. 4-2847		Earl W. Fessler, Pres. & Gen. Mgr. Bob Culp, Coml. Mgr.	Marion Weisensei, Prog. Dir. Elmer Weisensei, Chief Engr.	UP Collins
*WHA 1919	970 5,000-D	University of Wisc. Radio Hall 5-2988		H. B. McCarthy, Gen. Mgr. Wm. G. Harley, Prog. Dir. H. A. Engel, Prom. Mgr.	Ray Stanley, Prod. Mgr. John H. Stiehl, Chief Engr.	Associated UP
WIBA 1925	1310 5,000 DA-N	Badger Bcstg. Co. 3800 Regent St. 3-5311	NBC Avery-Knodel	William T. Evjue, Pres. Kenneth F. Schmitt, Gen. Mgr. Howard A. Johnson, Bus. Mgr.	Robert Dick, Prog. Dir. Norman Hahn, Chief Engr.	Thesaurus Standard AP, UP Western Electric
WIBA-FM 1948	Ch. 268 (B) 101.5mc 45kw					
WISC 1948	1480 1,000 DA-1	Radio Wisconsin Inc. Commercial State Bank Bldg. 7-2588	ABC Arrowhead Hollingbery	Morgan Murphy, Pres. W. C. Bridges, Exec. Dir. Ralph O'Connor, Gen. Mgr. Joann Markward, Prog. Dir.	Richard S. Nickeson, Coml. & Prom. Mgr. M. W. Greely, Chief Engr.	Associated UP
WISC-FM 1948	Ch. 255 (B) 98.9mc 52kw					
WKOW 1948	1070 10,000-LS 5,000-N DA-2	Monona Bcstg. Co. 215 W. Washington St. Gifford 7100	MBS Headley-Reed	Stewart A. Watson, Pres. Ralph A. Ammon, Gen. Mgr. Phil Wood, Coml. Mgr.	William T. Wagner, Prog. Dir. Will Sumner, Prom. Mgr. Vincent Vanderheiden, Chief Engr.	World UP RCA

DA-N Directional Antenna, night only. FM's in italic.
DA-1 Directional Antenna, same pattern day and night.
DA-2 Directional Antenna, different pattern day and night.

*-Non-Commercial Station D-Day. N-Night. ST-Share Time. SH-Specified Hours.
U-Unlimited. CP-Construction Permit Issued. LS-Local Sunset.
L-Limited Time with Dominant Station. SA-Special Authorization.

**Hooper
Up!**

**2 GREAT SHOWS
2 GREAT HOOPERATINGS***

**I "1340 CLUB"—5:00-7:00 P.M. Mon. Thru Fri.-with TOM MERCEIN
No. 2 Hooperating***

**II "OLD TIMERS PARTY"—7:00-8:00 P.M. Mon. Thru Fri.-with
BILL BRAMHALL
No. 2 Hooperating***

Hugh Boice, Gen'l Mgr.

Headley-Reed, National Rep.

WEMF

Milwaukee, Wis.

AM-FM

* May thru Sept., 1949 Hooperatings

Milwaukee's ONLY Full Time Independent

City Call Letters Established	Chan. or Freq. Power	Name of Licensee Headquarters Address Telephone Number	Network Representative	Executive Personnel	Transc. Library News Service Transmitter Make	
MANITOWOC						
WOMT 1926	1240 250	Francis M. Kadow Radio Bldg. 6015	MBS Wisconsin Ra-Tel	Francis M. Kadow, Pres. & Gen. Mgr. John Kadow, Coml. Mgr.	George H. Erdman, Prog. Dir. W. F. Duben, Chief Engr.	UP
MARINETTE						
WMAM 1939	570 250-LS 100-N	M. & M. Bcstg. Co. Radio Park 2-6631	NBC Meeker	William E. Walker, Pres. Joseph D. Mackin, Gen. Mgr. Howard L. Emich, Coml. Mgr.	Robert Southard, Prog. Dir. Patrick Kehoe, Prom. Mgr. A. L. Stewart, Chief Engr.	UP RCA
MARSHFIELD						
WDLB 1947	1450 250	Dairyland's Bcstg. Service Inc. 1710 N. Central Ave. 1212	KBS	Lloyd L. Felker, Pres. Robert W. Behling, Gen. & Prom. Mgr.	Duwayne Allen, Coml. Mgr. Bob Hansen, Prog. Dir. Gerald J. Boos, Chief Engr.	Capitol SESAC UP Raytheon
WDLB-FM 1949	Ch. 280 (A) 103.9mc 0.25kw					General Electric
MEDFORD						
WIGM 1941	1490 250	George F. Meyer Medford 5147	MBS. KBS Continental	George F. Meyer, Owner, Gen. Coml. & Prom. Mgr.	Irma Meyer, Prog. Dir. Raymond Bohnert, Chief Engr.	SESAC RCA
MERRILL						
WLIN 1948	730 1,000-D	Alvin E. O'Konski Merrill	Walker	Alvin E. O'Konski, Pres. Tony Marta, Gen. & Coml. Mgr.	Elizabeth Obey, Prog. Dir. Chris Zercher, Chief Engr.	Capitol Standard AP Collins
WLIN-FM	Ch. 264 (B) 100.7mc 9.7kw					
MILWAUKEE						
WEMP 1935	1340 250	Milwaukee Bcstg. Co. 710 N. Plankinton Ave. Marquette 8-7722	Headley-Reed	Robert M. LaFollette Jr., Pres. Hugh K. Boice Jr., Gen. Mgr. John C. Gagliano, Coml. Mgr.	Tom Shanahan, Prog. Dir. Rolland E. Paske, Chief Engr.	World UP RCA
WEMP-FM 1948	Ch. 231 (B) 94.1mc 35kw					Western Electric
WEXT 1947	1430 1,000-D	WEXT Inc. 2501 S. 43rd St. Evergreen 3-1430		Gerald A. Bartell, Pres. John A. Reddy, Sta. Mgr.	Ralph Evans, Chief Engr.	UP Raytheon
WFOK 1946	860 250-D	Wisconsin Bcstg. System Inc. 739 North Broadway Broadway 2-1272		Charles J. Lanphier, Pres., Gen. & Coml. Mgr.	Carl Zimmermann, Prog. Dir. & Prom. Mgr. George Dodge, Chief Engr.	AP Western Electric
WISN 1922	1150 5,000 DA-1	Hearst Radio Inc. 540 N. Plankinton Division 2-3000	CBS Katz	G. W. Grignon, Gen. & Coml. Mgr. Jack Raymond, Prog. Dir.	George DeGrace, Prom. Mgr. Don Weller, Chief Engr.	World UP, INS RCA
WISN-FM 1948	Ch. 275 (A) 102.9mc 4.1kw					
WMAW 1948	1250 5,000 DA-2	Midwest Bcstg. Co. 723 N. Third St. Daly 8-2154	ABC Avery-Knodel	Clifford A. Randall, Pres. Jack Bundy, Gen. Mgr. Donald McClellan, Prog. Dir.	Lou Riepenhoff, Prom. Mgr. Raymond H. Host, Chief Engr.	Associated Lang-Worth UP Collins

In MILWAUKEE . . .
More People

Lis'n to Wish

ALL DAY — EVERY DAY!

**BEST
NETWORK
SHOWS**

**BEST
LOCAL
SHOWS**

★ You'll find it a pleasure to do business with WISN, too . . . The Best Radio Buy in the Entire Milwaukee Market

WISN 5,000 watts day and night
Gaston W. Grignon, General Manager
Milwaukee's CBS Outlet

REPRESENTED BY THE KATZ AGENCY

DIRECTORY OF AM, FM, and TV STATIONS OF THE UNITED STATES

(Data corrected to December 6, 1949)
If executives or services for FM or TV stations are same as AM affiliate names are not repeated.

WISCONSIN—(Continued)

City Call Letters Established	Chan. or Freq. Power	Name of Licensee Headquarters Address Telephone Number	Network Representative	Executive Personnel	Transc. Library News Service Transmitter Make	
MILWAUKEE (Continued)						
WML 1947	1290 1,000-D	Cream City Bcstg. Co. 2625 W. Wisconsin Ave. West 3-1290	Forjoe	Jerome Sill, Gen. Mgr.	Cole UP Collins	
WTMJ 1927	620 5,000 DA-N	The Journal Co. 720 E. Capital Dr. Marquette 8-6000	NBC Petry	Walter J. Damm, V. P. & Gen. Mgr. L. W. Herzog, Asst. Gen. Mgr.	Bruce Wallace, Asst. Mgr. Frank Bignell, Prog. Mgr. William Hebal, Chief Engr.	Lang-Worth Standard AP Western Electric
WTMJ-FM 1940	Ch. 227 (B) 93.2mc 322kw					
WTMJ-TV 1947	Ch. 3 60-66mc 10.2kw-aur.; 16.1kw-vis.		ABC, CBS, NBC DuMont Harrington, Righter & Parson	R. G. Winnie, Sta. & Coml. Mgr. James Robertson, Prog. Dir.	Phillip B. Laesar, Chief Engr. RCA	
NEENAH						
WNAM 1947	1280 1,000-D CP 1,000 DA-N	Neenah-Menasha Bcstg. Co. 101 East Wisconsin 2-2871		Don C. Wirth, V. P., Gen. & Prom. Mgr. Fred W. Sample, Coml. Mgr.	Roland McBain, Prog. Dir. E. W. Filegel, Chief Engr. Associated UP	
WNAM-FM 1947	Ch. 253 (B) 98.5mc 3.1kw					
OSHKOSH						
WOSH 1941	1490 250	Oshkosh Bcstg. Co. 151 Main St. Stanley 4156	ABC Cooke	William F. Johns Jr., Chief Owner George Greeley, Gen. Mgr.	Warren Haines, Prog. Dir. Wallace M. Morton, Chief Engr. World UP RCA Western Electric	
WOSH-FM 1948	Ch. 225 (B) 92.9mc 3.5kw					
POYNETTE						
WIBU 1925	1240 250	William C. Forrest Poynette 98	Wisconsin Burn-Smith	William C. Forrest, Pres., Gen. & Coml. Mgr. Sarah Forrest, Prog. Dir.	Doris MacPherson, Prom. Mgr. L. Stanley Sadler, Chief Engr. SESAC Standard UP Collins Western Electric	
WWCF(FM) 1947	Ch. 235 (B) 94.9mc 37kw	(WIBU, AM affiliate)				
RACINE						
WRJN 1926	1400 250	Racine Bcstg. Corp 441 Main St. Jackson 290	ABC Wisconsin Walker	Frank R. Starbuck, Pres. Harry R. LePoidevin, Gen. Mgr. Harold J. Newcomb, Sta. & Coml. Mgr.	Lyman Merens, Prog. Dir. Amelia French, Prom. Mgr. F. Lee Dechant, Chief Engr. AP RCA	
WRJN-FM 1948	Ch. 264 (B) 100.7mc 15kw					
RHINELANDER						
WOBT 1947	1240 250	Oneida Bcstg. Co. Rhinelander 1240	MBS	John R. Tomek, Pres. Hugh O. Rowlands, Gen. & Coml. Mgr.	Dick Berger, Prog. Dir. & Prom. Mgr. Charles Bresette, Chief Engr. Lang-Worth UP Gates	
RICE LAKE						
WJMC 1939	1240 250	WJMC Inc. 1615 South Main St. 550	MBS Arrowhead Hollingbery	W. C. Bridges, Pres. Greg Rouleau, Gen. & Coml. Mgr. Harry Wills, Prog. Dir.	Richard Moore, Prom. Mgr. Robert Kolsky, Chief Engr. Associated SESAC RCA	
WJMC-FM 1947	Ch. 242 (B) 96.3mc 4.4kw					
RICHLAND CENTER						
WRCO 1949	1450 250	Richland Bcstg. Corp. P. O. Box 192 20		Arthur Overgaard, Pres. Thomas R. Kelley, Gen. Mgr. & Chief Engr.	Robert J. Boddien, Prog. Dir. & Prom. Mgr. Lang-Worth UP	
SHAWANO						
WTCH 1948	960 1,000-D	Shawano Co. Leader Pub. Co. 107 E. Green Bay St.		(Mrs.) Jeanne Heal, Pres.	D. W. Hodgins, Gen. Mgr. World UP	
SHEBOYGAN						
WHBL 1924	1330 1,000-LS 250-N	WHBL Inc. Press Bldg. 4844	ABC Meeker	A. Matt Werner, Pres. G. P. Richards, Gen. & Coml. Mgr.	Glen James, Prog. Dir. Doris Donnie, Prom. Mgr. Herbert J. Mayer, Chief Engr. AP RCA	
WHBL-FM 1948	Ch. 262 (B) 100.3mc 15kw					
SPARTA						
WJBA (CP)	990 250-D	Wm. M. Gleiss				
STEVENS POINT						
*WLBL	930 5,000-D	State of Wisc. Depart- ment of Agri.				
WTWT 1948	1010 250-D	Evans Radio Co. 414 Main St. 2744	Holman	Claire Miller, Pres. S. J. Kelbanowski, Gen. Mgr. F. J. Komasa, Coml. Mgr.	Frank Kostuck, Prog. Dir. Catherine Carew, Prom. Mgr. Justin Sioniker, Chief Engr. SESAC UP Gates	
SUPERIOR						
WDSM 1939	1230 250; CP 710 5,000 DA-2	Ridson Inc. 921 Tower Ave. 4451	ABC Free & Peters	Robert B. Ridder, Pres. Carl Bloomquist, Gen. Mgr. William Lukoskie, Coml. Mgr.	Lewis D. Martin, Prog. Dir. Harry Gradin, Prom. Mgr. J. Melvin Laskey, Chief Engr. Capitol AP Collins	
WSBR 1946	1490 250	WSBR Inc. Superior 4405	KBS	James J. Conroy, Pres. & Gen. Mgr. Clifford J. Lue, Coml. & Prom. Mgr.	Dave Martin, Prog. Dir. Donald J. Rasky, Chief Engr. Standard AP	
WATERTOWN						
WTIN (CP)	1580 250-D	Watertown Radio Inc.				

DA-N Directional Antenna, night only. FM's in italic.
DA-1 Directional Antenna, same pattern day and night.
DA-2 Directional Antenna, different pattern day and night.

*—Non-Commercial Station. D—Day. N—Night. ST—Share Time. SH—Specified Hours.
U—Unlimited. CP—Construction Permit Issued. LS—Local Sunset.
L—Limited Time with Dominant Station. SA—Special Authorization.

City Call Letters Established	Chan. or Freq. Power	Name of Licensee Headquarters Address Telephone Number	Network Representative	Executive Personnel	Transc. Library News Service Transmitter Make	
WAUKESHA						
WAUX 1947	1510 250-D	Waukesha Bcstg. Co. 319 W. Main St. 6619		Carl Taylor, Pres. Mig Figi, Gen. Mgr. Charles Williams, Sales Mgr.	Don Froelch, Prog. Dir. Adin Randall, Chief Engr.	Lang-Worth AP Gates
WAUX-FM 1948	Ch. 237 (A) 95.3mc 0.19kw			 Collins	
WAUSAU						
WSAU 1937	1400 250	The Journal Co. 714 Fifth St. 6521	NBC Petry	Ben F. Hovel, Mgr. J. W. Killeen, Sales Mgr. R. J. Topinka, Prog. Dir.	LaVerne R. Peterson, Prom. Mgr. Roland W. Richardt, Tech. Supvsr.	Thesaurus AP General Electric
WSAU-FM 1948	Ch. 238 (B) 95.5mc 46kw			 REL	
WISCONSIN RAPIDS						
WFHR 1940	1340 250	Wm. F. Huffman Radio Inc. 143 West Grand Ave. 1340	MBS Wisconsin	(Mrs.) Louise Huffman, Pres. George T. Frechette, Gen. & Prom. Mgr.	Bruce G. Beichl, Coml. Mgr. James Tighe, Prog. Dir. Bert E. Zielesch, Chief Engr.	Capitol AP Collins
WFHR-FM 1948	Ch. 277 (B) 103.3mc 2.1kw			 General Electric	
WYOMING						
CASPER						
KSPR 1930	1470 1,000	Donald Lewis Hathaway 1st & Lennox 407	MBS, KBS Intermountain Sears & Ayers	Donald Lewis Hathaway, Pres. & Gen. Mgr. Frederic W. Hufsmith, Coml. Mgr.	Marcus R. Nichols, Prog. Dir. I. E. Shahan, Prom. Mgr. Duane Simmons, Chief Engr.	Thesaurus Lang-Worth UP RCA
KVOC 1946	1230 250	KVOC Bcstg. Co. 1540 S. Wolcott St. 130	ABC Donahue	Jack W. Perry, Pres. John R. Bailey Jr., Gen. Mgr. Don Christopher, Coml. Mgr.	E. L. Peiss, Prog. Dir. Clifford Ewing, Prom. Mgr. W. C. Bates, Chief Engr. AP Gates
CHEYENNE						
KFBC 1940	1240 250 CP 710 10,000-LS 1,000-N DA-2	Frontier Bcstg. Co. Plains Hotel 4461	ABC McGillvra	Tracy S. McCracken, Pres. William C. Grove, Gen. Mgr. Frank Flynn, Coml. Mgr.	Dale Sunderland, Prog. Dir. Max Young, Prom. Mgr. Harold Roberts, Chief Engr. UP RCA
CODY						
KODI 1947	1400 250	Absaroka Bcstg. Co. P.O. Box 319 444		William J. Garlow, Pres. & Gen. Mgr. Mary Jean LeClere, Coml. Mgr.	Philip H. Barnhart, Prog. Dir. & Chief Engr.	Lang-Worth World AP RCA
LANDER						
KOVE 1948	1230 250	Edward J. Breece Lander 488	MBS Intermountain	Edward J. Breece, Pres. Frank A. Toomey, Gen. Mgr. Mrs. Ruth Dorr, Coml. Mgr.	Clayt Holm, Prog. Dir. Francis Uhlis, Prom. Mgr. Gordon Nelson, Chief Engr.	Capitol UP Collins
LARAMIE						
KOWB 1947	1340 250	Snowy Range Bcstg. Co. Inc. P.O. Box 972 4888	MBS Intermountain Grant	Fred O. Rice, Pres. Clem L. Rawlins Jr., Gen. & Coml. Mgr.	Lynn O. Smith, Prog. Dir. John C. Steele, Prom. Mgr. Jack Sneddon, Chief Engr.	Standard AP Collins
POWELL						
KPOW 1941	1260 1,000 DA-N	Al J. Meyer 243 E. 2nd St. 222	MBS, KBS Intermountain Avery-Knodel	Al J. Meyer, Pres., Gen. Mgr. & Prog. Dir.	Mel Whitmire, Coml. & Prom. Mgr.	SESAC, Cole UP Gates
RAWLINS						
KRAL 1947	1240 250	Rawlins Bcstg. Co. Rawlins 1015	ABC, KBS Donahue	D. A. Fisher, Gen. & Coml. Mgr.	 AP
RIVERTON						
KWRL 1948	1450 250	Joseph P. Ernst Radio Station KWRL 789		Joseph P. Ernst, Owner, Gen. & Prom. Mgr., Prog. Dir. & Chief Engr.	Mildred V. Ernst, Coml. Mgr. AP Collins
ROCK SPRINGS						
KVRS 1938	1360 1,000-LS 500-N DA	Wyoming Bcstg. Co. 1307 Wyoming St. 93	MBS Intermountain Avery-Knodel	Mrs. Marjorie L. McCracken, Pres. & Gen. Mgr. Michael Reid, Coml. & Prom. Mgr.	Imogene Parr, Prog. Dir. Archie W. Buchanan, Chief Engr.	Standard AP Collins
SHERIDAN						
KWYO 1934	1410 1,000-LS 500-N	Big Horn Bcstg. Co. 21 N. Main St. 601	MBS Intermountain Avery-Knodel	Jim Carroll, Pres. & Gen. Mgr. Don Tannehill, Coml. Mgr.	Bob Wilson, Prog. Dir. Bob Crosthwaite, Chief Engr.	Lang-Worth UP RCA
WORLAND						
KWOR 1945	1490 250	Joseph P. Ernst P.O. Box 92 308		Joseph P. Ernst, Pres., Gen Coml. & Prom. Mgr. & Chief Engr.	 AP

Directory of BROADCASTING STATIONS OF U. S. POSSESSIONS AND TERRITORIES

(Data corrected to December 6, 1949)

ALASKA

City Call Letters Established	Chan. or Freq. Power	Name of Licensee Headquarters Address Telephone Number	Network Representative	Executive Personnel	Transc. Library News Service Transmitter Make	
ANCHORAGE						
KBYR 1948	1240 250 CP: 1450	Aleutian Bcstrs. Fourth & B Sts. Black 395	Cooke	Douglas Sparks, Dir.	Capitol MacGregor UP	
KENI 1948	550 5,000	Midnight Sun Bcstg. Co. 4th Ave. Theater Bldg. 20301	ABC, MBS Don Lee Wellington	Austin E. Lathrop, Pres. A. G. Hiebert, Gen. Mgr. J. Fred Thomas, Coml. Mgr.	Frank Brink, Prog. Dir. & Prom. Mgr. Jack M. Walden, Chief Engr.	Standard Associated AP, UP RCA
KFQD 1924	790 5,000	Wm. J. Wagner 830 Securities Bldg. Seattle, Wash. Seneca 6333		Wm. J. Wagner, Owner & Gen. Mgr.		
FAIRBANKS						
KFAR 1939	660 10,000	Midnight Sun Bcstg. Co. Box 910 East 380	ABC, MBS Wellington	Austin E. Lathrop, Pres. Alvin O. Bramstedt, Gen. Mgr. Arvid Erickson, Coml. Mgr.	Richard Gruehl, Prog. Dir. Del Day, Prom. Mgr. August Hiebert, Chief Engr.	Capitol AP, UP RCA
KFRB 1948	1290 1,000	Wm. J. Wagner 830 Securities Bldg. Seattle, Wash. Seneca 6333	CBS Alaska Pan American Scott	Wm. J. Wagner, Owner Jim Fletcher, Mgr. Jack McCahill, Prog. Dir.	Bill Chase, Prom. Mgr. Robert W. Porter, Chief Engr.	Cole Lang-Worth AP RCA
JUNEAU						
KINY 1935	1460 5,000	Wm. J. Wagner 830 Securities Bldg. Seattle, Wash. Seneca 6333	CBS KBS Alaska Pan American Scott	Wm. J. Wagner, Owner & Gen. Mgr. John Ashbaugh, Coml. Mgr.	Richard Peter, Prog. Dir. Charles Gray, Chief Engr.	Lang-Worth AP
KETCHIKAN						
KTKN 1942	930 1,000	Wm. J. Wagner 830 Securities Bldg. Seattle, Wash. Seneca 6333	CBS KBS Alaska Pan American Scott	Wm. J. Wagner, Owner & Gen. Mgr.	Thomas J. Durant, Coml. Mgr. James R. Kemp, Prog. Dir. Robert C. Mehan, Chief Engr.	Lang-Worth AP Collins
SEWARD						
KIBH 1948	1340 250	Wm. J. Wagner 830 Securities Bldg. Seattle, Wash. Seneca 6333	CBS KBS Alaska Pan American Scott	Wm. J. Wagner, Owner & Gen. Mgr.	James Lawson, Coml. Mgr. Bud Hegeman, Chief Engr. RCA
SITKA						
KALA (CP)	1400 250	Baranof Enterprises Inc.				
KIFW 1949	1230 250	Wm. J. Wagner 830 Securities Bldg. Seattle, Wash. Seneca 6333		Wm. J. Wagner, Owner & Gen. Mgr.		

HAWAII

HILO						
KHBC 1936	970 1,000	Hawaiian Bcstg. System Ltd. P. O. Box 1476 4616	CBS Free & Peters	J. Howard Worrall, Pres. C. T. Thrumston, Gen. Mgr.	D. W. Rose, Coml. Mgr. Robert Moore, Chief Engr.	World Standard UP RCA
KIPA 1947	1110 1,000	Big Island Bcstg. Co. Ltd. 140 Haili St. 2177	MBS Aloha Walker	James E. Jaeger, Pres. & Gen. Mgr. Rex Wills II, Coml. Mgr. & Prog. Dir.	Harold L. Marques, Chief Engr.	Lang-Worth UP RCA
HONOLULU						
KGMB 1930	590 5,000	Hawaiian Bcstg. System Ltd. 1534 Kapiolani Blvd. 90914	CBS Free & Peters	J. Howard Worrall, Pres. & Gen. Mgr. E. Fitz Donnell Jr., Sta. & Coml. Mgr.	Louis T. Dwyer, Prog. Dir. (Mrs.) Faye Johnson, Prom. Mgr. Ernest G. Lindemann, Chief Engr.	Standard World UP RCA
KGU 1922	760 2,500 L-WJR	Advertiser Pub. Co. Ltd. P. O. Box 3110 52977	NBC Katz	Lorin P. Thurston, Pres. M. A. Mulrony, Gen. Mgr. & Chief Engr. William O. Paine, Coml. Mgr.	Owen Cunningham, Prog. Dir. William K. Knowles Jr., Prom. Mgr.	Thesaurus UP
KHON 1946	1380 5,000	Aloha Bcstg. Co. Ltd. P. O. Box 1380 95295	MBS Aloha Walker	Ralph M. Fitkin, Pres. A. H. Green, V. P. & Gen. Mgr. L. Roy Turner, Coml. & Prom. Mgr.	Lynn Sonn, Prog. Dir. Ira Mercer, Chief Engr.	Capitol Lang-Worth UP
KPOA 1946	630 5,000	Island Bcstg. Co. Box 3499 95281	Hollingbery	John Keating & J. Elvov McCaw, Principals John D. Keating, Gen. Mgr. Sam Styles, Coml. Mgr.	Hal Lewis, Prog. Dir. Gene Miller, Prom. Mgr. Robert Bird, Chief Engr. INS Western Electric
KULA 1947	690 10,000	Pacific Frontier Bcstg. Co. Ltd. 1525 Kapiolani Blvd. 90926	ABC Avery-Knodel	Jack Burnett, Gen. & Coml. Mgr. Irving Phillips, Local Sales Mgr. Jock Fearnhead, Prog. Dir.	Ernest Beattie, Prom. Mgr. Richard S. Smith, Chief Engr.	Standard UP RCA
LIHUE						
KTOH 1940	1490 250	Garden Island Pub. Co. Lihue	Walker Don Lee Aloha	C. J. Fern, Gen. Mgr. C. M. Ashman, Sta. Mgr.	Dwight Mossman, Coml. Mgr.	Standard UP
WAILUKU						
KMUI 1947	550 1,000	Maui Pub. Co. Box 374 981	MBS Don Lee Walker	J. Walter Cameron, Pres. Ezra J. Crane, Gen. Mgr. Chales C. Young, Coml. Mgr.	Richard E. Mawson, Sta. Mgr. Ronald Miyahira, Chief Engr.	Lang-Worth Standard Cole UP RCA

DA-N Directional Antenna, night only. FM's in italic.
DA-1 Directional Antenna, same pattern day and night.
DA-2 Directional Antenna, different pattern day and night.

*—Non-Commercial Station. D—Day. N—Night. ST—Share Time. SH—Specified Hours.
U—Unlimited. CP—Construction Permit Issued. LS—Local Sunset.
L—Limited Time with Dominant Station. SA—Special Authorization.

PUERTO RICO

City	Call Letters Established	Chan. or Freq. Power	Name of Licensee Headquarters Address Telephone Number	Network Representative	Executive Personnel	Transc. Library News Service Transmitter Make
AQUADILLA	WABA (CP) 1947	1240 250	Hector Reichard			
ARECIBO	WCMN 1947	1280 1,000	Caribbean Bcstg. Corp. P. O. Box 755		Artsides Santoni Ledesmo, Pres. Nabal Bavreto, Gen. Mgr.	
	WKUM 1946	1070 10,000 DA-1	American Colonial Bcstg. Corp.			
BAYAMON	WENA 1947	1560 250	Bayamon Bcstg. Corp. Box 157 161		Dr. Alberto Diaz Atilas, Pres. D. Diaz Alejandro, Gen. & Coml. Mgr.	Juan Alfredo Arias, Chief Engr. Gates
CAGUAS	WJFR (CP) 1947	1240 250	Jorama—Fer Radio Corp.		Jose A. Gautier, Mgr.	
	WRIA 1947	1450 250	Inter-American Radio Corp.; Caguas; 678		Hector Pereira Buonomo, Gen. Mgr.	Ramon Mojica Sola, Prog. Mgr. World
	WVJP 1947	1110 250	Borinquen Bcstg. Co. Box 207			
FAJARDO	WMDD 1947	1490 250	Madrazo Diaz P. O. Box 187 132		Jose R. Madrazo, Pres. Andrew S. Sweet, Gen. & Coml. Mgr.	Mariano Artau, Prog. Dir. Reinaldo Moreria, Prom. Mgr. Herbert K. Honness, Chief Engr. Gates
GUAYAMA	WXRF 1948	1590 1,000	Rafael Fuster Calle Hostos #42 243		Rafael Fuster, Owner Charles L. Cordero, Gen. Mgr. Jose Colon Melendez, Prog. Dir.	Timoteo Rodriguez Quinones, Chief Engr. Gates
MAYAGUEZ	WAEI 1948	1400 250	Mario Acosta Iglesia No. 12 789		Mario Acosta, Pres. & Gen. Mgr. Adolfo Alvarez, Coml. Mgr.	Wallace Ramirez, Prog. Dir. Alfonso Pagan, Prom. Mgr. Fulgencio Sanchez, Chief Engr. RCA
	WKJB 1946	710 1,000-LS 500-N	Jose A. Bechara Jr. Box 1293 983	Clark	Jose A. Bechara Jr., Pres. Arturo Cortes, Gen. Mgr. Jaime Sanjurjo, Coml. Mgr.	Alberto Basora, Prog. Dir. Rafael Colon Diaz, Prom. Mgr. Henry Fischback, Chief Engr. AP
	WORA 1947	1150 1,000	Radio Americas Corp. P. O. Box 43 1150	Guzman	Alfredo R. de Arellano Jr., Pres. Reinaldo Maldonado Dupont, Asst. Mgr. Nestor Figarella, Prom. Mgr.	Maria Alvarez de Moran, Coml. Mgr. Ramon S. Olivencia, Prog. Dir. Jesus M. Aviles Brunet, Chief Engr. General Electric
	WPRB 1937	990 10,000 DA-1	Puerto Rico Adv. Co., Inc. Box 869; 269		Andres Camara, Pres. & Gen. Mgr. Virginia Di Cristina, Coml. Mgr.	Ismael Torrellas, Prog. Dir. Esteban Rosado Baez, Prom. Mgr. Luis E. Freyre, Chief Engr.
PONCE	WPAB 1940	1370 5,000	Porto Rican American Bcstg. Co. Inc. P. O. Box 786; 783		A. Gimene Aguayo, Gen. Mgr. Radames Mayoral, Coml. Mgr.	Eliseo Borrero, Prog. Dir. Luis A. Morales, Prom. Mgr. AP; RCA
	WPRP 1948	910 5,000 DA-1	Voice of Porto Rico Inc. P. O. Box 430 .015		Guillermo A. Marques, Pres. Ramon Montaner, Gen. Mgr. Antonio Miro, Coml. Mgr.	Jose E. Franco, Prog. Dir. Jose Arzuaga, Chief Engr. Lang-Worth Gates
RIO PIEDRAS	WR10 1949	1140 1,000-LS 500-N	The Master Bcstg. Corp. P. O. Box 1824 Hato Rey 1096		Isidro Quinones Vidal, Pres. Julio Morales Ortiz, V.P. & Chief Engr. Rafael Quinones Vidal, Coml. Mgr.	Luis Vigoreau, Prog. Dir. SESAC Collins
	WVWW 1949	1520 250	Frank A. Gandia			

WORA of Mayaguez Covers All Western Puerto Rico

THE rich WORA market area in Western Puerto Rico has 26% of the population of the entire island, 21% of all the radio homes, 20% of all the refrigerators and 23% of all retail sales.

THE rich WORA market area in Western Puerto Rico produces many products for home and international distribution such as beer, candy, coffee, furniture, flour, hats, needlecraft, rum, salt and sugar. This merchandize brings dollars — increases purchasing power.

THE rich WORA market area is the home of the College of Agriculture and Mechanical Science of the University of Puerto Rico and a \$24,000,000 power and irrigation project (under construction) which will make this area richer than before.

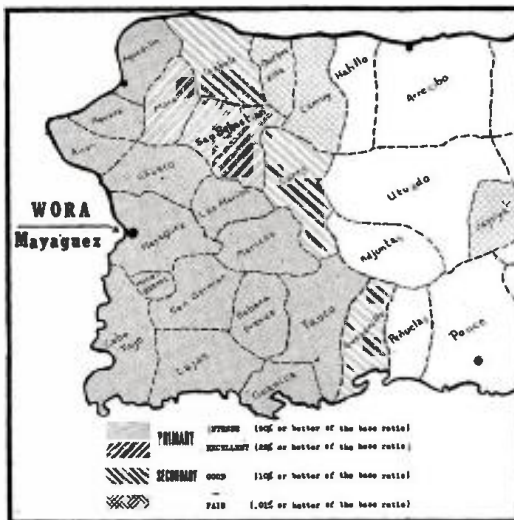

WORA operates a GE 1000 watt transmitter on 1150 kc

Write for complete details.

Exclusive Advertising Representatives in the United States and Canada:

MELCHOR GUZMAN COMPANY INC.
45 Rockefeller Plaza New York (20) N. Y.
Phone: Circle 7-0624

List of principal advertisers:

- ALKA SELTZER
- AMMIDENT TOOTH PASTE
- ATLANTIC MOTOR OIL
- AUTO-LITE BATTERIES
- CAMAY SOAP
- CAMEL'S CIGARETTES
- CAMPBELL'S SOUPS
- CARNATION MILK
- CARIBBEAN ATLANTIC AIRLINES
- COCA COLA
- COLGATE DENTAL CREAM
- COLLINS AXES & MACHETES
- CORONA BEER—CORONA MALT DRINK
- DENIA POWDER MILK
- DR. MORSE MEDICINES
- DON Q RUM—DRENE SHAMPOO
- DRETT—DUZ
- EASTMAN KODAK—FELCHA SOAP
- FRIGIDAIRE
- KLIM POWDER MILK—KRESTO
- KOLYNOS DENTAL CREAM
- INDIA SOFT DRINKS
- LA JOTA COOKING OIL
- LIFEBOUY SOAP
- LISTERINE TOOTH PASTE
- LUCKY STRIKE CIGARETTES
- MOBIL OIL
- NATIONAL BELLAS HESS
- OLD COLONY SOFT DRINKS
- PABST BLUE RIBBON BEER
- PALMOLIVE SOAP
- PAN AMERICAN AIRWAYS
- PET MILK—PONCE CEMENT
- PUERTO RICO FOODS
- REAL MALT DRINK—RED SEAL RICE
- RHEINGOLD BEER
- RINSO—RIO SOAP
- ROCHESTER POWDER MILK
- ROYAL CROWN COLA—ROYAL GELATIN
- ROYAL PUDDINGS—RUMRICO
- SANALAC—SAN ISIDRO FURNITURE
- SCOTT EMULSION—SEVEN-UP
- SMITH, KLINE & FRENCH
- SUPER-A-FERTILIZER
- VATRONOL-VAPORUB—VEL WESTINGHOUSE

DIRECTORY OF AM and FM STATIONS OF U. S. POSSESSIONS and TERRITORIES

(Data corrected to December 6, 1949)

PUERTO RICO—(Continued)

City Call Letters Established	Chan. or Freq. Power	Name of Licensee Headquarters Address Telephone Number	Network Representative	Executive Personnel	Transc. Library News Service Transmitter Make
SAN JUAN					
WAPA 1947	680 10,000	Jose Ramon Quinones P. O. Box 4563 3-0100	ABC, MBS Raymer	Jose Ramon Quinones, Chief Owner Harwood Hull Jr., Gen. Mgr.	Segismundo Quinones, Coml. Mgr. Jose A. Fernandez, Chief Engr. Thesaurus RCA
WIAC 1942	580 5,000	Radio Station WIAC Inc. Ponce de Leon 654 2-0014	Guzman	Mrs. Enrique Abarca, Pres. Tomas Muniz, Gen. Mgr. Enrique Abarca de Juan, Coml. Mgr.	Eli Buck Canel, Prog. Dir. Francisco Rodriquez, Prom. Mgr. Alfonso Sanchez, Chief Engr. Standard AP RCA
WITA 1947	1400 250	Electronic Enterprises Inc.; P. O. Box 3726		Hector L. Almodovar, Studio Dir.	
WKAQ 1922	620 5,000-DA-1	Angel Ramos P. O. Box 3746 2-2023	CBS Inter-American Publications	Angel Ramos, Pres. John A. Zerbe, Gen. Mgr. Domingo Emanuelli, Coml. Mgr.	Santiago Garcia, Prog. Dir. Roy Fornier, Prom. Mgr. Rafael V. Acosta, Chief Engr. Associated World UP RCA
WNEL 1934	860 5,000 DA-1	Juan Piza 960 Ponce de Leon Ave.	NBC	Juan Piza, Owner Rodulfo Blanco, Gen. Mgr.	Roberto Bocantgra, Coml. Mgr.
SANTURCE					
WIBS 1947	740 10,000 DA-1	Jose E. del Valle P. O. Box 4809 2-1558	Pan American	Jose E. del Valle, Owner & Gen. Mgr. Francisco Avosta, Prog. Dir.	Jose A. Ferreras, Coml. Mgr. Albert D. Sear, Chief Engr. Westinghouse
WIPR 1949	940 10,000 DA-1	P. R. Communications Authority Santurce; 2-3010		Rafael Delgado Marquez, Pres. Jose A. Buitrago, Sta. Mgr.	Jose A. Torres Martino, Prog. Dir. Pedro Luis Jimenez, Chief Engr. World Westinghouse

VIRGIN ISLANDS

CHARLOTTE AMALIE, St. Thomas					
WIVI (CP)	1230 250	Radio American West Indies	Edward M. Vickers, Gen. Mgr. & Tech. Supvsr.	R. E. Higdon, Chief Engr.	
WSTA (CP)	1340 250	William N. Greer			
..... (CP)	1090 250	John W. Boler			

DA-N Directional Antenna, night only. FM's in italic.
DA-1 Directional Antenna, same pattern day and night.
DA-2 Directional Antenna, different pattern day and night.

*—Non-Commercial Station. D—Day. N—Night. ST—Share Time. SH—Specified Hours.
U—Unlimited. CP—Construction Permit Issued. LS—Local Sunset.
L—Limited Time with Dominant Station. SA—Special Authorization.

BUSINESS SECTION, SAN JUAN, BUSY CAPITOL OF PUERTO RICO, YOUR \$300 MILLION MARKET IN THE CARIBBEAN



ONE of the most important of all U. S. world markets, Puerto Rico buys drugs and foods, shoes and soap and other U. S. products totalling more than \$300 million annually. And Puerto Rico has more radios per 1000 than any country in the Caribbean . . . responsive radios anxious for more U. S. products. Ask Raymer.

WAPA covers all Puerto Rico, your \$300 million market in the Caribbean

WAPA

1ST IN PUERTO RICO
First in

- POWER
- PROGRAMS
- POPULARITY
- PERFORMANCE

"The Voice of the Caribbean"
WAPA 10,000 WATTS
ON 680 KC
SAN JUAN, PUERTO RICO
BOX 4563

Paul H. Raymer
Representative

Harwood Hull, Jr.
Gen. Mgr.



NO, SIR... WE DO NOT SELL TIME

We do sell audience... the biggest audience in Puerto Rico. We also sell coverage... almost 98% of this great American market.

Superior programming and consistent audience promotion keep the majority of Puerto Rico's radios tuned to 620 Kc. throughout the broadcasting day. Recent impartial surveys indicate that the four top shows in Puerto Rico are broadcast over WKAQ, Puerto Rico's First Station.

We offer you the prestige and know how of the FIFTH OLDEST STATION IN THE WORLD. Twenty-seven years of service to the people of Puerto Rico, have made WKAQ welcome in thousands of homes. Your sales message receives high acceptance in these homes when the "messenger" is an old friend of the family.



620 KC. 5,000 WATTS



INTER - AMERICAN PUBLICATIONS, INC.

41 East 42nd Street, New York 17, N. Y. — MUrray Hill 2-0886

Directory of BROADCASTING STATIONS IN CANADA

(Data corrected to December 6, 1949)
If executives or services for FM or TV stations are same as AM affiliate names are not repeated.

ALBERTA

City Call Letters Established	Chan. or Freq. Power	Name of Licensee Headquarters Address Telephone Number	Network Representative	Executive Personnel	Transc. Library News Service Transmitter Make	
CALGARY						
CFAC 1922	960 5,000 DA-N	Calgary Bcstg. Co. Ltd. Greyhound Bldg. Renfrew 1036	CBC All-Canada Weed	H. R. Carson, Gen. Mgr. A. M. Cairns, Mgr. F. R. Shaw, Coml. Mgr.	D. MacMillan, Prog. Dir. W. C. Paulin, Prom. Mgr. E. C. Connor, Chief Engr.	Associated Thesaurus World PN, BUP RCA
CFCN 1922	1060 10,000-DA-N	The Voice of the Prairies Ltd. Toronto General Trusts Bldg. M 1161	CBC Radio Representa- tives Young	H. G. Love, Pres. E. H. McGuire, Coml. Mgr. Jas. A. Love, Prog. Dir.	G. L. Carter, Prom. Mgr. Robert Lamb, Chief Engr.	Standard Lang-Worth PN, BUP RCA
CJCJ 1927	1140 1,000	Albertan Pub. Co. Ltd. Victory Bldg. Main 9986	CBC Alexander McGillvra	G. M. Bell, Pres. Donald H. McKay, Mgr.	E. K. Elton, Coml. Mgr.	SESAC, BUP
EDMONTON						
CBX 1948	1010 50,000	Canadian Bcstg. Corp. Macdonald Hotel	CBC	Dr. Augustin Frigon, Gen. Mgr. (CBC)	Dan E. Cameron, Mgr., Alberta C. E. L'Ami, Prom. Mgr. (CBC) R. D. Cahoon, Chief Engr. (CBC)	PN, BUP Reuters Federal
CFRN 1934	1260 5,000	G. R. A. Rice 109 CPR Bldg. 22101	CBC Radio Repre- sentatives Young	G. R. A. Rice, Pres. & Gen. Mgr. A. J. Hopps, Coml. Mgr. George A. Duffield, Prog. Mgr.	Audrey J. Hincks, Prom. Mgr. Frank G. Makepeace, Chief Engr.	Lang-Worth Standard PN, BUP RCA
CHFA 1949	680 5,000	Radio Edmonton Ltd. La Survivance Bldg. 20912	Renaud	Romain Le Clair, Gen. Mgr. Paul de Grandpre, Coml. Mgr.	T. Gareau, Prog. Dir. Gordon N. Sadler, Chief Engr.	World PN
CJCA 1922	930 5,000 DA-N	Edmonton Bcstg. Co. Ltd. Birks Bldg. 26131	CBC All-Canada Weed	Gerry Gaetz, Mgr. Rolfe Barnes, Asst. Mgr. Joe MacKenzie, Coml. Mgr.	Dalt Elton, Prog. Dir. (Miss) Win Sutton, Prom. Mgr. Frank Hollingworth, Chief Engr.	World Thesaurus Standard AF, PN, BUP, Marconi
CJCA-FM 1949	Ch. 25B 99.5mc 0.28kw					
*CKUA 1927	580 1,000	Alberta Govt. Telephones Provincial Bldg. 22191		F. Walter Blake, Gen. Mgr. James McRae, Prog. Dir.	Roy Usher, Chief Engr.	Associated PN RCA
CKUA-FM	Ch. 25I 98.1 mc 0.33kw					General Electric
GRAND PRAIRIE						
CFGP 1937	1050 1,000	Northern Bcstg. Corp. Richmond Ave. & 99th 109	CBC All-Canada	A. J. Balfour, Gen. Mgr. Jack E. Soars, Coml. Mgr. Gordon Cockburn, Prog. Dir.	Kay Anderson, Prom. Mgr. D. J. McKinnon, Chief Engr.	United Cole, SESAC Thesaurus PN
LETHBRIDGE						
CJOC 1928	1220 5,000 DA-N	Lethbridge Bcstg. Ltd. 1015 3rd Ave. S. 3161	CBC Weed All-Canada	Harold R. Carson, Pres. William M. Guild, Gen. Mgr. Cameron A. Perry, Coml. Mgr.	George A. Brown, Prog. Dir. Robert A. Reagh, Chief Engr.	Thesaurus Lang-Worth PN Marconi
MEDICINE HAT						
CHAT 1946	1270 1,000	Monarch Bcstg. Co. Ltd. 520 First St. 2821	CBC All-Canada Weed	J. H. Yuill, Pres. R. J. Buss, Gen. & Coml. Mgr. Bartley Brown, Prog. Dir.	Eleanor McDougall, Prom. Mgr. Ian Carson, Chief Engr.	Standard PN RCA
RED DEER						
CKRD 1949	1230 250	Central Alberta Bcstg. Co. Ltd.	Radio Repre- sentatives Young	Gordon S. Henry, Pres. & Gen. Mgr.	Hal Yerxa, Coml. Mgr.	Standard BUP
BRITISH COLUMBIA						
CHILLIWACK						
CHWK 1927	1270 1,000	Fraser Valley Bcstg. Ltd. 50 Yale East 7511	CBC All-Canada Weed	C. Casey Wells, Pres. Jack Pilling, Mngng. Dir.	William G. Teetzel, Coml. Mgr. J. M. MacIachlan, Prod. Mgr. United Cole
DAWSON CREEK						
CJDC 1947	1350 1,000	Radio Station CJDC Ltd. 2nd St. & 9th Ave.	CBC Radio Repre- sentatives Hunt	W. B. Michaud, Pres. Lewis R. Roskin, Gen. Mgr. W. Michaud Jr., Coml. Mgr.	Roy Darling, Prog. Dir. George Kidd, Prom. Mgr. Edward Pfeifer, Chief Engr.	Associated PN Marconi
KAMLOOPS						
CFJC 1926	910 1,000	Sentinel Pub. Co. 310 St. Paul St. 1021	CBC All-Canada Weed	Ian Clark, Mgr.		United PN
KELOWNA						
CKOV 1931	630 1,000	Okanagan Bcstg. Ltd. 1491 Pendozi St. 200	CBC All-Canada Weed	J. W. B. Browne, Pres. J. H. Browne, Sta. Mgr. W. Harwood, Coml. Mgr.	Frank Bond, Prog. Dir. J. Fred Weber, Chief Engr.	Lang-Worth SESAC Thesaurus World PN
NANAIMO						
CHUB 1949	1570 250	George Randall Malaspina Hotel	Nat'l Bcstg. Sales Hunt Cooke	George Randall, Pres.	Joan Orr, Gen. Mgr.	World PN
NELSON						
CKLN 1939	1240 250	News Pub. Co. Ltd. P. O. Box 250 19	Stovin, Young Fremantle	(Mrs.) Kay Haryett, Mgr.		World PN

DA-N Directional Antenna, night only. FM's in italic.
DA-1 Directional Antenna, same pattern day and night.
DA-2 Directional Antenna, different pattern day and night.

*-Non-Commercial Station. D-Day. N-Night. ST-Share Time.
U-Unlimited. CP-Construction Permit Issued. LS-Local Sunset.
L-Limited Time with Dominant Station. SA-Special Authorization.

Merchandising

IS THE OTHER

Half of the Battle

IF there is any one outstanding characteristic of the member stations of the Canadian Association of Broadcasters it is their realization that making a program *sell merchandise* involves greater effort than merely putting it on the air.

The *local* merchants must be sold on the program. The *local* sales force must be enthusiastic. Everyone connected with the *local, privately owned* broadcasting station is on their toes to follow up—to insure that every effort is made to *make listeners buy*.

To a degree unknown anywhere else in the world of radio, the member stations of the "C.A.B." bend every effort to see that *merchandise is sold*, not merely programs aired.

BRING YOUR PROBLEMS,
WITHOUT COST OR OBLIGATION
TO

**CANADIAN
ASSOCIATION
OF
BROADCASTERS**

HEAD OFFICE: 108 Sparks St., Ottawa.

ADVERTISERS SERVICE: 37 Bloor St. W., Toronto.

DIRECTORY OF AM and FM STATIONS OF CANADA

(Data corrected to December 6, 1949)
If executives or services for FM or TV stations are same as AM affiliate names are not repeated.

BRITISH COLUMBIA—(Continued)

City Call Letters Established	Chan. or Freq. Power	Name of Licensee Headquarters Address Telephone Number	Network Representative	Executive Personnel	Transc. Library News Service Transmitter Make
NEW WESTMINSTER					
CKNW 1944	1320 1,000 DA-N	William Rea Jr. 732 Columbia St. 3000	Radio Repre- sentatives Forjoe	William Rea Jr., Pres. & Prog. Dir. David M. Armstrong, Gen. Mgr.	Gordon Reid, Coml. Mgr. Philip Baldwin, Prom. Mgr. Bill Collins, Chief Engr. Associated Cole, World PN RCA
PENTICTON					
CKOK 1948	800 250	CKOK Ltd. 152 Main St. 900	Hunt, Wright Cooke	J. Ree Beattie, Pres. Harry O. Watts, Gen. Mgr. Jean Griffiths, Coml. Mgr.	Vince Duggan, Prog. Dir. James English, Chief Engr. Standard PN Gates
PORT ALBERNI					
CJAV 1948	1240 250	CJAV Ltd. 735 Third Ave. N. 604	Radio Repre- sentatives	Margaret Rea, Pres. Charles J. Rudd, Gen. Mgr. Ken H. Hutcheson, Coml. Mgr.	Thomas A. Rannie, Prog. Dir. Hugh Hollway, Chief Engr. Cole Lang-Worth PN Northern Electric
PRINCE GEORGE					
CKPG 1946	550 250	CKPG Ltd. Ritz-Keifer Hall 140	CBC All-Canada Weed	Frank H. Elphicke, Pres. Cecil G. Elphicke, Mngng. Dir. Jack Carbutt, Coml. Mgr.	Art Hall, Prog. Dir. John Boates, Prom. Mgr. Ralph Spencer, Chief Engr. Marconi
PRINCE RUPERT					
CFPR 1937	1240 250	Northwest Bcst. & Serv- ice Co. Ltd. P. O. Box 848 863	CBC Stovin	F. E. Batt, Pres. C. H. Insulander, Gen. Mgr. & Chief Engr. S. J. Anderson, Coml. Mgr.	M. Furunes, Prog. Dir. Gates
TRAIL					
CJAT 1934	610 1,000	Kootenay Bcstg. Co. 815 Victoria St. 737	CBC All-Canada Weed	E. W. Hazlewood, Pres. John W. Loder, Gen. Mgr.	Joseph P. Kobluk, Prog. Dir. John D. Hepburn, Chief Engr. Thesaurus PN RCA
VANCOUVER					
CBR 1936	1130 5,000	Canadian Bcstg. Corp. Hotel Vancouver Marine 6121	CBC	Dr. Augustin Frigon, Gen. Mgr. (CBC) Kenneth Caple, B. C. Reg. Rep. Douglas Nixon, Prog. Dir.	E. A. Weir, Coml. Mgr. (CBC) W. G. Clark, Prom. Mgr. A. Hilton, Chief Engr. CP BP, BUP Reuters
CBR-FM	Ch. 289 105.7mc 1.4kw				
CJOR 1926	600 5,000 DA-1	CJOR Ltd. 846 Howe St. Marine 6464	CBC Stovin Young	George C. Chandler, Pres. & Gen. Mgr. Don Laws, Coml. Mgr. Dorwin Baird, Prod. Mgr.	Ross Mortimer, Prog. Dir. A. H. Chandler, V.P. & Chief Engr. Thesaurus United UP, PN, BUP Northern Electric
CKMO 1922	1410 1,000	B. C. Bcstg. System Ltd. 812 Robson St. Marine 1271	Nat'l Bcst. Sales Cooke	(Mrs.) R. J. Sprott, Pres. (Mrs.) K. M. Willis, Mgr. Thomas Slattery, Coml. Mgr.	George Dewey, Prog. Dir. Ross L. Whiteside, Chief Engr. SESAC Standard AP, PN
CKWX 1923	980 5,000 DA-1	Western Bcstg. Co. Ltd. 543 Seymour St. Marine 3344	MBS All-Canada Weed	Arthur Holstead, Pres. Frank H. Elphicke, Gen. Mgr. John L. Sayers, Coml. Mgr.	Laurie Irving, Prog. Mgr. Joe Midmore, Prom. Mgr. J. K. Gordon, Chief Engr. Lang-Worth World PN, BUP RCA
VERNON					
CJIB 1947	940 1,000	Interior Bcstrs. Ltd. 3330 Barnard Ave. 900	CBC Radio Repre- sentatives Cooke	J. T. Mutrie, Pres. Sid S. Lancaster, Gen. Mgr. Charles H. Pitt, Secy-Treas. Don McGibbon, Prog. Dir.	Don Warner, Prom. Mgr. Lorne Merriman, Chief Engr. Associated, Cole PN RCA
VICTORIA					
CJVI 1941	900 1,000-LS 250-N	Island Bcstg. Co. 620 View St. Garden 2014	CBC All-Canada Weed	H. T. Matson, Pres. M. V. Chesnut, Mgr. L. F. Hallberg, Coml. Mgr.	T. R. Batey, Prog. Dir. & Prod. Mgr. Betty Garnett, Prom. Mgr. J. Sommers, Chief Engr. Thesaurus World PN Intervox
BRANDON					
CKX 1928	1150 1,000	Western Manitoba Bcstrs. Ltd. 8th St. & Princess Ave. 4532	CBC Radio Repre- sentatives Cooke	John B. Craig, Mngng. Dir. E. D. Holland, Coml. Mgr.	Eric Davies, Prog. Dir. Humphrey Davies, Chief Engr. Thesaurus World PN Northern Electric
FLIN FLON					
CFAR 1937	590 1,000	Arctic Radio Corp. Ltd. 75 Hill St. 590	CBC Stovin Young	S. J. Beaufoy, Pres. C. H. Witney, Gen. Mgr. Don Willis, Prog. Dir.	Ev Smallwood, Prom. Mgr. Gordon Woodward, Chief Engr. Lang-Worth PN General Electric
ST. BONIFACE					
CKSB 1946	1250 1,000 DA-1	Radio St. Boniface Ltd. 607 College St. 20865	Renaud McGillvra	Roland Couture, Pres. & Coml. Mgr.	World BUP
WINNIPEG					
CBW 1948	990 50,000	Canadian Bcstg. Corp. 300 Manitoba Telephone Bldg. 922191	CBC	Dr. Augustin Frigon, Gen. Mgr. (CBC) J. R. Finlay, Prairie Reg. Rep. E. A. Weir, Coml. Mgr. (CBC)	Nairn Mogridge, Sta. Mgr. C. E. L'Ami, Prom. Mgr. (CBC) R. D. Cahoon, Chief Engr. (CBC)
CJOB 1946	1340 250	Blick Bcstg. Ltd. Lindsay Bldg. 9-6374	Radio Repre- sentatives Cooke	J. O. Blick, Pres. & Gen. Mgr. A. J. Messner, Coml. Mgr. C. E. Farey, Prog. Dir.	George Davies, Asst. Prom. Mgr. R. V. Durio, Chief Engr. Associated Standard United, World PN, BUP
CJOB-FM 1948	Ch. 276 103.1mc 0.25kw				
CKRC 1934	630 5,000 DA-N	Trans-Canada Communications Free Press Bldg. 922266	CBC Weed All-Canada	V. Sifton, Pres. W. A. Speers, Gen. Mgr. B. M. Pirie, Coml. Mgr.	J. Hill, Prog. Dir. F. M. Desourdy, Prom. Mgr. A. W. Hooper, Chief Engr. Lang-Worth Standard BUP, CP RCA
CKY 1949	1080 5,000	Bergman-Moffat Bcstg. Co. Ltd. 432 Main St.	Stovin Young	Lloyd E. Moffat, Gen. Mgr.	Jack Shortreed, Coml. Mgr. Capitol BUP

MANITOBA

DA-N Directional Antenna, night only. FM's in italic. *—Non-Commercial Station. D—Day. N—Night. ST—Share Time. SH—Specified Hours.
DA-1 Directional Antenna, same pattern day and night. U—Unlimited. CP—Construction Permit Issued. LS—Local Sunset.
DA-2 Directional Antenna, different pattern day and night. L—Limited Time with Dominant Station. SA—Special Authorization.

NEW BRUNSWICK

City Call Letters Established	Chan. or Freq. Power	Name of Licensee Headquarters Address Telephone Number	Network Representative	Executive Personnel	Transc. Library News Service Transmitter Make	
CAMPBELLTON						
CKNB 1939	950 1,000 DA-1	Restigouche Bcstg. Co. Ltd. P. O. Drawer 226 8	CBC All-Canada Weed	J. W. MacDonald, Pres. Dr. Charles Houde, Gen. Mgr. Stan Chapman, Coml., Prom. & Sta. Mgr.	Robert Richards, Prog. Dir. L. P. Paquet, Chief Engr. Northern Electric
EDMUNDSTON						
CJEM 1944	1230 250	Edmundston Radio Ltd. 91 Canada Rd. 296	CBC Stovin Young	Hon. Jules Brillant, Pres. Maurice Lacasse, Gen. Mgr.	Georges Guerrette, Coml. Mgr.	World Northern Electric
FREDERICTON						
CFNB 1923	550 5,000 DA-N	Jas. S. Neill & Sons Ltd. York St. 5501	CBC All-Canada Weed	D. Malcolm Neill, Gen. Mgr. C. Austin Moore, Sales & Prom. Mgr.	J. T. H. Fenety, Prog. Dir. D. Glenn Love, Chief Engr.	Cole, Standard Thesaurus BUP, RP Marconi
MONCTON						
CKCW 1934	1220 5,000 DA-N	Moncton Bcstg. Ltd. Knights of Pythias Bldg. 9111	CBC Stovin McGillvra	Fred A. Lynds, Pres. William Brown, Office Mgr. F. Alan Bestall, Coml. Mgr.	C. Robertson Tabor, Prog. Dir. Alfred T. Parkes, Prom. Mgr. James A. White, Chief Engr.	Lang-World World, United BUP, RP RCA
NEWCASTLE						
CKMR 1949	1340 250	Miramichi Bcstg. Co. Ltd., Castle St.	Wright	Arthur Martin, Gen. Mgr.		Standard PN
SACKVILLE						
CBA 1939	1070 50,000	Canadian Bcstg. Corp. 100 Sackville St. 3-6188	CBC	Dr. Augustin Frigon, Gen. Mgr. (CBC) Wyn Rhydwen, Prom. Mgr.	W. E. S. Briggs, Maritime Reg. Rep. E. A. Weir, Coml. Mgr. (CBC) H. M. Smith, Chief Engr. CP, PN BUP, Reuters
SAINT JOHN						
CFBC 1946	930 5,000 DA-1	Fundy Bcstg. Co. Ltd. 4 Carleton St. 3-2421	CBC Alexander Weed	Dr. A. M. A. McLean, Pres. Robert T. Bowman, Gen. Mgr. Charles E. Wasson, Coml. Mgr. R. J. Gallagher, Prom. Mgr.	F. E. Church & C. V. Godwin, Supvsrs. H. M. Stout, Chief Engr.	Standard RP RCA
CHSJ 1934	115 5,000 DA-N	New Brunswick Co. Ltd. 14 Church St. 3-3304	CBC Stovin Young	T. F. Drummie, Pres. George A. Cromwell, Mgr. & Com. Mgr. Cleve G. Stillwell, Prog. Dir.	J. D. Bishop, Chief Engr.	Associated Lang-Worth Standard United, World PN
CHSJ-FM	Ch. 263 100.5mc 0.25kw					

NEWFOUNDLAND

CORNER BROOK						
CBY 1949	790 1,000	Canadian Bcstg. Corp. Corner Brook	CBC	Dr. Augustin Frigon, Gen. Mgr. (CBC) E. A. Weir, Coml. Mgr. (CBC) William F. Galgay, Nfld. Reg. Rep.	C. V. Hierlihy, Sta. Mgr. Ron C. Fraser, Prom. Mgr. (CBC) CP, PN, BUP Reuters

Canada's Selective Radio Headquarters

THE little All-Canada man represents all phases of Canadian broadcasting—both time and talent.

Through the years he has come to symbolize not only the company he represents, but the medium he champions: SELECTIVE Radio.

In a vast country with wide "skip-distances" between major markets, All-Canada offers you the most economical, most effective method of

reaching the consumer at home through a select group of key Canadian stations.

Call on the All-Canada man whenever your campaign plans extend into the Canadian market. He'll be ready to discuss times and stations; and All-Canada also offers you selection from the world's largest library of transcribed programs.

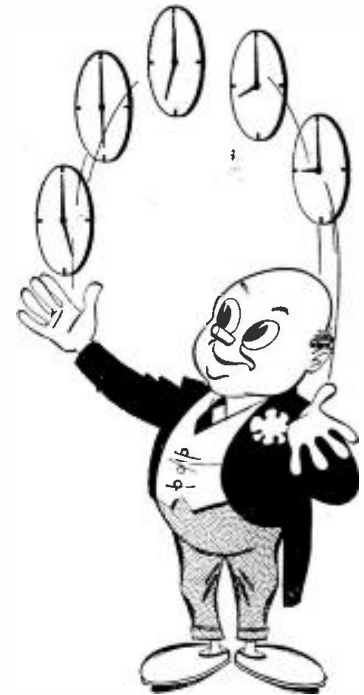

ALL-CANADA RADIO FACILITIES *Limited*

VANCOUVER CALGARY WINNIPEG TORONTO MONTREAL

Canada's Foremost Broadcast Service Organization

DIRECTORY OF AM and FM STATIONS OF CANADA

(Data corrected to December 6, 1949)
If executives or services for FM or TV stations are same as AM affiliate names are not repeated.

NEWFOUNDLAND—(Continued)

City Call Letters Established	Chan. or Freq. Power	Name of Licensee Headquarters Address Telephone Number	Network Representative	Executive Personnel	Tran. Library News Service Transmitter Make
FORT PEPPERRELL					
VOUS	1480 500	U. S. Air Force Fort Pepperell			
GANDER					
CBG 1949	1450 250	Canadian Bcstg. Corp. Gander	CBC	Dr. Augustin Frigon, Gen. Mgr. (CBC) William F. Galgay, Nfld. Reg. Rep. E. A. Weir, Coml. Mgr. (CBC)	A. Barrett, Sta. Mgr. Ron C. Fraser, Prom. Mgr. (CBC) CP, PN, BUP Reuters
GOOSE BAY					
CGB	1340 250	Royal Canadian Air Force Goose Bay			
GRAND FALLS					
CBT 1949	1350 1,000	Canadian Bcstg. Corp. Grand Falls	CBC	Dr. Augustin Frigon, Gen. Mgr. (CBC) William F. Galgay, Nfld. Reg. Rep.	John J. Grace, Sta. Mgr. Ron C. Fraser, Prom. Mgr. (CBC) CP, PN, BUP Reuters
HARMON FIELD					
VOHF	1490 50	U. S. Air Force Harmon Field			
ST. JOHN'S					
CBN 1949	640 10,000	Canadian Bcstg. Corp. St. John's	CBC	Dr. Augustin Frigon, Gen. Mgr. (CBC) William F. Galgay, Nfld. Reg. Rep.	E. A. Weir, Coml. Mgr. (CBC) Ron C. Fraser, Prom. Mgr. (CBC) CP, PN, BUP Reuters
*VOAR	1230 100 SH	Newfoundland Mission of Seventh Day Ad- ventists 52 Cookstown Rd.			
VOCM 1936	1000 250	Colonial Bcstg. System Parade St. 2741	Stovin	J. L. Butler, Mngng. Dir. M. Shulman, Coml. Mgr.	J. M. Murdoch, Prog. Dir. W. B. Williams, Chief Engr. Thesaurus World PN Gates
*VOWR	700 500 SH	Wesley Radio Board Patrick St.			

NOVA SCOTIA

ANTIGONISH					
CJFX 1943	580 5,000 DA-1	Atlantic Bcstrs. Ltd. Broadcasting Bldg.	CBC Young Nat'l Bcst. Sales	J. Clyde Nunn, Gen. Mgr. Ralph J. Ricketts, Coml. Mgr.	James Boroughs, Sales Mgr. Lang-Worth United PN
BRIDGEWATER					
CKBW 1947	1000 1,000 DA-N	Acadia Bcstg. Co. Ltd. 399 King St. 445	CBC Radio Repre- sentatives Cooke	C. J. Morrow, Pres. J. F. Hirtle, Gen. Mgr. J. S. Harris, Coml. Mgr.	L. L. Rogers, Sales Mgr. D. B. Hirtle, Chief Engr. Associated PN RCA
HALIFAX					
CBH 1944	1330 100	Canadian Bcstg. Corp. 100 Sackville St. 3-6188	CBC	Dr. Augustin Frigon, Gen. Mgr. (CBC) E. A. Weir, Coml. Mgr. (CBC) W. E. S. Briggs, Maritime Reg. Rep.	S. R. Kennedy, Sta. Mgr. H. M. Smith, Chief Engr. CP, INS, PN BUP, Reuters
CHNS 1926	960 5,000 DA-N	Maritime Bcstg. Co. 10 Tobin St. 3-8318	CBC Weed All-Canada	Andrew W. Robb, Pres. William Coates Borrett, Gen. Mgr. Gerald J. Redmond, Coml. Mgr., & Prog. Dir.	De LeBlanc, Prom. Mgr. Arthur W. Greig, Chief Engr. World Thesaurus Lang-Worth PN, BUP Northern Electric
CHNS-FM 1949	Ch. 241 96.1mc 0.25kw				RCA
CJCH 1944	920 5,000	Radio Station CJCH Lord Nelson Hotel 3-7311	Nat'l Bcst. Sales Cooke	E. Finlay MacDonald, Gen. Mgr. C. L. Chambers, Coml. Mgr.	H. E. Gerard, Prom. Mgr. A. R. MacWilliams, Chief Engr. Standard, World AP, PN Reuters Northern Electric
KENTVILLE					
CKEN 1948	1490 250	Evangeline Bcstg. Co. Radio Center Ltd. Kentville 400	Alexander	A. M. Bishop, Pres. & Chief Engr. J. A. C. Lewis, Gen. Mgr.	Robert Sanborn, Coml. Rep. Willard A. Bishop, Prog. Dir. United PN General Electric
SYDNEY					
CBI 1948	1570 1,000	Canadian Bcstg. Corp. 247 Charlotte St.	CBC	Dr. Augustin Frigon, Gen. Mgr. (CBC) E. A. Weir, (CBC), Coml. Mgr. Barry MacDonald, Sta. Mgr.	W. E. S. Briggs, Reg. Rep. H. M. Smith, Reg. Chief Engr. PN, BUP, CP Reuters
CJCB 1929	1270 5,000-LS 1,000-N	Eastern Bcstrs. Ltd. Radio Bldg. 5596	CBC All-Canada Weed	N. Nathanson, Pres. & Gen. Mgr. J. Marven Nathanson, Coml. Mgr. Lloyd MacInnis, Prog. Dir.	Charles J. MacDougall, Prom. Mgr. Alfred Vernon, Chief Engr. Lang-Worth Thesaurus World PN Marconi
CJCB-FM 1948	Ch. 235 94.9mc 0.25kw				General Electric
TRURO					
CKCL 1947	1400 250	Truro Bcstg. Co. Ltd. 7 Pleasant St. 491	Wright	J. A. Manning, Pres. & Mngng. Dir. Alex Thomson, Coml. Mgr.	Edward Belcher, Prog. Dir. Sidney Bernasconi, Chief Engr. Associated PN Northern Electric
WINDSOR					
CFAB 1945	1450 250	Evangeline Bcstg. Co. Windsor Radio Center Ltd. 498	Alexander	A. M. Bishop, Pres. & Chief Engr. J. A. C. Lewis, Gen. Mgr.	Robert Sanborn, Coml. Rep. Willard A. Bishop, Prog. Dir. United PN Northern Electric
YARMOUTH					
CJLS 1934	1340 250	Gateway Bcstg. Co. Ltd. 222 Main St. 500	CBC All-Canada Weed	Laurie L. Smith, Pres., Gen. & Coml. Mgr. Denny Comeau, Prog. Dir.	Fred Ball, Prom. Mgr. Donald L. Smith, Chief Engr. United Lang-Worth PN

DA-N Directional Antenna, night only. FM's in italic.
DA-1 Directional Antenna, same pattern day and night.
DA-2 Directional Antenna, different pattern day and night.

*—Non-Commercial Station. D—Day. N—Night. ST—Share Time. SH—Specified Hours.
U—Unlimited. CP—Construction Permit Issued. LS—Local Sunset.
L—Limited Time with Dominant Station. SA—Special Authorization.

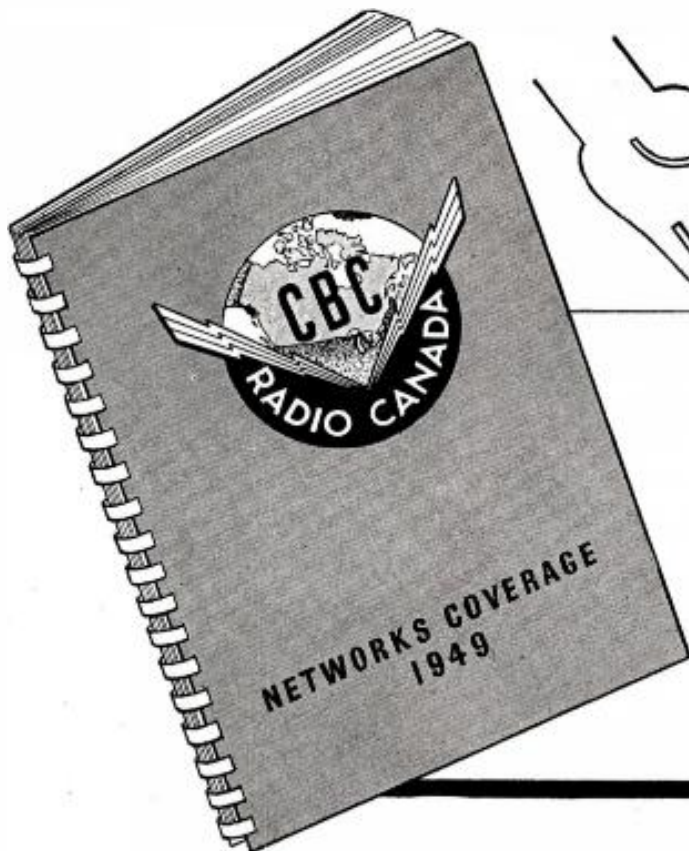

At your fingertips

The basic facts about **CANADIAN NETWORK RADIO**

The moment Canadian Radio enters your advertising plans, you should have this book. It's the only book of its kind! Based on the 1948 Survey of the Bureau of Broadcast Measurement, it puts you completely "in the picture" about Canadian Network Radio Coverage.

You'll find in this concise
reference guide:

- Comprehensive breakdown of network circulation by provinces, in the areas covered by the three Canadian Networks—Trans-Canada, French and Dominion.
- Three big, easy-to-read maps, showing locations of basic and supplementary stations of the three Canadian Networks in the markets they serve.
- Population of Canada by provinces, showing the number of households, the number and percentage of English and French-speaking Radio Homes.
- Network Stations, power, frequencies and time zones.



Yes, this book is invaluable to every radio advertiser and agency interested in Canada! Write for a copy now . . . and if you have any additional questions on your mind about the use of Canadian Network Radio, send them along, too. Ask for "Networks Coverage—1949".

CANADIAN BROADCASTING CORPORATION

COMMERCIAL DIVISION

354 Jarvis Street
Toronto 5, Ontario

1231 St. Catherine Street West
Montreal 25, Quebec

DIRECTORY OF AM and FM STATIONS OF CANADA

(Data corrected to December 6, 1949)
If executives or services for FM or TV stations are same as AM affiliate names are not repeated.

ONTARIO

City Call Letters Established	Chan. or Freq. Power	Name of Licensee Headquarters Address Telephone Number	Network Representative	Executive Personnel	Transc. Library News Service Transmitter Make
BARRIE					
CKBB 1949	1230 250	Ralph T. Snelgrove 26 Elizabeth St.	Nat'l Bcst. Sales	Ralph T. Snelgrove, Pres. & Gen. Mgr.	PN
BELLELEVILLE					
CJBQ 1946	1230 250	Quinte Bcstg. Co. Ltd. 11 Victoria Ave. 3200	Stovin Young	A. M. Haig, Pres. W. H. Stovin, Gen. Mgr. J. H. MacDonald, Coml. Mgr. W. E. Arnold, Prog. Dir.	S. Hannah, Prom. Mgr. J. B. Buchanan, Chief Engr. Thesaurus World PN, CP Western Electric
BRANTFORD					
CKPC 1923	1380 1,000 DA-N	Telephone City Bcst. Ltd. 49 Colborne St. 32664	Alexander	Mrs. Florence M. Buchanan, Pres. Hugh Bremner, Coml. Mgr.	World, United PN Northern Electric
CKPC-FM	Ch. 234 94.7mc 0.42kw				BUP General Electric
BROCKVILLE					
CFJM 1943	1450 250	Eastern Ontario Bcstg. Co. Ltd. Brockville 4628	CBC Stovin Young	Jack R. Radford, Pres., Gen. & Coml. Mgr. Pat Byrne, Prog. Dir.	Tom Statham, Prom. Mgr. John G. Brasford, Chief Engr. BUP Gates
CHATHAM					
CFCO 1926	630 1,000	John Beardall 42 King St. W. 2626	CBC	John Beardall, Pres. & Gen. Mgr. P. A. Kirkey, Coml. Dir.	George Sulman, Prog. Dir. Gordon D. Brooks, Chief Engr. Cole BUP Northern Electric
CORNWALL					
CKSF 1945	1230 250	Standard-Freeholder Ltd. 36 Pitt St. 1703	CBC Stovin McGillvra	Phillip Robertson, Pres. H. Harrison Flint, Gen. & Coml. Mgr.	Howard H. Bailey, Prog. Dir. Mahlon Clark, Chief Engr. World London PN Marconi
CKSF-FM 1949	Ch. 283 104.5mc 0.52kw				
FORT FRANCES					
CKFI 1944	1340 250	J. G. McLaren 240 Scott St. 200	KBS, CBC Hunt Cooke	J. G. McLaren, Pres. W. H. McLellan, Gen. & Coml. Mgr. Leon Jourard, Prog. Dir.	Harry Munro, Prom. Mgr. George Bishop, Chief Engr. Northern Electric
FORT WILLIAM					
CKPR 1931	580 1,000	Dougall Motor Car Co. Ltd. 414 Victoria Ave. 3-3477	CBC Radio Repre- sentatives All-Canada Stovin Young	H. F. Dougall, Pres. G. D. Jeffrey, Coml. Mgr.	Eldon Wilcox, Prog. Dir. W. T. Ross, Chief Engr. United Thesaurus PN RCA
CKPR-FM 1948	Ch. 232 93.4mc 0.25kw				
GUELPH					
CJOY 1948	1450 250	CJOY Ltd. Bond Bldg. 555	Radio Repre- sentatives	Wallace O. Slatter, Sta. Mgr. Frederick T. Metcalf, Coml. Mgr.	Laurie J. Lohman, Prog. Dir. Desmond A. Page, Chief Engr. Lang-Worth Cole PN RCA
HAMILTON					
CHML 1948	900 5,000 DA	Maple Leaf Bcstg. Co. Ltd. 848 Main St. E. 9-2411	CBC Nat'l Bcst. Sales Young Hunt	K. D. Soble, Pres. Tom Darling, Mgr. & Prog. Dir. W. D. Whitaker, Coml. Mgr.	Edward S. Stock, Asst. Mgr. P. Tahany & H. Potter, Chief Engrs. Associated Standard BUP RCA
CHML-FM	Ch. 231 94.1mc 0.25kw				
CJSH(FM) 1949	Ch. 275 102.9mc 0.74kw	Hamilton Spectator 163 Jackson St. W. 3-0631		Gerald Quinney, Gen. & Coml. Mgr.	PN General Electric
CKOC 1922	1150 5,000 DA-N	Wentworth Radio Bcstg. Co. Ltd. 23 John North 7-4483	CBC All-Canada Weed	H. R. Carson, Pres. W. T. Cranston, Sta. Mgr. J. L. Potts, Asst. Mgr.	L. A. Westmoreland, Coml. Mgr. J. O. Stone, Prog. Dir. Leslie Horton, Chief Engr. World Thesaurus AP, PN Reuters Marconi
KENORA					
CJRL 1938	1220 1,000	Kenora Bcstg. Co. Ltd. Brydon Block 717	CBC Stovin Cooke	(Mrs.) James Richardson, Pres. George A. McLean, Mgr. & Coml. Mgr. Ernest C. Mutimer, Prog. Dir.	Murray C. Cooke, Prod. Mgr. William Hackett, Chief Engr. Thesaurus PN
KINGSTON					
CFRC 1942	1490 100 980 5,000 DA-1	Queen's U. Fleming Hall The Brookland Co. Ltd. King St. 4404	CBC Nat'l Bcst. Sales Cooke	Hon. W. R. Davies, Pres. R. H. Thomson, V. P. R. W. Hofstetter, Sta. & Prom. Mgr.	G. Sweetman, Coml. Mgr. Jack Pollie, Prog. Dir. Albert Cobb, Chief Engr. Lang-Worth World PN RCA
CKWS-FM 1942	Ch. 242 96.3mc 0.25kw				
KIRKLAND LAKE					
CJKL 1934	580 5,000 DA-N	Northern Bcstg. Co. Govt. Rd. West 27	CBC Nat'l Bcst. Sales Cooke	Roy Thomson, Pres. Harry M. Edgar, Mgr. Donald R. Lawrie, Coml. Mgr.	Cliff M. Harrison, Prog. Dir. Leceister Oliver, Chief Engr. Lang-Worth Thesaurus Standard PN RCA
CJKL-FM 1948	Ch. 229 93.7mc 0.25kw				

DA-N Directional Antenna, night only. FM's in italic.
DA-1 Directional Antenna, same pattern day and night.
DA-2 Directional Antenna, different pattern day and night.

*—Non-Commercial Station. D—Day. N—Night. ST—Share Time. SH—Specified Hours.
U—Unlimited. CP—Construction Permit Issued. LS—Local Sunset.
L—Limited Time with Dominant Station. SA—Special Authorization.

City Call Letters Established	Chan. or Freq. Power	Name of Licensee Headquarters Address Telephone Number	Network Representative	Executive Personnel	Transc. Library News Service Transmitter Make
KITCHENER					
CFCA(FM) 1949	Ch. 291 106.1mc 10kw	C. A. Pollock, 47 King St. W.		C. A. Pollock, Pres. & Gen. Mgr.	(Miss) Chris Fairly, Coml. Mgr. Cole, World Lang-Worth PN
CKCR 1929	1490 250	Kitchener-Waterloo Bcstg. Co. Ltd. 125 King St. W. 3-3628	CBC Wright	W. C. Mitchell, Owner & Pres. G. Liddle, Owner & V. P.	Ed Manning, Prog. Dir. & Prom. Mgr. Bill Marchand, Chief Engr. Associated United PN RCA
CKCR-FM 1929	Ch. 244 96.7mc 0.35kw				
LONDON					
CFPL 1922	980 5,000 DA-N	London Free Press Printing Co. 442 Richmond St. Metcalfe 5200	CBC All-Canada Weed	W. J. Blackburn, Pres. Murray T. Brown, Gen. Mgr. K. S. Chase, Sales Mgr.	R. A. Reinhart, Prog. Dir. G. A. Robitaille, Chief Engr. Standard Lang-Worth PN RCA
CFPL-FM 1948	Ch. 240 95.9mc 4.5kw			 General Electric
NIAGARA FALLS					
CHVC 1947	1800 1,000 DA-N	Radio Station CHVC Ltd. Rainbow Bridge 4110	Alexander Cooke	B. Howard Bedford, Pres. Wesley M. Schwab, Asst. Mgr. Jack B. Howey, Sales Mgr.	Arthur W. Blakely, Prom. Mgr. George S. Slinn, Chief Engr. World BUP RCA
NORTH BAY					
CFCH 1931	600 1,000 DA-1	Northern Bcstg. Co. Ltd. Fraser & First 2400	CBC Nat'l Bcst. Sales Cooke	R. H. Thomson, Pres. J. M. Davidson, Gen. Mgr. C. O. Pickrem, Sta. Mgr. K. Packer, Coml. Mgr.	P. Clayton, Prog. Dir. J. Macgregor, Prom. Mgr. J. Barnaby, Chief Engr. Standard Lang-Worth PN RCA
CFCH-FM 1949	Ch. 292 106.3mc 0.25kw				
ORILLIA					
CFOR 1945	1570 1,000	Gordon E. Smith 101 Mississaga St. E. 3511	CBC Stovin	Gordon E. Smith, Pres. & Gen. Mgr. Alex Gilmour, Coml. Mgr. James McGarvey, Prog. Dir.	Russ Waters, Prom. Mgr. Donald McBride, Chief Engr. Cole BUP Gates
OSHAWA					
CKDO 1946	1240 100	Oshawa Bcstg. Co. Ltd. 16 Centre St. 4481	Alexander Weed	Walter A. Dales, Pres. Ross R. Rowlands, Gen. Mgr.	William Swinton, Prog. Dir. Bert McCollum, Chief Engr. World PN RCA
OTTAWA					
CBO 1924	910 1,000	Canadian Bcstg. Corp. Chateau Laurier 2-1151	CBC	Dr. Augustin Frigon, Gen. Mgr. (CBC) E. A. Weir, Coml. Mgr. (CBC)	Charles P. Wright, Sta. Mgr. Maxted Gilbert, Chief Oper. CP. BUP Reuters
CBO-FM	Ch. 277 103.3mc 0.25kw				
CFRA 1947	560 1,000 DA-2	Radio Station CFRA Auditorium Catherine St. 3-6241	Weed All-Canada	Frank Ryan, Pres. George Gowling, Coml. Mgr.	Fred Davis, Prog. Dir. World Standard Cole BUP RCA
CFRA-FM 1948	Ch. 230 93.8mc 0.25kw				
CKOY 1949	1310 5,000-LS 1,000-N DA	CKOY Ltd. 272 Somerset St. W. 3-5658	CBC Cooke Nat'l Bcst. Sales	Duncan McTavish, Pres. T. Edgar Guest, Gen. Mgr.	Don Davis, Coml. Mgr. Jack Alexander, Prog. Dir. John McGrail, Chief Engr. Lang-Worth Associated AP. UP. BUP Reuters RCA
OWEN SOUND					
CFOS 1940	1470 1,000 DA-N	Grey & Bruce Bcstg. Co. Ltd. Ninth St. E. 1940	Stovin Young	Howard Fleming, Pres. W. N. Hawkins, Gen. Mgr. D. Ferry, Coml. Mgr.	E. Smith, Prog. Dir. D. Smith, Prom. Mgr. R. Turnpenney, Chief Engr. World PN RCA
PEMBROOKE					
CHOV 1942	1350 1,000 DA-1	Ottawa Valley Bcstg. Co. Ltd. 97 Albert St. 1350	CBC Stovin Young	E. Gordon Archibald, Pres. & Gen. Mgr. Bill Kutshke, Prog. Dir.	M. Miller, Prom. Mgr. W. E. Schmidt, Chief Engr. Thesaurus SESAC BUP
PETERBOROUGH					
CHEX 1942	1430 1,000 DA-1	The Brookland Co. Ltd. Examiner Bldg. 4641	CBC Nat'l Bcst. Sales Cooke	Senator W. R. Davies, Pres. Roy H. Thomson, V. P. Russ Baer, Sta. Mgr.	Don Nairn, Prog. Dir. Bert Crump, Chief Engr. Lang-Worth Thesaurus United PN
CHEX-FM	Ch. 268 101.5mc 0.25kw				
PORT ARTHUR					
CFPA 1944	1230 250	Ralph H. Parker Public Utilities Bldg. 5-7651	CBC Weed Nat'l Bcst. Sales Broadcast Representa- tives Hunt	Ralph H. Parker, Pres. & Gen. Mgr. R. P. McGowan, Coml. Mgr.	Standard Lang-Worth RCA
ST. CATHARINES					
CKTB 1930	1550 1,000 CP-620 1,000 DA-DN	The Niagra District Bcstg. 12 Yates St. 5-7351	CBC McGillvra Nat'l Bcst. Sales	W. B. C. Burgoyne, Pres. H. B. Burgoyne, Gen. Mgr. V. A. Lococo, Coml. Mgr. W. Wheeler, Prog. Dir.	W. C. Wingrove, Prom. & Asst. Mgr. W. H. Allen, Chief Engr. Thesaurus United PN RCA
CKTB-FM	Ch. 249 97.7mc 0.25kw			 General Electric
ST. THOMAS					
CHLO 1948	680 1,000 DA-1	J. F. Peterson Radio Centre 3696	CBC Radio Repre- sentatives	John Frederick Peterson, Pres. & Gen. Mgr. George N. Miller, Coml. Mgr.	Len C. Evans, Prog. Dir. John C. Warder, Chief Engr. Lang-Worth Associated PN Northern Electric
SARNIA					
CHOK 1946	1070 5,000-LS 1,000-N DA	Sarnia Bcstg. Co. Ltd. 148½ North Front St. 4000	CBC Nat'l Bcst. Sales Cooke	H. M. Hueston, Pres. A. D. McKenzie, V. P. C. R. Irvine, Mngg. Dir. Gerald Hall, Coml. Mgr.	J. Grant Webber, Prog. Dir. Jim Kirkpatrick, Prom. Mgr. R. F. Cooke, Chief Engr. Standard Lang-Worth Thesaurus PN RCA

DIRECTORY OF AM and FM STATIONS OF CANADA

(Data corrected to December 6, 1949)
If executives or services for FM or TV stations are same as AM affiliate names are not repeated.

City Call Letters Established	Chan. or Freq. Power	Name of Licensee Headquarters Address Telephone Number	Network Representative	Executive Personnel	Transc. Library News Service
SARNIA (Continued)					
CHOK-FM	Ch. 248 97.5mc 0.25kw				
SAULT ST. MARIE					
CJIC	1490 250	Hyland Bcstg. Co. Windsor Hotel 3500	CBC Alexander McGillvra	J. G. Hyland, Pres., Gen. & Coml. Mgr. J. B. Scully, Prog. Dir. & Prom. Mgr.	World PN
CJIC-FM	Ch. 263 100.5mc 0.25kw				
STRATFORD					
CJCS	1240 250	Frank M. Squires Reynolds Bldg. 1675	CBC All-Canada Weed	Frank M. Squires, Pres. & Gen. Mgr. Stanley Tapley, Asst. Mgr. Ken Lott, Coml. Mgr.	World UP
SUDBURY					
CHNO 1947	1440 1,000 DA-1	The Sudbury Bcstg. Co. Ltd. 166 Elm St. W. 6-6416	CBC Wright Young	F. Baxter Ricard, Pres. & Gen. Mgr. Rene Riel, Coml. & Sta. Mgr. Don Killoran, Prog. Dir.	Associated PN RCA
CKSO 1935	790 5,000 DA-N	CKSO Sudbury Ltd. 21 Elgin St. 77-505	CBC All-Canada Weed	G. M. Miller, Pres. W. L. Woodill, Gen. Mgr.	Thesaurus World PN
TIMMINS					
CKGB 1933	680 5,000 DA-N	Northern Bcstg. Co. Ltd. Thomson Bldg. 2000	CBC Nat'l Bcst. Sales Cooke	R. H. Thomson, Pres. J. M. Davidson, Gen. Mgr. Ed Bowser, Coml. Mgr.	Standard Lang-Worth PN RCA
CKGB-FM 1948	Ch. 233 94.5mc 0.25kw				General Electric
TORONTO					
CBL 1927	740 50,000	Canadian Bcstg. Corp. 354 Jarvis St. Midway 5481	CBC	Dr. Augustin Frigon, Pres. (CBC) E. A. Weir, Coml. Mgr. (CBC) Harry J. Boyle, Prog. Dir.	Ron C. Fraser, Prom. Mgr. Howard Hilliard, Supvsrg.
CBL-FM	Ch. 256 99.1mc 5.58kw				CP, PN, BUP Reuters
CFRB 1927	1010 50,000 DA-2	Rogers Radio Bcstg. Co. Ltd. 37 Bloor St. W. Midway 3515	CBS All-Canada Young	Harry Sedgwick, Pres. Lloyd Moore, Sta. Mgr. Waldo Holden, Coml. Mgr.	Wes McKnight, Prog. Dir. Ken Marsden, Prom. Mgr. Clive Eastwood, Chief Engr.
CFRB-FM 1949	Ch. 260 99.9mc 0.20kw				World Thesaurus Associated PN, BUP, RCA
CHUM 1945	1050 1,000-D	York Bcstrs. 225 Mutual St. Elgin 4271	Alexander McGillvra	John Q. Part, Pres. Rolly Ford, Mgr. Larry Mann, Prog. Dir.	Phil Stone, Pub. Rel. Mgr. Leigh Stubbs, Sales Mgr. Dr. Curt Borchardt, Chief Engr.
CJBC 1936	860 50,000	Canadian Bcstg. Corp. 354 Jarvis St. Midway 5481	CBC	Dr. Augustin Frigon, Gen. Mgr. (CBC) Ernest L. Bushnell, Dir. Gen. of Prog. E. A. Weir, Coml. Mgr. Eric L. Patin, Gen. Mgr. John W. Barnes, Prog. Dir.	H. G. Walker, Prog. Dir. Ron C. Fraser, Prom. Mgr. Howard Hilliard, Super. Engr.
*CJRT-FM 1949	Ch. 233 88.3mc 9.9kw	Byerson Inst. of Tech. 50 Gould St. Waverley 2631			Andrew Kufstak, Chief Engr.
CKEY	580 5,000-LS 1,000-N DA-2	Toronto Bcstg. Co. Ltd 444 University Ave. Waverly 3881	Nat'l Bcst. Sales Cooke	Jack K. Cooke, Pres. & Gen. Mgr. Hal E. Cooke, Sta. & Coml. Mgr.	Don Insley, Prog. Dir. Gordon Allen, Prom. Mgr. Ernest Swan, Chief Engr.
WINDSOR					
CKLW 1932	800 50,000	Western Ont. Bcstg. Co. Ltd. Canada Trust Bldg. 4-1155 Cadillac 7200 (Detroit)	MBS, CBC Young Stovin	J. E. Campeau, Pres. & Gen. Mgr. E. Wilson Wardell, Coml. Mgr.	S. Campbell, Ritchie, Prog. Dir. R. Johnson, Prom. Mgr. W. C. Carter, Chief Engr.
WINGHAM					
CKOX 1926	920 1,000 DA-N	Radio Station CKNX Ltd. Josephine St. 158	Alexander Young	W. T. Crickshank, Pres. G. W. Crickshank, Asst. Mgr. & Prog. Dir. J. J. Crickshank, Sta. Mgr.	V. Dittmer, Prom. Mgr. S. C. Reid, Chief Engr.
WOODSTOCK					
CKOX 1947	1340 250	Oxford Bcstg. Co. Ltd. 380 Hunter St. 2400	Wright	Monty J. Werry, Gen. Mgr. W. Stanley Smith, Coml. Mgr.	G. Bruce Marsh, Prog. Dir. R. A. Clark, Chief Engr.
CKOX-FM 1948	Ch. 295 106.9mc 0.25kw				World Lang-Worth PN RCA
PRINCE EDWARD ISLAND					
CHARLOTTETOWN					
CFCY 1924	630 5,000-LS 1,000-N	Island Radio Bcstg. Co. Ltd. 85 Kent St. 741	CBC Weed All-Canada	Lt. Col. K. S. Rogers, Pres. R. F. Large, Sta. Mgr.	W. J. Brown Jr., Prom. Mgr. A. L. Finlay, Acting Chief Engr.
SUMMERSIDE					
CJRW 1948	1240 250	Gulf Bcstg. Co. 218 Water St. 792	Radio Repre- sentatives	H. E. Gaudet, Pres. A. G. Rogers, Gen. & Prom. Mgr. & Chief Engr.	L. C. Dunfield, Prog. Dir.

DA-N Directional Antenna, night only. FM's in *italics*.
DA-1 Directional Antenna, same pattern day and night.
DA-2 Directional Antenna, different pattern day and night.

*—Non-Commercial Station. D—Day. N—Night. ST—Share Time. SH—Specified Hours.
U—Unlimited. CP—Construction Permit Issued. LS—Local Sunset.
L—Limited Time with Dominant Station. SA—Special Authorization.

City Call Letters Established	Chan. or Freq. Power	Name of Licensee Headquarters Address Telephone Number	Network Representative	Executive Personnel	Transc. Library News Service	
QUEBEC						
AMOS						
CHAD 1942	1340 250	Northern Radio Inc. Rouyn, Que.	Renaud Weed	David Armand Gourd, Pres. Joseph Duguay, Sta. Mgr.	Associated World PN	
CHICOUTIMI						
CBJ 1933	1580 10,000 DA-1	Canadian Bcstg. Co. 286a rue. Racine 155	CBC	Vilmond Fortin, Sta. Mgr. Maurice Valiquette, Coml. Mgr. Marcel Ouimet, Prog. Dir.	Jean Saint-Georges, Prom. Mgr. J. E. Roberts, Chief Engr. Marconi
GRANBY						
CHEF 1945	1450 250	Granby Bcstg. Co. Ltd. 7 Johnson St. 353	Renaud	Gerald La Liberte, Gen. Mgr.	World United PN	
HULL						
CKCH 1933	970 1,000 DA-1	La Cie Radiodiffusion CKCH 121 Notre Dame St. 2-1701	CBC Renaud McGillvra	Louis J. Billy, Pres. J. Paul Lemire, Gen. & Coml. Mgr. Henri Bergeron, Prog. Dir.	Georges Huard, Prom. Mgr. Max Gebhardt, Chief Engr.	PN, CP Marconi
JONQUIERE						
CKRS 1947	1240 250	Henri Lepage 223 St. Dominique St.	Hardy Young	Henri LaPage, Pres.	Gaston Voyer, Mgr.	
LA SARRE						
(CP)	1240 250	Radio La Sarre Inc.				
MATANE						
CKBL 1948	1250 1,000 DA-1	Roger Bergeron 144 St. Jerome Ave. 355	Trans-Quebec Hardy	Roger Bergeron, Pres., Gen. & Prom. Mgr., Prog. Dir. Rene Lapointe, Coml. Mgr.	Paul DuBerger, Chief Engr.	World PN Northern Electric
MONTREAL						
CBF 1937	890 50,000	Canadian Bcstg. Co. 1231 St. Catherine St. W. Plateau 7161	CBC, ABC MBS, NBC	Dr. Augustin Frigon, Pres. & Gen. Mgr. (CBC) Maurice Valiquette, Coml. Mgr. Marcel Ouimet, Prog. Dir.	Jean Saint-Georges, Prom. Mgr. Henri Audet, Chief Engr. CP, PN, BUP Reuters Northern Electric
CBF-FM 1947	Ch. 236 95.1mc 10kw				 RCA
CBM 1937	940 5,000 DA	Canadian Bcstg. Co. 1231 St. Catherine St. W. Plateau 7161	CBC, ABC MBS, NBC	Dr. Augustin Frigon, Pres. & Gen. Mgr. (CBC) Marcel Ouimet, Dir., French Net- work Maurice Valiquette, Coml. Mgr.	William J. O'Reilly, Prog. Dir. Jean Saint-Georges, Prom. Mgr. Henri Audet, Chief Engr. CP, BUP, PN Reuters RCA
CBM-FM 1947	Ch. 299 100.7mc 5kw					
CFCF 1919	800 5,000 DA-1	Canadian Marconi Co. 1231 St. Catherine St. W. Plateau 2575	CBC ABC All-Canada Weed	W. Victor George, Bcstg. Mgr. Gordon F. Keeble, Sta. Mgr. T. J. Quigley, Sales Supvsr. J. Howlett, Prod. Mgr.	P. O. Steven, Prod. Supvsr. L. W. Rasberry, Prom. Mgr. J. N. Gettenby, Chief Engr.	Standard BUP Marconi
CFCF-FM 1947	Ch. 293 106.5mc 3kw					
CHLP 1933	1410 1,000 DA-1	La Cie de Pub. "La Patrie" Sun Life Bldg. Plateau 5225	Alexander McGillvra	Hon. Pamphile DuTremblay, Pres. & Gen. Mgr. C. A. Berthiaume, Mngng. Dir. & Coml. Mgr.	Fernand Bergevin, Asst. Mngng. Dir. Andre Chabot, Prog. Dir. Alphonse Cloutier, Chief Engr.	Associated PN, BUP Reuters General Electric
CJAD 1945	800 5,000 DA-1	CJAD Limited 1191 Mountain St. Plateau 1805	Nat'l Bcst. Sales Young	J. Art. Dupont, Pres., Gen. & Coml. Mgr. Ron Morrier, Prog. Dir.	Robert Laurion, Traffic Mgr. Al Taylor, Chief Engr.	Associated World Lang-Worth PN, BUP Northern Electric
CJAD-FM 1949	Ch. 232 94.3mc 6.02kw					
CKAC 1922	730 10,000-LS 5,000-N	La Cie de Pub. "La Presse" 980 Ste. Catherine St. W. Marquette 361	CBS Wright Young	Hon. P. R. DuTremblay, Pres. Phil Lalonde, Gen. Mgr. George Bourrassa, Coml. Mgr.	Ferdinand Biondi, Prog. Dir. Marcel Theoret, Prom. Mgr. Len Spencer, Chief Engr.	Associated World Lang-Worth PN, BUP RCA
NEW CARLISLE						
CHNC 1933	810 5,000 DA-1	Gaspesia Radio Bcstg. Main St. 64	CBC Hardy Young	Dr. Charles E. Dumont, Pres. Dr. Charles H. Houde, Gen. Mgr.	Viateur Bernard, Coml. Mgr. & Prog. Dir. Gordon S. Coleman, Chief Engr.	
QUEBEC						
CBV 1934	980 1,000	Canadian Bcstg. Corp. Palais Montcalm 5-8155	CBC	Dr. Augustin Frigon, Pres. & Gen. Mgr. (CBC) E. A. Weir, Coml. Mgr (CBC) Maurice Valiquette, Coml. Mgr. E. L. Bushnell, Prog. Dir. (CBC)	Marcel Ouimet, Prog. Dir. (CBC) Guy Dumais, Sta. Mgr. Gordon Olive, Chief Engr. BUP, CP Marconi
CHRC 1926	800 5,000 DA-1	CHRC Limitee 39 St. Jean 2-8177	Trans-Quebec Young Hardy	Herve Barbeau, Pres. Henri Lepage, Gen. Mgr. Aurele Pelletier, Coml. Mgr.	Magella Alain, Prog. Dir. & Prom. Mgr. Arsene Nadeau, Chief Engr.	Thesaurus Lang-Worth PN, BUP Marconi
CHRC-FM 1949	Ch. 251 98.1mc 0.25kw					
CJNT 1949	1340 250	Goodwill Bcstrs. Co. of Quebec Inc. 405 Blvd. Hamel		J. N. Thivierge, Gen. Mgr.		SESAC
CKCV 1926	1280 1,000 DA-N	CKCV Ltd. 142 St. John St. 2-1585	CBC Weed Renaud	Gaston Pratte, Pres. Paul Lepage, Gen. & Coml. Mgr. Marie-Paule Vachon, Asst. Mgr.	Marcel Leboeuf, Prog. Dir. Jean Bender, Prom. Mgr. Albert DuBerger, Chief Engr.	World United PN Marconi
RIMOUSKI						
CJBR 1937	900 5,000 DA-N	Central Public Service Corp. St. John St. 396	Stovin Young	Hon. J. A. Brilliant, Pres. Guy Caron, Gen. Mgr. Guy Ross, Prog. Dir. & Prom. Mgr.	Andre Lecomte, Coml. Mgr. Cecil Doak, Chief Engr.	Standard United PN Northern Electric
CJBR-FM 1947	Ch. 266 101.5mc 1kw					
RIVIERE DU LOUP						
CJFP 1947	1400 250	Radio Temiscouata Ltee 203 Lafontaine St. 536	CBC Renaud Young	Armand Belle, Pres. Bertrand Potvin, Gen. Mgr. Lue Simard, Coml. Mgr.	Lucien Emond, Prog. Dir. Lucien Emond, Prog. Dir. Raymond Lavole, Chief Engr. TP RCA

DIRECTORY OF AM and FM STATIONS OF CANADA

(Data corrected to December 6, 1949)
If executives or services for FM or TV stations are same as AM affiliate names are not repeated.

QUEBEC—(Continued)

ROBERVAL							
CHRL 1949	1340 250	Radio Roberval Inc. Hotel Maison Blanche	Renaud	Fernand Levesque, Pres.	L. Morin, Gen. Mgr.	PN	
ROUYN							
CKRN 1939	1400 250	Northern Radio Inc. Reilly Block	CBC Renaud	David Armand Gourd Jr., Pres. & Gen. Mgr. Maurice Doboys, Prog. Dir.	George Pope, Chief Engr.	Associated World PN	
STE. ANNE DE LA POCATIÈRE							
CHGB	570 1,000 DA-N	G. Thomas Desjardins Main St.	CBC				
SHAWINIGAN							
(CP)	1220 1,000	Shawinigan Falls Bcstg. Co. Ltd.					
SHERBROOKE							
CHLT 1937	900 1,000 DA-N	La Tribune Limitee 3 Marquette St. 2071	CBC Hardy Young	Hon. Jacob Nicol, Pres. Alphee Gauthier, Gen. Mgr. Gordon Beerworth, Coml. Mgr.	Jean-Louis Gauthier, Prog. Dir. & Prom. Mgr. Romeo Paquette, Chief Engr.	World Thesaurus Marconi	
CKTS 1946	1240 250	Telegram Printing & Pub. Co. Ltd. 3 Marquette St. 2071	CBC Hardy Young	Hon. C. B. Howard, Pres. Alphee Gauthier, Gen. Mgr. Gordon Beerworth, Coml. Mgr.	Jean-Louis Gauthier, Prog. Dir. & Prom. Mgr.	World Thesaurus Marconi	
SOREL							
CJSO 1945	1400 250	Radio Richelieu Ltd. 72 du Roi St. 3318	CBC Radio Renaud	J. Arthur Villeneuve, Pres. Maurice Boulianne, Mgr.	Wilfred Mondoux, Prog. Dir. Joseph Cardin, Chief Engr.	PN Northern Electric	
THREE RIVERS							
CHLN 1937	550 1,000 DA-2	La Nouvelliste Ltd. Chateau de Blois Hotel 4500	Hardy Young	Leon Pretanrer, Sta. Mgr.		World United PN	
VAL d'OR							
CKVD 1939	1230 100	Northern Radio Inc. Reilly Block Rouyn, Que.	Renaud Weed	David Armand Gourd, Pres.	Louis Hiller, Sta. Mgr.		
VERDUN							
CKVL 1946	980 1,000 DA-1	Jack Tietolman 211 Gordon Ave. Trenmore 2525	Stovin Cooke	Jack Tietolman, Pres. Corey Thomson, Gen. & Prom. Mgr. Judah Tietolman, Coml. Mgr.	Hal Stubbs, Prog. Dir. (English). Omer Duranceau, Prog. Dir. (French). J. C. Charlebois, Chief Engr.	United Lang-Worth Marconi	

SASKATCHEWAN

MOOSE JAW							
CHAB 1922	800 5,000 DA-1	Radio Station CHAB Ltd. Grant Hall Hotel 3282	CBC Stovin Weed	J. Slaughter, Pres. J. S. Boyling, Gen. Mgr. L. Crittenden, Coml. Mgr.	J. A. E. Cloak, Prog. Dir. Bernice Ward, Prom. Mgr. M. Pickford, Chief Engr.	Lang-Worth Cole BUP Marconi	
NORTH BATTLEFORD							
CJNB 1947	1240 250	Northwestern Bcstg. Co. Ltd. 86 E. 1st Ave. 2373		Hume A. Lethbridge, Gen. Mgr.	G. R. Nichol, Prog. Dir. A. C. Nichol, Chief Engr.	World, United BUP Northern Electric	
PRINCE ALBERT							
CKBI 1934	900 5,000 DA-2	Central Bcstg. Co. Ltd. Prince Albert 2621	CBC All-Canada Weed	E. A. Rawlinson, Pres. & Gen. Mgr. F. F. Rawlinson, Asst. Mgr. G. Prest, Coml. Mgr.	J. J. Cennon, Prog. Dir. J. Johnson, Prom. Mgr. T. Vaness, Chief Engr.	Thesaurus PN Northern Electric	
REGINA							
CKCK 1922	630 5,000 DA-N	Broadcasting Station CKCK Leader Post Bldg. 8525	CBC All-Canada Weed	Victor M. Sifton, Pres. Harold A. Crittenden, Gen. Mgr. A. Gilbert Seabrook, Coml. Mgr.	Donald R. Dawson, Prod. Mgr. Maxine M. Vance, Prom. Mgr. E. A. Strong, Chief Engr.	World PN, BUP RCA	
CKRM 1926	980 5,000-DA-N	Transcanada Communi- cations Ltd. 1819 Cornwall St. 7631	CBC All-Canada Weed	N. Botteril, Sta. Mgr. D. Oaks, Coml. Mgr.	Wm. Walker, Prog. Dir. F. Laight, Prom. Mgr. Wm. McDonald, Chief Engr.	Lang-Worth PN BUP	
SASKATOON							
CFQC 1923	600 5,000 DA-N	A. A. Murphy & Sons Ltd. 216 1st Ave. N. 7917	CBC Young Radio Representatives	A. A. Murphy, Pres. Vernon Dallin, Gen. & Coml. Mgr.	W. Gilbey, Prog. Dir. Godfrey Hudson, Prom. Mgr. Lyn Hoskins, Chief Engr.	Standard Lang-Worth Cole PN, BUP Marconi	
WATROUS							
CBK 1939	550 50,000	Canadian Bcstg. Corp. Telephone Bldg. Winnipeg, Man. 922	CBC	Dr. A. Frigon, Gen. Mgr. E. A. Weir, Coml. Mgr. A. D. Dunton, Chmn.	Nairn Mogridge, Sta. Mgr. C. E. L'Ami, Prom. Mgr. R. D. Cahoon, Chief Engr.	PN, BUP RCA	
YORKTON							
CJGK 1927	940 1,000	Yorkton Bcstg. Co. Ltd. Broadway 324	CBC Stovin Young	Dawson Richardson, Pres. K. S. Parton, Gen. Mgr.	Jack C. Goodman, Coml. Mgr. Bill Liska, Prog. Dir. A. Mills, Chief Engr.	World PN Marconi	

NORTHWEST TERRITORY

HAY RIVER		
(CP)	1230 100	
NORMAN WELLS		
CFNW (CP)	1240 100	
YELLOW KNIFE		
(CP)	1450 150	Department of Nat'l Defense

YUKON TERRITORY

DAWSON CITY	
(CP)	1230 250
CFYT	1400 100

DA-N Directional Antenna, night only. FM's in italic.
DA-1 Directional Antenna, same pattern day and night.
DA-2 Directional Antenna, different pattern day and night.

*—Non-Commercial Station. D—Day. N—Night. ST—Share Time. SH—Specified Hours.
U—Unlimited. CP—Construction Permit Issued. LS—Local Sunset.
L—Limited Time with Dominant Station. SA—Special Authorization.

ADVERTISING AGENCIES HANDLING RADIO AND TV ACCOUNTS

WITH EXECUTIVE RADIO AND TV PERSONNEL AND ACCOUNTS

N indicates network, S spot

A

AARONS, SILL & CARON INC.
Architects Bldg., Detroit 1
Tel.: Temple 1-3515
Radio Dept.: V. E. Sutfin, radio director & timebuyer.

ACCURATE ADVERTISING AGENCY
9 W. 60th St., New York 23
Tel.: Circle 7-3882

A. L. ADKINS CO.
693 Mission Street, San Francisco 5
Tel.: Exbrook 2-7867

WILLIAM HART ADLER INC.
720 N. Michigan Ave., Chicago 11
Tel.: Whitehall 4-5210

Radio Dept.: Wm. H. Adler, Kenneth C. Ring, account executives.

ADMIRAL ADVERTISING AGENCY INC.
39 Highlawn Ave., Brooklyn 23
Tel.: Esplanade 2-2035

Radio Dept.: J. P. Victor, radio director, account executive.
New York 7-180 Broadway. Tel.: Worth 2-6179
(Offices in Italy, Germany & Austria)

ADVERTISING ASSOCIATES INC.
Bryant Bldg., Charlotte 1, N. C.
Tel.: 3-9281

Radio Dept.: Mark I. Moffett, radio director.

ADVERTISING ASSOCIATES INC.
Southland Life Bldg., Dallas 1
Tel.: Prospect 7-2569

Radio Dept.: Bert Clardy, radio director.

ADVERTISING-BUSINESS AGENCY
263 Texas St., Fort Worth 2, Tex.
Tel.: 3-4473

ADVERTISING ENGINEERS CORP.
448 S. Hill St., Los Angeles 13
Tel.: Mutual 5039; Michigan 6912.

Radio Dept.: Robert Light, radio director; Jack Nelson, television director; Dorothy Kildare, timebuyer.

ADVERTISING INCORPORATED
American Fidelity Bldg., Forth Worth 4
Tel.: 3-2006 & 3-7282

Radio Dept.: Timothy L. Thomas, vice president & radio director.

ADVERTISING INC.
Central Nat'l Bank Bldg., Richmond 19, Va.
Tel.: 3-2809

Radio Dept.: A. F. Watson, television director; Alicia G. Smithers, radio timebuyer.

ADVERTISING INC. OF WASHINGTON
1025 Vermont Ave., N. W., Washington 5, D. C.
Tel.: Republic 3447

Radio Dept.: King Pedlar, radio director; Edna Holstrom.

Radio Accounts: Seventh Day Adventists (E. Pa., Potomac, W. Va. and general Conferences); United Typewriter Co. (S); Kitt's (S); Pine State Creamery Co. (S); Arlington Motors (S).

ADVERTISING & SALES CONSULTANTS AGENCY
2404 West 7th St., Los Angeles 5
Tel.: Drexel 5231

Radio Dept.: Gene Franke, radio timebuyer; George Burtit, radio and television director.

ADVERTISING SERVICE AGENCY
7 State St., Charleston 35, S. C.
Tel.: 3-1129

Radio Dept.: M. Bishop Alexander, radio timebuyer.

ADVERTISING TRADE SERVICE INC.
303 Fifth Ave., New York 16
Tel.: Murray Hill 4-3800

Radio Dept.: Phil Abrahams, radio director, timebuyer.

AGENCY ASSOCIATES INC.
1509 Wilshire Blvd., Los Angeles 14
Tel.: Drexel 5341

Radio Dept.: J. B. von Brecht, radio and television director, timebuyer.

AGENCY SERVICE CORP.
66 E. South Water St., Chicago 1
Tel.: Central 6-5255

Radio Dept.: Alfred C. Houser, executive vice president and general manager; George Janda, radio director.

Radio Accounts: Chicago Motor Club (S); Family Life Ins. Co. (S); Inter-Insurance Exchange (S); Travel Bureau of Chicago Motor Club (S); North American Acceptance Corp. (S); Wisc. Div. American Automobile Assn. (S).

AGRICULTURAL ADVERTISING & RESEARCH
Agricultural Research Bldg., 306 E. State St., Ithaca, N. Y.
Tel.: 3376

Radio Dept.: Roy H. Park, head of radio; Mrs. Grace Smiley, timebuyer.
Albany, N. Y.—240 State St. Tel.: 8-3157.
New York 19—113 W. 57th St. Tel.: Luxembourg 2-5090.

Raleigh, N. C.—Raleigh Bldg. Tel.: 3-2786.
Washington, D. C.—930 "F" St. NW. Tel.: Executive 1494.

Radio Accounts: Cooperative G. L. F. Exchange; Smith-Melville Products; Melville Products; Hines-Park Foods; National Grange Insurance Co.

THE AITKIN-KYNETT CO.
1400 S. Penn Square, Philadelphia 2
Tel.: Rittenhouse 6-7810

Radio Dept.: E. M. Gretz, timebuyer.

R. H. ALBER CO.
439 N. Larchmont Blvd., Los Angeles 4
Tel.: Hollywood 9-8273

Radio Dept.: Pauline Hagen, radio director and timebuyer.

Radio Accounts: Gospel Bcstg. Assn. (N & S).

ALLEN & CLENAGHEN
1135 S. W. Yamhill, Portland 5, Ore.
Tel.: Atlantic 5233

Radio Dept.: Everett Mitchell, radio director.

ALLEN, HEATON & McDONALD INC.
617 Vine St., Cincinnati 2
Tel.: Cherry 3414

ALLEN & REYNOLDS
1300 WOW Bldg., Omaha 2
Tel.: Atlantic 4445

Radio Dept.: Milt Stephan, director of radio and television. Earl Allen, M. H. Reynolds, Karl Joens, Robert Reynolds, Milt Stephan, Floyd Mellen, account executives.

Radio Accounts: Byron, Reed Co. (S); Omaha Public Power District (S); General Electric (S); T. H. Maenner Co. (S); Graybar-Hotpoint (S); Webber Motors (S); Mueller-Selby (Motorola) (S); Omaha Stationery Co. (S); U. S. National Bank (S); Paramount Radio Shop (S); Ted's Pen Shop (S); Albert's Finest Salad Dressings (S); Merchants Biscuit Co. (S); Allied Chicks (S); Omyo Feeds (S); Iowa Power & Light (S); P. F. Petersen Bakery (S); Elagaus Service (S); Carpenter Oil Co. (S).

Television Accounts: Harry's Cafe (S); Motorola (N & S); Omaha Public Power District (S); Emerson (S); Zenith (S); Crosley (S); KMTV (S); U. S. National Bank (S).

ALLEY & RICHARDS CO.
370 Lexington Ave., New York 17
Tel.: Lexington 2-3020

Radio Dept.: H. M. Billerbeck, radio director; Elaine Akst, Grace Kipp, timebuyers.
Boston 16—Statler Bldg. Tel.: Hubbard 8850. Barbara G. Keane, radio director.

Radio Accounts: R. C. Williams & Co. Inc.; Allen V. Smith & Co. Inc.; Edgar P. Lewis & Sons Inc.; Glen Wood Range Co.

ALLIED ADVERTISING AGENCIES
167 S. Vermont Ave., Los Angeles 4
Tel.: Drexel 7331

Radio Dept.: Stuart Heinemann, radio director.

San Francisco 3—Flood Bldg. Tel.: Douglas 2-7018. Jack Gregory.
Seattle 1—Henry Bldg. Tel.: Elliott 0936. Deon Routh, mgr.

ALDOMARI ADV. AGENCY INC.
20 Vesey St., New York 7
Tel.: Digby 9-1510

Radio Dept.: Leonard S. Morvay Jr., radio and television director.

AMBRO ADVERTISING AGENCY
333 Dows Bldg., Cedar Rapids
Tel.: 4139

Media Dept.: Eileen Gould, director.
Radio Accounts: Cedar Rapids & Iowa City Railway; Iowa Electric Light & Power Co.; Iowa Southern Utilities Co.; Potosi Brewing Co.; Sanitary Farm Dairies; Iowa Mutual Liability Insurance Co.; Vigortone Products Inc.; Merchants National Bank.

AMBROSE & GUILFOYLE
801 Bangs Ave., Asbury Park, N. J.
Tel.: 2-1483

Radio Dept.: R. J. Guilfoyle, television director.

ANDERSON, DAVIS & PLATTE INC.
50 Rockefeller Plaza, New York 20
Tel.: Plaza 7-2300

Radio Dept.: Victor Seydel, director of radio and television; Vera J. Muenzer, timebuyer; Donald Foote, assistant to director, radio and television.

Radio Accounts: Alexander Smith & Sons Carpet Co. (S); Alderney Dairy (S); Hillman Minx Motor Cars (S).

Television Accounts: Alexander Smith Carpet Co. (S); C. H. Maslund & Sons (N).

MERRILL ANDERSON CO. INC.
142 E. 39th St., New York 16
Tel.: Murray Hill 5-3045

ROBERT ARCHER & CO.
20 N. Wacker Dr., Chicago 6
Tel.: Randolph 6-7466

Radio Dept.: H. Stanley Fern, timebuyer.

ARMSTRONG-SCHRAMM CO.
Spreckles Building, San Diego 1
Tel.: Franklin 0101

Radio Dept.: G. E. Vinson, radio director and timebuyer.

JOHN FALKNER ARNDT & COMPANY INC.
123 South Broad St., Philadelphia 9
Tel.: Kingsley 5-8500

Clarence R. Palmer, media director (timebuyer); Norton Bond, Earle C. Thompson, account executives (radio).

ARNOLD & CO. INC.
262 Washington St., Boston 8
Tel.: Richmond 2-1220

Radio Dept.: Arnold Z. Rosoff, radio director; Arnold Z. Rosoff, Oscar E. Rudsten, Harold Glickman, Leonard Meyers, T. P. O'Neill, John J. Daniels, account executives.

Radio Accounts: Community Produce Co.; Colonial Provision Co.; Ben Gluck; Newtonville Outlet Co.; Home Owners Federal Savings Bank; Rosoff's Restaurant; Renmore's; Stetson Fuel Co.; Louis Hair Fashions; Old Monastery Wine Co.

Television Accounts: National Creamery Co.; Coleman's Fashion Shop.

RUPERT ARNOLD ADVERTISING AGENCY
610 S. Broadway, Los Angeles 14
Tel.: Vandike 4472

ART-COPY ASSOCIATES
11 Hill St., Newark 2, N. J.
Tel.: Michell 2-4899

Radio Dept.: Martin Steinhardt, president & radio director.

THE ARTWIL CO.
22 W. 48th St., New York 19
Tel.: Plaza 7-1355

Radio Dept.: Arthur Bandman, Miles Shefferman.

Radio Accounts: Durnol Prod. (S); Popular Mole Co. (S); Ralston Pub. Co. (S).

ASHER, GODFREY & FRANKLIN INC.
404 Fourth Ave., New York 16
Tel.: Oregon 9-4754

Radio Dept.: Arthur Kearns, radio timebuyer.

ASSOCIATED ADVERTISING AGENCY INC.
Dixie Terminal Bldg., Cincinnati 2
Tel.: Main 5784

Radio Dept.: Stephen Freiberg, radio and television director.

ASSOCIATED ADVERTISING AGENCY INC.
2624 W. 6th St., Los Angeles
Tel.: Dunkirk 8-3145

ASSOCIATED BROADCASTING CO., Ltd.
Toronto, Ont.—1139 Bay St. Tel.: Princess 1111. Mgr. M. Raymond.
Now advertising agency.

ASSOCIATED BUSINESS COUNSELORS INC.
Fox Bldg., Detroit 1
Tel.: Cadillac 7878

New York 1—Empire State Bldg., Tel.: Longacre 3-7260. Lansing Moore, manager.

ATHERTON ADVERTISING AGENCY
8455 Melrose Pl., Los Angeles 46
Tel.: Webster 3-8488

Radio Dept.: Al Atherton, owner; Tom Mullins, Alice Asdour, timebuyers.

Radio Accounts: Dictograph Products Inc. (S); Pacific Citrus Products Co. Inc. (S).

ATHERTON & CURRIER INC.
420 Lexington Ave., New York 17
Tel.: Lexington 2-8795

Radio Dept.: John P. Atherton, radio and television director; W. T. Tieman, timebuyer; N. C. Rothstein, assistant timebuyer; J. Wm. Atherton, J. Denis Molnar, account executives.

Toronto—100 Adelaide St., West. Tel.: Adelaide 5418, K. C. Utley, vice president.

Radio Accounts: Potter D. C. Corp. (S); Scott and Bonne; County Perfumery Co. (S); Humphreys Medicine Co. (S).

AUBREY, MOORE & WALLACE INC.
230 N. Michigan Ave., Chicago 1
Tel.: Financial 6-1600

Radio Dept.: J. H. North, director and timebuyer; R. Fechheimer, L. D. Milligan, account executives.

Radio Accounts: International Harvester (S); Williamson Candy Co. (N); Double Cola Co. (S); Dubuque Packing Co. (S); Julian & Kokenge Co. (S); Lockwedge Shoe Corp. (S); Tested Papers of America (S); Wayne Knitting Mills (S).

J. J. AUERBACH CO.
103 Park Ave., New York 17
Tel.: Lexington 2-9660

Radio Dept.: J. J. Auerbach, radio director.

RAY AUSTRIAN AND ASSOC.
16 E. 41st, New York 17
Tel.: Murray Hill 5-7511

EVERY & BRUGIERE ADV.
617 Montgomery St., San Francisco 11
Tel.: Yukon 6-0181. C. E. Avery.

N. W. AYER & SON INC.
30 Rockefeller Plaza, New York 20
Tel.: Circle 6-0200

Radio Dept.: H. L. McClinton, vice-president and director of radio-television; James E. Hanna, vice president, manager radio-television dept.; T. J. McDermott, radio-television plans; John W. Purves, Paul F. Kizenberger, Charles Wilds, Dirk A. Watson, timebuyers.

Boston 16—Statler Office Bldg. Tel.: Hubbard 4970.

Chicago 3—135 South LaSalle St. Tel.: Randolph 3456.

Detroit 28—Penobscot Bldg. Tel.: Randolph 3800.

Hollywood 28—1680 North Vine St. Tel.: Hempstead 4871.

Philadelphia 6—West Washington Sq. Tel.: Lombard 3-0100.

San Francisco 4—235 Montgomery St. Tel.: Sutter 2534.

Honolulu 16, Hawaii—Dillingham Bldg.,

Radio Accounts: The Atlantic Co. (S); The Bell Telephone System (N); Chesapeake and Potomac Telephone Co. (S); Plymouth Division, Chrysler Corp. (S); Clicoquet Club Co. (S); Electric Companies Advertising Program (N); Hawaiian Pineapple Co. Ltd. (S); Charles F. Hires Co. (S); Illinois Bell Telephone Co. (S); Michigan Bell Telephone Co. (S); Regal Shoe Co. (S); Sealtet (S); Supplee Wills Jones Milk Co. (S); United Air Lines (S); Lever Bros. (Surf) (S); Webster Tobacco Co. (S); Steinyway & Sons (S).

Television Accounts: The Atlantic Refining Co.; American Tobacco Co. (Continued)

ADVERTISING AGENCIES HANDLING RADIO AND TV ACCOUNTS

(Continued)

N indicates network, S spot

Illinois Bell Telephone Co.; Sheffield Farms Co. Inc.; Brooklyn Union Gas Co.; Gordon Baking Co.; Michigan Bell Telephone Co.; Seal-test Div.—National Dairy.

AYLIN ADVERTISING AGENCY

522 Waugh Dr., Houston 6
Tel.: Keystone 7469
Radio Dept.: Richard Dumit, radio director.

Radio Accounts: Foxworth-Galbraith (S); Temple Lumber Co. (S); Weldon Cafeteria (S); Taylor Lumber (S).

AYRES ADVERTISING

1310 Sharp Bldg., Lincoln 8. Neb.
Tel.: 2-6619

B

BACON, HARTMAN & VOLLBRECHT INC.

Exchange Bank Bldg., St. Augustine, Fla.
Tel.: 1514

Radio Dept.: John J. Vollbrecht, radio director; John W. Hartman, television contacts; Milton E. Bacon, timebuyer.

Radio Accounts: City of Daytona Beach (S); Fountain of Youth Properties Inc. (N&S); Barnett Banks of Florida (S).
Television Accounts: City of Daytona Beach (S).

BADGER & BROWNING & HERSEY INC.

30 Rockefeller Plaza, New York 20
Tel.: Circle 7-3720

Radio Dept.: Edward Whitley, radio and television timebuyer; Jack Wilcher, radio-TV director; Marie H. Missing, Shirley Helmich, radio time dept.

Boston 10—75 Federal St. Tel.: Liberty 3364.

Radio Accounts: American Chiclé Co. (S); Whitetown Restaurants.

Television Accounts: American Chiclé Co. (S).

S. C. BAER CO.

Times-Star Bldg., Cincinnati 2
Tel.: Parkway 0409-0410

Radio Dept.: C. M. Spicer, television director; Ray Kemble, radio.

FREDERICK E. BAKER & ASSOCIATES

Vance Bldg., Seattle 1
Tel.: Elliott 0957

Radio Dept.: Peter Lyman, radio and television director.

BALDWIN, BOWERS & STRACHAN INC.

374 Delaware Ave., Buffalo 2
Tel.: Washington 6854

Radio Dept.: Everett L. Thompson, radio director; Joseph H. Raddar, Catharine D. Walsh, radio producers; Jean A. MacMurray, traffic manager.

Radio Accounts: Iroquois Beverage Corp. (S); General Ice Cream Corp. (S); First Federal Savings & Loan Assn. (S); International Railway Co. (S); Sears, Roebuck & Co. (S); Thomas Products Inc. (S); Kobler and Miller (S); Prechtel Optical Co. (S); Kenmore Motors Inc. (S); Dadds Dairy (S); Buffalo Industrial Bank (S); Farmer Brown, Inc. (S); Martin Jacobi Inc. (S); Crystal Beach Co. (S); Quality Laundry (S); The Sample Shop (S); Erie Savings & Loan (S); Red & White Stores (S); Hambleton Terminal Corp. (S); Joseph Strauss Co. (S); Trico Products (S); Old Dutch Foods (S); West Side Business Men's Assn. (S); Hoddick & Taylor Inc. (S); Rochester & Pittsburgh Coal Co. Inc. (S).

Television Accounts: Iroquois Beverage Corp. (S); General Ice Cream Corp. (S); Martin Jacobi Inc.

BALL & DAVIDSON ADVERTISING AGENCY

Colorado National Bank Bldg., Denver 2
Tel.: Main 1291

Radio Dept.: Mark Schreiber, television and radio director.

Radio Accounts: Denver Dry Goods Co. (N); Arthur Murray Studios.
Los Angeles—Wilshire-LaBrea Bldg., Tel.: York 7947. Craig Davidson, executive vice president.

BARNES ADVERTISING AGENCY

312 E. Wisconsin Ave., Milwaukee 2
Tel.: Daly 8-2393

BARNES-CHASE CO.

530 Broadway, San Diego 1
Tel.: Franklin 7771

Radio Dept.: Edwina B. Sample, radio director.
Los Angeles 15—1121 South Hill St. Charles John Hawkins, manager.

STUART BART ADVERTISING

114 E. 32nd St., New York
Tel.: Lexington 2-2323

BASS-LUCKOFF OF HOLLYWOOD

439 S. La Cienga Blvd., Los Angeles 36
Tel.: Bradshaw 2-3396

TED BATES & CO.

630 5th Ave., New York 20
Tel.: Circle 3-9700

Radio Dept.: Thomas F. Harrington, radio and television head, account executive; Jay Clark, Frank O'Connor, Harry Saz, H. Allan Dingwall, Wm. Harding, producers; Edgar Small, Betty Bruns, Genevieve Schubert, McDonald Dunbar, timebuyers; D. R. Parman, W. L. Musser, account executives.

Hollywood 28—1680 N. Vine St. Tel.: Hollywood 9-2161.

Radio Accounts: Brown & Williamson Tobacco Corp. (S); Continental Baking Co. (S); Colgate-Palmolive-Peet Co. (N).

BATTEN, BARTON, DURSTINE & OSBORN INC.

383 Madison Ave., New York 17
Tel.: Eldorado 5-5800

Radio Dept.: Arthur Pryor, vice president in charge of radio; W. W. Crider, vice president in charge of new programs and talent; Carroll Newton, business manager; Robert L. Foreman, vice president in charge of commercial copy; Frank Silvernail, head timebuyer; Elenore Scanlan, local radio manager; Herbert West, head of television dept.; George Kondolf, chief story editor; Fred Stoutland, local TV manager; Hope Martinez, Mildred Eberhard, John Bestechi, Mary Ellis, Norman Chester, William Kennedy, Charles Allen, Ann Janowicz, time buyers; James A. McGarry, manager radio promotion and merchandising; Paul Markman, Richard Coblens, Gertrude Scanlan, Harold Blackburn, Carroll Newton, J. D. Danforth, Robert Beuchner, W. J. O'Donnell, S. A. Harned, Frank Mahoney, Vinton Freedley Jr., Wm. Heese, Lee White, Thomas Dillon, E. H. Cashim, account executives.

Boston 16—Statler Bldg. Tel.: Hubbard 2-0430. F. W. Hatch, vice president.

Buffalo 3—Rand Bldg. Tel.: Cleveland 7915. S. P. Irvin, vice president.

Chicago 11—919 N. Michigan Ave. Tel.: Superior 7-9200. H. H. Haupt, vice president.

Cleveland 13—Terminal Tower Bldg. Tel.: Towers 1-7270. E. E. Haring, manager.

Detroit 26—Penobscot Bldg. Tel.: Woodward 5-0620. Mgr. D. B. Hamilton.

Hollywood 28—1680 N. Vine St. Tel.: Hollywood 9-7337. Wayne Tiss, vice president.

Los Angeles 14—6363 Wilshire Blvd. Tel.: Webster 1-1234. A. W. Nealy, vice president.

Minneapolis 2—Northwestern Bank Bldg. Edward A. Cashin, vice president. J. C. Cornelius, executive vice president.

Pittsburgh 19—Grant Bldg. Tel.: Grant 1-8060. Leon D. Hansen, vice president.

San Francisco 14—Russ Bldg. Tel.: Sutter 1-2232. C. H. Ferguson, vice president.

Radio Accounts: Armstrong Cork Co.; E. I. du Pont de Nemours & Co. Inc.; Cream of Wheat; Emerson Drug Co.; Curtis Publishing Co.; Wildroot Co. Inc.; Chamberlain Sales Corp.; De Soto Division, Chrysler Corp.; First National Bank of Boston; Fort Pitt Brewing Co.; General Baking Co.; Peter Hand Brewing Co.; Minneapolis Brewing Co.; Murline Co.; Nehi Corp.; New York Telephone Co.; Pacific Telephone & Telegraph Co.; Penick & Ford Ltd.; Reader's Digest; Southern New England Telephone Co.; Rexall Drug Co.; Tennessee Coal, Iron & R. R. Co.; F. & M. Schaefer Brewing Co.; General Electric Co.; Fruit Dispatch Co.; Gamble-Skogmo Inc.; Golden State Co., Ltd.; George A. Hormel Co.; Northwestern Bell Telephone Co.; Sea Breeze Labs.; Standard Oil Co. of California; Tea Garden Products Co.; Trans-World

Airlines, Inc.; Waitt & Bond, Inc.; American Tobacco Co.; Berwin Fuel Corp.; Bon-Ami Corp.; Circus Foods, Inc.; Cons. Edison Co.; B. F. Goodrich Co.; Marine Trust Co.; Maywood Park Trotting Assn.; Minneapolis Mining & Manufacturing Co.; Roosevelt Raceway; Savings Bank Assn. of Mass.; Serval Inc.; R. H. Stearns Co.; Timken Roller Bearing Co.; William Underwood Co.; Republican National Committee; U. S. Steel Corp.; Lever Bros.; Black Horse Ale Inc.; F. W. Cook Co.; Ethyl Corp.; Easy Washing Machine Co.; General Mills Co.; Infra Roast Inc.; Liberty Mutual Insurance Co.; MJB Co.; National Pet Foods; Hamilton Watch Co.; Northrop King & Co.; Shick Inc.; Oneida Ltd.; Fedders Quigun Co.; Barcalo Mfg. Co.

BAWDEN BROS. INC.

121 E. 3rd St., Davenport, Iowa
Tel.: 2-3553

ROGER BEANE ADVERTISING AGENCY

136 N. Delaware St., Indianapolis 4
Tel.: Franklin 2517

Radio Accounts: L. S. Ayres & Co. and others.

BEAUMONT, HELLER & SPERLING INC.

6th and Walnut St., Reading, Pa.
Tel.: Reading 5-4311

Radio Dept.: Dorathea A. Hassler, radio director.

Radio Accounts: Maier's Bakery (S); Automotive Service (S); Fuhrmann & Schmidt Brewery (S); Crystal Rock Beverage Co. (S); Bowers Battery (S).

Television Accounts: Bowers Battery (S); Crystal Rock (S).

Transit FM: Allen Laundry.

BEAUMONT & HOHMAN INC.

6 N. Michigan Ave., Chicago 2
Tel.: Central 6-4230

Radio Dept.: Perry R. Thomas, manager.

Atlanta 3—32 Peachtree St. N. W. Tel.: Main 4770. J. J. Hanna, manager.

Charleston 1—Knight Bldg. Tel.: 34-431. Russ Cheadle, manager.

Cleveland 14—NBC Bldg. Tel.: Cherry 3658. W. B. Grosvenor, manager.

Dallas 1—1905 Elm. Tel.: Central 5388. Paul H. Leech, manager.

Detroit 26—1249 Washington Blvd. Tel.: Cherry 4409. I. C. Bettiker, manager.

Kansas City 6—921 Walnut St. Tel.: Victor 3063. Harvey Pearman, manager.

Los Angeles 13—816 W. Fifth St. Tel.: Trinity 8173. J. C. Arnold, manager.

New York 20—630 Fifth Ave. Tel.: Circle 6-7040.

Portland 4, Ore.—Pacific Bldg. Tel.: Beacon 1922. Elwood Enke, manager.

San Francisco 4—Russ Bldg. Tel.: Garfield 0848. H. D. Cayford, V. P. West Coast Office.

Seattle 4—Central Bldg. Tel.: Seneca 0066. Ted White, manager.

Omaha 2—638 Insurance Bldg. Tel.: Atlantic 0369. J. B. Mayo, manager.

JULIAN J. BEHR CO.

Dixie Terminal Bldg., Cincinnati 2
Tel.: Cherry 7635

HERBERT S. BENJAMIN ASSOCIATES INC.

234 Main St., Baton Rouge, La.
Tel.: 3-2847

Radio Dept.: Richard K. Goldberger, radio director; Allen R. Brent, Lee Herzberg Jr., account executives.

Radio Accounts: Capital Bedding Co. (S); Fidelity Natl. Bank; Jack's Cookie Co.; Jordan Home Appliance (S); Kormeys Furniture (S); Olinde Hardware & Supply Co. (S).

HARRY BENNETT ADVERTISING

412 W. Sixth St., Los Angeles, 14
Tel.: Trinity 2391

Radio Dept.: Joseph Donohue, radio director.

VICTOR A. BENNETT CO. INC.

511 Fifth Ave., New York 17
Tel.: Murray Hill 7-2189.

Radio Dept.: John L. Moore, vice president.

Radio Accounts: Longines-Wittnauer Watch Co. (N-S).

BENNETT, WALTHER & MENADIER INC.

69 Newbury St., Boston 16
Tel.: Kenmore 6-3820

Radio Dept.: Edwin C. Whittemore, account executive.

Radio Accounts: Kendall Mfg. Co. (S).
Television Accounts: Kendall Mfg. Co. (S).

BENTON & BOWLES INC.

444 Madison Ave., New York 22
Tel.: Murray Hill 8-1100

Radio Dept.: Walter Craig, vice president in charge of radio & television;

Thomas J. McDermott, radio director; William Schneider, business mgr. radio and television dept.;

Herb Leder, television director.

Hollywood 28—6253 Hollywood Blvd. Tel.: Hillside 9151. Ted Steele, vice president, general manager of West Coast Operations. Albert E. Kaye, vice president & West Coast representative.

Radio Accounts: General Foods (Posts Bran Flakes, Postum, Maxwell House Coffee & Instant Coffee, Raisin Bran, Gables Dogfood) (N); Prcter & Gamble (Ivory Snow, Tide) (N); Prudential Life Insurance Co. (N); American Assn. of Railroads (N).

Television Accounts: Crosley Div.-Avco (N); General Foods (Maxwell House Coffee) (N); Best Foods Co. (N); Procter & Gamble (Tide) (S); Arnold Bread (S); Diamond Crystal Salt (S); General Electric Textolite (S); Crosley Div.-Avco (S).

BERMINGHAM, CASTLEMAN & PIERCE INC.

136 E. 38th St., New York 16
Tel.: Lexington 2-7550

Radio Dept.: George C. Castleman, radio director; John Collins, timebuyer.

Radio Accounts: Griffin Mfg. Co. (S); Conti Products (S); Saben Airlines (S); Monarch Wine Co. (S).

Television Accounts: Personal Finance Co. (S).

TED BERNSTEIN ASSOCIATES

51 Madison Ave., New York 10
Tel.: Murray Hill 5-3730

Radio Dept.: Sylvester J. Bernstein, radio and television director, timebuyer.

BERTLEY, SINGER & STONEHILL
119 W. 57th St., New York 19
Tel.: Circle 5-4913

Radio Dept.: Robert G. Bertley, radio director; Joseph Stonehill, account executive.

Radio Accounts: Chesterfield Music Shops (S); Twin Gabel Foods Corp. (S).

FRANK BEST & CO. INC.

9 Rockefeller Plaza, New York 20
Tel.: Circle 7-6760

Radio Dept.: A. H. Van Buren, radio director.

GORDON BEST COMPANY

Chicago 1—228 N. LaSalle St. Tel.: State 2-5060.

Radio Dept.: Edwin A. Trizil, media director.

BEN BEZOFF & CO.

220 Majestic Bldg., Denver 2
Tel.: Keystone 8139

Radio Dept.: A. K. Barnes Jr., radio director and account executive; Ben Bezoff, account executive.

Radio Accounts: Aetna Trailer Sales; Denver Industrial Bank; North Denver Furniture Co.; Abbey Rents; Built-Rite Auto Body; Denver Willys Inc.; E-Z Do Food Products; Empire Wool Co.; Ludwig & Co.; McIntosh Barton; Orchid Shop; all spot users.

LEE S. BIESPIEL, ADV.

605 N. Michigan Ave., Chicago 11
Tel.: DElaware 7-4190

Radio Dept.: Lee S. Biespiel, president, in charge of all radio.

Radio Accounts: Dr. Butler Tooth Brush (S); Arnolt Corp. (S); Burton Mfg. Co. (S).

BING AND HAAS

208 Frederick Building
Cleveland 15, Ohio
Tel.: Superior 2773-74

Radio Dept.: Ralph S. Bing, radio and television director.

Radio Accounts: Al Sirat Grotto Circus (S); Cadillac Lounge; (Blauschild Motors (S); Borsellino's (S); L. N. Gross Co. (S); Self Service Laundry (S).

BIOW CO. INC.
Crowell-Collier Bldg., New York 20
Tel.: Plaza 7-4100
Radio Dept.: Thomas Revere, radio director; John Kucera, Ethel Wiedner, timebuyers; Jack Mosman, producer; John Hamm, manager of radio dept.

Hollywood—6111 Sunset Blvd. Tel.
Hempstead 2377. Jack Runyon, manager.

San Francisco—703 Market St. Tel.
Garfield 4854. Les Hannah, Mgr.

WILLIAM S. BISHOP CO.
6 N. Michigan Ave., Chicago 2
Tel.: State 2-6065
Radio Dept.: William S. Bishop, president & timebuyer.

BLACKSTONE CO.
221 W. 57th St., New York 19
Tel.: Circle 7-4915
Radio Dept.: Martin Rodman, radio director, timebuyer.

BLAINE-THOMPSON CO.
234 W. 44th St., New York 18
Tel.: Longacre 4-0800
Radio Dept.: Mario Lewis, executive vice-president; Mina Bess Lewis, radio copy chief; Charles Stark, television director.

THE BLAKEMORE CO.
2021 Grand Ave., Des Moines 12
Tel.: 2-0221

BLAKER ADVERTISING AGENCY
501 Madison Ave., New York 22
Tel.: Eldorado 5-7563
Radio Dept.: Jean Zipser, radio timebuyer.

BLISS & MARCES INC.
Times Tower, New York 18
Tel.: Bryant 9-5228
Radio Dept.: S. Marsten, radio director; Sidney Morse, television consultant; H. Sadowsky, assistant radio director in charge of copy.

CHARLES BLUM ADVERTISING CORP.
1120 Spruce St., Philadelphia 7
Tel.: Pennypacker 5-4424
Radio Dept.: Charles Blum, president, radio director, account executive.

FRANK L. BLUMBERG AGENCY
401 North Charles St., Baltimore 1
Tel.: Mulberry 6672
Radio Dept.: Horace J. Elias, radio director, account executive.

Radio and Television Accounts: Park Circle Motor Co.; Legum Distributing Co.; Kress Farm Dairy. All spots.

BOCK ADVERTISING CO.
Second National Bldg.
Akron 8, Ohio; Tel.: Portage 4616
Yellow Creek Milling Co., Belle Isle Farm Products, Haven of Rest, Spencer Leather Co.

BOND & STARR INC.
248 Fourth Ave., Pittsburgh 22
Tel.: Grant 1-1827
Radio Dept.: John M. Huggett, radio and television director; Helen R. Wischmeyer, timebuyer.

Radio Accounts: A. J. Logan Co.; Ludwig Hommel & Co.; Higrade Prod. Co.

BOOKER-COOPER INC.
601 S. Rampart St., Los Angeles 5
Tel.: Fitzroy 9127
Radio Dept.: A. R. Booker, pres.

BORTON, F. L.—ADVERTISING
Monticello, Ill.
Tel.: 376
Radio Dept.: B. R. Miller, timebuyer.

W. EARL BOTHWELL
600 Grant St., Pittsburgh 19
Tel.: Court 6565
Radio Dept.: Nathan A. Tufts, radio director; G. Taylor Urquhart, television director and radio timebuyer.

New York 16—22 E. 40th St., Lexington.
2-1522. T. Howard Black, manager.

Chicago 11—520 N. Michigan Ave.
Whitehall 4-2917 Charles D. Pettengill, general manager.

Hollywood—1680 N. Vine St. Nathan A. Tufts, manager.

BOTSFORD, CONSTANTINE & GARDNER
115 SW. Fourth Ave., Portland 4
Tel.: Atwater 9541
Seattle 4—Central Bldg. Tel. Elliott 3523.
San Francisco 4—156 Montgomery. Tel.: Exbrook 2-7565
Los Angeles 14—629 S. Hill St. Tel.: Vandike 0796
New York 1—Empire State Bldg. Tel.: Bryant 9-4845.

LEO P. BOTT JR., ADVERTISING
64 East Jackson, Chicago 4
Tel.: HARRISON 7-9177
Radio Dept.: A. Weister, radio timebuyer.

THE LEO BOULETTE AGENCY
303 North Main St., Three Rivers, Mich.
Tel.: 755
Radio Dept.: Carol Boulette, radio director.

Radio Accounts: Miller Protecto Products Co. (S); Floral Gardens (S).

BOURNE ASSOC. INC.
60 E. 42nd St., New York 17
Tel.: Vanderbilt 6-1423
Radio Dept.: Severin Bourne, radio director; Victor Arden, radio consultant; Suzanne C. Lloyd, television director.

JOHN R. BOYD CO.
4814 Loma Vista, Los Angeles 11
Radio Dept.: John R. Boyd, radio timebuyer.

STANLEY G. BOYNTON
410-411 Fisher Bldg., Detroit, 2
Tel.: Trinity 1-2552
Radio Dept.: Stanley G. Boynton, president; S. G. Boynton Jr., production and traffic manager; J. Hartleb, assistant producer.

Radio Accounts: Radio Bible Class (N-S); The Calvary Hour (S); Wesley Radio League (S); American Society of Industrial Engineers; Highland Park Baptist Church; National Tennis Matches; Ster-L-Ray Sales & Service.

New York 17—17 E. 42nd St. Tel.:
Murray Hill 2-0086

BOZELL & JACOBS INC.
326 W. Madison St., Chicago 6
Tel.: Central 6-6505
Radio Dept.: Phillip Rouda, radio director.

Minneapolis 15—415 S. 6th. Tel.:
Main 4527. Sam Kaufman, radio director.

Los Angeles—6711 Sunset Blvd. Tel.:
Hillside 2695. Joseph Jacobs.

New York 19—31 W. 47th St. Tel.:
Judson 6-5588. Katherine Storm, radio production.

Indianapolis 4—Traction Terminal Bldg.
Tel.: Lincoln 6326. C. A. Gallup.

Seattle 4—2123 Smith Tower. Tel.:
Main 0145. R. H. Wensberg.

Shreveport 23—622 Travis St. Tel.:
6124. W. T. Pfeiffer.

Houston 2—United Gas Bldg. Tel.:
Fairfax 4106. Carl Storey.

Dallas 1—813 Thomas Bldg. Tel.:
Central 5428.

Louisville 2—1222 Heyburn Bldg. Tel.:
CLAY 3819.

Omaha 2—Electric Bldg. Tel.:
JACKSON 8030.

BRADHAM & CO.
Piedmont Bldg., Greensboro, N. C.
Tel.: 3-4321 & 3-7435
Radio Dept.: W. T. Williamson, radio director.

Toledo 2—1220 Madison Ave. Tel.:
AD 8419.

ARTHUR BRAITSCHE ADVERTISING
Hospital Trust Bldg., Providence 3
Tel.: Dexter 1-5313
Radio Dept.: Arthur Braitsch, radio and television director; John A. Lorimer, timebuyer, account executive.

Radio Accounts: Sally's Fur Studio (S); Baird North Inc. (S); Strand Theatre (S); Weybosset Markets (S); Rocky Point Park; Interstate Navigation; Hospital National Bank (S); Merchants Storage (S); Roger Williams Savings (S); Ming Garden Restaurant (S); Silvertown Chevrolet (S); Ovaco Paints (S); Republican State Central Committee (S); Woodland Manor (S).

MICHAEL BRAND ASSOCIATES
1746 N. Las Palmas Ave., Hollywood 28
Tel.: Hollywood 9-4427
Radio Dept.: Michael Brand, radio director; Anne Glass, media director.

Radio Account: Karseal Corp. (S).

THE J. CARSON BRANTLEY ADV. AGENCY
Owen Building, Salisbury, N. C.
Tel.: 900
Radio Dept.: J. Carson Brantley, radio and television director.

Radio Accounts: Duke Power Co. (S); Owen Drug Co. (S); Carolina Beverage Corp. (S); CM Company (S); Nye Drug Co. (S); Isenhour Brick & Tile Co. (S).

BRENNAN ADVERTISING AGENCY
812 Scalan Bldg., Houston
Tel.: Charter 2596
Radio Dept.: Cecil Carnes, director of radio and television; Edward B. Hall, director of radio advertising, timebuyer.

Radio Account: Houston Bank & Trust Co.

BRESNICK & SOLOMONT
216 Tremont St., Boston 16
Tel.: Liberty 2-7751

R. C. BRETH INC.
310 Pine St., Green Bay 1, Wis.
Tel.: Howard 134
Radio Accounts: Brillion Iron Works Inc. (S); Home Mutual Insurance Co. (S).

BRUCE B. BREWER & CO.
400 Union Nat'l Bank Bldg., Kansas City 6, Mo.
Tel.: Harrison 4890
Radio Dept.: W. J. Woods, radio and television director; R. T. Pries, Bruce B. Brewer, Quentin Brewer, John Barton, Kent Boyd, account executives; M. E. Klein, timebuyer.

Minneapolis—700 Foshay Tower. Tel.:
Atlantic 4307. M. L. Henderson, manager.

BRIGGS & VARLEY INC.
14 E. 48th St., New York 17
Tel.: Wickersham 2-8533

BRINDLEY-ROTH INC.
131 Lafayette W., Detroit 26
Tel.: Cadillac 8295
Radio Dept.: R. Benton Brindley, radio director.

BRISACHER, WHEELER & STAFF
620 Market St., San Francisco 4
Tel.: Garfield 1-0276
Radio Dept.: Deane Weinburg Jr., radio and television timebuyer.

Los Angeles—1133 Crenshaw Blvd. Tel.:
Webster 8143. Charles Chaplin, radio and television director; Joy Molliepod, radio timebuyer.

New York 16—140 E. 39th St. Tel.:
Oregon 9-4960. Darrell McCain, radio and television timebuyer.

Radio Accounts: Peter Paul; C. Mondovi & Sons (S); Foodcraft Products Co. (S); Los Angeles Dons; Sav-On Drugs Inc.; Old Homestead Bakery; R'chmond Chase Co.; Pict-sweet Foods Inc.; Dennison's Foods.

Television Accounts: Peter Paul (S); Globe Bottling Co.; Old Homestead Bakery; Sunset Line & Twine.

BROADCAST ADVERTISING INC.
8 Newbury St., Boston 16
Tel.: Kenmore 6-0854
Radio Dept.: J. E. Murley, president and radio-television director; J. J. Manning, timebuyer; F. P. Russell, account executive.

Radio Accounts: R. G. Sullivan Inc. (S); Hy-Trous Sales Co. (S); Marjorie Mills Hour (N); The Yankee Kitchen (N); China House (S).

BROADCAST SERVICE INC.
1226 E. Dayton St., Madison, Wis.
Tel.: 6-4104
Radio Dept.: Richard S. Nickeson, manager; Virginia Green, timebuyer.

Radio Accounts: Ace of Clubs (S); C. W. Anders Co.; Badger Furniture (S); Badger Realty; Flore Coal Co.; Schwartz Jewelers (S); Badger Office Supply (S); C & P Drive-In (S); Crescent Clothing Co. (S); Hanny Bros. Milling (S); Refrigeration Equipment (S); Nedrebo Custom Clothing (S).

ANNE BROCK ENTERPRISES
122 N. W. 1st St., Evansville, Ind.
Tel.: 4-9612

BROOKE, SMITH, FRENCH & DORRANCE INC.
8469 E. Jefferson, Detroit 14
Tel.: Valley 2-9700
Radio Dept.: Hugh Hole, radio and television director; Clyde Vortman, timebuyer; Frederick A. Malsom, Gerald J. Weipert, assistants to radio-television director.

New York—52 Vanderbilt. Tel.:
MURRAY Hill 6-1800.

Radio Accounts: Goebel Brewing Co. (N-S); Hudson Motor Car Co. (S); Mullins Mfg. Co. (S); Reo Motors Inc.; John Bean Mfg. Corp.

Television Accounts: Goebel Brewing Co. (N-S); Hudson Motor Car Co. (S); Ironrite Ironer Co.; Mullins Mfg. Co. (S).

BROOKS ADVERTISING AGENCY
416 W. 8th St., Los Angeles 14
Tel.: Trinity 0558
Radio Dept.: A. R. Brooks, timebuyer.

S. M. BROOKS ADV. AGENCY
Union Nat'l Bank Bldg., Little Rock, Ark.
Tel.: 2-1874
Radio Dept.: Earl L. Saunders, vice president and radio director.

BROOMFIELD-PODMORE-BURNSIDE ADVERTISING
Commonwealth Bldg., Trenton 8, N. J.
Tel.: Trenton 5-3409
Radio Dept.: Donald E. Mattern, director of radio and television.

D. P. BROTHER & CO. INC.
General Motors Bldg., Detroit 2
Tel.: Trinity 2-8250
Radio Dept.: Carl George Jr., vice president, director of media, timebuyer; Wm. J. Davis, timebuyer, media dept.; Clarence Hatch Jr., account executive.

Radio Account: Oldsmobile Div. (S).

Television Account: Oldsmobile Div. (N-S).

C. FRANKLIN BROWN, INC.
20 N. Wacker Drive, Chicago 6
Tel.: Central 6-5377

E. H. BROWN ADV. AGENCY
20 N. Wacker Drive, Chicago 6
Tel.: Franklin 2-9494
Radio Dept.: Lizbeth Huntsman.

E. L. BROWN ADVERTISING
1606 Walnut St., Philadelphia 3
Tel.: Pennypacker 5-7510
Radio and Television Department: Roland Israel, media director.

BURTON BROWNE ADVERTISING
619 N. Michigan, Chicago 11
Tel.: Delaware 7-8300

FRANKLIN BRUCK ADVERTISING CORP.
RKO Bldg., New York 20
Tel.: Circle 7-7660
Radio Dept.: Rae B. Elbroch, timebuyer.

Los Angeles 46—1405 N. Formosa Blvd. Tel.:
Gladstone 4528. Howard Blake.

BUCHANAN & CO. INC.
1501 Broadway, New York 18
Tel.: BRYANT 9-7900
Radio Dept.: John R. Sheehan, director of radio and television; Bill Smith, timebuyer.

Chicago 11—919 N. Michigan Ave. Tel.:
Delaware 5522. Burton Feldman, vice president.

San Francisco 4—155 Montgomery St. Tel.:
Yukon 6-2927. Leland Blair, vice president.

Los Angeles—1521 Wilshire Blvd. Tel.:
Dunkirk 8-2313. Frederick N. Polaugin, vice president and executive head.

Radio Accounts: Paramount Pictures (S); United Artists Corp. (S); Helene Curtis (S); Associated Oil (N); Reynolds Wrap (S).

Television Accounts: Allen B. DuMont Labs Inc. (N-S); Eskimo Pie (S); Associated Oil (N).

BUCHANAN-THOMAS ADV. CO.
412 S. 19th St., Omaha 2
Tel.: Atlantic 2125
Radio Dept.: C. Coe Buchanan, L. H. Thomas, partners; Adam Reinemund, radio and television director.

THE BUCHEN CO.
400 W. Madison St., Chicago 6
Tel.: Randolph 6-9305
Radio Dept.: C. W. Fisher.
Radio Accounts: Michigan Natl. Bank (S); Capper's Farmer Magazine (S); Fairbanks Morse & Co. (S).

BUCKNER-CRAIG-WEBSTER ADVERTISING AGENCY
22 Park Place, Lubbock, Texas
Tel.: 2-2314
Radio Dept.: Rex Webster, radio director; Leon E. Harris, continuity director.

H. W. BUDDEMEIER CO.
516 N. Charles St., Baltimore 1
Tel.: Saratoga 4606
Radio Dept.: Marcus E. Smith, vice president.

G. NORMAN BURK INC.
233 Fourth Ave., Pittsburgh 22
Tel.: Atlantic 1-4139
Radio Dept.: G. Norman Burk, radio and television director; Dolores McCarthy, timebuyer; G. Norman Burk, Edgar E. Eaton, account executives.

Radio Accounts: Meadow Gold Dairies Inc.; Midtown Motors Inc.; Standard Floor; Liberty Baking Co.

BURLINGAME-GROSSMAN ADVERTISING
201 N. Wells St., Chicago
Tel.: Financial 6-4616

LEO BURNETT CO.
360 N. Michigan Ave., Chicago 1
Tel.: Central 6-5959
Radio Dept.: William L. Weddell, V.P. in Chg. radio and television; Mac-Lean Chandler, timebuyer; E. G. Eisenmenger, manager, radio dept.

(Continued)

ADVERTISING AGENCIES HANDLING RADIO AND TV ACCOUNTS

(Continued)

N indicates network, S spot

Clair Callihan, radio and TV production manager.
New York—743 Fifth Ave. Tel.: Plaza 5-2772. William J. McIlvain.
Los Angeles—3630 Wilshire. Tel.: MU-5167. Wendell Williams.

Radio Accounts: Brewing Corp. of Am. (S); Minnesota Valley Canning Co. (N-S); Pure Oil Co. (N); Pillsbury Mills (N-S); American Meat Institute (N); Brown Shoe Co. (N); Club Aluminum Products Co. (N); Santa Fe System Lines (S); Kellogg Co. (S); Horlicks Corp. (S).
Television Accounts: Santa Fe Railroad (S); Dean Milk Co. (S); Pillsbury Mills (S); Minnesota Valley Canning (S); Brown Shoe Co. (S); Pure Oil Co. (S); Horlicks Corp. (S); Brewing Corp. of America (S); Kellogg Co. (N); Hoover Co. (S).

BUSBY ADVERTISING AGENCY
44 East Main St., Springfield, O.
Tel.: 3-4909

ELLIOTT BUSE ADVERTISING AGENCY
1425 Fidelity Bldg., Baltimore 1
Tel.: Mulberry 3561

Radio Accounts: Kress Farm Dairy (S); C. E. Kimmel & Co. (S); TriState Electrical Supply Co. (N); Tongue, Brooks & Co. (S).

KENNETH B. BUTLER & ASSOCIATES
Press Bldg., Mendota, Ill.
Tel.: 621

Radio Dept.: Robert Moogk, Kenneth B. Butler, timebuyers.

BYER & BOWMAN ADVERTISING AGENCY
203 E. Broad St., Columbus 15
Tel.: Main 3276

Radio Dept.: William Copeland, radio and TV director; Reg Testement, Sandy Hallock, account executives.

Radio Accounts: Ashland Oil & Refining Co. (N); Ben Brew (S); Buckeye Potato Chips (S).

C

HAROLD CABOT & CO. INC.
136 Federal St., Boston 10
Tel.: Hancock 6-7600

Radio Dept.: Miss Jan Gilbert, radio and television director; John Lord, Donald D. Douglass, Russell Hunt, Langley Keyes, Richard P. Holland, Courtney A. Crandell, account executives.

Radio Accounts: Boston Consolidated Gas Co. (S); Boston Globe (S); Boston & Maine R.R. (S); Boston & Maine Trans. Co. (S); H. P. Hood & Sons (S); Rock of Ages Corp. (S); Adams & Swett; Haffenreffer & Co. Inc.; Quincey Savings Bank.

CAHN-MILLER INC.
413 N. Charles St., Baltimore 1
Tel.: Saratoga 4466

Radio Dept.: George Gettman, radio director and timebuyer; C. LeRoy Miller, account executive and vice president.

Radio Accounts: Baums Restaurant; The Fidelity Trust Co.; Jarman Motors; Elite Laundry; Hamline Bros.; Pre-Fab Homes & Supplies Inc. All spot users.

CALDWELL, LARKIN & CO. INC.
Merchants Bank Bldg., Indianapolis 4
Tel.: Market 6501

Radio Dept.: Charles D. Cavett, copy director; V. James Story, media director.

CALKINS & HOLDEN
247 Park Ave., New York 17
Tel.: Plaza 5-6900

Radio Dept.: Chester H. Miller, director radio and television.
Chicago 1—333 N. Michigan Ave. Tel.: Randolph 6-3831.

Radio Accounts: Oakite Products Inc. (S); Stokeley-Van Camp Inc. (S);
Television Accounts: Weston Biscuit Co. (S).

JOS. F. CALLO INC.
349 E. 149th St., New York 51
Tel.: Mott Haven 9-6300

Radio Dept.: Lewis Tubarolo, media director.

CALVERT, WHITLOCK & WILLIAMS
107 Camp St., New Orleans 12
Tel.: Canal 1685

Radio Dept.: Bache McE. Whitlock, timebuyer & television research director.

D. T. CAMPBELL INC.
222 W. Adams St., Chicago 6
Tel.: State 2-2713.

CAMPBELL-EWALD CO.
1 East 57th St., New York 22.
Radio and Television Dept.: Winslow Case, vice-president in charge. Tel.: Murray Hill 8-3190.

General Motors Bldg., Detroit 2
Tel.: Trinity 2-6200

Radio Dept.: J. J. Hartigan, vice-president and director of media.
Los Angeles 15—714 W. Olympic Blvd. Tel.: Richmond 6204. R. C. Francis, vice-president.

San Francisco—995 Market St. Tel.: Sutter 1-8736
Chicago 1—230 N. Michigan Ave. Tel.: Central 8-1946. Earl W. Clements, vice-president.

CAMPBELL-MITHUN INC.
1370 NW Bank Bldg., Minneapolis 2
Tel.: Lincoln 8824

Radio Dept.: Arthur H. Lund, radio director; Loren Sorensen, timebuyer.
Chicago 11—1024 Palmolive Bldg. Tel.: Delaware 7-7553.

Radio Accounts: Atwood Coffee Co. (S); Campbell Cereal Co. (S); Gold Seal Co. (N-S); Theo. Hamm Brewing Co. (S); Hilex Co. (S); Land O'Lakes Creameries, Inc. (S); Northwestern National Bank (S); Russell-Miller Milling Co. (S); Zinsmaster Baking Co. (S); Churning Sales; Luther Ford & Co.; Our Own Hardware Co.; F. H. Peavey & Co.

SOLIS S. CANTOR ADV. AGENCY
1711 Walnut St., Philadelphia 3
Tel.: Locust 7-8141

Radio Dept.: Robert Weiner, radio and television director.

Radio Accounts: Lou Block Studebaker; David T. Robinson; Granoff School of Music; Medico Rents; Jackie Gordon; Food Fair; Thrifty Laundry Starch. All spot users.

CAPLES CO.
225 E. Erie St., Chicago 11
Tel.: Superior 7-6016

Radio Dept.: Don J. Powers, manager.
Omaha—1504 Dodge St. Tel.: Jackson 7795. Geo. McCulloch, manager.

Los Angeles 14—412 W. 6th St. Tel.: Mutual 4143. J. E. Erickson, manager.
New York 17—535 Fifth Ave. Tel.: Murray Hill 7-3577. Hudson Meyer, vice-president in charge.

W. G. CARNEY ADVERTISING AGENCY INC.
238 W. Wisconsin Ave., Milwaukee 3
Tel.: Broadway 2-3008

Radio Dept.: W. Carney, radio director; Leon Wozniak, television director; Donald Cox, art director; Betty Venatta, production manager; Eugene T. Van Handel, Richard E. White, account executives; Irene H. Miels, copywriter.

CARPENTER ADVERTISING CO.
Citizens Bldg., Cleveland 14
Tel.: Ma. 1570

Radio Dept.: V. J. Siena, timebuyer, account executive.

CARTER ADVERTISING AGENCY
912 Baltimore St., Kansas City 6, Mo.
Tel.: Harrison 1356

Radio Dept.: Herbert True, director of radio & television; Charles Carter, William G. Rowe, Fred Klomp Jr., Curt Bogash, account executives.

Radio Accounts: Perry Pontiac (S); May Potato Chips (S); R. B. Jones and Sons; Homestate Bank; Security National Bank.

R. H. CARY INC.
Liberty Bldg., Des Moines 9
Tel.: 4-0375

Radio Dept.: Joanne Still, timebuyer.

CAYTON INC.
350 Fifth Ave., New York 1
Tel.: Bryant 9-0390

Radio Dept.: Allan Black, radio and television director; Margaret Eaton, timebuyer; Bill Cayton, account executive.

Radio Accounts: Tradivision Corp. (S); Re-Clean Corp. (S).

Television Accounts: Chesebrough Mfg. (N); Pioneer Scientific Corp. (S); Tradivision Corp. (S); Re-Clean Corp. (S).

CECIL & PRESBREY INC.
247 Park Avenue, New York 17
Tel.: Plaza 5-8200

Radio Dept.: Edw. B. Simmons, radio director; Thaddeus S. Kelly, timebuyer; Harry Parnas, media director, timebuyer.

CENTRAL ADVERTISING CORP.
Board of Trade Bldg., Indianapolis 4
Tel.: Franklin 4731

CENTURY ADVERTISING AGENCY
1840 National Bank Bldg., Detroit 26
Tel.: Cadillac 7760

Radio Dept.: G. Hazzard, timebuyer.

CHARLES J. CHARNEY ASSOCIATES
1776 Broadway, New York 19
Tel.: Plaza 7-0955-56

Radio Dept.: Alvin George, radio director; Charles J. Charney, television director; Seymour Chodoroff, Tom Dundon, Melvin H. Levy, account executives.

CHERNOU ADVERTISING CO.
350 Fifth Ave., New York 1
Tel.: Pennsylvania 6-3520

Radio Dept.: William Travis, radio and television director.

NELSON CHESMAN CO.
Hamilton Trust Bldg., Chattanooga 8
Tel.: 6-4942

Radio Dept.: James R. Fox, John E. Fontaine, radio directors; J. Manning Sullivan, Sara Kelly, account executives.

Radio Accounts: The Chattanooga Medicine Co.; Capital Nursery Co. (S); Tennessee Nursery Co. (S).

CHICAGO ADV. AGENCY
20 W. Jackson Blvd., Chicago 4
Tel.: Wabash 2-3732

Radio Dept.: Simon Levin, radio director.

JAMES THOMAS CHIRURG CO.
44 Park Square Bldg., Boston 16
Tel.: Hancock 6-7310

Radio Dept.: Edmund J. Shea, radio director; Richard M. Mason, Edmund P. Lord, Wallace L. Sheppardson, account managers; J. Nelson Clifford, film director.

New York 17—48 E. 43rd St. Tel.: Murray Hill 7-5040.

Radio Accounts: Lifetime Stainless Steel Co.; D'Arrigo Bros. Co.; Bates Shoe Co.; Rumford Chemical Works; Davis Bros. Fisheries; New England Coke Co.; Chase-Shawmut; all spot users.

Television Accounts: Bates Shoe Co.; D'Arrigo Bros.; Davis Bros. Fisheries; Lifetime Stainless Steel Co.; Chase-Shawmut; all spot.

CHRISTIANSEN ADV. AGENCY
135 S. LaSalle St., Chicago 3
Tel.: Central 6-2484

CHURVIS ADVERTISING CO.
55 E. Washington St., Chicago 2
Tel.: Central 6-1031

Radio Dept.: Art Churvis, radio director.

C. P. CLARK INC.
James Robertson Hotel, Nashville 3, Tenn.
Tel.: 6-4179

Radio Dept.: C. P. Clark, radio director.

DARWIN H. CLARK
1139 W. 6th St., Los Angeles 14
Tel.: MADISON 9-1661

Radio Dept.: Karl Lott Jr., radio director.

ROBERT E. CLARKE ASSOCIATES INC.
Ingraham Bldg., Miami 32, Fla.
Tel.: 2-3282

Radio Dept.: E. S. Hamburger, radio director; C. Bonnell, account executive.

Atlanta—1325 Rhodes Haverly Bldg.
Radio Accounts: Pet Dairy Products Co. (S); Home Finance Co. (S); Colin English (S); Biscayne Kennel Club (S); Home Milk Producers Association (S); First National Bank of Miami.

THE CLEMENTS CO. INC.
1601 Chestnut St., Philadelphia 3
Tel.: Rittenhouse 6-0236

Radio Dept.: Alice Clements, radio and television director; Robert H. Smith, Marilyn Gusten, radio-TV producers; K. E. King, Alvin L. King, timebuyers.

Radio Accounts: Horn & Hardart (S); Hudson Coal Co. (N); P. J. Ritter Co. (S); Hornung Beer (S); Northwestern Nat'l. Bank (S); Campana Sales Co. (N).

Television Accounts: Mrs. Morrison; Horn & Hardart Co.; Horn & Hardart Baking Co.; Jacob Hornung Co.

THE ARNOLD COHAN CORP.
101 West 55th St., New York 19
Tel.: Plaza 7-7730

Radio Dept.: Arnold Cohan, radio director.

Radio Accounts: Bruno-New York Inc.

HARRY B. COHEN ADVERTISING CO. INC.
1 East 57th Street, New York
Tel.: Murray Hill 8-3030

Radio Dept.: Edward Aleshire, vice president and radio and television director; John Donaldson, timebuyer; Viola Nolan, assistant timebuyer.

Radio Accounts: Grove Laboratories (N-S); Pearson Pharmacal Co. (S).

I. T. COHEN ADVERTISING
519 Sixth St. N.W., Washington 1, D. C.
Tel.: Sterling 3333

Radio Dept.: Alvin I. Miller, radio director; Sidney B. Wolfe, television director.

COLE & CO. INC.
Sterick Bldg., Memphis 3
Tel.: 5-3604

Radio Dept.: Bernard L. Cohn, vice president and timebuyer.

COLE & CHASON INC.
331 Madison Ave., New York 19
Tel.: Murray Hill 7-6414

COLE & WERNER ADV.
Insurance Bldg., Omaha 2
Tel.: Jackson 7868

MAURICE C. COLEMAN & ASSOC.
Bona Allen Bldg., Atlanta 3
Tel.: Main 4012

Radio Dept.: John W. Mu'oo, radio and television director; E. J. Kimmel, S. Coppedge.

RUSSELL C. COMER CO.
15 W. 10th St., Kansas City 6, Mo.
Tel.: Harrison 3964

Radio Dept.: Bill Godden, radio director; Dan Martin, timebuyer, Gardner Reames, Ralph S. Durkin, John C. Fehandt, Frank E. Otey, Russell C. Comer, account executives.

COMMERCIAL BROADCASTERS
188 W. Randolph St., Chicago 1
Tel.: Dearborn 2-0203

Radio Dept.: Dave Edelson, radio director; M. F. Edelson, account executive; Catherine O'Heron, timebuyer.

Radio Accounts: Chicago Cardinals (S); Fireside Restaurant (S); Blue Bird Bus Lines (S); Stromberg-Carlson; Republic Printing Co.; Commercial Tire Co.; Irving Beverage Co.; Graemere Hotel; Hennie Bros. Shows; Internat'l Air Shows; Sterling Kitchen Designers; Green Bay Brewers.

COMPTON ADVERTISING INC.
630 Fifth Ave., New York 20
Tel.: Circle 6-2800

Radio Dept.: Lewis Titterton, director, radio and television department; Brewster Morgan, radio and television department; Frank Kemp, assistant media director; Guy Richards, vice president, media director; Henry Clochessy, head time buyer; Julia Brown, Jean Carroll, Martin Hansen, timebuyers.

Chicago 5—59 E. Van Buren St. Tel.: Harrison 7-3570. L. O. Holmberg, manager.

Hollywood 28—6253 Hollywood Blvd. Tel.: Hollywood 8107. Floyd R. Holm, manager.

Milwaukee 3—744 N. Fourth St. Tel.: Marquette 2778.

Cincinnati 2—Gwynne Bldg. Tel.: Parkway 6961.

Radio Accounts: Procter & Gamble (N-S); Socony Vacuum Oil Co. Inc. (S); Goodyear Tire & Rubber Co. (S); Standard Brands Inc. (S).

Cincinnati 2—Gwynne Bldg. Tel.: Parkway 6961.

THE CONDON CO. INC.
Rust Bldg., Tacoma 2, Wash.
Tel.: Main 8155

Radio Dept.: Howard R. Smith, timebuyer.

CONNER ADVERTISING AGENCY
1525 Welton St., Denver 2
Tel.: Keystone 5351
Radio Dept.: Cecil R. Conner, president; James MacPherson, radio and television director.

CONNER, JACKSON, WALKER, McCURE INC.
544 Market St., San Francisco 4
Tel.: Yukon 6-0196
Radio Dept.: Marjorie Lawrence, media director.

THOMAS F. CONROY INC.
Majestic Bldg., San Antonio 5, Tex.
Tel.: Garfield 3458
Radio Dept.: Ward M. Wilcox, radio director.

EDWARD C. COONTZ INC.
Colcord Bldg., Oklahoma City
Tel.: 7-0591
Radio Dept.: Edward C. Coontz, secretary; Suzanne Prentice, program arranger.

COOPER & CROWE
260 E. 1st South, Salt Lake City
Tel.: 4-2668
Radio Dept.: Gordon Crowe, account executive and timebuyer; Bill Rice, account executive and timebuyer.
Ogden—200 Kiesel Bldg. Tel.: 3-1214. Don Watkins, manager.

Radio Accounts: Axelrad Furniture Co. (S); Wilson's Products Co. (S); McFarlane Wholesale Meat Co. (S); Yancey Co. (S); Kearns Townsite (S); Norman Motor (S); Taylor Motor (S); Darling Store (S); Bruce Transfer & Storage (S); Silver King Window Co. (S); Western Supply Co. (S); Western Broom Co. (S); Federal Bldg. & Loan Assn. (S); Pence Grain Co. (S); Reliable Furniture (S).

COPLEY ADVERTISING AGENCY
457 Stuart St., Boston 16
Tel.: Commonwealth 7350

COWAN & DENGLER INC.
527 Fifth Ave., New York 17
Tel.: Murray Hill 2-0940
Radio Dept.: Thomas H. Moore Jr., radio and television director. A. Marie Maus, timebuyer.
Radio Accounts: Isbrandtsen-Moller (S); Schrafft's (S).

CRAMER-KRASSELT CO.
733 N. Van Buren St., Milwaukee 2
Tel.: Daly 8-3500
Radio Dept.: L. H. Ness, V.P., media dir.; Loretta Mahar, timebuyer.
Television Dept.: J. S. Stolzoff, director.

CHET CRANK CO.
6518 Selma Ave., Hollywood 28
Tel.: Hempstead 5129
Radio Dept.: Chet Crank, manager.

CRAVEN & HEDRICK INC.
522 Fifth Ave., New York 18
Tel.: Murray Hill 2-5010

CRAWFORD & PORTER ADV.
5 Ivy St., Atlanta 2
Tel.: Lamar 0656-7
Radio Dept.: Carol Porter, timebuyer.

CRITCHFIELD & CO.
720 N. Michigan Ave., Chicago 11
Tel.: Superior 7-3061
Radio Dept.: E. Groenboom, media director.

CROLLY ADVERTISING AGENCY
42 E. Market St., Wilkes-Barre, Pa.
Tel.: 2-8171
Radio Dept.: Phil A. O'Neill, account executive; William T. Kelly, radio director, timebuyer.

Radio Accounts: Stegmaier Brewing Co. (S).

CROMWELL ADVERTISING AGENCY
175 Fifth Ave., New York 10
Tel.: Oregon 3-1000
Radio Dept.: Lillian Drobin, media director; L. C. Kane, production manager, copy chief.

CROOK ADVERTISING AGENCY
Southwestern Life Bldg., Dallas 1
Tel.: R-1775

SAMUEL C. CROOK CO.
23 W. 44th St., New York 18
Tel.: Bryant 9-2588

ARTHUR CROSBY SERVICE
516 Fifth Ave., New York 18
Tel.: Murray Hill 7-5268
Radio Dept.: Benjamin F. Landsman, radio director, timebuyer.

CRUTTENDEN & EGER
69 W. Washington St., Chicago 2
Tel.: Financial 6-3830
Radio Dept.: Harry C. Pick.

EARL R. CULP ADVERTISING AGENCY
601 S. Rampart Blvd., Los Angeles 5
Tel.: Fairfax 8406
Radio Dept.: Earl R. Culp.

CUMMINGS, BRAND & McPHERSON
Gas-Electric Bldg., Rockford, Ill.
Tel.: 2-0677
Chicago 6—20 N. Wacker Drive. Tel.: Dearborn 2-5026.

CUNNINGHAM & WALSH INC.
40 E. 34th St., New York 16
Tel.: Murray Hill 3-4900
Radio Dept.: Helen Lee, radio director; N. F. McEvoy, media director; George Foley, television director; Thomas J. Lynch, Miss Mary Dunlavey, radio & television timebuyers.
Hollywood 46—8420 Sunset Blvd. Tel.: Granite 6131. Blayne Butcher, radio director.

Radio Accounts: Liggett & Myers Tobacco Co. (N-S); Electric Auto-Lite Co. (N); Kirkman & Son (S); Sunshine Biscuits (S); Northwest Airlines (S).
Television Accounts: Liggett & Myers Tob. Co. (N-S); Sunshine Biscuits Inc. (S); Sylvania Electric Co. (N).

D

DANCER-FITZGERALD-SAMPLE INC.
247 Park Avenue, New York 17
Tel.: Murray Hill 5-4200

Radio Dept.: Lyndon O. Brown, director of research and media; J. James Neale, radio director; Carl Stanton, supervisor nighttime shows, television & motion pictures; Lester Vail, head of daytime radio; W. S. Doughten, Mrs. M. Bowman, show supervisors; Adrian Samish, V.P., radio and television director; Thomas Carson, Frank Moriarty,

Stanley H. Pulver, timebuyers; Don Manchester, Gordon Johnson, Ted Mertz, Joseph Horne Holmes, Jr., M. Read, G. G. Tormey, W. B. Stewart, Charles Hotchkiss, A. W. Spence Jr., H. R. Potter, Jerald Melum, account executives.
Chicago 1, Ill.—221 North LaSalle St. Tel.: Financial 6-4700
Radio Dept.: Sewall Gardner, Paul Keenan, V.P.; James Fitzmorris, Elliot Detchon, account executives; James Neale, V.P., radio director; Helen Stanley, timebuyer; Lyndon O. Brown, V.P., media & research director; Frances Kennedy, copy chief.

Hollywood 28—1680 North Vine St. Tel.: Hudson 2-3256. Alvin Kabaker, manager.
Toronto 1—6 King Street East. Tel.: Adelaide 2851. Gilbert Nunns, manager.

D'ARCY ADVERTISING CO.
Missouri Pacific Bldg., St. Louis 3
Tel.: Central 6700

Cleveland 13—Terminal Tower. Tel.: Cherry 6158. S. P. Seward, vice-president in charge.
New York 22—515 Madison Ave. Tel.: Plaza 8-2600. Paul Louis, V.P., radio director.
Toronto, Ont.—90 Broadview Ave. Tel.: Gladstone 7591. G. P. Altenbernd, vice-president in charge.

Mexico City, D. F.—Reforma No. 164. E. A. Hallett Jr.; C. Riveroll del Prado, V.P., radio director and vice-president.
Atlanta—800 Peachtree St. N.E. Tel.: VE 8815. J. M. Kinsella, V.P. in charge.

JIMM DAUGHERTY INC.
706 Chestnut St., St. Louis 1
Tel.: Main 0790
Radio Dept.: James M. Daugherty, radio director; Emerson Russell, Melvin A. Randall, account executives.
Radio Accounts: Pepsi-Cola Bottlers of

St. Louis (S); St. Louis Dairy Co. (S); So-Good Potato Chips (S); GE Supply Corp. (S); Win You Preserving Co. (S).

DAVID, INC.
1st Nat'l. Bank Bldg., St. Paul 1
Tel.: Garfield 3872
Radio Dept.: Melba Sands, radio director.

DAVIS & CO.
Pacific Mutual Bldg., Los Angeles 14
Tel.: Michigan 3808
Radio Dept.: Beth M. Freeman, timebuyer.

DAVIS-HOOD & ASSOCIATES
315 West 9th St., Los Angeles 15
Tel.: Trinity 7377

LEONARD DAVIS ADVERTISING
274 Main St., Worcester 8, Mass.
Tel.: 7-3717

Radio Dept.: Leonard Davis, radio and television director; Harvey Grove, account executive.

Radio Accounts: Park and Greendale Theatres; W. T. Grant Co.; Reck's Fur Shop; Alpert Fur; Constitution Coffee; R & R Plumbing Supply; Singer's Furniture; Grand View Market; Park Ave. Shop. All spot users.

WALLACE DAVIS & CO.
3401 Buffalo Drive, Houston 6
Tel.: Lynchburg 6191

DAVIS-WHITE-DRAKE INC.
Ninth-Chester Bldg., Cleveland 14
Tel.: Main 9653

Radio Dept.: Annie R. Stevens, timebuyer.

FRANK T. DAY INC.
739 Boylston St., Boston 16
Tel.: Kenmore 6-4854

(Continued)

WEVD

5000 WATTS
1330 K.C.

PROGRAMS OF DISTINGUISHED FEATURES IN

- ENGLISH
- JEWISH
- ITALIAN

3 RESPONSIVE AUDIENCES
MARKETS WITHIN

THE NEW YORK METROPOLITAN AREA

Send for WHO'S WHO Among Advertisers on WEVD

Henry Greenfield,
Managing Director

WEVD 117-119 West 46th Street, New York 19, N. Y.

ADVERTISING AGENCIES HANDLING RADIO AND TV ACCOUNTS

(Continued)

N indicates network, S spot

- Radio Dept.: Frances B. Day, time-buyer & account executive.
- DAY, DUKE & TARLETON INC.**
270 Park Ave., New York 17
Tel.: Plaza 8-1910
- Radio Dept.: Maria J. White, time-buyer.
Toronto—100 Adelaide St. W. Tel.: Waverly 1275. Peregrine Acland, manager.
- JOHN L. de BRUEYS ADVERTISING**
1305 Capitol Ave., Houston 1
Tel.: Preston 9601
Radio Dept.: John L. de Brueys.
- DENMAN & BETTERIDGE INC.**
Penobscot Bldg., Detroit 26
Tel.: Woodward 5-1474
- Radio Dept.: Harry W. Betteridge, radio and television director; Don Fox, timebuyer; Rudrick R. Otto, Jerry Abbs, account executives.
- Radio Accounts: Michigan Mutual Liability Co.; DeSoto-Plymouth Dealer Assn. of Greater Detroit; Glitter Products; Peters Sausage Co.; New Era Potato Chips; Philco Distributors; Fort Industry Co.; Nat'l Automobile Transporters Assn.
- ROBERT F. DENNIS INC.**
117 W. 9th St., Los Angeles 15
Tel.: Trinity 4691
- Radio Dept.: R. E. (Joe) Messer, radio and television director and time-buyer; Ted Bailie and Ralph Donahue, account executives.
- Radio Accounts: Sparkletts Drinking Water Corp. (S); Paul Trousdale & Assoc. (S).
- Television Accounts: Paul Trousdale & Assoc. (S); Los Angeles Federal Savings & Loan Assn. (S).
- CRAIG E. DENNISON ADV.**
225 N. Michigan Ave., Chicago 1
Tel.: Randolph 6-0038
Radio Dept.: Lester E. Rosenberg, vice president.
- DEUTSCH & SHEA INC.**
Times Bldg., New York 18.
Tel.: Longacre 4-5900
Radio Dept.: Stephen Lewis, radio director.
- DEVEREUX & CO. INC.**
266 Genessee St., Utica 2, N. Y.
Tel.: 4-1718
- Radio Dept.: John T. Farquhar, radio and television director; Leslie W. Devereux, Theodore R. Darvoe, account executives.
- Radio Accounts: Frank J. Baker & Sons (S); Kleen-Maid Baking Corp. (S); Dawes & Judkins Inc. (S); Utica Brewing Co.; Harry Heiman Inc. (S).
- DEVINE ADVERTISING AGENCY INC.**
1457 Broadway, New York 18
Tel.: Wisconsin 7-0056
Radio Dept.: J. J. O'Hearne.
- THE ZAN DIAMOND CO.**
475 Fifth Ave., New York 17
Tel.: Murray Hill 3-4350
Radio Dept.: Stanley Diamond, television director; Neals Rasmussen, associated television advertising director.
- DICKLOW ADVERTISING AGENCY**
1324 National City Bldg., Dallas 1
Tel.: Central 8295
Radio Dept.: Mrs. Irene Scott Dicklow.
- DIENER & DORSKIND**
147 W. 42nd St., New York 18
Tel.: Bryant 9-8300
Radio Dept.: Alvin Haas, radio and television director; William Mann, advertising director.
- DIXIE ADVERTISERS**
Lampton Bldg. Annex, Jackson, Miss.
Tel.: 3-6383
Radio Dept.: George W. Godwin, Larry G. Painter, Albert P. Hand, Sallie L. Whitney, George L. Sugg, W. L. Cooper, Larry E. Davis, Heber E. Darton, Charles D. Kilgore, Rex A. Moody.
- DOHERTY, CLIFFORD & SHENFIELD INC.**
350 Fifth Ave., New York 1
Tel.: Bryant 9-0445
Radio Dept.: Chester MacCracken, V.P., radio and television director; Helen Wilbur, timebuyer.
- RALPH L. DOMBROWER CO. INC.**
11 East Franklin, Richmond 20, Va.
Tel.: 3-1113
- Radio Dept.: Malcolm B. Dombrower, in charge of television; Phyllis King, timebuyer; Ralph L. Dombrower Jr., account executive.
- Radio Accounts: Southland Wine Co.; Chelco Corp.; Etchison Hat Co.; Chesterfield Hat Corp.; Jones & Davis Inc.
Washington, D. C.—Woodward Bldg.
Tel.: Republic 1420. Philip Rosenfeld, manager.
- DONAHUE & COE**
1270 Avenue of Americas, New York 20
Tel.: Columbus 5-4252
- Radio Dept.: A. Carl Rigrod, director of radio, motion picture and television division; Evelyn Lee Jones, time-buyer.
- Atlanta 3—Hurt Bldg. H. L. Morrill, Jr.
Radio Accounts: Loew's Inc. (S); Republic Pictures (S); Sholl Mfg. Co. (S); New York Herald-Tribune (S); Southland Coffee Co. (S); DeLaval Separator Co.; Riverbrand & Carolina Brand Rice Products (S); Aborn's Coffee (S); Sunset Appliance Stores Inc. (S); New York World-Telegram (S); Gold Metal Candy Corp.; Radio City Music Hall (S); Brandt Theaters (S); Scripto Pencil; Cosmopolitan Magazine (S).
- DICK DONALD ADVERTISING**
338 S. Western Ave., Los Angeles 5
Tel.: DUnkirk 8-2371
- Radio Dept.: Dick Donald, radio director; Helen P. Konkolis, timebuyer.
- Radio Accounts: Bozzani Motors (S); Wiz Vacuum Stores (S); Walker Farms (S); Star Motors (S); Dr. Young Shoes (S); Seely Furniture.
- W. B. DONER & CO.**
Washington Blvd. Bldg., Detroit 26
Tel.: Woodward 5-7400
- Radio Dept.: Charles Rosen, director of radio and television; Cherie Lee, assistant director.
Chicago—203 N. Wabash. Tel.: Dearborn 2-4676. Marvin Frank, manager.
- New York 17—18 E. 48th St. Tel.: Murray Hill 8-2034. Charles M. Higgins, manager.
- Television Accounts: E & B Beer; Speedway Petroleum; Everkrisp Potato Chips; Federal Dept. Stores; Grand River Chevrolet.
- Radio Accounts: Everkrisp Food Products; Big Bear Markets; Speedway Petroleum Corp.; Annis Furs; De Roy Jewelers; E & B Beer; Faygo Beverages; Teal Bros.; Enggass Jewelers; Richards' Car-Peterias.
- DORLAND INC.**
247 Park Ave., New York 17
Tel.: Eldorado 5-2685
- Radio Dept.: Howard G. Barnes, director of radio & television; Katherine Kirkbride, assistant to director, timebuyer; Atherton Pettingell, president and account executive; Harry Deutsch, Abner Rubien, account executives.
- Radio Accounts: A. S. Beck (S); Helbros Watch Co. (N); Pepto Mangan (S).
- Television Accounts: A. S. Beck (N & S); Amer. Tex Fabrics (S).
- DOUGHERTY ADVERTISING**
32 Bartlett St., Highland Park 2, Mich.
Tel.: TO. 8-5031.
Radio Dept.: G. I. Dougherty, radio director & timebuyer.
- JOHN C. DOWD INC.**
212 Park Square Bldg., Boston 16
Tel.: Hubbard 2-8050
Radio Dept.: Theodore B. Pitman Jr., radio and television director; Helen Gorabedian, assistant radio and television director; Lois H. Scott, timebuyer.
- Radio Accounts: First National Stores (S); Studio Shop (S); Clinton Clothing Co.; Albany Carpet Cleaning; National Company; City Fuel Co. (S); Staple Cool Co. (S); Victor Coffee; Boston Edison; Harvard Brewing (S); Ring Clear Hosiery.
- Television Accounts: Clinton Clothing Co.; Albany Carpet Cleaning; National Company; Ring Clear Hosiery; Carpenter-Morton (N & S).
- DOYNE ADVERTISING**
Warner Bldg., Nashville 3
Tel.: 6-0811
Radio Dept.: George W. Doyne, time-buyer.
- DUFFY & FABRY INC.**
918 N. 4th St., Milwaukee 3
Tel.: Broadway 2-7851
- Radio Dept.: C. J. Duffy, account executive; Joel Berrall, timebuyer.
- Radio Accounts: Wisconsin Independent Co. (S); Hebenstreit Furniture Shops Inc. (S).
- L. J. DU MAHAUT ADVERTISING AGENCY**
Book Tower, Detroit 26
Tel.: WO. 2-8246
Radio Dept.: Hazel R. Belman, time-buyer.
- DUNDES & FRANK INC.**
64 West 48th St., New York 19
Tel.: Plaza 7-0750
- Radio Dept.: Sydney D. Ritter, radio and television director.
- ROY S. DURSTINE INC.**
730 Fifth Ave., New York 19
Tel.: Circle 6-1400
- Radio Dept.: Maurice Condon, director of radio and television; Bergi Boe, timebuyer and manager of radio dept.
Los Angeles—2853 W. 7th St. Tel.: 8-3411. William Sloan.
San Francisco—703 Market St. Tel.: Yukon 6-6239. Robert England.
- Radio Accounts: The Serutan Co. (N-S); National Selected Products, Inc. (S); Van Houten & Zoone Inc. (S).
- EASTBURN-SIEGEL**
623 Spring St., Atlanta 3
Tel.: Vernon 4707
Birmingham—524 N. 18th St. Tel.: 7-4016.
- FRED H. EBERSOLD INC.**
20 N. Wacker Drive, Chicago 6
Tel.: Franklin 2-0107
Radio Dept.: B. B. Pope, radio director.
- ADAM F. EBY & ASSOC.**
336 Andrews Bldg., Buffalo 2 N. Y.
Tel. Madison 2922
- Radio Dept.: Adam F. Eby, radio director; Lillian Kirk, Samuel E. Eby, Pauline S. Fergusson, account executives.
- EDELSTEIN AND NELSON ADV. AGENCY**
27 E. Monroe St., Chicago 3
Tel.: Andover 3-3867, Dearborn 2-5976
Radio Dept.: Edward Edelstein, television and radio director.
- Television Accounts: Conway Camera Co. (S); Chicago Slip Cover (S).
- ELLINGTON & CO.**
535 Fifth Ave., New York 17
Tel.: Murray Hill 7-4300
- Radio Dept.: Hal James, radio director; Robert F. Hamilton, media director; George Cardenas, films and public relations.
Philadelphia 2—1400 S. Penn Square.
Tel.: Rittenhouse 6-2878.
- ELLIS ADVERTISING CO.**
Rand Bldg., Buffalo 3
Tel.: Cleveland 0422
- Radio Dept.: Toby Treger, radio and television director; Karl Manhardt, radio account executive; Gordon Cole, production manager; Seymour Goodman, account executive.
Toronto—96 King St. E. Tel.: Elgin 2785. Al May, manager.
Montreal—1168 St. Catherine's St. W. Tel.: Plateau 4466, Ben Cossman, manager.
- EMERY ADVERTISING CORP.**
2 North Ave. E., Baltimore 2
Tel.: Vernon 3731
- Radio Dept.: R. I. Highleyman, radio and television director.
- Radio Accounts: Floorcrafters; Weaver Bros.; C. M. Athey Paint Co.; Davison Chemical Corp.; Monumental Storage and Carpet Cleaning Co.
- ROBERT J. ENDERS ADVERTISING**
1415 K St., N.W., Washington 5, D. C.
Tel.: Sterling 2222
- Radio Dept.: Margot Phillips, radio and television director; William F. Fitzgerald, Leonard C. Rennie, Robert J. Enders, account executives; Sam Rosenberg, chief photographer.
- Radio Accounts: Amvets (N); Occidental Restaurant; Al's Motors; George's Radio & Television Co. (S); Simon Distributing Co.; Abbot Refrigerators; Travel Inc.; Home Appliance Co.; McCoy's
- Mid-Atlantic Appliances; Gimbels (S); Pierce-Phelps (S); Julius Garfinkel & Co.; Briggs Filtration Co.; Federal Security Agency (N); Scott Jewelers; Jos. A. Wilner & Co.; VFW (N); Snellenburg (S); Economic Cooperation Ad. (N).
Philadelphia—1420 Walnut St. Tel.: Kingsley 6-1858. Howard Enders, manager.
Alexandria—1912 Duke St. Tel.: Temple 9337. Leonard C. Rennie, manager.
- ENGEL ADVERTISING INC.**
185 N. Wabash, Chicago 1
Tel.: State 2-1366
- ENNIS-ANDERSON ADV. AGENCY**
Anglo Bank Bldg., Fresno, Calif.
Tel.: 3-2613
- Radio Dept.: Lon McAdams, radio director.
- F. A. ENSIGN ADV. AGENCY INC.**
513 Second Ave., Pittsburgh 19
Tel.: Atlantic 1-4028
- Radio Dept.: H. E. Ryman, radio director.
- ALVIN EPSTEIN ADVERTISING**
825 Victor Bldg., Washington, D. C.
Tel.: Sterling 8550
- Radio Dept.: Toni Pearson, radio and television director, timebuyer; Alys Farrell, assistant timebuyer; Alvin J. Raider, Ruth G. Graze, Sol Slade, account executives.
New York—1775 Broadway. Tel.: PLaza 7-7115. Jean Epstein. V. P.
- ERLAND ADVERTISING AGENCY**
18 E. 41st St., New York 17
Tel.: Murray Hill 5-4764
- Radio Dept.: Louis H. Ehrlich, radio director.
- ERWIN, WASEY & COMPANY INC.**
420 Lexington Ave., New York 17
Tel.: Mohawk 4-8700
- Radio Dept.: Richard L. Eastland, director of radio and television; Raymond Simms, timebuyer.
Chicago—230 N. Michigan Ave. Tel.: Randolph 6-4952. John L. Gwynn.
Los Angeles 36—5045 Wilshire Blvd. Tel.: Webster 1-1211. C. H. Cottington, executive director of radio and television.
- BENJAMIN ESHLEMAN CO.**
1522 Locust St., Philadelphia 2
Tel.: Kingsley 5-2590
- Radio Dept.: Leon H. Greenhouse, vice-president, radio director, account executive; Joseph R. Rollins Jr., media director.
- ALBERT EVANS ADVERTISING**
Dan Waggoner Bldg., Fort Worth 2
Tel.: 3-9521
- Radio Dept.: Gene M. Lightfoot, radio and TV director.
- DAVID W. EVANS ADV. AGENCY**
Wasatch Oil Bldg., Salt Lake City 1
Tel.: 5-2935
- Radio Dept.: Edward E. Kash, radio and television director and producer; Von Paul, assistant; Patricia Bowman, timebuyer.
- Radio Accounts: Amalgamated Sugar; Anderson Jewelry Stores; Boise-Winnemucca Stages; Desert News; Fox Studios; L. D. S. Business College; Milk White Frozen Chicken; Milk White Eggs; Rheem Mfg. Co.; State Savings & Loan Assn.; Utah-Idaho Sugar; Wasatch Electric Co.; Z.C.M.I. Wholesale Distributors.
- Television Accounts: Anderson Jewelry Co.; Shepherd Posture Chair Co.; Z. C. M. I. Dept. Store; Z.C.M.I. Wholesale Distributors.
- LAWRENCE I. EVERLING INC.**
1700 Walnut St., Philadelphia 3
Tel.: Pennypacker 5-7927
- Radio Dept.: Alice L. Mooney, time-buyer.
- Radio Accounts: Adam Scheidt Brewing Co. (S); M. A. Bruder and Sons Inc. (S); Foster, Miller and Bierly (S); Fleming & Bates (S).
- Television Accounts: Adam Scheidt Brewing Co. (S).
- EWELL & THURBER ASSOC.**
25 E. Jackson Blvd., Chicago 4
Tel.: Webster 9-0911
- Radio Dept.: A. J. Engelhardt, radio director.
Toledo—520 Madison Ave. Tel.: MAIN 8205
New York—350 5th Ave. Steve Mudge, manager. Longacre 4-1553.
Hollywood 28—6671 Sunset Blvd. Lynn Gordon, manager. Hollywood 4994.

EXPORT ADVERTISING AGENCY
919 N. Michigan Ave., Chicago 11
Tel.: Superior 7-3875

F

TED H. FACTOR AGENCY
1709 W. 8th St., Los Angeles 14
Tel.: Drexel 7187

Radio Dept.: J. M. Janeway, media director; Jere Bayard, Ted H. Factor, Jimmy Fritz, account executives.

FADELL CO.
525 Northwestern Bank Bldg., Minneapolis 2
Tel.: Atlantic 3416

Radio Dept.: Michael J. Fadell, manager; Eben M. Grundy, John E. Gibson Jr., account executives; Arthur H. Leemis, radio director; Patricia Madden, ass't. radio director; John J. Polian, timebuyer.

FRANKLIN FADER CO.
605 Broad St., Newark 2
Tel.: Market 3-7964

Radio Dept.: Sanford C. Reynolds, director of media.

Radio Accounts: Standard Varnish Works (S); Flory Milling Co. (S).
Television Accounts: Metal Textile Corp. (S).

O. K. FAGAN ADVERTISING AGENCY
530 West 6th St., Los Angeles 14
Tel.: Vandike 2192

H. W. FAIRFAX ADV. AGENCY INC.
551 Fifth Ave., New York 17
Tel.: Murray Hill 2-8680

Radio Dept.: Janice Hamilton, media director and copy chief.

FEDERAL ADV. AGENCY INC.
385 Madison Ave., New York 17
Tel.: Murray Hill 8-4200

Radio Dept.: Francis C. Barton Jr., vice president and director of radio and television; George Burbach, assistant; Penelope Simmons, timebuyer; Jacqueline Ruta, assistant; Jules B. Singer, Pat Bartels, copywriter.

Radio Accounts: American Safety Razor Corp. (S); General Cigar Co. (L-S); John F. Trommer Inc. (L-S); Lever Bros. (L-S); Harriet Hubbard Ayer (L-S); Gerber Products Co. (S); Pan-American Coffee Bureau; Doerskin Products Inc.; McCall's Magazine; Stromberg-Carlson.

Television Accounts: American Safety Razor Corp; John F. Trommer.

HARRY FEIGENBAUM ADV. AGENCY
2011 Walnut St., Philadelphia 3
Tel.: Locust 4-1536

Radio Dept.: Erwin Rosner, radio and television director; David Wermen, timebuyer; Meyer A. Cohen, J. Leonard Schoor, Daniel Gurst, account executives.

LEFLER FELDMAN INC.
119 Main St., E., Rochester 4, N. Y.
Tel.: Hamilton 0520

Radio Dept.: Samuel H. Feldman, director; Nancy R. Tobin, account executive.

Radio Accounts: Bravo Macaroni Products (S); Neisner Bros. (S); Hart Food Stores (S); Star Markets (S); Lauer Furniture Co. (S).

FELLOWS-HOGARDUS ADVERTISING
410 Larned Bldg., Syracuse 2
Tel.: 2-2197

Radio Dept.: Byron F. Fellows Jr., timebuyer.

FENSHOLT CO.
360 N. Michigan Ave., Chicago 1
Tel.: Randolph 6-1670

Radio Dept.: A. H. Fensholt, president; Frank Ewing, vice president and account executive and John B. Rodgers, radio director.

COURTLAND D. FERGUSON INC.
National Press Bldg., Washington 4
Tel.: National 7713

Radio Dept.: William R. Groome, radio director; Walter J. Kerwin, television director; George D. McGuinness, radio and television account executive.

Baltimore—525 N. Charles St. Tel.: Vernon 7211. George W. Ross, manager.
Richmond, Va.—Life Insurance Co. of Va. Bldg. Tel.: 7-0788. Frank G. Christian, manager.

Radio Accounts: L. S. Briggs Inc.; James G. Gill Co.; Highland Farms Dairy; High's Ice Cream; Lincoln Warehouse Corp.; Little Tavern Shops; Manbeck Break; Mann's Potato Chips; Schindler Peanut Products; Smith-Douglass Co.; Knox-Crutchfield; Uline Arena; Waynesboro Nurseries; T. W. Wood

& Son; Pin Money Pickles; Smith's Transfer & Storage Co.

Television Accounts: Uline Arena; Solarine Co.; L. S. Briggs; Schindler Peanut Products, and others.

LAWRENCE FERTIG & CO. INC.
149 Madison Ave., New York 16
Tel.: Murray Hill 9-7100

Radio Dept.: Henry Bretzfeld, radio director and timebuyer.

FERWERDA-BOONE INC.
15 E. 40th St., New York 16
Tel.: Murray Hill 6-1964

Radio Dept.: Paul R. Ferwerda, radio director.

ROBERT G. FIELDS & CO.
1100 Warner Bldg., Nashville 3
Tel.: 6-1977

Radio Dept.: W. R. Culbertson, account executive.

JOHN A. FINNERAN INC.
1475 Broadway, New York 18
Tel.: Bryant 9-1290

Radio Dept.: E. Pryde, timebuyer.

FIRESTONE-GOODMAN ADVERTISING AGENCY
445 Loeb Arcade, Minneapolis 2
Tel.: Main 4393

Radio Dept.: Allan L. Firestone, radio director; Archie Goodman and Richard J. Firestone.

FIRST UNITED BROADCASTERS
201 N. Wells, Chicago 6
Tel.: Randolph 6-7800

Radio Dept.: Hugh Rager, managing director; Maryellen Convery, timebuyer.

M. M. FISHER ASSOCIATES
134 N. LaSalle St., Chicago 2
Tel.: Central 6-1610

Radio Dept.: Jack L. Fisher, owner; Helene Heinz, timebuyer for radio and television.

Radio Accounts: United Artists Corp. (S); Universal Pictures (S); Warner Bros. (S); Central Committee of the Democratic Party of Cook County; Shubert Theatres; Bell Savings and Loan Assoc.; Balaban & Katz (S); Eagle-Lion Films (S); Selznick Releasing Org. (S); Essaness Theatres (S); Tam O'Shanter Country Club (S).

Television Accounts: Selznick Releasing Org. (S); Tam O'Shanter Country Club (S).

FITZGERALD ADVERTISING AGENCY
833 Howard Ave., New Orleans 12
Tel.: Tulane 3131

Radio Dept.: Aubrey Williams, radio director; Darrell Brisbin, timebuyer; Thomas Newman, television director.

Radio Accounts: Wesson Oil & Snowdrift Sales Co. (N); H. G. Hill Stores (S); Jackson Brewing Co. (S); Maison Blanche Co. (S); New Orleans Laundries Inc. (S).

Television Accounts: Jackson Brewing Co.; Maison Blanche Co.; H. A. Hill Stores.

FLACK ADVERTISING AGENCY INC.
1110 Hills Bldg., Syracuse 2
Tel.: 2-3129

Radio Dept.: Grover H. Hubbell, William P. Conklin, account executives.

JAMES R. FLANAGAN ADV. AGENCY
505 Fifth Ave., New York 17
Tel.: Murray Hill 2-1048

GEORGE F. FLOREY INC.
135 S. LaSalle St., Chicago 3
Tel.: Dearborn 2-1634

Radio Dept.: Stanton Kramer, radio and television director.
Los Angeles 36-117 N. Robertson Blvd.
Tel.: BR. 2-6488.

C. C. FOGARTY CO.
307 N. Michigan Ave., Chicago 1
Tel.: Randolph 6-7000

Radio Dept.: C. C. Fogarty, Robert E. Potter, John G. Fogarty, partners.

FOLEY ADVERTISING AGENCY
N B C Bldg., Cleveland 14
Tel.: Cherry 1490

Radio Dept.: Robert B. Foley, radio director.

Radio Accounts: I. J. Fox; Grismer Motors Inc.; M. S. Pine Co.

RICHARD A. FOLEY ADV.
1528 Walnut St., Philadelphia 2
Tel.: Kingsley 5-1560

Radio Dept.: James L. Tabor, radio director; Wesley Winning, vice president & media director.

(Continued)

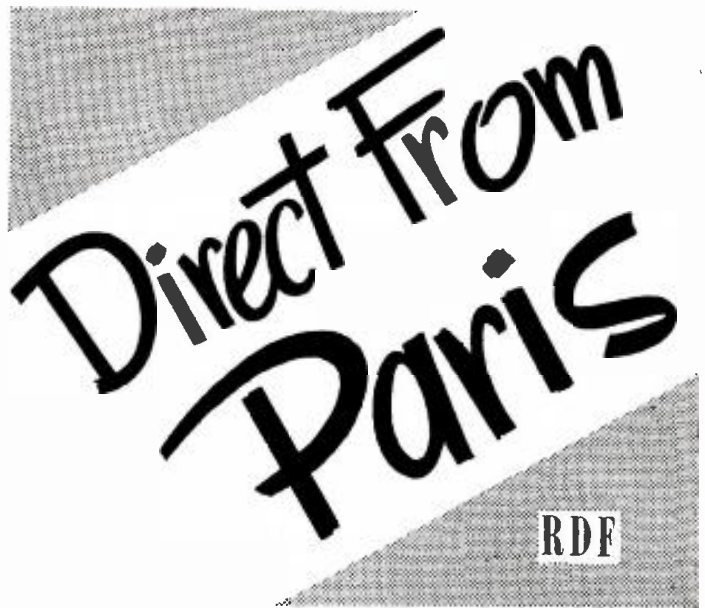

**THE FRENCH BROADCASTING SYSTEM (RDF)
BRINGS YOU FREE OF CHARGE A REGULAR
TRANSCRIBED SERVICE**

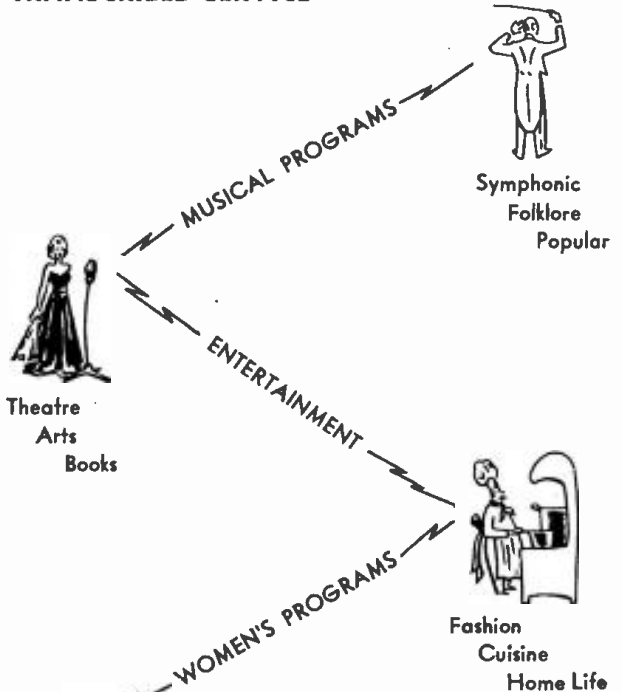

**BY SPECIAL SHORTWAVE FEED
ON-THE-SPOT NEWS • INTERVIEWS • REPORTS**

The French Broadcasting System

PIERRE CRENESSE—Director in North America

934 Fifth Avenue • New York 21, N. Y. • REgent 4-1501

ADVERTISING AGENCIES HANDLING RADIO AND TV ACCOUNTS

(Continued)

N indicates network. S spot

FOOTE, CONE & BELDING
247 Park Ave., New York 17
Tel.: Plaza 5-6600

Radio Dept.: Thomas M. McDonnell, in charge of radio in New York; Lillian Selb, radio business manager; Roger Pryor, television director.
San Francisco 4—235 Montgomery St. Tel.: Sutter 1-2355. Ford Sibley, vice-president and manager.
Los Angeles 13—601 W. Fifth St. Tel.: Michigan 7651. J. H. Scruggs, time-buyer; Eugene Duckwall, business manager; William J. Pringle, executive vice-president and manager.
Hollywood 28—6233 Hollywood Blvd. Tel.: Hollywood 6265. Robert Ballin, vice-president; C. Burt Oliver, general manager.

Chicago 11—919 N. Michigan Ave. Tel.: Superior 7-4800. Richard Davis, radio production manager; Harry F. Dieter, radio business manager; J. Hugh E. Davis, executive vice-president; Genevieve Lemper, time-buyer.

FORCE INC.
7 Church St., Paterson 1, N. J.
Tel.: Lambert 5-2266

FORD & DAMM ADVERTISING AGENCY
918 11th St., Sacramento 14
Tel.: 2-3645

Radio Dept.: Adeline Mork, timebuyer; William Cummings, media director and copy chief.

FOREIGN ADV. & SERVICE BUREAU
342 Madison Ave., New York 17
Tel.: Murray Hill 2-3444

Radio Dept.: Joseph L. Palmer, vice-president.

FORT & CO.
Wilder Bldg., Charlotte 1, N. C.
Tel.: 4-7122

Radio Dept.: Mark I. Moffett, media director.

HERBERT W. FRANK ADVERTISING AGENCY
Park Square Bldg., Boston 16
Tel.: Hancock 6-4463

Radio Dept.: Herbert W. Frank, president and radio director.

ALBERT FRANK-GUENTHER LAW INC.

131 Cedar St., New York 6
Tel.: Cortlandt 7-5060

Radio Dept.: John V. McAdams, radio and television director.

Boston—10 Post Office Square. Tel.: Hancock 6-5900
Chicago—1 LaSalle St. Tel.: Dearborn 2-6424
Philadelphia—Packard Bldg. Tel.: Rittenhouse 6-3915

San Francisco—235 Montgomery St. Tel.: Yukon 6-4641.

Radio Accounts: Chase National Bank. Television Accounts: Camden Trust Co.; Noma Electric Co. (S).

EDWARD I. FRANKEL ASSOCIATES
418 Seventh St., Des Moines 9
Tel.: 3-1854

Radio Dept.: Lois G. Campbell, radio director and account executive.

JONES FRANKEL CO.
180 N. Wabash Ave., Chicago 1
Tel.: Dearborn 2-5745

Radio Dept.: Lew Sanders, radio and television director; Ira L. Morton, Ben Rubin, and J. B. Frankel (President), account executives.

FRANKLIN ADVERTISING AGENCY
34 N. State St., Chicago 2
Tel.: Central 6-1082

Radio Dept.: J. B. Castino, timebuyer.

ROBERT FRANKLIN & ASSOCIATES
2501 Tulare St., Fresno, Calif.
Tel.: 4-6566

Radio Dept.: R. C. Franklin Jr., radio director and timebuyer.

FREDERICK-CLINTON CO.
545 Fifth Ave., New York 17
Tel.: Murray Hill 2-7433

Radio Dept.: Sidney Rubin, radio director and timebuyer.

NEWTON A. FREE CO.
510 S. Spring St., Los Angeles 13
Tel.: Michigan 1195

Radio Dept.: Newton A. Free, owner.

JOHN FREIBERG & CO.
1436 N. Kenmore, Los Angeles 27
Tel.: Normandy 3-2111

Radio Dept.: Edward Loveton, radio and television director, timebuyer.

CURT FREIBERGER & CO. INC.
Cooper Bldg., Denver 2
Tel.: Alpine 2048

Radio Dept.: Virginia Murray, radio director; Curt Freiberger, time-buyer.

Radio Accounts: Brecht Candy Co.; Central Bank & Trust Co.; Securities Credit Corp.; Toner's Inc.; American Beauty Macaroni Co.; Associated Grocers; Burns Realty & Trust Co.; Colorado Potato Flake Co.; Colorado Hospital Service.

FREITAG ADV. AGENCY
988 Spring St., N. W., Atlanta 5
Tel.: Hemlock 1345-6

Radio Dept.: Norman Frankel, radio director, copy chief.

FREMONT ADV. AGENCY
203 N. Wabash Ave., Chicago 2
Tel.: State 2-3188

Radio Dept.: Ad Rovin, vice-president and account executive.

OKLEIGH R. FRENCH & ASSOCIATES
4235 Lindell Blvd., St. Louis 8
Tel.: Newstead 0037

Radio Dept.: A. Maeschler Jr., time-buyer.

FRENCH & PRESTON INC.
1 E. 43rd St., New York 19
Tel.: Murray Hill 7-8550

Radio Dept.: Marcel Ross, timebuyer; Charles R. Tanton, media director; Victor G. Bloede, John C. Conover, Marjorie Dorrance, account executives.

Washington 6, D. C.—1730 I St., N. W. Tel.: Republic 4041. Samuel Bledsoe, manager.

Radio Accounts: Grand Union Co.; Dif. Corp.; Family Circle; Francis I. du Pont & Co.; French Lick Springs Hotel. All spot users.

MORTON FREUND ADV. AGENCY
400 Madison Ave., New York 17
Tel.: Plaza 9-7110

E. M. FREYSTADT ASSOC. INC.
570 Lexington Ave., New York 22
Tel.: Plaza 3-1253

JEAN SCOTT FRICKELTON ADV. AGENCY

1355 Market St., San Francisco 3
Tel.: Hemlock 1-6030

Radio Accounts: Gas Appliance Society of California; Northern California Electrical Bureau (S).

AD FRIED ADVERTISING AGENCY
318 15th St., Oakland 12
Tel.: Higate 4-6580

Radio Dept.: Ad Fried, owner, radio and television director; Ruth Grenman, radio timebuyer and publicity director; Elaine Trigger, program manager; Joseph A. Babando, production manager.

Radio Accounts: Darling Shops (S); Bigelow Films (S); Dr. J. J. Citron Dental Offices (S); Cochran & Celli Chevrolet Dealers (S); Commercial Sales Co. (S); Cochran & Celli Home Appliance Store (S); Coy Hair Curler (S); Crescent Jewelry Co. (S); Davi Miracle Foam (S); Fox West Coast Theatres (Oakland only) (S); Guarantee Furniture Co. (S); 30th & San Pablo Furniture Warehouse (S); Henry de Lugach Real Estate (S); Oakland Lodge #324, Moose (S); General Appliance Co.; Morse Starrett Products Co. (S); Oakland Frame & Axle Co.; Rocil Shoe Co. (S); Rhodes & Jameison Ltd. (S); Swan's Market; Sports Unlimited; Williams Dairy Co. (S); The Quiet Hour; Jim McCann Radio Center; Royal Art Galleries (S); Minit Man Auto Laundries (S); Foster & Louis Insurance (S); Lo Fare Cab Co. (S); Lou Winston Co. (S).

Television Accounts: Davi Miracle Foam; G&W Refrigeration Co. (S); Quality Laundries (S); West Coast Soap Co. (S); POWOW Scouring Cleanser (S); The Quiet Hour; Lo Fare Cab Co. (S).

FRIEDLANDER & MEYER
724 Fifth Ave., New York 19
Tel.: Plaza 7-0925

FRIZZELL ADV. AGENCY INC.
Plymouth Bldg., Minneapolis 2
Tel.: Main 1915

Radio Dept.: F. C. Sigurdson, production manager.

HARRY M. FROST CO. INC.
260 Tremont, Boston 16
Tel.: Liberty 2-0813

Radio Dept.: Karl M. Frost, president; Harvey P. Newcombe, radio director, timebuyer; Sherman Keene, Raymond E. McLaughlin, John D. O'Leary, Edward W. Young, Charles H. Bauer, Edward W. Wood, account executives.

Radio Accounts: Durkee-Mower Inc. (N); Supreme Wine Co. (S); Campbell Fairbanks Exposition (S); Genoa Packing Co. (S); Reliable Flour (S).

FULLER, SMITH & ROSS
71 Vanderbilt Ave., New York 17
Tel.: Murray Hill 6-5600

Radio Dept.: Miss Lee Williams, radio and television director.

Cleveland 15—1501 Euclid Ave. Tel.: Cherry 6700.
Chicago 3—105 W. Adams St. Tel.: ANdover 3-5041. E. J. Lauesen, vice president in charge.

JUSTIN FUNKHOUSER ADV. FUNKHOUSER INDUSTRIES BLDG., RANSON, W. VA. Harry H. Wright, vice president, general manager.

New York—9 E. 45th St. Tel.: Murray Hill 7-2991. Richard P. Jeffrey, timebuyer.

Hagerstown, Md.—901 Pope Ave.

HUNT COMPANY
12 East 41st Street, New York 17
Tel.: Murray Hill 3-8875

Radio Dept.: Tex Weiner, radio director.

FURMAN CO., INC.
41 E. 28th St., New York 16
Tel.: Murray Hill 9-1850

FURMAN, FEINER & CO. INC.
117 W. 46th St., New York 19
Tel.: Plaza 7-6265

Radio Dept.: Norman Furman, president and timebuyer; Irving Gottlieb, V.P.; Nathan Rothenberg, Secy.; Lester Persky, copy chief.

Radio Accounts: International Ladies Garment Workers Union (L-S); Liberal Party (N-S); George Ehlenberger & Co. (N-S); National Hair Net; Plastelectronics Inc. (S); Reimann & Bresse (S).

G

ANDREW GAHAGAN ASSOC. INC.
270 Park Ave., New York 17
Tel.: Plaza 9-2500

Radio Dept.: Andrew Gahagan, president, radio director; Margaret Deady, timebuyer.

JOHN M. GALLAGHER ADVERTISING AGENCY
Monadnock Bldg., San Francisco 5
Tel.: Executive 2-8538

Radio Dept.: John M. Gallagher, radio and television director and time-buyer.

GANO-BACHRODT-EDWARDS INC.
Union National Bank Bldg., Houston 2
Tel.: Charter 4-6083

Chicago 1—75 E. Wacker Drive. Tel.: Franklin 1-4883. J. C. Bachrodt.

GARDNER ADVERTISING CO.
915 Olive St., St. Louis 12
Tel.: Garfield 2915

Radio Dept.: Arthur J. Casey, radio & television director, May Kohler, Asst.; E. A. W. Schulenburg, vice president in charge of media; Champ Humphrey, media director; John C. Naylor, John Hetherington, timebuyers.

New York 20—9 Rockefeller Plaza. Tel.: Columbus 5-2000. Roland Martini, vice president.

Arlington, Va.—2531 Wilson Blvd. Tel.: Chestnut 3214.

Radio Accounts: H. D. Lee Co. (S); Lion Oil Co. (S); Pet Milk Co. (N-S); Ralston Purina Co. (N-S); St. Louis Public Service Co. (S); Union Electric Co. (S); H. C. Cole Milling Co. (S); Grove Laboratories, Inc. (N-S); Barton Mfg. Co. (S); Godfrey Mfg. Co. (S); Old Judge Coffee (S); Stokely-Van Camp Inc. (S); National Guard (S); Cook Chemical Co. (S).

Television Accounts: Pet Milk Co. (N-S); Stokely-Van Camp Inc. (S); Banquet Canning Co. (S); St. Louis Independent Packing Co. (S).

ALVIN GARDNER CO.
67 W. 44th St., New York 18
Tel.: Murray Hill 2-4655

Radio Dept.: Alvin I. Gardner, radio director.

FRED GARDNER CO. INC.
299 Madison Ave., New York 17
Tel.: Murray Hill 7-4626

Radio Dept.: Fred Gardner, president; F. M. Hoagland, media director.

GARFIELD & GUILD ADVERTISING
45 Second St., San Francisco 5
Tel.: Exbrook 2-3420

Radio Dept.: William Morrison, radio and television director; Sidney Garfield, account executive.

Radio Accounts: Chemicals Inc. (S); Kay Jewelers (S); Smith's Men's Store (S); El Dorado Oil Works (S); Charles E. Leukens (Valley Church) (S); S & C Motors (S).

W. W. GARRISON & CO.
400 N. Michigan Ave., Chicago 11
Tel.: Superior 7-8388

Radio Dept.: G. E. Schill, timebuyer.

GATES-BOURGEOIS ADVERTISING AGENCY
3030 Euclid Avenue, Cleveland 15
Tel.: Utah 1-3484

Radio Dept.: Charles W. Heminger, radio director and account executive; Russell W. Bourgeois, Joseph E. Mason, account executives.

Radio Accounts: Neal Storage Co.; Dittman's House of Television; Smayda's Home Bakeries.

HARRY GATTON, ADVERTISING
226 W. Broad St., Statesville, N. C.
Tel.: 5187

Radio Dept.: Harry Gatton.

Radio Accounts: Barger Lumber Co.; Mitchell College; Superior Dairies; Bunch Hatchery; Fraley's Food Stores; Hollingsworth Motors; Sherrill Lumber Co.; Watts Plumbing & Heating, Lulo Toys.

GEARE-MARSTON INC.
21 S. 12th St., Philadelphia 7
Tel.: Locust 4-0530

Radio Dept.: Hal S. Lamb, radio and television director.

New York 17—420 Lexington Ave., Tel.: Lexington 2-0880.

Radio Accounts: Ranger Joe Inc.; Pennsylvania Salt Co.; Western Saving Fund Society of Philadelphia; Strawbridge & Clothier; Icy Point Salmon; A. H. Gueting Co.; Keasbey & Mattison Co.

GEMMER-CULP INC.
208 Strauss Bldg., Ft. Wayne 2, Ind.
Tel.: Anthony 1158

Radio Dept.: Armond Gemmer, president; Louis J. Culp, vice president; Glen Smith, radio director; Guy Harris, account executive.

Radio Accounts: Internat'l Dairy exposition (S); Indiana State Fair (S); Eskay Dairy Co. (S); Coal Heating Service of Allen County (S); Wayne Candies (S); City of Ft. Wayne (S); Bluffton Grocery Co. (S); Frank Schulz Inc. (S).

GENERAL ADVERTISING AGENCY INC.

6518 Selma Ave., Los Angeles 28
Tel.: Hempstead 5129

Radio Dept.: Ralf M. Spangler, president, timebuyer.

JOSEPH R. GERBER CO.
1305 S. W. 12th Ave., Portland 1
Tel.: Broadway 0515

Radio Dept.: Charles H. Devlin, radio director.

GEYER, NEWELL & GANGER INC.
745 Fifth Ave., New York 22
Tel.: Plaza 5-5400

Radio Dept.: F. A. Long, radio and television director; Barbara Fisher, traffic; George Zachary, associate director.

Detroit 32—14250 Plymouth Rd. Tel.: Hogarth 5520. John McQuigg.

Dayton—Third National Bldg. Tel.: Fulton 4145. E. G. Frost, manager.

Radio Accounts: Nash - Kelvinator Corp.; Knox Hats; Continental Oil Co.; P. Lorillard Co.; G. Krueger Brewing Co.; Chicopee Mills.

GIBBONS ADVERTISING AGENCY INC.

Daniel Bldg., Tulsa 3, Okla.
Tel.: 4-2444

Radio Dept.: John B. Gibbons, vice president; Mercedes Freiday, radio director.

Radio and Television Accounts: Tom P. McDermott, Inc.; Stanley's Funeral Service; State Federal Sav-

ings & Loan; National Bank of Tulsa; Thurston Chemical Co.; Hale Halsell Co.; BEM Brand Fertilizer; Hale's Pride Coffee; Oklahoma Osteopathic Hospital.

GIBRALTAR ADVERTISING AGENCY
17 E. 45th St., New York
Tel.: Murray Hill 7-7896

Radio Dept.: Buddy Basch, radio and television director; Carol F. Skydell, timebuyer; Clarence Schmidt, film director; Leo Berman, account executive.

Television Accounts: Bonafide Mills Inc. (N); Genasco Roofing (N).

GILLHAM ADV. AGENCY
220 Continental Bank Bldg., Salt Lake City 1
Tel.: 4-5516

Radio Dept.: Victor V. Bell, radio and television director, account executive, talent & timebuyer; Bob Rohlfing, ass't radio director; Richard V. Thiriot, film technician; Endi Ogaard, secretary.

Radio Accounts: Salt Lake City Chamber of Commerce (S); J. I. Case Co. (S); Cloverleaf Dairy (S); First Federal Savings (S); Fisher Brewing Co. (S); Mountain Fuel Supply Co. (S); Porter-Scarpelli Macaroni Co. (S); Royal Baking Co. (S); Salt Lake Hardware (S); Sego Milk Products Co. (N-S); Sweet Candy Co. (S); Utah Finance (S); Utah Oil Refining Co. (RN-S); Utah Power & Light Co. (RN-S); Ogden First Federal Savings (S); Walker Bank & Trust Co. (S); Western Colorado Power Co. (S); Colville Ice Cream Co. (S); Streater Chevrolet Co. (S); Union Pacific Railroad Co. (RN-S); General Electric Supply Corp. (N-S); Petty Motor Inc. (S); Utah Finance Co. (S); Ford Motor Co. (S); Graybar Electric Co. (N-S); Purity Electric Co. (S); Tracy-Collins Trust Co. (S).

Television Accounts: General Electric Supply Corp.; Petty Motor Inc.; Sego Milk Products Co.; Union Pacific Railroad Co.; Utah Power and Light Co.

BERT S. GITTINS ADVERTISING
739 N. Broadway, Milwaukee 2
Tel.: Daly 8-5948

Radio Dept.: Gerald L. Seaman, radio executive; Robert J. Rice, M. C. Ivey, Bert S. Gittins, account executives.

GLASSER-GAILEY INC.
301 S. Harvard Blvd., Los Angeles 5
Tel.: Dunkirk 4-2141

Radio Dept.: Howard W. Gambrill, director; Jeanne Stemler, timebuyer. San Francisco—79 Post St. Tel.: Exchange 2-6468.

Radio Accounts: Bu-Tay Products Ltd.; Ralph Grocery Co. (S); Bluhill Foods, Inc. (S); Santa Clara Packing Co. (S); MicroTone (S); Pearson Motor; Beckman Furs.

GLEASON ADVERTISING AGENCY
Fisher Bldg., Detroit 2
Tel.: Trinity 3-8181

Radio Dept.: Marjorie Sawyer, radio director & timebuyer.

GLENN ADVERTISING INC.
5450 Harold Way, Hollywood 27
Tel.: Hillside 8379

Fort Worth 2—National Bank Bldg. Tel.: 2-4476.
Dallas 1—1915 Elm St. Tel.: Riverside 6886.

GLEW ADVERTISING AGENCY
Murray Bldg., Grand Rapids 2, Mich.
Tel.: 8-1848

Radio Dept.: Francis K. Glew, owner. Radio Account: Valley City Milling Co. (S).

GODOY & CROSS ADVERTISING AGENCY
Prado 51, Havana, Cuba
Tel.: A-1941

Radio Dept.: Enrique Marrero, radio director; Antonio Herbella, timebuyer.

JACK GOEHRING ADVERTISING
20 W. 43d St., New York 18
Tel.: Chickering 4-7658

H. J. GOLD CO.
123 E. 18th St., New York 3
Tel.: Oregon 3-2550

Radio Dept.: Arthur W. Burten, radio & television timebuyer.

Radio Accounts: Transvision Inc.

MAX GOLDBERG ADV. AGENCY
609 E. & C Bldg., Denver 2
Tel.: Cherry 5533

GOLDE ADVERTISING CO.
31 Union Square, New York 3
Tel.: Orchard 4-7346-7

Radio Dept.: Henry Golde, radio director & timebuyer.

GOLDMAN AND WALTER ADVERTISING AGENCY INC.
36 State St., Albany, N. Y.
Tel.: Albany 5-8864

Radio Dept.: Jack Goldman, timebuyer & account executive.

I. A. GOLDMAN & CO.
7 St. Paul St., Baltimore 2
Tel.: Lexington 7670

Radio Dept.: Phillip Goldman, vice president and radio director.

LEON S. GOLDNICK & ASSOCIATES
1300 N. Calvert St., Baltimore 2
Tel.: Saratoga 4454

Radio Dept.: Bernard Nachlas, timebuyer. New York 18—107 W. 43rd St. Tel.: Lackawanna 4-8429.

GOODKIND, JOICE & MORGAN
919 N. Michigan Ave., Chicago 11
Tel.: Superior 7-6747

Radio Dept.: Wayne G. Williams, radio and television director; Florence Neighbors, media director and timebuyer.

GLENN GORDON, ADVERTISING
610 So. Broadway, Los Angeles 14
Tel.: Richmond 6333

PHIL GORDON AGENCY INC.
309 W. Jackson Blvd., Chicago 6
Tel.: Harrison 7-2103

Radio Dept.: John Gillis, radio director.

JESSE GOROV CO.
666 Lake Shore Drive, Chicago 11
Tel.: Superior 7-4312

Radio Dept.: Jesse Gorov.

GOTHAM ADVERTISING CO.
2 W. 46th St., New York 19
Tel.: Luxemburg 2-2880

Radio Dept.: Hugh Gigante, timebuyer.

THE GOULSTON CO.
35 Court St., Boston
Tel.: Lafayette 5866

Radio Dept.: George N. Merritt, radio director; Kevin R. Cash, William R. Gobson, account executives.

Radio Accounts: John P. Squire; H. L. Handy Co.; Sperry & Barnes Co.; Boston Record-American.

GOURFAIN-COBB ADVERTISING AGENCY
400 N. Michigan Ave., Chicago 11
Tel.: Whitehall 4-5230

Radio Dept.: Louise Adams, media director. Hollywood—6533 Hollywood Blvd.

ROBERT L. GRACEMILL ADVERTISING AGENCY
3235 Curtis, San Diego 6
Tel.: Franklin 5551

Radio Dept.: Robert L. Gracemill, president & timebuyer.

GRADY & WAGNER CO.
1790 Broadway, New York 19
Tel.: Columbus 5-5358

Radio Dept.: George V. Potts, media director; Maureen McMahon, timebuyer.

GRANT ADVERTISING INC.
919 N. Michigan Ave., Chicago 11
Tel.: Superior 7-6500

Radio Dept.: Harry Holcombe, radio and television director; George McGovern, visual media director; Frank Reed, radio media director; W. R. Watson, Howard Jones, R. E. Ellis, C. von Ammon, E. Garvy, account executives.

Hollywood 28—6836 Hollywood Blvd. Tel.: Hollywood 9-5371 Mrs. J. Henderson.

New York—Empire State Bldg. Tel.: Bryant 9-1600. David Echols.

Dallas 1—1313 Gulf States Bldg. Tel.: Riverside 8121. S. W. Hepworth.

Detroit 26—2866 Fenobscot Bldg. Tel.: Cherry 9400. E. R. Grace.

Miami 32—Langford Bldg. Tel.: Miami 3-0773. John A. Dey. (20 International Offices)

Radio Accounts: Cudahy Packing Co. (N-S); Mars Inc. (N); Folger Coffee Co. (S); American Burlington Busines (S); Skillern's Drugs (S); Dallas-Ft. Worth Brewing Corp. (S); Southland Life Ins. Co. (S); Conro Manufacturing Co. (S); Texas Textile Mills (S); Fuchs Baking Co. (S); Florists Telegraph Delivery Association; Hubinger Co. (S); Excell Labs (S); Outside Venetian Blind (S); Texas Bank & Trust Co. (S); Farm Crest Bakeries (S).

Television Accounts: Mars Inc. (N); Burdine's; Unique Art; Skillern's.

J. GRANT CO. INC.
Hotel William Penn, Pittsburgh 19
Tel.: Grant 3331

Radio Dept.: Lionel Poulton, radio production.

PAUL GRANT ADVERTISING
520 N. Michigan Ave., Chicago 11
Tel.: Delaware 7-5671

Radio Dept.: Paul Grant, account exec.; Helen Royn, timebuyer.

WILL GRANT ADVERTISING AGENCY
315 W. 9th St., Los Angeles 15
Tel.: Trinity 1384

D. M. GRATTAN CO.
565 5th Ave., New York 17
Tel.: Plaza 5-5440

Radio Dept.: Violet Grattan, media director.

GRAY & ROGERS
12 S. 12th St., Philadelphia 7
Tel.: Walnut 2-3636

Radio Dept.: Edmund N. Rogers, partner, radio director.

FINLEY H. GREENE ADV. AGENCY
425 Franklin St., Buffalo 2
Tel.: Lincoln 8846

Radio Dept.: Addison F. Busch, radio and television director; R. D. Schnell, radio and television production.

Radio Accounts: Frank Meyers Appliances (S); Loblaw Groceries (N-S); Aiola Macaroni Co. (N-S); Peter Gust Food Prod. (S); Peller's Ale (S); Kalamazoo Stores (S).

GREENFIELD-LIPPMAN ADVERTISING AGENCY
Rand Bldg., Buffalo 3
Tel.: Cleveland 4340

Radio Dept.: Jack Greenfield, Albert Lippman, timebuyers.

MONROE GREENTHAL CO. INC.
445 Park Ave., New York 22
Tel.: Plaza 9-8640

Radio Dept.: Thaddeus Suski, radio director. Universal City, Calif.—Tel.: Stanley 7-1211, Clark Ramsay, manager.

GREGORY & HOUSE INC.
33 Public Square, Cleveland 13
Tel.: Main 7824

Radio Dept.: Bromley House, radio director; Duke Lidyard, TV director; Evelyn Engle, timebuyer; Bromley House, Wm. Nash, Honor Gregory, Duke Lidyard, account executives.

Radio Accounts: Pilsener Brewing Co. (S); Fisher Bros. Co. (S); RKO Theatres; Nash Dealers; Cedar Point (S); Diamond Fertilizer.

Television Accounts: Pilsener Brewing Co.; RKO Theatres; Marshall Drug Stores.

GREY ADVERTISING AGENCY INC.
186 W. 32nd St., New York 1
Tel.: Chickering 4-3900

Radio Dept.: Jack Wyatt, radio and television director; Joseph Bailey, radio and television manager; Phillip Leshem, timebuyer; Barbara Jones, radio and television supervisor; Frank Waldecker, radio producer.

Radio Accounts: Gruen Watch Co.; Disney Inc.; Lee Hats Inc. (N); Ronson Art Metal Works (N).

Television Accounts: Hats Inc. (S); Ronson Art Metal Works Inc. (S).

GRIFFITH ADVERTISING AGENCY
Times Bldg., St. Petersburg 1
Tel.: 7-4311

Radio Dept.: Robert J. Bullard, radio director.

GRIFFITHS & PIERCE
Brooks Building, Scranton, Pa.
Tel.: 2-4147

Radio Dept.: Dave Griffiths, radio director.

H. M. GROSS CO.
221 N. LaSalle St., Chicago 1
Tel.: Dearborn 2-1380

Radio Dept.: Harold Gross, president, account executive; E. Bell, radio director, account executive; Josephine Myanson, copy chief.

JULIAN GROSS ADV. AGENCY INC.
11 Asylum St., Hartford 3
Tel.: 7-7179

Radio Dept.: Erwin B. Needles, Timebuyer, account executive.

STANLEY S. GROSS & ASSOCIATES
Flat Iron Bldg., Norfolk 10, Va.
Tel.: Norfolk 5-8229

Radio Dept.: Stanley S. Gross, radio director & timebuyer.

(Continued)

"VIC" DIEHM says:

Watch

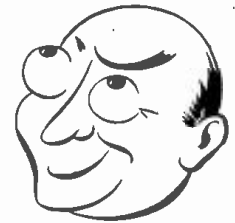

Your

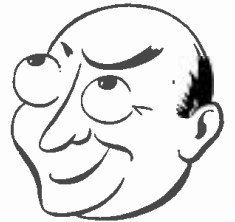

Profits

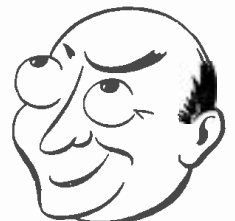

Triple!!

when you air your
Sales Message on

WAZL

HAZLETON, PENNA.

for further Enlightenment
write to Vic Diehm

or

Robert Meeker Associates

521 Fifth Avenue, New York City 17, N.Y.

ADVERTISING AGENCIES HANDLING RADIO AND TV ACCOUNTS

(Continued)

N indicates network, S spot

GRUBB & PETERSEN ADVERTISING
37-39 Main St., Champaign, Ill.
Tel.: 3812

Radio Dept.: Frank L. Strand, radio director; Vivian B. Montgomery, timebuyer.

GUENTHER BRADFORD & CO.
15 E. Huron St., Chicago 11

Tel.: Superior 7-9474
Radio Dept.: Charles J. Zeller Jr., radio director and timebuyer.

GUILD, BASCOM & BONFIGLI
45 Second St., San Francisco

LAWRENCE C. GUMBINNER ADV. AGENCY

9 E. 41st St., New York 17
Tel.: Murray Hill 2-5680
Radio Dept.: Paul Gumbinner, radio director.

GUNN-MEARS ADVERTISING AGENCY

1475 Broadway, New York 18
Tel.: Bryant 9-2900
Radio Dept.: Mel Mohr, radio and television director.

LEONARD GUSSOW-JAMES HYMAN ADV.

200 Madison Ave., New York 16
Tel.: Oregon 9-2345

GUTMAN ADVERTISING CO.

1600 Main St., Wheeling, W. Va.
Tel.: 5110
Radio Dept.: Phyllis Kalany, radio director.

I. R. GWIRTZ ADVERTISING INC.

1650 Broadway, New York 19
Tel.: Circle 6-4933
Radio Dept.: I. R. Gwirtz, timebuyer.

H

WM. J. HACKENBERG ADVERTISING

206 Main St., Wheeling, W. Va.
Tel.: 1289-J
Radio Dept.: Wm. J. Hackenberg.
Radio Accounts: Cooney-Bentz Furniture Co.; Dr. K. A. Rosenberg.

M. H. HACKETT CO.

9 Rockefeller Plaza, New York 20
Tel.: Circle 6-1950
Radio Dept.: Aida Stearns, timebuyer; Helen Gunn, copy chief.

HAEHNLE ADVERTISING

Dixie Terminal Bldg., Cincinnati 2
Tel.: Main 9185
Radio Dept.: Walter F. Haehnle, radio director, timebuyer.

HALPERN ADVERTISING AGENCY

1497 Broadway, New York 18
Tel.: Longacre 5-7167

JOHN L. HALPIN ADVERTISING

208 State St., Schenectady 5, N. Y.
Tel.: 2-0492
Radio Dept.: John L. Halpin, Emily Genels.

Radio Accounts: Chas. Freihofer Baking Co. (S); Jonathan Levi Co. (S).

HAMILTON ADVERTISING AGENCY INC.

221 N. LaSalle St., Chicago 1
Tel.: RAndolph 6-7060

WM. IRVING HAMILTON INC.

287 Fifth Ave., New York 16
Tel.: Murray Hill 5-1737

HAMMER ADVERTISING AGENCY

171 Church St., Hartford 3, Conn.
Tel.: 7-0183
Radio Dept.: M. H. Hammer, Herbert Sherman.

Radio Accounts: Cutt Beverages (S); Berkline Corp. (N).

ROBERT HAMMOND ADVERTISING

56 E. Pine St., Orlando, Fla.
Tel.: Orlando 5640
Radio Dept.: Robert G. Hammond, radio director.

Radio Accounts: Dr. Phillips (S); Phillips Industries (S); Rutland's Men's Store (S); Evans Drug Store (S); First Federal Savings & Loan (S); Orlando Retail Merchants Association (S).

HANLY, HICKS & MONTGOMERY INC.

500 Fifth Ave., New York 18
Tel.: Longacre 5-5000
Radio Dept.: H. E. Lehman, media director.

Chicago—400 W. Madison St. Tel.: FR 2-6440.

HARGREAVES ADVERTISING

519 N. W. Park Ave., Portland 9, Ore.
Tel.: Broadway 6679
Radio Dept.: Bob Hargreaves, timebuyer.

HARRINGTON, WHITNEY & HURST

256 Sutter Street, San Francisco 8, Calif.
Tel.: Ex. 2-6025
Radio Dept.: Jean D. Wherland, media & radio director; Charles Kellogg, account executive.

Los Angeles 36—5816 Wilshire Blvd.
Tel.: Webster 3-5577.

Radio Accounts: E. & J. Gallo Winery; Marlo Packing Corp.; Squirt Co. (S); Western Pacific Railroad Co. (S); Pacific Can Co. (S).

R. T. HARRIS ADVERTISING AGENCY INC.

Walker Bank Bldg., Salt Lake City 1
Tel.: 3-8815
Radio Dept.: Keith Montague, R. T. Harris.

Radio Accounts: Morning Milk Co. (S); Hotel Temple Square (S); Prudential Federal Savings & Loan Assn. (S); Southeast Furniture (S); Fisher Baking Co. (S); Clover Club Foods Co. (S); East Idaho Brewing Co. (S); W. H. Butz Co. (S); Tribune Telegram (S); Hotel Utah (S).

LESTER HARRISON INC.

341 Madison Ave., New York 17
Tel.: Murray Hill 9-1630

RALPH A. HART ADVERTISING

1700 Walnut St., Philadelphia 3
Tel.: Pennypacker 5-0837
Radio Dept.: Ralph A. Hart, radio director & timebuyer; Alvin Schultzeberg, television director and production manager.

HART-CONWAY CO. INC.

45 Exchange St., Rochester 14, N. Y.
Tel.: Locust 3520
Radio Dept.: J. P. Street, radio and television director; H. L. Hart, J. P. Brown, H. E. Kennedy, L. F. Luecher, J. N. Nixon, Ward Phillips, account executives.

GEORGE H. HARTMAN CO.

307 N. Michigan Ave., Chicago 1
Tel.: State 2-0055
Radio Dept.: Thomas Kivlan, radio director; R. Laughlin, J. T. Holloway, Robert Collins, account executives.

Radio Accounts: E. J. Brach & Sons; Chicago Show Printing Co.; Hartz Mountain Products; Kaempfers Bird Foods; Nash-Underwood Inc.; Nelson Bros.; P. A. Starck Piano Co.; Vermont Marble Co.; Goldberg's Clothiers; E. J. Berst Co.; Lanahan Co.; United Biscuit Co. (Lakeside, Manchester and Sawyer Divisions).

L. H. HARTMAN CO. INC.

50 Rockefeller Plaza, New York 20
Tel.: Circle 5-4664

HARVEY-MASSENGAL CO. INC.

Walton Bldg., Atlanta 3, Ga.
Tel.: Walnut 9117
Durham, N. C.—Snow Bldg.

H. W. HAUPTMAN ADV.

19 E. 48th St., New York 17
Tel.: Plaza 9-2284.

HAYS ADVERTISING AGENCY

252 College St., Burlington, Vt.
Tel.: 852
Radio Dept.: Norman H. Myers.
Radio Accounts: Cary Maple Sugar Co. (S).

HEINTZ & CO. INC.

323 W. 8th St., Los Angeles 13
Tel.: Michigan 6052

PAUL LYNN HELLER ADVERTISING AGENCY

930 F St., NW, Washington 4, D. C.
Tel.: National 7638
Radio Dept.: Paul Lynn Heller, Jerome F. Horwitz Jr., radio and television director; M. Justin Baum.

Shaffer Fur Co.; Custom Craft Radio Accounts; Jerome W. Witt; Hollywood Clothing Co.; Metropolitan Haberdashers; Eagle Wine & Liquor; Tri-Vac Vacuum Cleaner; Mt. Vernon Cycle & Sport Shop; Radio; all spot users.

JIM HENDERSON ADVERTISING AGENCY

Woodside Bldg. P. O. Box 725 Greenville, S. C.
Tel.: 3-8381

Radio Dept.: Gladys Bryant, copywriter & timebuyer; Jim Henderson, J. E. Fitzpatrick, account executives.

Radio Accounts: Texize Chemicals Inc. (S); Southern Margarine Co. (S); V. D. Ramseur & Sons (S); Ross Builders Supplies (S); Greenwood Packing Co. (S).

HENING & CO. INC.

1700 Walnut St., Philadelphia 3
Tel.: Kingsley 5-5897
Radio Dept.: E. J. Hening, media director.

HENRI HURST & McDONALD INC.

520 N. Michigan, Chicago 11
Tel.: Superior 7-3000
Radio Dept.: W. E. Jones, radio and TV director; Dorothy Ayres, timebuyer; Dorothy Trapp, traffic manager.

Radio Accounts: Ballard & Ballard Co. Inc. (N-S); Carolene Products Co. (S); John Morrell & Co. (N); Skelly Oil Co. (N); Kroehler Mfg. Co.; Iowa Soap Co.; Coopers Inc.; Field Enterprises Inc.; International Shoe Co.; Perfect Circle Corp.

Television Account—Bell & Howell.

HERALD ADVERTISING AGENCY INC.

441 Lexington Ave., New York 17
Tel.: Murray Hill 7-2280
Radio Dept.: M. J. Middleman, president and radio director.

HERALD ADVERTISING CO. INC.

610 N. Medina St., San Antonio 7
Tel.: Fannin 7095
Radio Dept.: Charlotte F. Buyers, president, timebuyer; Katherine H. Netting, radio director.

LOUIS F. HERMAN ADVERTISING

207 Market St., Newark 2, N. J.
Tel.: Market 2-2608-9
Radio Dept.: Louis F. Herman, timebuyer.

AL HERR ADVERTISING AGENCY INC.

225 E. Michigan St., Milwaukee 2
Tel.: Broadway 2-8040
Radio Dept.: John Rock, timebuyer; Pat Kocian, television director; R. L. Haligas, account executive.

Radio Accounts: Pate Oil Co.; John Graf Co. (S); Union Dye Unique Inc. (S); King Braeger Chevrolet (S).

Television Accounts: Pate Oil Co.; John Graf Co.

HEVENOR ADVERTISING AGENCY INC.

11 North Pearl St., Albany 7, N. Y.
Tel.: 5-1586.

J. M. HICKERSON INC.

110 E. 42nd St., New York 17
Tel.: Murray Hill 6-3513
Radio Dept.: Edward H. Pearson, vice president; W. Kelly Jr., timebuyer and media director.

Washington 6, D. C.—1510 19th St., N.W. Tel.: Columbia 8459.

HICKS & GRIEST INC.

420 Lexington Ave., New York 17
Tel.: Murray Hill 3-9135
Radio Dept.: Peter A. Krug, radio and television director; J. A. Drake, account executive.

Radio Accounts: Lewyt Corp. (S); Home Decorators Inc. (S).

Television Accounts: L. Sonneborn Sons Inc. (S); Lewyt Corp. (S); Dixie Cup Co. (S).

IVAN HILL INC.

900 N. Michigan Ave., Chicago 11
Tel.: Superior 7-3116
Radio Dept.: Elinor Fahrenholz, radio director; Fred E. Willson, account executive; Helen Aiber, timebuyer.

Radio Accounts: The Fair Store; Thomas J. Webb Coffee; Sno-Brite; Hydrox Corp.; Sealtest Ice Cream.

DAVID S. HILLMAN INC.

9130 Sunset Blvd., Los Angeles 46
Tel.: Bradshaw 2-6586

MAURICE LIONEL HIRSCH ADVERTISING CO.

316 N. 8th St., St. Louis 1
Tel.: Central 2389
Radio Dept.: Arthur L. Richman, media director and timebuyer; Ann Vinsonhale, account executive; M. L. Hirsch, account executive.

HIRSHON-GARFIELD INC.

580 Fifth Ave., New York 19
Tel.: Plaza 7-6300
Radio Dept.: Stanley Wolf, radio director.

Boston 16—Park Square Bldg. Tel.: Liberty 2-0485. Herbert Stern, radio director.

HIXSON & JORGENSEN, INC.

600 St. Paul Ave., Los Angeles 14
Tel.: Madison 6-5811
Radio Dept.: H. D. Walsh, V.P. and director of television and radio; Pearl B. Cameron, media director and timebuyer.

Radio Accounts: Richfield Oil Corp. (N); Day-and-Night Div.—Affiliates National Trust & Savings Bank; Local Loan Co. Volt Rubber Corp. (S); Payne Furnace Div.—Affiliated Gas (S); City-

HOEFER, DIETERICH & BROWN, ADV.

303 Sutter St., San Francisco 8
Tel.: Sutter 1-2609
Radio Dept.: Marjorie Kirk, timebuyer; John H. Hoefer, account executive.

HOEL ADV. AGENCY

213 S. Broadway, Los Angeles 12
Tel.: Vandike 2949

DAVID HOFF

31 Exchange St., Lynn, Mass.
Tel.: Lynn 3-6171

HOFFMAN & YORK

Century Building, Milwaukee 3
Tel.: Daly 8-8510
Radio Dept.: Howard L. Peck, radio and television director.

W. F. HOLLAND AGENCY

Hotel Sinton, Cincinnati 2
Tel.: Main 3450
Radio Dept.: Earl L. Holland, radio and television director; William F. Holland, timebuyer.

HOLST & CUMMINGS LTD.

1370 Kapiolani Blvd., Honolulu 14, T.H.
Tel.: 9-5291
Co.'s of Hawaii; Hawaiian Electric; Hawaiian Tuna Packers; Kodak

Radio Dept.: James Wahl, radio director and timebuyer; Catherine Cunningham, assistant.

San Francisco—215 Market St., Lloyd B. Myers, manager.

Hawaii; Theo. H. Davies & Co.; Radio Accounts: Hawaiian Airlines; Hawaiian Sugar Planters; Pineapple ailed Gas Equipment Inc. (S); W. J. Alexander & Baldwin; Inter-Island Steam Navigation; Lewers & Cooke Ltd.; Bank of Hawaii; Muller & Phipps; Canada Dry, Hawaii.

HONIG-COOPER CO.

333 Montgomery St., San Francisco 4
Tel.: Exbrook 2-7004
Radio Dept.: John W. Davis, radio and TV buyer; Louis Honig, television production.

Seattle 1—455 Skinner Bldg. Los Angeles 15—714 W. Olympic Blvd.

Radio Accounts: Holsum Bread; C & H Sugar; Guild Wine; Well Fargo Bank; Hotel Mark Hopkins; Wieland's Beer; Calso Water; Morris Plan; Levi Strauss; Haas Bros.

HOOT ADVERTISING AGENCY

15 E. 40th St., New York 16
Tel.: Murray Hill 6-3714
Radio Dept.: Ronald Dawson, radio and television director; Marianna Lautmann, timebuyer; Don Passante, account executive.

GEORGE C. HOSKIN ASSOCIATES

105 W. Adams St., Chicago 3
Tel.: Randolph 6-2899

HOUCK & CO. ADV.

625 First St., S.W., Roanoke 16, Va.
Tel.: 2-3411
Radio Dept.: Emily Rice, radio director and timebuyer.

Miami 39—Alfred I. duPont Bldg. Tel.: 2-6809. Karl Bishopric, president.

HOUSE & LELAND

Municipal Terminal Bldg., Portland 4, Ore.
Tel.: Broadway 3431

(Continued)

Radio Dept.: Polly Knickerbocker, radio director.

Radio Accounts: Ann Palmer Bakeries; Barnard Motors; Kupp Motor Co.; Triangle Milling Co.; Pacific International; Livestock Exposition; Trailways Buses; Dairy Coop.

LELAND K. HOWE ASSOCIATES INC.

38 West 32nd St., New York 1
Tel.: Longacre 4-2563

Radio Dept.: Joseph R. Horenstein, director of radio and television; Richard M. Heim, ass't; Ed Shapiro, Ralph Parness, account executives.

Radio Accounts: Peerless Pen Co.; Tele King Corp.; Tele King of New Jersey; Deita Brush Mfg. Corp.; Revelation Suitcase Corp.

CHARLES W. HOYT CO. INC.

551 Fifth Ave., New York 17
Tel.: Murray Hill 2-0850

Radio Dept.: William Philip Smith, radio and television director.
Hartford, Conn.—15 Lewis St. Tel.: 5-6066. Frank Whipple, manager.

THE HUBBELL ADV. AGENCY INC.

1900 Euclid Ave., Cleveland 15
Tel.: Cherry 0212

Radio Dept.: Frank Hubbell, time-buyer; Inez Wallace, radio director.

HUFFMAN ADVERTISING COMPANY

Arcade Bldg., St. Louis 1
Tel.: Central 7041

Radio Dept.: Larry Neville, radio director; James V. Huffman, account executive; R. Ratcliffe, timebuyer.

CHRISTY HUMBURG ADVERTISING AGENCY

818 Olive St., St. Louis 1
Tel.: Chestnut 9271

Radio Dept.: Christy Humburg, radio director.

E. ROSS HUMPHREY & ASSOCIATES

330 E. Grand Ave., Chicago 11
Tel.: Whitehall 4-6718

Radio Dept.: E. Ross Humphrey, James Sleenman.

Radio Accounts: Cushman Rug Co. (S); C. A. Boushelle & Son (S); St. Clair Hotel.

Television Account: Sheraton Hotel.

H. B. HUMPHREY CO.

1235 Statler Bldg., Boston 18
Tel.: Liberty 2-4714

Radio Dept.: William H. Eynon, vice president and Sally Larkin, asst. to radio director; Humphrey Ireland, account executive.

New York 19—25 West 45th St. Tel.: Judson 6-2640. William H. Eynon, vice president and radio director; Walton Butterfield, vice president and account executive; Humphrey Ireland, account executive.

Radio Accounts: The Christian Science Pub. Co. (N); First Church of Christ, Scientist (N&S); National Council of the Protestant Episcopal Church (N-S); The Greystone Press (N&S); Harry Collins (S).

Television Accounts: The Greystone Press (S); Idea Inc. (S).

HUMPHREY, PRENTKE & ASSOCIATES INC.

11406 Euclid Ave., Cleveland 6
Tel.: Randolph 4582

Radio Dept.: Ralph B. Humphrey, radio director.

HURLEY ADVERTISING CO.

213-215 Securities Bldg., Des Moines 9, Iowa
Tel.: 4-6289

Radio Dept.: Phyllis Reymen, radio director.

HUTCHINS ADVERTISING CO. INC.

42 East Ave., Rochester 4, N. Y.
Tel.: Hamilton 1160

New York 19—18 W. 46th St. Tel.: Plaza 7-8526.

Philadelphia 40—3701 N. Broad St. Tel.: Baldwin 36200. Max Enelow, vice-president.

Toronto—1244 Dufferin St. Tel.: Kenwood 2737. Walter Engwer, manager.

IDAHO ADVERTISING AGENCY

906½ Jefferson St., Boise, Ida.
Tel.: 2064

Radio Dept.: B. R. Hutton, timebuyer; E. F. Casebeer.

Radio Accounts: Empire Air Lines; Music Center; Thrifty Drug; City Dye Works; Home Federal Savings & Loan Assn. All spot users.

IDEAS ADVERTISING

670 Lexington Ave., New York 22
Tel.: Murray Hill 8-0220

Radio Dept.: A. H. Harris, timebuyer, account executive.

I. F. I. ADVERTISING AGENCY

606 Lonsdale Bldg., Duluth 2, Minn.
Tel.: Radcliff 1549

Radio Dept.: Nancy Gale, media director.
Grand Forks, N. D. Tel.: 211-J. Mick Simmons, manager.

INDUSTRIAL ADVERTISING ASSOCIATES

400 N. Michigan Ave., Chicago 11
Tel.: Delaware 7-7875

Radio Dept.: Milton G. Peterson.
Radio Account: Ar-Ex Cosmetics Inc. (S).

INGALLS-MINITER CO.

137 Newbury St., Boston 16
Tel.: Commonwealth 6-5767

Radio Dept.: Alice Liddell, timebuyer; J. R. Minitter, Robert F. O'Brien, account executives.

INTERNATIONAL ADVERTISERS

153 Guild, Grand Rapids 2, Mich.
Tel.: 7-1146

Radio Dept.: S. Charles De Groot, trustee executive.

INTERNATIONAL ADVERTISING AGENCY

6636 Hollywood Blvd., Hollywood 28
Tel.: Hillside 2748

Radio Dept.: Miro Brunetti, radio director, account executive; Joseph Tricoli, account executive.

NEAL D. IVEY COMPANY

Architects Building, Philadelphia 3
Tel.: Locust 7-7909

Radio Dept.: Stella M. Kilcullen, media buyer.

JACKSON & CO.

49 Worth St., New York 13
Tel.: Worth 4-7005

Radio Dept.: Wallace H. Lancton, radio & TV director; John Yeagain, account executive & copy; James Frankenberg, account executive.

Radio Accounts: Pequot Mills (S); J. W. Valentine Co.; Richard E. Thibaut Inc. (S); Deninger Inc. (S).

Television Accounts: Pequot Mills (S); Berkshire Fine Spinning Assoc. (S); Richard E. Thibaut Inc. (S); Warner Wallpaper Co. (S); Flo-Bar Ltd. (S).

JOSEPH JACOBS JEWISH MARKET ORGANIZATIONS

303 W. 42nd St., New York 18
Tel.: Murray Hill 7-6234

Radio Dept.: Joseph Jacobs, timebuyer.

M. J. JACOBS INC.

303 W. 42nd St., New York 18
Tel.: Columbus 5-4219

Radio Dept.: M. J. Jacobs, media director.

JEFFERSON ADVERTISING AGENCY

Exchange Bldg., LaCrosse, Wis.
Tel.: 856

W. C. JEFFRIES CO.

1720 W. 9th St., Los Angeles 15
Tel.: Dunkirk 2-8271

Radio Dept.: Dolores Werdel, radio director.

Radio Account: Independent Druggists of California (S).

JESSOP ADVERTISING CO.

First National Tower, Akron 8
Tel.: Franklin 2169

Radio Dept.: R. Gilbert, radio director; R. J. Cobak, timebuyer.

JOHNSON, READ & CO. INC.

53 W. Jackson Blvd., Chicago 4
Tel.: Wabash 2-7071

Radio Dept.: M. B. Sutherland, vice president.

JONES & BRAKELY INC.

150 Nassau, New York 7
Tel.: Beekman 3-1912

Radio Dept.: Marie C. Power, time-buyer.

JONES & JONES ADVERTISING AGENCY

Braniff Bldg., Oklahoma City 2
Tel.: 7-3226

Radio Dept.: Henry C. Jones, time-buyer.

Radio Account: Canadian Mills; New State Hatchery (S); Harter Marblecrete (S).

(Continued)

1899—1950

51 Years Publishing

FACTS!

marshalled to do

Your bidding—

Modern business and Sales Management depends for its vigor upon accurately marshalled **FACTS**—conclusive **FACTS**—ready for instant reference.

There are approximately 14,000 complete business data items in the **McKITTRICK DIRECTORY OF ADVERTISERS**—Geographical Section and Classified Section respectively. Items that yield all the essential **FACTS** about National Advertisers—their Products, Trade Names, Executive Personnel, Appropriations, Media, When Lists are made up, Distribution, etc.

Sales problems are always changing and maximum Spot-Sales can be obtained through

* **FACTS** that help increase the time spent with prospects.

* **FACTS** that help make calls more profitable.

* **FACTS** that reveal additional opportunities in the territory.

Why not plan your Sales and Promotional campaigns on the basis of these determinable **FACTS**?

Why not send for further information as to the cost and other essential details concerning this directory and Service?

GEORGE McKITTRICK & COMPANY

108 Fulton Street

New York 7, N. Y.

ADVERTISING AGENCIES HANDLING RADIO AND TV ACCOUNTS

(Continued)

N indicates network, S spot

DANA JONES CO.
756 S. Broadway, Los Angeles 14
Tel.: Tucker 6131
Radio Dept.: R. J. Black, account executive.
Chicago 3—122 S. Michigan Ave. Tel.: Harrison 7-8023

DUANE JONES CO. INC.
570 Lexington Ave., New York 22
Tel.: Plaza 3-4848
(Radio Dept.—11 E. 52nd St. Tel.: Plaza 9-4516)
Radio Dept.: R. Schuebel, radio and television director; Chet Gierlach, radio program director; Vera Brennan, head timebuyer; Jeanne Sullivan, Sally Reynolds, Ann Small, Thelda Cordani, timebuyers; Walter Ware, television director; Joseph Scheideler, Robert Hayes, C. Frederic Bell, Brent Groves, Eugene Hulshizer, Paul Werner, Robert McNell, Philip Brooks, Joseph Beck, George Bruce, Bruce Allen, Donald Gill, account executives.

Radio Accounts: B. T. Babbitt Inc. (N-S); Curtice Bros. Co. (S); Hudson Pulp & Paper Co. (S); Manhattan Soap Co. (N-S); Megowan Educator Food Co. (S); The Mennen Co. (S); C. F. Mueller Co. (S); Pierce's Proprietaries Inc. (S); Wesson Oil &

Snowdrift Sales Co. (S); Whitehall Pharrical Co. (S); Haskins Bros. & Co. (S); International Salt Co. (S); Kilmor & Co. (S); Marlin Firearms Co. (S); Megowan Educator Food Co. (S); Pharmaco Inc. (S); Staze Inc. (S).

THE RALPH H. JONES CO.
Carew Tower, Cincinnati 2
Tel.: Garfield 2300

Radio Dept.: C. M. Robertson Jr., radio director; Kathryn M. Hardig, asst. radio and TV director; Ann Smith, timebuyer; C. M. Robertson Jr., Stanley A. Willer, account executives.
New York—580 Fifth Ave. Tel.: Plaza 7-4600.

Radio Accounts: Bavarian Brewing Co.; Kroger Co.; Miami Margarine Co.; Martin Rosenberger Wall Paper Co.; The Heekin Co.; M. Werk Co.; Ten-B-Low; Dow Drug Co. All spot users.
Television Account: Bavarian Brewing Co. (S).

THE JORDAN CO.
2404 W. 7th St., Los Angeles 5
Tel.: Dunkirk 2248
Radio Dept.: Bob Struble, radio and TV director; Jim Ward, Jack Hood, George Stellman, account executives.

Radio and TV Accounts: Louis Milani Foods; Towne Talk Co.; Pachmayer Gun Works; Cal-Dak Corp.; Westlake Camera Exchange; Archer School of Photography; Kermin Food Prod.; Armstrong Nurseries; Bradson Corp. All spot users.

C. B. JUNEAU INC.
2412 W. 7th St., Los Angeles 5
Tel.: Drexel 1361
Radio Dept.: S. H. Schaffer, radio and marketing director.

K

ROBERT KAHN & ASSOCIATES
430 N. Michigan Ave., Chicago 11
Tel.: Delaware 7-5480

Radio Dept.: Norman F. Hirsch, radio and television director.

Radio Accounts: The Weatherman (S); Niresk Industries (S); Dorothy Filcek Industries (S); Spiegel Inc. (S); Permatized Shoe Co. (S); Edward Sales Co. (S); Specialty Prod. Co. (S); Biltmore Flowers (S).

Television Accounts: Niresk Industries (S); Dorothy Filcek Industries (S); Homer Bros. (S); Bonnie Gay Inc. (S).

KAL, EHRlich & MERRICK ADV. INC.
314 Evening Star Bldg., Washington 4, D. C.
Tel.: Executive 3700

Radio Dept.: Alvin Q. Ehrlich, vice president in charge of radio and television; David Thomas, Larry Dabrow, Fred Harris, Dana Dillon, Christine Pierce, Marilouise Grey-mont, copy writers; R. Entwisle, Alexander L. Charles, William B. Mullett, Ralph Easton, William Roberts, Joseph Weinstein, account executives; Nan Volckman, time-buyer.

Radio Accounts: Akers Oldsmobile Cadillac Co.; Aidan Upholstering Co.; Alber Oldsmobile; Arcade Pontiac; Bamby Bread; Belmont Radio; Brodt's; Call Carl; Capital Fur Shop; Capital Appliance Co.; Capital Jamboree; Caswell Clothes; Cherner Motors; Colony House; Eiseman's; Evening Star; E. Filene; Harrington Hotel; Hill & Tibbetts; A. Kahn Inc.; Long's; Lustine-Nicholson Motors; Major Radio & Appliance; Arthur Markel; Marvin's; Mayflower Hotel; McKee Pontiac; Mitchell Motors; Morton's; Nash-Arlington; New England Raw Bar & Restaurant; New York Jewelry Co.; Ourisman Chevrolet; Perpetual Building Assn.; Randall Motors; Leo Rocca; Roosevelt Hotel; William Rosendorf; Safford-Chandler; Malcolm Skates; Schmid's Pet Shop; Standard Tire & Battery; L. P. Stewart; Stuart Motors; Suburban National Bank; Harold Sugar Radio Mart; Sun Radio; Thompson Bros.; Washington Post.

Television Accounts: Alan Upholstering Co.; Atlas Sport Store; Capital Fur Shop; Cherner Motors; Chevy Chase Ice Palace; Evening Star; Harrington Hotel; Miles Glass Co.; New England Raw Bar & Restaurant; Phillips Radio & TV; Leo Rocca; Rock Creek Ginger Ale; Safford-Chandler; L. P. Stewart; Stuart Motors; Sun Radio; Washington Figure Skating Club; Joseph Zamolski.

SEYMOUR KAMENY ASSOCIATES
118 E. 28th St., New York 16
Tel.: Lexington 2-7478

Radio Dept.: Vernon Delston, radio director.

KANE ADVERTISING
508 North East St., Bloomington, Ill.
Tel.: 7969

Radio Dept.: Arthur P. Kane, president; James W. McNoldy, radio di-

rector; Edmund R. Kane, account executive.

BEN KAPLAN ADVERTISING INC.
57 Eddy St., Providence 3, R. I.
Tel.: Union 1-7878

Radio Dept.: Robert Kaplan, radio and TV director; Ben Kaplan, time-buyer.

THE KAPPS CO.
64 East Lake St., Chicago 1
Tel.: State 2-0460

Radio Dept.: Caplco Kapps, radio & television director; Joseph Kapps, vice president in charge of radio & TV accounts; Albert Kapps, time-buyer; D. Daily, C. Koung, account executives.

JOHN KARCH ADVERTISING AGENCY
280 Broadway, New York 7
Tel.: Barclay 7-1045

Radio Dept.: John George Karch, radio director, timebuyer.

Radio Accounts: Giroux Co.

LEW KASHUK & SON ADV. CO.
Empire State Bldg., New York 1.
Tel.: Longacre 3-7040.

Radio Dept.: Jay E. Kashuk.

Radio Accounts: I. J. Fox Inc.; Morris Square Deal Jeweler, and other accounts.

KASTOR, FARRELL, CHESLEY & CLIFFORD, INC.
274 Madison Ave., New York 16
Tel.: Oregon 9-4440

Radio Dept.: Ted Palmer, radio and television director; Jack Peters, timebuyer.

H. W. KASTOR & SONS ADVERTISING CO.
75 E. Wacker Drive, Chicago 1
Tel.: Central 6-5331

Radio Dept.: James H. West, radio and television director.

Radio Accounts: Procter & Gamble (S); International Milling Co. (S); Union Starch & Ref. Co. (S).

THE JOSEPH KATZ CO.
444 Madison Ave., New York 22
Tel.: Plaza 5-2740

Radio Dept.: N. C. Wildman, vice president in charge; Elizabeth Black, director of media.
Baltimore 2—8 South St. Tel.: Lexington 1500. Robert G. Swan, director of radio.

HENRY J. KAUFMAN & ASSOCIATES
1419 H St., N.W., Washington 5, D. C.
Tel.: District 7400

Radio Dept.: Jeffrey A. Abel, radio and television director; Robert S. Maurer, radio & TV producer; Al Sarra, Clark Brant, R. G. O'Donnell, account executives; Jeffrey A. Abel, timebuyer; Jean McDonald, Jan Dooley, radio writers.

Radio Accounts: Potomac Electric Power Co.; Frank Small Jr. Inc.; Valley Forge Distributing Corp.

Television Accounts: Lacy's Store; Tom's Auto Service; Kassan Stein; Peake Motor Co.; William Hahn Co.; Manhattan Auto & Radio; Charles Schwartz & Son; Valley Forge Distributing Co.; Simon Distributing Co.

KAYTON-SPIERO CO. INC.
230 W. 41st St., New York 18
Tel.: Longacre 5-5090

RAYMOND KEANE ADVERTISING AGENCY INC.
707 S. Broadway, Los Angeles 14
Tel.: Tr. 2915

Radio Dept.: Wes Battersea, radio director; Ethel N. Keane, timebuyer.
Denver 2—1441 Welton St. Tel.: Main 6201. Harold Neumann, manager.

KEELING & CO. INC.
Chamber of Commerce Bldg., Indianapolis 4
Tel.: Riley 1476

Radio Dept.: M. C. Dill, timebuyer; Lawrence T. Sogard, copy director.

THE KEELOR & STITES CO.
Carew Tower, Cincinnati 2
Tel.: Parkway 1310

Radio Dept.: Sue D. Fletcher, radio and television director.

KELLY AND LAMB ADVERTISING AGENCY
85 E. Gay St., Rm. 808, Columbus 15
Tel.: Adams 2261

Radio Dept.: J. V. Williams, radio and TV director; P. A. Kelly, G. J. Lamb, account executives.

KELLY, ZAHNRNDT & KELLY INC.
3529 Franklin Ave., St. Louis 6
Tel.: Jefferson 8337

Radio Dept.: D. C. Chopin, radio director.

KENT ADVERTISING INC.
511 East 72nd St., New York 21
Tel.: Butterfield 8-0900

Radio Dept.: Claude S. Welton, president; Arthur J. Kinsman, time-buyer.

KENYON & ECKHARDT INC.
247 Park Ave., New York 17
Tel.: Plaza 3-0700

Radio Dept.: Wm. A. Chalmers, vice president and radio and TV director; C. G. Alexander, admin. asst.; Garth Montgomery, TV mgr.; T. K. Carpenter, comm. & continuity mgr.; Sylvan Taplinger, prog. & talent buyer; Philip K. Kenney, director of timebuying; Herb Landon, radio publicity director.
Hollywood 28—Equitable Bldg. Tel.: Hillside 8368. R. D. Wolfe, manager.

Radio Accounts: Borden Co. (N-S); Richard Hudnut (N); Kellogg Co. (N); White Rock Corp. (S); Wesson Oil & Snowdrift Sales Co. (N-S); Ford Motor Co. (N); American-Malze Products Co. (S); Swerl-Natl Aniline Div. Allied Chemicals & Dye Corp.; Beech-Nut Packing Co.

Television Accounts: Ford Motor Co.; Lincoln-Mercury Div.; Kellogg Co.; Stetson.

KERMIN-THALL
222 Fourth Ave., New York 3
Tel.: Orchard 4-5500

Radio Dept.: S. I. Altman, account executive and television.

WILLIAM KESTER & CO.
6533 Hollywood Blvd., Hollywood 28
Tel.: Hillside 9251

Radio Dept.: George Stellman, radio director, timebuyer and account executive; Paul Radin, vice president and television director.

Radio Accounts: Tace Co. (S); B-Z-B Honey Co. (S); Yami Yogurt Products, Inc. (S); Perma-Nall Co. (S).

KETCHUM, MacLEOD & GROVE INC.
411 Seventh Avenue, Pittsburgh 19
Tel.: Court 1-5100

Radio Dept.: William Schroeder, radio and television director; Ruth Rowland, assistant radio and television director; W. R. Parker, director of research and merchandising; C. E. Livingston, media director; J. C. Stuart, timebuyer.

Radio Accounts: Hamburg Bros.; The Peoples Natural Gas Co.; Peoples First National Bank and Trust Co.; Natural Gas Companies; East Ohio Gas Co.; Chevrolet Dealers; Calsion Inc.; Thorfare Mkts. All spot users.

FRANK KIERNAN & CO.
55 Liberty Street, New York 5
Tel.: Corlandt 7-3148

Radio Dept.: Samuel D. Mallin, general manager.

KIESEWETTER, WETTERAU & BAKER INC.
9 E. 40th St., New York 16
Tel.: Lexington 2-0025

KILROY ADVERTISING INC.
Paul Brown Bldg., St. Louis 1
Tel.: Plateau 3728

Radio Dept.: LeRoy F. Dinges, time-buyer.

ABBOTT KIMBALL CO. INC.
250 Park Ave., New York 17
Tel.: Plaza 3-9600

Radio Dept.: Abbott Kimball, president; Harry Muller, vice president; Miriam Traeger, timebuyer.
Chicago 1—333 N. Michigan Ave. Tel.: Franklin 0673.

Kansas City, Mo.—1004 Baltimore. Tel.: Victor 1950. David Mindlin.

Los Angeles 5—4015 Wilshire Blvd. Tel.: Drexel 7305.

San Francisco 4—155 Sansome St. Tel.: Exbrook 5188.

Radio Account: Family Laundry Owners Assoc. (S).

Television Accounts: Norcross Inc.; Artra Cosmetics Inc.; Lamp! Fashions; Jackson Furniture Co. All spot users.

WILLIAM H. KINSALL & CO.
101 W. Monroe St., Bloomington, Ill.
Tel.: 7606

Radio Dept.: Ann Liggett, radio director.

RATINGS ★

TELL THE STORY

IN

LUFKIN, TEXAS

K T R E

MORNING	AFTERNOON	NIGHT
50.4	63.6	59.4

THAT'S WHAT THE

only

NETWORK AFFILIATE

IN THIS SECTION OF

EAST TEXAS HAS

TO OFFER!

1,000 WATTS — 1420 KC

MUTUAL—LIBERTY—LONE STAR CHAIN

RICHMAN LEWIN,
General Manager

★ Conlan, Fall 1949

ALBERT KIRCHER CO.
1001 W. Washington Blvd., Chicago 7
Tel.: Chesapeake 3-2800
Radio Dept.: E. Jette, media director.

KIRCHER, HELTON & COLLETT INC.
Hulman Bldg., Dayton 2
Tel.: Fulton 5181
Radio Dept.: Charles E. Gay, radio and television director; Ralph Kirchner, Watson Metcalfe, Norman Van Zant, account executives.

Radio Accounts: Gem City Bldg. & Loan Assn. (S); August Wagner Breweries Inc. (S); Fredericks-Helton Travel Service (S); Wingwax Corp. (S); Automotive Gear Works (S).

PHILIP KLEIN ADVERTISING
1928 Spruce St., Philadelphia 3
Tel.: Rittenhouse 6-5200
Radio Dept.: Edward Felbin, radio and television director, timebuyer.

KLEPPNER CO.
551 Fifth Ave., New York 17
Tel.: Murray Hill 2-0730
Radio Dept.: Leon Balsam, partner, media director.

H. M. KLINGENSMITH CO.
Commercial Bldg., Canton 2, Ohio
Tel.: 4-5115
Radio Dept.: E. J. Kopf, media director.

KLINGER ADVERTISING CORP.
119 W. 57th St., New York 19
Tel.: Circle 6-3680
Radio Dept.: Atwood A. Klinger, president, radio director.

MARTIN R. KLITTEN, INC.
2614 West 9th St., Los Angeles 6
Tel.: Drexel 8396
Radio Dept.: Martin R. Klitten, president, television director.

KNAPP-SHEPARD INC.
480 Lexington Ave., New York 17
Tel.: Eldorado 5-4122

KNOLLIN ADVERTISING AGENCY
105 Montgomery St., San Francisco 4
Tel.: Sutter 1-6110
Radio Dept.: J. C. Knollin, president and general manager; Robert H. Knollin, asst. general manager.
Radio Accounts: Grand National Live-stock Exposition (S); Mannings Inc. (S).

M. R. KOPMEYER CO. ADV. AGENCY
Realty Bldg., Louisville 2
Tel.: Wabash 3357
Radio Dept.: W. A. Freeman, vice president.

KORETZ, IDEAS & CO., INC.
899 Broad St., Newark 2
Tel.: Mitchell 2-4492
Radio Dept.: E. Goldwasser.

ROBERT KOTTWITZ ADVERTISING INC.
Audubon Bldg., New Orleans 16
Tel.: Canal 8158

KRONSTADT ADVERTISING AGENCY
711 14th St. N.W., Washington 5
Tel.: Republic 0272
Radio Dept.: Esther Kravitz, radio director, timebuyer.
Radio Accounts: E. Burk Jewelers; Colonial Pianos; Corrado's Furniture; Felsler-Scott Shoes; Gabriels; Haber & Co.; Latt's Tiebar; Mazor Masterpieces; Miller's Furs; National Institute of Commerce & Technology; Wardell; Robert Winston Candies.
Television Accounts: E. Burk Jewelers; Felsler-Scott Shoes; Latt's Tiebar; Mazor Masterpieces.

JULIAN A. KRUPNICK CO.
1089 E. Broad St., Columbus 5, O.
Tel.: Fairfax 8862
Radio Dept.: Julian Krupnick, president, timebuyer; Stuart M. Krupnick, account executive.

KUDNER AGENCY INC.
630 Fifth Ave., New York 20
Tel.: Circle 6-3200
Radio Dept.: Myron P. Kirk, executive head of radio and television; Carlos Franco, business manager; William Templeton, production manager; Mary V. King, timebuyer; Edmund Cashman, radio director.
Los Angeles 15—315 W. 9th St. Tel.: Vandyke 0196.
Detroit 2 Mich.—710 New Center Bldg. Tel.: Madison 5315.
San Francisco 5—681 Market St. Tel.: Garfield 1-5433.
Washington, D. C.—Albee Bldg. Tel.: National 5506. Frank Getty.

R. L. KULZICK INC.
409 E. Washington Ave., Madison 3.
Wis.
Tel.: 7-2295
Radio Dept.: Eddie Peabody, radio director; R. L. Kulzick; R. Kulzick; M. Thornell.

J. R. KUPSICK ADVERTISING
122 E. 42nd St., New York 17
Tel.: Murray Hill 5-9145
Radio Dept.: J. R. Kupsick, president and account executive; Saul Kämpf, vice president and account executive.

KUTTNER & KUTTNER
646 N. Michigan Ave., Chicago 11
Tel.: Superior 7-7940
Radio Dept.: L. G. Kurtze, radio director; Stanley Kuttner, account executive.

THOMAS J. LA BRUM & ASSOCIATES
1315 Walnut St., Philadelphia 7
Tel.: Kingsley 5-1816
Radio Dept.: Joseph P. McLoughlin and Nancy Lawrence.

LAKE-SPIRO-SHURMAN INC.
Radio Center Bldg., Main & Union Sts., Memphis 3
Tel.: 5-1571
Radio and Television Depts.: Hugh Murphy, manager; Mrs. Lucille Simmons, timebuyer.

LAMB & KEEN INC.
1616 Walnut St., Philadelphia 3
Tel.: Pennypacker 5-9650
Radio Dept.: Roy T. Lochten, media director.

LAMBERT & FEASLEY INC.
9 Rockefeller Plaza, New York 20
Tel.: Columbus 5-3721
Radio Dept.: Frank W. Mace, vice-president and general manager; Joseph Burland, media director; Ray H. Kremer, radio director.

LAMPORF, FOX, PRELL & DOLK INC.
J.M.S. Bldg., South Bend 5
Tel.: 2-2161
Radio Dept.: C. F. Prell, vice president and radio director.

A. B. LANDAU ADV. AGENCY
150 Broadway, New York 7.
Tel.: Rector 6685.
Radio Dept.: Paul Berkowitz, radio director; Herman Youngleib, president, timebuyer.

LANG, FISHER & STASHOWER, INC.
1010 Euclid Ave., Cleveland 15
Tel.: Main 6579
Radio Dept.: Alvin B. Fisher, vice-president in charge of radio; Mary Jayne Haring, Robert A. Goldberger, assistants.
Radio and Television Accounts: Babe-Tenda Corp.; Dowd-Feder Inc.; Yellow Cab; Burrows; Lane Drug Co.; Miller-Becker; World Pub. Co.; Bing Furniture; C.C.D. Inc.; General Electric; Hobby House Inc.; Olrich Motors; Ostendorf-Morris Co.; Republic Pictures; Sears, Roebuck & Co.; Strong, Carlisle & Hammond Co. (Philco).

LANNAN & SANDERS INC.
Fidelity Bldg., Dallas 2, Texas
Tel.: Prospect 7-1583
Radio Dept.: George S. Lannan, J. M. Sanders, account executives; Robert E. Stuart, radio director; Monte Hurst, copy chief.
Los Angeles—1127 Wilshire Blvd. I. E. Gilbert, account executive.
Wichita—P. O. 730. C. E. Palmer, account executive.
Radio Accounts: Arkansas Motor Coach; Beaumont-Port Arthur Bus-lines; Dixie Chrome Prod. Inc.; Doctor Boiler Inc.; Capital Trailways; Central Bus Depot; Continental Central; Continental Pacific; Continental Rocky Mountain; Continental Southern; Trailways Bus Terminal; Continental Western; Moran Co.; Panhandle Trailways; Queen City Trailways; Santa Fe Transportation; Southern Trailways; Transcontinental; Southern Trailways of Georgia; Union Bus Lines.

C. J. LaROCHE & CO.
247 Park Ave., New York 17
Tel.: Plaza 5-7711
Radio Dept.: William R. Stuhler, vice-president in charge of radio and

television; Sally Mansfield, media director.
Chicago—141 W. Jackson Blvd. Tel.: Harrison 7-8612. John F. Price, vice-president.

LLOYD LARSON & ASSOC. INC.
53 W. Jackson Blvd., Chicago 4
Tel.: Harrison 7-7127
Radio Dept.: Lloyd Larson, president.

LAUESEN & SALOMON
520 N. Michigan Ave., Chicago 1
Tel.: Superior 7-0738
Radio Dept.: Wendell Walker, account executive.

LAVENSON BUREAU OF ADVERTISING
12 S. 12th St., Philadelphia 7
Tel.: Market 7-6767
Radio Dept.: Jerrie C. Rosenberg, radio director and account executive.

LAWRENCE ADVERTISING AGENCY
203 North Wabash, Chicago, Ill.
Tel.: Dearborn 2-2841.
Radio Dept.: Clayton W. Bergman, partner, television director and timebuyer.

CARL LAWSON CO. ADVERTISING
4722 Broadway, Kansas City 2
Tel.: Jefferson 5155

LAYNE, LEENE & GREENE
225 W. 34th St., New York 1
Tel.: Chickering 4-3138
Radio Dept.: H. Donald Lavine, radio and television director.
Radio Accounts: Joseph Furniture Co. (S); Ida Kay Inc. (S).
Television Account: Till's Fruit Cake (S).

HARRY J. LAZARUS & CO.
430 N. Michigan Ave., Chicago 11
Tel.: Superior 7-3933
Radio Dept.: Eddie Borgan, radio-TV director.
Radio Accounts: Central Nat'l Bank (S); Beer Shampoo Inc. (S).
Television Accounts: Hudson on Broadway (S); Kool Vent in Chicago (S).

LEE-MURRAY ADVERTISING
71 West 45th Street, New York
Tel.: Luxemburg 2-3838
Radio Dept.: Leo Steinfeld, account executive.

AL PAUL LEFTON CO. INC.
1617 Pennsylvania Ave., Philadelphia 3
Tel.: Rittenhouse 6-1500
New York 17—521 Fifth Ave. Tel.: Vanderbilt 6-4340. E. S. Friendly, radio director.
Chicago 11—435 N. Michigan Ave. Tel.: Superior 7-9511.

HART LEHMAN ADVERTISING
118 E. 28th St., New York 16
Tel.: Murray Hill 6-9458

SIDNEY K. LENBY ADVERTISING
168 N. Michigan Ave., Chicago 1
Tel.: Andover 3-7477
Radio Dept.: Arthur A. Kohn, radio director and timebuyer; A. D. Lowenthal, Sidney K. Lenby, account executives.

LENNEN & MITCHELL
17 E. 45th St., New York 17
Tel.: Murray Hill 2-9170
Radio Dept.: Frank Daniel, radio time-buyer; Sidney T. Hertz, assistant; Nicholas Keesely, V.P. in charge of radio & television; H. Lawrence Holcomb, assistant.
Beverly Hills, Calif.—308 N. Rodeo Dr. Tel.: Crestview 1-7221. Ben Potts.
Radio Accounts: P. Lorillard Co.; Tide Water Assn. Oil Co. (S).
Television Accounts: Colgate-Palmolive-Peet; Lehn & Fink Inc. (S).

S. R. LEON CO.
1 Madison Ave., New York 10
Tel.: Murray Hill 9-4455
H. B. LeQUATTE INC.
200 Madison Ave., New York 16
Tel.: Murray Hill 3-5570
Radio Dept.: H. B. LeQuatte, president.
(Continued)

WROY 1460

CARMI, ILLINOIS

—SERVING—

THE RICH TRI-STATE

1000 WATTS

AREA OF THE WABASH AND
OHIO RIVER VALLEYS

CONLAN SAYS 54.4

Average for all periods in CARMi DISTRICT

including 4 TOWNS in 2 COUNTIES

Survey made August 21 through September 3, 1949

TOTAL PRIMARY POPULATION.....368,696

ANNUAL RETAIL SALES.....\$289,248,818

IN 1948 WHITE COUNTY ALONE PRODUCED:

OIL worth \$25,000,000

CORN worth 5,000,000

WHEAT worth 1,500,000

SOYBEANS worth 900,000

Over 2,200 Oil Wells in White County produce Petroleum

Worth: \$ 70,000 per day

\$ 490,000 per week

\$25,000,000 per year

GET YOUR SHARE—"BUY WROYSLY"



ADVERTISING AGENCIES HANDLING RADIO AND TV ACCOUNTS

(Continued)

N indicates network, S spot

LeVALLY INC.
360 N. Michigan Ave., Chicago 1
Tel.: State 2-1202
Radio Dept.: James G. Cominos, vice-president, radio and television director; Mildred Dudley, timebuyer.

LEVY ADVERTISING AGENCY
850 Broad St., Newark 2
Tel.: Mi. 2-0433
Radio Dept.: Hyman R. Levy, president and timebuyer; David Howard, radio director, copy chief.

TED LEVY ADVERTISING AGENCY
515 Insurance Bldg., Denver 2
Tel.: Main 7133
Radio Dept.: Ted Levy, president and timebuyer; Kathleen Friend, radio director.

LEWIS ADVERTISING AGENCY
339 Main St., Worcester 8, Mass.
Tel.: Worcester 3-1718
Radio Dept.: Robert W. Blumenthal, radio director, account executive, timebuyer; E. B. Rickles, account executive.

Radio Accounts: Eastern Oil Co.; Kranch Jewelry Co. (S); World Pants Co. (S); Kin-Berg Inc. (S); Food Advertisers Inc. (S); M. H. Laipson Co.; Narcus Bros. Inc.; Brown's Laundry.

ADDISON LEWIS & ASSOCIATES
2310 Stevens, Minneapolis 4
Tel.: Atlantic 6235
Radio Dept.: W. A. Grove, radio and TV director; Nina Irey, radio timebuyer.

LEWIS & GILMAN INC.
1528 Walnut St., Philadelphia 2
Tel.: Pennypacker 5-9900
Radio Dept.: Graham S. Mason, radio and television director.

LEY & LIVINGSTON
260 California St., San Francisco 11
Tel.: Yukon 6-4478
Radio Dept.: Robert J. Livingston, radio director.

LILLER, NEAL & BATTLE AGENCY
Walton Bldg., Atlanta 3
Tel.: Cypress 6521
Radio Dept.: C. K. Liller, W. W. Neal, John K. Ottley, Howard Axelburg, Al Sharp, account executives; Sarah Williams, timebuyer.

Radio Accounts: Brock Candy Co. (S); H. W. Lay & Co. (S); Colonial Stores Co. (S); Southern Radio Commission (N); Southern Baptist Convention; Gold Shield Laundries (S).

Television Accounts: Brock Candy Co.; H. W. Lay Co.

LINDEKE ADV.
302 S. Brand Blvd., Glendale 4.
Tel.: Chapman 5-3613
Beverly Hills—Tel.: CR 5-7907.

LINDSAY ADVERTISING AGENCY
95 Crown St., New Haven 10, Conn.
Tel.: 5-2142
Radio Dept.: Francis B. Schipper, vice president, radio and television director.

LINDSAY & CO. INC.
10 N. Fourth St., Richmond 19
Tel.: 7-3065
Radio Dept.: W. Leroy Hoerter, vice president, radio director; Arthur C. Beck Jr., timebuyer.

LITTLE & CO.
3757 Wilshire Blvd., Los Angeles 5
Tel.: Exposition 1267
Radio Dept.: Gayb Little, owner and radio director.

ROSS LEWELLYN INC.
209 S. LaSalle St., Chicago
Tel.: STate 2-4366
Radio Dept.: Tom J. Montgomery, vice president and radio director.

LLOYD, CHESTER & DILLINGHAM INC.
9 Rockefeller Plaza, New York 20
Tel.: Circle 5-8800
Radio Dept.: John J. Hagan, timebuyer.
Radio Accounts: Sonotone Corp. (S).
Television Account: Sonotone Corp. (S).

LOCKWOOD-SHACKLEFORD ADV. AGENCY
2001 Beverly Blvd., Los Angeles 4.
Tel.: Dunkirk 8-3121
Radio Dept.: Lou Holzer, radio director; Robert Purcell, John Sparling, account executives.
New York 17—420 Madison Ave. Tel.: Plaza 3-5412. R. T. O'Connell.
Chicago 4—57 E. Jackson Blvd. Tel.: Harrison 7-0665. Scott Robertson, vice president.
San Francisco 4—Russ Bldg. Tel.: Yukon 6-5030.

LOEWY ADVERTISING AGENCY
41 Park Row, New York 7
Tel.: Worth 2-3773
Radio Dept.: Henry H. Loewy, vice-president.

HENRY A. LOUDON ADVERTISING INC.
Statler Office Bldg., Boston 16
Tel.: Hubbard 2-2950
Radio Dept.: Henry A. Loudon, president.

T. ROBLEY LOUITT INC.
58 Weybosset St., Providence 3
Tel.: Jackson 1-5858
Radio Dept.: Robert K. Rockwell, radio and TV director.
Radio Accounts: Buckley & Scott (S); Swiss Cleansing Co. (S); What Cheer Laundry (S); Gibsons Inc. (S); Academy Tailors (S); Allen Airways (S); Providence Inst. for Savings.

LOWE & HALL ADVERTISING
News Bldg., Greenville, S. C.
Tel.: 2-7242
Radio Dept.: Elliott H. Hall Jr., radio director and timebuyer.

LOWE RUNKLE CO.
First National Bldg., Oklahoma City 2
Tel.: 3-5439
Radio Dept.: Howard Neumann, radio and television director; Lowe Runkle, timebuyer and account executive; Harold Kranz, Howard Neumann, account executives.

LUCERNA CO. INC.
17 E. 45th St., New York 19
Tel.: Murray Hill 2-7267
Radio Dept.: Emanuel Goldman, president, radio director.

EARLE LUDGIN & CO.
121 W. Wacker Drive, Chicago 1
Tel.: ANdover 3-1888
Radio Dept.: Vincent R. Bliss, radio director; Jane Daly, timebuyer.

ROBERT LURIE INC.
722 Chestnut St., St. Louis 1
Tel.: Chestnut 8425
Radio Dept.: Leota Keir, radio director and account executive.

LYNN-FIELDHOUSE
15 S. Franklin St., Wilkes-Barre, Pa.
Tel.: 2-7182
Radio Dept.: W. B. Pritchard, radio director and timebuyer.
New York 17—51 E. 42nd St. Tel.: Murray Hill 2-4048.

Radio Accounts: Wise Potato Chips Co.; Carr-Consolidated Biscuit Co.; Planters Nut & Chocolate Co.; Planters Edible Oil Co. All spot users.

THE LYON AGENCY
293 8th St., San Francisco 3
Tel.: Market 1-2620
Radio Dept.: Dwight Lyon.

S. DUANE LYON INC.
9 Rockefeller Plaza, New York 20
Tel.: Circle 5-8181
Radio Dept.: S. Duane Lyon, president; Chester Radven, vice-president.

W. D. LYON CO.
303 2nd Ave., S.E., Cedar Rapids, Ia.
Tel.: 5139

Radio Dept.: Robert H. Schubert, radio and television director; Robert B. Creswell, account supervisor; Frank N. Phelps, account executive.
Radio Accounts: Tendersweet Sales Co. (S); Colonial Baking (S); Eupane Gas (S); Chick Bed (S); Barron Motor Supply Co. (S); Gordon Hatchery (S); Crescent Electric (S); General Electric Supply (S); Rapids Chevrolet (S).

M

MACAULEY CO. INC.
1121 S. Hill St., Los Angeles 15
Tel.: Prospect 6287
Radio Dept.: J. S. Macauley, president; Norman J. Boroughs, timebuyer.

MacDONALD-COOK COMPANY
Sherland Bldg., South Bend 9, Ind.
Tel.: 3-8244
Chicago—360 N. Michigan Ave. Tel.: Andover 3-1224.
Los Angeles 14—1052 W. 6th St., Professional Bldg. Tel.: Madison 6-3194.

W. W. MacGRUDER INC.
1666 California, Denver 2
Tel.: Alpine 1478
Radio Dept.: Joseph W. Palmer, radio director; W. W. MacGruder, George Bakewell, Louise Hewlett, J. M. McGrane, account executives.

Radio Accounts: Adolph Coors Co.; Citizens Savings Bank; Fairmont Cem. Assn.; Town Talk Baking Co.; Empire Savings (S); Silver State Savings (S).

W. B. MacKENNEY & BERT SHONTZ INC.
Commercial Trust Bldg., Philadelphia 2
Tel.: Lo 4472
Radio Dept.: Gloria Lorch, radio director; Bert Shontz, vice president & timebuyer.

MacKENZIE INC.
431 Clifton Ave., Minneapolis 3
Tel.: Bridgeport 7661

MacLAUGHLIN ADVERTISING AGENCY
601 Ellicott Sq. Bldg., Buffalo 3
Tel.: Mohawk 5703
Radio Dept.: Frederick R. MacLaughlin, radio director; Wm. H. Hughes, account executive; Jane Hart, timebuyer.

Radio Accounts: Arthur Ball Inc. (S); Perry Ice Cream Co.; Kreher's Poultry Breeding Farm.

MacMANUS, JOHN & ADAMS
Fisher Bldg., Detroit 2
Tel.: Trinity 2-8300
Radio Dept.: Elmer W. Froehlich, media director; Martha Ude, timebuyer.
Baltimore 18—Federal Land Bank Bldg. Tel.: Tuxedo 0357

MacWILKINS, COLE & WEBER
Corbett Bldg., Portland 4
Tel.: Broadway 6401
Seattle 1—Republic Bldg. Tel.: Elliott 7377.

MADISON ADVERTISING CO.
400 Madison Ave., New York 17
Tel.: Plaza 9-3200
Radio Dept.: David R. Gibson, radio and television director; Dorothy A. Wollheim, timebuyer.
Radio Account: Adam Hat Stores (S).

MAHOOL ADVERTISING INC.
12 E. Lexington St., Baltimore 2
Tel.: Plaza 3617
Radio Dept.: Frank Katz, radio director & timebuyer.

MALCOLM-HOWARD ADVERTISING
203 N. Wabash, Chicago 1
Tel.: Randolph 6-7942
Radio Dept.: A. M. Holland, owner, timebuyer; Norman Lindquist, television director.

W. H. MALE LTD.
320 Ward Ave., Honolulu 13
Tel.: 53981

DAVID MALKIEL ADVERTISING AGENCY
260 Tremont St., Boston 16
Tel.: Liberty 2-1421
Radio Dept.: Julian Malkiel, chief timebuyer.
Radio Accounts: Serta Mattresses (S); Steubens Restaurants (S); Royal Crown Cola (S); D. Monsson & Son (S); Kasanof Bakeries (S); West Peabody Speedway (S).

LLOYD MANSFIELD CO.
110 Pearl St., Buffalo 2
Tel.: Washington 2762
Radio Dept.: Lloyd Mansfield, president, timebuyer.

MANSON-GOLD-MILLER ADV. AGENCY
1004 Marquette Ave., Minneapolis 2
Tel.: Geneva 9619
Radio Dept.: Robert P. Miller, vice president, radio director and timebuyer.

LOISE MARK & ASSOC.
808 N. Third St., Milwaukee 3, Wis.
Tel.: Marquette 8-8344
Radio Dept.: Edith Hennig, television director; Esther Hotton, radio director; Milton Beckman, account executive; Carl Wille, production.

Chicago—1253 N. LaSalle St. Tel.: Mohawk 4-4428. Ilean L. Rabens, radio director.
Radio Accounts: Hotel Wisconsin; Block Daneman (S); Air Way Sanitizer (S).

Television Accounts: Boston Store; Fabric Shops; Samsons.

MARK, MAUTNER & BERMAN
808 N. Third St., Milwaukee 3
Tel.: Broadway 2-8385
Radio Dept.: Jerome H. Berman, timebuyer; A. Marcus, radio director.

MARKETERS INC.
3142 Wilshire Blvd., Los Angeles 5
Tel.: Drexel 5303
Radio Dept.: H. J. Carter, media director.

MARSCHALK & PRATT CO.
535 Fifth Ave., New York 17
Tel.: Vanderbilt 6-2022

Radio Dept.: Curt A. Peterson, radio director; E. J. Whitehead, television director; Herbert Gesregan, timebuyer.
Radio Account: Esso Standard Oil Co. Television Account: Esso Standard Oil.

TERRILL BELKNAP MARSH ASSOCIATES
480 Lexington Ave., New York 17
Tel.: Eldorado 5-4570
Radio Dept.: T. B. Marsh, radio director.

HAROLD MARSHALL ADVERTISING CO.
565 Fifth Ave., New York 17
Tel.: Plaza 3-0404
Radio Dept.: Harold Marshall, radio and television director.

★

Greatest Buy

in the

Rich Wabash Valley

WTHI

TERRE HAUTE
(CBS)

AM and FM
1480 kc 100 watts

Represented by
The Bolling Co., Inc.

★

HARWOOD MARTIN ADVERTISING AGENCY
 Colorado Bldg., Washington, D. C.
 Tel.: Republic 2966
 Radio Dept.: Harwood Martin, president; Harriot Item, radio-TV production; Jean Ort, timebuyer.
 Radio and Television Accounts: Woodward & Lothrop; Hecht Co.; P. J. Neer Furniture; William Hahn Co.; Arcade-Sunshine; Young Men's Shop; Washington Gas & Light; American Wholesalers; Clements Bakery; Auto Wholesalers; Beckers.

MASON-RELKIN CO.
 20 East 35th St., New York 16
 Tel.: Murray Hill 9-3891
 Radio Dept.: Mary R. Miller, radio director.

J. M. MATHES INC.
 122 E. 42nd St., New York 17
 Tel.: Lexington 2-7450
 Radio Dept.: Read H. Wight, radio and television director; Edna S. Cathcart, timebuyer; Anne Moore, motion pictures.

Radio Accounts: Canada Dry Ginger Ale Inc. (S); The Pure Food Co. (S); Sylvania Industrial Corp. (S); Ludden's Inc. (N-S); Fred Fear & Co. (S); American Viscose Corp. (S); Judson Dunway Corp. (S); Houbikant Sales Corp. (S); Imperial Paper & Color Corp. (S); Air France (S); Austin Motor Co. Inc. (S); Bakelite Corp.; Delaware Floor Products Corp. (S); Union Carbide & Carbon Corp. (S); Capehart-Farnsworth Corp.
 Television Account: Canada Dry Ginger Ale Inc. (N).

MATHISSON & ASSOCIATES INC.
 411 E. Mason, Milwaukee 2
 Tel.: Daly 8-4090
 Radio Dept.: C. A. Mathisson, radio director; Edward G. Ball, timebuyer.
 Radio Accounts: Edwards Motor Co. (S).

JOSEPH MAXFIELD CO.
 87 Weybosset St., Providence 3, R. I.
 Tel.: Gaspee 1-4456
 Radio Dept.: Joseph M. Finkle, timebuyer; Richard D. Brugman, radio director; Archie M. Finkle, Herbert Bolotow, account executives.

MAXON INC.
 2761 E. Jefferson Ave., Detroit 7
 Tel.: Lorain 7-5710
 New York 22—12 E. 53rd St. W. Ray Baker, vice president; E. Wilhelm, timebuyer.
 Chicago—664 N. Rush St. Tel.: Whitehall 4-1676. L. J. Sholty, manager.

MAY ADVERTISING CO.
 Commercial Trust Bldg., Philadelphia 2
 Tel.: Rittenhouse 6-7642
 Radio Dept.: Bertram May, president; J. P. Monahan, radio director.

THE MAYERS CO.
 2301 West Third St., Los Angeles 5
 Tel.: Dunkirk 8-2111
 Radio Dept.: Bea Davies, timebuyer.
 Radio Accounts: Sears, Roebuck & Co. (S); Hoffman Candy Co. (S); Gordon Bread Co.; Grand Central Market; National Schools (S); Adolphs Food Products (S); L. E. Laboratories (S).

CHARLES H. MAYNE CO.
 1709 W. 8th St., Los Angeles 14
 Tel.: Drexel 4363
 Radio Dept.: S. N. Austin, radio director and timebuyer.

MAYS & CO.
 412 W. 6th St., Los Angeles 14
 Tel.: Trinity 8534
 Radio Dept.: Thomas Monahan, television director; Catherine Abner, timebuyer.

Radio Accounts: Barker Bros.; J. W. Robinson Co. (S); General Electric Appliances (S).

McCANN-ERICKSON INC.
 50 Rockefeller Plaza, New York 20
 Tel.: Circle 5-7000.

Radio Dept.: William C. Dekker, director of radio service & station relations; Lee Cooley, director of TV; Alfred J. Scalpone, radio director; Hendrik Booraem, executive radio producer; Gertrude Gentzel, chief timebuyer.

Boston 16—31 St. James Ave., Tel.: Liberty 5468. Watson M. Gordon, vice president & manager.

Chicago 4—318 S. Michigan Ave., Tel.: Webster 2-3701. Horer Havermale, vice president & manager.

Cleveland 14—1300 Guardian Bldg. Tel.: Cherry 3490. A. A. Sommer, vice president.

Detroit 26—3546 Penobscot Bldg. Tel.: Randolph 9782. Paul Holder & Frank Townsend, vice presidents.

Hollywood 28—5331 Hollywood Bldg. Tel.: Hillside 8268. J. Neil Reagan, manager.

Los Angeles 13—448 S. Hill St. Tel.: Mutual 1181. Burt Cochran, vice president & manager.

Minneapolis 2—809 Second Ave. S. Tel.: Bridgeport 6801. Jackson Taylor, vice president & manager.

Portland 4, Ore.—1309 Public Service Bldg. Tel.: Atwater 4305. Harry Burton, manager.

San Francisco 4—114 Sansome St. Tel.: Douglas 5560. H. Q. Hawes, vice president & manager.

Radio Accounts: New York & Hollywood—American Molasses Co.; Beverwyck Breweries Inc.; Bosco Co.; Chesebrough Mfg. Co. (N); Columbia Records Inc.; Consolidated Edison Co.; Cowles Magazines Inc.; Junket Brand Foods; Lehn & Fink Products Corp.; National Biscuit Co.; Pacific Coast Borax Co. (N); Westinghouse Electric Corp. (N).
 Boston—John Hancock Mutual Life Insurance Co.
 Chicago—Chase Candy Co.; Milk Foundation Inc.; International Harvester Co. (N); Standard Oil Co. of Indiana; Swift & Co. (N); Trans Canada Airlines.

Cleveland—Brush Development Co.; Leisy Brewing Co.; National City Bank; Ohio Bell Telephone Co.; Perfection Stove Co.; Richman Bros. Co.; Standard Oil Co. of Ohio.
 Detroit—Altes Brewing Co.; Briggs Mfg. Co.; Chrysler Corp.; Petzold Motor Sales.
 Los Angeles — Broadway Dept. Stores; Soil-Off Mfg. Co.; Southern Calif. Gas Co.; Southern Counties Gas Co.

Minneapolis—Gluek Brewing Co.; Minneapolis Gas Light Co.; Northland Milk & Ice Cream Co.; Pillsbury Mills Inc. (N); Twin City Federal Savings & Loan Assoc.
 Portland — Northwestern Electric Co.; Pacific Power & Light Co.; Portland Gas & Coke Co.
 San Francisco—Avoset Co.; Calif. Packing Corp.; Calif. Walnut Growers Assn.; Coldstream Products Co.; Dwight Edwards Co.; W. P. Fuller & Co.; General Brewing Corp.; Macey's; San Francisco Baseball Club Inc.; The S.O.S. Co.
 Television Accounts: Leisy Brewing Co.; National Biscuit Co.; Standard Oil Co. of Ohio; Swift & Co.

L. F. McCARTHY & CO.
 Provident Bank Bldg., Cincinnati 2
 Tel.: Parkway 0368
 Radio Dept.: Emil Bauer, timebuyer.

R. E. McCARTHY ADVERTISING AGENCY
 206 South Franklin, Tampa 2, Florida
 Tel.: 2-9644
 Radio Dept.: R. E. McCarthy, timebuyer.

Radio Accounts: Southern Brewing Co. (S); Borden's Dairy (S); Peninsular Telephone Co. (S); Pioneer Tire Co. (S).

MCCARTY CO.
 1206 Maple Ave., Los Angeles 15
 Tel.: Prospect 7011
 Radio Dept.: Alden Weis, media director.

San Francisco 5—116 New Montgomery St. Tel.: Sutter 1-8224. Willard H. Wilde, manager.

Pittsburgh 19—600 Grant St. Tel.: Grant 6993. R. S. Reed Jr., manager.

MCCORMICK CO.
 217 E. 7th St., Amarillo, Texas
 Tel.: 5333

Radio Dept.: John R. Forkner, account executive.

L. E. McGIVENA CO. INC.
 444 Madison Ave., New York 22
 Tel.: Plaza 3-7422

McKEE & ALBRIGHT INC.
 1400 S. Penn Square, Philadelphia 2
 Tel.: Locust 7-4737

Radio Dept.: J. A. McFadden, vice president; E. R. Wamsley, timebuyer.

McNEILL & McCLEERY INC.
 1655 N. Cherokee Ave., Hollywood 28
 Tel.: Hudson 2-2337

Radio Dept.: Madelyn Miles, timebuyer.

(Continued)

Want to SELL EUROPE?

—your ideas?—
—your products?

RADIO LUXEMBOURG

Europe's only privately owned station!

You will reach more people with greater conviction

Morning:	3 million
Noon:	5 million
Night:	10 million

SHARE OF RADIO AUDIENCE:

French	25.9%	} sets in use
British	14.0%	

Details on request

Exclusive Representative USA

Guy Bolam

American Sales & Servicing Agency

175 Fifth Ave.

New York 10, N. Y.

Tel. AL. 4-7881

ADVERTISING AGENCIES HANDLING RADIO AND TV ACCOUNTS

(Continued)

N indicates network, S spot

PHILIP J. MEANY CO.
816 West 5th St., Los Angeles 13
Tel.: Michigan 3601
Radio Dept.: Ray Clinton, media director.

MENEUGH, MARTIN & SEYMOUR INC.
707 Locust St., Des Moines 9
Tel.: 3-1221
Radio Dept.: Don D. Alt, radio director.
Radio Accounts: Anderson Erickson; Capital City State Bank; El-States Dist. Co.; Hennings Inc.; Home Federal Savings; Iowa Bankers Assn.; Food Vitamins; Leachman Lumber; Queal Lumber; Des Moines Saving and Loan League; Woodside Lumber; Powers Bakery; Tone's Coffee; Winston Newell; Super Valu Stores; Supreme Baking Co.; Service Optical; Triplett Toys; One Minute Washer, all spot radio.

ARTHUR MEYERHOFF & CO.
410 N. Michigan Ave., Chicago 11
Tel.: Delaware 7-7860
Radio Dept.: Benjamin J. Green, radio and television director; Carol Perel, timebuyer.
Milwaukee 2-759 N. Milwaukee St. Tel.: Marquette 3144.

C. L. MILLER CO. INC.
521 Fifth Ave., New York 17
Tel.: Murray Hill 2-1010
Radio Dept.: G. V. Carhart, radio timebuyer; Rita Driscoll, spot radio timebuyer.
Chicago 1-333 N. Michigan Ave. Tel.: Central 6-1640.

J. W. MILLER CO.
76 Broad St., Guilford, Conn.
Tel.: Guilford 920
Radio Dept.: James W. Miller, president and radio director; L. S. Love-day, television director; Albert M. Simmons, timebuyer and account executive.

Radio Accounts: Safety Associates (S); Playano Corp. (S).

W. H. MILLHAEM & CO.
Fleming Bldg., Des Moines 9
Tel.: 4-4203
Radio Dept.: J. A. McCulla, radio director.

RAY MILLS ADVERTISING AGENCY
108 Court St., Auburn, Me.
Tel.: 3-0571
Radio Dept.: Ray Mills, radio director.

MILNE & CO. INC.
New World Life Bldg., Seattle 4, Wash.
Tel.: Main 2136

DAN B. MINER CO. INC.
756 S. Spring St., Los Angeles 14
Tel.: Trinity 9711
Radio Dept.: Hildred Sanders, vice president in charge; Terri Brady, timebuyer; Isabel Barnes, John Christie, Andrew Carpenter, Hosel Smith, account executives.

Radio Accounts: Interstate Bakeries (N-S); American Beauty Macaroni (S); Luer Packing Co. (S); Los Angeles Transit Lines (S); Foreman & Clark (S); Kerr Glass Mfg. Corp. (S); Awful Fresh MacFarlane Inc. (S); Log Cabin Bread (S); Dolly Madison (S); Kendall Foods (S); Prepared Products Inc. (S).

MITCHELL & KNEPPER
Daniel Baldwin Bldg., Erie, Pa.
Tel.: 22-912
Radio Dept.: George J. Mitchell, partner and radio director.

MITCHELL & MITCHELL INC.
1645 Hennepin Ave., Minneapolis 3
Tel.: Main 5387
Radio Dept.: J. K. Engstrom, timebuyer.

MITHOFF ADVERTISING
811 N. Stanton St., El Paso
Tel.: 3-4041

MOGGE-PRIVETT INC.
699 S. Grand Ave., Los Angeles 14
Tel.: Madison 6-9191
Radio Dept.: John A. Privett Jr., Norton W. Mogge, Snowden Hunt Jr., account executives.

Radio Accounts: Ben-Hur Products Inc. (S); Holmes Tuttle Co., California Lima Bean Owners Assn. (S); Key Brands Inc. (S); Forest Lawn Mem. Park; Bisceglia Bros. Wine (S); Cabany Products Co. Vins' Grocery Co.

EMIL MOGUL CO.
250 West 57th Street, New York 19
Tel.: Columbus 5-2482
Radio Dept.: Emil Mogul, president, radio and television director; Helen Monroe, timebuyer; Myron Mahler, program and talent buyer.

RICHARD G. MONTGOMERY & ASSOCIATES
American Bank Bldg., Portland 5 Ore.
Tel.: Beacon 3109

MOREY, HUMM & JOHNSTONE INC.
350 Park Ave., New York
Tel.: Bryant 9-5950
Radio Dept.: L. B. Van Doren, executive vice president; Kathryn Shanahan, timebuyer.

Radio Accounts: Sinclair Refining Co. (S); Richfield Oil Corp. of N. Y. (N-S).
Television Accounts: Sinclair Refining Co. (S).

RAYMOND R. MORGAN CO.
6233 Hollywood Blvd., Hollywood 28
Tel.: Hempstead 4194

Radio Dept.: James Morgan, vice president in charge of radio and television; Mary Ellen Ryan, timebuyer.
Radio Accounts: White King Soap Co. (N-S); J. A. Folger & Co. (N-S); Planters Nut & Chocolate Co.; Germain's Seed & Plant Co. (S); Institute of Religious Science (N-S); All State Insurance (S).

MORRISON ADVERTISING ASSOCIATES
Mine Works Bldg., Springfield, Ill.
Tel.: 8-5666

MORSE INTERNATIONAL INC.
122 E. 42nd St., New York 17
Tel.: Oregon 9-4800
Radio Dept.: C. C. Slaybaugh, manager, radio dept.

MOSS ASSOCIATES
415 Lexington Ave., New York 17
Tel.: Murray Hill 7-7337
Radio Dept.: Ely A. Landau, television director; Hal Goldin.

Radio Accounts: Ziploc Co.; Purofed Down Products Corp.; Nat Pater-son Motors; Semca Clock Co.; Starcor Co.

C. WENDEL MUENCH & CO.
75 E. Wacker Dr., Chicago 11
Tel.: Financial 6-3481
Radio Dept.: Victor Fabian, media director.

MUIR AND CO. INC.
9 Rockefeller Plaza, New York 20
Tel.: Circle 7-6641

STANLEY MUSSELMAN INC.
247 Park Avenue, New York 17
Tel.: Plaza 5-1161

IRVIN MYERSON AGENCY
330 S. Wells St., Chicago 6
Tel.: Harrison 7-6823
Radio Dept.: Irvin P. Myerson, owner and timebuyer.

Radio Account: Wine Corp. of America.

N

NACHMAN-RHODES INC.
Marion Bldg., Augusta, Ga.
Tel.: 2-8301
Radio Dept.: Herbert Nachman, timebuyer.

WESLEY K. NASH CO.
1218 Olive St., St. Louis 3
Tel.: Chestnut 4155
Radio Dept.: R. L. White, radio director & account executive.

NATIONAL ADVERTISING SYNDICATE
Crosby Bldg., Buffalo, N. Y.
Tel.: Washington 0826
Radio Dept.: A. H. Longbotham, managing director; Thomas Lienert, radio director.

NATIONAL EXPORT ADVERTISING SERVICE
405 Lexington Ave., New York 17
Tel.: Murray Hill 9-6835

Radio Dept.: James G. Zea, radio and television director; James A. MacDonald, assistant to director; Alex Cardenas, Jean A. Volpe.

Radio Accounts: American Safety Razor; Borden Co.; Carter Products; Electric Autolite; Esterbrook Pen; H. J. Heinz Co.; Lambert Co.; Lever Bros.; Richard Hudnut; Quaker Oats Co.; Ruppert Brewery; William R. Warner.
Associates in principal cities throughout the world.

NATIONAL RADIO ADVERTISING CO.
303 Empress Bldg., Seattle 4
Tel.: Eliot 5488
Radio Dept.: Edwin A. Kraft, radio director; Lei English, Norma Naylor, Lois Baker, account executives.
Radio Accounts: Gardner Nursery Co.; Canterbury Gardens; Calpro Sales Co.; Rhodius Perfumes; Alaska Life Magazine; Fur-Brite Sales Co. All spot users.

NEALE ADVERTISING ASSOCIATES
448 S. Hill Street, Los Angeles 13
Tel.: Michigan 2149
Radio Dept.: Leslie B. Cowell, television director; Ted Neale Jr., timebuyer.

NEDHAM & GROHMANN INC.
630 Fifth Ave., New York 20
Tel.: Circle 5-6200
Radio Dept.: Harry C. Ledingham, media director.

NEDHAM, LOUIS & BRORBY
135 S. LaSalle St., Chicago 3
Tel.: State 2-5151
Radio Dept.: Alan Wallace, radio and television director; Chris Ford, producer; F. G. Van Etten, facilities; Otto R. Stadelman, media director; Jane McKendry, timebuyer.

Hollywood 28-1680 N. Vine St. Tel.: Hudson 2-2391. Frank Pittman, vice president.
Radio Accounts: Kraft Foods Co. (N-S); Swift & Co. (N-S); Wieboldt Stores, Inc.; Derby Foods, Inc. (N); Eagle-Picher Sales Co. (S); Pepsodent Div., Lever Bros. (N); Morton Salt Co. (S).

NEFF-ROGOW INC.
30 Rockefeller Plaza, New York 20
Tel.: Circle 7-4230
Radio Dept.: William Rogow, president, account executive; Stewart Pierce Brown, account executive and copy chief; Robert Rogow.

Radio Accounts: Bond Stores Inc.; Melville Shoe Corp.; Joseph Martinson & Co., all spot.

RALPH NELMS INC., ADVERTISING
312½ W. Walnut, Springfield, Mo.
Tel.: 3-4050
Radio Dept.: Naomi Philbeck, radio director.

GEORGE R. NELSON INC.
208 State St., Schenectady 5, N. Y.
Tel.: 4-4135
Radio Dept.: Jack Rourke, radio director; Edward F. Flynn, television director; Anne F. Pratt, timebuyer.

Radio Accounts: Carl Co.; Cowell's Shell Station; Hub Store; William W. Lee & Co.; A. L. Parsons & Sons; Parsons Inc.; Rudolph Bros. Inc.; Saratoga Assn.; Industrial Bank; Cummings Motors Inc.; Devenpeck Coal Co.; Chas. Miller Coal Co.; Rodgers Liquor Co.; Union-Fern Inc.; also radio transcription production accounts.

Television Accounts: Mohawk Carpet Mills (N); Allen's Appliances; Apex Department Store; Carl Co.; Central Candy Corp.; Central Markets Inc.; Curtale Motors Inc.; Empire State Distributors Inc.; William W. Lee Co.; Nusbaum's; A. L. Parsons & Sons; Parsons Inc.; Saratoga Assn.; Wm. Sherry Tire Co.; Empire State Bedding Co.; Smith Food Co.; also television film production accounts.

NEW ERA ADVERTISING
16 St. Paul St., Baltimore 2
Tel.: Lexington 1024
Radio Dept.: Betty Van Weeldin, radio director; Albert Tralins, timebuyer.

NEWBY & PERON
59 E. Van Buren, Chicago 5
Tel.: Harrison 7-9494
Radio Dept.: Shirley Mares, media director and timebuyer.

NEWMAN, LYNDE & ASSOCIATES INC.
400 Fla. Natl. Bank Bldg., Jacksonville 2
Tel.: 5-7720
Radio Dept.: M. T. Newman, president; Hunter Lynde, executive vice president, timebuyer; Kenneth F. Small, vice president.
Miami—Chamber of Commerce Bldg. Tel.: 82-9975. Allan C. Gottschaldt, vice president.

Radio Accounts: Jax Brewing Co. (S); Bond Howell Lumber Co. (S); Florida Times-Union (S); John H. Swisher & Son Inc. (S).
Television Account: Jax Brewing Co.

NEWMARKS ADVERTISING AGENCY
217 Seventh Ave., New York 11
Tel.: Watkins 9-5400

NOLAN & TWICHELL ADVERTISING AGENCY INC.
55 State St., Albany 7, N. Y.
Tel.: Albany 3-5284
Radio Dept.: Chas Bell Jr., director of radio and television; Rosemary Clarke, timebuyer and copywriter.

KELSO NORMAN ADVERTISING
215 Kearny St., Norman Bldg., San Francisco 8
Tel.: Douglas 2-3942
Radio Dept.: Irv Cotanch, television director; Jean Gavin, media director.

NORTHWEST RADIO ADVERTISING CO.
Empress Bldg., Seattle 4
Tel.: Elliott 5488
Radio Dept.: Edwin A. Kraft, manager and radio director; W. L. Paul, timebuyer.

NORTON ADV. SERVICE
615 Orchard Pkwy, Niagara Falls, N. Y.
Tel.: 2-3508

EARL C. NOYES ADV. AGENCY
129 State St., Rutland Vt.
Tel.: 56
Radio Dept.: Al Taylor, radio director; Laura Vay, timebuyer; F. S. Webster, Gladys Miller, R. L. Scott, account executives.
Washington 5, D. C.—Washington Bldg. Tel.: Sterling 2440.

O

R. T. O'CONNELL CO.
420 Madison Ave., New York 17
Tel.: Plaza 3-5412

O'CONNELL-RAGAN COMPANY
10th & A Sts., Tacoma 2, Wash.
Tel.: Broadway 8309
Radio Dept.: M. Coffman, production manager.

Radio Accounts: Washington Gas & Electric (S); Wood Coffee (S); Buckley King Co. (S); G. C. Inelli Co. (S).

OHIO ADVERTISING AGENCY INC.
Warner Bros. Bldg., Cleveland 14
Tel.: Superior 7070
Radio Dept.: Melvin Tanenbaum, radio and television director; Ruben Polen, timebuyer.

O'LEARY ADVERTISING AGENCY
115 Chauncy St., Boston 11
Tel.: Liberty 2-2408
Radio Dept.: Virginia M. Connolly, radio director.

DAVID OLEN ADV.
1127 Wilshire Blvd., Los Angeles 14
Tel.: Trinity 6144
Radio Dept.: David Olen, owner and account executive.

OLIAN ADVERTISING CO.
Ambassador Bldg., St. Louis 1
Tel.: Central 8380
Radio Dept.: Margaret Hart Nelson, radio director; Margaret Smith, timebuyer.
Chicago 1—Pure Oil Bldg.

OLMSTEAD & FOLEY
1200 Second Ave., Minneapolis 3
Tel.: Atlantic 8166
Radio Dept.: James D. McTighe, radio and television director.

Radio Accounts: King Midas Flour and Feeds (S); Marshall-Wells (S); Rochester Co-Op Dairy (S); Regan Bros. Bakery (S); First National Bank (S); Schmidt's Beer (S); De Soto Ice Cream (S); Red Owl (S).

WJR

Penetration ● ● ●

WJR's 50,000 watts power, choice 760 frequency, clear channel, finest equipment, engineering know-how and favored location give this station "coverage" which includes one-eleventh of the U. S. population within its daytime half-millivolt contour and two-thirds of the population nighttime.

But WJR is even prouder of its "penetration" than it is of its "coverage". "Penetration" is indicative of the use the station makes of its facilities and is measured by LISTENERS rather than by square miles. How well WJR is performing in this regard is shown by its continuing leadership as revealed on the following pages.



WJR LEADER OF ALL DETROIT STATIONS

For 28 Consecutive Months

At the time this is written, (December 1949) WJR's "penetration" in Metropolitan Detroit has been deeper than that of any other station for 28 consecutive months. Following is the Hooper Station Audience Index in Detroit for the month of November 1949.

SHARE OF BROADCAST AUDIENCE									
TIME	HOMES USING SETS	Sta. WJR	Sta. B	Sta. C	Sta. D	Sta. E	Sta. F	Sta. G	Sta. H
Weekday Morning Mon. thru Fri. 8:00 AM-12 Noon	14.7	41.2	20.6	23.6	5.2	3.6	2.1	0.6	1.8
Weekday Afternoon Mon. thru Fri. 12 Noon-6:00 PM	19.4	26.4	21.8	16.0	12.7	7.9	2.5	3.1	3.5
Evening Sun. thru Sat. 6:00 PM-10:30 PM	33.9	25.4	18.6	12.3	5.4	6.4	1.7	1.3	0.9
Sunday Afternoon 12 Noon-6:00 PM	22.9	26.4	13.0	13.7	9.0	12.0	2.3	0.7	1.3
Saturday Daytime 8:00 AM-6:00 PM	17.2	19.7	12.5	17.6	11.4	15.6	1.0	2.1	3.1
Total Rated Time Periods	22.9	27.4	18.9	15.3	8.0	7.5	2.0	1.7	1.9

And— **AMONG TOP STATIONS IN 5 MAJOR MARKETS . . .**

The Number 1 Station is **WJR**

(MONDAY THROUGH FRIDAY)

5 Top Markets	8 A.M.—12 Noon	12 Noon—6 P.M.	6 P.M.—10 P.M.
WJR	32.29	28.80	32.39
Sta. A—New York	24.28	24.56	20.48
Sta. A—Chicago	34.46	27.24	24.96
Sta. A—Philadelphia	29.20	30.60	28.50
Sta. A—Los Angeles	23.27	29.42	29.70
WJR Superiority Over Average	4.49	.85	6.48

WJR RANKS HIGH IN CITIES IN ITS AREA OUTSIDE DETROIT

Below are shown the respective Hooper ratings of the three leading stations in 18 cities in the WJR Primary Area outside of Detroit. The audience measurement from which these ratings were taken was made by C. E. Hooper in the winter of 1949.

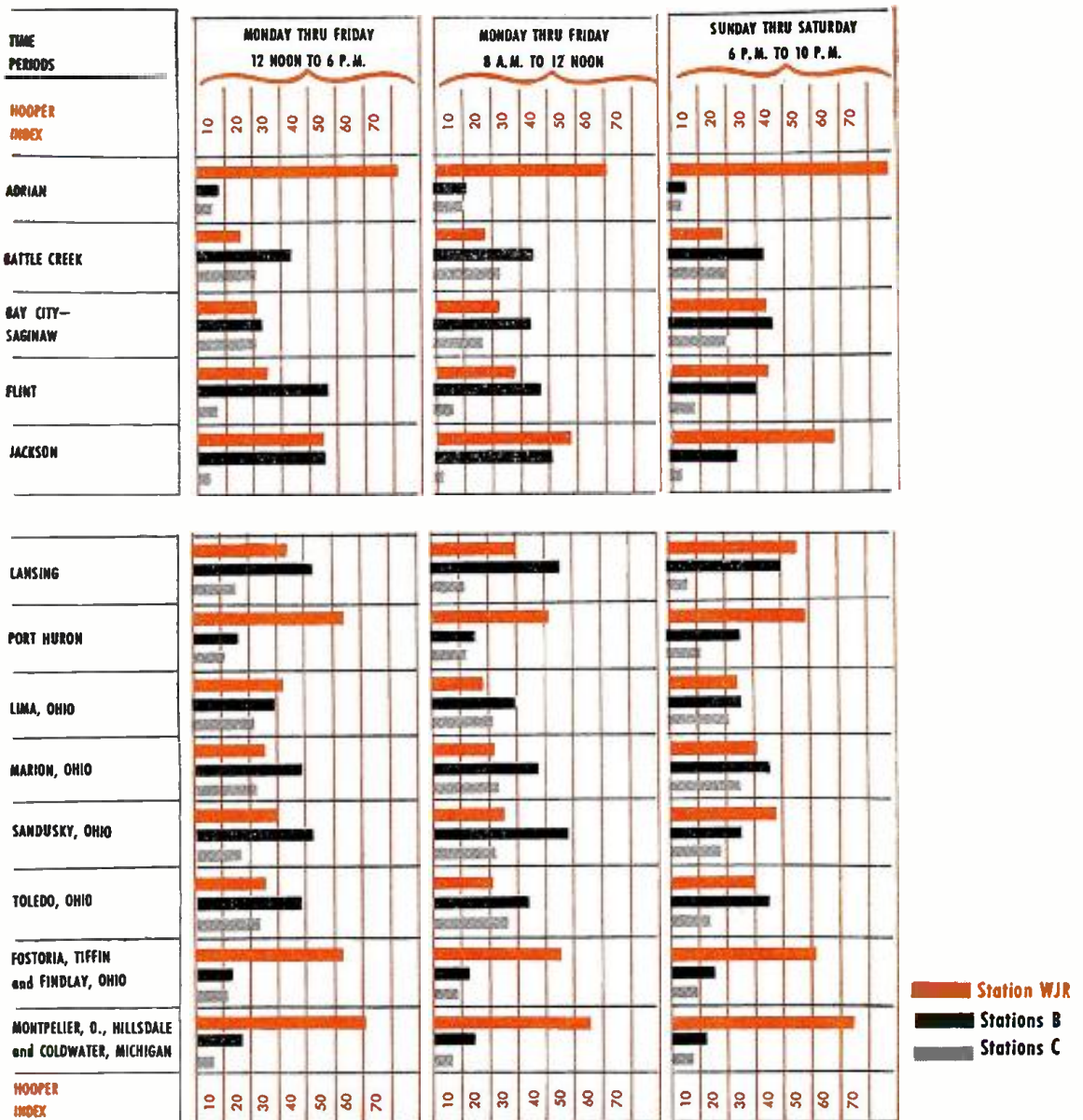

WJR Is Listened To Most –

Nearly THREE to ONE over its Nearest Competitor

The map below indicates the 94 counties in which C. E. Hooper made a mail survey of radio listeners. The figures in the table show the percent of mentions received by stations in answer to the question: "To which station do you and your family listen most frequently or the most time?" Thirty-seven different stations are represented in the "All Others Combined" classification but no station so classified received more than 2% for any time period.

STATIONS	MORNING		AFTER-NOON	EVENING	
	6 A.M.-7 A.M.	7 A.M.-Noon	12:00 Noon-6 P.M.	6 P.M.-11 P.M.	11 P.M.-Midnight
WJR	35%	34%	27%	37%	31%
Station B (Detroit)	6%	12%	12%	17%	13%
Station C (Detroit)	5%	9%	8%	8%	8%
Station D (Detroit)	6%	4%	8%	4%	6%
Station E (Cincinnati)	7%	4%	4%	4%	5%
Station F (Detroit)	4%	3%	5%	2%	4%
Station G (Toledo)	4%	3%	3%	3%	4%
Station H (Cleveland)	2%	2%	2%	2%	3%
Station I (Flint)	2%	2%	2%	2%	LT
Station J (Fort Wayne)	3%	2%	2%	1%	LT
Station K (Toledo)	1%	2%	2%	2%	LT
All Others Combined	25%	33%	25%	18%	26%



By every comparison whether it be newspapers, magazines, or other radio stations, in the great market centering around Detroit; the *best advertising buy* is—

Michigan's Greatest Advertising Medium

Call or Write
your nearest
PETRY office

WJR



THE GOODWILL STATION, INC., FISHER BUILDING, DETROIT

CBS

HARRY WISMER
GENERAL MANAGER AND ASSISTANT TO THE PRESIDENT

50,000 Watts

O'MALLEY ADVERTISING & SELLING CO. INC.
44 School St., Boston 8
Tel.: Capitol 7-0600
Radio Dept.: M. C. O'Malley, radio director and timebuyer.

O'NEIL, LARSON & McMAHON
230 N. Michigan Ave., Chicago 1
Tel.: ANdover 3-4470
Radio Dept.: Walter Zivi, timebuyer.

THE E. A. OPPENHEIM COMPANY
Michigan Bldg., Detroit 26
Tel.: Woodward 1-6765
Radio Dept.: E. A. Oppenheim, timebuyer; R. Craig, E. Bruny, account executives.

Radio Accounts: Powell Studios; Bill Brown Inc. (Ford Dealer); Ridley Upholsterers.

Television Account: Friedberg's.

ORMSBEE, MOORE & GILBERT
21 Daniel St., Milford, Conn.
Tel.: 2-1691

Radio Dept.: E. N. Gilbert, media director.

ROBERT W. ORR & ASSOCIATES INC.
4 W. 58th St., New York 19
Tel.: Plaza 9-8050

Radio Dept.: Richard Diggs, radio director.
Los Angeles 46—8611 Sunset Blvd. Richard Diggs, manager
Offices in London, Paris.

Radio Accounts: Selznick Releasing Organization (S); Andrew Jergens Co. (Jergens & Woodbury Products) (N-S).

OWEN & CHAPPELL INC.
595 Madison Ave., New York 22
Tel.: Plaza 8-2400

Radio Dept.: David Hale Halpern, radio and television director; Harry Torp, timebuyer; John J. Schneider, account executive.

Radio Account: National Bohemian Beer (S); National Premium Beer (S).

M. M. OWEN INC.
122 E. 42nd St., New York 17
Tel.: Murray Hill 6-1590

Radio Dept.: M. M. McLay, media director.

MERRITT OWENS ADV. AGENCY INC.
New Brotherhood Bldg., Kansas City 11, Kan.
Tel.: Drexel 7250

P

PACIFIC ADVERTISING STAFF
1624 Franklin St., Oakland 12
Tel.: Templebar 2-2885

PACIFIC NATIONAL ADVERTISING AGENCY
605 Union St., Seattle 1
Tel.: Eliot 1401

Radio Dept.: Trevor Evans, radio director; G. M. Nyman, timebuyer; Wm. H. Horsley, H. O. Stone, L. R. McIntosh, Frank Horsley.
Portland 4, Ore.—Cascade Bldg. Tel.: Capitol 1021. Mr. & Mrs. Milton Poland.

Spokane—801 Review Bldg. Tel.: Madison 6479. Vernon Cary.

Radio Accounts: Fisher Flouring Mills Co. (N-S); Washington Co-op. Farmers Assn. (N-S); Seattle-First Nat'l. Bank (S); Washington State Fruit Commission (S); Federal Old Line Insurance Co. (S); Wm. McKay (Ford Dealer) (S); Alaska Airlines (S); Cowman & Campbell (S); Pacific Lincoln Mercury (S); Idaho Prune Adv. Comm. (S); Ivar Haglund Restaurant (S); Floradent Toothpaste (S); Wash. Title Ins. Co. (S).

PAIRO ADVERTISING AGENCY
223 Peachtree St., Atlanta 3
Tel.: Main 6935

Radio Dept.: V. A. Pairo, president; W. L. Dix, account executive.
Radio Account: Lee Baking Co.

PARIS & PEART
370 Lexington Ave., New York 17
Tel.: Murray Hill 9-2424

Radio Dept.: Paul A. Danielson, media director and timebuyer; W. F. James, Remus Harris, George Cleland, A. A. Kohler, account executives.

PARKER-ALLSTON ASSOCIATES
116 John St., New York 7
Tel.: Rector 2-6514

Radio Dept.: Raymond D. Parker, president.

AMOS PARRISH & CO.
500 Fifth Ave., New York 18
Tel.: Longacre 4-5600
Radio Dept.: David T. Levine, agency director.

PATCH & CURTIS ADVERTISING AGENCY
730 E. 3rd St., Long Beach 12
Tel.: 6-1259

Radio Dept.: Gene Curtis, general manager; L. A. Patch, Nancy Purvine, account executives.

HANCOCK PAYNE ADVERTISING ORGANIZATION
12 S. 12th St., Philadelphia 7
Tel.: Lombard 3-2405

Radio Dept.: M. J. McManamy, radio director and timebuyer.

PEARSON ADVERTISING AGENCY
50 E. 42nd St., New York 17
Tel.: Vanderbilt 6-0029

Radio Dept.: C. H. Pearson, radio director.

Radio Accounts: Manufacturers Trust Co. (S).

PECK ADVERTISING AGENCY INC.
400 Madison Ave., New York 17
Tel.: Plaza 3-0900

Radio Dept.: Arthur J. Daly, radio-television director and timebuyer; Audrey Harris, assistant timebuyer; Harry Krawit, president and account executive; Norman A. Mack, vice president and account executive; Sidney G. Alexander, Herbert J. Stefel, Byron H. Clark, Herman Stolley, John Schuman, account executives.

Radio Accounts: Howard Stores Corp.; Old Dutch Coffee; Charles of the Ritz; Premier Foods' Sauce; I. J. Fox, all spot.

PEDLAR AND RYAN INC.
250 Park Ave., New York 17
Tel.: Plaza 5-1500

Radio Dept.: Wilfred S. Roberts, dir. of radio and television; G. Douglas Morris, vice-president and account executive (P & G); Elizabeth C. Shay, production supervisor; T. C. Fisher, vice-president and media director; William G. White, timebuyer; Donald R. Lamb, vice president, account executive; Charles Lamb, account executive.

Radio Accounts: Procter & Gamble (N); Northeast Airlines (S); La Prima dora Cigars.

Television Accounts: La Prima dora Cigars.

PERRY-BROWN INC.
2831 Vernon Pl., Cincinnati 19
Tel.: Plaza 8200

Radio Dept.: Edward J. Doran, radio director and timebuyer.

HAROLD PETTUS ADVERTISING
Jones Bldg., Corpus Christi, Tex.
Tel.: 2-5621

Radio Dept.: Bee Cooper, radio director; Harold Pettus, timebuyer.

Radio Accounts: Grisham Dairy (S); C. C. Bank & Trust Co. (S); Guaranty Title & Trust Co. (S); T. M. Bell, Builder (S); First Savings & Loan Assn. (S); Maverick-Clarke Litho Co. (S); Nueces Coffee Co. (S); Weil Bros. Grocers (S); Robert Driscoll Hotel (S).

THE PHILLIPS COMPANY
First Nat'l Bldg., San Diego 1
Tel.: Franklin 2121

Radio Dept.: Bill Mesmer, radio and television director; Charles C. Ramsey, Fred J. Volz and W. L. Phillips, account executives; Robert F. Lewis, media buyer.

Radio Accounts: Davidson Furniture Co. (S); Home Federal Savings & Loan Assn. (S); Tufford Motor Co. (S); Dr. Raichart (S); Dennstedt Electro-Mart; Baker Distributing; General Electric; Plymouth Dealers of San Diego; Tufford Television; Valle's Restaurant; Denison Mattress; First National Bank.

A. D. PHILLIPS ADVERTISING INC.
58 E. Washington, Chicago 2
Tel.: Central 6-7529

Radio Dept.: Lawrence Alden, media director.

PHILLIPS-REICK-FARDON ADVERTISING

1012 Baltimore St., Kansas City 6, Mo.
Tel.: Harrison 7650

Radio Dept.: Dorothy L. Fox, media director.

PICARD ADVERTISING CO.
250 W. 37th, New York 19
Tel.: Columbus 5-4121

Radio Dept.: John North, account executive.

CASPER PINSKER
150 Nassau St., New York 7
Tel.: Beekman 3-8680
Radio Dept.: Norman Gladney, radio director.

PITLUK ADVERTISING COMPANY
Alamo Nat'l Bldg., San Antonio 5
Tel.: Garfield 7268

Radio Dept.: Sam Riklin, timebuyer; Bob Holleron, radio director and account executive.

PLATT-FORBES INC.
386 Fourth Ave., New York 16
Tel.: Murray Hill 6-3440

Radio Dept.: George Kraus, timebuyer. Hartford 5—3 Van Dyke Ave. Tel.: 7-0758. G. Frank Sweet, vice-president & manager.

PLAZA ADVERTISING AGENCY INC.
9 Rockefeller Plaza, New York 20
Tel.: Circle 6-6550

Radio Dept.: John T. O'Flaherty, president.

JULIAN G. POLLOCK CO.
1717 Sansome St., Philadelphia 3
Tel.: Locust 7-1686

Radio Dept.: Julian G. Pollock, owner, account executive.

POLLYEA ADVERTISING
670 Cherry St., Terre Haute, Ind.
Tel.: Crawford 6707

Radio Dept.: M. Black, timebuyer; F. Boyer, radio director.

PONDROM & COLLINS
912 Commerce St., Dallas 2
Tel.: Riverside 6381

Radio Dept.: Sam Pondrom, partner, timebuyer.

POSNER-ZABIN ADVERTISING
222 Fifth Ave., New York 1
Tel.: Murray Hill 9-2676

Radio Dept.: James B. Zabin.

POST, JOHNSON & LIVINGSTON INC.

108 Gillette St., Hartford 5
Tel.: Hartford 2-1717

Radio Dept.: Jack Livingston, president and radio director.

POTTS-TURNBULL CO.
912 Baltimore Ave., Kansas City 6
Tel.: Victor 9400

Radio Dept.: N. P. Rowe, vice president and radio director.

R. J. POTTS-CALKINS & HOLDEN
215 W. Pershing Road, Kansas City 8, Mo.

Tel.: Victor 2530

Radio Dept.: R. J. Potts, J. B. Woodbury, E. A. Warner, C. C. Tucker, C. L. Robinson, Al Coleman, account executives.

Radio Accounts: Mid-Continent Petroleum Corp. (S); Interstate Bakeries Corp. (N-S); Forum Cafeterias of America (S); Cook Paint & Varnish Co. (S); American Beauty Macaroni Co.; Braniff International Airways (S); Ambrose Wine Company (S); Muehlebach Brewing Co. (S); Pay Way Mills Inc. (S); Peppard Seed Co. (S); Kansas City Custom Garment Co. (S); City National Bank & Trust Co. (S); Griffin Grocery Co.

POWELL-GRANT INC.
Penobscot Bldg., Detroit 26
Tel.: Woodward 1-4321

Radio Dept.: Robert H. Powell, radio and television director, account executive and timebuyer; Bill Gayek, assistant radio & television director, account executive; Pat Freeman, assistant timebuyer and copy chief.
Cleveland 14—Union Commerce Bldg. Tel.: Cherry 3458.

Radio Accounts: Ken Brown; Floyd Rice; Lee & Cady; Park Motor Sales; Louis Rose Co.; Millenbach Motors; Plymouth Dealers; Fort Pontiac; Sterling Coal; Jack Powell; Miller Boat Co. All spot.

JOHN O. POWERS CO.
110 William St., New York 7
Tel.: Worth 4-7361

Radio Dept.: Robert W. Powers.

PRATER ADVERTISING AGENCY INC.
705 Chestnut St., St. Louis 1
Tel.: Garfield 6490

Radio Dept.: Graham Black, radio and television director, timebuyer.

F. W. PRELLE ADVERTISING CO.
983 Main St., Hartford 3, Conn.
Tel.: 7-3233

Radio Dept.: B. J. Clark, media director; F. W. Prelle, John S. Gallagher, A. Hickox, account executives.

(Continued)

PROGRAMS-PICTURE ALBUMS PRINTED PROMOTION-SPECIAL FEATURE

IF YOUR TV-AM-FM STATION NEEDS PROMOTIONAL IDEAS SOLD TO PRODUCE CASH REVENUE OF FROM \$200-\$1,000 PER WEEK FOR SEVERAL MONTHS AS WE HAVE DONE FOR OVER 300 STATIONS FROM COAST TO COAST DURING THE PAST 12 YEARS—

Wire, call, or write

Edgar L. Bill

Merle V. Watson

NATIONAL RADIO PERSONALITIES

100 Walnut Street
Peoria, Illinois

Telephone 6-4607

ADVERTISING AGENCIES HANDLING RADIO AND TV. ACCOUNTS

(Continued)

N indicates network, S spot

PRESBA, FELLERS & PRESBA CO.
360 N. Michigan, Chicago 1
Tel.: Central 6-7683

Radio Dept.: Charles O. Dabney, television director, account executive; Marquis M. Smith, vice president and radio director.

E. J. PRESSER & CO.
210 E. Fifth St., Charlotte 1, N. C.
Tel.: 4-7754

J. G. PROCTOR CO. INC.
250 Park Ave., New York 17
Tel.: Plaza 3-5252

Radio Dept.: J. G. Proctor, president; George Proctor, account executive.

Q

QUALITY PARK ADVERTISING AGENCY

450 N. Syndicate St., St. Paul 4, Minn.
Tel.: Nestor 7873

Radio Dept.: J. H. Fischbein, radio director; D. J. Holstad, timebuyer.

R

RADIO ADVERTISING CORP. OF AMERICA

47 Audubon Ave., Jersey City, N. J.
Tel.: Bergen 4-2332

Radio Dept.: Michael A. Fiore, radio and television director; Paul Apollo, production manager and account executive; B. Wilman, account executive.

Radio Accounts: China Clipper Inc.; Non-Sectarian Church Inc.; Radio Church Evangelistic Phophetic Testimony of Phila.; Watching Lake Inc.; Casino Beach & Pool; Post Auto Exchange; Alexander Beverages; D. Wolf & Co.; Circle Auto Sales; South Beach Businessmen's Assn.; Village Businessmen's Assn.; Eastern School of Musical Instrument Repair; Newark Rosant School of Upholstery; Newark School of Auto Body Repair, all spot.

L. W. RAMSEY CO.
230 N. Michigan Ave., Chicago 1
Tel.: Franklin 2-8155

Radio Dept.: L. H. Copeland, vice president; Dorothy Parsons, timebuyer
Davenport, Ia.—111 E. 3rd St. Tel.: 3-1889. E. G. Naeckel, general manager.
Hollywood—6671 Sunset Blvd.

RANDALL CO.
75 Pearl St., Hartford 3, Conn.
Tel.: 7-1179

Radio Dept.: Florence F. Grady, radio and television director.

FRED M. RANDALL CO.
Book Tower, Detroit 26
Tel.: Woodward 1-4662

Radio Dept.: R. D. Hughes, radio director; Charles E. Foerster, timebuyer.

RATCLIFFE ADVERTISING AGENCY
Mercantile Bank Bldg., Dallas 1
Tel.: Central 8035

Radio Dept.: M. K. Ratcliffe, radio director.

RAY-HIRSCH & CO.
37 W. 57th St., New York 19
Tel.: Murray Hill 8-3515

Radio Dept.: Murray Hirsch.

RAYMOND ADVERTISING AGENCY
11 Commerce St., Newark 2
Tel.: Ma 2-6811

LARRY RAYMOND COMPANY
959 Crenshaw Blvd., Los Angeles 6
Tel.: York 8125

Radio Dept.: Larry Raymond, timebuyer.

CHAS. DALLAS REACH CO.
69 Washington St., Newark, N. J.
Tel.: Market 3-5100

Radio Dept.: Jerome B. Harrison, radio and television director; Rose Italia, timebuyer; Eleanor Leonard, asst.; James Little, Howard Sands Jr., James Symington, Frank Risley, account executives.
New York—46 W. 55th St. Tel.: Circle 5-4176. Jerome B. Harrison.

Radio Accounts: Waterman Fountain Pen Corp. (N.); Dugan Bros.; New Jersey Bell Telephone Co. (S); Burry Biscuit Co.; Curtiss Wright (S); Koppers Co. (S).

READINGER CORP.
20 S. 15th St., Philadelphia 2
Tel.: Locust 4-0240

Radio Dept.: Ruth Berman, timebuyer.

REALSERVICE ADV. AGENCY
110 W. 34th St., New York 1
Tel.: Pennsylvania 6-4412

Radio Dept.: J. Elkins, J. Hanft.

REDFIELD-JOHNSTONE INC.
420 Madison Ave., New York 17
Tel.: Plaza 3-6120

Radio Dept.: LeGrand L. Redfield, radio director; Mary Rippel, timebuyer.

KNOX REEVES ADVERTISING INC.
First National Bldg., Minneapolis 2
Tel.: Bridgeport 7701

Radio Dept.: Russell E. Neff, radio and television director; Phil Archer, radio timebuyer; Elizabeth Reeves, script editor.

San Francisco 5—625 Market St. Tel.: Sutter 1-6744. H. R. Ohleyer, manager; Walter A. Johnson, timebuyer.

Radio Accounts: General Mills Inc. (N-S); Midland Bank; Art Instruction Inc.; Sperry Co.

Television Account: General Mills (S).

REINCKE, MEYER & FINN INC.
520 N. Michigan Ave., Chicago 11
Tel.: Whitehall 4-7440

Radio Dept.: Frank M. Baker, radio and television director.

Radio Accounts: Chicago, Burlington & Quincy Railroad (S); Anderson Co. (S); Reliable Typewriter (S); American Technical Society (S).

Television Accounts: Reed Candy Co.; Powderene (S).

REINGOLD CO. INC.
10 Sta. St., Boston 9
Tel.: Capitol 7-7611

Radio Dept.: Thomas J. Bowen, media director, timebuyer.

EMIL REINHARDT
1736 Franklin St., Oakland 12
Tel.: Templebar 2408

Radio Dept.: Joseph Connor, account executive.

REISS ADVERTISING
221 W. 57th St., New York 19
Tel.: Plaza 7-8030

Radio Dept.: Stanley Sussman, television director.

WILLIAM B. REMINGTON INC.
196 Worthington St., Springfield 4, Mass.
Tel.: 2-2135

Radio and Television Dept.: Betty McGonigle and Richard A. Strout.

Radio and Television Accounts: Springfield Institution for Savings; Eastern States Exposition.

RHOADES & DAVIS
79 Post St., San Francisco 4
Tel.: Exbrook 2-6468

Radio Dept.: Harold M. Walker, radio and television, general manager.

FLETCHER D. RICHARDS, INC.
10 Rockefeller Plaza, New York 20
Tel.: Circle 7-6383

Radio Dept.: J. S. Davidson, vice president and radio and television supervisor; E. A. Elliot, vice president and media director; G. E. Parental, timebuyer; Tom Hicks Jr., television and radio program director.

Chicago—75 E. Wacker Dr. Tel.: Financial 6-3585. French Eason.

Radio Accounts: United States Rubber Co.; Eastern Air Lines; Durham Enders Razor Corp.; Berghoff Brewing Corp.; Foremost Dairies Inc.

IRWIN S. RICHLAND CO.
59 West 46th St., New York 19
Tel.: Luxemburg 2-0270

Radio Dept.: Irwin S. Richland, account executive.

M. EVANS RICHMOND ADV. AGENCY
1518 Walnut St., Philadelphia 2
Tel.: Pennypacker 5-2334

Radio Dept.: M. Evans Richmond, director.

Boston 18—230 Boylston St. Tel.: Columbia 6-4491. Robert S. Richmond.
Hollywood—Yucca-Vine Bldg. Marey Reiss.

R. C. RIEBEL ADVERTISING AGENCY

151 S. 5th St., Louisville 2

Tel.: Wabash 6039

Radio Dept.: Sally V. Wolehen, radio-television director.

LEE RINGER, ADVERTISING
3142 Wilshire Blvd., Los Angeles 5
Tel.: Dunkirk 7-8131

JOHN H. RIORDAN CO.
605 Lucas Ave., Los Angeles 14
Tel.: Madison 6-2291

Radio Dept.: John H. Riordan, owner; Shirley A. Smith, timebuyer.

ARTHUR G. RIPPEY & CO.
First National Bank Bldg., Denver 2
Tel.: Tabor 0221

Radio Dept.: Arthur G. Rippey, C. G. Henderson.

PHILIP RITTER CO. INC.
511 Fifth Ave., New York 17
Tel.: Murray Hill 7-6574

RITTS ADVERTISING AGENCY

123 E. 6th St., Cincinnati 2

Tel.: Dunbar 0532

Radio Dept.: Charles Rittenhouse, radio director and timebuyer.

DAN RIVKIN AGENCY
1418 Walnut St., Philadelphia 2
Tel.: Pennypacker 5-5768

Radio Dept.: Dan Rivkin.

Radio Accounts: Ismak Rug Mills; Joe Krass & Sons Clothing; Moskin Clothes; Richard's Clothes; Royal Shoe Markets; Spiro's Apparel; John Kohler Clothes; Berg Bros. Clothes; Shubin Furniture; Ford Optical Co.

ROBERTS & REIMERS INC.
551 Fifth Ave., New York 17
Tel.: Murray Hill 2-3175

Radio Dept.: Robert Power Reimers, president; Leon Kelley, vice president; John Kerevin Lucken, media director.

ROBERTSON ADVERTISING
U.S.N. Bank Bldg., Denver 7
Tel.: Keystone 6269-60

Radio Dept.: Walter Kranz, radio director; Mary A. Robertson, Marshall G. Robertson, timebuyers; John Eby, James Briggs, account executives.

Radio Accounts: Miller Super-Markets; Frumes Jewelry Co.; Cottrell Clothing; Thoro Products; Wecker Transfer; Grayson Apparel Co.; Lindner Packing; Edelweiss Cafe; Britze-Ize Cleanser; Cinch Cake Mix; Elitch Gardens Co.

ELWOOD J. ROBINSON ADV. AGENCY

634 S. Spring St., Los Angeles 14

Tel.: Mutual 6239

Radio Dept.: Larry Kraft, media director; Robert C. Neuman, timebuyer.

ROCHE, WILLIAMS & CLEARY INC.
135 S. LaSalle St., Chicago 3
Tel.: Randolph 6-9760

Radio Dept.: Phil Stewart, radio director; N. J. Kavanagh, timebuyer.

IRVING ROCKLIN & ASSOCIATES
32 W. Randolph, Chicago 1
Tel.: Randolph 6-2324

Radio Dept.: M. S. Lovinger, radio director; Irving Rocklin, account executive; D. C. Cohen, television director.

Radio Accounts: Balaban Floor Covering (S); Lenard Industries (S); Libby Furniture Co. (S); Town House; Union Life Ins. Co. (S); Walton Motors; Ace Window Screen Co.; Atlas Piano Co.; Clark Industries (S); Dresen Sales Co. (S); Electric Center Inc.; Fisherman's Club (S); Martin Fur Co.; International Events (S); Martin Jewelers (S); Northtown Check Cashing Service (S); Maynard Inc. (S); Linoleum City (S); American School (S); Chicago Furniture Mart (S); Illinois Sewing Machine (S); Richards Drive-In (S); Sandra Motors Inc. (S); Cover & Kantor (S); Community Stores (S); Doin' the Town Enterprises (S); Father Baker's Victorian Mag. (S); Frank Gill Co. (S); Ill. Sheet Metal Ltd. (S); Kent Clothiers (S); Lincoln Home Prod. (S); Muntz TV (S); Main Home Builders (S); Majestic Tie Co. (S); Marshall Sales & Service (S); Permanent Stainless Steel (S); Quality Metal Finishing Co. (S); Real Toiletries Co. (S); U.A.S. Corp. (S); Victor Storage & Moving (S); Town Pump (S).

Television Accounts: Balaban Floor Covering (S); Libby Furniture Co. (S); M. B. Auto Sales (S); North Town Check-Cashing (S); Adams Weaving Co. (S); Atlas Piano Co. (S).

ROCKMORE COMPANY
37 West 57th St., New York 19
Tel.: Plaza 8-2506

ROGERS & SMITH ADVERTISING AGENCY

20 N. Wacker Dr., Chicago 6

Tel.: Dearborn 2-0020

Dallas 1—Reserve Loan Life Bldg. Tel.: Riverside 6044. Marie Callahan, radio director.

Kansas City 6—Dwight Bldg. Tel.: Baltimore 4567. James W. Coy, manager.

ROIZEN ADVERTISING AGENCY * INC.

291 Delaware Ave., Buffalo 2

Tel.: Cleveland 5975

Radio Dept.: Manus Roizen, radio timebuyer, account executive; Arthur H. Rich, television director and account executive; David I. Levy, account executive and timebuyer; Miss Mary A. Riley, timebuyer.

Radio Accounts: Sattlers; 20th Century Theater; Buffalo Housewrecking Co.; Music House; Cook Untereckers Inc.; Rich Products Corp.; Rich Ice Cream Co.; Sauls Auto Sales Inc.; Pfeiffer's Food Products; Neuman Motors Inc.; Delaware Park Shopping Centre; Lalle's; RKO Pictures Inc., all spot.

Television Accounts: Sattlers; Cook Untereckers Inc.; Rich Ice Cream Co.; Buffalo 20th-Century; RKO Pictures Inc.

ROOT-MANDABACH ADV. AGENCY
676 N. Michigan Ave., Chicago 11
Tel.: Superior 7-8247

CHARLES EDSON ROSE CO.
100 E. Chicago Ave., Chicago 11
Tel.: Superior 7-3486

Radio Dept.: William Perry and M. B. Cooper, timebuyers.

ROSE-MARTIN INC.
21 W. 48th St., New York 19
Tel.: Luxemburg 2-3550

Radio Dept.: G. M. Rundbaken, media director.

IRVING ROSEN ADVERTISING
101 West 30th St., New York 1.

Radio Dept.: Irving Rosen, director; E. Wayne, associate director.

ROSS ADVERTISING AGENCY
4053 Lindell Blvd., St. Louis 8
Tel.: Lucas 1322

Radio Dept.: Clark F. Ross, owner.
Los Angeles 26—1282 West Second St. Tel.: Van Dyke 4411. Harvey Olson, manager.

New Orleans 13—1023 Baronne St. Tel.: Magnolia 7805.

New York—489 Fifth Ave. Tel.: Murray Hill 2-2492. William E. Taylor.

ROSS, GARDNER & WHITE ADV.
2412 West 7th St., Los Angeles 5
Tel.: Drexel 7211

Radio Dept.: Edward B. Ross, radio director; Frank Ryhlick, television director.

W. B. ROSS & ASSOCIATES
672 W. Washington Blvd., Los Angeles 15
Tel.: Prospect 7656

A. JAMES ROUSE CO.
521 N. La Cienega Blvd., Los Angeles 36
Tel.: Bradshaw 2-5608

Radio Dept.: Bertram Feinberg, television director, account executive; Eleanor Dorfman, timebuyer; A. James Rouse, account executive.

Radio Account: Original Barbecue.
Television Accounts: Pensick & Gordon Inc.; Original Barbecue; Buckley Harris Co.; Harold's Shoes.

WALTER L. RUBENS & CO. INC.
410 N. Michigan Ave., Chicago 11
Tel.: Whitehall 4-3540

Radio Dept.: Walter Rubens, president.

CHARLES RUMRILL CO. INC.
339 East Ave., Rochester 4, N. Y.
Tel.: Baker 4340

RUTHRAUFF & RYAN INC.
405 Lexington Ave., New York 17
Tel.: Murray Hill 6-6400

Radio Dept.: Wilson Tuttle, vice president in charge of radio and television; Grant Y. Flynn, television manager; Tom Slater, network timebuyer and director of program and talent development; John G. Cole, production manager; Robert Steel, senior director; Miss Kathleen McMahon, casting director; Bernard Rasmussen, business manager; Sidney Slon, script editor; Bernard Zwin, publicity director; Louis DeMilhau, manager of Canadian operation.

Chicago 1—360 N. Michigan Ave. Tel.: Franklin 2-9485. R. W. Metzger, V.P.

Hollywood 28—1680 N. Vine St. Tel.: Hillside 7593.

Detroit 2—7430 Second Blvd. Tel.: Madison 1980.

Baltimore—7 West Hamilton St.

Toronto—90 Richmond St. W. Tel.: Adelaide 4069.

Radio Accounts: American Safety Razor (S); Allied Florists (S); Chrysler (Dodge) (S); D. L. & W. "Blue Coal" (N-S); Prestolite Battery (S); Auto-Lite (N); Garrett Co. (S); Gunther Brewing (N-S); David E. Kennedy (S); Lever, U. S. (N-S); Lever, Canada (N-S); N. Y. Savings Banks (S); United Florists (S); Wrigley Gum (N); Mutual of Omaha (S); Griesdieck Brewery (S); Morris B. Sacks (S); Galveston-Houston Brewery (S).

Television Accounts: Chrysler (Dodge) (S); Garrett & Co. (S); Gunther Brewing (N-S); Lever, U. S. (N-S); N. Y. Savings Banks (S); Griesdieck Brewery (S); Tower Grove Bank & Trust Co. (S); United Wallpaper Co. (S); Baldwin Piano (S); Goodall Fabric (S).

LEWIS EDWIN RYAN
726 Jackson Place, N.W., Washington 6, D. C.
Tel.: Republic 7606

Radio Dept.: Gordon Manchester, radio and television director; Bette Murphy, continuity.

Radio Accounts: Capital Airlines; Wilkins Coffee; Appalachian Apples; Safeways Stores (Mid-Atlantic Div.); Millstream Cereal Co. (Covered Wagon Corn Meal); Jekyl Island Packing Co.; Dixiana Brand Frozen Foods.

Television Accounts: Thompson Dairies; Chas. Schneider Baking Co.

RYDER & INGRAM LTD.
1924 Franklin St., Oakland 12
Tel.: Templebar 2-0363

Radio Dept.: Ross H. Ryder, Robert L. Ingram, E. A. Bonfield, account executives; Estelle Guy, timebuyer.

S

BEN SACKHEIM INC.
22 W. 59th St., New York 19
Tel.: Plaza 9-5141

Radio Dept.: Leonard H. Spring, timebuyer.

MAXWELL SACKHEIM & CO.
670 Fifth Ave., New York 19
Tel.: Plaza 8-2086

Radio Dept.: Richard Shack, radio and television director.

ST. GEORGES & KEYES INC.
250 Park Avenue, New York 17
Tel.: Plaza 5-1180

Radio Dept.: Stanley J. Keyes Jr., radio director.

Baltimore 18—2112 N. Charles St. Tel.: Belmont 7095.

Stamford, Conn.—322 Main St. Tel.: 3-7514

RICHARD SALINGER
99 Chauncy St., Boston 11
Tel.: Liberty 2-5332

Radio Dept.: Richard Salinger, timebuyer; Irving Sacks, television director.

SALOW & RIEDL
82 Lexington Ave., Passaic, N. J.
Tel.: Gregory 3-1414

Radio Dept.: H. Harvey Salow, timebuyer and media director.

WALKER SAUSSY ADVERTISING
318 Carondelet St., New Orleans 12
Tel.: Magnolia 3218

Radio Dept.: Walter Saussy, Moise Bloch, W. S. Pleasants, Dorothea Schlesinger, P. J. Stakleum Jr.

Radio Accounts: American Brewing Co. (S); Elmer Candy Co.; J. T. Gibbons Inc.; Petrolane Gas Co. (S); Wm. B. Reilly Co.; E. A. Stephens Buick Co. (S).

SAVAGE & TALLEY
Fountain Square Bldg., Cincinnati 2
Tel.: Main 1164

Radio Dept.: William Savage Jr., Thomas M. Talley, partners.

SAWDON ADVERTISING CO.
480 Lexington Ave., New York 17
Tel.: Plaza 5-2516

Radio Dept.: Frank B. Sawdon, president; Jerry Bess, radio director. Chicago—737 N. Michigan. Tel.: Superior 7-8121. Marty Hogan, manager.

Radio Accounts: Robert Hall Clothes (S); Abelson's Inc. (S).

ROSS SAWYER ADV.
8438 Melrose Ave., Los Angeles 46
Tel.: Webster 6275

Radio Dept.: Ross Sawyer, timebuyer and account executive.

SCHACTER AND FAIN INC.
18 East 41st Street, New York 17
Tel.: Le 2-2909

Radio Dept.: Priscilla E. Kerman, media director.

SHECK ADVERTISING AGENCY INC.
9 Clinton St., Newark 2
Tel.: Market 2-0490

Radio Dept.: E. Grant Scheck, Morris Scheck, Julius Scheck, Wm. Andrews, account executives.

HUGO SCHEIBNER INC.
111 W. 7th St., Los Angeles 14
Tel.: Michigan 6636

Radio Dept.: Hugo Scheibner, president, radio and television director, timebuyer.

SCHOENFELD, HUBER & GREEN
380 N. Michigan Ave., Chicago 1
Tel.: Central 6-5593

Radio Dept.: Merritt R. Schoenfeld, president and account executive; Lewis G. Green, vice president, radio and television director; Ken Ward, timebuyer, account executive; Marie Karlstrom, production manager.

Radio Accounts: Fruit Industries Ltd. (S); Enzo Jel Co.; Venice Maid.

SCHOLTS ADVERTISING SERVICE
1201 West Fourth St., Los Angeles 13
Tel.: Michigan 2396

Radio Dept.: Tom Scholts, radio and television director; L. G. Myhro, promotion and merchandising.

GORDON SCHONFARBER & ASSOC. INC.
58 Weybosset St., Providence 3
Tel.: Gaspee 1-4813

Radio Dept.: Claire R. Grenier, radio director; Gordon Schonfarber, account executive.

Radio Accounts: Old Colony Cooperative Bank (S); Tilden-Thurber Inc. (S); Colonial Laundry (S); Gladings Inc. (S); Otto Seidner Inc. (S); Kestenman Bros. Mfg. Co. (S).

Television Account: Kestenman Bros. Mfg. Co.

HAROLD S. SCHWARTZ & ASSOC.
1227 Loyola Ave., Chicago 26
Tel.: Rogers Park 4-1502

Radio Dept.: Harold S. Schwartz, president.

Radio Accounts: Hollywood Film Studios (S); Guarantee Reserve Ins. Co. (S); Lancaster Seed Co. (S).

SCHWIMMER & SCOTT INC.
75 E. Wacker Drive, Chicago 1
Tel.: Dearborn 2-1815
Evelyn Vanderpoeg, media director.

Radio and Television Accounts: Keeley Brewing Co.; Walgreen Drug Co.; Puritan Co. of America (Realemon); Salerno-McGowen Biscuit Co.; National Tea Co.; Hawthorne Melody Farms; Mickelberry Sausage Co.; Banquet Chicken Co.; Congress Cigar Co. (La Palina); Dutch Mill Candy Co.; Spiegel Inc.; Helzberg Jewelry Co.; U. S. Government Treasury Division; Coronet Magazine; Esquire Magazine; Chicago Stadium; Lehon Co. (Mulehide Roofing Products); Schutter Candy Co.; Erie Clothing Co.

HUNTER SCOTT ADVERTISING AGENCY
752 Fulton St., Fresno 1, Calif.
Tel.: 3-3283

Radio Dept.: Helen Andrews, timebuyer.

SCOTT'S AGENCY INC.
11 Pemberton Square, Boston 8
Tel.: Capitol 7-2425

Radio Dept.: George L. Stingel, radio director and timebuyer.

J. B. SEBRELL ADVERTISING AGENCY
300 S. Los Angeles St., Los Angeles 13
Tel.: Madison 6-9397

Radio Dept.: P. W. Thomas. Radio Accounts: Children's Mart (S); Eject Donut Sales (S); J. B. Sebrell Corp. (S).

RUSSEL M. SEEDS CO.
919 North Michigan Ave., Chicago 11
Tel.: Delaware 7-1045

Radio Dept.: Jack Simpson, radio and television director; Merle Myers, timebuyer.

Hollywood—1469 N. Vine St. Tel.: Hudson 2-1206.
New York—4421 Empire State Bldg. Tel.: Longacre 3-2655.
Indianapolis—Lemcke Bldg. Tel.: Market 1395.

Radio Accounts: Brown & Williamson Tobacco Co. (N-S); the Pinex Co. (S); Procter & Gamble (Red Skelton) (N); W. A. Sheaffer Pen Co. (N).

ROSCOE W. SEGAR AGENCY
2125 N. E. 48th Ave., Portland 13, Ore.
Tel.: Trinity 3445

Radio Dept.: R. W. Segar, radio director; D. Segar, timebuyer and account executive.

Radio Accounts: Miklas & Son (S); G. B. Wallace Co. (S).

WM. G. SEIDENBAUM ADV. AGENCY
9 E. 40th St., New York 16
Tel.: Murray Hill 3-3763

SEWELL, THOMPSON & CARIE
852 Carondelet, New Orleans 12
Tel.: Raymond 7114

Radio Dept.: Granville Sewell, president.

SHAFFER, BRENNAN, MARGULIS ADV. CO.
4 N. 8th St., St. Louis 1
Tel.: Main 2579

Radio Dept.: Sam B. Margulis, partner, radio director.

ED SHAPIRO ADVERTISING
1612 Market St., Philadelphia 3
Tel.: Locust 4-2877

Radio Dept.: R. Goddes, media director.

SHAPPE-WILKES INC.
215 Fourth Ave., New York 3
Tel.: Gramercy 5-5560

Radio Dept.: Louis Shappe, president and radio director.

THE SHAW COMPANY
816 W. 5th St., Los Angeles 13
Tel.: Mutual 5161

JOHN W. SHAW ADVERTISING INC.
221 N. LaSalle St., Chicago 1
Tel.: Dearborn 2-5082

Radio Dept.: Robert Zelens, radio and television director.

Radio Accounts: Jacob E. Decker & Sons (Div. of Armour & Co.); Drummond Packing Co.; Chicago Laundry Owners Assn.

Television Account: Standard Milling Co.

K. E. SHEPARD ADVERTISING AGENCY
75 E. Wacker Dr., Chicago 1
Tel.: Andover 3-5966

Radio Dept.: K. E. Shepard, owner; Ben Homan, Frank McBride, account executives.

SHERMAN & MARQUETTE
919 N. Michigan Ave., Chicago 11
Tel.: Delaware 7-8000

Radio Dept.: Louis E. Tilden, radio director. Chicago: C. E. Bolgard, R. G. Dexter, media, Chicago: J. B. Crandall, media director, New York: L. D. Griffith, television department.

New York—10 Rockefeller Plaza, Tel.: Plaza 7-6400

Radio Accounts: Colgate Palmolive Peet Co. (N-S); The Quaker Oats Co. (N-S); Dr. W. B. Caldwell Co. (S); (Breath-o-lator); Oscar Mayer & Co.

SHERMAN AND SHORE ADV.
235 Montgomery St., San Francisco, Calif.
Tel.: Douglas 2-2318

New York—4616 Chrysler Bldg. Tel.: Murray Hill 3-3293.
Hollywood—6331 Hollywood Blvd. Tel.: Hudson 2-2321.

Radio Dept.: Robert Sherman and Sig Steven Shore, co-radio directors and timebuyers.

(Continued)

In the
4,000,000
Los Angeles
MARKET

K X L A

with
10,000 watts
on
1110 Kc

**Can do
A
REAL
JOB
for YOU!**

We're loaded with
local business . . .
have no . . .
Nat'l. Rep. . . .
*but your
inquiry will
be welcomed.*

**1949 - Our Best
Loyal K. King, Pres.-Mgr.**

K X L A

10,000 on 1110

ADVERTISING AGENCIES HANDLING RADIO AND TV ACCOUNTS

(Continued)

N indicates network, S spot

SHORT & BAUM ADVERTISING
718 W. Burnside St., Portland 9,
Oregon.
Tel.: Beacon 3167
San Francisco—240 Stockton St. Hal
E. Short, manager.

H. CHARLES SIECK, INC. LTD.
407 Commercial Center St., Beverly
Hills, Calif.
Tel.: Bradshaw 2-6403
Radio Dept.: H. Charles Sieck, presi-
dent; Gerald T. Sieck, account
executive.

CHARLES SILVER & CO.
737 N. Michigan Ave., Chicago 11
Tel.: Superior 7-6825

SILVERMAN ADV. AGENCY
400 N. Michigan Ave., Chicago 11
Tel.: Superior 7-1040
Radio Dept.: M. B. Silverman, owner,
account executive.

**ALFRED J. SILVERSTEIN-BERT
GOLDSMITH INC.**
16 E. 40th St., New York 16
Tel.: Oregon 9-3100
Radio Dept.: Robert H. Sill, media di-
rector.

SIMMONDS & SIMMONDS INC.
201 N. Wells St., Chicago 6
Tel.: Andover 3-8645
Radio Dept.: Phil W. Tobias Sr., presi-
dent and account executive; Sher-
win Tobias, timebuyer.
St. Louis—811 Olive St. Tel.: Garfield
6357. Merle Fuller, vice-president.

JAMES F. SIMONS CO.
914 Warner Bldg., Nashville 3
Tel.: 6-4633

SIMON & GWYNN
Commerce Title Bldg., Memphis 3
Tel.: 5-2404
Radio Dept.: Ralph Bubis, television di-
rector.

SIMONS-MICHELSON CO.
1126 Lafayette Bldg., Detroit 26
Tel.: Woodward 3-3000
Radio Dept.: Marian Sanders, radio and
television director; Ruthven Simons,
assistant director; Sam Rubin,
Joshua Sarasbon, Charles Stone,
Joe Morrison, account executives.

Radio Accounts: Benrus Watch Co. (S);
Burt's Inc. (S); Cunningham's Drug
Stores; Dossins Food Products;
Greenwald's Jewelry; Koeppinger
Bakery (S); Schmidt Brewing Co.
(S); Scotland Woolen Co. (S); Simons
& Clark (S); Taylors Inc. (S);
Velvet Peanut Products (S); Phil
Bloomgarden Inc. (S); Kaiser Frazer
Dealers (S); Frazer Paint Co.
(S); Marine Foods Inc. (S); Marks
Furs (S); Benjamin Rich; Troy
Laundry (S); Worth Clothes (S);
Colonial Dept. Stores.

Television Accounts: Cunningham's
Drug Stores; Schmidt Brewing Co.;
Marks Furs; Benjamin Rich; Velvet
Peanut Products; Worth Clothes.

SIVE & ROSENFELD INC.
22 W. 7th St., Cincinnati 2
Tel.: Garfield 3000

**PAUL SMITH ADVERTISING
AGENCY**
24 W. 45th St., New York 19.
Tel.: Murray Hill 7-8337.
Radio Dept.: Robert R. Smith, radio
and television director.
Television Accounts: Rison Mfg. Co.
(S); Princes Eve Inc. (S).

SMITH & BULL AGENCY
6642 Sunset Blvd., Hollywood 28
Tel.: Hemstead 5671
Radio Dept.: Georgia Small, timebuyer;
Dick Garton, radio and television
director; Henry R. Konysky Sr.,
publicity and public relations; Mel
Roach, Dick Smith, Frank Bull,
account executives.

Radio Accounts: Marshall and Clamp-
pert (S); Western Harness Racing
Assn. (S); Los Angeles Rams Foot-
ball Club (S); Seaboard Finance
Co. (S); Triangle Pub. (West
Coast) (S); J. E. Coberly Inc. (S).

SMITH, TAYLOR & JENKINS INC.
223 Fourth Ave., Pittsburgh 22
Tel.: Atlantic 1-9312
Radio Dept.: T. J. MacWilliams, radio
and television director; Les Sterne,
copy and production; L. C. Thomp-
son TV films.

W. J. SMITH CO.
Martin Brown Bldg., Louisville 2
Tel.: Jackson 2165
Radio Dept.: I. M. Diebold, radio di-
rector.

**SON DE REGGER ADVERTISING
AGENCY**
1020 Locust St., Des Moines 9
Tel.: 3-3185
Radio Dept.: Les Son De Regger, presi-
dent, timebuyer.

SORENSEN & CO.
919 N. Michigan, Chicago 11
Tel.: DELaware 7-5030

SOUTH AGENCY
Farley Bldg., Birmingham 3
Tel.: 4-8554
Radio Dept.: Suzie Tubbs, radio di-
rector; James Crim, timebuyer.

**SPARROW ADVERTISING AGENCY,
INC.**
Farley Bldg., Birmingham 3
Tel.: 3-0287
Radio Dept.: J. Martin Smith, radio
director.

CHARLES N. STAHL ADV.
542 S. Broadway, Los Angeles 13
Tel.: Madison 7844
Radio Dept.: Tom Cafferty, radio di-
rector, account executive; Charles N.
Stahl, television director; K. Hul-
dermann, account executive.

Radio Accounts: Dr. Beauchamp South-
ern California Dental Offices (S);
Dr. A. Reed Shoe Co.; Model Fur-
niture Manufacturing; A. E. Nug-
ent Chevrolet; Kling Mfg. Co.;
Lighthouse Restaurant.
Television Accounts: Dr. Beauchamp
(S); Murphy Motors Co.

STANDARD ADVERTISING AGENCY
188 W. Randolph St., Chicago 1
Tel.: Randolph 6-1188
Radio Dept.: William Erny, timebuyer.

**THE STANLEY ADVERTISING
AGENCY, INC.**
David Broderick Tower, Detroit 26
Tel.: Woodward 5-6155
Radio Dept.: Stanley Altschuler, man-
ager; Leonard Kotowski, continuity
writer; Virginia Branson, time-
buyer.

BARTON A. STEBBINS
1250 Wilshire Blvd., Los Angeles 14
Tel.: Trinity 8821
Radio Dept.: E. C. Bloodworth, radio
director; A. W. Gudelman, time-
buyer; Walter Jensen, Nat Jeffras,
account executives.

STERLING ADVERTISING AGENCY
70 W. 40th St., New York 18
Tel.: Longacre 5-4610
Radio Dept.: Myron L. Broun, director
of radio and television.

JEWELL F. STEVENS CO.
28 E. Jackson Blvd., Chicago 4
Tel.: Wabash 2-7941
Radio Dept.: Wilson Brown, vice presi-
dent and radio director.

THE STEWART-JORDAN CO.
Lincoln-Liberty Bldg., Philadelphia 7
Tel.: Locust 7-4637
Radio and Television Dept.: Garry Bub,
vice president and radio director.

GLEE R. STOCKER & ASSOCIATES
721 Olive St., St. Louis 1
Tel.: Central 0742
Radio Dept.: John T. Southwell, radio
director; Granville Rutledge, time-
buyer.

STOCKTON-WEST-BURKHART, INC.
First National Bank Bldg., Cincinnati 2
Tel.: Dunbar 5600
Radio Dept.: R. S. West, vice-president
radio and television director; Her-
bert S. Lenz, Joseph D. Nelson,
Edward P. Broome, Harry S. Robin-
son, account executives.

Radio Accounts: Cincinnati Gas &
Electric Co. (S); Cincinnati En-
quirer (S); U. S. Shoe Co. (S);
The Ohio Oil Co. (S).
Television Accounts: Cincinnati Gas &
Electric Co.; Ohio Oil Co.

STOCKWELL & MARCUSE
Industrial Bank Bldg., Detroit 26
Tel.: Woodward 2-4484
Radio Dept.: W. H. Stockwell, radio
director.

STORM & KLEIN INC.
50 E. 42d St., New York 17
Tel.: Murray Hill 6-2820
Radio Dept.: Edward Klein, media di-
rector; Arthur Klein, timebuyer.

**STRANG & PROSSER ADVERTISING
AGENCY**
Securities Bldg., Seattle 1
Tel.: Elliot 1322

**STRAUCHEN & MCKIM ADVERTIS-
ING**
6 E. 4th St., Cincinnati 2
Tel.: Main 1618
Radio Dept.: John G. Maupin, radio
and television director; Charles
Diebel, assistant TV director;
Mary Trauer, timebuyer; Edmund
R. Strauchen, Gordon F. McKim
Jr., John Quackenbush, account
executives.

Radio Accounts: Geo. Weideman Brew-
ing Co. (S); Crosset Co. (S); Cin-
cinnati Raceways Inc. (S); Numm
Motors (S); Brand-Amour Inc. (S);
Geo. Byers Sons (S); Four-Way
Aluminum (S).
Television Account: Geo. Weideman
Brewing Co.; Crosset Co.; Cincin-
nati Television Sales (S); Myers
Y. Cooper Co. (S); Hyde Park
Lumber Co. (S); Four-Way Alu-
minum (S).

J. M. STRAUS & CO.
422 South Western Ave., Los Angeles 5
Tel.: Dunkirk 3-5072
Radio Dept.: Lester Jay, radio and
television director; J. M. Straus,
account executive.

STREET & FINNEY INC.
76 9th Ave., New York 11
Tel.: Watkins 4-8510
Radio Dept.: Howard Miller, radio di-
rector; Warren Faxon, John T.
Kelly Jr., account executives;
Helen A. Thomas, timebuyer.
Chicago—120 South LaSalle St. Tel.:
Randolph 6-3657, Frank E. Dug-
gan, account executive.

CHARLES R. STUART ADVERTISING
625 Market St., San Francisco 5
Tel.: Douglas 5-2438
Radio Dept.: Henry L. Buccello, ac-
count executive; John Crain, time-
buyer.
Radio Account: Bank of America.

SUDLER COMPANY
412 W. Sixth St., Los Angeles 14
Tel.: Trinity 0709
Radio Dept.: Robert B. Hunt, director.

DANIEL F. SULLIVAN CO.
216 Tremont St., Boston 16
Tel.: Hancock 6-7643
Radio Dept.: Eugene Stafford, radio
and television director.

Radio Accounts: F. H. Snow (S); Ham-
id Morton Circus (S); Revere Rac-
ing (S); Middlesex County Banks;
Eastern Mass. State Railway Co.;
Metro Distributors; R. S. Robie
Inc.; Davis Brothers Fisheries (S);
Carlings Red Cap Distributors;
Kaler Carney Lifter & Co.; Nu-
Enamel (S); Cranada Wines Inc.;
N. E. Studebaker Dealers Assn.;
Roberts Tech. Schools; Hickox
School; Nutters System; Serago-
Moc (S); Wilbur-Williams (S).

**SULLIVAN, STAUFFER, COLWELL
& BAYLES INC.**
437 Fifth Ave., New York 16
Tel.: Oregon 9-2500
Radio Dept.: Phil Cohen, vice presi-
dent; radio and television director.
Hollywood 28—6253 Hollywood Blvd.
Tel.: Gladstone 5046. J. J. Van No-
strand Jr., vice-president, radio
and television director.

G. LYNN SUMNER CO.
444 Madison Ave., New York 22
Tel.: Plaza 3-8730

MORRIS F. SWANEY INC.
135 South La Salle St., Chicago 3
Tel.: Andover 3-4171.
Leonard F. Thornton, media director.
Detroit 2—Fisher Building. Tel.: Trin-
ity 3-3750.
New York 22—445 Park Avenue. Tel.:
Plaza 9-6920. Earl G. Thomas, ra-
dio director.

SYMONDS, MACKENZIE & CO. INC.
407 S. Dearborn St., Chicago 5
Tel.: Wabash 2-8056
Radio Dept.: J. Morse Ely.

T

TAGGART & YOUNG
7364 Beverly Blvd., Los Angeles
Tel.: Webster 3-8108
Radio Dept.: E. L. Taggart, radio and
television timebuyer.
Radio and Television Accounts: Pontiac
Dealers of Southern California (S).

J. D. TARCHER & CO.
630 Fifth Ave., New York 20
Tel.: Circle 6-2626
Radio Dept.: Edmund C. Ridley, Len
Tarcher, account executives.

TATHAM-LAIRD INC.
20 N. Wacker Drive, Chicago 6
Tel.: Randolph 6-2171
Radio Dept.: George A. Bolas, radio
and television director; Dan P.
Ryan, radio and television pro-
ducer; Paul Schlesinger, radio and
television timebuyer.

Radio Accounts: General Mills, Inc.
(N-S); Jelke Div.—Lever Bros.
(S); Bendix Home Appliance (S);
Bear Brand Hosiery (S).

SAMUEL TAUBMAN & CO.
150 N. Sansom St., Philadelphia 2
Tel.: Locust 4-0792
Radio Dept.: S. Taubman, Raymond H.
Love.

GEORGE TAYLOR ADV. AGENCY
420 Market St., San Francisco 11
Tel.: Garfield 1-6812
Radio Dept.: George Taylor, Carl
Christopher.

Radio Accounts: J. E. French Co. (R);
Byington Electric Co. (S); Church
of the Nazarene (R); Roberts at the
Beach (S); Exposition Grotto (S);
Hobergs Resorts (S); Henry Doelger
(S); Glad Tidings Temple (S);
Larkspur Fire Dept. (S); Panell's.

J. WALTER THOMPSON COMPANY
420 Lexington Avenue
Tel.: Murray Hill 3-2000

Radio Dept.: Stanley Resor, president;
John U. Reber, vice president in
charge of radio and television; Lin-
nea Nelson, radio and television
timebuyer; Virginia Spragle, radio
and television talent buyer.

Chicago—410 North Michigan Ave. Tel.:
Superior 7-0303. Henry T. Stanton,
vice president and general man-
ager; Harold R. Rorke, radio di-
rector; Ed Fitzgerald, radio and
television timebuyer.

Hollywood—1549 North Vine St. Tel.:
Hillside 7241. Cornwell Jackson,
vice president and manager.

San Francisco—320 California St. Tel.:
Garfield 3510. Fred Fidler, vice
president and manager; Henry M.
Jackson, radio director; Frances
Young, radio timebuyer.

Los Angeles—645 South Flower St. Tel.:
Madison 2661. Robert B. Shirey,
general manager; Jane Herbert, ra-
dio timebuyers.

Radio Accounts: Atlantis Sales Corp.
(S); P. Ballantine & Sons (S);
Fanny Farmer Candy Shops (S);
Ford Dealer Advertising Groups
(S); General Cigar Co. (S); Johns-
Manville Corp. (N); Kraft Foods
Co. (N-S); Lever Brothers Co. (S);
Libby, McNeill & Libby (S);
Northern Trust Co. (S); Pan
American World Airways (S); Pen-
ick & Ford, Ltd. Inc. (S); RCA Vic-
tor-Division of Radio Corporation of
America (S); Safeway Stores,
Inc. (S); Shell Oil Co. Inc. (S);
Standard Brands Inc. (S); Swift &
Co. (N-S); Ward Baking Co. (S);
Washington State Apple Commis-
sion (S); Devoe & Reynolds (S);
Indiana Bell Telephone Co. (S);
International Minerals & Chemi-
cal Corp. (S); Lamont Corliss &
Co. (S); San Francisco Chronicle
(S); Scott Paper Co. (S); Trailer
Coach Mfg. Co. (S).

Television Accounts: Elgin National
Watch Co.; Ford Dealers; Scott
Paper Co.; Kraft Foods; RCA Vic-
tor; F. Ballantine & Sons (N); Bow-
man Dairy (S); Holly Sugar Corp.
(S); Lever Bros. (N); Libby, Mc-
Neill & Libby (N); Parker Pen Co.
(S); Pharma Craft Corp. (S); Swift
& Co. (S); Ward Baking Co. (S);
J. B. Williams (S); Wine Advisory
Board (N).

MORRIS TIMBES ADVERTISING INC.
214 St. Michael St., Mobile 3, Ala.
Tel.: 2-7577

Radio Dept.: Jack Lewis, radio director and account executive; Morris Timbes, account executive.

Radio Accounts: Haas-Davis Packing Co. (Meats); China Doll Rice; Spearman Beer; Sharpe-Wheyland; Goldstein (Jewelry).

RALPH TIMMONS INC.
1 S. Pinckney St., Madison 3, Wisc.
Tel.: Gifford 3681

Radio Dept.: L. H. Stafford, radio director & timebuyer.

ALFRED F. TOKAR
850 Broad St., Newark 2
Tel.: Mitchell 2-2561

Radio Dept.: Norman Tokar, radio director & timebuyer.

THE TOLLE CO.
1340 3rd Ave., San Diego 1
Tel.: Franklin 6606

Radio Dept.: Julian M. Kaufman, radio and television director; Muriel Tolle, V. P., timebuyer and account executive; Norman Tolle, Robert C. Wilson, account executives.

Radio Accounts: Hage's Ltd.; McCune Motors; City Chevrolet Co.
Television Accounts—Hage's Ltd.; Hage & Lunch.

CHARLES TOMBRAS & ASSOCIATES
Knafel Bldg., Knoxville, Tenn.
Tel.: Knoxville 2-5046

Radio Dept.: Kenneth Wright, radio director.

TOMOWSKE ADVERTISING AGENCY INC.

Chronicle Bldg., Spokane 8
Tel.: Riverside 1159

Radio Dept.: W. Ogle, president; J. Walter McLean, vice president; Milton M. Myers, account executive.

ARTHUR TOWELL INC.
119 Monona Ave., Madison 3, Wis.
Tel.: 6-2668

Radio Dept.: Edward Kirley, radio director.

TRACY, KENT & CO. INC.
515 Madison Ave., New York 22
Tel.: Eldorado 5-4404

Radio Dept.: Alfred G. Moss, radio and television director; P. A. Baecker, timebuyer.

Radio Accounts: The Taylor-Reed Corp. (S); Celomat Corp. (S); Teddys, the House of Sea Food Inc. (S).

Television Account: Celomat Corp. (S).

TRACY-LOCKE CO. INC.
1307 Pacific Ave., Dallas 1
Tel.: Riverside 8655

Radio Dept.: Ernestine Parker, media director and timebuyer; Morris L. Hite, Ernest L. Lovan, Clay W. Stephenson Jr., account executives.

Radio Accounts: Burrus Mill & Elevator Co. (N); Imperial Sugar Co. (N); Mrs. Baird's Bread Co. (S); Republic National Bank (S); Neuhoff Brothers (S); Resistol Hats Inc. (S).

TRIANGLE ADV. AGENCY
201 N. Wells St., Chicago 6
Tel.: Randolph 6-4394

Radio Dept.: Kenneth A. Ford, president, account executive.

THE TULLIS CO.
6000 Sunset Blvd., Hollywood 28
Tel.: Hempstead 6831

Radio Dept.: Howard L. Tullis, president; Willy Brasile, timebuyer; Ben Lang, television director.

TURNER ADVERTISING AGENCY
520 N. Michigan Ave., Chicago 11
Tel.: Superior 7-2161

Radio Dept.: A. F. Marthens, director radio and television.

U

C. J. ULRICH & ASSOCIATES
77 W. Washington, Chicago 2
Tel.: Andover 3-5328

Radio Dept.: C. J. Ulrich, president and manager.

PHILIPS WEBB UPHAM & CO.
110 Whitney Ave., New Haven, Conn.
Tel.: 6-6828

Radio Dept.: Philips Webb Upham, in charge of radio research.

V

VALLEY ADV. CO.
113 W. 4th St., Weslaco, Tex.
Tel.: Weslaco 175

Radio Dept.: J. D. Grafton, president, radio director & timebuyer.

VAN AUKEN, RAGLAND & STEVENS
326 W. Madison St., Chicago 6
Tel.: Franklin 2-2910

Radio Dept.: B. F. Stevens, Kenneth L. Van Auker, C. A. Ragland, account executives.

JOHN B. VAN DOMELEN AGENCY
Federal Square Bldg., Grand Rapids 2, Mich.
Tel.: 9-3453

Radio Dept.: John B. Van Domelen, owner and timebuyer; Robert Riekse, television director.

VANGUARD ADVERTISING
15 E. 40th St., New York 18
Tel.: Murray Hill 5-4686

VAN HECKER INC.
664 N. Michigan Ave., Chicago 11
Tel.: Delaware 7-3122

Radio Dept.: C. E. Van Hecker, president; Wm. F. Barkow, account executive.

VAN SANT, DUGDALE & CO. INC.
Court Square Bldg., Baltimore 2
Tel.: Lexington 5400

Radio Dept.: Robert V. Walsh, director of radio and television; R. E. Daiger, C. M. Buchanan, H. G. Erck, Wm. Dugdale, T. F. C. Quinn, Daniel J. Loden, account executives; media director, Urban Moss.

Radio Accounts: Fram Corp. (N-S); Sherwood Bros. (N-S); York Wallpaper (S); Esskay Meats (S); Anchor Post (S); Glenn L. Martin (S); Home Utility (S); Crosse & Blackwell (S); International Bedding (N-S); Koppers Co. (S); Manhattan Laundry (S); Marbert Products Inc. (S); Interstate Building and Savings (S); Maryland Title Guarantee (S); Miller Metal Prod. (S); Wm. Montgomery Co. (S); Rice's Bakery (S); F. S. Royster Guano (N); Weaver Bros. (S).

VENABLE-BROWN CO. INC.
211 E. Fourth St., Cincinnati 2
Tel.: Dunbar 0667

Radio Dept.: Dolores Mescher, timebuyer.

M. BELMONT VER STANDIG
1917 I St., N.W., Washington, D. C.
Tel.: Republic 2929

Radio Dept.: M. Belmont Ver Standig, president; James Milloy Jr., account executive.

Radio Accounts: Kretol Chemical Co.; Southern Venetian Blind Co.; Tru Blue Beer; General Electric Supply Corp.; Dowd's Radio & Electric Co.; Lincoln Loan; Colony Radio Sales & Service; General Electronics; Greenspring Dairy; Embassy Dairy.

Television Accounts: General Electric Supply Corp.; Dowd's Radio & Electric Co.; Colony Radio Sales & Service; General Electronics; Greenspring Dairy.

CARLO VINTI ADVERTISING
431 Fifth Ave., New York 16
Tel.: Lexington 2-9477

Radio Dept.: Carlo Vinti, owner and production manager; Ben Vinti Jr., account executive.

W. L. VOMACK INC.
420 Madison Ave., New York 17
Tel.: Eldorado 5-4874

HENRY Von MORPURGO & CO.
256 Sutter St., San Francisco 8
Tel.: Douglas 2-8920

Radio Dept.: William Pucock, radio director.

Los Angeles—521 N. La Cienega Blvd.
Tel.: Crestview 6-6211

San Francisco—406 Sutter. Tel.: Douglas 2-8920.

Piedmont—65 Crocker Ave.
New York—205 E. 42nd St.
Chicago—Banker's Bldg.

Radio Accounts: Shanghai Syndicate; Sister Kenny Foundation; Fer-Aide.

Television Account: Mitchell Camera.

W

WADE ADVERTISING AGENCY
20 N. Wacker Dr., Chicago 6
Tel.: SState 2-7369

Radio Dept.: Jeff Wade, radio director; Louis J. Nelson, radio media director; L. W. Davidson, Booth Luck, R. O. Archer, account executives; W. B. Condon, timebuyer.

Los Angeles 13—411 W. Fifth St. Tel.: Michigan 2-8608. Robert E. Dwyer, manager; F. O. Owen Jr., radio director.

Radio Accounts: Miles Labs. (N-S); Murphy Products Co. (S); Wait-Cahill Co. (S); Shotwell Mfg. Co. (S); Miles California Co. (N-S); Farmer's Union Jobbing Assn. (S); Los Angeles Nut House (S).

WADSWORTH & WALKER INC.
4071 Barbarossa Ave., Miami 33, Fla.
Tel.: Miami 4-9823

Radio Dept.: Ralph K. Wadsworth, timebuyer.
New York 17—389 Lexington Ave. Tel.: Murray Hill 5-6100

HUGO WAGENSELL & ASSOCIATES
Talbot Bldg., Dayton 2
Tel.: Hemlock 5542

Radio Dept.: James Bridges, radio and television director; F. R. Harwood, account executive; A. M. Hogue, timebuyer.

Radio Accounts: Gallaher Drug Co. (S); Bonded Oil Co. (S); First Nat'l Bank (S); Albers Super Markets (S); Dayton Power & Light Co. (S); Gem City Ice Cream (S); Ohio Yellow Cab Co. (S); Christian Rural Overseas Program (N); Third Nat'l Bank (S).

Television Accounts: Gem City Ice Cream (S); Chrystal Rug & Carpet Co. (S); Anderson Plano Co. (S); Grismer Tire Co. (S).

CARL C. WAKEFIELD ADV. AGENCY

Kohl Bldg., San Francisco 4
Tel.: Douglas 2-5407

Radio Dept.: Carl C. Wakefield, president.

WALKER & DOWNING
Oliver Bldg., Pittsburgh 22
Tel.: Grant 1900

Radio Dept.: R. C. Woodruff, radio director; Walter Sickles, television director.

WALLACE-FERRY-HANLY CO.
400 W. Madison St., Chicago 6
Tel.: Franklin 2-6440

(For Personnel, see Hanly, Hicks and Montgomery.)

WARD, MACDONALD & STAGG
12 Geary St., San Francisco 8
Tel.: Yukon 6-0389

Radio Dept.: A. H. Stagg, timebuyer and account executive.

HAROLD WARNER CO.
M & T Bldg., Buffalo 2
Tel.: Madison 2100

Radio Dept.: Harold J. Warner, president.

WARNER, SCHULENBURG, TODD & ASSOC.
1415 North & South Blvd., St. Louis 17
Tel.: Republic 9160

Radio Dept.: Ralph E. Schulenburg, vice president and radio director.
Alton, Ill.—Tel.: 2-2311

WILLIAM WARREN AGENCY
45 W. 45th St., New York 19.
Tel.: Judson 6-0350

Radio Dept.: William W. Solow, radio director; Stevens P. Jackson, television director; Harry Solow Jr., timebuyer; J. C. Silverman, George Deller, William Solow, L. W. Kaye, S. P. Jackson, account executives.

Radio Accounts: Alexanders Dept. Store; Sachs Quality Stores; Strauss Stores; Cardinal Tie Shops; Pierce School of Radio and Television; Flag Pet Food; Sophia Bros. Inc.; Lord & Taylor; Warren-Connelly; Speers Furniture; Federal Life & Casualty Co.; Snow White Products; Stevens Appliances; Regent Clothes; Bop City; Ritz Thrift Shop; Ivel Furs, all spot.

WARWICK & LEGLER INC.
230 Park Ave., New York 17
Tel.: Murray Hill 6-8585

Radio Dept.: Tevis Huhn, director of radio; L. M. Malitz, media director; H. Paul Warwick, president; J. R. Warwick, C. E. Staudinger, vice presidents.
Hollywood 28—6331 Hollywood Blvd.

NORMAN D. WATERS & ASSOC. INC.
6 East 39th St., New York 16
Tel.: Murray Hill 5-8950

Radio Dept.: Louis Landesman, radio director.

WATTS-PAYNE ADVERTISING INC.
205 South Cheyenne, Tulsa 3
Tel.: 3-8108

Radio Dept.: Don Watts, president; Don Mitchell, in charge of radio.
Dallas—Fidelity Bldg. Tel.: Riverside 5625. Burke Gilliam, manager.

(Continued)

Air Features INCORPORATED



247 PARK AVENUE
NEW YORK CITY

ADVERTISING AGENCIES HANDLING RADIO AND TV ACCOUNTS

(Continued)

N indicates network, S spot

WAXELBAUM ADVERTISING CO.
10 E. 43rd St., New York 17
Tel.: Murray Hill 2-7398

Radio Dept.: Ben Waxelbaum, in charge of radio and timebuyer.

Radio Accounts: Tree Mark Shoes; Marcus Orthopedic shoes; European Railway Express Corp.

TUCKER WAYNE & CO.
1175 Peachtree St., N. E., Atlanta 5
Tel.: Walnut 8701

Radio Dept.: Douglas D. Connah, radio director and account executive.

LUTHER WEAVER & ASSOCIATES
Globe Bldg., St. Paul 1
Tel.: Cedar 3777

Radio Dept.: Donald F. Gardner, radio director and account executive.

JOHN P. WEIDENHAMER & ASSOCIATES
1735 37 Park St., Harrisburg, Pa.
Tel.: 4-1808

Radio Dept.: N. H. Weidenhamer, radio director & timebuyer.

H. J. WEIL INC.
Walbridge Bldg., Buffalo 2, N. Y.
Tel.: Madison 6755

Radio Dept.: Stephen Gotthelf, radio and television director, timebuyer.

ARMAND S. WEILL CO. INC.
170 Franklin, Buffalo 2
Tel.: Washington 6250

MILTON WEINBERG ADV. CO.
325 W. 8th St., Los Angeles 14
Tel.: Tucker 4111

Radio Dept.: Bernard Weinberg, president and radio talent buyer; William H. Krauch, radio director; Ray Keplinger, timebuyer.

Radio Accounts: May Co. (S); Mike Lyman (Grills) (S); Thrifty Drug Stores (S); Capitol Milling Co. (S); Hollywood Pantages Theater Corp. (S); Hollywood Turf Club (N-S); Maier Brewing Co. (S); Grayson's Shops (N-S); Comfort Bedding Mfg. Co. (S); Capitol Milling Co. (S).

WILLIAM H. WEINTRAUB & CO.
30 Rockefeller Plaza, New York 20
Tel.: Circle 74282

Radio Dept.: Noran Kersta, vice president, radio and television director; Theo Gannon, radio director.

WEISS & GELLER INC.
400 N. Michigan, Chicago 11
Tel.: DElaware 7-1124

Radio Dept.: Marvin L. Mann, vice president, television and radio director; John Michel, account executive; Helena Clayton, timebuyer. New York 17-400 Madison Ave. Tel.: Plaza 7-4070. Max Geller, president.

WAYNE WELCH INC.
Keith Bldg., Denver 2
Tel.: Acoma 3731

Radio Dept.: J. B. Armstrong, media director.

WELLMAN ADVERTISING AGENCY
Empire Bldg., Philadelphia 7
Tel.: Lombard 3-5169

Radio Dept.: F. A. Wellman.

WELSH-HOLLANDER ADVERTISING AGENCY
412 West 6th St., Los Angeles 14
Tel.: Michigan 0876

Radio Dept.: Hugh Bland, account executive.

ADOLPHE WENLAND & ASSOC.
8533 Sunset Blvd., Hollywood 46
Tel.: Crestview 4-5241

Radio Dept.: Harold L. Wolff, radio and television director; Adolphe Wenland, owner; Harold Higgins, Leonard J. Globus, account executives.

San Francisco—607 Market St., Tel.: Garfield 1-0426. William Shea Jr.

WERTHEIM ADV. ASSOC.
11 W. 42nd St., New York 18
Tel.: Wisconsin 7-5978

Radio Dept.: E. Taylor Wertheim, media director.

Philadelphia—1031 Arch St., Tel.: Lombard 3-0934. Jean H. Breig, manager.

THE WESLEY ASSOCIATES
347 Madison Ave., New York 17
Tel.: Murray Hill 6-7077

Radio Dept.: Harry Weiner, director of media.

BRONSON WEST ADVERTISING
500 Robert St., St. Paul 1
Tel.: Garfield 4422

Radio Dept.: A. J. Wagner, radio director.

WEST & BENTLEY CO. INC.
185 Devonshire St., Boston
Tel.: HANcock 6-0707

Radio Dept.: Merrill M. Miller, director.

WESTERN ADVERTISING AGENCY INC.
35 E. Wacker Dr., Chicago 1
Tel.: ANdover 3-2545

Radio Dept.: Paul W. Limerick, Lee Hammett, account executives.

Racine, Wis.—610 Wisconsin Ave. Tel.: Jackson 974.

WESTERN ADV. AGENCY
668 S. Coronado St., Los Angeles 5
Tel.: DUNKirk 7367

Radio Dept.: Milton Carlson, radio and television director; Ruth D. Johnson, timebuyer. Mexico, D. F.—Av. L. Ejido 9. Tel.: Desp. 36-20-41.

Radio Accounts: Voice of Prophecy Inc. (N-S); Inter-American Div. of Seventh Day Adventists (S); Damerel-Allison Co. (S); Kit Mfg. Co. (S); Billway of Hollywood (S); Old Colony Paint Co. (S); Wild Life Film Co.; Booth Import & Export; Chromatoscope; Hangzall Mfg. Co. (S); Naco Mfg. Co. (S); Brown Manly Plow Co.

WESTHEIMER & BLOCK
315 N. 7th St., St. Louis 1
Tel.: Garfield 4080

Radio Dept.: Samuel Westheimer, vice president, director.

WEST-MARQUIS INC.
1220 Wilshire Blvd., Los Angeles 14
Tel.: Madison 7758

Radio Dept.: J. Scogin, media director. San Francisco 3—Humboldt Bldg. Tel.: Garfield 1-1716. James DePauli, manager.

Seattle 4—Dexter Horton Bldg. Tel.: Seneca 5269. Welles Wiley, manager.

Portland 4—American Bank Bldg., Richard Stanton, manager.

WESTON-BARNETT INC.
217 W. Fifth, Waterloo, Ia.
Tel.: 4677

Radio Dept.: Wells Barnett, president. Chicago 11—520 N. Michigan. Tel.: Whitehall 4-7725. A. C. Barnett, vice president.

TOM WESTWOOD ADV. AGENCY
416 W. 8th St., Los Angeles 14
Tel.: Trinity 8496

Radio Dept.: Tom Westwood, radio director, account executive; Marguerite Thomas, timebuyer.

Radio Accounts: Voice of China (S); S. Calif. Lutheran Synod (S); Hebrew Evangelization Society Inc. (S); Anglica Lutheran Church (S).

WARD WHELOCK COMPANY
Lincoln-Liberty Bldg., Philadelphia 7
Tel.: Rittenhouse 6-7500

Radio Dept.: Robert Alexander, department head. New York 22—444 Madison Ave. Tel.: Plaza 3-7120.

Hollywood 28—Guaranty Bldg. Tel.: Hillside 9221. Diana Bourbon, radio director.

Radio Accounts: Campbell Soup Co. (N-S); Stephen F. Whitman (S).

WHITE ADVERTISING AGENCY
19 West Tenth, Tulsa 14
Tel.: 2-5194

Radio Dept.: L. E. White, Jr., radio and television director; Marguerite Hyden, timebuyer; Bruce Hall, Heloise Gray, account executives.

Radio Accounts: Ed Wright Tire Co. (S); Doenges Motors Inc. (S); Nu-Way Products (S); Leon McAuliffe (S); Shannon Feed Co. (S); Healing Waters (S); Phillips Tire (S); Palace Office Supply (S); Coca-Cola Bottling (S); Leddy Boots (S); Comet Moving & Storage (S); Royal Feather Co. (S); Elsing Blouses (S); Chicadee Products (S); United States Television (S).

Television Accounts: Doenges Motors; Nu-Way Products; Leon McAuliffe; Phillips Tire; Coca Cola Bottling; Royal Feather Co.; Elsing Blouses; Chicadee Products; United States Television.

CHARLES A. WHITE JR. & CO.
423 Walnut St., Philadelphia 6
Tel.: Market 7-6586

Radio Dept.: Charles A. White Jr., president and account executive; Maxham Metcalf, production manager.

WILEY, FRAZEE & DAVENPORT INC.
41 E. 50th St., New York 22
Tel.: Murray Hill 8-1700

Radio Dept.: Harold D. Frazee, president.

WILHELM - LAUGHLIN - WILSON & ASSOC.
Esperson Bldg., Houston 2
Tel.: Capitol 2287

Radio Dept.: William C. Bryan, vice president and radio director; John White, account executive.

Dallas—Melba Theatre Bldg., Tel.: Central 6718. Don L. Baxter, manager.

Memphis—Three Sisters Bldg. Tel.: 37-0431. John Ward, manager.

New York—57 Park Ave. Tel.: Murray Hill 6-8133. Howard Persons, manager.

WILLIAMS ADVERTISING AGENCY
347 Fifth Ave., New York 16
Tel.: Murray Hill 3-8592

WILLIAMS & SAYLOR INC.
271 Madison Ave., New York 16
Tel.: Lexington 2-3493

HARRY G. WILLIS & ASSOCIATES
110 W. Broadway, Glendale 4
Tel.: Chapman 5-3325

Radio Dept.: Pearl S. Willis, radio director & timebuyer.

THOMAS C. WILSON ADVERTISING AGENCY
33 E. Truckee River Lane, Reno, Nev.
Tel.: 27011

Radio Dept.: William D. Atkinson Jr., radio director.

WILSON HAIGHT & WELCH INC.
10 Allyn St., Hartford 3, Conn.

Radio Dept.: Alan R. Burman, radio and television director; Ronald W. Donahue, account executive.

New York—220 West 42nd St. Tel.: Murray Hill 7-8780. Howard Shaw.

WILTMAN & CALLAHAN
223 Fourth Ave., Pittsburgh 22
Tel.: Atlantic 1892

Radio Accounts: Breakfast Cheer Coffee (N); Oswald and Hess Meats (N); Polling Rock Beer (N); Steelworkers of America-CIO (N); Republic Oil Refining Co. (N); Zevger Milk (S); Darlington Nurseries (S); Pittsburgh Sun-Telegraph (S); Keystone Chipsteaks Co. (R); Hawkinson Treads (R); Tru-Tread Tires (S); Purity Soap (R); Bennet Clothes (S); Matthew Lawrence Corp. (N); L. Rossen Co. (R).

PAUL WINANS ADVERTISING
426 S. Spring St., Los Angeles 13
Tel.: Michigan 3884

Radio Dept.: Paul Winans, manager.

Radio Accounts: All local now.

WINIUS-DRESCHER-BRANDON INC.
1706 Olive St., St. Louis 3
Tel.: Chestnut 6380

Radio Dept.: Vernon L. Morelock, vice-president, radio and television director; Shirley Crespi, assistant radio director.

New Orleans 12—Canal Bldg. Tel.: Raymond 0845.

Radio Accounts: American Packing Co. (S); Emerson Electric Mfg. Co. (S); Boatman's Nat'l. Bank (S); Missouri-Kansas-Texas Railroad Co. (S); Endicott Johnson Shows (S); F. Burkart Mfg. (S); Deep Rock Oil Corp. (S); Mexican American Hat Co. (S); Sinoret Chemical Co. (S).

Television Accounts: American Packing Co.; M-K-T Railroad; Boatman's National Bank (S); Deep Rock Oil Corp. (S).

N. A. WINTER ADVERTISING AGENCY
Paramount Bldg., Des Moines 9, Iowa
Tel.: 4-9154

Radio Dept.: N. A. Winter, director and account executive; Bryce Spruill, Bill Winter, account executives.

FRED WITTNER ADVERTISING
2 W. 45th St., New York 19
Tel.: Vanderbit 6-0560

Radio Dept.: Mack Leblang, general manager.

WOLFE-JICKLING-CONKEY INC.
76 W. Adams Ave., Detroit 26
Tel.: Woodward 1-1865

Radio Dept.: Cyrilla Anderson, radio and television director; J. G. Sherman, radio-television publicity; Ralph L. Wolfe, sales director; Ruth Rice, Jean Eddy, research and continuity; Florentine Urban, account executive.

Radio Accounts: Schafer Bakeries (S); Taub's Peanut Butter (S); Detroit Employers Assoc. (S).

ED WOLFF & ASSOCIATES
Taylor Bldg., Rochester 4
Tel.: Baker 2090

Radio Dept.: Al Scheible, radio director.

LESTER "L." WOLFF INC.
14 E. 39th St., New York 16
Tel.: Murray Hill 9-1444

Radio Dept.: Charlotte Conkle, radio director; Lester "L." Wolff, account executive.

Radio Accounts: Associated Food Stores (S); Ermet Food Stores (S); Sunrise Food Stores (S); Kute Kiddies.

THE ALBERT WOODLEY CO.
500 Fifth Ave., New York 18
Tel.: Wisconsin 2-0380

Radio Dept.: Edith M. Knoth, timebuyer.

New Haven—205 Church St. Tel.: New Haven 5-2919.

WOODWARD AND FRIS INC.
24 James St., Albany 7, N. Y.
Tel.: 3-1248

Radio Dept.: Mary Elizabeth Gaynor, radio director; Tedford L. Woodward, television director; R. David Fris, account executive.

Radio Accounts: First Trust Co.; Albany Savings Bank; Dobler Brewing Co. (S).

WORLD WIDE ADV. CORP.
11 W. 42nd St., New York 18
Tel.: Longacre 5-4500

Radio Dept.: N. T. Scholz, president.

WORTMAN, WILCOX & CO. INC.
345 Madison Ave., New York 17
Tel.: Murray Hill 4-5920

Radio Dept.: E. B. M. Wortman, president, account executive.

Television Accounts: Balcony Downs Plantation; Esquire Novelty Co.

Y

THE RALPH YAMBERT ORGANIZATION
840 Seward St., Hollywood 38
Tel.: Hillside 3159

Radio Dept.: Ralph Yambert, radio and television director; Jean Richards, timebuyer; James A. Dean, account executive.

ROBT. B. YOUNG ADVERTISING AGENCY
625 Market St., San Francisco 5
Tel.: Sutter 1-5411

Radio Dept.: Robert B. Young, account executive.

YOUNG & RUBICAM INC.
285 Madison Ave., New York 17
Tel.: Murray Hill 9-5000

Radio Dept.: Everard W. Meade, vice-president & director of radio & television; Joseph A. Moran, vice-president & associate director of radio and television; Roland Gillett, V.P. in charge of radio and television production; Rodney Erickson, supervisor radio-television operations; John L. Swazey, manager, radio-TV commercial copy; Harry Rauch, manager radio-TV publicity department; Frank Coulter Jr., manager radio station relations.

Chicago 1—333 N. Michigan Ave. Tel.: Financial 0750. Phillip Bowman, radio director; Marion Reuter, timebuyer.

Detroit 26—Penobscot Bldg. Tel.: Cadillac 1-0067. Vance Nicks, media director and vice president.

San Francisco 4—235 Montgomery St. Tel.: Douglas 2-6977. Edward Merrill, manager.

Hollywood 28-6253 Hollywood Blvd. Tel.: Hollywood 2734. Walter Bunker, V. P. & Mgr. Hollywood Radio Div.

Montreal—University Tower. Tel.: Plateau 4691. A. R. McGill, V. P. & mng. director.

Toronto—80 King St. West. Tel.: Adelaide 5055. W. D. Eyles, supervisor.

Mexico. D. F.—Edijo 7—Sexto Piso 608. Tel.: 10-49-00, 35-24-12. Luis Gurza, radio director.

London—Roxburgh House, 285 Regent St. W1. Tel.: Regent 0211-4. George D. Bryson, managing director.

Radio Accounts: The Borden Co. (S); Bristol-Myers Co. (N); General Foods (N-S); Gulf Oil Corp. (N-S); Duffy-Mott Co. Inc. (S); Thomas J. Lipton Inc. (N); Metropolitan Life Insurance Co. (N); Petri Wine Co. (N); Purity Bakeries (S); Rath Packing Co. (S); Sanforized; K. Arakelian Inc. (S); The Drackett Co. (S); Live Savers Corp. (S); National Sugar Refining Co. (S); Rosefield Packing Co. (N); Schlitz Brewing Co. (S); Singer Sewing Machine Co. (S).

Television Accounts: The Borden Co. (S); Gulf Oil Corp. (N); Bigelow-Sanford Carpet Co. (N); Duffy-Mott Co. (S); General Electric Co. (N); General Foods Corp. (N-S); Good-year Tire & Rubber Co. (N-S); International Silver (N); Johnson & Johnson (S); Thomas J. Lipton (N); O-Cedar Corp. (S); Petri Wine Co. (S); Rosefield Packing Co. (S); Simmons Co. (S).

Z

DAVID ZIBMAN ADVERTISING
1520 Locust St. Philadelphia 2
Tel.: Kingsley 5-0321
Radio Dept.: David Zibman, partner and timebuyer; Ida M. Nelson, media director.

ZIMMER-KELLER INC.
28 W. Adams St., Detroit 26
Tel.: Cadillac 9151

THE ZLOWE CO.
507 Fifth Ave., New York 17
Tel.: Vanderbilt 6-4885
Radio Dept.: Pauline Mann, media director.

CANADIAN AGENCIES

ARDIEL ADV. AGENCY LTD.
371 Bay St., Toronto, Ont.
Tel.: Waverley 2345
Radio Dept.: Clark Wright.
Hamilton—37 James St. S. Tel.: 7-9284.
S. P. Westaway, manager.

ATHERTON & CURRIER INC.
Concourse Bldg., Toronto 1, Ont.
Tel.: Adelaide 5418
Radio Dept.: Alf Lewis, radio director.

ATLANTIC ADVERTISING AGENCY LTD.
Main St., Sackville, N. B.
Tel.: 60 & 15
Radio Dept.: C. F. Johns, president, production manager and radio director.

THE BAKER ADVERTISING AGENCY LTD.
522 University Ave., Toronto 2, Ont.
Tel.: Adelaide 5315
Radio Dept.: Jack F. Horler, radio director; Hazel A. Blair, assistant radio director; Jean Honour, timebuyer.
Montreal—1557 Mackay St. Tel.: Ha 9247. Gabriel Langlais, manager.

BROADCAST ADVERTISING CO.
44 Sherbourne St., Toronto 5, Ont.
Tel.: Michigan 3889
Radio Dept.: Don H. Copeland, general director.

CANADIAN ADVERTISING AGENCY LTD.
Sun Life Bldg., Montreal 2, P. Q.
Tel.: Plateau 8046
Radio Dept.: Andre Sauve, radio director.
Toronto—89 Young St. Tel.: Adelaide 3051. J. Teitel, manager.
Vancouver, B. C.—Province Bldg. Tel.: Tatlow 1938. R. M. Dagg, manager.
Radio Accounts: B. C. Tree Fruit Growers Assn. (S); N. G. Valiquette Ltd. (S); Vian Ltd. (S); City of Montreal (S); Andrew Baile & Co. Ltd. (S); Canadian Arena Co. (S); Domestic Brands Inc. (S); Famflex Products Co. (N); C. W. Lindsay & Co. Ltd. (S); Milk Distributors Assn. of P. Q. (S); Julius Kayser & Co. Ltd. (S); Canada Drug Co. Ltd. (S); World Wide Chewing Gum Co. (S); Laval Transport Ltd. (S).

GARRY J. CARTER OF CANADA LTD.
59 Avenue Rd., Toronto, Ont.
Tel.: Princess 2505
Radio Dept.: Bob Howe, radio director and account executive; Claude Nash, copy chief; Wm. Gent, account executive.

Radio Accounts: Walter Thornton of Canada Ltd. (S); Met-Wo Industries Ltd. (S); Siberry's Ltd. (S); Anne Graham Logan (S); Blue Top Brewing Co. Ltd. (S); Paige Credit Jewelers Ltd. (S); Stone's Car Market (S); Taylor Service Stores (S); Swears & Wells (Canada) Ltd. (S).

COCKFIELD, BROWN & CO. LTD.
Canada Cement Bldg., Montreal 2, Que.
Tel.: Harbour 4171
Radio Dept.: R. W. de L. Harwood, radio dept. manager; W. D. Hannah, timebuyer; C. H. Ellis, M. A. Bedard, C. Duhamel, radio dept.

Toronto, Ont.—Metropolitan Bldg. Tel.: Elgin 9201. T. L. Anderson, vice-president and managing director; C. W. McQuillin, radio director; P. C. Logan, timebuyer.

Vancouver, B. C.—Royal Bank Bldg. Tel.: Pacific 7557. Peter M. Downes.

Winnipeg, Man.—Electric Railway Chambers. Tel.: 9-7068. Murray Turner, manager; L. G. Holmes, radio director.

DANCER-FITZGERALD-SAMPLE LTD.
6 King St. E., Toronto, Ont.
Radio Dept.: Gilbert Nunn, general manager.

A. J. DENNE & Co. LTD.
90 King St. W., Toronto, Ont.
Tel.: Elgin 3444
Radio Dept.: R. O. McKeown, manager; W. M. Findlay, E. R. White, account executives.

JAMES FISHER CO. LTD.
204 Richmond St. W. Toronto 1, Ont.
Tel.: Waverly 8091
Radio Dept.: David M. Fenn, radio director; Douglas C. Brace, account executive; James Matthews, writer.
Montreal—679 Belmont St. Tel.: Lancaster 1205. G. Humphrys, manager.
Radio Accounts: Wm. Wrigley Jr. Co. (N); Panther Rubber Co. Ltd. (S); Kist (Canada) Ltd. (S); W. Symington & Co., Ltd. (S); Victory Mills Ltd. (S); Thor-Canadian Co., Ltd. (S); Tide-Water Oil Co. (S).

HARRY E. FOSTER ADVERTISING LTD.
King Edward Hotel, Toronto, Ont.
Tel.: Plaza 4661
Radio Dept.: G. Forsyth, director; R. B. Wakely, radio department manager; Miss Mary Newton, timebuyer.
Montreal, Que.—128 Sun Life Bldg. J. C. Nicholls, manager.
Vancouver, B. C.—407 Dominion Bldg. Leah Webster.
Halifax, N. S.—612 Barrington St. Ervin S. Murray.
Radio Accounts: Colgate - Palmolive - Peet Co. Ltd.; The Globe and Mail; Imperial Tobacco Sales Co. of Canada Ltd.; Northern Electric Co. Ltd.; Royal Winter Fair; The Robert Simpson Co. Ltd.; Smith Brothers; Supertest Petroleum Corp. Ltd.; Dominion Stores Ltd.; Gurney Foundry Co. Ltd.; Orange Crush Ltd.; Reliance Petroleum Co.; The Telegram.

J. J. GIBBONS LTD.
200 Bay St., Toronto, Ont.
Tel.: Elgin 2111
Radio Dept.: Don Bassett, radio director.
Montreal, Que.—Dominion Sq. Bldg. Tel.: Harbour 6207. H. M. McGibbon.
Regina, Sask.—Leader Bldg. Tel.: 6-141. S. Wayte.
Calgary, Alta.—Renfrew Bldg. Tel.: M 5437. Reg. G. Smith.
Edmonton, Alta.—Agency Bldg. Tel.: 27-512. J. H. Fulton.
Winnipeg, Man.—Scott Block. Tel.: 97-373. A. E. Johnston.
Vancouver, B. C.—Province Bldg. Tel.: Pacific 0157. Gordon Rowntree, radio director.

THE F. H. HAYHURST CO. LTD.
38 King St. W., Toronto 2, Ont.
Tel.: Elgin 9263
Radio Dept.: Robert D. Amos, radio director; Ann Gilbert, radio secretary.
Montreal—1409 Peel St. Tel.: Marquette 2212.
Radio Accounts: American Safety Razor (S); Bromo-Seltzer Co. (N-S); Blatchford Feeds (S); British Ceramics and Crystal (Canada) Ltd.; Canadian Canners (S); Dr. A. W. Chase Medicine Co.; Edgeworth

Tobacco (S); F. W. Fitch Co.; G. T. Fulford Ltd. (S); Gooderham & Worts (S); Hudson's Bay Co. Lavoline Cleanser (S); Hy-Pa-Ceds (S); Lakeside Milling (S); Lektrolite Corp. (S); Meccano Ltd. (S); Nucoa Margarine; Templeton's Ltd.; Wintrol & Co. (S).

L. J. HEAGERTY LTD.
19 Melinda St., Toronto, Ont.
Tel.: Adelaide 1186
Radio Dept.: L. J. Heagerty, president; Helen Whitcombe, media director.

RUSSELL T. KELLEY LTD.
447 Main St. E., Hamilton, Ont.
Tel.: 2-1155
Radio Dept.: R. T. Kelley.
Montreal, Que.—480 Lagachetiere St., W. Tel.: Plateau 5025.
Vancouver, B. C.—Dominion Bank Bldg. Toronto, Ont.—86 Adelaide St. E. Tel.: Elgin 6415. J. M. Bingham, manager. C. W. Scarlett, radio director.

LOCKE, JOHNSON & CO. LTD.
Harbour Commission Bldg., Toronto 1, Ont.
Tel.: Elgin 6271
Radio Dept.: Elton Johnson, vice president; Gordon Hill, account executive.

JAMES LOVICK & CO. LTD.
535 Homer St., Vancouver, B. C.
Tel.: Tatlow 3371
Radio Dept.: Frederick J. McDowell, radio director; Florence Asson, writer-producer; Wm. Reade, traffic.
Calgary—21 Canada Life Bldg. Tel.: Main 4445. L. Duncliffe.
Toronto—21 Dundas Sq. Tel.: Adelaide 8203. N. Sharp
Montreal—634 Dominion Sq. Bldg. Tel.: Plateau 8757. J. Collyer.
Radio Accounts: Assoc. Salmon Canners of B. C. (S); B-A Oil Co. Ltd. (N-S); Burns & Co. Ltd. (N-S); Canada Nut Co. (S); Canadian Bakeries Ltd. (S); Marpole Coal Co. (S); Nelson's Laundries (S); Nabob Foods Ltd. (N); Pacific Milk Co. (S).

MCCONNELL, EASTMAN & CO. LTD.
147 University Ave., Toronto, Ont.
Tel.: Adelaide 7004
Radio Dept.: E. Gould, radio and television director.
Montreal—Dominion Square Bldg. Tel.: Plateau 1146. J. E. McConnell Jr., manager.
Winnipeg—Confederation Life Bldg. Tel.: 93317. B. McCrean.
Vancouver—Stock Exchange Bldg. S. Griffiths, manager.
London, Ont.—Huron & Erie Bldg. Tel.: Metcalfe 544. J. E. McConnell, manager.
Radio Accounts: Tip Top Tailors, Ltd.; National Dry Ltd.; London Life Insurance Co.; Libby, McNeil & Libby of Canada Ltd.; McCormick's Ltd.; St. Lawrence Starch Co. Ltd.; Muirhead's Cafeterias Ltd.; Honey Dew Coffee Shops; Swift-Canadian Co. Ltd. (Cleanser Div.); Paulin Chambers Ltd.; Barker's Biscuits Ltd.

MCGUIRE ADVERTISING LTD.
Canadian Bank of Commerce Bldg., Windsor, Ont.
Tel.: 2-7297

MCKIM ADVERTISING LTD.
47 Fraser Ave., Toronto, Ont.
Tel.: Melrose 4642
Radio Dept.: E. W. Brodie, radio director; F. C. Flint, timebuyer; G. Henderson.
Montreal, Que.—Dominion Square Bldg. Tel.: Lancaster 5182. James Baxter.
Winnipeg, Man.—Paris Bldg. A. A. Brown, manager.
Vancouver, B. C.—Province Bldg. Tel.: Marine 3284. W. J. Sandstrom, manager.
Radio Accounts: General Dry Batteries of Canada Ltd.; Langley's Ltd.; Purity Flour Mills Ltd.; Templeton's Ltd.; A. Wander Ltd.; Canadian Painters' Association; International Painters (Canada) Ltd.; National Drug & Chemical Co. of Canada Ltd.; Laurentian Agencies Ltd.

METROPOLITAN BROADCASTING SERVICE LTD.
21 Dundas Square, Toronto 6, Ont.
Tel.: Adelaide 0181
Radio Dept.: Don E. Wright, manager; W. Len Smith, account executive; Harvey Dobbs, producer.

O'BRIEN ADVERTISING LIMITED
928 W. Pender St., Vancouver, B. C.
Tel.: Pacific 9174
Radio Dept.: James S. Beard, radio director; Mary MacAlpine, timebuyer.
Radio Accounts: Vancouver Daily Province (N-S); Fred Deeley Ltd. (S); Jordans Ltd. (S); Little Dipper Food Prod. (S); Standard Oil Co. of B. C. (S); Vancouver Motors Ltd. (N).

THORNTON PURKIS ADV. AGENCY
330 Bay St., Toronto, Ont.
Tel.: Adelaide 3762
Radio Dept.: Miss Gladys Race.
Montreal—Dominion Square Bldg. Tel.: Marquette 5947. Thomas L. Marchant.
E. W. REYNOLDS & CO.
145 Yonge St., Toronto, Ont.
Tel.: Waverly 6157
Radio Dept.: Howard C. Caine, radio director and timebuyer.

RONALDS ADV. AGENCY LTD.
1440 St. Catherine St., Montreal 25, Que.
Tel.: Plateau 4803
Radio Dept.: Frank Starr, radio and television director; S. B. Hayward, assistant.
Toronto, Ont.—New Wellington Bldg., Tel.: Adelaide 0237.
Radio Accounts: Bristol-Myers Co. (N); Dominion Corset Co. (S); Canadian Industries Ltd. (Paint & Varnish); Canadian Industries Ltd. (Agricultural Chemicals); Canadian Arena Co.; Canada Packers; Mt. Royal Hotel; Montreal Shoe Stores Ltd.; Bank of Canada (S); Dept. of Nat'l Defense (N-S); Bovril (Canada) Ltd. (S).

RUTHRAUFF & RYAN INC.
2 Toronto St., Toronto, Ont.
Tel.: Plaza 1515
Radio Dept.: Ramsay Lees, radio producer.

R. C. SMITH & SON LTD.
80 King St. W., Toronto, Ont.
Tel.: Elgin 9396
Radio Dept.: G. Alec Phare, radio director.

SPITZER & MILLS LTD.
50 King St. W., Toronto, Ont.
Tel.: Plaza 2811
Radio Dept.: T. R. Hart, acting radio manager.
Montreal—1010 St. Catherine St. Tel.: Harbour 9147. Paul Corbeil, French radio director.
Vancouver—875 W. Hastings St. Tel.: Pacific 2102. J. H. Randle.
Radio Accounts: Brading's Brewing Co. Ltd. (Qu. & Ont.) (N); Canadian Laco Lamps (S); Colgate-Palmolive-Peet Co. Ltd. (N-S); Fruitatives Ltd. (S); Jarmain's Ltd. (S); Langley's Lt. (S); Monarch Overall Co. (S); Quaker Oats Co. (N-S); Toni Co. (N-S); Bell Telephone Co. (S); General Bakeries Co. (S); RCA Victor (N).

HAROLD F. STANFIELD LTD.
1010 St. Catherine St., Montreal, Que.
Tel.: Plateau 9777
Radio Dept.: R. H. Geary, radio director and timebuyer; Wallace Tilford, timebuyer.
Toronto, Ont.—67 Richmond St. W. Tel.: Elgin 0477. A. T. Gowe, manager.

(Continued)

WKAN
KANKAKEE,
Illinois
SERVING 738,372 radio homes in the rich industrial and agricultural areas of Northeastern Illinois and Northwest Indiana.
1,000 w 1320 kc
1950 Yearbook Number • Page 363

NATIONAL AND REGIONAL RADIO AND TV ADVERTISERS AND THEIR AGENCIES

United States and Canada

N Network programs S Spot programs and announcements
Compiled and Copyrighted 1949 by Broadcasting Publications, Inc. R Regional
D-C Dealer Cooperative

A
AC SPARK PLUG DIV., General Motors Corp., Flint 2, Mich., spark plugs, oil filters, fuel pumps. S. Agency: D. P. Brother & Co., Detroit.
A. M. R. CHEMICAL CO., New York. A. M. R. Lighter Fuel. S. Agency: Diener & Dorskind, Inc., N. Y.
ABBEY'S EFFERVESCENT SALT Co., Toronto (proprietary) S. Agency: Erwin Wasey & Co., Toronto.
ABELSON'S Inc., N. J. (chain of jewelers & opticians) R. S. Agency: Sawdon Adv. Co., N. Y.
ACME BREWERIES, San Francisco. TV Agency: Foote, Cone & Belding, San Francisco.
ACME WHITE LEAD & COLOR WORKS, Detroit, Mich., Lin-X Clear Gloss, self-polishing wax, cream polish, Kern-Tone. N. Agencies: Henri, Hurst & McDonald, Chicago; Holden-Clifford Flint, Inc., Detroit. D-C.
ACOUTICAN of San Francisco (hearing aids) R. S. Agency: Atherton Adv. L. A.
ADAM HAT STORES, N. Y., Adam hats, shirts, N. & S. Agency: Madison Ave. Co. Inc., N. Y.
ADAM HATS, Ltd., Toronto, Canada Agency: MacLaren Adv., Toronto.
ADLER SHOES, New York, shoes. S. Agency: Emil Mogul Co., N. Y.
ADMIRACION LABS. National Oil Products Co., Harrison, N. J., Admiration Shampoo, S. Agency: Chas. Dallas Reach Co., Newark.
ADMIRAL CORP., Chicago, Admiral Radios, Television Receivers, N. TV Agencies: Crutenden & Eger & Tatham-Laird, Chicago; Kudner Agency, Chicago, D-C.
AFFILIATED PRODUCTS Inc., Toronto, Anacin. S. Agency: Young & Rubicam, Toronto.

ALBERS MILLING Co., S.F., Flour, Cereal Products. N. Agency: Erwin, Wasey & Co., S.F.
ALBERTA PRODUCTS Co., Portland, Oregon. S. TV. Agency: H. C. Morris & Co., Holly.
ALBERTS PRODUCTS Co., Portland, Ore. Portland Punch. R-N. Agency: H. C. Morris & Co., Los Angeles.
ALKINE Co., New Brunswick, N. J. Fiem-O-Lyn. Agency: Chas. W. Hoyt Co., Inc., N. Y.
ALLEGHENY LUDLUM STEEL Corp., Pittsburgh, Pa., Stainless Steel, tools (electrical) Agency: Walker & Downing, Pittsburgh.
ALLEN MFG. Co., Nashville, Tenn. Heating Appliances. Agency: S. C. Bear Co., Cincinnati.
ALLES & FISHER, Boston. J. A. Cigars. R. Agency: L. B. Hawes General Adv. Agency, Boston.
ALLIANCE MFG. Co., Alliance, Ohio. (TV accessory equipment). TV. Agency: Foster & Davies Inc., Cleveland.
ALLIED MILLS Inc., Chicago, Livestock, poultry & supplies. Agency: Western Adv. Agency Inc., Chicago.
ALLIS-CHALMERS MFG. Co., Milwaukee. N. Agency: Bert S. Gittins, Milwaukee.
ALLOCK POROUS PLASTER, New York, plaster. S. Agency: Small & Seiffer, N. Y.
ALTA VINEYARDS Co., Fresno, Cal., Alta Wines, Mattel, and St. Charles wines. S. Agency: Carl C. Wakefield Adv., S. F.
ALTES BREWING Co., San Diego, Altes Lager Beer. R.S. Agency: Seder-Talbot, Hollywood.
ALTORFER BROS. Co., Peoria, Ill., ABC Washers and Ironers. S. Agency: Cramer Krasselt, Milwaukee.
ALUMNUM COMPANY OF AMERICA,

Pittsburgh. Institutional. N. Agency: Fuller & Smith & Ross, N. Y.
AMALIE DIVISION, L. Sonneborn Sons Inc., N. Y. (Amalie Penna. Motor Oil & Lubricants) TV. Agency: Hicks & Greist Inc., N. Y.
FRED W. AMEND CO., Chicago, Chuckles. S. Agency: Foote, Cone & Belding, Chicago.
AMERICAN BAKERIES, Atlanta, Merita Breads, Cakes, and Crackers. R.N. Agency: Tucker Wayne & Co., Atlanta.
AMERICAN BIRD PRODUCTS, Chicago Vees Bird Products. N. Agency: Weston-Barnett, Chicago.
AMERICAN BOWLING CONGRESS, Milwaukee. Agency: Bishop & Assoc., L. A.
AMERICAN BROADCASTING CO., New York. TV. Agency: BBDO, New York.
AMERICAN-BURLINGTON BUSLINES, Inc. S. Agency: Grant Adv., Inc., Chicago.
AMERICAN CHICLE Co., Long Island City, New York, Beemans chewing gum. S. Agencies: Badger, Browning & Hershey, N. Y.; Baker Adv. Agency, Ltd., Toronto.
AMERICAN CHIROPRACTIC ASSN., Los Angeles. S. Agency: Tullis-Victor Co., Los Angeles.
AMERICAN CIGARETTE & CIGAR Co., New York, Pall Mall cigarettes. N.S. Agency: Sullivan, Stauffer, Colwell & Bayles, N. Y.
AMERICAN CYANAMID Co., New York, Pharmaceuticals and Biologicals. N. Agency: Hazard Adv. Co.
AMERICAN DAIRY ASSN., Chicago, dairy products. N. Agency: Campbell-Mithun, Chicago. D-C.
AMERICAN FEDERATION OF LABOR (Entertainment Unions Committee) N. Agency: Furman & Feiner, New York.
AMERICAN FRUIT GROWERS, Los Angeles, Blue Goose fresh & processed foods. Agency: Davis & Co., Los Angeles.
AMERICAN HOME PRODUCTS Corp., New York, Anacin, Bisodol & Kolyngos, Duffs Ready-to-Bake Mixes. N. TV Agencies: Dancer - Fitzgerald - Sample, New York; W. Earl Bothwell, Pittsburgh; Ruthrauff & Ryan, New York and Toronto; Sullivan, Stauffer, Colwell & Bayles, New York; Young & Rubicam, N. Y.; Duane Jones Co., New York; McCann-Erickson, New York.
AMERICAN INSTITUTE OF FOOD PRODUCTS Inc., New York, Food Products. S.
AMERICAN IRON & STEEL INSTITUTE, New York. Institutional. N. Agency: Hill & Knowlton, New York.
AMERICAN KITCHEN PRODUCTS, Ozone Park, New York, Noxon Polish. S. Agency: Rose-Martin Inc., New York.
AMERICAN MEAT INSTITUTE, Chicago, Institutional. N. Agency: Leo Burnett Co., Chicago.
AMERICAN MERCHANDISE Co., Montgomery, Ala. Electrical appliances. Agency: O'Neil, Larson & McMahon, Chicago.
AMERICAN MOTO-SCOOT CO., Chicago, (power scooters) Adv. placed direct.
AMERICAN OIL Co., American Bldg., Baltimore, Amoco, American Gas, N. Agency: Joseph Katz Co., Baltimore.
AMERICAN POULTRY JOURNAL, Chicago. S. Agency: Shaffer, Brennan, Margulis Adv., St. Louis.
AMERICAN PRODUCTS Co., Cincinnati, Jiffy Starch, Swiss. S. Agency: Franklin Bruck Corp., New York.
AMERICAN RED CROSS (Joint Sponsorship), Washington, D. C. Service. N. Agency: Cecil & Presbrey, New York.
AMERICAN SAFETY RAZOR Corp., Brooklyn, Gem Razor Blades. N. Agencies: Federal Adv. Agency, New York; Ruthrauff & Ryan, N. Y.; Dorland, Inc., N. Y. (export adv.); F. H. Hayhurst, Ltd., Toronto.
AMERICAN STORES Co., Philadelphia, Foods. S. Placed direct.
AMERICAN TELEPHONE & TELE-

GRAPH Co., N. Y. N. S. Agency: N. W. Ayer & Son, Phila.
AMERICAN TOBACCO Co., New York, Tobacco. N. TV. Agencies: N. W. Ayer & Son, N. Y.; M. H. Hackett Co., N. Y.; Sullivan, Stauffer, Colwell & Bayles, N. Y.; Lawrence B. Grebinner, N. Y.; Mather & Crowther Ltd., London (Kentstas cigs.); BBDO, N. Y.
AMERICAN TRANSIT ASSN., New York. N. Agency: Owen-Chappell, New York.
AMERICA'S FUTURE Inc., New York, Publication. Agency: Gahagan & Turnbull, N. Y.
ELIZABETH AMES INC., New York, Purse atomizers, TV. Agency: Roy-Hirsch Co., N. Y.
AMRED PRODUCTS Co., Omaha, Neb. Extracts, cereals. S. Agency: Buchanan-Thomas, Omaha.
ANCHOR HOCKING GLASS Corp., Lancaster, O., Anchorglass, Fire King, Ovensglass Products. N. Agencies: Wm. H. Weintraub & Co., N. Y.; Griswold-Eshleman Co., Cleveland.
E. O. ANDERSON Co., Santa Monica, Calif., shontex shampoo. Agency: Barton A. Stebbins Adv., Los Angeles.
ANDREA RADIO CORP., Long Island City, N. Y. Agency: Royal & de Guzman, New York.
ANDRESEN-RYAN COFFEE Co., Duluth, Minn. Arco Coffee. S. Agency: Stewart-Taylor Co., Duluth.
ANGOSTURA - WUPERMANN Corp., New York, Angostura Bitters. S. Agencies: Donahue & Coe, N. Y.; Robt. W. Orr & Assoc., N. Y.; Cockfield, Brown & Co., Ltd., Montreal.
AQUATOGS, New York, Rainwear for Women, Misses, and Children. S. Agency: Jack Berman Co., N. Y.
ARABIAN AMERICAN OIL Co., N. Agency: Kudner Agency, N. Y.
K. ARAKELIAN Inc., Madera, Calif., Madeira wines. S. Agencies: Kalso Norman Adv., S.F.; M. J. Jacobs, Inc., N. Y.; Young & Rubicam, N. Y.
ARCO PUBLISHING Co., New York, books. Agency: Maxwell Sackheim & Co., N. Y.
ARDEN FARMS, Los Angeles, dairy products. S. Agencies: Productive Adv., Los Angeles. Allied Adv. Agencies, Los Angeles.
ARMAND Co., Des Moines, Pearls in Wine Lipstick. S. Agency: Ivan Hill Agency, Chicago.
ARMEN Inc., N. Y. (plastic "Keepsake" novelties) S. TV. Agency: Bliss & Marces Inc., N. Y.
ARMOUR & Co., U. S. Yards, Chicago, Treet, canned meats, sausage products, margarine. N. Agency: Foote, Cone & Belding, Chicago.
ARMSTRONG CORK Co., Lancaster, Pa., Armstrong's Quaker Rugs. N. Agency: BBDO, N. Y.
ARTRA COSMETICS, Bloomfield, N. J. (sun lotion & cream) S. Agency: Kelly-Nason, N. Y.
ARVEY CORP., Chicago, R-V-Lite. S. Agency: Burlingame & Grossman, Chicago.
ASSOCIATED DENTAL SUPPLY Co., San Francisco, Tooth paste & powder. R. Agency: Brisacher, Wheeler & Staff.
ASSOCIATED OIL Co., Los Angeles, Gasoline. N. Agency: Buchanan & Co., L. A.
ASSN. OF AMERICAN RAILROADS, Wash., D. C. N. Agency: Benton & Bowles, N. Y.
ATLANTIC BREWING Co., Chicago, Tavern Pale Beer. S. TV. Agency: Grant Adv. Inc. & W. D. Doner & Co., Chi.
ATLANTIC SALES CORP., Rochester (French's instant potatoes). Agencies: J. Walter Thompson, Co., N. Y.; Richard A. Foley Adv., Phila.
ATLAS LABORATORIES, Akron, Ohio, I-O-Sal. S. Agency: McDaniel-Fisher & Spelman, Akron.
AUSTIN, NICHOLS Co., Brooklyn, N. Y. (Mouquin Wines). TV. S. Agency: Alfred Lilly Co., N. Y.
AVALON LANE Co., New York, Lashene, Lashoor, Belador Formula No. 7.

AGENCIES HANDLING RADIO and TV

(Continued)

Vancouver, B. C.—234 Copp Block.
Edmonton, Alta.—LaFleche Bldg. D. Wood, manager.
STEVENSON & SCOTT LTD.
660 St. Catherine St. W., Montreal, Que. Tel.: Harbour 4131
Radio Dept.: H. E. Smith.
Vancouver, B. C.—402 W. Pender St. Roy Hunter, manager.
Toronto, Ont.—100 Adelaide St. W. Tel.: Adelaide 1166. S. Young, manager.
STEWART-LOVICK & MACPHERSON LTD.
Province Bldg., Vancouver, B. C. Tel.: Pacific 3531
Radio Dept.: V. L. Stewart.
Montreal—1516 Mountain St. Tel.: HA. 4960.
Toronto—Concourse Bldg. Tel.: Waverley 8648. R. R. Threlfall, manager.
Edmonton, Alta. — Birks Bldg. Tel.: 2-3264.
Calgary, Alta.—Southern Bldg. Tel.: Main 1432.
Winnipeg—Somerset Bldg. Tel.: 9-7072.
TANDY ADVERTISING AGENCY LTD.
66 Portland St., Toronto 2B Ont. Tel.: Adelaide 6362
Radio Dept.: A. C. Haight Jr., radio director; W. H. Wilkes, A. S. Collins, account executives.
Radio Accounts: Continental Casualty Co. (S); Sun Oil Co. Ltd.; Arthur Coleman & Co. (S); Leader Fur Co. (S); W. H. Comstock Co. (S); Mustang Book Co. Ltd. (S); Hiscott Inst. (S); Allcock, Laight & Westwood (S); Nat'l Sanitarium Assn. (S).
VICKERS & BENSON LTD.
Keefer Bldg., Montreal, Que. Tel.: Plaza 5051
Radio Dept.: Miss Jeanne Berube, time-buyer.

Toronto, Ont.—Reford Bldg. Tel.: Waverly 1603. R. W. Ball, account executive; T. W. Kober, radio director.
WALLACE ADV. LTD.
Roy Bldg., Halifax, N. S. Tel.: 3-7557
Radio Dept.: F. R. Wallace.
Saint John, N. B.—Tel.: 3-2355. J. B. Whalley, manager.
WALSH ADV. CO. LTD.
Guaranty Trust Bldg., Windsor, Ont. Tel.: 2-7224
Radio Dept.: R. A. Mason, radio director.
Toronto—Concourse Bldg. Tel.: Adelaide 3055. E. Palmer.
Montreal—University Tower Bldg. Tel.: Belair 8431. Ajves Bourassa.
WHITEHALL BROADCASTING LTD.
502 Dominion Square Bldg., Montreal, Que. Tel.: Lancaster 6500
Radio Dept.: W. L. Charland, radio director; Joan A. Bridge, timebuyer; Claude Sutton, producer.
Radio Accounts: Imperial Tobacco Co. of Canada Ltd. (S); B. Houde & Grothe Ltd. (N).
YOUNG & RUBICAM LTD.
660 St. Catherine St. W., Montreal, Que. Tel.: Plateau 4691
Radio Dept.: A. R. McGill, managing director and vice-president; L. C. Arbutnot, manager; William H. Poole, supervisor of research; Brian Devlin, copy; Ronald I. Sweeney, media; Donna Powers, radio.
Toronto, Ont.—80 King St. W. Tel.: Adelaide 5035. G. T. Berthon, manager; William McDonald, copy; W. D. Byles, supervisor of radio.

WALLACE ADV. LTD.
Roy Bldg., Halifax, N. S. Tel.: 3-7557
Radio Dept.: F. R. Wallace.
Saint John, N. B.—Tel.: 3-2355. J. B. Whalley, manager.
WALSH ADV. CO. LTD.
Guaranty Trust Bldg., Windsor, Ont. Tel.: 2-7224
Radio Dept.: R. A. Mason, radio director.
Toronto—Concourse Bldg. Tel.: Adelaide 3055. E. Palmer.
Montreal—University Tower Bldg. Tel.: Belair 8431. Ajves Bourassa.
WHITEHALL BROADCASTING LTD.
502 Dominion Square Bldg., Montreal, Que. Tel.: Lancaster 6500
Radio Dept.: W. L. Charland, radio director; Joan A. Bridge, timebuyer; Claude Sutton, producer.
Radio Accounts: Imperial Tobacco Co. of Canada Ltd. (S); B. Houde & Grothe Ltd. (N).
YOUNG & RUBICAM LTD.
660 St. Catherine St. W., Montreal, Que. Tel.: Plateau 4691
Radio Dept.: A. R. McGill, managing director and vice-president; L. C. Arbutnot, manager; William H. Poole, supervisor of research; Brian Devlin, copy; Ronald I. Sweeney, media; Donna Powers, radio.
Toronto, Ont.—80 King St. W. Tel.: Adelaide 5035. G. T. Berthon, manager; William McDonald, copy; W. D. Byles, supervisor of radio.

S. Agencies: Reuben Barkow, N. Y.; World Wide Traders, Export Agts., N. Y. AVCO, CROSLEY DIV., S. N. TV. Agency: Benton & Bowles, N. Y.

B

B-1 BEVERAGE Co., St. Louis. B-1 lime soda, sparkling water. S. Agency: Simmonds & Simmonds, Inc., Chicago.

B. B. PEN CO., Hollywood, S. TV. Agency: Foote, Cone & Belding, L. A. B. C. ELECTRIC RAILWAY CO., Vancouver (public utility) R. Agency: O'Brien Gourlay Ltd., Vancouver.

B. C. REMEDY Co., Durham, N. C., Headache powders. S. Agencies: Harvey-Massengale Co., Atlanta; Chas. W. Hoyt Co., N. Y.

B. T. BABBITT Inc., New York, Babo cleaner, Lyons. N. S. Agencies: Duane Jones Co., New York; Botsford, Constantine & Gardner, S. F.

BABSON BROS. Co., Chicago, Dairy farm equipment. S. Agency: C. C. Fogarty Co., Chicago.

E. B. BADGER & SONS, Boston (chemical engineering) N. S. Agencies: Herbert W. Frank Adv.; N. W. Ayer & Son, Boston.

BALABAN & KATZ Corp., Chicago. S. Agency: M. M. Fisher Assoc., Chicago.

BALLAN ICE CREAM Co., South Gate, Calif. Franilla Ice Cream. S. TV. Agency: Tullis-Victor Co., L. A.

BALL BROTHERS Co., Muncie, Ind., Ball Fruit Jars, Caps, Rubbers and Jelly Glasses. Agencies: Applegate Adv., Muncie, Ind.; Vander Co., Chicago.

P. BALLANTINE & SONS, Newark, Beer and Ale. N. TV. Agency: J. Walter Thompson Co., New York.

BALLARD & BALLARD, Louisville, Oven Ready Biscuits, Ballard's Obelisk Flour and other milling products. S. N. Agency: Henri, Hurst & McDonald, Chicago. D-C.

BANK OF AMERICA N. T. & S. A., San Francisco. N. S. Agency: Charles R. Stuart, San Francisco.

BARBASOL Co., Indianapolis, Barbasol. N. TV. Agency: Erwin, Wasey & Co., New York.

BARCALO MFG. Co., Buffalo (summer furniture) TV. Agency: BBDO, N. Y. H. BARON & CO., Linden, New Jersey (Sundaettes). R. S. Agencies: Samuel Croot Co., N. Y.; Chas. Dallas Reach Co., Newark.

G. BARR & Co., Chicago, Balm Barr Creme Whipped Lotion, Balm Barr Creme Shampoo. N. & S. Agency: H. W. Kastor & Son, Chicago.

BARRON-GRAY PACKING Co., San Jose, Health Vegetable Juice. N. Agency: N. W. Ayer & Son, S. F.

HERMAN BASCH Co., New York, Hammer brand Persian Lamb. S. N. Agency: Kelley-Nason, New York.

BATES FABRICS Inc., N. Y. N. TV. Agency: James P. Sawyer Inc., N. Y.

BATHASWEET Corp., New York, Soap and bath salts. S. Agency: Kleeswetter, Wetterau & Baker, New York.

BATTLE PHARMACEUTICALS Co., Victory Bldg., Toronto, "All-in-One" Brand Vitamin Tablets, Daisy Diaper Dip. R. S. Agency: Grant Adv., Toronto.

THE BAYER Co., N. Y. (Bayer Aspirin) Agencies: Dancer-Fitzgerald-Sample, N. Y.; Thompson-Koch Co., N. Y.

BAYUK CIGARS, Inc., Philadelphia, Pa., Phillies cigars. N. Agency: Neal D. Ivey Co., Phila.

CLYDE BEATTY CIRCUS, Los Angeles. S. Agency: Allied Adv. & Ted H. Factor, L. A.

DR. BEAUCHAMP, L. A. (dentist) R. S. Agency: Charles N. Stahl Adv., L. A.

BEAUMONT Co., St. Louis, Four-Way Cold Tablets and Grove B-Complex. N. S. Agency: Harry B. Cohen Inc., N. Y.

A. S. BECK SHOES, N. Y. N. TV. Agency: Dorland Inc., N. Y.

BEECHAMS PILLS INC. (Scott & Bowne, J. C. Eno Inc., County Perfumery Co.), Bloomfield, N. J., Beecham's laxative pills, Scott's Emulsion, Brylcreem Hair Dressing, Scott's Ointment, Eno Salts, MacLeans Toothpaste, N. S. Agencies: Atherton & Currier, New York (all products except Beechams and MacLeans); Street & Finney, New York.

BEECHNUT PACKING CO., Canajoharie, N. Y. Food. S. Agency: Newell-Emmett, N. Y.

BEKINS VAN & STORAGE Co., Seattle, Los Angeles. Storage. N. Brooks Adv. Agency, L. A.

BELL & HOWELL, Chi. (Filmo home movie equipment) N. TV. S. Agency: Henri, Hurst & McDonald, Chi.; McCann-Erickson, Chi.

BELL TELEPHONE SYSTEM, New York. Telephone Service. N. Agency: N. W. Ayer & Son, New York.

BELTONE HEARING AID Co., Chicago. S. Agencies: Ruthrauff & Ryan, Guenther-Bradford Inc., Chicago.

BEN HUR PRODUCTS Inc., Los Angeles, Coffee, Spices & Extract. R. N. Agency: Mogge-Privett Inc., L. A.

BENDIX AVIATION Corp., Detroit. N. Agency: MacManus, John & Adams, Inc., Detroit.

BENDIX HOME APPLIANCES Inc., South Bend, Ind., Bendix Automatic Home Laundry, Home Ironer, Home Dryer. S. Agency: Tatham-Laird Inc., Chicago.

BENRUS WATCH Co., New York, watches. S. N. TV. Agency: J. D. Tarcher Inc., N. Y.

BENSON & HEDGES, New York, Virginia Rounds cigarettes. Havana Cigars. S. Agency: Kudner Agency, Inc., N. Y.

BERKSHIRE KNITTING MILLS, Reading, Pa., Full Fashioned Stockings. N. Agencies: Ceyer, Cornell & Newell, N. Y.; Williams & Saylor, N. Y.

BEROLIO IMPORT CO., New York (olive oil). S. Agency: Emil-Mogul Co., N. Y.

BEST FOODS Inc., New York, Nucoa margarine and Shinola shoe polish. N. TV. Agency: Benton & Bowles, New York.

BEST FOODS, ONTARIO, Rit. dte. S. Agency: P. H. Hayhurst & Co., Toronto.

BETTY LOU FOODS (Remar Baking Co., Gravem-Ingils Baking Co.), Oakland and Stockton, Calif., Betty Lou Foods, Shoe String Potatoes, Potato Chips, Remar Bread, Gravem-Ingils Bread. S. Agency: Garfield & Guild, S. F.

BEVERWYCK BREWERIES, ALBANY, N. Y. Beer. R. S. Agency: McCann-Erickson, N. Y.

BIGELOW-SANFORD CARPET CO., New York. N. TV. Agency: Young & Rubicam.

BIRDS EYE-SNIDER, New York, Birds Eye frosted foods. N. Agency: Young & Rubicam, N. Y.

BISCEGLIA BROS. WINES CORP., Long Island City, N. Y., "Paradise" wines. Agency: St. Georges & Keyes Inc., New York.

BLACKHAWK BREWING CO., Davenport, Ia. S. Agencies: N. A. Winter Adv., Des Moines; L. W. Ramsey Co., Davenport, Ia.

BLANTON Co., St. Louis, Creamo margarine. S. Agency: Wesley K. Nash Co., St. Louis.

BLATZ BREWING Co., Milwaukee (Blatz Pilsener Beer) S. N. TV. Agency: Kaster, Farrell, Chesley & Clifton, N. Y.

BLOCK DRUG Co., Jersey City, Poll-dant, S. Agencies: Cecil & Presbrey; Redfield-Johnstone; Harry B. Cohen Adv., N. Y.; Wesley Assoc., N. Y.; J. D. Tarcher Inc., N. Y.; Noyes & Sproul Inc., N. Y.

THE BLOSSER Co., Atlanta, Ga., Medical Cigarettes for Asthma. S. Agency: Atherton & Currier, N. Y.

BLUE BUS LINES, Terminal Bldg., Batavia, N. Y., S. Agency: Hart-Conway Co., Rochester.

BLUE MOON FOODS, Thorp, Wis., cheese spread, Gold N'Rich Cheese. Agency: Reincke, Meyer & Flinn, Inc., Chicago.

BLUE RIBBON Corp., Toronto, Canned food vacuum sealed jars. S. Agency: Cockfield Brown & Co., Toronto.

BLUEBIRD DIAMOND SYNDICATE, Chicago, Ill., Bluebird rings. S. Agency: O'Neal, Larson & McMahon, Chicago.

BOHEMIAN DISTRIBUTING CO., Los Angeles. Acme Beer. TV. Agencies: Brisacher, Wheeler & Staff, L. A.; Davis & Co., L. A.

BONAFIDE MILLS INC., N. Y. (linoleum, roofing) N. TV. Agency: S. R. Leon Co., N. Y.

BONCQUET LABS, Glendale, Cal., vitamins. S. Agency: Brisacher, Wheeler & Staff, L. A.

BOND STORES, Inc., New York. Agency: Neff-Rogov, N. Y.

BONNE BELL, Inc., Cleveland, O., Ten-O-Six, Plus 30, Nite & Day. S. Agency: Lewis & Gilman Inc., Phila.

BOOK-OF-MONTH CLUB, New York, Books. S. Agency: Schwab & Beatty, New York.

BORDEN Co., New York, Milk and ice cream, Hemo and Instant Coffee. N. S. TV. Agencies: Kenyon & Eckhardt, New York; Young and Rubicam, New York.

BORDON CO., Toronto. N. Agency: Young & Rubicam, Toronto.

BOSTON & MAINE RR, Boston. N. S. Agency: Harold Cabot Co., Boston.

BOTANY MILLS INC., Passaic, N. J. S. TV. Agency: Alfred J. Silberstein-Bert Goldsmith Inc., N. Y.

BOURJOIS Inc., New York, Evening in Paris cosmetics. N. Agency: Foote, Cone & Belding, N. Y.

BOWEY'S Inc., Chicago, Dari-Rich Products. N. Agency: Sorensen & Co. Chi.

BOWMAN'S GUM Inc., Phila. Warren's chewing gum. S. Agency: Foote, Cone & Belding, N. Y.

BOYLE-MIDWAY (Canada) Ltd., Toronto. (Fly-Ded). S. Agency: W. Earl Bothwell Inc., N. Y.

E. J. BRACH & SONS, Chicago, Confectionery. N. Agencies: Geo. H. Hartman Co., Chi.; Maxon Inc., Detroit.

JOHN H. BRECK Inc., Springfield, Mass, shampoo. Agency: Charles Sheldon Adv., Springfield, D-C.

M. J. BREITENBACH Co., New York, Gude's Pepto Mangan. N. Agency: Dorland Inc., N. Y.

BREWING CORP OF AMERICA, Cleveland. S. Agencies: Leo Burnett Co., Chi.; Lang, Fisher & Stashower, Cleveland.

BRISTOL-MEYERS Co., New York, Sal Hepatica & Trushay, Vitalls, Ipana & Benex. N. R. S. TV. Agencies: Young & Rubicam; Doherty, Clifford & Shenfield, N. Y.

BRISTOL MYERS Co., of Canada, Montreal, Sal Hepatica, Vitalls, Trushay. Agency: Ronalds Adv., Montreal.

BRITISH AMERICAN OIL Co., Toronto. Agencies: Spitzer & Mills, Toronto; Stewart, James Lovick Co., Vancouver.

BROADMOOR HOTEL Inc., Colorado Springs, Col., Ice Skating, Ice Shows and Revues, Scenic Trips, Broadmoor Tavern (all spot). Agency: Galen Broyles Adv., Denver.

BROMO-SELTZER LTD., Toronto (Bromo-Seltzer) R. S. Agency: F. H. Hayhurst Co., Toronto.

BROTHERHOOD OF RAILROAD TRAINMEN, N. Agency: William Von Zehle & Co., N. Y.

BROWN & HALEY, Tacoma, Almond Roca, Mountain Bars, Yankee Toffee. Agency: Honig-Cooper, Seattle.

BROWN SHOE Co., St. Louis, Shoes. N. Agency: Leo Burnett Co., Chicago. D-C.

BROWN & WILLIAMSON TOBACCO Corp., Louisville, Raleigh & Life Cigarettes, Sir Walter Raleigh Tobacco, Kool Cigarettes. N. TV. Agencies: Russel M. Seeds, Chicago; Ted Bates, Inc.

BROWNELL-FIELD Co., Providence, R. I. (Autocrat coffee) S. R. Agency: Standish Inc., Providence.

BROWNSTEIN-LOUIS Co., Los Angeles, Shirts. TV. Agency: The Mayers Co., Los Angeles.

E. L. BRUCE Co., Memphis, floor cleaner. N. Agency: Christiansen Adv., Chi.; Greenshaw & Rush Inc., Memphis.

BRUNER-RITTER Inc. (jewelry) Agency: Raymond Specter Co., N. Y.

W. K. BUCKLEY, INC., Chicago. S. Agency: Grant Adv., N. Y.

W. K. BUCKLEY & Co., Toronto, proprietary. Agency: Grant Adv., Toronto.

BUDGET FINANCE PLAN, L. A. R. Agency: Irwin-McHugh Adv., L. A.

BUDGET PACK, L. A. (gelatin dessert & concentrated fruit drink) TV. Agency: Brishacher, Wheeler & Staff, L. A.

BULOVA WATCH Co., New York, Bulova S. TV. Agency: Blow Co., N. Y. D-C.

BUNTE BROS., Chicago, Candy. N. Agency: Presba, Fellers & Presba, Chi.

BURLINGTON BREWING CO., Chicago. (Van Merritt beer) N. Agency: Good-kind, Joice & Morgan Inc., Chi.

BURNS CO., Vancouver, B. C. Neet. N. Agency: Stewart-Lovick & MacPherson, Vancouver, B. C.

BURPEE CAN SEALER Co., Barrington, Ill. S. Agency: Rogers & Smith, Chi.

BU-TAY PRODUCTS, Ltd., Los Angeles, Raindrops Water Softener. N. Agency: Glasser-Galley & Co., Los Angeles.

BURTON-DIXIE Corp., Chicago, Bedding. Agency: Campbell-Ewald Co., Chicago.

BUTLER PACKING CO., Oakland, Calif. (Dennisson's Foods) N. Agency: Brisacher, Wheeler & Staff, S. F.

C

C-Z CHEMICAL Co., Beloit, Wis., Marvene Suds, C-Z Floor Wax. S. Agency: Roche, Williams & Cleary, N. Y.

CALAVO GROWERS of California, Los Angeles, avocados. S. Agency: The Perrett Co., L. A.

DR. W. B. CALDWELL Co., Monticello, Ill., Campho-Phenique. S. Agency: Sherman & Marquette, N. Y.

CALIFORNIA ASSOCIATED PRODUCTS Co., Los Angeles, Monterey Concord grape juice punch, Yankee Doodle Root Beer. N. & S. Agency: Lockwood-Shackelford Adv., L. A.

CALIFORNIA BILL OF RIGHTS COMMITTEE. R. Agency: Cinema Adv., L. A.

CALIFORNIA FIG INSTITUTE, Fresno, Calif. Agency: Etwood J. Robinson Adv., Los Angeles.

CALIFORNIA FRUIT GROWERS EXCHANGE, Los Angeles, Cal., Sunkist Oranges. S. Agency: Foote, Cone & Belding, L. A.

CALIFORNIA LIMA BEAN GROWERS ASSN., Oxnard, Calif. (Seaside canned & cellophane packed lima beans) R. S. Agency: Mogge-Privett Inc., Los Angeles.

CALIFORNIA MEDICAL ASSN., N. Agency: Lockwood-Shackelford, L. A.

CALIFORNIA NURSERY Co., Niles, Cal., nursery stock. S. Agency: Ryder & Ingram, Oakland, Cal.

CALIFORNIA PACKING CORP., S. F. (Del Monte foods) R. N. Agency: McCann-Erickson, S. F.

CALIFORNIA PHYSICIANS SERVICE, San Francisco. (Voluntary Medical Insurance) R. Agency: Lockwood-Shackelford Adv., Hollywood.

CALIFORNIA PROCESSORS & GROWERS Inc., Oakland, Cal., cooperative. S. Agency: Foote, Cone & Belding, San Francisco.

CALIFORNIA PRUNE & APRICOT GROWERS ASSN., San Jose, Cal., Sun-sweet. S. N. Agency: Long Adv. Service, San Jose.

CALIFORNIA SPRAY - CHEMICAL CORP., Richmond, Cal., Ortho garden spray. R. S. agencies: Cosby & Cooper, S. F.; Vance Shelhamer Adv., Yakima; The Ardiel Adv. Agency, Hamilton, Ont.

CALIFORNIA WINE GROWERS GUILD, San Francisco. Agency: Honig-Cooper, San Francisco.

CAMCO PRODUCTS Inc., New York, Camco Portable Cloverleaf Table Range. Agency: J. B. Pershall, Chi.

CAMEO CORP., Chicago, (cleanser) R. Agency: J. B. Pershall, Chi.

CAMINOL CO., Stockton, Calif. Beacon gasoline. R. Agency: Duane Jones Co. CAMPANA SALES Co., Batavia, Ill., Cosmetics and Toilet Goods. N. Agencies: Wallace-Ferry-Hanly, Chi.; Hixson-Jorgensen Inc., N. Y.; Cockfield, Brown & Co., Ltd., Toronto.

CAMPBELL CEREAL Co., Minneapolis, Malt-o-Meal. Agency: Campbell-Mithun, Minneapolis.

CAMPBELL SOUP Co., Camden, N. J., soup. N. S. Agencies: Ward Wheelock Co., Philadelphia; Cockfield, Brown & Co., Toronto; Dancer-Fitzgerald-Sample, N. Y.

CAMPBELL SOUP Co., Ltd., New Toronto, Ont. N. Agencies: Cockfield Brown & Co., Toronto, Ward Wheelock Co., Phila.

CANADA DRY GINGER ALE Inc., New York, Gingerale. S. N. TV. Agency: J. M. Mathes Inc., N. Y. D-C.

CANADA STARCH Co., Montreal 2, Que., Crown Brand Corn Syrup, Karo, Benson's Corn Starch, Canada Corn Starch, Mazola oil, Limit starch. S. Agency: Vickers & Benson, Montreal.

(Continued)

The Best Buy
for
Quality
Advertisers

WNMP

EVANSTON
AND
GREATER CHICAGO
1000 WATTS DAYTIME

DIRECTORY OF NATIONAL AND REGIONAL ADVERTISERS

(Continued)

CANADIAN ACE BREWING Co., Chicago. TV. Agency: Louis Weitzman Agency, Los Angeles.

CANADIAN AID TO CHINA, Toronto. Welfare. S. Agency: McKim Adv., Toronto.

CANADIAN BREWERIES LTD., Toronto (beer). Agency: Spitzer & Mills Ltd., Toronto.

CANADIAN CANNERS Ltd., Hamilton, Ont. Aylmer Products Canned Foods. S. Agency: F. H. Hayhurst Co., Toronto.

CANADIAN CHEWING GUM SALES, Toronto (Dentyls Chicles, Sen-Sen). S. Agency: Baker Adv., Toronto.

CANADIAN CHINCHILLA Co., Toronto. S. Agency: Frontenac Broadcasting Co., Toronto.

CANADIAN INDUSTRIES, Ltd., Montreal (paints div.). S. R. Agencies: Ronalds Adv., Montreal; Cockfield Brown & Co., Montreal.

CANADIAN INSECTICIDE & CHEMICAL Co., Toronto. S. Agency: Locke, Johnson & Co., Toronto.

CANADIAN MARCONI CO., Montreal (receivers). N. Agency: Cockfield Brown & Co., Montreal.

CANADIAN NATL. CARBON Co. Ltd., Toronto. Can. Radio Batteries, Flashlight Batteries. N. Agency: Locke, Johnson & Co., Toronto.

CANADIAN OIL LTD., Montreal. Oil & gasoline. Agency: McConnell Eastman & Co., Montreal.

CANADIAN RED CROSS, Toronto (financial campaign). S. Agencies: Cockfield Brown & Co.; MacLaren Adv., Toronto; Russell T. Kelly Ltd.; Hamilton & Canadian Adv., Montreal.

CANADIAN SHREDDED WHEAT CO., Ltd., Niagara Falls, Ont. (Shreddies). N. Agencies: Cockfield Brown & Co., Toronto; MacLaren Adv., Toronto.

CANDO Co., Boston, Mass., Cando Silver Polish, Cando Metal Polish. S. Agency: Chambers & Wiswell, Boston.

CANNON SHOE Co., Baltimore. shoes. S. Agency: Van Sant, Dugdale & Co., Baltimore.

CAPITAL AIRLINES, Washington. Agency: Lewis Edwin Ryan Inc., Washington.

CAPITAL CITY PRODUCTS Co., Columbus, Dixie Margarine, Kingstade Dressings. S. Agencies: R. W. Knopf Co., Columbus, O.; Chambers & Wiswell, Boston; Merrill-Kremer, Memphis.

CAPITOL MILLING Co., L. A. R. Agency: Milton Weinberg Adv., L. A.

CARDINET CANDY CO., Oakland, Calif. (U-No Bars, Baffle Bars) R. Adv. placed direct.

CAREY SALT Co., Hutchinson, Kans. Carey Salt. N. Agency: Gordon Best Co., Chicago.

CARGILL Inc., Minneapolis, feeds and seeds, Blue Streak Dog Food. Agency: Bruce B. Brewer & Co., Minneapolis.

CARNATION Co., Los Angeles, Evaporated Milk, Faskies Dog Food. N. Agency: Erwin, Wasey & Co., Chicago & L. A.

CARNATION MILK CO. LTD. Toronto (evaporated milk). N. Agency: Baker Adv., Toronto.

DALE CARNegie SALES TRAINING COURSES, St. Louis, R. Agency: Warner, Schulenburg, Todd & Assoc., St. Louis.

CAROLINE PRODUCTS CO., Litchfield, Ill. "Milnot" milk compounds. Agency: Henri, Hurst & McDonald, Inc., Chicago.

CARSON PIRIE SCOTT & Co., Chicago. Department store. S. Agencies: Earle Ludgin & Co.; Hoskinson & Rohloff, Chicago.

CARTER PRODUCTS Inc., New York. Carter's Little Liver Pills, Arrid. N. S. Agencies: Ted Bates Inc.; Sullivan, Stauffer, Colwell & Bayles, New York; Raymond Spector Co., N. Y.

CARTER PRODUCTS INC., Toronto (liver pills). Agency: J. Walter Thompson Co., Toronto.

CASSILL DISTRIBUTING Co., Los Angeles, Sandra Cassill Hand Creme, Mocombo After-Shave Cologne Lotion. S. CASTLE COAL & OIL CO., Bronx, N. Y. Agency: Adair & Director, N. Y.

CAT'S PAW AND RUBBER CO., Baltimore. Soles and heels. S. Agency: S. A. Levyne Co., Baltimore.

CATALINA KNITTING MILLS, Los Angeles. Agency: David S. Hillman, Inc., L.A.

CELANESE CORP. OF AMERICA, New York, All Products. N. TV. Agencies:

Young & Rubicam; Ellington & Co., N. Y.

CELLO WAX Co., Baltimore, Bluko and Cellowax. S. Agency: Maurice Azrael Adv., Baltimore.

CELOMAT CORP., New York. (Vue Scope TV enlarging lenses & teleroto turntables.) S. TV. Agency: Tracy, Kent & Co., N. Y.

CENTAUR-CALDWELL DIV., Sterling Drug Inc., New York. Ironized Yeast, Molle shaving cream. N. Agencies: Young & Rubicam; Pedlar & Ryan; Thompson-Koch Co., & Sherman & Marquette, N. Y.

CENTENNIAL FLOURING MILLS Co., Seattle, Silk-sifted Flour, Peach Blossom Cake Flour, Pancake and waffle flour, dog meal, poultry feed, dairy feed, hog feeds, turkey feeds. Agency: Honig-Cooper Co., Seattle.

CENTILVRE BREWING Corp., Fort Wayne, Ind., Old Crown Ale, Old Crown Beer. S. Agency: Westhelmer & Co., St. Louis.

CENTRAL CHEVROLET Co., L.A. (dealers) R. Agency: Hunter Adv., L.A.

CENTRAL NATIONAL BANK IN CHICAGO, Bank Services, Chicago. S. Agency: Harry J. Lazarus & Co., Chicago.

CHALLENGE CREAM & BUTTER ASSN., L.A. (dairy products) R. Agency: Ross Sawyer Adv., L.A.

CHALMERS GELATINE Corp., Williamsville, N. Y. Chalmers gelatine. S. Agency: Armand S. Weill Co., Buffalo.

CHAMBERLAIN SALES Corp., Des Moines, Chamberlain's Lotion. Agency: BBDO, Chicago.

CHAMPION SPARK PLUG Co., Toledo, N. Agencies: McManus, John & Adams, Detroit; Walsh Adv. Co. Ltd., Windsor, Ont.

CHARIS Corp., Allentown, Pa. (foundation garments). Agency: Fuller, Smith & Ross, N. Y.

CHASE CANDY Co., St. Louis, High Crest, Chocolates. S. Agency: McCann-Erickson Inc., Chicago.

DR. A. W. CHASE MEDICINE Co., Oakville, Ont., proprietary. R. Agency: F. H. Hayhurst Ltd., Toronto.

CHATHAM MFG. Co., New York, Blankets. N. Agencies: M. H. Hackett Co., N.Y.; E. J. Presser Co., Charlotte, N. C.

CHATTANOOGA MEDICINE Co., Chattanooga, Tenn. Agency: Nelson Chesman Co., Chattanooga, Tenn.

CHEF BOY-AR-DEE QUALITY FOODS, Inc., Milton, Pa., Spaghetti Dinner, S. N. Agency: Young & Rubicam, N.Y.

CHEMICALS Inc., Oakland, Vano. S. N. Agency: Garfield & Guild, S.F.

CHESAPEAKE & OHIO RAILWAY Co., Cleveland, Service. N. Agencies: Kenyon & Eckhardt; Robert Conahay & Assoc., N.Y.

CHESEBROUGH MFG. Co., New York, Vaseline hair tonic. N. S. TV. Agencies: McCann-Erickson; J. Walter Thompson, N. Y.; Coyton Inc., N.Y.; Cockfield Brown & Co., Montreal.

CHEVROLET DEALERS of N.Y. TV. Agency: Campbell-Ewald Co., N.Y.; Benton & Bowles, N.Y.

CHEVROLET MOTOR DIVISION, General Motors Corp., Detroit, TV. Agency: Campbell-Ewald Co., Detroit.

CHICAGO, MILWAUKEE, ST. PAUL & PACIFIC RR., Union Station, Chicago. S. Agency: Roche, Williams & Cleary, Chi.

CHICAGO & NORTH WESTERN SYSTEM, Chicago, railway. Agency: Caples Co., Chi.

CHICAGO TITLE & TRUST Co., Chicago. R. Agency: Earle Ludgin & Co., Chicago.

CHICK-BED Co., Cedar Rapids, Iowa, Poultry Litter. S. Agency: Campbell Sanford Co., Chicago.

CHRISTIAN HERALD ASSN., New York. S. Placed direct.

CHRISTIAN SCIENCE PUB. SOCIETY, Boston, Christian Science Monitor. N. Agency: H. B. Humphrey Co., Boston.

CHRISTMAS CLUB Corp., New York. N. Agency: Brooke, Smith, French & Dorrance, N. Y.

CHRYSLER Corp., Detroit, Plymouth, Dodge, De Soto. Chrysler cars, Dodge

trucks. N. Agencies: Ruthrauff & Ryan, N.Y.; McCann-Erickson, Detroit; N. W. Ayer & Son, Phila.; BBDO, N.Y.; Grant Adv., Detroit.

CINCY PRODUCTS Co., Cincinnati, wallpaper cleaner. Agency: Ralph H. Jones Co., Cincinnati.

CITIES SERVICE Co., New York, fuels, lubricants, accessories. R. Agency: Ellington & Co., N.Y.

CITIZEN'S NATIONAL TRUST & SAVINGS BANK, L.A. TV. Agency: Hixson & Jorgensen Inc., L.A.

CLAIROL Inc., New York, color accenting shampoo. S. Agency: Cole & Chason Inc., N.Y.

CLARK BROS. CHEWING GUM Co., Pittsburgh, gum. N. Agencies: Duane Jones Co., Buchanan & Co., N.Y.

D. L. CLARK Co., Pittsburgh, Candy. N. Agency: BBDO, Pittsburgh.

CLARY MULTIPLIER Corp., Los Angeles (Flo-Ball pen). R. Agencies: Brisacher, Wheeler & Staff, L.A.; Dana Jones Co., L.A.

CLAWSON PROTECTIVE COATINGS Co., L.A. TV. Agency: Allied Adv., L.A.

CLEAN PRODUCTS Co., Columbus, O., Clean wallpaper and hand cleaners. Agency: Byer-Bowman Adv., Columbus.

CLEVELAND & BUFFALO STEAMSHIP Co., Chicago, Lake Cruises. S. Agency: Walter L. Rubens & Co., Chicago.

CLICQUOT CLUB Co., Millis, Mass. S. Agency: N. W. Ayer & Son, Boston.

CLIPPER CRAFT CLOTHES (formerly Trimout Clothing Co., New York), Clipper Craft Clothes. N. Agency: Emil Mogul Co., N.Y.

CLUB ALUMINUM Co., Chicago, Hammercraft cookware, glassware, cleaners, polishes. N. Agencies: Morris F. Swaney Inc.; Leo Burnett Inc., Chi.

CLUETT-PEABODY Co., New York, Manufacturer of men's shirts. N. TV. Agency: Young & Rubicam, N. Y.

COAST-CURRIE ICE CREAM Co., Los Angeles. S. Agency: Barton A. Stebbins Adv. Inc., L.A.

COCA COLA Co., Atlanta, Ga. N. Agencies: D'Arcy Advertising Co. & Grant Adv. Inc., N.Y. D-C.

COCA-COLA LTD., Toronto. Agency: D'Arcy Adv. Ltd., Toronto.

COCLANA, Inc., Brooklyn, Coughdrops. S. Agency: Al Paul Lefton Co., N.Y.

COHN-HALL-MARX Co., New York, Cohnama fabrics. S. TV. Agencies: The Albert Woodley Co., N.Y.; Henry Bach Assoc. Inc., N.Y.; Abbott Kimball Inc., L.A.; Dorland Inc., N.Y.

COLE MILLING Co., Chester, Ill., Omega flour. N. Agencies: J. Walter Thompson Co., Chi.; Gardner Adv., St. Louis.

COLGATE - PALMOLIVE - PEET Co., Jersey City, Colgate's Dental Cream, Super Suds, Palmolive Soap, Shave Cream, Vel. S. N. TV. Agencies: Ted Bates, Inc., N.Y.; Sherman & Marquette, N.Y.; Wm. Esty & Co., Inc., N.Y.; Lennen & Mitchell, N.Y.; Leon Livingston Adv., N.Y. Newell-Emmett Co., N.Y. D-C.

COLGATE - PALMOLIVE - PEET Co. Ltd., Toronto. S. Agencies: Spitzer & Mills Ltd., Toronto; Harry E. Foster Agencies, Toronto; L. J. Haegerty Ltd., Toronto.

COLLEGE INN FOOD PRODUCTS Co., Chicago, soup, juices, chicken. Agency: Weiss & Geller, Chicago.

COLONIAL DAMES, Inc., Hollywood, cosmetics. S. N. Agency: Hixson-Jorgensen, L.A. D-C.

COLORADO MILLING & ELEVATOR Co., Denver, Family Flour, Poultry and Livestock Feeds, Farm Supplies. S. Agency: Ed. M. Hunter, Denver.

COLUMBIA BREWING Co., St. Louis. N. Agency: Olian Adv. Agency, St. Louis.

COLUMBIA BROADCASTING SYSTEM, Inc., New York. Agency: McCann-Erickson Inc., New York.

COLUMBIA PICTURES Corp., New York, pictures. S. Agency: Weiss & Geller, N.Y. D-C.

COMET RICE MILLS, Beaumont, Tex., Comet rice. S. Agency: Leche & Leche, Dallas.

COMMERCIAL ALCOHOLS Ltd., Toronto, Anti-freeze. S. Agency: McCann-

Eastmann & Co., Toronto.

COMMERCIAL CREDIT Co., Baltimore. N. Agencies: Sheldon, Quick & McElroy, N.Y.; Van Sant Dugdale, Inc., Balt.; Walsh Adv., Ltd., Toronto.

COMMERCIAL SOLVENT, Terre-Haute, Indiana (Dry-Ex Anti-Freezer). S. Agency: Fuller, Smith & Ross, N.Y.; L. G. Maison & Co., Chicago.

COMMONWEALTH EDISON Co., Chicago. Agency: J. R. Pershall Co., Chicago.

COMPAGNIE PARISIENNE Inc., San Antonio, Tex., Perfumes. S. Agencies: Shaffer, Brennan, Margulis Adv., St. Louis; Northwest Radio Adv., Seattle.

COMPTONE Co., New York, Oculens Sunglasses. N. Agency: Bryde-Richard & Pound, N.Y.

CONFECTIONS INC., Chicago, Candy and Snacks, Karmel Korn. S. Agencies: Olian Adv. Co., Chi.; Schoenfeld, Huber & Green, Chi.

CONGRESS CIGAR Co., Inc., New York, La Palina cigars. S. Agency: Schwimmer & Scott, Chi.

CONGRESS OF INDUSTRIAL ORGANIZATIONS, New York, CIO of America. N. Agency: Wiltman & Pratt, N.Y.

CONRO MFG. Co., Dallas, overalls, work clothes, uniforms. N. S. Agency: Grant Adv., Dallas.

CONSOLIDATED BISCUIT Co., Chicago. Biscuits. S. Agency: Lynn-Fieldhouse Adv., Wilkes-Barre, Pa.

CONSOLIDATED DRUG Co., Chicago (Kolorback) R. Agency: Harry O'Neill Adv., Chicago.

CONSOLIDATED PRODUCTS Co., Danville, Ill., Semi-Solid Chick-Emulsion, Semi-Solid "T" Emulsion, Semi-Solid Pig Emulsion, Kaff-A. S. Agency: Bert S. Gittins, Milwaukee.

CONSOLIDATED ROYAL CHEMICAL Corp., Chicago, Feruna, Kolor-Bak, Zymole Trokeys, Acidene, Hamlins, Krank's Shave-Kreem. S. R. Agencies: O'Neill Adv., Chi.; Arthur Meyerhoff & Co., Chi.

CONSTRUCTION SUPPLIES CORP., Toronto (Aquila waterproofer). Agency: S. A. Rutland & Co., Toronto.

CONTI PRODUCTS Corp., Bklyn., New York, Conti Shampoo & soap. N. Agencies: Bermingham, Castelman, and Pierce & Murray Breese Assoc., N.Y.

CONTINENTAL AIR LINES, Stapleton Airfield, Denver, air line seats. Agency: Galen E. Broyles Co., Denver.

CONTINENTAL BAKING Co., Inc., New York, Wonder Bread & Hostess Cake. N. S. Agency: Ted Bates Inc., N.Y.

CONTINENTAL CAN Co., New York, Cans, Institutional, Packaging, Plastic Products. N. Agency: BBDO, N.Y.

CONTINENTAL OIL Co., Ponca City, Okla. Oil. S. Agency: Cornell & Newell, N.Y.

CONTINENTAL PHARMACEUTICAL Co., Chicago, N. Agencies: Arthur Meyerhoff, Chi.; O'Neill Adv., Chi.

CONTINENTAL SANTA FE BUS SYSTEM OF CALIF., N. Mexico & Ariz. R. Agency: Lannan Sanders, Dallas.

COOK PAINT & VARNISH Co., Paint, wall paper. Kansas City, Mo. S. Agency: R. J. Potts, Calkins & Holden, Kansas City, D-C.

COOPER BREWERY, Philadelphia. S. Agency: Ralph A. Hart Adv., Phila.

COOPER & COOPER Inc., Brooklyn, N. Y. Razor blades. S. Agency: Pearson Adv. Agency, N.Y.

COOPERATIVE G. L. F. EXCHANGE, Terrace Hill, Ithaca, N. Y., institutional, Agency: Agricultural Advertising & Research, Ithaca.

CORN PRODUCTS REFINING Co., New York, Dextrose, Mazola & other products. N. Agencies: C. L. Miller Co., & McCann-Erickson Inc., N.Y.

CORTLAND BAKING Co., Cortland, N. Y., Bread, doughnuts. S.

COTY Inc., New York, Cosmetics. N. Agency: J. D. Tarcher Inc., N.Y.

G. N. COUGHLAN Co., West Orange, N. J., Chimney Sweep Soot Destroyer. N. Agency: Roche, Williams & Cleary, N.Y.

COUNTY PERFUMERY Co., Bloomfield, N. J., Erylcream, hair dressing, S. N. Agency: Atherton & Currier, N.Y.

E. L. COURNAND Co., New York (Walco Tele-vue Lens) N. TV. Agency: Cayton Inc., N.Y.

DR. S. M. COWEN, Los Angeles, credit dentist chain. S. Agency: Dean Simmons Adv., Hollywood.

CRACKER JACK Co., Chicago. S. Agency: Rogers & Smith Adv., Chicago.

CREAM OF WHEAT Corp., Minneapolis, Cream of Wheat Cereal, N. Agencies: BBDO, Minn.; Robert Otto & Assoc., N.Y.

CREOMULSION Co., Atlanta. Proprietary medicine. Agency: Harvey-Masengale Co., Atlanta.

CRESCENT ELECTRIC SUPPLY Co., Dubuque, Iowa (Gen. Elec. distributor) R. S. Agency: W. D. Lyon Co., Cedar Rapids.

CRESTA BLANCA WINE Co., New York. Dubonnet wine. S. N. TV. Agencies: McCann-Erickson Inc., S.F.; Blow Co., N.Y.

CRESTONE Co., New York. Crestone. Agency: Direct.

CRISTY CHEMICAL CORP., Worcester, Mass. (Christy Drygas, anti-freeze) S. Agency: Cory Snow Inc., Boston.

CROSSE & BLACKWELL Co., Baltimore. Agencies: Van Sant, Dugdale & Co., Balt.; Emery Adv. Co., Balt.

CROSSE & BLACKWELL Co., Toronto. Agency: McKim Adv., Toronto.

CROWELL-COLLIER PUBL. Co., N.Y. R. Agency: Kudner Adv., N.Y.

CROWN DIAMOND PAINT Co., Toronto. Paint. S. Agency: McConnel. Eastman & Co., Toronto.

CROWN MILLS, Portland, Oreg., N. S. Agency: Richard G. Montgomery & Assoc., Portland.

CUDAHY PACKING Co., Chicago. Old Dutch Cleanser. N. Agency: Grant Adv., Chi.

THE CUMMER CO. DIVISION OF STERLING DRUG Inc., Brattleboro, Vt. Emergine cleaning fluid, shoe white. N. Agency: Dancer-Fitzgerald-Sample, N.Y.

CURTICE BROS. Co., Rochester, N.Y., Blue Label Ketchup. N. Agency: Duane Jones Co., N.Y.

HELEN CURTIS INDUSTRIES, Chicago. cosmetics. Agency: Buchanan & Co., Chicago.

CURTIS PUB. Co., Philadelphia, Sat. Evening Post, Holiday, Ladies Home Journal. N. S. Agencies: BBDO, N.Y.; N. W. Ayer & Son Inc., & Lamb, Smith & Keen Inc., Phila.; BBDO, N.Y.

CURTISS CANDY Co., Chicago. Butterfinger & other candy products. N. Agency: C. L. Miller Co., Chicago.

CYNTHIA SWEETS Co., Boston, candy. N. Agency: Hirshon-Garfield, Boston.

D

D. L. & W. COAL Co., Toronto (Blue Coal) Agencies: Vickers & Benson, Toronto; Birmingham. Castleman, Pierce, New York. Ruthrauff & Ryan.

DADANT & SONS, Hamilton, Ill. Honey and bee supplies. S. Agency: Mace Adv., Peoria, Ill.

DAILEY MILLS, Olean, N. Y., animal, poultry feeds. S. Agency: Birmingham, Castleman & Pierce, New York.

DALGLISH Ltd., London, Ont., Javex cleanser. Agency: MacLaren Adv. Co., Toronto.

DALY BROS. SHOE Co., Boston. Air-O-Magic men's shoes. S. Agency: Norman D. Waters & Assoc., New York.

DAMEREL-ALLISON Co., Covina, Calif. (D & A Orange Juice) R. Agency: Western Adv., Los Angeles.

KAY DAUMIT Inc., Chicago. Lustre-Creme Shampoo. TV. Agency: Lennen & Mitchell Inc., N.Y.

H. R. DAVI Co., Oakland, Cal. Miracle Foam. S. Agency: Ad Fried Adv., Oakland, D-C.

H. B. DAVIS Co., Baltimore, Md., Paint products. S. Agency: John Falkner Arndt Inc., Phila. D-C.

DAVIS MOTOR Co., Los Angeles N. Agency: Tellamerica Inc., Hollywood.

DAY & NIGHT MFG. Co., Monrovia, Calif., water heaters and equipment. N. S. TV. Agency: Hixson-Jorgensen Adv., L.A. D-C.

DAZEY CORP., St. Louis, Kitchen aids and gadgets. S. Agency: Gardner Adv., St. Louis.

DEAN MILK Co., Chicago. S. TV. Agency: Morris F. Swaney Inc., Chi.

DECORATIVE CABINET Co., New York E-Z-Do wardrobes & chests. S. Agency: Reiss Adv., New York.

DEERFIELD PACKING Corp., Bridgeport, N. J. Seabrook Farms frozen food products. R. S. Agency: Peter Hilton Adv. Agency, N.Y.

DEKALB AGRICULTURAL ASSOC., DeKalb, Ill., Hybrid Corn and Seed. S. Agency: Western Adv., Chicago.

DELTA MFG. DIV., ROCKWELL MFG. Co., Milwaukee. TV. Agency: Hoffman & York Inc., Milwaukee.

DELAWARE, LACKAWANNA & WESTERN COAL Co., New York. Blue Coal. N. Agency: Ruthrauff & Ryan, New York.

DELAWARE, LACKAWANNA & WESTERN COAL Co., Montreal (blue coal) R. Agency: Vickers & Benson Ltd., Montreal.

DELAWARE PUNCH Co., San Antonio (soft drinks) R. S. Agency: Grant Adv. Dallas.

DELCO APPLIANCE DIV., General Motors Corp., Rochester, N. Y. Agency: Foote, Cone & Belding, Chicago.

DE LUXE GIRDECRAFT Co., New York. girdles. S. Agency: Gussow-Kahn Co., N.Y.

L. DeMARTINI Co., San Francisco. S. Agency: Garfield & Guild Adv., S.F.

DENALAN Co., Inc., San Francisco. Denalan Dental Plate Cleaner. Agency: Rhoades and Davis, S.F. D-C.

DENNISON'S FOODS, Oakland, Calif. (Dennison's Catsup & Chili Sauce) R. S. Agencies: Honig-Cooper Co., Brischacher Wheeler & Staff, S.F.

H. C. DERBY Co. Div of Swift & Co., Philadelphia, Pa. Table Ready Meats. N. Agency: Aitken-Kynett Co., Phila.

DERBY FOODS, Chicago. N. TV. Agency: Needham, Louis & Brorby, Chicago.

DeSOTO DIVISION OF CHRYSLER Corp., Detroit. S. Agency: BBDO, N.Y.

DeSOTO-PLYMOUTH DEALERS, N. Agency: BBDO.

DIAPERWHITE Inc., New York, Diaperwhite, a detergent. S. Agency: Adair & Director, N.Y.

DIF CORP., Garwood, N.J. (Dif hand cleaner, washing powder) R.S. Agency: French & Preston Inc., N.Y.

DISNEY HATS, New York. TV Agency: Grey Adv., N.Y.

DODGE DIVISION, CHRYSLER Corp., Detroit. Agency: Ruthrauff & Ryan, Inc., New York.

PETER DOELGER, Harrison, N. J. Malt Products Corp. S. Agency: J. M. Mathes Inc., New York.

DOLCIN CORP., N.Y. (pharmaceuticals). N. Agency: Victor Van Der Linde Inc., N.Y.

DOMINION OF CANADA, Dept. of National Defense, Ottawa (recruiting) S. Agency: MacLaren Adv., Toronto.

DOMINION SEVEN-UP Co., Montreal. 7-Up beverages. S. Agency: Vikers & Benson, Toronto.

DON JUAN LIPSTICK Co., New York. Lipstick. S. Agency: Craven & Hedrick Inc., N.Y.

DONOVAN COFFEE Co., Birmingham, Ala. (Red Diamond Coffee). Agency: Barnett & Barnett, Birmingham.

DOUBLEDAY & Co., New York. N. Agencies: Huber Hoge & Sons, & Thwing & Altman Inc., N.Y.

DOUGHBOY MILLS, New Richmond, Wis., flour, pancake flour, cereals. S. Agency: Dwyer & Devoy, Minneapolis.

DOUGLAS AIRCRAFT Corp., Santa Monica, Cal., employment. S. Agencies: J. Walter Thompson, L.A.; Dorland, Inc.

DOYLE PACKING Co., Long Branch, N. J. (Strongheart Dog Food) R.S. Agency: John H. Riordan Co., Los Angeles.

DRACKETT Co., Cincinnati (Drano & Windex) Agencies: Young & Rubicam, N. Y. Straucher & McKim Adv., Cinn.

DUFFY-MOTT Co., New York, Apple Juice and other processed fruit. N. TV. Agency: Young & Rubicam, New York.

ALLEN B. DuMONT LABS., Receiver Sales Div., Passaic, N.J. N. TV. Agencies: Geyer, Newell & Ganger, N.J.; Buchanan & Co., N.Y.

E. I. duPONT de NEMOURS & CO., Wilmington, Del., Institutional. N. Agencies: BBDO, N.Y.; Robt. Otto & Assoc., N.Y. D-C.

DURALACQUE MFG. Co., St. Louis, household cleaner. Agency: Warner, Schulenburg, Todd & Assoc., St. Louis.

DURKEE'S FAMOUS FOODS, Cleveland. Foods. S. Agencies: Wendel Muench & Co., Chic., Emil Reinhardt, Oakland, Calif.; Federal Adv. Agency, N.Y.

DURO FURNITURE Co., L.A. R. Agency: Raymond Keane Adv., L.A.

DUSTBANE PRODUCTS, Ottawa. (sweeping compound) S. Agency: McKim Adv., Toronto.

DUTCH MILL CANDY SHOP, Chicago. R.S. Agency: Schwimmer & Scott, Inc., Chicago.

E

EASTERN WINE Corp., Bronx Terminal Market, N. Y. Chateau Martin vermouths, wines, champagne. Agencies: Aetna A. A., N. Y.; Robert Feldman Inc., N.Y.

EASTMAN KODAK Co., Rochester, N. Y., film and cameras. N. Agency: J. Walter Thompson Co., New York.

EASY WASHING MACHINE Corp., Syracuse, N.Y. Washers and Ironers. TV. Agency: BBDO.

EDELBEW BREWERY, Brooklyn, R. TV. Agency: Gordon & Mattern, N.Y.

EDISON BROTHERS STORES Inc., Chicago, St. Louis. Burt Shoes. S. N. Agencies: United Broadcasting, Chicago; Adolph Wendland, Los Angeles.

ALBERT EHLERS, Inc., New York, Ehlers Tea. S. Agency: Weiss & Geller, New York.

JOHN EICHLER BREWING Co., New York, Eichler's beer. S. Agency: Foote, Cone & Belding, N.Y.

ELECTRIC AUTO-LITE Co., Toledo. Auto-Lite spark plugs, batteries, ignition systems. N. TV. Agencies: Ruthrauff & Ryan, N.Y.; Newell-Emmett Co., N.Y. D-C.

ELECTRIC COMPANIES ADVERTISING PROGRAM, New York, Institutional. N. Agency: N. W. Ayer & Son, New York.

ELECTRICAL RESEARCH LABORATORIES, Inc., Evanston, Ill., Institutional. N. Agency: Evans Assoc., Chicago.

ELGIN NATIONAL WATCH Co., Elgin, Ill., Institutional Watches. N. TV. Agencies: J. Walter Thompson Co., Chi.; Weiss & Geller, Chi.; Robt. Otto & Assoc., N.Y. (export adv.).

ELKEYS Co., L.A. (venetian blinds) S. TV. Agency: John Freilburg & Co., L.A.

DR. ELLIS SALES Co., Pittsburgh, Pa. Waveset, nail polish, shampoo, brilliantine. Agency: Smith-Taylor & Jenkins, Pittsburgh.

EMERSON DRUG Co., Baltimore. Bromo-Seitzer, N. S. TV. Agency: BBDO, N.Y.

EMPLOYER'S GROUP INSURANCE Co., Boston, Insurance. N. Agency: Sutherland-Abbott, Boston.

EMERSON RADIO & PHONOGRAPH Corp., New York. TV. Agency: Blaine-Thompson Co., New York.

END-O-CORN, Rutland, Vt., End-O-Corn, Seyon. S. Agency: Earl C. Noyes Adv. Agency: Rutland.

ENOZ CHEMICAL Co., Chicago, moth spray, moth crystals. S. Agency: Harry J. Lazarus & Co., Chicago.

ENTERPRISE PRODUCTIONS, N. Y. & Hollywood. S. Agency: Donahue & Coe, New York.

EOPA Co., San Francisco, Cal., Eopa Medicines. Agency: Miller & Coffee Adv. Agency, Richmond, Calif.

EPISCOPAL CHURCH N. Agency: H. B. Humphrey Co., Boston.

EQUITABLE LIFE ASSURANCE SOCIETY OF U. S., New York. Life Insurance. N. Agency: Warwick & Legler, New York.

ESKIMO PIES, Bloomfield, N. J. R.S. Agency: Buchanan & Co., N.Y.

ESQUIRE Inc., Chicago, Coronet Magazine and Esquire. N. Agencies: Schwimmer & Scott, Chicago. Jack Murray, Ltd., Toronto; Doherty, Clifford & Shenfield, N.Y.

ESSO STANDARD OIL Co., N.Y. S. TV. Agency: Marschalk & Pratt Co., N.Y.

J. H. ESTABROOKS Co., St. John, N. B., Red Rose tea. Agency: McConnell-Eastman Co., Toronto.

ETHYL Corp., New York, gasoline. S. Agency: BBDO, New York.

EVANS PEN CORP., Hollywood (Evantette ball-point pen) S. Agency: Capka, Kennedy & Duke Adv., Hollywood.

EVERSHARP Inc., Chicago, Eversharp Pencils, Pens, Red Top Lead, Razors. N. Agencies: Blow Co., N.Y.; J. M. Mathes, Inc., N.Y.; McCann-Erickson, N.Y.

EVERSHARP INTERNATIONAL INC., Toronto (pens, pencils, Schick razors). Agency: Baker Adv.

EXCELL LABS., Chicago, New Plant Life. Agency: Grant Adv., Chicago.

EX-LAX Inc., New York. S. Agency: Joseph Katz Co., New York.

F

F. R. CORP., New York, Photographic products, chemicals & acces. & Scoop detergent. Agencies: Kastor, Farrell, Chesley & Clifford, Inc., N. Y.; Walter Weir, Inc., N. Y.

FAIRBANKS-MORSE & Co., Chicago. Agency: The Buchen Co., Chicago.

FAIRBANKS-MORSE, Toronto, automatic stokers. S. Agency: Stevenson & Scott, Montreal.

FALLS CITY BREWING Co., Louisville. S. Agency: Prater A.A.; St. Louis.

FALSTAFF BREWING Corp., St. Louis, Falstaff beer. S. N. Agency: Dancer-Fitzgerald-Sample, Chicago.

FAMILY KITCHEN PRODUCTS Corp., Los Angeles (pastry mixes). S. Agency: Botsford, Constantine & Gardner.

FAMOUS FLOURS Inc., Omaha, N. Agency: J. Walter Thompson, New York.

FARM CREDIT ADMINISTRATION, Springfield, Mass., loans. N. S.

FARNSWORTH TELEVISION & RADIO Corp., Fort Wayne, Ind., radios. N. T. V. Agency: Warwick & Legler Inc., N. Y. D-C.

FATHER JOHN'S MEDICINE Co., Lowell, Mass., Father John's Medicine. S. Agency: John W. Queen, Boston.

FAULTLESS STARCH Co., Kansas City Mo., Faultless Starch. S. Agency: Bruce B. Brewer & Co., Kansas City.

FEDERAL SAVINGS & LOAN COUNCIL, Chicago, Ill. S. Agency: Williams Assoc., Chicago.

FEHR BAKING CO., Houston, Fair Maid bread & cakes. S. Agency: Ruthrauff & Ryan, Houston.

FELTON, SIBLEY & Co., Philadelphia. Paints & varnishes. R. Agency: Aitken-Kynett Co., Philadelphia.

H. FENDRICH, Evansville, Ind., Charles Denby Cigars, La Fendrich Cigars, Black Hawk Cigars. N. Agency: Ruthrauff & Ryan, Chicago.

(Continued)

WIBS covers Puerto Rico
with Programs—with Audiences that Buy!



Your Best Radio Buy In Puerto Rico For Bigger Sales

10,000 W
740 KC

WIBS

PRIMARY AREA
SECONDARY AREA

REPRESENTED BY: PAN AMERICAN BROADCASTING CO., 330 Madison Ave., N.Y.

DIRECTORY OF NATIONAL AND REGIONAL ADVERTISERS

(Continued)

FENTON'S-VIGORTONE Co., Cedar Rapids Iowa. Livestock feed supplement. S. Agency: Ambro Advertising, Cedar Rapids.

FERRY-MORSE SEED Co., Detroit, Seeds. N. Agency: McManus, John & Adams, Detroit.

FILTER KLEEN MFG. Co., Everett, Mass. Polishes & cleansers. Agency: Herbert W. Frank Co., Boston.

FIRE UNDERWRITERS (national insurance organization). N. Agency: MacFarland, Aveyard & Co., N. Y.

FIRESTONE TIRE & RUBBER Co., Akron, Tires, Tubes. S. N. Agency: Sweeney & James Co., Cleveland.

FIRST & MERCHANTS NATIONAL BANK OF RICHMOND, Richmond bank, S. Agency: Edwin Bird Wilson Inc., New York.

FIRST NATIONAL STORES, Somerville, Mass. N. Agency: John C. Dowd Inc., Boston.

FISHER FLOURING MILLS Co., (Packaged Products Div.) Harbor Island, Seattle Wash., flour, cereal. N. & R. Agency: Pacific National Adv. Agency, Seattle.

F. W. FITCH Co., Des Moines, Shampoo, Dandruff Remover Shampoo, Shaving Cream. Agency: L. W. Ramsey Adv., Davenport, Ia.

FITZGER BREWING CO., Duluth, Minn., Rex Imperial Dry Beer, Squirt, N. S. Placed direct.

FITZPATRICK BROS., Chicago, Kitchen Klenzer, N. Agency: Russel M. Seeds Co., Chicago.

FLORIDA CITRUS COMMISSION, Lakeland, N. Agencies: Benton & Bowles, N. Y.; Noyes & Sproil Inc., N. Y.

FLOTILL PRODUCTS, Stockton, Calif. Tomatoes & tomato paste. Agency: Roy S. Durstine Inc., Chicago.

FOLEY & Co., Chicago, Honey and Tar Cough Syrup. S. Agency: Lauesen & Salomon, Chicago.

J. A. FOLGER & Co., San Francisco, Folger's Coffee, N. Agency: Raymond R. Morgan Co., S.F.

FOOD MACHINERY Corp., Riverside, Cal. N. Agency: Neale Adv. Assoc., L.A.

FORD DEALERS ASSNS., Dearborn, Mich. N. TV. Agencies: J. Walter Thompson; Kenyon & Eckhardt, N.Y.

FORD MOTOR Co., Detroit, Ford, Lincoln & Lincoln Zephyr Automobiles. N. TV. Agencies: J. Walter Thompson, Chicago, Kenyon & Eckhardt, Detroit, D-C.

FORD MOTOR Co., Canada; Windsor, Ont. Agency: Cockfield, Brown & Co., Toronto.

FOREMAN & CLARK, Los Angeles, chain clothiers. S. Agency: Botsford, Constantine & Gardner, L. A., Dan B. Miner, L.A.

FOREMOST FARMS Inc., Jacksonville, Fla. (dairy products). Agency: Newman, Lynde & Assoc., Jacksonville, Fla.

FOREST LAWN LIFE INSURANCE Co., Glendale, Cal., life insurance. S. Agency: Dan B. Miner Co., Los Angeles.

B. FORMAN Co., Rochester, N. Y., Fashions. S. Agency: Hart-Conway, Rochester.

FORMFIT Co., Chicago, Foundation Garments. N. Agency: McFarland Aveyard & Co., Chicago, D-C.

FORT PITT BREWING Co., Pittsburgh. TV. Agency: BBDO, New York.

"42" PRODUCTS Ltd., Los Angeles, shampoo & hair tonic. S. Agency: Brischacher, Wheel & Staff, Los Angeles.

FOSTER MILBURN Co., Buffalo, Doan's Pills, Icemint. S. Agency: Street & Finney, New York.

F. FOUGERA & Co., New York, Ramsdell Sulphur Cream. S. Agencies: Small & Seifer, Street & Finney and Redfield & Johnstone, N.Y.

FOULDS MILLING Co., Libertyville, Ill. S. Agency: Campbell-Ewald Co., Chicago.

FOWNES BROS. & Co., New York, Gloves. S. Agency: Rockmore Co., N.Y.

PETER FOX BREWING Co., Chicago, Silver Fox Deluxe Beer. S. TV. Agency: H. W. Kastor & Sons Adv., Chicago.

FRAM Corp., East Providence, R. I. Oil, gasoline and air filters. R. Agency: Van Sant, Dugdale & Co., Baltimore.

FRANCK, HEINRICH & SONS, Inc., Port Huron, Mich. Chicory. S. Agency: Buillard Agency, Port Huron.

FRASER HAIR FASHIONS, Inc., N.Y. Agency: Harry B. Cohen Adv. Co., N.Y.

FREDONIA PRODUCTS Co., Fredonia, N. Y. Wines. Agency: Firsum Adv. Service, New York.

FREED RADIO Corp., New York, Freed-Eiseman radio-phonograph combinations. Agency: Lawrence Fertig & Co., N. Y.

FREIHOFFER BAKING Co., Philadelphia. S. Agency: Stanley Musselman, Inc., N. Y.

FREMONT RUBBER Co., Fremont, Ohio. TV. Agency: Wendt Adv., Toledo, Ohio.

FRENCH KETTLE FOOD PRODUCTS, New York (onion soup). N. Agency: Emil Moful Co., New York.

FRONTIER FOODS OF PHOENIX, Phoenix, Ariz., Potato Chips. N. Agency: Garfield & Guild Adv. Los Angeles.

FRUEHAUF TRAILER Co., Detroit. N. Agency: Zimmer-Keller, Detroit.

FRUIT INDUSTRIES, Ltd., San Francisco. F. I. Special Wines. S. Agency: Davis & Co., L. A.

G. T. FULFORD Ltd., Toronto (proprietary). Agency: Street & Finney, N. Y.

W. P. FULLER & Co., San Francisco (paints, household products). R. Agency: McCann-Erickson, San Francisco, D-C.

G

GALLENKAMP STORES Co., San Francisco, Shoes. N. Agencies: Long Adv. Service, San Francisco; Bruce Eldridge Adv., San Francisco.

E. J. GALLO WINERY, Modesto, Cal., wines. S. Agency: Harrington, Whitney & Hurst, S. F.

GALLOWHUR CHEMICAL CORP., N. Y. (chemical, pharmaceutical products). Skol. S. Agency: Buchanan & Co., N. Y.

GARDNER NURSERY Co., Osage, Ia., Perennial plants and general nursery products. Agency: Northwest Radio Adv. Co., Seattle.

GAROD ELECTRONICS Corp., Brooklyn, N. Y. Agency: Shappe-Wilkes, New York.

GARRET WINE Co., Brooklyn, Garret Wine, Virginia Dare. S. Agency: Ruthrauff & Ryan, New York.

GASTERIA: BONDED GAS & OIL SYSTEM, Indianapolis. S. Agency: Hugo Wagmont & Assoc., Dayton.

GAYMONT LABS, Chicago. Agency: Vandyne, Barlowe & Capsiaff, Chi.

GENERAL ANILINE & FILM CORP., New York. S. Agencies: Doherty, Clifford & Shenfield Inc., N. Y.; Bostford, Constantine & Gardner, S. F.; Young & Rubicam, N. Y.

GENERAL BAKERIES Ltd., Toronto (bread). Agency: McConnell Eastman & Co., Toronto.

GENERAL BAKING Co., New York, Bond Bread. S. TV. Agency: BBDO, N. Y. D-C.

GENERAL CIGAR Co., N. Y., Van Dyck cigar. White Owl Cigars. S. Agencies: Federal Adv. Agency, N. Y.; J. Walter Thompson, N. Y.; Donahue & Coe, N. Y.

GENERAL DRY BATTERIES OF CANADA, Toronto. S. Agency: McKlim Adv., Toronto.

GENERAL ELECTRIC Co., Bridgeport. Appliance & Merchandise Dept. Agencies: Young & Rubicam, N. Y.; G. M. Basford Co., N. Y.; Tarler & Skinner, Boston.

GENERAL ELECTRIC Co., Syracuse, N. Y. Electronics Dept. Agencies: Maxon Inc., N. Y.; Ross, Gardner & White, L.A. D-C.

GENERAL ELECTRIC Co., East Cleveland. Lamp Department. TV. Agencies: Foster & Davis, BBDO, & Lang, Fisher & Stashower, Cleveland.

GENERAL ELECTRIC Co., Toronto (appliances) N. Agency: MacLaren Adv., Toronto.

GENERAL FOODS Corp., New York, Sanka Coffee, Cereals, Flour, Birdseye Frosted Foods, Calumet Salt, Baker's Choc., LaFrance & Satina, Maxwell House Coffee. S. N. TV. Agencies: Young & Rubicam, New York; Benton & Bowles, New York; Foote, Cone & Belding, New York; Baker Adv. Agency, Ltd., Toronto.

GENERAL FOODS, Toronto, Maxwell House Coffee. R. Agency: Baker Adv., Toronto.

GENERAL GROCER CO., St. Louis, Corn, coffee. Agency: Olian Adv. Co., St. Louis.

GENERAL MILLS, Minneapolis, Gold Medal flour, Softassilk, Red Band flour, Betty Crocker Vegetable Noodle Soup Ingredients, Betty Crocker Pea Soup Ingredients, Bisquick. N. Agencies: Dancer-Fitzgerald-Sample, Chi.; Knox-Reeves Adv. Mpls.; BBDO, Mpls.; Tatham-Laird, Chicago; Zimmer-Keller Inc., Detroit, D-C.

GENERAL MOTORS Corp., Detroit, Automobiles, Frigidaire. N. TV. Agencies: D. P. Brothier & Co., Detroit; Kudner Agency, Inc., Detroit; Foote, Cone & Belding, N. Y.; BBDO, N. Y.; Campbell-Ewald, N. Y.; Geyer, Newell & Ganger, Dayton, D-C.

GENERAL PETROLEUM Corp., Los Angeles, Mobilgas, Flying Horsepower gas, Taverner products, oil. S-N. TV. Agency: West-Marquis, Inc., Los Angeles.

GENERAL TIRE & RUBBER Co., Akron, Tires and Rubber Products. N. Agency: D'Arcy Adv. Co., Cleveland.

GERITY - MICHIGAN Corp., Adrian, Mich., chrome bathroom accessories, automotive and plumbing hardware. S. Agency: Albert Frank-Guenther Law Inc., N. Y.

GERMAINE SEED & PLANT Co., Los Angeles (seeds, plants). Agency: Dudley L. Hogan Adv., Los Angeles.

GIBSON ART Co., Cincinnati. Greeting Card. Agency: Christianson Adv., Chicago.

GIBSON REFRIGERATOR Co., Greenville, Mich. Agency: W. W. Garrison & Co., Chicago, D-C.

GILLETTE SAFETY RAZOR Co., Boston. Blue Blades shaving cream, safety razors. N. Agencies: Maxon Inc., N. Y.; J. Walter Thompson Co., N. Y.; Foote Cone & Belding International (export only). D-C.

GILLETTE SAFETY RAZOR Co., of Canada, Montreal. Agency: MacLaren Adv. Co., Montreal.

GILMORE OIL Co., (consolidated with General Petroleum Co., Los Angeles) Oil & Gasoline. S. Agencies: West-Marquis Inc., L. A.

I. GINSBERG & BROS., New York, Queen Make Dresses. N. Agency: Abbott Kimball Co., New York.

GLASS CONTAINER MFRS. INSTITUTE, N. Agency: Foote, Cone & Belding, N. Y.

GLOBE MILLS (Div. of Pillsbury Mills, Inc.), Los Angeles, Flour. N. Agency: Leo Burnett Co., L. A.

GLOSTEX PRODUCTS Inc., Chi. S. Agency: Bennett, Pétesch & O'Connor, Chi.

GOEBEL BREWING Co., Detroit. N. S. TV. Agency: Brooke, Smith, French & Dorrance, Detroit.

GOLD SEAL WAX Co., Chicago. N. Agency: Campbell-Mithun Inc., Chicago.

GOLDEN STATE DAIRY PRODUCTS, S. F. R. Agency: BBDO, L. A.

GOLDEN STATE FOODS INC., Berkeley, R. Agency: BBDO, L. A.

GOLDEN STATE FOODS INC., Berkeley, Calif. Gold Coast Preserves. R-S. Agency: Botsford, Constantine & Gardner, San Francisco.

GOLDENROD ICE CREAM Co., Chicago, Goldenrod Ice Cream. S. Agency: Goodkind, Joice & Morgan, Chi.

GOLDWATERS, Phoenix, Gifts, toiletries. S. Agency: Adver. Counselors of Arizona, Phoenix.

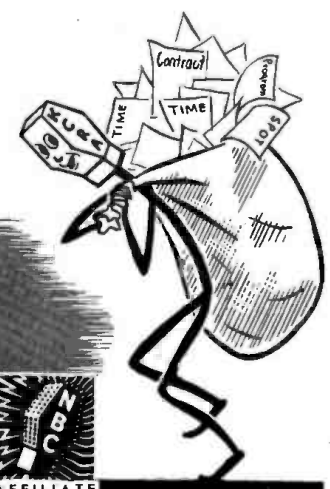

AFFILIATE

KCRA

... carries MORE LOCAL BUSINESS*
than any other TWO Sacramento
stations combined!

Sacramento, California
Representatives:
Robert Meeker & Associates
Pacific Coast - W. S. Grant Co.

* Both DOLLAR-VOLUME and total
number of accounts
(includes both spot announcements and programs)

SAMUEL GOLDWYN PRODUCTIONS Inc., Hollywood, motion pictures. S. Agencies: Foote, Con & Belding, L. A.; Monroe Greenthal Co., Hollywood.

CONSET CO., Burbank, Calif. (mfg. TV antennae & special TV & radar equipment) TV. Agency: Allied Adv., L. A.

THE GOODALL CO., Cinn. (Palm Beach, Springdale & Sunfrost suits & slacks) TV. Agency: Ruthrauff & Ryan, Chi.

B. F. GOODRICH CO., Akron, O. Rubber Products; Retail service and general merchandise. S. N. Agencies: BBDO, N. Y.; Griswold-Eshleman & Co., Cleveland; McCann & Erickson, Inc., N. Y. D-C.

GOODYEAR TIRE & RUBBER CO., Akron, Tires and rubber products. S. N. Agencies: Compton Advertising, N. Y.; Young & Rubicam, N. W. Ayer & Son, N. Y.; Kudner Agency Inc., N. Y. D-C.

GOSPEL BROADCASTING ASSN., Evangelical Talks. N. Agency: R. H. Alber Co., L. A.

JOHN GRAF CO., Milwaukee, Wis. Gran'pa Graf's Creamy Top Root Beer. S. Agency: Al Herr Adv., Milwaukee.

GRAPETTE CO., Camden, Ark., soft drink. S. Agency: Bryan & Bryan Adv. Co., Shreveport, La.

GRAYSON'S SHOPS, L. A. (women's apparel chain) S. R. Agency: Milton Weinberg Adv., L. A.

GREAT ATLANTIC & PACIFIC TEA CO., New York, groceries. S. Agency: Paris & Peart, New York.

GREATER CHICAGO HOTEL ASSN., Chicago. S. Agency: M. M. Fisher Assoc., Chicago.

GREYHOUND LINES, Chicago Bus Service. N. Agency: Beaumont & Hohman, Cleveland.

GREYSTONE PRESS, N. Y. N. Agency: H. B. Humphrey & Co., N. Y.

GRIESEDECK BROS. BREWERY, St. Louis, S. & N. Agencies: Ruthrauff & Ryan, St. Louis; McCann-Erickson, Chi.

GRIFFIN MFG. CO., Brooklyn, shoe polishes. S. Agency: Birmingham, Castleman & Pierce, New York.

GRIGGS, COOPER & CO., St. Paul, food products. Agency: Melamed-Hobbs, Minneapolis.

GROVE LABS., St. Louis, Grove Cold Tablets, 4-Way Cold Tablets, Defender, Complex and ABD vitamins, Grove Chill Tonic, Dr. Porter's Oil, Jitterbug. N. S. Agencies: Harry B. Cohen, N. Y.; Gardner Adv., St. Louis; Small & Seiffer Inc., N. Y.; Vickers & Benson, Toronto.

GRUEN WATCH CO., Cincinnati, Gruen Watches. N. S. TV. Agencies: Grey Adv., N. Y.; Cockfield Brown & Co., Toronto, D-C.

GUITTARD CHOCOLATE CO., San Francisco, Chocolates. N. S. Agency: Garfield & Guild, San Francisco.

CHARLES GULDEN Inc., New York, Guldens' prepared mustard. S. Agency: Charles W. Hoyt Co., New York.

GULF OIL Corp., Pittsburgh, Gulf Gas, Oil, Lubricants. N. TV. Agency: Young & Rubicam, New York.

GUM LABS Inc., Clifton Heights, Pa., Ivoryne Gum. N. Agency: Makelim Assoc., Chicago.

S. GUMPERT CO., Ozone Park, New York, Stearns bouillon cubes. S. Agency: Rose Martin Adv., New York.

H

HAAS, BARUCH & CO., Los Angeles, Grocery Products. S. Agency: Robert Smith Adv., L. A.

HALL BROTHERS, Kansas City, Hallmark Greeting Cards. N. Agency: Foote, Cone & Belding, New York.

HALL & RUCKEL, New York, (X-Bazin, depilatory) S. Agency: Redfield-Johnstone, N. Y.

THEO. HAMM BREWING CO., St. Paul, Hamm's Preferred Stock Beer. S. Agency: Campbell-Mithun, Minneapolis.

JOHN HANCOCK MUTUAL LIFE INS. Co., Boston, Agency: McCann-Erickson Inc., N. Y.; BBDO, N. Y.

PETER HAND BREWERY Co., Chicago, TV. Agency: BBDO, Chicago.

HANDMACHER-VOGEL (suits) S. TV. Agency: Zan Diamond Co.

HANNA COAL Co., Cleveland, Coal. S. Agency: John C. Dowd Agency, Boston.

HANSCOM BAKING Corp., Long Island City, N. Y., Bakery products, fruit cake, ice cream. S. Agency: Ehrlich & Neuwirth, N. Y.

HARMAN WATCH CO., N. Y. Watches. N. S. Agency: Lester Harrison, N. Y.

HARPER METHOD, Rochester, N. Y., Harper Gene Creme, skin treatment. S. Agency: Hutchins Adv. Agency, Rochester.

A. S. HARRISON Co., New York (Green floor wax & K. T. wall wax) R. S. Agency: Alfred Tokar Adv., Newark, N. J.

HARTFORD BULB Co., Hartford, Mich. Agency: Leo Boulette Agency, Three Rivers, Mich.

HARTFORD TEXTILE Co., New York, plasticized fabrics. S. Agency: Alfred J. Silverstein-Bert Goldsmith, Inc., N. Y.

HARTZ MOUNTAIN PROD., New York, Bird & Pet Foods, Dog Food Supplies. N. S. Agency: Geo. H. Hartman, Chicago.

HARVEL WATCH Co., New York, Watches. N. Agency: Roy S. Durstine, Inc., New York.

HARVEY-WHIPPLE Inc., Springfield, Mass., Master Kraft heating equipment placed direct.

HASSENSTEIN Co., Hollywood, Movie Wave. S. N. Agency: Dean Simmons Adv., Hollywood.

HASTINGS MANUFACTURING Co., The Casite Corp., Hastings, Michigan, Piston rings, Casite, N. & S. Agency: Keeling & Company, Indianapolis, D-C.

HAYSMA Co., Chicago, Hay fever remedy. S. Agency: O'Neil, Larson & McMahon, Chicago.

HEADQUARTERS FIFTH ARMY, Chf. Army & Army Air Force recruiting S. Agency: John W. Shaw Adv., Chi.

HEBREW EVANGELIZATION SOCIETY, Los Angeles, (religious). S. Agency: Tom Westwood Adv., Los Angeles.

HECHT Co., Washington, R. Agency: Harwood Martin Adv., Washington.

LOU HEFT & Co. Inc., Montreal (Migo shirts & men's sportswear) N. Agency: Russell T. Kelley Ltd., Toronto.

G. HEILEMAN BREWING Co., La Crosse, Wis. "Old Style Lager" Beer. Agency: Gordon Best Co., Chicago.

H. J. HEINZ Co., Pittsburgh (57 Variety Foods & Swerl Suds). N. Agencies: Maxon Inc., Detroit; MacLaren Adv., Toronto.

HELBROS WATCH Co., N. Y. N. Agency: William H. Weintraub & Co., New York; Dorland Inc., N. Y.

HELLER BROS. Co., New York, Vegetables and Fruits. S. Agency: John A. Finneran, New York.

HELMES BAKERIES, Los Angeles, Home-delivered baked products. S. Agency: Dana Jones Co., Los Angeles.

HENKEL FLOUR MILLS, Detroit, Velvet Cake Flour, Robin Hood Flour, pancake mix. Agency: H. W. Kastor & Sons, Chicago.

DR. HESS & CLARK, Ashland, O., livestock tonic. S. Agency: N. W. Ayer & Son, Philadelphia, D-C.

CHRISTIAN HEURICH BREWING CO., Washington, D. C. Beer. S. Agencies: Romer Adv. Inc., Wash.; Henry J. Kaufman & Assoc., Wash.

HILLS BROS., New York, Dromedary Mixes. S. Agency: Biow Co., New York.

CHARLES E. HIRES Co., New York, Hires Root Beer. N. Agency: N. W. Ayer & Son, D-C.

HIRSCH BROS. & CO., Louisville, Ky., Soups, mayonnaise, chili, pickles, catsup. Agency: R. C. Riebel Adv., Louisville.

DR. HISS CLINIC, Los Angeles, Calif., Shoes. N. Agency: Honig-Cooper, L.A.

HOBERG PAPER MILLS, Green Bay, Wis., (Charmin facial, bathroom tissues) R. Agency: Cramer-Krasselt Co., Milwaukee.

HOEFLER CANDY Co., San Francisco, S. Agency: Frank Wright National Co., San Francisco.

E. A. HOFFMAN CANDY CO., L.A. S. Agency: The Meyers Co., L.A.

HOFFMAN RADIO Corp., Los Angeles, TV. Agency: Dan B. Miner Co., Los Angeles.

R. M. HOLLINGSHEAD Corp., Camden, N. J., Whiz Motor Rhythm, Whiz Floor Wax and Whiz-Off Cleaner. N. & S. Agency: Altken-Kynett Co., Philadelphia.

HONEY BEE Co., Chicago, Potato Chips. S. Agency: Newby & Peron, Chicago.

HOOKER GLASS & PAINT MFG. Co., Chicago, Hooker Paints, varnishes, enamels. S. Agency: Goodkind Joice & Morgan, Chicago.

GEORGE A. HORMEL & CO. (food products) Austin, Minn. N. Agency: BBDO, Mnpls.

HORNBLOWER & WEEKS, New York, investment house. S. Agency: Wiley, Frazee & Davenport, N.Y.

HORWITZ & DUBERMAN, New York, Junior Miss fashions. N. Agency: Sterling Adv., New York.

HOUSE OF DELICACIES, New York, French, kettle onion soup. N. Agency: Emil Mogul Co., N.Y.

HOUSE OF OLD MOLINEAUX, Boston, wines. N. S. Agency: Hirshon-Garfield, Boston.

HOUSEHOLD FINANCE Corp., Chicago. S. Agency: LeVally, Inc., Chi.

HOUSEHOLD FINANCE Corp., Canada, Toronto (loans). N. Agency: LeVally Inc., Chi.

HOWARD RADIO Co., Chicago, TV. Agency: Turner Adv., Chicago.

HUBBARD MILLING Co., Mankato, Minn., Hubbard's Sunshine Concentrates, Mother Hubbard Enriched Flour. S. Agency: Foulke Agency, Minneapolis.

HUDNUT SALES Co. Inc., New York, Hudnut-DuBarry Success School—cosmetics. S. Agencies: G. Lynn Sumner Co., N. Y.; Kenyon & Eckhardt, N.Y.; Kieswetter, Wetterau & Baker Inc., N.Y.; Biow Co., N.Y.; James Fisher, Toronto, D-C.

HUDSON'S BAY Co., Winnipeg, Department stores. N. Agencies: Cockfield Brown & Co., Winnipeg; F. H. Hayhurst Co., Toronto.

HUDSON COAL CO., Scranton, Pa., Coal. N. Agency: Clement Co., Philadelphia, D-C.

HUDSON DEALERS OF SOUTHERN CALIF., Los Angeles, R. Agency: Irwin-McHugh Adv., L. A.

HUDSON MOTOR CAR CO., Detroit, S. Agency: Brooke, Smith, French & Dorrance, Detroit, D-C.

HUDSON PULP & PAPER Corp., New York, R. Agency: Duane Jones Co., New York.

HUGHES PRODUCTIONS & CALIFORNIA PICTURE CORP., New York, Agency: Weiss & Geller, New York.

HUNT FOODS Inc., Los Angeles, Cal. Hunt's food products. N. S. Agency: Young & Rubicam, Hollywood.

HUNT'S Ltd., Toronto, Chain Candy Shops and Restaurants. S. Agency: Ellis Adv. Co., Toronto.

HYGRADE FOOD PRODUCTS Corp., N. Y. R. Agency: Maxwell Dane Inc., N. Y.

HY-PHEN Corp., Mataoka, W. Va., Hy-Phen tablets. S.

IDEAL Co., Waco, Tex., Architectural Woodwork (Built-In), Building Millwork, Ideal Step-Saving Kitchen. N. Agency: Richard Bush Adv., Waco.

ILLINOIS BAKING, Chicago, Safe-T-Cakes. S. Agency: Sibert Co., Chi.

ILLINOIS MEAT Co., Chicago, Meats. S. TV. Agencies: Arthur Meyerhoff & Co., Chicago; B. Meier & Son Inc., N. Y. D-C.

IMPERIAL OIL LTD., Toronto, Gasoline, oils, tires, batteries. N. Agency: MacLaren Adv., Toronto.

IMPERIAL PRODUCTS Co., Philadelphia, Pa., Air-Oma, Dee-Tea. S. Agency: Solis Cantor Agency, Phila.

IMPERIAL SUGAR Co., Sugar Land, Tex., Imperial Pure Cane Sugar, Extra Fine Granulated Sugar, Confectioners Powdered Sugar, Old Time Brown Sugar. N. Agency: Tracy-Locke Co., Inc., Dallas.

IMPERIAL TOBACCO Co., Montreal, cigarettes. S. Agency: Whitehall Broadcasting, Montreal.

INDEPENDENT DRUGGISTS ASSN., Toronto (retail stores) R. Agency: J. J. Gibbons Ltd., Toronto.

INDIAN RIVER MEDICINE Co., Lafollette, Tenn., Scalf's Indian River medicine, Herbal Stomachic. S.

INDIANA STATE DEPT. OF COMMERCE AND PUBLIC RELATIONS, Indianapolis, Ind., State of Indiana. S. Agency: Pettinger-Harding Inc., Indianapolis.

INDUSTRIAL MFG. Corp., Los Angeles, Insect-O-Bit. N. Agency: Lockwood-Shackelford, L. A.

INDUSTRIAL TAPE Corp., New Brunswick, N. J., Bondee, hot iron mending tape. S. Agency: Kenyon & Eckhardt, N. Y.

INSTITUTE OF RELIGIOUS SCIENCE, Los Angeles, R. Agency: Raymond R. Morgan Co., Hollywood.

INTERCHEMICAL Corp., Finishes Division, New York, Paints, dyes and oil cloths. S. Agency: Fuller & Smith & Ross, N. Y.

INTERNATIONAL BUSINESS MACHINES Corp., New York, (Joint Sponsorship), Business Machines. N. Agency: Cecil & Presbrey, N. Y.

(Continued)

AXAJ • AMERICAN CHICLE • AMERICAN HOME FOODS • ARIZONA CANNING • BEEMAN'S • BEST FOODS • BIRDS-EYE • BLONDEX • BLUE BONNET MARGARINE • BROWN & WILLIAMSON • CARTER PRODUCTS • CHEVROLET • CINCH MIXES • COLGATE-PALMOLIVE-PEET • CROSLY-SHELVADOR • CURTIS PUBLISHING • DUFF'S MIX • ESKIMO PIE • FORD • FOUR-WAY COLD TABLETS • GARRETT WINE • GENERAL FOODS • GENERAL MILLS CAKE MIXES • HOLIDAY • KOOLS • LEVER BROWN & WILLIAMSON • LIPTON TEA • MUSTEROLE • NATIONAL BISCUIT • NUTRENA DOG FOOD • POLL PARROT SHOES • POPSICLES • RAINDROPS • RALEIGHTS • REDDI-WIP • ROBERT HALL CLOTHES • ROYAL DESSERTS • SATURDAY EVENING POST • SHINO STANDARD BRANDS • SURF • SUN VISTA • TENDERLEAF TEA • VANTA SHAMPOO • VICK CHEMICAL • YOUNG & RUBICAM • ZAN DIAMOND CO.

You're in good company on

KFEL'S RAY PERKINS SHOW

Roy Perkins, Rocky Mountain region's favorite disc jockey, is now on 1 hour every morning, 2 hours every afternoon, thanks to this fine list of national advertisers (and top local accounts, too) who sponsored Ray Perkins in 1949.

KFEL Mutual in Denver
MANAGED BY GENE O'FALLON
REPRESENTED BY JOHN BLAIR

AXAJ • AMERICAN CHICLE • AMERICAN HOME FOODS • ARIZONA CANNING • BEEMAN'S • BEST FOODS • BIRDS-EYE • BLONDEX • BLUE BONNET MARGARINE • BROWN & WILLIAMSON • CARTER PRODUCTS • CHEVROLET • CINCH MIXES • COLGATE-PALMOLIVE-PEET • CROSLY-SHELVADOR • CURTIS PUBLISHING • DUFF'S MIX • ESKIMO PIE • FORD • FOUR-WAY COLD TABLETS • GARRETT WINE • GENERAL FOODS • GENERAL MILLS CAKE MIXES • HOLIDAY • KOOLS • LEVER BROWN & WILLIAMSON • LIPTON TEA • MUSTEROLE • NATIONAL BISCUIT • NUTRENA DOG FOOD • POLL PARROT SHOES • POPSICLES • RAINDROPS • RALEIGHTS • REDDI-WIP • ROBERT HALL CLOTHES • ROYAL DESSERTS • SATURDAY EVENING POST • SHINO STANDARD BRANDS • SURF • SUN VISTA • SWIFT ICE CREAM • TENDERLEAF TEA • VANTA SHAMPOO • VICK CHEMICAL • GARRETT WINES • ARIZONA CANNING

DIRECTORY OF NATIONAL AND REGIONAL ADVERTISERS

(Continued)

INTERNATIONAL CELLUCOTTON PRODUCTS Co., Chicago. Kleenex. N. TV. Agency: Foote, Cone & Belding, Chicago.

INTERNATIONAL HARVESTER Co., Motor Trucks & Farm Machinery. N. Agencies: McCann-Erickson, N. Y.; Arnold & Co., Boston. D-C.

INTERNATIONAL LATEX CORP., Dover, Del. (Playtex girdles). S. Agency: Foote, Cone & Belding, N. Y.

INTERNATIONAL MILLING Co., Minneapolis. Robin Hood flour, Velvet cake flour, Velvet pancake flour. Agencies: H. W. Kastor & Sons, Chi.; Crook Adv. Agency, Dallas.

INTERNATIONAL PICTURES, New York. Moving Pictures. S. Agency: Buchanan & Co., N. Y.

INTERNATIONAL SAFETY RAZOR Corp., Bloomfield, N. J. Razors. Agency: Edger & Browning & Hersey Inc., New York.

INTERNATIONAL SHOE Co., St. Louis. (Roberts, Johnson & Rand branch). Children's shoes. N. TV. Agency: Henri Hurst & McDonald, Chicago.

INTERNATIONAL SILVER Co., Meriden, Conn. Sterling & 1847 Rogers Bros. Silver. N. Agencies: Young & Rubicam, N. Y.; Newell-Emmett Co., N. Y.; Fuller & Smith & Ross, N. Y.

INTERNATIONAL SILVER Co. of Canada, Hamilton, Ont. S. Agency: Young & Rubicam, Montreal.

INTERSTATE BAKERIES Corp., Kansas City, Mo. Weber's bread. S. Agencies: Dan B. Miner Co., L. A.; R. J. Potts-Calkins & Holden, Kansas City, Mo.

INTERSTATE ENGINEERING CORP., El Segundo, Calif. Vacuum cleaners. S. Agencies: Frazar & Hansen, Export Agts., S. F.; Honig-Cooper, L. A.

INTERSTATE LABS. INC., Louisville (Oculine-eye preparations) R. Agency: L. W. Roush Co., Louisville.

INTER-STATE NURSERIES, Hamberg, Iowa. Nursery Stock & Seeds. Placed direct.

IODENT CHEMICAL Co., Detroit, Mich. Iodent tooth paste and powder. N. Agency: Grant Adv., Detroit.

IOWA DAIRY INDUSTRY COMMISSION, Des Moines, Dairy Products. N. Agency: Blackmore Co. Des Moines.

IOWA MASTER BREEDERS Inc., Onawa, Ia. poultry supplies. S. Agency: Coles, Inc., Des Moines, Iowa.

IOWA SOAP Co., Burlington, Ia. Magic Washer, Nola Flakes, Protex Toilet Soap, Nola Toilet Soap. S. Agencies: Goodkind, Joice & Morgan, Inc., Chi.; McKee & Albright, Phila.; Weston-Barnett Inc., Waterloo, Ia.

IROQUOIS BEVERAGE Corp., Buffalo N. Y. Iroquois ale, beer. N. S. Agency: Baldwin, Bowers & Strachan, Buffalo.

ITALIAN SWISS COLONY, San Francisco (table wines). S. Agency: Platt-Forbes Inc., N. Y.

J. I. FANCY FROZEN FOODS, Stockton, Calif. N. Agency: Garfield & Guild, S.F.

M. JACKMAN & SONS, Los Angeles. Men's clothing mfr. TV. Agency: Ted H. Factor, Los Angeles.

JACKSON BREWING Co., New Orleans. Jax Beer. R. Agency: Anfenger Agency, St. Louis.

JACQUES MFG. Co., Chicago. KC Baking Powder. N. S. Agencies: MacFarland, Aveyard & Co., Chi.; Gordon Best Co., Chi.

JAMES MFG. Co., Fort Atkinson, Wis. Agency: Klau-Van Pietersom-Dunlap.

JOHN F. JELKE Co., Chicago. (Subsidiary of Lever Bros.) Margarine & salad dressings. S. Agency: Tatham-Laird, Chicago.

JAVEX MANUFACTURING Co., Toronto (Javex cleaner). N. Agency: MacLaren Adv., Toronto.

ANDREW JERGENS Co., Cincinnati, O. Woodbury soap, powder and cream, Jergens lotion. N. S. Agencies: Robert Orr & Assoc., N.Y.; Gotham Adv. Co., N.Y. (export adv.).

JOHN HANCOCK MUTUAL LIFE INSURANCE Co., Boston. Agency: McCann-Erickson Inc., New York.

JOHNS-MANVILLE Corp., New York. Building Materials, Insulations, Power Products, and Brake Linings. N. Agency: J. Walter Thompson Co., N.Y. D-C.

JOHNSON & JOHNSON, New Brunswick. Red Cross Division Surgical Dressings. N. S. Agencies: Young &

Rubicam, N.Y. & Montreal; N. W. Ayer & Son, Phila.; Noyes & Sproul, N.Y.; Wm. Hart Adler Inc., Chicago.

S. C. JOHNSON & SON, Racine, Wisc. Paste, liquid wax and cream wax; Glo-Coat, Carnu. N. Agencies: Needham, Louis & Brorby, Chi.; Erwin, Wasey & Co., London (export).

S. C. JOHNSON & SON, Brantford, Ontario (wax). N. Agencies: Vickers & Benson, Montreal; Needham, Louis & Brorby, N.Y.

WALTER JOHNSON CANDY CO., Chicago. Powerhouse candy bars. TV. Agency: Gresham-Allen-Morton Agency, New York.

J. W. JONES Co., Caledonia, N. Y. Sunny Sol Household Bleach, Sunny Sol Magic Crystals. Agency: Armand S. Weill Co., N.Y.

JUNG ARCH BRACE Co., Cincinnati, O. Keyes corn pads and plasters. S. Agency: H. W. Kastor & Sons Co., Chi.

K

K-R-O Co., Springfield, O. K-R-O Red Squill Powder, Bis-Kit Form. Agency: Erwin, Wasey & Co., Chicago.

KAEMPFER'S, Chicago, Ill. Bird and pet foods. S. Agency: George H. Hartman, Chi.

KATZ DRUG Co., Kansas City, Drugs. S. Agency: Bruce B. Brewer & Co., Kansas City, Mo.

KAY PREPARATIONS, New York. Formula 301. S. Agency: Irving Rosen Adv., N.Y.

JULIUS KAYSER & CO., New York (Kaysers Hosiery). N. TV. Agency: Cecil & Presbrey Inc.; Canadian Adv. Agency, Montreal.

KEELEY BREWING Co., Chicago. TV. Agency: Schwimmer & Scott, Chicago.

KELITE PRODUCTS Inc., Los Angeles, Kenu. N. Agency: Little & Co., L.A.

KELOGG Co., Battle Creek, Mich. Breakfast food. N. S. Agencies: Kenyon and Eckhardt, N.Y. & Chicago; N. W. Ayer & Son, Phila.; Klau-Van Pietersom-Dunlap, Milwaukee; Leo Burnett, Chicago.

KELOGG CO. OF CANADA, London, Ont., cereals. S. Agencies: J. Walter Thompson Co., Toronto; Kenyon & Eckhardt, Montreal.

KELLY BROS. NURSERIES, Dansville, N. Y., seeds, nursery stock. Agency: Baldwin-Bowers and Strachan, Buffalo.

KELLY DOUGLAS & Co. Ltd., Nabob Tea. N. Agency: Stewart-Lovick & McPherson, Vancouver.

KELLY KAR Co., Los Angeles. Dealer. R. S. Agency: Tullis-Victor Co., Los Angeles.

KELVINATOR DIV., Nash-Kelvinator Corp., Detroit. N. TV. Agency: Geyer, Cornell & Newell, N.Y. D-C.

KENDALL MFG. Co., Lawrence, Mass., New Speed Soapine. N. S. Agency: Kastor, Farrell, Chesley & Clifford, N.Y.

ELIZABETH KENT Co., New York. Cosmetics. S.

KENT PRODUCTS Co., Chicago. Kent Glass Coffee Maker Sets, Electric Stoves, Electric Toasters. S. Agency: Kuttner & Kuttner, Chi.

KERR GLASS MFG. Corp., Los Angeles. Mason jars. S. N. Agency: Lennen & Mitchell, Beverly Hills, L.A.

KEYSTONE VARNISH Co., New York, Agency: Blackstone Co., N.Y. D-C.

C. M. KIMBALL, Co., Boston. Red Cap cleaner. N. Agency: Hoag & Provandie Inc., Boston.

KING KAR SUTTON, Columbus, Ohio (used cars) R. Agency: Harry J. Wendland Adv., L. A.

KINGSBURY BREWERIES Co., Manitowoc, Wis., pale beer. Agency: Christiansen Adv. Agency, Chi.

KIP Corp., Ltd., Los Angeles, Calif., Kip. S. Agency: Philip J. Meany Co., L.A.

KIRKMAN & SON DIVISION, COLGATE-PALMOLIVE-PEET Co., Brooklyn, N.Y., Kirkman Flakes and Complexion Soap. N. Agency: Newell Emmett & Co., N.Y.

KIRSCH'S BEVERAGES, Brooklyn, N. Y. N. S. Agency: Morris Adv. Agency, Brooklyn.

KLEIN CHOCOLATE CO., Elizabethtown, Pa. (Nic-L-Nut Chocolate Bar) S. Agency: Frank L. Blumberg, Baltimore.

E. L. KNOWLES, Inc., Springfield, Mass. Rub-in liniment. S. Agency: Chas. Sheldon Adv., Springfield, Mass.

KNOX Co., Los Angeles, Cystex, Men-daco Romind, N. & S. Agency: Allen C. Smith Adv. Agency, Kansas City.

KOENIG LABORATORIES, Chicago, Ill., Koenig's Nervine. Placed direct.

KORAL LABS., Mt. Vernon, N. Y., Korral toothpowder. S. Agency: L. H. Hartman Co., N.Y.

KORET OF CALIFORNIA, San Francisco (women's sportswear). Agency: Abbott Kimball Co., N.Y. D-C.

KRAFT FOODS Co., Chicago, Kraft Cheeses, Parkay Margarine, Velveeta, Philadelphia Brand Cream Cheese, Kraft Salad Products, Kraft Powdered Whole Milk, Miracle Whip, Kraft Cream Cheese Spreads. N. S. TV. Agencies: J. Walter Thompson Co., Needham, Louis & Brorby, Dancer-Fitzgerald-Sample, all Chi.

KREML HAIR TONIC, New York. Agency: Erwin, Wasey & Co., New York.

S. S. KRESGE Co., Detroit. N. Agency: Maxon Inc., Detroit.

KRETOLD Co., Washington, D. C. Household insecticide, deodorant. S. Agency: M. Belmont ver Standig, Wash., D. C.

KRISPY KREME DOUGHNUT Co., Winston-Salem, N. C. S. Agency: Herman Halpern Adv. Co., Winston-Salem, N. C.

KROGER Co., The Cincinnati Co., Kroger's Clock Bread, Kroger's Tenderly Beef. S. Agency: Ralph H. Jones Co., Cincinnati.

G. KRUEGER BREWING Co., Newark, N. J. (beer & ale). N. S. TV. Agency: Geyer, Newell & Ganger, N. Y. D-C.

L

L. B. LABORATORIES, Inc., Los Angeles, L. B. Hair Oil, N. Agencies: Glasser-Galley & Co., L. A.; Irwin-McHugh Adv., Hollywood; Mayers Co., L. A.

LACO PRODUCTS, Waltham, Mass., Laco Castile soap and shampoo. S. Agency: Dorland Inc., N. Y.; Kastor, Farrell, Chesley & Clifford, N. Y.

LADY ESTHER, Ltd., Chicago, Cosmetics, S-N. Agency: Ruthrauff & Ryan, Chicago. D-C.

LA FLOREAL PERFUME Co., Los Angeles. Perfumes. S. Agency: Advertising & Sales Council, L. A.

LAMBERT PHARMACAL Co., New York, St. Louis, Listerine Toothpowder. N. S. Agency: Lambert & Feasley, New York.

LAMBERT PHARMACAL Co., Toronto. Listerine toothpaste. N. Agency: Lambert & Feasley, N. Y.

LAMONT, CORLISS & Co., New York. Nestle's Chocolate prod. & Pond's Toilet preps. N. Agencies: J. Walter Thompson, N. Y.; Cecil & Presbrey Inc., N. Y.

LAMONT CORLISS & Co., Toronto. (Ponds cosmetic products), N. Agency: J. Walter Thompson Co., Toronto.

CHAS. E. LANE & Co., St. Louis, Lane's Pills. S. Agency: Jasper, Lynch & Fishel Inc., N. Y.

LANGENDORF UNITED BAKERIES, San Francisco, Bakery Products. S. N. Agencies: J. Walter Thompson Co., S. F.; Honig Cooper Co., S. F.; Blow Co., S. F.; Atkins-Gilbert, Hollywood.

V. LAROSA & SONS (LaRosa macaroni, spaghetti, egg noodles & pasta) N. Y. Agency: Kiesewetter, Weterau & Baker Inc., N. Y.

LARUS & BROS., Richmond, Chelsea Cigarettes & Edgeworth Tobacco, Alligator Cigarettes. N. Agencies: Warwick & Legler, New York; Duane Jones Co., N. Y.; Robt. Otto & Assoc. Inc., N. Y.

H. P. LAU Co., Lincoln, Neb., Mlady Coffee, Blackbird foods. S. Placed direct.

LAURENTIAN AGENCIES, Montreal (Air-Whiff). S. Agency: McKim Adv., Montreal.

LEAF GRAND Inc., Chicago Leaf Chewing gum. N. S. Agency: Bozell & Jacobs, Inc., Chicago.

LEAM PUBLISHING Corp., New York. Two to Six Magazine. S. Agency: Direct.

LEAR Inc., Grand Rapids, Mich., Home radio division. N. Agency: Irving J. Rosenbloom Adv., Chicago.

FRANK H. LEE Co., Danbury, Conn., Lee hats. N. Agencies: William H. Weintraub, N. Y.; Grey Adv., N. Y.

GEORGE H. LEE Co., Omaha, stock and poultry remedies. S. Agency: Allen & Reynolds Adv., Omaha.

LEE PHARMACAL Co., Beverly Hills. Spray-A-Wave. N. Agency: Dancer-Fitzgerald-Sample, New York.

DR. L. D. LEGAR MEDICINE Co., St. Louis, Poultry Prescription, Stock Powder, Hog Prescription, Cow Prescription, A-A Poultry Tabs, Calf Vitamins. S. Agency: Simmonds & Simmonds, Chicago. D-C.

FRANCES H. LEGGETT & Co., N. Y. ("Sauce Arturo," spaghetti sauce). R. Agency: Peck Advertising Inc., N. Y.

LEHIGH NAVIGATION COAL Co., Phila. Agency: Lewis & Gilman Inc., Phila.

LEHN & FINK PRODUCTS Corp., N. Y. Dorothy Gray cosmetics, Hinds Hysol & Almond Cream, Elquet, Pecco, Lysol. N. TV. Agencies: McCann-Erickson, N. Y.; Lennen & Mitchell, N. Y.; Grey Adv., N. Y.; Spitzer & Mills, Toronto; Duane Jones, Inc., N. Y.; D'Arcy Adv., N. Y. (export). D-C.

LEKTROLITE CORP., N. Y. (flameless cigarette lighters) R. S. TV. Agency: Bermingham, Castleman & Pierce, Inc., N. Y.

LEVER BROS. Co., Cambridge, Mass., Lifebuoy Soap, Rinso, Lux Toilet Soap & Flakes, Breeze, Silver Dust, N.S. TV. Agencies: Ruthrauff & Ryan, New York; J. Walter Thompson Co., New York; Young and Rubicam, New York; Federal Adv. Agency, N. Y.; National Export Adv. Service, N. Y.; Sullivan, Stauffer, Colwell & Bayles; Day, Duke & Tarleton Inc., N. Y.; N. W. Ayer & Son, N. Y.

LEVER BROS. Ltd., Toronto. N. Agencies: J. Walter Thompson Co., Toronto; Ruthrauff & Ryan, Toronto; Day, Duke & Tarleton, N. Y.; Young & Rubicam, Toronto.

LEWIS FOOD Co., Los Angeles, dog and cat food. S. Agencies: Lennen & Mitchell, Beverly Hills; Rocket & Lauritzen, L. A.

I. LEWIS CIGAR MFG. Co., Newark, N. J., La Coronado, Flor De Melba and John Ruskin Cigars. N. Agency: Lewis Adv., Newark.

LEWIS-HOWE Co., St. Louis, Mo., Tums, Natures Remedy, N. Agencies: Roche, Williams & Cleary Inc., N. Y. and Chicago; Dancer-Fitzgerald-Sample, Chicago.

LEWIS-HOWE Co., Windsor, Ont. Nature's Remedy and Tums. S. Agency: Grant Adv. of Canada, Toronto.

LIBBY, McNEILL & LIBBY, Chi., Canned Goods. N. TV. Agencies: J. Walter Thompson Co., Chi., McConnell, Eastman Co., Toronto.

LIBERTY CHERRY & FRUIT Co., Covington, Ky. S. Agency: Joseph Adv., Cincinnati.

LIBERTY CHERRY & FRUIT Co., Toronto. S. Agencies: James Fisher Co., Toronto; Jesse M. Joseph Adv., Cincinnati.

LIEBMAN BREWERIES Inc., Brooklyn, N. Y. "Rheingold" Beer. R. TV. Agency: Foote, Cone & Belding, New York.

LIFE SAVER CORP., Port Chester, N. Y. (candy). S. Agencies: Young & Rubicam, N. Y.; McKee & Albright, Phila.; Young & Rubicam, Toronto.

LIGGETT & MYERS TOBACCO Co., New York, Chesterfield, Fatima Cigarettes. N. TV. Agency: Newell Emmett Co., N. Y.

L. K. LIGGETT Co., Toronto, chain drug stores. R. Agency: Ronalds Adv., Toronto.

LINCO PRODUCTS DIST. Co., Chicago. Linco, Juno. S. Agency: Schwimmer & Scott, Chicago.

LIONEL CORP., New York. TV. Agency: Reiss Adv., N. Y.

THOMAS J. LIPTON Co., Hoboken, N. J., tea and soups. S. Agencies: Young & Rubicam, New York; Ruthrauff & Ryan, N. Y.; Vickers & Benson, Montreal.

LITTLE CROW MILLING Co., Warsaw, Ind., Coco Wheats. N. Agency: Rogers & Smith Co., Chicago.

LIVE FOOD PRODUCTS Co., Burbank, Cal., Health Foods. S. Agency: The Mayers Co., Los Angeles.

LOEW'S INC., New York. Motion pictures. Agency: Donahue & Coe Inc., New York.

LOMA LINDA FOOD PRODUCTS, Arlington, Cal., Ruskets. S. Agency: Elwood J. Robinson Adv. Co., Los Angeles.

LONGINES-WITTMANER WATCH Co., New York. N. S. Agency: Victor A. Bennett Co., N. Y. D-C.

LOOK MAGAZINE, N. Y. S. Agency: McCann-Erickson, N. Y.

LORD DAVENPORT PIPES, Ltd., New York. S. Agency: Byrne, Harrington & Roberts, N. Y.

LORIE LTD., Toronto. Watches. S. Agency: Ellis Adv., Toronto.

P. LORILLARD Co., New York. Old Gold & Embassy cigarettes. S-N. TV. Agencies: Lennen & Mitchell, N. Y.; Gever, Cornell & Newell, N. Y.

LOS ANGELES BREWING Co., L. A. (Eastside beer) R. Agency: Lockwood-Shackelford Adv., L. A.

LOS ANGELES SOAP Co. and/or WHITE KING SOAP Co., Los Angeles. White King Granulated Soap, Sierra Pine Toilet Soap, Scotch Triple Action Cleanser. Agency: Raymond R. Morgan Co., Hollywood.

M. LOUIS HAIR DESIGN INSTITUTE, New York, Egnog Shampoo. S.

JOE LOWE Corp., N. Y., Popsicle. N. TV. Agency: Blaine-Thompson Co., N. Y.

LUCKY TIGER Mfg. Co., Kansas City. Agency: Hill Blackett & Co., Chicago.

LUDENS Inc., Reading, Pa., menthol cough drops, honey-licorice drops, C-cillana drops. S. N. Agency: J. M. Mathes Inc., New York.

LUER PACKING Co., Los Angeles. Canned meat products. S. Agency: Dan B. Miner Co., L. A.

GEORGE W. LUFT Co., New York. Tangee and cosmetics. S. N. Agencies: Warwick & Legler, N. Y.; Robt. Otto & Assoc., N. Y. (export).

LUMBERMAN'S MUTUAL CASUALTY Co., Chicago, Insurance. N. Agency: John W. Shaw Inc., Chicago.

LUTHERAN LAYMEN'S LEAGUE, St. Louis, Religion. N. Agencies: Gotham Adv. Co.; Pan American Broadcasting Co., New York.

M. LYON & Co., Kansas City, Mo., Wool, furs, hides. Placed direct.

LYON VAN & STORAGE Co., Los Angeles. S. R. Agencies: BBDO, Los Angeles, & Smalley, Levitt & Smith, L. A.

M

M. J. B. Company, San Francisco, coffee & tea. N. TV. Agency: BBDO, S.F.

M & M Ltd., Newark, N. J., M & M Candy, N. S. Agency: Lynn Baker Inc., N. Y.

M & N CIGAR MFRS., Cleveland. Student Prince Cigars. Agency: Ohio Adv., Cleveland.

MACDONALD TOBACCO Co., Montreal. Tobacco. S. Agency: Harold F. Stanfield Ltd., Montreal.

MAC MILLAN BREWING Corp., Los Angeles. TV. Agency: Marketers Inc., Hollywood.

MAGGI Co., New York, Seasonings. S. Agency: Needham & Grohmann, New York.

MAIDEN FORM BRASSIER Co., N. Y. N. TV. Agency: William Weintraub Co., N. Y.

MAIL POUCH TOBACCO Co., Wheeling, W. Va., Mail Pouch chewing tobacco, Kentucky Club smoking tobacco. N. Agency: Walker & Downing, Pittsburgh.

MAINE DEVELOPMENT COMMISSION Promotion of Agricultural, Sea Food and Poultry Products. N. Agency: Brooke, Smith, French & Dorrance, N.Y.

MANHATTAN SOAP Co., N. Y., Sweetheart Toilet Soap, Blu-White, N. S. Agency: Duane Jones Co., N.Y.

MANTLE LAMP Co. OF AMERICA, Chicago. Aladdin lamps. S. Agency: Wm. Hart Adler Inc., Chicago. D-C.

MANTLE LAMP Co. OF AMERICA, Toronto (Aladdin lamps) Agency: Locke, Johnson Co., Toronto.

MAPLE LEAF MILLING Co., Toronto, flour. S. Agency: Cockfield, Brown & Co., Toronto.

MARINE ELECTROLYSIS ELIMINATOR Co., Seattle (Red Devil soot remover). R. S. Agency: Penman-Nell Adv., Seattle.

MARINE TRUST Co., Buffalo, Banking service. S. Agency: BBDO, Buffalo.

MARLIN FIREARMS Co., New Haven, Razor Blades. S. Agencies: Craven & Hedrick, N.Y.; Duane Jones Co., N.Y.

MARS, Inc., Chicago. Candy. S. N. TV. Agency: Grant Adv., Chicago.

MARSHALL & CLAMPETT, Los Angeles. Auto Dealers. TV. Agency: Smith, Bull & McCreery Adv., Los Angeles.

MARSHALL DRUG Co., Philadelphia. Agency: Abner J. Gelula & Assoc., Philadelphia.

MARTIN FOOD PRODUCTS INC., Chicago. R. Agency: Morris F. Swaney Inc., Chicago.

MARTIN-SENOUR Co., Chicago, Ill., Paints, varnishes. Agency: MacFarland, Aveyard & Co., Chi. D-C.

JOS. MARTINSON & Co., Inc., New York. Martinson's coffee. Agencies: Neff-Rogov, Inc., New York; Al Paul Lefton Co., New York.

MARYLAND PHARMACEUTICAL Co., Baltimore, Md., Rem. S. Agency: Joseph Katz Co., Baltimore.

C. H. MASLAND & SONS, Carlisle, Pa. Carpet mfrs. N. TV. Agency: Anderson, Davis & Platte, New York.

MASON, AU & MAGENHEIMER CONF. MFG. Co. Inc., Brooklyn, N. Y., R. TV. N. Agency: Moore & Hamm Adv., N.Y.

MASON'S CHICKS Inc., Plainfield, N. J. Agency: Metropolitan Adv. Co., New York.

MASSACHUSETTS RADIO & TELEGRAPH SCHOOL, Boston, school. Agency: N. W. Ayer & Son, Boston.

MATUSEK ACADEMY OF MUSIC, Chicago. Music stores. R. TV. Agency: Salesvertising Assoc., Chi.

MAX FACTOR & Co., Los Angeles, cosmetics. S. Agency: A. Carman Smith Inc., Los Angeles.

EARL MAY SEED Co., Shenandoah, Iowa, nursery stock, seeds. S. Agency: Conley Adv., Chicago.

MAYFLOWER HOTEL, Akron, Ohio. Terrace Room. S. Agency: Koehl, Landis & Landon, Cleveland.

MCCOLL-FRONTENAC OIL Ltd., Montreal, oil and gasoline. N. Agency: Ronalds Adv. Agency, Montreal.

MCCONNOR & Co., Winona, Minn., Mack-O-Blend insecticide. S. Agency: Cramer-Krasselt Co., Milwaukee.

MCCOY'S WILSHIRE, Beverly Hills, Imperial washable wallpapers. S. Agency: Atherton & Co., Los Angeles.

MCKESSON & ROBBINS, Bridgeport, Calox toothpowder, Bax, Bexel Vitamin B Complex. S. N. Agencies: J. D. Tarcher Co., New York; Ellington & Co., New York. D-C.

W. F. McLAUGHLIN & Co., Chicago. Manor House Coffee. S. Agency: Sherman & Marquette Inc., Chicago.

McMAHAN FURNITURE STORES, Los Angeles, House Furnishings. N. M-C-M Adv. Agency, Santa Monica, Cal.

MEGOWEN EDUCATOR FOOD Co., Lowell, Mass. "Crax." Agency: Duane Jones Co., New York.

B. MEIER & SON, New York. Golden Center Toasted Wheat Germ. S. Agency: H. C. Morris Adv., New York.

MEM Co., New York, Mem toiletries. S. Agency: Ellis Adv., N.Y.

MENNEN Co., Newark, Lather Shave Cream & Brushless Shave Cr. S-N Agencies: Duane Jones Co., New York; Grey Adv., Irwin Vladimir & Co., New York, & A. J. Denne & Co., Toronto.

MENTHOLATUM Co., Buffalo. Mentholatum, N. S. Agencies: J. Walker Thompson Co., N. Y.; Export Adv. Agency, Chicago.

MERCANTILE-COMMERCE BANK & TRUST Co., St. Louis, Mo., Banking, trust, safe deposits, loans. Agencies: Oakleigh R. French & Assoc., St. Louis; Albert Frank-Guenther Law, New York.

MERRILL LYNCH, PIERCE, FENNER & BEANE, New York. Investment firm. S. Agency: Albert Frank-Guenther Law, New York.

METRO-GOLDWYN-MAYER, New York. Moving Pict. S. Agency: Donahue & Co., New York.

MET-WO INDUSTRIES LTD., Toronto. S. Agency: Gary J. Carter of Canada Ltd., Toronto.

METROPOLITAN ICE CO., Boston. Agency: Ruthrauff & Ryan, N. Y.

METROPOLITAN LIFE INS., New York. N. Agency: Young & Rubicam, New York.

MEYER & WELCH, Los Angeles. (Ford, Mercury distributors). R. Agency: Ad Assoc., Los Angeles.

MICHIGAN BULB Co., Grand Rapids, flower bulbs. Agency: O'Neill, Larson & McMahon, Chicago.

MICHIGAN MUSHROOM Co., Niles, Mich., fresh and canned mushrooms, canned soup, asparagus, tomatoes, peaches. Agency: L. W. Ramsey Co., Chicago.

MICHIGAN MUTUAL LIABILITY Co., Detroit Casualty insurance. S. Agency: Wm. I. Denman Inc., Detroit.

MICHIGAN STATE APPLE COMMISSION, Lansing, Mich., Apples. S. Agency: Brooke, Smith, French & Dorrance, Detroit.

MID CONTINENT AIRLINES, Inc., Kansas City. Air transportation. S. Agency: Bruce & Brewer Co., Kansas City, Mo.

MID-CONTINENT PETROLEUM Corp., Tulsa, Okla., D-X Motor Fuel, D-X Motor Oil, Diamond Motor Oil. Agency: Potts-Calkins & Holden, Kansas City.

LOUIS MILANI FOODS, Maywood, Calif. 1890 French Dressing, DeCisco Dressing. R. TV. Agencies: Smith, Bull & McCreery Adv., Hollywood; C. J. LaRoche & Co., L.A.; Garfield & Guild, S.F.

MILES LABS, Elkhart, Ind., vitamin tablets, Nervine, Anti-Pain pills, Alka-Seltzer, N. S. TV. Agencies: Wade Adv. Co., Chicago; Ruthrauff & Ryan, Chicago; Robert, Otto & Assoc., New York; Zimmer-Keller Inc., Detroit.

MILES LABS, Toronto, Alka-Seltzer, One-A-Day Vitamins. Agency: Cockfield, Brown & Co., Toronto.

MILLER BREWING Co., Milwaukee. Miller's High Life Beer. R. N. TV. Agency: Klau, Van Pietersom, Dunlap Assoc., Milwaukee.

I. MILLER & SONS, Long Island City, N. Y., shoes. S. Agency: Diener & Dorskind, N. Y.

MILROSE PRODUCTS Co., New York. Rad Cleanser. S. Agency: Frederick-Clinton Co., N.Y.

MINNESOTA VALLEY CANNING Co., Le Sueur, Minn. (canned vegetables) Agency: Leo Burnett Co.

MINUTE MOP Co., Chicago. Minute Mop & Drainer, Soap Bank, cellulose sponge products. Agency: Guenther-Bradford, Chicago.

MISS SALYOR'S CHOCOLATES Inc., Alameda, Calif. S. Agency: Albert Frank-Guenther Law, San Francisco.

MISSION HOSIERY MILLS, Los Angeles. Placed direct.

MISSION PAK Co., Los Angeles, California. Glazed and candied fruits. Agency: Brisacher, Wheeler & Staff, L.A.

MISS SWANK, INC., New York. Miss Swank slips & pajamas. N. Agency: Ben Sackheim Inc., N.Y.

MODE O'DAY Corp., Los Angeles (retail dress chain). R. Agencies: Brisacher, Wheeler & Staff, L.A.; Glasser-Gailey Inc., L.A.

MODGLIN Co., (Perma-Broom) L.A. N. Agency: W. Earl Bothwell, L.A.

H. MOFFATT CO., San Francisco (Manteca Fed Beef) N. Agencies: Makelim Assoc., Hollywood; Honig-Cooper Co., S.F.

S. A. MOFFETT Co., Los Angeles. Polar Brand Frosted Foods. N. Agencies: Honig-Cooper Co., Seattle; Erwin, Wasey & Co., Inc., Seattle.

MOLSON'S BREWERY, Montreal, N. Agency: Cockfield, Brown & Co., Montreal.

MONOGRAM MFG. Co., Los Angeles (Plasti-Craft curlers). Agency: Western Adv., Los Angeles.

MONTGOMERY WARD, Chicago. Department Store. R. S. Agency: Foote, Cone & Belding, Chicago.

MONTICELLO DRUG Co., Jacksonville, Fla. (666 cough medicine). Agency: Chas. W. Hoyt Inc., N.Y.

BENJAMIN MOORE & Co., New York. Paint. N. Agency: St. Georges & Keyes Inc., New York.

L. H. MOORE CANNING Co., McAllen, Tex. (fruits and vegetables). Agency: Garfield & Guild, San Francisco.

JOHN MORRELL & Co., Ottumwa, Iowa. Red Heart Dog Food. N. Agency: N. W. Ayer & Son, Chicago.

PHILIP MORRIS & Co., New York. Cigarettes. N. TV. Agencies: Biow Co. and Cecil & Presbrey, N.Y. Albert Woodley Co., New York.

MOTOROLA INC., Chicago N. R. TV. Agency: Gourfain-Cobb Agency, Chicago. D-C.

C. F. MUELLER Co., Jersey City, N. J., Macaroni products. S. Agency: Duane Jones, New York.

MUIR CUT RATE DRUGS, Michigan, Ohio, Indiana, and Wisconsin Drugs. S.

MUL-SO-LAX LABORATORIES Dowagiac, Mich., Mul-So-Lax Patent Medicine.

MURINE Co., Chicago, Murine. S. Agency: BBDO, Chi.; Baker Adv., Ltd., Toronto.

MURPHY PRODUCTS Co., Burlington, Wis., Farm Feeds. S. Agency: Wade Adv., Chicago.

ARTHUR MURRAY SCHOOL OF DANCING, New York. Agency: Ruthrauff & Ryan Inc., N.Y.

ARTHUR MURRAY PACIFIC COAST STUDIOS, Los Angeles. R. S. Agency: Hunter Adv., L.A.

**DAY AFTER DAY
THE SAME STORY
MEANS MORE SALES**

**GROWING WITH THE
OAKLAND • SAN FRANCISCO BAY AREA**



SINCE 1925

**NEWS - SPORTS
MUSIC - IDEAS**

KROW —OAKLAND

Phone: TWinoakes 3-9600

DIRECTORY OF NATIONAL AND REGIONAL ADVERTISERS

(Continued)

MUSICAL DIGEST MAGAZINE, N. Agency: Kenyon-Eckhardt, New York.
 MUSTEROLE Co., Cleveland, O. Mustero. S. Agency: Erwin, Wasey Co., N.Y.
 MUTUAL BENEFIT HEALTH & ACCIDENT ASSN., Omaha, Insurance, N. Agency: Ruthrauff & Ryan, Chicago.
 MUTUAL BENEFIT LIFE INSURANCE OF NEW JERSEY, Newark, N.J. TV. S. Agencies: Anaigraph Assoc., N. Y.; Chas. Dallas Reach Co., Newark.
 MUTUAL ORANGE DISTRIBUTORS, Redlands, Cal. Red Gold orange concentrate. S. Agency: J. Walter Thompson Co., Los Angeles.
 MYSTIC FOAM Co., Cleveland. Upholstery Cleaner. S. Agency: Carpenter Adv. Co., Cleveland.

N

NASH BROS. DRUG Co., Jonesboro, Ark. chill tonic, cold capsules, purgative tablets, cough syrup. S. Agency: Cole & Co., Memphis.
 NASH-KELVINATOR Corp., Detroit. Refrigerators. S. N. TV. Agency: Geyer, Newell & Ganger, N. Y.
 NATIONAL BAKERS SERVICES, Inc., Chicago, Hollywood Bread.
 NATIONAL BISCUIT Co., New York (Nabisco, Premium Saltines and Honey Maid graham crackers). N. S. TV. Agency: McCann-Erickson, N. Y. & Hollywood.
 NATIONAL BISCUIT Co., San Francisco. Nabisco. N. Agency: Botsford, Constantine & Gardner, S. F.
 NATIONAL BOARD OF FIRE UNDERWRITERS, New York. S-N. Agency: J. M. Mathes Inc., N. Y.
 NATIONAL BROADCASTING Co., New York. TV. Agency: J. Walter Thompson, New York.
 NATIONAL CANDY Co., St. Louis. Bobcat Candy Bar. S. Agency: Oakleigh R. French & Assoc., St. Louis.
 NATIONAL CARBON Co., New York. Prestone Anti-Freeze. R. S. Agency: Wm. Esty Co., N. Y.
 NATIONAL DAIRY PRODUCTS CORP. New York (Sealtest products). Agency: N. W. Ayer & Son, N. Y.
 NATIONAL DIE CASTING Co., Chicago. Juice King orange juicer. S. TV. Agency: O'Grady-Anderson, Chicago.
 NATIONAL DRUG & CHEMICAL CO., Montreal. (C.B.Q. & Pasmore remedies & gin pills). R. S. Agencies: Cockfield Brown & Co.; McKim Adv., Montreal.
 NATIONAL ECONOMIC COUNCIL, Chicago, N. Placed direct.
 NATIONAL GUARD BUREAU, Wash., D. C. N. Agency: Gardner Adv., St. Louis.
 NATIONAL LEAD Co., San Francisco. Dutch Boy Paint. N. Agencies: Honig-Cooper Co., S. F. D-C.
 NATIONAL PRESSURE COOKER Co., Eau Claire, Wis. R. Agency: Melamed-Hobbs, Minneapolis. D-C.
 NATIONAL RADIO INSTITUTE, Washington, D. C., Correspondence course in technical radio. S. Agency: Van Sant, Dugdale & Co., Baltimore.
 NATIONAL SHAWMUT BANK OF BOSTON, Boston. R. Agency: Doremus & Co., Boston.
 NATIONAL TOILET Co., Paris, Tenn., Nadinola bleach cream. S. Agency: Roche, Williams & Cleary, Chicago.
 NEHI Corp., Columbus, Ga. Royal Crown Cola. S. Agency: BBDO, N. Y. D-C.
 NESTLE'S MILK PRODUCTS, Inc., New York. (Nesta soluble tea, Nescafe). S. Agencies: Doherty, Clifford & Schenfeld, N. Y.; Needham & Grohmann, N. Y.; Compton Adv., N. Y.
 NESTLE'S MILK PRODUCTS, LTD., Toronto. (Nescafe). S. Agency: Cockfield Brown & Co., Toronto.
 NEUMODE HOSIERY Co., Chicago. Hosiery. S. Agency: George H. Hartman Co., Chicago.
 NEW ENGLAND CONFECTIONERY Co., Cambridge, Mass. S. Agency: C. J. LaRoche, N. Y. & Chicago.
 NEW HAVEN CLOCK & WATCH Co., New Haven. R. Agency: Weiss & Geller, N. Y.
 NEW YORK TELEPHONE Co., New York, toll calls. S. Agency: BBDO, N. Y.
 NEW YORKER HOTEL, New York. R. TV. Agency: Peter Hilton Inc., New York.
 NEWELL GUTRADT Co., San Francisco. Striker's soap. N. Agency: Garfield & Guild, S. F.

NIX COSMETICS Co., Memphis, Tenn. Nix deodorant. S. Agency: Cole & Co., Memphis.
 NOMA ELECTRIC CORP., New York. Lamps, Xmas lights, toys, heaters, etc. Agencies: Albert Frank-Guenther Law Inc., N. Y.; Foster & Davies Inc., Cleveland; Thomas & Delehanty Inc., N. Y.
 NOMA ELECTRIC Co., of Canada, Toronto, toys. Agency: MacLaren Adv. Toronto.
 NORTHERN ELECTRIC Co., Montreal, radios, electrical appliances. Agency: Harry E. Foster Agencies, Toronto.
 NORTHRUP KING & Co., Minneapolis, farm, lawn, garden seeds, feeds. S. Agency: Olmsted & Foley, Minneapolis.
 NORWICH PHARMACAL, Norwich, N. Y. Pepto-Bismol. N. Agencies: Kieswetter, Weterau & Baker, N. Y.; Lawrence C. Gumbinner Adv., N. Y.; Benton & Bowles, N. Y.
 NORWICH PHARMACAL Co., Toronto. (Pepto-Bismol). N. Agency: McKim Adv., Toronto.
 NOX Co., Los Angeles, Cystex, Menzies, Los Angeles. Agency: Robert Raisbeck, Hollywood.
 NOXZEMA CHEMICAL Co., Noxzema, Noxzema Shave Cream, N. Agency: Sullivan, Stauffer, Colwell, & Bayles, N. Y.
 NURSERYTIME PRODUCTS, Brooklyn. TV. Agency: Jules Mirel, N. Y.

O

O-CEDAR Corp., Chicago, polish. S-N. Agency: Young & Rubicam, Chicago. D-C.
 OGLVIE FLOUR MILLS Co., Ltd., Montreal, cereals. S. Agencies: J. F. Gibbons Ltd., MacLaren Adv., & E. W. Reynolds & Co. Ltd., Toronto.
 OHIO BELL TELEPHONE Co., R. Agency: McCann-Erickson, Cleveland.
 O'KEEFE & MERRITT Co., L. A. (stoves). S. Agency: R. B. Atchison Adv., L. A. D-C.
 OLD DUTCH COFFEE Inc., N. Y. Coffee. S. Agency: Peck Adv., N. Y.
 OLD JUDGE COFFEE Co., St. Louis, Mo. S. Agency: Glee Stocker & Assoc., St. Louis.
 OLD MISSION WINERIES, Los Angeles, Old Mission Wines. S. Agency: Milton Weinberg Adv. Co.
 OLDSMOBILE DIV. OF GENERAL MOTORS Corp., Lansing, Mich., Oldsmobile cars, GM Hydra-Matic Drive, General Motors, N-S. TV. Agency: D. P. Brother & Co., Detroit.
 OMAR INC., Omaha. R. Agency: Fitzmorris & Miller, Chicago.
 OLNEY & CARPENTER, Wolcott, N. Y., potato sticks. R. S. Agency: Fuller & Smith & Ross Inc., N. Y.
 OMNIBOOK, New York, Magazine and Book Publishing Co. S. Agency: Huber Hoge & Sons, N. Y.
 ONTARIO FRUIT & VEGETABLE GROWERS' Assn., Toronto. Agency: McKim Adv. Ltd., Toronto.
 ONTARIO HYDRO ELECTRIC SYSTEM, Toronto. (conservation campaign for electric current) S. N. Agency: J. J. Gibbons Ltd., Toronto.
 O-P-E-E-C-H-E-E GUM Co., Toronto. Agency: Walsh Adv., Toronto.
 ORANGE CRUSH Co., Chicago, Soft Drink. S. Agency: Ruthrauff & Ryan, N. Y. D-C.
 OSHKOSH B'GOSH, Inc., Oshkosh, Wis. Overall and Work Clothing. Agency: Ruthrauff & Ryan, Inc., Chicago.
 OSHKOSH BREWING Co., Oshkosh, Wis. Beer. R. Agency: Gersh-Murray Co., Oshkosh.
 OWENS-ILLINOIS GLASS Co., Toledo, Institutional. N. Agencies: J. Walter Thompson Co.; Brooke, Smith, French & Dorrance, Detroit.
 OYSTER SHELL PRODUCTS Corp., New York. S. Agency: Cecil & Presbrey, New York.

P

PABST SALES Co., Chicago, Pabst Blue Ribbon Beer. N. TV. Agencies: Warwick & Legler, Inc., N. Y.; Irwin Vladimir & Co., Chicago.
 PACIFIC BREWING & MALTING Co., San Jose, Cal., Wieland's beer. N. S. Agency: Honig Cooper Co., S. F.

PACIFIC COAST BORAX Co., New York. N. Agency: McCann-Erickson, N. Y.
 PACIFIC CHEESE DIV., Borden Co., Los Angeles. Dairy products. R. S. TV. Agency: Young & Rubicam, San Francisco.
 PACIFIC CAN Co., San Francisco. S. Agency: Blow Co., New York.
 PACIFIC GREYHOUND Co., San Francisco (bus transportation). R. Agency: Beaumont & Hohman, S. F.
 PACIFIC MUTUAL LIFE INSURANCE Co., Los Angeles. R. TV. Agency: Foote, Cone & Belding, Hollywood.
 PACKARD-BELL Co., Los Angeles (radio & television mgrs.) R. S. TV. Agency: Abbott Kimball Co. Inc., L. A. D-C.
 PACKARD MOTOR Co., Detroit. S. TV. Agency: Young & Rubicam, N. Y. D-C.
 PAL BLADE Co., New York. N. TV. Agency: Al Paul Lefton Co., N. Y.
 PAN-PACIFIC AUDITORIUM, Los Angeles. Agency: Smith, Bull & McCreery, Hollywood.
 PAN AMERICAN PETROLEUM Corp., New Orleans, Oil. N. Agency: Jos. Katz Co., Baltimore. D-C.
 PAR SOAP Co., Oakland, Calif. (Par Soap). R. Agency: Brisacher, Wheeler & Staff, S. F.
 PARAMOUNT PEST CONTROL Co., Oakland, Cal., Insecticide. S. N. Agency: Ad Fried Adv., Oakland.
 PARAMOUNT PICTURES Inc., New York, moving pictures. S. TV. Agency: Buchanan & Co., N. Y.
 PARFUME WEIL PARIS, New York. S. Agency: Kelley, Nason, Inc., New York.
 PARK & TILFORD, New York, Tints and Dyes. S. Agency: Charles M. Storm Co., N. Y.
 PARKER BOULDIN Co., St. Paul, Priscilla Parker dual purpose lipstick. S. Agency: Van DeMark Adv. Inc., Mnpls.
 PARKER-HERBEX Corp., Stamford, Conn., hair preparations. S. Agency: Charles W. Hoyt Co., N. Y.
 PARKER PEN Co., Janesville, Wisc., Parker Pens, Pencils & Quink. N. Agencies: J. Walter Thompson Co., Chi.; Walsh Adv. Co., Ltd., Windsor, Ont.
 PARKER WATCH Co., New York. Watches. S-N. Agency: Peck Adv. Agency, N. Y.
 JOHN G. PATTON Co., New York. TV. S. Agency: Peter Hilton Adv., N. Y.
 PAXTON & GALLAGHER Co., Omaha, Butter-Nut coffee. S. Agency: Buchanan-Thomas Adv., Omaha.
 PAYNE FURNACE Co., Beverly Hills, Calif. S. Agency: Knollin Adv. Agency, L. A. D-C.
 PEERLESS LAUNDRY, Los Angeles. TV. Agency: Weston Adv. Inc., Los Angeles.
 PEERLESS PEN AND PENCIL Co., New York, pens and pencils. S. Agency: Furman Co., N. Y.; LeLand K. Howe Assoc. Inc., N. Y.
 PENICK & FORD, New York, Br'er Rabbit Molasses, My-T-Fine Dessert. S. Agencies: J. Walter Thompson Co., N. Y.; BBDO, N. Y.
 PENNSYLVANIA SALT MANUFACTURING Co., Philadelphia, Pa., Kryoclide, Iye, Ethel. S. Agency: Geare-Marston Inc., Philadelphia.
 PENNZOIL Co., Los Angeles, Lubricants. N. S. Agency: The Mayers Co., L. A.
 PENNZOIL Co., Oil City, Pa. Gasoline, oil, lubricants. Agency: Fuller & Smith & Ross, Cleveland.
 PEOPLE'S CREDIT JEWELERS, Toronto, Chain stores. Agency: McLaren Adv., Toronto.
 PEP BOYS-MANNY, MOE & JACK OF CALIFORNIA, Los Angeles, Calif., Auto accessories, parts, radio, bicycles and parts, tools, tires and tubes. S. Agency: Milton Weinberg Adv., L. A.
 PEPPARD SEED Co., Kansas City, Mo., Hybrid Corn. S.
 DR. PEPPER Co., Dallas. Dr. Pepper Carbonated Beverage. N. Agency: Tracy-Locke Co. Inc., Dallas, Tex. D-C.
 PEPSI-COLA Co., New York, beverage. TV. (Everev sparkling water). S. TV. Agencies: Blow Co., N. Y.; Young & Rubicam, N. Y.; Presba, Fellers & Presba, Chicago. D-C.
 PEPSI-COLA Co., Montreal (soft drinks). S. Agency: J. Walter Thompson Co., Montreal.
 PEPSODENT Co., Chicago, Pepsodent Toothpaste. N. Agencies: Foote, Cone & Belding, N. Y.; Ruthrauff & Ryan Inc. N. Y., Export Adv., Chi.; J.

Walter Thompson, N. Y.
 PEPSODENT DIVISION OF LEVER BROS. Co., Canada. Agency: Ruthrauff & Ryan Inc., N. Y.
 PERALTA WINE Co., San Francisco, Monte Cristo wines. N. Agency: Foote, Cone & Belding, S. F.
 PERFECT CIRCLE Co., Hagerstown, Ind., piston rings. N. Agency: Henri, Hurst & McDonald, Chi.
 PERFECTION CORSETS Co., Quebec. Agency: R. C. Smith & Son, Toronto.
 PREFEX Co., Omaha, Perfex cleaner. Agency: Buchanan-Thomas, Omaha.
 DOROTHY PERKINS Co., St. Louis, Mo., Cosmetics. S. Agency: Gardner Adv. Co., St. Louis. D-C.
 PET MILK SALES Co., St. Louis, 400 D Pet Milk. N. Agency: Gardner Adv. Co., St. Louis.
 PETER FOX BREWING Co., Chicago. S. R. Agency: H. W. Kastor & Sons Adv. Co., Chicago.
 PETER PAUL, Inc., Naugatuck, Conn., Mounds & Ten Crown Gum. N. S. TV. Agencies: Brisacher, Wheeler & Staff, S. F.; Platt-Forbes Inc., N. Y.
 PETERS SHOE Co. (Division of International Shoe Co.), St. Louis, Mo., City Club Shoes, Velvet Step Shoes, Weather Bird Shoes, Peters Shoes. S. Agencies: Henri, Hurst & McDonald Inc., Chi.; Datche Adv., St. Louis; Russell C. Comer, K. C.
 PETRI CIGAR Co., San Francisco. Agency: Young & Rubicam, S. F.
 PETRI WINE Co., San Francisco & Los Angeles, Wine. N. Agency: Young & Rubicam, N. Y. & S. F.
 PETROL CORP., Los Angeles, PDQ gasoline. S. Agency: McNeill & McCleary Adv., L. A.
 PFEIFFER BREWING Co., Detroit. R. Agency: Maxon Inc., Detroit.
 PHARMACO, Inc., Newark, Feen-A-Mint and Chooz. N. Agencies: Baker A.A. Ltd., Toronto; Duane Jones & Co., N. Y.
 PHARMACRAFT Corp., New York, Fresh deodorant. N. Agencies: J. Walter Thompson; McCann-Erickson; Wm. Esty Co., all New York.
 PHILCO Corp., Philadelphia, Pa., Philco radio receivers, radio-phonographs, refrigerators, air conditioners, N. TV. Agency: Hutchins Advertising Co., Inc., Phila.; Foote, Cone & Belding, N. Y.
 PHILCO Corp. of Canada, Toronto, receivers. Agency: Hutchins Adv., Toronto.
 PHILLIPS & BENJAMIN Co., New York, Sno-Mist, powder spray deodorant. Agency: Lindstrom, Leach & Co., New York.
 DR. P. PHILLIPS Co., Orlando, Fla., Canned and fresh citrus products. Agency: Robt. Hammond Adv., Orlando, Fla.
 PHILLIPS PACKING Co., Cambridge, Md., N. TV. Agency: Aitkin-Kynett Co., Philadelphia.
 PHILLIPS PETROLEUM Co., Bartlesville, Okla., Gasoline, motor oil. N. S. Agency: Lambert & Feasley Inc., N. Y.
 PICTSWEET FOODS, Inc., Mt. Vernon, Wash., Canned & frozen foods. N. Agency: Brisacher, Wheeler & Staff, San Francisco.
 PIEDMONT SHIRT Co., Greenville, S. C. N. Agency: Wm. Weintraub & Co., N. Y.
 PIERCE WATCH Co., New York, Watches. Agency: Jos. Katz Co., N. Y.
 PIERCE'S PROPRIETARIES, Buffalo, Pierce's special vitamin formula. S. Agencies: Duane Jones Co., N. Y.; Irwin Vladimir & Co., N. Y.
 FIG 'N WHISTLE CORP., Los Angeles. (Calif. restaurant chain) S. Agencies: The Mayers Co., L. A.; Brisacher, Wheeler & Staff, L. A.
 PILLSBURY MILLS, Minneapolis. Pillsbury's Best Flour, Pancake Flour, Sno Sheen Cake Flour, Farina. R. N. S. Agencies: McCann-Erickson, Mnpls.; Leo Burnett Agency, Chi.
 PILLSBURY MILLS, INC., FEED MILLS DIV., Clinton, Iowa, flour. S. Agency: McCann-Erickson, Chi.
 PILOT RADIO CORP., N. Y. (Pilotuner) R. Agencies: Grey Adv., N. Y.; Alfred Paul Berger Co., N. Y. D-C.
 PILSNER BREWING Co., Cleveland, Beer. S. Agency: Gregory & House, Cleveland.
 ED PINAUD Inc., New York, Cosmetics. N. Agency: Wesley Assoc., N. Y.

PINEX Co., Fort Wayne, Ind., Pinex Cough Syrup. S. Agency: Russel M. Seeds Co., Chi.

LYDIA E. PINKHAM MEDICINE Co., Lynn, Mass. Vegetable compound. R. Agency: Erwin, Wasey & Co., N. Y.

PIONEER HI-BRED CORN Co., Des Moines, Iowa. Agency: Wallace Adv. Agency, Des Moines.

PIONEER SCIENTIFIC CORP. (Polaroid TV screen filters). N. TV. Agency: Cayton Inc., N. Y.

PLANTER'S NUT & CHOCOLATE Co., Wilkes-Barre, Pa. Peanuts & Peanut Oil. N. Agencies: Raymond R. Morgan Co., S. F.; Goodkind, Joice & Morgan, Chi.; J. Walter Thompson Co., N. Y.

PLOUGH, Inc., Memphis, Penetro, St. Joseph Aspirin and family medicines, Mexana, Muffin products, Everready oil, Pen-o-rub, Moroline, Black & White beauty preparations. Agency: Lake-Spiro-Shurman, Memphis.

POLAR FROSTED FOODS, Seattle, Wash. Frozen foods. Agency: Honig-Cooper Co., Seattle.

POLAROID SCIENTIFIC Co., New York. TV. Agency: Cayton Inc., New York.

POLK-MILLER PRODUCTS Corp., Richmond, Va., Disinfectant. S. Agency: N. W. Ayer & Son, Phila.

DR. A. POSNER SHOES Inc., New York. R. Agency: Hirshon-Garfied, New York.

POTTER DRUG & CHEMICAL CORP., Malden, Mass. (Cuticura). R. Agencies: Masons United Radio Adv., Toronto; Atherton & Currier, N. Y.

PREMIER VACUUM CLEANER DIV., GENERAL ELECTRIC Co., Bridgeport, Conn. Premier Vacuum Cleaners. S. Agency: J. M. Hickerson, Inc., N. Y. D-C.

PRIEBE & SONS, Chicago, Poultry Eggs. S. Agency: Goodkind, Joice & Morgan, Chi.

PRINCE MATCHABELLI Inc., New York. Perfumes. N. Agency: Morse International, N. Y. D-C.

PROCTER & GAMBLE Co., Cincinnati. Ivory bar, Ivory Flakes, Ivory Snow, Duz, Oxydol, Camay, Spic & Span, Teal, Lava, Crisco, Drene & Drefl. N. TV. Agencies: H. W. Kastor & Sons, Chicago; Dancer-Fitzgerald-Sample, Chicago; Compton Adv. N. Y.; Benton & Bowles, N. Y.; Blow Co., N. Y.; Pedlar & Ryan, N. Y.; Russel M. Seeds Co., Chicago.

PROCTER & GAMBLE, Toronto (Drefl). Agency: Dancer - Fitzgerald - Sample. (Canada) Toronto.

PRUDENTIAL INSURANCE CO. OF AMERICA, Newark, N. J., life insurance. N. Agencies: Benton & Bowles, N. Y.; Botstord, Constantine & Gardner, L. A.; Cockfield, Brown & Co., Ltd., Toronto.

JOHN PUHL PRODUCTS Co., Chicago. Laundry Bleaches. S. Agency: Roche, Williams & Cleary, Chicago.

PURE DRINKS, Cleveland, Breakfast Orange. Agency: Foster & Davies, Inc., Cleveland.

PURE FOOD Co., Inc., Mamaroneck, N. Y. Herb-Ox bouillon. S. Agency: J. M. Mathes, Inc., N. Y.

PURE OIL Co., Chicago, oil. S-N-TV. Agency: Leo Burnett Co., Chi.

PUREPAC Corp., N. Y., Flemax, Baby Flemax, Lubinol mineral oil, Purepac health aids, Kilnzmoth insecticides. Agency: Kent Adv., N. Y.

PUREX Corp., Southgate, Calif. (liquid bleach). R. Agency: Foote, Cone & Belding, L. A.

PURINA MILLS, St. Louis, Purina Foods. N. Agency: Gardner Adv. Co., St. Louis.

PURITY BAKERIES, Chicago, Taystee bread, Grennan Cakes. S. TV. Agency: Young & Rubicam, Chi.

PURITY FLOUR MILLS Ltd., Toronto. (cereals). N. Agency: McKim Adv., Ltd., Toronto.

Q

QUAKER OATS Co., Chicago, Ful-O-Pep cereals. N. Agencies: Ruthrauff & Ryan, N. Y. & Chicago; Spitzer & Mills, Ltd.; Sherman-Marquette, Inc.; C. J. LaRoche & Co., all Chicago. D-C.

QUAKER OATS Co., Peterborough, Ont. (Quaker Hour). S. Agency: Spitzer & Mills, Toronto.

QUAKER SUGAR, Philadelphia, S. Agency: Young & Rubicam, N. Y.

R

RCA VICTOR DIVISION of Radio Corp. of America, Camden, N. J., records, home radios, radio phonographs. N. TV. Agency: J. Walter Thompson Co., N. Y.

RCA VICTOR Co., Montreal (receivers, records). R. Agency: Spitzer & Mills, Toronto.

RKO RADIO PICTURES, New York. S. and N. Agency: Foote, Cone & Belding, N. Y.

RADBILL OIL Co., Philadelphia, Re-nuzit, French dry cleaner, Penn-Rad motor oil. S. Agency: Feigenbaum Adv., Phila.

RADIO BIBLE CLASS ORGANIZATION, Los Angeles. R. Agency: Stanley G. Boynton, Los Angeles.

RADIO GOSPEL FELLOWSHIP, Los Angeles (religious). Agency: Glasser-Galey, Inc., L.A.

RADIO OFFERS Co., New York. N. Agency: Huber Hoge & Sons, New York.

RAINIER BREWING Co., San Francisco. Rainier Beer, Malt & Ale. N. Agency: Buchanan & Co., S.F.

RAISIN BRAN, New York. S. Agency: Benton & Bowles, N.Y.

RALSTON-PURINA Co., St. Louis, Cereals. N. Agencies: Garner Adv., St. Louis; James Fisher Co., Toronto; Brown & Bowers, Nashville. D-C.

A. RAMSEY & SON, Montreal, points. S. Agency: McKim Adv., Montreal.

RAND TRAILER SALES CO., L. A. (So. Calif. trailer chain) R. S. Agency: Harry J. Wendland Adv., L. A.

RAPINWAX PAPER Co., S. E., Minneapolis. Minn., Rapinwax Household Roll. S. Agency: Mitchell Faust Adv., Chi.

RATH PACKING Co., Waterloo, Iowa. Complete Line of Meat Products. Agency: Young & Rubicam, Chi.

RAYMOND LABORATORIES Inc., St. Paul, Minn., Rayve Creme Shampoo, Rayette Creme Permanent Wave. N. Agency: Melamed-Hobbs, Inc., St. Paul.

RAYMOND LABORATORIES, Toronto, Rayve Creme Shampoo. S. Agency: Jas Fisher Co., Toronto.

RAYTHEON MFG. Co., Newton, Mass., Electrical goods. S-N. Agency: Walter B. Snow & Staff, Inc., Boston.

READERS DIGEST ASSN. INC., Pleasantville, N. Y., Magazine Readers Digest. N. S. Agency: BBDO, N.Y.

RED ROCK BOTTLERS, Atlanta, Ga., Red Rock Cola. S. Agency: R. S. Durstine Co., N. Y.

RED STAR YEAST & PRODUCTS Co., Milwaukee. Agency: Ellington & Co., N.Y.

REDDI-WIP, St. Louis. Canned whipping cream. S. Agency: Ruthrauff & Ryan, Chicago.

REGAL AMBER BREWING Co., San Francisco. N. Agency: Abbott Kimball Adv., San Francisco.

REICHOLD CHEMICALS, Detroit, Cosmopolitan Records. N. Agencies: MacManus, John & Adams, Detroit; Kopyon & Eckhardt, Detroit.

REID MURDOCH & Co., Chicago; Mon-ruch Fine Foods. S. Agency: Weiss & Geller Inc., Chi.

WM. B. REILY & CO., Inc., New Orleans. La., Luzzianna Coffee and Tea. S. Agency: Walker-Saussy Adv., New Orleans.

L. N. RENAULT & SONS, Egg Harbor City, N. J., wines and champagne. Agency: N. M. Dittmar Adv., Phila.

RENEE PRODUCTS OF CHICAGO, Chicago. S. Agency: Rocklin Irving and Association, Chi.

RENOIR PARFUMS, New York, Chichi and My Alibi perfumes. S. Agency: Abbott Kimball Co., N. Y.

RENSIE WATCH Co., New York. Watches. N. Agency: Weiss & Geller, N.Y.

REPUBLIC PICTURES Corp., New York, moving pictures. S. Agency: Donahue & Coe, N.Y.

REPUBLIC STEEL Corp., Cleveland. Agency: Meldrum & Fewsmith, Cleveland.

RESINOL CHEMICAL Co., Baltimore. Agencies: L. A. Sandlass Adv., Balt.; Street & Finney Inc., N.Y.

REVERE CAMERA Co., Chicago, N. Agency: Roche, Williams & Cleary, Chi.

REVERE COPPER & BRASS Inc., New York, Institutional. N. Agency: St. Georges & Keyes, N. Y.

REKALL DRUG Co., Los Angeles. Retail chain. N. R. TV. Agencies: BBDO, L.A. & N.Y.; L. W. Ramsey Co., Chi.

REKALL DRUG Co., Toronto. S. Agency: Ronalds Adv. Co., Toronto.

REYNOLDS PEN Co., Chicago. Agency: MacFarland, Avoyard, Chi.

REYNOLDS, R. J., TOBACCO Co., Winston-Salem, N. C., Camel and Cavalier (Continued)

RADIO AND TELEVISION

TV News On Its Own, Faces Popularity Test

By Jerry Walker

The news arm of television has a romantic twist to it, too. Francis C. McCall could not have said that when he moved from the AM payroll of the National Broadcasting Co. to the separate TV

more than one of the newscasts will attract those who like to see the news on TV. The newscasts will be broadcast on TV.

RADIO AND TELEVISION

Newspaper Reading Gains in TV Homes

By Jerry Walker

Newspaper reading has increased steadily since the growth of television. A survey of the country by the National Bureau of Census shows that the average length of newspaper articles in 1954 was 1,200 words, up from 1,100 in 1953. The survey also shows that the average number of newspapers read per person per week has increased from 1.5 in 1953 to 1.7 in 1954.

Apartment Antenna A survey for bringing video to 20th-century dwellers was demonstrated last week at a meeting of the National Apartment Association. The survey showed that 75% of apartment dwellers have an antenna on their roof, and 60% have a television set.

COMPETITIVE PARTNERS

45% of the TV Stations now on the air are Newspaper-Owned or Affiliated.

EDITOR & PUBLISHER Tells the Top Newspaper Executives What They Want To Know . . . What They Need to Know . . . about Television.

THERE is an ever-increasing affiliation between Newspapers and Television. The two in combination seem to represent one of the modernized methods of service.

However this may be, **EDITOR & PUBLISHER** recognizes the need of a thoroughly alert news coverage of Television as it relates to newspapers and to the 45% status of newspaper-owned or affiliated TV stations.

This need is accentuated by the fact that **EDITOR & PUBLISHER** is read as a news habit by owners, publishers, high executives of newspapers. They are not easy men to reach. But they CAN be reached, intimately, through **E & P**.

These top men give final approval to the purchase of radio and TV equipment, services, etc. They are deeply interested in the special articles and also the AM-TV advertising which appears in **E & P**.

Subscription rates: U. S., \$5 per year; Canada, \$5.50; Foreign, \$6 (including YEAR BOOK number).

EDITOR & PUBLISHER
Times Tower, Times Square, New York 18, New York

RADIO AND TELEVISION

Radio Research Asked: Who's Listening Where.

By Jerry Walker

Huon M. Beville, Jr., director of the National Radio and Television Survey, says that the survey will be completed in the next few months.

RADIO AND TELEVISION

TV Era Is Hitched To Kansas City Star

Kansas City's WDAF-TV station will be the first to broadcast on the air. The station is expected to start in the next few weeks.

The 170-page Sunday Star will include two sections of news coverage. The first section will be a 10-minute news program, and the second will be a 15-minute news program.

Four Weeks, Texas - The WFAA-TV station in Dallas is expected to start in the next few weeks. The station will be the first to broadcast on the air.

Texas Television - The WFAA-TV station in Dallas is expected to start in the next few weeks. The station will be the first to broadcast on the air.

At Cost of \$100,000 - The WFAA-TV station in Dallas is expected to start in the next few weeks. The station will be the first to broadcast on the air.

The newspaper explained why it was not a TV station. The newspaper said that it was not a TV station because it was not a TV station.

The Star is not open to the public. The Star is not open to the public. The Star is not open to the public.

The Star is not open to the public. The Star is not open to the public. The Star is not open to the public.

The Star is not open to the public. The Star is not open to the public. The Star is not open to the public.

DIRECTORY OF NATIONAL AND REGIONAL ADVERTISERS

(Continued)

cigarettes. N. S. TV. Agency: William Esty & Co., N.Y.

RHEEM MFG. CO., New York (water & home heating equipment) S. Agency: Foote, Cone & Belding, N.Y.

RHODES PHARMACAL Co., Cleveland. N. Agency: O'Neil Adv., Chicago.

H. U. RHODIUS, San Antonio, Perfumes. S. Agencies: Shaffer-Brennan-Margulis Adv., St. Louis; Northwest Radio Adv., Seattle.

RICHARDS INSURANCE Co., Los Angeles, Life Insurance. S. Agency: Dean Simmons Adv., Hollywood.

RICHFIELD OIL CORP., Los Angeles. Agency: Hixson-Jorgensen Inc., Los Angeles.

RICHFIELD OIL CORP. OF N. Y., New York. Richfield gasolines, Richfield and Richlube oils. N. TV. Agency: Hixson-Jorgensen Adv., N.Y.

JACOB RIES BOTTLING WORKS, Inc., Shakopee, Minn., Rock Spring sparkling water. S. Agency: Erwin, Wasey & Co., Minneapolis.

RIESER CO., New York. Mfgs Venida hair nets. TV. Agency: Ralph Harris Adv., New York.

RIGGIO TOBACCO Co., Brooklyn. Drake cigarettes. Brooke, Smith French & Dorrance Inc., N.Y.

RINGLING BROS., BARNUM & BAILEY CIRCUS, Sarasota, Fla., Circus. S. Agencies: Robert Seidel Adv., N.Y.; Deglin-Wood Inc., N.Y.

RIT PRODUCTS Corp., Chicago. Dyes. S. Agency: Earle Ludgin & Co., Chi.

HAROLD F. RITCHIE & Co., Toronto. Dipfoam cleanser. S. Agency: Tandy Adv. Agency, Toronto.

RITE-WAY PRODUCTS Co., Chicago, Ill., Milking machines, electric water heaters, cream separators. S. Agency: Roy D. Zeff & Assoc., Chicago.

P. J. RITTER Co., Bridgeton, N. J. Food products. N. Agency: Clements Co., Philadelphia.

RKO RADIO PICTURES Inc., New York. Agency: Foote, Cone & Belding, New York.

ROBESON CUTLERY Co., Perry, N.Y. N. TV. Agency: Wm. Weintraub Co., N.Y.

ROBIN HOOD FLOUR MILLS, Montreal. Agency: Young & Rubicam, Toronto.

ROCKWOOD & Co., Brooklyn. Chocolate Bits. S. Agency: Campbell-Ewald Co., N.Y.

ROMA WINE Co., San Francisco, Calif., wines, champagne. N-S. Agency: Biow Co., S.F.

ROMAN CLEANSER Co., Detroit, Mich., Roman Cleanser. Agency: Gleason Adv., Detroit.

ROMAN MEAL Co., Tacoma, Wash. Cereals. R. Agencies: Milne-Hefferman Inc., Seattle; Guild, Bascom & Bonfigli, San Francisco.

RONSON ART METAL WORKS, Newark, lighters. N. TV. S. Agencies: Cecil & Presbrey, N.Y.; Grey Adv., N.Y.

HOTEL ROOSEVELT, N. Y. S. Agency: Kelly-Nason, N. Y.

ROOSEVELT RACEWAY, Westbury, L. I. S. Agency: L. H. Hartman Co., N.Y.

ROSEDALE KNITTING Co., Reading, Pa. S. Agency: Duane Lyon Inc., N.Y.

ROSEFIELD PACKING Co., Alameda, Calif., Skippy peanut butter. S. Agency: Young & Rubicam, S.F.

MORRIS ROSENBERG Co., Los Angeles, Rose vacuum-packed nuts. S. Agency: The Meyers Co., L.A.

E. ROSENTHAL & SONS, N. Y., Clothing Mfgs. Agency: Gunn-Mears, N. Y.

DR. ROSS DOG FOOD, Los Angeles. R. N. Agency: Rocett-Lauritzen, Los Angeles.

LOUIS ROTH & Co., Los Angeles. Women's clothing mfr. R. TV. Agency: Ted H. Factor Agency, Los Angeles.

ROYAL TOBACCO Corp., New York, Lion Cigarettes. S.

ROYAL TYPEWRITER Co., New York, typewriters. Agency: Young & Rubicam, N. Y.

RUBSAND AND HORMAN BREWING Co., Staten Island, N. Y., R & H Beer and Ale. Agency: Paris & Peart, N. Y.

RU-EX CO., St. Paul (proprietary) S. Agency: Harry B. Cohen Adv. Co., N. Y.

RUM & MAPLE TOBACCO Corp., New York, Tobacco. S. Agency: Al Paul Letton Co., N. Y.

JACOB RUPPERT BREWERY, N. Y., Beer. S. N. TV. Agency: Biow Co. and National Export Adv. Service, N. Y.

RUSSELL-MILLER MILLING CO., Minneapolis, Occidental flour, American Beauty flour. S. Agency: Campbell-Mithun, Inc., Minneapolis.

BABE RUTH WATCH CO., New York. Children's watches. S. Agency: Ted Neuhoft & Co., Baltimore.

S

S.O.S. Co., Chicago, Magic Scouring Pads. R. S. Agency: McCann-Erickson, S. F.

S AND W FINE FOODS, Inc., San Francisco, Food and Coffee. N. Agency: Foote, Cone & Belding, S. F.

SAFeway STORES, Oakland, Calif., grocery chain. N. S. TV. Agencies: Foote, Cone & Belding; J. Walter Thompson Co. S. F.; McCann-Erickson; Ruthrauff & Ryan; Crosby & Cooper; Hannah Adv. Co. and M. E. Harlan Adv., D-C.

SAF-KIL CO., Benton Harbor, Mich., rat bait, roach powder. S. Agency: O'Neil Adv., Chi.

ST. LAWRENCE STARCH Co., Port Credit, Ont., Beehive products. N. Agency: McConnell Eastman & Co., Toronto.

ST. LOUIS INDEPENDENT PACKING Co., St. Louis, Mayrose meat products. S. Agency: Gardner Adv. Co., St. Louis.

SALERNO-MEGOWEN BISCUIT Co., Chicago. S. TV. Agency: Schwimmer & Scott, Chicago.

SALES BUILDERS, Inc., Los Angeles, Max Factor Cosmetics. N. Agency: A. Carman Smith, Los Angeles.

DR. SALSBUURY'S LABS., Charles City, Iowa, Ren-O-sol, Ari-tab. S. Agency: N. A. Winter Adv. Agency, Des Moines.

SAND SPRING Corp., Williamstown, Mass., Carbonated beverages.

SANDURA CO., Phila. S. Agency: Gray & Rogers, Phila.

SANITEX BRUSH AND PRODUCTS Co., Chicago, Sanitex Aluminum Open-Back Brushes. N.

SANKA COFFEE, New York. S. Agency: Young & Rubicam, New York.

SAN-NAP-PAK Mfg. Co., New York, Lydia Grey Doskin tissues & dinner napkins. S. Agency: Federal Adv. Agency, New York.

SANTA FE VINTAGE Co., Los Angeles, Santa Fe Supreme Wines. S. Agencies: Dan B. Miner Co., L. A.; Erwin, Wasey & Co., L. A. Lockwood-Shackelford Adv. L. A.

SARGENT & Co., Des Moines, Iowa, All types commercial feeds. S. Agency: Fairall & Co., Des Moines.

SAWYER BISCUIT Co., Chicago, Ill., Biscuits and crackers. Agency: George H. Hartman Co., Chicago.

SAYMAN PRODUCTS Co., St. Louis, Mo., Sayman soap, salves, shampoo. S. Agency: Krupnick & Assoc., St. Louis.

F. & M. SCHAEFER BREWING Co., Brooklyn. S. TV. Agency: BBDO, N. Y.

ADAM SCHEIDT BREWING Co., Norristown, Pa. S. Agency: Lawrence I. Everling Adv., Phila.

SCHENLEY DISTILLERS Corp., New York, Roma Wine. N & S; Penicillin; Schenley, Cresta Blanca Wine, N. S. TV. La Boheme Wine. S. Agencies: Biow Co., McCann-Erickson Inc., Wm. Weintraub & Co., Federal Adv. Agency, Kleppner A. A., all N. Y.

SCHENLEY LABS., New York, Penicillin-Schenley. N. Agency: Paul Klemmer & Co., Newark.

SCHICK Inc., Stamford, Conn. Schick Electric Shaver. R. N. TV. Agency: BBDO, N. Y.

R. SCHIFFMAN Co., Los Angeles, Asthmador Powder, cigarettes, and pipe mixture. N. Agency: Philip J. Meany Co., Los Angeles.

A. SCHILLING & Co., San Francisco (coffee & spices). S. Agency: Beaumont & Hohman, San Francisco.

SCHLITZ BREWING Co., Milwaukee. Agencies: Young & Rubicam. & Export Adv., Chicago.

WM. SCHLUDERBERG-T. J. KURDLE Co., Baltimore, meats, meat products, cheese, butter, poultry, eggs, shortening, lard. S. Agency: Van Sant, Dugdale & Co., Baltimore.

SCHOENHOFEN EDELWEISS Co., Chicago, Edelweiss Beer. S. Agency: Ollian Adv. Co., Chi.

S. A. SCHONBRUNN & Co., Inc., New York, Savarin, Medaglia D'Oro Coffee.

Agencies: L. C. Gumbinner, N. Y.; Pettinella Adv. Co., N. Y.

SCHUBACH JEWELRY Co., R. Agency: Cooper & Crowe, Salt Lake City.

SCHULZE AND BURCH BISCUIT Co., Chicago, Ill., Cookies and crackers, Local & S. Agency: Gordon Best Co., Chi.

SCHUTTER CANDY Co., Chicago, Candy Bars. N. Agencies: Schwimmer & Scott, Chicago; Westheimer & Co., St. Louis; Kaplan & Bruck, New York.

SCOTT & BOWNE, Bloomfield, N. J., Emulsion & ointment. S. Agency: Atherton & Currier, New York.

SCOTT TOWEL Co., Chester, Pa. N. TV. Agency: J. Walter Thompson Co., New York.

WM. S. SCULL Co., Camden, N. J., Boscul coffee, S. Agencies: Kastor, Farrell, Chesley & Clifford Inc., N. Y.; Lewis & Gillman, Inc., Phila.

SCRIPTO MFG. Co., Atlanta, Pencils. N. Agencies: Danahue & Coe Inc., N. Y.; Grant Adv. Inc., Miami (export).

SEABOARD FINANCE Corp., Los Angeles (personal loans). S. Agency: Smith, Bull & McCreery Adv., Hollywood.

SEAL COTE Co., Hollywood, Calif., Seal Cote nail protector. S-N Agency: Milton Weinberg Adv., L. A.

SEALTEST, Inc., New York, Milk & Ice Cream. N. TV. Agency: N. W. Ayer & Son, N. Y.

SEALY Inc., Mattress. N. Agency: Ollian Adv., Chicago.

SEARS, ROEBUCK & Co., Chicago (mail order & retail stores). S. TV. Agency: Roche, Williams & Cleary Inc., Chicago.

SEASIDE OIL Co., Santa Barbara (petroleum products, accessories). R. Agency: McCarty Co., L. A.

SEASONETTE DISTRIBUTING AGENCY, Pasadena, Calif., Seasonettes.

SEATTLE BREWING & MALTING Co., Seattle, Sick's Beer. N. Agency: Western Agency, Inc., Seattle.

LAURA SECORD CANDY SHOPS, Toronto. Agency: Cockfield, Brown & Co., Toronto.

SECURITY FIRST NATIONAL BANK OF LOS ANGELES, Savings Bonds. S. Agency: Foote, Cone & Belding, Hollywood.

SEEK & KADE, Inc., New York, Pertussin. N. S. Agency: Erwin, Wasey & Co., N. Y.

SEEMAN BROS., Inc., Philadelphia, Airwick, White Rose Food products. S. N. TV. Agencies: William H. Weintraub, Inc., N. Y.; J. D. Tarcher & Co., N. Y.

SEIBERLING RUBBER Co., Akron. S. Agency: Meldrum & Fewsmith, Cleveland, D-C.

DAVID O. SELZNICK AND VANGUARD FILMS, Inc., Culver City, Calif., Selznick pictures. S. & N. Agencies: Foote, Cone & Belding, Hollywood; Robert Orr & Assoc., N. Y.

R. B. SEMLER, Inc., New Canaan, Conn., Kreml Hair tonic & shampoo. S-N. Agency: Erwin, Wasey & Co., N. Y.

SENN PRODUCTS Corp., Brooklyn, N. Y., Sambo chocolate drink. Agencies: Tracy Kent, Inc., N. Y.; Morris Adv., Brooklyn.

SENTINEL RADIO Corp., Evanston, Ill., home and portable radios. Agency: W. W. Garrison & Co., Chicago.

SERUTAN Co., New York, Jersey City, Serutan-Nutrex. N. Agency: Roy S. Durstine Inc., N. Y.

SERTA ASSOC. Inc., Chicago, Bedding. Agency: Advertising Agency Asso., Chicago.

SERVEL, Inc. Evansville, Ind., Refrigerators and Air Conditioning. N. Agency: BBDO, N. Y. D-C.

SEWALL PAINT & VARNISH Co., Kansas City, paint and varnish. Agency: Philips-Reick Fardon Adv., Kansas City.

W. A. SHEAFFER PEN Co., Ft. Madison, Iowa, Pens, Pencils & Skrip Ink. N. TV. Agencies: Russel M. Seeds, Chicago; W. W. Garrison & Co., Chicago.

W. A. SHEAFFER PEN Co. of Canada Ltd., Toronto. Agency: R. C. Smith & Son Ltd., Toronto.

Peron, Chicago.

SHED BARTUSH FOODS, Detroit, Keyko Margarine. N. Agency: Clark & Rickard Inc., Detroit.

SHEFFIELD BRICK & TILE Co., Sheffield, Iowa, Farm drainage tile, building tile, common brick, face brick and other clay products. R. Agency: W. D. Lyon Co., Cedar Rapids, Iowa.

SHEFFORD CHEESE Co., Chicago, Cheese. S. Agency: Leo Burnett Co., Chicago.

SHELL OIL Co., New York, Gasolines, motor oil, fuel oil. S. Agency: J. Walter Thompson, N. Y.

SHELL OIL Co., Toronto, Gas & oil. S. Agency: J. Walter Thompson Co., Toronto.

SHERMAN BROS. RAINWEAR Inc., New York. Agency: Sterling Adv., N. Y.

SHERWIN-WILLIAMS Co., Cleveland, Paint. N. Agencies: Newell-Emmett Co., N. Y.; Henri, Hurst & MacDonald Inc., Chi.; Griswold-Eshleman Co., Cleveland; Fuller & Smith & Ross, Cleveland. D-C.

SHIPSTEAD & JOHNSON, N. Agency: Smith, Bull & McCreery, Hollywood.

SHIRIFF'S Ltd., Toronto (food products). Agency: Cockfield, Brown & Co., Toronto.

S. A. SHONBRUNN & Co., New York, Savarin Coffee. N. and S. Agency: Roy S. Durstine Inc., N. Y.

SHONTEK Corp., Los Angeles, hair conditioner and shampoo. N. Agency: Barton A. Stebbins, L. A.

SHOTWELL MFG. CO., Chicago. Agencies: C. Wendel Muench & Co., Chicago; Wade Adv. Agency, Chicago.

SHUPTINE Co., Savannah, Tetterline. S. Agency: Harvey-Massengale Co., Atlanta.

SIERRA CANDY Co., San Francisco, candy. N. Agency: Robert B. Young, San Francisco.

SIGNAL OIL Co., Los Angeles, petroleum products. S. N. TV. Agency: Barton A. Stebbins Adv., L. A.

SIMMONS Co., N. Y. (electronic blanket) S. N. TV. Agencies: Geyer, Cornell & Newell, N. Y.; Young & Rubicam, N. Y. D-C.

SIMONIZ Co., Chicago, car polish. N. Agencies: Decora Inc., Chi.; Irwin Vladimir Co., Chi.

ROBERT SIMPSON Co., Toronto, National department store chain. N. S. Agencies: Harry E. Foster Agencies; Locke Johnson & Co., Toronto; Associated Broadcasting Co., Montreal.

SINCLAIR REFINING Co., New York, Sinclair H-C and Ethyl gasoline. N. S. Agency: Hixson-Jorgensen, N. Y. D-C.

SITROUX, Inc., New York, facial tissues, paper napkins, sanitary napkins, toilet tissue. Agency: Franklin Bruck, N. Y.

SKELLY OIL Co., Kansas City, Skelgas service, appliances, motor oils and greases, gasoline, tires, batteries. N. Agency: Henri, Hurst & MacDonald, Chi. D-C.

SKINNER MFG. Co., Omaha, macaroni, falsin bran. S. Agency: Bruce Brewer Co., Kansas City.

SLOAN, DR. EARL R., Inc., New York, Sloan's Lintiment. S. N. Agencies: Wesley Assoc., N. Y.; Warwick & Legler, Inc., N. Y.

W. & J. SLOANE, Beverly Hills, home furnishings. S. Agency: William & John Adv., Beverly Hills, Calif.

SMART & FINAL Co., Los Angeles, S&F Foods, Table Queen Foods. R. Agency: Heintz & Co., L. A.

ALEXANDER SMITH & SONS CARPET Co., Yonkers, N. Y., rugs, carpets. S. TV. Agency: Anderson, Davis & Platte, N. Y.

SMITH BROS., Inc., Poughkeepsie, N. Y., Smith Bros. Cough Drops. S. Agency: Sullivan, Stauffer, Colwell & Bayles, N. Y.

SNOW CROP MARKETERS, Inc. New York (Snow Crop Frozen Foods). N. S. Agency: Maxon Inc., N. Y.

SOCONY VACUUM OIL Co. (Lubrite Div.), St. Louis, Mobilgas, Mobiloil, Bug-a-boo, Tavern household products. S-N Agency: Compton Adv., N. Y.

SOCONY-VACUUM OIL Co., Inc. (Wadhams Div.), Milwaukee, Petroleum products, household products, tires, batteries and accessories. S. Agency: Compton Adv. Inc., Milwaukee.

SOCONY VACUUM OIL Co., Toronto. S. N. Agency: Cockfield, Brown & Co., Toronto.

SOFWASH Co., Chicago, Sofwash cleaner. S and N. Agency: Newby &

SOLARINE Co., Baltimore, silver polish, S. Agency: Courtland D. Ferguson, Inc., Wash., D. C.

SONORA RADIO & TELEVISION Corp., Chicago, radio receivers, S. Agency: Robert Kahn & Assoc., Chicago, D-C.

SOUTH TEXAS COTTON OIL Co., Houston, Tex., Crustene Shortening, S. Agency: Steele Adv. Agency, Houston.

SOUTHEASTERN MICHIGAN TOURIST & PUBLICITY ASSN., Detroit, Mich., Tourist attractions of Michigan, S. Agency: Powell-Grant Adv., Detroit.

SOUTHERN CALIFORNIA TELEPHONE Co., Los Angeles, S. Agency: The Mayers Co., Los Angeles.

SOUTHERN COTTON OIL Co., New Orleans, Wesson Oil & Snowdrift, N. Agencies: Fitzgerald Adv. Agency, New Orleans; Duane Jones Co., N. Y.

SOUTHERN PACIFIC Co., San Francisco, Railroad transportation, Agency: Foote, Cone & Belding, S. F.

SOUTHERN SPRING BED Co., Atlanta, Ga., Beds & Bedding, N. Agency: Tucker Wayne & Co. Inc., Atlanta.

SOUTHGATE FOODS, Norfolk, Va., Red Mill peanut butter, R. Agency: W. Wallace Orr Inc., Philadelphia.

SOUTHLAND PRODUCTS Co., Los Angeles, Lyk-Nu Carwax, S. Agency: Atherton & Co., Hollywood.

SOY FOOD MILLS, Inc., Chicago, Ill., Golden Mix for griddle cakes and waffles, Agency: Jim Duffy Co., Chi.

SPARKLETS DRINKING WATER Corp., Los Angeles, S. Agencies: McNeill & McCleary, L.A.; Robt. F. Dennis Adv. L.A.; Raymond R. Morgan Co., Hollywood.

A. G. SPALDING & BROS., New York, Sports equipment, S and N, Agencies: Hanly, Hicks & Montgomery, N. Y.; American Sports Adv., N. Y.

SPERRY DIV.-GENERAL MILLS INC., San Francisco, Flour, Cereal, N. Agency: Knox-Reeves Adv., S. F.

SPRATT'S PATENT Ltd., New York, dog and cat foods, S. Agency: Paris & Peart, N. Y.

SPRING HILL NURSERIES, Tipp City, Ohio, Nursery stock, S. Agency: Don Kemper Co., Dayton.

E. R. SQUIBBS & SONS, New York, Tooth Powder, Dental Cream & Pharmaceutical Products, N. Agencies: Wm. Douglas McAdams; Wildrick & Miller Inc.; J. Walter Thompson, N.Y.; A. McKim Ltd., Toronto; Newell-Emmett Co., N. Y.; BBDO, N.Y.

SQUIRT Co., Beverly Hills, Calif. (beverage), Agency: Harrington, Whitney & Hurst, L.A. D-C.

FRANK STACK HATS, Inc., South Norwalk, Conn., men's fur felt hats, S. Agency: John A. Cairns, Inc., N.Y.

STAHL-MEYER, New York, meat products, S. Agency: Blaker Adv. Agency, N.Y.

STANBACK Co., Ltd., Salisbury, N. C., Stanback Headache Powders, S. Agency: Piedmont Adv. Agency, Salisbury, N. C.

STANCO Inc., New York, Flit, R. S. Agency: McCann-Erickson, N.Y.

STANDARD BRANDS, Inc., New York, Tender Leaf Tea and Royal Gelatin desserts, Chase & Sanborn coffee, Fleischman's Yeast, N. Y., S. Agencies: J. Walter Thompson, N.Y.; Ted Bates, Inc., N.Y.; Dancer-Fitzgerald-Sample, N.Y.; Wildrick & Miller, N.Y.; Leo Burnett Co., Chi.; L. H. Hartman Co., N.Y.; Bisferne Adv. Co., Chi.

STANDARD BRANDS LTD., Montreal (Magic Baking Powder), S. Agency: J. Walter Thompson Co., Montreal.

STANDARD LABS., New York, Sloan's liniment, S. Agencies: Wesley Assoc., N.Y.; Kieswetter, Wetterau & Baker, N.Y.; Robt. Blake Co., N.Y.; Al Paul Lefton Co., N.Y. D-C.

STANDARD OIL CO. OF CALIF., San Francisco, Petroleum products for farm use, Product advertising S & N Agencies: BBDO, S. F. D-C.

STANDARD OIL CO. OF INDIANA, Indiana, Oil, S. R. TV Agencies: McCann-Erickson, Chi.; BBDO, Chi.

STANDARD OIL CO. OF N. J., New York, Petroleum tires, batteries, accessories, S. Agency: McCann-Erickson Inc., N.Y. D-C.

STANDARD PAINT & VARNISH CO. Ltd., Windsor, Ont., S. Agency: McGuire Adv. Ltd., Windsor.

STANDARD REMEDY Co., Baltimore, OSR-stomachic and laxative, Agency: Redfield-Johnstone, N. Y.

STAR OUTFITTING Co., Los Angeles, Retail clothing chain, TV. Agency: The Mayers Co., L.A.

THE STARKIST Co., San Antonio, Flo-tation toothpaste, toothpowder, brushless shave cream, lather shave cream, B-Complex Vitamins, Agency: Pitluk Adv. Co., San Antonio.

STATLER TISSUE Co., Somerville, Mass., toilet tissue, household (roll) towels, S. Agency: Chambers & Wiswell, Boston.

STAZE, Inc., New York, denture adhesive, S and N, Agency: Duane Jones Co., N.Y.

STERLING DRUG, Inc., New York, Drugs, N. Agencies: Dancer-Fitzgerald-Sample, N.Y.; Sherman & Marquette, Chicago; Thompson-Koch Co., N.Y.; Foreign Adv. & Service Bureau, N.Y.

A. STEIN & Co., Chicago, Paris garters, suspenders, belts, TV. Agency: Louis A. Smith, Chicago.

STEWART-WARNER, Chicago, Agency: O'Grady-Andersen, Chicago.

STOKELY-VAN CAMP, INC., Indianapolis, Tenderoni and other Van Camp Products, N. Agencies: Calkins & Holden, N.Y.; Kelso Norman Agency, S.F.; Dancer-Fitzgerald-Sample, Toronto, D-C.

STRATHMORE PRODUCTS Co., New York, Agency: Irving Rosen Adv., N. Y.

W. F. STRAUB & Co., Chicago, Honey Mellowed Prune Juice, S. Agency: Mitchell-Faust Co., Chicago.

STREET & SMITH PUBLICATIONS, New York, magazine publishers, S. Agency: Hanly, Hicks & Montgomery, N.Y.

STRIETMANN BISCUIT Co., Cincinnati, R. Agency: Harry M. Miller, Inc. Columbus, Ohio.

THE STROH BREWERY Co., Detroit, Mich., Stroh's Bohemian beer, N. Agency: Zimmer-Keller, Inc., Detroit.

STROMBERG-CARLSON Co., Rochester, N. Y., radios, radio-phonographs, FM and television, R. Agencies: Federal Adv. Agency, N.Y.; Charles L. Rumrill & Co., Rochester; Casler, Hempstead & Hanford, Rochester, D-C.

JOHN STUART SALES Co., Toronto (Edgeworth Tobacco) S. Agency: F. H. Hayhurst & Co., Toronto.

THE STUDEBAKER Corp., South Bend, Ind., Motor Cars and Trucks, S. Agency: Roche, Williams & Cleary, Chi. D-C.

STUDIO GIRL SHAMPOO MFRS., Los Angeles, Shampoo, S. Agency: Morgan Adv. Agency, Phoenix.

SUCCESS PUBLICATIONS, Chicago, Books, N and S Agency: Bozell & Jacobs, Chi.

SUFFOLK FARMS PACKING Co., Boston, vegetable products, R. Agency: Hirshon-Garfield, Boston.

R. G. SULLIVAN, Inc., Manchester, N. H., 7-20-4 and Dexter cigars, S. Agency: J. P. Cox, Inc., Boston.

SUN OIL Co., Philadelphia, Sunoco Dynafuel, oil, automotive products, tires, batteries and accessories, Sun-heat fuel oil, Agencies: Roche, Williams & Cleary, Phila.; Gray & Rogers, Phila. D-C.

SUNNYBANK MARGARINE, San Francisco, TV, Agency: McCann-Erickson, San Francisco.

SUNNYVALE PACKING Co., San Francisco, Rancho soups, S. Agency: Long Adv. Service, S.F.

SUNSET OIL Co., Pacific Coast Independent Petroleum Co., S. Agency: David S. Hillman, Inc., L.A.

SUNSHINE BISCUIT Co., N. Y. S. Agency: Newell-Emmett Co., N.Y. D-C.

SUPERIOR FEED MILLS, Oklahoma City, Okla., livestock, poultry feeds, N. (Okla. only) Agency: James R. Reese Adv. Co., Kansas City.

SUPERTEST PETROLEUM, Inc., London, Ont., gasoline, S. Agency: Harry E. Foster Agencies, Toronto.

SUTCLIFFE & BURGHAM of Canada, Toronto, Savory food products, Agency: McLaren Adv. Co., Toronto.

SWEETS CO. OF AMERICA, Hoboken, N. J., Tootsie Rolls, Tootsie VM, Tootsie Fudge, N. S. Agencies: Duane Jones, N.Y.; Mosell & Eisen, N.Y.

SWIFT & Co., U. S. Yards, Chicago, Swifts Premium Ham and Bacon, Brookfield Sausage, Prem, Brookfield Butter, Eggs, Cheese, Ice Cream, All-sweet, Jewell Shortening, Bland Lard, Morton Salt, N. S. TV Agencies: J. Walter Thompson Co., Needham, Lewis & Brorby, McCann-Erickson and Foote, Cone & Belding, all Chicago, D-C.

SWIFT CANADIAN Co., Ltd., Toronto (meats, dairy products) R. Agency: J. Walter Thompson, Toronto.

IT SELLS!

IS ANY OTHER
STATEMENT NECESSARY?

WOSC

FULTON, N. Y.

THE VOICE OF OSWEGO COUNTY

1000 W

1300 Kc

DON J. KESTERKE, PRES.

GERALD MAYER, VICE-PRES.

JOSEPH HERSHEY MCGILLVRA, INC.

NATIONAL REPS.

T

TABLE PRODUCTS, Inc., Oakland, Calif. NuMade Mayonnaise, Agency: Foote, Cone & Belding, San Francisco.

(Continued)

DIRECTORY OF NATIONAL AND REGIONAL ADVERTISERS

(Continued)

TAPPIN'S JEWELERS, Newark, N. J., Jewelry, watches, hearing aids, optical, radios, appliances. S. Agency: F. R. Waxman Adv., Newark.

TAYLOR BEDDING MFG. Co., Taylor, Tex., "Morning Glory" Mattresses, "Tul-Cotton" Mattresses, "Taylor Made" Quilt & Comfort Batts. N. Agency: Rogers & Smith, Dallas, Texas.

TAYLOR-REED Corp., Mamaroneck, N. Y. (Cocoa Marsh Q-T pie crust) TV. Agencies: Ruthrauff & Ryan, N.Y., Tracy-Kent Co., N.Y., St. Georges & Keyes Inc., Stamford, Conn. & N.Y.

TEENTIMERS, Inc., New York, Dresses and Cosmetics. N. Agency: Buchanan & Co., N. Y.

TENNESSEE COAL, IRON AND RAILROAD Co., Birmingham, U.S.S. American Fence, U.S.S. Tennessee V-Drain Roofing. S. Agency: BBDO, Pittsburgh.

TEXAS CHIROPRACTIC COLLEGE, San Antonio, education.

TEXAS Co., New York, gasoline. N. TV. Agencies: Buchanan & Co.; Kudner Agency; Erwin, Wasey & Co.; Newell-Emmett Co., all N.Y.

TEXAS GULF SULPHUR Co., Houston, R.

TEKSUN CITRUS EXCHANGE, Weslaco, Tex. (Citrus fruits). N. S. Agency: W. B. Geissinger & Co., L.A.

TEXTRON, Inc., New York, Cotton Goods. N. TV. Agency: J. Walter Thompson, N. Y.

THEOBALD INDUSTRIES, Kearney, N.J. S. Agency: Franklin Bruck Adv., N.Y.

THERMODYNE CORP. (Carrier Air Conditioning) S. Agency: Van Diver & Carlyle, N.Y.

RICHARD E. THIBOUT Inc., New York, Wallpaper mgr. R. TV. Agency: Jackson & Co., New York.

THIS MONTH Magazine, New York, magazine. S. Agency: H. C. Morris & Co., N. Y.

TIDEWATER OIL Co., New York, Oil. N. TV. Agencies: Lennen & Mitchell, N. Y.; G. M. Basford Co., N. Y.

TIDEWATER OIL Co., Toronto (Veedol Motor Oil) S.R. Agency: James Fisher Co. Ltd., Toronto.

TIDY HOUSE PRODUCTS Co., Des Moines, cleaners and polishers. Agency: Ben Sackheim Inc., N. Y.

TILFORD RESTAURANT, Los Angeles. Agencies: Atherton & Co., Hollywood; A. James Rouse Co., Los Angeles.

TILLAMOOK COUNTY CREAMERY Assoc., Tillamook, Ore., Cheese. N. Agency: Botsford, Constantine & Gardner, Portland, Ore.

TIME, Inc., New York, Time Magazine. N. Agency: Young & Rubicam, N. Y.

TIP TOP TAILORS, Ltd., Toronto, Ontario, Clothes for men and women. Agency: McConnell, Eastman & Co., Ltd., Toronto.

TIVOLI BREWING Co., Detroit, Mich., Atlas Lager Beer. S. Agency: McCann-Erickson, Detroit.

TONI, Inc., St. Paul, Minn., hair wave. N. TV. Agency: Foote, Cone & Belding, Chi. D-C.

TONI CORP., Toronto, N. Agency: Spitzer & Mills, Toronto.

TOWNE TALK Co., L.A. (Towne Pride Toppings Flavoring) N. Agency: Mel Smith Adv., L.A.

J. R. TOWNSEND INC., San Diego. Auto, radio distributors. R. Agency: Tullis Co., San Diego.

TRANSMIRRA PRODUCTS CORP., N.Y. (Television filters) TV. Agency: Conti Adv., N.Y.

TRANS-WORLD AIRLINES, Kansas City, Mo. S. Agency: BBDO, N.Y.

TRAUBEE PRODUCTS, Inc., Brooklyn. Pressure cookers. Agency: Ray Hirsch Inc., N.Y.

TRIANGLE PUBLICATIONS, New York. Seventeen, Official Detective Stories. N. Agency: Al Paul Lefton Inc., N.Y.

TRIMOUNT CLOTHING Co., New York. Clipper Craft clothes for men. N. TV. Agency: William H. Weintraub & Co., N.Y. D-C.

JOHN F. TROMMER INC., Brooklyn. (Trommer's Beer) S. TV. Agency: Federal Adv., N.Y.

TRUSCON LABS., Caniff & Grand Trunk R. R., Detroit. Paratex, floor coating, floor dye. Agency: Wolfe, Jickling, Dow & Conkey, Detroit.

TRUVAL MFG. Inc., New York. Shirts & sportswear. Agency: McCann-Erickson Inc., New York.

TUCKETT LTD., Hamilton (cigarettes & tobacco). S. Agency: MacLaren Adv., Toronto.

TURCO PRODUCTS, Inc., Los Angeles Turco & Tay Cleaning Compounds. Agency: Botsford, Constantine & Gardner, Los Angeles.

20TH CENTURY-FOX FILM Corp., New York, Moving Pict. S. Agency: Kayton-Spiro Co., N. Y.

U

UNICORN PRESS, N. Y., N. Agency: Leonard Adv., N. Y.

UNION OIL CO. OF CALIFORNIA, Los Angeles. N. TV. Agency: Foote, Cone & Belding, L. A.

UNION PACIFIC RAILROAD, Omaha, Institutional. N. Agency: Caples Co., Chicago.

UNION PHARMACEUTICAL CO. Inc., Bloomfield, N. J., Saraka. S. Agency: Abbott Kimball Co., N. Y.

UNION STARCH & REFINING Co., Columbus, Ind., Pennant syrup. Agency: Caldwell-Baker Co., Indianapolis.

UNITED AIRLINES, Chicago. S. TV. Agency: N. W. Ayer & Son, Chicago.

UNITED ARTISTS, moving pictures. S. Agencies: Buchanan & Co., N. Y.; Lawrence Fertig & Co., N. Y.; Mal Boyd & Assoc., Hollywood; Foote, Cone & Belding, N. Y.

UNITED CIGAR-WHELAN DRUG STORES CORP., Drugs. S-N Agency: Stanton B. Fisher Inc., N.Y.

UNITED FRUIT Co., Boston, Fruit. S. Agencies: BBDO, N. Y.; Wendell P. Colton, N. Y.

UNITED FRUIT Co., New York, Fruit. S. Agency: Wendell P. Colton Co., N. Y.

UNITED STATES ARMY & AIR FORCE RECRUITING SERVICE, Wash. D. C. N. TV. Agencies: N. W. Ayer & Son, N. Y.; Gardner Adv., St. Louis.

UNITED STATES COAST GUARD, Recruiting Drive. Agency: Newell-Emmett, N. Y.

UNITED STATES RUBBER Co., New York. N. TV. Agencies: Campbell-Ewald Co., N. Y.; Fletcher D. Richards Inc., N.Y., D-C.

UNITED STATES STEEL Corp., New York, Steel. N. Agency: BBDO, N. Y.

UNITED STATES TOBACCO Co., New York. (Model, Tweed, Old Briar, Dill's Best). N. TV. Agency: Kudner Agency, N. Y.

UNITED WALLPAPER, Inc., Chicago (Varlar Div.). Trimz Ready-Pasted Wall Paper. Agencies: MacFarland-Aveyard & Co., Chi.; MacLaren Adv., Toronto.

UNIQUE ART MFG. CO., Newark, N. J. (mechanical toys). N. TV. Agency: Grant Adv. Inc., N. Y.

UNIVERSAL CARLOADING & DISTRIBUTING CO., New York. N. Agency: Raymond Spector Co., N. Y.

UNIVERSAL MATCH Corp., St. Louis. Agency: Westheimer & Co., St. Louis.

UNIVERSAL PICTURES Co., New York. Agency: Monroe Greenthal Inc., N. Y.

UTILITIES ENGINEERING INSTITUTE, Chicago, Ill. Agencies: First United Broadcasters, Chi.; The Phil Gordon Agency, Chi.

V

VAN HEUSEN SHIRTS, TV. Agency: Grey Adv., N.Y.

VELLO PRODUCTS, Lyndonville, Vt. Vello. S. Agency: Badger & Browning, Boston.

VELMONT OF CANADA, Windsor, Ont. (Anacin). Agency: Young & Rubicam, Toronto.

VEGETABLE JUICE & PRODUCTS Co., Rochester, N. Y., Viv-Juice & Ta Superior Wheat Germ. S.

VESS BEVERAGE Co., St. Louis. Whistle, Vess Cola, Bubble Up. S. Agency: Olian Adv. Co., St. Louis. D-C.

VICK CHEMICAL Co., New York. Vick Products. N. S. TV. Agency: Morse International, N.Y.

VICK CHEMICAL Co., Toronto, Cough Drops. S. Agency: Morse International N. Y.

VIOBIN Corp., Monticello, Ill. Rex Wheat Germ Oil. N-S. Agency: Borton Adv., Monticello.

VOICE OF PROPHECY, Inc. (Seventh Day Adventist Church Radio Commission), Washington, D. C., Religious talks and music, Free Radio Bible Correspondence Course. N. & S. Agency: George C. Hoskin Assoc., Chi.

W

W. B. ASSOC., New York, Softol cuticle sets. S. Agency: Slans & Maury, N.Y.

WAIT-CAHILL Co., Decatur, Ill., Wait's Green Mt. Cough Syrup & G-M Lintiment. S. Agency: Wade Adv., Chicago.

WALGREEN DRUG Co., Chicago. Drugs. S. TV. Agency: Schwimmer & Scott, Chicago.

WALKER'S AUSTEX CHILI Co., Austin Tex., Mexene Chili powder seasoning. S. Agency: Crook Adv. Agency, Dallas.

WALTHAM WATCH Co., Waltham, Mass. Watches. N. Agency: Kastor, Farrell, Chesley & Clifford, N.Y.

WANDER Co., Chicago. Ovaltine. N. Agency: Hill Blackett & Co., Chicago.

WARD BAKING Co., New York, Bread & Cake. N. Agency: J. Walter Thompson Co., N. Y.

WARNER BROS. PICTURES, New York, moving pictures. S. Agency: Blaine-Thompson Co., New York.

WM. R. WARNER DRUG Co., N. Y. (Richard Hudnut and other beauty products.) N. Agency: Kenyon & Eckhardt, N.Y.

WASHINGTON COOPERATIVE FARMERS Assoc., Seattle. Lynden, Wash. Co-op., Farmer-cooperative Marketing & Purchasing agent for farmer members. N. & S. Agency: Pacific Natl. Adv. Agency, Seattle.

G. WASHINGTON COFFEE REFINING Co., Morris Plains, N. J. S. Agency: W. Earl Bothwell Inc., Pittsburgh.

WASHINGTON STATE APPLE ADV. COMMISSION, Wenatchee, Apples. N. Agency: J. Walter Thompson, Seattle.

WASHINGTON STATE FRUIT COMMISSION, Seattle. Peaches, Bartlett pears & prunes. S. Agency: Pacific National Adv., Seattle.

L. E. WATERMAN Co., New York, Fountain Pens, Pencils and Ink. N. Agency: Charles Dallas Reach Co., N. Y.

WELCH GRAPE JUICE Co., New York. N. Agencies: Buchanan & Co., N. Y., & S. F.; Lennen & Mitchell, N. Y.

WENE CHICK FARMS, Vineland, N. J. Hatchery. S. Agency: Shaffer, Brennan, Margulis, St. Louis.

WENZEL TENT & DUCK Co., St. Louis. Agency: Olian Adv. Co., St. Louis.

M. WERK Co., Cincinnati. (Soap). R. Agency: Ralph H. Jones Co., Cincinnati.

WESCO WATERPAINTS, LTD., Montreal, Canada, R. S. Agencies: T. O'Connell Co., N. Y.; Walsh Adv., Montreal.

WESSON OIL & SNOWDRIFT SALES Co., New Orleans. R. N. Agencies: Kenyon & Eckhardt, N.Y.; Fitzgerald Adv. Agency, New Orleans; Duane Jones Co., N. Y.

WEST COAST SOAP Co., Oakland, Calif. Powow Cleanser. N. Agency: Brisacher, Wheeler & Staff, S.F.

WESTERN HARNESS RACING ASSN., Los Angeles. Harness racing. S. Agency: Smith, Bull & McCreery Adv., Hollywood.

WESTERN NEW YORK MOTOR LINES, Inc., Batavia, New York. Blue Bus Lines. S. Agency: Hart-Conway Co., Inc., Rochester.

WESTERN STATIONERY Co., Topeka, Kan., stationery, novelties. S. Agency: Shaffer, Brennan, Margulis Agency, St. Louis.

WESTERN STOVE Co., Culver City, Calif. (Institutional) deluxe six-burner gas range. S. Agency: Mays & Bennett Adv., L.A.

WESTINGHOUSE ELECTRIC Corp., Pittsburgh, Pa., Electrical goods. N. Agencies: McCann-Erickson, Inc., N. Y.; Fuller & Smith & Ross, Cleveland. D-C.

GEORGE WESTON LTD., Toronto, (biscuits). N.S. Agencies: Alford R.

Poyntz Adv., & Harry E. Foster Agencies Ltd., Toronto.

WETALENE LAB., Columbus, Ohio, household cleaner. S. Agency: Byer & Bowman, Columbus.

WHELAN DRUG STORES, New York. N. TV. Agency: Stanton B. Fisher Inc., New York.

WHITE LABS, INC., Newark. Medical products, Aspergum, Vitamin B tablets, etc. Agencies: Harry C. Phiffs Adv., Chi.; Lawrence I. Everling Adv., Phila.; Robert Otto & Assoc., N.Y. (export adv.)

WHITE LABS., Toronto, Feenamint. S. Agency: Baker Adv. Agency, Toronto.

WHITE KING SOAP CO., L.A. R. Agency: Raymond R. Morgan Co., Hollywood.

THE S. S. WHITE DENTAL MFG. Co., Philadelphia, Oraline tooth paste and powder and mouth wash (mouth specialties). N. S. Agencies: Clements Co., Phila., Peterson & Kempner, N.Y.

WHITE ROCK CORP., N.Y. Mineral water & ginger ale. S. Agency: Kenyon & Eckhardt, N.Y.

WHITEHALL PHARMACAL Co., New York, Anacin and Hill's cold tablets, Heet, Bisodol & Kolynos Toothpaste. N. S. TV. Agencies: Sullivan, Stauffer, Colwell & Bayles, N.Y.; Dancer-Fitzgerald-Sample, N.Y.; Duane Jones Co., N.Y.; Donahue & Coe Inc., N.Y.; Joseph Katz Co., N.Y.; Street & Finney Inc., N.Y.; Hanly, Hicks & Montgomery, N.Y.; John F. Murray Inc., N.Y.; Benton & Bowles, N.Y.

WHITEHALL PHARMACAL Co. (Canada), Walkerville, Ont. Agency: Young & Rubicam, Toronto.

WILCO Co., Los Angeles. Clearax. Bif. R. S. Agency: Elwood J. Robinson Adv., Los Angeles.

WILCOX-GAY Corp., Charlotte, Mich. Recordio. Agency: Cramer-Krasselt, Milwaukee, D-C.

WILDFROOT Co., Buffalo. Hair tonic. N. S. TV. Agency: BBDO, Buffalo & Hollywood.

JOHN H. WILKINS Co., Wash. D. C., coffee, tea. N-S. Agency: Lewis Edwin Ryan, Wash.

OSCAR H. WILL & CO., Bismarck, N. D., Field, garden, nursery seed and greenhouse merchandise. S. Agency: Lessig Adv., Des Moines.

WILLARD TABLET Co., Chicago (proprietary). S. Agency: First United Broadcasters, Chicago.

THE WILLIAMS Co., Kokomo, Ind., Bouffant cleaning preparation. Agency: Caldwell-Baker Co., Indianapolis.

AL WILLIAMS HEALTH SYSTEMS, Los Angeles, Physical Culture. S. Agency: Western Adv. Agency, Los Angeles.

THE J. B. WILLIAMS Co., Glastonbury, Conn., Gilder Shaving Cream, Aqua Velva. N.S. TV. Agencies: J. Walter Thompson Co., N. Y.; Baker, Cameron, Soby & Penfield, Hartford.

WILLIAMSON CANDY Co., Chicago, O'Henry candy bars. N. Agency: Aubrey, Moore & Wallace, Chicago.

WILMINGTON FISH CANNERS Assn., Terminal Island, Calif., canned fish. S. Agency: Allied Adv. Agencies, Los Angeles.

WILSON SPORTING GOODS Co., Chicago. Sporting goods. N. Agency: Ewell & Thurber Assoc., Chicago.

WILSHIRE OIL Co., Los Angeles. Motor Oil. Agency: Dan B. Miner Co., Los Angeles.

WINE GROWERS GUILD, Lodi, Calif. S. TV. Agency: Honig-Cooper, S.F.

JOHN C. WINSTON Co., Philadelphia. Books. Agencies: Schwab & Beatty, N.Y.; Charles Blum Adv. Corp., Phila.

WM. H. WISE & CO. INC., New York, Publishers. N. Agencies: Huber Hoge & Sons, N.Y.; Thwing & Altman, N.Y.

WOOL NOVELTY Co., New York. Woolfoam. S. Agency: Redfield-Johnstone, N.Y.

WM. WRIGLEY JR. Co., Chicago. Chewing gum. N. TV. Agencies: Ruthrauff & Ryan, Chi.; Arthur Meyerhoff & Co., Chi.

WM. WRIGLEY JR. Ltd., Toronto. (chewing gum) N. Agency: Walsh Adv., Toronto.

CHAS. W. WRIGLEY Co., Chicago. Agency: Frances Hooper Adv., Chicago.

RUDOLPH WURLITZER Co., Chicago. Musical Instruments. N. Agency: Leo Burnett Co., Chicago. D-C.

RADIO CORRESPONDENTS GALLERIES OF CONGRESS

Elmer Davis, *Chairman*
William R. McAndrew, *Vice Chairman*

George E. Reedy, *Member-at-Large*
Rex R. Goad, *Member-at-Large*
Albert L. Warner, *Member Ex-Officio*

Francis W. Tully Jr., *Secretary*
Willard F. Shadel, *Treasurer*
Howard L. Kany, *Member-at-Large*

SENATE: D. Harold McGrath, *Supt.*
Senate Phone Branches: 1263-1264

Telephone: NAational 3120

HOUSE: Robert Menough, *Supt.*
House Phone Branches: 1410-1411

AMERICAN BROADCASTING CO.

724 14th St., N. W.
Martin Agronsky
Malcolm Allen
H. R. Baukhage
Jack Beall
Tris Coffin
William E. Coyle
Ruth Crane
Elmer Davis
Peg Eck
John Edwards
Alice Barry Freer
Arthur Gaeth
William R. P. Neel
Bryson Rash
Richard Rendell
Kenneth Romney Jr.
Albert L. Warner
Harrison Wood

ARROWHEAD NETWORK

1738 18th St., N. W.
George E. Reedy
KVOL LaFayette, La.; WEAU Eau Claire, Wis.; WEBC Duluth, Minn.; WHLB Virginia, Minn.; WISC Madison, Wis.; WJMC Rice Lake, Wis.; WMFG Hibbing, Minn.

ASSOCIATED PRESS RADIO

330 Star Bldg.
James S. Cannon
Anthony P. Catella
Fred S. Hoffman
Howard L. Kany

BAUKHAGE RADIO ASSOCIATES

1306 18th St., N. W.
Beatrice M. Gudridge
Virginia C. Shisler

BILL HENRY ASSOCIATES

Dorchester House
Washington, D. C.
Virginia Blum
William M. (Bill) Henry

BRITISH BROADCASTING CORP.

1150 Connecticut Ave., N. W.
Leonard Miall

CAPITAL BROADCASTING CO.

1000 Connecticut Ave., N. W.
Charles A. Wakeman

CENTRAL BROADCASTING CO.

National Press Club
Ralph E. Young

COLUMBIA BROADCASTING SYSTEM

854 Warner Bldg.
Griffing Bancroft
Charles Collingwood
George E. Connerly
Lawrence Haas
Lionel Horwitz
Allen Jackson
Theodore F. Koop
Stephen Laird
Elinor Lee
Robert Lewis
Claude A. Mahoney
Hazel Markel
Edwin Newman
Robert E. Nichols
Eric Sevareid
Willard F. Shadel
Lewis Shollenberger
Joe Wershba

CONTINENTAL NETWORKS

1319 F St., N. W.
Sherman Butler
Paul S. Green
Nelson M. Griggs

DUMONT TELEVISION NETWORK

(WTTG)
12th & E Sts., N. W.
Roger M. Coelos
Walter Compton
Donald C. Roper
Clarke Thornton
O. Gordon Williamson

ED HART & ASSOCIATES

1737 H St., N. W.
Eugene F. Hart
Edward Hart

ERWIN NEWS SERVICE

433 Star Bldg.
WBBO Forest City, N. C.; KPOJ Portland, Ore.; WBIG Greensboro, N. C.; WDNC Durham, N. C.; WGGA Gainesville, Ga.; WIS Columbia, S. C.; WJNO West Palm Beach, Fla.; WRUF Gainesville, Fla.; WTMA Charleston, S. C.
Julia G. Erwin
Roulhac Hamilton Jr.
J. A. Mock Jr.

KING SEATTLE, WASH.

KXLE ELLENSBURG, WASH.

KXLY SPOKANE, WASH.

1415 Tuckerman St., N. W.
Florence C. Hoff

KOMO SEATTLE, WASH.

KGA SPOKANE, WASH.

KGZ KALISPELL, MONT.

KPOA HAWAII

1090 National Press Bldg.
Rudolph Block

MIDLAND BROADCASTING CO.

(KMBC Kansas City)

KFRM CONCORDIA, KANS.

KOMA OKLAHOMA CITY, OKLA.

KSCJ SIOUX CITY, IOWA

KSO DES MOINES, IOWA

KTUL TULSA, OKLA.

KWK ST. LOUIS, MO.

877 National Press Bldg.
Walter L. Cronkite Jr.
Eileen Shanahan

MUTUAL BROADCASTING SYSTEM

1627 K St., N. W.
John E. Ballinger
Virginia Blum
Gail C. Bowlby
Bill Henry
Leslie W. Higbie
William Hillman
Fulton Lewis Jr.
Joe McCaffrey
Stephen J. McCormick
Signe O'Brien
F. S. Roosa
Hollis M. Seavey
C. Russell Turner Jr.
Charles Warren

NATIONAL BROADCASTING CO.

724 14th St., N. W.
Theodore A. Ayers
Arthur Barriault
Morgan Beatty
Bjorn Bjornson
Frank Bourgholtzer
David Brinkley
Ned Brooks
John Connolly
Leif Eid
John Ghilain
Lewie V. Gilpin
Earl Godwin
Julian Goodman
Frank C. Hanighen
Richard Harkness
Ray Henle
Cassius M. Keller
Helen J. Keller
William R. McAndrew
Robert McCormick
Felix Morley
Fred Morrison
Nancy Osgood
Walter Jay Royen
Ray L. Scherer

PACIFIC NORTHWEST BROADCASTERS

704 Southern Bldg.
KXL Portland, Ore.; KXLE Ellensburg, Wash.; KXLF Butte, Mont.; KXLJ Helena, Mont.; KXLK Great Falls, Mont.; KXLQ Bozeman, Mont.; KXLY Spokane, Wash.
Marion Wheeler Scott

CHARLES PARMER & ASSOC.

318 N. Washington St., Alexandria, Va.
STONEHOUSE NEWS AGENCY
410 Albee Bldg.
Merlin F. Stonehouse

THE UNITED BROADCASTING CO.

(WOOK)
1143 Conn. Ave., N. W.
Richard Eaton

TRANSRADIO PRESS SERVICE

1258 National Press Bldg.
Ann M. Corrick
Eduin Darby
Wallace R. Fanning Jr.
Rex R. Goad
Robert S. Horowitz
Betty Lersch
Robert E. Lee Moore
Macon Reed Jr.
Ronald J. W. Tighe

UNITED PRESS RADIO

705 National Press Bldg.
Alan E. Adams
Bryce Burke
Paul W. McCloskey
George J. Marder
Robert J. Serling
Helen Thomas

WASHINGTON REPORTERS INC.

1397 National Press Bldg.
WEAN Providence, R. I.; WICC Bridgeport, Conn.; WNAC Boston, Mass.; WONS Hartford, Conn.

YANKEE NETWORK

Jack R. Reed
Francis W. Tully Jr.
Irene Fox

WBCC BETHESDA, MD.

5 Wilson Lane, Bethesda, Md.
Paul A. Shinkman

WCBM BALTIMORE, MD.

411 N. Charles St., Baltimore, Md.
Ian Ross MacFarlane
Louise Anne MacFarlane

WCFM COOPERATIVE BROADCASTING ASSN.

1120 Connecticut Ave., N. W.
Louis Alken Jr.
George A. Bernstein
Olive E. Clapper
Imogene Putnam
S. W. Slappay

WEAM ARLINGTON, VA.

2030 N. 16th St., Arlington, Va.
Matthew Warren

WGAR CLEVELAND, OHIO

1524 29th St., N. W.
Katherine M. Halle

WGAY SILVER SPRING, MD.

Ernest Tannen

WINX WASHINGTON, D. C.

8th and I St., N. W.
WIOC TELEVISION (CBS-MBS)
40th & Brandywine St., N. W.
John Francis Hardesty

WPIK ALEXANDRIA, VA.

Virginia Theater Bldg., Alexandria
Robert J. McBride Jr.

WQQW WASHINGTON, D. C.

Nelson M. Griggs

WTAG WORCESTER, MASS.

724 14th St., N. W.
Gilbert T. Hodges

WWDC WASHINGTON, D. C.

1000 Connecticut Ave., N. W.
Irving Lichtenstein
Denis Sartain
W. Norman Reed

WWJ DETROIT, MICH.

4818 Woodway Lane, N. W., Washington
James G. Crowley

ASSOCIATE MEMBERS

AMERICAN ASSN. OF RADIO ANALYSTS

470 W. 24th St., New York, N. Y.
Charles Collingwood
Quincy Howe
Edward R. Murrow
Robert Trout
George Hamilton Combs
Charles Hodges
Cecil Brown
William Shirer
Paul Shubert
Leland Stowe
John W. Vandercok
Ned Calmer
W. W. Chaplin
H. V. Kaitenborn
John Macvane

AMERICAN BROADCASTING CO.

30 Rockefeller Plaza, N.Y.C.
Julian C. Anthony
A. Burke Crotty
J. Gordon Fraser
Pauline Frederick
John T. Madigan
Michael Roshkind
Thomas Velotta

COLUMBIA BROADCASTING SYSTEM

485 Madison Ave., N.Y.C.
Wells Church
John Charles Daly Jr.
Richard C. Hottelet
Sig Mickelson
Lowell Thomas
Jesse Zougmer

THE FRIENDLY GROUP RADIO STATIONS, STEUBENVILLE, OHIO

John J. Lutz
KFH WICHITA, KAN.
George E. Gow
KFVD LOS ANGELES, CALIF.
338 So. Western Ave.
J. F. Burke
KGFV LINCOLN 1, NEB.
Box 1564
George W. Kline
KMBC KANSAS CITY, MO.
Pickwick Hotel
Erle H. Smith

KOIL OMAHA, NEB.

Theodore L. Haas

KUOA SILOAM SPRINGS, ARK.

Storm Whaley

KVOO TULSA, OKLA.

Ken Miller

MUTUAL BROADCASTING SYSTEM

1440 Broadway N.Y.C.
Milton Burgh
Jack S. Paige
A. A. Schechter

NATIONAL BROADCASTING CO.

30 Rockefeller Plaza, N.Y.C.
Adolph J. Schneider
W. F. Brooks
Ann Gillis
Francis C. McCall
Joseph O. Meyers

TRANSRADIO PRESS SERVICE INC.

521 Fifth Ave., N.Y.C.
Herbert Moore
Beckley Smith
Dixon Stewart

TRAVELERS BROADCASTING SERVICE CORP.

26 Grove St., Hartford, Conn.
Tom Eaton
Andre Sotanker

WBT CHARLOTTE, N. C.

Wildor Bldg.
Jack Knell

WCBM BALTIMORE, MD.

Jerry Mares
Charles A. Roeder

WCOT ATLANTA, GA.

Lockwood Doty

WEGO CONCORD, N. C.

WAYN ROCKINGHAM, N. C.

WWNF FAYETTEVILLE, N. C.
Box 72, Concord, N. C.
Wayne M. Nelson

WGN CHICAGO, ILL.

Tribune Tower
Robert Hurligh

(Continued on page 397)

DIRECTORY OF NATIONAL AND REGIONAL ADVERTISERS

(Continued)

X

XZIT SOOT ERADICATOR, Los Angeles, soot eradicator. S and N Agency: Steller-Millar-Ebberts Adv., Los Angeles.

Y

YAGER LINIMENT Co., Baltimore, Liniment. S. Agency: Harvey-Massengale Co., Durham, N. C.

YORK KNITTING MILLS, Toronto, N. Agency: Cockfield, Brown and Co., Toronto.

YOUNG PEOPLE'S CHURCH OF THE AIR, Religious Talks. N. Agency: Alpha Adv., Phila.

W. F. YOUNG, Inc., Springfield, Mass., Absorbine Jr. Liniment. S. Agency: J. Walter Thompson, N. Y.

Z

ZEEMAN CLOTHING Co., Los Angeles. Apparel chain. R. Agency: C. Evers Whyte Agency, L.A.

ZENITH RADIO Corp., Chicago. Agency: Critchfield & Co., Chicago.

ZERBST PHARMACAL Co., St. Joseph, Mo., Zerbst capsules, Choloryne cough syrup. S. Agency: Allan Adv. Co., St. Louis.

ZIPPO MFG. CO., Bradford, Pa. (Pocket and table lighters). S. Agency: Geyer, Newell & Ganger, N.Y.

ZONITE PRODUCTS Corp., New York. Larvex, Zonite antiseptic. Argyrol and Ovoferin, Forhan's toothpaste. N. Agencies: Erwin, Wasey & Co., N.Y.; Gotham Adv., N.Y.

ZONITE PRODUCTS Corp., St. Therese, Quebec (Kreml). Agency: Erwin, Wasey & Co. of Canada Ltd., Toronto.

JOSEPH ZUKIN OF CALIF., Los Angeles, Women's Dresses. N.

AMERICAN BROADCASTING COMPANY INC.: EXECUTIVES and STAFF

RCA Bldg., 30 Rockefeller Plaza, New York 20, N. Y. Telephone: Circle 7-5700

BOARD OF DIRECTORS

Edward J. Noble, Chairman
Mark Woods, Vice Chairman
Earl E. Anderson
Alger B. Chapman
Robert H. Hinckley
Robert E. Kintner
C. Nicholas Priaulx
Franklin S. Wood
Owen D. Young

OFFICERS

Edward J. Noble, Chairman of the Board
Mark Woods, Vice Chairman
Robert E. Kintner, President
Earl E. Anderson, Vice President
Charles Barry, Vice President
Murray B. Grabhorn, Vice President
Robert H. Hinckley, Vice President
Ernest L. Jahncke, Vice President
Ivor Kenway, Vice President
Joseph A. McDonald, Vice President, Secretary & General Attorney
Frank Marx, Vice President
John H. Norton, Vice President
C. Nicholas Priaulx, Vice President & Treasurer
Robert Saudek, Vice President
Frank Samuels, Vice President
Fred Thrower Jr., Vice President
Thomas Velotta, Vice President
Paul Whiteman, Vice President
Ernest Felix, Assistant Treasurer
Anthony M. Hennig, Assistant Treasurer
Walter C. Tepper, Controller
Geraldine B. Zorbaugh, Attorney & Assistant Secretary

DEPARTMENTS & DIVISIONS

Advertising & Promotion, Research
Theodore I. Oberfelder, Director of Advertising, Promotion & Research
Mitchell DeGroot, Manager of Advertising & Promotion
Ben Gedalecia, Manager of Research

Engineering

Frank Marx, Vice President
James L. Middlebrooks, Chief Facilities Engineer
George O. Milne, Director of Technical Operations
Clure Owen, Administrative Assistant
John Preston, Chief Allocations Engineer
William R. Ahern, Television Operations Supervisor
William Trevarthen, AM Operations Supervisor

Legal

Joseph A. McDonald, Vice President, Secretary & General Attorney
Omar F. Elder, Attorney
David S. Smith, Attorney
Geraldine B. Zorbaugh, Attorney & Assistant Secretary

News & Special Events

Thomas Velotta, Vice President
John Madigan, Director of News
Michael Roshkind, Director of Special Events
Paul Scheffels, Assistant to Vice President
Harry Wismer, Sports Division

**Owned & Operated Stations, Co-operative Programs
Local & Spot Sales, Station WJZ**

Murray B. Grabhorn, Vice President
Harold Day, Director of Sales Development
Ralph Dennis, National Spot Sales Manager
Clarence L. Doty, Assistant to Vice President & Sales Manager WJZ & WJZ-TV
Concetta Porreca, Local & Spot Sales Service Manager
Earl Salmon, Eastern Spot Sales Manager
Ludwig Simmel, Manager of Co-operative Program Sales

Program

Charles C. Barry, Vice President in Charge of Programs—AM & TV
Paul Whiteman, Vice President in Charge of Music—AM
Leonard Reeg, Eastern Program Manager & Manager of WJZ Programming—AM
Alexander Stronach, Eastern Program Manager—TV
Richard Bannier, Director of Music Rights & Music Library—AM & TV
Anne Kelly, Manager, Announcing Office

Henry Cox, Eastern Production Manager—AM
Burke Crofty, Executive Producer—TV
Helen Guy, Manager of Program Department—AM
Helen Hedeman, Supervisor of Casting—AM
Charles F. Holden, Production Manager—TV
Ruth Kiersted, Production Office Supervisor—AM
Bertha Kurtzman, Broadcast Supervisor—TV
Harold Morgan, Business Manager—TV
Florence Morris, Manager of Central Booking—AM
Paul Mowrey, National Director of Program Sales—TV
Helen Grosskurth, Facilities Supervisor—TV
John C. Turner, Manager of Script & Program Promotion—AM & TV
Frank Vagnoni, Manager of Music Division—AM & TV

**Public Affairs—Continuity Acceptance, Publicity,
Public Service**

Robert Saudek, Vice President
Ruth Crawford, Librarian
Arthur B. Donegan, Manager TV Publicity
Ellen Heagerty, Supervisor of Audience Information
Grace Johnsen, Director of Continuity Acceptance
Earl Mullin, Publicity Director
John Pacey, Trade News Editor
Ruth Trexler, Manager of Religious & Educational Activities

Sales

Fred Thrower, Jr., Vice President
Ivor Kenway, Vice President in Charge of New Business
Charles T. Ayres, Eastern Radio Sales Manager
Slocum Chapin, Eastern Television Sales Manager
Maurice Gaffney, Director of Presentations
Thomas P. Robinson, Sales Service Manager

Stations—Station Relations, Traffic

Ernest Lee Jahncke, Jr., Vice President
Otto Brandt, National Station Relations Director
Raymond Diaz, Traffic Manager

**Finance, Purchasing, Office & Studio Services,
Personnel & Recording**

C. Nicholas Priaulx, Vice President & Treasurer
Henry T. Hede, Purchasing Agent & Office & Studio Services Director
Anthony M. Hennig, Assistant Treasurer & Budget Officer
Frederick Lynch, Jr., Director of Personnel
Lawrence A. Ruddell, Recording Director
Walter C. Tepper, Controller

WASHINGTON

1703 K Street
Washington, D. C.
Robert H. Hinckley, Vice President

CENTRAL DIVISION

20 North Wacker Drive
Chicago 6, Ill.

John H. Norton, Vice President
Robert L. Anderson, Research Supervisor
Robert Atwood, Sales Service Manager
Kenneth Christlans, Traffic Supervisor
Francis J. Coveney, Auditor
Wilbur Cummings, AM Engineering Operations Supervisor
Frances Dixon, Program Booking Supervisor
Walter L. Emerson, Legal Counsel
Clarence Heider, Supervisor of Announcers
Elliott Henry, Jr., Publicity Manager
E. C. Horstman, Engineering Manager
Donald Kilian, Director of Television Programs
Burr E. Lee, Production Manager
Jack McCord, Program Business Manager
Roy McLaughlin, Manager of Station WENR, National Spot and Local Sales Manager
Francis McNulty, Music Rights Supervisor
John J. Manley, Manager of Office & Studio Services
Cornelius O'Dea, News Supervisor
Robert M. Savage, Continuity Supervisor
James L. Stirton, General Manager and Sales Manager
Harold Stokes, Program Manager
Karl R. Sutphin, Sales Promotion Supervisor
James Valentine, TV Engineering Operations Supervisor
Gerald R. Vernon, Coordinator of Television Sales

WESTERN DIVISION

6363 Sunset Boulevard
Hollywood 28, Calif.

Frank Samuels, Vice President
Clifford Anderson, Program Business Manager
Dorothy L. Brown, Continuity Acceptance Editor
Philip G. Caldwell, Western Division Manager of Technical Operations
Francis Conrad, Western Division Station Relations Manager
Dresser M. Dahlstead, Chief Announcer
R. C. Denechaud, AM Engineering Operations Supervisor
John I. Edwards, Program Manager Western Division
Ernest Felix, Assistant Treasurer, Personnel Director, and Office Manager
Paul Gates, Evening Program Manager
Edward B. Hullinger, Publicity Manager
Francis LaTourette, Western Division News Editor
Robert F. Laws, Pacific Coast Sales Manager
Adolph Leifer, Recording & Sales Service Manager
Walter W. Lonner, Traffic Supervisor
Richard A. Moore, Assistant General Manager & Director of Television
J. Norman Nelson, Sales Promotion Manager
Cameron Pierce, TV Engineering Operations Supervisor
James T. Vandiveer, Western Division TV Field Director
Elwood C. Winckler, Television Production Manager

KECA

Clyde Scott, General Manager KECA
Amos T. Baron, Spot Sales Manager
Philip Booth, Television Program Director
Rollo Hunter, Production Manager

SAN FRANCISCO

Taylor & O'Farrell Streets
San Francisco 2, Calif.

Gayle Grubb, General Manager KGO
Maurice Baker, Promotion & Publicity Manager
David M. Crandell, Production Director
A. E. Evans, Engineering Manager
Vincent A. Francis, Local Sales Manager
Edith Kirby, Traffic Manager
Victor Reed, News Editor
Kenneth Stedman, Auditor
Manus Ward, Continuity Editor
Bloyce Wright, Program Manager

ABC FOREIGN CORRESPONDENTS

Frederick B. Opper, London
Robert Sturdevant, Paris
Lyford Moore, Berlin

STRINGERS

Wentworth Linebarger, Batavia
Gerry Wilmot, Bermuda
Herbert M. Clark, Buenos Aires
Everett Bauman, Caracas
William Freed, Copenhagen
Victor Lusinchi, Geneva
Frank Valenti, Honolulu
Edna Phillips, Lima
Arno Dosch Fleurot, Madrid
Raymond Spencer, Manila
Carl Kupfer, Mexico City
Vincent DePascal, Montevideo
Edmund Stevens, Moscow
Blair Fraser, Ottawa
Philip Payne, Panama
David Gottlieb, Prague
Philip E. Fogarty, Quito
Walter Weisbecker, Rome
Harwood Hull, San Juan
Burnett Anderson, Stockholm
Arthur Holtzman, Tel Aviv
Ray Falk, Tokyo
John Rich, Tokyo
Ernest Reed, Vienna

STATIONS PLANNING AND ADVISORY COMMITTEE

Roger W. Clipp, WFIL, Philadelphia, Pa., Chairman, District 1
J. P. Williams, WING, Dayton, Ohio, District 2
E. K. Hartenbower, KCMO, Kansas City, Mo., District 3
Henry P. Johnston, WSGN, Birmingham, Ala., District 4
Harold Hough, WBAP, Fort Worth, Texas, District 5
Frank Carman, KUTA, Salt Lake City, Utah, District 6
Arch Morton, KGR, Seattle, Washington, District 7
Owen Uridge, WQAM, Miami, Florida, District 8

BROADCASTING • Telecasting

American Broadcasting Company

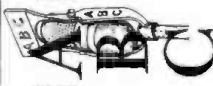

NETWORK

LINE MAP

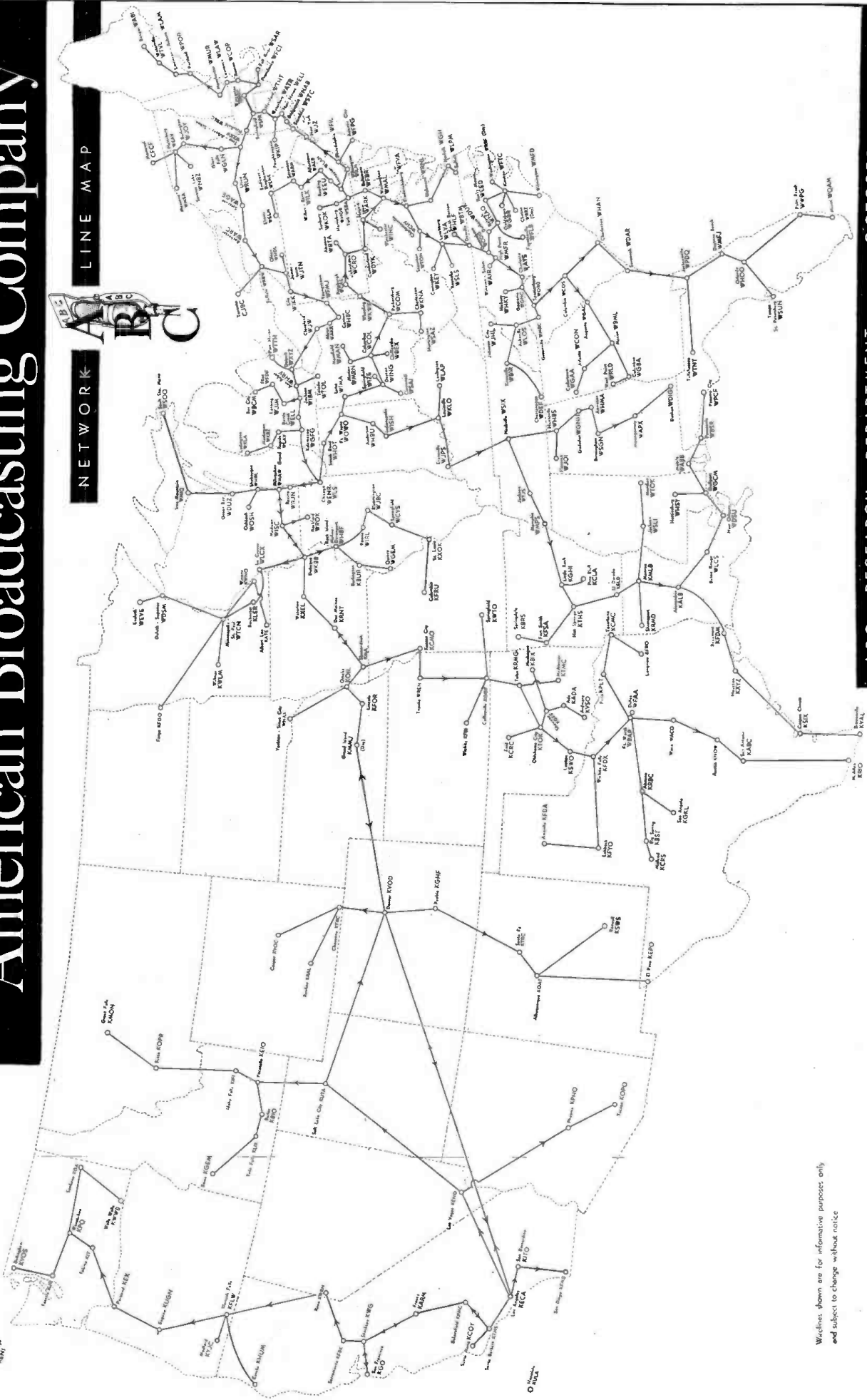

Wireless shown are for informative purposes only
and subject to change without notice

COLUMBIA BROADCASTING SYSTEM, Inc.: EXECUTIVES and STAFF

485 Madison Ave., New York 22, N. Y. Telephone: Plaza 5-2000

BOARD OF DIRECTORS

Prescott S. Bush
Ralph F. Collin
J. A. W. Iglehart
Isaac D. Levy
Leon Levy
Edward R. Murrow

Samuel Paley
William S. Paley
Joseph H. Ream
Dorsey Richardson
Frank Stanton
Edward Wallerstein

OFFICERS

William S. Paley, Chairman of the Board
Frank Stanton, President
Joseph H. Ream, Executive Vice President
Adrian Murphy, Vice President and General Executive
Howard S. Meighan, Vice President and General Executive
Lawrence W. Lowman, Vice President and General Executive
William C. Gittinger, Vice President and Assistant to the President
Harry S. Ackerman, Vice President in Charge of Network Programs, Hollywood
H. V. Akerberg, Vice President in Charge of Station Relations
H. Leslie Atlass, Vice President in Charge of Central Division
Frank B. Falknor, Vice President in Charge of Program Operations
Earl H. Gammons, Vice President in Charge of Washington Office
Howard L. Hausman, Vice President in Charge of Personnel Relations
Arthur Hull Hayes, Vice President in Charge of San Francisco Office
William E. Lodge, Vice President in Charge of General Engineering
Hubbell Robinson Jr., Vice President in Charge of Network Programs
James M. Seward, Vice President in Charge Business Affairs, Network Programs
J. Kelly Smith, Vice President in Charge of Station Administration
J. L. Van Volkenburg, Vice President in Charge of Network Sales
Julius F. Brauner, Secretary and General Attorney
S. R. Dean, Treasurer
William J. Flynn, Assistant Treasurer
Arthur S. Padgett, General Auditor
Edward L. Saxe, Controller
General Counsel: Rosenman, Goldmark, Colin, and Kaye

Accounting Department

S. R. Dean, Treasurer
William J. Flynn, Assistant Treasurer
L. C. Merrick, Assistant Comptroller
Norman C. Hadley, Chief Accountant

Auditing and Tax Department

Arthur S. Padgett, General Auditor
Norman DuFrane, Chief Auditor

Budget Department

Paul Nagel, Director

Business Affairs, Network Programs

James M. Seward, Vice President in Charge of Business Affairs, Network Programs
I. S. Becker, Director of Business Affairs, Network Programs
William Bratler, Assistant to the Director
Merritt Coleman, Assistant to the Director
Walter Shiver, Assistant to the Director
Kenneth Youd, Director of Business Affairs, Network Programs Hollywood
Martin Leeds, Associate Director
Janice O'Connell, Supervisor Literary Clearance and New Program Ideas

Editing Department

James C. Shattuck, Director of Editing

Engineering Research and Development Department
Peter C. Goldmark, Director of Engineering Research and Developments
John W. Christensen, Chief Engineer
John Martin, Executive Assistant

General Engineering Department

William B. Lodge, Vice President in charge of General Engineering
A. B. Chamberlain, Chief Engineer
H. A. Chinn, Chief Audio-Video Engineer
J. W. Wright, Chief Radio Engineer

Legal Department

Julius F. Brauner, Secretary and General Attorney
Henry Howard Jr., Senior Attorney

Network Sales

J. L. Van Volkenburg, Vice President in Charge of Network Sales
John J. Karol, Sales Manager
William J. Fagan, Administrative Manager
Allan Jay Marsh, Assistant Sales Manager
Thomas D. Connolly, Manager of Program Sales
C. E. Midgley Jr., Sales Service Manager
T. P. Maguire, Assistant Sales Service Manager

Chicago Office of Network Sales, 410 North Michigan Avenue

W. Donald Roberts, Western Manager

Detroit Office of Network Sales, Fisher Building

Joseph Spadea, Manager

Personnel Relations Department

Howard L. Hausman, Vice President in Charge of Personnel Relations

Dr. Jack Nelson, Director of Medical Office
Charles Burt, Personnel Administrator
John Anderson, Personnel Research Manager
Robert Kalaidjian, Employment Manager

Press Information

George Crandall, Director of Press Information
Michael Foster, Assistant Director
Michael Boscia, Executive Assistant
Harry Warner, Manager of Operations
Walter Selgal, Manager of Photographic Division
Harry Feeney, Trade News Editor
Dorothy Leffler, Manager of Magazine Division
Anne Harding, Manager of Service Division

Program Department

Hubbell Robinson Jr., Vice President in Charge of Network Programs
Harry Ackerman, Vice President and Director of Network Programs, Hollywood
Robert Heller, Executive Producer
Guy della-Cioppa, Associate Director of Network Programs, Hollywood
Gerald Maulsby, Manager of Broadcasts
Lester Gottlieb, Director of Popular Music and Talent Scout
James H. Fassett, Director of Serious Music
Marjorie Morrow, Casting Director
Charles Monroe, Associate Script Editor

Program Operations

Frank B. Falknor, Vice President in Charge of Operations
Gilson Gray, Director of Operations
R. L. Hopkins, Manager of Set Construction
John E. Forsander, Purchasing Agent
Robert Ray, Director Network Scheduling
Albert H. Bryant, Manager, Transportation, Mail, File, Mimeograph
Julius Mattfeld, Director of Music Library
Horace Guillotte, Manager of Network Operations
Lucile Singleton, Director of Vocal Auditions and Manager of Record and Script Library
Davidson Vorhes, Manager of Sound Effects
Laurette Banks, Manager of Ticket Division
W. C. Harrington, Manager, Copyright Division
Harriet Hess, Supervisor of Program Typing
Emily Scheiner, Supervisor of Ediphone
Henry Grossman, Director of Plant and Construction
Hugh Cowham, Assistant to Mr. Grossman
R. G. Thompson, Manager, Network Technical Operations and Chief Engineer of WCBS
Paul Wittlig, Manager TV Technical Operations
Walter Pierson, Manager, Building Operations
A. H. Peterson, Traffic Manager
Roland Young, Assistant Director of Construction

Public Affairs

Sig Mickelson, Director of Public Affairs
Edward R. Murrow, Counselor on Public Affairs
Werner Michel, Chief of Documentary Unit
Sam Abelow, Assistant, Documentary Unit

Education and Opinion Broadcasts

Helen Sloussat, Director of Talks
Leon Levine, Director of Discussion Broadcasts
Edward Scovill, Director of Talks and Special Events, Washington, D. C.
George Crothers, Director of Religious Broadcasts

News

Edmund A. Chester, Director, CBS News
Wells Church, Editor-in-Chief, CBS News
Robert Bendick, Director of Special Events
Theodore F. Koop, Director of News and Public Affairs, Washington
Henry Wefing, Assistant Director of News Broadcasts
Walter L. Barber, Director of Sports Division
John Derr, Associate Director

Radio Sales, Radio and Television Stations' Representative

Carl Burkland, General Sales Manager
H. A. Carlborg, Eastern Sales Manager, New York
George Dunham, Eastern Television Sales Manager
Chicago Office of Radio Sales, 410 North Mich. Ave.
Gordon F. Hayes, Sales Manager
Memphis Office of Radio Sales, 63 South Main St.
H. H. Holtshouser, Southern Sales Manager
San Francisco Office of Radio Sales, Palace Hotel
Edwin Buckalew, Office Manager
Los Angeles Office of Radio Sales, Columbia Square
Richard Elpers, Office Manager

Detroit Office of Radio Sales, Fisher Building

Ralph Patt, Manager

Reference Department

William C. Ackerman, Director of the Reference Department
May Dowell, Manager of General Information Division
Agnes Law, Librarian

Research Department

Oscar Katz, Director of Research
Harper Carraive, Assistant Director of Research
Edward Reeve, Research Projects Manager
Sales Promotion and Advertising Department
Louis Hausman, Director
William Golden, Associate Director
John F. Cowden, General Manager
Charles Oppenheim, Manager of Program Promotion

Station Relations

Herbert V. Akerberg, Vice President in Charge of Station Relations
William A. Schudt, Jr., Director of Station Relations
Edward E. Hall, Eastern Division Manager

Station Administration Department

J. Kelly Smith, Vice President in Charge of Station Administration
Edward DeCarra, Assistant to the Vice President
James V. Melick, Executive Assistant

Housewives' Protective League Productions Columbia Square, Hollywood

Fletcher Wiley, General Manager
Edward W. Woods Jr., Sales Manager, N. Y.
Gordon Owen, Sales Manager of Central Division

Columbia-Owned Stations

KMOX, 401 South Twelfth Boulevard, St. Louis 2
Erwin Shomo, General Manager
Carter Ringlep, Assistant Manager in Charge of Nighttime Operations
G. Gilman Johnson, National Sales Manager
Percy Anderson, Local Sales Manager
Robert F. DeVoe, Supervisor of Accounting, Personnel and Office
Harry Harvey, Chief Engineer

KNX and KNX-FM and Columbia Pacific Network, Columbia Square, Los Angeles 28

Howard Meighan, Vice President and General Executive
Merle Jones, General Manager, KNX
A. E. Joscelyn, Director CBS Operations, Hollywood
Wayne Steffner, Sales Manager of KNX and CPN
Ned Marr, West Coast Attorney
John Minzowski, Manager of Accounting and Purchasing
Edith Todesca, Director of Personnel Relations
Benjamin Paley, Director of Program Operations
Lester H. Bowman, Chief Engineer of KNX and Manager of Technical Operations Western Division

WBBM and WBBM-FM, 410 N. Michigan Ave., Chicago 11

H. Leslie Atlass, Vice President in Charge of Central Division and General Manager of WBBM
J. V. McLoughlin, Executive Assistant
Robert Livingston, Sales Manager
Louis L. Lazarus, Supervisor of Accounting
George V. Sherman, Chief Engineer

WCBS and WCBS-FM, Ninth Floor, 485 Madison Avenue, New York 22

G. Richard Swift, General Manager of WCBS
Don Ball, Program Director and Director of Continuity Editing
Don Miller, Sales Manager
D. Gordon Graham, Assistant Program Director
William Ehlwell, Manager, WCBS Program & Office Operations
Robert Patt, Director of Sales Promotion

WCCO—625 Second Avenue, S. Minneapolis

Wendell Campbell, General Manager
Eugene B. Wilkey, Assistant General Manager and General Sales Manager
Alfred Harding, Sales Manager
John R. Lucas, Accountant and Office Manager

WEEI and WEEI-FM—182 Tremont Street, Boston 2

Harold E. Fellows, Manager of New England Operations for CBS and General Manager of WEEI
Wilbur S. Edwards, Assistant General Manager and Director of Sales, WEEI
J. J. Murray, Director of Accounting and Personnel and Executive Assistant
Guy H. Cunningham, Sales Executive, National Spot

KCBS—Palace Hotel, San Francisco

Arthur Hull Hayes, Vice President in Charge, San Francisco Office
Jules Dundes, Director Advertising and Sales Promotion

CBS Television

Richard Redmond, Director of General Television Operations
Charles M. Underhill, Director of Programs
Jerome Danzig, Associate Director of Programs
Worthington C. Miner, Manager of Television Program Development
David Sutton, Sales Manager
George Moskovics, Manager of Sales Development
Arthur Rothafel, Sales Program Coordinator
James Connors, Business Manager
Allan Parr, Program Manager
Barry Wood, Production Supervisor, Musical Shows
Gil Fates, Supervising Director, Daytime Shows
Eleanor Kilgallen, Casting Director
John DeMott, Manager, Special Effects
Robert Wood, Traffic Manager
Harold Meler, Manager of Program Operations
Paul Wittlig, Manager of Technical Operations

Columbia Affiliates Advisory Board

I. R. Lounsbury, WGR Buffalo, Chairman, representing District No. 2
E. E. Hill, WTAG Worcester, Mass., Secretary, District No. 1
C. T. Lucy, WRVA Richmond, Va., District No. 3
Glenn Marshall Jr., WMBR Jacksonville, Fla., District No. 4
Howard Sumerville, WWL New Orleans, District No. 5
Richard Borel, WBNS Columbus, O., District No. 8
William Quarton, WMT Cedar Rapids, Iowa, District No. 7
Kenyon Brown, KWFT Wichita Falls, Tex., District No. 8
Clyde Coombs, KROX Sacramento, Calif., District No. 9

DuMONT TELEVISION NETWORK

A Division of Allen B. DuMont Laboratories, Inc.

515 Madison Avenue, New York 22, New York Telephone: MU 8-2600

Board of Directors

Allen B. DuMont
Leonard F. Cramer
Bruce T. DuMont
Thomas T. Goldsmith Jr.
Bernard Goodwin
Arthur Israel Jr.
Paul Raibourn
David Van Alstyne Jr.

Network Executives

Dr. Allen B. DuMont, *President*
Mortimer W. Loewl, *Director of the Network*
Chris J. Witting, *Executive Assistant to Director of the Network*
Julian Armstrong, *Assistant Network Director, in Charge of Sales & Research*
Walter Compton, *Manager of Station WTTG Washington, D. C.*
Donald Stewart, *Manager of Station WDTV Pittsburgh, Pa.*
Rodney D. Chipp, *Director of Engineering*
James L. Caddigan, *Director of Programming & Production*
Tom Gallery, *Director of Sales*
Gerald Lyons, *Director of Public Relations & Publicity*
Arthur C. Schofield, *Manager of Sales Promotion & Advertising*
Joseph Merkle, *Manager of Station Relations*
Edward R. Carroll, *Manager of Teletypewriting Department*
Robert Jamieson, *Manager of Network Traffic Department*
Melvin A. Goldberg, *Manager of Research*

Sales

Tom Gallery, *Director of Sales*
J. Trevor Adams, *Assistant Director of Sales*
Gilbert I. Berry, *Western Sales Manager, Field Building, Chicago, Illinois*
Richard S. Railton, *West Coast Sales Representative, Monahanock Building, San Francisco 5, Calif.*
Betty L. Lefel, *Sales Service Manager*
Arthur C. Elliot, *Sales Service Manager (WABD)*

Theodore Bergmann, *Account Executive*
David Gross, *Account Executive*
John Bachem, *Account Executive*
William Koblenzer, *Account Executive*
Halsey Barrett, *Manager of Spot Sales*
Martin Harrison, *Assistant Manager of Spot Sales*

Sales Promotion & Advertising

Arthur C. Schofield, *Manager of Sales Promotion & Advertising*
Jack C. Lewis, *Assistant Manager of Sales Promotion & Advertising*

Public Relations & Publicity

Gerald Lyons, *Director of Public Relations & Publicity*

Program and Production

James L. Caddigan, *Director of Programming & Production*
M. Bernard Fox, *Assistant to the Director of Programming & Production*
Lawrence Menkin, *Manager of Program Planning*
Andrew Jaeger, *Manager of the Film Department*
Frank Bunetta, *Production Supervisor*
Elizabeth Mears, *Manager of Casting Department*
Lynn Cleary, *Manager of Continuity Acceptance Department*
Leslie Arries, *Director of Sports-Special Events*
Harry Coyle, *Manager of Remote Production*
Duncan MacDonald, *Assistant Program Supervisor*
Al Hollander, *Assistant Program Supervisor*
Kleina Jones, *Assistant Program Supervisor*
Rudy Lucek, *Scenic Designer*

Traffic

Robert Jamieson, *Traffic Manager*
George Faust, *Assistant Traffic Manager*

Station Relations

Joseph L. Merkle, *Manager of Station Relations*

Teletypewriting Department

Edward R. Carroll, *Manager of Teletypewriting Department*

Robert S. Woolf, *Assistant Manager of Teletypewriting Department*

Operations

Roy Passman, *Director of New York Operations*
Leonard Sang, *Operations Supervisor, Studio A*
Saul Abrams, *Operations Supervisor, Adelphi Theatre*
Sam Fairchild, *Operations Coordinator*
Albert Tilt III, *Operations Coordinator*
Ed Lieberthal, *Operations Coordinator*

Engineering Department

R. D. Chipp, *Director of Engineering*
Robert Bigwood, *Facilities Engineer*
S. Patremio, *Maintenance and Operations Engineer*
H. Milholland, *Teletypewriting Engineer*

Accounting Department

W. P. Popp, *Chief Accountant*
R. M. Skaar, *Accountant*
W. W. Walsh, *Accounts Payable Supervisor*
Mae K. Blake, *Accounts Receivable Supervisor*

Research

Melvin A. Goldberg, *Manager of Research*

Du Mont Owned & Operated Stations

WABD New York, New York (See Network Listing)
WTTG Washington, D. C.
Walter Compton, *General Manager*
Harold E. Sheffers, *Sales Manager*
Roger M. Coelos, *Program Operations Manager*
Donald Roper, *Sports Director*
M. M. Burleson, *Chief Engineer*
Jules Huber, *Film Supervisor*
Helen Price, *Accountant*
WDTV Pittsburgh, Pa.
Donald A. Stewart, *General Manager*
John J. Cole, *Sales Manager*
Larry Israel, *Program Coordinator & Publicity Manager*
Harry Munson, *Program & Film Supervisor*
Leslie Arries Jr., *Operations Manager*
Raymond Rodgers, *Chief Engineer*
Viola Ely, *Accountant*

Advertisers Using DuMont Network During 1949

Sponsor, Product No. of Stations	Program Day, Time EST	Duration of Contract	Agency
Admiral Radio Corp.; Admiral Radio Sets, 22	Admiral Broadway Review; Fri. 8-9 PM.	1-14-49— 6-3-49	Kudner Agency, New York
Brunswick, Balke, Collender Bowling Equip., 18, 14	All Star Nat'l Ind. Match Championships Thurs. 11-11:30 PM Sun. 11-11:30 PM	12-8-49— 12-11-49	Stanton B. Fisher New York
Chevrolet Motor Division; Chevrolet Automobiles, 22	Notre Dame Football Games; Sat. 2:45—GN.	9-24-49— 11-26-49	Campbell-Ewald, New York
Co-op, 7	Amateur Boxing Fri. 10 to Concl.	9-9-49	
Co-op, 7	Chicagoland Mystery Players, Sun. 8-8:30 PM	9-11-49	
Co-op, 5	Cross Question Sun. 9-10 PM	9-11-49	
Co-op, 10	Al Morgan Show Mon. 8:30-9 PM	9-5-49	
Co-op, 15	Professional Wrestling Sat. 10 to Concl.	9-17-49	
Drug Store Television Productions; Drug Products, 14	Cavalcade of Stars; Sat. 9-10 PM.	6-4-49— 5-27-50	Stanton B. Fisher, New York
Du Mont Receiver Sales; Du Mont Television Sets, 9	Morey Amsterdam; Thurs. 9-9:30 PM.	4-21-49— 4-13-50	Direct
13	School House Tues. 9-9:30 PM	1-18-49— 4-12-49	Direct
9	The O'Neills Tues. 9-9:30 PM	9-6-49—	Direct

Sponsor, Product No. of Stations	Program Day, Time EST	Duration of Contract	Agency
12	Talent Jackpot Tues. 9-9:30 PM	7-19-49— 8-30-49	Direct
13	Window of the World Thurs. 9-9:30 PM	1-20-49— 4-14-49	Direct
General Foods; Post Toasties, 3	Small Fry Club; Mon.-Fri. 6-6:30 PM.	1-3-49— 9-29-49	Benton & Bowles, New York
P. Lorillard Co.; Old Gold Cigarettes, 22	The Original Amateur Hour; Sun. 7-8 PM.	10-3-48— 8-25-49	Lennen & Mitchell, New York
Mall Pouch Tobacco Co.; Kentucky Club Tobacco, 3	The Fishing and Hunting Club on the Air; Fri. 9-9:30 PM.	9-30-49— 12-23-49	Walker & Downing, Pittsburgh
George S. May Co.; Industrial Engineers, 15	All America in Golf Tourney; Sun. 6-7 PM	8-14-49—	M. M. Fisher Assoc.
Phillips Packing Co.; Canned Soups & Foods, 15	Easy Aces	12-14-49—	Aitkin-Kynett
R. J. Reynolds Co.; Camel Cigarettes, 12	Camel Caravan of Sports; Mon.—Concl.	2-26-49— 5-16-49	William Esty, New York
Sterling Drug, Inc.; Bayer Aspirin, 4	Okay Mother Mon.-Fri. 1-1:30 PM	12-12-49— 12-29-50	Dancer-Fitzgerald-Sample, Inc.
United Cigar-Whelan Stores Corp.; Drug Store Products, 3	Hotel Broadway; Thurs. 8:30-9 PM.	1-20-49— 4-14-49	Stanton B. Fisher, New York
6	Front Row Center Thurs. 8:30-9 PM	1-20-49— 4-14-49	Stanton B. Fisher New York
Whitehall Pharmacal Co.; Kolynos Tooth Paste, 3	Small Fry Club; Mon.-Fri. 6-6:30 PM.	9-29-48— 8-28-49	Sullivan, Stauffer, Colwell & Bayles, New York

AFFILIATED STATIONS OF THE DU MONT TELEVISION NETWORK

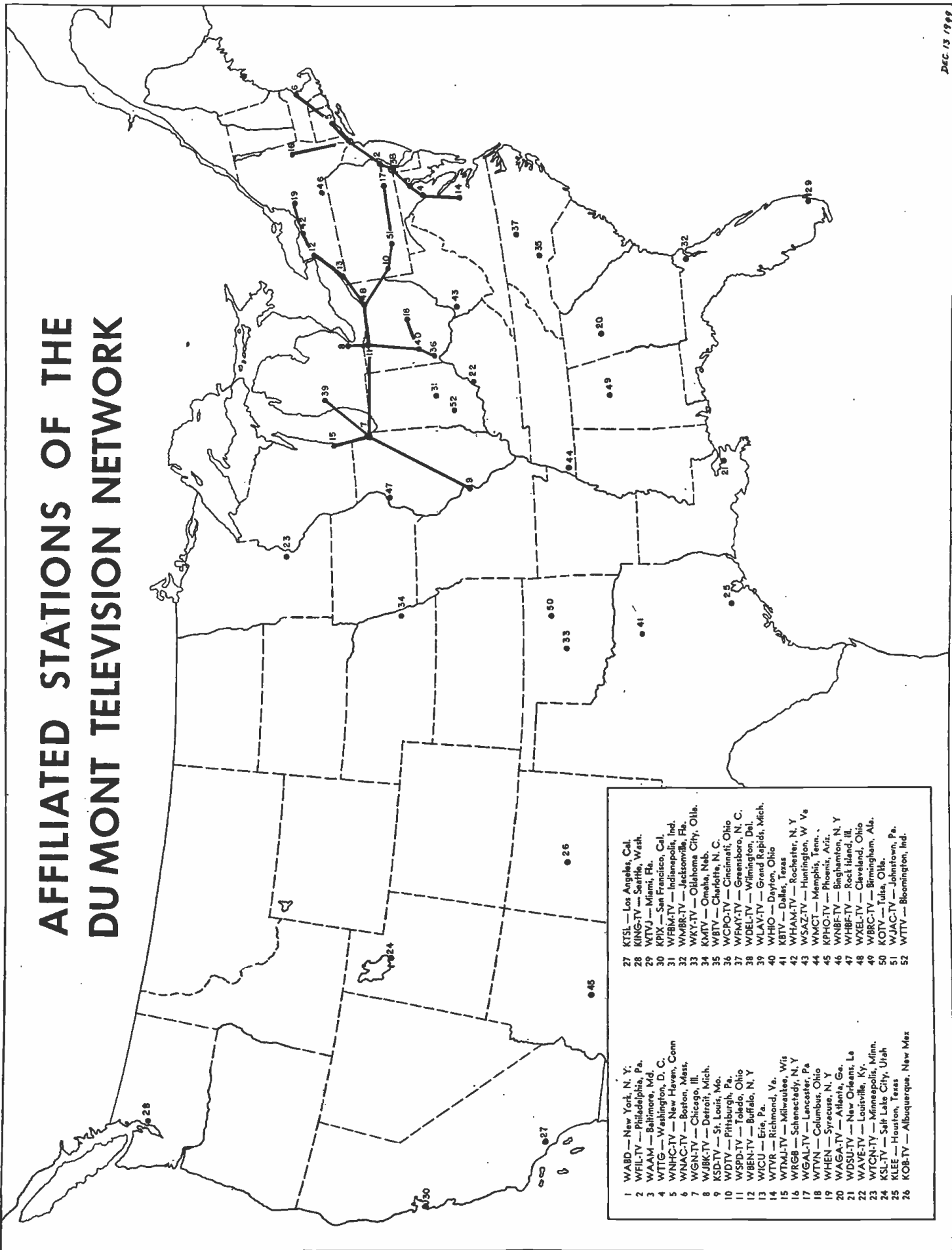

- | | | | |
|----|--------------------------------|----|-------------------------------|
| 1 | WABD — New York, N. Y. | 27 | KTSL — Los Angeles, Cal. |
| 2 | WFIL-TV — Philadelphia, Pa. | 28 | KING-TV — Seattle, Wash. |
| 3 | WAAM — Baltimore, Md. | 29 | WTVJ — Miami, Fla. |
| 4 | WTTG — Washington, D. C. | 30 | KPIX — San Francisco, Cal. |
| 5 | WNHC-TV — New Haven, Conn. | 31 | WFBM-TV — Indianapolis, Ind. |
| 6 | WHNC-TV — Boston, Mass. | 32 | WMBR-TV — Jacksonville, Fla. |
| 7 | WGN-TV — Chicago, Ill. | 33 | WKY-TV — Oklahoma City, Okla. |
| 8 | WJBK-TV — Detroit, Mich. | 34 | KMTV — Omaha, Neb. |
| 9 | KSD-TV — St. Louis, Mo. | 35 | WBT — Charlotte, N. C. |
| 10 | WDTV — Pittsburgh, Pa. | 36 | WCPO-TV — Cincinnati, Ohio |
| 11 | WSPD-TV — Toledo, Ohio | 37 | WFMY-TV — Greensboro, N. C. |
| 12 | WBEN-TV — Buffalo, N. Y. | 38 | WDEL-TV — Wilmington, Del. |
| 13 | WICU — Erie, Pa. | 39 | WLAV-TV — Grand Rapids, Mich. |
| 14 | WTVR — Richmond, Va. | 40 | WHIO — Dayton, Ohio |
| 15 | WTMJ-TV — Milwaukee, Wis. | 41 | KBTV — Dallas, Texas |
| 16 | WRGB — Schenectady, N. Y. | 42 | WHAM-TV — Rochester, N. Y. |
| 17 | WGAL-TV — Lancaster, Pa. | 43 | WSAZ-TV — Huntington, W. Va. |
| 18 | WTNH — Columbus, Ohio | 44 | WMCY-TV — Memphis, Tenn. |
| 19 | WHEN — Syracuse, N. Y. | 45 | KPHO-TV — Phoenix, Ariz. |
| 20 | WAGA-TV — Atlanta, Ga. | 46 | WNBE-TV — Babylon, N. Y. |
| 21 | WDSU-TV — New Orleans, La. | 47 | WHRE-TV — Rock Island, Ill. |
| 22 | WAVE-TV — Louisville, Ky. | 48 | WXLN-TV — Cleveland, Ohio |
| 23 | WTGN-TV — Minneapolis, Minn. | 49 | WBKC-TV — Birmingham, Ala. |
| 24 | KSL-TV — Salt Lake City, Utah | 50 | KOTV — Tulsa, Okla. |
| 25 | KLEE — Houston, Texas | 51 | WJAC-TV — Johnstown, Pa. |
| 26 | KOB-TV — Albuquerque, New Mex. | 52 | WTTV — Bloomington, Ind. |

KEYSTONE BROADCASTING SYSTEM, INC.

OFFICES

134 North LaSalle Street
Chicago 2, Illinois
State 2-4590

580 Fifth Avenue
New York 19, New York
Plaza 7-1460

OFFICERS & DIRECTORS

Naylor Rogers, Exec. Vice-President
Arthur Wolf, Vice-President (Director)
Joseph Bayer, Vice-President (Director)
Sidney J. Wolf, Secretary-Treasurer (Director)
William Bayer, Assistant Secretary (Director)

NEW YORK

580 Fifth Avenue

Noel A. Rhys, Eastern Sales Manager
Eve Banner, Office Manager
James A. Yergin, Research Director

CHICAGO

134 North LaSalle St.

Naylor Rogers, Exec. Vice-President
Sidney J. Wolf, Secretary-Treasurer
Edwin R. Peterson, Special Representative
Elizabeth M. Jacobs, Accountant & Office Manager
Emma G. Rogers, Director of Station Relations

SERVICES OFFERED: Keystone Broadcast System is a transcription network principally covering beyond-Metropolitan markets from coast to coast. Its affiliated stations are joined together in a national system by means of transcription, eliminating wire charges. At time of going to press, the network included 385 affiliated stations. This is the only national network in the United States offering national radio advertisers the opportunity to cover the beyond-Metropolitan markets exclusively, in a single transaction, by means of electrical transcription. The System offers its facilities in time periods from one hour down to five minutes, and also makes available announcement periods of one-minute, half-minute and 25 words in length. Keystone makes its facilities available nationally or in selected groups. The list of stations affiliated with Keystone as of Jan. 1, 1950, is as follows:

ALABAMA—WCTA Andalusia; WJLD Bessemer; WEBJ Brewton; WKLF Clanton; WKUL Cullman; WMSL Decatur; WXAL Demopolis; WOOF Dothan; WULA Eufaula; WMFT Florence; WBHP Huntsville; WWWW Jasper; WJHO Opelika; WHTB Talladega; WTBW Troy; WTBC Tuscaloosa.

ALASKA—KFQD Anchorage; KFRB Fairbanks; KINY Juneau; KTKN Ketchikan; KIBH Seward.

ARIZONA—KTYL Mesa.

ARKANSAS—KHOZ Harrison; KVRC Arkadelphia; KAMD Camden; KXJK Forest City; KFFA Helena; KWFC Hot Springs; KBTM Jonesboro; KDRS Paragould; KOTN Pine Bluff; KXRJ Russellville; KGRH Fayetteville; KWAK Stuttgart; KXAR Hope.

CALIFORNIA—KGFN Grass Valley; KCVR Lodi; KPRL Paso Robles; KTIP Porterville; KSON San Diego; KVEC San Luis Obispo; KVVC Ventura; KUBA Yuba City; KSMA Santa Maria; KMBY Monterey.

COLORADO—KGIW Alamosa; KRLN Canon City; KUBC Montrose; KVRH Salida; KGEK Sterling; KCRT Trinidad; KOKO La Junta.

CONNECTICUT—WICH Norwich.

FLORIDA—WSWN Belle Glade; WDHL Bradenton; WTAN Clearwater; WCNU Crestview; WINK Ft. Myers; WJVB Jacksonville Beach; WKWF Key West; WTMC Ocala; WDLF Panama City; WTRR Sanford; WRHP Tallahassee; WLBF Leesburg; WNER Live Oak; WPLA Plant City.

GEORGIA—WGAU Athens; WMGR Bainbridge;

WMOG Brunswick; WLBB Carrollton; WBHF Cartersville; WGAA Cedartown; WMJM Cordele; WMOC Covington; WBLJ Dalton; WMLT Dublin; WSGC Elberton; WGGA Gainesville; WKEU Griffin; WLAG La Grange; WMVG Milledgeville; WMGA Moultrie; WLAQ Rome; WWNS Statesboro; WLET Toccoa; WVOV Vidalia; WAYX Waycross; WRLD West Point; WBGR Jesup.

IDAHO—KGEM Boise; KBIO Burley; KIFI Idaho Falls; KEIO Pocatello; KPST Preston; KLDX Twin Falls; KWAL Wallace; KWEI Weiser; KSPT Sand Point.

ILLINOIS—WMRO Aurora; WDWS Champaign; WEBQ Harrisburg; WJPF Herrin; WKAI Macomb.

INDIANA—WTOM Bloomington; WTRC Elkhart; WLBC Muncie; WTCJ Tell City.

IOWA—KSIB Creston.

KANSAS—KVAK Atchison; KGNO Dodge City; KTSW Emporia; KIUL Garden City; KWHK Hutchinson; KIND Independence.

KENTUCKY—WLBJ Bowling Green; WCTT Corbin; WZIP Covington; WHIR Danville; WHLN Harlan; WHOP Hopkinsville; WOMI Owensboro.

LOUISIANA—KVOB Alexandria; WHHL Hammond; KWCJ Natchitoches; KSLO Opelousas.

MAINE—WJOR Bangor; WAGM Presque Isle.

MARYLAND—WASA Havre de Grace.

MASSACHUSETTS—WOCB Cape Cod-West Yarmouth.

MICHIGAN—WATZ Alpena; WGRO Bay City; WATT Cadillac; WHDF Calumet; WDBC Escanaba; WMRP Flint; WMS Ironwood; WKLA Ludington; WMBN Petoskey; WTCM Traverse City.

MINNESOTA—WXLT Ely; KBZY Grand Rapids; CKFI International Falls, (Fort Frances, Ont.); KTRF Thief River Falls.

MISSISSIPPI—WROX Clarksdale; WCJU Columbia; WCBI Columbus; WCMA Corinth; WJPR Greenville; WGRM Greenwood; WNAG Grenada; WGCM Biloxi-Gulfport; WFOR Hattiesburg; WAML Laurel; WAPF McComb; WMOX Meridian; WMIS Natchez; WHOC Philadelphia; WELO Tupelo; WQBC Vicksburg; WROB West Point; WAZF Yazoo City; WKOZ Kosciusko.

MISSOURI—KDMO Carthage; KREI Farmington; KWOS Jefferson City; KWOC Poplar Bluff; KTTR Rolla; KSGM Ste. Genevieve; KDRO Sedalia; KWPM West Plains.

MONTANA—KBMY Billings; KAVR Havre; KPRK Livingston; KRJF Miles City; KIYI Shelby; KGCX Sidney; KXLO Lewistown.

NEBRASKA—KFGT Fremont; KHAS Hastings; KGFV Kearney; KBRL McCook; KODY North Platte.

NEVADA—KRAM Las Vegas.

NEW HAMPSHIRE—WMOU Berlin; WLNH Laconia.

NEW JERSEY—WSNJ Bridgeton.

NEW MEXICO—KSVP Artesia; KWEW Hobbs; KCHS Hot Springs; KGFL Roswell; KTNM Tucumcari.

NEW YORK—WMBO Auburn; WHUC Hudson; WICY Malone; WALL Middletown; WSLB Ogdensburg; WHDL Olean; WNBZ Saranac Lake; WJOC Jamestown; WWSO Glens Falls.

NORTH CAROLINA—WABZ Albemarle; WBBB Burlington; WEGO Concord; WCKB Dunn; WCNC Elizabeth City; WBBO Forest City; WGNC Gastonia; WHNC Henderson; WHKP Hendersonville; WHKY Hickory; WHPE High Point; WLOE Leaksville; WFGV Fuquay Springs; WJRI Lenoir; WBUI Lexington; WTSB Lumberton; WMAP Monroe; WFRS Reidsville; WCBT Roanoke Rapids; WCEC Rocky Mount; WSTS Southern Pines.

NORTH DAKOTA—KDDX Dickinson; KOVC Valley City.

OHIO—WMOA Marietta; WJEL Springfield; WFIN Findlay.

OKLAHOMA—KWHW Altus; KVSO Ardmore; KWCO Chickasha; KSEO Durant; KASA Elk City; KTJS Hobart; KTMC McAlester; KHBG Okmulgee; KVLH Paul's Valley; WBBZ Ponca City; KTAT Frederick; KCHE El Reno; KADA Ada.

OREGON—KWIN Ashland; KAST Astoria; KBBK Baker; KBND Bend; KWRO Coquille; KRUL Corvallis; KASH Eugene; KLBW La Grande; KOCO Salem; KODL The Dalles; KTLT Tillamook.

PENNSYLVANIA—WKAP Allentown; WISR Butler; WCED Du Bois; WHUN Huntingdon; WDAD Indiana; WMCK McKeesport; WKRZ Oil City; WMAJ State College.

SOUTH CAROLINA—WOLS Florence; WFGN Gaffney; WLBG Laurens-Clinton; WMRA Myrtle Beach; WKDK Newberry; WRHI Rock Hill; WGCD Chester; WACA Camden.

SOUTH DAKOTA—KDSJ Deadwood; KGFX Pierre; KWAT Watertown.

TENNESSEE—WLAR Athens; WJZM Clarksville; WKRM Columbia; WHUB Cookeville; WDSG Dyersburg; WHBT Harriman; WDXI Jackson; WETB Johnson City; WIBK Knoxville; WGAP Maryville; WMMT McMinnville; WTPR Paris; WENK Union City; WJIG Tullahoma.

TEXAS—KVLF Alpine; KRUN Ballinger; KIOX Bay City; KRCT Baytown; KTRM Beaumont; KNEL Brady; KSTB Breckenridge; KWHI Brenham; KBWD Brownwood; KAND Corsicana; KDNT Denton; KERP El Paso; KGAF Gainesville; KLUF Galveston; KGVF Greenville; KSAM Huntsville; KEBE Jacksonville; KOCA Kilgore; KPET Lamesa; KPAB Laredo; KFRO Longview; KRBA Lufkin; KMHT Marshall; KORC Mineral Wells; KVKM Monahans; KOSF Nacogdoches; KNET Palestine; KIUN Pecos; KVOP Plainview; KDWT Stamford; KSTV Stephenville; KSST Sulphur Springs; KXOX Sweetwater; KTEM Temple; KTFB Texarkana; KTLW Texas City; KVOU Uvalde; KVWC Vernon; KVIC Victoria; KTAN Sherman.

UTAH—KSUB Cedar City; KVNU Logan; KOPP Ogden; KOAL Price; KJAM Vernal.

VERMONT—WSYB Rutland.

VIRGINIA—WKEY Covington; WSVS Crewe; WCVA Culpeper; WFVA Fredericksburg; WVEC Hampton; WMVA Martinsville; WNVA Norton; WPUV Pulaski; WHLF South Boston; WLPM Suffolk; WAYB Waynesboro; WINC Winchester; WREL Lexington.

WASHINGTON—KXRO Aberdeen; KELA Centralia-Chehalis; KWLK Longview; KSEM Moses Lake; KGY Olympia; KONP Port Angeles; KWVB Walla Walla.

WEST VIRGINIA—WHAR Clarksburg; WDNE Elkins; WLOG Logan; WAJR Morgantown; WLOH Princeton; WRON Ronceverte; WBRW Welch.

WISCONSIN—WATW Ashland; WLDY Ladysmith; WOMET Manitowoc; WDLB Marshfield; WIGM Medford; WIBU Poynette; WRJN Racine; WOBT Rhineland; WBSR Superior.

WYOMING—KSPR Casper; KPOW Powell; KRAL Rawlins; KQRS Rock Springs; KWYO Sheridan; KWOR Worland.

LIST OF ASSOCIATED STATIONS (Carrying KBS Commercials on Special Working Agreements)

WHBB Selma, Ala.; WGIL Galesburg, Ill.; KVOL Lafayette, La.; WESX Salem, Mass.; WGBB Freeport, N. Y.

BROADCASTING • Telecasting

KEYSTONE NETWORK

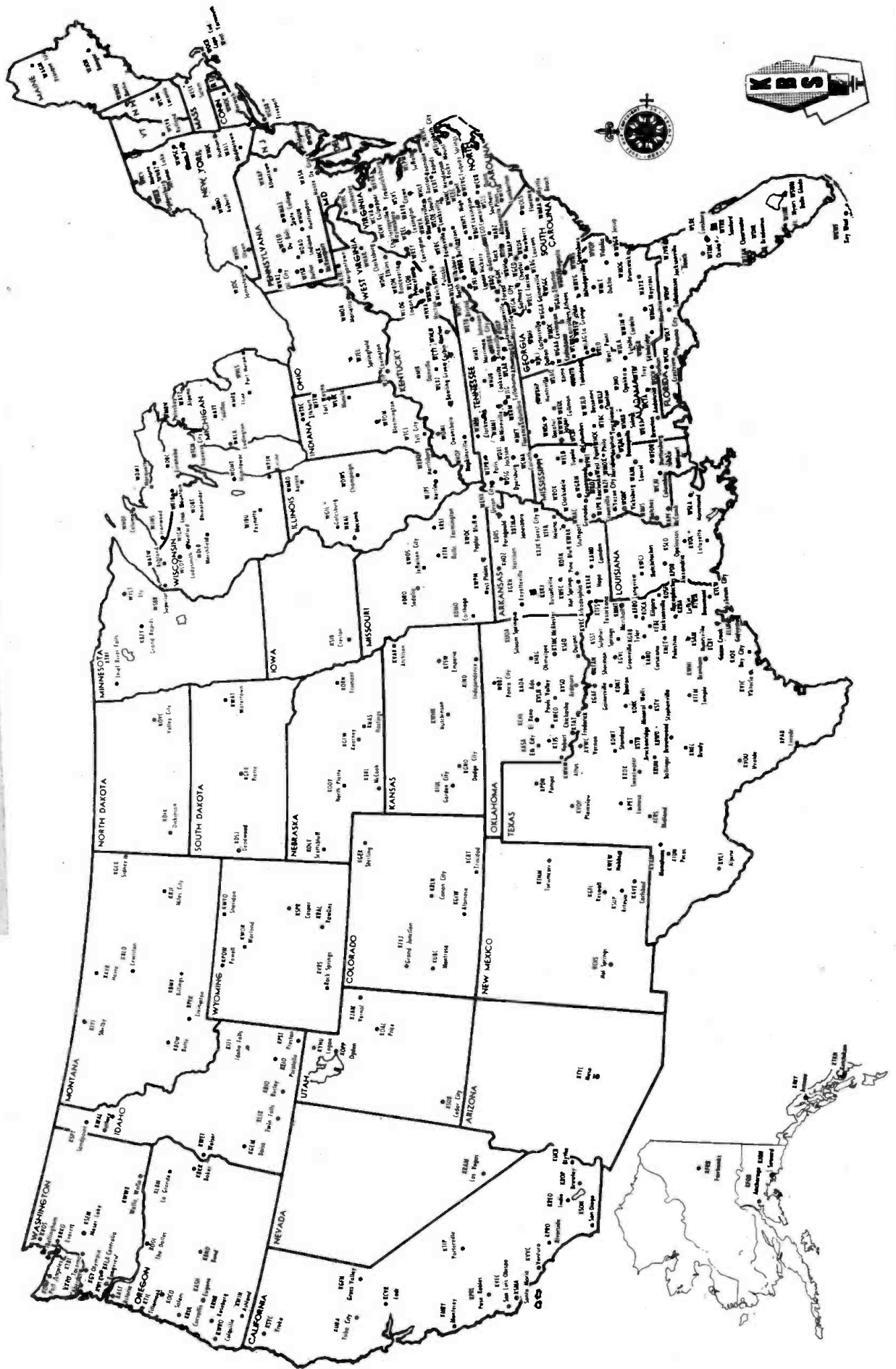

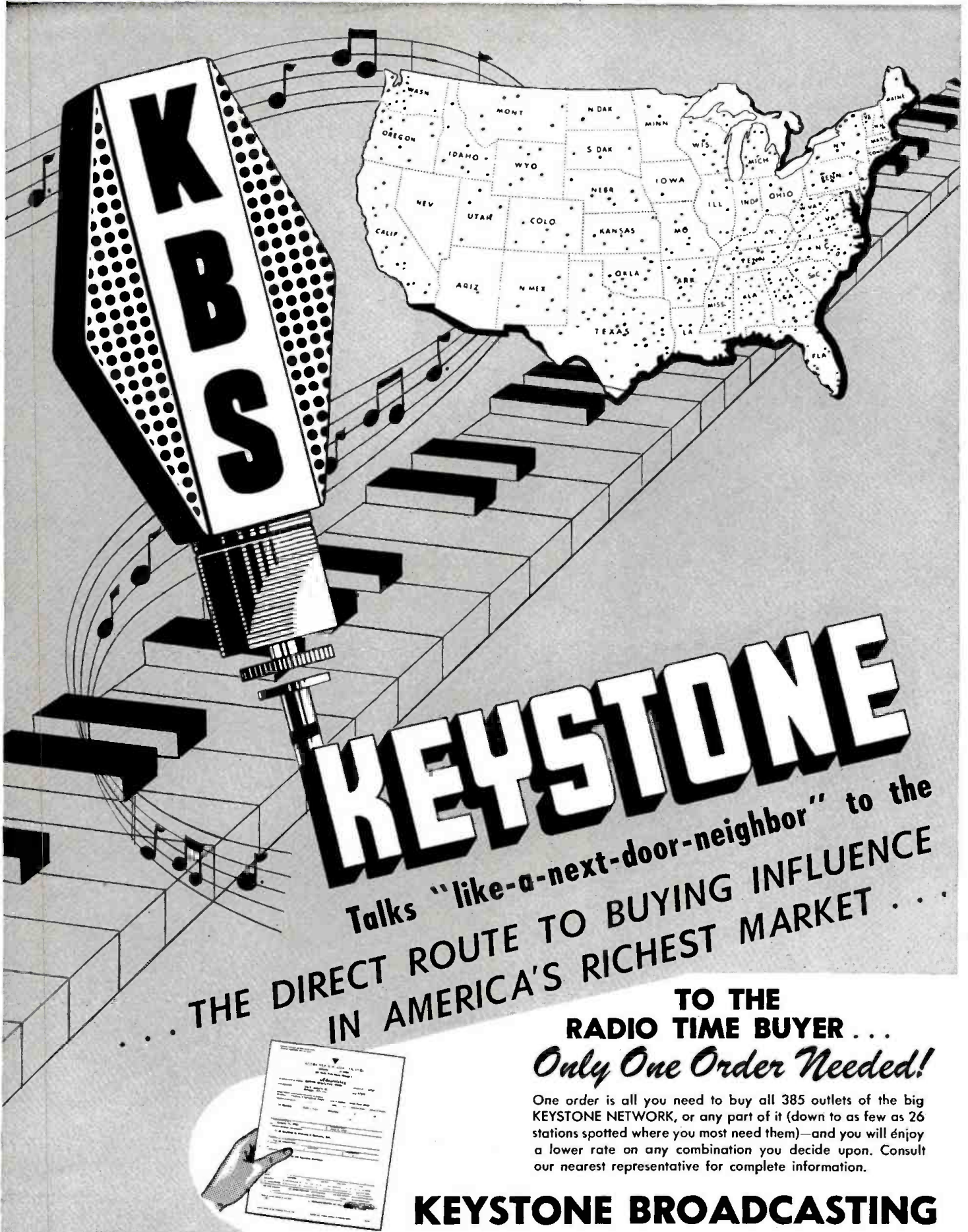

KEYSTONE

Talks "like-a-next-door-neighbor" to the
 ... THE DIRECT ROUTE TO BUYING INFLUENCE
 IN AMERICA'S RICHEST MARKET ...

**TO THE
 RADIO TIME BUYER ...**
Only One Order Needed!

One order is all you need to buy all 385 outlets of the big
 KEYSTONE NETWORK, or any part of it (down to as few as 26
 stations spotted where you most need them)—and you will enjoy
 a lower rate on any combination you decide upon. Consult
 our nearest representative for complete information.

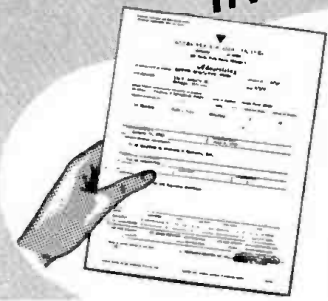

KEYSTONE BROADCASTING

Reaches the 14,427,017 Radio Families Whose Income Has More than Doubled in the Last 8 Years!



These are the "Backbone of America" families who live in small towns and on farms, in the richest agricultural sections of the country—people who buy breakfast foods, toilet articles, canned goods, household appliances and many other items in greater quantities than any other people on earth!

More than 88% of these families can be reached on the friendly, neighborly, influential KBS community level by no other stations than the local Keystone outlet.

BROADCASTING SYSTEM

40,000,000 radio listeners reached through the 385 KBS outlets

A market which represents 56% of all retail outlets and 43% of all retail sales!

Do you know that the 16,340 cities and towns of 25,000 population or less have more than half of all retail outlets and do nearly half of all the retail business? America's leading brand name manufacturers are becoming more keenly aware of these facts every day. In 1949 they spent much more on their radio advertising at the local community level than for either national network radio or national spot radio. Do these facts convey any special significance for your future radio advertising plans?

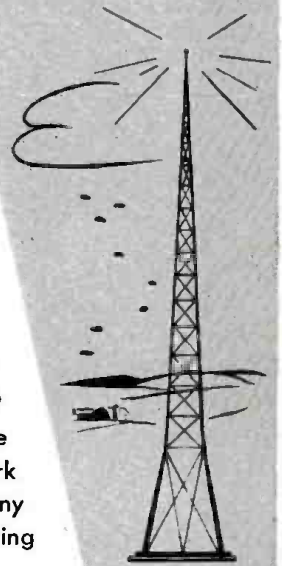

KBS is the **ONLY** established and growing Transcription Network covering small town and rural areas exclusively.

IN OPERATION SINCE 1940

TO ADVERTISERS AND AGENCIES . . .

Keystone can effect many economies for you

You can furnish us with your own scripts or transcriptions, or we will help you in developing the right type of transcription or script for this market—and we will also cooperate in getting you the best time and the best show that your money can buy anywhere. Call your nearest Keystone representative to help you plan a "Keystone campaign for greater sales volume."

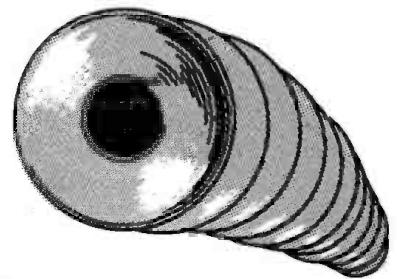

SYSTEM, New York

580 Fifth Ave.
Phone PLaza 7-1460

Chicago

134 North LaSalle St.
Phone STate 2-4590

NATIONAL BROADCASTING COMPANY

30 Rockefeller Plaza 20, New York City. Telephone: Circle 7-8300

Registered Telegraphic Address: NATBROCAST, NEW YORK

BOARD OF DIRECTORS

Niles Trammell, Chairman of the Board

Arthur E. Braun
John T. Cahill
Charles R. Denny
Gano Dunn
Frank M. Folsom
George L. Harrison
Harry C. Ingles
Charles B. Jolliffe
Joseph H. McConnell
Edward F. McGrady
Edward J. Nally
Brig. Gen. David Sarnoff

OFFICERS

Niles Trammell, Chairman of the Board
Joseph H. McConnell, President
Charles R. Denny, Executive Vice President
Harry C. Kopf, Administrative Vice President
Sylvester Weaver, Vice President
John H. MacDonald, Administrative Vice President
Sidney N. Strotz, Administrative Vice President
William Brooks, Vice President
Sydney Elges, Vice President
Charles P. Hammond, Vice President
O. B. Hanson, Vice President
William S. Hedges, Vice President
Gustav B. Margraf, Vice President & General Attorney
John F. Royal, Vice President
Frank M. Russell, Vice President
I. E. Showerman, Vice President
H. F. McKeon, Controller
R. J. Teichner, Treasurer & Assistant Secretary
Lewis MacConnach, Secretary
Wayne Mason, Assistant Secretary

DEPARTMENTS and DIVISIONS

EXECUTIVE OFFICERS

Joseph H. McConnell, President
Charles R. Denny, Executive Vice President
John H. MacDonald, Administrative Vice President in Charge of Finance
Charles P. Hammond, Vice President Assistant to the President
William Hedges, Vice President in Charge of Planning and Development
John F. Royal, Vice President
David C. Adams, Assistant to the Executive Vice President
George MacGovern, Rate Specialist
Albert Walker, Executive Assistant
William Burke Miller, Night Executive Officer

ADVERTISING AND PROMOTION

James Nelson, Director
Roy C. Porteous, Manager
Allen Huriburt, Art Director
William E. Webb, Audience Promotion Manager for Radio and Television
George W. Wallace, Television and Network Sales Promotion Manager
Edward Antonioli, Promotion and Production Manager

BUDGET

John Tiedeman, Budget Officer

CONTINUITY ACCEPTANCE DEPARTMENT

Stockton Helffrich, Manager
Carl Watson, Assistant Manager

CONTROLLERS DEPARTMENT

Harry F. McKeon, Controller
Harold M. Kelly, Assistant Controller
Hugh R. McGeachie, Assistant Controller

ENGINEERING DEPARTMENT

O. B. Hanson, Vice President and Chief Engineer
George McElrath, Director of Engineering Operations
William A. Clarke, Administrative Assistant
Edward R. Cullen, Operations Assistant
Joseph D'Agostino, Liaison Engineer
Raymond F. Guy, Manager, Radio and Allocations Engineering
George M. Nixon, Manager, Engineering Development
Chester A. Rackey, Manager, Audio and Video Engineering
Thomas H. Phelan, New York Division Engineer
James Wood, Manager of Technical Services

GENERAL SERVICE DEPARTMENT

Edward M. Lowell, Director
Walter E. Giebelhaus, Manager of Building Maintenance Division
Helen Davis, Manager of Office Services Division

GUEST RELATIONS

Peter M. Tintle, Manager
Joseph Phillips, Assistant Manager in Charge of Reception Division

Alton Porter, Assistant Manager in Charge of Tours Division
James Van Gaasbeek, Assistant Manager in Charge of Ticket Division

INFORMATION DEPARTMENT

Anita Barnard, Director

LEGAL DEPARTMENT

Gustav B. Margraf, Vice President & General Attorney
Robert P. Myers, Assistant General Attorney
Thomas E. Ervin, Assistant General Attorney
George H. Halbert, Senior Attorney
John V. Shute, Senior Attorney
John P. King, Attorney
Paul B. Lynch, Attorney
Cahill, Gordon, Zachry & Reindel, Counsel (New York & Washington)

NATIONAL SPOT SALES DEPARTMENT

James V. McConnell, Director
John de Russy, Manager
Jacob Evans, Promotion Manager

NETWORK SALES DEPARTMENT

Harry C. Kopf, Administrative Vice President in Charge of Sales for Sound Broadcasting
Walter Scott, Eastern Sales Manager
F. Melville Greene, Sales Service Manager

NEWS AND SPECIAL EVENTS AND INTERNATIONAL RELATIONS DEPARTMENT

William F. Brooks, Vice President in Charge
Joseph O. Meyers, Manager of Operations
Francis Littlejohn, Night Manager of Operations
Cal Abraham, Station Liaison & Public Relations Director

PERSONNEL DEPARTMENT

Ernest de la Ossa, Director
Edmund Souhaml, Labor Relations Assistant to the Director
Theodore Thompson, Manager
Doris Ann, Employment Manager
Donald Bogert, Employee Services Manager
William Roden, Records & Research Manager

PRESS DEPARTMENT

Sydney Elges, Vice President in Charge
Josef Dine, Director
Sam Kaufman, Special Services Manager
Allan Kalmus, Television Manager
Michael Dann, Trade Editor
Leo Hershendorfer, Feature & Copy Editor
Don Bishop, Magazine Editor
Leonard Meyers, Music Editor
Sidney Desfor, Photo Editor

PROGRAM DEPARTMENT

Thomas C. McCray, National Program Director
Arch Robb, Operations Manager
Leslie Harris, Assistant National Program Director
Mitchell Benson, Administrative Assistant; Co-ordinator of New Package Programs
Mary Cooper, Supervisor of Booking Office
Allin Robinson, Night Program Manager
Patrick J. Kelly, Manager of Announcers
Samuel Chotzinoff, General Music Director
Thomas H. Belviso, Manager of Music Library
James Kovach, Manager of Production Division
Richard McDonagh, Executive Producer
Joel Hammill, Manager, Literary Rights & Material Review
Bill Stern, Director of Sports
Frederick Knopke, Manager of Sound Effects
Wade Arnold, Assistant to the Program Director in Charge of Special Programs
Van Woodward, Manager of Script Division

PUBLIC AFFAIRS AND EDUCATION DEPARTMENT

Sterling Fisher, Manager
Doris Corwith, Director of Talks & Religious Broadcasts
Margaret Cuthbert, Director of Public Affairs
Jane T. Wagner, Director of Education

RADIO RECORDING DEPARTMENT

Charles G. Hicks, Commercial Recording Sales Manager

RESEARCH DEPARTMENT

Hugh M. Beville Jr., Director
Barry T. Ruple, Manager

STATIONS DEPARTMENT

Easton C. Woolley, Director
Paul Hancock, Administrative Assistant to the Director

TRAFFIC DEPARTMENT

Harry A. Woodman, Manager

TELEVISION DEPARTMENT

Sylvester L. Weaver, Vice president in Charge of Television

Television Operations

Carleton D. Smith, Director
Fred Shawn, Manager of Operations
J. Robert Myers, Controller
Leslie C. Vaughan, Television Cost and Billing Manager
Joseph Berhalter, Television Budget Officer
Neil Knox, Television Personnel Supervisor
N. Ray Kelly, Assistant to the Director of Television Film Division
Sheldon B. Hiccox Jr., Director of Station Relations
Robert E. Shelby, Director of Television Engineering Operations
F. A. Wankel, Assistant Director of Television Engineering Operations

Television Production

Frederic W. Wile, Director
Fred Coe, Manager of New Program Development
Carl Stanton, Talent and Program Procurement Manager
Francis C. McCall, Director of Television News and Special Events
Adolph J. Schneider, Manager of Operations-Television News and Special Events

Television Sales

George H. Frey, Director
Edward R. Hitz, Eastern Sales Manager
Robert W. Sarnoff, Program Sales Manager

TRANSPORTATION DEPARTMENT

Marie F. Dolan, Manager

TREASURER'S DEPARTMENT

Rudolph J. Teichner, Treasurer
William A. Williams, Assistant to the Treasurer
William D. Bloxham, Purchasing Agent

OWNED & OPERATED STATIONS

James M. Gaines, Director of Owned and Operated Stations
Hamilton Shea, Controller Owned & Operated stations

WNBC, WNBC-FM, WNBT New York

Thomas B. McFadden, Manager of WNBC, WNBC-FM, WNBT
Harvey Cannon, Program Manager WNBC, WNBC-FM
John H. Reber, Program Manager, WNBT
John C. Warren, Sales Manager
Murry Harris, Advertising & Promotion Manager
George Stevens, Sales Traffic Director
Schuyler Chapin, Press Manager
Thomas Page, Farm Director

WTAM, WTAM-FM, WNBK (TV) Cleveland

815 Superior Ave. N. E., Cleveland 14, Ohio
Tel. Cherry 0942

John McCormick, General Manager
Jacob Hines, Program Manager
Edward Wallace, Director of News & Special Events
Albert Henderson, Press Manager
Harold Gallagher, Sales Manager
Howard Barton, Sales Promotion & Public Relations Manager
Samuel Leonard, Engineer in Charge
Joseph Jenkins, Manager of TV Station WNBK
Philip Worcester, Program Manager, WNBK
Andrew Hammerschmidt, TV Engineering Operations Supervisor

KOA, KOA-FM Denver

1625 California St., Denver 2, Colorado
Tel. Main 6211

Lloyd Yoder, General Manager
Dale Newbold, Auditor & Personnel Director
Robert Owen, Engineer in Charge
William Day, Director of News & Special Events & Press
Clarence Moore, Program Manager
Randolph Smith, Promotion Manager
Donald Peach, Agricultural Director
L. Berry Long, Sales Manager

KNBC, KNBC-FM San Francisco

Taylor & O'Farrell Sts., San Francisco 2, California
Tel. Graystone 4-8700

John Elwood, General Manager
George Greaves, Assistant General Manager
A. G. Diederich, Auditor & Office Manager
Byron Mills, Manager of Continuity Acceptance
Curtis Peck, Engineer in Charge
John Thompson, Manager of Press, Public Affairs and News
William Minette, Director of Public Affairs

(Continued on page 402)

BROADCASTING • Telecasting

NETWORK RADIO FACILITIES OF THE NATIONAL BROADCASTING COMPANY, INC.

JANUARY 1, 1950



Figures shown are for information purposes only and subject to change without notice.

ADVERTISERS USING ABC NETWORK DURING 1949

Sponsor, Product No. of Stations	Program Day, Time EST	Duration of Contract	Agency	Sponsor, Product No. of Stations	Program Day, Time EST	Duration of Contract	Agency
RADIO							
Adam Hat Stores Inc. New York; Adam Hats, 260	Drew Pearson; Sun. 6:15 PM.	9-4-49	William H. Weintraub & Co.	Farnsworth Television & Radio Corp. Ft. Wayne, Ind.; Farnsworth Radios, Television Sets & Railway Communication Equipment, 72	Metropolitan Opera Auditions of the Air; Sun. 4:30-5 PM.	11-28-48-3-13-49	Warwick & Legler Inc.
A F of L-CIO Joint Labor Committee, New York; Political, 7	Political Speeches; Thurs. 8-8:30 PM.	11-3-49 only	Klinger Advertising Corp.	First National Stores Inc.; Somerville, Mass.; Food Products & Institutional Advertising, 19	Guy Lombardo Show; Thurs. 9:30-10 PM.	10-2-47-7-21-49	John C. Dowd Inc.
American Bakeries Co. Atlanta, Ga.; Merita Bread and Cake, 34	Lone Ranger; Mon.-Wed.-Fri. 7:30-8 P.M.	6-13-49	Tucker Wayne and Co.	Fisher Body Division De Genera Motors, Detroit, Mich.; Institutional, 37	Fisher Body Craftsman's Guild Annual Scholarship Award; Wed. 9-9:15 PM.	8-24-49 only	Kudner Agency Inc.
American Oil Co. Baltimore, Md.; Amoco Gas, Oil and Tires, 103	Carnegie Hall; Sun. 7:30-8 P.M.; Tues. 8:30 P.M.	9-26-48-9-18-49-9-27-49	Joseph Katz Co.	Fisher Flouring Mills Co. (PC) Seattle, Wash.; Fisher's Cereal & Flour Products, 27	Afternoon Final; Mon.-Fri. 5:25-5:30 PM.	9-6-48-3-4-49	Pacific National Advertising Agency
Anahist Co. Inc., Yonkers, N. Y.; Anahist, 56	David Harding-Coun- terspy; Thurs. 7:30-8 P.M.	12-1-49-12-29-49	Foote, Cone & Belding	Fruehauf Trailer Co. Detroit, Mich.; Trail- ers & Institutional Advertising, 97	This Changing World; Sun. 3:3-15 PM.	6-20-48-9-11-49	Zimmer-Keller Inc.
Association of Ameri- can Railroads, Wash- ington, D. C.; Institu- tional, 259	The Railroad Hour; Mon. 8-8:45 P.M.; Mon. 8-8:30 P.M.	10-4-48-4-25-49-5-2-49-9-26-49	Benton & Bowles Inc.	General Electric Co. (Appliance & Mer- chandise Dept.) Bridgeport, Conn.; General Electric Ap- pliances, 265	General Electric Houseparty; Mon.-Fri. 3:30-4 PM.	1-3-49-7-1-49	Young & Rubicam Inc.
Beauty Facteurs Inc. Los Angeles, Calif.; Insta Curl, 45	Meet the Stars; Thurs. 9:55-10 PM.	1-6-49-3-10-49	Mackenzie Advertising	General Foods Corp. New York City; Jell-O, 144	Meredith Willson; Wed. 10:30-11 PM. Surprise Package; Tues. & Thurs. 5:05-5:15 PM.	10-6-48-3-30-49-5-17-49-9-29-49	Young & Rubicam Inc.
Bristol-Myers New York, N. Y.; Ipana, Mum, Vitalis, 201	Break the Bank; Fri. 9-9:30 P.M.	7-5-46-9-23-49	Doherty, Clifford & Shenfield Inc.	Sure-Jell (PC), 9			Benton & Bowles Inc.
Bruner-Ritter Inc. New York, N. Y.; Bruton Watch Bands, Bracelets, 187	Chance of a Lifetime; Sun. 9:30-10 PM.	9-4-49	Raymond Spector Co. Inc.	General Mills Inc. Minneapolis, Minn.			
Budget Finance Plan Inc. (PC) Los Ang- eles, Calif.; Personal Loans, 7	James Roosevelt Speaks; Sun. 11:45-12 Midnight	4-3-49-9-25-49	Irwin-McHugh Advertising	Gold Medal Flour, Bisquick, Cake Flour, Ginger Cake, 186	Betty Crocker Maga- zine of the Air; Mon.-Fri. 10:25-10:45 AM.	3-24-47	Dancer-Fitzgerald- Sample Inc.
Butler Packing Co. (PC) Oakland, Calif.; Dennison's Food Prod- ucts, 21	Newsweek Looks Ahead; Sun. 10:45-11 PM.	8-15-48-2-6-49	Brisacher, Wheeler & Staff Inc.	Kix, Wheaties, Gold Medal Kitchen Tested Flour, 242	Breakfast Club; Mon.-Fri. 9-9:15 AM. Modern Romances; Mon.-Fri. 11-11:15 AM.	8-16-48-11-14-49	Tatham-Laird Inc.
California Medical Ass'n (PC) San Fran- cisco, Calif.; Insur- ance-Hospitalization & Physician's Service, 11	California Caravan; Sun. 7-7:30 PM.; Sun. 6-6:30 PM.	9-26-48-1-2-49-1-9-49-7-24-49	Lockwood- Shackelford Adv.	Wheaties, Cheerios, Kix, 201	Jack Armstrong; Altern- ate Pgms. 5:30-6 PM. (Mon.-Wed.-Fri.) (Tu- Thurs.)	9-6-48-6-3-49-9-5-49	Knox Reeves Advertis- ing Inc.
Carter Products New York City; Arrid, Car- ter's Little Liver Pills, 117	Jimmie Fidler; Sun. 10:30-10:45 PM.; Sun. 10-10:15 PM.	9-7-47-6-5-49-6-12-49	Sullivan, Stauffer, Col- well and Bayles Inc.	Cheerios, Kix & Pyrequick, 108	Lone Ranger; Mon.-Wed.-Fri. 7:30-8 PM.	5-4-42	Dancer-Fitzgerald- Sample Inc.
Champion Spark Plug Toledo, Ohio; Spark Plugs, 237	Champion Roll Call; Fri. 9:55-10 PM.	10-4-46	MacManus, John & Adams Inc.	General Motors Corp. Detroit, Mich.; Insti- tutional, 259	Henry L. Taylor; Mon. 8:30-8:45 PM.	12-20-48-12-5-49-12-12-49	Kudner Agency Inc.
Chesebrough Manu- facturing Co. New York City; Vaseline, Petroleum Jelly, 143	Little Herman; Sat. 9:30 PM.; Tues. 8-8:30 PM.	1-1-49-4-30-49-5-10-49-7-12-49	McCann-Erickson Inc.	General Petroleum Corp. (PC) Los Ang- eles, Calif.; Institu- tional, 33	Dedication of New General Petroleum Building; Fri. 4:30-5 PM.	4-1-49 only	West-Marquis Inc.
Christian Science Publishing Society Boston, Mass.; The Christian Science Monitor, 76	Erwin D. Canham; Tues. 9:30-9:45 PM.	9-14-48	H. B. Humphrey Co.	Gillette Safety Razor Co. Boston, Mass.; "Probak" & "Vale- Auto Strap" Safety Razors & Blades, 261	Gillette Fights; Fri. 10 PM.—Conclusion 9-9-49 Sugar Bowl Game; Sat. 2:30 PM.—Conclusion Jersey Stakes Race; Sat. 4:45 PM. Walcott-Charles Heavyweight Cham- pionship Fight; Wed. 10:30 PM.—Conclusion Ezzard Charles-Gus Lesnevich Heavy- weight Championship Fight; Wed. 10 PM.— Conclusion	9-10-48-8-3-49-9-9-49-1-1-49 only-5-28-49 only-6-22-49 only-8-10-49 only	Maxon Inc.
Club Aluminum Products Chicago, Ill.; Aluminum Household Utensils, 65	Club Time; Tues. 10:45-11 AM.	8-5-47	Leo Burnett Co. Inc.	Globe Mills (PC) (Div. of Pillsbury Mills) East Los Angeles, Calif.; Flour Products, 13	Surprise Package; Mon.-Fri. 5:15-5:30 PM.	3-28-49	Leo Burnett Inc.
Dawn Bible Students Ass'n East Rutherford, N. J.; Institutional, 180	Frank and Ernest; Sun. 11:15-11:30 AM.	10-16-49	W. L. Gleason & Co.	Goodyear Tire & Rub- ber Co. Akron, Ohio; Institutional, 224, 64	The Greatest Story Ever Told; Sun. 6:30-7 PM.; Sun. 5:30-6 PM.	9-12-48-6-12-49-9-18-49	Kudner Agency Inc.
Democratic Volunteer Committee (PC); Pol- itical, 11	James Roosevelt for Governor of State of California; Tues. 11:15-11:30 PM.	11-15-49 only	Raymond Jacobs Adv. Agency	Gospel Broadcasting Association Pasadena, Calif.; Institutional, 94	The Old Fashioned Re- vival Hour; Sun. 8-9 AM.	6-19-49	R. F. Alber Co.
Derby Foods Chicago, Ill.; Peter Pan Peanut Butter, Derby Line of Canned Meats & Meat Specialties, 201	Sky King; Alt (M-W-F) (T-Th) 5:30-6 PM.	9-7-48-6-2-49-9-6-49	Needham, Louis & Brorby Inc.	Green Spot Inc. (PC) Los Angeles, Calif.; Green Spot Orange- ade, 14	Detective of the Week; Wed. 10:55-11:00 PM. Surprise Package; Tues. & Thurs. 6-6:15 PM.	11-2-49-12-28-49-11-3-49	Philip J. Meany Co.
Doubleday & Co. Inc., New York Book—Mil- ton Cross' Opera Al- bum, 55	Jacques Fray; Sat. 1:45-2 PM., 5:45-6 PM.	12-3-49 only	Huber Hoge & Sons	Greystone Press, New York City; Books, 60	Mrs. Fix It; Tues- Thurs. 3:00-3:15 PM.	9-20-49-10-13-49	H. B. Humphrey Co.
Dr. Posner's Scientific Shoes for Children New York City; Shoes, 3	Big 'n' Little Club; Sat. 10:30-11 AM.	1-5-49-4-9-49	Hirshon-Garfield Agency	Heinz, H. J. Co. New York; 57 Varieties, 270	Adv. of Ozzie & Har- riet; Fri. 9:00-9:30 PM.	10-14-49	Maxon, Inc.
Drackett Co. Cincin- nati, Ohio; Drano & Windex, 170	Star Time with Dor- othy Kilgallen; Thurs. 10:45-11 AM.	9-18-47-7-28-49	Young & Rubicam Inc.	Hormel, George A & Co. Austin, Minn.; Meat & Dairy Prod- ucts, 216	Hormel Girls' Corps; Sat. 12:00-12:30 PM. Sun. 6:30-7 PM. 11-20-49	3-5-49-11-12-49	Batten, Barton, Durstine & Osborn, Inc.
Elgin American Divi- sion of The Illinois Watch Case Co. Elgin, Ill.; Compacts, Ciga- rette Cases, Dresser Sets, etc., 145	Groucho Marx; Wed. 9:30-10 PM.	9-29-48-5-25-49	Weiss & Galler Inc.	Independent Citizens Committee for the Election of Senator Dulles, New York; Political, 15 Stations	Speeches by Sen. Dulles & others; 5 days at 6:15-6:30 PM. Speeches by J. Foster Dulles & others; Sat. 9:30-10 PM. Speech by Former Gov. Stassen; Thurs. 8:30-8:45 PM.	10-25, 27, 28-49-11-1, 3-49 only-11-5-49 only-11-3-49 only	BBD&O
Equitable Life Assur- ance Society of US New York; Insurance, 262	This is Your FBI; Fri. 8:30-9 PM.	4-6-46	Warwick & Legler Inc.	Eversharp Inc. Chi- cago, Ill.; Razors, Ra- zor Blades, Pens & Pencils, 182	Stop the Music; Sun. 8:15-8:30 PM.	9-19-48-9-11-49	Blow Co. Inc.

(PC) Pacific Coast only.

Sponsor, Product No. of Stations	Program Day, Time EST	Duration of Contract	Agency	Sponsor, Product No. of Stations	Program Day, Time EST	Duration of Contract	Agency
Independent Citizens Committee continued	Speech by John Foster Dulles & others; Wed. 8-8:15 PM. Wed. 8-8:30 PM. Mon. & Fri. 7:15-7:30 PM.	10-26-49 only 11-2-49 only 10-24, 28, 31-49 11-4, 7-49 only 11-5-49 only		Philip Morris & Co. Ltd., New York City; Philip Morris Cigarettes, 216, 216	Ladies Be Seated; Mon.-Fri. 3:30-3:55 PM. One Man's Opinion; Mon.-Fri. 12:25-12:30 PM.	10-24-49— 10-24-49—	Cecil & Presbrey, Inc.
Independent Citizens for the Election of Lehman, New York; Political, 12	Speech by William Pfeiffer; Sat. 7-7:15 PM.	10-13-49 only	Blow Co.	Phillips Petroleum Co., Bartlesville, Okla.; Phillips 66 Gasoline, Phillips 66 Motor Oil, 70	National Barn Dance; Sat. 10:00-10:30 PM.	3-19-49—	Lambert & Feasley, Inc.
Inland Steel Co., 260	Speeches by Robert Sherwood & Franklin D. Roosevelt, Jr.; Thurs. 7:15-7:30 PM.	10-13-49 only	Blow Co.	Pillsbury Mills, Inc., Minneapolis, Minn.; Family Flour, Cake Flour, Wheat Bran, Corn Meal, 216, 214, 218	Galen Drake; Mon.-Fri. 11:45-12:00 Noon. Mon.-Fri. 4:00-4:15 PM. Kay Kyser's College of Fun and Knowledge; Mon.-Fri. 4:15-4:30 PM. Mon.-Fri. 4:00-4:15 PM.	1-3-49— 9-16-49 9-19-49— 12-30-49 1-3-49— 1-7-49 1-10-49— 7-29-49	Leo Burnett Co., Inc.
Institute of Religious Science (PC), Los Angeles, Calif.; Institutional, 11	This Thing Called Life; Sun. 7-7:30 PM.	10-2-49 11-13-49 10-20-49	Raymond R. Morgan Co.	Procter & Gamble Co., Cincinnati, Ohio; Crisco, Tide, Soaps, Cleaners, 202	Welcome Travelers; Mon.-Fri. 12:00-12:30 PM.	6-30-47— 7-8-49	Compton Adv. (Crisco) Benton & Bowles
Jergens, The Andrew Co., Cincinnati, Ohio; Jergens Lotion Toilet Soaps, Perfumes, 259	The Jergens-Woodbury Journal; Sun. 9:15-9:30 PM.	12-23-45—	Robert W. Orr & Associates Inc.	Quaker Oats Co., Chicago, Ill.; Quaker Puffed Wheat, Sparkies, 205	Challenge of the Yukon; Mon.-Wed.-Fri. 5:00-5:30 PM.	9-13-48— 6-10-49 9-12-49—	Sherman & Marquette, Inc.
Kaiser-Frazier Sales Corp., Willow Run, Mich.; Automobiles, Parts, Servicing, 279	Walter Winchell; Sun. 9:00-9:15 PM. Your Kaiser Traveler; Sun. 9:00-9:15 PM. Walter Winchell; Sun. 9:00-9:15 PM.	1-2-49— 9-4-49 9-11-49— 12-25-49	William H. Weintraub & Co.	Aunt Jemima Pancake Flour, Muffets, Bakery Goods, 221, 223	Ladies Be Seated; Mon.-Fri. 3:00-3:15 PM. Talk Your Way Out of It; Mon.-Wed.-Fri. 3:00-3:30 PM.	9-16-46— 6-10-49 3-30-49— 6-10-49 9-12-49— 12-9-49	La Roche, C. J. & Co.
Kelvinator Division of Nash-Kelvinator Corp., Detroit, Mich.; Kelvinator Refrigerators, Electric Ranges, 126	Human Side of the News; Mon.-Fri. 7:00-7:05 PM.	4-26-49— 6-24-49	Geyer, Newell & Ganger Inc.	Radio Offers or Doubleday Co. New York; Plastic Products, books; 55	Pick a Date; Tues. 10:30-10:45 AM. Pick a Date; Wed. 11:30-12 Noon This Romantic Song Shop; Tues. & Thurs. 3-3:15 PM.	11-15-49 12-6-49 11-16-49— 12-8-49 11-15-49— 12-8-49	Huber Hoge & Sons
Langendorf United Bakeries Inc. (PC), San Francisco, Calif.; Bakery Products, 8	Zeke Manners; Mon.-Fri. 10:45-11 AM.	5-9-49— 9-30-49	The Blow Co., Inc.	Radio Offers Co.; Plastic Products & Toys, 55	Pick a Date; Mon. & Fri. 11:30-12 Noon Shoppers Special; Sat. 9:30-10 AM.	11-28-49— 12-9-49 11-26-49— 12-3-49	Huber Hoge & Sons
Lee, Frank H. Co., Danbury, Conn.; Men's Hats, 260, 266	Drew Pearson; Sun. 6:00-6:15 PM. Robert Montgomery Speaking; Thurs. 10:10-10:25 PM. Thurs. 9:45-10:00 PM.	9-12-48— 8-28-49 9-15-49— 11-3-49	William H. Weintraub & Co. Grey Advertising	Radio Offers Co., New York City; Plastic Products, 56	New William Lang; Thurs. 10:45-11:00 AM.	9-8-49—	Huber, Hoge & Sons.
Libby McNeill & Libby, Chicago, Ill.; Canned & Frozen Juices, Meats, Fish, Fruit, Baby Foods, 206	My True Story; Mon.-Fri. 10:00-10:25 AM.	4-17-44 6-3-49	J. Walter Thompson Co.	Regal - Amber Brewing Co. (PC), San Francisco, Calif.; Regal Pale Beer, 12	Regal - Amber Show with Hank Weaver; Fri. 5 min. between 10:30 - 11:00 PM.	9-9-49—	Abbott Kimball Co., Inc. of Calif.
Lorillard P. Co. New York City; Old Gold Cigarettes, 182, 182, 178	Stop the Music; Sun. 8:00-8:15 PM. Stop the Music; Sun. 8:45-9:00 PM. Original Amateur Hour; Wed. 8:00-9:00 PM. Thurs. 9:00-9:45 PM. Party Time; Mon.-Wed.-Fri. 7:00-7:15 PM.	4-3-49— 12-25-49 5-23-48— 9-29-48— 7-20-49 7-28-49— 4-18-49 7-15-49	Lennen & Mitchell, Inc.	Revere Camera Co., Chicago, Ill.; Movie Cameras, Projectors & Accessories, 49, 50, 51	Jo Stafford Show; Thurs. 9:30-9:55 PM. Name the Movie; Thurs. 9:30-9:55 PM. Thurs. 9:45-10:10 PM.	1-6-49— 5-5-49 5-12-49— 7-21-49 7-28-49— 11-3-49	Roche, Williams & Cleary, Inc.
(PC), 21	The Lutheran Hour; Sun. 3:30-4:00 PM.	10-2-49—	Gotham Advertising Co.	Richfield Oil Corp. (PC), Los Angeles, Calif.; Petroleum Products, 21	Richfield Reporter; Sun-Sat. 1:00-1:15 AM. Sun.-Fri. 1:00-1:15 AM.	9-26-48— 9-24-49 9-25-49	Hixson-Jorgensen, Inc.
Lutheran Laymen's League, St. Louis, Mo.; Institutional, 190	Lawrence Welk Show; Wed. 9:30-10:00 PM. Wed. 10:00-10:30 PM.	6-1-49— 8-24-49 8-31-49	Klau-Van Pietersom-Duniap Associates.	RCW Enterprises, Los Angeles, Calif.; Circus balloon toys, 260	Johnny on the Spot; Sun. 7:55-8 PM.	11-27-49 only	Cowan & Whitmore Advertising Agency
Miller Brewing Co., Milwaukee, Wisconsin; Miller High Life Beer, 21	Surprise Package; Mon.-Wed.-Fri. 5:15-5:25 PM.	10-4-48— 1-7-49	Glasser-Galley, Inc.	Retail Clerks Union Local #770 (PC), H'wood, Calif.; Political 11	Vote No on Proposition No. 2, California Ballot; Sun. 10:15-10:30 PM.	11-6-49 only	Leonard Shane Co.
Mode O'Day Corp. (PC), Los Angeles; "Mode O'Day" Wash Dresses	Address by Mr. Earl Bunting; Tues. 10-10:30 PM.	10-18-49 only	Benton & Bowles Inc.	Richfield Oil Co. of N. Y. New York City; Richfield Oil & Gas	Richfield Sports Reporter; Sat. 7:30-7:45 PM.	9-17-49—	Morey, Humm & Johnstone, Inc.
National Association of Manufacturers, New York; None, 260	Political Speeches; Thurs. 7:30-8 PM.	11-3-49 only	Furman, Feiner & Co.	Ritter, R.J. Co., Bridge- ton, N. J.; Ritter's Catsup, Chill Sauce, Relish, 11, 16	Betty Clark Sings; Sun. 3:15-3:30 PM. Sun. 6:30-6:45 PM. Sun. 3:15-3:30 PM.	1-16-49— 6-12-49 6-19-49— 9-11-49 9-18-49	The Clements Co., Inc.
National Committee for an Effective Congress, New York; Political, 15	Political Speeches; Sun. 7:45-8 PM.	11-6-49 only	Ben Sackheim Agency	Safeway Stores Inc. (PC) Oakland, Calif.; Lucerne Milk, 8	Zeke Manners; Mon.-Fri. 10:45-11:00 AM.	4-18-49—	J. Walter Thompson Co.
New York State Democratic Committee, New York; Political, 9	Speeches by John Foster Dulles & others; Mon. & Wed. 8-8:15 PM. Tues. & Thurs. 6:15-6:30 PM.	10-10, 12-49 only 10-11, 13-49 only	Batten, Barton, Durstine & Osborn	Seaman Brothers Inc., New York City; Air-Wick, 126, 253	Tomorrow's Headlines; Sat. 11:30-11:45 AM. Monday Morning Headlines; Sun. 6:15-6:30 PM.	7-31-48— 1-22-49 2-9-47	William H. Weintraub & Co., Inc.
New York State Republican Committee, New York; Political, 15	Fat Man; Fri. 8:00-8:30 PM.	2-14-47—	Lawrence C. Gumbiner.	Serve! Inc., Evansville, Indiana; Serve! Gas Refrigerators, 101	What's My Name; Sat. 11:30-12:00 Noon. Sat. 12:30-1:00 PM.	2-5-49— 4-23-49 4-30-49— 7-30-49	Batten, Barton, Durstine & Osborn, Inc.
Norwich Pharmacal Co., Norwich, New York; Pepto-Bismol, Unguentine, 216	The Sheriff; Fri. 9:30-9:55 PM.	6-29-45—	McCann-Erickson, Inc.	Serutan Inc., New York City; Serutan Nutex R-D-X, Lemel and Hi-V, 69	Victor H. Lindlahr; Mon.-Wed.-Fri. 10:45-11:00 AM. Sun. 11:00-11:15 AM.	9-7-49—	Roy S. Durstine, Inc.
Pacific Coast Borax Co., New York City; Twenty Mule Team Borax and Boraxo, 174	Romance of the High-Lines (PC), San Francisco, Calif.; Bus Transportation, 9	10-24-48	Beaumont & Hobman, Inc.	Smith Bros., Pough- keepsie, New York; Cough drops & cough syrup, 187	Stop the Music; Sun. 8:00-8:15 PM. Sun. 8:15-8:30 PM.	10-3-48— 3-27-49 9-18-49—	Sullivan, Stauffer, Colwell & Bayles Inc.
Pacific Greyhound Lines (PC), San Francisco, Calif.; Bus Transportation, 9	Counter - Spy; Tues.-Thurs. 7:30-8:00 PM.	1-11-49—	The Blow Co., Inc.	Southern Baptist Convention, Atlanta, Ga.; Institutional, 135	The Baptist Hour; Sun. 3:30-4:00 PM.	10-2-49—	Liller, Neal & Battle
Pepsi-Cola Co., New York City; Pepsi-Cola & Evervess, 286	Adventures of Sherlock Holmes; Wed. 8:30-8:55 PM.	9-21-49—	Young & Rubicam, Inc.	Speidel Co., Providence, R. I.; Wrist- watch Bands, Children's Jewelry, 187	Stop the Music; Sun. 8-8-48—	8-8-48—	Cecil & Presbrey, Inc.
Petri Wine Co., San Francisco, Calif.; Petri Wine, 45	Breakfast Club; Mon. 9:45-10:00 AM.	9-3-45—	Hutchins Adv. Co., Inc.				
Philo Corporation, Phila., Pa.; Refrigerators, Radios, Freezers, Air-Conditioning & Television Receivers, 271, 238	Bing Crosby; Wed. 10:00-10:30 PM.	9-29-48— 6-1-49					

(Continued on page 396)



Some sales are more profitable than others . . .

American Broadcasting Company

ABC

NEW YORK • CHICAGO • DETROIT
LOS ANGELES • SAN FRANCISCO





... So sell hardest where you sell best!

NO MATTER WHAT YOU HAVE TO SELL

ABC COVERS AMERICA'S BEST MARKETS...EFFICIENTLY

ADVERTISERS USING ABC NETWORK DURING 1949

(Continued from page 393)

Sponsor, Product No. of Stations	Program Day, Time EST	Duration of Contract	Agency
Stanley Home Products, Westfield, Mass.; Kitchen Equipment, 266	Choral Festival: Sun. 3:30-4:00 PM.	5-15-49 only	None
Boys' Town Choir; Sun. 5-5:30 PM.	12-11-49 only		Charles W. Hoyt Co.
U.S. Steel Workers of America; Institutional, 260	Phil Murray Talks About the Steel Strike; Wed. 8:15-8:30 PM.	10-12-49 only	Wiltman & Callahan
Sterling Drug Inc., New York City; Philip's Toothpaste, Milk of Magnesia, Tablets, Creams, Mulsified Shampoo, 218, 204	Bride & Groom; Mon.-Fri. 2:30-3:00 PM. My True Story; Tues. 10:00-10:25 AM.	1-7-46— 6-7-49	Dancer-Fitzgerald-Sample, Inc.
Swift and Co., Chicago, Ill.; Meat, Meat Products, Shortening & Cooking Oils, 299	Breakfast Club; Mon.-Fri. 9:15-9:45 AM. Special Breakfast Club Program; Sat. 7:45-8:00 AM.	6-3-46— 10-1-49 only	J. Walter Thompson Co.
Texas Co., New York City; Gasoline & Motor Oil, 290, 292	Metropolitan Opera; Sat. 2 PM.—Conclusion Milton Berle Show; Wed. 9-9:30 PM.	12-4-48— 3-18-49 11-26-49 9-22-48 8-15-49	Buchanan & Co. Inc. Kudner Agency Inc.
Textile Workers Union of America, New York; Institutional, 126	From Where We Came; Sat. 8:30-9 PM.	5-14-49 only	Furman, Feiner & Co. Inc.
Toni Inc. Chicago, Ill.; Toni Home Permanent Wave & Toni Shampoo, 222	Ladies be Seated; Mon.-Wed.-Fri. 3:15-3:30 PM.	12-27-48— 3-25-49	Foote, Cone & Belding Inc.
United Electrical, Radio & Machine Workers of America New York City; Institutional, 115	Arthur Gaeth; Mon. 10-10:15 PM.	4-19-48—	Weinstein Co.
U.S. Army & U.S. Air Force Recruiting Service Washington, D.C.; Recruiting, 268	Game of the Week; Sat. approx. 2 PM.—Conclusion	10-1-49 11-19-49	Gardner Advertising Co.
U.S. Sixth Army Command (PC) San Francisco, Calif.; U.S. Army Recruitment, 21	Blue Book of Sports; Fri. 5 minutes between 11:30-12 Mid.	10-1-48— 8-24-49	Russell, Harris & Wood Inc.
U.S. Steel Corporation New York City; Institutional, 258	Theatre Guild on the Air; Sun. 9:30-10:30 PM.	9-12-48— 6-5-49	Batten, Barton, Durstine & Osborn
Voice of Prophecy Inc. Glendale, Calif.; Institutional, 205	The Voice of Prophecy; Sun. 9:30-10 AM.	6-19-49	Western Advertising Agency Inc.
Waltham Watch Co. Waltham, Mass.; Waltham Watches, 21	Share the Wealth; Mon. 8-8:25 PM.	10-17-49—	Hirshon-Garfield Inc.
Westinghouse Electric Corp. Pittsburgh, Pa.; Ranges, Laundromats, Refrigerators, Irons, 222	Ted Malone; Mon.-Fri. 11:30-11:45 AM.; Mon.-Fri. 3:55-4 PM.	7-19-48— 6-24-49 9-19-49	McCann-Erickson Inc.
Whitehall Pharmacal Co. (PC) New York City; Anacin, Kolyon, Bisodal, Freezone, 13	Zeke Manners; Mon.-Fri. 10:45-11 AM.	1-5-48— 4-1-49	Dancer-Fitzgerald-Sample Inc.
Wise, William & Co. New York City; Books, 109	Get More Out of Life; Mon.-Fri. 11-11:15 AM.; Mon.-Wed.-Fri. 10:45-11 AM.	1-24-49— 3-4-49 3-7-49 4-29-49	Thwing & Alaman. Inc.

Radio Correspondents Gallery

(Continued from page 377)

WBBF ROCK ISLAND, ILL. Safety Bldg. Leslie C. Johnson	WLW CINCINNATI, OHIO Crosley Square Howard Chamberlain Gene Martin
WHO DES MOINES, IOWA 914 Walnut St. John D. (Jack) Shelley	WNYC NEW YORK CITY 2500 Municipal Bldg. Seymour N. Siegel
WINS NEW YORK CITY 28 W. 44th St. Joe Durso Don Goddard	WOR NEW YORK CITY 1440 Broadway David E. Driscoll Helen Hall
WIOU KOKOMO, IND. William Randolph Cox	WOW OMAHA, NEB. 1712 Farnam Soren H. Munkof
WJR DETROIT, MICH. Fisher Bldg. George W. Cushing	YANKEE AND MUTUAL NETWORKS, BOSTON, MASS. Cedric Foster
WLIB NEW YORK CITY 430 East 88th St. Estelle M. Sternberger	KONO SAN ANTONIO, TEX. 317 Arden Grove M. J. Shoemaker
WLS CHICAGO, ILL. 1230 W. Washington Ervin Lewis	

TELEVISION

Sponsor, Product No. of Stations	Program Day, Time EST	Duration of Contract	Agency
Admiral Corp.; Radios, TV Sets, Refrigerators, Ranges, 22	Stop the Music; Thurs. 8-8:30 PM.	5-5-49—	Kudner Agency
American Bakeries Co.; Bread & Bakeries Prod., 6	Lone Ranger; Thurs. 7:30-8:00 PM.	10-6-49	Tucker Wayner Co.
Amer. Jewish Congress, 3	Democratization of Germany; Tues. 9:30-10 PM.	10-25-49 only	Direct
Bell & Howell; Motion Picture Cameras, Projectors & Equipment, 5	Action Autographs; Sun. 10-10:15 PM.; Sun. 6:30-6:45 PM.	4-24-48— 6-26-49 9-25-49	Henri, Hurst & McDonald Inc.
Blatz Brewing Co.; Blatz Beer, 13	Roller Derby; Thurs. 10:30—Concl. PM.	9-29-49	Kastor, Farrell, Chesley & Clifford Inc.
Bristol-Myers Co.; Mum & Vitals, 9	Break the Bank; Fri. 9-9:30 PM.	10-22-48— 9-23-49	Doherty, Clifford & Shenfield Inc.
Canada Dry Ginger Ale; Ginger Ale, Sparkling Water, 13	Super Circus; Sun. 5-5:30 PM.	4-3-49	J. M. Mathes Inc.
Chesebrough Mfg. Co.; Vaseline Prods., 10	Roller Derby; Thurs. 10-10:30 PM.	10-13-49	McCann-Erickson Inc.
Chevrolet Dealers; Motor Cars & Trucks, 2	Roller Derby; Fri. 10 PM.—Concl.	5-20-49— 7-1-49	Campbell-Ewald Co.
Delta Mfg. Div. of the Rockwell Mfg. Co.; Power Tools, 7	That's O'Toole; Sun. 4:45-5 PM.	3-13-49— 6-5-49	Hoffman & York Inc.
Derby Foods Inc. Peter Pan Peanut Butter, 10	Super Circus; Sun. 5:30-6 PM.	5-1-49— 10-23-49	Needham, Louis & Brorby Inc.
General Mills; Cereals, 27	Lone Ranger; Thurs. 7:30-8 PM.	9-15-49—	Dancer-Fitzgerald-Sample Inc.
Gillette Safety Razor Co.; Razor Blades & Shaving Cream, 7	Jersey Stakes; Sat. 4:45-5 PM.	5-28-49 only	Maxon Inc.
Goodrich, The B. F. Co.; Tires, Tubes & Rubber Prods., 21	Celebrity Time; Sun. 8:30-9 PM.; Sun. 10-10:30 PM.	4-3-49— 6-28-49 7-3-49	Barton, Batten, Durstine & Osborne
Goodyear Tire & Rubber Co. Inc., 40	Paul Whiteman, Good-year Revue; Sun. 7:00-7:30 PM.	11-6-49—	Young & Rubicam
International Cellucotton Products Co.; Kleenex, 9	Fun for the Money; Fri. 9:30-10 PM.	6-17-49— 12-9-49	Foote, Cone & Belding
Kellogg Co.; Shredded Wheat & Corn Soya 12	Irene Wicker—The Singing Lady; Sun. 6-6:30	2-13-49—	N. W. Ayer & Son Inc.
Libby, McNeill & Libby; Libby Products, 5	"Auction—Aire"; Fri. 9-9:30 PM.	9-30-49—	J. Walter Thompson
Lorillard, P. Co.; Old Gold Cigarettes, 22	Stop the Music; Thurs. 8:30—9 PM.	5-5-49— 10-27-49	Lennen & Mitchell Inc.
Pal Blade Co. Inc.; Pal Razor Blades, 25	Pal Headliners; Thurs. 9:25-9:30 PM.	5-5-49— 10-27-49	Al Paul Lefton Co.
R. J. Reynolds Tobacco Co.; Cameels, 8	International Finals of the Golden Gloves; Wed. 9:30 PM.—Concl.	5-18-49 only	Wm. Estey Co.
Saguer's, A. Son Inc.; "Northcool" Suits & "Englishtown" Men's Clothing, 6	Northcool Pimlico Races; Fri., May 6-Sun., May 15. Various evening hours	5-6-49— 5-15-49	J. A. Goodman & Co.
Stein, A. & Co.; Paris Garters, Belts & Suspenders, 12	Identify; Mon. 9-9:15 PM.	2-14-49— 5-9-49	Louis A. Smith
Sun Oil Co.; Oil, Gas, Accessories, 12, 10 approx.	Phila. Eagles vs. Chic. Cardinals; Mon. 9:30 PM.—Concl.; National League Football Games Various	8-29-49 only St. 9-25-49 (14 times)	Hewitt, Ogilvy Benson & Mather Inc.
Texas Co., 6	Opening Night of the Metropolitan Opera; Mon. 7:45 concl.	11-21-49 only	Kudner Agency Inc.
Time Inc.; Time Magazine, 33	Crusade in Europe; Thurs. 9-9:25 PM.	5-5-49— 10-27-49	Young & Rubicam Inc.
Young People's Church of the Air, 12	Youth on the March; Sun. 10:30-11 PM.	10-9-49	J. M. Camp & Co.

ADVERTISERS USING CBS NETWORK DURING 1949

(Contract dates cover only those contracts effective in 1949)

Sponsor, Product No. of Stations	Program Day, Time EST	Duration of Contract	Agency	Sponsor, Product No. of Stations	Program Day, Time EST	Duration of Contract	Agency
Alberts Products Co. Portland, Ore.; Soft Drinks, 13	Meet the Missus; Sat. 3:30-3:45 PM. CNYT; 10-1-49 Sat. 2:30-2:45 PM. CNYT	8-20-49—	H. C. Morris & Co., Los Angeles	Franco-American, 153	Edward R. Murrow; M-F 7:45-8 PM.	8-29—Dec	Ward Wheelock Co., Phila.; 10-31, Dancer- Fitzgerald-Sample, N. Y.
American Home Products Corp. Jer- sey City; (Whitehall Pharmaceutical Co. Div.), AnacIn, 84-159	Our Gal Sunday; M-F 12:45-1 PM.	Jan-Dec	Dancer-Fitzgerald- Sample, Inc., New York; 1-17-49 John F. Murray Advertising Agency, Inc.	Carnation Co. Los Angeles; Evaporated Milk, 175+ CBC	Contented Hour; Sun. 10-10:30 PM.	10-2-49— Dec	Erwin Wasey & Co., Ltd., Los Angeles
Anacin, Koly nos, 150	Mr. Keen, Tracer of Lost Persons; Thurs. 8:30-9 PM.	Jan-Dec	Dancer-Fitzgerald- Sample, Inc., New York; 1-17-49 John F. Murray Advertising Agency, Inc.	Evaporated Milk, 14	Carnation Family Par- ty; Sat. 3:30-4 PM. CNYT	9-24-49— Dec	Erwin Wasey & Co., Ltd., Los Angeles
Aero Wax, Antrol Ant Spray, Black Flag, Koly nos Tooth Powder & Toothpaste, Wizard Wick, Wizard Glass Wax, 84-166	Romance of Helen Trent; M-F 12:30-12:45 PM.	Jan-Dec	Dancer-Fitzgerald- Sample, Inc.; 1-17-49 John F. Murray Ad- vertising Agency, Inc., New York; W. Earl Bothwell, Inc., Los Angeles	Cartier Products, Inc. N.Y.; Arrid, 123	Sing It Again; Sat. 10:30-10:45 PM.	10-1-49— Dec	Sullivan, Stauffer, Col- well & Bayles, Inc., New York
American Tobacco Co. New York; Lucky Strike Cigar- ettes, 180	Jack Benny Show; Sun. 7-7:30 PM.; 12:30- 1 AM.	1-2-49— May 9-11—Dec	Batten, Barton, Dur- stine & Osborn, Inc., New York	Chesebrough Mfg. Co. Consolidated New York; Petroleum Jelly, Hair Tonic, Vaseline, Shampoo, 157	Dr. Christian, with Jean Hersholt; Wed. 8:30-9 PM.; 11:30-12 Mid.	Jan-Dec	McCann-Erickson, Inc., New York
Lucky Strike Cigarettes, 151	Your Hit Parade; Sun 7-7:30 PM.; 12:30-1 AM.	6-5—9-4	Batten, Barton, Dur- stine & Osborn, Inc., New York	Coca-Cola Co. New York; Coca-Cola, 161+ CBC	The Pause that Re- freshes, with Percy Faith's Orch.; Jane Froman; Fri. 10:30-11 PM.	Jan—2-11	D'Arcy Advertising Co., Inc., New York
Rio-Tan Cigars, 174	Your Lucky Strike; M-F 3:30-4 PM.	12-6-49— 3-4-49	Batten, Barton, Dur- stine & Osborn, Inc., New York	Coca-Cola, 167+ CBC	Spike Jones Show; Sun. 6:30-7 PM.; 3-12 Sat. 7-7:30 PM.; 12- 12:30 AM.	Jan—6-25	D'Arcy Advertising Co., Inc., New York
Animal Foundation, Inc. Sherburn, N.Y.; Div. of Maritime Milling Co., Inc.; Hunt Club Dog Food, 63	Leave It To Joan; Fri. 9-9:30 PM.	9-9-49— Dec	Lawrence C. Gumbin- ner Advertising Agency	Coca-Cola, 180+ CBC	Charlie McCarthy Pro- gram; Sun. 8-8:30 PM.; 11:30-12 Mid.	10-2—Dec	D'Arcy Advertising Co., Inc., New York
Armour & Co. Chica- go; Perk Soap, Chif- fon Flakes, Dash Dog Food, Dial Soap, Canned Meats, 157	Allan Jackson & the News; Sun. 11-11:05 AM.	9-11-49— Dec	Comstock, Duffes & Co., Buffalo	Colgate-Palmolive- Peet Co. Jersey City; Colgate Dental Cream, Halo Sham- poo, 151	Mr. & Mrs. North; Tues. 8:30-9 PM.; 11:30-12 Mid.	Jan-Dec	Sherman & Marquette, Chicago
Canned Meats, Dial Soap, Lard, Mar- garine, Cheese, 168	Hint Hunt; M-F 4-4:25 PM.	Jan— 5-13-49	Foote, Cone & Belding, Chicago	Halo Shampoo, 8	Your Stand In; M-F 7:15-7:30 PM. CNYT	3-21—Dec	Sherman & Marquette, Chicago
Armstrong Cork Co. Lancaster, Pa.; Arm- strong Quaker Rugs, 166	Stars Over Hollywood; Sat. 1-1:30 PM.	Jan-Dec	Foote, Cone & Belding, Chicago	Lustre Creme Shampoo, Palm- olive Soap, 152+ CBC	Our Miss Brooks; Sun. 9:30-10 PM.; 9-11 Sun. 6:30-7 PM.; 11-11:30 PM.	Jan-Dec	Ted Bates & Co.
Associated Oil Co. San Francisco; Lubricants, 16	Armstrong Theater of Today; Sat. 12-12:30 PM.	Jan-Dec	Batten, Barton, Dur- stine & Osborn, Inc., New York	Continental Baking Co., Inc. New York; Wonder Bread, Hos- tess Cakes, 48	Grand Slam; M-F 11:30-11:45 AM.	Jan-Dec	Ted Bates & Co.
B. T. Babbitt, Inc. New York; Bab-O, Glim, 55	Football Games; Sat. 2:15-5 PM. CNYT	9-17— 11-19	Buchanan & Co., Inc., San Francisco	Cream of Wheat Corp. Minneapolis; Cream of Wheat, 154	Let's Pretend; Sat. 11:05-11:30 AM.	Jan-Dec	Batten, Barton, Dur- stine & Osborn, Inc., New York
P. Ballantine & Sons Newark, N.J.; Bal- lantine Beer & Ale, 172	David Harum; M-F 3-3:15 PM.	Jan-Dec	Duane Jones Co., Inc., New York	Curtiss Candy Co. Chicago; Candy, 149	Warren Sweeney— News; Sat.-Sun. 11- 11:05 AM.	Jan—1-16	C. L. Miller Co., Chicago
Ballard & Ballard Co. Louisville; Ballard's Obelisk, 30	Robinson & Beloise Fight; Wed. 10-10:35 PM.	8-24 only	J. Walter Thompson Co., New York	De Soto-Plymouth Dealers, division of Chrysler Corp.; De Soto-Plymouth Cars, 172	Hit the Jackpot; Tues. 10-10:30 PM.	Jan-Dec	Batten, Barton, Dur- stine & Osborn, Inc., New York
Bekins Van & Stor- age Co. Seattle; Stor- age, 13	Renfro Valley Folks; Sun. 9:15-9:45 AM.	Jan— 1-23-49	Henri, Hurst & Mc- Donald, Inc., Chicago	Democratic State Committee, Political, 9*	Paul Fitzpatrick; Fri. 6:15-6:30 PM.	10-28 only	Ben Sackheim, Inc., New York
Block Drug Co., Inc. Jersey City; Amm-i- dent, 150	Bekins Hollywood Music Hall; Wed. 10- 10:30 PM. CNYT; 5-11 Wed. 11:30-12 Mid. CNYT; 10-5 Wed. 10:30-11 PM. CNYT	Jan-Dec	Brooks Adv. Agency, Los Angeles	Dennison Food Co.; Canned Foods, 12	Bob Garrod, News; Tues.-Thurs.-Sat. 8:45-8:55 PM. CNYT	Jan-Dec	Brisacher, Wheeler & Staff, San Francisco
The Borden Co. New York; All Products, 167	Burns & Allen Show; Wed. 10:10:30 PM.	9-21-49— Dec	Cecil & Presbrey, Inc., New York	Electric Auto-Lite Co. Toledo; Spark Plugs, Auto Acces- sories, 169+ CBC	Suspense; Thurs. 9- 9:30 PM.	Jan-June Sept.-Dec	Newell-Emmett Co., New York
California Packing Corp. San Francisco; Del Monte Products, 26	County Fair; Wed. 9- 9:30 PM.; 7-9 Sat. 2- 2:30 PM.	Jan-Dec	Kenyon & Eckhardt, Inc., New York	Electric Companies Advertising Program, New York; Institutional, 163	Electric Theater with Helen Hayes; Sun. 9- 9:30 PM.	Jan-May	N. W. Ayer & Son, Inc., New York
Campana Sales Co. Batavia, Ill.; All Products, 62	Rocky Jordan; Sun. 9- 9:30 PM. CNYT; 10-2 Sun. 8:30-9 PM. CNYT	8-7-49— Dec	McCann-Erickson, Inc., San Francisco	Institutional, 163	Corliss Archer; Sun. 9-9:30 PM.	7-31—Dec	N. W. Ayer & Son, Inc., New York
Campbell Soup Co. Camden, N.J.; Camp- bell Soups, 153	First Nighter; Thurs. 10:30-11 PM.; 6-9—9-1 Thurs. 10-10:30 PM.	Jan— 10-20-49	Wallace-Ferry-Hanly Co.	Elgin-American, division of Illinois Watch Case Co. El- gin, Ill.; Compacts, Watch Cases, Light- ers, etc., 151	You Bet Your Life, with Groucho Marx; Wed. 9-9:30 PM.	10-5—Dec	Weiss & Geller, Inc., New York
Campbell Soups, 153+ CBC	Edward R. Murrow; Mon.-Fri. 7:45-8 PM.	Jan-June	Ward Wheelock Co., Phila.	Emerson Drug Co. Baltimore; Bromo- Seitzer, 157	Inner Sanctum; Mon. 8-8:30 PM.; 12-12:30 AM.	Jan-Dec	Batten, Barton, Dur- stine & Osborn, Inc., New York
Franco-American, 154+ CBC	"Club 15" with Dick Haymes, Andrew Sis- ters, Evelyn Knight; M-F 7:30-7:45 PM.; 12:45-1 AM.	8-29—Dec	Ward Wheelock Co., Phila.	Evans Case Co. No. Atleboro, Mass., Cigarette Lighters, Handbags, Compacts, 11**	Evans Show Case; Sat. 8:30-9 PM.	6-25—9-17	Don Horter & Co., Boston
	"Club 15" with Bob Crosby, Andrew Sis- ters, Margaret Whiting, Modernaires; M-F 7:30-7:45 PM; 5-16 1:45-2 AM.	Jan-June	Ward Wheelock Co., Phila.	Farry-Morse Seed Co. Detroit; Seeds, 167	Garden Gate, with Tom Williams; Sat. 9:45-10 AM.	2-5—5-21	MacManus, John & Adams, Inc.
				Seeds, 32	Garden Gate, with Tom Williams. Sat. 9:45-10 AM.	9-10— 10-29	MacManus, John & Adams, Inc.
				"42" Products, Inc. Los Angeles; Hair Oil, other products, 12	Bob Garrod, News; Tues.-Thurs.-Sat. 6:45-6:55 PM PST	1-1 only	McNeill & McCleery, Inc., Los Angeles
				Ford Motor Co. Dearborn; Ford Motor Cars, 170+ CBC	Ford Theater; Fri. 9-10 PM.	Jan—7-1	Kenyon & Eckhardt, Inc., New York

(Continued on page 400).

Abbott-Kimball & Co.
Los Angeles, Calif.
Acme Adv. Agency
Dallas, Texas
Advertising Engineers Corp.
Tulsa, Okla.
Advertising, Inc.
Richmond, Va.
Advertising Inc. of Washington
Washington, D. C.
Advertising, Inc.
Charleston, W. Va.
Allen & Reynolds, Adv.
Omaha, Nebr.
Allied Adv. Agency
Los Angeles, Calif.
Atlas Adv. Agency
Sioux City, Iowa
Ayer, N. W. & Son, Inc.
Philadelphia, Penna.
Aylin Adv. Agency
Houston, Texas
Baker, Jim Associates, Inc.
Milwaukee, Wisc.
Baldwin, Bowers & Strachan,
Buffalo, N. Y.
Barnes Advertising Agency, Inc.
Milwaukee, Wis.
Barratta Wardell Agency
Worcester, Mass.
Stuart Bart & Getschal, Inc.
New York City
Bartz, Rudolph, Advertising Co.,
Peoria, Ill.
Basford, G. M. Co.
New York, N. Y.
Bass-Luckoff Adv.
Los Angeles
Batten, Barton, Durstine, Osborn
New York City
Baxter & Crim, Inc.
Coral Gables, Fla.
Beaumont & Hahman, Inc.
Kansas City, Mo.
Benton & Bowles, Inc.
New York City
Benjamin, Herbert S., Assoc.,
Baton Rouge, La.
Benson, Vickers, Ltd.
Montreal, Quebec, Canada
Bennett Adv., Inc.
High Point, N. C.
Berger, Alfred Paul, Inc.
New York City
Bergman-Jarrett Co.
New York City
Bernstein, Bo & Co., Inc.
Providence, R. I.
Biow, The Co.,
New York City
Black, Fred Adv. Agency
Reading, Penna.
Blumberg, Frank L. Adv.
Baltimore, Md.
Baynton, Stanley, Agency
Detroit, Mich.
Bozell & Jacobs, Inc.
Chicago, Ill.
Bozell & Jacobs, Inc.
Indianapolis, Ind.
Bowman & Block, Inc.
Buffalo, N. Y.
Brantley, J. Carson, Agency
Salisbury, N. C.
Browne, Burton Adv.
Chicago, Ill.
Brown, E. H. Adv.
Chicago, Ill.
Brown, E. Scott Agency
New Canaan, Conn.
Buchanan & Co.
New York City
Bull Adv. Agency
Indianapolis, Ind.
Harold Cabot & Company, Inc.
Boston, Mass.
Cahn-Miller Inc.
Baltimore, Md.
Campbell-Ewald Co.
Detroit

Casler, Hempstead & Hanford,
Rochester
Cary, R. H. Inc.
Des Moines, Iowa
Chernow Co., Inc.
New York City
Chesman, Nelson Co.
Chattanooga, Tenn.
Clarke, Robert E. & Assoc.
Miami, Fla.
Cline Adv. Agency
Boise, Idaho
Cohen, I. T. Advertising Agency
Washington, D. C.
Cole & Werner
Omaha, Nebr.
Collins, Cusick, Schwerte, Wild
San Antonio, Texas
Conti Adv.
Ridgewood, N.J.
Cox & Tanz Adv.
Philadelphia, Penna.
Thomas F. Conroy, Inc.
San Antonio, Texas
Craig, John Gilbert Adv.
Wilmington, Dela.
Cramer-Krosselt Co.
Milwaukee, Wis.
Critchfield & Co.
Chicago, Ill.
Crolly Adv. Agency
Wilkes-Barre, Penna.
Crook Advertising Agency
Dallas, Texas
Dayton, Johnson & Hacker Adv.
Milwaukee
Denhard, Pfeiffer & Wells, Inc.
New York City
Denman, William I. Inc.
Detroit, Mich.
Deutsch & Shea, Inc.
New York City
Dinerman & Company, Inc.
Cincinnati, Ohio
Dixie Advertisers, Inc.
Jackson, Miss.
Doe-Anderson Agency
Louisville, Ky.
Donahue & Coe
New York City
Doner, W. B., Co.
Detroit, Mich.
Doremus & Company
New York City
Durstine, Roy S., Inc.
New York City
Elliott, Daly & Schnitzer
Oakland, Calif.
Engel Adv. Agcy.
Chicago, Ill.
Erwin, Wasey & Co.
New York City
Evans, Albert Adv.
Ft. Worth, Texas
Featherstone Adv. Agency
Salt Lake City, Utah
Firestone Adv. Agcy.
New York City
Fitzgerald Adv. Agency
New Orleans, La.
Flack Adv. Agency
Syracuse, N. Y.
Florey, George F., Inc.
Chicago
Foote, Cone & Belding
Chicago, Ill.
Foote, Cone & Belding
New York City
Ford, Frank Adv.
Hollywood 3B, Calif.
Foster & Davies, Inc.
Cleveland, Ohio
Fowler, Norton, Inc.
Wilmington, Del.
Frost, Harry M. Co.
Boston, Mass.
Romig Fuller & Associates
Seattle, Wash.
Fuller & Smith & Ross, Inc.
Cleveland, Ohio

HONOR...

On these two pages is an honor roll of leading advertising agencies who found it profitable to use BROADCASTING display space for their clients during 1949. Combined, these agencies placed more business with us than has ever before been carried by

Gondy Adv. Agency
Dallas, Texas
Gerst Advertising Agency
Cleveland, Ohio
Gillham Adv. Agency
Salt Lake City, Utah
Gold, H. J., Co.
New York City
Goerl, Stephen Associates
New York City
Harry S. Goodman Agency
New York City
Goodman-Firestone Adv.
Minneapolis, Minn.
Goodwin, The Co.
Houston, Texas
Gotham Adv. Co.
New York, N. Y.
Gottschildt, Morris & Slack, Inc.
Miami
Gray & Rogers
Philadelphia, Pa.
Greene, Finley H., Adv. Agency
Buffalo, N. Y.
Greer, Hawkins & Allen, Inc.
Houston, Texas
Gross, Stanley S. & Assoc.
Norfolk, Va.
Gruber, Art, Advertising
Minneapolis, Minn.
Albert Frank Guenther Law, Inc.
New York City
Hall, Raymond. Adv.
Richmond, Va.
Halpern, Herman
Winston-Salem, N. C.
Edward Hamburger Adv. Co.
New York City
Hamilton Adv. Agcy, Inc.
Chicago, Ill.
Hammond, Robert Associates,
Orlando, Fla.
Harrington, Whitney & Hurst
Los Angeles, Calif.
Harris, R. T. Adv. Agency
Salt Lake City, Utah
Hart-Conway Co.
Rochester, N. Y.
Hartman, George H., Co.
Chicago, Ill.
Harvey-Massengale Co.
Durham, N. C.
Hevenor Adv. Agency
Albany, New York
Ward Hicks Adv.
Albuquerque
Hiddleston, Evans & Merrill,
Seattle, Wash.
Haag & Provandie, Inc.
Boston
R. J. Potts, Calkins & Holden,
Kansas City, Mo.
Hasler, Arzbingast, Thomson & Becht
Peoria, Ill.
Hauck & Company of Florida,
Miami, Fla.

Howell Adv. Agency
Elmira, N. Y.
Hoyt, Charles W. Co.
New York City
Huckins-Smith, Inc.
New York City
Hurley Adv. Co.
Des Moines, Iowa
Edwin Huster Company
Knoxville, Tenn.
Hutchins Adv. Co.
Philadelphia
International Media Corp.
New York City
Jackson & Jefferson Adv.
Miami, Fla.
Jenkins, Smith, Taylor &, Inc.
Pittsburgh, Penna.
Jennings, Duncan Advertising
Phoenix, Ariz.
Jessop Adv. Co.
Akron, Ohio
Jones, Ralph H. Co.
Cincinnati, Ohio
Mort Junger Advertising
New York City
Kal, Ehrlich & Merrick, Inc.
Washington, D. C.
Karlowski, Walter A., Adv.
Spokane, Wash.
Katz, Joseph Co.
Baltimore, Md.
Kaufman Adv. Agcy.
Washington 5, D.C.
Keegan Advertising Agency
Birmingham, Ala.
St. Georges & Keyes, Inc.
Baltimore, Md.
Kirkland, White & Schell
Atlanta, Ga.
John R. Kneebone Corp.
Chicago, Ill.
Knopf, R. W. & Co.
Columbus, Ohio
Knox, George Adv.
Oklahoma City, Okla.
Kopmeyer, M. R. Co.
Louisville, Ky.
Robert Kottwitz Advertising, Inc.
New Orleans, La.
Kremer, Merrill, Inc.
Memphis, Tenn.
Kuff and Feldstein
Baltimore, Md.
Kudner Adv. Agency, Inc.
New York City
Paul A. Lago Co.
Wichita, Kansas
Lampart, Fox, Prell & Dolk, Inc.
South Bend, Ind.
Lang, Fisher & Stashower, Inc.
Cleveland, Ohio
Lake-Spira-Shurman, Inc.
Memphis, Tenn.
Lavin, Barney, Inc.
Fargo, N. D.
Lee, Parks, Greer & Hawkins,
Houston, Texas

THERE MUST BE A REASON . . . and there is! For BROADCASTING is the one publication that gives everybody concerned with broadcasting and telecasting the fullest coverage of everything significant, everything newsworthy about broadcasting and telecasting. That makes BROADCASTING the most logical route to these agencies' clients' best clients. And BROADCASTING is not only the most profitable way to create new and renewal business . . . but lowest in cost as well! Be sure your agency is on our honor roll (on your behalf) for 1950.

with profit

any trade journal serving the broadcasting (and telecasting) field. Thus, they have affirmed once more the unquestioned leadership that has been BROADCASTING's for 19 consecutive years.

Lefton, Al Paul Co.
Philadelphia, Penna.
Lescarboura, Austin C. & Staff
Croton-on-Hudson, NY
Levy Adv. Agency
Newark, N. J.
Buford Lewis & Co.
Nashville, Tenn.
Liller, Neal & Battle
Atlanta, Ga.
Lippitt, Jules
New York, N. Y.
W. H. Long Company
York, Pa.
Lowe & Hall Advertising
Greenville, S. C.
Luerbach, Leon & Co., Inc.
New York City
Ludgin, Earle & Co.
Chicago, Ill.
Lustig Adv. Agency
Cleveland, Ohio
Lynch, Showalter Agency
Portland, Oregon
S. Duane Lyon, Inc.
New York City
Mace Adv. Agency
Peoria, Ill.
MacManus, John & Adams, Inc.
Detroit, Mich.
Madden-Barrett Inc.
Dallas, Texas
Malcolm-Howard Adv. Agency
Chicago, Ill.
Manhattan Adv. Agcy.
New York City
George C. Mansfield Adv.
Honolulu, Hawaii
Mann-Ellis, Inc.
New York City
Louise Mark & Assoc.
Milwaukee, Wis.
Gordon Marshall, Inc.
St. Louis, Mo.
Market Research & Adv. Inc.
Newark, N. J.
Martin, George Homer Assoc.
Newark, N. J.
Mason-Relkin Agency
New York City
J. M. Mathes, Inc.
New York City
Mac Wilkins, Cole & Weber
Seattle, Wash.
Maxon, Inc.
New York City
Maxfield Advertising
Providence, R. I.
Maxon, Inc.
Detroit, Mich.
McCann-Erickson Co.
Chicago, Ill.
MacBride, James Adv. Agency
Fort Worth, Texas
McCarthy, R. E. Adv. Agency
Tampa, Florida
MacKay, Wallace, Co.
Seattle, Wash.
McGivena, L. E. & Co., Inc.
New York City

McCormick-Armstrong Co.
Wichita, Kansas
Melamed-Hobbs, Inc.
Minneapolis, Minn.
Meldrum & Fewsmith Agcy.
Cleveland, Ohio
Mendte, J. Robert Inc.
Philadelphia, Penna.
Meneough & Martin & Seymour
Des Moines, Iowa
Meyerhoff & Co., Arthur
Milwaukee, Wis.
Michel-Cather, Inc.
New York City
Mithoff & White, Adv.
El Paso, Tex.
Mogge-Privett, Inc.
Los Angeles, Calif.
Mohawk Adv. Agency
Schenectady
Moore & Hamm, Inc.
New York City
Moran, Bruce & Co.
Atlanta, Ga.
Moreland Co., Chester C.
Cincinnati, Ohio
Morgan, Raymond R., Co.
Hollywood, Calif.
Mort Duff Agency
Omaha, Nebr.
Morse International, Inc.
New York City
Morris Timbes Adv.
Mobile, Alabama
Moss Associates
New York City
Murphy, Carroll Dean, Inc.
Chicago, Ill.
George R. Nelson, Inc.
Schenectady, N. Y.
Newell-Emmett Co.
New York City
Theodore Newhoff Agency
Baltimore, Md.
Newman, Lynde & Associates
Jacksonville, Fla.
Nolan, Charles H., Advertising
Pawtucket, R. I.
Notzon Adv. Agency
San Antonio, Texas
O'Brien Adv. Ltd.
Vancouver, B. C.
O'Brien & Dorrance, Inc.
New York City
Olian Adv. Agency
St. Louis, Mo.
Orr, W. Wallice, Inc.
Philadelphia, Penna.
Pace-Wiles, Inc.
Huntington, W. Va.
Pacific National Adv. Agency
Seattle, Wash.
Pettus, Harold Adv.
Corpus Christi, Texas
Pitluk Adv. Co.
San Antonio, Texas
Presba, Fellers & Presba
Chicago, Ill.

Ramsey, L. W. Co.
Chicago, Ill.
Ratcliffe Adv. Agency
Dallas, Texas
Redfield-Johnstone, Inc.
New York City
Reinhardt, Emil Adv.
Oakland, Calif.
Reiss Advertising
New York City
Reese, James R. Adv. Co.
Kansas City, Mo.
George Riseman & Company
Boston, Mass.
Rem. Prod. & Adv.
Los Angeles, Calif.
Rex Advertising Agency
Detroit, Mich.
Richards, Wilbur O., Adv.
Syracuse, N. Y.
Rickard & Company, Inc.
New York City
Richard & Gunther, Inc.
New York City
The Ridgway Co.
St. Louis, Mo.
Riardon, John H. Co.
Los Angeles, Calif.
Robinson-Rapp Agcy.
New York City
Rockett-Lauritzen Adv.
Los Angeles, Calif.
Rosenberg, Arthur Co.
New York City
Rosengarten & Steinke, Inc.
Memphis, Tenn.
H. L. Ross Advertising
Indianapolis, Ind.
Ruder & Finn Adv.
New York City
Rumrill, Charles L., & Co., Inc.
Rochester, N. Y.
Runkle, Lowe, Co.
Oklahoma City, Okla.
Ruthrauff & Ryan, Inc.
Chicago, Ill.
Schneider, Joseph P. Inc.
New York City
Schuyler-Hopper Agency
New York City
Schwimmer & Scott, Inc.
Chicago, Ill.
Shepard, K. E., Advertising
Chicago, Ill.
Schoenfeld, Huber & Green
Chicago, Ill.
Sherman & Marquette
Chicago, Ill.
Simon & Gwynn, Inc.
Memphis, Tenn.
Simmonds & Simmonds, Inc.
Chicago, Ill.
Seeman & Peters Inc.
Saginaw, Mich.
Shaffer, Brennen & Margules
St. Louis, Mo.
Shappe-Wilkes, Inc.
New York City
Smallen-Ross, Advertising
New York City
Smith, Gordon Advertising
Yakima, Washington
Smith, R. C. & Son, Ltd.
Toronto, Canada
Snead, C. N., Adv. Agency
Roanoke, Va.
Walter B. Snow & Staff, Inc.
Boston, Mass.
Southern Adv. Agcy.
Lexington, Ky.
Southwest Advertising Agency
Waco, Texas
Spangler & Jaster, Inc.
Beloit, Wisconsin
Spartanburg Adv.
Spartanburg, N. C.
Spaulding, C. Jerry Inc.
Worcester, Mass.
Spier, Franklin, Inc.
New York City

Steele, Howard D., Adv. Agency
Detroit, Mich.
Strauchen & McKim Adv.
Cincinnati, Ohio
Sullivan, Daniel F., Co.,
Boston, Mass.
Swink, Howard Advertising
Marion, Ohio
Teplitz, Henry H. Adv.
Chicago, Ill.
William G. Teters Adv.
Baton Rouge
Thomas, Gerald F. Adv.
Fresno, Calif.
Thompson, J. Walter Co., Ltd.
Toronto, Ontario
New York City
San Francisco 4, Calif.
Thurston, Smith & Jenkins Adv.
Flint, Mich.
Arthur Towell, Inc.
Madison, Wis.
Turner Adv. Agency
Chicago, Ill.
Richard H. Ullman
Buffalo, N. Y.
C. J. Ulrich & Associates
Chicago, Ill.
VanDiver & Carlyle, Inc.
New York City
Van Sant, Dugdale & Co.
Baltimore, Md.
Virginia Electric News Inc.
Richmond, Va.
Wagenseil, Hugo & Associates
Dayton, Ohio
Walker & Downing
Pittsburgh, Penna.
Wallice-Lindeman, Inc.
Grand Rapids, Mich.
Walker-Saussy Advertising
New Orleans, La.
Wapshare, James A. Co.
Newark, N. J.
Warren, William Agency
New York City
Weorstler Adv. Agency
Youngstown, Ohio
Webster, R. W. Adv.
Los Angeles, Calif.
H. J. Weil, Inc.
Buffalo, N. Y.
J. J. Weiner Advertising
San Francisco, Calif.
Wellam Adv. Co.
Lansing, Mich.
Welsh-Hollander Advertising
Los Angeles, Calif.
Watts-Payne Agency
Tulsa, Okla.
Weightman, Inc. Adv.
Philadelphia, Penna.
Jack C. Wemple Adv. Agency
Green Bay, Wis.
Wertheim Adv. Assoc.
New York City
Weston-Barnett, Inc.
Waterloo, Iowa
Whalen, Frank E. Agency
Kansas City, Mo.
White, Dan & Associates
El Paso, Texas
Wiley, Frozee & Davenport
New York City
Winius-Drescher-Brandon, Inc.
St. Louis, Mo.
Workman, Ted, Advertising
Dallas, Texas
Yambert, Ralph Organization
Hollywood, Calif.
Young & Rubicam
New York City
Yaunt Agency
Erie, Pa.
William Von Zehle & Co., Inc.
New York City
Zimmer-McCloskey-Kintner Adv.
Louisville, Ky.

BROADCASTING
The Newsweek of Radio and Television
TELECASTING

ADVERTISERS USING CBS NETWORK DURING 1949

(Continued from page 397)

Sponsor, Product No. of Stations	Program Day, Time EST	Duration of Contract	Agency	Sponsor, Product No. of Stations	Program Day, Time EST	Duration of Contract	Agency
General Foods Corp. New York; Bakers Coconut, Certo, Instant Swans Down, Minute Rice, Jell-O, Jell-O Puddings, Regular Swans Down 96-68	Second Mrs. Burton; M-F 2-2:15 PM.	Jan-Dec	Young & Rubicam, Inc., New York	Pepsodent Toothpaste, 153-176+ CBC	My Friend Irma; Mon. 10-10:30 PM.	Jan-Jun 8-28-Dec	Foote, Cone & Belding, New York
Grape Nuts, 75	Gangbusters; Sat. 9-9:30 PM.; 11:30-12 Mid.	Jan-6-25	Young & Rubicam, Inc., New York	Rayve Home Permanent, 162	Winner Take All; M-F 4:30-4:45 PM.	2-28-8-26	J. Walter Thompson Co., Chicago
Grape Nuts, 84	Gangbusters; Sat. 9-9:30 PM.; 12-12:30 AM.	10-1-Dec	Young & Rubicam, Inc., New York	Rinso, 150+ CBC	Amos 'n' Andy; Sun. 7:30-8 PM.	Jan-May Oct-Dec	Ruthrauff & Ryan, Inc., New York
Jell-O, Jell-O Puddings, 151	My Favorite Husband; Fri. 8:30-9 PM.	Jan-7-1 9-2-Dec	Young & Rubicam, Inc., New York	Rinso, 150+ CBC	Call The Police; Sun. 7:30-8 PM.	June-Sept	Ruthrauff & Ryan, Inc., New York
Maxwell House Coffee, Instant Maxwell House Coffee, 151	Wendy Warren and the News; M-F 12-12:15 PM.	Jan-Dec	Benton & Bowles, Inc., New York	Spry, 84+ CBC	Aunt Jenny; M-F 12:15-12:30 PM.	Jan-Dec	Ruthrauff & Ryan, Inc., New York
Sanka, Instant Sanka, 151	Jack Carson Show; Fri. 8-8:30 PM.; 11:30-12 Mid.	Jan-7-1	Young & Rubicam, Inc., New York	Lewis Food Co. Los Angeles; Dog & Cat Foods, 14	Free for All; Sat. 3:30-4 PM. CNYT	Jan-6-4	Rockett-Lauritzen, Los Angeles
Sanka, Instant Sanka, 151	The Goldbergs; Fri. 8-8:30 PM.; 11:30-12 Mid.	9-2-Dec	Young & Rubicam, Inc., New York	Liggett & Myers Tobacco Co. N.Y.; Chesterfield Cigarettes, 179	The Bing Crosby Program; Wed. 9:30-10 PM.	9-21-Dec	Newell-Emmett Co., New York
General Mills, Inc. Minneapolis; All Products, 165	Bing Crosby Wheaties; Sun. 10-11 PM.	4-17 only	Knox Reeves Advertising, Inc.	Chesterfield Cigarettes, 179	Arthur Godfrey; M-F 11-11:30 AM.; 8-1-9-23 Robert Q. Lewis; 6:30-7 PM.	Jan-Dec	Newell-Emmett Co., New York
General Motors Corp. Detroit; Chevrolet Motor Division; Chevrolet Cars, 169	All American Soap Box Derby; Sun. 4:30-4:45 PM.	8-14 only	Campbell-Ewald Co., Inc., Detroit	Fatima Cigarettes, 26	Tales of Fatima, with Basil Rathbone; Sat. 9:30-10 PM.	Jan-10-1	Newell-Emmett Co., New York
Frigidaire Division; Refrigerators, 164	Lum 'n' Abner; Sun. 8:30-9 PM.; 10-10:30 PM.	Jan-6-26	Foote, Cone & Belding, Chicago	Longines-Wittnauer Watch Co., Inc. N.Y.; Longines Watches, 167	Festival of Music; Sun. 2-2:30 PM.; 3-13 Symphonette with Mischel Pastro Conducting; 7-3 Sun. 5:30-6 PM.	Jan-Dec	Victor A. Bennett Co., Inc., New York
Pontiac Division; Pontiac Cars, 55 Sta.	Notre Dame-So. Calif. Football Game; Sat. 2:30-5 PM.	11-26-49 only	MacManus, John & Adams, Inc., Det.	Wittnauer Watches, 167	Festival of Song; Sun. 5-5:30 PM.; 3-13 Chorallers, with Eugene Lowell Conducting; 7-3 Sun. 2-2:30 PM. Muscial Variety; Thurs. 5-6 PM.	Jan-Dec	Victor A. Bennett Co., Inc., New York
Gillette Safety Razor Co. Boston; All Products, 169	Orange Bowl Game & Rose Bowl Football Games; Sat. 2 PM. to Concl.	1-1 only	Maxon, Inc., New York	Lucern Milk Co. division of Safeway Stores, Inc. San Francisco; All Products, 8	Boston Blackie; Sun. 6:30-7 PM. CNYT	9-11-Dec	J. Walter Thompson Co., San Francisco
All Products, 170	Kentucky Derby; Sat. 6:15-6:45 PM.	5-7 only	Maxon, Inc., New York	Luden's, Inc. Reading; All Products, 149	Sing It Again; Sat. 10:45-11 PM.	11-26-Dec	J. M. Mathes, Inc., New York
All Products, 169	Preakness Stakes; Sat. 5-5:30 PM.	5-14 only	Maxon, Inc., New York	Fifth Ave. Candy Bar, 160	Strike It Rich; Sun. 5:30-6 PM.	Jan-2-20	J. M. Mathes, Inc., New York
All Products, 168	Belmont Stakes; Sat. 4:30-5 PM.	6-11 only	Maxon, Inc., New York	M & M Limited Newark; M & M Candies, 15	Joe Di Maggio Show; Sat. 10-10:30 AM.	9-17-Dec	Lynn Baker, Inc., New York
Gold Seal Co. Bismark, N.D.; 'Gold Seal' Wax, Cleaning Products, 172	Arthur Godfrey; M-F 10:30-10:45 AM.; 8-1-9-23 Robert Q. Lewis; 6-6:15 PM.	Jan-Dec	Campbell-Mithun, Inc., Minneapolis	Manhattan Soap Co., Inc. New York; All Products, 13	Front Page Features, with Knox Manning; M-W-F 8-8:15 PM. CNYT; 4-9 M-F 8-8:05 PM. CNYT	Jan-7-1	Duane Jones Co., Inc., New York
"Gold Seal" Wax, Cleaning Products, 16	Meet the Missus; Sat. 2:30-3 PM. CNYT	Jan-5-28	Campbell-Mithun, Inc., Minneapolis	Mennen Co. Newark; All Products, 15	Bob Garrod-News; M-W-F 10:30-10:45 AM. CNYT	Jan-Dec	Duane Jones Co., Inc., New York
Gulf Oil Corp. Pittsburgh; Gulf Oil Products, 126	We, the People; Tues. 9-9:30 PM.	Jan-10-25	Young & Rubicam, Inc., New York	Metropolitan Life Insurance Co. New York; Institutional, 11	Eric Sevareid-News; M-F 6-6:15 PM.	Jan-Dec	Young & Rubicam, Inc., New York
Hall Bros., Inc. Kansas City, Mo.; "Hallmark" Greeting Cards, 158	Hallmark Playhouse; Thurs. 10-10:30 PM.	Jan-6-2 9-8-Dec	Foote, Cone & Belding, New York	Miles Laboratories, Inc. Elkhart; All Products, 12	Fred Beck; M-F 10:45-11 AM. CNYT	Jan-Dec	Wade Advertising Agency, Chicago
Hotpoint, Inc. Chicago; All Products, 173	The Servant in the House; Sun. 5-6 PM.	Jan-Dec	Maxon, Inc., New York	All Products, 142	Herb Shriner Time; M-F 5:45-6 PM.; 8:30-6:45 PM.; 7-7:15 PM.	Jan-6-3	Wade Advertising Agency, Chicago
Household Finance Corp. Chicago; Personal Loans, 11	Chet Huntley; M-W-F 8:30-8:45 PM. CNYT	Jan-Dec	LeVally, Inc., Chicago	All Products, 148	Curt Massey Time, with Martha Tilton and Orchestra; M-F 5:45-6 PM.; 6:30-6:45 PM.; 7-7:15 PM.	6-6-Dec	Wade Advertising Agency, Chicago
Independent Citizens' Committee for election of Herbert Lehman; Political, 10**	Political Talks; Mon., Wed. 6:15-6:30 PM.	9-28, 10-5, 10-12, 10-17-11-7	The Blow Co., Inc., New York	All Products, 129	Hilltop House; M-F 3:15-3:30 PM.	Jan-Dec	Wade Advertising Agency, Chicago
International Harvester Co. Chicago; All Products, 168	Harvest of Stars, with James Melton; Wed. 9:30-10 PM.	Jan-3-30	McCann-Erickson, Inc., New York	Modglin Co., Inc. Los Angeles; Perma Brooms, 11	Meet the Missus; M-F 5:45-6 PM. CNYT	Jan-3-18	W. Earl Bothwell, Inc., Los Angeles
International Silver Co. Meriden, Conn.; Sterling & 1847 Rogers Bros. Silver, 150	Adventures of Ozzie & Harriet; Sun. 6:30-7 PM.	4-3-7-10	Young & Rubicam, Inc., New York	Nalley's Inc. Tacoma; Salad Dressing, 17	Meet the Missus; Wed. 5:45-6 PM. CNYT	3-2-5-25	Milne-Heffernan, Inc., Seattle
Kellogg Co. Battle Creek; All Products, 31	Mother Knows Best; Sat. 3-3:30 PM. CNYT	1-8-7-2 10-8-Dec	Kenyon & Eckhardt, Inc., New York	National Biscuit Co. New York; All Products, 173	Arthur Godfrey; M-F 10:45-11 AM.; 8-1-9-23 Robert Q. Lewis; 6:15-6:30 PM.	Jan-Dec	McCann-Erickson, Inc., New York
Lee Pharmaceutical Co. Beverly Hills; Spray-A-Wave, 156	Arthur Godfrey; M-F 10:15-10:30 AM.; 8-1-8-28 Robert Q. Lewis; 6:45-7 PM.; 9-26 M-W-F 10:15-10:30 AM.; alternate weeks Tues.-Thurs.	5-30-8-26 9-26-10-14	Dancer-Fitzgerald-Sample Inc., New York	New York State Republican Committee; Political, 9**	Political Talks; Tues. 6:15-6:30 PM.; Sat. 6:30-6:45 PM.	10-11-11-3 10-29 only	Batten, Barton, Durstine & Osborn, Inc., New York
Lever Brothers Co. Cambridge; Lipton's Tea, Lipton's Soup Mixes, 156+ CBC	Arthur Godfrey's Talent Scouts; Mon. 8:30-9 PM.; 11:30-12 Mid.	Jan-Jun 9-29-Dec	Young & Rubicam, Inc., New York	Packard Bell Co. Los Angeles; Packard Bell Radios, Television, 14	CBS World News, with Chet Huntley; Sun. 8:30-8:45 PM. CNYT	1-2-3-27	Abbott Kimball Co., Inc., Los Angeles
Lux Toilet Soap, Lux Flakes, 153-176+ CBC	Lux Radio Theater; Mon. 9-10 PM.	Jan-Jun 8-29-Dec	J. Walter Thompson Co., New York	Peter Paul, Inc. Naugatuck, Conn.; Candy Bars, 12	Bob Garrod, News; M-W-F 8:45-8:55 PM. CNYT	Jan-Dec	Brisacher, Wheeler & Staff, Los Angeles
Pepsodent Toothpaste, Pepsodent Tooth Powder, Rayve Creme Shampoo, Rayve Home Permanent Wave, 167	Junior Miss; Sat. 11:30-12 Noon.	Jan-Dec	Needham, Louis & Brorby, Inc., Chicago	Philip Morris & Co. Ltd., Inc. New York; Philip Morris Cigarettes, 172	Bob Garrod, News; Tu-Th-Sa 10:30-10:45 AM. CNYT	Jan-Dec	Brisacher, Wheeler & Staff, Los Angeles
					Horace Heidt Show; Sun. 9:30-10 PM.	9-4-Dec	The Blow Co., Inc., New York

* NY State Regional
** New England Regional

ADVERTISERS USING CBS NETWORK DURING 1949

(Continued from page 401)

Sponsor, Product No. of Stations	Program Day, Time Est	Duration of Contract	Agency	Sponsor, Product No. of Stations	Program Day, Time EST	Duration of Contract	Agency
Gillette Safety Razor Co.; Shaving Cream, Blades, Razors	Highlights of the Rose Bowl and Orange & Sugar Bowl Games; Sun. 10:15-10:45 PM.	1-2 only	Maxon, Inc.	Philip Morris & Co., Ltd., Inc.; Philip Morris Cigarettes	Preview; 9-12 Candid Camera; Mon. 8-8:30 PM.; 7-11 Mon. 9-9:30 PM.	3-7-Dec	The Biow Co., Inc.
	Kentucky Derby; Sun. 10:30-10:45 PM.	5-8 only	Maxon, Inc.		Ruthie on the Telephone; 11-7 Herb Shriner Show; Sun., Mon., Tues., Thurs., Fri., Sa. 7:55-8 PM.	8-7-Dec	The Biow Co., Inc.
	Preakness; Sat. 5:5-30 PM.	5-14 only	Maxon, Inc.		10-3 Mon., Tues., Thurs. Fri., Sat. 7:55-8 PM.		
	The Belmont Stakes; Sat. 4:30-5 PM.	6-11 only	Maxon, Inc.	Phillips Packing Co.; Phillips Soups	Lucky Pup; Wed. 6:30-6:45 PM.	5-11-11-9	Aitkin-Kynett Co.
	All Star Baseball Game at Ebbetts Field; Tues. 1-4 PM.	7-12 only	Maxon, Inc.	Pioneer Scientific Corp.; Polaroid Filters	Pioneer Polaroid Magic Show; Wed. 7:45-8 PM.	2-16-5-11	Cayton, Inc.
Gulf Oil Corp.; Gulf Products	We the People; Tues. 9-9:30 PM.	Jan-10-25	Young & Rubicam, Inc.	R. J. Reynolds Tobacco Co.; Camel Cigarettes	Sports Events from Madison Square Garden; various times	Jan-3-26	Wm. Esty & Co., Inc.
Hotpoint, Inc.; Electrical Appliance	Hotpoint Holiday; Thurs. 4-5 PM.	11-24 only	Maxon, Inc.		Golden Gloves Boxing Event; Mon., Wed., Fri. 10-11:30 PM.; Tues. 9:30-11 PM.	Feb. 21, 22, 23, Mar. 4	Wm. Esty & Co., Inc.
Household Finance Corp.; Finance Loans	Backstage with Barry; Tues. 10-10:15 PM.	3-1-5-24	LeVally, Inc.		Man Against Crime; Fri. 8:30-9 PM.	10-7-Dec	Wm. Esty & Co., Inc.
	People's Platform; Fri. 10-10:30 PM.	10-7-Dec	LeVally, Inc.	Scott Towel Co.; Paper Towels	Dione Lucas; Thurs. 8:15-8:30 PM.; 7-11 Mon. 8:15-8:30 PM.; 10-6 Thurs. 7-15-7:30 PM.	2-10-11-3	J. Walter Thompson Co.
International Silver Co.; Sterling & 1847 Rogers	The Silver Theater; Mon. 8-8:30 PM.	10-3-Dec	Young & Rubicam, Inc.		Vanity Fair; M-W-F 4:30-4:45 PM. partic.	10-17-Dec	Wm. H. Weintraub & Co., Inc.
Larus Bros. Co.; Edgeworth Tobacco	Sportsman's Quiz; Fri. 8-8:05 PM.	Jan-8-26	Warwick & Legler, Inc.		This Week in Sports; Tues. 10-10:15 PM.	9-20-Dec	Russel M. Seeds Co., Inc.
Liggett & Myers Tobacco Co.; Chesterfield Cigarettes	Columbia Football Games; Sat. 2-4:30 PM.	9-24-11-19	Newell-Emmett Co.		Ed Wynn Show; Watchbands	10-6-Dec	Cecil & Presbrey, Inc.
	Arthur Godfrey and his Friends; Wed. 8-9 PM.; 8-9-21 Robert Q. Lewis	1-12-49-Dec	Newell-Emmett Co.		Trimount Clothing Co.; Clipper Craft Clothes	9-16-10-21	Wm. H. Weintraub & Co., Inc.
	Toast of the Town; Sun. 8-9 PM.	3-27-6-19	Kenyon & Eckhardt, Inc.		U.S. Army & U.S. Air Forces Recruiting Service; Recruiting	7-2-9-24	Gardner Adv. Co.
	Arthur Godfrey's Talent Scouts; Mon. 8:30-9 PM.	Jan-5-30	Young & Rubicam, Inc.		U.S. Rubber Co.; Keds	3-25-6-17	Fletcher D. Richards, Inc.
	Thanksgiving Day Program; Thurs. 5-6 PM.	11-24 only	Victor A. Bennett Co., Inc.		1948 Annual Report; Wed. 8:30-10 PM.	8-12-11-4	Foote, Cone & Belding
	Lucky Pup; Mon. 6:30-6:45 PM.	5-2-7-25	Blaine-Thompson Co., Inc.		Westinghouse Electric Corp.; Washing Machines, Driers, Water Heaters, etc.	5-11-6-29	McCann-Erickson, Inc.
	Vanity Fair; M-W-F 4:30-5 PM. partic.	10-17-Dec	Wm. H. Weintraub & Co., Inc.		Wine Advisory Board; Wine	3-3-Dec	J. Walter Thompson Co.
	Masland at Home Party; Wed. 7:45-8 PM.	9-14-Dec	Anderson, Davis & Platte, Inc.				
	Homemakers Exchange; M-F 4-4:30 PM. partic.	10-10-Dec	Geyer, Newell & Ganger, Inc.				
	Dog Show at Madison Square Garden; Mon. 9-11 PM.; Tues. 9:30-11 PM.	2-14 & 2-15	McCann-Erickson, Inc.				
Lincoln Mercury Dealers; Lincoln, Mercury Cars							
Lever Brothers Co.; Lipson's Tea & Lipson's Soup Mixes							
Longines-Wittnauer Watch Co., Inc.; Watches							
Joe Lowe Corp.; Popsicles							
Maiden Form Brassiere Co., Brassieres							
C. H. Masland & Sons; Masland Rugs							
Nash-Kelvinator Corp.; Nash Cars							
National Biscuit Co.; Milkbone Dog Biscuits							

NBC Executives

(Continued from page 390)

Paul Speegle, Program Manager
Ethel Gilchrist, Manager of Promotion & Advertising
Alfred Crapsey, Local Sales Manager

CENTRAL DIVISION—CHICAGO

Merchandise Mart, Chicago 34, Illinois
Tel. Superior 7-8300
WMAQ, WMAQ-FM, WNBQ (TV)

I. E. Showerman, Vice President in Charge
John F. Whalley, Business Manager
Robert Guilbert, Manager of Continuity Acceptance
Howard Lutigen, Division Engineer
William Ray, Manager of News & Special Events
Jack Ryan, Manager of Press
Frederick Jacobson, Program Manager
Judith Waller, Public Affairs and Education Director
Oliver Morton, Local & National Spot Sales Manager
Paul McCluer, Network Sales Manager
David Lasley, Network Sales Promotion Manager
A. W. Kaney, Station Relations Manager
Jules Herbeveaux, Manager WNBQ
Eugene Hoge, Television Sales Manager
Paul Moore, TV Engineering Operations Supervisor
Edwin S. Mills, TV Program Manager
Everett G. Mitchell, WMAQ Director of Agricultural Programs

WESTERN DIVISION—HOLLYWOOD

Sunset Blvd. & Vine St., Hollywood 28, California
Tel. 9-6161
KNBH (TV)

Sidney N. Strotz, Administrative Vice President in Charge of the Western Division
Lewis S. Frost, Assistant to the Vice President
Norman Blackburn, Director Western Network Television Operations
Frank V. Delleit, Auditor
Donald Honrath, Manager of Continuity Acceptance
Alfred Saxton, Western Division Engineer
Robert Howard, National Spot Sales Manager Western Division
Frank Berend, Network Sales Manager Western Division
Roger Sprague, Manager of News & Special Events Western Division
Leslie Raddatz, Manager of Press Western Division

Homer Canfield, Program Manager Western Division
Helen Hall, Acting Manager, Sales Promotion & Advertising

Jennings Pierce, Manager of Public Affairs, Station Relations & Guest Relations
Henry Maas, Manager of Sales & Program Traffic
Harold Bock, Manager of Television Operations
William W. Boone, Business Manager
Robert Clark, TV Engineering Operations Supervisor
Robert Brown, Western network TV Program Manager
Paul B. Gale, Traffic Manager
Richard Graham, Attorney

WRC, WRC-FM, WNBW(TV) Washington

Trans Lux Bldg., 14th St. & N.Y. Ave.,
Washington 5, D. C.
Tel. Republic 4000

Frank M. Russell, Vice President in Charge
William R. McAndrew, Assistant to the Vice President; General Manager
Mahlon Glascock, Sales Manager
Eugene Juster, Director of Programs
Donald Cooper, Chief Engineer
Cassius Keller, Director of News & Special Events
Thomas Geoghegan, Manager of Advertising & Promotion
R. G. Coldenstroth, Auditor & Office Manager
Walter Royen, Manager of Press
Ralph Burgin, TV Program Manager
Charles Colledge, TV Engineering Operations Supervisor

FOREIGN REPRESENTATIVES

Paul Archinard, France
Henry Cassidy, France
Merrill Mueller, England
Osman Ferda, Turkey
Sven Norberg, Stockholm
Henry Bagley, Rio de Janeiro
Charles Griffin, Chile
Paul Sjoelblom, Finland
George T. Folster, Japan
Jack Begon, Italy
Edwin Haaker, Germany
Bert Silen, Philippines
Marion Mulrone, Honolulu
Amos Landman, China

NBC STATIONS PLANNING & ADVISORY COMMITTEE

Harold Essex, WSJS, Winston-Salem, N. C.
Martin Campbell, WFAA, Dallas, Texas
Clair McCollough, WGAL, Lancaster, Pa.
Harry Bannister, WWJ, Detroit, Mich.
Wiley Harris, WJDX, Jackson, Miss.
Walter Damm, WTMJ, Milwaukee, Wis.
Ed Yocum, KGHL, Billings, Mont.
Ewing Kelly, KCB, Sacramento, Calif.
Harold Burke, WBAL-TV, Baltimore, Md.
John Outler, WSB-TV, Atlanta, Ga.

STATIONS OWNED AND OPERATED BY THE NATIONAL BROADCASTING COMPANY AM & FM

WNBC, WNBC-FM New York
WMAQ, WMAQ-FM Chicago
WRC, WRC-FM Washington
WTAM, WTAM-FM Cleveland
KNBC, KNBC-FM San Francisco
KOA, KOA-FM Denver

Television

WNBT New York
WNBW Washington
WNBK Cleveland
WNBQ Chicago
KNBH Hollywood

AFFILIATED TV STATIONS

Interconnected Network

WBAL-TV, WBZ-TV, WBEN-TV, WNBQ, WNBK, WWJ-TV, WICU, WLAV-TV, WGAL-TV, WTMJ-TV, WNBC-TV, WNET, WPTZ, WDTV, WJAR-TV, WHAM-TV, WRGB, KSD-TV, WSPD-TV, WNEB, WDEL-TV, WLW-C, WLW-D, WLW-T, WTVR.

Non-interconnected Network

KOB-TV, WSB-TV, WBRCT-TV, WBAP-TV, KNBH, WAVE-TV, WMCT, WDSU-TV, WKY-TV, WOW-TV, KDYL-TV, KSTP-TV, KING-TV, WSAZ-TV, KFMB-TV, WFMB-TV, WIAC-TV, WSYR-TV, WMBR-TV, KRON-TV, WKTV, WNEF.

BROADCASTING • Telecasting

ADVERTISERS USING MUTUAL NETWORK DURING 1949

Sponsor, Product No. of Stations	Program Day, Time EST	Duration of Contract	Agency	Sponsor, Product No. of Stations	Program Day, Time EST	Duration of Contract	Agency
Ace Markets Inc. N.Y.; Art Dealers, 47.	Songs by Great Singers; Sun. 1:45-2 PM; Eff. 2-13-49; Sun. 3-3:30 PM.	1-16-49— 3-6-49	Klinger Adv. Corp. New York.	Mail Pouch Tobacco Co. Wheeling, W. Va.; Tobaccos, 133	Fishing & Hunting Club of the Air; Mon. 9:30-9:55 PM; Eff. 5-26- 49, Thurs. 8:30-8:55 PM.	12-23-46—	Walker & Downing, Pittsburgh. Eff. 12-22 Charles W. Hoyt Co., New York
American Bird Products, Inc. Chicago; Bird Food, 16.	American Radio Warblers; Sun. 1:30-1:45 PM.	10-31-48— 4-24-49; 10-23-49—	Weston-Barnett, Chicago.	Miami Margarine Co. Cincinnati; Nu-Maid Margarine, 235	Queen for A Day; Tues.-Thurs. 2-2:30 PM.	1-4-49— 4-14-49	Ralph H. Jones Co., Cincinnati.
Bayuk Cigars, Inc. Philadelphia; Phillies Cigars, 179.	Inside of Sports; Mon-Fri. 7:45-8 PM.	9-10-45— 9-2-49	Neal D. Ivey Co., Philadelphia.	Miles Laboratories, Inc. Elkhart, Ind.; Alka-Seltzer, 422	Queen for A Day; Mon.-Fri. 2-2:30 PM. Eff. 11-14-49—2:30-3 PM.	10-29-45—	Wade Adv., Chicago.
Brown Shoe Co. St. Louis; Roblee Shoes, 56.	Sports Magazine Annual Awards; Wed. 10-10:30 PM.	1-19-49 only	Leo Burnett Co., Chicago.	Benjamin Moore & Co. New York; Paints & Varnishes, 383	Your Home Beautiful; Sat. 10:30-10:45 AM.	3-8-49— 5-28-49	St. Georges & Keyes, New York.
Burrus Mill & Elevator Co. Fort Worth; Light Crust Flour, 125.	Light Crust Dough Boys; Mon - Wed - Fri. 12:30-12:45 PM., Eff. 12-12, 11:45-12 N—M-W-F	9-5-49	Tracy-Locke Co., Dallas.	Murine Co. Chicago; Murine, 399	John B. Kennedy; Sat. 7:55-8 PM.	9-24-49— 12-17-49	Batten, Barton, Durstine & Osborn, Chicago.
Capehart-Farnsworth Inc. New York, 450	"Christmas Carol"; Sun. 3:00-3:30 PM.	12-25-49 only	J. M. Mathes, Inc., New York	Mutual Benefit Health & Accident Assn. of Omaha; Insurance, 454	Mayor of the Town; Sun. 7:30-7:55 PM.	1-9-49— 7-3-49	Ruthrauff & Ryan, Chicago.
Carter Products Inc. New York; Carter's Little Liver Pills & Arrid, 59.	Jimmie Fidler; Sun. 9:30-9:45 PM.	9-7-47— 6-26-49	Sullivan, Stauffer, Colwell & Bayles, New York.	National Biscuit Co. New York; Shredded Nabisco, 345	Straight Arrow; Mon. 8-8:30 PM. Tues.-Thurs. 5-5:30 PM.	2-7-49—	McCann-Erickson, New York.
Chamberlain Sales Corp. Des Moines, 400	"John B. Kennedy"; Sat. 7:55-8:00 PM.		Batten, Barton, Durstine & Osborn, Inc., N. Y. (BBDO)	National Council of Protestant Episcopal Great Plays; Fri. 8- Churches; Religion, 470	Great Scenes from Great Plays; Fri. 8- 8:30 PM.	10-1-48— 2-25-49	H. B. Humphrey Co., New York.
Christian Reformed Church Religion, 260.	Back to God; Sun. 11-11:30 AM.	12-7-47—	Evans Associates, Chicago. Eff. 6-15-49, Glenn-Jordan-Stoetzel, Chicago.	Noxzema Chemical Co. Baltimore; Noxzema Products, 214	Gabriel Heatter; Mon. 9-9:15 PM; Eff. 4-25-49, Mon. 7:30-7:45 PM.	12-27-48—	Sullivan, Stauffer, Colwell & Bayles, New York.
H. C. Cole Milling Co. Chester, Ill.; Omega Flour, 59.	Ernie Lee Omega Show; Sun. 3-3:30 PM.	9-28-48— 6-19-49	Gardner Advertising, Chicago.	Perfect Circle Co. Hagerstown, Ind.; Piston Rings, 490, 356, 375	Indianapolis Speedway Race; Mon. 11:45-12:15 PM, 1:30-1:45 PM, 2:45-3 PM, 4-4:30 PM.	5-30-49 only;	Henri, Hurst & MacDonald, Chicago.
Contl Products Co., Inc. Brooklyn;	Yours for A Song; Fri. 8:30-8:55 PM.	11-29-48— 5-13-49	Birmingham, Castleman & Pierce, New York.	Philip Morris & Co., Ltd. New York; Cigarettes. 356. 375.	Kate Smith Sings; Mon.-Fri. 12:15-12:30 PM; Eff. 4-25-49, Against the Storm; Mon.-Fri. 11:30 - 11:45 AM.	9-20-48— 10-21-49;	Cecil & Presbrey, New York.
Cudahy Packing Co. Chicago;	Nick Carter; Sun. 6:30-7 PM.	9-15-46— 6-5-49; 9-11-49—	Grant Advertising, Chicago.	Piedmont Shirt Co. Greenville, S. C.; Wings Shirts, 355	Man on the Farm; Sat. 12-12:30 PM; Eff. 10-8-49, Sat. 11:30-12:30 PM. Roy Rogers Show; Sun. 6-6:30 PM.	8-27-49— 8-29-48—	Sherman & Marquette, Chicago.
Old Dutch Cleanser, 475.				Radio Bible Class; Religion, 289	Radio Bible Class; Sun. 10-10:30 AM.	11-10-40	Stanley G. Boynton Co., Detroit.
Delaware, Lackawanna & Western Coal Co. New York; "Blue Coal," 37.	The Shadow; Sun. 5-5:30 PM.	9-21-48— 6-5-49; 9-11-48—	Ruthrauff & Ryan, New York.	Ralston-Purina Co. St. Louis, Mo.; Chow Products, 202	Checkerboard Jamboree; Mon. - Fri. 12:15-12:30 PM (East), 1:45-2 PM (Repeat).	11-17-45—	Brown & Bowers, Nashville, Eff. 9-15-49, Brown Radio Prod. Inc.
Doubleday & Co. New York;	John B. Kennedy—Sidney Walton; Sun. 1-1:15 PM.	1-2-49— 4-24-49; 9-25-49—	Huber Hoge & Sons, New York	Ralston-Shredded Ralston & Instant Ralston, 482	Tom Mix & His Ralston Straight Shooters; Mon.-Fri. 5:45-6 PM LCL.; Eff. 9-26-49, Mon. - Wed. - Fri. 5:30-6 PM. Eff. 11-14-49 Erskine Johnson; M-W-F, 5:55-6 PM.	6-7-44— 6-24-49; 9-26-49—	Gardner Adv. Co., St. Louis.
Book Publishers, 60, 63	Doubleday's Quiz Show; Mon-Fri. 11:45-12 N; Eff. 9-19-49; Mon.-Fri. 12:15-12:30 PM.	3-28-48— 4-22-49; 9-19-49—	H. B. Humphrey Co., New York.	R. J. Reynolds Tobacco Co. Winston-Salem, N. C.; Camels, 457	Cotton Bowl Football Game; Sat. 2 PM to concl.	1-1-49 only	Wm. Esty & Co., New York.
First Church of Christ Scientist; Religion, 64.	Healing Ministry of Christian Science; Sat. 4:45-5 PM.	4-3-48—	H. B. Humphrey Co., New York.	Rhodes Pharmacal Co. Cleveland; Imdrin, 132	Gabriel Heatter; Tues.-Thurs. 7:30-7:45 PM.	9-20-49	O'Neil, Larson & McMahon, Chicago.
Fram Corp. East Providence, R. I.; Gas, Oil & Air Filters, 117.	Sports Thrill of the Week; Sat. 9:55-10 PM.	3-12-49— 6-4-49	Van Sant, Dugdale & Co., Baltimore.	Ronson Art Metal Works Newark, N. J.; Ronson Lighters, 434, 464	Johnny Desmond; Sun. 7:55-8 PM. Twenty Questions; Sat. 8-8:30 PM.	1-9-49— 1-1-49 7-6-48—	Cecil & Presbrey, New York. Eff. 7-1-49, Grey Advertising, New York.
Wally Frank Ltd. New York, 60	"Profiles in the News"; Sun. 11:45-12 N	11-20, 27-49	Huber Hoge & Sons, New York	R. B. Semler, Inc. New Canaan, Conn.; Krem Hair Tonic & Shampoo, 221	Gabriel Heatter; Wed. & Fri. 9-9:15 PM; Eff. 4-25-49; Wed. & Fri. 7:30-7:45 PM; Eff. 7-1-49; Wed. 7:30-7:45 PM.	10-16-48—	Erwin, Wasey & Co., New York.
General Foods Sales Corp. New York;	House of Mystery; Sun. 4-4:30 PM.	9-15-45— 10-3-48— 6-26-49; 10-2-49—	Benton & Bowles, New York.	Serutan Co. Jersey City; Serutan-Nutrex-RDX, 79, 171	Victor H. Lindlahr; Mon.-Fri. 11:15 - 11:30 AM. Gabriel Heatter; Tues.-Thurs. 9-9:15 PM. Eff. 6-28-49, 4-26-49; 7:30-7:45 PM.	1-2-47— 6-28-49	Roy S. Durstine Co., New York.
Post Bran Toasties & Raisin Bran - Gaines Dog Food, 482, 213.	Juvenile Jury; Sun. 3:30-4 PM.	10-3-48— 6-26-49; 10-2-49—		Shipstad & Johnson Hollywood; Ice Follies, 56	Ice Follies of 1950; Thurs. 12:30-1 AM.	9-8-49 only	Smith, Bull & McCreery, Hollywood.
Gillette Safety Razor Corp. New York;	All-Star Baseball Game; Tues. 1:15 PM to concl.; World Series of 1949; 12:45 PM to concl.; 1:45 PM on Sun.	7-12-49 only; 10-5-49	Maxon, Inc., New York.	Shotwell Manufacturing Co. Chicago; Puritan Marshmallows, 493	True or False; Sat. 5:30-6 PM.	2-7-48— 4-30-49	Wade Advertising, Chicago.
Gillette Safety Blades & Razors, 450, 600	Army vs. Navy; Sat. 1:15 PM. 11-26-49 Blue-Grey Game; Sat. 2:30 PM. 12-31-49			Charles B. Silver Co. Patimore; Red Cross & Silver Cross Brand Foods, 24	Take A Break; Sat. 10:45-11 AM.	3-12-49— 6-4-49	Brooks & Co., Baltimore.
Greystone Press New York; Publishers, 66	Mr. Fix-It; Sun. 5:30-5:45 PM.	6-5-49— 8-28-49	H. B. Humphrey Co., New York.	Trimount Clothing Co. New York; Clipper Craft Clothes, 236	Sherlock Holmes; Mon. 8:30-8:55 PM.	9-25-48— 6-6-49	Wm. H. Weintraub & Co., New York.
Grove Laboratories, Inc. St. Louis, Mo.;	The Shadow; Sun. 5-5:30 PM.	9-11-49—	Harry B. Cohen Adv., New York.	Universal Carloading & Distributing Co.; Institutional, 12	American Forum of the Air; Tues. 10-10:30 PM. Eff. 1-24-49; Mon. 10-10:30 PM.	10-19-48— 5-16-49	Raymond R. Spector, New York.
Fitch Shampoo & Fitch Hair Tonic, 435	"Hollywood Quiz"; Sat. 5:45-6 PM. (Local Time)		Sorensen & Co., Chicago				
Hallcrafters, Inc. Chicago, 61	Quick As A Flash; Sun. 5:30-6 PM. Eff. 9-24-49, Sat. 7:30-7:55 PM.	1-18-44— 5-29-49; 9-24-49— 12-17-49	Wm. H. Weintraub & Co., Eff. 9-24-49; Dorland Inc., New York.				
Helbros Watch Co. New York;	Hormel Girls Corps.; Sat. 11-11:30 AM.	6-5-48— 2-26-49	Batten, Barton, Durstine & Osborn, Minneapolis.				
Helbros Watches, 480	Anniversary; Mon. 3-3:30 PM.	4-18-49 only	Brooke, Smith, French & Dorrance, Detroit.				
George A. Hormel & Co. Austin, Minn.;	Queen for A Day; Mon.-Wed.-Fri. 2-2:30 PM.	10-13-47— 4-8-49	Crook Advertising, Dallas.				
Spam & other canned meats, 165	Bill Henry & the News; Mon.-Fri. 9:55-10 PM. Eff. 4-25-49, Mon.-Fri. 8:55-9 PM.	8-23-48—	J. Walter Thompson, New York.				
Hudson Motor Co. Detroit; Automobiles, 512	Adv. of the Thin Man; Thurs. 10-10:30 PM. Meet the Boss; Sat. 9:30-10 PM.	10-28-48— 1-20-49; 10-23-48— 1-15-49—	Wm. H. Weintraub Co., New York.				
International Milling Co. Minneapolis; Robin Hood Flour, 120	Lutheran Hour; Sun. 12:30-1 PM.	10-24-37—	Gotham Adv. Co., New York.				
Johns-Manville Corp. New York; Industrial Products, 380							
Kaiser-Frazer Corp. Willow Run, Mich.;							
Automobiles, 481							
Lutheran Laymen's League; Religion, 392							

(Continued on page 533)

ADVERTISERS USING NBC NETWORK DURING 1949

RADIO

Sponsor, Product No. of Stations	Program Day, Time EST	Duration of Contract	Agency	Sponsor, Product No. of Stations	Program Day, Time EST	Duration of Contract	Agency
Albers Milling Co., Seattle; Albers Quick Oats, 26	Aunt Mary; Mon.-Fri. 3:30-3:45 PM PST	Feb. 1948	Erwin, Wasey.	E. I. duPont de Nemours & Co., Inc., Wilmington, Del.; Institutional, 152.	Cavalcade of America; (off July-Aug.) Tues. 8:00-8:30 PM.	Jan. 1940	Batten, Barton, Durst- ine & Osborn.
Albers Milling Co., Seattle; Friskies Dog Food, 12	Elmer Peterson; Wed. Thurs., Fri. 5:45-6:00 PM PST	Apr. 1949	Erwin, Wasey.	Eversharp Inc., Chi- cago, Ill.; Pens & Pencils, 164.	Take It or Leave It; (off July-Aug.) Sun. 10:00-10:30 PM.	Aug. 1947	Blow Co.
Allis-Chalmers Mfg. Co., Milwaukee; Farm Equipment, 164	The National Farm & Home Hour; Sat. 1:00- 1:30 PM	Sept. 1945	Bert. S. Gittins Adv.	Falstaff Brewing Corp., St. Louis; Beer, 33.	Music From the Heart of America; Thurs. 10:30-11:00 PM.	Feb. 1948- Aug. 1949	Dancer-Fitzgerald- Sample
American Cigarette & Cigar Co., New York; Pall Mail Cigarettes, 64	The Big Story; Wed. 10:00-10:30 PM	Apr. 1947	Sullivan, Stauffer, Col- well & Bayles, Inc.	Faultless Starch Co., Cincinnati; Faultless Starch, 50.	Faultless Starch Time; Sun. 11:00-11:15 AM.	Oct. 1948	Bruce B. Brewer & Co.
American Meat Insti- tute Chicago; Meat & Allied Prod- ucts, 162	Fred Waring; Thurs. 10:00-10:30 AM	Jan. 1946- July 1949	Leo Burnett Co.	Firestone Tire & Rubber Co., Akron; Tires & Tubes, 140.	Voice of Firestone; Mon. 8:30-9:00 PM.	Dec. 1928	Sweeney & James Co.
American Tobacco Co., New York; Lucky Strike Cigar- ettes, 163	Light Up Time; Mon.- Fri. 7:00-7:15 PM	Sept. 1949	Batten, Barton, Durst- ine & Osborn.	Ford Motor Co., Dear- born, Mich.; (Ford Dealers of America) Motor Cars & service, 163.	The Fred Allen Show; Sun. 8:00-8:30 PM.	Jan. 1948- June 1949	J. Walter Thompson Co.
American Tobacco Co., New York; Lucky Strike Cigar- ettes, 164	Your Hit Parade; Sat. 9:00-9:30 PM	Apr. 1947	Batten, Barton, Durst- ine & Osborn.	General Electric Co., Schenectady; Institutional, 160.	Fred Waring; Thurs. 10:30-11:00 PM.	Oct. 1947- Sept. 1949	Batten, Barton, Durst- ine & Osborn.
Animal Foundation, Inc., Sherburne, New York; Hunt Club Dog Food, 60	Confidential Closeups; Sat. 5:45-6:00 PM	Sept. 1949	Comstock, Duffes.	General Foods Corp., New York; Maxwell House Coffee, 154.	Burns & Allen; (off July-Aug.) (eff 8/25/49 Father Knows Best); Thurs. 8:30-9:00 PM.	Sept. 1945	Benton & Bowles
Association of Ameri- can Railroads, Wash- ington, D. C.; Institutional 164	The Railroad Hour; Mon. 8:00-8:30 PM	Oct. 1949	Benton & Bowles.	General Foods Corp., New York; Jello, Jello Puddings, 147.	Aldrich Family; (off June-July) (Aug.-Sept- Meredith Willson) Thurs. 8:00-8:30 PM.	July 1939- July 1944 Sept. 1946	Young & Rubicam.
B. T. Babbett, New York; Bab-o Cleaner, Glim, 135	Lora Lawton; Mon.- Fri. 11:45-12:00 N	May 1943	Duane Jones Co.	General Foods Corp., New York; Calumet, Swans Down, Diamond Crystal Salt, 81.	When A Girl Marries; Mon.-Fri. 5:00-5:15 PM.	Sept. 1941	Benton & Bowles and Young & Rubicam.
Bell Telephone Sys- tem New York; Telephone Service, 153	The Telephone Hour Mon. 9:00-9:30 PM.	Apr. 1940	N. W. Ayer & Son.	General Foods Corp., New York; Posts 40% Bran Flakes, Instant Postum, 89.	Portia Faces Life; Mon.-Fri. 5:15-5:30 PM.	Apr. 1941- Mar. 1944 Oct. 1944	Benton & Bowles.
Blatz Brewing Co., Milwaukee; Beer, 156	Duffy's Tavern; Thurs. 9:30-10:00 PM.	Sept. 1949	Kaster, Farrell, Ches- ley & Clifford.	General Mills, Inc., Minneapolis; Sperry Flour, Cereals, Wheaties, 11.	This Woman's Secret; Mon.-Fri. 4:00-4:15 PM PST.	Mar. 1945	Knox-Reeves.
Bristol-Myers Co., New York; Ipana, Vitallis, 163	Duffy's Tavern; (July- Sept. Henry Morgan Show) (eff. 10-49-Break the Bank) Wed. 9:00- 9:30 PM	Sept. 1944	Young & Rubicam, 10- 5-49 Doherty, Clifford & Shenfield.	General Mills, Inc., Minneapolis; Sperry Pancake Flour, Waffle Flour, Wheathearts, 8.	Sam Hayes; Mon.-Sat. 7:45-8:00 PM PST.	Aug. 1939	Knox-Reeves.
Bristol-Myers Co., New York; Sal Hepatica & Vit- allis, 163	Mr. District Attorney; Wed. 9:30-10:00 PM.	Apr. 1940	Doherty, Clifford & Shenfield Co. 10-5-49, Young & Rubicam.	General Mills, Inc., Minneapolis; Sperry Pancake Flour, Waffle Flour, Wheathearts, 8.	Sam Hayes, Night Re- porter; Sun, Tues. Thurs. Sat, 10:00-10:15 PM PST.	June 1949	Knox-Reeves.
Brown Shoe Co., St. Louis; Childrens Shoes, 162	Smilin' Ed McConnell; Sat. 11:30-12:00 N.	Feb. 1944	Leo Burnett Co.	General Mills, Inc., Minneapolis; Bisk- quick, Crustquick, 137.	Today's Children; Mon.-Fri. 2:30-2:45 PM.	June 1942	Knox-Reeves.
Brown & Williamson Tobacco Co. Louis- ville; Raleigh Cigarettes, 164	People Are Funny; (July-Sept.-A Life In Your Hands); Tues. 10:30-11:00 PM.	Apr. 1942	Russel M. Seeds Co.	General Mills, Inc., Minneapolis; Pye- quick, Gold Medal Flour, Soup, 67.	Light of the World; Mon.-Fri. 2:45-3:00 PM.	Mar 1940- June 1944 Dec. 1946	Knox-Reeves.
Brown & Williamson Tobacco Co. Louis- ville; Raleigh Cigarettes, 17	People Are Funny; Sat. 9:30-10:00 AM.	Sept. 1949	Russel M. Seeds Co.	Greystone Press, New York; Popular Mechanics, 34.	Mr. Fixit; Sun. 12:00-12:15 N.	Sept. 1949	H. B. Humphrey Co.
Campana Sales Co., Batavia, Ill.; Solitair Make-up, 20.	Solitair Time; Sun. 11:45-12:00 N	Oct. 1945	The Clements Co.	Gruen Watch Co., Cincinnati; Watches, 163.	Hollywood Calling; Sun. 7:00-7:30 PM.	Sept. 1949	Grey Advertising.
Campbell Soup Co., Camden, N. J.; Soup, Pork & Beans, Franco-American Spaghetti, 132.	Double or Nothing; Mon.-Fri. 2:00-2:30 PM.	May 1948	Ward Wheelock Co.	Gulf Oil Corp., Pitts- burgh; Gas, Oil, Lubricants Insecti- cides, 115.	We, the People; Fri. 8:30-9:00 PM.	Nov. 1949	Young & Rubicam
Carnation Co., Mil- waukee; Evaporated Milk, 161.	Carnation Contented Hour; Mon. 10:00-10:30 PM.	Apr. 1931- Sept. 1949	Erwin, Wasey.	Hudson Coal Co., Scranton, Pa.; Coal, 13	The D & H Miners; Sun. 9:45-10:00 AM.	Oct. 1945	The Clements Co.
Cities Service Co., New York; Gas & Oil, 82.	Cities Service Band of America; Mon. 9:30- 10:00 PM.	Feb. 1927	Ellington & Co.	International Harvest- er Co., Chicago; Institutional, Motor Trucks, Farm Ma- chinery, 165	Harvest of Stars; (off July-Aug.) Sun. 5:30- 6:00 PM.	Oct. 1945- Mar. 1948 Apr. 1949	McCann-Erickson.
Coca Cola Co., New York; Coca Cola, 148.	Songs by Morton Dow- ney; (off June-Sept.) Tues. Thurs. Sat. 11:15- 11:30 PM.	June 1948	D'Arcy Advertising Co.	International Silver Co., Meriden, Conn.; Sterling Silver & Silver Plate, 142	Ozzie & Harriet; Sun. 6:30-7:00 PM.	Oct. 1948- Mar. 1949	Young & Rubicam
Colgate-Palmolive Peet Co., Jersey City; Palmolive Shave Cream & Soap, 144.	Judy Canova Show; (off July-Sept.) Sat. 10:00-10:30 PM.	Jan. 1945	Ted Bates & Co.	S. C. Johnson & Son, Inc. Racine, Wis.; Wax Products, 165	Fibber McGee & Molly; (June-Sept.-King's Men) Tues. 9:30-10:00 PM.	Apr. 1935	Needham, Louis & Brorby.
Colgate-Palmolive Peet Co., Jersey City; Colgate Shave Cream, 139.	Sports Newsreel of the Air; Fri. 10:30-10:45 PM.	Oct. 1939	Sherman Marquette.	Kraft Foods Co., Chicago; Cheese Spreads, Kraft Dinner Mayon- naise, 148	Kraft Music Hall; (June-Sept.-Nelson Eddy) Thurs. 9:00-9:30 PM.	June 1933- Sept. 1949	J. Walter Thompson Co.
Colgate-Palmolive Peet Co., Jersey City; Palmolive Soap, Colgate Dental Cream, Lustre-Creme, 144.	A Day in the Life of Dennis Day; (off July- Aug) Sat. 9:30-10:00 PM	Oct. 1946	Ted Bates.	Kraft Foods Co., Chicago; Parkay, Kraft Din- ner, 151	Great Gildersleeve; (June-Aug.-Archie Andrews) Wed. 8:30- 9:00 PM.	Aug. 1941	Needham, Louis & Brorby.
Colgate-Palmolive Peet Co., Jersey City; Colgate Dental Cream, Supersuds, 152.	Blondie; Wed. 8.00-8:30 PM.	Sept. 1948- June 1949	William Esty Co.,	Kraft Foods Co., Chicago; Miracle Whip Salad Dressing, Dairy Prod- ucts, 146	Marriage for Two; Mon.-Fri. 10:30-10:45 AM.	Oct. 1949	J. Walter Thompson Co.
				Lever Bros. Co., Cambridge, Mass.; Swan Soap, 153	Bob Hope; (off June- Sept.) Tues. 9:00-9:30 PM.	Sept. 1938	Young & Rubicam, 7/19/49 Batten, Barton, Durstine & Osborn.

(Continued on page 408)

NBC...America's No.1

* *In the long run, it's results that count . . . solid, measurable results that have linked these national advertisers to NBC year after year, together with dozens of other leaders now building up similar long runs . . . obvious effectiveness that in 1949 won 24 new network sponsorships for NBC . . . busiest network in America.*

THE NATIONAL BROADCASTING COMPANY
A service of Radio Corporation of America

** on NBC for more than 20 years:*

The American Tobacco Company

Bristol-Myers Company

Cities Service Company

General Foods Corporation

General Mills, Incorporated

Standard Oil Company of California

National Dairy Products Corporation

The Procter & Gamble Company

Radio Corporation of America

Sterling Drug, Incorporated

Sun Oil Company

** on NBC for more than 10 years:*

Brown & Williamson Tobacco Corporation

Advertising Medium

** on NBC for more than 15 years:*

American Home Products Corporation

B. T. Babbitt, Incorporated

Colgate-Palmolive-Peet Company

The Firestone Tire and Rubber Company

S. C. Johnson & Son, Incorporated

Miles Laboratories, Incorporated

Philip Morris & Company, Ltd., Inc.

Campana Sales Company

E. I. du Pont de Nemours & Company, Inc.

Lever Brothers Company

Lewis-Howe Company

Liggett & Myers Tobacco Company

Manhattan Soap Company

The Pure Oil Company

R. J. Reynolds Tobacco Company

Skelly Oil Company

ADVERTISERS USING NBC NETWORK DURING 1949

(Continued from page 405)

Sponsor, Product No. of Stations	Program Day, Time EST	Duration of Contract	Agency	Sponsor, Product No. of Stations	Program Day, Time EST	Duration of Contract	Agency
Lever Bros. Co., Cambridge, Mass.; Life Buoy, 133	Big Town; Tues. 10:00-10:30 PM.	Sept. 1948	Sullivan, Stauffer, Colwell & Baylies.	Procter & Gamble Co., Cincinnati; Duz, 141	Truth or Consequences; (off July-Aug.) Sat. 9:30-9:00 PM.	Aug. 1940	Compton Adv.
Lewis-Howe Co., St. Louis; Turns, 153	A Date with Judy; (Jan.-June—Alan Young Show) (July-Oct.—Me and Janie Starring George O'Hanlon (Eff. 11/49—Fanny Brice—Baby Snooks) Tues. 8:30-9:00 PM.	Jan. 1944	Roche, Williams & Cleary, Inc. 1/31/49 Dancer-Fitzgerald & Sample.	Procter & Gamble Co., Cincinnati; Tide, 151	The Red Skelton Show; Fri. 9:30-10:00 PM.	Sept. 1948- May 1949	Benton & Bowles.
Liggett & Myers Tobacco Co., New York; Chesterfield Cigarettes, 163	Chesterfield Supper Club; Thurs. 10:00-10:30 PM.	June 1939	Newell-Emmett Co.	Procter & Gamble Co., Cincinnati; Drest, Spic & Span, Drene, 141	Welcome Travelers; Mon.-Fri. 10:00-10:30 AM.	July 1949	Dancer, Fitzgerald, Sample, and Blow Co.
Liggett & Myers Tobacco Co., New York; Fatima Cigarettes, 140	Dragnet; Thurs. 10:30-11:00 PM	Oct. 1949	Newell-Emmett Co.	Prudential Insurance Co., Newark; Insurance, 139	Jack Berch Show; Mon.-Fri. 11:30-11:45 AM.	Sept. 1946	Benton & Bowles.
Manhattan Soap Co., New York; Sweetheart Soap, 162	We Love and Learn; Mon.-Fri. 11:00-11:15 AM.	June 1948	Duane Jones Co.	Pure Oil Co., Chicago; Pure Oil Petroleum Products, 30	Kaltenborn Edits the News; Mon., Wed., Fri. 7:45-8:00 PM. Harkness of Washington; Tues., Thurs. 7:45-8:00 PM.	May 1940	Leo Burnett Co.
Mars, Inc., Chicago; Candy, 135	Dr. I.Q.; Fri. 10:00-10:30 PM.	Apr. 1939- Mar. 1942 Apr. 1944- Oct. 1948	Grant Advertising	Radio Corp. of America, New York; Institutional, 168	Music America Loves Best; Sun. 5:00-5:30 PM.	Sept. 1944- May 1949	J. Walter Thompson Co.
Mars, Inc., Chicago; Candy, 41	Dr. I.Q., Jr.; Sat. 5:30-6:00 PM.	May 1941- Aug. 1941 Mar. 1948- Aug. 1948 Jan. 1949- Apr. 1949	Grant Advertising	Reall Drug Co., Los Angeles; Rexall Drugs, 163	The Phil Harris-Alice Faye Show; (July-Sept. Guy Lombardo Show) Sun. 7:30-8:00 PM.	Oct. 1948	Batten, Barton, Durstine & Osborn.
Mars, Inc., Chicago; Candy, 145	Curtain Time; Wed. 10:30-11:00 PM.	July 1946	Grant Advertising	R. J. Reynolds Co., Winston Salem, N. C.; Prince Albert Tobacco, 159	Grand Ole Opry; Sat. 10:30-11:00 PM.	Oct. 1939	William Esty & Co.
Miles Laboratories, Inc. Elkhart, Ind.; Alka-Seltzer & Vitamins, 140	News of the World; Mon.-Fri. 7:15-7:30 PM.	Mar. 1941	Wade Adv.	R. J. Reynolds Co., Winston Salem, N. C.; Camel Cigarettes, 162	The Jimmy Durante Show; (off July-Sept.) Fri. 9:30-10:00 PM.	Oct. 1948	William Esty & Co.
Miles Laboratories, Inc. Elkhart, Ind.; Alka-Seltzer & Vitamins, 11	Second edition; Mon.-Fri. 11:15-11:30 PM.	Sept. 1947	Wade Adv.	R. J. Reynolds Co., Winston Salem, N. C.; Camel Cigarettes, 162	Screen Guild Players; (off July-Sept.) (Eff. 10/49—Camel Screen Guild Theatre) Thurs. 9:00-9:30 PM.	Oct. 1948	William Esty & Co.
Miles Laboratories, Inc. Elkhart, Ind.; Alka-Seltzer & Vitamins, 162	Quiz Kids; Sun. 3:30-4:00 PM.	June 1940- Jan. 1942 Sept. 1946	Wade Adv.	Sealtest Inc., New York; Dairy Products, 77	Dorothy Dix at Home; Mon.-Fri. 10:45-11:00 AM.	Oct. 1949	N. W. Ayer & Son.
Minnesota Valley Canning Co., Le Sueur, Minn.; Canned Vegetables, 149	Fred Waring; Sat. 10:00-10:30 AM.	Mar. 1947	Leo Burnett Co.	Sealtest Inc., New York; Milk & Ice Cream, 94	Sealtest Variety Theatre; Starring Dorothy Lamour; Thurs. 9:30-10:00 PM.	Sept. 1948- July 1949	N. W. Ayer & Son.
John Morrell & Co., Ottumwa, Ia.; Red Heart Dog Food, 164	Lassie; (off June-Aug.) Sat. 11:00-11:15 AM.	June 1948	Henri, Hurst & McDonald.	Skelly Oil, Kansas Petroleum Products, 24	Alex Dreier; (Mon.-Fri.) This Farming Business and News Spot; (Sat.) Mon.-Sat. 8:00-8:15 AM.	July 1940	Henri, Hurst & McDonald.
Pabst Sales Co., Chicago; Pabst Blue Ribbon Beer, 151	The Eddie Cantor Show; (July-Sept. Screen Directors Playhouse) (Eff. 10/49—Life of Riley) Fri. 9:00-9:30 PM.	Sept. 1946	Warwick & Legler.	Southern Cotton Oil Co., San Francisco; Wesson Oil & Snow-drift, 8	Noah Webster Says; Thurs. 9:30-10:00 PM PST.	Oct. 1944- Oct. 1949	Fitzgerald Adv.
Pet Milk Sales Corp., St. Louis; Evaporated Milk, 144	The Pet Milk Show with Vic Damone; (July-Aug.—The Pet Milk Show) (Eff. 9/49 —The Pet Milk Show with Kay Armen) Sun. 10:30-11:00 PM.	Oct. 1948	Gardner Adv.	Standards Brands, Inc. New York; Chase & Sanborn Coffee, Instant Chase & Sanborn Coffee, 150	One Man's Family; Sun. 3:30-4:00 PM.	Apr. 1935- Jan. 1945 July 1945- Apr. 1949	J. Walter Thompson Co.
Pet Milk Sales Corp., St. Louis; Evaporated Milk, 148	Mary Lee Taylor; Sat. 10:30-11:00 AM.	Oct. 1948	Gardner Adv.	Standard Oil Co. of California San Francisco; Petroleum Products, 23	The Standard Hour; Sun. 8:30-9:30 PM PST.	Oct. 1926	Batten, Barton, Durstine & Osborn.
Philip Morris & Co., Ltd. New York; Cigarettes & Tobacco, 162	Philip Morris Night with Horace Heidt; Sun. 10:30-11:00 PM.	Dec. 1947- Aug. 1949	Blow Co.	Standard Oil Co. of California San Francisco; Petroleum Products, 22	Standard School Broadcast; (off June-Sept) Fri. 10:00-10:30 AM PST.	Oct. 1928	Batten, Barton, Durstine & Osborn.
Philip Morris & Co., Ltd. New York; Cigarettes, 144	This Is Your Life; (June-Sept.—Hogan's Daughter) Wed. 8:00-8:30 PM.	Nov. 1948	Blow Co.	Sterling Drug Co., New York; Dr. Lyon's Tooth Powder & Paste, Double Danderine, Astring-O-Sol, 146	Backstage Wife; Mon.-Fri. 4:00-4:15 PM.	Mar. 1936	Dancer, Fitzgerald, Sample.
Planters Nuts & Chocolate Co., Wilkes-Barre, Pa.; Planters Peanuts & Peanut Oil, 12	Elmer Peterson; Wed.-Fri. 5:45-6:00 PM PST.	Oct. 1944- Mar. 1949	Raymond R. Morgan Co.	Sterling Drug Co., New York; Phillips Milk of Magnesia & Tablets, Ironized Yeast, Bayer Aspirin, 146	Stella Dallas; Mon.-Fri. 4:15-4:30 PM.	June 1938	Dancer, Fitzgerald, Sample.
Pillsbury Mills, Inc. Minneapolis; Pillsbury Pie Crust Mix, 56	Bob Trout & the News Sun. 4:30-4:35 PM.	Apr. 1948- Mar. 1949	Leo Burnett Co.	Sterling Drug Co., New York; Phillips Creams, Energine Cleaning Fluid, Multisfied Coconut Oil, Bayer Aspirin, 146	Lorenzo Jones; Mon.-Fri. 4:30-4:45 PM.	Apr. 1937	Dancer, Fitzgerald, Sample.
Procter & Gamble Co., Cincinnati; Drest, 154	The Brighter Day Mon.-Fri. 10:45-11:00 AM.	Oct. 1948- July 1949	Dancer, Fitzgerald, Sample.	Sterling Drug Co., New York; Haley's M-O, Phillips Toothpaste, Phillips Milk of Magnesia, 146	Young Widder Brown; Mon.-Fri. 4:45-5:00 PM.	Sept. 1938	Dancer, Fitzgerald, Sample.
Procter & Gamble Co., Cincinnati; Tide, 149	Road of Life; Mon.-Fri. 3:15-3:30 PM.	Sept. 1937	Compton Adv.	Sterling Drug Co., New York; Dr. Lyon's Tooth Powder & Tooth Paste, 152	Manhattan Merry-Go-Round; Sun. 9:00-9:30 PM.	Nov. 1932- Feb. 1949	Dancer, Fitzgerald, Sample.
Procter & Gamble Co., Cincinnati; Oxydol, 148	Life Can Be Beautiful; Mon.-Fri. 3:00-3:15 PM.	Sept. 1938- Apr. 1941 June 1945	Blow Co. 7/11/49 Benton & Bowles.	Sterling Drug Co., New York; Bayer Aspirin, 155	American Album of Familiar Music; (off Aug.-Sept.) Sun. 9:30-10:00 PM.	Oct. 1931	Dancer, Fitzgerald, Sample.
Procter & Gamble Co., Cincinnati; Camay Soap, 153	Ma Perkins; Mon.-Fri. 3:15-3:30 PM.	Dec. 1933- July 1949	Dancer, Fitzgerald Sample.	Studebaker Corp., South Bend, Ind.; Automobiles, 8	Sam Hayes; Mon., Wed., Fri. 10:00-10:15 PM PST.	Jan. 1949	Roche, Williams & Cleary.
Procter & Gamble Co., Cincinnati; Ivory Soap, Duz, 152	Pepper Young's Family; Mon.-Fri. 3:30-3:45 PM.	Jan. 1936	Pedlar & Ryan.	Sun Oil Co., Philadelphia; Gas & Oil, Fuel Oil, 34	Sunoco Three Star Extra; Mon.-Fri. 6:45-7:00 PM.	Sept. 1947	Roche, Williams & Cleary, 3/1/49 Hewitt, Ogilvy, Benson & Mather
Procter & Gamble Co., Cincinnati; Frell, 141	Right to Happiness; Mon.-Fri. 3:45-4:00 PM.	Oct. 1939- Jan. 1940 Dec. 1941	Compton Advertising				
	Life of Riley; Fri. 10:00-10:30 PM.	Sept. 1945- May 1949	Benton & Bowles.				

Sponsor, Product No. of Stations	Program Day, Time EST	Duration of Contract	Agency	Sponsor, Product No. of Stations	Program Day, Time EST	Duration of Contract	Agency
Swift & Co., Chicago; Allsweet Margarine, 162	Meet the Meeks; Sat. 11:00-11:30 AM.	Nov. 1947- Apr. 1949	J. Walter Thompson Co.	Cluett Peabody & Co., Inc., New York; Neckwear, Sports- wear, Men's Shirts, Collars, 14 Intercon- nected	The Arrow Show; Thurs. 8:00-8:30 PM	Nov. 1948- May 1949	Young & Rubicam, Inc.
The Toni Co., St. Paul, Minn.; Home Permanent Wave, 157	This Is Nora Drake; Mon.-Fri. 11:00-11:15 AM.	Oct. 1947- Jan. 1949	Foote, Cone & Belding	Colgate-Palmolive- Peet Co., Jersey City; Vel. Lustre Creme, 21 Intercon- nected	The Colgate Theatre; Sun. 8:30-9:00 PM	Jan. 1949	William Esty Co.
United States Steel Corp., New York; Institutional, 164	NBC Summer Sym- phony; (Eff. 9/49—The Theatre Guild on the Air) Sun. 8:30-9:30 PM.	June 1949	Batten, Barton, Durst- ine & Osborn.	Colgate-Palmolive- Peet Co., Jersey City; Colgate Dental Cream, 24 Intercon- nected	Howdy Doody; Tues. & Thurs. 5:45-6:00 PM	Apr. 1949	Ted Bates & Co.
Western Auto Supply Co., Kansas City, Mo.; Automobile Acces- sories & Household Appliances, 59	Circle Arrow Show; Sun. 10:30-11:00 AM.	Oct. 1945- June 1949	Bruce B. Brewer & Co.	E. L. Cournand Co., New York; Walco- Tele-Vue-Lens, 7 In- terconnected	Greatest Fights of the Century; Fri. 11:00- 11:05 PM Approx	Oct. 1948- Jan. 1949	Cayton, Inc.
Whitehall Pharmacal Co., New York; Kolyons, Anacin, 129	Anacin Hollywood; Star Theatre; (off July-Aug.) Sat. 8:00- 8:30 PM.	Sept. 1947	Sullivan, Stauffer, Col- well & Bayles.	Crosley Division, AVCO Mfg. Corp., Cincinnati; Radio, Television Sets, Home Appliances, 26 Interconnected, 22 Non-Interconnected	Who Said That?; (off Aug.-Sept.); Sat. 9:00- 9:30 PM	Apr. 1949	Benton & Bowles, Inc.
Whitehall Pharmacal Co., New York; Kolyons, Aerowax, 59	Front Page Farrell; Mon.-Fri. 5:45-6:00 PM.	Sept. 1942	Dancer, Fitzgerald, Sample, Inc. 1/17/49 John F. Murray Adv.	Disney, Inc., Dan- bury, Conn.; Hats, 6 Interconnected, 12 Non-Interconnected	NBC News Review of the Week; Sun. 10:00- 10:10 PM	Sept. 1948- Apr. 1949	Grey Advertising Agency, Inc.
White King Soap Co., Los Angeles; Soap Products, 12	Elmer Peterson; Sat. 5:45-6:00 PM PST.	Mar. 1948	Raymond R. Morgan Co.	Elgin American- Watch Co., Chicago; Watches, 25 Intercon- nected	Thanksgiving Day Pgm.; Thurs. 8:30- 10:00 PM	Nov. 24, 1949 only	Weiss & Geller
Wildroot Co., Inc. Buffalo; Wildroot Cream Oil, Hair Tonic, 165	Adventures of Sam Spade; Sun. 8:00-8:30 PM.	Sept. 1949	Batten, Barton, Durst- ine & Osborn.	Firestone Tire & Rubber Co., Akron, Ohio; Tires & Tubes, 19 Interconnected, 2 Non-Interconnected	Americana; (eff. 9-5- 49—Voice of Fire- stone); (off July- Aug.); Mon. 8:30-9:00 PM	Apr. 1948	Sweeney & James Co.

TELEVISION

Admiral Corp., Chi- cago; Refrigerators, Ranges, Radios, Tele- vision Sets, 10 Inter- connected, 7 Non-Inter- connected	Admiral Broadway Re- view; Fri. 8:00-9:00 PM	Jan. 1949- June 1949	Kudner Agency, Inc.	Ford Dealers of America, Dearborn, Mich.; Ford Cars, 28 Interconnected	Kay Kyser; Thurs. 9:00-10:00 PM	Dec. 1949	J. Walter Thompson Co.
Admiral Corp., Chi- cago; Television, Radio Sets, Refrigerators, 21 Interconnected, 11 Non-Intercon- nected	Lights Out; Mon. 9:00- 9:30 PM	Nov. 1949	Kudner Agency, Inc.	General Foods Corp., New York; Jello Products, 15 Inter- connected	Author Meets the Critics; Sun. 8:30-9:00 PM	Dec. 1947- July 1949	Young & Rubicam, Inc.
Allis-Chalmers Mfg. Co., Milwaukee; Farm Equipment, 24 Interconnected	International Live Stock Exposition; Tues. 3:00-4:00 PM	Nov. 29, 1949 only	Bert Gittins, Inc.	General Foods Corp., New York; Maxwell House Coffee, 16 In- terconnected	Meet the Press; (eff. 2-27-49—The Lamb Gambol); (eff. 5-29-49 —Leave It to the Girls); Sun. 8:00-8:30 PM	Sept. 1948- Aug. 1949	Benton & Bowles, Inc.
American Cigarette & Cigar Co., New York; Pall Mall Cigarettes, 26 Interconnected, 7 Non-Interconnected	The Big Story; Alter- nate Fri. 9:30-10:00 PM	Sept. 1949	Sullivan, Stauffer, Col- well & Bayles, Inc.	General Foods Corp., New York; Jello Products, 17 Inter- connected	The Aldrich Family; Sun. 7:30-8:00 PM	Oct. 1949	Young & Rubicam, Inc.
American Oil Co., Maryland; Oil Prod- ucts, 11 Intercon- nected	Army Championship Bouts; Sat. 8:00-11:00 PM	Feb. 26, 1949 only	Joseph Katz Co.	Gillette Safety Razor Co., Boston, Mass.; Safety Razor Blades & Shaving Cream, 24 Interconnected	Boxing Bouts; (off June-Sept.); Fri. 10:00- 11:00 PM	Sept. 1944	Maxon, Inc.
American Tobacco Co., New York; Lucky Strike Cigar- ettes, 20 Intercon- nected, 13 Non-Inter- connected	Your Show Time; Fri. 9:30-10:00 PM	Jan. 1949- July 1949	N. W. Ayer & Sons, Inc.	Gulf Oil Corp., Pitts- burgh, Pa.; Gasoline, Oil & Lubricants, 13 Interconnected, 6 Non-Interconnected	Gulf Road Show with Bob Smith; Thurs. 9:00-9:30 PM	Sept. 1948- June 1949	Young & Rubicam, Inc.
American Tobacco Co., New York; Lucky Strike Cigar- ettes, Varies	College Football Games; Sat. afternoons & Thanksgiving After- noon	Sept. 1949- Nov. 1949	N. W. Ayer & Sons, Inc.	Gulf Oil Corp., Pitts- burgh, Pa.; Gasoline, Oil & Lubricants, 19 Interconnected, 8 Non-Interconnected	We, the People; Fri. 8:30-9:00 PM	Nov. 1949	Young & Rubicam, Inc.
Bates Fabrics Inc., New York; Fabrics and Sheets, 16 Inter- connected	A Girl About Town; (eff. 3-13-49—Around the Town); Sun. 10:10- 10:30 PM	Sept. 1948- Apr. 1949	James P. Sawyer, Inc.	Hamilton Watch Co., Pennsylvania; Watches, 26 Inter- connected	New Years Eve Party; Sat. 11:45-12:05 AM	Dec. 31, 1949 only	Batten, Barton, Durstine & Osborne
Bigelow-Sanford Carpet Co., Inc., New York; Carpets, 17 Interconnected, 13 Non-Interconnected	The Bigelow Show; Thurs. 9:30-10:00 PM	Oct. 1948- July 1949	Young & Rubicam, Inc.	International Shoe Co., St. Louis, Mo.; Shoes, 24 Intercon- nected	Howdy Doody; Wed. 5:45-6:00 PM	Aug. 1949	Henri, Hurst & McDonald, Inc.
BonaFide Mills, Inc., New York; Linoleum, 17 Interconnected, 13 Non-Interconnected	Stop Me If You've Heard This One; (eff. 4-29-49—Benny Rubin's Theatrical Agency); (eff. 8-26-49—Bonny Maid Versatile Vari- ties); (off July-Aug.); Fri. 9:00-9:30 PM	Jan. 1949- Nov. 1949	S. R. Leon & Co., Inc.	Kraft Foods Co., Chi- cago, Ill.; Mayon- nalse, 21 Intercon- nected, 1 Non-Inter- connected	Kraft Television Thea- tre; Wed. 9:00-10:00 PM	May 1947	J. Walter Thompson Co.
Bond Clothes, Inc., New York; Clothes, 20 Interconnected	Sport Highlights of the Week; 5 min. follow- ing Boxing on Fri.	Oct. 1949	Cayton, Inc.	Lever Bros., Cam- bridge, Mass.; Lux, Rinso, 26 Intercon- nected, 16 Non-Inter- connected	The Clock; Wed. 8:30- 9:00 PM	Oct. 1949	J. Walter Thompson Co.
Bristol Myers, New York; Ipana, Vitals, Sal Hepatica, 17 In- terconnected	Break the Bank; Wed. 10:00-10:30 PM	Oct. 1949	Doherty, Clifford & Shenfield	Liggett & Myers, New York; Chester- field Cigarettes, 16 Interconnected, 21 Non-Interconnected	Chesterfield Supper Club; (off June-Sept.); Sun. 8:00-8:30 PM	Dec. 1948	Newell-Emmett Co.
Buick Motor Division of General Motors, Flint, Michigan; Buick Cars, 21 Inter- connected, 19 Non- Interconnected	Fireball Fun-For-All; (off Aug.-Sept.); Thurs. 9:00-10:00 PM	June 1949- Oct. 1949	Kudner Agency, Inc.	P. Lorillard Co., New York; Old Gold Cigarettes, 25 Inter- connected, 1 Non- Interconnected	Original Amateur Hour; Tues. 10:00-11:00 PM	Oct. 1949	Lennen & Mitchell, Inc.
Chevrolet Dealers, Detroit, Mich.; Chev- rolet Cars, 24 Inter- connected, 11 Non- Interconnected	Chevrolet Tele-Thea- tre; (off July-Aug.); Mon. 8:00-8:30 PM	Sept. 1948	Campbell Ewald Co., Inc.	Mars, Inc., Chicago, Ill.; Candy, 22 Inter- connected	Howdy Doody; Mon. 5:45-6:00 PM	Sept. 1949	Grant Advertising, Inc.
Chesebrough Mfg. Co., New York; Vaseline Cream Hair Tonic, 15 Intercon- nected	Greatest Fights of the Century; (off July- Aug.); Fri. 11:00-11:15 PM Approx	Apr. 1949	Cayton, Inc.	Mason, Au & Magen- heimer Confectionery Mfg. Co., Brooklyn, New York; Coconut Candy Bars, 13 In- terconnected	Howdy Doody; Mon. 5:45-6:00 PM	Dec. 1948- July 1949	Moore & Hamm, Inc.
Cities Service, New York; Gasoline, Oil, 23 Interconnected	Band of America; Mon. 9:30-10:00 PM	Oct. 1949	Ellington & Co., Inc.	Miles Laboratories, Inc., Elkhart, Ind.; Vitamins, Alka-Selt- zer, 18 Intercon- nected	Quiz Kids; Mon. 10:00- 10:30 PM	Sept. 1949	Wade Advertising Agency

(Continued on page 412)

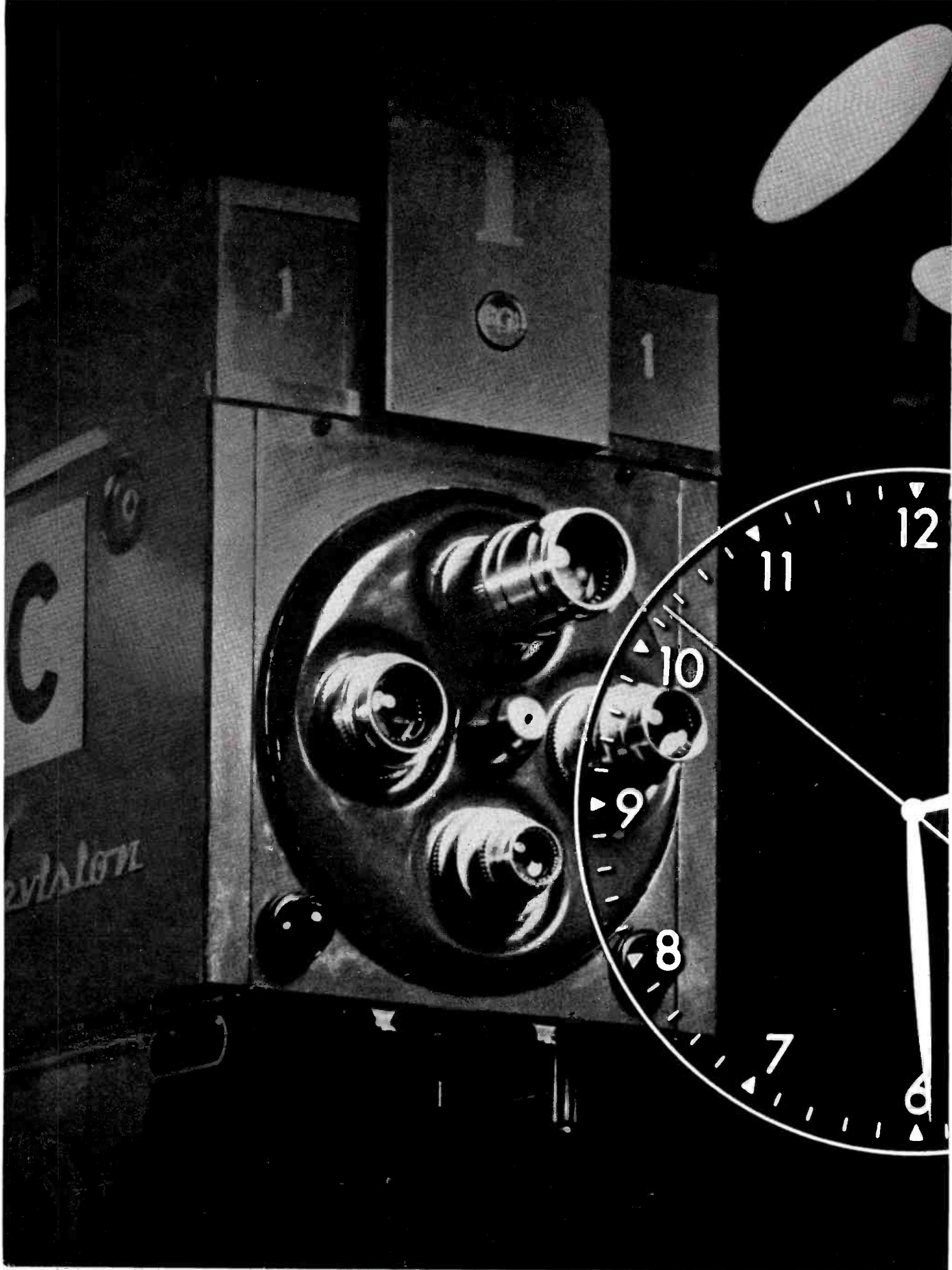

television-year ten

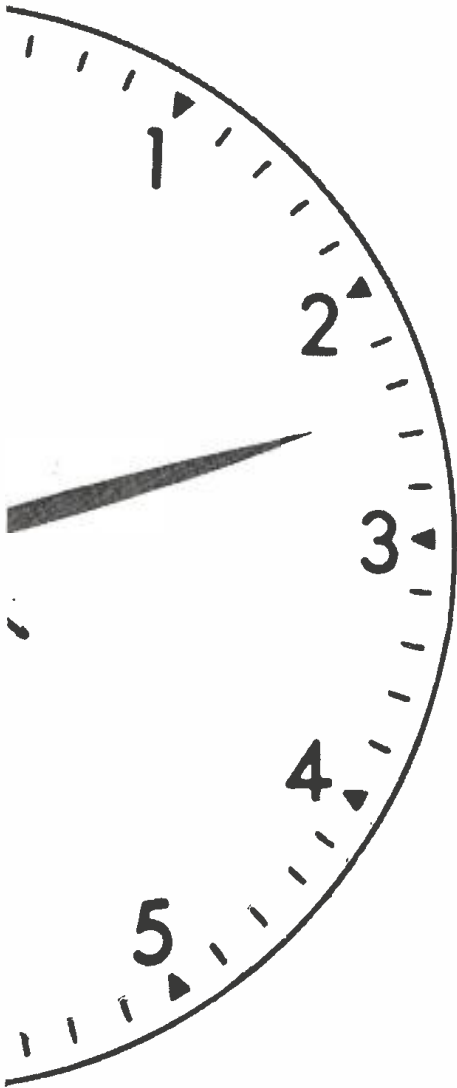

2: 29: 50 PM

That was nine years ago . . . the first television commercial . . . a Bulova time signal on NBC.

In those days, television was an advertising luxury, even for its few hardy pioneers . . . its biggest reward the prestige of a historic role in developing a radically new medium.

Today, only a decade later, it's as plain as TV's myriad roof-top antennas that *television has changed from an advertising adventure to an advertising necessity.*

This is the year NBC Television will blanket areas containing 60% of America's families . . . 144 of the nation's 200 leading counties . . . the richest sales markets from coast to coast. And the products sold by NBC Television sponsors will range all the way from mass consumer items to deluxe motor cars.

Amid these gargantuan strides, only one key fact in television remains unchanged. In 1950, just as in '47 and '48 and '49, NBC Television plays to far more viewers . . . with more popular programs . . . for more advertisers . . . than any other network.

NBC *America's No. 1 Television Network*

ADVERTISERS USING NBC NETWORK DURING 1949

(Continued from page 409)

Sponsor, Product No. of Stations	Program Day, Time EST	Duration of Contract	Agency	Sponsor & Product No. of Stations	Program Day & Time EST	Duration of Contract	Agency
Mohawk Carpet Mills Inc., Amsterdam, N. Y.; Rugs & Carpets, 17 Interconnected, 5 Non-Interconnected	Mohawk Showroom; (off Aug.); Mon.-Fri. 7:30-7:45 PM	May 1949	George R. Nelson, Inc.	Radio Corp. of America, Camden, New Jersey; 45-RPM Phonographs, Television Sets, 23 Interconnected, 26 Non-Interconnected	The Kukla, Fran and Ollie Show; (off June-Aug.); Mon.-Wed.-Fri. 7:00-7:30 PM	Nov. 1948	J. Walter Thompson
Motorola, Inc., Chicago, Ill.; TV & Radio Sets, 7 Interconnected	Nature of Things; (eff. 3-1-49—Believe It or Not); Tues. 9:30-10:00 PM	Apr. 1948- Apr. 1949	Gourfain-Cobt Advertising Agency	R. J. Reynolds Tobacco Co., Winston-Salem, N. C.; Camel Cigarettes, 22 Interconnected	Camel Newsreel Theatre; (eff. 2-16-49—Camel News Caravan); Mon. thru Fri. 7:45-8:00 PM	Feb. 1948	William Esty Co., Inc.
National Dairy Products Corp., New York; Sealtest Ice Cream, 22 Interconnected, 21 Non-Interconnected	Kukla, Fran & Ollie; Tues. & Thurs. 7:00-7:30 PM	Sept. 1949	N. W. Ayer & Son, Inc.	Swift and Co., Chicago, Ill.; Swift Products, 18 Interconnected	The Swift Show; Thurs. 8:30-9:00 PM	Apr. 1948- Aug. 1949	McCann-Erickson, Inc.
Oldsmobile Div. General Motors Corp., Flint, Mich.; Cars, 7 Interconnected	NBC Newsreel; Wed. 10:00-10:45 PM	Nov. 1948- Feb. 1949	D. P. Brothier & Co., Inc.	Standard Oil Co. of Indiana, Chicago; Oil, Gasoline, 8 Non-Interconnected	The Wayne King Program; Thurs. 10:30-11:00 PM	Sept. 1949	McCann-Erickson, Inc.
Pabst Sales Co., Chicago, Ill.; Beer, Ale & Hoffman Beverages, 20 Interconnected, 2 Non-Interconnected	The Life of Riley; Tues. 9:30-10:00 PM	Oct. 1949	Warwick & Legler, Inc.	The Texas Co., New York; Gasoline, Oil, Grease, 24 Interconnected, 10 Non-Interconnected	Texaco Star Theater, Starring Milton Berle; (off July-Aug.); Tues. 8:00-9:00 PM	June 1948	Kudner Agency, Inc.
Philco Corp., Philadelphia, Pa.; Radios & Television Sets, 24 Interconnected, 23 Non-Interconnected	Philco Television Playhouse; (off Apr.-July); Sun. 9:00-10:00 PM	Oct. 1948	Hutchins Advertising, Inc.	Unique Art Mfg. Co., Newark, N. J.; Mechanical Toys, 22 Interconnected	Howdy Doody; (off July-Aug.); Fri. 5:45-6:00 PM	Oct. 1948	Grant Advertising, Inc.
Procter & Gamble Co., Cincinnati, Ohio; Ivory Soap, Crisco & Duz, 22 Interconnected	I'd Like To See; (eff. 4-5-49—Fireside Theatre; (off July-Aug.); Tues. 9:00-9:30 PM	Nov. 1948	Compton Advertising, Inc.	United States Tobacco Co., New York; Model, Old Briar, Dill's Best, Tweed, 23 Interconnected, 5 Non-Interconnected	Martin Kane, Private Eye; Thurs. 10:00-10:30 PM	Sept. 1949	Kudner Agency, Inc.

CANADIAN BROADCASTING CORPORATION: EXECUTIVES AND STAFF

BOARD OF GOVERNORS

A. Davidson Duntun, Ottawa, Ont., *Chairman*
 Rene Morin, Montreal, Que., *Vice-Chairman*
 Mrs. T. W. Sutherland, Parksville, B. C.
 F. J. Crawford, Toronto, Ont.
 Dr. G. D. Steel, Charlottetown, P.E.I.
 Dean Adrien Pouliot, Laval University, Que.
 John J. Bowlen, Calgary, Alta.
 W. H. Phillips, Ottawa, Ont.
 (H. M. Palmer, secretary, 140 Wellington St., Ottawa, Ont.)
 J. A. Corry, Queens U., Kingston, Ont.

HEAD OFFICE

Victoria Bldg., 140 Wellington St., Ottawa, Ont.
 P. O. Box 806, Ottawa, Ont.

Dr. Augustin Frigon, *General Manager*
 (also Radio Canada Bldg., Bishop and Dorchester Sts., Montreal, Que.)
 Donald Manson, *Assistant General Manager*
 R. P. Landry, *Director, Personnel and Administrative Services*
 G. W. Richardson, *Assistant Director, Personnel and Administrative Services*
 K. M. Kelly, *Supervisor of Personnel and Welfare*
 Marcel Carter, *Supervisor of Administrative Services*
 A. E. Tetu, *Chief of Records*
 H. Eramah, *Treasurer*
 S. Schobb, *Assistant to Treasurer*
 W. R. Mortimer, *Supervisor of Expenditures*
 F. W. Savignac, *Assistant to Executive-Legal*
 H. M. Palmer, *Executive Assistant and Secretary to Board of Governors*

NATIONAL PROGRAM OFFICE

354 Jarvis St., Toronto 5, Ont.
 P. O. Box 500, Toronto, Ont.

Ernest L. Bushnell, *Director-General of Programs*
 Charles Jennings, *General Supervisor of Programs*
 Harry J. Boyle, *Program Director Trans-Canada Network*
 H. G. Walker, *Manager, Dominion Network*
 W. H. Brodie, *Supervisor of Broadcast Language*
 W. J. Dunlop, *Supervisor of International Exchange & Institutional Broadcasts*
 R. S. Lambert, *Supervisor of School Broadcasts*
 Neil M. Morrison, *Supervisor of Talks and Public Affairs*
 Ferguson Mutrie, *Supervisor of Farm Broadcasts*
 D. C. McArthur, *Chief News Editor*
 E. W. Jackson, *Traffic Manager*
 Elizabeth D. Long, *Women's Interests*
 H. Z. Palmer, *Assistant Program Director Trans-Canada Network*
 A. E. Powley, *News Features Editor*
 H. E. S. Hamilton, *Supervising Engineer (Network Operations)*

TORONTO OFFICES AND STUDIOS

354 Jarvis St., Toronto 5, Ont.
 P. O. Box 500, Toronto, Ont.

D. C. Claringbull, *Manager, Personnel and Administrative Services*
 J. M. Kannawin, *Supervisor of Presentation*
 Walter Anderson, *Supervisor of Program Clearance*
 R. W. McGall, *Program-Director (CJBC)*
 E. Misener, *Supervisor of Copyright Clearance*
 H. Hilliard, *Supervising Engineer (Toronto Area)*

COMMERCIAL DIVISION

354 Jarvis St., Toronto 5, Ont.
 P. O. Box 500, Toronto, Ont.

E. A. Weir, *Commercial Manager*
 W. E. Powell, *Assistant Commercial Manager*
 W. R. Johnston, *Supervisor of Acceptance and Production*
 Hugh Clark, *Sales Representative*
 T. T. Odell, *Sales Representative*
 L. E. Pegg, *Sales Representative*
 Arthur Barr, *Sales and Commercial Traffic*
 H. F. Chevrier, *Coverage Statistics*

PRESS AND INFORMATION SERVICE

NATIONAL OFFICE

354 Jarvis St., Toronto 5, Ont.

Ron C. Fraser, *Supervisor of Press and Information Service*
 Robert S. Bryden, *Chief of Publications*
 Mabel J. Cotton, *Press and Information Representative*
 T. C. Fairley, *Editor, CBC Times*
 Marjorie C. Beaton, *Reference Librarian*

REGIONAL OFFICES

Wyn Rhydwen, *Press and Information Representative*
 (100 Sackville St., Halifax, N.S.—P.O. Box 175, Halifax, N.S.)
 Jean Saint-Georges, *Supervisor of Press and Information (French)*
 (1231 St. Catherine St. W., Montreal, Que.)
 Robert Elie, *Press and Information Representative*
 (1231 St. Catherine St. W., Montreal, Que.)
 C. E. L'Ami, *Press and Information Representative*
 (300 Manitoba Telephone Bldg., Winnipeg, Man.)
 W. G. Clark, *Press and Information Representative*
 (701 Hornby St., Vancouver, B. C.)
 Ralph Marvin, *Press and Information Representative for CBC International Service*
 (Radio-Canada Bldg., 1160 Bishop St., Montreal, Que.—P. O. Box 189, Postal Station "H," Montreal, Que.)

BROADCAST REGULATIONS DIVISION

354 Jarvis St., Toronto 5, Ont.
 P. O. Box 500, Toronto, Ont.

Geo. R. Young, *Manager, Broadcast Regulations*
 R. E. Keddy, *Assistant to Manager*
 R. Kerr, *Food and Drug Continuity Clearance*

STATION RELATIONS DIVISION

354 Jarvis St., Toronto 5, Ont.
 P. O. Box 500, Toronto, Ont.

Geo. R. Young, *Director of Station Relations*
 R. E. Keddy, *Assistant to Director*
 I. M. Ritchie, *Program Distribution*
 Maurice Goudraut, *Supervisor of Station Relations (Que.)*
 (Radio-Canada Bldg., 1160 Bishop St., Montreal, Que.—P. O. Box 6000, Montreal, Que.)

STAFF MAGAZINE "RADIO"

354 Jarvis St., Toronto 5, Ont.
 P. O. Box 500, Toronto, Ont.

V. F. Segee, *Editor*

ENGINEERING DIVISION

Radio-Canada Bldg., 1160 Bishop St., Montreal, Que.
 P. O. Box 6000, Montreal, Que.

Gordon W. Olive, *Chief Engineer*
 J. A. Ouimet, *Assistant Chief Engineer*
 W. A. Nichols, *Plant Engineer*
 D. G. McKinstry, *Chief Architect*
 W. G. Richardson, *Transmission and Development Engineer*
 N. R. Olding, *Operations Engineer*
 M. L. Poole, *Project Engineer*
 C. E. Stiles, *Supervisor of Purchasing and Stores*
 H. E. S. Hamilton, *Supervising Engineer (Network Operations)*
 (354 Jarvis St., Toronto 5, Ont.)

REGIONAL OFFICES

Newfoundland Region, St. John's, Nfld.
 P. O. Box E5372, St. John's, Nfld.
 Wm. Galgay, *Regional Representative*
 Maritime Region, United Service Bldg.
 100 Sackville St., Halifax, N. S.
 (P. O. Box 175, Halifax, N. S.)
 W. E. S. Briggs, *Regional Representative*
 H. M. Smith, *Regional Engineer (CBA, Sackville, N. B.)*
 S. R. Kennedy, *Station Manager (CBH)*
 L. B. McDonald, *Station Manager (CBI) (Sydney, N.S.)*

Quebec Region, King's Hall Bldg.
1231 St. Catherine St. W, Montreal, Que.
Marcel Oulmet, Director of French Network
Armand Berube, Supervisor of Farm Broadcasts (Fr.)
R. Daveluy, Supervisor of Presentation
Benoit Laffeur, Supervisor of Talks and Public Affairs (Fr.)
W. J. O'Reilly, Program Director, CBM
J. R. Samson, Manager, Personnel and Administrative Services
Aurele Seguin, Supervisor of School Broadcasts (Fr.)
Maurice Valiquette, Commercial Manager

Prairie Region, 300 Manitoba Telephone Bldg.,
Winnipeg, Man.

James R. Finlay, Regional Representative
J. N. Mogridge, Station Manager (CBK-CBW)
R. D. Cahoon, Regional Engineer
W. Carpentier, Commercial Representative
Dan E. Cameron, Manager for Alberta
(Macdonald Hotel, Edmonton, Alta.)

British Columbia Region, 701 Hornby St.,
Vancouver, B. C.
Kenneth Caple, Regional Representative

F. B. C. Hilton, Regional Engineer
H. W. Paulson, Commercial Representative
CBC INTERNATIONAL SERVICE
Radio-Canada Bldg., 1160 Bishop St., Montreal, Que.
P. O. Box 189, Montreal, Que.
Ira Dilworth, General Supervisor
C. R. Delafield, Assistant General Supervisor
F. P. Johnson, Senior Engineer
A. D. Monk, Manager Personnel and Administrative Services
J. S. Peach, Supervisor, English Language Section
G. Arthur, Supervisor, French Language Section
S. W. Griffiths, Supervisor, European Section (Foreign Languages)
H. W. Morrison, Supervisor, Latin American Section
F. Brickenden, CBC International Service Representative (100 Sackville St., Halifax, N. S.)
T. Benson, CBC International Service Liaison Officer (Acting) (Victoria Bldg., 140 Wellington St., Ottawa, Ont.)
Madeline Charlebois, CBC International Service Representative (CBO Studios, Chateau Laurier, Ottawa, Ont.)
Ernest Morgan, CBC International Service Representative

(354 Jarvis St., Toronto 5, Ont.)
Peter Francis, CBC International Service Representative (354 Jarvis St., Toronto 5, Ont.)
L. B. McIlhagga, CBC International Service Representative (Acting) (300 Manitoba Telephone Bldg., Winnipeg, Man.)
W. Herbert, CBC International Service Representative (701 Hornby St., Vancouver, B. C.)
Andrew G. Cowan, European Representative (c/o BBC, 200 Oxford St., London, W.I, England)
King Gordon, United Nations Representative (CBC United Nations, Room K601, Lake Success, N. Y., U.S.A.)

CBC OVERSEAS OFFICE
c/o BBC, 200 Oxford St., London W.I, England
Andrew G. Cowan, European Representative
Matthew Halton, European Correspondent

NEW YORK OFFICE
CBC United Nations, Room K601,
Lake Success, N. Y., U.S.A.
King Gordon, United Nations Representative

UNIONS AND LABOR GROUPS AFFECTING RADIO AND TELEVISION FIELDS

Name of Organization	Affiliation	Address Telephone No.	Executives	Name of Organization	Affiliation	Address Telephone No.	Executives
American Communications Assn.	CIO	5 Beekman St. New York City Courtland 7-1374	Joseph P. Selly, Pres. William Bender, V.P. Atlantic Branch Local #1	Radio Guild Local 50, United Office & Professional Workers of America (UOPWA)	CIO	50 E. 29th St. New York City Murray Hill 6-2977	Arnold Platt, Pres. Sylvia Sheridan, Guild Rep.
American Federation of Labor	AFL	901 Mass. Ave., N.W. Washington, D. C. National 3870	William Green, Pres.	Radio & Television Directors Guild	AFL	114 E. 52nd St. New York City PLaza 3-4300	Ernest Ricca, 3rd V.P. Earle L. McGill, Natl. Treas. Oliver Nicoll, Nat'l Secy.
American Federation of Musicians	AFL	570 Lexington Ave. New York City PLaza 8-0600	James C. Petrillo, Pres. Leo Cluesmann, Secy. (Chicago Local 10)			203 N. Wabash Ave. Chicago, Ill. ANDover 3-5458	Mel Williams, 1st V.P. Lyle D. Barnhardt, 2nd V.P.
American Federation of Musicians Mutual Protective Assn. Local 47	AFL	1417 S. Georgia St. Los Angeles 15, Calif. Richmond 5411	J. K. Wallace, Pres. Phil Fisher, Radio Rep.			6305 Yucca St. Hollywood 28, Calif. Granite 5868	
American Newspaper Guild	CIO	99 University Pl. New York City GRamercy 3-8503	Harry Martin, Pres. Sam Eubanks, Exec. V.P. Ralph B. Novak, Secy.-Treas.	Radio Writers' Guild of Authors League of America	----	6 E. 39th St. New York City Murray Hill 6-5251	Erik Barnouw, Natl. Pres. Weibourn Kelley, V.P. Eastern Region
Associated Actors & Artists of America	AFL	45 W. 47th St. New York City PLaza 7-7660	Paul Dullzell, Pres.			203 N. Wabash Ave. Chicago, Ill. ANDover 3-5458	
Broadcast-Television Recording Engineers Local 45 IBEW	AFL	1591 Cross Roads -of-the-World Hollywood 28, Calif. Gladstone 8889	Roy Tindall, Bus. Mgr.			1655 N. Cherokee Ave. Hollywood 28, Calif. Gladstone 7128	Milton Merlin, V.P. Western Region
Communication Workers of America	CIO	917 G Pl., N.W. Washington, D. C. EXecutive 2778	Joseph A. Beirne, Pres.	Screen Publicists Guild	----	2700 N. Highland Ave. Hollywood 28, Calif. Hempstead 6828	Dan Thomas, Pres. Milton Gottlieb, Bus. Mgr.
Congress of Industrial Organizations	----	718 Jackson Pl., N.W. Washington, D. C. EXecutive 5581	Philip Murray	Screen Writers' Guild of Authors League of America	----	1655 N. Cherokee Ave. Hollywood 28, Calif. Hollywood 9-3601	George Seaton, Pres. Alice Tennesmen, Exec. Secy.
International Alliance of Theatrical Stage Employees & Moving Picture Machine Operators	AFL	630 Fifth Ave. New York City Circle 5-4370	Richard F. Walsh, Pres. William P. Raoul, Secy.-Treas.	Organizations affiliated with Associated Actors & Artistes of America			
		188 W. Randolph St. Chicago, Ill. CENTral 6-4582	Local 110	Actors Equity Assn.	AFL	45 W. 47th St. New York City BRyant 9-3550	Clarence Derwent, Pres.
		2837 W. Ninth St. Los Angeles 6, Calif. Fairfax 2321	Carl G. Cooper, Bus. Rep.			6331 Hollywood Blvd. Hollywood 28, Calif. Hillside 5125	I. B. Kornblum Western Rep.
International Brotherhood of Electrical Workers	AFL	1200 15th St., N.W. Washington, D. C. District 3764	D. W. Tracy, Pres. J. Scott Milne, Secy.	American Federation of Radio Artists	AFL	2 W. 45th St. New York City VAnderbilt 6-1810	Clayton Colyer, Pres. George Heller, Natl. Exec. Secy.
		49 N. Ogden Ave. Chicago, Ill. SEely 3-7890	Local 134			540 N. Michigan Ave. Chicago, Ill. DELaware 7-7017	Ray Jones, Exec. Secy. Chicago Local
National Assn. of Ind. Broadcast Engineers & Technicians	IND	421 Seventh Ave. New York City PLaza 7-0327	J. R. McDonell, Pres. Edward Lynch, Exec. V.P.			6331 Hollywood Blvd. Hollywood 28, Calif. Hillside 5125	Claude L. McCue, Western Reg. Dir.
		80 E. Jackson Blvd. Chicago, Ill. WAbash 2-2462	George Maher, Natl. Rep.	American Guild of Musical Artists	AFL	276 W. 43rd St. New York City LOnacre 5-7508	Lawrence Tibbett, Pres. Hyman R. Faine, Exec. Secy.
		375 O'Farrell St. San Francisco, Calif. Ordway 3-8484	John R. McDonnell, Pres.			6331 Hollywood Blvd. Hollywood 28, Calif. Hillside 5121	I. B. Kornblum, Western Rep.
National Assn. of Broadcast Unions & Guilds (NABUG)	----	37 W. 46th St. New York 19 Luxemburg 2-5130	Oliver W. Nicoll, National Chairman, Chairman of N. Y. Council	American Guild of Variety Artists	AFL	1697 Broadway New York City Circle 6-7130	Gus Van, Pres. Dewey Barto, Secy.
		102 E. Hubbard St. Chicago 11 Delaware 7-7017	Raymond A. Jones, Chairman Geo. Maher, Secy.-Treas.			1510 Cross Roads -of-the-World Hollywood 28, Calif. Hillside 8281	Edward Rio, Western Reg. Dir.
		6331 Hollywood Blvd. Hollywood 28 Hillside 5125	Claude McCue, Chairman James H. Brown, Secy.-Treas.	Screen Actors Guild	AFL	545 Fifth Ave. New York City Murray Hill 2-0184	Mrs. Florence Marston, Eastern Rep.
		375 O'Farrell St. San Francisco 2 Ordway 3-8484	John R. McDonnell, Chairman William S. Gavin, Secy.-Treas.			7046 Hollywood Blvd. Hollywood 28, Calif. Hollywood 9-7311	Ronald Reagan, Pres. John L. Dales Jr., Exec. Secy.
Office Employees' International Union Local 174 (OEIU)	AFL	7268 1/2 Sunset Blvd. Hollywood 48, Calif. Granite 9178	Lauren P. Amell, Local Pres. Max Krug, Bus. Mgr.	Screen Extras Guild	AFL	723 N. Western Ave. Los Angeles 27, Calif. Garfield 3301	Richard H. Gordon, Pres. H. O'Neil Shanks, Exec. Secy.

RADIO, TELEVISION PROGRAM PRODUCTION & TRANSCRIPTION SERVICES

Including Recording, TV, Film, Talent and Script Writing Firms

A

ABT PRODUCTIONS INC.

460 W. 54th St., New York; Tel.: Columbus 5-7200; Ira Simmons, president.

Services: Films for TV.

ACME TELETRONIX (NEA)

1200 W. 3rd St., Cleveland, O.; Tel.: Main 7300; Meade Munroe, manager.

Services: Newspictures & Telephoto; complete news & weather programs, script & strip film.

ACUS PICTURES CORP.

165 West 46th St., New York 19; Tel.: Plaza 7-2265; Patrick E. Shanahan, president.

Services: TV film rental.

JOHN ADASKIN PRODUCTIONS

67 Yonge St., Toronto 1; Tel.: Elgin 9296; John Adaskin, owner.

Services: Production, package programs.

ADVANCE TEL. PICTURE SERVICE INC.

729 Seventh Ave., New York; Tel.: Circle 5-6873; Charles A. Alicoate, president.

Services: TV films.

ADVENTURE FILMS, INC.

165 W. 46th St., New York 19; Tel.: Plaza 7-2320; William Alexander, president.

Services: Film distribution.

ADVERTISERS RECORDING SERVICE INC.

113 W. 57th St., New York 19; Tel.: Circle 6-0141; James A. Miller, president.

Services: Recording Service.

ADVERTISERS TELEVISION SERVICE

35 W. 53rd St., New York; Tel.: Plaza 7-7150; John Sheppard Jr., president.

Services: TV films, show packagers.

A. F. FILMS INC.

1600 Broadway, New York; Tel.: Circle 7-2850; Miss Rosalind Kossoff, director.

Services: TV educational film subjects.

AFFILIATED ARTS LTD.

1175 Bay St., Toronto; Tel.: Midway 2956; S. McKeown, manager.

Services: Talent.

AFFILIATED PROGRAM SERVICE INC.

535 Fifth Ave., New York 17; Tel.: Murray Hill 7-1881; Paul F. Adler, president.

Services: Recording, syndicated transcriptions, scripts, package programs, syndicated script library, live and film TV programs.

NICHOLAS T. AGNETA

RKO Bldg., New York 19; Tel.: Columbus 5-0232; Nicholas T. Agneta, manager.

Services: Recording, production, scripts, talent, TV.

AIR FEATURES INC.

247 Park Ave., New York 17; Tel.: Plaza 5-2700; Maurice Scopp.

Services: Production.

AIRSHOWS INC.

(See W. Biggie Levin Agency.)

EDDIE ALBERT PRODUCTIONS

1133 N. Highland Ave., Hollywood 38; Tel.: Gladstone 4116; Eddie Albert, manager.

Services: TV film programs.

ALEXANDER FILM CO.

Alexander Film Bldg., Colorado Springs, Col.; Tel.: Main 4200; W. A. Hillhouse, TV director.

Services: TV film production & distribution.

New York—500 Fifth Ave.; L. E. Wyson, eastern sales manager.

Chicago—Wrigley Bldg., E. C. Corbett, special representative.

Monroe, Mich.—324 Colonial Dr.; J. J. DeVine, assistant to president.

Dallas—308 S. Harwood; J. A. McInaney, assistant to president.

Tulsa—1634 S. Boston Ave.; Max Heidenreich, special representative.

Hollywood—707 N. Ridgewood Pl.; C. J. Dexter, district manager.

ALTON ALEXANDER RADIO & TV PRODUCTION

825 W. 187th, New York 33; Tel.: Lorraine 8-3100; Lottie Ritter.

Services: Production, scripts.

ALL-CANADA RADIO FACILITIES LTD.

80 Richmond St. West; Tel.: Elgin 2464; Guy F. Herbert, general manager.

Services: Station representative, transcription distributor and producer.

Montreal—Dominion Square Bldg.; Tel.: Lancaster 6400; Burt Hall, manager.

Winnipeg—Childs Bldg.; Tel.: Lancaster 6400; P. H. Gayner, manager.

Calgary—Taylor, Pearson & Carson Bldg.; Tel.: M-7591; H. R. Carson, manager.

Vancouver—198 W. Hastings St.; Tel.: Marine 9542; J. E. Baldwin, manager.

ALLEN & ALLEN PRODUCTIONS

3947 W. 59th Pl., Los Angeles 43; George E. Allen, managing director.

Services: Film rental to sponsors, advertisers and TV stations.

ALLIED RECORD MFG. CO.

1041 N. Las Palmas, Hollywood 38; Tel.: Hollywood 9-5107; D. K. Broadhead, manager.

Services: Transcriptions, processing, phonograph records.

ALL-SCOPE PICTURES INC.

407 Yucca Vine Bldg., Hollywood 28; Tel.: Hollywood 9-6386; Gordon S. Mitchell, president.

Services: TV film production.

AMBASSADOR FILMS INC.

118 W. 57th St., New York 19; Tel.: Judson 6-2680; Eugen Sharin, president.

Services: Production & distribution of TV films.

AMERICAN DRAMA GUILD OF TELEVISION

9885 Charleville Blvd., Beverly Hills; Tel.: Crestview 4-5223; Philip Nasser & John Darrow.

Services: Packaging of live & film TV programs.

New York—150 E. 54th St.; Tel.: Plaza 3-0871; Earl Blackwell, manager.

AMERICAN FILM CO.

1329 Vine St., Philadelphia 7; Tel.: Walnut 2-1800; Ben Harris, manager.

Services: TV film.

AMERICAN FILM PRODUCERS

1600 Broadway, New York; Tel.: Plaza 7-5918; Robert Gross, L. A. Glesnes, partners.

Services: TV films.

AMERICAN FILM & TELEVISION CO.

759 W. 7th St., St. Paul; Tel.: Dale 4620; Bart O. Foss, manager.

Services: TV films.

AMERICAN FOUNDATION FOR THE BLIND

15 W. 16th St., New York 11; Tel.: Watkins 4-0420; R. B. Irwin, executive director.

Services: Talking book records for the blind.

AMERICAN INSTITUTE OF FOOD PRODUCTS INC.

509 Madison Ave., New York 22; Tel.: Murray Hill 8-4900; Robert A. Borjes, general manager.

Services: Production, scripts, talent for food merchandising.

AMERICAN INSTITUTE OF THE AIR

5 W. Lake St., Minneapolis 8; Tel.: Pleasant 5290; R. C. Brown, director.

Services: Recording service.

AMERICAN JEWISH BCSTG. CO. INC.

150 Broadway, New York 7; Tel.: Worth 2-3322; Herman Younglieb, manager.

Services: Jewish programs.

AMERICAN ROYAL PRODUCTIONS

7928 Michigan Ave., Oakland 5; Tel.: Lockhaven 8-8698; Scott Weakley, manager.

Services: Recording, production.

AMERICAN TELEVISION INC.

5050 N. Broadway, Chicago 40; Tel.: Ardmore 1-9010; U. A. Sanabria, president.

Services: Courses in film production, package programs, scripts, talent, slide film.

AMELCO (American Merchants Telev. Co.)

635 S. Kenmore Ave., Los Angeles 5; Tel.: Dunkirk 7-3265; Wallace Worsley, president.

Services: TV film commercials.

ANIMATED VIDEO CARTOONS

322 Victor Bldg., Washington 1, D.C.; Tel.: Sterling 2450; C. Wes Doty, owner.

Services: Production of animated TV commercials.

ANIMATED VIDEO FILMS INC.

1001 N. Vermont Ave., Los Angeles 27; Tel.: Normandy 3-2884; Ace Gamer, president.

Services: Animated and live TV film to order.

Detroit—360 W. Lafayette Ave.; Tel.: WO 5-6721; Walter La Driere.

EVAN J. ANTON PRODUCTIONS LTD.

20 E. 42nd St., New York 17; Tel.: Murray Hill 7-6315; Evan J. Anton, president.

Services: TV film production, recording.

APEX FILM CORP.

971 N. La Cienega Blvd., Los Angeles 46; Tel.: Crestview 5-5521; Jack Chertok, president.

Services: TV film commercials.

New York—361 E. 50th St.; Tel.: Eldorado 5-0008; W. H. Buch, eastern representative.

APEX RECORDING STUDIOS INC.

119 W. 57th St., New York 19; Tel.: Plaza 7-7067; Robert E. Scheuing, president.

Services: Recording service.

ARGOSY TELEVISION CORP.

9336 Washington Blvd., Culver City, Calif.; Tel.: Texas 0-2931; Merian C. Cooper, business manager.

Services: TV live & film programs.

ARIZONA RECORDING PRODUCTIONS

834 N. Seventh Ave., Phoenix; Tel.: 2-2016; Raymond Boley, owner & manager.

Services: Recording, production, talent.

LAURA ARNOLD

545 Fifth Ave., New York 17; Tel.: Murray Hill 2-2795.

Services: Talent agency.

ARTISTS RECORDING BUREAU

4242 Pinewood Ave., Jacksonville 7, Fla.; Tel.: 9-2767; M. C. Bishop, manager.

Services: Recording, production, package programs, scripts, talent, TV film.

ARTS RECORDING STUDIOS

29 W. 57th St., New York 19; Tel.: Plaza 8-0407; M. Cieferskor, manager.

Services: Recording, package programs, record pressing.

ASSOCIATED BROADCASTING CO. LTD.

1139 Bay St., Toronto; Tel.: Princess 1111; M. R. Raymond, general manager.

Services: Production, scripts, spot campaigns.

THE ASSOCIATED BROADCASTERS INC. (KSFO)

Mark Hopkins Hotel, San Francisco 6; Tel.: Exbrook 2-4567; Phillip G. Lasky, manager.

Services: Recording, production.

ASSOCIATED PROGRAM SERVICE (Division of Muzak Corp.)

151 W. 46th St., New York 19; Tel.: Plaza 7-7710; Richard S. Testut, vice president & general manager.

Services: Transcription library for colleges and universities, scripts, production.

ASSOCIATION FILMS INC.

35 W. 45th St., New York; Tel.: Ju 2-3020; J. R. Bingham, president.

Services: TV and 16 mm films.

ASTOR PICTURES CORP.

130 W. 46th St., New York; Tel.: Luxembourg 2-1287; R. M. Savini, manager.

Services: TV films.

ATLAS FILM CORP.

1111 South Blvd., Oak Park, Ill.; Tel.: Euclid 6-3100; K. W. Lineberry, president.

Services: TV films, recording, scripts, slide films.

ATLAS TELEVISION CORP.

1619 Broadway, New York 19; Tel.: Circle 7-2900; Henry Brown, president.

Services: TV films.

AUDIO PRODUCTIONS INC.

630 Ninth Ave., New York; Tel.: Columbus 5-6771; P. B. Nichols, sales manager.

Services: TV films.

AUDIO-VIDEO RECORDERS INC.

418 S. Robertson Blvd., Los Angeles 48; Robert E. Kearney, executive vice president.

Services: Recording-transcription service, TV films, live radio & TV production.

AUDIO-VISUAL ENGINEERING CO. (AVEC Productions)

232 E. Erie St., Chicago 11; Tel.: Mohawk 4-4435; Alfred M. Zemlo, in charge of production.

Services: Film production, sound recording.

B

CLAUDE BARRERE

70 E. 45th St., New York 17; Tel.: Murray Hill 6-0238; Claude Barrere, owner.

Services: Live & transcribed package programs.

BASCH RADIO & TELEVISION PRODUCTIONS

17 E. 45th St., New York 17; Tel.: Murray Hill 2-8877; Charles J. Basch Jr., president.

Services: Production, transcriptions, TV shows, package programs.

Indianapolis—5515 Lowell Ave.; Tel.: Irvington 8241; R. C. Hester.

Albany, N. Y.—55 State St., Tel.: 3-5284; Charles Bell Jr.

(Continued on page 418)

REPEATED RENEWALS
PROVE...

ZIV

DELIVERS
THE
AUDIENCE!



***SENSATIONAL
SELLING
PERFORMANCE!**

***BIG-
NAME
SHOW!**

***AMAZINGLY
LOW
PRICED!**

***HIGHER
HOOPERS!**

***UP
TO
5
PROGRAMS
EVERY WEEK!**

***3
COMMERCIALS
ON EVERY
PROGRAM!**

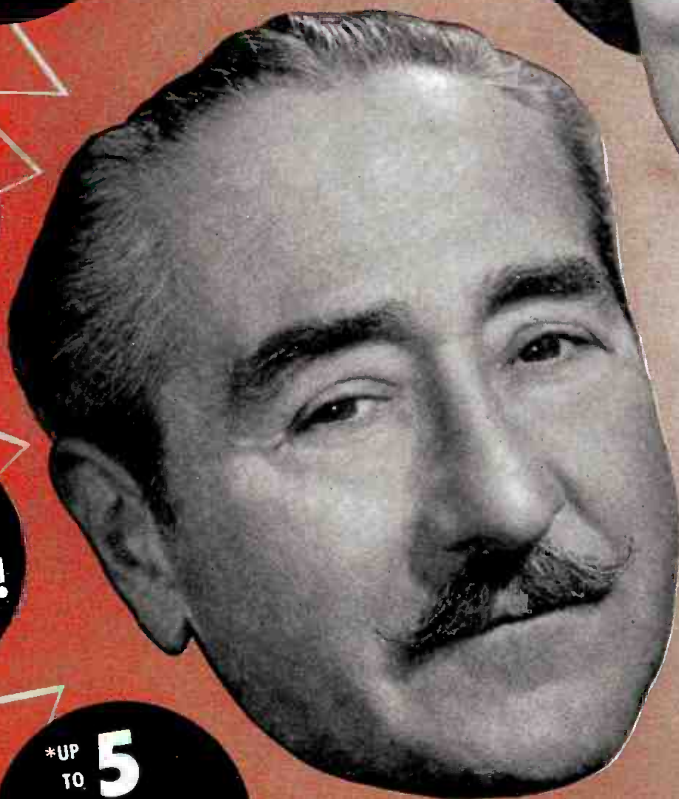

BE THE

ZIV'S N

*Radio's Most
Entertaining
Quarter-Hour
Show... AT A
SURPRISINGLY
LOW PRICE!*

**THE CRITICS
ARE UNANIMOUS**

NEW YORK TIMES

"Easily among... the most
enjoyable items on the day-
time schedule!"

VARIETY MAGAZINE

"A breath of fresh air to
jaded... listeners!"

N. Y. DAILY

"Radio's answer
to the length of daytime

ADDITIONAL CURRENT ZIV HIT SHOWS: THE CISCO KID, IT'S SHOWTIME FROM HOLLYWOOD, GUY LOMBARDO SHOW, FAVORITE STORY (with Ronald Colman), WAYNE KING SHOW, BARRY WOOD SHOW, SINCERELY-KENNY BAKER, PLEASURE PARADE, KORN KOBBLERS,

"MEET THE MENJOUS"

**FIRST TO GET THE STORY OF
W, SMASH-HIT, 1/4-HOUR SHOW!***

IT'S THE SENSATIONALLY SUCCESSFUL ANSWER TO YOUR DEMAND FOR A HARDER-SELLING PROGRAM!

Here's today's most refreshing, most informal, most informative show! Here's today's new listening habit—"Meet The Menjous." It's paying off for sponsors with bigger audiences, faster sales, greater profits—at lower cost! That the public prefers the new and exciting "Meet The Menjous" technique is evidenced by the instant and sensational success of this power-packed program wherever it is tuning!

There's magic in the MENJOU name—sales magic that enables your sponsors to capitalize on their fame. The readily-recognized Menjou faces—publicized by powerful promotion on hundreds of great Hollywood movies—lend themselves perfectly to hard-selling, localized campaigns that are hitting the jackpot for result-minded sponsors!

"MENJOU" NAME IS OPEN SESAME TO BIGGER AUDIENCES AT LOWER COST!

The combination of the increasingly popular "Meet The Menjous" programming technique, plus the terrific nation-wide acceptance for the big, box-office "Menjou" name accounts for the instant success of this sensational program! Listeners are impressed with the glamour and magic of Adolphe Menjou and Verree Teasdale Menjou—regard them as America's most happily married Hollywood couple—consistently tune in to them because they represent today's most vital and charming sounding board of American folk, fact, and fancy.

MIRROR
to the chal-
television!"

N. Y. HERALD TRIBUNE
"Conversation has been
given a shot of unexpected
adrenalin!"

FREDERIC W. **ZIV** COMPANY
Radio Productions
1529 MADISON ROAD • CINCINNATI 6, OHIO
NEW YORK CHICAGO HOLLYWOOD

TAILORED TO SUIT REQUIREMENTS OF:

- DEPARTMENT STORES
- DRUG CHAINS
- GROCERY CHAINS
- STATIONS
(for participation sponsors)
- ... AND MANY MORE!



• Adolphe Menjou and Verree Teasdale have terrific and continuing appeal for housewives.



• They talk about movie greats and music—fashions and food—teen-agers and travel—problem parents and pets—a host of headline topics!



• Peter, their 12-year old son, completes the family group. Their charm and personality, their keen and humorous discussions, keep audience interest at a boiling point.

SONGS OF GOOD CHEER, BOSTON BLACKIE, PHILO VANCE, MANHUNT, EASY ACES, FORBIDDEN DIARY, DEAREST MOTHER, CAREER OF ALICE BLAIR, CALLING ALL GIRLS, OLD CORRAL, LIGHTNING JIM, SPARKY & DUD, PARENTS' MAGAZINE ON THE AIR, ONE FOR THE BOOK.

RADIO, TV PROGRAM PRODUCTION, TRANSCRIPTION AND RELATED SERVICES
(Continued from page 414)

BATCHELOR ENTERPRISES INC.
30 Rockefeller Plaza, New York 20; Tel.: Circle 6-4224; Walter Batchelor, president.
Services: Radio & TV package shows, talent.

ZACH BAYM FILMS
13 E. 37th St., New York 18; Tel.: Murray Hill 9-4175; Zach Baym, director.
Services: Package TV film production.

BECK STUDIOS INC.
(Twin City Television Lab.)
Lyceum Theatre, Minneapolis 2; Tel.: Lincoln 4708; Joseph H. Beck, director.
Services: Radio & TV school, non-technical.

V. S. BECKER PRODUCTIONS
562 Fifth Ave., New York 19; Tel.: Luxemburg 2-1040; Viola Becker, owner.
Services: Package and produce radio and TV programs, manage talent.

BELL INTERNATIONAL PICTURES INC.
633 N. La Cienega Blvd., Hollywood 46; Tel.: Bradshaw 2-2022; Jack Gilson, president.
Services: TV film production.

BELL PICTURES CORP.
630 Ninth Ave., New York 19; Tel.: Circle 6-1383; Bert Kulick, sales director.
Services: TV film distribution.

BELTONE RECORDING CORP.
709 8th Ave., New York; Tel.: Luxemburg 2-2920; Leslie C. Cahon, president.
Services: Recording service.

BENNETT FILMS
5617 Harcourt Ave., Los Angeles 43; Tel.: Axminster 2-7174.
Services: TV film.

GEORGE R. BENTEL & ASSOC.
6606 Sunset Blvd., Hollywood 28; Tel.: Granite 8608; George R. Bentel, president.
Services: Production, scripts, TV film subjects, package programs.

HARRY BESTRY
1776 Broadway, New York 19; Tel.: Circle 6-7094.
Services: Talent.

BEVERLY RECORDING STUDIO
1803-05 W. 95th St., Chicago; Tel.: Cedarcrest 3-4677; Roy Young, manager.
Services: Recording service.

WALTER BIDDICK CO.
1151 S. Broadway, Los Angeles 16; Tel.: Richmond 6184; Guy Biddick, manager.
Services: Transcribed programs, sacred music library, spots.

BILLBOARD ATTRACTIONS INC.
203 N. Wabash Ave., Chicago 23; Tel.: Central 6-3353; Milo Stelt, president.
Services: Package programs, talent.

WADE BINGHAM STUDIOS
208 W. Lafayette St., Tampa 1, Fla.; Tel.: H-5436; Wade Bingham, owner.
Services: Complete production facilities for TV film.

BIRMINGHAM RECORDING STUDIOS
1926 1/2 Fourth Ave. N., Birmingham 3, Ala.; Tel.: 7-1854; Harold G. Peck, owner.
Services: Recording, transcriptions, phonograph records.

BLOCH-JOSEPH & ASSOCIATES
Citizens Bldg., Cleveland 14; Tel.: Superior 3850; Louis M. Bloch Jr., manager.
Services: Transcriptions, production, package programs.

FRITZ BLOCKI PRODUCTIONS
7118 1/2 Hollywood Blvd., Hollywood 46; Tel.: Hudson 2-8971; Fritz Blocki, manager.
Services: Radio & TV package programs.

JOSEPH BLOOM
19 W. 44th St., New York 18; Tel.: Murray Hill 7-5343; Joseph Bloom, president.
Services: Production, programs, scripts.

FORD BOND RADIO PRODUCTIONS INC.
RCA Bldg. W, New York 20; Tel.: Circle 7-2236-7; Ford Bond, president.
Services: Open end transcribed programs.

BOWMAN FILMS
360 Michigan Ave., Chicago 1; Tel.: Dearborn 2-6292; Gordon Lind, manager.
Services: Sound, slide films for television.

BOYD ENTERPRISES
1003 1/2 Houston St., Fort Worth 2; Tel.: 2-9231; Harvey R. Boyd, owner.
Services: Recording, transcriptions, package programs, talent, scripts.
Dallas 14—5922 Tremont; Tel.: Union 6-2026.

BRANDON FILMS INC.
1700 Broadway, New York 19; Tel.: Circle 6-4868; Thomas J. Brandon, president.
Services: TV film distribution.

BRAY STUDIOS INC.
729 Seventh Ave., New York 19; Tel.: Circle 5-4582; J. R. Bray, president.
Services: TV film library.

BRINKLEY RECORDING CO.
232 E. Erie St., Chicago 11; Tel.: Delaware 7-4786; Jack Brinkley, owner.
Services: Recording on tape, disc & film; masters, pressings, phonograph records, TV film.

BRISCOE & GOLDSMITH INC.
522 Fifth Ave., New York; Tel.: Murray Hill 2-6244.
Services: Talent.

BRITISH INFORMATION SERVICE
30 Rockefeller Plaza, New York 20; Tel.: Circle 6-5100; Thomas Hodge, director.
Services: Film rental & sales.

BROADCAST PRODUCTIONS CORP.
25 E. Jackson Blvd., Chicago 4; Tel.: Wabash 2-0711; John Stamford, president.
Services: Recording, production, scripts, talent.

BROADCAST PRODUCTIONS INC.
1313 Lafayette Bldg., Detroit 26; Tel.: Woodward 5-0909; Lois Michels, president.
Services: TV film production, package programs, transcriptions.

BROADCASTING PROGRAM SERVICE
23 W. 45th St., New York 19; Tel.: Plaza 7-3224; Herbert Rosen, manager.
Services: Production, transcriptions, package programs, TV films.

BROADCASTERS PROGRAM SYNDICATE
(Bruce Eells & Assoc.)
2217 Maraville Dr., Hollywood; Tel.: Hollywood 5869; Bruce Eells, manager.
Services: Radio programs; production and distribution.

CHAMBERLAIN BROWN
145 W. 45th St., New York 19; Tel.: Luxemburg 2-2207; Chamberlain Brown, manager.
Services: Production, talent, scripts.

IRVING BROWNING STUDIOS
70 W. 45th St., New York; Tel.: Murray Hill 2-7490; Irving Browning, manager.
Services: Films to order, rentals.

THE AL BUFFINGTON CO.
6711 Sunset Blvd., Hollywood 28; Tel.: Gladstone 0876; Albert B. Buffington, president.
Services: Recording, production, package TV and radio shows.
New York 1—225 W. 34th St.; Tel.: Longacre 5-8128; Maurice F. S. Penn, eastern sales manager.

ALLEN BURG, PHOTOGRAPHY
819 N. La Cienega, Los Angeles 46; Tel.: Bradshaw 2-3737.
Services: TV film.

ALLYN BUTTERFIELD PRODUCTIONS
6823 Santa Monica Blvd., Los Angeles 38; Tel.: Hollywood 9-3961; A. Butterfield, manager.
Services: Films to order.

BYRON INC.
1226 Wisconsin Ave., N. W. Washington, D. C.; Tel.: Dupont 1800; T. Byron, manager.
Services: Film production & processing, magnetic film sound reproduction.

BYRON PRODUCTIONS CO.
730 Fifth Ave., New York 19; Tel.: Circle 6-2677; Edward A. Byron, president.
Services: Package programs.

C

C. F. S. PRODUCTIONS INC.
153 S. Spaulding Drive, Beverly Hills; Tel.: Crestview 6-9026; Sid Fields, manager.
Services: TV film.

C. & G. FILM EFFECTS CO.
723 Seventh Ave., New York 19; Tel.: Plaza 7-4558; H. A. Casolaro, Milton M. Gottlieb.
Services: TV film production, animation, slidefilm.

CALIF. COM'L & INDUSTRIAL FILM CO.
9629 Brighton Way, Beverly Hills; Tel.: Crestview 6-3196; Stanley Bergerman, manager.
Services: TV film programs.

CAMPBELL-CAHILL STUDIO
360 North Michigan; Chicago; Tel.: Franklin 2-4649; Jerry Campbell.
Services: Television commercials.

CAMPUS FILM PRODUCTIONS
161 Remsen St., Brooklyn; Tel.: Triangle 5-6296; Nat Campus, owner.
Services: TV films.
New York—340 Third Ave.; Tel.: Murray Hill 9-5399.

CAPITAL FILM EXCHANGE
309 N. 13th St., Philadelphia 7; Tel.: Spruce 4-2698; E. J. Gabriel, manager.
Services: Film distribution, cutting & booking.

CAPITOL ARTISTS CORP.
1650 Broadway, New York 60; Tel.: Plaza 7-8270; Harold K. Halpern, president.
Services: TV packages, film production, transcriptions, talent, promotion.
Hollywood—204 S. Beverly Dr.; Tel.: Crestview 6-9892; Martin Bregman, vice president.

CAPITOL RECORDS INC.
(Broadcast Div.)
Sunset & Vine, Hollywood 28; Tel.: Hollywood 9-8171; Clifford E. Ogden, sales manager.

Services: Production & distribution of Capitol transcription libraries & TV film programs.

New York—250 W. 57th St.; Tel.: Circle 5-5725; James M. Flenniken, eastern representative.

Chicago 5—1449 S. Michigan Ave.; Tel.: Harrison 9195; Robert L. Howell, central representative.

Dallas 1—1505 Young St.; Tel.: Central 8188; William T. Stubblefield, southern representative.

CARAVEL FILMS INC.
730 Fifth Ave., New York 19; Tel.: Circle 7-6111; David I. Pincus, president.
Services: Industrial & TV films to order.

THE CARDINAL CO.
6000 Sunset Blvd., Hollywood 28; Tel.: Hemstead 1177; Joseph F. MacCaughy, president.
Services: Production, package programs, recording, TV live & film shows.

CARSON-STEMPEL ENTERPRISES
717 N. La Cienega Blvd., Los Angeles 46; Tel.: Crestview 1-7141; Frank Stempel, partner.
Services: Scripts, talent, package programs, TV live & film shows.

GERRY J. CARTER, INC.
1373 Fillmore Ave., Buffalo, N.Y.; Tel.: Bailey 0520; Jerry Grant.
Services: Transcriptions, package programs, TV.

New York—366 Madison Ave., Tel.: Vanderbilt 6-3417; Garry Carter.
Toronto—59 Avenue Rd.; Tel.: Princess 2505; Bob Howe.

CASCADE PICTURES OF CALIF.
8822 Washington Blvd., Culver City, Calif.; Tel.: Texas 0-2761; Bernard Carr, president.
Services: Film production.

CASINO FILM EXCHANGE INC.
210 E. 86th St., New York 28; Tel.: Butterfield 8-0561, Regent 4-2057; Munio Podhorzer, secretary.
Services: Foreign film distributors.

(Continued on page 420)

Campbell-Cahill Studio

FILM COMMERCIALS

360 N. MICHIGAN AVENUE

CHICAGO 1

Franklin 2-4649

Now! A fresh up-to-date  Library that
FILLS EVERY PROGRAMMING NEED!



*Program Directors
 LOVE IT...*



*Sales Managers
 CASH IN on it...*

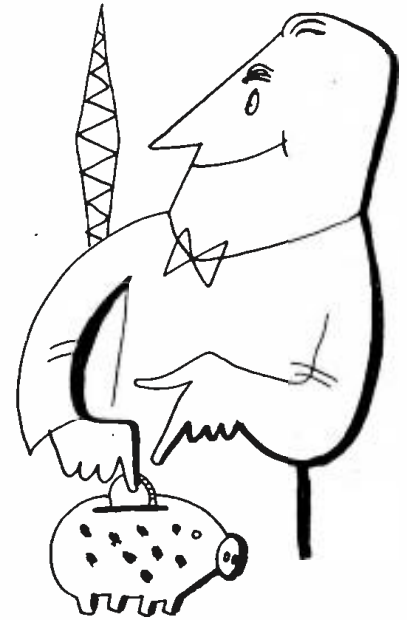

*Station Managers GO for
 its LOW, LOW price!*

A COMPLETE LIBRARY . . . Think of it! Capitol Transcription Library now contains over 4000 selections, and growing fast. Music of every kind . . . *all recorded since the war!* New, fresh arrangements of current tunes, by nationally famous artists. PLUS . . . mood music, themes, sound effects, voice tracks, and other vital program aids.

STAR-STUDED PROGRAMS . . . Capitol gives you big-time programs . . . the kind that hold their own against network features! Complete shows built around top stars, current songs and patter . . . with special script and format service included.

100% USABLE MATERIAL . . . Capitol Transcription library is *balanced* . . . to eliminate waste. Surveys prove that Capitol subscribers use a greater percentage of the music they receive . . . that the size of each musical category is in exact proportion to their overall programming needs!

NEW SPEEDY-REFERENCE CATALOG . . . A miracle of simplicity, Capitol's new catalog is alphabetically indexed three ways: by tune title, by artist, and by musical categories. Makes program planning a cinch!

ALL THIS . . . AT MODEST COST! Today, you have to make every dollar do the work of two. And Capitol Transcriptions help by providing for *all* your basic programming needs . . . and giving you outstanding local shows to sell. Both at one sensible low price. A price that enables you to meet competition and make a profit, as well!

FOR THE WHOLE STORY . . .
 write or wire now:

Capitol Records, Inc.
 Broadcast Division, Dept. B50
 Sunset & Vine
 Hollywood 28, California



A UNIQUE LIBRARY PROGRAM SERVICE

RADIO, TV PROGRAM PRODUCTION, TRANSCRIPTION AND RELATED SERVICES
(Continued from page 418)

CASTON PRODUCTIONS
8611 Sunset Blvd., Los Angeles 46; Tel.: Crestview 5-0113; Robert L. Cashy, co-owner.
Services: TV film programs.

CATHOLIC MOVIES
220 W. 42nd St., New York; Tel: Wisconsin 7-9130; Stan Lewek, manager.
Services: Religious films for TV rental.

CAVALCADE PICTURES INC.
959 Seward St., Hollywood 38; Tel.: Hollywood 9-5458; Harvey Pergament, president.
Services: TV film production & rental. New York—c/o Sol R. Kunkis, 1501 Broadway; Tel.: Bryant 9-2929; Sol R. Kunkis, counselor.

CENTURY ARTISTS LTD.
6331 Hollywood Blvd., Hollywood 28; Tel.: Hudson 2-1288; Richard J. Dorso, president.
Services: TV film programs, artists, writers, directors.

CENTURY TELEVISION PRODUCTIONS INC.
9336 Washington Blvd., Culver City, Calif.; Tel.: Texas 0-2931; Allen H. Miner, manager.
Services: TV live & film production.

HU CHAIN ASSOCIATES
41 E. 41st St., New York 17; Tel.: Murray Hill 2-7123; Hubert V. Chain, president.
Services: Transcriptions, production. TV live & film shows, scripts.

THE BRUCE CHAPMAN CO.
145 W. 41st St., New York 18; Tel.: Wisconsin 7-9244; Bruce Chapman, president.
Services: Package programs, production.

Boston 15—21 Brookline Ave.; Tel.: Commonwealth 6-0800; Charles Forrester, manager.
Chicago 11—441 N. Michigan Ave.; Tel.: Superior 7-0100; Dell Crosby.
Rochester 3—201 Humboldt St.; Tel.: Culver 7240; Lansing Hatfield.
Hollywood 28—1313 N. Vine St.; Tel.: Hudson 2-2133; Joseph Mansfield.

MARY D. CHASE PRODUCTIONS
25 W. 45th St., New York 19; Tel.: Luxembourg 2-1700; Mary Chase, manager.
Services: Production, scripts, talent.

CHICAGO FILM LABORATORY INC.
18 W. Walton Pl., Chicago; Tel.: Whitehall 4-6971; A. G. Dunlap, president.
Services: TV film production, animation, sound recording, film processing.

CHICAGO RECORDING STUDIOS INC.
64 E. Jackson Blvd., Chicago; Tel.: Webster 9-7288; R. W. Kittinger, manager.
Services: Recording, phonograph records.

CHICAGO TRIBUNE-NEW YORK NEWS SYNDICATE INC.
220 E. 42nd St., New York 17; Tel.: Murray Hill 2-1234; Mollie Slott, manager.
Services: Newspaper features adaptable to broadcasting.

CHINA FILM ENTERPRISES OF AMERICA INC.
132 W. 43rd St., New York 18; Tel.: Wisconsin 7-6872; Wango H. C. Weng, president.
Services: Film production and rental.

CHOREOGRAPHERS' WORKSHOP INC.
471 Park Ave., New York; Tel.: Plaza 9-6239; Trudy Goth, manager.
Services: Live programs.

CHRISTIAN FILMS
642 N. Mansfield, Hollywood 36; Tel.: York 1783; Rev. H. K. Rasbach, manager.
Services: Religious motion picture, radio and TV production, special recordings.

CHRISTL & WEBBER
521 N. La Cienega Blvd.; Los Angeles 46; Tel.: Crestview 1-6452; Frank Christl, manager.
Services: TV film and live shows.

ARTHUR B. CHURCH PRODUCTIONS
Pickwick Hotel, Kansas City 6; Tel.: Harrison 2650; George E. Halley, manager.
Services: The Texas Rangers transcription library, recording, package programs, transcription, scripts, talent, live & film TV.

CHURCHILL-WEXLER FILM PRODUCTIONS
137 N. La Brea Blvd., Los Angeles 36; Tel.: Wyoming 7738; R. B. Churchill, Sy Wexler.
Services: TV film programs, commercial spots.
New York—9 Rockefeller Plaza; John E. Gibbs.
Chicago—612 N. Michigan Blvd.; W. B. Levin.

CINECRAFT PRODUCTIONS INC.
2515 Franklin Ave., Cleveland 13; Tel.: Superior 2300; Ray Culley, president.
Services: Recording, 16mm film production.

CINEFFECTS INC.
115 W. 45th St., New York; Tel.: Circle 6-0951; Nathan Sobel, manager.
Services: TV films.

CINEMA STUDIOS INC.
106 West End Ave., New York 23; Tel.: Trafalgar 3-1411; Joseph Seiden, president.
Services: TV film production.

CINEMART INC.
565 Fifth Ave., New York 17; Tel.: Murray Hill 8-3837; Varian Fry, vice president.
Services: Disc and film recording, film production.

CINEQUE LABORATORIES INC.
424 E. 89th St., New York; Tel.: Sacramento 2-4894; Sam Marcus, manager.
Services: TV films.

CINETECH CO. INC.
106 W. End Ave., New York; Tel.: Trafalgar 3-1411; Joseph Seiden, manager.
Services: Rental of recording and TV equipment.

CINETEL CORP.
119 W. 57th St., New York 19; Tel.: Judson 2-4813; Ed Woodruff, president.
Services: TV films.

CINE-TELE PRODUCTIONS
1161 N. Highland Ave., Hollywood 38; Tel.: Hillside 7475; Harry J. Lehman, owner.
Services: TV film, package programs.

CIVIC CONCERT SERVICE INC.
(Subsidiary of Natl. Concert & Artists Corp.)
711 Fifth Ave., New York 22; Tel.: Plaza 9-6000; O. O. Bottorff, president.
Services: Promotion of the civic music associations.

CKEY RECORDING SERVICE
(Toronto Broadcasting Co. Ltd.)
444 University Ave., Toronto; Tel.: Waverly 3881; William McAlpine, manager.
Services: Complete recording facilities.

BOB CLAMPETT
5514 Wilshire Blvd., Los Angeles 36; Bob Clampett, producer.
Services: Live TV package programs.

COASTAL RECORDING CO.
136 W. 52nd St., New York 19; Tel.: Circle 6-3900; Robert Hoffman, manager.
Services: Disc & tape recording.

GEO. W. COLBURN LAB. INC.
164 N. Wacker Dr., Chicago 6; Tel.: State 2-7316; John E. Colburn, manager.
Services: All forms of film laboratory work, recording.

M. M. COLE TRANSCRIPTION CO.
823 S. Wabash Ave., Chicago 5; Tel.: Harrison 7-4561; J. Berg, manager.
Services: Transcription library.

TED COLLINS CORP.
1819 Broadway, New York 23; Tel.: Circle 7-0094; Ted Collins, manager.
Services: Talent, production.

COLONIAL FILMS
Rear 2118 Massachusetts Ave., N. W., Washington 8, D. C.; Tel.: Adams 8101; Harold L. Lassiter, executive director.
Services: TV films, newsreels.

COLUMBIA ARTISTS MANAGEMENT INC.
113 W. 57th St., New York 19; Tel.: Circle 7-6900; Lawrence Evans, president.
Services: Talent.

Chicago—Wrigley Bldg.; Tel.: Superior 2542; Arthur Wisner, manager.
Los Angeles—Auditorium Bldg.; David Ferguson, manager.
San Francisco—San Francisco Opera Assn.; Tel.: Underhill 4008; Paul Posz, manager.

COLUMBIA TRANSCRIPTIONS
(Div. of Columbia Records Inc.)
799 Seventh Ave., New York 19; Tel.: Circle 5-7300; Robert J. Clarkson.

Services: Disc & tape recording, studio facilities, scripts, production. Manufacturing plants in Hollywood & Bridgeport, Conn.
Chicago—410 N. Michigan Ave.; Tel.: Whitehall 4-6000; Gerard D. Ellis.
Los Angeles—8723 Alden Dr.; Tel.: Crestview 6-1034; Andrew J. Schrade

COMMODORE PRODUCTIONS & ARTISTS INC.
1350 N. Highland Ave., Hollywood 28; Tel.: Hollywood 9-8229; Walter White Jr., president.
Services: Production, package programs, TV production.

COMMONWEALTH FILM & TELEVISION INC.
723 Seventh Ave., New York; Tel.: Circle 5-6456; Jerome Hyams, manager.
Services: TV film distribution.

COMPO CO. LTD.
485 18th Ave., Lachine, Que.; Tel.: Walnut 5653; R. A. Chislett, general manager.
Services: Processing and pressing of electrical transcriptions & phonograph records.

CONSOLIDATED RADIO ARTISTS INC.
30 Rockefeller Plaza, New York 20; Tel.: Columbus 5-3580; Charles E. Green, president.

CONTINENTAL TRANSCRIPTIONS
(Div. of Continental Nameplate & Engraving Co.)
687 Kenwick Rd., Columbus 9, Ohio; L. B. Lamp, director.
Services: Disc, wire, tape and film recording, package programs, scripts, talent.

HALLAM COOLEY AGENCY
9111 Sunset Blvd., Hollywood 46; Tel.: Crestview 5-6161.
Services: Talent.

FRANK COOPER ASSOCIATES
521 Fifth Ave., New York 17; Tel.: Vanderbilt 6-5661.
Services: Talent, radio & TV productions.

COOPERATIVE BROADCASTING ASSN.
1120 Conn. Ave., Washington 6; Tel.: Republic 8688; George A. Bernstein, general manager.
Services: Program production, recording.

COURNEYA PRODUCTIONS
1566 N. Gordon, Hollywood 28; Tel.: Granite 5920; Jerry Courneya, manager.
Services: Package programs, TV film features, scripts.

LOUIS G. COWAN INC.
485 Madison Ave., New York 22; Tel.: Plaza 9-3700; Louis G. Cowan, president; Alfred L. Hollender, vice president.
Services: Program production, live and transcribed; transcriptions; package programs, TV shows.
Chicago 3—8 S. Michigan Ave.; Tel.: Randolph 6-2022; R. D. Michels, vice president, sales; J. B. Lewellen, vice president, production.

CRAFTON BROTHERS INC.
3303 W. Lawrence Ave., Chicago; Tel.: Juniper 8-0396; David M. Crafton, president.
Services: TV stills, shorts and commercials.

CRANDALL ENTERPRISES INC.
Box 548, Rt. 6, Tucson, Ariz.; Tel.: 3-2803; Anthony Padrez, general manager.

CRAWFORD PICTURES
6764 Lexington Ave., Hollywood 38; Tel.: Hempstead 6856; Robert Crawford, owner.
Services: Motion picture, film strip and 2 x 2 slide production.

CROSBY & FOGLE RADIO PRODUCTION
6365 Selma Ave., Hollywood 28; Tel.: Granite 3171; Leigh Crosby, manager.
Services: Production, transcriptions, TV production.

BING CROSBY ENTERPRISES INC.
9028 Sunset Blvd., Los Angeles 46; Tel.: Crestview 1-1171; Everett N. Crosby, president.
Services: Package programs, production, recording.

CROSLY BROADCASTING CORP. (WLW)
140 W. Ninth St., Cincinnati 2; Tel.: Cherry 1822; R. E. Dunville, vice president & general manager.

Services: Production, scripts, package programs, live talent shows, radio & TV.
New York 20—630 Fifth Ave.; Tel.: Circle 6-1750; Warren Jennings, manager.
Chicago 1—360 N. Michigan Ave.; Tel.: State 2-0366; Harry Albrecht, manager.
Hollywood 28—6381 Hollywood Blvd.; Tel.: Hollywood 5408; Tracy Moore, manager.
Columbus 2—3165 Olentangy River Rd. Tel.: Jefferson 5441; James Leonard.
Dayton 9—4595 S. Dixie Highway; Tel.: Walnut 2101; John T. Murphy.

DALE CROWLEY PRODUCTIONS
Box 1, Washington 4, D. C.; Tel.: Franklin 5109; Dale Crowley, manager.
Services: Bible quiz, transcribed programs.

CRYSTAL PICTURES INC.
1564 Broadway, New York; Tel.: Plaza 7-5130; Melvin M. Hirsh, president.
Services: TV films, rentals.

(Continued on page 422)



APPLAUSE

for the sensational new

COLUMBIA

MICRO **Lp** GROOVE

TRANSCRIPTIONS

Radio stations and advertisers enthusiastically endorse all the advanced features of the amazing new micro-groove radio transcription technique—pioneered and perfected by Columbia!

Wire, Write or Phone for Details

COLUMBIA TRANSCRIPTIONS

A DIVISION OF COLUMBIA RECORDS, INC. ©

Trade-Marks "Columbia" © and ® Reg. U. S. Pat. Off. Marcas Registradas

New York: 799 Seventh Ave., Circle 5-7300

Los Angeles: 8723 Alden Drive, CRestview 6-1034

Chicago: Wrigley Building, 410 North Michigan Ave., Whitehall 4-6000

NOW!

15 MINUTES ON A 10" RECORD!

22 Minutes
On a 12" Record*

NEW BANDING TECHNIQUE

Makes it possible to
separate program
segments for
quick cueing.

EASIER AND CHEAPER TO PACK

Lower Shipping Costs
Saves Storage Space

UP TO 42% SAVINGS!

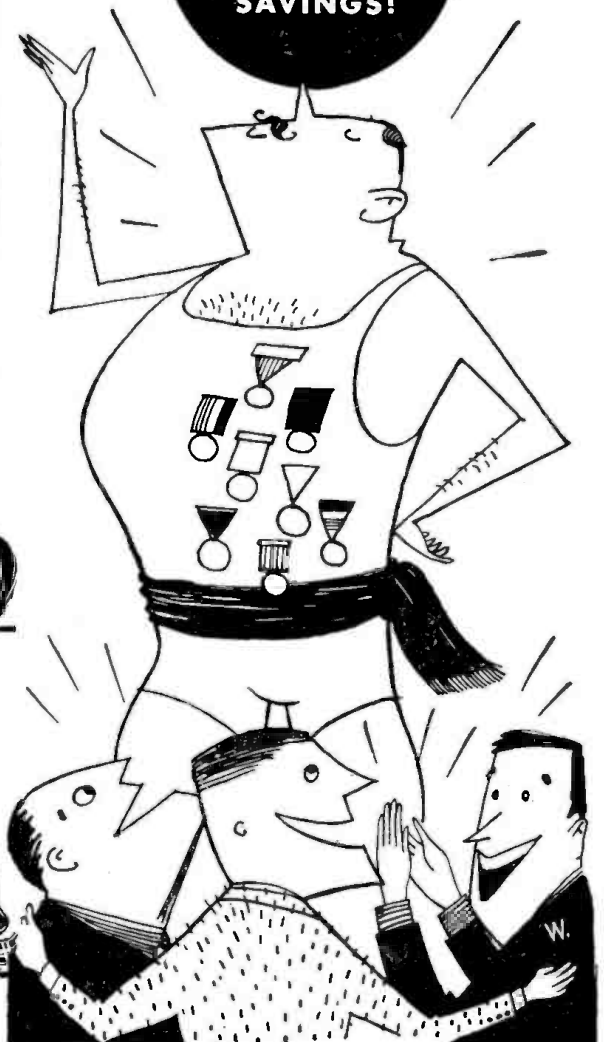

RADIO, TV PROGRAM PRODUCTION, TRANSCRIPTION AND RELATED SERVICES
(Continued from page 420)

SHAMUS CULHANE PRODUCTIONS INC.
440 W. 34th St., New York; Tel.: Long-acre 3-1971; Shamus Culhane, president.
Services: TV film.

D

D. P. M. PRODUCTIONS INC.
55 W. 45th St., New York; Tel.: Luxemburg 2-4534; Dorothy P. Mausby, manager.

Services: TV films, European footage.

DAMON RECORDING STUDIOS INC.
1221 Baltimore Ave., Kansas City 6; Tel.: Victor 2585; Vic Damon, president.

Services: Recording, production, phonograph record masters.

RONALD DAWSON ASSOCIATES
545 Fifth Ave., New York 17
Tel.: Murray Hill 7-6885; Ronald Dawson, director.

Services: Scripts (second rights only), program packaging.

GORDON M. DAY PRODUCTIONS
108 E. 30th St., New York 16; Tel.: Oregon 9-3595; Gordon M. Day, president.

Services: Production, transcriptions, package programs for radio and TV.

DECCA RECORDS INC.
50 W. 57th St., New York 19; Tel.: Columbus 5-2300; Edward R. Strauss, manager, special service.

Services: Records, transcriptions.

DeFRENES CO.
1909 Buttonwood St., Philadelphia 30; Tel.: Rittenhouse 6-1686; Joseph DeFrenes, president.

Services: TV film production.

DELBRIDGE & GORRELL
301 Fox Theatre Bldg., Detroit 28; Tel.: Woodward 3-6990; Bill O'Halloran, manager.

Services: TV films.

JOSEPH DEPHOURE STUDIO
1018 Commonwealth Ave., Boston 15; Tel.: Longwood 6-1499; Joseph Dephoure, owner.

Services: TV films, film laboratory service, recording, package programs.

DEPICTO FILMS INC.
245 W. 55th St., New York 19; Tel.: Columbus 5-7621; John Hans, president.

Services: Live & animated commercials.

Toronto—Audio Pictures Ltd.: 310 Lakeshore Rd.; Tel.: Murray 7226; Arthur Gottlieb, president.

LOUIS deROCHEMONT ASSN. INC.
35 W. 45th St., New York; Tel.: Chickering 4-8873; Louis deRochemont, manager.

Services: TV films.

DES AUTELS & GRAHAM
1471 N. Tamarind Ave., Hollywood 28; Tel.: Hudson 2-4202; Van Des Autels, Frank Graham, partners.

Services: TV live & film programs, package shows.

JERRY DEVINE PRODUCTIONS
6331 Hollywood Blvd., Hollywood 28; Tel.: Hudson 2-1228; Jerry Devine, producer.

Services: Package programs.

DICKSON & EDINGTON LTD.
30 Bloor, W., Toronto 5; Tel.: Randolph 1488; Roy Ward Dickson, general manager.

Services: Production, package programs.

DISCO RECORDING CO. INC.
334 Arcade Bldg., St. Louis 1; Tel.: Chestnut 5937; William L. Atwood, president.

Services: Recording, package programs, transcriptions.

ALFRED DIXON SPEECH SYSTEMS INC.

424 Madison Avenue, New York 17; Tel.: Plaza 8-1246.

Services: Production, educational film, recording.

WM. B. DOLPH RADIO & TELEVISION PRODUCTIONS
910 17th St., N. W. Washington, D. C.; Tel.: District 2717; Wm. B. Dolph, manager.

Services: TV Washington films, talent.

DOMINION BROADCASTING CO.
4 Albert St., Toronto; Tel.: Adelaide 3383; Hal B. Williams, manager.

Services: Transcriptions, production, recording, talent.

DOUGLAS PRODUCTIONS
1425 S. Racine Ave., Chicago 8; Haymarket 1-1601; Arthur R. Jones, sales manager.

Services: Film production.

SHERMAN H. DRYER PRODUCTIONS
57 W. 58th St., New York; Tel.: Plaza 5-5998; Sherman H. Dryer.

Services: TV films.

HARRY S. DUBE
1270 Sixth Ave., New York 20; Tel.: Columbus 5-7035; Harry S. Dube, owner.

Services: Talent, recording, scripts, package programs, TV film production.

JEAN DUBOIS MOTION PICTURES
927 21st St., Denver 2 (P. O. Box 235); Tel.: East 8122; Jean M. F. Dubois, owner.

Services: TV film production.

DUDLEY PICTURES CORP.
9908 Santa Monica Blvd., Beverly Hills; Tel.: Crestview 1-7258; Carl Dudley, president.

Services: TV film production, stock shot library.

New York—501 Madison Ave.: Tel.: Eldorado 5-1076; Carl Dudley, president.

CAL DUNN STUDIOS
104 S. Michigan Ave., Chicago 3; Tel.: State 2-0247; Cal Dunn, president.

Services: TV cartoon and film production.

DYNAMIC FILMS INC.
112 West 89th St., New York 24; Tel.: Schuyler 4-3654; Henry Morley, president.

Services: TV film production.

E

EASTERN STUDIOS
3460 32nd St., Astoria, N. Y.; Tel.: Ravenswood 6-4787; R. V. Pollock, manager.

Services: TV film productions.

ECCLES RECORDINGS INC.
6233 Hollywood Blvd., Hollywood 28; Tel.: Hillside 8351; Robert P. Newman, president.

Services: Recording service.

CHARLES ECKART CO.
4880 Santa Monica Blvd., Los Angeles 27; Tel.: Olympia 2901; Charles Eckart, manager.

Services: Phonograph record matrices.

BRUCE EELLS & ASSOC.
(Broadcasters Program Syndicate)
2217 Maraville Dr., Hollywood 28; Tel.: Hollywood 5869; Bruce G. Eells, president.

Services: Radio & TV production and distribution.

ELECTRO-VOX RECORDING STUDIOS
5546 Melrose Ave., Hollywood 38; Tel.: Gladstone 2189; Bert B. Gottschalk, manager.

Services: Recording, phonograph records.

W. M. ELLSWORTH
75 E. Wacker Drive, Chicago 1; Tel.: Central 6-0942; W. M. Ellsworth, owner.

Services: Talent, program production.

EMPIRE BROADCASTING CORP.
480 Lexington Ave., New York 17; Tel.: Plaza 9-4500; Helen Kelleher, president.

Services: Production, recording, transcriptions, package programs.

ENCYCLOPEDIA BRITANNICA FILMS INC.
1150 Wilmette Ave., Wilmette, Ill.; Tel.: Wilmette 6404; C. Scott Fletcher, president.

Services: Educational TV films for rental.

Chicago 7—207 S. Green St.: Tel.: Dearborn 2-6272; Joseph E. Dickman.

Dallas 1—712 N. Haskell St.: Tel.: Victor 4-8660; George H. Mitchell.

Boston 16—30 Huntington Ave.: Tel.: Kenmore 6-1663; Barton F. Plimpton.

New York 18—450 W. 58th St.: Tel.: Circle 7-2682; Ray P. Kroggel.

Pasadena 7, Calif.—1640 E. Mountain St.: Tel.: Sycamore 4-6006; Paul Cox.

Atlanta—3232 E. Roxboro Rd.: Tel.: 9579; Claude E. Brock.

LAWRENCE EVANS AND WEINHOLD INC.
(Division of Columbia Artists Management Inc.)
113 W. 57th St., New York 19; Tel.: Circle 7-6900.

ROBERT EVANS PRODUCTIONS INC.
113 W. 57th St., New York 18; Tel.: Circle 6-9861; Robert Evans, manager.

Services: Production, package programs.

EXCELSIOR PICTURES CORP.
723 Seventh Ave., New York 19; Tel.: Circle 5-6157; Walter Bibo, president.

Services: TV film rental.

EXCLUSIVE RADIO FEATURES CO. LTD.
225 Mutual St., Toronto, Tel.: Adelaide 5112.; John Part, president.

Services: Recording, production, transcriptions, package programs, talent.

F

F & M STAGESHOWS INC.
1501 Broadway, New York 18; Tel.: Chickering 4-3956; M. D. Howe, vice president.

Services: Production, scripts, talent, TV live & film shows.

FADIMAN ASSOCIATES LTD.
1501 Broadway, New York 18; Tel.: Lackawanna 4-3544; Edwin Fadiman, manager.

Services: Production.

JERRY FAIRBANKS INC.
6052 Sunset Blvd., Hollywood 28; Tel.: Hudson 2-1101; Jerry Fairbanks, executive producer.

Services: TV film production.

FAIR DEAL MOTION PICTURE SERVICE
2040 Chatterton Ave., New York 61; Tel.: Talmadge 9-6723; Louis Colson, manager.

Services: TV films, rentals.

FAMOUS ARTISTS CORP.
California Bank Bldg., Beverly Hills; Tel.: Crestview 1-5222; Jack Gordon, manager.

Services: Package programs, talent.

FANCHON & MARCO INC.
6838 Hollywood Blvd., Hollywood 28; Tel.: Hempstead 3263; Marco Wolff, manager.

Services: Talent.

FEATURE BUREAU
152 W. 42nd St., New York 18; Tel.: Wisconsin 7-9715; Bert Nevins, managing editor.

Services: Script service for women commentators.

(Continued on page 424)

YOU OWE IT TO YOURSELF

Have Your MASTERS recorded on the

WORLD'S FINEST EQUIPMENT

Including New SCULLY (3-speed direct drive Lathes)

- Send your original records, tapes and transcriptions for copies or masters for pressing.
- Make Our Complete Studio Facilities, Script and Production Service a part of your organization.



**Damon
Recording
Studios
Inc.**

1221 Baltimore Ave.
Kansas City (6)
Missouri



TV Shorts
after June 1st.

*Now, You
save dollars and get Quality, too!*

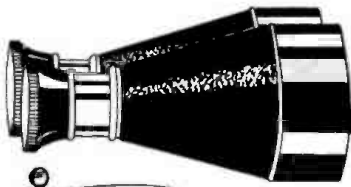

LOOK INTO OUR STABLE



Always... Winners

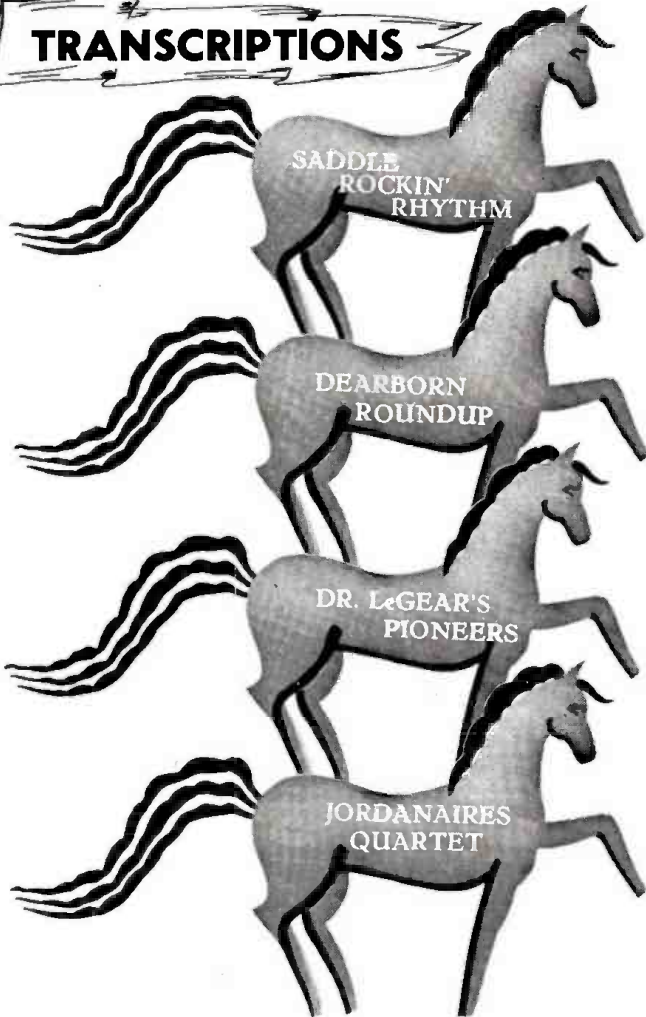

ON THE NOSE INFO

A fast paced quarter-hour that is doing a great job for sponsors. Results plus customer and client comment available on request. A sure-fire salesman for you—this show drew over \$20,000.00 in actual cash orders in less than 3 months. 78 quarter hours available. Free audition.

A THOROUGHBRED

52 quarter hours available to Ford Tractor and Dearborn Farm Equipment Dealers everywhere. The "Dearborn Roundup" is a tailor-made package with local commercials. Cooperatively available and transcribed by the designer of professional western music.

SALES WINNER

39 five-minute programs starring Dr. LeGear's Pioneers. Available only to dealers throughout the U. S. A. A fine western group with sales know-how. Client reports sales up 40% since programs started.

WIN, PLACE AND SHOW

200 individual numbers available. Here's a deal for agencies and stations with working budgets. It's a big show at small market price. Spirituals, hymns, and barber shop harmonies transcribed by the Jordanaires of Nashville, Tennessee, Decca recording artists. 45 broadcasts on one 5,000 watt station pulled 21,178 booklet orders. Free audition.

STARS ON ALL TRACKS

A network show of network calibre available for sponsorship. Saddle Rockin' Rhythm starring Shorty Thompson is now heard coast-to-coast each Saturday 6:30 CST. Don't play long shots, have a listen and see if you don't agree it's a real buy for your client. P. S. We do not charge Broadway prices.

ALL TIME WINNERS

The Carter Sisters, with Mother Maybelle and Chet Atkins, is radio's greatest real family act. June Carter, of RCA Victor Record fame, emcees this air package that's a "thoroughbred" for clients wanting "sales." A show with "Homey-Down to Earth Atmosphere." Soon available on ET.

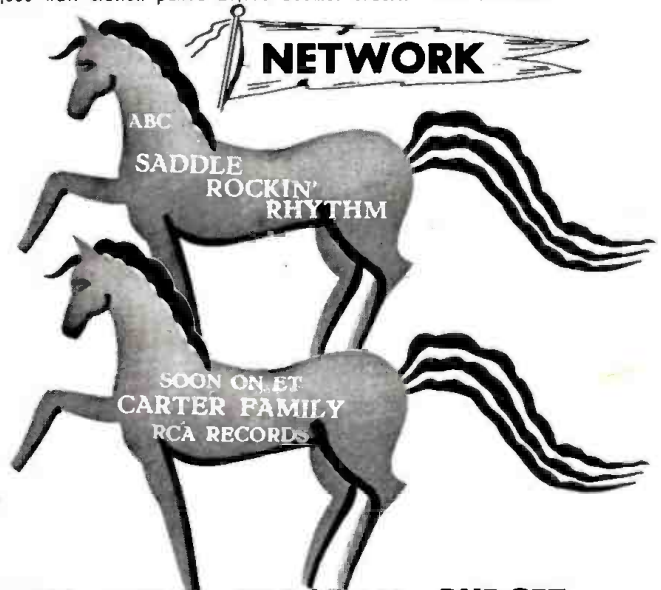

**LET US SHOW YOU HOW TO SOLVE YOUR PROGRAM BUDGET
TRANSCRIBED AND LIVE SHOWS • SPOTS AND SINGING JINGLES**

WRITE — PHONE — WIRE

RADIOZARK ENTERPRISES

606 ST. LOUIS STREET • SPRINGFIELD, MISSOURI • PHONE 2-4620

BROADCASTING • Telecasting

1950 Yearbook Number • Page 423

RADIO, TV PROGRAM PRODUCTION, TRANSCRIPTION AND RELATED SERVICES
(Continued from page 422)

FEATURE PRODUCTIONS

228 N. LaSalle St., Chicago 1; Tel.: State 2-3156; Georgene O'Donnell, managing director.

Services: Transcriptions, production, package shows, talent, TV shows.

Los Angeles—719 Taft Bldg.; Tel.: Gladstone 5072; Thomas G. Hargis.

FEDERAL ARTISTS CORP.

8734 Sunset Blvd., Hollywood 46; Tel.: Crestview 5-5251; W. H. Buffington, sec'y-treas.

Services: Package programs, TV live & film shows, talent.

FEDERATED TELEVISION PRODUCTIONS INC.

41 E. 41st St., New York 17; Tel.: Murray Hill 2-7125; Hubert V. Chain, president.

Services: TV film production.

PAUL J. FENNEL CO.

1159 N. Highland Ave., Hollywood 28; Tel.: Gladstone 1857; Paul J. Fennell, president.

Services: Animated film production, TV commercials.

FENTON PRODUCTIONS

40 E. 49th St., New York 17; Tel.: Plaza 9-8236; Mildred Fenton, president.

Services: Package programs, production, scripts, talent, live TV.

HERMAN FIALKOFF THEATRICAL AGENCY
(Celebrity Concerts Inc., Programs and Lectures, Inc.)

545 Fifth Ave., New York 17; Tel.: Vanderbilt 6-1807.

Services: Talent, general booking agency.

Branch Offices in Hollywood, Rio de Janeiro and Anchorage, Alaska.

FILM ARTS CORP.

1032 N. Sixth St., Milwaukee 3; Tel.: Daly 9-5670; Milton Abram II, vice president.

Services: Recording, talent, scripts, package programs, film, film laboratory service.

FILM ASSOCIATES INC.

440 E. Schantz Ave., Dayton 9; Tel.: Walnut 2164; E. Raymond Arn Jr., president.

Services: Recording, TV film production and laboratory service.

FILM CENTER

45 W. 45th St., New York 19; Tel.: Luxemburg 2-1324; Myron Bresnick, president.

Services: TV film.

FILM DEVICES INC.

13 E. 37th St., New York; Tel.: Murray Hill 9-4175; Leo R. Dratfeld, manager.

Services: TV industrial film subjects.

FILM EQUITIES CORP.

10 E. 49th St., New York 19; Tel.: Plaza 9-6132; Irvin Shapiro, president.

Services: TV films, package programs.

FILM FEATURES ASSOC.

320 W. 95th St., New York 25; Tel.: Monument 2-5111; Edmund F. Lindner, director.

Services: All TV services.

FILM-MAKERS INC.

1600 Broadway, New York 19; Tel.: Regent 7-7549; J. H. Lenauer, president.

Services: Film production.

FILM PRODUCTIONS CORP.

3650 Fremont Ave. N., Minneapolis; Tel.: Aldrich 1202; Ralph St. J. Perry, owner.

Services: TV film production.

FILM PROGRAM SERVICES INC.

1173 Ave. of the Americas, New York 19; Tel.: Luxemburg 2-4440; Robert Snyder, executive director.

Services: TV films, rentals, consulting.

FILM PUBLISHERS INC.

25 Broad St., New York; Tel.: Hanover 2-0100; Sherman Price, manager.

Services: TV films, rentals.

FILM STUDIOS OF CHICAGO

135 S. LaSalle St., Chicago 3; Tel.: Central 6-8147; H. A. Spanuth, manager.

Services: TV film.

FILMACK TRAILER CORP.

(Filmack Labs)
1327 S. Wabash, Chicago; Tel.: Harrison 7-3395; Irving Mack.

Services: TV & movie film producers.

FILMCRAFT PRODUCTIONS

201 Boston Bldg., Salt Lake City 1; Tel.: 3-5337; L. Clyde Anderson, manager of production.

Services: Film production.

FILMEFFECTS OF HOLLYWOOD

1153 N. Highland Ave., Hollywood; Tel.: Hollywood 5808; Gilbert R. Scott, manager.

Services: TV special effects and sequences.

FILMS FOR INDUSTRY INC.

135 W. 52nd St., New York 19; Tel.: Plaza 3-2300; Joseph M. McCaffery, president.

Services: TV film production, animation.

FILMS OF THE NATIONS INC.

55 W. 45th St., New York; Tel.: Chickering 4-8420; Maurice T. Groen, manager.

Services: TV educational film subjects.

LARRY FINLEY TRANSCRIPTIONS INC.

8983 Sunset Blvd., Hollywood 46; Tel.: Bradshaw 2-5841; Larry Finley, president.

Services: Transcriptions, package programs, TV live & film production.

FRIEDA FISHBEIN

11 W. 42nd St., New York 18; Tel.: Longacre 5-1379; Frieda Fishbein, owner.

Services: Scripts, talent representative.

FISHER PRODUCTIONS

1501 Broadway, New York; Tel.: Bryant 9-7122; Maggy Fisher, owner.

Services: Radio and TV productions, package shows, scripts.

ED FISHMAN AGENCY

8734 Sunset Blvd., Hollywood 46; Tel.: Crestview 5-5253; Ed Fishman, manager.

Services: Package programs, talent, transcriptions, TV live & film production.

FIVE STAR PRODUCTIONS

6325 Sunset Blvd., Hollywood 28; Tel.: Hollywood 9-5280; Harry Wayne McMahan, executive producer.

Services: Film and radio package program producers, commercial film production.

FLAMINGO FILMS INC.

538 Fifth Ave., New York 19; Tel.: Murray Hill 7-8865; Sy Weintraub, vice president in charge of television.

Services: Film distribution, syndicated programs.

(Continued on page 426)

More Sales...Profits for You!

Low cost, high powered, personalized Film Commercials save you time and money . . . gain you more customers!



Film Associates Teleskits*

"Finest in Film since 1937"

Programming - Laboratory - Animation

Your TV dollars go further and work harder! Pack an entertaining sales wallop into your commercials. Get them faster—at lower prices—from Film Associates. Visual salesmanship . . . mastery of skills and techniques . . . perfected through years of experience. Individual analysis of your product. Complete delivery from start to finish around 3 weeks. Extra prints within 24 hours.

Fast Service!

Laboratory . . . 72 hours

Fully Equipped to handle ANY type 16 m.m. Processing



***Teleskits**

Registered Trademark . . . Film Associates, Inc.

EXTRA!
Low Cost - High Rating
TV PROGRAMS

Exclusive in Your Area. Top Entertainment! 5 and 10 minute shows!

Write, Phone or Wire . . .
for Free Estimates Today.

WALNUT 2164



When you can
get RCA "Know-How"

Your recording need of the moment may be a super-smooth dubbing job . . . or recorded spots utterly faithful to the original . . . or pressings turned out in a hurry, with no sacrifice of quality. Whatever your requirement, you get *top satisfaction* when RCA Victor does the job for you.

RECORDING • PROCESSING • PRESSING

- ★ All types of phonograph records
- ★ Transcriptions of every description for every need
- ★ Slide film and promotion recording facilities
- ★ Careful handling and prompt delivery

CONTACT AN RCA VICTOR CUSTOM RECORD SALES STUDIO:

120 East 23rd Street 445 North Lake Shore Drive 1016 North Sycamore Avenue
New York 10, New York Chicago 11, Illinois Hollywood 38, California
Murray Hill 9-0500 Whitehall 4-2900 Hillside 5171

You'll find useful facts in our Custom Record Brochure. Send for it today!

First in the field!

...why
take
anything
less
?



BROADCASTING • Telecasting



1950 Yearbook Number • Page 425

RADIO, TV PROGRAM PRODUCTION, TRANSCRIPTION AND RELATED SERVICES
(Continued from page 424)

FLORY FILMS INC.

303 E. 71st St., New York 21; Tel.: Regent 4-0862; John Flory, president. Services: Recording, package programs, TV film production & distribution.

FORTUNE RECORD DISTRIBUTORS

12005 12th St., Detroit 6; Tel.: Townsend 7-3077; Dorothy Brown, manager.

Services: Recording & record distribution, music publication.

HARRY E. FOSTER ADVERTISING LTD.

King Edward Hotel, Toronto, Ont.; Tel.: Plaza 4661; G. Forsyth, manager.

Services: Recording, production, package programs, talent.

Montreal—128 Sun Life Bldg.; Tel.: Belair 1984; J. C. Nicholls, executive vice president.

Vancouver—407 Dominion Bldg.; Tel.: Tatlow 1171; Leigh Webster, manager.

Halifax—612 Barrington St.; Tel.: 3-7301; Ervin S. Murray, manager.

NEWTON L. FOUSEY

605 N. Michigan Ave., Chicago 11; Tel.: Whitehall 4-3844; Newton L. Fousey, manager.

Services: Production, talent, AM and TV.

FOX MOVIE TONE NEWS

460 W. 54th St., New York; Tel.: Columbus 5-7200; Edmund H. Reek, manager.

Services: TV newsreel films.

FRANKAY & JACKSON RECORDING STUDIOS INC.

48 W. 48th St., New York 19; Tel.: Judson 6-9030; Harry Jackson, president.

Services: Recording, transcription service.

HARDIE FRIEBERG TELEVISION ENTERPRISES INC.

270 Park Ave., New York 17; Tel.: Murray Hill 8-0230; Hardie Friberg, president.

Services: Program production, talent, live and film TV programs.

ALLEN A. FUNT RADIO PRODUCTIONS

100 Central Park S., New York 17; Tel.: Murray Hill 5-1211; Allen A. Funt, manager.

Services: Production, TV show.

G

BLANCHE GAINES

47 W. 58th St., New York 19; Tel.: Plaza 7-1149; Blanche Gaines, owner. Services: Radio & TV scripts.

GAINSBOROUGH ASSOCIATES INC.

234 W. 44th St., New York 18; Tel.: Chickering 4-0626; Mike Jablons, director.

Services: Radio and TV production, package programs, publicity, program consultant for new TV stations.

GALE INC.

48 W. 48th Street, New York 19; Tel.: Plaza 7-7100. Moe Gale, president. Services: Talent.

GALLAGHER FILMS

113 S. Washington St., Green Bay, Wis.; Tel.: Adams 2554; J. C. Gallagher, president.

Services: TV film production, recording.

Milwaukee 3—639 N. 7th St.; Tel.: Marquette 8-2354; R. S. Bonner, manager.

GALLUCCI BROS. & ASSOC.

727 Meriden Rd., Waterbury 63, Conn.; Tel.: 3-5272; Joe Gallucci, president.

Services: Production & sale of shows.

GAMBLE RECORDING STUDIO

228 S. Wabash Ave., Chicago 4; Tel.: Harrison 7-1360; "Chuck" Schroeder, manager.

Services: Recording service.

AL GARRY PRODUCTIONS

48 W. 48th St., New York 19; Tel.: Plaza 7-6554; Al Garry, owner. Services: Radio & TV packages.

GENERAL ARTISTS CORP.

1270 Avenue of the Americas, New York 20; Tel.: Circle 7-7550; Thomas G. Rockwell, president.

Services: Talent.

Chicago 1—360 N. Michigan Ave.; Tel.: State 2-6288; Russell Facchine.

Hollywood 46—9028 Sunset Blvd.; Tel.: Crestview 1-8101; Milton W. Krasny, manager.

Cincinnati—Carew Tower; Tel.: Main 1197; Joe Higgins, manager.

GENERAL FILM PRODUCTION CORP.

25 W. 45th St., New York 19; Tel.: Luxemburg 2-1700; Elbert S. Kapit, manager.

Services: TV films, rentals.

GENERAL PICTURES PRODUCTIONS INC.

621 Sixth Ave., Des Moines 9, Iowa; Tel.: 3-4553; D. H. Bonine, vice president.

Services: Film production, laboratory and sound service.

GENERAL TELEVISION ENTERPRISES INC.

1117 Guaranty Bldg., Hollywood; Tel.: Gladstone 4146; Gordon Levoy, president.

Services: Distributors of motion pictures for TV.

MITCHELL GERTZ AGENCY INC.

240 S. Beverly Dr., Beverly Hills, Calif.; Tel.: Crestview 4-5491; Mitchell Gertz, president.

Services: Production, transcriptions, package programs, talent, TV shows.

JOHN E. GIBBS & CO.

30 Rockefeller Plaza, New York 20; Tel.: Columbus 5-7504; John Gibbs, president.

Services: Radio & TV production, talent representation.

GIBRALTAR PICTURES INC.

1041 N. Formosa Ave., Hollywood 46; Tel.: Granite 5111; Albert Rogell, manager.

Services: TV films.

GRACE GIBSON RADIO PRODUCTIONS

6700 Sunset Blvd., Hollywood 28; Tel.: Granite 5543; B. Eaton Lawrence, director of sales.

Services: Package programs, syndicated transcriptions.

RODNEY GILLIAM CO.

7904 Santa Monica Blvd., Hollywood 46; Tel.: Hillside 2220; Rodney Gilliam, manager.

Services: TV film programs, production.

OGDEN GOELET

9421 Wilshire Blvd., Beverly Hills; Tel.: Hollywood 9-5111.

Services: TV films.

GOLDSTONE-WILLNER AGENCY

9121 Sunset Blvd., Hollywood 46; Tel.: Crestview 6-1071.

Services: Talent.

HARRY S. GOODMAN RADIO AND TELEVISION PRODUCTIONS

19 E. 53rd St., New York 22; Tel.: Plaza 5-6131; Harry S. Goodman, president.

Services: Transcribed and live programs, syndicated and custom-built spot announcements, syndicated TV spots on film.

MARTIN A. GOSCH PROD. INC.

14 E. 65th St., New York 17; Tel.: Trafalgar 9-7060; Martin A. Gosch, manager.

Services: Live productions and open end programs.

GRAND INTERNATIONAL PICTURES CO.

366 Madison Ave., New York 17; Tel.: Vanderbilt 6-3417; J. J. Balaber, vice president.

Services: TV film distribution.

GRANT-REALM PRODUCTIONS

8822 W. Washington Blvd., Culver City, Calif.; Tel.: Texas 0-2761; Norman Elzer, manager.

Services: TV film production.

New York—724 Fifth Ave.; Harry Ommeale.

GRAPHIC FILMS CORP.

1108 Lillian Way, Hollywood 38; Tel.: Granite 2191; Lester Novros, president.

Services: TV film production, animation.

GRAY-O'REILLY STUDIOS

480 Lexington Ave., New York; Tel.: Plaza 3-1531; James E. Gray, manager.

Services: TV film production.

GREEN ASSOCIATES

360 N. Michigan Ave., Chicago 1; Tel.: Central 6-5593; Lewis G. Green, vice president.

Services: Radio and TV production.

BEN GREENE FILM PRODUCTIONS

48 W. 48th St., New York 19; Tel.: Plaza 7-3858; Ben Greene, owner.

Services: Transcriptions, TV film production.

AL GROSSMAN

RKO Bldg., New York 20; Tel.: Circle 5-8422.

Services: Talent.

GUARANTEED PICTURES CO. INC.

723 Seventh Ave., New York 19; Tel.: Circle 5-6456; M. D. Sackett, president.

Services: TV films, rentals.

JOHN GUEDEL RADIO PRODUCTIONS

Taft Bldg., Hollywood 28; Tel.: Hempstead 5186; John Guedel, president.

Services: Package programs, scripts, production, TV live & film shows.

GUERIN ENTERPRISES INC.

427 N. Euclid Ave.; St. Louis 12; Tel.: Rosedale 5592; Fort B. Guerin Jr., president.

Services: TV film production, transcriptions, slide film.

GUILD RADIO FEATURES LTD.

150 Simcoe St., Toronto 2; Tel.: Waverley 2714; Dan V. Carr, manager.

Services: Recording, production, transcriptions, package programs, talent.

H

SYLVIA HAHLO

711 Fifth Avenue, New York 22; Tel.: Plaza 9-6000.

Services: Talent.

HACK PRODUCTIONS

535 N. Laurel Ave., Los Angeles 48; Tel.: Walnut 2068; Herman Hack, president.

Services: Religious films.

WENDELL HALL MUSIC MAKER PRODUCTIONS

4355 N. Paulina St., Chicago 13; Tel.: Graceland 2-6418; Wendell Hall, owner.

Services: Musical spots, TV shows.

MITCHELL J. HAMILBURG AGENCY

8776 Sunset Blvd., Hollywood 48; Tel.: Crestview 5-4111; M. J. Hamilburg, manager.

Services: Talent, writers, packaged production.

HAMILTON-WHITNEY PRODUCTIONS INC.

357 S. Robertson Blvd., Beverly Hills; Tel.: Bradshaw 2-2111; Alvin C. Gershenson, president.

Services: Produce transcribed shows, scripts, talent, live & film TV.

LAWRENCE HAMMOND PRODUCTIONS INC.

45 E. 51st St., New York 22; Tel.: Plaza 9-2210; Lawrence Hammond, president.

Services: Production, TV live & film packages.

JAM HANDY ORGANIZATION

2121 E. Grand Blvd., Detroit 11; Tel.: Trinity 5-2450; Jamison Handy, president.

Services: Film production, slidefilms. **New York 19—1775 Broadway;** Tel.: Columbus 5-7144.

Washington 6, D.C.—544 Transportation Bldg.; Tel.: District 0611.

Dayton 2—310 Talbot Bldg.; Tel.: Adams 6289.

Chicago 1—230 N. Michigan Ave.; Tel.: State 2-6757.

Los Angeles 28—7046 Hollywood Blvd.; Tel.: Hempstead 5809.

Pittsburgh 22—917 Liberty Ave.; Tel.: Express 1840.

MARK HANNA

654 Madison Ave., New York 21; Tel.: Templeton 8-8730; Mark Hanna, owner.

Services: Talent.

HARRIS & STEELE INC.

50 W. 67th St., New York 23; Tel.: Endicott 2-9555; Helen Steele, manager.

Services: Production, talent.

HARTLEY PRODUCTIONS

20 W. 47th St., New York 19; Tel.: Judson 2-3960; Elda Hartley, manager.

Services: TV and radio production, recording, package programs.

HARVARD FILM SERVICE INC.

421 Washington St., Somerville, Mass.; Tel.: Elliot 4-3057; J. F. Barclay, president.

Services: Film production, recording, package programs, talent, film strip production.

HATHEN PRODUCTIONS

246 S. Van Pelt St., Philadelphia; Tel.: Locust 7-0126; Stanley P. Hathen, manager.

Services: TV film production & rentals.

HAWLEY-LORD INC.

61 W. 56th St., New York 19; Tel.: Circle 7-2444; Andre Lord, president.

Services: Film rental.

HAYES-PARNELL PRODUCTIONS INC.

6000 Sunset Blvd., Hollywood 28; Tel.: Hollywood 9-4584; Sam S. Hayes, president.

Services: TV film production.

GEORGE HEID PRODUCTIONS

Century Bldg., Pittsburgh 22; Tel.: Grant 1-3696; George Heid, president.

Services: Recording, radio and TV production, talent, scripts, slide film.

LESLIE HELHENA

932 N. La Brea Ave., Los Angeles 38; Tel.: Granite 3174; Leslie Helhena, owner.

Services: TV commercial spots, production, recording.

WALTER HERZBRUN AGENCY

9000 Sunset Blvd., Los Angeles 46; Tel.: Crestview 6-4157.

Services: Talent.

HISPANO BROADCASTING CO.

4448 Brooklyn Ave., Los Angeles 22; Tel.: Angelus 9-3557; Tony Sein, manager.

Services: Spanish programs.

HI-WAYS & BI-WAYS PRODUCTIONS

242 S. Orange Dr., Los Angeles 38; Tel.: York 8665; Chick Collins, manager.

Services: TV films.

PAUL HOEFLER PRODUCTIONS

612½ S. Ridgeley Dr., Los Angeles 36; Tel.: Whitney 9045; Paul L. Hoefler, president.

Services: Film production. **New York—Zach Baym Films, 13 E. 37th St.;** Tel.: Murray Hill 9-4175; Zach Baym.

HOFFBERG PRODUCTIONS INC.
620 Ninth Ave., New York; Tel.: Circle 6-9031; J. H. Hoffberg, president.
Services: TV film rental.

WILLIAM F. HOLLAND AGENCY
Hotel Sinton, Cincinnati 2; Tel.: Main 3450; William F. Holland, owner.
Services: Recording, transcriptions, production, package programs, script, talent, live and film TV.

HOLLYWOOD ASSOCIATE PRODUCERS
1245 N. Edgemont, Hollywood 27; Tel.: Olympia 3484; Chet Petersen, manager.
Services: Program counsel, scripts.

HOLLYWOOD CENTRAL RECORDING STUDIOS
1538 Cahuenga Blvd., Hollywood 28; Tel.: Hempstead 0270; Clifford C. McDonald, consulting engineer, general manager.
Services: Disc, tape and film recording, masters, transcriptions.

HOLLYWOOD FILM ENTERPRISES INC.
6060 Sunset Blvd., Hollywood 28; Tel.: Hillside 2181; Thomas H. Emmett, president.
Services: Movie film subjects suitable for TV, film laboratory service.

WEST HOOKER TELEFEATURES INC.
2 W. 46th St., New York 19; Tel.: Judson 2-3026; West Hooker, president.
Services: TV live & film package shows, talent.

HOPWOOD, LAUFMAN, FOMUND & CROSS TELEVISION
236 N. Clark St., Chicago 1; Tel.: Randolph 6-1644; Herbert S. Laufman, director of production.
Services: TV live & film production.

SANDY HOWARD PRODUCTIONS
234 West 44th St., New York 18; Tel.: Longacre 4-2763; Sandy Howard, president.
Services: Radio & TV production, package programs, recording, scripts, talent.

MARY HOWARD RECORDINGS
37 E. 49th St., New York 17; Tel.: Plaza 3-4800; Mary Howard, owner.
Services: Package & TV shows.

HOWELL RECORDING STUDIO
2703 Delaware Ave., Buffalo 17; Tel.: Delaware 8728; David F. Howell, owner.
Services: Recording, record pressing plant.

HARRY O. HOYT PRODUCTIONS
2543 Kelton Ave., Los Angeles 64; Tel.: Brighton 0-4757; Harry O. Hoyt, president.
Services: TV film production, package programs, script, program production.

HUBBELL TELEVISION INC.
118 E. 40th St., New York 16; Tel.: Murray Hill 3-0028; Richard W. Hubbell, president.
Services: TV live & film programs, production, distribution.
London—117 Regent St.; Tel.: Regent 2695; W. T. Richardson.
Paris—11 bis Rue Lord Byron; Tel.: Balzac 3399; Anne Buydens.

TED HUDES RADIO PRODUCTIONS
17 East 42nd St., New York; Tel.: Murray Hill 2-0276; Ted Hudes, owner.
Services: Radio and TV production, recording, package programs.

HUDIBURG PRODUCTIONS INC.
131 E. 51st St., New York; Tel.: Eldorado 5-3508; Lucille Hudiburg, manager.
Services: TV fashion films.

R. JOHN HUGH PRODUCTIONS INC.
809 Union Trust Bldg., Washington; Tel.: National 6670; R. John Hugh, producer.
Services: Film production, package programs, scripts, talent.

IDEAL PICTURES CORP.
65 E. South Water St., Chicago; Tel.: Dearborn 2-7676; Paul R. Foght, general manager.
Services: TV film rental.

Atlanta 2—52 Auburn Ave., N.E.; Tel.: Cypress 2321; George Deen.

Boston 16—40 Melrose St.; Tel.: Hancock 6-1133; Jerry Wells.

Chicago 5—28 E. Eighth St.; Tel.: Harrison 7-5354; Harold Laatz.

Cincinnati—127 W. Fifth St.; Tel.: Garfield 0142; Jack C. Waits.

Dallas 4—4000 Ross Ave.; Tel.: Taylor 0821; John Gunstream.

Denver 2—714 18th St.; Tel.: Tabor 5525; Hal Stewart.

Des Moines—1108 High St.; Tel.: 8-0471; Ernie Ryan.

Detroit 1—7338 Woodward Ave.; Tel.: Trinity 3-0355; Charles W. Dobbertin.

Honolulu—1370 S. Beretania St.; Tel.: 6-5336; O. H. Strauser Jr.

Indianapolis 2—1214 N. Pennsylvania St.; Tel.: Lincoln 8953; Robert Mirabella.

Kansas City 6—1402 Locust St.; Tel.: Harrison 2461; Paul Humston.
Los Angeles 5—2408 W. Seventh St.; Tel.: Drexel 8228; Howard Smith.
Louisville 2—423 W. Liberty St.; Tel.: Jackson 8418; C. M. Hadden.
Memphis 3—18 S. Third St.; Tel.: 37-4313; Stanley Nolan.
Miami 36—1348 N. Miami; Tel.: 9-9875; Jack Spire.
Minneapolis 8—301 W. Lake; Tel.: Regent 6203; Virgil Price.
New Orleans 19—3218 Tulane Ave.; Tel.: Amherst 1682; Gene Brandon.
New York 16—207 E. 37th St.; Tel.: Murray Hill 2-0955; R. D. Faber.
Oklahoma City 3—312 N. W. Second St.; Tel.: 3-8162; C. F. Kirkpatrick.
Oakland 11—4247 Piedmont Ave.; Tel.: Piedmont 5-4886; A. J. Gerber.
Portland 5, Ore.—915 S. W. Tenth St.; Tel.: AT 6579; Barton Willoughby.
Richmond 19—219 E. Main St.; Tel.: 7-2973; Dan Browning Jr.
Salt Lake City 1—10 Post Office Pl.; Tel.: 3-5417; Scott Hillam.

IMAGINEERING ASSOC. INC.
1030 N. McCadden Pl., Hollywood 38; Tel.: Hollywood 9-8777; Ronald F. Kennard, manager.
Services: TV commercial films.

IMPACT TV FILMS
1153 N. Highland Ave., Hollywood 38; Tel.: Hollywood 9-5808; Albert W. Hellenthal, manager.
Services: TV film production.

IMPRO INC.
Hal Roach Studios, Culver City, Calif.; Tel.: Vermont 8-2185; Herbert L. Strook, president.
Services: Film and live TV production, animation, talent.
New York 17—420 Madison Ave.; Tel.: Plaza 9-7490; Arthur Simon (transcontinental television).

(Continued on page 428)



Our newest triumph!
"THE CLYDE BEATTY SHOW" . . . with the circus itself as background . . . is now available to regional and t.c. advertisers. The world's greatest wild animal trainer comes to radio in a live 30-minute series of danger, excitement . . . harrowing escapes from the claws and fangs of ferocious jungle beasts!

CLYDE BEATTY ★ ★ HOPALONG CASSIDY

America's top favorite!
"HOPALONG CASSIDY" starring William Boyd, is riding range on the Mutual Network. This courageous cowboy is mighty proud of his sponsor, General Foods, and we of Commodore are proud of the way America has gone all out for "Hopalong"!



Commodore Productions
and Artists, Inc.

Walter White, Jr., President—Shirley Thomas, Vice President
1350 N. HIGHLAND AVE., HOLLYWOOD 28, CALIF.

RADIO, TV PROGRAM PRODUCTION, TRANSCRIPTION AND RELATED SERVICES
(Continued from page 427)

IMPS INC.
515 Madison Ave., New York 22; Tel.: Eldorado 5-6620; Ben Gradus, president.
Services: Complete film production, recording, talent.

INSTRUCTIONAL FILMS INC.
330 W. 42nd St., New York; Tel.: Longacre 3-5189; Miller McClintock, manager.
Services: Educational TV films, rentals.

INTER-CALIFORNIA BROADCASTING SYSTEM
253 S. Broadway, Los Angeles 12; Tel.: Mutual 2759; Gustavo Faist Moran, manager.
Services: Spanish programs, scripts and package programs.

INTERNATIONAL 16mm CORP.
165 W. 48th St., New York 19; Tel.: Plaza 7-2265; Patrick E. Shanahan, president.
Services: Film rental, musical moods, cinelogs, package programs.

INTERNATIONAL FILM FOUNDATION INC.
1600 Broadway, New York 19; Tel.: Circle 6-9438; Julien Bryan, executive director.
Services: Documentary & educational films, production & distribution.

INTERNATIONAL GEOGRAPHIC PICTURES
1776 Broadway, New York; Tel.: Circle 8-4486; J. Allen Julier, president.
Services: Educational films.

INTERNATIONAL MOVIE PRODUCTION SERVICE
515 Madison Ave., New York; Tel.: Eldorado 5-6620; Ben Gradus, manager.
Services: TV films, rentals.

INTERNATIONAL NEWS SERVICE (Telenews Productions Inc.)
235 E. 45th St., New York 17; Tel.: Murray Hill 2-0131; Robert H. Reid, manager.
Services: Daily and weekly newsreels, spot news, documentary picture package.

INTERNATIONAL PRODUCTIONS LTD.
149 Alcorn Ave., Toronto; Tel.: Randolph 6291; G. Forsyth, manager.
Services: Recording, production, package programs, talent.
Montreal—128 Sun Life Bldg.; Tel.: Belair 1984; J. C. Nicholls.

INT'L RADIO & TELEVISION FEATURES
322 E. 55th St., New York; Tel.: Plaza 5-5781; Jack Lloyd, manager.
Services: TV films.

INTERNATIONAL TELE-FILM PRODUCTIONS INC.
331 Madison Ave., New York; Tel.: Murray Hill 7-7306; Paul F. Moss, president.
Services: TV live & film package shows, recordings, talent.

INTERNATIONAL TRANS-VIDEO INC.
61 E. 52nd St., New York 14; Tel.: Murray Hill 8-1380; Paul White, president.
Services: Production & distribution of live & film TV shows.

LOU IRWIN INC. AGENCY
9134 Sunset Blvd.; Hollywood 46; Tel.: Crestview 1-3171; Lou Irwin, president.
Services: Talent, recordings, scripts, TV-live & film.

JACK-O-GRAM STUDIO
152 W. 42nd St., New York 18; Tel.: Lackawanna 4-1173; S. Jack Solomon, president.
Services: Film production, disc & tape recording.

FREDERICK JACKY PRODUCTIONS
520 N. Michigan Ave., Chicago 11; Tel.: Delaware 7-3262; Frederick Jacky, owner.
Services: Production, transcribed package shows.

THE JAFFE AGENCY INC.
8553 Sunset Blvd., Hollywood 46; Tel.: Crestview 6-6121; Sanford Cummings, manager.
Services: Scripts, transcriptions, package shows, talent.

JASON COMIC ART
1860 Broadway, New York 23; Tel.: Judson 6-4280; Leon Jason, director.
Services: TV film, production, talent.

ROBERT JOSEPH PRODUCTIONS
846 N. Cahuenga Blvd., Hollywood; Tel.: Hollywood 9-5981; Robert Joseph, president.
Services: Package & produce live TV shows.

JUNIOR PROGRAMS INC.
22 Lawrence St., Newark 5, N. J.; Tel.: Market 3-0770; Dorothy L. McFadden, president.
Services: Scripts, package programs, live TV shows.

K

K AND S FILMS INC.
50 N. West St., Indianapolis 2, Ind.; Tel.: Riley 3981; Roger T. Sneden, secretary-treasurer.
Services: TV film production, package programs, recording, distribution.
St. Louis 1—1017 Olive St.; Tel.: Chestnut 9459; F. S. Pollock, representative.

BERNARD E. KARLEN PRODUCTIONS
475 Fifth Ave., New York 18; Tel.: Murray Hill 4-6303; Bernard E. Karlen, executive producer.
Services: Live and film television production, television scripts and package programs.

ESTELLA H. KARN
49 W. 45th St., New York; Tel.: Luxembourg 2-2170; Estella H. Karn, manager.
Services: Radio-TV program productions.

BEULAH KARNEY INC.
ABC, 1942 Merchandise Mart, Chicago; Tel.: ANdover 3-7800; Beulah Karney, manager. (Home: 940 Crescent Blvd., Glen Ellyn.)
Services: Food transcriptions.

KASPER-GORDON INC.
140 Boylston St., Boston 16; Tel.: Devonshire 8-7357; Aaron S. Bloom, director.
Services: Recording, production, transcriptions, package programs, scripts, talent, live & film TV programs.

JOHN KEATING
Alderway Bldg., Portland 5, Ore.; Tel.: Beacon 4107; John D. Keating, manager.
Services: Custom made recordings and transcriptions.
Seattle 1—2nd & Pine Bldg. Tel.: Elliott 6520; James A. McLoughlin, manager.

KEMP TELEVISION PRODUCTIONS
1650 Broadway, New York 19; Tel.: Circle 6-0691; Jack J. Kemp, producer.
Services: TV film.

KEITH KERBY LTD.
111 Sutter St., San Francisco 4; Tel.: Yukon 2-5532; Keith Kerby, president.
Services: Individually designed radio & TV commercials featuring "name" talent.

HERBERT KERKOW INC.
480 Lexington Ave., New York; Tel.: Eldorado 5-5635; Herbert Kerkow.
Services: TV films.

KILLINGSWORTH TV PRODUCTIONS INC.
150 W. 49th St., New York 19; Tel.: Plaza 7-0759; Oland Killingsworth, president.
Services: TV package production—live & film.

PETER & ELIZABETH KIRK
One Tryon Ave., Providence 8, R. I. Tel.: East Providence 1-3154M; Peter Kirk.
Services: Serial & documentary drama, TV production.

KISSINGER PRODUCTIONS
1650 Broadway, New York 19; Tel.: Judson 6-5572; Richard D. Kissinger, president.
Services: Radio & TV production, recording, package programs.

WALTER E. KLINE & ASSOCIATES
8445 Melrose Ave., Hollywood 46; Tel.: Webster 6156; Fred W. Kline, manager.
Services: Public relations, publicity, advertising, film & live TV productions.

KLING STUDIOS INC.
601 N. Fairbanks Ct., Chicago 11; Tel.: Delaware 7-0400; Jack H. Lieb, executive producer; Fred Niles, TV producer.
Services: Film production, package programs, live TV.

KNICKERBOCKER PRODUCTIONS INC.
1600 Broadway, New York 19; Tel.: Circle 6-9850; Howard A. Lesser, president.
Services: TV film production.

KNOWLEDGE BUILDERS
625 Madison Ave., New York; Tel.: Eldorado 5-2848; John R. McCrory, director.
Services: Documentary films for TV.

L

LANG-WORTH FEATURE PROGRAMS
113 W. 57th St., New York 19; Tel.: Judson 6-5700; C. O. Langlois, president.
Services: Music program service, recording, production, package programs.

LAWRENCE-PHILIP MOTION PICTURES
321 S. Plymouth Ct., Chicago 4; Wabash 2-7735; Philip Weinstein, owner.
Services: Film production & processing.

LAWRENCE PRODUCTIONS
6700 Sunset Blvd., Hollywood 28; Tel.: Granite 5543; B. Eaton Lawrence, president.
Services: Live and transcribed production, live TV production, package programs.

LES LEAR PRODUCTION CORP.
139 N. Clark St., Chicago 2; Tel.: Andover 3-7233; Les Lear, manager.
Services: Talent, production.

LEON TELEVISION PICTURES CORP.
1501 Broadway, New York 18; Tel.: Pennsylvania 6-1780; Earle W. Hammons, president.
Services: TV production and consultant.

JULIAN LESSER PROGRAMS
9336 W. Washington Blvd., Culver City, Calif.; Tel.: Texas 0-2931; Julian Lesser, manager.
Services: TV films.

TED LESSER AGENCY
8820 Sunset Blvd., Los Angeles 46; Tel.: Crestview 1-3696.
Services: Talent.

GENE LESTER PRODUCTIONS
1487 N. Vine St., Hollywood 28; Tel.: Hillside 7287; Gene Lester.
Services: TV film production, package TV programs.

LEEVE-STARK INC.
8782 Sunset Blvd., Los Angeles 46; Tel.: Crestview 1-5781; Ben Benjamin, manager.
Services: Talent.

W. BIGGIE LEVIN AGENCY (Television Airshows Inc.)
612 N. Michigan Ave., Chicago 11; Tel.: Superior 7-0506; W. Biggie Levin, manager; W. G. T. Hyer, production director.
Services: Scripts, production, talent, TV live & film shows.

JACK LEWIS THEATRICAL ENTERPRISES
1564 Broadway, New York 19; Tel.: Plaza 7-0412.
Services: Production, talent, scripts.

LESTER LEWIS ASSOCIATES
1 Christopher St., New York 14; Tel.: Watkins 4-8582; Lester Lewis, manager.
Services: Production, scripts, radio & TV talent.

LIBRA FILM DISTRIBUTORS & PRODUCERS
6525 Sunset Blvd., Hollywood 28; Tel.: Gladstone 7960; C. M. McCoy, vice president.
Services: Film production & distribution.

LICHTIG-ENGLANDER AGENCY
8776 Sunset Blvd., Los Angeles 46; Tel.: Crestview 1-2141; Harry Lichtig, manager.
Services: Talent, writers.

LIEB-BROTMAN STUDIO
14 W. 58th St., New York; Tel.: Plaza 3-9355; Leo Lieb, manager.
Services: TV films.

LIFETONE TRANSCRIPTIONS
2013 Peoria Ave., Peoria 4; Tel.: 2-9443; Norris John Buechele, president.
Services: Recording, production, transcriptions, TV film production.

LINDNER VIDEO PRODUCTIONS (See Film Features Associates.)
ART LINICK ENTERPRISES
400 N. Michigan Ave., Chicago 11; Tel.: Superior 7-3311; Art Linick, manager.
Services: Production.

EDWARD C. LOBDELL ASSOC.
17 E. 48th St., New York 17; Tel.: Plaza 5-1127; E. C. Lobdell, general manager.
Services: Talent, management consultant.

BOB LOEWI PRODUCTIONS INC.
255-A E. 49th St., New York; Tel.: Murray Hill 8-2600; Bob Loewi, president.
Services: TV film production.

LONDON LIBRARY SERVICE
16-18 W. 22nd St., New York 10; Tel.: Oregon 5-6060; Joseph F. Hards, manager.
Services: Transcription library service, wired music.

W. E. LONG CO.
188 Randolph Tower, Chicago; Tel.: Randolph 6-4606; Harold Gingrich, director, radio & TV.
Services: Transcriptions package programs, scripts, TV film.

PHILLIPS H. LORD INC.
501 Madison Ave., New York 22; Tel.: Plaza 5-2211; Phillips H. Lord, president; John O. Ives, vice president; Dorothy E. Levy, manager.
Services: Package productions.

LOTT ADVERTISING AGENCY
1273 Westwood Blvd., W. Los Angeles; Tel.: Arizona 7-4137; Davis Lott, president.
Services: TV production.

LOUCKS & NORLING STUDIOS
245 W. 55th St., New York; Tel.: Columbus 5-6974; A. H. Loucks, J. A. Norling, partners.
Services: TV film production.

(Continued on page 432)

when
you want. . .

HIGH QUALITY,

LOW-BUDGET TELEVISION PROGRAMS

that will build enthusiastic audiences and sell a
sponsor's products

write,
wire
or phone. . .

OFFICIAL TELEVISION, INC.

A national institution

- specially created to serve the television programming needs of advertisers, advertising agencies and stations
- staffed with specialists, who know from experience what constitutes good entertainment and good merchandising
- prepared to deliver, promptly, programs for all types of audiences and all time segments.

THE 1950 OFFICIAL TELEVISION PROGRAM CATALOGUE PRESENTS



"Mark of Guaranteed Quality and Service in Television Programs"

- Syndicated Packages (Recorded on Film) for Adult Audiences—for Juvenile Audiences—for General Audiences
- Library Services for Station Use (Recorded on Film) Production Sequences—Religious Music—Parade of Events
- Custom-Built Packages—(Live or Film) Specially created to solve a particular merchandising problem

Official Television, Inc.

**National Distributors of
Television Programming Materials**

HOME OFFICE: 25 West 45th Street, New York 19, N. Y.

HEADQUARTERS — MIDWEST DIVISION — 209 W. Jackson Blvd., Chicago, Illinois

IT

IS

INEVITABLE!

It is inevitable that Lang-Worth will continue to lead with a program service pledged to increased profits for broadcasters!

Lang-Worth was **FIRST** with a transcribed library of all Non-ASCAP music—which spearheaded the copyright victory and saved the industry millions of dollars. **FIRST** to separate, on individual discs, ASCAP from Non-ASCAP for "per program" operation. **FIRST** to stop waste and confusion in the program department by ditching the elusive index card for "Talendex". **FIRST** to furnish voice tracks of name artists...authentic program themes, mood music and production aids in abundance.

...and Lang-Worth was **FIRST** to build "Network Calibre Programs at Local Station Cost". **FIRST** to publicize these programs with Agencies and Advertisers. In the past ten months over 2000 individual advertisers sponsored 141,856 quarter-hours of these "Network Calibre Programs". Lang-Worth is the most widely sponsored library service in the world!

THE CAVALCADE OF MUSIC

Now on 486 stations! Features the glamorous Cavalcade Orchestra and Chorus (56 pieces)—directed by D'Artega, with top-name guests. Says Ted Cott, V.P. and Director of Programs, WNEW, New York, "...best rating-bait we know. Tied for first place among all New York Stations when Hooperated on WNEW!"

30 minutes, 1 weekly



MIKE MYSTERIES

On 392 stations. Musical show incorporating 2-minute mystery gimmick, written for Lang-Worth by Hollywood's John Evans ("Halo for Satan", "Halo in Blood", etc.) From Bill Laurie, KEBE, Jacksonville, Texas. "...My Sales Manager says easiest-to-sell-show ever offered. Twelve minutes with first prospect and order signed for entire 52-week series!"

15 minutes, 5 weekly

THE CONCERT HOUR

An imperishable Lang-Worth regular! Continuous use by more than 300 stations. Universal appeal of immortal classics, enhanced by the dignified interpretations of the celebrated Lang-Worth Symphony and Concert orchestras—direction by such outstanding conductors as Howard Barlow, Erno Rapee and D'Artega. Eminent guest soloists—interesting and informative program notes.

30 minutes, 1 weekly





THROUGH THE LISTENING GLASS

Heard over 416 Lang-Worth Stations! "A Wonderland of Music", enchanted by the dynamic performance of the "Silver Strings". Features Johnny Thompson, romantic baritone starring on Broadway—"Miss Liberty". From WFAA, Dallas, "... Wilkins Travel Goods reports proven audience response to "LISTENING GLASS"... another example of a Lang-Worth network-calibre program at local station cost."

30 minutes, 1 weekly



THE EMILE COTE GLEE CLUB

One of the most commercial units in radio today. Sixteen male voices and soloists, with a repertoire of more than 200 well-known songs, performed with warmth and friendliness. Audience ratings? WTIC, Hartford, Connecticut—17.0; WCAU, Philadelphia, Pa. (Pulse)—7.8; WFEA, Manchester, New Hampshire—31.7; WHDH, Boston, Mass. (Pulse)—11.5; WSYR, Syracuse, New York—8.3; WHP, Harrisburg, Pa.—8.7; WLEC, Sandusky, Ohio.—35.9!

15 minutes, 5 weekly



MEET THE BAND

Now on 403 stations! Participating sponsorship. Cream of the Lang-Worth Dance Band section: Dorsey, Monroe, Carle, Busse, Barnett, Nichols, Morgan, Basie, Fields, Anthony, Clinton, Pastor, Mooney and more. Voice tracks of name band-leaders give personalized openings and signatures to programs. Entertaining copy on "life and works" of America's leading bandmen.

30 minutes, 5 weekly



11 MORE NETWORK CALIBRE PROGRAMS!

Eleven more carefully prepared, intelligently written programs—along with special Production Shows for nationally important holidays—round out the Lang-Worth Program Service. Western—"RIDERS OF THE PURPLE SAGE"; Religious—"YOUR COMMUNITY CHAPEL"; Dance—"KEYNOTES BY CARLE"; etc. Additional pre-selected "listening music" formats.

Always **FIRST**
in the past...
Lang-Worth is

FIRST in the FUTURE!

with the **NEW**
Lang-Worth Transcription

1. GREATER TONAL FIDELITY: A newly developed cutter, important refinements in processing, and a revolutionary patented process of manufacturing combine to produce a plastic reproduction with the highest degree of tonal fidelity ever achieved!

2. LATERAL CUT: Reproduces perfectly with the same sound system you are presently using for phonograph records and commercial transcriptions.

3. ANY STANDARD STYLUS: Not microgroove! Tapered like the letter "V", the groove accommodates standard coarse-line styli of 2½ or 2 mil radius, down to 1 mil.

4. UNIFORM LEVEL: Reproduction of every disc is uniform in overall level.

5. MINIMUM SURFACE: Superior processing and a special plastic result in surface noise that is nil!

6. SUPERIOR DURABILITY: Laboratory tests prove no wear or loss of high frequency response until after the 200th playing.

7. SIZE AND WEIGHT: 8 inches against 16...2 ounces against 12½...½ the diameter, ¼ the area, less than ¼ the weight!

8. SHIPMENTS PREPAID: ALL shipments and releases (including basic library and cabinet) sent PREPAID to subscribers.

9. FREE REPLACEMENTS: Increased 50%. Additional above quota furnished at 60¢ each, transportation PREPAID.

10. CUEING AND LABELING: Optical cueing device—simple, accurate. Cue it in the dark! New label gives title, timing, tempo, source, copyright and vocal entrance.

11. CABINETS AND FILING: One Globe-Wernicke steel cabinet (22x25x-32) with roller-bearing suspension, houses the entire basic library (5000 tunes) and 3 years of subsequent releases.

12. ASCAP and Non-ASCAP: ASCAP music never on same disc with Non-ASCAP. Separate discs—distinctively colored labels—vital to "per program" operation.

13. SPECIAL THEMATIC MUSIC: All "special" and program themes, mood music, production aids on separate discs.

14. INSTRUMENTALS AND VOCALS: On separate discs, so labeled. Indispensable in building "all instrumental" or "all vocal" programs.

15. EASIER HANDLING: Minimum weight, size, tougher surface, guarantee easier handling. 1 hour of recorded music weighs 8 ounces!

Samples of the NEW Lang-Worth Transcription—covering every category of good radio programming—are available to you. Use coupon below or your letterhead.

LANG-WORTH FEATURE PROGRAMS, Inc.

113 WEST 57th STREET, NEW YORK 19, N. Y.

Network Calibre Programs at Local Station Cost

LANG-WORTH FEATURE PROGRAMS, INC.
113 WEST 57TH STREET, NEW YORK 19, N. Y.

Gentlemen:

Send full information on Lang-Worth Program Service, with FREE audition samples of "The NEW Lang-Worth Transcription".

STATION: _____

CITY: _____ STATE: _____

TO: _____ TITLE: _____

RADIO, TV PROGRAM PRODUCTION, TRANSCRIPTION AND RELATED SERVICES
(Continued from page 428)

ESTELLE LUTZ ARTISTS BUREAU
25 E. Jackson Blvd., Chicago 4; Tel.: Harrison 7-3435; Estelle Lutz, manager.
Services: Production, talent, scripts, TV shows.

A. & S. LYONS INC.
515 Madison Ave., New York 22; Tel.: Plaza 3-5181; Irene Etkin, manager.
Services: Talent, package production. Beverly Hills—177 S. Beverly Drive; Tel.: Crestview 1-6131.

M

C. P. MacGREGOR CO.
729 S. Western Ave., Los Angeles 5; Tel.: Dunkirk 4-4191; George R. Jones, manager.

Services: Transcribed music library, package programs, recording service. New York—342 Madison Ave.; Tel.: Vanderbilt 6-0492; Nat V. Donato, eastern manager.

Chicago—612 N. Michigan Ave.; Tel.: Superior 7-8181; William M. Mertz Jr., midwest representative.

MAJESTIC PRODUCTIONS INC.
2008 RKO Bldg., New York 20; Tel.: Circle 7-7956; Jules Levey, president.
Services: TV film.

MANAGEMENT CORP. OF AMERICA
598 Madison Ave., New York 22; Tel.: Plaza 9-7500; Herbert I. Rosenthal, vice president.

Services: Production.

GENE MANN INC.
2700 N. Vermont, Los Angeles 27; Tel.: Normandy 2-8115; Gene Mann, manager.
Services: Talent.

MANNON SOUND STAGES
112 W. 89th St., New York; Tel.: Trafalgar 3-1800; George Orth, general manager.
Services: Recording, film production.

THE MARCH OF TIME
269 Lexington Ave., New York 17; Tel.: Judson 6-1212; Richard de Rochemont, producer.
Services: TV film production; package programs, talent.

MASTER MOTION PICTURE CO.
50 Piedmont St., Boston; Tel.: Hancock 6-3592; Maurice Master, president.
Services: TV film production and processing.

MASTERTON, REDDY & NELSON
6331 Hollywood Blvd., Hollywood 28; Tel.: Hillside 0188; John Masterton, John Reddy, John Nelson, partners.
Services: Packaging & production of radio & TV programs.
Los Angeles 5—3401 Wilshire Blvd.; Tel.: Drexel 4391; Wayne Reeves, manager.
New York 22—745 Fifth Ave.; Tel.: Plaza 9-1120; Charles Brown, New York manager.

ROBERT MAXWELL ASSOCIATES
480 Lexington Ave., New York 17; Tel.: Plaza 9-5700; Robert Maxwell, manager.
Services: Production, package programs.

MAYFAIR TRANSCRIPTION CO.
8511 Sunset Blvd., Hollywood 46; Tel.: Crestview 1-8151; B. A. Joslin, exec. vice president.
Services: Production, package programs, transcriptions.

McCOLLUM PICTURE PRODUCTIONS
4557 Produce Plaza, Los Angeles 11; Tel.: Jefferson 8255; J. L. McCollum, producer.
Services: TV film production, talent, scripts, recording.

RALPH S. McFEELY CO.
714 Hartman Theatre Bldg., Columbus 15, Ohio; Tel.: Adams 4116; Ralph S. McFeely.
Services: Transcribed programs, TV film programs & spots.

McLARTY PICTURE PRODUCTIONS
45 Stanley St., Buffalo, N. Y.; Tel.: Taylor 0332; Henry D. McLarty, owner.
Services: TV film production.

ALEXANDER McQUEEN & ASSOC.
5222 N. Lakewood Ave., Chicago 40; Tel.: Ravenswood 8-9010; Alexander McQueen, manager.
Services: Scripts, transcriptions, program production.

MEDIA PRODUCTION INC.
4 W. 58th St., New York 19; Tel.: Plaza 3-1551; T. Edward Hambleton, secretary.
Services: Radio & TV packaging & production.

MELOTONE RECORDING STUDIO
25 Central Park W., New York 23; Tel.: Circle 8-1366; Mera M. Weinstein, manager.
Services: Recording, transcriptions.

MERCURY INT'L PICTURES INC.
1415 Coast Blvd., Corona del Mar, Calif.; Tel.: Harbor 1212; V. E. Ellsworth, president.
Services: TV film production.
Chicago 11—230 E. Ohio St.; Tel.: Delaware 7-3934; Walter B. Wentzel.
Seattle 1—803 Fischer Studio Bldg.; Tel.: Seneca 2788; William E. McKee.

MERRITT PRODUCTIONS INC.
(See Joseph Bloom listing.)

METRO ARTIST BUREAU
(Ted Nelson Assoc.)
730 Fifth Ave., New York 19; Tel.: Circle 6-8470; Ted Nelson, manager.
Services: Talent.

METROPOLITAN BCSTG. SERVICE LTD.
21 Dundas Sq., Toronto 6; Tel.: Adelaide 0181; Don E. Wright, manager.
Services: Production, recording, talent.

METROPOLITAN STUDIOS FOR RECORDING INC.
1697 Broadway, New York 19; Tel.: Circle 7-3428; Leo Kahn, president; Alan C. Raynor, secretary-treasurer.
Services: Recording, transcriptions, production.

CHARLES MICHELSON INC.
23 W. 47th St., New York 19; Tel.: Plaza 7-0695; Charles Michelson, president.
Services: Transcriptions, package programs, sound effects.
Los Angeles—1344 S. Flower St.; Tel.: Prospect 2035; Philip Johnson, manager.
Richmond, Ind.—S. 1st & B Sts.; Tel.: 1117; Harry Gennett Jr., manager.
Toronto—19-A Bloor St.; Tel.: Princess 3685; R. E. McGuire, manager.
Sidney, Australia—29 Bligh St.; Tel.: BW 4681; Grace Gibson, manager.
Johannesburg, South Africa—127 Anderson St., H. M. Boesch, manager.

MICHELSON & STERNBERG INC.
23 W. 47th St., New York 19; Tel.: Plaza 7-1269; A. Michelson, president.
Services: Exporters of electrical transcriptions, and sound effects records.

MICHIGAN FILM LIBRARY
14540 Grand River Ave., Detroit; Tel.: Vermont 7-2322; Alban J. Norris, manager.
Services: TV religious films.

MIDWEST FILM STUDIOS
6808 N. Clark St., Chicago 26; Tel.: Sheldrake 3-1239; Alfred K. Levy, production manager.
Services: TV film production, slide film.

MILLER BROADCASTING SYSTEM INC.
113 W. 57th St., New York 19; Tel.: Circle 6-0141; James A. Miller, president.
Services: Millertape recording.

MILMAUR THEATRE GUILD
5927 Sunset Blvd., Hollywood; Tel.: Hudson 2-1153; Milton Syde, president.
Services: Radio & TV production.

MINI-FILMS INC.
1017 N. La Cienega Blvd., Hollywood 46; Tel.: Crestview 4-5194; Sol Dolgin, manager.
Services: TV film.

VICTORIA MIX INC.
356 S. Roxbury Drive, Beverly Hills; Tel.: Crestview 6-1276; Victoria Mix, manager.
Services: TV films.

MODANDRE SERVICE
34 New York Ave., N. E., Washington 2, D. C.; Tel.: North 1205; Albert N. Dennis.
Services: Syndicated news program, Washington news representation.

MOGULL'S
112 W. 48th St., New York 19; Tel.: Plaza 7-1414; Charles Mogull, manager.
Services: Film distribution.

MOLE, DAVIS INC.
105 W. 55th St., New York 19; Tel.: Circle 6-0006; John Mole, president.
Services: Package shows for radio & television.

MONARCH PROGRAM LIBRARY INC.
933 Milwaukee Way, Denver 9; Tel.: Pearl 1178; Robert W. Fouse, president.
Services: Package programs, recording, scripts.

MONTER-GRAY INC.
717 N. La Cienega Blvd., Hollywood 46; Tel.: Crestview 1-1191; Edward M. Gray, manager.
Services: Talent.

symbol
of the
finest in
radio
transcriptions



a select list of fine programs:
BLACKSTONE - MAGIC DETECTIVE
LOU HOLTZ LAFF CLUB
SMILIN' ED McCONNELL
MUSICAL COMEDY THEATRE
THE AVENGER
THE SEALED BOOK

FOR COMPLETE DETAILS & LISTINGS
WRITE OR PHONE

CHARLES MICHELSON
INCORPORATED
23 west 47th st.
new york 19, n. y.
plaza 7-0695

EMPIRE
RECORDING
TAPE - DISC
STUDIOS
AIR/LINE CHECKS
AM-FM-TV
PORTABLE JOBS
FILM
SYNCHRONIZATION

EMPIRE BROADCASTING CORP.
480 LEXINGTON AVE.
NEW YORK 17, N. Y.

MOONBEAMS BROADCASTS INC.

701 Seventh Ave., New York 19; Tel.: Columbus 5-7495; George Shackley, president.

Services: Live and transcribed radio and TV scripts, production.

WILLIAM MORRIS AGENCY INC.

1270 Sixth Ave., New York 20; Tel.: Circle 7-2160; William Morris Jr., president.

Services: Package shows for radio & TV, scripts, talent.

Chicago—203 N. Wabash Ave.; Tel.: State 3632; Sidney Epstein.

Beverly Hills—202 N. Canon Dr.; Tel.: Crestview 1-6161; Abe Lastfogel.

LEO MORRISON INC.

328 S. Beverly Drive, Beverly Hills; Tel.: Crestview 1-9191.

Services: Talent.

CARLTON E. MORSE PRODUCTIONS

1500 N. Vine St., Hollywood 28; Tel.: Hollywood 9-6161; Carlton E. Morse, manager.

Services: TV film programs, production.

MORTON RADIO PRODUCTIONS INC.

360 N. Michigan Ave., Chicago 1; Tel.: Central 6-4144; Morton Jacobson, president.

Services: Transcribed radio shows.

MOSS FILM PRODUCTIONS

29 California St., San Francisco 11; Tel.: Sutter 1-3697; Elmer Moss, owner.

Services: TV film & slidefilm production.

HERBERT M. MOSS PRODUCTIONS

100 W. 55th St., New York 19; Tel.: Columbus 5-1661.

Services: Radio & TV productions.

MOTION PICTURE SERVICE CO.

125 Hyde St., San Francisco; Tel.: Ordway 3-9162; Gerald L. Karski, manager.

Services: TV films, newsreels.

MOVIE ADVERTISING BUREAU

70 E. 45th St., New York; Tel.: Murray Hill 6-3717; J. F. Barry, manager.

Services: TV films.

MURPHY-LILLIS INC.

59 Park Ave., New York 16; Tel.: Murray Hill 6-2142; Owen Murphy, president.

Services: Film production & distribution, live package programs.

MARTIN MURRAY PRODUCTIONS INC.

5746 Sunset Blvd., Hollywood 28; Tel.: Hollywood 9-0022; Martin Murray, president.

Services: 16mm TV shorts & musicals.

MUSIC CORPORATION OF AMERICA

598 Madison Ave., New York; Tel.: Plaza 9-7500; David Werblin, manager.

Services: TV films, rentals, talent.

N**NASSOUR STUDIOS**

5746 Sunset Blvd., Hollywood 28; Tel.: Hollywood 9-7381; Edward Nassour, vice president.

Services: TV film programs.

NATIONAL BROADCASTING CO.

30 Rockefeller Plaza, New York 20; Tel.: Circle 7-8300; Charles G. Hicks, recording sales manager.

Services: Custom recording.

Washington 5—Trans-Lux Bldg.; Tel.: Republic 4000; Eugene Juster, manager.

Chicago—Merchandise Mart; Tel.: Superior 8300; Scott Keck, manager.

Hollywood—Sunset & Vine; Tel.: Hollywood 6161; Alfred M. Wooley, manager.

NATIONAL CONCERT AND ARTISTS CORP.

711 Fifth Ave., New York 22; Tel.: Plaza 9-6000; Lawrence J. Fitzgerald, radio-TV manager.

Services: Artist management, package programs.

Chicago—105 W. Adams St.; Tel.: Dearborn 2-5813; D. L. Cornet, vice president.

Los Angeles 13—427 W. Fifth St.; Tel.: Madison 9-1241; Alexander F. Hass, vice president.

NATIONAL LAUGH WEEK FOUNDATION

62 W. 46th St., New York 19; Tel.: Judson 6-0478; George Lewis, director; Ruth Sudler, Women's Div.

Services: Talent, scripts.

NATIONAL PRODUCTIONS

1415 K St., N. W., Washington 5; Tel.: Executive 5834; Robert J. Enders, manager.

Services: Transcriptions, production, talent, package programs, TV live & film shows.

NATIONAL SAFETY COUNCIL

20 N. Wacker Dr., Chicago 4; Tel.: State 2-5020; J. V. Scully, manager, Film Bureau.

Services: TV film.

NATIONAL SCREEN SERVICE CORP.

1600 Broadway, New York; Tel.: Circle 6-5700; Melvin L. Gold, director of advertising.

Services: Film production.

NATIONAL SOUND CORP.

1841 Broadway, New York 23; Tel.: Columbus 5-5430; Albert B. Green, president.

Services: Phonograph records.

NATIONWIDE TELEVISION CORP.

10 E. 49th St., New York 17; Tel.: Plaza 9-3868; Robert H. Wormhaudt, TV director.

Services: TV film distribution.

NEAL-MORGAN INC.

Michigan Bldg., Detroit 26; Tel.: Woodward 2-1439; William E. Morgan, president.

Services: Recording & production service, TV film.

NEFF RADIO-TV PRODUCTIONS

Stroh Bldg., Detroit 26; Tel.: Woodward 2-3006; M. A. Neff, owner.

Services: Production, talent, recording, TV live & film production.

TED NELSON ASSOCIATES

730 Fifth Ave., New York 19; Tel.: Circle 6-8470; Ted Nelson, director.

Services: Radio and TV production, scripts, package programs, consultants.

NELSON PRODUCTIONS INC.

341 Madison Ave., New York; Tel.: Murray Hill 6-5862; Raymond E. Nelson, president.

Services: TV production—live & film.

TED NEMETH STUDIOS

729 7th Ave., New York 19; Tel.: Circle 5-5147; Ted Nemeth, director.

Services: TV film.

NETHERLANDS INFORMATION BUREAU

10 Rockefeller Plaza, New York 20; Tel.: Columbus 5-6216; J. P. Bourdrez, director.

Services: Programs about Holland for AM or TV.

San Francisco—988 Mills Bldg.; Tel.: Exbrook 7948; Julie Lynch, director.

Holland, Mich.—City Hall; Tel.: Holland 3174; Willard C. Wichers, director.

Washington, D. C.—1472 Euclid St.; Tel.: Adams 4301; Carroll Healy.

BERT NEVINS INC.

152 W. 42nd St., New York 18; (See Feature Bureau listing.)

NEW TOOLS FOR LEARNING BUREAU

N. J. State Teachers College, Upper Montclair, N. J.; Tel.: Montclair 2-9210; Edgar C. Bye, director.

Services: Educational transcriptions.

NEW WORLD PRODUCTIONS

5746 Sunset Blvd., Hollywood 28; Tel.: Hollywood 9-5827; T. C. Robinson, owner.

Services: TV film production.

NEWS REEL LABORATORY

1733 Sansom St., Philadelphia; Tel.: Rittenhouse 6-3892; Louis W. Kellman, manager.

Services: Film production, motion picture projector rental & service.

OLIVER W. NICOLL PRODUCTIONS

(Towers of London Ltd.) (Radio Features of America)

37 W. 46th St., New York 19; Tel.: Luxemburg 2-5130; Oliver W. Nicoll, executive director.

Services: Transcriptions, production, scripts, radio & TV program producers & packagers.

London W. 1—84 Hallam St.; Tel.: Langham 6248; Harry Alan Towers, London representative.

NOCTURNE PRODUCTIONS

88 Diamond Bridge, Hawthorne, N. J.; Tel.: Hawthorne 7-1531R; Jack Hartley, general manager.

Services: Scripts, production, recording, live TV shows, talent.

MEYER B. NORTH

1564 Broadway, New York 19; Tel.: Plaza 7-3445.

Services: Talent, programs for radio & TV.

JOHN O'CONNOR

1697 Broadway, New York 19; Tel.: Circle 5-4920; John O'Connor, manager.

Services: Talent, production, scripts.

OFFICIAL TELEVISION INC.

25 W. 45th St., New York 19; Tel.: Luxemburg 2-1700; W. W. Black, vice president.

Services: TV film package productions.

LILIAN OKUN INC.

2 W. 67th St., New York 23; Tel.: Trafalgar 7-8916; Lilian Okun, president.

Services: Women's & children's programs, scripts.

OLIO VIDEO TELEVISION PRODUCTIONS

131 W. 52nd St., New York; Tel.: Judson 6-0874; Harvey Cort, director.

Services: TV live & film production, film library.

JOHNNY OLSEN'S AMERICAN PRODUCTIONS

565 Fifth Ave., New York 19; Tel.: Plaza 5-7123; John L. Olsen, owner.

Services: Package shows for radio & TV.

ORIGINAL RADIO PRODUCTIONS INC.

36 W. 74th St., New York 24; Tel.: Schuyler 4-8896; Harmon Yaffa, president.

Services: Radio & TV productions.

OULMAN TELEVISION PRODUCTIONS INC.

19 Rector St., New York; Tel.: Whitehall 4-1327; R. J. Oulman, manager.

Services: TV entertainment films.

OUTDOOR ACTION PRODUCTIONS

1434 N. Western Ave., Hollywood 27; Tel.: Hillside 4800; Bernard B. Ray, producer-director.

Services: Film features.

(Continued on page 434)

These Outstanding Shows Produced by
MORTON RADIO PRODUCTIONS
Are Now Available

THE HOMETOWNERS...
156 fifteen minute episodes
NBC Stars—Americana Music

JOE EMERSON'S HYMN TIME...
Star of "Hymns of all churches"
156 fifteen minute episodes.
America's top hymn show.

SO THE STORY GOES...
260 fifteen minute episodes
The greatest story telling series
in the history of radio.

LOUISE MASSEY and the WESTERNERS ...
Starring CURT MASSEY
Network Stars
156 fifteen minute episodes.
Radio's finest western musical.

THIS IS THE STORY...
260 fifteen minute episodes ...
America's newest story telling
series, featuring network star,
Ed Prentiss.

★

★

★

★

★

MORTON RADIO PRODUCTIONS, INC.
360 N. MICHIGAN AVE., CHICAGO 1, ILL.

RADIO, TV PROGRAM PRODUCTION, TRANSCRIPTION AND RELATED SERVICES
(Continued from page 433)

P

PACKAGED PROGRAMS INC.

211 Smithfield St., Pittsburgh 22; Tel.: Grant 1-4756; M. E. Flerst, general manager.

Services: Radio & TV production, package programs, scripts, TV film.

PADULA PRODUCTIONS

331 E. 83rd St., New York; Tel.: Regent 7-8678; Edward Padula, manager.

Services: TV production—live & film.

GEORGE PAL PRODUCTIONS INC.

1041 N. McCadden Pl., Hollywood 38; Tel.: Hollywood 9-1466; George Pal, producer.

Services: Animated "Puppetoon" production & live film and production.

PARAMOUNT TELEVISION PRODUCTIONS INC.

1501 Broadway, New York 18; Tel.: Bryant 9-8700, George T. Shupert, director of commercial operations.

Services: Recording, TV programs on 35mm or 16mm film.

Hollywood 38—5451 Marathon St., Tel.: Hollywood 9-6363; Klaus Landsburg, West Coast director.

PARMELEE-PATIN STUDIO

4201 Sunset Blvd., Hollywood 27; Tel.: Normandy 2-9931; Ray Patin, manager.

Services: Animated cartoons for TV.

PAUL PARRY PRODUCTIONS

7557 Sunset Blvd., Hollywood 46; Tel.: Granite 4774; Paul Parry, manager.

Services: TV film production.

PAX PRODUCTIONS

210 Post St., San Francisco 8; Tel.: Sutter 1-5022; Carol Levene, director. Services: Production, package programs, TV film.

PETERSON RADIO PRODUCTIONS

1457 Broadway, New York 18; Tel.: Wisconsin 7-0069; Donald Peterson, owner.

Services: Religious programs.

GERARD PICK TELEVISION & RADIO PRODUCTIONS

1775 Broadway; Tel.: Circle 6-5595; Gerard Pick, owner.

Services: Kinescopic recordings, TV production, package programs.

PICTORIAL FILMS INC.

625 Madison Ave., New York; Tel.: Plaza 5-9600; Geo. J. Bonwick, president.

Services: TV film rental.

PICTORIAL PRODUCTIONS INC.

1357 N. Gordon St., Hollywood 28; Tel.: Hillside 3108; Jerry Altfilisch, president.

Services: TV film production, rental of production facilities.

PIONEER TELEFILMS INC.

(Telespots Inc.)

18 E. 48th St., New York 17; Tel.: Murray Hill 8-0780; Ralph Cohn, president.

Services: Producers and distributors of TV live and film entertainment.

Washington, D. C.—420 Victor Bldg.; Tel.: Sterling 0780; Al Sherman, manager.

POLARIS PICTURES INC.

5859 W. 3rd St., Los Angeles 36; Tel.: York 8058; Perry King, TV vice president.

Services: Scripts, animation, film production.

POLISH BROADCASTING BUREAU

754 Fillmore Ave., Buffalo 12; Tel.: Cleveland 6876; Joseph F. Mikolajczak, director.

Services: Polish programs.

POST PICTURES CORP.

115 W. 45th St., New York 19; Tel.: Luxemburg 2-4870; Harry A. Post, president.

Services: TV film rentals.

LELAND POWERS SCHOOL OF RADIO & THEATRE

31 Evans Way, Boston 15; Tel.: Aspinwall 7-2900; Haven M. Powers, principal.

Services: Talent, writers, announcers.

RALPH POWERS PRODUCTIONS

618 N. Calvert St., Baltimore 2; Tel.: Mulberry 6088; Ralph Powers, general manager.

Services: Transcriptions, scripts, TV & radio production.

PRB INC.

745 Fifth Ave., New York 22; Tel.: Murray Hill 8-1067; Mal Boyd, vice president.

Services: Radio-television packaging, talent.

Beverly Hills—9533 Brighton Way; Tel.: Crestview 6-4136; Mal Boyd.

PREMIER RADIO ENTERPRISES INC.

3033 Locust St., St. Louis 3; Tel.: Newstead 3555; Theodore F. Desloge, president.

Services: Recording, production, transcriptions, scripts, talent, pressing facilities, TV film.

PRESS ASSOCIATION INC. (AP)

50 Rockefeller Plaza, New York; Tel.: Circle 6-4111; Oliver Gramling, manager.

Services: News & photo services.

GEORGE LOGAN PRICE INC.

946 S. Normandie Ave., Los Angeles 6; Tel.: Dunkirk 2-7372; G. L. Price, president.

Services: Transcriptions, production, package programs.

PRINCETON FILM CENTER

Princeton, N. J.; Tel.: Princeton 3550; Gordon Knox, executive director.

Services: TV film production. New York 22—625 Madison Ave.; Tel.: Murray Hill 8-0840.

PROCKTER PRODUCTIONS INC.

221 W. 57th St., New York 19; Tel.: Judson 6-4360; Bernard J. Prockter, president.

Services: Package programs for radio and TV.

PRODUCTION FOR TELEVISION

250 W. 57th St., New York; Tel.: Circle 6-9759; Joseph M. Seifert, manager.

Services: Animated films for TV.
(Continued on page 438)

Revere

16mm Sound Projector...Magnetic Tape Recorder

Preferred by Radio and Television Studios because they're
DEPENDABLE . . . ECONOMICAL . . . COMPACT . . . EASY TO OPERATE



16mm Sound Projector

750-watt brilliancy . . . operates on AC-DC . . .
1600-ft. reel capacity . . . simple 4-point threading . . . speedy automatic re-wind. "Theatre-Tone" speaker doubles as carrying case; single compact unit weighs only 33 pounds. **\$299.50**

Magnetic Tape Recorder

Every voice and tone recorded and re-played with life-like clarity and fidelity. Full hour of recording on every reel. Tapes can be "erased" and used repeatedly. Simplified controls . . . time and footage indicator . . . easy portability. **\$159.50**



REVERE CAMERA COMPANY • CHICAGO 16

There's A
TELEWAYS SHOW

- ★ **FOR EVERY BUDGET**
- ★ **FOR EVERY PRODUCT**
- ★ **FOR EVERY AUDIENCE**

*The following Transcribed Shows
are Now Available*

AT LOW COST!

- **JOHN CHARLES THOMAS**
260 15-Min. Hymn Programs
- **SONS OF THE PIONEERS**
260 15-Min. Musical Programs
- **RIDERS OF THE PURPLE SAGE**
156 15-Min. Musical Programs
- **STRANGE WILLS**
26 30-Min. Dramatic Programs
- **FRANK PARKER SHOW**
132 15-Min. Musical Programs
- **MOON DREAMS**
156 15-Min. Musical Programs
- **BARNYARD JAMBOREE**
52 30-Min. Variety Programs
- **DANGER! DR. DANFIELD**
26 30-Min. Mystery Programs
- **STRANGE ADVENTURE**
260 5-Min. Dramatic Programs
- **CHUCKWAGON JAMBOREE**
131 15-Min. Musical Programs

**SEND FOR FREE AUDITION PLATTER
AND LOW RATES FOR YOUR STATION**

Write! Wire! Phone!



TELEWAYS
H O L L Y W O O D

RADIO PRODUCTIONS, Inc.
8949 SUNSET BLVD., HOLLYWOOD 46
PHONES: CRestview 6-7238 • BRadshaw 2-1447

Your sales go **up**



FRAN WARREN sings . . . a dramatic voice and personalized style just for you and your listening audience. Allen Roth directs.



The TEX BENEKE Show . . . exclusive Beneke and Miller arrangements by one of America's top bands!



Music by ROTH . . . Allen Roth's orchestra and 16-voice chorus. Everything from barrelhouse to Beethoven . . . richly arranged.



"Swing and Sway with SAMMY KAYE" . . . featuring The Kaydets, the Kaye Glee Club, other name artists.



The RAY McKINLEY Show
... Ray McKinley, his vocals,
his drums and the most versatile
band in the land.

Here's JUNE CHRISTY
with the Johnny Guarneri
Quintet—a new approach in
sophisticated rhythm.



**"CLAUDE THORNHILL presents
Win A Holiday"**... a famous
band plus a local-national contest:
listeners name untitled melodies,
win trips to New York.

with the new era

in *Thesaurus*

These big names and many
more . . . for top sponsor-appeal,
top sales power!

You get more practical help than ever before from
the **new** Thesaurus. More big stars are being
added to the Thesaurus family . . . drawn from the
vast fund of recording artists at RCA Victor and
other talent sources (just a few are shown on this
page). You get comprehensive programming,
promotion, publicity . . . a steady flow of **current**
hit tunes, weekly continuity, special shows. Skilled
network writers do your scripting. Lots of production
"extras." New THESAURUS can help you to
more sponsored programming!



recorded
program
services

Radio Corporation of America
RCA Victor Division
120 East 23rd Street, New York 10, N. Y.
MU 9-0500

Regional Offices:

445 No. Lakeshore Drive
Chicago 11, Ill.
Whitehall 4-2900

1016 No. Sycamore Ave.
Hollywood 38, Cal.
Hillside 5171

PROFILE ADVERTISING

1008 Elm St., Manchester, N. H.; Tel.: 4-4991; Falko Max Schilling, manager.

Services: Recording, production, package programs, scripts, talent, commercial film.

PROGRESSIVE PICTURES

6351 Thornhill Dr., Oakland; Tel.: Olympic 2-0560; Ray Bainbridge, manager.

Services: TV films.

R

RADIO COMICS INC.

241 Church St., New York 13; Tel.: Duncan Hill 6-0190; Louis H. Silberkleit, manager, John L. Goldwater, president.

Services: Comic strip characters adapted for radio and television.

RADIO EVENTS INC.

535 Fifth Ave., New York; Tel.: Murray Hill 7-1668; Julianne Dupuy, manager.

Services: Scripts, production, talent.

RADIO FEATURES INC.

75 E. Wacker Dr., Chicago 1; Tel.: Franklin 2-4392; Walter Schwimmer, president.

Services: Syndicated radio & TV programs. New York—60 E. 42nd St.; Bob Wood.

RADIO FEATURES OF AMERICA

37 W. 46th St., New York 19; Tel.: Luxemburg 2-5130; Oliver W. Nicoli, executive director.

Services: Radio & TV program producers & packagers.

RADIO FEATURES OF AUSTRALIA

31 Macquarie Pl., Sydney, New South Wales; Tel.: Bu. 5995; F. I. I. Barnes, managing director.

Services: Transcribed programs & scripts, recording, package programs.

RADIO PRODUCERS OF HOLLYWOOD INC.

(Lou R. Winston Co.)
1651 Cosmo St., Hollywood 28; Tel.: Hollywood 8318; Lou R. Winston, president.

Services: Package programs, transcribed features.

RADIO PRODUCTION SERVICE

501 Madison Ave., New York 22; Tel.: Plaza 3-8940; Irene Beasley, owner. Services: Live & transcribed packaged shows.

RADIO PROGRAM PRODUCTION

1 E. 54th St., New York 22; Tel.: Plaza 5-9800; John L. Clark, president. Services: Scripts and production.

RADIO PROGRAMME PRODUCERS

317 Keefer Bldg., Montreal; Tel.: Marquette 1182; Paul L'Anglais, president.

Services: Production, scripts, talent, package programs.

RADIO PROVIDENCE PRODUCTIONS INC.

Howard Bldg., Providence 3, R. I.; Tel.: Gaspee 1-6893; Frank Jones, president.

Services: Production, package transcriptions.

RADIO RECORDERS

7000 Santa Monica Blvd., Hollywood 38; Tel.: Hemstead 3282; J. Joseph Sameth, sales manager.

Service: Recording service.

RADIO RECORDING STUDIOS

1244 Carmen Ave., Chicago 40; Tel.: Edgewater 4-6461; Myron Bachman, owner.

Services: Recording service.

RADIO RESULTS

8641 Escanaba Ave., Chicago 17; Tel.: S. Chicago 8-5374; Mrs. Z. George Jaworowski, manager.

Services: Foreign language advertising.

RADIO SCRIPT SERVICES

218 N. Duke St., Lancaster, Pa. Tel.: Lancaster 3-4337; Dorothy S. Brown, manager.

Services: Script service.

RADIO TELEVISION ARTS ACADEMY

3819 Wilshire Blvd., Los Angeles 5; Tel.: Du 4-7520; Doria Balli, manager.

Services: Live & filmed public service programs.

RADIO & TELEVISION CENTER

6000 Sunset Blvd., Hollywood 28; Tel.: Hemstead 6811.

Services: Recording, phonograph records, transcriptions, TV live & film.

RADIO WRITERS LABORATORY

RWL Scripts Bldg., Lancaster, Pa. Tel.: 2-1387; H. R. von Dorster, director.

Services: Scripts, radio continuity.

RADIOVISION CORP.

1125 S. Elm Dr., Los Angeles 35; Tel.: Crestview 5-1723; Walter J. Nelson, president.

Services: TV shorts, film sales.

RADIOZARK ENTERPRISES

806 St. Lotis St., Springfield 4, Mo.; Tel.: 2-4620; E. E. Siman Jr., general manager.

Services: Transcriptions, recording, production, talent, live TV. Chicago—75 E. Wacker Dr.; Tel.: Andover 3-7169; William Ermeling, manager. Nashville—Monogram Bldg.; Tel.: 4-1751; Bill Brown, representative.

REID H. RAY FILM INDUSTRIES INC.

2269 Ford Pkway., St. Paul 1, Minn.; Tel.: Emerson 1393; Reid H. Ray, president.

Services: Film production. Chicago 4—208 S. LaSalle St.; Tel.: Financial 6-0897; Frank Balkin, manager.

RCA RECORDED PROGRAM SERVICES

120 E. 23rd St., New York 10; Tel.: Murray Hill 9-0500; Donald J. Mercer, manager.

Services: Thesaurus transcription library.

RCA VICTOR DIV. (Record Dept. of RCA)

30 Rockefeller Plaza, New York 20; Tel.: Columbus 5-2035; Paul A. Barkmeyer, general manager.

Services: Recording, phonograph records, and transcriptions.

Custom Record Sales: 120 East 23rd St., New York; Tel.: Murray Hill 9-0500; (Recording Studios: 155 East 24th St., New York); James P. Davis, manager.

Chicago—445 North Lakeshore Dr.; Tel.: Whitehall 4-2900; A. E. Hindle, manager.

Hollywood—1016 North Sycamore Ave.; Tel.: Hillside 5171; R. C. Bucholz, manager.

Recorded Program Services: (Thesaurus Program Service and Syndicated Transcribed Features): 120 East 23rd St. New York; Tel.: Murray Hill 9-0500; Donald J. Mercer, manager.

Chicago—445 North Lakeshore Dr.; Tel.: Whitehall 4-2900; William F. Reilly, representative.

Hollywood—1016 North Sycamore Ave.; Tel.: Hillside 5171; William C. Gartland, representative.

RCA VICTOR CO. LTD. (Radio Recording Div.)

Royal York Hotel, Toronto 1; Tel.: Adelaide 3091; L. D. Headley, manager.

Services: Recording production. Montreal—1001 Lenoir St.; Tel.: Wellington 7551.

REC-ART STUDIOS

1203 S. Main St., Los Angeles 15; Tel.: Prospect 9232; A. Nazareth, owner.

Services: Recording, transcriptions, dubbing.

RECORDO-SCRIPTS OF HOLLYWOOD

2919 S. Norton Ave., Los Angeles 16; Tel.: Republic 2-4602; Walter Addison Watson, manager.

Services: Scripts, sound effects.

ROLAND REED PRODUCTIONS INC.

375 S. Beverly Dr., Beverly Hills; Tel.: Crestview 6-1101; Roland Reed, president.

Services: TV film programs.

REEVES SOUND STUDIOS INC.

304 E. 44th St., New York 17; Tel.: Oregon 9-3550; Chester L. Stewart, manager.

Services: Recording service, TV film.

REGAL TELEVISION PICTURES CORP.

151 W. 46th St., New York 19; Tel.: Luxemburg 2-1877; Leo Seligman, treasurer.

Services: TV film distribution.

REGENCY PRODUCTIONS INC.

11 E. 49th St., New York 17; Tel.: Plaza 9-3680; Joseph Schaeffer, president.

Services: TV shows, live & film.

THE RELIGIOUS FILM ASSN. INC.

45 Astor Pl., New York; Tel.: Gramercy 7-2397; W. L. Rogers, executive secretary.

Services: Film distribution.

RELIGIOUS NEWS SERVICE

381 Fourth Ave., New York 16; Tel.: Murray Hill 4-1463; Louis Minsky, managing editor.

Services: Scripts on religion.

RELIGIOUS TELEVISION INC.

7904 Santa Monica Blvd., Hollywood 46; Tel.: Hillside 0381; Ray Berquist, manager.

Services: TV religious films.

REPUBLIC RADIO & TELEVISION FEATURES

64 E. Lake St., Chicago 1; Tel.: State 2-0460; Capico Kapps, director.

Services: Recording, production, transcriptions, package programs, TV live & film shows, talent.

H. D. RICHERT CO.

545 Fifth Ave., New York 17; Tel.: Murray Hill 7-4256; H. D. Richert, director.

Services: Radio & TV package shows.

RICHMAN PRODUCTIONS

17 E. 45th St., New York 17; Tel.: Murray Hill 2-5854; William Richman, general manager.

Services: Transcriptions, production, package programs, scripts, live TV shows.

RKO-PATHE

625 Madison Ave., New York 22; Tel.: Plaza 9-3800; Jay Bonafield, producer.

Services: TV film shows.

HAL ROACH STUDIOS INC.

8822 Washington Blvd., Culver City, Calif.; Tel.: Texas 0-2761; Hal E. Roach, president.

Services: Film production. New York 19—729 7th Ave.; Tel.: Circle 5-4135; Grace Rosenfield.

(Continued on page 440)

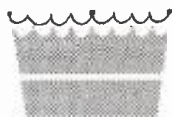

*THE KING OF THEM ALL

Jingles

● SPECIAL TAILORED SINGING ANNOUNCEMENTS FOR AGENCIES.

● JINGL - LIBRARY FOR RADIO STATIONS.

*Over 3600 advertisers and agencies use our jingles on over 600 radio stations.

WRITE OR WIRE:

RICHARD ULLMAN, INC.
295 DELAWARE AVE.
BUFFALO, N. Y.

For Truly Fine Recording and Reproduction



audiorecords*

For more than a decade, Audiorecords have consistently set the standards for quality and uniformity in every field of instantaneous disc recording. A superior lacquer, applied by a patented, precision-machine coating process, gives a mirror-smooth cutting surface with positive thread throw, brilliant h-f response, and freedom from background noise. An important improvement, perfected in 1948, makes all Audiorecords permanently resistant to humidity.

There's an Audiorecord for every recording need—conventional or microgroove.

RED LABEL AUDIORECORDS—exceed the most exacting demands for highest quality professional recordings. Aluminum base. *Double sided*—Sizes: 6½", 8", 10", 12" and 16". *Single face*—Sizes: 10", 12" and 16".

YELLOW LABEL AUDIORECORDS—the popular choice for all general-purpose recording. Aluminum base. *Double sided*. Sizes: 6½", 8", 10", 12" and 16".

BLUE LABEL AUDIORECORDS—ideal for schools, homes, and general amateur use. Same lacquer as professional discs, but thinner aluminum base. *Double sided*. Sizes: 6½", 8" and 10".

MASTER AUDIORECORDS—the choice of professional recordists for use where pressings are to be made. Give fine results with either silvering or gold sputtering. Aluminum base. *Double sided* or *single face*. Sizes: 12", 13¼" and 17¼".

REFERENCE LABEL AUDIORECORDS—provide maximum economy for test cuts, reference recordings, auditions, etc. Aluminum base. *Double sided*. Sizes: 10", 12" and 16".



audiotape*

After 2½ years of research and development, Audio Devices now offers a *complete line* of professional quality magnetic recording tape—on plastic or paper base, with red or black oxide coating, permitting matched performance in any tape recorder.

Audiotape is precision manufactured to the same exacting standards of quality and uniformity which have characterized Audiorecords for the past decade—your assurance of maximum fidelity, uniformity, frequency response, and freedom from background noise and distortion.

The following types of Audiotape are now available:

1250 Feet, on 7" all-aluminum reel
600 Feet, on 5" sturdy plastic reel

Type No.		Coating	Wound on Reel with
7" Reel	5" Reel		
PLASTIC BASE AUDIOTAPE (in the Red Box)			
1240	640	Black Oxide	Oxide Out
1241	641	Black Oxide	Oxide In
1250	650	Red Oxide	Oxide Out
1251	651	Red Oxide	Oxide In
PAPER BASE AUDIOTAPE (in the Blue Box)			
1200	600	Black Oxide	Oxide Out
1201	601	Black Oxide	Oxide In
1220	620	Red Oxide	Oxide Out
1221	621	Red Oxide	Oxide In

Audiotape is also available on larger reels. Write for information.



audiopoints*

The newly expanded line of Audiopoints covers the full range of recording and playback needs—for the most exacting professional recordists, as well as for the non-professional and the general public.

Recording Audiopoints

SAPPHIRE NO. 14—long recognized as the finest recording stylus made. Short or long dural shank, and 87° or 70° included angle.

SAPPHIRE NO. 202—a high-quality professional stylus. Short or long brass shank.

SAPPHIRE NO. 20—especially designed for professional microgroove recording. Short or long dural shank.

STELLITE NO. 34—a favorite with many professional and non-professional users. Short or long shank. 87° included angle.

DIAMOND LAPPED STEEL NO. 50—most practical and economical stylus for non-professional use.

Playback Audiopoints

SAPPHIRE NO. 113—meets the requirements of the most critical professional recordists. Straight dural shank.

"RED CIRCLE" SAPPHIRE NO. 103—for professional use with instantaneous recordings or vinyl transcriptions. Straight dural shank.

"RED CIRCLE" SAPPHIRE NO. 303—same as No. 103, except with bent dural shank. Ideal for phonograph records.

STEEL TRANSCRIPTION NEEDLE NO. 151—finest steel needles made. 100% shadowgraphed to assure perfection of every needle.

The above Audio Devices' products are available through more than 300 authorized distributors, located in principal cities from coast to coast.

Audiorecords are manufactured in the U.S.A. under exclusive license from PYRAL, S.A.R.L., Paris



AUDIO DEVICES, INC.

444 MADISON AVE., NEW YORK 22, N. Y.

EXPORT DEPT.: ROCKE INTERNATIONAL, 13 EAST 40TH ST., NEW YORK 16, N. Y.

*Trade Mark

RADIO, TV PROGRAM PRODUCTION, TRANSCRIPTION AND RELATED SERVICES

(Continued from page 438)

ROBBINS BROS. AGENCY

67 W. 44th St., New York 24; Tel.: Murray Hill 7-2033; Fred Robbins, manager.

Services: Production, talent.

ROBERTS & CARR PRODUCTIONS

216 E. 49th St., New York 17; Bob Roberts.

Services: Radio & TV program packagers.

ROBERTS RADIO PRODUCTIONS

David Broderick Tower, Detroit 26; Tel.: Cadillac 0003; Jack Roberts.

Services: Transcriptions, package programs.

ROBERTS RADIO, TELEVISION, STAGE & SCREEN STUDIOS

806 Seventh Ave., New York 19; Tel.: Plaza 7-2162; Bob L. Roberts, president.

Services: Radio & TV production, recording, talent.

ROBINSON RECORDING LABORATORIES

c/o WIP, 35 S. Ninth St., Philadelphia 7; Tel.: Walnut 2-6800; W. P. Robinson, president & manager.

Services: General recording, manufacture disc recording equipment.

ROCKETT PICTURES INC.

6063 Sunset Blvd., Hollywood 28; Tel.: Granite 7131; J. Richard Western, vice president & general manager.

Services: TV film production, slide films.

ROCKHILL RADIO

18 E. 50th St., New York 22; Tel.: Plaza 9-7979; Stanley J. Wolf, manager.

Services: Production, recording.

MAURICE ROFFMAN

540 W. 122nd St., New York 28; Tel.: Monument 2-3288; Maurice Roffman, president.

Services: Radio & TV program ideas, program development.

ROLLOW-CLARK & CO.

108 Oak St., Denton, Tex.; Tel.: 1523; Bill Rollow, co-owner.

Services: Film production.

ALLEN ROTH RADIO PRODUCTIONS

48 W. 48th St., New York 19; Tel.: Plaza 7-1162; Allen Roth, manager.

Services: Talent, recording, production.

JACK ROURKE PRODUCTIONS

6331 Hollywood Blvd., Hollywood 28; Tel.: Hempstead 7178; Jack Rourke, owner.

Services: Production, package programs scripts, talent, live TV.

ROYAL RECORDING CO.

601 Ashby Ave., Berkeley 2, Calif.; Tel.: Ashberry 3-5453; Arthur Westlund, manager.

Services: Recording service.

RUBY FILM CO.

729 Seventh Ave., New York; Tel.: Circle 5-5640; Edward Ruby, manager.

Services: TV films, rentals.

ART RUSH INC.

California Bank Bldg., Vine St. at Selma, Hollywood 28; Tel.: Hillside 5161; Art Rush, manager.

Services: Talent, packaged programs.

RYDER 16mm SERVICES INC.

6526 Sunset Blvd., Hollywood 28; Tel.: Granite 3651; Loren L. Ryder, president.

Services: Sound recording and stage rental.

S

SACK TELEVISION ENTERPRISES

Film Exchange Bldg., Dallas 1; Tel.: Riverside 6474; Alfred N. Sack, manager.

Services: TV films.

SACKETT TELEVISION-RADIO PRODUCTIONS

Bankers Security Bldg., Philadelphia 7; Tel.: Kingsley 5-7055; Bernard L. Sackett, manager.

Services: Production of live and film TV shows, radio production, talent.

SACRED RECORDS INC.

1206 S. Hill St., Los Angeles 15; Tel.: Prospect 1283; Earle E. Williams, president.

Services: Sacred transcription library, religious records.

PAUL BRON SALINER RADIO ADVERTISING

307 North Michigan Ave., Chicago 1; Tel.: Financial 6-0650; Paul Bron Saliner, president.

Services: Production, package programs, talent, foreign language program consultant.

SAM SAMUELS

1654 Broadway, New York 19; Tel.: Judson 6-9012; Sam Samuels.

Services: Talent, package programs.

SANFT-COSTA TELEVISION FEATURES

17 E. 42nd St., New York 17; Tel.: Murray Hill 2-6770; Sidney Sanft & Don Costa, producers.

Services: Production of TV package shows.

JAMES L. SAPHIER AGENCY INC.

9538 Brighton Way, Beverly Hills; Tel.: Crestview 1-7231; James L. Saphier, president.

Services: Production, talent, package programs, TV film shows.

Chicago—20 N. Wacker Dr.; Tel.: Andover 3-6038; Stefan Hatos, manager.

SARRA INC.

200 East 56th St., New York; Tel.: Murray Hill 8-0083; Jack Henderson.

Services: TV film production.

Chicago—16 E. Ontario St.; Tel.: Whitehall 4-5151; Harry Lange.

Hollywood—445 S. LaCienega Blvd.; Tel.: Crestview 1-7464; Peter Keane.

SCHUCK, DAHLMAN & BLACK

654 Madison Ave., New York; Tel.: Templeton 8-8300; Lou Dahlman, manager.

Services: TV shows.

SCIENCE PICTURES INC.

139 E. 47th St., New York 17; Tel.: Plaza 3-5925; Frances C. Thayer, manager.

Services: TV film production.

SCREEN GEMS INC.

729 Seventh Ave., New York 19; Tel.: Circle 7-5044; Ralph Cohn, manager.

Services: Film production and distribution.



... this label

THE SCRIPT LIBRARY

535 Fifth Ave., New York; Tel.: Murray Hill 7-1668; Julienne Dupuy, manager.

Services: (radio and television); Scripts, packages.

SEARLE & PARKS INC.

6331 Hollywood Blvd., Hollywood 28; Tel.: Hudson 2-3281; Don Searle, president.

Services: Production, transcriptions, package programs.

Chicago 1—333 N. Michigan Ave.; Tel.: Central 6-7980.

SEIDEL FILMS

853 Seventh Ave., New York 19; Tel.: Circle 7-0375; Tom Seidel.

Services: Film production.

SELLERS CO.

905½ Main St., Dallas 2, Tex.; Tel.: Central 5978; J. E. Sellers, partner.

Services: All types of recording, masters.

SELS PRODUCTIONS

5220 S. Harper Ave., Chicago 15; Tel.: Butterfield 8-8371; Len Segall, general manager.

Services: Recording, production, scripts, talent, package programs, live & film TV.

SENTINEL ENTERPRISES INC.
Sentinel Productions Div.

5746 Sunset Blvd., Hollywood 28; Tel.: Hempstead 6828; Earle Harper, president.

Services: Film production, package programs.

SESAC INC.

475 Fifth Ave., New York 17; Tel.: Murray Hill 5-5365; K. A. Jadassohn, general manager.

Services: Transcription library, package programs, performance licensing, scripts.

SHERMAN PLAN INC.

420 Victor Bldg., Washington 1; Tel.: Sterling 0780; Al Sherman, president.

Services: TV film production, consultants.

SHERWOOD PICTURES CORP.

1569 Broadway, Brooklyn; Tel.: Glenmore 2-6192; T. Marc Sherwood, manager.

Services: TV films.

BOB SHUTTLEWORTH'S AGENCY

834 Yonge St., Toronto, Ont.; Tel.: Kingsdale 9121; Robert J. Shuttleworth, president.

Services: Talent, scripts.

W. DAVID SIEVERS

3444 Bentley Ave., Los Angeles 34; Tel.: Vermont 8-1911.

Services: Packaging & producing programs for radio & TV.

SIMMEL-MESERVEY INC.

321 S. Beverly Dr., Beverly Hills; Tel.: Bradshaw 2-3874; Louis Simmel, president.

Services: Production & distribution of educational films.

SIXTEEN SCREEN SERVICE CO.

6710 Melrose Ave., Hollywood 38; Tel.: Wyoming 1491; Leonard Clairmont, manager.

Services: TV film subjects, titles & inserts.

6000 SUNSET RADIO & TELEVISION CENTER

6000 Sunset Blvd., Hollywood 28; Tel.: HE, 6811; J. S. Fredericks, general manager.

Services: Recording, live TV.

SKIBO PRODUCTIONS INC.

165 W. 46th St., New York 19; Tel.: Plaza 7-2265; Patrick E. Shanahan, president.

Services: TV film rental.

STEPHEN SLESINGER INC.

247 Park Ave., New York 17; Tel.: Eldorado 5-2544; Stephen Slesinger, president.

Services: Transcriptions, package programs.

EDWARD SLOMAN PRODUCTIONS

17520 Stretto Way, Pacific Palisades, Calif.; Tel.: Santa Monica 5-6558; Edward Sloman, manager.

Services: Transcriptions, production.

THE SMALL COMPANY

8272 Sunset Blvd., Hollywood 46; Tel.: Hollywood 9-2722; Morris Small, manager.

Services: Talent.

K. R. SMITH CO. INC.

619 W. 54th St., New York 19; Tel.: Judson 2-3791; K. R. Smith, president.

Services: Processing & pressing of transcriptions & records, recording.

FLETCHER SMITH STUDIOS INC.

1585 Broadway, New York 19; Tel.: Judson 6-3950; Fletcher Smith, president.

Services: TV film production, animated commercials.

SOUND MASTERS INC.

165 W. 46th St., New York 19; Tel.: Plaza 7-6600; Harold E. Wondsel, president.

Services: TV film production, package programs.

SOUND STAGES INC.

112 W. 89th St., New York; Tel.: Trafalgar 3-1800; C. F. Vetter Jr., manager.

Services: TV equipment & studio rental.

THE SOUVAINÉ CO.

30 Rockefeller Plaza, New York 20; Tel.: Circle 7-5666; Henry Souvaine, president.

Services: Radio & TV production.

SIGMUND SPAETH

400 E. 58th St., New York 22; Tel.: Plaza 8-0879; Sigmund Spaeth, manager.

Services: Program production, talent.

SPEAK-O-PHONE RECORDING & EQUIPMENT CO.

23 W. 60th St., New York 23; Tel.: Columbus 5-1350; C. A. Austin, manager.

Services: Recording service & equipment.

SPECIAL PURPOSE FILMS INC.

44 W. 56th St., New York 19; Tel.: Judson 6-0020; John Fox, president.

Services: Production, package programs, TV film.

SPEEDY-Q & GENNETT SOUND EFFECTS

1344 S. Flower St., Los Angeles 15; Tel.: Prospect 2035; Phillip Johnson, manager.

Services: Recorded sound effects.

SPOT FILM PRODUCTIONS INC.

339 E. 48th St., New York 17; Tel.: Plaza 5-0808; Clarence Schmidt, manager.

Services: Sound-on-film recordings; industrial motion pictures for television.

SPRINGER PICTURES INC.

341 E. 43rd St., New York 17; Tel.: Oregon 9-0966; Richard D. Farrell, manager.

Services: TV films, package programs, industrial & educational motion pictures.

Detroit 21—Fisher bldg.; Tel.: Trinity 1-6220; Ray W. Springer, president.

(Continued on page 442)

appears only on the nation's finest transcriptions

- Recording studios—vertical, lateral and tape
- Gold-sputtered masters—masterpieces of invariable quality
- Muzak-compounded Vinylite
- Transcriptions and phonograph records
- Most advanced methods and facilities
- Experienced, conscientious craftsmanship

All or any of these Muzak specialized services are available to you.

Your next transcription will sound better—and will be better—if processed by Muzak.

Muzak TRANSCRIPTION DIVISION

Reg. U.S. Pat. Off.

a service of Muzak Corporation

ADDRESS ALL INQUIRIES TO: Sales Dept., 250 W. 54th St., New York 19, N. Y. PLaza 7-7700

BROADCASTING • Telecasting

1950 Yearbook Number • Page 441

(Continued from page 441)

STANDARD RADIO TRANSCRIPTION SERVICES INC.

140 N. La Brea, Hollywood 36; Tel.: Webster 9181; Gerald King, president. Services: Transcription library, recording, scripts, sound effects.
Chicago 1—360 N. Michigan Blvd.; Milton M. Blink, vice president.
New York 22—865 Fifth Ave.; Tel.: Plaza 3-6690; Alex Sherwood, vice president.

STARK-GLEN PRODUCTIONS

P. O. Box 891, Santa Fe, N. M.; Tel.: 321-W; Evelyn Stark, co-owner. Services: Transcribed programs.
Hollywood 28—3221 N. Knoll Dr.; Tel.: Hudson 2-5595; Irma Glen, co-owner.

CHARLES STARK PRODUCTIONS CORP.

366 Madison Ave., New York 17; Tel.: Murray Hill 7-2186; Charles Stark, president. Services: Transcribed package shows, TV live & film production.

WILBUR STARK-JERRY LAYTON

551 Fifth Ave., New York 17; Tel.: Murray Hill 7-6320; Diane Werfel, executive secretary. Services: Radio & live TV production, talent, scripts.

STARR PIANO CO.

1344 S. Flower St., Los Angeles 15; Tel.: Prospect 2035; Philip Johnson, secretary. Services: Sound effects records.

D. RICHARD STATILE

62 W. 46th St., New York; Tel.: Judson 8-9407; D. Richard Statile, manager. Services: TV film.

BRUCE FORD STAUDERMAN

242 Audley St., South Orange, N. J.; Tel.: South Orange 2-5650; Bruce Stauderman, manager. Services: Scripts, production.

STEMPEL-OLENICK AGENCY

717 N. La Cienega Blvd., Los Angeles 46; Tel.: Crestview 1-7141; Frank Stempel, Radio Dept.; Julian Olenick, Motion Picture Dept.; Associate Miles B. Auer; Ben Pearson, director of radio. Services: Talent.

STERLING FILMS INC.

316 W. 57th St., New York 19; Tel.: Judson 6-3750; Saul J. Turell, president. Services: Package programs, live & film TV.

STEVEN TELEVISED PRESENTATIONS INC.

153 Fifth Ave., New York; Tel.: Gramercy 3-5226; Jewel Steven, president. Services: TV live & film shows.

STOKEY & EBERT TELEVISION ENTERPRISES

6123½ Selma Ave., Hollywood 28; Tel.: Hudson 2-1241; Michael Stokey, Theodore Ebert. Services: Live TV programs.

STRICKLAND FILM CO.

141 Walton St., N. W., Atlanta; Tel.: Lamar 7991; C. L. Strickland, general manager. Services: TV film production.

DICK STROME TELEVISION

1416 S. Penn Square, Philadelphia 2; Tel.: Locust 7-5834; Dick Strome, owner-manager. Services: TV film production, direction & production of live package programs, special events.

RICHARD STROUT PRODUCTIONS

1544 N. Hudson Ave., Hollywood 28; Tel.: Hudson 2-2245; Richard Strout, president. Services: Production of radio & TV programs & spots.
New York—507 Fifth Ave.; Tel.: Murray Hill 2-6924.

STUDIO & ARTISTS RECORDERS

6087 Sunset Blvd., Hollywood 28; Tel.: Hillside 8241; Lewis Finston, manager. Services: Recording, live & film TV.

STUDIO OF THE VILLAGER

1142 Westgate, Oak Park, Ill.; Tel.: Village 8-0260; Alois A. Mastalerz. Services: Film production.

IRVIN PAUL SULDS INC.

654 Madison Ave., New York 21; Tel.: Temple 8-7025; Irvin P. Sulds, president. Services: TV production.

SUN DIAL FILMS INC.

341 E. 43rd St., New York 17; Tel.: Murray Hill 6-2046; Samuel A. Datlowe, president. Services: TV film production, slides.

SUPERMAN

480 Lexington Ave., New York 17; Tel.: Plaza 9-5700; Robert Maxwell, manager. Services: Production.

JOHN SUTHERLAND PRODUCTIONS INC.

201 N. Occidental Blvd., Los Angeles 26; Tel.: Dunkirk 2-8213; John Sutherland, manager. Services: Animated & live action TV commercials, film programs.

SWANK FILMS INC.

19 W. 4th St., Dayton 2, O.; Tel.: Hemlock 2379; Jerrold A. Swank, president. Services: TV film production, slide-film.

H. N. SWANSON INC.

8523 Sunset Blvd., Hollywood 46; Tel.: Crestview 1-5115; H. N. Swanson, manager. Services: Scripts & writers.

T

THE GEORGE TAGGART ORGANIZATION

48 Bloor St. E., Toronto 5; Tel.: Randolph 3161; George A. Taggart, owner. Services: Production, talent, TV shows.

HAL TATE RADIO PRODUCTIONS

612 N. Michigan Ave., Chicago 1; Tel.: Superior 7-1044; Hal Tate, president. Services: Syndicated program producers.
Toronto—(Representative) Guild Radio Features Ltd., 150 Simcoe St.; Tel.: Waverley 2714; Dan V. Carr, president.

TECHNISONIC STUDIOS

818 S. Kingshighway, St. Louis 10; Tel.: Franklin 2060; Charles E. Harrison, president. Services: Recording, transcriptions TV film.

TEEVEE FILM CO.

170 S. Beverly Dr., Beverly Hills, Calif.; Tel.: Bradshaw 2-1376; Gifford Phillips, president. Services: Film production.
New York 22—38 E. 57th St.; Tel.: Plaza 3-1030; Alfred Levy.

TEL-AIR ASSOCIATES

366 Madison Ave., New York 17; Tel.: Vanderbilt 6-3417; Seymour Kaplan, partner. Services: Production of package radio & TV shows, film production.
Los Angeles 46—1350 N. Hayworth; Tel.: Gladstone 2070; Mort H. Singer Jr., partner.

TELAMUSE PRODUCTIONS

295 Madison Ave., New York 17; Tel.: Lexington 2-3195. Services: TV shows.

TELECAST FILMS INC.

145 W. 45th St., New York 19; Tel.: Luxemburg 2-4326; Gordon Hedwig, secretary-treasurer. Services: TV films.

TELECOM

1142 Westgate, Oak Park, Ill.; Tel.: Village 260; Mr. and Mrs. Mastalerz.

TELECOMICS INC.

1154 N. Western Ave., Hollywood 27; Tel.: Gladstone 2591; Dick Moores, president. Services: Comic strip & cartoon type film for TV, film production.

TELECOMICS INC.

247 Park Ave., New York 17; Tel.: Eldorado 5-2544; Stephen Slesinger, president. Services: TV film of syndicated comic strip characters.

TELE-CRAFT PRODUCTIONS

1943 Sherbourne Dr., Los Angeles 34, Calif.; Tel.: Vermont 8-6744; J. Allen Rinehart & Russ Weinstein. Services: Live TV production.

TELEFILM INC.

6039 Hollywood Blvd., Hollywood 28; Tel.: Hollywood 9-7205; Don C. McNamara, director of TV. Services: Recording, TV film production & distribution.

TELEMATED CARTOONS

70 E. 45th St., New York 17; Tel.: Murray Hill 6-8933; Saul Taffet, owner. Services: TV film production.

TELENEWS PRODUCTIONS INC.

(Affiliated with INS)
630 Ninth Ave., New York; Tel.: Judson 6-2450; John H. Tobin, manager. Services: Newsreels for television.

TELEPAK INC.

250 Park Ave., New York; Tel.: Plaza 8-0628; C. Robert Longenecker, president. Services: Design, produce & distribute radio & TV programs.
Los Angeles 24—201 N. Carmelina Ave.

TELEPICTURES INC.

247 Park Ave., New York 17; Tel.: Eldorado 5-2544; John F. Howell, manager. Services: Radio properties.

TELEPIX CORP.

6233 Hollywood Blvd., Hollywood 28; Tel.: Hillside 8351; Robert Newman, president. Services: TV film programs, production, animation.

TELE REELS PRODUCTIONS

1840 N. Avon St., Burbank, Calif.; Tel.: Charleston 0-3832; Jack R. Berne, producer-director. Services: TV film production.

TELESCRIPTS

823 Victor Bldg., Washington 1, D. C.; Tel.: Sterling 4650; Edward F. Hopper, general manager. Services: 16mm animated films, TV commercials.

TELESHO OF CALIF.

725 N. Western Ave., Hollywood 27; Tel.: Gladstone 7680; William Wooten, manager. Services: TV film production.

TELESPOTS INC.

(See Pioneer Telefilms listing)
Services: Producers and distributors of TV film commercials.

TELETRAN

480 Lexington Ave., New York; Tel.: Plaza 3-5791; Sherman Price, owner. Services: Package film TV shows.

TELEVISION AIRSHOWS INC.

612 N. Michigan Ave., Chicago 11; Tel.: Superior 7-0506; W. G. T. Hyer, production director. Services: Live & film TV production.

TELEVISION ART ENTERPRISES

440 W. 34th St., New York; Tel.: Longacre 3-1971; Shamus Culhane, producer. Services: TV live & film shows.

TELEVISION ARTS PRODUCTIONS

2733 Stuart St., Berkeley, Calif.; Tel.: Berkeley 7-5301; J. T. Ward, business manager. Services: Cartoon films.

(Continued on page 444)

For Dramatic Sound Effects Records... use

MAJOR RECORDS

Over 500 realistic sound effects

"From a Cat's Meow to a Lion's Roar... a Pistol Shot to a World War"

Send for catalog by

MAJOR RECORDS

Distributed by

THOMAS J. VALENTINO, Inc.

150 West 46th St. New York, N. Y.



THE SESAC TRANSCRIPTION LIBRARY

Greatest Value at Lowest Cost
Used successfully every day by
hundreds of broadcasters as one of

THE BEST MONEY EARNERS

OVER 3200 Distinctive Recorded Selections

MUSIC OF LASTING VALUE

American Folk . . . Band . . . Concert . . .
Novelty . . . Religious . . . Hawaiian . . . Spanish

NEW FOR 1950

The **PHILHARMONIA ORCHESTRA** conducted by the renowned **Rosario Bourdon**

Internationally famous **TRINITY CHOIR** of St. Paul's Chapel

. . . great sacred chorals

AEOLIAN STRING SYMPHONY

VILLAGE GREEN FOUR with way
back home Barbershop harmonies

ALL-AMERICAN BAND with rousing march tunes

STAMPS-BAXTER GOSPEL QUARTETS . . .

A brand new catalog of moods, bridges, themes

Professional **SCRIPT SERVICE**, commercially written, endorsed and
successfully used by hundreds of subscribers

LOWEST PRICE

BEST BUY IN THE MARKET

SESAC, INC.

475 Fifth Avenue

New York 17, N. Y.

TELEVISION CARTOONS INC.
361 W. Broadway, New York 13; Tel.: Beekman 3-7176; Robert N. Brotherton, president.
Services: TV film commercials, animated cartoons.

TELEVISION FILM INDUSTRY CORP.
340 Third Ave., New York; Tel.: Lexington 2-6780; Catherine Cole, manager.
Services: TV films.

TELEVISION IDEAS & FILMS
152 W. 42nd St., New York 18; Tel.: Longacre 4-0198; Ann Viola, administrator.
Services: Talent, production, films, scripts.

TELEVISION MOTION PICTURES CO.
1650 Broadway, New York; Tel.: Circle 6-0691; Jack Goldberg, manager.
Services: Films featuring Negroes.

TELEVISION PICTURES DISTRIBUTING CORP.
3123 W. Eighth St., Los Angeles 5; Tel.: Drexel 7-3361; Toby Anguish, president.
Services: Production & distribution of TV film.
New York—25 W. 45th St.; Tel.: Luxemburg 2-1700; George Hirshman, vice president.

TELEVISION SCREEN PRODUCTIONS INC.
17 E. 45th St., New York 17; Tel.: Murray Hill 2-8877; Charles J. Basch Jr., president.
Services: TV films.

TELEWAYS RADIO PRODUCTIONS INC.
8949 Sunset Blvd., Hollywood 46; Tel.: Bradshaw 2-1447; Charles A. Kennedy, president.
Services: Transcribed programs, package shows.

TEL RA PRODUCTIONS
1518 Walnut St., Philadelphia 2; Tel.: Kingsley 5-8540; W. Wallace Orr, director.
Services—Production of radio and TV programs.
New York—250 Park Ave.; Tel.: Plaza 3-7800; W. Wallace Orr, director.

MARSHAL TEMPELTON INC.
214 Ford Bldg., Detroit 26; Tel.: Woodward 1-6868; Marshal E. Tempelton, president.
Services: TV film.
Chicago 11—62 N. Michigan Ave.; Tel.: Superior 7-3782.

MISCHA TERR PRODUCTIONS
1276 N. Crescent Heights Blvd., Hollywood 46; Tel.: Hudson 2-7038; Mischa Terr, producer.
Services: TV film production.

TEXAS INDUSTRIAL FILM CO.
911 M & M Bldg., Houston 2; Tel.: Charter 9371; Don Macon, owner.
Services: Film production, slides.

ARTHUR TIBBALS
101 S. Robertson, Beverly Hills, Calif.; Tel.: Crestview 5-6984; Arthur Tibbals, owner.
Services: Production, scripts.

TODDY PICTURES CO.
723 Seventh Ave., New York 19; Tel.: Circle 6-9446; Ted Toddy, president.
Services: Film production & releasing.
Atlanta—148 Walton St.; Tel.: Main 3117; L. Hickman, manager.
Los Angeles—P. O. Box 745 Hollywood Station, Fred Pollock, manager.

L. S. TOOGOOD RECORDING CO.
221 N. LaSalle St., Chicago 1; Tel.: Central 6-5275; L. S. Toogood, owner.
Services: Recording service.

TOP PRODUCTIONS (Television On Parade Inc.)
551 Fifth Ave., New York 17; Tel.: Murray Hill 7-0272; Leon Roth, president.
Services: TV live & film programs, scripts, talent.

TORCHLIGHT PRODUCTIONS INC.
229 W. 42nd St., New York 18; Tel.: Wisconsin 7-0771; Jane White, vice president.
Services: Package radio & TV programs.

TOWERS OF LONDON LTD.
(see Oliver W. Nicoll listing)
37 W. 46th St., New York 19; Tel.: Luxemburg 2-5130; vice president & director for U. S.
Services: Program producers, international radio service.
London, W. 1—84 Hallam St.; Tel.: Langham 6248; Harry Alan Towers, international president.

TOWERS OF LONDON (Canada) LTD.
67 Yonge St., Toronto 10; Tel.: Elgin 9296; John Adaskin, general manager.
Services: Syndicated transcriptions.
London W. 1—84 Hallam St.; Tel.: WE. 4248; Harry Alan Towers.
New York—37 W. 46th St.; Tel.: Luxemburg 2-5130; Oliver W. Nicoll.

TRANSAMERICAN BROADCASTING AND TELEVISION CORP.
1 E. 54th St., New York 22; Tel.: Plaza 5-9800; William A. Wasmuth, manager.
Services: Package programs.

TRANSCRIBED RADIO SHOWS
2 W. 47th St., New York 19; Tel.: Luxemburg 2-3530; M. E. Moore, president.
Services: Transcriptions, jingles, package program & TV film.

TRANSCRIPTION SALES INC.
117 W. High St., Springfield 35. O.; Tel.: 2-4974; John F. Hyle, vice president & general manager.
Services: Transcriptions, package programs.
New York 19—47 W. 56th St.; Tel.: Columbus 5-1544; Ed. Hochhauser Jr., manager.
Hollywood 28—6381 Hollywood Blvd.; Tel.: Hollywood 9-5600.

TRANSFILM INC.
35 W. 45th St., New York 19; Tel.: Luxemburg 2-1400; M. J. Glaubman, sales manager.
Services: TV film, package programs.

TRANSDIAGRAM CORP. OF AMERICA
2 West 46th St., New York; Tel.: Luxemburg 2-1280; George Luttinger, manager.
Services: TV film production & distribution.

TRENDLE-CAMPBELL ENTERPRISES INC.
1803 Stroh Bldg., Detroit 28; Tel.: Woodward 2-9184; H. Allan Campbell, president.
Services: Production.

TRESSSEL TELEVISION PRODUCTIONS INC.
2214 E. 75th St., Chicago 49; Tel.: Essex 5-6096; George Tressel, general manager.
Services: Projectall distributor, live & film TV.

TRIANGLE FILMS
1697 Broadway, New York 19; Tel.: Columbus 5-1403; Wilbur Streech, Gordon McEvoy, partners.
Services: Film production, animation.

TRI-STATE 16mm PRODUCTIONS
P. O. Box 112, Pittsburgh 30; Tel.: Atlantic 1-8337; George LaRay, production manager.
Services: TV film production.

TV ADS INC.
3839 Wilshire Blvd., Los Angeles 5; Tel.: Dunkirk 8-1323; Doria Balli, president.
Services: Film production, recording, package programs, live & film TV.

TWENTIETH CENTURY FOX CO.
444 W. 58th St., New York; Tel.: Columbus 5-3320; Peter G. Lavathes, manager.
Services: TV films.

TWIN CITY TELEVISION LAB.
(Division of Beck Studios Inc.)
Lyceum Theatre, Minneapolis 2; Tel.: Lincoln 4708; Joseph H. Beck, executive director.
Services: TV production and facilities.

GEORGE ULLMAN AGENCY INC.
8979 Sunset Blvd., Los Angeles 46; Tel.: Crestview 4-5238; George Ullman, president.
Services: Talent.

RICHARD H. ULLMAN INC.
295 Delaware Ave., Buffalo 2, N. Y.; Tel.: Cleveland 2066; Richard H. Ullman, president.
Services: Transcriptions, package programs.

UNITED BROADCASTING CO.
301 E. Erie St., Chicago 11; Tel.: Superior 7-9114; William Klein, president.
Services: Production, recording and pressing, transcriptions, talent recording on film, TV film production.

UNITED FEATURE SYNDICATE INC.
220 E. 42nd St., New York 17; Tel.: Murray Hill 2-3020; Laurence Rutman, vice president & general manager.
Services: Newspaper features, TV film.

UNITED PRESS ASSOCIATIONS
220 E. 42nd St., New York; Tel.: Murray Hill 2-0460; Leroy Keller, general sales manager.
Services: News & multiscopes.

UNITED PRODUCTIONS OF AMERICA
4440 W. Olive Ave., Burbank, Calif.; Tel.: Charleston 0-7171; Stephen Bostow, president.
Services: Scripts, TV film production, package programs.
New York 21—208 E. 72nd St., Tel.: Regent 4-7609; Edward L. Gershan, director.

UNITED RECORDING ARTIST BUREAU
245 W. 34th St., New York 1; Tel.: Chickering 4-3314; Mark Rubens, manager.
Services: Transcriptions.

UNITED SOUND SYSTEMS
5840 Second Blvd., Detroit 2; Tel.: Trinity 1-2570; James V. Syracuse, proprietor.
Services: Record pressing, transcriptions, slide film, film recording, production, talent.

UNITED VIDEOGRAM INC.
33 S. Clark St., Chicago; Tel.: Andover 3-3339; Otis Carney, president.
Services: Package programs, production, live & film TV.
New York 17—11 E. 47th St.; Tel.: Plaza 3-4428; Henry T. McKnight, vice president.
Minneapolis — 1233 McKnight Bldg.; Tel.: Main 2654; Mark A. Forgette, vice president.

UNITED WORLD FILMS INC.
1445 Park Ave., New York 22; Tel.: Trafalgar 6-5200; Stephen Alexander, director.
Services: TV films.

UNITEL OF CALIFORNIA INC.
1730 N. Las Palmas Ave., Hollywood 28; Tel.: Hudson 2-7268; J. Dabah, vice president.
Services: TV film production.

UNIVERSAL RADIO PRODUCTIONS
P. O. Box 847, Phoenix, Ariz.; Tel.: 4-8754; Robert E. Burke, manager.
Services: Production, scripts.

UNIVERSAL RECORDERS INC.
6757 Hollywood Blvd., Hollywood 28; Tel.: Hollywood 9-3282; Will H. Voeller, executive vice president.
Services: Transcriptions, recording, package programs.
Washington 9—1701 16th St., N. W.; Tel.: DuPont 1000; George E. Hughes, vice president.

UNIVERSAL RECORDING CORP.
100 E. Ohio St., Chicago 11; Tel.: Michigan 2-9302; Milton T. Putnam, president.
Services: Recording, transcriptions, package programs, record masters & pressing.

UNUSUAL FEATURES SYNDICATE
333 N. Michigan Ave., Chicago 1; Tel.: Franklin 2-3862; Dean Schaefer, owner.
Services: Transcriptions, package programs, scripts.

U. S. RECORDING CO.
1121 Vermont Ave., N. W., Washington 5, D. C.; Tel.: Sterling 3626; Joseph Tait, general manager.
Services: Recording, package programs, studio service for broadcast stations.

V

THOMAS J. VALENTINO INC.
150 W. 46th St., New York 19; Tel.: Circle 6-4675; Thomas J. Valentino, president.
Services: Sound effects records, transcriptions, TV film, recording & record pressing.

VIDEO ASSOCIATES INC.
515 Madison Ave., New York; Tel.: Lackawanna 4-1168; Philip Vrotsky, manager.
Services: TV films.

VIDEO DRAMA PRODUCTIONS
505 Fifth Ave., New York 17; Tel.: Murray Hill 2-0326; Henri E. Marcuse & Harvey S. Janovic.
Services: Live & TV production.

VIDEO EVENTS INC.
535 Fifth Ave., New York 17; Tel.: Murray Hill 7-1668; Julianne Dupuy, president.
Services: Radio & TV package production.

VIDEO FILMS
1004 E. Jefferson Ave., Detroit 7; Tel.: Woodward 2-3400; Clifford Hanna, William R. Witherell Jr., senior partners.
Services: Film production.

VIDEO VARIETIES CORP.
41 E. 50th St., New York 22; Tel.: Murray Hill 8-1162; George W. Goman, president.
Services: Film production, recording, live & film programs, talent.

VIDEOR PRODUCTIONS
34 S. 17th St., Philadelphia 3; Tel.: Locust 4-3866; Franklin O. Pease, manager.
Services: Talent.

CHICK VINCENT CO.
509 Madison Ave., New York 56; Tel.: Eldorado 5-0734; Chick Vincent, owner.
Services: Radio & TV package programs, direction & production.

OWEN VINSON & CO.
1845 N. Gramercy Pl., Hollywood 28; Tel.: Granite 3368; Owen Vinson, owner.
Services: Production, package programs, direction.

J. FRANKLYN VIOLA
152 W. 42nd St., New York 18; Tel.: Chickering 4-3254; J. Franklyn Viola, president.
Services: Recording, program production, scripts, talent.

VISUAL ARTS PRODUCTIONS INC.
2 W. 46th St., New York 19; Tel.: Luxemburg 2-4047; Sidney Rosenbaum, vice president.
Services: TV live & film production.

VOGUE-WRIGHT STUDIOS INC.
469 E. Ohio St., Chicago 1; Tel.: DE-7-8350; George Becker, manager.
Services: TV film shows, commercials.

VON BAUMANN STUDIOS INC.
331 E. 71st St., New York 21; Tel.: Rhinelander 4-5508; Cyril von Baumann, executive vice president.
Services: Radio & TV productions.

W

WADE-FARNHAM PRODUCTIONS
15 W. 46th St., New York 19; Tel.: Circle 7-6797; Roger W. Wade, Moulton H. Farnham, partners.
Services: Film production, slide film, animation.

C. LAWRENCE WALSH & CO.
801 Brighton Rd., Pittsburgh 12; Tel.: Fairfax 1-5255; C. Lawrence Walsh, owner.
Services: Film production, slides, recording, scripts.

Memo to:

WORLD AFFILIATES *Only!*

8

... great firsts were sent to you during 1949!

10

... terrific money-making features—never before released by a library—will be sent to you during 1950!

CURRENTLY...

738

...World-Affiliates are enthusiastically translating World's dramatic new *showmanship* into increasingly profitable *sponsorship*! They're saying: "It pays to make 'Watch World' your 'Watch Word!'"

WORLD PROGRAM SERVICE **LIBRARY**

WORLD BROADCASTING SYSTEM, INC.
501 Madison Avenue, New York 22, N. Y.

(Continued from page 444)

LOUIS WEISS & CO.
4336 Sunset Blvd., Hollywood 27; Tel.: Normandy 1-6883; Adrian Weiss, partner.
Services: TV film rental, film production.

WELGOT TRAILER SERVICE
630 Ninth Ave., New York 19; Tel.: Circle 6-6450; Martin Gottlieb, Charles L. Welsh, proprietors.
Services: TV film production.

RUPE WERLING
Hidden Haven, Chalfont, Bucks County, Pa.; Tel.: Lexington 707; Rupe Werling, owner.
Services: Scripts, new program ideas.

WEST COAST PRODUCTIONS
1914 S. Vermont Ave., Los Angeles 7; Tel.: Republic 2-0621; Milton L. Smith, general manager.
Services: TV commercial spot films.

WFAA RECORDING SERVICE
1122 Jackson St., Dallas 2; Tel.: Riverside 9631; Bert Mitchell, production manager.
Services: Production, talent, recording, scripts.

WIEDERHOLD RECORDING STUDIO
Norton Bldg., Louisville 2; Tel.: Jackson 7808; Geo. Wiederhold, manager.
Services: Recording, production, talent, TV shows, package programs.

WILDING PICTURE PRODUCTIONS INC.
1345 Argyle St., Chicago 40; Tel.: Longbeach 1-8410; C. H. Bradfield Jr., president.
Services: Motion pictures for TV application, TV commercials and films.
New York 17-385 Madison Ave.; Tel.: Plaza 8-1727; J. W. Inglefield, vice president.
Cleveland 15-310 Swetland Bldg.; Tel.: Tower 1-6440; Jack Rheinstrom, vice president.

Detroit 24-4925 Cadieux Rd.; Tel.: Tuxedo 2-4600; Ralph Cattell, vice president.
Los Angeles 34-5981 Venice Blvd.; Tel.: Webster 0183.
St. Louis-4053 Lindell Blvd.; Tel.: Lucas 0986; James Darst.
Cincinnati 2-Enquirer Bldg., Rm 1334, 617 Vine St.; Tel.: Garfield 0477; E. F. Cullen.

WILLARD PICTURES INC.
45 W. 45th St., New York; Tel.: Luxemburg 2-0430; John M. Squiers Jr., manager.
Services: TV films.

WILLOUGHBY PICTURES INC.
207 E. 37th St., New York; Tel.: Murray Hill 2-0955; E. T. Anderson, manager.
Services: Religious films.

HAL WILSON RADIO PRODUCTIONS
6000 Sunset Blvd., Hollywood 28; Tel.: Hollywood 9-1714; Hal Wilson, owner.
Services: Production, packaged shows, transcriptions, TV shows.

WINIK FILMS INC.
625 Madison Ave., New York; Tel.: Plaza 3-0684; Leslie Winik, manager.
Services: TV films.

LOU R. WINSTON .CO.
(see Radio Producers of Hollywood Inc.)

WITTE RADIO PRODUCTIONS
1064 S. Genesee Ave., Los Angeles 35; Tel.: Webster 8716; I. Oscar Witte, owner.
Services: Transcriptions, package programs, scripts.

WLS ARTIST BUREAU
1230 Washington Blvd., Chicago 7; Tel.: Monroe 6-9700; George Ferguson, Earl Kurtz, co-partners.
Services: Talent.

WMCA INC.
1637 Broadway, New York 19; Tel.: Circle 6-2200; Louis Wacks, musical director.
Services: Talent.

WOLF ASSOCIATES INC.
420 Madison Ave., New York 17; Tel.: Plaza 5-7620; Edward Wolf, manager.
Services: Production.

RAPHAEL G. WOLFF STUDIOS
1714 N. Wilton Pl., Hollywood 28; Tel.: Granite 6126; Raymond Ring, TV manager.
Services: TV film programs, production facilities.

WOODRUFF ASSOC.
328 E. 38th St., New York 16; Tel.: Murray Hill 5-8216; Frank L. Woodruff, executive producer.
Services: Package producers, consultants, talent, furniture & property service, film & radio production.
New York 19-1619 Broadway; Tel.: Judson 6-5272; George Walker, associate.

WOR ENTERTAINMENT DEPT.
1440 Broadway, New York 18; Tel.: Longacre 4-8000; Nat M. Abramson, manager.
Services: Talent.

WOR RECORDING STUDIOS
1440 Broadway, New York 18; Tel.: Longacre 4-8000; Henry B. Lockwood, manager.
Services: Recording, scripts, talent.

WORLD BROADCASTING SYSTEM INC.
501 Madison Ave., New York 22; Tel.: Murray Hill 8-4700; John L. Sinn, president.

Services: Production, transcriptions, scripts, package programs, transcription library.
Chicago 1-360 N. Michigan Ave.; Tel.: Franklin 2-8917; W. C. Hutchings, divisional manager.
Cincinnati 6-1529 Madison Road; Tel.: Plaza 1323; Samuel Glueck, promotion director.
Hollywood 28-Equitable Bldg.; Tel.: Hempstead 5141; M. Marquardt, divisional manager.

WORLD TRAVEL FILMS
Wynnewood, Pa.; Tel.: Ardmore 7089; Harry Dugan, production manager.
Services: Film production.

WORLD VIDEO INC.
15 E. 47th St., New York 17; Tel.: Plaza 9-3870; Henry S. White, president.
Services: Produce & package TV shows.

WPIX INC.
(N. Y. Daily News)
220 E. 42nd St.; Tel.: Murray Hill 2-1234; Robert L. Coe, manager.
Services: TV film, newsreels.

CARTER WRIGHT ENTERPRISES INC.
1707 N. Hudson Ave., Hollywood 28; Tel.: Hollywood 3636; Carter Wright, manager.
Services: Recording, production, TV programs, transcriptions, talent.

WYNN WRIGHT ASSOCIATES
17 W. 57th St., New York 19; Tel.: Plaza 3-4417; Charles Granzow, manager.
Services: Production, package programs, TV production.

WRIGHT-SONOVOX INC.
6331 Hollywood Blvd., Hollywood 28; Tel.: Hollywood 9-3614; John T. Abbott, manager.
Services: Sound articulation, recording, production, film.
Chicago 1-180 N. Michigan Ave.; Tel.: Financial 6-3088; J. M. Gleason, manager.
New York 22-444 Madison Ave.; Tel.: Plaza 5-4130; E. C. Redding, manager.

WURTELE FILM PRODUCTIONS
1838 Gerda Terrace, Orlando, Fla.; Tel.: 9755; H. S. Wurtele, owner.
Services: Motion picture production.

Y

YOUNG AMERICA FILMS INC.
18 E. 41st St., New York 17; Tel.: Lexington 2-4111; James R. Brewster, assistant editor.
Services: TV film rental.

HAROLD YOUNG PRODUCTIONS INC.
119 W. 57th St., New York 19; Tel.: Circle 5-8459; Harold Young, president.
Services: Film production.

Z

ZEDER TALBOTT INC.
1762 Penobscot Bldg., Detroit 26; Tel.: Woodward 1-7288; Fred M. Zeder Jr., manager.
Services: TV films.

FREDERIC W. ZIV CO.
1529 Madison Rd., Cincinnati 6; Tel.: Plaza 1323; Frederic W. Ziv, president.

Services: Transcribed programs, package shows.
New York 22-501 Madison Ave.; Tel.: Murray Hill 8-4700; John L. Sinn, exec. vice president.
Hollywood 28-8253 Hollywood Blvd. at Vine; Tel.: Hempstead 5121; N. L. Rogers.

ZIV TELEVISION PROGRAMS INC.
1529 Madison Rd., Cincinnati 6; Tel.: Plaza 1323; Paul Blair, sales manager.

Services: TV live & film programs.
New York 22-501 Madison Ave.; Tel.: Murray Hill 8-4700; Maurice J. Rifkin, eastern sales manager.

The Cardinal Company

6000 Sunset Boulevard . . . Hollywood 28, California

"SLEEPY JOE" starring Jimmy Scribner
Children's Program

"MARVIN MILLER" STORYTELLER
Dramatic Vignettes

"ADVENTURES BY MORSE"
Mystery

"THE ANDERSON FAMILY"
Situation Comedy

"THE JOHNSON FAMILY"
Dialect Comedy

"BARNYARD JAMBOREE"
Corn Comedy

Producers of Radio and Television Productions

TV SPOTS

without
worry . . .
trouble . . .
bother . . .
. . . to you!





- CRESTA BLANCA WINES
- MACMILLAN OIL
- SUNKIST
- ICE FOLLIES 1950
- RANCHO SOUPS
- CATALINA SWIM SUITS

These are but a few of the many TV spots in which we have completed all production from storyboard to shipment of final prints.

Let Us Take Over
Your Problem



TELEFILM
INCORPORATED

6039 HOLLYWOOD BLVD.
HOLLYWOOD 28, CALIF.

Detroit  is not only the world's  greatest automotive  center, it is also one of the nation's most important radio production centers.  And the center of Detroit's radio production  is.....

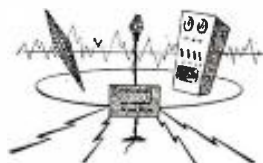
TRENDLE-CAMPBELL ENTERPRISES, INC.



Because Trendle-Campbell originates eight (8) half hours of live programs for ABC. These are the nationally famous LONE RANGER  (Monday-Wednesday-Friday weekly, 7:30 to 8:00 p.m.) the CHALLENGE  of the YUKON (Monday-Wednesday-Friday, 5 to 5:30 p.m.) and the GREEN HORNET (Tuesday-Thursday, 5:00 to 5:30 p.m.) 

TRENDLE-CAMPBELL ENTERPRISES, INC.

1800 Stroh Building

Detroit 26, Michigan

DIRECTORY OF AM-FM-TV EQUIPMENT MANUFACTURERS

NAME OF COMPANY	CITY	ADDRESS	TELEPHONE	MANAGER	PRODUCTS
H. W. Acton Co.	New York 1	370 Seventh Ave.	Pa. 6-0111	H. Bengesfield	Transcription needles, playback and cutting needles
Adlew Jewelry Co.	New York 16	117 W. 42 St.	Bryant 9-6243	J. Fredericks	Chronographs
Advance Recording Products Co.	Long Island City 1	36-12 34th St.	Stillwell 4-7837	I. H. Goldman	Recording disc
Aerovox Corp.	New Bedford, Mass. Chicago 31 Los Angeles 15 New York 16 Hamilton, Ont.	740 Belleville Ave. 6663 N.W. Highway 1169 S. Broadway 347 Fifth Ave. 1551 Barton St., E.	New Bedford 6-8221 Rodney 3-1570-71-72 Prospect 2105 Lexington 2-2184. 5-1186-7-8	Charles Golenpaul Fred R. Ellinger, W. C. Hitt J. A. Simberkoff W. H. Furneaux	Capacitors—resistors, test equipment
Allied Radio Corp. (Broadcast Div.)	Chicago 7	833 W. Jackson Blvd.	Haymarket 1-6800	Chet Wharfield	Special stocks of parts and equipment for broadcast stations including pads, patch panels and cords, C.A.A. approved tower light controls and complete stock of transmitting and TV tubes
Allied Record Mfg. Co.	Hollywood 38	1041 N. Las Palmas	Hollywood 9-5107	D. K. Broadhead	Transcriptions
Allied Recording Products Co.	Long Island City 1, N. Y.	21-09 43rd Ave.	Stillwell 4-2318	Murray Lehrer	Recording blanks and machines
Altec Lansing Corp.	Hollywood 38 Chicago 5 Cincinnati 2 New York 13	1161 N. Vine St. 608 S. Dearborn St. 525 Walnut St. 181 Sixth Ave.	Hillside 1121 Wabash 2-6644 Garfield 2165 Algonquin 5-3636	A. A. Ward R. Hilton M. G. Thomas H. S. Morris	Transformers, reproducers, amplifiers, loud-speakers, microphones, monitors, test equipment
American Microphone Co.	Pasadena 1, Calif.	370 S. Fair Oaks Ave.	Ryan 1-7444	F. A. Yarbrough	Microphones; microphone stands; phonograph pick-up, arms, crystal and dynamic cartridges; recording heads and mechanisms
American Transformer Co.	Newark 5	173 Emmet St.	Bigelow 3-4444	F. K. Hankinson	Audio, plate and filament transformers, reactors—wave filters—voltage regulators. FM, TV, facsimile: Transformers
Amperex Electronic Corp.	Brooklyn 1, N. Y.	25 Wash. St.	Main 5-2050	Sam Norris	Transmitting and rectifying tubes
Amperite Co., Inc.	New York 12	561 Broadway	Canal 6-1446	S. Ruttenberg	FM: Microphones (ribbon, dynamics) TV: Same plus ballast and delay relay tubes
Andrew Corp.	Chicago 19	363 E. 75th St.	Triangle 4-4400	C. Russell Cox	Coaxial cables and accessories, antenna tuning, phasing and filtering equipment and components, tower lights and lighting accessories, high frequency antennas, phase monitors, remote antenna ammeters. FM: Coaxial transmission line and accessories; folded quadrupole antenna; dry air pumps. TV: Same plus receiving antenna
The Astatic Corp.	Conneaut, Ohio Cleveland (Export) Toronto, Ont.	Harbor & Jackson Sts. 4900 Euclid Ave. 2271 Danforth Ave.	12-656 Henderson 0414 Oxford 1127	W. J. Doyle C. O. Brandes L. D. Cahoon	Crystal, magnetic & ceramic phonograph cartridges & pickups. Crystal, dynamic & ceramic microphones. Crystal & magnetic cutting heads. TV: All-channel booster
Audio Devices, Inc.	New York 22 Hollywood 38	444 Madison Ave. 844 Seward St.	Plaza 3-0973 Hollywood 8902	Bruce Haynes Alan H. Bodge	Recording discs, recording and playback points, magnetic recording tape
Audio-Master Co.	New York 19	23 W. 45th St.	Plaza 7-3224	Herbert Rosen	Portable transcription players & tape recorders
Audio & Video Products Corp.	New York 19	1650 Broadway	Plaza 7-0780	Russell O. Hudson	Tape recorders, recording tape
Aurex Corp.	Chicago 10	1117 N. Franklin St.	Whitehall 4-1117	W. H. Huth	Magnetic recorders
BDN Steel Erecting Co.	Chicago 2	82 W. Wash. St.	Financial 6-3496	A. A. Belda	Tower, antenna erectors, engineers
Bell & Howell	Lincolnwood, Ill. Hollywood New York	7100 McCormick Blvd. 716 N. LaBra 30 Rockefeller Plaza	Ambassador 2-1600 Wyoming 3131 Circle 5-5800	H. W. Remerscheid W. Moen	Projector, rear-projection device, 1000 w rear-projector with slides, 16 mm continuous automatic film printers, splicing machines, 16 mm movie cameras
Berndt-Bach, Inc. (Auricon Div.)	Hollywood 36	7377 Beverly Blvd.	York 8294 Webster 6963	Walter Bach	16 mm sound-on-film camera recording equipment for making TV film material
Blaw-Knox Division (Blaw-Knox Co.)	Pittsburgh 22 Birmingham 3 Chicago 3 New York 17 Philadelphia 3 Wash. 4, D. C.	Farmers Bk. Bldg. Brown-Marx Bldg. Peoples Gas Bldg. 342 Madison Ave. 1617 Pa. Blvd. Munsey Bldg.	Sterling 2700 3-4931 Harrison 7-7833 Vanderbilt 6-0661 Rittenhouse 6-1681 Republic 3142	E. J. Staubitz William E. Balliet J. C. McQuide T. M. Avery W. F. Simmons Marvin Marcus	AM: Vertical radiators, FM: Supporting antenna towers. TV, facsimile: Same
Biley Electric Co.	Erie, Pa.	Union Station Bldg.	2-2287	W. S. Riblet	Quartz crystals, temperature controlled ovens
Browning Labs., Inc.	Winchester, Mass.	750 Main St.	Winchester 6-2121, 6-2850	R. L. Purrington	AM, FM: Tuners
Califone Corp.	Los Angeles 38	1041 N. Sycamore Ave.	Hudson 2-2353	Robert G. Metzner Eugene H. Levy	Portable transcription players
Camera Equipment Co.	New York 19	1600 Broadway	Circle 6-5080		Balanced TV tripod head, motion picture accessories, rentals all types motion picture equipment
Canadian Marconi Co.	Montreal 16 Halifax, N.S. St. John's, Nfld. Toronto, Ont. Vancouver, B. C. Winnipeg, Man.	2440 Trenton Ave. 578 Barrington St. 3 Prescott St. 881 Bay St. 550 Burrard St. 149 Portage Ave. E.	Atlantic 9441 3-1325 3-4931 Midway 0976 Marine 0464 9-7255	R. R. Desaulniers D. J. Murphy W. A. Brown H. A. Rice L. S. Hawkins W. F. Souch	AM: Transmitters, studio equipment, turntables, remote control equipment, transmitting and receiving tubes. FM: Turnstile antennas, transmitters. TV: Transmitters, cameras, studio equipment. Facsimile: Transmitters, recorders
Clarkstan Corp.	Los Angeles 64	11921 W. Pico Blvd.	Arizona 9-6129	R. S. Clarke	Audio sweep frequency generators (AM & FM) and transcriptions; test films and records; wide range reproducers, tone arms, equalizers, audio transformers, needle force gauges, recording stylus
Clar-O-Stat Mfg. Co., Inc.	Dover, N. H. New York	205 E. 42nd St.	Murray Hill 9-2518	Victor Mucher George Higgins	Electronic equipment for sound system controls. For FM, TV: Same
Classophone, Inc.	Long Island City 1, N. Y.	35-05 36th St.	Ravenswood 8-5900	A. Spector	Record containers
Clebar Watch Agency	New York 17	551 Fifth Ave.	Murray Hill 2-6895	Edward Trauner	Stopwatches, timers, chronographs, water-resistant watches
Collins Radio Co.	Cedar Rapids Burbank, Calif. Dallas 1 Knoxville	855 35th St., N.E. 2700 W. Olive Ave. M & W Tower Fountain City Bk. Bldg.	3-0281 Charleston 0-7117 Riverside 2408 6-4711	R. H. Hollister Carl W. Service T. B. Moseley John F. Stanbery	AM: Complete stations: 250 watt, 1, 5, 10 & 50 kw transmitters, studio consoles, monitoring, program and pre-amplifiers, specially designed studio installations, remote pickup amplifiers, antenna tuning units & tower lighting chokes. FM: Same plus 3, 25 kw transmitters, 10 watt educational broadcast transmitters and accessories, antennas and accessories
Colortran Converter Co.	Hollywood 46	7045 Romaine St.	Granite 4461 Hillside 4267	Thomas E. Hunt	TV: Portable lighting kits for location work. Grip equipment. Front lights for cameras

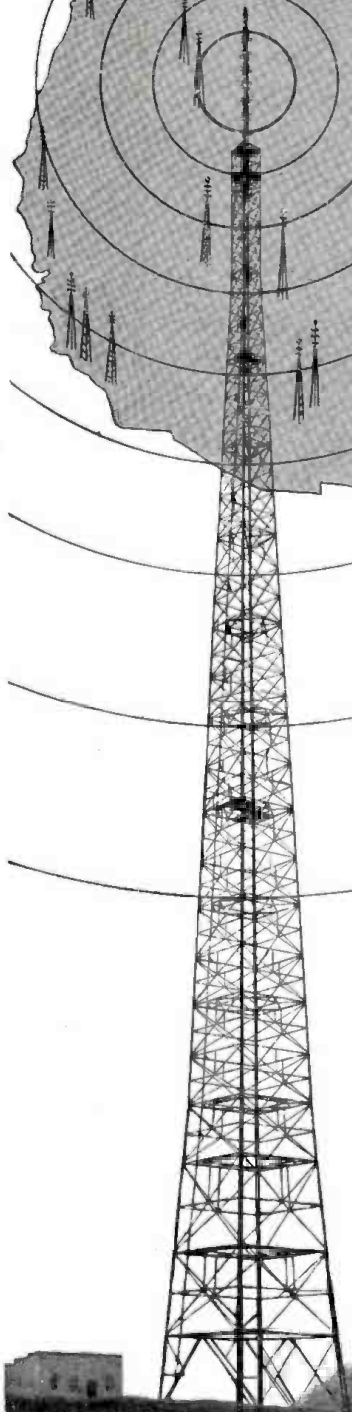
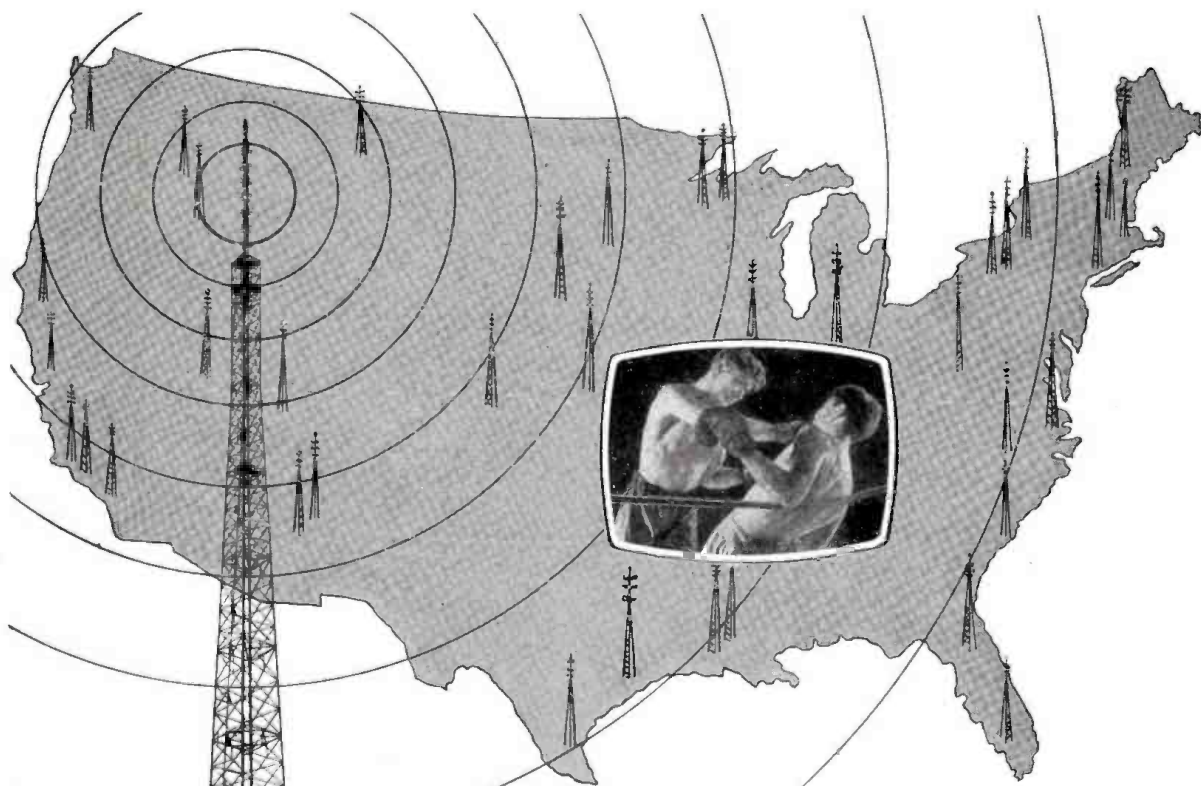

Blaw-Knox is building
MORE RINGSIDE SEATS
for the fast-growing TV audience

Not complete stations, of course, but those outward and visible signs of top video transmission efficiency—Blaw-Knox Antenna Towers . . . Electronic Engineers know what they want, and know what suppliers can best meet their requirements. For the design, fabrication and erection of their antenna support, Blaw-Knox comes to mind first because it "came to radio" first.

BLAW-KNOX DIVISION

OF BLAW-KNOX COMPANY

2058 FARMERS BANK BUILDING • PITTSBURGH 22, PA.



BLAW-KNOX ANTENNA TOWERS

YOU CAN BE **SURE**... IF IT'S
Westinghouse

MR. STATION OWNER:
How much does it cost you to do...



DIRECTORY OF AM-FM-TV EQUIPMENT MANUFACTURERS

(Continued from page 448)

NAME OF COMPANY	CITY	ADDRESS	TELEPHONE	MANAGER	PRODUCTS
Commercial Radio Sound Corp.	New York 22	570 Lexington Ave.	Volunteer 5-1700	Alexander Fisher	Sound effects machines, speech input, rack and console wiring, audition equipment, jack cleaning tool. TV: Antenna distributing systems
Consolidated Radio Products Co.	Chicago	350 W. Erie St.	Delaware 7-6900	Joe Kruglick	AM, FM, TV receiver components
Continental Electronics Mfg. Co.	Dallas 1	1728 Wood St.	Riverside 3611	James O. Weldon	Antenna phasing and coupling equipment, transmitters
Cornish Wire Co., Inc.	New York 7	15 Park Row	Barclay 7-5140	W. F. Osler, Jr.	Wires & cables
Cyl-Ray Antenna Corp.	Portland 13, Ore.	6100 N.E. Columbia Blvd.	Trinity 7303	C. H. Fisher	FM antennas
The Daven Co.	Newark 4, N. J.	191 Central Ave.	Mitchell 2-6555	Lewis Newman	Components: Variable fixed and tone compensating attenuators, attenuators with built-in cueing feature, single and dual potentiometers, multipliers, faders, step-type rheostats, special step-type rotary switches, super precision wire-wound resistors, hermetically-sealed resistors. Test Sets: Transmission measuring sets (rack type and portable), attenuation boxes, output meters, power output meters, volume level indicators, power level indicators, decade voltage dividers, program line equalizers, electronic frequency meters, decade resistance boxes, power supply ratio arm boxes and logarithmic resistor boxes, FM: RF fixed and variable attenuators, TV: Same plus complete line of step type video attenuators; switches; special control and test equipment; camera switching units
Allen B. DuMont Labs., Inc.	Clifton, N. J.	1000 Main Ave.	Sherwood 2-7400	H. E. Taylor, Jr.	Inputtuners (3, 4 section), wide-angle deflection yokes, oscillographs and record, cathode ray, masks and accessories for mounting cathode ray tubes, indicators, power supplies, high voltage. TV: Transmitters, receivers, studio equipment; remote field camera equipment, monitoring, test, studio transmitter and inter-city relay equipment, motion picture projection equipment for TV, mobile pickup units
Eastern Mike-Stand Co.	Brooklyn 12 Chicago 47 Cleveland 7 Columbus 6 Pittsburgh 4 Los Angeles 21 Toronto	56 Christopher Ave. 3600 Fullerton Ave. 1456 Waterbury Rd. 1086 Oakwood Ave. 3239 Faronia St. 1935 Bay St. 1926 Gerrard St.	Dickens 2-3538 Humboldt 9-1961 Academy 4932 Garfield 2425 Walnut 2959 Trinity 4493 East Oxford 7435	S. Sherman W. L. Holst John O. Olsen Norbert F. Derr W. F. Lowry Henry Feldman C. W. Poinon	Microphone stands
Eidson Electronic Co.	Temple, Texas	1802 N. Third St.	3901	M. Eidson	Quartz crystals, frequency measuring service
Eitel-McCullough, Inc.	San Bruno, Calif. Atlanta 5 Boston 8 Chicago 5 Dallas 1 Denver 7 Kansas City 2, Mo. Los Angeles 15 New York 7 Seattle 1	798 San Mateo Ave. 1000 Peachtree St., N.E. 11 Beacon St. 600 S. Mich. Ave. 505 N. Ervay St. 5522 E. Colfax Ave. 4550 Main St. 1406 S. Grand Ave. 220 Broadway 2626 Second Ave.	Juno 8-1212 Hemlock 1648 Capitol 7-0050 Harrison 7-5948-9 Central 8764 Keystone 8511 Westpost 4660 Richmond 6191 Prospect 8086 Worth 4-1757 Beekman 3-8899 Main 5512	Orrin H. Brown J. E. Joyner, Jr. Tim Coakley Royal Higgins M. B. Patterson W. Clif McLoud Clyde H. Schryver Herb Becker Adolph Schwartz	Transmitting type vacuum tubes, fixed and variable vacuum capacitors, vacuum switches, air system tube sockets
Electronic Service Corp.	Louisville 2 Lincoln, Nebr.	121 S. Seventh St. 3327 Starr St.	Clay 4150 6-5233	S. A. Cisler H. A. Shuman	Buy and sell new and used standard, FM and specialized broadcast, mobile, telephone and electronic surplus equipment of all types
Electro-Voice, Inc.	Buchanan, Mich. New York 16	13 E. 40th St.	1000 Murray Hill 90-200	W. F. Soules Jack E. Willson	Microphones, phonograph playback
The Elmor Co.	Melbourne, Fla.	P. O. Box 637	433	M. J. Stillman	Stop watches, chronographs, timers
Emsco Derrick & Equip. Co.	Houston 1 Los Angeles 1	P. O. Box 1289 6811 S. Alameda St.	Milby 3361 Jefferson 5261	Howard D. Hilborn K. F. Forsyth	Towers; custom-built towers upon order
Fairchild Recording & Equip. Corp.	Whitestone, L. I., N. Y.	154th St. & 7th Ave.	Independence 3-2100	Jay H. Quinn	Sound recorders (disc and magnetic tape, cutterheads, transcription tables, dynamic pickups, unitized amplifier systems, FM: Same. TV: Same. Sync. recording and playback tables. Facsimile: Same as TV with frequency controlled power supply
Federal Telecommunication Labs., Inc.	Nutley 10, N. J.	500 Wash. Ave.	Nutley 2-3600	T. H. Clark	TV: Antenna 8 gain, broadcast monitor, transmitter, UHF radio relay link
Federal Telephone and Radio Corp.	Clifton, N. J. Chicago 4 Wash. 6, D. C.	100 Kingsland Rd. 208 S. LaSalle St. 1025 Conn. Ave., N.W.	Nutley 2-3600 Central 6-6900 Executive 1697	Raymond S. Perry R. P. Lamons E. J. Girard	AM: Complete broadcasting systems; transmitters; transmitting and rectifying tubes; consoles, microphones and associated speech input and transmitter control equipment; field intensity meters. FM: Same plus square loop transmitting antennae; studio-transmitter links; microwave relay systems; transmitter monitors; dummy antennae. TV: Transmitter and complete broadcast equipment; high-gain triangular loop antennae; remote pick-up, studio-transmitter and intercity relay microwave link equipment; transmitter monitors and control consoles. HF coaxial cables and selenium rectifier DC power supplies
Ferranti Electric, Inc.	New York 20	30 Rockefeller Plaza	Circle 7-0912	R. H. Davies	Transformers, chokes, filters, assemblies. FM. TV: Same
Finch Telecommunications, Inc.	Passaic, N. J. New York 16	4th & Va. Sts. 10 E. 40th St.	Prescott 7-3440 Murray Hill 5-7976	W. G. H. Finch W. G. H. Finch	Facsimile scanner, consoles (transmitter input equipment), combination radio receiver-recorder and home recorder
Furst Electronics	Chicago 6	12 S. Jefferson St.	Financial 6-4165	U. R. Furst	AM, FM, facsimile: Instrument to measure speed variations of phonograph turntables, wire and tape recorders, etc.
Gates Radio Co.	Quincy, Ill. Wash. 4, D. C.	123 Hampshire Warner Bldg.	522 & LD23 Metropolitan 0522	Fred O. Grimwood Owen J. McReynolds	Transmitters, speech equipment, turntables, recording equipment, microphones. FM: Transmitters, studio equipment, antennae, coaxial cable

CUT THESE COSTS AND SAVE ...with Westinghouse +’s

You don't buy a transmitter every day. It's a long-term investment . . . a considered purchase. So isn't it just good sense to put your money into equipment that pays continuing dividends in the form of cost savings throughout its entire life? That kind of equipment is Westinghouse. And these are just a few of the Westinghouse "plus" features that add up to cost savings and better operation: **Installation** is quick, easy and inexpensive. Compactness means a smaller building . . . air-cooled components allow the building to be more economically built. And, because *all* transmitter ratings are completely factory-tested, no extended grooming of the equipment need be done on the purchaser's premises.

Tube replacement cost slashed. Only a small number of tubes are required for full complement and these of but a few types. Reliable metal rectifiers having life commensurate with that of the transmitter and included in the transmitter warranty, replace expensive vapor tubes. No longer need you fear lost air time due to rectifier failure.

Service at your "doorstep" wherever you are. The extensive Westinghouse field organization of transmitter specialists is available to you, whatever the problem. They will work with you and your consultant in modernizing your station or in planning a

new installation. They can offer emergency service or can give you information about new equipment. And, in addition to this, you are continually benefited by the Westinghouse program of research and development.

Every Westinghouse transmitter carries with it these and many other "plusses". Remember them when you consider the purchase of new broadcasting equipment. Contact your Westinghouse office, or write direct to Westinghouse Electric Corporation, 2519 Wilkens Avenue, Baltimore 3, Maryland. J-02174



Westinghouse

FIRST IN BROADCASTING



NAME OF COMPANY	CITY	ADDRESS	TELEPHONE	MANAGER	PRODUCTS
General Electric Company	Syracuse, N. Y.	Electronics Park	6-4411	Paul L. Chamberlain	FM and AM transmitters, receivers, antennas, frequency and modulation monitors, studio-transmitter relay equipment, speech input equipment, test equipment, transmitting and receiving tubes, audio amplifiers, consoles, cabinet racks, pickups, TV: Transmitters, receivers, antennas, studio-transmitter and intercity relay equipment, field and studio cameras and control, master control, portable camera equipment, remote pickup trucks, test equipment. Facsimile: Receivers, transmitter
	Atlanta 1	187 Spring St., N.W.	Walnut 9787	T. B. Willard	
	Boston 1	140 Federal St.	Hubbard 21800	R. L. Hanks	
	Chicago 54	Merchandise Mart	Whitehall 4-3915	G. S. Peterson	
	Cleveland 14	Williamson Bldg.	Superior 6622	R. F. VanZile	
	Dallas	Norman Bldg.	Riverside 9121	H. G. Randolph	
	Kansas City 6, Mo.	106 W. 14 St.	Victor 9745	R. J. Meigs	
	New York 22	570 Lexington Ave.	Plaza 5131	G. L. Roark	
	Philadelphia	1405 Locust St.	Pennypacker 5-9000	H. A. Crossland	
	San Francisco 6	235 Montgomery St.	Douglas 3740	W. M. Boland	
General Radio Co.	Cambridge 39, Mass.	275 Mass. Ave.	Trowbridge 6-4400	M. T. Smith	Frequency and modulation monitors, distortion meters; broadcast test equipment; vacuum tube voltmeters, audio-frequency oscillators, R-F bridges, sound-measuring equipment, variable auto-transformers
	Chicago 5	920 S. Mich. Ave.	Wabash 2-3820	K. Adams	
	Los Angeles 38	1000 N. Seward St.	Hollywood 9-8201	F. Ireland	
	New York 6	90 West St.	Worth 2-5837	G. Ross	
Grady Instrument Co.	Belmont 78, Mass.	689 Belmont St.	Belmont 5-5005	Ed Grady	FM, TV transmitters, S-T links
Graybar Electric Co., Inc.	New York 17	420 Lexington Ave.	Lexington 2-4000	J. W. LaMarque	AM & FM transmitters, antennae, antenna towers, transmission line products, phase monitors, antenna phasing equipment, transmitter and studio measuring equipment, speech input equipment, speech input amplifiers and accessories, microphones and accessories, transcription turntables and pickups, loudspeakers, power supplies, meters, electron tubes, relays, keys, condensers, jacks, mountings, thermistors, varistors, sound measuring equipment, public utility radio telephone equipment, motor generators, emergency power plants and associated apparatus
	Atlanta 1	167 Walton St., N.W.	Cypress 1751	E. W. Stone	
	Boston 16	287 Columbus Ave.	Kenmore 6-4567	J. P. Lynch	
	Chicago 7	850 W. Jackson Blvd.	Canal 4104	E. H. Taylor	
	Cincinnati 10	115-129 W. McMicken Ave.	Main 0600	W. H. Hansher	
	Cleveland 14	1010 Rockwell Ave.	Cherry 1360	W. S. Rockwell	
	Dallas 2	400 S. Austin St.	Central 6454	C. C. Ross	
	Detroit 1	55 W. Canfield Ave.	Temple 1-5500	P. L. Gundy	
	Jacksonville 1, Fla.	12th & Main Sts.	5-7180	W. C. Winfree	
	Kansas City 8, Mo.	1644 Baltimore Ave.	Baltimore 1644	R. B. Uhrig	
	Los Angeles 12	201 Santa Fe Ave.	Trinity 3321	R. E. Thompson	
	Minneapolis 15	824 S. Fourth St.	Geneva 1621	W. G. Free	
	New York 14	180 Varick St.	Watkins 4-3000	F. C. Sweeney	
	Philadelphia 7	910 Cherry St.	Walnut 2-5405	G. I. Jones	
	Pittsburgh 22	37 Water St.	Court 4000	R. F. Grossett	
	Richmond 19, Va.	6th & Cary Sts.	2-2833	E. C. Toms	
	San Francisco 3	1750 Alameda St.	Market 1-5131	K. G. Morrison	
	Seattle 4	King & Occidental Sts.	Main 4635	D. I. Craig	
	St. Louis 3	2642 Washington Ave.	Newstead 4700	J. P. Lenkerd	
Gray Research & Development Co.	Washington, D. C.	1329 E St., N. W.	Executive 0022	L. H. Whitten	Transcription arms, equalizers, turntables, variable speed turntables, sound effects consoles, TV: Optical slide projectors, sound effects consoles, Diplexers, diplexer pedestals, camera chain turrets, projection accessories
	Hartford 1	16 Arbor St.	33-1244	Arthur H. Jones	
Hallicrafters Co.	Chicago	4401 W. 5th Ave.	VanBuren 6-6300	Charles Nesbitt	AM: All-wave portable, communications receivers, FM: Same plus all-wave home high-fidelity receiver. TV: Home receivers
Hammarlund Mfg. Co., Inc.	New York 1	460 W. 34th St.	Longacre 5-1300	W. C. King	AM: Communications receivers. FM, TV, facsimile: Components
	Chicago	664 N. Mich. Ave.		L. G. Cushing	
	Cleveland 2	11621 Detroit Ave.		Albert Baehr	
	Dallas 8	Box 4116, Station A		R. M. Campion	
	Detroit 30	130 Kercheval, Grosse Pointe		H. E. Walton	
	Kansas City 2, Mo.	406 W. 34th St.		R. W. Farris	
	Los Angeles 15	1148 S. Grand Ave.		G. S. Tivy	
	Pittsburgh 19	600 Grant St.		M. O. Tanner	
	Minneapolis 1	409 Lumber Exchange		Gel Foster	
	Portland 5, Ore.	917 S.W. Oak St.		Don H. Burcham	
	Salt Lake City 1	200 S. Main St.		F. Y. Gates	
Harvey Radio Co.	New York 18	10 W. 43rd St.	Luxemburg 2-1500	M. Alexander	Amplifiers, microphones, disc and wire recorders, associated electronic equipment
Hewlett-Packard Co.	Palo Alto, Calif.	395 Page Mill Rd.	Davenport 2-4651	W. Noel Eldred	AM: Test oscillators, distortion analyzers, vacuum tube voltmeters. FM: Audio signal generators, distortion analyzers, high frequency vacuum tube voltmeters, frequency and modulation monitors. TV: Test oscillators, video and aural monitors
Hogan Labs., Inc. (formerly Radio Inventions, Inc.)	New York 14	155 Perry St.	Chelsea 2-7855	Elliott Crooks	Broadcast, commercial facsimile equipment, research and development in all fields and applications of facsimile
The Houston Corp.	W. Los Angeles 25	11801 W. Olympic Blvd.	Bradshaw 24331	Paul R. Morrill	16mm film processing machines, TV studio crane
Hughey & Phillips	Los Angeles 48	326 N. La Cienega	Bradshaw 2-3113	H. E. Whittemore,	Tower lighting, photo electric controls, lighting chokes and associated equipment FM, TV: Same
	New York 17	60 E. 42nd St.	Murray Hill 7-1550	H. J. Geist	
	San Francisco 5	272 Fremont St.	Exbrook 2-4464	Wm. McWatters	
Hytren Radio & Electronics Corp.	Salem, Mass.	76 Lafayette St.	2260	John Q. Adams	AM, FM: Receiving, transmitting and special purpose tubes. TV: Same plus picture tubes. Facsimile: Receiving tubes
	Chicago	4000 W. North Ave.	B-Capitol 6500	George M. Deters	
	New York 16	432 Fourth Ave.	Murray Hill 4-4178-9	Fred H. Garcelon	
Industrial Television, Inc.	Clifton, N. J.	359 Lexington Ave.	Gregory 3-0900	Edwin B. Hinck	TV: Remote control, home and commercial, self-contained home receivers
International Derrick & Equip. Co.	Columbus 8	875 Mich. Ave.	University 2123	F. Rofer Hayden	FM, TV & facsimile: Towers to support antenna
	Dallas	1315-17 Pacific Ave.	Riverside 1031	J. E. Swain	
	Torrance, Calif.	2410 Carson St.	Zenith 1406	K. H. Brust	
International Electronics Corp.	Dallas 1	2422 Alamo St.	Riverside 4488	J. A. Frazier	Speech input equipment, remote amplifiers
Jennings Radio Mfg. Co.	San Jose, Calif.	1098 E. William St.	Columbia 6674	Calvin K. Townsend	Capacitors, vacuum, fixed, variable; parts, miscellaneous, special vacuum components; transformers, vacuum microwave
Jensen Mfg. Co.	Chicago 38	6601 S. Laramie Ave.	Portsmouth 7-7600	Bayard H. Clark	FM: Loudspeakers, reproducers, projectors, cabinets
Johns-Manville Sales Corp.	New York 16	22 E. 40th St.	Lexington 2-7600	Paul J. Washburn	Acoustical materials
E. F. Johnson Co.	Waseca, Minn.	206 Second Ave., S.W.	Waseca 990	E. R. Johnson	Directional antenna phasing and coupling equipment, tower lighting filters and chokes, gas-filled and air condensers, inductors and RF chokes, coaxial lines and open wire transmission line supports, RF contactors and switches, insulators, tube sockets, high frequency antennas, panels, racks and cabinets. FM: "Iso-Coupler" for feeding FM antennas mounted on an AM tower
The James Knights Co.	Sandwich, Ill.		465	Leon A. Faber	Quartz crystals and frequency standards
Langevin Mfg. Corp.	New York 23	37 W. 65 St.	Endicott 2-7200	Mr. Zolinier	Broadcast audio facilities including preliminary, booster, program and monitoring amplifiers, power supplies, console equipment and program guardian and limiter amplifier (prog), rack mounting accessories. FM: Same plus audio amplifiers, specialty transformers. TV: Same except console, audio amplifiers, specialty transformers
Leach Relay Co.	Los Angeles 3	5915 Avalon Blvd.	Adams 8221	Joseph F. Clark	Relays
Lear, Inc.	Los Angeles 34	11916 W. Pico Blvd.	Arizona 97765	Burnham Adams	Wire recorders and components; magnetic phonograph pickups

(Continued on page 454)

DIRECTORY OF AM-FM-TV EQUIPMENT MANUFACTURERS

(Continued from page 453)

NAME OF COMPANY	CITY	ADDRESS	TELEPHONE	MANAGER	PRODUCTS
Lehigh Structural Steel Co. Lewis & Kaufman, Inc.	New York 4 Los Gatos, Calif.	17 Battery Pl. P. O. Box 337 90 El Rancho Ave.	Whitehall 4-1424 1242	J. F. Neary Jack Kaufman	Vertical radiators, towers Electron tubes
John E. Lingo & Son, Inc.	Camden 5, N. J.	2814 Buren Ave.	Woodlawn 4-0487	John E. Lingo	Tubular steel vertical radiators; VHF antennas and supporting towers. FM, TV: Antennas and supporting towers. Facsimile: Supporting poles
Link Radio	New York 11	125 W. 17 St.	Chelsea 2-1100	Fred M. Link	Mobile relay pickup equipment, transmitters, studio transmitter links
Machlett Labs., Inc.	Springdale, Conn.	1063 Hope St.	Stamford 4-5781	H. J. Hoffman	AM, FM: High power electron tubes including UHF communication types
Magnecord, Inc. Magnetic Recorders Co.	Chicago Los Angeles 46	225 W. Ohio St. 7120 Melrose Ave.	Whitehall 4-1889 Wyoming 9600	C. G. Barker E. G. Van Leeuwen	Magnetic tape and film recorders, reproducers Magnetic recorders
J. A. Maurer, Inc.	Long Island City, N. Y.	37-01 31 St.	Stillwell 4-4601	L. A. Root	FM: 10,000 cycle sound-on-film recorders and film phonograph. TV: 16mm professional motion picture cameras
Measurements Corp.	Boonton, N. J. Detroit	116 Monroe St. 7635 E. Jefferson Ave.	8-2131	Nelson C. Doland, Jr. Anthony R. Satullo	Pulse, square wave, standard signal, TV signal generators. UHF radio noise and field strength, megohm, megacycle mters. Peak, vacuum tube voltmeters, R. F. attenuators, inductance, capacitance br.dges, special test instruments
Meletron Corp.	Los Angeles 38	950 N. Highland Ave.	Hempstead 4841	George A. Starbird	FM, TV, facsimile: Microphone booms and stand. Also TV: Hydraulic mike boom
Merit Coil & Transformer Corp. Miles Reproducer Co., Inc.	Chicago 40 New York 3	4427 N. Clark St. 812 Broadway	Longbeach 1-6311 Spring 7-7670-1	W. J. Barron J. M. Kuchlik	Transformers TV: Sound recorders on plastic film for permanent playback and for synchronizing sight and sound with 8 and 16mm. projectors
Mirror Record Corp. Mole-Richardson Co.	Bayside, L. I., N. Y. Hollywood 38 (Ltd.) London, N.W. 10 England (Italia S.R.L.) Rome, Italy	40 25 206th St. 937 N. Sycamore Ave. Chase Rd. Via Savola, 84	Bayside 4-4999 Hillside 8305	P. K. Trautwein E. C. Palmer C. G. Heys Hallett	FM: Wire recorder TV: Specialized lighting equipment
Mycalex Corp. of America	New York 20	30 Rockefeller Plaza	Columbus 5-5989	Jerome Taishoff	FM, TV, facsimile: Glass bonded mica insulation Mycalex
National Union Radio Corp.	Orange, N. J.	350 Scotland Rd.	2-6600	E. J. Maginot	AM, FM: Electron tubes. TV: Same plus picture tubes
Newark Transformer Co. Newcomb Audio Products Co.	Linden, N. J. Hollywood 38	6824 Lexington Ave.	Linden 2-2426 Hollywood 9-5381	N. A. Lunenfeld Robert Newcomb	FM, TV, facsimile: Transformers Amplifiers, phonograph, P. A., musical inst., recording, wired music, power-transcription players; phonograph scratch filters; special matching transformers; sound systems; pre-amplifiers
North American Philips Co.	New York 17 Oak Ridge, Ill.	100 E. 42nd St. 13 Berry Parkway	Lexington 2-0900	L. J. Chatten Raymond Huttmacher	Projection television system
Otto K. Olesen Co.	Hollywood 28 Hollywood 28	Guaranty Bldg. 1534 Cahuenga Blvd.	5111 Gladstone 5194	Harold Kittleson Noble B. Gowing	TV: Lighting equipment
Pierce Wire Recorder Corp.	Evanston, Ill.	1328 Sherman Ave.	Davis 8-1328	Richard J. Roundtree	Wire recorders
Permaflux Corp.	Chicago 39 Glendale 5, Calif.	4900 W. Grand Ave. 236 S. Verdugo Rd.	Berkshire 7-9170 Citrus 2-1811	L. M. Heineman David Van Winkle	Public address loud speakers; headssets—earphones, ear cushions; microphones; speaker baffles
Phonograph Needle Mfg. Co., Inc.	Providence 5	42-46 Dudley St.	Gaspee 1-5032	John H. Moody	100% shadowgraphed special reproducing and disc needles for records and transcriptions; kit for radio repair and maintenance. Facsimile: Screw machine parts
Pickering & Co., Inc.	Oceanside, L. I., N. Y.		Rockville Centre 6-0442	F. C. Powell	Pickups, equalizers, equalizer-amplifiers. FM: Same
Pioneer Scientific Corp.	New York 12	295 Lafayette St.	Worth 4-0144	Hunter L. DeLa-tour, Jr.	TV: Polaroid filter
Polarad Electronics Corp.	New York 7	9 Ferry St.	Digby 9-2080	Leo Gross	TV: Studio equipment, cameras, monitors, test and measuring equipment, synchronizing generators, monoscopes
Precision Piezo Service Press Wireless Mfg. Co., Inc.	Baton Rouge 10 Hicksville, N. Y. Arlington, Va. West Newton 65, Mass.	427 Mayflower St. 2059 N. Glebe Rd. 25 Prospect Pl.	2-5359 Fieldstone 7-2330 Chestnut 6809 LaSalle 7-5690	C. E. Pearce J. Harvey McCoy Chester Jones Norman Hoard	Quartz crystals, holders and ovens AM transmitters for both broadcast band and high frequencies—100 watts to 100 kilowatts, amplifiers—line bridging preamp, limiter, monitoring, steel towers, custom built equipment, including consoles, phasing equipment, VHF links, engineering services. FM: Transmitters. Facsimile: Scanners and recorders, complete stations
Presto Recording Corp.	Paramus, N. J. New York	P. O. Box 500, Hackensack, N. J. 248 W. 55th St.	Hackensack 3-5700 Plaza 7-5669	Thomas B. Aldrich Al Zrike	Disc and magnetic tape recorders; associated amplifiers, transcription turntables, cutting heads, reproducers, equalizers, lacquer coated recording discs
Producers Service Co.	Burbank, Calif.	2815 W. Olive Ave.	Stanley 7-3144 Charleston 6-2158	Edward Furer	TV: Special effects equipment
Q R K Electronic Products	Fresno 4, Calif.	445 N. Circle Dr.	7-1423	Bert Williamson	Transcription turntables, custom audio equipment, antenna coupling and phasing equipment
Racon Electric Co., Inc.	New York 3	52 E. 19th St.	Algonquin 4-1760-1	Robert L. Allan	Loudspeakers, marine and high fidelity speakers, horns, baffles, tweeters, paging horns. TV: Loudspeakers
Radex Corp. Radio Corp. of America (RCA Victor Div.)	Chicago Camden 2, N. J. Atlanta Chicago 11 Cleveland 15 Dallas 1 Hollywood 28 New York 20 Wash. 6, D. C.	2076 N. Elston Ave. Front & Cooper Sts. Forsythe Bldg. 666 N. Lake Shore Dr. Keith Bldg. 1907-11 McKinney Ave. 1560 N. Vine St. 36 W. 49th St. 1625 K St., N.W.	Armitage 6-6900 Camden 4-8000 Walnut 5946 Delaware 0700 Cherry 3450 Riverside 1371 Hollywood 2154 Circle 6-4030 District 1250	A. R. Hopkins E. D. Eades H. A. Renholm L. E. Swanson J. W. Cocke H. R. Maag J. R. Little F. H. Engel	Pocketracer for radio repairmen's testing AM, FM transmitters, antennas and transmission lines, phasing equipment, audio equipment. TV: Transmitters, studio equipment, field and relay equipment, antennas and associated equipment, test and measuring equipment

(Continued on page 456)



"Top Fidelity...the most dependable
Tape Recorder yet!" says WOR's STAN LOMAX

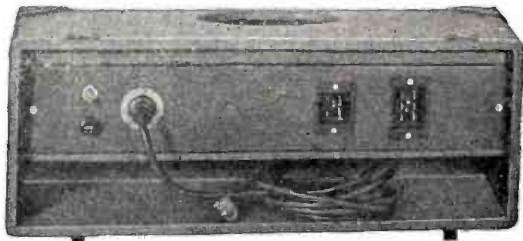
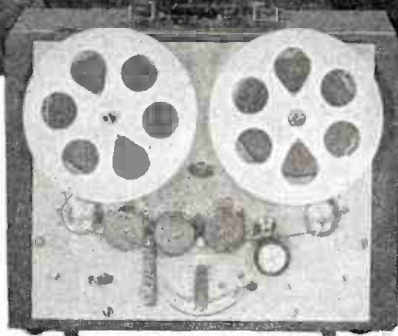

NEW PRESTO PORTABLE TAPE RECORDER

PRESTO'S PT-900 is the answer for delayed sports broadcasts—field recording—wherever there is a need for a portable recorder of complete broadcast quality. Look at these outstanding engineering features:

- Three separate heads for superior performance (and for monitoring direct from tape). One head each to erase, record and play back.
- 3 microphone channels with master gain control in recording amplifier.
- Large V.U. meter with illuminated dial to indicate recording level, playback output level, bias current and erase current, and level for telephone line.
- 2-speed, single motor drive system. Toggle switch to change tape speeds from 7½" to 15" per second.

Don't choose your tape recorder until you see the *new* Presto Portable Tape Recorder. Write for complete details today.

PRESTO

RECORDING CORPORATION
Paramus, New Jersey

Mailing Address: P. O. Box 500, Hackensack, N. J.

In Canada: WALTER P. DOWNS, Ltd., Dominion Sq. Bldg., Montreal

WORLD'S GREATEST MANUFACTURER OF INSTANTANEOUS SOUND RECORDING EQUIPMENT AND DISCS

DIRECTORY OF AM-FM-TV EQUIPMENT MANUFACTURERS

(Continued from page 454)

NAME OF COMPANY	CITY	ADDRESS	TELEPHONE	MANAGER	PRODUCTS
RCA Victor Co., Ltd.	Montreal 30 Montreal, Que. Calgary, Alta. Halifax, N. S. Toronto, Ont. Vancouver, B. C. Winnipeg, Man.	1001 Lenoir St. 978 Lacasse St. 523 Eight Ave. 99 Brunswick St. 1140 Yonge St. 1207 Homer St. 168 Market St.	Wellington 7551 Wellington 7551 M-3928 3-6186 Midway 5421 Marine 4241 97-201	H. S. Walker A. Bayard C. W. Smith C. C. Bowers L. W. Boothe F. T. Myles E. P. Burns	Transmitters, transmitter accessories, transcription turntable equipment, microphone accessories, monitoring and test equipment, transmitting tubes, speech input equipment, acetate recording blanks, amplifier equipment, recording equipment, microphones, faradon condensers, facsimile equipment, television equipment, FM transmitters, antenna phasing equipment, engineering services, loudspeakers, transmission line accessories, crystals and crystal holders, receivers. TV: Transmitters
Radio Engineering Labs., Inc.	Long Island City 1, N. Y.	35-54 36th St.	Astoria 8-1010	C. R. Runyon III	Transmitters, FM and AM, 250 watts to 50 kw; antennas—FM, speech input equipment, monitors, receivers, FM studio to transmitter link equipment, custom-built high quality audio equipment, quadriline amplifiers, serrasoid modulators, ten watt FM educational transmitter, broadcast mobile transmitter link equipment, point-to-point communications equipment, FM relay links, special communications systems, store receivers, bus receivers
Radio-Music Corp.	Port Chester, N. Y.	84 S. Water St.	Byram River 6-8620	D. C. Heyel	Transcription turntables, reproducers, loudspeakers, amplifiers
Rangertone, Inc.	Newark 4	73 Winthrop St.	Humboldt 5-2550	R. H. Ranger	Magnetic tape recorders. TV: Synchronized magnetic tape recorders
Raytheon Mfg. Co.	Waltham 54, Mass. Chattanooga Dallas 8 Evanston, Ill. New York 17 San Francisco Seattle 2	136 River St. Signal Mt. 414 E. 10th St. 720 Main St. 60 E. 42nd St. 49 California St. 135 Harvard, N.	Waltham 5-5860 88-2487 Yale 2-1904 Davis 8-4800 Murray Hill 7-1550 Sutter 1-0475 Minor 3537	L. A. Rooney W. B. Taylor H. D. Crissey Warren Cozzens Henry J. Geist Emile J. Rome Adrian Van Santen William A. Eaton J. L. Lovett	AM, FM, TV transmitters and accessories, tubes, TV microwave relay equipment, communications microwave equipment, TV camera equipment, FM antennas, antenna phasing and coupling, transmission line accessories, speech input equipment, amplifiers-audio and video equipment, engineering services, custom-built transmitting and studio equipment
Recoton Corp.	Wash. 4, D. C. Wilmington, Calif.	Munsey Bldg. 404 N. Avalon Blvd.	Republic 5897 Terminal 4-8575	William A. Eaton J. L. Lovett	Sapphire cutting, styli, phonograph needles, recording blanks, magnetic cartridges
Recorders Labs., Inc.	Hollywood 38	6916 Santa Monica Blvd.	Hudson 2-1251	R. L. Burgess	Electrical transcriptions
The Recordisc Corp.	New York 13	395 Broadway	Worth 4-8082	Sidney S. Gould	Recording discs and wire
Reeves Soundcraft Corp.	New York 22	10 E. 52nd St.	Murray Hill 8-4580	A. C. Travis, Jr.	TV: Large screen projection, transcription blank records, transformers
Rek-O-Kut Co., Inc.	Long Island City 1, N. Y.	38-01 Queens Blvd.	Stillwell 4-7062	George Sieber	Disc recorders, overhead mechanisms, recording tables and amplifiers, phono playback units, three speed and transcription turntables
Remler Co., Ltd.	San Francisco 10	2101 Bryant St.	Valencia 4-3435	Robert C. Gray	Sound systems, marine, announcing and heavy duty P.A.; electrical plugs and connectors; custom plastic molding; metal specialties; microphones
Revere Camera Co.	Chicago 16	320 E. 21st St.	Calumet 5-7900	Col. L. A. Boening	Projectors, cameras, tape recorders
Charles E. Schuler Engineering Co.	Newark, Ohio		6624	Charles E. Schuler	AM, FM: Towers. TV: Same (commercial and small sectional tower for private use)
Schumaker Construction Co.	Michigan City, Ind.	E. Mich. St. at Warnke Rd.	5700	K. F. Schumaker	AM, FM, TV: Tower, antenna and coaxial line erection
Scientific Radio Serv.	Hyattsville, Md.	4301 Sheridan St.	Hyattsville 0535	H. D. Eisenhauer	Piezo electric crystals
Hermon Hosmer Scott, Inc.	Cambridge 39, Mass. Austin, Texas Chicago 39 Ft. Myers, Fla. Hollywood 28 New York 7 Philadelphia 7 Rochester 13, N. Y.	385 Putnam Ave. 304 E. Fifth St. 4949 W. Diversey Ave. P. O. Box 466 Guaranty Bldg. 11 Park Pl. 121 N. Broad St. 39 Bennington Dr.	Kirkland 7-0566 Austin 3193 National 2-2370 1269-M Hollywood 5111 Worth 4-0996 Locust 7-5470 Spencerport 312F41	E. G. Dyett Edwin K. Lassberg Loren Green Arthur H. Lynch Harold A. Kittleson S. S. Egert Milton J. Shapp Edward A. Ossmann Robert A. Waters	Dynamic noise suppressors for AM, FM & TV. Sound level and vibration meters, octave filters, noise generators and other measuring equipment for studio use
Scully Machine Co.	New York 7 Philadelphia 7 Rochester 13, N. Y.	11 Park Pl. 121 N. Broad St. 39 Bennington Dr.	Worth 4-0996 Locust 7-5470 Spencerport 312F41	Milton J. Shapp Edward A. Ossmann Robert A. Waters	Precision disc recording machines. TV: Same
Shallcross Mfg. Co.	Bridgeport 8, Conn. Collingdale, Pa.	62 Water St. 520 Pusey Ave.	Bridgeport 4-5300 Sharon Hill 4700	L. J. Scully Charles H. Fritz	Audio, fixed and variable, key operated attenuators; rotary tapped instrument and attenuator switches; V.U. meter multipliers; audio transmission test equipment; wirewound precision resistors, pre-emphasis and de-emphasis networks
Sherron Electronics Co.	Brooklyn 6	1201 Flushing Ave.	Hyacinth 7-2820	M. V. Barasch	FM: Transmitters 250 watts, upwards; audio studio equipment. TV: Transmitter 250 watts, upwards, master control with sync generator and monoscope equipment, studio director's control. TV test equipment
Shure Brothers, Inc.	Chicago 10	225 W. Huron	Delaware 7-4550	H. T. Harwood	AM, FM, TV: Microphones, wire and tape recording heads, cable transformers and microphone switches
Sierra Electronic Corp.	San Carlos, Calif.	Old Country Rd.	Belmont 2333	W. Feldscher	Transmitting and receiving equipment
Mark Simpson Mfg. Co., Inc.	Long Island City 3, N. Y.	32-28 49th St.	Ravenswood 8-5810	Miriam Simpson	TV: Boosters
Skyline Tower Co.	Chicago 36	5900 S. Ashland Ave.	Walbrook 5-1288	Walter E. Smith	Towers. TV, facsimile: Radio towers and passive repeater relay towers, reflecting screens
Small Motors, Inc.	Chicago 14	2076 Elston Ave.	Armitage 6-6900	R. R. Cook	Blowers and ventilating motors

(Continued on page 458)

The Gates Radio Company

presents

Mid-Century FACTS

A story, unfolding through the years,
of up-to-date broadcasting equipment
and why today Gates . . . around the
world . . . is *the* leader.

QUALITY
PLUS
MAKES
GATES
A MUST

50 to 60

QUALITY
PLUS
MAKES
GATES
A MUST

50 to 60

Leadership is a word that must be backed by facts . . .

Leadership is an achievement that has no association with luck or coincidence.

Then why, from a humble start in 1922, has Gates broadcasting equipment consistently led in sales in a field of aggressive and powerful competition?

Reasons! . . . (1) Progressive Gates engineering. Tremendous strides are continually being made in the application of engineering to the practical side. (2) Twenty-four hour, seven-day-a-week Gates service. (3) Cooperative assistance to the customer — well above normal requirements of doing business. (4) A most liberal guarantee policy — up to five years on major transmitter equipment components. (5) Reasonable selling prices through more efficient manufacturing operations.* Result! . . . More value in materials and workmanship for each dollar.

*All Gates stock is owned by Gates personnel.

DISTRIBUTION

Gates Radio Co.
Warner Building
Washington, D. C.

IN CANADA

Canadian Marconi Co.
Montreal, Quebec

EXPORT

Rocke International Corp.
13 East 40th Street
New York, N. Y.

Direct factory paid Sales
Engineers in all sections of the
United States. One is near you.



GATES RADIO COMPANY

Factory and Offices

QUINCY, ILLINOIS, U. S. A.

DIRECTORY OF AM-FM-TV EQUIPMENT MANUFACTURERS

(Continued from page 456)

NAME OF COMPANY	CITY	ADDRESS	TELEPHONE	MANAGER	PRODUCTS
Sonic Recording Products, Inc.	Freeport, N. Y.	50 Mill Rd.	8-9988	A. Snyder	Instantaneous professional recording blanks
Sonocraft Corp.	New York 19	45 W. 45th St.	Luxemburg 2-1750	H. H. Borchardt	Distributors of sound and recording equipment
Sorensen & Co., Inc.	Stamford, Conn.	375 Fairfield Ave.	3-3159	Edward R. McCarthy	AC line voltage regulators; regulated DC supplies; saturable-core reactors; power transformers and chokes
Sound Apparatus Co.	Stirling, N. J.		Millington 7-0600	L. P. Reitz, Jr.	Graphic recorders
Speak-O-Phone Recording & Equip. Co.	New York 23	23 W. 60 St.	Columbus 5-1350	C. A. Austin	Disc recording equipment
Special Purpose Products Co.	New York 14	155 Perry St.	Chelsea 3-5505	Roscoe Kent	AM, FM, TV: Woundwood (non-conductive) antenna masts; TV to 90 ft.
SREPCO, Inc.	Dayton 2	135 E. 2nd St.	Fulton 2174	Clem E. Wolford	Nameplates for microphones, autos, panels, studio door, desk etc., lapel buttons, felt banners, recording labels
Stainless, Inc.	North Wales, Pa. New York 16 (Export) New York Phoenix	13 E. 40th St. 50 Church St. 15 W. Medlock Dr.	Murray Hill 9-0200	Henry Guzewicz D. W. A. Pleasanton Walter L. Guzewicz Frank Cooke	Towers
Stancil-Hoffman Corp.	Los Angeles 38 Chattanooga Dallas 8 New York 17 Seattle 2	1016 N. Highland Ave. Signal Mountain 414 E. 10th St. 60 E. 42nd St. 135 Harvard, N.	Hillside 7461 88-2487 Yale 21904 Murray Hill 7-1550 Minor 3537	William V. Stancil W. B. Taylor Howard D. Criss Henry J. Geist Adrian Van Santen	AM, FM: Magnetic recording, reproducing equipment. Accessory amplifier, electronic equipment. TV: Synchronous magnetic recording, reproducing equipment. Dummies, interlock equipment, dubbing consoles
Sun Copper & Wire Co.	Paterson, N. J.	132 Beckwith Ave.	Van Houten 4-2550	J. Emil Weissman	Plain enamel magnet wire
Superior Electric Co.	Bristol, Conn. Des Moines Los Angeles 15	Box 1491 1496 S. Grand Ave.	3141, 42, 43 7-0439 Hudson 2-7209	J. S. Louden L. C. Hardie J. C. Van Groos	Stabiline automatic voltage regulators, dimmers and variable transformers
Sylvania Electric Products, Inc.	New York 18 Chicago Cincinnati Washington, D. C.	500 Fifth Ave. 20 N. Wacker Dr. Terrace Plaza Bldg. Wash. Bldg.	Wisconsin 7-9500 Franklin 4512 Garfield 1550 Republic 7733	C. W. Shaw L. A. Wheelock J. T. Mallen A. C. Viebranz	AM, FM: Receiving, transmitting tubes; germanium diodes, oscilloscopes, signal generators, audio oscillators, vacuum tube voltmeters. TV: Same, picture tubes. Facsimile: Glow modulator tubes
Teletronics Corp.	Culver City, Calif.	8479 Hieguera St.	Texas 0-4384	Edwin B. Block	Amplifiers, recording; recording devices
Television Associates, Inc.	Michigan City, Ind.	E. Michigan St.	3655	Capt. W. C. Eddy	Studio lighting fixtures, incandescent, ceiling mounted fluorescent, dolly mounted fluorescent, microwave relay reflectors and supports, parapet clamps, tripods, dollies, continuous reel magazines for projection, kaleidoscope projectors, projection accessories and specialized films for continuous reel use
Television Utilities Corp.	New York 1	1261 Broadway	Murray Hill 4-2532	A. E. Siegel	TV monitors—10"—12½"—15" kinescopes
Terminal Radio Corp.	New York 7	85 Cortlandt St.	Worth 4-3311	Jack Simon	Pickups, studio speakers, call letter plates, amplifiers, microphones, accessories. TV: Receiving chassis and kits
Tower Sales & Erecting Co.	Portland 13, Ore.	6100 N. E. Columbia Blvd.	Trinity 7303	C. H. Fisher	Radio towers-vertical radiators, erecting, lighting, painting and ground systems. Installation coaxial lines
Trans-Lux News-Sign Corp.	New York 20	1270 Sixth Ave.	Circle 7-4970	Bert W. Roth	News signs. TV: Rear projection screens
Transmitter Equip. Mfg. Co., Inc.	New York 14	345 Hudson St.	Watkins 4-1550	Morton B. Kahn	Transmitters, studio speech amplifying equipment, relay transmitters and receivers, mobile equipment, studio-transmitter links, marine and public utilities communication equip. FM, TV, facsimile: Relay and studio-transmitter link
Truscon Steel Co.	Youngstown 1 Boston 27 Buffalo 3 Chicago 6 Cleveland 15 Dallas Kansas City 6 Long Island City Los Angeles 22 Minneapolis 2 Omaha 2 Portland 12, Ore. St. Louis 3 San Francisco 5 Wash. 5, D. C.	1315 Albert St. 307 Dorchester Ave. Rand Bldg. 201 N. Wells St. Hanna Bldg. Annex M & W Tower Bldg. 1012 Baltimore Ave. 48-18 Northern Blvd., corner 48 St. 5480 E. Slauson Ave. P. O. Box 6788, E. Los Angeles Branch Baker Bldg. Insurance Bldg. 2139 N. Kerby Ave. Shell Bldg. 604 Mission St. Continental Bldg.	3-2171 South Boston 8-2420-21-22 Washington 1351 Franklin 2-4600 Cherry 6282-3 Central 5448 Harrison 3673 Astoria 4-2410 Angeles 3-6160-5-7	George F. Bateson C. H. Watt R. A. Bohling C. L. Spatholt L. F. Stormont H. T. Swanson A. A. Raymond C. D. Love'and G. R. Roden	Self-supporting and uniform cross section guyed masts for AM and to support FM, TV and facsimile antennas, copper mesh ground screen, complete line of steel building products
The Turner Co.	Cedar Rapids	909 17th St., N.E.	3-2607	William J. Nezerka	Microphones, accessories
United Electronics Co.	Newark 2 Jackson, Mich. Kansas City 3, Mo. Los Angeles Minneapolis 5 New Orleans 12 San Francisco 5	42 Spring St. 1100 S. West Ave. 3119 Gillham Rd. Suite A 800 W. 11th St. 237 Sheridan Ave., S. 715 Camp St. Cunard Bldg.	Humboldt 2-0576 Jackson 2-2061 Logan 9545 Prospect 7503 Raymond 9009	C. A. Rice P. M. Day Maury E. Pettis J. T. Hill Marvin H. Kirkeby George H. Peirce R. E. Smiley	Broadcast transmitting tubes

(Continued on page 461)



GENERAL ELECTRIC

Transmitting Tubes

Up-to-the-minute types
FOR FM AND
TELEVISION



6L-7021



6L-5513



6L-5518



6L-9C10

**FOREMOST IN DESIGN—
PRECISION-BUILT—
PERFORMANCE-PROVED!**

● RECTIFIER TUBES in a wide range of sizes complete the G-E line. All your tube requirements can be filled from one responsible source—*your General Electric tube distributor.* He's near you; stocks the replacement types you need; gives fast service. Phone him today! *Electronics Department, General Electric Company, Schenectady 5, New York.*

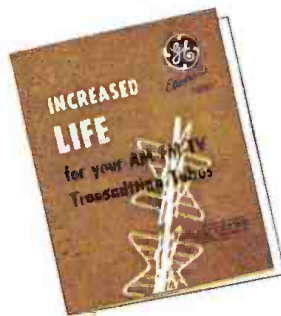

Want maximum service from your tubes? Ask your G-E tube distributor for the new booklet on increased tube life prepared by General Electric engineers as a help to radio-TV station operators. It's a cost-saver. It's free!

Standard types for
AM—LOW, MEDIUM,
AND HIGH-POWER



6L-810



6L-828



6L-892-R



6L-893-R

GENERAL ELECTRIC



GIVES YOU TWICE AS MUCH POWER GAIN PER DOLLAR!

NEW *Andrew* MULTI-V FM ANTENNA

TYPE	NO. OF BAYS	POWER GAIN	PRICE
1308	8	7.3	\$2800
1304	4	3.7	850
1302	2	1.6	320

This table shows you why the new Andrew Multi-V is your best FM antenna buy! NOW! Minimize your investment in equipment. Get top performance for only half the cost. The new Andrew Multi-V FM antenna is made and guaranteed by the World's Largest Antenna Equipment Specialists. It's another Andrew "First."

FEATURES

- ★ Twice as much power gain per dollar as any other FM transmitting antenna!
- ★ Top performance, yet half the cost of competitive antennas.
- ★ Side mounting construction permits installation on towers too light to support heavier antennas.
- ★ Circular radiation pattern.
- ★ Factory tuned to required frequency — no further adjustments necessary.

It will pay you to use the Andrew Multi-V Antenna on your FM station. Write for Bulletins 86 and 186 for complete details TODAY.

Andrew
CORPORATION

363 EAST 75th STREET · CHICAGO 19

World's Largest Antenna Equipment Specialists

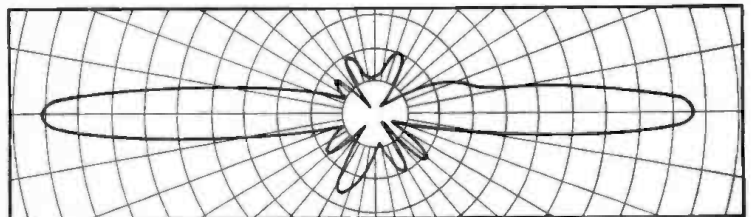

Typical vertical plane field intensity pattern of 4 bay Multi-V FM Antenna.

DIRECTORY OF AM-FM-TV EQUIPMENT MANUFACTURERS

(Continued from page 458)

NAME OF COMPANY	CITY	ADDRESS	TELEPHONE	MANAGER	PRODUCTS
U. S. Recording Co.	Wash. 5, D. C.	1121 Vermont Ave.	Sterling 3626	Robert L. Kaufman	Panacoustic line of electronic products, audio control consoles, salesman's and educational AC-DC playbacks, complete line recording, studio broadcast, intercommunication and sound equipment. FM, TV: Studio audio and special. FM: Amplifiers and installation
United States Television Mfg. Corp.	3 W. 61st St.	New York 23	Circle 6-4255	Francis H. Hoge, Jr.	TV: Receivers: 10" to 19" direct view sets and also projection
University Loudspeakers, Inc.	White Plains, N. Y.	80 S. Kensico Ave.	6-7700	Irving Golin	Co-axial loudspeakers, paging and talk back speakers; re-entrant projectors all types; driver units; power mike systems (tubeless system including microphone and loudspeaker-portable)
Webster Electric Co.	Racine	1900 Clark St.	3-3511	D. H. Darnold	Ekotape magnetic tape recorders
West Coast Electronics Co.	Los Angeles 6	1601 S. Burlington Ave.	Prospect 5041	P. J. Brady	Amplifiers, UHF, VHF, fixed and mobile, dipole, FM, ground plane; communications systems, radio-teletype, vehicular, FM-AM; recorders, magnetic tape
Westinghouse Electric Corp.	Baltimore 3 Atlanta 2 Boston 10 Chicago 8 New York 5 Philadelphia 4 Pittsburgh 30 St. Louis 1 San Francisco 4 Wash. 6, D. C.	2519 Wilkens Ave. 1299 Northside Dr. 10 High St. 20 N. Wacker Dr. 40 Wall St. 3001 Walnut St. 306 Fourth Ave. 411 N. 7th St. 1 Montgomery St. 1625 K St., N.W.	Edmonson 2300 Atwood 1641 Liberty 0600 Franklin 5520 Whitehall 3-4321 Evergreen 6-8700 Atlantic 8-400 Central 1120 Exbrook 5353 National 8843	H. D. Moreland A. W. Rose E. C. Delano A. M. Fisher J. S. Parry T. P. Jones L. H. Loufek A. F. Buck S. H. Harrison J. F. Hanlon	Amplitude and frequency modulated transmitters (5, 50 and 50 kw AM; 1, 3, 10, 50 kw FM) standard transmitter consoles, antenna phasing and tuning equipment, transmitting tubes, instruments, meters, relays, studio and tower lighting equipment, transformer, capacitors, circuit breakers, regulators, precipitrons and switchgear
Weston Electrical Instrument Corp.	Newark 5 Chicago 6 New York 7 Wash. 11, D. C.	614 Frelinghuysen Ave. 205 W. Wacker Dr. 50 Church St. 8230 Third St., N.W.	Franklin 2-4656 Cortlandt 7-0507-8-9 Tuckerman 2414	E. T. Higgons P. A. Westburg L. C. Nichols L. F. Parachini	Testing instruments. Foot-candle meters, shop portables, miniature portables, clamp ammeters, relays; panel, service switchboard instruments; volt-ohm-milliammeters, laboratory portables
Wincharger Corp.	Sioux City 6	E. 7th & Division Sts.	8-6513	M. M. Lasensky	Towers, lighting equipment. FM: Antennas, supporting towers for antenna
Wind Turbine Co.	West Chester, Pa.	E. Market St. & Pa. R. R.	3110	Davis B. Oat	Antennas, supply and installation of towers; ground systems, transmission lines, TV, FM: Same
The Workshop Associates, Inc.	Newton Highlands 61, Mass.	86 Needham St.	Bigelow 4-3330	K. P. Bloch	FM: Receiving antennas. TV: Same and accessories, studio-transmitter relay equipment antennae. Facsimile: Relay antennae. Complete line fixed frequency antennae for point-to-point service, emergency service, mobile, etc.
Zephyr Products Co.	New York 29	160 E. 116th St.	Sacramento 2-1800	Arthur Heine	Recording discs, wire recording spools, needles, accessories

califone

lightweight • portable • 3-speed
TRANSCRIPTION PLAYERS



MODEL 6U
\$64.95 plus federal excise tax

MODEL 12MU
\$89.95 plus federal excise tax
Special Trade Discounts to Radio Station,
Representatives and Advertising Agencies

SALES WORK... Over 700 radio stations are now using lightweight, portable Califone transcription players. Three speeds for up to 16" recordings produce professional quality sound reproduction for the most expensive transcribed shows and spots.

BROADCAST TURNTABLES... Many radio stations are using Califone for broadcasting turntables where quality and economy are factors. In addition to their versatility (3-speeds); prolonged peak performance and longer life of valuable records is assured by Califone's unique wrist-action pick-up.

**PROFESSIONAL QUALITY • UNEQUALLED VERSATILITY
ULTIMATE PORTABILITY**

"Easier to Carry than a Portable Typewriter"

CALIFONE corporation

1041 NORTH SYCAMORE AVENUE
HOLLYWOOD 38, CALIFORNIA

AMPERITE Studio Microphones at P.A. Prices

Ideal for BROADCASTING
• RECORDING
• PUBLIC ADDRESS

"The ultimate in microphone quality," says Evan Rushing, sound engineer of the Hotel New Yorker.

- Shout right into the new Amperite Microphone—or stand 2 feet away—reproduction is always perfect.
- The only type microphone that is not affected by any climatic conditions.
- Guaranteed to withstand more "knocking around" than any other type mike.

Special Offer: Write for Special Introductory Offer, and 4-page illustrated folder.

AMPERITE Company, Inc.
561 BROADWAY • NEW YORK 12, N. Y.

In Canada: Atlas Radio Corp., Ltd., 560 King St. W., Toronto



Models
RBLG—200 ohms
RBHG—Hi-imp.
List \$42.00



"Kontak" Mikes
Model SKH, list \$12.00
Model KKH, list \$18.00

FCC RULES & REGULATIONS FOR BROADCAST SERVICES

Selected Sections as Amended to Jan. 1, 1950

Allocations and Definitions

IN AM RULES' . . .

§3.1 *Standard broadcast station*.—The term "standard broadcast station" means a station licensed for the transmission of radio-telephone emissions primarily intended to be received by the general public and operated on a channel in the band 550-1600 kilocycles, inclusive.

§3.2 *Standard broadcast band*.—The term "standard broadcast band" means the band of frequencies extending from 550-1600 kilocycles, inclusive, both 550 kilocycles and 1600 kilocycles being the carrier frequencies of broadcast channels.

§3.3 *Standard broadcast channel*.—The term "standard broadcast channel" means the band of frequencies occupied by the carrier and two side bands of a broadcast signal with the carrier frequency at the center. Channels shall be designated by their assigned carrier frequencies. Carrier frequencies assigned to standard broadcast stations shall begin at 550 kilocycles and be in successive steps of 10 kilocycles.

§3.4 *Dominant station*.—The term "dominant station" means a class I station, as hereinafter defined, operating on a clear channel.

§3.5 *Secondary station*.—The term "secondary station" means any station except a class I station operating on a clear channel.

§3.6 *Daytime*.—The term "daytime" means that period of time between local sunrise and local sunset.

§3.7 *Nighttime*.—The term "nighttime" means that period of time between local sunset and 12 midnight local standard time.

§3.8 *Sunrise and sunset*.—The terms "sunrise and sunset" mean, for each particular location and during any particular month, the average time of sunrise and sunset as specified in the license of a broadcast station. (For tabulations of average sunrise and sunset times for each month at various points in the United States, see "Average Sunrise and Sunset Times.")

§3.9 *Broadcast day*.—The term "broadcast day" means that period of time between local sunrise and 12 midnight local standard time.

§3.10 *Experimental period*.—The term "experimental period" means that time between 12 midnight and local sunrise. This period may be used for experimental purposes in testing and maintaining apparatus by the licensee of any standard broadcast station on its assigned frequency and with its authorized power, provided no interference is caused to other stations maintaining a regular operating schedule within such period. No station licensed for "daytime" or "specified hours" of operation may broadcast any regular or scheduled program during this period.

Co-Channel Interference Measurements

Measurement of daytime or nighttime co-channel
interference can now be made

Without interruption of any station's operation

By use of method and equipment covered by U. S.
patent #2,079,205

Equipment is available under reasonable rental and
royalty basis to competent engineers
or measurements by our own engi-
neers.

Glenn D. Gillett

Owner of U. S. Patent

#2,079,205

INDEX TO SECTIONS

Allocations and Definitions	462
Censorship	486
Facsimile	474
Indecent Language	486
License Renewals	480
Lotteries	486
Multiple Ownership	468
Network Affiliation	474
Operating Schedules	470
Operator Requirements	474
Political Broadcasts	484
Rebroadcasts	484
Recordings and Transcriptions	484
Reports to Be Filed	478
Revocations; Modifications; Suspensions	484
Sponsored Programs	482
Station Identification	482
Transfers and Assignments	486

(EDITOR'S NOTE: For convenience, rules for AM, FM and TV have been consolidated under the above general headings.)

[EDITOR'S NOTE: FCC had pending on Jan. 1, but had not acted finally upon, a proposal to define "experimental period" as the period between 1 a.m. and 6 a.m., local standard time.]

§3.11 *Service areas*.—(a) The term "primary service area" of a broadcast station means the area in which the ground wave is not subject to objectionable interference or objectionable fading.

(b) The term "secondary service area" of a broadcast station means the area served by the sky wave and not subject to objectionable interference. The signal is subject to intermittent variations in intensity.

(c) The term "intermittent service area" of a broadcast station means the area receiving service from the ground wave but beyond the primary service area and subject to some interference and fading.

§3.12 *Main studio*.—The term "main studio" means, as to any station, the studio from which the majority of its local programs originate, and/or from which a majority of its station announcements are made of programs originating at remote points.

[EDITOR'S NOTE: FCC had pending but had not acted upon Jan. 1, a proposal to require each station to originate a majority of its non-network programs (majority from standpoint of time) from the city in which the station is located as shown in its license.]

§3.13 *Portable transmitter*.—The term "portable transmitter" means a transmitter so constructed that it may be moved about conveniently from place to place, and is in fact so moved about from time to time, but not ordinarily used while in motion. In the standard broadcast band, such a transmitter is used in making field intensity measurements for locating a transmitter site for a standard broadcast station. A portable broadcast station will not be licensed in the standard broadcast band for regular transmission of programs intended to be received by the public.

§3.14 *Auxiliary transmitter*.—The term "auxiliary transmitter" means a transmitter maintained only for transmitting the regular programs of a station in case of failure of the main transmitter.

Allocations—(AM)

§3.21 *Three classes of standard broadcast channels*.—(a) Clear channel: A "clear channel" is one on which the dominant station or stations render service over wide areas and which are cleared of objectionable interference within their primary service areas and over all or a substantial portion of their secondary service areas.

(b) *Regional channel*: A "regional channel" is one on which several stations may operate with powers not in excess of 5 kilowatts. The primary service area of a station operating on any such channel may be limited as a consequence of interference, to a given field intensity contour.

(c) *Local channel*: A "local channel" is one on which several stations may operate with powers not in excess of 250 watts. The primary service area of a station operating on any such channel may be limited as a consequence of interference, to a given field intensity contour.

§3.22 *Classes and power of standard broadcast stations*.—(a) *Class I station*: A "class I station" is a dominant station operating on a clear channel and designed to render primary and secondary service over an extended area and at relatively long distances. Its primary service area is free from objectionable interference from other stations on the same and adjacent channels and its secondary service area free from interference except from stations on the adjacent channel, and from stations on the same channel in accordance with the channel designation in section 3.25 or in accordance with the Engineering Standards of Allocation. The operating power shall be not less than 10 kilowatts nor more than 50 kilowatts. (Also see section 3.25 (a) for further power limitation.)

(b) *Class II station*: A "class II station" is a secondary station which operates on a clear channel (see section 3.25) and is designed to render service over a primary service area which is limited by and subject to such interference as may be received from class I stations. A station of this class shall operate with power not less than 0.25 kilowatts nor more than 50

¹ Other definitions which may pertain to standard broadcast stations are included in sections 2.1 to 2.35 and the Communications Act of 1934, as amended. (Continued on page 464)

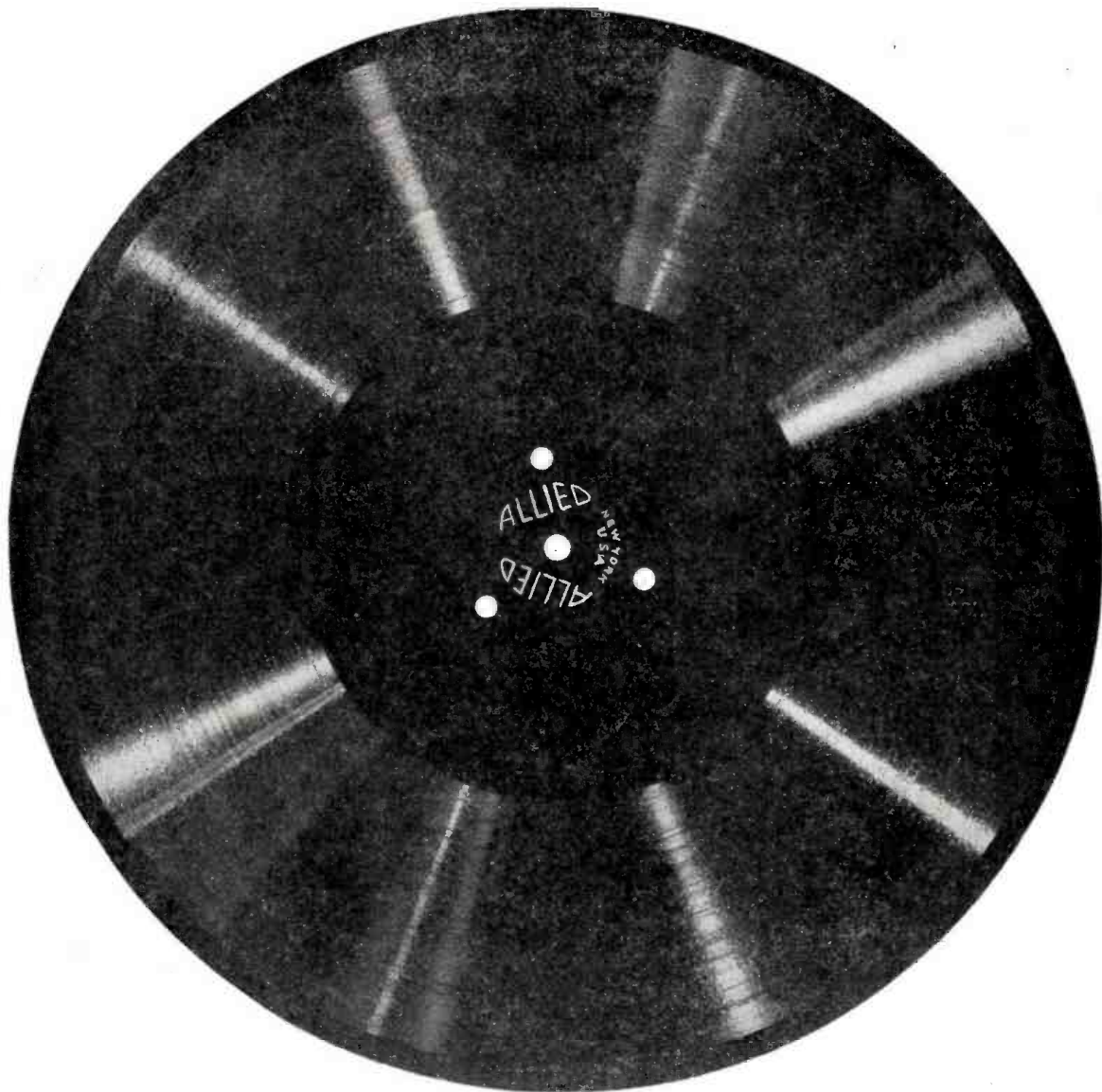

TOP QUALITY PROFESSIONAL RECORDING

will result from the use of ALLIED Professional Recording Discs. ALLIED is no new name in the field of instantaneous sound recording. ALLIED is one of the pioneers in this field!

The new improved ALLIED Professional Recording Discs are the result of 15 years of research and experimentation. It is a quality product made to meet the specific needs of professional users of recording discs, and has been so used since the start of instantaneous sound recording.

ALLIED

RECORDING PRODUCTS CO.

21-09 43rd AVENUE
LONG ISLAND CITY 1, NEW YORK

FCC RULES AND REGULATIONS
(Continued from page 462)

kilowatts. Whenever necessary, a class II station shall use a directional antenna or other means to avoid interference with class I stations and with other class II stations, in accordance with the Engineering Standards of Allocation.

(c) *Class III station:* A "class III station" is a station which operates on a regional channel and is designed to render service primarily to a metropolitan district¹ and the rural area contiguous thereto. Class III stations are subdivided into two class:

(1) *Class III-A station:* A "class III-A station" is a class III station which operates with power not less than 1 kilowatt nor more than 5 kilowatts, and the service area of which is subject to interference in accordance with Engineering Standards of Allocation.

(2) *Class III-B station:* A "class III-B station" is a class III station which operates with a power not less than 0.5 kilowatt nor more than 1 kilowatt night and 5 kilowatts daytime, and the service area of which is subject to interference in accordance with the Engineering Standards of Allocation.

(d) *Class IV station:* A "class IV station" operating on a local channel and designed to render service primarily to a city or town and the suburban and rural areas contiguous thereto. The power of a station of this class shall not be less than 0.1 kilowatt nor more than 0.25 kilowatt, and its service area is subject to interference in accordance with the Engineering Standards of Allocation.

§3.23 *Time of operation of the several classes of stations.*¹—The several classes of standard broadcast stations may be licensed to operate in accordance with the following.

(a) "Unlimited time" permits operation without a maximum limit as to time.

(b) "Limited time" is applicable to class II (secondary stations) operating on a clear channel only. It permits operation of the secondary station during daytime, and until local sunset if located west of the dominant station on the channel, or if located east thereof, until sunset at the dominant station; and in addition during night hours, if any, not used by the dominant station or stations on the channel.

(c) "Daytime" permits operation during the hours between average monthly local sunrise and average monthly local sunset. (For exact time of sunset at any location see "Average Sunrise and Sunset Times.") Daytime stations operating on local channels may, upon notification to the Commission and the engineer in charge of the district in which they are located, operate at hours beyond those specified in their license.

(d) "Sharing time" permits operation during hours which are so restricted by the station license as to require a division of time with one or more other stations using the same channel.

(e) "Specified hours" means that the exact operating hours are specified in the license. (The minimum hours that any station shall operate are specified in section 3.71.) Specified hours stations operating on local channels except

those sharing time with other stations may, upon notification to the Commission and the engineer in charge of the district in which they are located, operate at hours beyond those specified in their license.

§3.25 *Clear channels: class I and II stations.*—The frequencies in the following tabulations are designated as clear channels and assigned for use by the classes of stations given:

(a) To each of the channels below there will be assigned one class I station and there may be assigned one or more class II stations operating limited time or daytime only: 640, 650, 660, 670, 700, 720, 750, 760, 770, 780, 820, 830, 840, 870, 880, 890, 1020, 1040, 1100, 1120, 1160, 1180, 1200, and 1210 kilocycles. The power of the class I stations on these channels shall not be less than 50 kilowatts.

(b) To each of the channels below there may be assigned class I and class II stations: 680, 710, 810, 850, 940, 1000, 1030, 1060, 1070, 1080, 1090, 1110, 1130, 1140, 1170, 1190, 1500, 1510, 1520, 1530, 1550, and 1560 kilocycles.

(c) For class II stations which will not deliver over 5 microvolts per meter groundwave or 25 microvolts per meter 10 percent time sky wave at any point on said border and provided that such stations operating nighttime (i.e., sunset to sunrise at the location of the class II station) are located not less than 650 miles from the nearest Canadian border, 690, 740, 860, 990, 1010⁴ and 1580 kilocycles.

(d) For class II stations which operate daytime only with power not in excess of 1 kilowatt and which will not deliver over 5 microvolts per meter ground wave at any point on the nearest Mexican border, 730, 800, 900, 1050,⁵ 1220,⁶ and 1670 kilocycles.

(e) For class II stations which will deliver not over 5 microvolts per meter ground wave or 25 microvolts per meter 10 per cent time sky wave at any point of land in the Bahama Islands, and provided that such stations operating nighttime (i.e., sunset to sunrise at the location of the class II station) are located not less than 650 miles from the nearest point of land in the Bahama Islands, 1540 kilocycles.

§3.26 *Regional channels: classes III-A and III-B stations.*—The following frequencies are designated as regional channels and are assigned for use by class III-A and III-B stations⁷: 550, 560, 570,⁸ 580, 590,⁹ 600, 610, 620, 630,⁹ 790, 910, 920, 930, 950, 960, 970, 980, 1150, 1250, 1260, 1270,⁹ 1280, 1290, 1300, 1310, 1320, 1330, 1350, 1360, 1370, 1380, 1390, 1410, 1420, 1430, 1440, 1460, 1470, 1480, 1590, and 1600 kilocycles.

§3.27 *Local channels: class IV stations.*—The following frequencies are designated as local channels and are assigned for use by class IV stations: 1230, 1240, 1340, 1400, 1450, and 1490 kilocycles.

§3.28 *Assignment of stations to channels.*—(a) The individual assignments of stations to channels which may cause interference to other United States stations only shall be made in accordance with the standards of good engineering practice prescribed and published from time to time by the Commission for the respective classes of stations involved. (For determining objectionable interference see "Engineering Standards of Allocation" and "Field Intensity Measurements in Allocation", Section C.)

(b) In all cases where an individual station assignment may cause interference with or may involve a channel assigned for priority of use by a station in another North American country, the classifications, allocation requirements and engineering standards set forth in the North American Regional Broadcasting Agreement shall be observed.

§3.29 *Assignment of class IV stations to regional channels.*—On condition that interference will not be caused to any class III station and that the channel is used fully for class III stations, and subject to interference as may be received from class III stations, class IV stations may be assigned to regional channels.

§3.30 *Station location.*—(a) Each standard broadcast station shall be considered located in the State and city where the main studio is located.

(b) The transmitter of each standard broadcast station shall be so located that primary service is delivered to the borough or city in which the main studio is located in accordance with the Standards of Good Engineering Practice, prescribed by the Commission.

§3.31 *Authority to move main studio.*—The licensee of a standard broadcast station shall not move its main studio outside the borders of the borough or city, State, district, Territory, or possession in which it is located without first making written application¹⁰ to the Commission for authority to so move, and securing written permission for such removal. The licensee shall promptly notify the Commission of any other change in location of the main studio.

IN FM RULES . . .

§3.201 *Numerical designation of FM broadcast channels.*—For convenience, the frequencies available for FM broadcasting (including those assigned to non-commercial educational broadcasting) are given numerical designations which are shown in the table below:

[EDITOR'S NOTE: The band is 88-108 mc. Noncommercial educational FM occupies 88-92 mc. Class A commercial channels are shown in 3.203(b), below. The rest are Class B.]

§3.202 *Areas of the United States.*—For the purpose of allocation the United States is divided into two areas. The first area—Area I—includes southern New Hampshire; all of Massachusetts, Rhode Island, and Connecticut; southeastern New York as far north as Albany-Troy-Schenectady; all of New Jersey, Dela-

¹ The term "metropolitan district" as used in this paragraph is not limited in accordance with the definition given by the Bureau of the Census but includes any principal center of population in any area.

² Formal application required for change in time of operation of existing broadcast station. See Standards of Good Engineering Practice for form number.

³ A station on 1010 kilocycles shall also protect a class I-B station at Havana, Cuba.

⁴ See North American Regional Broadcasting Agreement for use of this channel by a station in New York (Appendix I, Table IV.)

⁵ See Agreement with Mexico for further use of this channel.

⁶ See section 3.29 in regard to assigning class IV stations to regional channels.

⁷ See North American Regional Broadcasting Agreement for special provisions concerning the assigning of class II stations in other countries of North America to these regional channels. Such stations shall be protected from interference in accordance with appendix II, Table I, of said Agreement.

⁸ Formal application required. See Standards of Good Engineering Practice for form number.

(Continued on page 466)

For The Midwest

JOHN B. HEFFELFINGER

CONSULTING RADIO ENGINEER

A M - F M - T V

Application Work

Allocation and Field Engineering

Proof Measurements

815 East 83rd
Street

Telephone
HIland 7010

KANSAS CITY 5, MISSOURI

CALL **BDN** TO PUT UP YOUR STEEL TOWER ... QUICKLY, SAFELY

Ask the Chief Engineer of any large network why.

BDN is the choice of chief engineers everywhere who want a competent organization to assume the *entire responsibility* of completing a tower erection satisfactorily and on schedule. BDN's expertly trained field force will go anywhere . . . at any time . . . on any call.

BDN'S EXCEPTIONAL QUALIFICATIONS INCLUDE:

- An Experienced Engineering Organization
- An Impressive Experience Record with many years' background in heavy steel construction work.
- An Expertly Trained Crew with the ability to go up any tower to do the job properly.
- Adequate financial resources to complete the job. Each job is fully bonded.
- Perfect erection and operation guaranteed upon completion.
- Erection completed when promised—no matter how difficult the job.
- Complete liability insurance carried.
- FREE ESTIMATE furnished upon request.

BDN has handled a greater number of *difficult* tower erections than any other erecting company. Representative jobs are illustrated. This performance record is your best guarantee of a completely satisfactory job.

Write today for FREE ESTIMATE—no obligation whatsoever.



82 W. WASHINGTON ST., CHICAGO 2, ILL.



BROADCASTING • Telecasting

1950 Yearbook Number • Page 465

Matched for your TV needs

70-DA Camera

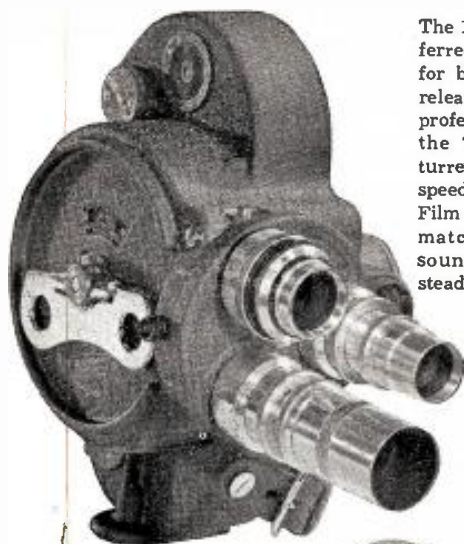

The 16mm camera that's preferred by leading TV stations for both spot news and full releases. Long the choice of professionals in every field, the 70-DA has three-lens turret head, seven operating speeds including slow motion. Film movement mechanism matches that of the Filmosound to give you brilliant steady pictures.

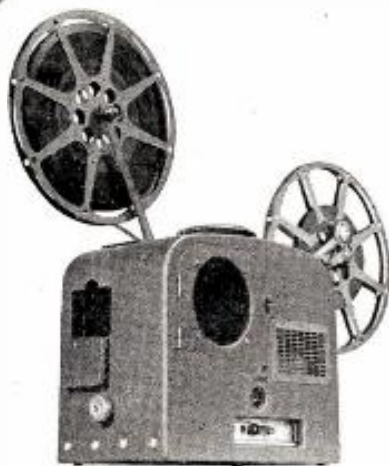

One-Case Filmosound Sound Projector

First choice of TV experts for previewing film before broadcasting... and for showing film to clients. Projects 16mm film—sound or silent—with a perfection that's made it No. 1 choice among experienced users. Light, compact, easy to carry and operate. With six-inch built-in speaker. Larger separate speakers available for audiences up to auditorium size.

Send for Bell & Howell TV Booklet

Complete catalogue of fine Bell & Howell TV equipment and how you can use it to improve your TV services! Write for it today!

You buy for a lifetime when you buy

Bell & Howell

7151 McCormick Road, Chicago 45, Ill.

FCC RULES AND REGULATIONS

(Continued from page 464)

ware, and the District of Columbia; Maryland as far west as Hagerstown; and eastern Pennsylvania as far west as Harrisburg.¹⁰ The second area—Area II—comprehends the remainder of the United States not included in Area I.

§3.203 *Class A Stations.*—(a) A class A station is a station which operates on a class A channel and is designed to render service primarily to a community or to a city or town other than the principal city of an area, and the surrounding rural area. The coverage of a Class A station shall be not more than the equivalent¹¹ of 1 kilowatt effective radiated power and antenna height of 250 feet above average terrain, as determined by the methods prescribed in the Standards of Good Engineering Practice Concerning FM Broadcast Stations. A Class A station will not be licensed with more than 1 kilowatt effective radiated power. The power rating of the transmitter used for a Class A station shall be not less than 250 watts nor more than 1 kilowatt. The signal intensity requirements of Section 2 of the Standards of Good Engineering Practice Concerning FM Broadcast Stations shall determine the minimum coverage of a Class A station. Class A stations will normally be protected to the 1 mv/m contour; however, assignments will be made in a manner to insure, insofar as possible, a maximum of service to all listeners, whether urban or rural, giving consideration to the minimum signal capable of providing service.

(b) The following frequencies are designated as Class A channels and are assigned for use by Class A stations:

Frequency (mc.)	Channel No.	Frequency (mc.)	Channel No.	Frequency (mc.)	Channel No.
92.1	221	96.7	244	102.3	272
92.7	224	97.7	249	103.1	276
93.5	228	98.3	252	103.9	280
94.3	232	99.3	257	104.9	285
95.3	237	100.1	261	105.5	288
95.9	240	100.9	265	106.3	292
		101.7	269	107.1	296

These channels are available for assignment (1) in cities which are not the central city or cities of a metropolitan district, and (2) in central cities of metropolitan districts which have fewer than six class B stations.

(c) The main studio of a class A station shall be located in the city served and the transmitter shall be located as near the center of the city as practicable.

§3.204 *Class B Stations.*—(a) A class B station is a station which operates on a class B channel and is designed to render service primarily to a metropolitan district or principal city and the surrounding rural area, or to rural areas removed from large centers of population. The service area of a class B station will not be protected beyond the 1 mv/m contour; however, class B assignments will be made in a manner to insure, insofar as possible, a maximum of service to all listeners, whether urban or rural, giving consideration to the minimum signal capable of providing service. Standard power ratings of transmitters used for class B stations shall be 1 kw or greater. The signal intensity requirements of Section 2 of the Standards of Good Engineering Practice Concerning FM Broadcast Stations shall determine the minimum coverage of a class B station. In the following sub-sections, antenna height above average terrain and effective radiated power are to be determined by the methods prescribed in the Standards of Good Engineering Practice Concerning FM Broadcast Stations.

(1) The coverage of a Class B station in Area I shall be not more than the equivalent¹¹ of 20 kilowatts effective radiated power and antenna height of 500 feet above average terrain¹². A class B station in Area I will not be licensed with an effective radiated power greater than 20 kilowatts.

(2) The coverage of a Class B station in Area II shall normally be not more than the equivalent¹¹ of 20 kilowatts effective radiated power and antenna height of 500 feet above average terrain.¹² The use of greater power and antenna height will be encouraged in those portions of area II where such use would not result in undue interference to stations already authorized or to probable assignments insofar as can be determined at the time of the grant. In such case, the power, antenna height, and area will be determined on the merits of each application with particular attention being given to rural areas which would not otherwise receive service.

(b) The following frequencies are designated as Class B channels and are assigned for use by Class B stations.

[EDITOR'S NOTE: Class B channels are those channels between 92 mc and 108 mc which are not designated as Class A channels in §3.203(b).]

§3.205 *Station location.*—(a) Each FM broadcast station shall be considered located in the state and city where the main studio is located.

(b) The transmitter of each FM broadcast station shall be so located that satisfactory service is delivered to the city where the main studio is located, in accordance with the Standards of Good Engineering Practice Concerning FM Broadcast Stations; *Provided, however,* upon special showing of need, authorization may be granted to locate the transmitter so that adequate service

¹⁰ In some of the territory contiguous to area 1, the demand for frequencies requires that applications be given careful study and consideration to insure an equitable distribution of facilities throughout the region. This region includes the remainder of Maryland, Pennsylvania, and New York (except the northeastern corner) not included in area I; Virginia, West Virginia, North Carolina, South Carolina, Ohio and Indiana; southern Michigan as far north as Saginaw; eastern Illinois as far west as Rockford-Decatur; and southeastern Wisconsin as far north as Sheboygan. Other regions may be added as required.

¹¹ For the purpose of determining equivalent coverage, the 1 mv/m contour should be used.

¹² In the determination of appropriate coverage, consideration should be given to population distribution, terrain, service from other FM stations, trade area and other economic factors. Among the recognized trade area authorities are the following: J. Walter Thompson (Retail Shopping Areas), Hearst Magazines, Inc. (Consumer Trading Areas), Rand McNally Map Co. (Trading Areas) and Hagsstrom Map Co. (Four Color Retail Trading Area Map.)

(Continued on page 468)

Right: Truscon Guyed Radio Tower rises 938 feet above the Oklahoma plain, with a General Electric 8-bay circular FM antenna and its beacon, for KOCY-FM, Oklahoma City, Oklahoma.

938 FEET

336 FEET

Above: Truscon Self-Supporting Steel Radio Tower, operated by WMRI-FM, Marion, Indiana, lifts its Collins 8-ring side-mounted antenna 336 feet into the Hoosier sky.

Below: WSAR, Fall River, Mass., uses four Truscon Guyed Steel Radio Towers, each 329 feet high.

329 FEET

Up they go . . . more and more Truscon Radio Towers . . . strong, sturdy steel fingers setting new high standards of antenna performance . . . reaching far out to serve audio and video broadcasters and their audiences everywhere. The six new towers shown here vary from 329 feet to a lofty 1220 feet, yet all have one characteristic in common—each is designed to meet exactly the particular operating and geographical needs of its specific location. Truscon draws upon a background of world-wide experience to engineer and erect exactly the tower you need—tall or small . . . guyed or self-supporting . . . tapered or uniform in cross-section . . . for AM, FM and TV transmission. Your phone call or letter to any convenient Truscon district office, or to our home office in Youngstown, will bring you immediate, capable engineering assistance. Call or write today.

1220 FEET

Left: These new 1220-foot Towers, designed and engineered by Truscon, are the world's tallest radio towers.

485 FEET

Above: This Truscon Self-Supporting Tower meets FM and TV needs for WRVB, Richmond, Va. It mounts both an R.C.A. 2-section pylon FM antenna and an R.C.A. 6-section TV antenna.

Below: Rising to an overall height of 425 feet, this Truscon Type H-30 Self-Supporting Tower is topped with an 8-bay General Electric antenna. It is operated by WEXL-FM, Royal Oak, Michigan.

425 FEET

**TRUSCON
TOWERS
OF
STRENGTH
STANDARD OF THE WORLD**

TRUSCON
SELF-SUPPORTING
AND UNIFORM
CROSS SECTION GUYED
TOWERS

COPPER GROUND SCREEN
TRUSCON STEEL COMPANY
YOUNGSTOWN 1, OHIO
Subsidiary of Republic Steel Corporation



Look to ALLIED

for Your Station Supplies



SERVICE EVERYWHERE

Over 600 stations—coast to coast and border to border—look to ALLIED as their dependable source for station supplies and accessories.

ALL STATION SUPPLIES

Our great in-stock resources (largest in the country) and close contacts with all major manufacturers, guarantee the fastest and most complete service for the BC and TV engineer. Name your need—we have it!

IN STOCK

PERSONAL EXPERT SERVICE

You get exactly what you want—when you want it! All station orders, large or small, get preferred speedy handling. Our Broadcast Division is headed by commercially licensed operators who cooperate intelligently to keep your station running at top efficiency.

GET IT QUICK

EMERGENCY SERVICE

Write for details of our Day and Night station supply service. We've made many an "impassible delivery" to keep station schedules moving smoothly. Drop a line to "Chet" Wharfield at ALLIED to learn how this service works.

DAY & NIGHT



GET THE ALLIED CATALOG

Here's the outstanding 196-page Buying Guide to standard radio and electronic equipment. If you haven't a copy, let us know—we'll be glad to send one to you promptly.

If you don't receive our Broadcast Bulletins, send us your name and we'll see that you get them regularly.

FOR EVERYTHING—ANYTIME, ANYWHERE
CALL: HAYmarket 1-6800

or wire or write to

ALLIED RADIO

BROADCAST DIVISION

833 W. Jackson Blvd., Chicago 7, Ill.

FCC RULES AND REGULATIONS

(Continued from page 466)

is not rendered to this city, but in no event shall this city be beyond the 50 uv/m contour.

§3.206 *Main Studio*.—The term "main studio" means the studio from which the majority of local programs originate and/or from which a majority of station announcements are made of programs originating at remote points.

[EDITOR'S NOTE: FCC has proposed, but on Jan. 1 had not adopted the proposal, to amend §3.205(a) to add a requirement that a majority of a station's non-network program time be originated in the city where the station is located.]

IN TELEVISION RULES . . .

§3.601 *Numerical designation of television channels*.—The channels or frequency bands set forth below are available for television broadcast stations.*

Channel No.	Megacycles	Channel No.	Megacycles
1	44-50	8	180-186
2	54-60	9	186-192
3	60-66	10	192-198
4	66-72	11	198-204
5	76-82	12	204-210
6	82-88	13	210-216
7	174-180		

* [EDITOR'S NOTE: By order adopted May 5, 1948, effective June 14, 1948, FCC deleted TV channel No. 1 by allocating 44-50 mc to non-government fixed and mobile services. The sharing of Channels 2-13 by non-television services was eliminated at the same time. At year's end, FCC had pending a proposal to allocate 42 channels in the 470-890 mc area for commercial television operation, and to revise drastically the existing TV rules and standards.]

Multiple Ownership*

IN AM RULES . . .

§3.35 *Multiple Ownership*.—No license shall be granted for a standard broadcast station, directly or indirectly owned, operated or controlled¹³ by any person¹⁴ where such station renders or will render primary service to a substantial portion of the primary service area of another standard broadcast station, directly or indirectly owned, operated or controlled by such person, except upon a showing that public interest, convenience and necessity will be served through such multiple ownership situation.

IN FM RULES . . .

§3.240 *Multiple Ownership*.—(a) No person (including all persons under common control)¹⁵ shall, directly or indirectly, own, operate, or control more than one FM broadcast station that would serve substantially the same service area as another FM broadcast station owned, operated, or controlled by such person.

(b) No person (including all persons under common control), shall, directly or indirectly, own, operate, or control more than one FM broadcast station, except upon a showing (1) that such ownership, operation or control would foster competition among FM broadcast stations or provide an FM broadcasting service distinct and separate from existing services, and (2) that such ownership, operation, or control would not result in the concentration of control of FM broadcasting facilities in a manner inconsistent with public interest, convenience, or necessity: *Provided, however*, That the Commission will consider the ownership, operation, or control of more than six FM broadcast stations to constitute the concentration of control of FM broadcasting facilities in a manner inconsistent with public interest, convenience, or necessity.

IN TELEVISION RULES . . .

§3.640—[EDITOR'S NOTE: Identical with §3.240, above, with two exceptions: "television broadcast station" is substituted for "FM broadcast station" wherever it appears; and, in the proviso clause of paragraph (b), "ownership, operation, or control of more than five television broadcast stations" is regarded as concentration of control.]

* [EDITOR'S NOTE: FCC had pending on Jan. 1, but had not acted upon, a proposal to set seven stations as the maximum for common ownership in AM. Six would remain the maximum in FM; five in TV.]

[The proposed rule would also extend to minority interests. In each class (AM, FM, TV) the number of stations controlled by a single person or entity would determine the number of other stations in which the same person (or any stockholder, officer or director, in the case of corporations) might have less than controlling interests. The following table would govern. The numbers in the column "S-C" refer to stations controlled. Directly, opposite each such number is shown, in the column headed "M-I," the number of other stations in which minority interests would be permitted.]

AM		FM		TV	
S-C	M-I	S-C	M-I	S-C	M-I
7	0	6	0	5	0
6	1 or 2	5	1 or 2	4	1 or 2
5	3 or 4	4	3 or 4	3	3 or 4
4	5 or 6	3	5 or 6	2	5 or 6
3	7 or 8	2	7 or 8	1	7 or 8
2	9 or 10	1	9 or 10	0	9 or 10
1	11 or 12	0	11 or 12		
0	13 or 14				

¹³ The word "control", as used herein, is not limited to majority stock ownership but includes actual working control in whatever manner exercised.

¹⁴ The word "person", as used herein, includes all persons under common control.

(Continued on page 470)

BROADCASTING • Telecasting

For high quality transmission of programs

TELEVISION UHF RADIO RELAY LINK

*Studio to transmitter link
Inter-city relay
Remote portable pickup*



Transmitter

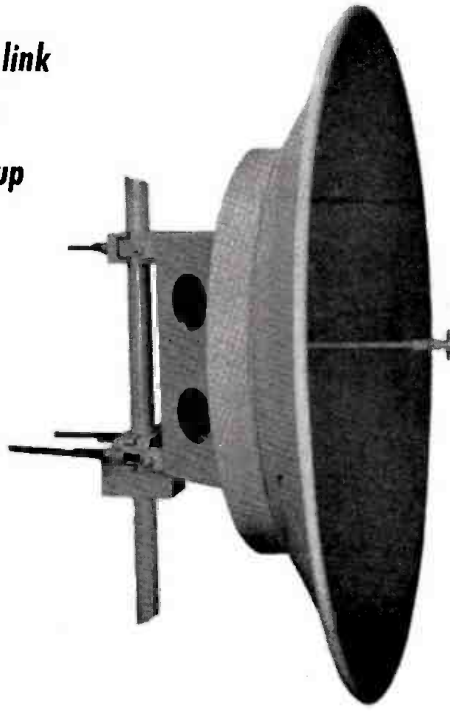

Parabolic Antenna



Receiver

The FTL-27A Radio Relay Link is a studio to transmitter link, inter-city relay or remote portable pickup for broadcast television programs. It provides a high quality video circuit meeting all television requirements in each case. Wire or coaxial circuits are eliminated. Single hop transmissions up to forty five miles or multiple relay operation for inter-city service are supplied as required. This equipment meets all FCC and RMA standards and is suitable for unattended service without modification.

Write for complete FTL-27A brochure.

Federal Telecommunication Laboratories, Inc.

The finest in television broadcasting equipment

500 WASHINGTON AVENUE

NUTLEY 10, NEW JERSEY

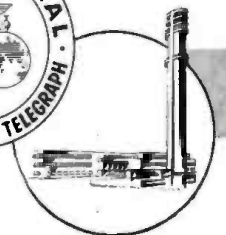

TAPE OR DISK

YOU CHOOSE FAIRCHILD

FOR TOP PERFORMANCE

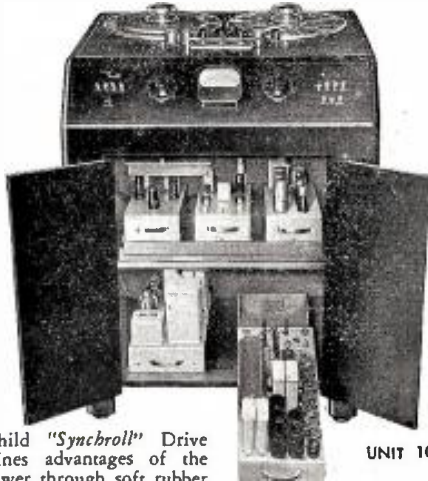

UNIT 100

★ The Fairchild "Synchrol" Drive System combines advantages of the transfer of power through soft rubber idlers with those of direct gear control of the capstan. This unique development of Fairchild results in a *no-slip synchronous* tape drive.

★ High Frequency Flutter causes roughness in a reproduced sine wave tone. *Smooth motion* in the Fairchild Tape Recorder is apparent in the *cleanliness* of simple musical tones.

★ Hum problems are generally recognized as inherent in magnetic recorders. The high efficiency of Fairchild Playback Head design and amplifier construction results in a hum measurement at least *68 db down*. (ref. 2% distortion).

THE FAIRCHILD PROFESSIONAL TAPE RECORDER easily outperforms requirements set by NAB Standards. Features include: "plug-in" type construction, both mechanical and electrical, for uninterrupted service; interlock system to prevent accidental erasing; volume indicator and circuit metering; adjustment of playback head during operation for optimum performance with all tapes; simultaneous monitoring from the tape during actual recording. Major network and recording studios are using Fairchild Tape Recorders. Write for complete information.

FAIRCHILD SYNCHRONOUS DISK RECORDERS



ACCURATE PROGRAM TIMING—Synchronous direct to the center gear drive for shows "on the nose".

FREEDOM FROM WOW—No slip-page. No musical pitch change to make listeners aware the show is transcribed.

SOUND ON FILM DUBBING—Many of the motion picture sound tracks you hear and enjoy are first recorded on Fairchild Synchronous Disk Recorders.

Above are some of the features that have gained FAIRCHILD the reputation for the finest in recording equipment. Fairchild Synchronous Disk Recorders are manufactured in 3 models; Unit 523 for Microgroove recording and for the finest fixed studio installations; Unit 539K for the small budget studio; Unit 539G (shown above) for console performance in a portable unit. Maintain your reputation for making the finest transcriptions and masters with Fairchild equipment. Write for illustrations and complete specifications.



RECORDING EQUIPMENT CORPORATION

154TH ST. AND 7TH AVE.

WHITESTONE, L. I., N. Y.

FCC RULES AND REGULATIONS

(Continued from page 468)

Operating Schedules

FOR AM STATIONS

§3.71 *Minimum operating schedule*.—Except Sundays, the licensee of each standard broadcast station shall maintain a minimum operating schedule of two-thirds of the total hours that it is authorized to operate between 6 a.m. and 6 p.m., local standard time, and two-thirds of the total hours it is authorized to operate between 6 p.m. and midnight, local standard time, except that in an emergency when, due to causes beyond the control of the licensee, it becomes impossible to continue operating, the station may cease operation for a period of not to exceed 10 days, provided that the Commission and the inspector in charge¹⁵ shall be notified in writing immediately after the emergency develops.

§3.72 *Operation during experimental period*.—The licensee of each standard broadcast station shall operate or refrain from operating its station during the experimental period as directed by the Commission in order to facilitate frequency measurement or for the determination of interference. (Stations involved in the after-midnight frequency monitoring programs are notified of their operating and silent schedule.)

§3.73 *Specified hours*.—If the license of a station specifies the hours of operation, the schedule so specified shall be adhered to except as provided in sections 3.71 and 3.72.

§3.86 *Local standard time; license provisions*.—The time of operation of any broadcast station which does not share time with other stations on the same channel shall be understood to have reference to local standard time unless modification of such license with respect to hours of operation is authorized by the Commission. [EDITOR'S NOTE: See "Time and Time Changes," below.]

Time Sharing—(AM)

§3.74 *Sharing time*.—If the licenses of stations authorized to share time do not specify hours of operation, the licensees shall endeavor to reach an agreement for a definite schedule of periods of time to be used by each. Such agreement shall be in writing and each licensee shall file the same in triplicate original with each application to the Commission for renewal of license. If and when such written agreements are properly filed in conformity with this section the file mark of the Commission will be affixed thereto, one copy will be retained by the Commission, one copy forwarded to the engineer in charge, and one copy returned to the licensee to be posted with the station license and considered as a part thereof. If the license specifies a proportionate time division, the agreement shall maintain this proportion. If no proportionate time division is specified in the license, the licensees shall agree upon a division of time. Such division of time shall not include simultaneous operation of the stations unless specifically authorized by the terms of the license.

§3.75 *Sharing time; equivalence of day and night hours*.—For the purpose of determining the proportionate division of time of the broadcast day for sharing time stations 1 night hour shall be considered the equivalent of 2 day hours.

§3.76 *Sharing time; experimental period*.—If the license of a station authorized to share time does not specify the hours of operation, the station may be operated for the transmission of regular programs during the experimental period provided an agreement thereto is reached with the other stations with which the broadcast day is shared and further provided such operation is not in conflict with section 3.72. Time-sharing agreements for operation during the experimental period need not be submitted to the Commission.

§3.77 *Sharing time; departure from regular schedule*.—A departure from the regular operating schedule set forth in a time-sharing agreement will be permitted only in cases where an agreement to that effect is reduced to writing, is signed by the licensees of the stations affected thereby and filed in triplicate by each licensee with the Commission prior to the time of the proposed change. If time is of the essence, the actual departure in operating schedule may precede the actual filing of written agreement, provided appropriate notice is sent to the Commission and the Engineer in Charge.¹¹

§3.78 *Sharing time stations; notification to Commission*.—If the licensees of stations authorized to share time are unable to agree on a division of time, the Commission shall be so notified by statement to that effect filed with the applications for renewals of licenses. Upon receipt of such statement the Commission will designate the applications for a hearing and, pending such hearing, the operating schedule previously adhered to shall remain in full force and effect.

§3.79 *License to specify sunrise and sunset hours*.—If the licensee of a broadcast station is required to commence or cease operation of the station at the time of sunrise or sunset, the license will specify the hour of the day during each month of the license period when operation of such station will commence or cease. (See Average Sunrise and Sunset Time.)

§3.80 *Secondary station; filing of operating schedule*.—The licensee of a secondary station authorized to operate limited time and which may resume operation at the time the dominant station (or stations) on the same channel ceases operation shall, with each application for renewal of license, file in triplicate a copy of its regular operating schedule, bearing a signed notation by the licensee of the dominant station of its objection or lack of objection thereto. Upon approval of such operating schedule, the Commission will affix its file mark and return one copy to the licensee authorized to operate limited time, which shall

¹⁵ See Field Offices of the Commission.

¹¹ See Field Offices of the Commission.

(Continued on page 472)

With more and still more telecasters it's Du Mont
TV camera equipment because of outstanding

DEPENDABILITY



DU MONT
Type TA-124-B

Image Orthicon Chains

Many TV stations either on the air or under construction, are Du Mont-equipped throughout. That means the Du Mont Type TA-124-B Image Orthicon Chain for studio and remote pickups, alike.

But of even greater significance is the growing use of Du Mont cameras and auxiliary equipment by TV stations originally using other makes of equipment; by intra-store television demonstrations; by wired television installations; by movie producers experimenting with television production possibilities; by TV training schools; by government

agencies both here and abroad.

The Du Mont advantages are many: Split-second action through quick set-

up; finger-tip controls; superlative image pickup with precise electronic viewfinder checkup; accessibility for time-saving inspection and immediate maintenance; handy matched units, jiffy-connected, for all required power, synchronizing, amplifying and monitoring functions, plus the latest camera effects.

But the outstanding characteristic of this popular Du Mont Type TA-124-B Image Orthicon Chain is **DEPENDABILITY**. That, in the final analysis, is the all-important consideration. For "The show must go on," regardless.

$$SD + QW = \frac{D}{FWFT}$$

(Simple Translation)

**SUPERIOR DESIGN plus
QUALITY WORKMANSHIP equals
DU MONT**

First With the Finest in Television

Consult us on your TV plans and requirements. Literature on request.

©ALLEN B. DU MONT LABORATORIES, INC.

DU MONT *First with the Finest in Television*

ALLEN B. DU MONT LABORATORIES, INC. • TELEVISION TRANSMITTER DIVISION, 1000 MAIN AVE., CLIFTON, N. J. • DU MONT NETWORK, 515 MADISON AVE., NEW YORK 22, N. Y. • GENERAL OFFICES, 2 MAIN AVE., PASSAIC, N. J. • PLANTS IN PASSAIC, CLIFTON, ALLWOOD AND EAST PATERSON, N. J.

2 Reasons Why

**MORE
RADIO STATIONS USE**

Magnecorders

**THAN ANY OTHER
PROFESSIONAL TAPE RECORDER**

- 1 **BROAD BAND REPRODUCTION** — Users are really enthusiastic about the amazing tone quality and low distortion of Magnecordings. Magnecord frequency response extends from below 40 cps to 15 kc \pm 2 db with less than 2% rms harmonic distortion at all frequencies. Magnecord programs from remote pickups or studio lines meet the most critical broadcast standards.
- 2 **UNIT CONSTRUCTION** — Only Magnecord offers you the greater flexibility in use and greater economy of Unit Construction. Magnecord recorders, amplifiers, and other equipment are available as individual units. Buy only those you need. Combine or carry only those you need where you need them.

PT6-AH RECORDER is the heart of all Magnecord combinations. Weighs only 29 lbs. in carrying case, easily removable for rack mount. Quick-change capstans for recording at 7½ or 15 in./sec. High speed rewind and high forward cueing speed. \$294.00

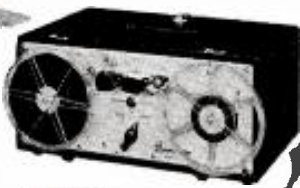

PT6-JA RECORDER AND AMPLIFIER is the only combination on the market today that offers such high professional quality at such a low price. Includes PT6-A Recorder plus amplifier with low impedance microphone and bridging inputs, 10-watt audio amplifier with monitor, speaker and jack for external speaker, zero level output terminal. only \$499.50

PT6-P PORTABLE AMPLIFIER is a highly versatile, light weight, self-contained unit including a record-playback-remote amplifier and power supply for use with PT6-A Recorder. Amplifier has 3 low level, independently mixed mike inputs plus bridging input for use with line level input. Power supply section has monitor amplifier and speaker.



PT6-R RACK-MOUNT AMPLIFIER is a high fidelity, single channel amplifier that quickly combines with the PT6-A Recorder in only 14 inches of rack space. Excellent with existing audio amplifiers.

See, Hear, Operate a Magnecorder Today. Write for complete specifications and name of nearest dealer.

magnecord, INC., CHICAGO 1, ILL.

360 N. MICHIGAN AVENUE

World's Largest and Oldest Manufacturers of Professional Magnetic Recorders

FCC RULES AND REGULATIONS

(Continued from page 470)

be posted with the station license and considered as a part thereof. Departure from said operating schedule will be permitted only in accordance with the procedure set forth in section 3.77.

§3.81 *Secondary station; failure to reach agreement.*—If the licensee of a secondary station authorized to operate limited time and a dominant station on a channel are unable to agree upon a definite time for resumption of operation by the station authorized limited time, the Commission shall be so notified by the licensee of the station authorized limited time. After receipt of such statement the Commission will designate for hearing the applications of both stations for renewal of license, and pending the hearing the schedule previously adhered to shall remain in full force and effect.

§3.82 *Departure from schedule; material violation.*—In all cases where a station licensee is required to prepare and file an operating schedule, any deviation or departure from such schedule, except as herein authorized, shall be considered as a violation of a material term of the license.

Time; Time Changes

§3.83 *Local standard time.*—All references herein to standard time or local standard time refer to local standard time as determined and fixed by the Interstate Commerce Commission.

§3.84 *Daylight saving time.*—If local time is changed from standard time to daylight saving time at the location of all stations sharing time on the same channel, the hours of operation of all such stations on that channel shall be understood to refer to daylight saving time, and not standard time, as long as daylight saving time is observed at such locations. This provision shall govern when the time is changed by provision of law or general observance of daylight saving time by the various communities, and when the time of operation of such stations is specified in the license or is mutually agreed upon by the licensees: *Provided, however,* That when the license specifies average time of sunrise and sunset, local standard time shall be observed. In no event shall a station licensed for daytime only operate on regular schedule prior to local sunrise, or shall a station licensed for greater daytime power than nighttime power or for a different radiation pattern for daytime operation than for nighttime operation operate with the daytime power or radiation pattern prior to local sunrise.

§3.85 *Changes in time; agreement between licensees.*—Where the local time is not changed from standard time to daylight saving time at the location of all stations sharing time on the same channel, the hours of operation of such stations shall be understood to have reference to standard time, and not daylight saving time, unless said licensees mutually agree upon a new schedule which shall be effective only while daylight saving time is observed at the location of some of these stations.

Pre-Sunrise Operation

§3.87 *Program transmissions prior to local sunrise.*—(a) The provisions of sections 3.6, 3.8, 3.9, 3.10, 3.23, 3.79 and 3.84 shall not prevent the transmission of programs between four o'clock a.m., local standard time, and local sunrise, of standard broadcast stations with their authorized daytime facilities, *Provided:* That the provisions of this rule shall not extend to:

(1) Stations regularly sharing time during daytime hours either under licenses pursuant to which time-sharing agreements have been entered into or licenses specifying hours of operation, unless time-sharing agreements have been reached covering such operation prior to local sunrise. Sections 3.74, 3.77, and 3.78 of these rules shall be applicable to such agreements.

(2) Any class II station causing interference¹⁸ by use of its daytime facilities within the 0.5 mv/m 50% sky wave contour of any class I station either of the United States or of any country party to the North American Regional Broadcasting Agreement, except (a) where the class I station is located east of the class II station, in which case operation may begin at local sunrise at the class I station; (b) where an agreement has been reached with the class I station to begin operation prior to local sunrise.

(3) Operation by use of its daytime facilities of any class II station on any class I-A channel not assigned to the United States under the North American Regional Broadcasting Agreement.

(b) Any station operating during such hours receiving notice from the Commission that undue interference is caused shall refrain from such operation during such hours pending further notice from the Commission.

(c) Nothing contained in outstanding instruments of authorization for such stations shall prohibit such operation except as herein provided.

(d) The period 4:00 a.m. to 6 a.m., local standard time, shall not be included in determining compliance with section 3.71 of these rules.

FOR FM STATIONS . . .

§3.261 *Time of Operation.*—All FM broadcast stations will be licensed for unlimited time operation. Until further notice a minimum of 6 hours per day of operation will be required, which shall consist of 3 hours during the period of 6 a.m. to 6 p.m., local standard time, and 3 hours during the period of 6 p.m. to midnight, local standard time. In an emergency, however, when due to causes beyond the control of a licensee, it becomes impossible to continue operation, the station may cease operation for a period not to exceed 10 days, provided that the Commission and the engineer in charge of the radio district in which the station is located shall be notified in writing immediately after the emergency develops.

§3.262 *Experimental Operation.*—The period between 12:00 midnight, and 6 a.m., local standard time, may be used for experimental purposes in testing and maintaining apparatus by the licensee of any FM broadcast station on its

¹⁸ As determined by the Standards of Good Engineering Practice Governing Standard Broadcast Stations and the North American Regional Broadcasting Agreement.

(Continued on page 474)

This free book on Sound Control has helped others plan better studios ... can it help you?



- ↗
 Analyzes 7 major problems in studio acoustical treatment, such as Location and Layout, Reverberation Control, etc. . . .
 Discusses modifications possible for small studios . . .
 Recommends the proper acoustical materials to use . . .
 Presents best engineering practice.

TELEVISION, fastest-growing young genius of electronics, is among the many phases of broadcasting covered in this up-to-date book by Johns-Manville, describing correct applications of Sound Control.

Whether you are planning a studio for up-and-coming television, AM, FM, or recording, you'll find this brochure helpful in solving your acoustical problems.

Tells concisely how you can get desired sound control along with sufficient sound isolation . . . how to get the optimum in acoustical results.

And when you're ready for the construction, Johns-Manville gives you an *all-inclusive* service—"J-M materials installed by Johns-Manville." Trained J-M construction crews install the sound-absorbing materials to assure you the *utmost in benefits*.

Thus, you get *undivided responsibility* for the complete job—whether your acoustical project is large or small, simple or complex.

Why not send today for a FREE copy of this booklet, "The Control of Sound in Broadcasting Studios." Write Johns-Manville, Box 290, New York 16, N. Y.

Johns-Manville *Pioneers in* **Sound Control**
Member of

FCC RULES AND REGULATIONS

(Continued from page 472)

assigned frequency and not in excess of its authorized power, without specific authorization from the Commission.

[EDITOR'S NOTE: FCC had pending on Jan. 1 a proposal to amend §3.262 by defining "experimental period" as the period between 1 a.m. and 6 a.m., local standard time.]

FOR TELEVISION STATIONS . . .

§3.661 *Time of operations.*—(a) All television stations will be licensed for unlimited time operation. Each such station shall maintain a regular program operating schedule as follows: Not less than two hours daily in any five broadcast days per week and not less than a total of 12 hours per week during the first 18 months of the station's operations; not less than two hours daily in any five broadcast days per week and not less than a total of 16 hours, 20 hours and 24 hours per week for each successive six-month period of operation, respectively; and not less than two hours in each of the seven days of the week and not less than a total of 28 hours per week thereafter.

"Operation" includes the period during which a station is operated pursuant to special temporary authority or during program tests, as well as during the license period. Time devoted to test patterns, or to aural presentations accompanied by the incidental use of fixed visual images which have no substantial relationship to the subject matter of such aural presentations, shall not be considered in computing periods of program service. If, in the event of an emergency due to causes beyond the control of a licensee, it becomes impossible to continue operation, the Commission and the Engineer in Charge of the radio district in which the station is located shall be notified in writing immediately after the emergency develops and immediately after the emergency ceases and operation is resumed.

(b) The aural transmitter of a television broadcast station shall not be operated separately from the visual transmitter except for experimental or test purposes.¹⁹

(c) Persons desiring to enter into a voluntary sharing arrangement of a television channel may file application therefor with the Commission. Copies of the time-sharing agreement should be filed with the application.

§3.662 *Experimental operation.*—Television broadcast stations may conduct technical experimentation directed to the improvement of technical phases of operation and for such purposes may utilize a signal other than the standard television signal subject to the following conditions:

(a) That the licensee complies with the provisions of section 3.661 with regard to the minimum number of hours of transmission with a standard television signal.

(b) That no transmissions are radiated outside of the authorized channel and subject to the condition that no interference is caused to the transmissions of a standard television signal by other television broadcast stations.

(c) No charges either direct or indirect shall be made by the licensee of a television broadcast station for the production or transmission of program when conducting technical experimentation.

Operator Requirements

IN AM RULES . . .

§3.165 *Licensed operator required.*—(a) The licensee of each station shall have a licensed operator or operators of the grade specified by the Commission on duty during all periods of actual operation of the transmitter at the place where the transmitting equipment is located. (See sec. 2.53.)

(b) *Licensed operator; other duties.*—The licensed operator on duty and in charge of a standard broadcast transmitter may, at the discretion of the licensee, be employed for other duties or for the operation of another radio station or stations in accordance with the class of operator's license which he holds and by the rules and regulations governing such other stations: *Provided, however,* That such duties shall in no wise interfere with the proper operation of the standard broadcast transmitter.

IN FM RULES . . .

§3.265 *Operator requirements.*—One or more licensed radio-telephone first class operators shall be on duty at the place where the transmitting apparatus of each station is located and in actual charge thereof whenever it is being operated. The original license (or Form FCC No. 759) of each FM broadcast station operator shall be posted at the place where he is on duty. The licensed operator on duty and in charge of an FM broadcast transmitter may, at the discretion of the licensee, be employed for other duties or for the operation of another station or stations in accordance with the class of operator's license which he holds and by the rules and regulations governing such stations. However, such duties shall in no wise interfere with the operation of the broadcast transmitter.

IN TELEVISION RULES . . .

§3.665—[EDITOR'S NOTE: Identical with §3.265, above, except that "a television broadcast transmitter" is substituted for "an FM broadcast transmitter" in third sentence.]

Facsimile

§3.266 *Facsimile broadcasting and multiplex transmission.*—(a) FM broadcast stations may transmit simplex facsimile in accordance with transmission standards set forth in the Standards of Good Engineering Practice Concerning FM Broadcast Stations during periods not devoted to FM aural broadcasting. However, such transmissions may not exceed one hour during the period between 7 a.m. and midnight (no limit for the hours between midnight and 7 a.m.) and may not be counted toward the minimum operation required by Sec. 3.261.

(b) FM broadcast stations may, upon securing authorization from the Commission, transmit multiplex facsimile and aural broadcast programs for a maximum of three hours between the hours of 7 a.m. and midnight (no limit for the hours between midnight and 7 a.m.) in accordance with transmission standards set forth in the Standards of Good Engineering Practice Concerning FM Broadcast Stations provided that the transmission of facsimile does not impair the quality of the aural program below 10,000 cycles per second, and that a filter or other additional equipment is not required for receivers not equipped to receive facsimile.

[EDITOR'S NOTE: FCC on Jan. 1 was considering a petition of Radio Inventions Inc. asking for removal of the restriction on the hours in which multiplex facsimile may be transmitted, and for substitution of "15,000 cycles" for "10,000 cycles" as the standard below which the quality of the aural program may not be impaired.]

Network Affiliation

IN AM RULES . . .

§3.101 *Exclusive affiliation of station.*—No license shall be granted to a standard broadcast station having any contract, arrangement, or understanding, expressed or implied, with a network organization²⁰ under which the station is prevented or hindered from, or penalized for, broadcasting the programs of any other network organization.

¹⁹ FCC interpreted this to mean:

(1) Duplication of AM or FM programs on the aural transmitter of a TV station—

(a) while the same program is broadcast on the visual transmitter—is consistent with §3.661(b).

(b) while a test pattern is broadcast on the visual transmitter—is NOT consistent with §3.661(b).

(2) Broadcast on the aural transmitter of a TV station of transmission originated by the TV station—

(a) while a printed moving text is broadcast on the visual transmitter—is consistent with §3.661(b).

(b) while still pictures or slides are broadcast on the visual transmitter—is NOT consistent with §3.661(b) except for the purpose of necessary tests of station equipment, and except when the aural and visual transmissions are integral parts of a program and the visual transmissions have a substantial relationship to the aural transmissions. (An example of the latter type of program would be a travel lecture in which the words of the lecturer are broadcast simultaneously with still pictures or slides of scenes illustrating the lecture. Another example would be a newscast in which the words of the newscaster are broadcast simultaneously with still pictures or slides of the news events.)

(c) while a test pattern is broadcast on the visual transmitter—is NOT consistent with §3.661(b) except for the purpose of necessary tests of station equipment, and except for the purpose of the actual demonstration of TV receivers to prospective purchasers. In such cases the aural transmissions shall not consist of any program material or musical composition but shall consist only of a single tone or a series of variable tones.

²⁰ The term "network organization" as used herein includes national and regional network organizations. See Chapter VII, J, of Report on Chain Broadcasting.

(Continued on page 476)

BROADCASTING • Telecasting

Your Solution for Better TV Broadcasting at LOWEST COST—The New Stage No. 1 and the **GRAY TELOP**



This most versatile telecasting optical projector enables dual projection with any desired optical dissolve under exact control.

The accessory STAGE NUMBER 1 adds three functions separately or simultaneously: a) teletype news strip, b) vertical roll strip and c) revolving stage for small objects.

The TELOP, used with TV film cameras, permits instant fading of one object to another, change by lap dissolve or by superimposing. Widest latitude is given program directors for maximum visual interest and increased TV station income.

For full details write for Bulletin T-101

GRAY RESEARCH and Development Co., Inc.
16 Arbor St., Hartford 1, Conn.

Everything Electrical to keep you on the air

-FROM ONE SOURCE:



dependable, convenient, helpful **GraybaR**

And we do mean *everything*. For Graybar can provide not only the whole gamut of equipment — *from mike to antenna* — for building or maintaining an entire AM or FM station; Graybar also is your best source of everything for *wiring, ventilating, signaling, and lighting* . . . for your entire structure and grounds!

Graybar is a *dependable* source. We've been serving broadcasters ever since 1925. We know the business. We have the nation's outstanding lines of equipment. Our supply service has expanded steadily and rapidly to the all-inclusive operation it is today. Like broadcasting service itself, Graybar service

tomorrow will be even greater and better.

Graybar is a *convenient* source. No matter where you are in the U. S. A., one of our more than 100 offices (with warehouses) is near-by.

Graybar is a *helpful* source. Our Broadcast Equipment Representatives are well qualified to assist with technical recommendations. And our business philosophy of extra service to every customer is reinforced by the fact that Graybar is owned entirely by its operating and retired personnel.

Why not discuss *your* needs with the nearest Graybar Representative? *Graybar Electric Company, Inc. Executive offices: Graybar Building, New York 17, N. Y.* 5000

GRAYBAR BRINGS YOU BROADCASTING'S BEST:

- Amplifiers (1, 20) (See key to numbers below)
- Antenna Equipment (1)
- Cabinets (5)
- Consoles (1)
- Loudspeakers and Accessories (1, 3, 20)
- Microphones, Stands, and Accessories (1, 3, 6, 7, 8, 20)
- Monitors (1, 4)
- Recorders and Accessories (9, 19, 21)
- Speech Input Equipment (1)
- Test Equipment (4, 10)
- Towers (Vertical Radiators) (11)
- Tower Lighting Equipment (2, 12)
- Transmission Line and Accessories (13)
- Transmitters, AM and FM (1)
- Tubes (1, 2, 18)
- Turntables, Reproducers, and Accessories (1, 21)
- Wiring Supplies and Devices (3, 8, 14, 15, 16, 17)

MANUFACTURED BY:

- (1) Western Electric;
- (2) General Electric; (3) Whitney Blake;
- (4) General Radio; (5) Karp Metal;
- (6) Hugh Lyons; (7) Meletron;
- (8) Hubbell; (9) Presto; (10) Weston;
- (11) Blaw-Knox; (12) Crouse-Hinds;
- (13) Communication Products;
- (14) General Cable;
- (15) National Electric Products;
- (16) Triangle; (17) Bryant; (18) Mochlett;
- (19) Ampex; (20) Altec Lansing;
- (21) Fairchild.

In the list of Graybar locations below, the names and phone numbers of Graybar Broadcast Equipment Representatives in key cities are included:



ALABAMA
Birmingham

ARIZONA
Phoenix

ARKANSAS
Little Rock

CALIFORNIA
Fresno
Long Beach
Los Angeles—R. B. Thompson
Angelus 3-7283
Oakland
Sacramento
San Diego
San Francisco—K. G. Morrison
Market 1-5131

COLORADO
Denver

CONNECTICUT
West Hartford
New Haven

DELAWARE
Wilmington

DISTRICT OF COLUMBIA
Washington

FLORIDA
Jacksonville—W. C. Winfree
Jacksonville 5-7180
Miami
Orlando
Tampa

GEORGIA
Atlanta—E. W. Stone
Cypress 1751
Savannah

IDAHO
Boise

ILLINOIS
Chicago—E. H. Taylor
Canal 6-4100
Peoria

INDIANA
Evansville
Hammond
Indianapolis

IOWA
Davenport
Des Moines

KANSAS
Wichita

KENTUCKY
Louisville

LOUISIANA
New Orleans
Shreveport

MAINE
Portland

MARYLAND
Baltimore

MASSACHUSETTS
Boston—J. P. Lynch
Kenmore 6-4567
Springfield
Worcester

MICHIGAN
Detroit—P. L. Gundy
Temple 1-5500
Flint
Grand Rapids
Lansing

MINNESOTA
Duluth
Minneapolis—W. G. Pree
Geneva 1621
St. Paul

MISSISSIPPI
Jackson

MISSOURI
Kansas City—R. B. Uhrig
Baltimore 1644
St. Louis—J. P. Lenkerd
Newstead 4700

MONTANA
Butte

NEBRASKA
Omaha

NEW HAMPSHIRE
Portsmouth

NEW JERSEY
Newark

NEW YORK
Albany
Binghamton
Buffalo
Jamestown
New York—F. C. Sweeney
Warkins 4-3030
Rochester
Syracuse

NORTH CAROLINA
Asheville
Charlotte
Durham
Winston-Salem

OHIO
Akron
Cincinnati—W. H. Hansher
Main 0620
Cleveland—W. S. Rockwell
Cherry 1260
Columbus
Dayton
Toledo
Youngstown

OKLAHOMA
Oklahoma City
Tulsa

OREGON
Eugene
Portland

PENNSYLVANIA
Allentown
Harrisburg
Philadelphia—G. I. Jones
Walnut 2-5405
Pittsburgh—R. F. Grossett
Allegheny 1-4100
Reading

RHODE ISLAND
Providence

SOUTH CAROLINA
Columbia

SOUTH DAKOTA
Aberdeen

TENNESSEE
Bristol
Chattanooga
Knoxville
Memphis
Nashville

TEXAS
Amarillo
Austin
Daumont
Corpus Christi
Dallas—C. C. Ross
Central 6454
Fort Worth
Houston
San Antonio

UTAH
Salt Lake City

VIRGINIA
Norfolk
Richmond—E. C. Toms
Richmond 7-3491
Roanoke

WASHINGTON
Seattle—D. I. Craig
Main 4635
Spokane
Tacoma

WEST VIRGINIA
Charleston

WISCONSIN
Milwaukee

*Burned up—
but still "alive"!*



THE "556" Broadcast Dynamic shown here unretouched was badly burned in a fire January 7 that gutted the Rita Theatre in Longview, Texas, where it was being used in a remote show for Radio Station KFRO. Surprising part of the story is that the Microphone worked perfectly when tested in our Service Department.



The excellent showing made by the Shure "556" Broadcast Dynamic Microphone is a "living" testimonial to the ruggedness and dependability of all Shure Microphones.

SHURE BROTHERS, Inc.

Microphones and Acoustic Devices

225 West Huron Street

Chicago 10, Illinois

§3.102 *Territorial exclusivity.*—No license shall be granted to a standard broadcast station having any contract, arrangement, or understanding, express or implied, with a network organization which prevents or hinders another station serving substantially the same area from broadcasting the network's programs not taken by the former station, or which prevents or hinders another station serving a substantially different area from broadcasting any program of the network organization. This section shall not be construed to prohibit any contract, arrangement, or understanding between a station and a network organization pursuant to which the station is granted the first call in its primary service area upon the programs of the network organization.

§3.103 *Term of affiliation.*—No license shall be granted to a standard broadcast station having any contract, arrangement, or understanding, express or implied, with a network organization which provides, by original term, provisions for renewal, or otherwise for the affiliation of the station with the network organization for a period longer than two years: *Provided*, That a contract, arrangement, or understanding for a period up to two years, may be entered into within six months prior to the commencement of such period.

§3.104 *Option time.*—No license shall be granted to a standard broadcast station which options²¹ for network programs any time subject to call on less than 56 days' notice, or more time than a total of three hours²² within each of four segments of the broadcast day, as herein described. The broadcast day is divided into 4 segments, as follows: 8:00 a.m. to 1:00 p.m.; 1:00 p.m. to 6:00 p.m.; 6:00 p.m. to 11:00 p.m.; 11:00 p.m. to 8:00 a.m.²³ Such options may not be exclusive as against other network organizations and may not prevent or hinder the station from optioning or selling any or all of the time covered by the option, or other time, to other network organizations.

§3.105 *Right to reject programs.*—No license shall be granted to a standard broadcast station having any contract, arrangement, or understanding, express or implied, with a network organization which (a), with respect to programs offered pursuant to an affiliation contract, prevents or hinders the station from rejecting or refusing network programs which the station reasonably believes to be unsatisfactory or unsuitable; or which (b), with respect to network programs so offered or already contracted for, prevents the station from rejecting or refusing any program which, in its opinion, is contrary to the public interest, or from substituting a program of outstanding local or national importance.

§3.106 *Network ownership of stations.*²⁴—No license shall be granted to a network organization, or to any person directly or indirectly controlled by or under common control²⁵ with a network organization, for more than one standard broadcast station where one of the stations covers substantially the service area of the other station, or for any standard broadcast station in any locality where the existing standard broadcast stations are so few or of such unequal desirability (in terms of coverage, power, frequency, or other related matters) that competition would be substantially restrained by such licensing.

§3.107 *Dual network operation.*—No license shall be issued to a standard broadcast station affiliated with a network organization which maintains more than one network: *Provided*, That this section shall not be applicable if such networks are not operated simultaneously, or if there is no substantial overlap in the territory served by the group of stations comprising each such network.

§3.108 *Control by networks of station rates.*—No license shall be granted to a standard broadcast station having any contract, arrangement, or understanding, express or implied, with a network organization under which the station is prevented or hindered from, or penalized for, fixing or altering its rates for the sale of broadcast time for other than the network's programs.

IN FM RULES . . .

§3.231-3.238, inclusive—

[EDITOR'S NOTE: Same as §3.101-3.108, above, with the following exceptions: (1) references are to FM rather than standard stations and networks; and (2) the section on "Network Ownership of Stations" is changed to read as follows:]

§3.236 *Network ownership of stations.*—No license shall be granted to a network organization, or to any person directly or indirectly controlled by or under common control²⁶ of a network organization, for an FM broadcast station in any locality where the existing FM broadcast stations are so few or of such unequal desirability (in terms of coverage, power, frequency, or other related matters) that competition would be substantially restrained by such licensing.

IN TELEVISION RULES . . .

§3.631-3.638, inclusive—

[EDITOR'S NOTE: Identical with the FM rule, §3.231-3.238, above, except that "a television broadcast station" is substituted for "an FM broadcast station" wherever it appears.]

²¹ As used in this section, an option is any contract, arrangement, or understanding, express or implied, between a station and a network organization which prevents or hinders the station from scheduling programs before the network agrees to utilize the time during which such programs are scheduled, or which requires the station to clear time already scheduled when the network organization seeks to utilize the time.

²² All time options permitted under this section must be for specified clock hours, expressed in terms of any time system set forth in the contract agreed upon by the station and network organization. Shifts from daylight saving to standard time or vice versa may or may not shift the specified hours correspondingly as agreed by the station and network organization.

²³ These segments are to be determined for each station in terms of local time at the location of the station but may remain constant throughout the year regardless of shifts from standard to daylight saving time or vice versa.

²⁴ Effective date of this section with respect to any station may be extended from time to time in order to permit the orderly disposition of properties; and it shall be suspended indefinitely with respect to regional network organizations.

²⁵ The word "control" as used herein, is not limited to full control but includes such a measure of control as would substantially affect the availability of the station to other networks.

²⁶ See footnote 25, above.

(Continued on page 478)

**AM • FM • TELEVISION
TOWERS**

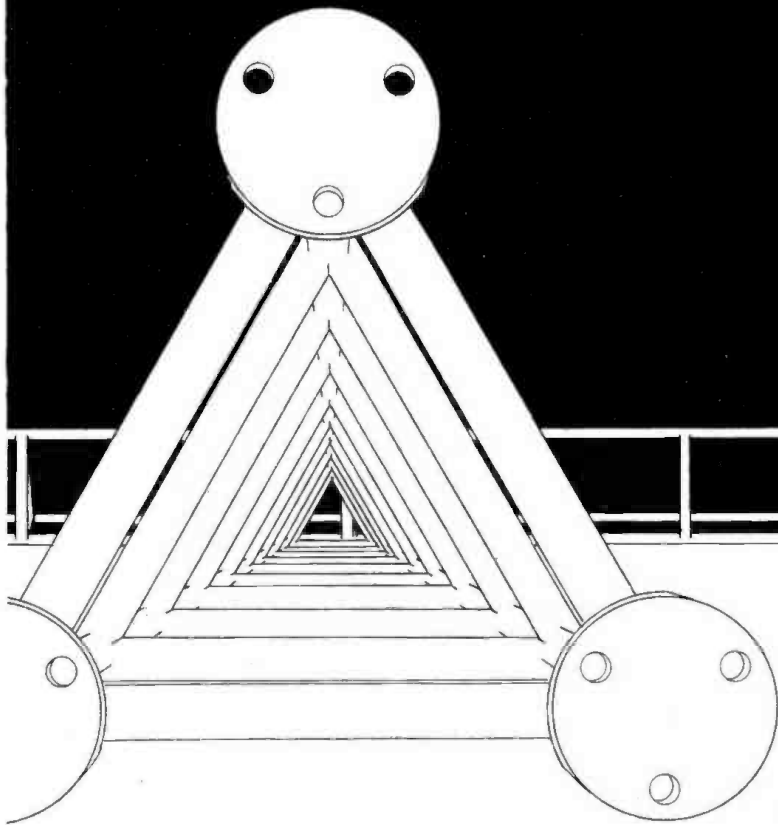

STAINLESS, INC.

Plant—North Wales, Pa.
Export Office—13 E. 40 St. N.Y.C.
Western Office—Box 841—Phoenix, Ariz.

Reports to Be Filed*

ALL BROADCAST STATIONS . . .

§1.341 *Financial report, broadcast licensees and permittees.*—(a) Each licensee of a broadcast station (standard, FM, television, and international) and each permittee of a broadcast station engaged in interim operation shall file with the Commission on or before April 1 of each year on Form 324, together with supporting schedules, a balance sheet showing its financial condition as of December 31 of the preceding calendar year and an income statement for said calendar year.

(b) Each licensee of a broadcast station (standard, FM, television, and international) and each permittee of a broadcast station engaged in interim operation shall file with the Commission on or before Feb. 1 of each year on Form 324A an estimate of the station's total broadcast revenues and total broadcast expenses for the preceding calendar year.

§1.342 *Filing of contracts.*—Each licensee or permittee of a broadcast station (standard, FM, television, and international) shall file with the Commission within 30 days of execution thereof verified copies of all documents, instruments, contracts (the substance of oral contracts or understandings shall be reported in writing) together with amendments, supplements, and changes therein and cancellations thereof relating to ownership, management or control of licensee or permittee of station, or of any of licensee's or permittee's stock, rights or interests therein; the use, management, or operation of licensed facilities; and agreements relating to network service, transcription service or bulk time sales (amounting to two hours or more per day); including but not limited to: (a) Articles of partnership, association, or incorporation; (b) By-laws affecting character of organization, control, number of powers of its officers or directors, the classification or voting rights of any stock; (c) Any document, instrument, or contract relating to or affecting ownership of licensee or permittee, rights or interests therein, its stock or voting rights thereto; (d) Management contracts, network contracts, transcription network contracts, and time sales to brokers.

§1.343 *Ownership reports, broadcast licensees and permittees.*—(a) *Annual ownership reports.* The licensee or permittee of each broadcast station (standard, FM, television, and international) shall file on or before April 1 of each year on FCC Form 323 an annual ownership report and shall show the following information as of December 31 of the preceding calendar year.

- (1) In the case of an individual, the name of such individual.
- (2) In the case of a partnership; the names of the partners and the interests of each partner.²⁷
- (3) In the case of a corporation or association: (i) Capitalization, with a description of the classes and voting power of stock authorized and the shares of each class issued and outstanding; (ii) the name, residence, citizenship, and stockholdings of officers and directors, and stockholders; (iii) full information with respect to the interest and identity of any person whether or not a stockholder of record, having any interest, direct or indirect, in the licensee or permittee or any of its stock.

FOR EXAMPLE:

- (a) Where A is the beneficial owner or votes stock held by B, the same information should be furnished for A as is required for B.
- (b) Where X corporation controls the licensee or permittee, or holds 25% or more of the stock of the licensee or permittee, the same information should be furnished with respect to X corporation (its capitalization, officers, directors, and stockholders and the amount of stock in X held by each) as is required in the case of the licensee or permittee, together with full information as to the identity and citizenship of the person authorized to vote licensee's or permittee's stock.
- (c) The same information should be furnished as to Y corporation if it controls X corporation or holds 25% or more of the stock of X, and as to Z corporation if it controls Y corporation or holds 25% or more of the stock of Y and so on back to natural persons.
- (d) Full information as to family relationship or business association between two or more officials and/or stockholders.
- (4) In the case of all licensees or permittees: (i) the name, residence, position and date of appointment of operating personnel determining program policy (such as general manager, program director, etc.); (ii) a list of all contracts still in effect required to be filed with the Commission by Section 1.342 showing the date of execution and expiration of each contract; (iii) any interest which the licensee may have in any other broadcast station.

(b) *Interim ownership reports.* An interim ownership report shall be filed by each licensee or permittee on FCC Form 323A describing any change in information required in the annual ownership report (the application or construction permit in the case of a permittee who has not filed an annual ownership report) from that previously reported within 30 days after any such change occurs, including without limitation:

- (1) Any change in capitalization or organization.
- (2) Any change in officers and directors or in operating personnel determining program policy.

* EDITOR'S NOTE: Regarding reports filed in compliance with these sections, §1.206(c) provides, in part: "The information filed under §1.341 and network and transcription contracts filed pursuant to §1.342 shall not be open to public inspection."

²⁷ Any change in partners or in their rights will require prior consent of the Commission upon an application for consent to assignment of license.

(Continued on page 480)

Only LINGO
OFFERS THESE "6 EXTRAS"
AT NO EXTRA COST

- 1 Moderate Initial Cost**
Complete prices including construction, equipment and erection quoted in advance.
- 2 Peak Performance**
Working and field tests indicate within 3% of 100% efficiency, due to low base capacitance, high characteristic impedance, practically sinusoidal current distribution and the nearest approach to the classical vertical wire.
- 3 Low Maintenance Cost**
Occasional painting, for example, is usually one-quarter that of a structural steel tower of similar height.
- 4 53 Years' Experience**
Since 1897 Lingo has constructed and erected vertical round structures. They have proved their stability in wind velocities over 100 mph and in climates the world over.
- 5 Single Responsibility**
We erect our own radiators by factory-trained specialists. Foundations are designed to meet each individual location. Lingo sees the whole job through.
- 6 Helpful Suggestions**
Our staff is qualified and willing to assist in the solution of technical problems that arise in planning installations. Call on us.

JOHN E. LINGO & SON, INC.
EST. 1897 CAMDEN, NEW JERSEY

Write for
Recommendations
—pertaining to
such problems
as proper radi-
ator height,
ground sys-
tems, etc. In
writing please
indicate loca-
tion, power
and the fre-
quency pro-
posed.

LINGO VERTICAL
TUBULAR STEEL
RADIATORS

An Important Statement by



MYCALEX CORPORATION OF AMERICA

Issued in an effort to clear up and to avoid continued confusion

It has come to our attention that some electronic engineers and purchasing executives are under the erroneous impression that the MYCALEX CORPORATION OF AMERICA is connected or affiliated with others manufacturing glass-bonded mica insulation under other trade names, and that genuine "MYCALEX" and glass-bonded mica insulation made by such other companies are "all the same thing". . . are "put out by the same people," . . . and "come from the same plant." NONE OF THIS IS TRUE.

THE FACTS ARE:

1. The MYCALEX CORPORATION OF AMERICA is not connected or affiliated with any other firm or corporation manufacturing glass-bonded mica insulation materials, except Mycalex Products Sales Corporation and Mycalex Tube Socket Corporation, which are exclusively licensed by the Mycalex Corporation of America to distribute and sell Mycalex components. These "Mycalex" companies are 100% American in ownership.
2. The word "MYCALEX" is not a generic term. It is a trade mark registered in the United States Patent Office, and owned by the MYCALEX CORPORATION OF AMERICA, and identifies the glass-bonded mica insulation products of formulae and design developed and manufactured in the plant of the MYCALEX CORPORATION OF AMERICA.
3. The General Electric Company, by virtue of a non-exclusive license it had under a MYCALEX patent through the MYCALEX COMPANY, LTD., of Great Britain, has been permitted to identify its glass-bonded mica insulating materials made under such license as "G-E Mycalex."
4. The MYCALEX CORPORATION OF AMERICA has behind it over 30 years of research leadership and owns U. S. patents and patent applications on improved glass-bonded mica insulation marketed under the trademarks "MYCALEX," "MYCALEX 410," "MYCALEX 410X," "MYCALEX 400," and "MYCALEX K."
5. All products of the MYCALEX CORPORATION OF AMERICA are given distinctive identifications incorporating the trade-marked name "Mycalex"; all such identifications are registered and may be legally used

only by the MYCALEX CORPORATION OF AMERICA and those authorized by it.

MYCALEX 410, is the most versatile and nearly perfect insulation material yet developed for the electronics industry. Widely specified because of its low dielectric loss, high dielectric strength, high arc resistance, dimensional stability over wide humidity and temperature changes, resistance to high temperatures, mechanical precision, mechanical strength, and ability to be molded, with or without metal inserts, to extremely close tolerances and in irregular shapes. Priced to compete with less effective electrical insulation materials such as mica-filled phenolics, steatite, etc.

MYCALEX 410X (leadless formulation), can be injection molded, with or without metal inserts, to extremely close tolerances. Equal in versatility to MYCALEX 410, and used where somewhat lesser dielectric qualities are acceptable. Priced to compete with general purpose phenolics.

MYCALEX 400 fully approved by the Army and Navy as Grade L-4 insulation, is a low-loss Mycalex insulation—available in sheets and rods, and can be machined to size, shape and specifications.

MYCALEX K is a series of capacitor dielectrics that can be supplied in sheets, rods and molded parts, to special order.

6. "MYCALEX" in all the forms described above, is made by exclusive formulae and exclusive patented processes. It is impossible for anyone other than the MYCALEX CORPORATION OF AMERICA to supply any product, similar in appearance, as the very same thing.

Jerome Taisboff
President

MYCALEX STANDS ON ITS OWN REPUTATION



MYCALEX CORP. OF AMERICA

"Owners of 'MYCALEX' Patents"

Plant and General Offices, CLIFTON, N. J.

Executive Offices, 30 ROCKEFELLER PLAZA, NEW YORK 20, N. Y.



BERNARD ASSOCIATES



Consulting Radio and Television Engineers

A COMPLETE CONSULTATION AND ENGINEERING SERVICE FOR PROSPECTIVE AND PRESENT BROADCAST STATION OWNERS

- Frequency Studies
- Preparation of Engineering Data for F.C.C.
- Selection of Transmitter Sites
- Supervision of Station Construction
- Antenna Measurements and Tuning
- Studio Design and Measurement
- Field Surveys to Check Station Service
- Proof of Performance Measurements

TELEVISION ● AM ● FM ● FACSIMILE



BERNARD ASSOCIATES

5010 SUNSET BLVD.—HOLLYWOOD 27, CALIF.

NORMANDY 2-6715

FCC RULES AND REGULATIONS

(Continued from page 478)

(3) Any transaction affecting the ownership, direct or indirect, or voting rights of licensee's or permittee's stock, such as (i) a transfer of stock, (ii) issuance of new stock or disposition of treasury stock, (iii) acquisition of licensee's or permittee's stock by the issuing corporation.

(4) Any change in the officers, directors or stockholders of a corporation other than the licensee or permittee such as X, Y or Z Corporation described in the example above.

Provided, however, that in the case of a change in the officers, directors or stockholders of a corporation other than the licensee or permittee (such as X, Y or Z corporation described in the example above), such change need not be reported in the interim report unless that corporation directly or indirectly owns 25% or more of the voting stock in the licensee or permittee.²⁸

(c) *Exceptions.* Where information is required under paragraphs (a) or (b) of this section with respect to a corporation having more than 50 stockholders, such information need be filed only with respect to stockholders who are officers or directors of the corporation, or of other stockholders who have 1% or more of the stock of the corporation.

§1.344 *Definitions of terms used in Sections 1.341-1.343*—As used in Sections 1.341-1.343:

(a) "Stock" shall include any interest, legal or beneficial in, or right or privilege in connection with stock.

(b) "Officer" and "director" shall include the comparable officials in unincorporated associations.

(c) "Contract" shall include any agreement (including, without limitation, an option, trust, or pledge) or any modification thereof, express or implied, oral or written.

License Renewals

GENERAL . . .

§1.320 *Application for renewal of license; broadcast and non-broadcast.*—

(a) Unless otherwise directed by the Commission, each application for renewal of license shall be filed at least 60 days²⁹ prior to the expiration date of the license sought to be renewed. No application for renewal of license of a broadcast station will be considered unless there is on file with the Commission, the information currently required by Sections 1.341 to 1.344, reference to which by date and file number shall be included in the application.

(b) Whenever the Commission regards an application for a renewal of license as essential to the proper conduct of a hearing or investigation, and specifically directs that it be filed by a date certain, such application shall be filed within the time thus specified. If the licensee fails to file such application within the prescribed time, the hearing or investigation shall proceed as if such renewal application had been received.

IN AM RULES . . .

§3.34 *Normal license period.*—(a) All standard broadcast station licenses will be issued for a normal license period of 3 years. Licenses will be issued to expire at the hour of 3 a.m., Eastern Standard Time, in accordance with the following schedule, and at three-year intervals thereafter:

(1) For stations operating on the frequencies 640, 650, 660, 670, 680, 690, 700, 710, 720, 730, 740, 750, 760, 770, 780, 800, 810, 820, 830, 840, 850, 860, 870, 880, 890, 900, 940 kc., Nov. 1, 1946.

(2) For stations operating on the frequencies 990, 1000, 1010, 1020, 1030, 1040, 1050, 1060, 1070, 1080, 1090, 1100, 1110, 1120, 1130, 1140, 1160, 1170, 1180, 1190, 1200, 1210, 1220, 1500, 1510, 1520, 1530, 1540, 1550, 1560, 1570, 1580, kc., May 1, 1945.

(3) For stations operating on the frequencies 550, 560, 570, 580, 590, 600, 610, 620, 630, 790 kc., May 1, 1946.

(4) For stations operating on the frequencies 910, 920, 930, 950, 960, 970, 980, 1150, 1250 kc., May 1, 1947.

(5) For stations operating on the frequencies 1260, 1270, 1280, 1290, 1300, 1310, 1320, 1330, 1350, 1360 kc., Nov. 1, 1945.

(6) For stations operating on the frequencies 1370, 1380, 1390, 1410, 1420, 1430, 1440, 1460, 1470, 1480, 1590, 1600 kc., Nov. 1, 1947.

(7) For stations operating on the frequency 1230 kc., Feb. 1, 1946.

(8) For stations operating on the frequency 1240 kc., Aug. 1, 1946.

(9) For stations operating on the frequency 1340 kc., Feb. 1, 1947.

(10) For stations operating on the frequency 1400 kc., Aug. 1, 1947.

(11) For stations operating on the frequency 1450 kc., Feb. 1, 1948.

(12) For stations operating on the frequency 1490 kc., Aug. 1, 1948.

IN FM RULES . . .

Commercial Stations

§3.218 *Normal license period.*—(a) All initial licenses covering construction permits for new FM broadcast stations will be issued so as to expire at the hour of 3 a.m., eastern standard time, and will be issued for a minimum period of one year and a maximum period of one year and 11 months to expire in accordance with the following schedule:

(1) For stations operating on the frequencies 92.1, 92.7, 93.5, 94.3, 95.3, 95.9, 96.7, 97.7, 98.3, 99.3 mc., June 1.

(2) For stations operating on the frequencies 100.1, 100.9, 101.7, 102.3, 103.1, 103.9, 104.9, 105.5, 106.3, 107.1 mc., September 1.

²⁸ Before any change is made in the organization, capitalization, officers, directors or stockholders of a corporation other than licensee or permittee, which results in a change in the control of the licensee or permittee, prior Commission consent must be received under Sec. 310(b) of the Communications Act.

²⁹ The 60-day requirement does not apply to Amateurs.

(Continued on page 482)

Lower Maintenance Costs

WITH **H & P**

TOWER LIGHTING EQUIPMENT!

For nearly a quarter century, Hughey & Phillips have developed and produced specialized tower lighting equipment. Many exclusive features, designed by H & P engineers, assure easy installation, low maintenance costs and dependable operation under all climatic conditions. That is why H & P tower lighting equipment is consistently specified by outstanding radio engineers and is furnished as standard equipment by most leading tower manufacturers.

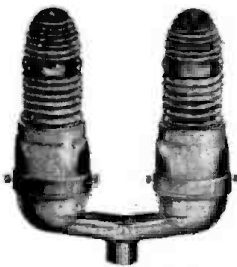

OB-11M



OB-10M

SINGLE AND DOUBLE OBSTRUCTION LIGHTS

H & P Obstruction Lights are ruggedly constructed of heavy aluminum alloy castings. Precision machining insures proper light center when used with specified lamp. Prismatic globes meet CAA light specifications. Drain port provides means of escape for condensation moisture. Designed to permit relamping without removing prismatic globes. Mounting base designed for standard A-21 traffic signal lamps.

SOLD ONLY THROUGH JOBBERS AND TOWER MANUFACTURERS

WRITE ON YOUR LETTERHEAD FOR CATALOG AND NAME OF YOUR NEAREST H & P DISTRIBUTOR

HUGHEY & PHILLIPS



TOWER LIGHTING EQUIPMENT

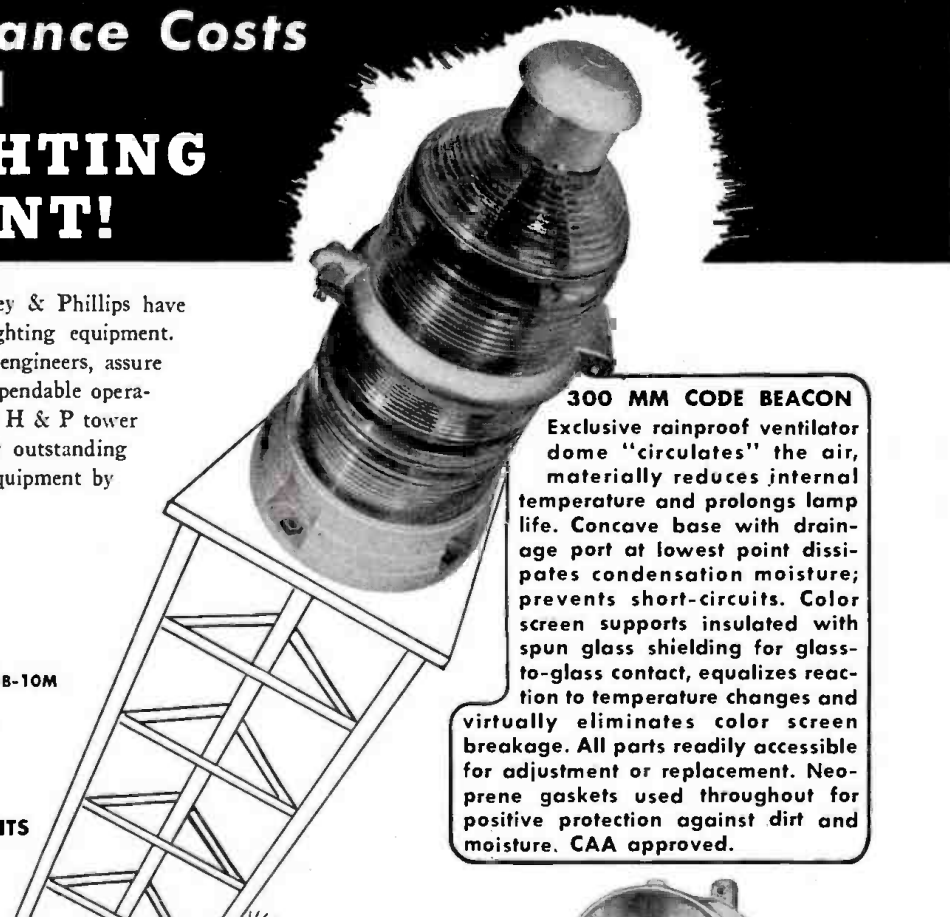

300 MM CODE BEACON

Exclusive rainproof ventilator dome "circulates" the air, materially reduces internal temperature and prolongs lamp life. Concave base with drainage port at lowest point dissipates condensation moisture; prevents short-circuits. Color screen supports insulated with spun glass shielding for glass-to-glass contact, equalizes reaction to temperature changes and virtually eliminates color screen breakage. All parts readily accessible for adjustment or replacement. Neoprene gaskets used throughout for positive protection against dirt and moisture. CAA approved.

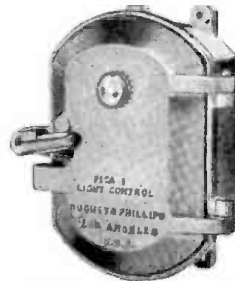

"PEC" Series Photo-Electric TOWER LIGHT CONTROL

Specifically designed for radio tower use. Set at factory to automatically turn lights on at 35 foot-candles; off at 58 foot-candles, as recommended by CAA. Completely self-contained in water-tight heavy cast aluminum housing. Circuits insulated throughout with low-loss insulation. High-wattage industrial type resistors. Tubes operated well below rating to insure long life. Fail-Safe: if any parts fail in service, lights automatically turn on.

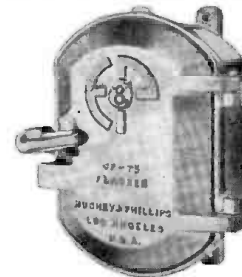

SF-75 MERCURY FLASHER

H & P Mercury Flasher has only four moving parts which run in lifetime-lubricated ball bearings. No contact points to wear out. Gears cut from highest quality bronze. 3000 watt Mercury Connector supplied with unit. Speed adjustment, 14 to 52 flashes per minute. Set at factory to operate 1 second on, 1/2 second off. Motor separately fused for continuous operation of lights in event of mechanical failure. Corrosion resistant aluminum alloy housing with provision for padlocking. Waterproof neoprene gasketing.

COMPLETE LIGHT KITS FOR A-2, A-3, A-4 and A-5 TOWERS
INCLUDE EVERY ITEM ESSENTIAL FOR COMPLETE TOWER INSTALLATION

HUGHEY & PHILLIPS

TOWER LIGHTING DIVISION

60 EAST 42nd STREET
NEW YORK 17, N.Y.

326 N. LA CIENEGA BLVD.
LOS ANGELES 48, CALIF.

FCC RULES AND REGULATIONS

(Continued from page 480)

(3) For stations operating on the frequencies 100.3, 100.5, 100.7, 101.1, 101.3, 101.5, 101.9, 102.1, 102.5, 102.7, 102.9, 103.3, 103.5, 103.7, 104.1, 104.3, 104.5, 104.7, 105.1, 105.3, 105.7, 105.9, 106.1, 106.5, 106.7, 106.9, 107.3, 107.5, 107.7, 107.9 mc., December 1.

(4) For stations operating on the frequencies 92.3, 92.5, 92.9, 93.1, 93.3, 93.7, 93.9, 94.1, 94.5, 94.7, 94.9, 95.1, 95.5, 95.7, 96.1, 96.3, 96.5, 96.9, 97.1, 97.3, 97.5, 97.9, 98.1, 98.5, 98.7, 98.9, 99.1, 99.5, 99.7, 99.9 mc., March 1.

(b) All renewals of FM broadcast station licenses will be issued so as to expire at the hour of 3 a.m., eastern standard time, and will be issued for a maximum period of three years to expire in accordance with the following schedule and at 3-year intervals thereafter:

(1) For stations operating on the frequencies 92.1, 92.7, 93.5 mc., June 1, 1948.

(2) For stations operating on the frequencies 100.1, 100.9, 101.7 mc., September 1, 1948.

(3) For stations operating on the frequencies 100.3, 100.5, 100.7, 101.1, 101.3, 101.5, 101.9, 102.1, 102.5, 102.7 mc., December 1, 1948.

(4) For stations operating on the frequencies 92.3, 92.5, 92.9, 93.1, 93.3, 93.7, 93.9, 94.1, 94.5, 94.7 mc., March 1, 1949.

(5) For stations operating on the frequencies 94.3, 95.3, 95.9 mc., June 1, 1949.

(6) For stations operating on the frequencies 102.3, 103.1, 103.9 mc., September 1, 1949.

(7) For stations operating on the frequencies 102.9, 103.3, 103.5, 103.7, 104.1, 104.3, 104.5, 104.7, 105.1, 105.3 mc., December 1, 1949.

(8) For stations operating on the frequencies 94.9, 95.1, 95.5, 95.7, 96.1, 96.3, 96.5, 96.9, 97.1, 97.3 mc., March 1, 1950.

(9) For stations operating on the frequencies 96.7, 97.7, 98.3, 99.3 mc., June 1, 1950.

(10) For stations operating on the frequencies 104.9, 105.5, 106.3, 107.1 mc., September 1, 1950.

(11) For stations operating on the frequencies 105.7, 105.9, 106.1, 106.5, 106.7, 106.9, 107.3, 107.5, 107.7, 107.9 mc., December 1, 1950.

(12) For stations operating on the frequencies 97.5, 97.9, 98.1, 98.5, 98.7, 98.9, 99.1, 99.5, 99.7, 99.9 mc., March 1, 1951.

Educational

§3.518 *Normal license period.*—(a) All initial licenses covering construction permits for new Non-Commercial Educational FM broadcast stations will be issued so as to expire at the hour of 3 a.m., eastern standard time, and will be issued for a minimum period of one year and a maximum period of one year and 11 months to expire in accordance with the following schedule:

(1) For stations operating on the frequencies 88.1, 88.3, 88.5, 88.7, 88.9, 89.1, 89.3, 89.5, 89.7, 89.9 mc., June 1.

(2) For stations operating on the frequencies 90.1, 90.3, 90.5, 90.7, 90.9, 91.1, 91.3, 91.5, 91.7, 91.9 mc., September 1.

(b) All renewals of Non-Commercial Educational FM broadcast station licenses will be issued so as to expire at the hour of 3 a.m., eastern standard time, and will be issued for a maximum period of three years to expire in accordance with the following schedule and at 3-year intervals thereafter:

(1) For stations operating on the frequencies 88.1, 88.3, 88.5 mc., June 1, 1948.

(2) For stations operating on the frequencies 90.1, 90.3, 90.5 mc., September 1, 1948.

(3) For stations operating on the frequencies 88.7, 88.9, 89.1 mc., June 1, 1949.

(4) For stations operating on the frequencies 90.7, 90.9, 91.1 mc., September 1, 1949.

(5) For stations operating on the frequencies 89.3, 89.5, 89.7, 89.9 mc., June 1, 1950.

(6) For stations operating on the frequencies 91.3, 91.5, 91.7, 91.9 mc., September 1, 1950.

IN TELEVISION RULES . . .

§3.618 *Normal license period.*—All television broadcast station licenses will be issued so as to expire at the hour of 3 a.m., E.S.T., and will be issued for a normal license period of one year.

Station Identification

IN AM RULES . . .

§3.187 *Station identification.*—(a) A licensee of a standard broadcast station shall make station identification announcement (call letters and location) at the beginning and ending of each time of operation and during operation (1) on the hour and (2) either on the half hour or at the quarter hour following the hour and at the quarter hour preceding the next hour: *Provided*,

(b) Such identification announcement need not be made on the hour when to make such announcement would interrupt a single consecutive speech, play, religious service, symphony concert, operatic production or forum of longer duration than 30 minutes. In such cases the identification announcement shall be made at the beginning of the program, at the first interruption of the entertainment continuity, and at the conclusion of the program.

(c) Such identification announcement need not be made on the half hour or quarter hours when to make such announcement would interrupt a single consecutive speech, play, religious service, symphony concert, or operatic production. In such cases an identification announcement shall be made at the first interruption of the entertainment continuity and at the conclusion of the program, *Provided*, That an announcement within 5 minutes of the times specified in subdivision (2) of paragraph (a) of this section will satisfy the requirements of identification announcements.

(d) In the case of variety show programs, baseball game broadcasts, or similar programs of longer duration than 30 minutes, the identification announcement

shall be made within 5 minutes of the hour and of the times specified in subdivision (2) of paragraph (a) of this section.

(e) In the case of all other programs the identification announcement shall be made within 2 minutes of the hour and of the times specified in subdivision (2) of paragraph (a) of this section.

(f) In making the identification announcement the call letters shall be given only on the channel of the station identified thereby, except as otherwise provided in §3.287 of the Commission's Rules Governing FM Broadcast Stations.

IN FM RULES . . .

§3.287 *Station identification.*—(a) A licensee of an FM broadcast station shall make separate station identification announcement (call letters and location) for such station, *Provided, however*, that if the same licensee operates an FM radio broadcasting station and a standard broadcast station and simultaneously broadcasts the same programs over the facilities of both such stations, station identification announcements may be made jointly for both stations for periods of such simultaneous operation. If the call letters of the FM station do not clearly reveal that it is an FM station, the joint announcement shall state that one of the stations is an FM station. Station identification announcement shall be made at the beginning and ending of each time of operation and during operation (1) on the hour and (2) either in the half hour or at the quarter hour following the hour and at the quarter hour preceding the next hour: *Provided*:

[EDITOR'S NOTE: Remainder is identical with paragraphs (b), (c), (d), (e), and (f) of §3.406, above.]

IN TELEVISION RULES . . .

§3.687 *Station identification.*—(a) A licensee of a television broadcast station shall make station identification announcement (call letters and location), at the beginning and ending of each time of operation and during the operation on the hour. The announcement at the beginning and ending of each time of operation shall be by both aural and visual means. Other announcements may be by either aural or visual means.

(b) Identification announcements during operation need not be made when to make such announcement would interrupt a single consecutive speech, play, religious service, symphony concert, or any type of production. In such cases the identification announcement shall be made at the first interruption of the entertainment continuity and at the conclusion thereof.

Sponsored Programs

(Announcement of)

IN AM RULES . . .

§3.189 *Sponsored programs, announcement of.*—(a) In the case of each program for the broadcasting of which money, services, or other valuable consideration is either directly or indirectly paid or promised to, or charged or received by, any radio broadcast station, the station broadcasting such program shall make, or cause to be made, an appropriate announcement that the program is sponsored, paid for, or furnished, either in whole or in part.

(b) In the case of any political program or any program involving the discussion of public controversial issues for which any records, transcriptions, talent, scripts, or other material or services of any kind are furnished, either directly or indirectly, to a station as an inducement to the broadcasting of such program, an announcement shall be made both at the beginning and conclusion of such program on which such material or services are used that such records, transcriptions, talent, scripts, or other material or services have been furnished to such station in connection with the broadcasting of such program: *Provided, however*, That only one such announcement need be made in the case of any such program of five minutes' duration or less, which announcement may be made either at the beginning or the conclusion of the program.

(c) The announcement required by this section shall fully and fairly disclose the true identity of the person or persons by whom or in whose behalf such payment is made or promised, or from whom or in whose behalf such services or other valuable consideration is received, or by whom the material or services referred to in subsection (b) hereof are furnished. Where an agent or other person contracts or otherwise makes arrangements with a station on behalf of another, and such fact is known to the station, the announcement shall disclose the identity of the person or persons in whose behalf such agent is acting instead of the name of such agent.

(d) In the case of any program, other than a program advertising commercial products or services, which is sponsored, paid for or furnished, either in whole or in part, or for which material or services referred to in subsection (b) hereof are furnished, by a corporation, committee, association or other unincorporated group, the announcement required by this section shall disclose the name of such corporation, committee, association or other unincorporated group. In each such case the station shall require that a list of the chief executive officers or members of the executive committee or of the board of directors of the corporation, committee, association or other unincorporated group shall be made available for public inspection at one of the radio stations carrying the program.

(e) In the case of programs advertising commercial products or services, an announcement stating the sponsor's corporate or trade name or the name of the sponsor's product, shall be deemed sufficient for the purposes of this section and only one such announcement need be made at any time during the course of the program.

IN FM RULES . . .

§3.289—[EDITOR'S NOTE: Identical with §3.189, above.]

IN TELEVISION RULES . . .

§3.689—[EDITOR'S NOTE: Identical with §3.189, above, except that "films" are added to the services mentioned in paragraph (b).]

(Continued on page 484)



The 16 mm. sound-on-film Recording System combines the highest fidelity in 16 mm. recording practice with

wide flexibility and extreme simplicity of operation. The six bilateral tracks, recorded in place of the usual single variable area track, substantially improve the playback quality of the average 16 mm. projector. The system is completely portable and is capable of recording either negative or direct positive variable area and variable density sound tracks. The system is sold as a unit and includes the recorder, 4 channel recording amplifier, and equalizer, power supply, voltage regulator, high quality poly-directional microphone and stand, cables and carrying cases.

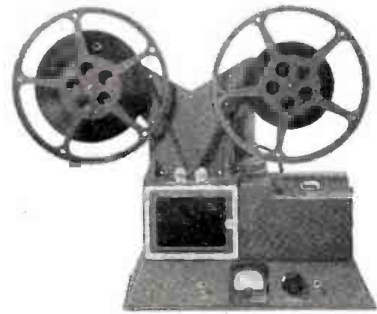

The 16 mm. Film Phonograph provides the finest quality re-recording in modern 16 mm. sound film production. The high fidelity playback is also valuable in judging the quality of sound tracks and demonstrating quality of production. The unique optical system, giving an unusually narrow reproducing image with high light output, accomplishes a material reduction in photocell hiss - essential for quality reproduction. Elimination of microphonic noise and an extremely uniform scanning beam reduces distortion to a very low value. The built-in pre-amplifier delivers an output signal at -37VU at 200 ohms impedance. Frequency response is flat from 50 cycles to 7,000 cycles - with 10,000 cycles available on special order.

THE NEW MAURER 16 MM CAMERA

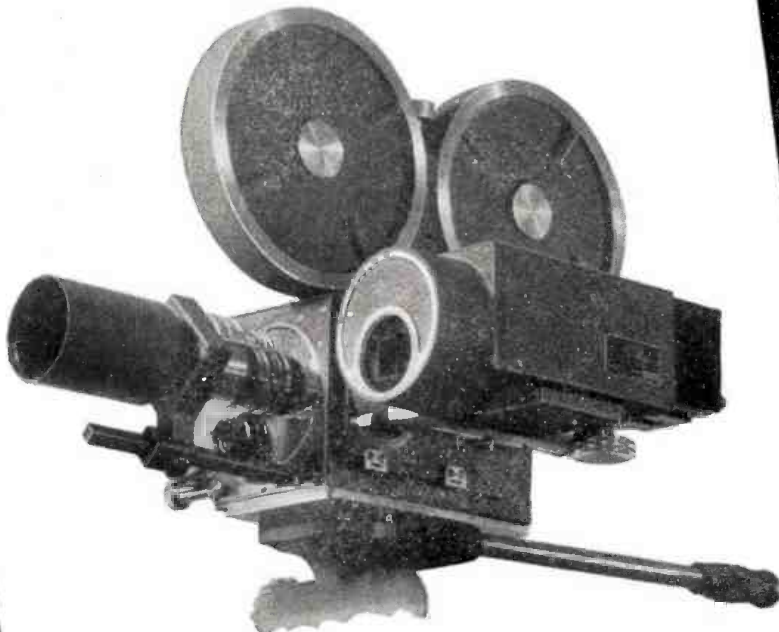

The 16 mm. Professional Camera produces the finest 16 mm. originals possible today. The result of J. A. Maurer research and development skill together with the finest engineering in the industry, it has been designed to a performance standard $2\frac{1}{2}$ times more accurate than is required for good 35 mm. camera construction. This is the only way to produce results comparable to 35 mm. Only the Maurer Professional 16 mm. camera is so designed! The intermittent movement and gate do not depend on perforation accuracy to produce perfect registration.

Equipped with a precision high-power focusing system, guarantying critically sharp focus, it also has the finest view-finder ever made for professional use. All controls and indicators are constantly at hand and available from shooting position behind the view-finder. Standard equipment includes 235-degree dissolving shutter, automatic fade control, view finder, sunshade and filter holder, one 400 foot gear-driven film magazine, 60-cycle 115-volt synchronous motor, one 8-frame handcrank, power cable and a rigid, lightweight filmboard carrying case.



The Model F Prime Recording Optical System and Galvanometer is a complete light modulating unit for recording sound photographically upon standard film and is designed to produce bilateral (symmetrical) form of variable area sound tract. This system requires no special servicing or spare parts (other than recording lamp). Detailed instructions for mounting in your recorder are included.

16mm
maurer

For additional information, please write us.

J. A. Maurer, INC.

37-01 31st ST., LONG ISLAND CITY 1, N. Y.

CABLE ADDRESS: JAMAURER

FCC RULES AND REGULATIONS
(Continued from page 482)

Recordings and Transcriptions
(Identification of)

IN AM RULES . . .

§3.188 *Mechanical records*³⁰—Each program broadcast which consists in whole or in part of one or more mechanical reproductions shall be announced in the manner and to the extent set out below.

(a) Each such program of longer duration than 30 minutes, consisting in whole or in part of one or more mechanical reproductions, shall be identified by appropriate announcement at the beginning of the program, at each 30-minute interval and at the conclusion of the program; *Provided, however*, that the identifying announcement at each of 30-minute interval is not required in case of a mechanical reproduction consisting of a continuous uninterrupted speech, play, religious service, symphony concert or operatic production of longer than 30 minutes.

(b) Each such program of a longer duration than 5 minutes and not in excess of 30 minutes, consisting in whole or in part of one or more mechanical reproductions, shall be identified by an appropriate announcement at the beginning and end of the program.

(c) Each such program of five minutes or less, consisting in whole or in part of mechanical reproductions shall be identified by appropriate announcement immediately preceding the use thereof; *Provided, however*, that each such program of one minute or less need not be announced as such.

(d) In case a mechanical reproduction is used for background music, sound effects, station identification, program identification (theme music of short duration) or identification of the sponsorship of the program proper, no announcement of the mechanical reproduction is required.

(e) The exact form of identifying announcement is not prescribed, but the language shall be clear and in terms commonly used and understood. A licensee shall not attempt affirmatively to create the impression that any program being broadcast by mechanical reproduction consists of live talent.

IN FM RULES . . .

§3.288—[EDITOR'S NOTE: Identical with §3.188, above.]

IN TELEVISION RULES . . .

§3.688 *Mechanical reproductions*.—(a) Each program which consists in whole or in part of one or more mechanical reproductions, either visual or aural, shall be accompanied by an appropriate announcement to that effect either at the beginning or end of such reproduction or at the beginning or end of the program in which such reproduction is used. No such announcement shall be required where a mechanical reproduction is used for background music, sound effects, station identification, program identification (theme music of short duration) or identification of sponsorship of the program proper.

(b)—[EDITOR'S NOTE: Same as paragraph (e) of §3.188, above.]

Political Broadcasts

FOR AM, FM, AND TV³¹ . . .

§3.190 *Definitions*.—(a) A "legally qualified candidate" means any person who has publicly announced that he is a candidate for nomination by a convention of a political party or for nomination or election in a primary, special, or general election, municipal, county, state or national, and who meets the qualifications prescribed by the applicable laws to hold the office for which he is a candidate, so that he may be voted for by the electorate directly or by means of delegates or electors, and who

(1) has qualified for a place on the ballot or

(2) is eligible under the applicable law to be voted for by sticker, by writing in his name on the ballot, or other method, and (1) has been duly nominated by a political party which is commonly known and regarded as such, or (2) makes a substantial showing that he is a *bona fide* candidate for nomination or office, as the case may be.

(b) *General requirements*.—No station licensee is required to permit the use of its facilities by any legally qualified candidate for public office, but if any licensee shall permit any such candidate to use its facilities, it shall afford equal opportunities to all other such candidates for that office to use such facilities. *Provided*, That such licensee shall have no power of censorship over the material broadcast by any such candidate.

(c) *Rates and practices*.—The rates, if any, charged all such candidates for the same office shall be uniform and shall not be rebated by any means, directly or indirectly; no licensee shall make any discrimination in charges, practices, regulations, facilities, or services for or in connection with the service rendered pursuant to these rules, or make or give any preference to any candidate for public office or subject any such candidate to any prejudice or disadvantage; nor shall any licensee make any contract or other agreement which shall have the effect of permitting any legally qualified candidate for any public office to broadcast to the exclusion of other legally qualified candidates for the same public office.

(d) *Records; inspection*.—Every licensee shall keep and permit public inspection of a complete record of all requests for broadcast time made by or on behalf of candidates for public office, together with an appropriate notation showing the disposition made by the licensee of such requests, and the charges made, if any, if request is granted.

Rebroadcasts

IN AM RULES . . .

§3.191 *Rebroadcast*.—(a) The term "rebroadcast" means reception by radio of the program³² of a radio station, and the simultaneous or subsequent retransmission of such program by a broadcast station.³³

(b) The licensee of a standard or high frequency broadcast station may, without further authority of the Commission, rebroadcast the program of a United States standard or high frequency broadcast station, provided the Commission

is notified of the call letters of each station rebroadcast and the licensee certifies that express authority has been received from the licensee of the station originating the program.³⁴

(c) (1) The licensee of a standard broadcast station located within a state or the District of Columbia may, without further authority of the Commission rebroadcast on a noncommercial basis a noncommercial program of a United States international broadcast station.

(2) The licensee of a standard broadcast station located in any territory or insular possession of the United States may, without further authority of the Commission, rebroadcast any program of a United States international broadcast station.

(3) In the case of any rebroadcast under the provisions of this paragraph (c), the Commission shall be notified of the call letters of each station whose programs are rebroadcast and the licensee shall certify that express authority has been received from the licensee of the station originating the program.

(d) No licensee of a standard or high frequency broadcast station shall rebroadcast the program of any other class of United States radio station without written authority having first been obtained from the Commission upon application accompanied by written consent or certification of consent of the licensee of the station originating the program.^{35, 36, 37}

(e) In case of a program rebroadcast by several standard broadcast stations, such as a chain rebroadcast, the person legally responsible for distributing the program or the network facilities may obtain the necessary authorization for the entire rebroadcast both from the Commission and from the person or licensee of the station originating the program.

Attention is directed to section 325(b) of the Communications Act of 1934, which reads as follows:

No person shall be permitted to locate, use, or maintain a radio broadcast studio or other place or apparatus from which or whereby sound waves are converted into electrical energy, or mechanical or physical reproduction of sound waves produced, and caused to be transmitted or delivered to a radio station in a foreign country for the purpose of being broadcast from any radio station there, having a power output of sufficient intensity, and/or being so located geographically that its emissions may be received consistently in the United States, without first obtaining a permit from the Commission upon proper application therefor.³⁸

IN FM RULES . . .

§3.291—[EDITOR'S NOTE: Identical in terms with §3.191, above, with two exceptions: Paragraph (e) of §3.191 is deleted in §3.291, and Paragraph (b) relates to rebroadcasts of programs of U.S. "standard, FM or noncommercial educational" stations.]

IN TELEVISION RULES . . .

§3.691—[EDITOR'S NOTE: Identical in terms with §3.191, above, except that television rebroadcasts naturally are limited to programs of other television stations; Paragraphs (d) and (e) of §3.191 are deleted in §3.691.]

Revocations, Modifications, Suspensions

OF STATION LICENSES (ALL CLASSES) . . .

§1.401 *Notice of violations*.—Any licensee who appears to have violated a provision of the Communications Act of 1934 or of the Rules and Regulation of the Federal Communications Commission, shall be served with a notice calling the facts to his attention and requesting a statement concerning the matter. Within three days from receipt of such notice or such other period as may be specified, the licensee shall send a written answer direct to the office of the Commission originating the official notice. If an answer cannot be sent nor an acknowledgment made within such three-day period by reason of illness or other unavoidable circumstances, acknowledgment and answer shall be made at the earliest practicable date with a satisfactory explanation of the delay. The answer to each notice shall be complete in itself and shall not be abbreviated by reference to other communications or answers to other notices. If the notice relates to violations that may be due to the physical or electrical characteristics of transmitting apparatus, the answer shall state fully what steps, if any, have

³⁰ During the annual periods in which Daylight Saving Time will be effective, the requirements of this section are waived with respect to network programs transcribed and rebroadcast one hour later because of the time differential resulting from the adoption of Daylight Saving Time in some areas, this waiver being applicable whether the off-the-line recording is made by the network itself at one of its key stations or by an individual station, but only when the off-the-line recording is for broadcast one hour later by those stations which operate on standard time. Furthermore, each station which broadcasts network programs one hour later in accordance with this waiver shall make an appropriate announcement at least once each day between the hours of 10 a.m. and 10 p.m., stating that some or all of the network programs which are broadcast by that station are delayed broadcasts by means of transcription, and indicating whether the transcriptions have been made by the network or the individual station. A network organization or individual station taking advantage of this waiver should so advise the Commission.

³¹ Sec. 3.190, reprinted here, is from AM rules. In FM it is 3.290; in TV, 3.690.

³² As used in sec. 3.408, program includes any complete program or part thereof, or any signals if other than A-3 emission.

³³ In case a program is transmitted from its point of origin to a broadcast station entirely by telephone facilities in which a section of such transmission is by radio, the broadcasting of this program is not considered a rebroadcast.

³⁴ The notice and certification of consent shall be given within three (3) days of any single rebroadcast, but in case of the regular practice of rebroadcasting certain programs of a standard or high frequency broadcast station several times during a license period, notice and certification of consent shall be given for the ensuing license period with the application for renewal of license, or at the beginning of such rebroadcast practice if begun during a license period.

³⁵ The broadcasting of a program relayed by a remote pickup broadcast station (sec. 4.401) is not considered a rebroadcast.

³⁶ Informal application may be employed.

³⁷ By order No. 82, dated and effective June 24, 1941, until further order of the Commission, section 3.191(d) is suspended only insofar as it requires prior written authority of the Commission for the rebroadcasting of programs originated for that express purpose by U. S. Government radio stations.

³⁸ Formal application required. See Standards of Good Engineering Practice for form number.

(Continued on page 486)

*WOR-tv's tower, built by Lehigh.
It rises 1050 feet above the Hudson River . . .
a miracle of engineering skill!*

AMERICA'S HIGHEST SELF-SUPPORTING TELEVISION TOWER IS A LEHIGH TOWER

WOR-tv—one of America's great television stations turned to Lehigh Structural Steel Co. when it wanted an answer to one of the most challenging jobs in modern broadcasting.

If you are planning to construct an AM, FM or Television station, or if you are looking for a better tower than you have, look to LEHIGH for the best in tower construction.

LEHIGH's leadership in the tower business is known nationwide. For dependable, durable towers, consult LEHIGH.

Lehigh Structural Steel Co.

17 Battery Place • New York 4, N. Y.

Plant at Allentown, Penna. Offices in Principal Cities



J. R. Poppele, right, vice-president in charge of engineering for Station WOR, congratulates T. R. Mullen, president, Lehigh Structural Steel Co., during a ceremony in which a bronze plaque was presented to the station by Lehigh Structural Steel Co., designers and fabricators of the tower.

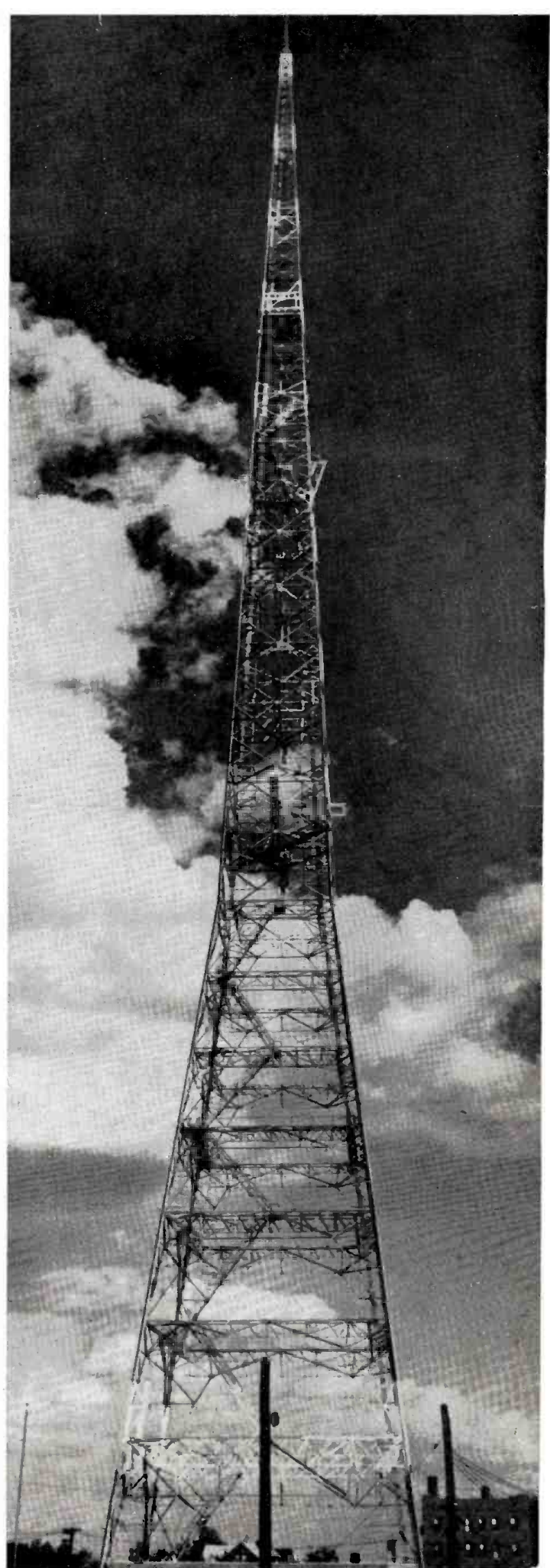

FCC RULES AND REGULATIONS

(Continued from page 484)

been taken to prevent future violations, and if any new apparatus is to be installed, the date such apparatus was ordered, the name of the manufacturer, and promised date of delivery. If the installation of such apparatus requires a construction permit, the file number of the application shall be given, or if a file number has not been assigned by the Commission such identification shall be given as will permit ready identification thereof. If the notice of violation relates to lack of attention to or improper operation of the transmitter, the name and license number of the operator in charge shall be given.

§1402 Revocation of licenses.—Whenever it appears that grounds exist for revocation of license, as provided in Section 312(a) of the Act, the Bureau of Law after conferring with the other bureaus of the Commission prepares a report and other necessary papers which are presented to the Commission for action. If the Commission concludes that a revocation proceeding should be instituted, an order of revocation will be issued effective not less than 15 days after written notice thereof is given the licensee. The order of revocation shall contain a statement of the grounds and reasons for such proposed revocation and a notice of the licensee's right to be heard by filing with the Commission a written request for hearing within 15 days after receipt of said order. Upon the filing of such written request for hearing by said licensee, the order of revocation shall stand suspended and the Commission will set a time and place for hearing and shall give the licensee and other interested parties notice thereof. If no request for hearing on any order of revocation is made by the licensee against whom such an order is directed within the time set forth, the order of revocation shall become final and effective, without further action of the Commission. When any order of revocation has become final, the person whose license has been revoked shall forthwith deliver the station license in question to the inspector in charge of the district in which the station is located.

§1403 Modification of licenses.—Whenever it appears that public interest, convenience, and necessity would be served, or the provisions of the Communications Act, or if any treaty ratified by the United States will be more fully complied with, by the modification of any radio station construction permit or license, the Bureau of Law and Engineering after conferring with the other bureaus prepare a report and other necessary papers which are presented to the Commission for action. If the Commission concludes that proceedings should be instituted, an order will be issued to show cause why such construction permit or license should not be modified. Such order to show cause shall contain a statement of the grounds and reasons for such proposed modifications, and shall specify wherein the said construction permit or license is required to be modified. It shall require the licensee against whom it is directed, to appear at a place and time therein named to show cause why the proposed modification should not be made and the order of modification issued. If the licensee against whom the order to show cause is directed does not appear at the time and place provided in said order, a final order of modification shall issue forthwith.

OF OPERATOR LICENSES . . .

§1404 Suspension of operator licenses.—Whenever it appears that grounds exist for suspension of an operator license, as provided in Section 303(m) of the Act, the Bureau of Law after conferring with the other bureaus of the Commission prepares a report and other necessary papers which are presented to the Commission for action. If the Commission concludes that suspension proceedings should be instituted, a suspension order will be issued. No order of suspension of any operator's license shall take effect until 15 days' notice in writing thereof, stating the cause for the proposed suspension, has been given to the operator licensee who may make written application to the Commission at any time within said 15 days for a hearing upon such order. The notice to the operator licensee shall not be effective until actually received by him, and from that time he shall have 15 days in which to mail the said application. In the event that physical conditions prevent mailing of the application before the expiration of the 15-day period, the application shall then be mailed as soon as possible thereafter, accompanied by a satisfactory explanation of the delay. Upon receipt by the Commission of such application for hearing, said order of suspension shall be held in abeyance until the conclusion of the hearing which shall be conducted under such rules as the Commission shall deem appropriate. Upon the conclusion of said hearing the Commission may affirm, modify, or revoke said order of suspension. If the license is ordered suspended, the operator shall send his operator license to the office of the Commission in Washington, D. C., on or before the effective date of the order, or, if the effective date has passed at the time notice is received, the license shall be sent to the Commission forthwith.

Lotteries

FOR ALL STATIONS . . .

§1392³⁰ Lotteries and Give-Away Programs.—(a) An application for construction permit, license, renewal of license, or any other authorization for the operation of a broadcast station, will not be granted where the applicant proposes to follow or continue to follow a policy or practice of broadcasting or permitting "the broadcasting of any advertisement or information concerning any lottery, gift enterprise, or similar scheme, offering prizes dependent in whole or in part upon lot or chance, or any list of the prizes drawn or awarded by means of any such lottery, gift enterprise, or scheme, whether said list contains any part or all of such prizes." (See U.S.C. §1304.)

(b) The determination whether a particular program comes within the provisions of subsection (a) depends on the facts of each case. However, the Commission will in any event consider that a program comes within the provisions of subsection (a) if in connection with such program a prize consisting of money or thing of value is awarded to any person whose selection is dependent in whole or in part upon lot or chance, if as a condition of winning or competing for such prize:

(1) such winner or winners are required to furnish any money or thing of value or are required to have in their possession any product sold, manufactured, furnished or distributed by a sponsor of a program broadcast on the station in question; or

(2) such winner or winners are required to be listening to or viewing the program in question on a radio or television receiver; or

(3) such winner or winners are required to answer correctly a question, the answer to which is given on a program broadcast over the station in question or where aid to answering the question correctly is given on a program broadcast over the station in question. For the purposes of this provision the broadcasting of the question to be answered over the radio station on a previous program will be considered as an aid in answering the question correctly; or

(4) such winner or winners are required to answer the phone in a prescribed manner or with a prescribed phrase, or are required to write a letter in a prescribed manner or containing a prescribed phrase, if the prescribed manner of answering the phone or writing the letter or the prescribed phrase to be used over the phone or in the letter (or an aid in ascertaining the prescribed phrase or the prescribed manner of answering the phone or writing the letter) is, or has been, broadcast over the station in question.

§1304 (of U. S. Criminal Code) Broadcasting Lottery Information.—Whoever broadcasts by means of any radio station for which a license is required by any law of the U. S., or whoever, operating any such station, knowingly permits the broadcasting of any advertisement or information concerning any lottery, gift enterprise, or similar scheme, offering prizes dependent in whole or in part upon lot or chance, or any list of the prizes drawn or awarded by means of any such lottery, gift enterprise or scheme, whether said list contains any part or all of such prizes, shall be fined not more than \$1,000 or imprisoned not more than one year, or both.

Each day's broadcasting shall constitute a separate offense.

Censorship

FOR ALL STATIONS . . .

§326 [of Communications Act].—Nothing in this Act shall be understood to give the Commission the power of censorship over the radio communications or signals transmitted by any radio station, and no regulation or condition shall be promulgated or fixed by the Commission which shall interfere with the right of free speech by means of radio communication.

Indecent Language

§1464 (of U. S. Criminal Code) Broadcasting Obscene Language.—Whoever utters any obscene, indecent, or profane language by means of radio communication shall be fined not more than \$10,000 or imprisoned not more than two years, or both.

Transfers and Assignments

VOLUNTARY . . .

§1321 Application for voluntary assignment or transfer of control; broadcast.—(a) Applications for consent to the assignment of construction permit or license for an AM, FM, television or other broadcast station or for consent to the transfer of control of a corporation holding such a construction permit or license shall be filed with the Commission on FCC Form No. 314 (Assignment of License), FCC Form No. 315 (Transfer of Control), or FCC Form No. 316 (Short Form). Such applications shall be filed with the Commission at least 60 days prior to contemplated effective date of assignment or transfer of control.

(b) *Pro forma* assignment or transfer applications shall be filed on FCC Form 316. Such cases are defined as cases in which:

(1) There is an assignment from an individual or individuals (including partnerships) to a corporation owned and controlled by such individuals or partnerships without any substantial change in their relative interests;

(2) There is an assignment from a corporation to its individual stockholders without effecting any substantial change in the disposition of their interests;

(3) There is an assignment or transfer by which certain partners or stockholders retire but no new ones are brought in, provided that the interest transferred is not a controlling one;

(4) There is a corporate reorganization which involves no substantial change in the beneficial ownership of the corporation;

(5) There is an involuntary transfer to an executor, administrator or other court appointed officer caused by death or legal disability except that this form does not cover assignments (or transfers) from the executor, administrator or other court appointed officers to the ultimate beneficiary;

(6) There is an assignment or transfer from a corporation to a wholly owned subsidiary thereof or vice versa, or where there is an assignment from a corporation to a corporation owned or controlled by the assignor stockholders without substantial change in their interests;

(7) There is an assignment of less than a controlling interest in a partnership.

INVOLUNTARY TRANSFERS

AND ASSIGNMENTS . . .

§1323 Application for involuntary assignment or transfer of control; broadcast and non-broadcast.—In the event of the death or legal disability of a permittee or licensee, or a member of a partnership, or a person directly or indirectly in control of a corporation, which is a permittee or licensee:

(a) the Commission shall be notified in writing promptly of the occurrence of such death or legal disability, and

(b) within thirty days after the occurrence of such death or legal disability (except in the case of a ship or amateur station), application shall be filed for consent to involuntary assignment of such permit or license or for involuntary transfer of control of such corporation to a person or entity legally qualified to succeed to the foregoing interests under the laws of the place having jurisdiction over the estate involved. The procedure and forms to be followed are the same as those specified in Sections 1.321 and 1.322. In the case of ship and amateur stations, involuntary assignment of licenses will not be made; such licenses shall be surrendered for cancellation upon the death or legal disability of the licensee.

³⁰ Effective date of the lottery rules was postponed by FCC until current court tests of their legality have been completed. The same is true of §3.292 (FM) and §3.692 (TV), which are identical to §3.192, reprinted here.

REPRESENTING 192 YEARS of SERVICE TO THE Broadcast Industry



ADRIAN VAN SANTEN
SEATTLE,
WASHINGTON

Radio engineering training followed by ten years' experience covering radio, radar, broadcast, sound and communications. Now serves Raytheon broadcast customers in the Northwest. Address: 135 Harvard North, Seattle. Phone, Minor 3537.



WARREN COZZENS

Active in nearly every phase of the industry since 1938 — plus Navy service in radar and communications and broadcast experience in AM, FM and TV.

Address: Cozzens & Farmer
720 Main Street, Evanston, Illinois
Phone, Davis 8-4800



BEN FARMER

A "20 year man" with an excellent background including station ownership and operation, equipment design, production, sales and service.



**L. E. (ED)
PAMPHILON**
WALTHAM, MASS.

23 years in broadcasting and broadcast service including local station ownership, network and regional station operation, and field service. Served as Raytheon representative at WMAU-TV's recent record-breaking microwave pick-up of the Orange Blossom Festival. Address: Raytheon Manufacturing Company, 138 River Street, Waltham, Mass. Phone, Waltham 5-5860, Ext. 422.



**HENRY J. (HANK)
GEIST**
NEW YORK, N. Y.

Literally "grew up" in broadcasting with 20 years' experience covering engineering phases of factory production, station layout, equipment installation and operation. Has contributed important development work in radio and TV relay, transmission, and antenna and audio system design. Address: 60 East 42nd St., N. Y. Phone, Mu 7-1550.



EMILE J. ROME
SAN FRANCISCO,
CALIF.

Qualified "from the ground up" by wide experience as a radio and electronics instructor, inspector, procurement officer and field engineer. With Raytheon since 1944 as a sales engineer and district manager serving stations on the West Coast. Address: Raytheon Manufacturing Co., 49 California St., San Francisco. Phone, Sutter 1-0475.



J. L. LOVETT
WILMINGTON, CALIF.

A Raytheon district manager with 15 years' experience in broadcast and marine communications. FCC license holder since 1932. Address: Raytheon Manufacturing Co., P. O. Box 425, Wilmington, Calif. Phone, Terminal 4-1721.



**HOWARD D.
CRISSEY**
DALLAS, TEXAS

22 years of radio broadcast experience including installation, maintenance and engineering. Thoroughly understands broadcasting problems encountered throughout the Southwest. Address: 414 East 10th St., Dallas 8, Texas. Phone, Yale 2-1904.



**W. B. (BUCK)
TAYLOR**
CHATTANOOGA,
TENN.

The "Radio Man" of the South. A veteran with 35 years of experience in early "wireless" and broadcasting in South-eastern areas. Your informal consultant on "40 meter" or 250 to 10,000 watt AM or FM broadcasting stations. Address: Signal Mountain, Tenn. Phone, 88-2487.

Back of dependable Raytheon broadcast equipment stands a dependable sales and service organization — alert, intelligent, familiar with every phase of Broadcasting. Each of these men has topped wide experience in station operation, engineering and management with long service on the Raytheon team. Together, they represent a combined experience of 192 years in broadcasting and are responsible for over 300 complete station installations. Strategically located throughout the country, they stand ready to serve you promptly, efficiently and to the best of their very capable ability.

RAYTHEON

Excellence in Electronics

RAYTHEON MANUFACTURING COMPANY

Industrial and Commercial Electronic Equipment;
FM, AM and TV Broadcast Equipment; Tubes and Accessories

WALTHAM 54, MASSACHUSETTS

U. S. AM BROADCASTING STATIONS BY FREQUENCIES.

(Licensed or Authorized by FCC as of January 1, 1950)

* CP granted for increase in power. † Construction permit for new station. ‡ Special authorization for power or frequency. CP—Construction permit for frequency. L—Limited time; operates night hours only when dominant station is not operating. DA—Directional antenna. D—Daytime operation. LS—Local sunset. N—Night. U—Unlimited time. SH—Specified hours. Class of Station shown in parentheses.

Call Letters	City	Power in Watts	Call Letters	City	Power in Watts	Call Letters	City	Power in Watts	Call Letters	City	Power in Watts
550 KC. REGIONAL											
KOY	Phoenix, Ariz. (III-A)	LS-5,000	WILL	Urbana, Ill. (III)	DA-D-5,000	KWAL	Wallace, Idaho (III-B)	DA-N-1,000	KEPO	El Paso, Tex. (II)	DA-5,000
KAFY	Bakersfield, Cal. (CP from 1490 kc)	DA-1,000	KSAC	Manhattan, Kan. (III-B)	LS-5,000	KCOM	St. Louis, Mo. (III-A)	DA-1,000	KPET	Lamesa, Tex. (II)	D-250
KFMB	San Diego, Cal. (III-B)	DA-1,000	WIBW	Topeka, Kan. (III-A)	DA-N-5,000	WLBZ	Bangor, Me. (III-A)	DA-N-5,000	KSYC	Richfield, Utah (II)	D-1,000
†WFIR	Danbury, Conn. (III-B)	LS-1,000	KALB	Alexandria, La. (III-B)	LS-5,000	WRBC	Jackson, Miss. (III-B)	LS-5,000	WCYB	Bristol, Va. (II)	D-10,000
WCON	Atlanta, Ga. (III-A)	DA-N-5,000	WTAG	Worcester, Mass. (III-A)	DA-5,000	WVNV	Newark, N. J. (III-A)	DA-5,000	WNNT	Warsaw, Va. (II)	D-250
KFRM	Kansas City, Mo. (III)	DA-D-5,000	WHP	Harrisburg, Pa. (III-A)	DA-N-5,000	WAGE	Syracuse, N. Y. (III-B)	LS-5,000	KULA	Honolulu, T. H. (II)	10,000
KSD	St. Louis, Mo. (III-A)	DA-N-5,000	WCHS	Charleston, W. Va. (III-A)	DA-N-5,000	WDNC	Durham, N. C. (III-B)	LS-5,000	WLW	Cincinnati, O. (I-A)	50,000
KOPR	Butte, Mont. (III-B)	DA-N-1,000	WKTY	La Crosse, Wis. (III-B)	DA-1,000	KGW	Portland, Ore. (III-A)	DA-5,000	WKRK	Mobile, Ala. (II)	LS-1,000
WGR	Buffalo, N. Y. (III-A)	DA-N-5,000	WIAC	San Juan, P. R. (III-A)	5,000	WHJB	Greensburg, Pa. (III-B)	LS-1,000	KMPC	Los Angeles, Cal. (II)	LS-50,000
KFYR	Bismarck, N. D. (III-A)	DA-N-5,000	590 KC. REGIONAL			WROL	Knoxville, Tenn. (III-A)	DA-5,000	WGBS	Miami, Fla. (II)	LS-50,000
WKRC	Cincinnati, O. (III-B)	LS-5,000	KFXM	San Bernardino, Cal. (III-B)	DA-1,000	KWFT	Wichita Falls, Tex. (III-A)	DA-N-5,000	WROM	Rome, Ga. (II)	D-1,000
KOAC	Corvallis, Ore. (III-A)	DA-5,000	KCSJ	Pueblo, Colo. (III-B)	DA-N-1,000	WCAX	Burlington, Vt. (III-A)	DA-5,000	KTBS	Shreveport, La. (II)	LS-10,000
KCRS	Midland, Tex. (III-B)	LS-5,000	WDLF	Panama City, Fla. (III-B)	DA-N-1,000	WTMJ	Milwaukee, Wis. (III-A)	DA-N-5,000	WHB	Kansas City, Mo. (II)	LS-10,000
KTSA	San Antonio, Tex. (III-A)	DA-N-5,000	WAGA	Atlanta, Ga. (III-A)	DA-N-5,000	WKAQ	San Juan, P. R. (III-A)	DA-5,000	WOR	New York, N. Y. (I-B)	DA-50,000
WDEV	Waterbury, Vt. (III-B)	DA-1,000	WVLK	Versailles, Ky. (III-B)	DA-1,000	630 KC. REGIONAL			WTOB	Winston-Salem, N. C. (II)	D-1,000
WSVA	Harrisonburg, Va. (II)	D-1,000	WEEL	Boston, Mass. (III-A)	DA-5,000	WAVU	Albertville, Ala. (III)	D-500	WTPR	Paris, Tenn. (II)	D-250
KEMM	Wailuku, T. H. (II-A)	1,000	WKZO	Kalamazoo, Mich. (III-A)	DA-N-5,000	KVMA	Magnolia, Ark. (III)	D-1,000	KGNC	Amarillo, Tex. (II)	DA-10,000
560 KC. REGIONAL											
WOOF	Dothan, Ala. (III)	D-1,000	WOW	Omaha, Neb. (III-A)	5,000	KVOD	Denver, Colo. (III-A)	DA-5,000	KIRO	Seattle, Wash. (I-B)	DA-N-50,000
KYUM	Yuma, Ariz. (III-B)	DA-N-1,000	WROW	Albany, N. Y. (III-B)	LS-5,000	WMAV	Savannah, Ga. (III-A)	DA-5,000	WDSM	Superior, Wis. (II)	DA-5,000
KCBS	San Francisco, Cal. (III-A)	DA-N-5,000	WGTM	Wilson, N. C. (III-A)	DA-5,000	WJMS	Ironwood, Mich. (III-B)	DA-N-5,000	KFBC	Cheyenne, Wyo.	LS-10,000
KSFO	San Francisco, Cal. (III-A)	LS-5,000	WMBS	Uniontown, Pa. (III-B)	DA-N-1,000	KXOK	St. Louis, Mo. (III-A)	DA-5,000	WKJB	Mayaguez, P. R. (II)	LS-1,000
KLZ	Denver, Colo. (III-A)	DA-5,000	KTBC	Austin, Tex. (III-B)	DA-N-1,000	KOH	Reno, Nev. (III-A)	DA-N-1,000	720 KC. CLEAR		
WQAM	Miami, Fla. (III-A)	LS-5,000	KSUB	Cedar City, Utah (III-B)	DA-N-1,000	WIRC	Hickory, N. C. (III)	D-1,000	WGN	Chicago, Ill. (I-A)	50,000
WIND	Chicago, Ill. (III-A)	DA-5,000	WLVA	Lynchburg, Va. (III-B)	DA-1,000	WMFD	Wilmington, N. C. (III-B)	DA-1,000	730 KC. (Mexican) CLEAR		
WCFM	Middlesboro, Ky. (III)	D-500	KHQ	Spokane, Wash. (III-A)	5,000	WQAN	Scranton, Pa. (CP from 910 kc)	D-500	†	Montevallo, Ala.	D-250
WGAN	Portland, Me. (III-A)	DA-5,000	KGMB	Honolulu, T. H. (III-A)	5,000	WPRO	Providence, R. I. (III-A)	DA-N-5,000	WKTG	Thomasville, Ga. (II)	D-1,000
WHYN	Holyoke, Mass. (III-B)	DA-1,000	600 KC. REGIONAL			KGFX	Pierre, S. D. (IV)	D-200	KWGB	Goodland, Kan. (II)	D-1,000
KWTO	Springfield, Mo. (III-B)	LS-5,000	KVCV	Redding, Cal. (III-B)	DA-1,000	KMAC	San Antonio, Tex. (III-A)	DA-5,000	WCIF	Madisonville, Ky. (II)	D-250
KMON	Great Falls, Mont. (III-A)	DA-N-1,000	KFSD	San Diego, Cal. (III-A)	DA-5,000	KPOA	Honolulu, T. H. (III-A)	5,000	WMTC	Vancleve, Ky. (II)	D-1,000
WGAI	Elizabeth City, N. C. (III)	D-500	WICC	Bridgeport, Conn. (III-B)	LS-1,000	WQAN	Scranton, Pa. (CP from 910 kc)	D-500	KTRY	Bastrop, La. (II)	D-250
WFIL	Philadelphia, Pa. (III-A)	DA-5,000	WPDQ	Jacksonville, Fla. (III-A)	DA-U-N-500	WRCR	Nashville, Tenn. (I-A)	50,000	WIHL	Hammond, La. (II)	D-250
WIS	Columbia, S. C. (III-A)	DA-N-5,000	WMT	Cedar Rapids, Ia. (III-A)	DA-N-5,000	KRCT	Baytown, Tex. (II)	D-250	WACE	Chicopee, Mass. (II)	D-1,000
WHBQ	Memphis, Tenn. (III-B)	LS-5,000	WMRY	New Orleans, La. (III)	D-500	KOWH	Omaha, Neb. (II)	D-500	KWOA	Worthington, Minn. (II)	D-1,000
KFDM	Beaumont, Tex. (III-A)	DA-N-5,000	WCAO	Baltimore, Md. (III-A)	DA-5,000	WNBC	New York, N. Y. (I-A)	DA-50,000	740 KC. (Canadian) CLEAR		
KPQ	Wenatchee, Wash. (III-A)	DA-N-1,000	WTAC	Flint, Mich. (III-B)	LS-1,000	WESC	Greenville, S. C. (II)	D-500	KSFO	San Francisco, Cal. (II)	DA-50,000
WJLS	Beckley, W. Va. (III-B)	LS-1,000	WSJS	Winston-Salem, N. C. (III-A)	DA-5,000	KSKY	Dallas, Tex. (II)	D-1,000	WCBS	San Jose, Cal. (II)	DA-5,000
570 KC. REGIONAL											
WGWD	Gadsden, Ala. (II)	D-1,000	KSJB	Jamestown, N. D. (III-A)	DA-5,000	†KFAF	Fairbanks, Alaska (III-A)	10,000	WORZ	Orlando, Fla. (II)	DA-1,000
KLAC	Los Angeles, Cal. (III-A)	LS-5,000	WREC	Memphis, Tenn. (III-A)	DA-5,000	WLAQ	Rome, Ga. (II)	D-1,000	WVLY	Olney, Ill. (II)	D-250
WQQW	Washington, D. C. (III)	D-1,000	KROD	El Paso, Tex. (III-A)	DA-N-5,000	WMAQ	Chicago, Ill. (I-A)	50,000	†KBIG	Des Moines, Ia. (II)	D-250
WKYB	Paducah, Ky. (CP from 800 kc)	DA-D-1,000	KERB	Kermitt, Tex. (III)	DA-D-1,000	680 KC. CLEAR			WNOP	Newport, Ky. (II)	DA-D-1,000
†WVMI	Biloxi, Miss. (II)	D-1,000	KTBB	Tyler, Tex. (III)	D-500	KNBC	San Francisco, Cal. (I-B)	50,000	WTAO	Cambridge, Mass. (II)	D-250
WMCA	New York, N. Y. (III-A)	DA-5,000	WSGN	Birmingham, Ala. (III-B)	LS-5,000	WCLE	Clearwater, Fla. (II)	D-1,000	†KPBM	Carlsbad, N. M. (II)	D-1,000
WSYR	Syracuse, N. Y. (III-A)	DA-5,000	KFRC	San Francisco, Cal. (III-A)	DA-N-1,000	WCBM	Baltimore, Md. (II)	LS-10,000	WMBL	Morehead City, N. C. (II)	D-1,000
WWNC	Asheville, N. C. (III-A)	DA-N-5,000	WIOD	Miami, Fla. (III-A)	DA-5,000	WDLA	Lawrence, Mass. (II)	DA-50,000	WFAQ	Mt. Airy, N. C. (II)	D-1,000
WKBN	Youngstown, O. (III-A)	DA-N-5,000	KDAL	Duluth, Minn. (III-A)	DA-N-5,000	WDBC	Escanaba, Mich. (II)	DA-1,000	KRMG	Tulsa, Okla. (II)	DA-U-N-10,000
WNAX	Yankton, S. D. (III-A)	DA-N-5,000	WDAF	Kansas City, Mo. (III-A)	5,000	KFEQ	St. Joseph, Mo. (II)	DA-5,000	WVCH	Chester, Pa. (II)	D-250
WFAA	Dallas, Tex. (III-A)	DA-N-5,000	†KYES	Butte, Mont. (III-B)	DA-N-1,000	WRNY	Rochester, N. Y. (II)	D-250	WNCN	Aiken, S. C. (II)	D-1,000
WBAP	Ft. Worth, Tex. (III-A)	DA-N-5,000	WMUR	Manchester, N. H. (III-B)	LS-5,000	WPTF	Raleigh, N. C. (II)	DA-N-50,000	WIRJ	Humboldt, Tenn. (II)	D-250
KUTA	Salt Lake City, Utah (III-A)	DA-5,000	KGGM	Albuquerque, N. M. (III-A)	DA-N-5,000	WISR	Butler, Pa. (II)	D-250	WJIG	Tullahoma, Tenn. (II)	D-250
KVI	Seattle, Wash. (III-A)	5,000	WAYS	Charlotte, N. C. (III-B)	LS-5,000	WMPS	Memphis, Tenn. (II)	LS-10,000	KTRH	Houston, Tex. (II)	DA-50,000
WMAM	Marinette, Wis. (IV)	LS-250	WHKC	Columbus, O. (III-A)	DA-U-N-1,000	KABC	San Antonio, Tex. (II)	LS-50,000	WBS	Santurce, P. R. (II)	DA-10,000
580 KC. REGIONAL											
KMJ	Fresno, Cal. (III-A)	5,000	WIP	Philadelphia, Pa. (III-A)	DA-5,000	KOMW	Omak, Wash. (II)	D-1,000	750 KC. CLEAR		
WDBO	Orlando, Fla. (III-A)	DA-N-5,000	KLEE	Houston, Tex. (III-A)	DA-5,000	WAPA	San Juan, P. R. (II)	D-1,000	WSB	Atlanta, Ga. (I-A)	50,000
WGAC	Augusta, Ga. (III-B)	LS-5,000	KVNU	Logan, Utah (III-B)	DA-5,000	690 KC. (Canadian) CLEAR			KSTT	Davenport, Ia. (II)	D-250
KFXD	Nampa, Ida. (III-B)	DA-N-1,000	WLSL	Roanoke, Va. (III-B)	DA-N-1,000	WVOK	Birmingham, Ala. (II)	D-50,000	WBMD	Baltimore, Md. (II)	D-1,000
620 KC. REGIONAL											
KTAR	Phoenix, Ariz. (III-A)	DA-N-5,000	KFAR	Fairbanks, Alaska (III-A)	5,000	KELD	El Dorado, Ark. (II)	DA-N-1,000	KMMJ	Grand Island, Neb. (II)	LS-1,000
KNGS	Hanford, Cal. (III-B)	DA-N-1,000	WSUN	St. Petersburg, Fla. (III-A)	DA-N-5,000	KGGF	Coffeyville, Kan. (II)	LS-1,000	WHEB	Portsmouth, N. H. (II)	LS-1,000
630 KC. CLEAR											
WWEZ	New Orleans, La. (II)	DA-5,000									
KSTL	St. Louis, Mo. (II)	D-1,000									
†KRCO	Prineville, Ore.	D-1,000									
WLTR	Bloomburg, Pa. (II)	DA-D-1,000									

(Continued on page 490)

SIGNS OF Recording Progress



The Premium
'BROADCASTER'
For super-critical recording.



" 'PLAYBACK,'
The standard of
the networks."



The economical
'AUDITION.'

SOUNDCRAFT

SOUNDCRAFT DISCS
are stocked for you
by 411 foremost radio
parts distributors in
all principal cities.
Send for catalog and
list.

REEVES Soundcraft CORP.
10 EAST 52nd STREET • NEW YORK 22, N. Y.

DELIVERED FROM LOCAL STOCKS BY YOUR DISTRIBUTOR

AM STATIONS BY FREQUENCIES

(Continued from page 488)

Call Letters	City	Power in Watts	Call Letters	City	Power in Watts	Call Letters	City	Power in Watts
770 KC. CLEAR								
KUOM	Minneapolis, Minn. (II)	D-5,000	WQXI	Buckhead, Ga. (III)	D-5,000	WEAU	Eau Claire, Wis. (III-A)	DA-N-5,000
WCAL	Northfield, Minn. (II)	D-5,000	KXXX	Colby, Kan. (III)	D-5,000	KFQD	Anchorage, Alaska (III-A)	5,000
WEW	St. Louis, Mo. (II)	D-1,000	WGRC	Louisville, Ky. (III-B)	DA-U-N-1,000	800 KC. (Mexican) CLEAR		
KOB	Albuquerque, N. M. (II)	LS-50,000	(CP from 1400 kc)			WHOS	Decatur, Ala. (II)	D-1,000
(See also 1030 kc)			†WSGW	Saginaw, Mich. (III-B)	DA-1,000	WGMG	Montgomery, Ala. (II)	D-1,000
WJZ	New York, N. Y. (I-A)	50,000	KGHL	Billings, Mont. (III-A)	DA-N-5,000	WLAD	Danbury, Conn. (II)	D-250
KXA	Seattle, Wash. (II)	LS-1,000	WVNY	Watertown, N. Y. (III-B)	DA-N-1,000	WMBM	Miami Beach, Fla. (II)	D-1,000
780 KC. CLEAR			WTNC	Thomasville, N. C. (III)	D-1,000	WVWF	Palatka, Fla. (II)	D-250
WBBM	Chicago, Ill. (I-A)	50,000	KFGO	Fargo, N. D. (III-A)	DA-N-5,000	†WJAT	Swainsboro, Ga. (II)	D-1,000
WJAG	Norfolk, Neb. (II)	LS-1,000	WAEB	Allentown, Pa. (III-B)	LS-500	KKIC	Iowa City, Ia. (II)	DA-D-1,000
(N-L-1,000)			WPIC	Sharon, Pa. (III)	DA-U-N-1,000	WKYB	Paducah, Ky. (II)	D-1,000
WCKB	Dunn, N. C. (II)	D-1,000	WEAN	Providence, R. I. (III-A)	D-1,000	WCCM	Lawrence, Mass. (II)	D-1,000
WBBO	Forest City, N. C. (II)	D-1,000	WETB	Johnson City, Tenn. (III)	DA-5,000	WKDN	Camden, N. J. (II)	D-1,000
KSPI	Stillwater, Okla. (II)	D-250	WMC	Memphis, Tenn. (III-A)	DA-N-5,000	KTOW	Oklahoma City, Okla. (II)	D-250
WARL	Arlington, Va. (II)	D-1,000	KTHT	Houston, Tex. (III-A)	DA-5,000	KPDQ	Portland, Ore. (II)	D-1,000
790 KC. CLEAR			WTAR	Norfolk, Va. (III-A)	DA-5,000	WCHA	Chambersburg, Pa. (II)	D-1,000
KECA	Los Angeles, Cal. (III-A)	DA-N-5,000	KVOS	Bellingham, Wash. (III-B)	DA-1,000	WDSC	Dillon, S. C. (II)	D-1,000
WLBE	Eustis, Fla. (III-B)	DA-1,000				WEAB	Greer, S. C. (II)	D-250

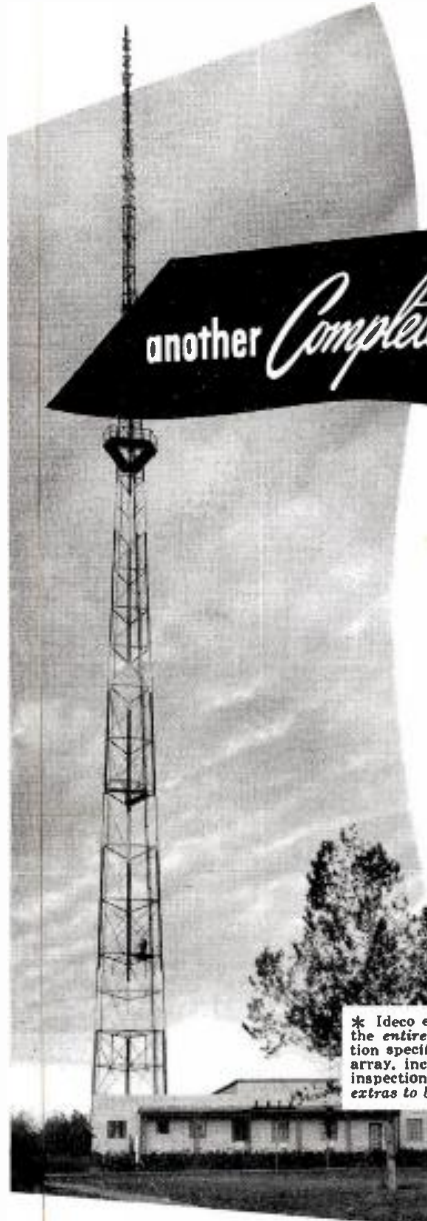

KBTV... first television tower in Dallas...

another *Completely Engineered* TV TOWER by IDECO

KBTV lights the television screens in the Dallas area... beams from an IDECO 340' triangular, self-supported tower, topped by a 43'6" antenna. Every phase *completely engineered* by IDECO. KBTV, privately owned by Tom Potter, selected IDECO tower design for two important reasons:

Triangular-Section Safety—provides extra rigidity and freedom from distortion—designed to withstand a 30 pound wind load. IDECO's triangular design, based on accepted aerodynamic principles, perpetuates the outstanding safety record of IDECO radio and television towers.

Complete Engineering—IDECO personnel supervised and erected the *entire job*—including foundation, fabrication, platforms, service ladders, transmission lines, mounting the antenna, and all other accessories required.

IDECO is prepared to handle all details of your tower needs. For more information, write for Bulletins RT-46 and SSRT-1.

INTERNATIONAL DERRICK AND EQUIPMENT COMPANY
Columbus, Ohio • Torrance, California

* Ideco engineering covers the entire job, from foundation specifications to antenna array, including erection and inspection after erection. No extras to buy.

IDECO

TRIANGULAR SECTION

towers

AM • FM • TV

WFAA	Dallas, Tex. (I-A)	50,000	WVBO	Forest City, N. C. (II)	D-1,000	WVNY	New York, N. Y. (II)	LS-1,000
WBAP	Fort Worth, Tex. (I-A)	50,000	WVPI	Providence, R. I. (III-A)	D-1,000	WVTV	Wilmington, N. C. (II)	DA-N-1,000
(See 570 kc.)			WVVA	Virginia Beach, Va. (II)	D-1,000	WVVA	Virginia Beach, Va. (II)	D-1,000
830 KC. CLEAR			WVVA	Virginia Beach, Va. (II)	D-1,000	WVVA	Virginia Beach, Va. (II)	D-1,000
WCCO	Minneapolis, Minn. (I-A)	50,000	WVVA	Virginia Beach, Va. (II)	D-1,000	WVVA	Virginia Beach, Va. (II)	D-1,000
KBOA	Kennett, Mo. (II)	D-1,000	WVVA	Virginia Beach, Va. (II)	D-1,000	WVVA	Virginia Beach, Va. (II)	D-1,000
WNYC	New York, N. Y. (II)	LS-1,000	WVVA	Virginia Beach, Va. (II)	D-1,000	WVVA	Virginia Beach, Va. (II)	D-1,000
(DA-N-L-1,000)			WVVA	Virginia Beach, Va. (II)	D-1,000	WVVA	Virginia Beach, Va. (II)	D-1,000
840 KC. CLEAR			WVVA	Virginia Beach, Va. (II)	D-1,000	WVVA	Virginia Beach, Va. (II)	D-1,000
WKAB	Mobile, Ala. (II)	D-1,000	WVVA	Virginia Beach, Va. (II)	D-1,000	WVVA	Virginia Beach, Va. (II)	D-1,000
WKBN	New Britain, Conn. (II)	D-1,000	WVVA	Virginia Beach, Va. (II)	D-1,000	WVVA	Virginia Beach, Va. (II)	D-1,000
WHAS	Louisville, Ky. (I-A)	50,000	WVVA	Virginia Beach, Va. (II)	D-1,000	WVVA	Virginia Beach, Va. (II)	D-1,000
WVPO	Stroudsburg, Pa. (II)	D-250	WVVA	Virginia Beach, Va. (II)	D-1,000	WVVA	Virginia Beach, Va. (II)	D-1,000
850 KC. CLEAR			WVVA	Virginia Beach, Va. (II)	D-1,000	WVVA	Virginia Beach, Va. (II)	D-1,000
WTNB	Birmingham, Ala. (II)	LS-5,000	WVVA	Virginia Beach, Va. (II)	D-1,000	WVVA	Virginia Beach, Va. (II)	D-1,000
(CP from 1490 kc.)			WVVA	Virginia Beach, Va. (II)	D-1,000	WVVA	Virginia Beach, Va. (II)	D-1,000
KOA	Denver, Colo. (I-A)	50,000	WVVA	Virginia Beach, Va. (II)	D-1,000	WVVA	Virginia Beach, Va. (II)	D-1,000
WRUF	Gainesville, Fla. (II)	DA-N-5,000	WVVA	Virginia Beach, Va. (II)	D-1,000	WVVA	Virginia Beach, Va. (II)	D-1,000
WHDH	Boston, Mass. (II)	DA-50,000	WVVA	Virginia Beach, Va. (II)	D-1,000	WVVA	Virginia Beach, Va. (II)	D-1,000
WKBZ	Muskegon, Mich. (II)	DA-1,000	WVVA	Virginia Beach, Va. (II)	D-1,000	WVVA	Virginia Beach, Va. (II)	D-1,000
KFTC	Clayton, Mo. (II)	5,000	WVVA	Virginia Beach, Va. (II)	D-1,000	WVVA	Virginia Beach, Va. (II)	D-1,000
WKKW	Albany, N. Y. (II)	DA-10,000	WVVA	Virginia Beach, Va. (II)	D-1,000	WVVA	Virginia Beach, Va. (II)	D-1,000
WNAO	Raleigh, N. C. (II)	DA-N-5,000	WVVA	Virginia Beach, Va. (II)	D-1,000	WVVA	Virginia Beach, Va. (II)	D-1,000
WJW	Cleveland, O. (II)	DA-5,000	WVVA	Virginia Beach, Va. (II)	D-1,000	WVVA	Virginia Beach, Va. (II)	D-1,000
WEEU	Reading, Pa. (II)	DA-N-1,000	WVVA	Virginia Beach, Va. (II)	D-1,000	WVVA	Virginia Beach, Va. (II)	D-1,000
860 KC. (Canadian) CLEAR			WVVA	Virginia Beach, Va. (II)	D-1,000	WVVA	Virginia Beach, Va. (II)	D-1,000
KIFN	Phoenix, Ariz. (II)	D-250	WVVA	Virginia Beach, Va. (II)	D-1,000	WVVA	Virginia Beach, Va. (II)	D-1,000
KOSE	Oseola, Ark. (II)	D-1,000	WVVA	Virginia Beach, Va. (II)	D-1,000	WVVA	Virginia Beach, Va. (II)	D-1,000
KTRB	Modesto, Cal. (II)	LS-5,000	WVVA	Virginia Beach, Va. (II)	D-1,000	WVVA	Virginia Beach, Va. (II)	D-1,000
WERD	Atlanta, Ga. (II)	D-1,000	WVVA	Virginia Beach, Va. (II)	D-1,000	WVVA	Virginia Beach, Va. (II)	D-1,000
WDMG	Douglas, Ga. (II)	D-1,000	WVVA	Virginia Beach, Va. (II)	D-1,000	WVVA	Virginia Beach, Va. (II)	D-1,000
KVPC	Muscataine, Ia. (II)	D-250	WVVA	Virginia Beach, Va. (II)	D-1,000	WVVA	Virginia Beach, Va. (II)	D-1,000
KOAM	Pittsburgh, Pa. (II)	LS-10,000	WVVA	Virginia Beach, Va. (II)	D-1,000	WVVA	Virginia Beach, Va. (II)	D-1,000
WSON	Henderson, Ky. (II)	DA-N-5,000	WVVA	Virginia Beach, Va. (II)	D-1,000	WVVA	Virginia Beach, Va. (II)	D-1,000
WNAW	North Adams, Mass. (II)	D-500	WVVA	Virginia Beach, Va. (II)	D-1,000	WVVA	Virginia Beach, Va. (II)	D-1,000
KNUJ	New Ulm, Minn. (II)	D-1,000	WVVA	Virginia Beach, Va. (II)	D-1,000	WVVA	Virginia Beach, Va. (II)	D-1,000
WHOD	Homestead, Pa. (II)	D-250	WVVA	Virginia Beach, Va. (II)	D-1,000	WVVA	Virginia Beach, Va. (II)	D-1,000
WTEL	Philadelphia, Pa. (II)	D-250	WVVA	Virginia Beach, Va. (II)	D-1,000	WVVA	Virginia Beach, Va. (II)	D-1,000
WLBG	Laurens, S. C. (II)	D-250	WVVA	Virginia Beach, Va. (II)	D-1,000	WVVA	Virginia Beach, Va. (II)	D-1,000
†KCHC	El Paso, Tex. (II)	D-500	WVVA	Virginia Beach, Va. (II)	D-1,000	WVVA	Virginia Beach, Va. (II)	D-1,000
KPAN	Hereford, Tex. (II)	D-250	WVVA	Virginia Beach, Va. (II)	D-1,000	WVVA	Virginia Beach, Va. (II)	D-1,000
KSFA	Nacogdoches, Tex. (II)	D-1,000	WVVA	Virginia Beach, Va. (II)	D-1,000	WVVA	Virginia Beach, Va. (II)	D-1,000
KONO	San Antonio, Tex. (II)	LS-5,000	WVVA	Virginia Beach, Va. (II)	D-1,000	WVVA	Virginia Beach, Va. (II)	D-1,000
(CP from 1400 kc)			WVVA	Virginia Beach, Va. (II)	D-1,000	WVVA	Virginia Beach, Va. (II)	D-1,000
WFHG	Bristol, Va. (II)	D-1,000	WVVA	Virginia Beach, Va. (II)	D-1,000	WVVA	Virginia Beach, Va. (II)	D-1,000
WCAV	Norfolk, Va. (II)	D-1,000	WVVA	Virginia Beach, Va. (II)	D-1,000	WVVA	Virginia Beach, Va. (II)	D-1,000
WOAY	Oak Hill, W. Va. (II)	D-1,000	WVVA	Virginia Beach, Va. (II)	D-1,000	WVVA	Virginia Beach, Va. (II)	D-1,000
WFOX	Milwaukee, Wis. (II)	D-250	WVVA	Virginia Beach, Va. (II)	D-1,000	WVVA	Virginia Beach, Va. (II)	D-1,000
WNEJ	San Juan, P. R. (II)	DA-5,000	WVVA	Virginia Beach, Va. (II)	D-1,000	WVVA	Virginia Beach, Va. (II)	D-1,000
870 KC. CLEAR			WVVA	Virginia Beach, Va. (II)	D-1,000	WVVA	Virginia Beach, Va. (II)	D-1,000
KIEV	Glendale, Cal. (II)	D-250	WVVA	Virginia Beach, Va. (II)	D-1,000	WVVA	Virginia Beach, Va. (II)	D-1,000
WWL	New Orleans, La. (I-A)	DA-50,000	WVVA	Virginia Beach, Va. (II)	D-1,000	WVVA	Virginia Beach, Va. (II)	D-1,000
WKAR	E. Lansing, Mich. (II)	D-5,000	WVVA	Virginia Beach, Va. (II)	D-1,000	WVVA	Virginia Beach, Va. (II)	D-1,000
WHCU	Ithaca, N. Y. (II)	LS-1,000	WVVA	Virginia Beach, Va. (II)	D-1,000	WVVA	Virginia Beach, Va. (II)	D-1,000
WGTL	Kannapolis, N. C. (II)	D-1,000	WVVA	Virginia Beach, Va. (II)	D-1,000	WVVA	Virginia Beach, Va. (II)	D-1,000
KCNK	Fort Worth, Tex. (II)	D-250	WVVA	Virginia Beach, Va. (II)	D-1,000	WVVA	Virginia Beach, Va. (II)	D-1,000
WFLO	Farmville, Va. (II)	D-1,000	WVVA	Virginia Beach, Va. (II)	D-1,000	WVVA	Virginia Beach, Va. (II)	D-1,000
880 KC. CLEAR			WVVA	Virginia Beach, Va. (II)	D-1,000	WVVA	Virginia Beach, Va. (II)	D-1,000
WCBS	New York, N. Y. (I-A)	50,000	WVVA	Virginia Beach, Va. (II)	D-1,000	WVVA	Virginia Beach, Va. (II)	D-1,000
WRZ	Clinton, N. C. (II)	D-1,000	WVVA	Virginia Beach, Va. (II)	D-1,000	WVVA	Virginia Beach, Va. (II)	D-1,000
WRFD	Worthington, O. (II)	D-5,000	WVVA	Virginia Beach, Va. (II)	D-1,000	WVVA	Virginia Beach, Va. (II)	D-1,000
890 KC. CLEAR			WVVA	Virginia Beach, Va. (II)	D-1,000	WVVA	Virginia Beach, Va. (II)	D-1,000
WENR	Chicago, Ill. (I-A)	50,000	WVVA	Virginia Beach, Va. (II)	D-1,000	WVVA	Virginia Beach, Va. (II)	D-1,000
WLS	Chicago, Ill. (I-A)	50,000	WVVA	Virginia Beach, Va. (II)	D-1,000	WVVA	Virginia Beach, Va. (II)	D-1,000
WHNC	Henderson, N. C. (II)	D-1,000	WVVA	Virginia Beach, Va. (II)	D-1,000	WVVA	Virginia Beach, Va. (II)	D-1,000
KBYE	Oklahoma City, Okla. (II)	D-1,000	WVVA	Virginia Beach, Va. (II)	D-1,000	WVVA	Virginia Beach, Va. (II)	D-1,000
900 KC. (Mexican) CLEAR			WVVA	Virginia Beach, Va. (II)	D-1,000	WVVA	Virginia Beach, Va. (II)	D-1,000
WKAX	Birmingham, Ala. (II)	D-1,000	WVVA	Virginia Beach, Va. (II)	D-1,000	WVVA	Virginia Beach, Va. (II)	D-1,000
KLCN	Blytheville, Ark. (II)	D-1,000	WVVA	Virginia Beach, Va. (II)	D-1,000	WVVA	Virginia Beach, Va. (II)	D-1,000
KSGN	Sanger, Cal. (II)	D-1,000	WVVA	Virginia Beach, Va. (II)	D-1,000	WVVA	Virginia Beach, Va. (II)	D-1,000
†WJWL	Georgetown, Dela. (II)	D-1,000	WVVA	Virginia Beach, Va. (II)	D-1,000	WVVA	Virginia Beach, Va. (II)	D-1,000
WSWN	Belle Glade, Fla. (II)	D-1,000	WVVA	Virginia Beach, Va. (II)	D-1,000	WVVA	Virginia Beach, Va. (II)	D-1,000
WKYW	Louisville, Ky. (II)	D-1,000	WVVA	Virginia Beach, Va. (II)	D-1,000	WVVA	Virginia Beach, Va. (II)	D-1,000
WLSI	Pikeville, Ky. (II)	D-1,000	WVVA	Virginia Beach, Va. (II)	D-1,000	WVVA	Virginia Beach, Va. (II)	D-1,000
KTIS	Minneapolis, Minn. (II)	D-1,000	WVVA	Virginia Beach, Va. (II)	D-1,000	WVVA	Virginia Beach, Va. (II)	D-1,000
*KFAL	Jefferson City, Mo.	D-250	WVVA	Virginia Beach, Va. (II)	D-1,000	WVVA	Virginia Beach, Va. (II)	D-1,000
KJSK	Columbus, Neb. (II)	D-1,000	WVVA	Virginia Beach, Va. (II)	D-1,000	WVVA	Virginia Beach, Va. (II)	D-1,000
WOTW	Nashua, N. H. (II)	D-1,000	WVVA	Virginia Beach, Va. (II)	D-1,000	WVVA	Virginia Beach, Va. (II)	D-1,000
WAYN	Rockingham, N. C. (II)	D-1,000	WVVA	Virginia Beach, Va. (II)	D-1,000	WVVA	Virginia Beach, Va. (II)	D-1,000
†WIAM	Williamston, N. C. (II)	D-1,000	WVVA	Virginia Beach, Va. (II)	D-1,000	WVVA	Virginia Beach, Va. (II)	D-1,000
KWNJ	Fargo, N. D. (II)	D-1,000	WVVA	Virginia Beach, Va. (II)	D-1,000	WVVA	Virginia Beach, Va. (II)	D-1,000
WAND	Canton, O. (II)	D-500	WVVA	Virginia Beach, Va. (II)	D-1,000	WVVA	Virginia Beach, Va. (II)	D-1,000
WFRD	Fremont, O. (II)	DA-D-500	WVVA	Virginia Beach, Va. (II)	D-1,000	WVVA	Virginia Beach, Va. (II)	D-1,000
WCPA	Clearfield, Pa. (II)	D-1,000	WVVA	Virginia Beach, Va. (II)	D-1,000	WVVA	Virginia Beach, Va. (II)	D-1,000

(Continued on page 491)

Call Letters	City	Power In Watts
WCOR	Lebanon, Tenn. (II)	D-250
KCLW	Hamilton, Tex. (II)	D-250
†KALE	Richland, Wash. (II)	D-1,000
WATK	Antigo, Wis. (II)	D-250
910 KC. REGIONAL		
KPHO	Phoenix, Ariz. (III-A)	DA-N-5,000
KLX	Oakland, Cal. (III-A)	1,000
†KVNE	Oxnard, Cal. (III)	D-1,000
KPOF	Denver, Colo. (III-A)	LS-5,000
WHAY	New Britain, Conn. (III-A)	N-1,000
†WGAF	Valdosta, Ga. (III-A)	DA-5,000
WSUI	Iowa City, Ia. (III-A)	DA-5,000
WABI	Bangor, Me. (III-A)	DA-N-5,000
WFDF	Flint, Mich. (III-B)	DA-1,000
WCOC	Meridian, Miss. (III-A)	LS-5,000
WPFB	Middletown, O. (III)	N-100
KGLC	Miami, Okla. (III-B)	DA-1,000
WAVL	Apollo, Pa. (III)	D-1,000
WGBI	Scranton, Pa. (III-B)	LS-1,000
WQAN	Scranton, Pa. (III-B)	N-500
WSBA	York, Pa. (III-B)	DA-1,000
WJHL	Johnson City, Tenn. (III-A)	LS-5,000
KRIO	McAllen, Tex. (III-B)	DA-1,000
KRRV	Sherman, Tex. (III-B)	DA-1,000
KALL	Salt Lake City, Utah (III-B)	DA-1,000
WRNL	Richmond, Va. (III-A)	DA-N-5,000
KVAN	Vancouver, Wash. (III-B)	DA-1,000
WFRP	Pone, P. R. (III-A)	DA-5,000

920 KC. REGIONAL		
WWWR	Russellville, Ala. (III)	D-1,000
KARK	Little Rock, Ark. (III-A)	DA-N-5,000
KVEC	San Luis Obispo, Cal. (III-B)	LS-1,000
KFXJ	Grand Junction, Colo. (III-B)	N-500
WGST	Atlanta, Ga. (III-A)	LS-5,000
WBAA	W. Lafayette, Ind. (III-B)	N-1,000
KFNF	Shenandoah, Ia. (III-B)	LS-1,000
KDHL	Faribault, Minn. (III-B)	N-500
KWAD	Wadena, Minn. (III-B)	DA-1,000
KRAM	Las Vegas, Nev. (III-B)	DA-N-1,000
KOLO	Reno, Nev. (III-B)	LS-1,000
WTTM	Trenton, N. J. (III-B)	DA-1,000
WKRT	Cortland, N. Y. (III-B)	LS-1,000
WBBB	Burlington, N. C. (III)	N-500
†WKVA	Lewistown, Pa. (III)	D-1,000
WJAR	Providence, R. I. (III-A)	DA-5,000
KUSD	Vermillion, S. D. (III-B)	500
KELP	El Paso, Tex. (III)	D-1,000
KECK	Odessa, Tex. (III)	D-1,000
KTLW	Texas City, Tex. (III)	D-1,000
KXLY	Spokane, Wash. (III-A)	5,000
WMMN	Fairmont, W. Va. (III-A)	DA-N-5,000

930 KC. REGIONAL		
KHJ	Los Angeles, Cal. (III-A)	DA-5,000
WJAX	Jacksonville, Fla. (III-A)	DA-N-5,000
KSEI	Pocatello, Ida. (III-A)	DA-N-5,000
WTAD	Quincy, Ill. (III-B)	DA-N-1,000
WKCT	Bowling Green, Ky. (III)	D-1,000
WFMD	Frederick, Md. (III-B)	DA-N-1,000
†WREB	Holyoke, Mass. (III)	D-500
WBCK	Battle Creek, Mich. (III-B)	DA-1,000
WSLI	Jackson, Miss. (III-A)	DA-N-5,000
WWNH	Rochester, N. H. (III)	D-1,000
WPAT	Paterson, N. J. (III-A)	DA-5,000
WBEN	Buffalo, N. Y. (III-A)	DA-N-5,000
WRRF	Washington, N. C. (III)	D-5,000
WEOL	Elyria, O. (III-B)	DA-1,000
WKY	Oklahoma City, Okla. (III-A)	DA-N-5,000
WCNR	Bloomsburg, Pa. (III)	D-500
KSDN	Aberdeen, S. D. (III-B)	DA-1,000
KDET	Center, Tex. (III)	D-1,000
KITE	San Antonio, Tex. (III)	D-1,000
WSAZ	Huntington, W. Va. (III-B)	LS-5,000
WLBL	Stevens Point, Wis. (III)	DA-N-1,000
KTKN	Ketchikan, Alaska (III-A)	D-5,000

Call Letters	City	Power In Watts
940 KC. (Mexican & Canadian) CLEAR		
KFRE	Fresno, Cal. (II)	DA-50,000
WINZ	Hollywood, Fla. (II)	DA-1,000
WMAZ	Macon, Ga. (II)	DA-10,000
WMIX	Mt. Vernon, Ill. (II)	D-1,000
KJOA	Des Moines, Ia. (II)	LS-10,000
WTPS	New Orleans, La. (II)	DA-U-N-5,000
WESA	Charleroi, Pa. (II)	*LS-1,000
KLYN	Amarillo, Tex. (II)	D-250
WIPR	Rio Piedsas, P. R. (II)	DA-1,000

950 KC. REGIONAL		
KXJK	Forrest City, Ark. (III)	D-1,000
KFSA	Ft. Smith, Ark. (III-B)	LS-1,000
KFEL	Denver, Colo. (III-A)	DA-5,000
WLOF	Orlando, Fla. (III-A)	DA-5,000
WGOV	Valdosta, Ga. (III-A)	DA-N-5,000
KDSH	Boise, Ida. (III-A)	LS-5,000
WAAF	Chicago, Ill. (III)	DA-U-N-1,000
†KOEL	Oelwein, Ia. (III)	D-1,000
WWJ	Detroit, Mich. (III-A)	*DA-5,000
†KUMO	Columbia, Mo. (III-B)	DA-N-5,000
WARC	Rochester, N. Y. (III-B)	DA-1,000

Call Letters	City	Power In Watts
WIBX	Utica, N. Y. (III-A)	DA-5,000
WPEN	Philadelphia, Pa. (III-A)	DA-N-5,000
WSPA	Spartanburg, S. C. (III-A)	DA-N-5,000
KWAT	Watertown, S. D. (III-B)	DA-N-1,000
KPRC	Houston, Tex. (III-A)	(CP from 1240 kc) DA-N-1,000
KSEL	Lubbock, Tex. (III-B)	DA-N-5,000
WXGI	Richmond, Va. (III)	DA-N-500
KJR	Seattle, Wash. (III-A)	D-1,000
WKNA	Charleston, W. Va. (III-B)	DA-N-5,000

960 KC. REGIONAL		
WBRC	Birmingham, Ala. (III-A)	DA-N-5,000
KOOL	Phoenix, Ariz. (III-A)	DA-N-5,000
KROW	Oakland, Cal. (III-A)	DA-N-5,000
†KVRV	Victorville, Cal. (III)	1,000
WELI	New Haven, Conn. (III-B)	*DA-5,000
WRFC	Athens, Ga. (III)	D-5,000
WSBT	South Bend, Ind. (III-A)	D-1,000
KMA	Shenandoah, Ia. (III-A)	DA-5,000
†WPRP	Prentissburg, Ky. (III)	DA-N-5,000
KROP	Abbeville, La. (III)	D-1,000
WBOC	Salisbury, Md. (III-B)	D-1,000

Call Letters	City	Power In Watts
WHAK	Rogers City, Mich. (III)	D-1,000
†WABG	Greenwood, Miss. (III)	D-1,000
KFVS	Cape Girardeau, Mo. (III-B)	LS-1,000
WEAV	Plattsburg, N. Y. (III-B)	DA-N-500
WWST	Wooster, O. (III)	DA-1,000
†KGWA	Enid, Okla. (III-B)	D-500
WCMB	Lemoyne, Pa. (III)	DA-1,000
KIMP	Mt. Pleasant, Tex. (III)	D-1,000
KGKL	San Angelo, Tex. (III-B)	(III) D-1,000
KOVO	Provo, Utah (III-B)	LS-5,000
WDBJ	Roanoke, Va. (III-A)	DA-N-1,000
WTCH	Shawano, Wis. (III)	DA-N-5,000

970 KC. REGIONAL		
WFLA	Tampa, Fla. (III-A)	DA-N-5,000
WGLS	Decatur, Ga. (III)	DA-1,000
WAVE	Louisville, Ky. (III-A)	D-1,000
KVOB	Alexandria, La. (III-B)	DA-5,000
WCSH	Portland, Me. (III-A)	DA-N-1,000
KLER	Rochester, Minn. (III-B)	DA-N-5,000
†KOOK	Billings, Mont. (III-A)	LS-500
KNEB	Scotts Bluff, Nebr. (III)	DA-U-N-1,000

(Continued on page 492)

Floating Action!

"BALANCED" TV TRIPOD

(Pat. Pending)

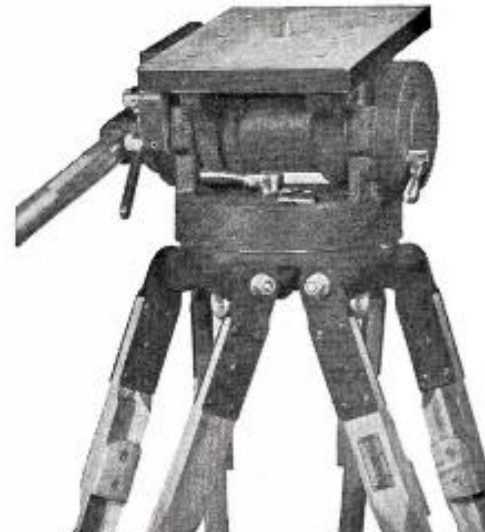

Complete 360° pan without ragged or jerky movement is accomplished with effortless control. It is impossible to get anything but perfectly smooth pan and tilt action with the "BALANCED" TV Tripod.

Quick-release pan handle adjustment locks into position desired by operator with no "play" between pan handle and tripod head. Tripod head mechanism is rust-proof, completely enclosed, never requires adjustments, cleaning or lubrication. Built-in spirit level. Telescoping extension pan handle.

Write for further particulars

This tripod was engineered and designed expressly to meet all video camera requirements. Previous concepts of gyro and friction type design have been discarded to achieve absolute balance, effortless operation, super-smooth tilt and pan action, dependability, ruggedness and efficiency.

Below:

3 wheel portable dolly with balanced TV Tripod mounted.



FRANK C. ZUCKER

CAMERA EQUIPMENT CO.

1600 BROADWAY NEW YORK CITY

AM STATIONS BY FREQUENCIES

(Continued from page 491)

Call Letters	City	Power in Watts	Call Letters	City	Power in Watts
WAAT	Jersey City, N. J. (III-B)	LS-5,000 DA-N-1,000	KMBC	Kansas City, Mo. (III)	DA-N-5,000
WEBR	Buffalo, N. Y. (III-A)	DA-5,000	WTRY	Troy, N. Y. (III-A)	DA-5,000
WRCS	Ahoskie, N. C. (III)	D-1,000	WONE	Dayton, O. (III-A)	DA-5,000
WDAY	Fargo, N. D. (III-A)	DA-N-5,000	WSIX	Nashville, Tenn. (III-A)	DA-N-5,000
WICA	Ashtabula, O. (III-B)	DA-U-N-1,000	KFRD	Rosenberg, Tex. (III)	D-500
KAKC	Tulsa, Okla. (III-B)	LS-1,000 DA-U-N-500	990 KC. (Canadian) CLEAR		
KOIN	Portland, Ore. (III-A)	DA-N-5,000	WWWF	Fayette, Ala. (II)	D-1,000
WWSW	Pittsburgh, Pa. (III-A)	DA-5,000	KWEM	W. Memphis, Ark. (II)	D-1,000
WJMX	Florence, S. C. (III)	D-5,000	KECC	Pittsburg, Cal. (II)	DA-N-1,000
KWBC	Ft. Worth, Tex. (III)	D-1,000	*KZYZ	Redlands, Cal.	D-1,000
WWYO	Pineville, W. Va. (III)	D-1,000	KTLN	Denver, Colo. (II)	D-1,000
WHA	Madison, Wis. (III)	D-5,000	WLCR	Torrington, Conn. (II)	D-1,000
KHBC	Hilo, T. H. (III-A)	1,000	WHDW	Orlando, Fla. (II)	LS-10,000
980 KC. REGIONAL					
WKLF	Clanton, Ala. (III)	D-1,000	WDWD	Dawson, Ga. (II)	D-1,000
KFWB	Los Angeles, Cal. (III-A)	5,000	WCAZ	Carthage, Ill. (II)	D-1,000
WRC	Washington, D. C. (III-A)	DA-N-5,000	WITZ	Jasper, Ind. (II)	D-1,000
WKLY	Hartwell, Ga. (III)	D-1,000	KAYL	Storm Lake, Ia. (II)	D-250
*KCLJ	Shreveport, La. (III)	D-5,000	WJMR	New Orleans, La. (II)	D-250
*WABW	Lawrence, Mass. (III)	D-1,000	WBET	Brockton, Mass. (II)	D-1,000
WPBC	Minneapolis, Minn. (III)	D-500	WSTS	Southern Pines, N. C. (II)	D-1,000
			WIBG	Philadelphia, Pa. (II)	DA-10,000
			*WVSC	Somerset, Pa. (II)	D-250
			WNOX	Knoxville, Tenn. (II)	DA-N-10,000
			KTRM	Beaumont, Tex. (II)	DA-1,000

Call Letters	City	Power in Watts	Call Letters	City	Power in Watts
*KBKX	San Antonio, Tex. (II)	D-1,000	†WJBA	Sparta, Wis. (II)	D-250
KFDX	Wichita Falls, Tex. (II)	LS-5,000	WPRM	Mayaguez, P. R. (II)	DA-10,000
		DA-N-1,000	1000 KC. (U. S. & Mexican) CLEAR		
†WJBA	Sparta, Wis. (II)	D-250	WCFL	Chicago, Ill. (I-B)	DA-50,000
WPRM	Mayaguez, P. R. (II)	DA-10,000	KTOK	Oklahoma City (II)	LS-5,000
					DA-U-N-1,000
			WSCR	Scranton, Pa. (II)	D-1,000
			KSTA	Colman, Tex. (II)	D-250
			KGRI	Henderson, Tex. (II)	D-250
			WHWB	Rutland, Vt. (II)	D-1,000
			KOMO	Seattle, Wash. (I-B)	DA-N-50,000
			1010 KC. (Canadian & Cuban) CLEAR		
			WJMW	Athens, Ala. (II)	D-250
			KLRA	Little Rock, Ark. (II)	LS-10,000
					DA-N-5,000
			KCHJ	Delano, Cal. (II)	D-1,000
			WCNU	Crestview, Fla. (II)	D-1,000
			WJVB	Jacksonville Beach, Fla. (II)	D-250
			WEAS	Decatur, Ga. (II)	D-10,000
			WSUA	Bloomington, Ind. (II)	D-1,000
			KSMN	Mason City, Ia. (II)	D-1,000
			KIND	Independence, Kan. (II)	D-250
			WAPF	McCumb, Miss. (II)	D-250
			*KCHI	Chillicothe, Mo.	D-250
			†KJCF	Festus, Mo. (II)	D-250
			WINS	New York, N. Y. (II)	LS-50,000
					DA-U-N-10,000
					*DA-50,000
			WABZ	Albemarle, N. C. (II)	D-1,000

Response ± 2.5 db, 40 cps to 15 kc; Output -46 db



Broadcast Engineers Helped Design it!
Network Shows Use it!
Now Compare it with Any in Your Studios!

You've wanted High Fidelity Broadcast Dynamic Microphones like these! Performance meets the highest FM and AM broadcast standards. The bass end is smooth and flat. The highs are particularly clean and peak-free. Construction is extremely rugged and shock-resistant. Has E-V Acoustalloy diaphragm. Omni-directional. Each microphone individually laboratory calibrated and certified. Try one. Compare it with any mike in your own studios.

Write for full facts today!

Electro-Voice

INC., BUCHANAN, MICH.
Export: 13 E. 40th St., New York 16, U.S.A. Cables: Arlab

New "650"

Response ± 2.5 db,
40 cps to 15 kc.
Output -46db.
External Shock Mount.
Impedance Selector
List Price.....\$150

New "645"

Response ± 2.5 db,
40 cps to 15 kc.
Output -50 db.
External Shock Mount.
Impedance Selector.
List Price.....\$100

The "635"

Response ± 2.5 db,
60 cps to 13 kc.
Output -53 db.
Impedance Selector.
For Hand or Stand.
List Price.....\$60



DAVEN

ENGINEERING LEADERSHIP

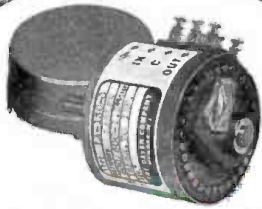

MINIATURE ATTENUATOR — TYPE LA-130
30 STEPS — DIAMETER 1 3/4 INCHES

30 step ladder network, provided in a minimum of space . . . recommended for use in high quality equipment requiring a wide range of attenuation, where mounting space is limited.

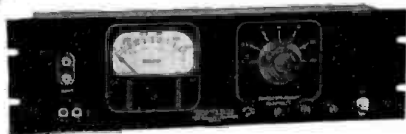

FREQUENCY METER TYPE 838

. . . frequencies read directly to 100,000 cycles with an accuracy of $\pm 2\%$ of full scale in use . . . 7 ranges available . . . low input voltage requirements . . . large, easy-to-read illuminated meter . . . mounted on a 5 1/4" relay rack panel.



TRANSMISSION MEASURING SET — TYPE 10A

Direct reading instrument . . . meters and associated range controls can be used independently as VU meters . . . range +26 to -100 DBM . . . total attenuation 111 DB in steps of 0.1 DB.
(Pat. Pend.)

Here are 4 of the more recent DAVEN "firsts".

DAVEN long has been known for leadership . . .

particularly in engineering and design. Many of

our developments have been incorporated in the

equipment of broadcasting stations, sound record-

ing studios, and electrical laboratories throughout

the world, and are specified as standard.

The DAVEN Engineering Department will be glad to discuss these new developments with you. Your inquiry is invited on the units shown or on any other DAVEN product.

THE DAVEN CO.

DAVEN

191 CENTRAL AVENUE
NEWARK 4, NEW JERSEY

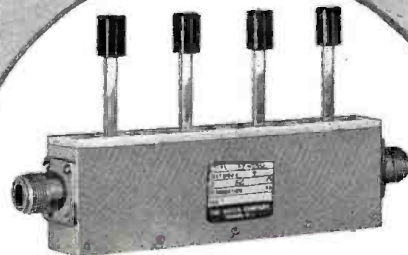

RF AND VIDEO ATTENUATORS

Video Range: 0-10 Mc
RF Range: 0-225 Mc
Fixed as well as step rotary and push-button attenuators are available. Technical information available upon request.

AM STATIONS BY FREQUENCIES

(Continued from page 492)

Call Letters	City	Power in Watts	Call Letters	City	Power in Watts	Call Letters	City	Power in Watts	Call Letters	City	Power in Watts
WHLI	Hempstead, N. Y. (II)	D-250	KSTT	Davenport, Ia. (II)	DA-1,000	KGDE	Fergus Falls, Minn. (IV)	250	KUBC	Montrose, Colo. (IV)	250
WTAM	Cleveland, O. (I-A)	50,000	KVOO	Tulsa, Okla. (I-B)	DA-N-50,000	KYSM	Mankato, Minn. (IV)	250	KCRT	Trinidad, Colo. (IV)	250
WGPA	Bethlehem, Pa. (II)	D-250	KPUG	Bellingham, Wash. (II)	DA-1,000	KTRF	Thief River Falls, Minn. (IV)	250	WWCO	Waterbury, Conn. (IV)	250
1110 KC. CLEAR			1180 KC. CLEAR			1190 KC. (U. S. & Mexican) CLEAR			1200 KC. CLEAR		
KXLA	Pasadena, Cal. (II)	DA-10,000	WVVA	Wheeling, W. Va. (I-B)	DA-N-50,000	WLSO	Washington, D. C. (I-B)	50,000	WMOU	Berlin, N. H. (IV)	250
WALT	Tampa, Fla. (II)	D-1,000	1180 KC. CLEAR			WMSV	Claremont, N. H. (IV)	250	WVOT	Alamogordo, N. M. (IV)	250
WMBI	Chicago, Ill. (II)	LS-5,000	WLDL	Jacksonville, Ill. (II)	D-1,000	WNEV	Rosemead, N. Y. (IV)	250	WVTF	High Point, N. C. (IV)	250
WFAB	Omaha, Neb. (I-B)	DA-N-50,000	WHAM	Rochester, N. Y. (I-B)	50,000	WVTV	Roanoke Rapids, N. C. (IV)	250	WVWC	Newton, N. C. (IV)	250
WBT	Charlotte, N. C. (I-B)	DA-N-50,000	1190 KC. (U. S. & Mexican) CLEAR			WVVB	DuBois, Pa. (IV)	250	WVWF	Newton, N. C. (IV)	250
WNAR	Norristown, Pa. (II)	D-500	KGYW	Vallejo, Cal. (II)	D-250	WVVO	Lock Haven, Pa. (IV)	250	WVXG	Wilmington, N. C. (IV)	250
WHIM	Providence, R. I.	D-1,000	WOWO	Ft. Wayne Ind. (I-B)	10,000	WVYD	Westerly, R. I. (IV)	250	WVYU	Yonkers, N. Y. (IV)	250
KHPA	Hilo, T. H. (II)	1,000	KWHK	Hutchinson, Kan. (II)	D-1,000	WVZL	Waukegan, Ill. (II)	DA-D-1,000	WVZM	Zanesville, O. (IV)	250
WVJP	Caguas, P. R. (II)	250	WANN	Annapolis, Md. (II)	D-1,000	WVZT	Warsaw, Ind. (II)	D-250	WVZV	Waukegan, Ill. (II)	DA-D-1,000
1120 KC. CLEAR			WKOK	Frammingham, Mass. (II)	D-1,000	WVZU	Waukegan, Ill. (II)	DA-D-1,000	WVZW	Waukegan, Ill. (II)	DA-D-1,000
WBCC	Bethesda, Md. (II)	D-250	WLIB	New York, N. Y. (II)	LS-1,000	WVZV	Waukegan, Ill. (II)	DA-D-1,000	WVZU	Waukegan, Ill. (II)	DA-D-1,000
KMOX	St. Louis, Mo. (I-A)	50,000	WLBK	New York, N. Y. (II)	LS-1,000	WVZV	Waukegan, Ill. (II)	DA-D-1,000	WVZU	Waukegan, Ill. (II)	DA-D-1,000
WWOL	Lackawanna, N. Y. (II)	D-1,000	KEX	Portland, Ore. (I-B)	DA-50,000	WVZV	Waukegan, Ill. (II)	DA-D-1,000	WVZU	Waukegan, Ill. (II)	DA-D-1,000
KCLE	Clackamas, Tex. (II)	D-250	KLFF	Oak Cliff, Tex. (II)	D-1,000	WVZV	Waukegan, Ill. (II)	DA-D-1,000	WVZU	Waukegan, Ill. (II)	DA-D-1,000
1130 KC. (U. S. & Canadian) CLEAR			1200 KC. CLEAR			1210 KC. CLEAR			1220 KC. (Mexican) CLEAR		
KSDO	San Diego, Cal. (II)	DA-5,000	WOAI	San Antonio, Tex. (I-A)	50,000	WCNT	Centralia, Ill. (II)	D-1,000	WEDR	Birmingham, Ala. (II)	D-1,000
KWKH	Shreveport, La. (I-B)	DA-N-50,000	1200 KC. CLEAR			WKNX	Saginaw, Mich. (II)	D-1,000	KIBE	Pal Alto, Calif. (II)	D-250
WCAR	Pontiac, Mich. (II)	D-1,000	WVZV	Waukegan, Ill. (II)	DA-D-1,000	WADE	Wadesboro, N. C. (II)	D-1,000	WFEC	Miami, Fla. (II)	D-250
WDGY	Minneapolis, Minn. (II)	LS-5,000	WVZV	Waukegan, Ill. (II)	DA-D-1,000	WWSO	Springfield, O. (II)	D-250	WSPF	Thomasston, Ga. (II)	D-250
WNEW	New York, N. Y. (I-B)	DA-U-N-25,000	WVZV	Waukegan, Ill. (II)	DA-D-1,000	WVZV	Waukegan, Ill. (II)	DA-D-1,000	WVZV	Waukegan, Ill. (II)	DA-D-1,000
1140 KC. (U. S. & Mexican) CLEAR			1220 KC. (Mexican) CLEAR			WVZV	Waukegan, Ill. (II)	DA-D-1,000	WVZV	Waukegan, Ill. (II)	DA-D-1,000
KGDM	Stockton, Cal. (II)	DA-N-5,000	WEDR	Birmingham, Ala. (II)	D-1,000	WVZV	Waukegan, Ill. (II)	DA-D-1,000	WVZV	Waukegan, Ill. (II)	DA-D-1,000
WMIE	Miami, Fla. (II)	DA-U-N-5,000	KIBE	Pal Alto, Calif. (II)	D-250	WVZV	Waukegan, Ill. (II)	DA-D-1,000	WVZV	Waukegan, Ill. (II)	DA-D-1,000
KGEM	Boise, Ida. (II)	DA-10,000	WFEC	Miami, Fla. (II)	D-250	WVZV	Waukegan, Ill. (II)	DA-D-1,000	WVZV	Waukegan, Ill. (II)	DA-D-1,000
WSIV	Pekin, Ill. (II)	D-1,000	WSPF	Thomasston, Ga. (II)	D-250	WVZV	Waukegan, Ill. (II)	DA-D-1,000	WVZV	Waukegan, Ill. (II)	DA-D-1,000
KLPR	Oklahoma City (II)	D-1,000	WVZV	Waukegan, Ill. (II)	DA-D-1,000	WVZV	Waukegan, Ill. (II)	DA-D-1,000	WVZV	Waukegan, Ill. (II)	DA-D-1,000
KSOO	Sioux Falls, S. D. (II)	LS-5,000	WVZV	Waukegan, Ill. (II)	DA-D-1,000	WVZV	Waukegan, Ill. (II)	DA-D-1,000	WVZV	Waukegan, Ill. (II)	DA-D-1,000
KORC	Mineral Wells, Tex. (II)	D-250	WVZV	Waukegan, Ill. (II)	DA-D-1,000	WVZV	Waukegan, Ill. (II)	DA-D-1,000	WVZV	Waukegan, Ill. (II)	DA-D-1,000
WRVA	Richmond, Va. (I-B)	DA-50,000	WVZV	Waukegan, Ill. (II)	DA-D-1,000	WVZV	Waukegan, Ill. (II)	DA-D-1,000	WVZV	Waukegan, Ill. (II)	DA-D-1,000
WRIO	Rio Piedras, P. R. (II)	LS-5,000	WVZV	Waukegan, Ill. (II)	DA-D-1,000	WVZV	Waukegan, Ill. (II)	DA-D-1,000	WVZV	Waukegan, Ill. (II)	DA-D-1,000
1150 KC. REGIONAL			WVZV	Waukegan, Ill. (II)	DA-D-1,000	WVZV	Waukegan, Ill. (II)	DA-D-1,000	WVZV	Waukegan, Ill. (II)	DA-D-1,000
WJRD	Tuscaloosa, Ala. (III-B)	LS-5,000	WVZV	Waukegan, Ill. (II)	DA-D-1,000	WVZV	Waukegan, Ill. (II)	DA-D-1,000	WVZV	Waukegan, Ill. (II)	DA-D-1,000
KCKY	Coolidge, Ariz. (III-B)	DA-N-1,000	WVZV	Waukegan, Ill. (II)	DA-D-1,000	WVZV	Waukegan, Ill. (II)	DA-D-1,000	WVZV	Waukegan, Ill. (II)	DA-D-1,000
KXOC	Chico, Cal. (III-B)	DA-N-5,000	WVZV	Waukegan, Ill. (II)	DA-D-1,000	WVZV	Waukegan, Ill. (II)	DA-D-1,000	WVZV	Waukegan, Ill. (II)	DA-D-1,000
KFSG	Los Angeles, Cal. (III-A)	LS-2,500	WVZV	Waukegan, Ill. (II)	DA-D-1,000	WVZV	Waukegan, Ill. (II)	DA-D-1,000	WVZV	Waukegan, Ill. (II)	DA-D-1,000
KRDK	Los Angeles, Cal. (III-A)	N-1,000	WVZV	Waukegan, Ill. (II)	DA-D-1,000	WVZV	Waukegan, Ill. (II)	DA-D-1,000	WVZV	Waukegan, Ill. (II)	DA-D-1,000
WCNX	Middletown, Conn. (III)	D-500	WVZV	Waukegan, Ill. (II)	DA-D-1,000	WVZV	Waukegan, Ill. (II)	DA-D-1,000	WVZV	Waukegan, Ill. (II)	DA-D-1,000
WDEL	Wilmington, Del. (III-A)	DA-5,000	WVZV	Waukegan, Ill. (II)	DA-D-1,000	WVZV	Waukegan, Ill. (II)	DA-D-1,000	WVZV	Waukegan, Ill. (II)	DA-D-1,000
WVZV	Waukegan, Ill. (II)	DA-D-1,000	WVZV	Waukegan, Ill. (II)	DA-D-1,000	WVZV	Waukegan, Ill. (II)	DA-D-1,000	WVZV	Waukegan, Ill. (II)	DA-D-1,000
WVZV	Waukegan, Ill. (II)	DA-D-1,000	WVZV	Waukegan, Ill. (II)	DA-D-1,000	WVZV	Waukegan, Ill. (II)	DA-D-1,000	WVZV	Waukegan, Ill. (II)	DA-D-1,000
WVZV	Waukegan, Ill. (II)	DA-D-1,000	WVZV	Waukegan, Ill. (II)	DA-D-1,000	WVZV	Waukegan, Ill. (II)	DA-D-1,000	WVZV	Waukegan, Ill. (II)	DA-D-1,000
WVZV	Waukegan, Ill. (II)	DA-D-1,000	WVZV	Waukegan, Ill. (II)	DA-D-1,000	WVZV	Waukegan, Ill. (II)	DA-D-1,000	WVZV	Waukegan, Ill. (II)	DA-D-1,000
WVZV	Waukegan, Ill. (II)	DA-D-1,000	WVZV	Waukegan, Ill. (II)	DA-D-1,000	WVZV	Waukegan, Ill. (II)	DA-D-1,000	WVZV	Waukegan, Ill. (II)	DA-D-1,000
WVZV	Waukegan, Ill. (II)	DA-D-1,000	WVZV	Waukegan, Ill. (II)	DA-D-1,000	WVZV	Waukegan, Ill. (II)	DA-D-1,000	WVZV	Waukegan, Ill. (II)	DA-D-1,000
WVZV	Waukegan, Ill. (II)	DA-D-1,000	WVZV	Waukegan, Ill. (II)	DA-D-1,000	WVZV	Waukegan, Ill. (II)	DA-D-1,000	WVZV	Waukegan, Ill. (II)	DA-D-1,000
WVZV	Waukegan, Ill. (II)	DA-D-1,000	WVZV	Waukegan, Ill. (II)	DA-D-1,000	WVZV	Waukegan, Ill. (II)	DA-D-1,000	WVZV	Waukegan, Ill. (II)	DA-D-1,000
WVZV	Waukegan, Ill. (II)	DA-D-1,000	WVZV	Waukegan, Ill. (II)	DA-D-1,000	WVZV	Waukegan, Ill. (II)	DA-D-1,000	WVZV	Waukegan, Ill. (II)	DA-D-1,000
WVZV	Waukegan, Ill. (II)	DA-D-1,000	WVZV	Waukegan, Ill. (II)	DA-D-1,000	WVZV	Waukegan, Ill. (II)	DA-D-1,000	WVZV	Waukegan, Ill. (II)	DA-D-1,000
WVZV	Waukegan, Ill. (II)	DA-D-1,000	WVZV	Waukegan, Ill. (II)	DA-D-1,000	WVZV	Waukegan, Ill. (II)	DA-D-1,000	WVZV	Waukegan, Ill. (II)	DA-D-1,000
WVZV	Waukegan, Ill. (II)	DA-D-1,000	WVZV	Waukegan, Ill. (II)	DA-D-1,000	WVZV	Waukegan, Ill. (II)	DA-D-1,000	WVZV	Waukegan, Ill. (II)	DA-D-1,000
WVZV	Waukegan, Ill. (II)	DA-D-1,000	WVZV	Waukegan, Ill. (II)	DA-D-1,000	WVZV	Waukegan, Ill. (II)	DA-D-1,000	WVZV	Waukegan, Ill. (II)	DA-D-1,000
WVZV	Waukegan, Ill. (II)	DA-D-1,000	WVZV	Waukegan, Ill. (II)	DA-D-1,000	WVZV	Waukegan, Ill. (II)	DA-D-1,000	WVZV	Waukegan, Ill. (II)	DA-D-1,000
WVZV	Waukegan, Ill. (II)	DA-D-1,000	WVZV	Waukegan, Ill. (II)	DA-D-1,000	WVZV	Waukegan, Ill. (II)	DA-D-1,000	WVZV	Waukegan, Ill. (II)	DA-D-1,000
WVZV	Waukegan, Ill. (II)	DA-D-1,000	WVZV	Waukegan, Ill. (II)	DA-D-1,000	WVZV	Waukegan, Ill. (II)	DA-D-1,000	WVZV	Waukegan, Ill. (II)	DA-D-1,000
WVZV	Waukegan, Ill. (II)	DA-D-1,000	WVZV	Waukegan, Ill. (II)	DA-D-1,000	WVZV	Waukegan, Ill. (II)	DA-D-1,000	WVZV	Waukegan, Ill. (II)	DA-D-1,000
WVZV	Waukegan, Ill. (II)	DA-D-1,000	WVZV	Waukegan, Ill. (II)	DA-D-1,000	WVZV	Waukegan, Ill. (II)	DA-D-1,000	WVZV	Waukegan, Ill. (II)	DA-D-1,000
WVZV	Waukegan, Ill. (II)	DA-D-1,000	WVZV	Waukegan, Ill. (II)	DA-D-1,000	WVZV	Waukegan, Ill. (II)	DA-D-1,000	WVZV	Waukegan, Ill. (II)	DA-D-1,000
WVZV	Waukegan, Ill. (II)	DA-D-1,000	WVZV	Waukegan, Ill. (II)	DA-D-1,000	WVZV	Waukegan, Ill. (II)	DA-D-1,000	WVZV	Waukegan, Ill. (II)	DA-D-1,000
WVZV	Waukegan, Ill. (II)	DA-D-1,000	WVZV	Waukegan, Ill. (II)	DA-D-1,000	WVZV	Waukegan, Ill. (II)	DA-D-1,000	WVZV	Waukegan, Ill. (II)	DA-D-1,000
WVZV	Waukegan, Ill. (II)	DA-D-1,000	WVZV	Waukegan, Ill. (II)	DA-D-1,000	WVZV	Waukegan, Ill. (II)	DA-D-1,000	WVZV	Waukegan, Ill. (II)	DA-D-1,000
WVZV	Waukegan, Ill. (II)	DA-D-1,000	WVZV	Waukegan, Ill. (II)	DA-D-1,000	WVZV	Waukegan, Ill. (II)	DA-D-1,000	WVZV	Waukegan, Ill. (II)	DA-D-1,000
WVZV	Waukegan, Ill. (II)	DA-D-1,000	WVZV	Waukegan, Ill. (II)	DA-D-1,000	WVZV	Waukegan, Ill. (II)	DA-D-1,000	WVZV	Waukegan, Ill. (II)	DA-D-1,000
WVZV	Waukegan, Ill. (II)	DA-D-1,000	WVZV	Waukegan, Ill. (II)	DA-D-1,000	WVZV	Waukegan, Ill. (II)	DA-D-1,000	WVZV	Waukegan, Ill. (II)	DA-D-1,000
WVZV	Waukegan, Ill. (II)	DA-D-1,000	WVZV	Waukegan, Ill. (II)	DA-D-1,000	WVZV	Waukegan, Ill. (II)	DA-D-1,000	WVZV	Waukegan, Ill. (II)	DA-D-1,000
WVZV	Waukegan, Ill. (II)	DA-D-1,000	WVZV	Waukegan, Ill. (II)	DA-D-1,000	WVZV	Waukegan, Ill. (II)	DA-D-1,000	WVZV	Waukegan, Ill. (II)	DA-D-1,000
WVZV	Waukegan, Ill. (II)	DA-D-1,000	WVZV	Waukegan, Ill. (II)	DA-D-1,000	WVZV	Waukegan, Ill. (II)	DA-D-1,000	WVZV	Waukegan, Ill. (II)	DA-D-1,000
WVZV	Waukegan, Ill. (II)	DA-D-1,000	WVZV	Waukegan, Ill. (II)	DA-D-1,000	WVZV	Waukegan, Ill. (II)	DA-D-1,000	WVZV	Waukegan, Ill. (II)	DA-D-1,000
WVZV	Waukegan, Ill. (II)	DA-D-1,000	WVZV	Waukegan, Ill. (II)	DA-D-1,000	WVZV	Waukegan, Ill. (II)	DA-D-1,000	WVZV	Waukegan, Ill. (II)	DA-D-1,000
WVZV	Waukegan, Ill. (II)	DA-D-1,000	WVZV	Waukegan, Ill. (II)	DA-D-1,000	WVZV	Waukegan, Ill. (II)	DA-D-1,000	WVZV	Waukegan, Ill. (II)	DA-D-1,000
WVZV	Waukegan, Ill. (II)	DA-D-1,000	WVZV	Waukegan, Ill. (II)	DA-D-1,000	WVZV	Waukegan, Ill. (II)	DA-D-1,000	WVZV	Waukegan, Ill. (II)	DA-D-1,000
WVZV	Waukegan, Ill. (II)	DA-D-1,000	WVZV	Waukegan, Ill. (II)	DA-D-1,000	WVZV	Waukegan, Ill. (II)	DA-D-1,000	WVZV	Waukegan, Ill. (II)	DA-D-1,000
WVZV	Waukegan, Ill. (II)	DA-D-1,000	WVZV	Waukegan, Ill. (II)	DA-D-1,000	WVZV	Waukegan, Ill. (II)	DA-D-1,000	WVZV	Waukegan, Ill. (II)	DA-D-1,000
WVZV	Waukegan, Ill. (II)	DA-D-1,000	WVZV	Waukegan, Ill. (II)	DA-D-1,000	WVZV	Waukegan, Ill. (II)	DA-D-1,000	WVZV	Waukegan, Ill. (II)	DA-D-1,000
WVZV	Waukegan, Ill. (II)	DA-D-1,000	WVZV	Waukegan, Ill. (II)	DA-D-1,000	WVZV	Waukegan, Ill. (II)	DA-D-1,000	WVZV	Waukegan, Ill. (II)	DA-D-1,000
WVZV	Waukegan, Ill. (II)	DA-D-1,000	WVZV	Waukegan, Ill. (II)	DA-D-1,000	WVZV	Waukegan, Ill. (II)	DA-D-1,000	WVZV		

Your broadcasting equipment is our business



Collins 21B five-kilowatt AM broadcast transmitter. A version of the 21B is also made for ten-kilowatt operation.



Collins 20T one-kilowatt AM broadcast transmitter is proving its reliability every day in many broadcasting stations.



The Collins 12Z four-channel remote amplifier is the leader of a complete line that contains a wide variety of single and dual channel models.

Collins 212A dual channel console. Many other models for single channel applications and comprehensive master control systems are also available.



The Collins 735A 25 kw FM transmitter is the largest of a complete line. 10, 5, 3, 1 and .25kw models are also available.



KCRG Control Room — Special speech equipment installations are a specialty of Collins. The equipment shown uses standard amplifiers and panels, thus taking advantage of price savings in mass production.

FOR BROADCAST QUALITY, IT'S ...



COLLINS RADIO COMPANY, Cedar Rapids, Iowa

11 West 42nd St.
NEW YORK 18

2700 West Olive Ave.
BURBANK

M & W Tower
DALLAS 1

Dogwood Rd., Fountain City
KNOXVILLE

Call Letters	City	Power in Watts	Call Letters	City	Power in Watts	Call Letters	City	Power in Watts	Call Letters	City	Power in Watts
KNAF	Fredericksburg, Tex. (IV)	250	WBGR	Jesup, Ga. (III)	D-1,000	WGYV	Greenville, Ala. (IV)	250	KDWT	Stamford, Tex. (IV)	250
KFBO	Lubbock, Tex. (IV)	230	†WPRC	Lincoln, Ill. (III)	D-500	WJHO	Opelika, Ala. (IV)	250	KTEM	Temple, Tex. (IV)	250
KRBA	Lufkin, Tex. (IV)	250	WTTS	Bloomington, Ind. (III-B)	LS-1,000	†KCLF	Clifton, Ariz. (IV)	250	KTFE	Texarkana, Tex. (IV)	250
KVKM	Monahans, Tex. (IV)	250			DA-N-500	KTUC	Tucson, Ariz. (IV)	250	WBOB	Galax, Va. (IV)	250
KPDN	Pampa, Tex. (IV)	250			LS-5,000	KELD	El Dorado, Ark. (IV)	250	WHLF	South Boston, Va. (IV)	250
KOLE	Port Arthur, Tex. (IV)	250			DA-U-N-500		(CP for 690 kc)		WTON	Staunton, Va. (IV)	250
KTXL	San Angelo, Tex. (IV)	250	†WGRY	Gary, Ind. (III)	D-500	KCLA	Pine Bluff, Ark. (IV)	250	WINC	Winchester, Va. (IV)	250
KVIC	Victoria, Tex. (IV)	250	KDTH	Dubuque, Ia. (III-B)	D-500	KRE	Berkeley, Cal. (IV)	250	KRKO	Everett, Wash. (IV)	250
KSUB	Cedar City, Utah (IV)	250			DA-N-1,000	KGFN	Grass Valley, Cal. (IV)	250		(CP for 1380 kc)	
					LS-1,000	KREO	Indio, Cal. (IV)	250	KWLK	Longview, Wash. (IV)	250
KJAM	Vernal, Utah (IV)	250	KGNO	Dodge City, Kan. (III-B)	LS-1,000	KCOY	Santa Maria, Cal. (IV)	250	WCAW	Charleston, W. Va. (IV)	250
WTWN	St. Johnsbury, Vt. (IV)	250			N-250	KSPA	Santa Paula, Cal. (IV)	250	WBLK	Clarksburg, W. Va. (IV)	250
WKEY	Covington, Va. (IV)	250	KSUM	Fairmont, Minn. (III-B)	DA-1,000	KKIN	Visalia, Cal. (IV)	250	WRON	Ronceverte, W. Va. (IV)	250
WHAP	Hopewell, Va. (IV)	250			DA-1,000	KRLN	Canon City, Colo. (IV)	SH-250	WKWK	Wheeling, W. Va. (IV)	250
WJMA	Orange, Va. (IV)	250	†KCRV	Caruthersville, Mo.	D-1,000	KIUP	Durango, Colo. (IV)	250	WBTH	Williamson, W. Va. (IV)	250
†WRAD	Radford, Va. (IV)	250	KXLF	Butte, Mont. (III-A)	5,000	KKRO	La Junta, Colo. (IV)	250	WATW	Ashland, Wis. (IV)	250
KXR0	Aberdeen, Wash. (IV)	250	WFEA	Manchester, N. H. (III-A)	DA-5,000	WICH	Norwich, Conn. (IV)	250	WBIZ	Eau Claire, Wis. (IV)	250
	(CP for 1320 kc)		WSAY	Rochester, N. Y. (III-A)	DA-1,000	WSTC	Ft. Lauderdale, Fla. (IV)	250	WDUZ	Green Bay, Wis. (IV)	250
KPKW	Pasco, Wash. (IV)	250			DA-1,000	WFTL	Ft. Pierce, Fla. (IV)	250	WRJN	Racine, Wis. (IV)	250
KREM	Spokane, Wash. (IV)	250			DA-N-5,000	WIRA	Jacksonville, Fla. (IV)	250	WSAU	Wausau, Wis. (IV)	250
KWNW	Wenatchee, Wash. (IV)	250	WLTC	Gastonia, N. C. (III)	D-1,000	†WRHC	Panama City, Fla. (IV)	250	KODI	Cody, Wyo. (IV)	250
WHAR	Charlottesville, W. Va. (IV)	250	WSPD	Toledo, O. (III-A)	DA-N-5,000	WPCF	Sanford, Fla. (IV)	250	KALA	Sitka, Alaska (IV)	250
WPEM	Martinsburg, W. Va. (IV)	250	KAST	Astoria, Ore. (III-B)	DA-1,000	WTRR	Elberton, Ga. (IV)	250	WAEI	Mayaguez, P. R. (IV)	250
WMON	Montgomery, W. Va. (IV)	250			(CP from 1230 kc)	WSGC	Gainesville, Ga. (IV)	250	WITA	San Juan, P. R. (IV)	250
WBRW	Welch, W. Va. (IV)	250	†WMAC	Pottstown, Pa. (III)	D-1,000	WJEN	Macon, Ga. (IV)	250			
WLDY	Ladysmith, Wis. (IV)	250	WDEF	Chattanooga, Tenn. (III-A)	LS-5,000	WNEK	Moultrie, Ga. (IV)	250			
WEMP	Milwaukee, Wis. (IV)	250			DA-N-1,000	WCOH	Newnan, Ga. (IV)	250			
WFHR	Wisconsin Rapids, Wis. (IV)	250			D-1,000	WDAR	Savannah, Ga. (IV)	250			
					DA-N-1,000	KIFI	Idaho Falls, Ida. (IV)	250			
KOWB	Laramie, Wyo. (IV)	250	KTXX	Austin, Tex. (III)	D-1,000	KRPL	Moscow, Ida. (IV)	250	WALA	Mobile, Ala. (III-A)	DA-N-5,000
KIBW	Seward, Alaska (IV)	SH-250	KFRO	Longview, Tex. (III-B)	DA-N-1,000	KSPJ	Sandpoint, Ida. (IV)	250	KERN	Bakersfield, Cal. (III-A)	1,000
†WSTA	Charlotte Amalie, Virgin Islands (IV)	250			DA-N-1,000	WDWS	Champaign, Ill. (IV)	250	KCOL	Ft. Collins, Colo. (III-B)	DA-N-1,000
			WPAB	Ponce, P. R. (III-A)	5,000	WGL	Galesburg, Ill. (IV)	250	WONS	Hartford, Conn. (III-A)	DA-N-1,000
						WCOL	Evanston, Ill. (IV)	250			
						KCOG	Springfield, Ill. (IV)	100	WDOV	Dover, Del. (III)	DA-5,000
						KVFD	Ft. Dodge, Ia. (IV)	250	WLAQ	Rome, Ga.	DA-N-1,000
						KVFD	Emporia, Kan. (IV)	250			
						KAYS	Hays, Kan. (IV)	250	WRMN	Elgin, Ill. (III)	D-500
						WCTT	Corbin, Ky. (IV)	250	†WTIM	Taylorville, Ill. (III)	DA-D-1,000
						†WIEL	Elizabethtown, Ky. (IV)	250			
						WGRC	Louisville, Ky. (IV)	250			
							(CP for 790 kc)		KCLO	Leavenworth, Kan. (III)	D-500
						KSXL	Alexandria, La. (IV)	500	KWBB	Wichita, Kan. (III-B)	DA-1,000
						WLCS	East Rouge, La. (IV)	250	WLBJ	Bowling Green, Ky. (IV)	DA-N-1,000
						KWSL	Lake Charles, La. (IV)	250			
						WRDO	Augusta, Me. (IV)	250	WGRJ	Grand Rapids, Mich. (III)	D-1,000
						WINE	Biddeford, Me. (IV)	250			
						WCBM	Baltimore, Md. (IV)	250	WFCB	Dunkirk, N. Y. (III-B)	DA-N-500
							(CP for 680 kc.)				
						WALE	Fall River, Mass. (IV)	250	WWSC	Glens Falls, N. Y. (III-B)	LS-1,000
						WHYN	Holyoke, Mass. (IV)	250			
							(CP for 560 kc)		WEGO	Concord, N. C. (III)	D-1,000
						WLLH	Lowell, Mass. (IV)	250	WING	Dayton, O. (III-A)	DA-N-5,000
						†WHMP	Northampton, Mass. (IV)	250	KQV	Pittsburgh, Pa. (III-A)	DA-5,000
						WELL	Battle Creek, Mich. (IV)	250			
						WJLB	Detroit, Mich. (IV)	250			
						WHDF	Houghton, Mich. (IV)	250	KBUD	Athens, Tex. (IV)	D-250
						WSAM	Saginaw, Mich. (IV)	250	KXIT	Dalhart, Tex. (III)	D-500
						WTCM	Traverse City, Mich. (IV)	250	KRIG	Odesa, Tex. (III-B)	DA-N-1,000
						KMHL	Brainerd, Minn. (IV)	250			
						WMIN	Marshall, Minn. (IV)	250	KNAL	Victoria, Tex. (III)	D-500
						WHLB	St. Paul, Minn. (IV)	250	WLOW	Norfolk, Va. (III)	D-1,000
						WVAG	Virginia, Minn. (IV)	250	WKBH	LaCrosse, Wis. (III-A)	DA-N-5,000
						WFOF	Grenada, Miss. (IV)	250			
						WJQS	Hattiesburg, Miss. (IV)	250	KWYO	Sheridan, Wyo. (III-B)	LS-1,000
						WMBG	Macon, Miss. (IV)	250			
						KFRU	Columbia, Mo. (IV)	250			
						KSIM	Sikeston, Mo. (IV)	250			
						KKMG	Springfield, Mo. (IV)	250			
						KXGN	Glendive, Mont. (IV)	250			
						KXLK	Great Falls, Mont. (IV)	250	KSTN	Stockton, Cal. (III-B)	DA-1,000
						KCOW	Alliance, Neb. (IV)	250	WRBL	Columbus, Ga. (III-A)	DA-N-5,000
						KOLN	Lincoln, Neb. (IV)	250			
						KENO	Las Vegas, Nev. (IV)	250	WIMS	Michigan City, Ind. (III)	D-1,000
						†	Pleasantville, N. J.	250			
						KCHS	Hot Springs, N. M. (IV)	250			
						KGFL	Roswell, N. M. (IV)	250	WOC	Davenport, Iowa (III-A)	DA-5,000
						KTRC	Santa Fe, N. M. (IV)	250			
						KTIM	Tucumcari, N. M. (IV)	250	WVJS	Owensboro, Ky. (III-B)	DA-1,000
						WBYN	Albany, N. Y. (IV)	250	†KTOE	Mankato, Minn. (III-A)	DA-N-1,000
						WBNY	Buffalo, N. Y. (IV)	250			
						WELM	Elmira, N. Y. (IV)	250	WQBC	Vicksburg, Miss. (III-B)	LS-1,000
						WSLB	Ogdensburg, N. Y. (IV)	250			
						WDOS	Oneonta, N. Y. (IV)	250	†WCLB	Cobleskill, N. Y. (III)	D-1,000
						WGBR	Ontsboro, N. C. (IV)	250	WFLA	Peekskill, N. Y. (III)	D-500
						WGBG	Greensboro, N. C. (IV)	250	WVOT	Wilson, N. C. (III)	D-1,000
						WSIC	Statesville, N. C. (IV)	250			
						WHCC	Waynesville, N. C. (IV)	250			
						KNOX	Grand Forks, N. D. (IV)	250			
						WMAN	Mansfield, N. D. (IV)	250			
						WPAY	Portsmouth, C. (IV)	250			
						KWON	Bartlesville, Okla. (IV)	250	WHK	Cleveland, O. (III-A)	DA-N-5,000
						KTMK	McAlester, Okla. (IV)	250			
						KNOR	Norman, Okla. (IV)	250	KTJS	Hobart, Okla. (IV)	D-250
						KWIN	Ashland, Ore. (IV)	250	WCOJ	Coatesville, Pa. (IV)	D-1,000
						KUGN	Eugene, Ore. (IV)	250	WFCI	Pawtucket, R. I. (III-A)	DA-5,000
						WEST	Easton, Pa. (IV)	250			
						†WFLN	Erie, Pa. (IV)	250	KFYN	Bonham, Tex. (IV)	D-250
						WHGB	Harrisburg, Pa. (IV)	250	KTRF	Lufkin, Tex. (III-B)	DA-N-1,000
						WHUN	Huntingdon, Pa. (IV)	250			
						WJAC	Johnstown, Pa. (IV)	250	†KGNB	New Braunfels, Tex. (III)	D-1,000
						WDAS	Philadelphia, Pa. (IV)	250			
						WARM	Scranton, Pa. (IV)	250	WWSR	St. Albans, Vt. (III)	D-1,000
						WRAP	Williamsport, Pa. (IV)	250	KUJ	Walla Walla, Wash. (III-A)	DA-N-5,000
						WBSC	Bennettsville, S. C. (IV)	250			
						WCOS	Columbia, S. C. (IV)	250			
						WGTN	Georgetown, S. C. (IV)	250			
						WORD	Spartanburg, S. C. (IV)	250			
						WJZM	Clarksville, Tenn. (IV)	250			
						WHUB	Cookeville, Tenn. (IV)	250	KARM	Fresno, Cal. (III-A)	DA-5,000
						WKSJ	Kingsport, Tenn. (IV)	250	KGMI	Pasadena, Cal. (III)	DA-D-1,000
						WGAP	Marshall, Tenn. (IV)	250	KWTV	Denver, Colo. (III)	D-1,000
						WHAL	Shelbyville, Tenn. (IV)	250	WLAK	Lakeland, Fla. (III-B)	1,000
						KRUN	Bellinger, Tex. (IV)	250	WIRE	Indianapolis, Ind. (III-A)	DA-N-5,000
						KTXC	Big Spring, Tex. (IV)	100			
						†KUNO	Corpus Christi, Tex. (IV)	100	KASI	Ames, Ia. (III)	D-1,000
						KLUF	Galveston, Tex. (IV)	250	WNAV	Annapolis, Md. (III-B)	DA-N-5,000
						KGLV	Greenville, Tex. (IV)	250			
						KEBE	Jacksonville, Tex. (IV)	250	WILS	Lansing, Mich. (III)	D-500
						KIUN	Pecos, Tex. (IV)	250			

Call Letters	City	Power in Watts	Call Letters	City	Power in Watts	Call Letters	City	Power in Watts	Call Letters	City	Power in Watts
KSTP	St. Paul, Minn.	(I-B) DA-50,000	KXEL	Waterloo, Ia. (II)	DA-N-50,000	WLIO	East Liverpool, O. (II)	D-1,000	WWHG	Hornell, N. Y. (III)	D-1,000
KTAN	Sherman, Tex. (II)	D-250	KXNE	McPherson, Kan. (II)	D-250	WPTW	Fiqua, O. (II)	D-250	WAKR	Akron, O. (III-A)	DA-N-5,000
1510 KC. CLEAR			KLKC	Parsons, Kan. (II)	D-250	WPTA	Frederick, Okla. (II)	D-250	KCHE	El Reno, Okla. (III)	D-500
KOCS	Ontario, Cal. (II)	D-250	†WCHF	New Orleans, La. (II)	LS-50,000	KAKC	Tulsa, Okla. (II)	D-1,000	KTIL	Tillamook, Ore. (IV)	D-250
KSDO	San Diego, Cal. (II)	LS-5,000	†WBEL	Beverly, Mass. (II)	D-250	WBUX	Doylestown, Pa. (II)	D-250	WPWA	Chester, Pa. (III)	D-1,000
(CP for 1130 kc)			†WLEW	Bad Axe, Mich. (II)	D-250	WFGN	Gaffney, S. C. (II)	D-250	WACA	Camden, S. C. (III)	D-1,000
KTIM	San Rafael, Cal. (II)	D-1,000	WPTA	Albany, N. Y. (II)	DA-50,000	†KIVY	Crockett, Tex. (II)	D-250	KATL	Houston, Tex. (III-A)	DA-1,000
WKAI	Macomb, Ill. (II)	D-250	WJMO	Cleveland, O. (II)	D-1,000	†KPLV	Plainville, Tex. (II)	D-250	KCBD	Lubbock, Tex. (III-B)	DA-1,000
WMEX	Boston, Mass. (II)	DA-5,000	WJMJ	Philadelphia, Pa. (II)	D-1,000	1580 KC. (Canadian) CLEAR					
WMRP	Flint, Mich. (II)	D-250	WRJM	Newport, R. I. (II)	D-1,000	WATM	Atmore, Ala. (II)	D-250	WAPX	Montgomery, Ala. (III-A)	DA-N-1,000
KIMO	Independence, Mo. (II)	D-1,000	KCUL	Fort Worth, Tex. (II)	LS-5,000	†WATL	Santa Monica, Cal. (II)	DA-5,000	KGST	Fresno, Cal. (III)	D-1,000
WLAC	Nashville, Tenn. (I-B)	DA-N-50,000	KGBC	Galveston, Tex. (II)	DA-U-N-1,000	†WLSL	Ft. Lauderdale, Fla. (II)	D-250	KPMO	Pomona, Cal. (III-B)	500
†KCTX	Childress, Tex. (II)	D-250	KIWW	San Antonio, Tex.	D-250	WKID	Urbana, Ill. (II)	D-250	KUBA	Yuba City, Cal. (III-B)	DA-500
KSTV	Stephenville, Tex. (II)	D-250	†KGB	Bremerton, Wash. (II)	D-1,000	WVCN	Connersville, Ind. (II)	D-250	WKWF	Key West, Fla. (III-B)	500
KGA	Spokane, Wash. (I-B)	DA-N-50,000	1550 KC. (Mexican) CLEAR			WJVA	South Bend, Ind. (II)	D-250	WBAT	Marion, Ind. (III)	D-500
WAUX	Waukesha, Wis. (II)	D-250	KSMO	San Mateo, Cal. (II)	DA-N-1,000	KCHA	Charles City, Ia. (II)	D-250	KCRG	Cedar Rapids Ia. (III-A)	DA-N-5,000
1520 KC. CLEAR			KENT	Shreveport, La. (II)	LS-1,000	†KFWK	Davenport, Ia. (II)	D-250	†KRAO	Red Oak, Ia. (III)	D-500
KTED	Laguna Beach, Cal. (II)	LS-1,000	WLOA	Braddock, Pa. (II)	DA-N-500	†WPKY	Princeton, Ky. (II)	D-250	WVOM	Brookline, Mass. (III-A)	DA-5,000
WHOW	Clinton, Ill. (II)	D-1,000	1560 KC. (Cuban) CLEAR			KLOU	Lake Charles, La. (II)	DA-1,000	WSFL	Springfield, Mass. (III)	DA-D-5,000
KSIB	Creston, Ia. (II)	D-1,000	KPMC	Bakersfield, Cal. (I-B)	1,000	†WFGM	Fitchburg, Mass. (II)	D-1,000	WHRV	Ann Arbor, Mich. (III-A)	DA-1,000
WKWB	Buffalo, N. Y. (I-B)	DA-50,000	WBYS	Canton, Ill. (II)	D-250	†WPMF	Pascagoula, Miss. (II)	D-250	WKNK	Muskegon, Mich. (III-B)	D-1,000
WKBS	Oyster Bay, L. I., N. Y. (II)	D-250	KSUI	Council Bluffs, Ia. (II)	D-500	WPAF	Allentown, Pa. (II)	D-500	WWRL	Woodside, N. Y. (III-A)	250
KOMA	Oklahoma City (I-B)	DA-N-50,000	WQXR	New York, N. Y. (II)	10,000	WBT	Butler, Pa. (II)	D-500	WGIV	Charlotte, N. C. (III)	D-1,000
WWWWR	Rio Piedras, P. R. (II)	250	WINS	Coshocton, O. (II)	D-1,000	KGAF	Gainesville, Tex. (II)	D-250	WFR	Charlottesville, N. C. (III-A)	DA-N-1,000
1530 KC. CLEAR			WTOO	Toledo, O. (II)	D-1,000	KWED	Seguin, Tex. (II)	D-250	WJEL	Springfield, O. (III)	D-500
KFBK	Sacramento, Cal. (I-B)	DA-50,000	KWCO	Chickasha, Okla. (II)	D-250	KEVA	Shamrock, Tex. (II)	D-250	KASH	Engene, Ore. (III-B)	DA-N-1,000
WCKY	Cincinnati, O. (I-B)	DA-N-50,000	KHBR	Hillsboro, Tex. (II)	D-250	†WTTN	Watertown, Wis.	D-250	WKIN	Kittanning, Pa. (III)	D-1,000
†KSOX	Harlingen, Tex. (II)	LS-50,000	WENA	Bayamon, P. R. (II)	250	1590 KC. REGIONAL					
†KSOX	Harlingen, Tex. (II)	DA-N-10,000	1570 KC. (Mexican) CLEAR			KSJO	San Jose, Cal. (III-B)	LS-1,000	WWR	Wheeling, W. Va. (III)	DA-D-1,000
1540 KC. (Bahama Island) CLEAR			KCVR	Lodi, Cal. (II)	D-1,000	KVVC	Ventura, Cal. (III-B)	DA-1,000	WVOC	Waterbury, Conn. (III-A)	DA-5,000
WXXY	Sarasota, Fla. (II)	D-1,000	WPLA	Plant City, Fla. (II)	D-250	WVBY	Waterbury, Conn. (III-A)	DA-1,000	†WELB	Tampa, Fla.	D-1,000
†	Boonville, Ind.	D-250	WOKZ	Alton, Ill. (II)	D-1,000	WALB	Albany, Ga. (III-A)	DA-N-1,000	WNP	Newport, N. B.	D-1,000
WLOI	La Porte, Ind. (II)	D-250	WFR	Freeport, Ill. (II)	D-1,000	WXL	Peoria, Ill. (III-B)	DA-1,000	WXXL	Peoria, Ill. (III-B)	DA-1,000
			WPLR	New Albany, Ind. (II)	D-1,000	WXLW	Indianapolis, Ind. (III)	D-1,000	WKBG	Boone, Ia.	D-1,000
			KJFJ	Webster City, Ia. (II)	D-1,000	KVGB	Great Bend, Kan. (III-A)	DA-N-5,000	KPRS	Olathe, Kan. (III)	DA-N-5,000
			KJCK	Junction City, Kan. (II)	D-1,000	WOC	Silver Spring, Md. (III)	D-1,000	WTVB	Coldwater, Mich. (III)	DA-D-1,000
			WSD	Essex, Md. (II)	D-1,000						
			WFEP	Taunton, Mass. (II)	D-1,000						
			WFUR	Grand Rapids, Mich. (II)	D-1,000						

* Construction permit for new station.
N—Night power.

DIRECTORY OF CANADIAN STATIONS BY FREQUENCIES

Licensed or Authorized by the Canadian Department of Transport as of January 1, 1950

D—Day power.
DA—Directional antenna.

Call Letters	Location	Power in Watts	690 KILOCYCLES	960 KILOCYCLES	1230 KILOCYCLES	1350 KILOCYCLES		
CBF	Montreal, Que.	50,000	CFAC	Calgary, Alta.	250	CHGB	St. Anne de la Pocatiere, Que.	1,000-D
540 KILOCYCLES			706 KILOCYCLES	5,000-DA-N	250	250-N		
CBK	Watrous, Sask.	50,000	VOWR	St. John's, Nfld.	100	CHOV	Pembroke, Ont.	1,000-DA
550 KILOCYCLES			710 KILOCYCLES	5,000-DA-N	250	CJDC	Dawson Creek, B. C.	1,000
CFNB	Fredericton, N. B.	5,000-DA-N	*	Ville Marie, Que.	250	CBT	Grand Falls, Nfld.	1,000
CHLN	Three Rivers, Que.	1,000-DA	730 KILOCYCLES	1,000-DA	250	CKPC	Brantford, Ont.	1,000-DA-N
CKPG	Prince George, B. C.	250	CKAC	Montreal, Que.	10,000-D	1400 KILOCYCLES		
560 KILOCYCLES			740 KILOCYCLES	5,000-DA-N	250	CKCL	Truro, N. S.	250
CJKL	Kirkland Lake, Ont.	5,000-DA-N	CBL	Toronto, Ont.	50,000	CKRN	Rouyn, Que.	250
CFRA	Ottawa, Ont.	1,000-DA-2	790 KILOCYCLES	5,000-DA-N	250	CJFP	Riviere du Loup, Que.	250
580 KILOCYCLES			CKSO	Sudbury, Ont.	5,000-DA-N	1410 KILOCYCLES		
CJFX	Antigonish, N. S.	(DA) 5,000	CBY	Corner Brook, Nfld.	1,000	CKMO	Vancouver, B. C.	1,000
CKUA	Edmonton, Alta.	1,000	800 KILOCYCLES	1,000-DA-N	250	CHLP	Montreal, Que.	1,000-DA
CKPR	Fort William, Ont.	1,000	CJAD	Montreal, Que.	1,000-DA	1430 KILOCYCLES		
CKEY	Toronto, Ont.	(DA) 5,000-D	CHAB	Moose Jaw, Sask.	5,000-DA	CHEX	Peterborough, Ont.	1,000-DA
590 KILOCYCLES			CKLW	Windsor, Ont.	50,000	1440 KILOCYCLES		
CFAR	Flin Flon, Man.	1,000	CHRC	Quebec, Que.	5,000-DA	CHNO	Sudbury, Ont.	1,000-DA
600 KILOCYCLES			CKOK	Pedicton, B. C.	250	1450 KILOCYCLES		
CJOR	Vancouver, B. C.	(DA) 5,000	860 KILOCYCLES	5,000-DA-N	250	CFJM	Brockville, Ont.	250
CFQC	Saskatoon, Sask.	5,000-DA-N	CJBC	Toronto, Ont.	50,000	CFCB	Grenby, Que.	250
CFCF	Montreal, Que.	5,000-DA-N	CJVI	Victoria, B. C.	1,000-D	CFAB	Windsor, N. S.	250
CFCH	North Bay, Ont.	1,000-DA	CJBR	Rimouski, Que.	5,000-DA-N	CJOY	Cueph, Ont.	250
610 KILOCYCLES			CHML	Hamilton, Ont.	(DA) 5,000	CBG	Gander, Nfld.	250
CJAT	Trail, B. C.	1,000	CKBI	Prince Albert, Sask.	5,000-DA	1470 KILOCYCLES		
CHNC	New Carlisle, Que.	5,000-DA	CHLT	Sherbrooke, Que.	1,000-DA-N	CFOS	Owen Sound, Ont.	1,000-DA-N
620 KILOCYCLES			910 KILOCYCLES	5,000-DA-N	250	1490 KILOCYCLES		
CKCK	Regina, Sask.	5,000-DA-N	CBO	Ottawa, Ont.	1,000	CKCR	Kitchener, Ont.	250
630 KILOCYCLES			CFJC	Kamloops, B. C.	1,000	CFRC	Kingston, Ont.	100
CFCY	Charlottetown, P. E. I.	5,000-D	*	Halleybury, Ont.	1,000	CJIC	Sault Ste. Marie, Ont.	250
CFCO	Chatham, Ont.	1,000-DA	920 KILOCYCLES	5,000-DA-N	250	CKEN	Kentville, N. S.	250
CKOV	Kelowna, B. C.	1,000	CJCH	Halifax, N. S.	5,000-DA	1550 KILOCYCLES		
CKRK	Winnipeg, Man.	5,000-DA-N	CKNX	Wingham, Ont.	1,000-DA-N	CKTB	St. Catharines, Ont.	1,000
640 KILOCYCLES			930 KILOCYCLES	5,000-DA-N	250	1570 KILOCYCLES		
CBN	St. John's, Nfld.	10,000	CJCA	Edmonton, Alta.	5,000-DA-N	CBI	Sydney, N. S.	1,000
680 KILOCYCLES			CFBC	St. John, N. B.	5,000-DA	CHUB	Nanaimo, B. C.	250
CKBG	Timmins, Ont.	5,000-DA-N	940 KILOCYCLES	5,000-DA-N	250	CFOR	Orillia, Ont.	1,000-DA-N
CHLO	St. Thomas, Ont.	1,000-DA	CBM	Montreal, Que.	5,000	1580 KILOCYCLES		
*CHFA	Edmonton, Alta.	5,000	CJGX	Yorktown, Sask.	1,000	CBJ	Chicoutimi, Que.	70,000-DA
			CJIB	Vernon, B. C.	1,000	1600 KILOCYCLES		
			950 KILOCYCLES	5,000-DA-N	250	CHVC	Niagara Falls, Ont.	1,000-DA-N
			CKNB	Campbellton, N. B.	(DA) 1,000			

DIRECTORY OF AM BROADCASTING STATIONS BY CALL LETTERS

* Construction permit for power or frequency change

† Construction permit for new station

‡ Special service authorization

Call Letters	City	Frequency in KC	Power in Watts	Call Letters	City	Frequency in KC	Power in Watts	Call Letters	City	Frequency in KC	Power in Watts	Call Letters	City	Frequency in KC	Power in Watts
KAAA	Red Wing, Minn.	1250	D-1,000	KCLO	Leavenworth, Kans.	1410	D-500	KFAB	Omaha, Neb.	1110	50,000	KGGF	Coffeyville, Kan.	690	LS-1,000
KABC	San Antonio, Tex.	680	LS-50,000	KCLW	Hamilton, Tex.	900	D-250	KFAC	Los Angeles, Cal.	1330	5,000				N-500
KADA	Ada, Okla.	1230	250	*KCLX	Colfax, Wash.	1450	250	*KFAL	Jefferson City, Mo.	900	D-250	KGGM	Albuquerque, N.M.	610	5,000
*KAFF	Petaluma, Cal.	1490	250	KCMC	Texarkana, Tex.	1230	250	KFAM	St. Cloud, Minn.	1450	250	KGHF	Pueblo, Colo.	1350	LS-5,000
KAFY	Bakersfield, Cal.	1490	250	KCMJ	Palm Springs, Cal.	1340	250	KFAR	Fairbanks, Alas.	610	5,000	KGHI	Little Rock, Ark.	1250	N-1,000
KAGH	Pasadena, Cal.	1300	1,000	KCMO	Kansas City, Mo.	810	LS-50,000	KFBB	Great Falls, Mont.	1310	5,000	KGIL	Billings, Mont.	790	N-500
KAKC	Tulsa, Okla.	1570	D-1,000	KCNC	Tucson, Ariz.	1340	250	KFCB	Cheyenne, Wyo.	1240	250	*KGIB	Bremerton, Wash.	1540	D-1,000
		*970	*LS-1,000	KCNI	Fort Worth, Tex.	870	D-250			*710	LS-1,000	KGLL	San Fernando, Cal.	1260	1,000
KAKE	Wichita, Kans.	1240	250	KCNY	Broken Bow, Nebr.	1490	250	KFBI	Wichita, Kans.	1070	LS-1,000	KGIW	Alamosa, Colo.	1450	250
KALA	Sitka, Alaska	1400	250	KCOG	San Marcos, Tex.	1470	D-250	KFDA	Sacramento, Cal.	1530	50,000	KGKB	Tyler, Tex.	1490	250
KALB	Alexandria, La.	580	LS-5,000	KCOH	Centerville, Ia.	1400	100	KFDM	Amarillo, Tex.	1440	LS-5,000	KGKL	San Angelo, Tex.	960	LS-5,000
*KALE	Richland, Wash.	900	N-1,000	*KCOI	Houston, Tex.	1430	D-1,000	KFDW	Beaumont, Tex.	560	5,000				N-1,000
*KALG	Alamogordo, N.M.	1230	D-1,000	KCOJ	Coalinga, Calif.	1470	D-250	KFDX	Helena, Mont.	1340	250	KGLC	Miami, Okla.	810	1,000
KALL	Salt Lake City, Utah	910	1,000	KCOL	Tulare, Cal.	1270	1,000					KGLU	Mason City, Ia.	1300	5,000
KAMD	Camden, Ark.	1450	250	KCOM	Ft. Collins, Col.	1400	250					KGLV	Safford, Ariz.	1480	1,000
KAMQ	Amarillo, Tex.	1010	D-1,000	KCOR	Sioux City, Iowa	620	1,000					KGMB	Honolulu, T.H.	960	5,000
			*LS-1,000	KCOW	San Antonio, Tex.	1350	LS-5,000					*KGMN	Denver, Colo.	1430	D-1,000
KANA	Anaconda, Mont.	1230	250	KCOY	Alliance, Neb.	1400	250	KFGA	Helena, Ark.	1380	1,000	KGNB	New Braunfels, Tex.	1420	D-1,000
KAND	Coriscana, Tex.	1340	250	KCOZ	Santa Maria, Cal.	1400	250	KFGG	Fargo, N.D.	790	5,000	KGNC	Amarillo, Tex.	710	10,000
KANE	New Iberia, La.	1240	250	KCRS	Sacramento, Cal.	1320	1,000	KFGH	Boone, Iowa	1260	D-250	KGNO	Dodge City, Kan.	1370	LS-1,000
KANS	Wichita, Kans.	1480	LS-5,000	KCRK	Enid, Okla.	1390	1,000	KFGI	Fremont, Nebr.	1340	100				N-250
			N-1,000	KCRG	Cedar Rapids, Ia.	1600	5,000	KFH	Wichita, Kans.	1330	5,000	KGO	S. Francisco, Cal.	810	50,000
KARK	Little Rock, Ark.	920	5,000	*KCRV	Englewood, Colo.	1380	D-1,000	KFIO	Los Angeles, Cal.	640	50,000	KGON	Oregon City, Ore.	1230	250
KARM	Fresno, Cal.	1430	5,000	KCRS	Midland, Tex.	550	LS-5,000	KFIZ	Spokane, Wash.	1230	250	KGRH	Fayetteville, Ark.	1450	250
KASA	Elk City, Okla.	1240	250	KCRT	Trinidad, Colo.	1240	N-1,000	KFJB	Marshalltown, Iowa	1230	250	KGRI	Henderson, Tex.	1000	D-250
KASH	Eugene, Ore.	1600	D-1,000	*KCRV	Caruthersville, Mo.	1370	D-1,000	KFJI	Klamath Falls, Ore.	1240	100	KGST	Fresno, Cal.	1600	D-1,000
KAST	Astoria, Ore.	1230	250	KCSB	San Bernardino, Cal.	1350	D-500			*1150	*LS-5,000	KGU	Honolulu, T.H.	760	LS-2,500
KATE	Albert Lee, Minn.	1450	250	KCSJ	Pueblo, Colo.	590	1,000	KFJM	Grand Forks, N.D.	1440	LS-1,000	KGVV	Greenville, Tex.	1400	250
KATL	Houston, Tex.	1590	1,000	KCSU	Provo, Utah	1490	250	KFJZ	Fl. Worth, Tex.	1270	5,000	KGVV	Missoula, Mont.	1290	LS-5,000
			*5,000	KCTI	Gonzales, Tex.	1450	250	KFKA	Greeley, Colo.	1310	1,000				N-1,000
KATO	Reno, Nev.	1340	250	KCTK	Childress, Tex.	1510	D-250	KFKU	Lawrence, Kans.	1250	5,000	KGW	Portland, Ore.	620	5,000
KAUS	Austin, Minn.	1480	1,000	KCUL	Ft. Worth, Tex.	1540	LS-5,000	KFLW	Klamath Falls, Ore.	1450	250	*KKGWA	Enid, Okla.	960	1,000
KAVE	Carlsbad, N.M.	1240	250	KCVR	Lodi, Cal.	1570	D-1,000	*KFKM	Davenport, Ia.	1580	D-250	KGY	Olympia, Wash.	1240	1,000
KAVR	Havre, Mont.	1240	250	KDAD	Fort Bragg, Cal.	1230	250	KFKB	San Diego, Cal.	550	1,000	KGYN	Guyton, Okla.	1220	D-1,000
KAWT	Douglas, Ariz.	1450	250	KDAL	Duluth, Minn.	610	5,000	KFKM	Tulsa, Okla.	1050	D-1,000	KGYW	Vallejo, Cal.	1190	D-250
KAYL	Storm Lake, Ia.	990	D-250	KDAN	Oroville, Cal.	1340	250	KFMJ	Flat River, Mo.	1240	250	KHAS	Hastings, Neb.	1230	250
KAYS	Hays, Kans.	1400	250	KDBA	Santa Barbara, Cal.	1490	250	KFMO	Shenandoah, Ia.	920	LS-1,000	KHBC	Hilo, T.H.	970	1,000
KAYX	Waterloo, Ia.	1090	D-1,000	KDDA	Dumas, Tex.	800	D-250	KFNF	Lincoln, Nebr.	1240	250	KHBO	Okmulege, Okla.	1240	250
		*1280	*1,000	KDDC	Decorah, Iowa	1240	SH-250	KFOR	Long Beach, Cal.	1280	1,000	KHBR	Hillsboro, Tex.	1560	D-250
*KBIG	Des Moines, Ia.	740	D-250	KDDT	Center, Tex.	930	D-1,000	KFOX	Fort Smith, Ark.	1230	250	KHHT	Lampasas, Tex.	1450	250
KBIO	Burley, Ida.	1230	250	KDHL	Faribault, Minn.	1400	1,000	KFPW	Anchorage, Alas.	790	5,000	KHJ	L. Angeles, Cal.	830	5,000
KBIX	Muskogee, Okla.	1490	250	*KDIA	Auburn, Calif.	1490	250	KFRB	Fairbanks, Alas.	1290	1,000	KHMO	Hannibal, Mo.	1070	LS-1,000
KBIZ	Ottumwa, Ia.	1240	D-1,000	KDIX	Dickinson, N.D.	1230	250	KFRS	S. Francisco, Cal.	610	5,000	KHON	Honolulu, T.H.	1380	5,000
KBKI	Atice, Tex.	1070	D-1,000	KDKA	Pittsburgh, Pa.	1020	50,000	KFRD	Rosenberg, Tex.	980	D-500	KHOZ	Harrison, Ark.	1240	250
KBKO	Portland, Ore.	1290	D-1,000	KDKL	Del Rio, Tex.	1230	250	KFRE	Fresno, Cal.	940	50,000	KHQ	Spokane, Wash.	590	5,000
KBKR	Baker, Ore.	1490	250	KDLR	Devils Lake, N.D.	1240	250	KFRM	Kansas City	550	D-5,000	KHSL	Chico, Cal.	1290	1,000
KBKW	Aberdeen, Wash.	1450	250	KDMO	Carthage, Mo.	1490	250	KFRP	Longview, Tex.	1370	1,000	*5,000			
KBWF	Red Bluff, Cal.	1490	250	KDMS	El Dorado, Ark.	1290	D-1,000	KFRU	Columbia, Mo.	1400	250	KHUM	Watsonville, Cal.	1340	250
*KBMN	Bozeman, Mont.	1230	250	KDNT	Denton, Tex.	1450	250	KFSA	Ft. Smith, Ark.	950	LS-1,000	KHVB	Eureka, Cal.	1240	250
	Breckenridge, Minn.	1450	250	KDRO	Santa Cruz, Cal.	1460	1,000	KFSB	Joplin, Mo.	1310	LS-5,000	KHUX	Borger, Tex.	1490	250
KBMY	Billings, Mont.	1240	250	KDRS	Paragould, Ark.	1490	250	KFSG	San Diego, Cal.	600	5,000	KIBB	Palo Alto, Cal.	1220	D-250
KBND	Bend, Ore.	1340	250	KDSH	Boise, Idaho	950	5,000	KFTM	San Diego, Cal.	1150	LS-2,500	KIBL	Seward, Alaska	1340	250
KBOA	Kennett, Mo.	830	D-1,000	KDSX	Deadwood, S.D.	1450	250	KFUN	Ft. Morgan, Colo.	1260	D-500	KICV	Beville, Tex.	1490	250
KBOB	Boulder, Colo.	1490	250	KDTH	Denison, Tex.	1220	D-1,000	KFUO	Las Vegas, N.M.	1230	250	KICW	Clovis, N.M.	1240	250
KBOC	Omaha, Neb.	1490	250	KDWT	Dubuque, Iowa	1370	1,000	KFVD	L. Angeles, Cal.	1020	LS-5,000	KICK	Spencer, Iowa	1240	250
KBOR	Brownsville, Tex.	1600	D-1,000	KDYL	Utah	1320	5,000	KFVS	Cape Girardeau, Mo.	960	LS-1,000	KICM	Springfield, Mo.	1340	250
KBOW	Butte, Mont.	1490	250	KDZA	Pueblo, Colo.	1230	250	KFWB	L. Angeles, Cal.	980	5,000	KICN	Mason City, Ia.	1490	250
KBPS	Portland, Ore.	1450	SH-100	KEBE	Jacksonville, Tex.	1400	250	KFXD	Nampa, Ida.	580	1,000	KICO	Calexico, Cal.	1490	250
KBRC	Mt. Vernon, Wash.	1430	D-500	KECA	Los Angeles, Cal.	790	5,000	KFXJ	Grand Jct., Colo.	920	LS-1,000	KID	Idaho Falls, Ida.	1350	LS-5,000
KBRL	McCook, Neb.	1450	250	KECC	Pittsburg, Cal.	980	1,000	KFXM	San Bernardino, Cal.	590	1,000	KIDO	Boise, Ida.	1380	LS-2,500
KBRO	Bremerton, Wash.	1490	250	KECK	Odessa, Tex.	920	D-1,000	KFYN	Bonham, Tex.	1420	D-250				N-1,000
KBRS	Springdale, Ark.	1340	250	KEEN	San Jose, Cal.	1370	1,000	KFYR	Bismarck, N.D.	550	5,000	KIEM	Eureka, Cal.	1480	1,000
KBST	Big Spring, Tex.	1490	250	KEIO	Pocatello, Ida.	1440	1,000	KGA	Spokane, Wash.	1510	50,000	KIEV	Glendale, Cal.	870	D-250
*KBTA	Batesville, Ark.	1340	250	KELA	Centralia, Wash.	1470	1,000	KGAF	Gainesville, Tex.	1580	D-250	KIFI	Idaho Falls, Ida.	1400	D-250
KBTM	Jonesboro, Ark.	1230	250	KELD	El Dorado, Ark.	1400	250	KGAP	Gallup, N.M.	1230	250	KIFN	Phoenix, Ariz.	860	D-250
KBUC	Corona, Cal.	1370	500	KELK	Elko, Nev.	1340	250	KGAN	Kingman, Ariz.	1230	250	KIFW	Sitka, Alaska	1230	250
KBUD	Athens, Tex.	1410	D-250	*KELL	Waxahachie, Tex.	1390	D-500	KGAR	Garden City, Kans.	1050	D-1,000	KIHN	Hugo, Okla.	1240	250
KBUR	Brigham City, U.	800	D-250	KELO	Sioux Falls, S.D.	1320	5,000	KGB	San Diego, Cal.	1360	1,000	KIHO	Sioux Falls, S.D.	1270	1,000
KBUN	Bemidji, Minn.	1450	250	KELP	El Paso, Tex.	920	D-1,000	KGBC	Galveston, Tex.	1540	LS-1,000	KIJV	Huron, S.D.	1340	250
KBUR	Burlington, Ia.	1490	250	KELS	Kelso, Wash.	1490	250	KGBX	Springfield, Mo.	1260	5,000	KILO	Grand Forks, N.D.	1440	LS-1,000
KBWD	Brownwood, Tex.	1380	LS-1,000	KELT	Electra, Tex.	1050	D-250	KGCU	Manding, N.D.	1270	LS-1,000				N-5,000
			N-500	KENE	Belen, N.M.	1230	250	KGDE	Sidney, Mont.	1480	5,000	KIOX	Bay City, Tex.	1270	1,000
KBYE	Okla. City, Okla.	890	D-1,000	KENO	Las Vegas, Nev.	1400	250	KGER	Long Beach, Cal.	1390	5,000	KIPA	Hilo, T.H.	1110	1,000
KBYS	Anchorage, Alas.	1240	250	KENT	Shreveport, La.	1550	LS-1,000	KGEZ	Shawnee, Okla.	1450	250	KIRO	Seattle, Wash.	710	50,000
KBZY	Grand, Rapids, Minn.	1490	250	KEPO	El Paso, Tex.	690	5,000	KGFF	Salinas, Cal.	1230	250	KIRX	Kirksville, Mo.	1450	250
		*1450	1,000	*KERB	Kermitt, Tex.	600	D-1,000	KGFL	L. Angeles, Cal.	1230	250	KISD	Sioux Falls, S.D.	1230	250
KCBC	Des Moines, Ia.	1390	1,000	KERG	Eugene, Ore.										

Call Letters	City	Frequency in KC	Power in Watts	Call Letters	City	Frequency in KC	Power in Watts	Call Letters	City	Power in Watts	Call Letters	City	Power in Watts		
KIWW	San Antonio, Tex.	1540	D-250	KOAM	Pittsburg, Kan.	860	LS-10,000	KQV	Pittsburgh, Pa.	1410	5,000	KSIX	Corpus Christi, Tex.	1230	250
KIDL	Dallas, Tex.	1040	D-1,000	KOAT	Albuquerque, N.M.	1450	250	KRAI	Craig, Colo.	1230	250	KSJB	Jamestown, N.D.	600	5,000
KIYI	Shelby, Mont.	1230	250	KOB	Albuquerque, N.M.	1030	10,000	KRAL	Rawlins, Wyo.	1240	250	KSJO	San Jose, Cal.	1590	LS-1,000
KJAM	Vernal, Utah	1340	250					KRAM	Las Vegas, Nev.	920	LS-1,000	KSKY	Dallas, Tex.	660	D-1,000
KJAY	Topeka, Kans.	1440	LS-5,000									KSL	Salt Lake City, Utah	1160	50,000
KJBS	S.Francisco, Cal.	1100	LS-1,000	KOBE	Las Cruces, N.M.	1450	250	†KRAO	Red Oak, Ia.	1600	D-500	KSLM	Salem, Ore.	1390	1,000
†KJCF	Festus, Mo.	1010	D-250	KOCC	Kilgore, Ore.	1240	250	KRBA	Lufkin, Tex.	1340	250	KSLQ	Opelousas, La.	1230	250
KJCK	Junction City, Kans.	1570	D-1,000	KOCO	Salem, Ore.	1490	250	KRCB	Abilene, Tex.	1470	LS-5,000	KSMA	Santa Maria, Cal.	1450	250
†KJFJ	Webster City, Ia.	1570	D-250	KOCS	Ontario, Cal.	1510	D-250	†KRCC	Prineville, Ore.	690	N-1,000				
KJR	Seattle, Wash.	950	5,000	KOCY	Okla. City, Okla.	1340	250	KRCD	Colorado Springs, Colo.	1240	250				
KJSK	Columbus, Neb.	900	D-1,000	KODI	Cody, Wyo.	1400	250	KRE	Dinuba, Cal.	1240	250	KSMI	Seminole, Okla.	1260	D-500
KKIN	Visalia, Cal.	1400	250	KODL	The Dalles, Ore.	1230	LS-250	KREI	Farmingington, Mo.	1350	D-1,000	KSMN	Mason City, Ia.	1010	D-1,000
KLAC	Los Angeles, Cal.	570	LS-5,000					KREB	Spokane, Wash.	1340	1,000	KSMO	San Mateo, Cal.	1550	1,000
KLAS	Las Vegas, Nev.	1230	250	KODY	N. Platte, Neb.	1240	N-100	KRES	St. Joseph, Mo.	1230	250	†KSNY	Snyder, Tex.	1280	D-500
KLBK	La Grande, Ore.	1450	250	†KOEI	Oelwein, Ia.	950	D-500	†KREW	Wash. Wash.	1050	D-250	KSO	Des Moines, Ia.	1460	5,000
KLCN	Blytheville, Ark.	900	D-1,000	KOFO	Ottawa, Kans.	1220	250	KRGV	Weslaco, Tex.	1290	1,000	†KSQL	Yuma, Ariz.	1280	1,000
KLEE	Houston, Tex.	510	5,000	KOGT	Orange, Tex.	1600	1,000	KRHD	Duncan, Okla.	1350	LS-250	KSON	San Diego, Cal.	1240	250
KLER	Rochester, Minn.	970	LS-5,000	KOH	Reno, Nev.	630	1,000	KRIC	Beaumont, Tex.	1450	250	KSOO	Sioux Falls, S.D.	1140	LS-5,000
KLFF	Lafayette, La.	1390	D-500	KOIL	Omaha, Neb.	1290	5,000	KRIE	Los Angeles, Cal.	1150	LS-5,000	†KSOX	Harlingen, Tex.	1530	LS-50,000
†KLLC	Monroe, La.	1230	250	KOIN	Portland, Ore.	970	5,000	KRIG	Odessa, Tex.	1410	1,000	KSPA	Santa Paula, Cal.	1400	250
KLIF	Oak Cliff, Tex.	1190	D-1,000	KOJM	Havre, Mont.	730	D-1,000	KRIO	McAllen, Tex.	910	1,000	KSPI	Stillwater, Okla.	780	D-250
KLIX	Twin Falls, Ida.	1340	250	KOKO	Lajunta, Colo.	1400	250	KRIS	Corpus Christi, Tex.	1360	1,000	KSPR	Casper, Wyo.	1470	1,000
KLIZ	Brainerd, Minn.	1400	250	KOKX	Keokuk, Iowa	1310	D-250	KRJA	Miles City, Mont.	1340	250	KSPD	Santa Rosa, Cal.	1350	1,000
KLMC	Parsons, Kan.	1540	D-250	KOKL	Keokuk, Iowa	1300	5,000	KRJD	Los Angeles, Cal.	1150	LS-5,000	KSRV	Ontario, Ore.	1450	250
KLMR	Longmont, Colo.	1050	D-250	KOLE	Port Arthur, Tex.	1340	250	KRKE	Kirkland, Wash.	1050	D-250	KSTB	Breckenridge, Tex.	1430	D-1,000
KLMW	Lamar, Colo.	1340	250	KOLN	Lincoln, Neb.	1400	250	KRKL	Everett, Wash.	1400	250	KSTL	St. Louis, Mo.	690	D-1,000
KLMS	Lincoln, Neb.	1480	1,000	KOLO	Reno, Nev.	920	1,000	KRKO	Lewiston, Ida.	1350	1,000	†KSTN	Stockton, Cal.	1420	1,000
KLMO	Lamar, Colo.	1340	250	KOLT	Scottsbluff, Neb.	1320	LS-5,000	KRKR	Dallas, Tex.	1080	50,000	KSTP	St. Paul, Minn.	1500	50,000
KLMP	La. Minot, N.D.	1390	1,000	KOMA	Okla. City, Okla.	1520	50,000	KRLL	Canon City, Colo.	1400	SH-250	KSTT	Davenport, Ia.	750	D-500
KLNR	Okla. City	1140	D-1,000	KOME	Tulsa, Okla.	1300	LS-5,000	KRLD	Shreveport, La.	1340	250	KSTU	Stephenville, Tex.	1510	D-250
KLRA	Little Rock, Ark.	1010	LS-10,000	KOMW	Omaha, Wash.	680	D-1,000	KRLE	Tulsa, Okla.	740	LS-50,000	KSUB	Cedar City, Utah	1340	250
KLTI	Longview, Tex.	1280	D-1,000	KONO	San Antonio, Tex.	1400	250	KRNO	San Bernardino, Cal.	1240	250	KSUE	Susanville, Cal.	1240	250
KLUF	Galveston, Tex.	1400	250	KONP	Port Angeles, Wash.	1450	250	KRNR	Roseburg, Ore.	1490	250	KSUM	Fairmont, Minn.	1370	1,000
†KLVV	Pasadena, Tex.	1480	D-1,000	†KOOK	Billings, Mont.	970	5,000	KRNT	Des Moines, Ia.	1350	5,000	KSVN	Bisbee, Ariz.	1230	250
KLVT	Levelland, Tex.	1230	250	KOOL	Phoenix, Ariz.	960	5,000	KROC	Rochester, Minn.	1340	250	KSVU	Richfield, U.	690	D-1,000
KLWT	Lebanon, Mo.	1230	250	KOOS	Coos Bay, Ore.	1230	250	KROD	El Paso, Tex.	600	5,000	KSWP	Artesia, N.M.	1450	250
KLX	Oakland, Cal.	910	1,000	KOPO	Tucson, Ariz.	1450	250	KROE	Abbeville, La.	960	D-1,000	KSWA	Graham, Tex.	1330	D-500
KLXN	Amarillo, Tex.	940	1,000	KOPP	Ogden, Utah	730	D-1,000	KROG	Sonora, Cal.	1450	250	KSWI	Iowa Council Bluffs,	1560	D-500
KLZ	Denver, Colo.	560	5,000	KOPR	Butte, Mont.	550	1,000	KROP	Sonora, Cal.	1300	LS-1,000	KSWM	Joplin, Mo.	1230	250
KMA	Shenandoah, Ia.	860	5,000	†KOPY	Glenwood Springs, Colo.	1240	250	KROW	Clinton, Iowa	1340	250	KSWO	Lawton, Okla.	1380	1,000
KMAC	S. Antonio, Tex.	630	5,000	KORA	Bryan, Tex.	1240	250	KRUX	Oakland, Cal.	960	1,000	KSWV	Roswell, N.M.	1230	250
KMAE	McKinney, Tex.	1600	D-1,000	KORC	Mineral Wells, Tex.	1140	D-250	KROY	Crookston, Minn.	1050	D-1,000	KSYX	Yreka, Cal.	1490	250
†KMAN	Manhattan, Kan.	1350	D-500	KORE	Eugene, Ore.	1450	250	KRPP	Sacramento, Cal.	1240	250	KSYL	Alexandria, La.	1400	250
KMBC	Kansas City, Mo.	980	5,000	KORN	Mitchell, S.D.	1490	250	KRPS	Crookston, Minn.	1050	D-1,000	KTAE	Taylor, Tex.	1280	D-1,000
KMBY	Monterey, Cal.	1240	250	KOSA	Odessa, Tex.	1230	250	KRRV	Moscow, Ida.	1400	250	KTAN	Sherman, Tex.	1500	D-250
KMCM	McMinnville, Ore.	1260	1,000	KOSF	Nacogdoches, Tex.	1230	250	KRSB	Sherman, Tex.	910	1,000	KTAR	Phoenix, Ariz.	620	5,000
KMED	Medford, Ore.	1440	LS-5,000	KOTA	Rapid City, S.D.	1380	5,000	KRSK	Seattle, Wash.	1150	1,000	KTAT	Frederick, Okla.	1570	D-500
KMHL	Marshall, Minn.	1400	250	KOTN	Pine Bluff, Ark.	1480	250	KRSN	Los Alamos, N.M.	1490	250	KTBK	Tyler, Tex.	600	D-250
KMHT	Marshall, Tex.	1450	250	KOVC	Valley City, N.D.	1490	250	KRTN	Raton, N.M.	1490	250	KTBC	Austin, Tex.	590	LS-5,000
KMJ	Fresno, Cal.	580	5,000	KOVE	Landar, Wyo.	1230	250	KRUL	Corvallis, Ore.	1340	250	KTCB	Tacoma, Wash.	810	D-1,000
KMLB	Monroe, La.	1440	LS-5,000	KOVO	Provo, Utah	980	1,000	KRUN	Ballinger, Tex.	1490	250	KTEB	Tyler, Tex.	600	D-500
KMMJ	Grand Island, Neb.	750	LS-1,000	KOWB	Laramie, Wyo.	1340	250	KRUS	Ruston, La.	1490	250	KTEC	Austin, Tex.	590	LS-5,000
KMMO	Marshall, Mo.	1300	D-500	KOWH	Omaha, Neb.	660	D-500	KRUX	Glendale, Ariz.	1340	250	KTBS	Shreveport, La.	710	LS-10,000
KMNS	San Luis Obispo, Cal.	1340	250	KOWL	Santa Monica, Cal.	1580	D-5,000	KSAC	Manhattan, Kans.	580	LS-5,000	KTED	Laguna Beach, Cal.	1520	LS-1,000
KMO	Tacoma, Wash.	1360	5,000	KOY	Phoenix, Ariz.	550	LS-5,000	KSAL	Salina, Kans.	1150	5,000	KTEM	Temple, Tex.	1400	N-250
†KMOD	Modesto, Cal.	1360	1,000	KPAB	Laredo, Tex.	1490	250	KSAM	Huntsville, Tex.	1490	250	KTFI	Twin Falls, Ida.	1270	LS-5,000
KMON	Great Falls, Mont.	560	5,000	KPAC	Port Arthur, Tex.	1250	LS-5,000	KSAN	S. Francisco, Cal.	1450	250	KTFY	Brownfield, Tex.	1050	D-250
KMOX	St. Louis, Mo.	1120	50,000	KPNC	Portland, Ore.	800	D-1,000	KSBW	Salinas, Cal.	1450	250	KTHS	Hot Springs, Ark.	1090	LS-10,000
KMPC	Los Angeles, Cal.	710	LS-50,000	KPDQ	Portland, Ore.	800	D-1,000	KSCB	Liberal, Kans.	1270	D-1,000	KTHV	Houston, Tex.	790	N-1,000
KMUR	Murray, Utah	1230	250	KPEI	Lamesa, Tex.	690	D-250	KSCJ	Sioux City, Ia.	1360	5,000	KTHL	Tillamook, Ore.	1590	5,000
KMUS	Muskogee, Okla.	1380	LS-1,000	KPHC	Walsenburg, Colo.	1450	250	KSCO	Santa Cruz, Cal.	1080	LS-1,000	KTIM	San Rafael, Cal.	1510	D-1,000
KMVI	Walluku, T.H.	550	1,000	KPHO	Phoenix, Ariz.	910	5,000	KSD	St. Louis, Mo.	550	5,000	KTIP	Porterville, Cal.	1450	250
KMYC	Warysville, Cal.	1450	250	KPKW	Pasco, Wash.	1340	250	KSDN	Aberdeen, S.D.	930	1,000	KTIS	Minneapolis, Minn.	900	D-1,000
KMYR	Denver, Colo.	1340	250	KPLC	Lake Charles, La.	1470	LS-5,000	KSDO	San Diego, Cal.	1510	LS-5,000	KTJS	Hobart, Okla.	1420	D-250
KNAF	Fredericksburg, Tex.	1340	250	KPLT	Paris, Tex.	1490	250	KSEI	Pocatello, Ida.	930	5,000	KTKN	Ketchikan, Alas.	930	1,000
KNAK	Salt Lake City, Utah	1280	LS-1,000	†KPLW	Plainview, Tex.	1570	D-250	KSEL	Pittsburg, Kans.	1340	250	KTKR	Taft, Cal.	1310	D-500
KNAL	Victoria, Tex.	1410	D-500	KPMC	Bakersfield, Cal.	1560	1,000	KSEM	Lubbock, Tex.	950	LS-1,000	KTKT	Tucson, Ariz.	1480	250
KNBC	San Francisco, Cal.	680	50,000	KPOM	Pomona, Cal.	1600	500	KSF	Moses Lake, Wash.	1450	250	KTLN	Tucson, Ariz.	1480	D-1,000
KNBY	Newport, Ark.	1280	D-1,000	KPOA	Honolulu, T.H.	630	5,000	KSEI	Wash. Wash.	1050	D-250	KTMC	McAlester, Okla.	920	D-1,000
KNEB	Scottsbluff, Neb.	970	D-1,000	KPOF	Denver, Colo.	910	LS-5,000	KSET	Durant, Okla.	750	D-250	KTMS	Santa Barbara, Cal.	1250	1,000
†KNED	McAllister, Okla.	1480	D-1,000	KPOJ	Portland, Ore.	1330	5,000	KSFA	El Paso, Tex.	1340	250	†KTOE	Mankato, Minn.	1420	250
KNEL	Brady, Tex.	1490	250	KPOW	Powell, Wyo.	1280	1,000	KSFO	Nacogdoches, Tex.	860	D-1,000	KTOH	Lihue, T.H.	1480	250
KNEM	Nevada, Mo.	1240	250	KPPC	Pasadena, Cal.	1240	SH-100	KSP	Needles, Cal.	1340	250	KTKO	Oklahoma City, Okla.	1000	LS-5,000
KNET	Palestine, Tex.	1450	250	KPQ	Wenatchee, Wash.	560	1,000	KSFT	S. Francisco, Cal.	560	LS-5,000	KTOP	Topeka, Kans.	1490	N-1,000
†KNEU	Provo, Utah	1450	250	KPRC	Houston, Tex.	950	5,000	KSAT	Trinidad, Colo.	1280	LS-1,000	KTOW	Oklahoma City, Okla.	800	D-250
KNEW	Spokane, Wash.	1430	5,000	KPRK	Livingston, Mont.	1340	250	KSGM	Ste. Genevieve, Mo.	1450	250	KTRB	Modesto, Cal.	860	LS-5,000
KNEX	McPherson, Kans.	1540	D-250	KPRL	Paso Robles, Cal.</										

AM STATIONS BY CALL LETTERS

(Continued from page 501)

Call Letters	City	Power in Watts	Call Letters	City	Power in Watts	Call Letters	City	Power in Watts	Call Letters	City	Power in Watts				
KTRY	Bastrop, La.	730	D-250	KWCR	Cedar Rapids, Ia.	1450	250	KYAK	Yakima, Wash.	1400	250	WAVU	Albertville, Ala.	630	D-500
KTSA	San Antonio, Tex.	550	5,000	KWCO	Chickasha, Okla.	1560	D-250	KYCA	Prescott, Ariz.	1490	250	WAVZ	New Haven, Conn.	1260	D-1,000
KTSM	El Paso, Tex.	1380	LS-1,000	KWCR	Cedar Rapids, Ia.	1450	250	KXYZ	Houston, Tex.	1320	5,000	WAWZ	Zarepath, N.J.	1380	LS-5,000
KTSM	Emporia, Kans.	1400	N-500	KWCR	Cedar Rapids, Ia.	1450	250	KYA	San Francisco, Cal.	1260	LS-5,000	WAYB	Waynesboro, Va.	1490	250
KTSS	Springfield, Mo.	1400	250	KWDM	Des Moines, Ia.	1150	1,000	KYAK	Yakima, Wash.	1400	250	WAYN	Rockingham, N.C.	900	D-1,000
KTUC	Tucson, Ariz.	1400	250	KWED	Seguin, Tex.	1580	D-250	KYCA	Prescott, Ariz.	1490	250	WAYS	Charlotte, N.C.	610	LS-5,000
KTUL	Tulsa, Okla.	1430	5,000	KWEI	Weiser, Idaho	1240	250	KYJC	Medford, Ore.	1230	250	WAYX	Waycross, Ga.	1230	N-1,000
KTUR	Turlock, Cal.	1390	1,000	KWEM	W. Memphis, Ark.	990	D-1,000	KYMA	Yuma, Ariz.	1240	250	WAZF	Yazoo City, Miss.	1230	250
KTWC	Seattle, Wash.	1250	1,000	KWFT	Hot Springs, Ark.	1490	250	KYNO	Fresno, Cal.	1300	1,000	WAZL	Hazleton, Pa.	1490	250
KTXX	Jasper, Tex.	1400	100	KWGC	Stockton, Cal.	1230	250	KYOS	Merced, Cal.	1480	5,000	WBAA	Lafayette, Ind.	920	LS-5,000
KTXL	San Angelo, Tex.	1340	250	KWHD	Goodland, Kans.	730	D-1,000	KYUM	Mankato, Minn.	1230	250	WBAC	Atlantic City, N.J.	1490	250
KTXN	Austin, Tex.	1370	D-1,000	KWHI	Brenham, Tex.	1280	D-1,000	KYWA	Philadelphia, Pa.	1060	50,000	WBAL	Baltimore, Md.	1090	50,000
KTYL	Mesa, Ariz.	1490	250	KWHK	Hutchinson, Kans.	1190	D-1,000	WAAB	Worcester, Mass.	1440	5,000	WBAP	Ft. Worth, Tex.	570	5,000
KUBA	Yuba City, Cal.	1600	500	KWHN	Ft. Smith, Ark.	1320	5,000	WAAC	Chicago, Ill.	950	D-1,000	WBAT	Marion, Ind.	1600	D-500
KUCB	Montrose, Cal.	1240	250	KWHE	Aitua, Okla.	1450	250	WAAT	Jersey City, N.J.	970	D-1,000	WBAX	Wilkes-Barre, Pa.	1240	250
KUGN	Eugene, Ore.	1400	250	KWIE	Kennewick, Wash.	1230	250	WABA	Aguadilla, P.R.	1240	250	WBAY	Green Bay, Wis.	1360	5,000
KUIN	Grants Pass, Ore.	1340	250	KWIK	Burbank, Cal.	1490	250	WABB	Mobile, Ala.	1480	5,000	WBBD	Burlington, N.C.	920	D-1,000
KUJ	Walla Walla, Wash.	1420	5,000	KWIL	Albany, Ore.	1240	250	WABI	Bangor, Maine	910	5,000	WBBL	Richmond, Va.	1450	SH-250
KULA	Honolulu, T.H.	690	10,000	KWIN	Ashland, Ore.	1240	250	WABJ	Adrian, Mich.	1500	D-250	WBDM	Chicago, Ill.	780	50,000
JKULE	Ephrata, Wash.	730	D-250	KWJG	Globe, Ariz.	1240	250	WABW	Lawrence, Mass.	980	D-1,000	WBDO	Forest City, N.C.	780	D-1,000
KULP	El Campo, Tex.	1380	D-500	KWJJ	Portland, Ore.	1080	10,000	WABY	Albany, N.Y.	1400	250	WBEG	Augusta, Ga.	1340	250
JKUMO	Columbia, Mo.	950	1,000	KWK	St. Louis, Mo.	1380	5,000	WABZ	Albany, N.Y.	1400	250	WBEB	Brooklyn, N.Y.	1330	5,000
JKUNO	Corpus Christi, Tex.	1400	100	KWKC	Abilene, Tex.	1340	250	WAC	Camden, S.C.	1010	D-1,000	WBEB	Youngstown, O.	1240	250
KUOA	Shioam Springs, Ark.	1290	D-5,000	KWKE	Shreveport, La.	1130	50,000	WACB	Kittanning, Pa.	1380	D-500	WBCC	Bethesda, Md.	1120	D-250
KUOM	Minneapolis, Minn.	770	D-5,000	KWKF	Pasadena, Cal.	1430	D-1,000	WACE	Chicopee, Mass.	730	D-1,000	WBCK	Battle Creek, Mich.	930	1,000
KURV	Edinburg, Tex.	710	D-250	KWLG	Decorah, Iowa	1240	D-250	WACO	Waco, Tex.	1460	1,000	WBDM	Bay City, Mich.	1440	LS-1,000
KUSD	Vermillion, S.D.	920	500	KWLK	Longview, Wash.	1400	250	WADR	Colonus, Miss.	1050	D-250	WBEB	Bessemer, Ala.	1450	250
KUTA	Salt Lake City	570	5,000	KWLM	Willmar, Minn.	1340	250	WADE	Akron, O.	1350	5,000	WBEC	Union, S.C.	1460	1,000
KVAK	Atchison, Kans.	1470	1,000	KWNO	Winona, Minn.	1230	250	WAEB	Wadesboro, N.C.	1210	D-1,000	WBEC	Pittsfield, Mass.	1490	250
KVAL	Brownsville, Tex.	1490	250	KWNW	Wenatchee, Wash.	1340	250	WAEB	Allentown, Pa.	790	LS-500	WBEJ	Elizabethton, Tenn.	1240	250
KVAN	Vancouver, Wash.	910	1,000	KWOC	Worthington, Minn.	730	D-1,000	WAEL	Mayaguez, P.R.	1400	250	WBEL	Beloit, Wis.	1380	D-1,000
KVCV	Redding, Cal.	600	1,000	KWOF	Poplar Bluff, Mo.	1340	250	WAFB	Baton Rouge, La.	1460	1,000	WBEN	Buffalo, N.Y.	930	5,000
KVEC	San Luis Obispo, Cal.	920	LS-1,000	KWOG	Clinton, Okla.	1320	D-1,000	WAG	Atlanta, Ga.	590	5,000	WBET	Brockton, Mass.	990	D-1,000
KVEN	Ventura, Cal.	1450	N-250	KWON	Bartlesville, Okla.	1400	250	WAGC	Chattanooga, Tenn.	1450	250	WBFB	Chillicothe, O.	1490	250
KVER	Albuquerque, N.M.	1340	250	KWOR	Jefferson, Wyo.	1490	250	WAGE	Syracuse, N.Y.	620	LS-5,000	WBGE	Atlanta, Ga.	1340	250
KVET	Austin, Tex.	1300	1,000	KWOS	Jefferson City, Mo.	1240	250	WAGF	Dothan, Ala.	1320	1,000	WBGR	Jesup, Ga.	1370	D-1,000
KVFD	Ft. Dodge, Iowa	1400	250	KWPC	Muscataine, Ia.	860	D-250	WAGM	Presque Isle, Me.	1450	250	WBHB	Fitzgerald, Ala.	1240	250
KVGB	Great Bend, Kans.	1590	5,000	KWPM	West Plains, Mo.	1450	250	WAIM	Anderson, S.C.	1230	250	WBHP	Cartersville, Ga.	1450	250
KVI	Seattle, Wash.	570	5,000	KWRC	Pendleton, Ore.	1240	250	WAIR	Winston-Salem, N.C.	1340	250	WBHP	Huntsville, Ala.	1230	250
KVIC	Victoria, Tex.	1340	250	KWRE	Warrenton, Mo.	730	D-250	WAJ	Chicago, Ill.	820	LS-5,000	WBIB	Knoxville, Tenn.	1470	5,000
KVKM	Monahans, Tex.	1340	250	KWRL	Riverton, Wyo.	1450	250	WAJR	Morgantown, W.Va.	1230	250	WBIS	Bristol, Conn.	1440	D-500
KVLC	Little Rock, Ark.	1050	D-1,000	KWRN	Reno, Nev.	1490	250	WAKR	Akron, O.	1590	5,000	WBIV	Bedford, Ind.	1340	250
KVLF	Alpine, Tex.	1240	250	KWRO	Coquille, Ore.	1450	250	WALA	Mobile, Ala.	1410	5,000	WBIZ	Eau Claire, Wis.	1400	250
KVLH	Pauls Valley, Okla.	1470	D-250	KWSC	Pullman, Wash.	1250	5,000	WALB	Albany, Ga.	1590	1,000	WBKA	Brockton, Mass.	1450	250
KVMA	Magnolia, Ark.	630	D-1,000	KWSD	Mt. Shasta, Cal.	1340	250	WALD	Walterboro, S.C.	1490	250	WBLJ	Dalton, Ga.	1230	250
JKVMC	Colorado City, Tex.	1320	D-500	KWSL	Lake Charles, La.	1400	250	WALE	Fall River, Mass.	1400	250	WBLK	Clarksburg, W.Va.	1400	250
KVMV	Twin Falls, Ida.	1450	250	JKWSO	Wasco, Cal.	1050	D-250	WALM	Laurel, Miss.	1340	250	WBLC	Bedford, Va.	1490	250
JKVNE	Oxnard, Cal.	910	D-1,000	KWTC	Barstow, Cal.	1230	250	WALS	Albany, Ga.	1590	1,000	WBMD	Baltimore, Md.	750	D-1,000
KVNI	Coeur d'Alene, Ida.	1240	250	KWTO	Springfield, Mo.	560	LS-5,000	WALD	Walterboro, S.C.	1490	250	WBML	Macon, Ga.	1240	250
KVNJ	Fargo, N.D.	900	D-1,000	KWTX	Waco, Tex.	1230	250	WALE	Fall River, Mass.	1400	250	WBMS	Boston, Mass.	1090	D-1,000
KVNU	Logan, Utah	610	1,000	KWVB	Walla Walla, Wash.	1490	250	WALF	Wilmington, N.C.	1380	1,000	WBNS	Columbus, Ohio	1460	LS-5,000
KVOA	Tucson, Ariz.	1290	1,000	KWVL	Waterloo, Ia.	1330	LS-5,000	WALT	Tampa, Fla.	1110	D-1,000	WBNU	New York, N.Y.	1380	N-1,000
KVOB	Alexandria, La.	970	1,000	KWVW	Wash.	1490	250	WAML	Laurel, Miss.	1340	250	WBNY	Buffalo, N.Y.	1400	5,000
KVOC	Casper, Wyo.	1230	250	KWVY	Sheridan, Wyo.	1410	LS-1,000	WAMS	Wilmington, Del.	1380	1,000	WBOD	Galax, Va.	1400	250
KVOD	Denver, Colo.	5,000	5,000	KXA	Seattle, Wash.	770	LS-1,000	WAND	Canton, Ohio	900	D-500	WBOD	Salisbury, Md.	960	1,000
KVOE	Santa Ana, Cal.	1480	1,000	KXAR	Hope, Ark.	1490	250	WANE	Ft. Wayne, Ind.	1450	250	WBOW	Terre Haute, Ind.	1230	250
KVOG	Ogden, Utah	1490	250	KXEL	Waterloo, Ia.	1540	50,000	WAN	Annapolis, Md.	1190	D-1,000	WBPA	Lock Haven, Pa.	1230	250
KVOL	LaFayette, La.	1340	250	KXEO	Mexico, Mo.	1340	250	WAN	Winnemac, Ind.	1450	250	WBPC	Birmingham, Ala.	960	5,000
KVON	Napa, Cal.	1440	500	KXGI	Ft. Madison, Ia.	1360	D-500	WANN	Annapolis, Md.	1190	D-1,000	WBRE	Wilkes-Barre, Pa.	1340	250
KVOO	Tulsa, Okla.	1170	50,000	KXGN	Glendive, Mont.	1400	250	WANS	Anderson, S.C.	1280	D-1,000	WBRI	Pittsfield, Mass.	1340	250
KVOP	Plainview, Tex.	1400	250	KXIC	Iowa City, Ia.	800	D-1,000	WAOV	Vincennes, Ind.	1450	250	WBRS	Marion, N.C.	1250	D-1,000
KVOR	Colorado Springs, Colo.	1300	1,000	KXIT	Dalhart, Tex.	1410	D-500	WAPA	San Juan, P.R.	680	10,000	WBRY	Waterbury, Conn.	1590	5,000
KVOS	Bellingham, Wash.	790	1,000	KXJK	Forrest City, Ark.	950	D-1,000	WAPP	McComb, Miss.	1010	D-250	WBSC	Bennettsville, S.C.	1400	250
KVOU	Uvalde, Tex.	1450	1,000	KXL	Portland, Ore.	750	LS-10,000	WAPI	Birmingham, Ala.	1070	5,000	WBSD	New Bedford, Mass.	1230	100
KVOW	Littlefield, Tex.	1490	250	KXLA	Pasadena, Cal.	1110	10,000	WAP	Chattanooga, Tenn.	1150	LS-5,000	WBST	Pensacola, Fla.	1450	250
KVOX	Moorhead, Minn.	1340	250	KXLE	Ellensburg, Wash.	1240	250	WAPX	Montgomery, Ala.	1600	1,000	WBTA	Charlotte, N.C.	1110	50,000
JKVPX	Snyder, Tex.	1220	D-250	KXLF	Butte, Mont.	1370	5,000	WAPY	Wilmington, N.C.	1400	250	WBTH	Batavia, N.Y.	1490	250
KVRC	Arkadelphia, Ark.	1240	250	KXLJ	Helena, Mont.	1240	250	WARC	Rochester, N.Y.	950	1,000	WBTV	Wilmington, N.C.	1400	250
KVRH	Rock Springs, Wyo.	1360	LS-1,000	KXLK	Great Falls, Mont.	1400	250	WARD	Johnstown, Pa.	1480	250	WBTV	Danville, Va.	1330	LS-5,000
JKVRV	Victorville, Cal.	960	D-5,000	KXLL	Missoula, Mont.	1450	250	WARE	Ware, Mass.	1250	D-1,000	WBUD	Morrisville, Pa.	1490	250
KVSV	Santa Fe, N.M.	1260	1,000	KXLO	Lewiston, Mont.	1230	250	WARK	Hagerstown, Md.	1490	250	WBUT	Butler, Pa.	1580	D-500
KVSM	San Mateo, Cal.	1050	D-250	KXLP	Bozeman, Mont.	1450	250	WARL	Arlington, Va.	780	D-1,000	WBUX	Doylestown, Pa.	1570	D-250
KVSO	Ardmore, Okla.	1240	250	KXLR	N. Little, Ark.	1450	250	WARM	Scranton, Pa.	1400	250	WBV	Lexington, N.C.	1450	250
KVVC	Ventura, Cal.	1590	1,000	KXLY	Spokane, Wash.	820	5,000	WASA	Havre de Grace, Md.	1330	D-1,000	WBVP	Beaver Falls, Pa.	1230	250
KVWC	Vernon, Tex.	1490	250	KXO	El Centro, Cal.	1230	250	WASK	Lafayette, Ind.	1450	250	WBYS	Canton, Ill.	1560	D-250
KWAD	Wadena, Minn.	920	1,000	KXOA	Sacramento, Cal.	1470									

Call Letters	City	Power in Watts	Call Letters	City	Power in Watts	Call Letters	City	Power in Watts	Call Letters	City	Power in Watts
WNAT	Natchez, Miss.	1450	WPLH	Huntington, W. Va.	1450	†WSGW	Saginaw, Mich.	790	WTON	Staunton, Va.	1400
WNAV	Annapolis, Md.	1430	WPLJ	Jackson, Tenn.	1490	WSHB	St. Water, Minn.	1220	WTOP	Washington, D.C.	1500
WNAW	N. Adams, Mass.	860	†WPLN	Erie, Pa.	1400	WSID	Essex, Md.	1570	WTOR	Toronto, Conn.	1490
WNAX	Yankton, S.D.	570	†WPMF	Pascagoula, Miss.	1580	WSIP	Paintsville, Ky.	1490	WTPR	Paris, Tenn.	710
WNBC	New York, N.Y.	660	†WPNF	Brevard, N.C.	1240	WSIR	Winter Haven, Fla.	1490	WTPS	New Orleans, La.	940
WNBF	Binghamton, N.Y.	1290	WPPA	Pottsville, Pa.	1360	WSIV	Pekin, Ill.	1140	†*LS-1,000		
WNBH	New Bedford, Mass.	1340	WPPA	Pottsville, Pa.	1360	WSIX	Nashville, Tenn.	980	WTRC	Elkhart, Ind.	1340
WNBS	Murray, Ky.	1340	WPPA	Pottsville, Pa.	1360	WSJS	Winston-Salem, N.C.	1250	WTRF	Bellaire, O.	1280
WNBZ	Saranac Lake, N.Y.	1450	WPPA	Pottsville, Pa.	1360	WSKB	McComb, Miss.	600	WTRR	Sanford, Fla.	1400
WNCA	Aiken, S.C.	740	WPPA	Pottsville, Pa.	1360	WSKI	Montpelier, Vt.	1240	WTRY	Troy, N.Y.	980
WNDB	Daytona Beach, Fla.	1150	WPPA	Pottsville, Pa.	1360	WSLB	Ogdensburg, N.Y.	1400	WTTA	Thomson, Ga.	1240
WNDR	Syracuse, N.Y.	1260	WPPA	Pottsville, Pa.	1360	WSLI	Jackson, Miss.	930	WTTN	Trenton, N.J.	980
WNEB	Worcester, Mass.	1230	WPPA	Pottsville, Pa.	1360	†WSLN	Ft. Lauderdale, Fla.	1580	WTTT	Trenton, N.J.	980
WNEL	San Juan, P.R.	860	WPPA	Pottsville, Pa.	1360	WSM	Roanoke, Va.	610	WTTT	Trenton, N.J.	980
WNER	Live Oak, Fla.	1450	WPPA	Pottsville, Pa.	1360	WSNB	Nashville, Tenn.	650	WTTT	Trenton, N.J.	980
WNEW	New York, N.Y.	1130	WPPA	Pottsville, Pa.	1360	WSNB	Nashville, Tenn.	650	WTTT	Trenton, N.J.	980
WNEZ	Macon, Ga.	1400	WPPA	Pottsville, Pa.	1360	WSNB	Nashville, Tenn.	650	WTTT	Trenton, N.J.	980
WNGV	Mayfield, Ky.	1320	WPPA	Pottsville, Pa.	1360	WSNB	Nashville, Tenn.	650	WTTT	Trenton, N.J.	980
WNHC	New Haven, Conn.	1340	WPPA	Pottsville, Pa.	1360	WSNB	Nashville, Tenn.	650	WTTT	Trenton, N.J.	980
WNJR	Newark, N.J.	1430	WPPA	Pottsville, Pa.	1360	WSNB	Nashville, Tenn.	650	WTTT	Trenton, N.J.	980
WNLC	New London, Conn.	1490	WPPA	Pottsville, Pa.	1360	WSNB	Nashville, Tenn.	650	WTTT	Trenton, N.J.	980
WNLK	Norwalk, Conn.	1350	WPPA	Pottsville, Pa.	1360	WSNB	Nashville, Tenn.	650	WTTT	Trenton, N.J.	980
WNMP	Evanston, Ill.	1590	WPPA	Pottsville, Pa.	1360	WSNB	Nashville, Tenn.	650	WTTT	Trenton, N.J.	980
WNNC	Newton, N.C.	1230	WPPA	Pottsville, Pa.	1360	WSNB	Nashville, Tenn.	650	WTTT	Trenton, N.J.	980
WNNT	Warsaw, Va.	690	WPPA	Pottsville, Pa.	1360	WSNB	Nashville, Tenn.	650	WTTT	Trenton, N.J.	980
WNOE	New Orleans, La.	1450	WPPA	Pottsville, Pa.	1360	WSNB	Nashville, Tenn.	650	WTTT	Trenton, N.J.	980
WNOK	Columbia, S.C.	1230	WPPA	Pottsville, Pa.	1360	WSNB	Nashville, Tenn.	650	WTTT	Trenton, N.J.	980
WNOF	Newport, Ky.	740	WPPA	Pottsville, Pa.	1360	WSNB	Nashville, Tenn.	650	WTTT	Trenton, N.J.	980
WNOB	Norfolk, Va.	1230	WPPA	Pottsville, Pa.	1360	WSNB	Nashville, Tenn.	650	WTTT	Trenton, N.J.	980
WNOX	Knoxville, Tenn.	990	WPPA	Pottsville, Pa.	1360	WSNB	Nashville, Tenn.	650	WTTT	Trenton, N.J.	980
WNOY	Norton, Va.	1450	WPPA	Pottsville, Pa.	1360	WSNB	Nashville, Tenn.	650	WTTT	Trenton, N.J.	980
†WNPX	Portsmouth, O.	1260	WPPA	Pottsville, Pa.	1360	WSNB	Nashville, Tenn.	650	WTTT	Trenton, N.J.	980
WNYC	New York, N.Y.	830	WPPA	Pottsville, Pa.	1360	WSNB	Nashville, Tenn.	650	WTTT	Trenton, N.J.	980
WOAI	San Antonio, Tex.	1020	WPPA	Pottsville, Pa.	1360	WSNB	Nashville, Tenn.	650	WTTT	Trenton, N.J.	980
WOAP	Owosso, Mich.	1080	WPPA	Pottsville, Pa.	1360	WSNB	Nashville, Tenn.	650	WTTT	Trenton, N.J.	980
WOAY	Oak Hill, W. Va.	830	WPPA	Pottsville, Pa.	1360	WSNB	Nashville, Tenn.	650	WTTT	Trenton, N.J.	980
WOBS	Jacksonville, Fla.	1360	WPPA	Pottsville, Pa.	1360	WSNB	Nashville, Tenn.	650	WTTT	Trenton, N.J.	980
WOBT	Pelican, Wis.	1240	WPPA	Pottsville, Pa.	1360	WSNB	Nashville, Tenn.	650	WTTT	Trenton, N.J.	980
WOC	Davenport, Ia.	1420	WPPA	Pottsville, Pa.	1360	WSNB	Nashville, Tenn.	650	WTTT	Trenton, N.J.	980
WOCB	W. Yarmouth, Mass.	1240	WPPA	Pottsville, Pa.	1360	WSNB	Nashville, Tenn.	650	WTTT	Trenton, N.J.	980
WOHI	East Liverpool, O.	1490	WPPA	Pottsville, Pa.	1360	WSNB	Nashville, Tenn.	650	WTTT	Trenton, N.J.	980
WOHS	Shelby, N.C.	730	WPPA	Pottsville, Pa.	1360	WSNB	Nashville, Tenn.	650	WTTT	Trenton, N.J.	980
WOI	Ames, Iowa	640	WPPA	Pottsville, Pa.	1360	WSNB	Nashville, Tenn.	650	WTTT	Trenton, N.J.	980
WOKO	Albany, N.Y.	1460	WPPA	Pottsville, Pa.	1360	WSNB	Nashville, Tenn.	650	WTTT	Trenton, N.J.	980
WOKL	Alton, Ill.	1570	WPPA	Pottsville, Pa.	1360	WSNB	Nashville, Tenn.	650	WTTT	Trenton, N.J.	980
WOL	Washington, D.C.	1260	WPPA	Pottsville, Pa.	1360	WSNB	Nashville, Tenn.	650	WTTT	Trenton, N.J.	980
WOLF	Syracuse, N.Y.	1490	WPPA	Pottsville, Pa.	1360	WSNB	Nashville, Tenn.	650	WTTT	Trenton, N.J.	980
WOLS	Florence, S.C.	1230	WPPA	Pottsville, Pa.	1360	WSNB	Nashville, Tenn.	650	WTTT	Trenton, N.J.	980
WOMI	Owensboro, Ky.	1490	WPPA	Pottsville, Pa.	1360	WSNB	Nashville, Tenn.	650	WTTT	Trenton, N.J.	980
WOMT	Manitowoc, Wis.	1240	WPPA	Pottsville, Pa.	1360	WSNB	Nashville, Tenn.	650	WTTT	Trenton, N.J.	980
WONE	Dayton, O.	980	WPPA	Pottsville, Pa.	1360	WSNB	Nashville, Tenn.	650	WTTT	Trenton, N.J.	980
WONN	Lakeland, Fla.	1230	WPPA	Pottsville, Pa.	1360	WSNB	Nashville, Tenn.	650	WTTT	Trenton, N.J.	980
WONS	Hartford, Conn.	1410	WPPA	Pottsville, Pa.	1360	WSNB	Nashville, Tenn.	650	WTTT	Trenton, N.J.	980
WONW	Danville, O.	1280	WPPA	Pottsville, Pa.	1360	WSNB	Nashville, Tenn.	650	WTTT	Trenton, N.J.	980
WOOD	Anniston, Ala.	1490	WPPA	Pottsville, Pa.	1360	WSNB	Nashville, Tenn.	650	WTTT	Trenton, N.J.	980
WOOD	Grand Rapids, Mich.	1300	WPPA	Pottsville, Pa.	1360	WSNB	Nashville, Tenn.	650	WTTT	Trenton, N.J.	980
WOOF	Dothan, Ala.	560	WPPA	Pottsville, Pa.	1360	WSNB	Nashville, Tenn.	650	WTTT	Trenton, N.J.	980
WOOK	Silver Spring, Md.	1590	WPPA	Pottsville, Pa.	1360	WSNB	Nashville, Tenn.	650	WTTT	Trenton, N.J.	980
WOPI	Bristol, Tenn.	1490	WPPA	Pottsville, Pa.	1360	WSNB	Nashville, Tenn.	650	WTTT	Trenton, N.J.	980
†WOPN	Scriba, N.Y.	1220	WPPA	Pottsville, Pa.	1360	WSNB	Nashville, Tenn.	650	WTTT	Trenton, N.J.	980
WORA	New York, N.Y.	710	WPPA	Pottsville, Pa.	1360	WSNB	Nashville, Tenn.	650	WTTT	Trenton, N.J.	980
WORA	Mayaguez, P.R.	1150	WPPA	Pottsville, Pa.	1360	WSNB	Nashville, Tenn.	650	WTTT	Trenton, N.J.	980
WORC	Worcester, Mass.	1310	WPPA	Pottsville, Pa.	1360	WSNB	Nashville, Tenn.	650	WTTT	Trenton, N.J.	980
WORD	Spokane, W. Va.	1400	WPPA	Pottsville, Pa.	1360	WSNB	Nashville, Tenn.	650	WTTT	Trenton, N.J.	980
WORK	York, Pa.	1350	WPPA	Pottsville, Pa.	1360	WSNB	Nashville, Tenn.	650	WTTT	Trenton, N.J.	980
WORZ	Orlando, Fla.	740	WPPA	Pottsville, Pa.	1360	WSNB	Nashville, Tenn.	650	WTTT	Trenton, N.J.	980
WOSC	Fulton, N.Y.	1300	WPPA	Pottsville, Pa.	1360	WSNB	Nashville, Tenn.	650	WTTT	Trenton, N.J.	980
WOSH	Oshkosh, Wis.	1490	WPPA	Pottsville, Pa.	1360	WSNB	Nashville, Tenn.	650	WTTT	Trenton, N.J.	980
†WOST	Sparta, Tenn.	1050	WPPA	Pottsville, Pa.	1360	WSNB	Nashville, Tenn.	650	WTTT	Trenton, N.J.	980
WOSU	Columbus, Ohio	820	WPPA	Pottsville, Pa.	1360	WSNB	Nashville, Tenn.	650	WTTT	Trenton, N.J.	980
WOTW	Nashua, N.H.	900	WPPA	Pottsville, Pa.	1360	WSNB	Nashville, Tenn.	650	WTTT	Trenton, N.J.	980
WOY	New York, N.Y.	1280	WPPA	Pottsville, Pa.	1360	WSNB	Nashville, Tenn.	650	WTTT	Trenton, N.J.	980
WOY	Omaha, Neb.	590	WPPA	Pottsville, Pa.	1360	WSNB	Nashville, Tenn.	650	WTTT	Trenton, N.J.	980
WOYO	Ft. Wayne, Ind.	1190	WPPA	Pottsville, Pa.	1360	WSNB	Nashville, Tenn.	650	WTTT	Trenton, N.J.	980
WOXF	Oxford, N.C.	1340	WPPA	Pottsville, Pa.	1360	WSNB	Nashville, Tenn.	650	WTTT	Trenton, N.J.	980
WPAB	Ponca, P.R.	1370	WPPA	Pottsville, Pa.	1360	WSNB	Nashville, Tenn.	650	WTTT	Trenton, N.J.	980
WPAD	Paducah, Ky.	1450	WPPA	Pottsville, Pa.	1360	WSNB	Nashville, Tenn.	650	WTTT	Trenton, N.J.	980
WPAG	Ann Arbor, Mich.	1050	WPPA	Pottsville, Pa.	1360	WSNB	Nashville, Tenn.	650	WTTT	Trenton, N.J.	980
WPAL	Charleston, S.C.	730	WPPA	Pottsville, Pa.	1360	WSNB	Nashville, Tenn.	650	WTTT	Trenton, N.J.	980
WPAM	Pottsville, Pa.	1450	WPPA	Pottsville, Pa.	1360	WSNB	Nashville, Tenn.	650	WTTT	Trenton, N.J.	980
WPAQ	Mt. Airy, N.C.	740	WPPA	Pottsville, Pa.	1360	WSNB	Nashville, Tenn.	650	WTTT	Trenton, N.J.	980
WPAR	Parkersburg, W. Va.	1450	WPPA	Pottsville, Pa.	1360	WSNB	Nashville, Tenn.	650	WTTT	Trenton, N.J.	980
WPAT	Paterson, N.J.	930	WPPA	Pottsville, Pa.	1360	WSNB	Nashville, Tenn.	650	WTTT	Trenton, N.J.	980
†WPAW	Pawtucket, R.I.	1380	WPPA	Pottsville, Pa.	1360	WSNB	Nashville, Tenn.	650	WTTT	Trenton, N.J.	980
WPAX	Thomasville, Ga.	1240	WPPA	Pottsville, Pa.	1360	WSNB	Nashville, Tenn.	650	WTTT	Trenton, N.J.	980
WPAY	Portsmouth, O.	1400	WPPA	Pottsville, Pa.	1360	WSNB	Nashville, Tenn.	650	WTTT	Trenton, N.J.	980
WPBC	Minneapolis, Minn.	980	WPPA	Pottsville, Pa.	1360	WSNB	Nashville, Tenn.	650	WTTT	Trenton, N.J.	980
WPCF	Panama City, Fla.	1400	WPPA	Pottsville, Pa.	1360	WSNB	Nashville, Tenn.	650	WTTT	Trenton, N.J.	980
WPDQ	Jacksonville, Fla.	600	WPPA	Pottsville, Pa.	1360	WSNB	Nashville, Tenn.	650	WTTT	Trenton, N.J.	980
WPDJ	Clarksville, W. Va.	750	WPPA	Pottsville, Pa.	1360	WSNB	Nashville, Tenn.	650	WTTT	Trenton, N.J.	980
WPEN	Philadelphia, Pa.	850	WPPA	Pottsville, Pa.	1360	WSNB	Nashville, Tenn.	650	WTTT	Trenton, N.J.	980
WPEP	Taunton, Mass.	1570	WPPA	Pottsville, Pa.	1360	WSNB	Nashville, Tenn.	650	WTTT	Trenton, N.J.	980
WPFB	Middletown, O.	910	WPPA	Pottsville, Pa.	1360	WSNB	Nashville, Tenn.	650	WTTT	Trenton, N.J.	980
WPGH	Pittsburgh, Pa.	1080	WPPA	Pottsville, Pa.	1360	WSNB	Nashville, Tenn.	650	WTTT	Trenton, N.J.	980
WPIC	Sharon, Pa.	790	WPPA	Pottsville, Pa.	1360	WSNB	Nashville, Tenn.	650	WTTT	Trenton, N.J.	980
WPIK	Alexandria, Va.	730	WPPA	Pottsville, Pa.	1360	WSNB	Nashville, Tenn.	650	WTTT	Trenton, N.J.	980
WPKT	Pittsburgh, Pa.	730	WPPA	Pottsville, Pa.	1360	WSNB	Nashville, Tenn.	650	WTTT	Trenton, N.J.	980
WPKI	Pikeville, Ky.	1240	WPPA	Pottsville, Pa.	1360	WSNB	Nashville, Tenn.	650	WTTT	Trenton, N.J.	980
†WPKY	Princeton, Ky.	1580	WPPA	Pottsville, Pa.	1360	WSNB	Nashville, Tenn.	650	WTTT	Trenton, N.J.	980
WPLA	Plant City, Fla.	1570	WPPA	Pottsville, Pa.	1360	WSNB	Nashville, Tenn.	650	WTTT	Trenton, N.J.	980
WPLH	Huntington, W. Va.	1450	WPPA	Pottsville, Pa.	1360	WSNB	Nashville, Tenn.	650	WTTT	Trenton, N.J.	980
WPLJ	Jackson, Tenn.	1490	WPPA	Pottsville, Pa.</							

DIRECTORY OF TELEVISION STATIONS BY CALL LETTERS

† Construction permit

Call Letters	City	Frequen- cy in Mc.	Chan- nel	Call Letters	City	Frequen- cy in Mc.	Chan- nel	Call Letters	City	Frequen- cy in Mc.	Chan- nel	Call Letters	City	Frequen- cy in Mc.	Chan- nel
KBTW	Dallas, Texas	180-186	8	WATV	Newark, New Jersey	210-216	13	†WHBF-TV	Rock Island, Illinois	66-72	4	WNBW	Washington, D. C.	66-72	4
KDYL-TV	Salt Lake City, Utah	66-72	4	WAVE-TV	Lexington, Kentucky	76-82	5	WHEN	Syracuse, New York	180-196	8	WNHC-TV	New Haven, Connecticut	82-88	6
KECA-TV	Los Angeles, California	174-180	7	WBAL-TV	Baltimore, Maryland	198-204	11	WHIO-TV	Dayton, Ohio	210-216	13	WOAI-TV	San Antonio, Texas	66-72	4
†KEYL	San Antonio, Texas	76-82	5	WBAP-TV	Fort Worth, Texas	76-82	5	WICU	Erie, Pennsylvania	204-210	12	WOC-TV	Davenport, Iowa	76-82	5
KFI-TV	Los Angeles, California	186-192	9	WBEN-TV	Buffalo, New York	66-72	4	WJAC-TV	Johnstown, Pennsylvania	210-216	13	†WOI-TV	Ames, Iowa	66-72	4
KFMB-TV	San Diego, California	180-186	8	WBKB	Chicago, Illinois	66-72	4	WJAR-TV	Providence, Rhode Island	198-204	11	WOIC	Washington, D. C.	186-192	9
KGO-TV	San Francisco, California	174-180	7	WBNS-TV	Columbus, Ohio	192-198	10	†WJAX-TV	Jacksonville, Florida	54-60	2	WÖR-TV	New York, New York	186-192	9
KING-TV	Seattle, Wash.	76-82	5	WBRC-TV	Birmingham, Alabama	66-72	4	WJBK-TV	Detroit, Michigan	54-60	2	WOW-TV	Omaha, Nebraska	82-88	6
KLAC-TV	Los Angeles, California	210-216	13	WBTW	Charlotte, North Carolina	60-66	3	†WJIM-TV	Lansing, Michigan	82-88	6	WPIX	New York, New York	198-204	11
KLÉE-TV	Houston, Texas	54-60	2	WBZ-TV	Boston, Massachusetts	66-72	4	WJZ-TV	New York, New York	174-180	7	WPTZ	Philadelphia, Pennsylvania	60-66	3
KMTV	Omaha, Nebraska	60-66	3	WCAU-TV	Philadelphia, Pennsylvania	192-198	10	WKRC-TV	Cincinnati, Ohio	198-204	11	WRGB	Schenectady, New York	66-72	4
KNBH	Los Angeles, California	66-72	4	WCBS-TV	New York, New York	54-60	2	†WKTU	Utica, New York	210-216	13	†WRTV	New Orleans, Louisiana	66-72	4
KOB-TV	Albuquerque, New Mexico	66-72	4	†WCQN-TV	Atlanta, Georgia	54-60	2	WKY-TV	Oklahoma City, Oklahoma	66-72	4	WSAZ-TV	Huntington, West Virginia	76-82	5
KOTV	Tulsa, Oklahoma	82-88	6	WDAF-TV	Kansas City, Missouri	66-72	4	WLAV-TV	Grand Rapids, Michigan	174-180	7	WSB-TV	Atlanta, Georgia	180-186	8
KPHO-TV	Phoenix, Ariz.	76-82	5	WDEL-TV	Wilmington, Delaware	174-180	7	WLWC	Columbus, Ohio	60-66	3	†WSM-TV	Nashville, Tennessee	66-72	4
KPIX	San Francisco, California	76-82	5	WDSU-TV	New Orleans, Louisiana	82-88	6	WLWD	Dayton, Ohio	76-82	5	WSPD-TV	Toledo, Ohio	210-216	13
KRLD-TV	Dallas, Texas	66-72	4	WDTV	Pittsburgh, Pennsylvania	60-66	3	WLWT	Cincinnati, Ohio	66-72	4	†WSYR-TV	Syracuse, New York	76-82	5
KRON-TV	San Francisco, California	66-72	4	WENR-TV	Chicago, Illinois	174-180	7	WMAL-TV	Washington, D. C.	174-180	7	†WTAR-TV	Norfolk, Virginia	66-72	4
KSD-TV	St. Louis, Missouri	76-82	5	WEWS	Cleveland, Ohio	76-82	5	WMAR-TV	Baltimore, Maryland	54-60	2	WTCN-TV	Minneapolis, Minnesota	66-72	4
KSL-TV	Salt Lake City, Utah	76-82	5	WFBM-TV	Indianapolis, Indiana	82-88	6	WMBR-TV	Jacksonville, Florida	66-72	4	WTMJ-TV	Milwaukee, Wisconsin	60-66	3
KSTP-TV	St. Paul, Minnesota	76-82	5	WFIL-TV	Philadelphia, Pennsylvania	82-88	6	WMCT	Memphis, Tennessee	66-72	4	WTTG	Washington, D. C.	76-82	5
KTLA	Hollywood, California	76-82	5	WFMY-TV	Greensboro, North Carolina	54-60	2	WNAC-TV	Boston, Massachusetts	174-180	7	WTTV	Bloomington, Indiana	192-198	10
KTSL	Hollywood, California	44-50	1	WGAL-TV	Lancaster, Pennsylvania	66-72	4	WNB-TV	Binghamton, New York	204-210	12	WTVJ	Miami, Florida	66-72	4
KTTV	Los Angeles, California	198-204	11	WGN-TV	Chicago, Illinois	186-192	9	WNBK	Cleveland, Ohio	66-72	4	WTVN	Columbus, Ohio	82-88	6
WAAM	Baltimore, Maryland	210-216	13	WHAM-TV	Rochester, New York	82-88	6	WNBQ	Chicago, Illinois	76-82	5	WTVR	Richmond, Virginia	82-88	6
WABD	New York, New York	76-82	5	†WHAS-TV	Louisville, Kentucky	186-192	9	WNBT	New York, New York	66-72	4	†WXEL	Parma, Ohio	186-192	9
WAFM-TV	Birmingham, Alabama	210-216	13									WWJ-TV	Detroit, Michigan	66-72	4
WAGA-TV	Atlanta, Georgia	76-82	5									WXYZ-TV	Detroit, Michigan	174-180	7

DIRECTORY OF FM STATIONS BY CALL LETTERS

* Construction permit

Call Letters	Location	Frequen- cy Mcs.	Chan- nel No.	Call Letters	Location	Frequen- cy Mcs.	Chan- nel No.	Call Letters	Location	Frequen- cy Mcs.	Chan- nel No.
KAKC-FM	Tulsa, Okla.	95.5	238	KFOR-FM	Lincoln, Neb.	102.9	275	KOA-FM	Denver, Col.	95.7	239
KALB-FM	Alexandria, La.	96.9	245	KFPW-FM	Fort Smith, Ark.	94.9	235	KOAD	Omaha, Neb.	92.9	225
KARM-FM	Fresno, Calif.	101.9	270	KFSA-FM	Fort Smith, Ark.	107.7	289	KOCY-FM	Oklahoma City, Okla.	94.7	234
KARS	Pasadena, Calif.	98.3	252	KFSD-FM	San Diego, Calif.	94.1	231	KOIN-FM	Portland, Ore.	101.1	266
*KASL-FM	Ames, Iowa	95.5	238	KFUO-FM	Clayton, Mo.	99.1	256	KOKX-FM	Keokuk, Iowa	102.7	274
*KAYL-FM	Storm Lake, Iowa	101.5	268	KFVS-FM	Cape Girardeau, Mo.	95.7	238	KOMA-FM	Oklahoma City, Okla.	105.9	290
KBEE	Modesto, Calif.	103.3	277	KFXD-FM	Nampa, Idaho	101.9	270	KOMO-FM	Seattle, Wash.	98.9	258
*KBX-FM	Muskogee, Okla.	98.5	253	KFYC-FM	Lubbock, Tex.	99.5	258	KONO-FM	San Antonio, Tex.	92.9	225
*KBMA	Beaumont, Tex.	107.9	300	KGAR-FM	Garboden City, Kan.	99.3	257	KOPP-FM	Ogden, Utah	103.9	280
KBMT	San Bernardino, Calif.	99.9	260	KGBS-FM	Harlingen, Tex.	94.7	234	KOTA-FM	Rapid City, S.D.	94.7	234
KBOA-FM	Kennett, Mo.	98.9	255	KGDM-FM	Stockton, Calif.	92.9	225	KOWN	Conway, Ark.	97.7	249
KBON-FM	Omaha, Neb.	98.7	254	KGKB-FM	Tyler, Tex.	101.5	268	KOZY	Kansas City, Mo.	98.1	251
KBTM-FM	Jonesboro, Ark.	101.9	270	KGLO-FM	Mason City, Iowa	101.1	266	KPFA	Berkeley, Calif.	100.1	261
KBUR-FM	Burlington, Iowa	92.9	225	KGNC-FM	Amarillo, Tex.	104.3	282	KPFM	Portland, Ore.	97.1	246
KCBS-FM	Des Moines, Iowa	94.1	231	KGO-FM	San Francisco, Calif.	106.1	281	KPOJ-FM	Portland, Ore.	98.7	254
KCBS-FM	San Francisco, Calif.	103.7	279	KGPS	Grants Pass, Ore.	96.9	245	KPOR	Riverside, Calif.	97.5	248
KCKN-FM	Kansas City, Kan.	106.7	294	KGSF	San Francisco, Calif.	97.3	247	KPRC-FM	Houston, Tex.	102.9	275
KCLE-FM	Cleburne, Tex.	94.3	232	KGWF-FM	Portland, Ore.	100.3	262	KQV-FM	Pittsburgh, Pa.	98.1	251
KCMC-FM	Texarkana, Tex.	98.1	251	KHJ-FM	Los Angeles, Calif.	101.1	266	KRBA-FM	Lufkin, Tex.	95.5	238
KCMO-FM	Kansas City, Mo.	94.9	235	*KHWO	Brownwood, Tex.	105.9	290	KRBC-FM	Abilene, Tex.	96.9	245
KCRS-FM	Sacramento, Calif.	96.1	241	KIDO-FM	Boise, Idaho	106.1	291	KRE-FM	Berkeley, Calif.	102.9	275
KCRC-FM	Enid, Okla.	102.7	274	KIMV	Hutchinson, Kan.	94.5	233	KRED	Eureka, Calif.	96.3	242
KCRK	Cedar Rapids, Iowa	96.9	245	KIRO-FM	Seattle, Wash.	100.7	264	KREI-FM	Farmington, Mo.	100.1	261
KDFC	San Francisco, Calif.	102.1	271	KISS	San Antonio, Tex.	99.5	258	KREL-FM	Goose Creek, Tex.	92.1	221
KDKA-FM	Pittsburgh, Pa.	92.9	225	*KISW	Seattle, Wash.	99.9	260	KRFM	Fresno, Calif.	93.7	229
KDNT-FM	Denton, Tex.	106.3	292	KIXL-FM	Dallas, Tex.	104.5	283	KRIC-FM	Beaumont, Tex.	99.5	258
KDRO-FM	Sedalia, Mo.	99.7	259	KJBS-FM	San Francisco, Calif.	98.9	255	KRKD-FM	Los Angeles, Calif.	96.3	242
KDTH-FM	Dubuque, Iowa	100.5	263	KKLA	San Francisco, Calif.	97.1	249	KRLD-FM	Dallas, Tex.	92.5	225
KDYL-FM	Salt Lake City, Utah	98.7	254	KLCN-FM	Blytheville, Ark.	96.1	241	KRMJ-FM	Shreveport, La.	101.1	266
KECA-FM	Los Angeles, Calif.	95.5	238	KLFD-FM	Longview, Tex.	105.9	290	KRNT-FM	Des Moines, Iowa	104.5	283
KEDZ-FM	Los Angeles, Calif.	93.5	228	KLUF-FM	Galveston, Tex.	97.7	254	KROC-FM	Rochester, Minn.	94.7	234
KENO-FM	Las Vegas, Nev.	103.9	280	KLX-FM	Oakland, Calif.	101.3	267	KRON-FM	San Francisco, Calif.	96.5	243
KERN-FM	Bakersfield, Calif.	94.1	231	KLZ-FM	Denver, Col.	94.1	231	KROS-FM	Clinton, Iowa	96.1	241
KEX-FM	Portland, Ore.	92.3	222	KMAU	Bakersfield, Calif.	92.5	223	*KROY-FM	Sacramento, Calif.	94.5	233
KFAC-FM	Los Angeles, Calif.	104.3	282	KMFM	Los Angeles, Calif.	97.9	250	KRPO	San Jose, Calif.	92.3	222
KFAM-FM	St. Cloud, Minn.	104.7	284	KMGM	Monroe, La.	104.1	281	KSBR	San Bruno, Calif.	100.5	263
KFBK-FM	Sacramento, Calif.	96.9	245	KMH	Los Angeles, Calif.	98.7	254	KSCJ-FM	Sioux City, Iowa	94.9	235
KFDA-FM	Amarillo, Tex.	100.3	262	KMH	Belton, Tex.	97.1	246	KSDO-FM	San Diego, Calif.	96.5	243
KFEL-FM	Denver, Col.	97.3	247	KMJ-FM	Fresno, Calif.	97.9	250	KSEI-FM	Pocatello, Idaho	96.5	243
KFEQ-FM	St. Joseph, Mo.	92.3	222	KMPC-FM	Los Angeles, Calif.	100.3	262	KSEF-FM	Durant, Okla.	107.3	297
KFGQ-FM	Boone, Iowa	99.3	257	KMUS-FM	Muskogee, Okla.	101.5	268	KSFH	San Francisco, Calif.	94.9	237
KFH-FM	Wichita, Kan.	100.3	262	KMYC-FM	Marysville, Calif.	99.9	260	*KSGM-FM	Ste. Genevieve, Mo.	105.7	289
KFI-FM	Los Angeles, Calif.	105.9	290	KNEC-FM	San Francisco, Calif.	99.7	259	KSJO-FM	San Jose, Calif.	95.3	237
*KFLW-FM	Klamath Falls, Ore.	94.5	233	KNEX-FM	McPherson, Kan.	103.1	276	KSL-FM	Salt Lake City, Utah	100.3	262
KFMB-FM	San Diego, Calif.	101.5	268	KNOB	Long Beach, Calif.	103.1	276	KSPI-FM	Stillwater, Okla.	93.9	230
KFMX	Council Bluffs, Iowa	96.1	241	*KNOE-FM	Monroe, La.	103.3	277	KSTP-FM	St. Paul, Minn.	102.1	271
KFMY	Fort Dodge, Iowa	102.7	274	KNX-FM	Los Angeles, Calif.	93.1	226	KTEM-FM	Temple, Tex.	107.5	298

Call Letters	Location	Frequency Mcs.	Channel No.
KTFI-FM	Twin Falls, Idaho	89.7	259
KTIS-FM	Minneapolis, Minn.	103.9	290
KTOW-FM	Tacoma, Wash.	97.3	247
KTOK-FM	Oklahoma City, Okla.	104.3	282
KTRB-FM	Modesto, Calif.	104.1	281
KTRH-FM	Houston, Tex.	101.1	266
KTT5-FM	Springfield, Mo.	94.7	234
KTUL-FM	Tulsa, Okla.	97.1	246
KUGN-FM	Eugene, Ore.	99.1	256
KUOA-FM	Siloam Springs, Ark.	105.7	289
KURV-FM	Edinburg, Tex.	104.9	285
KVCJ	Chico, Calif.	101.1	266
KVEC-FM	San Luis Obispo, Calif.	99.9	260
KVLC-FM	Little Rock, Ark.	94.1	231
KVME	Merced, Calif.	97.5	248
KVNF-FM	Fargo, N. D.	92.3	222
KVOB-FM	Alexandria, La.	99.7	259
KVOE-FM	Santa Ana, Calif.	86.7	244
KVOL-FM	Lafayette, La.	96.1	241
KVRE	Redding, Calif.	103.9	280
KVSO-FM	Ardmore, Okla.	83.7	229
KVWC-FM	Vernon, Tex.	98.7	254
KWBX-FM	Wichita, Kan.	82.1	232
KWFM	San Diego, Calif.	104.1	284
KWFT-FM	Wichita Falls, Tex.	99.9	260
KWLL-FM	Albany, Ore.	101.7	269
KWJJ-FM	Portland, Ore.	95.5	238
KWK-FM	St. Louis, Mo.	98.1	251
KWKH-FM	Shreveport, La.	94.5	233
KWKL-FM	Longview, Wash.	103.9	280
KWNO-FM	Winona, Minn.	97.5	248
KWOC-FM	Bluff, Mo.	94.5	233
KWPC	Jefferson City, Mo.	98.5	253
KWPC-FM	Moscatoe, Iowa	95.9	258
KWRN-FM	Reno, Nev.	95.5	238
KXEL-FM	Waterloo, Iowa	105.7	289
KXOA-FM	Sacramento, Calif.	107.9	300
KXOK-FM	St. Louis, Mo.	93.7	229
KXYZ-FM	Houston, Tex.	96.5	243
KYBS	Dallas, Tex.	107.9	300
KYSM-FM	Mankato, Minn.	103.5	278
KYW-FM	Philadelphia, Pa.	92.5	223
*WAAF-FM	Chicago, Ill.	93.9	230
*WAFB-FM	Newark, N. J.	104.1	284
*WABW-FM	Mobile, Ala.	102.1	271
*WABF	New York, N. Y.	99.5	258
*WABX	Harrisburg, Pa.	100.9	265
*WACE-FM	Chicopee, Mass.	100.3	262
*WAFB-FM	Baton Rouge, La.	104.3	282
*WAFM	Birmingham, Ala.	99.5	258
*WAGA-FM	Atlanta, Ga.	103.3	277
*WAGE-FM	Syracuse, N. Y.	98.5	253
*WAIR-FM	Winston-Salem, N. C.	93.1	226
*WAJL	Flint, Mich.	107.1	287
*WAJR-FM	Morgantown, W. Va.	89.3	237
*WAKR-FM	Akron, Ohio	97.5	248
*WAMS-FM	Wilmington, Del.	96.1	241
*WAND-FM	Canton, O.	92.5	223
*WAPQ-FM	Chattanooga, Tenn.	94.7	234
*WARD-FM	Johnstown, Pa.	105.3	287
*WARL-FM	Arlington, Va.	105.1	286
*WARM-FM	Scranton, Pa.	93.7	229
*WASH	Washington, D. C.	87.1	246
*WATG	Ashland, O.	101.3	267
*WATL-FM	Atlanta, Ga.	97.5	248
*WAXK-FM	Waukesha, Wis.	85.3	237
*WAVU-FM	Albertville, Ala.	105.1	286
*WAVZ-FM	New Haven, Conn.	95.1	236
*WAYS-FM	Charlotte, N. C.	107.7	299
*WAZL-FM	Hazlet, Pa.	97.9	250
*WBAB-FM	Atlantic City, N. J.	100.7	264
*WBAP-FM	Ft. Worth, Tex.	100.5	263
*WBAY-FM	Green Bay, Wis.	102.5	273
*WBBS-FM	Burlington, N. C.	101.1	266
*WBBO-FM	Chicago, Ill.	97.1	246
*WBBC-FM	Forest City, N. C.	93.3	227
*WBCE-FM	Schenectady, N. Y.	101.1	266
*WBCE-FM	Bethesda, Md.	102.1	278
*WBCE-FM	Bay City, Mich.	96.1	241
*WBCE-FM	Pittsfield, Mass.	94.3	232
*WBEN-FM	Buffalo, N. Y.	106.5	293
*WBET-FM	Brockton, Mass.	97.7	249
*WBEB	Bay Shore, N. Y.	107.1	296
*WBEG-FM	Atlanta, Ga.	95.5	238
*WBIB	New Haven, Conn.	100.7	264
*WBIC	Chicago, Ill.	96.3	242
*WBIR-FM	Knoxville, Tenn.	100.3	262
*WBKA-FM	Brockton, Mass.	107.1	296
*WBML-FM	Macon, Ga.	100.7	264
*WBMS-FM	Boston, Mass.	104.1	281
*WBMY	Worcester, Mass.	95.1	236
*WBND	Beloit, Wis.	107.3	297
*WBNU	Aurora, Ill.	103.9	280
*WBNY-FM	Buffalo, N. Y.	92.9	225
*WBOC-FM	Salisbury, Md.	97.5	248
*WBON	Bowling Green, Ky.	101.1	266
*WBOW-FM	Terre Haute, Ind.	101.1	266
*WBXX	Louisville, Ky.	100.7	264
*WBRE-FM	Wilkes-Barre, Pa.	98.5	253
*WBRL	Baton Rouge, La.	98.1	251
*WBSM-FM	New Bedford, Mass.	97.3	247
*WBTT-FM	Charlotte, N. C.	99.9	260
*WBTV-FM	Danville, Va.	97.9	250
*WBUT-FM	Butler, Pa.	103.9	280
*WBUX-FM	Lexington, N. C.	94.3	232
*WBZZ	Bradbury Heights, Md.	96.7	244
*WBYS-FM	Canton, Ill.	100.9	265
*WBZF-FM	Boston, Mass.	92.9	225
*WBZA-FM	Springfield, Mass.	97.1	246
*WBZC	Anderson, S. C.	101.1	266
*WCAE-FM	Pittsburgh, Pa.	96.1	241
*WCAI-FM	Northfield, Minn.	95.7	239
*WCAO-FM	Baltimore, Md.	102.7	274
*WCAP-FM	Asbury Park, N. J.	107.1	296
*WCAR-FM	Pontiac, Mich.	99.5	258
*WCAU-FM	Philadelphia, Pa.	98.1	251
*WCAV-FM	Norfolk, Va.	103.3	277
*WCBC-FM	Anderson, Ind.	106.3	292

Call Letters	Location	Frequency Mcs.	Channel No.
WCBM-FM	Baltimore, Md.	93.1	226
WCBS-FM	New York, N. Y.	101.1	266
WCBS-FM	Rochester, N. Y.	98.5	253
WCED-FM	Dubois, Pa.	102.1	271
WCFC	Beckley, W. Va.	101.3	267
WCFM	Washington, D. C.	99.5	258
WCHA-FM	Chambersburg, Pa.	95.9	240
WCHI	Chicago Heights, Ill.	95.9	246
WCIF-FM	Madisonville, Ky.	104.9	285
WCIL-FM	Carbondale, Ill.	100.7	264
WCLO-FM	Janesville, Wis.	99.9	260
WCLT-FM	Newark, O.	100.3	262
WCMJ-FM	Ashland, Ky.	93.7	229
WCMW-FM	Canton, O.	94.9	235
WCNB-FM	Connersville, Ind.	100.3	262
WCNT-FM	Centralia, Ill.	96.5	243
WCOA-FM	Pensacola, Fla.	98.9	255
WCOD	Richmond, Va.	88.1	251
WCOH-FM	Newman, Ga.	92.3	222
WCOL-FM	Columbus, O.	92.3	222
WCOP-FM	Atlanta, Ga.	98.5	253
WCOP-FM	Boston, Mass.	107.7	294
WCOU-FM	Lowell, Me.	94.9	254
WCOV-FM	Montgomery, Ala.	93.9	230
WCPO-FM	Cincinnati, O.	105.1	286
WCPS-FM	Tarboro, N. C.	104.3	282
WCRS-FM	Greenwood, S. C.	95.7	239
WCSC-FM	Charleston, S. C.	96.9	245
WCST	Columbus, Ind.	93.7	229
WCCT-FM	New Brunswick, N. J.	98.3	252
WCCT	Cincinnati, O.	101.9	270
WCDF-FM	New Castle, Ind.	102.5	213
WCUM-FM	Sparks, Md.	100.9	275
WCUC	Cleveland, Ohio	103.3	277
WCVS-FM	Springfield, Ill.	102.9	275
WDAE-FM	Tampa, Fla.	105.7	289
WDAK-FM	Columbus, Ga.	107.9	300
WDAW-FM	Savannah, Ga.	96.5	243
WDBJ-FM	Roanoke, Va.	94.9	235
WDBO-FM	Orlando, Fla.	92.3	222
WDBQ	Dubuque, Iowa	103.3	277
WDBT	Wilmington, Del.	107.7	294
WDET-FM	Detroit, Mich.	91.9	270
WDHN	New Brunswick, N. J.	93.5	228
*WDLB-FM	Marshfield, Wis.	103.9	280
WDMG-FM	Douglas, Ga.	95.7	239
WDNC-FM	Durham, N. C.	105.1	286
WDOD-FM	Chattanooga, Tenn.	96.5	243
WDRS-FM	Hartford, Conn.	93.7	229
WDSU-FM	New Orleans, La.	105.3	287
WDUN-FM	Gainesville, Ga.	103.9	280
WDVS-FM	Champaign, Ill.	97.5	248
WDXY	Spartanburg, S. C.	101.5	263
WEAU-FM	Eau Claire, Wis.	94.1	231
WEAW	Evansville, Ind.	105.1	286
WEBC-FM	Duluth, Minn.	92.3	222
WEBC-FM	Harrisburg, Ill.	99.9	260
WEBQ-FM	Buffalo, N. Y.	96.9	245
WEED-FM	Rocky Mount, N. C.	92.1	221
WEEL-FM	Boston, Mass.	103.3	277
*WEEL	Erie, Pa.	97.1	246
WEEU-FM	Reading, Pa.	92.9	225
WEEX	Easton, Pa.	98.3	252
WEFM	Chicago, Ill.	95.9	258
WEHS	Chicago, Ill.	97.9	250
WEIM-FM	Fitchburg, Mass.	104.7	286
WELD	Columbus, O.	97.1	246
WELL-FM	New Haven, Conn.	92.1	221
WELL-FM	Battle Creek, Mich.	102.1	261
*WEMB-FM	San Juan, P. R.	101.1	266
WEMP-FM	Milwaukee, Wis.	94.1	231
WENE-FM	Endicott, N. Y.	101.7	269
WENR-FM	Chicago, Ill.	94.7	234
WENY-FM	Elmira, N. Y.	106.9	295
WEOG-FM	Elyria, Ohio	107.3	297
WEPM-FM	Martinsburg, W. Va.	94.3	232
WEQR	Goldsboro, N. C.	93.3	227
WERE-FM	Erie, Pa.	99.9	260
WERE-FM	Cleveland, O.	98.5	253
WESB-FM	Bradford, Pa.	97.5	248
WESC-FM	Greenville, S. C.	92.5	223
WEST-FM	Easton, Pa.	107.9	300
WEWS-FM	St. Louis, Mo.	95.1	236
WEWS-FM	Cleveland, O.	102.1	271
WEXI	Chicago, Ill.	106.3	297
WEXL-FM	Royal Oak, Mich.	97.9	250
WFAA-FM	Dallas, Tex.	97.9	250
WFAH	Alliance, O.	101.7	269
WFAM	Lafayette, Ind.	95.1	236
WFAS-FM	White Plains, N. Y.	103.9	280
WFBC-FM	Greenville, S. C.	93.7	229
WFBG-FM	Altoona, Pa.	103.7	279
WFBL-FM	Syracuse, N. Y.	93.1	226
WFBR-FM	Baltimore, Md.	101.9	270
WFRD	New York, N. Y.	104.3	282
WFHA	New Britain, Conn.	103.7	278
WFHR-FM	Wisconsin Rapids, Wis.	103.3	277
WFIL-FM	Philadelphia, Pa.	102.1	271
WFIN-FM	Findlay, O.	100.5	263
WFJL	Chicago, Ill.	93.1	226
WFJS	Freeport, Ill.	102.5	273
WFLA-FM	Tampa, Fla.	93.3	227
WFLN	Philadelphia, Pa.	95.7	239
WFLY	Troy, N. Y.	92.3	247
WFMA	Rocky Mount, N. C.	100.7	264
WFMB	St. Charles, Mo.	95.5	238
WFMD-FM	Frederick, Md.	101.5	268
WFME	Chicago, Ill.	100.3	262
WFMI	Cullman, Ala.	100.9	265
WFMJ-FM	Youngstown, O.	105.1	286
WFML	Washington, Ind.	106.5	293
WFMN	Alpine, N. J.	93.1	226
WFMR	New Bedford, Mass.	98.1	251
WFMU	Crawfordsville, Ind.	102.9	275
WFMY	Madisonville, Ky.	103.1	276
WFMY	Greensboro, N. C.	97.3	247
*WFMX	La Salle-Peru, Ill.	108.9	295
WFMZ	Allentown, Pa.	100.7	264
WFNC-FM	Fayetteville, N. C.	98.1	251
WFNF	Wethersfield, N. Y.	107.7	299
WFNS-FM	Burlington, N. C.	93.9	230
WFOB	Fostoria, O.	105.5	288

Call Letters	Location	Frequency Mcs.	Channel No.
WFOR-FM	Hattiesburg, Miss.	97.9	250
WFOV	Madison, Wis.	104.9	295
WFGP-FM	Atlantic City, N. J.	96.5	253
WFRQ-FM	Fremont, O.	99.3	257
WFRS	Grand Rapids, Mich.	92.5	223
*WFSS	Coram, L. I. N. Y.	103.1	276
WGAA-FM	Cedartown, Ga.	96.1	241
WGAL-FM	Lancaster, Pa.	101.3	267
WGAU-FM	Athens, Ga.	99.5	258
WGAY-FM	Silver Spring, Md.	102.3	272
WGBE-FM	Columbus, Ga.	95.1	236
WGBG-FM	Greensboro, N. C.	100.3	262
WGBI-FM	Scranton, Pa.	101.3	267
WGBS-FM	Miami, Fla.	96.3	242
WGCH	Greenwich, Conn.	95.9	240
WGCM-FM	Gulfport, Miss.	101.5	268
WGFM	Schenectady, N. Y.	99.5	258
WGH-FM	Newport News, Va.	96.5	243
WGHF	New York, N. Y.	101.9	270
WGKV-FM	Charleston, W. Va.	98.5	253
WGNB	Chicago, Ill.	98.7	254
WGNB-FM	Gastonia, N. C.	101.9	270
WGNR	New Rochelle, N. Y.	93.3	235
WGOR	Ft. Lauderdale, Fla.	100.5	263
WGOV-FM	Valdosta, Ga.	92.5	223
WGPA-FM	Bethlehem, Pa.	95.1	236
WGTF-FM	Atlanta, Ga.	94.1	231
WGTR	Paxton, Mass.	99.1	256
WGUY-FM	Bangor, Me.	93.1	226
WGWR-FM	Asheboro, N. C.	92.3	222
WGYN	New York, N. Y.	97.9	250
WHA-FM	Greenfield, Mass.	98.3	252
WHAS-FM	Louisville, Ky.	99.7	259
WHAT-FM	Philadelphia, Pa.	103.9	283
WHAV-FM	Haverhill, Mass.	92.5	223
WHB-FM	Kansas City, Mo.	102.1	271
WHBC-FM	Canton, O.	94.1	231
WHBF-FM	Rock Island, Ill.	98.9	255
WHBL-FM	Sheboygan, Wis.	100.3	262
WHBS-FM	Huntsville, Ala.	95.1	236
WHCU-FM	Ithaca, N. Y.	97.3	247
WHDF-FM	Boston, Mass.	94.5	233
WHDL-FM	Allegany, N. Y.	95.7	239
WHEC-FM	Rochester, N. Y.	95.5	243
WHFB-FM	Benton Harbor, Mich.	99.9	260
WHFM	Rochester, N. Y.	98.9	255
WHHM-FM	Memphis, Tenn.	106.9	295
*WHIM-FM	Providence, R. I.	99.9	260
WHIO-FM	Dayton, Ohio	99.1	256
*WHIP	Silver Spring, Md.	105.9	290
WHIS-FM	Bluefield, W. Va.	104.5	283
WHK-FM	Cleveland, O.	100.7	264
WHKC-FM	Columbus, O.	98.7	254
WHKY-FM	Hickory, N. C.	102.9	282
WHLD-FM	Niagara Falls, N. Y.	98.5	253
WHLI-FM	Hempstead, L. I., N. Y.	98.3	252
WHMA-FM	Anniston, Ala.	100.5	263
*WHMB	Washington, D. C.	100.3	262
WHNC-FM	H		

FM CALL LETTERS

(Continued from page 507)

Call Letters	Location	Frequency Mcs.	Channel No.
WJPA-FM	Washington, Pa.	104.3	282
WJPF-FM	Herrin, Ill.	98.5	253
WJPG-FM	Green Bay, Wis.	101.1	266
WJPR-FM	Greenville, Miss.	101.9	270
WJR-FM	Detroit, Mich.	96.3	242
WJSW-FM	Altoona, Pa.	96.5	243
WJTN-FM	Jamestown, N. Y.	93.3	227
WJW-FM	Cleveland, O.	104.1	281
WJZ-FM	New York, N. Y.	95.5	238
WKAP-FM	Allentown, Pa.	106.3	292
WKAT-FM	Miami Beach, Fla.	93.1	226
*WKAX-FM	Birmingham, Ala.	97.9	250
WKBN-FM	Youngstown, O.	98.9	255
WKBR-FM	Manchester, N. H.	100.1	261
WKBZ-FM	Muskegon, Mich.	106.5	293
*WKFM	Sandusky, O.	94.5	233
WKID-FM	Urbana, Ill.	103.3	277
WKIL	Kankakee, Ill.	100.7	264
WKJF	Pittsburgh, Pa.	93.7	229
WKJG-FM	Ft. Wayne, Ind.	106.1	291
*WKMH-FM	Dearborn, Mich.	100.3	262
WKNA-FM	Charleston, W. Va.	97.5	248
*WKNE-FM	Keene, N. H.	107.9	300
WKNP	Corning, N. Y.	106.1	291
WKOK-FM	Sunbury, Pa.	94.1	231
WKPT-FM	Kingsport, Tenn.	98.5	253
WKRG-FM	Mobile, Ala.	99.9	260
WKRS-FM	Waukegan, Ill.	106.7	294
WKRT-FM	Cortland, N. Y.	99.9	260
WKST-FM	New Castle, Pa.	101.1	266
WKWK-FM	Wheeling, W. Va.	97.3	247
WKY-FM	Oklahoma City, Okla.	98.9	255
WKYC	Paducah, Ky.	93.3	227
WLAB	Lebanon, Pa.	104.1	281
WLAG-FM	LaGrange, Ga.	104.1	281
WLAL	Lakewood, O.	104.9	285
WLAN-FM	Lancaster, Pa.	96.9	245
WLAV-FM	Grand Rapids, Mich.	96.9	245
WLAW-FM	Lawrence, Mass.	93.7	229
WLBB-FM	Mattoon, Ill.	96.9	245
WLBR-FM	Lebanon, Pa.	100.1	261
WLCS-FM	Baton Rouge, La.	101.1	266
WLDM	Detroit, Mich.	95.5	238
WLDS-FM	Jacksonville, Ill.	100.5	263
WLEE-FM	Richmond, Va.	102.9	275
*WLET-FM	Toccoa, Ga.	106.1	291
WLEU-FM	Erie, Pa.	97.9	250
WLEY	Elmwood Park, Ill.	107.1	296
*WLFM	Pittsburgh, Pa.	96.9	245
WLIN-FM	Merrill, Wis.	100.7	264
WLIV	Providence, R. I.	107.7	299
WLLH-FM	Lowell, Mass.	99.5	258
WLOG-FM	Logan, W. Va.	103.3	277
WLOK-FM	Lima, O.	103.3	277
WLOS-FM	Asheville, N. C.	104.3	282
WLPM-FM	Suffolk, Va.	107.7	299
WLRD	Miami Beach, Fla.	93.9	230
WLTN	Lynchtown, Pa.	97.9	250
WLVA-FM	Lynchburg, Va.	97.5	248
WLWA	Cincinnati, O.	101.1	265
WLWB	Dayton, O.	97.5	248
WLWF	Columbus, O.	96.3	242
WLYC	Williamsport, Pa.	105.1	286
WLYN-FM	Lynn, Mass.	105.5	288
WMAL-FM	Washington, D. C.	107.3	279
WMAQ-FM	Chicago, Ill.	101.1	266
WMAR-FM	Baltimore, Md.	97.9	250
WMAS-FM	Springfield, Mass.	94.7	234
WMAZ-FM	Macon, Ga.	99.1	256
WMBD-FM	Peoria, Ill.	92.5	223
WMBH-FM	Joplin, Mo.	96.1	241
WMBI-FM	Chicago, Ill.	95.5	238
WMBO-FM	Auburn, N. Y.	96.1	241
WMBR-FM	Jacksonville, Fla.	96.1	241
WMBS	Uniontown, Pa.	105.7	289
WMCA-FM	New York, N. Y.	92.3	222
WMCF	Memphis, Tenn.	99.7	259
WMCK-FM	McKeesport, Pa.	104.9	285
WMCP	Baltimore, Md.	94.7	234
WMFD-FM	Wilmington, N. C.	96.3	242
WMFM	North Adams, Mass.	97.5	248
WMFR-FM	High Point, N. C.	99.5	258
WMGM-FM	New York, N. Y.	100.3	262
WMGW-FM	Meadville, Pa.	100.3	262
WMIN-FM	St. Paul, Minn.	99.5	258
WMIT	Charlotte, N. C.	106.9	295
WMIX-FM	Mt. Vernon, Ill.	94.1	231
WMLL	Evansville, Ind.	94.5	233

Call Letters	Location	Frequency Mcs.	Channel No.
WMLN	Mt. Clemens, Mich.	106.3	292
WMMW-FM	Meriden, Conn.	95.7	239
WMOH-FM	Hamilton, O.	103.5	278
WMOR	Chicago, Ill.	102.7	274
WMOT	Pittsburgh, Pa.	94.5	233
WMOX-FM	Meridian, Miss.	98.5	253
WMRC-FM	Greenville, S. C.	94.9	235
WMRI	Marion, Ind.	106.9	295
*WMRN-FM	Marion, O.	106.9	295
WMSA-FM	Massena, N. Y.	105.3	287
*WMSL-FM	Decatur, Ala.	92.5	223
WMUN	Muncie, Ind.	104.1	281
WMUR-FM	Manchester, N. H.	95.7	239
WMUS-FM	Muskegon, Mich.	100.5	263
*WMVA-FM	Martinsville, Va.	96.3	242
WNAC-FM	Boston, Mass.	98.5	253
WNAE-FM	Warren, Pa.	92.1	221
WNAM-FM	Neenah, Wis.	98.5	253
WNAO-FM	Raleigh, N. C.	96.1	241
WNAV-FM	Annapolis, Md.	99.1	256
WNBC-FM	New York, N. Y.	97.1	246
WNBFF-FM	Binghamton, N. Y.	100.5	263
WNDB-FM	Daytona Beach, Fla.	94.5	233
WNDR-FM	Syracuse, N. Y.	102.5	273
WNEX-FM	Macon, Ga.	96.9	245
WNHC-FM	New Haven, Conn.	99.1	256
WNIQ	Uniontown, Pa.	106.5	293
WNJR-FM	Newark, N. J.	102.7	274
WNLC-FM	New London, Conn.	99.5	258
*WNOI	Oak Park, Ill.	102.3	272
WNOW-FM	York, Pa.	105.7	289
WNYC-FM	New York, N. Y.	93.9	230
WQAK	Oak Park, Ill.	98.3	252
WQAP-FM	Owosso, Mich.	103.1	276
WQAY-FM	Oak Hill, W. Va.	94.1	231
WOC-FM	Davenport, Iowa	103.7	279
WOCB-FM	West Yarmouth, Mass.	94.3	232
WOHS-FM	Shelby, N. C.	98.1	241
WOKZ-FM	Alton, Ill.	99.9	260
WOLF-FM	Washington, D. C.	98.7	254
*WOLS-FM	Florence, S. C.	106.1	291
WOMI-FM	Owensboro, Ky.	92.5	223
WOOK-FM	Silver Spring, Md.	95.9	240
WOPI-FM	Bristol, Tenn.	96.9	245
WOPT-FM	Oswego, N. Y.	104.7	284
WOR-FM	New York, N. Y.	98.7	254
WOSH-FM	Oshkosh, Wis.	92.9	225
WOTW-FM	Nashua, N. H.	106.3	292
WOWO-FM	Ft. Wayne, Ind.	96.1	241
WPAD-FM	Paducah, Ky.	96.9	245
WPAG-FM	Ann Arbor, Mich.	98.7	254
WPAM-FM	Pottsville, Pa.	95.5	238
WPAP-FM	Parkersburg, W. Va.	106.5	293
WPAT-FM	Paterson, N. J.	103.5	278
WPAY-FM	Portsmouth, O.	104.1	281
WPDX	Clarksburg, W. Va.	95.1	236
WPEN-FM	Philadelphia, Pa.	102.9	275
*WPGH-FM	Pittsburgh, Pa.	102.5	273
WPI-CM	Sharon, Pa.	102.9	275
WPIT-FM	Pittsburgh, Pa.	101.5	268
WPJB	Providence, R. I.	105.1	286
*WPJV	Miami, Fla.	105.1	286
WPLH-FM	Huntington, W. Va.	102.5	273
WPOE	Elizabeth, N. J.	96.7	244
WPPA-FM	Pottsville, Pa.	101.9	270
WPRN	Princeton, Ind.	96.7	244
WPRO-FM	Providence, R. I.	92.3	222
WPTF-FM	Raleigh, N. C.	94.5	233
WQAM-FM	Miami, Fla.	94.9	235
WQAN-FM	Scranton, Pa.	92.3	222
WQDI	Quincy, Ill.	105.1	286
WQXW-FM	Washington, D. C.	103.5	278
WQXR-FM	New York, N. Y.	96.3	242
WRAK-FM	Williamsport, Pa.	100.3	262
WRAL-FM	Raleigh, N. C.	101.5	268
*WRBI	Blue Island, Ill.	94.3	232
WRBL-FM	Columbus, Ga.	93.3	227
WRC-FM	Washington, D. C.	93.9	230
WRCM	New Orleans, La.	97.1	246
WREV	Reidsville, N. C.	102.1	271
*WRFD-FM	Worthington, O.	97.9	250
WRFL	Winchester, Va.	92.5	223
WRFS-FM	Alexander City, Ala.	106.1	291
WRGA-FM	Rome, Ga.	106.5	293
WRGK	Brookfield, Ill.	103.1	276
WRHI-FM	Rock Hill, S. C.	97.5	248
WRJN-FM	Racine, Wis.	100.7	264
WRLD-FM	Lanett, Ala.	102.9	275
*WRMV	Richmond, Va.	92.9	226
WRNL-FM	Richmond, Va.	102.1	271
WRNY-FM	Rochester, N. Y.	97.9	250
WROK-FM	Rockford, Ill.	97.5	248
WROL-FM	Knoxville, Tenn.	97.3	247
WROV-FM	Roanoke, Va.	103.7	279
WROW-FM	Albany, N. Y.	93.9	230
WRR-FM	Dallas, Tex.	101.1	266
WRSW	Warsaw, Ind.	107.3	297

Call Letters	Location	Frequency Mcs.	Channel No.
WRUF-FM	Gainesville, Fla.	104.1	281
WRUN-FM	Utica, N. Y.	105.7	289
WRVB	Richmond, Va.	94.5	233
WRVC	Norfolk, Va.	102.5	273
WRXW	Louisville, Ky.	95.1	236
WRZE	York, Pa.	98.5	253
WSAI-FM	Cincinnati, O.	102.7	274
WSAM-FM	Saginaw, Mich.	98.1	251
WSAN-FM	Allentown, Pa.	99.9	260
WSAP-FM	Portsmouth, Va.	99.7	259
WSAU-FM	Wausau, Wis.	95.5	238
WSAV-FM	Savannah, Ga.	100.3	262
*WSAZ-FM	Huntington, W. Va.	94.3	232
WSB-FM	Atlanta, Ga.	104.5	283
WSBA-FM	York, Pa.	103.3	277
WSBT-FM	South Bend, Ind.	101.3	267
WSFL-FM	Springfield, Mass.	101.9	270
WSGN-FM	Birmingham, Ala.	93.7	229
WSIC-FM	Statesville, N. C.	105.7	289
WSIX-FM	Nashville, Tenn.	97.5	248
WSJS-FM	Winston-Salem, N. C.	104.1	281
WSLB-FM	Ogdenburg, N. Y.	106.1	291
WSLS-FM	Roanoke, Va.	99.1	256
WSM-FM	Nashville, Tenn.	103.3	277
WSMB-FM	New Orleans, La.	102.7	274
WSNJ-FM	Bridgeton, N. J.	98.9	255
WSOC-FM	Charlotte, N. C.	103.5	278
WSOY-FM	Henderson, Ky.	99.5	258
WSOY-FM	Decatur, Ill.	102.1	271
WSPA-FM	Spartanburg, S. C.	98.9	255
WSPD-FM	Toledo, Ohio.	101.5	268
WSPR-FM	Springfield, Mass.	97.9	250
WSRK	Shelbyville, Ind.	101.3	267
WSRS-FM	Cleveland Heights, O.	95.3	237
WSTC-FM	Stamford, Conn.	96.7	244
WSTP-FM	Salisbury, N. C.	106.5	293
WSTV-FM	Steubenville, O.	103.5	278
WSUA-FM	Bloomington, Ind.	103.7	279
WSVA-FM	Harrisonburg, Va.	100.7	264
WSVS-FM	Crewe, Va.	104.7	284
WSYR-FM	Syracuse, N. Y.	94.5	233
WTAD-FM	Quincy, Ill.	99.5	258
WTAG-FM	Worcester, Mass.	96.1	241
WTAL-FM	Tallahassee, Fla.	103.9	280
WTAM-FM	Cleveland, O.	105.7	289
WTAR-FM	Norfolk, Va.	97.3	247
WTAX-FM	Springfield, Ill.	103.7	279
WTBO-FM	Cumberland, Md.	106.9	295
WTCN-FM	Minneapolis, Minn.	97.1	246
WTFM	Tiffin, O.	98.3	252
WTHI-FM	Terre Haute, Ind.	99.9	260
WTHT-FM	Hartford, Conn.	106.1	291
WTIC-FM	Hartford, Conn.	96.5	243
WTJS-FM	Jackson, Tenn.	100.7	264
WTMA-FM	Charleston, S. C.	95.1	236
WTMJ-FM	Milwaukee, Wis.	93.3	227
WTMV-FM	East St. Louis, Ill.	102.5	273
*WTNB-FM	Birmingham, Ala.	106.9	295
WTNC-FM	Thomasville, N. C.	98.3	252
WTOA	Trenton, N. J.	97.5	248
WTOC-FM	Savannah, Ga.	97.3	247
WTOL-FM	Toledo, O.	104.7	284
WTOP-FM	Washington, D. C.	96.3	242
WTPS-FM	New Orleans, La.	95.7	239
*WTQS	Evanston, Ill.	107.9	300
WTRC-FM	Elkhart, Ind.	100.7	264
WTRF-FM	Bellaire, O.	100.5	263
WTRI	Troy, N. Y.	102.7	274
WTRT	Toledo, O.	99.9	260
WTSP-FM	St. Petersburg, Fla.	102.5	273
WTSV-FM	Claremont, N. H.	106.1	291
WTTH-FM	Port Huron, Mich.	99.1	256
WTWO	Dayton, O.	104.7	284
WVJ-FM	Lockport, N. Y.	99.3	257
WVBN	Highmarket, N. Y.	107.7	299
WVBT	South Bristol, N. Y.	101.9	270
WVCN	De Ruyter, N. Y.	105.1	286
WVCV	Cherry Valley, N. Y.	101.9	270
WVJS-FM	Owensboro, Ky.	96.1	241
WVKO	Columbus, O.	94.7	234
WVUN	Chattanooga, Tenn.	98.1	251
*WVVW-FM	Fairmont, W. Va.	92.3	222
WVCF	Greenfield, Wis.	94.9	235
WVDC-FM	Washington, D. C.	101.1	266
WVHG-FM	Hornell, N. Y.	105.3	287
WVJ-FM	Detroit, Mich.	97.1	246
WVLI	New Orleans, La.	100.3	262
WVNI	Wabash, Ind.	97.5	248
WVNY-FM	Watertown, N. Y.	100.5	263
WVOD-FM	Lynchburg, Va.	100.1	261
WVOL-FM	Buffalo, N. Y.	104.1	281
WVON-FM	Woonsocket, R. I.	105.5	288
WVWP-FM	Miami, Fla.	101.5	268
WVWP-FM	Palm Beach, Fla.	97.9	250
WVST-FM	Wooster, O.	104.5	283
WVSW-FM	Pittsburgh, Pa.	94.5	233
WVVA-FM	Wheeling, W. Va.	98.7	254
WVXH	Cambridge, Mass.	96.9	245
WVXW-FM	Albany, N. Y.	95.5	238
WVXW-FM	Indianapolis, Ind.	94.7	234
WVXJ	Plainfield, N. J.	103.9	280
WVXK	Buffalo, N. Y.	103.3	277
WVXR	Chicago, Ill.	101.9	270
WVYZ-FM	Detroit, Mich.	101.1	266

International Broadcasting Stations of the United States

Authorized by FCC as of January 1, 1950

Note: These U. S. shortwave stations, operated under contract by the Government, are programmed by the International Broadcasting Division, Office of International Information, Department of State. (Under the 1947 fiscal year Appropriations Act, private licensees are permitted to program their stations up to 25% of the broadcast time.)

Call Letters	Licensee and Transmitter Location	Frequency in mc.	Power in Watts	Call Letters	Licensee and Transmitter Location	Frequency in mc.	Power in Watts
KWID	The Associated Broadcasters Inc. San Francisco, Cal.	6.06, 7.23, 9.57, 11.87, 15.29, 17.76, 21.61	100,000	WBOS	Westinghouse Radio Stations Inc. Hull, Mass.	6.14, 9.57, 11.87, 15.21, 17.78, 21.54	50,000
KWIX	The Associated Broadcasters Inc. San Francisco, Cal.	6.06, 7.23, 9.57, 11.87, 15.29, 17.76, 21.61	50,000	WRUA	World Wide Broadcasting Corp. Scituate, Mass.	6.04, 9.7, 11.73, 15.35, 17.75, 21.46	50,000
KCBA	Columbia Broadcasting System Inc. Delano, Cal.	50,000	WRUL	World Wide Broadcasting Corp. Scituate, Mass.	6.04, 11.73, 11.79, 15.13, 15.35, 17.75, 21.46	50,000
KCBF	Columbia Broadcasting System Inc. Delano, Cal.	50,000	WRUS	World Wide Broadcasting Corp. Scituate, Mass.	6.04, 9.7, 11.73, 15.35, 17.75, 21.45	50,000
KCBR	Columbia Broadcasting System Inc. Delano, Cal.	200,000	WRUW	World Wide Broadcasting Corp. Scituate, Mass.	9.7, 11.73, 11.79, 15.13, 15.35, 17.75, 25.3	20,000
WCBN	Columbia Broadcasting System Inc. Brentwood, L. I., New York	6.12, 6.17, 9.65, 11.83, 15.27, 17.83, 21.52, 21.57	50,000	WRUX	World Wide Broadcasting Corp. Scituate, Mass.	7,000
WCBX	Columbia Broadcasting System Inc. Brentwood, L. I., New York	6.03, 6.12, 6.17, 9.65, 11.83, 15.27, 17.83, 21.52, 21.57	50,000	CANADA			
WCDA	Columbia Broadcasting System Inc. Brentwood, L. I., New York	6.08, 6.12, 6.17, 9.65, 11.83, 15.27, 17.83, 21.52, 21.57	10,000	Call Letters	Licensee and Transmitter Location	Frequency in mc.	Power in Watts
WABC	Columbia Broadcasting System Inc. Brentwood, L. I., New York	6.06, 6.12, 6.17, 9.65, 11.83, 15.27, 17.83, 21.52, 21.57	50,000	CBNX	Canadian Broadcasting Corp., St. John's, Newfoundland.	5.97	300
WOOC	Columbia Broadcasting System Inc. Wayne, N. J.	6.12, 6.17, 9.65, 11.83, 15.27, 17.83, 21.52, 21.57	50,000	CFCX	Canadian Marconi Co., Montreal, Que.	6.005	75
WOOW	Columbia Broadcasting System Inc. Wayne, N. J.	6.12, 6.17, 9.65, 11.83, 15.27, 17.83, 21.52, 21.57	50,000	CFRX	Rogers Radio Broadcasting Co. Ltd., Toronto Township of King, Ont.	6.07	1,000
WLWK	The Crosley Corp. Mason, O.	6.08, 9.59, 11.71, 15.25, 17.8, 21.65	50,000	CFVP	Voice of the Prairies Ltd., Calgary, Alta. Strathmore, Alta.	6.03	100
WLWL	The Crosley Corp. Mason, O.	17.8, 21.65, 6.08, 9.59, 11.71, 15.25, 17.8, 21.65	200,000	CHNX	Maritime Broadcasting Co. Ltd., Halifax, N. S. Bedford, N. S.	6.13	500
WLWO	The Crosley Corp. Mason, O.	6.08, 9.59, 11.71, 15.25, 17.8, 21.65	75,000	CJCX	Eastern Broadcasters Ltd., Sydney, N. S. South Bar Road near Sydney, N. S.	6.01	1,000
WLWR	The Crosley Corp. Mason, O.	6.08, 9.59, 11.71, 15.25, 17.8, 21.65	200,000	CKRO	TransCanada Communications Ltd., Winnipeg, Man. Middlechurch, Man.	6.15	2,000
WLWS	The Crosley Corp. Mason, O.	6.08, 9.59, 11.71, 15.25, 17.8, 21.65	200,000	CKRX	TransCanada Communications Ltd., Winnipeg, Man. Middlechurch, Man.	11.72	2,000
KGEE	General Electric Co. Near Belmont, Cal.	6.19, 7.25, 9.53, 9.55, 11.73, 15.21, 15.33	50,000	CKFX	Western Broadcasting Co. Ltd., Vancouver, B. C. Lulu Island, B. C.	6.08	10
KGEX	General Electric Co. Belmont, Cal.	100,000	CBFW	Canadian Broadcasting Corp., Montreal Vercheres, Que.	6.09	7,500
WGEA	General Electric Co. So. Schenectady, N. Y.	6.19, 7, 9.55, 11.8475, 15.33, 21.5, 21.59	50,000	CBFX	Canadian Broadcasting Corp., Montreal Vercheres, Que.	9.61	7,500
WGEO	General Electric Co. So. Schenectady, N. Y.	6.19, 7, 9.53, 11.8475, 15.33	100,000	CBFY	Canadian Broadcasting Corp., Montreal Vercheres, Que.	11.705	7,500
WGEX	General Electric Co. So. Schenectady, N. Y.	25,000	CBFZ	Canadian Broadcasting Corp., Montreal Vercheres, Que.	15.19	7,500
KNBA	National Broadcasting Co. Inc. Near Dixon, Cal.	50,000	CBRX	Canadian Broadcasting Corp., Vancouver, B. C., Lulu Island, B. C.	6.16	150
KNBI	National Broadcasting Co. Inc. Near Dixon, Cal.	50,000	VE9AI	Edmonton Journal Ltd., Edmonton, Alta.	6.005	200
KNBX	National Broadcasting Co. Inc. Near Dixon, Cal.	200,000	VE9AJ	Edmonton Journal Ltd., Edmonton, Alta.	9.54	200
WNBI	National Broadcasting Co. Inc. Bound Brook, N. J.	6.1, 9.67, 11.89, 15.15, 15.19, 17.78, 21.63	50,000 (100,000 on 9.67)	CKOB	Canadian Broadcasting Corp., Montreal Sackville, N. B.	6.09	50,000
WNRA	National Broadcasting Co. Inc. Bound Brook, N. J.	6.1, 9.67, 11.89, 15.15, 15.19, 21.63	50,000	CKLO	Canadian Broadcasting Corp., Montreal Sackville, N. B.	9.63	50,000
WNRE	National Broadcasting Co. Inc. Bound Brook, N. J.	6.1, 9.67, 11.89, 15.15, 15.19, 17.78, 21.63	50,000	CKXA	Canadian Broadcasting Corp., Montreal Sackville, N. B.	11.705	50,000
WNRI	National Broadcasting Co. Inc. Bound Brook, N. J.	6.1, 9.67, 11.89, 15.15, 15.19, 21.63	50,000	CKCX	Canadian Broadcasting Corp., Montreal Sackville, N. B.	15.19	50,000
WNRX	National Broadcasting Co. Inc. Bound Brook, N. J.	6.1, 9.67, 11.89, 15.15, 15.19, 21.63	50,000	CKNC	Canadian Broadcasting Corp., Montreal Sackville, N. B.	17.82	50,000
WRCA	National Broadcasting Co. Inc. Bound Brook, N. J.	6.1, 9.67, 11.89, 15.15, 15.19, 17.78, 21.63	50,000 (100,000 on 9.67)	CHAC	Canadian Broadcasting Corp., Montreal Sackville, N. B.	6.16	50,000
				CHLS	Canadian Broadcasting Corp., Montreal Sackville, N. B.	9.61	50,000
				CHOL	Canadian Broadcasting Corp., Montreal Sackville, N. B.	11.72	50,000
				CHLA	Canadian Broadcasting Corp., Montreal Sackville, N. B.	21.71	50,000
				CKEX	Canadian Broadcasting Corp., Montreal Sackville, N. B.	11.9	50,000
				CBLX	Canadian Broadcasting Corp., Montreal Vercheres, Que.	15.09	7,500
				CBFA	Canadian Broadcasting Corp., Montreal Vercheres, Que.	11.75	7,500
				CBFL	Canadian Broadcasting Corp., Montreal Vercheres, Que.	11.72	7,500
				CBFO	Canadian Broadcasting Corp., Montreal Vercheres, Que.	9.63	7,500
				CKCS	Canadian Broadcasting Corp., Montreal Sackville, N. B.	15.33	50,000
				CKLX	Canadian Broadcasting Corp., Montreal Sackville, N. B.	15.09	50,000
				CKRA	Canadian Broadcasting Corp., Montreal Sackville, N. B.	11.76	50,000
				CEFR	Canadian Broadcasting Corp., Montreal Vercheres, Que.	9.53	7,500
				CKRP	Canadian Broadcasting Corp., Montreal Sackville, N. B.	21.6	50,000
				CKRZ	Canadian Broadcasting Corp., Montreal Sackville, N. B.	6.06	50,000

DIRECTORY OF RADIO STATIONS UNDER NARBA

City	Call Letters	Station and Operator	Frequency in Kc.	Power in Kw.	Class	City	Call Letters	Station and Operator	Frequency in Kc.	Power in Kw.	Class						
BAHAMAS																	
Nassau	ZNS		1540	5.0	I-A												
CUBA																	
Artemisa	CMAR		1170	0.25	II	Havana	CMBZ	Manuel y Guillermo Salas	830	5.0-D	II						
Artemisa	CMAD		680	0.25	II	Havana	CMCB	Radio Metropolitana (Metropolitan Radio de Cuba S. A.)	DA-N 1330	1.0-N 1.0	III-A						
Bayamo	CMKX	Radiodifusion Vidal (Oscar Vidal Benitez)	1390	0.25	IV	Havana	CMCD	La Voz del Aire	740	10.0	II						
Caibarien	CMHD	Manuel Alvarez	1560	5.0	II	Havana	CMCF		910	5.0	III-A						
Camaguey	CMJA	Graceta de Puerto Principe (Rafael Valdes Jimenez)	1060	0.25	II	Havana	CMCG	Union Radio Habana	1420	0.25	IV						
Camaguey	CMJC	Cadena Camagueyana de Radio S. A.	1270	1.0	II	Havana	CMCH		790	5.0-D	III-A						
Camaguey	CMJE	Organizacion Insular de Radio S. A.	1230	0.25	IV	Havana	CMCJ	Rafael Rodriguez	1580	0.25	II						
Camaguey	CMJG		760	1.0		Havana	CMCK	Cia. Editorial "El Crisol" S. A.	980	5.0	III-A						
Camaguey	CMJF		1340	0.25	IV	Havana	CMCM	Radio Cadena Suaritos La Imaculada	1360	0.25	IV						
Camaguey	CMJK	La Voz de El Camagueyana	1150	5.0	III-B	Havana	CMCO	Emisora "Herco-CMCO" (Enrique Lasanta y Oliver)	1230	0.25	IV						
Camaguey	CMJL	Cirquito CMQ	920	5.0	III-A	Havana	CMCQ	Cia Radiodifusion de Public S. A. (Andres Martinez)	1460	0.25	IV						
Camaguey	CMJN	Radio Habana Cuba (Cadena Azul S. A.)	960	1.0	III-A	Havana	CMCR	La Voz Del Caribe (Juan Gonzales y Seneriz)	1580	0.25	II						
Camaguey	CMJW	Andres Moran Cisneros	1440	0.25	IV	Havana	CMCU	Jorge Garcia Serris	1190	5.0	II						
Camajuani	CMHF	Genaro Sabater	1040	0.1-D	II	Havana	CMCW	Ondas Deportivas (Jose Vilarino)	1290	0.25	IV						
Cardenas	CMGE	Luis Marauri Mendoza	1470	0.25	IV	Havana	CMCX	Radio Popular (Jose Custodio Milagro Rumbaut y Lanza)	1060	10.0	II						
Ciego de Avila	CMJH	Bonifacio Idefonso Movales	1470	0.25	IV	Havana	CMCY	Radio Habana Cuba (Cadena Azul S. A.)	590	25.0	II-A						
Ciego de Avila	CMJY		1900			Havana	CMOX	Cia. Electronica S. A.	1490	0.25	IV						
Ciego de Avila	CMJD		1190			Holguin	CMKI		970	1.0	III-A						
Cienfuegos	CMHJ	La Voz de las Villas (Romualdo Ugalde Cordero)	1350	0.25	IV	Holguin	CMKJ		1050	0.25	II						
Cienfuegos	CMHU	Rafael H. Pena y Arruebo	1450	0.25	IV	Holguin	CMKF		730	5.0	II						
Cruces	CMHK	Virgilia Villaneuva	1210	0.25-D	IV	Holguin	CMKG	Cirquito CMQ S. A.	1220	0.25	II						
Encrucijada	New		1090	0.1-N	II	Holguin	CMKO	Manuel Angulo Farran	1330	0.25	IV						
Florida	CMJI	La Voz de la Trocha (Dr. Osvaldo Andres y Moran Anteaiza)	1400	0.25	IV	Holguin	CMKV	Cadena Azul S. A.	600	1.0	III-A						
Guantanamo	CMKA		1250	0.25	IV	Jovellanos	CMGN		960	0.5	III-B						
Guantanamo	CMKH	Luis Coronado Estrado	1130	0.25	II	Manzanillo	CMKE	Cia. Radio Emisora Manzanillo S. A.	1320	0.25	IV						
Guantanamo	CMKS	Candido Savon Suarez	900	0.25	II	Manzanillo	CMKM	Raimundo Comas Dolar Merchán y P. Figueredo	560	0.25	IV						
Havana	CMK	Radiomisa CMK (Fausto Montiel)	1420	0.25	IV	Matanzas	CMGF		1240	0.25	IV						
Havana	CMQ	Cirquito CMQ S. A.	640	25.0	II	Matanzas	CMGW	Ramon A. de Zayas	1440	1.0	III-A						
Havana	CMW	Adolfo Gil y Miguel Troncosa	550	2.5	III-A	Matanzas	CMJQ	Juan Filgueiras Cabaleira	1580	0.25	II						
Havana	CMZ	Radio Emisora CMZ (Cuban Ministry of Education)	1010	10.0	I-B	Nuevitas	CMKZ	Maria Dominguez Doussou	1430	0.25	IV						
Havana	CMBC	Radio Progreso (Domingo Fernandez Cruz)	690	10.0	II	Pinar del Rio	CMAB	Francisco Martinez	1450	0.25	IV						
Havana	CMBD	Luis Perez Garcia	1460	0.25	IV	Pinar del Rio	CMAN	Radio Habana Cuba (Cadena Azul S. A.)	1300	1.0	III-B						
Havana	CMBF	Radio Universal (Cia. Radio Universal S. A.)	950	5.0-D	III-A	Pinar del Rio	CMAQ	Cirquito CMQ S. A.	920	1.0	III						
Havana	CMBG	Union Radio Habana (Raul Chibas)	1390	0.25	IV	Pinar del Rio	CMAW		800	0.25	II						
Havana	CMBH		1560	5.0	II	Placetas	CMHP	Candido de Los Angeles, Guevara Perdomo	1250	0.25	IV						
Havana	CMBL	Radio Cadena Suaritos	860	15.0	II	Pueblo de San Luis	CMKQ		1460	0.5	III-B						
Havana	CMBQ	Sevilla Biltmore (Amleto Battisti)	1150	5.0-D	III-A	Pueblo de San Luis	CMKY	Emisora Comercial (Pedro Zacca Cheda)	1350	0.1	IV						
Havana	CMBS	Enrique Artalejo Fernandez	1090	0.25-D	II	Sagua la Grande	CMHA	Obelardo Menocal	1280	0.25	IV						
Havana	CMBX	Radio Talleres Alvarez (Vicente Espinosa)	1390	0.25	IV	San Cristobal	CMAC	Guillermo Garcia Ovies	1030	0.25-D	II						
Havana	CMBY	Casa de Las Medias (Pages y Cia.)	1120	0.25-D	II	Sancti Spiritus	CMHB	Vicente Weiss (Per.)	1410	0.25	IV						
						Sancti Spiritus	CMHT	Alberto Ruiz Sanchez (Arr.)									
						Sancti Spiritus	CMHT	Juan M. Santana	980	1.0-D	II						
						Santa Clara	CMHI	Radio Habana Cuba (Cadena Azul S. A.)	570	15.0	II-A						
						Santa Clara	CMHM		610	1.0-D	II						
						Santa Clara	CMHO	Organizacion Insular de Radio	1310	1.0	III-A						
						Santa Clara	CMHQ	Cirquito CMQ (Goar Mestre)	630	15.0	II						
						Santa Clara	CMHX	Salvador S. Almanza y Lopez	DA-1	0.25	IV						
						Santa Clara	New		680	0.5-N	II						
						Santiago de Cuba	CMKC	Drs. Nagel Navarra Raca y Raul F. Rubio Catusas	1290	1.0	III-A						
						Santiago de Cuba	CMKL		800	0.25	II						
						Santiago de Cuba	CMKN	Radio Habana Cuba (Cadena Azul S. A.)	930	1.0	III-A						

DIRECTORY OF CANADIAN STATIONS BY CALL LETTERS

CBA.....Sackville, N. B.	CFCY.....Charlottetown, P.E.I.	CHLN.....Three Rivers, Que.	CJCH.....Halifax, N. S.	CKAC.....Montreal, Que.	CKOV.....Kelowna, B. C.
CBF.....Montreal, Que.	CFLD.....London, Ont.	CHLO.....St. Thomas, Ont.	CJCI.....Calgary, Alta.	CKBB.....Barrie, Ont.	CKOX.....Woodstock, Ont.
CBG.....Gander, Nfld.	CFGP.....Grande Prairie, Alta.	CHLP.....Montreal, Que.	CJCS.....Stratford, Ont.	CKBI.....Prince Albert, Sask.	CKOY.....Ottawa, Ont.
CBH.....Halifax, N. S.	CFJL.....Flin Flon, Man.	CHLT.....Sherbrooke, Que.	CJDC.....Dawson Creek, B.C.	CKBL.....Matane, Que.	CKPC.....Brantford, Ont.
CBJ.....Sydney, N. S.	CFJC.....Kamloops, B. C.	CHML.....Hamilton, Ont.	CJEM.....Edmonton, N. B.	CKBW.....Bridgewater, N. S.	CKPG.....Prince George, B.C.
CBK.....Chicoutimi, Que.	CFJM.....Brockville, Ont.	CHNC.....New Carlisle, Que.	CJFP.....Riviere du Loup, Que.	CKCH.....Hull, Que.	CKPR.....Fort William, Ont.
CBK.....Watrous, Sask.	CFNB.....Fredericton, N. B.	CHNO.....Sudbury, Ont.	CJFX.....Antigonish, N. S.	CKCK.....Regina, Sask.	CKRC.....Winnipeg, Man.
CBL.....Toronto, Ont.	CFOR.....Orillia, Ont.	CHNS.....Halifax, N. S.	CJGJ.....Yorkton, Sask.	CKCL.....Truro, N. S.	CKRD.....Red Deer, Alta.
CBM.....Montreal, Que.	CFOS.....Owen Sound, Ont.	CHOK.....Sarnia, Ont.	CJIB.....Vernon, B. C.	CKCR.....Kitchener, Ont.	CKRM.....Regina, Sask.
CBN.....St. John's, Nfld.	CFPA.....Port Arthur, Ont.	CHOV.....Pembroke, Ont.	CJJC.....Sault Ste. Marie, Ont.	CKCV.....Quebec, Que.	CKRN.....Rouyn, Que.
CBQ.....Ottawa, Ont.	CFPL.....London, Ont.	CHRC.....Quebec, Que.	CJJK.....Kirkland Lake, Ont.	CKCW.....Moncton, N. B.	CKRS.....Jonquiere, Que.
CBR.....Vancouver, B. C.	CFPR.....Prince Rupert, B.C.	CHRL.....Roberval, Que.	CJLS.....Yarmouth, N. S.	CKDO.....Oshawa, Ont.	CKSB.....St. Boniface, Man.
CBT.....Grand Falls, Nfld.	CFQC.....Saskatoon, Sask.	CHSJ.....St. John N. B.	CJNB.....North Battleford, Sask.	CKEN.....Kentville, N. S.	CKSF.....Cornwall, Ont.
CBV.....Quebec, Que.	CFRA.....Ottawa, Ont.	CHUB.....Nanaimo, B. C.	CJNT.....Quebec, Que.	CKEY.....Toronto, Ont.	CKSO.....Sudbury, Ont.
CBW.....Winnipeg, Man.	CFRB.....Toronto, Ont.	CHUM.....Toronto, Ont.	CJOB.....Winnipeg, Man.	CKFI.....Fort Francis, Ont.	CKTB.....St. Catharines, Ont.
CBX.....Edmonton, Alta.	CFRC.....Kingston, Ont.	CHVC.....Niagara Falls, Ont.	CJOC.....Lethbridge, Alta.	CKGB.....Timmins, Ont.	CKTS.....Sherbrooke, Que.
CBY.....Corner Brook, Nfld.	CFRN.....Edmonton, Alta.	CHWK.....Chilliwack, B. C.	CJOR.....Vancouver, B. C.	CKLN.....Nelson, B. C.	CKUA.....Edmonton, Alta.
CFAB.....Windsor, N. S.	CFSA.....St. John's, Nfld.	CJAD.....Montreal, Que.	CJOW.....Oshawa, Ont.	CKLW.....Windsor, Ont.	CKVD.....Val d'Or, Que.
CFAC.....Calgary, Alta.	CFST.....St. John's, Nfld.	CJAT.....Trail, B. C.	CJQJ.....Quebec, Que.	CKMO.....Vancouver, B. C.	CKVL.....Verdun, Que.
CFAR.....Flin Flon, Man.	CFST.....St. John's, Nfld.	CJAV.....Port Alberni, B. C.	CJQK.....Moncton, N. B.	CKMR.....Newcastle, N. B.	CKWS.....Kingston, Ont.
CFBC.....St. John, N. B.	CFST.....St. John's, Nfld.	CJCB.....Toronto, Ont.	CJQV.....Vancouver, B. C.	CKNB.....Campbellton, N. B.	CKWX.....Vancouver, B. C.
CFCE.....Montreal, Que.	CFST.....St. John's, Nfld.	CJCB.....Toronto, Ont.	CJRW.....Winnipeg, Man.	CKNW.....New Westminster, B. C.	CKX.....Brandon, Man.
CFCH.....North Bay, Ont.	CFST.....St. John's, Nfld.	CJCB.....Toronto, Ont.	CJSE.....Sorel, Que.	CKNX.....Wingham, B. C.	CKY.....Winnipeg, Man.
CFCN.....Calgary, Alta.	CFST.....St. John's, Nfld.	CJCB.....Toronto, Ont.	CJVI.....Victoria, B. C.	CKOC.....Hamilton, Ont.	VOAR.....St. John's, Nfld.
CFCO.....Chatham, Ont.	CFST.....St. John's, Nfld.	CJCB.....Toronto, Ont.		CKOK.....Penticton, B. C.	VOCM.....St. John's, Nfld.
					VOWR.....St. John's, Nfld.

City	Call Letters	Station and Operator	Frequency in Kc.	Power in Kw.	Class
Santiago de Cuba	CMKR	Jaime Nadal	1090	0.25	II
Santiago de Cuba	CMKU	Cirquito CMQ (Goar Mestre)	850	2.0	II
Santiago de Cuba	CMKW	Ricardo Miranda, Cortez y Raul S. Echevarria	1000	1.0	II
Victoria de las Tunas	CMKG		1490	0.25	IV

NETWORKS OF CUBA

CMQ CIRCUIT: Key station—CMQ Havana.
RADIO HABANA CUBA CADENA AZUL (RHC): Key station—CMCY Havana.

DOMINICAN REPUBLIC

Ciudad Trujillo	HIN	Radiofusoras Nacionales (Partido Dominicano)	1220	0.75	II
Ciudad Trujillo	HIL		790	0.5	III-B
Ciudad Trujillo	HIZ	Radiodifusoras Nacional (Frank Hatton)	1350	1.0	III-B
Ciudad Trujillo	H13T		1040	10.0	II
Ciudad Trujillo	HIG		950	0.25	III-B
Ciudad Trujillo			1500	1.0	III-B
Ciudad Trujillo			690	1.0	II
Ciudad Trujillo			1120	1.0	III-B
Ciudad Trujillo			1170	1.0	II
Ciudad Trujillo			1490	0.2	IV
Fuero Plata	HI2H		1240	0.25	IV
San Cristobal	HI2R		1450	0.2	IV
Santiago	HI9Z		820	0.5	III-B
Santiago	HIIL		1230	0.25	IV

HAITI

Leogane	4VK		1130	50.0	
Leogane	HHK		DA		
Leogane	HHK		1080	25.0	II
Port-au-Prince	HHGM		DA		
Port-au-Prince	HHW	C. Ricardo Widmaier Jr.	1230	0.3	III-A
Port-au-Prince	4VW		1230	0.25	IV
Port-au-Prince	4VGM		DA-N		
Port-au-Prince	4VGM		1470	0.4	IV
Port-au-Prince	4VGM		DA-N		

MEXICO

Acambaro	XEGW	Jose Martinez Ramirez	1270	0.25	IV
Acapulco	XEKJ	Refugio Acosta de Valdivieso (Plaza Alvarez)	1400	0.25	IV
Acapulco	New		1600	0.5	III-B
Acapulco	New		1340	0.25	IV
Acapulco	New		600	1.0	III
Agua Prieta	New		1310	1.0	III
Agua Prieta	New		1490	0.25	IV
Agua Prieta	New		1010	1.0	II
Agua Prieta	New		1360	1.0-D	IV
Agua Prieta	XEBI	Radio Central (Pedro C. Rivas)	1360	1.0-D	IV
Agua Prieta	New		1560	0.25	II
Agua Prieta	New		1170	0.5-D	II
Agua Prieta	XERO	Radio Hidretermopolitana	1490	0.25	IV
Apamtingan	New		1340	0.1	IV
Campeche	XEA	El Echo de las Murallas (Luis A. Maury)	1370	1.0	III-B
Cananea	XEFQ	Pedro L. Diaz	980	0.5	III-B
Casas Grandes	XETX		1400	0.25	IV
Celaya	XENC	El Heraldo del Bajio S. de R. L.	1540	0.25	II
Chihuahua	XEBU	Enriqueta G. de Uranga	1240	0.25	IV
Chihuahua	XEBW	Radio Emisora del Norte	1280	1.0-D	III-B
Chihuahua	XEFI	El Pregonero del Estado de Chihuahua (Ramiro G. Uranga)	1440	1.0	III-B
Chihuahua	XEM	El Heraldo del Norte (Pedro Meneses Jr.)	1390	0.5	III-B
Chihuahua	XERA		1490	0.25	IV
Chihuahua	New		580	1.0-D	IV
Ciudad Camargo	XEOH		1270	0.15	IV
Ciudad Chetumal	XEQZ		1240	0.25	IV
Ciudad Delicias	XEJK		1340	0.25	IV
Ciudad Guzman	New		1430	0.25	IV
Ciudad Juarez	New		1460	1.0	III-B
Ciudad Juarez	XEF	Jose Carlos Amaza	1420	0.25	IV
Ciudad Juarez	XEFV	Dario Cordoba	1240	0.25	IV
Ciudad Juarez	XEJ	La Voz de la Frontera (Pedro Meneses Jr.)	970	5.0	III-A
Ciudad Juarez	XELO	Cia. Radiodifusion de Piedras Negras	800	150.0	I-A
Ciudad Juarez	XEP	La Voz Panamericana (Esteban Parra)	1300	0.5	III-B
Ciudad Juarez	XEWG	Carlos Mendez	1490	0.25	IV
Ciudad Juarez	New		1450		III-B
Ciudad Mante	New		1450	0.15	IV
Ciudad Obregon	XEAP	La Voz del Valle del Yaqui (Emilio Manzanilla)	1290	0.1	IV
Ciudad Obregon	XEOX		1430	1.0-D	III-B
Ciudad Obregon	XEOX		1430	0.5-N	III-B
Ciudad Valles	XETR	Thomas Olivia Bannelos	1490	0.125	IV
Ciudad Victoria	XEBJ	La Voz de Tamarelipas (Fernando Elizalde Ramos)	1340	0.25	IV
Ciudad Victoria	New		1450	0.1	IV
Coatzacoalcos	XEOM		1340	0.25	IV
Colima	XERL	J. Roberto Levy	1280	0.25	IV
Cordoba	XEAG	Diodoro Zuniga	1280	0.5	III-B
Cuautla	New		1400	0.1	IV
Cuernavaca	XEJC	La Voz del Sur (Edwardo Jimenez de la Cuesta)	1420	0.25	IV
Cuernavaca	XEY	Radio Gugambilla de Cuernavaca (Juan Gutierrez Jr.)	980	0.15	IV
Culiacan	XEBL	La Voz del Noroeste (Max Gomey Blanco)	1260	1.0-D	III-B
Culiacan	XECQ		1300	0.5-N	III-B
Culiacan	XESA	La Voz de Sinaloa (Pablos y Elizalde, S. de R. L.)	1360	0.5	III-B

Culiacan	XEGF		1450	0.25	IV
Durango	XEDU	Carlos C. Armas	1400	0.25	IV
Durango	XEE	La Voz de Durango (Jose G. Venezuela)	1280	0.25	IV
Durango	New		1340	0.25	IV
Empalme	XEBQ		1240	0.5-D	IV
Ensenada	XEPF		1400	0.25-N	IV
Fresnillo	XEMA	Jose Miguel Acevedo Moya	1340	0.25	IV
Gomez Palacio	XEFK		1450	0.5-D	IV
Gomez Palacio	XEMG		1310	0.25	IV
Gomez Palacio	XERS		1400	0.25	IV
Guadalajara	XEAD	Radio Economico (Alejandro A. Diaz)	1150	0.125	IV
Guadalajara	XEAV	Radio Guadalajara (Alfredo Vasquez)	580	1.0	III-B
Guadalajara	XEBA		840	0.25-D	II
Guadalajara	XEDG		1370	0.5	III-B
Guadalajara	XEDK	Radio Sonido de Occidente (Salvador Vasquez Tello)	1250	1.0	III-B
Guadalajara	XEHK	Francisco E. Fregoso	960	0.25	IV
Guadalajara	XERP		1190	50.0	I-B
Guadalajara	XEHL	Radio Annunciadora Kist, S. de R. L.	1010	10.0-LS	II
Guadalajara	XEJB	Gobierno del Estado de Jalisco	630	0.5	III-B
Guadalajara	XEJE	Guillermo Johnston	1310	0.25	IV
Guadalajara	XELT	Jose Tostado Lomeli	920	0.25	III-B
Guadalajara	XELW	Radio Occidental (Salvador Galindo de la Torre)	1340	0.25	IV
Guanajuato	XEWZ		610	0.25-D	IV
Guasave	New		1490	0.25	IV
Guaymas	XEDR	El Vocero de Guaymas	1490	0.5-D	IV
Guaymas	XEDR		1490	0.25-N	IV
Hermosillo	XEBH	El Heraldo de Sonora (Carlos Balderrana)	920	5.0-D	III-B
Hermosillo	XEDL	Eufemia Esquer de Vidal	1250	0.5	III-B
Hermosillo	XEHQ	Radio Hermosillo, S. de R. L.	960	0.5	III-B
Hermosillo	XEOP		1540	5.0	II
Hermosillo	XEQN		1580	50.0	II
Hermosillo	New		1250	0.25	IV
Hidalgo del Parral	XEAT	Sucs. Jorge Perez	1490	0.1	IV
Hidalgo del Parral	XEJR	XEW Network (Anastasio Gomez Gallardo)	1490	0.1	IV
Hidalgo del Parral	XEJS		1150	0.5	III-B
Huatabampo	XEHX		1450	0.25	IV
Huamantla	New		1520	0.25-D	II
Iguuala	XEKF		1450	0.25	IV
Irapuato	XEBO	La Voz del Centro de la Republica (Alfonso Martinez)	1330	0.5	III-B
Irapuato	XEWE	Felipe Gallardo	1420	0.1	IV
Jalapa	XEFA		1340	0.25	IV
Jalapa	XEJA	La Voz de las Atenas Veracruzana (Daniel Schacht Perez)	1400	0.25	IV
Jalapa	XEJW	Mariano Caraza	1270	0.25	IV
Jalapa	XEKL	Carlos Ferraz Matos	550	1.0-D	IV
Jalapa	XEJB		580	0.5	III-B
La Barca	New		1090	0.25-D	II
La Paz	XEPX		550	0.25	IV
La Paz	XEAL		580	0.5	III-B
La Paz	XELC		1600	1.0	III-A
Leon	XEFM	La Voz del Comercio (Sucs. R. Ortiz Gonzalez)	1270	0.1	IV
Leon	XELG	Radio Impulsora del Centro S. A.	680	10.0	II
Leon	XERW	Rafael C. Navarro	1390	0.25	IV
Leon	XERZ	XEW Network (Rafael C. Navarro)	1240	0.25	IV
Linares	XER	Radio Linares S. A.	1260	0.25	IV
Los Mochis	XECF	Le Voz del Valle del Fuerte (Francisco Perez H.)	1410	1.0-D	III-B
Magdalena	XEDJ	XEW Network (Enrique Sorolegui)	1450	0.1	IV
Magdalena	XESY		1320	0.2	IV
Magdalena	XEAM	XEW Network (Manuel L. Salinas)	1400	0.25	IV
Matamoros	XEO		970	1.0	III-B
Matamoros	XEXP		1450	0.1	IV
Matamoros	New		1340	0.25	IV
Mazatlan	XEDS	El Heraldo de Sinaloa (Alejandro A. Schober)	1420	1.0-D	III-B
Mazatlan	XETK	Radio Emisora Occidental S. de R. L.	1390	0.5-N	III-B
Mazatlan	XERJ		1320	0.5-N	III-B
Mazatlan	XERJ		1320	1.0-D	III-B
Progreso	New		1400	0.25	IV
Puebla	XECD	Ricardo Vazquez A. Costa	1170	0.35	II
Puebla	XEHR	Heraldo Angelopeditano (Manuel R. Canale)	1090	0.25	II
Queretaro	XEJX	Radiomisorra Queretaro	1450	0.25	IV
Queretaro	New		1520	1.0-D	II
Queretaro	New		1570	1.0-D	II
Queretaro	XERT		590	5.0-D	IV
Reynosa	New		1390	1.0	III-B
Rosario	XERB		1090	50.0	I-B
Rosario	XERB		1090	50.0	I-B
Sabinas	XEBX		610	0.5	III-B
Sahuayo	XEGC		1450	0.25	IV
Salamanca	XERX		970	0.5	III-B
Saltillo	XEDE	Blas Narro Dunn	1400	0.25	IV
Saltillo	XEKS	Elfrain Lopez	1330	0.1	IV
Saltillo	XESJ	La Llamada de la Cultura (Froilan Mier Narro)	1250	1.0-D	III-B
Saltillo	XEXU	Rafael Caranza	1490	0.1	IV
Saltillo	New		920	0.25	IV
San Andres Tuxtla	New		1400	0.25	IV
San Luis Potosi	XEBM	Benjamin Briones	920	1.0	III-B
San Luis Potosi	XECZ	La Voz de la Mesa Central (Zeferino Z. Jimenez)	1430	1.0	III-A
San Luis Potosi	XESL	Josefina Delegado	1340	0.1	IV
San Luis Potosi	XEXQ		1460	0.25	IV
San Luis Potosi	XELX		1120	0.25-D	II
San Luis Potosi	XEPO		1400	0.1	IV
San Luis Potosi	XEWA		540	150.0	I-A
San Luis Rio Colorado	XEYI	Lucinda Arenaxde de Maza Millan	1450	0.25	IV

(Continued on page 512)

RADIO STATIONS UNDER NARBA

(Continued from page 511)

City	Call Letters	Station and Operator	Frequency in Kc.	Power in Kw.	Class
San Miguel	XESQ		1280	0.1	IV
Allende					
San Pedro	XESP		1400	0.25	IV
Tlaquepaque					
Santa Ana	XEAB		1400	0.25	IV
Santa Ana	New		1240	0.25	IV
Santa Barbara	XESB		1400	0.15	IV
Santa Rosalia	New		560	0.1	IV
Santa Rosalia	New		1320	0.5	III-B
Tala	New		550	0.15	IV
Tampico	XECA	El Vocero de Tampico (Nicolas M. Picot)	980	1.0	III-B
Tampico	XEFW	La Voz de Tampico	810	50.0	II
Tampico	XES	The Voice of Mexico From Tampico	1240	0.25	IV
Tampico	XETO	Radio Tiempo S. de R. L. de C. V.	1400	0.25	IV
Tampico	XETU	Impulsora Moderna del Radio, S. A.	1460	1.0	III-A
Tapachula	XETS	Wadley Dominguez Correa	630	0.5-D	IV
Tecate	New		1590	0.25-N	III
Tecate	New		580	0.25	IV
Tehuacan	XEWJ		1420	0.25	IV
Tehuacan	New		1520	0.25	II
Tepic	XERK	El Echo del Pacifico desde Tepic, Nayarit (Dario Mondragon)	1380	0.5	III-B
Tepic	XEXT	Gobierno del Estado de Nayarit	980	1.0	III-A
Tijuana	XEAC	Jorge I. Rivera	690	5.0	II
Tijuana	XEAU	Radio Panamericana (Manuel Acuna Varela)	1470	5.0	III-A
Tijuana	XEAZ		1270	0.5	III-B
Tijuana	XEBG	Roberta Salazan	1550	1.0	II
Tijuana	XEC	Luis E. Enicisco	1310	0.25	IV
Tijuana	XEGM	Gustavo Faist Fernandez	950	2.5	III-A
Tijuana	XEMO	Fernando Frederico Ferreira	860	5.0	II
Tijuana	XEXX	Cia. Radio Mexicana	1420	2.0	III-A
Tijuana	New		800	0.5-D	II
Toluca	XECH	Rodolfo Llamas	1490	0.25	IV
Merida	XEFC	La Voz de Yucatan desde Merida (Rafael Rivas Franco)	1330	0.6	III-B
Merida	XEME	XEW Network (Perfecto Villamil Cicero)	1270	0.5	III-B
Merida	XEMH		1490	0.25	IV
Merida	XEMQ	Lazaro Achurra Suarez	1240	0.25	IV
Merida	XEZ	La Voz de la Peninsula (Jorge L. Palomeque)	600	2.0	III-A
Merida	XEQW		1450	0.25	IV
Mexicali	New		940	0.25-D	II
Mexicali	XEAA	La Voz de los Valles (Consuelo T. Eguia)	1340	0.25	IV
Mexicali	XEAO	Juan C. Chavez	910	0.25	IV
Mexicali	XECL	Alfonso A. Lacarra	990	5.0	II
Mexicali	XED		1050	5.0-D	II
Mexico City	XEB	El Buen Tono, S. A.	1220	100.0	I-A
Mexico City	XEK	Arturo Martinez	970	1.0-D	III-B
Mexico City	XEL	Fidel Hernandez Calderon	1260	5.0-D	III-B
Mexico City	XEN	Radio Mundial	690	5.0	II
Mexico City	XEQ	Radio Panamericana	940	150.0-D	I-B
Mexico City	XEW	Cadena Radiodifusora Mexicana	900	250.0	I-A
Mexico City	XEX		730	500.0	I-A
Mexico City	XEAI	Carmen Gutierrez	1320	1.0	III-B
Mexico City	XEBS	Hispano Mexicano	1410	1.0	III-B
Mexico City	XEBZ	El Vocero Mexicano	660	0.5	II
Mexico City	XEDA		1030	1.0	II
Mexico City	XEDP		1290	50.0	III-A
Mexico City	XEFO	Cadena Radio Nacional	1110	20.0	II
Mexico City	XEJP	Vocero de los Productos Dandy (Delia Cubielas de Fernandez)	1150	1.0-D	III-B
Mexico City	XELA	Radio Metropolitana	830	1.0	II
Mexico City	XELZ	La Voz de la Industria Nacional (Marie Cardora de Zetina)	1440	5.0-D	III-A
Mexico City	XEMC	Delores G. Estrada de Ferreiro	1500	5.0	III-A
Mexico City	XEML	Robert Valezzi Esparza	1550	20.0	I-B
Mexico City	XEMX	Guillermo Robles	1380	5.0	III-B
Mexico City	XENK	Gral. Brig. Ferrando Prool Pardo	620	5.0	III-A
Mexico City	XEOF		560	1.0	III-B
Mexico City	XEOY	Fomento de Radio, S. A.	1000	50.0	I-B
Mexico City	XEPH	Padro Riestra Diaz	590	5.0	III-A
Mexico City	XEQK	Guillermo Morales B.	1350	1.0	III-A
Mexico City	XEQR	Corporacion Mexicana de Radio, S. A.	1030	1.0	II
Mexico City	XERC	Radio Difusora Commercial (Radio Popular de Mex., S. A.)	790	1.0	III-A
Mexico City	XERH	Sal de Uvas Picot (Arse S. A.)	1500	5.0-D	II
Mexico City	XESM	Salvador San Martin	1470	5.0	III-A
Mexico City	XEUN		860	5.0	II
Minatitlan	XEDW		1260	0.25	IV
Monclova	XEMF		1260	0.25	IV
Monclova	XEKN		1390	0.5	III-B
Monterrey	New		1560	0.5-D	II
Monterrey	XEOK		950	0.5-D	III
Monterrey	XEAR	Radio Tiempo, S. de R. L.	1450	0.25	IV
Monterrey	XEAW	Jesus D. Gonzales	1280	1.0-D	III-B
Monterrey	XEFB	La Voz del Norte de Mexico (Emisoras Incorporadas de Monterrey)	630	5.0-D	III-B
Monterrey	XEG	La Voz de Norteamerica, S. A.	1050	150.0	I-A
Monterrey	XEH	Radio Ta'navá	1420	1.0	III-A
Monterrey	XEMR	Henrique Serna Martinez	1370	0.5	III-B

City	Call Letters	Station and Operator	Frequency in Kc.	Power in Kw.	Class
Monterrey	XET	El Pregonero del Norte, S. A.	990	5.0	II
Montemorelos	XEMS		1310	0.25-D	IV
Morelia	XEI	Tiburecio Ponce	1400	0.25	IV
Morelia	XELQ	Radio Commercial Michoacana (Francisco Lario Iturbido)	570	1.0	IV
Morelia	XESF	Jose Martinez Ramirez	1300	0.5	III-B
Naco	XETM	El Herald de la Frontera (Jesus Manuel Franco)	1350	1.0	III-B
Navojoa	XEAJ	El Pregonero de Mayo (Emilio Manzanilla)	1400	0.1	IV
Navojoa	XEGL	XEW Network (Fausto M. Gomez)	1270	0.5	III-B
Nogales	XEHF	XEW Network (Gaster Mascarenas)	1370	5.0	III-A
Nogales	XENS		1590	5.0	III-A
Nuevo Laredo	XEAS		1410	0.25	IV
Nuevo Laredo	XEBK	M. M. Cortes	1340	0.1	IV
Nuevo Laredo	XEDF	Ruperto Villarreal	790	1.0-D	III-B
Nuevo Laredo	XEFE	La Voz de la Frontera (Rafael T. Carranza)	960	1.0	III-A
Nuevo Laredo	XENT	Cia. Industrial Universal, S. A.	1140	50.0	I-B
Nuevo Laredo	New		1090	0.25-D	II
Nuevo Laredo	XERN		1430	0.1	IV
Neuva Rosita	XELF		1380	0.25	IV
Oaxaca	New		1240	0.25	IV
Oaxaca	XEAX	XEW Network (Alvaro Rodriguez A.)	1270	0.5	III-B
Ocotlan	New		800	0.25	II
Orizaba	XEPP	La Voz de Orizaba (Radio Impulsora Orizabena)	1450	0.25	IV
Orizaba	XETQ	Mensajero del Progreso Orizabena (Francisco Campos H.)	1370	0.25	IV
Pachuca	XEPK	Radio Publicidad de Pachuca S. A.	1180	5.0-D	II
Piedras Negras	XEMJ	Jesus F. Elizalde	920	0.5-D	IV
Piedras Negras	XEMU	Alfonso L. Bres Piedras Negras, S. A.	580	5.0-D	III-B
Torreón	XEBP	La Voz de la Laguna (Alejandro O. Stevenson Jr.)	1260	1.0-D	IV
Torreón	XEDN		800	1.0	III-B
Torreón	XEOB		1490	0.1	IV
Torreón	XETB	El Heraldo de Torreón	1350	5.0-D	III-B
Tuxpan	XETL	La Voz de la Haulticas (Calixto Almazan)	1390	1.0	III-B
Tuxpan	New		1340	0.25	IV
Tuxtla Gutierrez	XEON		920	1.0-D	III-B
Uruapan	XEUF	Ignacio Navarro	610	0.5	III-B
Veracruz	XEHV	Radiodifusora Veracruzana (Juan A. Palavincini)	1310	1.0	III-A
Veracruz	XELL	Delores G. Estrada de Ferreiro	1430	0.25	IV
Veracruz	XELR		610	0.1	IV
Veracruz	XETF	La Voz de Veracruz (Jose Rodriguez Lopez)	1250	0.5	III-B
Veracruz	XEU	Fernando Pazos Sosa	960	0.5	III-B
Veracruz	New		1490	0.1	IV
Villa Acuna	XEAE		1600	5.0	III-A
Villa Acuna	XEDH	Vincente Hernandez	1340	0.25	IV
Villa Acuna	XERF		1570	150.0	I-A
Villa Acuna	New		570	0.5-D	II
Villahermosa	XEVV	Ernesto E. Trujillo Gurrío	970	0.5	III-B
Zacatecas	XELK	Jose Macias Guerrero y Acevedo	1280	0.25	IV
Zacatecas	New		1450	0.25	IV
Zamora	XEZM		1480	0.25	III-A
Zamora	XEGT	Radio Zamora	1270	0.25	IV
Zopopan	New		760	0.5-D	II
Zitacuaro	XETA		760	0.25-D	II

NETWORKS OF MEXICO

XEW NETWORK: 80 affiliates. Key station—XEW Mexico City.
 RADIO MIL NETWORK: 13 affiliates. Key station—XEOY Mexico City.
 XEB NETWORK: 12 affiliates. Key station—XEB Mexico City.
 XEQ NETWORK: 35 affiliates. Key station—XEQ Mexico City.
 RADIO PROGRAMS DE MEXICO: 24 affiliates.

TRADE ORGANIZATION

Camara Nacional de la Industria Radiodifusion, Paseo de la Reforma No. 35, Despacho 1, Mexico City.

LABOR GROUPS

Sindicato de Anunciadores y Empleados de Radiodifusoras.
 Sindicato de Filarmónicos y Artistas de Radio.

NEWFOUNDLAND

Broadcasting Corp. of Newfoundland

Corner Brook	CBY		790	1.0	III-A
Fort Pepperrell	VOUS		1480	0.5	III-B
Gander	CBG		1450	0.25	IV
Grand Falls	New		1350	1.0	III-A
Harmon Field	VOHF		1490	0.05	IV
St. Johns	VOAR	(5 hrs. wkly.)	1230	0.1	IV
St. Johns	VOCM		1000	0.25	II
St. Johns	CBN		640	10.0	I-B
St. Johns	VOWR	(4 hrs. Sun. only)	700	0.5	II

LABRADOR

Goose Bay	VOUG		1340	0.25	IV
-----------	------	--	------	------	----

MEXICO

THE NEW SALES FRONTIER IS SOUTH

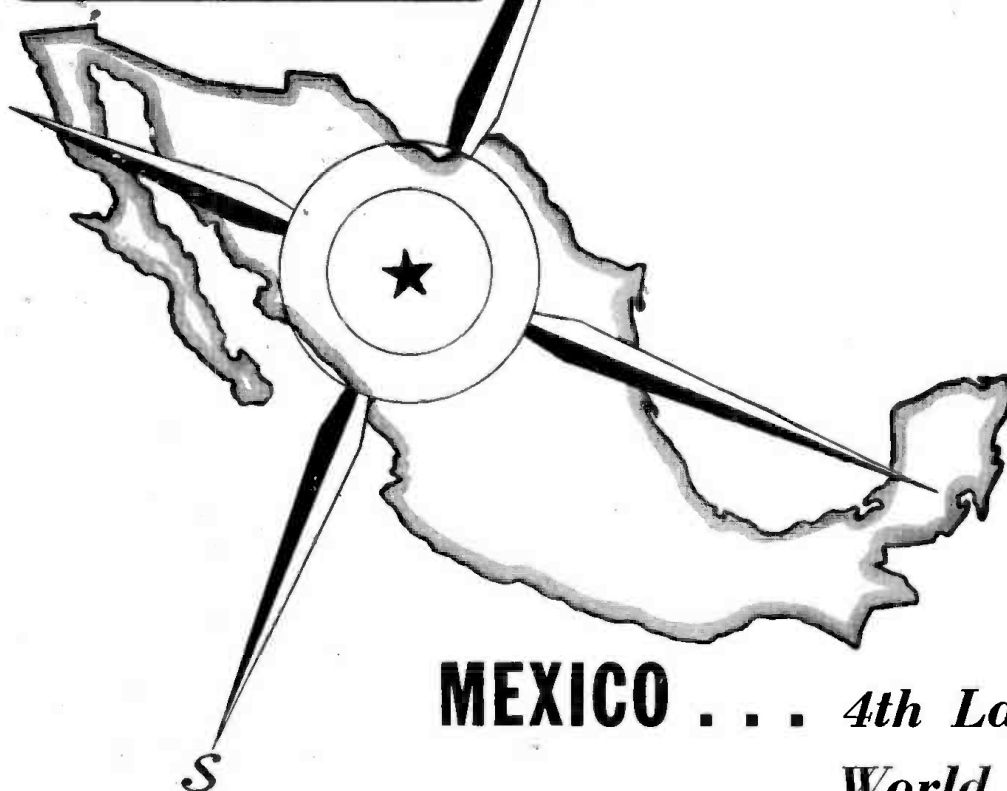

MEXICO . . . 4th Largest U. S. World Market

KNOWLEDGE

of the people and their buying habits.

EXPERIENCE

with successful campaigns of U. S.'s most successful sponsors.

FACILITIES

to reach all Mexico's 22 million consumers and more . . . economically.

MEXICO is a *mighty* good neighbor in dollar-volume purchases of U. S. goods: 5 times more in 1946 than in 1940, totalling nearly a half billion dollars. Mexico, 4th largest market in U. S. world trade, is a new world of trade for advertisers like Bayer, Canada Dry, Colgate, Parker, Sidney Ross, GE, Coca Cola and scores more. They sell Mexico's 22 million consumers through Latin America's most important network—the 116 stations of Radio Programas de Mexico. RPM covers *all* the Mexican (Central and South American) market. Its 50,000 watters pour into centers of population; its 250 watters conserve power (and your budget) where buying centers are smaller.

Here is a market equal in population to Ohio and New York combined. But, unlike the U. S., where channels of distribution are filling, Mexican demand is never-ending. Competition is almost unknown. Investigate your opportunity for mass distribution in this virtually untapped mass market. *YOUR* new sales frontier is South . . . through the 116 stations of RPM.



RADIO PROGRAMAS DE MEXICO

Largest Latin American Broadcasting System

The New Sales Frontier is South

P. O. Box 1324, Mexico, D. F. • Emilio Azcarraga, Pres. • Clemente Serna Martinez, V. Pres. & Gen. Mgr.

FREQUENCY ALLOCATIONS FOR EUROPEAN BROADCASTING STATIONS

(Agreed upon by a majority of nations at the European Broadcasting Convention in Copenhagen and scheduled to go into effect Mar. 15, 1950. However, large number of nations, including the United States, has taken exception to the plan and has asked modifications.)

Station	Fre- quen- cy kc. kw.	Station	Fre- quen- cy kc. kw.
LONG WAVES (150 to 285 kc.)			
Tromsø (Norway)	155 10	Poznan (Poland)	818 100
Erasov (Rumania)	150 150	Sofia I (Bulgaria)	827 100
Allouis (France)	164 450	Nancy (France)	836 150
Moscow I (USSR)	173 500	Beirut I (Lebanon)	845 150
Lulea (Sweden)	10 10	Rome I (Italy)	854 150
Ankara (Turkey)	120 120	Bucharest (Rumania)	863 150
Motala (Sweden)	191 200	Paris I (France)	872 150
Droitwich (G. B.)	200 400	Moscow III, Russia (U.S.S.R.)	872 150
(or Ottringham)		Aberystwyth (Great Britain)	881 5
Kiev I, Ukraine (USSR)	209 150	Fennon (Great Britain)	881 5
Oslo (Norway)	218 200	Washford (Great Britain)*	(881) 150
Warsaw I (Poland)	227 200	Wrexham (Great Britain)	5 5
Leningrad I (USSR)	236 100	Cetinge (Yugoslavia)	20 20
Kalundborg (Denmark)	245 150	Algiers I (Algeria)**	890 100
Lahti (Finland)	254 200	Bergen (Norway)	20 20
Moscow II (USSR)	254 200	Kristiansand (Norway)	20 20
Ceskoslovensko (Czechoslovakia)	281 100	Trondheim (Norway)	20 20
		Dniepropetrovsk, Ukraine (U.S.S.R.)	899 150
		Milan (Italy)	908 150
		Brookmans Park (Great Britain)	917 135
		Ljubljana (Yugoslavia)	926 150
		Brussels II (Belgium)	935 100
		Lwow, Ukraine (U.S.S.R.)	944 100
		Toulouse (France)	944 100
		Voronezh, Russia (U.S.S.R.)	953 150
		Morava (Czechoslovakia)	962 100
		Turku (Finland)**	120 120
		Tunis I (Tunisia)**	971 70
		British Zone (Germany)	10 10
		Izmir (Turkey)	20 20
		Kalinin, Russia (U.S.S.R.)	20 20
		Smolensk, Russia (U.S.S.R.)	980 100
		Algiers II (Algeria)**	150 150
		Goteborg (Sweden)**	989 10
		Rovaniemi (Finland)	70 70
		American Zone (Germany)	20 20
		Beirut II (Lebanon)	998 100
		Kishinev, Moldavia (U.S.S.R.)	1,007 120
		Hilversum II (Netherlands)	1,016 150
		Aleppo I (Syria)	1,025 100
		Istanbul (Turkey)	20 20
		Graz-Dobl (Austria)	20 20
		Jerusalem II (Palestine)	1,034 10
		Turin II (Italy)	40 40
		Lisbon (Portugal)	100 100
		Tallinn, Estonia (U.S.S.R.)	1,043 70
		U.S.S.R. Zone (Germany)	5 5
		Kalamata (Greece)	20 20
		Agadir I (Morocco)	20 20
		Marrakesh (Morocco)	20 20
		Ujda I (Morocco)	20 20
		Hartland Point (Great Britain)	1,052 10
		Start Point (Great Britain)**	50 50
		Tripoli (Libya)**	10 10
		Jassi (Rumania)	5 5
		Focșani (Rumania)	1,061 60
		Eastern Denmark	10 10
		Cagliari (Italy)	15 15
		Lisbon (Portugal)	1,070 100
		Paris II (France)	20 20
		Krasnodar, Russia (U.S.S.R.)	1,079 50
		Breslau (Poland)	1,038 10
		Korca (Albania)	10 10
		Shkodra (Albania)	150 150
		Droitwich (Great Britain)	20 20
		Norwich (Great Britain)	1,097 150
		Bratislava (Czechoslovakia)	5 5
		Czechoslovakia sync. network	1,106 100
		Moghilev, Byelorussia (U.S.S.R.)	1,115 50
		Bari I (Italy)	50 50
		Bologna I (Italy)	5 5
		S. Remo (Italy)	20 20
		Norwegian sync. network	1,124 20
		Brussels III (Belgium)	5 5
		Varna (Bulgaria)	40 40
		Viborg, Russia (U.S.S.R.)	1,133 135
		Zagreb (Yugoslavia)	1,142 20
		Constantine I (Algeria)	40 40
		Oran I (Algeria)	20 20
		Kaliningrad, Russia (U.S.S.R.)	1,151 5
		Carlisle (Great Britain)	100 100
		Lisnagarvey (Great Britain)	5 5
		Londonderry (Great Britain)	100 100
		Stagshaw (Great Britain)	5 5
		Bala Mare (Rumania)	5 5
		Clug (Rumania)	20 20
		Oradea (Rumania)	1,160 150
		Strasbourg I (France)	1,169 150
		Odessa, Ukraine (U.S.S.R.)	1,178 100
		Horby (Sweden)	

Station	Fre- quen- cy kc. kw.	Station	Fre- quen- cy kc. kw.
Budapest II (Hungary)	1,187 135	Genoa II (Italy)	5 5
French Zone (Germany)	1,196 70	Milan II (Italy)	50 50
Kerkyra (Greece)	15 15	Naples II (Italy)	5 5
Agadir II (Morocco)	20 20	Venice II (Italy)	5 5
Marrakesh II (Morocco)	20 20	Portuguese sync. network	20 20
Ujda II (Morocco)	20 20	Swedish sync. network	5 5
Brussels I (Belgium)	1,205 100	Bartley (Great Britain)	1,457 60
Haifa (Palestine)	5 5	Clevedon (Great Britain)	60 60
Lublin (Poland)	10 10	Craiova (Rumania)	20 20
Ayr (Great Britain)	1,214 5	Monte-Carlo (Monaco)	1,466 120
Brookmans Park (Great Britain)	60 60	Norwegian sync. network	2 2
Burghed (Great Britain)	20 20	Vienna II (Austria)	1,475 30
Dundee (Great Britain)	5 5	Salzburg (Austria)	20 20
Lisnagarvey (Great Britain)	1 1	Klagenfurt (Austria)	20 20
Londonderry (Great Britain)	58 58	International common frequency*	1,484 60
Moorside Edge (Great Britain)	2 2	French sync. network	1,493 20
Plymouth (Great Britain)	2 2	Gomel, Byelorussia (U.S.S.R.)	20 20
Redms (Great Britain)	2 2	Cracow (Poland)	1,502 50
Redruth (Great Britain)	10 10	Warsaw II (Poland)	20 20
Stagshaw (Great Britain)	50 50	Zaragoza (Spain)	50 50
Westerglen (Great Britain)	70 70	Brussels IV (Belgium)	1,511 20
British troops in Germany	2 2	Chania (Greece)	5 5
Azores (Portugal)	2 2	Jihlava (Czechoslovakia)	1,520 5
Kursk, Russia (U.S.S.R.)	20 20	Ostrava (Czechoslovakia)	30 30
Stara Zagora (Bulgaria)	1,223 20	Pilzen (Czechoslovakia)	30 30
Barcelona (Spain)	20 20	Corunna (Spain)	20 20
Salun (Sweden)	100 100	Funchal (Madeira Is.)	1,529 20
Budejovice (Czechoslovakia)	1,232 5	Swedish sync. network	1 1
Cechy-Zapad (Czechoslovakia)	25 25	Vatican City	100 100
Morava-Vychod (Czechoslovakia)	25 25	French Zone (Germany)	1,538 70
Prague II (Czechoslovakia)	100 100	Spanish sync. network	5 5
Vaasa (Finland)	1,241 50	British sync. network†	1,546 5
Bayonne (France)	20 20	Vinnitza, Ukraine (U.S.S.R.)	5 5
Clermont-Ferrand (France)	20 20	Germany: U. S. Forces	1,554 70
Corse (France)	20 20	Nice (France)	75 75
Crechob (France)	20 20	Turi, Estonia (U.S.S.R.)	20 20
Le Havre (France)	20 20	Portuguese sync. network	1,562 5
Montbeliard (France)	20 20	Swedish sync. network	20 20
Nice (France)	20 20	Swiss sync. network	5 5
Quimper (France)	20 20	U.S.S.R. Zone (Germany)	1,570 70
Tiraspol, Moldavia (U.S.S.R.)	20 20	Spanish sync. network	5 5
Lower Egypt	1,250 5	Sfax II (Tunisia)	5 5
Nyiregyhaza (Hungary)	20 20	Italian sync. network	1,578 10
Zalaegerzeg (Hungary)**	10 10	Fredrikstad (Norway)	70 70
Athlone II (Ireland)	50 50	British Zone (Germany)	1,586 10
Stettin (Poland)	1,259 100	Spanish sync. network	5 5
Belgrade II (Yugoslavia)	1,268 135	International common frequency†	1,594 1
Lille (France)	1,277 150	U. S. Zone (Germany)	1,602 70
Kosice (Czechoslovakia)	1,286 100	Norwegian sync. network	2 2
Radio Catolica (Portugal)	20 20	Portuguese sync. network	5 5
Ottringham (Great Britain)	1,295 150		
Constantine II (Algeria)	1,304 20		
Oran II (Algeria)	40 40		
Danzig (Poland)	50 50		
Stravanger (Norway)	1,313 100		
Ouchgod, Ukraine (U.S.S.R.)	1,322 100		
Genoa I (Italy)	1,331 50		
Messina (Italy)	25 25		
Pescara (Italy)	25 25		
Rome II (Italy)	50 50		
Venice (Italy)	25 25		
Alexandria (Egypt)	1,340 5		
Crowborough or Stagshaw (Great Britain)	150 150		
Budapest (Hungary)	5 5		
Magyarvar (Hungary)	5 5		
Miskolc (Hungary)	5 5		
Pecs (Hungary)*	5 5		
Corse (France)	1,349 10		
Marseilles (France)	50 50		
Nantes (France)	10 10		
Toulouse (France)	50 50		
Kuldiga, Latvia (U.S.S.R.)	20 20		
Modona, Latvia (U.S.S.R.)	20 20		
Tirana I (Albania)	1,358 100		
Thorshavn (Faroe Islands)	1,367 5		
Caltanissetta (Italy)	25 25		
Torun (Poland)	24 24		
Oporto (Portugal)	5 5		
Strasbourg II (France)	1,376 150		
Madrid I (Spain)	1,385 100		
Kaunas, Lithuania (U.S.S.R.)	150 150		
Dornbirn (Austria)	1,394 5		
Graz (Austria)	15 15		
Innsbruck (Austria)	5 5		
Linx (Austria)	5 5		
Rhodes (Greece)	5 5		
Swedish sync. network	20 20		
Bayonne (France)	1,403 20		
Lille (France)	20 20		
Paris (France)	(1,403) 10		
Quimper (France)	20 20		
Montpellier (France)	10 10		
Nice (France)	20 20		
French troops in Germany	25 25		
Komotini (Greece)	5 5		
Baranovich, Byelorussia (U.S.S.R.)	20 20		
Banja Luka (Yugoslavia)	1,412 20		
Bitolja (Yugoslavia)	20 20		
Maribor (Yugoslavia)	20 20		
Pristina (Yugoslavia)	20 20		
Rijeka (Yugoslavia)	20 20		
Split (Yugoslavia)	60 60		
Sarrebrucken (Germany: French Zone)	1,421 20		
Sfax I (Tunisia)	5 5		
Chernigov, Ukraine (U.S.S.R.)	5 5		
Argyrokastrò (Albania)	1,430 5		
Western Denmark	70 70		
Copenhagen (Denmark)	10 10		
Madrid II (Spain)	50 50		
Luxembourg	1,439 150		
Ancona (Italy)	1,448 25		
Florence II (Italy)	3 3		

* DA protecting S.W.
 † DA protecting S.W.
 ‡ DA protecting S.
 † Directional aerial protecting Switzerland.
 † Directional aerial. Apparent power towards Sweden 10 kw.
 † Directional aerial. Apparent power towards Bulgaria 20 kw.
 † Directional aerial protecting Norway.
 † Power to be reduced to 20 kw if directional aerial protecting Portugal is not used.
 † Directional aerial. Apparent power toward Egypt 20 kw.
 † Directional aerial. Apparent power towards Yugoslavia 150 kw.
 † Directional aerial protecting Norway.
 † Directional aerial protecting Tunisia.
 † Directional aerial protecting Finland.
 † Directional aerial protecting Sweden.
 † Directional aerial protecting Algeria.
 † Directional aerial protecting Libya.
 † Directional aerial protecting Great Britain.
 † Directional aerial protecting Ireland.
 † Shared by: Albania, Austria, Belgium, Cyprus, Czechoslovakia, Denmark, Finland, France, Germany, British Zone, Gibraltar, Great Britain, Greece, Hungary, Ireland, Italy, Lithuania, Malta, Morocco, Norway, Poland, Portugal, Rumania, Russia, San Marino, Spain, Syria, Trieste, Tripoli, Tunisia, Ukraine, and Yugoslavia. Vatican City is permitted to use this frequency with a power of 5 kw until receivers covering 1,529 kc/s are more generally in use.
 † Belfast (5kw); Bournemouth (2); Brighton (5); Bristol (2); Cardiff (2); Dundee (2); Edinburgh (5); Exeter (5); Fareham (2); Glasgow (5); Hull (5); Leeds (5); Liverpool (5); London (20); Manchester (2); Middlesbrough (2); Newcastle-on-Tyne (5); Plymouth (5); Preston (2); Redms (2); Redruth (2); Sheffield (2).
 † Shared by: Andorra; Austria; Belgium; Bulgaria; Cyrenaica; Czechoslovakia; Denmark; Finland; France; Great Britain; Greece; Ireland; Latvia; Madeira Is.; Morocco (Tangier); Norway; Netherlands; Poland; Portugal; Spain; Switzerland; Syria; Trieste; Yugoslavia.

SERVICES RELATED TO THE BUSINESS OF BROADCASTING

ADVERTISING AND TRADE ASSOCIATIONS

ADVERTISING ASSOCIATION OF THE WEST—Monadnock Bldg., San Francisco 5. Tel.: Garfield 1-6868. *Officers:* Herbert H. Kirschner, president; Charles W. Collier, executive vice president; Lela M. Huey, executive secretary.

THE ADVERTISING COUNCIL INC.—25 W. 45th St., New York 19, N. Y. Tel.: LUxemburg 2-1520. *Officers:* Charles G. Mortimer Jr., vice president charge of marketing, General Foods Corporation, chairman; Lee H. Bristol, Leo Burnett, Albert E. Winger, vice chairmen; Paul B. West, secretary; Frederic R. Gamble, treasurer; Theodore S. Repplier, president; Allan M. Wilson, vice president; George P. Ludlam, vice president & New York manager; Maxwell Fox, public relations director; Gordon C. Kinney, radio director; Mrs. L. S. Schwartz, Chicago representative; Robert Coleson, Hollywood representative. Washington office: 1200 18th St., N. W. Tel.: STerling 9153. Chicago office: 203 North Wabash Ave. Tel.: RAndolph 6-1753. Hollywood office: 1680 N. Vine St. Granite 7166.

ADVERTISING FEDERATION OF AMERICA—330 W. 42nd St., New York 18. Tel.: Bryant 9-0430. *Officers:* George S. McMillan, chairman of the board; E. G. Borton, president.

AMERICAN ASSOCIATION OF ADVERTISING AGENCIES—420 Lexington Ave., New York. Tel.: Lexington 2-7980. *Officers:* Frederic R. Gamble, president; Clarence B. Goshorn, Benton & Bowles, Inc., New York, chairman of the board; Fairfax M. Cone, Foote, Cone & Belding, Chicago, vice chairman; Warren E. Kraft, Honig-Cooper Co., Seattle, secretary-treasurer.

AMERICAN MARKETING ASSOCIATION—1525 E. 53d St., Chicago 15, Ill. Tel.: Museum 4-5267. *Officers:* Everett R. Smith, president; Wilford White, Robert F. Elrick, vice presidents; George H. Brown, secretary; Donald E. West, treasurer. (Association for the advancement of science in marketing.)

AMERICAN NEWSPAPER PUBLISHERS ASSOCIATION—370 Lexington Ave., New York 17. Tel.: Murray Hill 5-2000. *Officers:* Edwin S. Friendly, president; Charles F. McCahill, vice president; J. L. Stackhouse, secretary; W. L. Fanning, treasurer; Cranston Williams, general manager. Branch office: 360 N. Michigan Ave., Chicago 1. Tel.: Franklin 2-3746. George N. Dale, manager.

ASSOCIATION OF CANADIAN ADVERTISERS—Federal Bldg., Toronto 1. Tel.: Adelaide 8047.

Officers: Lee Trenholm, Provincial Paper Ltd., president; J. G. Hagey, B. F. Goodrich Rubber Co. of Canada, executive vice president; J. W. Lawrence, Borden Co., vice president and treasurer; H. T. Venning, Shirriff's Ltd., John O. Pitt, Canadian Fairbanks-Morse Co., Robert E. Day, Bulova Watch Co., vice presidents; John A. M. Galilee, secretary; Athol McQuarrie, general manager. *Directors:* T. M. Atkinson, Canadian Industries Ltd.; George S. Bertram, Swift Canadian Co.; G. Walter Brown, Bristol-Myers Co. of Canada; D. O. Durkin, John Inglis Co. Ltd.; E. T. Gater, Sterling Products Ltd.; R. R. McIntosh, General Foods Ltd.; H. T. Markey, Dominion Textile Co.; John M. Meldram, Canadian National Carbon Co.; M. M. Schneckenburger, House of Seagram; R. C. Scrivener, Bell Telephone Co. of Canada; R. E. Sewell, Coca-Cola Ltd.

ASSOCIATION OF NATIONAL ADVERTISERS Inc.—285 Madison Ave., New York 17. Tel.: Oregon 9-4940. *Officers:* W. B. Potter, Eastman Kodak Co., chairman of the board; Albert Brown, Best Foods Inc., vice chairman; Paul B. West, president; J. F. Kurie, vice president; Cy Norton, vice president; E. T. Batchelder, vice president-secretary.

DIRECT MAIL ADVERTISING ASSN. Inc.—17 E. 42nd St., New York 17. Tel.: Vanderbilt 6-1479. Harry A. Porter, Harris Seybold Co., president; Harry A. Porter, Harris-Seybold Co., American vice president; Fred Kirby, Saturday Night Press, Canadian vice president; Richard Messner, E. E. Brogle & Co., secretary-treasurer; Frank Frazier, executive director.

FINANCIAL PUBLIC RELATIONS ASSOCIATION—231 S. LaSalle St., Chicago 4. Tel.: State 2-5547. Allen Cranford, president; Preston E. Reed, executive vice president.

NATIONAL ASSN. OF MANUFACTURERS—14 W. 49th St., New York. Tel.: Circle 5-6600. *Officers:* Wallace F. Bennett, chairman of the board; (not elected until first week in December, 1949) 1950, president; Earl Bunting, managing director; Noel Sargent, secretary; Kenneth R. Miller, treasurer; Holcombe Parkes, vice president in charge of public relations; G. W. (Johnny) Johnstone, director, radio and television dept., public relations div.

NATIONAL BETTER BUSINESS BUREAU—405 Lexington Ave., New York 17. Tel.: Murray Hill 6-3535. R. P. Clayberger, president; Edward L. Greene, general manager; Warren C. Agry, vice-president.

NATIONAL RETAIL DRY GOODS ASSN.—100 W. 31st St., New York 1. Tel.: Chickering 4-8780. *Officers:* Lew Hahn, presi-

dent and treasurer; J. Gordon Dakins, general manager and assistant treasurer; Howard P. Abrahams, manager, Sales Promotion Division. Office: Munsey Bldg., Washington, D. C. Tel.: National 3680; John C. Hazen, manager.

THE PROPRIETARY ASSOCIATION OF AMERICA—810 18th St., N. W., Washington 6, D. C. Tel.: National 1914. *Officers:* Dr. Frederick J. Cullen, Washington, D. C., executive vice-president; Walter L. Beardsley, Miles Laboratories, Elkhart, Ind., president; A. K. Barta, secretary - treasurer, Washington, D. C.

COMMUNICATIONS CARRIERS

AT & T LONG LINES DEPT.—32 Avenue of the Americas, New York 13. Telephone: Exchange 3-9700. *Officers:* H. T. Killingsworth, vice-president; Charles E. Wampler, general manager.

BELL TELEPHONE LABORATORIES—463 West St., New York 14. Telephone: Chelsea 3-1000. *Officers:* O. E. Buckley, president; M. J. Kelly, executive vice-president; D. A. Quarles, vice president; A. B. Clark, vice president; W. H. Martin, vice president; W. H. Doherty, director of electronic and television research.

FEDERAL TELECOMMUNICATION LABORATORIES Inc. (An IT & T associate)—500 Washington Ave., Nutley, N. J. Tel.: Nutley 2-3600. *Officers:* Harold H. Buttner, president; R. B. Colton, executive vice-president; vice president & comptroller, J. G. Copelin. Technical directors: H. Busignies, E. Labin, A. J. Warner and E. N. Wendell.

GLOBE WIRELESS Ltd.—141 Battery St., San Francisco, Calif. Telephone: Exbrook 2-6181. *Officers:* R. Stanley Dollar, president; R. H. Andersen, Walter P. Boatwright, J. D. Hopkins, Neil D. Brown, R. Stanley Dollar Jr., vice-presidents.

INTERNATIONAL TEL & TEL Corp.—67 Broad St., New York 4. Telephone: Bowling Green 9-3800. William H. Harrison, president and director.

MACKAY RADIO & TELEGRAPH CO. (AC & R)—67 Broad St., New York 4. Tel.: Bowling Green 9-3800. *Officers:* Luke McNamee, president; F. L. Henderson, executive vice-president; J. A. Kennedy, vice president and general attorney; B. B. Tower, vice president and controller; Haraden Pratt, A. C. Jorgensen, Gordon Kern, C. R. McPherson, C. C. Chapman, Morgan Heiskell, E. H. Price, Carl E. Scholz, L. Spangenberg, vice presidents; D. M. Day, secretary; J. J. Brosnan, assistant treasurer.

RCA COMMUNICATIONS—66 Broad St., New York 4. Tel.: Han-

over 2-1811. *Officers:* Harry C. Ingles, president; Sidney Sparks, vice-president, Commercial Activities, Program and Photo Transmission Service; F. H. Goring, N. Y.; H. E. Austin, San Francisco.

WESTERN UNION TELEGRAPH Co.—60 Hudson St., New York 13. Tel.: Worth 2-7300. *Officers:* Walter P. Marshall, president; T. B. Gittings, public relations vice-president; H. P. Corwith, development and research vice-president; J. R. Redman, plant and engineering vice-president; J. Z. Millar, director of research; F. B. Bramhall, transmission research engineer; W. B. Sullinger, radio research engineer; E. C. Homer, electronics research engineer.

BELL TELEPHONE Co. of Canada—Beaver Hall Hill, Montreal, Quebec. Tel.: University 3911.

CANADIAN PACIFIC COMMUNICATIONS—204 Hospital St., Montreal, Quebec. Tel.: Marquette 7531. *Officers:* W. D. Neil, general manager; E. L. Scott, superintendent of broadcast services; W. G. Keating, general contract and tariff supervisor.

CANADIAN NATIONAL TELEGRAPHS—347 Bay St., Toronto 1, Ont. Tel.: Waverly 6071. *Officers:* W. M. Armstrong, general manager; J. R. White, chief of commercial operation.

MUSIC LICENSING GROUPS

AMERICAN SOCIETY OF COMPOSERS, AUTHORS & PUBLISHERS (ASCAP)—RCA Bldg., New York 20. Tel.: Plaza 7-2700. *Officers:* Fred E. Ahlert, president; Saul H. Bowine, Otto A. Harbach, vice presidents; George W. Meyer, secretary; Louis Bernstein, treasurer; Donald Gray, assistant secretary; Frank H. Connor, assistant treasurer; Richard F. Murray, George A. Hoffman, Herman Greenberg, Herman Finkelstein, administrative executives; Schwartz & Frohlich, general counsel. Board of Directors: Stanley Adams, Fred E. Ahlert, Louis Bernstein, Saul Bourne, Gene Buck, Irving Caesar, Max Dreyfus, Otto A. Harbach, A. Walter Kramer, Edgar Leslie, George W. Meyer, Jack Mills, Oscar Hammerstein II, John Tasker Howard, J. J. Robbins, Herman Starr, Gustave Schirmer, Deems Taylor, Donald Gray, Ray Henderson, Frank H. Connor, Paul Cunningham, Abe Olman, Lester Santly.

ASSOCIATED MUSIC PUBLISHERS (AMP)—BMI Subsidiary. 25 W. 45th St., New York 19. Tel.: Luxemburg 2-1790. Merritt E. Tompkins, president; Earl B. Hall, Karl Bauer, vice presidents; Charles A. Wall, treasurer.

BROADCAST MUSIC INC. (BMI)—580 Fifth Ave., New York 19. (Continued on page 516)

SERVICES RELATED TO RADIO

(Continued from page 515)

Tel.: Plaza 7-1800. **Officers:** Carl Haverlin, president; Sydney M. Kaye, vice president & general counsel; Charles A. Wall, vice president in charge of finance; Robert J. Burton, vice president in charge of publisher relations; **Directors:** Justin Miller, NAB, chairman; Sydney M. Kaye, vice chairman; Herbert Akerberg, CBS; John Elmer, WCBM, Baltimore; Carl Haverlin, BMI; William S. Hedges, NBC; Herbert Hollister, KBOL; Leonard Kapner, WCAE; Joseph McDonald, ABC; Paul Moroney, WTIC, Hartford; J. Leonard Reinsch, WSB, Atlanta; J. Harold Ryan, Fort Industry Co.; James E. Wallen, MBS.

COMPOSERS, AUTHORS and PUBLISHERS ASSN. OF CANADA LTD.—132 St. George St., Toronto. Tel.: Mi 8457. Sir Ernest MacMillan, president; W. S. Lov, gen. mgr.

HARRY FOX—45 Rockefeller Plaza, New York 20. Tel.: Circle 6-3084. (Agent and trustee for music publishers.)

MUSIC PUBLISHERS PROTECTIVE ASSOCIATION Inc.—45 Rockefeller Plaza, New York 20. Tel.: Circle 6-3084. Harry Fox, general manager; Walter G. Douglas, chairman of board.

NATIONAL ASSOCIATION OF PERFORMING ARTISTS—630 Fifth Ave., New York 20. Tel.: Circle 7-8194. Fred Waring, president and chairman of the board; Alfred Rice, general counsel.

G. RICORDI & Co.—12 West 45th St., New York 19. Tel.: Murray Hill 2-0300. Dr. Renato Tasselli, managing director.

SESAC Inc.—475 Fifth Ave., New York 17. Tel.: Murray Hill 4-5365. Paul Heinecke, president; Ruth C. Heinecke, treasurer; K. A. Jadasohn, general manager.

PUBLIC RELATIONS AND PROMOTION SERVICES

DAVID O. ALBER ASSOCIATES Inc.—654 Madison Ave., New York 21. Tel.: Templeton 8-8300. **Associates:** Michael Ames, Eugene Sheffer, Arnold Peyser, Robert Wendt, Sheila McKeon, Al Boyars.

AMERICAN RADIO PUBLICATIONS Inc.—121 N. Washington St., Peoria 2, Ill. Tel.: 4-3262. Rex G. Howard, president; John Sloane, vice president; S. C. Zinser, treasurer; Olive M. Howard, secretary. Radio Albums.

WILLIAM J. BAILEY—2500 Q St., N. W., Washington 7, D. C. Tel.: Dupont 3400, 0935.

BALDWIN & MERMEY—205 E. 42nd St., New York 17. Tel.: Murray Hill 4-4540. **Partners:** William H. Baldwin, Maurice Mermey.

BANNER & GRIEF—250 W. 57th St., New York 19. Tel.: Plaza 7-4713. Jack Banner and Ed Grief, partners.

BENTLEY & LIVINGSTONE Inc.

—220 S. State St., Chicago 4. Tel.: Webster 9-7439. George Livingstone, president; H. S. Fisher, secretary-treasurer.

EDWARD L. BERNAYS—26 E. 64th St., New York 21. Tel.: Butterfield 8-5000.

IVAN BLACK ASSOCIATES—400 Madison Ave., New York 17. Tel.: Plaza 5-4760.

BRAND NAMES FOUNDATION Inc.—119 W. 57th St., New York 19. Tel.: Circle 5-8118. Henry E. Abt, president; Nathan Keats, asst. to the president; William R. Sands, director of member services.

BROADCASTERS PROMOTION SERVICE—Atlantic City, N. J. Tel.: 4-6118. James Dooley, business manager.

H. A. BRUNO & ASSOC.—30 Rockefeller Plaza, New York. Tel.: Circle 6-8040. **Associates:** Russell Gudgeon, Hudson Phillips, Victor Oristano, Theon Wright, William Pearsall, Gerald Whitman, K. L. Harris.

CARL BYOIR & ASSOCIATES—10 E. 40th St., New York 16. Tel.: Murray Hill 3-3464. **Officers:** Carl Byoir, chairman of the board; Gerry Swinehart, president; George Hammond, executive vice president; Bob Davis, radio director. **Offices:** Washington, D. C., National Press Bldg. Tel.: Sterling 6565; William Wight vice president. Chicago, 39 LaSalle St., Tel.: Dearborn 2-6300; George Dye, vice president. Los Angeles, 639 S. Spring St., Tel.: Van Dyke 8119; Charles McVarish, vice president.

HARRY COLEMAN & CO.—664 N. Michigan Ave., Chicago 11. Tel.: Mohawk 4-3883. Harry M. Coleman, president.

COLL & FREEDMAN Inc.—49 W. 51st St., New York 19. Tel.: Plaza 3-9872. **Principals:** Fred Coll, Zac Freedman. **Office:** Hollywood 38, 1103 El Centro. Tel.: Gladstone 5146.

JAMES A. COWAN—Odeon Tower, Toronto, Ont., Canada. Tel.: Adalaide 5961.

ARTHUR EDDY—Taft Bldg., Hollywood 28, Cal. Tel.: Gladstone 5305, 9082.

GEORGE EVANS—251 W. 57th St., New York. Tel.: Circle 6-2765.

THE FAUGHT COMPANY, Inc.—342 Madison Avenue, N.Y.C. 17. Murray Hill 7-1171. Millard C. Faught, President.

THE EARLE FERRIS CO. Inc.—40 E. 49th St., New York. Tel.: Plaza 5-3100. Earle Ferris, president; Roger Brown, general manager.

FLANLEY & WOODWARD—30 E. 40th St., New York 16. Tel.: Murray Hill 3-3928. Mable G. Flanley and Sally Woodward, partners.

CHARLES H. GALE ASSOC. Inc.—515 Madison Ave., New York 22. Tel.: Plaza 5-3211.

DIXON GAYER-SCOPE—68 West 58th St., New York 19. Tel.: Murray Hill 8-3540. Dixon Gayer, president.

GILCREST-SPRIGGS & Co.—100 Boylston St., Boston 16. Tel.: Hubbard 2-2365. **Partners:** Charles

J. Gilcrest, Marjorie L. Spriggs. **STEVE HANNAGAN**—247 Park Ave., New York. Tel.: Plaza 5-2900. **Associates:** Larry Smits, Joe Copps.

INSTITUTE OF PUBLIC RELATIONS Inc.—Graybar Bldg., New York. Tel.: Lexington 2-6850. John W. Darr, president; David Hinshaw, vice president.

ROBERT S. KELLER, Inc.—72 Barrow St., New York 14. Tel.: Watkins 4-6599. Robert S. Keller, president; E. Benjamin Wright, treasurer.

KRIEDT & MYERS—J. Clarence Myers, Gary Kriedt, Palace Hotel, San Francisco 5. Tel.: Exbrook 2-7443, 2-8600.

MARK LARKIN—152 W. 42d St., New York. Tel.: Bryant 9-6999.

IVY LEE & J. T. ROSS—405 Lexington Ave., New York. Tel.: Murray Hill 6-2727. **Senior Partner:** T. J. Ross. **Partners:** James W. Lee II, J. M. Ripley, John L. Dupree.

AUSTIN C. LESCARBOURA & STAFF—Croton-on-Hudson, N. Y. Tel.: 3444. Austin C. Lescarboura, senior partner, account executive; Stanley A. Lescarboura, junior partner, account executive. Winifred Phillips, production.

HAL LEYSHON & ASSOCIATES—19 West 44th St., New York. Tel.: Murray Hill 2-5250.

HOWARD J. MCCOLLISTER—10660 Bellagio, Los Angeles. Tel.: BRi 04705. Regional promotional campaigns.

J. W. MILFORD & CO. Inc.—55 W. 42nd St., New York 18. Tel.: Wisconsin 7-5968. President: J. W. Milford.

ARTHUR H. MILLER—40 E. 49th St., New York 17. Tel.: Eldorado 5-6092.

WIN NATHANSON & ASSOC. Inc.—60 E. 42nd St., New York 17. Tel.: Murray Hill 2-6560. Win Nathanson, president.

JACK PERLIS—2109 Broadway. Tel.: Triangle 3-5284.

PUBLICITY ASSOCIATES Inc.—Empire State Bldg., New York 1. Tel.: Longacre 5-3209. Joseph A. Bernstein, president; Bernard Lewis, vice-president; Josef Israels, II, vice-president; Amy Vanderbilt, vice-president.

RADIO TELEVISION PUBLICITY CORP.—159 E. Chicago Ave., Chicago 11.

RICHARD H. ROFFMAN—140 W. 42nd St., New York 18. Tel.: Lackawanna 4-4617. Richard H. Roffman, president. (Also law counsel.)

SELVAGE & LEE—One E. 43rd St., New York 17. Tel.: Murray Hill 7-8550. James P. Selvage, Morris M. Lee Jr., partners. **Offices:** 135 S. LaSalle St., Chicago 3. Tel.: Franklin 2-4821. R. N. Swanson; 1730 Eye St., NW, Washington 6. Tel.: Republic 4041. S. B. Bledsoe.

BENJAMIN SONNENBURG—247 Park Ave. Tel.: Plaza 5-2200.

ROBERT S. TAPLINGER & ASSOC.—9507 Santa Monica Blvd., Beverly Hills, Calif. Robert S. Tapingler, manager.

GEORGE R. TURPIN & ASSOCIATES—P. O. Box 802, Fort Worth 1, Texas. George R. Turpin, general manager; Ed Niehat, manager. (Promotional and visual advertising campaigns for radio stations.)

NANCY LEE WARING—18 E. 48th St., New York 17. Nancy Lee Waring, president. Judy Friedman, assistant to president. Tel.: Murray Hill 8-2034.

WORLD PHOTO NEWS CORP.—354 Fourth Ave., New York. Tel.: Murray Hill 9-5347. Louis Duglin, general manager. (Promotional newspaper and display service.)

JOHN ORR YOUNG & ASSOCIATES, Inc.—347 Madison Avenue, N.Y.C. 17. Murray Hill 6-5500. John Orr Young, president.

RADIO ASSOCIATIONS AND COMMITTEES

AMERICAN RADIO RELAY LEAGUE—38 LaSalle Rd., West Hartford 7, Conn. **Officers:** George W. Bailey, president; J. L. McCargar, vice president; A. L. Budlong, secretary; D. H. Houghton, treasurer; F. E. Handy, communications manager.

AMERICAN TELEVISION SOCIETY—17 E. 45th St., New York 17. Tel.: Murray Hill 7-9250. **Officers:** David Hale Halpern, president; Donald E. Hyndman, vice president; Reynold R. Kraft, secretary; Archibald U. Braunfeld, treasurer.

ASSOCIATION OF FEDERAL COMMUNICATIONS CONSULTING ENGINEERS—Munsey Bldg., Washington 4. Tel.: Sterling 0111. Glenn D. Gillett, president; Andrew W. Ring, vice president; George C. Davis, secretary; James C. McNary, treasurer.

BROADCAST ADVERTISING BUREAU (National Assn. of Broadcasters)—270 Park Ave., New York 17. Tel.: Murray Hill 8-4020. Maurice B. Mitchell, director; Charles A. Batson, Lee Hart, Robert M. McGredy, assistant directors.

CANADIAN ASSOCIATION OF BROADCASTERS—Main office 108 Sparks St., Ottawa. Tel.: 3-4036. Branch, 37 Bloor St., W., Toronto, Ont. Tel.: Princess 3729. T. J. Allard, manager; T. Arthur Evans, secretary-treasurer; Pat Freeman, director of advertiser and station services, Joseph Sedgwick, general counsel; W. M. Guild, chairman of the board; R. T. Snelgrove, Montreal, honorary president. **Directors:** E. Finlay MacDonald, Halifax, N.S.; Malcolm Neill, Fredericton, N.B.; Phil Lalonde, Montreal; Dr. Charles Houde, New Carlisle, P. Q.; Harry Sedgwick, Toronto; K. D. Soble, Hamilton; J. O. Blick, Winnipeg; E. A. Rawlinson, Prince Albert; George Chandler, Vancouver.

CLEAR CHANNEL BROADCASTING SERVICE—Shoreham Bldg., Washington, D. C. Tel.: Executive 0255. **Officers:** Ward L. Quaal, director; Edwin W. Craig, WSM Nashville, chairman; Harold

Hough, WBAP Fort Worth, treasurer; Louis G. Caldwell, counsel; Norma C. MaDan, secretary. *Executive Committee:* Edwin W. Craig, WSM; Victor A. Sholis, WHAS Louisville; Harold Hough, WBAP; James Shouse, WLW Cincinnati; W. B. Ryan, KFI Los Angeles.

ELECTRONICS MFRS. ASSN. Inc.—1450 Broadway, New York 18. Tel.: Longacre 5-4120. David Wald, DeWald Radio, president; Sol W. Gross, Tele-Tone Radio Corp., vice president; I. A. Mitchell, United Transformer Corp., vice president; Allen Bernstein, Adams Laboratories Inc., secretary; Irving Golin, University Loud-Speakers, Inc., treasurer.

FEDERAL COMMUNICATIONS BAR ASSN.—Guilford Jameson, president; Neville Miller, first vice president; Wm. A. Porter, second vice president; Corwin Lockwood, secretary; Joseph F. Zias, treasurer. *Executive Committee:* John F. Gibbons, Arthur W. Scharfeld, Fred W. Albertson, George S. Smith, Omar L. Crook, Ralph L. Walker. John W. Willis, editor, *Federal Communications Bar Assn. Journal.*

INDEPENDENT TELEVISION PRODUCERS ASSN. Inc.—234 W. 44th St., New York 18. Tel.: Chickering 4-0626. Martin A. Gosch, president; Henry White, vice president; Irvin Paul Sulds, treasurer; James Lawrence Fly, general counsel.

INSTITUTE OF RADIO ENGINEERS Inc.—One E. 79th St., New York 21. Tel.: Regent 7-9600. Officers: Raymond F. Guy, president; Sir Robert Watson-Watt, vice president; Donald B. Sinclair, treasurer; Haraden Pratt, secretary; Alfred N. Goldsmith, editor.

JOINT TECHNICAL ADVISORY COMMITTEE—1 E. 79th St., New York 21. Tel.: Regent 7-9600. Donald G. Fink, chairman; J. V. L. Hogan, vice chairman; L. G. Cumming, secretary. Ralph Brown, Melville Eastham, E. K. Jett, Haraden Pratt, D. B. Smith, Philip F. Siling.

NATIONAL ASSOCIATION OF BROADCASTERS—1771 N St. N.W., Washington 6, D. C. (see page 32.)

NATIONAL ASSOCIATION OF RADIO FARM DIRECTORS—*Officers:* Wallace Kadderly, KGW Portland, Ore., president; Gordon Loudon, Agricultural Extension Service, La. State U., Baton Rouge, La., vice president; Phil Alampi, WJZ New York, secretary-treasurer.

NATIONAL ASSOCIATION OF RADIO NEWS DIRECTORS—Jack Shelly, WHO Des Moines, president; Ben Chatfield, WMAZ Macon, first vice-president; Jim Borman, WMT Cedar Rapids, second vice-president; Sheldon Peterson, KLZ Denver, treasurer; Soren Munkhof, WOW Omaha, secretary.

NATIONAL ASSN. OF RADIO STATION REPRESENTATIVES

—101 Park Ave., New York. Tel: Murray Hill 5-4141. Lewis H. Avery, president; Richard Buckley, vice president; James LeBaron, secretary; Joseph Timlin, treasurer; Eugene Katz, Joseph J. Weed, Frank Headley, directors; T. F. Flanagan, managing director.

NATIONAL ELECTRICAL MFRS. ASSN.—155 E. 44th Street, New York 17. Tel.: Murray Hill 2-1500. C. T. Lawson, vice president, Nash-Kelvinator Corp., president; Everett Morss, president, Simplex Wire and Cable Co., treasurer; Vice Presidents: C. W. Higbee, manager, Electrical Wire and Cable Dept., United States Rubber Co.; J. H. Jewell, vice president, Westinghouse Electric Corp.; J. F. Lincoln, president; The Lincoln Electrical Co.; E. E. Potter, vice president, General Electric Co.; A. F. Sheldon, vice pres. & gen. mgr., Kennecott Wire and Cable Co.

RADIO EXECUTIVES CLUB OF NEW YORK—485 Madison Ave., New York 22. John J. Karol, president; Gordon Mills, vice president; Claude Barrere, secretary; Lewis H. Avery, treasurer.

RADIO MANUFACTURERS ASSN.—1317 F St., N.W., Washington 4. Tel.: National 4901. R. C. Cosgrove, Crosley Division, Avco Mfg. Corp., president; Bond Geddes, executive vice president and general manager; Leslie F. Muter, Muter Co., treasurer; John W. Van Allen, Buffalo, general counsel; G. M. Gardner, Wells-Gardner & Co.; R. E. Carlson, Tung-Sol Lamp Works, W. J. Barkley, Collins Radio Co., A. D. Plamondon, Jr., Indiana Steel Products Co., A. Liberman, Talk-A-Phone Co., vice presidents; James D. Secrest, Washington, director of public Relations. *Committees (and chairmen):* Stanley H. Manson, Stromberg-Carlson Co., advertising (set div.); R. E. Carlson, Tung-Sol Lamp Works, cathode ray safety Committee; W. W. Paul, Radio Condenser Co., credit; S. Insull Jr., Stewart-Warner Electric Division, excise tax; V. S. Mameyeff, Raytheon Manufacturing Co., export; G. W. Thompson, Noblitt-Sparks Industries, industrial relations; Frank W. Mansfield, Sylvania Electric Products Inc., industry statistics; John W. Van Allen, RMA general counsel, legislative; J. J. Kahn, Standard Transformer Corp., membership; A. K. Ward, RCA, school equipment; A. T. Alexander, Motorola Inc., service; Max F. Balcom, Sylvania Electric Products Inc., television; R. C. Sprague, Sprague Electric Co., Town Meetings; Richard C. Colton, RCA Victor Division, traffic; Leslie F. Muter, Muter Co., finance. *Division Organization:* G. M. Gardner, chairman, set division; Max F. Balcom, chairman, tube division; T. A. Smith, chairman, transmitter division; A. D. Plamondon Jr., chairman, parts division; A. G. Schifino, chairman, amplifier and sound equipment division. *Engineering Dept.:* 90 West St., New York 6. Tel.: Cortland

7-0850. Dr. W. R. G. Baker, General Electric Co., director; Virgil M. Graham, Sylvania Electric Products Corp., assoc. director; L. C. F. Horle, chief engineer.

RADIO MFRS. ASSN. OF CANADA—159 Bay St., Toronto. Tel.: Adelaide 1531. S. D. Brownlee, executive secretary; F. R. Deakins, president; R. A. Hackbusch, vice-president; H. A. Frankel, chairman, parts division; R. Tewsley, chairman, service committee; M. B. Oxley, chairman, engineering committee.

RADIO PIONEERS—30 Rockefeller Plaza, New York 20. *Officers:* William S. Hedges, president; Frank E. Mullen, 1st vice-president; Arthur Church, 2nd vice-president; Paul W. Morency, vice-president & secretary; O. H. Caldwell, vice-president & treasurer; Edgar Bill, J. R. Poppele, vice-presidents.

TELEVISION BROADCASTERS ASSN.—500 Fifth Ave., New York 18. Tel.: Lackawanna 4-4788. (see page 38.)

TELEVISION PRODUCERS ASSN. 7063 Sunset Blvd. Hollywood 28, Calif. Tel.: GRanite 6930. Mal Boyd, Mal Boyd & Assoc., president; Bernard Ebert, Stokey - Ebert Television Enterprises, president pro tem; Michael Stokey, Stokey - Ebert Television Enterprises, vice-president; Gladys Rubens, secretary; Maleese Black, treasurer.

WESTERN ASSOCIATION OF BROADCASTERS — C/o CJOC Lethbridge, Alta.; William Guild, president; CJOC Lethbridge, Alta. *Directors:* W. Rea, CKNW New Westminster; E. A. Rawlinson, CKBI Prince Albert; F. H. Elphickie CKWX, Vancouver.

COLLEGE NETWORK

INTERCOLLEGIATE BROADCASTING SYSTEM—507 Fifth Avenue, New York 17. Tel.: Murray Hill 2-8288; 2808 Erie St., Washington 20, D. C. Tel.-Victor 7210. Officers, Russell Potter, Columbia U., president; Roger Clipp, WFIL Philadelphia, vice president; Judith Waller, NBC, secretary; Guy Della-Cioppa, CBS, treasurer. *Directors,* R. R. Lowdermilk, U. S. Office of Education; Morris Novik, consultant; Robert B. Hudson, CBS. George Abraham, executive chairman; David Borst, technical manager; David Linton, program manager.

CONSULTANTS ALLIED ARTS

MERLIN H. AYLESWORTH—30 Rockefeller Plaza, New York 20. Tel.: Circle 6-2535. (Advisory counsel.) Chairman of the Executive Committee, Ellington & Co. Inc., 535 Fifth Avenue, NYC.

BLACKBURN-HAMILTON CO.—Washington Bldg., Washington 5, D. C. Tel.: Sterling 4341. 333 N. Michigan Ave., Chicago; Tel.: Ran-

dolph 6-4550. 235 Montgomery St., San Francisco 4; Tel.: Exbrook 2-5672. Media brokers. *Officers:* James W. Blackburn, partner; Ray V. Hamilton, partner.

BOOZ, ALLEN & HAMILTON—135 S. LaSalle St., Chicago 3. Tel.: Financial 6-1900; New York—285 Madison Ave., New York 17. Tel.: Oregon 9-1900; Los Angeles—523 W. Sixth St., Los Angeles 14; Washington—1511 K. St., Washington 5. Tel.: Trinity 3215. *Partners:* Edwin G. Booz, James L. Allen, James C. Olson, Edward J. Burnell, John L. Burns, Sherrill A. Parsons, Stuart M. Campbell, Stanley M. Humphrey, Harry W. Knight, Stewart M. Lowry, William C. Eldridge, Arnold F. Emch, Joseph M. Kubert, Perry Addleman, Kendrick Porter, Charles P. Bowen, Robert Wise, John W. Pockock, Robert M. Browning, George F. Hamson, Thomas C. Coulter, Clarence R. Chase, Edwin L. Morris.

BROADCAST SERVICE BUREAU Inc.—1025 Vermont Ave., N. W., Washington 5, D. C. Tel.: National 7808. C. B. Collins, president; Erna K. Bachmeier, secretary. (F.C.C. Broadcast Rules and Standards with amendment service.)

CARL H. BUTMAN—National Press Bldg., Washington, D. C. Tel.: National 7846. (Consultant on FCC procedural, regulatory and technical matters; applications supervised.)

SMITH DAVIS CORP.—Waldorf-Astoria Towers, New York. Smith Davis, president; Albert Zugsmith, executive vice president; Ruth Zugsmith, treasurer; Vincent Manno, general manager; Alvin Freemont, director newspaper division and manager, Philadelphia office; Howard E. Stark, director of radio sales. (Radio station brokers.)

MARTIN DODGE & Co.—RKO Bldg., New York 20. Tel.: Circle 5-6767. (Consultants on labor public relations; publishes D-M Digest, digest of labor press.)

THE REUBEN H. DONNELLEY Corp.—350 E. Cermak Rd., Chicago 16. Tel.: Victory 3232. *Officers:* T. E. Donnelley, chairman of the board; Raymond M. Gunnison, president; Clarence O. Lillyblade, Arthur H. Bamforth, David L. Harrington, William J. Clark, vice presidents; Harry W. Warner, secretary-treasurer. (Contest judging, premium mailing and packaging, classified telephone directory Publishers; house to house distribution; Store service direct mail advertising, mailing lists.)

VINCENT EDWARDS & CO.—342 Madison Ave., New York. Tel.: Vanderbilt 6-5555. President: V. Edward Borges. (Advertising mat and idea syndicate services and trade magazine publishers.)

FRAZIER & PETER—Bond Bldg., Washington 5, D. C. Tel.: National 2173. Howard S. Frazier, Paul F. Peter, partners.

(Continued on page 518)

SERVICES RELATED TO RADIO

(Continued from page 517)

RICHARD W. HUBBELL & ASSOCIATES—118 E. 40th St., New York, 16. Murray Hill 3-0028. Richard W. Hubbell, chairman. 597 Fifth Ave. (Efficiency studies, financial analysis, market research, public relations, general managerial advice and assistance in all branches of television and radio.)

EDGAR KOBAK—Hotel Ambassador, Park Avenue, New York. Tel.: Plaza 5-1000.

EDWARD C. LOBDELL ASSOC.—17 E. 48th St., New York 17. Edward C. Lobdell, general manager; M. Morris, assistant to general manager. (Management consultants, station brokers, staff personnel placement.)

McKINSEY & Co.—60 E. 42d St., New York 17. Tel.: Murray Hill 7-3123. *Partners and Principals:* H. G. Crockett, Marvin Bower, Gordon G. Bowen, J. Alex Smith, Howard C. Adams, Ewing W. Reilly, Gerald L. Murphy, Richard D. Elwell, Carl T. Hoffman, E. Everett Smith Jr., Phillip S. Babb. Office: 75 Federal St., Boston 10; Tel.: Hubbard 2-9626; Stanley L. Balmer, Arthur T. Caruso. Office: 208 South LaSalle St., Chicago 4; Tel.: Randolph 6-6980; Harrison A. Roddick, Frank Wallace. Office: 235 Montgomery St., San Francisco 4; Tel.: Garfield 1-3638; Alf E. Werolin. Office: 612 South Flower St., Los Angeles 14; Tel.: MADison 6-6801; John G. Neukom.

GEORGE McKITTRICK & Co.—108 Fulton St., New York 7. Tel.: Barclay 7-4828. Branch Office: 185 N. Wabash St., Chicago 1. Tel.: State 8911. (Publishes McKittrick's Geographical and Classified Directory of Advertisers and Advertising Agency list.)

EDWIN CLAUDE MILLS—522 Fifth Ave., New York 18. Tel.: Murray Hill 2-0882. (Consultant on commercial use of copyright musical works.)

NATIONAL REGISTER PUBLISHING Co. Inc.—330 W. 42nd St. New York 18. Tel.: Longacre 3-5850. *President:* R. W. Ferrel. *General manager:* C. H. Brown. Branch: 333 N. Michigan Ave., Chicago; tel.: Randolph 6-5744; manager, A. J. Crane. (Publishes Standard Advertising Register services, listing national advertisers, agencies and their personnel.)

TED NELSON ASSOCIATES—730 Fifth Ave., New York 19. Tel.: Circle 6-8740. *Director:* Ted Nelson. (Radio and television consultants, television packages.)

M. S. NOVIK—630 Fifth Ave. New York 20. Tel.: Circle 6-3976. (Public service radio consultant.)

FRED A. PALMER Co.—6800 N. High (P. O. Box 108), Worthington, Ohio. Tel.: Franklin 2-7346. Fred A. Palmer, president. (Radio management consultant.)

PIKE & FISCHER—Dupont Circle Bldg., Washington, D. C. (FCC

Rules, amendments, decisions and related radio documentary service, publishers of Pike & Fischer *Radio Regulation*.)

RADIO REPORTS Inc.—220 E. 42nd St., New York 17. Tel.: Murray Hill 7-6658. Edward F. Loomis, president; P. R. Rieber, vice president; Gorton V. Carruth, vice president. Branch offices: 5050 Joy Road, Detroit 4; 1642 E. 52nd St., Chicago; 36 Springfield St., Wilbraham, Mass.; 2024 W. Sixth St., Los Angeles 5; 519 6th St., N. W., Washington 1, D. C.; 1706 W. Girard St., Philadelphia. (Recordings, digesting, transcribing radio news and comments, surveys of program content; monitoring of commercials in about 200 markets.)

TRADE-WAYS Inc.—285 Madison Ave., New York. Tel.: Murray Hill 3-1363. William H. Lough, president and treasurer; Frank H. Twyeffort, secretary. (Marketing counsellors specializing in sales training.)

MERRITT R. SCHOENFELD & Co.—360 N. Michigan Ave., Chicago 1. Tel.: Central 6-5593. Merritt R. Schoenfeld, president; Lewis G. Green, vice-president; R. Hall Adams, secretary-treasurer.

CLIFFORD YEWDALL—350 Fifth Ave., New York 1. Tel.: Pennsylvania 6-7861. Branches: 11 S. LaSalle St., Chicago; Sharp Bldg., Lincoln 8, Neb. Tel.: B 3135. (Accountant specializing in radio.)

SURVEYS AND MARKET RESEARCH

ADVERTEST RESEARCH—New Brunswick & Newark, N. J. 133 Albany St., New Brunswick. Tel.: Charter 7-1564. *Directors:* Seymour Smith, Richard Bruskin. (Measurement of radio and television audience habits and reactions. Publishers of monthly *The Television Audience of Today* and monthly *TV Spot Ratings*.)

ADVERTISING RESEARCH FOUNDATION Inc.—11 West 42nd St., New York. Tel.: Longacre 3-5100. *Officers:* H. M. Warren, chairman of the board; B. B. Geyer, vice chairman of the board; Frederic R. Gamble, treasurer; Paul B. West, secretary; A. W. Lehman, managing director; D. B. Lucas, technical director. *Directors:* John F. Apsey Jr., Albert Brown, Allan Brown, Robert B. Brown, Marion Harper Jr., Gordon E. Hyde, Abbott Kimball, H. H. Kynett, Walter P. Lantz, Ferguson Mead, Stuart Peabody, Frederick B. Ryan Jr., D. P. Smelser, Howard D. Williams.

AMERICAN RESEARCH BUREAU—National Press Bldg., Washington 4, D. C. Tel.: Republic 6002. James W. Seiler, director. (Radio and television audience measurement.)

AUDIT BUREAU OF CIRCULATIONS—165 W. Wacker Drive, Chicago 1. Tel.: Central 6-7994. *Managing director:* James N. Shroyok. Branch: 330 W. 42nd St., New York 18; Tel.: Longacre 3-2322; William F. Hoffmann,

manager. (Newspaper and periodical circulation audit service.)

A. S. BENNETT ASSOCIATES Inc.—347 Madison Ave., New York. Tel.: Murray Hill 6-9282. Archibald S. Bennett. (National consumer and dealer research.)

BROADCAST MEASUREMENT BUREAU (BMB)—270 Park Ave., New York 17. Tel.: Eldorado 5-1620. *Officers:* Kenneth H. Baker, acting president; J. Harold Ryan, Fort Industry Co., Toledo, chairman of the board; Frederic R. Gamble, president, American Assn. of Advertising Agencies, vice-chairman; Justin Miller, president, National Assn. of Broadcasters, vice-chairman; Paul West, president, Assn. of National Advertisers, vice-chairman; Roger W. Clipp, WFIL Philadelphia, secretary-treasurer.

Members of the Board:

NAB—Messrs. Ryan, Clipp, and Miller; Dr. Hugh M. Beville Jr., NBC director of research; Richard Shafto, general manager, WIS Columbia, S. C.; Hugh Terry, KLZ Denver.

ANA—Mr. West; Joseph M. Allen, vice president, Bristol-Myers Co.; Herbert D. Bissell, advertising manager, The Electric Auto Lite Co.; A. H. Caperton, advertising manager, Dr. Pepper Co.; Lowry Crites, General Mills, Minneapolis; Albert S. Dempewolf, assistant to the director of advertising, Celanese Corp. of America; Alden James, advertising director, P. Lorillard Co.

AAAA—Mr. Gamble; Leonard T. Bush, vice-president, Compton Adv. Agency; Linnea T. Nelson, chief timebuyer, J. Walter Thompson Co.; D. E. Robinson, director of research, C. J. La Roche & Co.; Melvin Brorby, vice-president, Needham, Louis & Brorby; C. Burt Oliver, manager, Hollywood office, Foote, Cone & Belding.

BUREAU OF BROADCAST MEASUREMENT—Federal Bldg., Toronto. Tel.: Adelaide 8047. *Officers:* L. E. Phenner, Canadian Celucon Products Co. Ltd., Toronto, president; Athol McQuarrie, Assn. of Canadian Advertisers Inc., Toronto, secretary-treasurer; H. N. Stovin, Horace N. Stovin & Co., Toronto, vice-president. *Directors:* W. T. Cranston, CKOC Hamilton; E. A. Weir, CBC, Toronto; C. R. Vint, Colgate-Palmolive-Peet Co., Ltd., Toronto; Harold E. Stephenson, The Canada Starch Co., Ltd., Montreal; G. Frank Mills, Spitzer & Mills Ltd., Toronto; Stuart B. Smith, Canadian Advertising Agency Ltd., Toronto; W. E. Trimble, Baker Adv. Agency Ltd., Toronto.

WALTER P. BURN—17 Washington St., Middlebury, Vt., Tel.: 593. (Maps and coverage data.)

CANADIAN FACTS LTD.—146 Wellington St. West, Toronto, Ont. Tel.: Adelaide 2067. John F. Graydon, president; Mrs. M. Sims, director of personnel; George Severs, chief statistician. Branch

Office: 1466 Drummond St., Montreal, Tel.: Lancaster 3852. Ethel Colwell, vice-president.

ROBERT S. CONLAN & ASSOCIATES Inc.—928 Main St., Kansas City 6. Tel.: Victor 3038. Robert S. Conlan, president; John L. Guyant, vice-president; Erwin Stern, director of sales.

CONTROLLED CIRCULATION AUDIT Inc.—420 Lexington Ave., New York. Tel.: Lexington 2-6380. Frank L. Avery, managing director; Douglas Wakefield Cutlee, president; Adin L. Davis, vice-president; F. Morse Smith, secretary; T. Norman Tvetter, treasurer. (Auditing circulation of business publications.)

CROSSLEY Inc.—4 Mercer St., Princeton, N. J. and 330 W. 42nd St., New York 18. Tel.: Bryant 9-5462. Archibald M. Crossley, president; James A. Ward, vice-president.

DAVID DARRIN—2115 F. St. NW, Washington, D. C. Republic 0645—Ext. 501.

CORNELIUS DU BOIS & CO.—551 Fifth Ave., New York. Cornelius Du Bois, president; Louise Payne McCarty, vice-president. Audience, opinion, brand rating, and market surveys.

ELLIOTT-HAYNES Ltd.—515 Broadview, Toronto, Ont. Tel.: Gerard 1144. Walter E. Elliott, president; J. Myles Leckie, vice-president; E. R. Comte, secretary-treasurer. Branch Office: Sun Life Bldg., Montreal. Tel.: Plateau 6494.

EXECUTIVES RADIO SERVICE—1889 Palmer Ave. Larchmont, N. Y. Tel.: 20833. James M. Boerst, managing editor. (Publishers of pocket-size FACTuary containing commercial data on sponsored network television and radio: Programs, Agencies, rates, etc. Periodic loose-leaf revisions.)

FACT FINDERS ASSOCIATES Inc.—400 Madison Ave., New York. Tel.: Plaza 9-3710. Frank R. Coutant, president; Wm. J. O'Brien, executive vice president.

FACTS CONSOLIDATED—461 Market St., San Francisco. Tel.: Douglas 2-2445. *Partners:* Roy S. Frothingham and Dorothy D. Corey. Los Angeles Office: 8461 Melrose Pl. Tel.: Wyoming 3181. (Marketing and opinion research, radio audience analysis, television surveys.)

EDGAR H. FELIX—176 Franklin Ave., Malverne, L.I., N.Y. Tel.: Lynbrook 3-9755-R. (Publisher of Radio Coverage Reports.)

GALLUP & ROBINSON—Palmer Square, Princeton, N. J. Tel.: 3400 Dr. George Gallup & Dr. Claude Robinson. (Advertising research.)

GILBERT YOUTH RESEARCH ORGANIZATION—512 Fifth Ave. New York 18. Tel.: LA 4-8590. Eugene Gilbert, president. (National and regional media and consumer research; merchandising consultants to NBC for youth market.)

GRAHAM RESEARCH SERVICE
—424 Madison Ave., New York 17.
Tel.: Plaza 3-4565. Director: J. E. Graham.

HOOPER-HOLMES BUREAU Inc.
—102 Maiden Lane, New York 5.
Tel.: Whitehall 3-9700. Director of market research: William L. Henry.

C. E. HOOPER Inc.—Executive headquarters, 10 E. 40th St., New York 16. Tel.: Lexington 2-3000. *Officers:* C. E. Hooper, president; Fred H. Kenkel, executive vice-president and treasurer; W. Ward Dorrell, vice-president; A. M. Wharfield, vice-president; Thomas H. Brown Jr., vice-president. Dorothy M. Behrens, manager, radio program reports; Edythe F. Bull, manager special surveys. *Offices:* Equitable Bldg., Hollywood 28. Tel.: Hollywood 3553. Jack O'Mara, manager; Dry Hill, Norwalk, Conn. Tel.: 8-0606; 230 N. Michigan Ave., Chicago. Tel.: Randolph 7-8150. Carl Tillmanns, manager.

INDUSTRIAL SURVEYS CO. Inc.—292 Madison Ave., New York 17. Tel.: Murray Hill 3-0690. Samuel G. Barton, president; C. C. Rogers, Fremont J. Knittle, vice-presidents; Larkin Osborn, comptroller. *Office:* 425 Michigan Ave., Chicago. Tel.: Mohawk 4-4600. Manager: Stanley Womer; John Rhodes, Donald Connell, vice-presidents.

JAY & GRAHAM RESEARCH Inc.—64 E. Jackson Blvd., Chicago 4. Tel.: Harrison 7-1375. President, Allan V. Jay; secretary-treasurer, Edward F. Graham; production and office manager, Shepard Chartoc; statistical manager, Charles Callard. (Videodex Ratings, quantitative and qualitative TV audience rating service.)

JOHN B. KNIGHT Co.—6530 Sunset Blvd., Hollywood 28. Tel.: Hillside 4174. John B. Knight.

RICHARD MANVILLE RESEARCH—15 W. 45th St., New York 19. Tel.: Luxemburg 2-4378. (Consultants on advertising and research; radio, program, commercial effectiveness studied. Coml. and market research, local or national.)

MARKET RESEARCH COMPANY OF AMERICA—250 East 43rd St., New York 17. Tel.: Murray Hill 3-3652. President: Percival White; vice-president, Pauline Arnold.

MARKET RESEARCH OF CLEVELAND—1220 Huron Rd., Cleveland. Tel.: Main 0186. Albert E. Strass, director. (Radio research for midwest stations, advertisers and agencies.)

MARKETSCOPE RESEARCH Co.—156 Washington St., Newark, 2, N. J. Tel.: Mitchell 2-1753. Director of Television, Robert E. Spinner; public relations director, Jacqueline N. Bennett.

PENN McLEOD & ASSOCIATES
—Head Office: 445 Richards St., Vancouver, B.C. Branch Offices: 134 King St., East, Toronto, Ont.;

3322 White Bldg., Seattle, Wash. Managing Director: J. D. Penn McLeod; Director of Radio Research, William B. Watts; Statistical Consultant: Dr. Robert M. Clark; Toronto Manager: R. B. Dickinson. Seattle Manager: John Bolan. Seattle Office Consultant Analyst: Dr. Nathanael H. Engle. (Marketing, Public Opinion and Radio Research, Political Research specialists.)

ROBERT N. McMURRY & Co.—332 S. Michigan Ave., Chicago. Tel.: Harrison 7-5930. Robert N. McMurry, president.

MEDIA RECORDS Inc.—354 Fourth Ave., New York 10. Tel.: Murray Hill 5-9376. John Halpin, general manager; L. H. Collins, vice-president. *Offices:* 174 E. Long St., Columbus 15, Ohio; Tel.: Main 7784; Frances Davis, manager. 10 N. Clark St., Chicago 2; Tel.: Anderson 3-5683; A. J. Stansfield, manager. 381 Bush St., San Francisco 4; Tel.: Garfield 4989; E. J. Raleigh Jr., manager.

MOFFETT RESEARCH Co.—6253 Hollywood Blvd., Hollywood 28. Tel.: Hempstead 5653, Jessie Locke Moffett, owner.

NATIONAL ANALYSTS Inc.—1425 Chestnut St., Philadelphia 2. Tel.: Rittenhouse 6-7545. Arnold J. King, managing director; Valter Monroe, field manager; Robert K. McMillan, chief statistician. (Commercial market research, audience measurement, general surveys for media and business accounts.)

A. C. NIELSEN Co.—2101 Howard St., Chicago 45. Tel.: Hollywood 5-4400. *Officers:* A. C. Nielsen, president; Frederick K. Leisch, executive vice-president. *Offices:* 500 Fifth Ave., New York; Tel.: Pennsylvania 6-2850; James O. Peckman, exec. vice-president. 109 St. Aldates, Oxford, England; Dr. E. L. Lloyd, managing director. 2436 Yonge St., Toronto, Ont., Canada; D. M. Prather, president. Petersham, N. S. W., Sydney, Australia, Justin Power, president.

NOBLE & SWARS Inc.—7 W. 44th St., New York 18. Tel.: Murray Hill 2-7461. William Noble, president; M. Lawrence Swars, vice-president and general manager. (Coverage maps and sales promotion brochures.)

EDWARD J. NOONAN MARKET RESEARCH ORGANIZATION—157 Federal St., Boston 10. Tel.: Liberty 2-2606. Edward J. Noonan, director.

OFFICE OF RESEARCH Inc.—3470 Broadway, New York 31. Tel.: Audubon 3-2335. John G. Peatman, president and director. (Radio consultants and publishers of weekly surveys of network music.)

OPINION RESEARCH CORP.—44 Nassau St., Princeton, N. J. Tel.: 3600. Dr. Claude Robinson, president; Hugh Rusch, vice-president; Dilman M. K. Smith, vice-president. New York Office: 10 Rockefeller Plaza; Tel.: Circle 5-5977.

ALFRED POLITZ RESEARCH Inc.—400 Madison Ave., New York 17. Tel.: Plaza 9-5200. Alfred Politz, president. (Marketing, advertising and media research.)

PUBLISHERS INFORMATION BUREAU Inc. (PIB)—271 Madison Ave., New York 16. Tel.: Murray Hill 5-2210. Frank Braucher, president; W. H. Mullen, secretary. Branch Office: c/o Leading National Advertisers, 21 E. Hubbard St., Chicago 11. Tel.: Whitehall 4-6533.

THE PSYCHOLOGICAL CORP.—522 Fifth Ave., New York 18. Tel.: Murray Hill 2-2145. Walter R. Miles, chairman of the board; George K. Bennett, president; Albert D. Freiberg, 1st vice-president; Harold Seashore, 2d vice-president; Henry C. Link, Rose G. Anderson, vice-presidents; Richard A. Fear, secretary; Philip G. Corby, treasurer.

THE PULSE Inc.—110 Fulton St., New York 7. Tel.: Digby 9-4532. Director: Dr. Sydney Roslow; Manager: David Klein; asst. director: Nelle Kelly; statistician, Laurence Roslow (Radio, television, market research).

RESEARCH CO. OF AMERICA—341 Madison Ave., New York 17. Tel.: Murray Hill 4-0075. General Manager: A. Edwin Fein; Director of Sales Management Division: John W. Hall.

ELMO ROPER—30 Rockefeller Plaza, New York 20. Tel.: Plaza 7-4900. *Associates:* Carolyn Crusius, Louis Harris, Burns Roper, Robert Williams, Julian Woodward.

N. C. RORABAUGH Co.—347 Madison Ave., New York 17. Tel.: Murray Hill 6-2193. President: N. Charles Rorabaugh. Radio Editor: Frances Leeds; TV Editor, Margaret Miller. (Publishes monthly Rorabaugh Reports on Spot Radio & TV Advertising.)

SCHWERIN RESEARCH Corp.—2 W. 46th St., New York 19. Tel.: Luxemburg 2-4690. Horace S. Schwerin, president; Leonard Kudisch, executive vice president. (Radio, television, motion picture program testing and qualitative research.)

DANIEL STARCH & STAFF—420 Lexington Ave., New York. Tel.: Lexington 2-6622. Daniel Starch, director. (Business research.)

STEWART, DOUGALL & ASSOCIATES—30 Rockefeller Plaza, New York 20. Tel.: Plaza 7-2430. *Partners:* Paul W. Stewart, Arthur B. Dougall, Paul W. Atwood, Johanna B. Cooke. *Senior Research Associates:* R. C. Allen, E. A. O'Brien, F. T. Smith, C. Roberts, P. E. Gerhold, F. R. Haviland.

TELEVISION RESEARCH INSTITUTE—207 E. 43d St. Tel.: Murray Hill, 2-2092. John H. Eckstein, director. (Publishers of *Video*, television news letter and television market surveys.)

RADIO NEWS SERVICES

ASSOCIATED PRESS (Radio)—50 Rockefeller Plaza, New York 20. Tel.: Plaza 7-1111. Executives: Kent Cooper, executive director. Frank Starzel, general manager. Oliver S. Gramling, asst. to the general manager for radio; Tom O'Neil, news director; Howard L. Kany, Washington representative; Bob Cavagnaro, executive representative, San Francisco. Field Representatives: Tom Cunningham, Boston; H. R. Mason, New Orleans; Gerald Swisher, Columbus, O.; J. Mark Knight, Seattle; Frank Stearns, Wash., D. C.; Al Stine, southwestern div. manager, Kansas City, Mo.; Paul Breining, Harrisburg, Pa.

PRESS ASSOCIATION (Associated Press subsidiary)—50 Rockefeller Plaza, New York. Tel.: Plaza 7-1111; Kent Cooper, president; Oliver S. Gramling, vice president.

INTERNATIONAL NEWS SERVICE—235 E. 45th St., New York. Tel.: Murray Hill 7-8800. *Executives:* Seymour Berkson, general manager; William B. Goode, business manager; Frank J. Nicht, general sales manager; Robert H. Reid, manager, I N S - I N P - T V Dept.; John M. Cooper, director, radio dept. (Worldwide news, feature scripts, daily and weekly TV newsreels, Projectall, spot news and feature photos.)

NEWS STORY WORLDWIDE Inc.—521 Fifth Ave., New York 17. Tel.: Murray Hill 7-4694. Herbert Moore, president; Dixon Stewart, vice-president.

TRANSRADIO PRESS SERVICE Inc.—521 Fifth Ave., New York 17. Tel.: Murray Hill 2-4053. Herbert S. Moore, chairman of the board; Dixon Stewart, president. Branch Offices: 203 N. Wabash, Chicago. Manager: Cyril Kornbluth. National Press Bldg., Washington 4, D. C. Manager: Rex Goad. Taft Bldg., Hollywood; Manager: Milton Fishman.

UNITED PRESS ASSOCIATIONS—220 E. 42nd St., New York. Tel.: Murray Hill 2-0400. *Officers:* Hugh Baille, president; Earl J. Johnson, vice president and general news manager; Jack Bisco, vice-president and general manager; Le Roy Keller, general sales manager; Phil Newsom, radio news manager; A. F. Harrison, radio sales manager. (News, feature scripts, dramatized feature scripts, sports commentaries, business news, research, suggested programs.)

BRITISH UNITED PRESS LTD.—231 St. James St. W., Montreal, Que. Tel.: Plateau 9947. Phil R. Curran, managing director; Dennis Landry, executive news editor; N. M. MacLeod, assistant general manager and chief correspondent at Ottawa; Fred A. Darrell, chief

(Continued on page 520)

TELEVISION APPLICATIONS PENDING

Pending Before FCC as of
November 15, 1949

(*) Designates application in hearing.

ALABAMA

Birmingham—The Birmingham News Co., Ch. 9.

ARIZONA

Phoenix—KTAR Bcstg. Co., Ch. 4; T. M. & J. M. Gibbons, Ch. 7.
Tucson—Leland Holzer, Ch. 6.

ARKANSAS

Little Rock—Mid-South Television Bcstg. Co., Ch. 10; Southwestern Pub. Co., Ch. 8.

CALIFORNIA

Bakersfield—Paul R. Bartlett, Ch. 8; Pearl Lerner, Ch. 10.

Fresno—California Inland Bcstg. Co., Ch. 5; Donroy Bcstg. Co., Ch. 4; KARM, The George Harm Station*, Ch. 7; McClatchy Bcstg. Co., Ch. 7; Television Fresno Co., Ch. 2; Pacific Bcstg. Co., Ch. 4; Edward Lasker*, Ch. 7.

Los Angeles—Los Angeles Bcstg. Co., Ch. 13.

Oakland—KROW Inc., Ch. 11 (Also see San Francisco).

Riverside—Bcstg. Corp. of America, Ch. 6.

Sacramento—Harmco Inc., Ch. 3; McClatchy Bcstg. Co., Ch. 10; Sacramento Bcstg. Co., Ch. 6.

San Diego—Airfan Radio Corp. Ltd., Ch. 10; Balboa Bcstg. Co., Ch. 3; Pacific Bcstg. Co., Ch. 12; Television Bcstg. Co., Ch. 10; Video Bcstg. Co., Ch. 3; Charles E. Salik, Ch. 6.

San Francisco—Columbia Bcstg. System*, Ch. 9; Don Lee Bcstg. System*, Ch. 2; Paramount Television Productions Inc., Ch. 9; Television California*, Ch. 11; 20th Century-Fox of California Inc., Ch. 11 (See Oakland).

San Jose—FM Radio and Television Corp., Ch. 13; Radio Diablo Inc., Ch. 13.

San Luis Obispo—The Valley Electric Co., Ch. 3.

Santa Barbara—M. R. Schacker, Ch. 6; Radio KIST Inc., Ch. 6.

Visalia—Sierra Bcstg. Co., Ch. 10.

COLORADO

Denver—Alladin Television Inc., Ch. 9; The Daniels & Fisher Stores Co., Ch. 4; KMYR Bcstg. Co., Ch. 4; Landon Television Bcstg. Co., Ch. 5; Edward Lasker, Ch. 2; Gifford Phillips, Ch. 9; Denver Television Co., Ch. 2.

CONNECTICUT

Bridgeport—Yankee Network Inc., Ch. 10.

Hartford—The Connecticut Bcstg. Co., Ch. 10; The Hartford Times Inc., Ch. 10; Travelers Bcstg. Service Corp., Ch. 10.

Waterbury—Connecticut Radio Foundation Inc., Ch. 12; Nutmeg State Bcstg. Co., Ch. 12.

DELAWARE

Wilmington—Wilmington Tri-State Bcstg. Co. Inc., Ch. 7 (Assigned WDEL-TV there).

FLORIDA

Miami—Fort Industry Co., Ch. 7; Isle of Dreams Bcstg. Corp., Ch. 5; Miami Bcstg. Co., Ch. 5; Miami-Hollywood Television Corp., Ch. 7.

Miami Beach—WKAT Inc., Ch. 7.

Orlando—Orlando Daily Newspapers

Inc., Ch. 3; Sunshine Television Corp., Ch. 10.

St. Petersburg—Pinellas Bcstg. Co., Ch. 5 (Also see Tampa).

Tampa—Gulf Theatres Inc., Ch. 2; Tampa Times Co., Ch. 4; The Tribune Co., Ch. 9 (Also see St. Petersburg).

GEORGIA

Atlanta—Board of Regents, University System of Georgia, Georgia School of Technology*, Ch. 11; E. D. Rivers Jr., Ch. 8; General Bcstg. Co., Ch. 11.

Macon—Southeastern Bcstg. Co., Ch. 7.

IDAHO

Boise—Leland Holzer, Ch. 6.

ILLINOIS

Chicago—Columbia Bcstg. System Inc., Ch. 11; Johnson-Kennedy Radio Corp., Ch. 2; Sun and Times Co., Ch. 13; Zenith Radio Corp., Ch. 2.

Moline—Tri-City Telecasting Co., Ch. 9.

Quincy—Lee Bcstg. Inc., Ch. 11.

Rockford—Rockford Bcstg. Inc., Ch. 12.

Springfield—Trans-American Television Corp., Ch. 10; Sangamon Valley Television Corp., Ch. 8; WCBS Inc., Ch. 10.

INDIANA

Evansville—Trans-American Television Corp., Ch. 11.

Fort Wayne—Farnsworth Television and Radio Corp., Ch. 4; Northeastern Indiana Bcstg. Co. Inc., Ch. 4; Westinghouse Radio Stations Inc., Ch. 2.

Indianapolis—Crosley Bcstg. Co., Ch. 12; Indiana Bcstg. Corp., Ch. 12; Indianapolis Bcstg. Inc., Ch. 8; Universal Bcstg. Co. Inc., Ch. 8.

South Bend—South Bend Tribune, Ch. 13.

Terre Haute—Wabash Valley Bcstg. Co., Ch. 4.

IOWA

Boone—Boone Bcstg. Co., Ch. 7.

Davenport—Davenport Bcstg. Co., Ch. 2.

Des Moines—Central Bcstg. Co., Ch. 12; Cowles Bcstg. Co., Ch. 9; Independent Bcstg. Co., Ch. 5; Murphy Bcstg. Co., Ch. 2; Tri-State Meridith Bcstg. Co., Ch. 2.

Iowa City—The State University of Iowa, Ch. 11.

Oelwein—Northeast Iowa Radio Corp., Ch. 6.

KANSAS

Topeka—Midland Bcstg. Co., Ch. 7; Topeka Bcstg. Assn. Inc., Ch. 11.

Wichita—Okkan Television Chain Inc., Ch. 4.

KENTUCKY

Louisville—Mid-America Bcstg. Corp., Ch. 13.

LOUISIANA

Baton Rouge—Baton Rouge Bcstg. Co. Inc., Ch. 9.

New Orleans—Loyola University*, Ch. 10; New Orleans Television Co., Ch. 2.

Shreveport—Mid-South Television Bcstg. Co., Ch. 6; International Bcstg. Co., Ch. 8; Shreveport Television Co., Ch. 8; Fairfield Manor Television Co., Ch. 11; Radio Station KTBS Inc., Ch. 4.

MAINE

Portland—Congress Square Hotel Co., Ch. 11; Oliver Bcstg. Corp., Ch. 8.

MARYLAND

Cumberland—The Tower Realty Co., Ch. 2; Cumberland Bcstg. Co., Ch. 2.

Frederick—The Monocacy Bcstg. Co., Ch. 3.

Hagerstown—Hagerstown Bcstg. Co. Inc., Ch. 6.

MASSACHUSETTS

Boston—Boston Metropolitan Television Co., Ch. 9; Columbia Bcstg. System*, Ch. 9; Massachusetts Bcstg. Corp., Ch. 9; Matheson Radio Co. Inc., Ch. 13; New England Television Co. Inc., Ch. 13; New England Theatres Inc., Ch. 13; 20th Century-Fox New England Inc., Ch. 13.

Fall River—Fall River Herald News Pub. Co., Ch. 8; New England Television Co. Inc., Ch. 8 (Also see New Bedford).

Holyoke—Hampden-Hampshire Corp., Ch. 3 (Also see Springfield).

Lawrence—Hildreth & Rogers Co., Ch. 6 (Also see Lowell).

Lowell—Lowell Sun Pub. Co., Ch. 6 (Also see Lawrence).

New Bedford—E. Anthony & Sons Inc., Ch. 8 (Also see Fall River).

Springfield—New England Television Co. Inc., Ch. 3; Yankee Network Inc., Ch. 3 (Also see Holyoke).

Worcester—New England Television Co. Inc., Ch. 5; WTG Inc., Ch. 5.

MICHIGAN

Detroit—United Detroit Theatres Corp., Ch. 5; WJR, The Goodwill Stations Inc., Ch. 5.

Duluth—Head of the Lakes Bcstg. Co., Ch. 3.

Flint—Advertisers Press Inc., Ch. 11; Booth Radio Stations Inc., Ch. 11.

Grand Rapids—Grandwood Bcstg. Co., Ch. 9.

Saginaw—Booth Radio Stations Inc., Ch. 8; Saginaw Bcstg. Co., Ch. 13.

MINNESOTA

Minneapolis—St. Paul—Beck Studios Inc., Ch. 7; Independent Merchants Bcstg. Co., Ch. 7; WMIN Bcstg. Co., Ch. 2.

MISSISSIPPI

Jackson—Mid-South Television Bcstg. Co., Ch. 7.

MISSOURI

Clayton—Evangelical Lutheran Synod*, Ch. 2 (Also see St. Louis).

Kansas City—The KCKN Bcstg. Co., Ch. 2; KCMO Bcstg. Co., Ch. 5; New England Television Co. Inc., Ch. 5; 20th Century-Fox of Missouri Inc., Ch. 9; WHB Bcstg. Co., Ch. 5; Midland Bcstg. Co., Ch. 9.

St. Joseph—KFEQ Inc., Ch. 13; Midland Bcstg. Co., Ch. 13.

St. Louis—New England Television Co. Inc., Ch. 4; Thomas Patrick Inc., Ch. 9; The St. Louis University*, Ch. 7; Star-Times Pub. Co., Ch. 4; 20th Century-Fox of St. Louis, Ch. 9.

NEBRASKA

Lincoln—Inland Bcstg. Co., Ch. 10.

Omaha—Central States Bcstg. Co., Ch. 7; KFAB Bcstg. Co., Ch. 7.

NEW HAMPSHIRE

Manchester—Grandview Inc., Ch. 12.

Portsmouth—WHEB Inc., Ch. 5.

NEW JERSEY

Atlantic City—Atlantic City Television Bcstg. Co., Ch. 8; Neptune Bcstg. Corp., Ch. 8; Press-Union Pub. Co., Ch. 8.

New Brunswick—Home News Pub. Co., Ch. 8.

Trenton—Trent Bcstg. Corp., Ch. 8.

NEW MEXICO

Albuquerque—Leland Holzer, Ch. 5; William J. Baker, Ch. 5.

NEW YORK

Albany—Hudson Valley Bcstg. Co. Inc., Ch. 7; Meredith Champlain Television Corp., Ch. 11; Patroon Bcstg. Co. Inc., Ch. 9; Van Currier Bcstg. Co., Ch. 9 (Also see Troy).

Buffalo—WKBW Inc., Ch. 9; Buffalo Courier Express Inc., Ch. 7; New England Television Co. Inc., Ch. 9; WGR Bcstg. Corp., Ch. 9 (Also see Niagara Falls).

Corning—Corning Leader Inc., Ch. 9.

Elmira—Elmira Star Gazette Inc., Ch. 9.

Ithaca—Cornell University, Ch. 4.

Niagara Falls—Niagara Falls Gazette Pub. Co., Ch. 9 (Also see Buffalo).

Rochester—Meredith Pub. Co., Ch. 11; WARC Inc., Ch. 11; WHEC Inc., Ch. 2.

Troy—Troy Bcstg. Co. Inc., Ch. 9 (Also see Albany).

NORTH CAROLINA

Asheville—Mary Pickford Rogers, Ch. 5.

Charlotte—Inter-City Adv. Co., Ch. 11; Radio Station WSOC Inc., Ch. 9; Surety Bcstg. Co., Ch. 9.

Durham—Durham Radio Corp., Ch. 4; Mary Pickford Rogers, Ch. 4; Harold H. Thoms, Ch. 7.

Greensboro—Inter-City Adv. Co., Ch. 10.

High Point—Radio Station WMFR Inc., Ch. 12.

Raleigh—WPTF Radio Co., Ch. 5.

Salisbury—Mid-Carolina Bcstg. Co., Ch. 4.

Winston-Salem—Piedmont Pub. Co., Ch. 6; Mary Pickford Rogers, Ch. 6.

OHIO

Akron—Allen T. Simmons*, Ch. 11; Summit Radio Corp., Ch. 11.

Bellaire—Tri-City Bcstg. Co., Ch. 12 (Also see Wheeling, W. Va.).

Canton—Brush-Moore Newspapers Inc., Ch. 7.

Cincinnati—Allen B. DuMont Labs. Inc., Ch. 2.

Cleveland—Cleveland Bcstg. Inc., Ch. 2; Allen B. DuMont Labs. Inc., Ch. 2; United Bcstg. Co., Ch. 7; The WGAR Bcstg. Co., Ch. 7; WJW Inc., Ch. 2.

Toledo—Maumee Valley Bcstg. Co., Ch. 11; Toledo Blade Co., Ch. 10; Community Bcstg. Co., Ch. 3.

Youngstown—Mansfield Radio Co., Ch. 13; Vindicator Printing Co., Ch. 13; WKBN Bcstg. Corp., Ch. 13.

OKLAHOMA

Oklahoma City—KOMA Inc., Ch. 5; Mid-South Television Bcstg. Co., Ch. 5; Oklahoma City Television Co., Ch. 9; Southwestern Pub. Co., Ch. 9.

Tulsa—Public Radio Corp., Ch. 10; Tulsa Bcstg. Co., Ch. 8; Tulsa Television Co., Ch. 10; Southwestern Pub. Co., Ch. 8; Southwestern Sales Corp., Ch. 8.

OREGON

Portland—KOIN Inc., Ch. 8; KPOJ Inc., Ch. 12; Edward Lasker*, Ch. 10; Oregonian Pub. Co., Ch. 6; Westinghouse Radio Stations Inc., Ch. 10.

PENNSYLVANIA

Allentown—Lehigh Valley Bcstg. Co., Ch. 8; Penn-Allen Bcstg. Co., Ch. 8 (Also see Bethlehem, Easton).

Altoona—Central Pennsylvania Corp., Ch. 9; The Gable Bcstg. Co., Ch. 9.

Bethlehem—Philco Television Bcstg. Corp., Ch. 8 (Also see Allentown, Easton).

Easton—Easton Pub. Co., Ch. 8 (Also see Allentown, Bethlehem).

Erie—Presque Isle Bcstg. Co., Ch. 3.

Harrisburg—Harold O. Bishop*, Ch. 8; WHP Inc., Ch. 8.

Hazleton—Hazleton Bcstg. Co., Ch. 2.

Meadville—Meadville Bcstg. Service Inc., Ch. 13.

Philadelphia—Daily News Television Co., Ch. 12; Pennsylvania Bcstg. Co., Ch. 12.

Pittsburgh—Allegheny Bcstg. Corp., Ch. 8; Matta Bcstg. Co., Ch. 10; Pittsburgh Radio Supply House Inc., Ch. 10; United Bcstg. Corp., Ch. 10; WCAE Inc., Ch. 10; Westinghouse Radio Stations Inc., Ch. 6; WWSW Inc., Ch. 10.

Reading—Eastern Radio Corp., Ch. 5; Hawley Bcstg. Co., Ch. 5.

Scranton—Appalachian Co., Ch. 7; The Scranton Times, Ch. 11 (Also see Wilkes-Barre).

Wilkes-Barre—Louis G. Baltimore*, Ch. 11; Wyoming Valley Bcstg. Co., Ch. 11 (Also see Scranton).

Williamsport—Central Pennsylvania Corp., Ch. 13; WRAC Inc., Ch. 13.

York—The Helm Coal Co., Ch. 8; Susquehanna Bcstg. Co., Ch. 8.

RHODE ISLAND

Providence—Cherry & Webb Bcstg. Co., Ch. 13.

SOUTH CAROLINA

Greenville—Greenville News Piedmont Co., Ch. 10.

TENNESSEE

Chattanooga—Charles S. Cornell, Ch. 10.

Knoxville—Charles S. Cornell, Ch. 8; Scripps-Howard Radio Inc., Ch. 8.

Memphis—Bluff City Bcstg. Co., Ch. 5; Mid-South Television Bcstg. Co., Ch. 9; WMPB Inc., Ch. 9; WREC Bcstg. Service, Ch. 7; Harding College, Ch. 2.

Nashville—Capitol Bcstg. Co., Ch. 9; WLAC Bcstg. Service, Ch. 7; WSIX Bcstg. Station, Ch. 5; Charles S. Cornell, Ch. 2.

NEWS SERVICES

(Continued from page 519)

accountant; James R. Nelson, bureau manager.

PRESS NEWS LIMITED—Subsidiary of Canadian Press, 55 University Ave., Toronto 1, Ont. Tel.: Elgin 2692. Victor Sifton, president; Gillis Purcell, chief executive; C. B. Edwards, manager; C. A. Day, treasurer.

REUTERS LTD. OF LONDON—Times Building, 229 West 43rd. New York. Tel.: Bryant 9-8558. D. K. Rogers, manager.

TEXAS

Abilene—Abilene Television Co., Ch. 11.

Amarillo—Amarillo Television Co., Ch. 5; C. C. Woodson d/b as The Amarillo Television Co., Ch. 5.

Austin—The Austin Television Co., Ch. 8; Texas Telenet System Inc., Ch. 10.

Beaumont—Lufkin Amusement Co., Ch. 10; Beaumont Television Co., Ch. 8; Sabine Television Co., Ch. 3.

Brownsville—Brownsville Television Co., Ch. 7.

Corpus Christi—Corpus Christi Television Co., Ch. 6; Texas Telenet System Inc., Ch. 3.

Dallas—A. H. Belo Corp., Ch. 12; Texas Television*, Ch. 10; City of Dallas*, Ch. 10; Lechner Television Co., Ch. 11; Variety Bcstg. Co. Inc., Ch. 2.

El Paso—Claude H. Craig, Ch. 5; El Paso Television Co., Ch. 7.

Fort Worth—Texas State Network Inc., Ch. 2; Texas Telenet System Inc., Ch. 10.

Galveston—Galveston Television Co., Ch. 9.

Harlingen—Harlingen Television Co., Ch. 9.

Houston—Harris County Bcstg. Co., Ch. 5; Texas Television*, Ch. 7; Houston Post Co., Ch. 4; KTRH Bcstg. Co., Ch. 5; Shamrock Bcstg. Co., Ch. 7; Lechner Television Co., Ch. 4.

Longview—East Texas Television Co., Ch. 5.

Lubbock—Lubbock Television Co., Ch. 6.

McAllen—McAllen Television Co., Ch. 12.

Midland—Midland Television Co., Ch. 7.

San Angelo—San Angelo Television Co., Ch. 8; Texas Telenet System Inc., Ch. 2; Texas State Network Inc., Ch. 2; The Walmac Co., Ch. 9; Mission Bcstg. Co., Ch. 12.

Sherman—Sherman Television Co., Ch. 6.

Tyler—Tyler Bcstg. Co., Ch. 9.

Waco—The Waco Television Co., Ch. 6; Texas Telenet System Inc., Ch. 3.

Wichita Falls—Wichita Falls Television Co., Ch. 8; Leland Holzer, Ch. 10.

UTAH

Salt Lake City—Edward Lasker, Ch. 7; Salt Lake City Bcstg. Co. Inc., Ch. 7; Utah Bcstg. Co., Ch. 2; Granite District Radio Bcstg. Co., Ch. 9.

VIRGINIA

Newport News—Hampton Roads Bcstg. Corp., Ch. 7.

Norfolk—Commonwealth Bcstg. Corp., Ch. 11; Beachview Bcstg. Corp., Ch. 11; Larus & Bro. Co. Inc., Ch. 13.

Richmond—Larus & Bro. Co. Inc., Ch. 10; Lee Bcstg. Co., Ch. 10; Richmond Radio Corp., Ch. 3; Southern Bcstrs. Inc., Ch. 8.

Winchester—Richard Field Lewis Jr., Ch. 12.

WASHINGTON

Seattle—Fishers' Blend Station Inc., Ch. 2; Edward Lasker*, Ch. 7; Queen City Bcstg. Co., Ch. 11; Totem Bcstrs. Inc., Ch. 7; 20th Century-Fox of Washington Inc., Ch. 11.

Spokane—Harry L. Crosby Jr., Ch. 7.

Tacoma—Television Tacoma Inc., Ch. 4; Harry L. Crosby Jr., Ch. 9; Carl E. Raymond, Ch. 13.

Yakima—Harry L. Crosby Jr., Ch. 6.

WEST VIRGINIA

Charleston—Joe L. Smith Jr., Ch. 2; Charleston Television Inc., Ch. 7; Charleston Bcstg. Co., Ch. 13.

Oak Hill—Robert R. Thomas Jr., Ch. 6.

Wheeling—West Virginia Bcstg. Corp., Ch. 12 (See Bellaire, Ohio).

WISCONSIN

Madison—Badger Bcstg. Co., Ch. 9; Radio Wisconsin Inc., Ch. 9; Monana Bcstg. Co., Ch. 9.

Milwaukee—Hearst Radio Inc., Ch. 10; Milwaukee Bcstg. Co., Ch. 6; Wisconsin Bcstg. System Inc., Ch. 8.

Green Bay—WBXY Inc., Ch. 4.

BROADCAST STATIONS IDENTIFIED WITH NEWSPAPER OWNERSHIP

The following tabulation, showing newspaper ownership or affiliation of AM, FM and TV broadcast stations in the United States, Hawaii and Alaska, is based on information procured from the operating companies or from official sources. Minority interests are indicated where the information was available. In many instances stations and newspapers are owned by the same interests but operations are entirely separated.

ALABAMA

WRFS, Alexander City—Licensed to Piedmont Service Corp. Publisher of Alexander City Outlook is minority stockholder.

WHMA, WHMA-FM, Anniston—Licensed to Anniston Bcstg. Co. Harry M. Ayers, owner of Anniston Star, principal stockholder.

WSGN, WSGN-FM, Birmingham—Licensed to the Birmingham News Co., publisher of The Birmingham News and The Birmingham Age Herald; 82 1/4% of stock owned by estate of Victor H. Hanson, deceased. The Birmingham News Co. also owns all capital stock of The Huntsville (Ala.) Times.

WEBJ, Brewton—Licensed to Brewton Broadcasting Co., under same ownership as the Brewton Standard.

WKUL, Cullman—Licensed to Cullman Broadcasting Co., under same ownership as Cullman Banner.

WGNH, Gadsden—Licensed to General Newspapers Inc.; Carmage Walls, president; Charles E. Marsh, chairman of the board. General Newspapers Inc. owns 3/4 interest Macon (Ga.) Publishing Co.; the Gadsden (Ala.) Times; The Tuscaloosa (Ala.) News; The Spartanburg (S.C.) Herald-Journal, the Cleveland (Tenn.) Daily Banner, the Martinsville (Va.) Bulletin Inc., and minority interest in the Orlando (Fla.) Sentinel-Star.

WHBS, WHBS-FM, Huntsville—Licensed to The Huntsville Times Co. Inc., publisher, Huntsville Times.

WRLD, WRLD-FM, Lanett—Licensed to Valley Broadcasting Co. President J. C. Henderson is publisher or substantial owner of Lanett Valley Tribune; Alexander City Outlook, Dadesville Record, and Opelika Eagle. Stockholder William G. Jones owns stock in Valley Tribune and Opelika Eagle.

WABB, WABB-FM, Mobile—Licensed to The Mobile Press Register Inc., publishers of the Mobile Press Register.

WSFA, Montgomery—Licensed to Montgomery Broadcasting Co. Inc.; one-fourth interest owned individually by R. F. Hudson, publisher of Montgomery Advertiser.

ARIZONA

KGAN, Kingman—Licensed to J. James Glancy, publisher of Mohave County Miner.

KGLU, Safford—Licensed to Gila Broadcasting Co. President L. F. Long is principal owner of Graham County Guardian.

KCNA, Tucson—Licensed to Catalina Broadcasting Co.; ownership affiliated with Tucson Newspapers Inc., printers of Arizona Star and Daily Citizen, Tucson; the State Publishing Co., publishers of the Star, and the Citizen Publishing Co., publishers of the Citizen.

ARKANSAS

KFSA, KFSA-FM, Fort Smith—Licensed to Donald W. Reynolds, owner of Times Publishing Co., Okmulgee, Okla. (Okmulgee Times Democrat and Okmulgee Times), owner of Southwestern Publishing Co., Fort Smith (Southwest Times, Record and Southwest American), owner Enterprise Publishing Co., Bartlesville, Okla. (Bartlesville Enterprise, Bartlesville Examiner); owner Southwestern Publishing Co., Las Vegas, Nev. (Las Vegas Review Journal).

KXAR, Hope—Licensed to the Hope Broadcasting Co.; Alex Washburn, publisher Hope Daily Star, owns 42%.

KTHS, Hot Springs—Licensed to Radio Broadcasting Inc., chief owners identified with the Times Publishing Co. Inc., publishers of the Shreveport, La., Times, same ownership as Monroe (La.) World and News-Star.

KLRA, Little Rock—Licensed to Arkansas Broadcasting Co., 88.8% of stock owned by Gazette Publishing Co., publishers of Arkansas Gazette.

KBRS Springdale—Licensed to Southwestern Publishing Co. President is Donald W. Reynolds (see KFSA Ft. Smith).

CALIFORNIA

KERN, KERN-FM, Bakersfield—Licensed to McClatchy Broadcasting Co.; same ownership as Sacramento Bee, Fresno Bee, Modesto Bee (McClatchy Newspapers).

KXO, El Centro—Licensed to Valradio Inc., 10% of which is owned by Imperial Valley Publishing Co. (El Centro Morning Post, Imperial Valley Press, Braulley Daily News); 61% is owned by Paul and Edith Jenkins, and 20% by Mr. and Mrs. Harry Hovey.

KIEM, KRED (FM), Eureka—Licensed to Redwood Broadcasting Co. Inc., 20.8% of stock owned by Standard Printing Co., publisher of Humboldt Standard; 20% by Times Publishing Co., publisher of Humboldt Times; 59.3%, William B. Smullin.

KMJ, KMJ-FM, Fresno—Licensed to McClatchy Broadcasting Co.; same ownership as Fresno Bee, Sacramento Bee, Modesto Bee (McClatchy Newspapers).

KLAC, KLAC-TV, Hollywood—Licensed to KMTT Radio Corp., owned by Dorothy Schiff, publisher New York Post.

KNGS, Hanford—Licensed to Hanford Publishing Co., publishers of the Hanford Sentinel-Journal.

KTTV (TV) Los Angeles—Licensed to KTTV Inc., 51% of which is owned by The Times Mirror Co., publisher of The Los Angeles Times, and 49% by CBS.

KBEE (FM), Modesto—Licensed to McClatchy Broadcasting Co. (See KERN, Fresno).

KROW, KROW-FM (CP), Oakland—Licensed to KROW Inc., owned by Sheldon F. Sackett, chief owner of KVAN, Vancouver, Wash., owner of KOOS, Coos Bay, Ore., and publisher and editor of the Coos Bay Times.

KDAN, Oroville—Licensed to the Oroville Mercury Bcstg. Co. Publisher of the Mercury Register, Oroville, principal owner.

KVNE, Oxnard—Licensed to Eva Miller Grimes, pres. of Oxnard Press Courier, Inc., publisher Oxnard Press Courier.

KSRO, Santa Rosa—Licensed to Ruth W. Finley, president, Press-Democrat Pub. Co., publisher of Santa Rosa Evening Press and Press-Democrat. Operated independently of newspapers.

KLX, KLX-FM, Oakland—Licensed to Tribune Building Co.; affiliated with Oakland Tribune.

KOCS, KEDO (FM), Ontario—Licensed to Daily Report Co., same ownership as Daily Report, Ontario-Upland, Calif.

KFBK, KFBK-FM, Sacramento—Licensed to McClatchy Broadcasting Co.; same ownership as Sacramento Bee, Fresno Bee, Modesto Bee (McClatchy Newspapers).

KSNI (formerly KDON-FM), Salinas—Licensed to Monterey Peninsula Broadcasting Co. Owned by Salinas Newspapers Inc., publisher Salinas Californian (Speidel Newspapers). See also WGNV Newburgh, N. Y.; WKIP Poughkeepsie, N. Y.; and KWRN Reno, Nev.

KSDO (formerly KUSN), KSDO-FM, San Diego—Licensed to San Diego Bcstg. Co., 50% owned by Copley Press, publisher of Springfield (Ill.) State Journal, San Diego Union and San Diego Tribune Sun, Calif.

KBMT (FM), San Bernardino—Licensed to The Sun Co., publishers San Bernardino Sun and Telegram.

KRON-FM, KRON-TV, San Francisco—Licensed to Chronicle Publishing Co., publishers San Francisco Chronicle.

KYA, San Francisco—Licensed to Palo Alto Radio Station Inc., owned by Dorothy Schiff, publisher, New York Post.

KTMS, Santa Barbara—Licensed to News-Press Publishing Co., publisher of Santa Barbara News-Press (T. M. Storke, publisher, owns 60% of common stock).

KDON, Santa Cruz—Licensed to Central Coast Counties Radio Inc.; 50% owned by Salinas Newspapers Inc. publisher Salinas Californian (Speidel Newspapers). See also WGNV Newburgh, N. Y.; WKIP Poughkeepsie, N. Y., and KWRN Reno, Nev., 50% owned by Grant Wrathall, consulting radio engineer.

KSCO, Santa Cruz—Licensed to Radio Santa Cruz; Fred D. McPherson Jr., publisher of Santa Cruz Sentinel News, is a partner.

KSJO, KSJO-FM, San Jose—Licensed to Santa Clara Broadcasting Co. President Patrick H. Peabody is publisher Gilroy Dispatch, Los Gatos Daily Times.

KWG, Stockton—Licensed to McClatchy Broadcasting Co.; same ownership as Sacramento Bee, Modesto Bee, Fresno Bee (McClatchy Newspapers).

KSMO, San Mateo—Licensed to Amphlett Printing Co., publisher, San Mateo Times & News Leader.

KTIM, San Rafael—Licensed to Marin Broadcasting Co., owned by San Rafael Independent-Journal.

KHUB, Watsonville—Licensed to Luther E. Gibson, editor and publisher of Vallejo Chronicle-News and Times-Herald.

COLORADO

KPKA, Greeley—Licensed to Midwestern Radio Corp.; same ownership (H. E. Green) as The Record Stockman, Denver, weekly.

KLMR, Lamar—Licensed to Southeast Colorado Broadcasting Co., Inc. Fred M. Betz, 1/2 owner, owns Lamar Daily News.

KCSJ, Pueblo—Licensed to the Star Broadcasting Co. Frank S. Hoag, Jr., president, owns 20% of the Star-Journal Pub. Corp., publisher, Pueblo Chieftain and Star-Journal; Frank S. Hoag, 1% owner of Star Broadcasting, is president and general manager of publishing firm.

CONNECTICUT

WTHT, WTHT-FM, Hartford—Licensed to the Hartford Times Inc., publisher of Hartford Times; 73.58% of stock owned by the Gannett Newspapers; see WENY, Elmira, N. Y.

WCNX, Middletown—Licensed to Middlesex Broadcasting Co. Middletown Press Publishing Co. (Middletown Press) owns 50%.

WICH, Norwich—Licensed to Eastern Connecticut Broadcasting Co. Stockholders Harrison C. Noyes and Clifford C. Oat are co-publishers of Norwich Bulletin and Record.

WSTC, WSTC-FM, Stamford—Licensed to Western Connecticut Broadcasting Co., owned 51% by Kingsley Gillespie, publisher of Stamford Advocate.

WLCR, Torrington—Licensed to Litchfield County Radio Corp. Herbert L. Crapo, president of Litchfield Enquirer Publishing Co., is secretary.

WBRY, Waterbury—Licensed to the American-Republican Inc., publisher of Waterbury Republican, Sunday Republican and Waterbury American.

DISTRICT OF COLUMBIA

WMAL, WMAL-FM, WMAL-TV, Washington—Licensed to The Evening Star Broadcasting Co., subsidiary of The Evening Star.

WOL, WOL-FM, Washington—Licensed to Cowles Broadcasting Co. Gardner Cowles Jr., president, also publisher of Look magazine, president of Register & Tribune Co., publisher of Des Moines Register and Tribune; John A. Cowles, vice-president of Register & Tribune Co., also president of Minneapolis Star Journal and Tribune Co. (WOL has been sold to Capital Broadcasting Co. and the sale app-

(Continued on page 522)

NEWSPAPER OWNERSHIP

(Continued from page 521)

proved by FCC, subject to Capital disposing of WWDC Washington.)
WTOP, WTOP-FM, Washington—Licensed to WTOP Inc. 55% owned by The Washington Post.

DELAWARE

WDEL, WDEL-FM, WDEL-TV, Wilmington—Licensed to WDEL Inc. Operated independently. J. Hale Steinman and John F. Steinman, owners, also own Lancaster (Pa.) Newspapers Inc.

FLORIDA

WNDB, WNDB-FM, Daytona Beach—Licensed to the News-Journal Corp., Publishers of the Morning Journal, Evening News, and Sunday News-Journal.

WFTL, WGOR(FM), Ft. Lauderdale—Licensed to the Gore Pub. Co., publishers of Ft. Lauderdale News.

WJHP, WJHP-FM, Jacksonville—Licensed to The Metropolis Co.; same ownership as Jacksonville Journal. (See WCOA, Pensacola.)

WIOD, WIOD-FM, Miami—Licensed to Isle of Dreams Broadcasting Corp., stock owned by Miami Daily News Inc.

WQAM, WQAM-FM, Miami—Licensed to Miami Broadcasting Co., owned by Miami Herald Publishing Co., publisher of The Miami Herald (Knight Newspapers).

WGBS, WGBS-FM, Miami—Licensed to Fort Industry Co., George E. Storer, president, is also president of Miami Beach Publishing Co., which publishes the Florida Sun, Miami Beach, and the Riviera Times, Coral Gables.

WTMC, Ocala—Licensed to Ocala Broadcasting Co. Inc.; (see WCOA).

WHOO, WHOO-FM, Orlando—Licensed to Orlando Daily Newspapers, publishers of the Orlando Morning Sentinel and Evening Star.

WDLF, Panama City—Licensed to Panama City Bstg. Co. and owned by publishers of Panama City News-Herald. (See WCOA).

WCOA, WCOA-FM, Pensacola—Licensed to Pensacola Broadcasting Co.; John H. Perry, 79% stockholder; is publisher of Pensacola Journal News, Jacksonville Journal, Panama City (Fla.) News-Herald. Mr. Perry is also president of Western Newspaper Union, a newspaper syndicate.

WTSP, WTSP-FM, St. Petersburg—Licensed to Pinellas Broadcasting Co., 53% of stock owned by Nelson Foynter, publisher of St. Petersburg Times.

WDAE, WDAE-FM, Tampa—Licensed to Tampa Times Co., publisher of Tampa Daily Times.

WFLA, WFLA-FM, Tampa—Licensed to The Tribune Co. J. C. Council, publisher of The Tampa Tribune.

GEORGIA

WALB, Albany—Licensed to Herald Publishing Co., publisher of Albany Herald.

WDEC, Americus—Licensed to Americus Broadcasting Co. President James R. Blair is publisher of Times Recorder.

WGAU, WGAU-FM, Athens—Licensed to J. K. Patrick & Co. Stockholder E. B. Braswell is editor of the Athens Banner-Herald.

WAGA, WAGA-FM, WAGA-TV, Atlanta—see WGBS, Miami, Fla.

WCON, WCON-FM, WCON-TV, Atlanta—Licensed to Constitution Publishing Co., publishers of the Atlanta Constitution.

WSB, WSB-FM, WSB-TV, Atlanta—Licensed to Atlanta Journal Co., publisher of Atlanta Journal (James M. Cox; see also WIOD, Miami, and WHIO, Dayton, O.)

WBHF, Cartersville—Licensed to W. R. Frier who is owner of the Bartow Herald, Cartersville.

WGBA, WGBA-FM, Columbus—Licensed to Georgia-Alabama Broadcasting Corp. Twenty percent interest each held by A. H. Chapman, president, M. R. Ashworth, publisher of the Ledger and Enquirer; Wylene Page Chapman; Annie Laurie Page Ashworth, and W. E. Page, owners of stock in the Ledger-Enquirer Co.

WMOC, Covington—Licensed to Covington News Inc., publisher of the Covington News, the Conyers (Ga.) News, and the Monroe (Ga.) Walton Times.

WSGC, Elberton—Licensed to Elberton Broadcasting Co., controlled (75%) by G. T. Christian, owner of the Elberton Star, semi-weekly newspaper.

WDUN, WDUN-FM, Gainesville—Licensed to Northeast Georgia Broadcasting Co. Albert S. Hardy, minority stockholder, publishes the Gainesville News.

WGGA, Gainesville—Licensed to Blue Ridge Broadcasting Co. Charles Smithgall, publisher Gainesville Daily Times, is president and majority stockholder.

WKLY, Hartwell—Licensed to Louie L. Morris, publisher of the Hartwell Sun.

WLAG, WLAG-FM, La Grange—Licensed to La Grange Broadcasting Co.; 33 1/3% of stock owned by Roy C. Swank, publisher of La Grange News.

WNEK, WNEK-FM, Macon—Licensed to Macon Broadcasting Co.; 16% held by the Telegraph Publishing Co., publishers of the Telegraph, the News and the Telegraph-News, Macon.

WMVG, Milledgeville—Licensed to Jere N. Moore, editor, Union Recorder, a weekly.

WCOH, WCOH-FM Newnan—Licensed to Newnan Broadcasting Co. Evan W. and James Thomason, who own 50% of Newnan Times-Herald.

WROM, Rome—Licensed to Coosa Valley Radio Corp. General manager is owner of Floyd County Herald.

WLAQ, Rome—Licensed to the News Tribune Publishing Co., publishers of the Rome News-Tribune.

WSFT, Thomaston—Licensed to the Thomaston Broadcasting Co. J. E. Hardy, S. J. Carswell, co-owners, Thomaston Times, own 40% of station.

WVOP, Vidalia—Licensed to Vidalia Broadcasting Co., one-half owned by R. E. Ledford, owner of the Vidalia Advance.

WAYX, Waycross—Licensed to Jack Williams, publisher, Waycross Journal-Herald.

IDAHO

KBIO, Burley—Licensed to KBIO Inc. President Jessica L. Longston is publisher of Burley Bulletin and Herald and St. Helens (Ore.) Sentinel. Mist. (See KAVR Havre, Mont., KSEM Moses Lake, and KPUG Bellingham, Wash.)

KCID, Caldwell—Licensed to Caldwell Bstg. Co. Inc. Station stock is 50% owned individually by stockholders of Caldwell News-Tribune Inc., publisher of Caldwell News-Tribune.

KVNI, Coeur d'Alene—Licensed to Coeur d'Alene Broadcasting Co., identified in ownership with Coeur d'Alene Press (see KNEW Spokane, Wash.).

KIFI, Idaho Falls—Licensed to Eastern Idaho Bstg. & Tele. Co. Idaho Falls Post-Register is part owner (see KEIO Pocatello).

KEIO, Pocatello—Licensed to Eastern Idaho Broadcasting and Television Co. (See KIFI Idaho Falls).

ILLINOIS

WBNV(FM), Aurora—Licensed to the Copley Press, Inc., publishers of the Aurora Beacon News.

WJBC, WJBC-FM, Bloomington—Licensed to Bloomington Broadcasting Corp., owned by the Daily Pantagraph Co., publishers of the Daily Pantagraph.

WBYS, WBYS-FM, Canton—Licensed to Fulton County Broadcasting Co. President Harold R. Winsor is publisher of Canton Daily Ledger.

WDWS, WDWS-FM, Champaign—Licensed to The Champaign News-Gazette Inc., publisher of The News-Gazette.

WAAF, WAAF-FM, Chicago—Licensed to Corn Belt Publishers Inc. (Drivers Journal division).

WGN, WGNB(FM), WGN-TV, Chicago—Licensed to WGN Inc., 100% subsidiary of the Chicago Tribune Co., publisher of the Chicago Tribune.

WIND, Chicago—Licensed to the Johnson-Kennedy Radio Corp., Knight Newspapers own 42% (Chicago Daily News, Detroit Free Press, Akron Beacon Journal, etc.)

WJJD, WJJD(FM), Chicago—Licensed to WJJD, Inc., owned by Field Enterprises Inc., controlled by Marshall Field, publisher, Chicago Sun-Times.

WLS, Chicago—Licensed to Agricultural Broadcasting Co.; 100% of stock owned by Prairie Farmer Publishing Co., publisher of The Prairie Farmer, bi-weekly.

WDAN, Danville—Licensed to Northwestern Publishing Co., publisher of Danville Commercial-News (Gannett Newspaper); see WENY, Elmira, N. Y.

WCRA, Effingham—Licensed to the Effingham Bstg. Co. Some stockholders also hold stock in Effingham Daily News.

WSOY, WSOY-FM, Decatur—Licensed to Illinois Broadcasting Co., 100% of stock owned by Decatur Newspapers Inc., publisher of Decatur Herald and Review; same ownership as Campaign-Urbana (Ill.) Evening Courier and others.

WFJS (FM), Freeport—Licensed to Freeport Journal Standard Publishing Co., publishers Journal-Standard.

WGIL, Galesburg—Licensed to Galesburg Broadcasting Co.; 60 out of 100 shares of issued stock owned by executives of Galesburg Printing & Publishing Co.

WKAN, WKIL (FM), Kankakee—Licensed to the Kankakee Daily Journal Co., publisher, Kankakee Daily Journal.

WLPO, La Salle—Licensed to La Salle County Broadcasting Corp., 100% owned by Mr. and Mrs. Peter Miller, who publish the La Salle Daily News-Tribune.

WPRC, Lincoln—CP held by Prairie Radio Corp., one-third owned by Lincoln Evening Courier.

WMBD, WMBD-FM, Peoria—Licensed to Peoria Broadcasting Co., owned 49% by Edgar L. Bill; 8.6% by Carl P. Slane, president-publisher Peoria Journal-Transcript Inc.; 2.2% by Frances P. Slane and 2.2% by Elizabeth P. Talbott, interested in same publishing firm.

WGEM, WQDI (FM), Quincy—Licensed to Quincy Bstg. Co., affiliated with Quincy Herald-Whig.

WTAD, WTAD-FM, Quincy—Licensed to Lee Broadcasting Inc., affiliated with ownership of KGLO, Mason City, Ia., Lee P. Loomis, president, also publisher of Mason City (Ia.) Globe-Gazette, a Lee Syndicate newspaper.

WQDI (FM), Quincy—Licensed to Quincy Newspapers Inc., publishers of the Quincy Herald-Whig.

WROK, WROK-FM, Rockford—Licensed to Rockford Broadcasters Inc., 100% of stock owned by Rockford Consolidated Newspapers Inc., publishers of Rockford Morning Star and Rockford Register Republic.

WHBF, WHBF-FM, WHBF-TV, Rock Island—Licensed to Rock Island Broadcasting Co.; controlling stockholders, officers and directors own all stock of The J. W. Potter Co., publisher of Rock Island Argus.

WCVS, WCVS-FM, Springfield—Licensed to WCVS Inc., identified with ownership of the Springfield Illinois State Journal and Register.

WKRS, Waukegan—Licensed to News-Sun Broadcasting Corp., subsidiary of the Waukegan News-Sun. WKRS-FM is licensed to Keystone Printing Service Inc., publishers of Waukegan News-Sun.

INDIANA

WFMU (FM), Crawfordsville—Licensed to Journal Review, publisher of Crawfordsville Journal Review.

WCNB and WCNB-FM, Connersville—Licensed to News Examiner Co., publishers Connersville News-Examiner.

WTRC, WTRC-FM, Elkhart—Licensed to the Truth Publishing Co. Inc., publisher of Elkhart Daily Truth.

WGL, Ft. Wayne—Licensed to News Sentinel Broadcasting Co., which is owned by the Ft. Wayne News-Sentinel.

WIRE, Indianapolis—Licensed to Indianapolis Broadcasting Inc. 100% of stock owned by Central Newspapers Inc., publisher of The Indianapolis Star, E. C. Pulliam, president.

WIOU, Kokomo—Licensed to North Central Broadcasting Corp. President Richard Blackledge is also president of the Kokomo Tribune.

WSBT, WSBT-FM, South Bend—Licensed to the South Bend Tribune.

WMRI (FM), Marion—Licensed to Chronicle Publishing Co., Inc., publishers of the Leader-Tribune and the Chronicle.

WCTW (FM), New Castle—Licensed to Courier-Times Inc., publishers of the New Castle Courier-Times.

WSRK (FM), Shelbyville—Licensed to Shelbyville Radio Inc. Stockholders have interest in Shelbyville News.

WAOV, Vincennes—Licensed to Vincennes Sun Co., publisher of Vincennes Sun-Commercial (same ownership as WIRE, Indianapolis).

WRSW (FM), Warsaw—Licensed to Reub Williams & Sons Inc., publishers of the Warsaw Daily Times and Union.

WFML (FM), Washington—Licensed to Washington Radio Inc., majority interest held by owner of Washington (Ind.) Herald.

IOWA

KASI, Ames—Licensed to Ames Broadcasting Co. President W. S. Rupe and Hollis Nordyke, stockholders, own stock in Ames Tribune.

KBUR, KBUR-FM, Burlington—Licensed to Burlington Broadcasting Co.; 25% of stock owned by controlling interests in the Burlington Hawk-Eye Gazette.

KCRG, KCRK (FM), Cedar Rapids—Licensed to the Gazette Co., publishers of the Cedar Rapids Gazette.

KCOG, Centerville—Licensed to Centerville Broadcasting Co. President Robert K. Beck and several other stockholders own interests in Centerville Daily Iowegian.

KSWI and KFMX (FM), Council Bluffs—Licensed to the Nonpareil Broadcasting Co., affiliated with the Nonpareil Co., publishers of the Council Bluffs Nonpareil.

KDEC, Decorah—Licensed to Telegraph-Herald, Dubuque.

KCBC, Des Moines—Licensed to Majestic Bstg. Co., identified with Plain Talk, weekly Iowa newspaper.

KRNT, KRNT-FM, Des Moines—Licensed to Cowles Broadcasting Co., subsidiary of the Register & Tribune Co., publisher of Des Moines Register and Des Moines Tribune; also publisher of Minneapolis Star-Journal and Look magazine.

KSO, KSO-FM, Des Moines—Licensed to Murphy Broadcasting Co. Kingsley H. Murphy, newspaper executive and stockholder of Minneapolis Star Journal, is president.

KDTH, KDTH-FM, Dubuque—Licensed to Dubuque Telegraph-Herald.

KFJB, Marshalltown—Licensed to Marshall Electric Co., owned by the Times Republican, Marshalltown.

KGLO, KGLO-FM, Mason City—Licensed to Lee Radio Inc., affiliated with ownership of WTAD, Quincy, Ill. Lee P. Loomis, president, also publisher of Mason City Globe-Gazette, a Lee Syndicate newspaper.

KSCJ, KSCJ-FM, Sioux City—Licensed to the Perkins Brothers Co. William R. Perkins, president, also is president-publisher of the Journal-Tribune Pub. Co., publisher of Journal and Journal-Tribune.

KTRI, Sioux City—Licensed to Sioux City Broadcasting Co.; owned in equal shares by Lennon, Fred T., John C. and Eugene F. Kelly, later two identified with ownership of Sioux City Journal-Tribune.

KJFI, Webster City—Licensed to Land-O-Corn Bstg. Co., owners affiliated with Freeman Journal.

KANSAS

KSOK, Arkansas City—Licensed to KSOK Broadcasting Co. Stauffer Pub. Inc., publisher of several papers including Arkansas City Daily Traveler, is beneficial owner of stock (see KSEE Pittsburg and KGFF Shawnee).

KGGF, Coffeyville—Licensed to The Midwest Bstg. Co. Inc. Ownership affiliated with Coffeyville Daily Journal.

KGNO, Dodge City—Licensed to Dodge City Broadcasting Co. Inc. President J. C. Denious and other stockholders also own Dodge City Daily Globe.

KTSW, Emporia—Licensed to the Emporia Broadcasting Co. Inc., majority stockholders also own Telegram Publishing Co., publishers Garden City Telegram.

KIUL, Garden City—Licensed to the Telegram Publishing Co., publishers of the Garden City Telegram.

KVGB, Great Bend—Licensed to KVGB Inc., ownership affiliated with the Great Bend Tribune and Russell Daily News.

KAYS, Hays—Licensed to KAYS Inc. President Frank Motz is stockholder of *Hays Daily News*.

KIMV (FM), Hutchinson—Licensed to Hutchinson Publishing Co., publishers of *Hutchinson News-Herald*.

KCKN, KCKN-FM, Kansas City—Licensed to The KCKN Broadcasting Co., controlled by Capper Publications Inc., publisher of *Kansas City Kansas* and *Topeka Daily Capital*.

KIND Independence—Licensed to Central Broadcasting Inc., 20% owned by H. A. Meyer Jr., business manager, *Independence Daily Reporter*.

KMAN, Manhattan—Licensed to Manhattan Broadcasting Co. Fred A. Seaton, 33% owner, publishes *Hastings (Neb.) Daily Tribune*; Richard M. Seaton, 33%, publishes *Coffeyville Daily Journal*; Fay N. Seaton, 33%, publishes *Manhattan Mercury-Chronicle* and *Weekly Republican*.

KNEK and KNEK-FM, McPherson—Licensed to McPherson Broadcasting Co. Stockholder Ken Krebbel owns *McPherson Daily Republican*.

KLKC, Parsons—Licensed to Community Broadcasting Co. President Clyde M. Reed Jr. is managing editor of *Parsons Sun*.

KSEK, Pittsburg — Licensed to the Pittsburg Publishing Co., publishers of the *Pittsburg Herald* and *Pittsburg Sun* (Stauffer Publications; also see KSKO Arkansas City and KGFF Shawnee).

KSAL, Salina—Licensed to KSAL Inc. Controlling stock owned by Salina Journal Inc. and Hutchinson Publishing Co. (News Herald). Also see KFBI Wichita.

WIBW, WIBW-FM, Topeka—Licensed to Topeka Broadcasting Assn. Inc., controlled by Capper Publications Inc., publisher of *Topeka Daily Capital* (see KCKN, Kansas City).

KFBI, Wichita—Licensed to KFBI Inc. Stockholders include John P. and Sidney Harris of Hutchinson Pub. Co. and Salina Journal Co., and R. J. Laubengayer of Salina Journal Co. (also see KSAL Salina).

KFH, KFHF-FM, Wichita—Licensed to Radio Station KFHF Co.; 51% of stock owned by Wichita Eagle Inc., publisher of the *Wichita Eagle*.

KWBB (FM), Wichita—Licensed to Wichita Beacon Broadcasting Co., affiliated with Beacon Publishing Co., publishers *Wichita Beacon*.

KENTUCKY

WKCT, Bowling Green—Licensed to Daily News Broadcasting Co., controlled by John B. and J. Ray Gaines family partnership which owns *News Publishing Co.*, *Bowling Green*.

WCTT, Corbin—Licensed to Corbin Times-Tribune Inc., publisher *Corbin Tribune* and *Times* and 50% owner of *Harlan (Ky.) Enterprise*.

WHAS, WHAS-TV, WHAS-FM, Louisville—Licensed to WHAS Inc., subsidiary of *Courier-Journal* & *Louisville Times Co.*, publishers of *Louisville Courier Journal* & *Louisville Times*.

WFMW (FM) Madisonville—Licensed to Messenger Broadcasting Co., affiliated with *Madisonville Messenger*.

WKTM, Mayfield—Licensed to Mayfield Broadcasting Co. President Frank O. Evans owns the *daily Messenger*.

WMIK, Middlesboro—Licensed to Cumberland Gap Broadcasting Co. Some stockholders also own stock in *Middlesboro Daily News*.

WOMI, WOMI-FM, Owensboro — Licensed to Owensboro Broadcasting Co., stock owned by principal stockholders of Owensboro Publishing Co., publisher of *Owensboro Messenger* and *Inquirer*.

WKYB, WKYB (FM), Paducah — Licensed to Paducah Newspapers Inc., publishers *Paducah Sun-Democrat*.

WLSI, Pikeville—Licensed to Cumberland Pub. Co., publisher of *Pikeville Daily News*.

LOUISIANA

WJBO, WRBL (FM), Baton Rouge—Licensed to Baton Rouge Broadcasting Co. Inc.; same ownership as *Baton Rouge Advocate* and *Baton Rouge State Times*.

KSIG, Crowley—Licensed to the Acadia Broadcasting Co. Owner Max Thomas is publisher *Crowley Daily Signal*.

KVOL, KVOL-FM, Lafayette—Licensed to Evangeline Broadcasting Co. Inc.; 50% of stock owned by G. H. Thomas, Lafayette; 50% owned by *Lafayette (La.) Advertiser-Gazette*.

WDSU, WDSU-FM, WDSU-TV, New Orleans—Licensed to WDSU Broad-

casting Services. Affiliated with *New Orleans Item* (no stock connection). WTPS, WTPS-FM, New Orleans—Licensed to Times Picayune Publishing Co., publishers *Times Picayune* and *New Orleans States*.

KRUS, Ruston—Licensed to Ruston Broadcasting Corp. C. E. Faulk Jr., owner, is also publisher *Ruston Leader*.

KWKH, KWKH-FM, Shreveport—Licensed to International Broadcasting Corp.; 100% of stock owned by Times Publishing Co. Ltd., publisher of *Shreveport Times*; same ownership as *Monroe (La.) World* and *News-Star*. (See also KTHS, Hot Springs, Ark.)

MAINE

WGUY, WGUY-FM, Bangor—Licensed to the Guy Gannett Bcstg. Services, owned by Guy Gannett Publishing Co., owner of *Portland Sunday Telegram*, *Portland Press Herald* and *Portland Evening Express*; Kennebec Journal, Augusta; and *Waterville Morning Sentinel*.

WCOU, WCOU-FM, Lewiston—Licensed to Twin City Broadcasting Co. Inc. Stockholders are Faust Couture, pres. & treas.; Nancy L. Couture, sec. Coutures own *Le Messenger Pub. Co.*, publisher of *Le Messenger*, French-language daily.

WGAN, Portland — Licensed to Guy Gannett Broadcasting Services; 495 out of 500 shares owned by Guy Gannett Publishing Co., publisher of *Portland Sunday Telegram*, *Portland Press Herald* and *Portland Evening Express*; Kennebec Journal, Augusta, and *Waterville Morning Sentinel*.

MARYLAND

WBAL, WBAL-TV, Baltimore — Licensed to Hearst Radio Inc.; affiliated with *Baltimore News-Post* and *Sunday American*.

WMAR (FM), WMAR-TV, Baltimore—Licensed to the A. S. Abell Co., owners *Sunpapers*. (*Baltimore Sun*).

WARK, Hagerstown—Licensed to Antietam Broadcasting Corp. R. J. Funkhouser, owner, is publisher *Jefferson-Republican*.

MASSACHUSETTS

WCOP, WCOP-FM, Boston—Licensed to Massachusetts Broadcasting Corp., subsidiary of Register-Tribune Co. of Des Moines (see KRNT, Des Moines).

WHDH, WHDH-FM, Boston—Licensed to Matheson Radio Co., owned by Boston Herald-Traveler Corp., publisher *Boston Herald* and *Traveler*.

WBET, WBET-FM, Brockton—Licensed to Enterprise Pub. Co., publisher, *Brockton Enterprise* & *Times*.

WSAR, Fall River—Licensed to Fall River Broadcasting Co., affiliated Fall River Herald News Publishing Co.

WHAU, WHAU-FM Haverhill — Licensed to the Haverhill Gazette Co., publishers of the *Haverhill Gazette*.

WHYN, WHYN-FM, Holyoke — Licensed to Hampden Hampshire Corp.; all stock of station owned by owners of *Holyoke Transcript-Telegram* and *Daily Hampshire Gazette*, Northampton (Mass.).

WLAW, WLAW-FM, Lawrence — Licensed to Hildreth & Rogers Co.; under same ownership as *Eagle-Tribune Publishing Co.*, publishers of the *Lawrence Daily Eagle* and *Evening Tribune*.

WNBH, WFMF (FM) New Bedford—Licensed to Bristol Broadcasting Co. Inc., subsidiary of E. Anthony & Sons Inc., publisher of *New Bedford Standard Times* and *Hyannis (Mass.) Cape Cod Standard-Times*.

WMFM (FM), North Adams—Licensed to James A. Hardman, publisher of *North Adams Transcript*.

WBEC, WBEC-FM, Pittsfield—Licensed to Western Mass. Broadcasting Co. Principals are Donald B. Miller, president-publisher, *Eagle Pub. Co.*, publisher of the *Pittsfield Berkshire Eagle*; his brother, Lawrence K. Miller, editor, vice president and assistant treasurer of publishing firm.

WPEP, Taunton—Licensed to Silver City Broadcasting Corp. J. Milton Hammond, part owner and general manager, owns the *Catholic Observer* magazine in Pittsfield and several newspapers in Pittsfield area.

WOCB, WOCB-FM, West Yarmouth—Licensed to Bristol Broadcasting Co. Inc., subsidiary of E. Anthony & Sons Inc., publisher of *New Bedford Standard Times* and *Hyannis (Mass.) Cape Cod Standard-Times*.

WTAG, WTAG-FM, Worcester — Licensed to WTAG Inc., affiliated with

Worcester Telegram Publishing Co. Inc., publisher of *Worcester Telegram* & *The Evening Gazette*.

MICHIGAN

WELL, WELL-FM, Battle Creek—Licensed to Federated Publications Inc., publisher of *Battle Creek Enquirer* & *News*, *Grand Rapids Herald* and *Lansing State Journal*.

WHFB, WHFB-FM, Benton Harbor—Licensed to Palladium Pub. Co., publisher of *Benton Harbor News-Palladium*, St. Joseph (Mich.) *Herald-Press*.

WJLB, WJLB-FM, Detroit—Licensed to Booth Radio Stations Inc. Mr. J. L. Booth personally owns stock in Booth Newspapers Inc. (*Grand Rapids Press*, *Flint Journal*, *Muskegon Chronicle*, *Kalamazoo Gazette*, *Saginaw News*, *Bay City Times*, *Jackson Citizen-Patriot*, *Ann Arbor News*.) Mr. Booth is not active in operation of the newspapers.

WJBK, WJBK-FM, WJBK-TV, Detroit — See WGBS, Miami, Fla.

WWJ, WWJ-FM, WWJ-TV, Detroit—Licensed to Evening News Association, publishers of the *Detroit News*.

WDDB, Escanaba—Licensed to Delta Broadcasting Co., owners publish *Escanaba Daily Press*.

WBCC, Flint—Licensed to Booth Radio and Television Stations Inc. J. L. Booth, owner, personally has stock in Booth Newspapers Inc. (See WJLB).

WAJL (FM), Flint—Licensed to Advertisers Press Inc., publishers of *Flint News Advertiser*.

WHDF, Houghton—Licensed to Upper Michigan Broadcasting Co.; affiliated with *Houghton Daily Mining Gazette*, 40% of radio stock owned by John W. Rice, publisher.

WMIQ, Iron River—Licensed to the Iron Mountain-Kingsford Bcstg. Co. President Frank J. Russell is publisher of *Iron Mountain News*.

WDMJ, Marquette—Licensed to Lake Superior Broadcasting Co. Inc.; majority owned by the *Mining Journal Co. Ltd.*, publisher *Marquette Mining Journal*.

WMDN, Midland—Licensed to Rich Publishing House Inc. publishers of *The Midland Daily News*.

WMLN (FM), Mt. Clemens—Licensed to Macomb Publishing Co., publishers of the *Mt. Clemens Monitor Leader* and *South Macomb News*.

WOAP, WOAP-FM, Owosso—Licensed to the Argus Press Co., publishers of the *Argus Press*, Owosso.

WTHH, WTHH-FM, Port Huron—Licensed to the *Times-Herald Co.*, publishers of the *Port Huron Times-Herald*.

WSGW, Saginaw—Licensed to Booth Radio Stations Inc. (See WJLB Detroit.)

WSOO, Sault Ste. Marie — Licensed to Hiawathaland Broadcasting Co. George A. Osborn, publisher of *Sault Ste. Marie Evening News*, owns 30%.

MINNESOTA

WEBC, WEBC-FM, Duluth—Licensed to Head of the Lakes Broadcasting Co.; 32% of stock owned by *Evening Telegram Co.*, Superior, Wis., publisher of *Superior Telegram*; 32% by Northwest Paper Co., 20% by Morgan Murphy, president of *Evening Telegram Co.*; 10% by W. C. Bridges, manager of WEBC. Mr. Murphy is also interested in WMFG Hibbing, Minn.; WHLB Virginia, Minn.; WISC Madison; WEAU Eau Claire, Wis.; KVOL Lafayette, La., and the *Maritotoc (Wis.) Herald-Times*, *Chippewa Falls (Wis.) Herald-Telegram*, *Two Rivers (Wis.) Reporter*, *Virginia (Minn.) Mesabi Daily News* and *Range Facts*, Los Angeles (Calif.), *Eagle Rock News-Herald* and *Highland Park News-Herald*, and *Lafayette (La.) Daily Advertiser*.

WEVE, Eveleth—Licensed to Ridson Inc. affiliated with *Duluth Herald* and *News Tribune* through interlocking ownership with Ridder Publications (also see WDSM Superior, Wis.; KSDN Aberdeen, S.D.; KILQ Grand Forks, N.D.; WTCN Minneapolis).

WMFG, Hibbing—Licensed to Head of the Lakes Bcstg. Co., See WEBC, Duluth.

WPBC, Minneapolis—Licensed to People's Broadcasting Co., affiliated with *North Minneapolis Post*.

WTCN, WTCN-FM, WTCN-TV, Minneapolis—Licensed to Minnesota Broadcasting Corp.; 50% of stock owned by

Ridder interests' Northwest Publications Co., publisher of the *St. Paul Dispatch* and *St. Paul Pioneer Press*; 50% of stock owned by Minnesota Tribune Co.

KNUJ, New Ulm—Licensed to Brown County Journal Inc., publisher of the *New Ulm Daily Journal*.

KFAM, KFAM-FM, St. Cloud—Licensed to Times Publishing Co., publisher of *St. Cloud Times*.

WHLB, Virginia—Licensed to Head of the Lakes Broadcasting Co.; see WEBC, Duluth.

KWNO, KWNO-FM, Winona—Licensed to Winona Radio Service; a partnership comprising M. H. White, publisher of the *Winona Republican-Herald* and H. R. Weicking, assistant public relations director of The Great Northern Railroad.

MISSISSIPPI

WJMB, Brookhaven — Licensed to Brookhaven Broadcasting Co. Stockholder Dalton Brady is editor of *Brookhaven Leader Times*.

WROX, Clarksdale—Licensed to Birney Imes Jr., administrator of the estate of Birney Imes Sr., deceased. Mr. Imes Jr. owns *Columbus (Miss.) Commercial Dispatch* (see WCBI Columbus).

WJCU, Columbia—Licensed to Lester Williams, editor and publisher of the *Columbian Progress*.

WCBI, Columbus—Licensed to Birney Imes Jr., owner-publisher of the *Commercial Dispatch*.

WCMA, Corinth — Licensed to the Corinth Broadcasting Co. of which Aaron B. Robinson, publisher of the *Daily Corinthian*, is V.P. and general manager.

WNAG, Grenada—Licensed to Birney Imes Jr. (See WCBI Columbus).

WCOC, Meridian—Licensed to Mississippi Broadcasting Co. D. W. Gavin and Mrs. R. S. Gavin, owners, own the weekly *Quitman (Miss.) Clarke County Tribune*.

WMOX, WMOX-FM, Meridian — Licensed to Birney Imes Jr. (See WCBI Columbus).

WELQ, Tupelo—Licensed to Tupelo Broadcasting Co. President, Birney Imes Jr. (See WCBI Columbus).

WQBC, Vicksburg—Licensed to Delta Broadcasting Co. Inc. President L. P. Cashman is publisher of the *Vicksburg Morning Herald* and *Vicksburg Evening Post*.

MISSOURI

KFRU, Columbia—Licensed to KFRU Inc.; controlled by H. J. Walters Jr., publisher of *Columbia Tribune*.

KHMO, Hannibal—Licensed to Courier-Post Publishing Co., publisher of *Hannibal Courier-Post* (Lee Syndicate newspaper).

KIMO, Independence—Licensed to the Blue Valley Co. Craig Siegfried, general manager and 25% owner, owns the *Independence Daily News*.

KWOS, KWOS-FM, Jefferson City—Licensed to the Capital Broadcasting Co. R. C. Goshorn, president, is also president of the *News Tribune Co.*, publishers of the *News* and *Tribune* Jefferson City.

WMBH, WMBH-FM, Joplin—Licensed to Joplin Broadcasting Co. Joplin Globe Publishing Co., publisher of *Joplin Globe* and *Joplin News-Herald* owns majority of stock.

WDAF, WDAF-TV, Kansas City—Licensed to The Kansas City Star Co., publisher of *The Kansas City Star*.

KCKN, Kansas City—Licensed to the KCKN Broadcasting Co. Owned by Capper Publications, publishers of the *Kansas City Kansas* and the *Topeka Daily Capital*.

KBOA, KBOA-FM, Kennett—Licensed to the Kennett Broadcasting Co. General manager, Paul G. Jones, is 1/2 owner *Dunklin Democrat*.

KWOC, KWOC-FM, Poplar Bluff—Licensed to A. L. McCarthy & John Wolpers. Mr. Wolpers is publisher of *Poplar Bluff Daily American* Republic.

KGBB, Springfield — Licensed to Springfield Broadcasting Co.; owned 98% by Springfield Newspapers Inc.

KFEQ, KFEQ-FM, St. Joseph — Licensed to KFEQ Inc. 43% of stock owned by the *News Corp.*, publisher of the *St. Joseph News-Press* and *St. Joseph Gazette*.

KSD, KSD-FM, KSD-TV, St. Louis—Licensed to Pulitzer Publishing Co., publisher of *St. Louis Post-Dispatch*.

(Continued on page 524)

NEWSPAPER OWNERSHIP

(Continued from page 523)

KWK, KWK-FM, St. Louis—Licensed to Thomas Patrick Inc. St. Louis Globe-Democrat is minority stockholder.

KXOK, KXOK-FM, St. Louis—Licensed to Star-Times Publishing Co., publisher of St. Louis Star-Times.

MONTANA

KMON, Great Falls—Licensed to the Montana Farmer Broadcasting Corp., owned by Montana Farmer Stockman, semi-monthly journal, and Great Falls Tribune.

KAVR, Havre—Licensed to KAVR Inc. Jessica L. Longston is president (See KBJO Burley, Ida.).

KXLO, Lewistown—Licensed to Montana Broadcasting Co. Victor J. Morgan, partner, is owner and publisher of the Kalispell Daily Inter Lake.

KRFJ, Miles City—Licensed to Star Printing Co., publisher of the Miles City Star.

NEBRASKA

KHAS, Hastings—Licensed to Nebraska Broadcasting Co.; majority owned by Hastings Daily Tribune.

KFAB, Lincoln—Licensed to KFAB Broadcasting Co., 50% of stock owned by Sidles Co., 25% of stock owned by Lincoln Nebraska State Journal; 25% of stock owned by Lincoln Star.

WJAG, Norfolk—Licensed to the Norfolk Daily News.

KFGT, Fremont—Licensed to Walker Newspapers Inc., publishers of the Fremont Guide and Tribune.

NEVADA

KELK, Elko—Licensed to Elko Broadcasting Co. Chris H. Sheerin, 50% owner Elko Daily Free Press is president and 17.86% owner of station.

KOH, Reno—Licensed to McClatchy Broadcasting Co. of Nevada. Same ownership as Sacramento Bee, Fresno Bee, Modesto Bee, all in California (McClatchy Newspapers).

KWRN, KWRN-FM, Reno—Licensed to Reno Newspapers Inc., publishers of The Reno Gazette and Nevada State Journal, and affiliated with Speldel Newspaper interests.

NEW JERSEY

WJLK (FM), Asbury Park—Licensed to Asbury Park Press Inc., publishers Asbury Park Press.

WBAB, WBAB-FM, Atlantic City—Licensed to Press Union Publishing Co. Inc., publisher of Atlantic City Press and Atlantic City Evening Union.

WHOM, Jersey City—Licensed to II Progresso Pub. Co.

WDHN (FM), New Brunswick—Licensed to Home News Pub. Co. publishers of the New Brunswick Home News and Saturday Times.

WNJR, WNJR-FM, Newark—Licensed to North Jersey Radio Inc., owned by the Newark News.

WPAT, WPAT-FM, Paterson—Licensed to No. Jersey Broadcasting Co., 90% owned by Passaic Daily News.

WTOA (FM), Trenton—Licensed to the Mercer Broadcasting Co. Owned by Trenton Times Newspapers.

NEW MEXICO

KOB, KOB-TV, Albuquerque—Licensed to Albuquerque Broadcasting Co.; 100% of stock owned by T. M. Pepperday, president, Albuquerque Publishing Co., publisher of Albuquerque Journal.

KSWS, Roswell—Licensed to McEvoy Broadcasting Co. President Paul B. McEvoy and Maurice F. McEvoy own stock in Roswell Morning Dispatch.

KSIL, Silver City—Licensed to Dorrance D. Roderick, majority stockholder, El Paso Times.

NEW YORK

WABY, Albany—Licensed to Adirondack Broadcasting Co. Inc.; 67½% of stock owned by the Press Co. Inc., publisher of the Knickerbocker News (Gannett Newspaper; see WENY, Elmira, N. Y.).

WMBO, WMBO-FM, Auburn—Licensed to Auburn Publishing Co., publisher of Auburn Citizen-Advertiser.

WBEN, WBEN-FM, Buffalo—Licensed to WBEN, Inc.; stock owned by same ownership as Buffalo Evening News.

WEER, WEER-FM, Buffalo—Licensed to WEER Inc. 75% of stock owned by Buffalo Courier-Express.

WFSS (FM), Coram, L. I.—Licensed to Suffolk Broadcasting Co., affiliated with 10 Long Island newspapers.

WKNP (FM), Corning—Licensed to The Corning Leader Inc., publishers of the Corning Leader.

WKRT, WKRT-FM, Cortland—Licensed to Cortland Broadcasting Co. Principal stockholders control the Cortland Tribune.

WELM, Elmira—Licensed to Corning Leader Inc., publisher of Corning (N.Y.) Leader.

WENY, WENY-FM, Elmira—Licensed to Elmira Star-Gazette Inc., publisher of Elmira Star-Gazette, Elmira Advertiser and The Sunday Telegram, affiliated with Frank E. Gannett Newspapers; Rochester Times-Union and Democrat & Chronicle, Albany Knickerbocker News, Utica Observer-Dispatch and Press, Newburgh News, Beacon News, Ithaca Journal, Olean Times-Herald (minority), Ogdensburg Journal, Malone Telegram, Saratoga Springs Saratogian, Massena Observer and Binghamton Press all in New York State; Hartford (Conn.) Times, Plainfield (N. J.) Courier-News, Danville (Ill.) Commercial News.

WENE, WENE-FM, Endicott—Licensed to Empire Newspapers-Radio Inc., publishers Endicott Daily Bulletin.

WGLN, Glens Falls—Licensed to Glens Falls Publicity Corp., owned by Glens Falls Post Co. publisher Glens Falls Post-Star and Times.

WVOS, Liberty—Licensed to Sullivan County Broadcasting Corp. President S. D. Lupin and Commercial Manager H. G. Borwick, stockholders, own Sullivan County Evening News and Sunday News-Republican.

WUSJ, WUSJ-FM, Lockport—Licensed to Lockport Union Sun and Journal Inc., publishers of the Lockport Union Sun & Journal.

WMSA, WMSA-FM, Massena—Licensed to the Brockway Co. owned and operated by the Watertown (N. Y.) Times (See WWNW, Watertown).

WGNW, Newburgh—Licensed to WGNW Broadcasting Co. Inc. Stockholders are publishers of Poughkeepsie (N. Y.) New Yorker, Town City (Ia.) Press-Citizen, Chilton (O.) Gazette; Fort Collins (Colo.) Coloradan; Salinas (Calif.) Californian; Reno Gazette; Nevada State Journal and Visalia (Calif.) Times-Delta. (See also KDON Monterey, Calif., WKIP Poughkeepsie, N. Y., WHVA-FM, Poughkeepsie, N. Y.)

WEVD, New York—Licensed to Debs Memorial Radio Fund Inc.; among cooperative backers are directors of the Jewish Daily Forward; the newspaper company itself has no interest or control.

WQV, New York—Licensed to Wodaam Corp.; Richard E. O'Dea, minority stockholder, is director and stockholder of the Paterson Morning Call.

WPIX (TV), New York—Licensed to News Syndicate Co., publishers of the New York Daily News.

WQXR, WQXR-FM, New York—Licensed to the Interstate Broadcasting Co., subsidiary of the New York Times Co.

WHLD, WHLD-FM, Niagara Falls—Licensed to Niagara Falls Gazette Publishing Co., publisher of Niagara Falls Gazette.

WHDL, WHDL-FM, Olean—Licensed to WHDL, Inc., 100% of stock owned by Olean Times-Herald Corp., publisher of Olean Times-Herald.

WDOS, WDOS-FM, Oneonta—Licensed to Oneonta Star Inc., publishers of the Star and the Herald, Oneonta.

WOPT (FM), Oswego—Licensed to Palladium Times Inc., publishers Oswego-N.Y. Palladium Times.

WKIP, WHVA (FM), Poughkeepsie—Licensed to Poughkeepsie newspapers Inc. (See WGNW, Newburgh).

WHEC, WHEC-FM, Rochester—Licensed to WHEC Inc., 86% of stock owned by the Gannett Co. Inc., publisher of the Rochester Democrat & Chronicle and Rochester Times-Union, (Gannett Newspapers; see WENY Elmira, N. Y.)

WRUN, WRUN-FM, Utica-Rome—Licensed to the Rome Sentinel Co., publishers of the Rome Daily Sentinel.

WSYR, WSYR-FM, WSYR-TV, Syracuse—Licensed to Central New York Broadcasting Corp., owned by S. I. Newhouse, N. Y. and N. J. newspaper owner, and owner of the Syracuse Herald-Journal and Post-Standard.

WHEN (TV), Syracuse—Licensed to Meredith Syracuse Television Corp., controlled by Meredith Publishing Co., Des Moines.

WFLY (FM), Troy—Licensed to the Troy Record Co., publishers of the Troy Record and Times-Record.

WWNW, WWNW-FM, Watertown—Licensed to the Brockway Co. owned and operated by the Watertown Daily Times.

WFAS, WFAS-FM, White Plains—Licensed to Westchester Broadcasting Corp. J. Noel Macy and Valentine E. Macy Jr., co-owners, publish Yonkers Herald-Statesman, Tarrytown News, Port Chester Item, Ossining Citizen-Register, Mt. Vernon Argus, New Rochelle Standard-Star, Mamaroneck Times, all in New York.

NORTH CAROLINA

WGWR, Asheboro—Licensed to the Asheboro Broadcasting Co.; owners including Roy Cox, publisher Asheboro Courier Tribune, a semi-weekly newspaper.

WWNC, Asheville—Licensed to Asheville Citizen-Times Co., publisher of the Asheville Citizen Times.

WPNF, Brevard—Licensed to Pisgah Broadcasting Co.; same newspaper ownership associations as WBBO Forest City, below.

WEGO, Concord—Licensed to Concord Tribune Inc., publishers of the Concord Tribune.

WDNC, WDNC-FM, Durham—Licensed to the Durham Radio Corp.; 100% owned by the Durham Herald Co., publisher of Durham Morning Herald and Sun.

WGAI, Elizabeth City—Licensed to the Advance Inc., publishers of the Daily Advance.

WBBO, WBBO-FM, Forest City—Licensed to Rutherford County Radio Co. Inc., stockholders affiliated with following newspapers: Forest City Courier (wkly), Spindale Sun, Spindale, N. C. (wkly), and Rutherford County News. (See WPNF Brevard.)

WGBR, WEQR (FM), Goldsboro—Part owned by Talbot Patrick, publisher of the Goldsboro News Argus and the Evening Herald, Rock Hill, S. C. and by Talbot P. M. Patrick, secy. and director Goldsboro News-Argus.

WFMY (FM), WFMY-TV, Greensboro—Licensed to the Greensboro News Co., publishers of the Greensboro Daily News and The Greensboro Record.

WHKY, WHKY-FM, Hickory—Licensed to Catawba Valley Broadcasting Co.; stockholders include Lester C. Gifford, publisher of the Hickory Daily Record.

WHPE, WHPE-FM, High Point—Licensed to High Point Enterprise Inc., publisher of the High Point Enterprise.

WTSB, Lumberton—Licensed to the Robeson Broadcasting Corp., affiliated with the Lumberton Robesonian through ownership interests of Jack and Albert Sharpe.

WNAO, WNAO-FM, Raleigh—Licensed to the Raleigh News Observer Publishing Co., publishers of the Raleigh News Observer.

WCRC, WFMA (FM), Rocky Mount—Licensed to Josh L. Horne, publisher. Rocky Mount Evening Telegram.

WREV (FM), Reidsville—Licensed to W. M. and C. R. Oliver, d/b as Reidsville Broadcasting Co. Olivers also own stock in Reidsville Review.

WSTP, WSTP-FM, Salisbury—Licensed to Piedmont Broadcasting Co.; 37% of stock owned by the Salisbury Post and Post stockholders.

WOHS, WOHS-FM, Shelby—Licensed to the Western Carolina Radio Corp., affiliated in ownership with the Shelby Star.

WENC, Whiteville—Licensed to Whiteville Broadcasting Co., equally owned by five stockholders, including L. S. Thompson, publisher Whiteville News Reporter, a semi-weekly.

WSJS, WSJS-FM, Winston-Salem—Licensed to Piedmont Publishing Co., publisher of the Winston-Salem Journal and Twin City Sentinel.

WHCC, Waynesville—Licensed to Smoky Mountain Broadcasters Inc.

President Holt McPherson is identified with Shelby Star (see WOHS Shelby); two other stockholders own Waynesville Mountaineer.

WMIT (FM), Charlotte—Licensed to Radio WMIT. Gordon Gray, president, is publisher of Winston-Salem Journal and Twin City Sentinel.

NORTH DAKOTA

WDAY, Fargo—Licensed to WDAY Inc.; 44.44% of stock owned by stockholders of Forum Publishing Co., publisher of Fargo Forum.

KILO, Grand Forks—Licensed to Grand Forks Herald Inc., publishers of Grand Forks Herald which is 80% owned by Ridder Publications (see WDSM Superior, Wis.; WTCN Minneapolis and WEVE Eveleth, Minn.; KSDN Aberdeen, S.D.).

OHIO

WAKR, WAKR-FM, Akron—Licensed to Summit Radio Corp., and 45% owned by the Akron Beacon Journal.

WHKK, Akron—Licensed to United Broadcasting Co.; owned by Forest City Publishing Co., publisher of Cleveland Plain Dealer and Cleveland News.

WFAH (FM), Alliance—Licensed to the Review Pub. Co., publishers Alliance Review.

WATG, Ashland—Licensed to Beer & Koehl, publishers Ashland Times Gazette, Galion (O.) Inquirer.

WICA, WICA-FM, Ashtabula—Licensed to WICA Inc.; 94% of stock owned by estate of the late C. A. Rowley, who was publisher of the Ashtabula Star-Bacon, Geneva Free Press, Palmerville Telegraph, Conneaut News-Herald, all Ohio dailies.

WHBC, WHBC-FM, Canton—Licensed to Ohio Broadcasting Co., subsidiary of Brush-Moore Newspapers Inc., publisher of Canton Repository, Steubenville Herald-Star, Marion Star, East Liverpool Review, Portsmouth Times and Salem News, all in Ohio; Salisbury (Md.) Times.

WTRF, WTRF-FM, Bellaire—Licensed to Tri-City Broadcasting Co. Albert & Gordon Dix own 25% interest in station, and also have interest in The Times, Martins Ferry; The Leader, Bellaire, and The Record, Wooster.

WCPO, WCPO-FM, WCPO-TV, Cincinnati—Licensed to Scripps-Howard Radio, Inc.; 100% owned by E. W. Scripps Co., chief stockholders in Scripps-Howard Newspapers, publishers of Cincinnati Post, New York World-Telegram, Cleveland Press, Pittsburgh Press, Columbus Citizen, San Francisco News, Washington News, Indianapolis Times, Knoxville News-Sentinel, Memphis Press-Scimitar, Memphis Commercial Appeal, Birmingham Post, Houston Press, Fort Worth Press, El Paso Herald-Post, Albuquerque Tribune, Covington (Ky.) Post, Denver Rocky Mountain News, Evansville (Ind.) Press.

WKRC, WCTS (FM), WKRC-TV, Cincinnati—Licensed to Radio Cincinnati, Inc., subsidiary of the Cincinnati Times-Star Co.

WSAI, WSAI-FM, Cincinnati—Licensed to Buckeye Broadcasting Co., owned by Field Enterprises Inc., which is controlled by Marshall Field, proprietor of the Chicago Sun-Times.

WHK, WHK-FM, Cleveland—Licensed to United Broadcasting Co., controlling interest owned by Forest City Publishing Co., publisher of the Cleveland Plain Dealer and the Cleveland News.

WEWS (TV), WEWS-FM, Cleveland—Licensed to Scripps-Howard Inc., affiliated with Scripps-Howard newspapers. (See WCPO Cincinnati.)

WBNS, WELD (FM), WBNS-TV, Columbus—Licensed to RadiOhio, Inc., owned 28% by Edgar T. Wolfe, board chairman who is 54% owner and president-publisher of Ohio State Journal; 24% each by Richard S. Wolfe, treasurer; Columbus Dispatch; H. Preston Wolfe, president; Dispatch; Robert H. Wolfe, co-publisher.

WTVN (TV), Columbus—Licensed to Picture Waves Inc. Edward Lamb, president, is publisher of the Erie (Pa.) Dispatch (see WICU Erie, Pa.)

WHKC, WHKC-FM, Columbus—Licensed to United Broadcasting Co.; controlling interest owned by The Forest City Publishing Co., publisher of the Cleveland Plain Dealer and the Cleveland News. (See WHKK Akron.)

WTNS, Coshocton—Licensed to Coshocton Broadcasting Co. Bob, Bill and Bruce Wallace control both licensee and Coshocton Tribune.

WHIO, WHIO-FM, WHIO-TV, Dayton—To Miami Valley Broadcasting Corp.; same ownership as Dayton Daily News, Springfield (O.) News, Springfield (O.) Sun, Miami Daily News and Atlanta Journal (James M. Cox).

WING, Dayton—Licensed to Great Trails Broadcasting Corp.; controlled by Charles Sawyer, Secretary of Commerce and owner of Lancaster (O.) Eagle-Gazette (see also WIZE Springfield).

WFNL, WFNL-FM, Findlay—Licensed to Findlay Publishing Co., publishers of the Findlay Republican Courier.

WLOK, WLOK-FM Lima—See WGBS Miami, Fla.

WCLT, WCLT-FM, Newark—Licensed to the Advocate Printing Co., publishers of the Newark Advocate and American Tribune.

WPAY, WPAY-FM, Portsmouth—Licensed to The Scoto Broadcasting Co.; 100% owned by Brush-Moore Newspapers Inc., publishers of Portsmouth Times, Canton Repository, Steubenville Herald-Star, Marion News (all in Ohio); and Salisbury Times, Maryland.

WIZE, Springfield—Licensed to Radio Voice of Springfield Inc.; 55% of stock owned by Charles Sawyer, owner of Lancaster (O.) Eagle-Gazette (see WING Dayton).

WSPD, WSPD-FM, WSPD-TV, Toledo—See WGBS, Miami, Fla.

WTOD, WTRT (FM), Toledo—Licensed to Unity Corp. Inc. Ed Lamb, president, is publisher Erie (Pa.) Dispatch.

WHHH, Warren—Licensed to The Tribune Co., publishers of Warren Tribune-Chronicle.

WWST, WWST-FM, Wooster—Licensed to Wooster Republican Printing Co., publishers of the Wooster Daily Record.

WFMJ, WFMJ-FM, Youngstown—Licensed to WFMJ Broadcasting Co. President William F. Maag Jr. and other stockholders control the Youngstown Indicator.

WKBN, WKBN-FM, Youngstown—Licensed to WKBN Broadcasting Corp. Forest City Publishing Co. (Cleveland Plain Dealer and Cleveland News) owns 40% (see WHKK Akron.)

WHIZ, Zanesville—Licensed to Southeastern Ohio Broadcasting System Inc., Clay Littick, president, is business manager of the Signal and Times Recorder, Zanesville.

OKLAHOMA

KWHW, Altus—Licensed to Altus Broadcasting Co., 47% owned by Altus Times-Democrat.

KVSO, KVSO-FM, Ardmore—Licensed to John F. Easley, owner of Ardmore Daily Ardmoreite.

KSEO, KSEO-FM, Durant—Licensed to Democrat Printing Co., publishers Durant Democrat, Durant Weekly News.

KCRC, KRCR-FM, Enid—Licensed to Enid Radiophone Co.; all stock owned by same interests owning Enid Publishing Co., publisher of Enid News and Enid Eagle.

KBIX, KBIX-FM, Muskogee—Licensed to Oklahoma Press Publishing Co., publisher of Muskogee Daily Phoenix and Muskogee Times Democrat.

KMUS, KMUS-FM, Muskogee—Licensed to Eastern Oklahoma Broadcasting Corp. Two stockholders own stock in Muskogee County News.

WKY, WKY-FM, WKY-TV, Oklahoma City—Licensed to WKY Radiophone Co.; same stock owners as Oklahoma Publishing Co., publisher of The Daily Oklahoman, Oklahoma City Times and The Farmer Stockman.

KHBB, Okmulgee—Licensed to Times Publishing Co., publisher of Daily Times, Okmulgee.

KVLH, Pauls Valley—Licensed to KVLH Broadcasting Co. James T. Jackson, principal stockholder, is publisher of the Pauls Valley Daily Democrat.

WBBZ, Ponca City—Licensed to Ponca City Publishing Co., publishers of the Ponca City News.

KCFE, Shawnee—Licensed to KGFF Broadcasting Co. Inc. Controlling

stock interest (94%) owned by Stauffer Publications Inc. (Topeka, Kans.) owner and publisher of Shawnee (Okla.) News-Star; Grand Island (Nebr.) Independent; Arkansas City (Kan.) Traveler; Maryville (Mo.) Forum; Pittsburg (Kan.) Headlight & Sun; Nevada (Mo.) Daily Mail; and Topeka (Kan.) State Journal. (See KSKO Arkansas City and KSEK Pittsburg, Kan.)

KSPI, KSPI-FM, Stillwater—Licensed to Stillwater Pub. Co., publisher Stillwater News-Press.

OREGON

KWIL, KWIL-FM, Albany—Licensed to Central Willamette Broadcasting Co.; all stock owned by W. L. Jackson Estate and R. R. Cronise, co-publishers of Albany Democrat-Herald.

KAST, Astoria—Licensed to Astoria Broadcasting Co.; ownership affiliated with Astoria Astorian-Budget.

KOOS, Coos Bay—Licensed to KOOS Inc. Sheldon F. Sackett, owner, is publisher of Coos Bay Times.

KERG, Eugene—Licensed to Eugene Broadcasters Inc. Principal stockholder is Guard Publishing Co., publisher of the Eugene Register-Guard.

KUIN, KGPO (FM), Grants Pass—Licensed to Southern Oregon Bcstg. Co.; 50% of stock owned by A. E. Voorhies, publisher of Grants Pass Courier; 50% by Redwood Bcstg. Co., operator of KIEM, Eureka, Calif., in which Eureka Humboldt Times owns 20% of stock, and Eureka Humboldt Standard 20.8%.

KFLW, Klamath Falls—Licensed to Herald Pub. Co., publisher Klamath Falls Herald & News.

KMCM, McMinnville—Licensed to Yamhill Broadcasters. Same ownership as weekly McMinnville Telephone-Register.

KYJC, Medford—Licensed to the Medford Printing Co., publishers Medford Mail Tribune.

KGW, KGW-FM, Portland—Licensed to Oregonian Publishing Co., publisher of the Oregonian, Portland, Ore.

KOIN, KOIN-FM, Portland—Licensed to KOIN, Inc. Owned by Marshall Field. (See WJJD, Chicago, Ill.)

KPOJ, KPOJ-FM, Portland—Licensed to KPOJ Inc.; stock owned by Portland Oregon Journal 100%.

KRRR, Roseburg—Licensed to The News-Review Co., publishers of Roseburg News-Review and Klamath Falls (Ore.) Herald-News; same interests also own 20% interest in Medford (Ore.) Mail-Tribune.

PENNSYLVANIA

WSAN, WSAN-FM, Allentown—Licensed to Lehigh Valley Broadcasting Co.; 77% of stock owned by stockholders of Call-Chronicle Newspapers Inc., publisher of The Morning Call and The Evening Chronicle.

WGPA, WGPA-FM, Bethlehem—Licensed to Bethlehem's Globe Pub. Co., publisher Bethlehem Globe-Times.

WCNR, Bloomsburg—Licensed to Columbia-Montour Broadcasting Corp., affiliated with the Bloomsburg Morning Press.

WESB, WESB-FM, Bradford—Licensed to Bradford Pub. Co., publishers of the Bradford Era.

WBUT, WBUT-FM, Butler—Licensed to the Eagle Printing Co., publishers Butler Eagle.

WCPA, Clearfield—Licensed to Clearfield Broadcasters Inc., wholly owned by publishers of the Clearfield Progress.

WBUX, Doylestown—Licensed to Charles M. Meredith, publisher Quakertown Free Press.

WCED, WCED-FM, DuBois—Licensed to the Tri-County Bcstg. Co. Inc., affiliated with the DuBois Courier Express.

WEEX (FM), Easton—Licensed to the Easton Pub. Co., publishers of the Easton Express.

WEST, WEST-FM, Easton—Licensed to Associated Broadcasters Co. Operated independently. Owned by J. Hale and John F. Steinman, owners of Lancaster Newspapers Inc. (See WGAL, Lancaster.)

WICU (TV), Erie—Licensed to Dispatch Inc., publishers of the Erie Dispatch. (See WTVN Columbus, O.)

WKBO, Harrisburg—Licensed to Keystone Broadcasting Corp. Operated independently. Owned by J. Hale and John F. Steinman, owners of Lancaster Newspapers Inc. (See WGAL, Lancaster.)

WHUN, Huntingdon—Licensed to Joseph F. Biddle Pub. Co., publisher Huntingdon Daily News.

WJAC, WJAC-FM, WJAC-TV, Johnstown—Licensed to WJAC Inc.; 100% owned by Johnstown Tribune Publishing Co., publisher of Johnstown Tribune and Democrat.

WGAL, WGAL-FM, WGAL-TV, Lancaster—Licensed to WGAL Inc. Operated independently. Owned by J. Hale and John F. Steinman, owners of Lancaster Newspapers Inc.

WMRF, WLTV (FM), Lewistown—Licensed to Lewistown Broadcasting Co.; 25% of stock owned by the Sentinel Co., publishers of Lewistown Sentinel.

WCAU, WCAU-FM, WCAU-TV, Philadelphia—Licensed to WCAU Inc., owned by Philadelphia Bulletin.

WFIL, WFIL-FM, WFIL-TV, Philadelphia—Licensed to Triangle Publications Inc., publisher Philadelphia Inquirer.

WCAE, WCAE-FM, Pittsburgh—Licensed to WCAE Inc., owned by the Hearst Publishing Co.

WKJF (FM), Pittsburgh—Licensed to West Virginia Radio Corp. (See WAJR Morgantown, W. Va.)

WWSW, WMOT (FM), Pittsburgh—Licensed to WWSW Inc. Controlled by P-G Publishing Co., publishers of the Pittsburgh Post-Gazette.

WEEU, WEEU-FM, Reading—Licensed to the Hawley Broadcasting Co., affiliated with the Reading Eagle Times.

WRWA, Reading—Licensed to the Reading Broadcasting Co. Ownership affiliated with Lancaster Newspapers Inc.

WRYO, Rochester—Licensed to Beaver Valley Radio Inc. Minority interest held by owners of Beaver Valley Times.

WQAN, WQAN-FM, Scranton—Licensed to the Scranton Times.

WPIC, WPIC-FM, Sharon—Licensed to Sharon Herald Broadcasting Corp. One stockholder holds stock in Sharon Herald Publishing Co.

WVPO, Stroudsburg—Licensed to Pocono Broadcasting Inc., affiliated with Stroudsburg Daily Record.

WKOK, WKOK-FM, Sunbury—Licensed to Sunbury Broadcasting Corp.; majority ownership identified with Sunbury Daily Item.

WNIQ (FM), Uniontown—Licensed to Uniontown Newspapers Inc., publishers Uniontown Herald and Standard.

WRAC, WRAC-FM, Williamsport—Licensed to WRAC Inc.; 66.6% of stock owned by Sun Gazette Co., publisher of Williamsport Gazette & Bulletin and Williamsport Sun; 27% owned by R. T. S. Steele Estate; 3.8% by Margaret T. Steele; 1.3% each by Mary E. Steele and George E. Joy.

WWPA, Williamsport—Licensed to Williamsport Radio Broadcasting Associates. Harry J. W. Kiessling, Grit Publishing Co. executive, is president and owns 10%.

WILK, WILK-FM, Wilkes-Barre—Licensed to Wyoming Valley Broadcasting Co. Stockholders in station also own interests in DuBois (Pa.) Courier Express and Butler (Pa.) Eagle.

WORK, York—Licensed to York Broadcasting Co. Operated independently. Owned by J. Hale and John F. Steinman, owners of Lancaster Newspapers Inc. (See WGAL, Lancaster.)

RHODE ISLAND

WDEM, Providence—Licensed to Narragansett Bay Broadcasting Co. Has same board of directors as Rhode Island Pilot.

WPJB (FM), Providence—Licensed to Providence Journal Co., publisher of the Providence Journal-Bulletin.

SOUTH CAROLINA

WAIM, WCAC (FM), Anderson—Licensed to Wilton E. Hall, 50% owner of Anderson Independent and Anderson Daily Mail.

WTMA, WTMA-FM, Charleston—Licensed to Atlantic Coast Broadcasting Co.; affiliated with Charleston News & Courier and Charleston Post.

WFBC, WFBC-FM, Greenville—Licensed to Greenville News-Piedmont Co., publisher of Greenville News and Greenville Piedmont.

WEAB, Greer—Licensed to Greer Bcstg. Co. One partner is publisher of the Greer Citizen.

WTND, Orangeburg—Licensed to the Sims Publishing Co., publishers of the Times and Democrat, Orangeburg.

WSNW, Seneca—Licensed to Blue Ridge Broadcasting Co., owned by J. A. Gallimore, publisher of Seneca Journal, and Mrs. Gallimore, publisher of Walthalla (S. C.) Keowee Courier.

WFIG, Sumter—Licensed to WFIG Inc. Hubert Osteen, president, is publisher of the Sumter Daily Item.

SOUTH DAKOTA

KSDN, Aberdeen—Licensed to Aberdeen News Co., publishers of the Aberdeen News (identified with Rider Publications; also see WDSM Superior, Wis.; WEVE Eveleth, Minn.; KILQ Grand Forks, N. D.; WTCN Minneapolis).

WNAX, Yankton—Licensed to Cowles Broadcasting Co. (See WOL Washington, D. C. and KRNT, Des Moines).

TENNESSEE

WLAR, Athens—Licensed to Athens Broadcasting Co., owned by Lowell F. Arterburn, editor-publisher Athens Post-Athletian.

WOPI, WOPI-FM, Bristol—Licensed to Radiophone Broadcasting Station WOPI Inc.; 50% owned by C. J. Harkrader, publisher of Bristol Herald-Courier and News Bulletin; 50% owned by W. A. Wilson, president and general manager of WOPI.

WDSG, Dyersburg—Licensed to State Gazette Broadcasting Co. Stockholders include owners of Dyersburg State Gazette.

WTJS, WTJS-FM, Jackson—Licensed to Sun Publishing Co. Inc., publisher of Jackson Sun.

WETB, Johnson City—Licensed to the East Tennessee Broadcasting Co., ownership interlocks with Press Inc., publishers of the Press-Chronicle.

WKPT, WKPT-FM, Kingsport—Licensed to Kingsport Broadcasting Co. Same stockholders as Kingsport Times.

WNOX, Knoxville—Licensed to Scripps-Howard Radio Inc., subsidiary to E. W. Scripps Co., chief stockholder in Scripps-Howard Newspapers (Knoxville News-Sentinel etc., see WCPO, Cincinnati).

WMC, WMC-FM, WMCT (TV), Memphis—Licensed to Memphis Publishing Co., publisher of Memphis Commercial Appeal, a Scripps-Howard newspaper. (See WCPO, Cincinnati).

WMAK, Nashville—Licensed to the Volunteer State Broadcasting Co., Frank Maybourn, president of the Temple Telegram, Temple, and the Sherman News is 75% owner, and president.

WHAL, Shelbyville—Licensed to Shelbyville Broadcasting Co. Same owners as Bedford County News.

TEXAS

KRBC, KRBC-FM, Abilene—Licensed to Reporter Broadcasting Co.; 64% of stock owned by Mrs. Eva May Hanks, director and a principal stockholder in Abilene Reporter-News, director in Big Spring Herald, Paris News, Corpus Christi Caller-Times, Denison Herald, all in Texas.

KVLF, Alpine—Licensed to Big Bend Broadcasters Barney Hubbs, majority stockholder in Pecos (Tex.) Enterprise, 40% owner (also see KIUN, Pecos, KVKK Monahans, KRIG, Odessa, Tex.).

KGNC, KGNC-FM, Amarillo—Licensed to Plains Broadcasting Co. 80% of stock owned by Globe News Publishing Co. Inc., publisher of Amarillo Globe-News employees pool. Same interests also control Lubbock Avalanche, Lubbock Journal and Achi-son (Kan.) Globe. (See KFYO Lubbock.)

(Continued on page 526)

NEWSPAPER OWNERSHIP

(Continued from page 525)

KNOW, Austin—Licensed to Pioneer Broadcasting Co. C. C. Woodson, half owner, is publisher of the *Brownwood Bulletin* and other Texas newspapers.

KREL, KREL-FM, Baytown—Licensed to Tri-Cities Broadcasting Co. President Robert Matherne is stockholder in Baytown Sun.

KRIC, KRIC-FM, Beaumont—Licensed to Enterprise Co., publishers Beaumont Enterprise and Journal.

KBST, Big Spring—Licensed to the Big Spring Broadcasting Co., affiliated with the *Big Spring Herald* (see KRBC Abilene).

KFYN, Bonham—Licensed to the Fannin County Broadcasting Co. Sole owner is Frank Svoboda, publisher of the *Bonham Daily Favorite* and the *Bonham Weekly*.

KWHI, Brenham—Licensed to Thomas S. Whitehead, owner of the *Brenham Banner Press*.

KRLD, KRLD-FM, KRLD-TV, Dallas—Licensed to KRLD Radio Corp.; subsidiary of Times Herald Printing Co., publishers *Dallas Times Herald*.

WFAA, WFAA-FM, Dallas—Licensed to A. H. Belo Corp., publisher of the *Dallas Morning News*.

KROD, El Paso—Licensed to the Roderick Broadcasting Corp. Dorrance D. Roderick, president, is also majority stockholder of El Paso Times.

WBAP, WBAP-FM, WBAP-TV, Fort Worth—Licensed to Carter Publications Inc., publisher of *Fort Worth Star-Telegram*.

KGAF, Gainesville—Licensed to Gainesville Broadcasting Corp. Joe M. Leonard, editor and publisher of *Daily Register* and *Weekly Register*, is 80% owner.

KSIJ, Gladewater—Licensed to Gladewater Broadcasting Co. Principal owners also own stock in Gladewater Times Tribune.

KATL, Houston—Licensed to Texas Broadcasters Inc. Affiliated with *Houston Press* (no interlocking ownership).

KPRC, KPRC-FM, Houston—Licensed to Houston Post Co., publisher of *Houston Post*; 97% of stock owned by Houston Post Co.

KTRH, KTRH-FM, Houston—Licensed to KTRH Broadcasting Co., subsidiary of Houston Chronicle Pub. Co., publisher of *Houston Chronicle*.

KPET, Lamesa—Licensed to Lamesa Bestg. Co., a partnership composed of R. O. Parker, R. A. Woodson and K. S. Ashby. Mr. Woodson owns 25% stock of KPET, and is publisher and half owner of *Lamesa Newspapers Inc.* (*Brownwood, (Tex.) Bulletin*).

KLVT, Levelland—Licensed to Herald Broadcasting Co. Forrest Weimholy, owner, also owns *Hockey County Herald (Levelland)*, and *Morton (Tex.) Tribune*.

KFYO, KFYO-FM, Lubbock—Licensed to Plains Radio Broadcasting Co. (See KGNC Amarillo).

KTRE, Lufkin—Licensed to Forest Capital Broadcasting Co. Two stockholders own interest in *Lufkin Daily News*.

KVKM, Monahans—Licensed to Monahans Broadcasters Inc., part owned by Barney Hubbs, owner of the *Pecos Enterprise* (see KIUN Pecos.)

KOSA, Odessa—Licensed to Southwestern Broadcasting Co.; Dorrance Roderick, majority stockholder, is owner and publisher *El Paso Times* (see KROD El Paso).

KRIG, Odessa—Licensed to Oil Center Broadcasting Co., part owned by Frank Mayborn, publisher of *Temple (Tex.) Telegram*, and Barney Hubbs, chief owner of *Pecos (Tex.) Enterprise* (see KIUN Pecos, KVLF Alpine, KVKM Monahans).

KPDN, Pampa—Licensed to C. H. Harry and Jane Holles, d/b as Radio Station KPDN. Owners are co-publishers of *Pampa Daily News*.

KIUN, Pecos—Licensed to Jack W. Hawkins and Barney H. Hubbs, Mr. Hubbs is chief owner of *Pecos (Tex.) Enterprise* (see KRIG Odessa, KVLF Alpine, KVKM Monahans).

KGKL, San Angelo—Licensed to KGKL Inc.; Ownership affiliated with *San Angelo Standard-Times*.

KTSA, KTSA-FM, San Antonio—Licensed to Sunshine Broadcasting Co. owned by *San Antonio Express* and *Evening News*.

KEVA, Shamrock—Licensed to Shamrock Broadcasting Co. Albert Cooper is principal owner of both KEVA and the *Shamrock Texan*.

KXOX, Sweetwater—Licensed to Sweetwater Radio Inc.; owned by J. S. McBeath, owner of the *Sweetwater Reporter*.

KTEM, KTEM-FM, Temple—Licensed to Bell Broadcasting Co. Frank W. Mayborn, president and 85% owner, also president and 95% owner of Bell Pub. Co., publisher of *Temple Daily Telegram*.

KCMC, KCMC-FM, Texarkana—Licensed to KCMC Inc., identified with ownership of *Texarkana Gazette* and *News*.

KTBB, Tyler—Licensed to Blackstone Broadcasting Co. whose principal owners are also principal owners of Tyler's two newspapers, *Courier-Times* and *Telegraph*.

KVWC, KVWC-FM, Vernon—Licensed to Northwestern Broadcasting Co. R. H. Nichols, 49% owner, is chief stockholder of *Vernon Daily Record*.

KTRN, Wichita Falls—Licensed to Texoma Broadcasting Co., affiliated with publishers *Wichita Daily Times*, *Wichita Falls Record News*, *Times Publishing Co.* owns 49% stock.

UTAH

KSUB, Cedar City—Licensed to Southern Utah Broadcasting Co.; 60% of stock held by Radio Service Corp. of Utah, licensee of KSL; 28% of stock owned by Leland M. Perry.

KLO, Ogden—Licensed by Interstate Broadcasting Corp.; majority stock owned by A. L. Glasmann, publisher of *Ogden Standard-Examiner*.

KALL, Salt Lake City—Licensed to Salt Lake City Broadcasting Co., 50% owned by Telegram Pub. Co., publishers of *Salt Lake City Tribune-Telegram*.

VERMONT

WSKI, Montpelier—Licensed to Montpelier-Barre Broadcasting Co. Non-profit Christian-Leader Publishing Co., publisher of the *Christian Leader Magazine* and religious and educational books, owns 26.3%.

VIRGINIA

WPIK, Alexandria—Licensed to Potomac Broadcasting Corp. C. C. Carlin Jr., publisher of the *Alexandria Gazette*, is stockholder.

WDVA, Danville—Licensed to Virginia-Carolina Broadcasting Co. Publisher of *Danville Register* owns 63%.

WHAP, Hopewell—Licensed to Hopewell Broadcasting Co. President Augustus Robbins Jr. is editor of the *Hopewell News*.

WMEV, Marion—Licensed to Mountain Empire Broadcasting Corp. President Robert Anderson owns weekly *Smyth County News*.

WGH, WGH-FM, Newport News—Licensed to Hampton Roads Broadcasting Corp.; 75% of stock owned by Daily Press Inc., publisher of *Newport News Daily Press* and *Times-Herald*; 25% by Edward E. Bishop.

WTAR, WTAR-FM, WTAR-TV, Norfolk—Licensed by WTAR Radio Corp.; subsidiary of Norfolk Newspapers Inc., publisher of *Norfolk Ledger-Dispatch* and *Norfolk Virginian-Pilot*.

WPUV, Pulaski—Licensed to Southwest Broadcasting Corp. President Howard R. Imboden, 50% owner, publishes the *Pulaski Southwest Times*.

WRNL, WRNL-FM, Richmond—Licensed to Richmond Radio Corp.; owned by Richmond Newspapers, Inc., operating *Richmond News-Leader* and *Richmond Times Dispatch*.

WDBJ, WDBJ-FM, Roanoke—Licensed to Times-World Corp., publisher of *Roanoke Times* and *Roanoke World-News*.

WASHINGTON

KPUG, Bellingham—Licensed to KPUG Inc. President Jessica L. Longston is publisher of the *Burley (Ida.) Bulletin* and *Herald* and the *St. Helens (Ore.) Sentinel Mist* (see KBIO Burley, Ore.) KSEM Moses Lake, Wash).

KWLK, KWLK-FM, Longview—Licensed to Twin City Broadcasting Corp.; 32% of stock owned by J. M. McClelland, publisher of *Longview Daily News*.

KSEM, Moses Lake—Licensed to KSEM Inc. President is Jessica L. Longston (see KPUG Bellingham, Wash. and KBIO Burley, Ida.).

KONP, Port Angeles—Licensed to Radio Pacific, subsidiary of Port Angeles Evening News Inc., publisher of *Port Angeles Evening News*.

KJR, Seattle—Licensed to Totem Broadcasters Inc., owned by Field Enterprises, controlled by Marshall Field, publisher *Chicago Sun-Times* (See WJJD Chicago).

KHQ, Spokane—Licensed to KHQ Inc.; owned by Spokane Chronicle Co.

KNEW, Spokane—Licensed to Coeur d'Alene Broadcasting Co., identified in ownership with Coeur d'Alene Press (see KVNI Coeur d'Alene, Ida.).

KTNT (FM), Tacoma—Licensed to the Tribune Publishing Co., publishers of the *Tacoma News Tribune*.

KVAN, Vancouver—Licensed to Vancouver Radio Corp.; controlled by Sheldon F. Sackett, publisher of *Coos Bay Times*, 95% owner of *KOOS, Coos Bay*, and sole owner of *KROW, Oakland, Calif.*

WEST VIRGINIA

WCFC (FM), Beckley—Licensed to Beckley Newspapers Corp., publishers of *Beckley Post Herald* and *The Raleigh Register*.

WHIS, WHIS-FM, Bluefield—Licensed to Daily Telegraph Printing Co., publisher of *Bluefield Daily Telegraph* and *Bluefield Sunset News*.

WBLK, WBLK-FM, Clarksburg—Licensed to News Publishing Co., publishers of the *Intelligencer* and *News-Register*, Wheeling.

WMMN, Fairmont—See WGBS, Miami, Fla.

WVWV, Fairmont—Licensed to Fairmont Broadcasting Co. J. Patrick Beacom, 96% owner, publishes the *Mannington (W. Va.) Times*.

WSAZ, WSAZ-FM, WSAZ-TV, Huntington—Licensed to WSAZ Inc., 52% of stock owned by Huntington Publishing Co.; 48% owned by Charleston Broadcasting Co.

WLOG, WLOG-FM, Logan—Licensed to Clarence H. Frey, publisher of the *Logan Banner*, and Robert O. Greever, Merrill Coal Mines Inc., partners.

WAJR, Morgantown—Licensed to West Virginia Radio Corp. Stockholders own stock in West Virginia Newspaper Publishing Co., publishers of *Morgantown Post* and *Dominion News*; *New Martinsville Wetzel Republican*. (See WKJF Pittsburgh).

WPAR, WPAR-FM, Parkersburg—Licensed to Ohio Valley Broadcasting Corp., owned by News Publishing Co., publishers of the *Intelligencer* and *News-Register*, Wheeling, and 12 other W. Va. newspapers.

WBRW, Welch—Licensed to McDowell Service Co.; ownership includes W. R. Keyser, 25 shares, editor *Welch Daily News*; Clarence H. Frey, 25 shares, publisher, *The Logan Banner*.

WVVA, WVVA-FM, Wheeling—See WGBS, Miami, Fla.

WISCONSIN

WATK, Antigo—Licensed to Antigo Broadcasting Co. Artemas F. Berner, 90% owner, is co-publisher of the *Antigo Journal*.

WEAU, WEAU-FM, Eau Claire—Licensed to Central Broadcasting Co.; 25% of stock owned by Eau Claire Press Co., publisher of *Eau Claire Telegram* and *Eau Claire Leader*; 40% owned by Elizabeth Murphy, wife of publisher of *Superior (Wis.) Telegram*; 14% owned by Morgan Murphy, publisher of *Superior Telegram*.

KFIZ, Fond du Lac—Licensed to KFIZ Broadcasting Co. Same owners as Fond du Lac Commonwealth Reporter.

WJPG, WJPG-FM, Green Bay—Licensed to the Green Bay Newspaper Co., publishers of the *Press Gazette*.

WCLO, WCLO-FM, Janesville—Licensed to Southern Wisconsin Radio Inc., subsidiary of Gazette Printing Co., publishers of the *Janesville Daily Gazette*.

WIBA, WIBA-FM, Madison—Licensed to Badger Broadcasting Co., Inc.; 66% owned by the Capital Times Co., publisher of the *Madison Capital Times*. Other stockholders and directors include officers of the Wisconsin State Journal Publishing Co., publishers of the *Wisconsin State Journal* (Lee Syndicate).

WISC, WISC-FM, Madison—Licensed to Radio Wisconsin, Inc., controlled by Morgan Murphy, publisher of *Superior (Wis.) Evening Telegram*, and Mrs. Murphy.

WLIN, WLIN-FM, Merrill—Licensed to Alvin E. O'Konski, owner, *Montreal River Miner*, Hurley, Wis.

WISN, WISN-FM, Milwaukee—Licensed to Hearst Radio Inc. (See WBAL Baltimore).

WTMJ, WTMJ-FM, WTMJ-TV, Milwaukee—Licensed to The Journal Co., publisher of *Milwaukee Journal*.

WRJN, WRJN-FM, Racine—Licensed to Racine Broadcasting Corp.; principal stockholders: F. R. Starbuck, president and Harry R. Le Poidevin, secretary-treasurer of the *Journal Times Co.*

WTCH, Shawano—Licensed to Shawano Leader Pub. Co., publishers of *Shawano Leader*.

WHBL, WHBL-FM, Sheboygan—Licensed to WHBL Inc., same ownership as *Sheboygan Press*.

WDSM, Superior—Licensed to Ridson Inc. Stockholders also own stock in Ridder Publications (see WEVE Eveleth, Minn.; KSDN Aberdeen, S. D.; KILQ Grand Forks, N. D.; WTCN Minneapolis).

WSAU, WSAU-FM, Wausau—Licensed to The Journal Co., publisher *Milwaukee Journal*.

WFHR, WFHR-FM, Wisconsin Rapids—Licensed to Wm. F. Huffman Radio, Inc. Mrs. Huffman is principal owner Wisconsin Rapids Tribune Co., publishers *Wisconsin Rapids Daily Tribune*.

WYOMING

KVOC, Casper—Licensed to KVOC Broadcasting Co. Owners also own stock in *Natrona County Tribune*.

KFCB, Cheyenne—Licensed to Frontier Bestg. Co. Ownership affiliated with Cheyenne Newspapers Inc., publishers of the *Wyoming Eagle* and the *Wyoming State Tribune*.

KOVE, Lander—Licensed to Edward J. Breece, publisher of semi-weekly *State Journal*.

KRAL, Rawlins—Licensed to Rawlins Broadcasting Co., 50% owned by *Rawlins Daily Times*.

ALASKA

KENI, Anchorage—Licensed to Midnight Sun Bestg. Co. (See KFAR).

KFAR, Fairbanks—Licensed to Midnight Sun Broadcasting Co.; 969 of 1,000 shares owned by A. E. Lathrop, Alaska industrialist, who also publishes the *Fairbanks News Miner*.

HAWAII

KHBC, Hilo—Licensed to Hawaiian Broadcasting System Ltd. (See KGMB Honolulu.)

KGMB, Honolulu—Licensed to Hawaiian Broadcasting System Ltd.; 24% of stock owned by *Honolulu Star-Bulletin*; 8% of stock by Consolidated Amusement Co. Ltd.; 20% by Corp. of the President of the Church of Jesus Christ of Latter Day Saints.

KGU, Honolulu—Licensed to Marion A. Mulrony and Advertiser Publishing Co. Ltd., publisher of *Honolulu Advertiser*.

KTOH, Lihue—Licensed to Garden Island Publishing Co. Ltd., publisher of *Garden Island* (weekly).

KMVI, Wailuku, Maui—Licensed to Maui Publishing Co., publishers of the *Maui News*.

RADIO & TV REFERENCE BOOKS AND PUBLICATIONS—1949

Editor's Note: This selected literature on radio and television, and related fields, is limited to material published in 1949 or too late in 1948 for inclusion in the 1949 Yearbook. This list has been prepared especially for BROADCASTING by Agnes Law, Librarian, CBS Reference Department.

ADVERTISING

MODERN RADIO ADVERTISING: Surveys, Analyses, Interpretations, Recommendations. By Charles Hull Wolfe. N. Y., Funk & Wagnalls, 1949. 738p. 7.50. An authoritative guide covering every phase of radio advertising, with each chapter introduced by an expert. One chapter devoted to the potentialities of TV, FM and Facsimile.

SPOT RADIO PROMOTION HANDBOOK. By Standard Rate & Data Service Co., 333 No. Michigan Ave. Chicago 1. 1949. 64p. \$1.00. A new book for radio station managers, promotion men and sales representatives which analyzes the viewpoints, practices and needs of spot radio time buyers and users.

SUCCESSFUL RADIO ADVERTISING. By Robert I. Garver. N. Y., Prentice-Hall, 1949. 321p. \$5.75. An experienced account executive analyzes sponsor participation programs such as disc jockey, farm, musical clock, women's service, audience participation and husband-wife combinations, on 260 stations, presenting observations and conclusions with detailed data, charts and tables.

A SURVEY OF ADVERTISERS AND AGENCY BUYING PRACTICES AND PATTERNS FOR SPOT RADIO. By Standard Rate & Data Service Co. Chicago 1. 1949. 155p. Free to purchasers of Spot Radio Promotion Handbook. This is a study of functions in spot radio advertising.

GENERAL

AN INTRODUCTION TO JOURNALISM RESEARCH. Edited by Ralph O. Nafziger and Marcus M. Wilkerson. Baton Rouge, Louisiana State University Press, 1949. 142p. \$2.50. A presentation of some mass communication fields and methods of research which journalism students and public opinion analysts are investigating and using. Each chapter is written by an expert and includes a selected bibliography.

COMICS, RADIO, MOVIES—AND CHILDREN. By Josette Frank. N. Y., Public Affairs Comm. 1949. 32p. (PA pamphlet no. 148) 20 cents. An associate of the Child Study Association offers constructive recommendations to parents concerning the effects of mass media, including television, on children.

COMMUNICATIONS RESEARCH, 1948-1949. Edited by Paul F. Lazarsfeld and Frank N. Stanton. N. Y., Harper, 1949. 332p. \$4.50. A continuation of a former series, *Radio Research*. This volume includes children's reaction to the comics; analysis of radio's programming; the morning audience, missing the newspaper; overlapping magazine reading; "influential" people in a community and domestic broadcasting in Russia.

INVENTION AND INNOVATION IN THE RADIO INDUSTRY. By W. Ru-

pert Maclaurin. N. Y., Macmillan, 1949. 304p. \$6.00. (MIT Studies in Innovation, no. 1) A study of technological progress from the past to the present, including FM and Television, analyzing the relationship of inventor and corporation together with consideration of the patent system.

MASS COMMUNICATIONS. Edited by Wilbur Schramm. Urbana, Univ. of Illinois Press, 1949. 552p. \$4.50. A supplement to *Communications in Modern Society*. Selections from books and articles by specialists in the social sciences and mass media, used in the Institute of Communications Research.

RADIO AND POETRY. By Milton A. Kaplan. N. Y., Columbia University Press, 1949. 333p. \$4.50. A study of poetry on the air and the techniques of the radio verse play.

RADIO AND TELEVISION BIBLIOGRAPHY. Prepared by Gertrude G. Broderick. Washington, U. S. Govt. print. off., 1949. 33p. 15 cents. (Educational bulletin 1948, no. 17) A classified, annotated bibliography covering publications for the last decade, with particular application to the educational field.

RADIO FAMILIES—USA, 1949. N. Y., Broadcast Measurement Bureau, 270 Park Ave. (17) 97p. \$5.00. A continuing study of radio ownership as of January 1st, by geographic areas and states; counties, cities and metropolitan areas. Canadian supplement is not included in this issue.

RADIO LISTENING IN AMERICA. The People Look at Radio-Again. Report on a survey conducted by the National Opinion Research Center, analyzed and interpreted by Paul F. Lazarsfeld and Patricia L. Kendall. N. Y., Prentice-Hall, 1948. 178p. \$2.50. A second survey made in 1947 with an analysis of the radio audience, types of programs appealing to various groups, attitude toward radio, its control or improvement.

WHO GETS THE AIR? The U. S. Broadcaster in World Affairs. By Forney A. Rankin. Washington, National Association of Broadcasters, 1949. 64p. The NAB reviews the problems of freedom for the American broadcaster: frequency allocations in international broadcasting and political restrictions at home and abroad hampering the free flow of information via the radio. Data on international conferences included in Appendix.

LEGAL ASPECTS, REGULATION

AMENDMENTS TO THE COMMUNICATIONS ACT OF 1934, AS AMENDED. Hearings before the Subcommittee of the Committee on Interstate and Foreign Commerce, U. S. Senate, 81st Congress, 1st ses. on S 1973. June 16 & 17, 1949. Washington, U. S. Govt. print. off. 1949. 151p. 14 maps. A bill introduced by Sen. E. W. McFarland, Chm. of the Subcommittee on Communications, to reorganize FCC procedures.

THE MODERN LAW OF ADVERTISING AND MARKETING: A Layman's Guidebook for Everyone Concerned with the Marketing of America's Goods and Services. By I. W. Digges. N. Y., Funk & Wagnalls, 1948. 310p. \$5.00. A concise, comprehensive and authoritative handbook of the legal aspects of advertising including sixteen pages devoted to radio broadcasting and television.

NEWS

ATTACKS ON FREEDOM OF COMMUNICATION. By Justin Miller. Washington, National Association of Broadcasters, 1949. 24p. A consideration of the dangers from government controls at home and abroad by the President of the NAB in an address to the American Society of Newspaper Editors, Washington, Apr. 23, 1949.

NEWS BY RADIO. By Mitchell V. Charnley. N. Y., Macmillan, 1948. 403p. \$4.00. Techniques of the radio newsmen described by an educator with practical experience. Special chapters devoted to multivoice news shows, local news service, special events, news in special fields and legal aspects, with Appendices of Codes, standards and style.

NEWSMEN AT WORK: Reporting and Writing the News. By Laurence R. Campbell and Roland E. Wolseley. Boston, Houghton Mifflin, 1949. 560p. \$4.75. Intended for those who want to gather and write news for any medium of mass communication. Radio, news magazines, house organs, business papers, syndicates and wire services are included.

RADIO'S SOURCES OF INFORMATION MUST BE PROTECTED. By E. R. Vadeboncoeur. Washington, National Association of Broadcasters, 1949. 9p. A defense for the extension of the newspaperman's legal rights to radio newsmen by the Chairman of the NAB Radio News Committee.

RECORDING

CATALOG OF RADIO RECORDINGS. A Transcription Service for Schools. Prepared by Gertrude G. Broderick. Washington, Federal Radio Education Committee, 1949. 51p. A classified and annotated list of recordings available either through loan or purchase from the FREC.

ELEMENTS OF SOUND RECORDING. By John G. Frayne and Halley Wolfe. N. Y., John Wiley, 1949. 686p. \$8.50. Authorities on sound from Western Electric provide a textbook on the basic problems of recording and reproducing with a brief treatment of closely related fields. Well illustrated.

MAGNETIC RECORDING. By S. J. Begun. N. Y., Murray Hill Books. 1949. 242p. \$5.00. The first comprehensive book on magnetic recording which provides full and accurate information on this fast growing elec-

tronic development in all of its design, engineering, application and experimental phases. The author, an experienced engineer, is Chm. of the NAB committee on magnetic recording.

THE RECORDING AND REPRODUCTION OF SOUND. By Oliver Read. Indianapolis (1) Howard W. Sams, 1949. 364p. \$5.00. Includes basic principles of sound waves, history of recording and the technique of modern sound recording and reproduction of lateral disc, wire, tape and magnetic tape, together with proposed standards of the NAB and American Standards Assn. acoustical terminology.

TECHNICAL ASPECTS

BROADCAST OPERATORS HANDBOOK. By Harold E. Ennes. N. Y., John F. Rider, 1949. 265p. \$3.50. An experienced engineer writes not only for newcomers but discusses the problems of the technician. Six chapters deal with the control room and studio; master control, remote control operations; the transmitter; maintenance and equipment.

ELECTRON TUBES, Vol. I and II. Edited by Alfred N. Goldsmith and others. Princeton, N. J. RCA Laboratories div. 1949. \$2.50 each. Reprints of papers originally published in the RCA Review "for scientists, engineers and others whose work involves the design of tubes or their application." Vol. I covers the period from 1935-1941 and Vol. II through 1948.

ELECTRONICS MANUAL FOR RADIO ENGINEERS. By Vin Zeluff and John Marcus. N. Y., McGraw-Hill, 1949. 879p. \$9.50. 289 articles published in ELECTRONICS during 1940-1948 compiled for quick reference by the associate editors. Information for radio design engineers, including mathematics, measuring and operating techniques, as well as for radio production technicians.

FACSIMILE. By Lee Hills and Timothy J. Sullivan. N. Y., McGraw-Hill, 1949. 332p. \$3.50. The technique of broadcasting via facsimile by the Managing and Facsimile editors of the Miami Herald. For the student, journalist and radioman.

FREQUENCY MODULATION, Vol. I. Edited by Alfred N. Goldsmith and others. Princeton, N. J. RCA Laboratories div. 1948. 515p. \$2.50. A collection of papers originally published in the RCA Review.

NAB ENGINEERING HANDBOOK. 4th ed. By Dept. of Engineering, National Assn. of Broadcasters. Washington, NAB, 1949. 675p. loose-leaf. Available to members only at \$17.50. In six sections, this revised and enlarged handbook contains FCC regulations and standards, transmitter, studio, field and general engineering. Includes AM, FM and TV, with prac-

(Continued on page 528)

REFERENCE BOOKS

(Continued from page 527)

tically all new or revised material. Many charts, graphs and tables.

RADIO AND TELEVISION MATHEMATICS: A Handbook of Problems and Solutions. By Bernhard Fischer. N. Y., Macmillan, 1949. 484p. \$6.00. A practical reference for technicians in the field of electronics. Includes a complete compilation of formulas, tables, review of basic mathematics and the use of the slide rule, the J-operator, powers of ten and polar vectors.

THE RADIO MANUAL. By George E. Sterling and Robert Monroe. N. Y., Van Nostrand, 1950. \$12.00. A practical handbook, especially valuable for commercial and broadcast operators, covering structure, installation, upkeep, operation and control of all forms of radio apparatus and equipment. The new edition will contain much new material including a large chapter on Television.

REFERENCE DATA FOR RADIO ENGINEERS, 3rd ed. N. Y., Federal Telephone and Radio Corp. 1949 640p. \$3.75. A comprehensive compilation of basic electrical, physical and mathematical data frequently needed in the solution of engineering problems. Designed to fill a gap between textbooks and handbooks.

TECHNIQUES & CAREERS

AUDITIONS FOR RADIO AND SCHOOL. Vol. 2. By Emily Davis. Boston, Baker's plays, 1949. 69p. \$1.00. A well-selected collection of monologues and dialogues suitable for auditions and also useful for radio workshops and teaching material.

EMPLOYMENT AND EARNINGS OF RADIO ARTISTS. Reports 1-2. By Bureau of Labor Statistics. Washington, U. S. Dept. of Labor, 1949. Report no. 1, Employment and Unemployment, 10p. issued March 9, 1949; No. 2, Earnings from Radio Performing, 9p. issued April 1949.

EMPLOYMENT OUTLOOK IN RADIO AND TELEVISION BROADCASTING OCCUPATIONS. By U. S. Bureau of Labor Statistics in cooperation with the Veterans Administration. Washington, U. S. Govt. print. off., 1949. 69p. (Bul. 958). 30c. The introduction presents the national scope of the industry, its occupations, outlook and earnings, followed by statistics for each individual state.

FUNDAMENTALS OF WRITING FOR RADIO. By Rome Cowgill. N. Y., Rinehart, 1949. 301p. \$3.50. "Drama, talks, continuities, and non-dramatic features, with guidance in program planning, production and marketing" are presented by a successful radio writer and teacher.

HANDBOOK OF RADIO PRODUCTION: An Outline of Studio Techniques and Procedures in the U. S. By Erik Barnouw. Boston, Little, Brown, 1949. 342p. \$4.50. A professional presentation of the elements of production from rehearsal to the broadcast itself. Chapters devoted to the medium, modern studio equipment and personnel, together with consideration of problems involved, con-

clude with a script and production notes, and a glossary of production terms.

THE PROFESSION OF RADIO FARM BROADCASTING. By Justin Miller. Washington, Nat. Assn. of Broadcasters, 1949. 16p. An address by the President of NAB to the National Association of Radio Farm Directors, Chicago, Nov. 23, 1948, in which he discusses farm broadcasting as a profession, its problems and methods for solution.

THE RADIO PLAY: ITS TECHNIQUES AND POSSIBILITIES. By Felix Felton. Forest Hills, N. Y., Transatlantic arts, 1949. 151p. \$2.50. The author, an actor, writer and producer for the British Broadcasting Corporation, explains the production of radio plays.

YOUR CAREER IN MOTION PICTURES, TELEVISION, RADIO. Edited by Charles R. Jones. N. Y., Sheridan House, 1949. 255p. \$2.98. Practical information and advice by 27 experts from Hollywood and New York, edited by an experienced film man.

YOUR OPPORTUNITIES IN TELEVISION. By Ruth Lee Harrington. N. Y., Medill McBride Co., Nov. 1949. 192p. \$3.00. Precise information on the expanding job opportunities in the total industry, requirements and duties, qualifications, education and experience necessary and the salary range. Illustrated.

TELEVISION

NEW TELEVISION: The Magic Screen. By Raymond F. Yates. N. Y., Didier pub. co., 1948. 175p. \$2.75. A history of Television including its wartime uses.

PHOTOELECTRICITY AND ITS APPLICATION. By V. K. Zworykin and E. G. Ramberg. N. Y., John Wiley, 1949. 494p. \$7.50. "A unified study of the whole field of photo-electricity, the basic principles, methods of preparation, and the main applications of photosensitive devices with emphasis on the practical aspects." Chapters on TV and facsimile included.

SOME BILLION DOLLAR QUESTIONS ABOUT TELEVISION AND SOME SUGGESTIONS ON HOW TO THINK ABOUT THEM. The Fought Co., 342 Madison Ave., New York 17. 1949. 110p. \$5.00. A public relations firm analyzes TV's balance sheet and recommends some form of pay-as-you-view system to augment advertising income.

THE BASIC ISSUES IN COLOR TELEVISION. By Frank Stanton. N. Y., CBS, 1949. 21p. apply. Statement by the President of CBS before the Federal Communications Commission at the Color TV hearings, Docket 8736, et al, on CBS' interest as a broadcaster.

THE MIRACLE OF TELEVISION. By Luther S. H. Gable. Chicago, Wilcox & Follett, 1949. 151p. \$2.50. Although written particularly for the student by a scientist and inventor, its popular style will appeal to those interested in the history, operations and possibilities of TV. Illustrated with photos and line drawings.

THE STORY OF TELEVISION: The Life of Philo T. Farnsworth. By

George Everson. N. Y., Norton, 1949. 266p. \$3.75. Television transmission and reception included in this biography of the inventor of electronic TV.

TELEVISION. By Marcus Graham Scroggie. 2nd Ed. London, Blackie & son, 1948. 77p. 6s. An English radio engineer explains "as simply as possible how modern television works, its difficulties and achievements and what its future may hold." Intended for the general reader with an interest in modern invention.

TELEVISION AS AN ADVERTISING MEDIUM. By Philip A. Bennett. Washington, U. S. Govt. print. off., 1949. 30p. 60 cents. The General Products Division of the U. S. Office of Domestic Commerce examines the many facets of the TV industry and analyzes the current facts of its potentialities. Data on stations, sets, marketing areas, program costs and possible influence on advertisers and agencies.

TELEVISION BOOM. By Buel W. Patch. Washington Editorial Research Reports, vol. I, no. 4, Jan. 26, 1949. 16p. \$1.00. Analysis of TV's rapid growth, uses and programs as well as a comparison of TV with the radio, movies and press.

TELEVISION STATUS AND TRENDS. By Alfred N. Goldsmith. N. Y., Assn. of National Advertisers, 285 Madison Ave. 1949. 8p. 21 charts. \$4.00. Address by well-known consultant on radio and TV before the ANA, March 1949. Includes statistics on stations, sets and coverage, industry facts and figures and an appendix on Stratovision and Phonevision.

TELEVISION WORKS LIKE THIS. By Jeanne and Robert Bendick. N. Y., Whittlesey House, McGraw-Hill, 1949. 62p. \$1.75. A behind-the-scenes, fully illustrated story of TV by experienced authors who know how to get it across in a non-technical manner. Interesting to both adults and juveniles.

THE USE OF TELEVISION BY THE PUBLIC LIBRARY. By the Audio Visual Board of the American Library Association and the Library Public Relations Council. American Library Assn. publishing Dept. 50 E. Huron St. Chicago 11. 1949. 35p. \$1.00. A forum discussion with a moderator and four speakers representing TV production, network programs, radio entertainment and library services.

VIDEO HANDBOOK. By Morton G. Scheraga and J. J. Roche. Montclair, N. J., Boland and Boyce, 1949. 892p. \$5.00. A complete handbook in fourteen sections covering the history of TV, technical details, stations, program building, together with a data section, glossary and bibliography. Written by an experienced technician and radio editor.

FILM IN TELEVISION

16MM SOUND MOTION PICTURES: A Manual for the Professional and the Amateur. By William H. Offenhausser Jr. N. Y., Interscience publishers, 1949. 592p. \$10. The author, an experienced sound film recording engineer, devotes a complete chapter to the use of 16mm film in television.

DIRECTORY OF 897 16-mm FILM
(Continued on page 533)

U. S. GOVERNMENT AGENCIES DEALING WITH RADIO

(For FCC see page 462)

EXECUTIVE OFFICE OF THE PRESIDENT
Blair House
17th & Pennsylvania Ave. N.W.
National 1414

The White House Office: Assistant to the President, John R. Steelman. Special Counsel to the President, Charles S. Murphy. Secretaries, Matthew J. Connelly, Charles G. Ross, William D. Hassett. Administrative Assistants to the President, David K. Niles, Donald S. Dawson.

DEPT. OF AGRICULTURE
14th St. & Independence Ave. S.W.
Republic 4142

Office of Information: Director, Keith Himebaugh. Associate Director, R. L. Webster. Assistant Director of Information in charge of Radio and Video: Kenneth M. Gopen. In charge of operations, Dana Reynolds. TV Information Specialists, Tom Noone and Maynard Speece. In charge of Network Programming, Mrs. Elizabeth Pipp. Syndicated Services, C. A. Herndon. Assistant Director in charge of Motion Pictures, Publications and Exhibits: J. H. McCormick.

DEPT. OF COMMERCE
14th St. & Constitution Ave. N.W.
Sterling 9200

Director of Publications: Donald R. Burgess.
Census Bureau: Acting Director Philip M. Hauser.

National Bureau of Standards: Director, E. U. Condon. Chief Central Radio Propagation Labs., Dr. Newbern Smith. Chief Frequency Utilization Research Section, Kenneth A. Norton.

Bureau of Foreign and Domestic Commerce, Office of Domestic Commerce: Director, H. B. McCoy. Assistant Director, Dean O. Bowman. Production and Market Specialist in radio-TV receivers, James B. Forman. Chief Marketing Division, Nelson A. Miller. Consumers Merchandise, Kenneth R. Davis. Foreign Market Analyst Radio-TV Transmitters, and Receivers, John V. McCarthy.

Civil Aeronautics Administration: Acting Chief, Aids & Hazards Section, T. H. Chapman. Assistant Administrator for Aviation Information, Ben Stern.

FEDERAL SECURITY AGENCY
4th St., & Independence Ave., S.W.
Executive 8300

Administrator: Oscar R. Ewing. Office of Publications and Reports: Director, Zilpha C. Franklin. Food and Drug Administration. Office of Education. Office of Vocational Rehabilitation: Chief Information Service, W. Oliver Kincannon. Public Health Service. Social Security Administration.

FEDERAL TRADE COMMISSION
Pennsylvania Ave., & 6th St. N.W.
Executive 6800

Commissioners: Lowell B. Mason, acting chairman; W. A. Ayres, James Mead, John Carson.

Assistant to the Chairman in Charge of Public Relations: Nick M. Carey. Assistant to the Director of Public Relations: Donald R. Moore.

GENERAL SERVICES ADMINISTRATION

General Services Bldg.
F Between 18th & 19th
Executive 4900

Office of Public Information and Reports: Joseph S. Cohen, director.

DEPT. OF INTERIOR

C. St. Between 18th & 19th St. N.W.
Republic 1820

Acting Director of Information: William J. Dougherty. Information Specialist, J. G. Kendrick. (Radio-TV section transferred to Dept. of State.)

DEPT. OF JUSTICE

9th & Pennsylvania Ave., N.W.
Republic 8200

Attorney General: J. Howard McGrath. Assistant Attorney General in charge of Anti-Trust Division: Herbert A. Bergson. Special Assistant to the Attorney General, Chief of Litigation Section, Anti-Trust Division, Holmes Baldrige.

Director of Public Information: Dean

Awards and citations listed herewith were presented during 1949 and were not necessarily for that year.

MAJOR AWARDS AND CITATIONS—1949

American Assn. for the United Nations Award

NATIONAL BROADCASTING CO. for "outstanding record in the past year in the field of public service programs and efforts toward the building of a better-informed public opinion in support of the United Nations."

City College Broadcasting Awards*

Plaques

Top awards for best in class entrants regardless of type of entry have been awarded to:
WEEI Boston, best promotion 1948.
WMAQ Chicago, and **Chicago Industrial Health Assn.**, best radio program.
Johnson & Johnson firm's It's Your Life.
KUDNER Agency Inc., New York, best

L. Schedler, Assistant Director, Leo M. Cadison.

NATIONAL LABOR RELATIONS BOARD

815 Connecticut Ave., N.W.
 S Sterling 7373
 REpublic 7500

Members: Paul M. Herzog, chairman; James J. Reynolds Jr., John M. Houston, Abe Murdock.
 General Counsel: Robert N. Denham.
 Director of Information: Louis G. Silverberg.
 Assistant Director: Jay E. Shanklin.

NATIONAL SECURITY RESOURCES BOARD

17th St. & Pennsylvania Ave., N.W.
 S Sterling 4700
 Director of Information: Charles Schwarz.

DEPT. OF DEFENSE

Pentagon Bldg.
 REpublic 6700

Office of Public Information: Director. William Frye, Deputy Director, Os-good Roberts, Chief, Public Relations, Lt. Col. Donald T. Jones, Assistant, Lt. Col. Clark S. Newlon.
 Radio-Television Branch: Chief, Charles Dillon, Chief, TV Section, Maj. Robert P. Keim (Air Force), News & Special Events, Maj. George Blackburn, Maj. Thomas O. Mathews, Chief, Script & Production, Stanley Field.
 Press Branch: Chief, Lee Hargus, Deputies, Lieut. Comdr. C. H. Schooley and Joseph R. Flynn, Executive Assistants, Edward Cottrell, Comdr. John D. Pillsbury, Navy, Maj. Jesse E. Stay, Air Force, Administrative Assistant, John E. Garland.

MUNITIONS BOARD

Pentagon Bldg.
 REpublic 6700

Chairman: Hubert E. Howard.
 Advisor on Public Information, Floyd Brinkley, Assistant, Hunt Clement.

NATIONAL MILITARY ESTABLISHMENTS (By Branches)

DEPT. OF THE ARMY

Pentagon Bldg.

Republic 6700 Extension 3201

Acting Chief of Information, Public Information Division Chief: Maj. Gen. Floyd R. Parks.

DEPT. OF THE NAVY

Pentagon Bldg.

Republic 6700 Extension 4435

Director of Media Division: Capt. Charles G. Duffy.
 Acting Director of Public Information: Capt. H. E. Sears.

DEPT. OF THE AIR FORCE

Pentagon Bldg.

Republic 6700 Extension 3201

Air Information Division: Director of Public Relations, Steve Leo, Deputies: Brig. Gen. Sory Smith, Nils A. Lennartson.

television program, Tezaco Star Theater.

Awards of Merit

N. W. AYER & Son, New York, for the creation of the most effective spot television announcements for the year 1948—the Lucky Strike dancing cigarette spots sponsored by American Tobacco Co., New York.

WHAS Louisville for creation of the most effective direct-selling sponsored radio program by a 50 kw radio station—*Kaufman's Coffee Call*, (sponsor, Kaufman-Straus Co.)

KXLY Spokane for creation of the most effective institutional sponsored radio program by a 5 to 10 kw station—*Excerpts From the March of History*, (sponsor, Standard Securities Corp.)

WHB Kansas City for the creation of the most effective sponsored spot radio announcement by a 5 to 10 kw Station jingles (sponsor, Cook Paint & Varnish Co.).

WLOK Lima, Ohio for creation of radio program most

MARINE CORPS

Navy Annex, Arlington, Va.

Republic 7400

Office of Public Information: Brig. Gen. Clayton C. Jerome, Col. J. R. Hester, assistant director.

COAST GUARD

1300 "E" St. NW

Executive 6400 Extension 2993

Office of Public Information: Chief, Capt. Samuel F. Gray, Special Assistant in Charge of All Media, Wade W. McCoy, Editorial Assistant, Lt. James N. Ashbrook.

DEPT. OF STATE

21st & Virginia Ave., N.W.

REpublic 5600

Secretary of State: Dean Acheson.
 Assistant Secretary of State for Public Affairs: Edward W. Barrett.

Office of International Information: Director, Lloyd A. Lehrbas, General Manager, Charles M. Hulten.

Division of International Broadcasting: Acting Chief, Foy Koehler, Chief Program Branch, Mucio Del Gado, Facilities Chief, George Herrick, Chief Washington Branch, Morton Glatzer, Director Washington Special Events, John F. Hogan, Chief Washington Program Operations Section, Sidney Sulkin, Washington Information Officer, Mrs. Barbara Pryor.

Division of International Press and Publications: Chief, Jack C. McDermott, Assistant, George Garrott, News Editor for Congressional coverage: Joseph M. Sitrick, Public Affairs Overseas Program Staff: Acting Chief, Morrill Cody, Office of Educational Exchange (OEX): Director, William C. Johnstone Jr.

Office of Transportation and Communications, Telecommunications Division: Chief, Francis Colt De Wolf, Associate Chief, Harvey Otterman, Assistants: John S. Cross, Cecl G. Harrison, Arthur L. Lebel, Trevion Henry, Ernest Nesbitt.

Special Assistant to the Secretary in Charge of Press Relations: Michael J. McDermott, Executive Assistant, Lincoln White, Assistant on Economic Affairs: Roger W. Tubby.

TREASURY DEPT.

U. S. Savings Bond Division

Washington Bldg.

15th St. & New York Ave., N.W.

EXecutive 6400

National Director: Vernon L. Clark, Director of Promotion and Publicity: Louis Carow, Chief, Radio Section: N. P. Colwell.

VETERANS ADMINISTRATION

Vermont Ave. & H. St., N.W.

EXecutive 4120

Administrator: Carl R. Gray Jr., Director of Public Relations: A. W. Wollford, Assistant Director for Radio-TV Division, H. D. Silva.

effective in station promotion by a 100 to 250 w station—National Radio Week series.

WOW Omaha for creation of program most effective in station promotion by a 5 to 10 kw station—*Farm Service Reporter*.

COLUMBIA Pacific Network for creation of radio program most effective in network promotion by a regional or intrastate network—*The Last Waterhole*.

KENYON & ECKHARDT, New York for the most effective promotion of a national program by a sponsor, advertising agency or program producer—*County Fair*. (Sponsor, Borden Co.)

FREDERIC W. ZIV INC., Cincinnati for most effective promotion of a regional or intrastate radio program by a sponsor, advertising agency or program producer—*Favorite Story*.

KLZ Denver for most effective promotion of local radio program by a 5 to 10 kw station—*Knave of Hearts*.

WGAR Cleveland for most effective promotion of a local radio program by a 50 kw station—*Fairyland Theater*. (Sponsor, Clark Restaurant Co.)

KTUC Tucson for most effective over-all station promotion by a 100 to 250 w station.

WCCO Minneapolis for most effective over-all station promotion by a 50 kw station.

Honorable Mentions
FOOTE, CONE & BELDING, Chicago for creation of a unusually effective television program—*Uncle Mistletoe* (sponsor, Marshall Field Co.).

CECIL & PRESBREY, New York for creation of unusually effective television announcements, (sponsor, Rensselaer Metal Works).

SIBLEY, LINDSAY & CURR CO., Rochester, N. Y. for creation of an unusually effective direct-selling program—*Dawn Patrol* (WARC Rochester).

KXLY Spokane for the creation of an unusually effective direct-selling program—*Farming for Profit* (sponsor, Sears, Roebuck & Co.).

RURAL RADIO NETWORK, Ithaca, N. Y. for the creation of an unusually effective institutional, sponsored radio program—*Weather Roundup* (Grange Insurance Companies, Keene, N. H.).

KWG Stockton, Calif. for the creation of programs unusually effective in station promotion—*KWG Was There*.

WNEW New York for the creation of programs unusually effective in station promotion—*Little Songs About UN*.

MATTHEWS BROS., APPLIANCES, Wichita Falls, Texas for unusually effective promotion of a national radio program—*Mr. President* (KFDX Wichita Falls).

KLX Oakland, Calif. for unusually effective promotion of a local radio program—promotion of its baseball broadcasts.

WING Dayton, Ohio for unusually effective promotion of a local radio program—*Kittyhawk Broadcast* (sponsored by National Cash Register Co.).

WMT Cedar Rapids, Iowa for unusually effective promotion of a local program—*Sports by Tait Cummins* (with multiple sponsors).

WNEW New York for unusually effective promotion of a local radio program—*You Can Lose Your Shirt* (sponsor, Bendix Home Appliances).

WEEK Peoria for unusually effective all-over station promotion.

WKRC Cincinnati for unusually effective all-over station promotion.

WKY Oklahoma City for unusually effective all-over station promotion.

WLW Cincinnati for unusually effective all-over station promotion.

* The CCNY Awards are granted annually by a committee of radio editors from the advertising and amusement press, under the Chairmanship of Dr. John Gray Peatman, associate dean, CCNY.

duPont Awards*

WLS Chicago
KLZ Denver
HENRY J. TAYLOR, MBS and ABC analyst

* Cash award of \$1,000 to each winner accompanied by embossed recognition plaques. The three annual awards are presented under a special irrevocable and perpetual trust fund established in 1942 by the widow of Alfred I. duPont in his memory. Selection committee: Mrs. Alfred I. duPont; Dr. Francis P. Gaines, president of Washington & Lee University; M. H. Aylesworth, Mrs. J. L. Blair Buck, president of the General Federation of Women's Clubs, and Mark Ethridge, publisher of the Louisville, Ky., Courier Journal.

Educational Radio Awards*

"Men of the Year"

KENNETH G. BARTLETT, dean of the University College at Syracuse, chairman of Television Broadcasters Assn. Educational Committee, and chairman of committee to set standards for radio teaching in colleges.

RICHARD B. HULL, radio director at Iowa State College, manager of school's station WOI, and president of National Assn. of Educational Broadcasters.

Both commended for their use of educational radio and television.

Citations

WABE (FM) ATLANTA, *Uncle Dan from Froggy Hollow Farm*; **KYW PHILADELPHIA**, *Once Upon a Time*; **KDKA PITTSBURGH**, *Miss Hickory*; **KATL HOUSTON**, *Square Dancing*; **WQXR NEW YORK**, *New York Times Youth Forum*; **WCTC NEW BRUNSWICK**, N. J., *Children Have Their Problems*; **KCMO KANSAS CITY, MO.**, *Report Card from Your Schools*; **WLS CHICAGO**, *Let's Go Places*; **KUOM U. OF MINNESOTA**, *Look What We Found*. Two awards—**WEW ST. LOUIS** for *Science for You and Our Missouri Constitution*, and **WBZ BOSTON** for *Children's Corner and Listen and Learn*.

School Commendations

ITHACA COLLEGE RADIO WORKSHOP, for its School of the Air program "Trees."

U. of Colorado, for *Today's Frontiers*.
EMPIRE STATE RURAL NETWORK, for *Revolt of the Unhappy Clothes*.

* Awards presented annually by the advisory committee of the School Broadcast Conference.

Freedom Awards*

BEST RADIO PROGRAMS
 Gold Medal and Cash Awards.

First Award (\$2,000), *The Greatest Story Ever Told*, sponsored by Goodyear Tire & Rubber Co., on ABC.

Second Award (\$750), *Cavalcade of America*, sponsored by E. I. duPont de Nemours Co., on NBC.

Others Winners—
 (Awards from \$600 to \$50)

GEORGE TUNNELL, Negro disc jockey on **WDAS Philadelphia**, for his *The Bon-Bon Show*.

CBS, for its *You Are There* show on the battle of Gettysburg.

DR. GEORGE S. BENSON, for *The Land of the Free*, on the Don Lee-Mutual network.

WILLARD WILSON, script-writer for "It Might Have Been You" show, one of *Northwest Neighbors* series sponsored by Pacific Power & Light Co.

WWJ DETROIT, for *24 Hours Un-der Communism*.

(Continued on page 530)

MAJOR AWARDS

(Continued from page 529)

Freedom Awards (Continued)

WCAU PHILADELPHIA, for *The Blessings of Liberty*.
 SPIRITUAL MOBILIZATION, for *The Freedom Story* on KFAC Los Angeles.
 WJR DETROIT, for series, *Know Your America*.
 Medal Awards—
 KNOX MANNING, for the program, *Open Letter to Paul Robeson* on KNX Los Angeles.
 JACK BEALL, for his "Anti-Communist" series on ABC.
 RADIO COUNCIL OF CHICAGO PUBLIC SCHOOLS for *These Things Are America* on WBEZ Chicago.

NBC, for its documentary series, *Living 1949*.
 COL. ROBERT R. McCORMICK, for his talk, "Responsibility in a Free Enterprise State" on the Chicago *Theater of the Air* (MBS).

Unclassified Awards (each \$1,500)—
 HOWARD REYNOLDS, of 2522 N. 23 St., Philadelphia, for his song, "Speak Up for Freedom," first heard on WDAS Philadelphia's *The Bon Bon Show*.

BEST ADVERTISING CAMPAIGN
 ADVERTISING COUNCIL, New York, for its "American Economic System" campaign.

BEST SERMONS
 DR. PAUL J. GOODWIN, minister of the First Presbyterian Church, San Jose, Calif., for a sermon "Can a Good Christian be a Good Communist?" delivered on KLOK San Jose last July 24.

BEST COMPANY EMPLOYEE PUBLICATIONS
Prairie Farmer—WLS Round-Up, monthly publication of WLS Chicago.
 Some 200 awards made annually at Valley Forge, Pa., by Freedoms Foundation in recognition of contributions to the American way of life on "Speaking Up for Freedom." Awards established 1949.

Helm Athletic Foundation Award

HARRY WISMER, sportscaster and general manager, WJR Detroit, for noteworthy contribution to sports.

IRE Memorial Awards

IRE Medal of Honor

DR. RALPH BROWN, Director of Research, Bell Telephone Laboratories, for "his extensive contributions to the field of radio and for his leadership in Institute affairs."

Browder J. Thompson Memorial Prize
 R. V. POUND, junior fellow of the Society of Fellows at Harvard University, for "his work on frequency stabilization of microwave oscillators."

1949 Morris Leibmann Award
 DR. CLAUDE E. SHANNON, Bell Telephone Laboratories engineer, "for his original and important contributions to the theory of the transmission of information in the presence of noise."

National Association of Radio News Directors*

Class I Award

ARTHUR STRINGER, NAB News Committee secretary, for "contribution to progress of radio news."

Class II Award

WHAS LOUISVILLE, to "radio station with best record of community service in news." Honorable mention, KNX Los Angeles, WMAQ Chicago.

Class III Award

WBAP-TV FORT WORTH, for "outstanding TV news presentations." Honorable mention, WFIL-TV Philadelphia. WTMJ-TV Milwaukee.

NCTE Awards*

The NBC University Theatre, for "the program doing the most during the 1948-1949 school year to promote greater understanding and appreciation of our literary heritage."

Honorable Mention

You Are There (CBS), *The Greatest Story Ever Told* (ABC, Goodyear Tire & Rubber Co.) and *Invitation to Learning* (CBS)
 *Awards are presented by the National Council of Teachers of English.

National Society for Crippled Children and Adults

Citations

BOB HOPE, radio comedian, and Don Quinn, radio writer, "for service to the country's handicapped."

Special Awards

CBS and NBC networks.

Ohio State Awards*

Group I—National Network Programs

RELIGIOUS BROADCASTS
 First Awards, *Greatest Story Ever Told*, ABC, and *Way of the Spirit*, CBC; *Catholic Hour*, NBC, and *Eternal Light*, NBC—both honorable mention.

AGRICULTURAL BROADCASTS
 First Award, *Columbia's Country Journal*, CBS. Special award, *Garden Gate*, CBS—citation, "... of particular appeal to the expressed needs of urban and suburban listeners. . . ."

National Retail Dry Goods Association Awards

GENERAL FAMILY PROGRAMS

Store	City	Program	Station	Award
1. Class "C" (\$15 million and over in volume)				
Hecht Co.	Washington	Community Reporter	WGAY	Grand
Wieboldt's	Chicago	Metody Lane	WBBM	Grand
Sibley, Lindsay & Curr	Rochester	Dawn Patrol	WHAM	First
The Fair	Chicago	News On The Spot	WMAQ	Second
Bon Marche	Seattle	Piano Melodies	KOMO	Second
Joske's	San Antonio	Good Morning Show	KTSA	Third
2. Class "B" (\$5 million to \$15 million)				
James Black Dry Goods Co.	Waterloo	RFD 1540	KXEL	First
McCurdy & Co.	Rochester	Little Symphony	WHAM	Second
Rhodes Dept. Store	Seattle	Top Seven	KJR	Second
Zion's Co-op Mercantile Inst.*	Salt Lake City	Utah Symphony Hour	KSL	Third
3. Class "A" (Up to \$5 million)				
Pomeroy's	Pottsville	Tone Portraits	WPAM	Grand
Bigelow's Dept. Store	Jamestown	Dunigan Family	WJTN	First
Sam Shainberg Dry Goods Co.	Memphis	High Noon Roundup	WMPS	Second
John Bressmer Co.	Springfield, Ill.	Upon Reflection	WCVS	Third
WOMEN'S PROGRAMS				
1. Class "C"				
Ed Schuster & Co.	Milwaukee	The Carla Program	WTMJ	Grand
Sibley, Lindsay & Curr	Rochester	Tower Clock Time	WHAM	First
Polsky's	Akron	Lynn Lawrence	WAKR	Second
Joske's	San Antonio	For the Ladies	KTSA, KONO	Third
2. Class "B"				
Kaufman-Straus Pomeroy's	Louisville	Coffee Call	WHAS	First
	Reading	Priscilla Pomeroy	WHUM	Second
3. Class "A"				
B and M.	Peoria	Serenade in Style	WMBD	First
George Wyman & Co.	South Bend	The Time, The Place The Tune	WSBT	Second

CHILDREN'S PROGRAMS

Zion Co-op Mercantile Inst.	Salt Lake City	The Story Princess	KSL	Grand
Lit Bros.	Philadelphia	Magic Lady Supper Club	WFIL	Grand
Emporium	St. Paul	Once Upon a Story Time	WMIN	First

TEEN-AGE PROGRAMS

John Shillito Co.	Cincinnati	Junior Town Meeting	WSAI	Grand
Polsky's	Akron	Teen-Age Hi Jinx	WHKK	First
Zion Co-op Mercantile Inst.	Salt Lake City	Campus Varieties	KUTA	First

FARM PROGRAMS

C. M. Guggenheimer	Lynchburg	Farm Reporter	WLVA	First
James Black Dry Goods Co.	Waterloo	Neighbors News	KXEL	Second
Joske's	San Antonio	Farm and Ranch News	KTSA	Third

MEN'S PROGRAMS

James Black Dry Goods Co.	Waterloo	Grant Price and The News	KXEL	First
Polsky's	Akron	Evening News	WHKK	Second

* Special [NAB] commendation award for best over-all job of radio programming and advertising by a retail store.

CULTURAL PROGRAMS

First Awards, *Stage 48-49*, CBC, and *NBC University Theatre*, NBC.
 Special Awards, *CBC Wednesday Night*, CBC, and *You Are There*, CBS.

MUSICAL

First Award, *Boston Symphony Dress Rehearsal*, NBC.
 Honorable Mention, *E. Power Biggs*, CBS, and *Your Ballad Man*, MBS.

PUBLIC AFFAIRS (drama)

First Awards, *Living 1949*, NBC, and *V. D.—The Conspiracy of Silence*, ABC.
 Honorable Mention, *Mind in the Shadow*, CBS, and *Doorway to Life*, CBS.

PUBLIC AFFAIRS (talks, discussions)

First Award, *Child's World*, ABC.
 Honorable Mention, *On Trial*, ABC; *Cross-Section U.S.A.*, CBS; *Meet the Press*, MBS, and *America United*, NBC.

CHILDREN'S PROGRAMS

First Award, *Mind Your Manners*, NBC.
 Honorable Mention, *Tell It Again*, CBS.

ONE-TIME BROADCASTS

First Awards, *V. D.—A Conspiracy of Silence*, ABC, and *Between the Dark and the Daylight*, CBS.
 Special Award, *One Great Hour*, planned, produced by the Church World Service and H. B. Humphrey Co. Inc. ABC, CBS, MBS.

SCHOOL BROADCASTS

First Awards, *We Build a Nation*, CBC and *Canadians at Work*, CBC.

Television Awards

PROGRAMS OF VARIOUS TYPES—

Information on Awards

Following is partial list of addresses for obtaining information in connection with radio awards:

duPont—Write W. H. Goodman, P. O. Box 720, Jacksonville, Fla. (deadline for entries, Dec. 31; announced in March).

National Assn. of Radio News Directors—Jack Shelley, WHO Des Moines, Ia.; (deadline for entries, Sept. 1; awards announced at annual NARND convention in November).

National Headliners' Club—Mal Dodson, Convention Hall, Atlantic City; (awards announced in May each year at Atlantic City, N. J.).

Ohio State—Keith Tyler, director, Institute for Education by Radio, Ohio State U., Columbus, Ohio.

George Foster Peabody—Dean John E. Drewry, Henry W. Grady School of Journalism, University of Georgia, Athens, Ga. (entries taken January or later; annual awards in April).

First Awards, *The Nature of Things*, NBC; *Kukua, Fan and Ollie*, NBC; *Operation Success*, DuMont; *Julius Caesar*, CBS.

SHORT OPERAS

First Awards, *The Medium*, CBS, and *The Old Maid and the Thief* and *Last Act of La Boheme*, NBC.

Group II—Regional Networks, and Organizations, Regional and Clear Channel Stations.

RELIGIOUS BROADCASTS

First Award, *Treasury of Jewish Folklore*, WNEW New York.
 Honorable Mention, *World Over Playhouse*, WNBC New York.

AGRICULTURAL

First Award, *Rural Reporter*, WNBC New York.
 Honorable Mention, *McClatchy Farm Review*, KFBK Sacramento, KWG Stockton, KMJ Fresno, KERN Bakersfield, KBEE Modesto, all California; *KOH Reno, Nev.*, and *WOW Farmers' Trip to Europe*, WOW Omaha, Neb.

WOMEN'S PROGRAMS

First Award, *Martha Dean Program*, WOR New York.
 Honorable Mention, *Keep Up With the Times*, WQXR New York, and *Especially for Women*, KOAC Corvallis, Ore.

CULTURAL

First Awards, *Student Writers' Workshop*, WIA Madison, Wis., and *Concert of Corn*, KMOX St. Louis.
 Honorable Mention, *Stories for Marmaduke*, WOW Fort Wayne; *Author Meets the Critic*, WNBC New York; *Knowledge in Action*, KVOO Denver; *Natural Treasure*, WNBC New York.

PERSONAL AND SOCIAL PROBLEMS
 First Awards, *It's Your Life*, WMAQ Chicago, and *Destination Freedom*, WMAQ Chicago.

Honorable Mention, *Keeping Well*, WFER Baltimore; *The Knave of Hearts*, KLZ Denver; *Roger Kilgore Public Defender*, WOR New York; *New World A-Coming*, WMAA New York; *Inside New York*, WMAA New York; *Man and Medicine*, KFEL Denver.
 Special Award, *Il Prossimo Tu*, WOV New York.

PUBLIC ISSUES

First Award, *Generation on Trial*, WLW Cincinnati.
 Honorable Mention, *State of the City*, WCAU Philadelphia.

NEWS INTERPRETATION

First Award, *Reporter at Large*, WMAQ Chicago.
 Honorable Mention, *This Week in History*, CJOR Vancouver, B. C.

FURTHERING INTERNATIONAL UNDERSTANDING

SPECIAL ONE-TIME BROADCASTS
 First Awards, *WOW Farmers' Trip to Europe*, WOW Omaha, and *Destination Palestine*, CJOR Vancouver, B. C.

Special Award, *Little Songs About UN*, WNEW New York.
 First Awards, *Malice Toward None*, WMAQ Chicago, *Twenty Four Hours Under Communism*, WWJ Detroit; *And Sudden Death* by Don Lee Broadcasting Co., KHJ Los Angeles.

Special Citation, *Thousands of Characters in Search of a University*, CBM Montreal.

CHILDREN'S OUT OF SCHOOL LISTENING

First Awards, *Children's Bookshelf*, WCAE Pittsburgh, and *Santa Claus Land*, WBNS Columbus.
 Honorable Mention, *Children's Song Bag*, WCOP Boston.

TEEN AGERS OUT OF SCHOOL LISTENING

First Awards, *Record Rendezvous*, WPTR Albany, and The Youth Forums, WQXR New York.

Honorable Mentions, *Mind Your Manners*, WTIC Hartford, and *Youth Looks at the News*, KDKA Pittsburgh.

PRIMARY GRADES SCHOOL BROADCASTS

First Award, *Music Time*, KMBC, KFRM Kansas City.

Honorable Mention, *Radio Express*, WFIL Philadelphia.

INTERMEDIATE GRADES SCHOOL BROADCASTS

First Awards, *Standard School Broadcast*, KNBC San Francisco; *Healthy Living in Travis County*, KTBC Austin, Tex., and *Going Places*, WSUI Iowa City.

Honorable Mention, *Journey Through Musicians*, WWL New Orleans, and *Music in the Air*, WFIL Philadelphia.

JUNIOR AND SENIOR HIGH SCHOOL

First Award, *Exploring the Bookshelf*, CBR Vancouver, B. C.

Honorable Mention, *Ecoutez*, CBR Vancouver, B. C.

Group III—Local Stations and Organizations

RELIGIOUS

Honorable Mention, *Religion Views the News*, WTRY Troy, N. Y., and *Chapel Chimes*, WAER Syracuse.

AGRICULTURAL

First Award, *Noon-time Neighbors*, WCRC, WBOX-FM Louisville.

PERSONAL AND SOCIAL PROBLEMS

Honorable Mention, *City Rent Laws*, WNYC, WNYC-FM New York.

CULTURAL

First Award, *Behind the Scenes of Music*, WNYC New York.

Honorable Mention, *Hands Across the Sea*, WNYC New York, and *Ray Zamer, the Poet Scout*, WSBA York, Pa.

PUBLIC ISSUES

First Award, *The American Crisis*, WFEL Syracuse.

Honorable Mention, *Crossroads of the Future*, WEEI Boston.

NEWS INTERPRETATION

Honorable Mention, *Views on the News*, KCVN Stockton, Calif.

FURTHERING INTERNATIONAL UNDERSTANDING

First Award, *U. N. Proceedings*, WNYC New York.

Honorable Mention, *Your United Nations*, WAER Syracuse.

SPECIAL ONE-TIME BROADCASTS

First Awards, *Estrellita*, the Little Star, WAER Syracuse, and *Election Day 1948*, WDW Tuscola, Ill.

Honorable Mention, *Snatch-Cat and Tournepail*, KUSD Vermillion, S.D.

CHILDREN'S OUT OF SCHOOL LISTENING

First Award, *Strange Adventures of Cuddles and Tuckie*, WDAF Kansas City.

Honorable Mention, *Saturday Morning Story Fair*, WNYC New York, and *Junior Journey*, WEAW Evanston.

TEEN AGERS' OUT OF SCHOOL LISTENING

Honorable Mention, *Junior Achievement Radio Workshop*, WICC Bridgeport, Conn.

PRIMARY GRADES SCHOOL BROADCAST

First Award, *Tales from the Four Winds*, WNYE New York.

Honorable Mention, *The Poetry Parade*, WBOE Cleveland.

INTERMEDIATE GRADES SCHOOL BROADCASTS

Honorable Mention, *Lady Make Believe*, WBEZ Chicago.

JUNIOR AND SENIOR HIGH SCHOOL BROADCASTS

First Award, *Grand Jury*, WNYE, WNYC New York.

Honorable Mention, *America in Song and Story*, WNYE, WNYC New York.

Group IV—Organizations Preparing and Distributing Transcribed Series.

RELIGIOUS

First Award, *All Aboard for Adven-*

ture, Joint Religious Radio Council.

Honorable Mention, *The Ave Maria Hour*, Franciscan Friars of the Atonement, and *Families Need Parents*, Upper Room Radio Parish.

CULTURAL

First Award, *The University Hour*, U. of North Carolina.

Honorable Mention, *Favorite Story*, Frederic W. Civ. Co., and *Songs of the People*, U. of Tennessee.

PERSONAL AND SOCIAL PROBLEMS

First Awards, *Pride of Service* and *Fellowship*, both by Army Air Forces Troop Information Service, OCS.

Honorable Mention, *Stories to Remember*, Institute for Democratic Education; *Marriage for Millions*, Family Service Assn. of America, and *The Inquiring Parent*, National Committee for Mental Hygiene.

Special Award, *V. D. Radio Project—Dramatic Series*, Columbia U. Radio Bureau.

PUBLIC ISSUES

First Award, *Citizens' Committee on Displaced Persons Series*, Citizens' Committee on Displaced Persons.

FURTHERING INTERNATIONAL UNDERSTANDING

First Award, *Quaker World Service*, American Friends Service Committee.

Honorable Mentions, *Operation U. N.*, Radio Division of United Nations, and *Stories of Today and Yesterday*, CBC International Service.

ONE-TIME BROADCASTS

First Award, *Christmas in New York*, State Radio Bureau of New York State Dept. of Commerce.

* Sponsored by the 19th Annual Institute for Education by Radio, Ohio State University, Columbus.

One World Award

IRA HIRSCHMANN, president and manager WAEB-FM New York. Silver trophy for "outstanding contribution to cause of international understanding."

John H. Potts Memorial Award*

DR. H. F. OLSON, of RCA Labs, for outstanding contribution to the progress of audio engineering.

C. J. LeBEL, of Audio Instruments, for "distinguished services to the Audio Engineering Society."

* Awards established in 1949 by the Audio Engineering Society.

School Broadcast Conference Awards*

EDUCATIONAL BROADCASTERS

"Man of the Year" Award (tie vote) Kenneth G. Bartlett, dean of the University College at Syracuse U., chairman of the Television Broadcasters Assn. Educational Committee, and chairman of the committee to set standards for radio teaching in colleges; Richard B. Hull, radio director at Iowa State College, manager of the school's station WOIFM Ames, and president of National Assn. of Educational Broadcasters, for their use of educational radio and television.

Citations to Commercial Stations

WABE(FM) Atlanta, *Uncle Dan from Froggy Hollow Farm*; KWY Philadelphia, *Once Upon a Time*; KDKA Pittsburgh, *Miss Hickory*; KATL Houston, *Square Dancing*; WQXR New York, *New York Times Youth Forum*; WCTC New Brunswick, N. J., *Children Have Their Problems*; KCMO Kansas City, Mo., *Report Card from Your Schools*; WLS Chicago, *Let's Go Places*; KUCM U. of Minnesota, *Look What We Found*; (dual awards) WEW St. Louis, *Science for You and Our*

Missouri Constitution, and WBZ Boston, *Children's Corner* and *Listen and Learn*.

Citations to Schools
Ithaca College Radio Workshop for School of the Air Program *Trees*, and U. of Colorado for *Today's Frontiers*.

Citation to Network
Empire State Rural Network for program, *Revolt of the Unhappy Clothes*.

* Awards are made annually by the advisory committee of the School Broadcast Conference.

NOTE—Information in connection with awards may be obtained from following:

duPont—W. H. Goodman, P. O. Box 720, Jacksonville 1, Fla. (announced March).

NARN—Sig Mickelson, WCCO Minneapolis (announced November).

National Headliners Club—Mal Dodson, Convention Hall, Atlantic City, N. J. (announced in May).

Ohio State—Keith Tyler, director, Institute for Education by Radio, Ohio State University, Columbus, O.

George Foster Peabody—Dean John E. Drewry, Henry W. Grady School of Journalism, U. of Georgia, Athens, Ga.

Sigma Delta Chi Award*

MERRILL MUELLER, manager of NBC London office, for "objective reporting from Britain."

* Award made annually by Sigma Delta Chi journalism fraternity.

Alfred P. Sloan Awards*

NETWORKS

CBS commercial plaque for *No Escape*, weekly suspense series. Sponsored by Electric Auto-Lite Co.

NBC commercial plaque for sustaining programs for *Death on a Weekend*.

LOCAL STATIONS

KNUZ Houston, Tex. for *Voice of Safety*. Sponsored by Brakefield General Agency.

REGIONAL STATIONS

WING Dayton for *Road Reporter*. Sponsored by T. D. and P. A. Peffley Inc.

CLEAR CHANNEL STATIONS

WFDF Flint, Mich. for *Singing Cop*. Sponsored by Hamady Bros.

LOCAL STATIONS

WTTN Jamestown, N. Y. for *Driver of the Week*.

REGIONAL STATIONS

WWJ Detroit for all-around program on *Safety*.

CLEAR CHANNEL

KOMA Oklahoma City, Okla.

HONORABLE MENTION

KOIN Portland, Ore., and WNAX Yankton, S. D.

* Alfred P. Sloan Radio Awards for Highway Safety established in 1948 by Alfred P. Sloan, chairman of the board of General Motors, to be administered by the Automotive Safety Foundation. Selection committee; chairman, Kenneth G. Bartlett, dean of University College, Syracuse U. and director of Syracuse Radio Workshop; Sidney Williams, National Safety Council; Mrs. J. L. Blair Buck, Nat. Fed. of Women's Clubs; George E. Keneipp, National Highway Safety Committee; Harold P. Jackson, National Committee for Traffic Safety.

George Foster Peabody Awards*

KNBC San Francisco for outstanding regional public service program, *Forests Aflame*.

WNEW New York Special Citation of Honor for initiative in creating *Little Songs* about the United Nations in interest of international understanding.

WDAR Savannah, Ga. For outstanding public service by a local station, *You and Youth*.

EDWARD R. MURROW, CBS for outstanding reporting and interpretation of the news.

NBC

for outstanding entertainment in drama, *University Theater*.

ABC

for outstanding entertainment in comedy, *You Bet Your Life*.

NBC

for outstanding entertainment in music, special reference to *NBC Symphony, Orchestras of Nations* and *First Piano Quartet*.

ABC

for outstanding educational program, *Communism—U. S. Brand*.

ABC

for outstanding contribution to the art of television, *Actors Studio*.

NBC

for outstanding children's program, television show *Howdy Doody*.

CBS

for promotion of international understanding, special reference to Larry Lesueur.

ROCKY Mt. Radio Council special citation for public service by utilizing educational, club groups, etc.

LOWELL INSTITUTE COOP. BROADCASTING COUNCIL

Special citation for series of programs devoted to adult education.

* Established in 1940 in honor of the late George Foster Peabody by the board of regents of the University of Georgia, to be jointly administered by its Henry W. Grady School of Journalism and the NAB.

Voice of Democracy Awards*

RICHARD CAVES, Bath High School, Everett, Ohio (participating NAB stations, WAKR, WHKK Akron).

CHARLES KURALT, Central High School, Charlotte, N. C. (participating NAB stations, WAYS WBT, WGIV, WSOC, Charlotte, N. C.).

GEORGE MORGAN JR., Hutchinson High School, Hutchinson, Kan. (KWBW Hutchinson).

KERRON JOHNSON, Wilson High School, St. Paul, Minn. (WMIN, KSTP St. Paul-Minneapolis).

* Awards of college scholarships of \$500 each for efforts in writing and voicing the best five-minute radio scripts on the subject, "I speak for Democracy." Contest is jointly sponsored by the National Assn. of Broadcasters, the U. S. Chamber of Commerce and Radio Mfrs. Assn., and endorsed by the U. S. Office of Education, Federal Security Agency, Judges—Margaret Culkin Banning, author; Aity Gen. Tom C. Clark; Dr. Harry Emerson Fosdick, pastor emeritus, Riverside Church, New York; Mrs. Oveta Culp Hobby, vice president, Houston Post, operating KPRC Houston; Eric Johnston, president, Motion Pictures Assn. of America; Francis Perkins, Civil Service Commissioner; Glenn E. Snow, Dixie Junior College, St. George, Utah, retiring president, National Educational Assn.; James Stewart, actor.

American Assn. for the United Nations Award

NATIONAL BROADCASTING CO. for "outstanding record in the past year in the field of public service programs and efforts toward the building of a better-informed public opinion in support of the United Nations."

vice president; A. E. Joscelyn, secretary-treasurer. Board of Directors: Harry Witt, Calvin J. Smith, Jennings Pierce, Robert O. Reynolds, Robert J. McAndrews, Arlette M. Bartley, executive secretary.

Florida Association of Broadcasters

W. Wright Esch, WMFJ Daytona Beach, president; Jerry Stone, WNDB Daytona Beach, secretary-treasurer.

(Continued on page 532)

1950 Yearbook Number • Page 531

State Broadcasters Associations

Arkansas Broadcasters Association
G. E. Zimmerman, KARK Little Rock, president; Sam W. Anderson, KFFA Helena, vice president; Al Godwin, KFPW Fort Smith, secretary-treasurer.

Alabama Broadcasters Association
(established March, 1946)
Howard E. Pill, WSFA Montgomery, president; Bert Bank, WTBC Tuscaloosa, vice president; T. E. Martin, WAPX Montgomery, secretary-treasurer.

Southern Calif. Broadcasters Assn.
1757½ N. Ivar St., Hollywood 28
301 Equitable Blvd. 6253 Hollywood Blvd.
William J. Beaton, president; Ernest Spencer,

California State Broadcasters Association
(established 1947)

Arthur Westlund, KRE Berkeley, *president*;
Donna Tatum, Don Lee Broadcasting System,
vice president; E. L. Barker, KLOK San Jose,
vice president; Paul R. Bartlett, KFRE Fresno,
secretary-treasurer.

Georgia Association of Broadcasters

Edwin Mullinax, WLAG LaGrange, *president*;
Ben Williams, WTOC Savannah, *secretary-treasurer*.

Illinois Broadcasters Association
(established April, 1948)

Merrill Lindsay, WSOY Decatur, *president*;
Harold Safford, WLS Chicago, *vice president*;
J. Ray Livesay, WLBH Mattoon, *secretary-treasurer*.

Indiana Broadcasters Association

C. Bruce McConnell, WHOT South Bend, *president*;
Robert G. Duffield, WOWO Ft. Wayne,
and E. D. Ogborne, WCTW New Castle, *vice presidents*; Daniel C. Park, WIRE Indianapolis,
secretary-treasurer; Warren G. Davis, WSUA
Bloomington, *assistant secretary*; W. Ferrall
Rippetoe, WBOW Terre Haute, *assistant treasurer*.

Kentucky Association of Broadcasters

F. Ernest Lackey, WHOP Hopkinsville, *president*;
J. Porter Smith, WGRC Louisville, *1st vice president*;
Charles C. Warren, WCMi Ashland, *2nd vice president*;
Hugh O. Potter, WOMI Owensboro, *secretary-treasurer*.

Louisiana Association of Broadcasters
(established June, 1947)

T. B. Lanford, KRMD Shreveport, *president*;
I. K. Corkern, Jr., WIKC Bogalusa, *vice president*;
Robert Dumm, KNOE Monroe, *secretary-treasurer*.

Maine Broadcasters Association
(established Nov. 1947)

Frank S. Hoy, WLAM Lewiston, *president*;
Harold D. Glidden, WAGM Presque Isle, *vice president*;
Gordon J. Lewis, WIDE Biddeford, *secretary-treasurer*.

Michigan Assn. of Broadcasters
(established Dec. 1948)

Stanley R. Pratt, WSOO Sault Ste. Marie, *president*;
Howard K. Finch, WJIM Lansing, *vice president*;
J. P. Scherer, WHFB Benton Harbor, *secretary-treasurer*; *Board of Directors*:
Worth Kramer, WJR Detroit; Edward Baughn,
WPAG Ann Arbor; Willis Dunbar, WKZO
Kalamazoo and WJEF Grand Rapids; Milton
Greenebaum, WSAM Saginaw.

Minnesota Broadcasters Association

Melvin Drake, WDGy Minneapolis, *president*;
Carl Bloomquist, WEVE Eveleth, *vice president*;
Kenneth M. Hance, KSTP St. Paul, *secretary-treasurer*.

Mississippi Broadcasters Association

Hugh Smith, WLAU Laurel, *president*; Bob
Evans, WELO Tupelo, *secretary-treasurer*.

Missouri Broadcasters Association
(established June, 1948)

Wayne Cribb, KHMO Hannibal, *president*;
Mahlon R. Aldridge, KFRV Columbia, *vice president*;
Harry K. Renfro, KXOK St. Louis, *secretary-treasurer*.

Montana Broadcasters Association

Don Treloar, KGEZ Kalispell, *president*;
Cedar B. Aronow, KIYI Shelby, *vice president*;
P. B. McAdam, KPAK Livingston, *secretary*.

Nebraska Broadcasters Association

John Alexander, KODY North Platte, *president*;
Paul Fry, KBON Omaha, *secretary-treasurer*.

Nevada State Broadcasters Assn.
(established July, 1948)

H. G. Wells, KOLO Reno, *president*; Merrill
Inch, KWRN Reno, *secretary-treasurer*.

New Jersey Broadcasters Association
(established September, 1947)

Carl Mark, WTTM Trenton, *president*;
Ranulf Compton, WKDN Camden, *vice president*;
Thomas B. Tighe, WJLK Asbury Park, N. J.,
secretary-treasurer.

North Carolina Association of Broadcasters

Robert H. Wallace, WOHS Shelby, *president*;
Earl J. Gluck, WSOC Charlotte, *vice president*;
Jack S. Younts, WEEB Southern Pines,
secretary-treasurer. *Directors*: Louis Howard,
WIIIT New Bern; Cecil Hoskins, WWNC
Asheville.

Ohio Broadcasters Association

Carl George, WGAR Cleveland, *president*; Al
Abinger, WCOL Columbus, *vice president*;
Fred C. Bock, WADC Akron, *secretary-treasurer*.

Oregon State Broadcasters Association

Lee W. Jacobs, KBKR Baker, *president*;
H. J. Chandler, KFLW Klamath Falls, *vice president*;
Ted W. Cooke, KOIN Portland, *secretary-treasurer*.

Pennsylvania Association of Broadcasters

Frank R. Smith, WBVP Beaver Falls, *president*;
C. G. Moss, WLTR Bloomsburg, *vice president*;
David J. Bennett Jr., WKBO Harrisburg,
secretary; George E. Joy, WRAX Williamsport,
treasurer. *Directors*: Leonard Kapner, WCAE
Pittsburgh; Gordon Gray, WIP Philadelphia;
Clair R. McCollough, WGAL Lancaster; J. S.
Booth, WCHA Chambersburg; Victor C. Diehm,
WAZL Hazleton; W. K. Ulerich, WCPA Clearfield;
David M. Baltimore, WBRE Wilkes-Barre.

South Carolina Broadcasters Assn.
(established June, 1948)

B. T. Whitmire, WFBC Greenville, *president*;
James Hicks, WCOS Columbia, *vice president*;
Melvin Purvis, WOLS Florence, *secretary-treasurer*.

South Dakota Broadcasters Assn.
(established Feb. 1948)

Robert Tincheo, WNAX Yankton, *president*;
Robert Dean, KOTA Rapid City, *vice president*;
Irving R. Merrill, KUSD, *secretary-treasurer*.

Tennessee Assn. of Broadcasters
(established Dec. 1948)

F. C. Sowell, WLAC Nashville, *president*;
Earl Winger, WODD Chattanooga, *vice president*;
Jack Draughon, WSIX Nashville, *secretary-treasurer*.

Virginia State Association

Phillip Allen, WLVA Lynchburg, *president*;
Frank U. Fletcher, WARC Arlington, *vice president*;
John Shultz, WMVA Martinsville, *secretary-treasurer*.

Washington State Association of Broadcasters

Richard O. Dunning, KHQ Spokane, *president*;
James W. Wallace, KPQ Wenatchee, *vice president*;
Tom Olsen, KGY Olympia, *secretary-treasurer*.

West Virginia Broadcasters Association
(established 1946)

John S. Phillips, WCAW Charleston, *president*;
John T. Gelder, WCHS Charleston, *secretary-treasurer*.

Wisconsin League of Radio Stations

C. J. Lanphier, WFOX Milwaukee, *president*;
Kenneth F. Schmitt, WIBA Madison, *treasurer*.

GROUP OWNERSHIP

AMERICAN BROADCASTING CO. OWNED AND MANAGED STATIONS—WJZ, WJZ-TV, New York; WENR, WENR-TV, Chicago; KGO, KGO-TV, San Francisco; KECA, KECA-TV, Los Angeles; WXYZ, WXYZ-TV, Detroit. All affiliates of American Broadcasting Co.; all represented nationally by ABC Spot Sales.

CBS OWNED STATIONS—WCBS, WCBS-FM, WCBS-TV, New York; KCBS, KCBS-FM, San Francisco; KMOX, St. Louis; KNX, KNX-FM, Los Angeles; WBBM, WBBM-FM, Chicago; WCCO, Minneapolis; WEEL, WEEL-FM, Boston. All affiliates of CBS network; all represented nationally by Radio Sales.

CLEVELAND PLAIN DEALER STATIONS—WHK, Cleveland; WHKK, Akron; WHKC, Columbus; WKBN, Youngstown (minority interest).
G. W. COVINGTON STATIONS—WCOV, Montgomery; WGWC, Selma and, WGWD, Gadsden. All in Alabama. Operated by First National Bank, Montgomery, and Mrs. Margaret Covington Milwee as executors of estate of G. W. Covington.

THE COWLES STATIONS (Cowles Broadcasting Co.)—Comprising KRNT, Des Moines; WNAX, Sioux City-Yankton, WOL Washington, and principal stockholder of WCOP, Boston. Represented nationally by The Katz Agency. Executive Officers: Gardner Cowles, president; John Cowles, chairman of the board and vice president; Luther L. Hill, vice president and general manager; James S. Milroy, vice president; Craig Lawrence, vice president and general manager, WCOP; Phillip R. Hoffman, vice president and general manager, WOL; Robert Dillon, vice president and general manager, KRNT;

Robert R. Tincher, vice president and general manager, WNAX; Carl T. Koester, treasurer; Karl R. Haase, asst. treasurer; D. C. Peterson, asst. treasurer; Richard C. Percival, asst. treasurer; Vincent Starzinger, secretary; Arthur T. Gormley, asst. secretary. [Cowles has sold WOL to Capital Broadcasting Co. but actual transfer was awaiting Capital's sale of WDDC Washington.]

JAMES M. COX STATIONS—WSB, WSB-FM, WSB-TV, Atlanta; WIOD, WIOD-FM, Miami; WHIO, WHIO-FM, WHIO-TV, Dayton. Headquarters: WSB, James M. Cox Jr., vice president; J. Leonard Reinsch, managing director of radio and television.
ED CRANEY STATIONS—KXLF, Butte, Mont.; KXL, Portland, Ore.; KXLY, Spokane, Wash.; KXLJ, Helena, Mont.; KXLQ, Bozeman, Mont.; KXLL, Missoula, Mont.

CROSBLEY BROADCASTING CO.—(Division of AVCO Mfg. Co.) WLW, WLWA(FM) and WLWT-TV Cincinnati; WINS New York; WLWB(FM) and WLWD(TV) Dayton, Ohio; WLWF(FM) and WLWC(TV) Columbus Ohio. James D. Shouse, chairman of the board. Robert E. Dunville, president and general manager.

CURTIS RADIOCASTING CORP. STATIONS—WGBF, Evansville, Ind.; WBOW, Terre Haute, Ind.; WTMV, East St. Louis.

DON LEE BROADCASTING SYSTEM—Owned and managed stations: KHJ, Los Angeles; KFRC, San Francisco; KGB, San Diego; KDB, Santa Barbara; KHJ-FM and KTSL (W6XAO) (TV), Hollywood. Lewis Allen Weiss, chairman of the board; Willet H. Brown, president; Ward Ingram, vice president in charge of sales. 1313 N. Vine St., Hollywood 28.

FORT INDUSTRY CO. STATIONS (George B. Storer, president; J. Harold Ryan, senior vice president) — WSPD, WSPD-FM, WSPD-TV, Toledo; WVVVA, WVVVA-FM, Wheeling, W. Va.; WMMN,

Fairmount, W. Va.; WLOK, WLOK-FM, Lima, O.; WAGA, WAGA-FM, WAGA-TV, Atlanta; WGBS, WGBS-FM, Miami; WJBK, WJBK-FM, WJBK-TV, Detroit. Headquarters: 199 Pierce St., Birmingham, Mich. Lee B. Wailes, vice president in charge of operations; Glenn G. Boundy, chief engineer; B. C. Prestler, assistant secretary. New York Office: 527 Lexington Ave. Tom Harker, manager.

MARSHALL FIELD STATIONS (Field Enterprises Inc.)—WJJD, Chicago; WSAI, Cincinnati; KOIN, Portland, Ore.; KJR, Seattle. Headquarters: 211 W. Wacker Dr., Chicago. Marshall Field, president; Howard Lane, vice president in charge of radio. Nationally represented by Avery-Knodel Inc.

THE FRIENDLY GROUP—WSTV, Steubenville, O.; WFPG, Atlantic City; WPIT, Pittsburgh; WKNY, Kingston, N. Y.; WBMS, Boston, Mass., and their FM affiliates. John J. Laux, managing director.

GANNETT NEWSPAPERS STATIONS—WHEC, Rochester; WENY, Elmira, N. Y.; WHDL, Olean, N. Y. (minority); WHTT, Hartford; W DAN, Danville, Ill.; WABY, Albany, N. Y. All holdings through newspapers.

WITHERS GAVIN STATIONS—WJQS, Jackson; WACR, Columbus; WMBC, Macon, and WCOG, Meridian, all in Mississippi.

GENERAL FIRE & RUBBER CO. STATIONS—WNAC, Boston; WAAE, Worcester; WEAN, Providence; WICC, Bridgeport; WONS, Hartford; WMTW, Portland, Me. President: William F. O'Neil. Executive Vice President: Linus Travers. [See Yankee Network regional listing.]

GILA BCSTG. CO. STATIONS—Comprising KCKY Coolidge, KWJB Globe and KGLU Safford. All in Arizona. Lewis F. Long, president.

GRANITE STATE BROADCASTING CO.—WKBR, WKBR-FM Manchester, N. H.; WTSV-FM Claremont, N. H.; WTSA Brattleboro, Vt. Headquarters:

155 Front St., Manchester. W. J. Barkley, president; H. Scott Kilgore, vice president; W. F. Rust Jr., treasurer.

V. J. HARPOLE STATIONS—KVOP Plainview (sole owner); KVOU Uvalde and KVPH Snyder, all Texas.

HEARST RADIO INC.—Licensee of WBAL, WBAL-TV, Baltimore; WISN, WISN-FM, Milwaukee. Headquarters: 959 Eighth Ave., New York 19. Tom A. Brooks, vice president and general manager. Associated with WCAE and WCAE-FM, Pittsburgh, operated by WCAE Inc. Leonard Kapner, president.

OSCAR C. HIRSH STATIONS—WKRO Cairo, Ill.; KFVS Cape Girardeau, Mo.; KFMO Flat River, Mo.

ROY HOFHEINZ STATIONS — KTHT and KOPY (FM) Houston, KSXO Harlingen, all Texas; WCHF New Orleans; WTNB Birmingham (minority interest).

IMES STATIONS—WCBI, Columbus; WMOX and WMOX-FM, Meridian; WELO, Tupelo, WNAQ, Grenada, all in Mississippi and owned by Birney Imes Jr. Estate of Birney Imes Sr. is licensee of WROX, Clarksdale, Miss.

INLAND RADIO INC. STATIONS—KBKR, Baker, KLBK, LaGrande, and KSRV, Ontario, all in Oregon. Principal owner: Olive B. Cornett, 50%; Lee W. Jacobs, president and part owner. Headquarters: KBKR, Baker, Ore.

PIERCE E. LACKEY STATIONS—WPAD, Paducah, Ky.; WCFB, Madisonville, Ky.; WKTM, Mayfield, Ky. (part-ownership). Also WPAD-FM.

J. G. LONG STATIONS—KIOX Bay City, KVIC Victoria, KSAM Huntsville, and KTLW Texas City, all in Texas. (Long Texas Group, a package unit).

JOHN J. LOUIS STATIONS—KTAR, Phoenix, Ariz.; KVOA, Tucson, Ariz.; KYUM, Yuma, Ariz.; KYCA, Prescott, Ariz. Dick Lewis, general manager.

McCLATCHY BROADCASTING CO.—(Owned by McClatchy Newspapers): KFBK, KFBK-FM, Sacramento; KMJ, KMJ-FM, Fresno; KWG, Stockton; KERN, KERN-FM, Bakersfield; KBEE (FM), Modesto; KOH, Reno, Nev. Headquarters: 911 7th St., Sacramento, 4. President: Eleanor McClatchy.

McCLUNG STATIONS of California—KHSL, KVCI (FM), Chico; KYOS, KVME (FM), Merced; KVCV, KVRE (FM), Redding.

MORGAN MURPHY-WALTER C. BRIDGES STATIONS—WEBC, Duluth; WMFG, Hibbing, Minn.; WHLB, Virginia, Minn.; WEAU, Eau Claire, Wis.; WISC, Madison, Wis. Mr. Murphy also has an interest in KVOL, Lafayette, La. Mr. Bridges has interest in KJMC, Rice Lake, Wis.

NBC OWNED AND OPERATED STATIONS—WNBC, WNBC-FM, WNBT (TV), New York; WRC, WRC-FM, WNBW (TV), Washington; WMAQ, WMAQ-FM, WNBQ (TV), Chicago; WTAM, WTAM-FM, WNBK (TV), Cleveland; KNBC, KNBC-FM, San Francisco; KOA, KOA-FM, Denver; KNBH (TV), Hollywood. All members of NBC networks; all represented nationally by NBC Spot Sales.

THE NUNN STATIONS—WLAP, Lexington, Ky.; WCMI, Ashland, Ky.; KFDA, Amarillo, Tex.; WBIR, Knoxville, Tenn. Headquarters: Radio Bldg., Lexington, Ky. J. Lindsay Nunn, chairman of the board; Gilmore N. Nunn, president and general manager; John G. Ballard, national sales director; G. Don Bowie, treasurer. Represented nationally by John E. Pearson Co. and The Bolling Co.

JAMES H. OTTAWAY STATIONS—WENE, WENE-FM, Endicott, N. Y.; WDOS, WDOS-FM, Oneonta, N. Y.; WVPO Stroudsburg, Pa.

JOHN H. PERRY STATIONS—WCOA, Pensacola, Fla.; WJHP, Jacksonville, Fla.; WTMC, Ocala, Fla.; WDLF, Panama City, Fla.

RAHALL STATIONS — WKAP, Allentown, Pa.; WNAR, Norristown, Pa.; WWRN, Beckley, W. Va.; N. Joe Rahall, president.

GEORGE A. RICHARDS STATIONS—WJR, Detroit; WGAR, Cleveland; KMPC, Los Angeles. (Stock in WJR publicly held.)

ADELINE B. RINES STATIONS—WCSH, Portland, Me.; WRDO, Augusta, Me.; WLBZ, Bangor, Me.

DORRANCE D. RODERICK — Owns KSIL, Silver City, N. M.; holds 83% of KROD, El Paso, Tex., and 54% of KOSA, Odessa, Tex.

ROUNSAVILLE STATIONS — Comprising WBAC Cleveland, WBEJ Elizabethton, and KSKR Pulaski, all in Tennessee; WQXI Atlanta (Buckhead), Ga., and WEAT Lake Worth, Fla. Available on package basis. Information from R. W. Rounsaville, Station WQXI, 3165 Mathieson Drive, N.E., Atlanta.

SCRIPPS-HOWARD GROUP—Scripps-Howard Radio Inc. is licensee of WCPO, Cincinnati, WNOX, Knoxville, WEWS-TV and WEWS-FM, Cleveland. It holds construction permits for WCPO-FM and WCPO-TV, Cincinnati. Memphis Publishing Co. is licensee of WMC and WMC (FM) Memphis, and hold construction permit for WMCT (TV) Memphis, all of which are operated separately. Officials: Jack R. Howard, 230 Park Ave., New York, president; James C. Hanrahan, vice president and general manager, WEWS-TV, WEWS-FM; Richard B. Westergaard, vice president and general manager, WNOX; Mortimer C. Watters, vice president and general manager, WCPO, WCPO-FM, WCPO-TV.

STEINMAN STATIONS (see listing under Regional Networks, page 66).

O. L. (Ted) TAYLOR STATIONS—KANS Wichita, Kans.; KTOK Oklahoma City, Okla.; KRGV Westlaco, Tex.

UPPER MICHIGAN-WISCONSIN BCSTG. CO. — WJMS Ironwood, Mich.; WATW Ashland, Wis.; WIKB Iron River, Mich. Wm. L. Johnson, president; J. W. Huss, vice president and general manager.

WM. J. WAGNER STATIONS—KFQD, Anchorage; KFRB, Fairbanks; KINY, Juneau; KTKN, Ketchikan, KIPW Sitka, and KBBH, Seward, all in Alaska.

WESTINGHOUSE RADIO STATIONS INC.—Operating WBZ, WBZ-FM, WBZ-TV, Boston; WBZA, WBZA-FM, Springfield, Mass.; WBOS, Boston (International); KDKA, KDKA-FM, Pittsburgh; KYW, KYW-FM, Philadelphia; WOWO, WOWO-FM, Fort Wayne; KEX, KEX-FM, Portland, Ore. A subsidiary of Westinghouse Electric Corp. Headquarters: 1619 Walnut St., Philadelphia 3. Telephone: Rittenhouse 6-6870. Officers: Walter Evans, president; Walter E. Benoit, vice president; J. B. Conley, general manager; W. B. McGill, advertising manager; Gordon Hawkins, program and educational director; C. M. Meehan, director of public relations; L. R. Rawlins, industrial relations manager; I. C. Ruby, auditor. Washington Office: Commonwealth Bldg. Tel.: National 8850. Ralph N. Harmon, engineering manager; George E. Hagerty, asst. engineering manager; D. A. Myer, technical-field director; John W. Steen, legal representative; F. P. Nelson, Washington representative.

Mutual Advertisers

(Continued from page 403)

U. S. Tobacco Co. New York;	Take A Number; Sat. 8:30-9 PM.	6-5-48— 7-30-49;	Kudner Agency, New York.
Tobaccos, 376, 107, 339	The Man Next Door; Sat. 8:30-9 PM. (South only).	2-28-49— 8-7-49—	
	Martin Kane, Private Eye; Sun. 4:30-5 PM.		
Voice of Prophecy Inc.; Religion, 266	Voice of Prophecy; Sun. 10:30-11 AM.	1-4-42—	Western Adv., Los Angeles.
The Wander Co. Chicago; Ovaltine, 162	Captain Midnight; Mon.-Fri. 5:30-5:45 PM, Eff. 9-20-49; Tues.- Thurs. 5:30-6 PM.	9-26-48— 6-17-49; 9-20-49— 12-15-49	Hill Blackett Co., Chicago.
Williamson Candy Co. Chicago; Oh Henry Candy Bars, 492	True Detective Mysteries; Sun. 4:30-5 PM, Eff. 9-4-49; Sun. 5:30-6 PM.	3-3-46— 5-22-49; 9-4-49—	Aubrey, Moore & Wal- lace, Chicago.
White King Soap Products Co. Los Angeles; White King Soap Products, 10	Chandu, the Magician; Sun. 10:30-11 PM.	2-6-49— 5-1-49	Raymond R. Morgan Co., Hollywood.
Wilson Sporting Goods Co. Chicago; Sports Equipment, 500 concl.	All-Star Football Game; Fri. 9:30 PM to only	8-12-49	Ewell & Thurber Assoc., Chicago.

Reference Books

(Continued from page 528)

LIBRARIES. Washington, U. S. Govt. print. off., 1949. 32p. 15 cents. A guide to the libraries where films and filmstrips can be secured. Not complete because of rapid growth but useful.

EDUCATIONAL FILM GUIDE. Compiled by Dorothy E. Cook and Katherine M. Holden. N. Y., The H. W. Wilson co. An annual index, with supplements, of a selected, classified and annotated list of films. Useful for TV educational and news programs.

FILMSTRIPS: A Descriptive Index and Users' Guide. By Vera M. Falconer. N. Y., McGraw-Hill, 1948. 572p. \$5.00. A complete description of all filmstrips suitable for institutional use which were available on March 1, 1947. Arranged by subject with an alphabetical title index and a distributor directory, each listing includes technical data and supplementary material available.

140 MILLION LISTENERS: Tips on radio for Chambers of Commerce. Washington, D. C., Chamber of Commerce of the U. S., 1949. 22p. 15 cents. A frank assessment of the value of radio for Chambers of Commerce, trade associations, etc., with technical as-

sistance in radio programming on local stations.

RADIO PLAYERS' SCRIPTBOOK. Edited by Herbert Prescott. Portland, Me., J. Weston Walch, 1949. 410p. Non-royalty plays by professional writers, edited by the publicity and radio director of Grinnell College, easy to produce and within the acting range of high school and college groups. Collection divided into 15, 25 and 30 minute plays together with "Macbeth" in eight 15-minute parts.

THE SHOWBUSINESS

CENTER OF THE WORLD

- ★ Over 5000 sq. ft. of Rehearsal Studios for the Radio, Television, Stage, and Screen Industries.
- ★ Standard Broadcasting Equipment
- ★ Projection Room For Screening Recording Service
- ★ Theoretical training through the Cambridge School of Radio. Special thanks to Bess Stern and George Carlesco

PLUS

- ★ RADIO and TELEVISION PACKAGE PROGRAM PRODUCTIONS.
- ★ PERSONAL MANAGEMENT—Jack Lacy, Star of the "Listen to Lacy" and "Bushels of Fun" shows, WINS, New York—And other top name personalities.

ROBERTS STUDIOS

806 Seventh Ave., N.Y.C.
Tel. Judson 6-0025-26
Bob L. Roberts, Pres.

PROFESSIONAL & TECHNICAL SCHOOLS FOR RADIO & TELEVISION

Name, Address, Tel.	Courses Offered	Registrar & Registration Date	Name, Address, Tel.	Courses Offered	Registrar & Registration Date
Actors Company Creative Theatre Inc.* 218 S. Wabash Chicago 4, Ill. Tel.: Webster 9-7265	Television, radio & stage	Milton Galatzer Feb. 7, 1949	Cambridge School of Radio Broadcasting* 220 W. 42nd St. New York Tel.: Wisconsin 7-0038	All commercial and program techniques	George S. Carlesco Continuous
American Institute of the Air 5 West Lake Street Minneapolis 8, Minn. Tel.: Pleasant 5290	Announcing, writing, directing, control operating, Sports play-by-play, Radio Time selling	Helen S. Brown Weekly	Capitol Radio Engineering Institute* 3224 16th St. N. W. Washington, D. C. Tel.: Hobart 1520	Home study and residence courses in AM, FM & TV engineering and servicing; aeronautical engineering	Everett A. Corey Twice monthly
American Telecasting Corp. 5600 Sunset Blvd. Hollywood 28 Tel.: Hollywood 9-8347		S. R. Rabinoff	Central Radio & Television Schools Inc.* 1644 Wyandotte St. Kansas City 8, Mo. Tel.: Harrison 5852	Courses leading to 1st class FCC license in radio & television; airline station agent, flight radio operator	Phil J. Murray Monthly
American Television Inc. 5050 N. Broadway, Chicago 40, Ill. Tel.: ARdmore 1-9010	140-week TV engineering course, 72-week TV production. Night classes also.	U. A. Sanavia Continuous	Chicago Academy of Radio & Dramatic Arts* 1258 S. Michigan Ave. Chicago 5 Tel.: Harrison 7-5907	Radio, stage & television	Kathleen Kaye Weekly
American Television Labs. of Calif. 5606 Sunset Blvd. Hollywood 28 Tel.: Hollywood 9-8347		Bernard Goldsmith	Chicago Technical College* 2000 S. Michigan Ave. Chicago Tel.: CaLumet 5-8200	Radio and TV engineering, practical radio, day and night.	Charles E. Olson Every 12 weeks
Hal Bagg School of Broadcasting* 1674 Broadway, New York 19 Tel.: Columbus 5-5756	Announcing, acting, singing	Hal Bagg Continuous	Collins School of Speech & Dramatic Art 5154 N. Clark St. Chicago 40 Tel.: Sunnyside 4-4400	Voice, diction, microphone technique, stage technique	L. Aurelia Collins Continuous
Beck School for Radio* 1722 Hennepin Ave. Minneapolis Tel.: Main 8731	Radio announcing & associated subjects	Betty Harney Weekly	Columbia College* 410 S. Michigan Blvd. Chicago 5 Tel.: Wabash 2-6761	Radio broadcasting, television-radio broadcast engineering, advertising, journalism, stage	Kay Karrol Open during school year
Broadcasters Network Studios* 1522 Cassil Pl. Hollywood 28 Tel.: Gladstone 2985	Staff announcing	Elaine N. Dysart Continuous	Coyne Electrical School* 500 South Paulina St. Chicago 12 Tel.: Seeley 3-7722	Practical courses in television & radio servicing	S. C. Narland Every six weeks

CAMBRIDGE SERVICE

FOR

MANAGEMENT

Are you satisfied with your organization? Do you have a problem finding the right personnel—announcing, production, scripting, clerical, selling? Use Cambridge Service for New York radio station trained personnel—they're young and ready to go places for you.

THE INDIVIDUAL

Are you satisfied? Do you have the right training—in the right job? Cambridge teaches all phases of radio broadcasting on the air over New York stations. Phone for free counseling interview and voice audition. Write for free booklet "There's Success in the Air."

Cambridge instructors are top flight talent from NBC, CBS, ABC and Mutual Networks

Plenty of work space—5500 square feet of studios at 860 Seventh Avenue, New York City, equipped with modern control rooms and a music library of 1000 records.

WE PUT TALENT TO WORK

Cambridge graduates are working in stations across the nation.

Bess Stern,
President

George S. Carlesco,
Director

THE CAMBRIDGE SCHOOL OF RADIO BROADCASTING

Enrollment Office: 806 Seventh Ave., N. Y., N. Y. JU 6-0025
Administration: 220 West 42nd St., N. Y., N. Y. WI 7-0038

The Crescent School of Radio & Television* 129 Pierrepont St., Brooklyn 383 Pearl St., Brooklyn Tel.: Triangle 5-5888	Radio and television technician; radio telegraph communications; radio mathematics; servicing; FCC license.	Esther Schure Continuous
DeForest's Training Inc.* 2533 N. Ashland Ave. Chicago 14 Tel.: Lincoln 9-7260	Home study and Chicago laboratory training in television, radio & electronics.	Every six weeks
The Delhanty Institute, School of Radio, Electronics & Television* 105 E. 13th St. New York 3 Tel.: Grammercy 3-6900	Radio & television service and repair; telegraphy & telephony, radio technology.	Messrs. Geyer, Gorman, Wynne Twice monthly
Electronics Technical Institute 771 Venice Blvd. Los Angeles 15, Calif. Tel.: Richmond 9381		Allen B. Crews
Maren Elwood Professional Writing School* 4949 Hollywood Blvd. Hollywood 27, Calif. Tel.: Normandy 3-3123	Advertising, publicity; fiction writing; journalism; radio and screen writing.	Alice L. English Jan. 30 Sept. 11
Emerson College* 130 Beacon St. Boston 16 Tel.: Kenmore 6-7191	Radio production, script, news, advertising, dramatics, programming, announcing for men and for women, radio station management & organization, television & radio survey. A.B. and B.L.I. degrees.	Clara Fraser Sept. 12-15
Feagin School of Drama & Radio* 630 Fifth Ave., New York Tel.: Columbus 5-0926	Stage, screen, radio, television.	Sarah B. Cathey Oct., Dec., Feb., April, July

* GI approved.

Name, Address, Tel.	Courses Offered	Registrar & Registration Date
Geller Theatre Workshop* 6040 Wilshire Blvd. Los Angeles 36 Tel.: York 5205	Acting, announcing, radio programming, production, music fundamentals, sound effects, station & network operation, writing, stage, screen technique, piano, dance, voice.	Hazel R. Ayres. Jan., Apr. July, Sept.
Goodman Memorial Theatre, School of Drama of the Art Institute of Chicago* The Art Institute Chicago 3 Tel.: Central 6-2337	Acting, directing, radio scene & costume design, technical practice (B.F.A. & M.F.A. degrees).	Louise Dale Spoor Sept. & Jan.
Gotham Radio Institute* 3534 Broadway New York 31 Tel.: Wadsworth 6-0902	Radio service & repair including FM & TV.	Jeanne S. Faust Monthly
Hollywood Sound Institute 1040 North Kenmore Ave., Hollywood 28 Normandy 12345		H. M. Tremaine
Jo Keith School & Agency 14 W. Lake St. Chicago 1 Tel.: Dearborn 2-0134	Singing, dramatics, dancing, modeling, radio, stage, screen, TV.	Jo Keith Continuous
Harrison Lewis Dramatic School 113 W. 57th St. New York 19 Tel.: Circle 6-2994	Acting & singing for all branches of show business. Oct.-Jan.
Lincoln School of Radio & Television* 177 Dyckman St. New York 34 Tel.: Lorraine 7-4123	Radio mathematics, radio FM and television technician, communications.	Dorothy A. Abrams Monthly
The MacLean Studios* 410 South Michigan Ave. Fine Arts Bldg. Chicago 5 Tel.: Webster 9-3112	Radio and television acting, diction, speech, dialects, timing, dancing, etc.	M. A. O'Leary Continuous
Manhattan Technical Institute* 165 W. 46th St. New York 19 Tel.: Plaza 7-4830	Radio technician, FM & television technician, radio, FM & television technician (combined course).	L. G. Herman Weekly
The Don Martin School of Radio Arts* 1653 N. Cherokee Hollywood 28 Tel.: Hudson 2-3281	Script writing, radio sales, production, music appreciation, announcing & 1st class FCC license training.	Monthly
Midway Television Institute* 4825 Indiana Ave. Chicago 15	Radio & television servicing, practical radio engineering & communication, electronics.	Rosa W. Morgan Monthly
National Academy of Broadcasting Inc.* 3338 16th St., N.W. Washington 10, D. C. Tel.: Decatur 5580	Announcing, languages, drama, diction, continuity, script, production, publicity & news writing.	Mildred L. Sovine January, May & September
National Schools Inc. 4000 S. Figueroa St., Los Angeles 37 Tel.: Century 2-9061		Lou Mandelbaum
National Schools* 4000 S. Hill St. Los Angeles 37 Tel.: Century 2-9061	Radio, television, allied electronics; diesel, automotive and allied mechanics.	Sam Goldberg Monthly
New Institute for Film & Television* 29 Flatbush Avenue Brooklyn 17 Tel.: Sterling 3-9444	All phases of motion picture production, camera and lighting techniques, editing, sound, writing, directing, live dialogue production. Television production and news-reel.	Adelaide Solomon Fall, winter, spring
William R. Ogden Radio Operational Engineering School 2625 W. Olive Ave. Burbank, Calif. Tel.: Charleston 0-8291	Short, directed courses leading to FCC licenses.	Tally Ogden Continuous

Name, Address, Tel.	Courses Offered	Registrar & Registration Date
Pasadena Institute for Radio* 386 S. Los Robles Ave. Pasadena 5, Calif. Tel.: Sycamore 2-2668	Voice, announcing, news-casting, radio writing, advertising, public relations, network procedure, radio telephone operation.	C. G. Renier Jan. 2, Feb. 25, April 24, June 19, June 20, Aug. 28, Oct. 23, Oct. 24, 1949
Pierce School of Radio & Television* 13-25 Astor Pl. New York 3 Tel.: Grammercy 3-6770	Radio FM-television technician, radio communications, radio mathematics, radio and TV service.	Mr. Silberman Every six weeks
Leland Powers School Inc.* 31 Evans Way, Boston 15 Tel.: Aspinwall 7-2900	Announcing, continuity writing, acting, music, advertising, production, make-up, public speaking.	Haven M. Powers Sept. 25
RCA Institutes Inc.* 350 W. 4th St. New York 14 Tel.: Watkins 4-7845	Radio servicing, operating, broadcasting, design, advanced technology.	C. E. Tomson March, June, Sept., Dec.
Radio-Electronics School of N. Y.* 52 Broadway New York 4 Tel.: Bowling Green 9-1120	Preparatory radio mathematics, radio technician, FM-television technician, radio and television receiver servicing.	James R. Singleton Monthly
Radio Institute of California 1117 Venice Blvd. Los Angeles 15, Calif. Tel.: Drexel 8277		Eugene Raymond
Radio Institute of Chicago* 165 N. Michigan Ave. Chicago 1 Tel.: Andover 3-6767	Announcing, drama, radio writing, production, advertising, etc., television & radio engineering, music.	Howard L. Rooney Monthly
Radio Operational Engineering School 2625 W. Olive Ave. Burbank, Calif. Tel.: Charleston 0-8291	Engineering training.	Tally Ogden
Radio Television Arts Academy* 3819 Wilshire Blvd. Los Angeles 5 Tel.: Dunkirk 8-1323	Announcing, dramatics, singing, directing, programming & writing, television film.	Doria Balli Continuous
Radio-Television Institute Inc.* 480 Lexington Ave. New York 17 Tel.: Plaza 9-5665	Radio-television technician's course.	Wm. R. MacDonald Continuous

* GI approved.

(Continued on page 536)

**Are you looking for
WELL TRAINED MEN**

... to operate and
maintain TV, FM or
AM station equipment?

Tell us your needs! Our graduates have thorough, technical training in one of the nation's finest Television-Radio-Electronic training laboratories. These men are high grade... with F.C.C. Licenses and are well qualified to operate and maintain Television and Radio Broadcast equipment. Our graduates are employed by many of the best known TV-Radio-Electronic concerns across the nation. Write, phone or wire:

DeFOREST'S TRAINING, INC.
2523 N. Ashland Ave., Chicago 14, Ill.
Phone Lincoln 9-7260

Professional Technical Schools

(Continued from page 535)

Name, Address, Tel.	Courses Offered	Registrar & Registration Date	Name, Address, Tel.	Courses Offered	Registrar & Registration Date
Radio & Television Writing Institute 1238 N. Vine St. Hollywood 38 Tel.: Hillside 0413	Radio script writing Tele-script writing (correspondence).	William O. Mager	Hal Styles School of Radio & Television* 8800 Wilshire Blvd. Beverly Hills, Cal. Tel.: Bradshaw 2-1490	Announcing, drama, news, editing, control operation, continuity, script, dialects, TV, management.	Mildred Mullins Monthly
The Celeste Rush Radio Preparatory System* 6119 Harold Way Hollywood 28 Tel.: Hollywood 7123	Drama motives & radio, elements of production.	Celeste Rush Monthly	Television Workshop of N. Y.* 1780 Broadway New York 19 Tel.: Plaza 7-3721	Television studio operation, camera operation, program production, television advertising.	Mary C. Scourby Sept., Dec., Jan., March, June
The School of Radio Technique Inc.* RKO Bldg., Radio City New York 20 Tel.: Circle 7-0193	Radio & television production. TV studios, 316 W. 57th St., N. Y.	Winifred S. Van Sickle or Doris Ann Dixon Continuous	Theatre School of Dramatics & The Childrens Theatre School* Carnegie Hall, 154 W. 57th St. New York, N. Y. Tel.: Plaza 7-1316	Childrens & adult classes in dramatics. Jan-April-Oct.
School of Radio Technique* 228 S. Wabash Ave. Chicago Tel.: Wabash 2-0712	Announcing, writing, news-casting, production, direction, acting, speech.	Gloria Del Campo	Twin City Television Lab., Affiliated with Beck Studios, Inc. Lyceum Theatre Minneapolis 2 Tel.: Lincoln 4708	Program production, creative & commercial writing, announcing, camera operation (in fully equipped TV studios).	Burkely Towle Every 13 weeks
Syd Simons Studios 540 N. Michigan Ave. Chicago Tel.: Delaware 7-1822	Professional television makeup.	Syd Simons	Western Radio-Television Institute* 341 W. 18th St. Los Angeles 15, Calif. Tel.: Prospect 8855	Radio Communications; radio, TV servicing.	Virginia Moore Monthly
Frederick H. Speare Professional Radio & Television School* 5927 Sunset Blvd., Hollywood Tel.: Hollywood 9-2325	Announcing, news, sports, acting, control and production techniques, writing, TV, sound effects.	R. L. Speare Sept., Nov., Feb., April, June	Wiggins Trade Technical Institute 1646 S. Olive St. Los Angeles, Calif. Tel.: Prospect 7021	Radio servicing, FM & television, radio operating & radio code.	David Wersen

* GI approved.

Radio's Payroll and Operating Costs

(Continued from page 14)

\$92.44 compared to an average of \$64.81 at the remaining 1,602 stations. Total pay of \$442,486 went to 8,777 part-time employes during the sample week. During the survey week there were 1,789 licensed AM stations with 1,602 reporting figures to the FCC in time for the tabulations.

Approximately half the reporting stations employed 15 or more

persons who were paid \$2,546,725 of the total weekly payroll. At the 809 stations having fewer than 15 employes, weekly payroll totaled \$456,385 for 7,936 persons including those working part-time. There were 38,676 employes at the 804 stations having 15 or more employes.

Complete data for all reporting stations are reported in the table below.

Figures are for actual hours worked and actual pay received, including overtime payments. On the average, the difference between scheduled hours of work and actual hours was less than one hour, and the difference between actual and scheduled payments was about \$2.50 per week per employe.

Total operating costs (based on relation to station income) were highest for stations with less than \$50,000 annual revenue, falling steadily to the \$125,000-\$150,000

class, according to a study of 1948 station costs by the National Assn. of Broadcasters (see table below).

At this point costs ran higher into the \$150,000-\$200,000 class, then fell off rapidly all the way up to stations with over \$1 million annual revenue.

In general program salaries comprised the highest expense item, based on relation to station revenue, followed by administrative salaries and then technical salaries.

4 NATION-WIDE NETWORKS, 3 REGIONAL NETWORKS AND 1,613 AM BROADCAST STATIONS (1): ACTUAL HOURS & ACTUAL COMPENSATION OF FULL-TIME EMPLOYEES FOR THE WEEK ENDING OCT. 16, 1948.

Classification of Employes	Total, 7 Networks and 1,613 Stations			7 Networks and 11 Key Stations			1,602 Other Stations			
	Number of Employes	Total Weekly Actual Hrs.	Total Actual Compensation	Number of Employes	Total Weekly Actual Hrs.	Total Actual Compensation	No. of Reporting Stations	Number of Employes	Total Weekly Actual Hrs.	Total Actual Compensation
I General Officers and Assistants	2,121	(2)	\$335,851	111	(2)	\$43,190	1,337	2,010	(2)	\$292,661
II Staff Program Employes:										
A. Supervisory	1,919	79,450	186,514	166	6,429	34,479	1,277	1,753	73,021	152,035
B. Non-supervisory	11,880	457,152	865,742	1,299	47,420	172,227	1,602	10,581	409,732	693,515
III Technical Employes: (1)										
A. Supervisory	1,811	77,068	168,539	85	3,363	14,066	1,387	1,726	73,705	154,473
B. Non-supervisory	7,786	330,782	586,053	887	38,814	106,175	1,602	6,899	291,968	479,878
IV Commercial Employes:										
A. Supervisory	866	35,909	106,717	61	2,360	13,186	763	805	33,549	93,531
B. Non-supervisory	2,961	120,469	260,523	216	8,375	30,832	1,392	2,745	112,094	229,691
V Promotion and Publicity Employes:										
A. Supervisory	280	11,119	30,566	63	2,460	10,616	191	217	8,659	19,950
B. Non-supervisory	510	20,140	35,249	270	10,507	22,479	145	240	9,653	12,770
VI Clerical Employes	7,595	301,803	337,348	2,495	97,527	122,664	1,602	5,100	204,276	214,684
VII Building Service Employes	1,556	62,643	71,392	557	22,355	34,912	516	999	40,288	36,480
VIII All Other Employes	287	11,431	18,617	82	3,262	9,759	127	205	8,169	8,858
IX Full-time Employes (excluding General Officers and Assistants)	37,451	1,507,966	\$2,667,260	6,181	242,872	\$571,395	1,602	31,270	1,265,094	\$2,095,865
X Average Hours and Average Compensation	—	40.27	\$71.22	—	39.29	\$92.44	—	—	40.46	\$67.02
XI Total: Full-time Employes (including General Officers and Assistants)	39,572	(2)	\$3,003,111	6,292	(2)	\$614,585	1,602	33,280	(2)	\$2,388,526

(1) Includes AM-FM employes in a few instances where licensees report they are unable to make a segregation of personnel for jointly operated stations.

(2) No actual hours reported for general officers and assistants.

(3) No totals of actual hours possible because of the absence of data for general officers and assistants.

(4) Of the 9,597 technical employes reported, 7,066 were reported to hold first class radiotelephone licenses. These were distributed as follows: Network and key stations, 418; all other stations, 6,647.

SREPCO Cloth Banners

Display your station call letters more prominently with these colorful and economical cloth banners. You will want to use them for all studio guest programs, sports events, remotes, publicity pictures and for all public occasions.

All banners are made with large prominent letters of durable tackle twill and colorful felt backgrounds. White or gold letters on a blue or green background make excellent color combinations, however, others can be furnished.

STYLE M-1 MICROPHONE BANNER

This is our most popular banner for all occasions. 6" wide by 19" high with long cord and tie loop provided for adjusting to desired height of suspension. Will take four 3-inch-high letters.

Price, each **\$2.75**
In lots of 3 or more, each . . . **\$2.25**

STYLE M-2 MICROPHONE BANNER

A popular banner for displaying additional lettering, such as affiliation or FM and TV designations. station call in 4-inch-high letters with affiliation in 2 or 3-inch-high letters.

Price, each **\$3.25**
In lots of 3 or more, each . . . **\$2.75**

We can furnish large or small banners of any size or shape for studio backdrop, mobile truck, sports events, and other uses. Special designs and insignias can be flocked on silk or felt backgrounds. Send us your sketch or artwork when writing for quotation on special banners.



SREPCO Recording Labels

More than 500 stations now acclaim our Recording Labels the finest they have ever used.

Why all this popularity, you ask? SREPCO Labels dry-applied provide perfect permanent adhesion with NO MESS. No more rubber cement cans — no more ruined discs. All you do is write or type on them — pull off the protective backing — and apply to the disc.

SREPCO Labels are the right thickness, too. Thick enough to hold up well, yet not too thick to interfere with cutting on the reverse side.

SREPCO Labels are printed to order. You have complete freedom in selection of copy, choice of white or beautiful pastel colored backgrounds and a selection of five imprint colors.

Write for samples and special order blank today.

White Background Labels

4" Dia.	Style No. 500	500	1,000
	4W1	\$15.35	\$27.65
3-1/8" Dia.	3W1	14.25	25.50

Yellow, Blue or Green Background Labels

4" Dia.	Style No. 500	500	1,000
	4C1	\$16.50	\$29.70
3-1/8" Dia.	3C1	15.30	27.35

2-inch Label for Tape Recording Reels

This label will solve your problem of identifying tape recordings. Designed to be applied to top-center. Fits all reels. Printed in your choice of color on white background.

500 — \$13.95 250 — \$8.95 1,000 — \$23.75

Prices are Net, F.O.B., Dayton, Ohio.

Lapel Buttons

An attractive metal button with highly polished raised letters against a black background. Add 15¢ for each letter over 5.



B-61P with pin backing, either type **\$1.00** each
B-61L with screw backing, type

This Microphone Call Letter Button is very popular with commercial broadcasters. It is die-cut to the shape of the microphone with the microphone and letters highly polished against a black background.

B-64P with pin backing.
B-64L with screw backing.
1 to 4 Buttons, each **\$1.75**
5 to 19 Buttons, each **1.50**
20 to 99 Buttons, each **1.25**
100 or more, each **1.00**

Type 1-A — 2 1/4" by 8 1/4". Price includes up to 5 letters.
Each **\$2.75**

Auto Plates



Type 2-A — 2 1/4" by 8 1/4" with affiliation letters at each end. Price includes up to 10 letters.
Each **\$3.25**



Mike Stand Plate

Type 101-S (illustrated) 2 1/4" x 8 1/4". Equipped with brackets for fastening to stand. Price includes 5 letters.
Each **\$3.25**
Type 102-S — same as 101-S but with affiliation letters across top. Price includes 8 letters.
Each **\$3.75**

SREPCO MICROPHONE NAMEPLATES FOR BROADCASTING STATIONS



Shure 556



RCA-77



RCA-74



WE-633A



WE-639A

Top Plates Only		With Side Plates		Top Plates Only		With Side Plates	
RCA-44	\$8.00	WE-618A	\$8.00	EV-630/635	8.50		
RCA-74	8.00	WE-630A	8.50	EV V2/V3	7.50		11.50
RCA-77	8.00	WE-633A	8.50	EV-643/650	8.00		12.00
RCA-88	8.00	WE-639A	12.00	EV-725/731	12.00		12.00
RCA-KB2C	9.50	Turner 101-A	8.00	EV-730/731	12.00		12.00
RCA MI-6203	11.50	Turner 211	8.00	Shure 55/555/556	12.00		12.00
RCA MI-6206	8.50	Turner U9S/99/999	8.00	Shure 508/708	8.50		12.00

SREPCO Call Letter Plates are beautiful streamlined accessories for every microphone. Your call letters appear on both front and back with their lustrous satin-silver finish gleaming in relief against the black crackle enamel background. Plates may be had with letters inverted for boom suspension at no additional cost.

Block lettering may also be had, instead of Roman (as used in the illustrated plates), at no additional cost, but we can furnish it only by eliminating the border. Unless specified on your order, standard Roman letters with border designs will be furnished.

Double Stand Plate

Type 101-DSV
Consists of two 101-S Stand Plates with "V" mount brackets. Price includes five letters on each plate.
Each **\$9.50**

* This is only a partial listing of nameplates for Broadcast use. Write for a *
* complete catalog showing plates for desks, doors, equipments, attractive ash *
* trays, celluloid promotion buttons and gold-plated pins. *

Prices on microphone nameplates include up to 5 letters on top plate, both front and back, and on side plates. For each additional letter over 5 add 30¢ for top plate and 30¢ per pair of side plates.

Plates are made of sturdy, light-weight cast aluminum with letters and borders raised and satin-finished against the baked crackle-enamel background. Black is standard but red, green, blue, gray, or goldenrod may be had for 50¢ additional per plate.

Terms are accorded Broadcast Stations when rated in Dun and Bradstreet or when credit references accompany order.



We pay transportation on nameplates and lapel buttons when order is accompanied with payment in full. Prices are Net, F.O.B., Dayton, Ohio.

FISHER TOWERS

TOPS THEM ALL

625-foot Tower — KGW Portland, Oregon

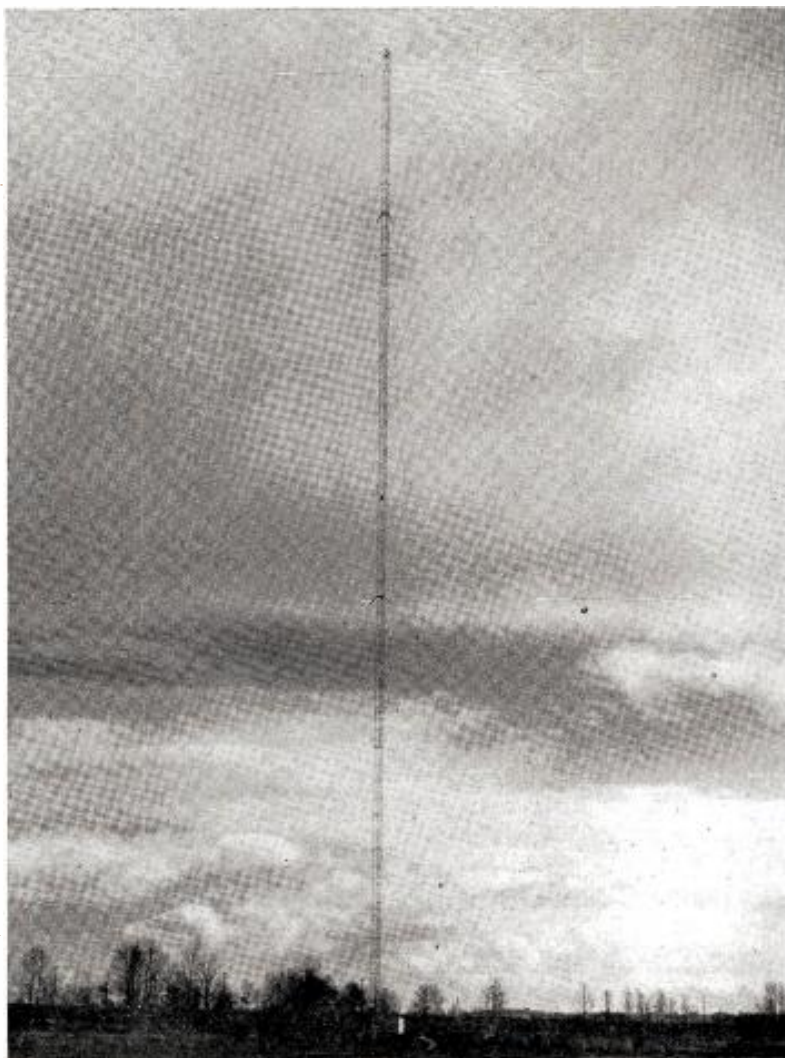

GALVANIZED
AM - FM - TV
TOWERS

TOWER
ERECTION

TOWER
LIGHTING

TOWER
PAINTING

GROUND SYSTEMS

COAXIAL LINE
INSTALLATIONS

C. H. FISHER & SON

Exclusive National Agents for

TOWER SALES & ERECTING COMPANY

6100 N. E. Columbia Blvd., Portland, Oregon

Phone — TRinity 7303

1949 URBAN, RURAL-NONFARM AND RURAL-FARM RADIO OWNERSHIP

BY REGIONS, GEOGRAPHIC AREAS AND STATES

Source: Broadcast Measurement Bureau, *Radio Families—USA, 1949*

	FAMILIES	TOTAL % RADIO	RADIO FAMILIES	FAMILIES	URBAN % RADIO	RADIO FAMILIES	FAMILIES	RURAL-NONFARM % RADIO	RADIO FAMILIES	FAMILIES	RURAL-FARM % RADIO	RADIO FAMILIES
THE UNITED STATES	41,692,900	94.2	39,281,230	26,599,390	95.5	25,400,790	8,621,690	94.5	8,144,670	6,471,820	88.6	5,735,770
REGION												
AREA												
STATE												
THE NORTHEAST	11,028,100	96.7	10,668,810	8,613,160	97.0	8,354,160	1,882,350	96.6	1,818,420	532,590	93.2	496,230
NEW ENGLAND	2,594,000	98.2	2,548,000	1,993,320	98.9	1,972,380	465,780	96.4	449,150	134,900	93.8	126,470
MAINE	251,000	95.3	239,320	108,980	98.2	106,990	101,760	93.8	95,450	40,280	91.6	36,880
NEW HAMPSHIRE	159,400	96.7	154,080	94,730	98.0	92,850	47,650	95.0	45,270	17,020	93.8	15,960
VERMONT	101,900	95.7	97,550	42,140	98.4	41,480	34,660	94.7	32,820	25,100	92.6	23,250
MASSACHUSETTS	1,294,700	98.9	1,280,650	1,163,870	99.1	1,153,450	106,290	97.5	103,630	24,540	96.0	23,570
RHODE ISLAND	214,600	98.8	211,970	195,500	98.9	193,430	16,930	97.2	16,450	2,170	96.3	2,090
CONNECTICUT	572,400	98.6	564,430	388,100	99.0	384,160	158,490	98.1	155,530	25,810	95.8	24,720
MIDDLE ATLANTIC	8,434,100	96.3	8,120,810	6,619,840	96.4	6,381,780	1,416,570	96.7	1,369,270	397,690	93.0	369,760
NEW YORK	4,205,700	96.8	4,069,840	3,511,330	96.8	3,400,180	522,320	97.3	507,990	172,050	94.0	161,670
NEW JERSEY	1,329,900	96.5	1,283,770	1,078,880	96.4	1,039,790	218,440	97.4	212,840	32,580	95.6	31,140
PENNSYLVANIA	2,898,500	95.5	2,767,200	2,029,630	95.7	1,941,810	675,810	96.0	648,440	193,060	91.7	176,950
THE NORTH CENTRAL	12,882,300	97.0	12,496,390	8,160,020	97.6	7,968,150	2,467,330	96.8	2,387,620	2,254,950	94.9	2,140,620
EAST NORTH CENTRAL	8,777,400	97.5	8,556,190	5,992,800	97.9	5,868,510	1,632,830	97.2	1,587,480	1,151,770	95.5	1,100,200
OHIO	2,311,300	97.4	2,251,560	1,608,820	97.8	1,573,320	439,270	97.3	427,250	263,210	95.4	250,990
INDIANA	1,170,200	96.5	1,129,530	690,780	97.1	670,860	258,650	96.5	249,700	220,790	94.6	208,970
ILLINOIS	2,584,700	97.5	2,519,830	1,950,500	97.9	1,909,090	377,720	96.9	366,050	256,480	95.4	244,700
MICHIGAN	1,774,800	98.1	1,740,560	1,177,920	98.4	1,159,410	380,440	97.9	372,600	216,440	96.4	208,550
WISCONSIN	936,400	97.7	914,710	564,800	98.4	555,840	176,750	97.2	171,880	194,850	96.0	186,990
WEST NORTH CENTRAL	4,104,900	96.0	3,940,200	2,167,220	96.9	2,099,640	834,500	95.9	800,140	1,103,180	94.3	1,040,420
MINNESOTA	829,300	97.7	810,010	484,000	98.2	475,210	148,540	97.8	145,310	196,760	96.3	189,490
IOWA	780,100	97.1	757,340	389,190	97.3	378,850	161,850	96.8	156,720	229,060	96.8	221,770
MISSOURI	1,194,200	94.4	1,127,530	718,250	96.1	689,970	215,070	94.1	202,330	280,880	90.2	235,230
NORTH DAKOTA	145,900	97.0	141,480	46,500	97.9	45,510	31,460	96.3	30,300	67,940	96.7	65,670
SOUTH DAKOTA	170,700	95.9	163,660	55,110	97.0	53,430	37,410	95.4	35,700	78,180	95.3	74,530
NEBRASKA	384,200	95.8	368,180	185,250	96.9	179,490	84,610	95.7	80,950	114,340	94.2	107,740
KANSAS	600,500	95.3	572,000	288,920	95.9	277,180	155,560	95.7	148,830	156,020	93.8	145,990
THE SOUTH	12,003,800	87.3	10,478,010	6,090,920	89.1	5,424,100	2,945,320	89.9	2,647,120	2,967,560	81.1	2,406,790
SOUTH ATLANTIC	5,138,000	88.5	4,549,060	2,603,350	90.3	2,350,190	1,426,930	90.8	1,295,750	1,107,720	81.5	903,120
DELAWARE	86,800	95.4	82,770	46,930	95.9	45,020	27,040	96.7	26,140	12,830	90.5	11,610
MARYLAND	596,400	95.7	570,650	368,160	96.6	355,770	175,330	95.6	167,670	52,910	89.2	47,210
DISTRICT OF COLUMBIA	238,800	96.8	231,180	238,800	96.8	231,180	-----	-----	-----	-----	-----	-----
VIRGINIA	770,300	89.5	689,070	374,350	92.2	345,170	206,450	90.9	187,660	189,500	82.4	156,240
WEST VIRGINIA	473,300	92.0	435,430	168,580	94.7	159,680	194,550	93.2	181,310	110,170	85.7	94,440
NORTH CAROLINA	898,500	87.1	782,830	358,850	88.4	317,340	241,320	90.9	219,390	298,330	82.5	246,100
SOUTH CAROLINA	489,400	83.2	406,950	180,910	83.6	151,160	162,960	88.1	143,510	145,530	77.2	112,280
GEORGIA	855,900	83.4	713,600	403,230	83.8	337,960	214,510	88.1	188,950	238,180	78.4	186,690
FLORIDA	728,600	87.4	636,600	463,540	87.8	406,930	204,770	88.5	181,120	60,290	80.5	48,550
EAST SOUTH CENTRAL	2,877,300	85.0	2,446,830	1,187,820	86.9	1,032,170	678,620	89.2	605,320	1,010,860	80.1	809,340
KENTUCKY	734,400	89.2	655,190	289,950	92.7	268,920	192,830	91.0	175,430	251,620	83.8	210,840
TENNESSEE	830,800	87.0	722,520	370,450	88.4	327,320	197,140	90.4	178,130	263,210	82.5	217,070
ALABAMA	742,500	82.7	614,360	333,120	84.1	280,150	174,580	87.6	152,880	234,800	77.2	161,330
MISSISSIPPI	569,600	79.8	454,760	194,300	80.2	155,780	114,070	86.7	98,880	261,230	76.6	200,100
WEST SOUTH CENTRAL	3,988,500	87.3	3,482,120	2,292,750	88.8	2,041,740	839,770	88.8	746,050	848,980	81.8	694,330
ARKANSAS	531,100	83.9	445,600	186,940	85.7	160,260	141,520	87.0	123,180	202,640	80.0	162,160
LOUISIANA	700,400	84.1	588,750	383,840	86.0	330,000	172,500	86.2	148,760	144,060	76.4	109,890
OKLAHOMA	673,300	89.5	602,930	361,340	91.5	330,470	152,420	89.9	137,070	159,540	84.9	135,390
TEXAS	2,083,700	88.5	1,844,840	1,367,630	89.3	1,221,010	373,330	90.3	337,040	342,740	83.7	286,790
THE WEST	5,778,700	97.6	5,638,020	3,735,290	97.8	3,654,380	1,326,690	97.3	1,291,510	716,720	96.6	692,130
MOUNTAIN	1,329,200	96.0	1,275,970	733,200	96.5	707,190	329,850	95.8	316,060	266,150	95.0	252,720
MONTANA	155,600	97.2	151,260	88,380	97.4	86,090	30,560	97.1	29,670	36,660	96.8	35,500
IDAHO	156,000	97.3	151,820	69,290	97.1	67,310	33,630	97.3	32,720	53,080	97.6	51,790
WYOMING	81,900	97.1	79,510	40,560	97.2	39,420	24,570	97.6	23,970	16,770	96.1	16,120
COLORADO	363,100	96.9	351,920	240,840	97.3	234,220	87,730	96.6	85,420	54,530	95.9	52,280
NEW MEXICO	168,000	90.9	152,740	82,570	91.5	75,670	41,930	91.1	38,200	43,500	89.6	38,970
ARIZONA	184,100	93.7	172,580	75,290	94.1	70,880	76,860	94.5	72,670	31,950	90.9	29,030
UTAH	175,200	98.5	172,500	112,770	98.5	111,040	36,070	98.7	35,610	26,360	98.1	25,850
NEVADA	45,300	96.3	43,640	23,500	96.4	22,660	18,500	96.2	17,800	3,300	96.4	3,180
PACIFIC	4,449,500	98.0	4,362,050	3,002,090	98.2	2,947,190	996,840	97.9	975,450	450,570	97.5	439,410
WASHINGTON	729,900	97.8	713,720	403,650	97.5	393,740	209,520	98.2	205,660	116,730	97.9	114,320
OREGON	497,000	97.4	483,830	273,530	97.7	267,110	141,060	97.3	137,300	82,410	96.4	79,420
CALIFORNIA	3,222,600	98.2	3,164,500	2,324,910	98.3	2,286,340	646,260	97.9	632,490	251,430	97.7	245,670

Executive and Staff Personnel of the Federal Communications Commission

Headquarters Office: New Post Office Bldg., Washington 25, D. C., Phone Executive 3620
(For Field Offices and Staffs see Page 541)

Commissioners and Assistants

ALBERT WAYNE COY, Chairman
(Democrat: Term 1947-1951)
Assumed office December 29, 1947
Assistant to the Chairman: Earl Minderman
Confidential Assistant: Farrell McGonigal
Secretaries: Johanna Oswald, Helen Wisner
Clerk: Grace Miner

PAUL ATLEE WALKER, Vice Chairman
(Democrat: Term 1948-1953)
Assumed office July 11, 1953
Confidential Assistant: Phyllis Hancock
Secretary: Josephine L. Curren
Clerk Stenographer: (Vacancy)

FRIDA BARKIN HENNOCK
(Democrat: Term 1948-1955)
Assumed office July 6, 1948
Confidential Assistant: Stanley S. Neustadt
Legal Assistant: Sol Schildhouse.
Secretary: Rita Lanier
Clerk Stenographer: Mary Boesche

ROSEL HERSCHEL HYDE
(Republican: Term 1948-1952)
Assumed office April 17, 1946
Confidential Assistant: Minnie Sparks
Secretary: Vera F. Nordness
Clerk Stenographer: Mollie V. Burgess

ROBERT FRANKLIN JONES
(Republican: Term 1947-1954)
Assumed office September 5, 1947
Confidential Assistant: Elizabeth L. Dannelly
Legal Assistant: Paul Dobin
Secretary: Mary R. Moose
Clerk Stenographer: Frances A. Cassese

GEORGE EDWARD STERLING
(Republican: Term 1948-1950)
Assumed office January 2, 1948
Confidential Assistant: Neva Bell Perry
Secretaries: Catherine Lane and Ethel Herriman

EDWARD MOUNT WEBSTER
(Independent: Term 1949-1956)
Assumed office April 10, 1947
Confidential Assistant: Arnold A. Ulin
Legal Assistant: Robert Koteen
Secretary: Ruth T. Kopplakly
Clerk Stenographer: Dolly H. Snyder

Charles Boram, Frederick W. Ford, Parker D. Hancock, Sylvia D. Kessler, Horace Slone, Special Legal and Technical Assistants to Commissioners.

Bureau of Law

BENEDICT P. COTTONE, General Counsel
Secretaries: Fausta M. Puffenberger, Florence I. Smetch
Assistant: Joseph M. Kittner

HARRY M. PLOTKIN, Asst. General Counsel
(Broadcast Division)
Secretary: Margaret Cureton
Assistant: David H. Deibler

MAX GOLDMAN, Asst. General Counsel
(Litigation and Administration Division)
Secretary: Elizabeth Kaplan

HAROLD J. COHEN, Asst. General Counsel
(Common Carrier Division)
Secretary: L. Grace Klein

LESTER W. SPILLANE, Asst. General Counsel
(Safety & Special Services Division)
Secretary: Bernice E. Hase

WILLIAM H. BAUER, Chief of Technical Section

BROADCAST DIVISION

AM Branch—Dwight D. Doty, Chief of Branch; Forest L. McClennings, Howard Schellenberg, Robert J. Rawson, Max Paglin, Dave Stevens, Bob Koteen, Earl R. Stanley, L. P. B. Emerson, Albert A. Dovskind.

FM Branch—Hilda D. Shea, Chief of Branch; E. Theodore Mallyck, Henry Geller, Tyler Berry.

TV Branch—John E. McCoy, Chief of Branch; Joe Nelson, Herbert M. Schukind.

Transfer Branch—Walter R. Powell, Chief of Branch; C. Lamont Griffith, H. Gifford Irion, Bob Alford, James O. Juntilla.

Renewals and Revocations Branch—Walter B. Emery, Chief of Branch; Max H. Aronson, Arthur Schelner, Thomas H. Donahue.

LITIGATION AND ADMINISTRATION DIVISION

Litigation Branch—Richard A. Solomon, Chief of Branch; Mary Jane Morris, Robert Greenberg, Daniel R. Ohlbaum, Thomas H. Wall.

Administration Branch—A. Harry Becker, Chief of Branch; Dee W. Pincock, Erich Saxl, Maurice W. Wilson, John Edgerton, Raymond Lewis (Investigator).

COMMON CARRIER DIVISION

Asst. Chief of Division—Jack Werner.

Rate Branch—Bernard Strassburg, Chief of Branch; Robert W. Hudson, Herbert Sharfman, Edwin S. Smith Jr., Martin I. Levy.

International Service Branch—(Vacancy) Chief of Branch; Asher E. Ende.

Domestic Wire Branch—Annie N. Hunting, Chief of Branch; Donald J. Berkemeyer, Willis S. Ryzza, Pasquale W. Valicenti.

Domestic Radio Branch—Arthur A. Gladstone, Chief of Branch; J. Russell Smith.

SAFETY AND SPECIAL SERVICES DIVISION

Emergency, Experimental and Miscellaneous Branch—Benito Gaguine, Chief of Branch; Julian P. Freret, Violet L. Haley.

Marine, Operator and Amateur Branch—George MacClain, Chief of Branch; Irving Brownstein, Robert M. Fenton, John E. Wicker, Dave Landis.

Aviation and General Mobile Branch—Marshall S. Orr, Chief of Branch; Douglas A. Anello, Margaret M. Connolly, John H. McAllister.

Bureau of Engineering

JOHN A. WILLOUGHBY, Acting Chief Engineer
Secretary: Estelle Bunn

WILLIAM N. KREBS, Asst. Chief Engineer
(Marine Radio and Safety Division)
Secretary: Willie C. Herbert

GEORGE S. TURNER, Asst. Chief Engineer
(Field Engineering and Monitoring Division)
Secretary: Genevieve Posnak

MARION H. WOODWARD, Asst. Chief Engineer
(Common Carrier Division)
Secretary: Annie Belle Bischoff

OFFICE OF CHIEF ENGINEER

Virgil R. Simpson, Asst. to the Chief Engineer
Secretary: Mary A. Nalls

Ralph J. Renton, U. S. Member, North American Regional Broadcasting Committee
Secretary: Ollin Irene Cline

Braxton L. Peele, Chief, Cartographic and Drafting Unit

Members of Former FEDERAL RADIO COMMISSION

Feb. 23, 1927—July 10, 1934

Admiral W. H. G. Bullard, Pennsylvania
March 15, 1927—November 24, 1927 (Deceased)

Orestes H. Caldwell, New York
March 15, 1927—February 23, 1929

Eugene O. Sykes, Mississippi
March 15, 1927—July 10, 1934 (Deceased)

Henry A. Bellows, Minnesota
March 15, 1927—October 31, 1927 (Deceased)

Colonel John F. Dillon, California
March 15, 1927—October 3, 1927 (Deceased)

Sam Pickard, Kansas
November 1, 1927—Jan. 31, 1929

Harold A. Lafount, Utah
November 14, 1927—July 10, 1934

Ira E. Robinson, West Virginia
March 29, 1928—January 15, 1932

General C. McK. Saltzman, Iowa
May 2, 1929—July 19, 1932 (Deceased)

William D. L. Starbuck, New York
May 2, 1929—February 23, 1934

Thad H. Brown, Ohio
January 21, 1932—July 10, 1934 (Deceased)

James H. Hanley, Nebraska
April 1, 1933—July 10, 1934 (Deceased)

Former Members of FEDERAL COMMUNICATIONS COMMISSION

Hampson Gary, Texas
July 11, 1934—December 24, 1934

Anning S. Prall, New York
January 17, 1935—July 23, 1937 (Deceased)

Irving Stewart, Texas
July 11, 1934—June 30, 1937

Frank R. McNinch, North Carolina
October 1, 1937—August 31, 1939

Eugene O. Sykes, Mississippi
July 11, 1934—April 5, 1939 (Deceased)

Thad H. Brown, Ohio
July 11, 1934—June 30, 1940 (Deceased)

Frederick I. Thompson, Alabama
April 8, 1939—June 30, 1941

George H. Payne, New York
July 11, 1934—June 30, 1943 (Deceased)

T. A. M. Craven, District of Columbia
August 21, 1937—June 30, 1944

Norman S. Case, Rhode Island
July 11, 1934—June 30, 1945

James Lawrence Fly, Texas
Sept. 1, 1939—November 13, 1944

William H. Wills, Vermont
July 1, 1945—March 6, 1946 (Deceased)

Paul A. Porter, Kentucky
December 21, 1944—February 25, 1946

Charles R. Denny, District of Columbia
March 30, 1945—October 31, 1947

Ewell K. Jett, Maryland
February 15, 1944—December 31, 1947

Ray C. Wakefield, California
March 22, 1941—June 30, 1947 (Deceased)

Clifford J. Durr, Alabama
November 1, 1941—June 30, 1948

STANDARD BROADCAST DIVISION

James E. Barr, Chief, Standard Broadcast Division
Secretary: Helena C. Osman

Engineers

Herbert L. Beury	Daniel Jacobson
Roger B. Carey	Wallace E. Johnson
Daniel K. Child	Donald C. Kanode
Jack Damelin	Harold L. Kassens
Elton Davis	Albert L. Kreis
Vernon F. Esgar	Leslie E. Kulberg
Samuel J. Farraro	Louis Light
Ralph H. Garrett	Robert D. Linx
Kenneth G. Gillette	Bruce Longfellow
H. Underwood Graham	Edward P. Lynch
Otis T. Hanson	Louis Manning
Harry Bayman	George F. Padberg
Ernest D. Herder	Henry Seibel
Frederick S. Holliday	George E. Shea
Daniel B. Hutton	Robert G. Weston

FM BROADCAST DIVISION

Cyril M. Braum, Chief, FM Broadcast Division
Secretary: Helen C. Davidson

Engineers

Harold C. Anderson	Harold C. Kelley
Julian T. Dixon	McIvor L. Parker
John E. Doane	John Rosebrough
Edward H. Hackman	Arnold Skrivseth

TELEVISION BROADCAST DIVISION

Curtis B. Plummer, Chief, Television Broadcast Division
Secretary: Agnes B. Carr

Engineers

Hart Cowperthwait	Hideyuki Noguchi
Carl Jones	Louis H. Rein
Kenneth Miller	Ernest C. Thelemann
	A. Prose Walker

AVIATION DIVISION

Edwin L. White, Chief, Aviation Division
Secretary: Zula M. Byram

Engineers

James D. Durkee	Albert Mantwill
John R. Evans	John J. McCue
William Hawthorne	Donald Mitchell
John S. MacDonald	Stuart Pettingill
	Robert L. Stark

MARINE RADIO & SAFETY DIVISION

William N. Krebs, Chief, Marine Radio & Safety Division
Secretary: Willie C. Herbert

Engineers

Robert I. Brown	Howard C. Looney
Alfred De La Croix	Lewis Merriwether
William E. Dulin	William F. Minners
Leo C. Haisjman	Duncan D. Peters
C. A. Higginbotham	T. M. Stevens
James T. Kyne	Harold R. Woodyard

PUBLIC SAFETY & SPECIAL SERVICES DIVISION

Glen E. Nielsen, Chief, Public Safety and Special Services Division
Secretary: Frances S. Klein

Engineers

Daniel H. Arnold	Everett G. Henry
George R. Boardman	George J. Ikelman
Frank W. Cook	Edward P. McDermott
Merle E. Floegel	Alfred P. Miller
Charles I. Fonger	Emile R. Reniere
John D. Fulmer	Milburne O. Sharpe
Herman Garlan	Floyd A. Trueblood
	William H. Watkins

RADIO OPERATOR & AMATEUR DIVISION

George K. Rollins, Chief, Radio Operator and Amateur Division
Secretary: Euna P. Wiley

Engineers

Roland W. Archibald	Alvin C. Holmes
John C. Currie	Ivan H. Loucks
Daniel P. Herlihy	Robert W. Percy
	Leland C. Quaintance

COMMON CARRIER DIVISION

Marion H. Woodward, Chief, Common Carrier Division
Secretary: Annie Belle Bischoff

Engineers

Kosmo J. Affanasiev	William R. Jarmon
Payson D. Carter	Carl A. Johnson
E. L. Clinkscales	Ralph D. Jones
John F. Corkill	John J. Koopmann
George J. Dempsey	Wallace McGregor
George B. Donohue	Fred H. Miller
P. Howard Duckworth	Paul V. Overmyer
Charles E. Goeking	Frank Paik
	John A. Russ

(Continued on page 541)

TECHNICAL RESEARCH DIVISION

Edward M. Allen, Chief, Technical Research Division
 Secretary: Ruby F. Floyd
 Technical Standards Branch—Glen E. West, Chief.
 Low Frequency Radio Branch—Edgar F. Vandivere, Chief.
 High Frequency Radio Branch—William C. Boese, Chief.

Engineers

Jules Deitz George A. Gadea
 Harry Fine George V. Waldo
 George L. Waters

FREQUENCY ALLOCATION & TREATY DIVISION

A. L. McIntosh, Chief, Frequency Allocation and Treaty Division
 Secretary: Jane A. Rudy

Engineers

Joseph Appel Theodore McCartney
 William F. Bradley William L. North
 Charles A. Brooks Marvin A. Price
 Louis E. De la Fleur George V. Steizenmuller
 William Grenfell Robert L. Tosch

LABORATORY DIVISION

E. W. Chapin, Chief, Laboratory Division
 Secretary: Anne F. Janco

Engineers

A. G. Craig Milton Mobley
 F. D. Craig Lawrence C. Middlekamp
 Joseph Dougherty Ward J. Moore
 Francis Downey Wilmar K. Roberts
 Everett N. Shinn

FIELD ENGINEERING & MONITORING DIVISION

George S. Turner, Chief, Field Engineering and Monitoring Division
 Secretary: Genevieve Posnak
 (For regional managers, district officers, primary and secondary monitoring stations, see listing below)

Engineers

Willard J. Beale Stacy W. Norman
 Ernest Blankinship Carl Nuhn
 Alfred H. Brodie Bernard Pemberton
 Arthur T. Caplan John C. Petersen
 Nathan Hallenstein Lloyd S. Quinn
 Clayton W. Hanson Howard L. Randall
 Thomas L. Heron Harold R. Richman
 George L. Jensen Warren C. Stickler
 Alfred H. Kleist Frank Toth
 Frank Kratokvil Floyd Wickenkamp
 Edwin L. Lovejoy Eldridge S. Willey
 Everett H. Marshall Charles O. Wilson
 Robert K. Morrell Rex H. Wilson

Office of Information

George O. Gillingham, Director of Information
 Assistants: Salina M. Lindo, Eva O. Melton, Mary O'Leson.

Division of Hearing Examiners

Jack P. Blume J. Fred Johnson Jr.
 J. D. Bond Fanny Neyman Litvin
 James D. Cunningham Leo Resnick
 Hugh B. Hutchinson Elizabeth Smith
 Basil P. Cooper

Bureau of the Secretary

T. J. Slowie, Secretary
 Administrative Asst.: Laura M. Hollingsworth
 Secretary: Ethel M. Richardson
 Clerk: Ozella T. Drake

LICENSE DIVISION

William P. Massing, Chief, License Division
 Secretary: Catherine Lunders
 Chief of Broadcast License Branch: Clara M. Iehl
 Chief of Commercial License Branch: William H. Irvin
 Chief of Amateur, Citizens Radio and Operator License Branch: Frank Gentile

SERVICE DIVISION

Paul H. Sheehy, Chief, Service Division
 Secretary: Helen E. Vetterman

RECORDS DIVISION

Walter S. Davis, Chief, Records Division

MINUTE BRANCH

Lavelle W. Hughes, Chief of Branch

LIBRARY BRANCH

Helen A. Clark, Chief of Branch

Bureau of Accounting

WILLIAM J. NORFLEET, Chief Accountant
 Secretary: Lily M. Marshall
 HUGO REYER, Executive Asst. Chief Accountant
 Secretary: Elizabeth S. Harris
 ROBERT E. STROMBERG, Asst. Chief Accountant

ACCOUNTING REGULATION DIVISION

Henry M. Long, Chief, Accounting Regulation Division.
 Chief of Development and Compliance Branch: H. R. Morris.
 Chief of Original Cost and Depreciation Branch: J. J. Nordberg.

ECONOMICS AND STATISTICS DIVISION

H. H. Goldin, Acting Chief, Economics and Statistics Division.
 Acting Chief of Common Carrier Branch: Alexander Fifler
 Chief of Broadcast Branch: James B. Sheridan.
 Chief of Special Studies Branch: Ted E. McHold.

BROADCAST DIVISION

LeRoy Schaaf, Chief, Broadcast Division.
 Chief of Applications Branch: E. E. Hensinger.
 Chief of Renewals and Annual Reports Branch: Robert F. Eraden
 Chief of Hearings Branch: Guy E. Douglas.

RATES DIVISION

William G. Butts, Chief, Rates Division.
 Chief of Tariffs and Telephone Rates Branch: John R. Lambert.
 Acting Chief of Telegraph Rates Branch: A. M. Booth.

FIELD ACCOUNTING OFFICES

Jack E. Buckley Henry G. Gothard
 624 Federal Office Bldg. 515 First National Bank
 90 Church St. Bldg.
 New York 7, N. Y. Atlanta 3, Ga.
 H. Pierce Niedermeyer Paul Summerhays
 Old Customhouse 316 Customhouse
 815 Olive St. 555 Battery
 St. Louis 1, Mo. San Francisco 28, Calif.

FIELD LEGAL OFFICES

Charles Hubert Joseph Brenner
 90 Church St. 100 McAllister St.
 Federal Office Bldg. San Francisco
 New York

Bureau of Administration

W. K. Holl, Acting Executive Officer
 Secretary: Rita Clayton

BUDGET AND FISCAL DIVISION

Robert W. Cox, Budget Officer
 Secretary: Reka Mathais

ORGANIZATION AND METHODS DIVISION

Charles R. Weeks, Planning Officer

PERSONNEL DIVISION

Gilbert H. Hatfield, Personnel Officer
 Secretary: Dorothy Glen

Field Offices of the Federal Communications Commission

FIELD ENGINEERING AND MONITORING DIVISION

REGIONAL OFFICES

Chief of Field Division: George S. Turner, Washington, D. C.

Region	Headquarters	Districts
Charles C. Kolster North Atlantic Region	506 Federal Bldg. 641 Washington St. New York 14	1, 2, 3, 4, 5
Paul H. Herndon Jr. South Atlantic Region	411 Federal Annex Atlanta 3, Ga.	6, 7, 22
Joe H. McKinney Gulf States Region	7300 Wingate St. Houston 11, Tex.	8, 9, 10
Kenneth G. Clark South Pacific Region	323A Customhouse San Francisco 28	11, 12, 15
Geo. V. Wiltse North Pacific Region	801 Federal Office Bldg. Seattle 4, Wash.	13, 14
William J. McDonald Central States Region	878 U. S. Court House Chicago 4	16, 17, 18
Emery H. Lee Great Lakes Region	1029 New Federal Bldg. Detroit 26, Mich.	19, 20
Lee B. Dawson Hawaiian Region	P. O. Box 1142 Lanikai, Oahu, T. H.	21
Charles T. Manning Alaskan Region	Room 52 Federal Bldg. Anchorage, Alaska	23

DISTRICT OFFICES

District No.	City	Address	Engineer in Charge
1	Boston 9, Mass.	1800 Customhouse	Walter Butterworth
2	New York 14	746 Federal Bldg. 641 Washington St.	Arthur Batcheller
3	Philadelphia 6, Pa.	1005 U. S. Customhouse	Roger A. Phelps
4	Baltimore 2, Md.	508 Old Town Bank Bldg. Gay St. & Fallway	Hyman A. Cohen
5	Norfolk 10, Va.	Room 402, New Post Office Bldg. 106 New Post Office Bldg. (Ship Office)	Edward Bennett Paul Schmidt
6	Atlanta 3, Ga. Savannah, Ga.	411 Federal Annex 214-218 Post Office Bldg. (Sub-Office)	W. D. Johnson Andrew R. Bahley
7	Miami 1, Fla. Tampa 2, Fla.	P. O. Box 150 312 Federal Bldg. 409-410 Post Office Bldg. (Sub-Office)	Arthur Fish Chalmer H. Neeb
8	New Orleans 16, La. Mobile 10, Ala.	400 Audubon Bldg. 324 U. S. Court House and Customhouse Bldg. (Sub-Office)	Theodore G. Deiler Walter M. Hammond
9	Houston 11, Tex. Beaumont, Tex.	324 U. S. Appraisers Bldg. 7300 Wingate St. P. O. Box 1527 329 Post Office Bldg. (Sub-Office)	Louis L. McCabe Eric D. Coburn
10	Dallas 2, Tex.	P. O. Box 5238 500 U. S. Terminal Annex	John H. Homsy
11	Los Angeles 12, Cal.	539 U. S. Post Office & Courthouse Bldg. Temple & Spring Sts.	Bernard H. Linden

District No.	City	Address	Engineer in Charge
	San Diego 1, Cal.	230 U. S. Customhouse and Courthouse (Sub-Office)	Harold De Voe
	San Pedro, Calif.	326 U. S. Post Office and Courthouse Bldg. (Ship Office)	James Homsy
12	San Francisco 26, Cal.	323A Customhouse	Francis V. Sloan
13	Portland 5, Ore.	307 Fitzpatrick Bldg.	James M. Chapple
14	Seattle 4, Wash.	801 Federal Office Bldg.	Herbert H. Arlowe
15	Denver 2, Col.	521 Customhouse	William E. Clyne
16	St. Paul 2, Minn.	208 Uptown Post Office & Fed. Cts. Bldg. 5th & Wash St.	Donald A. Murray
17	Kansas City, Mo.	3200 Fidelity Bldg.	Harold T. Gallaher
18	Chicago 4, Ill.	246 U. S. Court House	H. D. Hayes
19	Detroit 26, Mich.	1029 New Federal Bldg.	Edwin S. Heiser
20	Buffalo 3, N. Y.	328 Post Office Bldg.	Paul A. Holloway
21	Honolulu 1, T. H.	609 Stangenwald Bldg. 119 Merchant St.	Paul R. Fenner
22	San Juan 13, P. R.	P. O. Box 2987 322-323 Federal Bldg.	Irl D. Ball
23	Juneau, Alaska Anchorage, Alaska	P. O. Box 1421 7-8 Shattuck Bldg. P. O. Box 644 53 U. S. Post Office & Courthouse (Sub-Office)	Sigfred F. Berge (Vacancy)

PRIMARY MONITORING STATIONS

City	Address	Engineer in Charge
Allegan, Mich.	P. O. Box 89	Irving L. Weston
Grand Island, Neb.	P. O. Box 788	Arthur A. Johnson
Kingsville, Tex.	P. O. Box 632	William R. Foley
Millis, Mass.	P. O. Box 308	Edward W. Sanders
Santa Ana, Calif.	P. O. Box 744	William Hoffert
Laurel, Md.	P. O. Box 31	Adolph Anderson
Livermore, Calif.	P. O. Box 989	George McLeod
Portland, Ore.	P. O. Box 5165	Robert A. Landsburg
Powder Springs, Ga.	P. O. Box 4	Henry B. Dunphey Jr.
Lanikai, Oahu, T. H.	P. O. Box 1142	Lee R. Dawson

SECONDARY MONITORING STATIONS

City	Address	Engineer in Charge
Belfast, Me.	P. O. Box 44	Vernon K. Wilson
North Scituate, R. I.	P. O. Box 3	Thomas B. Cave
Spokane, Wash.	P. O. Box 37, Station "A"	Adelbert C. Lawrence
Twin Falls, Idaho	P. O. Box 499	John L. Kurdeka
Fort Lauderdale, Fla.	P. O. Box 187	Homer V. Thompson
Lexington, Ky.	P. O. Box 99	James E. Gilfooy
Muskogee, Okla.	P. O. Box 1448	J. F. DeBardeleben
Bay St. Louis, Miss. (near New Orleans)	P. O. Box 300	H. Frank Rawls
Anchorage, Alaska	P. O. Box 719	Edwin G. Forsyth
San Juan, P. R. (Pt. Maldonado)	P. O. Box 2987	Irl D. Ball

Audience Analysis

(Continued from page 30)

ban held in abeyance pending court determination of its legality, but the public has already begun to tune them out without waiting for a court order.

Hooper records show that *Stop the Music*, which in the fall of 1948 knocked the competing Fred Allen program out of the First 15, went on to hit a top rating of 20.7 in March 1949. But by November of last year *Stop the Music* had dropped to a 10.1, which ranked it 51st among all evening network commercial programs.

NBC's *Hollywood Calling*, launched in September 1949 to compete with Jack Benny on CBS, reached its highest rating with its first broadcast when it hit 4.1. In November this program rated 4.0, ranked 104th among all nighttime network commercials. The veteran *Truth or Consequences*, which in March 1948 reached a peak rating of 31.7, by November 1949 had sunk to 11.4, in 41st place on the popularity scale.

One would expect a difference in a telephone giveaway show's popularity with listeners in homes with

phones, who have a chance to be called and so get a crack at the jackpot, and with listeners in non-phone homes, who must accept the show as pure entertainment. Chart IX, based on Nielsen's total U.S. sample, including homes with and without phones, shows a composite rating for *Stop the Music* last May of 10.2. In telephone homes the rating was 12.1; in non-phone homes it was less than half as much, 6.0.

What of the Future?

What about 1950? One major expectation is that the television audience will grow at an even faster rate than during 1949, when the number of video-equipped homes increased from one million at the beginning of the year to well over three million at its end. This will probably lead to further inroads by TV programs into the audience for radio shows, particularly among big city dwellers in the evening hours.

It is possible that the AM and FM broadcasters will meet this video threat by developing new and more attractive program formats. The odds are, however, that the same program types and even the same programs which now hold top favor with the listening audience (and have held it year after year) will remain at the top during the year ahead.

Chart VIII
DISTRIBUTION OF "NATIONALLY" SPONSORED
NETWORK TIME BY PROGRAM TYPES

November 1-7, 1948

EVENING

November 1-7, 1949

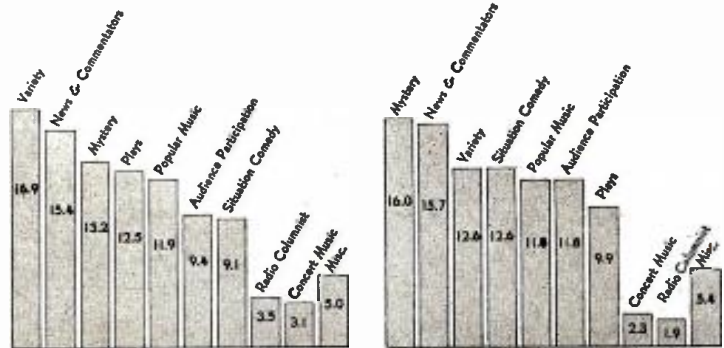

DAYTIME

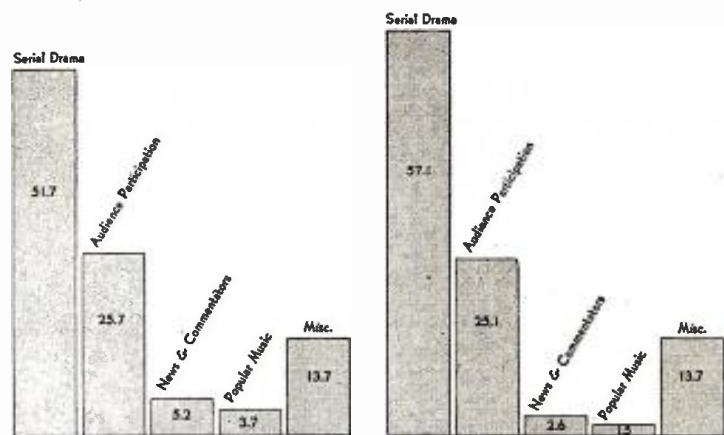

RECORDING "open-end" transcriptions?
That's a man-sized job...better do it at UNIVERSAL
IN CHICAGO



transcription masters
phonograph masters
processing and pressing

FREQUENCY MEASURING SERVICES

JAMES N. BARCLAY CO., FREQUENCY MEASURING DIVISION—1506 Red River St., Austin, Tex. Telephone: 8-3749. Marion T. Hill, engineer in charge.

WILLIAM W. L. BURNETT RADIO LABORATORY—4814 Idaho St., San Diego 4, Calif. Telephone Talbot 4943. William W. L. Burnett, engineer in charge.

COMMERCIAL RADIO MONITORING CO.—Porter Bldg., Kansas City 2. Telephone: Logan 8821. Robert F. Wolfskill, engineer in charge of frequency measurements.

HUTTON MONITORING SERVICE AM-FM-TV—Rockwell and Westchester Aves., Catonsville 28, Md. Telephone: Catonsville 9078. J. W. Hutton, owner.

RCA COMMUNICATIONS INC.—66 Broad St., New York 4. Tel.: Hanover 2-1811. Officers: Harry C. Ingles, president; Sidney Sparks, vice president for commercial activities; Frank Flood, manager of

special services. Branch: Riverhead, L. I., N. Y.; Tel.: 2290; E. C. Rundquist, manager. Branch: San Francisco 8; Tel. Garfield 4200, H. E. Austin, manager.

T & T RADIO MEASUREMENTS CO.—1228 E. Compton Blvd., Compton 1, Calif. Tel.: Nevada 6-3170. Jay E. Tapp and Raymond B. Torian, co-owners.

NATHAN WILLIAMS FREQUENCY MEASUREMENTS, AM-FM-TV—20 Algoma Blvd., Oshkosh, Wis., Tel.: Blackhawk 22.

VAN NOSTRAND RADIO ENGINEERING SERVICE—339 Leland Terrace, N.E., Atlanta, Ga. Tel.: Dearborn 4774.

CHARLES S. GOETZ CO.
1030 20th St., N. W.
Washington 6, D. C.
Telephone NA 0747

Official Duplicating Company for all FCC public records

Experienced personnel for special selection of FCC material available on request.

Write Us Direct

INDEX TO ADVERTISERS IN 1950 YEARBOOK NUMBER

AGENCIES

Batten, Barton, Durstine & Osborn, Inc.	3
Foote, Cone & Belding	5
McCann-Erickson, Inc.	8-9
Raymond R. Morgon Co.	20
Sherman & Marquette, Inc.	14
Young & Rubicam, Inc.	1

EQUIPMENT

Allied Radio	468
Amperite Co., Inc.	461
Andrew Corp.	460
Audio Devices, Inc.	439
BDN Steel Erecting Co.	465
Bell & Howell	466
Blow-Knox Co.	449
Colifone Corp.	461
Camero Equipment Co.	491
Collins Radio Co.	53, 495
The Doven Co.	493
Allen B. DuMont Labs, Inc.	471
Electro-Voice, Inc.	492
Fairchild Recording and Equip. Corp.	470
Federal Telecommunications Labs., Inc.	469
Gotes Radio Co.	457
General Electric Tubes	459
Groybor Electric Co., Inc.	475
Groy Research & Development Co., Inc.	474
Hughey & Phillips	481
International Derrick & Equipment Co.	490
Johns-Manville	473
Lehigh Structural Steel Co.	485
Lingo, John E. & Son, Inc.	478
Mognecord, Inc.	472
J. A. Maurer, Inc.	483
Mycolex Corp. of America	479
Presto Recording Corp.	455
Radio Corp. of America	Back Cover
RCA (Engineering Products Dept.)	(Leaf Insert) 452-453
Raytheon Mfg. Co.	487
Reeves Soundcraft Corp.	489
Revere Comero Co.	434
Shure Brothers, Inc.	476
Stainless, Inc.	477
SREPCO, Inc.	537
Tower Soles & Erecting Co.	538
Truscon Steel Co.	467
Westinghouse Electric Corp.	450-451

GENERAL

Air Features, Inc.	361
All-Canada Radio Facilities, Ltd.	333
Allied Recording Products Co.	463
AFCCE	56-57
ASCAP	67
Bernard Associates	480
Broadcast Music, Inc.	62-63
Cambridge School of Radio Broadcasting	534
Campbell-Cahill Studio	418
Canadian Association of Broadcasters	331

GENERAL—Contd.

Capitol Records, Inc. (Broadcast Div.)	419
The Cardinal Co.	446
Columbia Transcriptions	421
Commodore Radio Productions & Artists, Inc.	427
Louis G. Cowan, Inc.	27
Damon Recording Studios, Inc.	422
DeForest's Training, Inc.	535
Editor & Publisher	373
Empire Broadcasting Corp.	432
Film Associates	424
Frazier & Peter	29
Gollucci Brothers & Associates ..	101
Glenn D. Gillett	462
Charles S. Goetz Co.	542
John B. Heffelfinger	464
IBEW, Local 45, Hollywood	98
Kukla, Fran & Ollie	15
Lang-Worth Feature Programs, Inc.	430-431
McKittrick, George & Co.	351
Charles Michelson, Inc.	432
Morton Radio Productions, Inc.	433
Muzak (Transcription Division) ..	440-441
National Radio Personalities ...	357
Official Television, Inc.	429
RCA Custom Record Sales	425
RCA Recorded Program Services ..	436-437
Radio Television Publicity Corp. ..	47
Rodizork Enterprises	423
Roberts Studios	533
SESAC, Inc.	443
Smith DAVIS Corp.	51
Telefilm, Inc.	446
Teleways Radio Productions, Inc.	435
Trendle-Campbell Enterprises ..	447
George R. Turpin & Associates ..	303
United Press	39
Richard H. Ullmon, Inc.	59, 438
United States Steel	7
Universal Recording Corp.	542
Thomas J. Valentino, Inc.	442
World Broadcasting System, Inc.	445
Ziv, Frederic W. Co.	415-417
Ziv Television Programs, Inc.	19

NETWORKS AND GROUPS

American Broadcasting Co.	394-395
Arizona Broadcasting System ..	75
Canadian Broadcasting Corp.	335
Chicago Perimeter Bcstg. Assn. ...	137
Columbia Broadcasting System ..	16-17
The Covington Stations	71
Don Lee Broadcasting System ..	86-87
DuMont Television Network ...	13
The French Broadcasting System (Radio Diffusion Francaise) ..	347
Gannett Radio Group	219
Georgio Trio	123
The Granite State Network, Inc. ..	202
Keystone Broadcasting System ..	386-387
Liberty Broadcasting System ...	65
Mutual Broadcasting System, Inc.	30
Notional Broadcasting Company ..	406-407
NBC Television	410-411

NETWORKS AND GROUPS—Contd.

Northern Network	179
Northwest Network	183
The Nunn Stations	21
Paramount Television Network ..	93
Radio Luxembourg	355
Radio Programmes de Mexico ..	513
Razorback Network	79
Steinman Stations	107, 253
Texas Quality Network	287

REPRESENTATIVES

The Branham Co.	49
Free & Peters, Inc.	10
Headley-Reed Co.	43
Hollingbery, George P., Co.	41
NBC Spot Sales	45
Edward Petry & Co., Inc.	Front Cover
Stovin, Horace N., Co.	52
Toylor-Borrorff & Co., Inc.	Spine

STATIONS

CKLW, Detroit	174
KABC, San Antonio	299
KALE, Richlond, Wash.	316
KARK, Little Rock	77
KARM, Fresno	82
KAWT, Douglos, Ariz.	75
KCBQ, San Diego	94
KCKY, Coolidge, Ariz.	73
KCRAC, Sacramento	368
KDAL, Duluth	181
KFAC, Los Angeles	83
KFDA, Amarillo	21
KFDM, Beoumont, Texas	286
KFEL, Denver	369
KFI, Los Angeles	85
KFJZ, Ft. Worth	297
KFMB, San Diego	95
KFMV, Hollywood	80
KFVD, Los Angeles	84
KFWB, Hollywood	89
KGER, Long Beach, Calif.	79
KGLU, Safford, Ariz.	75
KGW, Portland, Ore.	251
KHMO, Hannibal, Mo.	189
KIEM-KRED FM, Eureka, Calif. ..	81
KIRO, Seattle	313
KJR, Seattle	315
KLYN, Amarillo	302
KMBC-KFRM, Kansas City, Mo. ...	190-191
KMPC, Hollywood	91
KOOL, Phoenix	73
KOPO, Tucson	73
KOWH, Omaha	199
KPIX, San Francisco	97
KPRC, Houston	287, 295
KRIS, Corpus Christi	287
KRLD, Dallas	289
KRNT, Des Moines	146
KROW, Oakland	371
KROY, Sacramento	92
KSD, St. Louis	195
KSFO, San Francisco	97
KSL, Salt Lake City	304
KSON, San Diego	96
KSTP, St. Poul	183

INDEX TO ADVERTISERS IN 1950 YEARBOOK NUMBER

(Continued from page 543)

STATIONS—Contd.

KTAR, Phoenix	75
KTBS, Shreveport	287
KTLA, Los Angeles	93
KTRE, Lufkin, Texas	352
KTUL, Tulsa	247
KUIN-KGPO, Grants Pass, Ore.	249
KUOA, Siloam Springs, Ark.	79
KVAL, Brownsville, Texas	287
KVER, Albuquerque	204
KVOA, Tucson	75
KWBW, Hutchinson, Kans.	150
KWFT, Wichita Falls	302
KWIK, Hollywood	80
KWJB, Globe, Ariz.	75
KWKH, Shreveport	159
KXLA, Pasadena	359
KXOK, St. Louis	197
KYAK, Yakima	316
KYCA, Prescott, Ariz.	75
KYUM, Yuma	75
WAEB, Allentown, Pa.	252
WAGA, Atlanta	117, 123
WAPA, San Juan, Puerto Rico	328
WAVE, Louisville	155
WAVZ, New Haven	104
WAZL, Hazleton, Pa.	349
WBAP, Ft. Worth	293
WBEN, Buffalo	207
WBIG, Greensboro	227
WBIR, Knoxville	21
WBNS, Columbus, Ohio	238
WBOC, Salisbury, Md.	22
WBRE FM, Baton Rouge	160
WBT, Charlotte	225
WBTV, Danville, Va.	307
WCAU, Philadelphia	261
WCAX, Burlington, Vt.	305
WCFL, Chicago	129
WCLO, Janesville, Wisc.	321
WCMT, Ashland, Ky.	21
WCOD-FM, Richmond	309
WCOV, Montgomery, Ala.	71
WCSC, Charleston, S. C.	270
WDAF, Kansas City, Mo.	193
WDAY, Fargo	233
WDBO, Orlando	113
WDEL-TV, Wilmington	107
WDGY, Minneapolis	185
WDIA, Memphis	278
WDMJ, Marquette, Mich.	179
WDOK, Cleveland	28
WDSU, New Orleans	161
WEAS, Decatur, Ga.	118-119
WEIM, Fitchburg, Mass.	168
WEMP, Milwaukee	322
WEOA, Evansville	175, 177
WERI, Westerly, R. I.	60
WEST, Easton, Pa.	253
WEVD, New York	345
WEXL, Royal Oak, Mich.	173
WFAA, Dallas	287, 291

STATIONS—Contd.

WFAS, White Plains, N. Y.	213
WFBC, Greenville, S. C.	273
WFBG, Altoona	254
WFBM, Indianapolis	175, 177
WFCI, Pawtucket	267
WFDF, Flint	175, 177
WFIL, Philadelphia	259
WFLA, Tampa	115
WFMJ, Youngstown	243
WGAL, Lancaster	253
WGEZ, Beloit, Wisc.	321
WGN, Chicago	131
WGST, Atlanta	120
WGTM, Wilson, N. C.	231
WGWC, Selma, Ala.	71
WGWD, Gadsden, Ala.	71
WGY, Schenectady	221
WHAM, Rochester	31
WHAS, Louisville	157
WHBQ, Memphis	277
WHEC, Rochester	219
WHHM, Memphis	279
WHLI, Hempstead, L. I.	211
WHO, Des Moines	147
WHOM, New York	212
WHP, Harrisburg, Pa.	257
WHTN, Huntington, W. Va.	318
WIBS, San Juan, Puerto Rico	367
WIBW, Topeka	153
WICH, Norwich, Conn.	105
WIL, St. Louis	194
WIRE, Indianapolis	141
WIS, Columbia, S. C.	271
WISL, Shamokin, Pa.	265
WISN, Milwaukee	323
WJAS, Pittsburgh	25
WJAX, Jacksonville, Fla.	111
WJBO, Baton Rouge	160
WJEF, Grand Rapids	178
WJJD, Chicago	128
WJOB, Hammond	137
WJOL, Joliet	137
WJR, Detroit	356A-359A
WJW, Cleveland	237
WKAN, Kankakee, Ill.	363
WKAQ (Radio El Munda)	329
WKBO, Harrisburg, Pa.	253
WKBR, Manchester, N. H.	202
WKBW, Buffalo	209
WKJF, Pittsburgh	262
WKRS, Waukegan	137
WKRT, Cortland, N. Y.	208
WKZO, Kalamazoo	178
WKY, Oklahoma City	245
WLAP, Lexington, Ky.	21
WLAW, Lawrence, Mass.	167
WLBK, DeKalb, Ill.	133
WLEC, Sandusky, Ohio	241
WLEW, Bad Axe, Mich.	180
WLS, Chicago	Inside Front Cover
WLW, Cincinnati	33-34-35-36
WMAR-TV, Baltimore	165

STATIONS—Contd.

WMAZ, Macon	123
WMBG, Richmond	309
WMBI, Chicago	23
WMC, Memphis	280
WMCT, Memphis	276
WMEX, Boston	166
WMFJ, Daytona Beach	110
WMGM, New York	215
WMIQ, Iron Mountain, Mich.	179
WMPS, Memphis	281
WMRN, Marion, Ohio	240
WMT, Cedar Rapids	145
WNAX, Yankton, S. D.	274
WNEW, New York	Back Cover
WNMP, Evanston	365
WOAI, San Antonio	287, 301
WOC-TV, Davenport, Iowa	144
WOOD, Grand Rapids	175, 177
WORA, Mayaguez, Puerto Rico	327
WORK, York, Pa.	253
WOSC, Fulton, N. Y.	375
WOTW, Nashua, N. H.	202
WPIK, Wash., D. C.	108
WPRO, Providence	269
WPTF, Raleigh, N. C.	229
WQXR, New York	217
WRAW, Reading, Pa.	253
WRC, Wash., D. C.	109
WRGA, Rome, Ga.	125
WREN, Topeka	152
WRGB-TV, Schenectady	221
WRMN, Elgin	137
WRNL, Richmond	310
WROK, Rockford, Ill.	135
WROY, Carmi, Ill.	353
WRR, Dallas	297
WRXW FM, Louisville	155
WSAM, Saginaw, Mich.	180
WSAP, Portsmouth, Va.	311
WSB-TV, Atlanta	121
WSCR, Scranton	264
WSIX, Nashville	284
WSJS, Winston-Salem, N. C.	232
WSM, Nashville	282-283
WSOO, Sault Ste. Marie, Mich.	179
WSPC, Anniston, Ala.	68
WSRS, Cleveland	236
WSYR, Syracuse	215
WTHI, Terre Haute	354
WTIC, Hartford	103
WTOC, Savannah	123
WTRC, Elkhart, Ind.	21
WTTA, Brattleboro, N. H.	202
WTSV, Claremont, N. H.	202
WTTT-WTTV, Blainington, Ind.	139
WTVR, Richmond	309
WWCA, Gary	140
WWJ-TV, Detroit	171
WWNH, Rochester, N. H.	202
WWPA, Williamsport, Pa.	266
WWRL, Woodside, L. I., N. Y.	216
WWSW, Pittsburgh	263
WXRT, Chicago	132



World Leader in Radio— First in Television

The year 1949 completed a half-century of historic achievements in electric communications, with the electron tube as the greatest basic radio invention in 50 years. It has been the master key to radio progress. It opened the pathways through space for world-wide radio and telegraphy and telephony, for radio broadcasting, television, radar, Ultrafax and numerous industrial applications. It will continue to unlock new developments from year to year.

As a result, RCA moves into the next 50 years determined to progress in service to the nation and to people everywhere.

Chairman of the Board

Radio Corporation of America

Radio City, New York