



# ANTIQUE RADIO CLASSIFIED



VOLUME 25

NOVEMBER 2008

NUMBER 11

## PHILCO *Transitones* IN COLORS

[ YOUR CHOICE OF 55 COLOR COMBINATIONS ]

Yes... the new PHILCO Transitone in COLORS is Philco's answer to the growing demand for radios that will harmonize with the colorful decorative schemes of today. And too... its 55 distinctive color combinations include the colors of nearly every school and college in America.

This new PHILCO Transitone in COLORS is a super-performing radio for its size. Efficient Attached Aerial—no ground. AC-DC Superheterodynes. 5 Loudspeaker Tubes. Automatic Volume Control. High-Output Speaker. Full-View Dial. Covers Standard American Broadcasts, Municipal and State Police Calls. Approved by Underwriters' Laboratories, Inc. Cabinet 3-5/16" High, 9-1/16" Wide, 4-1/8" Deep.

Ask your distributor for the complete list of colors and model numbers...and have him show you the newspaper ads.

- To suit the decorative scheme of any home or office.
- To fill the student demand for a radio finished in school, college, club, fraternity and sorority colors.

# \$14<sup>95</sup>

MODEL PT-10C

*Smart!*



*New!*

★ TEN YEARS OF PHILCO LEADERSHIP ★

A.R.C. — THE NATIONAL PUBLICATION FOR BUYERS AND SELLERS OF OLD RADIOS AND RELATED ITEMS — WWW.ANTIQUERADIO.COM

# This Holiday Season, Give a Gift To a Friend... Or Treat Yourself !!



- Subscriptions ..... Center Coupon
  - Books & Videos ..... pgs. 34, 35, 50-66
  - Gift Subscriptions ..... pg. 26
  - Back Issues ..... pg. 30
- (Great for new subscribers) \$5 each or  
Full Calendar Year of Back Issues - only \$24!*



## Antique Radio Classified Is Your Gift Source !!

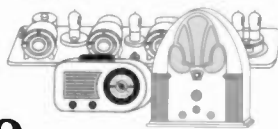

Order From Our Web Site At [www.antiqueradio.com](http://www.antiqueradio.com)

...Or, Call Us Toll Free At (866) 371-0512

...Or, Fax Us At (978) 371-7129





## Want to learn how to fix old radios, we have the answer - RCA Training Course

We have the complete RCA Electronics Training Course on CD and already hundreds have been sold. This is a very extensive CD covering theory, experiments and repair lessons. Read full info at <http://www.radioera.com/mall/RCATrainingCourse.asp>!  
**ONLY \$ 99 + S&H**

**We now have a small mountain of vacuum tubes at very competitive prices - Thousands sold since our first posting of these tubes. All types including receiving and transmitting types. Call, write or email your inquiries. All tubes are tested before shipment!**

### Other CD-ROM Publications:

Riders Professional database driven 6-CD set - now only \$ 299 or \$ 59 per CD (4 volumes/CD) .....  
Cunningham-Radiotron Hi-Rez CD \$ 85 .....  
Service Manual Series Sets 1-200 - 8 CD's, with Sets 1-25, 26-50, 51-75, 76-100, 101-125, 126-150, 151-175 & 176-200. Only \$ 79 each CD-ROM  
**AN 8 SMS CD's (1-175) - \$ 569.00** .....  
Radiophile Vol. 1 - \$ 85 .....  
Radiophile Vol. 2 - \$ 85 .....  
Radiophile Vol. 3 - \$ 85 .....  
Antique Radio Repair Vol. 1 - \$ 85 .....  
Antique Radio Repair Vol. 2 - \$ 85 .....  
R390-R390A/URR Technical CD - \$ 57 .....  
RCA Radiotron Handbook - \$ 67 .....  
RCA HB-3 Tube Manual - \$ 80 .....  
Zenith Trans-Oceanic - \$ 89 .....  
The Radio Boys - \$ 44 .....  
Amos 'N Andy - Vol. 1 - \$ 26 .....  
DialCord series - \$ 49 .....  
Collins Radio - Receivers - \$ 79 .....  
Collins Radio - Xmtrs/Amps - \$ 79 .....  
Collins Radio - Transceivers - \$ 79 .....

Collins Radio - Accessories - \$ 79 .....  
**Complete 4 CD Collins Set - \$ 279** .....  
RCA Service Notes - 4 CDs covering sets manufactured from 1923-1928, 1929-1932, 1933-1936 and 1937-1940, The most detail you will find on old sets. \$ 79 each. 4-CD set - \$ 299.  
REA-Riders Complete Index - \$ 34 .....  
Record Changers - \$ 85 .....  
Military Radio V1 - (Compendium) \$ 57 .....  
Military Radio V2 - (Compendium) \$ 57 .....  
QST Series - 85 years of QST (1915-1999) in 12 sets of CD-Rom's @ \$ 39.95 per set or \$ 399 for all 12 sets .....  
The Hallicrafters CD-ROM - \$ 89 .....

### Special Editions:

Collins R1051B technical manual - \$ 79 .....  
Collins ART-13 technical manual - \$ 39 .....  
Collins 618T technical manual - \$ 79 .....  
Collins 651S-1 technical manual - \$ 79 .....  
National R1490GRR17 technical manual - \$49 .....  
Dept. of Commerce - 1929 Ham Call Book - \$ 29 .....  
\*\* We have hundreds of other publications available on CD-ROM or DVD - Please inquire

## SCHEMATIC DIAGRAM & MANUAL SERVICE

Over a Million schematics & 100 000 manuals and growing! Schematics and most manuals may be emailed instantly via the internet

Check the web - On-line antique radio flea market - Radios for sale - Antique radio museum - Zenith Trans-Oceanic museum - thousands of old catalogs, manuals, literature, information, how-to data, reference, auction price section and much-much more! Visit antique radios largest web address today!

## RADIO ERA ARCHIVES

2043 Empire Central  
Dallas, Texas 75235  
Inquiries: 214-358-5195

Visit us on the Internet:  
[www.radioera.com](http://www.radioera.com)

# ANTIQUÉ RADIO CLASSIFIED

November 2008 • Volume 25 • Number 11

The National Publication for Buyers and Sellers of Old Radios and Related Items — Published Monthly  
[www.antiqueradio.com](http://www.antiqueradio.com)

- 5 **Editor's Comments**  
Always a new challenge for radio collectors.
- 5 **On the Cover**  
55 color combinations!
- 6 **Philco Dealer Poster and the PT-10C**  
Matching every decorative scheme.
- 8 **The Zenith Royal 1000 Trans-Oceanic**  
Going strong at 50!
- 10 **The Edwards Signaling Company Crystal Set**  
Distinguished by a buzzer.
- 15 **Philco Milestone Celebrations — Armistice Day 1937**  
Major media advertising campaigns.
- 16 **RM Auctions — The Astor Collection**  
Quality auction brings quality prices.
- 24 **A.R.C. Rates and Policies**  
Subscription, display and classified ad rates and policies.
- 26 **Classified & Display Ads**
- 42 **Coming Radio Events**
- 44 **Mark Your Calendar**
- 48 **Business Card Ads**



## ANTIQUÉ RADIO CLASSIFIED

Antique Radio Classified (ISSN:8750-7471) is published monthly, 12 times per year, by John V. Terrey, 498-A Cross Street, P.O. Box 2, Carlisle, MA 01741. Periodicals postage paid at Carlisle, MA, and additional mailing offices. Telephone: (866) 371-0512, 9:00 AM to 5:00 PM ET weekdays; machine answers phone at other times.

Annual subscription rates within the U.S. are \$45.00 by Periodicals mail and \$60.00 by First Class mail.

Annual foreign rates. By air: Canada - \$61.00; Mexico - \$67.00; Other foreign countries - \$105.00.

Two-year subscriptions are twice these rates and receive an extra month. Sample issues are available free on request.

© Copyright 2008 by John V. Terrey.

If A.R.C. inadvertently has infringed on a copyright, A.R.C. will pay an appropriate usage fee when notified.

**POSTMASTER: Send address changes to Antique Radio Classified, P.O. Box 2, Carlisle, MA 01741. Printed in U.S.A.**

**PURPOSE.** Antique Radio Classified is published for people involved in the radio collecting hobby. Its purpose is to stimulate growth of the hobby through the buying, selling and trading of radios and related items, and to provide a monthly forum for the interchange of ideas and information.

### STAFF:

**Publisher and Editor:** John V. Terrey  
**Assistant Publisher:** Cindie Bryan  
**Managing Editor:** Dorothy Schecter  
**Advertising Manager:** Cindie Bryan  
**Publishing & Editorial Staff:** Ray Bintliff, Dave Crocker, Bobby Lyman  
**Founding Publisher/Editor:** Gary B. Schneider  
**Contributing Writers & Consultants:** Mike Adams, Richard L. Arnold, Richard Begbie, Ray Bintliff, Norman Braithwaite, Ray Chase, Dave Crocker, Dick Desjarlais, Alan Douglas, Richard Foster, Andrew Hayden, Jim Kreuzer, Phil MacArthur, Ron Ramirez, Gary Schneider, Daniel Schoo, Frank White, Walter Worth

**CONTACTING ANTIQUÉ RADIO CLASSIFIED.** All correspondence should be sent to:

A.R.C., P.O. Box 2, Carlisle, MA 01741.

Only UPS, FedEx, etc. items to street address; 498-A Cross Street.

Telephone: (866) 371-0512; Fax: (978) 371-7129

E-mail: [ARC@antiqueradio.com](mailto:ARC@antiqueradio.com)

Web: [www.antiqueradio.com](http://www.antiqueradio.com)

Please, no classified ads by telephone; thanks.

Your ads, renewals, letters, etc. can be handled faster and more efficiently if your name, address and SUB# are written on each.

Unfortunately, A.R.C. is not staffed to answer all letters with questions about antique radios or requests for advice. However, A.R.C. does solicit letters of interest from its readers and publishes them as space permits. (See "Publishing Rights" paragraph.)



## EDITOR'S COMMENTS

Antique radio collectors love a challenge. Whether it has to do with history, restoration techniques, technical issues, whatever — we pursue answers. Sometimes a single line in an article tweaks a memory, and the reader rises to the challenge of finding more information.

So it was with Mike Masar when he read the article in the March 2008 *A.R.C.* in which Phil MacArthur says that the eleven colors offered by Flavoradio were “probably a record for the largest color variety of any radio ever made.” Mike was off to rummage in his archives, and he came up with an advertising poster, a section of which is on our cover, offering no fewer than 55 color combinations for the Philco PT-10C Transitone.

So Mike offers the next challenge: Who out there can tell us more about this set? Our research came up with only one known set, so the PT-10 appears to be rare. An article or “Photo Review” contribution would be welcome. We’re hoping someone rises to Mike’s challenge.

Inherent in a challenge, of course, is competition. Philco entered the radio market competition of the mid-20th century with supercharged advertising campaigns that put it at the top of the industry. Phil Turney describes one highly successful Philco advertising tool used from the late 1930s to the 1960s — the celebration of key production milestones.

The 5th, 7th, 10th, 15th, and 20th millionth sets were all given major advertising blitzes, but, as Paul points out, the 10 millionth set celebration was the most attention-getting. The Model 38-116XX was presented to the veterans at the Walter Reed Hospital in Washington, D.C., on Armistice Day (now Veterans Day) on November 11, 1937. Needless to say, this was an advertising triumph. A limited number of replicas with engraved plaques were sold to the public and are coveted by collectors today.

Far more available is the Zenith Royal 1000 Trans-Oceanic, the subject of an article by Phil MacArthur, who is obviously a fan of transistorized portables. This too was an advertising success story. Zenith managed to convince the public that replacing the vacuum-tube Trans-Oceanic with a transistorized version was worth twice the price. Phil is also a great salesman in that he writes convincingly about the rewards of keeping this set operative in his everyday family life.

Ever the historian, Bob Murray tells us about the rare crystal set made by the Edwards Signaling Company and now on display in its re-

stored state at the AWA Museum in Bloomfield, New York. Though largely a manufacturer of signaling, communications, and protection equipment, Edwards saw fit to celebrate its 50th anniversary in 1922 with a crystal set.

New examples of crystal sets show up fairly regularly; however, this one is especially unusual because it has a buzzer to help adjust the crystal detector, an asset generally included only in commercial sets.

For the second month in a row, we are able to report on auctions of high-profile collections. Both Bonhams with its Catalin auction in the October issue and this month’s RM Auctions of the Art Astor collection demonstrate that a prestigious collection, a catalog identifying specific sets, and an organization promoting absentee bids yield exceptional results.

Though classic cars were a major focus of Art Astor’s collection, hundreds of radios and related items, especially microphones, from early broadcasting days to the 1940s brought impressive prices. A Zenith 9S232 “Walton” selling at \$11,500 and a Wurlitzer Victory jukebox at \$17,250 are good examples.

We’re happy to report on an interesting private collection auction that we might not have known about if Ray Chase and RM Auctions had not alerted us and contributed the information. We hope that all you readers will keep us in mind when such events occur in your area.

**A.R.C. Benefits.** Be sure to take advantage of A.R.C. benefits: a toll-free number (866) 371-0512; Discover, MasterCard, American Express, Visa accepted; the Web, [www.antiqueradio.com](http://www.antiqueradio.com); books shipped free in the U. S. by USPS media mail; and for current subscribers, a 10 percent discount on all book orders

**Coming Radio Events.** In the waning days of fall, there are still many activities to enjoy before winter sets in. Listed this month are seven meets, twenty-six meetings, and three auctions. Get out and enjoy!

Happy Collecting!

John V. Terrey, Editor

---

## ON THE COVER

Our colorful cover this month is a 16" x 21½" section of the large (32" x 21½"), two-sided, dealer poster that lays out the Philco radio lineup for the 1940 model year. Phil Masar provided the poster to illustrate his article on Philco’s offer of “A complete line of Philco Transitone” available in 55 color combinations. In all, 21 Transitone models and a portable 82T with a folding lid are illustrated.

# WITH THE COLLECTORS

## Philco Dealer Poster and the PT-10C

BY MIKE MASAR

*Radios in colorful cabinets have been the subject of several articles in A.R.C. But, Philco may be the king of color in terms of variety, as Mike Masar explains in this article. (Editor)*

I enjoyed reading Phil MacArthur's story "Flavoradios Become More Flavorful" in the March 2008 issue about the many colors of Flavoradios. However, his statement that the eleven colors he has discovered "Probably setting a record for the largest color variety of any radio ever made" got me thinking about an old Philco poster I thought I remembered having somewhere.

Sure enough, a little digging turned up a Philco dealer poster announcing the radio lineup for the 1940 model year. A section of the poster described the 5-Loktal tube, Transitone Model PT-10C priced at \$14.95. Figure 1 shows a Model 10C image extracted from the poster photo on this month's cover. What astounded me was the number of color combinations offered — fifty-five! Sure makes eleven seem puny.

The poster advises you to contact your distributor for a list of colors, but no mention is made of the actual number of basic colors available, or



Figure 1. The Philco Model PT-10C, priced at \$14.95 and available in 55 color combinations!

how fifty-five color combinations could be achieved. Why so many colors? The poster touted that the variety was "Philco's answer to the growing demand for radios that will harmonize with the colorful decorative schemes of today." This statement would seem to coincide with the movement toward color in other products, such as cars.

The poster tries to entice you with other reasons for multiple colors, such as "To suit the decorative scheme of any home or office" and



Figure 2. The Philco Model PT-43 had a rich walnut cabinet with handle, dial, knobs, and speaker grille in cream plastic.



Figure 3. The Philco Model PT-55 came in a brown and amber plastic cabinet with a carrying handle.

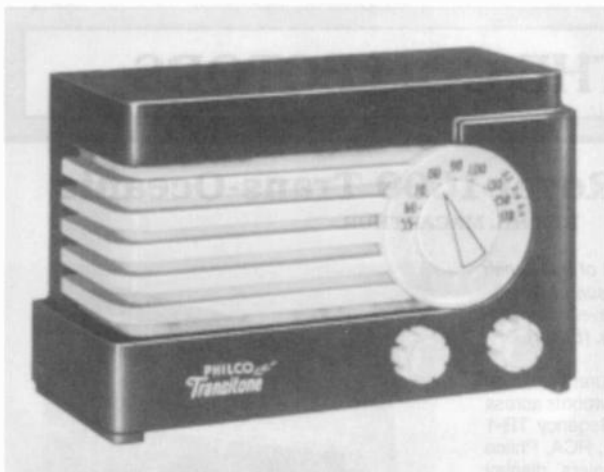

Figure 4. The Philco PT-35 had great eye-appeal with its bright ebony cabinet and dial, knobs, and speaker grille in contrasting cream.

"To fill the student demand for a radio finished in school, college, club, fraternity and sorority colors."

Although my wife would have you believe that I already own too many Philco radios, I do not own a PT-10C. In fact, I'm not sure I have ever seen one, which leads me to believe they are very rare, especially for a major national brand. The body and louver area appear to be made out of the same plastic type material. Were the same color choices available for both areas, and how many different base colors were there? I wonder how many different color combinations were actually sold.

I'd be interested to know if anyone has any more information on this radio or if anyone actually owns one. If so, is it in your fraternity colors?

#### SIMILAR PHILCO TRANSITONS

Philco produced several other sets in the same style as the PT-10C, as indicated in another part of the Philco poster for the 1940 model lineup. However, none could match the PT-10C in variety of color.

Most were in darker tones of brown and ebony. For example, the PT-43, shown in Figure 2, was advertised as "Refreshingly different!" It had a rich walnut cabinet with handle, dial, knobs, and speaker grille of cream plastic. The PT-55, shown in Figure 3, had a rich brown and amber plastic cabinet and carrying han-

dle. It was touted as "Bound to be a favorite!" The PT-35, shown in Figure 4, might have had even more eye-appeal with its gleaming ebony cabinet and dial, knobs, and speaker grille in contrasting cream.

Models with electric push-button tuning like the PT-59, shown in Figure 5, and the PT-67 are described as having a more "distinctive modern design." The PT-59 has a two-tone brown and amber plastic cabinet, while the PT-67 is "a beauty" in amber and brown plastic with a molded handle.

In all, Philco advertised 21 Transitons models. All are described in the poster as "Powerful AC-DC superheterodynes, with 5 super-efficient Loktal tubes...all working — no ballast tubes. And they have Automatic Volume Control, High-Output Speaker, Full-Vision Dial. All approved by Underwriters' Laboratories — Safe from fire and

shock."

Obviously, Philco could easily fill its promise of providing a radio to suit the needs and decor of any home or office.

*(Mike Masar, 3880 Red Oak Drive, Green Bay, WI 54313)*

*Mike Masar has worked as an electrical engineer in the paper industry for 30 years. His radio collecting began in 1985 when his wife bought him a console for 50 cents at auction with the stipulation that she take along a second console for free.*



Figure 5. A "distinctive modern design," the Model PT-59 came in a two-tone brown and amber plastic cabinet.

# WITH THE COLLECTORS

## The Zenith Royal 1000 Trans-Oceanic

BY PHIL MACARTHUR

*Having explored the development of the Zenith Royal 500 series in the July 2008 issue of A.R.C., Phil MacArthur takes us to the next level of transistorized portables, the Trans-Oceanics. (Editor)*

It's mid-1955 and several manufacturers are shipping the early transistor radios to showrooms across the country. The ground breaking Regency TR-1 and the initial entries from Raytheon, RCA, Philco and others are headed for the dealers' display cases. At Zenith the prototypes for the Royal 500 are being evaluated and assembly lines are in the planning stage at the Chicago plant, looking for a November debut.

Engineering discussions have been held for several months on the next update for Zenith's flagship portable, the Trans-Oceanic. The latest model, the 5-tube L-600 is only a year old and is selling briskly, but the transistor won't wait. Designing the next edition for this all-wave portable presents unique challenges.

First, the design team is charged with transforming a very popular product. The Trans-Oceanic is the top-of-the-market choice for a diverse public. The earlier H-500 has sold about one quarter million units at \$125 each in its three-year run, and the recent redesign is maintaining that sales pace, even at \$140 each. (These prices are just shy of \$1000 in 2008 dollars.) Second, the eminently recognizable



Figure 1. The Zenith Royal 1000 Trans-Oceanic with its lid closed.

suitcase appearance will be downsized, modernized, and built more like an expensive camera than any radio currently on the market. All this has to be accomplished using revolutionary transistor technology and at a price of \$250, almost double that of its predecessor.

As an indication of reluctance over terminating an established design, Zenith continued to produce the tube-type Model 600 in parallel with the new solid-state model from 1957 through 1962. It was possible to see three different models of the Trans-Oceanic in some showrooms during 1962 — the B-600, the Royal 1000, and the Royal 3000.

### THE ROYAL 1000 TRANS-OCEANIC VARIATIONS

Introduced in December 1957, the nine-transistor Royal 1000, shown in Figure 1, had eight bands: the standard broadcast band, 2-4 Mc, 4-9 Mc, and the 31, 25, 19, 16, and 13 meter bands (identical to the L-600). In July 1958, the \$275 1000-D, which added the longwave band, appeared.

Both models used nine D cells in the battery pack. In 1964, the \$199.95 1000-1 model added an AC power adapter. (The price was reduced in 1962 due to the introduction of the \$275 Royal 3000, which had FM.) The Royal 1000 stayed in the Zenith product line-up through 1968, an 11-year run.

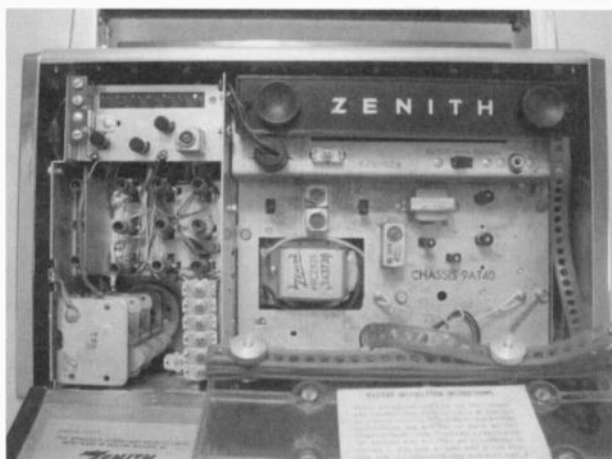

Figure 2. A view of the chassis showing such early features as the clear plastic battery box, the wavemagnet cable dressed down the far right rear and bolted to the battery box, the RCA transistors, the 9A740 chassis number, and the upside-down serial number, as well as the 738, 731, and 732 date codes.





Figure 3. The Zenith Royal 1000 Trans-Oceanic with its lid open.

Today, collectors are documenting the variations in the early production runs of the Royal 1000. First, Zenith made no formal designation of the model name until after production had started. Hence, there is no "Royal 1000" identification found on the earliest receivers. Second, the wavemagnet cable originally exited from the right-hand side (viewed from the back) and was clamped to the battery box. This was soon changed to the left side and coiled beneath the speaker magnet for a neater appearance. This rare wavemagnet appears only for the first couple of months.

Third, the earliest 1000s had a full set of black RCA transistors. Later, the transistors would be made for Zenith in Holland. Fourth, the original telescoping antenna had a "press to release" mechanism. Fifth, for at least a year, the 1000 had real leather covering and the words "genuine leather" appeared on the fold down cover. All of these early indicators appeared with the original chassis number 9AT40.

The earliest date codes are 731 (Aug. 1957) on the tuning cap and 738 (Sept. 1957) on the speaker. The hard plastic, bolt-on battery box appeared for about two years before being replaced by the newer box; hence, both are quite common.

Figure 2 shows several early features: the clear plastic battery box, the red wavemagnet cable dressed down the far right rear and bolted to the battery box; the 9AT40 chassis number; the black RCA transistors; the 343738 (738 is the 38<sup>th</sup> week of 1957) date code on the speaker; the 731 date code on the tuning cap; the 732 date code on the little output transformer; and the (upside down) serial number 6250523.

#### PRODUCTION TOTALS

The production totals for the first 15 years of the solid-state Trans-Oceanic were only about half of the totals for the last 15 years of the tube-type Trans-Oceanics. This might be attributed to changes in the market and increasing competition, first domestic, then from Japan and Germany. Perhaps this also shows that Trans-Oceanic buyers were more conservative and wouldn't trade their tube radios for transistors.

Solid production totals for each of the transistor-

ized Trans-Oceanics don't exist, so the big question remains, how many of each model were sold? We can estimate the totals by analyzing the frequency that they appear in A.R.C. ads and on eBay. For every 10 of the tube 600s there are about three 1000s, six 3000s, five 7000s, and only one R7000. Based on the known total of about 270,000 for the 600, the totals for the solid-state versions would be as follows: 90,000 Royal 1000s, 150,000 Royal 3000s, 130,000 Royal 7000s and only 30,000 of the R7000s. These numbers are just rough estimates, but for the moment, they're all we have.

We are fortunate to have so many of these fine all-wave receivers available 50 years after they were built, ready to serve new generations of listeners. Many of us

have them at our chair sides or on the night stand. They can be found daily on eBay for \$35 to \$250 depending on condition. They have turned out to be easy to repair, usually requiring the replacement of about a dozen capacitors and perhaps a plug-in transistor or two.

#### REWARDS OF OWNERSHIP

It's rewarding work to give another 50 years of life to a good receiver. Generic PNP germanium transistors are plentiful and inexpensive, around a buck each. I keep a stock of Hitachi 2SA70 or RCA SK-3007 transistors handy since they look just like the original 4-pin shielded RF and IF transistors from Zenith. Replacing the D cell pack with a rechargeable 12-volt sealed, lead-acid battery (about \$20) eliminates battery box problems and adds months between chargings.

Please e-mail the author with date code, chassis and serial number for and of the Royal 1000 or 3000 radios you have.

We've carried a Royal 1000 in our camper and on our boat for years, and it never fails to draw attention and start conversations. Get one for yourself, and listen in on the world through a radio with real class.

#### References:

- Antique Radio Classified*, 2005-2008.
- Bryant, John H. & Harold N. Cones. *Zenith Trans-Oceanic, The Royalty of Radios*. Atglen, Pa.: Schiffer Publishing Ltd., 1995.
- eBay auctions, May through August 2008.
- Smith, Norman. *Zenith Transistor Radios, Evolution of a Classic*. Atglen, Pa.: Schiffer Publishing, Ltd., 1998.

(Phil MacArthur, 60 W. Schuyler St., Oswego, NY 13126. [keywestmac@verizon.net](mailto:keywestmac@verizon.net))

After 25 years of teaching in Key West, Florida, Phil MacArthur and his wife June happily retired and returned to the "four-seasons Northeast." ("And while we were gone, you guys invented the snow blower.") He collects Zenith Royal 500s and Trans-Oceanics as well as the (probably famous) Realistic Flavoradicos.

## WITH THE COLLECTORS

### The Edwards Signaling Company Crystal Set

BY BOB MURRAY

In the following article, Bob Murray tells us about a piece of crystal radio history. His Edwards crystal set is now a museum piece, but there may be other Edwards sets out there that we can add to this bit of history. (Editor)

Edwards and Company, now a subsidiary of General Electric Security, was founded in 1872 by Robert Edwards and David Rousseau to explore the new phenomenon of electricity and to manufacture battery-operated gas fixture igniters. Among the company's first customers was a New York City church where sextons had climbed a 100-foot ladder to light gas fixtures located high above the pews. In 1873, Rousseau withdrew from the company and was replaced by Adam Lungen. Edwards and Lungen invented an electric door-bell and a burglar alarm.

In 1881, Robert Edwards obtained his first patent for an electric bell. In 1882, he patented a drop-type annunciator. In 1883, he patented an electric gas burner lighter for push-button operation, and in 1884, an electric door opener.

In 1884, Edwards displayed his wares at the first electrical show in the United States. Held in Philadelphia, it was called the "Electrical Exhibit, National Conference of Electricians."

In 1886, the Edwards catalog listed for the first time electrically wound clocks, program systems, and coils. In 1896, Edwards stopped installing electrical devices and limited its activities to the design and manufacture of signaling, communications and protection equipment. In 1903, Edwards installed the New York Stock Exchange bell to signal the start and end of trading each day.

#### EDWARDS CRYSTAL SETS

The year 1922 marked the 50th anniversary of the Edwards Company. In recognition of the anniversary, the Company built a number of crystal sets. These sets seem to have been used as corporate gifts in areas where the company was



Figure 1. This Edwards Company crystal set, ca 1922, was found in Winnipeg, Manitoba, Canada.

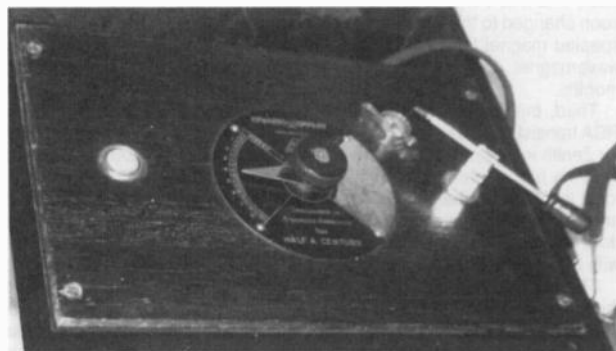

Figure 2. The top of the panel contains a dial plate etched in silver and naming the company as "Specialists in Signaling Apparatus for half a century."

seeking to install industrial signals and alarms.

An example of an Edwards crystal set, found in Winnipeg, Manitoba, Canada, is shown in Figure 1. A dial plate etched in silver, shown in Figure 2, identifies "Edwards and Company Inc., New York City," as "Specialists in Signaling Apparatus for HALF A CENTURY."

The company apparently did not make a large number of these sets, since they escaped the attention of crystal set expert Maurice Sievers in his *Crystal Clear* books and the early receiver historian Morgan McMahon in *Vintage Radio*.

#### THE RESTORATION PROCESS

The panel of the set as found was in good condition. Missing were the detector arm, the crystal, and the cabinet. These have been fabricated.

The detector arm was made from  $\frac{1}{8}$ " brass rod and plated with nickel. Its knob was turned from a scrap of mahogany and finished with black enamel.

The panel appeared to be made from mahogany and stained with mahogany. The case was made from  $\frac{3}{4}$ " mahogany and finished with Minwax mahogany stain followed by Minwax Jacobean stain. The case was then lacquered with three coats of Deft brush-on, semi-gloss lacquer. The cabinet catches are from discarded 35mm slide storage cases. The handle is from a Canadian military surplus instrument case.

Figure 3 shows the back of the panel with the company triangular logo on a metal label also containing the catalog number 0117 and "1872 Edwards."

The circuit, shown in Figure 4, is rudimentary. It would have been a poor performer in an area like New York City where discrimination of adjacent stations would have been an issue. It may have performed somewhat better in Winnipeg.

The set consists of a tuning coil with a single slider, operated by a knob on the panel. The tuning dial is calibrated from 0 to 9, and there is an area to the right of the tuning knob where the operator could write in pencil the names and settings for stations received. See Figure 2 again.

There is also a buzzer to help with setting the cat's whisker. This feature does not generally appear in books for home builders in 1922, but it was more common in earlier years. Bucher describes it in 1917 in his *Wireless Telegraphy*.

While it is not really essential on this crystal set, the Edwards Company made buzzers! They also made the phone condenser on the underside of the panel. According to the Edwards historian in a response to a website query, there is no record of Edwards having made a radio receiver.

The restored Edwards crystal set featured in this article is now in the AWA Museum in Bloomfield, New York. I would be interested to hear from anyone who has found another one.

#### References:

Bucher, Elmer E. *Practical Wireless Telegraphy*, Revised Edition. New York, NY: Wireless Press, 1917, page 167.

<http://edwardssignals.com/index.cfm?PG=21&level=50&sid=0>.

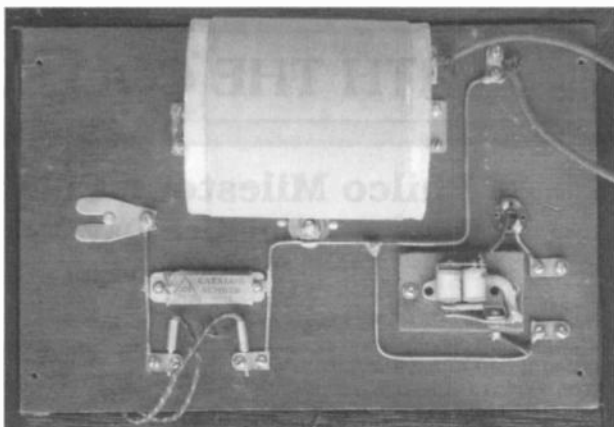

Figure 3. The back of the panel showing crystal set components, the coil at top, and the buzzer lower right. Lower left, the metal label is marked with the company triangular logo stating "1872 Edwards" and the catalog number 0117.

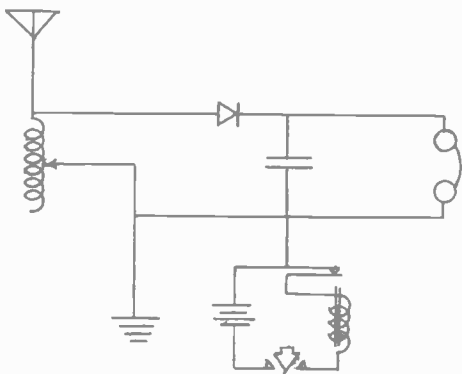

Figure 4. A schematic of the rudimentary circuit. The tuning coil with slider is on the left; the phones are on the right; the crystal is at the upper middle; and the buzzer circuit is on the lower right. A capacitor, center, couples the buzzer to the crystal detector.

McMahon, Morgan E. *Vintage Radio*, Third Edition. Palos Verdes Peninsula, CA: Vintage Radio, 1981.

Sievers, Maurice L. *Crystal Clear*, Vol. 1. Vestal, NY: The Vestal Press Ltd., 1991.

\_\_\_\_\_. *Crystal Clear*, Volume 2. Chandler, AZ: Sonoran Publishing LLC, 1995.

(Bob Murray, #605 -1000 Beach Ave., Vancouver, BC, Canada V6E 4M2)

Bob Murray has been collecting radios for over 25 years, and has gradually come to emphasize radios made in Canada in the 1920s. He is interested in restoration and research in radio history. Bob is the current editor of the "Antique Wireless Association Review."

# WITH THE COLLECTORS

## Philco Milestone Celebrations Armistice Day 1937

BY PAUL TURNEY

*The Philco brand loomed large in the first half of the 20th century when every household realized it had to have a radio. Paul Turney traces Philco's amazing production record through its radio milestone celebrations from 1934 to 1947 when it began to shift into TV milestone celebrations. (Editor)*

The Philco Radio and Television Corporation commenced the manufacture of radio sets in 1928 and quickly became one of the tube radio era's most prodigious manufacturers. Within a span of just three years, Philco grew to occupy the number one spot in the industry in terms of units sold. By 1935, so impressive were its sales that it would claim, "The American public bought three times as many Philcos as any other make... almost half as many Philcos as all other makes combined." The company continued to ride this tide of success for many years.

From the very outset, Philco realized that in order to sell lots of radios, a flamboyant big-budget marketing policy was necessary, backed by modern, attractive, and reliable products that were readily available for sale at the right price. Whatever steps necessary were taken to ensure that these basic business tenets were maintained. One does not have to delve too deeply into the era's advertising before realizing that Philco succeeded admirably in positioning both its name and products to be omnipresent before the radio buying public.

Whether it was through the production of jumbo-sized "demonstrator" radios, or through extravagant media advertising campaigns, sponsoring of radio shows and celebrities, and seemingly endless announcements for new technological innovations, the company always kept the public abreast of its latest accomplishments and offerings.

A recurrent theme in Philco media advertising was its celebration of key production milestones. This trend was perhaps borrowed from the automobile trade and appears to have started with the announcement of the five millionth set towards the end of 1934. It continued with commemorations for the seventh, tenth, fifteenth, and twentieth million sets over the course of the next 15 years or so. Perhaps the most interesting of these was the celebration of the 10 millionth set, the Model 38-116XX, which happened to coincide with Armistice Day in late 1937.



*Figure 1. The Model 38-116XX, the ten millionth Philco set, presented to the Walter Reed Hospital in Washington, D.C., as part of the 1937 Armistice Day celebration.*

### THE MODEL 38-116XX AND ARMISTICE DAY 1937

Philco's ten millionth set celebration, held during late 1937, followed in the tradition of the earlier ceremonies for which the Philco Models 16X and 116X had taken center stage. The ten millionth set, by design or otherwise, was the Model 38-116XX, shown in Figure 1. This was Philco's next to top-of-the-line set for 1938, a \$200 (initially), 15-tube, hi-fi behemoth.

For the occasion, over and above the usual advertising and in-store promotions, Philco gained publicity by presenting the set to the Walter Reed Hospital in Washington, D.C., at a ceremony that was part of the 1937 Armistice Day celebrations in the nation's capital. The 38-116XX was presented to veterans in the hospital by Boake Cart-

er, the famous, if not controversial, Philco Radio news commentator, representing the Philco Radio and Television Corporation.

Secretary of War Harry H. Woodring accepted the radio on behalf of the veterans and servicemen. The interest in this event was such that every seat in the Red Cross House auditorium in the Great Army Medical Center was occupied by soldiers and patients, with yet more space occupied by patients in wheelchairs.

On a silver plate attached to the base of the inclined control panel of the radio was the following inscription:

"This, the ten millionth Philco, is presented to the World War veterans in the Walter Reed Hospital in the hope that it will bring them in closer contact with 'the good things in the air.' November Eleventh, 1937."

During the ceremony, Boake Carter spoke of some of his own wartime exploits twenty years earlier, for which he himself had been hospitalized. He likened listening to the radio while in the hospital to having "a ringside seat as the world rolls by," and added, "Not only in the hospital here, but to other Veterans' hospitals all over the country, replicas of this ten millionth Philco are being presented by the Philco Company at the same [sic] time."

Secretary Woodring concluded the proceedings:

"I know of no greater pleasure than to come here and accept this generous gift on behalf of the Walter Reed hospital. To my mind there is no greater invention than the radio, especially for those who are hospitalized. Philco has given its 10,000,000th radio to the Walter Reed hospital. I recall that when Philco produced its 7,000,000th radio, it gave that instrument to the Warm Springs Foundation, in which our president is so interested. I say now that we express our admiration to Philco for this gift."

In addition to the ten-millionth set and the replicas thereof presented to hospitals, Philco offered a limited number of replicas for sale to the public. Each was sold with a personalized plaque affixed to its inclined control panel bearing an engraving of the purchaser's name preceded by the words, "Exact Replica of the Ten Millionth Philco. Built for ....."

Today the 15-tube Philco 38-116XX is much coveted by collectors, with a few appearing for sale yearly at radio shows and on-line venues. Some of the actual ten-millionth replicas complete with engraved plaques, also do occasionally turn up — for sure, there are known surviving examples. However, one cannot help but wonder what happened to the "exact ten-millionth" set, as presented to the Walter Reed Hospital over seventy years ago. Where was this radio used? Did the resident veterans of a former "World Crisis" use it to keep up with the unfolding events of the next?

We may never know, but what we can say is that this story serves to remind us of the important role that radio once played, and to some extent still does, in various of the nation's institutions that care for the injured and infirm, especially those who fought and paid a heavy price for the freedoms we enjoy today.



Figure 2. The five millionth Philco set, a Model 16X, was promoted by a widespread advertising campaign, including contests and special offers. (Photo courtesy of John Goller)

#### EARLIER PRODUCTION CELEBRATIONS — THE FIVE MILLIONTH PHILCO RADIO

In celebration of the production of the five millionth Philco, a 1935 Model 16X, shown in Figure 2, the company and its dealers ran a widespread advertising campaign, offering "greater values, easier terms and more liberal trade-in allowances than ever before." Contests, such as one that ran in stores in western Oklahoma, eastern New Mexico and the Texas Panhandle, gave away Philco prizes to the top 50 entrants of a 100-word letter entitled, "Why I would like to own the five millionth Philco."

The first prize was the five millionth Philco, a \$175 Model 16X. It was won by a Mrs. J.M. Hurst, whose letter was read aloud at the opening ceremony of a newly-retrofitted furniture store in Wellington, Texas, where Philco radios were sold.

Another advertising theme was comprised of special offers made on "furniture ensembles," a Philco radio being the centerpiece. One such ensemble, advertised by a furniture store in Valparaiso, Indiana, included a 6-tube Model 45L console, a world globe, a walnut end table, a modernistic bridge lamp complete with parchment shades, a luxurious armchair, and a beautiful wall mirror, all for the price of \$59.95. This was the normal price of the radio alone! A rider was added to this deal to the effect that "any Philco model may be had in combination with this ensemble."

(Continued on following page)

(Philco Milestone Celebrations, continued)

# THE TEN MILLIONTH PHILCO

TAKE ADVANTAGE OF OUR  
**EXTRA** VALUES — EASY TERMS  
TRADE-IN ALLOWANCES

It's radio's most outstanding achievement . . . the Ten Millionth Philco . . . and to celebrate this great event, we're making it easy for you to own an exact replica of this—the world's finest radio!

Here's Philco Automatic Tuning on the new *Infratone* Control Panel . . . here's High-Fidelity reception as you've never heard before . . . here's all the enjoyment that radio can offer! And, as a special feature, we'll engrave your name FREE on a commemorative medalion.



PHILCO 116 XT\* — All the razz and groov, speed and accuracy which *Philco Automatic Tuning* on the *Infratone* Control Panel & *Hi-Fi* High-Fidelity Audio System, Magnesia Tuning, *Infratone* Sound, *Philco Foreign Tuning* System, *Arcatone* Chatterbox—everything you want in a radio!

**\$240**

\*16 Tubes

\*See only add *Philco High-Fidelity* *Control* in feature booklet for *Philco* description.

**NO SQUAT  
NO STOOP  
NO SQUINT**

**\$50,000  
IN CASH PRIZES**



**FREE!**

AT OUR STORE  
JUST PRESENT  
THE COUPON!

Without obligation, please give me a copy of the *Servant's* Brochure describing "The Ten Millionth Philco" and the *Philco* Mystery Book with official entry blank for *Philco's* Radio Mystery Contest with \$50,000 in cash prizes.

NAME \_\_\_\_\_  
STREET \_\_\_\_\_  
CITY & STATE \_\_\_\_\_

**For Christmas . . .**

A typical widespread advertisement promoting a Philco milestone radio — the 10 millionth set, the Model 38-116XX. Note the interesting sales pitch: "No squat, No stoop, No squint," plus \$50,000 in cash prizes and a free brochure. Given to the Walter Reed Hospital on Armistice Day 1937, this set was also ready for the Christmas market. (From the Charleston, West Virginia, "Daily Mail," Nov. 21, 1937.)

This ensemble was rather more generous than most I've seen advertised, but the general intent was no doubt to entice the public into stores. Once there, the hope was that they would buy Philco radios of equal or greater value than the one offered, even if the ensembles had all been sold. Imagine the rush once these deals were announced!

A newspaper report from the *Texas Wellington Leader*, December 1934, summarizes the Philco advertising planned for this grand occasion: "Philco will celebrate the production of its five millionth radio with a stupendous 11-week continuous advertising campaign in every important medium, including newspapers, magazines and broadcasting. It is estimated that 1,100,089,883 separate Philco advertisements will appear during this campaign. This is approximately ten advertisements for every person in the United States between now and Christmas"

### THE SEVEN MILLIONTH RADIO

Just over a year after the five millionth event, in early 1936, Philco staged a promotion for its seven millionth set, which was a 1936 Model 116X, a \$175 11-tube hi-fi console, shown in Figure 3. Once again, Philco mounted a media advertising blitz, with special promotions, contests and drawings used to attract people into the stores where Philcos were sold.

As the seven millionth set completed its trip down the production line in Philco's Philadelphia factory, S. Davis Wilson, the city's mayor, was present at the plant to place his official blessing on the radio. He and several of his staff, accompanied by members of the press, had traveled to the plant to congratulate Philco on its "unprecedented record" and "to offer the city's gratitude for having given steady employment to thousands of Philadelphians and having added more than \$37,000,000 to the city's payroll."

On behalf of Philco, the ceremony was attended by James M. Skinner, president, Philadelphia Storage Battery, and Larry E. Gubb, president, Philco Radio & Television Corp. Shortly thereafter, perhaps at yet another ceremony, this exact seven millionth set was presented to the Warm Springs Foundation, renowned for its association with polio survivor President Franklin D. Roosevelt.

Limited numbers of replicas of the seven millionth set were offered for sale to the public, bearing a commemorative medallion stating the set to be an "exact replica of the seven millionth Philco." Has anyone seen or heard of the existence of one of these commemorative sets in recent times? I haven't.

### LATER MILESTONES

Philco celebrated the production of its fifteen millionth set in late 1940, three years after the tenth. The big feature at this time was Philco's "Beam-Of-Light" phonograph. "Reproduces Records On A Beam-Of-Light" was the catch phrase.

The twenty millionth Philco radio was produced in late 1947, seven years after the fifteenth, in-



Figure 3. The seven millionth Philco set, a 1936 Model 116X, produced in the Philadelphia factory and given an official blessing by the mayor.

cluding a lull of three or four years caused by World War II. Philco commissioned Bing Crosby to make a phonograph recording especially for this occasion, containing *Blue of the Night*, his famous theme song from "Philco Radio Time," and the popular lullaby *Home on the Range*. Autographed copies were given away with Philco radio and phonograph purchases made during the celebrations.

The instance of the twenty millionth set appears to have been Philco's last publicized celebration of radio production. However, perhaps that was because the company had switched to commemorating television milestones, starting with the one millionth set in 1954! But that's quite another story.

### References:

- Brainerd Daily Dispatch*, Brainerd, Minnesota, December 13, 1934, p 16.
- Indiana Evening Gazette*, Indiana, Pennsylvania, March 3, 1936, p 7.
- The Charleston Daily Mail*, Charleston, West Virginia, November 21, 1937, p 10.
- Vidette-Messenger*, Valparaiso, Indiana, November 21, 1934, p 8.
- Wellington Leader*, Wellington, Texas, December 20, 1934, p 1.

(Paul Turney, 11 Bradford Rd., Woburn, MA 01801)

Paul Turney has been collecting vintage radios on and off since he was a teenager. He has been a serious collector since 2001, focusing on sets from the 1930s and early 1940s. You can see more of his collection, and learn more about the sets and events described in this article, at his website:- [www.tuberadioland.com](http://www.tuberadioland.com)



## AUCTION REPORT

### RM Auctions — The Astor Collection Anaheim, California — June 27-29, 2008

CONTRIBUTIONS BY RAY CHASE AND RM AUCTIONS

Southern California broadcasting veteran Art Astor gave collectors a "day in the sun" when his impressive collection of vintage automobiles and memorabilia crossed the RM Auctions block on June 27-29 in Anaheim, California. Included were 200 classic cars and 786 lots of pre- and postwar memorabilia. The three-day event attracted over 200 onsite bidders and others from across the continent and Europe. The Astor Collection represented over 30 years of careful and dedicated selection of early automobiles and technology, including radio.

#### THE COMMUNICATIONS COLLECTION

The widely diverse range of memorabilia included one of the world's largest assemblages of early radios and telephones, as well as an assortment of Art Deco items and furnishings. One striking top seller, for example, was a Ford

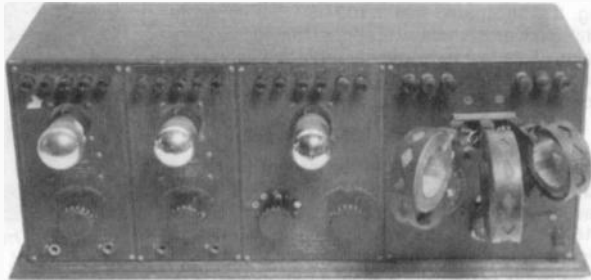

*This original DeForest Interpanel, unrestored, sold for \$4,025.*

Neon sign once used by a Ford Dealership and selling at \$21,850.

Not to be outdone by the many dazzling automobile offerings were the vintage radios and related items. Art Astor is well known for his passion for radio throughout Southern California. As the owner of several prominent California stations, his interest in the medium is professional.

But, it is also deeply personal, as his collection of hundreds of sets from early broadcasting days to the Catalin and Bakelite sets of the 1940s attested.

The collection included an interesting mix of styles from table sets to consoles and chairsides. Among the outstanding items was a 1940 Scott Phantom radio, which sold for \$12,937. In the radio-related category, a vintage Victory Jukebox from the 1940s brought \$17,250.

Given that Art Astor has long been in the broadcasting business, it was no surprise that he had an impressive collection of microphones. One example was a Western Electric 3B7W microphone selling at \$12,650. A number of other manufacturers, such as Shure, Electro-Voice, RCA, and Amperite were represented.

No expense had been spared to restore many of the sets to look and sound as they did when new,



*A notable high-bid item was this ornate Fletcher phonograph console which sold for \$8,050.*





A Zenith 9S232 "Walton" selling at \$11,500.

and at auction, many of them exceeded their pre-auction estimates. In fact, radio prices seemed high. Examples are an RCA Model 18 selling at \$1,610, and a big, heavy Majestic Model 70 selling at \$1,035.

#### VINTAGE AUTOMOBILES

Art Astor's collection of classic automobiles was outstanding. The top seller of the sale was a 1938 Cadillac V16 convertible coupe, one of 10 examples for 1938 and believed to have been once owned by movie star Gary Cooper. It sold for \$616,000. Another Hollywood connection was a 1941 Lincoln Continental Coupe thought to have been the classy conveyer of the glamorous Rita Hayworth. It sold for \$209,000. As you might expect, auto radios were also part of the sale.

Onsight bidders had competition from a large number of telephone and internet bidders. Total sales, including the buyer's premium, surpassed \$15.4 million. Radios and related items totaled \$546,822 on which the buyer's premium was 15 percent. Multiple item lots and passed items are not included in the listing. All prices include buyer's premium.

**A warning:** Auction prices are not current values. Our selection of auction items is not necessarily complete. A listing such as this cannot adequately include the condition of cabinets, chassis, transformers, tubes, the operating status of the set, and the inclusion of incorrect, restored or replica components, etc. Auction prices are the result of the excitement of the auction process, the skill of the auctioneer and the specific interests of the participants. Nevertheless, auction prices serve as useful references and as another element in the value determining process. The possibility of error always exists, and if we are notified, corrections will be reported.



A Majestic Master "Mighty Midget," fully restored, selling at \$3,162.

FR=fully restored; UR=unrestored; Orig=Original; OF=Original Finish; RF=restored finish; RC=Restored chassis; WT=with tubes; g=good; vg=very good; wk=working

Adams-Morgan Paragon RD-5, Orig, UR ... \$1,035  
 Airline 62-1101 console, FR ..... 1,610  
 Airline 62-123 console, FR ..... 1,725  
 Airline 62-311 console, "movie dial" ..... 1,955  
*(Continued on following page)*



This beautiful Majestic Model 70-71 console sold for \$1,035.

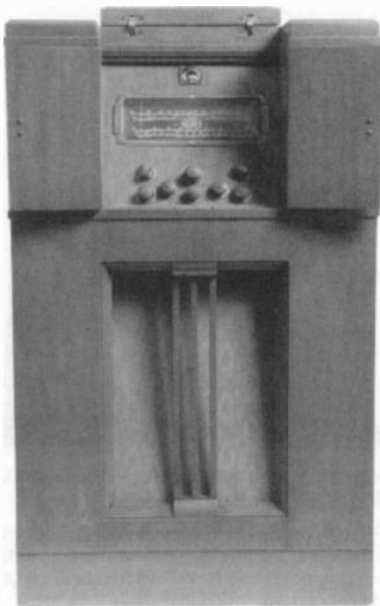

*In the original finish with a restored chassis, this Scott Phantom 30-tube console sold for \$12,937.*

*(Astor Collection Auction, continued)*

- Airline 409 console, multicolor dial, FR ..... 2,012
- Arvin and Silvertone silver radios, small table sets, (6) ..... 2,415



*A fully restored Zenith 8S443 console selling at \$4,888.*

- Astor "Mickey," Plaskon, missing back, white, vg ..... 1,035
- Atwater Kent 60 highboy console, FR ..... 2,070
- Atwater Kent 82 cathedral ..... 1,725
- Atwater Kent 217 cathedral, FR ..... 977
- Atwater Kent 376K6 console, OF ..... 2,415
- Atwater Kent 447 tombstone, FR ..... 1,150
- Atwater Kent H-76 highboy console, OF, RC .. 1,380
- Brandes B15 console, FR ..... 1,380
- Breting 14 ..... 1,380
- Brunswick radio/phono highboy console, w/RCA Radiola panel ..... 2,300
- Brunswick radio/phono, w/RCA Radiola Model III-A, & Brunswick phonograph ..... 2,012
- Bush & Lane 10 Deluxe highboy console, FR . 1,725
- Capehart radio/phono console, RF ..... 2,070
- Cointrola coin-operated radio, floor model, g ... 805
- Coronado 56-A77 console, FR ..... 1,150
- Crosley 127 lowboy console, "Adventurer," OF, RC ..... 1,380
- Crosley 158 grandfather clock radio ..... 2,300
- Crosley DeForest "Windsor" lowboy console, chassis modified, OF ..... 1,150
- DeForest Interpanel, Orig, UR ..... 4,025
- DeWald A-502, Catalin, butterscotch, w/yellow grille, g ..... 3,450
- Emerson 156 tombstone, FR ..... 690
- Emerson 176 tombstone, FR ..... 1,610
- Eveready 52 highboy console, FR ..... 1,265
- FADA 42 lowboy console, FR ..... 2,990
- FADA 252-BA, Catalin, "Temple," brown cabinet, yellow trim ..... 2,415



*A handsome Zenith 12S265 console, fully restored, sold for an equally handsome price of \$4,715.*

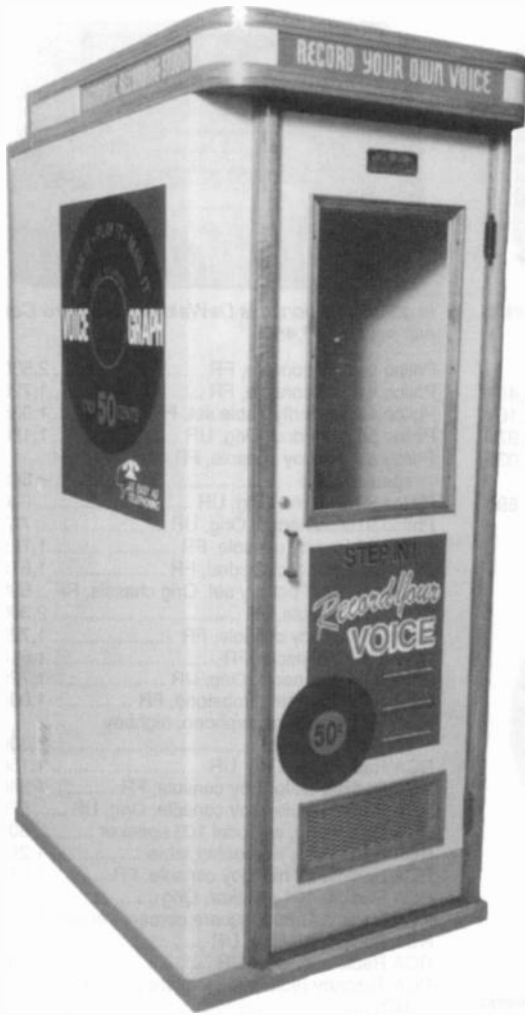

*This restored, 1957 Mutoscope Voice-O-Graph recording booth sold for \$6,325.*



*This elegant Silvertone Model 1390 grandmother clock radio brought a strong bid of \$3,450.*

FADA 700, Catalin, yellow w/orange knobs,  
orig back & label, vg ..... 3,450  
FADA 1000 bullet, Catalin, butterscotch, light  
scratch on top, vg ..... 1,610  
FADA 1000 bullet, Catalin, butterscotch, vg . 2,588  
Fada "Seven" battery set, w/folding loop  
antenna, UR ..... 1,380  
Firestone S-7403-4 "Air Chief" table set ..... 1,035  
Freed-Eisemann 78 highboy console, FR ..... 1,150  
GE A-87 console, FR ..... 1,840  
GE E-105 Colorama console ..... 1,610  
GE F-96 console, Orig, UR ..... 1,840  
GE M-86 console, FR ..... 1,150  
General Motors 130-A highboy console, FR . 2,875  
General Motors 255 lowboy console ..... 1,955  
Giffillan 66 lowboy console, FR ..... 1,380  
Giffillan Midget tombstone, FR ..... 977  
Grebe M-34 highboy console, FR ..... 1,725

Grunow 11G console, FR ..... 1,840  
Grunow 1297 console, Shirley Temple ..... 2,185  
Grunow 1761 console, FR ..... 1,955  
Guild Stereodeon, spinnet piano radio,  
OF, RC ..... 4,025  
Hammarlund HQ-140-X communications  
receiver, Orig ..... 402  
International RPG, small cathedral radio, OF .. 460  
Kennedy 20 lowboy console, FR ..... 1,150  
Kennedy 63A cathedral, FR ..... 1,150  
Kenneth Harkness "Counter Phonic Six," RF ... 1,150  
Kolster K-132 lowboy console, RC ..... 2,070  
Magnavox R3-B speakers, (2) ..... 1,035  
Majestic 70-71 highboy console ..... 1,035  
Majestic 70-B highboy, FR ..... 1,093  
Majestic 214 lowboy console, FR ..... 1,955  
Majestic 314 lowboy console, FR ..... 1,035

*(Continued on following page)*



Fully restored, this Philco 45 "Butterfly" tabletop sold for \$1035.



In good condition, this DeWald A-502 yellow Catalin sold for \$3,450.

(Astor Collection Auction, continued)

Majestic 996 console, "Ritz" .....	5,463
Master "Mighty Midget" cathedral, FR .....	3,162
Meteor Deco 11, barn-top cathedral, FR .....	977
Music Master horn, wood bell, 14" dia. ....	1,035
Pathé "Grecian" cone speaker, 15" dia., ca 1926 .....	690

Philco 40-180 console, FR .....	2,530
Philco 41-315 console, FR .....	1,725
Philco 45 "Butterfly" table set, FR .....	1,035
Philco 50 cathedral, Orig, UR .....	1,150
Philco 65 highboy console, FR, ornate speaker grille .....	862
Philco 89 console, Orig, UR .....	920
Philco 91D cathedral, Orig, UR .....	747
Philco 96 lowboy console, FR .....	1,725
Pilot "Broadcast" cathedral, FR .....	1,610
Rauland "Duet" battery set, Orig chassis, RF ..	690
RCA 9K3 console, FR .....	2,300
RCA 224 lowboy console, FR .....	1,725
RCA 810K1 console, FR .....	1,610
RCA C-11-1 console, Orig, UR .....	1,725
RCA R-7 superette tombstone, FR .....	1,035
RCA Radiola 18, radio/phono, highboy console version .....	2,300
RCA Radiola 28, Orig, UR .....	1,150
RCA Radiola 32 lowboy console, FR .....	1,840
RCA Radiola 51 lowboy console, Orig, UR .....	575
RCA Radiola 60, w/Model 103 speaker .....	805
RCA Radiola 60, w/speaker table .....	1,265
RCA Radiola 62 highboy console, FR .....	1,610
RCA Radiola 104 speaker, Orig .....	1,035
RCA Radiola Grand, square corners version	1,035
RCA Radiola IV, Orig, UR .....	1,955
RCA Radiola X, Orig, UR .....	1,035
RCA Tuscanly radio/phono, lowboy console, UR .....	1,265
RCA Victor 9-25 radio/phono console .....	3,450
RCA Victor R-32 console, FR .....	1,265
RCA Victor RE57 radio/phono, lowboy console .....	2,645
Scott Phantom, "Acousticraft," 30-tube console, OF, RC .....	12,937



A Pathé "Grecian" cone speaker, ca 1926, selling at \$690.

Philco 14 cathedral, Orig, UR .....	1,150
Philco 18X console, RF .....	1,035
Philco 38-7 console, FR .....	1,380
Philco 39-70 battery console .....	1,380



Missing its back, but in very good condition, this white Astor "Mickey" Plaskon set sold for \$1,035.



This Fada 1000 bullet, a yellow Catalin in very good condition, sold for \$2,588.



An original Adams-Morgan Paragon RD-2, unre-stored, sold for \$1,035.

Scott Philharmonic, 3-tube, radio/phono console, OF .....	4,025
Sentinel 284, Catalin, yellow, vg .....	2,300
Silvertone 1390, grandmother clock radio .....	3,450
Silvertone 1589 cathedral, FR .....	1,035
Silvertone 1805 tombstone, FR .....	805
Silvertone 4586 console, FR .....	2,012
Silvertone 4786 console .....	3,105
Silvertone 6641 chairside, FR .....	920
Sparton 15 lowboy console, FR .....	1,150
Sparton 65 tombstone, "Sunrise" grille, FR ..	1,265
St. Regis 553 tombstone, FR .....	1,380
Stewart-Warner 07-51, Plaskon, bullet style, white, w/orange knobs .....	1,035
Stromberg-Carlson 231-R chairside, mirror top, FR .....	4,025
Stromberg-Carlson 846-B highboy console, FR .....	2,530
US Apex 10-B lowboy console, FR .....	1,035
Western Air Patrol 8C8 console, FR .....	1,610
Western Electric 7A amplifier, WT, Orig .....	1,150
Westinghouse H-127, "Refrigerator" radio, white, w/blue knobs .....	402
Westinghouse RC (RADA) battery set, Orig, UR .....	690
Zenith 4-V-31 tombstone, FR .....	1,265

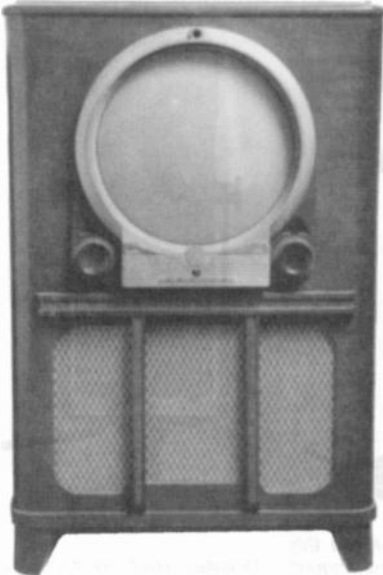

This Zenith porthole TV console sold for \$1,610.

Zenith 5S119, "Laveme & Shirley," table model, FR .....	1,495
Zenith 5S126 table set, FR .....	1,150
Zenith 5S127 tombstone, FR .....	1,380
Zenith 5S29 tombstone, FR .....	575
Zenith 6R230, FR .....	977
Zenith 6S128 tombstone, RC .....	1,380
Zenith 6S321, painted wood-grain, Deco, Orig finish, RC .....	1,035
Zenith 6S362 console, "Stars and Stripes," black-face dial, OR, RC .....	2,070
Zenith 7S547 small chairside, FR .....	1,725
Zenith 8S154 console, OF, RC .....	1,725
Zenith 8S443 console, FR .....	4,888
Zenith 8S563 console, Orig, UR .....	2,185
Zenith 9S232 "Walton" tombstone .....	11,500
Zenith 9S262 console, black-face dial, FR ..	7,475
Zenith 9S369 console, RC .....	2,760
Zenith 10H571 spinnet console, OF, RC .....	6,037
Zenith 10S464 console, FR .....	2,300
Zenith 11S474 console, w/theatre grille, FR ..	3,162
Zenith 12S265 console, black-face dial, FR ..	4,715
Zenith 12S494 radio/phono console, FR .....	4,600
Zenith 12S669 console, FR .....	3,795
Zenith 15S372 console, FR .....	8,050
Zenith 40A radio/phono console, large, ornate, OF .....	9,775
Zenith 220, "Zenette" baby console, FR .....	1,610
Zenith 807 tombstone, FR .....	1,035
Zenith 860 lowboy console, FR .....	1,725
Zenith 908 tombstone, FR .....	1,495
Zenith 960 lowboy console .....	4,313

**Car radios:**

Ford car radio, 1933-1934 .....	920
GE B-52, universal car radio, 1934 .....	690
Packard car radio, 1954, Orig, UR .....	173
Silvertone, universal car radio, 1934 .....	1,035

**Microphones (Note: Microphones included a desk stand unless otherwise stated.)**

Amperite RBMH .....	690
Electro-Voice 726, w/NBC flag .....	2,415
Electro-Voice 911 .....	575

(Continued on following page)



A handsome, octagonal Crosley Neon clock selling at \$2,875.



An RCA 4030-E microphone with a KDKA flag selling at \$1,380.



With its CBS flag, this spring-mounted Western Electric 387 microphone brought \$3,220.



This hanging Western Electric RA-1142 microphone with an NBC flag sold for \$4,313.

(Astor Collection Auction, continued)

Electro-Voice V-2, w/CBS flag .....	1,035	RCA 77-A .....	5,750
Electro-Voice V-3, w/CBS flag .....	920	RCA 77-D, w/KQED flag .....	2,875
General Electric 387, w/NBC flag .....	4,888	RCA 77-DX, w/NBC flag .....	5,463
National Specialties Co. ....	1,610	RCA 77A, w/CBS flag .....	7,475
RCA 4-A-1, w/NBC logo .....	2,875	RCA 88, w/KRML flag, (2) .....	690, 920
RCA 44-BX, w/CBS flag .....	3,162	RCA 88-A, w/KRML flag .....	1,035
RCA 44-BX, w/NBC flag .....	6,325	RCA 4030-C .....	460
RCA 50-A .....	1,150	RCA 4030-E, w/KDKA flag .....	1,380
RCA 50-A, w/KDKA flag .....	1,265	RCA BK-5B, (2) .....	2,012, 2,185
RCA 50-A, w/Voice of America flag .....	3,162	RCA carbon microphone, (2) .....	805, 1,035
RCA 50-A inductor microphone, w/MUTUAL flag .....	1,380	RCA double-button microphone, w/COLUMBIA flag, spring mount .....	3,450
RCA 74 Junior, ribbon microphone .....	1,150	RCA KU-2A, no stand .....	4,313
RCA 74 Junior, ribbon microphone, w/ABC flag .....	1,610	RCA MI-4045-E, w/KCSM flag .....	3,450
		RCA MI-6204-C, w/ABC flag .....	2,588
		RCA PB90 .....	1,035



This RCA KU-2A microphone with no stand sold for \$4,313.



An NBC flag distinguished this RCA 77DX microphone enough to bring a high bid of \$5,463.



Definitely a high-end microphone, this RCA-77-A brought \$5,750.

RCA PB90A2 .....	1,093
Shure 55S Unidyne .....	1,380
Shure 55S Unidyne, w/floor stand .....	920
Shure 55S Unidyne, w/ELVIS flag, (2) .....	1,725, 2,415
Shure 55S Unidyne, w/floor stand .....	690
Shure 55S Unidyne, w/KRML flag .....	1,035
Shure 55S Unidyne, w/NHK flag .....	920
Shure 55SH, w/NBC flag .....	2,760
Shure 55SW .....	690
Shure S36, w/ELVIS flag .....	1,840
Turner 33D, "SharkFin," on floor stand .....	1,265
Western Electric 387 .....	1,150
Western Electric 387, w/CBS flag, spring mount .....	3,220
Western Electric 387W, spring-mounted microphone pair on table stand, w/COLUMBIA flags .....	12,650
Western Electric 394 .....	2,300
Western Electric 600, double-button, carbon microphone .....	920
Western Electric 600A, spring mount .....	1,495
Western Electric 600A, w/NHK flag, spring mount .....	1,955
Western Electric 618 A .....	518
Western Electric 618 moving coil microphone, w/VOICE OF AMERICA flag .....	2,990
Western Electric 618A .....	1,035
Western Electric 639, w/KGO flag .....	2,012
Western Electric 639, w/MUTUAL and DON LEE flags .....	2,645
Western Electric carbon microphone .....	575
Western Electric RA-1142, w/KCBS flags on right and left sides .....	2,300
Western Electric RA-1142, w/NBC flag, microphone hangs .....	4,313

#### Phonographs:

B Z N Hornless Talking Machine, disc, ca 1910, ... ..	1,265
Brunswick 1017A highboy console .....	4,025
Columbia Grafonola console .....	1,380
Columbia Viva-Tonal 810 console, disc machine ..	1,610
Edison B-80 disc machine, ca 1914 .....	2,875
Edison Home Model A .....	1,840
Emerson "Wonder Gram" portable, 45 rpm, 7" records, ca 1955 .....	920
Fletcher phonograph, ornate console, disc machine ..	8,050
Mutoscope Voice-O-Graph recording booth, restored, ca 1957 .....	6,325
Sonora RE-57 console, disc machine .....	2,300
Victor VV-XI console, disc machine, (2) 1,438, 1,610	
Victrola VE-XVI console, disc machine .....	2,012
Victrola VV-215 console, disc machine .....	2,300

#### Jukebox:

Rock-Ola 1422 jukebox, 1946, wk, FR .....	9,200
Seeburg 100 jukebox .....	4,600
Wurlitzer Victory jukebox, 1942-45, wk, g ...	17,250

#### Television:

Admiral 1201 console, cast Bakelite cabinet, 10" screen .....	1,955
DuMont console, 1950 .....	1,150
Motorola 9T1, 8" screen, g .....	1,265
Packard-Bell console, 1953, w/swing-away doors & storage shelves .....	1,380



*In very good condition and working, this Wurlitzer Victory jukebox, 1942-1945, brought a commanding price of \$17,250.*

#### Philco Predicta Continental console, 1957,

21" screen, g .....	2,530
Philco Predicta Princess, metal cabinet, g ....	1,725
Philco Safari 2010, Orig .....	1,150
Zenith porthole console, 1949 .....	1,610

#### Paper and Advertising:

Columbia Records sign, 28" dia. ....	1,035
Crosley Neon clock, 22" x 22" .....	2,875
David Sarnoff signed letter display .....	633
GE Drum Major figure, 18" tall, ca 1927 .....	1,380
GE Radio Television Appliances illuminated sign, 72" wide .....	3,162
Motorola Auto Radio neon sign, 25" x 11" ....	2,875
RCA Radiotron figure, 18" tall .....	920
RCA Victor Electric Tuning, illuminated sign, 16" wide .....	460
Titanic photo, signed by a survivor, & White Star Line Poster, 17" x 21" .....	920
Wurlitzer Music neon clock, yellow & green, 28" dia. ....	1,380

*(Ray Chase, 1350 Marlborough Ave., Plainfield, NJ 07060; RM Auctions, 135 E. Foothill Blvd., Monrovia, CA 91016.)*

*Ray Chase has been a radio enthusiast and a collector of many types of radios for years. Currently, he specializes in World War II electronics equipment, as well as early battery superheterodynes. He also has an extensive collection of radio documentation and ephemera.*



## A.R.C. RATES & POLICIES

**GUARANTEE.** You may cancel your subscription at any time and receive a pro rata refund for issues not yet mailed. If errors to ads are made by A.R.C., upon request a free correction will be run in the next available issue.

**PAYMENT.** Please send in full payment with your order or ad. A.R.C. does not carry accounts; all subscriptions, ads, etc. must be prepaid (except for the 6 and 12 month display ads indicated below). Pay in U.S. funds. Checks drawn on a U.S. bank, money orders, VISA or MasterCard (\$10.00 min.) are preferred. Make check out to "A.R.C." Cash is OK for small amounts. Canadian payers may send a Canadian check but specify *U.S. funds*. Subscriptions will be prorated to amount sent if amount is incorrect.

**FAX & E-MAIL PROCEDURES/PAYMENT.** Subscriptions, book orders, classified ads, display ads, etc. are welcome by fax or e-mail. Deadlines are the same as for ads received by mail. Please calculate the amount due. Payment by VISA or MasterCard is preferred if your order is over \$10. If under \$10, or if you prefer to send a check or money order, state the amount being sent and that the payment is in the mail. **Do not** send another copy of your ad with your payment; simply indicate that it is a fax or e-mail payment. If you want confirmation of our receipt of your fax, call immediately after sending your fax.

**CHANGE OF ADDRESS.** Please notify us 4 weeks in advance of a change of address. Send both your new and old addresses, and include your SUB# and effective date of your new address. Temporary address changes can be made also.

**SUBMISSION OF MATERIAL.** *Antique Radio Classified* welcomes and solicits information that pertains or relates to radio history or collecting. This may include articles, book reviews, photos, information on upcoming radio events, meetings, antique radio organizations, radio auctions, sources of old radio and restoration supplies, and other related and interesting material. All material submitted should be carefully researched, typed and accompanied by good photos, if appropriate. Computer disks are appreciated. Writing guidelines are available upon request.

**PUBLISHING RIGHTS.** Unless other arrangements are made: (1) All received materials (ads, articles, letters, correspondence, e-mail, photos, artwork, etc.) become the property of A.R.C., may be edited, combined with other material, published, and will not be returned. (2) For all received materials, A.R.C. is granted publishing and reprint rights in all forms of media including the monthly printed magazine, internet, etc. (3) Publication is subject to approval by A.R.C. and to time and space constraints.

**MAILING OF ISSUES.** U.S. subscribers can receive A.R.C. by First Class or Periodicals mail (Periodicals is the way most magazines are mailed). The mailing of First Class copies is staggered with faraway copies mailed before local copies. Non-U.S. copies are mailed on the first day. Periodicals copies are mailed on the last day. Mailing dates change each month, but mailing is usually completed by the 27th of the month. First Class copies usually are received by the 5th of the month; copies by Periodicals mail, by the 10th.

**ETHICS.** No person involved in the production of A.R.C. is to act on any information in the magazine until the first delivery day after local copies are mailed.

**DISCLAIMER.** The publisher is not responsible for any buying and selling transactions incurred, or for any other use of the contents of this publication.

*Antique Radio Classified* subscription rates, frequency of publication, content, policies, size and ad details, and rates are subject to change at any time by A.R.C.

## DISPLAY AND BUSINESS CARD ADS • DETAILS AND RATES

*The deadline is the first of the month for display and business card ad artwork, payment and repeat requests.*

**Advertising is accepted only for early items related to radio, communication, etc. All items must be described fairly; reproductions, reprints and not-original items must be so identified. Advertisers must agree to respond promptly to inquiries and orders, to resolve problems promptly if the buyer is not satisfied, and to comply with a buyer's refund request on unaltered returned items.**

Advertising must be prepaid, except as noted below; see "Payment" paragraph above for details. Late ads will be run only if space and time permit. Originals must be the artwork size listed below. Send all artwork on disk or ask us to typeset it for you. Do not send in artwork on art board or send negatives. Please call for instructions on how to send your electronic ad. If used, reverse type must be limited to 25% of the ad. If you want us to prepare your ad, include the one-time cost below for A.R.C. to make up the ad.

Add \$16.00 per photo for screening unless part of an existing electronic ad. Do not cut or trim photos or glue photos to artwork; submit separately.

If you are confused by these requirements and terms, please

contact A.R.C. before beginning to prepare your ad. We will be happy to advise you on your ad ideas, estimate how much the ad will cost, recommend an ad size, etc.

We assume that advertisers want all ads which are submitted to run without delay; therefore, we will run the ad and bill for any additional work required for the ad to meet these specifications. A late ad will run beginning with the next month. "Tear sheets" will be sent only for 1/16-page or larger ads and only if requested when the ad is submitted.

**First business card per advertiser is at lower rate.**

The 3-month rates represent about an 11% discount, the 6-month rates 23%, the 12-month rates 30%. Placement requests: add 15% but call first. Clubs: write for discount policy.

Page	ARTWORK SIZE (SEND IN THIS SIZE)		As Printed (size in magazine)		Cost for 1-month	Cost for 3-months	Cost for 6-months*	Cost for 12-months**	One Time to make up Ad
	H x W (inches)	H x W (inches)	H x W (inches)	H x W (inches)					
Full	7 3/4 x 4 3/4	7 3/4 x 4 3/4	7 3/4 x 4 3/4	7 3/4 x 4 3/4	\$289.00	\$769.00	\$1329.00*	\$2325.00**	\$69.00†
1/2 H	3 5/16 x 4 3/4	3 5/16 x 4 3/4	3 5/16 x 4 3/4	3 5/16 x 4 3/4	146.00	389.00	675.00*	1175.00**	37.00†
1/2 V	7 3/4 x 2 1/4	7 3/4 x 2 1/4	7 3/4 x 2 1/4	7 3/4 x 2 1/4	146.00	389.00	675.00*	1175.00**	37.00†
1/4	3 5/16 x 2 1/4	3 5/16 x 2 1/4	3 5/16 x 2 1/4	3 5/16 x 2 1/4	74.00	197.00	342.00	595.00	19.00†
1/8	1 5/8 x 2 1/4	1 5/8 x 2 1/4	1 5/8 x 2 1/4	1 5/8 x 2 1/4	38.00	101.00	177.00	305.00	9.00†
Business Card (1st)	2 x 3 3/4	1 1/4 x 2 3/8	1 1/4 x 2 3/8	1 1/4 x 2 3/8	not avail.	53.00	90.00	159.00	7.00†
Business Card (2nd...)	2 x 3 3/4	1 1/4 x 2 3/8	1 1/4 x 2 3/8	1 1/4 x 2 3/8	not avail.	68.00	118.00	205.00	7.00†

\* Full & 1/2 page. 6-mos.: 1/2 due with order; 1/2 due in 3 mos. \*\* Full & 1/2 page. 12-mos.: 1/4 due with order; 1/4 due at 3, 6 & 9 mos. † For 6 and 12 month ads, no ad make-up charge if no change is made to ad for entire run.

E-mail: [arc@antiqueradio.com](mailto:arc@antiqueradio.com)

Web: [www.antiqueradio.com](http://www.antiqueradio.com)



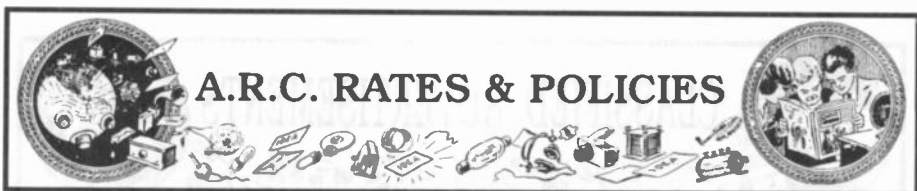

## A.R.C. RATES & POLICIES

### CLASSIFIED ADS • DETAILS AND RATES

**ONE FREE 20-WORD AD** for subscribers in each issue; additional words are 29¢ each. See details below. Classified ads sent by mail, fax, e-mail or by any other method must be received (not just postmarked!) by **Noon Eastern Time** on the classified ad deadline date to guarantee inclusion in the current issue. Late ads are held for the following issue. Please enclose correct payment with all ads. Cash is OK for small amounts. (Canadian and other foreign advertisers, please see "Payment" on opposite page for methods.) "Free words" cannot be accumulated from month to month; free words must be requested when ad is submitted.

**Faxed & e-mailed ads: Please see additional information on opposite page.**

**When including ads with other A.R.C. correspondence, write the ads on a separate piece of paper.** Include SUB# with ad. Ads may be sent in advance; but, write each ad on a separate piece of paper and indicate the month (or successive months up to your subscription expiration; 12-months, maximum) you want the ad to run.

**To minimize our typing errors: Please write legibly.** Use both capital and small letters. Do not use a dash between words. Carefully write the following numbers and letters (especially in model numbers) since some can look alike; for example 1, l and I (the number one, the capital i and the small l.) Also: 0, O, o, Q and D; v, r and n; 6, b and G; V, U, u, v and Y; A and R; 5, S and s; 2, Z and z. We try to correct spelling errors, so when using an uncommon word or manufacturer which we might mistake as a more common word or manufacturer, note it so that we do not "correct" it. Editor's annotations are in [brackets] in ads.

**Advertising is accepted only for early items related to radio, communication, etc. All items must be described fairly; reproductions, reprints and not-original items must be so identified. Advertisers must agree to respond promptly to inquiries and orders, to resolve problems promptly if the buyer is not satisfied, and to comply with a buyer's refund request on unaltered returned items.**

Classified ads must have a standard heading such as **WANTED, FOR SALE, FOR TRADE, FOR SALE/TRADE, SERVICES, MESSAGE, HELP, AUCTION, MEET, FREE.** This heading is the only bold or all-capitalized words allowed in the ad. Capitalize only manufacturer names, model names, etc. This standard ad format makes scanning the ads easier.

Before writing your ad, please look over the ads in a recent issue of A.R.C., and try to write your ad in the same style. Full name (or company name) and address is **required** in all classified ads; we will add it if you forget.

The publisher reserves the right to edit ads without notification to the advertiser and to reject ads for any reason. Names other than the advertiser will be edited out of ads. Ads with non-radio-related items will be returned or edited unless the non-radio-related items are for trade of radio-related items, or they are incidental to and appear at the end of an otherwise acceptable ad. The publisher is not responsible for errors due to illegibly written ads or for any other reason. See also Publishing Rights on opposite page.

**Clubs:** Since club activities receive free coverage on the *Coming Radio Events* pages, the free 20 words may not be used for club activity ads. A discount on display advertising is available for clubs.

#### Classified Ad Rates per Month

**Deadline: NOON ET— 10th of the month!**

Subscribers:

First 20 words: **FREE\***

29¢ per word for extra words over 20 plus

10¢ per word for a shaded ad (count all words including free words).

\* Subscribers may take 20 free words on only **one** ad each month.

Non-Subscribers:

47¢ per word plus

10¢ per word for shaded ad.

Please do not forget to send in the extra 29¢ per word when your classified ad runs over the free 20 words; your payment will be appreciated, and it will help to keep A.R.C. healthy.

#### PHOTO & DRAWING DETAILS

**Deadline: 1st of the month  
for all ads with drawings or photos!**

Drawings and photos are encouraged as the response to your ad is much larger and the reader knows better what you want or are selling. Send in your drawing or photograph, and A.R.C. will reduce it or enlarge it as needed.

#### Photo and Drawing Rates per Month

\$23.00 per month for each photo or drawing  
(If ad is canceled, this amount cannot always be refunded.)

#### CHANGES & CANCELLATIONS

Please check your ads carefully before sending them in. Once ads are received, it is not always possible to refund the amount sent, pull the ad or make changes.

#### IMPORTANT — COUNTING WORDS — IMPORTANT

The standard headings: **WANTED, FOR SALE, etc.**, count as one word each time used in an ad. Name, address and (one) telephone number, count as 6 words, regardless of length. Ham call letters and business name can be included in the 6 words and do not count extra. Full name (or company name) and address is required in all classified ads. Each additional word, abbreviation, model number or number group, extra telephone numbers, fax, e-mail, etc. count as one word each. Hyphenated words count as two words.

E-mail: [arc@antiqueradio.com](mailto:arc@antiqueradio.com)

Web: [www.antiqueradio.com](http://www.antiqueradio.com)



# CLASSIFIED ADVERTISEMENTS

**FOR SALE:** Atwater Kent dual speed tuner repair kit, complete details at [www.adamsradio.com](http://www.adamsradio.com). Adams Manufacturing Co., PO Box 1005, Lincoln Park, MI 48146

**FOR SALE:** Military URR-392 - \$275, call; Sentinel 1U363 CD marks, plays, needs filter caps - \$50; Trans-Oceanic, parts and Zenith radios in various conditions, need repair, some working; Hallicrafters, National, parts and knobs, call; Philco console, parts, various; (2) Radiotron #45 tubes, tested on Hickok 600 - \$60; Radio Field Service Data, supplement to Modern Radio Servicing, circa 1935, scarce - \$50; Philco 41-295 complete knob and push button set with operating instructions - \$40; various Bunis and other radio books, tubes, parts; call or e-mail; all above + shipping. Ron Crowe, PO Box 117, Handley, WV 25102. (304) 550-1973. E-mail: [rcrowe@wvutec.edu](mailto:rcrowe@wvutec.edu)

**FOR SALE:** Sencore Model SM-158 speed aligner sweep generator w/man, all leads, as new - \$100 plus shipping. John Snow, 1910 Remington Ct., Andover, KS 67002. (316) 733-1856

**FOR SALE:** Over 30 communication receivers including R390A, R388, NC-183D, NC-183, RBL-5, HRO-60. Pick up only. Restorations available. Bob Eslinger, 20 Gary School Rd., Pomfret Center, CT 06259. (860) 928-2628. E-mail: [bob@oldradiodoc.com](mailto:bob@oldradiodoc.com)

**FOR SALE:** Kodak microphone-speaker, black senior model - \$315. Ernie Nagy, PO Box 822, Elk Rapids, MI 49629. (231) 264-9412. E-mail: [elnagy1599@webtv.net](mailto:elnagy1599@webtv.net)

A.R.C. Advertising Policy  
Sellers and Buyers, Please Note!

Advertising is accepted only for early items related to radio, communication, etc. All items must be described fairly; reproductions, reprints and not-original items must be so identified. Advertisers must agree to respond promptly to inquiries and orders, to resolve problems promptly if the buyer is not satisfied, and to comply with a buyer's refund request on unaltered returned items.

**FOR SALE:** Go to our newly updated website at [gn4radios.com](http://gn4radios.com) for an extensive listing of items for sale. For an up to the minute update, call (612) 727-2489 during business hours. We offer the highest quality electrical restoration for Zenith Trans-Oceanics and all other vintage radios, including the solid-state TOs. Also AC line cords for the xstr TOs. We have in stock over 100 different Zenith repro knobs and cosmetic parts. Call with your needs. Excellent repro Scott knobs. We are the largest retailer of E.H. Scott radios with 7 excellent examples on our showroom floor at this time. Call for details. Philco 37 690. Zeniths: Super rare 15U246 McDonald chairside; rare 908 tombstone; 15U271; 12U159 and many others. Trans-Oceanics: 7G605; R7000 and all of the others. Also many other fine brands for sale. Restoration supplies. Request our free catalog of parts and supplies. Visiting Minneapolis? We have the finest vintage radio showroom in the country with over 50 exceptional consoles on the floor, and shelves and shelves of table models. Experience our store, Great Northern Vintage Radios, just 5 minutes from the airport. We ship consoles and we do it right. We accept cash, check, money orders, plastic and Paypal. Alan Jespersion, PO Box 17338, Minneapolis MN 55417. (612) 727-2489. 11am-4:30, Tuesday-Friday, Saturday 10-3. Fax during business hours (612) 821-4820. E-mail: [alan@alanjespersion.com](mailto:alan@alanjespersion.com) and [mte612@aol.com](mailto:mte612@aol.com)

**FOR SALE/TRADE:** Excellent RCA-Victor 811K w/ remote. Zenith Shutterdial Twelves. Stromberg-Carlson Fifteens & others. Delivery to auctions & shows. C.R. Nevins Museum of Radio, Ken Nevins, 406 Jipson St., Blissfield, MI 49228. (517) 486-3019, evenings. E-mail: [ken@kennevins.com](mailto:ken@kennevins.com)

**FOR SALE:** Citizen LCD pocket television, B/W, 2 1/2 inch screen, Model 06TA - \$20 OBO. Bob Puttre, 637 Stratford Rd., Baldwin, NY 11510. (516) 223-9667

This Holiday Season...  
Give A Gift Subscription to  
Antique Radio Classified

BONUS: December 2008 Free!

All gift subscriptions received before December 31 will be sent the December 2008 issue free!

To Order:

1. Fill out the card in this issue with the recipient's name and address.
2. Enclose a gift card which we will send along with the bonus issue. (We will enclose our card with your name if you wish.)
3. Include payment or charge to Visa, MasterCard, Discover, or American Express, and send to:

A.R.C., PO Box 2, Carlisle, MA 01741  
E-mail: [ARC@antiqueradio.com](mailto:ARC@antiqueradio.com)

Or Call (866) 371-0512.

P.S. There are more gift ideas from  
A.R.C. on the inside front cover.

\* If already a subscriber, a 13-month extension will be made to the recipient's subscription.

**WANTED:** 16-tube or 25-tube Zenith Stratosphere, complete or cabinet only. Chassis parts also needed. Will trade from our vast array of fine radios. Alan Jesperson, 5200 Bloomington Ave., Minneapolis, MN 55417. (612) 727-2489. Fax (612) 821-4820

**WANTED:** Working chassis (no cabinet) for Philco 40-135, 145, 170, 503, 506, 525, 526, 527. Dick Friedman, 1502 Elmwood, Wilmette, IL 60091. (847) 256-1432

**WANTED:** Radiola 28 loop antennae. **FOR SALE:** RCA 29K chassis and assorted parts - \$40. Brian Kurlle, 2222 Nodleigh Ter., Jarrettsville, MN 21084. (410) 692-0450. E-mail: briansoldradios@aol.com

**WANTED:** Restorable wood or plastic Macey's brand radio from '30s or '40s. Send pic and price wanted to Charlie Poplin, 3518 Courtland Dr., Durham, NC 27707. E-mail: Popawapado1@yahoo.com

## One Month Free!

### BONUS FOR EARLY RENEWALS

If you renew before the month shown on your mailing label (your expiration month), you will receive an extra month on your subscription: 13 months instead of 12! 26 months for an early 2-year renewal!

**WANTED:** Hi-fi commercial speakers: Altec, Electro-Voice, JBL, Jensen, Goodmans, Tannoy, Stephens, Western Electric, working or not. Sonny Goldson, 520 Pocahontas Dr., Ft. Walton Beach, FL 32547. (850) 314-0321. Fax: 0824. E-mail: SonnySound@aol.com

**WANTED:** Philco portable Model PT89. Also Radiola 18 or 17 chassis. Louis Yadevia, 249 Priscilla Ln., Aidan, PA 19018. (610) 622-2573

# Philco knobs, pushbuttons, and escutcheons!

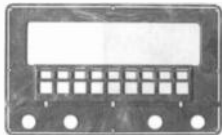

Quality marbled repros. **For 1941 models:** Escutcheon \$29.95. Knobs, set of four \$20. Pushbuttons, set of eight \$16 your choice opaque brown or non-marbled translucent wine red. **For 1942 models:** Escutcheon with gold trim as per original \$32.95. Knobs, set of four \$20. Pushbuttons, set of nine \$31.50. Money order gets immediate shipment. Add \$5 s&h. Calif. residents add 8.25% sales tax. Old Time Replications, 5744 Tobias Avenue, Van Nuys, CA 91411. Phone (818) 786-2500. Email oldtimerep@aol.com

1941 models 41-250, 255, 256, 280, 285, 287, 290, 296, 610  
1942 models 42-355, 42-355T, 42-380, 42-380X, 42-390, 42-390X

**WANTED:** R390 or A, TCS-9 xmitter ant relay or parts, McIntosh audio parts, plate modulation transformer for 100 watts (i.e. arc5plate mod). Bob Hoppe, 523 Clark St., Waverly, NY 14892. (607) 565-2696. E-mail: n2ric@arast.org

## — WANTED — PICTURES FOR PHOTO REVIEW OR TELEGRAPH REVIEW

**PHOTOS MUST BE SHARP IN DETAIL  
A SHORT DESCRIPTION IS A MUST!  
SEE PHOTO REVIEW PAGES FOR  
ADDITIONAL INFORMATION**

**WANTED:** Crosley Broadcaster newsletters, and brochure or advertising for Arvin Model 818. Steve Hansman, 855 Arundel Dr. N, Arnold, MD 21012. (410) 974-0561. E-mail: shansma@JHML.edu

**WANTED:** Zenith 5S29 speaker, Airline 62-101 chassis & spkr, 21FJP22 CRT, Breting 14 cover, Fada 7 ant. bracket. Keith Park, 31 Barkwood Ln., Clifton Park, NY 12065. (518) 373-0417. E-mail: topnotch@nycap.rr.com

**WANTED:** Zenith Y-724, H-723, T-723, Y-825 or similar restored or excellent original. Jeff Forrest, 10535 Farmington Rd., Livonia, MI 48150. (734) 525-7616. E-mail: drforrest3515@sbcglobal.net

**WANTED:** For Super Zenith 27, power supplies ZE3 & ZE-4. Also need a metal mount for the dial, prefer with plastic dial... to fit Atwater Kent Model 84, 627 or 588. Frank Kamer, 12432 Elizabeth Cove, Midwest City, OK 73130. (405) 769-4656. E-mail: fkamer@cox.net

**WANTED:** TV sets with 7-inch screens from the late 1940s: Grunow table model radios. Thanks! Charles Harper, 2000 Jackstown Rd., Paris, KY 40361. (859) 484-9393. E-mail: charper@kyk.net

## A.G. Tannenbaum

### Electronic Service Data

2043 Empire Central  
Dallas, Texas 75235  
Phone: (214) 654-0033  
Fax: (214) 357-4693

STILL THE



FOR

**Service Data — 1920s - Present  
Newly Expanded Library**

**Now Under New Management  
We answer all phone inquiries!**

Browse our on-line catalog at  
[www.agtannenbaum.com](http://www.agtannenbaum.com)

FOR SALE: Vibrator transformers new in box, all 6 volt - \$20 for all plus shipping. John Snow, 1910 Remington Ct., Andover, KS 67002. (316) 733-1856

FOR SALE: Bogen KDB110, 12 watt amp - \$80. Pioneer TX-6500 II AM/FM tuner - \$30. Emerson 510 - \$45. Paul Lisowski, 5603 E. 100 N, Knox, IN 46534. (574) 772-2021

## WANTED TO BUY

Collections and estates  
complete service

We pick up!

No packing or shipping

## CASH PAYMENTS

\*\*\*\*\*

Call: 336-547-8744

E-mail:

[exceptionalradios@triad.rr.com](mailto:exceptionalradios@triad.rr.com)

## RADIO XL

OUR 40th  
GET-TOGETHER  
An Indoor Old Radio  
Flea Market

7,900 square feet - 100+ tables available

**Sunday, February 15, 2009**

**8:00 A.M. 'til 12:00 NOON**

Westford Regency Inn - Regency Room

Westford, Mass. (I-495 at Exit 32)

Look for additional information

Dec., Jan. & Feb. A.R.C.

**Sponsored by:**  
The Greater Boston  
Antique Radio Collectors

*Not a club, no dues, no newsletter...  
just a great group of collectors!*

Thanks to Antique Radio Classified for organizing this meet.

FOR SALE: North Star direction finder, circa 1946, omni, mic button, pwr. supply, disassembled - \$62 + fgt. Ye Olde Radio Shoppe, 228 Beck Rd., Avon Lake, OH 44012. (440) 933-5668. Fax: (440) 933-8864. E-mail: [yeolderadioshoppe@oh.rr.com](mailto:yeolderadioshoppe@oh.rr.com)

FOR SALE/TRADE: Zeniths: 12S568, 12S569, 10S669, 10S464, 8S463, 15T. Emersons & Stromberg-Carlsons. WANTED: Airite/Kadette deskset & accessories. C.R. Nevins Museum of Radio, Ken Nevins, 406 Jipson St., Blissfield, MI 49228. (517) 486-3019, evenings. E-mail: [ken@kennevins.com](mailto:ken@kennevins.com)

E-MAIL ADDRESS FOR  
ANTIQUE RADIO CLASSIFIED  
[ARC@antiqueradio.com](mailto:ARC@antiqueradio.com)

Ads - Subscriptions - Book Orders  
See policy pages for details

FOR SALE: Antique radio schematics - \$3, TV - \$5 ppd. Joseph R. Forth, 119 Long Vue Acres Rd., Wheeling, WV 26003. (304) 277-3154. E-mail: [wa2trt@1st.net](mailto:wa2trt@1st.net)

FOR SALE: Fundamentals of Radio & Electronics, Everitt, 1958, 805 pages, vg - \$12 ppd. Henry C. Loos, 542 Tomahawk Ct., Palm Beach Gardens, FL 33410. (561) 352-8172. E-mail: [hcloos@comcast.net](mailto:hcloos@comcast.net)

FOR SALE: Hundreds of tubes, N.O.S. and used. Also available many miscellaneous radios, parts, manuals & books. Tell us your needs. Howard McAuliffe, 20 Thayer Rd., Higganum, CT 06441. (860) 345-0943. E-mail: [M\\_Howard@att.net](mailto:M_Howard@att.net)

FOR SALE/TRADE: Delivery MARC Kalamazoo; Atwater Kent Kiel table, Midwest SS-18 Ghost dial. WANTED: Airite/Kadette desk set & accessories. Ken Nevins, C.R. Nevins Museum of Radio, 406 Jipson St., Blissfield, MI 49228. (517) 486-3019, evenings. E-mail: [ken@kennevins.com](mailto:ken@kennevins.com)



**Portland Antique Radio Supply**  
Hundreds of Original Tube Radio Parts

Escutcheons, Dial Scales, Knobs,  
Set Screws, Dial Pointers

[www.PortlandAntiqueRadio.com](http://www.PortlandAntiqueRadio.com)



# Estes Auctions



*Specializing in Vintage Radios  
Complete Auction & Appraisal Service*

## Vintage Radio Auction

**Saturday, November 22, 2008 – 10 AM EST**

at the Expo Auction Center

8157 Garman Rd., Burbank Ohio (Exit 204 off I-71)  
then south on SR #83 to the Love's Truck Stop, turn left  
onto Garman Rd. and follow one mile to the auction site.

This is a collection from New York and offers a variety of items to include an Atwater Kent Model 9 breadboard #4560, Atwater Kent Model 9 breadboard short version, Atwater Kent Model 10B breadboard, rare Atwater Kent breadboard Type 3945, Federal DX-58, Ware Type T, Radiola 26, RK 3-tube, Columbia 5-tube, Zenith 4R, Radiola 2, Standardyne XL-5, Freed-Eisemann NR-6, Crosley 51, Crosley 52, Crosley 50, Crosley Pup, Crosley Ace Type V, Grebe MU-1, Atwater Kent Model 33, Atwater Kent Model 30, Model 20, Grebe CR-9, Akradyne 5-tube, and many more. A good selection of horn speakers, Music Master, Thorola, Bristol, Magnavox, Atwater Kent, Stromberg-Carlson, Western Electric 10-D, Jewett Super Speaker, Radiola, Rola, cone speakers, Pathé, Dictogrand roll speaker, Western Electric 560, Crosley Dynacone, Atwater Kent cone types. Many other speakers, Peerless, Utah, Philco, Brunswick. There are over 100 wood and Bakelite table style radios. Many makes and models. We have many very clean cathedral and tombstone radios in this sale including Philcos, Atwater Kent, RCA, General Electric, Stewart-Warner, Zenith, Gloritone, U.S. Apex, Stromberg-Carlson, General Motors, and others. Many pieces of radio test equipment. Lots of books and radio magazines, Radio Craft, Radio News, radio catalogs, price guides, tube manuals, etc. A very large selection of tubes. Several thousand to be sold in bulk box lots. Many collector tubes. Early Types 245, 345, 46, 47, 201A, 301A, 200A, 300A, WD-11, WD-12, 280, 281, 6L6, UV-199, UX-199, 250, 5U4, 6SN7, 6V6, UV-199, UX-199, 250, 5U4, 6SN7, 6V6, blue Arcturus tubes. Also many nice console floor model radios. This will be another good radio sale. We hope to see you there. Terms: cash, check, Visa, M/C. 5% gallery fee.

**Richard Estes, K8LRY - Auctioneer**

**ESTES AUCTIONS**

**7404 Ryan Road**

**Medina, Ohio 44256**

**Bob Dobush & Bob White – Tubes**

**Kim Graca – Tech Support**

**Allan Ferris – Set Up**

**Mark Delauter – Set Up**

**John Estes – Auctioneer**

**Toll free: (888) 769-4992**

**Fax: (330) 769-4116**

**E-mail: [estesauctions@aol.com](mailto:estesauctions@aol.com)**

**Web: [www.estesauctions.com](http://www.estesauctions.com)**

Call us to sell one radio or an entire collection. Pick up service also.

# A.R.C. Back Issues – Full Calendar Years

**A sampling of articles and topics is listed below. Topics may appear in more than one issue. Order by calendar year. (Single issues are \$5 each in the U.S.). All recent issues (2002-2008) are also available.**

- 1984 A.R.C.'s First Year. The June Sample Copy plus September-December. First Kreuzer's Value Guide,\* Heathcote's Collectors' Corner, Crocker's Crosley Review,\* With The Collectors' and Meet Reports.\* (5 Issues. Photocopies; 16-20 pgs.) ..... \$10
- 1985 First Photo Review,\* Radio Novelties,\* Collector Profile,\* Telegraph Key Review,\* Crystal Set Review\* and Atwater Kent Breadboard Review.\* Also Value Guide A-T, Penna Wireless, Marconi 106, WD-11. (Photocopies; 20-24 pgs.)..... \$24
- 1986 First Collecting British Crystal Sets.\* Collectors' Corner, Value Guide S-Z, Horn Speaker Values, Speaker Review, Precision Ace, Quaker Oats Crystal Set, HQ-120X, First Issue Published by John Terrey. (Jan.-Sept. Photocopies; Oct.-Dec. reprints; 24-28 pgs.) ..... \$24
- 1987 First full-color covers. First Foster's Restoration Topics,\* Vintage Television,\* Philco 38-3, EHScott 48-Tube Set, Marconi Multiple Tuner, Vacuum Tube Value Guide, Freed Eisemann, Crosley Pup, Fada Bullet, Vitus, Sparton Mirrored Radios. (Jan.-Mar. reprints; Apr.-Dec. originals; 32-36 pgs.) ..... \$24
- 1988 First Old Tyme Radio Services Directory,\* Jim Fred's Repairing AC Radios,\* Vintage Test Equipment.\* Also DuMont Clifton TV, Mechanical TV, Aeriola Senior, A-K Model 20, Kennedy 220, Philco Prediclas, Martian and Gem Crystal Sets. (40-60 pgs.) \$24
- 1989 Automatic Radio, Clapp-Eastham HR/HZ, Mechanical TV,\* Western Electric 1920-1927, Radiola 44, Ace Radio Repair on June cover, Arvin & the Hopalong Radio, Magnavox TRF-5, A-K Crystal Set, A-K 9A, Philco Block Capacitors, Marconi 106D, Patterson PR-10, Oriole 7B. (52-68 pgs.) ..... \$24
- 1990 First Radio Adventures.\* Also California Earthquake, Transistor Radios, Cleaning Bakelite, EH Scott Telematic, Ekco Round Radios, Radiola Grand, Horn Speaker Survey, Atlantic Radio, GE 901 TV, Philco Block Capacitors, Tuska 224, RCA 816K, RCA Theremin. (68-92 pgs.)\$24
- 1991 First Collecting Foreign Sets,\* Out-Of-Sight Radios, Philco 20, 90, Wilcox-Gay Recordio, A.R.C. Index '84-'90, Westinghouse RC-RA-DA-DR-RT-AR, Radio Stock Certificates, German Radios, Subminiature Tube Radios, Early Navy Radio Equipment, Gonset. (84-100 pgs. Index Issue is 148 pgs.) ..... \$24
- 1992 Vintage Microphones, Gonset, Early Navy Equipment, Superhets of the 20s,\* The Neurodyne, Telmaco, Atlantic Radio, Vintage Hi-Fi, Battery Eliminators, Radio Fans, A-K 35, RCA 648PTK TV, Repairing IF Transformers, Paragon RA-10/DA-2, A-K 21, 33, WLW, 1991 Index. (88-100 pgs.) ..... \$24
- 1993 Arvin Metal Radios, Repairing RCA Catacombs, Philco Armchair Radios, Kenrad Crystal Set, Transistor Radios, A-K 52, Philco Cabinet Design,\* Webster Electric Co., Kylectron Electrostatic Speaker, Vintage Guitar Amp, Tower Cone Speakers, EH Scott Allwave, 1992 Index. (100-104 pgs.) ..... \$24
- 1994 Radiola I, Radiola 60 series, Pot Metal, Fada Neurodyne, Clinton Mfg. Co., Kardon Radios, Philco Cabinet Designers, Palco, SCR-609 & 610, Philco Survey, Permeability Tuning, Weston, Regency TR-1, Charles Herrold, Nipper, 1993 Index. (100-116 pgs.) ..... \$24
- 1995 Zenith Trans-Oceanic, Stehway Capehart, Ken-Rad, Radio Shop J, Freshman Master Speaker, Broadcast Equipment, Philco Survey, Power Transformers, Tube Testers,\* Radio Apparatus Co., L.E. Knott Apparatus Co., Ford Museum Auction in color, Ozarka, 1994 Index. (108-116 pgs.) ..... \$24
- 1996 Communications Receivers, KDKA, Philco Designers, Radiola IV, WJZ, Art Deco Radios, Herrold Microphone, Tuning Battery Sets, Paul Godley & Paragon, Soldering, Webb Microphone Collection, Mirrored Glass Radios, Samson Electric Co., Russian Red Star, Echophone EC-1. (100-116 pgs.) ..... \$24
- 1997 Thompson Minuet, Marconi Archive Auction Saga, Frank Krantz, Emerson Multivalve Radios, DeForest Detectors & Tuners, Remote Control Radios, Ekko Stamps, Freshman Polydyne, Vintage Audio Recorders, Selenium Rectifiers, DeForest Reflex Sets, Early Zenith. (100-116 pgs.) ..... \$24
- 1998 Sears Commentator, 300B Tube, Replica Nameplates, Australian Radios, WMAZ, Espey, Nipper, Early Wireless, Rider's Volume 1, Pilot Radio, Browning-Drake, Army-Navy Numbering System, Cortlandt St. Radio Row,\* Pooley Co., Transistor's Early History. (100-108 pgs.) .... \$24
- 1999 Reinartz Receiver, Cone Ship Speakers, The Internet, WebTV, Military Equipment,\* Krantz Estate Auction, Atwater Kent Time Capsule, Atwater Kent Radiodyne, RCA Radiolas for 1923/24, 15th Year Special Issue, Australian Pedal-Operated Radio, Early RCA TV, Battery Set Power Supplies. (100-108 pgs.) ..... \$24
- 2000 Early Ham Radio, Rider's Manuals, Meets & Auctions, Canadian Independent Telephone Company, Military Equipment,\* Early Wireless, Wilcox-Gay, Grundig-Majestic, Recasting Metal Parts, Leutz, TV, Riga, Superhets, Loose Couplers, Musette, Nordmende, E.H. Scott, Victor. (84-100 pgs.) ..... \$24
- 2001 Grebe, Philco, Home Brews, Airline, Loose Couplers,\* Mignon, Radio Postcards, DeForest, RCA, Restoration & Repair,\* Kolster, Meets & Auctions, Zenith, Million Dollar Muchow Auction, Crosley, Early Wireless, New York Radio Row,\* Marconi. (84-100 pgs.) ..... \$24

\* These articles continued for one or more years and some continue today.

**A.R.C., P.O. Box 2, Carlisle, MA 01741 – Toll Free: (866) 371-0512**

**Fax: (978) 371-7129 – E-mail: ARC@antiqueradio.com – Web: www.antiqueradio.com**



Free shipping & handling on all U.S. orders (typical U.S. order will be received within 7 days, but allow 2-3 weeks).

Mass. residents add 5% sales tax. Non-U.S. orders, write for shipping costs, or use credit card. Most orders shipped by next business day. If using credit card, include name on card, card number and expiration date. Send payment with order. Money back return policy. Subscribers, ask for discount when placing order: 10% off books.



(#14-Jul08)

**WANTED:** Dial escutcheon for Radiola 18, Ed Baugher, 710 Duncan Ave. Apt. 1422, Pittsburgh, PA 15237

**WANTED:** Truetone Model D-724, the AC version, using a 3 gang tuning condenser, eye tube, #80 rectifier, AM & 2 bands of shortwave, restorable cabinet, working not important, but don't want a train wreck. The one I had as a kid got away somehow & I've been looking ever since, 60+ years. Please help. Irv Sanders, 242 Hunter Ln., Harrisburg, PA 17112. E-mail: radioirv@verizon.net

**WANTED:** Tube hi-fi/commercial sound equipment tubes: Altec, Fisher, Scott, Pilot, Eico, Marantz, Dynaco, Leak, Quad, Tannoy, Western Electric, etc. Sonny Goldson, 520 Pochahontas Dr., Ft. Walton Beach, FL 32547. (850) 314-0321. Fax: 0824. E-mail: SonnySound@aol.com

**WANTED:** RCA Receiving Tube Manual at a reasonable price. Larry Cook, 362 East South, Richland Center, WI 53581-2721

**WANTED:** Speaker for Westinghouse WR-209 or complete chassis with speaker for parts. Also need three tube shields for same. Doug Donaghu, 1033 Sheriffs Posse Trl., Prescott, AZ 86303. (928) 717-4973

**WANTED:** Battery box w/plug for Zenith T-O Royal 3000-1. Will pay top dollar. Jeff Heller, 3724 Nicanoa Ln., Naperville, IL 60564. (630) 605-4723. E-mail: hellerj1@comcast.net

**WANTED:** To buy: Weston VOMeters, any condition for parts. Model 564, 600, 663, 665, 697, CV-22193. Charles Kirsten, 7626 Cloudy Bay Ct., Rancho Cucamonga, CA 91739. (909) 803-2447

**WANTED:** Connecticut J-112 vacuum crystal detector, John Firth, N.Y., variable condenser and other Circo parts. J.C. Woychowski, 81 Penn. Ave., Niantic, CT 06357. (860) 739-6579. E-mail: jc.woy@snet.net

**WANTED:** Eisemann (not Freed) round audio transformer. Pre-1924 radios, components, and related items. Steve Wallace, 3707 Pricetown Rd., Fleetwood, PA 19522. (610) 944-7230. E-mail: soidar@verizon.net

**WANTED:** Basket case Hickok tube testers. John Snow, 1910 Remington Ct., Andover, KS 67002. (316) 733-1856

## HAS YOUR SUBSCRIPTION

### *EXPIRED?*

**It has if your mailing label reads  
"EXP=NOV08" or earlier.  
Renew now!**

***BONUS: Renew before  
your "EXP" month and receive  
13 issues per year instead of 12!***

Renewal rates are:

\$45.00 for Periodicals Mailing

\$60.00 for First-Class Mailing

(Two-year renewals are twice above rates.)

**WANTED:** National SW3 coil sets. Oddball six pin. Gary Henman, WA91YF, 3429 Gaddy Ct., Falls Church, VA 22043. E-mail: garyhenman1000@yahoo.com

**WANTED:** 12" Stromberg-Carlson speaker, 500 ohm field coil used in 350R, 240R, 245R models. Also knobs Zenith 410 or 770B. John Hagman, 781 Mechanicsville Rd., Hinesburg, VT 05461. E-mail: hagstar@gmavt.net

**WANTED:** 1936 Philco Model 650 or 655 tombstone. Mark Hewitt, 6659 Tipperary Trl., Roscoe, IL 61073. (815) 623-8729

## New Wireless Pioneers

### **Books, Magazines, Literature Bought and Sold**

New Wireless Pioneers buys and sells books, catalogs, magazines and other literature from the 1800's to 1950 that deal with early radio, wireless and electricity. A selection from our list of specialties:

**Pre-1900 Electricity • Pre-1900 Telegraphy • Pre-1925 Radio or Wireless  
Pre-1940 Television • Pre-1950 Computers • Early X-Ray**

Magazines, Catalogs, Autographs or Ephemera related to the above topics. Also: Pre-1920 Wireless and Telegraph Apparatus – Radio-Related Novelties and Advertising – Early Vacuum Tubes and Electrical Devices.

*Some items available in other technical subject areas also.*

**Several catalogs featuring items for sale are published each year.**

**NOTE: NEW  
ADDRESS &  
TELEPHONE  
NUMBERS**

**New Wireless Pioneers – Jim & Felicia Kreuzer  
1541 Bronson Rd., Grand Island, NY 14072  
Phone: (716) 773-4999 Fax: (716) 773-5757  
wireless@pce.net www.marconi-wireless.com**

**FOR SALE:** Philco 38 cathedral, good cabinet, plays – \$40. Crosley Type D Musicone speaker – \$20. James S. Looney, 1135 Harman Jct. Rd., Grundy, VA 24614. (276) 531-8677

**FOR SALE:** (2) Thomas collection edition radios AM/FM Model 13D217. Many boom box radios collection. Send for list. TR61, AR23, AR156 manuals. Ajjala Repair, 50 Fir Cir., Babbitt, MN 55706-1220

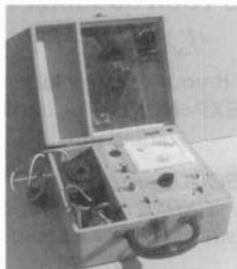

**FOR SALE:** Mercury Electronics Corp. Model 800 CRT tester-reactivator. All there in nice condition with wooden case and adapters. Don't ask me if it works, I'm not a TV guy! – \$38. Dave Crocker, 35 Santuit Pond Rd., #4B, Mashpee, MA 02649. (508) 477-1578, before 9 PM ET please

**FOR SALE:** Crosley 525D complete with tubes and owner's manual – \$135. Crosley Trirdyn Super regular, less tubes – \$125. Phil Guinan, 106 Page Rd., Litchfield, NH 03052. (603) 889-6213

**FOR SALE:** In Door County, antique electronics. Open 2-5, off 42. List – \$1.50 LSASE. John Enigl, Sr., Cherry Lane Old Radios, 5425 Tart Cherry Ln., Egg Harbor, WI 54209. (920) 743-3672

**FOR SALE:** NRI/Conar unbuilt #7TT radio kit with construction/training manual, unbuilt – \$45. NRI training course, approx. 75 various manuals – \$20. Amplivox Roving Rostrum portable PA system, AC/DC, working – \$50. Oscilloscopes: 8 different models, call or write for list. B&K Model 1601 bench/lab style DC power supply, adjustable 0-50V @ 2A – \$45. RCA 8T241, 1948, 10-inch B&W TV, mint condition – \$275. Telequipment S-51, 5-inch tube type oscilloscope, 1960s from England, working – \$75. GE 7" B&W TV w/AM/FM, 1990, runs on AC or 12 volt DC, work good – \$45. Sony 11" B&W TV, 1974, Model TV-115, runs on AC or 12 volt DC, working – \$55. Zenith portable radio, Model Z222W, AM/FM/TV clock w/alarm – \$35. All prices plus UPS. Bob Lynn, 26 E. Orchard St., Somerville, NJ 08876. (908) 685-9070

**RATE FOR ADDITIONAL WORDS:**

**29c per word**

**FIRST 20 WORDS FREE!**

**Cash OK for small amounts.**

**Your payment helps to keep A.R.C. healthy!**

**FOR SALE:** Beitman Radio and Television Publications, Sams Auto and Transistor Books, other books; also tubes. E-mail for prices. Kenneth Gregory, 5180 Ada Ave., Beaumont, TX 77708. (409) 898-7270. E-mail: kenspage38@hotmail.com

**FOR SALE:** Clearance by lots, radios, phonographs, televisions, equipment, tubes, needles, parts, data. Ray Seppeler, Sunshine Radio, 8 E. Main St., Sodus, NY 14551. (315) 483-8451. Web: [www.SunshineRadioMuseum.org/collector](http://www.SunshineRadioMuseum.org/collector)

**FOR SALE:** Western Electric audio, empty Scott Philharmonic cabinet, tons of McIntosh audio, tons audio tubes. V. Vogt, 2311 Pimmit Dr., #114, Falls Church, VA 22043. (206) 898-0880. E-mail: [archaicaudio@msn.com](mailto:archaicaudio@msn.com)



# We Sell Tubes...

... and lots of other radio parts too!

6221 S Maple Ave Tempe, AZ 85283

480/820.5411 fax: 480/820.4643

or 800/706.6789

[www.tubesandmore.com](http://www.tubesandmore.com)

[info@tubesandmore.com](mailto:info@tubesandmore.com)





# Estes Auctions



*Specializing in Vintage Radios  
Complete Auction & Appraisal Service*

## Vintage Radio Auction

**Saturday, December 13, 2008 – 10 AM EST**

at the Expo Auction Center  
8157 Garman Rd., Burbank Ohio (Exit 204 off I-71)  
then south on SR #83 to the Love's Truck Stop, turn left  
onto Garman Rd. and follow one mile to the auction site.

The inventory of Vans Electronics in Ida, Michigan, Dan and Nancy Kay owners of Van Electronics are ready to pursue other interests and have commissioned us to auction off the entire contents of their electronic store and warehouses. This will be spread out over 5 or 6 auctions. Some of the items at the first auction are Kennedy 521, Grebe CR-5, Kennedy Type 5, Radiola II, Radiola V, Radiola IV, Grebe CR-14, Michigan MRC-3, Crescent battery set, King, Crosley Pup, Crosley 4-29, Western Coil & Electric WC-11, Aeriola Senior, DeForest 666, Aladdin, Parmak, Day Fan, Kolster, Master Dyne, Freed-Eisemann NR-7, Radiola 26 w/battery box, Atwater Kent 20, 30, 36, Orpheus battery set, one of the nicest Atwater Kent Model 10 breadboard radios we've sold. Amateur radio items: Drake SW 4-A, Drake 4A, Drake MS-4, Drake 2NT, Drake T4X, Drake R-4, Drake TR-7, Drake 2A, Drake MN-2000, Drake MS-7 speaker, Drake TR3, Drake 1A, National NC-98, Hammarlund HQ-170, Hammarlund NE-HQ-180, Swan 1200X, Drake DC-3 P/S, Ten Tec tuner, Kenwood TS-520, Hallicrafters SX-80, Lafayette HE-80, Collins 75A5, Hallicrafters Sky Buddy, Knight 150, Yaesu FT-101F w/speaker, MFJ Versa Tuner, MFJ-77 keyer, Knight Ranger, Space Spanner, Span Master, Hallicrafters Sky Champ, Hallicrafters S-40A, and many more pieces. Other radios, cathedrals, Crusader, Universal, Philco, Atwater Kent 84, Philco 70, Echophone, Ellsworth, tombstones, RCA, Crosley, Philco, General Electric. Nice selection of table radios. Also selling over 100 transistor radios in this sale. There are many horn speakers including a beautiful Burns petal speaker, a Thomas loop antenna, Zenith Trans-Oceanic. All the last versions, U.S.A., Japan, Taiwan, The amount of amateur radio items in this collection is beyond belief. Many of the transceivers by Kenwood, Icom, Yaesu, are new stock, many new stock amateur antennas. Dan was a distributor for Butternut and Hustler. Lots of new stock, coax and fittings, microphones, antenna tuners, power supplies, amplifiers, handhelds, towers fold over, crank up, rotors, hard line, steel guy cable, antenna kits, transmitting tubes. We have only moved one load to our Ohio location and will continue to bring items in. We will update this listing next month. This will be a wonderful series of radio auctions. Terms: cash, check, Visa, M/C. 5% gallery fee.

**Richard Estes, K8LRY - Auctioneer**

**ESTES AUCTIONS**

**7404 Ryan Road**

**Medina, Ohio 44256**

**Bob Dobush & Bob White – Tubes**

**Kim Graca – Tech Support**

**Allan Ferris – Set Up**

**Mark Delauter – Set Up**

**John Estes – Auctioneer**

**Toll free: (888) 769-4992**

**Fax: (330) 769-4116**

**E-mail: [estesauctions@aol.com](mailto:estesauctions@aol.com)**

**Web: [www.estesauctions.com](http://www.estesauctions.com)**

Call us to sell one radio or an entire collection. Pick up service also.

# Order These Popular Books From Antique Radio Classified



**Collector's Guide to Antique Radios 7th Edition** by John Slusser. 10,000+ sets from the 1920s to the 1950s. Updated 2007 prices. 1,200 color photos, 317 pages. — \$24.95



**Philco Radio: 1928-1942, 2nd Edition** by Ron Ramirez. A reference book on Philco. Shows receivers and company history year-by-year. 464 color photos, 364 B&W photos and drawings. 160 pages. — \$29.95

Price  
Guide

**Collectable Transistor TVs, Bunis.** Identification and values for 150 transistor TVs from 29 manufacturers. B&W photos. 44 pgs. .... \$19.95

**Classic Cones, Chidester.** Pictorial reference & value guide for 1920s radio cone speakers. 100s of color photos. 2001. 122 pgs. .... \$25.95



**A. Atwater Kent, The Man, the Manufacturer and His Radios** by Ralph Williams and John P. Wolkonowicz. A compilation of the articles on Atwater Kent which were published in *Radio Age* by Ralph Williams in the 1970s. Covers 1920s Atwater Kent sets. Also included is John P. Wolkonowicz's 1976 article *WPI's Forgotten Millionaire*. This is a "must have" book for any Atwater Kent enthusiast. Donald O. Patterson, Editor. 108 pages. — \$25.95



**Fixing Up Nice Old Radios** by Ed Romney. Written by a retired radio instructor. Plastic binding. 300+ figures, 185 pages. — \$35.00

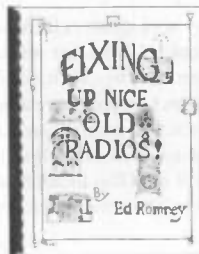

**Old Time Radios Restoration and Repair** by Joseph J. Carr. A self-paced training guide. History, theory and practical operation of antique and classic radios. 200 illustrations, 256 pages. — \$19.95

**Everything stocked and shipped promptly — Radio is our middle name.**

A.R.C., P.O. Box 2, Carlisle, MA 01741 – Toll Free: (866) 371-0512  
Fax: (978) 371-7129 – E-mail: ARC@antiqueradio.com – Web: www.antiqueradio.com



Free shipping & handling on all U.S. orders (typical U.S. order will be received within 7 days, but allow 2-3 weeks).

Mass. residents add 5% sales tax. Non-U.S. orders, write for shipping costs, or use credit card. Most orders shipped by next business day. If using credit card, include name on card, card number and expiration date. Send payment with order. Money back return policy. Subscribers, ask for discount when placing order: 10% off books.



(#1-2-Oct08)

# Order These Popular Books From Antique Radio Classified



**E.H. Scott... The Dean of DX**, the definitive book on the E.H. Scott Company for over 15 years, has been revised and expanded by author Marvin Hobbs with the assistance of John Slusser of Radio Daze Press. This is a "must have" book for any E.H. Scott enthusiast. 8 1/2 x 11", 240 pages. 2002 Second Edition - Expanded! Additional Chapters Color Photo Section - 24 pages — \$29.95



**Flick of the Switch** by Morgan McMahon. *The classic photo reference guide for 1930s - 1950s radios. 1,000+ photos of radios, 5" x 8", 263 pages.* — \$11.95

Ham! We have ham books. See our full page ad

**The Collector's Vacuum Tube Handbook, Vol. 1**, Millard. *Hard-to-find electrical data on 200+ tube types that pre-date the RMA standardized numbering system (1934). Basing diagrams, photos & brief developmental histories.* 196 pgs. .... \$25.95

**Tickling the Crystal**, Sanders. *Comprehensive coverage of British crystal sets from the 1920s. Volumes 1, 2, 3, & 4.* ..... \$64.95 each

**Zenith - The Glory Years 1936-1945** by Harold Cones, John Bryant & Martin Blankinship. Two Volumes:

**History and Products**  
256 pages — \$34.95

**Illustrated Catalog & Database** 182 pages — \$29.95



**Radiola - The Golden Age of RCA, 1919-1929** Wenaas. Documents & pictures every radio receiver and the major accessories sold by RCA during the first decade. 700 color photos, 485 pgs. Hardcover — \$65.00

**Everything stocked and shipped promptly — Radio is our middle name.**

A.R.C., P.O. Box 2, Carlisle, MA 01741 – Toll Free: (866) 371-0512  
Fax: (978) 371-7129 – E-mail: ARC@antiqueradlo.com – Web: www.antiqueradlo.com



Free shipping & handling on all U.S. orders (typical U.S. order will be received within 7 days, but allow 2-3 weeks). Mass. residents add 5% sales tax. Non-U.S. orders, write for shipping costs, or use credit card. Most orders shipped by next business day. If using credit card, include name on card, card number and expiration date. Send payment with order. Money back return policy. Subscribers, ask for discount when placing order: 10% off books.



(#1-2-Oct08)

**FOR SALE/TRADE:** Consider mere paper dollars: WWI BC 138 tuner; HRO 50 w/coils, nice; Collins 32S-1, exc; Drake R7, TR7, L7, PS7, all nice! RCA CR 91, rare, exc; Scott RCH LF set, very nice; Hallicrafters SX 28, great case & cosmetics, works fine. **WANTED:** 800 cycle generator, remotes, accessories for GP 7, Navy CAY 52173A, Dynamotors DY 12, DY 17, PE 73 for ART 13 & BC 375; bottom for ART 13; anything for Aussie AWA HRO. Always looking for: vintage broadcast/recording mics; stands; tube pre's; compressors; amps; EQ's. Ward Kremer, K14JHA, 57262 Poppy Rd., South Bend, IN 46619. Ph./fax: (574) 204-2877. E-mail: witzend99@comcast.net. Web: <http://www.radioattic.com/kremer>

**PHONE NUMBER FOR  
ANTIQUE RADIO CLASSIFIED  
TOLL FREE (866) 371-0512**

**Best time to call is weekdays:  
9 am to 5 pm Eastern Time**

**(Please no classified ads by phone. Thanks!)**

**FOR SALE:** Westinghouse beautiful walnut cabinet table radio, left side is curved, looks great with eye tube, 6 tubes, 3 bands, 6 push buttons. 1920s brand name is Future Select with 6 Vesta 01-A tubes, aluminum chassis 3 gang condenser, Model 20, beautiful front panel, looks new. Philco 71 cathedral, nice condition. Zenith 7S29, like new. Emerson 729 blue plastic cabinet with gold checkerboard panel in front, very attractive. Some items available from previous ad. I have hundreds of items for sale, very reasonable. Please call after 9 pm CST. Bill Kalcik, Meadowbrook Resort, 1533 River Rd., Wisconsin Dells, WI 53965. (608) 253-9855

**FOR SALE:** (20) black chicken head knobs - \$10. (78) various pointer knobs, some sets - \$60. Bob Barr, 9660 S.E. Little Club Way N, Tequesta, FL 33469. (561) 741-1907

**FOR SALE:** Crosley Showbox Model 706-60 w/speaker, dynacone Type F, g - \$160. Globe transistor radio, (Breed 47), 1960s, vg - \$80 OBO. Jackson tube tester, vg - \$50 OBO. Buzz Miller, 725 Mt. Rock Rd., Carlisle, PA 17015. E-mail: buzz2@embarqmail.com

**HAVE YOU MOVED? ARE YOU MOVING?**

**PLEASE NOTIFY US A.S.A.P.**

**SEND US YOUR...**

**OLD ADDRESS**

**NEW ADDRESS and**

**SUB #**

**MANY THANKS!!!!**

**FOR SALE:** Silvertone tombstone to restore, Sears #100-359 (no model info) 8 tubes, 8 P/B, 4 bands, 18, 11, 16, cabinet tight, need one knob - \$65. GE M-404 table model, deep red, mottled plastic, BC, 2 knobs - \$35. Portable Columbia W. Germany, AM/FM, DC, clean - \$40. Radiola 18, complete except no hood - \$65. Have (20) pre-1932 spkr, ask for info. Bernie Samek, 113 Old Palmer Rd., Brimfield, MA 01010. (413) 245-7174. E-mail: bernies@samnet.net

**FOR SALE:** Hickok Model 532 tube tester, very good condition - \$150 plus shipping. John Snow, 1910 Remington Ct., Andover, KS 67002. (316) 733-1856

**FOR SALE/TRADE:** Hundreds of old catalogs (Allied, BA, Walter Ashe, etc.), manuals (Hickok, Heathkit, Knight, EICO, Conar, Hallicrafters, National, etc.), books, radio magazines, handbooks, tube manuals, data books, and more. A.J. Bernard, PO Box 690098, Orlando, FL 32869-0098. (407) 351-5536. E-mail: ni4q@juno.com

**FOR SALE:** Restored record changers, bases, dust covers for Christmas! Gary Stork, 37530 E. Meadowhill, Northville, MI 48167. (248) 478-0990. E-mail: info@thevoiceofmusic.com

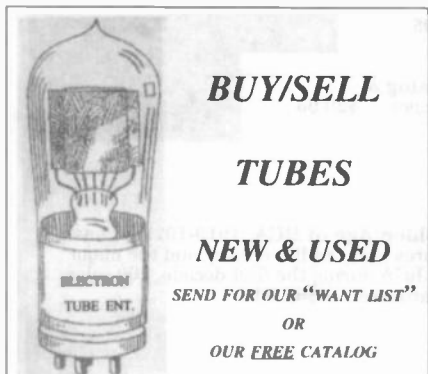

**BUY/SELL**

**TUBES**

**NEW & USED**

SEND FOR OUR "WANT LIST"

OR

OUR FREE CATALOG

**ELECTRON TUBE ENTERPRISES**

**P.O. BOX 652**

**SPRINGVALE, ME 04083**

TEL: 207-490-5870

FAX: 207-490-2228

Visit or contact us via our web site at:  
<http://members.aol.com/etetubes>

Join the **AWA**

**ANTIQUE WIRELESS ASSOCIATION**

**THE ORIGINAL AND LARGEST HISTORICAL RADIO-COLLECTOR GROUP**

- Publishes *AWA Journal* with:
  - Battery and AC receiver restoration
  - Vacuum-tube history and collecting
  - Old-time amateur-radio contests
  - Communications receivers
  - Free want-sell-swap ads
  - Early television
  - Horn loudspeakers
  - Reviews of current books
  - Keys and land-line telegraphy
  - News of U. S. and foreign clubs
  - Information on public radio museums.
- Maintains unique radio-TV museum.
- Produces the annual Rochester meet.
- Co-sponsors local meets.
- Publishes the annual *AWA Review*.



Membership is only \$20 per year U.S.A. (\$25 per year elsewhere). Write to:

**AWA Membership Director**  
PO Box 421, Bloomfield, NY 14469-0421  
[www.antiquewireless.org](http://www.antiquewireless.org)

**WANTED:** Heathkit HP-23, AC power supply, Hallicrafters SX-115 receiver. Wild Bill Busch, 6678 Condor Run, Littleton, CO 80125. E-mail: WildBillK0IKP@aol.com

**WANTED:** Ace Radio Repair print by Bill Bell offered in the late 80s. Need A.R.C. issues 9-12, 1984, 1-4 1985. Patrick Franzis, 235 Millville Ave., Naugatuck, CT 06770-3848. (203) 949-6313. E-mail: old\_radios@yahoo.com

**WANTED:** Xerox copy of manual or a used manual for an Eico 2050 integrated amplifier. Thomas Rocheleau, PO Box 132, Franklin, MA 02038. (508) 528-3061, between 6-10 pm

**WANTED:** Philco chassis for any of the following: 37-641X, 37-643X, 37-660X, 37-665X, 37-650, 37-640, 37-630, chassis & speaker. Ed DeCann, 309 W. Main St., Osakis, MN 56360. (320) 859-4282

**WANTED:** Old posters. Collector buying vintage movie, concert and radio posters, photos and related memorabilia. Also wanted jazz and blues 78 rpm records. Top \$\$\$ paid. Call toll free. Ralph DeLuca, 157 Park Ave., Madison, NJ 07940. (800) 392-4050. E-mail: ralph@ralphdeluca.com

**WANTED:** Chassis for Airline console 93WG382, pushbuttons thumbwheel tuning eye or will sell cabinet only. Bill Drewes, 311 Brookridge Dr., Waterloo, IA 50702. (319) 233-4653

**WANTED:** 8874 and 8877 tubes, good pulls fine as long as you don't break my bank. E-mail price and description. H. Dave Meitzen, AA9TT, 6421 Brazos Cir., The Colony, TX 75056. E-mail: dave@meshlinx.com

**WANTED:** Stewart-Warner Century of Progress presswood, Model 111-1 and Head Motif radios. Joseph DiCaro, 4155 Lastrada Hts., Mississauga, Ontario, Canada L5C 3V1. (905) 848-7759. E-mail: decoradio@primus.ca

**WANTED:** Guitars/amps/effects pedals, Vox, Selmer, Marshall, Gibson, Fender, Gretsch, Ricken Backer, FuzzFace, Cry Baby, Electro Harmonix, etc. Sonny Goldson, 520 Pocahontas Dr., Ft. Walton Beach, FL 32547. (850) 314-0321. Fax: 0824. E-mail: SonnySound@aol.com

**WANTED:** Broadcast microphones. Early carbon, condenser, ribbons, etc. James Steele, PO Box 610, Kingsland, GA 31548-0620. (912) 729-2242. E-mail: JSteele@k-bay106.com. Microphone collectors website: <http://www.k-bay106.com/mics.htm>

**WANTED:** AK 447 tombstone cabinet or complete set in any condition for cabinet parts. Joe Milano, 57 Hillcrest Dr., Wayne, NJ 07470. (973) 694-3721

**WANTED:** Junker Philco TP-7/TP-10 Bakelite radio as long as insert grille is OK. Gary Schneider, 2324 Fawn Haven Dr., Medina, OH 44256. (330) 558-0208. E-mail: gbsptop@aol.com

**WANTED:** McGohan WA330A amplifier, Fisher 50C preamp, McIntosh MC3500/M1350 amplifier. Sean Brady, 3202 N. Manor Dr. W, Phoenix, AZ 85014. (602) 284-7000. E-mail: rosemanor@cox.net

**WANTED:** Tubes, tube testers, and Western Electric tubes from estates, shops, or collectors. Jeff Arndt, 4021 South Parker Way, DePere, WI 54115. (920) 323-6789

**WANTED:** N.O.S. Delco auto radio parts, vibrators, tubes, transformers, volume controls. Hans Kleeman, 1070 Riviera Ave., Banning, CA 92220. (951) 845-4222

**WANTED:** Books or manuals about real flight simulators from 1950s. Include price. Chris Cross, PO Box 94, McConnell, IL 61050

**WANTED:** Zenith Trans-Oceanic Model 7G605 parts or radios, any condition. Joe Kiser, 6160 S. Olathe St., Centennial, CO 80016. (303) 680-1589

## CAPACITORS

## ELECTROLYTICS

**NEW!!!**

### 630 VOLT AXIAL LEADS

PART	VALUE	PRICE/25
.001-630	102K	\$6.00
.0022-630	202K	6.15
.0033-630	332K	6.20
.0047-630	472K	6.25
.0068-630	682K	6.35
.01-630	103K	6.50
.022-630	223K	7.00
.033-630	333K	7.25
.047-630	473K	7.50
1-630	104K	8.00
.22-630	224K	15.00
.47-630	474K	20.00
1.0-630	105K	26.00

### 160 VOLT AXIAL LEADS

PART	VALUE	PRICE/25
10-160	10	\$13.00
22-160	22	16.00
33-160	33	21.00
47-160	47	24.00
100-160	100	30.00 NEW!

### 450 VOLT AXIAL LEADS

PART	VALUE	PRICE/25
10-450	10	\$18.75
22-450	22	28.00
33-450	33	36.00
47-450	47	45.00
PART	VALUE	PRICE/10
47-450-10	47	\$20.00
100-450-10	100	28.00

### PILOT LAMPS

NUMBER	PACK	PRICE
40	(10 PK)	\$2.75
41	(10 PK)	2.75
43	(10 PK)	2.75
44	(10 PK)	2.75
46	(10 PK)	2.75
47	(10 PK)	2.75
51	(10 PK)	2.75
57	(10 PK)	2.75 NEW PRICE
81	(10 PK)	4.50 NEW PRICE

Phone: 1-708-352-0648

Fax: 1-708-352-0647

Email: radiobob1@sbcglobal.net

Visit: RADIOANTIQUES.COM

## BOB'S ANTIQUE RADIOS & ELECTRONICS

111 East 29th St., LaGrange Park, IL 60526

TO ORDER PLEASE SEND CHECK, MONEY ORDER OR PAYPAL.  
AS ALWAYS, PACKED IN 25 & FREE SHIPPING WITHIN THE USA.

FOR SALE: Walsco idler wheels, pressure rollers, turret drives, spindles, 45 rpm adapters, cartridges, needles. Angelo J. Milardo, 201 English St., New Haven, CT 06513. (203) 624-1015

FOR SALE: N.O.S. used tubes, other N.O.S., used electronic parts. Alan Batson, 32117 S. Autumn Ct., Laurel, DE 19956. (302) 280-6563. E-mail: roal311@comcast.net

FOR SALE: Zenith Trans-Oceanic 3000Y, vg - \$125; D7000Y, excellent working, vg condition - \$375. Ted Demski, 5806 225 Pl. SW, Mountlake Terrace, WA 98043. (425) 778-7100

FOR SALE: Items in old ads & new at radioexchange.net, search IL, category, sold by richsequip. Richard Flaws, 212 Mondovi Dr., Oswego, IL 60543. (630) 554-9207, before 9 pm CT

FOR SALE: Used tested - \$3 ea; 5U4GB, 5Y3GT, 6SN7GTB, 6V6GTB, 12A7, 12AU7 plus \$5 S&H prepaid on \$25+ order. James R. Lopaz, 5467 S. 975 E., Ogden, UT 84405. (602) 373-4002

FOR SALE: KLH 51 receiver, works - \$25 + shipping. Tested 80 rectifier tubes - \$13 U.S.A., ppd. each. N.O.S. Astatic 89T needle - \$20 ea. Don Maurer, 7 Bricker Rd., Berwyn, PA 19506. (717) 507-0628. E-mail: dmradios@aol.com. Radiosale website: <http://members.aol.com/dmradios/tube.html>

FOR SALE: Visit RadioWorld-OnLine.com you will find new items and information every month! Carl Blomstran, PO Box 890473, Houston, TX 77289

FOR SALE: Heathkit 10-4550 dual trace scope, vg - \$49. RCA 15X Bakelite TM, vg - \$49. Zenith 807Q TM radio-phono, vg - \$89. Bob Fuerderer, Holly Farm, 813 Rte. 12A, Surry, NH 03431. (603) 352-3005. Fax: (603) 355-2942

FOR SALE: American Bosch Model 38 (same as 28), 1928 radio - \$95. John Zima, 1360 Reed Rd., Churchville, NY 14428. (585) 293-3023. E-mail: jfz\_rhy@yahoo.com

FOR SALE: Reproduction radio dial belts for radios of the 1930s and 40s. Made of durable non-slip 1/8 inch round polyurethane. Ready for installation, no cutting/gluing. Available for all makes and models. Complete details at [www.Adamsradio.com](http://www.Adamsradio.com). Adams Manufacturing Company, PO Box 1005, Lincoln Park, MI 48146

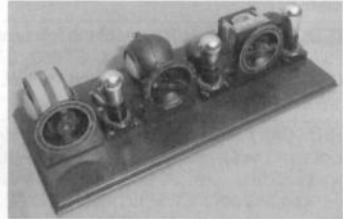

FOR SALE: Eismann board set, very unusual...one of a kind! Has all Eismann parts including variometer, variable condenser, coupler and 3-stages of detector/amplifier sockets. This was put together some time ago, but never wired... but I do have a wiring diagram. Also included is a copy of the Eismann components folder, original box one socket came in, another original box with an extra potentiometer inside, and a pair of hard-to-find Eismann headphones, all for just - \$295. Dave Crocker, 35 Santuit Pond Rd., #4B, Mashpee, MA 02649. (508) 477-1578, before 9 PM ET please

FOR SALE: Philco radios, CB radios, base mobile handheld. Specify which. SASE to: Howard Felder, 7517 Granada Dr., Bethesda, MD 20817

# ELECTRIC RADIO



Are you tired of plastic modern radios that you can't work on and are hard to understand? Are you looking for information on restoration of quality vintage receivers and transmitters? Electric Radio is the magazine for you! In print since May, 1989, we also have the largest vintage-only Ham classified section available. Please send \$1 for a sample copy to:

ER, PO Box 242, Bailey CO, 80421  
720-924-0171 email: [1editor2@indra.com](mailto:1editor2@indra.com)  
[WWW.ERMAG.COM](http://WWW.ERMAG.COM)



# WANTED

☆☆☆  
*Western Electric*

MAY GO BY  
THE NAMES:

VT-52, 211D/E, 274A  
274B, 300A/B, 310A



NEW OR  
SLIGHTLY  
USED

348A, 350B, 101D  
and 205D

IN GOOD  
CONDITION

## REWARD!

CONTACT US FOR CURRENT WANTED TUBES

**TUBEWORLD**.com

2708 Superior Ave, Sheboygan, WI 53081  
[tekman@tubeworld.com](mailto:tekman@tubeworld.com) (920) 208-0353

FOR SALE: Zenith 11S474, 421 (dual speaker, sliding doors), other Zeniths and parts, inquire. Philco 86 console (page 20 Ramirez, nice!), 37-116 (complete, needs restoration, solid), Atwater Kent Red Lion desk radio (Model 36 chassis, nice!), Fada TV (like RCA 630 type), Philco 95, 60 cathedral, 20 plain and DeLuxe (both need work), and parts for these type radios. Majestic 90, 320 chassis, (2) speakers, General Electric K-66 (nice!), RCA Radiola 30, 242, 80 chassis, many others, inquire. U.S. Apex Type 42 chassis (uses 280, 27s & 45s), more. Send me your updated want lists. I can deliver consoles to the Parsippany November meet. Wilbur Gilroy, PO Box 459, Lake Winola, PA 18625. (570) 378-2508. E-mail: wlbgr@aol.com

Classified Ad Deadline Noon

Nov. 10 for Dec. 2008 Issue

Dec. 10 for Jan. 2009 Issue

Photo & Display Ads - 1st

FOR SALE: Tubes 5U4/GT/WGTA/VT197, Pixie HB 105 w/sockets N.I.B., many tubes. Tube transistor radios, books, semiconductors, more. 20 pages, 14 lists, send 2 stamp LSASE. Bill Horn, 13110 Marsh Rd., Bealeton, VA 22712

FOR SALE: Microphones, CB radios, old ham gear. Send large SASE for inventory & prices. James M. Cole, 240 Gillespie Dr., Abingdon, VA 24210-2104. (276) 628-2835

FOR SALE: Nice Drake MN7 antenna tuner - \$175. 1920s breadboard link coupled antenna tuner - \$200. 1920s Airway radio catalog - \$75. (2) 1950s Johnson mobile transmitters - \$150 ea. Nice EF Johnson mobile VFO - \$125. Stu Mount, W2AO, 18 Bedford Ave., Fishkill, NY 12524. E-mail: jensdad@optonline.net

FOR SALE: 1948 Motorola 9T1 8" Bakelite TV - \$95 + S/H. Pictures on ETF classified. Sam Mannino, PO Box 6, Broomall, PA 19008. (610) 325-0195. E-mail: psbaker@verizon.net

FOR SALE: Hopalong Cassidy 441T paper backed foils, either style - \$125 ea. Jack Gray, 1162 Broadmoor Dr., Napa, CA 94558. E-mail: trustmej@aol.com

FOR SALE: Hickok 288X crystal controlled signal generator & manual - \$70 + shipping. Martin Gottstine, 11136 79th St., Pleasant Prairie, WI 53158. (262) 948-0421. E-mail: m.l.gottstine@att.net

FOR SALE: Phonograph parts, N.I.B., check box - \$12. Plexiglass displays holding 12 tubes each - \$100/pr. or \$55 ea. Virginia Chen, 2609 Dudley Rd., Kilgore, TX 75662

FOR SALE: Liquidating 60 year collection commercial, broadcast, WWII, antiques. Lexington, KY. Robert E. Johnson, PO Box 806, Georgetown, KY 40324. (502) 863-9387. E-mail: Robertjohnson-1@att.net

FOR SALE: Extremely rare stone lithograph Radio Queen Cigar label, bought from original A.R.C. owner in the 1980s. Picture available - \$200 firm plus shipping. Richard Arnold, PO Box 275, Lone Grove, OK 73443. (580) 657-3319. E-mail: arnold@brightok.net

FOR SALE: Heathkit Model HP-13 DC power supply with power plug - \$35 plus shipping. John Snow, 1910 Remington Ct., Andover, KS 67002. (316) 733-1856

# audioXpress

The Audio Technology Authority

*Subscribe to  
12 Great Issues of  
Hands-on Audio...*

## BUILDING RESTORING MODIFYING

From vintage tubes to classic speaker designs and cutting-edge uses of today's technologies...find all of this and more in the pages of each monthly issue of *audioXpress*.

### **SUBSCRIBE TODAY!**

Only \$37 for 12 monthly issues

You save \$47 off the cover price  
CANADA ADD \$12 • OVERSEAS RATE: \$63.00

To subscribe call 1-888-924-9465  
or order on-line at  
[www.audioXpress.com](http://www.audioXpress.com)



audioXpress

PO Box 876, Peterborough NH 03458-0876 USA

Phone: 603-924-9464 • Fax: 603-924-9467

E-mail: [custserv@audioXpress.com](mailto:custserv@audioXpress.com) • [www.audioXpress.com](http://www.audioXpress.com)

**HELP:** I need information and/or parts for an Ace Precision Company (Crosley) TTR. Randy James 5544 Trail Lake Dr., Fort Worth, TX 76133. (817) 292-7435 E-mail: randy-jeannine@sbcglobal.net

**MESSAGE:** Look for Sparten Nocturne with black glass on eBay in January. Phil Harris, 1910 E. Chestnut Ct., Statesboro, GA 30458. (912) 852-3212

**MESSAGE:** Attend NJARC meetings live on the web. Second Friday of the month. 7:30 pm EST. Dave Sica, 30 Reynolds Ave., Parsippany, NJ 07854. (732) 382-0618

**MESSAGE:** Tubes - all types. Buy and sell. Daily Electronics, PO Box 822437, Vancouver, WA 98682. (800) 346-6667. Fax: (360) 896-5476. E-mail: daily@wa-net.com. Web: dailyelectronics.net

**SERVICES:** Professional restoration of antique radios and vintage hi-fi. Repairs, upgrades & detailing. Mike Urban, 58 Naugatuck Ave., Milford, CT 06460. (800) 594-4359. Web: www.urban-antiqueradio.com

**SERVICES:** Repair & restoration of pre-1960 televisions, Predictas, auto radios, jukebox amps, vintage AM/FM tuners, 40 years experience. Tom's Antique Radio, 8 Howe Ln., Millbury, MA 01527. (508) 865-6293

**SERVICES:** Repair/replacement meters, over four hundred available prior to 1930. Ye Olde Meter Cellar, Leonard W. Cartwright, 16730 N.W. Pebble Beach Way, Beaverton, OR 97006. (503) 690-0472. E-mail: lencartwright@msn.com

**SERVICES:** Logan's TV & Radio Repair. Logan's has over 3,000 rare radio tubes for sale. We also repair old radios, through our repair and ship service. Please contact: George for further details at Logan's, Rear 526 Mt. Pleasant St., Greensburg, PA 15601. (724) 837-5580

**SERVICES:** Antique Radio of Iowa, experienced collector, will repair your home tube radios and auto, 30s thru 60s (no foreign), speaker service, cabinet restorations and more! PayPal welcome. Communicate first. Don Nordboe, 3131 Avenue A, Council Bluffs, IA 51501-1948. (712) 322-2255, CDT. E-mail: dnordboe@aol.com. Web: www.antiqueradioofiowa.com

**SERVICES:** Clear plastic repro dial covers - \$18 ppd. U.S.A. Mark Palmquist, 5033 Arbor Ln., Lilburn, GA 30047. (770) 923-8929. E-mail: jmpalm@mindspring.com. Web: http://jmpalm.home.mindspring.com

**SERVICES:** All American Five-Tube, table radio restoration special - \$49.99. 6-Tube - \$59.99. Call for details. Dave's Antique Radio and TV Restorations, PO Box 285, Liverpool, NY 13088-0285. (315) 457-5099. E-mail: dave2@dreamscape.com or dave2@tubesandtransistorsandmore.com. Web: www.dreamscape.com/dave2/daves.htm or www.tubesandtransistorsandmore.com or www.davesantiqueradio.com

**SERVICES:** Glayzit Bakelite restorer. Will bring back the shine on almost any condition Bakelite radio case - \$10.99 per can + \$4 shipping. Go to Radiotiques.com or send \$14.99 to: Jeff Goldstein, 4 Curry Ct., Wilmington, DE 19810

**SERVICES:** Repairs to vintage tube equipment including home receivers, phonographs and auto radios. South Bay Radio, 7187 Lakeshore Rd., Cicero, NY 13039. (315) 699-7341

**SERVICES:** Tubes, parts, supplies and literature. Your source for all your radio needs! Antique Electronic Supply, 6221 S. Maple Ave., Tempe, AZ 85283. (480) 820-5411. Web: www.tubesandmore.com



# RADIO VINTAGE RADIO DAZE & ELECTRONICS



**Repair Services • Books • Capacitors Of All Kinds • Chassis-Aluminum/Steel • Chokes • Custom Cloth-Covered Solid/Stranded Wire • Decals • Dial Belts & Cord • Dial Lamps & Sockets • Diodes • Enclosures • Fuses & Fuseholders**

- Grillecloth • Hardware • Kits • Knobs • Potentiometers • Power Cord
- Power Plugs • Refinishing Supplies • Reproduction Dial Scales
- Resistors Of All Kinds • Service Supplies • Sockets • Soldering Items
- Speakers • Switches • Technical Data • Terminal Strips • Tools
- Transformers - Classic Audio, Power, Filament, Isolation, etc.
- Vacuum Tubes - One of the largest inventories of NOS tubes



**Radio Daze, LLC • 7620 Omnitech Place • Victor, New York USA 14564**  
Inquiries: 585-742-2020 • e-mail: info@radiodaze.com • Web: www.radiodaze.com  
U.S. Orders Toll-Free: Phone 877-OLDTUBE (877-653-8823) Fax 800-456-6494



# Estes Auctions



*Specializing in Vintage Radios  
Complete Auction & Appraisal Service*

## Vintage Radio Auction

**“The Fred Schultz Collection”**

**Saturday, January 17, 2009 – 10 AM EST**

at the Expo Auction Center  
8157 Garman Rd., Burbank Ohio (Exit 204 off I-71)  
then south on SR #83 to the Love’s Truck Stop, turn left  
onto Garman Rd. and follow one mile to the auction site.

This sale consists of items from the late Fred Schultz that Fred displayed in the Indiana Historical Radio Museum in Ligonier, Indiana. Fred was well known in the radio collecting community. He was at most of the radio meets and would set up with a nice array of items to sell. Fred was the type of person that would take time to talk to you and discuss radios with you and offer help with any problem you might have. Fred will be missed by all of us. Some of the items to be auctioned are all three versions of the Neutrowound receiver, the red model, blue model and black model. Three spherical DeForest audions with the boxes. DeForest DT-600 and DeForest DT-700. Crosley Pups, a Grebe Synchrophase MU-2 with Type 99 tubes and battery box, Marconi coherer, Stewart-Warner Chicago World’s Fair radio with the original carton, Majestic Melody Cruiser, Stetson, William Duck loose coupler, Navy style loose coupler, Wallace detector, spark transmitter with Amrad parts, kit set with Paragon parts, selection of old tube cartons, beautiful Philco 90 cathedral, Zenith 12U158 console. A nice selection of radio-related clocks, advertising signs with a beautiful Cunningham tube clock sign. Parts and other items. We will be adding to this sale as time passes and will list it in A.R.C. This will be a good sale to start the new year off. We hope you will plan to be with us for the auction. Preview: Jan. 16 4 PM-8 PM. Day of sale 8 AM-10 AM. Terms: Cash, check, Visa, M/C. 5% gallery fee.

**Richard Estes, K8LRY - Auctioneer**

**ESTES AUCTIONS**

**7404 Ryan Road**

**Medina, Ohio 44256**

**Bob Dobush & Bob White – Tubes**

**Kim Graca – Tech Support**

**Allan Ferris – Set Up**

**Mark Delauter – Set Up**

**John Estes – Auctioneer**

**Toll free: (888) 769-4992**

**Fax: (330) 769-4116**

**E-mail: [estesauctions@aol.com](mailto:estesauctions@aol.com)**

**Web: [www.estesauctions.com](http://www.estesauctions.com)**

Call us to sell one radio or an entire collection. Pick up service also.



### **CALIFORNIA – Nov. 1**

#### **CALIFORNIA HISTORICAL RADIO SOC. SWAP MEET**

Berkeley, CA - KRE Bldg.  
601 Ashby Ave.  
9 am

Info: CHRS Hotline - (415) 821-9800  
[www.californiahistoricalradio.com](http://www.californiahistoricalradio.com)

### **ARKANSAS – Nov. 6**

#### **ANTIQUE RADIO COLLECTORS CLUB OF FORT SMITH MEETING**

Fort Smith, AR – 1st Baptist Church  
1400 Grand Ave. • 7:30 pm

Info: Paul Tucker - (479) 782-8178

### **WASHINGTON – Nov. 1**

#### **RADIO ENTHUSIASTS OF PUGET SOUND MEETING**

Seattle, WA - Queen Ann Library  
400 W. Garfield  
2 pm

Info: REPS - (206) 488-9518  
[www.repsonline.org](http://www.repsonline.org)

### **MICHIGAN – Nov. 8**

#### **MICHIGAN ANTIQUE RADIO CLUB FALL MEET**

Kalamazoo, MI - County Fairgrounds  
2900 Lake St.  
8 am

Info: John Den Hartigh - (269) 217-0539  
[www.michiganantiqueradio.org](http://www.michiganantiqueradio.org)

### **NEW YORK – Nov. 2**

#### **GREATER NEW YORK VINTAGE WIRE- LESS ASSOCIATION SWAP MEET & MEETING**

Locations: TBA  
8 am - 1 pm

Info: Jim Koehler - (516) 623-0035  
Rich Lee - (914) 589-3751

### **NEW JERSEY – Nov. 8**

#### **NEW JERSEY ANTIQUE RADIO CLUB FALL SWAP MEET**

Parsippany, NJ - Parsippany PAL bldg.,  
Smith Field, Rt. 46 & 33, Baldwin Rd.  
8 am - 1 pm

Vendor Setup: 7 am  
Info: Phil Vourtsis - (732) 446-2427  
Richard Lee - (854) 359-3809  
[www.njarc.org](http://www.njarc.org)

### **OHIO – Nov. 4**

#### **ANTIQUERADIO COLLECTORS OF OHIO MEETING**

Dayton, OH - 2929 Hazelwood Ave.  
7 pm

Info: Karl Koogler - (937) 294-8960  
E-mail: [karlkrad@siscom.net](mailto:karlkrad@siscom.net)

### **OKLAHOMA – Nov. 8**

#### **OKLA. VINTAGE RADIO COLLECTORS MEETING**

Oklahoma City, OK – Hometown Buffet  
3900 N.W. 63rd St.

6 pm: Dinner - 7 pm: Meeting  
Info: Frank Karner - [fkarner@cox.net](mailto:fkarner@cox.net)  
(405) 769-4656

<http://members.cox.net/okvrc/>

### **OREGON – Nov. 8**

#### **NORTHWEST VINTAGE RADIO SOCIETY MEETING & TAILGATE SWAP**

Oregon City, OR - Abernathy Grange Hall  
15745 S. Harley Ave.

Swap: 8:30 am - Meeting: 10 am  
Info: [www.nwvrs.org](http://www.nwvrs.org)

**NOTE:** The "Coming Radio Events" pages are tabulated from the best information available to A.R.C. However, changes, cancellations and errors do occur. To avoid disappointment, verify place, date and time especially for events which are new to you.

**COLORADO – Nov. 9**

**COLORADO RADIO COLLECTORS  
MEETING**

Call David Boyle for details  
1 pm

Info: David Boyle - (303) 681-3258

**NEW MEXICO – Nov. 9**

**NEW MEXICO RADIO COLLECTORS CLUB  
MEET**

Albuquerque, NM - Kaseman Presbyterian  
Hospital

8300 Constitution Ave. (W. of Wyoming)

1:30 pm: Tailgate Swap Meet

2 pm: Program, Show & Tell and Auction

Info: Chuck Burch - (505) 286-9674

chuckBurch@aol.com

<http://members.aol.com/NMRCC>

**GEORGIA – Nov. 10**

**SOUTHEASTERN ANTIQUE RADIO SOC.  
MEETING WITH SHOW & TELL**

Norcross, GA - Fire Mountain Rest.

Jimmy Carter Blvd.

6:30 pm

Info: Rich Rodgers - (678) 591-3619

[www.sarsradio.com](http://www.sarsradio.com)

**MISSOURI – Nov. 11**

**ANTIQUe RADIO COLL. & HIST. SOC.  
OF GREATER ST. LOUIS  
MEETING**

Kirkwood, MO - Kirkwood Comm Ctr

111 S. Geyer Rd. Room 201-A

7:30 pm

Meeting - Show & Tell - Swap Table

Info: Joe Tauser - (314) 616-0745

[joe@jtauser.com](mailto:joe@jtauser.com)

**NORTH CAROLINA – Nov. 11**

**EAST CAROLINA ANTIQUe RADIO CLUB  
MEETING**

Greenville, NC - Sheppard Memorial Library

Meeting Room A

530 Evans St.

7 pm

Info: Herman Schnur - (252) 752-2264

**OHIO - Nov. 11**

**SOCIETY FOR THE PRESERVATION OF  
ANTIQUe RADIO KNOWLEDGE (SPARK)  
MEETING**

Kettering, OH - Parkview Comm. Center  
4100 Glenheath

7:30 pm

Info: Jeff Bothwell - (937) 854-7106

[jbothwell@butlertownship.com](mailto:jbothwell@butlertownship.com)

**PENNSYLVANIA - Nov. 11**

**DELAWARE VALLEY HIST. RADIO CLUB  
MEETING - SWAP - AUCTION**

Telford, PA - Telford Community Building

Hamilton & Hamlin • 7:30 pm

Info: Delaware Valley Historic Radio Club

PO Box 5053, New Britain, PA 18901

[www.dvhrc.org](http://www.dvhrc.org)

**ARKANSAS – Nov. 13**

**ARKANSAS ANTIQUe RADIO CLUB  
MEETING**

Call for location and directions

7 pm

Info: Tom Burgess - (501) 455-0773

**NEW JERSEY – Nov. 14**

**NEW JERSEY ANTIQUe RADIO CLUB  
MEETING**

Princeton, NJ - The David Sarnoff Library

U.S. Route 1 • 7:30 pm

Info: Marv Beeferman - (609) 693-9430

Phil Vourtsis - (732) 446-2427

[www.njarc.org](http://www.njarc.org)

**CALIFORNIA – Nov. 14-15**

**SOUTHERN CALIFORNIA ANTIQUe  
RADIO SOCIETY  
TWO-DAY SWAP MEET**

Carlsbad, CA - Holiday Inn, Carlsbad by the Sea

850 Palomar Airport Rd. • 7 am

Info: Mary Curry - (619) 461-9327

[currycat@cox.net](mailto:currycat@cox.net)

**TEXAS – Nov. 14-16**

**VINTAGE RADIO & PHONOGRAPH SOC.  
ANNUAL CONVENTION**

Mesquite, TX - Hampton Inn

Info: George Potter - (972) 353-4862

[vrps@sbcglobal.net](mailto:vrps@sbcglobal.net) - [www.vrps.org](http://www.vrps.org)

## MARK YOUR CALENDAR

Nov. 1 - CA, Berkeley - CHRS Meet  
Nov. 1 - WA, Seattle - REPS Meeting  
Nov. 2 - NY, "Call" - GNYVWA Meeting  
Nov. 4 - OH, Dayton - ARCO Meeting  
Nov. 6 - AR, Fort Smith - ARCC Meeting  
Nov. 8 - MI, Kalamazoo - MARC Meet  
Nov. 8 - NJ, Parsippany - NJARC Fall Meet  
Nov. 8 - OK, Oklahoma City - OVRC Meeting  
Nov. 8 - OR, Oregon City - NWVRS Meeting  
Nov. 9 - CO, "Call" - CRC Meeting  
Nov. 9 - NM, Albuquerque - NMRCC Meet  
Nov. 10 - GA, Norcross - SARS Meeting  
Nov. 11 - MO, Kirkwood - ARCH Meeting  
Nov. 11 - NC, Greenville - ECARC Meeting  
Nov. 11 - OH, Kettering - SPARK Meeting  
Nov. 11 - PA, Telford - DVHRC Meeting  
Nov. 13 - AR, "Call" - AARC Meeting  
Nov. 14 - NJ, Princeton - NJARC Meeting  
Nov. 14-15 - CA, Carlsbad - SCARS Meet  
Nov. 14-16 - TX, Mesquite - VRPS Convention  
Nov. 15 - Ont., Ottawa - OVRC Meeting  
Nov. 15 - TX, Kyle - TARC Meeting  
Nov. 16 - MD, Davidsonville - MAARC Meeting  
Nov. 16 - TN, Memphis - MARC Meeting  
Nov. 16 - WA, Seattle - PSARA Meeting  
Nov. 17 - FL, Jacksonville - JARS Meeting  
Nov. 18 - CA, Shingle Springs - CHRS-Sac Mtg  
Nov. 19 - OH, Columbus - COARA Meeting  
Nov. 19 - OH, Cincinnati - CARS Meeting  
Nov. 20 - OK, Catoosa - HLARA Meeting  
Nov. 21 - NY, Highland Falls - HARPS Meeting  
Nov. 22 - OH, Burbank - Estes Auction  
Nov. 23 - NY, Schenectady - SARC Meeting  
Nov. 24 - AL, Birmingham - AHRM Meeting  
Dec. 2 - OH, Dayton - ARCO Meeting  
Dec. 4 - AR, Fort Smith - ARCC Meeting  
Dec. 6 - CA, Berkeley - CHRS Swap Meet  
Dec. 6 - CT, Windsor - VRCM Meet  
Dec. 6 - FL, Sarasota - SARC Meet  
Dec. 6 - TX, Houston - HVRA Party  
Dec. 6 - TX, Irving - VRPS Party  
Dec. 6 - WA, Seattle - REPS Meeting  
Dec. 7 - NY, "Call" - GNYVWA Meeting  
Dec. 7 - WV, Huntington - MRT Banquet  
Dec. 8 - GA, Norcross - SARS Meeting  
Dec. 9 - MO, Kirkwood - ARCH Meeting  
Dec. 9 - NC, Greenville - ECARC Meeting  
Dec. 9 - OH, Kettering - SPARK Meeting  
Dec. 9 - PA, Telford - DVHRC Meeting  
Dec. 10 - Ont., Ottawa - OVRC Meeting  
Dec. 11 - AR, "Call" - AARC Meeting  
Dec. 12 - NJ, Princeton - NJARC Meeting  
Dec. 13 - OH, Burbank - Estes Auction  
Dec. 13 - OR, Oregon City - NWVRS Meeting  
Dec. 14 - IL, Carol Stream - ARCI Meet  
Dec. 14 - NM, Albuquerque - NMRCC Meet  
Dec. 14 - WA, Seattle - PSARA Meeting  
Dec. 21 - VA, Centerville - MAARC Meeting  
2009  
Feb. 15 - MA, Westford - GBARC Radio XL

Clubs, have you set date(s) for your 2009 annual major meets/shows/conventions? Submit them now for listing in Mark Your Calendar.

## ONTARIO - Nov. 15

### OTTAWA VINTAGE RADIO CLUB GENERAL AUCTION

Ottawa, Ont. - The Ottawa Citizen  
Conference Room, 1101 Baxter Rd.  
7 pm

Info: OVRC - (613) 832-3097 - [www.ovrc.org](http://www.ovrc.org)

## TEXAS - Nov. 15

### TEXAS ANTIQUE RADIO CLUB MEETING

Kyle, TX - Railroad BBQ  
10:30 am

Info: Ed Engelken - [EdEngel@gvtc.com](mailto:EdEngel@gvtc.com)  
(830) 899-3864  
[www.gvtc.com/~edengel/TARC.htm](http://www.gvtc.com/~edengel/TARC.htm)

## MARYLAND - Nov. 16

### MID-ATLANTIC ANTIQUE RADIO CLUB MEETING

Davidsonville, MD - Davidsonville Rec Center  
3727 Queen Anne Bridge Road

Tailgating: 11:30 - Meeting: 1:30 pm

Info: Geoff Shearer - (703) 818-2686  
[www.maarc.org](http://www.maarc.org)

## TENNESSEE - Nov. 16

### MEMPHIS ANTIQUE RADIO CLUB MEETING

Memphis, TN - St. Timothy United Methodist  
Church - 4105 St. Elmo Ave. • 2 pm

Info: Ray Eaton - (731) 989-7089  
[marcmemphis@gmail.com](mailto:marcmemphis@gmail.com)

## WASHINGTON - Nov. 16

### PUGET SOUND ANTIQUE RADIO ASSN. MEETING

Seattle, WA - Shoreline Museum  
749 N. 175th & Linden Ave.

10 am - 12 Noon: Tailgate Swap

12 Noon: Meeting, Program, Show & Tell

Info: Pete Peterson - (425) 747-1323

<http://www.eskimo.com/~hhagen/psara.html>

*Although non-members are  
welcome at all events, joining  
may be required at some.  
Admission is charged at some.*

## **FLORIDA - Nov. 17**

### **JACKSONVILLE ANTIQUE RADIO SOC. MEETING**

Jacksonville, FL - Countryside Village  
Clubhouse, 10960 Beach Blvd. • 7:30 pm  
Info: Sean Olin - (904) 386-8332  
[www.jararadioclub.com](http://www.jararadioclub.com)

## **CALIFORNIA - Nov. 18**

### **CALIFORNIA HISTORICAL RADIO SOC. SACRAMENTO CHAPTER- MEETING**

Shingle Springs, CA - 3755 Durock Rd. • 7 pm  
Info: Bob Moore - [remoore@directcon.net](mailto:remoore@directcon.net)  
[www.californiahistoricalradio.com](http://www.californiahistoricalradio.com)

## **OHIO - Nov. 19**

### **CENTRAL OHIO ANTIQUE RADIO ASSOC. MEETING**

Columbus, OH - DeVry Institute of Tech.  
1350 Alum Creek Rd., I-70 Exit 103B • 7:30 pm  
Info: Barry Gould - (614) 777-8534  
Chuck Davis - (614) 792-6237  
[http://members.tripod.com/~COARA/  
Index.htm](http://members.tripod.com/~COARA/Index.htm)

## **OHIO - Nov. 19**

### **CINCINNATI ANTIQUE RADIO SOCIETY MEETING**

Westchester, OH - National Voice of  
America Museum of Broadcasting  
8070 Tylersville Road • 7 pm  
Info: Bob White - (513) 385-8291

## **OKLAHOMA - Nov. 20**

### **HEARTLAND ANTIQUE RADIO ASSOC. MEETING**

See Website for meeting location • 7 pm  
Info: Dan Wellacher - 620 Spunky Rd.  
Catoosa, OK 74015  
[www.hlara.org](http://www.hlara.org)

## **NEW YORK - Nov. 21**

### **HUDSON VALLEY ANTIQUE RADIO AND PHONO SOCIETY MEETING**

Highland Falls, NY - Art Kingsley Residence  
7-9 pm  
(call to confirm details)  
Info: Art Kingsley - (845) 446-4091

## **OHIO - Nov. 22**

### **ESTES AUCTIONS RADIO AUCTION**

Burbank, OH - Expo Auction Center  
8157 Garmon Rd., Exit 204 off I-71  
10 am  
Info: (888) 769-4992 - Fax: (330) 769-4116  
[estesauctions@aol.com](mailto:estesauctions@aol.com)  
[www.estesauctions.com](http://www.estesauctions.com)

## **NEW YORK - Nov. 23**

### **SCHENECTADY ANTIQUE RADIO CLUB MEETING**

Schenectady, NY - Schenectady Museum &  
Planetarium, Knott Terrace  
Flea Market: 1:30 pm - Meeting: 2 pm  
Info: David Ellers - (518) 326-6042  
<http://dadellers.tripod.com/>

## **ALABAMA - Nov. 24**

### **ALABAMA HISTORICAL RADIO SOCIETY MEETING**

Birmingham, AL - Alabama Power Building  
Parkway East  
7 pm  
Info: Dave Cisco - (205) 822-6759  
[www.alabamahistoricalradiosociety.org](http://www.alabamahistoricalradiosociety.org)  
E-mail: [historicalradio@aol.com](mailto:historicalradio@aol.com)

## **OHIO - Dec. 2**

### **ANTIQUERADIO COLLECTORS OF OHIO MEETING**

Dayton, OH - 2929 Hazelwood Ave.  
7 pm  
Info: Kari Koogle - (937) 294-8960  
[karikrad@siscom.net](mailto:karikrad@siscom.net)

## **ARKANSAS - Dec. 4**

### **ANTIQUERADIO COLLECTORS CLUB OF FORTH SMITH MEETING**

Fort Smith, AR - First Baptist Church  
1400 Grand Ave.  
7:30 pm  
Info: Paul Tucker - (479) 782-8178

**SUBMISSION DEADLINE: 5TH OF MONTH**

## **CALIFORNIA - Dec. 6**

**CALIFORNIA HISTORICAL RADIO SOC.  
GENERAL MEETING/HOLIDAY SOCIAL**

Berkeley, CA - CHRS/KRE Bldg.

601 Ashby Ave.

1 pm

Info: CHRS Hotline - (415) 821-9800

[www.californiahistoricalradio.com](http://www.californiahistoricalradio.com)

## **CONNECTICUT - Dec. 6**

**VINTAGE RADIO & COMM. MUSEUM OF CT  
INDOOR SWAP MEET**

Windsor, CT - 115 Pierson Ln.

8 am

Info: John Ellsworth - (860) 673-0518

[radioclctr@aol.com](mailto:radioclctr@aol.com)

## **FLORIDA - Dec. 6**

**SARASOTA ANTIQUE RADIO CLUB  
WINTER SWAP MEET**

Sarasota, FL - Knights of Columbus

4880 Fruitville Rd.

8 am - 11 am

Info: Jack Warren - (941) 349-4875

Dave Hurt: [manager@findsales.com](mailto:manager@findsales.com)

## **TEXAS - Dec. 6**

**HOUSTON VINTAGE RADIO ASSOC.  
CHRISTMAS PARTY**

TBD

Info: Bilj Werzner - (713) 721-2242

[mingqi53@sbcglobal.net](mailto:mingqi53@sbcglobal.net)

[www.hvra.org](http://www.hvra.org)

## **TEXAS - Dec. 6**

**VINTAGE RADIO & PHONOGRAPH SOC.  
CHRISTMAS PARTY**

Irving, TX - Garden & Arts Building • 6 pm

Info: George Potter - (972) 353-4862

[vrps@sbcglobal.net](mailto:vrps@sbcglobal.net) - [www.vrps.org](http://www.vrps.org)

## **WASHINGTON - Dec. 6**

**RADIO ENTHUSIASTS OF PUGET SOUND  
MEETING**

Seattle, WA - Queen Ann Library

400 W. Garfield • 2 pm

Info: REPS - (206) 488-9518

[www.repsonline.org](http://www.repsonline.org)

## **NEW YORK - Dec. 7**

**GREATER NEW YORK VINTAGE WIRE-  
LESS ASSOCIATION**

**SWAP MEET & MEETING**

Location: TBA

8 am - 1 pm

Info: Jim Koehler - (516) 623-0035

Rich Lee - (914) 589-3751

## **W. VIRGINIA - Dec. 7**

**MUSEUM OF RADIO & TECHNOLOGY  
ANNUAL HOLIDAY BANQUET & SHOW**

Huntington, WV - 1640 Florence Ave.

Contact for time

Info: [www.mrtwv.org](http://www.mrtwv.org)

## **GEORGIA - Dec. 8**

**SOUTHEASTERN ANTIQUE RADIO SOC.  
MEETING WITH SHOW & TELL**

Norcross, GA - Fire Mountain Rest.

Jimmy Carter Blvd. • 6:30 pm

Info: Rich Rodgers - (678) 591-3619

[www.sarsradio.com](http://www.sarsradio.com)

## **MISSOURI - Dec. 9**

**ANTIQUÉ RADIO COLL. & HIST. OF  
GREATER ST. LOUIS  
MEETING**

Kirkwood, MO - Kirkwood Comm. Ctr

111 S. Geyer Rd., Room 201-A

7:30 pm Meeting, Show & Tell, Swap Table

Info: Joe Tauser - (314) 616-0745

[joe@jtauser.com](mailto:joe@jtauser.com)

## **NORTH CAROLINA - Dec. 9**

**EAST CAROLINA ANTIQUE RADIO CLUB  
MEETING**

Greenville, NC - Sheppard Memorial Library

Meeting Room A, 530 Evans St.

7 pm

Info: Herman Schnur - (252) 752-2264

## **OHIO - Dec. 9**

**SOCIETY FOR THE PRESERVATION OF  
ANTIQUÉ RADIO KNOWLEDGE (SPARK)  
MEETING**

Kettering, OH - Parkview Comm. Center

4100 Glenheath • 7:30 pm

Info: Jeff Bothwell - (937) 854-7106

[jbothwell@butlertownship.com](mailto:jbothwell@butlertownship.com)

## **PENNSYLVANIA – Dec. 9**

### **DELAWARE VALLEY HIST. RADIO CLUB MEETING - SWAP - AUCTION**

Telford, PA - Telford Community Building  
Hamilton & Hamlin

7:30 pm

Info: Delaware Valley Historic Radio Club  
PO Box 5053, New Britain, PA 18901  
[www.dvhrc.org](http://www.dvhrc.org)

## **ONTARIO – Dec. 10**

### **OTTAWA VINTAGE RADIO CLUB MEETING**

Ottawa, Ont. - The Ottawa Citizen  
Conference Room, 1101 Baxter Rd.

7 pm

Info: OVRC - (613) 832-3097 - [www.ovrc.org](http://www.ovrc.org)

## **ARKANSAS – Dec. 11**

### **ARKANSAS ANTIQUE RADIO CLUB MEETING**

Call for location and directions • 7 pm

Info: Tom Burgess - (501) 455-0773

## **NEW JERSEY – Dec. 12**

### **NEW JERSEY ANTIQUE RADIO CLUB MEETING**

Princeton, NJ - The David Sarnoff Library  
U.S. Route 1 • 7:30 pm

Info: Marv Beeferman - (609) 693-9430

Phil Vourtsis - (732) 446-2427 - [www.njarc.org](http://www.njarc.org)

## **OHIO – Dec. 13**

### **ESTES AUCTIONS RADIO AUCTION**

Burbank, OH - Expo Auction Center  
8157 Garmon Rd., Exit 204 off I-71

10 am

Info: (888) 769-4992 - Fax: (330) 769-4116

[estesauctions@aol.com](mailto:estesauctions@aol.com)

[www.estesauctions.com](http://www.estesauctions.com)

## **OREGON – Dec. 13**

### **NORTHWEST VINTAGE RADIO SOCIETY MEETING & TAILGATE SWAP**

Oregon City, OR - Abernethy Grange Hall  
15745 S. Harley Ave.

Tailgate: 8:30 am - Meeting: 10 am

Info: [www.nwvrs.org](http://www.nwvrs.org)

## **ILLINOIS – Dec. 14**

### **ANTIQUe RADIO CLUB OF ILLINOIS INDOOR SWAP MEET**

Carol Stream, IL - American Legion Hall  
7 am - 11 am

Info: [www.antique-radios.org](http://www.antique-radios.org)  
[clubinfo@vintage-radios.org](mailto:clubinfo@vintage-radios.org)

## **NEW MEXICO – Dec. 14**

### **NEW MEXICO RADIO COLLECTORS CLUB MEET**

Albuquerque, NM - Kaseman Presbyterian  
Hospital

8300 Constitution Ave. (W. of Wyoming)

1:30 pm: Tailgate Swap Meet

2 pm: Program, Show & Tell and Auction

Info: Chuck Burch - (505) 286-9674

[chuckBurch@aol.com](mailto:chuckBurch@aol.com)

<http://members.aol.com/NMRCC>

## **WASHINGTON – Dec. 14**

### **PUGET SOUND ANTIQUE RADIO ASSN. MEETING**

Seattle, WA - Shoreline Museum

749 N. 175th & Linden Ave.

10 am - 12 Noon: Tailgate Swap

12 Noon: Meeting, Program, Show & Tell

Info: Pete Peterson - (425) 747-1323

<http://www.eskimo.com/~hhagen/psara.html>

## **VIRGINIA – Dec. 21**

### **MID-ATLANTIC ANTIQUE RADIO CLUB MEETING**

Centerville, VA - Sully Station Comm. Center

5101 Sequoia Farms Dr.

Tailgating: 11:30 am - Meeting: 1:30 pm

Info: Geoff Shearer - (703) 818-2686

[www.maarc.org](http://www.maarc.org)

## **Always Updating Club List**

Please send A.R.C. the name, address, etc.  
of your club's contact person.

*A free\* listing on these pages is available for each coming radio event. Sponsors should provide description of event, date, time, place, directions, & information/contact person. Since listings are on a "space available" basis, no guarantee of listing is made.*

**BUSINESS CARD ADS - \$53.00 FOR 3 MONTHS**

**BETA-TEK**  
**ANTIQUE RADIO SERVICE**  
 ■ Quality Radio Repair & Restoration  
 ■ Prompt Service ■ Free Estimates  
 ■ Radios Bought & Sold

**RAY BINTLIFF**  
 2 Powder Horn Lane  
 Acton, MA 01720  
 978-263-7435  
 w1ry@msn.com



**Great Northern Vintage Radios**

**RADIO SERVICE**

Vintage Radio  
 Bought • Sold • Repaired  
 Knobs • Parts  
 Advertising • Antiques • Collectibles

Alan Jesperson Tel: (612) 727-2489  
 5200 Bloomington Ave. S. Email: alan@alanjesperson.com  
 Minneapolis, MN 55417 Web: www.gn4radios.com



**Vintage Electronics**  
 Cartridges/Needles  
 Phono & Tape Idlers  
 New / Rebuilt

www.vintageelectronics.com

Ed Crockett (601) 264-4755  
 128 Buccaneer Drive Monday - Friday  
 Hattiesburg, MS 39402 8am - 5pm CST only  
 e-mail: phonoed@aol.com Fax anytime (601) 264-0226



**RADIO BOOKS WANTED**

Always buying: Books, Magazines and Manuals.  
 Single items or collections. Call us toll free: 888-447-5037  
 We have a large selection of books on radio and related  
 technology for sale. Call us about our shop and catalogs or  
 visit our web site: <http://www.beqbooks.com>

**BEQUAERT OLD BOOKS**  
 P.O. BOX 775, FITZWILLIAM NH 03447  
 (603)-585-3448 info@beqbooks.com

**ADAMS MANUFACTURING CO.**

**RADIO DIAL BELTS**

To Fit All Radios

Visit our website  
[www.Adamsradio.com](http://www.Adamsradio.com)

**Old Time Replications**

"TURN TO US WHEN YOU NEED KNOBS"  
 KNOBS • PUSHBUTTONS • ESCUTCHEONS  
 PLASTIC GRILLS

**LARRY BORDONARO**  
 5744 TOBIAS AVE., VAN NUYS, CA 91411  
 PHONE (818) 786-2500 • FAX (818) 909-0241  
 E-MAIL: [oldtimerep@aol.com](mailto:oldtimerep@aol.com)  
[www.antiqueradioknobs.com](http://www.antiqueradioknobs.com)

PUT  
 YOUR BUSINESS CARD  
 HERE!  
**\$53 for 3 months - \$90 for 6  
 months**  
 Don't have one? Send an extra \$7  
 and we will typeset one for you.

**The Voice of Music®**

**V-M MANUFACTURED:**  
 • Phono & Tape Service Parts  
 • Service and Owner's Manuals  
 • 45 Adapters and Accessories  
 • Component Record Changer Sales  
 • Changer Restoration Services

**ALL BRANDS:**  
 • Wheels, Needles/Cartridges and more!

**V-M Audio Enthusiasts**  
 37530 E. Meadowhill, Northville, MI 48167 • (248) 478-0990  
[www.thevoiceofmusic.com](http://www.thevoiceofmusic.com) • [info@thevoiceofmusic.com](mailto:info@thevoiceofmusic.com) • Gary Stork



**WAVES L.L.C.**

ANTIQUES  
 EARLY RADIOS  
 &  
 PHONOGRAPHS  
 BOUGHT • SOLD  
 RENTALS • REPAIRS

11-6 MON-SAT  
 CLOSED SUNDAYS

FAX 201-461-7121  
 e-mail [clwave@aol.com](mailto:clwave@aol.com)  
[www.wavesradios.com](http://www.wavesradios.com)

251 W 30TH ST., NY, NY 10001 212 273-9616  
 PROPRIETORS Bruce and Charlotte Mager



**RADIOS & STRANGE MISCELLANEA**

IF YOU VISIT THE BRIMFIELD FLEA MARKET...  
 STOP BY FIRST!

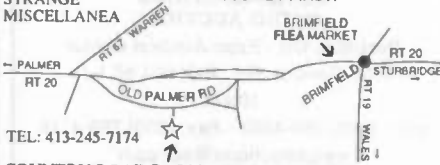

TEL: 413-245-7174

**COUNTRY ROAD BARN - BERNIE SAMEK**  
 OLD PALMER ROAD, BRIMFIELD, MASS.

**PLASTIC RADIO DIAL COVERS**

**WEST-TECH**  
 Antique Radio Dial Covers  
 No Tracings Required (some exceptions)  
 NO WAITING - QUICK TURNAROUND  
 West-Tech Services

NEW LOCATION: 615 Fairground Street  
 Caldwell, Ohio 43724  
 Hours: M-F 10 AM - 5 PM Ph/fax (740) 732-6056  
 E-mail: [westtechservices@yahoo.com](mailto:westtechservices@yahoo.com)  
 Web: [www.west-techservices.com](http://www.west-techservices.com)

\$15 ppdl



More than 900  
 molds for over  
 1,200 radios



**TOM'S ANTIQUE RADIO & TV**

• Repairs and Restorations  
 • All pre-1960 models  
 • 45 years experience

**Thomas Romano**  
 (508) 865-6293  
 8 Howe Lane, Millbury, MA 01527



## BUSINESS CARD ADS - \$53.00 FOR 3 MONTHS

Free Estimates  
Hrs. - 9 AM - 5 PM EST  
Tues - Sat.

Tel/Fax (860) 928-2628  
E-mail: bob@oldradiodoc.com  
www.oldradiodoc.com



### ANTIQUA RADIO RESTORATION & REPAIR

1920 - 1960's

Buy & Sell

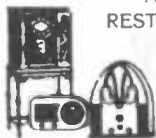

BOB ESLINGER

Reasonable Rates, Tubes, Professional Overhauls, Cabinet Refinishing Service For All Antique Car, Table & Console Radios, Communication Receivers & Tube Amplifiers.

20 Gary School Road  
Pomfret Center, CT 06259

## Antique Electric Radios Repair, Restore, Buy & Sell

Vintage table and console radios, phono, Hi-Fi audio, auto radios, crank phonographs  
**Hear them play again!**

John Hartman  
(603) 447-4821  
Sales web site:

P.O. Box 201, Eaton, NH 03832  
E-Mail: nm1h@hotmail.com  
www.radioatlantic.com/nm1h

## URBAN ANTIQUE RADIO AND VINTAGE HI-FI

Mike Urban  
Restoration and Sales  
**800-594-4359**

[www.urban-antiqueradio.com](http://www.urban-antiqueradio.com)

### Repro Dial Covers

<http://jmpalm.home.mindspring.com>

Mark Palmquist  
Retro Radio Repair  
5033 Arbor Lane  
Lilburn, GA 30047  
Phone 770 923 8929

**\$18.00 ppd**

[jmpalm@mindspring.com](mailto:jmpalm@mindspring.com)

Send Tracing & Model #

Free Mounting in your bezel

(add \$2.60 for Priority Mail return shipping of bezels)

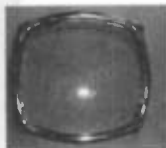

### ALLAN WEINER

Presents

The Antique Radio News

on

WBCQ RADIO

Fridays 8 PM Eastern

7515, 5110, 15420 kHz Shortwave

**WBCQ.com** 207-538-9180

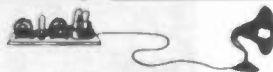

### ESTES AUCTIONS

Specializing in Vintage Radios  
& Radio Appraisal Service  
[www.estesauctions.com](http://www.estesauctions.com)

7404 Ryan Road  
Medina, Ohio 44256

Phone: (330) 769-4992  
Fax: (330) 769-4116

E-mail: [estes\\_auctions@aol.com](mailto:estes_auctions@aol.com)

### WANTED PRE 1900 ELECTRICITY

MEDICAL • X RAY  
TELEGRAPHY • TET EPHONE  
PRE 1925  
RADIO • WIRELESS  
PRE 1940  
TELEVISION

BOOKS • TUBES • ARTIFACTS  
MAGAZINES • AUTOGRAPHS  
CATALOGS • EPHEMERA



NEW WIRELESS PIONEERS  
1541 BRONSON RD.  
GRAND ISLAND, NY 14072  
(716) 773-4999 • Fax: (716) 773-5757  
E-mail: [wireless@pcc.net](mailto:wireless@pcc.net)  
[www.marconi-wireless.com](http://www.marconi-wireless.com)



### Just Radios

Capacitors & Schematics for Tube Radios

David and Babylyn Cantelon  
6 Ferncrest Gate, Scarborough,  
Ontario, Canada, M1W 1C2

[www.justradios.com](http://www.justradios.com)  
[justradios@yahoo.com](mailto:justradios@yahoo.com)  
(416) 502-9128



### TOM'S ANTIQUE RADIO REPAIR

937-258-0124

Lets get that old radio of yours working again

All makes and models  
Transistor Radio Repair

Cabinet Restoration  
Free Estimates

<http://tomsradiorepair.bizland.com>

### WEST-TECH SERVICES

"As the records spin ... the memories begin"

All your phono parts: idlers-needles-cartridges. Vulcanized idlers for VM, 45 changers and Zenith Cobra. Restoration of all record changers, wire recorders, record cutters and transcriptions. Rebuild crystal and magnetic cartridges for 78/33/45 changers, record cutters and wire recorders. Sales and service.

**WEST-TECH SERVICES - NEW LOCATION!**

615 Fairground St., Caldwell, OH 43724. Hours: Mon.-Fri. 10-5 EST

Tel/Fax (740) 732-6056 [www.westtechservices.com](http://www.westtechservices.com)

E-mail: [westtechservices@yahoo.com](mailto:westtechservices@yahoo.com)

### PUT YOUR BUSINESS CARD HERE!

\$53 for 3 months - \$90 for 6 months

Don't have one? Send an extra \$7 and we will typeset one for you.

### ANTIQUA RADIOS



Specializing in  
Horn  
Speakers

WANTED

DAVE CROCKER

35 Santuit Pond Rd. #4B

Mashpee, MA 02649

E-mail: [radio-1@comcast.net](mailto:radio-1@comcast.net)

(508) 477-1578

# *Genuine Plastic Radios of the Mid-Century*

By Ken Jupp & Leslie Piña

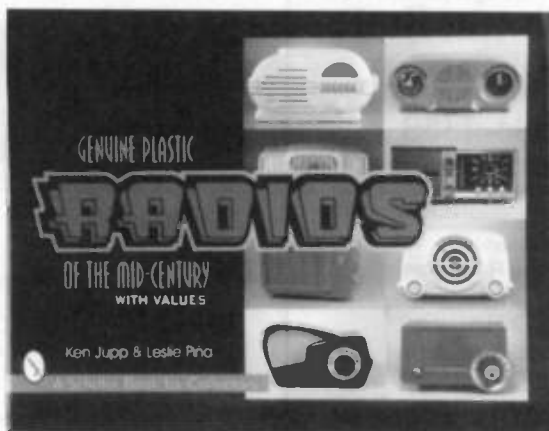

**55 Manufacturers from Admiral to Zephyr**

**Table Models – Portables**

**439 Color Photos – Price Guide**

**Advertisements**

**\$39.95 - Hardcover**

**Everything stocked and shipped promptly — Radio is our middle name.**

**A.R.C., P.O. Box 2, Carlisle, MA 01741 – Toll Free: (866) 371-0512**

**Fax: (978) 371-7129 – E-mail: [ARC@antiqueradio.com](mailto:ARC@antiqueradio.com) – Web: [www.antiqueradio.com](http://www.antiqueradio.com)**



*Free shipping & handling on all U.S. orders (typical U.S. order will be received within 7 days, but allow 2-3 weeks).*

*Mass. residents add 5% sales tax. Non-U.S. orders, write for shipping costs, or use credit card. Most orders*

*shipped by next business day. If using credit card, include name on card, card number and expiration date. Send payment with order. Money back return policy. Subscribers, ask for discount when placing order: 10% off books.*



(#13-Nov07)

***The Mark Wooley Collection  
of Vintage Radios  
Auction Catalog and Realized Price List  
Auction held Wednesday, December 19, 2007  
at Bonhams, New York***

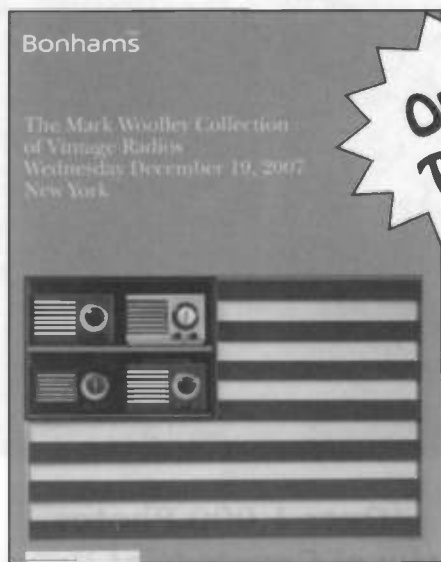

Excellent descriptions and large color photographs of  
over 200 Catalin & collectable radios.

Total sales of \$788,600.

Includes an insert of the realized prices

90 pages

**\$25 - Softcover**

**Everything stocked and shipped promptly — Radio is our middle name.**

A.R.C., P.O. Box 2, Carlisle, MA 01741 – Toll Free: (866) 371-0512  
Fax: (978) 371-7129 – E-mail: [ARC@antiqueradio.com](mailto:ARC@antiqueradio.com) – Web: [www.antiqueradio.com](http://www.antiqueradio.com)



Free shipping & handling on all U.S. orders (typical U.S. order will be received within 7 days, but allow 2-3 weeks).  
Mass. residents add 5% sales tax. Non-U.S. orders, write for shipping costs, or use credit card. Most orders  
shipped by next business day. If using credit card, include name on card, card number and expiration date. Send  
payment with order. Money back return policy. Subscribers, ask for discount when placing order: 10% off books.



(#43-Sep08)

# *Radios by Hallicrafters, 2nd Ed.*

By Chuck Dachis

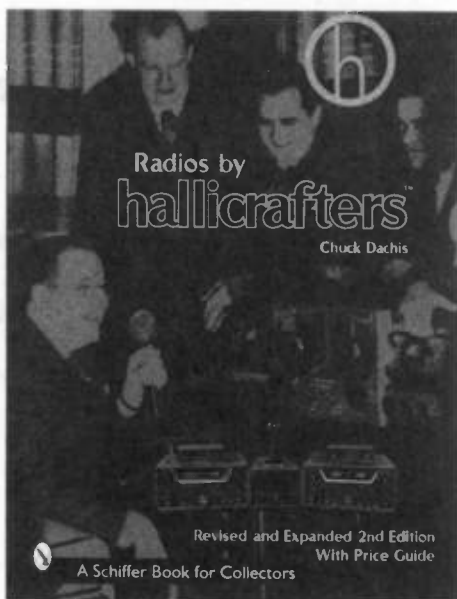

**Over 1,000 Photos**  
**Additional Coverage of Receivers**  
**6 Additional Pages of Special Purpose**  
**and Prototype Items**  
**Updated Pricing**

**\$29.95 - Softcover**

**Everything stocked and shipped promptly — Radio is our middle name.**

**A.R.C., P.O. Box 2, Carlisle, MA 01741 – Toll Free: (866) 371-0512**  
**Fax: (978) 371-7129 – E-mail: [ARC@antiqueradio.com](mailto:ARC@antiqueradio.com) – Web: [www.antiqueradio.com](http://www.antiqueradio.com)**



Free shipping & handling on all U.S. orders (typical U.S. order will be received within 7 days, but allow 2-3 weeks).

Mass. residents add 5% sales tax. Non-U.S. orders, write for shipping costs, or use credit card. Most orders shipped by next business day. If using credit card, include name on card, card number and expiration date. Send payment with order. Money back return policy. Subscribers, ask for discount when placing order: 10% off books.



(#16-Nov-07)

# Radio Manufacturers of the 1920's

All 3  
Volumes!

BY ALAN DOUGLAS

Order  
Today!

Available  
Again!



*"The definitive book on American broadcast receivers of the 1920s"*

**Volume 1:** A-C Dayton - Adams Morgan - Air-Way - All-American Mohawk - American Bosch - Amrad - Amrad S-Tube - Apex - Atwater Kent - Bremer Tully - Browning-Drake - Clapp-Eastham - Crosley - Cutting & Washington - Day-Fan - DeForest - Eagle - ERLA - FADA - Federal - Ferguson. Federal - Ferguson. 225 Pages.

**Volume 1: \$29.95**

**Volume 2:** Freed-Eisemann - Eisemann - Freshman - Garod - Gilfillan - Grebe - Howard - Jones (Lester/Melco) - Jones (Jos.) - Kellogg - Kennedy - King - Kodel - Kolster - Leutz - Magnavox - Majestic - Marti - Metro - Klitzen/Michigan - Midwest - Mu-Rad - Murdock - Music Master - Neutrowound - Operadio - Ozarka - Pfanstiehl - Philco - Pilot - Priess. 266 Pages.

**Volume 2: \$29.95**

**Volume 3:** RCA - Scott - Silver-Marshall - Slagle - Sleeper - Sonora - Sparton - Splitdorf - Steinitz - Stewart-Warner - Stromberg-Carlson - Thermodyne - R.E. Thompson - Thorola - Tri-City - C. D. Tuska - Ware - Western Coil - Western Electric - Workrite - Zenith. 292 Pages.

**Volume 3: \$29.95**

**Everything stocked and shipped promptly — Radio is our middle name.**

**A.R.C., P.O. Box 2, Carlisle, MA 01741 — Toll Free: (866) 371-0512**

**Fax: (978) 371-7129 — E-mail: [ARC@antiqueradio.com](mailto:ARC@antiqueradio.com) — Web: [www.antiqueradio.com](http://www.antiqueradio.com)**



Free shipping & handling on all U.S. orders (typical U.S. order will be received within 7 days, but allow 2-3 weeks). Mass. residents add 5% sales tax. Non-U.S. orders, write for shipping costs, or use credit card. Most orders shipped by next business day. If using credit card, include name on card, card number and expiration date. Send payment with order. Money back return policy. Subscribers, ask for discount when placing order. 10% off books.



(#39-Oct07)

# *Tube Testers and Classic Electronic Test Gear*

By Alan Douglas



**Overview of Pre-1970 Radio Test Equipment.  
Over 300 Photos & Illustrations.  
Discusses Tube Testing & Use of Testers.  
Compares Emission, Dynamic &  
Mutual Conductance Testers.  
Tabulates & Pictures Testers from  
23 Different Manufacturers.  
\$25.95 - Softcover**

**Everything stocked and shipped promptly — Radio is our middle name.**

**A.R.C., P.O. Box 2, Carlisle, MA 01741 – Toll Free: (866) 371-0512  
Fax: (978) 371-7129 – E-mail: [ARC@antiqueradio.com](mailto:ARC@antiqueradio.com) – Web: [www.antiqueradio.com](http://www.antiqueradio.com)**



Free shipping & handling on all U.S. orders (typical U.S. order will be received within 7 days, but allow 2-3 weeks).  
Mass. residents add 5% sales tax. Non-U.S. orders, write for shipping costs, or use credit card. Most orders  
shipped by next business day. If using credit card, include name on card, card number and expiration date. Send  
payment with order. Money back return policy. Subscribers, ask for discount when placing order. 10% off books.



(#23-Oct-07)

# Classic Cones

By Buford and Jane Chidester



**Order  
Today!**

## **Pictorial Reference & Value Guide for 1920's Radio Cone Speakers**

**Hundreds of Full Color Photographs  
Original Advertising  
Alphabetical Index of Mfrs.**

**122 pages**

**\$25.95 – Softcover**

**Everything stocked and shipped promptly — Radio is our middle name.**

**A.R.C., P.O. Box 2, Carlisle, MA 01741 – Toll Free: (866) 371-0512  
Fax: (978) 371-7129 – E-mail: [ARC@antiqueradio.com](mailto:ARC@antiqueradio.com) – Web: [www.antiqueradio.com](http://www.antiqueradio.com)**



Free shipping & handling on all U.S. orders (typical U.S. order will be received within 7 days, but allow 2-3 weeks). Mass. residents add 5% sales tax. Non-U.S. orders, write for shipping costs, or use credit card. Most orders shipped by next business day. If using credit card, include name on card, card number and expiration date. Send payment with order. Money back return policy. Subscribers, ask for discount when placing order: 10% off books.



(#32-Oct07)

# E.H. Scott... The Dean of DX

BY MARVIN HOBBS

2002 Second Edition – Expanded!

Additional Chapters

Color Photo Section – 24 pages

*E.H. Scott... The Dean of DX*, the definitive book on the E.H. Scott Company for over 15 years, has been revised and expanded by author Marvin Hobbs with the assistance of John Slusser of Radio Daze Press. This is a "must have" book for any E.H. Scott enthusiast. 8 1/2 x 11", 240 pages.

**\$29.95 – Softcover**

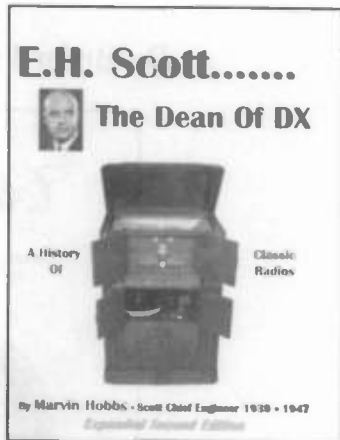

# A. Atwater Kent The Man, the Manufacturer and His Radios

BY RALPH WILLIAMS AND  
JOHN P WOLKONOWICZ

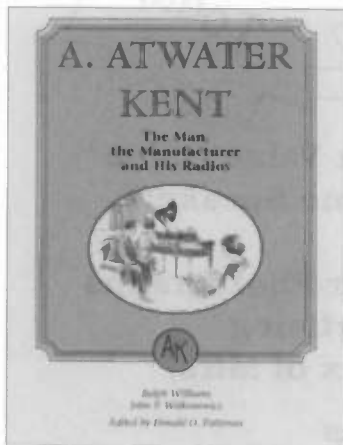

A compilation of the articles on Atwater Kent which were published in *Radio Age* by Ralph Williams in the 1970s. Covers 1920s Atwater Kent sets. Also included is John P. Wolkonowicz's 1976 article *WPI's Forgotten Millionaire*. This is a "must have" book for any Atwater Kent enthusiast. Donald O. Patterson, Editor. 8 1/2 x 11", 108 pages.

**\$25.95 – Softcover**

**Everything stocked and shipped promptly — Radio is our middle name.**

**A.R.C., P.O. Box 2, Carlisle, MA 01741 – Toll Free: (866) 371-0512**

**Fax: (978) 371-7129 – E-mail: [ARC@antiqueradio.com](mailto:ARC@antiqueradio.com) – Web: [www.antiqueradio.com](http://www.antiqueradio.com)**



Free shipping & handling on all U.S. orders (typical U.S. order will be received within 7 days, but allow 2-3 weeks). Mass. residents add 5% sales tax. Non-U.S. orders, write for shipping costs, or use credit card. Most orders shipped by next business day. If using credit card, include name on card, card number and expiration date. Send payment with order. Money back return policy. Subscribers, ask for discount when placing order. 10% off books.



(#33-Nov07)



# • ZENITH •

## THE GLORY YEARS 1936-1945

### TWO VOLUMES

By Harold Cones, Ph.D, John H. Bryant, FAIA,  
& Martin Blankinship

An exploration of Zenith from 1936-1945 PLUS color photos of many products manufactured during this period. Also, MacDonald's speeches, Zenith telepathy experiments and annual reports. Current market values for radios pictured. 11" x 8 1/2", 180 color & 183 b/w photos, price guide/index, 256 pages.

**\$34.95 – Softcover**

### HISTORY AND PRODUCTS

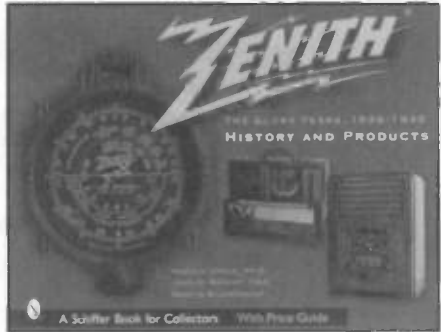

### ILLUSTRATED CATALOG & DATABASE



Illustrations from brochures and the most complete listing of Zenith products. Value and rarity codes are included. 11" x 8 1/2", 520 b/w photos, price guide/index, 182 pages.

**\$29.95 – Softcover**

**Everything stocked and shipped promptly — Radio is our middle name.  
FREE SHIPPING — 10% Discount for Subscribers**

A.R.C., P.O. Box 2, Carlisle, MA 01741 – Toll Free: (866) 371-0512  
Fax: (978) 371-7129 – E-mail: [ARC@antiqueradlo.com](mailto:ARC@antiqueradlo.com) – Web: [www.antiqueradlo.com](http://www.antiqueradlo.com)



Free shipping & handling on all U.S. orders (typical U.S. order will be received within 7 days, but allow 2-3 weeks). Mass. residents add 5% sales tax. Non-U.S. orders, write for shipping costs, or use credit card. Most orders shipped by next business day. If using credit card, include name on card, card number and expiration date. Send payment with order. Money back return policy. Subscribers, ask for discount when placing order. 10% off books.



(#34-Oct07)

# Radiola

## The Golden Age of RCA

1919-1929

By Eric P. Wenaas

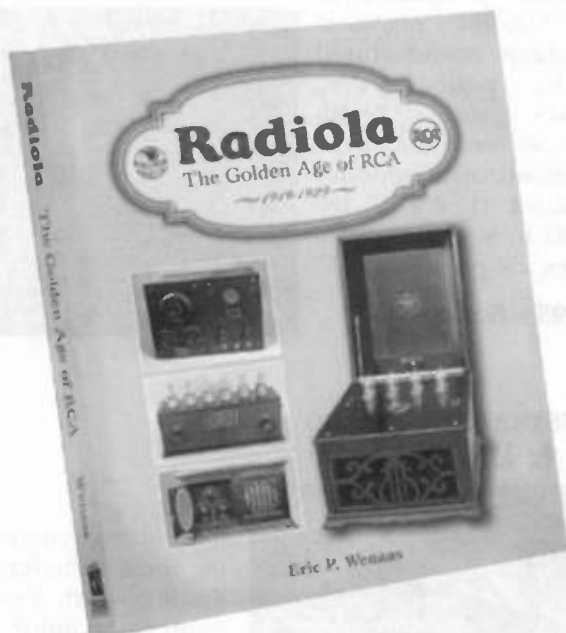

Documents & pictures every radio receiver and the major accessories sold by RCA during the first decade. Nearly 700 color photos of apparatus, magazine ads and promotional literature.

8 1/2 x 11" 485 pages

**\$65 - Hardcover**

**Everything stocked and shipped promptly — Radio is our middle name.**

A.R.C., P.O. Box 2, Carlisle, MA 01741 – Toll Free: (866) 371-0512

Fax: (978) 371-7129 – E-mail: [ARC@antiqueradio.com](mailto:ARC@antiqueradio.com) – Web: [www.antiqueradio.com](http://www.antiqueradio.com)



Free shipping & handling on all U.S. orders (typical U.S. order will be received within 7 days, but allow 2-3 weeks).

Mass. residents add 5% sales tax. Non-U.S. orders, write for shipping costs, or use credit card. Most orders shipped by next business day. If using credit card, include name on card, card number and expiration date. Send payment with order. Money back return policy. Subscribers, ask for discount when placing order: 10% off books.



(#40-Jun08)

# *The Antique Radio Collectors' Source Book* **PLASTIC RADIOS**

By Mark V. Stein



**Order  
Today!**

**For identification of Catalin, Bakelite,  
Plaskon, Beetle, Tenite & Styrene sets.**

Includes history, 3,000 radio listings with photos,  
120 manufacturers

**\$37.95 - Softcover**

**Everything stocked and shipped promptly — Radio is our middle name.**

**A.R.C., P.O. Box 2, Carlisle, MA 01741 – Toll Free: (866) 371-0512  
Fax: (978) 371-7129 – E-mail: [ARC@antiqueradio.com](mailto:ARC@antiqueradio.com) – Web: [www.antiqueradio.com](http://www.antiqueradio.com)**

**VISA**

Free shipping & handling on all U.S. orders (typical U.S. order will be received within 7 days, but allow 2-3 weeks).  
Mass. residents add 5% sales tax. Non-U.S. orders, write for shipping costs, or use credit card. Most orders  
shipped by next business day. If using credit card, include name on card, card number and expiration date. Send  
payment with order. Money back return policy. Subscribers, ask for discount when placing order: 10% off books.

**MasterCard**

**DISCOVER**

(#37-Feb08)

*The Antique Radio  
Collectors' Source Book*

**CATHEDRAL & TOMBSTONE RADIOS**

By Mark V. Stein

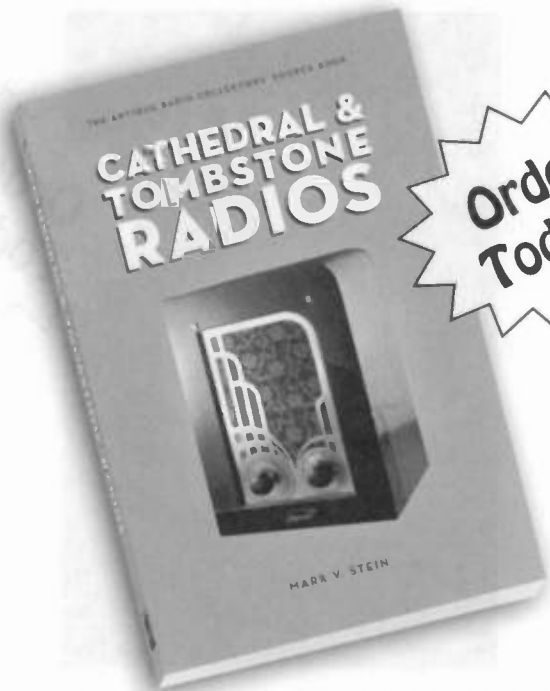

**Order  
Today!**

1,500 pictures of cathedral and tombstone radios  
from the U.S. and Canada with current values.

288 pages

**\$29.95 - Softcover**

**Everything stocked and shipped promptly — Radio is our middle name.**

A.R.C., P.O. Box 2, Carlisle, MA 01741 – Toll Free: (866) 371-0512

Fax: (978) 371-7129 – E-mail: [ARC@antiqueradio.com](mailto:ARC@antiqueradio.com) – Web: [www.antiqueradio.com](http://www.antiqueradio.com)



Free shipping & handling on all U.S. orders (typical U.S. order will be received within 7 days, but allow 2-3 weeks).  
Mass. residents add 5% sales tax. Non-U.S. orders, write for shipping costs, or use credit card. Most orders  
shipped by next business day. If using credit card, include name on card, card number and expiration date. Send  
payment with order. Money back return policy. Subscribers, ask for discount when placing order: 10% off books.



(#42-Apr08)

*Perera's*  
**Telegraph Collectors Guide**  
*Third Edition*  
by Tom Perera, W1TP

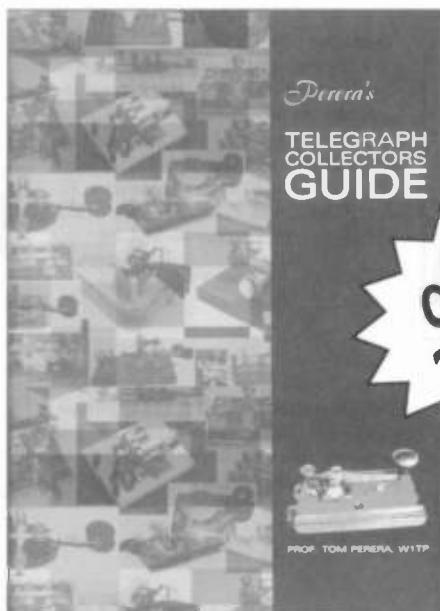

Basic information and reference material for collectors. 300 pictures and descriptions. 300 current prices (the prices the average collector would pay for them.) New 1,600 item cross-referenced index. Full color water-resistant cover (great for meets!).

104 pages

**\$19.95 - Softcover**

**Everything stocked and shipped promptly — Radio is our middle name.**

A.R.C., P.O. Box 2, Carlisle, MA 01741 – Toll Free: (866) 371-0512  
Fax: (978) 371-7129 – E-mail: [ARC@antiqueradio.com](mailto:ARC@antiqueradio.com) – Web: [www.antiqueradio.com](http://www.antiqueradio.com)



Free shipping & handling on all U.S. orders (typical U.S. order will be received within 7 days, but allow 2-3 weeks). Mass. residents add 5% sales tax. Non-U.S. orders, write for shipping costs, or use credit card. Most orders shipped by next business day. If using credit card, include name on card, card number and expiration date. Send payment with order. Money back return policy. Subscribers, ask for discount when placing order. 10% off books.



(#44-Sep08)

# Tickling the Crystal: Domestic British Crystal Sets of the 1920s

by Ian L. Sanders



**Tickling the Crystal.** *Comprehensive coverage of British crystal sets. Twelve chapters on history, circuits, aerials, headphones, etc. Chapter thirteen contains photos, detailed description, original price, etc. of hundreds of sets. Seven appendices. Index. B&W photos. 8 1/2" x 12", 2001, 256 pages. Hardcover — \$64.95*



**Tickling the Crystal 2,** *B&W photos, 2004, 208 pages. Hardcover, (slight corner dent on some for \$50.00) or — \$64.95 for perfect.*



**Tickling the Crystal 3,** *Third in a series on domestic British crystal sets. B&W photos, 2004, 240 pages. Hardcover — \$64.95*



**Tickling the Crystal 4,** *Cumulative index to Vols. 1, 2, 3, & 4. Many color photos in addition to B&W, 2008, 280 pages, Hardcover — \$64.95*

**Everything stocked and shipped promptly — Radio is our middle name.**

**A.R.C., P.O. Box 2, Carlisle, MA 01741 – Toll Free: (866) 371-0512**

**Fax: (978) 371-7129 – E-mail: [ARC@antiqueradio.com](mailto:ARC@antiqueradio.com) – Web: [www.antiqueradio.com](http://www.antiqueradio.com)**



Free shipping & handling on all U.S. orders (typical U.S. order will be received within 7 days, but allow 2-3 weeks).

Mass. residents add 5% sales tax. Non-U.S. orders, write for shipping costs, or use credit card. Most orders shipped by next business day. If using credit card, include name on card, card number and expiration date. Send payment with order. Money back return policy. Subscribers, ask for discount when placing order. 10% off books.



(#45-Jul08)

# CRYSTAL CLEAR

By Maurice L. Sievers

## Volume 1

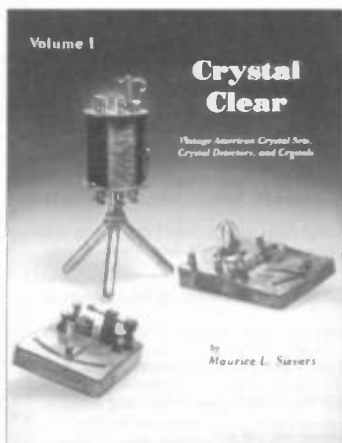

750 Illustrations – 570 Crystal Sets  
341 Detectors – 207 Crystals  
Perfect for the beginning collector!  
Useful for the experienced too!

*Crystal Clear* is the most comprehensive reference for collectors, historians and anyone interested in early radio. In addition to the many excellent photos and reproductions of ads, *Crystal Clear* includes lists showing all sets by manufacturer, set name, selling price and date of manufacture. 8 1/2" x 11", 282 pages.

**\$29.95 – Softcover**

## Volume 2

*Crystal Clear, Vol. 2* supplements the first volume. It identifies an additional 172 crystal radio sets, 91 crystal detectors and 26 crystals by manufacturer, model, year produced, description and original selling price. Further research on many of the crystal sets covered in Volume 1. Detailed history on the Philmore Manufacturing Company and the Western Manufacturing Company. 8 1/2" x 11", 252 pages.

**\$29.95 – Softcover**

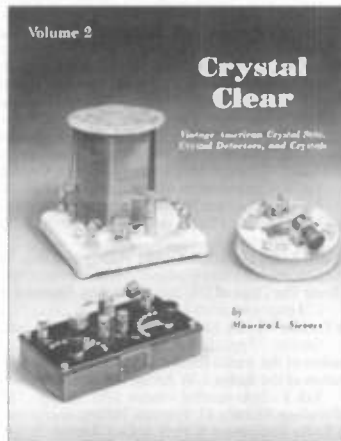

**Everything stocked and shipped promptly — Radio is our middle name.**

**A.R.C., P.O. Box 2, Carlisle, MA 01741 – Toll Free: (866) 371-0512**

**Fax: (978) 371-7129 – E-mail: [ARC@antiqueradio.com](mailto:ARC@antiqueradio.com) – Web: [www.antiqueradio.com](http://www.antiqueradio.com)**



Free shipping & handling on all U.S. orders (typical U.S. order will be received within 7 days, but allow 2-3 weeks). Mass. residents add 5% sales tax. Non-U.S. orders, write for shipping costs, or use credit card. Most orders shipped by next business day. If using credit card, include name on card, card number and expiration date. Send payment with order. Money back return policy. Subscribers, ask for discount when placing order: 10% off books.



(#7-Jul08)

# COLLECTOR BOOKS AVAILABLE FROM A.R.C.

BOOKS MARKED WITH "R" ARE THE MOST POPULAR AND ARE ESPECIALLY RECOMMENDED FOR NEW COLLECTORS!

Antique Phonograph Accessories & Contraptions, Fabrizio & Paul. Accessories from painted horns to record storage, 555 color photos, price guide, 224 pgs. ....	(hardcover) \$49.95
Antique Trader Radio & TV Guide, Husfloen, Editor. Covers 30 years of radio & 40 years of TV, 272 pgs. ....	\$19.95
The AWA Review. Vols. 1-5 on CD-ROM: Complete text of volumes 1, 2, 3, 4, and 5 of the AWA Review. Selections: AWA & its museum, Atwater Kent, DeForest, RCA-GE, Western Electric. ....	\$19.95
The AWA Review. Order by volume.	
Vol. 6: Hawaiian Wireless, U.K. Television, SCR-RC-BC Dir., NYC Wireless. ....	\$10.00
Vol. 7: Poldhu transmitters, Navy equipment, Arc transmitters. ....	\$10.00
Vol. 11: Scott Radio Products, National sliding coil receivers. ....	\$20.00
Vol. 13: Northern Electric Co., Marconi, Radio Direction Finding, Radio Station WBT, Early Radio Stations. ....	\$20.00
Vol. 14: Spark Keys, Canadian Marconi, Bakelite Radios. ....	\$27.50
Vol. 15: Marconi Wireless Telegraph Apparatus in R.M.S. Titanic. America's Broadcasting System. First Commercial Light-Socket operated radio receivers with AC tubes from Rogers Ltd., Toronto, Canada. Cumulative table of contents for all volumes of the AWA Review. ....	\$24.95
Vol. 19: Extraordinary Triplett 630 VOM Series, Radio Pioneer Dr. David G. McCaa, CQ Small Format Amateur Radio Books, TV Historian George Shiers, E.H. Scott Serial Numbers, Radio Intelligence in WWII, Fessenden's Christmas Eve Broadcast, Morse Code Training Devices. ....	\$14.00
Vol. 20: One Hundred Years of Electronic Communications, Henry J. Nolle & GE's High Power, Metal Envelope Tubes, Marconi vs. DeForest Audion Infringement Litigation, WWI Aircraft Radio, 1902 Wireless Connection, Electric Loudspeaker, Emil J. Simon, Francis A. Hart, Supreme Model 45 Tube Tester and the 1933 Tube Pin Standard. ....	No Discount \$15.00
A. Atwater Kent, The Man, the Manufacturer and His Radios. Patterson, Editor. Compilation of articles by Ralph Williams and John P. Wolkonowicz on Atwater Kent sets from the 1920s. 108 pgs. ....	\$25.95
The Antique Radio Boys and the Garrulous Grebe, Dryer. Adventure story written in the style of the '20s & '30s. 51 pgs. ....	\$4.95
The Auto Radio, Matteson. Info., photos & ads of the auto radio through the 1950s. 316 pgs. ....	(hardcover) \$34.95
Bonham's Catalog: Mark Woolley Vintage Radio Collection, Color photos of Catalins with realized price insert. ....	\$25.00
Bret's Old Radios Presents: Antique Radio Restoration, Vol 3, Menassa. (DVD). Plastic cabinet repair & refinishing. ....	\$39.95
Bret's Old Radios Presents: Antique Radio Restoration, Vol 4, Menassa. (DVD). Wood cabinet repair & refinishing. ....	\$39.95
Broadcasting's Forgotten Father. (Videotape, VHS). The Charles Herrold story. ....	\$29.95
Cathedral & Tombstone Radios, Stein. For identification of 1,500 cathedral & tombstone sets. 288 pgs. ....	\$29.95
Classic Cones, Chidester. Pictorial reference & value guide for 1920s radio cone speakers. 100s of color photos. 2001. 122 pgs. ....	\$25.95
Collectable Transistor TVs, Bunis. ID & values for 150 transistor TVs from 29 manufacturers. B&W photos. 44 pgs. ....	\$19.95
Collector's Guide to Antique Radios, 6th Edition, Slusser. Covers the 1920s to the 1950s. Over 10,000 models. 1,000 color photos. Updated 2004 pricing. 320 pgs. ....	\$20.00
Collector's Guide to Antique Radios, 7th Edition, Slusser. Covers the 1920s to the 1950s. Plus 14 additional manufacturers. Over 10,000 models. 1,200 color photos, (15% more than the last edition). Updated 2007 pricing. 320 pgs. ....	\$24.95
The Collector's Guide to Novelty Radios, Bunis & Breed. Descriptions with prices. 600+ color photos. 1994. 224 pgs. ....	\$18.95
The Collector's Vacuum Tube Handbook, Vol. 1, Millard. Hard-to-find electrical data on 200+ tube types that pre-date the RMA standardized numbering system (1934). Basing diagrams, photos & brief developmental histories. 196 pgs. ....	\$25.95
The Compleat Talking Machine, 5th Ed. Reiss. A guide to antique phonographs. Updated and revised price guide. Covers construction, cleaning and repairing of parts and cabinets. Over 700 pictures. 249 pgs. ....	\$29.95
The Complete Price Guide to Antique Radios: Pre-War Consoles, Stein. Identifies, grades, values & pictures 3,500 models. Tube & band count information & variations. Resource section. 240 pgs. ....	\$29.95
The Complete Price Guide to Antique Radios: Sears Silvertone Catalogs 1930-1942, Stein. 1,000+ radios. Original advertising, options, specs & pricing. Full model cross reference matrix with tube & band counts, variations. 240 pgs. ....	\$34.95
Crystal Clear - Vintage American Crystal Sets, Crystal Detectors and Crystals, Sievers.	
Vol. 1 - Comprehensive reference with 750 illustrations, 570 crystal sets, 341 detectors, 207 crystals, 282 pgs. ....	\$29.95
Vol. 2 - 479 all new & different illustrations, more crystal sets, detectors and crystals identified, 252 pgs. ....	\$29.95
Early Development of Radio in Canada, Murray, Editor. Illustrated history of Canada's radio pioneers, broadcast receiver manufacturers and their products. ....	\$26.95
E.H. Scott Radio Collectors Guide, 1925-1946, Clark. The reference for collectors of Scott radios, cabinets and accessories. Lists original prices of cabinets and accessories. Over 200 photos with descriptions. 88 pgs. ....	\$29.95
E.H. Scott The Dean of DX, 2nd Ed, Hobbs. Expanded, new edition of the definitive book on E.H. Scott. Additional chapters plus a 24-page color photo section. 240 pgs. ....	\$29.95
Ernst Fredrik Werner Alexanderson, Nilsson. One Individual's Life and Contributions to Electrical Science in the First Half of the 20th Century, 72 pgs. ....	\$25.00
Evolution of the Audio Recorder, Van Praag. Comprehensive guide to the audio recorder. 1997. 518 pgs. ....	\$39.95
Evolution of the Radio, L-W Books. Radios pictured and priced, plus reproductions of catalog pages and ads. Vol. 1 - Eight-hundred + radios. 1991. 227 pgs., 118 pgs. in color. ....	\$22.95
The Fabulous Victrola 45, Vourtsis. History, descriptions, price guide. 176 pgs. 389 color & 55 b/w photos. ....	\$29.95
Firco Radio Equipment (J. Firth & Co.), Reprint. 26 pgs, B&W. ....	\$4.95
Fixing Up Nice Old Radios, Romney. Written by a retired radio instructor, this book covers Ohm's law, through battery sets, superhets and communications receivers. 1990. 300+ figures, 185 pgs. ....	\$35.00
Flick of the Switch, McMahon. The classic photo reference guide for '30s - '50s radios. 1000+ photos. 263 pgs. ....	\$11.95
Genuine Plastic Radios of the Mid-Century, Jupp & Piña. Overview of plastic tube radios with advertisements, vintage black & white photos. 439 color photos. 208 pgs. ....	(hardcover) \$39.95
Grimeton Radio SAQ, Alexanderson. Submarine communication, world heritage. (English, Svenska, Deutsch) 32 pgs. ....	\$8.30
Ham Price Guide, 2nd, Rippen. Prices for over 3,800 transceivers, receivers, tuners, transmitters, amplifiers, antennas and test equipment. Additional prices for books, tubes and catalogs. 1999. 81 pgs. ....	\$10.95
Heathkit, A Guide to the Amateur Radio Products, 2nd Ed., Person. Updated and expanded documentation of Heathkit's amateur radio products and a history of the company, 328 pgs. ....	\$29.95
The Mechanics of TV, Yanczer. Explanation of mechanical tv, details for a working system. 170 pgs. ....	\$24.95
Minifon, Der Spion in Der Tasche, Schellin. German tape recorder book. Written entirely in German. 196 pgs. ....	\$23.95
Most Often Needed 1926-38 Radio Diagrams and Servicing Information (reprint). 600+ diagrams for mostly AC radios from '26-'38. 240 pgs. ....	\$18.50



# COLLECTOR BOOKS AVAILABLE FROM A.R.C.

★ BOOKS MARKED WITH "★" ARE THE MOST POPULAR AND ARE ESPECIALLY RECOMMENDED FOR NEW COLLECTORS!

- Novelty Radio Handbook and Price Guide, Weaver. 600+ Color photos. 160 pgs. .... \$29.95
- Old Radio Sets, Hill. *The development of the radio in Britain from the late Victorian era until the late 60s.* 60 photos. 32 pgs. .... \$4.95
- ★ Old-Time Radios! Restoration and Repair, Carr. *How to repair vacuum-tube and transistor radios. A self-paced training guide.* 200 illustrations, 256 pgs. .... \$19.95
- The Old Timer's Bulletin, AWA. *Back issue library on CD-ROMs. Vol. 2 only: Jun. 1985-Nov. 1996, searchable index.* .... \$49.95
- Perera's Telegraph Collectors Guide, Perera. *Basic info & reference material, 300 pictures, descriptions & current prices.* 104 pgs. .... \$19.95
- Philco Condensers and More, Third Edition, Bintliff. *Updated and expanded service data. 300 illustrations, 74 pgs.* .... \$14.95
- Philco Radio: 1928-1942. 2nd Ed., Ramirez. *A reference book on Philco. Shows receivers and company history year-by-year.* 464 color photos, 364 black & white photos and drawings. 160 pgs. .... \$29.95
- Phonographica, Fabrizio & Paul. *Early history of recorded sound, 1877-1930.* 224 pgs, 500 color photos .... \$49.95
- Plastic Radios, Stein. *For identification of Catalin, Bakelite, Plaskon, Beetle, Tenite & Styrene sets. Includes history, 3,000 radio listings with photos, 120 manufacturers, 255 pgs.* .... \$37.95
- A Pictorial History of Collins Amateur Radio Equipment, Miller. *The most complete story of Collins. Told in hundreds of photos and in the words of the men who made it happen.* 1999. 175 pgs. .... \$39.95
- Portable Radio In American Life, Schiffer. *Traces the development of the portable radio and how it affected American culture and society.* 450 photos and drawings, 259 pgs. .... Hardcover \$45.00 or Softcover \$27.95
- Radio Craft - 50 Years of Radio, (reprint), March 1938 issue of Radio Craft magazine. *Numerous articles on the development of radio, then 50 years old, and on early radio pioneers.* 144 pgs. .... \$15.95
- Radio Dial Belts, Bintliff. *A guide to the selection and replacement of dial belts in radios from the 1930 & 1940s.* 50 pgs .... \$15.95
- Radios by Hallicrafters, 2nd Ed., Dachis. *The most definitive book on the company. Over 1,000 photos (some color) on everything they made. Additional coverage & updated pricing. An invaluable tool for anyone interested in Hallicrafters.* 225 pgs. .... \$29.95
- Radio Manufacturers of the 1920's, Douglas. 3 volumes. .... \$29.95
- Vol. 1: A-C Dayton thru Ferguson, 225 pgs. .... \$29.95
- Vol. 2: Freed-Eisemann thru Priess, 266 pgs. .... \$29.95
- Vol. 3: RCA thru Zenith, 292 pgs. .... \$29.95
- Radio Tubes and Boxes of the 1920s, Fathauer. *A pictorial presentation of radio tubes of the 20s, including packaging and advertising.* 400+ color photos and illustrations. 1999. 105 pgs. .... \$26.95
- ★ Radiola - The Golden Age of RCA, 1919-1929, Wenaas. *Documents & pictures every radio receiver and the major accessories sold by RCA during the first decade.* 700 color photos, 485 pgs. .... Hardcover \$65.00
- Saga of the Vacuum Tube, Tyne. *The development of vacuum tubes - 1880 to 1930. From Edison, Thomson and Fleming to de Forest, Philips, Siemens and many more.* 100+ tube photos, 495 pgs. .... \$18.95
- S. Gernsback Radio Encyclopedia (reprint). *1927 classic encyclopedia on radio. From "A" battery to Zirconium, with 1000s of entries in between.* 100s of illustrations, 175 pgs. .... \$9.95
- Tickling the Crystal, Sanders. *Comprehensive coverage of British crystal sets from the 1920s.* 200+ B&W photos. 2001. 256 pgs. .... \$64.95
- Tickling the Crystal 2, Sanders. *Domestic British Crystal Sets of the 1920s.* 2004. 208 pgs. .... \$50.00  
(slight corner dent so the price is reduced from \$64.95 to)
- Tickling the Crystal 3, Sanders. *Third in a series on domestic British crystal sets.* 2004. 240 pgs. .... \$64.95
- Tickling the Crystal 4, Sanders. *Next in a series on domestic British crystal sets. Many color photos in addition to B&W.* Cumulative index to Vols. 1, 2, 3 & 4. 2008. 280 pgs. .... \$64.95
- Transistor Radios: 1954-1968, Smith. *Over 1,000 transistor radios identified by manufacturer, marketing organization, type, and style.* Color photos and price guide, 1998. 160 pgs. .... \$29.95
- Tube Lore, Sibley. *Trends in tube design, receiving and audio tubes, special-purpose and transmitting tubes, military types, tips on testing, repairing, adapting various tubes, auction prices from six major sales.* 186 pgs. .... \$19.95
- Tube Testers and Classic Electronic Test Gear, Douglas. *Overview of pre-1970 radio test equipment. Discusses tube testing & use of testers. Compares emission, dynamic & mutual conductance testers. Tabulates & pictures testers from 23 manufacturers. Over 300 photos & illustrations.* 163 pgs. .... \$25.95
- Wireless Communication in the U.S., Mayes. *Early development of American radio operating companies. Alternators, coherers, stock promotions, unpublished letters, etc.* 160 illustrations, 240 pgs. .... \$29.95
- The Xtal Set Society Newsletter. *Order by volume.*
- Vol. 3-The Crystal Set Handbook: *Formulas for coil inductance, procedure for measuring coil capacitance, circuit matching theory, etc.* .... \$10.95
- Vol. 4: *1/94 to 11/94 - Measuring Coil Capacitance, home-brew headphones and curve tracers, etc.* .... \$10.95
- Vol. 5: *AM Receiver Design, Marconi Type 107, Radio Outfit in a Headset, etc.* .... \$10.95
- Vol. 6-7-Crystal Set Building and More: *Projects and info. about crystal radios, mostly dealing with design and elec. issues, etc.* \$15.95
- Zenith The Early Years, 1919-1935, Bryant and Cones. *The 1st of a planned 3-book series. Explains the Zenith story. Discover never published photos, documents and info.* 300 photos and illustrations, 120 in color. 224 pgs. .... \$29.95
- Zenith The Glory Years, 1936-1945, Cones, Bryant & Blankinship. *Illustrated Catalog & Database, 520 B&W images* 182 pgs. .... \$29.95
- Zenith The Glory Years, 1936-1945, Cones, Bryant & Blankinship. *History & Products, 180 color, 183 B&W photos, 256 pgs.* .... \$34.95
- Zenith Radio Corporation (reprint). *The instructions for installation and operation for Models 39-39A Models 392-392A, and Electric Zenith Receivers.* 3 schematics, 3 photos. 16 pgs. .... \$4.50
- Zenith Transistor Radios, Evolution of a Classic, Smith. *A complete listing of all transistor radio models created by Zenith during the "Magic Years" from 1955-65. Color photos and price guide.* 1998. 160 pgs. .... \$29.95
- The Zenith Trans-Oceanic: *The Royalty of Radios, 2nd Edition, Bryant and Cones. Presents the fascinating story of the development and use of the Trans-Oceanic. Photos, documents, ads, etc. includes updated prices.* 176 pgs. .... NEW \$34.99

Everything stocked and shipped promptly — Radio is our middle name.

A.R.C., P.O. Box 2, Carlisle, MA 01741 – Toll Free: (866) 371-0512

Fax: (978) 371-7129 – E-mail: ARC@antiqueradio.com – Web: www.antiqueradio.com



Free shipping & handling on all U.S. orders (typical U.S. order will be received within 7 days, but allow 2-3 weeks). Mass. residents add 5% sales tax. Non-U.S. orders, write for shipping costs, or use credit card. Most orders shipped by next business day. If using credit card, include name on card, card number and expiration date. Send payment with order. Money back return policy. Subscribers, ask for discount when placing order. 10% off books.



# **Collector's Guide To Antique Radios 7th Edition**

**By John Slusser & the Staff of Radio Daze**

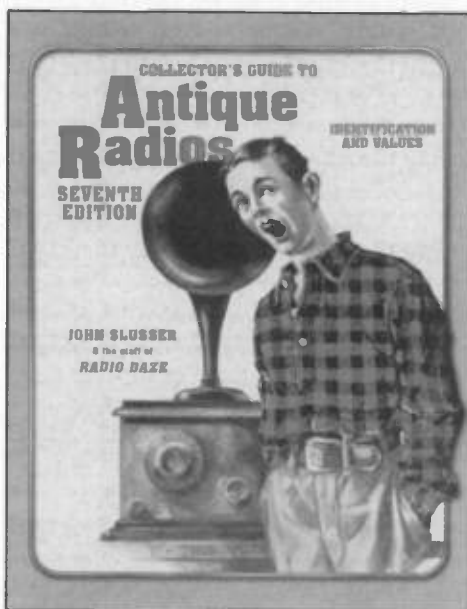

**Over 10,000 sets from the 1920s - 1950s  
(14 additional manufacturers included)**

**Approximately 1,200 Color Photographs  
(15% more than the last edition)**

**Updated 2007 prices  
\$24.95 - Softcover**

**Everything stocked and shipped promptly — Radio is our middle name.**

**A.R.C., P.O. Box 2, Carlisle, MA 01741 – Toll Free: (866) 371-0512**

**Fax: (978) 371-7129 – E-mail: [ARC@antiqueradio.com](mailto:ARC@antiqueradio.com) – Web: [www.antiqueradio.com](http://www.antiqueradio.com)**



Free shipping & handling on all U.S. orders (typical U.S. order will be received within 7 days, but allow 2-3 weeks). Mass. residents add 5% sales tax. Non-U.S. orders, write for shipping costs, or use credit card. Most orders shipped by next business day. If using credit card, include name on card, card number and expiration date. Send payment with order. Money back return policy. Subscribers, ask for discount when placing order. 10% off books.



(#41-Jun08)

# Classified Ads On-Line at [www.antiqueradio.com](http://www.antiqueradio.com)

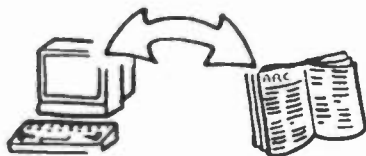

★ Classified Ads are On-Line! ★  
For Subscribers Only!  
Updated Monthly

Check the "Latest Web Site News" on the A.R.C. Web Site  
for the Release Date of the Next Month's Ads.

The Cover, On The Cover, Editor's Page  
One or More Feature Articles (Web Editions)  
Book Reviews, Radio Miscellanea  
Coming Radio Events & Mark Your Calendar  
Radio Club Listing (over 80 clubs, worldwide)  
Links to Over 200 Related Web Sites

Archives on the A.R.C. Web Site

Article Archive: Web Editions of A.R.C. since 1995

The A.R.C. Marketplace

Request a Free Sample Copy

Subscribe and Renew

Order From Over 80 Books and Videos

Also on the A.R.C. Web Site

Frequently Asked Questions (FAQ) about A.R.C.

E-mail A.R.C. With Your Ads and Comments

---

A.R.C., P.O. Box 2, Carlisle, MA 01741. Tel: (866) 371-0512  
Fax: (978) 371-7129 – E-mail: [arc@antiqueradio.com](mailto:arc@antiqueradio.com) – Web: [www.antiqueradio.com](http://www.antiqueradio.com)

(#15-Jan08)

PERIODICALS



A.R.C., P.O. Box 2, CARLISLE, MA 01741  
ADDRESS SERVICE REQUESTED

\*\*\*\*\*AUTO\*\*MIXED AADC 024  
G-BS SUB#=26-20441 [3592] 18  
EXP=SEP10 20

LAVERN VELAU  
1650 PALM AVE  
PO BOX 143  
KLEMME IA 50449-0143



[WWW.ANTIQUERADIO.COM](http://WWW.ANTIQUERADIO.COM)

**CLASSIFIED AD  
DEADLINE NOV. 10th  
Noon Eastern Time**