



ANTIQUE RADIO CLASSIFIED

VOLUME 14

AUGUST 1997

NUMBER 8

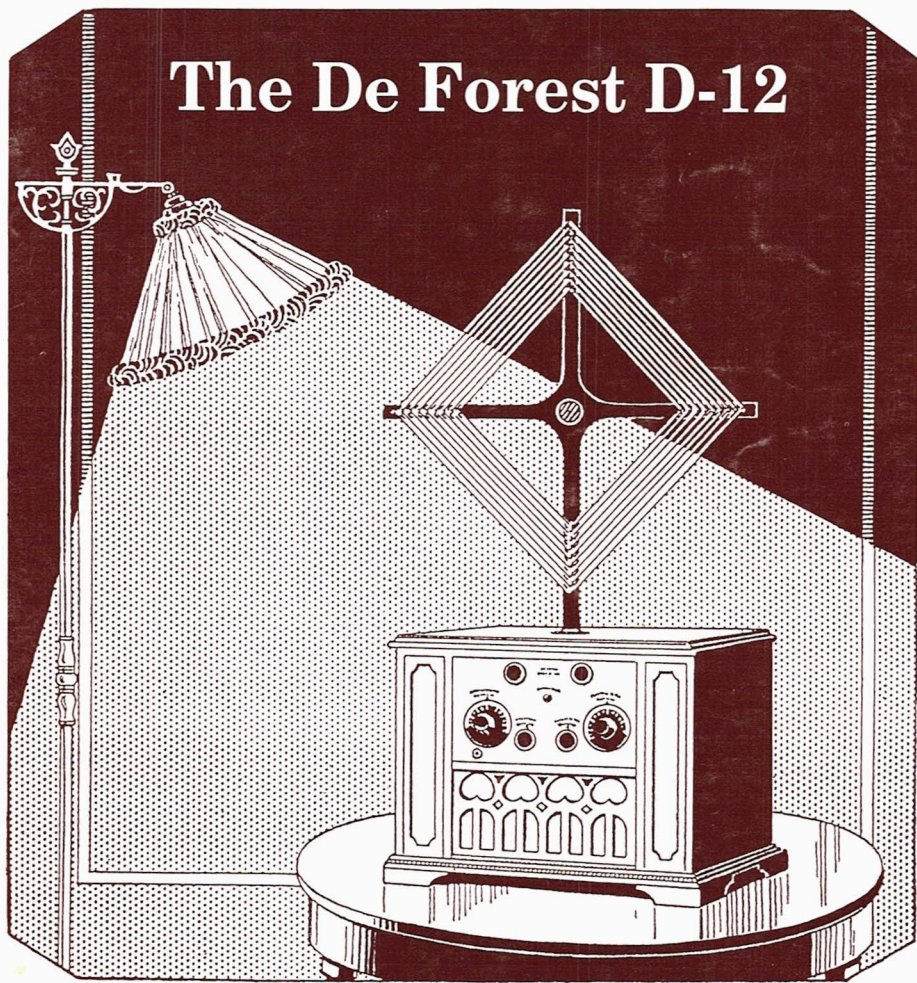

The De Forest D-12

A.R.C. — THE NATIONAL PUBLICATION FOR BUYERS AND SELLERS
OF OLD RADIOS AND RELATED ITEMS — PUBLISHED MONTHLY

ANTIQUE RADIO CLASSIFIED

Antique Radio Classified (ISSN:8750-7471) is published monthly, 12 times per year, by John V. Terrey, One River Road, P.O. Box 2, Carlisle, MA 01741. Periodicals postage paid at Carlisle, MA, and additional mailing offices. Telephone: (508) 371-0512, 8:30 AM to 6:00 PM ET weekdays; machine answers phone at other times.

Annual subscription rates within the U.S. are \$38.95 by Periodicals mail and \$55.95 by First Class mail.

Annual foreign rates. By air: Canada - \$59.00; Mexico - \$65.00; Other foreign countries - \$100.00. Surface mail: Canada - \$49.00; Other foreign countries - \$55.00. (Surface delivery to countries other than Canada may take two or more months and cannot be guaranteed.)

Two-year subscriptions are twice these rates and receive an extra month. Sample issues are available free on request.

© Copyright 1997 by John V. Terrey.

POSTMASTER: Send address changes to Antique Radio Classified, P.O. Box 2, Carlisle, MA 01741.

Printed in U.S.A.

STAFF:

Publisher and Editor: John V. Terrey
Production Manager: Scott J. Young
Office Manager: Lisa A. Friedrichs
Advertising Manager: Cindie P. Bryan
Managing Editor: Dorothy Schecter
Radio Events Editor: Chris Frederickson
Publishing & Editorial Staff: Ray Bintliff, Dave Crocker, Dick Desjarlais, Bobby Lyman, Jean Meldonian
Founding Publisher/Editor: Gary B. Schneider
Contributing Writers: Mike Adams, Richard L. Arnold, Ray Bintliff, Ron Boucher, Paul J. Bourbin, Norman S. Braithwaite, Dave Crocker, Alan S. Douglas, Richard C. Foster, Fred Geim, Jim Kreuzer, Ron Ramirez, Henry Rogers, Ian L. Sanders, Gary B. Schneider, Daniel Schoo, Dwane Stevens, Frank R. White, Ralph Williams

PURPOSE. *Antique Radio Classified* is published for people involved in the radio collecting hobby. Its purpose is to stimulate growth of the hobby through the buying, selling and trading of radios and related items, and to provide a monthly forum for the interchange of ideas and information.

CONTACTING ANTIQUE RADIO CLASSIFIED. All correspondence should be sent to:

A.R.C., P.O. Box 2, Carlisle, MA 01741.

Only UPS, Federal, etc. items to street address: One River Road.

Telephone: (508) 371-0512; Fax: (508) 371-7129

E-mail: ARC@antiqueradio.com - Web: www.antiqueradio.com
 Please, no classified ads by telephone; thanks.

Your ads, renewals, letters, etc. can be handled faster and more efficiently if your name, address and SUB# are written on each. Unfortunately, A.R.C. is not staffed to answer letters with questions about antique radios or requests for advice. However, A.R.C. does solicit letters of interest to its readers and publishes them as space permits. A.R.C. assumes that permission is given to edit and to publish all correspondence and articles received unless otherwise indicated.

GUARANTEE. You may cancel your subscription at any time and receive a pro rata refund for issues not yet mailed. If errors to ads are made by A.R.C., upon request a free correction will be run in the next available issue.

PAYMENT. Please send in full payment with your order or ad. A.R.C. does not carry accounts; all subscriptions, ads, etc. must be prepaid (except for the 6 and 12 month display ads indicated below). Pay in U.S. funds. Checks drawn on a U.S. bank, money orders, VISA or MasterCard (\$10.00 min.) are preferred. Make check out to "A.R.C." U.S. stamps or cash are OK for small amounts. Canadian payers may send a Canadian check but specify U.S. funds. Subscriptions will be prorated to amount sent if amount is incorrect.

FAX & E-MAIL PROCEDURES/PAYMENT. Subscriptions, book orders, classified ads, display ads, etc. are welcome by fax or e-mail. Deadlines are the same as for ads received by mail. Please calculate the amount due. Payment by VISA or MasterCard is preferred if your order is over \$10. If under \$10, or if you prefer to send a check or money order, state the amount being sent and that the payment is in the mail. Do not send another copy of your ad with your payment; simply indicate that it is a fax or e-mail payment. If you want confirmation of our receipt of your fax, call immediately after sending your fax.

CHANGE OF ADDRESS. Please notify us 4 weeks in advance of a change of address. Send both your new and old addresses, and include your SUB# and effective date of your new address. Temporary address changes can be made also.

SUBMISSION OF MATERIAL. *Antique Radio Classified* welcomes and solicits information that pertains or relates to radio history or collecting. This may include articles, book reviews, photos, information on upcoming radio events, meetings, antique radio organizations, radio auctions, sources of old radio and restoration supplies, and other related and interesting material. All material submitted should be carefully researched, typed and accompanied by good photos, if appropriate. Computer disks are appreciated. Writing guidelines are available upon request. Unless prior arrangements are made, all submitted materials may be edited, become the property of *Antique Radio Classified* and will not be returned. Publication is subject to approval by A.R.C. and to time and space constraints.

MAILING OF ISSUES. U.S. subscribers can receive A.R.C. by First Class or Periodicals mail (Periodicals is the way most magazines are mailed). The mailing of First Class copies is staggered with faraway copies mailed before local copies. Non-U.S. copies are mailed on the first day. Periodicals copies are mailed on the last day. Mailing dates change each month, but mailing is usually completed by the 27th of the month. First Class copies usually are received by the 5th of the month; copies by Periodicals mail, by the 10th.

ETHICS. No person involved in the production of A.R.C. is to act on any information in the magazine until the first delivery day after local copies are mailed.

DISCLAIMER. The publisher is not responsible for any buying and selling transactions incurred, or for any other use of the contents of this publication.

Antique Radio Classified subscription rates, frequency of publication, content, policies, size and ad details, and rates are subject to change at any time by A.R.C.

DISPLAY AND BUSINESS CARD ADS - DETAILS AND RATES

The deadline is the first of the month for display and business card ad artwork, payment and repeat requests.

Advertising is accepted only for early items related to radio, communication, etc. All items must be described fairly; reproductions, reprints and non-original items must be so identified. Advertisers must agree to respond promptly to inquiries and orders, to resolve problems promptly if the buyer is not satisfied, and to comply with a buyer's refund request on unaltered returned items.

Advertising must be prepaid, except as noted below: see "Payment" paragraph above for details. Late ads will be run only if space and time permit. Since artwork is reduced to 63% in the printing process, originals must be the artwork size listed below. Do not send in artwork on art board or send negatives. Ads should be typeset or typed neatly with a carbon ribbon, black ink (not pencil) on white. If used, reverse type must be limited to 25% of the ad. If you want us to prepare your ad, include the one-time cost below for A.R.C. to make up the ad.

Photos should be at an 85-line screen; otherwise, add \$15.00 per photo for screening. Do not cut or trim photos or glue photos to artwork; submit separately.

If you are confused by these requirements and terms, please

Page	ARTWORK SIZE (SEND IN THIS SIZE)		As Printed (size in magazine)		Cost for 1-month	Cost for 3-months	Cost for 6-months	Cost for 12-months	One Time to make up Ad
	H x W (inches)	H x W (inches)	H x W (inches)	H x W (inches)					
Full	12 7/16 x 7 1/2	7 3/4 x 4 3/4	7 3/4 x 4 3/4	7 3/4 x 4 3/4	\$269.00	\$719.00	\$1239.00*	\$2159.00**	\$69.00†
1/2 H	5 1/4 x 7 1/2	3 5/16 x 4 3/4	3 5/16 x 4 3/4	3 5/16 x 4 3/4	136.00	363.00	629.00*	1095.00**	37.00†
1/2 V	12 7/16 x 3 9/16	7 3/4 x 2 1/4	7 3/4 x 2 1/4	7 3/4 x 2 1/4	136.00	363.00	629.00*	1095.00**	37.00†
1/4	5 1/4 x 3 9/16	3 5/16 x 2 1/4	3 5/16 x 2 1/4	3 5/16 x 2 1/4	69.00	184.00	319.00*	555.00	19.00†
1/8	2 5/8 x 3 9/16	1 5/8 x 2 1/4	1 5/8 x 2 1/4	1 5/8 x 2 1/4	35.50	95.00	165.00	285.00	9.00†
Business Card (1st)	2 x 3 3/4	1 1/4 x 2 3/8	1 1/4 x 2 3/8	1 1/4 x 2 3/8	not avail.	49.00	84.00	147.00	7.00†
Business Card (2nd...)	2 x 3 3/4	1 1/4 x 2 3/8	1 1/4 x 2 3/8	1 1/4 x 2 3/8	not avail.	64.00	110.00	191.00	7.00†

* Full & 1/2 page, 6-mos.; ** Full & 1/2 page, 12-mos.; † 1/4 due with order; 1/4 due at 3, 6 & 9 mos.

† For 6 and 12 month ads, no ad make-up charge if no change is made to ad for entire run.

contact A.R.C. before beginning to prepare your ad. We will be happy to advise you on your ad ideas, estimate how much the ad will cost, recommend an ad size, etc.

We assume that advertisers want all ads which are submitted to run without delay; therefore, we will run the ad and bill for any additional work required for the ad to meet these specifications. A late ad will run beginning with the next month. "Tear sheets" will be sent only for 1/8-page or larger ads and only if requested when the ad is submitted.

First business card per advertiser is at lower rate.

The 3-month rates represent about an 11% discount, the 6-month rates 23%, the 12-month rates 30%. Placement requests: add 15% but call first. Clubs: write for discount policy.

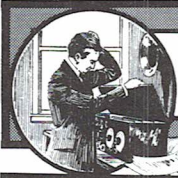

ANTIQUE RADIO CLASSIFIED



EDITOR'S COMMENTS

Well, here it is — A.R.C.'s very own "rogues' gallery." The photo below was taken at a fond farewell party for Chris Frederickson, our Radio Events Editor, and the subject in this issue of the first A.R.C. staff profile. The rarity of our all being together in one place with a camera also inspired the photo. And at last, we could fulfill a wish expressed often by some of you — to put a face to the voice on the phone or the signature on a letter. Perhaps we should have called in a *Life* photographer to show us in our usual perpetual motion, but we'll save that for next time.

While we are in the celebratory mood prompted by our recent party and the many summer radio events, we remind you of our "International Collector Reception" at Radiofest XVI. We are hoping to see you all poolside at the Holiday Inn on Wednesday, August 6, at 5:00 P.M. We'll meet Jonathan Hill and friends from England, among others from abroad and around the U. S., and enjoy a relaxing hour, topped off by the fun of prize drawings. See you there!

Bob Merriam reminds us of a February good time in his article on the Radio XXVIII meet here in Massachusetts where he had a reunion with a Philco 66. As curator of the New England Wireless & Steam Museum, Bob will sponsor the annual "Yankee Radio Tune Up" on August 9, in Rhode Island. This and the many other August radio events will make interesting summer excursions for all you collectors.

Our lead article by Dave Gonshor is about the De Forest Models D-10, D-12 and D-17. In Ray Bintliff's article, he presents the construction details for an AC

line control box. Ray shows that he practices what he preaches in handling the potential dangers of the 110-volt AC line.

Don Hauff reports that Catalin sets brought the highest bids at the Radio Daze '97 auction. McMurdo Silver items were hot at the seventh annual Gene Harris Vintage Radio Auction, while a Story and Clark grandfather clock radio brought the highest bid at a March estate auction in Connecticut, according to Ray Chase.

For the computer buffs out there, Ray Bintliff reviews Radio Era Archives' first CD-ROM — *Radiophile, Volume 1*. Over 3,800 pages of early radio documentation are available for viewing, yet they occupy only $\frac{3}{8}$ inch on the shelf!

Photo Review features a striking French battery set, and *Radio Miscellanea* includes several items on shipping, along with other reader feedback.

Happy collecting, and I hope to see you at Radiofest!

John Terrey, Publisher

ON THE COVER

In keeping with this month's lead article on the De Forest Radiophones, our cover features an advertisement for the D-12 from the February 1925 *QST*. The big features lauded by the ad are the set's movability, its simplicity of operation, and the fact that it came complete with batteries, tubes, and De Forest loud-speaker. Prospective buyers had to realize, "There is nothing quite like it."

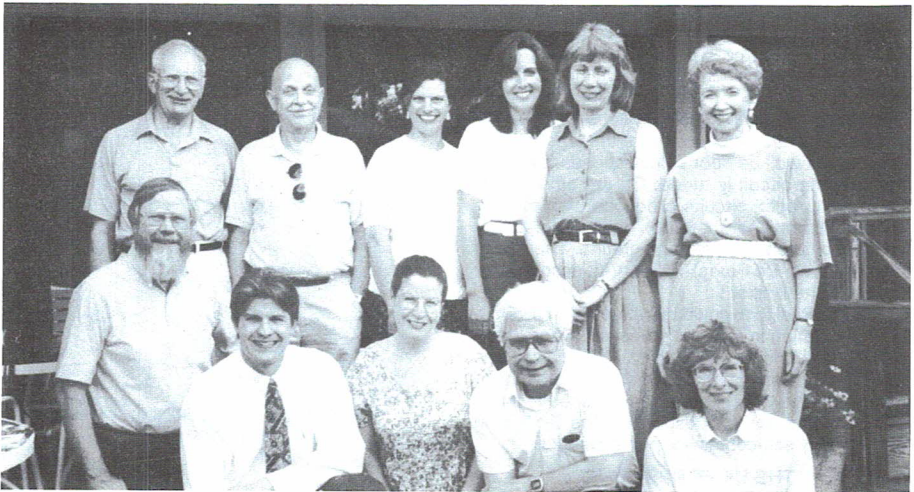

The A.R.C. Team. Front row, left to right: John Terrey, Editor; Scott Young, Production Manager; Lisa Friedrichs, Office Manager; Dave Crocker, Editorial Staff; Bobby Lyman, Office Staff. Second row, left to right: Dick Desjarlais, Editorial Staff; Ray Bintliff, Editorial Staff; Jean Meldonian, Office Staff; Cindie Bryan, Advertising Manager; Chris Frederickson, Radio Events Editor; Dorothy Schecter, Managing Editor.

WITH THE COLLECTORS

The De Forest Reflex Radiophones

BY DAVE GONSHOR

Dave Gonshor's description of the De Forest reflex Radiophone models provides another glimpse of Lee de Forest's bumpy ride through radio history. (Editor)

Studying the evolution of early broadcast receivers often reveals a fascinating combination of technology development and business decisions, sometimes showing folly in both. The De Forest D-12 Radiophone is no exception. The development of the D-12 begins with the D-10 design.

THE DE FOREST D-10

The D-10 is a 4-tube reflex receiver, using a crystal detector. Either Frank Squire or William Priess (the self-proclaimed "father of reflex") developed the D-10, although Gernsback gives credit for the invention of reflex to Marius Latour.

A reflex design simply means that one or more tubes are used for both RF and audio amplification. Reflexing reduces the number of tubes needed — an important factor in early radio when tubes were relatively expensive and battery depletion was a big headache.

In the D-10, two tubes have both RF and audio amplification functions. So, the receiver performs as a 6-tube radio (three stages of RF amplification and three stages of audio amplification) — seven if the detector is considered. Reflexing is a rather sophisticated electrical design technique, since the interstage RF and audio transformers are arranged so that a single tube can perform two functions. For a photo of the D-10, see Alan Douglas' *Radio Manufacturers of the 1920's, Volume 1*, page 176.

The D-10 has an obsolete (at the time) crystal detector as well as poor selectivity because only the antenna circuit is tuned. On the other hand, the radio's reflex circuits produced high amplification of both RF and audio. The poor selectivity is offset by the use of a loop antenna. The use of dry cell tubes, De Forest Type DV-3, accounts for the set's small size.

The external loop could be rotated to "null out" a stronger station in favor of a weaker station, compensating for the poor selectivity. At the time, it was the only loop set that had been made in production quantities. The only external item needed to make the radio play was a loudspeaker. The D-10 is an early, nearly self-contained, portable radio.

THE DE FOREST D-12 VERSIONS 1 AND 2

William Priess, De Forest's chief engineer, recognized the D-10's limitations in selectivity. He

added a tuned RF circuit to the design, but kept the rotatable loop antenna. A restyled larger cabinet (mahogany or leather-covered wood) and the addition of an internal horn speaker resulted in the first version of the D-12 radio. Figure 1 shows the D-12 with the detector hole uncovered.

Note how reflexing makes the circuit diagram, shown in Figure 2, appear complicated. The D-12 was designed to use either Type DV-2 storage battery tubes or Type DV-3 dry cell tubes, with a change in battery voltage and RF coils (according to the instruction book) necessary to switch from one tube type to the other.

The instruction book for the D-12 touts the crystal detector as superior to an audion detec-

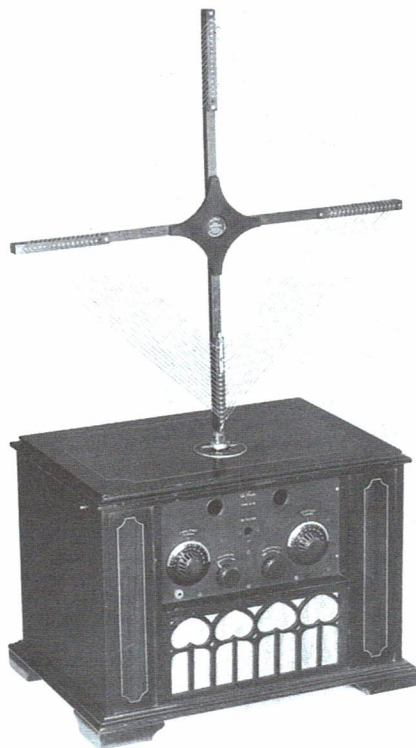

Figure 1. The De Forest D-12, showing the hole where the crystal detector has been removed. (Photo of Dave Crocker's set by Alan Douglas.)

tor due to the "practically perfect" rectification by the crystal and the "complete absence of the local generated noises" of an audion detector. Instructions are given on how to adjust the "gold wire" catwhisker for best reception. The first version of the D-12 used a crystal detector assembly like that of the D-10, and is considered quite rare. In the second version, a "bat wing" type of crystal detector replaced the D-10 type. Most of the D-12s found have this type of detector.

THE MODEL D-12 — VERSION 3

Roy Weagant, a new chief engineer hired by De Forest, must have recognized that using a crystal detector in an otherwise sophisticated radio design was antiquated. So, he upgraded the D-12 by replacing the crystal detector with an audion detector, and restyling the cabinet and panel. De Forest released this modified model as the D-17. One wonders whether the marketing implications of this new model were fully understood at the time.

Because of a temporary injunction obtained by RCA preventing de Forest from selling to jobbers and retailers, de Forest was forced to consign his radios to the selling agents. This meant that he,



Figure 3. Closeup of the detector hole cover plate on the De Forest D-12 panel, version 3.

not the seller, owned a radio until it was sold to a consumer. Weagant's redesign of the detector in the D-12 and sold as the D-17 immediately made obsolete all the D-12s in the showrooms.

In order to remedy this apparent blunder, the distributed D-12s were brought back to the factory, where tube detectors were added, and the crystal detectors, as well as one stage of reflex, were removed. Thus, these D-12s are the same as the newer D-17.

An easily identifiable characteristic of this new third version of the D-12 is that the detector adjustment hole in the front panel is covered by a small plate, shown in Figure 3. In addition, the "detector" label on the front panel was blackened to hide it. This tube detector version of the D-12 is fairly common.

Undoubtedly, these initial design deficiencies and the production changes, along with a complicated intertwining of patent rights and lawsuits, hurt De Forest's radio business. De Forest put his company into receivership in 1926, and the company produced no more radios after 1930.

It would be an interesting addition to a collection to have examples of all three models of the D-12s, but they're so scarce that the chances of finding more than one (at an affordable price) are very slim. Hopefully, this information will help you determine which version of the D-12 you have.

Information credit: Alan Douglas and Raymond Thompson

Reference:

Douglas, Alan. *Radio Manufacturers of the 1920s, Vol. 1*. Vestal, New York: Vestal Press, Ltd., 1988.

(Dave Gonshor, 7121 S. Jellison St., Littleton, CO 80123)

Dave Gonshor, an electrical engineer, is interested in collecting battery sets and wood AC sets for the 1930s. He enjoys both electrical and wood restoration, as well as the history of the development of radio. His collection includes two De Forest sets.

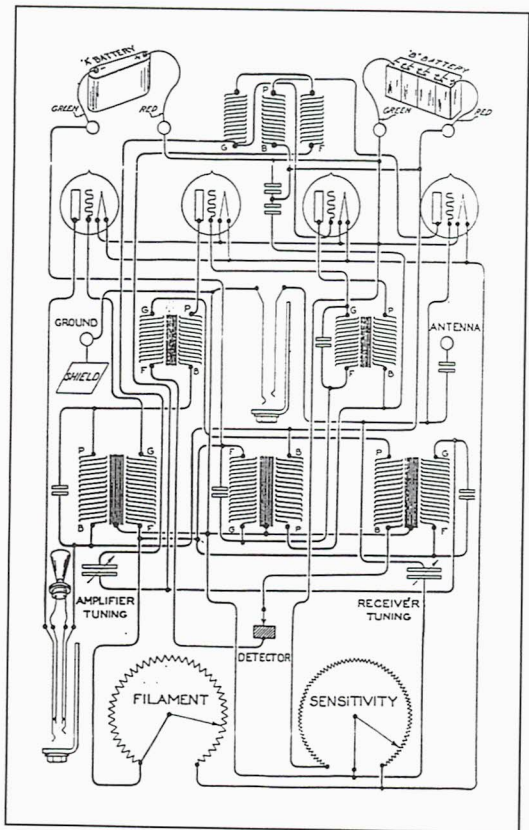

Figure 2. Schematic diagram of the first and second versions of the De Forest Model D-12.

WITH THE COLLECTORS

Radio XXVIII and the Philco 66

BY ROBERT W. MERRIAM

The Greater Boston Antique Radio Collectors (GBARC) held its 28th meet at the Westford Regency Inn, Westford, Mass., on February 23, 1997. Over 800 people viewed the wares of 92 exhibitor tables from 8 A.M. to 1 P.M., and that afternoon, some attendees stopped in nearby Carlisle to visit your editor John Terrey's collection. Feedback on the day's events has been uniformly positive, but the special success story told here by Bob Merriam, curator of the New England Wireless & Steam Museum and sponsor of the "Yankee Radio Tune-Up" on August 9, is one we hope every collector experiences sometime or other. No doubt you will also note in this story that Bob obviously has the perfect "radio wife." (Editor)

Radio XXVIII in Westford, Mass., was great. The A.R.C. staff did a splendid job, and my wife Nancy and I sure enjoyed ourselves meeting with new and old friends. Some of the old friends were radios; one such — a Philco 66, as shown in Figure 1 — went back to my boyhood.

We first saw the Model 66 early in the morning as we walked toward the main meeting room before the official opening. It was in a stack of interesting radios waiting to go in for setup. I pointed to it and mentioned to Nancy that my brother and I used to sit on the floor in front of that exact model listening to *Jack Armstrong — the All-American Boy*, *Bobby Benson* and the *H Bar O*, and the like.

The Model 66 introduced me to the 20-meter phone band, SW, BC, and more. Before my father bought that model, I had already been tinkering with crystal sets and flivver spark coils. But, with the Model 66 and plenty of help from Hugo Gernsback, the radio bug really got me.

Sometime during Radio XXVIII, Nancy had secretly acquired the Philco Model 66 [from A.R.C. staff member Dick Desjarlais, we're pleased to report] and happily surprised me with it as a gift when the show closed. [Your editor saw Bob during the meet frantically looking for the Philco 66, fearing someone had beat him to the purchase and made off with it.]

The tag on the set said that it hummed, perhaps a factor in slightly lowering the price. The reason for the hum, which I will get to later, prompts this article.

When we got back to Rhode Island, I dug out "Philco Service Bulletin 197," which covers the Model 66. This single sheet tells everything you need to know about the 66. It gives specifications, tube socket voltages, power transformer data, chassis layout and alignment procedures.



Figure 1. The Philco Model 66, a nostalgic reminder of Bob Merriam's boyhood radio days.

Figure 2 shows the tube and control layout for the Model 66.

This is the way an instruction sheet should be — a model of clarity and brevity. I wish the people at Microsoft would study it. Out of respect for the author of this bulletin, I will use "condenser" for capacitor and "kilocycle" for kilohertz, etc.

And like the instruction sheet, the design of the Model 66 is also a model of clarity and simplicity. Its design engineer gets high marks. He knew how to make the most of the least.

THE PHILCO MODEL 66

The Philco Model 66 came out in mid-1934 as part of Philco's 1935 lineup. An AC predecessor of the so-called AD-DC All-American Five — a 4-tube superheterodyne with a Type 80 tube rectifier, it was among the first to use the new 6-volt tube series: Types 6A7, 78, 75, and 42.

Its wide tuning range on the BC band goes all the way from 540 to 1720 kilocycles. The top end includes the old police band which fascinated us kids. The SW band goes from 5.5 megacycles to 16.0 megacycles and is surprisingly hot for no RF stage.

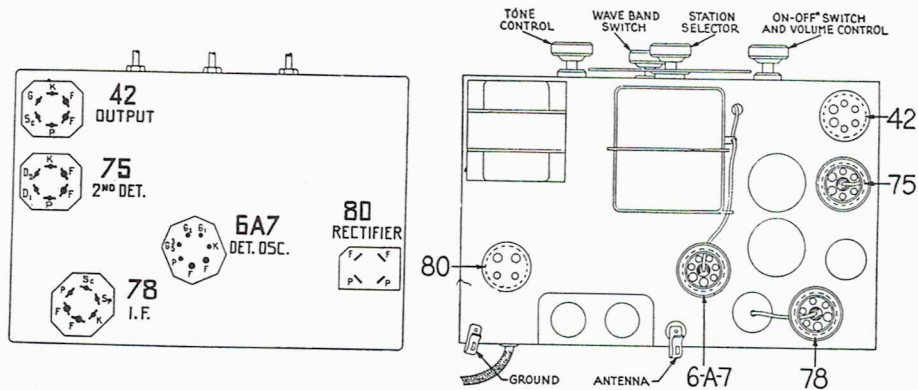

Figure 2. Tube and control layout for the Model 66 from the Philco Service Bulletin 197, page 1.

The set has a simple bass/treble control in the form of a switchable condenser across the primary of the output transformer. A serendipitous combination of capacitance and inductance in the Model 66 makes this system more effective than any other of the same kind I have seen.

Good engineering is making something just good enough. Philco understood this principle. The company was among the first to use self-tapping screws. There are no nuisance dial strings in the Model 66, nor is there a fancy Zenith-type dial. There is a built-in simple reduction gear in the 2-gang, equal section tuning condenser. Tracking is achieved with a series "compensating" condenser.

The four IF (460 kilocycles) adjustments are reachable through holes in the back apron and adjustable with a 1/4-inch socket driver. The fifth hole in the rear allows you to tune the 460-kilocycle wave trap. This was important back in 1933 because in those days the marine LF telegraph band was busy. Ship traffic in port cities — such as, Boston, Providence, New York, Philadelphia, Baltimore, etc. — often rode over the BC stations.

As a kid, I enjoyed listening to the marine band, but nobody else in the house did. They didn't know that I had detuned the trap, not that I knew what I was doing, but it made the code come in. A beat frequency oscillator (BFO) wasn't necessary because much of the traffic was modulated continuous wave (MCW). Later, I learned to tweak the oscillator to bring in 160 meters above the police band.

THE HUM

Now to the hum. Almost every radio technician assumes that a filter condenser's negative side should go to ground — nail down the hum by nailing it to ground. And most electrolytics in cans use the can for the negative connection, so that the negative side winds up connected to the chassis. Usually this is right, but not when you come to sets like the Model 66 that derive their bias from the voltage drop across a resistor connecting the transformer's center tap to ground. With this arrangement, the negative of the filter

condenser(s) must go to the transformer's tap and not the chassis. If, by mistake, it does go to the chassis, it sends a ripple to the grid of the audio system. Hum results.

Sometime in the past, my newly acquired Model 66 needed filter condensers. These had been installed, but grounded to the chassis and not the center tap per Philco's diagram. Upon correction — no more hum. I have come across this servicing error so often that I thought a note about it might be helpful to A.R.C. readers.

Of course, the set needed alignment (maybe another young Bob Merriam had gotten into it), and there were some minor scratches in its Art Deco upright cabinet. The finish is shiny black on top and the sides have a mahogany veneer front. From the manufacturer's point of view, the Model 66 cabinet is an easy-to-make, practical enclosure for the chassis and its somewhat hefty electrodynamic speaker. Form follows function in this straightforward, excellent design.

References:

Philco Service Bulletin 197, Philco Radio and Television Corporation Service Department.
 Ramirez, Ron. *Philco Radio 1928-1942*, Schiffer Publishing Ltd., Atglen, PA, 1993

(Robert W. Merriam, 697 Tillinghast Rd., East Greenwich, RI 02818)

Robert W. Merriam, a longtime collector and noted historian, is well known for his *New England Wireless & Steam Museum*, 1300 Frenchtown Rd., E. Greenwich, RI 02818. Each year, Bob issues a call to "All Sparks, Hams, Collectors & Historians" to attend the "Yankee Radio Tune Up" (this year on August 9) and the "Yankee Steam-Up" (this year on September 13). The *Steam-Up* features steam, hot air, and gas engines, while the *Tune-up* offers the opportunity to test antique receivers with A, B, C Juice, active antenna and ground. The *Yankee Radio Tune-Up* includes a tailgating flea market and a silent auction. For more information, call: (401) 885-0545. Fax: (401) 884-0683.

CD-ROM REVIEW

Radio Era Archives - Radiophile, Volume 1

REVIEWED BY RAY BINTLIFF

Radio collectors are always looking for new sources of information about their hobby. The latest one is packaged in a different form. Radio Era Archives (REA), a division of Electro Communication Systems, is now offering a series of CD-ROMs containing information about old radios. A.R.C. had an opportunity to examine one of these CDs, and our impressions are described in this article. (Editor)



Radiophile, Volume 1 contains a collection of 29 books dating from 1925 to 1962. This collection comes from such varied sources as ARRL, Atwater Kent, General Electric, Gernsback, National Radio Institute (NRI), Philco, Rider, and RCA. Material from NRI and Rider appears most frequently.

The 1955 edition of *The Radio Amateur's Handbook* from ARRL contains the most pages — a total of 764. Ghirardi's *Radio Troubleshooters Handbook* weighs in at 702 pages., while the NRI material runs about 30 pages each. The CD contains approximately 3,800 pages.

The material from Rider Publishing is made up of indices for Rider's *Troubleshooter's Manual* (Volumes I through XXIII) and books dealing with servicing techniques.

USING THE CD

Loading the program for the first time is a simple task. In our case, we loaded it using Windows 95 in fewer than 10 minutes. The CD will run under either Windows or Windows 95. A series of help screens are available to acquaint you with the program. There are a number of menus that provide manipulation of the page images, such as "image rotation," "zoom in/out," and "fit-to-width/fit-to-height."

Using the "Index Window," one or up to all four of the following search criteria can be used to locate a publication: Publisher, Name of Book, Author, and Year. For example, entering "John F. Rider" or simply "Rider" will produce a list of all books that were written by John F. Rider.

Also, entering "1947" in the "Year" block, will produce a list of books written by Rider in 1947. It should be noted that the "Name of Book" is not always the exact title of the book. Some of the book titles are much too long, so REA has chosen to use shortened,

simplified titles. The use of a wild card search (title*) can usually find the book you are looking for.

Once a book is found, you may step through and view the pages one at a time or use the "Go to" feature to jump to a particular page. The pages may be viewed half-screen size along with the index window, or changed to a full-screen with a single mouse click. Scroll bars permit you to view any area of the page when the image is magnified.

Because the pages are scanned, a text search cannot be performed. The search capability is limited to finding publications by using the four search criteria described above. REA literature indicates that other volumes offer an extended search capability.

Need a hard copy? One or more pages in a book may be printed with a simple command.

PAGE NUMBERS

Some of the books contained in the CD include a table of contents which carry a page number for each subject. However, the page number in the table of contents will not necessarily be the same as the page number that is displayed on the computer screen's "page number bar." For example, in the Ghirardi book, the table of contents shows a subject beginning on page 481, but the page number bar indicates that the subject begins on page 487.

This discrepancy occurs because the book does not number the foreword and other introductory pages, while the CD starts its numbering system on the first scanned page. ERA recognizes this problem but also realizes that the cost to incorporate a page number tracking feature would be excessive. A few clicks of the mouse will quickly step you through to the correct page.

Three other Radiophile series CDs are available from ERA and contain additional books, repair information, tube data and much more. All 23 Rider manual volumes are available on six CDs. All ten CDs are available from Radio Era Archives, 2043 Empire Central, Dallas, TX 75235. The cost of *Radiophile Volume 1* is \$85, postpaid in the U. S. Be sure to check the publisher for ordering information.

(Ray Bintliff, 2 Powder Horn Ln., Acton, MA 01720)

A.R.C. STAFF PROFILE

Chris Frederickson — A Farewell

BY DOROTHY SCHECTER

A.R.C. is feeling the rumblings of change. Christine Frederickson, our very efficient Radio Events Editor, is moving to Pasadena, California, where her physicist husband Robb has taken a new position with the Jet Propulsion Lab. She will be sorely missed.

This jolt to our smooth-working team seems to be the perfect opportunity to begin a series of "A.R.C. Staff Profiles" — a way to respond to frequent requests from subscribers to connect faces with the voices on the telephone and behind the lines of letters and articles.

Chris Frederickson has been typing, proofing and editing ads, articles, and club news for A.R.C. for ten years. That means that her memories go back almost to the beginning when John Terrey took over the magazine and began publishing it out of his home. Then, three or four part-time people did it all, including the basics — like sticking on labels and stuffing envelopes at the kitchen table! Chris has been an integral part of our phenomenal growth and the many developments in our publishing procedures.

In the beginning, A.R.C. had no full-time employees, except, of course, the editor. Now there are four, as well as seven more who are part-time in the office and on the editorial staff. Chris has always worked part-time, while also raising three children here in Carlisle. In that regard, Chris says that A.R.C. has always given her the "sanity break" from full-time motherhood.

Chris is a true New Englander — a New Hampshire native and a cum laude graduate of the University of New Hampshire. She also holds an M.Ed. from Boston College. Her deep interest in literature, especially drama, has led her to experiment with playwriting. Some of her works have been read by a local theatre group in its series of "New Play Readings." She is an associate member of the Dramatists Guild.

Soon Chris will be experiencing the "empty nest" syndrome. Her youngest child, Julie, will be off to college in the fall. Nathan, her middle child,

graduated in 1996 from Webb Institute and now works near Seattle as a marine engineer for Bayliner. Tim, her oldest child and a graduate of U. Mass. Lowell, was recently married and works in business administration in the Boston area. So, Chris' family interests will remain coast-to-coast.

But, there is no doubt that Chris will fill her new spare time well. If we were to name some of her

outstanding characteristics, they would include curiosity and the capacity to enjoy even the small things of life. She is already looking forward to living close to Caltech and exploring its many facilities. The California theatre scene is also more than intriguing.

Chris enjoys outdoor life — hiking and swimming are favorites. We hesitate to bring up ice skating, as a fall last year resulting in a broken wrist was a big blow to the A.R.C. schedule. But, Chris, with her usual aplomb, took it in stride and managed to function, cast and all, before long.

Once settled in Pasadena, Chris may find another job in publishing. Before her A.R.C. experience began, she worked in the editorial department of *Computerworld* newspaper.

And back at U.N.H., she worked on the college newspaper and studied under Don Murray, well known *Boston Globe* columnist. We fully expect Chris to put her red pen to copy somewhere.

Perhaps we'll even receive marked-up pages of A.R.C., as she has an eagle eye for little errors. In fact, though not a collector herself, she will no doubt keep tuned in to the radio world through A.R.C. and through her husband's ham radio activities. His current call sign is W1EEL.

Chris' longtime communication with radio clubs will make acquaintance with members in the West Coast clubs easy. Who knows — she may even send us a "Club Spotlight" article. We're sure that she won't forget us, especially when we're digging out of the snow in order to make a deadline. Perhaps she'll convince us all to move to Pasadena!

(Dorothy Schecter, c/o A.R.C., Box 2, Carlisle, MA 01741)



Chris Frederickson caught enjoying a farewell luncheon with her A.R.C. colleagues.



PHOTO REVIEW



This column presents in pictorial form many of the more unusual radios, speakers, tubes, advertising, and other old radio-related items from our readers' collections. The photos are meant to help increase awareness of what's available in the radio collecting hobby. Send in any size photos from your collection. Photos must be sharp in detail, contain a single item, and preferably have a light-colored background. A short, descriptive paragraph **MUST** be included with each photo. Please note that receipt of photos is not acknowledged, publishing is not guaranteed, and photos are not returned.



TINYTONE – This little red crystal radio measures approximately 3" x 1³/₈" x 2¹/₈". Found in a box of miscellaneous items purchased at an auction, it came in its original box, along with ground and antenna wires and earphone. The address on the box says it came from Mid-Way Sales, Inc., Kearney, Nebraska, February 1953. (*John Phipps – St. Charles, MO*)



PHILIPS "ANNETTE 480" PORTABLE — This large 7-tube radio from 1957, made in the Philips factory in West Germany, is quite unique for a portable radio. It includes FM, and contains a rechargeable Ni-Cad "A" battery. The set includes tone control, separate tuning dials and multi-AC voltage operation. (*Steve Kelsay – Aliso Viejo, CA*)

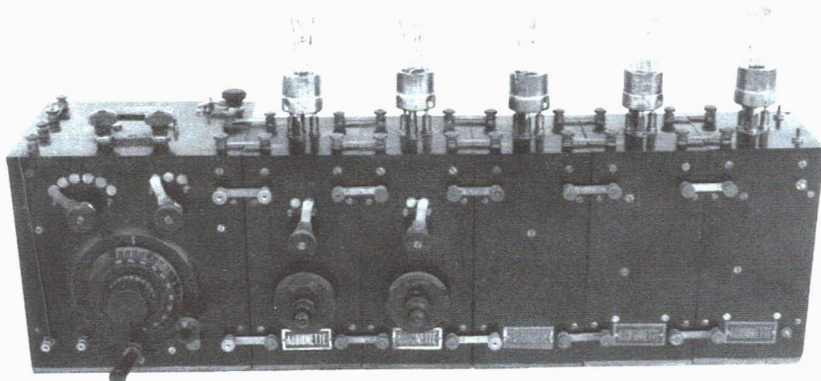

AUDIONETTE BATTERY SET – This 5-tube set has been in our family since 1923, the year it was built. An uncle bought it in Cognac, France, as an engagement gift, not for his fiancée, but for his future father-in-law! The radio was made by Etablissements Radio-L.L., owned by Lucien Lévy, the French inventor of the superheterodyne principle. Lévy obtained the French patent number 493660 in May 1919 and later sold his patent rights to AT&T. (*Hans Denyler – Weissenweg, Switzerland*)

PHOTO REVIEW

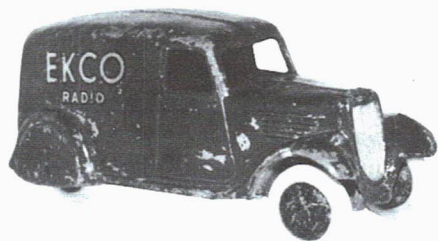

MECCANO LTD. RADIO TOY, BRITISH – This "dinky" but rare, 1937, Ford 8 toy radio service van is made of mazak alloy (slush!). (Jim Taylor – Winton-Bournemouth, England)

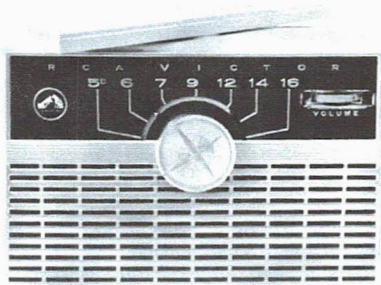

RCA MODEL 1-BX-78 – This portable radio has an ivory and black front and a pink back. It requires a 7½-volt and a 90-volt battery. The dimensions are 10" x 7½" x 3". (Harold Ford – Winnsboro, TX)

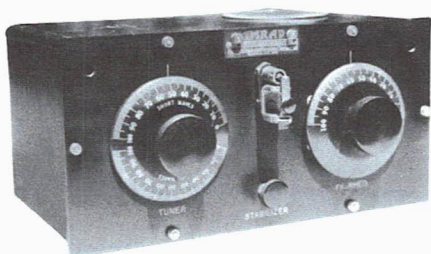

AMRAD MODEL 3366 – This 1923 1-tube reflex receiver is all original, except for the tube vent cover, a reproduction. Notice that the catwhisker stand is a horseshoe magnet. As noted in Douglas' *Radio Manufacturers of the 1920's*, the catwhisker is held in place magnetically! This system is quite stable and easy to use. (Robert Bailey – Jacksonville, FL)

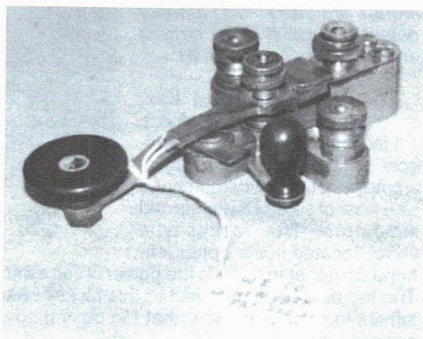

STEINER KEY – This solidly built Western Electric key carries a patent date of December 21, 1886. (Wally Worth – Wollaston, MA)

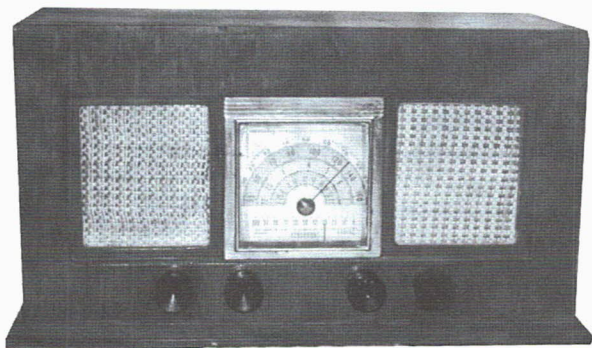

ECHOPHONE MODEL EC-113 – This model was built in 1948 by Hallicrafters, which had merged with Echophone in 1935. A 6-tube set, it has 3 bands — .55 to 22 MHz. It is similar to the EC-112 in plastic and the EC-114 in blond wood. The dimensions are 9½" high, 16½" wide, and 7" deep. (Bob Perry – Painted Post, NY)



HOMEBREWING

Build an AC Line Control Box

BY RAY BINTLIFF

Several articles in previous issues of A.R.C. have cautioned readers to use an isolation transformer when working on AC/DC radios. Other articles have mentioned the advantages of using a variable autotransformer when testing AC-operated radios. This article describes a control device that provides both isolation from the AC line and an adjustable output voltage. In addition, digital meters are included to monitor output voltage and the current drawn by the load. (Editor)

The AC line control box, shown in Figure 1, contains a 1:1 isolation transformer, a variable autotransformer, a digital ammeter, a digital voltmeter and a number of control switches and indicators. The rocker-type switch located in the upper left-hand corner of the unit is the power on/off switch. The red neon indicator next to this rocker switch serves to remind the user that the control box is powered up.

The autotransformer, a k a Variac or Powerstat, can be switched in or out of the circuit by the toggle switch located just below the power off/on switch. The adjacent yellow neon indicator glows when the autotransformer is in the circuit.

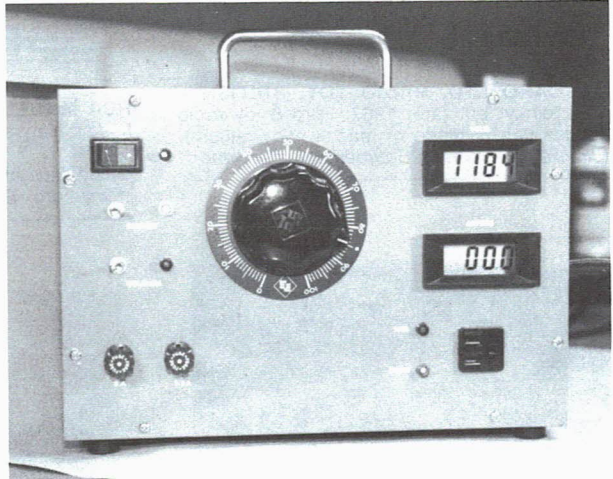

Figure 1. A front panel view of the AC line control box.

The isolation transformer can also be switched in or out of the circuit by means of the bottom toggle switch. The green neon indicator next to the toggle switch is illuminated when the isolation transformer is in the circuit.

Two digital meters are included. The AC voltmeter is located in the upper right-hand side of the front panel. This meter monitors the AC voltage at the power output socket. The AC current

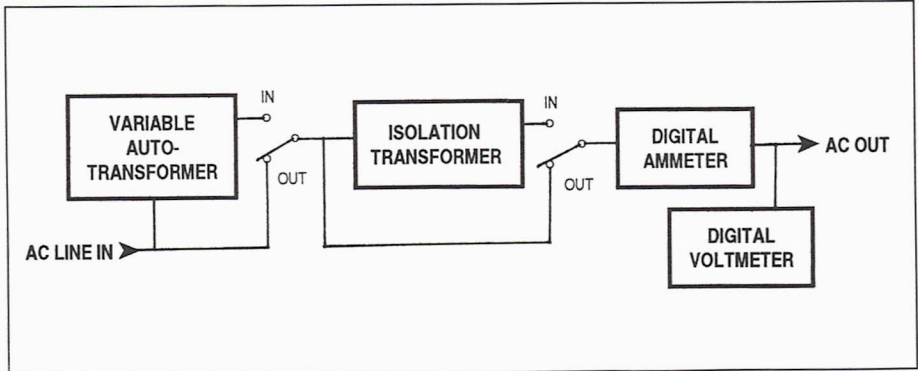

Figure 2. A simplified block diagram depicting the basic operation of the control box.

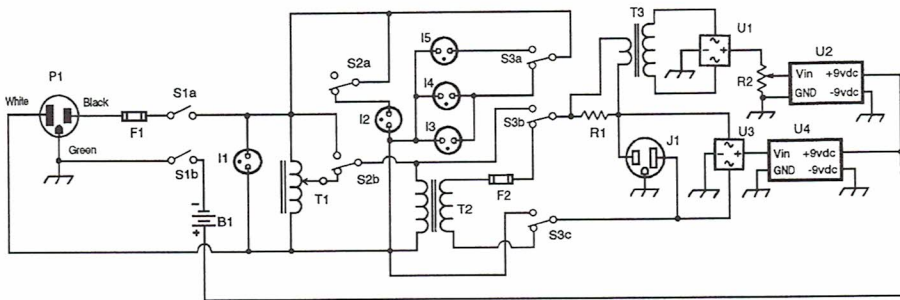

Figure 3. A schematic diagram of the control box.

drawn by the radio under test is displayed on the AC ammeter located just below the voltmeter.

The power output socket and two additional neon indicators are located in the lower right-hand side of the front panel. These indicators will be discussed later in this article. The large knob near the center of the front panel controls the voltage output of the autotransformer. Separate fuses are used to protect the isolation transformer and the autotransformer. These fuses are located at the lower left of the front panel.

ELECTRICAL DESIGN

As the simplified block diagram in Figure 2 shows, the variable autotransformer and the isolation transformer are switched separately. Thus, both the variable autotransformer and the isolation transformer can be (1) switched out of the circuit, (2) used in combination, or (3) either device can be used individually.

The schematic diagram, shown in Figure 3, provides a detailed look at the circuitry. Fuse F1 protects the autotransformer. The DPST switch S1 controls power to the control box, with one of its sections, S1a, in the AC line. The other section, S1b, switches the 9-volt battery power supply to the digital meters. When the contacts of S1a are closed, the red neon lamp I1 is energized to indicate that power is turned on.

The variable autotransformer T1 is controlled by the DPDT switch S2. Section S2b switches the output of T1, while section S2a controls the yellow neon lamp I2 to indicate that the variable autotransformer is in the circuit. I2 and S2 are labeled "VARIABLE" on the front panel.

T2 is the isolation transformer, and fuse F2 protects the transformer from overloads. The 3PDT switch S3 switches the isolation transformer in or out of the circuit and controls the neon lamp indicators I3, I4 and I5. Switch section S3a controls these indicators, while sections S3b and S3c switch the secondary winding of the isolation transformer.

Indicator I3 is located next to the isolation in/out switch S3 in the upper left-hand corner of the front panel. Indicator I3 and S3 are labeled "ISOLATION" on the front panel. The green indicator I3 glows when the isolation transformer is switched in. Indicator I4 serves the same purpose but is located near the AC output socket on the lower right-hand

Parts List

B1	9-volt battery
F1	Fuse, 5A
F2	Fuse, 1.5A
I1, I5	Neon lamp, red, Radio Shack RS272-712
I2	Neon lamp, yellow, Radio Shack RS272-707
I3, I4	Neon lamp, green, Radio Shack RS 272-708
J1	3-wire AC receptacle
R1	0.39 ohm, 10 watt resistor, Mouser 28PR009-0.39
R2	2k, 2-watt pot
Ra	9.9 megohm resistor, see text
Rb	10k resistor, see text
S1	DPDT switch, Radio Shack RS 275-691
S2	DPDT switch, Mouser 10TC260
S3	3PDT switch, Mouser 10TC280
T1	Variable autotransformer, 5A
T2	Isolation transformer, 120vac/1.3A
T3	Filament transformer, 220vac primary/3vac secondary
U1, U3	Bridge rectifier, 400v 1A
U2, U4	LCD digital panel meter, 3-1/2 digits, see text
Misc.	Fuse holders, line cord, battery connector and battery holder

side of the front panel. It is labeled "ISOL."

This redundant feature was included in the design to minimize the chance of an error during those late hours at the workbench when brain power seems to diminish. Indicator I4 can be eliminated if you choose. In fact, this article is not meant to be a "you gotta build it this way" construction article, but is intended to describe some design features than can be used singly or in combination to suit your specific needs.

In similar fashion, indicator I5 is also located near the AC output socket to warn that the control box is turned on and that the isolation transformer is switched out of the circuit. This red indicator is labeled "DIRECT."

(Continued on following page)

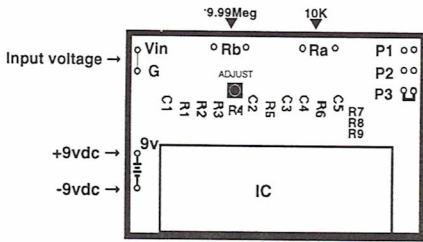

Figure 4. A rear-view drawing of the digital meters showing the connections and component layout.

(Build an AC Line Control Box, continued)

The AC output socket J1 is a single 3-wire socket that will accept three types of 120-volt AC plug: the 3-prong grounding plug, the 2-prong polarized plug and the commonly used 2-prong plug.

The digital meters U2 and U4 display AC volts and AC amperes respectively. These meters and their circuitry are described below.

DIGITAL METERS

Why use digital meters instead of analog meters? Sure, there are a lot of analog meters available at flea markets and hamfests but these old meters have their drawbacks. First, they need more panel space than digital meters. Second, they are less able to withstand rough handling (hence, the zero-adjustment screw), and third, they are not as easy to read. For old guys like me, the large numbers on a digital readout are a blessing.

The price of these 3-digit meters, with a full scale sensitivity of 200 mV, is now down in the \$10 range when purchased from electronic surplus houses. Obviously, analog meters can be used if you desire, but I opted for the digital meters.

The digital meters are DC devices, so a rectifier is needed to measure AC. Referring again to the schematic diagram in Figure 3, U3 is a full-wave bridge rectifier whose pulsating DC output is fed to the digital voltmeter U4 which in turn indicates the RMS value of the AC voltage across the AC output receptacle J1.

The ammeter circuit is a bit more complex. To read the current drawn by the radio under test, or whatever the load may be, a 0.39 ohm resistor R1 is inserted in series with the load. The small voltage drop across this resistor is raised to a useable level by a step-up transformer T3.

The output of T3 is rectified by the full-wave bridge rectifier U1. The output of U1 is a pulsating DC voltage that is proportional to the current passing through R1. The potentiometer R2 is a calibration control used to set the input voltage to the digital voltmeter. Although U2 is called an ammeter, it is really a voltmeter that reads a voltage that is directly related to the current passing through R1.

HOOKING UP THE DIGITAL METERS

The hookups for the ammeter U2 and the voltmeter U4 are identical, as shown in Figure 4. The meters are powered by a 9-volt battery connected to the points identified as +9vdc and -9vdc. The input voltage is connected to terminals Vin (Voltage in) and G (Ground). A jumper wire is connected to the two solder terminals adjacent to P3, as shown in Figure 4. The values of Ra and Rb determine the maximum voltage to be measured by the digital meters. In this application, the resistance values of Ra and Rb are 10,000 ohms and 9.99 megohms respectively.

When purchased, the digital meters may have a jumper connected to the terminals marked Rb. This jumper must be removed before the 9.99 megohm resistor is soldered in place. The instructions that accompany the meters will probably indicate that the resistors should be 1/2-watt,

0.5 percent metal film resistors. If you can locate such resistors, use them. If not, use an accurate digital ohmmeter to select resistors with suitable accuracy from your supply of carbon composition or carbon film resistors.

CONSTRUCTION

So much for all of that dreary theory stuff. Let's take a look at how the unit can be built. I housed the control box in a repainted cabinet salvaged from a junker EICO RC bridge. Incidentally, old test equipment is a good source of inexpensive cabinets for many construction projects. The EICO cabinet measures 11 3/4" wide x 8" high and 5" deep. The front panel was cut from a piece of 1/8" thick aluminum sheet and spray painted. The lettering on the front panel was added using "rub-off" dry transfers.

All components are mounted

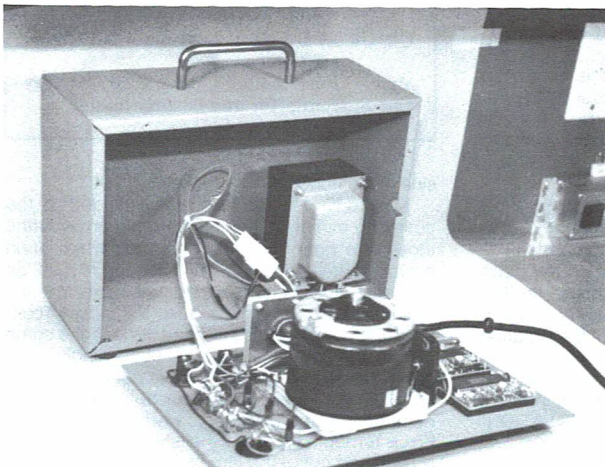

Figure 5. The front panel removed to show internal construction and components.

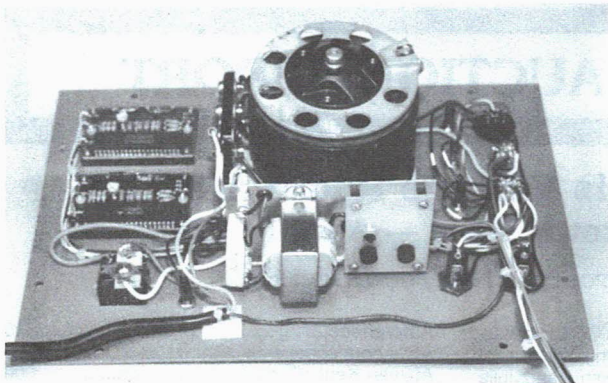

Figure 6. A detailed view of the components and subassembly.

on the front panel with the exception of the isolation transformer T2 and the 9-volt battery B1. In Figure 5, the front panel has been removed from the cabinet to show the interior of the control unit. A rear view of the front panel, shown in Figure 6, depicts the placement of components. The subassembly in the foreground contains R1, R2, T3, U1 and U3. Note: Since this photo was taken R2 has been changed to a 2-watt pot.

A close-up view of the digital meters is shown in Figure 7.

CALIBRATION

After installing the proper resistors and jumper on the back of the digital meters, but before connecting the wires to the input terminals, the meters should be calibrated. Calibration is accomplished by connecting an accurate 100 VDC source to the meter's input terminals and then adjusting R4, located on the back of the digital meter, for a reading of 100 volts.

After all wiring is completed, final calibration of the ammeter should be performed by adjusting R2. For this adjustment, an accurate AC ammeter must be installed in series with a suitable load connected to the output plug of the control box. A 100- or 150-watt light bulb will work nicely as a load. Next, switch the isolation transformer and the autotransformer out of the circuit and turn on the control box. Note the current reading on your external ammeter, and then adjust R2 until the digital ammeter in the control box reads the same value.

SOME ADDITIONAL THOUGHTS

A perfect isolation transformer would produce a secondary voltage equal to its primary voltage. Alas, even isolation transformers are not perfect. Without a load, an isolation transformer will produce a secondary voltage that is greater than its primary voltage. When a load is placed on the secondary winding, the secondary voltage will drop. Usually, a 1:1 ratio between the primary and secondary voltages occurs at the transformer's current rating. When a transformer's current rating is exceeded, the output voltage will begin to decrease.

Some examples of actual measurements may help to illustrate this point. The isolation transformer used in this control box was connected to a line voltage of 117.5 VAC. With no load, the secondary voltage was 124.3 VAC. The secondary voltage decreased as the load was increased. With a 100-watt load, the secondary voltage had dropped to 120.5 VAC.

Another isolation transformer, rated at 100 watts and of dubious quality, fared much worse. The output voltage was 128.5 volts with no load. With a 25-watt load the secondary voltage fell to 118.5 volts, and with a 100-watt load its output was only 92.5 volts.

A third transformer that seemed suitable for use with small AC/DC sets produced excessively high secondary voltages.

There are two lessons to be learned from these numbers. First, make certain that you use a good quality transformer with an adequate current rating. Second, with a low load you may be subjecting that AC/DC set being tested to a much higher than normal line voltage.

With a control box similar to the one described in this article, you can avoid the hazards associated with operating an AC/DC set directly from the AC line and at the same time monitor and control the line voltage that is applied to a radio.

(Ray Bintliff, 2 Powder Horn Ln., Acton, MA 01720)

Ray Bintliff, W1RY, holds an Amateur Extra Class license. A member of the A.R.C. staff and a retired RCA engineer, he enjoys repairing and restoring pre-1945 radios and test equipment. In addition to Amateur Radio, his interests include electronic equipment design and audio reproduction.

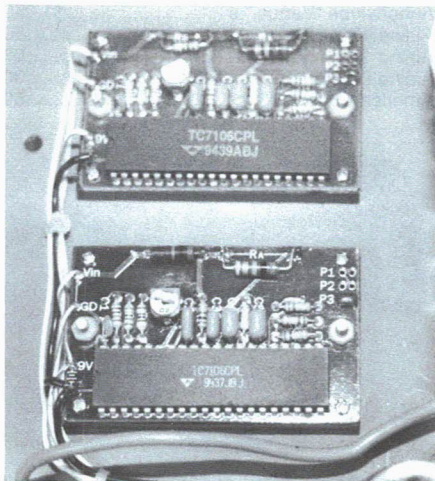

Figure 7. A close-up view of the digital meters.



AUCTION REPORT

Gene Harris Vintage Radio Auction Marshalltown, Iowa — April 5, 1997

REPORTED BY JIM BOELLSTORFF

The Gene Harris Antique Auction Center in Marshalltown, Iowa, held its seventh annual radio auction Saturday April 5, 1997. Tom Harris and Julie Harris Stern called the auction which drew 159 registered bidders for over 600 lots of merchandise.

This was the best auction in recent years. Buyers were quite enthusiastic about the many fine offerings of high quality radios. Several surprises made their appearance as late consignments which did not get listed or pictured in the countrywide advertising program. The overall quality of consignments was quite good with many desirable electric sets being offered along with a good showing of battery radios.

Auction highlights included a McMurdo Silver Masterpiece VI going for \$1,800 and an accompanying Clifton cabinet for \$3,600 to the same buyer; a Detrola Pee Wee in marbled red and white for \$2,250; a Scott Phantom in an Acousti-craft cabinet for \$1,500; an Atwater Kent 12 (4910) breadboard for \$1,400; a Zenith 990 console for \$1,200 and an Abbotwares "Venus" for \$1,050.

The following listing is a selection of lots from the auction. Some model numbers were missed, and accuracy of the report is not guaranteed. All listed sale prices do not include the 10% buyer's premium.

e=excellent, vg=very good, g=good, f=fair, p=poor, wks=works

Abbotwares "Venus," e	\$1,050
Airline 4BR-729, g	80
Airline 15(?), g	60
Airline 62-280, g	90
American Bosch 73, g	50

Arborphone 27, g	110
Atlas horn speaker, g	35
Atwater Kent 10, e	800
Atwater Kent 12, (4910), e	1,400
Atwater Kent 20, g	60
Atwater Kent 21 dry cell, e	150
Atwater Kent 35, g	40
Atwater Kent 52 small metal console, g	60
Atwater Kent 545, f	75
Atwater Kent 555, chest-type cabinet, w/lid ..	225
Atwater Kent in Kiel table, e	200
Atwater Kent 60 Pooley, f	70
Atwater Kent 70 console, g	70
Atwater Kent F-2 speaker, g	35
Atwater Kent M horn speaker, g	50
Brunswick 15, g	110
Clarion AC60, g	90
Coronado 400-A, g	35
Coronado 585, g	50
Crosley 9-120W, e	40
Crosley 10-135, e	50
Crosley 11-125U, e	110
Crosley 52, e	55
Crosley 117-U, e	80
Crosley 158, g	70
Crosley 546, g	55
Crosley 587, e	110
Crosley 819M, g	120
Crosley 855, e	70
Crosley D25-WE, g	60
Crosley E15-WE, g	30
Crosley Buddy Boy, Repwood, e	250
Crosley Elf, Repwood, e	375
Crosley Fiver, e	90
Crosley New Buddy, Repwood, e	180



An impressive array of Crosley Repwood radios. From top left to bottom right: Model 58 Buddy Boy, Model 54 New Buddy, Model 122 Super Buddy Boy, Model 48 Elf, and Model 59 Showboy.

A Monodyne 1-tube receiver with 2 coils and a pair of headphones.



In excellent condition, this Atwater Kent in a Kiel table sold for \$200.



RCA 10" TV Model 8TS30, circa 1948.

Crosley Smokerette console, Repwood, e ...	175
Crosley Super Buddy Boy, Repwood, e	300
Crosley Trirdyn Super, g	60
Crosley 59 Showboy, Repwood, e	450
Delco R, g	65
Deluxe, chrome front, e	120
Detrola Pee Wee, red and white, e	2,250
Dumont RA-346, g	45
Echophone 3V, wrong cabinet, g	130
Emerson 515, g	45
Emerson 520 Catalin, e	225
Emerson 540-A, g	100
Emerson 888, red, g	30
Emerson Aristocrat, Catalin, e	550
Emerson BW-231, g	60
Emerson CF-225, e	165
Fada 711 Catalin, g	375
Federal 110, g	350
Freshman Masterpiece, e	130
GE M-61 g	150
GE S-22AC, e	60
General, cabinet on stand, f	265
Grunow 450, e	180
Grunow Teledial console, g	250

Hammarlund HQ-110-A, g	75
Hallicrafters SX-43, g	90
Hartco, paper-maché, e	130
Hoffman solar transistor, e	150
Kennedy 281, p	350
Kent portable electric, e	80
Freed-Eisemann Marvel crystal set, g	160
McMurdo Silver V, g	300
McMurdo Silver VI, e	1,800
McMurdo Silver, Clifton cabinet, e	3,600
Majestic 20, e	150
Mitchell Lunitone lamp radio, g	40
Monodyne 1 tube, with both coils, phones, e	250
Motorola 5A5, g	30
Motorola 53H, e	140
National Union dealer service clock, e	425
Philco 16X console, g	200
Philco 17-B, g	70
Philco 20, e	150
Philco 37-10, g	75
Philco 37-34, g	50
Philco 37-38, g	45
Philco 37-600, f	40
Philco 37-620, g	45
Philco 38-3, g	90
Philco 38-8, g	75
Philco 38-10, g	55
Philco 38-37, g	90
Philco 40-185, g	50
Philco 70, e	380
Philco 80 Jr., g	100
Philco 90, e	325
Philco Predicta 17" TV, g	175
Pfanstiehl 34, g	110
Pilot TV-37, 3" screen w/case, e	250
RCA Radiola III, g	40
RCA Radiola 17, g	50
RCA Radiola 25, e	300
RCA Radiola 82, g	110
RCA Radiola R-7, g	150
RCA 6T, e	90
RCA 8TS30 television, g	75
RCA 19K, g	200
RCA 75X16, e	40
RCA 103 speaker, f	60
RCA 106 speaker, g	70
RCA 351, g	100
RCA 813K w/remote control, g	175
RCA advertising clock, g	120
RCA B-1, Canadian, g	95
RCA C8-15, g	100

(Continued on following page)

A warning: Auction prices are not current values. A listing such as this cannot adequately include the condition of cabinets, chassis, transformers, tubes, the operating status of the set, and the inclusion of incorrect, restored or replica components, etc. Auction prices are the result of the excitement of the auction process, the skill of the auctioneer and the specific interests of the participants. Nevertheless, auction prices serve as useful references and as another element in the value determining process. The possibility of error always exists, and if we are notified, corrections will be reported.



A Crosley Smokerette console with Repwood front.



A National Union Radio Tubes dealer display sign.

(Gene Harris Auction, continued)

RCA K-60, g	50
RCA R-22S, g	90
RCA T-80, g	75
Regency TR-1, e	200
Scott 800-B, g	350
Scott Phantom Acousticraft, e	1,500
Scott Tasman, g	1,100
Sentinel 284 Catalin, e	700
Sparton 6G, g	60
Stewart-Warner 01-987, g	60
Trav-Ler 5207, g	60
Trimmm Concert horn, g	85
Tube(s): 01-A rainbow, (2), e	35
Ultradyne superhet, g	100
Utah Superflex speaker, e	105
Westinghouse Aeriola Sr., g	95
Westinghouse RA-DA, e	300
Westinghouse RC, g	130
Zenith 5J217, e	110
Zenith 5S29, e	175

Zenith 6L40, g	45
Zenith 6S362, e	245
Zenith 6S527, e	60
Zenith 6S528, g	100
Zenith 7S657, g	80
Zenith 8H034, g	50
Zenith 8S661, e	150
Zenith 9S262, p	300
Zenith 10S464, g	100
Zenith 10S492, e	200
Zenith 10S549, e	800
Zenith 12S370, e	450
Zenith 12S471, e	225
Zenith 705, g	90
Zenith 990, e	1,200

(Jim Boellstorff, Gene Harris Auction Co., 608 Newcastle Rd., Marshalltown, IA 50158)

Northland Antique Radio Club Auction At Radio Daze '97 — May 16, 1997

REPORTED BY DON HAUFF

The Northland Antique Radio Club (NARC) held its consignment auction on May 16, 1997, as part of its annual Radio Daze event. Over 100 individuals attended the auction with auctioneer Ed Ripley providing the honors. Early Atwater Kent cathedral radios were consigned by the estate of a former NARC member. In addition, the auction included several attractive Catalin radios.

Terms included a \$25 minimum opening bid

and a sellers consignment fee of 5% (2% if bought back by the seller). Over 150 items were consigned.

g=good, wks=works

ABC battery eliminator	\$65
Admiral TV	50
Airline	50

Atwater Kent 20, g	50
Atwater Kent 33, g	55
Atwater Kent 35, Brandes phones, g	40
Atwater Kent 60 in Kiel table, wks	120
Atwater Kent 84 cathedral, AC	240
Atwater Kent 387 cathedral, (2)	300, 400
Atwater Kent 944 cathedral	210
Atwater Kent Type E speaker, driver g, (3) .25, 35, 35	
Atwater Kent Type L horn, driver good	45
Atwater Kent Type R speaker	95
Bendix electric sign	70
Cameron Sextette, Better Radio Co.	25
CBS tube clock	30
Crosley 9-121 Bakelite, wks	40
Crosley and Emud radios, wooden	25
Crosley, red Bakelite, w/clock	50
Crosley sign	160
Crosley 50	75
Crosley 51	40
Crosleys, white/tan, (2)	30
Crystal set in wood case	60
Crystal set, wks	35
Dahlberg coin-operated radio	50
Day-Fan 5	35
Dictophone shaving machine, 1917	25
Emerson 267	30
Emerson 331	30
Emerson 332	30
Emerson AN-187, wks	170
Emerson ED354, Ingraham cabinet	25
Fada Catalin	320
Fada Special	25

Novelty radios, box lot	65
Operadio, Atwater Kent, RCA, Platte speakers ..	25
Philco 17	110
Philco 37-61 cathedral	35
Philco 38-3, wks	90
Philco 42-345, AM, shortwave	35
Philco 46-10, "Bing Crosby" radio-phonograph ..	45
Philco 48-1201 radio-phonograph	50
Philco 57C baby tombstone	60
Philco 60, no sound	50
Philco 84 cathedral	55
Philco 84B cathedral	45
Philco 89 Baby Grand	70
Philco 610 tombstone, wks	65
Philco 3784, w/hum, wks	35
Philco console 38-10	30
Philco fans pkg/red, Polar fan, etc.	50
Philco transistor clock radio	55
Philmore crystal set, (2)	35, 45
RCA 1-MBT-6	25
RCA 5T, (2)	35, 75
RCA 46X24	30
RCA 66X8 Catalin	575
RCA 96T2	25
RCA 100A speaker, wks	25
RCA 102	30
RCA Radiola 17 and 18	40
RCA Radiola 20	90
RCA Radiola II	170
RCA Radiola V, detector/amp unit	70
RCA T6-1	30
Sears clock radio, restored	60
Sentinel Catalin	875
Silvertone radio-phonograph	25
Stewart-Warner AC table	35
Stromberg-Carlson 635-A	180
Swiss (?) transistor radio, lacquer	40
Thompson V-50	25
Tube(s): Arcturus blue, (3), g	30
Victor phonograph	95
Zenith 4G903 portable	40
Zenith 5G500	35
Zenith 5R216	95
Zenith 6G-001	60
Zenith 7S363 console	175
Zenith 8G005, wks	65
Zenith 130 console	230
Zenith 503	45
Zenith console, ca. 1940	50
Zenith 3000-1	145
Zenith G-516	25
Zenith radio-phonograph, (2)	25
Zenith Royal 500, (2)	55
Zenith T600, hums	105
Zenith table radio	30
Zenith, white/brown, (2)	40

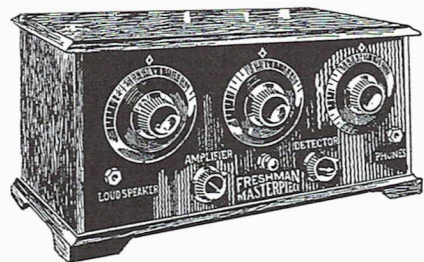

Freshman Masterpiece	55
Garod Catalin	250
GE 624	30
GE table, AC	25
GE F-65 console	40
GE M, wks	40
GE tombstone	50
Grundig radio, untested	25
Guild Country Belle radio	45
Guild Country Belle, AM/FM, wks	25
Hickock 6000 tube tester	35
Home brew, w/BBT 01-A (3)	35
Kellogg battery radio	40
Lenox Nipper, china	35
Magnavox J	55
Majestic, brown Bakelite	95
Majestic electric advertising sign	140
Majestic ship radio	245
Melodee battery radios and Wards	25
Mirrortone Catalin	450
Mohawk Lyric, 1920s, AC	25

(Don Hauff, PO Box 16351, Minneapolis, MN 55416)

For information on the Northland Antique Radio Club (NARC), write NARC at PO Box 18362, Minneapolis, MN 55418. Dues are \$10.00. The club publishes "The NARC Newsletter" quarterly and holds four meets, including two swap meets, per year. In addition, NARC sponsors the annual two-day Radio Daze event with the Pavek Museum of Broadcasting.

Radio Estate Auction

Stratford, Connecticut — March 22, 1997

CONTRIBUTED BY RAY CHASE

Auction Co. of New York conducted an estate auction on Saturday, March 22, 1997, in a storage warehouse at 838 Woodend Rd., Stratford, Conn. Arthur Horowitz was the auctioneer. The identity of the collector was never revealed, and none of the collectors I talked to could guess who the "well known" collector was.

It would be hard to imagine more difficult conditions for an auction of 500 radios than those experienced at this auction. The location was a second story loft in an industrial area. Most of the radios were arrayed on specially built stepped tables, while consoles were arranged against the wall around the room. Although the room was neat and clean, it was only 30' x 60', and the main problem was lack of space.

There was simply not enough room to accommodate those who showed up for the viewing from 9 A.M. until sale time at 11 A.M. There was no seating and no food concession. The sale was conducted as a "walk-around" with the radios staying in place and the auctioneer and the crowd moving around as items were sold. Many collectors left when the conditions became apparent.

Further complicating the situation was the requirement that 25 percent be paid immediately on each purchase at knock down. Auctioneer Arthur Horowitz set this requirement to prevent a buyer from leaving and not paying or taking the merchandise. You could circumvent this requirement, if you paid a preliminary \$100 deposit. Fortunately, many buyers took this option. As is increasingly common, a 10 percent buyers' premium was charged, and the prices listed here do not reflect that surcharge.

In view of the limited space, none of the items could be claimed until the auction was nearly complete — something that didn't happen until at least two hours beyond the 2 P.M. predicted by the optimistic auctioneer. I had to leave at 3:30 P.M., by which time I had recorded 277 lots, including 509 radios (cheaper ones were sold in groups). The total sale value was \$21,380. Several advertised items were withdrawn, and at least one item was sold outright during the preview — a questionable practice, but the price must have been right.

This collection had some battery sets, but was strong in 1930s and 1940s radios. Most of these were in very good condition, showing evidence of cosmetic restoration or clean up. The claim was that most of them worked, and nearly all had full sets of tubes. Little documentation was offered.

Because of the crowded conditions, the auction was extremely tiring, and at times, it was even difficult to determine what was being sold. Prices for wooden or plastic table radios, as well as for consoles, seemed high. Interest in battery sets was lower than usual. Those who stayed for

the full auction deserve an award for persistence. They also had to look forward to carrying their purchases down two flights of stairs.

e=excellent, vg=very good, g=good, f=fair, p=poor, wks=works, WT=with tubes.

Admiral table TV, 40s	\$150
Admiral TV	100
American Bosch console	200
Atwater Kent 20 big box, (2)	75, 75
Atwater Kent 20 small box, (2)	250
Atwater Kent 33	60
Atwater Kent 35, (2)	50, 60
Atwater Kent 40, nice	60
Atwater Kent 55 w/speaker	125
Atwater Kent 286 console	80
Atwater Kent console with a metal set inside, probably a Model 40	135
Atwater Kent E speaker	20
Atwater Kent E2 speaker, (2)	10, 15
Atwater Kent F2 speaker	20
Atwater Kent H horn, repainted, no driver	40
Bristol Audiophone horn speaker, g	160
Clock radios, plastic, (24)	ea. 5 to 10
Columbia shortwave receiver or tuner, metal box, unusual	70

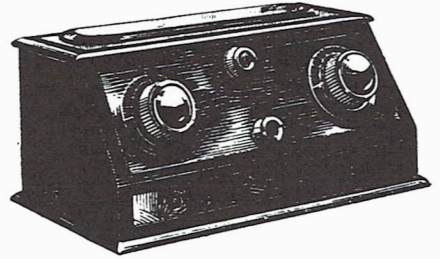

Crosley 4-29	135
Crosley 51	100
Crosley Fiver, table	45
Crosley Showbox	60
Croyden cathedral	195
Dahlberg hotel bed radio w/pillow speaker, (2), g	200, 100
DeWald tombstone, very nice	300
Electrola 3 dialer	145
Emerson 102 console	45
Emerson fabric portable	30
Emerson TV	110
Eveready Model 2, metal, WT	45
Fada 3 dialer	100
Federal 141 5-tube battery set, p	200
Firestone R306 wood table radio	45

(Continued on following page)

(Radio Estate Auction, continued)

Freed-Eisemann FM40 table radio	30
Freshman 3-dialer w/built-in speaker	60
Freshman Masterpiece	80
GE 5T15 large console, missing a remote (?) 25	
GE 26	40
GE 103 table, wooden, (2)	25, 70
GE 563 table, wooden, 2 wrong knobs	60
GE 165798 cathedral, vg	150
GE G61 table, wooden	35
GE J71 large table, wooden	75
GE L631 table, wooden	60
GE L660 table, wooden	45
GE M81 large tombstone, bad veneer	110
GE, plastic cabinet but Catalin handle	100
Goodyear 741 console	75
Grundig and Telefunken table, (2)	120
Guild Town Crier	55
Hallicrafters SX28, (3), and Sky Buddies, (2) ..	225
Halston table, wooden, very nice	70
Home brews, (10)	ea. 20 to 70
Kolster, ornate	60
Lafayette fabric portable	20
Lafayette tombstone	95
Magnavox radio phono console, 50s	25
Magnavox Telemegaphone horn	145
Majestic 15 tombstone, nice	175
Majestic 91 console	100
Minerva 702B plastic	40
Motorola 61T23 ornate table, wooden	100
Philco 12-1	175
Philco 20 cathedral	150
Philco 37-60 cathedral	125
Philco 37-611 table, wooden, Deco	150
Philco 38-62 table, wooden	60
Philco 38-116 console	100
Philco 39-40 console, (2)	50, 80
Philco 39-45 console, nice	75
Philco 40-145 table, wooden	50
Philco 41-24T	90
Philco 42-340 table, wooden	40
Philco 42-PT94 table, wooden, plastic trim, p ..	40
Philco 42-PT98 table, wooden	100
Philco 46-421 table, wooden	45
Philco 48-482 table, (2)	70, 85
Philco 48-1262 console	70
Philco 66 cathedral, (2)	110, 175
Philco 66 tombstone	175
Philco 70	200
Philco 71 table, wooden, Deco, nice	50
Philco 84 cathedral	100
Philco 89 console	250
Philco 100 large tombstone, g	180
Philco 123 cathedral, nice	225
Philco 10664A radio-phono, (Bing Crosby)	60
Philco 120629B plastic	35
Philco A52 table clock radio, wooden	85
Philco fabric portable	75
Philco Predicta TV with cart	225
Philco Transitone 52, plastic	100
RCA Radiola 17 radio-phono console	100
RCA Radiola 17, w/hood	150
RCA Radiola 18, w/hood, (2)	75, 95
RCA Radiola 18, no hood, (3)	50, 50, 75
RCA Radiola 20, (2)	135, 145
RCA Radiola 26, no tube cover, vg	200
RCA Radiola 28, w/loop	175
RCA Radiola 100 speakers, (8)	ea. 25 to 60



RCA Radiola 103 tapestry speakers, (2), g ..	190
RCA 372 radio-phono console	75
RCA 7BX Strato-World portable, (2), f	25, 40
RCA 28T table, wooden	35
RCA 56X6, table, wooden	25
RCA 97X table, wooden	55
RCA 103AA table, wooden	35
RCA Golden Throat Deco plastic	45
RCA R93 console	110
RCA V210 console, w/record player	25
Rider's manuals, high numbers, (6)	45
Sentinel portable TV, early suitcase style ..	145
Sextette 3 dialer	60
Sieberling 572 table, wooden	55
Silvertone 1563 table, wooden	70
Silvertone 1731 semi-cathedral	150
Silvertone 4206 table radio, plastic, 50s ..	45
Silvertone 8005 table	30
Silvertone console, nice	125
Silvertone M1 console	50
Silvertone WLS horn speaker	105
Splitdorf R500 3 dialer	40
Standardyne AC	50
Stratford Reflex battery set, kit-built, clean ..	55
Stewart-Warner 8061P1 fabric portable	20
Storey and Clark grandfather clock radio, nice ..	325
Stromberg-Carlson 523 Neutrodyne w/manual ..	275
Stromberg-Carlson SWP8 portable, similar to Trans-Oceanic, large	120
Test equipment, meters, etc., 15-piece lot ..	35
Truetone P0248 console	55
Truetone WG2407 console	25
Tube testers, (2), and scope, (1)	195
Tube(s), late numbers, (1,200)	35
Tube(s), late numbers, (500+), (2 lots)	40, 25
Tube(s), late, w/small tube tester, (850) ..	25
Tube(s), miniature, etc., (2,000)	25
Tube(s), some early, (46)	145
Tuska 305 Superdyne, f	175
Webster wire recorder	30
Zenith 4V31 farm tombstone, nice	125
Zenith 5G41 portable, flip-up dial model, (2) ..	30
Zenith 6G001 fabric portable	10
Zenith 9S367 console, Deco, nice	275
Zenith 600-29 table, wooden	75
Zenith 1000 Trans-Oceanic	40
Zenith 5678 table, wooden	45
Zenith A5456 black dial console	200
Zenith G23 porthole console TV, '40s	185
Zenith G500 Trans-Oceanic	45
Zenith H61 plastic, 1 white, 1 brown, (2) ..	40
Zenith Trans-Oceanic, (4)	ea. 25 to 50

(Arthur Horowitz, Auction Co. of New York,
402 E 90th St., New York, NY 10128)

(Ray Chase, 1350 Marlborough Ave., Plainfield,
NJ 07060)



RADIO MISCELLANEA

"Radio Miscellanea" includes items of general interest selected from A.R.C.'s incoming correspondence. "In The Marketplace" items are based on information submitted by the businesses themselves. "From The Internet" items are obtained from internet newsgroups and other internet resources. Submitted items should be verified for accuracy; items may be edited by A.R.C. for publication, and publication is not guaranteed. See the masthead for more details.

Philco "Lamp" ID

Dear Editor:

By now you must have stacks of mail on the Philco "lamp" in the July 1997 *Photo Review*. As Ron Ramirez can attest, this is not, and never was, a lamp. Someone butchered a good microphone and made a lamp out of it. I have an original magazine ad for it, and I also own two.

John Okolowicz, Ambler, PA

Worldwide Ad Response

Dear Editor:

A.R.C. is terrific! I've been a subscriber and classified advertiser for quite a few years. The results have been great. But my ad in the July issue tops them all. I advertised a Silver-Marshall Shield Grid Six Model 630SG for sale. No big deal. But, in two days I had calls from New Jersey, Pennsylvania, France and Australia! That's worldwide coverage and speaks well for our hobby and especially for A.R.C. Keep up the good work!

Ralph Michelson, Brighton, MI

"Circuit Oddity" Followup

Dear Editor:

I read with interest Ray Bintliff's article "A Circuit Oddity Explained" (August 1996), and his answer may be right in some circuits, as was Chet Gehman's in his original article. I have seen IF transformers with additional windings in several sets, each seeming to be used for different purposes. Research led me to the following technical data from the Meissner Manufacturing Co.:

"This transformer is actually a modification of the double-tuned IF transformer. In this transformer, the passband is varied by changing the coupling between primary and secondary. It is usually accomplished by means of a third winding consisting of a relatively few turns of wire wound under, over, or adjacent to one of the main windings. This winding produces the extra coupling required to produce a broad selectivity curve. Using this arrangement, a very high percent change in coupling can be accomplished with practically no change in the self-resonant frequency of the circuit."

The article goes on to say that when used for this purpose, this winding is not connected to the opposite winding, but is loosely wound, and one end is brought out of the transformer and is either connected to the screen grid or is switched in and out of circuit.

I feel that Chet was right when he thought that the purpose of the winding was to broaden the IF bandpass. Not being an engineer, I wouldn't know how to verify this.

Michael E. Franzen, Los Angeles, CA

Web Sightings

Dear Editor:

Wow! I'm playing with my new computer and decided to do some web crawling. Your web site is fabulous! It's up-to-date, and the graphics are astounding.

Not to worry... I'll still keep my subscription!

Jim Falls, Eureka, CA

Idaho Tubebank

Dear Editor:

I am the trustee for the Idaho Amateur Radio Tubebank, a nonprofit function of the Idaho Society of Radio Amateurs, Magic Valley Chapter. Any excess monies from this project help to keep two area repeaters on the air.

Currently we have about 2,500 assorted receiving and transmitting tubes available for noncommercial use. Individuals wanting to restore old radio/TV equipment are welcome to send an SASE for a current listing. The only charge is \$3 for shipping and handling. Some tubes are used (but tested), and many are new. Sorry, but we can't put a guarantee with them.

L.B. Bunch, Twin Falls, ID

Shipping in U.S. & Overseas

Dear Editor:

On-line computer users can get a shipping figure from UPS on the Internet at <http://www.ups.com/> which provides the rate for a package of known weight between any two zip codes. Lots of other useful information is available as well regarding shipments of packages. Check it out.

Stan Lopes, Concord, CA

Dear Editor:

In response to C.J. Poulos' "Overseas Mailing Inquiry" in the July 1997 *Radio Miscellanea*, I find that it is really simple to ship overseas. The most economical way is via International Parcel Post through the U.S. Postal Service. You simply pack the merchandise, weigh it, and call the post office for a quote for either surface mail or airmail.

Don't be too concerned about expense since the buyer pays the shipping costs. I have sent items to Hong Kong where the shipper wanted airmail, and the shipping came to two times the price of the merchandise.

You can also insure the shipment with the post office, just as with domestic mailing.

Ellsworth O. Johnson, Spokane, WA

Dear Editor:

Shipping small packages overseas lighter than 20 to 40 pounds is best done through the U.S. Postal Service which rarely charges much over \$3 a pound. Some small items can go for as little as about \$7 by Global Priority Mail (available from large U.S. cities to 27 countries).

Insurance and proof of delivery are also available to some countries. Postal money orders are one of the cheapest and most secure ways to send money both domestically and internationally.

The post office is usually the cheapest domestic shipper with several classes and speeds of shipping. No service has shipping more secure than registered mail for those very few items that cannot be replaced. The Hope diamond was once shipped by Registered Mail!

Donald Bisbee, Columbus, OH

CLASSIFIED ADVERTISING POLICY

ONE FREE 20-WORD AD for subscribers in each issue; additional words are 27¢ each. See details below. Classified ads sent by mail, fax or by any other method must be received (not just postmarked!) by **Noon Eastern Time** on the classified ad deadline date to guarantee inclusion in the current issue. Late ads are held for the following issue. Please enclose correct payment with all ads. Stamps or cash are OK for small amounts. (Canadian and other foreign advertisers, please see "Payment" on page 2 for methods.) "Free words" cannot be accumulated from month to month; free words must be requested when ad is submitted.

Faxed & e-mailed ads: Please see additional information on the inside front cover.

When including ads with other A.R.C. correspondence, write the ads on a separate piece of paper. Include SUB# with ad. Ads may be sent in advance; but, write each ad on a separate piece of paper and indicate the month (or successive two months) you want the ad to run.

To minimize our typing errors: Please write legibly. Use both capital and small letters. Do not use a dash between words. Carefully write the following numbers and letters (especially in model numbers) since some can look alike; for example 1, l and I (the number one, the capital i and the small L.) Also: 0, O, o, Q and D; r and n; 6, b and G; V, U, u, v and Y; A and R; 5, S and s; 2, Z and z. We try to correct spelling errors, so when using an uncommon word or manufacturer which we might mistake as a more common word or manufacturer, note it so that we do not "correct" it. Editor's annotations are in [brackets].

Advertising is accepted only for early items related to radio, communication, etc. All items must be described fairly; reproductions, reprints and not-original items must be so identified. Advertisers must agree to respond promptly to inquiries and orders, to resolve problems promptly if the buyer is not satisfied, and to comply with a buyer's refund request on unaltered returned items.

The publisher reserves the right to edit ads without notification to the advertiser and to reject ads for any reason. Names other than the advertiser will be edited out of ads. Ads with non-radio-related items will be returned or edited unless the non-radio-related items are for trade of radio-related items, or they are incidental to and appear at the end of an otherwise acceptable ad. The publisher is not responsible for errors due to illegally written ads or for any other reason.

Clubs: Since club activities receive free coverage on the *Coming Radio Events* pages, the free 20 words may not be used for club activity ads. See inside front cover for additional information.

CLASSIFIED AD DETAILS

Deadline: NOON ET- 10th of the month!

Classified ads must have a standard heading such as **WANTED, FOR SALE, FOR TRADE, FOR SALE/TRADE, SERVICES, MESSAGE, HELP, AUCTION, MEET**, etc. This heading is the only bold or all-capitalized words allowed in the ad. Capitalize only manufacturer names, model names, etc. This standard ad format makes scanning the ads easier.

Before writing your ad, please look over the ads in a recent issue of A.R.C., and try to write your ad in the same style. Full name (or company name) and address is required in all classified ads; we will add it if you forget.

To encourage varied content of the ads, the same classified ad may be run only once per issue and for only two consecutive months. (To run an ad longer, use a boxed classified or display ad.)

Classified Ad Rates per Month

Subscribers:

First 20 words: **FREE***

27¢ per word for extra words over 20 **plus**

10¢ per word for a shaded ad (count all words including free words).

* Subscribers may take 20 free words on only **one** ad each month.

Non-Subscribers:

45¢ per word **plus**

10¢ per word for shaded ad.

Please do not forget to send in the extra 27¢ per word when your classified ad runs over the free 20 words; your payment will be appreciated, and it will help to keep A.R.C. healthy.

BOXED CLASSIFIED AD DETAILS

Deadline: 1st of the month!

Boxed classified ads can run unchanged for three months or more. No words are free. Ads may be shaded and may include bold and all-capitalized words freely. The ad need not begin with "For Sale," etc. Minimum run is 3 months, prepaid. Discount: 10% for 6 months; 20% for 12 months.

Boxed Classified Ad Rates per Month

Nonshaded ads:

38¢ per word for all words,* none free, **plus**

10¢ per word for each bold word **plus**

10¢ per word for each all-caps word.

Shaded Ads (All words are bold at no charge):

48¢ per word for all words* **plus**

10¢ per word for each all-caps word.

Non-Subscribers:

Add 20¢ per word to above costs.

*Three words can be bold-all-caps at no extra charge.

PHOTO & DRAWING DETAILS

**Deadline: 1st of the month
for all ads with drawings or photos!**

Drawings and photos are encouraged as the response to your ad is much larger and the reader knows better what you want or are selling. Send in your drawing or photograph, and A.R.C. will reduce it or enlarge it as needed.

Photo and Drawing Rates per Month

\$22.00 per month for each photo or drawing (If ad is canceled, this amount cannot always be refunded.)

CHANGES & CANCELLATIONS

Please check your ads carefully before sending them in. Once ads are received, it is not always possible to refund the amount sent, pull the ad or make changes.

IMPORTANT — COUNTING WORDS — IMPORTANT

The **standard headings:** WANTED, FOR SALE, etc., count as **one word** each time used in an ad. **Name, address and (one) telephone number,** count as **6 words**, regardless of length. Ham call letters and business name can be included in the 6 words and do not count extra. Full name (or company name) and address is required in all classified ads. Each additional word, abbreviation, model number or number group, extra telephone numbers, fax, e-mail, etc. count as one word each. Hyphenated words count as two words.



A.R.C., P.O. Box 2, CARLISLE, MA 01741
RETURN POSTAGE GUARANTEED

PERIODICALS

**CLASSIFIED AD
DEADLINE AUG. 10th
Noon Eastern Time**