

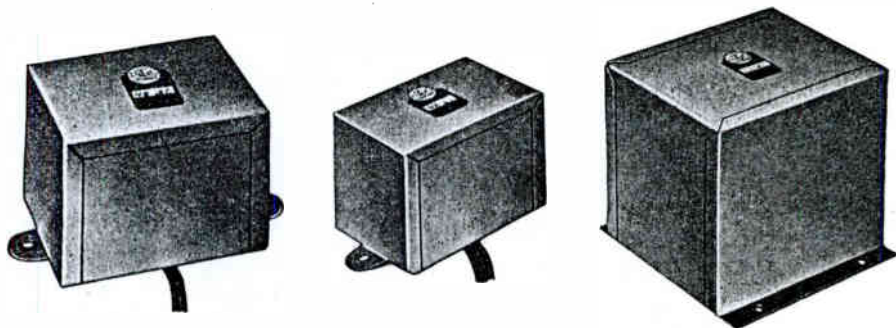

NIKLSHIELD

AUDIO . FILTER . POWER



NS-12, NS-29, NS-40, Types NS-1, NS-9, NS-37 Types NS-50, NS-51 Types  
For the Service Technician . Public Address Engineer . Experimenter  
with QUALITY of WORKMANSHIP and MATERIALS at Low Cost.

		List Price	Net to Dealers
<b>CLASS A INPUT TRANSFORMERS</b>			
NS-1	1 plate to 1 grid. 3½:1 ratio.....	\$2.35	\$1.41
NS-2	1 plate to 2 grids, split secondary. 2:1 ratio.....	2.50	1.50
NS-3	Push pull plates to push pull grids. 1.8:1 ration.....	2.75	1.65
NS-5	Single or double button mike to 1 grid.....	2.50	1.50
NS-10	Single plate and carbon mike to one or two grids.....	3.50	2.10
<b>CLASS A OUTPUTS</b>			
NS-15	Push pull 2A3 plates to 8, 4, or 2 ohm voice coil.....	3.00	1.80
NS-21	Push pull 2A3 plates to 500, 8, 4 or 2 ohms.....	3.50	2.10
<b>CLASS B INPUT TRANSFORMERS</b>			
NS-29	Driver plate to 49, 53, 79 or 89 grids.....	2.75	1.65
NS-30	Driver 46 or 59 plate to 46 or 59 grids.....	2.75	1.65
<b>CLASS B OUTPUT TRANSFORMERS</b>			
NS-33	Push push 49, 53, 79 or 89 plates to 5000 or 3500 ohms....	3.50	2.10
NS-34	Push push 46 or 59 plates to 5000 or 35000 ohms.....	3.50	2.10
<b>FILTER AND AUDIO CHOKES, FILAMENT TRANSFORMERS</b>			
NS-50	Plate Transformer for small power tubes, Class A and B. Pri. 115 V.A.C.. 60 cycles. Secondaries: 300-0-300 at 75 MA; 5 V.C.T. 3A., 6.3 V.C.T. 2½A., 2½ V.C.T. 6A.....	7.00	4.20
NS-51	Plate transformer for push pull power tubes Class A and B. Pri. 115 V.A.C. 60 cycles. Secondaries: 400-0-400 at 125 MA; 2½ V.C.T. 5A., 2½ V.C.T. 10 A., 5 V. C. T. 3A..	9.00	5.40

DISTRIBUTED BY

Radio Supply Co.                      Radio Television Supply Co.  
Pacific Radio Exchange              Radio Specialties Co.  
Complete Warehouse Stocks in Los Angeles  
Use - UTC - for - Quality

United Transformer Corp.

U-T-C Representative, C. R. STRASSNER, 1341 South Hope Street

# « The » "TECHNICIAN"

OCTOBER, 1934

BE  
SURE  
TO READ  
SPECIAL  
NOTICE  
ON  
PAGE 12

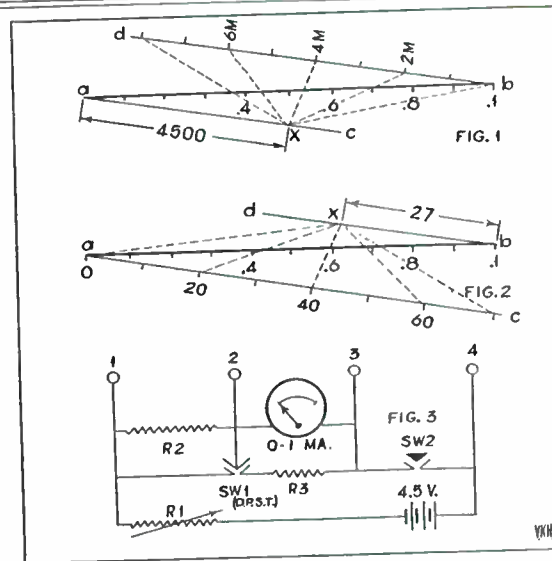

SEE  
PAGE 7  
FOR TEXT  
EXPLAIN-  
ING  
THESE  
CIRCUITS

## Standard Parts

AND

## Radio Accessories

Exclusively for Dealers and Service Dealers

### Radio-Television Supply Company

1701 SOUTH GRAND AVE.

LOS ANGELES

Excellent Parking Facilities Away from the Congested Downtown Area

# A TRIUMPH

## *in Radio Engineering* The distinguished **GRUNOW** "WORLD CRUISER"

● It has the "Signal Beacon", an exclusive Grunow invention that finds all world stations and tunes them in with clarity, and without distortion. Come in and try this amazing invention today.

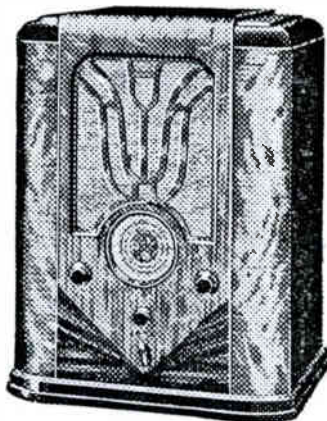

### Watson & Wilson, Inc.

DISTRIBUTORS

711-717 Mitchell Place

PRospect 7281

Los Angeles

### — INDEX —

Editorial by the Editor.....	5
Ohmmeters and Their Calibration.....	7
By V. K. Hatfield	
Checking Tubes.....	9
By Frank Herrfeld	
Factors Governing Design and Choice of Radio Transformers (Part 2).....	10
By I. A. Mitchell	
Something Can Be Done About Radio Interference (Part 2).....	11
By Fred B. Doolittle	
The "Technician" Moves.....	12
Traveling the Territory.....	14
Radio Interference Bureau.....	20
By W. F. Grimes	
Seeing the World Fair.....	22
By Norman B. Neely	

Dependable, Inexpensive, Efficient



"Western made for Western Reception"

Second installment of Chris O'Malley-son will appear in November issue.

### TUBE CHECKERS — and — SET ANALYZERS Repaired or Rebuilt—

All types of instruments  
Repaired or Calibrated  
Shunts or Multipliers made up  
for any instrument  
PROMPT — ACCURATE  
RELIABLE SERVICE  
Authorized Service Laboratory  
for Weston Electrical  
Instrument Corp.

Quality Electric Co.

Tel. TRinity 5981  
812 S. San Pedro Los Angeles

We Carry At All Times

Most Complete and Biggest Assortment of

## RADIO PARTS

— In The West —

All The Nationally Known Makes of

REPLACEMENT PARTS

TEST EQUIPMENT

PUBLIC ADDRESS SYSTEMS

RECEIVERS AND TRANSMITTERS

WHOLESALE TO DEALERS AND SERVICEMEN ONLY

## Radio Supply Co.

912 So. Broadway

Los Angeles, Calif.

Phones VAndike 3178 - 3179 3170

Mention The "Technician" when answering advertisements—It identifies you.

**\$1,000,000**

and more has been spent to make these Names internationally known — But twice that amount couldn't buy your approval and respect if they were not Good — they must be good to have such Universal Acceptance!!

For Better Radio  
**Hammarlund**  
PRECISION  
PRODUCTS

© H M I T E

DAYRAD

Micamold

THORPARSON

Centralab

YAXLEY

BUD

CLAROSTAT

Radiart

Philmore

**FLECHTHEIM**  
SUPERIOR CONDENSERS

WE ARE PROUD THAT WE HAVE BEEN CHOSEN TO  
DISTRIBUTE THEM

**RADIO SPECIALTIES COMPANY**

1816 West 8th Street

Los Angeles ♦ ♦ ♦ FEderal 6633

# The "TECHNICIAN"

Official Publication of the Certified Radio Technicians' Association, A Corporation  
An Organization of Competent, Qualified and Trustworthy Radio Technicians for the  
Purpose of Advancing the Radio Art and for the Protection of the Public.

A. PAUL, Jr., President

JOHN L. VINCENT, Vice-President

V. KARL HATFIELD, Secretary-Treasurer

NORMAN B. NEELY  
Editor - Manager



1656 N. Serrano Street  
Los Angeles, California

\$1.50 Per Year

15 Cents Per Copy

Vol. II

OCTOBER, 1934

No. 2

## EDITORIAL

By The Editor

### "L. A. Ry. and Radio Interference"

The subject of man-made static has become of ever-increasing importance during the past decade. With the advent of sensitive receivers the electrical interference caused by various electrical medical appliances, commercial equipment and public utilities equipment demanded the serious attention of those of us interested in the sale, maintenance and enjoyment of radio receiving apparatus. The evolution of interference elimination methods and procedure is familiar, in its general points, at least, to most of us. In Southern California we have one of the most efficient and active interference bureaus in the country with a personnel of leading engineers. However, this bureau can only function satisfactorily to the extent of the cooperation given by the agencies whose equipment and products are the chief causes of man-made static.

The manufacturers of various electrical appliances such as drink mixers, irons, washing machines, vacuum cleaners, Neon signs and beauty shop equipment are now, to a large extent, equipping their products with built-in filters to eliminate possible radio frequency disturbances at the source. Operators of electrical medical equipment shield and filter such units as are likely to create disturbances. The owners of commercial shop and manufacturing equipment respond without undue pressure, in most cases to the suggestion of the interference bureau to install interference filters.

The various public utilities, who support the bureau financially do, almost without exception, conscientiously en-

deavor to maintain their equipment and machinery in such a manner as to reduce radio interference to an absolute minimum. This is particularly true of the power and telephone companies who maintain radio engineers whose duties include activities supplementary and complementary to those of the interference bureau. Several years ago the Southern California Telephone Company installed filters on its office ringing machines for the benefit of radio listeners.

All of these agencies spare no reasonable expense or effort to minimize interference with radio entertainment which has been and is a means of joy and inspiration to countless millions of listeners. The small manufacturer and shop owner and other less powerful organizations have responded admirably to this example set by the larger corporations and utilities. On many of its lines the Pacific Electric Railway has installed new type trolley shoes to replace the old trolley wheels which are responsible for much disturbance, and the company is constantly extending this policy with the ultimate aim of using only that type of trolley. The electric railway system of San Diego is also equipped with trolley shoes with the result of greatly reduced radio interference from its lines.

The glaring exception to this cooperative spirit is the Los Angeles Railway. This public utility which, as a public carrier system, is notorious for its unsatisfactory service to passengers and its brazen disregard of traffic regulations and common traffic courtesy refuses to assist materially in spirit or letter in re-

Continued on page 25)

## ANNOUNCEMENT

### Advanced Technical Training Courses

IN  
PUBLIC ADDRESS SYSTEMS  
TELEVISION SOUND PICTURES  
PHOTO CELL CONTROL  
POLICE, AVIATION  
and SHORT-WAVE RADIO

Offered Only to men qualified by study or practice in the fundamentals of radio. Very low tuition enrollment includes two years full RTI consultation service and Advisory Board assistance on technical problems.

Call or Write for Information  
Radio and Television  
Institute, Inc.

Los Angeles Office  
311 Financial Center Bldg.  
Seventh and Spring Streets  
E. J. Mitchell, Representative

#### R. T. I. ADVISORY BOARD

Kendall Clough, Chief Engineer,  
The Clough-Brengle Co., Eng'rs.  
and M'frs.  
Karl Hassel, Chief Eng'r, Zenith  
Radio Corporation.

Homer Hogan, Gen'l Manager, Sta-  
tion KYW, Chicago.

R. MacGregor, Service Manager,  
Transformer Corporation of Amer-  
ica (Clarion).

B. B. Minnium, Chief Radio Eng'r,  
Stewart-Warner Corporation.

F. D. Whitten, Ass't. Supt. Chicago  
Branch Philco Radio & Television  
Corporation.

James Madison, Grigsby-Grunow  
Co., (Majestic).

This group of executives and en-  
gineers—all outside business men—  
actually have complete supervision  
of R. T. I. Training. Their very  
names and positions in the Radio  
Industry is your guarantee of a  
square deal.

# Ken-Rad

## Radio Tubes

DEPENDABLE LONG LIFE



## A. E. Ravenscroft, Inc.

Distributors

1818 So. Grand Ave. PRespect 1317

Los Angeles

## Ohmmeters And Their Calibration

By V. KARL HATFIELD

First Prize-Winner in Recent Technical  
Article Contest

The average technician has an ohm-meter and knows how to use it, but few know how to construct one, using any good meter which happens to be available. Then, too, the calibration is somewhat of a problem, after the meter has been completed. This article proposes to show how both may be done very easily.

The best meter is of the high resistance type, with a 0 to 1 milliampere movement. This type draws a low current, which prevents overloading sensitive apparatus and permits the use of small batteries. For purposes of example, a 0 to 1 milliampere meter, with a resistance of 27 ohms, will be used.

There are two types of common ohmmeters, the series and the shunt. The series meter will be considered first, as this type has the advantages of being simple and of requiring no accurate resistors. It has the disadvantages of the calibration depending upon the condition of the battery and of not reading low values of resistance. The average series meter uses a 4.5 volt battery and a limiting resistance of 4,500 ohms for full scale current. This resistor may be composed of a fixed and a variable, the fixed resistor being for the protection of the meter, and the variable being for compensation of battery ageing. Fig. 3 is a special case, and the limiting resistance is made of a 2,673 ohm fixed resistor and a 2,000 ohm variable resistor. The approximate range of such a meter is 1 to 10 times the limiting resistance, or 450 to 45,000 ohms.

Readings may be used above and below the given figures, but the degree of accuracy is low. To extend the range of the meter, a 45-volt battery could be used, with a limiting resistance of 45,000 ohms. With the higher voltage the range would be increased to approximately 4,500 to 450,000 ohms, and the calibration would be ten times that of the 4.5 volt ohmmeter.

The calibration of the series ohmmeter is easily done by the "Z" chart method, as shown in Fig. 1. Line "ab" is marked off in the number of divisions your particular meter happens to have, whether it be 0 to 1 or 0 to 75. Lines "db" and "ac" are parallel. Angles "dba" and "bac" may be any angle, 30 deg. being about right.

In the example ohmmeter the limiting resistance is 4,500 ohms, and is repre-

sented by "aX." X may be located at any point on "ac" and may be moved up and down "ac" to obtain finer calibrations at either end of the meter scale. "db" must be marked off with the same units as "aX," and if the point "X" is changed, "db" must be changed accordingly. Then using "X" as a point, draw lines through "ab" to any number of desired points on "db." The intersections of these lines with "ac" are the calibration points of the meter. If a different voltage is used, "aX" will simply change in value, as will the units on "db."

Shunt ohmmeters have advantages which make them more useful than the series type of meter. The shunt meter may be read to a fraction of an ohm, and to many thousands of ohms. The ohmmeter shown in Fig. 3 can be read with accuracy to lower than .27 ohm and to higher than 27,000 ohms. Much higher values will be indicated, but can not be read with accuracy. We saw that the limiting resistor of the series ohmmeter had a definite part to take in the calibration, but this resistor was made variable to compensate for ageing batteries. This means that the series ohmmeter will not hold its calibration for any length of time. It is easily seen that the shunt meter is superior when accuracy is desired. The only battery problem that need be considered with the shunt type of meter, is to be sure that full scale current is always available for each range.

The principle of the shunt ohmmeter is simply that of parallel resistors with a constant current. One branch, the meter, indicates its amount of current, and the other branch, the resistor under test, takes the remainder of the full scale current. The ohmmeter is calibrated as to the proportion of the full scale current that the meter takes when various resistors are placed under test.

The calibration of the shunt ohmmeter is also done with the "Z" chart, but with a few changes. Referring to Fig. 2, again, "ab" represents the meter scale, and "ac" and "db" are parallel. The point "X" is located on "db" this time, "Xb" representing the meter resistance and "ac" being marked off in the same units. Then using "X" as a point, draw lines through "ab" to "ac." The intersections of these lines with "db" are the calibration points of the meter. For the meter in Fig. 3, "Xb" will be 2.7

(Continued on page 24)

ORIGINATORS OF PRACTICAL RADIO ENGINEERING INSTRUCTION

# ... A Message To Men Who Use Their Pencils As Often As Their Pliers ...

Today, with so many new developments in Radio . . . technical training is more important than ever for the technician who is going to keep in step with the fast pace that Radio is setting. No matter how much business "picks up" this Winter, you are still handicapped by Time. With the help of CREI training you will be better equipped to handle more and better jobs.

**NEW COURSE  
OFFERED FOR FIRST TIME!**

A new series of lessons on "AUDIO AND ACOUSTICAL ENGINEERING" are now included as a part of all courses. They prepare the engineer to handle practical problems arising in the design and installation of audio and acoustical systems.

**44-PAGE CATALOG  
JUST OFF THE PRESS!**

We have just published our newest and largest catalog, with complete information in detail about our school and courses . . . with scores of photos of our equipment and laboratories. Write for your copy today—no cost, no obligation.

## Capitol Radio Engineering Institute

14th and PARK ROAD N. W.

Washington, D. C.

Dept. T-10

California Representative:  
**EDWARD H. GUILFORD**

236 South Brand Blvd., Glendale, Calif.

Phone KEnwood 843

Mr. Guilford, member of the CRTA, will be glad to be of assistance to you in answering inquiries and describing courses.

## CHECKING TUBES?

By FRANK HERRNFELD

Engineer—Radio Products Sales Co.

The usual tube-testing devices consist of a series of meters and rheostats and are designed to check the emission of the cathode (filament) and to measure certain so-called static characteristics. From these tests may be obtained the static amplification constant and other data of value.

Under most conditions, however, the dynamic characteristics of a tube are of far greater importance. All of these can be obtained by the vacuum-tube bridge method only. The three fundamental dynamic characteristics are:

- 1—Amplification constant
- 2—Plate impedance
- 3—Mutual conductance

Of these three constants, the mutual conductance gives the most positive indication of the tube performance, since it involves the ratio of the other two constants. While the mutual conductance is not a complete indication of the comparative merit of tubes of different types, it is a positive indication among tubes of the same type. If the tube fails to meet the standard specifications of its type, the mutual conductance will always be lowered. Since the mutual conductance is very easily measured, its value is the most suited for use as an acceptance standard for the laboratory.

Fig. 1 gives a diagram of the fundamental circuit of the tube-checker. It gives very satisfactory results and values can be read to within five per cent.

Mutual conductance is the ratio between grid input voltage (not to be confused with grid bias) divided by the a. c. plate current (not to be confused with the static plate current). The following example regards a 227 tube. One volt a. c. between grid and "C" minus will produce a one milliamperere a. c. plate current. If the filament, the "C" bias, and the plate voltages are of proper values.

In Fig. 1  $G_1$  is an a. c. generator which will deliver two volts to the grid.  $R_1$  is a resistance of 2000 ohms, preferably of the non-inductive type. By Ohm's Law we can see that any current change across the resistance  $R_1$  will cause a corresponding change in voltage drop therein. This voltage drop is measured with the five-volt a. c. meter  $V_2$  (2000 ohms per volt.) A capacity  $C_1$  is placed in series with this voltmeter to stop any flow of direct current in this

circuit. This capacity, if large enough will offer only a small resistance in series with the voltmeter to a. c. currents. With this arrangement mutual conductance can be read directly off the voltmeter. Full scale deflection will be about 2700 microhmhos-high enough for all present types of tubes.

The diode sections of the duplex diode tubes have to be treated as rectifiers separate from the diode or pentode sec-

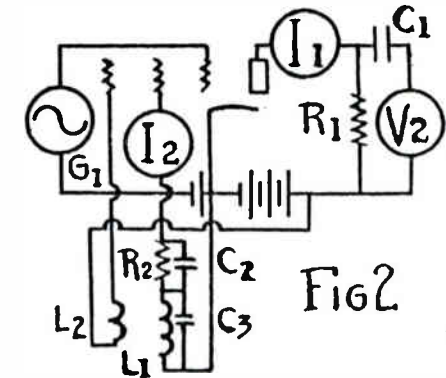
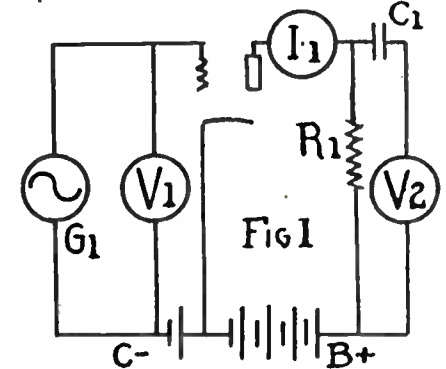

tion. Ten volts a. c. impressed on the diode plates will give a very good deflection on a 2 M. A. meter. Both diodes should check alike when used in full wave detection circuits in order to get the best performance of the radio receiver in which they are used.

The oscillator section of converter type tubes can be arranged in the manner shown in Fig. 2. This is a com-

Continued on page 24)

## Factors Governing Design and Choice of Radio Transformers

(Part Two)

### Filter Reactors

The design and construction of filter reactors is similar to that of power transformers in many respects. However, two important factors must be considered. The core must not saturate under the normal D C current and the core material must have high permeability at low A C flux density. This first point is very important as the entire effectiveness of the choke coil depends upon high inductance with normal D C. Until recently many manufacturers considerably over-rated their material in this respect. For example, a so-called 30 henry choke might have an inductance without D C of 25 to 40 henries, but with normal D C through the coil, this would drop to 6 to 8 henries. In many cases, 6 to 8 henries was all that was really required, so that this reactor was satisfactory. On the other hand, it is apparent that such a rating is definitely misleading.

The A C flux density in a reactor is often quite small, but is normally superimposed on a D C flux density of 25,000 to 35,000 lines per square inch. To obtain maximum efficiency under these conditions, a core material having high incremental permeability is employed. This incremental or working permeability is entirely different from the normal saturation curve of the steel and is generally measured under actual operating conditions. The air gap in filter reactors is also quite critical for maximum efficiency, and should be adjusted so that the D C flux density is approximately 30,000 lines per square inch.

Audio reactors such as are used for modulation purposes or output chokes are essentially the same as filter reactors. The A C flux densities appreciably higher so that fairly high values of incremental permeability can be obtained. High voltages are impressed across these coils in audio circuits and it is important that good insulation be used throughout.

In the final analysis, it is important that iron core components for radio receivers or amplifiers should not be judged on the basis of weight or size. One transformer may be twice the size of another, but if poor materials are used, or if improper design is employed, the larger transformer may be the poorer choice. The actual amount of reliance that can be placed on published data or ratings of a manufacturer depends solely on the reliability of the manufacturing organization itself.

## ADJUSTING J-B MODEL 62

By CHARLES NICHOLS

There has been so much question as to just how to properly adjust Jackson-Bell Model 62 receivers that the following item, submitted as a service kink, is given space as a feature article, as it is believed that this information is sadly needed but difficult to obtain. Mr. Nichols was formerly an engineer with Jackson-Bell at the time of the production of this model and the directions given below are authentic.—Editor.

Many technicians seem to be at a loss as to the method of adjusting Jackson-Bell Model 62 receivers or others using small variable condensers from the plate of one r. f. tube to the grid of the preceding stage. Here is the dope: The primary or plate coils in these receivers are very large and have a natural period of about 600 meters; consequently, the set will have good gain around that frequency, but when tuned to the higher frequencies the gain quickly drops. The small condensers are used to transfer energy to the preceding stage at these higher frequencies. When attempting to balance these sets proceed in the following manner: Screw all of the small condensers all the way in and then back off one turn on each. Remember, now, ONE turn, not three or four. Now turn the dial to about 1400 kc., turn on your oscillator or grid dip meter and check for resonance at this frequency. Now bring the first stage into resonance by adjusting the small condenser on the first r. f. coil. This condenser (on the Jackson-Bell 62) is just a trimmer on the first variable. Now proceed with the second, third and fourth stages in the same manner. Next, tune your oscillator to about 900 kc., and resonate here by bending plates of variable. Adjust again in same manner at 600 kc. If set oscillates at the higher frequencies unscrew each gain condenser slightly. Not too much, now, because you will upset the resonance at the higher frequencies. You may be forced to bend plates slightly at the higher frequencies in order to get the required gain and also keep the set in resonance. Practically all of the Jackson-Bell 62 sets were staggered at the higher frequencies because of the insufficient shielding of the r. f. portion of the receiver. This is no reflection on the engineering department, but instead, blame it on the purchasing department. The later Jackson-Bell 68 receivers did not need to be staggered, as they were well shielded and had tremendous gain over the entire portion of the dial.

## SOMETHING CAN BE DONE ABOUT RADIO INTERFERENCE

By FRED B. DOOLITTLE

Radio Engineer, Southern California Edison Co., Ltd.

(Part Two)

### Special Receiver Installations

Where distribution circuits are carrying interference from any cause, it is often possible to keep it from entering a radio receiver by certain precautions in the installation. A receiver may pick up radio signals or interference in any or all of the following ways:

1. Directly on its antenna.
2. On the antenna lead-in directly or by coupling between the lead-in and adjacent parallel electric wires.
3. Through the power supply wires to the radio set.
4. Directly on exposed circuit elements in the set itself or by coupling between these elements and adjacent wiring.

1. **Antenna.** To avoid interference picked up directly on the antenna it is necessary to erect the antenna in a location which is as free from interference as possible and where the desired signals are as strong as possible. Generally an outdoor antenna at right angles to the power line and as far from it as property boundaries will permit is the most satisfactory. Within practical limits, the higher the antenna can be placed the better, as the field strength of interference carried by overhead lines is much stronger between the conductors and ground than in the air above. Conversely, the amount of broadcast signal picked up by an antenna is proportional to the square of its height above ground so that any increase in antenna height will greatly improve the signal to noise ratio. No general recommendation can be made as to the length of an antenna because this will vary with the distance from the broadcast stations, the type of receiver and physical limitations. In general, antennas from 40 feet to 300 feet long are satisfactory for broadcast reception, the longer antennas being used in rural districts remote from local broadcast stations.

2. **Lead-In.** It is usually necessary for the lead-in from the antenna proper to the radio receiver to come in close proximity to electric circuits, service wires or house wiring, which may be carrying interference. By using shielded wire for the lead-in, pick-up of interference may be avoided. A good shielded lead-in consists of a No. 14 B. & S. gage

copper wire with rubber insulation and either a lead sheath or a copper braid over the rubber. The sheath or copper braid must be grounded either to the set ground or a separate ground of low resistance. Sometimes it is necessary to ground the shield at several points along its length. The use of a shielded lead-in introduces some loss in the antenna system which may be compensated for in the following ways:

(Shielded lead-ins are not suitable for systems intended for the reception of short-wave signals.—Editor).

- a. Increase the gain in the radio receiver by turning up the volume control.
- b. Increase the length of the antenna to pick up more signal.
- c. Install suitable coupling devices at one or both ends of the shielded lead-in.

3. **Power Supply.** Interference can be kept from entering a broadcast receiver through its power supply by means of a filter in the supply circuit. The usual filter consists of two one-tenth microfarad or larger condensers in series across the line with the common point connected to ground and a radio frequency choke coil in series with each side of the line between the condensers and the radio set. Such filters are commercially available. The degree of success of a filter application to a radio receiver depends on the merit of the ground to which the filter is connected. In fact, the grounding may be of more importance than the filter itself, for in many instances, interference has been sufficiently reduced to satisfy the consumer simply by grounding the neutral of the service to the water pipes.

(To Be Continued)

## NEW NATIONAL UNION 80

The National Union Radio Company of New York has recently developed a new and improved type 80 tube. This tube, while intended for replacement of ordinary 80 tubes, is designed to operate at a lower temperature and permit longer life in sets of ten to twelve tubes which have considerably overloaded the ordinary 80 tube. This end is accomplished by increased plate area which is made possible by corrugating the plates. Extensive tests have shown this tube to be a really worthwhile improvement.

## PERSONALS

Don Walker, formerly service manager for the Troy Radio Mfg. Co. has established his own service business, operating under the name of "Don's Radio Service."

John A. Orme, well-known CRTA member, is now getting "service headaches" for Richardson and Martin Music Company.

Charlie Miller, head of the Technical Board of the CRTA is now service manager for the Conner Music Co.

Our "knot-hole" reporter, Water Windshield, states having seen Charlie Nichols trying to chisel a wholesale price on an engagement ring!

Al Sexton, formerly of Radio Products Co., is now located as general manager of Radio "Doc."

## McGRAW-HILL ENGINEERING LIBRARY

The McGraw-Hill Book Co. announces a radio engineering library of five of the outstanding volumes covering nearly every phase of radio engineering and practice. The group of five volumes may be purchased on a special plan at a price which is a substantial saving over the sum of the individual prices of the books. Moreover, the company has evolved a time-payment plan which makes the ownership of a really complete and high grade radio reference library possible to everyone.

## GRUNOW S-W. ENGINEER

Lieut.-Commander Fred H. Schnell is now chief short wave engineer for the General Household Utilities Company, manufacturers of Grunow radio receivers. He has a very colorful and extensive background of radio experience in the high frequency field. During the war, at Delman, U. S. Navy, New Jersey (Transatlantic receiving station) he copied the first message sent from Italy to the United States, addressed to President Wilson. Among other outstanding points in his career are included the facts that he copied the Armistice acceptance message from Germany at the close of the World War; was traffic manager of the American Radio Relay League for six years; established the first two-way contact across the Atlantic on about 100 meters; and conducted the first long-range short-wave tests for the Navy.

## TECHNICIAN MOVES EDITORIAL AND BUSINESS OFFICES

After October 10 the editorial and business offices of the "Technician" will be located at 1656 North Serrano Street (corner of Hollywood Boulevard). The new phone number is GRanite 0755. This change has been made necessary by the rapidly increasing activity and growth of this publication necessitating a more centralized and spacious location.

All readers and patrons of the "Technician" are cordially invited to call at the new location and give us the "once over" in our new quarters. Every effort is and will be made to make this magazine an ever more valuable and helpful element in the radio industry of California with particular emphasis on Los Angeles and its environs.

Don't forget the new address—1656 North Serrano Street, and the new phone number—GRanite 0755.

NORMAN B. NEELY, Editor.

## TROY PRESENTS DIAGRAMS

At a recent meeting of the CRTA the Troy Radio Mfg. Co. presented a complete set of ten circuit diagrams to the members and guests present. These schematics include circuits of all-wave, dual-band, short-wave, and auto receivers and public address amplifiers. Technicians not present at the meeting will be given sets of these circuits gratis upon request in person at Radio "Doc," Troy distributor.

## WESTON SERVICE MEETINGS

Two meetings are planned for this winter by the Weston Electrical Instrument Co. One is to be held in the Trinity Auditorium (assembly hall) at 839 South Grand Avenue on Friday evening, December 7, 1934. Another meeting is to be held in the El Cortez Hotel in San Diego on Monday night, December 3, 1934. These meetings are being planned well in advance and will contain a wealth of valuable service material. Further details of these meetings will appear in these pages next month.

## CENTRALAB SOUND CONTROLS

The Central Radio Laboratories has recently announced a complete line of sound projection, public address and recording controls known as Series two. This series consists of "T" and "L" type attenuation pads and faders of improved design at reasonable prices for such a grade of equipment.

# AT LAST!

A line of test equipment which closely approaches laboratory precision at prices comparable to that of ordinary service instruments, is being manufactured by the Triumph Mfg. Co. of Chicago.

A real signal generator with a true ladder type attenuator which really operates satisfactorily, and many other outstanding features, at the astounding price of \$38.75 Complete f. o. b. Chicago.

An all-purpose, multirange meter which has all ranges available from one selector switch—separately calibrated a. c. scales—output leads on a. polarized plug—one zero ohms adjustment sets all scales—measures a. c. and d. c. voltages up to 1000 volts—easy reading lance-type pointer—AND—it reads resistance values accurately from 1/2 ohm to ten megohms. Net price, complete with test leads—\$19.95 f. o. b. Chicago.

## SOON TO BE RELEASED

A Tube Tester with a brand new principle will be ready for the market in a very few days—watch for it!

The Triumph engineers are now developing a complete line of instruments which will be worthy companions to the Model 100 signal generator and Model 300 multi-range meter. It will include a practical vacuum tube voltmeter, a service audio oscillator, an impedance bridge and a capacitor-resistor indicator.

FOR DEMONSTRATIONS AND DETAILS CONTACT

NORMAN B. NEELY, Calif. Representative  
1656 North Serrano Street GRanite 0755

## TRAVELING THE TERRITORY with MILTON

He's at it again! Yes, sir, the old Traveler once more is on the loose with the choicer bits of scandal picked up along the territory. Are you-all a-listenin'?

\* \* \*

When it comes to getting their dollar's worth in radio service, perapiring radio fans in Anaheim never worry. They just leave it to Warren Doller, the handsomest service man in Orange County, who adjusts and fixes 'em in said community.

\* \* \*

You people who have never had the pleasure of meeting Al Smith in person can do such by calling up Bob Sperry's Radio Shop in Santa Monica for a service call. Al Smith is the boy who puts 'em in order down there along the beach front.

\* \* \*

This week's lustiest chuckle: Little girls who insist on calling their mamas "Farina."

\* \* \*

Some of the boys along the route have been wondering what this Traveler fellow looks like. If you-uns are that curious, all that is necessary is to walk into one of the local wholesale supply emporiums and ask for the Ambassador. If you're in the right place, the rest is easy.

\* \* \*

The radio customers in El Segundo and thereabouts certainly show admirable discretion when paying their bills on time to Jim Neves, who keeps the solder flowing in that vicinity. Jim happens to be an accomplished wrestler with plenty of falls to his credit in the professional ring; and in such a case a word to the wise is quite unnecessary.

\* \* \*

Here's something that will keep you-all quiet. Bob Wilson, the mischievous skipper of the trim little sailing craft "Mischief," advises that on land it's so many miles per hour, but on sea it's just plain knots to you.

\* \* \*

Since the Navy squadron set sail for the East coast some months ago, the theme song of the merchants in Long Beach seems to be "I'm waiting for ships that never come in."

\* \* \*

It certainly tickles all of his friends at Mauricio Calderon's Repertoire Musical Mexicans on North Main Street, to have the Traveler drop in to pay his respects.

It has been said that people murder the King's English; but when the Traveler lets loose with what little Spanish he doesn't know, slaughter is far from being the word. Annihilation is what the Greeks would call it.

\* \* \*

And here's one on Hal Rowland, who keeps the service doors open at Kendall Tune's radio establishment on Glendale Boulevard. Hal recently spent an unsuccessful afternoon trying to obtain a special output transformer for a radio, and in disgust went back to the shop to see what could be done about the dilemma into which he was so unobtrusively thrust. After "messaging around" for a few minutes, he suddenly discovered that some back-yard service man had reversed the input and output transformers and that an ordinary input would do the trick right handsomely. Just ask Hal what he thinks about the "parlor, bedroom and bath" service man! Oh, boy!

\* \* \*

And if any of you readers enjoy reading columns like this one, the State of California is to be praised for maintaining institutions like those at Patton and Norwalk. Can you take a lesson from the lark?

### SERVICE KINKS

#### Zenith 462

In case the vibrator in Zenith Model 462 receivers works only half-wave, look for a piece of solder shorting out the other contact to the armature.

C. Nichols.

#### Majestics Using G-2 Tube

In Majestic Model 210 and similar models using the G-2 diode tube replacement is sometimes difficult due to the fact that few men carry Majestic replacement tubes. In this case substitution of a type 35 or 24 screen grid tube for the G-2 will be found to give entirely satisfactory service including operation of the A. V. C.

A. J. Moser.

#### Majestic Chassis Bolts

A Majestic set was found with odd size chassis bolt heads sunk into the wood. Pliers would not remove the bolts—A jack nut was driven down over the bolt head and a large screwdriver was driven into the jack nut and the chassis came out as easily as if the bolts were standard size.

John A. Orme.

# PETER PAN

SINCE ITS ORIGIN HAS MAINTAINED  
AND ALWAYS WILL MAINTAIN THE  
HIGH STANDARD OF QUALITY FOR  
WHICH IT HAS BEEN NOTED.

"Look For the Boy With The Flute"

JOHNSON & MACKAY  
Exclusive Distributors  
Los Angeles County

PETER PAN RADIO CO.  
1487 West Adams  
REpublic 6093

## Quality Merchandise Only

We offer a Complete Stock of Radio Parts, Supplies and Accessories  
PLUS active jobber cooperation and service.

*It Will Pay You to Get Our Price Bulletins*

## YALE RADIO ELECTRIC COMPANY

Wholesale Radio Equipment  
709 South Main Street  
Los Angeles, Calif.  
Phones—TUcker 1105 — TUcker 1106

# ARCTURUS RADIO TUBES

M. D. EALY, Consignment Agent

1214 Venice Blvd.

PRospect 9810

Los Angeles



**"Philco  
High Fidelity"**  
IS THE TOPIC OF  
THE HOUR—ARE YOU  
UP-TO DATE?

In an effort to cooperate with ser-  
vice technicians who wish to keep  
abreast of the times we have  
prepared a very comprehensive  
**TREATISE** on "PHILCO HIGH  
**FIDELITY,"** which will be given  
to technicians calling in person at  
our parts store.

**OUR PARTS STORE**  
Handles a Complete Line of  
**Replacement Parts for All Radios**

Be sure to get your copy of our  
new parts catalog—  
**IT'S FREE!**



**Listenwalter & Gough**

INCORPORATED

Sole Distributors of PHILCO RADIOS

819-27 East First St. TRinity 9711

Los Angeles

459 Golden Avenue, Long Beach

# Make Our Parts Dept. Your Headquarters--

We Maintain a Complete Parts Service on  
RCA-Victor . Tobe . Ohmite . Centralab  
Kenyon . Eveready Flashlights and Batteries  
Fuses . Pilot Lights . Wire . Tape . Solder  
Clamps . etc.

## Test Equipment

RCA-Victor . Weston . Supreme  
Dayrad . Tobe

Avail yourself of our Test Oscillator Calibration  
service—it's FREE

# Leo J. Meyberg | Co. Inc.

335 W. Washington PRospect 9255 Los Angeles  
L. C. LANGE, Parts Department

## A. PAUL JR. BACK ON JOB

Mr. A. Paul Jr.'s many friends and business acquaintances will be glad to know that he is back on the job at the Technical Service Laboratories and is again able to preside at the CRTA meetings. Mr. Paul was forced to undergo a very serious operation, but it was a successful one and he is glad to be free of the trouble which has been annoying him for some time. Moreover, he has a beautiful scar to show to all the salesmen and others who call upon him.

## RIDER REPRESENTATIVE IN LOS ANGELES

Mr. Nielson, Pacific Coast representative of the John F. Rider Publishing Co., was present at a recent meeting of the Certified Radio Technicians' Association held in the National Radio and Electrical School auditorium. Mr. Nielson is in Southern California to promote a closer understanding and greater cooperation with the local service industry and his company. We wish him much success.

## NATIONAL SCHOOL GETS OSCILLOSCOPE

Mr. J. L. Mahon, well-known in local engineering circles and distributor of Sylvania tubes, has recently designed and built a number of cathode ray oscilloscopes. One of these has been purchased by the National Radio and Electrical School for the use of their students interested in that type of work.

## INDEX FOR VOLUME ONE

A complete index containing cross listings of all the articles, service kinks, questions and answers and other items of interest appearing in the first twelve issues of the "Technician" has been compiled and prepared for publication by Mr. Henry James, Certified Radio Technician. This index is being published in separate form exactly the same size and the same stock as the regular issues of the magazine and may be very easily bound or filed with the complete volume. The cost of this index will be five cents and will be mailed to anyone sending that amount in stamps for each copy desired and return postage.

## RUSS HINES IN S. F.

Russ Hines, salesman for the W. Bert Knight Co. is now handling the San Francisco territory for his firm. Mr. Hines is well-known in and about Los Angeles, and we know his many friends will wish him success in the bay district.

## Announcement

Due to rapidly increasing material costs we have found it necessary, beginning Oct. 15, to return to our former discount schedule of 40% off list on some models of power transformer rewinds as listed on our green sheet.

The present 50% discount will hold on most models, however, until further notice.

We are going back to the former discount schedule on certain models in order to retain our high standard of quality which we have always insisted upon maintaining.

**"THERE IS STILL NO  
SUBSTITUTE FOR A GOOD  
REWIND"**

# California Radio Laboratories

2523 South Hill Street  
PRospect 3515  
Nites THornwall 4777

## RADIO INTERFERENCE BUREAU

MR. W. F. GRIMES, Chief Engineer Radio Interference Engineering Bureau

(This column is a regular feature and each month will consist of a report of interesting cases and activities of the RADIO INTERFERENCE ENGINEERING BUREAU. To report interference Phone Trinity 1244).

### UNIVERSAL MOTORS

A considerable number of investigations made by this Bureau result in locating universal or brush type single phase motors as sources of interference with radio reception. These investigations are frequently made at the request of servicemen, dealers and others engaged in the radio industry who are not aware of the simple remedy to eliminate such disturbances and consequently overlook the possibilities of additional business.

The type of noise produced by the brush type motor, whether operated on alternating or direct current, is easily distinguishable. It is usually distinguished by a singing or rotary sound and will be found to affect all parts of the broadcast band with approximately the same intensity. Motors of this type are ordinarily found driving sewing machines, vacuum cleaners, washing machines, fans, grinders, clippers, refrigerators, mixers and various other types of motor-driven electrical appliances.

A positive identification of the motor, once located, is to stop and start it while listening to the receiver affected. Once identified, the motor should be disconnected from the line and the commutator and brush rigging inspected; both should be thoroughly cleaned and polished to remove all traces of burning and oil and the brushes replaced or properly seated if required.

After the motor has been thoroughly overhauled, if the disturbing noise still persists, filter the motor. Filtering, almost without exception, can be satisfactorily and permanently accomplished by connecting two 0.1 mfd condensers which should be located inside the motor frame if space permits, otherwise as close as possible to the motor frame. The mid-point or contact between the two condensers should be securely bound to the motor frame, and not grounded to an independent ground. Precaution should be observed to have all leads of minimum length, all connections thoroughly cleaned and soldered or bolted and supply fuses checked to determine that proper protection is afforded the installation. The condensers may be of the type used in receiver construction but should have a voltage rating three to six times the supply line voltage.

### OVERHEARD IN THE R. G. LEITNER HOUSEHOLD

Four-year-old Son: "Mama, if God gives us our daily bread, the stork brings the babies and Santa Claus brings the Christmas presents, what's the use of having daddy hanging around?"

### CRTA MAN TAKES BIG LEAP

Kenneth Howard, certified radio technician on Whittier Blvd., has been missing some of the meetings lately and investigation uncovered the fact that he is contemplating a voyage on that much-discussed and often "cussed" stormy sea of matrimony. The brave little lady who has the courage to face the future as a "radio widow" is Miss Elizabeth Rummons. The zero hour will arrive on October 26. All joking aside, Kenneth, we know we speak for all the CRTA when we wish you everlasting happiness and success.

### CRTA IN PHONE DIRECTORY

The new issue of the phone directory buyer's guide will contain a sub-heading under the main heading of radio. This heading will call attention to the Certified Radio Technicians' Association and will tell the reader just what a Certified Radio Technician is and how to get in touch with the man in his locality. Separate listings of CRTA shops will appear below.

### ALL-WAVE COIL KIT

For those technicians who enjoy building their own all-wave receivers the J. W. Miller Company has designed an exceptionally efficient circuit and furnishes the diagram, constructional details and directions together with the kit of essentials at a surprisingly low figure. This kit includes the r. f. coils, i. f. transformers, waveband switches, and other essential small parts.

# AEROVOX makes them all ... and Everything in Between



ELECTROLYTIC, paper, mica . . . from smallest to largest . . . all types . . . all voltages and capacities. Also complete line of resistors . . . carbon and wire-wound vitreous-enamel coated . . . fixed and adjustable . . . all wattages and resistance values.

### ELECTROLYTICS

Aerovox offers hermetic sealing, preventing loss or absorption of moisture . . . metal can containers for better dissipation of internal heat . . . special composition spacers for safety against surge voltages . . . all internal parts of aluminum to eliminate corrosion . . . also cardboard case and tubular cartridge electrolytics.

### PAPER

Aerovox offers higher safety factor with more liberal use of highest grade linen paper dielectric . . . thorough impregnation under vacuum . . . metal can, uncased sections and tubular types . . . and in oil-filled units bathed in oil after thorough dehydration, with no air pockets in proximity of sections, an effective heat dissipating circulation of oil through sections for maximum safety and life . . . thorough sealing and no leakage.

### MICA

Aerovox offers highest grade mica and tinfoil sections thoroughly impregnated prior to molding in genuine bakelite . . . positive sealing and protection against extreme temperature, moisture and chemical action . . . finest dielectric India ruby mica . . . small physical dimensions.

### LOOK FOR GUARANTEE SLIP!

No matter what your requirements, Aerovox can meet them . . . meet them with better products . . . more advanced engineering . . . and right prices. Insist on Aerovox . . . in yellow and black cartons . . . with guarantee slip enclosed.

FREE COPY OF RESEARCH WORKER—a monthly engineering service to practical radio men . . . together with latest Aerovox catalog, sent on request.

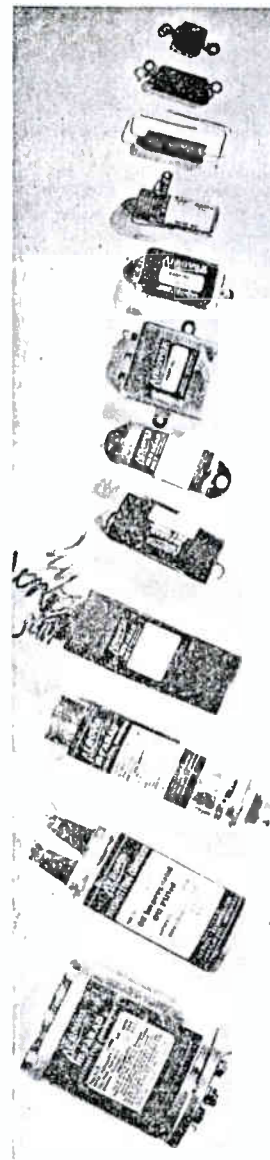

# AEROVOX

CORPORATION

83 Washington Street . . . Brooklyn, N. Y.

Pacific Coast Representatives

W. C. HITT  
1341 So. Hope St.  
Los Angeles, Calif.

R. R. BEAN  
2124 Smith Tower Bldg.  
Seattle, Wash.

## SEEING THE WORLD FAIR WITH THE EDITOR

By NORMAN B. NEELY

### THE SKY RIDE

The sky ride and observation towers are among the most interesting and attractive features of the fair. One tower stands on the island, which was filled in especially for the exposition, and the other is situated on the mainland near the north end of the grounds and at the south end of the Avenue of Flags. These towers are 1850 feet apart and are the highest man-made structures west of the Atlantic Coast, being 628 feet in height.

The boat-shaped observation cars, each of which carries thirty-six passengers, cross on a cable track at the 210-foot level. Riding across the lagoon at this height is truly a marvelous experience. Looking ahead past one tower one may see the skyline of Chicago and looking back past the colorful and animated island section of the fair, one sees an endless expanse of clear, blue water—Lake Michigan. A glance south along the lake shore gives one a matchless view of nearly three miles of the fair exhibits. There are dozens of fantastic and unusual buildings with long, specially-built Greyhound busses and thousands of spectators threading their ways among the numberless sights and attractions.

Past the southern entrance to the fair grounds at Thirty-sixth Street, may be seen an endless view of beach, luxurious apartment houses across Lakeshore Drive and beautiful Jackson Park in the extreme distance.

To the north may be seen the north shore with the Edgewater Beach Hotel and dozens of other beautiful buildings. Looking north and a little closer to the loop district is seen the Navy Pier and hundreds of yachts and fishing boats of all sizes and types riding at anchor on the gentle swells or making their way in and out of the breakwater. Looking northwest we see the Loop district with its tall buildings, elevated railway tracks and the bustle of business activity common to a busy city.

Each tower is crowned with an observation platform from which even more wonderful sights may be viewed. At night the sight presented to the observers from these towers is an incredible spectacle of colored light and movement. The platforms are reached by specially designed Otis elevators which descend the full 628 feet in 54 seconds

or about eleven and one-quarter feet per second.

At night the Sky Ride is a beautiful sight to be seen from all over the fair grounds. The top of each tower is bathed in soft green light and the observation platforms are circled with crimson light. Thousands of bulbs outline the lofty network of cables against the sky.

This is one of the outstanding engineering works of the century. The steel cable network connecting the towers is one of the longest suspension bridges in the world, being equal in length to Ambassador Bridge at Detroit, which connects the United States and Canada. The combined resources and engineering abilities of five great companies made this spectacle possible. The Great Lakes Dredge and Dock Co., the Mississippi Valley Structural Steel Co., the Inland Steel Co., the Otis Elevator Co., and John A. Roebling's Sons Co. joined forces to construct this enormous project at a cost of over one and one-half million dollars. During the 1933 Exposition 2,616,389 persons went up the towers and across in the observation cars.

(Continued on page 27)

### VASCO DISTRIBUTOR

T. B. Pritchard, California sales agent for Arcturus radio tubes, announces his appointment as California distributor for Vasco soldering irons. This complete line of irons offers a model for every radio and electrical use and Mr. Pritchard reports universal acceptance and expression of satisfaction by the trade. He carries a complete stock for the convenience of local jobbers.

### ALL-WAVE LINE NOISE FILTER

Keeping line noises out of present-day all-wave reception is the function of the new TACO H-F All-Wave Line Filter just announced by Technical Appliance Corp., 27-26 Jackson Ave., Long Island City, New York.

The all-wave line filter comprises separate filter circuits for broadcast and short-wave bands. The circuits have been worked out over a considerable period by Amy, Aceves & King, Inc., well-known engineers specializing in antenna problems and radio noise elimination. The present device is made under license from them.

# NOW--A High Powered Radio Engineering Library

- especially selected by radio specialists of McGraw-Hill publications
- to give most complete, dependable coverage of facts needed by all whose fields are grounded on radio fundamentals
- available at a special price and terms

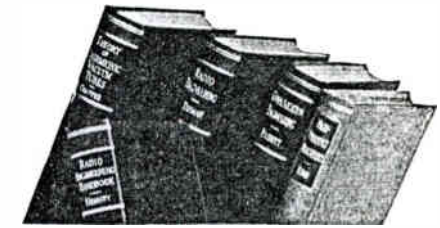

These books cover circuit phenomena, tube theory, networks, measurements, and other subjects—give specialized treatment of all fields of practical design and application. They are books of recognized position in the literature—books you will refer to and be referred to often. If you are a researcher or experimenter—if your interest in radio is deep-set and based on a real desire to go further in this field—these books will help you; they merit a preferred position in your library.

### Special Low Price and Easy Terms

Bought singly, the five volumes comprising this library would cost you \$26.00. Under this offer you save \$2.50 and, in addition, have the privilege of paying in easy installments beginning with \$2.50, 10 days after receipt of the books, and \$3.00 monthly thereafter. Already these books are recognized as standard works that you are bound to require sooner or later. Take advantage of these convenient terms to add them to your library now.

Send This Coupon Today

#### McGraw-Hill ON-APPROVAL COUPON

McGraw-Hill Book Co., Inc.,  
330 West 42nd St., N. Y. C.

Send the Radio Engineering Library (5 volumes) for 10 days' examination, subject to approval or return. Within 10 days of receipt I will send \$2.50, plus a few cents for postage and delivery, and \$3.00 monthly until \$23.50 has been paid, or return the books postpaid. (We pay postage on orders accompanied by remittance of first installment.)

Name.....

Address..... Position.....

City and State..... Company..... T-10-34

Books sent on approval in U. S. and Canada only.)

## OHMMETERS AND THEIR CALIBRATION

(Continued from page 7)

ohms for the very low range, 27 ohms for the low range, and 2,700 ohms for the high range. When the shunt calibrations are transferred to the meter scale, use the low range calibration. Then the very low range will be .1 times and the high range will be 100 times the calibration of the meter. Incidentally, if the resistance of the meter is not known, it may be found by working from calibrated resistors on "ac" back to the point "X." "R2" may be accurately adjusted also by the use of calibrated resistors. Make the chart first and place the known resistor under test, then adjust "R2" until the meter reads what it should for that resistor.

The ohmmeter in Fig. 3 embodies the principles discussed and may be built into a very small portable unit. The operation of the meter is very simple. For the very low shunt range, .27 to 27 ohms, both SW1 and SW2 are closed and terminals 2 and 3 are used. For the low shunt range, 2.7 to 270 ohms, SW1 is open and SW2 is closed and terminals 2 and 3 are used again. For the high shunt range, 270 to 27,000 ohms, SW1 is open and SW2 is closed and terminals 1 and 3 are used. In all the above cases R1 is varied for full scale reading with the test prods open. For series measurements both SW1 and SW2 are open and terminals 3 and 4 are used, R1 being varied for full scale reading with the test prods shorted. The fundamental range of the meter and a 10 milliamperes range may be obtained at terminals 1 and 3 with SW2 open. The unit used by the writer also has a high range voltmeter which is very handy. A unit of this type should find a place on every bench.

## CHECKING TUBES

(Continued from page 9)

mon oscillator circuit,  $L_1$  and  $C_1$  constitute the tuning unit,  $L_2$  the tickler,  $R_2$  and  $C_2$  gridleak and condenser (50,000 ohms and .00025 mfd.)  $I_2$  a one M. A. meter.

The L and C circuit is preferably tuned to above the broadcast band so it will not cause interference. The tickler coil is a few turns of wire, coupled to the LC circuit to cause regeneration.  $I_1$  measures the grid current (approximately .25 M. A.) of the tube. In case the tube under test does not oscillate, no grid current will flow. No tube checker without this device is worth the space it occupies, if it is necessary to test this type of tube for performance, as the most common trouble is no oscillation.

The class "B" twin tubes such as the 79, 53 and 19 must be tested under full load. The static current is very low and does not indicate the condition of the tube. Apply about 25 volts of a. c. on the grid with no "C" bias and measure the D. C. milliamperes (approximately 80 m. a.) in the plate circuit.

Complete photostatic copies of the diagrams will be furnished gratis on request to the author at 1314 South Hill St. or in care of the "Technician."

## UTC WAREHOUSE STOCK

Mr. C. R. Strassner, California representative for the United Transformer Corporation of New York, announces that a complete warehouse stock of UTC power, audio, and filter components in all lines is now located in Los Angeles for the benefit of the local trade.

We respectfully solicit Radio Dealers' and Servicemens' business on all of their replacement parts and supplies.

# The Daniel Specialty Co.

5234 MELROSE AVE.

HEmpstead 3491

If You Like Us and Our Service, Tell Your Friends,—  
and If You Don't, Tell Us.

## L. A. Ry. AND RADIO INTERFERENCE

(Continued from page 5)

ducing radio frequency noise caused by its lines and cars. Its equipment, the majority of which is all but obsolete, is a constant source of annoyance to citizens because of the extreme and unnecessary clatter and noise which its flat wheels and antiquated motors make.

This company still clings to the old-style trolley wheels and does not install the newer and improved shoe used by many other electric railways. Its tracks are poorly bonded and no effort is made to remedy the condition. The vast improvement in auto radio reception alone made possible by even a partial elimination of this interference would mean the sale of hundreds of auto radio receivers. Countless service technicians have talked themselves hoarse in an attempt to convince a critical customer that the crashing, clicking and sputtering in the receiver is not due to faulty parts or repairs. Very few laymen have any conception of radiation of radio frequency waves and cannot be convinced that a street car line which is out of optical range of the front porch can possibly be causing noise.

The guiding geniuses of this company are either poorly informed regarding the true state of affairs or are indifferent and inconsiderate of the efforts of honest radio dealers who are endeavoring to make a decent living and of the thousands of listeners in Southern California who derive a large percentage of their pleasure during these trying times from radio programs. Let us give the Los Angeles Railway the benefit of the doubt and assume ignorance to be the cause of neglect.

Why should this utility, depending upon the grace of the public,—the radio audience and dealers included—for possession of its franchises be allowed to hinder radio reception and maintain a common nuisance which very definitely retards radio sales and causes dissatisfaction on many service calls? Other utilities cooperate, the small concerns cooperate and the manufacturers of appliances build in filters. Why should the Los Angeles Railway not be forced to do its part? It cannot plead lack of funds because its street car depreciation fund for the past ten years has accrued to the amount of \$2,600,000. This money has not been used for the purchase of new cars, however, only two

new street cars having been purchased in the past five years.

The following interesting statistics of the Los Angeles Railway are brought to light by Ray Chesebro, City Attorney, in a recent report appearing in the Illustrated Daily News. "In 1928 when the street car company obtained 7-cent fares it had argued that the fare increase would be used for the purchase of new equipment and improvement of service. 64 per cent of the cars now in service are more than 20 years old and less than 15 per cent are less than 10 years old. The street car company owns 1082 cars, of which 224 are between 20 and 25 years old; 341 are between 25 and 30 years old and 130 are more than 30 years old. In 1928, seeking to increase fares, the company produced evidence to show that 100 new cars would be needed within the next three years. Since then only TWO 'sample cars have been purchased.' This information was contained in an application filed with the State Railroad Commission by Mr. Chesebro demanding the immediate purchase of 300 new cars and modernization of old cars.

It is very evident that large sums have not been spent on modernizing the equipment of the Los Angeles Railway and if the 7-cent rate was obtained on the claim that it was needed to buy 100 new cars in three years and in nearly twice that time only two have been purchased there must be a substantial surplus that the company should be forced to use to improve its service to the public and eliminate, to a large extent, its direct injury to the radio business and interference with the pleasure of thousands of listeners.

The alert and public-spirited action of City Attorney Chesebro is to be highly commended and he should receive the gratitude and confidence of all the citizens of Los Angeles.

Approved by  
Underwriters Laboratory



"Western made for Western Reception"

# Kierulff & Company

1133 Venice Blvd.  
Radio Institute Building Los Angeles  
Fltzroy 5111

Distributors

## National Union Tubes

ON CONSIGNMENT OR OUTRIGHT PURCHASE

New Models Supreme Tube Testers and Analyzers  
Rider's Manuals Available to National Union Dealers  
Without Cost

ASK US FOR PARTICULARS

## Packard-Bell Radios

This Season's Hit in Small Sets

### 1935 SPARTON LINE

The Sparks-Withington Company announces a new 1935 line of all-wave receivers at popular prices. In discussing the release of this new line. Capt. Wm. Sparks said, "There are 18,000,000 radio sets in the United States whose owners are missing a great thrill and a new source of entertainment because these sets are obsolete insofar as foreign short-wave reception is concerned. I want to make the programs of Davenport, Barcelona, Caracas, Berlin and Vienna available to the family of modest income, and our engineers have succeeded in accomplishing this by building a real international receiving set that can compete on the market with present-day low-priced models."

### WHOLESALE SERVICE

Henry N. James and Henry L. Cain, CRTA members who are now located with the Radio Equipment Co. of Los Angeles, at 1004 S. Broadway, are conducting a wholesale radio service for dealers and service technicians.

### RIDER MANUALS POPULAR

Be sure to watch the next issue of the "Technician" for an announcement of interest by the John F. Rider Publishing Co. The Rider manuals, so popular with service technicians, are gaining even greater popularity constantly, according to Mr. Nielson, West Coast representative.

### L & G ON THE AIR

Beginning Monday, October 8, Listenwaller & Gough, Philco distributors and associated Philco dealers presented a daily program over radio station KFVB. This program is presented from 6:30 to 7:30 a. m. daily and will include announcements concerning satisfactory radio repair service. Listeners are invited to call Listenwaller & Gough for radio manufacturers' service. These calls will be relayed to R. M. S. members in each locality. If you are not an R. M. S. member you should investigate at once. Full information will be given at the Philco parts store located at 819 East First Street.

### SEEING THE WORLD FAIR

(Continued from page 22)  
THE HALL OF SCIENCE

Radio Waves Produce Light in Nitrogen  
One of the many very interesting exhibits in the Hall of Science was a discussion of the theory involved and a demonstration of the production of light in nitrogen by radio waves. Radio waves produced by a spark oscillator were passed through a tube containing nitrogen gas and the gas was thus caused to produce light waves.

This is an unusual experiment and as there is considerable uncertainty as to just what takes place in the after glow of nitrogen the discussion of the various theories is quite interesting. One explanation is that energy passing through the coil, ionizes the nitrogen and causes clusters of nitrogen to be formed. The clusters are of short duration and continue only as long as energy is supplied. When input of energy ceases these clusters start to break up, the gas returns to its normal state and the energy given off by this breaking up is released in the form of light which is seen.

Atomic models by Rutherford-Bohr in the Great Hall show that electrons may be arranged in shells around the nucleus of an atom. When the r. f. waves strike an atom of nitrogen sufficient energy is imparted to cause electrons to move to the outer shells from the inner shells or to escape from the outer shell entirely. When electrons fall back from outer shells to inner shells the energy is released and light rays are released by the atom. The glow dissipates gradually after the radio waves have ceased, because the free electrons are gradually picked up by the atoms. The atoms reach stability again, the light ceases. It is pointed out that this theory of atomic behavior gives a plausible explanation of the differences in spectra from light emitted by different substances.

Still another explanation of this phenomenon is explained under the electron theory of matter. The radio waves transmit energy to the nitrogen atoms changing their structure in such a way that they subsequently give out the energy in the form of light which we see.

This is only one of the many interesting experiments and exhibits to be seen in the great Hall of Science and in future issues of the "Technician" others will be described.

### SPEERO JOINS RADIO-TEL.

Norbert Speero, well-known to the radio trade, is now located with the Radio-Television Supply Co.

# Advance

condensers have enjoyed greater volume of sales during the past two months than any other one brand of condensers.

THERE MUST BE A  
REASON!

Maximum Quality—  
Dependability—  
Service—  
At a Minimum Cost

## ADVANCE announces

a new line of auditorium and public address speakers for all sound installations. These units are of exceptionally sturdy construction and are capable of handling large amounts of power continually.

Same ADVANCE Quality at  
new low prices

## Radio Products Sales Co.

1314 South Hill Street  
PR. 0490 Los Angeles

### SYLVANIA SPONSORS LECTURE COURSE

The Hygrade Sylvania Corporation, manufacturers of Sylvania tubes, is now sponsoring a new series of technical lectures by Richard G. Leitner. This series, so ably begun by Mr. Leitner and maintained throughout the past fourteen months, has been very gratefully received by the CRTA membership and a survey shows that the men privileged to attend this lecture course have benefited greatly.

The Hygrade Sylvania Corporation and Mr. Demarest of the Sylvania Pacific Co. are to be congratulated on their consideration and kindness in making the continuation of this valuable series possible for the members of the CRTA. It is absolutely necessary for technicians who wish to keep abreast of the times to continue to increase their engineering knowledge and mathematical learning.

Mr. Leitner's lectures during the past year have followed a definite course and have included theor, mathematics, practical repairing hints, design and construction of all types of electronic equipment, and discussion of questions from the floor.

Mr. Demarest has been a loyal supporter of the CRTA from its inception and the Hygrade Sylvania Corporation has been a consistent and extensive supporter of the "Technician" and we point with pride to this further evidence of our worthiness of their support and assistance in attaining our aims.

### RADIO SPECS TAKES UTC

The Radio Specialties Co. announce their appointment as a local jobber for the complete United Transformer line of transformers and filter equipment.

### EDUCATIONAL DIRECTOR APPOINTED

At a recent meeting of the CRTA a new committee was formed known as the Educational Committee with Mr. Edw. H. Guilford as chairman. Inasmuch as Mr. Guilford is a graduate electrical and radio engineer and has had considerable experience in the educational field he is admirably suited to hold this post and we are indeed fortunate to be able to announce his acceptance. His duties will be to outline the general course of lectures to be given by Mr. Leitner and arrange for other supplementary information.

### R. T. I. OPENS L. A. OFFICE

The Radio Television Institute of Chicago, has recently opened a Los Angeles office under the supervision of Mr. E. R. Mitchell. This organization, pioneers in the home training field, has just announced a comprehensive course in refrigeration and air conditioning. These two fields offer great opportunities for the radio service technician and anyone interested is invited to call upon Mr. Mitchell in Room 311 Financial Center Bldg., at 7th and Spring streets. He is very anxious to be of any possible service in advising men of the details of this course.

### RADIO PATENT SERVICE

A weekly bulletin issued by Benjamin Chromy, patent attorney, gives the details of all the current patents granted on devices in the field of radio, television and talking pictures. Details of this service may be had by addressing Benjamin Chromy, National Press Bldg., Washington, D. C.

### AUTO-RADIO VIBRATOR REPLACEMENT CONDENSER

To take care of condenser replacements in auto-radio vibrators, a line of tiny units specifically designed for the purpose is announced by the Aerovox Corporation, Brooklyn, N. Y. These replacement units comprise oil-impregnated, oil-filled, pure linen paper sections in hermetically sealed metal containers, with mounting lug and pigtail lead. The units are designed to withstand heat, vibration, moisture and climatic conditions, as well as exceptional peak loads, without breakdown. They are available in standard capacities.

### NEW OHMMETER

The Triumph Manufacturing Co. has recently released a new ohmmeter possessing several unusual features. The instrument uses only one control and one polarized terminal plug. With this arrangement it is impossible to connect the test leads to the meter with reversed polarity or to have the leads connected to any range not indicated by the single selector switch. Another outstanding feature is the provisions for the measurement of resistance values with considerable accuracy from 1/2 ohm to ten meg-ohms.

REMEMBER THE NEW ADDRESS AND PHONE NUMBER OF THE TECHNICIAN  
1656 No. Serrano — Granite 0755



# LATEST SYLVANIA SERVICE HELP



COMPLETE DATA ON ALL TUBES—INCLUDING TYPES 15, 18, 255, 25Y5, 2Z2, 46B1 and 182B

A convenient 104-page Manual containing essential information users must have to get optimum performance from any device using vacuum tubes.

You need it on every service job. Complete data on over 90 tubes, with base symbols, recommended operating conditions, circuit applications, amplifier classifications. Over 150 cuts and diagrams. Much data never published before. Necessary as your voltmeter.

YOURS . . . FOR 10c IN STAMPS

10c TECHNICAL MANUAL 10c

Hygrade Sylvania Corporation (G-1)  
Emporium, Pennsylvania  
Please send me the new Sylvania Technical Manual. I enclose 10 cents in stamps.

Name .....

Address .....

City..... State.....

# Sylvania

The Set-Tested Radio Tube

Makers of Hygrade Lamps Sylvania Tubes Electronic Products

NRA Factories Emporium, Pa. St. Mary's, Pa. Salem, Mass. Clifton, N. J.

## Classified Advertisements

### For Sale—

250 watt crystal controlled C. W. transmitter in perfect condition. Rack and panel construction. Complete \$75.00. Phone PRospect 3515.

Triplett and Weston Meters. Complete stock. Radio "Doc."

5 ampere recording wattmeters by Westinghouse. \$7.50. Radio Specialties Co. FEderal 6633.

New Potter Condenser Blocks. Working voltage 400 volts. Contain 4-2-2-1-.5 mfd. John L. Vincent, KENwood 1640.

### Laboratory Service—

All types of laboratory measurements and calibration of electronic devices and component parts. Dr. John F. Blackburn, Consulting Physicist. GRanite 8179.

### Stolen—

One Jensen DA 7 a. c. dynamic speaker, complete with power supply. Reward for information leading to recovery. Communicate with A. F. Guion, 29 North Marengo, Pasadena. TER. 7257.

### NEW—1935 ALL-WAVE SET



"Western made for Western Reception"

## DAYRAD Radio Service Equipment

Represented by  
FRANK A. EMMETT CO.  
1341 South Hope St.  
Los Angeles, Calif.  
Richmond 6301



## Use INCA Replacements!

Most of the radio sets built on the Pacific Coast in the past few years use INCA transformers as original equipment. There is a reason for this. Only INCA has consistently been able to supply transformers to meet the stringent specifications as to size, weight, minimum heating, appearance and service made by the Pacific Coast radio industry. Only INCA transformers have met the widely varying line voltage, frequency and moisture conditions with a low percentage of failures, and now only INCA can supply transformers exactly duplicating the original performance of the receiver and exactly fitting the original mounting holes.

### USE INCA REPLACEMENTS!

Get a copy of INCA Catalog L-4 from your jobber or write direct to

Inca Mfg. Division  
Phelps-Dodge  
Copper Products Corp.  
Los Angeles Calif.

# You'll Be Interested--

Lots of New Items in Stock  
or enroute.

Full Stock of Nationally  
known lines.

*Come in and look around*



Phones: TRinity 2926 - 2927 - 2928