

RADIO
AUDIO
TELEVISION
ELECTRONICS

Service Management

PRICE
35¢
PER COPY

THE BUSINESS MAGAZINE OF THE
RADIO - ELECTRONICS SERVICE INDUSTRY

Volume 1 Number 5

February, 1952

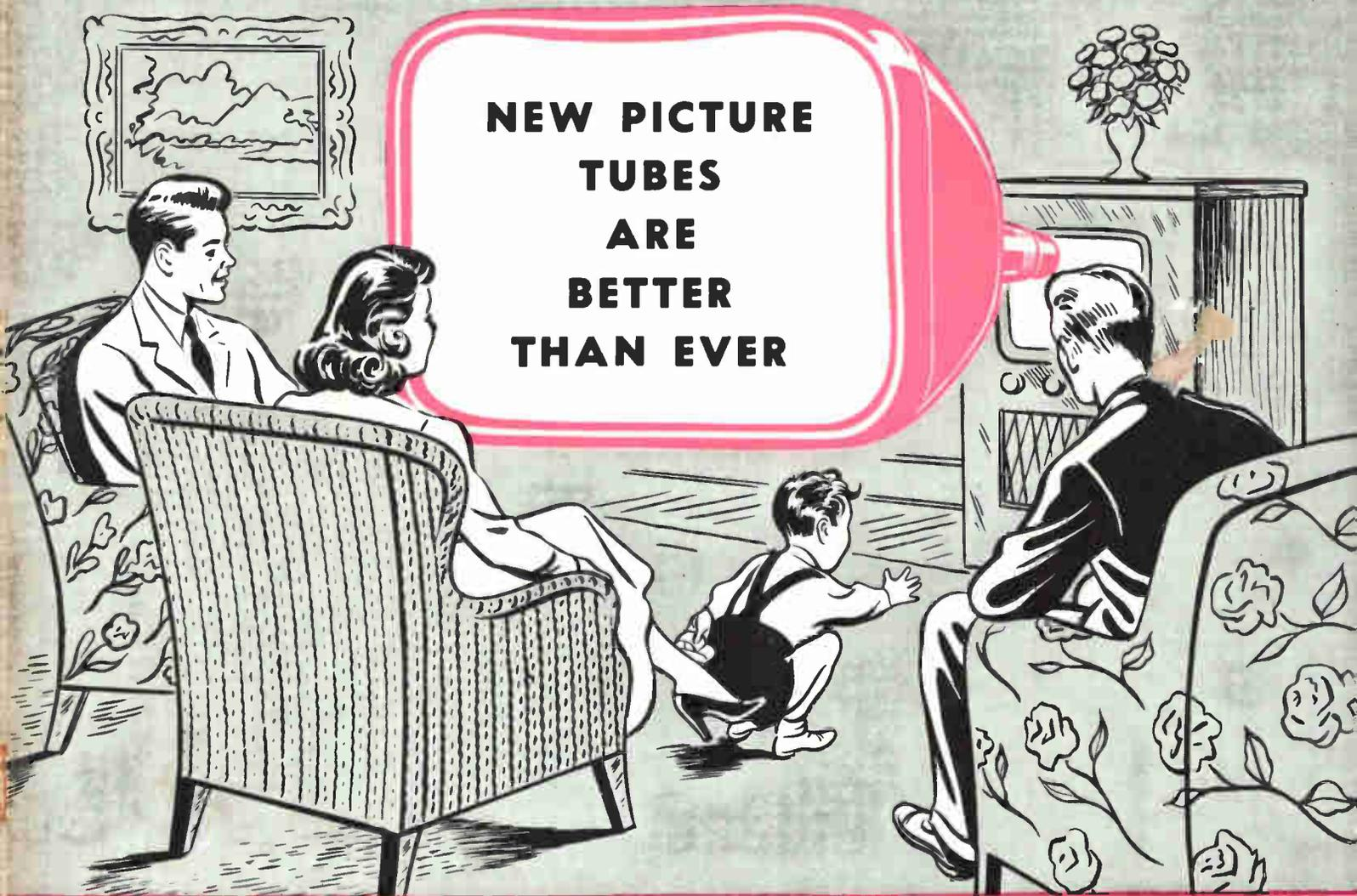

**NEW PICTURE
TUBES
ARE
BETTER
THAN EVER**

Sec. 34.66 P.L.&R.
U. S. POSTAGE
PAID
Permit No. 608
Atlanta, Ga.

Michael J. Kuiper
176 W. Union
Hawthorne, Pa.

SERVICE MANAGEMENT
(Previously named National TV Tuner)
161 Luckie St., N.W.
Atlanta 3, Georgia

POSTMASTER: If undeliverable for any reason, notify sender, stating reason, on Form 3547, postage for which is guaranteed.

RCA Offers "Treasure Chest" TV Data Books To All Dealers

In response to numerous trade requests, it was announced recently, the RCA Tube Department will make available to all radio service dealers its two new television data books, "RCA Kinescopes" and "Television Servicing." The books heretofore had been available only in conjunction with the company's "Treasure Chest" promotion campaign on television picture tubes.

"RCA Kinescopes" is believed to be the most comprehensive manual on kinescope data ever developed. It contains detailed data on more than 100 different kinescope types now in use, and provides such reference information as characteristics of RCA's complete line of kinescopes, a replacement directory listing competitive kinescopes and showing the corresponding RCA "direct replacement" type or the RCA "similar type," and a picture-tube conversion chart, helpful in modifying television receivers for larger kinescopes.

"TV Servicing," a collection of special articles prepared by RCA's well-known television authorities, John Meagher and Art Liebscher, is a comprehensive analysis of servicing problems. In addition to new articles on television servicing by Mr. Meagher, and a new paper on television tuner alignment by Mr. Liebscher, the book also contains all of the Meagher articles on television servicing which appeared originally in the RCA Radio Service News. Subjects covered include rf-if alignment, troubleshooting, and circuit analysis.

Because both books are regarded as important additions to the radio service dealer's technical information library, they are being made available at a nominal charge to cover production and handling costs. Both are available from RCA tube distributors or from the Commercial Engineering Section of the RCA Tube Department, Radio Corporation of America, Harrison, N. J. "RCA Kinescopes" is listed at 25 cents, "Television Servicing," at 35 cents.

RE: DECEMBER ISSUE

The illustrations for the article on the "Modern TV Service Shop" in the December issue of SERVICE MANAGEMENT failed to show that all power connections to test instruments and receivers (both transformer-powered and ac/dc) undergoing repairs are made through isolation transformers.

Al Saunders

Service Management

VOLUME 1, NUMBER 5

FEBRUARY, 1952

Features

- THE REBUILT PICTURE TUBE STORY** 9
 — *By Paul H. Wendel*
 An analysis of the rebuilt's place in the service market
- PICTURE TUBE WARRANTY STUDY** 11
 — *by THE EDITORS of Service Management*
 Proper understanding of the warranty rules important
- GOOD SERVICE MEANS MORE BUSINESS** 12
 — *by Ernest W. Fair*
 A southern dealer finds service essential
- RTMA EDUCATIONAL PROGRAM MOVES FORWARD** 16
 — *by E. W. Merriam*
 More technicians for the future are bound to be the result
- CUSTOMER RELATIONS** 17
 — *By E. C. Tompson*
 The importance of the little things in maintaining customer satisfaction

Departments

PEOPLE AND PLACES	4	TECHNICAL TOPICS	6
OUR OPINION	5	PRODUCT PREVIEWS	18

OFFICES: Editorial and Advertising, 501 5th Ave., New York 17 (tel. no. Mu 2-1650); Business and Publication, 161 Luckie Street, N.W., Atlanta 3, Ga.; Midwest advertising, 6171 North Winchester Ave., Chicago 26, Ill. (tel. no. Rogers Park 4-6254).

EXECUTIVE AND BUSINESS: Paul H. Wendel, editor and publisher; John Iraci, advertising manager; Lee B. Weyburn, Midwest advertising representative; **EDITORIAL:** Edward M. Noll, technical editor; A. C. W. Saunders, educational editor; Adelee Bowden, Faith Yeager, assistant editors. **CIRCULATION:** Billie Kiamy, manager.

SERVICE MANAGEMENT (previously named NATIONAL TV TUNER) is published monthly by the Lecture Bureau Publishing Company, 161 Luckie Street, N. W., Atlanta 3, Ga. All rights reserved. Subscription rates: \$3.00 a year for twelve issues; \$5.00 for two years.

COPYRIGHT 1952
 Lecture Bureau Publishing Company
 161 Luckie Street, N. W., Atlanta 3, Ga.

*more T-V set outlets
per dollar!*

with easy-to-install

Blonder-Tongue

ALL-CHANNEL MASTER ANTENNA SYSTEMS



Distribution Amplifier
8 TV Set Outlets
Model #DA8-1-M List Price \$87.50



Distribution Amplifier
2 TV Set Outlets
Model #DA2-1-M List Price \$39.50



Commercial Antensifier (30 Times
Gain) Use As Pre-Amplifier, Line
Amplifier or de-luxe Booster
Model #CA-1-M List Price \$77.50

More Gain Per Dollar!

B-T Home Antensifier Model HA-2-M
Finest All-Channel TV Booster, Fully
Automatic, 16 Times Gain. In Metal
Cabinet List Price \$57.50

Literature on Request write Dept. 83

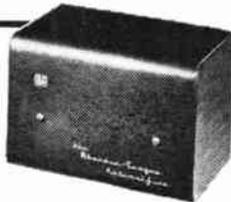

Blonder-Tongue Labs., Inc. Mt. Vernon, N. Y.



D. R. YODER has been assigned to the west coast equipment sales office by the RCA Tube Department. . . . JOHN W. MORRISEY has joined the staff of the television transmitter division of Allen B. DuMont Laboratories, Inc., as a sales representative. . . . TUNG-SOL SALES CORPORATION, Pacific Coast division of Tung-Sol Electric, Inc., has moved from Los Angeles to Culver City, California. . . . JACK BROWN named sales representative for the Electronic Instrument Co., Inc., for Upper New York State. . . . WALTER J. FITZPATRICK has been appointed central regional sales manager for G.E. replacement tubes by the General Electric Tube Department. . . . IRVING G. ROSENBERG named director of operations of the Allen B. DuMont television receiver and cathode-ray tube divisions. . . . RAY BRIDGE has joined the Arthur E. Akeroyd sales representative organization. . . . FRANK DELL'OLIO has been appointed general purchasing director of Haydu Brothers. . . . HENRY C. ROEMER, executive vice-president of Federal Telephone and Radio Corp., has been elected president. . . . MILLEN, DURNIN AGENCIES will represent JFD Manufacturing Company, Inc., in western Canada. . . . STEVEN E. LASEWICS has been appointed production manager of the LaPointe Plascomold Corporation. . . . HOFFMAN SALES CORPORATION named exclusive distributors for the Jerrold master and community antenna systems in Southern California. . . . The E. I. Guthman Company, Inc., has added two key men to their Attica factory staff: A. SCHWARZKOPF, as plant manager, and ROBERT MOORE, as production engineer. . . . ROGER BROWN has been appointed national sales manager of Emerson Radio and Phonograph Corporation. . . . Jensen Manufacturing Company announced that home office salesmen will take over additional territories in January. HAROLD HOFFMAN, who has been covering Michigan, Wisconsin and northern Illinois, will add eastern Iowa to his territory. TED FIRANECK, formerly distributor order supervisor at the home office, will cover the Indiana, Kentucky, southern Illinois and eastern Missouri territories. . . .

(Continued on page 19)

Television Data Chart

(Compiled by National Broadcasting Co.)

as of January, 1952

ESTIMATED TV SET OWNERSHIP

INTER-CONNECTED		
	No. of Stations	TV Sets Installed
Ames	1	76,000
Atlanta	3	152,000
Baltimore	3	358,000
Binghamton	1	50,200
Birmingham	2	68,300
Bloomington	1	21,000
Boston	2	848,000
Buffalo	1	248,000
Charlotte	1	117,000
Chicago	4	1,090,000
Cincinnati	3	305,800
Cleveland	3	568,000
Columbus	3	191,000
Davenport-Rock Island	2	85,100
Dayton	2	170,000
Detroit	3	604,000
Erie	1	58,900
Grand Rapids	1	81,000
Greensboro	1	76,000
Huntington	1	66,000
Indianapolis	1	188,000
Jacksonville	1	52,000
Johnstown	1	133,000
Kalamazoo	1	69,000
Kansas City, Mo.	1	181,000
Lancaster	1	131,000
Lansing	1	80,100
Los Angeles	7	1,090,000
Louisville	2	122,000
Memphis	1	115,000
Milwaukee	1	306,000
Minneapolis	2	302,000
Nashville	2	54,800
New Haven	1	224,000
New York	7	2,800,000
Norfolk	1	97,600
Omaha	2	112,000
Philadelphia	3	1,001,000
Pittsburgh	1	358,000
Providence	1	191,000
Richmond	1	105,000
Rochester	1	125,000
St. Louis	1	70,200
Salt Lake City	2	112,000
San Diego	1	315,000
San Francisco	3	194,000
Schenectady	1	363,000
Syracuse	2	160,000
Toledo	1	148,000
Utica	1	64,000
Washington	4	324,000
Wilmington	1	90,000
NON-INTER-CONNECTED		
Albuquerque	1	13,000
Brownsville	1	10,300
Dallas	2	
Fort Worth	1	149,000
Houston	1	116,000
Miami	1	82,000
New Orleans	1	78,400
Oklahoma City	1	92,300
Phoenix	1	39,000
San Antonio	2	63,400
Seattle	1	125,000
Tulsa	1	77,500
TOTAL TV SETS		15,777,000
CONSUMERS		



National sales representatives of Selenium-Intelin Division, Federal Telephone and Radio Corporation, Clifton, N. J., associate of International Telephone and Telegraph Corporation, at annual sales conference held at Commodore Hotel, New York.

Editorial

"OUR OPINION"

The time has come for each of us in the service business to re-examine our operation and determine just what it is we are selling. From the advertising and promotion carried on by various service organizations throughout the country one would think that the customer was guided more by cost than by any other buying incentive. If ever there was an incorrect appraisal of a sales situation, this is it. In the final analysis the customer is more interested in what he gets for his money than the money itself.

In the December issue *SERVICE MANAGEMENT* carried an article entitled "The Odyssey of Mr. Happy Soul." Many of you undoubtedly passed it off as an editorial jest. However, there were many who considered its serious implications. The truth of the matter is that the story was based upon actual fact—a customer we know who was looking for quality first. He was in search of a place of business that met his approval and looked like it was set up to do an efficient service job. He recognized the fact that a television receiver is an intricate mechanism which demands well-trained men utilizing specially manufactured test equipment.

Let us not be so misguided by all the alarming publicity heaped upon the service industry that we do not realize that the majority of people are interested in good service first and price second. Television, as an entertainment medium, has become too important to the American consumer for him to worry about cost when the set is operative. He wants his set fixed as

soon as possible and he wants it fixed right.

Quality is the guidepost for the sale of service by the average customer, not price. Therefore, all your efforts as service operators must be aimed at selling the customer reliable, efficient service . . . at a fair price.

What you charge for service should of necessity be determined on what you have to charge to stay in business. You must never forget that a great deal of business at no profit is just as dangerous to your future as no business at all. You are selling a tangible item which visually shows results. To make the cost of your talent more important than the talent itself is illogical. You must remember that you are being paid as a specialist to do a special job. As a doctor you should never quote a price until you have appraised the patient. Let us stop making the customer so price conscious that he relegates the quality of your work to a secondary position. Let us make him realize that quality is as important to you as it is to him.

Your future in this business lies in the understanding that you have something special to sell. Supported by all necessary technical equipment and personnel, you have made a basic investment which needs to give you the best possible return. Therefore, it is better for you to sell the quality of your service and your product rather than its price. Remember that every time you replace a tube or a part in the customer's home you have to be prepared to back it up. Just as your customer looks to you, so you should make sure of the company that stands behind the products you buy. P. H. W.

IN MARCH
SERVICE MANAGEMENT Presents
"FRINGE AREA STORY"
DON'T MISS IT!!

PHOTOFACT Users Write Our Best ADS!

Hundreds of unsolicited letters tell what the world's finest Radio & TV Data means to Service Technicians



James Goodwin
315 Mt. Eden Ave.
Bronx, N. Y.

"We want to tell you how wonderful and simple it is to repair receivers with PHOTOFACT Folders. Their usefulness and efficiency are especially brought out in TV work, where the mechanism is very complicated, and you must have complete and accurate information and pictures."



George W. Scott
Greenfield, Mo.

"I am a regular subscriber to PHOTOFACTS and think they are the best equipment a serviceman can own. Couldn't do without them."



Francis H. Curry
1018 W. Locust St.
Milwaukee, Wis.

"You're really doing a fine job to help the radio and television serviceman. PHOTOFACTS and the PF Index and Technical Digest can't be beat."

NOW! GET THE PROOF FOR YOURSELF!

FREE

We'll send you a Free Photofact Folder on any receiver listed in "PF Index & Technical Digest."

Learn for yourself—at our expense—how PHOTOFACT pays for itself by earning bigger repair profits for you! Select any Folder from the PF Index (if you haven't an Index, get a free copy from your distributor). When you write us for your Free Folder, be sure to state Photofact Set and Folder Number as shown in the Index. Get your Free Folder now. Examine, use, compare—see why you can't afford to be without PHOTOFACT!

HOWARD W. SAMS & CO., INC.
2201 East 46th Street • Indianapolis 5, Indiana

more than

2,000,000

set owners use

jfd panorama

indoor tv antennas

triple-chrome plated dipoles

absolutely tip-proof

MODEL TA135
DELUXE
6.95 list

MODEL TA136
STANDARD COMPANION
5.95 list

MODEL TA137
ECONOMY COMPANION
5.50 list

COMPLETE WITH
TWIN LEAD



JFD MFG. CO.,
BENSONHURST 6-9200 • BROOKLYN 4, N. Y.

Highest Service Standards Urged

Establishment of the highest professional standards throughout the television servicing industry was urged by Daniel R. Creato, RCA Service Company Vice-President and Counsel, in a talk before the Allied Technicians Association in West Collingswood, N. J.

Mr. Creato said that insistence on the highest possible service standards is doubly important now, in view of the projected lifting of the freeze on TV station construction in 1952 and the expected advent of commercial telecasting in the ultra-high frequencies. He stressed the importance of adequate training of technicians to insure satisfactory service to the public and a profit to the service organization.

"The most important asset a service organization has is the thoroughly-trained technician," he said. "It takes almost four years and costs more than \$1,000 to train an RCA Service Company technician, but we do not consider this an excessive expenditure of time and money. A service man who is not adequately trained is costly to his company in many ways. He causes customer ill will by repeated call-backs. This means lost business that, in a strictly competitive market, can put an organization out of business."

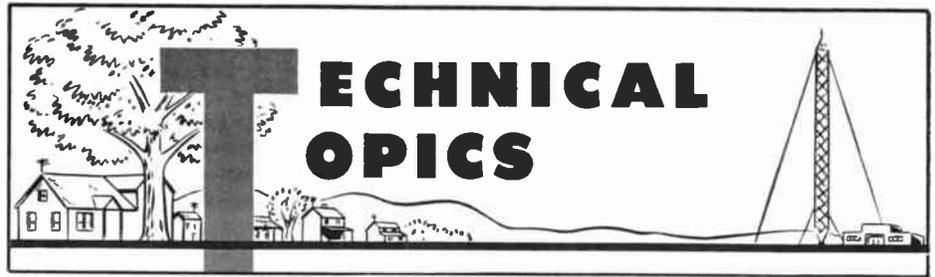

By EDWARD M. NOLL

Test Instrument Probes

There are several types of test instrument probes and a variety of uses for each. Probes are often hidden away and forgotten in the service shop. Despite the added convenience and application versatility offered they go unused and often unpurchased. Many manufacturers sell them as accessories while in reality they could very well be essential items insofar as television application is concerned. Check your shop to ascertain if probes are available and if they are used and applications understood.

Oscilloscope Probes

There are two basic scope probes — high-impedance, frequency-compensating probe and crystal rectifier probe. The high impedance probe minimizes scope loading of circuit under check and prevents distortion of high frequency components of signals under observation. The crystal rectifier or detector type probe permits observation of modulation present on a high frequency carrier. For example, video or other types of modulated signal can be observed in i.f. or r.f. sections of a television receiver.

The high-frequency compensating probe contains a parallel resistor and capacitor combination that is inserted in signal path to input of scope, figure 1. The combination along with the input impedance of scope (also an effective parallel RC combination) acts as a voltage divider and impedance trans-

former. Low frequencies divide across the resistances; high frequencies divide in same proportion across the capacitors. Thus, voltage division is uniform over a wide band of frequencies. However, addition of probe units raises the total impedance and presents a minimum load to any circuit under check. This means your technician can observe a television receiver waveform with more confidence that the pattern he sees is the one actually present at circuit under check. Location of RC combination up in probe also prevents cable capacity from loading circuit and shunting high frequency components off to ground.

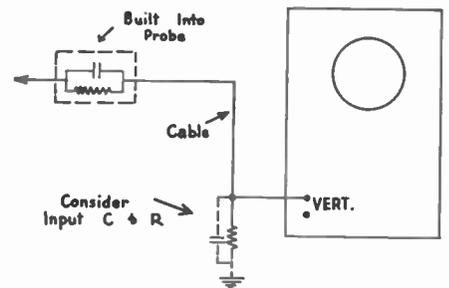

FIG. 1. High Impedance Compensating Probe

Values of probe resistor and capacitor are determined by a balance between how much the impedance can be raised and how much a reduction in scope sensitivity can be tolerated. As input impedance is raised the sensitivity

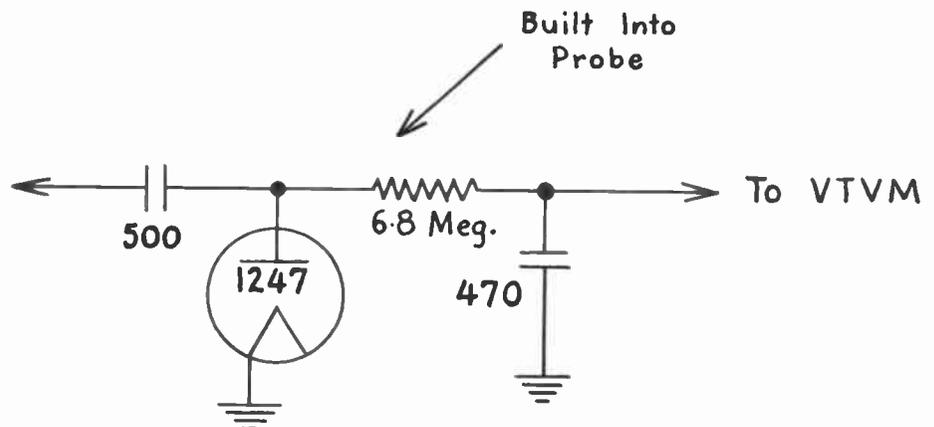

FIG. 3. Sylvania R.F. Probe for VTVM

becomes poorer. However, as input impedance is raised there is less and less loading of circuit under check. Very weak signals would not be able to produce suitable deflection when a probe is used with an insensitive scope. Fortunately, the waveforms we observe in the television receiver are of moderate or high amplitude and the utmost in sensitivity is not needed.

The compensated probe can be used in the same manner as conventional probe but with far less loading of circuits by scope and a more faithful reproduction of waveform shape and amplitude. Therefore, accurate comparisons can be made with manufacturer's recommended waveforms in regard to shape and amplitude—a definite time-saver in tracing down obscure and intermittent troubles in sync and sweep sections.

Crystal Detector Probe

A typical crystal detector probe, figure 2, consists of crystal, r.f. filter, and R-C combination. Probe can be attached to a modulated radio frequency source to observe modulation present on the r.f. carrier. A crystal probe, scope and source of signal (signal generator with 400 cycle tone modulation, 60 cycle sweep generator alignment pattern, or station signal) affords an easy means of signal tracing through r.f. and i.f. amplifier chains. Crystal probe can be used to signal trace or align boosters, multi-antenna ampli-

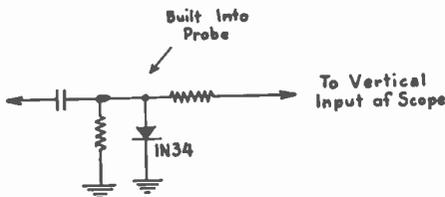

FIG. 2. Crystal Detector Probe

fiers, and UHF converters. What more convenient means is there to trace a video signal through a dead or intermittent amplifier? Changes in amplitude of detected modulation from stage to stage indicates relative gain of each stage.

A scope without accompanying compensating and detector probes is no longer a complete instrument for television work.

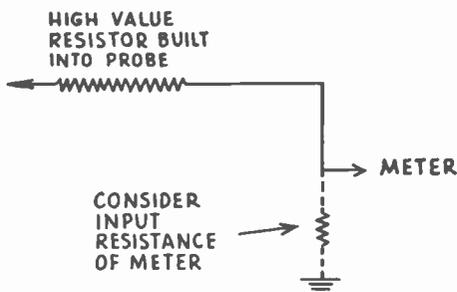

FIG. 4. High Voltage Probe

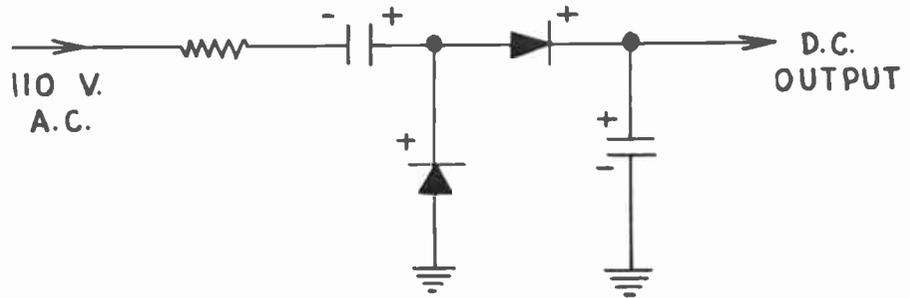

FIG. 5. Selenium Rectifier Doubler

VTVM Probes

The two most common accessory probes for the VTVM are the r.f. measurement probe and the high voltage probe. The r.f. probe not only presents a means of measuring r.f. voltages but with proper design need only present a light load on circuit to which it is attached. A typical probe for a VTVM, figure 3, consists of a small rectifying diode, RC time constant, and filter. By limiting conduction to just a very small portion of r.f. cycle (long time constant and very minimum of shunt input capacity) a very high impedance is presented to source of signal. The very small Sylvania probe presents an effective 2.3 megohms shunted by 3.3 uuf. Such a probe can measure signals up to 300 megacycles without excessive loading of r.f. circuits. Some of the uses for r.f. probe are as follows:

1. Measure and keep close watch on output of signal and sweep generators.
2. Assist in alignment of boosters, antenna amplifiers, and UHF converters.
3. Assist in alignment of tuners and i.f. amplifiers when single frequency procedures are used.
4. Can be used to signal trace through many types of r.f. amplifiers. Can be used to check relative gain of amplifiers.

High Voltage Probe

The high voltage probe is basic, acting simply as a voltage divider to permit measurement of voltages higher than the average VTVM or volt-ohm-mil meter is designed to handle safely. It is also designed to present a light load to the voltage source to be measured as, in general, the high voltage systems used in television receivers deliver a very limited current and voltage drops off rapidly with an increase in loading.

High voltage probe, figure 4, consists of a high-voltage high-value resistor inserted in series with meter so bulk of voltage is dropped across probe resistor and only a small percentage of total voltage is supplied to VTVM or volt-ohm-mil meter. The value of the resistor used is a function of the input resistance of the meter on the scale to be calibrated for high voltage measure-

ment. Probe must be constructed of good high voltage insulation and provide maximum protection for the user.

Sensible use of proper test equipment probes can speed trouble-tracing in your shop. They improve the versatility of your expensive test equipment and give you added dollar value in time saved and more thorough receiver repairs. For complete technical information on the construction and use of probes we refer your technicians to our notebook, "Television Test Equipment Application Manual."

THE SELENIUM RECTIFIER

The selenium rectifier which is now manufactured with higher current capacity and permissible voltage, and smaller in size will have expanded use this year. It is a natural for many applications—no heater, no heat, easy to mount in confined locations, and as fully effective in a great many uses as standard types of power supply systems. In fact, in these days of material conservation in civilian production, the selenium rectifier type of power supply can well become the standard type of supply for television-radio design.

The selenium rectifier, figure 5, can be used in most all types of rectifier circuits—half and full wave, doublers, triplers, quadruplers, and bridge circuits. The usual low voltage selenium rectifier supply does not use a power transformer—line voltage being built up to required level by proper choice of rectifier circuit. In fact, most seleniums have an applied a.c. voltage limit near to 130 to 160 volts. Some standard selenium rectifiers have an a.c. voltage limit of 160 volts and a step-up transformer (auto-transformer type) can be used to step up line voltage before application to rectifier circuit, figure 6.

(Continued on page 24)

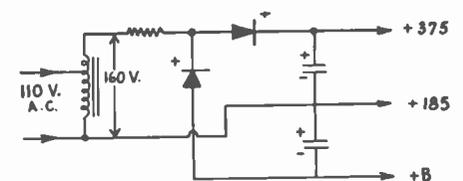
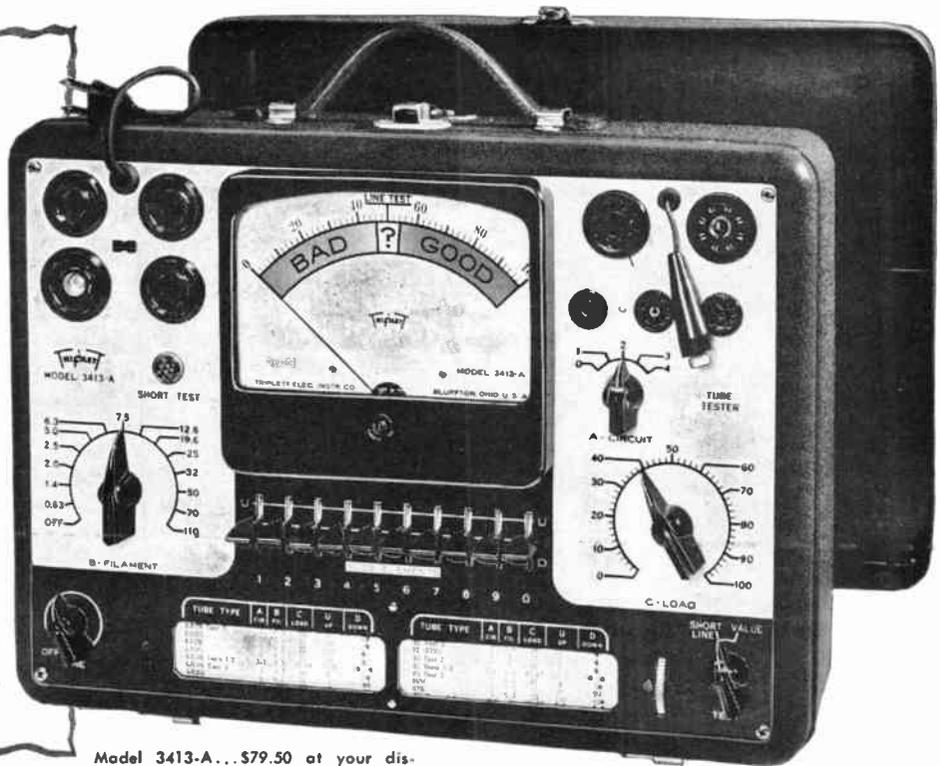

FIG. 6. Selenium Rectifier with Transformer

For accurate
flexible and
quick tube
testing at
low cost...
model 3413-A



Model 3413-A...\$79.50 at your distributor. (Price subject to change.) BV Adapter, \$7.90 Add'l.



1. YOU CAN TEST MORE TYPES of tubes, also appliances for shorts and open circuits.

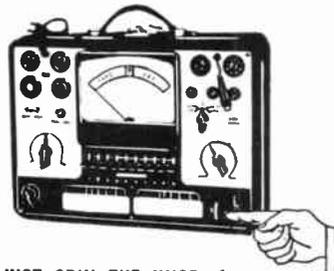

2. JUST SPIN THE KNOB—for correct, last-minute data, on the speed roll chart. Lists 700 tubes.

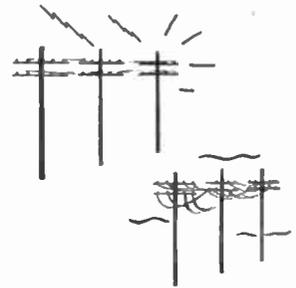

3. YOU CAN COMPENSATE for line voltage—just throw snap-action switch.

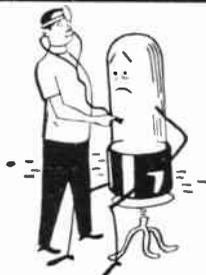

4. YOU CAN TEST EACH ELEMENT in each tube—by a simple flip of the switch.



5. YOU CAN TEST THE NEW TUBES—including those with low cathode current.



6. YOU GET NEW TUBE DATA—immediately, while it is still news. No waiting.

Nearly Half a Century of Service to the Service Man



TESTS PICTURE TUBES, TOO! With this BV Adapter, Model 3413-A tests every tube in a TV receiver, including the Picture Tube—without even removing tube from receiver or carton! Saves time!

FOR THE MAN WHO TAKES PRIDE IN HIS WORK

Triplett

TRIPLETT ELECTRICAL INSTRUMENT CO., BLUFFTON, OHIO, U. S. A.

THE REBUILT PICTURE TUBE STORY

By PAUL WENDEL, Editor,
Service Management

Stop and think about this:

When you go into a drug store to buy an item that you use regularly do you ask for it by **brand name** or do you accept any brand the druggist gives you without question?

Or when your wife goes grocery shopping does she select packaged goods by brand names or does she pick out the cans and packages by product name without regard for the brand of the manufacturer or processor?

If you are an average American family you will have a decided preference for the brand name of almost everything you buy regularly in drug stores and in grocery stores. You have acquired that decided preference because you have used those brands and found them to be of consistently good quality.

"The priceless ingredient in any product is the proven character of the man who made it," is a slogan that could well be adopted by any businessman who is building customer confidence through honest, straightforward dealing with those who patronize his ser-

vices. It is the foundation of consumer confidence in a 'brand name' product, a fact that motivates reliable manufacturers to go to great length, and considerable expense, to insure consistent quality in the products that carry their brand names.

In our industry a booming new business has blossomed in the rebuilding of worn out picture tubes. This business has captured the interest of many small tube repair shops. Some of these shops, in the process of repairing and reactivating worn out picture tubes, do not bother to remove the original manufacturer's brand. These tubes are channeled back into the open market. Sooner or later they may spell trouble for an unsuspecting service contractor or dealer who bought them in the belief they were new tubes produced by the original manufacturer.

At the outset it is well to point out that it is not a crime, nor is it dishonest to rebuild or repair a worn out picture tube. But it is both morally and legally wrong to neglect to remove the original manufacturer's brand name or trade

mark. It is dishonest to fail to label it a rebuilt used picture tube.

It is only when a repaired tube is plainly and permanently marked "Repaired" or "Rebuilt," the original brand name completely removed and the brand of the re-building company is substituted, can such a tube become a fair deal. The shipping carton should also be plainly marked and the selling price should reflect the fact that it is a repaired product.

It is, of course, a well-known fact that in the process of making new picture tubes, manufacturers often run into certain problems in production such as neck cracks, poor seals, mount shorts, etc. In order not to lose the cost of the bulb where such defects occur the manufacturer recovers the bottle by sealing on a new neck. Such tubes are



— SYLVANIA

Extensive manufacturing facilities needed to maintain manufacturer's established quality standards.

"The user is entitled to know when a 'Repaired' or 'Rebuilt' picture tube is used as a replacement in his television receiver."

in no sense either "repaired" or "rebuilt" tubes. Their reprocessing represents a normal production operation. Manufacturing facilities are provided to bring them through on the manufacturer's established quality standards. As completed tubes they must pass rigid quality tests and they carry the maker's brand name and guarantee.

A comprehensive outline of what is meant by a "Rebuilt Tube" was contained in an article by Mr. A. W. Mayer in a recent issue of the NEDA Journal:

"One type of rebuilding operation consists of merely replacing the gun, re-necking and re-processing. Obviously, this type of operation is not considered one that will result in a product as dependable as that marketed by an established tube manufacturer. We learn from those who know, that by far the greater percentage of trouble from picture tubes, results from screen defects. It is safe to say that eighty per cent of those tubes actually found defective, are so due to screen trouble. The rebuilder who leaves the original screen intact certainly is not marketing a product which will maintain customer good will for the service dealer.

Loss of Light

"The second type of operation is one, where the builder re-necks, re-screens, re-exhausts and processes. You may look at this tube from this type of operation as being equivalent to a first-run tube, disregarding the superior engineering and production facilities of the established tube manufacturer. However, one thing not generally known is, that after a tube has been in use for a few hundred hours, there is a definite loss of light transmission in the glass face plate. A rebuilt tube, using the original bulb, therefore would require a stronger beam current for the equivalent brightness of a new tube. In order to obtain an equivalent brightness level, the cathode on the rebuilt tube would have to work harder, with a consequent loss in expected life.

"Another thing that is important in considering the disadvantage of a rebuilt tube, is the fact that the more the bulb is handled, the more liable it is to glass bruises, due to handling, with consequent danger of implosion. When we consider the fact that on a 20-inch tube, there are approximately two tons of atmospheric pressure exerted on the face, we must realize the potential danger to the service dealer and consumer, from a tube having bruised face or inherent glass strain.

"From the foregoing discussion it becomes obvious that the small tube repair shop does not have adequate facilities for uniformly processing picture tubes and controlling their quality. Nor is it likely to have proper glass inspection to prevent future implosion, or adequate baking facilities to properly out-gassing the tube. Neither is a small shop likely to have sufficient continuous repair work to afford

adequate life prediction and control—hence a warranty (if given) is meaningless. The financial responsibility of the repair company would also vitally affect the value of any warranty.

"The quality of a tube manufacturer's product is a reflection of the quality of his production equipment, his tube manufacturing experience, and his engineering 'know-how'—quality cannot be tested into a product. It must be built into it.

"The established tube manufacturer has invested millions of dollars in equipment and engineering facilities to produce a product, the quality of which is backed by his financial resources and established reputation. A purchaser of a new first-grade picture tube is assured of a reasonable guarantee, based on proven field experience and backed by the multi-million dollar resources of the tube manufacturer."

Our obligation to the television-owning public is to insist that all tubes and parts that we use in repairs or replacements, be plainly marked for what

they are. The user is entitled to know when a "Repaired" or "Rebuilt" picture tube is used as a replacement in his television receiver.

How can you recognize a repaired or rebuilt used picture tube?

Only an expert can spot the rebuilt job unless the rebuilding was done in a very sloppy manner. This poses a serious problem for the entire industry, for, if a large number of rebuilt tubes of inferior quality but carrying brand name manufacturers' trade-marks found their way into the regular channels of distribution it would be reflected, sooner or later, in more caustic stories in the general press about unreliability of independent television servicers.

The answer is, of course, that independent television service contractors and dealers should join with Industry Trade Associations in insisting that the Fair Trade Commission take immediate steps to regulate the making of re-processed tubes.

TV GUIDE Reports

MOST set-owners are uneasy about the coming day when their picture tube will black out.

Some think they'll need a new set, with a war-caused shortage of tubes making it impossible to obtain a replacement. Others feel they may have to hock the family jewels to buy an expensive new tube.

What's the truth of the situation?

Ralph Batcher of the Radio and TV Manufacturers' Association says this: "There will be plenty of tubes for a while. Situation on nickel is important but there will be sufficient supply for replacements."

Herbert Suesholtz, General Manager of Transvision, Inc., one of the world's largest tube manufacturers, came up with this angle: "Picture tubes will be available because there can be plenty of rebuilt tubes. The glass envelope from your old tube can be used, with new parts built into it."

Mr. Suesholtz contends that rebuilt tubes, for which his company charges approximately \$10 less per tube than for new, are better than new ones, because the glass, having withstood

gases for some time, has proved its resistance ability.

* * *

EDITORIAL NOTE: We were a wee bit startled when we glanced through a column in a recent issue of *TV Guide* which was headed: "If Your Picture Tube Blows Out." The column warmed up with a suggestion that most set-owners "are uneasy about the coming day when their picture tube will black out." We think that this statement belies the experience of leading tube makers, that has shown picture tube life exceeding their fondest hopes when TV was first introduced. The fact is, their tubes are lasting up to three times as long, on average, as was originally expected. But if this is not generally known, *TV Guide* reveals another astounding discovery: that new glass is not as good as old glass because the latter "having withstood gases for some time, has proved its resistance ability." We, frankly, do not take such a dim view of picture tubes. We are not uneasy. Perhaps the reason is that we have always looked at the brighter side of TV on the screens of new picture tubes as they have been perfected by leading tube makers.



PICTURE TUBE

Warranty Study



By The Editors
of Service Management

A PICTURE tube warranty is a term guarantee that is dug out of its latent legal verbage when a picture tube dies prematurely. To the owner of a new TV set it is then welcome; to the industry, a customer responsibility. The warranty within the framework of the standard RTMA form contains five major sections:

- A. General Terms and Limitations of the Warranty
- B. Adjustments for Loss or Damage in Transit
- C. Replacement Procedures of Warranty
- D. Return Instructions for Defective Picture Tubes
- E. Types of Defects

The warranty period has been almost standardized at six months or as Raytheon puts it, "When used within its rating in a standard home television receiver, and if the conditions of adjustments and procedures for return are complied with, Raytheon television picture tubes are warranted against defects in material and workmanship for a period of six months from the date of installation in a user's receiver."

This means customer has picture tube protection for six months from the date of installation. Some manufacturers have a limiting factor to this six-month period if the picture tube has left the plant more than eighteen months prior or as stated by RCA, "Although the

warranty period is predicated on the date of installation of the owner's television receiver, the company does reserve the right to limit adjustments to picture tubes which fail eighteen months after shipment from the RCA Tube Department warehouse."

Warranty periods to manufacturer and distributor differ at times. For example, Thomas Electronics warranty to distributors is for a period of six months after installation into user's set while to manufacturers it is twelve months after shipment from their factory to manufacturer. Most of the six-month plans have been active since fall and extensions have been granted on tubes manufactured prior to August 31, 1951 — total period of 12 months from date of shipment.

With just a few exceptions, the six-month warranty period as above has been pretty well standardized in the replacement field. This is as it should be, reducing customer confusion. The set manufacturer, however, offers a twelve-month guarantee as a part of an insurance plan.

Labor Not Covered

There is a strong feeling among distributors, dealers, and service organizations in favor of re-establishment of a strictly uniform 90-day guarantee period and no charge made to buyer at time of receiver purchase. Still another

avenue of improvement would be emphatic instruction to customer that warranty involves the picture tube only and does not cover time and service charge. For example, a typical warranty states specifically, "Manufacturer shall not be obligated to furnish any labor in connection with the installation of the picture tube, its removal from the user's receiver, the installation of a replacement or otherwise . . ." As Herman Rosenberg of Colman Television, Phila., expresses it, "Apparently, many people are made to believe that the manufacturer will reimburse the serviceman for his labor and time spent exchanging the tube. Most set distributors and/or customers are located so it requires at least 1½ hours to make the exchange. If you charge customer on standard labor basis for all the time spent removing, exchanging, and replacing tube, they complain of unfair practice because they have been led to expect that all is free in regard to picture tube."

Replacement Procedures of Warranty

Replacement procedures and records are easy to handle with a warranty card system. A typical, understandable procedure as prepared by DuMont reads as follows:

METHOD OF OPERATION OF REPLACEMENT TELETRON WARRANTY

- A. To assure the proper use of this warranty, a Warranty Card accompanies each Teletron sold to franchised DuMont distributors. This Warranty Card is perforated into three sections which are designated as follows:
 1. Dealer's Copy
 2. User's Copy to be retained by user
 3. User's Registration Request to be mailed to DuMont by user at time of purchase.
- B. Each section bears the same registration number so that each portion of the card may be identified if and when a replacement is necessary.
- C. When a dealer sells or installs a Teletron in a user's set it becomes his responsibility to complete all the information requested above the line on both the Dealer's Copy and the User's Copy, obtaining the signature of the user on both the Dealer's Copy and the User's Copy. The dealer should retain his copy and give the User's Copy and User's Registration Request to the user.
- D. The user should, immediately after installation of his Teletron, complete, sign and mail the User's Registration Request to DuMont, retaining in his possession the User's Copy. If a defect of a type

(Continued on page 20)

Good Service Means More Business

Southern Dealer Finds Service Essential

By ERNEST W. FAIR

"Build business in your service department and you'll find it easy to sell new radios," declares P. A. DuPuy, Jr., sales manager of the Capitol Radio Company of Baton Rouge, Louisiana, "but it takes a lot more than just operating a service department to do the job. There's nothing more important to your business than that service department and you have to stay with it morning, noon and night."

That's what J. F. Burnett, owner of the firm who established the business in 1932, and DuPuy's father-in-law, has been doing for the 19 years in which he has built his radio sales and service business to leadership in Baton Rouge.

Burnett can never be found in the store—he's always out with his customers, helping the delivery man to pick up or deliver sets, supervising an installation, erecting a television aerial or in some way "building the business by being with his customers."

When Burnett built the big business home of his firm in 1945 he made it a service paradise. One-third of the front part of the building just outside Baton Rouge's main business district, is given over to office and sales room. The other two-thirds houses service facilities. When Burnett began his business he decided the best way to sell new radio sets was by building a reputation with service. As each year went by he improved that service operation. When his son, J. F. Burnett, Jr., came into the business he placed him in charge of the service department.

"We believe the day is fast coming when it will be almost impossible to operate a radio sales dealership without a top notch service department," DuPuy declares, "people are tired of buying sets that a dealer himself can-



not back up. They're looking to the man who keeps their radio or television set operating to take care of them when they get ready to buy a new set.

"And it's going to have to be more than just ordinary service to keep these customers ready to buy from that dealer. There's too much ordinary service being offered them now—they're looking for really thorough and efficient service not only from the man who's going to take care of their present set but from the firm where they will buy their next set."

What has Capitol Radio developed during those 19 years of experience? Here are some of the ideas and methods DuPuy presents.

"Good service begins right with the customer's call in," he declares, "the way you answer the telephone to show him how much you appreciate being chosen to take care of their radio troubles starts it. Next comes the courtesy and consideration you show him in handling the business side of the service need, and that is very important to the customer."

At Capitol it's done on the card shown herewith. When the service call comes

in the girl answering the telephone fills out the card as much as possible. The set is picked up as quickly as possible. Speed in pick-up is even more important to a customer than speed of delivery, DuPuy points out, for letting a pick-up call wait indefinitely invariably irritates any customer.

When the set is brought back it is sent to the shop immediately with this card. One of the service men checks the trouble and estimates the repair cost, then notes this on the card and returns it to the office. There the customer is called immediately and told what is wrong and what the charge will be. If they give approval the card is initialed at the estimate figure by the girl. If the customer cannot be reached by telephone the card is sent out immediately by the delivery boy and the customer's signed okay is secured to go ahead with the work.

"This completely eliminates the all too frequent bad feeling customers have for service men when they get a repair bill for a much larger sum than they had expected," DuPuy explains, "it assures the customer of exactly what needs to be done and no customer can

Invoice No. _____		Job No		9005
NAME _____		PHONE _____		
MAKE RADIO _____		DATE _____		
COMPLAINT—Low Vol.	Dead	Distorted	K.C. Align.	
Intermitting	Vol.—Tone Control	Dial	Est.	Not Over \$
Remarks _____				
SHOP ESTIMATE _____				

Finished		Est. O.K.		
PP28615, 1m				

Job sheet tells complete story.

ever charge us with having done work they did not authorize.

"We have managed to keep hundreds of our customers year-in and year-out both on service business and on new set purchases and we are certain this system has been the biggest feature in our holding their friendship."

Capitol also has a policy of replacing parts only with the original parts in the set even to tubes. They have found that customers actually have sent business to them for this reason. If a set has a certain make of tube in it the same make of tube is put in as a replacement if it is at all available.

"We've noted customers being more impressed with this lately than at any time in the past," Mr. DuPuy states, "and whether it's because they're learning more about their sets or from some outside influence we're not certain. We have a feeling that the tremendous amount of advertising done by automobile manufacturers and dealers along the same line with reference to automobile repairs is flowing over into other fields."

The firm has four service men and three salesmen. The service men work in individual sound proof small rooms shown in accompanying illustrations. Each man has his own room with the equipment therein built in and installed the way he wanted it and felt he could work best with it. The company pays for these installations.

"These booths have done more to produce speedy and efficient repair work than anything we have ever

done," DuPuy says, "for it permits the men to do their work without interference from one another or outside individuals coming into the shop. They like the idea of their own little private repair shop too. Three of our service men have been with us for more than ten years."

Capitol has built up a very nice business from the rural areas and small towns around Baton Rouge, not only in service but in new set sales also, because of the special attention they give this business.

When such a customer brings a set in to be repaired and he asks if he may get it back when he is ready to leave town for his home they do everything possible to perform this service. The set is sent back to the service department and the one the man is working on is set aside to handle the visitor's repair job.

"This builds up a nice out of town business because customers know they



Servicemen work in individually sound-proofed rooms.

can bring their set in, have it fixed, and take it back home when they leave Baton Rouge that night," DuPuy explains, "so naturally, it gives us a chance to reach a lot of prospective customers from the rural areas who otherwise would probably come nowhere near us when they were ready to buy a new set."

Capitol has recently found a new source of very profitable business. They have many customers who purchased combinations at from \$400 to \$800 and these customers, though they would like to be able to play the new 45 and LP records on their machines, are not about to trade them in on a complete new combination. Almost invariably they can be sold replacement of their old record players with new three-speed units.

"When you can't sell this customer a new set you'll find it takes almost no selling at all to persuade him to this change," explains DuPuy, "and there's a very good profit in it both on the sale of the new unit and on the sale of the old player you take in trade."

When things get slack in the office DuPuy and his salesmen pick up a stack of the service cards mentioned earlier and start calling these customers. The purpose of the call, they explain to the customer, is to find out if their old set is still working satisfactorily. It is easy to carefully steer such a conversation into sales talks for new sets. Many sales are made in this way or valuable leads secured on rainy or other bad weather days when store traffic is light are thus put to profitable use.

Thus, many sales approaches are used by the men of Capitol Radio Sales in Baton Rouge, but all are based on the proven axiom that the surest way to new set sales is through the efficient operation of a top-notch service and repair department.



DuPuy and his salesmen constantly follow up service customers by phone.

Will Sell Your RADIO-TV SERVICE in '52

Nation-wide weekly TV Show "BEAT THE CLOCK" will sell your service to every TV set owner



You're an "expert, reliable service-man who does a tough job well," Bill Shipley, crack CBS-TV announcer, tells your prospects. And, he adds: "Always look for that Sylvania Service Emblem." That's how the hard-hitting, full-minute commercials on Sylvania's CBS-TV show, "Beat the Clock," put Bill Shipley, Roxanne, and Bud Collyer on your sales staff.



Roxanne and Bud Collyer are seen weekly over CBS-TV in 35 cities... selling your service... when you display the Sylvania Service Emblem.



Make this great national ad campaign pay off in your store

Mail the coupon below for FREE, full-color folder giving complete details about Sylvania's compelling Spring Service Dealer Advertising Program. It contains everything to identify you unmistakably as the dealer advertised in Sylvania's magazine and TV advertising. If you want more business, you can't afford to miss it. But, time's awastin'... get that coupon in the mail NOW!



SYLVANIA

RADIO TUBES; TELEVISION PICTURE TUBES; ELECTRONIC PRODUCTS; ELECTRONIC TEST EQUIPMENT; FLUORESCENT TUBES, FIXTURES, SIGN TUBING, WIRING DEVICES; LIGHT BULBS; PHOTOLAMPS; TELEVISION SETS

Sylvania Electric Products Inc.
Dept. R-3202, Emporium, Pa.

Please send me full details about Sylvania's powerful business-building campaign for Service Dealers.

Name _____

Street _____

City _____ Zone _____ State _____

RTMA Educational Program Moves Forward

By E. W. MERRIAM,* *Service Manager,
Sylvania Electric Products Inc.*

Before and after the war, most of the television receivers were serviced by former radio technicians who, with the help of technical service data, were able in most cases, by hit or miss, to keep the receivers operating. A good many commercial schools were set up to include television courses in their curriculum. Several public schools, mainly of the vocational type, incorporated courses in their curriculum. However, in spite of this, receivers were built far faster than technicians were educated.

With this in mind, the RTMA is presently attempting to have the twenty-five hundred vocational schools in the country include a three-year course to properly train the future television technician. We are also attempting to have adult education courses incorporated to teach television to the qualified radio technician.

We have turned to the educators in the country and offered to assist them in the incorporation of such courses in the school systems. We, of course, know how our receivers should be serviced and how to service them, but we are lacking in the knowledge of how to teach, and it is for this reason that we have gone, naturally, to the educators rather than attempting to do it ourselves.

We have given the RCA Institutes, Inc., a contract to write both the three-year syllabus for the vocational schools

**This paper was written by Mr. Merriam while he was still RTMA Service Manager. Thus, he speaks in the first person.*

and a ten-month syllabus for the adult educational system. These syllabi will be incorporated in a booklet containing a great deal of additional valuable information. This book will incorporate such things as laboratory layouts, proper test equipment, bibliography, etc. It is our plan to distribute this book free of charge to the public schools throughout the country.

Once again feeling that we are not qualified as educators, we are fortunate in obtaining the services of Mr. Gilbert Weaver, Director of Training, Bureau of Vocational Curriculum, the University of the State of New York, to edit both of these syllabi. Other men that have assisted us greatly in our program, and well known to the educational fields are Dr. L. D. Jarvie and Mr. F. E. Almstead of the University of the State of New York, Dr. R. W. Gregory and Walter Cooper of the United States Office of Education, Mr. A. D. Althouse of the Detroit Board of Education, Mr. M. D. Mobley, Executive Secretary of the American Vocational Association, Mr. Thomas A. Van Sant of the Board of Education of Baltimore, Maryland, and many others. These people have made it possible for us to save a great deal of time in getting our project under way.

We are attempting to have this course included in a great many of the twenty-five hundred schools in September of 1952. We are attempting to have it placed in schools even though there is no television there at this time. This will mean that when television does arrive to these cities, there will be qualified technicians to take care of their installation and service.

We are not forgetting the existing commercial schools, which are doing an excellent job, and are talking about them in many of our meetings. There are several excellent home study courses which may be subscribed to by the boy or man interested in television as a career. In fact, it will be the combined efforts of all types of education that will give us the quantities of technicians that will be required in the future.

We have spent considerable time in working with the Better Business Bureaus throughout the country. Because of the newness of television and the lack of qualified technicians, the Better Business Bureaus have received excessive complaints. In fact, RTMA and the Better Business Bureaus throughout the nation are jointly sponsoring the publication of a booklet telling the prospective customer and customer what they may expect from a television receiver.

Along these lines, each of the manufacturers is carrying on training programs for the existing television technicians, to keep them up to date on improvements and changes in each of their receivers. This, of course, is of immediate assistance, whereas the vocational and adult educational courses are long-range programs.

Several cities in the country have brought up legislation for the licensing of television technicians. I feel that there are much better ways of improving the service end of the business than by the procurement of a license. For example, in the City of Detroit there has been set up an organization which acts as a clearing house for any complaints not properly taken care of by the dealer or service agency. We intend to have similar organizations set up, possibly made up of the distributor Service Manager, in order to see that owners of sets receive the proper service. You have often read of the case of the TV gyp, or of over-chargers and under-service performed for customers. Fortunately, these are in a very, very small percentage of cases, but it does make good reading matter for periodicals. To me the main thing that will offset this is to eventually obtain a surplus of qualified technicians. Once we attain this condition, the dealer or service agency will be able to secure the services of enough well-trained technicians so that his customers will be properly taken care of. It is with this in mind that the Service Manager and Service Committee, as well as the executives, of the Radio-Television Manufacturers Association are striving to satisfy the customers who have purchased our receivers, and who will purchase them in the future.

Customer Relations

AN ANALYSIS

Just the little things — How important they can be in keeping the customer happy

By E. C. TOMPSON
Public Relations Counsel

A few weeks ago, during a luncheon with a vice-president in charge of engineering for a leading television manufacturer, we were surprised to hear him announce that he was a TV Serviceman. "One of my jobs," he explained, "is to test our new models. They are shipped to my home from the factory before they are released to distributors. I install them in my home which serves as a sort of proving ground.

"One evening, while checking the performance of a new model," he continued, "a neighbor dropped in. He was one of those fellows that had a very dim view of TV, but, to my surprise, he took a look at the screen and then said that he had never seen such a good TV picture. Then he asked me if I would sell him the set. I decided that it would be easier to install the set in his home than to repack it for shipment back to the factory, so I sold it to him and agreed to service it for one year.

"Before the year had passed, he had some trouble which he told me about in a telephone call. I told him that I could fix the set in a couple of days, but he said he couldn't wait. 'Emory,' he said, 'you know how much I disliked TV until I saw this set. Now that I've had it, damned if I can live without it. Please hurry over and fix it!'"

The point of the story is, we believe, that failure of TV sets in the home is frequently considered as a minor crisis in family life. In a more literary way, Helen Prodoehl has expressed about the same thing in a poem which was published recently in the *Chicago Tribune*:

EMPTINESS

Our home is very quiet and still
And grief just fills the air;
We look upon an empty space
That we all know is there.

We always had such cheer and fun
When all at home would be;
But now we find the hours drag
Until they bring back our TV.

The experience of the engineering vice-president and Miss Prodoehl's poem shows that television is considered important in many homes, particularly when it is not working. Many people have become so attached to their television sets that operating failures have become emergencies in their homes.

This trend tends to make the TV Serviceman a very important person. Unfortunately, however, his new importance makes him susceptible to damnation as well as praise. Probably the reason why some TV Servicemen get damned is simply because it is so easy to win praise. Expressed differently, we might say that they still prefer to do things the hard way. The keys to good customer relations are so small, they are simply overlooked.

This is generally true in all service businesses. It is particularly true in technical service businesses. With emphasis on technical considerations, it is apparently assumed that everybody knows much more than many people, in fact, do know. Consequently, it seems easier to jump to conclusions, easier to jump right over the small, seemingly insignificant keys to better customer relations.

Technical proficiency is essential but other knowledge is needed . . . if work

is expected to bring a full measure of success. Let's review an interesting incident during World War II.

On February 21, 1945, the Allies successfully bombed Berchtesgaden and the news created a sensation. Correspondents immediately asked for an interview with the successful fliers, including the major who was flight leader. But they were shocked when they learned that the major and his pilots did not know that Berchtesgaden was the location of a fortress-palace from which Adolf Hitler directed enemy operations.

The major, the *New York Times* reported later in an editorial, had learned nothing of Berchtesgaden while studying at a mid-western university or during his employment in an aircraft factory before entering the Air Force. He just didn't know from nothing . . . except how to prosecute a technical bombing mission.

If the major had done just a little reading or listening to the radio while he attended the university or while he worked in the aircraft plant, how could he have failed to associate his bombing mission with human destiny?

TV Servicemen who rely wholly on their technical training and so fail to realize the significance of their work in terms of human relations, are missing the chance of a lifetime just as the Air Force major we have just cited.

(Continued on page 22)



"But, your Honor, who gets the television set."

PRODUCT REVIEWS



FEDERAL SELENIUM RECTIFIERS

Federal Telephone & Radio Corporation, 110 Kingsland Rd., Clifton, N. J. recently announced an attractive self-feeding counter dispenser for miniature selenium rectifiers that will service 90 per cent of existing radio and TV receivers that now use selenium rectifiers. Federal has also announced two new selenium rectifier kits for servicemen:



one containing replacement selenium rectifiers for the majority of TV receivers, and the other containing selenium rectifiers for the majority of radio receivers. The radio rectifier kit is supplied in a clear plastic utility container. Federal expects to be able to produce at least 50 per cent of the demand for selenium rectifiers through distributors. Improved manufacturing techniques are reported to have greatly overcome deterioration of selenium rectifier units in distributor stocks.

NEW HICKOK TUBE TESTER ROLL CHART

The Hickok Electrical Instrument Co., 10620 Dupont Ave., Cleveland 8, Ohio has announced a new roll tube chart, priced at \$1.00 direct. It includes all new tube data available up to January 1, 1952.

LOW COST MULTIMETER

Electronic Instrument Co., Inc., 84 Withers St., Brooklyn 11, N. Y. has announced a new low-cost multimeter providing six voltage readings: 0-1; 0-5;

0-10; 0-50; 0-500; and 0-5000, a-c or d-c. Current readings, a-c or d-c include: 0-1 ma; 0-10 ma; 0-100 ma; and 0-1 ampere. Resistance measurement range includes: 0-500 ohms; 0-100,000 ohms; and



0-1 megohm. Six db measurement ranges are provided between -20 db and +69 db. The model 536 multimeter is supplied with a 3½", 400 ua meter movement in a high-impact bakelite case that measures 6¼" x 3¾" x 2".

"CLOVER-V-BEAM" ANTENNA

Telrex, Inc., Asbury Park, New Jersey reports an improved antenna in preassembled, folded form that may be quickly erected by simply tightening two nuts. It is said to provide unusually high gain in indoor and outdoor installations, and is particularly well suited where there is objection to larger, heavier arrays. Characteristics of the "Clover-V-Beam" are attributed to the

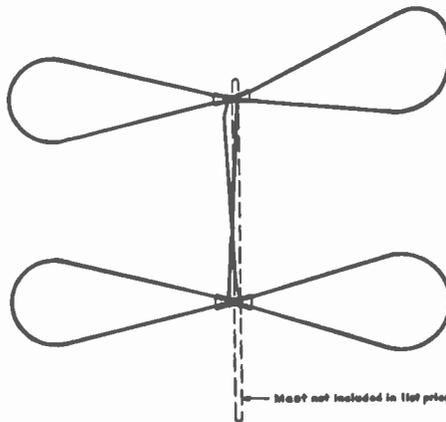

application of transposed co-linear elements combined with stacked closed loop "Conical-V-Beam" dipoles. Interconnecting rods load the dipoles for low frequency channels and serve as half-wave transformers at the high

channels. This design provides the sensitivity of resonant closed loop conical dipoles at the low frequencies, and long wire V-beam operation with an average gain of 9 db at the high channels. The "Clover-V-Beam" antenna weighs less than 24 ounces and has a lateral displacement of less than five feet. Other features include: negligible wind resistance; minimum ice loading; and small down thrust.

TUBE TESTER BULLETIN

The Hickok Electrical Instrument Co., 10620 Dupont Ave., Cleveland 8, Ohio has just published a new bulletin describing eleven types of dynamic mutual conductance tube testers. Form TT5 is free on request direct to Hickok.

NEW V-BEAM TV ANTENNA

Telrex, Inc., Asbury Park, New Jersey, has announced a new V-beam TV antenna that provides all-channel coverage in a single unit without high frequency head or dual transmission line. The design of the low cost, medium range TV antenna for urban and suburban areas, employs forward tilted dipoles for automatic transition from



low to high channels. It is said to provide well controlled unidirectional reception pattern on low and high frequencies and to simplify antenna orientation. The new Telrex V-Beam antenna is supplied with a Telrex Hi-V-Reflector as standard equipment. The reflector is a supplementary parasitic element, designed to improve high channel directivity where noise and secondary reflections are troublesome.

TV IGNITION INTERFERENCE FILTER

Telematic Industries, Inc., 1 Joralemon St., Brooklyn, N. Y., have announced a new TV ignition interference filter designed to reduce or eliminate ignition interference in TV receivers. The WT-28 unit, which is supplied in a compact, shielded case, is an antenna feeder filter that is tuned to ignition frequency peaks. It includes a resonant shunt inductance and a series line capacitance for unusually high attenuation of ignition interference. It can be easily installed at TV receiver antenna terminals.

PEAK ROOF MAST MOUNT

TV Products Company, 152 Sandford St., Brooklyn 5, N. Y., has announced a new type peak roof mast mount designed for faster, one-man installation. A sturdy steel bracket, treated with a

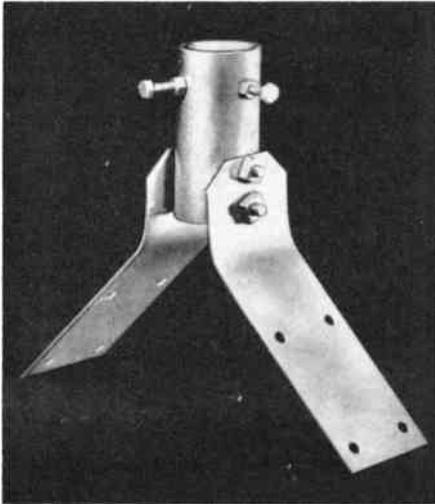

new polychrome coating, is said to withstand corrosion indefinitely and support antenna mast while it is being guyed. The model RM-3 roof mount is available through radio-electronics distributors.

AMPLIFIED TV DISTRIBUTION UNIT

Blonder-Tongue Laboratories, Inc., 38 North Second St., Mt. Vernon, N. Y., have announced a two-outlet distribution amplifier featuring two isolated TV set outlets and a through line output, for use with master antenna systems of any size or as a complete system for two-set homes. The DA2-1-M unit provides full electronic isolation and will amplify all-channels simultaneously to each TV receiver. Units may be used in series by use of a 75 ohm interconnecting line. All-channel amplification is provided to each TV set outlet. Correct

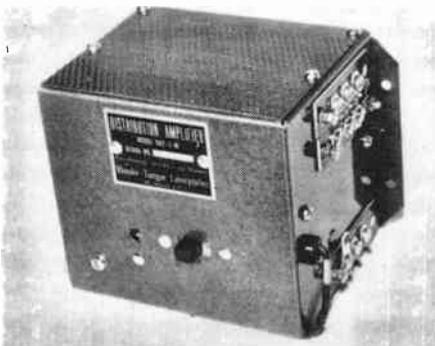

impedance match is provided at each terminal for 75 ohm and 300 ohm lines. Maximum input and output signal voltages are: .5 on 75 ohms and 1.0 on 300 ohms. The distribution amplifier unit may be used alone, in series with itself, or in any combination with other Blonder-Tongue units. It may also be

used to divide a master antenna system into two or three parts for community installations. The unit is supplied with attractive gray hammertone finish metal cabinet and is available through electronic distributors.

OPEN WIRE TRANSMISSION LINE

The Fretco Corporation, 1041 Forbes St., Pittsburgh 19, Pa., has announced a new open wire transmission line featuring clear, low-loss polystyrene insulators. The attractive open wire

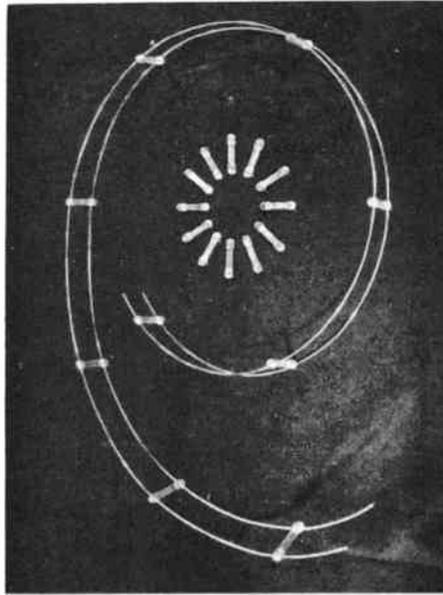

transmission line is formed with hard drawn precision-tolerance wire that is said to hold its shape even after extensive salt spray tests.

Belmont Warranty Policy

The December SERVICE MANAGEMENT issue carried an excerpt from a statement by W. L. Dunn, vice-president, Belmont Radio Corporation, concerning the company's new warranty program. It is the opinion of the company that by not carrying the entire statement we conveyed the wrong impression to our readers. We are herewith printing the following to correct any misapprehension.

"During the last quarter of 1950," W. L. Dunn, vice-president in charge of sales and engineering, said in the announcement, "Belmont became the first company in the industry to include the Federal excise tax and parts warranty charge in the suggested retail price of its Raytheon television line.

"In the third quarter of this year, many manufacturers in the industry instituted the practice of artificially marking up the parts warranty charge to several times its actual cost. This was done to compensate for extremely

close or loss pricing by many manufacturers."

The Belmont announcement specifically stated that in order to avoid any confusion or ambiguity which the new prices may engender, Raytheon television distributors will have the option of advertising the suggested retail price either with or without the Federal excise tax and parts warranty included. If the distributor advertises prices without the parts warranty and tax included, the reduction in the advertised price must be based on the exact amount of the tax and the actual parts warranty charge, and not on fictitiously high figures.

"Where this procedure is followed," Dunn's announcement continued, "Belmont will insist that the actual parts warranty charge and amount of the Federal excise tax be delineated in all advertising in prominent type. This will eliminate any possible chance of confusion on the part of the customer."

PEOPLE AND PLACES

(Continued from page 4)

HARRISON BLIND appointed a manufacturer's representative by Circle-X Antenna Corp. . . . ZEL MEYERS and CLYDE SCRIVER were elected president and vice-president, respectively, by the Missouri Valley Chapter of the Representatives. . . . MORT FARR, Upper Darby, Pennsylvania radio-television dealer, was re-elected president of National Appliance and Radio Dealers Association at their recent convention in Chicago. . . . DEAN W. PHILLIPS has taken over as district sales manager in the state of California for the Packard-Bell Company. . . . HAL DEITZ has been named general manager of Emerson-New York, Inc. . . . James B. Lansing Sound, Inc., has appointed F. A. DAUGHTY, of Ohio, as the company's representative in the Ohio, West Virginia and Western Pennsylvania area. . . . MOTOROLA, INC., has purchased additional plant space to house their growing Communications and Electronics Division. . . . P. R. MALLORY CO., INC., announced an expansion program for the provision of new capacitor manufacturing facilities. . . . LESLIE F. MUTER of the Muter Company was re-elected president of the Radar-Radio Industries of Chicago, Inc. PAUL V. GALVIN and RAYMOND F. DURST were re-elected vice-presidents. . . . Erie Resistor Corp. announced the appointment of B. B. MIMMIUM as vice-president and general manager of the Electronics Division. . . .

Picture Tube Warranty Study

(Continued from page 11)

- covered by the warranty should develop within the warranty period, the user must immediately return the Teletron to the dealer from whom it was purchased, accompanied by his signed User's Copy.
- E. If the dealer, after its inspection of the Teletron and a comparison of the Dealer's Copy with the returned User's Copy, determines that replacement of the Teletron is in order, it should proceed promptly to do so. At the same time the dealer (1) should fill in the serial number of the replacing Teletron and date of replacement in the space immediately below the line in the User's Copy and (2) should obtain the user's signature thereunder, to signify that a replacement has been made. A new Warranty Card applying to the replacing Teletron is then to be prepared, in accordance with the procedure outlined in C above, except that the date of purchase to be inserted in all three sections of such Warranty Card shall be the same as that shown on the original card. The dealer will then return the defective Teletron to the franchised DuMont distributor from whom it was purchased, accompanied by the Dealer's Copy and User's Copy relating to the original sale to the user. The nature of the failure should be indicated on the Dealer's Copy.
- F. If the distributor, after its inspection of the returned Teletron and a comparison of the Dealer's Copy with the User's Copy, determines that replacement of the Teletron is in order, it should proceed promptly to furnish a replacement Teletron to the dealer, obtaining the dealer's signature in the space below the line on the Dealer's Copy, to signify that a replacement has been made.

Tung-Sol uses a two-card system—one card either attached to receiver or filed by dealer and a second card that is mailed to wholesaler.

National Union at present has not initiated a warranty card system. Instead, a service report is submitted by distributor when tube is returned for adjustment.

Return Instructions for Defective Picture Tubes

Definite procedures are required in the preparation of tubes that are to be returned for adjustment. Again they have become more or less standardized within the RTMA suggested standard. Detailed instructions as supplied by Rauland read as follows:

RETURNING DEFECTIVE TUBES

- A. Periodically (in general not more frequently than twice a month) the distributor should return his defective tubes cheapest way prepaid to:

The Rauland Corporation
1500 North Kostner Avenue
Chicago, Illinois

- B. Each returned tube should be accompanied by the Dealer's and User's cards applicable to it.
- C. Tubes returned for adjustment should be packaged as carefully as when originally received, since damage sustained in return shipment will make a proper examination impossible. Furthermore, carriers will not accept claims on tubes improperly packed and we cannot allow credit.
- D. Transportation charges within the continental United States will be allowed on tubes found subject to adjustment. Only transportation charges for the cheapest method of shipment will be allowed. Tubes not subject to adjustment will be returned to the distributor, transportation charges collect, and billing will be rendered to cover any testing charges. Dealer and User warranty cards applicable to these tubes will be returned to the distributor.
- E. Returned tubes which are defective and not eligible for in-warranty adjustment will be destroyed unless instructions to the contrary are received with the tubes. Dealer and User warranty cards applicable to such tubes will be returned to the distributor.
- F. Repairs required for reasons beyond the responsibility of The Rauland Corporation will be made, unless instructions to the contrary are received with the tubes, and billing will be rendered to cover the cost of such repairs.
- G. We can accept no billing for packing, inspection, or labor charges in connection with tubes returned for adjustment.
- Some few manufacturers such as Federal request distributor to write, telephone, or telegraph for authorization before tubes are returned for adjustment. A special authorization number is sent to distributor to assure prompt and accurate identification when shipment arrives at plant.
- Rauland also lists in the form of a supplement the numerous defects for which tubes can be adjusted. Supplement also lists faults for which no compensation can be granted.

SUPPLEMENT

I. Electrical Defects

1. Shorted elements
2. Open or intermittent connection to elements
3. Excessive element leakage
4. Current out of limits (ion trap, focus coil, second grid, heater)

(Continued on page 25)

DEALER'S COPY		REGISTRATION No 15767
IMPORTANT		
DU MONT REPLACEMENT TELETRON WARRANTY		
Teletron Serial Number	Teletron Type Number	
Purchased From	(Date)	
User's Signature	(Portion above this line to be completed by dealer to user)	
(Portion below this line to be completed in event of adjustment)		
Received Adjustment	Date	
(To be detached and held by dealer upon sale to user)		
USER'S COPY		REGISTRATION No 15767
IMPORTANT		
DU MONT REPLACEMENT TELETRON WARRANTY		
Teletron Serial Number	Teletron Type Number	
Purchased From	(Date)	
User's Signature	(Portion above this line to be completed by user to dealer)	
(Portion below this line to be completed in event of adjustment)		
Received as Adjustment	Date	
User's Signature	DU MONT Serial No.	
NOTICE TO USER—WARRANTY ON REVERSE SIDE		
USER'S REGISTRATION		REGISTRATION No 15767
IMPORTANT		
DU MONT REPLACEMENT TELETRON WARRANTY		
Teletron Serial Number	Teletron Type Number	
Purchased From	(Date)	
User's Signature	(Portion above this line to be completed by user to dealer)	
(Portion below this line to be completed in event of adjustment)		
Make of TV Set	Teletron purchased for repair	
replacement <input type="checkbox"/> conversion replacement <input type="checkbox"/>	Indicate one.	
USER—COMPLETE, SIGN AND MAIL THIS SECTION IMMEDIATELY AFTER YOUR PURCHASE. UNLESS YOU DO SO YOUR WARRANTY IS NOT VALID.		

Typical of information found on manufacturer's warranty card.

New Tube Introduced By General Electric

The General Electric Company's Tube Department recently announced development of a new receiving tube which may lead to a considerable reduction in television receiver manufacturing costs.

Use of the new tube, type number 6BK5, in conjunction with tube 6BN6 in the sound circuit of television receivers, will result in the elimination of two additional tubes, associated components, and several assembly operations.

The 6BK5 is a power output pentode, while the 6BN6 is a combination limiter and discriminator. Used together, they eliminate use of a first audio amplifier tube and a limiter tube. The 6BK5 is specifically designed for use with the 6PN6.

The new tube needs only a small driving voltage for full audio output. It has extremely high power sensitivity, high transconductance, and high plate efficiency.

When operated with 250 volts on the plate and screen, the 6BK5 can deliver 3.5 watts at seven per cent distortion. The grid driving voltage required for full audio output is only five volts peak. The new tube has a plate dissipation of nine watts.

The 6BK5 was developed and is in production at General Electric's receiving tube plant at Owensboro, Ky.

Grayburne Equipment Catalog

The new 1952 electronic equipment catalog just announced by Grayburne Corporation, 103 Lafayette Street, New York 13, N. Y., contains four two-color pages comprehensively describing the complete Grayburne line. An outstanding feature of this catalog is its detailed analysis of the specific market potential for each Grayburne product — from the Service Dealer's viewpoint — combined with specific recommendations for the exploitation of these markets.

The Grayburne products described include such important basic accessories as: Ferri-Loopsticks and Vari-Loopsticks, TV Interference Filters, Tube Carriers, and TV-IF Signal Boosters.

For a free copy of this valuable catalog, write directly to Grayburne Corporation.

FRSAP Statement

At the recently held meeting of the Federation of Radio Servicemen's Association of Penna., which was held in Harrisburg, the delegates of its numerous chapters went on record requesting this office to make the following statement to the industry and the press, to correct an apparent one-sided picture of Service Relations:

"Neither this body nor any of its chapters are participating in or represented on the Joint Electronic Radio Committee on Service. Federation representatives were requested only to act on a sub-committee to help write the 50-POINT PROGRAM which was submitted to the various segments of the industry. The Joint Electronic Radio Committee on Service's chairman, Mr. Albert Steinberg, did not invite the representatives, the organized associations of service technicians, to sit with the Joint Electronic Radio Committee on Service's main body. The Federation, feeling the refusal to give the servicemen's associations full and equal recognition on the Joint Electronic Radio Committee on Service's main body, (on which were representatives of the Radio-Television Manufacturers Ass'n, set distributors, parts manufacturers, manufacturers' representatives, National Electronic Distributors Association and the Television Contractors Association) refused to participate further until this oversight has been completely rectified. Since an elected spokesman for the organized service technicians does not sit with the Joint Electronic Radio Committee on Service, we, the Federation, refuse to allow a hand-picked spokesman, Mr. Haas, of the Television Contractors Association, to represent the Federation or any of its membership, to speak for us. This does not preclude the possibility of actual and enthusiastic participation in any worthwhile program sponsored by the Joint Electronic Radio Committee on Service or any other group who would conscientiously promote the best interest of the service profession. The door is always open."

Systematic Thefts Bankrupt Big TV Service Operation

The recent bankruptcy petition of the fifty-year-old Conlan Electric Company of Brooklyn, N. Y., revealed that almost half a million dollars worth of stock had been systematically stolen by TV Service employees since 1947. During discussion of the petition, the company listed assets of \$908,802 and liabilities of \$1,031,802. It also revealed that it

had more than 50,000 accounts, including 20,000 TV service contracts.

The attorney for the company said that the systematic thefts reflected a condition that is very prevalent in the service industry and he recommended that legislation be enacted requiring that employees, who go into a person's home, furnish security as to their fitness, qualifications and trustworthiness.

He also suggested that the solution of the problem may lie in the licensing of all companies engaged in service work, to create certain safeguards and standards, and to give them ratings according to their financial ability, materials, personnel, and the nature of their services.

The shortages were discovered last summer when the company took inventory in connection with an application with the Securities and Exchange Commission, for permission to issue stock for sale to the public.

More than 200 employees had access to the stock room where losses, for the first seven months of 1951, amounted to about \$195,000. Thirty-seven of these employees have testified to a private investigating company that has taken tape recordings.

The company is in the process of reorganization but it will accept no new TV service contracts.

FM Promotion Initiated

Plans for the month-long FM "test pilot" promotional campaign, scheduled to open in North Carolina on Jan. 21 under the joint sponsorship of the National Association of Radio and Television Broadcasters and the Radio-Television Manufacturers Association, were finalized recently in Charlotte, N. C., at a meeting of broadcasters, manufacturers' representatives, distributors, dealers, and NARTB and RTMA representatives.

Following a welcoming address by Victor Shaw, the mayor of Charlotte, NARTB FM Director John H. Smith, Jr., revealed that North Carolina was selected as one of the three test areas because the state, having 41 stations engaged in some form of FM programming, is regarded as a "pilot territory for FM radio." Speaking for RTMA, General Manager-Secretary James D. Secrest complimented NARTB President Harold E. Fellows for fathering the teamwork idea in the promotion of FM receivers.

Don Whitting, a manufacturer's representative on the RTMA FM Promotional Committee, previewed material which the manufacturers have developed especially for the campaign.

CUSTOMER RELATIONS

(Continued from page 17)

During a recent meeting with two neighbors they pounced on us to tell us what they thought about TV Service. They both announced that there would be no more service contracts for them. When we researched for reasons we found that their contract service companies had made the easy fault of underestimating the importance of trivial things which are very important in good customer relations.

For example: the first neighbor complained that his serviceman had made several calls but had given up trying to center the image on his TV screen. "Impossible," said the servicemen. After patiently waiting, the set owner decided to try to center the image himself. He found that it could be done in a jiffy by making a simple external adjustment at the rear of the chassis. He also cited his fallen antenna, due to rusted chimney straps and a faulty tuning knob. Trivial things? Yes. But they were reasons why the service contract was cancelled.

The second neighbor's principal gripe was that his service calls, though answered promptly, were made by inexperienced "boys" who were, in his opinion, uninformed about TV. He also resented high pressure promotion for contract renewal, stating that it claimed far more than he could possibly expect.

These TV set owners have decided to service their own sets as best they can. But it is probable that neither contract would have lapsed if sponsoring TV Service organizations had considered a few trivial things that would have saved them from loss of good customer relations. And cost of service was not a gripe; our neighbors tell us that they favor licensing, they want assurance that their service will measure up to some sort of standard. Price is not a factor, they say. What they want is to keep their sets in operation, to have the little jobs done well.

Sylvania Announces TV Glass Tube Allowance Program

Radio-TV Service Dealers will be given a trade-in allowance of from \$2.25 to \$5.25 on used television picture tubes, under terms of a new Glass Allowance Program, announced by H. H. Rainier, Manager of Distributor Sales for Sylvania Electric Products, Inc.

The program will be operated through Sylvania's 450 radio and television tube distributors who will grant dealers allowances on more than 40

different picture tube types. Returned tubes of any make are being accepted, provided they are among the types listed on a suggested Glass Allowance List.

To obtain the trade-in credit, dealers are asked to purchase one new Sylvania Picture Tube of any type for each used tube returned. In announcing the Glass Allowance to dealers, Mr. Rainier pointed out that Sylvania was accepting only tubes under vacuum and free from glass defects such as scratches, chips, bruises and other indications of physical abuse. Glass quality must be such that when reduced to a raw bulb, the quality is equal to that of a brand new raw bulb purchased from glass manufacturers, he explained.

The glass allowances offered by Sylvania generally are slightly higher than current national average bulb prices prevailing in the rebuilding trade. Sylvania will pay transportation on the used tubes from distributor stores to newly designated "glass departments" in Seneca Falls, N. Y., Chicago and Los Angeles.

The types eligible for trade in by dealers, as listed in Sylvania's original Glass Allowance Program and glass allowances include:

Sylvania Suggested Glass Allowance Price List			
12KP4A	\$2.25	16RP4	3.25
12LP4A	2.25	16TP4	3.25
12VP4	2.25	16UP4	3.25
		16XP4	3.25
		16ZP4	3.25
17AP4	2.25		
17BP4	2.25		
17BP4A	2.25	20CP4	\$4.25
17BP4B	2.25	20CP4A	4.25
17FP4	2.25	20DP4	4.25
17FP4A	2.25	20DP4A	4.25
17HP4	2.25	20FP4	4.25
17JP4	2.25	20GP4	4.25
17KP4	2.25	20HP4	4.25
17LP4	2.25	20HP4A	4.25
17QP4	2.25	20JP4	4.25
17RP4	2.25		
17SP4	2.25	21EP4	5.25
		21EP4A	5.25
16JP4A	\$3.25	21FP4	5.25
16KP4	3.25	21FP4A	5.25
16KP4A	3.25	21KP4	5.25
16LP4A	3.25	21KP4A	5.25
16QP4	3.25		

RMS Sales Conference Goes Fringe

The Winter 1952 Sales Conference of RMS, New York manufacturers of nationally distributed television antennas and accessories, was held recently at the Grossinger Hotel and Country Club, New York.

At the meeting, sales personnel and representatives were introduced to the wide variety of new products recently

developed for the television servicing industry. Among these new items were three new antennas, which as a group, are said to provide more effective reception for urban, semi-fringe and fringe television areas. The new antennas are Fringe Master Senior, a Conical V, all aluminum unit and Fantenna, a super-fan array, both for fringe reception, and Fringe Master, Jr., a conical V-Beam for urban and semi-fringe areas. Also introduced were a line of television tube servicing kits and tool kits.

Previewed at the meeting were segments of the company's promotion plans and material for the year. New, streamlined Jobber price catalogs, complete with illustrations of the entire line, were flown from New York City to the meeting. Also displayed was the new Accessory and Antenna Wall Chart, a guide which the company had introduced several years ago and which has now become an important adjunct to all servicing literature.

Trade Practice Conference Committee Prepares For Public Hearing

Executive heads of leading trade associations, Radio and TV manufacturers and dealer representatives held a closed session at the Federal Trade Commission in Washington to discuss the proposed trade practice rules for their industry.

Louis B. Calamaras, executive vice-president of National Electronic Distributors Association, who has presided at the two closed sessions of the Trade Practice Conference Committee of the radio and television industry held in Washington during December and January, announced that there will be no more meetings.

Mr. Calamaras said that he expected to report shortly to H. Paul Butz, FTC attorney in charge of the conference, giving the points of agreement and the points of contention that resulted from the closed session.

Some points of contention still remain between manufacturers on one side and dealers and parts distributors on the other, but it was felt at the end of the meeting that discussions had advanced far enough for another public session scheduled tentatively for the latter part of March. Mr. Butz and FTC attorneys are preparing another draft of rules based on recommendations of Mr. Calamaras' committee. After the March conference, next public hearing will be before June.

Albert Coumont Appointed Service Manager of RTMA

Glen McDaniel, president of the Radio-Television Manufacturers Association, recently appointed Albert Coumont, formerly Sales Manager, Electronics Section, International General Electric Co., Inc., as RTMA Service Manager. The position was created by the RTMA Board of Directors early last fall to coordinate the Association's activities aimed at improving industry practices and policies on TV set servicing. The post previously was held by E. W. Merriam on a temporary basis.



ALBERT COUMONT

Mr. Coumont has had diversified experience in the radio and television industry and has been with General Electric since 1935. Mr. Coumont's entire business career has been spent in the radio and television field, beginning in 1932. His experience includes the operation of his own home radio repair company and an active participation in the home radio service divisions of manufacturing companies.

One of the first tasks to be undertaken by Mr. Coumont will be to promote training courses for service technicians in the nation's trade and vocational schools. A recommended agenda for a training course has been prepared by the RTMA Service Committee, under Chairman R. J. Yeranko, of the Magnavox Co., and has been distributed among trade and vocational schools.

L. B. Calamaras Opposes License Bill Before New York Council

When Mayor Vittorio Impelleri met with his cabinet January 10 to sign a bill for licensing of television service contractors and service dealers, a vigorous session took place with arguments for and against the bill.

Proponent of the bill was Councilman Abraham Sussman who explained the Council's action in approving the bill last November. Also heard in support of the bill were Max Liebowitz, president of the Associated Radio-Television Service Men of New York and several independent service men.

Louis B. Calamaras, executive vice-president of National Electronic Distributors Association, singly opposed the bill, and his opposition was the basis for postponing its signing until spokesmen from other sections of the industry might be given the opportunity to discuss the matter dispassionately and with the benefit of factual background and experience.

Mr. Calamaras' stand in New York marked his third appearance before the city administration. The law had already been approved by the city council by a vote of 19 to 4 when he undertook the opposition alone.

Mr. Calamaras, who has appeared at hearings in various parts of the country where similar legislation has been defeated, pointed out that while there may be instances of the kind of abuse the proposed law was intended to correct, nowhere in the present bill nor in any other he had read was there specific provision for correcting such abuse.

Private conversations with service men, declared Mr. Calamaras, have revealed to him that many who formerly opposed such legislation and who now appeared to be in favor of it did so only because they hope that the enactment of such legislation will relieve some of the pressure and unfavorable criticism they have been receiving from newspapers and magazines generally — not because they are convinced that the law would correct any evils which may exist.

NARDA Urges Code To Combat TV Advertising Practices

Newspaper ad executives were urged today (January 21) to cooperate with dealers in wiping out the practice of pulling such compulsory charges as parts warranty and excise taxes from

the price of TV sets in order to gain a false competitive advantage and to aid in the widespread adoption of the code of ethics created and followed by the *Milwaukee Journal* as a means of combating such unhealthy advertising practices.

Mort Farr, President of NARDA, addressed the following telegram to Louis E. Heindel, President of the Newspaper Advertising Executives Association, now holding its annual convention at the Edgewater Beach Hotel in Chicago.

"On behalf of the largest organized body of appliance and television retailers in the country, I respectfully urge your organization to give consideration to the widespread adoption of the excellent code of ethics created and followed by the *Milwaukee Journal* as a means of combating unhealthy advertising practices in our industry. These are causing tens of thousands of retailers whose practices do not justify reproach to be criticized. We would specifically urge that the unfair competitive advantage gained by withdrawing such compulsory charges as parts warranty and excise tax from the advertised retail price of certain makes of television be disallowed and that manufacturers, distributors and retailers be required to detail the full consumer purchase price save only local sales taxes in all television advertisements containing receiver prices. It is our conviction that truth in advertising is the very finest sales ammunition.

NEDA's Tri-State Chapter Meets in Youngstown, Ohio

January 22, 1952 — Kenneth Lawyer, chairman of Marketing Research at Western Reserve University, was guest speaker when Tri-State Chapter members of National Electronic Distributors Association met January 20 in Pick-Ohio Hotel, Youngstown, Ohio. His subject was "What's for you in 1952."

Following the lecture, a brief business session was held.

Tri-State will meet again on March 23 in Pittsburgh, Pa., for a panel discussion. Members of the panel will include three members from Tri-State Chapter and three from Buckeye Representatives. Buckeye Chapter of Representatives will be guests at this session.

Arthur E. Winter, Winteradio Inc., Cleveland, Ohio, and president of Tri-State, announces that the Chapter will sponsor a luncheon-meeting during the Chicago May Show at which time annual election of officers will take place.

TECHNICAL TOPICS

(Continued from page 7)

Philco uses a selenium rectifier low voltage power supply in their new line of TV receivers, figure 7. Low voltage plate supply uses a voltage doubler right off the a.c. line. A lower voltage secondary off the filament supply transformer is also rectified and supplies bias for video and sweep circuits.

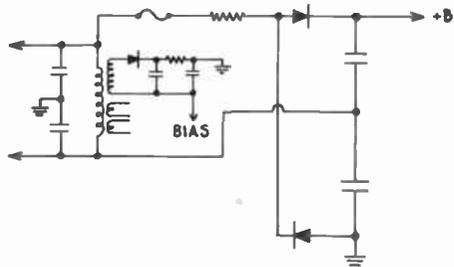

FIG. 7. Philco Low Voltage Selenium Supply

High Voltage Seleniums

There are high voltage seleniums available also—some self-supporting with pig-tails, others for mounting in clips, figure 8. Voltage ratings extend from 250 to 5,000 volts. The high voltage selenium permits simple power supply construction and design. For example, a 900 volt 2ma. supply for an industrial TV camera was obtained with a very small power transformer and two small high voltage seleniums, figure 9.

These high voltage units can be used to construct high voltage supplies for oscilloscopes, photoflash units, television receivers, etc. We can expect to find them used eventually with pulse type supplies. This application would simplify horizontal output circuits.



FIG. 8. International Rectifier High Voltage Selenium Rectifier

JFD Offers Decal

A new, colorful decal, prepared by the advertising department of the JFD Manufacturing Company, Inc., is being distributed to over 2,000 distributors of JFD television antennas and accessories.

The decal, which is completely weather resistant, is in a brilliant two-color design—red and black. It immediately identifies the distributor as one who handles JFD products.

This new JFD sales aid can be easily placed on windows, doors, counters or truck panels. Its diversified application is sure to prove of top value to those who put it to use.

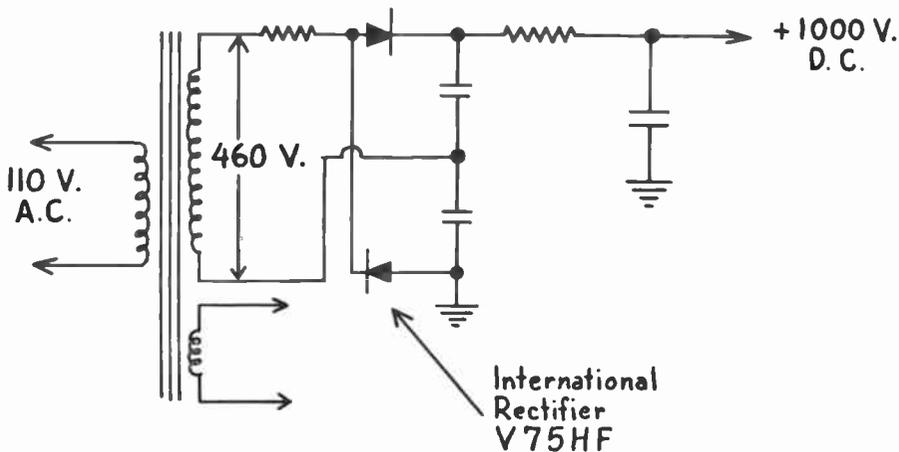

FIG. 9. Selenium High Voltage Supply

NARDA to Survey Costs-of-Doing-Business

Local organizations of retail appliance, radio and television dealers will receive specially compiled reports for their exclusive use on the costs-of-doing-business in their areas as a part of the nation-wide annual survey conducted by the National Appliance and Radio-TV Dealers Association, D. E. Urner of Bakersfield, Cal., Chairman of the NARDA Costs-of-Doing-Business Survey Committee, announced recently.

Mr. Urner pointed out that there will be no charge or obligation for these special studies but it is necessary that at least 20 dealers in each area participate in order to get an adequate sampling of that territory. He said this is the first time in the five years that the surveys have been made that individualized studies will be conducted. "We have come to realize the value of this type of research because of the extreme regional variations," he said. "Facts uncovered by a more specialized study will prove very helpful in giving these retailers a yardstick of their immediate geographic area against which they can measure their own operations."

He announced that the survey will again be under the direction of NARDA's Economist Consultant Richard E. Snyder, who has been in charge of the project since its inception.

Mr. Urner urged local groups throughout the nation to participate in the undertaking to broaden the base of the study which serves to trace industry trends, to indicate when and where adjustments are in order, and to give retailers facts which can be used to correct inequities in price stabilization and in other factors affecting the industry. He invited interested local groups to notify NARDA headquarters, 1437 Merchandise Mart, Chicago, so that questionnaires can be sent to them.

New Tube Type

The General Electric Tube Department announced that it is manufacturing a new receiving tube which will reduce vertical distortion on television receivers which are operated from a low B-plus supply voltage.

The new tube, type number 6BX7-GT, is a twin triode designed for the vertical output stage of television receivers as a combined vertical deflection amplifier and vertical oscillator.

It will provide better linearity and more sweep at a lower driving voltage. Because it will operate at a lower voltage, use of the tube will also result in a saving of transformer copper.

Among typical operating characteristics for each section are a cutoff voltage of 40 volts with 250 volts on the plate and 80 milliamperes plate current at zero bias with 100 volts on the plate.

More Powerful Receivers Expand Primary Reception Areas

The geographical area served by television is continuing to expand, in spite of the freeze on new station construction, J. B. Elliott, vice-president in charge of RCA Victor Consumer Products, told a group of merchandisers today. He said that super-power TV sets are making this possible.

"With the broadcasters frozen in their tracks, the set manufacturers have taken over," he told members of the Associated Merchandising Corporation at the Benjamin Franklin Hotel. "We are expanding television's service area, not by installing more transmitters, but by manufacturing better receivers. Some of the sets on the market today can bring in quality reception in fringe and 'difficult' areas that have always been considered television dust bowls."

Picture Tube Warranty Study

(Continued from page 20)

5. First grid cut-off voltage out of limits
6. Element breakdown under high voltage
7. Low emission
8. Arcing and singing (poor internal anode coating)
9. Beam improperly centered
10. Magnetized metal cone

II. Physical Defects

1. Air leaker
2. Gassy tube
3. Neck shadow
4. Broken tube if caused by defective glass
5. Defective outside paint
6. Loose elements in tube
7. Physical dimensions out of limits
8. Incorrect tube type marking

III. Base Defects

1. Loose base if due to poor cementing
2. Cracked base
3. Improper base orientation
4. Defective pin soldering

IV. Screen Defects

1. Uniformity of color out of limits (including streaks, watermarks, blue areas, dark areas, dark edges, etc.)
2. Insufficient screen area
3. Holes and cracks in screen out of limits
4. Dark or discolored spots in screen if out of limits
5. Dirt and lint marks out of limits
6. Excessive aluminum areas showing through screen
7. Ion burn out of limits
8. Excessive screen burn

V. Glass Face Defects

1. Blisters (large bubbles) out of limits
2. Seeds (small bubbles) out of limits
3. Chill wrinkle out of limits
4. Mold mark out of limits
5. Excessive impact mark
6. Excessive cords
7. Stones, scale, knots and embedded dirt out of limits
8. Rouge, rust, and unglazed scale out of limits
9. Shear marks, scum and spew out of limits
10. Dirt on mold marks, oil spots and cold glass marks out of limits

Following is a list of possible defects for which the manufacturer cannot accept responsibility when these conditions appear on picture tubes:

1. Scratched face
2. Patterns or holes burned in screen
3. Broken tubes caused by mishandling
4. Base loose due to mishandling
5. Bump checks in glass bulb
6. Base pins bent due to mishandling
7. Base broken due to mishandling
8. External coating defaced due to handling

SERVICE MANAGEMENT MEANS BUSINESS

Your present customers are somebody's good prospects. You want to *hold* the customers you have — and to *get more*. You are in the Service business to survive, to grow, to make money. That's why you need **SERVICE MANAGEMENT** — the *business* magazine of the Service industry.

The first step toward profit-making is to *stop losses*. For instance, how much do you *lose* if . . .

- If payroll dollars paid out for work-hours are wasted?
- if test-equipment is not up-to-date . . . if shop-routine is not streamlined for speed?
- if you don't know the secret of picking, training, supervising the **RIGHT** employees?
- if you charge too little, too much, have constant "misunderstandings" with customers?
- if the parts and supplies you need are not in stock when required?
- if you don't keep proper books, never discount your bills, can't get along with your banker?
- if you never use sales-helpers, never advertise, ignore elementary principles of salesmanship?
- if you "haven't time" to read about tested business methods in **Service Management**?

SERVICE MANAGEMENT is edited by men who really know Service business problems. It is the one magazine in the field of television, radio, audio, electronics which accents the need for business methods — which believes that maintaining solvency, making money, growing and prospering are as important as technical skill. At \$3.00 a year, a subscription means *less than a penny a day*. **SERVICE MANAGEMENT** can be your most important piece of "equipment." For some things you can wait 'til you "get" time — in this case, smart operators **MAKE** time — because they feel they **MUST**. They know that reading **SERVICE MANAGEMENT** means *business!*

**Mail
Your
Subscription
NOW!**

LECTURE BUREAU PUBLISHING CO.
161 Luckie Street, N. W.
Atlanta, Georgia

GENTLEMEN: PLEASE ENTER MY ORDER FOR A SUBSCRIPTION TO "SERVICE MANAGEMENT" AT \$3.00 A YEAR. (TWO YEARS, \$5.00.)

CHECK MONEY ORDER CASH

NAME _____ 152
(Please Print)

ADDRESS _____

CITY _____ STATE _____

SIGNED BY _____ POSITION _____

Type of Business:

- SERVICE CONTRACTOR; DEALER
 TECHNICIAN; DISTRIBUTOR
 PARTS JOBBER
 MANUFACTURER OF _____

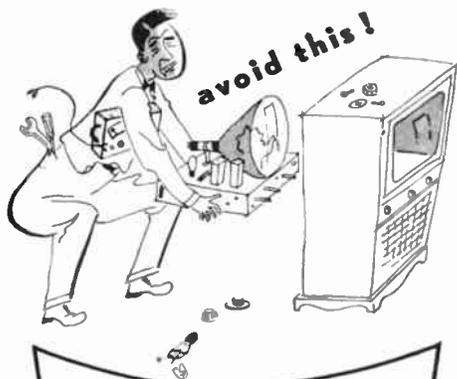

GET RMS

PIX-EYE

**CHECK PICTURE TUBE
and VITAL RECEIVER
CIRCUITS
ON-THE-SPOT**

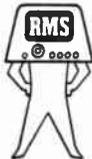

Model TE-5

\$9.95
LIST

PIX-EYE speeds TV trouble shooting . . . eliminates the time, labor and danger involved in unnecessary removal of picture tube. Plug Pix-Eye into the CRT socket . . . to help you quickly analyze the picture tube for shorts, intermit-tents, opens . . . make instant check of—

- brightness control circuits
- contrast control circuits
- video circuits
- low voltage circuits
- filament voltage circuits

Extension units EX-5 can be supplied for working at front of set. Take Pix-Eye on the call . . . keep one at the bench.

See your local RMS jobber today!

RADIO MERCHANDISE SALES, Inc.
NEW YORK 59, N. Y.

RCA Tube Dept. Announces Two UHF Sweep Generators

Anticipating market needs for specialized UHF-TV test equipment which will develop with the opening of the ultra-high frequency band, the RCA Tube Department today disclosed that it will soon put into production two newly developed UHF sweep generators. Initial units are expected to be available early in the Spring.

The new instruments are a UHF sweep-marker generator (WR-40A), designed for engineers developing UHF circuitry for home television receivers, and a UHF sweep generator (WR-41A), intended for use as test equipment in factory production of UHF equipment. The frequency range of both instruments is from 470 megacycles to 890 megacycles, which includes the new UHF band for TV. Both are continuously tunable over the entire range, and operate entirely on fundamental frequencies, obviating the need for use of either beat notes or harmonics.

Test FM Campaign

Plans for the first metropolitan market test FM campaign of the National Association of Radio and Television Broadcasters and Radio-Television Manufacturers Association were drawn here recently in a meeting between 26 distributors and broadcasters at NARTB headquarters.

The campaign will be staged in the District of Columbia wholesale trading area during the entire month of March.

Washington's position as FM capital of the nation was cited as the reason for its selection as the big city "laboratory." In opening the meeting, J. H. Smith, Jr., NARTB's FM Director, called attention to the fact that listeners in Washington have a choice of 11 stations on the FM dial after sundown as compared to 7 on standard radio.

NEDA Office Publishes 4-Page Brochure

In answer to many inquiries by people outside the electronic industry, particularly in government circles, as to what constitutes an electronic parts wholesaler, National Electronic Distributors Association has prepared a

four-page brochure outlining the basic structure and functions of electronic parts distributors.

Covered in the pamphlet are sources of supply, material handled, customers served, type of employees, services rendered, status of electronic parts distributor and functions in wartime.

George Wedemeyer, Wedemeyer Electronic Supply Co., Ann Arbor, Mich., and president of NEDA, prepared the copy for the leaflet.

A diagram indicating basic operations of electronic parts wholesalers in step by step pattern is also included.

High Fidelity Center

Westchester Electronic Supply Co., Inc., White Plains, New York, announces that they have opened a new place under the name of "High Fidelity Center," at 367 Mamaroneck Avenue, White Plains, New York.

In this new venture, approximately 1,600 square feet will be utilized solely for the sale of all the latest types of High Fidelity sound and recording equipment. The studio has been acoustically soundproofed and all the equipment is set up for instantaneous demonstration by means of a central switching system.

"High Fidelity Center" will be managed by Edgar Adler, formerly connected for many years with Lafayette-Wholesale Radio, in New York City.

EICO Buys Additional Plant

To meet the constantly increasing demand for the complete line of its EICO test equipment Kits and Instruments, Electronic Instrument Co., Inc., Brooklyn, New York, is now in full swing on its expansion program for tripling its production and engineering output.

In line with this expansion operation, EICO has purchased a six (6) story plant structure at 84-86 Withers Street, Brooklyn 11, New York, overlooking the new Meeker Avenue elevated highway. This new plant houses EICO's factory and offices and adds more than 30,000 square feet to their facilities.

"This move," said Harry R. Ashley, President of EICO, "was necessitated by our greatly expanded volume of sales and our desire to streamline our service to the many EICO jobbers and servicemen and industrial users throughout the country."

Sure-Fire Method of CUTTING COSTS

**WITHOUT
SACRIFICING
VOLUME!**

Here is a simple buying and merchandising plan which has been proven successful by just about every profit-making store in the USA!

Perhaps the best way to examine it is in the words of the President of one of America's largest and most successful stores.

He stated recently:

"We recognize the many advantages of...brands in our day-to-day merchandising.

"We know that it is much easier to sell branded merchandise because the advertising has pre-sold the product to the consumer.

"We know that self-service and self selection are possible with brands, thereby cutting selling costs.

"And in a business with a close margin of profit, we are constantly looking for just such ways to cut selling costs without changing the character of our operation."

The consumers of America favor manufacturers' brands by eight to one. Need we say more?

*Brand Names
Foundation*
INCORPORATED

INSIST on this label...

Admiral Bendix Television SCOTT Hallicrafters

Magnavox

CROSLLEY

Motorola

Kays-Halbock

Stewart-Warner

PILOT

Hoffman

Sturmit

Imperial

Philco

Caltech

the *Exact* original equipment

Thomas
PHOTOTRON
TELEVISION
PICTURE TUBE

Thomas Electronics Inc., Passaic, New Jersey, U. S. A.

Tile King Westinghouse Olympic

Replacement **16CP4A** Tube Chart

GROUP	LENGTH	ENVELOPE	DEFLECTION ANGLE	ION TEMP.	CAPACITANCE (pF)	TYPE FACE PLATE
16AP4	21 1/2	M	32	0	M	Clear
16CP4	21 1/2	M	32	0	M	Clear
16CP4A	21 1/2	O	32	0	2000	Grey
16PA	22 1/2	O	32	5	2000	Clear
16PA	22 1/2	O	32	0	2000	Grey
16PN	22 1/2	O	32	0	2000	Clear
16PN	22 1/2	O	32	0	2000	Grey
16PN	22 1/2	O	32	0	2000	Grey
16PN	22 1/2	O	32	0	2000	Grey

Tell tone

Meck

... it's your guarantee* of quality.

It means you're replacing a picture tube with the exact original equipment...chosen by these 20 manufacturers (and many more!) because of proved superior performance.

This means less time-killing tube coll-backs: more profit

for you in each replacement! So, insist on this label... and get the best—THOMAS!

*Every THOMAS Phototron picture tube is guaranteed for 6 months from the actual date of installation: regardless of how long the tube remains on your shelf.

Contact your jobber or distributor for the complete THOMAS Phototron line... or write THOMAS direct.

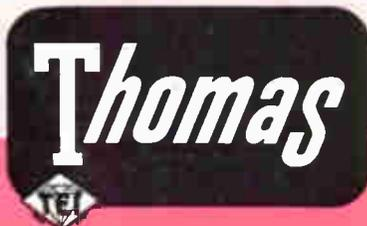

Phototron picture tube

ELECTRONICS Inc. PASSAIC, NEW JERSEY

Export Rep. Joseph Florentin - 401 Broadway, New York, N. Y.

Canadian Rep. Charles W. Pointon - 1926 Gerrard St. E., Toronto, Ontario