

INTERNATIONAL MUSICIAN

AND RECORDING WORLD TM

ISSN:0273-673X

Dec. 1981 \$2.00 Canada \$2.25



Stones Start Up!

Gary U.S. Bonds * Eddie Van Halen

Tascam Mixer * Alembic Bass * Randall RG80 SC
Fostex Recorder

World Radio History



0

71486 02175

Victory MV X . . . Ten distinct sounds from one great new guitar.

Now, all you need to achieve up to ten popular, distinct sounds is one Gibson Victory MV X guitar. Just set the blade switch to your desired preference, plug it in, start cookin'.

Gibson's Victory MV X guitar has the sounds the crowds are applauding and producers are calling for. Why not sound out a new Gibson MV X guitar at your Gibson dealer today?

. . . and for country cookin'
look into the new Gibson Victory CM MV II.

**Sounds like...
all of 'em.**



Gibson
Nashville, TN

European, Middle East
and African Offices
Postbus 2110 Dordrecht 48
3088 HJ Rotterdam
Nederland

For Victory MV Series literature, and poster reprint of this ad, send \$4.50 to: Gibson Literature Department, P.O. Box 100087, Nashville, TN 37210

16

NEW! from Studiomaster

4

the 16 into 4 into 2 Board

In the past our 16 x 4 has been very popular with small recording studios, live sound companies and touring bands because of its expandability, unique EQ, features, functions and reliability.

Now a 16 x 4 with the new 4 into 2 becomes even more flexible than before. The 16 x 4 can now become even easier to use for live performances and for recording live *and* remixing later. Conversely, it is equally at home in a strict recording application due to its remix functions and multi-track and ping-pong abilities.

When you next consider purchasing a console for live and/or recording and you expect to go places, you really owe it to yourself to check out Studiomaster.

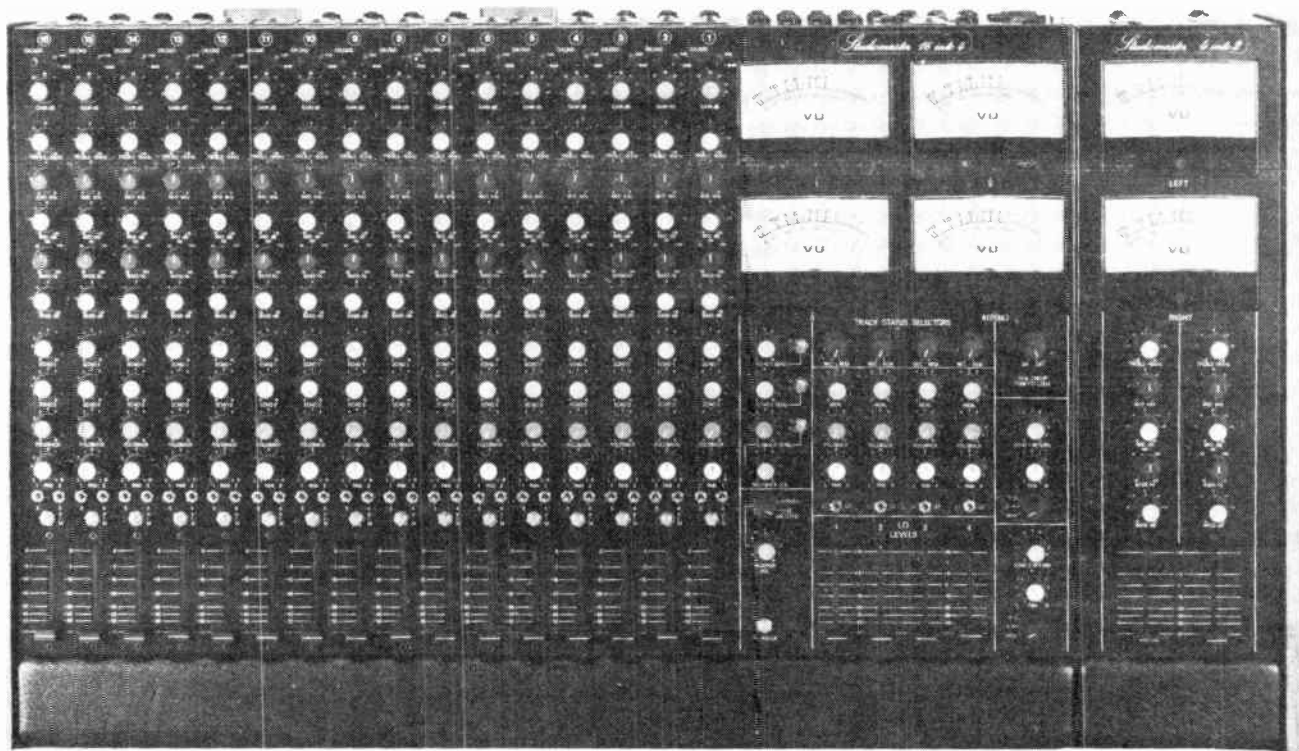

Studiomaster Inc.

Recording Studio Design

PLEASE SEND ME ADDITIONAL INFORMATION ABOUT THE NEW 16 INTO 4 STUDIOMASTER MIXER.

Name _____

Address _____

City _____ State _____ Zip _____

Studiomaster, Inc. 1365-C Dynamics St., Anaheim, CA 92806

Purchase Equipment —

Save Money

and Get 50% Off IM & RW —
a \$24.00 Total Value!

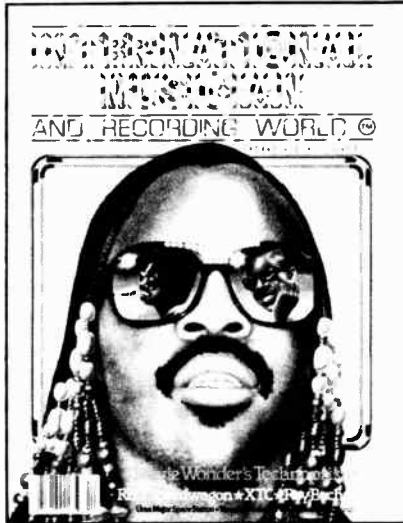

**50% OFF
COVER PRICE
Plus 1982 Equipment
Test Guide, Free!**

A guide to significant performance and recording equipment as evaluated by professional musicians and sound engineers.

The next investment you make in musical equipment could be your wisest. Any purchase of \$25 or more from your local dealer will qualify you for a special \$12 rate for a one year subscription to International Musician and Recording World, PLUS \$3.00 1982 Equipment Test Guide FREE. That one investment opens the door to a full year of:

- **No-holds-barred EQUIPMENT TESTS**
- **Valuable HOW-TO FEATURES and PLAYING COLUMNS**
- **Special sections on KEYBOARDS... GUITARS...DRUMS...**
- **NEWS of artists and happenings in the recording world**
- **Techniques and suggestions from TOP ARTISTS**
- **COMPLETE MUSIC COVERAGE**

CLIP and mail to: IM & RW, 1500 Broadway (1909) NY, NY 10036

Dealer Stamp Here
Offer valid only with dealer stamp.

Name of Product _____ \$ _____ Price

Name _____
(Please print)

Address _____

City _____

State/Zip _____

Payment must accompany order

Offer expires February 15, 1982

VISIT YOUR LOCAL MUSIC STORE TODAY!

INTERNATIONAL MUSICIAN AND RECORDING WORLD™

ISSN 0273-673X

**DECEMBER 1981
Volume 3 Number 12**

12 West 32nd Street,
New York, NY 10001

PUBLISHERS

President Richard Desmond
Vice President & General Manager Mitchell Haber

SALES AND ADVERTISEMENTS

Vice President & Sales Director Alan Marcuson
Advertisement Manager Robert R. Wood
Classified Advertisement Mark Warner
Advertisement Executive Nancy A. Davis

EDITORIAL

Group Editor Tom Stock
Associate Editor Steve Dupler
Assistant Production Editor Penny Ward
Contributors Lester Bangs, Mike Clark, Carol Cooper, Brian Cullman, Ken Dibble, Jim Farber, Deborah Feingold, David Ficke, Curtis Fields, Ricky Ford, Dan Forte, Fred Goodman, Jim Green, Bob Henrit, Harry Kolbe, Mike Mandel, Dave Mann, Mike Moran, Ed Naha, Mike Nock, Jon Parales, Bret Primack, Linda Reitman, Linda Reynolds, Ebet Roberts, Dave Schulpis, Michael Shore, Keith Spencer Allen, Zan Stewart, John Stix, John Swenson, Roy Trakin, Jack Walrath, Ron St Germain, Jack Wilkins

PRODUCTION & ADMINISTRATION

Group Production Dave Shaw
Production Manager Barbara S. Bloom
Art Director Jerry Pittam
Typesetting Malenka Limited
Accounting Dominick Savino
Circulation Melinda Mercusa Beauvais
Credit Murray Widerker

LONDON AGENTS

Cover Publications Ltd
Grosvenor House, 141-143 Drury Lane,
London WC2B 5TE
Tel: (01) 379 6917/(01) 379 6342
Telex: 24676
(Answer Back COVPUB G)

SWISS AGENTS

Badger Publications S.A.
16 Rue de l'Industrie
1700 Fribourg 5
Tel: (0371) 24 44 70
Telex: 36 450
(Answer Back SURAU)

International Musician and Recording World Limited
(ISSN 0273-673X) is published monthly by
International Musician and Recording World
USA, Ltd., 12 West 32nd Street, New York, NY
10001

Second class postage paid at Hialeah,
Florida 33010 and at New York 10001.
US and Canadian circulation by Curtis Circulation
Company, West Caldwell, NJ 07006.

International Musician and Recording World is a
registered trademark. © 1981 International Musician
and Recording World USA, Ltd. All rights reserved.
While every care is taken in the publication of the
magazine, the publishers cannot be held responsible
for any results arising from the contents thereof.
Published, produced and printed in USA.

Sole International Distribution Agents

Gordon & Gotch (Australia) Ltd
Melbourne, Sydney, Brisbane, Adelaide, Perth
Gordon & Gotch (NZ) Ltd., Wellington,
Auckland, Christchurch, Dunedin
International Magazine Distributors

SUBSCRIPTIONS

Subscriptions: U.S.A. — \$21 per year
Canada — \$24 per year
Foreign (Surface Mail) — \$41 per year

Manuscripts: Publisher assumes no responsibility
for the return of unsolicited manuscripts,
photographs or artwork.

Change of Address: Send address changes to
International Musician and Recording World,
12 West 32nd Street, New York, NY 10001
Allow at least six weeks. Send both old and new
addresses and the mailing label from a recent
issue.

IM&RW USA Ltd. is a member of
Northern & Shell

The new advanced-design GS 1 FM digital keyboard.

**ITS ONLY SIMILARITY TO OTHER KEYBOARDS
IS THAT IT HAS A KEYBOARD.**



Combo Products

THE WAY IT WILL BE.





Contents

December 1981

Complete Advertisers List

Aeolian Corporation 82	Ovation 81
Allen & Heath 57	Peavey 64
Aria 49	Peterson 73
Bose 29	Pulsar Labs 39
Carvin 50	Randall IBC
DOD 44	Renkus Heinz 54
Jim Dunlop 54	B.C. Rich 41
Duraline 53	Roland 36
Dyna-mite 47	Sandorn 60
Eastern Sound Recording 67	Scholz Power Soak 31
Electro Sonics 76	Sequential Circuits 13
Electro-Voice 59	Seymour Duncan 19
Fender 16	Shure 75
Fostex 27	Staccato 71
Gibson IFC	Steinberger 47
Gollehon 33	StuDiomaster 3, 9
Hurdy Gurdy 84	Sunn OBC
Jemar 62	Tama 15
Kustom 63	TDK 11
Mesa 25, 76	Times Square Lighting 76
Moog 38	Unicord 35
Nady Systems 47	Yamaha 5, 61, 69
Omni Craft 76	Zildjian 8

Announcing The World's First Musical Equipment Test Guide

Buying equipment is serious business. There are literally hundreds of products, manufacturers, and models from which to choose, and it gets confusing to know just what to look for and who to believe.

IM&RW understands the problems the contemporary musician faces when in the market for new equipment, and to help you hold onto your sanity, while getting the best equipment value for your dollars we've brought out the IM&RW 1982 Test Guide, the first publication of its kind.

This comprehensive volume covers a broad range of product categories: guitars and basses, amplifiers, keyboards, mixing boards, percussion, signal processors, and tape recorders, providing in-depth reviews and product evaluations, all written by professionals for professionals. Along with the reviews of specific products, there is valuable advice from the experts concerning all the factors to be considered in selecting equipment.

At last, there is an established standard for gauging performance, quality, and cost-effectiveness of hundreds of musical equipment products.

The IM&RW 1982 Equipment Test Guide is available at music dealers and news stands. The cover price is \$3.25 in the US, and \$3.75 in Canada.



10. NEW PRODUCTS

What's new?

14. EDDIE VAN HALEN

Guitar hero uncovered by John Stix

22. THE ROLLING STONES

Rolling along with the boys in the band by Chris Welch

30. DANNY ADLER

The hot Jazz guitarist talks with Harry George

32. RANDAL RG 80 SC

An outrageous new guitar amp

34. PULSAR RT 150

State-of-the-art real time analyzer

37. ALEMbic DISTILLATE BASS

The new Alembic is all you'd expect

40. ON SAX

Curtis Fields discussed practice technique

45. PA COLUMN

Ken Dibble checks out the Castle Donnington sound set up

48. GARY US BONDS

Life begins at 40 by Angus MacSwan

55. SEQUENTIAL CIRCUITS PRO-ONE

New ideas on a mono synth

58. FOSTEX RECORDER & MIXER

An affordable high quality home studio

66. A-Z TECHNICAL TERMS

First installment on our technical dictionary

Taste the power.

Neil Peart
Rush

Your drums are all over the place, not just at the end of a verse or chorus but between every line, every phrase. Jaw sagging, your limbs are snapping out really fast. You're channeling energy from the audience, directing it through your kit. The music swells around you and the power's flowing through you so strong you can taste it.

Your Zildjians are creating sound so solid that it fills the space with its presence. Like crystal-clear tones that explode with incredible volume from the extra weight, special taper, and large deep cup of your Zildjian Rock Crash. And the quick short crashes from your Zildjian Splash that fly up, stop fast, and cut out.



Because we put our best into each of our cymbals, you get your best out of all of them. No matter how long you've been tasting the power of your music or wanting to. And that same sharp clarity and super strength are handcrafted into all 120 different Zildjian models and sizes for every kind of drummer in every kind of music.

See for yourself how over 200 of the world's most famous performers taste the power of their Zildjians. In our new Cymbal Set-Up Book, the most comprehensive reference guide for drummers ever published. For your copy, see your Zildjian dealer or send us \$4 to cover postage and handling.

Zildjian

The only serious choice.

Avedis Zildjian Company, Cymbal Makers Since 1623, Longwater Drive, Norwell, MA 02061 USA

8

NEW! from Studiomaster

New from Studiomaster: a compact highly innovative mixing desk. The 8/4 is truly not "just another" mixer. What sets the 8/4 apart are the five most important things you must consider in purchasing a console.

1 Features/Benefits

- 19" rack mount or free standing
- 8 inputs 4 discrete outs
- Balanced and unbalanced inputs
- Patch points on all inputs
- Studiomaster's famous parametric EQ on inputs and outputs
- Switchable RIAA E.Q. on channels 1 thru 4, line in on channels 5-8
- Switchable phantom power for condensor mics
- 2 auxiliary sends with pre post select switch on auxiliary 1
- Headphone (stereo or mono) monitoring on any or all combinations of inputs and outputs
- Overall master fader
- Choice of LED ladder or VU meter output display

2 Applications (flexibility)

- Studio multi-track recording and remixing
- Live PA
- Keyboard mixer
- Monitor mixer

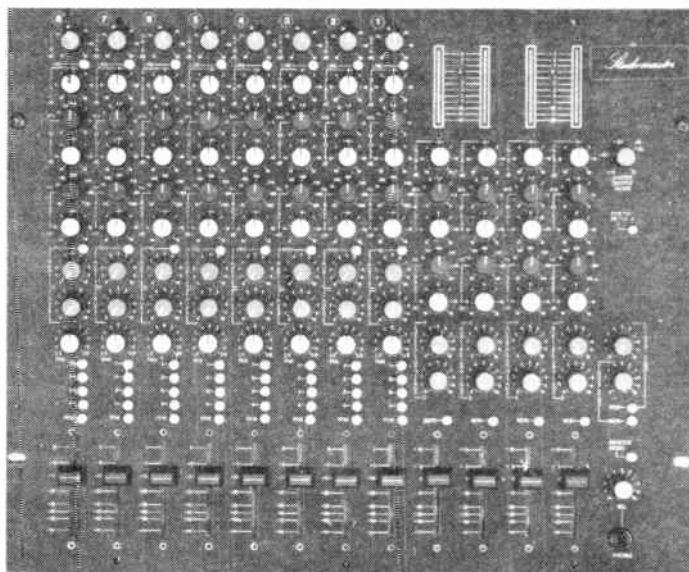

3 Specifications

Greater than 85 dB S. N., less than 0.015% distortion (@ 1 khz., +15 dBm), 126 dBm equivalent input noise, +19 dBm output, just to name a few.

4 Reliability

State of the art components, modular construction and rugged packaging make the 8/4 ultra reliable.

5 Economics

The price leaves the competition behind!



Recording Studio Design

PLEASE SEND ME ADDITIONAL INFORMATION ABOUT THE NEW 8 INTO 4 STUDIOMASTER MIXER

Name _____
 Address _____
 City _____ State _____ Zip _____

Studiomaster, Inc. 1365-C Dynamics St., Anaheim, CA 92806

New Products

Keyboards

GLEEMAN PENTAPHONIC

The Gleeman Pentaphonic is a 37-note, 5 voice polyphonic synthesizer with a built-in 300 note sequencer and its own amp and speaker. The oscillator bank contains three waveform generators which can produce eight waveforms. Each generator has its own gain and octave select controls. The Pentaphonic has mono and poly modes, and the performer can play along with the sequencer in either one.



Gleeman Pentaphonic keyboard

Prosound

RANDALL RG-80-112-SC GUITAR AMP

Randall's entry in the "tube sound" sweepstakes is a channel-switching amp, with a footswitch that allows the player to use the "hot" channel, the "clean" channel, or both simultaneously. Randall claims that their FET preamps and constant current output stage will fool into thinking there are some 6L6's inside the compact package. The RG-80 delivers 64 watts into its single Celestion 12" speaker. If the extension speaker output is used the power rises to 80 watts.

AUDY SERIES 2000 MONITOR MIXING CONSOLE

The Series 2000 is a 16 input mixer which can generate up to six separate monitor mixes. A dual LED system makes proper input attenuation easy and provides 25dB of headroom. Features such as auxiliary inputs, EQ in/out switch for each input, channel muting, talkback, and work light socket will make the soundman's job a lot easier.



MXR Micro Flanger



Randall RG-80 112-SC Guitar Amp

Effects

MXR MICRO FLANGER

The Micro Flanger, like its predecessor the Micro Chorus, is a compact package with one-third the power consumption of similar units, and a simple, user-oriented control format. The Rate control increases the speed of the flanging effect, while automatically decreasing the width, so that all settings are musically useable. The Regeneration knob varies the effect from 0% to 100%, for effects ranging from a classic flanging sound to a nasally, metallic ambient sound.

TDK SUPER AVILYN NOW MAKES OPEN REEL GO TWICE AS FAR.



No doubt you've heard of Super Avilyn before. It's the remarkable formulation that goes into TDK's outstanding SA and SA-X audio cassettes and Super Avilyn videocassettes. Now TDK's advanced Super Avilyn technology has been applied to open reel.

It's called Super Avilyn EE (Extra Efficiency) open reel. SA was specially developed for use with the new open reel decks with the Extra Efficiency EQ/bias setting. On these decks, this brand new formulation actually lets you record and play back at half the normal speed. And keep all the full, brilliant sound the finest open reel delivers. Which means that you get twice as much music from a single reel of tape as you could before.

This is due to the Super Avilyn high density formulation. It offers higher MOL and lower bias noise; virtually double the coercivity of standard ferric oxide tapes.

TDK, the company that's redefined the standards of recording tape, now brings you twice as much as you expected. You'd expect nothing less from TDK.

 **TDK**®

New Products

ROLAND MC-4 MICROCOMPOSER

Although it retails at a much lower price, the MC-4 is a major expansion of the MC-8, with up to 48K byte of RAM memory and 16K byte of ROM, for up to 11,500 notes of composition/performance at one time. Up to four pairs of voices can be programmed from the MC-4's calculator-style keyboard, or from a synthesizer keyboard. The MC-4 will program pitch, rhythm, dynamics, tempo and much more. Data storage/retrieval is accomplished with the self-contained tape memory interface, or through the optional MTR-100 Digital Data cassette recorder.



JBL 4430 and 4435 Bi-Radial Studio Monitor



Roland MC-4 Microcomposer



TC XII Programmable Phaser

JBL 4430 and 4435 BI-RADIAL STUDIO MONITORS

These two new studio monitors from JBL feature 15" woofers, and their new Bi-Radial constant coverage horn, with a new compression driver which is crossed over a 1000Hz. JBL states that the horn design allows flat frequency response on- and off-axis, which in turn allows stable stereo imaging, flexibility of speaker placement, and greatly diminished room equalization requirements. The 4430 is the single-15" version, and is designed to handle 150 watts input power to 27Hz, while the two-15" 4435 will handle 300 watts down to 22Hz. The second 15" speaker in the 4435 operates only below 100Hz. Sensitivity ratings for the 4430 and 4435 are 93 and 96dB respectively for 1 watt/1 meter.

TC XII & XII B/K PROGRAMMABLE PHASERS

These two phasers are identical except that the B/K (bass and keyboards) model has its filters shifted down one octave. In addition to the standard rotary controls for Speed and Width, a Function control regulates the amount of regenerated signal, and a three-position Filters switch offers a choice of four, eight or 12 filters. Provisions for external power and remote bypass switching are built in to the units. The most unique feature of the TC Phasers is the pair of Program plugs which come with the unit. These are standard ¼" phone plugs, with special circuits which alter the basic sound of the TC XII. The Blue Program plug provides a midrange cut, while the Red Program is a high frequency cut.

MXR DELAY SYSTEM II

The Delay System II is MXR's "second generation" digital time delay, and represents a significant price/performance breakthrough. The standard delay time varies up to 1.6 seconds, with 3.2 seconds available through the use of one of the optional plug-in memory. Bandwidth is a full 16kHz up to .8 seconds, 8kHz up to 1.6 seconds, and 4kHz up to 3.2 seconds. A repeat-hold feature enables tape loop effects to be created without a second tape recorder. The Delay System II features XLR and phone jack inputs, bypass and repeat-hold switching, and a level switch to optimize signal/noise ratios in line and instrument level operation.

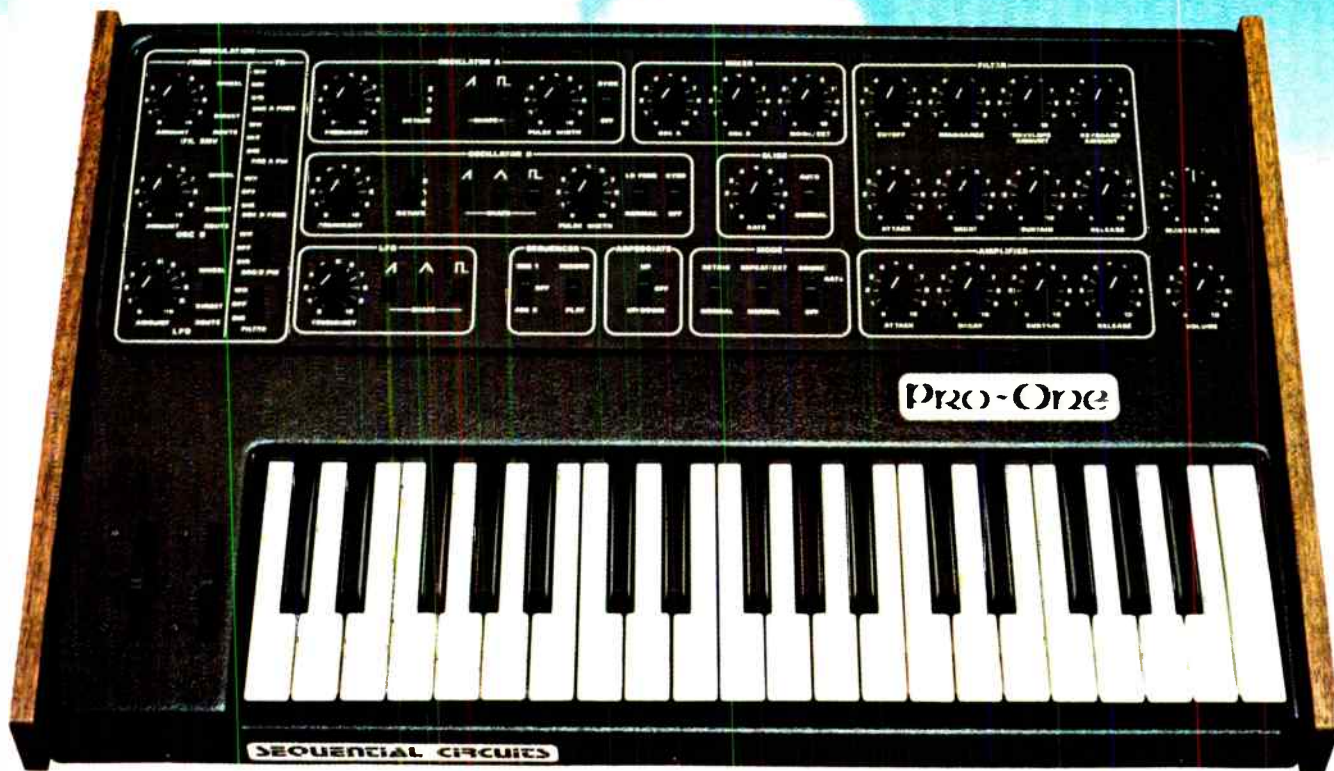

WHY WOULD ANYONE BUILD ANOTHER MONO-SYNTH?

Because it's about time that you stopped putting up with nasally filters, single oscillators, and stripped-down electronics when you buy a low-cost monophonic synthesizer. To put things back in perspective, SCI introduces the Pro-One, a synthesizer that delivers the quality sound and features you want, not just a cheap approximation.

To start with, the Pro-One has the same electronics as its big brothers, the infamous Prophet-5 and the Prophet-10. You get the same sounds with no compromises (front panel looks familiar, neh?). Add pitch and mod wheels, extensive modulation capabilities, a C-to-shining-C 3 octave keyboard, single and multiple triggering modes, repeat and drone switches, and an audio out that can drive stereo headphones.

Enough? Hardly. A built-in digital sequencer with 2 sequences and up to 40 notes storage between them. An arpeggiator (that can be latched) for up or up/down arpeggios. Complete interfacing facilities including standard 1V/octave CV in/out, gate in/out (also used for external clock on the sequencer and arpeggiator), an audio input with pre-amp for using microphones, guitars, other keyboards, etc. A special gate generator that automatically obtains gates from the external signal, which can then trigger envelopes, advance the sequencer, etc. A unique

"automatic" glide mode that allows selective glide between notes. Also, there is an internal digital interface — something that opens up a new realm in synthesizer/computer connections — especially with home computers.

We could keep going, but you must check out the Pro-One for yourself. Listen to the sound, look at the capabilities. No Compromises!

You're probably wondering how much this is going to cost. Would you believe \$745.00? Neither do our competitors.

The Pro-One from SCI.



We've done it again.

SEQUENTIAL CIRCUITS, INC.

Dept. 2, 3051 North First Street, San Jose, CA 95134 (408) 946-5240

World Radio History

EDDIE VAN HALEN

John Stix

Talking shop with Eddie Van Halen is an enjoyable though slightly odd experience. The reason that it's such a pleasure is the same one that makes it strange; Eddie may be the king of rock guitar as far as the fans and critics are concerned, but from his viewpoint he's just another guy that likes to play the instrument.

His rock & roll dreams were there from the beginning. But being a guitar hero wasn't necessarily part of it. In fact, he started out on drums while his brother Alex, Van Halen's drummer, started on guitar. Eddie is not without ego, and when pushed to admit it, will own up to adding something new to the rock vocabulary. It's just that Eddie Van Halen did not aim to make his mark with a killer's instinct. Rather, we ordained a quiet easygoing guy whose greatest joy happens to come from playing balls-out rock guitar.

Without a lesson in his life, unless you count the endless hours spent copping every breath Clapton breathed onto Cream records, Eddie tapped his own awesome natural ability to play with youthful exuberance and wild imagination. To his surprise, the result was a further stretching of the elastic boundaries of what we call the blues.

"I'm The One" from the first *Van Halen* album serves as an 80's textbook for rock guitar. The contents include unrestrained energy pumped into liquid hammer ons, splintered harmonics, tremelo bar contortions, and foot to the floor deliveries with an eye towards reshaping the punchline. Other excellent chapters include "When Push Comes To Shove" from *Fair Warning* and "Spanish Fly" from the *Van Halen II* collection. "Shove" has a Grand Prix of a solo with equal amounts of finesse and speed. It's the aural equivalent of watching the "S" turns on a race track, and serves notice that you can enter Jeff Beck territory without sounding like a copy. "Fly" is a rave up on the nylon string guitar.

Eddie shows his innocence by describing the origin of the piece. "It was New Year's Eve at Ted's (Templeman, Van Halen's producer) house, and I was drunk. I just picked up an acoustic guitar and started playing. Teddy said, 'So you can play the acoustic guitar too!! I'm thinking, 'What the fuck's the difference?'" He

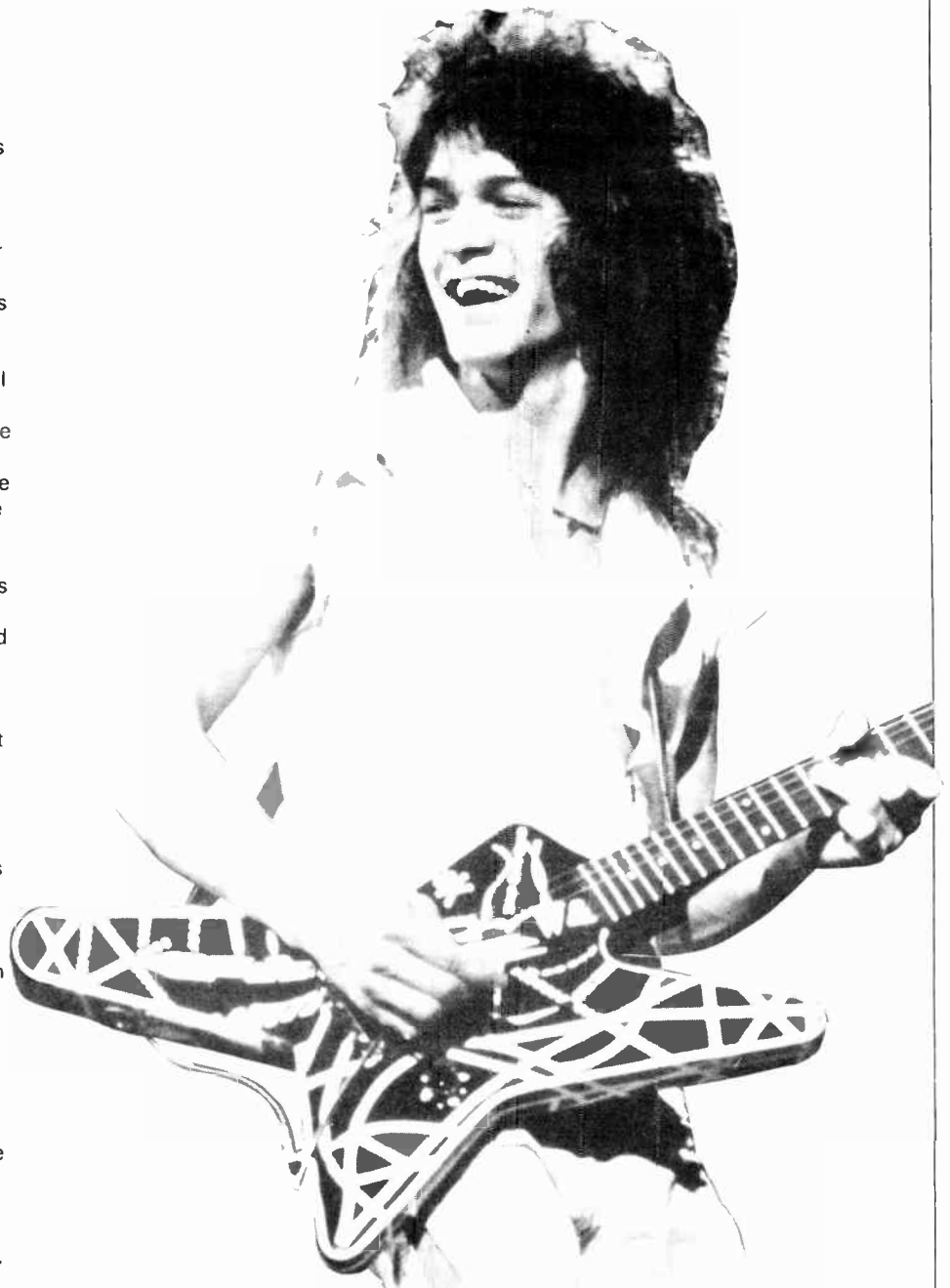

Continues on page 17

**It's important that your hardware's right,
so take a tip from Lenny White.**

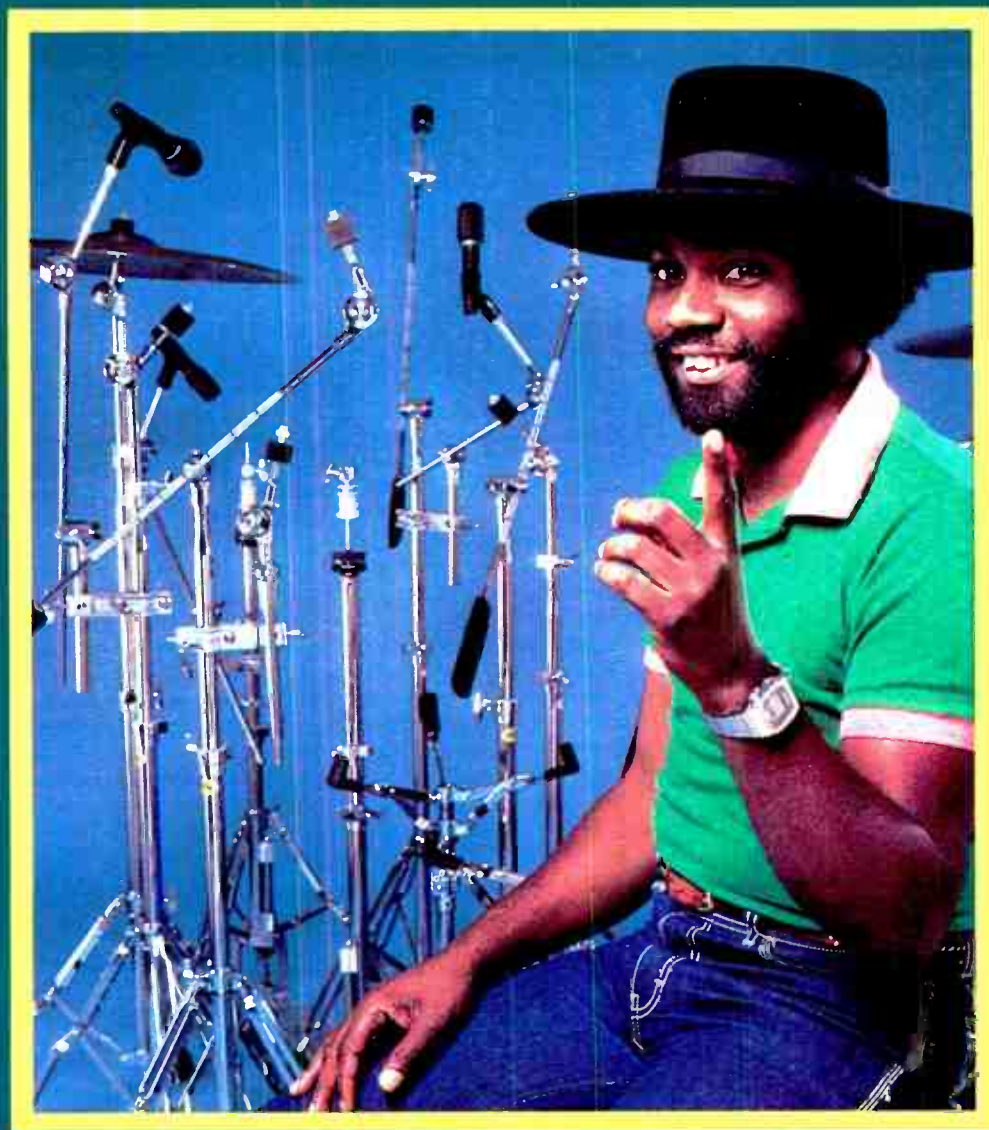

“Your drum kit has to be comfortable. You’ve got to be able to reach all of the pieces easily, without undue contortions. All that requires hardware that’s strong, versatile and durable. And all that requires is Tama.”



The Strongest Name in Hardware

For a full-color catalog of Tama drums and hardware send \$2.00 to:

Dept. IM

P.O. Box 469, Bensalem, PA 19020

327 Broadway, Idaho Falls, ID 83401

In Canada: 6355 Park Ave. Montreal, PQ H2V 4H5

ANNOUNCING FENDER'S NEW CHRISTMAS GIFT PACK.



You probably had to wait a long time for your first Fender.

Now there's a new guitar and amplifier package that delivers Fender sound and Fender quality at a price anyone can afford.

The guitar is our all-new Bullet. It's a tribute to Fender

value engineering, with two hot single-coil pickups and classic Fender playability.

It's teamed with our 20 watt Harvard amp, that features a full set of gain and tone controls to allow a wide range of sounds at any volume.

This specially-priced pack-

age is available now at Fender dealers, just in time for Christmas.

Don't you know someone who's dreaming about getting one?

Fender®

THE SOUND THAT CREATES LEGENDS.

World Radio History

EDDIE VAN HALEN

doesn't realize that "Spanish Fly" shows his dazzling sound and approach to be independent of the electric guitar, amp, or devices. It is the unadorned gifts of Eddie Van Halen that receive this praise, not some product of fuzzwhapowerboosting.

Amsterdam born and L.A. bred, Eddie started with the piano. Though outwardly successful from a classical point of view, rock was king and Eddie wanted to join the court. His muscles, designed for speed, not endurance, eventually chose the guitar over the drums. With the British blues invasion in full swing, Page, Beck, the MC5 and early Beatles made their impact. But like most rock guitarists of the late 60's, for Eddie Van Halen, Clapton was God. "I knew his licks inside and out," he sparkles with enthusiasm. "Alex and I had a group called Mammoth, which was a Jr. Cream."

Discarding those early licks and coming into his own was never a conscious decision. Looking back Eddie says, "When I stumbled onto the hammering things and the vibrato bar, that changed my style considerably. I was having more fun getting wierd noises with this than playing Clapton licks. I came up with the hammer idea by playing in the key of E and doing a triplet on the B string without picking. I thought if I had a long 6th finger on my left hand, I could do it anywhere on the neck. I remember sitting in my room experimenting with the idea.

"This was years before the first album. I remember we used to play at the Whiskey in L.A. and I would do an "Eruption" type solo and have to turn my back to the audience. There would always be these clowns from other bands trying to see how I did it. It doesn't take that much practice to get it. It's more a matter of knowing the scales and notes." This hammer-on pull off technique, used with harmonics and the funk slap technique of bass players (as heard on the intro to "Mean Streets") is Eddie's most visible contribution to the electric guitar thus far.

Van Halen, the group, (David Lee Roth, vocals; Alex Van Halen, drums; Michael Anthony, bass; and Eddie) started as a backyard party band that charged a buck a head to get in. At times the crowds swelled to over 1,000. It was obvious their brand of high voltage rock would also spill beyond the confines of the clubs on the L.A. strip. No less an experienced hand than Gene Simmons was excited



enough to finance their demo tapes. After catching a set at the Starwood Club, producer Ted Templeman and Mo Ostin signed them up with Warner Brothers. The concert halls and cash registers haven't stopped ringing since.

Of their four albums Eddie rates the first, *Van Halen*, and their latest, *Fair Warning*, to be equal from a guitar playing point of view. They contain the best he's put to wax. *Van Halen II* follows with *Women and Children First* the least guitaristic of the bunch.

All but *Fair Warning*, which is the best sounding, are as good as live from a production point of view. "I agree with you, *Fair Warning* is the best recorded album we've done." Eddie gathers his thoughts and then goes on to say, "I think I played well on that one, but I don't know why. I spent more time on this album. I did a lot more overdubbing than on any other record. I got tired of the guitar always coming out of the left side, like some old Beatles recording. The other three albums were recorded live as a trio, with the vocals added later. The reason I never overdubbed before is because I can't stand playing without the guys. I used to think I soloed better if we all played at the same time, so the guitar solo was always on the same track as the rhythm section. "Sinner's Swing" has the only live solo on *Fair Warning*.

On stage or in the studio, Eddie's is a make-your-own guitar recipe. His professional career began with a '59 Strat, but it buzzed too much and lacked balls without using the "fuzz garbage" he's never liked. Interested in the vibrato bar, Eddie switched to an

ES-335. Told he looked like Roy Orbison, he returned to a Strat, this time installing a humbucker. "The sound worked," he recalls, "but Fender wood is cheap. They use alder. I found out about Charvel, which makes its bodies out of ash, a denser wood. So I made my original red guitar and decided to rear-load it. It's still my favorite guitar."

"It cost about \$185 to make. I bought the body from Boogie Bodies in Seattle for about \$50. Their necks cost anywhere from \$80 to \$100. I use unfinished maple because I like to feel the wood. I only use one volume knob by accident. I just didn't know how to wire them up with the tone control. Then I discovered I actually like the sound a little better. You get more highs. For my pick up I use an old Gibson PAF or the Seymour Duncan model."

"I don't like the front position of any guitar except a Strat," he said, explaining his preference for using only one pick up. "I've got a second pick up in my red guitar, but it's not wired up. In order to get the neck pick up to sound the way I like it, I have to adjust the tone of the amp so trebly that the bridge pick up sounds like shit. Another reason is that the more wire you have inside your guitar the less output it has. It might be a psychological thing, but to me it makes a difference."

Asked how he decided where to place the pick up, Eddie responded, "I measured it with my finger. It's about an index finger and a half forward from the bridge."

"In the studio, I use a very old

EDDIE VAN HALEN

original Fender tailpiece with a brass nut. I put 3 In 1 Oil on the nut so it stays in tune when I use the vibrato bar. The way you wind your strings can also make a difference. I'm talking about the angle of the string when it goes over the nut to the tuning peg. If you wind the string down too far you've got a lot of tension on the nut. When you bring the vibrato bar down, the string will usually go sharp because it sticks. The more tension you put on the nut, the less it's gonna stay in tune."

"Live, I use three guitars with Floyd Rose tailpieces. I don't use them in the studio because they're hard for me to tune. You'd think it would be the other way around. But it gets a slightly brighter sound that I prefer live. With the Floyd Rose bridge you have to boil the strings in water for 10 minutes before putting them on. It's to stretch the strings out. The whole thing behind this bridge is that you clamp the string down on the nut and the tailpiece side. That way you can take it down or pull it up and it won't go out of tune unless the string stretches. When you boil them you also clean them. But I prefer older strings to record with because I like a muffled tone in the studio. "The specs that round it out include Schaller tuning pegs and a set of Fender .009 strings.

His favorite amplifiers are three old Marshalls. They're augmented by twelve new 100 watt heads that have been recorded to the older specs. Homite Voltage Regulators also help shape the sound. The amps power four 8 x 12" cabinets with Celestion speakers. For recording Eddie uses an old standard Marshall top and 4 x 12" cabinet.

Asked if tonal shaping isn't lost in the arenas, he responded by saying, "It's more for my personal enjoyment. Half the kids out there don't know what tone means. You can get my kind of sound without hurting your ears. Most people just crank up the high end which is like cranking your car radio all the way up. It distorts and sounds loud, even though decibel wise it isn't."

"You can also turn up your home stereo so it is loud by decibels, but it won't sound that loud. I crank everything all the way up but I have my guitar built compatibly to get the tone I like." By this he means a less powerful pick up is matched with a more powerful amp and vice-versa.

Getting new sounds by using different guitar techniques, not boxes,

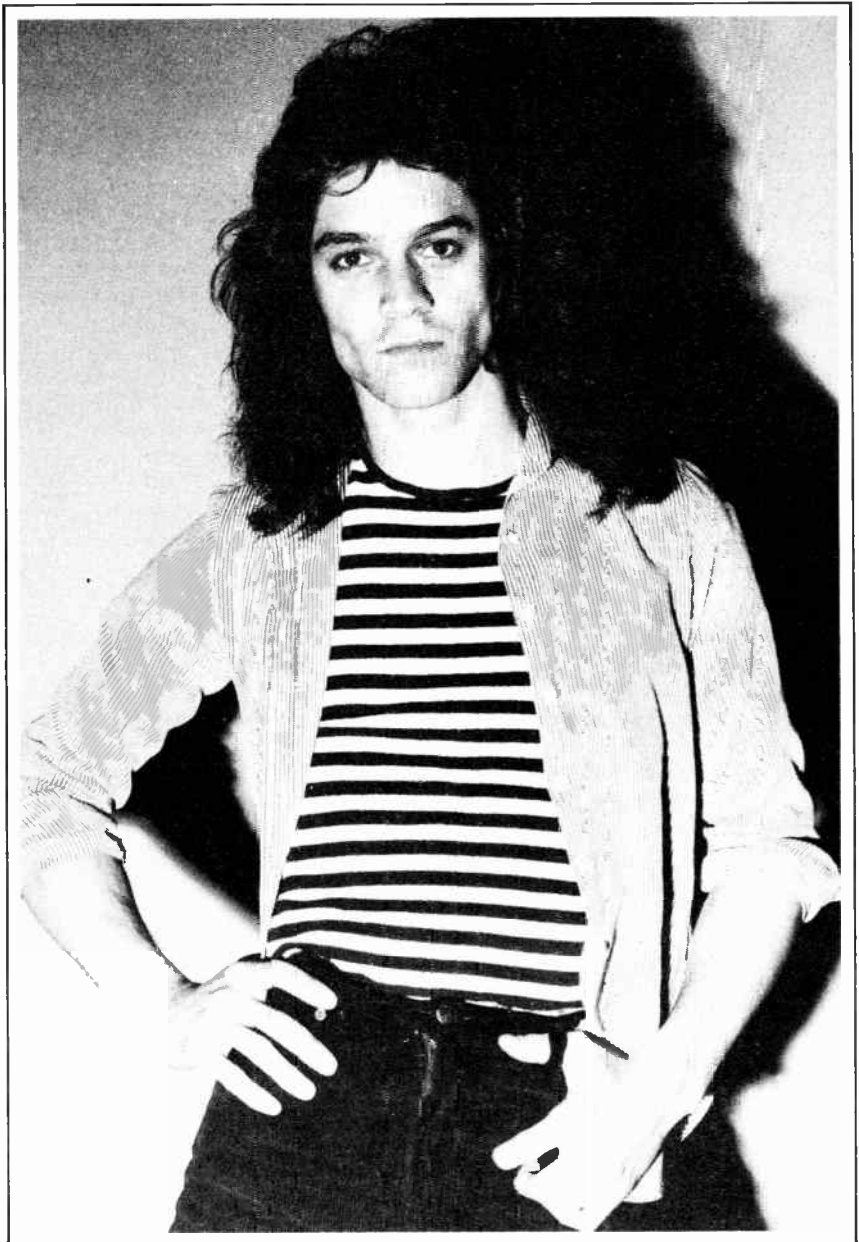

is of prime importance to the 25 year old guitarist. His pedal board is spartan by today's standards. It includes two MXR Flangers (in case one breaks down), an MXR Phase Shifter, an Echo Plex, and a Roland Chorus Echo. "I don't use much except the echo. The strangest toy I've used has been the Electro Harmonix Mini Synthesizer. (Heard on "Sunday Afternoon In The Park".) That sinister growl is a Mini Synth going through the Marshalls!"

With the band thinking of doing a live album, Eddie ends our conversation by explaining his attitude towards the stage. "I don't consider it work," he said with a smile. "We don't work, we play music. So many bands that open for us say 'Aw shit,

I've got to work again tonight!' They get too fucked up the night before. I've stayed up for four days with no sleep at all, no pills, and no drugs. I got on stage and played great. That's because when I'm on stage it's the high point of the day. It's like stepping into another world. I want the audience to have a good time and enjoy it." Reflecting further, he states, "I never imagined that we would get to where we are this quickly. I can't relate to all this star stuff. Whatever I've done to help the guitar wasn't intentional. I play out of enjoyment. I have fun playing. It wasn't like I set out to leave my mark on the world." Who is going to tell him it's too late? ●

The secret of power guitar.

This is my STL-3T (T for tapped) pickup; I call it the Quarter Pounder. It has twice the power of a standard Telecaster* guitar pickup.

The more magnetic power your strings have to work with, the more high-frequency tone gets through to your amp, and the brighter and more sharply-defined your notes become.

That's why I use quarter-inch-thick

magnetic pole pieces; they give you full tonal response and a biting attack.

When your strings vibrate they disturb the magnetic field. The 7,000 feet of copper coil windings resist the disturbance and change it into a *hot* electrical signal. Your amp will distort sooner, especially for midrange powerchords.

A hot output can garble the high frequencies, so I tap the coil part way into the

winding and bring out a second output wire so you can switch voltages and frequencies for different sounds. The tapped output has less resistance to the powerful magnetic field, and the high end punches through with electric clarity.

You can put Quarter-pound power into your guitar. I make Telecaster*, Stratocaster*, Jaguar*, Jazzmaster*, Precision Bass*, and Jazz Bass*

Quarter Pounders, and they fit right into most Fender guitars without alteration. I always give you instructions and wiring diagrams.

My color catalog has full information about my hot, vintage, and custom pickups. Send \$2 to Box 4746-P, Santa Barbara, CA, 93103.

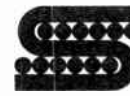

**Seymour
Duncan
Pickups**

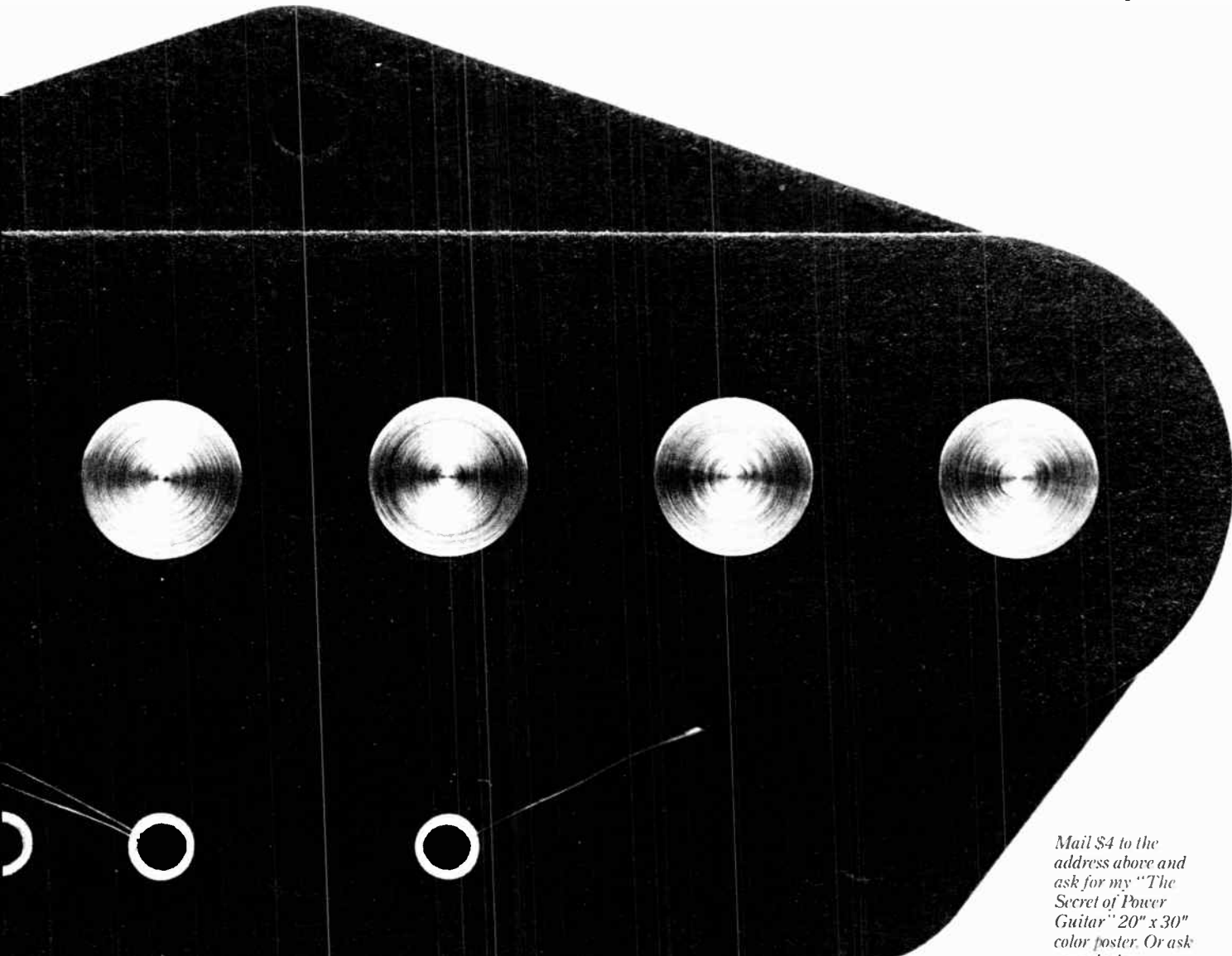

Mail \$4 to the address above and ask for my "The Secret of Power Guitar" 20" x 30" color poster. Or ask your dealer.

*Telecaster, Tele, Stratocaster, Jaguar, Jazzmaster and Jazz Bass are registered trademarks of CBS, Inc. Seymour Duncan is not affiliated with CBS, Inc.



New Products

Guitar

C.F. MARTIN DC-28

As is evident from the model name, Martin has introduced a long-awaited cutaway version of the D-28. This dreadnought features Martin's usual high-quality construction, with a rosewood back and sides, spruce top, and ebony fingerboard. The cutaway is rounded in the Venetian style, providing access to 20 of the 22 frets.

ARIA CS400 GUITAR and CSB450 BASS

Two new entries from Aria to their Cardinal series, the CS400 features coil-tap and phase reversal switches, as well as two brand new designs — a patented two-way quick-hook bridge and two Protomatic V pick ups.

The CSB450 Bass is designed on a medium scale fingerboard, and features the newly developed MB-III pick up with an Alnico magnet. Both guitars are crafted with a carved solid ash body.

FENDER BULLET AND BULLET DELUXE

Fender has come up with two all-new models designed to provide a quality guitar for a student budget. The Bullet and the Bullet Deluxe feature two single coil high-output pick ups, a three position selector switch, and master volume and tone controls. Both necks are full scale (25 1/2"), and feature curved rosewood fingerboards. prices are very reasonable, with the Bullet retailing for about \$249, the Deluxe for \$299.

Pro Sound

LEXICON MODEL 1200B

AUDIO TIME

COMPRESSOR/EXPANDER

The 1200B is a broadcast quality audio time compressor with a 1500 kHz bandwidth. It plays back any recorded audio, video, or film material at speeds up to 25% faster or 33% slower than the original without varying the original pitch. This allows the play time of commercials, films, or any other program material to be reduced or expanded to meet requirements.



The 1200B is engineered for interface to virtually any variable speed audio or video tape machine, or film to tape converter.

Effects

IBANEZ AF201 AUTO FILTER

The Ibanez auto filter offers a multi-capability design filter (low-pass, band-pass, and high-pass) which produces a wide variety of effects, including auto-wah and various synthesizer-type sounds. The unit features sensitivity and peak-slide controls, 3-way filter switching, and Up-Down and High-Low indicators, as well as an LED status indicator. Power is supplied by either a 9v battery or an external DC power supply.

Percussion

HAKUHODO CLAW

Hakuhodo's Claw offers a much awaited solution to the problems of drum miking. The Claw operates on a clamping system which attaches to the

stands of your percussion set up, thus eliminating the usual tangle of additional stands for miking. The Claw also allows the mike to move when the drum does, thus saving time readjusting the mike position.

DURALINE SUPER STICKS and SUPERHEADS

From the folks who gave us the Syndrum comes a new item for the space-age: Super Sticks are made from Kevlar, a material previously used in the manufacture of such diverse products as airplane fuselages and bulletproof vests. The new sticks have the feel of wood but last far longer. They're also impervious to warpage.

Also from Duraline are Superheads, constructed of the same material as the sticks. They are far stronger than the common mylar drum heads, and after the initial tuning they will not stretch, dent, or pull out of the rim.

Woodwinds

PHOENIX FLUTE and PICCOLO

Phoenix woodwinds are completely hand made by Michael Geoghegan and a small staff in Moretown, Vermont. Through a unique accelerated age-hardening metallurgical process, the Phoenix instruments are aged in the shop to between 75 and 100 years, which gives them all the desirable tonal qualities of the older instruments.

The flute is a hand made, sterling silver French model with either an A440 or A442 scale. The tone holes are silver-soldered and are permanently fused to its .014 body. It uses gold parts instead of silver on the thumb key tubing and on the center post between the right and left hands.

The piccolo has a major design innovation — the familiar cork tenon has been replaced by a silver one, which results in increased response and resonance. The scale is A440, and the pitch of each note can be varied. The head and body are of African black Grenadilla wood, with a mechanism of sterling silver. Waiting time for both the flute and piccolo is about four months from the time the order is placed.



ADAMAS II: Imagination Becomes Reality.

It started with a clean sheet of paper. We imagined a thinner, more responsive top . . . a more dynamic, even sound . . . a radically new sound hole design and bracing pattern. The result was Adamas. Now, several years later, we proudly introduce the next step: Adamas II.

A carbon graphite top—stronger, lighter, thinner than ordinary spruce—gives the Adamas II a virtually flat response throughout its entire range. Twenty-two soundholes, scientifically positioned and matched to our famous Lyrachord® Roundback bowl, reflect every note clearly and precisely. A unique neck reinforcing system called the Kaman Bar™ allows the Adamas II neck to achieve the maximum rigidity possible at the lowest

weight. A built-in stereo acoustic-electric pickup system, complete with



preamp, eliminates the need for complicated external miking and drastically reduces feedback. These and other features combine to make the Adamas II guitar a musical reality. Imagine the possibilities. Imagine what Adamas II can do for you and your musical image. Then, imagine no more! Send \$1.50 for your full color Adamas catalog today.

Ovation[®]

Ovation Instruments, Inc., A Kaman Company
Blue Hills Avenue Extension, Bloomfield, CT 06002

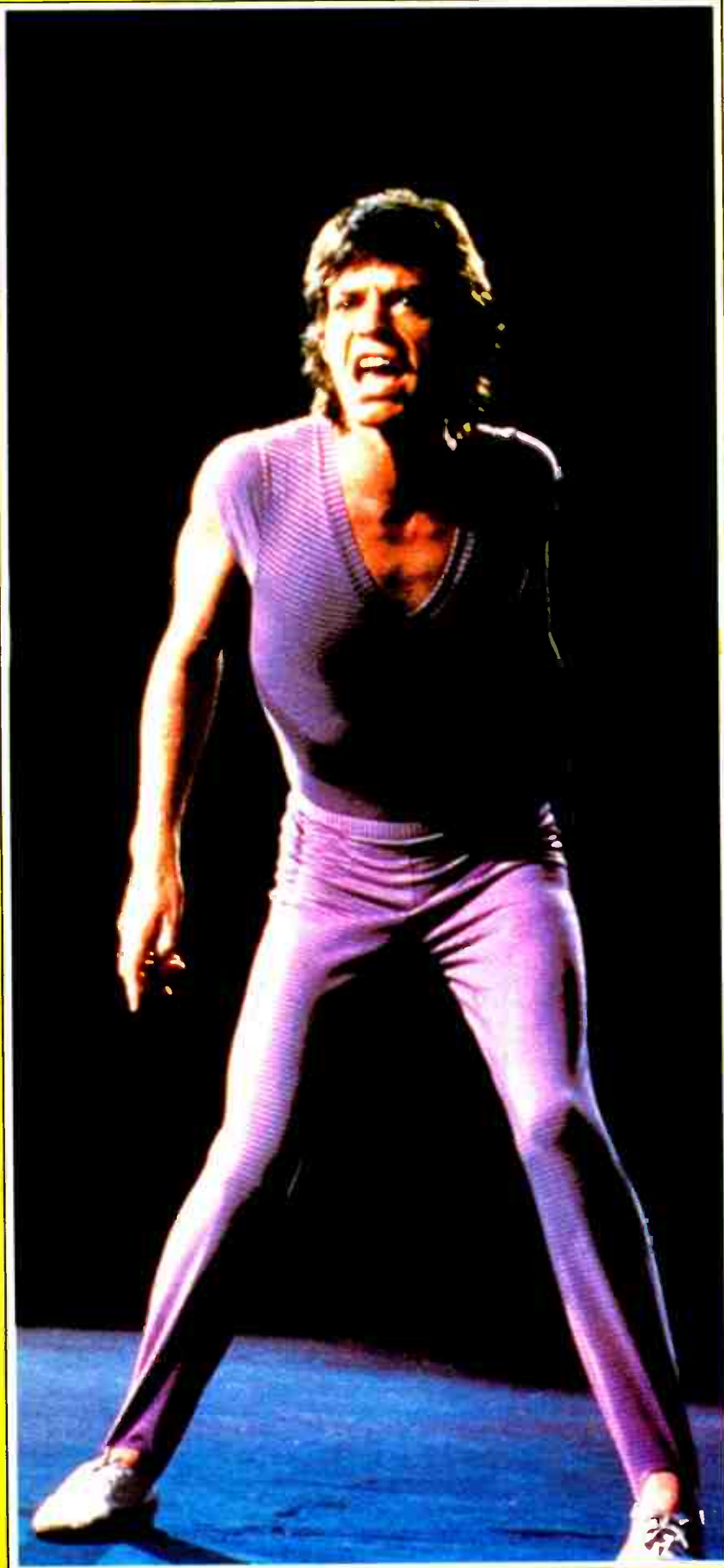

The I

Mick Jagger shook his maracas, and Charlie Watts set up a thunderous Bo Diddley beat on his tom toms. Keith Richards, looking menacing in his earring and black leather trousers thrust forward his Fender Telecaster and produced an echoing, shimmering roar. It was just like old times when the Stones were an R 'n B group and the rock world was young.

The Stones were busy rehearsing deep in the heart of the Massachusetts country side, psyching themselves into action for their first major tour in three years. And it was an emotional moment when the group began to dig back into its roots and play tunes they hadn't touched for years.

I was privileged to hear them in their inner sanctum, a converted loft in the back of an old barn, as they dusted down old favorites like "Down The Road Apiece", "Time Is On My Side" and "Not Fade Away". As I sat cross-legged on the floor, armed with bottles of beer thoughtfully provided by Keith, I mentally flashed back to the first time I saw the Stones, in strangely similar circumstances. It was inside a tent in a field at Richmond Jazz Festival in 1963. Brian Jones was on guitar then and he and Mick Jagger both looked amazing, sullen young men with long hair that made the Beatles look like skinheads. I remembered the rush of kids to pack the tent, deserting the Trad Jazz of Acker Bilk, who was plonking away on the main stage to a dwindling audience.

Interrupting my reverie came another figure from the past who was in that scene from long ago. Ian Stewart the "sixth Stone" who has played the piano for them ever since they started, announced cheerfully: "Your presence seems to be having an effect. That's the best I've heard them play all week."

When the Stones launched into "Not Fade Away" it was difficult to suppress a cheer. The two roadies who were the only others allowed into the rehearsal room nodded approvingly at the spectacle of Mick jiggling around, and as the number drew to a breathless conclusion, Ronnie Wood

Rolling Stones



called out "It's feeling so good, all we need now is an audience!"

In fact a few nights later the band were tempted to play a warm up concert, in the nearby town of Worcester, just outside of Boston. The story went that a radio station, miffed at lack of access to the Stones, broke the news that the group were to play under an assumed name, and thousands turned up at a club which could only hold 300. Police were called and as a result the band cancelled their major Boston date, in a 40 concert tour, due to start at the end of September.

The jam sessions, Blues blowing and more organized rehearsals were undisturbed by violence, only held up by a swarm of American reporters who descended on Long View Farm, where the Stones had sought sanctuary.

The "Electric Farmhouse" as it's known is owned by Gil Markle, an enterprising businessman, who started out in the youth travel business, then bought the farm and its outhouses to convert into two luxurious studios and a rehearsal room. Situated on top of a

hill it enabled the British security guards hired by the Stones to keep a watch out for the dozens of fans who had hitchhiked or driven in from as far away as New York to catch a glimpse of the Stones.

They camped out in the fields all night and were rewarded each midnight, when the band began to play in the unsoundproofed barn. The music echoed across the countryside and could be heard in the town of North Brookfield several miles away, or so the locals claimed.

Around 30 people were in the party including all the Stones, their wives, girlfriends and children. One of the most worried looking was Gil Markle who actually lives on the farm. The invasion seemed to be getting him down. "It's been madness, we never expected all this", he said nervously scouring the horizon for fresh arrivals.

Eventually police were hired to block off the roads and Select Men, the equivalent of local councillors, combed the fields to warn off the fans who seemed to be as adept as commandos at camouflage.

The nervous tension communicated to the Americans assigned to look after the Stones and they constantly tried to put off my interviews or block me from getting to see the Stones play. At one point Keith Richards even had to argue to allow the English visitor into his own rehearsal. Why was it that the Stones were friendly and communicative, but everybody else around them seemed nervous or even hostile? "Ah, that's deliberate," he said. "We like to keep them on their toes."

During the day the band took to playing tennis, horse riding, or just sleeping off the night's drinking. The farm was an attractive base, the buildings retaining their old world charm with open fires and low beams, whilst packed to the doors with hi-tech equipment. Stevie Wonder launched the studios when they opened a couple of years ago and Genesis are among forthcoming customers. The owner was a bit miffed that the Stones insisted they had access to the whole complex during their stay, which prevented any of the studios being hired out. "But we couldn't have two bands here at the same time" said Mick, "could we?"

The staff cooked endless meals and opening a cupboard door, unleashed a cascade of bottles of booze. The Stones, when they weren't playing or indulging in physical exercise, held business meetings with promoter Bill Graham, who ran the legendary Fillmores in the Sixties.

Bill paced around telling everyone who would listen how the Stones were selling out their concerts at lightning speed and indeed Mick seemed more excited about it than he has been about anything for years.

He's been closely involved with Graham in planning the tour which will feature many top support acts, plus a revolving stage, which has been the subject of some debate among the Stones. Keith Richards was trying hard at one meeting to get the idea dropped or amended. "What happens if we fall off?" he demanded. He threatened that if the band's sound was affected by the revolution of the stage, then he

would insist it was stopped.

Mick, clad in a blue and white-striped track suit was most amused at the row. He looks very fit and his body is as alive and skinny as ever, while his face is somewhat more haggard than photographs allow. He has been doing a lot of weight-training and running to keep fit.

"Everything has gone crazy," Mick told me, while sitting on a sofa in one of the studios. "Nearly every one of the shows has sold out in a day, and our last tour it took a week to sell out. We've already sold a million and a half tickets. And dare I say it? The new album is selling better than the last. People say we are pretentious, but this one is quite relaxed. "Heaven" is a nice song. I like that one. It started out with just me and Charlie Watts playing together in the studio, with just drums and vocals. Then we added Keith on guitar. He said it sounded really good and that we should leave it alone. But I decided that we should add some harmony vocals and guitar.

"I was just fooling around with the vocals, making it up as we went along. There's not much of a lyric, just a sound and a mood. Lots of people like that one."

The bluesy "Black Limousine" was co-written by Ronnie Wood and is also featured on *Rolling Stones Tattoo You*. "People always sniff their noses when we play a blues," said Mick, "but this one has turned out to be the one everyone likes. I'm not straining so much with my vocals now."

Ronnie Wood took over while Mick went off to have dinner, and we were later joined by Keith Richards. The pair have a kind of feud going and every time Ronnie started to talk, Keith literally told him to shut up. But Woody kept on smiling, and only gave up after a particularly vitriolic outburst from the Stones' senior guitarist.

Ronnie managed to tell me about his solo album on Epic called *1, 2, 3, 4* which is apparently how many months it took to make. He's got quite a few old mates on the record including Carmine Appice, Charlie Watts, Nicky Hopkins, Ian McLagan, and Bobby Keys. The cover is distinguished by a self portrait, and Ronnie told me fans can buy copies, if they so desire. Don't all rush.

He was suffering from a bad attack of hiccups when he tried to tell me about the album and his band the New Barbarians, mainly due to drinking cold American beer too quickly (and also caused, I suspect, by Keith's somewhat menacing presence). I told him to hold his breath — but he carried on talking.

"I've got a new version of the



Photo: Graham Wiltshire

Barbarians, hanging in there and ready to go. We did a whole American tour as well as that gig at Knebworth a couple of years ago. In some places they kept billing us to appear with Mick Jagger, and of course he wasn't coming, so there was usually a riot.

"I got invited to go on tour with Bob Dylan this year. He came over to my house in LA and asked me. But I couldn't because the Stones were starting rehearsals. We did a couple of weeks in New York before we came here. He's a funny guy, Bob. But I can loosen him up and confront him with all the subjects that are normally taboo."

Did Ronnie feel schizophrenic working for so many different artists at once? "No, I always put the Stones first because they are my favorite band. I've been with them for eight

years now. I wrote two of the songs on the album, 'Black Limousine' and 'No Use In Crying'."

He seemed anxious not to claim too much credit while Keith was around, and the latter eventually wandered over. He was in a wonderfully relaxed and good humored mood, but sparks of impatience occasionally flew. When one of the Stones' children rushed up to crave affection and attention, he suddenly shouted "F*** off you little creep!" and then added, "lovely boy."

"You might think," said Keith, "that after all the time we've been together we don't need to rehearse. But there has been a lot of detailed stuff to work out. It's partly psychological, to get us playing again. Everybody is playing well and the band sounds good."

Off the light On the Boogie Listen to the Big Difference

Frankly, we're flattered by the amount of recognition we've received from enthusiastic musicians as well as imitative manufacturers. Flattered, honored and just a bit surprised. Because we started with (and stuck with) two simple underlying principles: 1. Build the best musical amplifier possible...and 2. Treat each customer individually, the best way for him, as though we were in his place.

To follow these ideals means we are dedicated to staying small, and personalized — that's the way we like it. To mass produce and mass market the Boogies would be to sacrifice one crucial element of our world-wide success — our unique quality. To bear-out this truth, we invite you to compare any of the many imitations to the original.

Look for the quality of hand-made, all tube construction. Look for the fan and cooling fins, the sus-4™ shock mount suspension system, line surge protector — all of which insure outstanding reliability. (No one else has them.)

Our dove-tailed, single plank, continuous grain hardwood cabinet is a true masterpiece and an original MESA/Boogie design. The tough hand-rubbed finish alone takes more than a week to complete. You may see it "imitated" but certainly not duplicated.

Yet, most elusive of all, is our sound. In a recent series of articles *Guitar Player* magazine rated the MESA/Boogie as the "overall monster" for its ease of control, low noise and wide range of sounds.

We're proud of the success of our founding principles because they are so simple and so clearly right. Being the leader requires a host of followers, and surveying the amplifier market these days shows the influence and pioneering leadership over the years of MESA/Boogie.



1317 Ross Street
Petaluma, CA 94952
Telephone (707) 778-6565

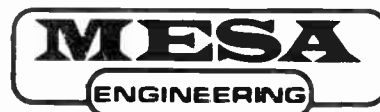

Please send for information on full MESA line
You may enclose \$1.00 for first class postage

Name _____
Street _____
City _____
State _____
Zip _____
(1M)

more vibrant and earthy. The pair sounded particularly effective on my favourite number of the evening "Mona"

The band gradually got louder, and Mick looked worried as he came over to pinch some of my beer. "Is it too loud?" he asked, then answered his own question. "It is too loud." And he told the group. "It's sounding really good boys, but it's getting awful LOUD." His words seemed to have no effect.

Stu set up a tape recorder and began playing back an old soul number by Otis Redding. "What's all this?" demanded Keith gazing suspiciously at the tape deck, then giggled an aside to Charlie, crouched over his tiny and antiquated drum kit. "Oh, he's always a one for innovations." Keith pretending to be gay is rather a disturbing experience. "Where's Mick, is he putting on a new frock?" He pouted, then cackled with laughter.

But when Mick reappeared toting his own guitar, Keith suddenly barked: "Who said you could play guitar on this one?" They are very much a gang of school kids still, with strict unspoken rules. Mick may be in charge of the frocks, but Keith is boss man of the guitar department.

But once Keith had asserted his authority, he softened and soon the two of them, like brothers went into a huddle, and Keith explained to Mick the best way to tune and strap up the guitar for maximum ease and flexibility.

During a break in the roaring R&B riffs, Ian Stewart began playing a swing tune, "Flying Home" on the piano, quickly picked up by Charlie on his hi-hat. "Stop that!" ordered Keith who didn't want alien jazz creeping into the Stones' style.

"When you look round at all the lunatics in this business, you wonder what we did right to survive eh?" said Keith coming over for further chat. "Well the only thing we did right was we didn't start out doing it for the bread. Maybe that's the bottom line. I dunno. I'm just offering that one up. It's better than human sacrifice I suppose."

What advice did Keith give to young musicians starting out in the business? "Never listen to advice. Feel your way, because every situation is different. There are far more shysters than you can possibly imagine. Everybody knows that, but they don't believe it, when it comes to their situation. They are always taken in by shysters. Kids are put in the yoke and worked to death. They are grabbed at the wrong point in their development and burned up. People want to turn them into superstars, but they should be left alone. If a kid gets a hit record, and is enormously successful, he is lead by the nose. The record



companies and managers see the green light turn on, and they never stop to think it doesn't always mean "Go!"

Keith revealed that he had recovered from the drug problems that plagued him from 1968 to 1977 and I wondered if being "clean" had made any difference to his playing ability. "Subtle difference," he allowed. "The period I was on dope — ten years — was when I participated on some of the best albums the Stones have made. So there is no formula about the Stones. We still don't know what makes a good album until it's out, and we can hear the results. You never can tell. Most of our albums consist of tracks that have been hanging ready. This album is a mixture of old, half-completed tracks that didn't get on *Emotional Rescue* and some are even older. We had to mix, edit and add on vocals and we had to plug away at the various tracks until they were right.

"People think that on an album every track has been newly made and freshly minted. None of our albums have been made like that for years. Not since *Exile On Mainstreet* have we done an album where some of the tracks haven't been cut years before. When does life begin? At conception or birth — a release date or when you did it? We sit in our tool

shed chuckling to ourselves watching the reviewers discuss our latest record and talking about all the changes, when we know it's a load of old scrapings, culled from millions of sessions over half a dozen years. But it's fun to watch."

Keith sounded terribly cynical. Did the Stones manipulate the press then? "No more than they manipulate us. As you well know, it's a constant jousting match. We both manipulate each other I guess. You do what you've gotta do."

The Stones still seem to be friends and have great respect for each other, despite all the kidding. "That's why we are all still here," says Keith. "Sometimes I don't see Bill for days, except on stage. Bill and I don't need a lot of contact. Our relationship goes well because we never probe each other deeper than a certain level. You don't have to soul search everyone because that sort of thing ruins a relationship. There is an automatic, instinctive relationship between everybody in the band, which is the main reason why Charlie is sitting on your knee now. He's coming out of the closet!"

Finally, when would the Stones come to Britain? "Next year!" said Mick.

Chris Welch



Introducing Personal Multitrack.

It's an old promise. Newly kept. And here's what Fostex delivers: Multitrack recording gear designed just for musicians and songwriters. Easy to use. And very easy to own. Equipment that works right, sounds great and costs less than you ever dreamed possible. We call it Personal Multitrack.

Eight tracks on 1/4" tape! A four-track on 1/2" tape. And a little miracle-worker we call The Multitracker — four tracks on cassette.

Discover Personal Multitrack. Send us the coupon and we'll send you our new 16-page brochure. You'll see what we call Personal Multitrack. What you'll call, "All Mine!"

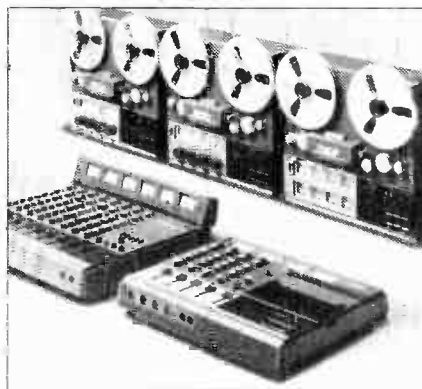

Fostex
Personal Multitrack

Keep Your Promise.

Send me your 16-page Personal Multitrack brochure.

Name

Address

City

State Zip

I play: (Instrument)

Mail completed coupon to:

Fostex Corp. of America, 15431
Blackburn Avenue, Norwalk, CA 90650.
ATT: Rachel.

Danny Adler...

Many music pressmen operational in London circa 1975/76 would have wagered confidently that by 1981 Danny Adler would be in the "needs-no-introduction" bracket. Roogalator, his then current band, were widely touted as almost the only one in the pub rock movement to create something idiosyncratic and memorable amid the down-home, good-timey ambience of the London music scene of that time. Potentially punchy and exciting enough to survive the Sex Pistols explosion, they were late in getting an album out and generally missed the boat, a recurring scenario which I suspect to be rooted in Adler's personality — of which more later.

But what makes this mustachioed American guitarist of contemporary interest, apart from the continuing merit of his work, is that he's spent most of 1981 playing in three different bands: Rocket 88, the DeLuxe Blues Band and his own combo.

Danny Adler comes from Cincinnati, Ohio, not too far from Akron, the industrial town publicized by Stiff's sampler album of three years ago and featuring such as Jane Aire and Rachel Sweet. Producer, writer and small-time svengali to these two was Liam Sternberg, with whom Adler once collaborated — in Hampstead!

"I used to play with him in Ginger Johnson's African Drummers in 1973."

Didn't they do a lot of festivals and suchlike?

"Yeah, it was that type of thing — a lot of percussionists, very exciting, very rhythmic stuff."

Prior to that, Adler's principal UK venture had been Smooth Loser ("sort of Rock & Roll"), a band managed by Radio DJ Emperor Rosko. The earlier American bands sound more relevant to his activities from Roogalator onwards.

"(They were) bands very much like the Deluxe Blue Band, really, other than the fact that Soul was quite popular... in fact, I worked almost exclusively in black clubs until the early 70s. I played Rhythm and Blues and Soul music and dabbled in Jazz, in Ohio and on both coasts as well."

Footnotes are in order hereabouts, for those unacquainted with the Deluxes. All four members — the others are Bob Brunning (bass), Mickey Waller



(drums) and Bob Hall (piano) — appear regularly with Rocket 88, the late 40s-style Boogie/Blues/Swing outfit formed by Rolling Stones associate Ian Stewart around the piano duo of Hall and George Green. As the Deluxe Blues Band, these four lean more towards the Chicago Blues of the mid-50s, Adler's fluent guitar well to the fore.

Kicking off 12 days in which I caught all three of Danny's bands were the Deluxe BB, attempting to galvanize 25-odd people in a small upstairs room. Despite the guitarist's somewhat stagey vocals — particularly on the slow Blues

— they succeed pretty well, the balding Waller (a rock titan in his time) keeping the beat motoring with an authentic jazzman's "real gone" look. Inevitably, the piano loses the amplification battle and Hall's largely solo performance of "Swanee River" made me realize what I'd been missing, his sneakers pummelling the pedals in a boogie tour de force that belied his scholarly look. (He's actually an authority on international patent law.) Joined by Pete Miles, the drummer from his own band, and a mystery bassist after the interval, Danny dazzled with spot-on impressions

The Bose® 802 Driver

High technology. High performance.

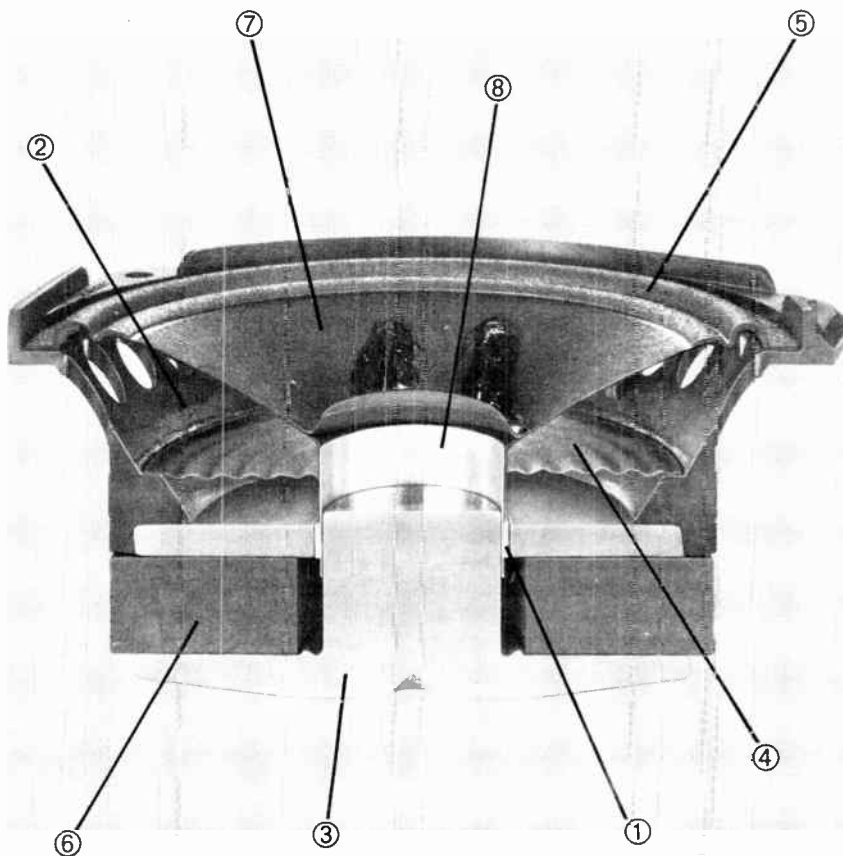

Efficiency.

Low-impedance voice coil ① uses edgewound aluminum ribbon for maximum conversion efficiency. Nonmagnetic frame ② and one-piece backplate/centerpole ③ reduce flux leakage and wasted fringe field energy.

Accuracy.

Planar spider assembly ④ and foam surround ⑤ provide high linear excursion and low distortion. Syncom® II computer analysis controls total radiated power spectrum of each unit for unprecedented manufacturing consistency.

Power.

12-ounce high-energy Ferrite V magnet ⑥ increases overall sensitivity and power output. Curvilinear cone shape ⑦ maximizes effective piston area.

Reliability.

Glass-reinforced polymer frame ② is impervious to warping. Aluminum bobbin ⑧ and exclusive high-temperature insulation system protect against voice coil deformation and burnout.

The advanced materials and construction of the Bose 802 Driver provide performance unobtainable from speakers of conventional design. And the acoustically coupled array of *eight* drivers in each Bose 802 System delivers smooth response, clarity and bass output that belie its compact size.

For more technical data and a demonstration of the Bose 802 Loudspeaker System, contact your authorized Bose Professional Products Dealer.

BOSE

Better sound through research.

Covered by patent rights issued and/or pending.
802 speaker design is a trademark of Bose Corporation.
© Copyright 1981 Bose Corporation.

Bose Corporation
Department RW
The Mountair,
Framingham, Massachusetts 01701
Please send me a copy of the Bose
Professional Products Catalog and
a complete dealer list.

Name _____

Address _____

City _____

State _____ Zip _____

Telephone () _____

Danny Adler...

of various Blues and Jazz guitarists — much as Chris Spedding did for rock on an album five years ago — the highlight being a hilarious John McLaughlin, complete with furious, over-busy drumming.

Nowadays this sort of thing is a relaxation from playing with the Danny Adler Band; in his formative years it was a prelude to something more original.

"A prototype to Roogalator was a band that I had on the West Coast in '71 called Dr Funk, which never recorded. But that gave me a sort of workshop situation in which I could develop the rhythmic ideas that I used in Roogalator."

Were they all-white bands, these early ones?

"No, they were all black musicians, but Dr Funk was an integrated band. In fact, the first fully professional all-white band I played in was Elephant's Memory in New York. I was with them for about three months."

Though a single, *Skyscraper Commando* resulted, Danny wasn't over-impressed and registered considerable surprise when John and Yoko used them for the studio half of the overtly political *Some time In New York City* album.

"They wouldn't allow any individuality. I myself have always tried to get away from that, I always wanted to put my mark on anything that I do."

This is particularly true as far as rhythms are concerned, which explains his high regard for the Meters, who started life as Allen Toussaint's studio band. Constantly playing tricks with the beat while maintaining a funky accessibility, their album in Charly's excellent series of R n' B reissues features enthusiastic sleeve notes by Adler. However, the suggestion that he might have learned a thing or two from this source is quickly discounted by a man who sometimes seems at pains to assert his originality.

"I think I've always been influenced by the older New Orleans things, so I feel like I've developed alongside them — although of course they've inspired me. I don't think I do anything that derivative, except the Deluxe Blues Band. I'd say the things that influenced me the most were shuffle rhythms and James Brown's sound from the 60s, the



funk rhythms — and Chuck Berry, of course."

How do you define shuffle rhythms?

"It's like a swing beat, but it's slower. You know my song "All Aboard"? That's a shuffle beat."

Was there any particular reason why you gravitated to England?

"Initially, it was just to sort of freshen up, but there were incidentals like the draft. . . I found that I fell into doing sessions and being able to work on my own material. I got a chance to do a lot of different things: I played Country and Western in an Irish band, I played with Ginger Johnson and got the first Roogalator together in '73. We actually did our first gig in November '72, at the Marquee.

"There was a bass player named Michelangelo Francesca who was from Philadelphia: he went back and he plays on a lot of the Philly sound things. But the first serious line-up had Bobbi Irwin on drums, who plays with the Sinceros now; and he also played with Carlene Carter and on Lene Lovich's first album. (Irwin has now left the Sinceros for Carlene's new band.) Then around '75 Steve Beresford and Dave Solomon were the rhythm section. They're both on the 'free' thing now, they play with Derek Bailey and Evan Parker."

Several others passed through the ranks, including sub rock veteran and bassist/producer Paul Riley and bass player Julian Scott, later to join brother Robin in M. ("Pop Muzik" etc.) Robin managed Roogalator and produced their album *Play It By Ear*, which came out in late 1977. Always adventurous and entertaining, they ranged from furious funk overdrive through a beguiling canter to the light, skimming Rock & Roll of "Sweet Mama Kundalini". Nick Plytas, a talented keyboard player and

songwriter, could have been more fully integrated, but otherwise Roogalator left little to be desired.

At a pitch, passengers can be carried in other departments, but if you've got one on the drum stool the consequences are usually dire. To play Danny Adler's music, a drummer must have plenty of drive, yet be flexible without being fussy: the guitarist has shown great taste in this area, from Irwin and his successor Justin Hildreth (who also followed him into Lena Lovich's ensemble) to the present incumbent, Pete Miles.

"And I also do a lot of work. A lot of the tunes involve pretty intricate drum parts, which have to be learned, so that dictates the character of the music."

Another striking aspect of that character is Danny's use of the famed "train whistle" effect. No: since Dave Edmunds tackled "Let It Rock" in the early 70s has it been employed with such devastating success, the American also adapting it for his own exploratory purposes.

"That's entirely my creation. That's what I call my 'smear' technique, which involved hitting a chord, bending it and . . . sustaining a chord is probably the most unique thing stylistically that I do."

Besides the Meters, Adler has also written the sleeve notes to a T-Bone Walker album on Charly. An influence on B.B. King, Walker bridged Blues and Jazz with a notably light tone.

"He pre-dated the heavy Blues, the really gutty, gutbucket sound, so he was an almost Charlie Christian-like sound. But it's very funky and if you listen to any Rock guitarist, they're doing things that are in some way derivative of what he did in the early 40s.

"Everybody obviously has influences, but I take my influences from such a wide spectrum. As far as guitar

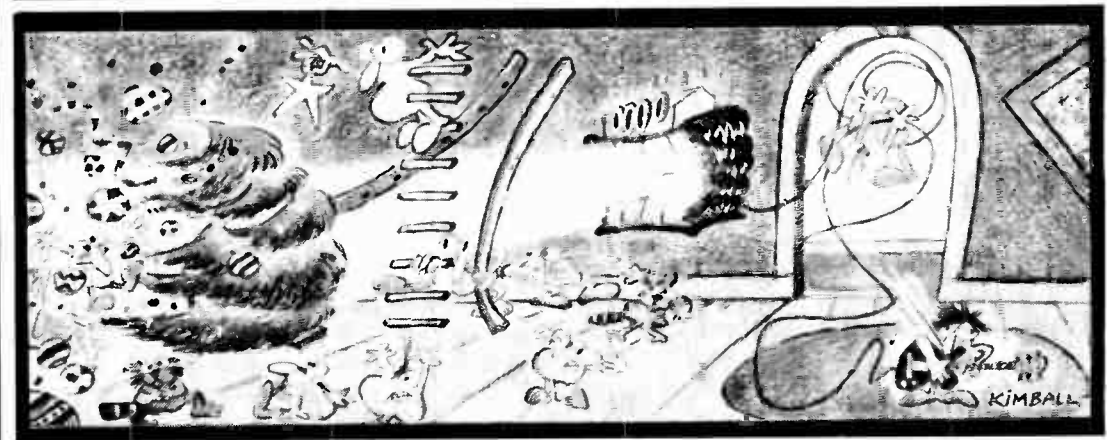

POWER SOAK

POWER SOAK allows you to turn your amp up to 10 to get the harmonics and sustain that come with full output, and then set the speaker level wherever you want it.

- Lets you play small clubs with big equipment
- Controls volume while rehearsing
- Perfect for practicing at home.
- Makes distortion effects unnecessary.
- Sounds better than a master volume.

Gives you total feedback control

Tom Scholz uses his POWER SOAK for all BOSTON recordings and live performances. Finally available to the professional musician.

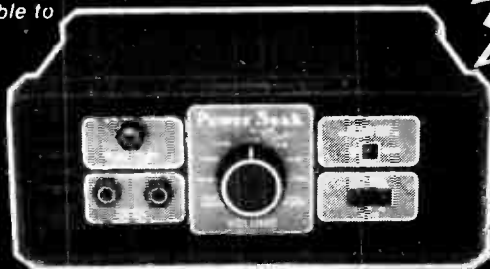

Safe for tube & solid state amps
Will not cause impedance mismatch like some power attenuators.

- Won't get too hot to handle.
- 120 Watts RMS.

New "tube - solid state" switch



Scholz Research & Development Inc., P.O. Box 191, Lincoln Center, MA 01773



Randall RG 80SC

How many of those ads have you seen where a solid-state guitar amp is hyped as having captured that mystical essence known as "tube sound"? How many times have you rushed down to the local music store after waiting three or four months for the latest solid-state sensation to appear on the floor, only to be instantly disappointed and thoroughly nauseated as soon as you turned the amp on and cranked up the gain? But no matter how often the pitch turns out to be a figment of an over eager copywriter's imagination, it remains an excellent come-on, because the combination of solid-state's portability, and reliability with tube's gutsy, open sound and singing sustain is something guitarists will always search for.

Randall's new RG 80-112 SC is not the end of that search, but it definitely represents a big step in the right direction. Without getting too technical, it's possible to point out a number of design features which contribute to the very pleasing sound

of the RG 80. The first of these is the use of discrete transistors in both the pre- and power-amps. It's cheaper to use one-piece integrated circuits, ICs or "chips" as they are known in the trade, but these devices are lacking in "headroom" (the amount of voltage they will pass before distortion or "clipping" of the signal occurs) compared to separate transistors. The devices in the RG 80 are known as FETs or "field effect transistors" for long. The main thing the average guitarist has to know about these little gizmos is that they distort in a way very similar to a vacuum tube, producing an oscilloscope trace that resembles a square with slightly rounded corners.

The most unusual feature of the RG 80, however, is its power amp section, which uses not only FETs, but a design which the Randall engineers call "constant current" to distinguish it from the "constant voltage" principle on which most solid state amplifiers are based. This design incorporates a much lower "damping factor" than is

usual in transistor designs, and it undoubtedly contributes to the RG 80's very warm and lively sound, which has almost none of the characteristic "tightness" or "dryness" by which most solid-state amps are instantly recognizable.

The RG 80 is a very trim package, 18" high, 19½" wide and 10" deep. It pumps 80 watts into its single Celestion G12-80 12" speaker, and is capable of 140 watts of clean power if an extension speaker is added. The amp is a bit heavier than most transistor amps of this size, but the extra weight comes from the ¾" hardboard cabinet, which is covered in standard black Tolex, with metal corners and feet on the bottom. The hardboard is a very dense material, routinely used in hi fi loudspeaker cabinets, and even though the RG 80 is an open-back design, the density and rigidity of the cabinet probably contribute to its projection and round, full tone. Despite the extra weight of the cabinet itself, this is a truly portable amp, which you can lift and carry one-handed. The speaker is protected from the front by a woven plastic grille cloth, which has an aluminum strip at the bottom, and an aluminum plate at the top which carries the Randall logo and the name of the amp. The look of the whole package is attractive in a subdued, tasteful way. Obviously this is one amplifier designed to be listened to more than looked at.

The control panel includes, from left to right, two inputs, clearly marked Hi +6dB and Lo 0dB. This is a very neat way of avoiding the confusion between high and low gain inputs and those designed for high and low output instruments. Next are the two sets of Gain and Master volume controls, identified by a green LED (for the clean stage) and a red LED (for the sustain stage). The Treble, Middle, Bass, Presence and Reverb controls are next, and the On/Off light and switch complete the front panel. Since the RG 80 has no tubes to warm up, it doesn't need a standby switch, and the power switch does double duty as a polarity reversing switch in case you run into hum problems.

The RG 80 includes two footswitches, housed in a sturdy aluminum chassis and connected to the back of the amp by a long cord and a six-prong "Jones plug", which pulls out of its socket if someone

accidentally trips on the cord. The chassis holds green and red LEDs which correspond to the clean and distortion gain stages of the preamp. One of the footswitches selects either gain stage, and the other selects both at once, no matter which one is on. So with one tap of the foot you can switch among three sounds, without having to go back to the amp.

The back of the control panel holds the circuit breaker, a convenience AC outlet, Effects Send and Return jacks, a Signal Output (line level), two speaker output jacks, a Reverb footswitch jack, and the six-pin jack for the footswitch connection. The reverb spring box is mounted on the bottom of the cabinet, as usual.

To those who have become totally skeptical about anything involving transistors in guitar amplification, the RG 80 will be a real eye-opener. The clean mode is especially pleasing, and almost indistinguishable from even the best tube designs. Another surprising feature of this amp is that it's LOUD, especially for a small package with an undramatic power rating. Keep in mind, though, that doubling (or halving) amplifier power produces only a 3dB change in volume level, which is just barely noticeable under most circumstances. Because of the RG 80's efficient speaker, and the headroom designed into it, you can crank it up to very high levels before the sound begins to break up. In fact, it will play louder than many amps rated at 100 watts.

The sustain sound, while it's not going to fool any blindfolded listeners the way the clean mode will, is very nice and thoroughly useable, especially when it's combined with the clean sound in the proper amount. By using both gain stages at once you can get a clean attack and a long sustain which can approximate the way tubes go into clipping very closely. The Treble control also doubles as a pull switch, adding extra diodes into the sustain circuit. This drops the volume somewhat, but in the average playing situation you can compensate for this by opening the Master volume a little further. With the treble control pulled out the sound is even further compressed, and the sustain becomes very long and smooth.

Although there is only one set of tone controls on the RG 80, they are very effective, and it's easy to get a

nicely balanced sound in both clean and sustain modes. The tone controls are placed in the circuit after the Master volumes, where they can shape not only the clean but the distorted sound. This greatly enlarges the tonal range of the RG 80, and the built-in treble boost in the sustain mode adds a useful degree of "bite" to the distortion sound. The reverb is on in both the clean and sustain

modes, and the level doesn't change when switching between the gain stages. Although there is a lot of gain built into the reverb circuit, it's easy to control, and the sound is bright, clean and airy, without too long a decay.

On the basis of sound alone, the RG 80 can stand up to many tube amps now on the market, and it clearly has it all over its solid-state competition. ●

The Penetrator[®] Connection.

Gollehon Penetrators are the best connection to your audience. A great way to insure a clean mix to the farthest wall of the room with all the muscle you need to be heard. You know all about PA's that can't project, systems without horns that can't carry, or little boxes with inefficient little speakers.

That's why our new Penetrators have become so popular. A large mid-horn with a big 10" cone driver punches out vocals with definitive separation. A horn-loaded super-tweeter projects a crisp top-end with equal efficiency, and a 15" bass driver kicks a bottom-end like only a 15" can deliver. Plus, Gollehon Penetrators project sound uniformly throughout the audience. Every seat is the best seat in the house!

Our new Penetrator 4 is a self-contained, biampable, 3-way system. An extra 15" bass driver on the bottom is the S6/P3 combination, and it's the best!



Visit your Gollehon dealer or write us:

GOLLEHON[®]
 2431 CLYDE PARK, S.W.
 GRAND RAPIDS, MI 49509
 © Gollehon Industries, Inc. 1981

If you would like a Gollehon "I'm Proud of My Penetrator" tee-shirt, send a money order for \$4.50, plus 75 cents postage and handling. Specify S, M, LG, EX LG.



Pulsar RTA-150

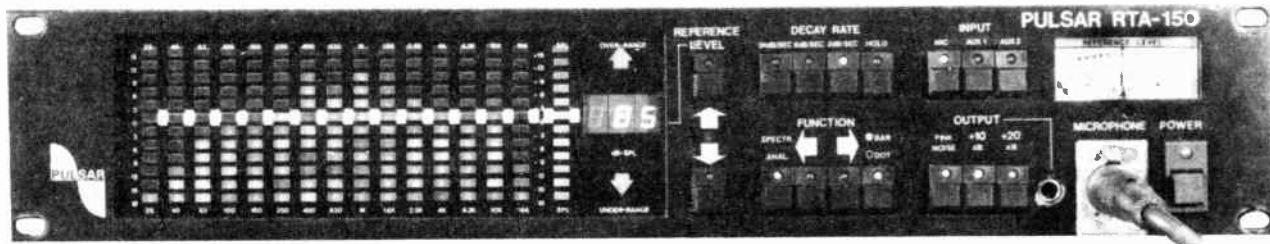

The RTA-150 from Pulsar Laboratories is billed as a real time analyzer, but is more accurately described as a 2/3 octave real time analyzer, plus a sound level meter, plus a wave analyzer, plus a noise generator. Weighing in at only 12 1/4 pounds, this mini sound-test set fits into a case 9.8" deep behind the 3.5" standard rack-mounted 19" wide front panel.

The left side of the front panel is occupied by a 209 high visibility LED bar graph type display. Fifteen vertical rows of 12 each red LEDs display the audio bandwidth, 25Hz to 16kHz in fifteen 2/3 octave bands in 3dB LED increments to give a 36dB display range.

Immediately to the right of the bandwidth display, a single column of 12 yellow LEDs continuously displays the broadband sound pressure level (SPL). A horizontal band of 17 yellow LEDs cuts across the 16 columns to establish an instantly readable reference line. At the right hand of the reference line, a yellow three digit display indicates the absolute value in dB of the reference line. Above and below the "Reference Level" display, two large high intensity red LED arrows indicate when the input signal level is over or under the displayed range.

On the right side of the front panel, a 1 1/2" analog sound level meter, calibrated in dB-SPL, indicates the averaged wideband SPL of the incoming signal. The 0dB line at the center of the meter is calibrated to match the level indicated by the "Reference Level" display. Below the meter is mounted an XLR type microphone input connector, and the power switch.

Nestled in between the bar graph display and the sound level meter are all of the central switches and indicators. Each one of the control

switches is of the large, square push button type, and each contains a red LED that indicates when the switch is engaged.

To the right of the "Reference Level" display, two switches adjust the "Reference Level" up or down in 5dB increments from 50dB-SPL to 125dB-SPL, for a total measurement of dynamic range extending from 32dB-SPL to 140dB-SPL. Holding in either one of these buttons will cause the reference level to shift automatically at a rate of 15dB per second.

Four pushbuttons select the response characteristic of the display. The fast 24dB/second decay rate follows transients as fast as your eye can follow the display, while the slower 6dB/second decay rate is good for monitoring music or speech. The 2dB/second decay rate is best employed for pink noise analysis. The "Hold" button will freeze the display for about five seconds. The display can also be switched from a bar graph to a moving dot display.

When the "Spectrum Analysis" switch is engaged, the RTA-150 simultaneously monitors the frequency components of the input signal. Engaging either one of the two "Scan" switches, converts the instrument into a wave analyzer. An intensified display cursor can be positioned at any one of the 15 frequency bands. This cursor can be moved left or right in single frequency band steps or continuously scanned across the entire frequency range by holding in the left or right scan buttons. The decay rate of the cursor band is increased to follow transients, and the analog sound level meter will read that frequency band's SPL directly.

Both white noise and pink noise are produced by the RTA-150. The output of the pink noise generator is available via an unbalanced 1/4" phone jack mounted on the front panel and

via a balanced XLR type connector on the rear panel. The 100mV RMS white noise output is from a 1/4" phone plug located on the rear panel. Three pushbutton activated attenuator controls pink noise output from 31mV RMS up to 1V RMS.

A very nice feature of the RTA-150 is the individual adjustability of the gain of the 15 frequency band pass filters. The filter adjustments are accessible through holes in the top of the case. This feature makes it possible to easily calibrate the analyzer to match the particular microphone used with the RTA-150.

Additional convenience features include, two front panel selectable, rear panel mounted 1/4" phone jack auxiliary inputs, and two rear panel BNC type connectors that provide a logarithmic analog output and a trigger output to drive an external oscilloscope.

Considering the RTA-150's heavy-duty construction, and its great versatility, this instrument is a natural for the touring band. The high visibility of the display and central switches make it easy to use in those dimly-lit sound booths during live performances. The many features provided by the RTA-150 greatly facilitate PS set-up. With this machine, it becomes a piece of cake to set sound levels, EQ, check driver frequency response, and control feedback. Although the RTA-150 has only half the frequency resolution of the very much more expensive 1/3 octave analyzers used for high accuracy sound surveys, it certainly is adequate for live performance PA work and EQing in home hi-fi situations.

In short, the RTA-150 offers a lot of very useful instrumentation at an affordable price.

MICRO SIZE MICRO PRICE MICRO SIX™

Korg's new palm size Tuner for acoustic and electric guitars

Korg, the world's leading manufacturer of tuners, now offers the new ultra-compact Micro Six. Whether for beginner or seasoned pro, the Micro Six is the perfect tuner for all acoustic and electric guitars and basses.

The secret is in Korg's specialized LSI circuitry. Since Korg designs and produces their own I.C., they have been able to advance the state-of-the-art to its maximum in the Micro Six. Superb quartz accuracy, used in the world's finest watches, provides precision tuning to within 1/4 of a cent. And Micro Six features extended tuning range for open bass string tuning instead of having to use 12th fret harmonics.

Compact, accurate, durable and micro-priced. See the new, micro-sized, micro-priced Micro Six Tuner at your Korg dealer today. And be sure to check out the Korg WT-12 all-instrument, Chromatic Tuner and the advanced, full feature GT-6 Guitar and Bass Tuner.

Actual Size

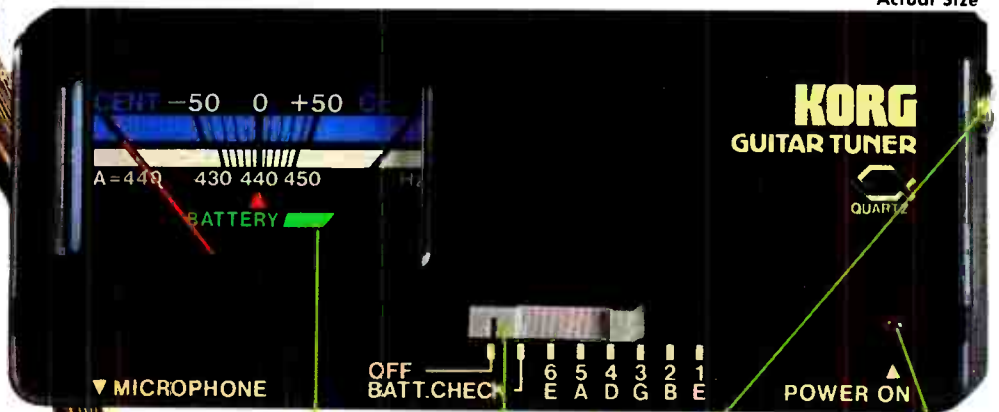

Built-in Microphone for tuning acoustic guitars, violins and double bass.

Meter gives accurate, steady readings for all instruments. String is in tune when needle stops on center "O" position.

Slide Switch (power, note selector and battery check) for tuning open strings one through six; and checking battery strength.

Instrument Jack for tuning electric guitars or basses (bypasses built-in mike).

Power On LED Indicator lights up when slide switch is set to NOTE SELECT or BATT. CHECK positions.

Case is made of durable, high impact ABS plastic.

FREE ELECTRONIC QUARTZ TUNING FORK

This beautiful fashion pendant tuning fork (a \$40 value) is yours free with the purchase of a Micro Six Tuner. Have your dealer sign this coupon, attach it with proof of purchase to your Micro Six warranty card, and mail with \$2.00 (check or money order) to cover handling and shipping, to: *Unicord, 89 Frost St., Westbury, NY 11590*. Allow 3-4 weeks for delivery. **IM 12**

Name _____

Address _____

City _____ State _____ Zip _____

Dealer's Signature _____

(Offer valid in states where permitted until December 31, 1981, while limited supply lasts)



KORG ... we put it all together

Exclusively distributed by:
Unicord 89 Frost Street, Westbury, N.Y. 11590

There are a number of devices that produce effects by a time delay circuit. The most common effects are Flanging, Chorus, and Echo Delay. Each of these effects mixes the original instrument signal in with the time delayed signal to produce the effect.

The time delay is the amount of time between the original note played and the note produced by the delay circuitry. These are very short, and are measured in

milliseconds (mS—thousandths of a second).

The time delay produced by a flanger is the shortest, usually less than 13 milliseconds. The time delays needed to produce echoes are quite a bit longer, with a maximum at around 300 milliseconds. The time delays of a chorus fall in between the two, the longest being about 25

BOSS makes three effect pedals that employ time delay circuitry. Each of these are designed to perform their effects with controls and features suited to the particular time delay application.

BOSS Standards
All three BOSS time delays feature the BOSS design features of FET switching, LED status indicators, Low noise operation, AC adaptability, easy battery access, and solid reliable performance—Standards that have made BOSS the world leader in effects.

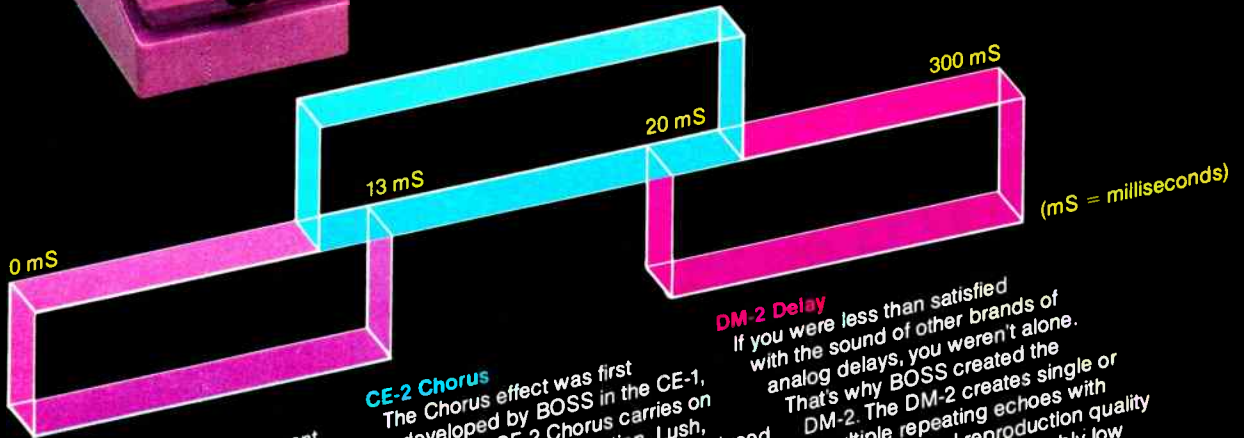

BF-2 Flanger

Solid performance resonant flanging in the BOSS tradition. The BF-2 combines a deep flanging effect with clean and quiet performance for any application. Flanging thick enough for any guitar, and even quiet enough (-95 dB, S/N) for recording.

CE-2 Chorus

The Chorus effect was first developed by BOSS in the CE-1, and the CE-2 Chorus carries on that spirit of innovation. Lush, thick Chorus effects are produced with control over both rate and depth for personal fine tuning.

DM-2 Delay

If you were less than satisfied with the sound of other brands of analog delays, you weren't alone. That's why BOSS created the DM-2. The DM-2 creates single or multiple repeating echoes with strong signal reproduction quality and literally unbelievably low noise. This is accomplished through the use of a custom delay chip used exclusively by BOSS. Just trying the DM-2 will make a believer of you.



We Want You To Understand The Future

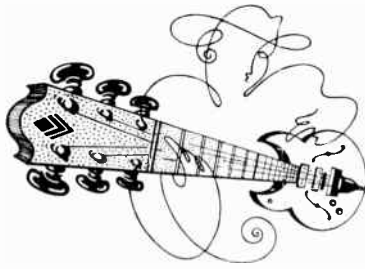

Basscheck

Alembic Distillate Bass

When Alembic's "G" series basses hit the market the promo literature credited aerospace technology with the development of the "Modulous Graphite" material that Alembic incorporated in the design. By replaying the standard wooden neck with this carbon fiber substance, Alembic hoped that the "marriage of art and science" would create an instrument with greater sustain, ringing harmonics and no dead spots. Who could argue with that, right? Well, that marriage has ended with the arrival of The Distillate. The conversion to wood is but one of the changes in this latest Alembic creation. I'll mention the other momentarily.

I like this instrument more than I thought I would after first laying eyes on it. Don't get me wrong, it is an exceptionally attractive machine. Yet in the past I've usually felt awkward holding Alembic basses. When trying to play while standing, I found the experience tantamount to dancing the Tango with a Rhino. Therefore, I was more than pleasantly surprised that the Distillate appears to be better balanced than its predecessors. For me this makes a world of difference. Though the body is just as wide in front and not contoured in the back, it's also thinner, thus the improvement. There is another structural change you should be aware of: the Distillate is the first Alembic Bass to sport a solid body construction. You'd think that Alembic's top of the line basses are solid bodies, but not so. It's just that there's so much electronic gadgetry inside the body that a solid wood frame isn't possible. This new feature represents more than just a change: it

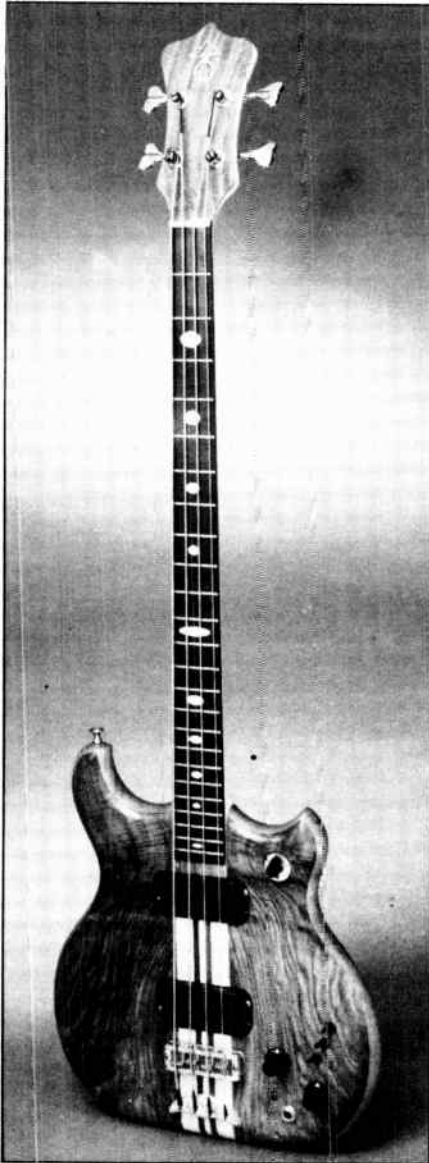

possibly marks a transition in the thinking of Alembic's braintrust. With the Distillate they have wisely scaled down the electronic complexities and, rather than produce another stereo instrument, have opted for their first ever mono bass. The Distillate hasn't sacrificed anything in the way of tone variety. The signal in all phases is just as strong, delivering both the muscular percussiveness of the past and a new found warmth.

By the left horn, there is a low noise four position switch for standby, treble, bass and treble — bass pick up combinations. There are three switches located above the volume and frequency (tone) knobs. Two of these are three way switches; one controls high frequencies by boosting, cutting or leaving flat the treble signals. The other does the same for low frequencies. At high volume, I found no rumble when the bass was cut — the low end was clear and deep. The third is a two-way "Q" switch which, when in the down position, works in conjunction with the frequency control knob (which functions as a continuously variable, active low pass filter) to create what the Alembic people refer to as "resonant peak", or what I call a "juice boost". Rotating the frequency knob produces a wah effect and emphasizes the beginnings of the overtone series. If I had any problems working with the Distillate sound, it was in adjusting the midrange to balance with the powerful low and high ends, but as I acclimatized myself to the options this situation worked itself out.

The woodwork is really top notch and a sight for anyone's eyes. The

Alembic...

walnut is glued onto the laminated neck which is comprised of maple and amaranth, also called "purple heart". The neck runs through the body and is supported by a double truss rod. The fingerboard is ebony with mother of pearl inlay. I found the neck fast, though it felt chunky in the first position until I got used to it. The middle and upper portions of the neck are built for serious speed and, while the frets are thick, they are founded with care and cause little unwanted friction.

Most of the hardware is made by Alembic except for the Schaller tuners which as always make tuning a breeze. The pick ups are Alembic's own, and each comes with its own preamp which allows for individual adjustment. A nine volt battery supplies the power, and a red light by the output jack lets you know it's in working order.

I've always respected the care with which Alembic instruments were built and designed. But in the past I've usually found them to be uni-dimensional. However, the Distillate marks a radical departure. This entire instrument has been streamlined to offer you the very same advantages that the "modular graphite" was supposed to achieve, and more. I tested the Distillate through three amps; a Music Man 130, a Polytone Mini-Brute III and an Acoustic 370. The midrange suffered a bit through the Music Man. Trying to achieve a blend with other instruments was difficult with this combination. Could the incompatibility have been caused by the tubes in the head? I can't say. However, the endless sustain, piercing sustain and thick percussive bottom were heard through all three. This instrument is in its glory when thumb slap and pull technique is used, and

with the "Q" switch active the frequency boost offers a variety of textures (you can even get a little dirty with this Alembic) for both ensemble and solo situations. So for you Alembic buffs reading this, I'm certain you'll want to check the Distillate out; to any Alembic critics out there, I recommend you try this axe. And to the people, at Alembic, I tip my hat
Congrats. ●

Shift into OVERDRIVE OVERDRIVE OVERDRIVE OVERDRIVE OVERDRIVE



Slide into the driver's seat of The Rogue.

Twin oscillators with hot new overdrive circuits.

Contoured sync-sweep for screaming lead voices.

Extensive Modulation, Noise, Auto-Trigger and Sample/Hold for exciting effects.

Interfacing with other synths or computers, even an audio input for processing external signals.

The Rogue.

Loaded with power, and the lowest priced Moog® on the market.

(Sorry, air conditioning and racing stripes unavailable.)

THE ROGUE

moog®

We're the people who started it all!

For further information, contact -

Moog Music Inc., 2500 Walden Avenue, Buffalo, NY 14225

Moog Music, Waalhaven Z.Z. 48, Rotterdam 3088 H.J.

Holland - The Netherlands

YOU'VE HEARD IT ALL BEFORE...

BUT - PULSAR LAB'S POWER AMPS OFFER:

- The industry's first three-year transferable warranty
- On-the-spot replacement of all driver and output circuitry within 15 minutes — without soldering!
- The largest SOA in the industry
- The most rugged built amp in the business
- Unequaled overall specifications
- Thermal stability — amp will not shut down until transistor case temperature exceeds 230° F
- The only amp designed to accept internal signal processing cards
- Direct coupled, full complimentary, differential input circuit design
- 4 protection circuits with independent power supply
- Road case designed for spare driver and output cards
- Factory hotline — air shipment of module cards in 24 hrs. upon warranty verification

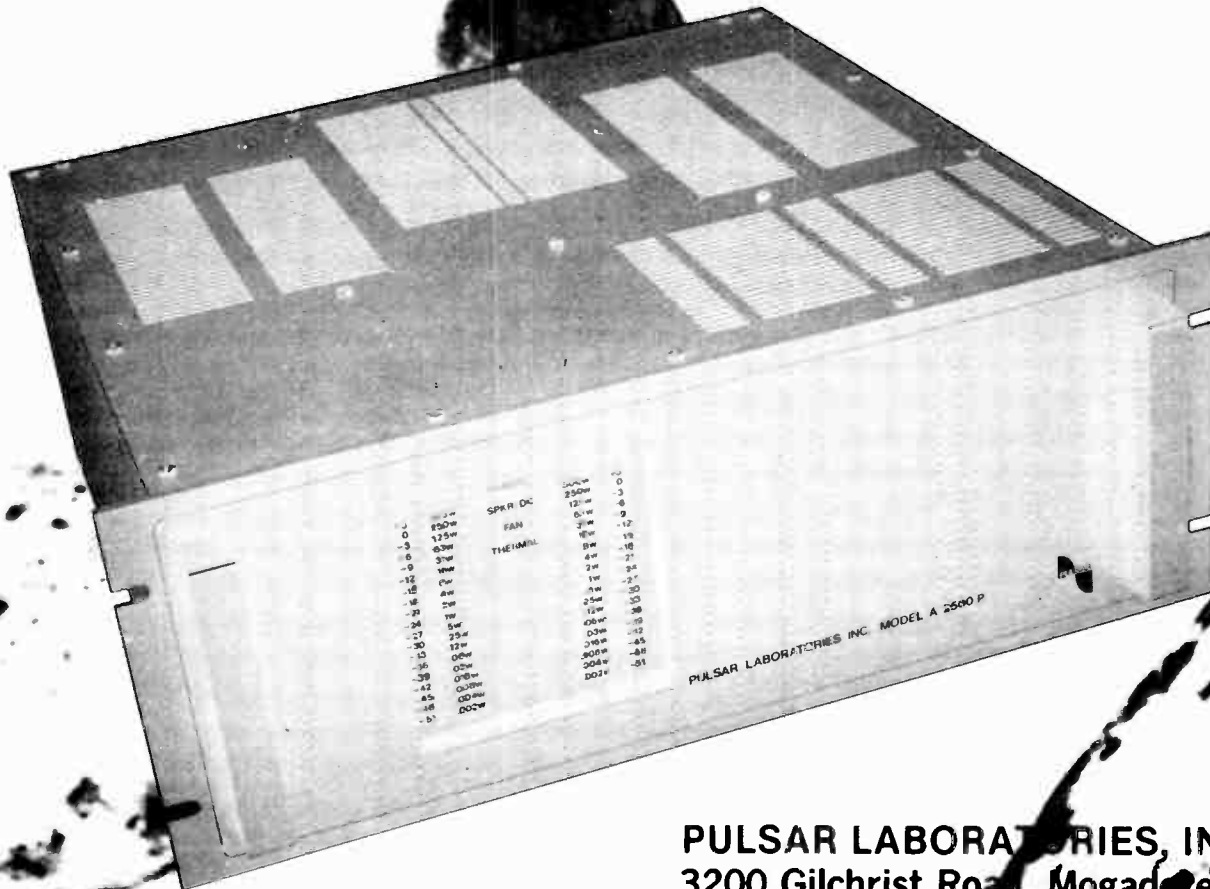

• shown with optional display

World Radio History

PULSAR

PULSAR LABORATORIES, INC.
3200 Gilchrist Road, Mogadore, Ohio 44260



On Sax

The way one's body learns anything — to walk, to ride a bicycle, to play a musical instrument, to discriminate pitch and rhythm — all of these learning functions are accomplished in pretty much the same manner: by reputation. Yet, one's body learns in many ways that are as mysterious as they are marvelous and necessary. Witness the fact that I've been playing sax for way over twenty years and have developed no callous whatsoever on my lip from it, yet my hands are very calloused from carrying a sax case around all those years. I am a compulsive, fanatical guitar practitioner, yet my fingers have no callouses on them. The music is never too loud for me, yet I seem to have no hearing difficulty or "notches" in my ears, and I can stand in front of a flame-throwing Marshall stack and still hear the back up singers. So can anybody else who's on the scene. Otherwise, how could they get by? I have heard that, of all people, symphony conductors suffer from hearing damage because the sound can run way over the 120dB on the podium. But then I see some prissy phonies in the subway holding their ears and wincing prettily as the train rumbles along. It's de voodoo I tells ya!

So, these many years ago down in my little hometown, as I worked one summer in a furniture mill where they had a machine called a "glue-edger", a gigantic rotary plane that could grab hold of an entire dining-room table top and shave both sides of it to what felt like a mirror finish. Naturally this thing made the loudest noise I've ever heard. I remember the foreman told me to "do whatever I do when I dive in deep water to keep my eardrums from bursting". So that's what I do. It kind of feels like swallowing.

But anyway, the most important single thing with regard to learning an instrument (or anything else) is to determine what one's prime "learning time" is. Mine is in the morning, the earlier the better. Maybe it's the farm boy in me, but late night cramming or jamming does me very little good. My way is to buckle down to it at dawn, overpractice just the right amount (not too much!) and then go on to something else or just go have breakfast. If there's a particular lick or passage I'm struggling with, my formula is to repeat it 25 times PERFECTLY no matter how slowly I must play in order to do so. Also, I must be able to hear it in my mind, executed perfectly at the proper tempo, for me ever to get it right for real.

Also there's a proper amount one should over practice. Obviously, one's musical muscles are going to ache from exertion because of the lactic acid build-up that is created when they flex. This substance is

the waste product caused by muscle functioning and it and its discomfort are washed away by the faithful blood stream when the muscle is allowed to relax a bit. This "washing" effect can be accomplished by shaking one's hands, arms, and shoulders occasionally during strenuous practice. Naturally, after intense practice it is necessary to continue exercising gently so as to clear the muscles before they are allowed to relax completely. If you can appreciate a bit of farm trivia, this is why it's necessary to "walk down" a horse (with a nice warm blanket over him, of course) after having run him. If you put him in his stall all lathered up and steaming he actually might not survive.

And last, it is wise to determine for oneself what one can realistically expect to glean from a certain amount of practice. If you try and master a certain passage one morning, and after wrestling for an hour, still haven't got it, then stop and take stock of the situation. Have you got it 25 (or 20 or 35 or however many) times perfectly at whatever creeping tempo? Or can you simply get through it one time, even at a virtual snail's pace? If this is the case then by all means consider that it might simply be too difficult for you at your present stage of development. It's no disgrace to let the devil take it if it's just impossible. Remember, in the words of the immortal Foots Harrison, "Nobody gives a damn about a million fuckin' notes." Remember Albert King, your father if you're a wise child. It ain't what ya play, it's how ya play it. There are performers whose technical accomplishments have never been duplicated: Liszt, Paganini, Mendez are a few. The devil take 'em. Remember — what you will realize from today's practice will not appear until at least the day after tomorrow. Most things are kind of like one-handed rolls on drums or ostinato sixteenth notes (burnin') on a horn: one day they just start happening if you keep at it, think about what you're doing, and don't give up.

NEIL GERALDO



B.C. RICH BICH "6"

Neil Geraldo, guitarist and producer with Pat Benatar takes the time out of his busy recording schedule to show off his new B.C. Rich Bich "6." Hear Neil and what he can do with a Bich "6" on the new Pat Benatar album "Precious Time." See them both in concert soon.

B.C. RICH, 4770 Valley Blvd., Suite 117, Los Angeles, California 90032

World Radio History







Selmer

Vincent
Bach

Choice of the month from:
INTERNATIONAL MUSICIAN
AND RECORDING WORLD

DOD Electronics proudly presents

THE PERFORMER 500 Series

We consider the new Performer 500 Series to be the finest studio-quality effects line available today.

Quality features include:

- FET Switching
- LED Status Indicator
- AC Adapter Included
- Unique circuit design for low battery drain
- Three year limited warranty
- Modular plug-in circuit card
- G-10 glass circuit board
- Easy, 'no tools' access battery compartment
- Rugged die cast metal chassis
- Rubber non-skid bottom plate

Other Performer 500 effects include:

- Compressor Limiter
- Wah Filter
- Distortion
- Chorus
- Analog Delay
- Phasor

See this state-of-the-art line at your local dealer



DOD Electronics Corp • 2953 South 300 West
Salt Lake City, Utah 84115 • (801) 485-8534

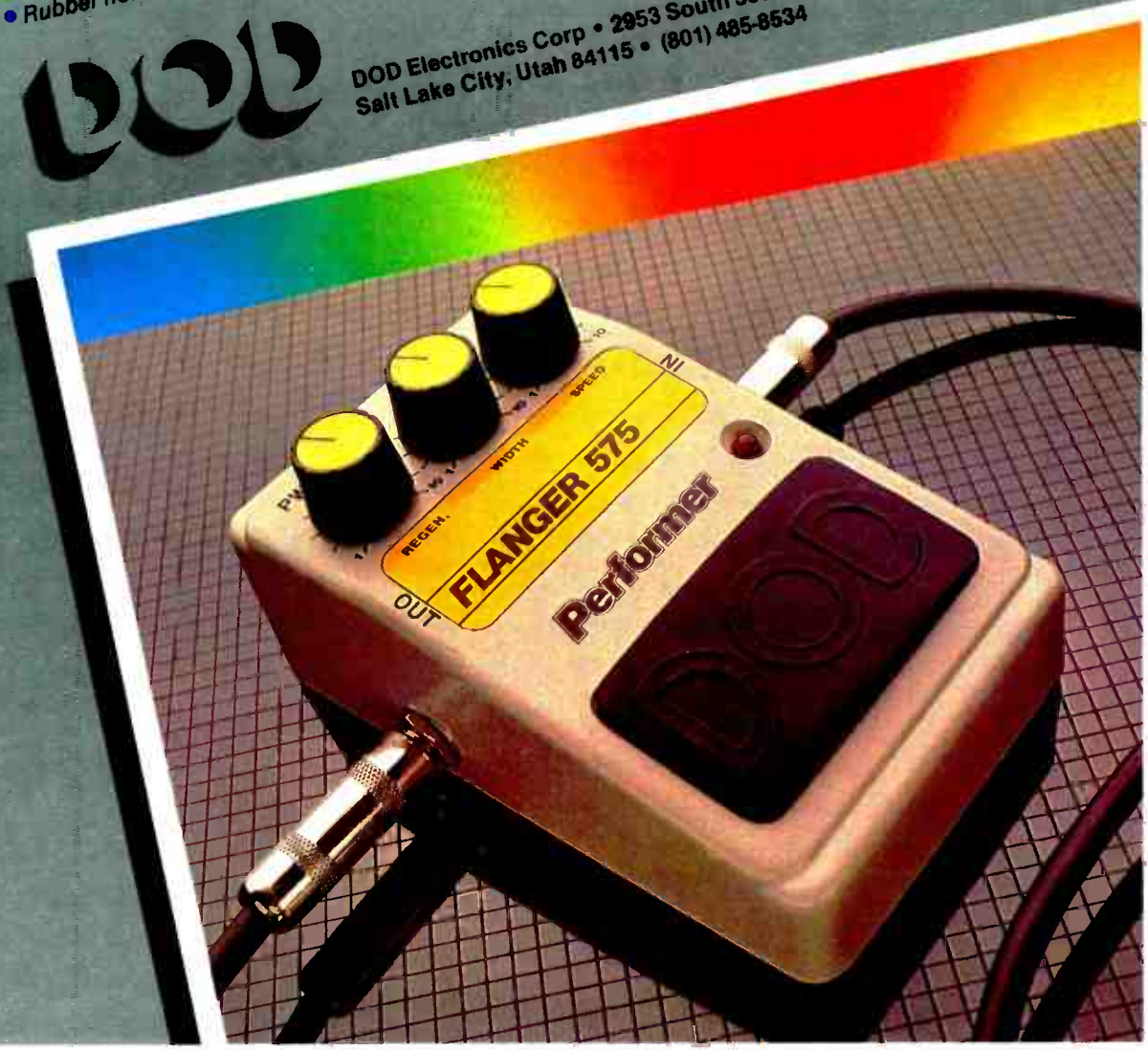

P.A. COLUMN

Venue: Castle Donnington Circuit, Derbyshire
P.A: Malcolm Hill Associates, Hollingbourne, Kent



It is doubtful if England has ever seen such a gathering as was assembled at Castle Donnington for the 1981 heavy metal festival — in every sense of the word, and Castle Donnington must now be firmly established as the premier UK festival as far as rock is concerned.

From a musical point of view, it is unlikely that a more formidable line-up of top names has ever been assembled anywhere — except perhaps at the Nuremberg Festival in Germany the previous weekend. Headlining were AC/DC, with Whitesnake, Blue Oyster Cult, Slade, Blackfoot, also from America, and More. There were no mediocre fill-in bands whatsoever, and the presentation was fronted by Radio One's Tommy Vance. From an attendance angle, the huge arena was literally full to capacity with over 70,000 tickets sold — a figure which astounded even the promoters, as while it had been hoped to exceed last year's figure of 35,000, no one had even dreamt that the figure would be doubled! Also, the PA rig, provided by Malcolm Hill Associates, must have been one of the biggest ever seen on this side of the Atlantic employing, as it did, some 86 self contained 4-way cabinets with a total amplifier power of 80,000 watts to drive them. The staging was also a huge structure with a motorized lift/tilt roof canopy some 60' x 45' and massive wings to accommodate the PA and to provide storage facilities for equipment and a VIP viewing gallery. This was provided

by Edwin Shirley Trucking using the American designed UPS 'Phoenix' staging/roof system. Even the site was ideal, with the stage way down at the bottom of a long slope, giving ideal viewing of the stage from practically every part of the arena, and also giving good propagation characteristics for the PA.

So everything seemed set. Even the sun shone, and by midday, the arena was filling up nicely.

Then the rains came down — just as the festival was about to start, and drenched everybody and everything. Water literally poured through the huge stage canopy onto Marshall and Hiwatt stacks onstage, into the monitor desk, all over a Yamaha CP80 electric grand piano, and seeped into hundreds of flightcases all stacked up at the rear of the stage, while stage crew and roadies rushed around with polythene sheeting in a frantic endeavor to get the gear under cover. The main PA stacks just stood no chance whatsoever as there was no forward extension of the canopy to keep the water off the front of the cabinets — all of which employed direct radiating cone drivers for the bottom and mid ranges, and which were therefore totally exposed to the elements. Even the amplifier racks were only protected by a series of not-quite-meeting tarpaulins draped from the top of the loudspeaker stacks and were repeatedly deluged as water built up in the tarpaulins and gushed in through the gaps. Out in the control

tower, the PA and lighting desks were soaked, as was much of the outboard equipment, due to the total absence of any protection across the front or back of the tower — which is understandable, because if there had been, then many thousands of spectators behind the tower would not have been able to see the stage.

Notwithstanding the difficulties, the first act, More, went onstage just about on schedule at around 1 o'clock, with makeshift umbrellas and numerous towels covering the two mixing desks, and all went reasonably well — until just before the end of More's set when the whole of the left-hand PA stack went out with a fizz and a bang! There were some 43 power amplifiers feeding the left-hand stacks, all of which had already fully loaded the 3-phase, 440v mains power feed to that side of the stage, when a mobile studio truck just drew up and plugged in, taking another 20A or so from the supply with the result that the whole feed was blown out. No sooner was this rectified, than the whole right hand stack went out due to water having got into the stage left power distribution board, which burned out the neutral return wire of the 3-phase supply. Despite the difficulties, More finished their set, and the rig was switched off for about 10 minutes while repairs were hastily carried out, and rainwater mopped up in readiness for Blackfoot. But still the rain kept coming as Blackfoot gave their performance, to be followed by

PA Column...

Slade. By the time Slade came onstage, the rain had eased somewhat and drying out operations began, and Slade were really about the first band to use both stacks of the PA; at any appreciable SPL. They clocked up a fairly steady 96dB(A) with odd peaks at 100dB(A) measured at the control tower. There was, however, an appreciable fall-off in level towards the back of the arena, due largely to the slope of the ground, the sheer numbers of people present providing a highly efficient acoustic absorber, and to the fact that there were no long-throw components or clusters in the system. The quality at the control tower was quite good — especially at the bottom end, where for some reason Malcolm Hill's systems always seem to excel — this despite the fact that only 12" drivers are used for the bass frequencies. Obviously, due to the fact that all the loudspeaker cones had been drenched, the level was being held in check so as to give the cones a chance of drying out before Whitesnake and AC/DC came on stage later in the evening. The Slade set went well, and Noddy Holder really worked hard at getting the vast crowd into a festive mood, and by the time they came off at about half past four the band were really motoring and a real party spirit was developing now that the rain had stopped. But just as things seemed to be settling down, Malcolm Hill found that there was worse to come. The next act on stage, Blue Oyster Cult, refused to operate within the limitations imposed by the wet equipment and oblivious to the screams of protest from the rig as the loudspeaker cones tore apart — which could be clearly heard above the actual sound being reproduced — their sound engineer continued to wind up the wick, succeeding in the process in taking out approximately half the 10" Tannoy midrange drivers and a third of the ATC 12" low frequency drivers. So for the rest of the day, the SPL never got very much above the level achieved by Slade due to almost half the loudspeaker system being out of action.

It really was a great shame, because a great deal of time and effort had been put into getting this one right. It was to have been the big one, and many of Hill's existing and prospective clients, along with the press, had been invited along to see and hear it all happen. Also, it was the

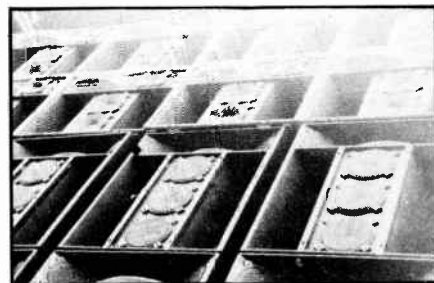
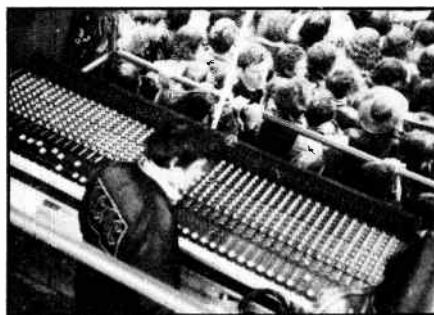

debut of the new Hill M3 4-way self contained PA cabinet, and was, as we said earlier, certainly among the biggest — if not *the* biggest PA rig ever assembled in the UK, and by a UK based company. What we heard earlier sounded good. It should have been good — it was as well engineered and built as any rig that I have yet seen and employs only the very best components — most of which is of UK manufacture. I have heard and read some not very encouraging reports in respect of the sound at Castle Donnington, but being a soundman myself, I am only too well aware of the problems that can beset even the best planned operations. As many readers — and many in the trade will know, I am the first to cast criticism in respect of bad sound quality where it is justified. But for my money, Hills did

all that could have been expected of anybody under the circumstances — and despite the numerous setbacks, still kept the show going and managed to produce a sound quality that was better than many I have reviewed in the dry comfort of a theater auditorium, and catering for a minutest fraction of the numbers that were at Castle Donnington.

Some idea of the sheer size of the rig can be gleaned from our photographs. The main loudspeaker stack comprised in total 42 of the new Hill M3 self contained 4-way cabinets and 44 Hill M2's — which are an earlier version of the M3 and are now used mainly for flown systems. These were arranged with the M3's stacked two cabinets high by 10 deep on each side of the stage, with the M2's stacked in a similar formation on top again, resulting literally in a gigantic wall of loudspeaker cabinets four high by 10 wide on each side. Each cabinet was powered by a separate 3-channel power amplifier specially matched to the cabinet. The M3's were powered by Hill TX1000 Tri-amps, delivering 600/300/300 watts a piece, while the M2's were fed from Hill TX800 Tri-amps delivering 450/220/220. A close inspection of the backstage set-up showed this to be a remarkably neat and tidy system, with just a single multiway cable linking each cabinet back to its associated power amplifier. The fourth way on the cabinets the HF, fed is via a passive filter from the upper mid amplifier channel. The M3 is fitted with three ATC PA75-314 Bass-LC 12" long coil low frequency drivers, two Tannoy 10" co-axial drivers, whose 10" cone diaphragms handle the lower mid band, and compression driven circular exponential horn section handles the high frequencies, and a single ASS MH570/2 radial horn fitted with a JBL 2441 compression drive unit handles the upper mid. The ATC 12" low frequency units are working as direct radiators, and are loaded by a large, double ported, bass reflex chamber behind.

The main PA desk was a Hill J Series 40 channel, eight group stereo monster which fed the power amplifier racks via a pair of White Series 4000, 27-band 1/3rd octave equalizers and a Hill 3-way stereo active crossover. The auxiliary equipment in use included an Eventide H910 Harmonizer, two Lexicon Prime-Time Digital Delay

Everybody's Gotta Have One

DYNA-LIGHTS

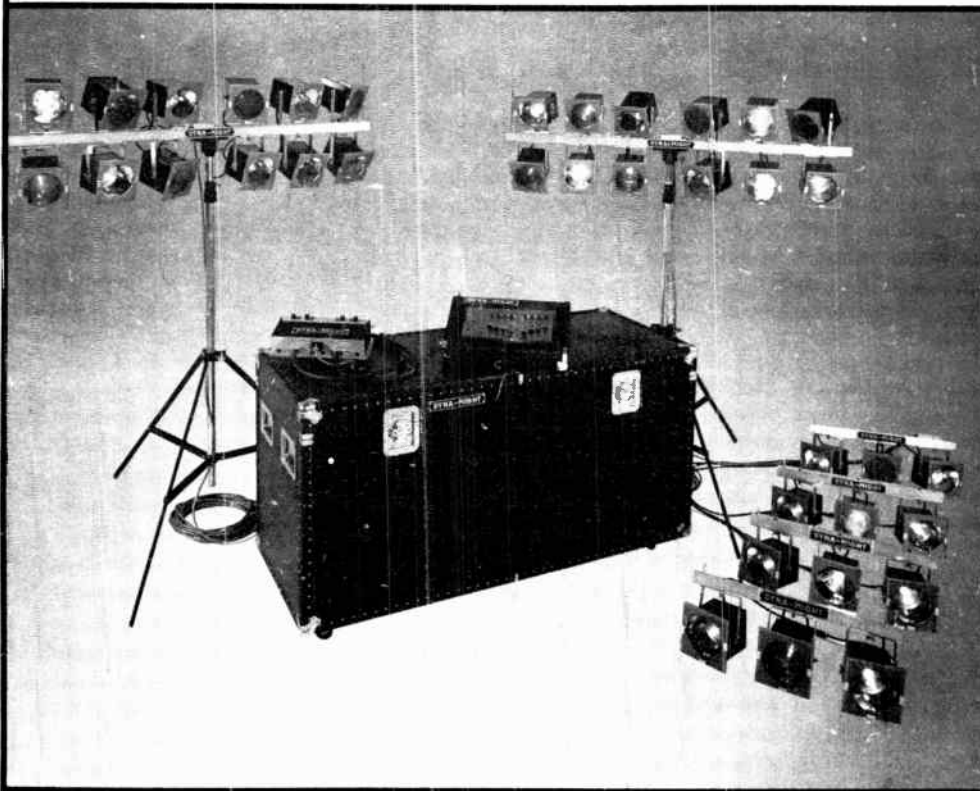

Dyna-Might Sound & Lighting announces the creation of — **DYNA-LIGHTS**. Pictured is the Mdl. 3600 Dyna-Light System featuring:

- Thirty-Six — 110,000 candle power P.A.R. aircraft landing lights. (3,960,000 total).
- "That's bright."
- A low voltage console with eight subscenes, four master scenes, scene selector and blackout.
- Four channels of dimmer with two 120 volt AC inputs. The total power required is ONLY 30 amps at 120 VAC.

The entire system can be set up in minutes as it is unpacked from a single Dyna-Might road case. **DYNA-LIGHTS** are what you need to present the total concert effect.

For information contact:
DYNA-MIGHT
 SOUND & LIGHTING
 3119-A SOUTH SCENE
 SPRINGFIELD, MO. 65807
 (417) 883-4549

— For color brochure — call Dyna-Might — (417) 883-4549 —

WIRELESS GUITARS **NADY PRO 49 SYSTEM!**



You've heard our wireless in action pros. Now you don't have to be a star to afford a Nady system.

THE ROLLING STONES • BRUCE SPRINGSTEEN • BOZ SCAGGS
 DOOBIE BROTHERS EARTH, WIND & FIRE
 TODD RUNDGREN STEVIE WONDER
 CHEAP TRICK ROD STEWART
 VAN HALEN DEVO • STYX
 NEIL YOUNG DIRE STRAITS
 BOB SEGER JOURNEY • etc.



- ✓ **Incredibly affordable**
- ✓ **25dB quieter** than any other unit. Compare before you buy. **No hiss**, even on those screaming solos
- ✓ **Proven quality** from the original wireless company.
- ✓ **No cords** for any instrument with a pickup. Use with any amp or effects. 250 foot range.

Made in USA (not a Far Eastern imitation)

Manufacturers of a full line of wireless equipment, including microphones. Ask your favorite dealer or write:
NADY SYSTEMS, INC., 1145 65TH STREET, OAKLAND, CA 94608



"Nady Lo-Noise" circuitry is covered by U.S. Patent #4,215,431 held by John Nady.

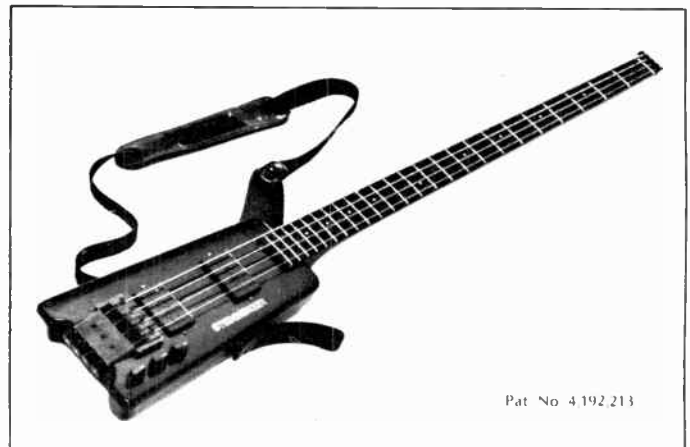

Pat No. 4,192,213

Evolution.

It's not an easy thing for those who live in the past to accept. For the rest, The Steinberger Bass.

STEINBERGER

Steinberger Sound, 148 Sullivan St., Brooklyn, NY 11231
 (212) 447-7500



GARY U.S. BONDS

Until recently the name Gary U.S. Bonds was merely a footnote in the history of Rock & Roll. He had made a reputation for himself in the early Sixties with a string of raucous singles: "New Orleans", "Quarter to Three" and "School is Out" that had sent teenagers wild on the dance-floor. But after a few years of stardom he slipped from the limelight and seemed destined to end his career playing discos and cabaret shows in one night stands across the country. It was one such night a few years ago at a club near the New Jersey turnpike when a certain Mr. Bruce Springsteen stopped by to see what had become of one of his early heroes. Bonds picks up the story.

"Someone told me there was someone in the club who sang and wanted to come up and play a few numbers. You usually get that in the clubs — some local act gets drunk and wants to try his luck. I figured it was one of those guys. I had never heard the name Bruce Springsteen. So I brought him up on stage and mentioned his name and the place went wild. Right away I knew he meant something."

And that was the start of a beautiful friendship, the end result of which is a powerful new album *Dedication* by Bonds, made under the guidance of Springsteen, and a series of shows that have delighted new fans and veteran supporters alike.

When I spoke to him, Gary was still weary from the previous night's show at The Venue in London — hardly surprising as the energy he put into it would have tired a man half his age. He's 42 now, but despite the ups and downs of his career he hasn't lost his easy going sense of humor, or his ability to tell a good story of how Rock & Roll was way back when.

He was born Gary Anderson in Jacksonville, Florida, but grew up in Norfolk, Virginia — a large navy town that is hardly the place you would expect legends to begin.

"I really didn't plan to get into this business — it was a lucky break for me, I never thought 'Hey, I want to be

NEW

Guitar of the 80's **PE-R80**



**Mike Pinera
(Alice Cooper Band)**

"PE-R80 is the best guitar I've ever played. I love the playability and it offers a crisp, clean sound when I need it."

Mike Pinera

**Robin LeMesurier
(Rod Stewart Band)**

"Honestly, my PE-R80 is my Number 1 guitar."

Robin LeMesurier

Aria Pro II
The New Legend In Electric Guitars

**ARIA ANNIVERSARY
25th**

Aria Distributors:

Aria Music USA Inc., 1201 John Reed Ct., City of Industry, CA 91745 Tillman Distributors Inc., 100 Centre St., Charlotte, NC 28216
Great West Imports Ltd., 788 Beatty St., Vancouver, B.C., Canada Canada Musical Supply Ltd., 8660 Jeanne-Mance, Montreal, Quebec, Canada
World Radio History

Proven on tour with Craig Chaquico and Jefferson Starship

Craig Chaquico's hot playing style requires the best. And he chooses the Carvin DN612 Koa Doubleneck and X100-B amp stacks because they deliver the performance and reliability he needs.

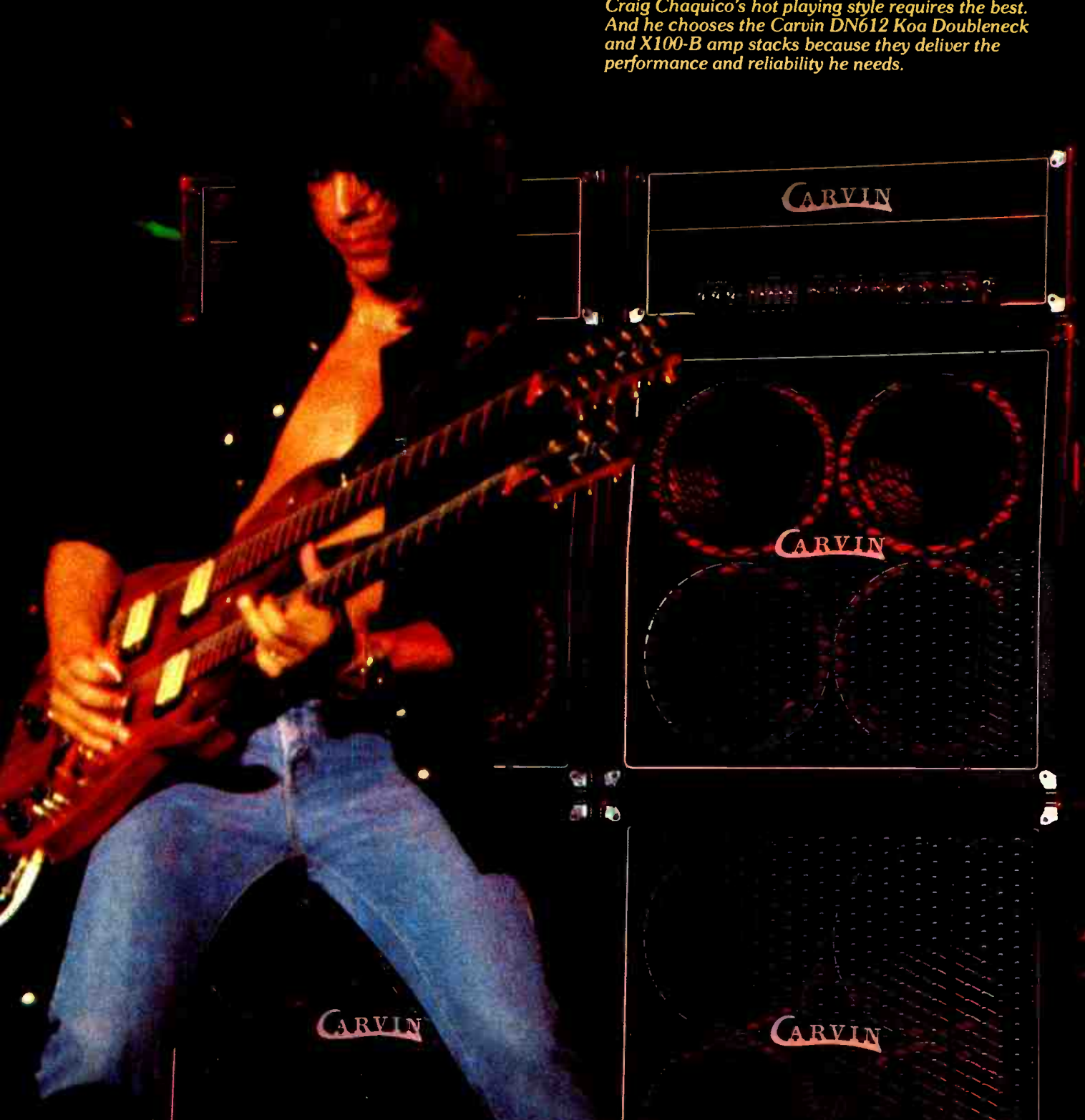

For your FREE 1982 Catalog write CARVIN, Dept IM-38, 1155 Industrial Ave., Escondido, CA 92025 or call Toll-Free 800-854-2235 (Calif. 800-542-6070). Carvin Products are only available direct. To RUSH a Large Poster of this Dynamic Photo plus Catalog send \$3.



GARY U.S. BONDS

a Rock & Roll star.' When you live in Norfolk you don't have those kind of goals — your biggest goal is to become captain of the USS Enterprise. All my family were navy — I didn't want that." And so, rejecting a life on the ocean wave, Gary took up singing, and joined a local group, the Turks. They modelled themselves on the scores of vocal groups that could be heard on r n' b stations across the country in the early Sixties. Top amongst them were The Drifters.

"Clyde McPhatter was my first idol. He had a high squeaky voice — I thought it was cute. He was the guy I tried to emulate. The Drifters had some great lead singers — they were an excellent group. I also used to listen to the Flamingoes, who had a hit with "I Only Have Eyes For You". There was a group called The Turbans, The Cadillacs (of "Speedo" fame), The Spaniels. That was basically what we had back then — or you'd get your kicks listening to Pat Boone. I wasn't too much into Pat Boone."

Then into the story comes an ex-G.I. named Frank Guida, who, along with his buddy Joe Royster, had written a song called "New Orleans". They borrowed Gary from The Turks to sing lead vocal, and the record turned out to be a huge hit. More hits followed, and Gary U.S. Bonds enjoyed his first taste of glory. When he toured over in this country in 1962 with Gene McDaniels and Johnny Burnette, the headlines described him as "The World's most exciting Rock Star".

But as the "British Invasion" of the States (led by The Beatles) got underway, performers such as Gary U.S. Bonds soon became unfashionable. The headline tours and the hits stopped, and the club dates became more frequent and less rewarding. Hearing Gary tell the story, it is quite easy to believe the scene in the *Blues Brothers* movie when they play the "Country Bunker".

"There were little clubs all over

the place. They would spring up over night then one would have a fire or disappear mysteriously. Then it was a new place with a different name. "Gregory's A Go-Go". You'd get stuck a lot for money — standing on stage and you'd see the promoter running out the back door. So you know you're not gonna get paid, but you think "what the hell" and keep on singing anyway. Many days we had gone out to do a job five or six hundred miles from home and at the end of the night there's nobody to pay you, so you have to go down the street to some other club and hope to pick up five or ten bucks so you can get something to eat. You learnt quite a few different selections of songs 'cos you never knew what kind of environment you were going to be in."

And so Bonds went from clubs to Oldies Shows and finally in the Seventies he ended up as a sub-Vegas style crooner on the supper lounge and disco circuit. Ry Cooder did a fine version of "School Is Out" on his *Showtime* album. But it was Bruce Springsteen, ending his shows every night with a frenetic version of "Quarter to Three", who introduced the name of Gary U.S. Bonds to a whole new generation of Rock fans.

Following their meeting, the two began to hang out together, and Bonds was going to ask Springsteen to work on some recordings with him. However, the Boss asked him first. The original idea was to cut an E.P. — the songs chosen were two written by Springsteen in the style of Bonds' old hits and "Way Back When", a Bonds

original. The studio used was the Power Station in New York, where Springsteen and the E-Street Band had just spent two years working on *The River*. It wasn't Gary's first trip back to the studio since his former glory days.

"I had been in the studio off and on, but it was mostly those fly-by-night labels. Some guy says 'I've got a great idea, I'll give you 2,500 dollars, go and do this.' So you go in, take the money, run like hell and don't look back. It was great to go in this time and put my mind and body into it knowing this could really be it."

However, the resulting tracks, cut with the E-Street Band, were so good that it was obvious that an E.P. wasn't going to be enough, and so it was decided to do a whole album. The only problem was that Bruce and the E-Street Band were about to go out on tour, which left them two weeks in which to do the album. So how do you make an album in two weeks?

"Basically, the songs were written in the studio or on the way to the studio. 'This Little Girl' Bruce started on at 4 o'clock in the morning over at my house. He's sitting there trying to play the piano, I'm sitting there sipping on a bottle of vodka. Everything was done in less than four takes. If you do it five or six times you lose the spontaneity. We wanted to keep that on the album, which I think we successfully did. It sounds fresh and as far as I'm concerned, that's what you've got to have.

"We didn't know what musicians we could get on the album because they were on vacation after making *The River*. We had to have who we could get, so there's a mixture of guys on the tracks — some E-Streeters, some of my band and some of the Asbury Jukes. There was a really good feeling in the studio — it reminded me of when we were doing the old recordings, only we didn't know what we were doing then. This time we knew what we were doing and had fun.

GARY V.S. BONDS

"Daddy's Come Home" is my favorite on the album. Miami Steve started writing it and I loved it, only he didn't have any words to it. So he said 'O.K., I'll have it ready for you tomorrow.' They laid down the track when I was on my way over to the studio and when I got there he sang it to me. We went in and did it in one take. I sang it just the way I felt at that moment."

The song is a key point on the album — prior to that the songs are straight ahead party records, but with the presence of Springsteen et al they tend to sound as if Bonds is just a guest on his own record. With the reflective, almost mournful *Daddy's Come Home* Bonds finally asserts himself, showing a less raucous, more soulful style, and claims the album as his own and not just as this year's project for Springsteen. This authority is borne out in his treatment of



Jackson Browne's song "The Pretender". The original version (coincidentally produced by John Landau) is a morbid hymn of despair. The way Bonds sings it, complete with gospel backing vocals, it becomes an affirmation of strength of will. Bonds was worried about how Browne would react to this version. ("I was afraid John Landau would get ticked off.") But Browne loved it, and he and Bonds performed the song together on stage at a recent benefit concert in Los Angeles. Another highlight for Gary occurred in the recording studio when Ben E. King, who sang lead vocals on such Drifters classics as "Up on the Roof" and "Under the Boardwalk", guested on the song "Your Love".

There is only one song written by Bonds on the album, though he had written several "Straight Rock & Roll Bob Seger sort of things". However he intends to use more original songs on

Continues on page 54



FROM A COMPACT PIANO and built to take it!

Factory installed Helpinstill sensors pick up real string sounds you can adjust to whatever volume you need or want. Plugs into a guitar amp or other sound equipment with a high impedance input.

Weighing less than 325 lbs., the Melodipro is built to work and travel. No nonsense black finish, cut out handles, heavy double casters . . . made to go on and off stage, in and out of vans and trucks.

Take off and go . . .

plug in and play as loud as you want.

For more information contact your dealer or

AEOLIAN Corporation 2718 Pershing,
Memphis, TN 38112

THE WORLD'S BEST DEAL ON SYNDRUMS IS RIGHT HERE ON THIS PAGE.

Quad Model 478 (4 Syndrums, control console, drum snake and internal power supply)



Twin Model 278 (2 Syndrums, control console, 2 drum cords and internal power supply)



Single Model 178 (1 Syndrum, control console, drum cord and power supply)

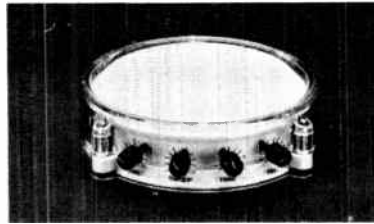

Syndrum CM (1 Syndrum w/power supply)

Here's my check for the famous Syndrum sound. Please send the items I've checked below to my favorite dealer.

Model	Quantity	World's Lowest Syndrum Prices	Total
Syndrum CM		\$79.00	
Single Model 178		179.00	
Twin Model 278		349.00	
Quad Model 478		699.00	
(Calif. residents add 6% sales tax)			
Total (Prices above include freight.)			

Name _____ Phone _____

Address _____

City _____ State _____ Zip _____

I'll pick up my Syndrums at:

Dealer Name _____

Address _____

City _____ State _____ Zip _____

Send payment and coupon to: Syndrum Factory Cash Plan
Dept. IM
11300 Rush Street
South El Monte, CA 91733

Please allow four weeks for delivery. Send check or money order only. No cash please. This offer good through 12/31/81

Syndrums are now available to you at wholesale prices.

Here's why: Our Factory Cash Plan is a new marketing approach which slashes your music dealer's overhead by eliminating warehouse storage, store displays and inventory financing. And reduced retail overhead means reduced prices for you.

On the coupon, just indicate which models you want. Also, fill in the name and address of your favorite dealer. After you send in your payment, you'll get a call from the dealer you chose, and you can pick up your Syndrums from him.

It's as simple as that. The best deals always are.

**SYNDRUMS
MINDRUM**®

11300 Rush Street,
South El Monte, CA 91733

GARY U.S. BONDS

the next album, as well as more songs by his daughter, Laurie Anderson. As yet though, with a heavy touring schedule to complete, no definite plans have been made for a follow up to *Dedication*.

Three of Gary's present road band played on the album — keyboards player Rusty Cloud, drummer Mike Micara and sax player Joey Stann. Joey was formerly with Southside Johnny and the Asbury Jukes, but he got fed up stuck at the back playing baritone, and he joined the Gary U.S. Bonds band so that he could play tenor. The others are all old friends and acquaintances. A final touch to an already romantic tale — guitarist Joe Martin was Gary's lawyer's delivery boy — he tried out for the band and landed the job.

On stage at The Venue, the band



had the unenviable task of having to emulate the formidable E-Street Band, whose memory is still fresh in many

people's minds. It took just a few bars of "Jole Blon" the opening number, to ease worries on that score, Gary U.S. Bonds sang with a voice full of strength and sweetness, he sweated and strutted around the stage and never once looked as though he wasn't having the time of his life. There were several references made to Mr. Springsteen, which brought yells of approval from an already lively crowd, but the biggest roar of all came when he substituted the words of "Daddy's Come Home" and sang instead "Gary's Come Home". And that he certainly has. ●

Angus MacSwan

Full Color

Musicians Only



#1



#2



#3

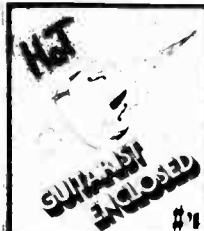

#4

Show the World YOUR A Member of the Arts

PROUD TO BE A MUSICIAN?
These Original T-shirts in full color
SAY IT ALL!
AVAILABLE IN LT. BLUE, YELLOW & SAND
IN SIZES: S M L XL

★ MONEY BACK GUARANTEE ★

DON'T DELAY SEND \$7.95 + \$1.00 FOR POSTAGE & HANDLING

QUANTITY	NUMBER	SIZE	COLOR	\$7.95 Each

SUB-TOTAL
(\$1.00 EACH SHIRT) POSTAGE & HANDLING
(FLA. RESIDENTS ADD 4%) PLUS TAX
(U.S. CURRENCY ONLY) TOTAL

HURDY GURDY PRODUCTIONS
 Box 17080, Dept. 1-12
 Plantation, Florida 33318

NAME _____
ADDRESS _____
CITY _____
STATE _____ ZIP _____

Now we can give you what he can't.

He's on the endangered species list. Jim Dunlop has synthetic Tortex picks, carefully designed and manufactured to give the characteristic maximum memory and minimum wear that made tortoiseshell famous. Now available in six popular gauges and bright rainbow colors.

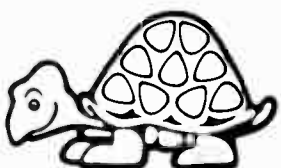

Dunlop Tortex Plectra

Dunlop Manufacturing
P.O. Box 846
Benicia, CA 94510

DUNLOP

As good as the best for a lot less:

Compression Drivers and Exponential Horns designed for unsurpassed natural sound with big power delivered just where you want it.



ask for the facts

RENKUS-HEINZ, INC.

17851AB Sky Park Circle
Irvine, CA 92714 • (714) 540-3154



Synthcheck

Sequential Circuits Pro-One

Synthesizer technology has advanced rapidly over the past 15 years, both in terms of functions and the conceptual framework of the musicians themselves. A venerable old dinosaur like the ARP 2600 offered keyboardists an incredible array of tonal possibilities and complex patches — a great axe, but too much, too soon; and rather unwieldy in terms of live presentations, so it became something of a designated hitter of the studio (now coming to the plate, Wendy Carlos), where its functions might be applied at leisure by people like Roger Powell, Patrick Gleeson and Josef Zawinul. But in less sophisticated hands even the most advanced machines came off unimaginatively. At one point in time, Keith Emerson had around \$30,000 worth of synthesizer gear, and all he was doing with it was running a square wave with some portamento . . . When synthesizers first came out," Jeff Baxter told IM&RW's Jim Green, "everybody was spending a fortune to sound like a Farfisa!"

Moog, Oberheim and the late, lamented ARP have made great strides in educating the public to the infinite possibilities of synthesizers, but if one had to single out the work of any company in terms of tapping the synthesizer's potential for performance and accessibility that would have to be Sequential Circuits. Their Prophet 5 set the standard for polyphonic synthesizers in both the areas of sound and ease of function — not to mention programmability. Now, with the introduction of the Pro-One, Sequential Circuits has taken *one* of the identical voices from the Prophet 5 and put it in a monophonic format, coupled with the kinds of features and performance that years ago used to sell for two or even three times the price.

Among the features that make the Pro-One unique in its price range are the inclusion of a 40-note sequencer

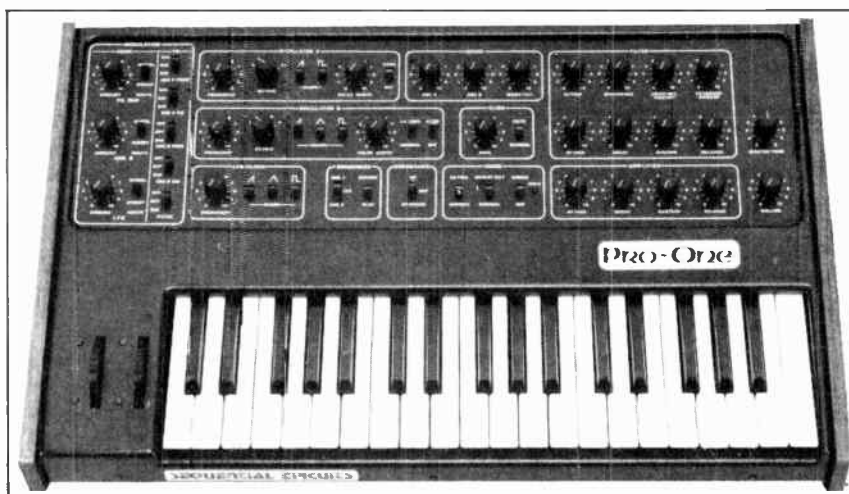

and an arpeggiator. The sequencer is not of the real-time variety (like Sequential Circuits' own Model 800 and Model 1015, which can record notes of varying duration), but nevertheless it is very useful for creating bass lines, motifs and sampling different patches and filter variations. When the Pro-One is initially switched on, Seq 1 is programmed with a 20-note ascending scale, while Seq 2 contains a 20-note descending scale. The 40 notes can be divided between Seq 1 of Seq 2 in any combination, but if you exceed the maximum of 40 you automatically erase your previous programs. To store a sequence you simply switch the Play-Record switch up, choose Seq 1 or Seq 2, and play the appropriate notes; rests are inserted by switching back to Play, then returning to Record for new notes. The most logical approach is to think in terms of quarter notes, which may then be speeded-up into eighths, sixteenths, triplets, etc. by adjusting the rate on the LFO/Clock Frequency knob; transposition may be achieved simply by touching a new key — turning off the power erases any stored sequences.

The Arpeggiator section may be switched to an ascending mode (Up)

or an ascending/descending one (Up/Down). The arpeggiator will automatically sequence between any held keys at a rate set by the LFO/Clock, with no limit to the number of keys that may be held down. This feature is especially effective for establishing odd rhythm patterns with a drummer, but even better are the possibilities when the arpeggiator is *latched*. To do this you simply hold down any number of keys, then switch on the Sequencer Play/Record switch to Record, and the Pro-One will continue to play the notes even after you've removed your hands; then by simply fingering new keys, you can modify the existing rhythm pattern and jump into new keys — 8 can become 11 while you layer as many sounds as you like, until you release the keys, at which point the Pro-One reverts back to the latched section. We found this to be an exceptional performance tool, particularly when we devised a Tamboura patch, which duplicated the shimmering, out-of-phase overtones of the Indian drone instrument.

Another delightful feature of the Pro-One is its Glide section. There is a Rate knob and a switch for moving from Normal to Auto Glide. In the Normal position the Glide operates as

Sequential Circuits Pro-One

a traditional portamento, but in the Auto position the notes glide only when a new key is fingered while the previous key remains held. What this does for keyboardists is allow them to achieve the kinds of graceful bends, slurs, and hammer effects that previously were only in the domain of guitarists (sitarists) and other string players; of course, you can achieve such effects by toying with the pitch wheel, but the Pro-One's Auto Glide let's you do it with one hand, leaving the other hand free to use the Modulation wheel or make adjustments in the Patch for expressive changes in mid-solo. This is a very subtle, musical effect, and many of the keyboardists (and guitarists) who tried it fell naturally into the kind of vocalized glisses and embellishments that someone like Indian virtuoso L. Shankar gets from a violin.

The Mode section gives you the following performance options: Retrig/Normal switch. This provides a choice of low-note priority in Normal (the next key sounding only when the previous key is released) or instantaneous retriggering of the envelope when any new key is hit (Retrig); the Repeat/Ext switch lets you play with continuously repeated notes, the notes being constantly retriggered at a rate set by the LFO clock. Finally there is a Drone switch, which allows for notes of indefinite duration, transposeable at the touch of a key.

At this point we come to the Pro-One's audio sources and sound modification features, which are no doubt what you'd expect to find on one of today's synthesizers: Modulation; Oscillator A & Oscillator B; LFO/Clock; Mixer Osc A & Osc B (with Noise and control functions for an external audio signal); Filter; Amplifier; Volume and Master Tune. But there is a big difference in terms of the Pro-One's performance potential. You can really blow on the Pro-One — there is a naturalness to the patches, a spontaneity to the function that makes it readily accessible to a musician or non-musician. There's a logic to the path and shaping of the signal flow that allows the user to readily conceptualize sounds and variations on the Pro-One. This is a most difficult thing to express via the written word; how does one truly explain the pitch, time and modulation characteristics of a patch with words? But that's what *true synthesis* is all about: taking the energy of each sound module, and

getting them to interact and interlock to produce musically interesting and useful waveforms.

Which is what the Pro-One does supremely well. The basic sound of Sequential Circuits' chips, oscillators and filters is remarkably warm and rich, with none of the nasal phoniness or gimmicky geek effects that have marked too many synthesizers of the past decade (although freak-out factory patches such as "Single-Engine Crop Duster" and "Dynamo" should please even the most confirmed aural psychotics). The Pro-One's Modulation section contains three sources (Filter Envelope, Oscillator B, LFO), all fully mixable and assignable, either routed Direct or through the Mod Wheel on the adjacent switches. Amount knobs determine the level of modulation, while Osc A Freq, Osc A PW (Pulse Width), Osc B Freq, Osc B PW and Filter switches determine the destination (Direct, Wheel or neither). The number of potential modulation combinations is impressive.

The best way to set up a useable patch is to turn all the destination switches off, rotate the amount knobs to zero, and concentrate on getting a good interaction between Osc A & Osc B, leaving the Modulation section free for subtle push-pull effects, generally routing at least one of the Mod sources direct and one through the wheel (*Double Modulation*) to create the most possible performance options without throwing off the player's basic patch orientation. We suggest leaving the Sync switch off (forces Oscillator A to follow Oscillator B in hard sync), which encourages the user to come up with more provocative tuning arrangements. Each oscillator has a Frequency knob, continuously variable over one octave; an Octave knob which transposes over a 4-octave range; and a Pulse Width knob to determine the pulse wave duty cycle. Osc A has a sawtooth and square wave, while Osc B (and the LFO) has sawtooth, triangle and square. Osc A has a Sync switch, while Osc B has a Frequency switch, which allows it to function in sub-audio regions and as a second LFO (for truly bizarre effects), as well as a Kybd/Off switch for independent operation of Osc B. Coming through the Mixer, the signal is then modified in the Filter section: with knobs for Cutoff, Resonance, Envelope Amount and Keyboard Amount, which allows you to open up the envelope so that you hear the harmonics you want, or to emphasize and suppress certain

overtones. Having come up with an appropriate *timbral* balance, the Attack, Decay, Sustain and Release knobs allow you to play with the *time* relationships of your signal, to create short, plucked, punchy sounds or long breath-like durations. The Amplifier section's Attack, Decay, Sustain and Release knobs perform a similar function, giving you an extra level of control, before feeding the final signal into the Volume and Master Tune controls.

The end results are quite gratifying given the rock-bottom list price. The Pro-One is above all an eminently practical instrument for the beginning synthesist — so it was important for Sequential Circuits to keep the instrument at a realistic price (but you can *add on* with their Model 700 Programmer). It would also have been a plus if the Pro-One had been built a little more robustly; it is a lightweight, and relatively delicate instrument, and unless one is contemplating nailing it down in a studio, a high-quality road case is an absolute must. Another caution is dust — the Pro-One's contacts are very susceptible to it, but *that* comes with the territory. Cleaning the contact wires with a high quality isopropyl alcohol (like they use for syringes) will remedy any noise or double hits, while leaving a minimum of water residue.

On the plus side, maintenance is relatively straightforward, and the owner's manual contains easy to follow instructions for user trim and tuning (trim pots are located right on the control manual). And on the back panel (Line Voltage; Power; Audio Out; Audio In; Filter CV In; Gate Out; CV Out; Gate/Clk In; CV In) are features for mono/or stereo line-level output (with sufficient level to drive headphones), processing of external audio signals, external control of oscillators, patching of several Pro-One's in sequence, and external gating. The latter is particularly useful when teamed up with a sophisticated rhythm machine; we synched the Pro-One to a Roland Rhythm Composer, and it was the perfect vehicle for creating interesting click tracks — on one track we tuned the oscillators a fifth apart and created a background that can best be described as Japanese Bo Diddley.

In conclusion, *sound* is why you'll buy the Sequential Circuits Pro-One — the instrument is supremely musical and flexible, a true synthesizer, not just a souped up string ensemble. The Pro-One is fun to use, and for the price, we can't imagine why you'd want to consider anything else. ●

Allen & Heath Present

FROM COAST TO COAST

The fastest rising stars of Radio
Stage and Recording Studio.

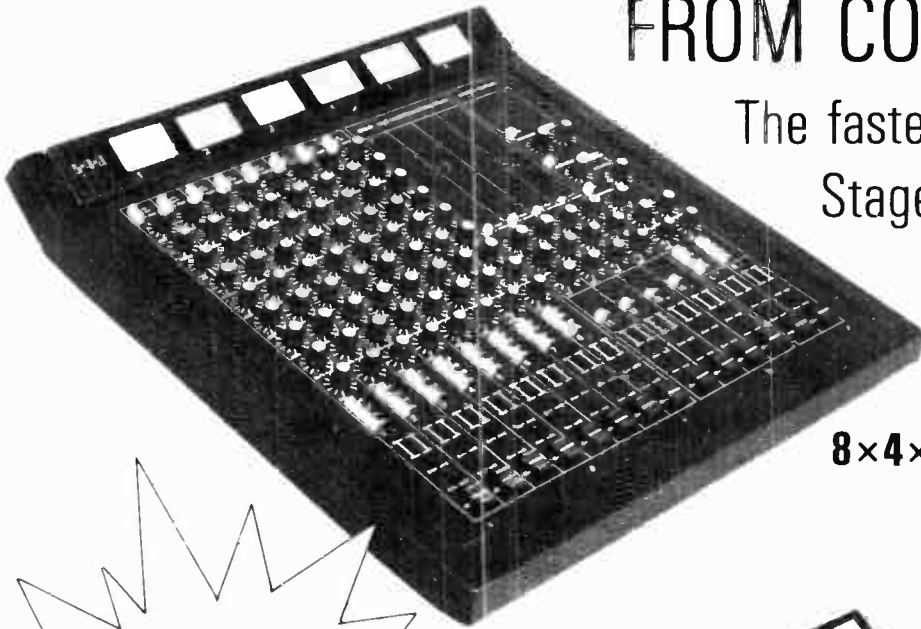

8x4x2

West Coast:

Cara Pacific Sales
California 90291
Tel: (213) 821 7898

24x4x2 - (Built-into 'bulldog'
Flight Case)

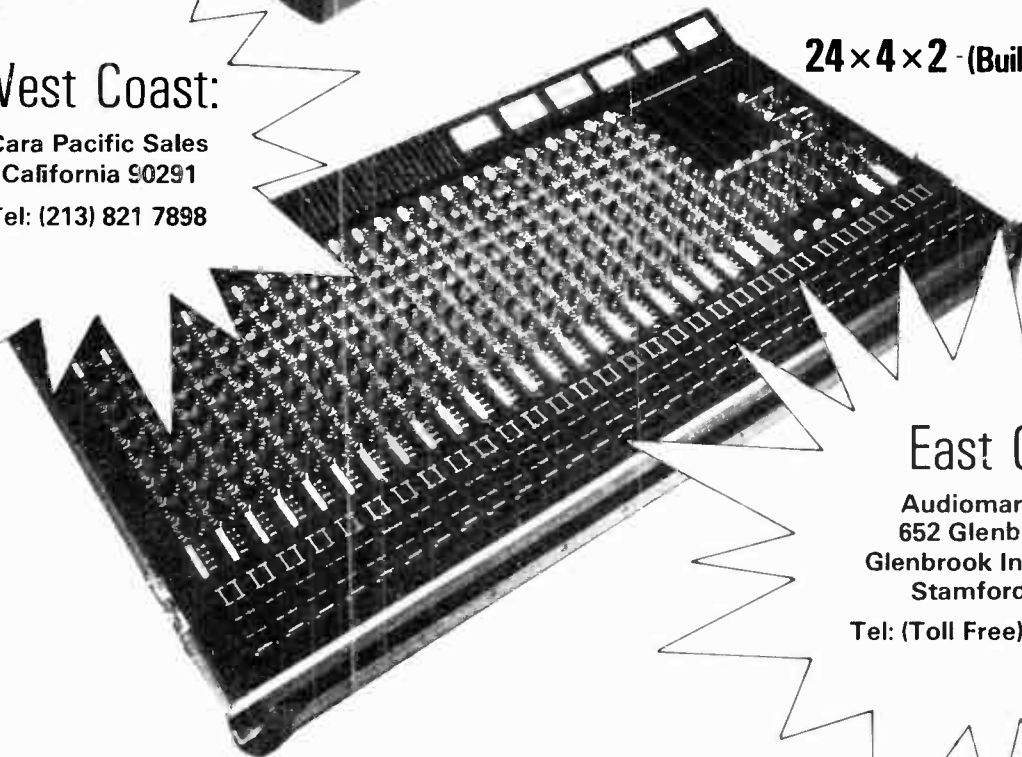

East Coast:

Audiomarketing Ltd
652 Glenbrook Road,
Glenbrook Industrial Park
Stamford Ct 06906
Tel: (Toll Free) (800) 243 2598

16x4x2

(Also available
built-into flight case.)

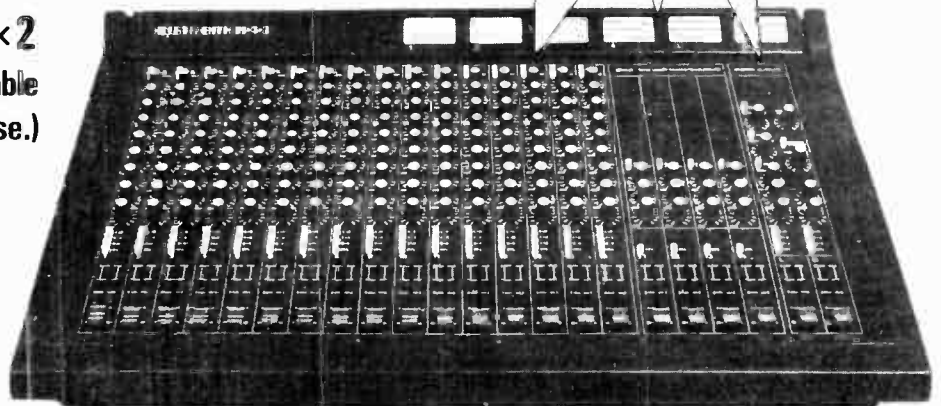

AHB
ALLEN AND HEATH BRENNELL LTD
LONDON ENGLAND



Recording

Fostex A8 Recorder & 350 Mixer

An idea whose time has come! To do justice to Fostex's wonderful new line of recording hardware, it must be examined within a context of an entire concept — *personal multi-track*. To Fostex, *personal multi-track* means high quality multi-track recording equipment that is easy to use and highly affordable.

The engineers and designers at Fostex begin with the premise that contemporary music is conceived, composed, developed and realized on the multi-track recorder. I don't think many musicians or songwriters today would disagree. But, to the very great frustration of the music makers, multi-track recording spells big bucks for either very expensive and complicated hardware, or costly studio time. Personal multi-track changes all that.

The heart of Fostex's personal multi-track system is the model A-8 eight track open reel tape recorder. The model A-8 is a compact, lightweight (only 29lb) machine that puts eight tracks on 1/4" tape. When this machine was introduced and I was asked to review it, my reaction was intensely skeptical, to say the least. I said, "Aw, come on, give me a break. Eight tracks squeezed onto 1/4" tape has got to mean a lousy signal-to-noise-ratio and outrageous crosstalk between tracks." Well, after torturing a model A-8 on my test bench for many hours, and actually using it in a recording session, I am impressed enough to unequivocally state that Fostex has really done it.

The A-8 uses 7" reels running at 15 ips. This works out to about 22 minutes of recording time with an 1800' reel of one mil 1/4" tape. The two DC reel motors and the DC servo capstan motor combine with the pushbutton activated solid state logic control to give smooth, accurate command of the tape transport. The DC servo system, in concert with a flutter filter on either side of the head block results in a measured speed accuracy of 0.2% and wow and flutter

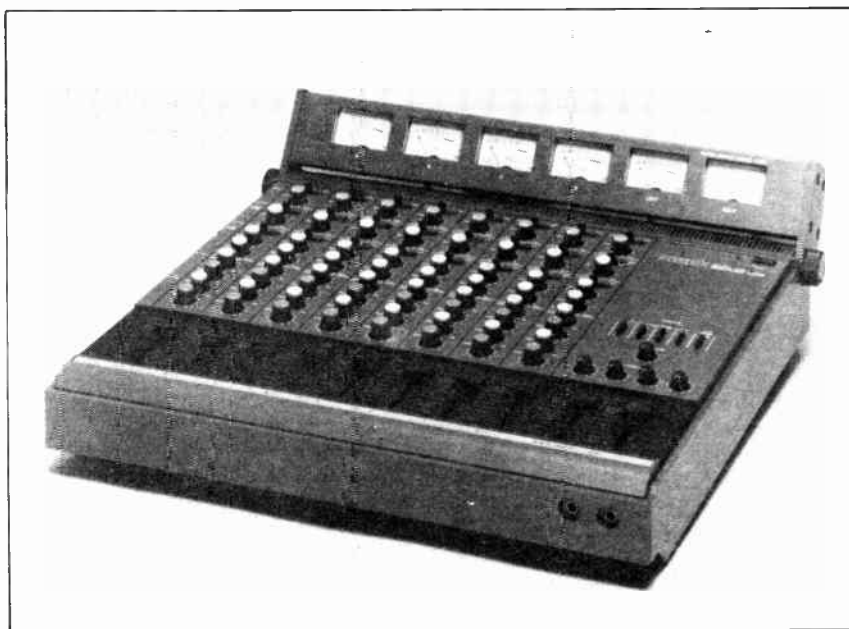

Continues on page 60

the entertainer™ by TAPCO

A lightweight, portable powered mixing system for entertainers on the move

The Tapco ENTERTAINER powered mixing system was designed with portability in mind. The three-piece system, a powered mixer and two speakers, weighs less than 100 lbs. - *total!* But the ENTERTAINER is no performance lightweight.

Both the mixer and the speaker systems have handles that are positioned at the center of gravity making the units lighter to carry. That means that more high-performance features can be built in without adding to your burden at set-up and tear-down time.

Some of these "performance plus" features include 12 inch, two-way constant directivity speakers that can be placed on stands, hung from walls, stacked and

used as stage or side-fill monitors - and all can be accomplished using optional mounting brackets and fittings that are integrated into the cabinet.

The mixer has 8 feature-loaded channels, plus two auxiliary channels complete with monitor sends. The two 150-watt power amps can be changed from stereo mode to a mono-monitor configuration with the flick of a switch. You also get two graphic equalizers, phantom powering capability for your condenser mikes, fluorescent bargraph metering that you can read from across the stage, and a connector panel that isn't in front, (where you could break connectors) but on a slanted rear panel where it is both visible and out of the way.

The ENTERTAINER is "performance plus" in a portable package. If you're an

entertainer on the move or one just in need of a top notch sound system, the ENTERTAINER is your answer. Audition the ENTERTAINER at your EV/TAPCO dealer.



TAPCO
3810 148th Ave. N.E.
Redmond, WA 98052
(206) 833-3510
TWX: 910-445-2594

In Europe:
EVSA
Römerstrasse 3
2560 Nidau
Switzerland

In Canada:
Gulton Industries, Ltd.
Box 520, 345 Harbert Street
Canaacoe, Ontario K7G 2V1

In Australia:
Electro-Voice Australia PTY-LTD
53 Waratah Street
Kirrawee, N.S.W. 2232

In Japan
Electro-Voice, Ltd.
6F, No. 2 Taro Building
2-10-10 Tsutsuya, Shinjuku-ku
Tokyo, Japan 160

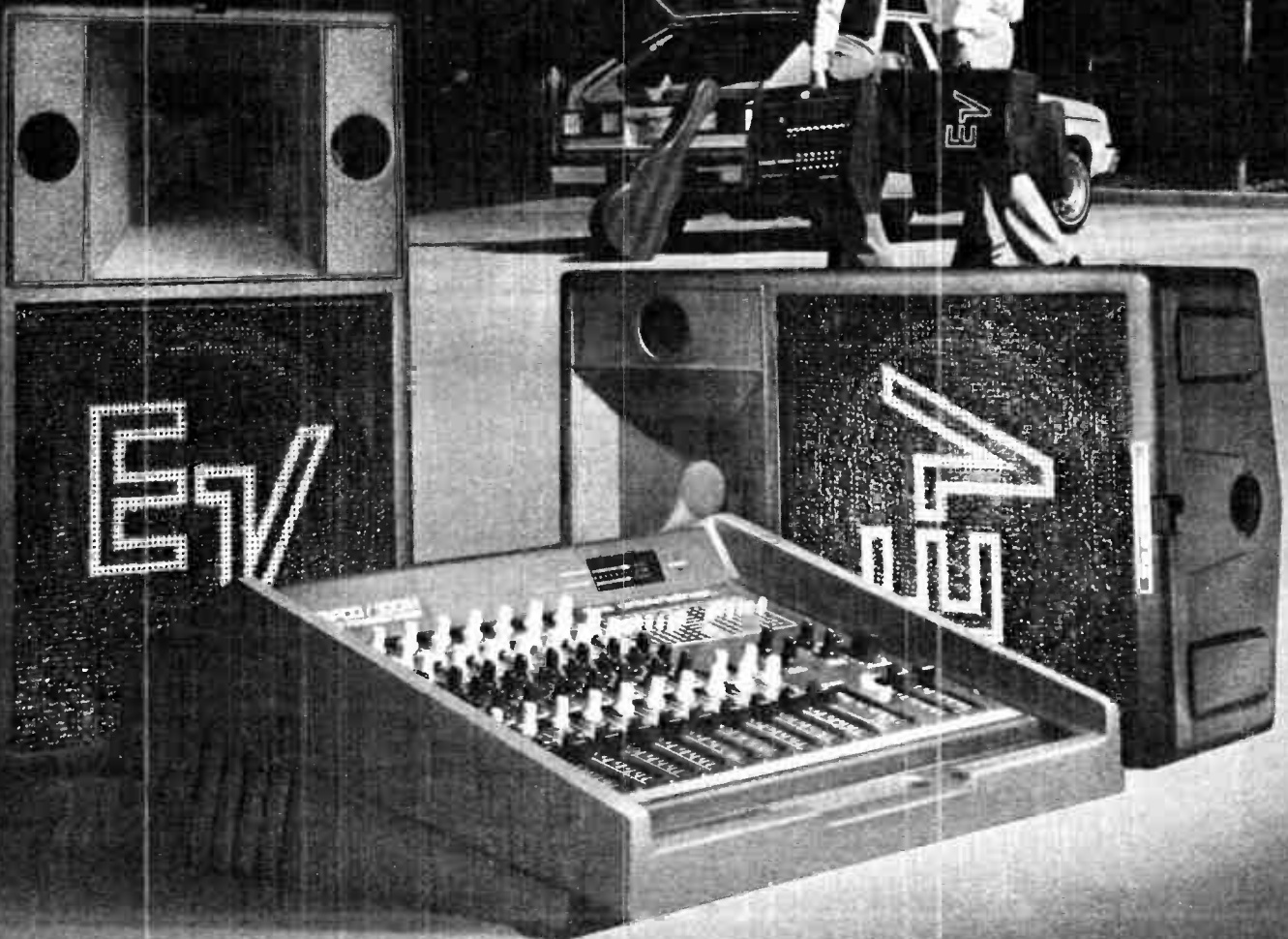

Fostex...

Continued from page 58

of 0.04%. Fostex claims +0.5% and +0.06%, respectively.

All eight tracks are available for simultaneous playback, while you can record up to four tracks at one time. A group select button — tracks 1-4 or 5-8 work with the four safe/ready recording switches and the four tape/input monitor switches — provides almost fool-proof operation of the machine in the playback, record, and sync modes. I measured the record/playback performance as follows:

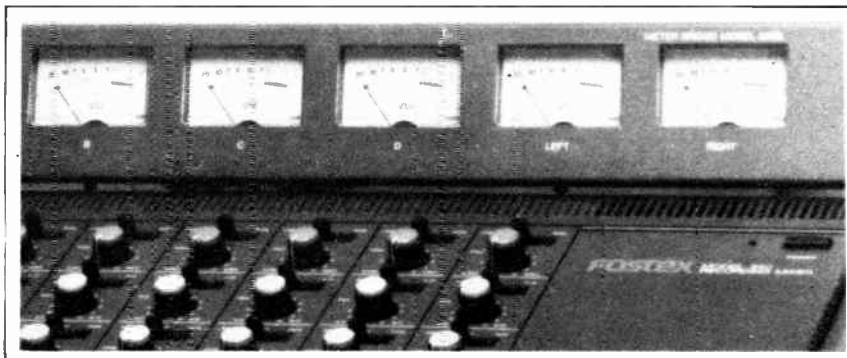

WHAT YOU ALWAYS NEEDED IN A REMOTE RECORDING SERVICE. SANBORN.

You've been there, you know the feeling. Watching the remote crew fumbling through poorly organized equipment. Sitting huddled in a cracker

box control room, sweating and praying the equipment doesn't break down in the middle of a once-in-a-lifetime show.

You know the

feeling, and so do we. Contact Carl Frost of Sanborn Productions. You'll get what you always needed in a recording service. It's a good feeling.

- Frequency response: 3dB at 21kHz (claimed 18kHz)
- Signal to Noise Ratio: 63dB unweighted (claimed 60dB unweighted)
- THD: 0.05% (claimed less than 1%)
- Crosstalk: 58dB

The electronics section includes Dolby C noise reduction on all eight tracks. The Dolby C circuitry is defeatable. Eight easily readable VU meters monitor the eight channels and a flashing LED in the corner of each VU meter indicates record ready. A large four digit display with a reset button and a return to zero button is quite accurate and makes it very easy to play locate any spot on the tape. The pitch control permits a +10% speed variation. Finally, a wonderful feature that is included particularly for musicians who have only two bands — punch in and punch out may be operated by a remote foot switch.

Now, on to the model 350 mixer, which is the mate to the A-8 recorder. This is a compact eight input mixing board. Each of the input channels is selectable for mic or line, and has a 50dB trim control to adjust for a wide range of input levels — anything from a mic to a musical instrument or audio component. An LED overload indicator on each input channel ensures proper level setting. Each input channel has two parametric-type equalizers that can be centered anywhere from 80Hz to 1.2kHz and 800Hz to 12kHz. Send and receive jacks are included on each channel for external signal processing. Each channel also has a direct output after the EQ and input fader. An input selector switch on each channel feeds signals from Pre or Post EQ and fader, or from the tape input jacks to the auxiliary busses.

The 350 has four main output busses and two auxiliary busses. The four channel buss selector and the pan control on each channel assigns the signal to the four buss output groups.



SANBORN PRODUCTIONS
BULL RUN STUDIOS OF NASHVILLE
 Box 120, Route 3, Ashland City, TN 37015
 615/254-6538

Continues on page 62



Yamaha Musical Products • A Division of Yamaha International Corporation • Box 7271 • Grand Rapids, MI 49510

The sound is resonant. Powerful.
The look and feel are rock-solid. The craftsmanship is uncompromised.
The total effect is nothing short of electrifying.
Yamaha drums.



Fostex...

Continued from page 60

Specifications and Bench Test

Parameter	Claimed	Measured
Tape Speed	15 ips \pm 0.5%	15 ips \pm 0.3%
Pitch Control	\pm 10%	confirmed
Line Input (x4)	- 10dBV 15kohms	confirmed
Line Output (x8)	- 10dBV 10kohms	confirmed
Level Calibration	0 VU level - 250nWb/m	confirmed
Equalization	35 μ s (IEC)	confirmed
Wow & Flutter	\pm 0.06% peak, weighted	\pm 0.04%
Signal-to-noise-ratio (referenced to 10dB above 0 VU)	60dB unweighted 72dB weighted	63 dB unweighted
Record/Playback frequency response	45Hz to 18kHz \pm 3dB	45Hz to 21kHz \pm 3dB
T.H.D.	less than 1% at 1kHz 0 VU	0.5% at 1kHz \pm 0 VU
Crosstalk, adjacent channels	N.A.	58dB

The pan pot positions the signal selected between the left and right auxiliary busses. Each of the four output busses has its own rotating pot level control, while the two auxiliary busses are controlled by two slider-type faders. Individual buss monitor switches and a six VU meter bridge provide complete monitoring of the board outputs. Two headphones jacks and a headphone level control are included. Another handy feature on the 350 is the four input equalized phone inputs.

Again, Fostex had the musician in mind when they designed the layout and features of this board. Not only is the 350 the perfect mate to the A-8 recorder, but it easily stands on its own as a compact, very flexible and affordable mixer for production or sound reinforcement work. ●

Tape Format:

¼" tape width
8 track, 8 channel (4 track x
2 Record, 8 track reproduces).

Reel Size:

7"

Dimensions:

14" wide x 13 ½" high x 6 ¾"
deep.

Weight:

29 lbs. (13 kg.)

The **U.S.A.** Strikes back
with
By Fagan

Pro Line Instrument
Working man's price

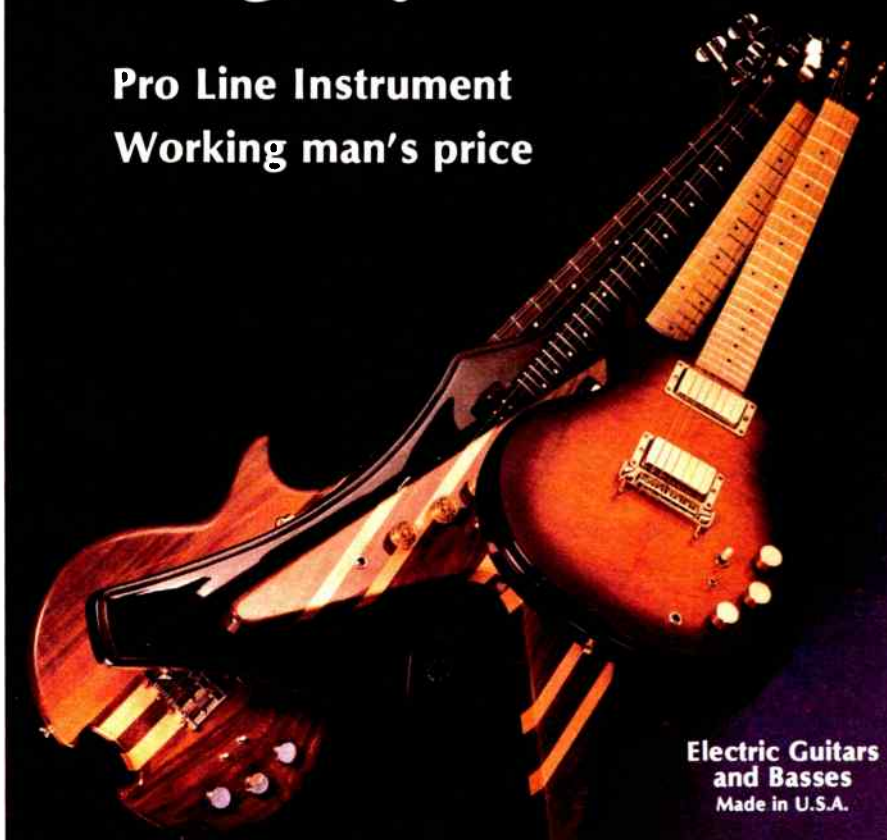

Electric Guitars
and Bases
Made in U.S.A.

JEMAR CORPORATION
3500 Bellline Boulevard • St. Louis Park, MN 55416

For more details, have your favorite dealer contact us for free product information.



"PURED MUSCLE"

Drum muscle. Barrels of it. Now you can rip, and it's not just noise...it's resonance and tonal power that rolls out over the crowd like a burst of liquid thunder. Gretsch has taken the most unreasonable demands of some of the country's leading drummers and turned them into an explosive competition thumper known as...the power drum. Attack and presence are layered into shells that are hand-sanded and stressed six ways to eliminate dead spots...painstakingly finished by patient Gretsch



craftsmen to create the ultimate in wood finishes. A lot more than that goes into these potent drums, but what comes out of them is a whole herd of controlled detonations...you are, indeed in command with Gretsch power drums. Mount them on our CR series hardware, designed for extra stability, and Great Gretsch—you've got the hammer! Ask for the Gretsch power drum, and muscle into a new dimension of sound.



THE POWER DRUM

Kustom/Gretsch A Division of Baldwin Piano & Organ Company, 928 West Chestnut, Cherokee, Kansas 66720 (316) 431-4380

PEAVEY PROFILE: Cory Lerios of Pablo Cruise

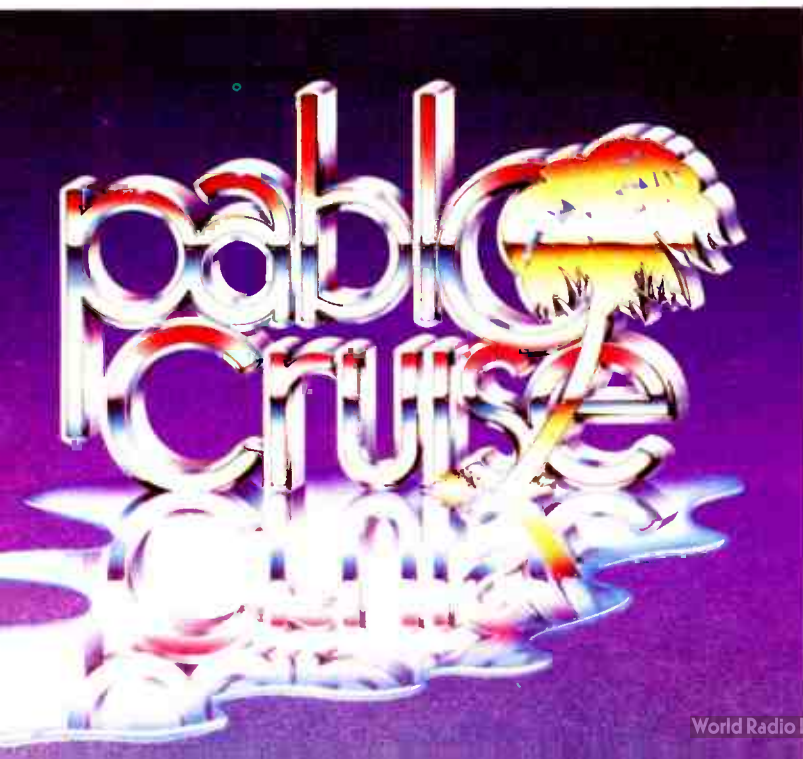

Peavey Electronics' philosophy of active support for touring musicians is a tradition that has existed for many years.

Through our endorsement program, we receive valuable information concerning the needs and trends of the performing arena as well as an honest and thorough evaluation of our equipment and methods.

When you see a performer using and endorsing a Peavey product, you may be assured that it is because ours was chosen as the best gear for his particular need. Unlike many companies, our philosophy prohibits any form of financial reward for the endorsement of Peavey sound gear.

We at Peavey are proud to be associated with Pablo Cruise. We thank them, along with the many other outstanding performers who play and endorse Peavey products.

CORY'S SET-UP

Cory uses a mono three-way stage amplification system for his versatile five keyboard setup.

All keyboards are routed through a Peavey Mark III™ mixing console and a Peavey 10-band Stereo Graphic™ to provide mixing and equalization functions.

Peavey CS-800™ power amplifiers drive Project Four™ speaker systems in a tri-amp configuration, with crossover/filtering functions and special signal conditioning being provided by Peavey CS Series™ plug-in modules.

Danny Adler...

players are concerned, I'd mention Grant Green, Benson — earlier George Benson, before he got really schmaltzy: he's got a lovely sound. A lot of Jazz guitarists can get around the instrument well and can play incredible harmonic combinations, but their sound isn't that good. I'd even say that Wes Montgomery didn't have that good a sound.

"A lot of jazz guitar players have a very *flat* sound — it's not a very singing sound, it's not a *guitar* sound. Most of them are too tame: too much from the mind and not enough from the body. Which is why I love people like Elmore James, Chuck Berry — and T-Bone as well."

Paul Riley once said to me that the trouble was you wanted musicians who would simply "play the dots", without contributing anything of their own.

"I've always been in the position where I'm writing the material and fronting the band: as such, the music has to fit with a certain concept. What I've always dreamt of doing is having a band with a secure line-up... so that it would eventually evolve into a thing where everyone could contribute. I've never been with one group of musicians long enough for that to work out.

"Musicians are so derivative and generally they're derivative of what's exactly current around them, which I'm not interested in because it's too shallow. A lot of times I have to stop people from doing that until they can come up with something that is more genuine."

As for himself, Danny reckons he's digested his influences, to the point where he need no longer strain self-consciously for originality.

"I'm now trying to simplify everything I do down to basics again. One of the things that's great about playing with Rocket 88 and the Deluxes is that, in going back to play Blues, it either works or it doesn't — you either deliver the goods or it just falls flat on its face."

Though not especially commercial, *The Danny Adler Story* had its moments, notably on the Utopian lope of "Humanitation" and on "Moving Easy", where the strings exactly capture the feeling of release and the open road expressed in the lyrics.



"The record to me is like some of those Brook Benton/Dinah Washington things in the 50s, where the strings come in and it creates a real mood and runs chills up your spine. I'm really proud of it, but no-one else seems to have ever liked it!"

Gusha-Gusha Music is a considerably more marketable proposition, despite the handicap of being on a small label with minimal publicity clout. Brighter in sound and mood than previous offerings — Danny's voice seems less strained than usual — the album contains a couple of out-and-out pop songs ("Fantasy Pants", "T.G.I.F.") and benefits from a smart production by the leader and Jo Julian, who's worked with Adam and the Ants, Jools Holland and ELO.

Danny Adler's main weapon is a green Fender Jazzmaster guitar, featured on the cover of *Play It By Ear*.

"That particular model's mid-60s. It's just a versatile guitar: it's got nice soft tones, it's good percussive, clicky sounds and it's got a nice lead sound as well. I go through an AC30 amplifier — that's the best combination I've found."

Do you have a lot of guitars?

"Not really that many. I've got a hollow-body jazz guitar that I can play on Jazz gigs: that's a Gibson. Then I've got a Yamaha acoustic that gets an awful lot of use — I write most of my tunes and do most of my practising on that. It's got heavy strings on it, so that I strengthen my technique.

"I actually play with heavier strings than most Rock guitarists, because you get a sweeter tone and — not having a lot of personal roadies or anything — I can't afford to break strings on stage. I'd like to get into having another guitar that I'd use, just to vary the sound a little bit, but the Fender's pretty well my main axe at the moment."

Did it take you a lot of experimenting to decide that?

"It did really. I had a Strat and I had a Telecaster. I've played Fenders an awful lot of the time — I had a Mustang as well. This guitar seems to combine the best aspects of the Gibson-y softer sound with the greasy Fender sound. I can get everything from a cry to a whisper, including a laugh, and nice chugging rhythms... throbbing."

What makes of strings and things do you use?

"I use medium and heavy plectrums, depending on my mood, and I always use a valve amp. The strings that I use are basically either Darco or Ernie Ball.

"I use heavier strings because you get a richer sound and also it's good to have to sort of wrench the sound out of an instrument, rather than having really cheesewire strings that play themselves. It's good to have to work to really get a sound out of an instrument. Charlie Parker, on a lot of the records he made he used very heavy reeds which no-one could even get a sound out of. Django Reinhardt used very heavy strings on his guitar — and those are people who have really good sounds."

Is it a positive help playing with three different bands and feeding off a wide variety of people?

"Yeah. When Roogalator was on the road it was very gratifying to be working non-stop on my own material, but I found that I didn't have the input. A lot of times, my playing wasn't as fresh as it could have been, because I was only doing one thing. Since I'm playing in a Jazz context with Rocket 88 and a really *hard* Blues context with the Deluxes and also doing my own material with the Danny Adler Band, it's really ideal."

Harry George

MUSICIANS A-Z

Have you ever wondered what an azimuth is, how a mellotron really works, or what exactly to do with slap-back? We will explain the whole alphabet of those technical terms which crop up in the reviews, checks and features in the magazine.

For some of you, this series may seem too obvious: you can go back to your postgraduate electronic courses! For others it will hopefully act as a refresher course, but for many more it is intended to present as concisely and simply as possible definitions of those words which may often spoil your enjoyment of an article as your hurriedly dive for the dictionary.

Acoustic screen

A screen made of sound absorbent material used in studios to confine the various instrumental sounds to particular areas. For example, a drummer may be completely surrounded by screens during a recording session, so that microphones on an acoustic guitar being recorded at the same time do not pick up too much sound from the drums.

Additive synthesis

The technique of producing complex sounds by superimposing simpler components, as for example adding together many sine waves (these have a "smooth" sound) to produce the sound of a brass instrument. Hammond organs use this approach, with "drawbars" to control the volume of the individual components (harmonics). With modern synthesizer technology, additive synthesis is rarely necessary because the oscillators alone can produce harmonically rich sounds.

ADSR

Stands for "Attack-Decay-Sustain-Release" which are four phases in the generation of a sound (see Figure 1). The attack phase is the time from the very start during which the sound is building up. The decay phase follows immediately, after the loudness has reached its maximum, when the sound progressively decreases in volume to the "sustain level" and stays at that level for the duration of the sustain phase. The release phase is the period following the sustain phase during which the sound dies away.

ADSR modules are used in synthesizers to generate a voltage which follows this general pattern, the attack and decay times, sustain level and release time being adjustable. The ADSR module's output usually controls the amplification of a voltage-controlled amplifier (VCA) so that the volume of the signal emerging from the VCA follows the patterns of the ADSR waveform.

AGC

Stands for "automatic gain control" and is a common feature of cassette recorders intended mainly for recording speech or pop music. This type of circuitry alters the gain (amplification) of an internal amplifier stage to compensate for variations in its average input signal, attempting to keep the average output of the amplifier (or in the case of a recorder, the recorded signal) as constant as possible. Because AGC modifies the variations in level of the input signal, or sound, it is usually *undesirable* when recording music.

Alignment

Setting up a system so that it functions most efficiently. A video engineer adjusts the alignment of TV camera electronics to produce an undistorted picture and correct color

balance. Tape heads must be aligned during the manufacture of a recorder so that they are at the correct angle with respect to the tape (see *azimuth*).

Ambience

A general term for the acoustic properties of a studio, theater, recording location etc., including "ambient noise" (uncontrollable background sounds e.g. traffic noise) and "reverberation" (slight echoes and reflections of sounds from hard surfaces). *Ambiophony* is a technique for artificially creating the required ambience, involving feeding carefully delayed signals from the source (say, an instrumentalist's microphone) to speakers in remote parts of the auditorium.

Ampere

A unit of electric current named after one of the pioneers of the physics of electricity. This is a large unit, a one kilowatt fire consumes about four amperes (amps). Commonly used sub-units in electronics are the "milliamp" (1/1,000 amp) and "microamp" (1/1,000,000 amp).

Amplitude

The extent of variation in a

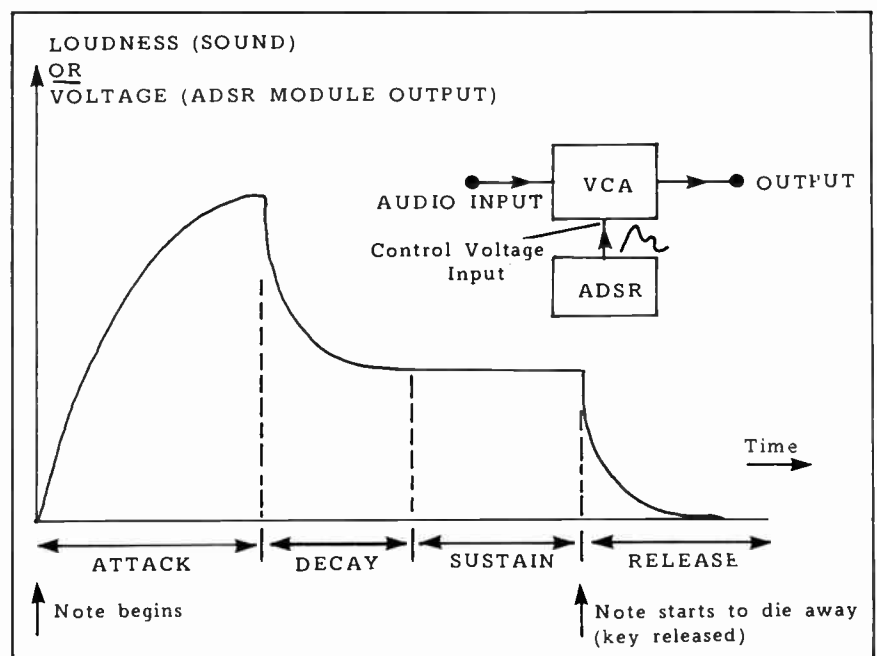

Fig. 1: ADSR waveform showing the four phases in the generation of a sound. In a synthesizer, a voltage-controlled amplifier is used to convert the ADSR module's output into fluctuations in amplitude or loudness (inset).



The shortest distance between letter A and B

Commercials, Video, Records, Jingles, Film Scores

The Recording Studio in Toronto



*48 Yorkville Avenue, Toronto, Ontario M4W 1L4
Telephone (416) 968-1855*

Musicians A-Z...

changing electrical signal or in fact any other kind of varying quantity. Voltage amplitudes are often quoted as "peak-to-peak" values, giving the range from the lowest to the highest voltage values present in the signal.

Analog

A type of signal or circuit in which voltages and currents can have any value (within limits), as distinct from a "digital" signal or circuit in which voltages and currents can have only two predefined values

An "analog gate" is an electronic switch capable of blocking out or passing through an analog signal; some distortion is always introduced, particularly at low signal levels.

Anechoic chamber

An un-earthly room in which there are virtually no reflected sounds (totally "dead"), used by audio engineers to test microphones and speakers.

Anode

The most positive electrode in a valve (the one you can see through the envelope), and the side of a "diode" which must be made relatively positive for the diode to conduct (except in the special cases of a Zener diode or reverse bias beyond breakdown).

Attack

Refers to the start of a sound, how it increases in amplitude, or loudness, and at what rate. The time taken to reach maximum amplitude is the "attack time" (see ADSR). Changes in sound quality, pitch and short bursts of noise during the attack time are called "attack transients" which although they last only a very short time (typically less than 1/10 second) greatly influence how the overall sound quality is perceived.

Attenuate

To reduce in amplitude, the opposite of amplify. An attenuator for audio signals can be made very simply from two resistors.

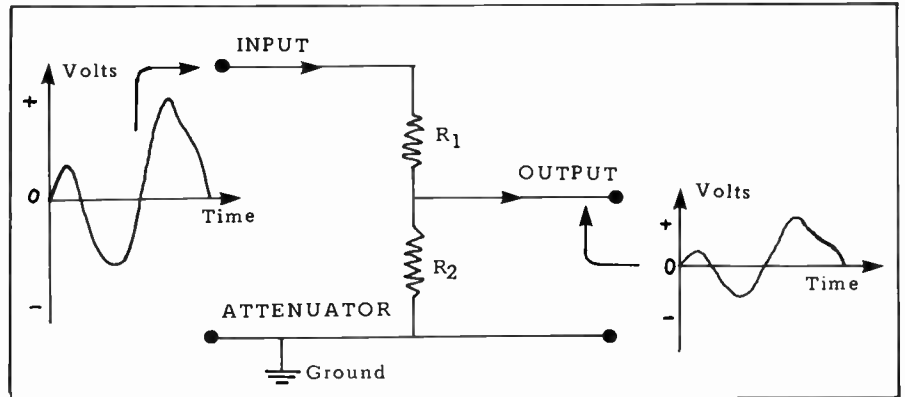

Fig. 2: An attenuator can be made very simply from two resistors, R_1 and R_2 , connected together as shown. The amplitude of the output relative to the input is R_2 divided by $R_1 + R_2$. So for example if both R_1 and R_2 are 1000 ohms, the output is $1000/2000 = 1/2$ of the input, and in that case the signal has been attenuated by a factor of 2.

Auto-glide

An effect to be found on some synthesizers in which a new note played on the keyboard is automatically approached from the semitone above or below. The effect is produced by temporarily modifying the keyboard voltage when a new key is depressed, but because it happens on every note it soon becomes tiresome. The same effect is better produced by a "bend lever" under the player's control.

Azimuth

A term used to describe the alignment (or otherwise) of tape heads, referring to the angle between the head gap and a line perpendicular to the motion of the tape. Small departures of this angle from zero can cause severe high frequency losses; the angulation effectively increases the head gap, making the head less efficient at detecting changes in magnetization of the tape over very short distances.

Baffle

Surface or object used to confine or change the direction of sound waves, e.g. the board at the front of speaker enclosures in which the speakers are mounted.

Balance

The relative levels of the left and right channel signals in a stereo set-up, or more generally, the relative loudness of the different component sounds in a mix. The balance is determined by the "channel faders" on a mixer, each of which determines the volume of one particular sound source. These faders are adjusted by the recording engineer/producer during a performance or mix-down, until he is satisfied that the individual instruments

can be heard clearly, and also that the overall sound is right.

Balanced line

A type of audio-signal cable with three conductors — an outer screen (ground) and two inner conductors carrying audio signals. These signals are identical apart from the fact that one is "inverted" with respect to the other, e.g. when one is +0.2 volts, the other is -0.2 volts. Balanced lines are less sensitive than unbalanced lines (conventional two-conductor cables) to extraneous pick up. The two balanced signals are usually subtracted in a "differential amplifier" at the end of the line, when spurious pick up, induced equally into both, disappears.

Band reject filter

A device which will not pass from input to output a particular range of frequencies. Frequencies above and below the reject band are (ideally) passed unaltered to the output. Band reject filters are useful for removing unwanted sounds in a particular frequency range (e.g. hum) and can be used to limit the amplitude of a particularly loud note in a recording without altering others of different pitch being played at the same time.

Bandpass filter

A device which will pass from input to output, frequencies in the input signal lying in a particular range. Bandpass filters are used extensively in sound synthesis and recording studios to modify sound qualities.

How serious are you about starting right?

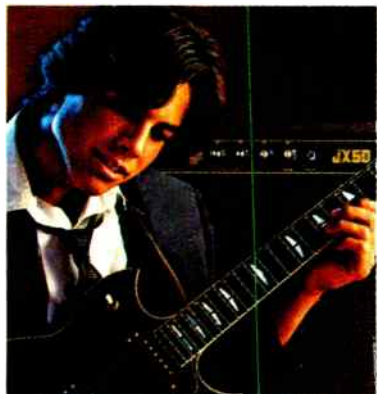

Maybe you don't have a lot to spend for an amp, but you still want the most sound for your money. Yamaha's new JX Series guitar and bass amps give you just that. And more. More power, features, quality and durability than is reasonable to expect in amps so reasonably priced.

For instance, the JX50 features 50 watts of power and a full complement of features. The Pull-Gain and Master Volume controls give you distortion effects. The three-stage EQ (bass, middle, treble) has advanced circuitry for wide tonal variety. The Fat control emphasizes the midrange for a rich, powerful sound.

The rest of the line (JX40, JX30 and JX20) vary in power, features and size. But each one has Yamaha-built speakers, a warm tube sound without the hassles of tubes, a headphone jack, and the quality of materials and workmanship Yamaha is famous for. Plus, for all their heavyweight sound, these amps weigh much less than you'd expect.

The JX50B bass amp has 50 watts of power driving a 15" speaker in a sturdy bass-reflex-type enclosure. The three-stage EQ has advanced circuitry for total tonal control. There's even a unique Bass Boost for a fatter, more powerful bottom end.



The JX30B bass amp has 30 watts of power driving a 15" speaker in a bass-reflex cabinet. Its compactness makes it ideal for portability and practice.

So if you're serious about starting right—and staying right—Yamaha's new JX Series amps are for you. They give you virtually unlimited sound possibilities. Even on a limited budget.

Write P.O. Box 6600, Buena Park, CA 90622 for more information. (In Canada write: 135 Milner Ave., Scarb., Ont. M1S 3R1.) Or better yet, visit your Yamaha dealer.

Because you're serious.



Your Holiday Gift To YOU

(And to someone else you like a lot...)

At Special Holiday Savings!



12 issues of International Musician and Recording World
Only \$18.00, First Gift Subscription
 (save a full \$6.00 off cover price)
and just \$16.00 each additional gift!
 (save \$8.00 off cover price)

Holiday Gift Certificate

International Musician and Recording World

YES, please enter the following Holiday Gift Subscriptions @ \$18 for the first gift, \$16 each additional gift. Each Gift Subscription includes the *Annual Equipment Test Guide*—a \$3.00 value—at no additional cost.

Payment of \$ _____ enclosed Please bill me

Gift #1: (Only \$18. Save \$6 off cover price)

Send to: _____
(Print Name)

Address _____

City/State/Zip _____

Gift #3: (Only \$16. Save \$8 off cover price)

Send to: _____
(Print Name)

Address _____

City/State/Zip _____

1101

GUARANTEE: Cancel at any time and receive a full refund of the unused portion.

Gift #2: (Only \$16. Save \$8 off cover price)

Send to: _____
(Print Name)

Address _____

City/State/Zip _____

BILL TO:

Name _____

Address _____

City _____

State _____ Zip _____

Signature _____

Holiday Gift Certificate

International Musician and Recording World

YES, please enter the following Holiday Gift Subscriptions @ \$18 for the first gift, \$16 each additional gift. Each Gift Subscription includes the *Annual Equipment Test Guide*—a \$3.00 value—at no additional cost.

Payment of \$ _____ enclosed Please bill me

Gift #1: (Only \$18. Save \$6 off cover price)

Send to: _____
(Print Name)

Address _____

City/State/Zip _____

Gift #3: (Only \$16. Save \$8 off cover price)

Send to: _____
(Print Name)

Address _____

City/State/Zip _____

1100

GUARANTEE: Cancel at any time and receive a full refund of the unused portion.

Gift #2: (Only \$16. Save \$8 off cover price)

Send to: _____
(Print Name)

Address _____

City/State/Zip _____

BILL TO:

Name _____

Address _____

City _____

State _____ Zip _____

Signature _____

PLUS this valuable **BONUS!**

IM&RW's Annual Equipment Test Guide, FREE!

A \$3.00 value. IM&RW's Equipment Test Guide clues you in on significant performance and recording equipment, evaluated by professional musicians and sound engineers. It's included FREE with each Gift Subscription you enter below. Total savings, \$11.00!

Get and give it all—every month!

- No-holds-barred INSTRUMENT & EQUIPMENT TESTS
- Valuable HOW-TO FEATURES and PLAYING COLUMNS
- Special sections on KEYBOARDS . . . GUITARS . . . DRUMS
- Up-to-the minute NEW PRODUCT ANNOUNCEMENTS
- NEWS of artists and happenings in the recording world
- Techniques and suggestions from TOP ARTISTS
- COMPLETE MUSIC COVERAGE

Complete and mail to:
International Musician and Recording World
12 West 32nd Street
New York, New York
10001

STACCATO

Thunderhorn

and tune-lock tension system

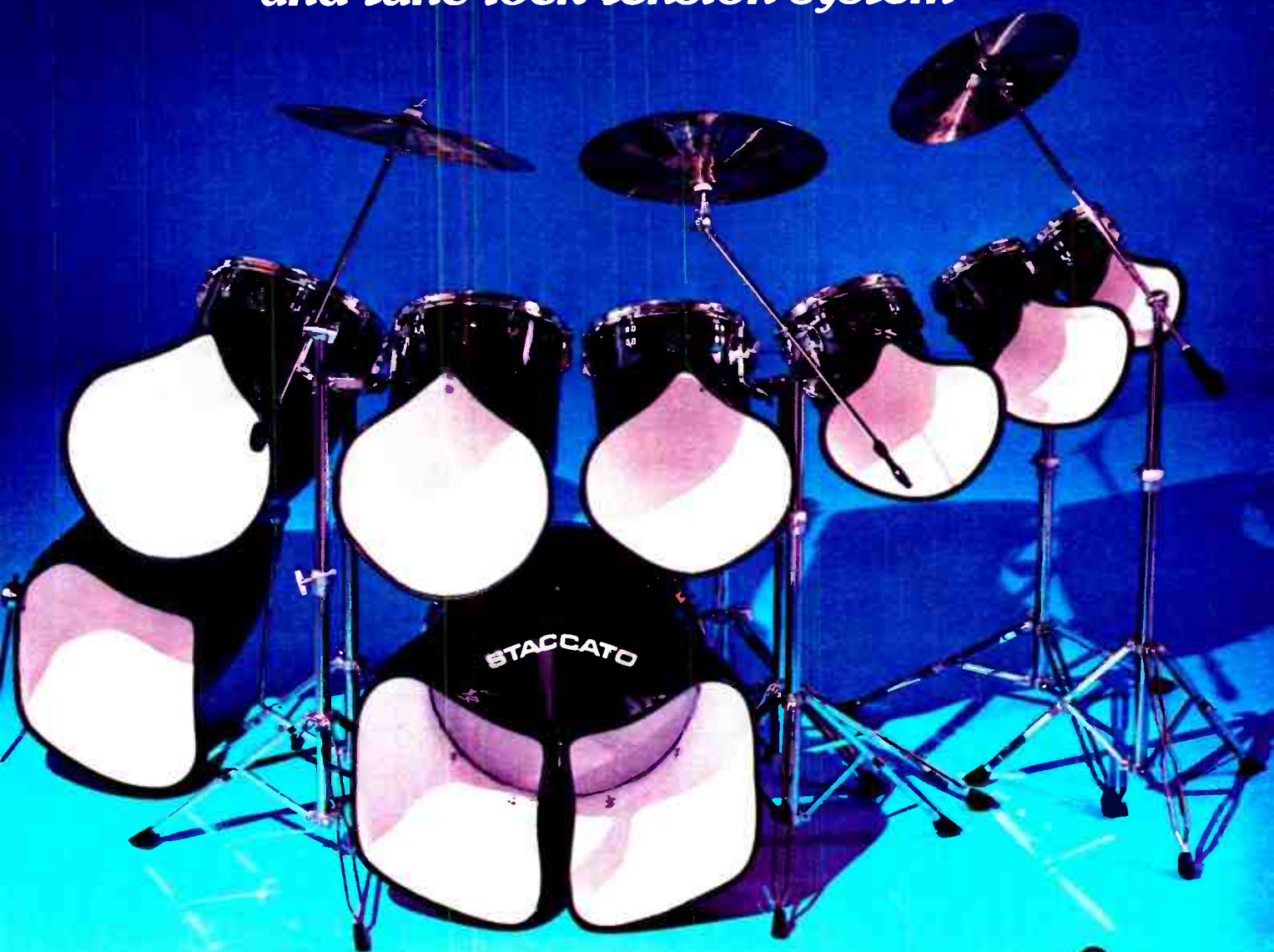

Staccato drums are also available in conventional shapes, THUNDERWOOD (maple) and THUNDERGLASS (fiberglass) extra-deep shells.

STACCATO DRUM COMPANY

CANADA
Staccato Mfg. Inc.
220 E. 7th Ave.
Vancouver, B.C. V5T 4M2
(604) 879-0322

ENGLAND
Staccato Drum Co.
40 Groveland Road
Reading, Berkshire, England
(0734) 56494

World Radio History



P.A. Column...

Units, two Audio & Design Complex Limiters, two Gemini Compressor/Limiter Units, a Roland RE-201 Space Echo machine and a Master Room Reverberation System. The auxiliary racks can be seen in our photograph, along with a Klark Teknik DN60 real time analyzer and the Hill crossover unit.

The monitor system consisted of a Hill 24 channel eight group monitor desk feeding a 15Kw monitor rig made up of two drum monitors, two sidefill stacks and nine floor monitors. The drum monitors in total included six Hill B212 2x 12 ATC bass bins, three Hill M109 horn loaded ATC 9" midrange drivers and three Hill HF20 high frequency horns fitted with HBL 2410 compression drive unit. The side fill stacks comprised in total eight more Hill B212's, four M109's and two Hill HF40 high frequency horns fitted with JBL 2441 compression drive units. All these systems were driven three-way active from a Hill crossover unit and White 4000 Series 27-band equalizers. Seven of the floor monitors were the new Hill W212HF Biamp systems fitted with two ATC 12" low frequency drivers and the components of the Hill HF20 high frequency horn described above. The remaining two floor cabinets were the older Hill design using 4" CTS cone loudspeakers for the top end, and with self contained passive crossover.

A variety of microphones were in use for various purposes, but most vocals were performed over either the ubiquitous Shure SM58 or its newer counterpart, the SM78, and most of the backline miking was done using Shure SM57's or 548 Unidyne 4's. The bass guitar stacks were either DI'ed or miked with an AKG D12 and an assortment of mikes, including AKG C451 capacitor mikes as overheads; D224 on hi-hat, D12 on kick drum were used on the drum kit, with a few more Shure SM57's on the tom toms and snares and the odd Beyer M101 and M201 thrown in for good measure. Unfortunately, I could not stay till the end to see how they miked up AC/DC's Hells Bell, which I had noticed hanging from the roof canopy on a block and tackle ready to lower at the appropriate time later in the evening!

So that is about it. It was without doubt an excellent festival, and seemed to be enjoyed by everyone.

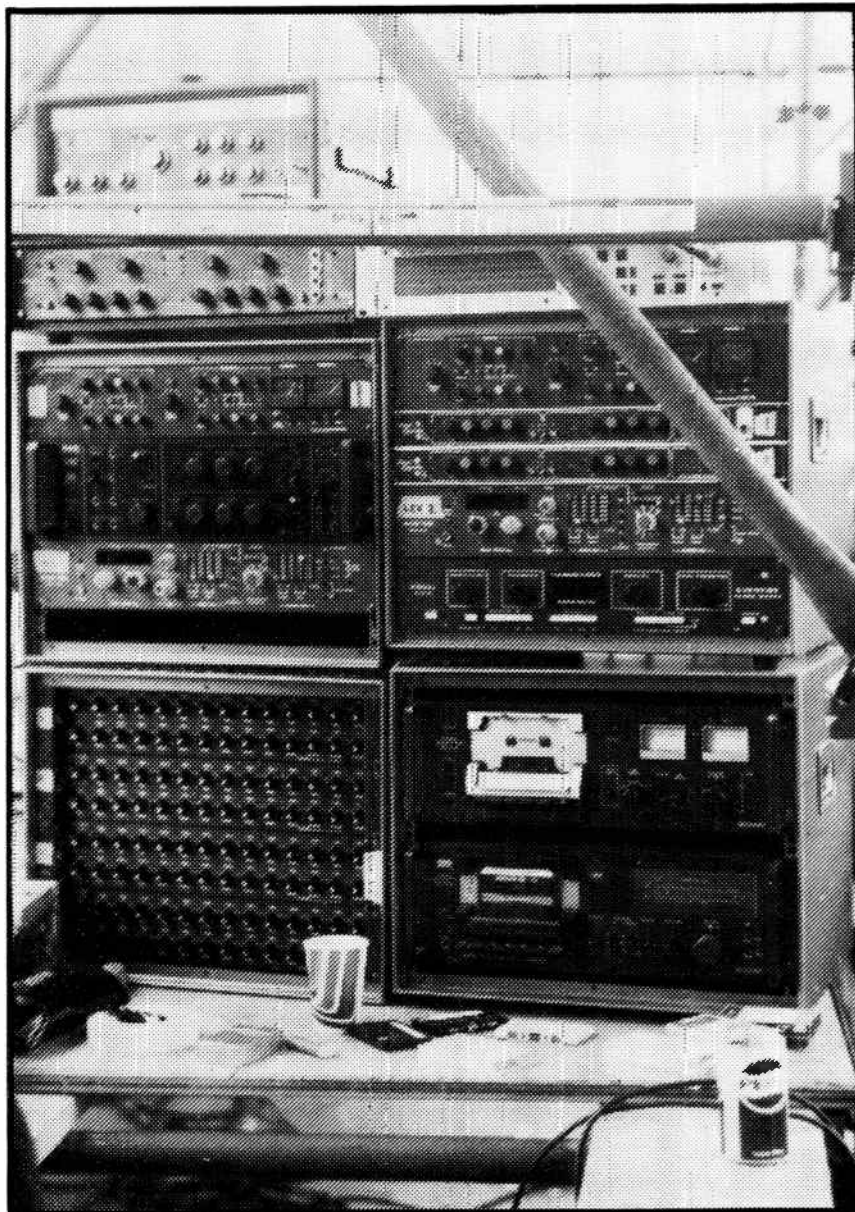

The music was good, the atmosphere was really good and for the most part, the audience were in good humor and had come to enjoy themselves. The sound wasn't at all bad by normal standards, if perhaps not as loud as some would have liked. It's a great pity that the rig just never had the chance of being wound up and put through its paces even once during the whole day due to the problems we have already discussed. For me, of far more concern, was the interminable length of time it took to get one band off stage and the next band on. About 45 minutes seemed to be the best time

achieved — but this also could well be due to the appalling weather conditions for the first few hours, as all the gear had to be kept under wraps in its flight cases until the very last minute, thereby precluding the possibility of equipment being made ready while one band was on stage playing. ●

Ken Dibble

STARVING FOR A PERFECT TUNE?



Peterson Strobe Tuners do more than whet your appetite for accuracy. We guarantee the temperament of our Tuners to be within 1/3 cent. Compare that to the "Plus or minus 3 cents" that is all most competitive units are able to offer.

The purpose of using an electronic tuner is to achieve accurate tuning. If immediately after using your tuning device your instrument is still 3 to 6 cents out of tune, doesn't this defeat the purpose of using that tuner?

A Peterson Model 420 will tune your instruments to within 1/3 of 100th of a semi-tone. This exceptionally accurate tuning not only helps when you start playing, but greatly minimizes the problems caused by instrument drift during a performance.

Feast your ears on the perfect tune you get with Peterson Strobe Tuners. Visit your local music dealer for a free demonstration. Or write to us to find out where there's a Peterson Dealer near you.

Features:

Temperament guaranteed to be within 1/3 of 1/100th of a semi-tone (the most accurate tuning device in the world.)

No calibration required... compensates for temperature and voltage variations.

Built-in condenser microphone.

Large visual readout with ambient light filter.

Standard input jacks permit direct connection of any amplified instruments.

Full eight octave range to accommodate any instruments, including keyboards.

peterson

ELECTRO-MUSICAL PRODUCTS / WORTH, ILLINOIS 60482 (312) 388-3311

World Radio History



Letters

SAX MAN SOUNDS OFF . . .

Dear Editor,

I've been reading your magazine for about a year, and though I find it extremely informative and well written, I do have a few suggestions.

First, when you run a technical test, why not *always* include the spec sheet so we can get an overall performance picture on one page, rather than having to constantly refer to the review paragraph by paragraph.

Also, as an alto player, I'd like to see more new products and product checks aimed toward woodwind players. Brass men too for that matter. You guys sometimes have a tendency to think that the galaxy revolves around guitar players and keyboardists — *definitely* not so!

Finally (and I'm really not picking on you guys — I just think that IM&RW has the potential to be absolutely the best around, and I'd like to see it happen), rock & roll is great, but there are lots of heavy duty jazzmen (especially avant gardists like Anthony Braxton) that you guys have been all but ignoring. If you're gonna be "The Complete Music Magazine", then be complete!

Well, now that I've ragged on you for a while, I'll finish up by saying that I wouldn't bitch if I didn't care. Keep it up, boys and girls.

Sincerely,
Roland Rice, Jr
Los Angeles, CA

SHE LOVES THE SKUNK

Dear Editor

Thanks for the informative profile of Skunk Baxter. Steeley Dan did its classic work with Baxter on board, and now I know why.

How about a piece on David Byrne? I just saw Tyle Tharp's "Catherine Wheel", and can't wait to read all about the man behind the music behind that momentous modern ballet.

Incidentally, I'm a newcomer to IM&RW, but I plan to become a regular reader — keep up the great work!

Sincerely
Diana Maychick, NYC

Ed. — Thanks. By the way we talked with the head "Head" in June '81.



REO IS AOK

Dear IM&RW

Thank you, thank you for the best article I've read on REO in months. Actually, I was surprised when I came across it. I'm an avid REO fan, but IM&RW has become such a habit that I didn't even read the cover listings — I just dived right in!

It's about time a good music magazine paid heed to the talent of REO has been displaying for 13 years. No one has ever come close to creating the right mixture of classic pop and hard rock that these guys have. No matter where you are, what time it is, what kind of mood you're in, etc, you can put on REO and really enjoy it!

Thanks again for letting them get the word out in a magazine that does them justice!!

Sincerely
Ronci LeBow
Springdale, Arizona

BLUES IN THE NIGHT

Dear Editor,

Thank you so much for your fantastic magazine. I have been a subscriber for the past year, and

eagerly await each issue. It's great to see a magazine that features artists who are not generally covered by other so-called music magazines. The October issue was your best yet, particularly the articles on Roy Buchanan and Albert Collins. As a blues fan, these were very special to me. I hope that in the future you could consider doing features on Johnny Winters and Muddy Waters. Others I would love to read about are Todd Rundgren, Kerry Livgren of Kansas, Lonnie Brooks, Anthony Phillips, Rick Wakeman, and Edgar Winter, to name a few. I know that some of these people are not necessarily the biggest name in the business, but all are fine musicians.

As a non-musician, some of the more technical talk goes right over my head. However, this does not at all diminish my enjoyment of IM&RW. Just to learn something of the creative process behind the music is enough.

Thanks for taking the time to read my letter and for International Musician and Recording World.

Sincerely
Holly Hansen,
New York

our new **711** professional loudspeaker system gives your music new direction



Hard rock? Middle of the road? Country? New wave? Whatever your application, our new hard-driving 711 Professional Loudspeaker System gives you more control over the direction of your sound than you ever thought possible! The key is Shure's exclusive, new VARAD™ variable dispersion horn. The first and only horn of its kind is designed to give you four radiation patterns from which to choose—60°, 90° left, 90° right, or 120°—so you can direct your sound to fit the shape of any room.

The 711 is designed to deliver clean sound even when pushed to the limit of its big, 150-watt power handling capability. Exceptional roadability—light weight and compact, yet it shrugs off road abuse. Other new field-tested features include:

- Exclusive new 15-inch Shure Woofer—rugged die-cast frame, high flux magnet, high temperature KAPTON® voice coil form.
- High Frequency Driver Protection Circuit—automatically protects against damage from feedback and excessive power.
- Instant External Biamp Capability—no rewiring required.
- Sculptured Metal Grille—contemporary see-through design offers maximum woofer protection.
- NEW SHURE 5-YEAR LIMITED WARRANTY.

Want to hear lots more? Ask for an ear-bending demo at your Shure dealer—or write for our brochure (AL670).

**push it
to
the
limit!**



SHURE

PROFESSIONAL LOUDSPEAKERS

SPECIAL ! MESA / BOOGIE TUBES & SPEAKERS

Is Tired Blood making your amplifier sound sluggish and weak? Are you straining for tone and still coming up short? Then why not take advantage of some of the years spent developing the legendary **MESA / Boogie** by upgrading your present amp with a transfusion of our special tubes and speakers. A set of MESA STR 415 type 6L6 power tubes can improve the punch and freshness of your amp like new strings can help your guitar, and may noticeably increase your amplifier's power, cleanly and safely. Each tube is built to our extra rugged and exacting specs, then subjected to a special 5 part performance evaluation (including max amp power) which it must pass at 100% to qualify as an STR 415. Therefore all tubes are fully matched; weaker ones have been rejected entirely — not "Matched" to other equally weak ones.

Having problems with noise, microphonics and excess feedback? Try a set of MESA 12AX7's for a cure. Special construction and careful individual screening make these quiet, long lasting preamp tubes.

And for vastly upgraded performance, try the MESA Black Shadow 12" speaker. Years of work and refinement were spent to produce this premium speaker value which compares closest in tone color and construction to the superlative EVM 12L — except the MESA Shadow uses an extra heavy stamped frame, not cast. It is rated at 150 watts and has just the right combination of punch, clarity, roundness and warmth to sound beautifully clear and detailed or to crank out a full balls blast of fat meatiness without straining or sounding tubby.

We guarantee your full satisfaction with all MESA products and will replace any tube or speaker which fails within six months of normal heavy duty use. The Black Shadow is \$65 + \$5 shpg (or \$72 + shpg if ordered COD). The STR 415: \$10 ea., we pay shpg on prepaid or credit card orders (\$12 + shpg if COD). The MESA 12AX7: \$6 prepaid, \$7 ea. COD. Special on Fender / Peavey upgrade kits: buy 2 Shadows & 4 STR's & we'll give you free freight on 4 12AX7. Orders by card, cash, MO or certified check shipped within 24 hrs.



(IM)

Name _____
 Street _____ City _____
 State _____ Zip _____ Phone _____

Quantity STR415 _____ Prepaid @ \$10 , COD @ \$12
 Quantity 12AX7 _____ Prepaid @ \$ 6 , COD @ \$ 7
 Quantity Black Shadows _____ Prepaid @ \$65 (+ \$5 shpg)
 COD @ \$72 (+ shpg)

Quantity TEE SHIRTS @ \$6 _____ S M L XL
 California residents must add 6% sales tax
 Visa & MC accepted "
 Exp. Date _____ Signature _____

GRAND TOTAL



1317 ROSS STREET • PETALUMA, CA 94952
 call (707)778-TUBE

NOISE GATE GT-4

The remarkably simple optical noise gate that contributes no noise or distortion to your signal, occupies only 1 3/4" of rack space and costs only \$395.00 for four channels.

To get the full story and a list of dealers call or write

OMNI CRAFT INC.
 RT. 4 BOX 40
 LOCKPORT, IL
 60441
 815-838-1285



THE FIRST SIGNIFICANT PRACTICE DEVICE FOR MUSICIANS SINCE THE METRONOME.



NOW with ordinary tape or cassette decks, you can make multi-track recordings and over-dubs at home. And that's only one of eight things this multi-function practice amplifier can do for you.

For complete details and a list of dealers near you that carry the MOJO BONE™ write to

Electro Sonics
P.O. Box 2-B
Stockton Sp., Me. 04981
(207) 567-3513

Pat. Pend. 1981 ElectroSonics, Inc.

TIMES SQUARE MEANS QUALITY



- As manufacturers of top-of-the-line stage lighting and special effects equipment, Times Square stands behind each item we sell.
- Quality products for the theatre professional.
- Our name is your guarantee of excellence.

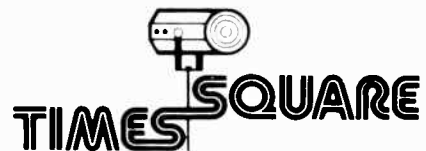

Theatrical & Studio Supply Corp.

Main Office & Showroom
 318 West 47th Street
 New York, NY 10036
 (212) 245-4155

ASK FOR YOUR FREE ILLUSTRATED CATALOG AND NAME OF YOUR STOCKING DISTRIBUTOR

Pro-Audio Buyers' Guide

KEY FOR PRO-AUDIO GUIDE

MT/R Multi-track recorders
 MD Mastering Decks
 MC Mixing Consoles
 SP Signal Processing
 MS Monitor Speakers
 PA/SYS PA Systems
 PA/SP PA Speakers
 TP Tape
 P/AM Power Amps
 M Microphones
 DR Drivers
 EA Electronic Accessories
 CW Custom Work
 UE Used Equipment
 R Rentals
 V Video

CALIFORNIA

NEOTEK WEST
 4007 West 6th Street,
 Los Angeles, CA 90020
 (213) 367-7999
 Distributor for Neotek products including:
 Recording Consoles, Multi-track Recording
 Console, PA Consoles & Theater Consoles.

SUNTRONICS
 1620 West Foothill Boulevard,
 (P.O. Box 734), Upland, CA 91786
 (714) 985-0701
 MT/R, MD, MC, SP, MS, TP, P/AM, M.
 EA, CW, UF.
 TEAC, Tascam, AKG, DeltaLab, UREI,
 Crown pzm.

COLORADO

SOUND LABS
 2520 W Colfax
 Denver, Co.
 (303) 892-9245
 MT/R, MD, MC, SP, MS, PA/SYS, PA/SP,
 TP, P/AM, M, DR, EA, CW, UE, R, V.
 JBL, Neotek, Electro-Voice, Tapco,
 Ecoplate, AKG.

CONNECTICUT

AUDIOTECHNIQUES
 652 Glenbrook Road, Stamford,
 CT 06906
 (203) 359-2312/(212) 586-5989
 MT/R, MD 2-4, MC, SP, MS, PA/SYS,
 PA/SP, TP ¼" ½" 1" 2", P/AM, M, DR,
 EA, CW, UE.
 Lexicon, Dolby, JBL, Otari, MCI.

DELAWARE

WONDER SOUND STUDIOS
 3501 Philadelphia Pike,
 Claymont, DE 19703
 (302) 798-0505
 MT/R, MD, MC, SP, MS, PA/SYS, PA/SP,
 TP ¼" ½" 1" 2", P/AM, M, DR, EA, CW,
 UE, V.
 Community Light & Sound, Crown, JBL,
 TAD, Shure.

FLORIDA

DISCOUNT MUSIC CENTER
 456 North Orange Avenue,
 Orlando, FLA 32801
 (305) 843-2025
 MT/R 2-4-8-16-24, MD, MC, SP, MS,
 PA/SYS, PA/SP, TP ¼" ½" 1" 2", P/AM,
 M, DR, EA, CW, UE, V.
 TEAC, Crown, JBL, Yamaha, Klipsch.

ILLINOIS

AUDIO TRACK RECORDING
 1025 West State Street
 Rockford, IL 61102
 (815) 968-2902
 MT/R, MD, SP, MS, PA/SYS, PA/SP, TP,
 P/AM, M, DR, EA, CW, UE, R, V.
 BGW, Tapco, Stanley Screamer, Eventide.

BRIDGEWATER CUSTOM SOUND
 (Pro-Audio Showroom)
 160th & Halstead,
 Harvey, IL 60426
 (312) 596-0309
 MT/R, MD, MC, SP, MS, PA/SYS, PA/SP,
 TP, P/AM, M, DR, EA, CW, UE, R.
 JBL, Crown, BGW, Bose Pro, Neuman.

GREAT AMERICAN MUSIC CO.
 403 North Broadway
 Urbana, IL 61801
 (217) 367-6615
 MC, SP, MS, PA/SYS, PA/SP, TP, P/AM,
 M, DR, EA, CW, UE, R, V.
 MusicMan, BGW, Marshall, Gauss, Electro
 Voice.

INDIANA

IRC AUDIO (Division of IRC Music)
 5911 East 82nd Street, Indianapolis,
 Indiana 46250
 (317) 849-7965
 MT/R 4-8, MD, MC, SP, MS, PA/SYS,
 PA/SP, TP ¼" 2", P/AM, M, DR, EA, CW,
 UE.
 JBL, Crown, TEAC, Tascam, Community
 Light & Sound, Biamp.

MASSACHUSETTS

BAYSTATE SOUND & RECORDING
 320 Plumtree Road,
 Springfield, MA 01118
 (413) 783-5084
 MT/R, MD, MC, SP, MS, PA/SYS, PA/SP,
 TP, P/AM, M, DR, EA, CW, UE, R,
 Electro-Voice, Ashly, Beyer, Tetrone,
 Lighting Electronics.

DISCTRONICS SOUND & LIGHTING

101 Bigelow Avenue,
 Watertown, MA 02172
 (617) 926-1919
 MT/R, MD, MC, SP, MS, PA/SYS, PA/SP,
 TP, P/AM, M, DR, EA, CW, UE, R, V, L.
 UREI, Delta Lab, Community Light &
 Sound, Bryston, AB Systems.

MICHIGAN

ARNOLDT WILLIAMS MUSIC INC.
 5701 Canton Center Road,
 Canton, Michigan 48187
 (313) 453-6586
 MT/R 4-8, MD 2-4, MC, SP, MS, PA/SYS,
 PA/SP, TP ¼" ½" 1" 2", P/AM, DR, EA, CW,
 UE.
 TAD, Otari, Deltalab, UREI, Community
 Light & Sound.

AUDIOLIGHT
 22017 Grand River
 Detroit, MI 48219
 (313) 477-5900
 MT/R, MD, MC, SP, MS, PA/SYS, PA/SP,
 TP, P/AM, M, DR, EA, CW, UE, R, V, L.
 Studiomastrer, BGW, Electro-Voice, Tapco,
 McUley, Ashford.

FERGUSON SOUND SYSTEMS & CO.
PRECISION AUDIO INC.
 1619 W. Atherton Road
 Flint, Mich 48507
 (313) 238-6322
 MT/R, MD, MC, SP, MS, PA/SYS, PA/SP,
 TP, P/AM, M, DR, EA, CW, UE, R
 Electro-Voice, dbx, Roland, Tapco, AB
 Systems.

NEBRASKA

SOUND SHOW
 6066 Maple Street,
 Omaha, Nebraska 68104
 (402) 553-3434
 MT/R, MD, MC, SP, MS, PA/SYS, PA/SP,
 TP, P/AM, M, DR, EA, CW, UE, R.
 Crest, Electro-Voice, Tapco, NEI, Milt City
 Systems, Renkus Heinz.

NEW HAMPSHIRE

EAR CRAFT
 14 Fourth Street, Dover, NH 03820
 (603) 749-3138
 MT/R, MD, MC, SP, MS, PA/SYS, PA/SP,
 P/AM, M, DR, EA, CW, UE, R.
 Gauss, Audio-Arts, Electro-Voice, BGW,
 Deltalab, Crest.

NEW JERSEY

CREIGHTON AUDIO LABS
 740 Haven Place, Linden, NJ 07036
 (201) 241 8233
 MC, SP, MS, PA/SYS, PA/SP, TP, P/AM,
 M, DR, EA, CW, UE, R.
 Audionation, ASR, Soundcraftsmen,
 Tangent, Kelsey, WAC Custom.

SOUND ENVIRONMENT INC.
 50 Park Avenue, Lakewood, NJ 08710
 (201) 364-3044
 MC, SP, MS, PA/SYS, PA/SP, TP ¼" ½"
 1" 2", P/AM, M, DR, EA, CW, UE, V.
 Crown, Electro-voice, JBL Professional,
 TAD, UREI.

TD AUDIO INC.
 7 Oak Place,
 Montclair, NJ 07042
 (201) 746-1233
 MC, SP, MS, PA/SYS, PA/SP, P/AM, M,
 DR, EA, CW, UE, V.
 Crown, Community Light & Sound, TAD,
 JBL, Ashly.

LOU ROSE MUSIC CENTER
 1627 Route 27
 Edison, NJ 08817
 (201) 985-3333
 MT/R, MC, SP, MS, PA/SYS, TP, P/AM,
 M, DR, EA, CW, UE, R.
 Biamp, BGW, Studiomastrer, Ashly, JBL.

NEW MEXICO

BLAKELY PRO-AUDIO
 3103 Central North East,
 Albuquerque, NM 87106
 (505) 266-0296
 MT/R, MD, MC, SP, MS, PA/SYS, PA/SP,
 TP, P/AM, M, DR, EA, CW, UE, R.
 Crest, dbx, Cerwin-Vega, DBM, Agia.

NEW YORK CITY

PROFESSIONAL AUDIO EQUIPMENT
 Expert advice, in-depth parts
 dept., ¼" video systems available.
 Broadest selection such as Otari,
 EXR, Ampex, Tascam and more.
 Write or call for price or product info.
 Harvey Professional Products Division
 25 W. 45th Street,
 New York, NY 10036
 (212) 921 5920

A.S.T. SOUND
 11 Ave. of Americas,
 New York, NY 10013
 (212) 925-8149/375-1700
 MT/R, MD, MC, SP, MS, PA/SYS, PA/SP,
 TP, P/AM, M, DR, EA, CW, UE, V.
 Orban, Altec Pro, Crown PZM, Gauss, JBL
 Pro.

NEW YORK STATE

BRIGHTON SOUND
 315 Mt. Read, Rochester, NY 14606
 (716) 328-1220
 MC, SP, MS, PA/SYS, PA/SP, P/AM, M,
 DR, CW, UE, R.
 Yamaha, Crown, Eastern Acoustics, JBL,
 Biamp.

MULTI-SONUS, INC.
 207 North Clinton Ave.,
 Rochester, NY 14604
 (716) 325-3006
 MT/R, MC, SP, MS, PA/SYS, PA/SP,
 P/AM, M, DR, EA, CW, UE, R.
 Crest, Altec, Cetec Gauss, AKG, Electro-
 Voice.

NORTH CAROLINA

STUDIO WORKS
 1018 Central Avenue,
 Charlotte, NC 28204
 (704) 377-4596
 MT/R 4-8-16-24, MD, MC, SP, MS, PA/SP,
 TP ¼" ½" 1" 2", P/AM, M, DR, EA, AKG,
 Otari, MCI, Lexicon, JBL.

OHIO

AUDIO-VIDEO EMPORIUM
 110 North Main,
 Fostoria, OH 44830
 (419) 435-8432/435-7305
 MT/R, MD, MC, SP, MS, PA/SYS, PA/SP,
 TP, P/AM, M, DR, EA, CW, UE, R, V, L.
 Home of Moseka Recording w/16 tracks.

HEY DAY SOUND
 1456 Sylvania Ave.,
 Toledo, OH 43612
 (419) 476-3835
 MT/R 4-8, MD 2-4, MC, SP, MS, PA/SYS,
 PA/SP, TP ¼" ½" 1" 2", P/AM, M, DR,
 Electro-voice, Tapco, BGW, JBL, Ashly, JHE.

PI CORP
 13329 Pearl Road,
 Cleveland, Ohio 44136
 (216) 238-0644
 MT/R 4-8, MD 2-4, MC, SP, MS, PA/SYS,
 PA/SP, TP ¼" ½" 1" 2", P/AM, M, DR, EA,
 Otari, BGW, Deltalab, AKG, Tapco.

PENNSYLVANIA

RO-CEL ELECTRONICS INC.
 731 Butler Street, Pittsburgh, PA 15223
 (412) 781-2326
 MT/R 2-4-8-16, MD, MC, SP, MS, PA/SYS,
 PA/SP, TP ¼" ½" 1" 2", P/AM, M, DR,
 EA, CW, UE, V.
 TEAC, Tascam, Crown, JBL, Biamp,
 Cerwin-Vega.

TENNESSEE

AUDIO ARCHITECTS
 112 Space Park Drive,
 Nashville, TN 37211
 (615) 331-3247
 MT/R 4-8-16-24, MD 2-4, MC, SP, MS,
 PA/SYS, PA/SP, TP ¼" ½" 1" 2", P/AM,
 M, DR, EA, V.
 Tascam 85-16, Sound Workshop, Otari,
 Eastern Acoustic, Tangent.

TEXAS

RIVER CITY MUSIC
 4402 San Pedro, San Antonio, TX 78712
 (512) 732-7151
 MC, SP, MS, PA/SYS, PA/SP, P/AM, M,
 DR, EA, CW, UE, R.
 Biamp, Peavey, JBL, Cerwin Vega, Electro-
 Voice.

ARNOLD & MORGAN MUSIC
 510 South Garland Road, Garland, TX 75040
 (214) 494-1378
 MT/R, MD, MC, SP, MS, PA/SYS, PA/SP,
 TP, P/AM, M, DR, EA, CW, UE, R, V, L.
 TEAC, Crown, JBL, Yamaha, Biamp.

ASI PROFESSIONAL AUDIO
 PO Box 6520, San Antonio, TX 78209
 (512) 824-8781
 MT/R 4-8-16-24, MD, MC, SP, MS,
 PA/SYS, TP ¼" ½" 1" 2", P/AM, M, DR,
 EA, CW, UE, V.
 TEAC, JBL, Crown, Altec, Soundcraft.

WASHINGTON

PUGET SOUND AUDIO
 5105 North 46th Street,
 Tacoma, Washington 98407
 (206) 759-4701
 MT/R, MD, MC, SP, MS, PA/SYS, PA/SP,
 TP, P/AM, M, DR, EA, CW, UE, R, V.
 Ampex, Crown, UREI, Lexicon, Otari.

Dealer Buyers' Guide

Below are paid listings of musical instrument dealers intended to help you identify stores in your locality so you can see and obtain the products described within our magazine.

Support your local dealer!

KEY FOR DEALER GUIDE

A	Amplifiers
B	Brass
BF	Books & Folios
D	Drums
E	Effects
EK	Electric Keyboards
ER	Electronic Repairs
G	Guitars
IN	Instruction
IR	Instrument Rental
K	Keyboard
M	Mikes
O	Organs
P	Parts
RE	Recording Equipment
RS	Repair Services
S	String (for Guitar)
S/H	Second Hand
SL	Stage Lighting
SM	Sheet Music
SR	Sound Reinforcement
SYN	Synthesizers
TC	Travel Cases
W	Woodwind

ARIZONA

INSALACO'S MUSIC
297 N. Broad St.
Globe, AZ 85501
(602) 425-7057
A. B. BF. D. E. EK. ER. G. IN. IR. K. M. O. P. R. S. S. S/H. SM. SR. W.

CALIFORNIA

CALIFORNIA MUSICAL INSTRUMENTS
1019 E. Vermont Ave
Anaheim, CA 92805
(714) 533-8610
A. B. D. E. EK. ER. G. IR. K. M. O. P. RE. RS. S. S/H. SL. SR. SYN. TC. W.

K. KALIE
2100 W. Lincoln
Anaheim, CA 92801
(714) 778-2011
A. B. BF. D. E. EK. ER. G. IN. IR. K. M. O. P. R. S. S. S/H. SM. SR. SYN. TC. W.

MUSIC WORLD
1420 E. Los Angeles Ave.
Simi Valley, CA 93065
(805) 526-9351
A. BF. D. E. EK. ER. G. IN. IR. K. M. O. P. R. S. S. S/H. SL. SM. SR. SYN. TC. W.

MAGIC MUSIC MACHINES
1207 Howard St.
San Francisco, CA 94103
(415) 864-3300
ER. K. P. RS. S/H. SR. SYN.

ACME MUSIC
3715 Mac Arthur Blvd.
Oakland, CA 94619
(415) 530-7234
A. B. BF. E. ER. G. IN. IR. K. M. P. RS. S. S/H. SM. W.

GOODMAN MUSIC CO.
Topanga Plaza Shopping Center,
Canoga Park, CA 91309
(213) 340-9100
A. B. BF. D. E. EK. ER. G. IN. IR. K. M. O. P. R. RS. S. SM. SYN. TC. W.
Also at:
5311 Lankershim Boulevard,
North Hollywood, CA 91601
(213) 760-4430

COLORADO

SOLID SOUND INC.
1638 Pearl St.
Boulder, CO 80302
(303) 444-1731
A. D. E. EK. ER. G. IN. IR. K. M. P. RE. RS. S. S/H. SR. SYN. TC.

COLFAX MUSIC
563 E. Colfax Ave.
Denver, CO 80203
(303) 832-6526
A. D. E. EK. ER. G. IR. M. P. RE. S. S/H. SL. SR. SYN. TC.

PRO SOUND MUSIC CENTER
2432 South Colorado Blvd.
Denver, CO 80222
(303) 759-4455
A. D. E. EK. ER. G. IR. M. O. P. RE. RS. S. S/H. SM. SR. SYN. TC.

PRO SOUND MUSIC CENTER
3520 N. Academy Blvd.
Colorado Springs, CO 80907
(303) 597-9962
A. D. E. EK. ER. G. IR. M. O. P. RE. RS. S. S/H. SM. SR. SYN. TC.

HIGH COUNTRY MUSIC
215 E. Platte Avenue,
Colorado Springs, CO 80903
(303) 635-0277
A. B. BF. D. E. EK. ER. G. IN. IR. M. P. R. S. S. Syn. TC. W.

CONNECTICUT

BANKO'S MUSIC
360 E. Main St.
Ansonia, CT 06401
(203) 734-0461
A. B. D. E. EK. ER. G. K. M. P. RS. S. S/H. SM. SR. SYN. TC. W.

CUSTOM GUITAR WORKSHOP
438 N. Colony Road
Wallingford, CT
(203) 265-3830
A. BF. E. EK. ER. G. M. P. RS. S. S/H. SM. SR. W.

DANBURY ELECTRONIC MUSIC CENTER
84 Federal Rd.
Danbury, CT 06810
(203) 792-2794
A. E. EK. ER. G. IN. IR. K. M. O. P. RE. RS. S. S/H. SL. SR. SYN. TC.

MUSIC GUILD
276 Main St.
Danbury, CT 06810
(203) 792-6760
A. B. BF. O. E. EK. ER. G. IN. IR. K. M. O. P. RE. RS. S. S/H. SL. SM. SR. SYN. TC. W.

CENTER MUSIC
214 Market Sq.
Newington, CT 06111
(203) 666-8311
A. O. E. G. IN. M. P. RE. RS. S. S/H. SR. SYN. TC.

SELECT GUITARS INC.
193 Bedford St. (2nd Floor)
Stamford, CT 06901
(203) 324-2756
A. E. G. P. RS. S. S/H. SR. TC.

THE SOUND STORE
136 Park St.
New Haven, CT 06511
(203) 787-8880
ER. IR. P. RS. S/H. SR.

FLORIDA

THOROUGHbred MUSIC
12311 Nebraska Ave.
Tampa, FL 33612
(813) 971-5822
A. O. E. EK. ER. G. IR. K. M. P. RE. RS. S. S/H. SL. SR. SYN. TC.

MODERN MUSIC
320 E. Oakland Park Blvd.
Ft. Lauderdale, FL 33334
(305) 565-1671
A. B. BF. D. E. EK. ER. G. IN. IR. K. M. O. P. RE. RS. S. S/H. SL. SM. SR. SYN. TC. W.

AESOP MUSIC CENTER
5223 Park Blvd.
Pinellas Park, FL 33565
(813) 541-2697
A. BF. D. E. EK. ER. G. IR. M. P. RS. S. S/H. SM. SR. SYN. TC.

GREEN SHIFT MUSIC & ELECTRONICS
6500 N. Florida Ave.
Tampa, Florida 33604
(813) 238-4177
A. BF. E. EK. ER. G. IN. K. M. O. P. RS. S. SM. SYN. TC.

GEORGIA

BAKER MUSIC SHOP
1820 Midtown Dr.
Columbus, GA 31906
(404) 563-7924
A. B. BF. D. E. EK. G. IN. IR. K. M. P. RS. S. S/H. SM. SR. TC. W.

ILLINOIS

BARTLETT PLAZA MUSIC CENTER
152 E. Bartlett Plaza Center
Bartlett, IL 60103
A. B. BF. D. E. EK. ER. G. IN. R. K. M. P. RS. S. S/H. SL. SM. SR. SYN. TC. W.

CHICAGO MUSIC CO.
3530 N. Lincoln Ave
Chicago, IL 60657
(312) 472-1023
A. BF. D. E. EK. ER. G. IN. IR. K. M. O. P. RS. S. S/H. SL. SM. SR. SYN. TC.

ROGUES GALLERY OF MUSIC
Oak & Elwood St., Grainery Shopping Mall,
Frankfort, IL 60423
(815) 835-2980
A. B. BF. D. E. EK. ER. G. IN. IR. K. M. O. P. RE. RS. S. S/H. SM. SR. SYN. TC. W.

MR. MUSIC
4871 E. State St.
Rockford, IL 61108
(815) 229-0438
A. D. E. EK. G. IN. M. S. S/H. SR. SYN

JACK MOORE MUSIC CENTER
1029 E. Golf Rd.
Schaumburg, IL 60195
(312) 882-1434
A. B. BF. O. E. ER. G. IN. K. M. P. RS. S. S/H. SM. SR. W.

YE OLDE MUSIC SHOP
15 N. Main St.
Marissa, IL 62257
(618) 295-208
A. D. E. EK. ER. G. IR. K. M. O. P. RE. RS. S. S/H. SR. SYN. TC.

INDIANA

TAULBEE MUSIC CENTER
5010 Old Decatur Rd.
Fort Wayne, IN 46806
(219) 745-3876
A. E. EK. ER. G. IN. K. M. P. RS. S. S/H. SR. TC.

MARGHEE'S MUSIC MART
6637 Kennedy Ave.
Hammond, IN 46323
(219) 845-9560
A. B. BF. O. E. EK. ER. G. IN. IR. K. M. O. P. RE. RS. S. S/H. SL. SM. SR. SYN. TC. W.

WAGONER'S MUSIC SHOP
611 E. Jefferson St.
Plymouth, IN 46563
(219) 936-8714
A. B. BF. D. E. EK. ER. G. IN. IR. K. M. O. P. RS. S. S/H. SL. SM. SR. SYN. TC. W.

IOWA

DES MOINES MUSIC HOUSE
5801 Franklin
Des Moines, IA 50322
(515) 274-1556
A. BF. D. E. EK. ER. G. IN. IR. K. M. O. P. RE. RS. S. S/H. SL. SM. SR. SYN. TC.

KANSAS

E.M. SHORTS GUITARS
2525 East Douglas
Whichita, KS 67211
(316) 684-6252
A. BF. D. E. EK. ER. G. IN. K. M. O. P. R. RS. S. SYN. TC.

LITTLE APPLE MUSIC
413 Poyntz
Manhattan, KS 66502
(913) 539-1926
A. D. E. G. IN. K. M. O. P. RS. S. SR. TC.

STEAM MUSIC
125 SW. Gage Blvd.
Topeka, KS 66606
(913) 273-3334
A. BF. D. E. EK. ER. G. IN. K. M. O. P. RS. S. SM. SYN. TC.

LOUISIANA

GUITAR MASTER
713A S. Lewis
New Iberia, LA 70560
(318) 367-2318
A. BF. D. E. EK. ER. G. K. M. P. RS. S. S/H. SM. SR. SYN. TC. W.

MAINE

CRAZY ED'S MUSIC CENTER, INC
610 Congress St.
Portland, ME 04101
(207) 774-7592
A. D. E. EK. ER. G. IN. IR. K. M. O. P. RS. S. S/H. SL. SR. SYN. TC.

MARYLAND

AL HOMBURG MUSIC SHOP
51 North Centre Street
Cumberland, MD 21502
(301) 777-7955
A. B. BF. DE. EK. G. IN. IR. M. P. R. RS. S. SM. W.

CHUCK LEVIN'S WASHINGTON MUSIC CENTER
11151 Viers Mill Rd.
Wheaton, MD 20902
(301) 946-2300
A. B. BF. D. E. EK. ER. G. IR. K. M. O. P. RE. RS. S. SL. SR. SYN. TC. W.

VENEMAN MUSIC CO.
1150 Rockville Pike
Rockville, MD 20852
(301) 762-5100
A. B. O. E. EK. ER. G. M. P. RE. RS. S. S/H. SL. SR. SYN. TC. W.

ALEXANDERS HOUSE OF MUSIC
Route 50 Shoppers World
Salisbury, MD 21801
(301) 749-6372
A. B. BF. O. E. EK. ER. G. IN. IR. K. M. O. P. RS. S. S/H. SM. SR. SYN. TC. W.

MASSACHUSETTS

THE MUSIC GALLERY
104 Russell St.,
Hadley, MA 01035
(413) 586-6228
A. O. E. EK. ER. G. K. M. O. P. RE. RS. S. S/H. SL. SR. SYN. TC.

MISTER MUSIC INC.
128-132 Harvard Ave.
Boston, MA 02134
(617) 783-1609
A. BF. O. E. EK. G. IN. K. M. P. RS. S. SYN. TC.

Dealer Buyers' Guide

BARNSTORM MUSIC
167 Main St.
Milford, MA 01757
(617) 473-9802
A. BF. D. E. EK. ER. G. IN. IR. K. M. P. R. S. S. SM. SYN. TC.

MICHIGAN

ANN ARBOR MUSIC MART
336 S. State St.
Ann Arbor, MI 48104
(313) 769-4980
A. B. BF. D. E. EK. ER. G. IN. IR. K. M. O. P. R. E. RS. S. S/H. SL. SM. SR. SYN. TC. W.

BRUCE WINCH MUSIC SHOP
3404 S. Dort Highway,
Flint, Mich 48507
(313) 742-2131
A. BF. D. E. EK. ER. O. IN. IR. K. M. O. P. R. E. RS. S. S/H. SL. SM. SR. SYN. TC.

J. RUPPEL INSTRUMENT CO.
2580 Dixie Highway,
Pontiac, Michigan 48055
(313) 674-1493
A. BF. D. E. ER. G. IN. M. RS. S. S/H. SYN. TC.

MUSIC CITY
29478 Ford Rd.
Garden City, MI 48135
(313) 427-2270
A. B. BF. D. E. ER. G. IN. IR. M. P. R. S. S. S/H. SR. TC. W.

MARSHALL MUSIC
540 Frandor Shopping Center
Lansing, MI 48912
(517) 337-9700
A. B. BF. D. E. EK. ER. G. IN. IR. K. M. O. P. R. S. S. S/H. SM. SR. SYN. TC. W.

WATERMELON SUGAR INSTRUMENTS
12 S. Hamilton St.
Saginaw, MI 48062
(517) 793-7600
A. BF. D. E. EK. ER. G. IN. IR. M. P. R. E. RS. S. S/H. SL. SR. SYN. TC.

PETERSON MUSIC
11755 15 Mile Rd.
Sterling Heights, MI 48077
(313) 979-8780
A. B. BF. D. E. ER. G. IN. IR. M. P. R. S. S. S/H. SM. SR. TC. W.

GOOD NEWS GUITAR SHOP
140 E. Front St.
Traverse City, MI 49684
(616) 946-1230
A. BF. D. E. EK. ER. G. IN. IR. M. P. R. S. S. S/H. SL. SM. SR. SYN. TC.

JACKSON-PRATT MUSIC CO.
2964 Biddle Ave.
Wyandotte, MI 48192
(313) 283 7959
A. D. E. ER. G. IN. M. P. R. S. S. S/H. SR.

MISSOURI

FAZIO'S FRETS AND FRIENDS
1159 Colonnade Ctr/12240 Manchester Road.
St. Louis, MO 63131
(314) 822 8710
A. BF. D. E. ER. G. IN. IR. M. P. R. S. S. S/H. SM. SR. TC.

NEVADA

MAYTAN MUSIC CENTER
777 S. Center,
Reno, NV 89501
(702) 323-5443
A. B. BF. D. E. EK. ER. G. IN. IR. K. M. O. P. R. S. S. S/H. SM. SR. SYN. TC. W.

NEW JERSEY

DLD TOWNE MUSIC
Turnersville, Mantua, NJ
(609) 228-003/468-2393
A. B. BF. E. EK. ER. G. IN. IR. K. M. D. P. R. S. S. S/H. SM. SR. SYN. TC. W.

NOLDES MUSIC BDX INC.
Hunterdon Shopping Center
Flemington, NJ 08822
(201) 782-2824
A. BF. D. E. EK. ER. G. IN. IR. K. M. O. P. R. E. RS. S. S/H. SL. SM. SR. SYN. TC.

MUSICIAN'S WORLD
1575 Route 23
Butler, NJ 07405
(201) 492-1110
A. E. EK. G. IN. IR. S. S/H. SYN.

STAR MUSIC
26 Washington St.
Morristown, NJ 07960
(201) 267-9250
A. B. BF. D. E. EK. ER. G. IR. M. O. P. R. E. RS. S. S/H. SM. SR. SYN. TC. W.

DAVE PHILLIPS MUSIC & SOUND
Route 57 Lopat Plaza
Phillipsburg, NJ 08865
(201) 454-3313
A. D. E. EK. ER. G. IN. IR. M. O. P. R. E. RS. S. S/H. SL. SR. SYN. TC.

RONDO MUSIC
Highway 22 at Vauxhall Rd.
Union, NJ 07083
(201) 687-2250
A. B. BF. D. E. EK. ER. G. IN. IR. K. M. O. P. R. E. RS. S. S/H. SL. SM. SR. SYN. TC. W.

NEW YORK CITY

ART-SHELL MUSIC
167 West 48th St.
New York, NY 10036
(212) 869-8337
A. B. E. EK. ER. G. K. M. O. P. R. S. S. S/H. SR. SYN. TC. W.

NIGHTOWL MUSIC SUPPLY
27 East 21st Street,
New York, NY 10010
(212) 677-8336
A. D. E. EK. ER. G. IN. IR. K. M. O. P. R. S. S. SM. SYN. TC. W.

SILVER & HORLAND
170 West 48th Street,
New York, NY 10036
(212) 869-3870
A. B. D. E. EK. G. K. M. D. P. R. R. S. S. SM. SYN. TC. W.

STUYVESANT MUSIC INC-THE GUITARMAN
174 West 48th St.
New York, NY 10036
(212) 221-5821
A. B. D. E. EK. ER. G. IR. K. M. O. P. R. S. S. SYN. TC. W.

TERMINAL MUSIC
166 W. 48th St.
New York, NY 10036
(212) 245-5249
A. B. BF. D. E. EK. G. K. M. O. P. R. S. S. SR. TC. W.

MAGGIO MUSIC CENTER
8403 18th Ave.
Brooklyn, NY 11214
(212) 259-4468
A. B. BF. D. E. EK. ER. G. IN. IR. K. M. O. P. R. S. S. SM. SYN. TC. W.

NEW YORK STATE

A & M MUSIC
Downstreet Market Place
Saratoga Springs, NY 12866
(518) 584-8600
A. BF. E. EK. ER. G. IN. IR. K. M. P. R. S. S. S/H. SM. SR.

OSSING MUSIC CENTER
Chilmark Shopping Center
Briarcliff Manor, NY 10510
(914) 762-0877
A. B. D. E. EK. ER. G. IN. IR. K. M. O. P. R. S. S. S/H. SM. SYN. TC. W.

GRACIN'S MUSIC ZOO
42A N. Franklin St.
Hempstead, NY 11550
(516) 483-6160
A. E. EK. ER. G. K. M. O. P. R. E. RS. S. S/H. SL. SR. SYN. TC.

H. NEEDHAM CUSTOM INSTRUMENTS / RESTORATIONS
178 2nd St.
Ilion, NY 13357
(315) 894 5149
G. P. R. S. S. S/H. TC.

HILTON MUSIC
900 Central Ave.
Albany, NY 11206
(518) 459-8298
A. B. D. E. EK. ER. G. IN. IR. K. M. O. P. R. S. S. S/H. SL. SR. SYN. TC. W.

HAMBURG & EAST AURORA MUSIC CENTERS
Camp Rd. at Sunset Dr.
Hamburg, NY 14075
(716) 649-6660
A. B. BF. D. E. ER. G. IN. IR. K. M. P. R. S. S. S/H. SM. W.

MAN-O-MANN PRODUCTIONS
3100 N. Tripphammer Rd.
Lansing, NY 14882
(607) 533-7122
A. D. E. EK. ER. G. IN. IR. K. M. O. P. R. E. RS. S. S/H. SL. SR. SYN. TC.

RAINBOW MUSIC
Dept A 236 Main St.
New Paltz, NY 12561
(914) 255-5552
A. E. ER. G. IR. M. P. R. S. S. S/H. SR. TC.

DUTCHESS ELECTRONIC MUSIC CENTER
328 Manchester Rd.
Poughkeepsie, NY 12603
(914) 471-4400
A. E. EK. ER. G. IN. IR. K. M. O. P. R. E. RS. S. S/H. SL. SR. SYN. TC.

ONONDAGA MUSIC
412 S. Clinton St.
(Downtown) Syracuse, NY 13202
(315) 422-8423
A. B. BF. D. E. EK. G. IN. IR. K. M. O. P. R. S. S. S/H. SM. SR. SYN. TC. W.

NORTH CAROLINA

AUDIO LIGHT & MUSICAL
4437 Beryl Rd.
Raleigh, NC 27606
(919) 832-0123
A. BF. D. E. EK. ER. G. K. M. O. P. R. E. RS. S. S/H. SL. SM. SR. SYN. TC.

CURTIS MUSIC CITY SOUNDS
Dgburn Station Shopping Center
Winston Salem, NC 27105
(919) 767-6480
A. BF. D. E. G. M. P. S. S/H. SR.

OHIO

J. J.'S MUSIC CENTER
612 Adams St.
Toledo, OH 43604
(419) 243-7781
A. BF. D. E. EK. ER. G. IN. IR. K. M. O. P. R. E. RS. S. S/H. S. SM. SR. SYN. TC.

LABASH MUSIC
252 Front
Berea, OH 44017
(216) 243-5616
BF. G. IN. IR. P. R. S. S.

MAYFIELD MUSIC
3084 Mayfield
Cleveland, OH 44118
(216) 371-8599
A. B. D. E. EK. ER. G. IR. K. M. O. P. R. S. S. SYN. TC. W.

MILLERS MUSIC
124 North Main St.
Bryan, OH 43506
(419) 636 5514
A. B. BF. D. E. ER. G. IN. IR. M. P. R. S. S. SM. TC. W.

METRANOME MUSIC STORE
40 S. Trimble Rd
Mansfield, OH 44906
(419) 529-8383
A. B. BF. D. E. EK. ER. G. IN. IR. K. M. O. P. R. S. S. SM. SYN. TC. W.

OKLAHOMA

MILLER BAND INSTRUMENT CO.
513 C Ave.
Lawton, OK
(405) 357-1211
A. B. BF. D. E. ER. G. IN. IR. M. P. R. S. S. SM. TC. W.

GRIFFIN MUSIC
8140 S. Harvard,
Tulsa, OK 74136
(918) 481-1167
A. BF. D. E. EK. ER. G. IN. IR. K. M. P. R. S. S. SYN. TC.

MUSIC SOUND WORLD
2715 South Memorial Drive,
Tulsa, OK 74129
(918) 664-2555
A. D. E. EK. ER. G. K. M. O. P. R. R. S. S. SYN. TC.

PENNSYLVANIA

MUSIC II
305 W. Trenton Ave.
Morrisville, PA 19067
(215) 295-5656
A. BF. D. E. EK. ER. G. IN. IR. K. M. O. P. R. S. S. S/H. SL. SM. SR. TC.

ZAPP'S MUSIC STORE INC.
5429 N. 5th St.
Philadelphia, PA 19120
(215) 924-8736
A. B. BF. D. E. EK. ER. G. IN. IR. K. M. P. R. S. S. S/H. SM. SR. SYN. TC. W.

SPECIALTY GUITAR SHOP
75 Noble Ave.
Pittsburgh, PA 15205
(412) 921-3204
A. BF. E. ER. G. IN. IR. M. P. R. S. S. S/H. SL. SM. SR. TC.

SWISSVALE MUSIC STORE
2035 Noble St.
Pittsburgh, PA 15218
(412) 351-5882
A. BF. D. E. ER. G. IN. IR. M. P. R. E. RS. S. S/H. SL. SR. TC.

FREDS MUSIC SHOP
140 N. Ninth St.
Reading, PA 19601
(215) 373-4545
A. B. BF. D. E. EK. ER. G. IN. K. M. O. P. R. E. RS. S. S/H. SL. SR. SYN. TC. W.

SIGHT & SOUND
2513 Main (Route 309)
Schnecksville, PA 18078
(215) 799-2500
A. E. ER. M. P. R. E. RS. S. S/H. SL. SR. TC.

THE MUSIC STORE, INC.
525 Main St.
Stroudsburg, PA 18360
(717) 424-6040
A. BF. D. E. EK. ER. G. IN. K. M. O. P. R. E. RS. S. S/H. SL. SM. SR. SYN. TC.

SOUTH CAROLINA

MELODY MUSIC CENTER
258 St. Andrews Rd
Columbia, SC 29210
(803) 772-1211
A. B. BF. D. E. EK. ER. G. IN. IR. K. M. O. P. R. S. S. SM. SYN. TC. W.

TEXAS

PICKER'S PARADISE
3809 North I H 35,
Austin, TX 78722
(512) 451-7373
A. D. E. EK. ER. G. IN. K. M. O. P. R. R. S. S. SM. SYN. TC. Kelsey/Crest, Tama, Roland, Acoustic, Sunn.

Dealer Buyers' Guide

Continued from previous page

EVANS MUSIC CITY
6240 Westheimer,
Houston, TX 77057
(713) 781-2100
A. B. F. D. E. EK. ER. G. IN. IR. K. M. O. P.
RS. S. SM. SYN. TC. W.

RICK HPHILLIPS MUSIC SPECIALTIES
2317 Winnie,
Galveston, TX 77550
(713) 762-8849
A. B. F. D. E. EK. ER. G. IN. IR. M. P. R.
RS. S. SM. SYN. TC. Peavey, Gibson,
Acoustic, Alvarez-Yairi, Polytone.

CROSSROADS AUDIO, INC.
4535 McKinney Ave.
Dallas, TX 75205
(214) 528-0600
A. E. ER. IR. M. P. RS. TC.

SOUND VIBRATIONS
1638 S. Staples
Corpus Christi, TX 78404
(512) 884-8981
A. B. F. D. E. EK. ER. G. IN. K. M. O. P.
RS. S. SM. SYN. TC. W.

FRETS AND STRINGS
4451 Lovers Lane
Dallas, TX 75225
(214) 526-8220
A. B. F. E. ER. G. IN. IR. M. P. RS. S. SM.

McCORD MUSIC CO.
1916 Elm St.
Dallas, TX 75201
(214) 741-3483
A. B. F. D. E. EK. ER. G. IN. IR. M. P.
RS. S. SM. TC.

McCORD MUSIC CO.
1074 Valley View Center
Dallas, TX 75240
(214) 661-9555
A. B. F. D. E. EK. ER. G. IN. IR. M. P.
RS. S. SM. TC.

ROLI'S MUSIC
1505 Zaragoza St. (2nd fl)
Laredo, TX 78040
(512) 724-5198
A. D. E. EK. G. IN. IR. K. M. O. P. RS. S.
SYN. TC.

LOVEALL MUSIC
3923 State Line Ave.
Texarkana, TX 75501
(214) 794-3735
A. B. F. D. E. EK. ER. G. IN. IR. M. P.
RS. S. SM. TC. W.

UTAH

GUITAR DOCTOR
573 N. State
Orem, UT 84057
(801) 226-3015
A. B. F. D. E. EK. ER. G. K. M. O. P. RS. S.
SYN. TC.

GUITAR CITY
470 North 1100 West
Centerville, UT 84014
(801) 292-8461
A. B. F. D. E. EK. ER. G. IN. IR. K. M. O. P.
RS. S. SM. SYN. TC. W.

VIRGINIA

AUDIO LIGHT & MUSICAL
3301 N. Military Highway
Norfolk, VA 23518
(804) 853-2424
A. B. F. D. E. EK. ER. G. K. M. O. P. RS. S.
SM. SYN. TC.

PICKER'S SUPPLY
606 William St.
Fredericksburg, VA 22401
(703) 371-4669
A. B. F. E. EK. ER. G. IN. K. M. P. RS. S.
TC.

TOM'S GUITAR SHOP
714 S. Newmarket Sq.
Newport News, VA 23605
(804) 245-3200
A. B. F. E. ER. G. IN. M. P. RS. S. TC

ROLLS MUSIC
1065 W. Broad
Falls Church, VA 22046
(703) 533-9500
A. D. E. EK. ER. G. K. M. O. P. RS. S.
SYN. TC.

VERMONT

DARRELL'S MUSIC
179 Pearl St.
Burlington, VT 05401
(802) 863-2950
A. B. F. D. E. EK. ER. G. IN. IR. K. M. O.
P. RS. S. SM. SYN. TC. W.

DOWNTOWN MUSIC
Main St.
Whiteriver Jct., VT 05001
(802) 295-7945
A. B. F. D. E. EK. ER. G. IN. IR. K. M. O.
P. RS. S. SM. SYN. W.

WEST VIRGINIA

GORBY'S MUSIC, INC.
214 7th Ave.
S. Charleston, W. VA 25303
(304) 744-9452
A. B. F. D. E. EK. ER. G. IN. IR. K. M. O.
P. RS. S. SM. SYN. TC. W.

MICHAUX MUSIC CTR.
5306 MacCorkle Ave.
Charlestown, W. VA 25304
(304) 925-2122
A. B. F. D. E. EK. ER. G. IN. IR. K. M. O. P.
RS. S. TC. W.

WISCONSIN

WARD-BRODT MUSIC CO.
315 N. Henry St.
Madison, WI 53703
(608) 257-2595
A. B. F. D. E. EK. ER. G. IN. IR. K. M. O.
P. RS. S. SM. SYN. TC. W.

WARD-BRODT MUSIC CO.
6725 Seybold Rd.
Madison, WI 53711
(608) 271-1460
BF. IN. IR. K. O. S. SM.

CANADA

STEVE'S MUSIC STORE
415 Queens St. W.
Toronto, ON M5S 1T5
(416) 366-8888/5641
A. B. F. D. E. EK. ER. G. M. O. P. RS. S.
SYN. TC. W.

**PRO MUSIC — DIV. OF INTERNATIONAL
MUSICLAND LTD.**
460 McArthur Rd. at St. Laurent Blvd.
Ottawa, Ontario K1K 3B8
(613) 749-6632
A. B. F. D. E. EK. ER. G. IN. K. M. P. RS. S.
SM. TC. W.

HOUSE OF MUSIC
115 Main Street, Dartmouth, NS,
Canada B2X 1R6
(902) 434-5020
D. E. ER. G. IN. IR. M. P. RS. S.

BILL LEWIS MUSIC LTD
3607 West Broadway,
Vancouver, BC V6R 2B8
(604) 738-3151
A. B. F. E. EK. ER. G. IN. K. M. O. P. R. RS.
S. SM. SYN. TC. W.

BOB INGLES MUSIC SHOP
329 8th Ave. SW.
Calgary, Alberta T2P 1C4
(404) 269-9286
A. B. F. D. E. EK. ER. G. IN. M. P. RS. S. SM. W

LIBRA MUSIC
840 Rossland Ave.
Trail, British Columbia V1R 3N3
(604) 364-2922
A. B. F. D. E. EK. ER. G. IN. K. M. O. P. RS.
S

AXIS MUSIC
3959 E. Hastings
Vancouver, British Columbia V5C 2H8
(604) 299-7521
A. E. EK. ER. G. M. P. RE. RS. S. SYN.
TC.

CHARLES HUTTON AND SONS LTD.
222 Water St.
St. Johns, NF A1C 5V3
(709) 754-0290
A. B. F. D. E. EK. ER. G. IN. IR. M. P. RS. S. SM.
SYN. TC. W.

INTERNATIONAL MUSIC CENTER LTD.
162 10th St.
Brandon, Manitoba R7A 4E6
(204) 727-1827
A. B. F. D. E. EK. ER. G. IN. IR. K. M. O. P.
RS. S. SM. SYN. W.

STEVE'S MUSIC STORE
51 St. Antoine St. W.
Montreal, PQ H2Z 1G9
(514) 878-2258/2216
A. B. F. D. E. EK. ER. G. M. O. P. RS. S.
SYN. TC. W.

AU DIAPASON ENGR.
7788 Sherbrooke St. E.
Montreal, PQ H1L 1A5
(514) 354-8008
A. B. F. D. E. EK. ER. G. IN. IR. K. M. O.
P. S. SM. SYN. W.

RICHARD AUDIO INC.
6078 Sherbrooke St. W.
Montreal, PQ H4A 1Y1
(514) 487-9950
A. E. ER. M. P. RS. TC.

EZZY'S MUSIC/DUTY FREE TO CAN.
POB 151
St. Leonard, NB EOLIMO
(207) 868-2838
A. B. F. D. E. EK. G. IR. K. M. O. P. S.
SM. SYN. TC. W.

CONTINENTAL MUSIC
220 Rideau St.
Ottawa, ON K1N 5Y1
(613) 235-4223
A. B. F. D. E. EK. ER. G. IN. K. M. O. P.
RS. S. SM. SYN. TC. W.

Percussion Dealer Directory

KEY FOR DRUM DIRECTORY

AP Assorted Percussion
CU Customizing
CY Cymbals
DR Drums
BR Brushes
G Gongs
H Heads
HD Hand Drums
INS Instruction
MA Mallets
MO Mail Order
MU Mutes
PS Percussion Syn
RC Road Cases
RP Repairs
RT Rental
ST Sticks
TB Timbales
TI Trade-Ins
TP Timpani
S/H Second Hand Equipment
PD Pedals
IN Information
BF Books & Folios

INDIANA

THE PERCUSSION CENTER
1701 North Harrison Street,
Fort Wayne, Indiana 46808
(219) 424-1125
AP. CU. CY. DR. BR. G. H. HD. MA. MO.
MU. PS. RC. RP. RT. ST. TB. TI. TP. S/H.
PD. IN. BF.

MASSACHUSETTS

HARVEY SIMON DRUM SHOP
295 Huntington St., Suite 214
Boston, MA 02115
(617) 536-9307
AP. CU. CY. OR. BR. G. H. HD. MA. MO.
MU. RC. RP. RT. ST. TB. TI. TP. S/H. PD.
IN. BF.

MONTANA

DROSTES DRUM DEN
18 N. 29th St.
Billings, MT 59101
(406) 248-5930
AP. CU. CY. OR. BR. G. H. MA. MO. PS.
RC. RP. ST. TB. TI. TP. S/H. PD. IN. BF.

NEW YORK CITY

STIX NICKSON DRUM STUDIO
27 East 21st Street,
New York, NY 10010
(212) 677-8336
AP. CU. CY. DR. BR. G. H. HD. INS. MA.
MO. MU. PS. RC. RP. RT. ST. TB. TI.
S/H. PD. IN. BF.

TEXAS

McCORD MUSIC
1074 Valley View Center,
Dallas, TX 75240
(214) 661-9555
AP. CU. CY. OR. BR. G. H. HO. MA. MU.
PS. RC. RP. ST. TB. TI. S/H. PD. IN. BF.

IM & RW BULLETIN BOARD

Classified Advertising Rates

\$10 per line (minimum 2 lines)
Display ads - \$75 per column inch
 6x rate: 10% discount
 12x rate: 20% discount

Check/Money Order must accompany copy and be received 6 weeks prior to the coming publication. All classified ads accepted at the discretion of the publisher.

Categories

Musician's Forum (singer; band; specific musician wanted or available); Instruction; Used equipment and instruments wanted or for sale; Repair service (custom or rebuilding work); Rehearsal Studios; Rentals (lighting and/or sound companies; road/trucking companies); Workshops & Seminars; Custom Recording.

For information call Mark Warner at (212) 921-9050 or write:

International Musician and Recording World
 1500 Broadway Suite 1909
 New York, NY 10036

NOISE N.Y.
 Otan 8 Trk. Fully equip'd studio
 34th St. Competitive prices. (212) 947-0048

CUSTOM DESIGNED STUDIOS

and acoustic consulting for rehearsal and recording studios.
ANALOGIQUE SYSTEMS,
 17 West 17th St. N.Y.C. 10011 Phone (212) 989-4240.

RHYTHM SECTION LAB

guitar • bass • keyboards • drums
Study with
 Rick Laird (bass), John Scofield and Jack Wilkins (gtr.), Robbie Gonzalez (drums) among many other top NY players
Private, group, ensemble classes
 RHYTHM SECTION LAB
 130 West 42nd St. Suite 948
 New York, N.Y. 10036 (212) 840-0433

"TRANE 'n ME"

A Treatise on the Music of John Coltrane by Andrew White the acknowledged world's leading authority on the music of John Coltrane.
 \$10.00 plus \$1.00 post in US; \$2.00 outside US, Direct from
 Andrew White
 4830 So. Dakota Ave., N.E.
 Washington, D.C. 20017

MOBILE RECORDING

314 ROMANO • CORAL GABLES, FLA. 33134
 (305) 446-2477 / 665-3487

GUITAR, Mancuso custom with natural finish. Mint condition, excellent tone and D'Armond pickup. Beautiful guitar less than one year old, \$2,600.00. Richard L. Aguilera, 60 South Hollywood Ave., Groversville, N.Y. 12078. Phone: (518) 725-7925 or (518) 725-6304.

FLEISHMAN INSTRUMENTS—Hand-built, custom designed, electric and acoustic, basses and guitars. Write for free brochure: 525 E. Ohio Ave., Denver, Colorado 80209. (303) 777-2168

Custom modifications and repairs, custom instruments. Fast personalized service. Modestly priced. Impeccable work guaranteed. Manny Salvador's Guitar Shop.
 212-594-5670 By appointment only.

GUITAR, Koontz custom scroll, collector's item. Natural finish with D'Armond pickup and custom case. Mint condition, \$4,200.00. Richard L. Aguilera, 60 South Hollywood Ave., Groversville, N.Y. 12078. Phone: (518) 725-7925 or (518) 725-6304.

PROFIT WITH THE BEST

16 models to choose from, superbly customized to your specifications. For beauty, sound, and playability: Ken Smith Basses Ltd.
 27 E. 13th St.
 New York, NY 10003
 (212) 243-2777
 Only Ken Smith can make a better bass than Ken Smith.

The Apprentice Shop
 OFFERING COURSES IN
 guitar repair
 and
 guitar construction
 write
 The Apprentice Shop
 Box 267, Spring Hill, TN 37174
 or call 615-486-2615

Semi-Hollow Bodies

Solid Bodies

Basses

Built to Order

J-Ruppel
 INSTRUMENT CO

2580 Dixie Highway
 Pontiac, Michigan 48055
 Phone (313) 674-1493

ELECTRIC GUITARISTS!

With the Guitar Pro Tool Kit you can make your guitar sound better and easier to play. This gig-tested kit is compact, durable and easy to carry. You don't have to be a repairman to use it. With each kit there's a list of 30 maintenance and repair uses. Kit includes 12 top grade hand tools in a sturdy 12" x 18" canvas tool roll. Introductory price \$29.95 + \$2 shipping. Use it

- On the job
 - On the road
 - At home
- Tool roll without tools \$9.95 + \$2 shipping.

Send ck or m.o. to:
 GUITAR PRO, INC., 723 7th Ave. (12 Fl) NY, NY 10019
 Dept. 1 (212) 391-2163 NY residents add sales tax

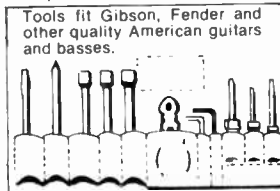

World Radio History

AGFA MASTERTAPE AND CASSETTES. Super prices. Example: 1/4" x 2400' bulk - 9.82 and C-60 for .86. (case quantities) Send for wholesale price list. Solid Sound, Inc., Box 7611-Dept. 1, Ann Arbor, Mich. 48105. Phone (313) 662-0667.

LPS BOUGHT, SOLD, new, used, out of print jazz, classical, pop, etc. Top dollar paid for your record collection. Want lists filled. Please include price offer. Princeton Record Exchange, 20 Nassau St., Princeton, NJ 08540. 609/921-0881.

FREE WEEKLY AUCTION LIST: All categories. LP's, 45's, 78's. Elmwood Record Sales, Box 10232, Elmwood, Ct. 06110.

BLANK AUDIO AND VIDEO CASSETTES

Direct from mfr. Below wholesale. Any length cassettes. 4 different qualities to choose from. Bulk & reel master tape from 1/4" to 2". Cassette duplication also available. Brochure.

ANDOL AUDIO PRODUCTS, INC., Dept IM,
 4212 14th Ave., Brooklyn, NY 11219
Toll Free: (800) 221-6578, Ext. 3.
 NY Res: (212) 435-7322, Ext. 3

\$ CASH \$ for your used Equipment

Sell your used drums, guitar, piano, organ, sax, trumpet, amplifier, speakers, PA system, violin, electronic accessory, synthesizer or what have you with Freeport Music.
 Send \$1.00 for information and catalog

FREEPORT MUSIC

144 Y Wolf Hill Rd Melville New York 11747

A SINGER'S DREAM!
 REMOVES VOCAL FROM MOST STEREO DISCS
 The Thompson Vocal Eliminator can actually remove most or virtually all of a solo vocalist from a standard stereo record and yet leave most of the background music untouched! Not an equalizer! We can prove it works over the phone. Write or call for a 24 page brochure and demo record.
 Write to: LT Sound, Dept. I M, P.O. Box 338, Stone Mountain, GA 30086. Phone (404) 493-1258 COST: \$295.00

WE'VE HAD A MOVING EXPERIENCE

Please note our new address:

International Musician and Recording World
 12 West 32nd Street
 New York, New York
 10001

A CLASS ACT.

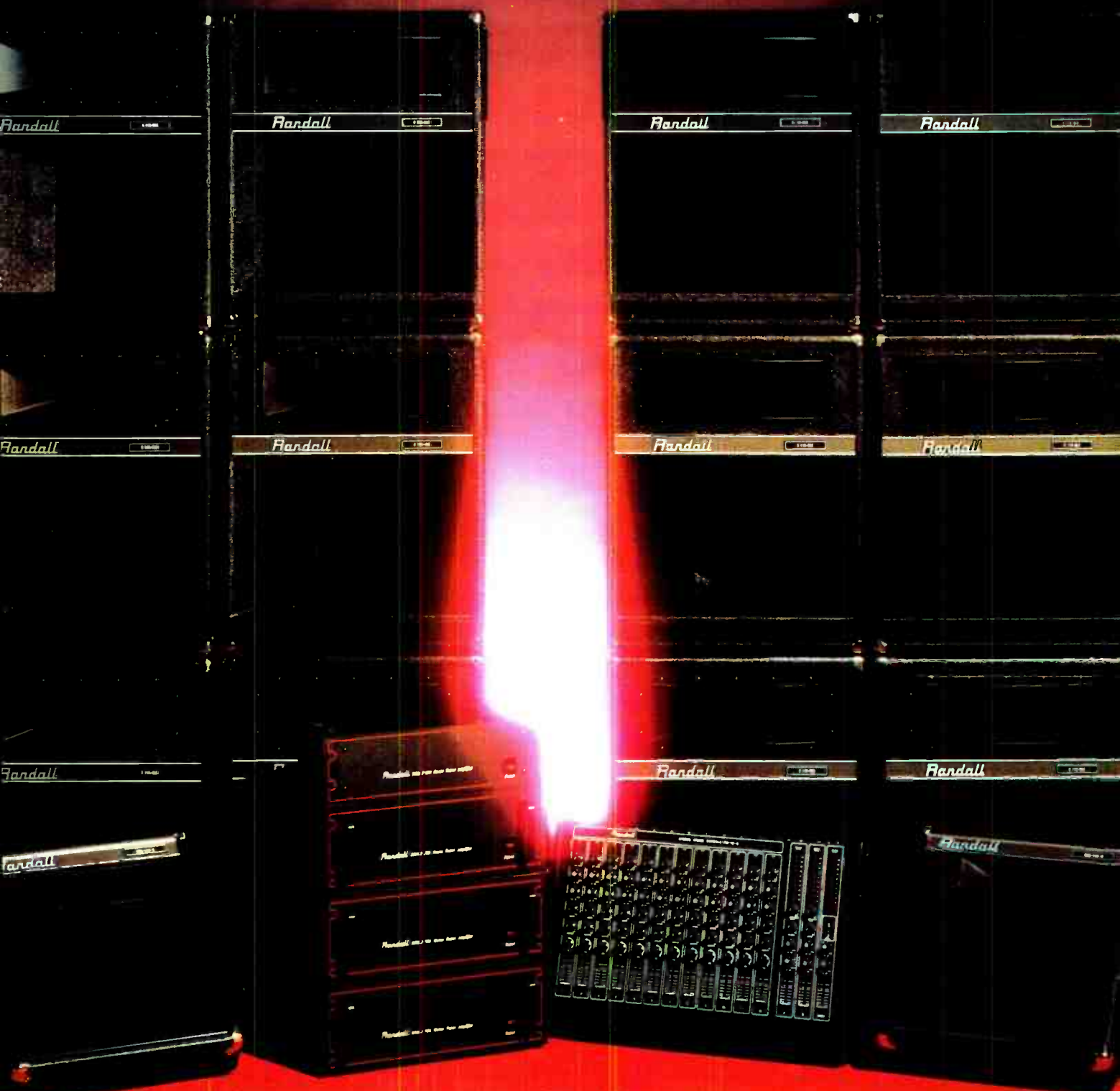

Equipment Pictured:

Enclosures R-115-HLC, Monitors RMS-112H, Power Amplifiers RRM 2-250, Power Amplifier RRM 2-120, 12 Channel Mixer RM 12-3

Randall

RANDALL INSTRUMENTS, INC.
1132 DURYEA, IRVINE, CALIF. 92714
P.O. BOX 10936, SANTA ANA, CALIF. 92711

Write for free short form catalog or send \$1.00 for complete loose leaf catalog with detailed specifications of other Randall products.

World Radio History

new from sunn®

AFFORDABLE QUALITY



Professional sound engineers agree that the sensitive, accurate controls of SUNN SPL mixing consoles are the finest available. Unlike other manufacturers, SUNN applies the latest in electronic technology then hand builds each product. This assures that original engineering design functions are not lost or distorted through automated assembly. Designed and manufactured at our factory in Oregon, every mixing console is sound-tested, adjusted, then carefully packaged and shipped to SUNN dealers world-wide. SUNN SPL mixing consoles have features, quality and affordable prices not available on our competitors products. Audition SUNN SPL mixing consoles today at your local SUNN dealer.

SUNN SPL 2212 (Twelve Channel Stereo)
SUNN SPL 2216 (Sixteen Channel Stereo)

sunn 

*The Name in
Quality Sound Products*

Sunn Musical Equipment Company
A Hartzell Corporation Company
19350 SW 89th Avenue
Tualatin, OR 97062